

TOSHIBA

SERVICE MANUAL

MULTIFUNCTIONAL DIGITAL COLOR SYSTEMS
**e-STUDIO2515AC/3015AC/
3515AC/4515AC/5015AC**

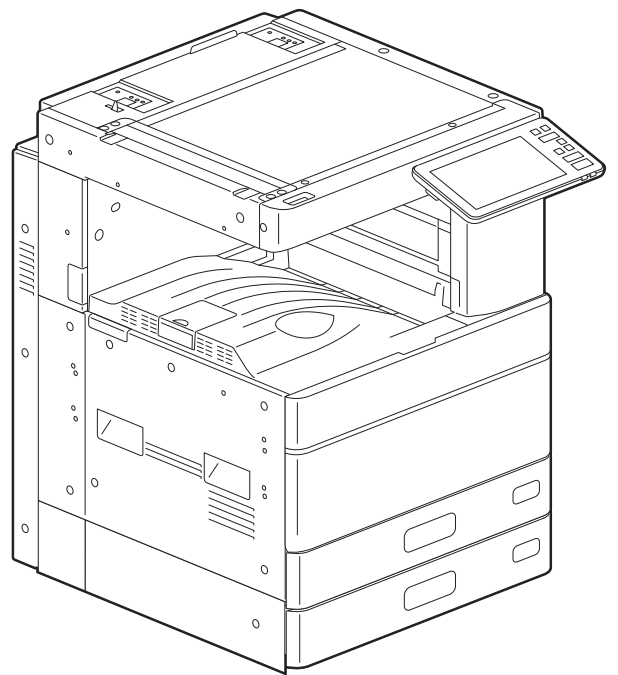

Model: FC-2515AC/3015AC/3515AC/4515AC/5015AC
Publish Date: June 2018
File No. SME180005B0
R180221U4502-TTEC
Ver02 F1_2020-09

Trademarks

- The official name of Windows[®] 7 is Microsoft Windows 7 Operating System.
- The official name of Windows[®] 8.1 is Microsoft Windows 8.1 Operating System.
- The official name of Windows[®] 10 is Microsoft Windows 10 Operating System.
- The official name of Windows Server[®] 2008 is Microsoft Windows Server 2008 Operating System.
- The official name of Windows Server[®] 2012 is Microsoft Windows Server 2012 Operating System.
- The official name of Windows Server[®] 2016 is Microsoft Windows Server 2016 Operating System.
- Microsoft, Windows, Windows NT, and the brand names and product names of other Microsoft products are trademarks of Microsoft Corporation in the US and other countries.
- Apple, AppleTalk, Macintosh, Mac, Mac OS, Safari, iPhone, iPod touch, TrueType, AirPrint, AirPrint logo, and iPad are trademarks of Apple Inc.
- IOS is a trademark or registered trademark of Cisco in the U.S. and other countries and is used under license.
- Adobe, Acrobat, Reader, and PostScript are trademarks of Adobe Systems Incorporated.
- Mozilla[®], Firefox[®] and the Firefox logo[®] are trademarks or registered trademarks of Mozilla Foundation in the U.S. and other countries.
- IBM, AT and AIX are trademarks of International Business Machines Corporation.
- NOVELL[®], NetWare[®] and NDS[®] are trademarks of Novell, Inc.
- FLOIL[®] is a registered trademark of Kanto Kasei., Ltd.
- MOLYKOTE[®] is a registered trademark of Dow Corning Corporation.
- KAPTON[®] is a registered trademark of E. I. du Pont de Nemours and Company.
- Sankol[®] is a registered trademark of SANKEIKAGAKU CO.,Ltd.
- e-STUDIO, e-BRIDGE, and TopAccess are trademarks of Toshiba TEC Corporation.
- Other company names and product names in this manual are the trademarks of their respective companies.

© 2018-2020 Toshiba Tec Corporation All rights reserved

Under the copyright laws, this manual cannot be reproduced in any form without prior written permission of Toshiba Tec Corporation.

GENERAL PRECAUTIONS REGARDING THE SERVICE FOR THIS EQUIPMENT

The installation and service shall be done by a qualified service technician.

1. Transportation/Installation

- When transporting/installing the equipment, employ two or more persons and be sure to hold the positions as shown in the figure.
The equipment is quite heavy and weighs approximately 78.1 kg (172.2 lb.), therefore pay full attention when handling it.

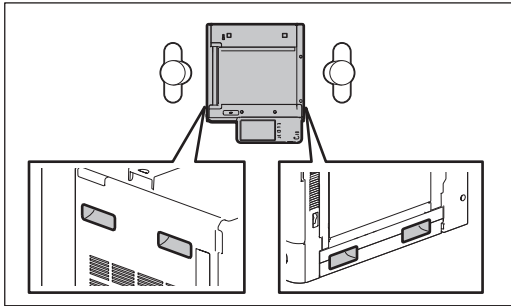

- Be sure not to hold the movable parts or units (e.g. the control panel, ADU or RADF) when transporting the equipment.
- Be sure to use a dedicated outlet with AC 110V/15A, 120V/12A, 220-240V/8A for its power source.
- The equipment must be grounded for safety.
- Select a suitable place for installation. Avoid excessive heat, high humidity, dust, vibration and direct sunlight.
- Provide proper ventilation since the equipment emits a slight amount of ozone.
- To insure adequate working space for the copying operation, keep a minimum clearance of 30 cm (11.8") on the left, 80 cm (32") on the right and 20 cm (7.9") on the rear.
- The equipment shall be installed near the socket outlet and shall be easily accessible.
- Be sure to fix and plug in the power cable securely after the installation so that no one trips over it.
- If the unpacking place and where the equipment is to be installed differ, perform image quality adjustment (automatic gamma adjustment) according to the temperature and humidity of the place of installation and the paper to be used.
- When the equipment is used after the option is removed, be sure to install the parts or the covers which have been taken off so that the inside of the equipment is not exposed.
- Do not lift the machine by the areas in the figure that are shaded when lifting it.

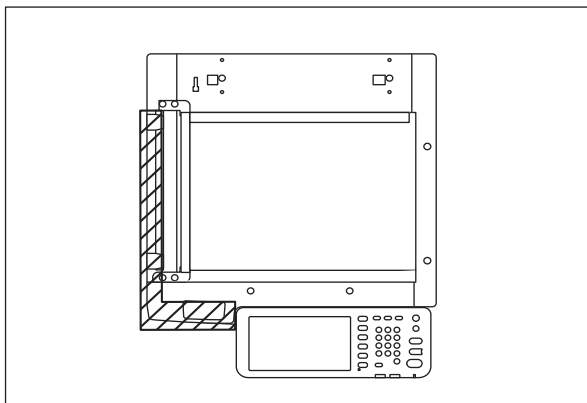

- Do not use an ozone generator near the MFP. Or, place any ozone generator as far away from the MFP as possible.
- Do not use an ultrasonic humidifier near the MFP.
Components such as chlorinate and mineral will be atomized by an ultrasonic humidifier and they will adhere to electric parts in the MFP. This could cause malfunctions.

2. General Precautions at Service

- Be sure to turn the power OFF and unplug the power cable during service (except for the service should be done with the power turned ON).
- After the power cable is disconnected, an electric charge may remain in the boards of the equipment. Therefore, be sure to disconnect or connect the connectors when about 1 minute (e.g.: the time for taking off the rear cover) has passed after the power cable is disconnected.
- The fuse could be in the neutral. The mains supply shall be disconnected to de-energize the phase conductors.
- Unplug the power cable and clean the area around the prongs of the plug and socket outlet once a year or more. A fire may occur when dust lies on this area.
- When the parts are disassembled, reassembly is the reverse of disassembly unless otherwise noted in this manual or other related documents. Be careful not to install small parts such as screws, washers, pins, E-rings, star washers, harnesses in the wrong places.
- Basically, the equipment should not be operated with any parts removed or disassembled.
- The PC board must be stored in an anti-electrostatic bag and handled carefully using an antistatic wrist strap since the ICs on it may be damaged due to static electricity.

Caution: Before using the antistatic wrist strap, unplug the power cable of the equipment and make sure that there are no charged objects which are not insulated in the vicinity.

- Avoid exposure to laser beam during service. This equipment uses a laser diode. Be sure not to expose your eyes to the laser beam. Do not insert reflecting parts or tools such as a screwdriver on the laser beam path. Remove all reflecting metals such as watches, rings, etc. before starting service.
- Be sure not to touch high-temperature sections such as the fuser unit, damp heater and areas around them.
- Be sure not to touch high-voltage sections such as the chargers, transfer belt, 2nd transfer roller, developer, high-voltage transformer, and power supply unit. Especially, the board of these components should not be touched since the electric charge may remain in the capacitors, etc. on them even after the power is turned OFF.
- Make sure that the equipment will not operate before touching potentially dangerous places (e.g. rotating/operating sections such as gears, belts pulleys, and fans and laser beam exit of the laser optical unit).
- Be careful when removing the covers since there might be the parts with very sharp edges underneath.
- When servicing the equipment with the power turned ON, be sure not to touch live sections and rotating/operating sections. Avoid exposing your eyes to laser beam.
- Use designated jigs and tools.
- Use recommended measuring instruments or equivalents.
- Return the equipment to the original state and check the operation when the service is finished.
- Be very careful to treat the touch panel gently and never hit it. Breaking the surface could cause malfunctions.
- Do not leave plastic bags where children can get at them. This may cause an accident such as suffocation if a child puts his/her head into a bag. Plastic bags of options or service parts must be brought back.
- There is a risk of an electric shock or fire resulting from the damage to the harness covering or conduction blockage. To avoid this, be sure to wire the harness in the same way as that before disassembling when the equipment is assembled/disassembled.

3. General operations

- Check the procedures and perform them as described in the Service Manual.
- Make sure you do not lose your balance.
- Avoid exposure to your skin and wear protective gloves as needed.

4. Important Service Parts for Safety

- The breaker, door switch, fuse, thermostat, thermofuse, thermistor, batteries, IC-RAMs including lithium batteries, etc. are particularly important for safety. Be sure to handle/install them properly. If these parts are short-circuited and their functions become ineffective, they may result in fatal accidents such as explosion or fire. Avoid short-circuiting and do not use parts not recommended by Toshiba Tec Corporation.

5. Cautionary Labels

- During servicing, be sure to check the rating label and cautionary labels to see if there is any dirt on their surface and if they are properly stuck to the equipment.

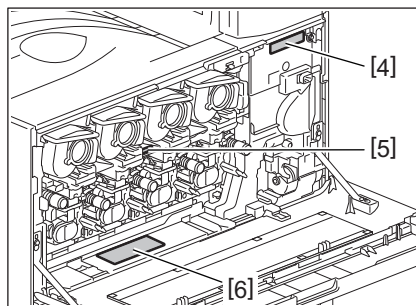
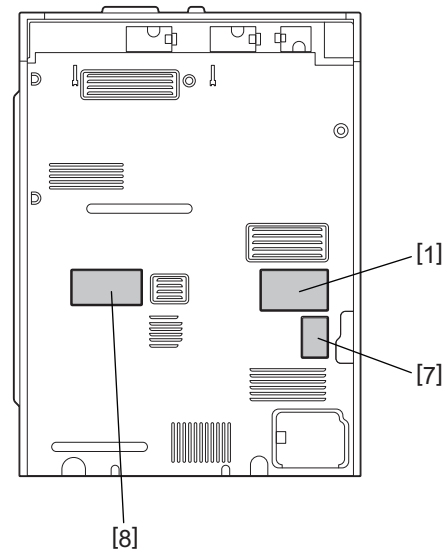
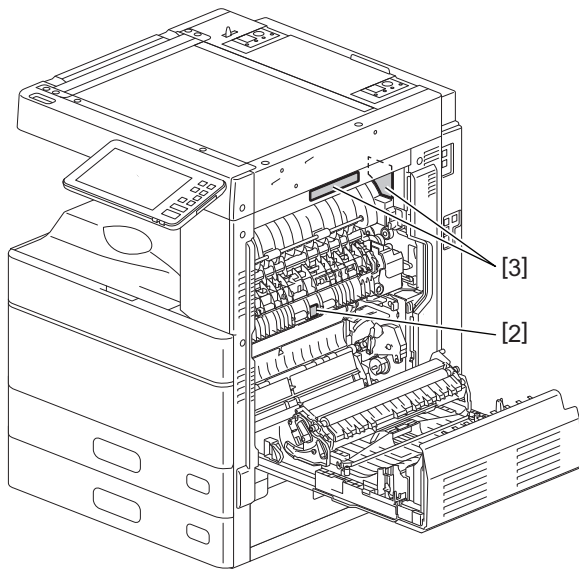

- [1] Rating label
- [2] Warning for high temperature area
- [3] Warning for high temperature area
- [4] Machine serial number label
- [5] Warning for high voltage area
- [6] Warning for laser
- [7] Warning for service
- [8] Warning for laser

6. Disposal of the Equipment, Supplies and Packing Materials

- Regarding the recovery and disposal of the equipment, supplies, packing materials, follow the relevant local regulations or rules.

7. Batteries and IC RAMs including lithium batteries etc.

CAUTION:

RISK OF EXPLOSION IF BATTERY IS REPLACED BY AN INCORRECT TYPE.

DISPOSE OF USED BATTERIES ACCORDING TO THE RELEVANT LOCAL REGULATIONS OR RULES.

1. Precautions for Transporting Equipment Once Unpacked

1.1 General Description

It is recommended to follow the procedure below when you transport equipment that has already been unpacked but has not been packed again. Note that the following procedure cannot guarantee the operation of the transported equipment.

[A] Fixing the carriage

- (1) Perform the PM code: FS-03-261 (Scan motor ON Automatically stops at limit position) so that the carriage is moved to the fixing position.
- (2) Tighten the 2 screws to fix the carriage.

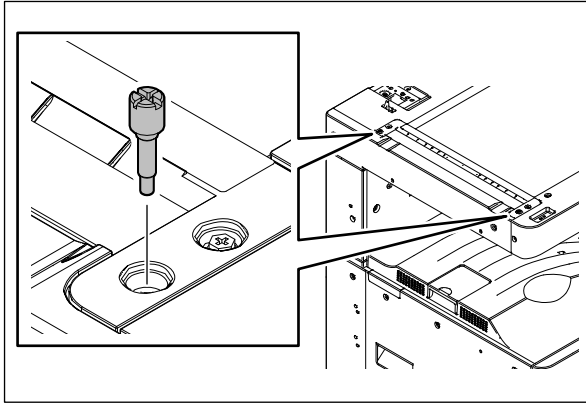

[B] Attach the packing material (scanner supporting member)

- (1) Attach the packing material under the scanner (if it is still kept immediately after the setup).

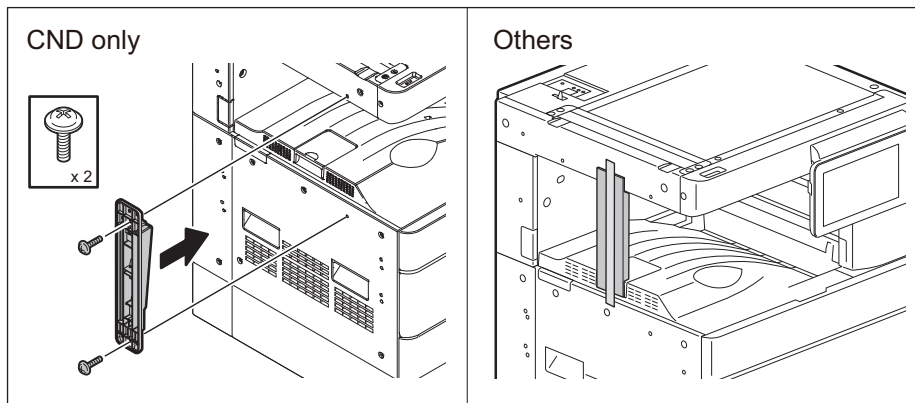

[C] Attach the cushioning material

When transporting the equipment with the DSDF installed, be sure to attach the cushioning material as below to prevent the cover in the scanner section from being scratched by the protrusion of the DSDF cover.

- (1) Fold the cushioning material (packing material) in two. (Utilize the packing material used in the scanner section, if available.) Place it on the upper surface of the scanner section so that it is covered.

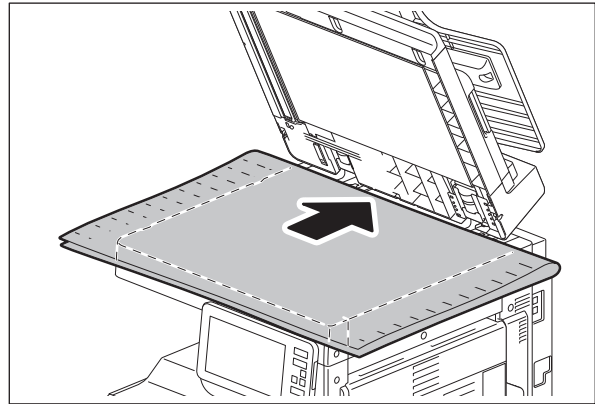
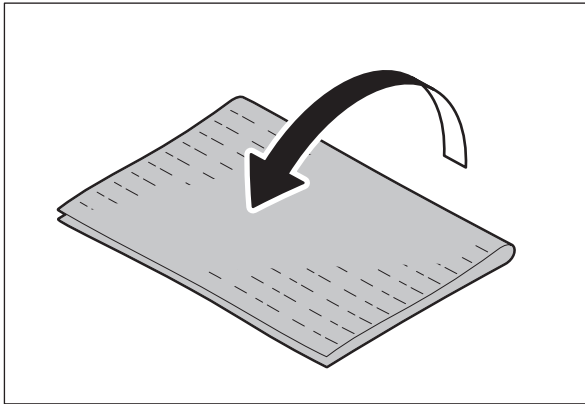

- (2) While paying attention to ensure that the cushioning material is not moved, slowly close the DSDF.

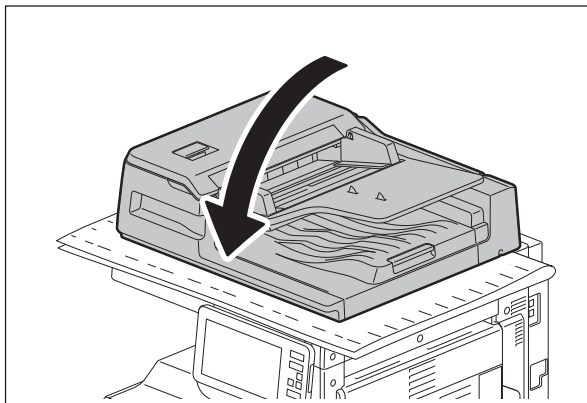

ALLGEMEINE SICHERHEITSMASSNAHMEN IN BEZUG AUF DIE WARTUNG

Die Installation und die Wartung sind von einem qualifizierten Service-Techniker durchzuführen.

1. Transport/Installation

- Zum Transportieren/Installieren des Gerätes werden 2 Personen benötigt. Nur an den in der Abbildung gezeigten Stellen tragen.
Das Gerät ist sehr schwer und wiegt etwa 78.1 kg; deshalb muss bei der Handhabung des Geräts besonders aufgepasst werden.

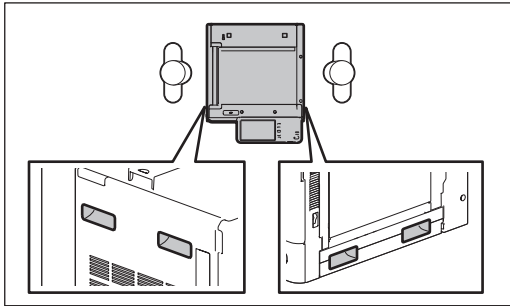

- Beim Transportieren des Geräts nicht an den beweglichen Teilen oder Einheiten (z.B. das Bedienungsfeld, die Duplexeinheit oder die automatische Dokumentenzuführung) halten.
- Eine spezielle Steckdose mit Stromversorgung von AC 110V/15A, 120V/12A, 220-240V/8A als Stromquelle verwenden.
- Das Gerät ist aus Sicherheitsgründen zu erden.
- Einen geeigneten Standort für die Installation wählen. Standorte mit zuviel Hitze, hoher Luftfeuchtigkeit, Staub, Vibrieren und direkter Sonneneinstrahlung sind zu vermeiden.
- Für ausreichende Belüftung sorgen, da das Gerät etwas Ozon abgibt.
- Um einen optimalen Kopierbetrieb zu gewährleisten, muss ein Abstand von mindestens 80 cm links, 80 cm rechts und 20 cm dahinter eingehalten werden.
- Das Gerät ist in der Nähe der Steckdose zu installieren; diese muss leicht zu erreichen sein.
- Nach der Installation muss das Netzkabel richtig hineingesteckt und befestigt werden, damit niemand darüber stolpern kann.
- Falls der Auspackungsstandort und der Installationsstandort des Geräts verschieden sind, die Bildqualitätsjustierung (automatische Gammajustierung) je nach der Temperatur und Luftfeuchtigkeit des Installationsstandorts und der Papiersorte, die verwendet wird, durchführen.
- Betreiben Sie keinen Ultraschall-Luftbefeuchter in der Nähe des MFP.
Chlorat- und mineralhaltige Komponenten werden von einem Ultraschallbefeuchter zerstäubt und die Partikel können sich an den elektrischen Teilen innerhalb des MFP anlagern. Dies kann zu Fehlfunktionen führen.

2. Allgemeine Sicherheitsmassnahmen in bezug auf die Wartung

- Während der Wartung das Gerät ausschalten und das Netzkabel herausziehen (ausser Wartung, die bei einem eingeschalteten Gerät, durchgeführt werden muss).
- Das Netzkabel herausziehen und den Bereich um die Steckerpole und die Steckdose die Umgebung in der Nähe von den Steckerzacken und der Steckdose wenigstens einmal im Jahr reinigen. Wenn Staub sich in dieser Gegend ansammelt, kann dies ein Feuer verursachen.
- Die Sicherung kann eingeschaltet bleiben. Der Stromstecker sollte jedoch gezogen werden, damit die internen Leiter von der Phase getrennt sind.
- Wenn die Teile auseinandergenommen werden, wenn nicht anders in diesem Handbuch usw erklärt, ist das Zusammenbauen in umgekehrter Reihenfolge durchzuführen. Aufpassen, dass kleine Teile wie Schrauben, Dichtungsringe, Bolzen, E-Ringe, Stern-Dichtungsringe, Kabelbäume nicht an den verkehrten Stellen eingebaut werden.
- Grundsätzlich darf das Gerät mit entfernten oder auseinandergenommenen Teilen nicht in Betrieb genommen werden.
- Das PC-Board muss in einer Anti-elektrostatischen Hülle gelagert werden. Nur Mit einer Manschette bei Betätigung eines Armbandes anfassen, sonst könnte es sein, dass die integrierten Schaltkreise durch statische Elektrizität beschädigt werden.

Vorsicht: Vor Benutzung der Manschette der Betätigung des Armbandes, das Netzkabel des Gerätes herausziehen und prüfen, dass es in der Nähe keine geladenen Gegenstände, die nicht isoliert sind, gibt.

- Setzen Sie sich während der Wartungsarbeiten nicht dem Laserstrahl aus. Dieses Gerät ist mit einer Laserdiode ausgestattet. Es ist unbedingt zu vermeiden, direkt in den Laserstrahl zu blicken. Keine reflektierenden Teile oder Werkzeuge, wie z. B. Schraubendreher, in den Pfad des Laserstrahls halten. Vor den Wartungsarbeiten sämtliche reflektierenden Metallgegenstände, wie Uhren, Ringe usw., entfernen.
- Auf keinen Fall Hochtemperaturbereiche, wie die Fixiereinheit, die Heizquelle und die umliegenden Bereiche, berühren.
- Auf keinen Fall Hochspannungsbereiche, wie die Ladeeinheiten, das Transferband, die zweite Transferwalze, die Entwicklereinheit, den Hochspannungstransformator und das Netzgerät, berühren. Insbesondere sollten die Platinen dieser Komponenten nicht berührt werden, da die Kondensatoren usw. auch nach dem Ausschalten des Geräts noch elektrisch geladen sein können.
- Vor dem Berühren potenziell gefährlicher Bereiche (z. B. drehbare oder betriebsrelevante Bereiche, wie Zahnräder, Riemen, Riemenscheiben, Lüfter und die Laseraustrittsöffnung der optischen Lasereinheit) sicherstellen, dass das Gerät sich nicht bedienen lässt.
- Beim Entfernen von Abdeckungen vorsichtig vorgehen, da sich darunter scharfkantige Komponenten befinden können.
- Bei Wartungsarbeiten am eingeschalteten Gerät dürfen keine unter Strom stehenden, drehbaren oder betriebsrelevanten Bereiche berührt werden. Nicht direkt in den Laserstrahl blicken.
- Ausschließlich vorgesehene Werkzeuge und Hilfsmittel verwenden.
- Empfohlene oder gleichwertige Messgeräte verwenden.
- Nach Abschluss der Wartungsarbeiten das Gerät in den ursprünglichen Zustand zurück versetzen und den einwandfreien Betrieb überprüfen.
- Das berührungsempfindliche Bedienungsfeld stets vorsichtig handhaben und keinen Stößen aussetzen. Wenn die Oberfläche beschädigt wird, kann dies zu Funktionsstörungen führen.
- Bewahren Sie Kunststofftüten kindersicher auf. Es besteht Erstickungsgefahr, wenn sich Kinder beim Spielen eine Kunststofftüte über den Kopf ziehen. Bitte nehmen Sie die Kunststofftüten von Optionen oder Serviceparts wieder zurück.
- Wenn der Schutzmantel eines Kabels oder die Steckerisolierung beschädigt werden, besteht Brandgefahr oder die Gefahr eines elektrischen Schlags. Um dies zu vermeiden, sollten Kabel in der gleichen Weise verlegt werden, wie sie vor der Demontage/dem Transport verlegt waren.

3. Allgemeine Sicherheitsmassnahmen

- Die Verfahren sind zu überprüfen und wie im Wartungshandbuch beschrieben durchzuführen.
- Vorsichtig, dass Sie nicht umfallen.
- Um Aussetzung zur Haut zu vermeiden, tragen Sie wenn nötig Schutzhandschuhe.

4. Sicherheitsrelevante Wartungsteile

- Der Leistungsschutzschalter, der Türschalter, die Sicherung, der Thermostat, die Thermosicherung, der Thermistor, der Akkus, die IC-RAMs einschließlich der Lithiumakkus usw. sind besonders sicherheitsrelevant. Sie müssen unbedingt korrekt gehandhabt und installiert werden. Wenn diese Teile kurzgeschlossen und funktionsunfähig werden, kann dies zu schwerwiegenden Schäden, wie einer Explosion oder einem Abbrand, führen. Kurzschlüsse sind zu vermeiden, und es sind ausschließlich Teile zu verwenden, die von der Toshiba TEC Corporation empfohlen sind.

5. Warnetiketten

- Im Rahmen der Wartung unbedingt das Leistungsschild und die Etiketten mit Warnhinweisen überprüfen [z. B. „Unplug the power cable during service“ („Netzkabel vor Beginn der Wartungsarbeiten abziehen“), „CAUTION. HOT“ („VORSICHT, HEISS“), „CAUTION. HIGH VOLTAGE“ („VORSICHT, HOCHSPANNUNG“), „CAUTION. LASER BEAM“ („VORSICHT, LASER“) usw.], um sicherzustellen, dass sie nicht verschmutzt sind und korrekt am Gerät angebracht sind.

6. Entsorgung des Geräts, der Verbrauchs- und Verpackungsmaterialien

- In Bezug auf die Entsorgung und Wiederverwertung des Geräts, der Verbrauchs- und Verpackungsmaterialien, sind die einschlägigen nationalen oder regionalen Vorschriften zu befolgen.

7. Akkus und IC RAMs einschließlich Lithiumakkus etc.

VORSICHT:

ES BESTEHT EXPLOSIONSGEFAHR; WENN DER AKKU DURCH DEN FALSCHEN TYP ERSETZT WIRD.

ENTSORGEN SIE GEBRAUCHE AKKUS ENTSPRECHEND DER EINSCHLÄGIGEN REGIONALEN BESTIMMUNGEN UND VORSCHRIFTEN.

CONTENTS

1. FEATURE	1-1
1.1 Main Features of this Equipment	1-1
2. SPECIFICATIONS / ACCESSORIES / OPTIONS / SUPPLIES	2-1
2.1 Specifications	2-1
2.1.1 General	2-1
2.1.2 Copy	2-4
2.1.3 Print	2-9
2.1.4 Scan	2-9
2.1.5 Internet Fax	2-10
2.1.6 Network Fax (Option).....	2-11
2.2 Accessories	2-12
2.3 System List	2-13
2.4 Option List	2-16
2.5 Supplies	2-17
3. OUTLINE OF THE MACHINE	3-1
3.1 Sectional View	3-1
3.1.1 Front side	3-1
3.1.2 Rear side	3-3
3.2 Electric Parts Layout	3-5
3.3 Symbols and Functions of Various Components	3-15
3.3.1 Motors, fans	3-15
3.3.2 Sensors and switches	3-17
3.3.3 Electromagnetic spring clutches	3-20
3.3.4 Solenoids	3-20
3.3.5 PC boards	3-21
3.3.6 Lamps, LEDs, heaters, and coil	3-22
3.3.7 Thermistors, thermostats	3-22
3.3.8 Others	3-23
3.4 Copy Process	3-24
3.5 Comparison with e-STUDIO2505AC/3005AC/3505AC/4505AC/5005AC	3-25
3.6 General Operation	3-28
3.6.1 Overview of operation	3-28
3.6.2 Description of operation	3-28
3.6.3 Detection of abnormality	3-32
3.6.4 Hibernation function	3-39
3.7 Control Panel	3-40
3.7.1 General description	3-40
3.8 Scanner	3-41
3.8.1 General description	3-41
3.8.2 Construction	3-42
3.8.3 Functions	3-43
3.8.4 Description of operation	3-45
3.8.5 Process of detection of original size	3-46
3.9 Writing Section	3-48
3.9.1 General description	3-48
3.9.2 Laser precautions	3-50
3.10 Driving Section	3-51
3.10.1 Drum TBU drive unit	3-52
3.10.2 Development drive unit/Paper feeding drive unit	3-53
3.10.3 Monochrome/color switching mechanism	3-54
3.11 Paper Feeding System	3-55
3.11.1 General descriptions	3-55
3.11.2 Composition	3-56
3.11.3 Functions	3-57

3.11.4	Description of operation	3-58
3.12	Process Unit Related Section	3-63
3.12.1	General description.....	3-63
3.12.2	Composition	3-65
3.12.3	Functions	3-66
3.12.4	Drum driving sleep mode	3-68
3.13	Developer Unit	3-69
3.13.1	General description.....	3-69
3.13.2	Composition	3-70
3.13.3	Functions	3-71
3.13.4	Functions of the toner cartridge PC board (CTRG)	3-72
3.13.5	Waste toner box.....	3-75
3.14	Transfer Unit	3-76
3.14.1	General descriptions	3-76
3.14.2	Composition	3-77
3.15	Image Quality Control	3-78
3.15.1	General description.....	3-78
3.16	Fuser Unit.....	3-79
3.16.1	General description.....	3-79
3.16.2	Composition	3-81
3.16.3	Pressure mechanism	3-81
3.16.4	Electric circuit description	3-82
3.17	Paper Exit Section / Reverse Section	3-85
3.17.1	General description.....	3-85
3.17.2	Functions	3-86
3.17.3	Exit motor drive	3-86
3.18	Automatic Duplexing Unit (ADU).....	3-87
3.18.1	General description.....	3-87
3.18.2	Composition	3-87
3.18.3	Drive of ADU	3-88
3.18.4	Description of operations	3-89
3.19	Power Supply Unit.....	3-90
3.19.1	General description.....	3-90
3.19.2	Functions	3-90
3.19.3	Operation of DC output circuits.....	3-90
3.19.4	Output channel	3-92
3.19.5	Fuse	3-93

4. DISASSEMBLY AND REPLACEMENT..... 4-1

4.1	Covers.....	4-1
4.1.1	Front cover.....	4-1
4.1.2	Left cover	4-1
4.1.3	Receiving tray	4-2
4.1.4	Tray rear cover	4-2
4.1.5	Left top cover	4-3
4.1.6	Left rear cover.....	4-3
4.1.7	Receiving rear cover	4-4
4.1.8	Rear left cover	4-4
4.1.9	Right top cover.....	4-4
4.1.10	Right front cover	4-5
4.1.11	Right rear cover	4-5
4.1.12	Front top cover.....	4-6
4.1.13	Control panel lower cover	4-6
4.1.14	Front right cover.....	4-7
4.1.15	Top rear cover	4-8
4.1.16	Rear top cover	4-8
4.1.17	Rear cover	4-10
4.1.18	Front cover switch (SW1)	4-10
4.1.19	Front cover interlock switch (SW2)	4-11

4.2	Control Panel	4-13
4.2.1	Control panel unit.....	4-13
4.2.2	KEY board/button	4-15
4.2.3	DSP board	4-17
4.3	Scanner Unit	4-19
4.3.1	Original glass	4-23
4.3.2	Lens cover	4-28
4.3.3	Automatic original detection sensor-1 (S24).....	4-28
4.3.4	Automatic original detection sensor-2 (S25).....	4-29
4.3.5	Lens unit/CCD driving PC board.....	4-29
4.3.6	Carriage home position sensor (S23).....	4-31
4.3.7	Exposure lamp (EXP)	4-32
4.3.8	Scan motor (M1).....	4-33
4.3.9	Platen sensor (S21, S22).....	4-35
4.3.10	Carriage-1	4-36
4.3.11	Carriage wire, carriage-2	4-39
4.3.12	Scanner damp heater (DH1).....	4-43
4.4	Writing Section.....	4-45
4.4.1	Laser optical unit cooling fan unit	4-45
4.4.2	Laser optical unit cooling fan	4-46
4.4.3	Laser optical unit.....	4-47
4.4.4	Flat cables / LRL board.....	4-52
4.5	Paper Feeding System.....	4-55
4.5.1	Bypass unit	4-55
4.5.2	Bypass feed roller	4-56
4.5.3	Bypass separation roller	4-58
4.5.4	Paper width detection PC board (SFB board) (S17).....	4-60
4.5.5	Bypass feed sensor (S16)	4-61
4.5.6	Side cover switch (SW5).....	4-63
4.5.7	Registration sensor (S19), Feed sensor (S20)	4-63
4.5.8	Registration roller (on the equipment side).....	4-66
4.5.9	Registration roller (on the ADU side)	4-67
4.5.10	Jam access cover	4-69
4.5.11	Transport roller	4-71
4.5.12	Jam access cover opening/closing switch (SW20).....	4-73
4.5.13	2nd drawer paper feed sensor (S32)	4-74
4.5.14	1st drawer paper feed unit	4-75
4.5.15	1st drawer separation roller guide	4-75
4.5.16	2nd drawer paper feed unit.....	4-77
4.5.17	2nd drawer separation roller guide	4-78
4.5.18	1st drawer paper feed roller, separation roller, and pick-up roller	4-79
4.5.19	2nd drawer paper feed roller, separation roller, and pick-up roller	4-81
4.5.20	1st drawer detection switch (SW8)	4-83
4.5.21	2nd drawer detection switch (SW19)	4-83
4.5.22	1st tray-up motor unit.....	4-84
4.5.23	2nd tray-up motor unit.....	4-86
4.5.24	Tray-up motor-1 (M15).....	4-87
4.5.25	Tray-up motor-2 (M16).....	4-88
4.5.26	1st drawer paper remaining sensor (S30)	4-89
4.5.27	2nd drawer paper remaining sensor (S33)	4-90
4.5.28	1st drawer empty sensor (S5) and 1st drawer tray-up sensor (S31)	4-91
4.5.29	2nd drawer empty sensor (S34) and 2nd drawer tray-up sensor (S35).....	4-93
4.5.30	1st drawer paper width detection switch (SW6) and 1st drawer paper length detection switch (SW7)	4-95
4.5.31	2nd drawer paper width detection switch (SW17) and 2nd drawer paper length detection switch (SW18).....	4-96
4.5.32	Transport clutch (H) (CLT5).....	4-97
4.5.33	Transport clutch (L) (CLT6)	4-100

4.5.34	1st drawer feed clutch (CLT1)	4-101
4.5.35	2nd drawer feed clutch (CLT4)	4-102
4.5.36	Registration motor (M14)	4-102
4.5.37	Paper feed drive unit	4-103
4.5.38	Paper feed drive gear	4-105
4.6	Process Unit (Developer Unit, Cleaner)	4-108
4.6.1	Waste toner box	4-108
4.6.2	Process unit (Developer unit, Cleaner)	4-109
4.6.3	Developer material	4-114
4.6.4	Doctor blade	4-118
4.6.5	Auto-toner sensor (S1, S2, S3, S4)	4-119
4.6.6	Developer sleeve	4-120
4.6.7	Mixer	4-122
4.6.8	Replacement of oil seal	4-123
4.6.9	Main charger	4-124
4.6.10	Drum and bushing	4-125
4.6.11	Drum cleaning blade	4-127
4.6.12	Side seal	4-128
4.6.13	Main charger grid	4-129
4.6.14	Main charger cleaner	4-130
4.6.15	Needle electrode	4-131
4.6.16	EPU old/new detection switches (SW9, SW10, SW11, SW12)	4-132
4.6.17	Drum thermistor	4-136
4.6.18	Discharge LED	4-137
4.6.19	Waste toner paddle rotation detection sensor (S9)	4-138
4.6.20	Waste toner paddle motor (M7)	4-138
4.6.21	Drum switching unit	4-140
4.6.22	Drum switching detection sensor (S11)	4-141
4.6.23	Mono/color switching motor (M3)	4-142
4.6.24	Paper feeding/developer unit drive motor (M2)	4-144
4.6.25	Developer drive unit	4-144
4.6.26	Toner motor assembly	4-148
4.6.27	Toner motor (M8, M9, M10, M11)	4-149
4.6.28	Ozone filter	4-151
4.6.29	Ozone exhaust fan (F2)	4-151
4.6.30	Suctioning fan (F3)	4-154
4.6.31	Power supply unit cooling fan (F8)	4-155
4.6.32	Drum drive gear	4-156
4.6.33	Developer drive gear	4-161
4.6.34	Main power switch (SW4)	4-163
4.6.35	Developer unit cooling exhaust duct	4-164
4.6.36	Developer unit cooling fan (F5)	4-165
4.6.37	Temperature/humidity sensor (S10)	4-166
4.7	Transfer Units (TBU, TRU)	4-167
4.7.1	Transfer belt cleaning unit	4-167
4.7.2	Transfer belt cleaning blade/blade seal/recovery blade	4-167
4.7.3	Transfer belt unit (TBU)	4-170
4.7.4	Transfer belt	4-171
4.7.5	Cleaner unit facing roller	4-174
4.7.6	Drive roller	4-175
4.7.7	1st transfer roller	4-176
4.7.8	2nd transfer roller	4-177
4.7.9	2nd transfer unit (TRU)	4-178
4.7.10	Paper clinging detection sensor (S18)	4-180
4.7.11	1st transfer contact/release clutch (CLT2)	4-181
4.7.12	1st transfer roller status detection sensor (S12)	4-182
4.7.13	Drum/TBU motor (M6)	4-183
4.7.14	Drum and TBU drive unit	4-184

4.8	Image Quality Control	4-187
4.8.1	Image quality control unit.....	4-187
4.8.2	Paper dust holder	4-187
4.8.3	Image position aligning sensor (Front) (S7).....	4-188
4.8.4	Image position aligning sensor (Rear) (S8)	4-188
4.8.5	Image position aligning sensor (Center)/Image quality sensor (S37)	4-189
4.8.6	Registration pass sensor (S6)	4-189
4.8.7	Sensor shutter solenoid (SOL1)	4-190
4.9	Fuser Unit.....	4-191
4.9.1	Fuser unit.....	4-191
4.9.2	Front side cover	4-194
4.9.3	Rear side cover.....	4-195
4.9.4	Separation finger	4-195
4.9.5	Separation guide <25ppm/30ppm/35ppm>	4-197
4.9.6	Exit sensor (S13)	4-198
4.9.7	Paper exit guide.....	4-199
4.9.8	Fuser belt.....	4-200
4.9.9	Front fuser oil recovery sheet 2 / Front fuser oil recovery sheet 1.....	4-207
4.9.10	Rear fuser oil recovery sheet.....	4-208
4.9.11	Fuser belt lubricating sheet / Fuser belt pad.....	4-209
4.9.12	Fuser belt center thermistor (THM1) / edge thermistor (THM2) / thermostat (THMO1).....	4-211
4.9.13	Pressure roller	4-212
4.9.14	IH-COIL.....	4-214
4.9.15	Fuser belt rotation detection sensor (S27).....	4-218
4.9.16	Pressure roller contact/release detection sensor (S29).....	4-219
4.9.17	Fuser motor (M4)	4-219
4.9.18	Fuser drive unit.....	4-220
4.9.19	Pressure roller contact/release motor (M13)	4-223
4.9.20	IH board cooling fan (F6).....	4-226
4.10	Paper Exit and Reverse Sections	4-230
4.10.1	Reverse unit.....	4-230
4.10.2	Paper exit unit.....	4-233
4.10.3	Lower exit roller	4-234
4.10.4	Reverse motor (M5).....	4-237
4.10.5	Reverse gate solenoid (SOL2)	4-238
4.10.6	Upper exit roller	4-239
4.10.7	Reverse roller	4-241
4.10.8	Exit section cooling fan (F7)	4-242
4.11	Automatic Duplexing Unit (ADU).....	4-243
4.11.1	Automatic duplexing unit (ADU).....	4-243
4.11.2	Bypass feed clutch (CLT3)	4-245
4.11.3	Transport unit.....	4-246
4.11.4	ADU guide assembly	4-249
4.11.5	ADU middle cover	4-250
4.11.6	ADU control PC board (ADU board) (ADU)	4-252
4.11.7	ADU motor (M12).....	4-253
4.11.8	ADU entrance sensor (S14).....	4-254
4.11.9	ADU exit sensor (S15)	4-254
4.11.10	Transport roller (Upper and lower).....	4-255
4.11.11	Reverse sensor (S26).....	4-256
4.11.12	Side cover interlock switch (SW3)	4-256
4.11.13	Fuser unit cooling fan 1 (F4).....	4-257
4.11.14	Fuser unit cooling fan 2 (F9).....	4-258
4.12	Removal and Installation of Options	4-259
4.12.1	Dual Scan Document Feeder	4-259
4.12.2	Reversing Automatic Document Feeder	4-262
4.12.3	Paper Feed Pedestal	4-265

4.12.4	Large Capacity Feeder	4-268
4.12.5	Bridge kit.....	4-272
4.12.6	Inner finisher	4-274
4.12.7	Saddle stitch finisher.....	4-278
4.12.8	Saddle stitch finisher (Hole punch unit)	4-279
4.12.9	Finisher	4-281
4.12.10	Finisher (Hole punch unit).....	4-283
4.12.11	Job separator	4-285
5.	SELF-DIAGNOSTIC MODE	5-1
5.1	Overview	5-1
5.2	Description rule for each menu and mode	5-4
5.3	Service UI.....	5-7
5.3.1	Overview	5-7
5.3.2	Operation procedure	5-7
5.3.3	Starting the FS Menu from the normal mode.....	5-7
5.4	03 TEST MODE	5-9
5.4.1	Output check.....	5-9
5.4.2	Input check	5-9
5.5	04 TEST PRINT MODE	5-10
5.6	05 ADJUSTMENT MODE	5-10
5.6.1	TEST PRINT	5-10
5.7	08 SETTING MODE.....	5-10
5.8	20 PM SUPPORT MODE.....	5-10
5.9	30 LIST PRINT MODE	5-11
5.9.1	Operation procedure	5-11
5.9.2	List printing	5-12
5.10	31 CHART OUTPUT MODE	5-26
5.11	FAX	5-27
5.11.1	11 FAX CLEAR MODE	5-27
5.11.2	12 FAX LIST PRINT MODE.....	5-30
5.11.3	13 FAX FUNCTION MODE	5-30
5.11.4	19 RAM EDIT MODE.....	5-30
5.12	35 DATA BACKUP/RESTORE MODE.....	5-31
5.13	36 CLONING.....	5-32
5.14	37 LICENSE MANAGEMENT	5-32
5.15	01 Control Panel Check Mode	5-32
5.15.1	Screen transition.....	5-33
5.15.2	Checking of the LCD backlight and LEDs.....	5-34
5.15.3	Checking of the LCD display, hard keys and digital keys	5-34
5.15.4	Checking of the LCD touch sensor and USB storage device connection	5-35
5.16	73 Firmware Assist Mode.....	5-36
5.16.1	Overview.....	5-36
5.16.2	Operation procedure	5-36
5.16.3	Functions	5-37
5.17	74 HDD Assist Mode.....	5-41
5.17.1	Overview.....	5-41
5.17.2	Operation procedure	5-41
5.17.3	Functions	5-43
5.18	75 File System Recovery Mode	5-45
5.18.1	Overview.....	5-45
5.18.2	Operation procedure	5-45
5.18.3	Functions	5-46
5.19	76 SRAM Maintenance Mode	5-52
5.19.1	Overview.....	5-52
5.19.2	Operation procedure	5-52
5.19.3	Functions	5-53
5.20	Pixel Counter.....	5-55
5.20.1	Outline	5-55

5.21	Batch Setting for Self-Diagnostic Codes	5-66
5.21.1	General description.....	5-66
5.21.2	Applicable codes.....	5-66
5.21.3	Setting files	5-66
5.21.4	Result files	5-68
5.21.5	Operation procedure	5-69
6.	SETTING / ADJUSTMENT.....	6-1
6.1	Image Related Adjustment.....	6-1
6.1.1	Adjustment order	6-1
6.1.2	Adjustment of the auto-toner sensor.....	6-2
6.1.3	Performing image quality control	6-4
6.1.4	Adjustment of color registration control	6-5
6.1.5	Image dimensional adjustment.....	6-6
6.1.6	Paper alignment at the registration roller.....	6-8
6.1.7	Image dimensional adjustment at the printing section.....	6-12
6.1.8	Image dimensional adjustment at the scanning section	6-20
6.2	Image Quality Adjustment (Copying Function).....	6-28
6.2.1	Automatic gamma adjustment	6-28
6.2.2	Density adjustment	6-30
6.2.3	Gamma balance adjustment.....	6-31
6.2.4	Text gamma balance adjustment.....	6-32
6.2.5	Color balance adjustment	6-33
6.2.6	Background adjustment	6-35
6.2.7	Judgment threshold for ACS (common for copy and scan)	6-35
6.2.8	Judgment threshold adjustment for blank originals (common for copy and scan)	6-36
6.2.9	Image area adjustment for blank original judgment and ACS judgment when an Image Repeat is used	6-36
6.2.10	Image area adjustment for blank original judgment and ACS judgment (common for copying and scanning).....	6-37
6.2.11	Sharpness adjustment.....	6-38
6.2.12	Setting range correction.....	6-39
6.2.13	Adjustment of smudged/faint text	6-39
6.2.14	Color adjustment of marker	6-40
6.2.15	Emission level adjustment	6-41
6.2.16	Maximum toner density adjustment to paper type	6-42
6.2.17	Maximum text density adjustment	6-42
6.2.18	Text/Photo reproduction level adjustment	6-43
6.2.19	Black header density level adjustment	6-43
6.2.20	Black area adjustment in twin color copy mode.....	6-44
6.2.21	Background offsetting adjustment for DF (common for copy, scan and fax) ...	6-44
6.2.22	Background offsetting adjustment in back side for DSDF (common for copy, scan and fax)	6-44
6.2.23	Mono color copy / twin color copy adjustment.....	6-45
6.2.24	Maximum density adjustment for each paper type	6-46
6.2.25	Color reproduction selection	6-47
6.2.26	Reproducibility adjustment of dark-color text and gray print pattern.....	6-48
6.2.27	Hue adjustment.....	6-49
6.2.28	Saturation adjustment.....	6-52
6.2.29	Drop out color adjustment.....	6-54
6.2.30	ADF noise reduction	6-54
6.3	Image Quality Adjustment (Printing Function).....	6-55
6.3.1	Automatic gamma adjustment	6-55
6.3.2	Gamma balance adjustment.....	6-58
6.3.3	Color balance adjustment	6-60
6.3.4	Fine line/text density adjustment	6-62
6.3.5	Upper limit value in the toner saving mode.....	6-62
6.3.6	Maximum toner density adjustment	6-63

6.3.7	Fine line enhancement switchover	6-63
6.3.8	“PureBlack/PureGray” threshold adjustment (PCL).....	6-64
6.3.9	“PureBlack/PureGray” threshold adjustment (Twin color mode)	6-64
6.3.10	“PureBlack/PureGray” threshold adjustment (PS).....	6-64
6.3.11	“PureBlack/PureGray” threshold adjustment (XPS).....	6-65
6.3.12	Toner limit threshold adjustment.....	6-65
6.3.13	Sharpness adjustment	6-66
6.3.14	Thin line width lower limit adjustment	6-67
6.3.15	Background adjustment	6-67
6.3.16	Color/black judgment setting for twin color printing images.....	6-67
6.3.17	Emission level adjustment	6-68
6.3.18	Density adjustment of graphic lines (1200 dpi).....	6-69
6.3.19	Gradation switching for black mode printing text	6-70
6.3.20	Color reproduction switching (Twin color printing).....	6-70
6.3.21	Auto Trapping adjustment.....	6-71
6.3.22	Adjustment of smudged text in black (600dpi).....	6-71
6.3.23	Adjustment of smudged text in black (1200dpi).....	6-71
6.3.24	Halftone setting	6-72
6.4	Image Quality Adjustment (Scanning Function).....	6-73
6.4.1	Gamma balance adjustment.....	6-73
6.4.2	RGB Color balance adjustment	6-73
6.4.3	Density adjustment	6-74
6.4.4	Background adjustment (Color)	6-75
6.4.5	Background adjustment (Black/Grayscale).....	6-75
6.4.6	Judgment for ACS adjustment	6-75
6.4.7	Sharpness adjustment	6-76
6.4.8	Contrast adjustment.....	6-76
6.4.9	Fine adjustment of black density	6-77
6.4.10	RGB conversion method selection	6-77
6.4.11	Adjustment of saturation	6-78
6.4.12	Background offsetting adjustment for DF (common for copy, scan and fax) ...	6-78
6.4.13	Background offsetting adjustment in back side for DSDF (common for copy, scan and fax)	6-78
6.4.14	Adjustment of the capacity and image quality of SlimPDF	6-79
6.4.15	Surrounding void amount adjustment	6-80
6.4.16	Surrounding void amount adjustment (custom size scan)	6-80
6.4.17	Judgment threshold adjustment for blank originals (common for copy and scan)	6-80
6.4.18	JPEG compression level adjustment	6-81
6.4.19	ADF noise reduction	6-82
6.5	Image Quality Adjustment (FAX Function).....	6-83
6.5.1	Density adjustment	6-83
6.5.2	Emission level adjustment	6-84
6.5.3	Background offsetting adjustment for DF (common for copy, scan and fax) ...	6-84
6.5.4	Background offsetting adjustment in back side for DSDF (common for copy, scan and fax)	6-85
6.6	Scanner.....	6-86
6.6.1	Adjustment carriages-1 positions.....	6-86
6.6.2	Position adjustment of CCD lens unit	6-87
6.6.3	Belt tension adjustment of the scan motor.....	6-87
6.7	Writing Section	6-88
6.7.1	Image adjustment in the writing section.....	6-88
6.7.2	Adjustment of image tilting at the leading edge	6-88
6.8	Paper Feeding System.....	6-96
6.8.1	Adjusting the clearance of the paper and side guides	6-96
6.8.2	Separation roller pressure force adjustment.....	6-97
6.9	Process Unit Related Section	6-98
6.9.1	High-voltage transformer setting.....	6-98

6.10	Developer Unit	6-99
6.10.1	Adjustment of the auto-toner sensor	6-99
6.10.2	Pole position adjustment.....	6-99
6.11	Image Quality Control	6-100
6.11.1	Performing image quality control	6-100
6.12	Fuser Unit.....	6-100
6.12.1	Adjustment of the separation guide gap	6-100
6.13	Control Panel Calibration	6-103
6.13.1	General description.....	6-103
6.13.2	Operation procedure	6-103
6.14	Adjustment of the DSDF	6-106
6.14.1	Adjustment of position	6-106
6.14.2	Adjustment of height	6-111
6.14.3	Adjustment of skew.....	6-113
6.14.4	Adjustment of the leading edge position	6-117
6.14.5	Adjustment of horizontal position.....	6-119
6.14.6	Adjustment of copy ratio	6-121
6.14.7	DSDF read-in sensor-1 adjustment	6-122
6.14.8	Platen sheet.....	6-124
6.14.9	DSDF separation roller pressure force adjustment.....	6-125
6.15	Adjustment of the RADF	6-127
6.15.1	Adjustment of RADF position.....	6-127
6.15.2	Adjustment of RADF height	6-132
6.15.3	Adjustment of skew.....	6-134
6.15.4	Adjustment of the leading edge position	6-137
6.15.5	Adjustment of horizontal position.....	6-139
6.15.6	Adjustment of copy ratio	6-140
6.15.7	RADF Separation roller pressure force adjustment	6-141
6.16	Adjustment of the Inner Finisher	6-143
6.16.1	Alignment position adjustment	6-143
6.16.2	Stapling position adjustment.....	6-144
6.16.3	Punch hole position adjustment.....	6-147
6.17	Adjustment of the Console Finisher	6-148
6.17.1	Adjusting the alignment position	6-148
6.17.2	Adjusting the stapling position	6-151
6.18	Adjustment of the Saddle Stitch Finisher	6-153
6.18.1	Adjusting the alignment position	6-153
6.18.2	Adjusting the stapling position	6-156
6.18.3	Stapling/folding position adjustment in saddle stitch unit.....	6-158
6.18.4	Folding position adjustment	6-160
6.18.5	Stapling position adjustment.....	6-160
6.18.6	Saddle stitch skew adjustment	6-161
6.19	Adjustment of Hole punch unit	6-162
6.19.1	Destination setting of hole punch control PC board.....	6-162
6.19.2	Stopping position adjustment (MJ-6105)	6-163
7.	PREVENTIVE MAINTENANCE (PM).....	7-1
7.1	General Description	7-1
7.2	PM Display	7-1
7.2.1	General description.....	7-1
7.2.2	PM display conditions	7-1
7.2.3	PM display contents.....	7-3
7.2.4	Counter clearing	7-4
7.3	General Descriptions for PM Procedure	7-5
7.4	PM Support Mode	7-6
7.4.1	General description.....	7-6
7.4.2	Operational flow.....	7-6
7.4.3	Operational screen	7-7
7.4.4	Access tree	7-10

7.5	Work Flow of Parts Replacement.....	7-12
7.6	Preventive Maintenance Checklist.....	7-13
7.6.1	Scanner	7-14
7.6.2	Laser optical unit.....	7-14
7.6.3	Feed unit.....	7-15
7.6.4	Automatic duplexing unit.....	7-15
7.6.5	Bypass feed unit	7-16
7.6.6	Main charger	7-16
7.6.7	Cleaner unit	7-17
7.6.8	Developer unit (K, Y, M, and C).....	7-19
7.6.9	Transfer belt unit / Transfer belt cleaning unit	7-25
7.6.10	Image quality control unit.....	7-27
7.6.11	2nd transfer unit.....	7-28
7.6.12	Fuser unit.....	7-29
7.6.13	Paper exit section / Reverse section	7-30
7.6.14	DSDF	7-31
7.6.15	RADF	7-33
7.6.16	PFP	7-34
7.6.17	LCF	7-35
7.6.18	Inner finisher	7-35
7.6.19	Saddle stitch finisher / Finisher	7-36
7.6.20	Hole punch unit (MJ-6105)	7-42
7.7	Machine Refreshing Checklist.....	7-43
7.8	Storage of Supplies and Replacement Parts	7-45
7.9	PM KIT	7-46
7.10	Maintenance Part List	7-48
7.11	Grease List.....	7-49
8.	ERROR CODE AND TROUBLESHOOTING	8-1
8.1	General Descriptions.....	8-1
8.1.1	If a problem continues even after performing all troubleshooting	8-2
8.1.2	Collection of debug logs with a USB device	8-3
8.1.3	Traceability label.....	8-5
8.2	Error Code List.....	8-6
8.2.1	Jam	8-6
8.2.2	Service call	8-16
8.2.3	Error in Internet FAX / Scanning function	8-31
8.2.4	Printer function error	8-43
8.2.5	TopAccess related error/Communication error with external application	8-46
8.2.6	MFP access error	8-48
8.2.7	Maintenance error.....	8-54
8.2.8	Network error	8-62
8.2.9	Notification	8-68
8.2.10	FAX error	8-72
8.2.11	Error history	8-103
8.3	Diagnosis and Prescription for Each Error Code	8-105
8.3.1	Check item.....	8-105
8.3.2	Paper transport jam (paper exit section).....	8-105
8.3.3	Paper misfeeding.....	8-108
8.3.4	Paper transport jam	8-112
8.3.5	Other paper jam	8-121
8.3.6	Cover open jam	8-129
8.3.7	RADF/DSDF jam	8-132
8.3.8	Jam in bridge unit	8-148
8.3.9	Paper jam in finisher section.....	8-152
8.3.10	Paper jam in saddle stitch section	8-167
8.3.11	Paper jam in puncher unit.....	8-171
8.3.12	Other paper jam.....	8-172
8.3.13	Drive system related service call	8-189

8.3.14	Paper feeding system related service call	8-190
8.3.15	Scanning system related service call.....	8-196
8.3.16	Fuser unit related service call	8-200
8.3.17	Communication related service call	8-207
8.3.18	RADF / DSDF related service call	8-211
8.3.19	Circuit related service call	8-216
8.3.20	Laser optical unit related service call.....	8-221
8.3.21	Finisher related service call	8-224
8.3.22	Image control related service call	8-247
8.3.23	Copy process related service call	8-263
8.3.24	Other service call	8-272
8.3.25	Error in Internet FAX / Scanning function	8-310
8.3.26	Printer function error	8-349
8.3.27	TopAccess related error/Communication error with external application	8-358
8.3.28	MFP access error	8-364
8.3.29	Maintenance error.....	8-369
8.3.30	Network error	8-374
8.3.31	FAX error	8-389
8.4	Other Errors	8-430
8.4.1	Equipment operation disabled after the installation of option(s).....	8-430
8.4.2	Wireless LAN connection disabled	8-430
8.4.3	“Invalid Department Code” is displayed.....	8-430
8.4.4	Paper folded on the leading edge.....	8-430
8.4.5	Toner cartridge unrecognized.....	8-430
8.4.6	Ethernet disabled in half-duplex communication	8-430
8.4.7	The equipment does not start after the power has been turned ON.....	8-431
8.4.8	Countermeasure to sudden power failure.....	8-438
8.4.9	“Authentication Failed” is displayed	8-439
8.4.10	Error code “M00” is displayed while updating firmware	8-440
8.4.11	“Fax line1 is out of order.” or “Fax line2 is out of order.” is displayed.....	8-440
8.4.12	“Close the cover on the right” is repeatedly displayed at intervals of a few seconds.....	8-440
8.4.13	“Latch the developer unit (Yellow, Magenta, Cyan, Black)” remains displayed.....	8-441
8.5	Troubleshooting for the Image	8-442
8.5.1	Color deviation.....	8-442
8.5.2	Uneven pitch and jitter image	8-444
8.5.3	Poor image density, color reproduction and gray balance.....	8-446
8.5.4	Background fogging 1	8-448
8.5.5	Background fogging 2 (1200 dpi printing).....	8-450
8.5.6	Moire /lack of sharpness.....	8-451
8.5.7	Toner offset.....	8-453
8.5.8	Toner offset (shadow image) at the edges	8-455
8.5.9	Blurred image	8-457
8.5.10	Poor fusing.....	8-458
8.5.11	Blank print.....	8-460
8.5.12	Solid print.....	8-462
8.5.13	White banding (in feeding direction)	8-463
8.5.14	White banding (at right angles to feeding direction)	8-465
8.5.15	Skew (slantwise copying)	8-466
8.5.16	Color banding (in feeding direction).....	8-467
8.5.17	Color banding (at right angles to feeding direction)	8-469
8.5.18	White spots	8-471
8.5.19	Poor transfer	8-473
8.5.20	Uneven image density 1 (in feeding direction).....	8-474
8.5.21	Uneven image density 1 (at right angles to feeding direction).....	8-476
8.5.22	Uneven image density 2	8-477
8.5.23	Faded image (low density, roughness).....	8-479

8.5.24	Image dislocation in leading edge	8-481
8.5.25	Image jittering	8-482
8.5.26	Poor cleaning	8-483
8.5.27	Uneven light distribution	8-485
8.5.28	Blotched image	8-486
8.5.29	Stain on the paper back side	8-487
8.5.30	White void in the halftone	8-489
8.5.31	Paper wrinkle	8-492
8.5.32	Staining at the leading/trailing edge.....	8-494
8.5.33	Faint image	8-495
8.5.34	Toner scattering.....	8-496
8.5.35	Feathered image.....	8-497
8.5.36	Image skewing on paper trailing edge	8-498
8.5.37	Staining on both edges of paper	8-502
8.5.38	Roller trace	8-503
8.5.39	Staining at the leading edge	8-504
8.5.40	Image distortion (dogleg image)	8-505
8.5.41	Low density level in halftone around a text or line	8-507
8.5.42	Shadow in copied/scanned images when using the DSDF	8-508
8.5.43	The exit paper surface feels rough like sand is adhering to it (carrier offset)	8-510
8.5.44	Scanned image abnormality	8-512
8.5.45	If an image-related problem continues after performing all troubleshooting ..	8-514

9. REPLACEMENT OF PC BOARDS/HDD 9-1

9.1	Removal and Installation of PC Boards/HDD.....	9-1
9.1.1	SYS board cover.....	9-1
9.1.2	SYS board cooling fan (F1)	9-1
9.1.3	Hard disk (HDD)	9-2
9.1.4	SYS board	9-3
9.1.5	SYS board case.....	9-5
9.1.6	LGC board	9-7
9.1.7	IH board	9-10
9.1.8	Switching regulator	9-13
9.1.9	High-voltage transformer (HVT).....	9-15
9.1.10	SRAM	9-17
9.1.11	Main memory (DIMM).....	9-17
9.1.12	EEPROM	9-18
9.1.13	PFC board	9-18
9.1.14	DAMP board	9-19
9.1.15	CTIF board.....	9-20
9.1.16	DSDF I/F board.....	9-21
9.2	Precautions, Procedures and Settings for Replacing PC Boards and HDD	9-22
9.2.1	Precautions when replacing PC boards.....	9-22
9.2.2	HDD fault diagnosis	9-23
9.2.3	Precautions and procedures when replacing the HDD	9-25
9.2.4	Precautions and procedures when replacing the SYS board	9-30
9.2.5	Precautions and procedure when replacing the SRAM	9-34
9.2.6	Procedures when replacing the LGC board.....	9-39
9.2.7	Procedures and settings when replacing EEPROM (for LGC board)	9-40
9.2.8	Procedures and settings when replacing the lens unit	9-44
9.2.9	Firmware confirmation after the PC board/HDD replacement	9-45
9.2.10	License re-registration using the one-time dongle	9-45
9.3	Precautions for Installation of GP-1070 and Disposal of HDD/Board	9-47
9.3.1	Precautions for Installation of GP-1070	9-47
9.3.2	Precautions when disposing of HDD	9-47
9.3.3	Precautions when disposing of the SYS board.....	9-47
9.3.4	Precautions when disposing of the SRAM.....	9-47

10. REMOTE SERVICE	10-1
10.1 Auto Supply Order.....	10-1
10.1.1 Outline	10-1
10.1.2 Setting item	10-2
10.1.3 Setting procedure	10-4
10.1.4 Order sheet format.....	10-18
10.2 Service Notification	10-22
10.2.1 Outline	10-22
10.2.2 Setting.....	10-22
10.2.3 Items to be notified	10-29
10.3 Remote Panel (VNC)	10-47
10.3.1 Outline	10-47
10.3.2 Setting.....	10-47
10.3.3 Operation	10-48
10.4 Remote Service.....	10-49
10.4.1 Outline	10-49
10.4.2 Setting.....	10-49
10.4.3 Operation	10-49
11. FIRMWARE UPDATING	11-1
11.1 Overview	11-1
11.2 Firmware Updating with USB Device	11-2
11.2.1 Updating methods.....	11-2
11.2.2 Firmware type and data file for updating	11-2
11.2.3 Folder configuration of a USB device	11-4
11.2.4 Update procedure	11-6
11.3 Confirmation of the updated data.....	11-14
12. BACKUP FUNCTION	12-1
12.1 Cloning (HS menu).....	12-1
12.1.1 General description.....	12-1
12.1.2 Precautions	12-1
12.1.3 Backup files	12-2
12.1.4 Cloning procedure	12-2
12.2 Cloning (FS menu).....	12-5
12.2.1 General description.....	12-5
12.2.2 Precautions	12-5
12.2.3 Clone file creation procedure	12-7
12.2.4 Clone file installation procedure.....	12-7
12.3 AES Data Encryption Function Setting	12-8
12.3.1 General description.....	12-8
12.3.2 Precautions	12-8
12.3.3 Setting procedure	12-9
12.3.4 Procedure for disabling data encryption function.....	12-13
12.3.5 Procedure for discarding HDD when data encryption function is enabled	12-13
12.4 High Security Mode.....	12-14
12.4.1 General description.....	12-14
12.4.2 Prior confirmation	12-14
12.4.3 Procedure for entering the High Security Mode	12-14
12.4.4 Precautions	12-15
12.5 Decommissioning.....	12-16
12.5.1 General description.....	12-16
12.5.2 Functions	12-16
12.5.3 Precautions	12-16
12.5.4 Procedures of decommissioning.....	12-16
13. EXTERNAL COUNTERS	13-1
13.1 Outline.....	13-1
13.2 Signal	13-1

13.2.1	Connector	13-1
13.2.2	Coin controller.....	13-1
13.2.3	Key copy counter	13-5
13.3	Notices	13-6
13.3.1	Setting code.....	13-6
13.3.2	Setting value change and restrictions when using the card controller	13-6
13.3.3	Setting value change and restrictions when using the coin controller	13-6
13.3.4	Installation of external counter	13-6
13.3.5	Setting value change and restrictions when using the key counter	13-7
13.3.6	Restrictions when using the external counter	13-7
14.	NOTES FOR THE INSTALLATION OF A CARD READER	14-1
15.	WIRE HARNESS CONNECTION.....	15-1
15.1	AC Wire Harness	15-1
15.2	DC Wire Harness / Electric Parts Layout	15-2
15.2.1	DC Wire Harness <25ppm/30ppm/35ppm>	15-2
15.2.2	DC Wire Harness <45ppm/50ppm>	15-3
15.2.3	Electric Parts Layout.....	15-4
APPENDIX.....		1
REVISION RECORD.....		1

1. FEATURE

1.1 Main Features of this Equipment

- **Resistive touch panel**
In order to improve the operability, a 10.1-inch resistive touch panel is adopted.
- **Laser optical unit**
A thermostat is embedded in the laser optical unit and detects the temperature inside the equipment. When the temperature varies, correction is performed corresponding to it.
- **PC board**
Each PC board is downsized.
- **Image related adjustment**
The standard of the image quality adjustment performed before factory shipment has been changed to the one using the center as a reference. When the image dimensional adjustment is performed in the field, utilize Type 2 which uses the center as a reference (the same adjustment performed before factory shipment). The correction can be applied more easily.

2. SPECIFICATIONS / ACCESSORIES / OPTIONS / SUPPLIES

In this document, a model name is replaced with an alias as follows:

Model name	Alias
e-STUDIO2515AC	25ppm
e-STUDIO3015AC	30ppm
e-STUDIO3515AC	35ppm
e-STUDIO4515AC	45ppm
e-STUDIO5015AC	50ppm

2.1 Specifications

2.1.1 General

Type	Desktop type (Console type: when optional Paper Feed Pedestal (PFP) or optional Large Capacity Feeder (LCF) is installed.)	
Original glass	Fixed	
Color	Full color, Twin color, Mono color	
Copy process	Indirect electrophotographic method (dry)	
Developing system	2-component magnetic brush developing	
Fixing method	Belt fusing system with external IH	
Photosensor type	OPC	
Original scanning sensor	CCD sensor	
Scanning light source	LED	
Resolution	Scanning	600 dpi x 600 dpi
	Writing (Copy)	Black: 600 dpi x 600 dpi, 5bit 2400 dpi (Equivalence) x 600 dpi Color: 600 dpi x 600 dpi, 5bit
Gradation	256	
Paper feeding	2 drawer + Bypass feeding 2 drawer + Bypass feeding+ PFP 1 drawer (optional) 2 drawer + Bypass feeding+ PFP 2 drawers (optional) 2 drawer + Bypass feeding+ LCF (optional)	
Paper supply	Drawer/PFP (optional)	Stack height 60.5 mm, Approx. 550 sheets (80 g/m ² , 21.3 lb. Bond), Approx. 500 sheets (105 g/m ² , 28 lb. Bond)
	Bypass feeding	Stack height 11 mm, Approx. 100 sheets (80 g/m ² , 21.3 lb. Bond), Approx. 80 sheets (105 g/m ² , 28 lb. Bond)
	LCF (optional)	Stack height 110 mm, Approx. 2000 sheets (80 g/m ² , 21.3 lb. Bond), Approx. 1660 sheets (105 g/m ² , 28 lb. Bond)
	Envelope Drawer (optional)	Plain paper: Approx. 550 sheets (80 g/m ² , 21.3 lb. Bond), Approx. 500 sheets (105 g/m ² , 28 lb. Bond) Envelope: Stack height 505 mm (Approx. 60 envelopes)
Paper size	Drawer/PFP (optional)	A3, A4, A4-R, A5-R, B4, B5, B5-R, FOLIO, 8K, 16K, 16K-R, A3 Wide (305 x 457 mm), SRA3 (320 x 450 mm), 320 x 460 mm, LD, LG, LT, LT-R, ST-R, COMPUTER, 13"LG, 8.5" x 8.5", Non-standard

	Bypass feeding	A3, A4, A4-R, A6-R (*1), A5-R, B4, B5, B5-R, FOLIO, 8K, 16K, 16K-R, A3 Wide (305 x 457 mm), SRA3 (320 x 450 mm), 320 x 460 mm, 305 x 1200 mm, LD, LG, LT, LT-R, ST-R, COMPUTER, 13"LG, 8.5" x 8.5", Full Bleed (12" x 18") Non-standard (*2) (*3) (*4): Paper size within 100 - 305 mm (3.9 - 12") (Width), 148 - 1200 mm (5.8 - 47") (Length) (*1) A6-R size paper: Thick 2 or larger is available. (*2) Non-standard size paper: Corner folding, paper wrinkling or skewing may occur. (*3) Thick 1 or smaller size paper: Skewing may occur in paper whose size is 140 (Width) x 210 (Length) mm or smaller. (*4) When printing is performed by using a printer driver, the available paper size may differ from the above one depending on the specifications of the printer driver.
	LCF (optional)	A4, LT
	Envelope Drawer (optional)	Plain paper: A4-R, A5-R, B5-R, 16K-R, LG, LT-R, ST-R, 13" LG Envelope DL (110 x 220 mm), Envelope Com10 (4 1/8 x 9 1/2"), Envelope Monarch (3 7/8 x 7 1/2"), Envelope Cho-3 (120 x 235 mm), Envelope You-4 (105 x 235 mm), Envelope KAKU-2 (240 x 332 mm) Non-standard envelope: Paper size within 100 - 240 mm (3.9 - 9.45") (Width), 162 - 380 mm (6.38 - 14.9") (Length)
Paper type	Drawer / PFP (optional)	Plain paper, Recycled paper, Thick, Thick 1, Thick 2, Thick 3
	Bypass feeding	Plain paper, Recycled paper, Thick, Thick 1, Thick 2, Thick 3, Thick 4, Special 1 (Waterproof paper), Special 2 (Waterproof paper), Special 3 (Coated paper), Thin paper, Sticker labels, OHP film, Tab paper, Extra large paper
	LCF (optional)	Plain paper, Recycled paper, Thick
	Envelope Drawer (optional)	Plain paper, Envelope, Thick 1, Thick 2, Thick 3
Paper weight	Drawer / PFP (optional)	60 g/m ² to 256 g/m ² (16 lb. Bond to 140 lb. Index)
	Bypass feeding	52 g/m ² to 280 g/m ² (16 lb. Bond to 100 lb. Cover)
	LCF (optional)	64 g/m ² to 105 g/m ² (17 lb. Bond to 28 lb. Bond)
	Envelope Drawer (optional)	60 g/m ² to 163 g/m ² (16 lb. Bond to 90 lb. Index)
Automatic duplexing unit	Type	Stackless, Switchback type
	Acceptable paper size	A3, A4, A4-R, A5-R, B4, B5, B5-R, FOLIO, 8K, 16K, 16K-R, A3 Wide (305 x 457 mm), LD, LG, LT, LT-R, ST-R, COMPUTER, 13"LG, 8.5" x 8.5", Full Bleed (12" x 18"), Non-standard
	Acceptable paper weight	60 g/m ² to 256 g/m ² (17 lb. Bond to 80 lb. Cover)
Toner supply		Automatic toner density detection/supply (Toner cartridge exchange type)
Density control		Automatic density mode and manual density mode selectable in 11 steps
Total counter		Electronic counter
Memory (RAM)	Main memory	4 GB (including page memory)
	Page Memory	Included in main memory
HDD		320 GB
Account Codes		10000 codes
Department Codes		1000 codes

Machine version	NAD: North America, Brazil MJD: Europe AUD: Australia ASD: Asia, Hong Kong, Latin America TWD: Taiwan CND: China ARD: Argentina JPD: Japan
Warm-up time	Normal start-up: Approx. 20 sec. (100 V/200 V series) <Stand-alone, temperature: 20°C> Start-up without hibernation: Approx. 70 sec. (100 V/200 V series) <Stand-alone, temperature: 20°C> * Varies depending on the settings, use conditions, and quality maintenance behavior such as toner refill.
Recovery from sleep	Approx. 12 sec. <Stand-alone, temperature: 20°C> * Varies depending on the settings, use conditions, and quality maintenance behavior such as toner refill.
Power requirements	AC 110 V / 13.2 A, 120 V / 15 A 220-240 V / 8 A (50/60 Hz) * The acceptable value of each voltage is ± 10%.
Power consumption	1.5 kW or less (100 V, 120 V) 2.0 kW or less (200 V series) * The electric power is supplied to the RADF, Finisher, PFP and LCF through the equipment.
Weight	Approx. 78.1 kg (172.2 lb.)
Dimensions of the equipment	W 585 x D 640 x H 787 (mm) * When the tilt angle of the control panel is 90 degrees.

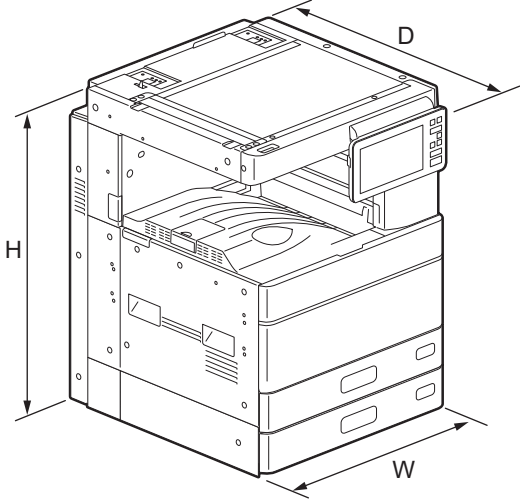

2.1.2 Copy

[1] Copy specifications

Storage capacity		Max. 1000 sheets or until the memory is full
Original glass	Original scanning system	Flat surface scanning system (the left rear corner used as guide to place originals)
	Original type	Sheets, books
	Original size	Max. A3/LD
Reversing Automatic Document Feeder (optional)	Original scanning system	Fixed scanning system by feeding the original (the center used as guide to place originals)
	Original type	Sheets (carbon, bounded or stapled originals cannot be accepted)
	Original size	A3, A4, A4-R, A5-R, B4, B5, B5-R, FOLIO, LD, LG, LT, LT-R, ST-R, COMPUTER
	Original paper weight	Single-sided copy: 35-157g/m ² (9.3 lb. Bond - 58 lb. Cover) Double-sided copy: 50-157g/m ² (13.3 lb. Bond - 58 lb. Cover)
	Original capacity	Max. 100 sheets (80 g/m ²) (Stack height 16 mm)
Dual Scan Document Feeder (optional)	Original scanning system	Fixed scanning system by feeding the original (the center used as guide to place originals)
	Original type	Sheets (carbon, bounded or stapled originals cannot be accepted)
	Original size	A3, A4, A4-R, A5-R, B4, B5, B5-R, FOLIO, LD, LG, LT, LT-R, ST-R, COMPUTER
	Original paper weight	35-209g/m ² (9.3 lb. Bond - 77.3 lb. Cover) (Bleed-through will occur when a 2-sided original with thin paper such as 35 g/m ² (9.3 lb.) is scanned.)
	Original capacity	Max. 300 sheets (80 g/m ²) (Stack height 38 mm)
Eliminated portion *	Black copy	Leading edges: 4.2 +2.8/-1.2 mm, Trailing edges: 3.0 ± 2.0 mm, Side edges: 2.0 ± 2.0 mm
	Color copy	Leading edges: 5.0 ± 2.0 mm, Trailing edges: 3.0 ± 2.0 mm, Side edges: 2.0 ± 2.0 mm
Multiple copying		Up to 999 copies

* Paper size: A3/LD or smaller.

[2] First copy time

25ppm/30ppm/35ppm	Black	Approx. 5.9 sec.
	Color	Approx. 7.8 sec.
45ppm/50ppm	Black	Approx. 4.4 sec.
	Color	Approx. 5.7 sec.

[3] Copy speed (Copies/min.)

[3-1] Plain paper / Thick

- Plain paper: 60 g/m² to 80 g/m² (16 lb. Bond to 21 lb. Bond)
Thick: 81g/m² to 105 g/m² (22 lb. Bond to 28 lb. Bond)
- * “-” means “Not acceptable”.
- * When originals are manually placed for single-sided, continuous copying.
- * Plain paper is selected for the paper type.
- * When the Reversing Automatic Document Feeder is used, the copying speed of the equipment is only possible under the following conditions:
 - Original: A4 or LT (single-sided)
 - Mode: APS and Automatic density not selected, Plain paper mode
 - Reproduction ratio: 100%
- * The values in () can be realized in the color mode.
- * “Wait” may be displayed or the print speed may decrease depending on the usage environment or print settings.

25ppm

Paper supply Paper size	Drawer	Bypass feed		PFP	LCF (A4/LT only)
		Size specified	Size not specified		
A4, LT	25 (25)	25 (25)	14 (14)	25 (25)	25 (25)
B5, A5-R, ST-R, 8.5" x 8.5"					-
A6-R	-	25 (25)	14 (14)	-	-
A4-R, B5-R, LT-R	20 (20)	20 (20)	14 (14)	20 (20)	-
B4, LG, FOLIO, COMPUTER, 13"LG	17 (17)	17 (17)	14 (14)	17 (17)	-
A3, LD	15 (15)	15 (15)	14 (14)	15 (15)	-
A3Wide, SRA3	14 (14) *	14 (14)	14 (14)	14 (14)	-

* 2nd drawer only.

30ppm

Paper supply Paper size	Drawer	Bypass feed		PFP	LCF (A4/LT only)
		Size specified	Size not specified		
A4, LT	30 (30)	30 (30)	15 (15)	30 (30)	30 (30)
B5, A5-R, ST-R, 8.5" x 8.5"					-
A6-R	-	30 (30)	15 (15)	-	-
A4-R, B5-R, LT-R	23 (23)	23 (23)	15 (15)	23 (23)	-
B4, LG, FOLIO, COMPUTER, 13"LG	19 (19)	19 (19)	15 (15)	19 (19)	-
A3, LD	16 (16)	16 (16)	15 (15)	16 (16)	-
A3Wide, SRA3	15 (15)	15 (15)	15 (15)	15 (15)	-

* 2nd drawer only.

35ppm

Paper supply Paper size	Drawer	Bypass feed		PFP	LCF (A4/LT only)
		Size specified	Size not specified		
A4, LT	35 (35)	35 (35)	17 (17)	35 (35)	35 (35)
B5, A5-R, ST-R, 8.5" x 8.5"					-
A6-R	-	35 (35)	17 (17)	-	-
A4-R, B5-R, LT-R	25 (25)	25 (25)	17 (17)	25 (25)	-
B4, LG, FOLIO, COMPUTER, 13"LG	21 (21)	21 (21)	17 (17)	21 (21)	-
A3, LD	18 (18)	18 (18)	17 (17)	18 (18)	-
A3Wide, SRA3	17 (17) *	17 (17)	17 (17)	17 (17)	-

* 2nd drawer only.

45ppm

Paper supply Paper size	Drawer	Bypass feed		PFP	LCF (A4/LT only)
		Size specified	Size not specified		
A4, LT	45 (45)	45 (45)	13 (13)	45 (45)	45 (45)
B5					-
A5-R, ST-R, 8.5" x 8.5"	30 (30)	30 (30)	13 (13)	30 (30)	-
A6-R	-	13 (13)	13 (13)	-	-
A4-R, B5-R, LT-R	32 (32)	32 (32)	13 (13)	32 (32)	-
B4, LG, FOLIO, COMPUTER, 13"LG	26 (26)	26 (26)	13 (13)	26 (26)	-
A3, LD	22 (22)	22 (22)	13 (13)	22 (22)	-
A3Wide, SRA3	22 (22) *	22 (22)	13 (13)	22 (22)	-

* 2nd drawer only.

50ppm

Paper supply Paper size	Drawer	Bypass feed		PFP	LCF (A4/LT only)
		Size specified	Size not specified		
A4, LT	50 (50)	50 (50)	13 (13)	50 (50)	50 (50)
B5					-
A5-R, ST-R, 8.5" x 8.5"	30 (30)	30 (30)	13 (13)	30 (30)	-
A6-R	-	13 (13)	13 (13)	-	-
A4-R, B5-R, LT-R	36 (36)	36 (36)	13 (13)	36 (36)	-
B4, LG, FOLIO, COMPUTER, 13"LG	29 (29)	29 (29)	13 (13)	29 (29)	-
A3, LD	25 (25)	25 (25)	13 (13)	25 (25)	-
A3Wide, SRA3	24 (24) *	24 (24)	13 (13)	24 (24)	-

* 2nd drawer only.

[3-2] Thick 1/Thick 2/Thick 3

- Thick 1: 106 g/m² to 163 g/m² (90 lb. Index)
- Thick 2: 164 g/m² to 209 g/m² (110 lb. Index)
- Thick 3: 210 g/m² to 256 g/m² (140 lb. Index)

Paper supply Paper size	Drawer	Bypass feed		PFP	LCF (A4/LT only)
		Size specified	Size not specified		
A4, LT	17.5 (17.5)	17.5 (17.5)	8 (8)	17.5 (17.5)	-
B5, A5-R, ST-R					-
A4-R, B5-R, LT-R	12.5 (12.5)	12.5 (12.5)	8 (8)	12.5 (12.5)	-
B4, LG, FOLIO, COMPUTER	10 (10)	10 (10)	8 (8)	10 (10)	-
A3, LD	8.5 (8.5)	8.5 (8.5)	8 (8)	8.5 (8.5)	-
A3Wide, SRA3	8 (8) *1	8 (8)	8 (8)	8 (8)	-

* 2nd drawer only.

* “-” means “Not acceptable”.

* When originals are manually placed for single-sided, continuous copying.

* The values in () can be realized in the color mode.

[3-3] Thick 4

- Thick 4: 257 g/m² to 280 g/m² (150 lb. Index)

Paper supply Paper size	Drawer	Bypass feed		PFP	LCF (A4/LT only)
		Size specified	Size not specified		
A4, LT	-	17.5 (17.5)	8 (8)	-	-
B5, A5-R, ST-R					-
A4-R, B5-R, LT-R	-	12.5 (12.5)	8 (8)	-	-
B4, LG, FOLIO, COMPUTER	-	10 (10)	8 (8)	-	-
A3, LD	-	8.5 (8.5)	8 (8)	-	-
A3Wide, SRA3	-	8 (8)	8 (8)	-	-

* “-” means “Not acceptable”.

* When originals are manually placed for single-sided, continuous copying.

* The values in () can be realized in the color mode.

[3-4] Special 1/Special 2/Special 3

Paper supply Paper size	Drawer	Bypass feed		PFP	LCF (A4/LT only)
		Size specified	Size not specified		
A4, LT	-	14.5 (14.5)	6 (6)	-	-
B5, A5-R, ST-R					-
A4-R, B5-R, LT-R	-	11 (11)	6 (6)	-	-
B4, LG, FOLIO, COMPUTER	-	9.5 (9.5)	6 (6)	-	-
A3, LD	-	7.5 (7.5)	6 (6)	-	-
A3Wide, SRA3	-	6 (6)	6 (6)	-	-

* “-” means “Not acceptable”.

* When originals are manually placed for single-sided, continuous copying.

* The values in () can be realized in the color mode.

[3-5] OHP film

Paper size	Paper supply	Drawer	Bypass feed		PFP	LCF (A4/LT only)
			Size specified	Size not specified		
A4, LT		-	14.5 (14.5)	-	-	-
A3, LD		-	7.5 (7.5)	-	-	-

* “-” means “Not acceptable”.

* When originals are manually placed for single-sided, continuous copying.

* The values in () can be realized in the color mode.

[4] System copy speed

Copy mode		Sec.				
		25ppm	30ppm	35ppm	45ppm	50ppm
Single-sided originals ↓ Single-sided copies	1 set	29.9 (31.9)	27.0 (28.2)	24.2 (25.7)	19.4 (20.8)	18.2 (19.6)
	3 sets	80.9 (82.9)	70.1 (71.9)	61.9 (63.2)	49.2 (50.9)	45.4 (46.5)
	5 sets	128.0 (130.3)	109.3 (111.1)	95.5 (97.3)	75.2 (76.8)	69.2 (71.6)
Single-sided originals ↓ Double-sided copies	1 set	35.9 (37.6)	33.9 (35.3)	32.2 (33.5)	26.1 (27.3)	26.2 (26.8)
	3 sets	83.4 (85.6)	73.4 (74.9)	65.8 (67.5)	53.1 (55.0)	49.4 (51.2)
	5 sets	130.7 (132.5)	112.9 (115.0)	101.9 (102.1)	79.7 (80.3)	73.5 (74.5)
Double-sided originals ↓ Double-sided copies	1 set	57.7 (59.7)	52.5 (55.1)	52.3 (56.0)	51.5 (52.9)	31.6 (52.9)
	3 sets	153.2 (154.8)	132.4 (134.5)	120.9 (124.6)	104.9 (106.2)	99.6 (100.8)
	5 sets	248.7 (249.8)	211.7 (213.8)	189.2 (192.1)	158.4 (159.1)	147.5 (148.6)
Double-sided originals ↓ Single-sided copies	1 set	62.2 (65.1)	60.6 (62.9)	59.4 (62.2)	56.3 (57.8)	56.2 (57.4)
	3 sets	157.4 (159.5)	139.8 (142.0)	127.6 (129.3)	109.6 (110.7)	104.0 (105.3)
	5 sets	252.4 (254.2)	219.2 (221.2)	195.8 (197.2)	162.7 (163.6)	151.9 (152.8)

* The values in () can be realized in the color mode.

* Shows the period of time from when the [START] button is pressed until the message “Ready” is displayed. (10 sheets of A4/LT size original are set on the RADF and one of the copy modes above is selected.)

* Setting: when in the Text/Photo mode with Automatic density and APS/AMS set to OFF, or when in the sort mode with paper fed from the 1st drawer.

* The finisher, saddle stitch finisher, and hole punch unit not installed.

2.1.3 Print

Supported Page Description Language (Printer Driver)		PCL6, PostScript 3 emulation, XPS
Supported Page Description Language (MFP)		PCL6, PostScript 3 emulation, XPS, PCL5e, PCL5c, PDF (emulation)
Supported Client OS		Windows 10 / Windows 7 / Windows 8.1 / Windows Server 2008 / Windows Server 2012 / Windows Server 2016 Mac OS X 10.6.8 or later Solaris v11.2 or later HP-UX ver.11iv3, HP-UX64 ver.11iv3 AIX 7.x Red Hat Enterprise Linux 5.x/6.x/7.x, SuSE Linux 11.2/11.3, CUPS
Resolution	Black	600 x 600 dpi, 5bit All PDL 1200 x 1200 dpi, 2bit (3600dpi (Equivalence) x 1200dpi) PS only
	Color	600 x 600 dpi, 5bit All PDL 1200 x 1200 dpi, 2bit (3600dpi (Equivalence) x 1200dpi) PS only
Eliminated portion *	Black / Color	Leading edges: 4.2+2.8/-1.2 mm, Trailing edges: 4.2+1.2/-2.8 mm, Side edges: 4.2 ± 2.0 mm
Interface	Standard	Ethernet (1000BASE-T/100BASE-TX/10BASE-T), USB 2.0 (High speed)
	Optional	Wireless LAN (IEEE 802.11b/g/n) Bluetooth V3.0 (HCRP/BIP/OPP/FTP/HID)
Paper size	Bypass feeding	Paper size within 100.0 - 305.0 mm (3.94 - 12.00") (Width), 148.0 - 1200.0 mm (5.83 - 47.24") (Length)

2.1.4 Scan

Scanning speed (A4/LT)	Color / Black / Gray scale	RADF: 73 spm (200 dpi / 300 dpi) 50 spm (600 dpi) DSDF: Simplex: 120 spm, Duplex: 240 spm (200 dpi / 300 dpi) Simplex: 70 spm, Duplex: 140 spm (600 dpi)
Resolution		100, 150, 200, 300, 400 and 600 dpi
Scan mode		Black, Gray scale, Color and ACS (Auto color Selection)
File formats		JPEG, Multi/Single page TIFF, Multi/Single page PDF, Slim PDF, Multi/Single page XPS

* When scanning single-sided A4/LT landscape originals using RADF/DSDF.

2.1.5 Internet Fax

[1] Internet FAX transmission

Resolution	TX Resolution < dots/mm >	Standard (8 x 3.85), Fine (8 x 7.7)
Scanning	Original Document Size	A3, B4, A4, A4-R, A5, B5, B5-R, A5-R, LT, LT-R, LG, LD, ST, ST-R, Computer, Folio
	Speed	0.7 sec. (per page/A4) Max. 50 spm (ITU-T No.1, A4, 8 x 3.85, Text mode)
	Gray scale	256 levels (Error Diffusion)
Address book	Address Book	400 stations
	Group	Max. 40 stations
Transmission Features	Broadcast transmission	Max. 80 destinations/job. (Fax number and E-mail address are available to registered in same job.)
	Message size limitation	Max. 100MB
	Message division	Page by page





[2] Internet FAX receiving

Format of receive attachment	TIFF-FX (Profile S, F, J)
------------------------------	---------------------------

2.1.6 Network Fax (Option)

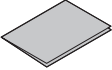
Compatibility		Super G3, G3 (ITU-T.30) Internet Fax (Simple mode) (ITU-T.37)
TX Resolution	PSTN	Standard: 200 x 100 dpi Fine: 200 x 200 dpi Super Fine: 200 x 400 dpi Ultra Fine: 400 x 400 dpi
	Internet Fax	200 dpi x 200 dpi
Original Document Size		A3, A4, A5, B4, B5, FOLIO, LD, LG, LT, ST, COMPUTER
Mail Box	User defined	Max. 300 boxes
Routed document format	Send to e-Filing	MMR
	Send to File (SMB)	Single TIFF, Multi-TIFF, Single PDF, Multi PDF
	Send to FTP	Single TIFF, Multi-TIFF, Single PDF, Multi PDF
	Send to E-mail	Single TIFF, Multi-TIFF, Single PDF, Multi PDF
	Send to I-Fax	TIFF-S
	Send to PSTN-FAX	MMR

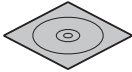
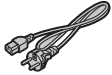
2.2 Accessories

Unpacking/Setup instruction		1 set
Operator's manual		1 set <ul style="list-style-type: none"> • Safety Information: 1 manual • Quick Start Guide: 1 manual
DVD		1 pc. Client Utilities / User Documentation DVD (Except NAD, AUD)
Power cable		1 pc.
Warranty sheet		1 pc. (for NAD)
Setup report		1 set (for NAD, MJD and CND)
Rubber plug		2 pcs.
Developer material (Y, M, C, K)		Developer material is pre-filled in each developer unit.
Toner (Y, M, C, K)		1 set (for AUD, MJD and CND)
Approval sheet		1 set (for CND)
Right lower cover		1 pc.
Screw (M3x8)		1 pc.

* Machine version

NAD: North America, Brazil
MJD: Europe
AUD: Australia
ASD: Asia, Hong Kong, Latin America
TWD: Taiwan
CND: China
ARD: Argentina
JPD: Japan

Notes:

Check that the above accessories are correctly co-packed at the time of unpacking.

2.3 System List

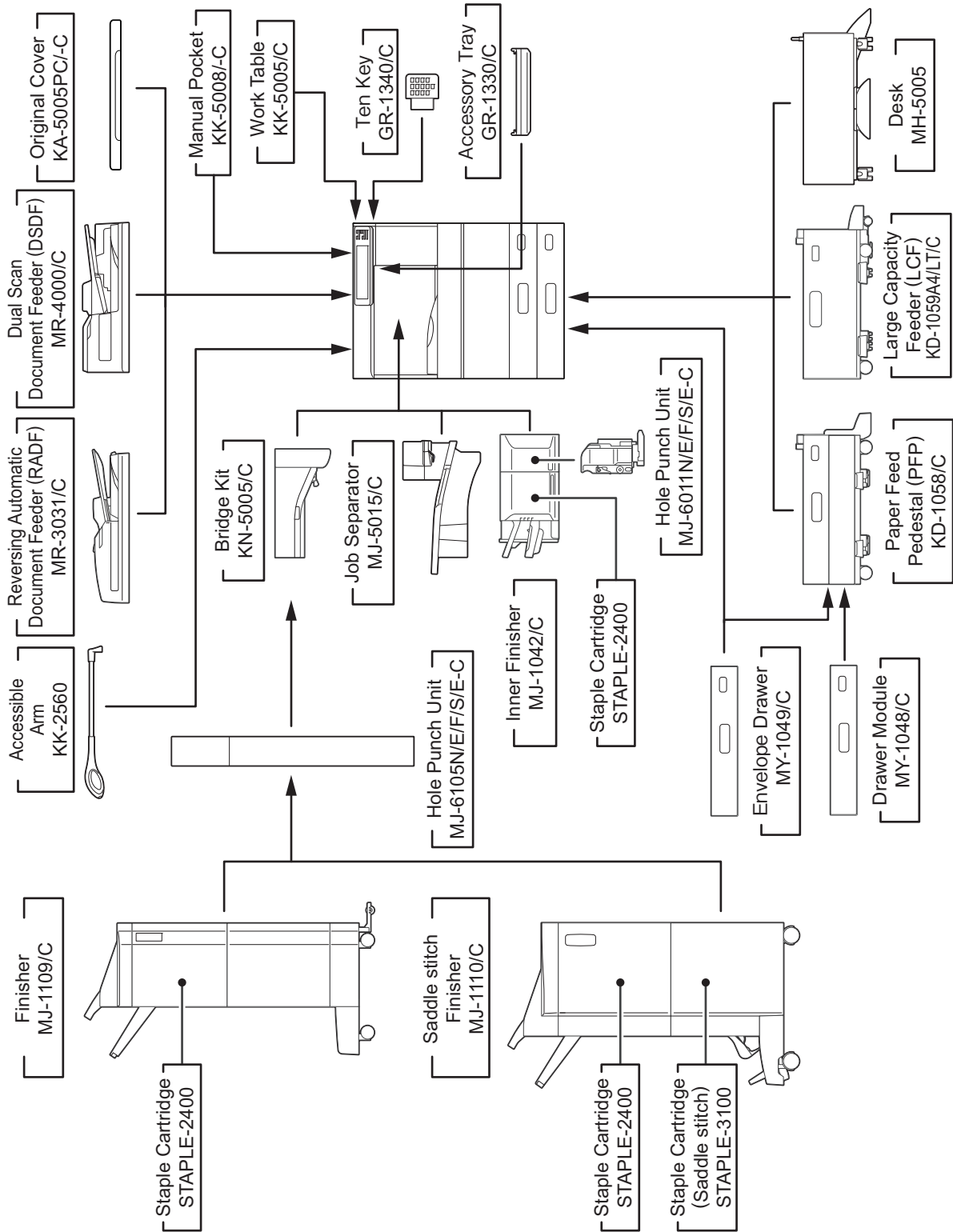

Fig. 2-1

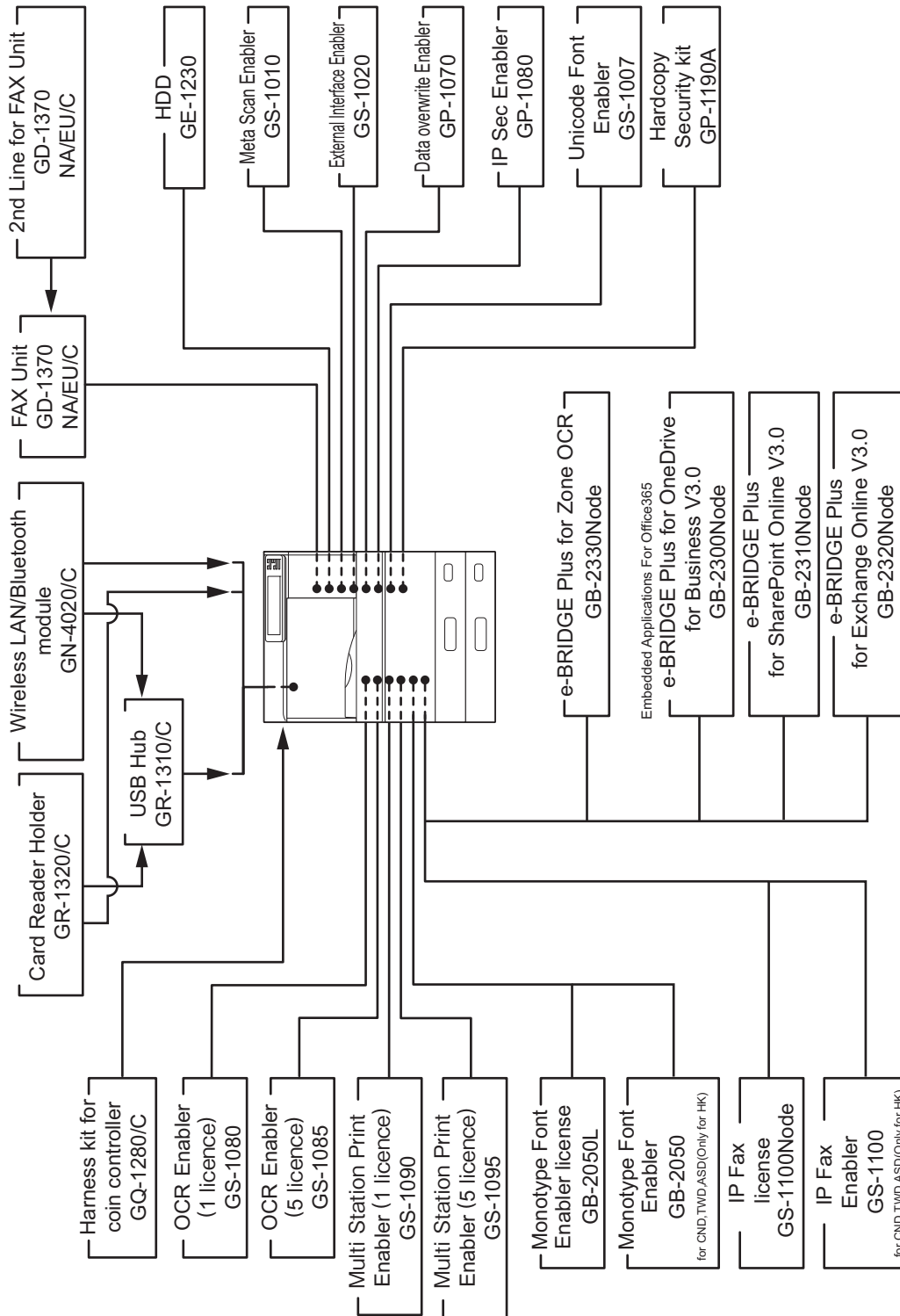

Fig. 2-2









Notes:

- The bridge kit (KN-5005/C) is necessary for installation of the finisher (MJ-1109/C or MJ-1110/C).
- The finisher (MJ-1042/C) is necessary for installation of the hole punch unit (MJ-6011E/N/F/S/E-C).
- The finisher (MJ-1109/C or MJ-1110/C) is necessary for installation of the hole punch unit (MJ-6105E/N/F/S/E-C).
- GE-1230 is FIPS SED.
- Install the Ten Key (GR-1340) first when it is done together with the Accessory Tray (GR-1330).
- Reversing Automatic Document Feeder (RADF): MR-3031-B and MR-3031C-B are used.
- Paper Feed Pedestal (PFP): KD-1058-B and KD-1058C-B are used.
- Large Capacity Feeder (LCF): KD-1059LT-B, KD-1059A4-B and KD-1059C-B are used.
- Drawer Module: MY-1048-B and MY-1048C-B are used.
- Envelope Drawer: MY-1049-B and MY-1049C-B are used.
- Inner Finisher: MJ-1042-B and MJ-1042C-B are used.
- Finisher: MJ-1109-B and MJ-1109C-B are used.
- Saddle Stitch Finisher: MJ-1110-B and MJ-1110C-B are used.
- The envelope drawer (MY-1049/C) can be installed as the 2nd drawer or as the 3rd or 4th drawer of the paper feed pedestal (KD-1058/C).

2.4 Option List

Model Name	Option
MR-3031/C	Reversing Automatic Document Feeder (RADF)
MR-4000/C	Dual Scan Document Feeder (DSDF)
KA-5005PC/PCC	Original Cover
KD-1058/C	Paper Feed Pedestal (PFP)
MY-1048/C	Drawer Module
MY-1049/C	Envelope Drawer
KD-1059LT/A4/C	Large Capacity Feeder (LCF)
MH-5005	Desk
KK-5008/C	Operator's Manual Pocket
KK-5005/C	Work Table
KK-2560	Accessible Arm
MJ-5015/C	Job Separator
KN-5005/C	Bridge Kit
MJ-1042/C	Inner Finisher
MJ-6011E/N/F/S/E-C	Hole Punch Unit (for MJ-1042/C)
MJ-1109/C	Finisher
MJ-1110/C	Saddle Stitch Finisher
MJ-6105/E/N/F/S/E-C	Hole Punch Unit (for MJ-1109/C, MJ-1110/C)
STAPLE-2400	Staple Cartridge (for MJ-1042/C, MJ-1109/C, MJ-1110/C)
STAPLE-3100	Staple Cartridge (for MJ-1110/C Saddle Stitch)
GD-1370NA/EU/C	Fax Unit / 2nd Line for FAX Unit
GR-1310/C	USB Hub
GR-1320/C	Card Reader Holder
GR-1330/C	Accessory Tray
GR-1340/C	Ten Key
GN-4020/C	Wireless LAN / Bluetooth Module
GQ-1280	Harness Kit for coin controller
GE-1230	HDD (FIPS Hard Disk)
GP-1190A	Hardcopy Security Kit
GS-1010	Meta Scan Enabler
GS-1020	External Interface Enabler
GP-1080	IPsec Enabler
GP-1070	Data Overwrite Enabler
GS-1007	Unicode Font Enabler
GB-2050L	Monotype Font license
GB-2050	Monotype Font enabler for CND, TWD, ASD (Only for HK)
GS-1080	OCR Enabler (1 license)
GS-1085	OCR Enabler (5 licenses)
GS-1090	Multi Station Print Enabler (1 license)
GS-1095	Multi Station Print Enabler (5 licenses)
GS-1100Node	IP Fax license
GS-1100	IP Fax enabler for CND, TWD, ASD (Only for HK)
GB-2330Node	e-BRIDGE Plus for Zone OCR
GB-2300Node	Embedded Applications For Office365 <ul style="list-style-type: none"> e-BRIDGE Plus for OneDrive for Business V3.0 (Node)
GB-2310Node	Embedded Applications For Office365 <ul style="list-style-type: none"> e-BRIDGE Plus for SharePoint Online V3.0 (Node)
GB-2320Node	Embedded Applications For Office365 <ul style="list-style-type: none"> e-BRIDGE Plus for Exchange Online V3.0 (Node)

2.5 Supplies

<p>Drum</p> 	<p>K: OD-FC505 YMC: OD-FC50</p>
<p>Developer material (K)</p> 	<p>D-FC505-K</p>
<p>Developer material (Y)</p> 	<p>D-FC505-Y</p>
<p>Developer material (M)</p> 	<p>D-FC505-M</p>
<p>Developer material (C)</p> 	<p>D-FC505-C</p>
<p>Toner cartridge (K)</p> 	<p>PS-ZTFC415UK(1) (for North America, Central and South America) PS-ZTFC415EK(1) (for Europe) PS-ZTFC415PK(1) (for Asia and Australia) PS-ZTFC415PKM(1) (for Asia and Australia) PS-ZTFC415CK(1) (for China) PS-ZTFC415CKS(1) (for China) PS-ZTFC415CK(10) (for China) PS-ZTFC415CKS(10) (for China) PS-ZTFC415TK(1) (for Taiwan)</p>
<p>Toner cartridge (Y)</p> 	<p>PS-ZTFC415UY(1) (for North America, Central and South America) PS-ZTFC415EY(1) (for Europe) PS-ZTFC415PY(1) (for Asia and Australia) PS-ZTFC415PYM(1) (for Asia and Australia) PS-ZTFC415CY(1) (for China) PS-ZTFC415CYS(1) (for China) PS-ZTFC415CY(10) (for China) PS-ZTFC415CYS(10) (for China) PS-ZTFC415TY(1) (for Taiwan)</p>
<p>Toner cartridge (M)</p> 	<p>PS-ZTFC415UM(1) (for North America, Central and South America) PS-ZTFC415EM(1) (for Europe) PS-ZTFC415PM(1) (for Asia and Australia) PS-ZTFC415PMM(1) (for Asia and Australia) PS-ZTFC415CM(1) (for China) PS-ZTFC415CMS(1) (for China) PS-ZTFC415CM(10) (for China) PS-ZTFC415CMS(10) (for China) PS-ZTFC415TM(1) (for Taiwan)</p>
<p>Toner cartridge (C)</p> 	<p>PS-ZTFC415UC(1) (for North America, Central and South America) PS-ZTFC415EC(1) (for Europe) PS-ZTFC415PC(1) (for Asia and Australia) PS-ZTFC415PCM(1) (for Asia and Australia) PS-ZTFC415CC(1) (for China) PS-ZTFC415CCS(1) (for China) PS-ZTFC415CC(10) (for China) PS-ZTFC415CCS(10) (for China) PS-ZTFC415TC(1) (for Taiwan)</p>

Waste toner box



PS-TBFC505 (expect for Europe and China)
PS-TBFC505E (for Europe)
PS-TBFC505C (for China)

3. OUTLINE OF THE MACHINE

3.1 Sectional View

3.1.1 Front side

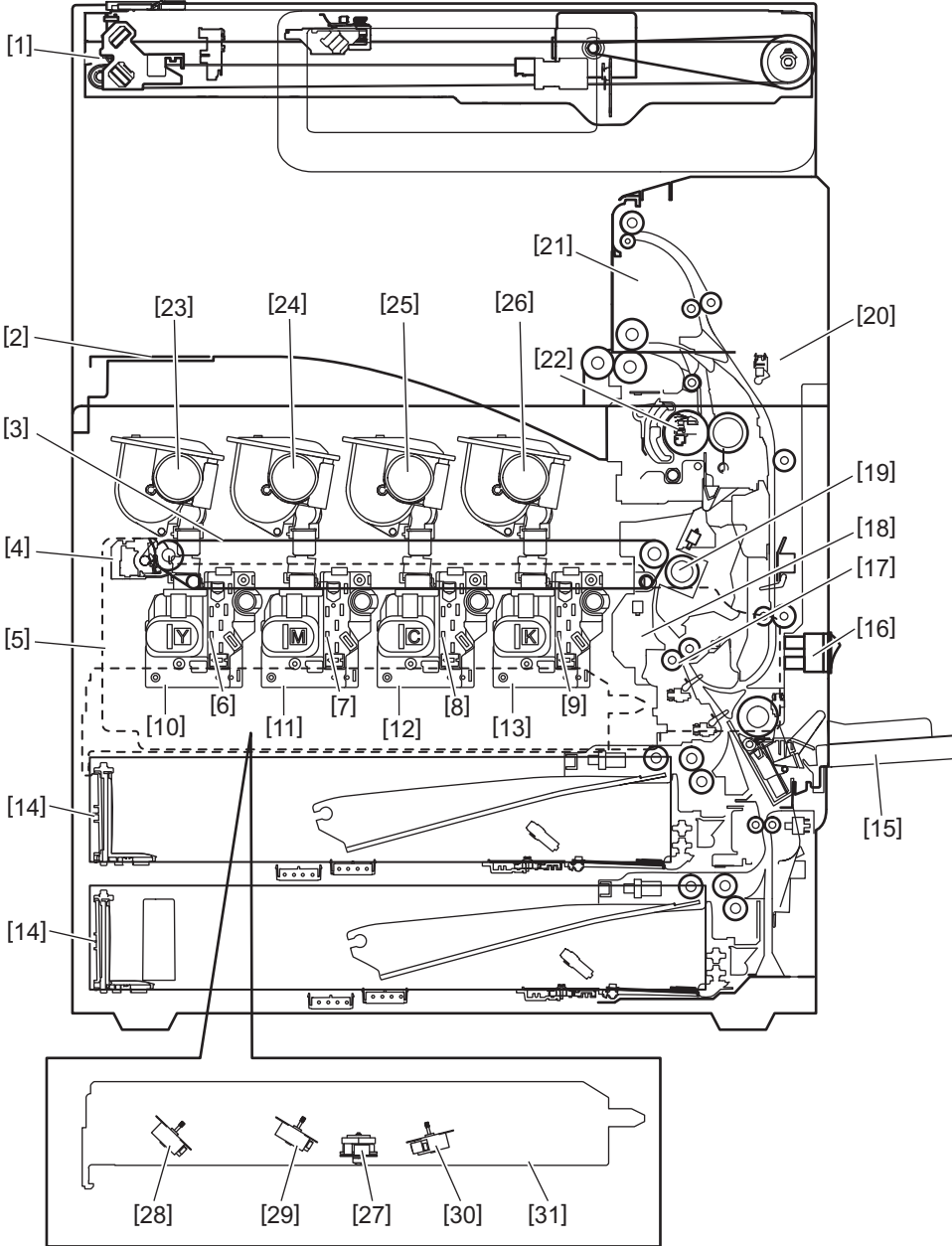

Fig. 3-1

1	Scanner unit	17	Registration roller
2	Inner tray	18	Image quality control unit
3	Transfer belt	19	2nd transfer roller
4	Transfer belt cleaning unit	20	Automatic duplexing unit (ADU)
5	Waste toner box	21	Paper exit section/reverse section
6	Drum (Y)	22	Fuser unit
7	Drum (M)	23	Toner (Y)
8	Drum (C)	24	Toner (M)
9	Drum (K)	25	Toner (C)
10	Developer unit (Y)	26	Toner (K)
11	Developer unit (M)	27	Polygonal motor
12	Developer unit (C)	28	Mirror motor-Y
13	Developer unit (K)	29	Mirror motor-M
14	1st drawer	30	Mirror motor-C
15	Bypass tray	31	Laser optical unit (LSU)
16	Main power switch		

3.1.2 Rear side

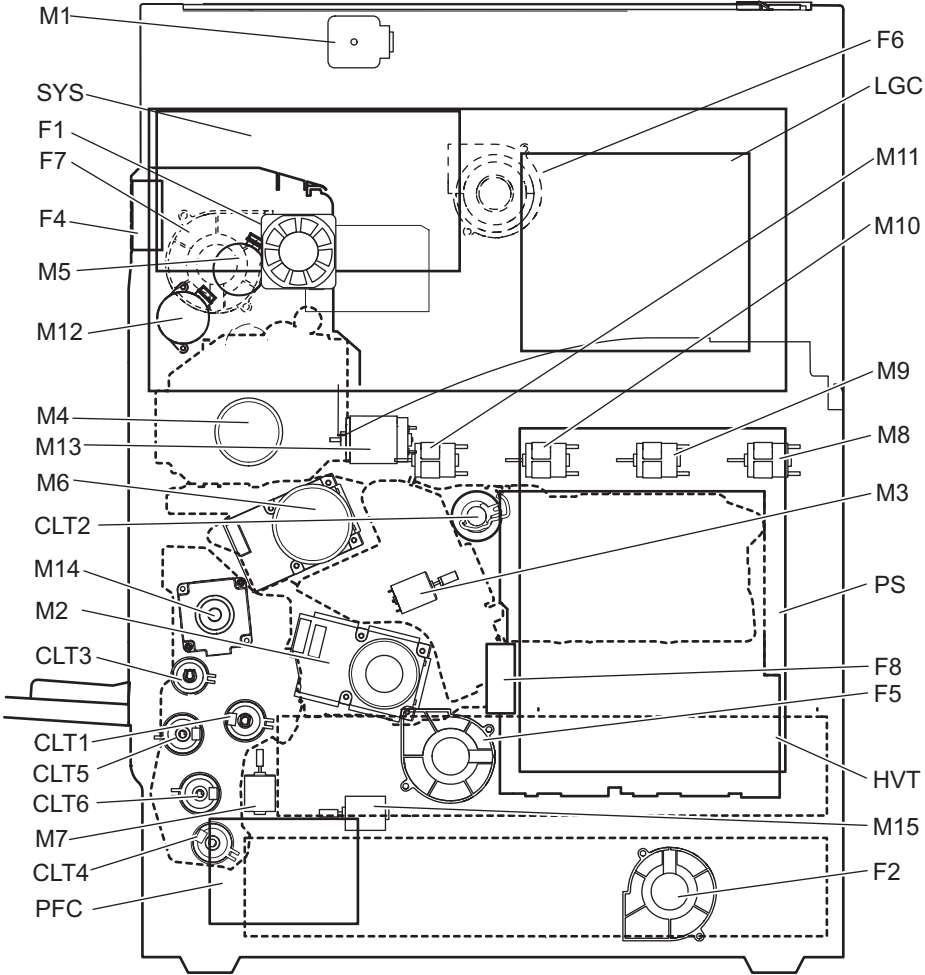

Fig. 3-2

M1	Scan motor	CLT3	Bypass feed clutch
M2	Feed/Developer motor	CLT4	2nd drawer feed clutch
M3	Mono/color switching motor	CLT5	Transport clutch (H)
M4	Fuser motor	CLT6	Transport clutch (L)
M5	Exit motor	F1	SYS cooling fan
M6	Drum/TBU motor	F2	Ozone exhaust fan
M7	Waste toner paddle motor	F4	Fuser unit cooling fan
M8	Toner motor-Y	F5	Developer unit cooling fan
M9	Toner motor-M	F6	IH board cooling fan
M10	Toner motor-C	F7	Exit section cooling fan
M11	Toner motor-K	F8	Power supply unit cooling fan
M12	ADU motor	SYS	System control PC board (SYS board)
M13	Pressure roller contact/release motor	LGC	Logic PC board (LGC board)
M14	Registration motor	HVT	High-voltage transformer
M15	Tray-up motor-1	PS	Switching regulator
CLT1	1st drawer feed clutch	PFC	Paper feed control PC board (PFC board)
CLT2	1st transfer contact/release clutch		

3.2 Electric Parts Layout

[A] Scanner unit, control panel

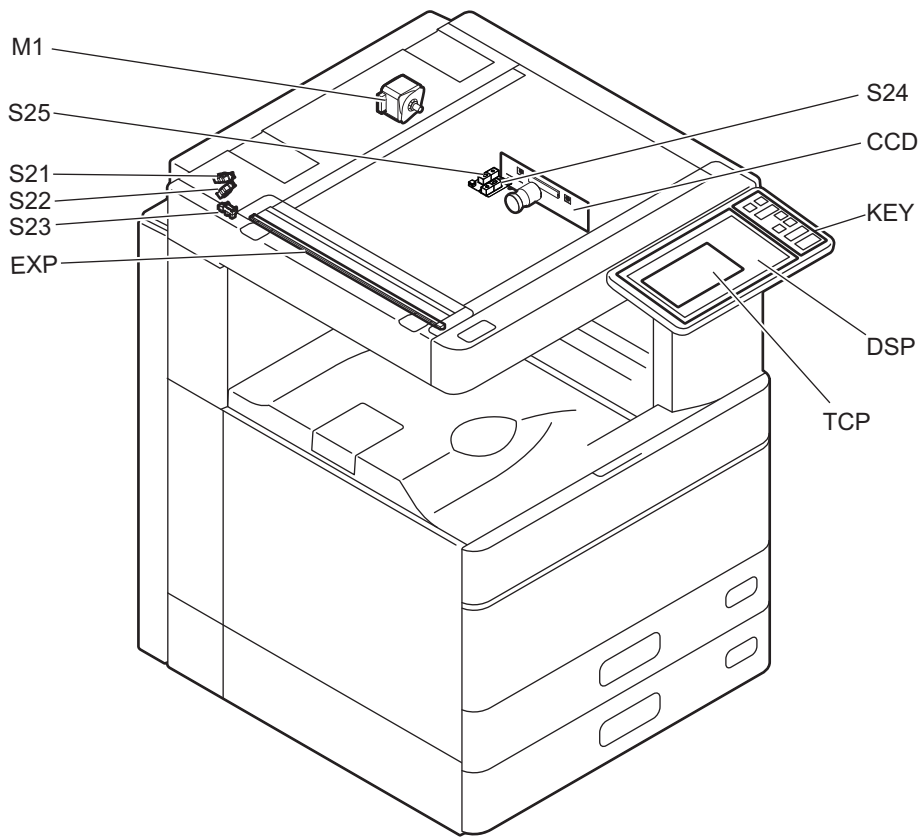

Fig. 3-3

[B] Toner cartridge, waste toner box

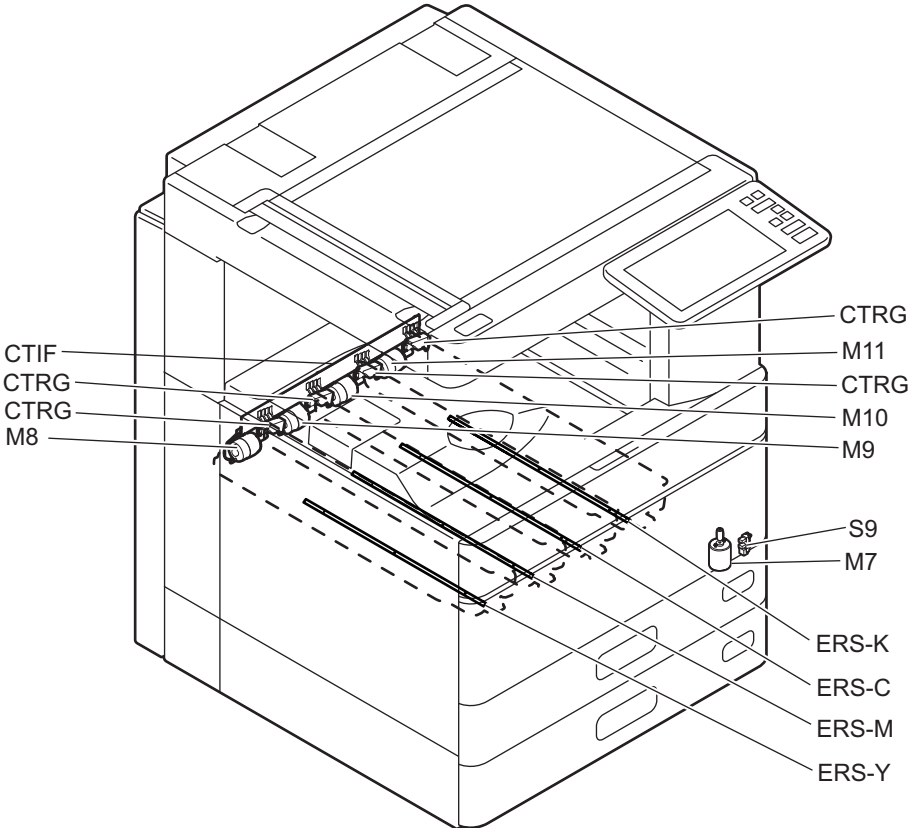

Fig. 3-4

[C] Developer unit

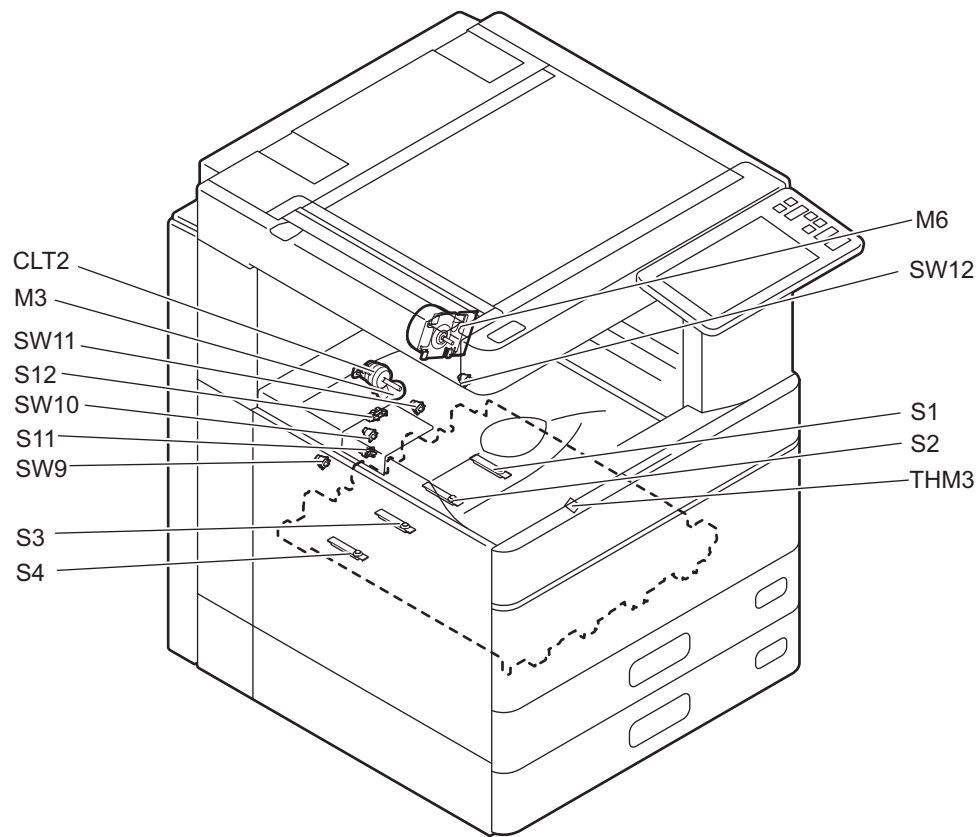

Fig. 3-5

[D] Data writing

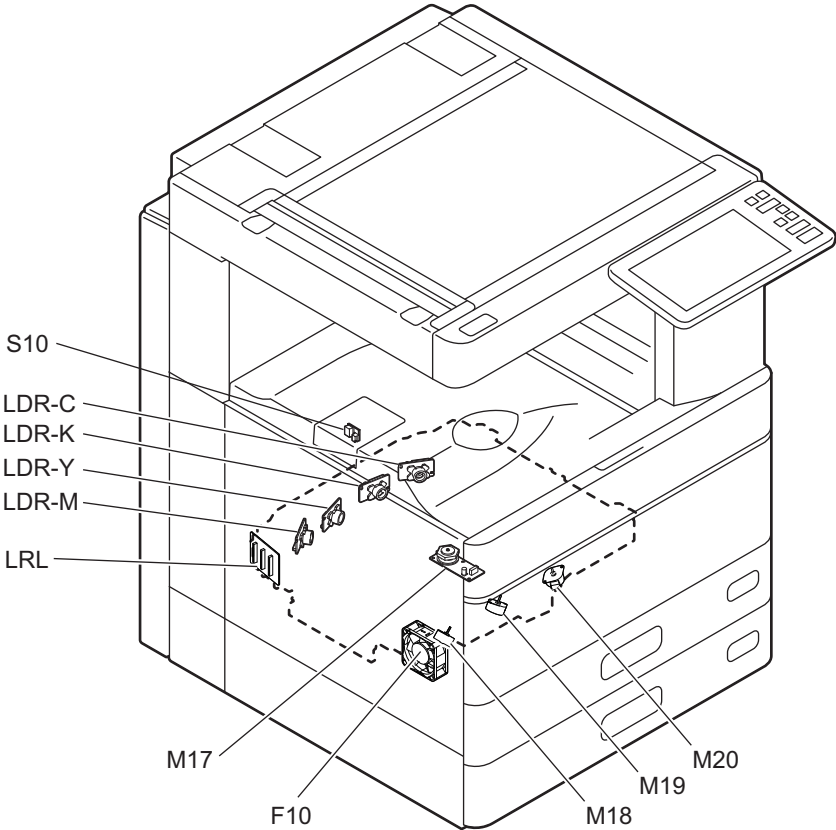

Fig. 3-6

[E] Fuser unit

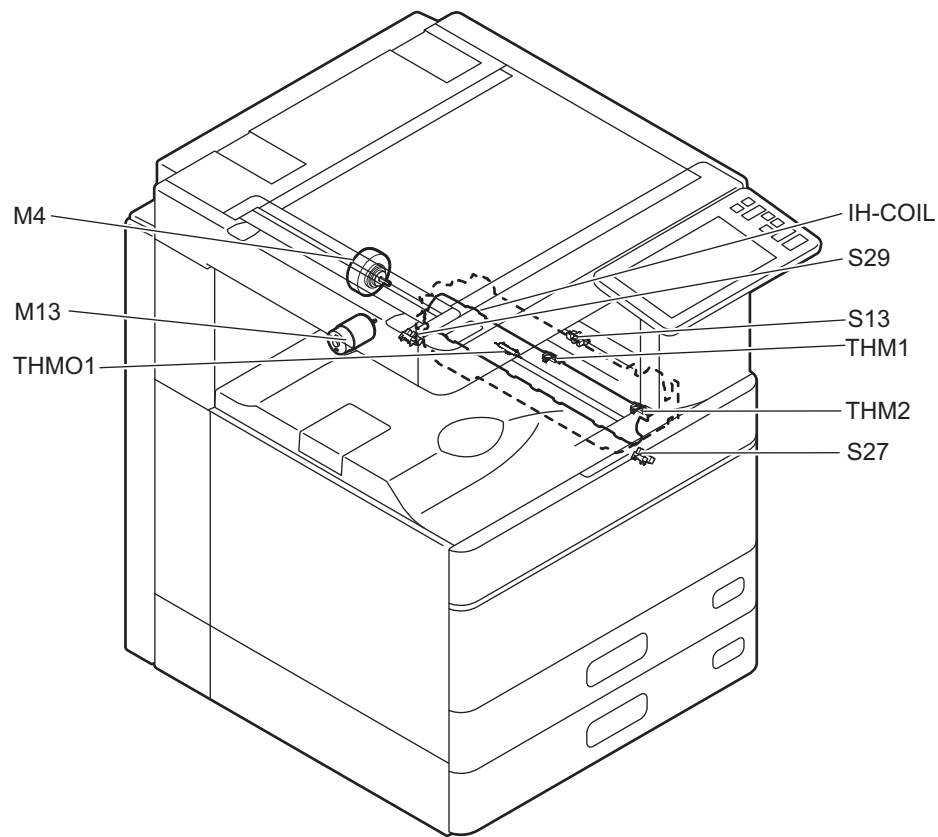

Fig. 3-7

[F] Image quality control

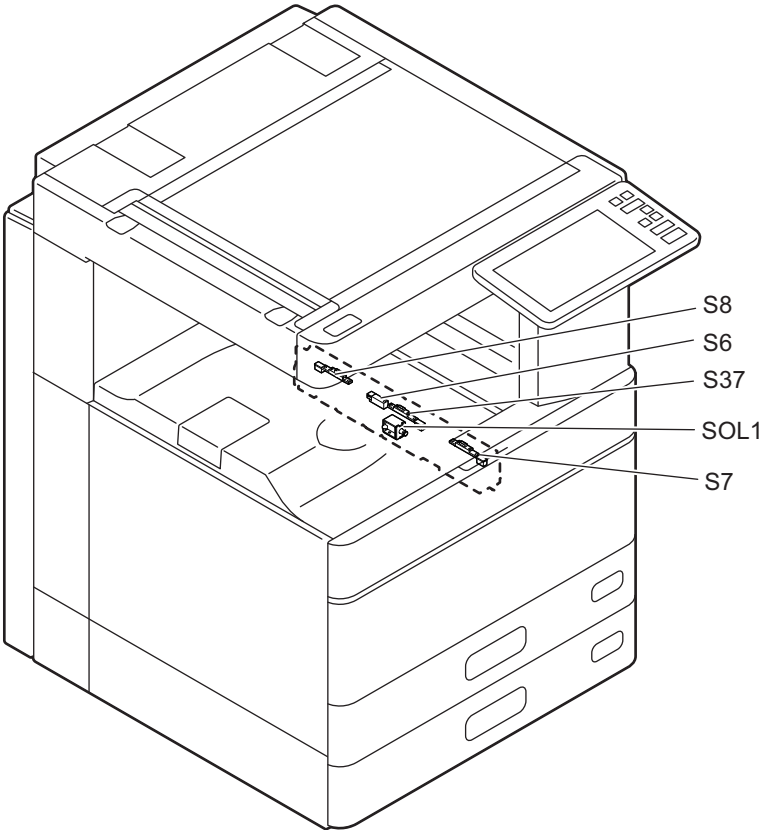

Fig. 3-8

[G] Paper feeding unit

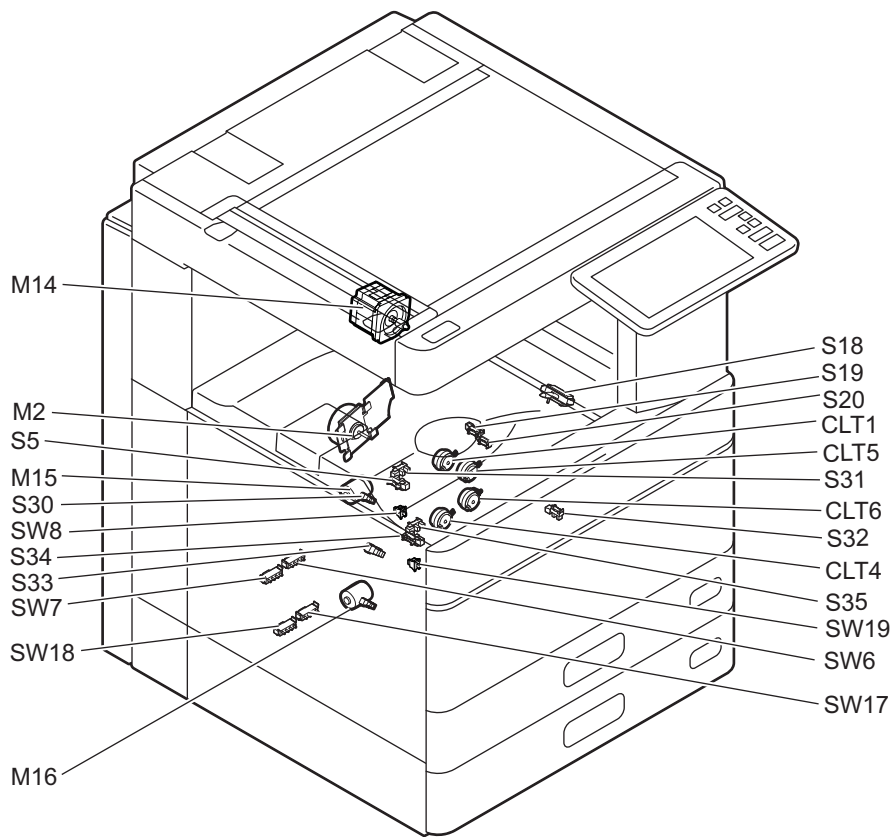

Fig. 3-9

[H] Automatic duplexing unit, bypass feed unit, paper exit/reverse unit

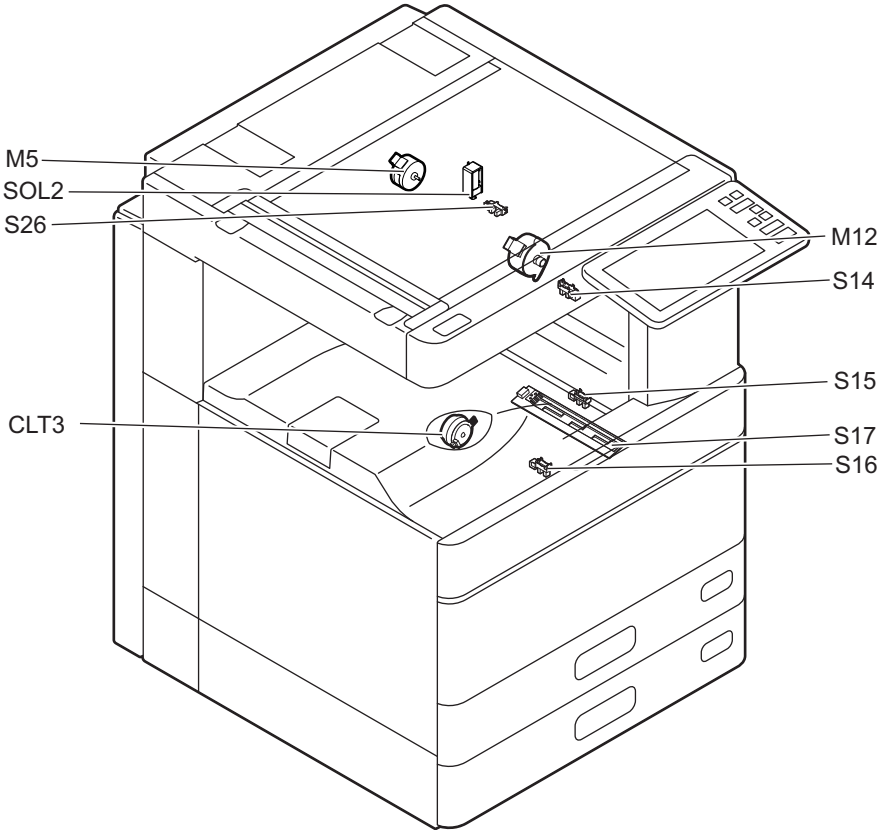

Fig. 3-10

[I] PC board, power supply, fan

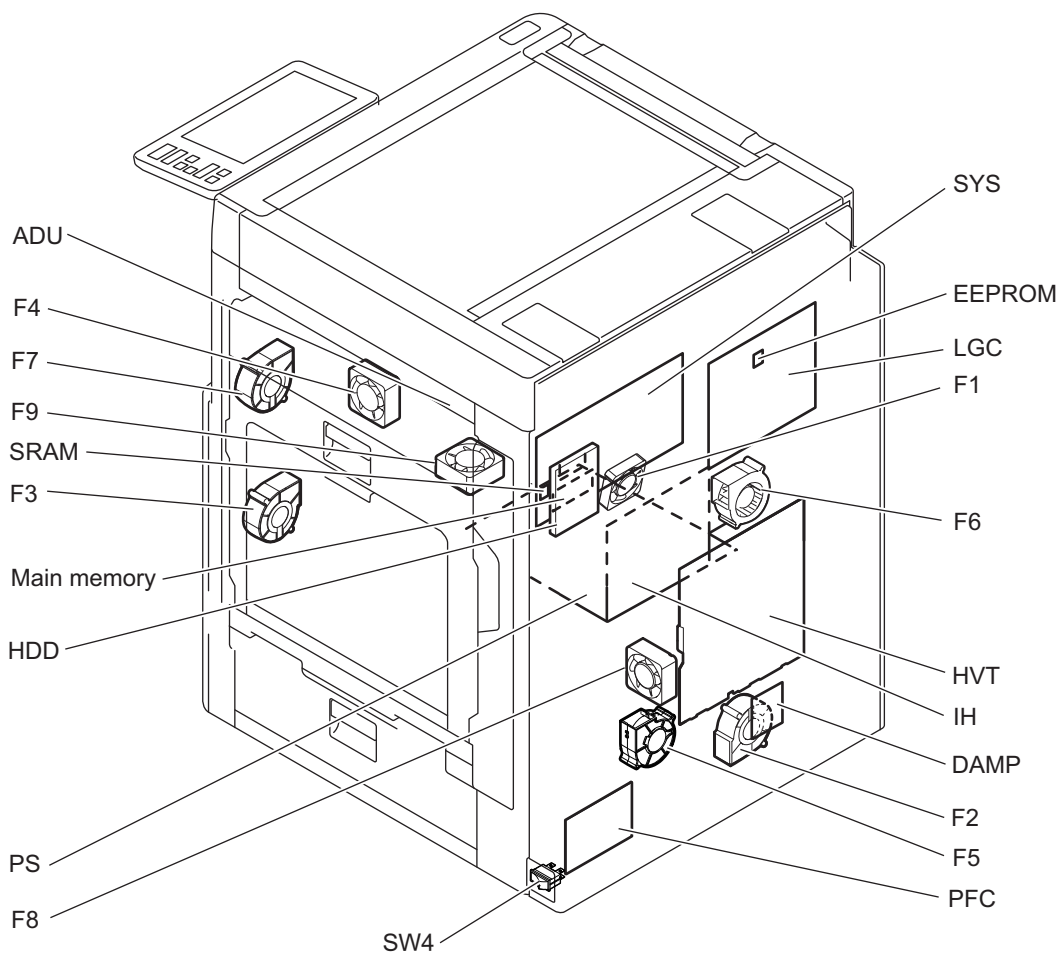

Fig. 3-11

[J] Cover switch, Damp heater

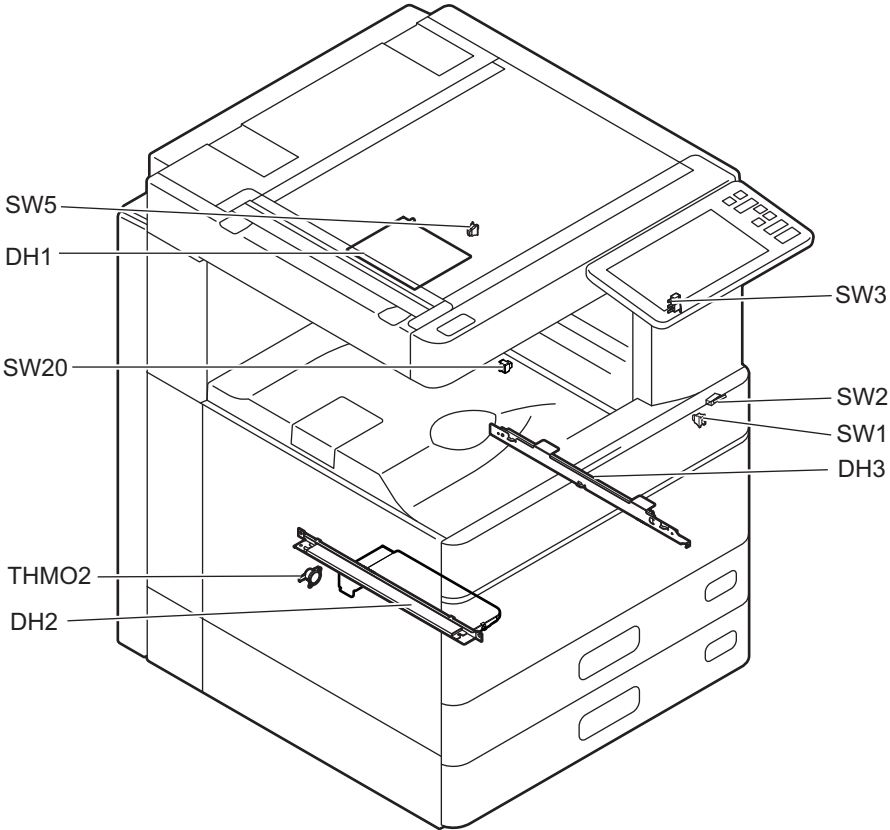

Fig. 3-12

3.3 Symbols and Functions of Various Components

The column "P-I" shows the page and item number in the parts list.

3.3.1 Motors, fans

Symbol	Name	Function	Remarks	P-I
M1	SCAN-MOT Scan motor	Driving the carriages	[A] Scanner unit, control panel	Fig. 3-3 19-8
M2	FEED/DEV-MOT Paper feeding/developer unit drive motor	Driving the feed roller and developer unit	[G] Paper feeding unit	Fig. 3-9 17-21
M3	DRM-SW-MOT Mono/color switching motor	Transmitting/releasing the drive to the Y/M/C drums	[C] Developer unit	Fig. 3-5 17-3
M4	FUS-MOT Fuser motor	Driving the fuser	[E] Fuser unit	Fig. 3-7 18-1
M5	EXIT-MOT Exit motor	Driving the upper exit roller and reverse roller	[H] Automatic duplexing unit, bypass feed unit, paper exit/reverse unit	Fig. 3-10 40-34
M6	DRM/TBU-MOT Drum / TBU motor	Driving the drum Driving the transfer belt	[C] Developer unit	Fig. 3-5 15-43
M7	USD-TNR-MOT Waste toner paddle motor	Driving the paddle in the waste toner box (agitating the accumulated waste toner)	[B] Toner cartridge, waste toner box	Fig. 3-4 24-9
M8	TNR-MOT-Y Toner motor-Y	Transporting toner from the Y toner cartridge to the developer unit	[B] Toner cartridge, waste toner box	Fig. 3-4 36-7
M9	TNR-MOT-M Toner motor-M	Transporting toner from the M toner cartridge to the developer unit	[B] Toner cartridge, waste toner box	Fig. 3-4 36-7
M10	TNR-MOT-C Toner motor-C	Transporting toner from the C toner cartridge to the developer unit	[B] Toner cartridge, waste toner box	Fig. 3-4 36-7
M11	TNR-MOT-K Toner motor-K	Transporting toner from the K toner cartridge to the developer unit	[B] Toner cartridge, waste toner box	Fig. 3-4 36-7
M12	ADU-MOT ADU motor	Driving the automatic duplexing unit	[H] Automatic duplexing unit, bypass feed unit, paper exit/reverse unit	Fig. 3-10 41-16
M13	FUS-CR-MOT Pressure roller contact/release motor	Driving the contacting/releasing operation of the pressure roller	[E] Fuser unit	Fig. 3-7 18-3
M14	RGST-MOT Registration motor	Driving the registration roller	[G] Paper feeding unit	Fig. 3-9 46-1
M15	TUP-MOT1 Tray-up motor-1	Lifting up the tray in the 1st drawer	[G] Paper feeding unit	Fig. 3-9 45-12
M16	TUP-MOT2 Tray-up motor-2	Lifting up the tray in the 2nd drawer	[G] Paper feeding unit	Fig. 3-9 45-12
M17	Polygonal motor	Driving the polygonal mirror	[D] Data writing	Fig. 3-6 31-47

Symbol	Name	Function	Remarks		P-I
M18	MIR-MOT-Y Mirror motor-Y	Adjusting the irradiation angle of the Y laser	[D] Data writing	Fig. 3-6	31-47
M19	MIR-MOT-M Mirror motor-M	Adjusting the irradiation angle of the M laser	[D] Data writing	Fig. 3-6	31-47
M20	MIR-MOT-C Mirror motor-C	Adjusting the irradiation angle of the C laser	[D] Data writing	Fig. 3-6	31-47
F1	SYS-FAN SYS cooling fan	Cooling down the SYS board	[I] PC board, power supply, fan	Fig. 3-11	9-20
F2	OZN-FAN Ozone exhaust fan	Exhausting ozone generated at charging	[I] PC board, power supply, fan	Fig. 3-11	7-63
F3	SCT-FAN Suctioning fan	Suctioning external air	[I] PC board, power supply, fan	Fig. 3-11	7-31
F4	FUS-FAN-1 Fuser unit cooling fan-1	Cooling down the fuser unit	[I] PC board, power supply, fan	Fig. 3-11	42-25
F5	DVP-FAN Developer unit cooling fan	Cooling down the developer unit	[I] PC board, power supply, fan	Fig. 3-11	7-31
F6	IH-FAN IH board cooling fan	Cooling down the IH board	[I] PC board, power supply, fan	Fig. 3-11	9-22
F7	EXT-FAN Exit section cooling fan	Cooling down the exit section	[I] PC board, power supply, fan	Fig. 3-11	7-51
F8	PS-FAN Power supply unit cooling fan	Cooling down the power supply unit	[I] PC board, power supply, fan	Fig. 3-11	7-53
F9	FUS-FAN-2 Fuser unit cooling fan-2	Cooling down the fuser unit	[I] PC board, power supply, fan	Fig. 3-11	42-25
F10	LSU-FAN Laser optical unit cooling fan	Cooling down the laser optical unit	[D] Data writing	Fig. 3-6	7-59

3.3.2 Sensors and switches

Symbol	Name	Function	Remarks	P-I
S1	ATTNR-SNR-K Auto-toner sensor-K	Detecting the toner density in the K developer unit	[C] Developer unit Fig. 3-5	33-4
S2	ATTNR-SNR-C Auto-toner sensor-C	Detecting the toner density in the C developer unit	[C] Developer unit Fig. 3-5	33-4
S3	ATTNR-SNR-M Auto-toner sensor-M	Detecting the toner density in the M developer unit	[C] Developer unit Fig. 3-5	33-4
S4	ATTNR-SNR-Y Auto-toner sensor-Y	Detecting the toner density in the Y developer unit	[C] Developer unit Fig. 3-5	33-4
S5	CST1-EMP-SNR 1st drawer empty sensor	Detecting the presence of paper in the 1st drawer	[G] Paper feeding unit Fig. 3-9	6-40
S6	RGST-PASS-SNR Registration pass sensor	Detecting paper transport at the registration roller section	[F] Image quality control Fig. 3-8	14-19
S7	IMG-POS-SNR-F Image position aligning sensor (Front)	Detecting the density of a toner image (test pattern) developed on the transfer belt surface (front)	[F] Image quality control Fig. 3-8	14-6
S8	IMG-POS-SNR-R Image position aligning sensor (Rear)	Detecting the density of a toner image (test pattern) developed on the transfer belt surface (rear)	[F] Image quality control Fig. 3-8	14-6
S9	USD-TNR-PDL-SNR Waste toner paddle rotation detection sensor	Detecting the rotation status of the waste toner paddle (Detecting the waste toner full)	[B] Toner cartridge, waste toner box Fig. 3-4	24-4
S10	TEMP/HUMI-SNR Temperature/humidity sensor	Detecting the ambient temperature/humidity of the equipment	[D] Data writing Fig. 3-6	7-29
S11	DRM-SW-SNR Drum switching detection sensor	Detecting contact/release status of the drive to the Y/M/C drums	[C] Developer unit Fig. 3-5	17-10
S12	1ST-TRNS-SW-SNR 1st transfer roller status detection sensor	Detecting contact/release status of the 1st transfer roller for each color	[C] Developer unit Fig. 3-5	16-5
S13	EXIT-SNR Exit sensor	Detecting paper exit	[E] Fuser unit Fig. 3-7	39-12
S14	ADU-U-SNR ADU entrance sensor	Detecting transported paper at the automatic duplexing unit entrance section	[H] Automatic duplexing unit, bypass feed unit, paper exit/reverse unit Fig. 3-10	41-19
S15	ADU-L-SNR ADU exit sensor	Detecting transported paper inside the automatic duplexing unit	[H] Automatic duplexing unit, bypass feed unit, paper exit/reverse unit Fig. 3-10	41-19
S16	SFB-FEED-SNR Bypass feed sensor	Detecting transported paper fed from the bypass feed unit	[H] Automatic duplexing unit, bypass feed unit, paper exit/reverse unit Fig. 3-10	42-9
S17	PWA-F-SFB Paper width detection PC board (SFB board)	Detecting the width of paper on the bypass tray	[H] Automatic duplexing unit, bypass feed unit, paper exit/reverse unit Fig. 3-10	20-6

Symbol	Name	Function	Remarks	P-I	
S18	CLNG-SNR Paper clinging detection sensor	Detecting whether the paper is clinging to the transfer belt or not	[G] Paper feeding unit	Fig. 3-9	14-19
S19	RGST-SNR Registration sensor	Detecting paper transport at the registration roller section	[G] Paper feeding unit	Fig. 3-9	13-5
S20	TRANS-SNR Feed sensor	Detecting paper transport at the from the bypass feed unit, drawer, and ADU.	[G] Paper feeding unit	Fig. 3-9	13-5
S21	PLTN-SNR1 Platen sensor-1	Detecting the opening/closing status of the platen cover or RADF	[A] Scanner unit, control panel	Fig. 3-3	19-13
S22	PLTN-SNR2 Platen sensor-2	Detecting the opening/closing status of the platen cover or RADF	[A] Scanner unit, control panel	Fig. 3-3	19-13
S23	HOME-SNR Carriage home position sensor	Detecting the carriage home position	[A] Scanner unit, control panel	Fig. 3-3	10-5
S24	APS1 Automatic original detection sensor-1	Detecting original size	[A] Scanner unit, control panel	Fig. 3-3	10-12
S25	APS2 Automatic original detection sensor-2	Detecting original size (for LT size)	[A] Scanner unit, control panel	Fig. 3-3	10-12
S26	REV-SNR Reverse sensor	Detecting the transportation of paper at the paper exit section/ reverse section	[H] Automatic duplexing unit, bypass feed unit, paper exit/reverse unit	Fig. 3-10	42-9
S27	FR-RD-SNR Fuser belt rotation detection sensor	Detecting the rotation of the fuser belt	[E] Fuser unit	Fig. 3-7	5-10
S29	PR-CR-SNR Pressure roller contact/ release detection sensor	Detecting the contact/release state of the fuser unit	[E] Fuser unit	Fig. 3-7	5-10
S30	CST1-PR-SNR 1st drawer paper remaining sensor	Detecting the remaining amount of paper in the 1st drawer	[G] Paper feeding unit	Fig. 3-9	45-7
S31	CST1-TRY-SNR 1st drawer tray-up sensor	Detecting the lifting status of the tray in the 1st drawer	[G] Paper feeding unit	Fig. 3-9	6-40
S32	CST2-FEED-SNR 2nd drawer paper feed sensor	Detecting paper transport and paper jam at the paper feeding system of the 2nd drawer	[G] Paper feeding unit	Fig. 3-9	13-5
S33	CST2-PR-SNR 2nd drawer paper remaining sensor	Detecting the remaining amount of paper in the 2nd drawer	[G] Paper feeding unit	Fig. 3-9	45-7
S34	CST2-EMP-SNR 2nd drawer empty sensor	Detecting the presence of paper in the 2nd drawer	[G] Paper feeding unit	Fig. 3-9	6-40
S35	CST2-TRY-SNR 2nd drawer tray-up sensor	Detecting the lifting status of the tray in the 2nd drawer	[G] Paper feeding unit	Fig. 3-9	6-40
S37	IMG-POS-SNR-C Image position aligning sensor (Center) / Image quality sensor	Detecting the density of a toner image (test pattern) developed on the transfer belt surface (center) Detecting the center side position a toner image (test pattern) developed on the transfer belt	[F] Image quality control	Fig. 3-8	14-6
SW1	FRT-COV-SW Front cover switch	Detecting the opening/closing status of the front cover	[J] Cover switch, Damp heater	Fig. 3-12	36-33

Symbol	Name	Function	Remarks	P-I	
SW2	F-COV-INTLCK-SW Front cover interlock switch	Supplying or shutting off AC power to the switching regulator (voltage-generating circuit interlocked with these covers) according to the opening/closing status of the front cover or automatic duplexing unit (Cover open: Shut off)	[J] Cover switch, Damp heater	Fig. 3-12	4-7
SW3	S-COV-INTLCK-SW Side cover interlock switch	Supplying or shutting off AC power to the switching regulator (voltage-generating circuit interlocked with these covers) according to the opening/closing status of the front cover or automatic duplexing unit (Cover open: Shut off)	[J] Cover switch, Damp heater	Fig. 3-12	5-21
SW4	MAIN-SW Main power switch	Turning the power of the equipment ON/OFF	[I] PC board, power supply, fan	Fig. 3-11	6-41
SW5	SIDE-COV-SW Side cover switch	Detecting the opening/closing status of the side cover	[J] Cover switch, Damp heater	Fig. 3-12	4-3
SW6	CST1-WDT-SW 1st drawer paper width detection switch	Detecting the width of paper in the 1st drawer	[G] Paper feeding unit	Fig. 3-9	45-16
SW7	CST1-LGT-SW 1st drawer paper length detection switch	Detecting the length of paper in the 1st drawer	[G] Paper feeding unit	Fig. 3-9	45-16
SW8	CST1-SW 1st drawer detection switch	Detecting the presence of the 1st drawer	[G] Paper feeding unit	Fig. 3-9	6-1
SW9	Y-EPU-SW Y EPU old/new detection switch	Detecting whether the Y drum / cleaner / main charger and developer unit are the old or the new one	[C] Developer unit	Fig. 3-5	31-2
SW10	M-EPU-SW M EPU old/new detection switch	Detecting whether the M drum / cleaner / main charger and developer unit are the old or the new one	[C] Developer unit	Fig. 3-5	31-2
SW11	C-EPU-SW C EPU old/new detection switch	Detecting whether the C drum / cleaner / main charger and developer unit are the old or the new one	[C] Developer unit	Fig. 3-5	31-2
SW12	K-EPU-SW K EPU old/new detection switch	Detecting whether the K drum / cleaner / main charger and developer unit are the old or the new one	[C] Developer unit	Fig. 3-5	31-2
SW17	CST2-WDT-SW 2nd drawer paper width detection switch	Detecting the width of paper in the 2nd drawer	[G] Paper feeding unit	Fig. 3-9	45-16
SW18	CST2-LGT-SW 2nd drawer paper length detection switch	Detecting the length of paper in the 2nd drawer	[G] Paper feeding unit	Fig. 3-9	45-16
SW19	CST2-SW 2nd drawer detection switch	Detecting the presence of the 2nd drawer	[G] Paper feeding unit	Fig. 3-9	6-1
SW20	JAM-CVR-SW Jam access cover opening/closing switch	Detecting the opening/closing status of the jam access cover	[J] Cover switch, Damp heater	Fig. 3-12	13-27

3.3.3 Electromagnetic spring clutches

Symbol	Name	Function	Remarks	P-I
CLT1	CST1-FEED-CLT 1st drawer feed clutch	Driving the feed roller of the 1st drawer	[G] Paper feeding unit Fig. 3-9	46-10
CLT2	1ST-TRNS-CLT 1st transfer contact/release clutch	Driving the contacting/releasing of the transfer belt and the drum	[C] Developer unit Fig. 3-5	15-40
CLT3	SFB-FEED-CLT Bypass feed clutch	Driving the feed roller of the bypass feed unit	[H] Automatic duplexing unit, bypass feed unit, paper exit/reverse unit Fig. 3-10	21-13
CLT4	CST2-FEED-CLT 2nd drawer feed clutch	Driving the feed roller of the 2nd drawer	[G] Paper feeding unit Fig. 3-9	46-10
CLT5	FEED-CLT-H Transport clutch (H)	Driving the feed roller (High speed)	[G] Paper feeding unit Fig. 3-9	46-10
CLT6	FEED-CLT-L Transport clutch (L)	Driving the feed roller (Low speed)	[G] Paper feeding unit Fig. 3-9	46-10

3.3.4 Solenoids

Symbol	Name	Function	Remarks	P-I
SOL1	SNR-SHUT-SOL Sensor shutter solenoid	Driving the sensor shutter of the image position aligning sensor (front / rear) and image quality sensor	[F] Image quality control Fig. 3-8	14-32
SOL2	REV-SOL Reverse gate solenoid	Changing the paper transportation route at the exit section/reverse section	[H] Automatic duplexing unit, bypass feed unit, paper exit/reverse unit Fig. 3-10	40-30

3.3.5 PC boards

Symbol	Name	Function	Remarks	P-I
CCD	PWA-H-CCD CCD driving PC board (CCD board)	Scanning originals with CCD	[A] Scanner unit, control panel	Fig. 3-3 10-9
DSP	PWA-H-DSP Display PC board (DSP board)	Controlling the whole control panel	[A] Scanner unit, control panel	Fig. 3-3 3-16
KEY	PWA-H-KEY Key PC board (KEY board)	Controlling the key switches and LEDs	[A] Scanner unit, control panel	Fig. 3-3 3-12
CTIF	PWA-H-CTIF Toner cartridge interface PC board (CTIF board)	Interface for detecting the toner cartridge (Detecting the CTRG board)	[B] Toner cartridge, waste toner box	Fig. 3-4 36-2
CTRG	PWA-H-CTRG Toner cartridge PC board (CTRG board)	Storing the status of the toner cartridge	[B] Toner cartridge, waste toner box	Fig. 3-4 -
ADU	PWA-H-ADU ADU control PC board (ADU board)	Controlling the automatic duplexing unit	[I] PC board, power supply, fan	Fig. 3-11 41-1
SYS	PWA-H-SYS System control PC board (SYS board)	Controlling the whole system and image processing Controlling the scanning section	[I] PC board, power supply, fan	Fig. 3-11 9-4
LGC	PWA-H-LGC Logic PC board (LGC board)	Controlling the print engine section	[I] PC board, power supply, fan	Fig. 3-11 9-5
PFC	PWA-PFC Paper feed control PC board (PFC board)	Controlling the bypass feed unit, 1st drawer, and 2nd drawer	[I] PC board, power supply, fan	Fig. 3-11 9-27
IH	PWA-H-IH Heater control PC board (IH board)	Controlling the IH coil of the fuser unit	[I] PC board, power supply, fan	Fig. 3-11 9-23
LDR-Y	LDR-Y Laser driving PC board-Y (LDR-Y board)	Driving the Y laser diode	[D] Data writing	Fig. 3-6 31-47
LDR-M	LDR-M Laser driving PC board-M (LDR-M board)	Driving the M laser diode	[D] Data writing	Fig. 3-6 31-47
LDR-C	LDR-C Laser driving PC board-C (LDR-C board)	Driving the C laser diode	[D] Data writing	Fig. 3-6 31-47
LDR-K	LDR-K Laser driving PC board-K (LDR-K board)	Driving the K laser diode	[D] Data writing	Fig. 3-6 31-47
LRL	PWA-H-LRL Laser control signal relay board (LRL board)	Relaying the control signals of the LDR and LGC	[D] Data writing	Fig. 3-6 31-47
DAMP	PWA-H-DAMP DAMP board (DAMP board)	Power supplying to each damp heater (AUD, ASD, ARD, TWD, CND)	[I] PC board, power supply, fan	Fig. 3-11 8-31

3.3.6 Lamps, LEDs, heaters, and coil

Symbol	Name	Function	Remarks	P-I
EXP	LP-EXPO Exposure lamp	Exposing originals	[A] Scanner unit, control panel Fig. 3-3	11-3
ERS-Y	LP-ERS-Y Discharge LED-Y	Eliminating residual charge on the Y drum surface	[B] Toner cartridge, waste toner box Fig. 3-4	31-15
ERS-M	LP-ERS-M Discharge LED-M	Eliminating residual charge on the M drum surface	[B] Toner cartridge, waste toner box Fig. 3-4	31-15
ERS-C	LP-ERS-C Discharge LED-C	Eliminating residual charge on the C drum surface	[B] Toner cartridge, waste toner box Fig. 3-4	31-15
ERS-K	LP-ERS-K Discharge LED-K	Eliminating residual charge on the K drum surface	[B] Toner cartridge, waste toner box Fig. 3-4	31-15
DH1	SCN-DH-L Scanner damp heater	Preventing condensation of the scanner	[J] Cover switch, Damp heater Fig. 3-12	10-17
DH2	DRM-DH-L Drum damp heater (Left)	Preventing condensation of the drum	[J] Cover switch, Damp heater Fig. 3-12	4-21
DH3	DRM-DH-R Drum damp heater (Right)	Preventing condensation of the drum	[J] Cover switch, Damp heater Fig. 3-12	4-21
IH-COIL	IH-COIL IH-COIL	Heating of the fuser belt	[E] Fuser unit Fig. 3-7	5-22

3.3.7 Thermistors, thermostats

Symbol	Name	Function	Remarks	P-I
THM1	THMS-FR-C Fuser belt center thermistor	Detecting the surface temperature of the center of the fuser belt	[E] Fuser unit Fig. 3-7	38-1
THM2	THMS-FR-E Fuser belt edge thermistor	Detecting the surface temperature of the front end of the fuser belt	[E] Fuser unit Fig. 3-7	38-1
THM3	THMS-DRM Drum thermistor	Detecting the surface temperature of the drum	[C] Developer unit Fig. 3-5	31-54
THMO1	THERMO-FR Fuser belt thermostat	Preventing overheating of the fuser belt	[E] Fuser unit Fig. 3-7	38-1
THMO2	THERMO-DRM-DH-L Drum damp heater thermostat (Left)	Controlling the temperature of the drum damp heater	[J] Cover switch, Damp heater Fig. 3-12	4-22

3.3.8 Others

Symbol	Name	Function	Remarks	P-I
TCP	TCP Touch panel	Displaying and entering various kinds of information	[A] Scanner unit, control panel Fig. 3-3	3-1
EEPROM	EEPROM Electrically Erasable Programmable Read Only Memory	Storing the setting or adjustment value, etc. used for the control by the logic PC board	[I] PC board, power supply, fan Fig. 3-11	9-36
SRAM	SRAM SRAM	Storing the setting or program, etc. used for the control by the system PC board	[I] PC board, power supply, fan Fig. 3-11	9-46
HDD	HDD Hard disk	Saving programs and data	[I] PC board, power supply, fan Fig. 3-11	9-15
Main memory	Main memory Main Memory	Saving data and programs temporarily (Also used as page memory in this equipment.)	[I] PC board, power supply, fan Fig. 3-11	9-35
PS	PS-ACC Switching regulator	Generating DC voltage and supplying it to each section of the equipment	[I] PC board, power supply, fan Fig. 3-11	4-27
HVT	PS-HVT High-voltage transformer	Generating high-voltage and supplying it to the following sections <ul style="list-style-type: none"> • Main charger needle electrode • Main charger grid • Developer bias • Transfer bias 	[I] PC board, power supply, fan Fig. 3-11	4-40

3.4 Copy Process

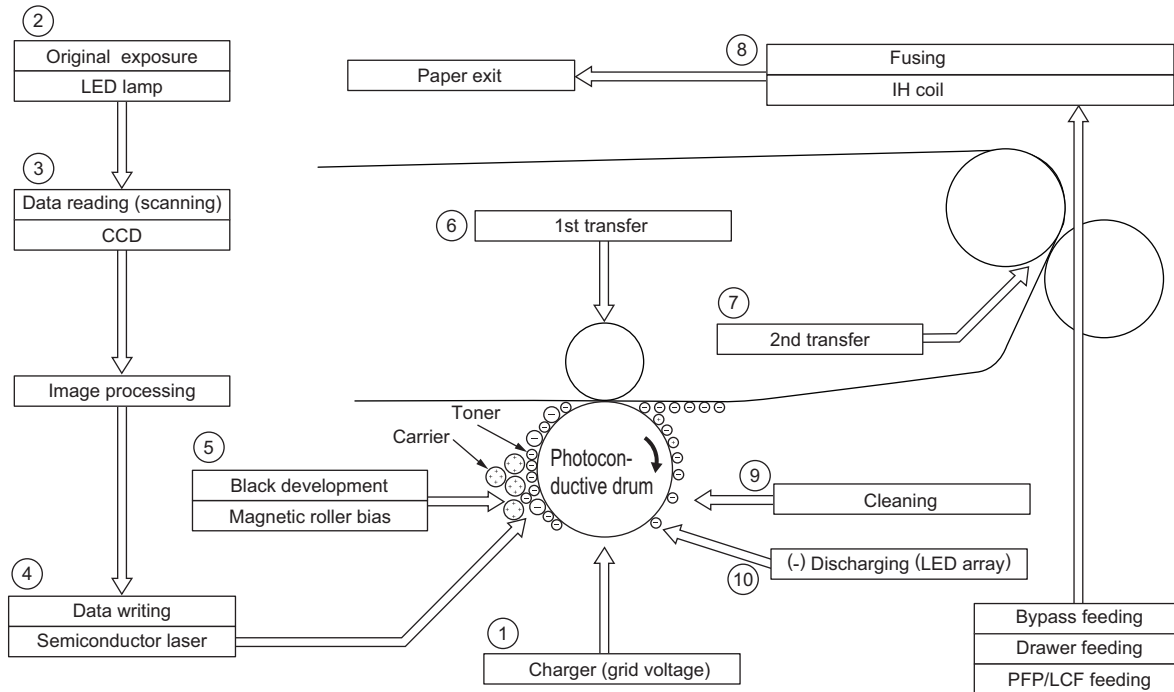

Fig. 3-13

- | | |
|--|--|
| <p>(1) Charging: Places a negative charge on the surface of the photoconductive drum.</p> <p style="text-align: center;">↓</p> <p>(2) Original exposure: Converts images on the original into optical signals.</p> <p style="text-align: center;">↓</p> <p>(3) Data reading: The optical image signals are read into CCD and converted into electrical signals.</p> <p style="text-align: center;">↓</p> <p>(4) Data writing: The electrical image signals are changed to light signals (by laser emission) which expose the surface of the photoconductive drum.</p> <p style="text-align: center;">↓</p> <p>(5) Development: Negatively-charged toner is made to adhere to the photoconductive drum, producing a visible image.</p> <p style="text-align: center;">↓</p> | <p>(6) 1st transfer: Transfers the visible image (toner) on photoconductive drum to the transfer belt.</p> <p style="text-align: center;">↓</p> <p>(7) 2nd transfer: Transfers the visible image (toner) on the transfer belt to paper.</p> <p style="text-align: center;">↓</p> <p>(8) Fusing: Fuses the toner image to the paper by applying heat and pressure.</p> <p style="text-align: center;">↓</p> <p>(9) Cleaning: Forcibly scrapes off the residual toner from the drum with the blade.</p> <p style="text-align: center;">↓</p> <p>(10) (-) Discharging: Eliminates the residual (-) charge from the surface of the photoconductive drum.</p> |
|--|--|

3.5 Comparison with e-STUDIO2505AC/3005AC/3505AC/4505AC/5005AC

Process		e-STUDIO2505AC/3005AC/3505AC/4505AC/5005AC	e-STUDIO2515AC/3015AC/3515AC/4515AC/5015AC
1. Photoconductive drum	Drum	K: PS-ODFC505 (OPC drum) YMC: OD-FC50 (OPC drum)	← ←
	Sensitivity	Highly sensitized drum (ø30)	←
2. Charging		Scorotron type -300 to -1100 V (grid voltage) (adjusting by image quality control)	←
3. Data writing	Light source	Semiconductor laser	←
	Light amount	3.5 nJ/mm ²	←
4. Image control		Image quality control by detecting toner adhesion amount	←
5. Development	Magnetic roller	One magnetic roller	←
	Auto-toner detection	Magnetic bridge-circuit method	←
	Toner supply	Toner cartridge replacing method	←
	Toner-empty detection	Density detection method	←

Process		e-STUDIO2505AC/3005AC/3505AC/ 4505AC/5005AC	e-STUDIO2515AC/3015AC/3515AC/ 4515AC/5015AC
5. Development	Toner	<p>NAD/ARD PS-ZTFC505UK(1), PS-ZTFC505UY(1), PS-ZTFC505UM(1), PS-ZTFC505UC(1)</p> <p>MJD PS-ZTFC505EK(1), PS-ZTFC505EY(1), PS-ZTFC505EM(1), PS-ZTFC505EC(1)</p> <p>ASD, AUD PS-ZTFC505PK(1), PS-ZTFC505PY(1), PS-ZTFC505PM(1), PS-ZTFC505PC(1)</p> <p>CND PS-ZTFC505CK(1), PS-ZTFC505CY(1), PS-ZTFC505CM(1), PS-ZTFC505CC(1), PS-ZTFC505CKS(1), PS-ZTFC505CYS(1), PS-ZTFC505CMS(1), PS-ZTFC505CCS(1)</p> <p>TWD PS-ZTFC505TK(1), PS-ZTFC505TY(1), PS-ZTFC505TM(1), PS-ZTFC505TC(1) (K: Black, Y: Yellow, M: Magenta, C: Cyan)</p>	<p>NAD/ARD PS-ZTFC415UK(1), PS-ZTFC415UY(1), PS-ZTFC415UM(1), PS-ZTFC415UC(1)</p> <p>MJD PS-ZTFC415EK(1), PS-ZTFC415EY(1), PS-ZTFC415EM(1), PS-ZTFC415EC(1)</p> <p>ASD, AUD PS-ZTFC415PK(1), PS-ZTFC415PY(1), PS-ZTFC415PM(1), PS-ZTFC415PC(1), PS-ZTFC415PKM(1), PS-ZTFC415PYM(1), PS-ZTFC415PMM(1), PS-ZTFC415PCM(1)</p> <p>CND PS-ZTFC415CK(1), PS-ZTFC415CY(1), PS-ZTFC415CM(1), PS-ZTFC415CC(1), PS-ZTFC415CKS(1), PS-ZTFC415CYS(1), PS-ZTFC415CMS(1), PS-ZTFC415CCS(1), PS-ZTFC415CK(10), PS-ZTFC415CKS(10), PS-ZTFC415CY(10), PS-ZTFC415CYS(10), PS-ZTFC415CM(10), PS-ZTFC415CMS(10), PS-ZTFC415CC(10), PS-ZTFC415CCS(10)</p> <p>TWD PS-ZTFC415TK(1), PS-ZTFC415TY(1), PS-ZTFC415TM(1), PS-ZTFC415TC(1) (K: Black, Y: Yellow, M: Magenta, C: Cyan)</p>
	Developer material	D-FC505-K (black) D-FC505-Y (yellow) D-FC505-M (magenta) D-FC505-C (cyan)	← ← ← ←
	Developer bias	DC -200 to -900V (adjusting by image quality control)	←
	6. Transfer	1st transfer	Transfer belt method
	2nd transfer:	Transfer roller method	←
7. Separation		Self-separation by transfer belt and 2nd transfer roller	←
8. Photoconductive drum cleaning	Method	Blade cleaning	←
	Recovered toner	Non-reusable	←
9. Transfer belt cleaning		Blade cleaning	←
10. Discharge		LED array (red)	←

Process		e-STUDIO2505AC/3005AC/3505AC/ 4505AC/5005AC	e-STUDIO2515AC/3015AC/3515AC/ 4515AC/5015AC
11.Fusing	Method	Belt fusing system	←
		Fuser belt: Resin base material belt Exothermic layer - rubber-coated belt (Surface-PFA tube)(ø30)	←
		Pressure roller: Silicon rubber roller, (Surface-PFA tube)(ø30)	←
	Cleaning	None	←
	Heater temperature	ON/OFF control and power control by thermistor	←
	Heater	IH coil	←

3.6 General Operation

3.6.1 Overview of operation

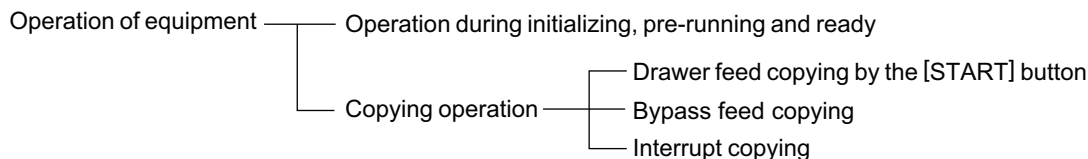

3.6.2 Description of operation

[1] Warming-up

1. Initialization

- Power ON
- Fuser motor (M4) is turned ON.
- IH coil (IH-COIL) ON
- “Wait Warming Up” is displayed.
- Fan motors ON
- Initialization of feeding system
 - Drum/TBU motor (M6) is turned ON.
 - Mono/color switching motor (M3) is turned ON and OFF.
- Cleaning of transfer belt
 - (Performs color registration control.)*¹
 - (Performs image quality control.)*¹
- Drum/TBU motor (M6) is turned OFF.
- Initialization of scanning system
 - The carriage moves to the home position.
 - The carriage moves to the peak detection position.
 - The exposure lamp (EXP) is turned ON.
 - Peak detection (white color is detected by the shading correction plate)
 - The exposure lamp (EXP) is turned OFF.
- “READY (WARMING UP)” is displayed.

2. Pre-running operation

Pre-running operation is started when the temperature of the fuser belt surface reaches a certain level.

- Fuser belt rotation.
- Fuser motor (M4) is turned OFF.
- Fuser belt rotation stops.

3. When the temperature of the fuser belt surface becomes sufficient for fusing,

- “READY” is displayed.

*1 Image quality control and color registration control should be performed only at change of environment or periodical performing timing.

[2] Ready (ready for copying)

- Buttons on the control panel enabled
- When no button is pressed for a certain period of time,
 - Set number “1” and reproduction ratio “100%” are displayed. Equipment returns to the normal ready state.

[3] Drawer feed copying (1st drawer paper feeding)

1. Press the [START] button ON
 - “READY” changes to “COPYING”
 - Exposure lamp (EXP) turned ON
 - Scan motor (M1) turned ON → Carriages-1 and -2 move forward
 - Drum/TBU motor (M6), Paper feeding/developer unit drive motor (M2), and fuser motor (M4) turned ON
 - Drum, transfer belt, fuser unit, and developer unit are driven, Polygonal motor rotates in high speed

2. Drawer paper feeding
 - Fans rotated at high speed and feed clutches (CLT5, CLT6) turned ON
 - Feed roller start to rotate
 - Paper reaches the feed sensor (S20)
 - Feed sensor (S20) is turned ON
 - Paper reaches the registration roller
 - Registration sensor (S19) is turned ON and aligning is performed
 - Feed clutches (CLT5, CLT6) are turned OFF after a certain period of time

3. A certain period of time passed after the carriage operation
 - Registration motor (M14) is turned ON → Paper is transported to the transfer area
 - Copy counter operates

4. Completion of scanning
 - Exposure lamp (EXP) turned OFF
 - Scan motor (M1) turned OFF
 - Registration motor (M14) is turned OFF (after the trailing edge of the paper passed the registration roller)
 - “READY (PRINTING)” is displayed

5. Printing operation
 - 1) Color printing operation**
 - Mono/color switching motor (M3) turned ON
 - The drum switching detection sensor (S11) checks whether the equipment is in the color or black printing status, and if it is in the black printing status, the motor (M3) is turned ON to switch the status to color printing.
 - Drum/TBU motor (M6), discharge LED-Y, -M, -C, -K (ERS) turned ON
 - Main charger bias turned ON
 - 1st transfer contact/release clutch (CLT2) turned ON
 - Contact the 1st transfer rollers (Y, M and C) to the transfer belt
 - YMCK developer bias (DC) and Paper feeding/developer unit drive motor (M2) turned ON
 - 2nd transfer bias turned ON
 - Laser emission (yellow image)
 - 1st transfer bias (Y) turned ON
 - 1st transfer of yellow image (Yellow image is transferred to the transfer belt)
 - 1st transfer bias (Y) turned OFF
 - Laser emission (magenta image)
 - 1st transfer bias (M) turned ON
 - 1st transfer of magenta image (Magenta image is transferred to the transfer belt)
 - 1st transfer bias (M) turned OFF
 - Laser emission (cyan image)
 - 1st transfer bias (C) turned ON
 - 1st transfer of cyan image (Cyan image is transferred to the transfer belt)
 - 1st transfer bias (C) turned OFF
 - Laser emission (black image)
 - 1st transfer bias (K) turned ON
 - 1st transfer of black image (Black image is transferred to the transfer belt)
 - 1st transfer bias (K) turned OFF

- 1st transfer contact/release clutch (CLT2) turned ON
- Release the 1st transfer rollers (Y, M and C) from the transfer belt
- 2nd transfer of YMCK image (YMCK image on the transfer belt is transferred to the paper)
- Main charger turned OFF
- Paper feeding/developer unit drive motor (M2) and developer bias (YMC and K) turned OFF
- 2nd transfer bias turned OFF
- Drum/TBU motor (M6), discharge LED-Y, -M, -C, -K (ERS) turned OFF

2) Black printing operation

- Mono/color switching motor (M3) turned ON
- The drum switching detection sensor (S11) checks whether the equipment is in the color or black printing status, and if it is in the color printing status, the motor (M3) is turned ON to switch the status to black printing.
- Drum/TBU motor (M6), discharge LED-K (ERS) turned ON
- Main charger bias turned ON
- K developer bias (DC) and Paper feeding/developer unit drive motor (M2) turned ON
- 2nd transfer bias turned ON
- Laser emission (black image)
- 1st transfer bias (K) turned ON
- 1st transfer of black image (Black image is transferred to the transfer belt)
- 1st transfer bias (K) turned OFF
- 2nd transfer of K image (K image on the transfer belt is transferred to the paper)
- Main charger turned OFF
- Paper feeding/developer unit drive motor (M2) turned OFF
- 2nd transfer bias turned OFF
- Drum/TBU motor (M6), discharge LED-K (ERS) turned OFF

6. Paper exiting

- The exit sensor (S13) detects the leading edge of the paper
- Exit motor (M5) turned ON
- The exit sensor (S13) detects the trailing edge of the paper
- Discharge LED (ERS) turned OFF
- Drum/TBU motor (M6), Paper feeding/developer unit drive motor (M2), fuser motor (M4) and exit motor (M5) turned OFF
- The polygonal motor (M4) rotates at low speed.
- Drum, fuser unit and developer unit are stopped
- Fans return to rotate at the normal rotation speed
- "READY" is displayed and the equipment enters into ready mode

[4] Bypass feed copying

1. Insert a paper into the bypass tray.
 - Bypass paper sensor (S16) is turned ON.
 - “Ready for bypass feeding” is displayed.
 - Carriages move to the home position.
2. Press the [START] button ON
 - “Ready for bypass feeding” changes to “COPYING”.
 - Exposure lamp (EXP) ON
 - Scan motor (M1) ON → Carriages-1 and -2 move forward.
 - Drum/TBU motor (M6), Paper feeding/developer unit drive motor (M2), and fuser motor (M4) turned ON
 - The drum, transfer belt, fuser unit and developer unit are driven.
3. Bypass feeding
 - Fans rotate at high speed.
 - Bypass feed clutch (CLT3) turned ON.
 - The bypass feed roller is rotated.
 - Aligning operation
 - Paper reaches the registration roller.
 - After a certain period of time, the bypass feed clutch (CLT3) turned OFF.
4. Hereafter, operations (3) through (6) of “5.2.3 Drawer feed copying (1st drawer paper feeding)” are repeated.

[5] Interruption copying

1. Press the [INTERRUPT] button
 - Copying operation in progress is temporarily stopped, and the carriages-1 and -2 return to appropriate positions.
 - “Job interrupted job 1 saved” is displayed.
 - Automatic density and reproduction ratio 100% are set. Set number remains the same.
2. Select the desired copy condition
3. After interruption copying is finished:
 - The equipment returns to the status before the interruption by pressing the [INTERRUPT] button.
4. Press the [START] button
 - The copying operation before the interruption is resumed.

3.6.3 Detection of abnormality

When something abnormal has occurred in the equipment, symbols corresponding to the type of abnormality are displayed.

[1] Types of abnormality

1. Abnormality which can be cleared even if the power is not turned off by the door switch
 - (A) Add paper
 - (B) Paper misfeed in bypass

2. Abnormality which can be cleared if the power is turned off by the door switch
 - (C) Misfeed in equipment
 - (D) No toner in the cartridge
 - (E) Developer unit not installed properly
 - (F) Waste toner box replacement

3. Abnormality which can be cleared if the power is turned off by the [ON/OFF] button
 - (G) Call for service

[2] Description of abnormality

[A] Add paper

[In case of the equipment drawer or PFP drawer] (When drawer is not installed)

Drawer not detected



Drawer is not installed:

Drawer is installed but there is no paper in it:



No paper



A signal sent to the control circuit



Drawer area of the control panel blinks
(When the drawer is selected)



[START] button is disabled.

[In case of the PFP or LCF drawers] (When drawer is installed)

Based on the combination of the tray-up motor movement and the status of tray-up sensor and empty sensor, CPU detects the presence of paper.

- When the power is turned ON or LCF drawer is inserted (When the power is turned ON or equipment/PFP drawers are inserted).
LCF performs initialization.



Detects the presence of paper

Tray-up motor ON - The tray goes up

- When the tray-up sensor is not turned ON in a fixed period of time it means that the tray is in abnormal condition
"Add paper" is displayed regardless of presence/absence of paper.
→ Cleared by turning the power ON/OFF

- Tray-up sensor is turned ON in a fixed period of time
 - The tray-up motor stops.

At this time, if the empty sensor is ON: It is judged that there is paper.
 OFF: It is judged that there is no paper.

↓

Drawer area of the control panel
blinks.
(When the drawer is selected)

- When the paper in the drawer gets short during copying,
 - The tray-up sensor turned OFF
 - The tray-up motor turned ON - Tray goes up
 - Tray-up sensor turned ON
 - Tray-up motor stopped
- Empty sensor turned OFF during the copying in spite of the tray-up sensor is ON

↓

It is judged that there is no paper.

↓

Drawer area of the control panel blinks.
(When the drawer is selected)

↓

The copying operation is stopped.

[B] Paper misfeed in bypass

During bypass feeding

Bypass feed clutch (CLT3) is turned ON

↓

Registration sensor (S19) is turned ON

* Registration sensor (S19) is not turned ON in a fixed period of time (E120)

↓

Bypass misfeeding



Bypass misfeed symbol is displayed



The copying operation is disabled.



Solution: The bypass sensor (S16) is turned OFF by removing the paper from the bypass tray.

[C] Misfeed in equipment

- Exit sensor (S13) detects jamming of the leading edge of paper

↓
 Registration motor (M14) turned ON
 ↓ Fixed time
 Exit sensor (S13) turned ON
 If the exit sensor (S13) is not turned ON after a fixed time,
 ↓
 Paper jam (E010) The copying operation is stopped.

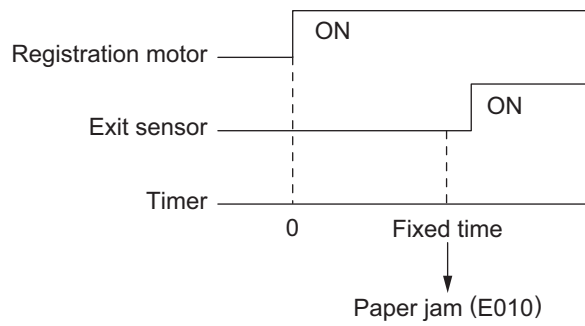

Fig. 3-14

- Exit sensor (S13) detects jamming of the trailing edge of paper

Registration motor (M14) turned OFF
 ↓ Fixed time.
 Exit sensor (S13) turned OFF
 If the exit sensor (S13) is not turned OFF a fixed time
 ↓
 Paper jam (E020) The copying operation is stopped.

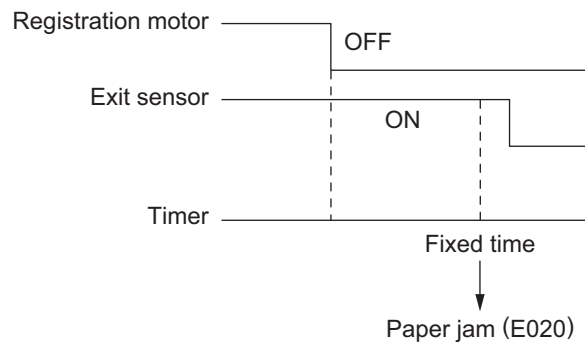

Fig. 3-15

- Immediately after the power ON
 ↓
 Any of all sensors on paper transport path detects paper (ON)
 ↓
 Paper jam (E030)
- Front cover is opened during copying
 ↓
 Paper jam (E410)

- Registration sensor (S19) detects jamming of the leading edge of paper:
The registration sensor (S19) is not turned ON in a fixed period of time after the leading edge of paper passed the transport roller.
↓
Paper jam (E200, E210, E270, E300, E330 and E3C0)
- During paper feeding from ADU:
The registration sensor (S19) is not turned ON in a fixed period of time after the ADU motor (M12) is turned ON.
↓
Paper jam (E110)
- During paper transporting from ADU:
ADU entrance/exit sensors (S14/S15) do not detect the paper at the fixed timing
↓
Paper jam (E510 and E520)
- During paper reversing:
The reverse sensor (S26) does not detect the paper at the fixed timing
↓
Paper jam (E570 and E580)
- During paper feeding from the equipment or PFP:
The feed sensor (S20), or the 2nd drawer paper feed sensor (S32) is not turned ON in a fixed period of time after the feed clutch is turned ON.
↓
Paper jam (E220, E310, E320, E340 to E360, E3D0 and E3E0: Error code defers depending on the paper source.)

[D] No toner in the cartridge

Toner density becomes low



Auto-toner sensor (S1/S2/S3/S4) detects the absence of the toner



Control circuit → “Install new ** toner cartridge” is displayed: the copying operation disabled

Solution: Open the front cover and replace the toner cartridge with new one.

Toner is supplied → copying operation enabled

[E] Developer unit not installed properly

Disconnection of the connectors of the developer unit



“Latch the developer unit” is displayed.

Solution: Install the developer unit and close the front cover.

[F] Waste toner box replacement

- Waste toner box is full of used toner



Rotation of the paddle has not been detected for a specified period



“Dispose of used toner” is displayed

- Waste toner box full is detected during printing



Printing is stopped after the paper being printed is exited

Solution: Replace the waste toner box with new one and close the front cover.

[G] Call for service

Check the error code displayed on the control panel when “Call for service” appears, and handle the abnormality in reference to the error code table.

 P. 8-6 “8.2 Error Code List”

3.6.4 Hibernation function

A hibernation function is embedded in this equipment. This function allows the equipment to store the last status of the system in the HDD immediately before the power is turned OFF, and to restart from this stored status at the next boot-up.

For warming-up time, refer to  P. 2-1 “2.1.1 General”

If hibernation is not performed when the power is turned OFF or the equipment boots up immediately after the settings, warming-up takes longer. It differs depending on the usage conditions; warming-up will take approx. 30 to 150 sec.

The following are the conditions which necessitate a longer warming-up time.

- Rebooting from TopAccess
- First booting after power interruption
- First booting after a self-diagnosis code is changed in the Service UI
- First booting after the power is turned OFF with the main power switch during the super sleep mode
- Installing options or finishers
- First booting after an option or a finisher is removed
- During toner supply
- Operating while “READY (WARMING UP)” is still on the control panel
- Shutting down during network initialization
- First booting after the power is turned OFF in a procedure other than the correct one described in the Quick Start Guide

3.7 Control Panel

3.7.1 General description

The control panel consists of button switches and touch-panel to operate the equipment and select various modes, and LEDs to display the state of the equipment.

When the operator’s attention is required, graphic symbols light or blink with messages explaining the condition of the equipment in the LCD panel. When paper jams and “Call for service” occur, error codes are also displayed to notify users of the problem.

A 10.1-inch resistance film touch panel is used in this equipment, resulting in the improvement of operability.

The [ON/OFF] button is placed on the control panel, and this button is used instead of the main power switch to turn the power ON/OFF. Press this button to turn the power of the equipment ON/OFF.

The digital keys are displayed on the touch panel instead of being located on the control panel. In addition to this, a digital key pad can be installed optionally for a user who wants to carry out the button operation by means of the actual keys.

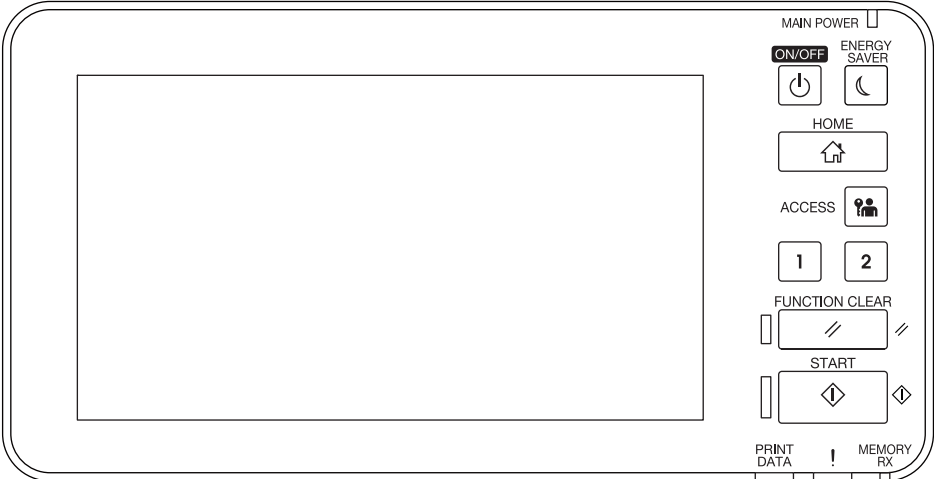

Fig. 3-16

3.8 Scanner

3.8.1 General description

In the scanning section of this equipment, the surface of an original is irradiated with a direct light and the reflected light is led through mirrors, a lens and a slit to CCD where optical-to-electrical conversion is performed, converting the optical image data into an electrical (analog) signal. This analog signal is changed to a digital signal, which then undertakes various corrective processes necessary for image formation. After that, arithmetic operation is performed on the digital signal, which is then transmitted to the data writing section.

In this equipment, a reduction-type CCD for color processing is used. What this CCD differs from black-and-white CCDs is that its devices are arranged in 3 lines and covered with color filters (Red, Green, and Blue). These lines are composed with 3-line color devices and black-and-white device with no filter.

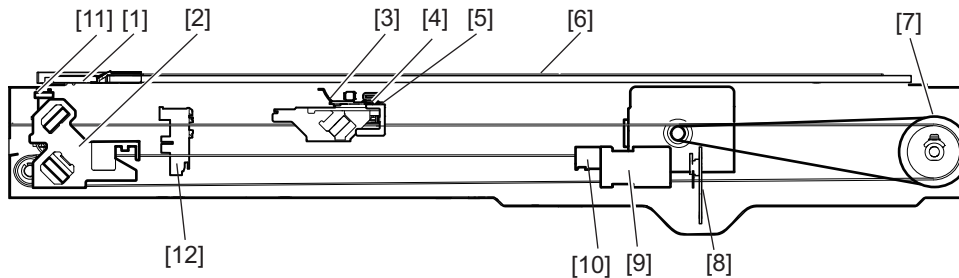

Fig. 3-17

- [1] ADF original glass
- [2] Carriage-2
- [3] Reflector
- [4] Exposure lamp
- [5] Carriage-1
- [6] Original glass
- [7] Drive pulley
- [8] CCD board
- [9] Lens
- [10] Automatic original detection sensor
- [11] Carriage home position sensor
- [12] Platen sensor

3.8.2 Construction

Scanner		
Original glass	Original glass	
	ADF original glass	
Carriage-1	Exposure lamp (EXP)	
	Reflector	
	Mirror-1	
Carriage-2	Mirror-2	
	Mirror-3	
Lens unit	Lens	
	CCD driving PC board (CCD)	
Automatic original detection sensor (S24, S25)		
Driving section	Scan motor (M1)	<ul style="list-style-type: none"> • 2-phase stepping motor • Driving the carriage-1 and carriage-2
Other	Carriage home position sensor (S23)	
	Platen sensor-1 (S21)	
	Platen sensor-2 (S22)	

3.8.3 Functions

The following shows the construction and purpose of the scanning system:

1. Original glass

This is a glass for placing original. The light from the exposure lamp (EXP) is irradiated to the original through this glass.

The ADF original glass is used when original is read with the Automatic Document Feeder. Original is transported on the ADF original glass by the Automatic Document Feeder, and the transported original is read under the ADF original glass by the carriage. Do not use such solvents as alcohol when cleaning the surface of the ADF original glass, because it is coated so as not to be scratched by originals.

2. Carriage-1

Carriage-1 consists of the exposure lamp (EXP), reflector, mirror-1, etc. It is driven by the scan motor (M1) and scans an original on the glass.

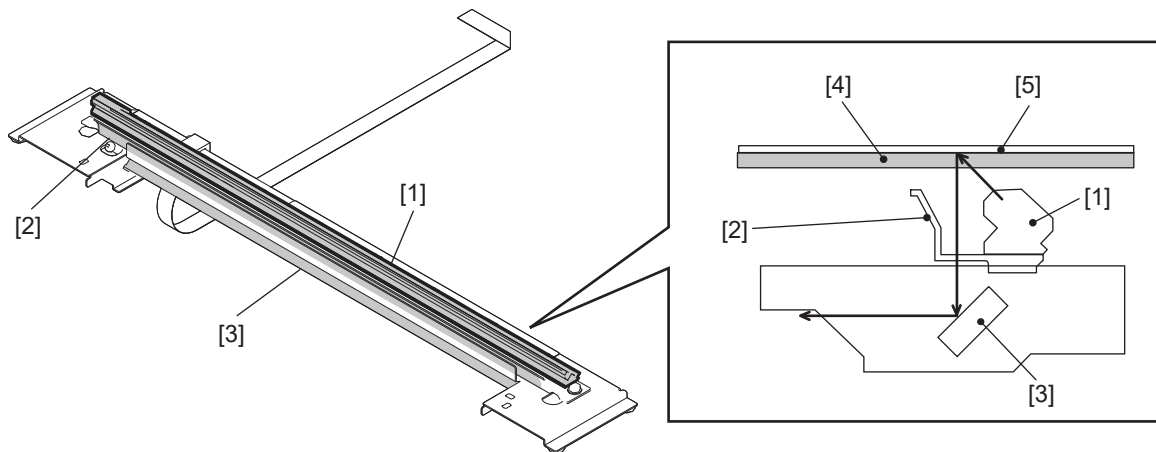

Fig. 3-18

- [1] Exposure lamp
- [2] Reflector
- [3] Mirror-1
- [4] Original glass
- [5] Original

- Exposure lamp (EXP)
This lamp is the light source to irradiate the original on the glass. (LED lamp)
- Reflector
This is a plate to efficiently direct the light from the exposure lamp (EXP) to the surface of the original on the glass.
- Mirror-1
This mirror directs the light reflected from the original to the mirror-2 described later.

3. Carriage-2

Carriage-2 mainly consists of the mirror-2, mirror-3, etc. and directs the reflected light from the mirror-1 through the mirrors-2 and -3 to the lens.

This carriage is driven by the same scan motor (M1) as that for the carriage-1 at half the scanning speed of the carriage-1 (The scanning distance is also half that of the carriage-1).

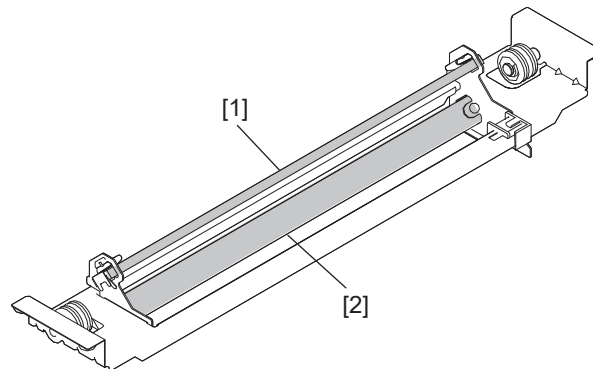

Fig. 3-19

[1] Mirror-2

[2] Mirror-3

4. Lens unit

The light reflected from the mirror-3 is led to the CCD placed at the focal point of the lens which is fixed in a position.

5. CCD driving PC board (CCD)

Processes such as signal amplification, signal integration and A/D conversion are applied on the electrical signal which was converted by CCD.

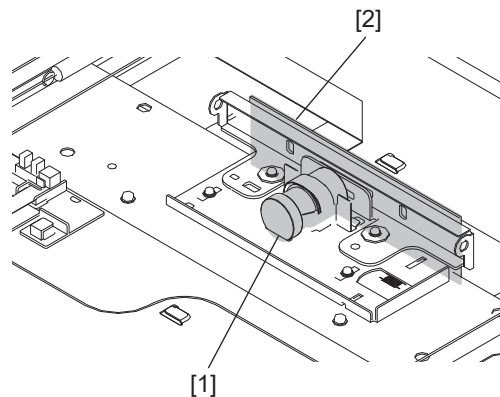

Fig. 3-20

[1] Lens

[2] CCD board

6. Automatic original detection sensor (S24, S25)

The size of an original placed on the glass is instantly detected using the automatic original detection sensors (S24, S25) fixed on the base frame without moving the carriage-1.

3.8.4 Description of operation

[1] Scanning operation

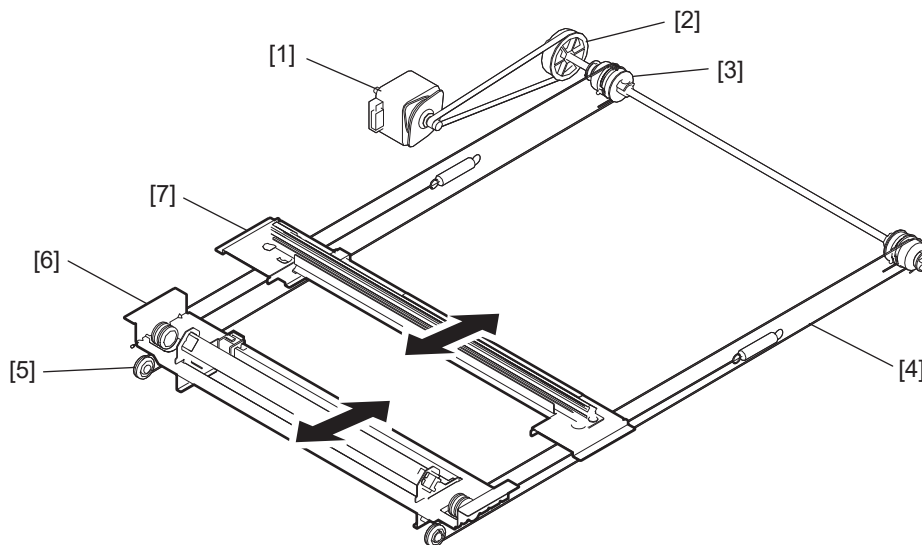

Fig. 3-21

- [1] Scan motor
- [2] Drive pulley
- [3] Wire pulley
- [4] Wire
- [5] Idler pulley
- [6] Carriage-2
- [7] Carriage-1

- Scanning of an original placed on the original glass
This motor drives the carriages-1 and -2 through the timing belt and carriage wire. First, the scan motor drives the carriages-1 and -2 to their respective home positions. The home positions are detected when the carriage-1 passes the home position sensor (S23). When the [START] button is pressed, the both carriages start to move and scan the original on the glass.
- Scanning of an original placed on the RADF
The carriage-1 stays at the shading position during shading correction, and at the scanning position during scanning operation.
- Carriage speed
The Carriage speed of the original placed on the original glass in the color mode is the same as that in the black mode.

3.8.5 Process of detection of original size

In this equipment, detection of original sizes is performed with the combination of a CCD and the automatic original detection sensors-1 and -2 (S24 and S25).

A size in the primary scanning direction is detected by the CCD while that in the secondary scanning direction is detected by the sensors.

[1] Original size detection procedure

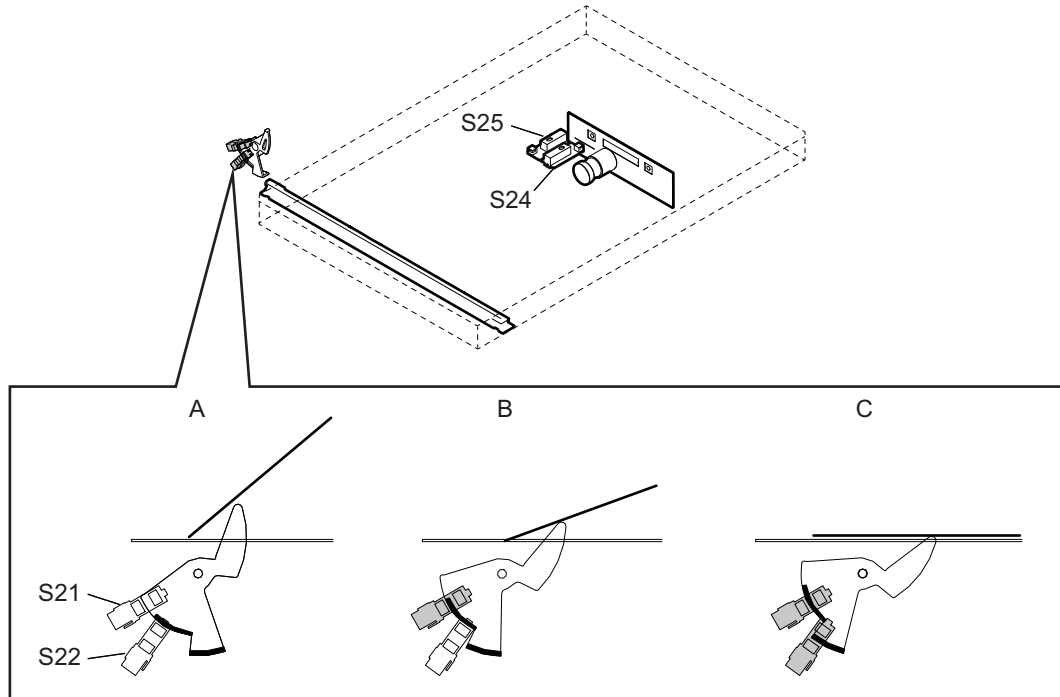

Fig. 3-22

A: Platen cover (or DF) fully opened

When the platen cover is fully opened, the original size is not detected.

B: Platen cover (or DF) opened by 25 degrees - Detected by the platen sensor-1 (S21)

When this status is detected, the exposure lamp of the scanner emits light and the presence/absence of the original in the secondary scanning direction and the paper size of the original in the primary scanning direction are detected by the automatic original detection sensor. (As for the LT series, two automatic original detection sensors are used.)

C: Platen cover (or DF) closed - Detected by the platen sensors-1 and -2 (S21 and S22)

This status is detected by the platen sensors-1 and -2. The exposure lamp of the scanner emits light for a short time and the sensors detect the length of the original in the primary scanning direction again.

Remarks:

When the platen cover (or the DF) is fully closed or closed by 25 degrees or less, the exposure lamp emits light as follows. Light emitted > OFF > light emitted > OFF > carriage moved. If the connectors are connected to the platen sensor-1 (S21) and -2 (S22) in reverse, the exposure lamp emits light as follows. Light emitted > OFF > carriage moved > light emitted.

When the following phenomena have occurred, the platen sensor-1 (S21) may be damaged. In such a case, check the sensors and harnesses.

- The exposure lamp does not emit light even when the platen cover is opened by 25 degrees.
- The detected paper size of the original is not correct.

[2] Detection points

Sensor detection points [A4, K Series]

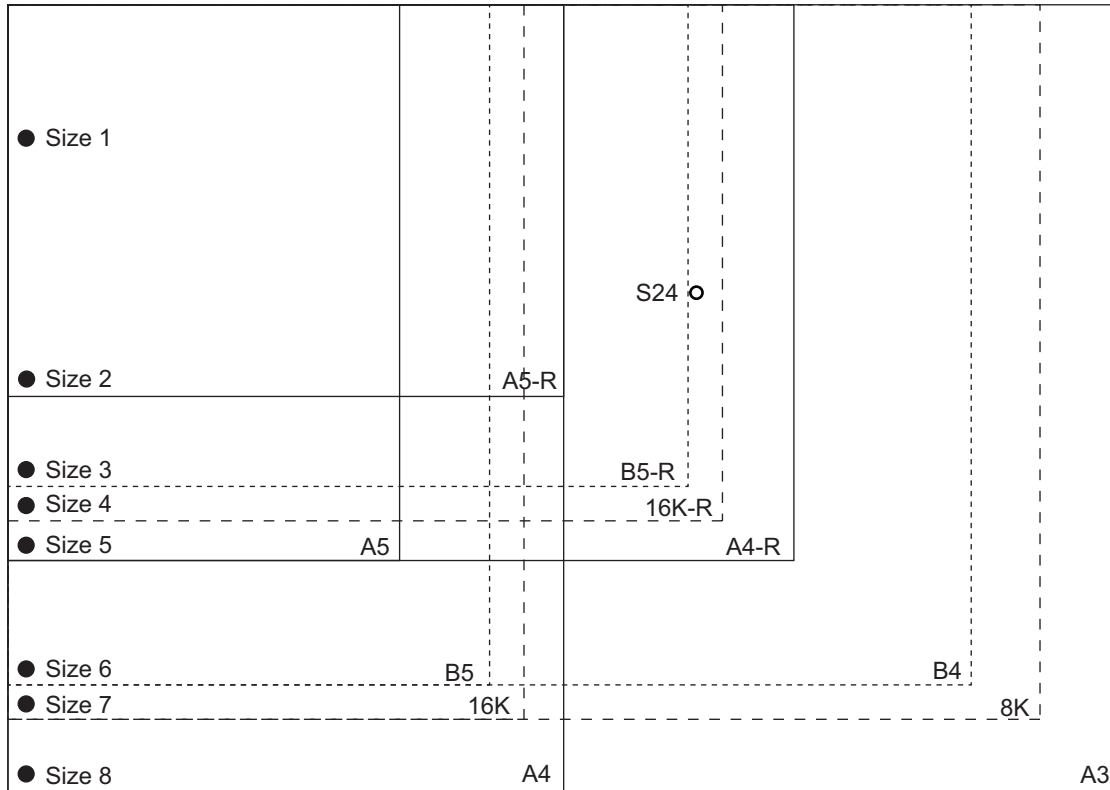

Fig. 3-23

Sensor detection points [LT Series]

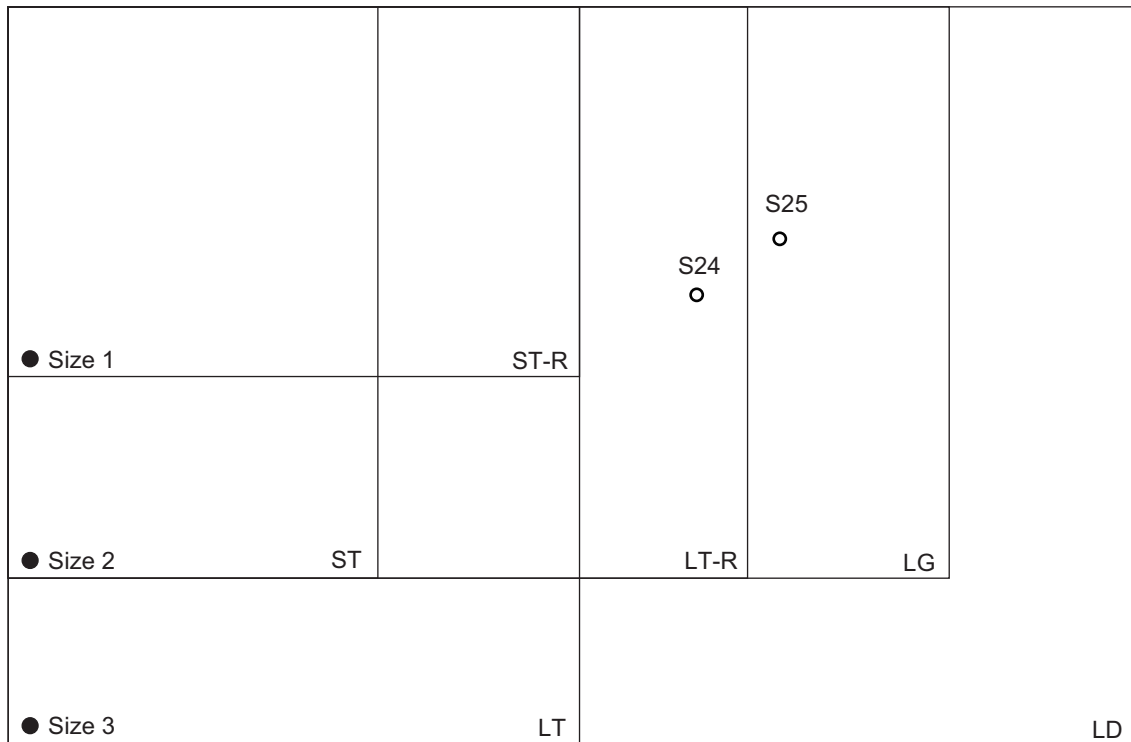

Fig. 3-24

3.9 Writing Section



3.9.1 General description

The laser optical unit radiates the laser beam onto the photoconductive drum in response to the digital image signals transmitted from the scanner, USB, network, etc. to create a latent image. The image signal is converted into the light emission signal of the laser diode on the laser driving PC board (LDR), then radiated on the photoconductive drum through optical elements such as a polygonal mirror (polygonal motor) and a lens. The units must not be disassembled in the field as they are very sensitive to dust and finely adjusted at the factory.

In this equipment, the polygonal motor is located at the center of the unit to downsize the laser optical unit. Therefore, the location of the LDR boards is different from that for current models. When disconnecting and connecting the connectors during service, be sure to connect them in the correct position.

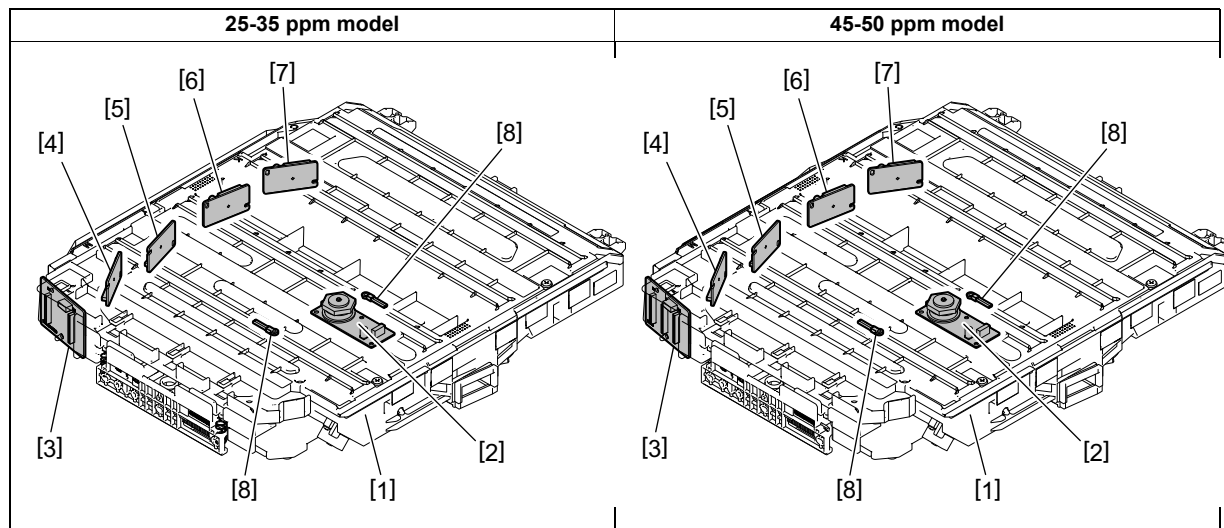
In addition to this, the different laser diode is used in the 25/35 ppm model and 40/50 ppm model. A 2-beam laser diode is used in the 25/35 ppm model and a 4-beam one is used in the 45/50 ppm model. In addition, the thermistor is built in the laser optical unit of this equipment.

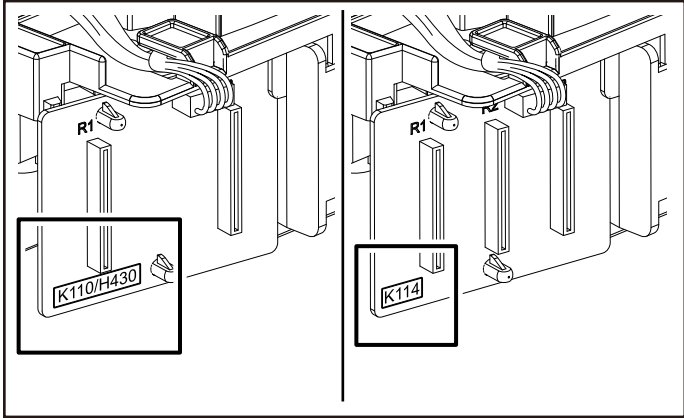

No.	Name	Remarks
[1]	Laser optical unit	<p>The laser optical unit differs between the 25/30/35ppm and 45/50ppm models. They can be identified by the 1st to 4th digits of the serial number.</p> <div style="display: flex; justify-content: space-around;">   </div> <p>W32L: 25ppm/30ppm/35ppm W34L: 45ppm/50ppm</p>
[2]	Polygonal motor	Common for 25/30/35ppm and 45/50ppm models.

No.	Name	Remarks
[3]	LRL board	<p>The LRL board differs between the 25/30/35ppm and 45/50ppm models. They can be identified by the silk print on the board.</p>  <p>K110/H430: 25ppm/30ppm/35ppm K114: 45ppm/50ppm</p>
[4] [5] [6] [7]	LDR board-M LDR board-Y LDR board-K LDR board-C	<p>The LDR board is common for Y, M, C and K. The LDR board differs between the 25/30/35ppm and 45/50ppm models. (25~35ppm: 2-beam laser diode, 45~50ppm: 4-beam laser diode)</p>
[8]	Laser optical unit thermistor	<p>This thermistor detects the temperature of the inside of the laser optical unit.</p>

3.9.2 Laser precautions

- Laser precautions

A laser diode is used for this equipment and radiates an invisible laser beam.

Since it is not visible, be extremely careful when handling the laser optical unit components, performing operations or adjusting the laser beam. Also never perform the procedure with other than the specified manuals because you could be exposed to laser radiation.

The laser optical unit is completely sealed with a protective cover. As long as only the operations of specified manuals are performed, the laser beam does not leak and you are in no danger of being exposed to laser radiation.

The following cautionary label for the laser is attached to the inner cover and can be seen when you open the front lower cover.

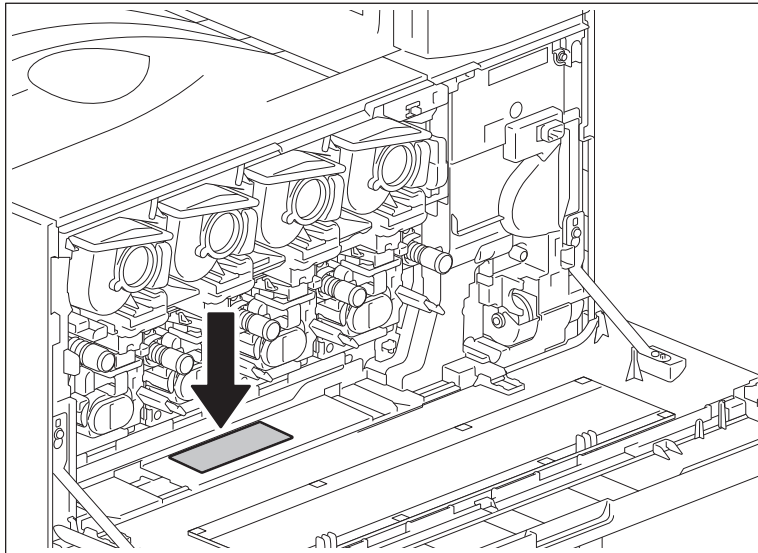

DANGER-CLASS 3B INVISIBLE LASER RADIATION WHEN OPTICAL UNIT OPEN OR DRUM UNIT REMOVED AND INTERLOCK DEFEATED. AVOID DIRECT EXPOSURE TO BEAM.

VORSICHT-KLASSE 3B UNSICHTBARE LASERSTRAHLUNG, WENN DIE ABDECKUNG GEÖFFNET ODER DIE TROMMEL ENTFERNT UND DIE VERRIEGELUNG UNWIRKSAM GEMACHT WIRD. NICHT DIREKT DEM STRAHL AUSSETZEN.

DANGER-CLASSE 3B RAYON LASER INVISIBLE LORSQUE LE BLOC OPTIQUE EST OUVERT, LE TAMBOUR RETIRE ET LE VERROUILLAGE HORS D'USAGE. EVITER L'EXPOSITION DIRECTE AU RAYON.

PELIGRO-RADIACION INVISIBLE DE LASER CLASE 3B CUANDO LA UNIDAD OPTICA ESTA ABIERTA O LA UNIDAD DEL CILINDRO ES RETIRADA Y CUANDO EL INTERRUPTOR DE SEGURIDAD ESTA DESACTIVADO. EVITE EXPOSICION DIRECTA AL RAYO.

危険-ドラムユニットを外したり光学ユニットを開けたときドアスイッチを無効にするとクラス3Bの不可視レーザー放射の恐れあり。ビームへの直接暴露を避けよ。 >PS<



Notes:

- Avoid exposure to the laser beam during service. This equipment uses a laser diode. Be sure not to expose your eyes to the laser beam. Do not insert reflecting parts or tools such as screwdrivers on the laser beam path. Remove all reflecting metals such as watches, rings, etc. before starting service.
- When servicing the equipment with the power turned ON, be sure not to touch live sections and rotating/operating sections. Avoid exposing your eyes to the laser beam.
- During servicing, be sure to check the rating label and cautionary labels such as “Unplug the power cable during service”, “CAUTION. HOT”, “CAUTION. HIGH VOLTAGE”, “CAUTION. LASER BEAM”, etc. to see if there is any dirt on their surface and if they are properly stuck to the equipment.

3.10 Driving Section

The driving section of this equipment consists of 4 units.

- Drum TBU drive unit
- Development drive unit
- Monochrome/color switching unit
- Paper feeding drive unit

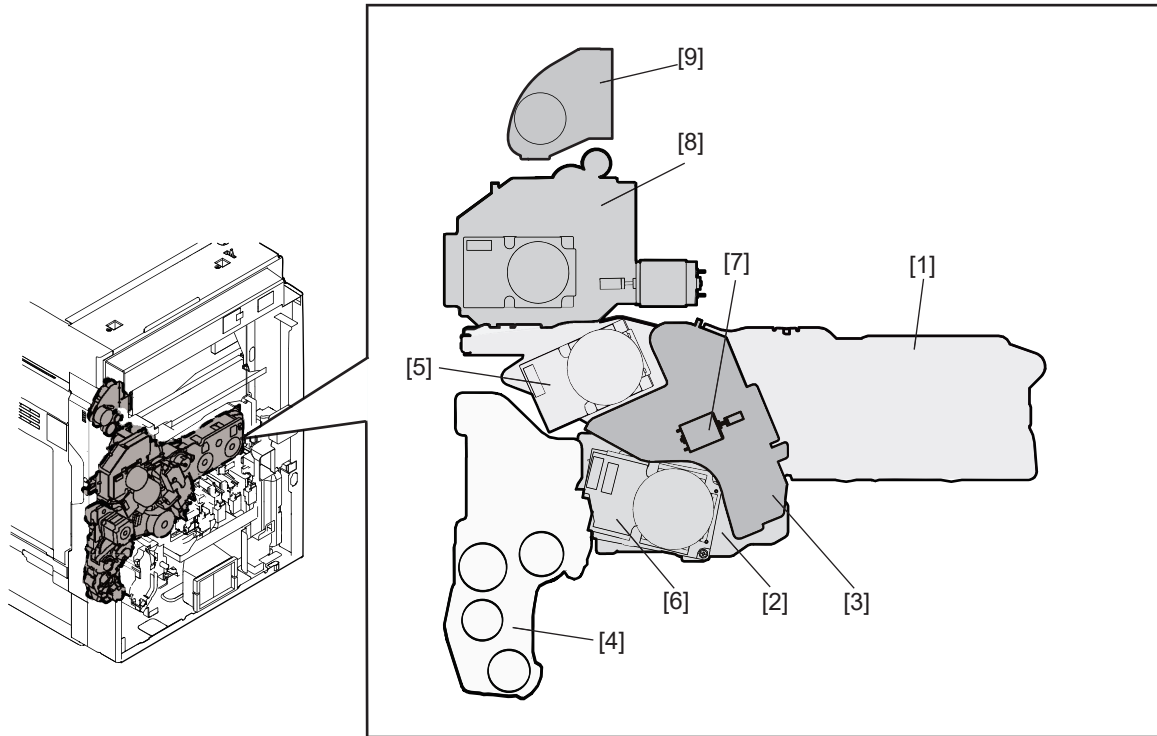

Fig. 3-25

- [1] Drum TBU drive unit
- [2] Development drive unit
- [3] Monochrome/color switching unit
- [4] Paper feeding drive unit
- [5] Drum/TBU motor
- [6] Paper feeding/developer unit drive motor
- [7] Mono/color switching motor
- [8] Fuser unit drive section
- [9] Exit/Reverse drive section

3.10.1 Drum TBU drive unit

The drum TBU drive unit is driven by the drum TBU motor to drive Y, M, C and K drums and the transfer belt unit (TBU).
 It also drives the contacting and releasing of the transfer belt.

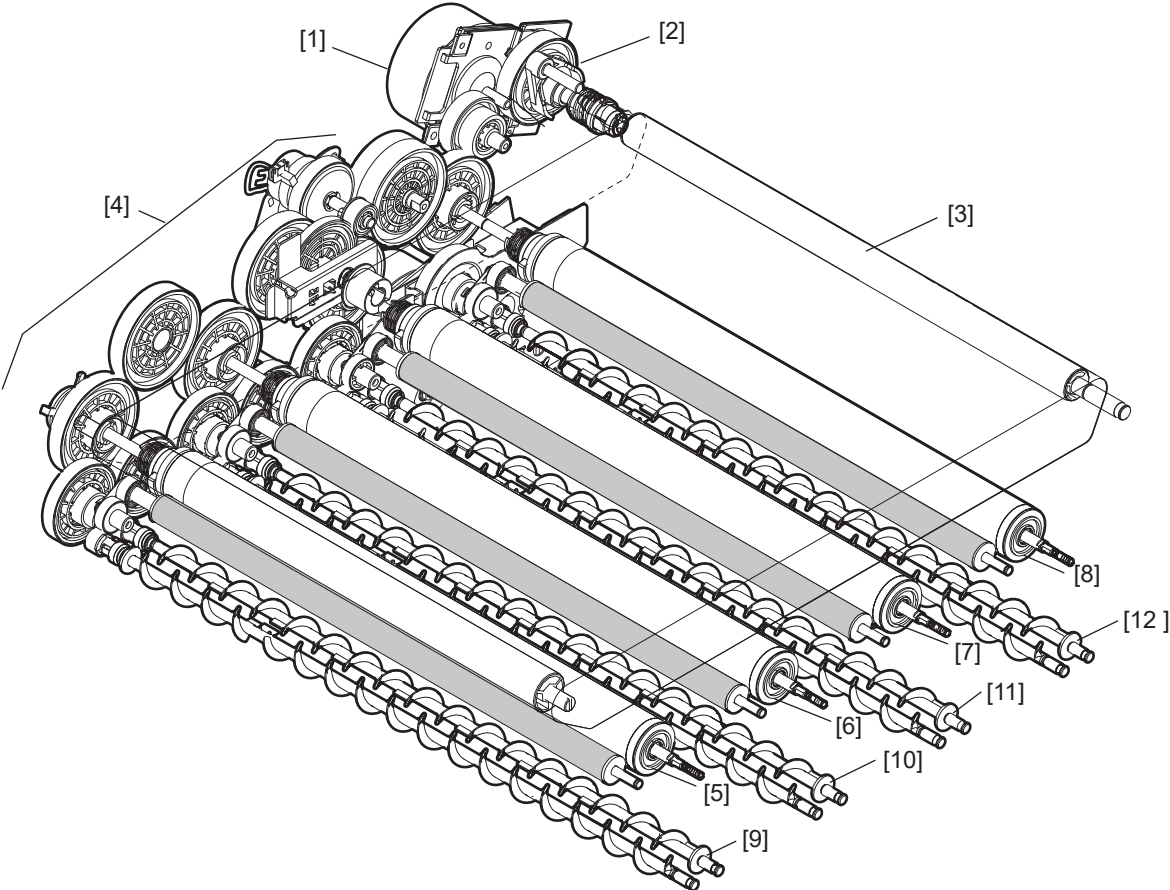

Fig. 3-26

- [1] Drum TBU motor
- [2] Drum TBU motor gear
- [3] TBU drive roller
- [4] Gear (row of gears)
- [5] Y drum
- [6] M drum
- [7] C drum
- [8] K drum
- [9] Y mixer
- [10] M mixer
- [11] C mixer
- [12] K mixer

3.10.2 Development drive unit/Paper feeding drive unit

The development drive unit and paper feeding drive unit are driven by the paper feeding/developer unit drive motor to drive the developer unit and the paper feeding section.

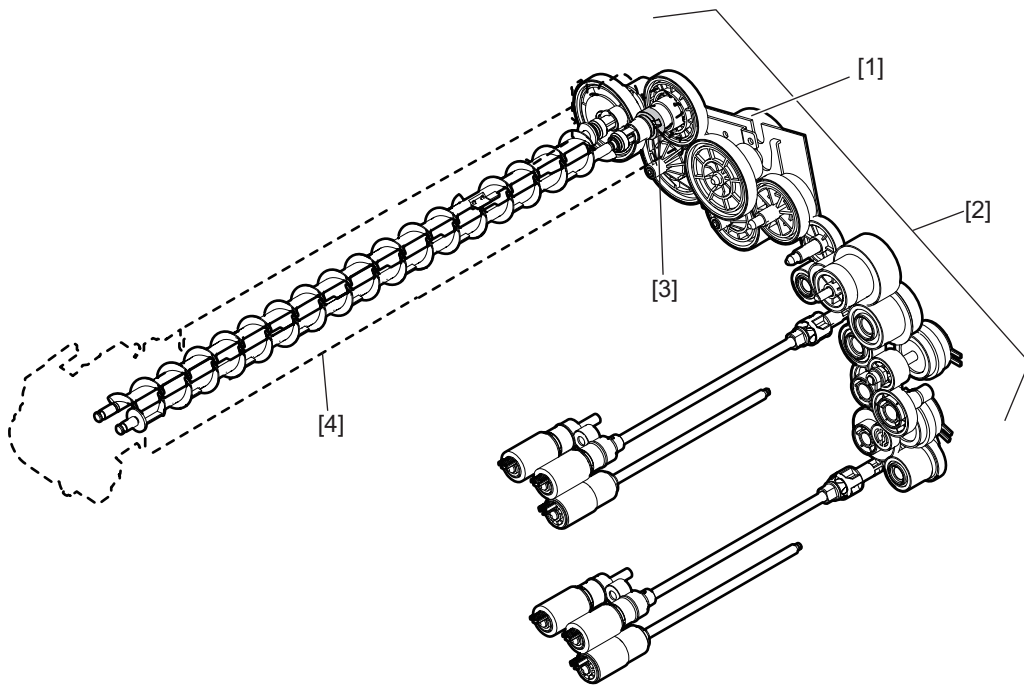

Fig. 3-27

- [1] Paper feeding/developer unit drive motor
- [2] Gear (row of gears)
- [3] Coupling
- [4] K developer unit

3.10.3 Monochrome/color switching mechanism

Switching of the monochrome and color modes is performed by the monochrome/color switching unit. In the monochrome mode, the switching plate is positioned at "A" in the figure below and the monochrome/color switching sensor (S11) is OFF.

At this time, the drive gears of the drum and the developer unit are not engaged. (Monochrome mode operation)

When the mono/color switching motor (M3) starts rotating, the switching plate is moved and the monochrome/color switching sensor (S11) is turned ON.

The coupling cam is rotated with a movement of the switching plate and then the idling gear and the color drive gear are engaged.

Thus the rotation of the motor is transmitted to each gear in the color drive gear rows.

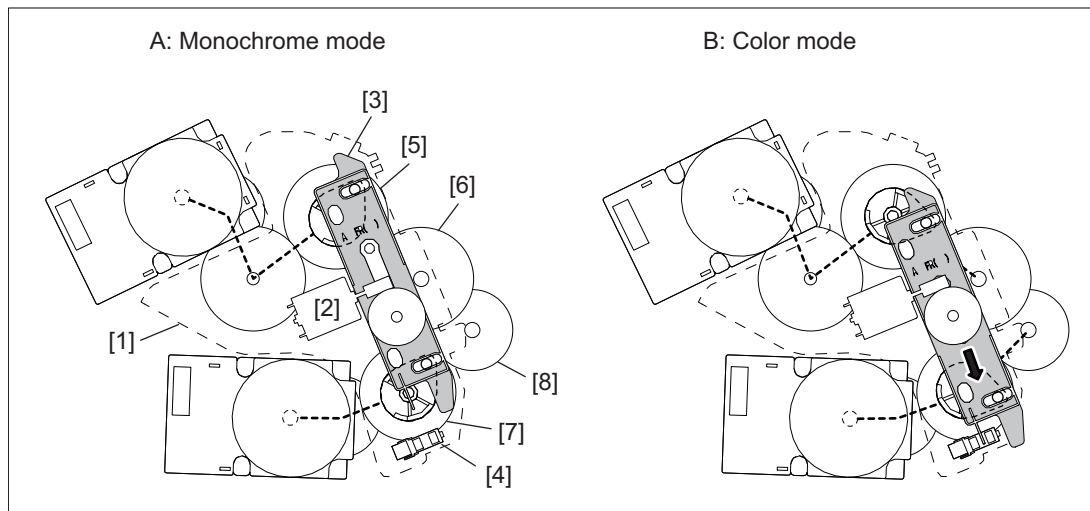

Fig. 3-28

- [1] Monochrome/color switching unit
- [2] Mono/color switching motor (M3)
- [3] Switching plate
- [4] Monochrome/color switching sensor (S11)
- [5] Color coupling gear (driving the drum)
- [6] Color drive gear (driving the drum)
- [7] Color coupling gear (driving the developer unit)
- [8] Color drive gear (driving the developer unit)

3.11 Paper Feeding System

3.11.1 General descriptions

This chapter explains how the system works to pick up paper from the drawer or bypass tray and transport it to the 2nd transfer position.

The paper feeding system mainly consists of the pickup roller, feed roller, registration roller, bypass paper sensor (S16), drawer empty sensor, feed sensor (S20), registration sensor (S19) and drive system for these components. The paper feeding/developer unit drive motor (M2) drives the above rollers.

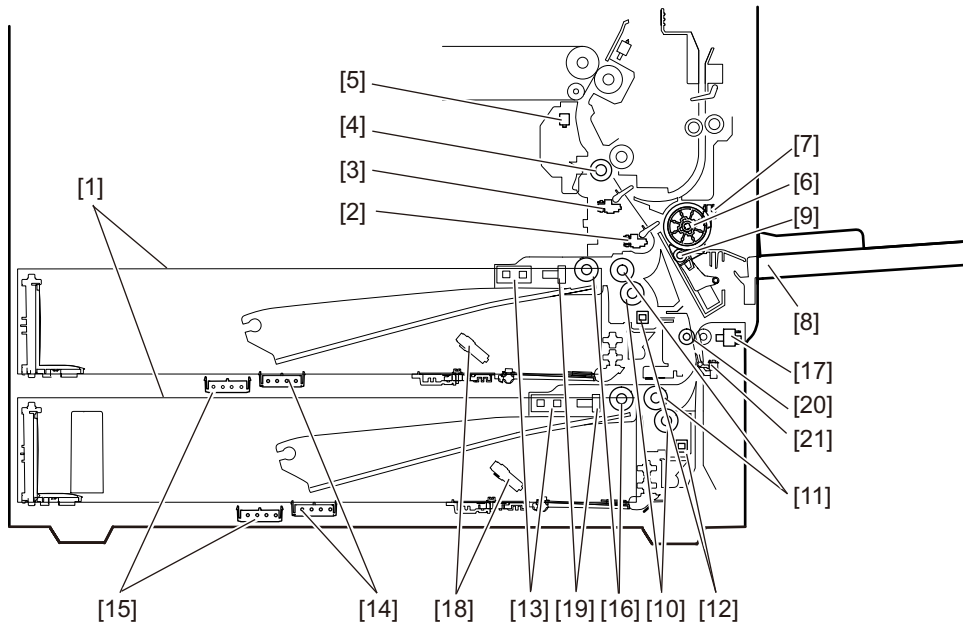

Fig. 3-29

- [1] Drawer
- [2] Feed sensor
- [3] Registration sensor
- [4] Registration roller
- [5] Registration pass sensor
- [6] Bypass feed roller
- [7] Bypass feed sensor
- [8] Bypass tray
- [9] Bypass separation roller
- [10] Separation roller (drawer)
- [11] Paper feed roller (drawer)
- [12] Drawer detection switch
- [13] Drawer empty sensor
- [14] Drawer paper width detection switch
- [15] Drawer paper length detection switch
- [16] Pickup roller
- [17] Jam access cover opening/closing switch
- [18] Drawer paper remaining sensor
- [19] Drawer tray-up sensor
- [20] Transport roller
- [21] 2nd drawer paper feed sensor

3.11.2 Composition

Feeding system		
Feed clutch		CLT1, CLT3
Feed sensor		S20
Paper feed sensor		S32
Feed roller		PM parts
Separation roller		PM parts
Pickup roller		PM parts
Drawer detection switch		SW8, SW19
Bypass unit	Bypass feed roller	PM parts
	Bypass separation roller	PM parts
	Bypass paper sensor	S16
	Bypass tray slide guide width detection PC board	S17
	Bypass feed clutch	CLT3
Paper feeding/developer unit drive motor		M2
Registration motor		M14
Registration roller		
Registration sensor		S19

3.11.3 Functions

1. Feed roller (Drawers and bypass feed)
This roller is placed against the separation roller. It transports the paper from the pickup roller to the transport roller.
2. Separation roller (Drawer and bypass feed)
When two or more sheets of paper are transported from the feed roller, since the resistance force of the separation roller is larger than the frictional force between the sheets, the lower sheets are not transported any further.
3. Registration roller
Paper transported from the transport roller is pushed against the registration roller which aligns the leading edge of the paper.
Then, the registration roller rotates to transport the paper to the transfer section.
4. Bypass paper sensor (S16)
This sensor detects if paper is set in the bypass tray. If it is, bypass feeding always comes before drawer feeding.
5. Empty sensor (S5, S34)
This is a transmissive-type sensor and detects the availability of paper in the drawer by using an actuator. When there is no paper in the drawer, the actuator blocks the light path of the sensor, and the sensor determines that there is no paper.
6. Registration sensor (S19)
This sensor detects that the leading edge of the paper has reached the registration roller and the trailing edge of the paper has passed the registration roller.
7. Drawer detection switch (SW8, SW19)
This switch detects if the drawer is fully inserted.
8. Feed clutch (drawer/bypass feed) (CLT1, CLT3, CLT4)
This is a clutch used to transmit the drive from the feed/dev motor to the feed roller.
When the clutch is turned ON, the feed roller rotates at high speed to transport paper.
9. Paper feeding/developer unit drive motor (M2)
This motor drives the transport rollers of the drawers and bypass tray.
10. Registration motor (M14)
This is an electromagnetic motor which drives the registration roller. When the registration motor (M14) is turned ON, the registration roller rotates.
11. Paper width detection board (S17)
This sensor works directly with the sidewalls of the bypass tray to detect the paper width on the tray.

3.11.4 Description of operation

[1] Drive of rollers

The drive of each motor in the paper feeding area activates the paper transfer roller as follows.

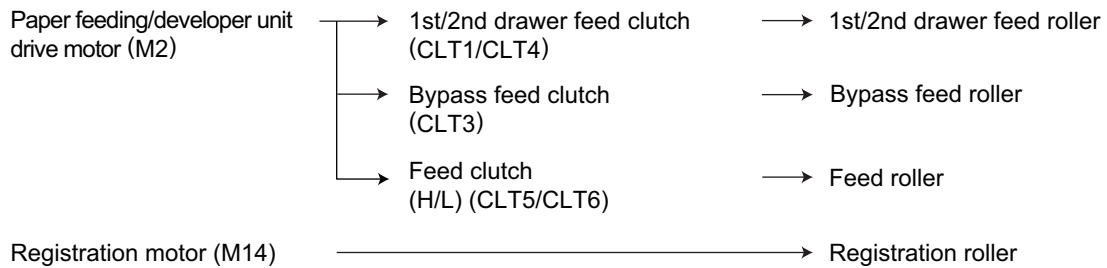

[2] Picking up System

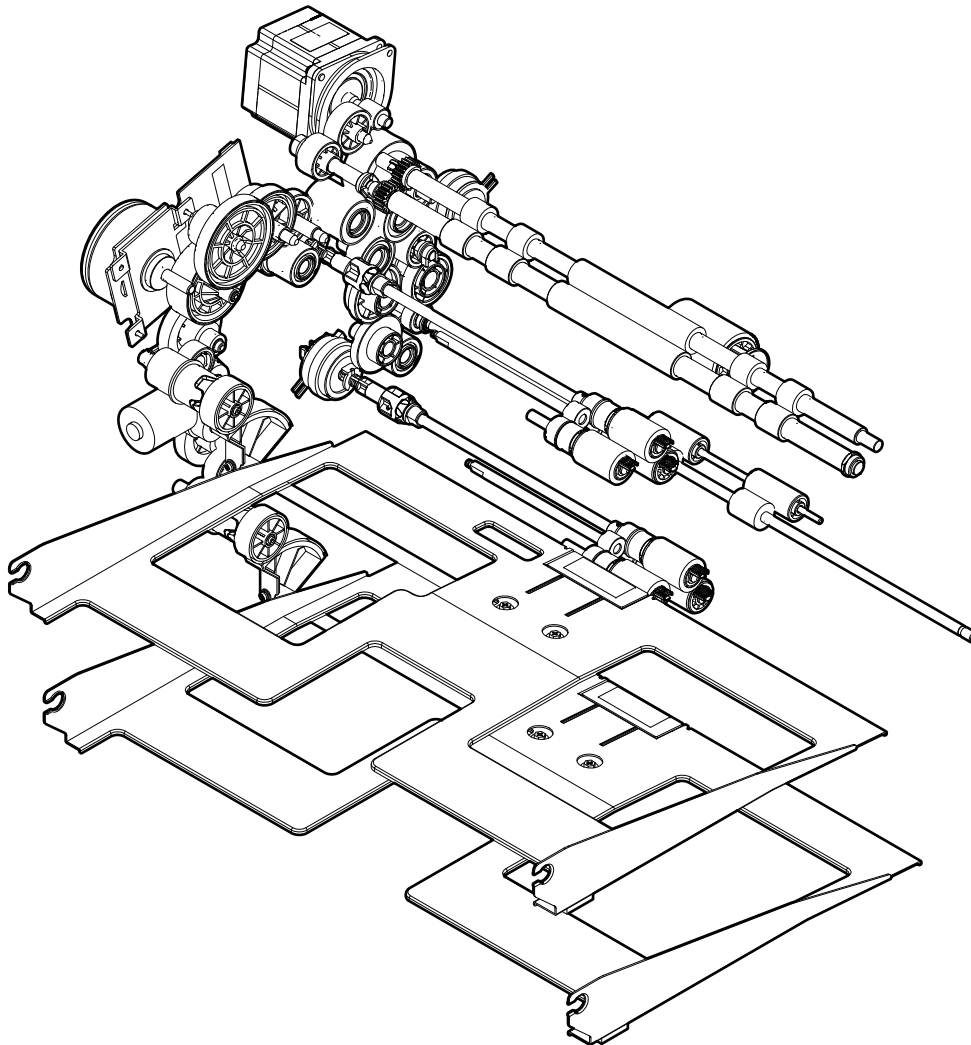

Fig. 3-30

When the drawer is inserted into the equipment, the drawer tray is raised by the tray-up motor and paper can be fed. An independent tray-up motor is equipped in the upper and lower drawers respectively.

Paper is fed and transported by transmitting the driving force from the paper feeding/developer unit drive motor to the pickup roller, paper feed roller and transport roller through the gears and clutches.

Paper is picked up by the movement of the feed clutch. When the feed clutch is turned ON, the pickup roller and feed roller rotate, and the paper is picked up from the drawer. The paper is separated by the separation roller.

[3] Paper Feed System

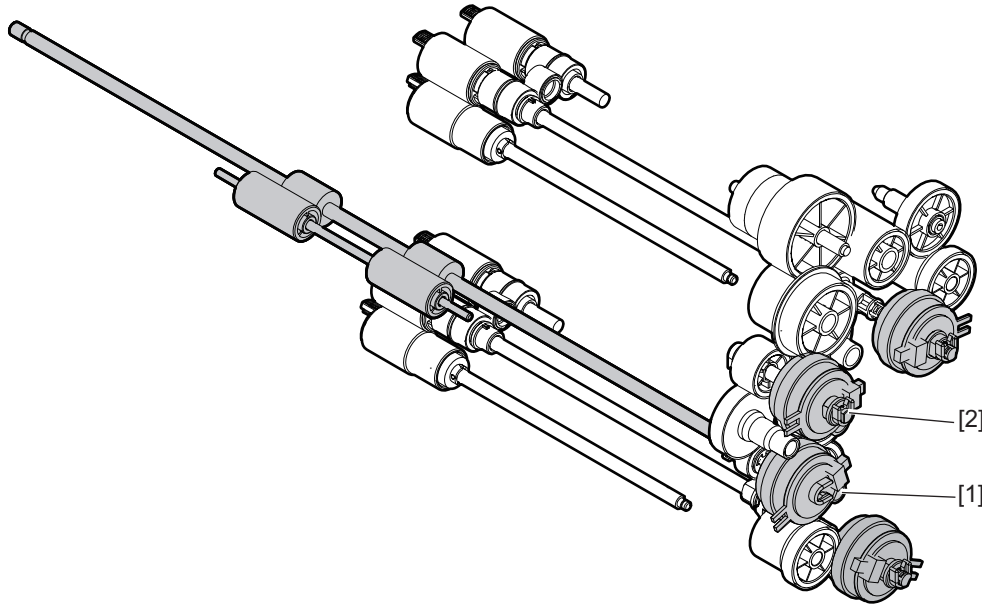

Fig. 3-31

- [1] The transport clutch (L)
- [2] The transport clutch (H)

The transport clutches (L/H) transmit the driving force from the paper feeding/developer unit drive motor to the transport roller. When transporting paper, they are turned ON. The transport clutch (Low speed) is turned ON when the low speed transportation is performed for printing. The transport clutch (High speed) is turned ON when high speed transportation is performed to transport the paper which has passed through the paper feed sensor to the registration position. High speed transportation is also performed when the paper is transported from the PFP to the registration position (When the PFP is connected).

[4] Operation of bypass feed roller

The driving force transmitted through the bypass feed clutch (CLT3) is transmitted to the bypass feed roller through the shaft. The roller is rotated by this driving force.

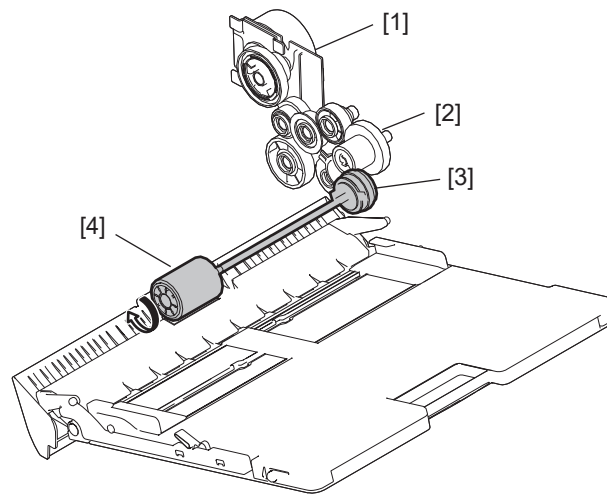

Fig. 3-32

- [1] Paper feeding/developer unit drive motor
- [2] Gear
- [3] Bypass feed clutch
- [4] Bypass feed roller

[5] Separation of paper

The separation roller is pushed to the paper feed roller by the spring force.

When two or more sheets of paper are fed, since the friction between two sheets of paper is smaller than that between a sheet and the separation roller, the lower sheets are not transported any further while the uppermost one is transported by the paper feed roller.

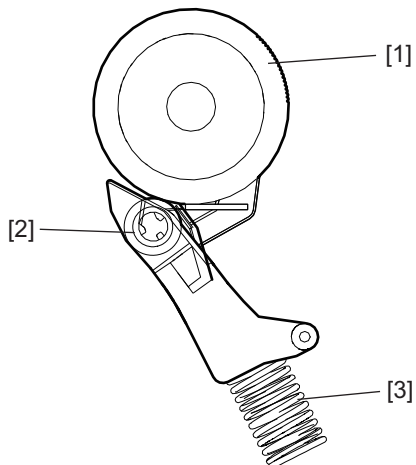

Fig. 3-33

- [1] Bypass feed roller
- [2] Bypass separation roller
- [3] Spring

[6] Paper size detection

This equipment automatically detects the size of the paper placed in each drawer.

The end and side guides in each drawer are moved according to the paper size and a pusher moves together with the end and side guides.

Then the protrusion of the pusher pushes each button of the drawer paper size detection sensors-1 and -2.

Thus the paper size is detected with the combination of the pushing statuses of the drawer paper size detection sensors-1 and -2.

The drawer paper size detection sensor-1 detects the movement of the side guides while the drawer paper size detection sensor-2 detects that of the end guide.

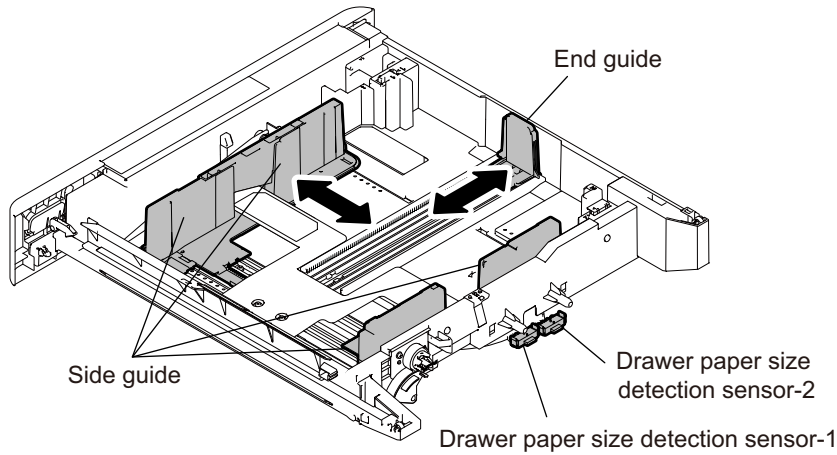

Fig. 3-34

[Example]

The positions of the guides and the pusher in cases of A3 and A4-R are shown below as examples.

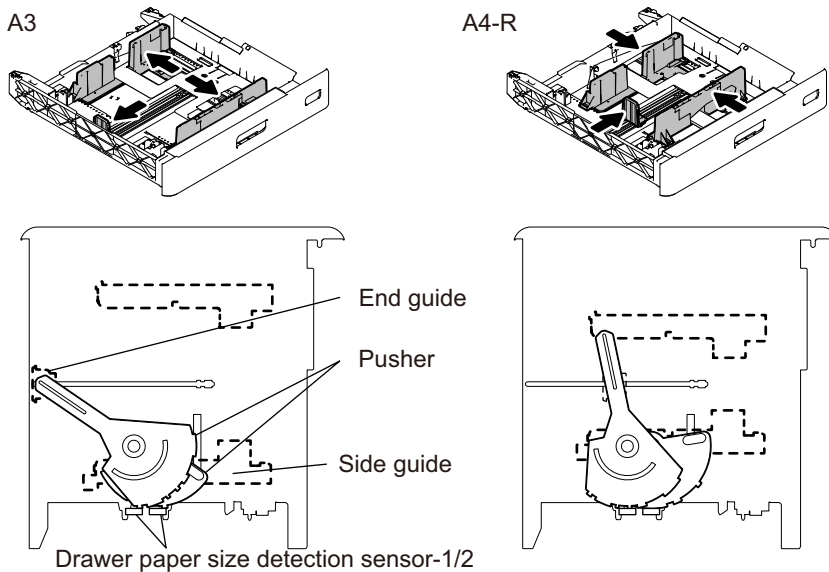

Fig. 3-35

[7] General operation

[A] From power-ON to ready status

If either of the sensors on the transport path is ON (means there is paper on the transport path) when the equipment is turned ON, it is determined that a paper jam has occurred and no operation is enabled until the paper is removed.

[B] Ready status

When a drawer is inserted or pulled out at the ready status, the availability of paper is checked.

[C] Bypass feeding

- The bypass feed sensor detects the absence of paper.
- The bypass feed clutch is turned ON, and the bypass feed roller is rotated to start feeding.
- The leading edge of the paper turns the registration sensor ON, and the paper is aligned with the registration roller.
- The bypass feed clutch is turned OFF, and the bypass feed roller is stopped.
- The registration motor is turned ON, and the paper is transported to the transfer unit.

[D] Paper feeding

- Lower drawer
 - The feed clutch and high speed clutch is turned ON, and the pickup roller, feed roller and transport roller rotate to start paper feeding.
 - The leading edge of paper turns the paper feed sensor ON, and the feed clutch is turned OFF. (Pick-up roller and feed roller stop rotating.)
 - The leading edge of paper turns the registration sensor ON and the paper is aligned by the registration roller.
 - The high speed clutch is turned OFF, and the transport roller stop rotating.
 - The registration motor and low speed clutch are turned ON, and the paper is transported to the transfer unit.
- Upper drawer
 - The feed clutch is turned ON and the pickup roller and feed roller rotate to start paper feeding.
 - The leading edge of paper turns the registration sensor ON, and the paper is aligned by the registration roller.
 - The feed clutch is turned OFF and the pickup roller and feed roller stop rotating.
 - The registration motor is turned ON, and the paper is transported to the transfer unit.

[8] Drawer damp heater

The drawer damp heater is located at the middle of the upper and lower drawers. It allows the prevention of an increase in the humidity by reducing the temperature alternation in the drawers. AC power is connected in the drawer damp heater via its switch. The drawer damp heater can go into its operable status at any of the following points when its switch is turned ON while the power cable of the equipment is connected and AC power is supplied.

- When the main power switch is turned OFF
- When the [ON/OFF] button on the control panel is turned OFF
- At the sleep mode
- At the super sleep mode

A heater whose maximum permissible power is 10.8 W is used in the drawer damp heater.

[9] Envelope drawer

The envelope drawer is an option so that a standard envelope can be fed from the drawer. Different side walls compared to those for current drawers are adopted. These side walls are positioned by being aligned to the width of an envelope and they have the function of holding envelopes.

By using the drawer paper size detection sensors 1 and 2, the level where the envelope drawer is installed is detected. Since the size of the paper in the envelope drawer is not detected automatically, it is necessary to set the size manually.

3.12 Process Unit Related Section

3.12.1 General description

There are 4 cleaner units and 4 developer units, corresponding to the image forming process of the Y, M, C and K colors. The main charger unit is installed with the cleaner units, while the discharge LEDs are installed on the equipment side.

This chapter explains about the process unit and parts around this unit which are provided for image formation. The developer unit, which is one of the units composing the process unit, is described in  P. 3-69 “3.13 Developer Unit” in details.

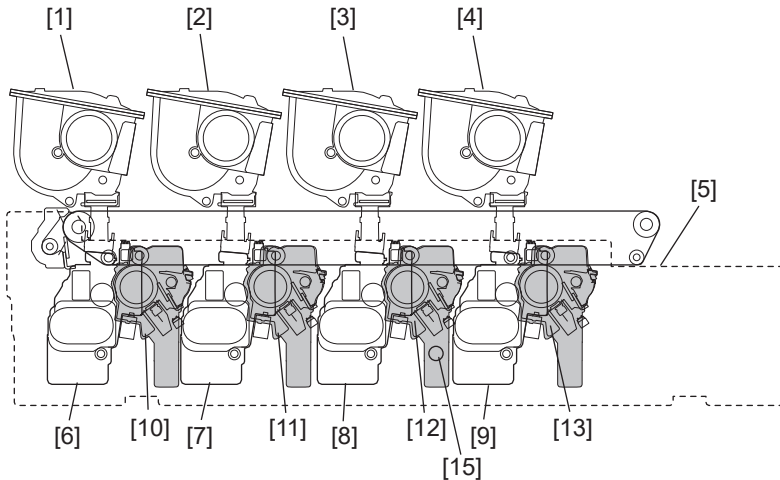

Fig. 3-36

- [1] Toner (Y)
- [2] Toner (M)
- [3] Toner (C)
- [4] Toner (K)
- [5] Waste toner box
- [6] Developer unit (Y)
- [7] Developer unit (M)
- [8] Developer unit (C)
- [9] Developer unit (K)
- [10] Process unit (Y)
- [11] Process unit (M)
- [12] Process unit (C)
- [13] Process unit (K)
- [15] Drum thermistor

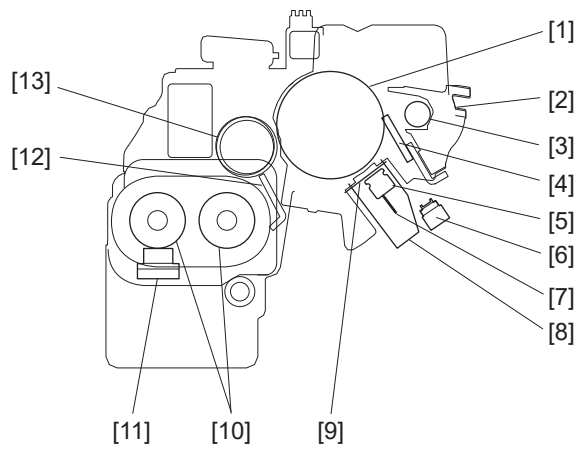

Fig. 3-37

- [1] Drum
- [2] Drum cleaner unit
- [3] Toner recovery auger
- [4] Drum cleaning blade
- [5] Needle electrode cleaner
- [6] Discharge LED
- [7] Needle electrode
- [8] Main charger unit
- [9] Main charger grid
- [10] Mixer
- [11] Auto-toner sensor
- [12] Doctor blade
- [13] Magnetic roller (Developer sleeve)

3.12.2 Composition

Process unit (Y, M, C, K)	Drum cleaner unit	Drum	PM parts
		Drum cleaning blade	PM parts
		Recovery blade	
		Toner recovery auger	
	Main charger unit	Main charger grid	PM parts
		Needle electrode	PM parts
		Needle electrode cleaner	PM parts
		Main charger case	
	Developer unit	Main charger duct	
			Ch3.13
Drum thermistor		THM3	
Discharge LED		ERS-Y, -M, -C, -K	
Temperature/Humidity sensor		S10	
Ozone filter			
Ozone exhaust fan		F2	
High-voltage transformer			
Drum/TBU motor		M6	
Mono/color switching motor		M3	
Developer unit cooling fan		F5	

3.12.3 Functions

1. Drum

Drum is made of a cylindrical aluminum base coated with thin film of organic photoconductive substance. Photoconductive object becomes insulative (high electrical resistance) when it is not exposed to lights and becomes conductive (low electrical resistance) when it is exposed to lights. This object is called photoconductor.

2. Drum cleaner unit

- Drum cleaning blade
This blade is pressed against the drum surface with a constant force and scrapes off the residual toner on the drum surface.
- Recovery blade
This blade prevents the toner which was scraped off by the drum cleaning blade from being scattered to the outside.
- Toner recovery auger
This auger carries the residual toner scraped off to the waste toner box.

3. Main charger

The main charger in this equipment consists of a metal rod with U-shaped section, insulated terminals at both ends of the rod and a needle electrode attached between them. When a high voltage is applied to the needle electrode, the air around it is charged (ionized). The ionized air then flows into the drum causing it to be charged. This phenomenon is called "corona discharge". At the same time, a control bias is applied to the main charger grid to control the charging amount. In a dark place, negative charge is evenly applied onto the drum surface by the corona discharge and this grid. In addition, a cleaner is installed to clean up the dust attached on the needle electrode.

- Needle electrode
The needle electrode has aligned needles and their points perform the corona discharge. These points (electrodes) discharge toward the drum in one direction to realize the more efficient discharging comparing to the charger wire which discharges in a radial direction. Therefore, the needle electrode enables the reduction of the ozone amount.

4. Drum thermistor (THM3)

Since the photoconductive characteristic of the drum surface changes depending on the temperature of the drum surface, the drum thermistor detects the temperature of the drum surface and controls to gain the charging potential according to the environment.

5. Discharge LED (ERS-Y, ERS-M, ERS-C, ERS-K)

Discharge is a process to decrease or eliminate the charge on the drum surface. The residual charge on the drum surface is neutralized and eliminated. Electrical potential of the drum surface is fixed to a certain amount before the drum is charged.

6. Temperature/humidity sensor (S10)

This sensor measures the environment inside the equipment. The values of the temperature and humidity detected inside the equipment are output to the LGC board.

7. Ozone filter

Ozone produced by corona discharge of the main charger is exhausted through this filter. The catalyzer of the ozone filter degrades the ozone.

8. Ozone exhaust fan (F2)

This fan exhausts air through the ozone filter.

9. High-voltage transformer (HVT)

This board generates the output control voltage V_c of the main charger bias, main charger grid bias, 1st transfer roller bias, 2nd transfer roller bias and developer bias.

10. Drum/TBU motor (M6)

This motor drives each drum and toner recovery auger. The drive of the motor is transmitted to each drum by gears in the following 2 lines: Drum/TBU motor → K drum → C drum → Y drum

The gears and drum couplings are assembled with high precision in order to improve accuracy of color overlay.

11. Mono/color switching motor (M3)

This motor switches ON/OFF the transmission of drive to the Y, M, C drums. The drum switching sensor detects the phase of the guide to control the mono/color switching motor, and checks whether the drive is transmitted to the Y, M, C drums or not.

3.12.4 Drum driving sleep mode

When the conditions of the accumulated number of outputs are met, the equipment is shifted to the drum driving sleep mode, in which the photoconductive drum is rotated without exposure several times. This mode prevents the photoconductive drum from being contaminated with ozone exhausted inside of the equipment.

[1] Function

In the standby mode, the photoconductive drum is rotated without exposure according to the specified number of times. The more rotations without exposure increase, the more drive count increases. Consequently, this may reduce the life of the drum.

To prevent a reduction in the life, the drum is rotated without exposure normally once. It is rotated without exposure several times only under certain conditions.

[2] Drum driving sleep mode related codes

FS-08-2380	Control for drum rotation without exposure at standby	Sets ON or OFF for the control of the photoconductive drum rotation without exposure in the standby mode after printing is finished.
FS-08-2381	Starting time of drum rotation without exposure at standby	Sets the time to start the 1st rotation of the photoconductive drum without exposure in the standby mode after printing is finished.
FS-08-2382	Control of drum rotation without exposure at standby: Rotation interval	Sets the rotation interval of the photoconductive drum without exposure between the 1st and 2nd rotations and subsequent intervals.
FS-08-2383	Control of drum rotation without exposure at standby: Maximum number of rotations	Sets the maximum number of rotations allowed without exposure.
FS-08-2385	Accumulated number of outputs to shift to drum driving sleep mode	Sets the number of outputs to shift to the drum driving sleep mode.

[3] The drum driving sleep mode setting

[3-1] Case in which the equipment needs to be shifted to the drum driving sleep mode frequently

When uneven density image problem in 94 mm pitch (the circumference of the drum) must be corrected

- Set a value smaller than “7” (default) for FS-08-2385.

Notes:

If MCV (monthly copy volume) is relatively small, the drive count tends to increase quickly when you set the equipment to shift to the drum driving sleep mode often, resulting in a shorter life.

[3-2] Cases in which the number of times to shift to the drum driving sleeve mode or the number of drum rotations without exposure must be fewer

A: When a user points out the noise of drum rotation without exposure

- The ozone exhaust fan keeps rotating for 1 minute after printing is finished. The rotation noise is not so annoying during this period. Therefore set “0” or “1” for FS-08-2383 so that the rotation of all drums without exposure will be finished within 1 minute.

B: When MCV is relatively small (e.g.; 1k)

- Set “20” for FS-08-2385 to reduce the number of times to shift to the drum driving sleep mode, or set “0” or “1” for FS-08-2383 to reduce the number of drum rotations without exposure.

3.13 Developer Unit

3.13.1 General description

This chapter describes the development (developer unit) which is a process of making toner adhere to the drum.

The developer material is comprised of a mixture of toner and carrier, and filled in the developer unit of each color. The toner is charged to a negative polarity and the carrier to a positive polarity, due to the friction with each other caused by mixing in the developer unit. The charged toner is supplied to the photoconductive drum surface by means of a magnetic roller, allowing it to adhere to the areas on the drum surface where the potential is lower than the developer bias which is applied to the magnetic roller. Through this process, the latent images are formed on the photoconductive drum surface.

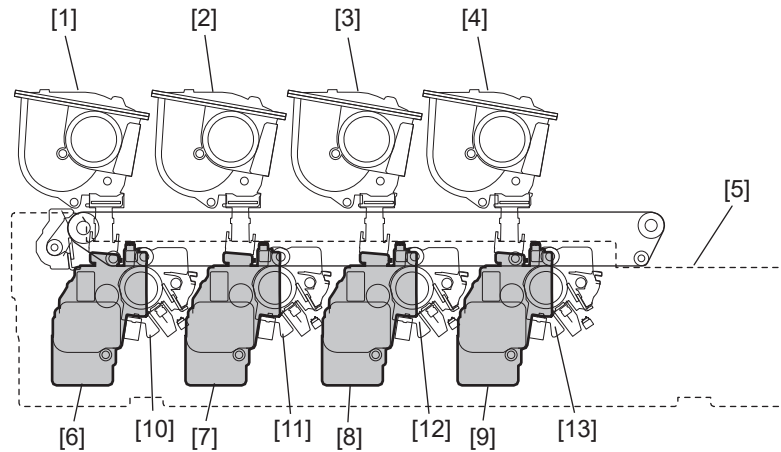

Fig. 3-38

- [1] Toner (Y)
- [2] Toner (M)
- [3] Toner (C)
- [4] Toner (K)
- [5] Waste toner box
- [6] Developer unit (Y)
- [7] Developer unit (M)
- [8] Developer unit (C)
- [9] Developer unit (K)
- [10] Process unit (Y)
- [11] Process unit (M)
- [12] Process unit (C)
- [13] Process unit (K)

3.13.2 Composition

Process unit (Y, M, C, K)	Drum cleaner unit		☞ P. 3-63 “3.12 Process Unit Related Section”	
	Main charger unit		☞ P. 3-63 “3.12 Process Unit Related Section”	
	Developer unit	Developer material		PM parts
		Mixer		
		Developer sleeve (Magnetic roller)		
		Doctor blade		
	Auto-toner sensor		S1, S2, S3, S4	
Paper feeding/developer unit drive motor			M2	

3.13.3 Functions

1. Developer material
The developer material consists of the carrier and toner. Since the developer material deteriorates after a long time use, periodic replacements are needed.
2. Mixer
The carrier and toner are frictionized each other when the developer material is stirred. Then the carrier is positively charged (+) and the toner is negatively charged (–), and the toner is adhered by the electrostatic force.
3. Developer sleeve (Magnetic roller)
These aluminum rollers have magnets inside. The developer material is pulled by these magnets to form a magnetic brush. The magnets are fixed at their position so only the sleeve rotates. By this rotation, the developer material is transported to the developer sleeve.
Then the magnetic brush formed at the developer sleeve sweeps over the drum surface and thus development is performed.
4. Doctor blade
The doctor blade controls the amount of the developer material from the developer sleeve so that the magnetic brush of the developer material can contact with the drum surface properly.
5. Auto-toner sensor (S1, S2, S3, S4)
To print out a precise image, the proportion (toner density ratio) of the carrier and the toner in the developer material needs to be always constant. The magnetic bridge circuit in the black auto-toner sensor detects the toner ratio in the developer material. This sensor supplies the toner from the toner cartridge.
6. Paper feeding/developer unit drive motor (M2)
This motor rotates the Y, M, C, K developer units. The drive of the motor is transmitted to each developer unit by gears in the following 2 lines: Developer motor → K developer unit, developer motor → C developer unit → M developer unit → Y developer unit. Switching of the monochrome and color modes is performed by the monochrome/color switching unit.
7. Toner motor (M8, M9, M10, M11)
These motors drive the paddles and auger in the toner cartridge and transport the toner filled in the cartridge to the developer unit. Each toner cartridge of Y, M, C and K mounts one toner motor correspondingly.
8. Waste toner paddle motor (M7)
This motor rotates the paddles mounted in the Waste toner box to level the Waste toner accumulated in the waste toner box.
9. Waste toner box
This collects the residual toner scraped off on the drum surface by the cleaning blade and residual toner scraped off on the transfer belt by the transfer belt cleaning blade.

3.13.4 Functions of the toner cartridge PC board (CTRG)

An IC chip is embedded in this board. Data such as identification information for the recommended TOSHIBA toner cartridge, thresholds to determine if the cartridge is nearly empty, and controlling data for the image quality to be optimal according to the toner characteristics are written in this chip. To measure the amount of toner remaining in the cartridge, when the value of the counter for the period of the toner cartridge rotation time is updated, this equipment writes the updated value into the toner cartridge PC board (CTRG).

These data written in the toner cartridge PC board (CTRG) enable the functions below, and accordingly this equipment operates as shown below.

Data reading is performed every time when the power is turned ON, the front cover is closed, a job is finished and the equipment has recovered from the sleep mode.

[1] Data read by the toner cartridge PC board (CTRG)

- Data to identify recommended TOSHIBA toner cartridges
- Thresholds to determine if the toner cartridge is nearly empty
- Value of the counter for the period of the toner cartridge rotation time
- Data for optimizing image quality
- Threshold of toner remaining displays

[2] Functions

- Cartridge detecting function
This function checks whether the toner cartridge is inserted correctly or not, and whether the recommended toner cartridge is used or not.
- Toner remaining check function
This function notifies the user of the near-empty status of toner. Normally, the message (Toner is low) is displayed when the toner is running out, and (Toner empty) when the toner cartridge is empty.
- Toner remaining check notification function
Upon detecting the near-empty status of toner, this function automatically notifies your service representative.
- Image optimization function
This function controls the quality of images to be optimal according to the characteristics of the toner used.
- Toner remaining display function
This function displays the remaining toner amount from 0% to 100%.

[3] Operations

A sign indicating that the toner cartridge is nearly empty appears in the following cases:

- The counter value for the toner cartridge rotation time has exceeded the threshold previously written in the toner cartridge PC board (CTRG). (Related code: FS-08-5155)
- The remaining amount of toner is equal to or less than the set amount (percentage or number of sheets). (Related code: FS-08-5155, FS-08-5810, FS-08-5811)

When a used cartridge refilled with new toner is used, a sign indicating that the toner cartridge is empty appears because information for determining the empty status is already written in the toner cartridge PC board (CTRG).

When a non-recommended toner cartridge is used, "Toner not recognized" appears on the control panel, and then the equipment may stop normal operations. The toner remaining display function, the toner remaining check function, the automatic remote supply order to TOSHIBA sales representatives and the image optimization function may also be disabled.

The self-diagnosis codes to adjust the timing for displaying the toner near-empty status are as follows.

- Toner near empty threshold setting (FS-08-5155)
<Setting value>
0: The period from the appearance of the toner near-empty sign to the actual complete consumption of the toner is set to long.
1: Normal (Default)
2: The period from the appearance of the toner near-empty sign to the actual complete consumption of the toner is set to short.
4: Toner near-empty status threshold value: (%)
5: Toner near-empty status threshold value: (Number of sheets)
- Toner near-empty status threshold value setting (%) (FS-08-5810)
Use this code to specify the threshold value (unit:%) for displaying the toner near-empty status. This code is used when the value of FS-08-5155 is set to “4”.
Sub-code 0: K, sub-code 1: Y, sub-code 2: M, sub-code 3: C
- Toner near-empty status threshold value setting (number of sheets) (FS-08-5811)
Use this code to specify the threshold value (unit: number of sheets) for displaying the toner near-empty status. This code is used when the value of FS-08-5155 is set to “5”.
Sub-code 0: K, sub-code 1: Y, sub-code 2: M, sub-code 3: C
- Fine adjustment of threshold value for displaying the toner remaining amount / toner near-empty (FS-08-5156)
Performs fine adjustment of the threshold value for displaying the toner remaining amount and toner near-empty.
Display threshold value = Default threshold value x setting value/100 (Unit:%)

[4] Toner near-empty / toner empty display adjustment

The toner empty appears when the auto-toner sensor in the developer unit detects that the level amount of toner in the developer unit has actually become low. The toner remaining amount is displayed by means of calculating it by counting the value of the counter for the period of the toner motor rotation time. Then the toner near-empty appears when the calculated toner remaining amount has reached the specified value (the toner amount which can print approx. 1,000 sheets of paper when an image whose print ratio is 6% is printed with the A4/LT equivalent paper size).

The relationship between the period of the toner motor rotation time and the actual toner consumption amount varies depending on the printed images and usage conditions. Therefore, the displaying of the toner remaining amount can be adjusted by the codes shown below. However, it is recommended to handle the toner remaining amount as the reference since the printed images and usage conditions are always unstable and there will be variations in the systems.

1. Fine adjustment of the toner remaining amount display
When the displayed toner remaining amount is decreased more quickly than that for the actual toner (when “1%” is being displayed for a long time), set a value in FS-08-5156 larger than the default one. When the displayed toner remaining amount is decreased more slowly than that for the actual toner (when the toner near-empty appears before “1%” is displayed), set a value in FS-08-5156 smaller than the default one.
2. Toner near-empty setting change
 - Setting change of the period from the toner near-empty to the toner empty
When the period is made longer, set “0” in FS-08-5155. When the period is made shorter, set “2” in FS-08-5155.
 - Setting change of the toner near-empty threshold value
When the threshold value (default: printing approx. 1,000 sheets of paper is available when an image whose print ratio is 6% is printed with the A4/LT equivalent paper size) used to designate toner near-empty is changed, perform the following setting change.

When the change is made by using the toner remaining amount (%), set "4" in FS-08-5155 and exchange the value of FS-08-5810. In order to designate the toner near-empty while the toner remaining amount is greater than the default value, set a larger value in FS-08-5810.

When the change is made by using the available remaining number of print sheets, set "5" in FS-08-5155 and exchange the value of FS-08-5811. In order to designate the toner near-empty while the available remaining number of print sheets is greater than the default value (printing approx. 1,000 sheets of paper is available when an image whose print ratio is 6% is printed with the A4/LT equivalent paper size), set a larger value in FS-08-5811.

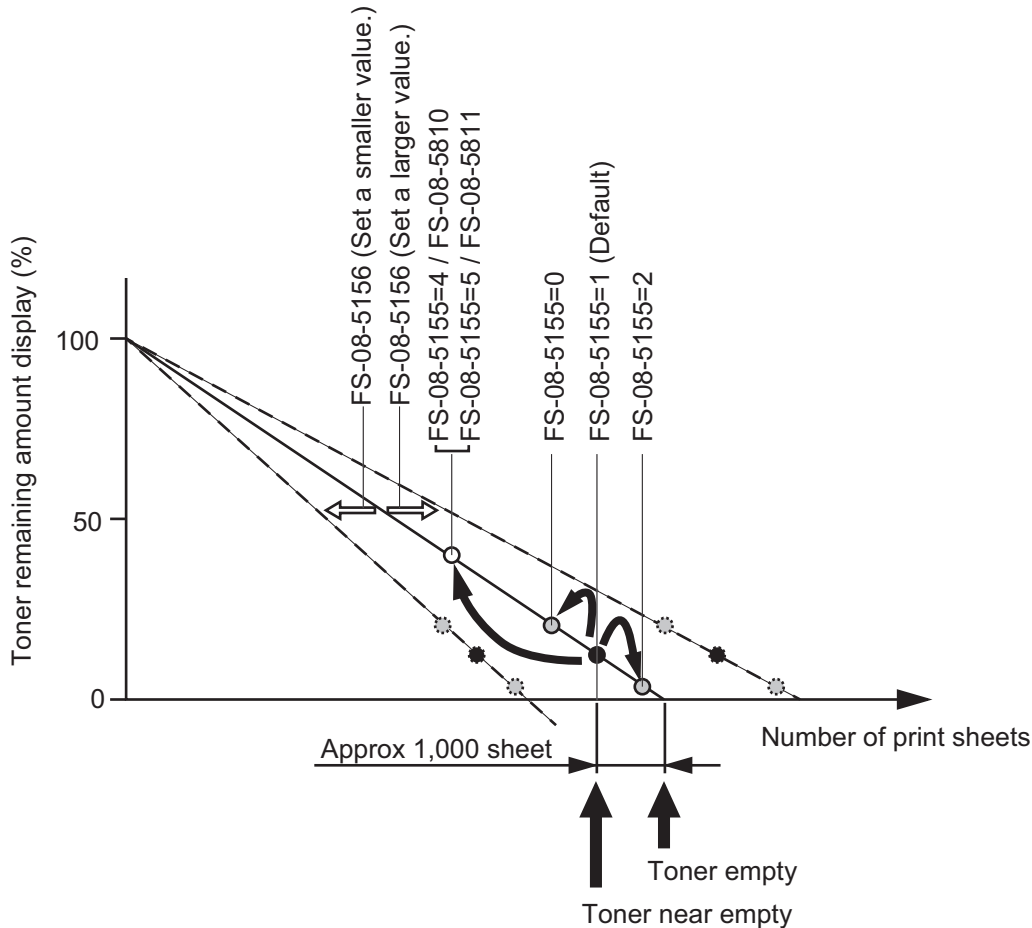

Fig. 3-39

Notes:

Do not perform the change operations 1 (Fine adjustment of the toner remaining amount display) and 2 (Toner near-empty setting change) simultaneously. Otherwise, the desired results may not be obtained. If the change is required by the combination of the operations 1 (Fine adjustment of the toner remaining amount display) and 2 (Toner near-empty setting change), only perform either of them first. Then change the setting for the other one while checking the results. The values of the toner remaining amount and the number of print sheets are the reference. They will vary depending on the printed images and usage conditions.

3.13.5 Waste toner box

The waste toner box is installed inside of the front cover, and collects waste toner discharged from a cleaner for each color and the transfer belt cleaner.

The front cover is designed not to be closed without installing the waste toner box in this equipment.

The paddle embedded in the waste toner box is rotated by the waste toner paddle motor (M7).

The rotation status of the paddle is detected by the waste toner paddle rotation detection sensor (S9).

In this equipment, a sensor detecting the full status of waste toner is not equipped.

Instead, the waste toner box full is judged when the waste toner has been accumulated in the box and the rotation of the paddle has not been detected for a specified period.

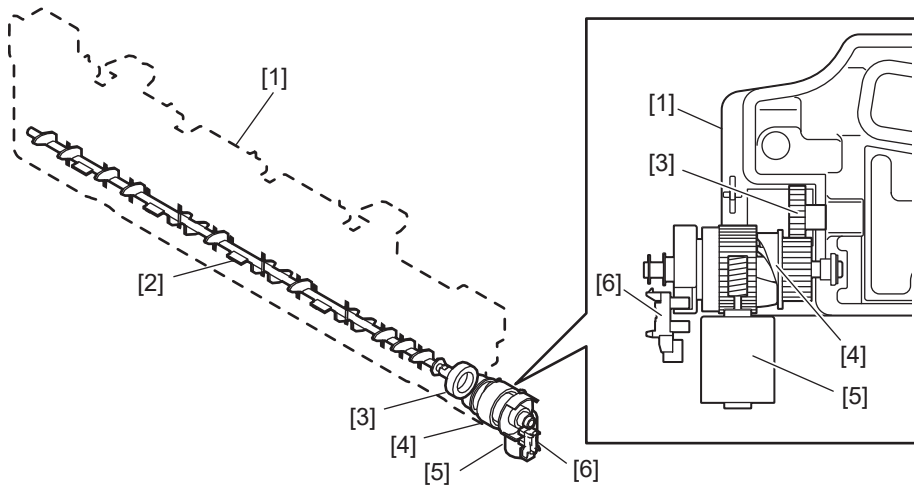

Fig. 3-40

- [1] Waste toner box
- [2] Paddle
- [3] Gear (Paddle)
- [4] Gear
- [5] Waste toner paddle motor (M7)
- [6] Waste toner paddle rotation detection sensor (S9)

3.14 Transfer Unit

3.14.1 General descriptions

Transfer is a process of decaling a toner image from the photoconductive drum onto paper. A toner image formed on the photoconductive drum is temporarily transferred onto the transfer belt, and the toner image is then transferred from the transfer belt onto paper. The first transfer from the drum to the transfer belt is called the 1st transfer, and the second transfer from the transfer belt to paper is called the 2nd transfer. To form a color image, the images of yellow (Y), magenta (M), cyan (C) and black (K) are transferred and overlaid on the transfer belt in order, and then the overlaid images are transferred onto paper.

After the completion of the 2nd transfer, the residual toner on the transfer belt is scraped off by the transfer belt cleaning blade and then transported to the waste toner box.

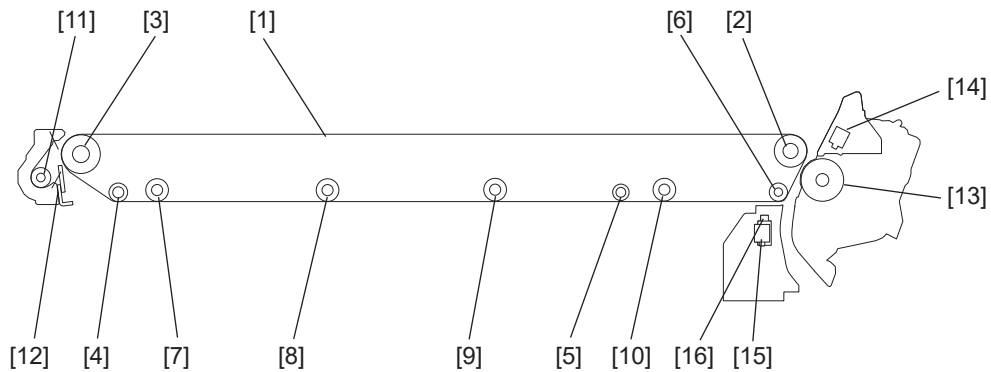

Fig. 3-41

- [1] Transfer belt
- [2] TBU drive roller
- [3] Cleaner unit facing roller
- [4] Lift roller
- [5] Winding roller (K)
- [6] Belt clinging roller before 2nd transfer
- [7] 1st transfer roller (Y)
- [8] 1st transfer roller (M)
- [9] 1st transfer roller (C)
- [10] 1st transfer roller (K)
- [11] Waste toner auger
- [12] Transfer belt cleaning blade
- [13] 2nd transfer roller
- [14] Paper clinging detection sensor
- [15] Registration pass sensor
- [16] Image position aligning sensor / Image quality sensor

3.14.2 Composition

Transfer belt unit	Transfer belt	
	1st transfer roller	Y, M, C, K
	Drive roller	
	Cleaner unit facing roller	
	Belt clinging roller before 2nd transfer	
	Lift roller	
	Drum / TBU motor	M6
	1st transfer roller status detection sensor	S12
Transfer belt cleaning unit	Transfer belt cleaning blade	
	Waste toner auger	
2nd transfer unit	2nd transfer roller	PM parts
	Paper clinging detection sensor	S18
Image position aligning sensor (Front) Image position aligning sensor (Rear) Image position aligning sensor (Center) / Image quality sensor		S7 / S8 / S37

3.15 Image Quality Control

3.15.1 General description

Three image position aligning sensors are mounted inside of the 2nd transfer front guide beneath the transfer belt.

The image position aligning sensors on the center side combines its own functions with those of the image quality sensors.

At this control, image forming conditions are automatically adjusted so as to minimize the change in the image density or tone reproduction caused by the fluctuation of working environment or life of supply items.

At first, the image position aligning sensor (center) / image quality sensor (S37) operates to output reflected light amount voltage when no toner image is formed on the transfer belt. The output voltage is then converted from analog to digital to be output as the reflected light amount signal. The light source amount voltage of the sensor is adjusted to correspond with the value set in advance and the output value of reflected light amount signal at this adjustment is stored. This output value is considered as the reading of the belt surface. Next, the sensor outputs the reflected light amount signal when a test pattern is developed on the transfer belt. This output value is considered as the reading of the toner image.

The difference between the reading of the transfer belt and that of the toner image is defined as toner adhesion amount. Image forming conditions are determined in approximating this toner adhesion amount to the value set in advance.

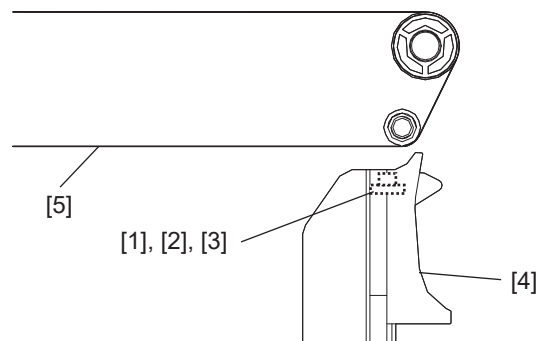

Fig. 3-42

- [1] Image position aligning sensor (Front)
- [2] Image position aligning sensor (Rear)
- [3] Image position aligning sensor (Center) / Image quality sensor
- [4] 2nd transfer front guide
- [5] Transfer belt

3.16 Fuser Unit

3.16.1 General description

Toner is fused by applying heat and pressure on the transferred image on the paper which is transported to the fuser unit. The paper is then transported to the inner tray, paper exiting options or ADU. The fuser unit consists of the IH coil, fuser belt, pressure roller, separation fingers, separation guide, thermistors, thermostats, etc.

The fuser belt in the fuser unit is driven by the fuser motor.

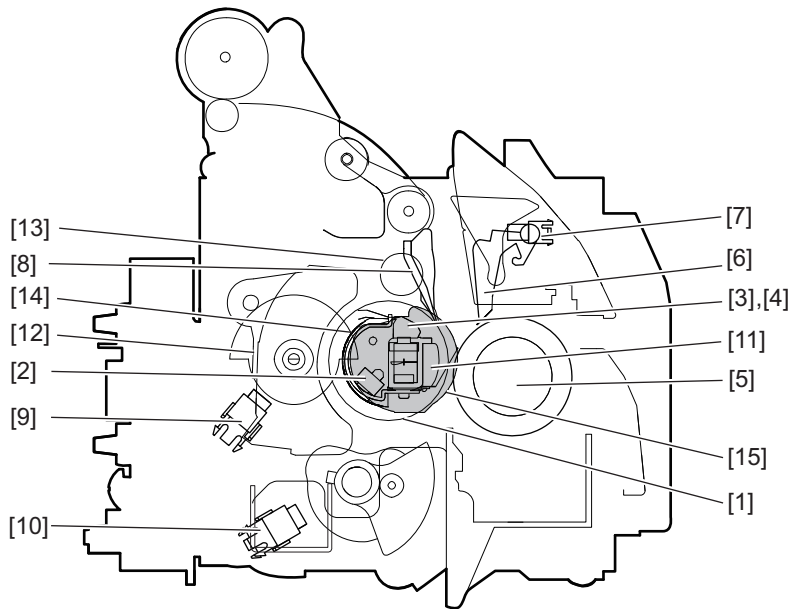

Fig. 3-43

- [1] Fuser belt
- [2] Fuser belt thermostat
- [3] Fuser belt center thermistor
- [4] Fuser belt edge thermistor
- [5] Pressure roller
- [6] Separation finger
- [7] Exit sensor
- [8] Separation guide
- [9] Fuser belt rotation detection sensor
- [10] Pressure roller contact/release detection sensor
- [11] Fuser belt pad
- [12] Rotation detection plate
- [13] Fuser belt drive shaft
- [14] Magnetic plate
- [15] Front fuser oil recovery sheet 1 / Front fuser oil recovery sheet 2 / Rear fuser oil recovery sheet

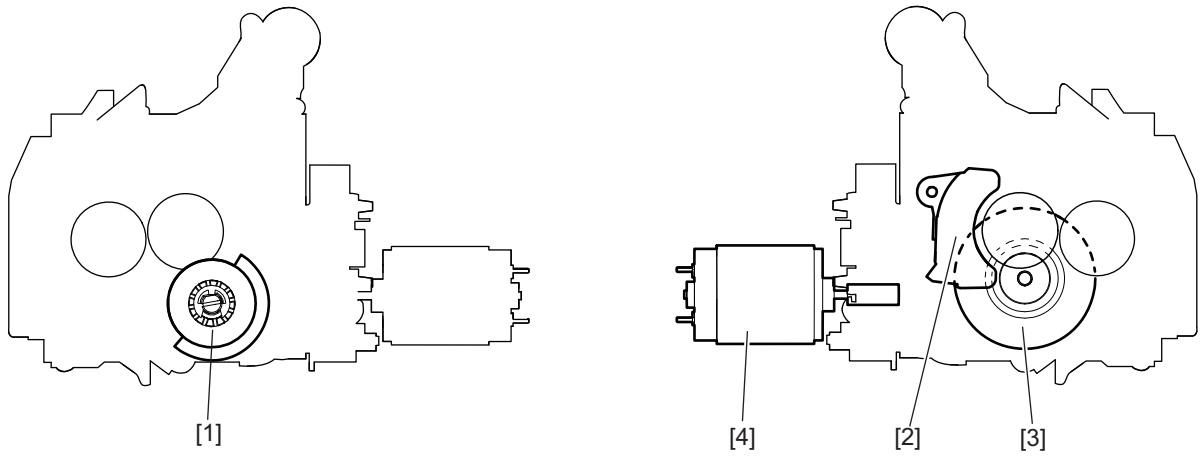

Fig. 3-44

- [1] Pressure roller contacting/releasing cam
- [2] IH coil
- [3] Fuser motor
- [4] Pressure roller contact/release motor

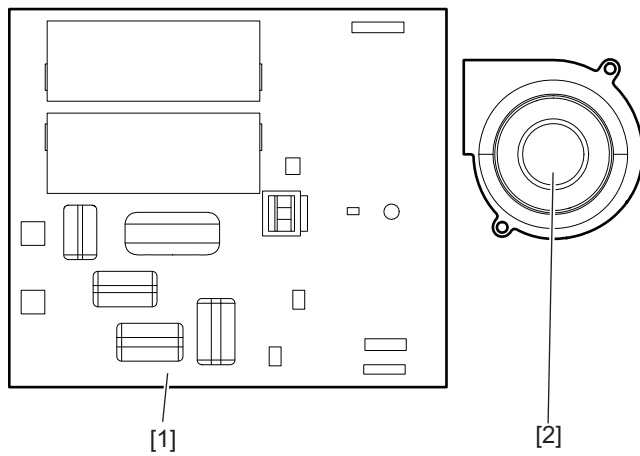

Fig. 3-45

- [1] IH board
- [2] IH board cooling fan

3.16.2 Composition

		25/30/35 ppm	45/50 ppm
Fuser belt center thermistor	THM1		
Fuser belt edge thermistor	THM2		
Fuser belt thermostat	THMO1		
Fuser belt		Screw: M2.6	Screw: M3
Pressure roller			
Separation finger			
Separation guide			
Fuser belt rotation detection sensor	S27		
Pressure roller contact/release motor	M13		
Pressure roller contact/release detection sensor	S29		
IH coil	IH-COIL	With a magnetic metal plate	With a magnetic metal plate
IH board	IH		
IH board cooling fan	F6		
Fuser unit cooling fan	F4		
Fuser motor	M4		
Front fuser oil recovery sheet 1			
Front fuser oil recovery sheet 2			
Rear fuser oil recovery sheet			

3.16.3 Pressure mechanism

In the equipment, when “Envelope” is selected from the menu on the LCD panel, the pressure roller contact/release cams rotate and come to the semi-contact position (envelope position). Then the pressure for the envelope printing is adjusted.

The pressure to the fuser belt [4] is adjusted by moving the arm [2] retaining the pressure roller [3] by means of the position of the pressure roller contact/release cam [1]. Moreover, the pressure is applied by using the force of the spring [5].

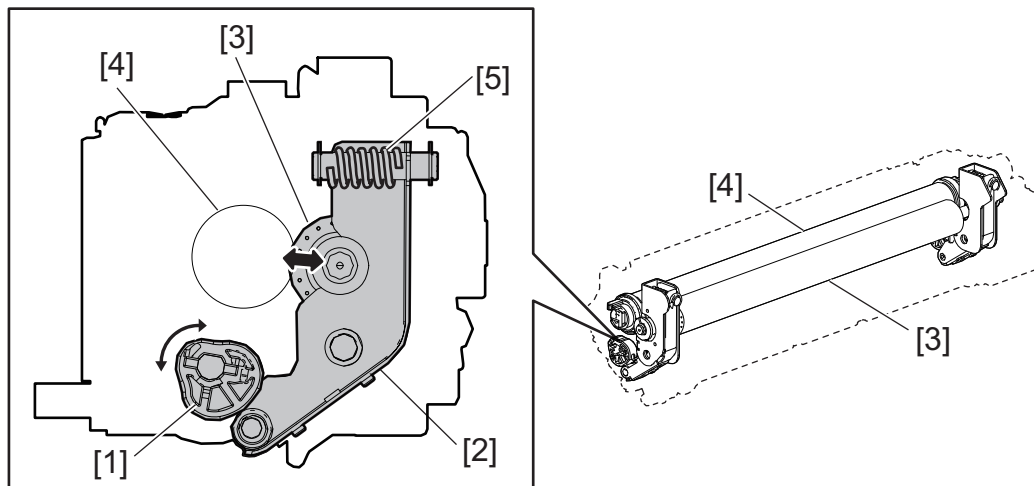

Fig. 3-46

- [1] Pressure roller contact/release cam
- [2] Arm
- [3] Pressure roller
- [4] Fuser belt
- [5] Spring

3.16.4 Electric circuit description

[1] Fuser unit control circuit

[1-1] Configuration

This equipment employs an external IH coil unit for heating the fuser belt. IH coil in the IH coil unit generate a magnetic field to heat the fuser unit with a high-frequency current carried inside of them. The surface temperature of the fuser belt is detected with the center and edge thermistors.

The detected temperature data are sent to the ASIC. Based on the received temperature data, the ASIC then controls the electricity of the IH coil. When the surface temperature of the fuser belt exceeds the preset temperature, the forcible power OFF circuit sends a power supply relay OFF signal as well as an overheating signal to the ASIC, and then shuts OFF power supply over all parts except the control panel.

If the circuit noted above does not operate due to problems such as thermistor malfunction and therefore the fuser belt is abnormally heated, the thermostat shuts OFF power supply to the IH coil to protect the equipment.

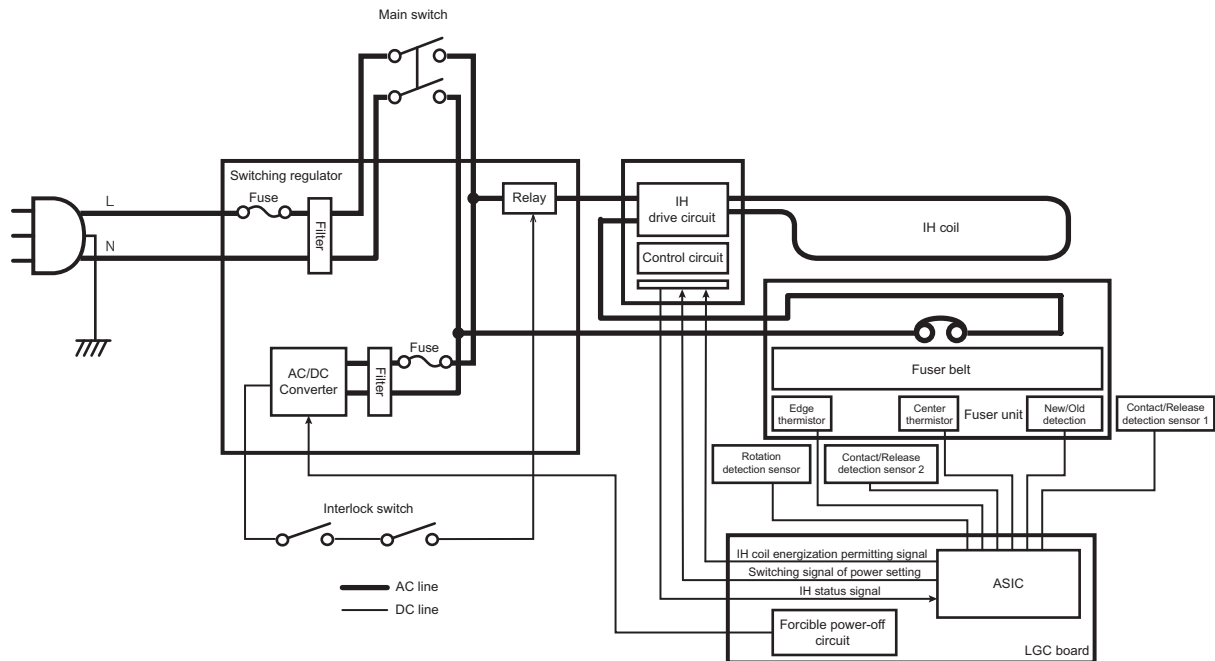

Fig. 3-47

[1-2] Temperature detection section

Fuser unit error status counter control

- To enhance the safety of the fuser unit section, the following protection is provided: When a third [C445] error has occurred after two consecutive [C445] errors, the IH coil is not turned ON and an error code [C446] is displayed immediately even if the operator turns the power OFF and then back ON. However, if the equipment goes into the ready state normally with the fuser unit error status counter value "5", the counter is cleared to "0".
- If any of the error codes [C445] to [C449] is displayed but the error is still not cleared and the heater lamp is not turned ON even after the thermistor, thermostat or heater lamps were repaired, check the fuser unit error status counter value (FS-08-2002) to clear the value to "0".

Remarks:

The fuser unit error status counter never has any values other than 0 to 70. If the counter value is "71" or over, data in EEPROM may possibly have been ruined due to causes such as leakage from the chargers. In this case, check the bias, high-voltage transformers and needle electrodes to see if any of them is defective, and also recheck all the data in the EEPROM.

- When the thermistors detect overheating, the engine CPU determines an error code and the fuser unit error status counter value. After turning OFF each output (from the heater lamp, exposure lamp, control panel, motors and so on) to protect the fuser unit, the engine CPU shuts OFF power supply to the main power switch.

Error code: C449

Fuser unit error status counter (FS-08-2002): 9, 22, 23, 25, 27, 29, 59, 61, 67 to 70

The thermistors continue detecting abnormal temperatures even after an error code and a counter value are determined. Even if the main power switch is turned ON immediately, the switch is automatically turned OFF unless otherwise the surface temperature of the fuser belt goes lower than the abnormal temperature detected. In this case, therefore, wait until the surface temperature of the fuser belt becomes lower than the abnormal temperature detected, and then turn ON the main power switch. Then check the counter value while you are waiting for the main power switch to be automatically turned OFF. After confirming that it is a fuser unit abnormality, correct the subject part in the unit and clear the counter value to "0" so that the equipment can be started up normally.

Temperature detection circuit

A thermistor is a device whose resistance varies according to the detected temperature. The ASIC detects voltages output from this device, and judges whether the operation of the fuser unit is normal or abnormal from the changes in voltages.

If any of the thermistors is broken, the control circuit judges that the surface temperature of the fuser belt is extremely low and keeps turning the IH circuit ON. As a result, the surface temperature of the fuser belt rises, and this possibly activates a thermostat which is a safety protection device. To prevent this in advance, the ASIC detects whether each thermistor is broken or not.

Also, the control circuit constantly monitors the surface temperature of the fuser belt to prevent them from excessive heating caused by abnormalities in circuits or thermistors, and automatically shuts OFF power supply when the surface temperature exceeds the preset temperature.

Abnormality detection by the thermistors

The following table shows the conditions for judging the temperature abnormality of the fuser belt, and the detecting timing.

Check timing	Error code	Counter	Center	Edge	Error judging timing
Power ON	C449	9 Fixed	220°C or above	237°C or above	
	C449	59 Fixed	Thermistor (HTERR signal: L)		
When pre-running end temperature or ready temperature is detected	C449	22 Fixed	220°C or above	237°C or above	On usual
	C449	61 Fixed	Thermistor (HTERR signal: L)		
	C445	5 Not fixed	Ready temperature or below	---	
	C446	6 Fixed			
During ready	C449	23 Fixed	220°C or above	237°C or above	On usual
	C449	67 Fixed	Thermistor (HTERR signal: L)		
	C447	7 Fixed	0°C or below	---	
	C447	63 Fixed	---	0°C or below	
During printing	C449	25 Fixed	220°C or above	237°C or above	On usual
	C449	68 Fixed	Thermistor (HTERR signal: L)		
	C440	35 Fixed	The WAIT control according to low temperatures is 2 minutes or more.		
	C447	24 Fixed	0°C or below	---	
	C447	64 Fixed	---	0°C or below	
	C447	65 Fixed	40°C or below	---	
	C447	66 Fixed	---	40°C or below	
At energy saving mode	C449	27 Fixed	220°C or above	237°C or above	On usual
	C449	69 Fixed	Thermistor (HTERR signal: L)		
At paper jam	C449	29 Fixed	220°C or above	237°C or above	On usual
	C449	70 Fixed	Thermistor (HTERR signal: L)		

3.17 Paper Exit Section / Reverse Section

3.17.1 General description

A sheet of paper with the toner fused on is transported to the inner tray, but the lower exit rollers do not switchback.

The reverse section is a path only for switchbacking to the ADU to enhance the high-speed printing. The reverse section has the reverse gate which switches the transport path to the paper exit section or the reverse section.

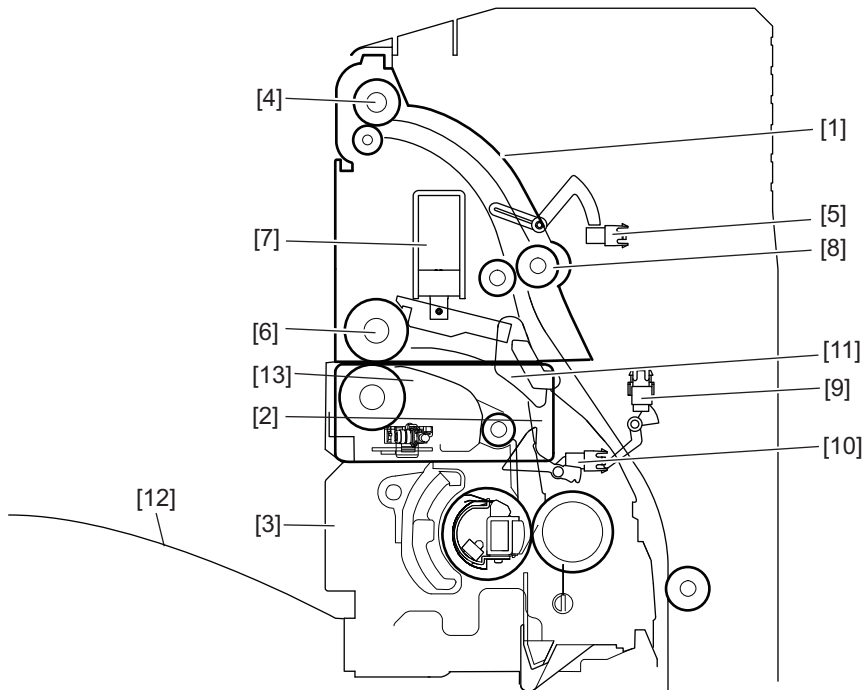

Fig. 3-48

- [1] Reverse section
- [2] Paper exit section
- [3] Fuser unit
- [4] Upper exit roller
- [5] Reverse sensor
- [6] Lower exit roller
- [7] Reverse gate solenoid
- [8] Reverse roller
- [9] ADU entrance sensor
- [10] Exit sensor
- [11] Reverse gate
- [12] Exit tray
- [13] Paper exit guide

3.17.2 Functions

1. Lower exit roller
The exit roller transports the paper from the fuser unit to the inner tray. This roller is driven by the fuser motor.
2. Reverse sensor (S26)
The reverse sensor detects if the leading edge of the paper from the fuser unit has reached to the reverse roller. This sensor is also used for the detection of a paper jam in the reverse section, and the detection of the trailing edge of the reversed paper at duplex printing as well.
3. Exit motor (M5)
The exit motor is a stepping motor which drives the reverse roller and upper exit roller. However, this motor rotates reversely to switchback when the paper is transported to the ADU.
4. Upper exit roller/Reverse roller
The reverse roller transports the paper from the fuser unit to the inner tray or ADU. This roller is driven by the exit motor.
5. Reverse gate solenoid (SOL2)
This reverse gate solenoid drives the reverse gate and switches the paper transport path (paper exit section or reverse section).

3.17.3 Exit motor drive

The figure shown below is the layout of the driving gears of the upper exit roller and reverse roller.

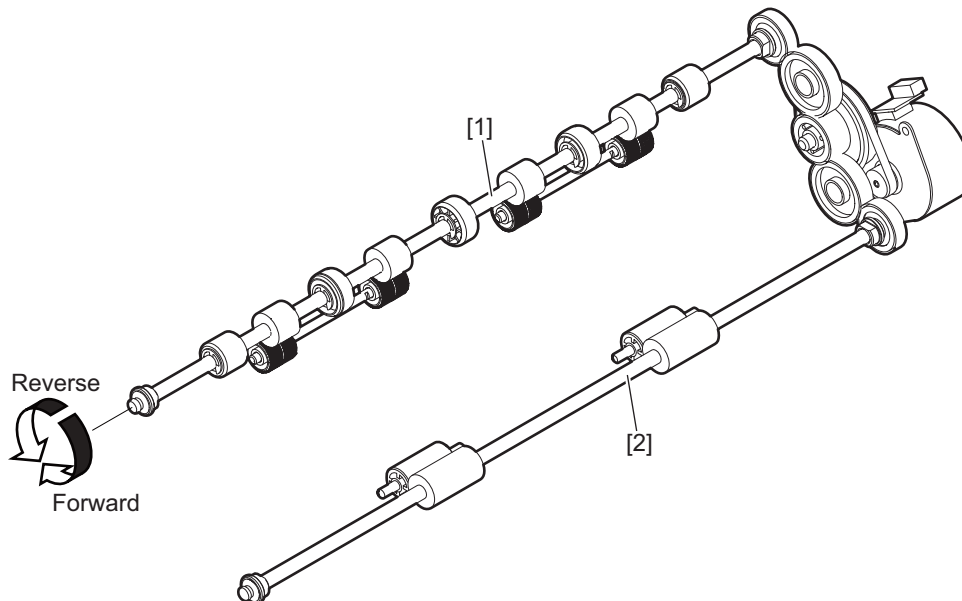

Fig. 3-49

[1] Upper exit roller

[2] Reverse roller

3.18 Automatic Duplexing Unit (ADU)

3.18.1 General description

The Automatic Duplexing Unit (ADU) is a unit to automatically print on both sides of paper. A switchback method using the reverse section is adopted for the ADU of this equipment.

A sheet of paper is switchbacked at the reverse section right after the printing operation (fusing operation) on one side is completed, and the reversed sheet is transported to the registration section for the other side of the sheet to be printed.

The ADU mainly consists of the transport rollers and their drive system, paper guide and ADU entrance / exit sensor.

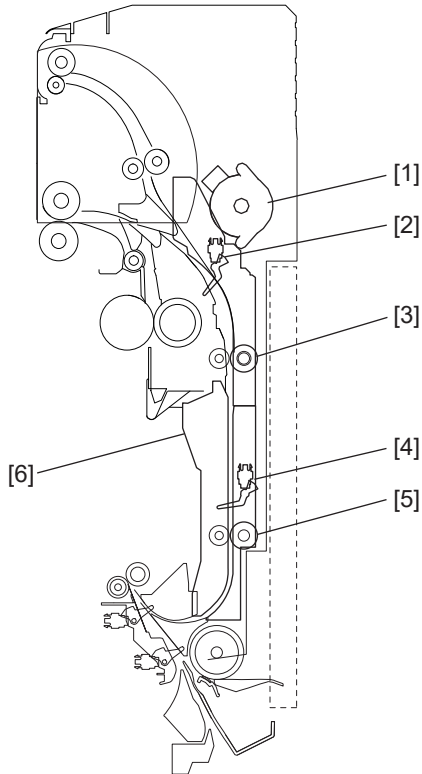

Fig. 3-50

- [1] ADU motor
- [2] ADU entrance sensor
- [3] Upper transport roller
- [4] ADU exit sensor
- [5] Lower transport roller
- [6] Paper guide

3.18.2 Composition

Automatic Duplexing Unit (ADU)	
ADU motor	M12: Stepping motor
ADU entrance sensor	S14
ADU exit sensor	S15
Reverse sensor	S26
ADU driving PC board	ADU
Upper transport roller	
Lower transport roller	

3.18.3 Drive of ADU

When the ADU motor (M12) rotates, the upper transport roller and lower transport roller are rotated driven by the gears and belt.

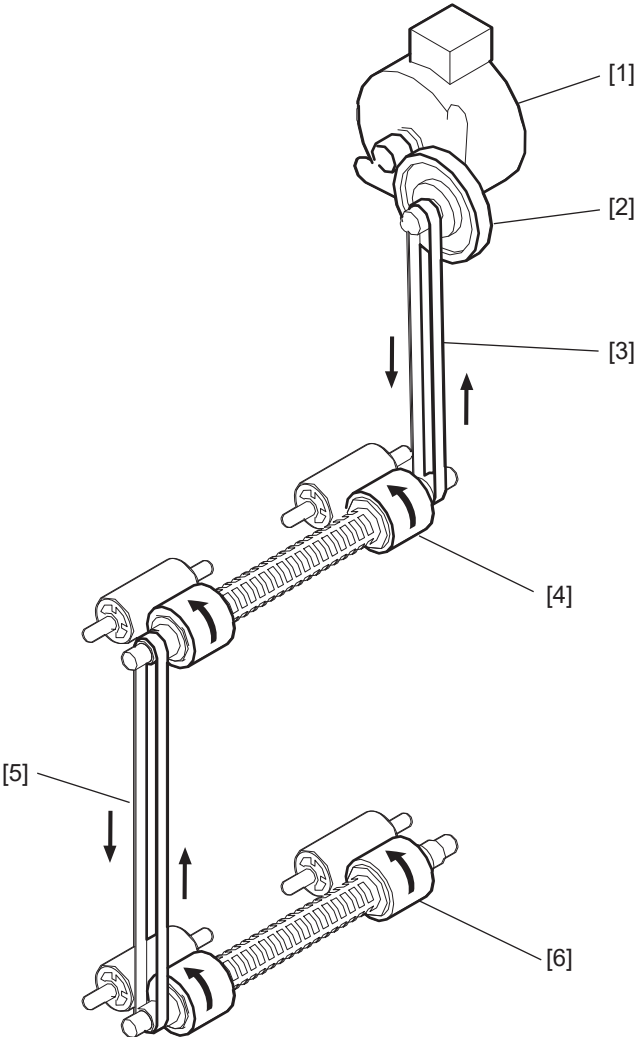

Fig. 3-51

- [1] ADU motor
- [2] Gear
- [3] Timing belt
- [4] Upper transport roller
- [5] Timing belt
- [6] Lower transport roller

3.18.4 Description of operations

The back side printing (recording data of the back side of paper) is performed first by selecting duplex printing mode.

When the paper passed the reverse sensor, the reverse gate solenoid switches the reverse gate, and the reverse roller switchbacks to transport the paper into the ADU.

The switchbacked paper is transported with acceleration. The transportation decelerates in front of the ADU exit sensor. The front side printing (recording data of the front side of paper) is performed at the registration section. The paper passes through the lower exit roller and is transported to the inner tray to complete duplex printing.

There are three methods of judging a paper jam: (1) whether the ADU entrance sensor is turned ON or not in a specified period of time after the switchback to the ADU started (E510). (2) whether the ADU exit sensor is turned ON or not in a specified period of time after the ADU entrance sensor is turned ON (E520). (3) whether the registration sensor is turned ON or not in a specified period of time after the paper feeding from the ADU to the equipment (E110).

If the ADU is opened during duplex printing, the ADU motor is stopped, namely, ADU open jam occurs (E430).

The equipment never stops during printing by interruption in any case except paper jam or service call.

3.19 Power Supply Unit

3.19.1 General description

The power supply unit consists of AC filters and insulation-type DC output circuits in order to supply stable DC and AC voltage to each electric part of this equipment.

3.19.2 Functions

The functions of each component of the power supply unit are described here.

1. AC filter
Eliminates noise from the outside and prevents the noise generated by the equipment from leaking to the outside.
2. DC output circuits
Converts AC voltage input from outside to DC voltage and supplies it to each electric part. The DC voltage is divided into the following two lines.
 - a. Main power switch line:
Power supply used in the entire equipment during image forming process. Two kinds of voltage (+5VS and +12 VA) are output when the main power switch of the equipment is turned ON.
 - b. Cover switch line:
Power supply used in the entire equipment during image forming process, being supplied via the cover switch. The voltage (+24 VD) is output only when the main power switch of the equipment is turned ON and two covers (front cover and automatic duplexing unit) are closed.

3.19.3 Operation of DC output circuits

1. Starting operation of the equipment
When the main switch of the equipment is turned ON, power starts supplying to all the lines only when two doors (front cover and ADU) are closed
2. Stopping line output
When the main switch of the equipment is turned OFF, PWR-DN signal is output after the instantaneous outage insurance time elapses and then the supply of each voltage stops. If the supply of voltage of the main line (+5VS, +12VA) stops earlier than the 24V line does, it may cause the damage of the electron device on each control circuit. To prevent this, the supply of these voltages stops after the PWR-DN signal is output and the minimum retaining time elapses.
3. Output protection
Each output system includes an overcurrent and overvoltage protection circuits (a fuse and internal protection circuit). This is to prevent the defectives (damage or abnormal operation of the secondary circuit) which may be caused by an overcurrent due to a short circuit or an overvoltage due to a short circuit between different voltages. If the protection circuit is activated (except the case the fuse is blown out), remove the causes such as short-circuit. Turn ON the power again to clear the overcurrent protection.
4. Recovering from super sleep mode (normal starting))
When the [ENERGY SAVER] button on the control panel is pressed during the super sleep mode, a super sleep mode shifting/recovering signal (SYS-EN) is output from the SYS board and then voltage starts being supplied to all the lines, if no error was detected.

5. Recovering from super sleep mode (when receiving a packet)

When a packet from a network is received during the super sleep mode, the mode is shifted to the sleep mode.

When packets are received frequently, a control is performed to keep the sleep mode for a specified period. It will be cleared when the power is turned OFF and then back ON.

6. Shifting to super sleep mode (normal stopping)

When the [ENERGY SAVER] button on the control panel is pressed while the main switch of the equipment is toggled ON, a super sleep mode shifting/recovering signal (SYS-EN) is output from the SYS board after the initialization is finished and then all lines for output voltage except +5VS are closed.

The Super sleep mode is disabled under the following conditions.

- When the Super sleep mode is set to be disabled on the control panel, TopAccess and with the code FS-08-8543
- When the Wireless LAN Module, e-BRIDGE ID Gate or Data Overwrite Enabler is installed, or when the IPsec Enabler is installed and its function is set to be enabled
- When operation is being performed in the self-diagnosis mode (Disabled until the main switch is turned OFF)

7. State of the power supply

- Power OFF
The main switch of the equipment is turned OFF. Since DC voltage is not supplied to each board, the equipment is not operable.
- Normal state (including Energy saving mode)
The main switch of the equipment is turned ON and DC voltage is supplied to each board. When the cover of the equipment is closed, 24V DC voltage is supplied and the equipment enters into the ready/printing state.
- Sleep mode
Since +24VD DC voltages are not supplied but +12VA and +5VS DC voltages only, the equipment does not enter into the ready state.
- Super Sleep mode
Only +5VS DC voltages are output from the power supply unit. The [ENERGY SAVER] button is monitored and the LED of the main switch is lit.

3.19.4 Output channel

The following are output channels for the main power switch line.

Main power switch line

Connector	Pin No.	Voltage	Destination
CN511	2	+12VA	SYS board DF (via SYS board)
	4	+5VS	
CN512	6	+12VA	LGC board
CN514	1	+12VA	Cover switch

The following are output channels for the cover switch line.

Cover switch line

Connector	Pin No.	Voltage	Destination
CN512	2	+24VD2	LGC board
	4	+24VD1	
CN513	2	+24VD3	Scanner
	4	+24VD4	Finisher
CN515	2	+24VD5	PFC board
CN517	1	+24VD	Fan

3.19.5 Fuse

When the power supply secondary fuse is blown out, confirm that there is no abnormality with each part using the following table.

Voltage	Board/Unit	Part		Fuse type
+24VD1	LGC board	Fuser motor	M4	F201: 4A
		Exit motor	M5	
		Waste toner paddle motor	M7	
		Pressure roller contact/release motor	M13	
		IH board cooling fan	F6	
		Suctioning fan	F3	
		Exit section cooling fan	F7	
		Sensor shutter solenoid	SOL1	
		Reverse gate solenoid	SOL2	
		Auto-toner sensor-K	S1	
		Auto-toner sensor-C	S2	
		Auto-toner sensor-M	S3	
		Auto-toner sensor-Y	S4	
		Discharge LED-Y	ERS-Y	
		Discharge LED-M	ERS-M	
		Discharge LED-C	ERS-C	
		Discharge LED-K	ERS-K	
		Key copy counter, coin controller	-	
		Bridge kit, Job Separator	-	
+24VD2	LGC board	Paper feeding/developer unit drive motor	M2	F202: 4A
		Mono/color switching motor	M3	
		Drum / TBU motor	M6	
		1st transfer contact/release clutch	CLT2	
		High-voltage transformer	HVT	
		Toner motor-Y	M8	
		Toner motor-M	M9	
		Toner motor-C	M10	
		Toner motor-K	M11	
		Polygonal motor	M17	
		Mirror motor-Y	M18	
		Mirror motor-M	M19	
		Mirror motor-C	M20	
		Laser optical unit cooling fan	F10	
+24VD3	SYS board	Scan motor	M1	F203: 4A
+24VD4	Finisher	-	-	F205: 4A

Voltage	Board/Unit	Part		Fuse type
+24VD5	PFC board	ADU motor	M12	F204: 4A
		Registration motor	M14	
		Tray-up motor-1	M15	
		Tray-up motor-2	M16	
		Ozone exhaust fan	F2	
		Fuser unit cooling fan-1	F4	
		Developer unit cooling fan	F5	
		Fuser unit cooling fan-2	F9	
		Bypass feed clutch	CLT3	
		1st drawer feed clutch	CLT1	
		2nd drawer feed clutch	CLT4	
		Transport clutch (H)	CLT5	
		Transport clutch (L)	CLT6	
		PPF/LCF	-	

Primary fuse

Part		Fuse type
MFP	-	F101
Switching regulator	PS	F102

4. DISASSEMBLY AND REPLACEMENT

4.1 Covers

4.1.1 Front cover

- (1) Open the front cover [1].
- (2) Disconnect the joint [2] of the band.
- (3) Pull out the front cover [1] at an angle toward the lower-front side.

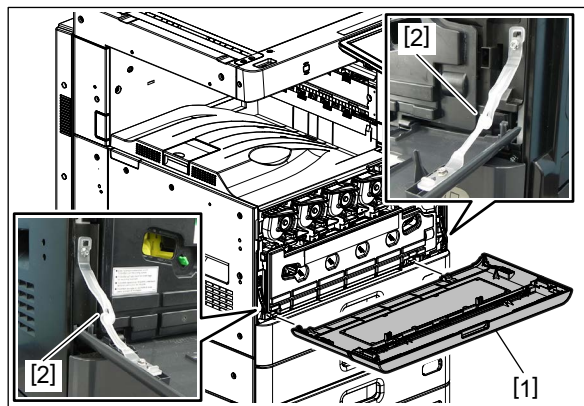

Fig. 4-1

4.1.2 Left cover

- (1) Open the front cover.
- (2) Pull out the 1st drawer.
- (3) Remove 8 screws and take off the left cover [1].

[2] M4x8

[3] M3x8

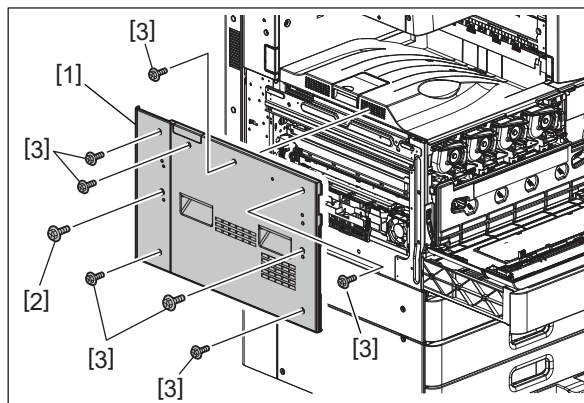

Fig. 4-2

4.1.3 Receiving tray

- (1) Remove the left cover.
☞ P. 4-1 "4.1.2 Left cover"
- (2) Remove the receiving tray [1].

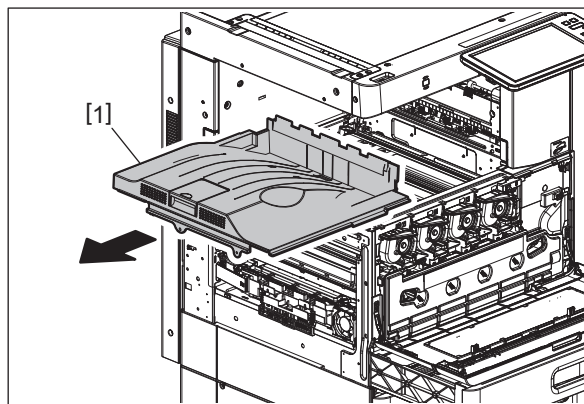

Fig. 4-3

4.1.4 Tray rear cover

- (1) Remove the receiving tray.
☞ P. 4-2 "4.1.3 Receiving tray"
- (2) Remove the left rear cover.
☞ P. 4-3 "4.1.6 Left rear cover"
- (3) Remove the receiving rear cover.
☞ P. 4-4 "4.1.7 Receiving rear cover"
- (4) Remove 1 screw and take off the tray rear cover [1] by sliding it to the left.

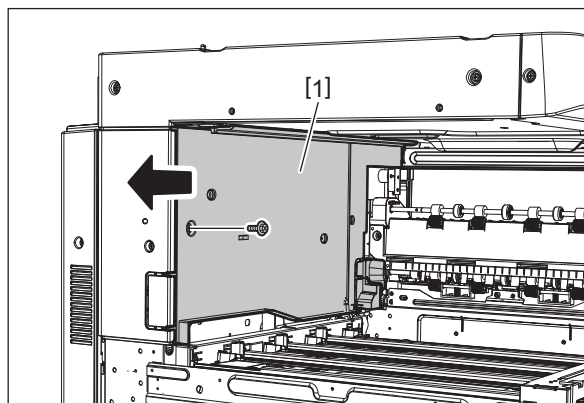

Fig. 4-4

Notes:

When installing, insert each latch to the holes of the frame as follows:

- Insert the latch [2] to the hole [3].
- Insert the latch [4] to the hole [5].

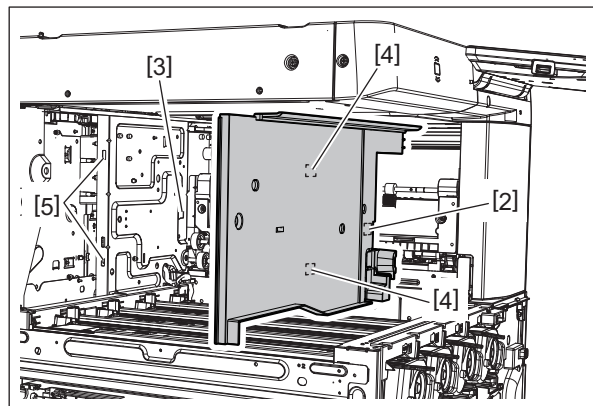

Fig. 4-5

4.1.5 Left top cover

- (1) Remove 2 screws and take off the left top cover [1].

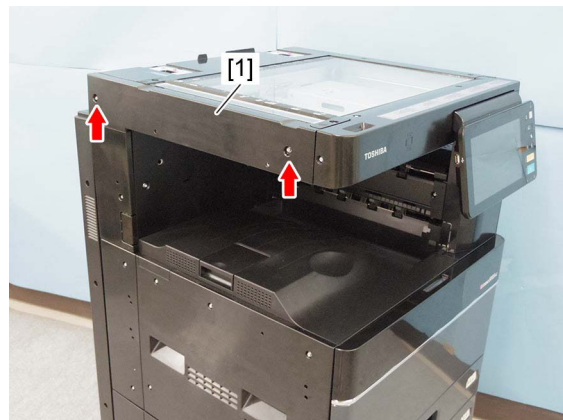

Fig. 4-6

4.1.6 Left rear cover

- (1) Remove the left top cover.
P. 4-3 "4.1.5 Left top cover"
- (2) Remove 1 screw and take off the left rear cover [1] by lifting it up.

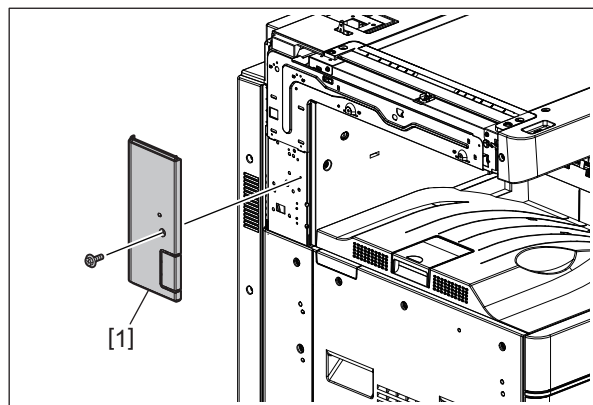

Fig. 4-7

4.1.7 Receiving rear cover

- (1) Open the ADU.
- (2) Remove 1 screw, and take off the receiving rear cover [1].

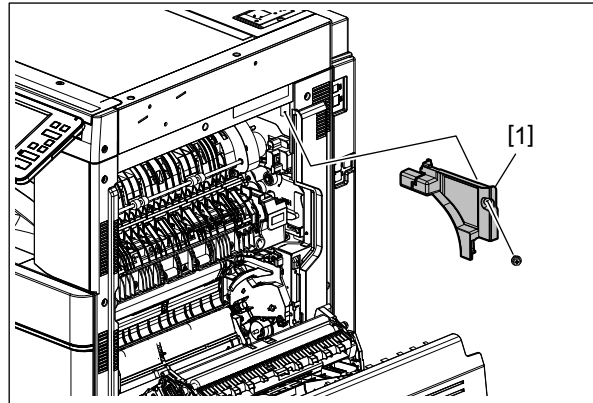

Fig. 4-8

4.1.8 Rear left cover

- (1) Remove 3 screws, and take off the left rear cover [1] by sliding it toward the rear side.

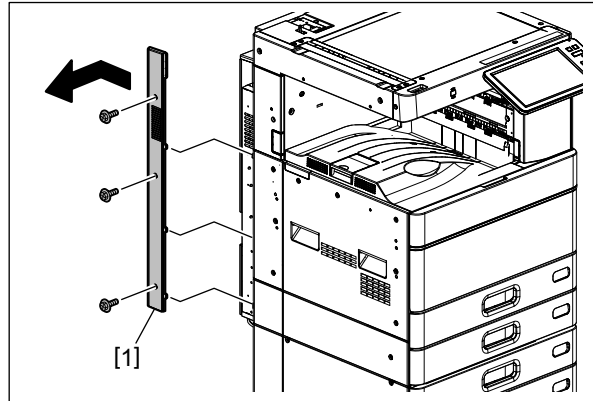

Fig. 4-9

4.1.9 Right top cover

- (1) Remove 3 screws and take off the right top cover [1] by lifting it up.

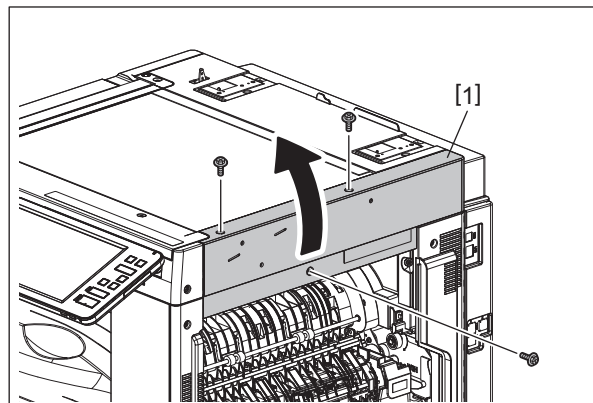

Fig. 4-10

4.1.10 Right front cover

- (1) Pull out the 1st and 2nd drawers.
- (2) Open the front cover.
- (3) Open the jam access cover.
- (4) Remove 2 screws and lift the right front cover [1] and take it off.

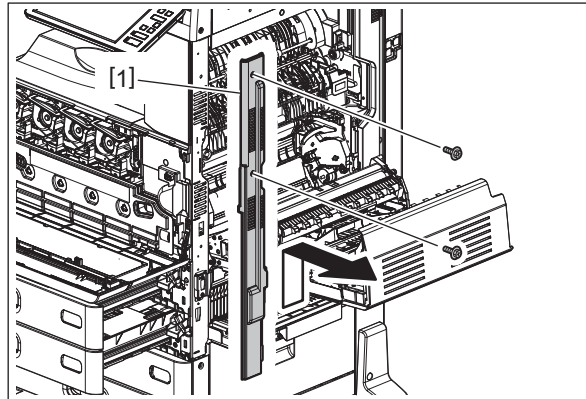

Fig. 4-11

4.1.11 Right rear cover

- (1) Open the jam access cover.
- (2) Remove the right top cover.
P. 4-4 "4.1.9 Right top cover"
- (3) Remove the rear top cover.
P. 4-8 "4.1.16 Rear top cover"
- (4) Open the side cover.
- (5) Remove 4 screws and take off the right rear cover [1].

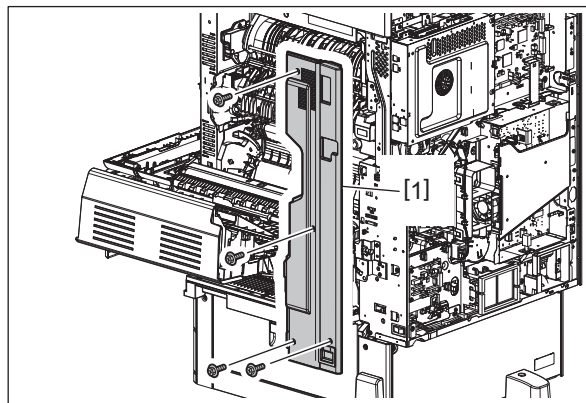



Fig. 4-12

4.1.12 Front top cover

- (1) Remove the right top cover.
 P. 4-4 "4.1.9 Right top cover"
- (2) Move the control panel to the position as indicated in the figure.

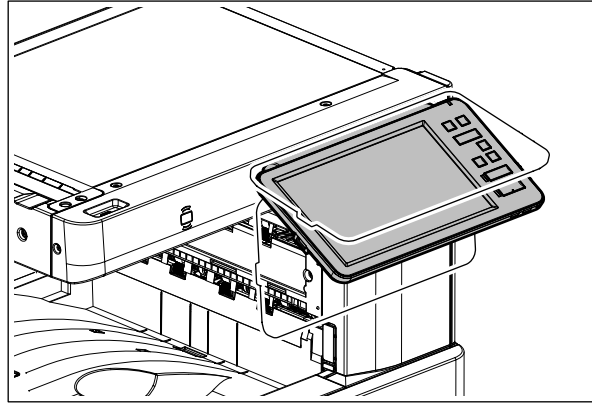

Fig. 4-13

- (3) Remove 2 caps.
- (4) Remove 3 screws and take off the front top cover [1] by sliding it toward the left side.

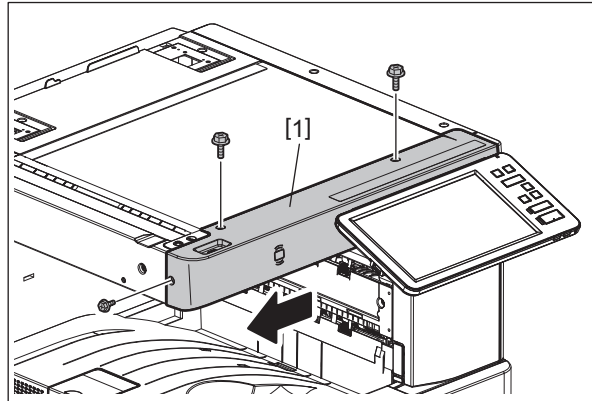

Fig. 4-14

4.1.13 Control panel lower cover

- (1) Make the control panel [1] level.

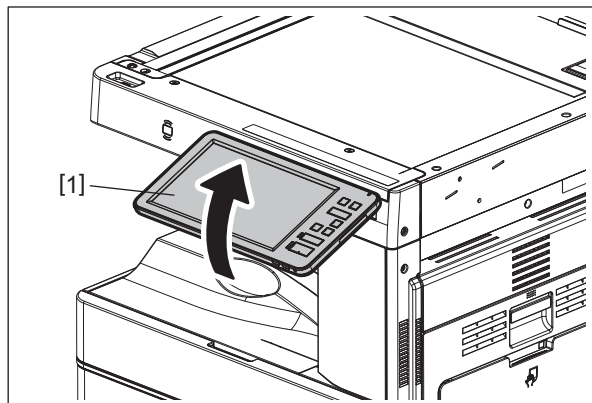

Fig. 4-15

- (2) Remove 2 screws, and then remove the control panel lower cover [2].

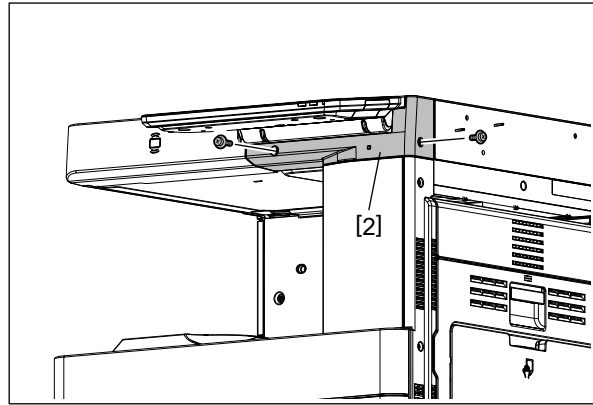

Fig. 4-16

4.1.14 Front right cover

- (1) Remove the control panel lower cover.
P. 4-6 "4.1.13 Control panel lower cover"
- (2) Open the right front cover.
P. 4-5 "4.1.10 Right front cover"
- (3) Remove 1 screw. Take off the front right cover [1] by lifting it up.

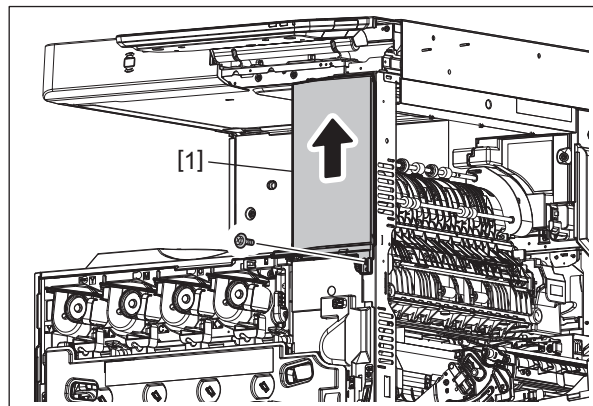

Fig. 4-17

4.1.15 Top rear cover

- (1) Remove the RADF/DSDf or the platen cover.
- (2) Remove the left top cover.
📖 P. 4-3 "4.1.5 Left top cover"
- (3) Remove the right top cover.
📖 P. 4-4 "4.1.9 Right top cover"
- (4) Remove 2 screws and take off the rear top cover [1].

Notes:

If the platen cover is installed, remove 2 brackets.

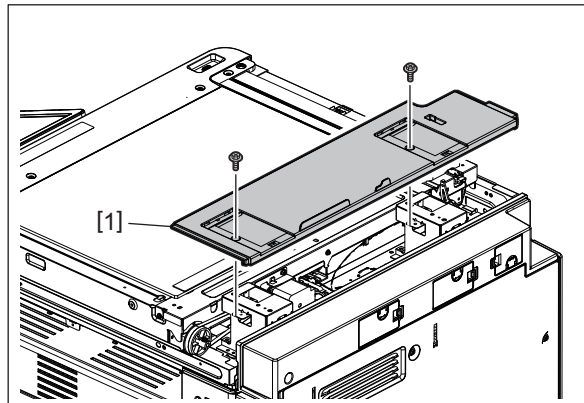

Fig. 4-18

4.1.16 Rear top cover

- (1) If the RADF is installed, remove the connector cover [1] and disconnect the 1 connector [2].
- (2) Remove the rear cover.
- 📖 P. 4-10 "4.1.17 Rear cover"

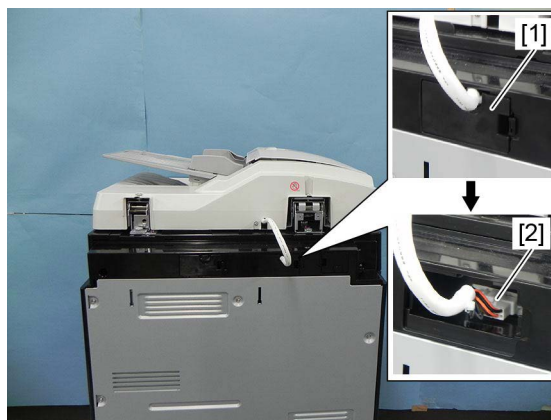

Fig. 4-19

- (3) If the DSDF is installed, remove the rear cover.
 ☞ P. 4-10 "4.1.17 Rear cover"
- (4) Remove the connector cover [3] and disconnect the 2 connectors [4] and [5].

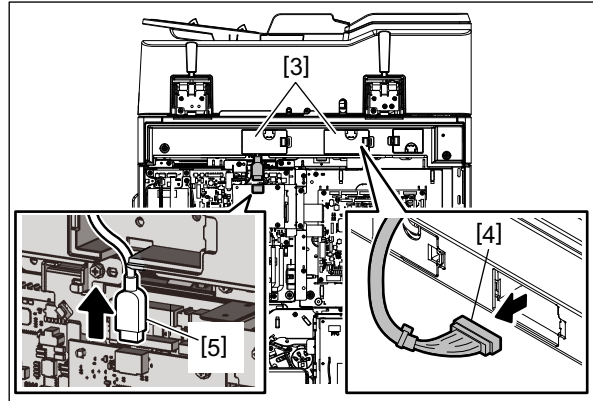

Fig. 4-20

- (5) If the original cover is installed, remove the rear cover.
 ☞ P. 4-10 "4.1.17 Rear cover"
- (6) Remove the connector cover [6].

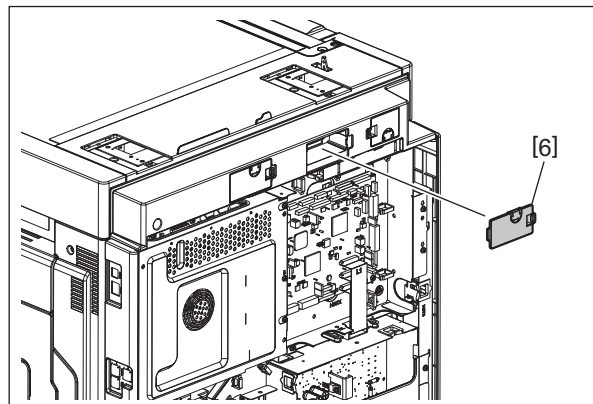

Fig. 4-21

- (7) Remove 3 screws, and take off the rear top cover [7].

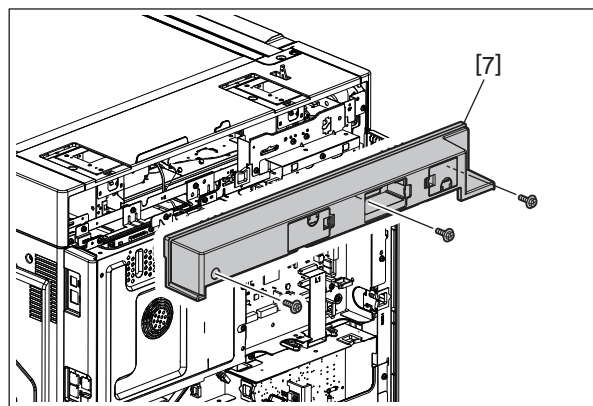

Fig. 4-22

4.1.17 Rear cover

- (1) Remove 6 screws and take off the rear cover [1].

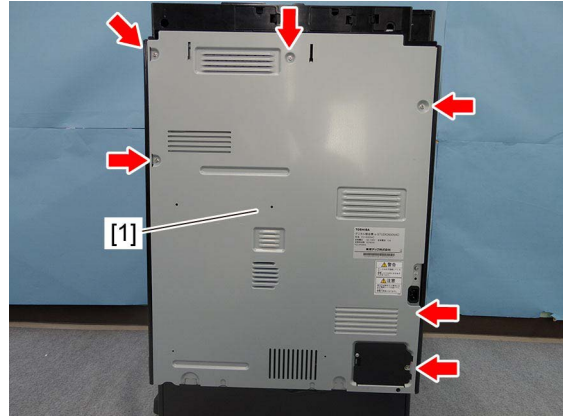



Fig. 4-23

4.1.18 Front cover switch (SW1)

- (1) Open the front cover.
 P. 4-1 "4.1.1 Front cover"
- (2) Remove 1 screw and take off the front cover switch bracket [1].

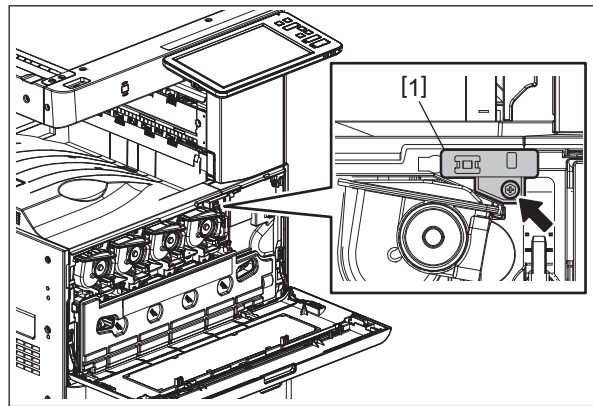

Fig. 4-24

- (3) Disconnect 1 connector and remove the front cover switch [2].

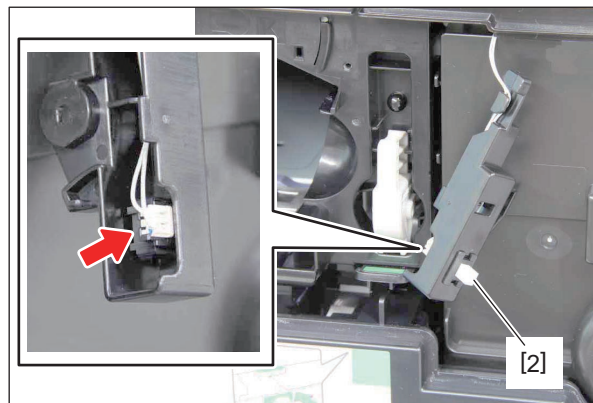

Fig. 4-25

4.1.19 Front cover interlock switch (SW2)

Notes:

If the interlock switch is not installed appropriately when it is replaced or installed, it may not work normally. If you carry out the maintenance of the equipment in such a situation, you could get an electric shock by touching live sections or be injured by touching moving sections. Therefore, to avoid this, be sure to perform correct handling and installation.

- (1) Remove the front cover.
☞ P. 4-1 “4.1.1 Front cover”
- (2) Remove the waste toner box.
☞ P. 4-108 “4.6.1 Waste toner box”
- (3) Remove the right front cover.
☞ P. 4-5 “4.1.10 Right front cover”
- (4) Remove 8 screws and take off the inner cover [1].

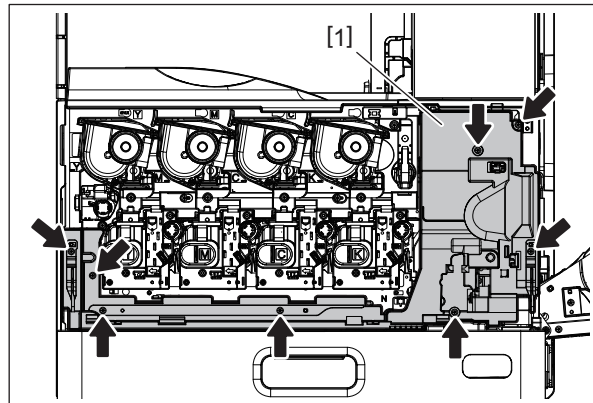

Fig. 4-26

- (5) Remove 1 screw and take off the front cover interlock switch bracket [2].

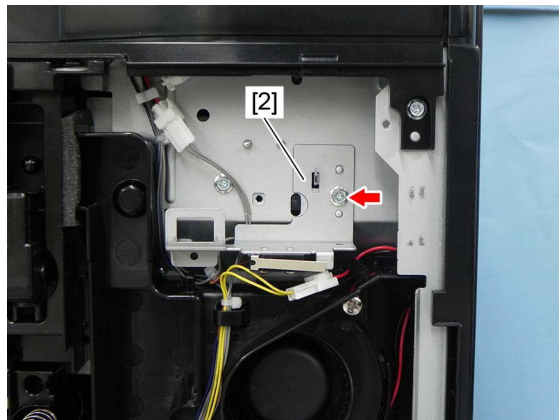

Fig. 4-27

(6) Remove 2 screws and disconnect 2 connectors [3], and then take off the front cover interlock switch [4].

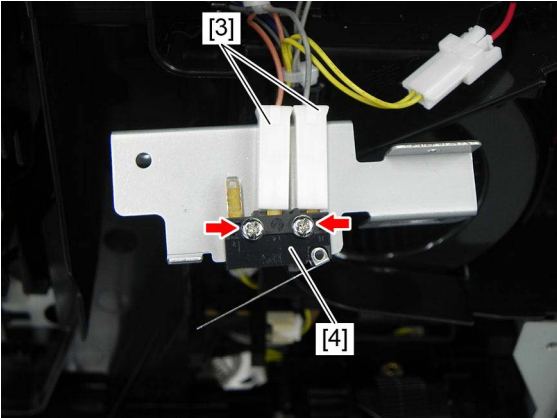

Fig. 4-28

4.2 Control Panel

4.2.1 Control panel unit

- (1) Remove the front top cover.
P. 4-6 “4.1.12 Front top cover”
- (2) Lower the control panel unit [1].

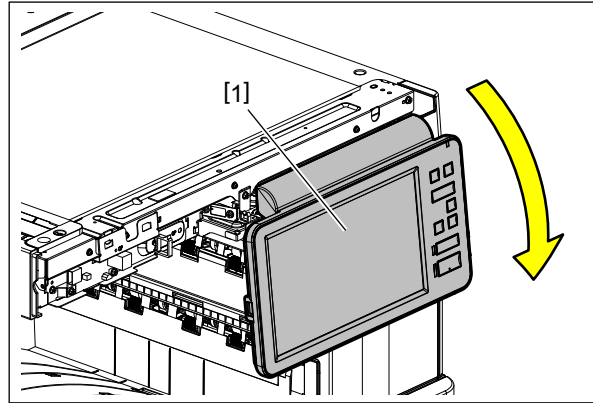

Fig. 4-29

- (3) Remove 2 screws. Remove the control panel unit [1] by sliding it.

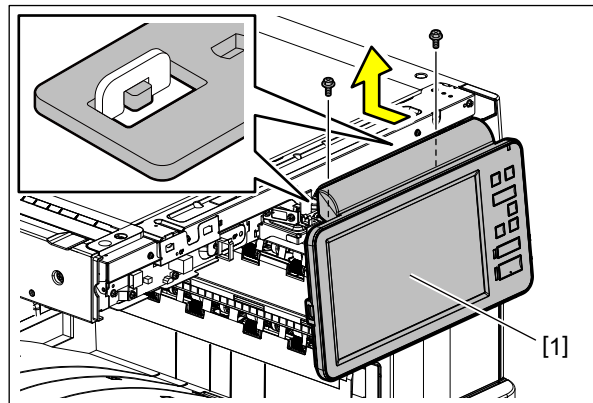

Fig. 4-30

- (4) Remove 4 screws.

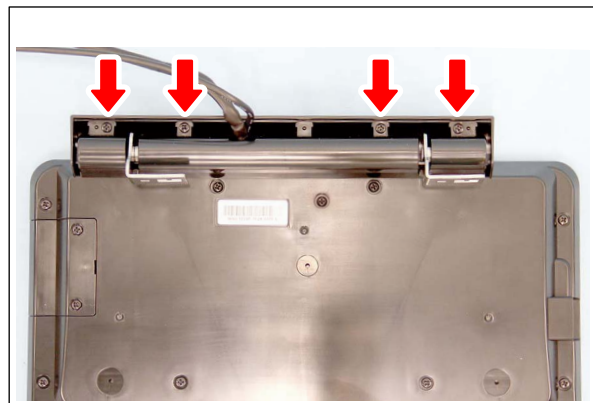

Fig. 4-31

(5) Raise 2 hinges and remove the hinge cover [2].

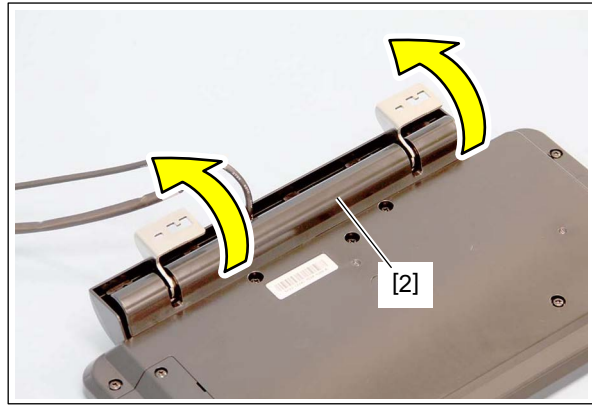

Fig. 4-32



Fig. 4-33

(6) Remove 9 screws and take off the cover [3].

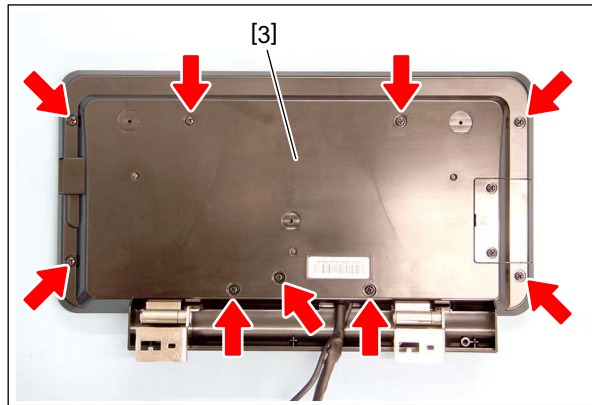

Fig. 4-34

- (7) Remove the harness from 5 hooks and disconnect connector [4] and [5], and then remove the USB harness/signal harness [6].

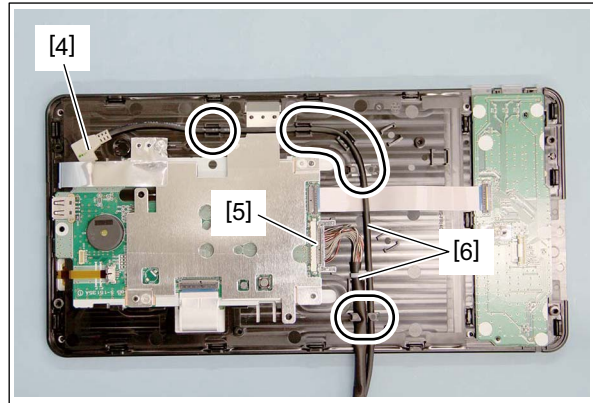

Fig. 4-35

Notes:

When disconnecting the connector [5], release the lock and disconnect it.

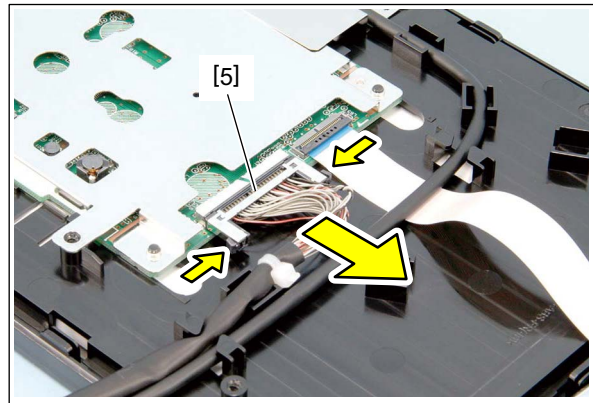

Fig. 4-36

4.2.2 KEY board/button

- (1) Remove the control panel unit.
P. 4-13 "4.2.1 Control panel unit"
- (2) Disconnect the connector [1] and remove 1 screw and take off the key PC board [2].

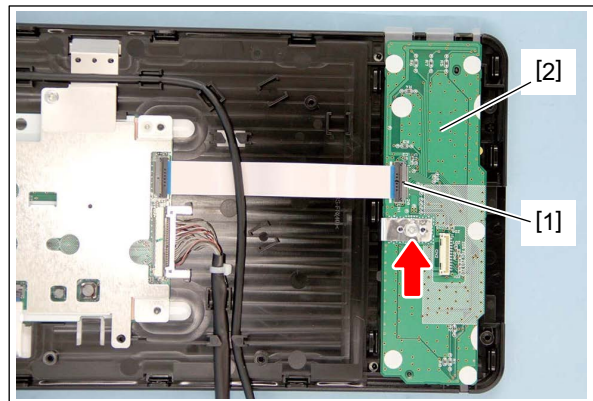

Fig. 4-37

Notes:

When disconnecting the connector [1], release the lock by raising the latch and disconnect it.

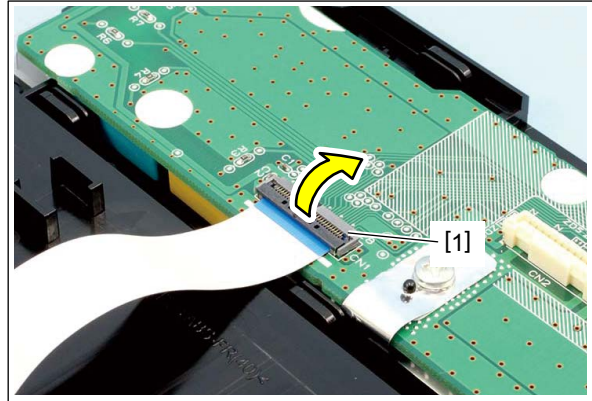

Fig. 4-38

(3) Remove 6 buttons [3].

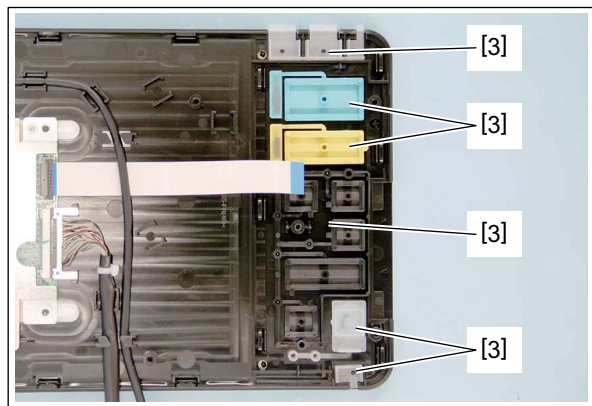

Fig. 4-39



Fig. 4-40

4.2.3 DSP board

- (1) Remove the control panel unit.
P. 4-13 "4.2.1 Control panel unit"
- (2) Remove 2 screws and take off the ground plate [1].
- (3) Remove the flat cable [2], [3], and [4].

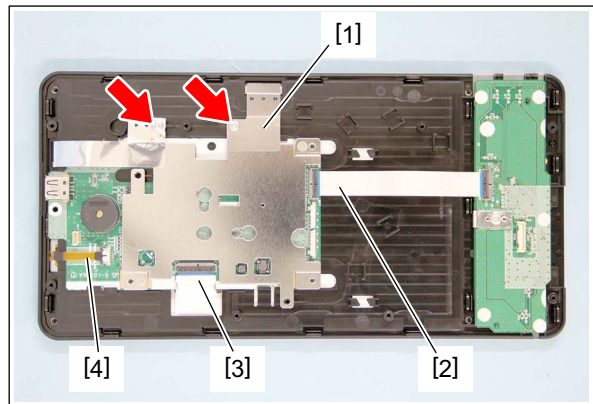

Fig. 4-41

Notes:

- When removing the flat cable [2], release the lock by raising the latch [5] and remove the flat cable.

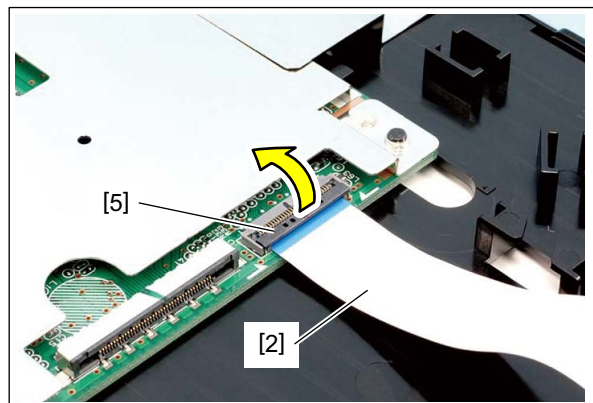

Fig. 4-42

- When removing the flat cable [3], release the lock by raising the latch [6] and remove the flat cable.

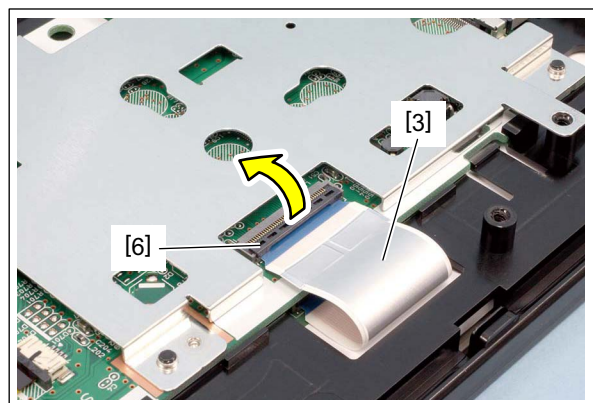

Fig. 4-43

- When removing the flat cable [4], release the lock by pulling the latch [7] toward the direction of the arrow shown in the figure, and then pulling it out.

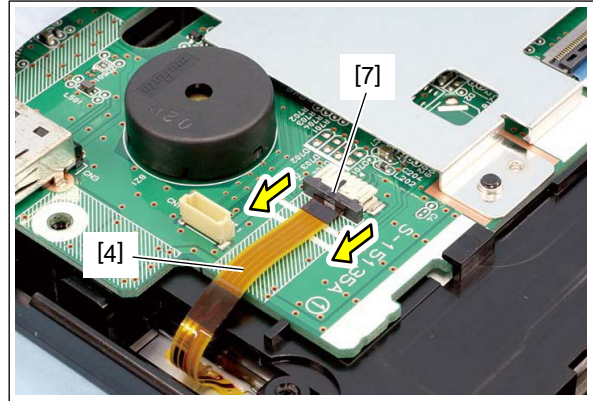

Fig. 4-44

- (4) Release 2 latches [8] and take off the DSP board [7] toward the direction of the arrow shown in the figure.

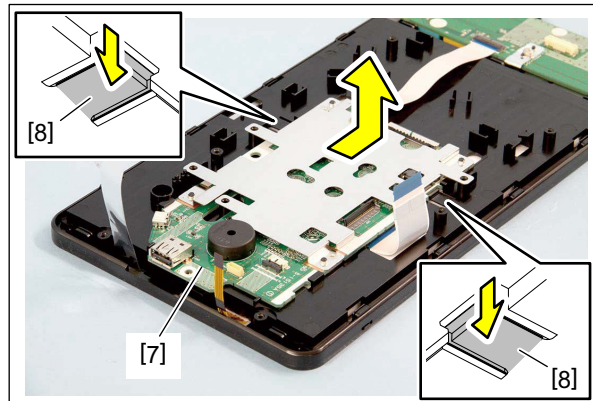

Fig. 4-45

Notes:

When the DSP board has been replaced, perform FS-08-9050 (Panel calibration execution) before normal start-up.

📖 P. 6-103 "6.13 Control Panel Calibration"

4.3 Scanner Unit

Notes:

- Since the scanner section is assembled with high precision, be sure not to perform any disassembling other than that instructed in the Service Manual.
- Precautions for the scanner fixing screws are shown below.
Since the scanner unit is adjusted, do not loosen the 5 scanner fixing screws shown in the figures below.

2 screws located on the right-hand surface of the equipment:

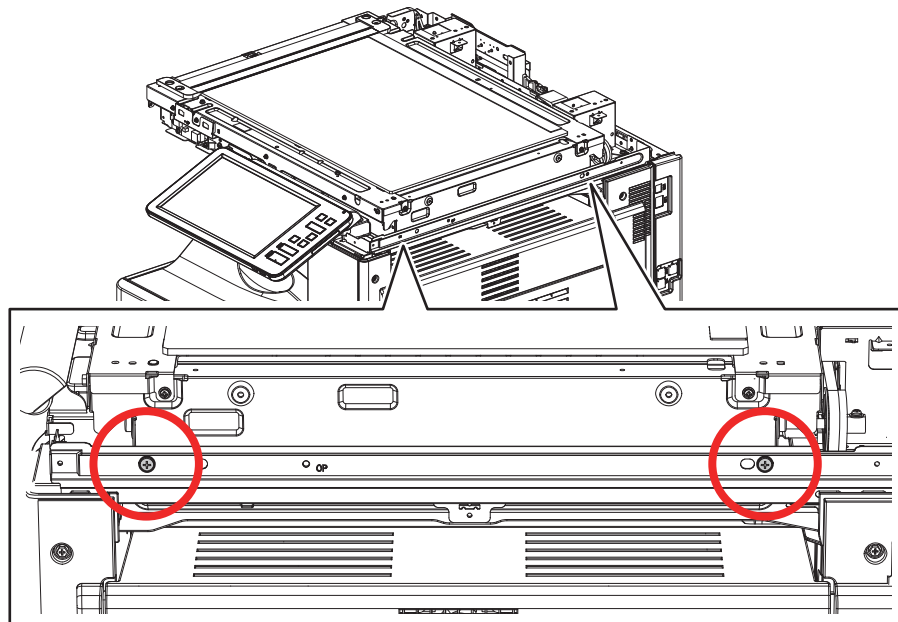

Fig. 4-46

3 screws located on the left-hand surface of the equipment:

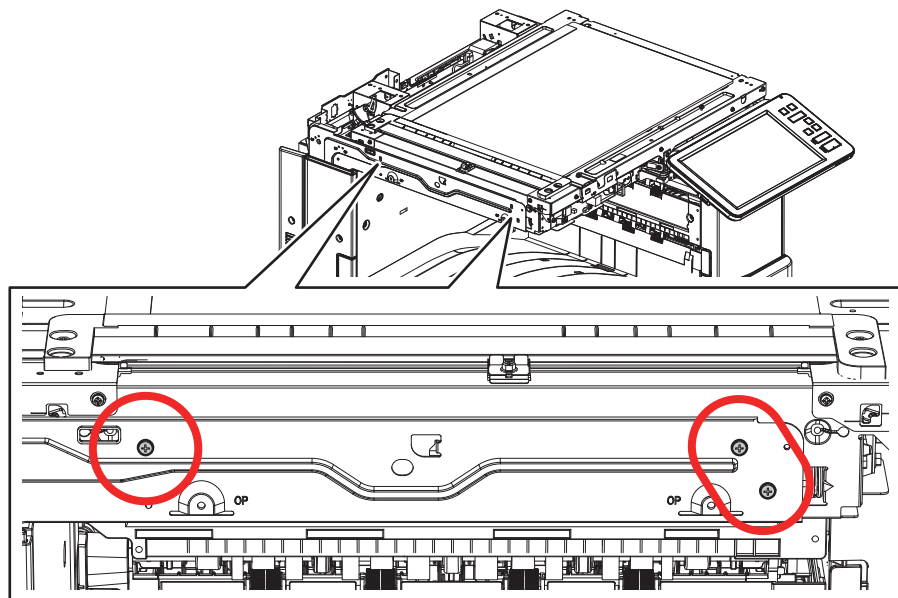

Fig. 4-47

Make sure the followings before loosening the scanner fixing screw, if it is unavoidable. Draw the mark-off lines [1] aligning with the edge of the hole on the rear side of the surface.

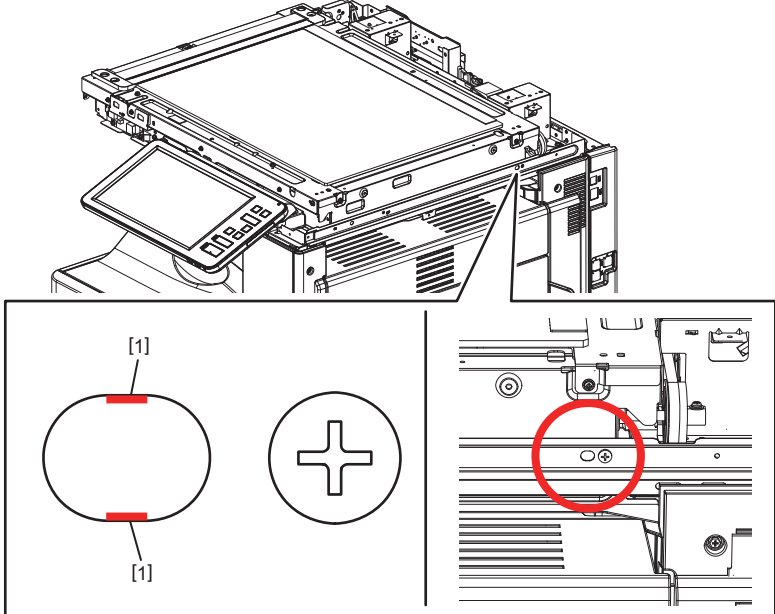

Fig. 4-48

Draw a mark-off line [2] on the edge of the front side frame on the left-hand surface.

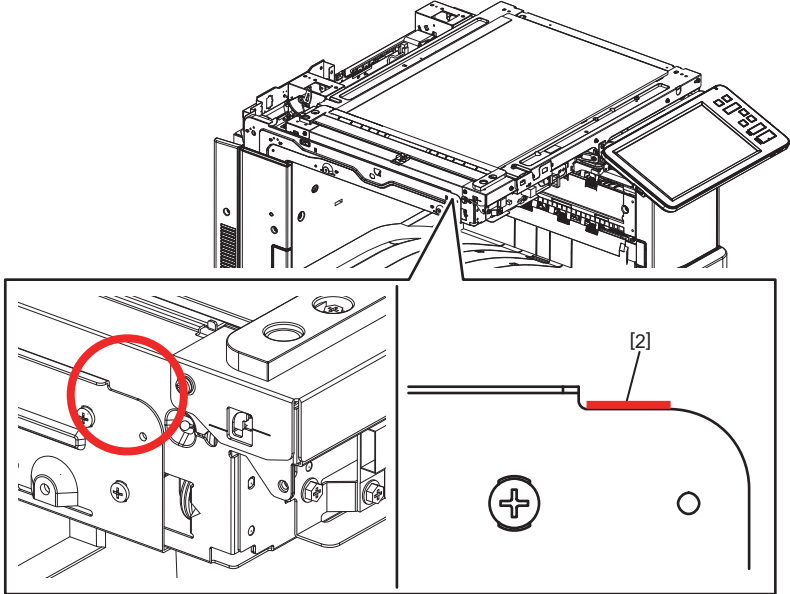

Fig. 4-49

Draw a mark-off line [3] on the edge of the rear side frame on the left-hand surface.

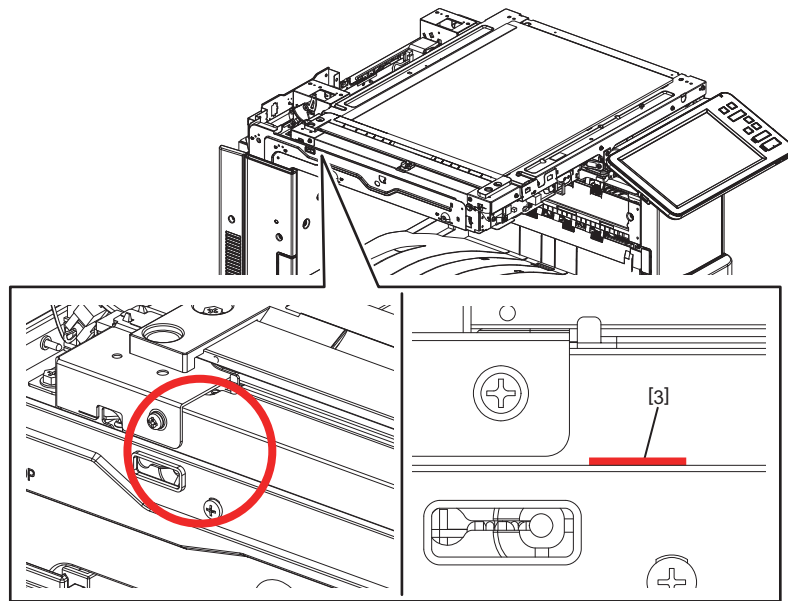

Fig. 4-50

When tightening the scanner fixing screws, align the scanner unit [4] with each mark-off line. Be sure to install the scanner unit [4] in the same position in which it was removed. In addition, the rear left/right side of the scanner unit [4] touches the DF bracket [5] and [6].

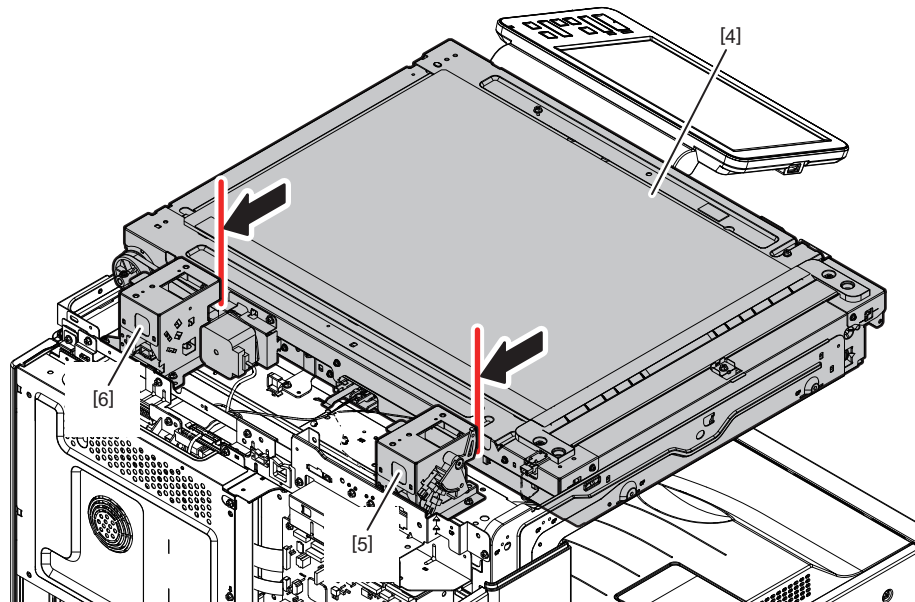

Fig. 4-51

If image distortion occurs after tightening the scanner fixing screws, adjust the image distortion according to the following procedure:

- 1. Loosen the 3 screws on the left-hand surface.
- 2. Move the front left side of the scanner unit up and down.

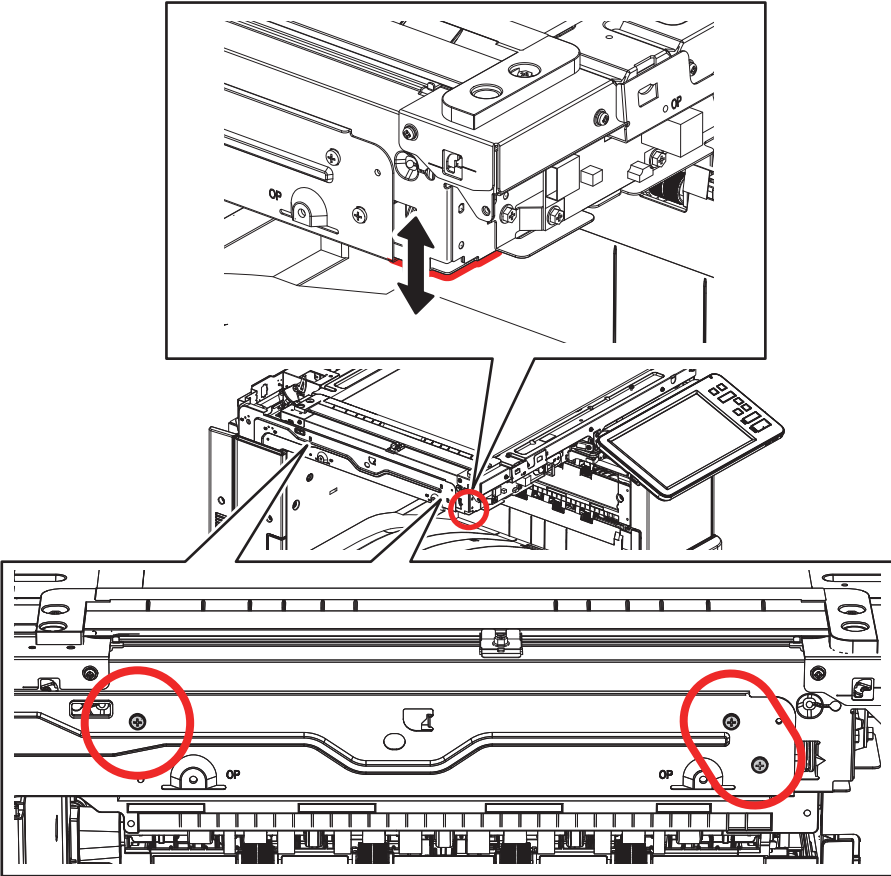



Fig. 4-52

4.3.1 Original glass

[A] Removal of the original glass

- (1) Remove the right top cover.
 P. 4-4 "4.1.9 Right top cover"
- (2) Remove 2 screws and take off the original glass [1] and ADF original glass [2].

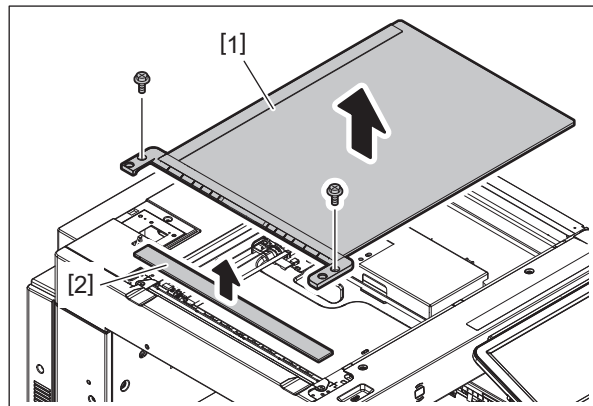

Fig. 4-53

Notes:

- Make sure that the ADF original glass [2] is securely inserted into the groove of the fixing part of the original glass [1].
- Securely insert 2 pins of the original glass [1] into the holes in the frame.

[B] Installation of the original glass

- (1) While taking care not to crush the cushion at the edge of the ADF original glass [2], slide it to the left side and then install the original glass [1].
- (2) Secure the original glass with 2 screws.

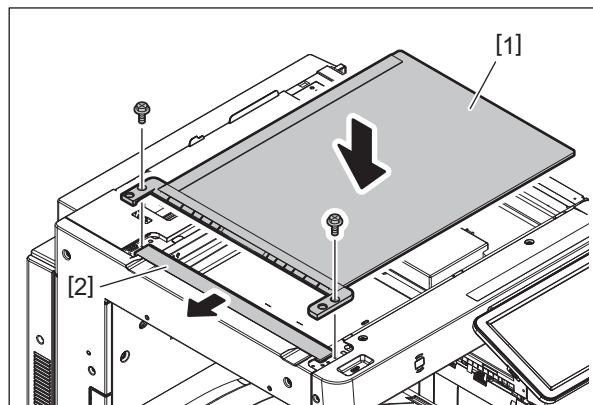

Fig. 4-54

[C] Replacement of the ADF original glass / original

- (1) Remove 2 screws and take off the left top cover [3].

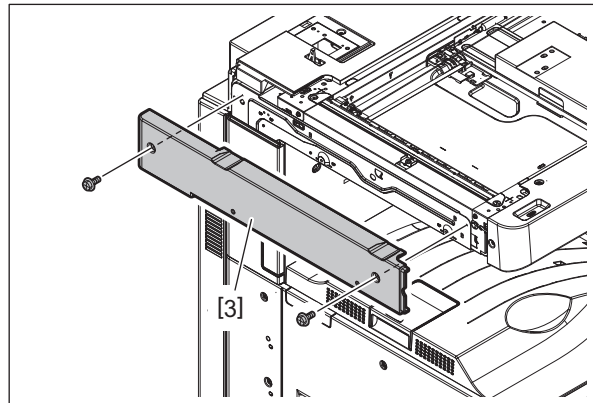

Fig. 4-55

- (2) Remove the film [5] and dispose of it.

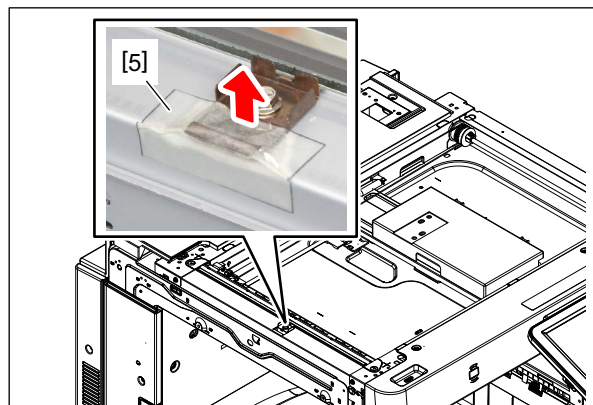

Fig. 4-56

- (3) Loosen the fixing screw of the leaf spring. Slide the leaf spring [4] by 1 mm in the direction indicated by arrow No. 2 and tighten the fixing screw temporarily.

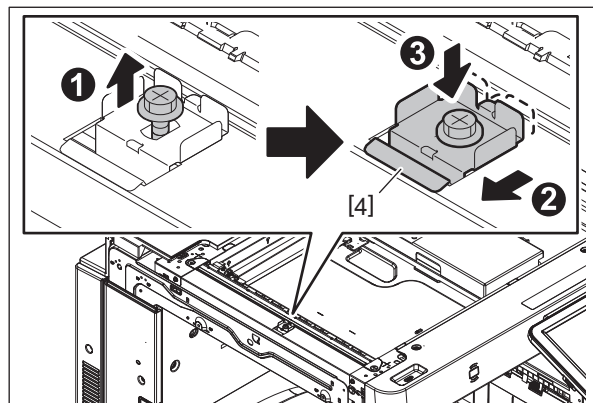

Fig. 4-57

- (4) Place the new ADF original glass [2] and set its position by aligning it to the mark-off lines.

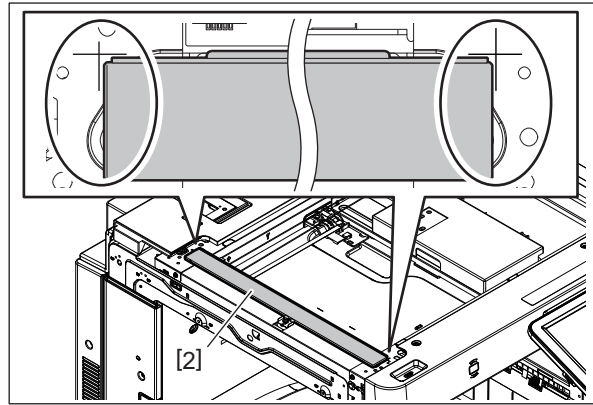

Fig. 4-58

- (5) Place the new original glass[1].

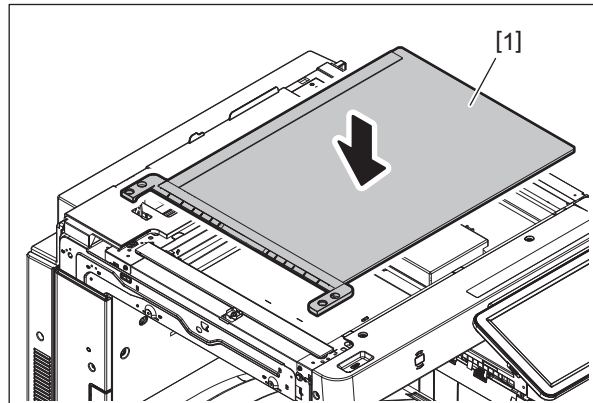

Fig. 4-59

Notes:

- Do not attach the fixing screws of the original glass in this step.
 - When installing the original glass, be careful not to crush the cushion added to the ADF original glass from above.
- (6) Loosen the fixing screw of the leaf spring. By means of the tension of the leaf spring, press the ADF original glass against the original glass. Tighten the fixing screw.

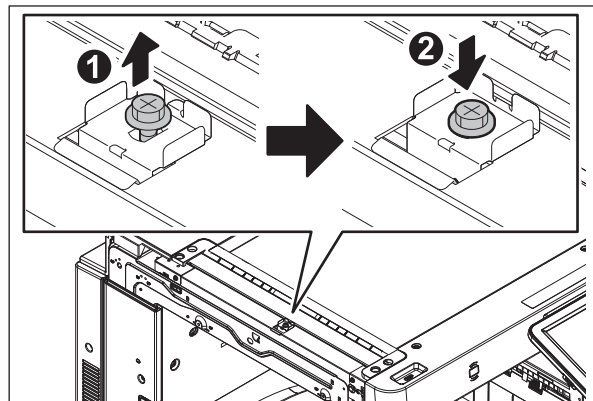

Fig. 4-60

(7) Attach a new film [6] on the scanner frame and the edges of the leaf spring [4].

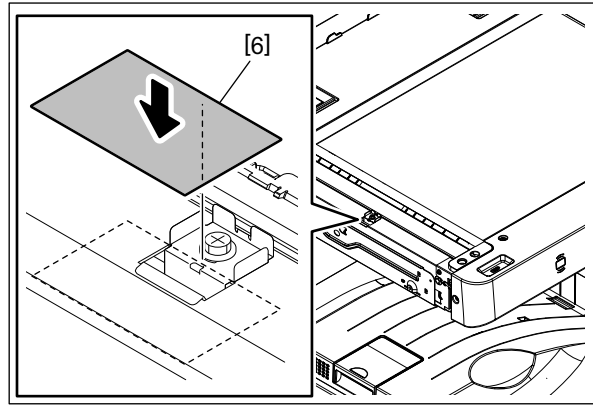

Fig. 4-61

Notes:

- Before attaching, clean the attachment surfaces with alcohol and wait until they have dried.
- Be sure to align the film [6] to the leaf spring [4] as shown in the figure.
- Be sure to attach the film [6] securely to the leaf spring [4].

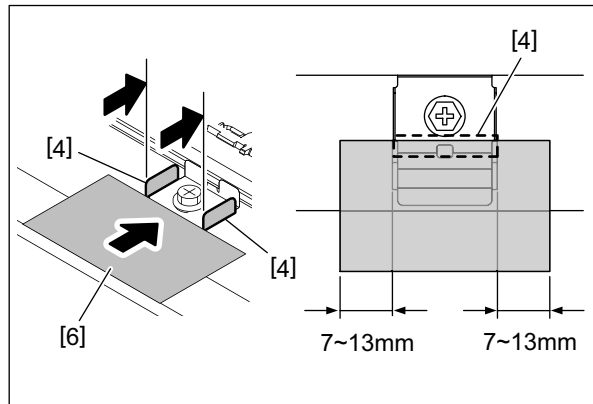

Fig. 4-62

(8) Fold the film [6] by aligning to the corner of the scanner frame and attach it. When the film is folded, lifting will be generated at the both edges on the folded portion. Therefore, in order to remove this lifting, pinch the folded portions of the film with your fingers so that its adhesive surfaces are stuck to each other.

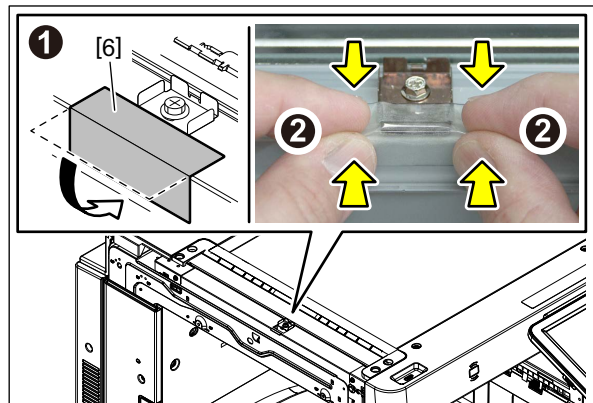

Fig. 4-63

Notes:

Confirm that the film is attached firmly.

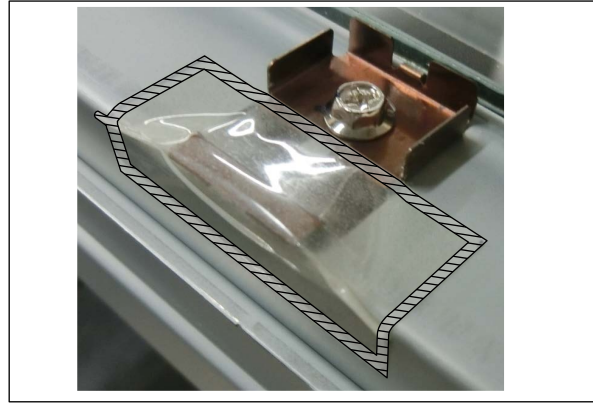

Fig. 4-64

- (9) Secure the original glass [1] with 2 screws.

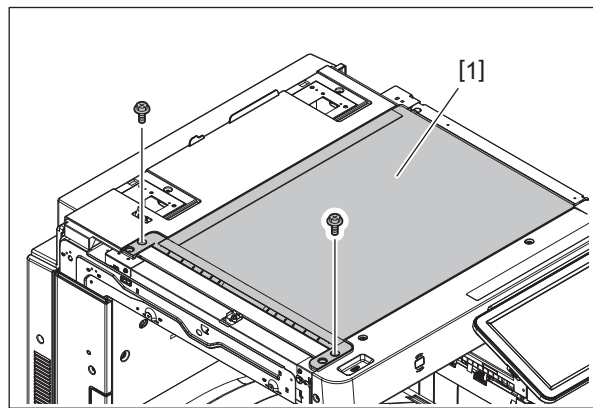

Fig. 4-65

- (10) Secure the left top cover [3] with 2 screws.

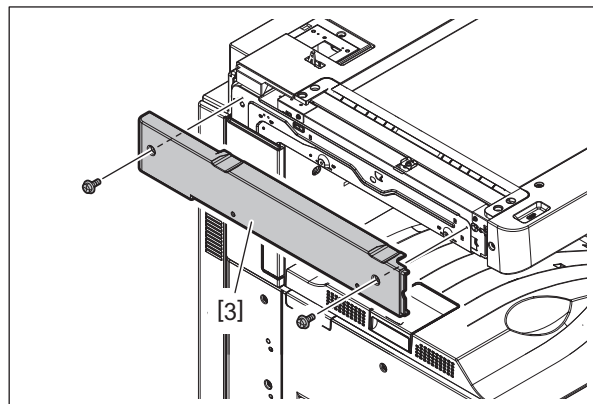

Fig. 4-66

4.3.2 Lens cover

- (1) Remove the original glass.
📖 P. 4-23 "4.3.1 Original glass"
- (2) Remove 1 screw and take off the lens cover [1] as shown in the figure.

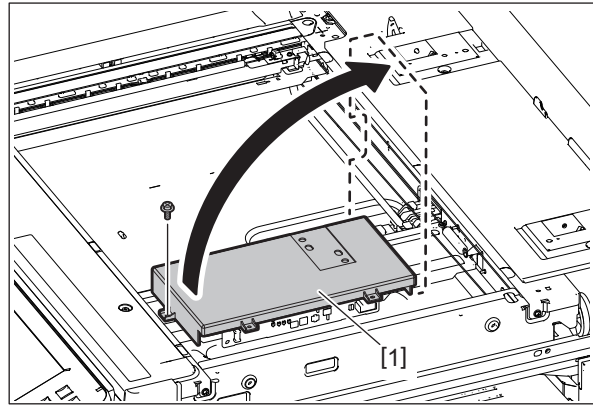

Fig. 4-67

4.3.3 Automatic original detection sensor-1 (S24)

- (1) Remove the lens cover.
📖 P. 4-28 "4.3.2 Lens cover"
- (2) Remove 1 screw and disconnect 1 connector [1], and then take off the automatic original detection sensor-1 [2].

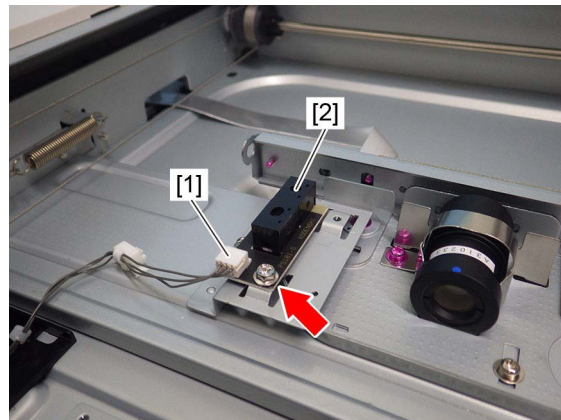



Fig. 4-68

4.3.4 Automatic original detection sensor-2 (S25)

- (1) Remove the lens cover.
 P. 4-28 "4.3.2 Lens cover"
- (2) Remove 1 screw and disconnect 1 connector [1], and then take off the automatic original detection sensor-2 [2].

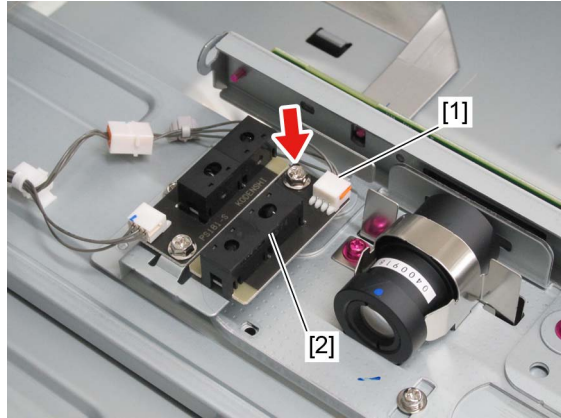

Fig. 4-69

4.3.5 Lens unit/CCD driving PC board

- (1) Remove 1 screw and take off the automatic original detection sensor with the bracket [1].

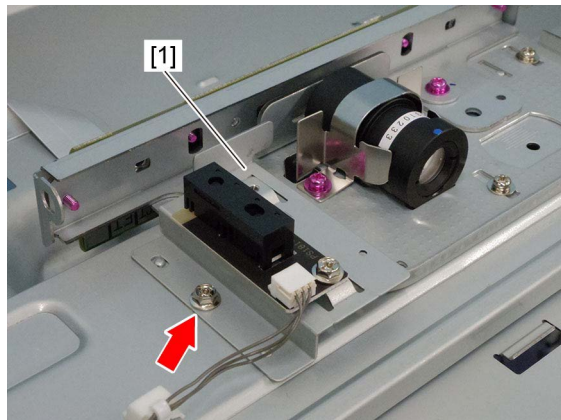

Fig. 4-70

- (2) Disconnect the HDMI cable [2].

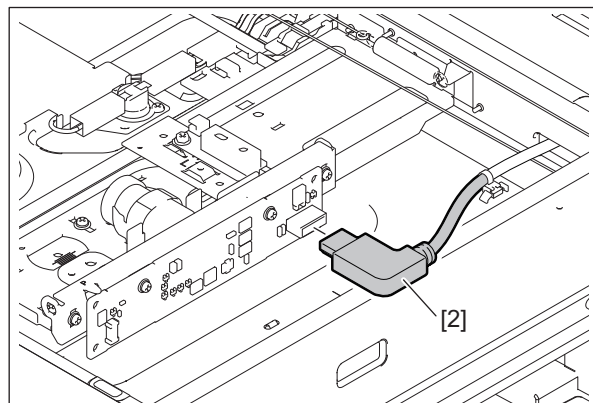

Fig. 4-71

(3) Remove 3 screws and take off the CCD lens unit [3].

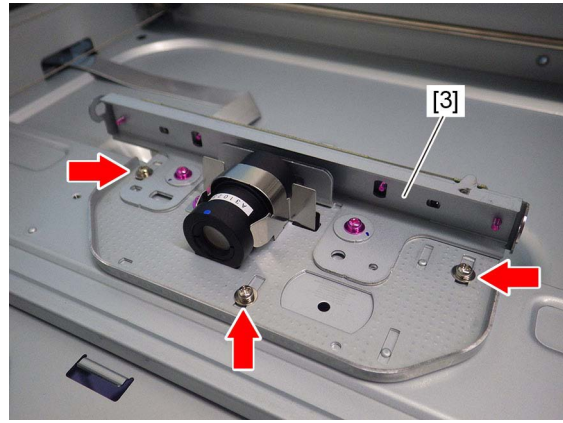

Fig. 4-72

Notes:

- The CCD lens unit is adjusted finely, so the re-adjustment or replacement of some parts are impossible in the field. The lens unit must be replaced on a unit basis.
- Handle the lens unit with care. Do not hold the adjustment unit or lens.
- Count the number of lines [4] and write it down for later reference before removing the CCD lens unit. When installing the CCD lens unit, the same number of lines needs to be visible.

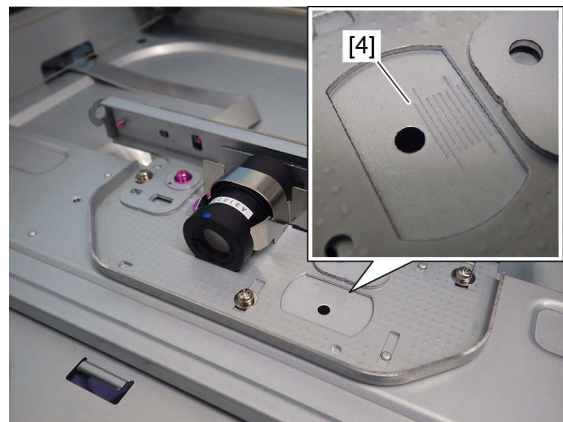

Fig. 4-73

- When replacing the lens unit, do not touch the screws (7 places).

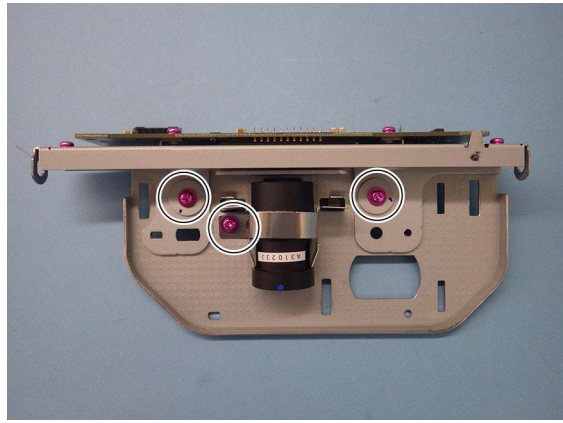

Fig. 4-74

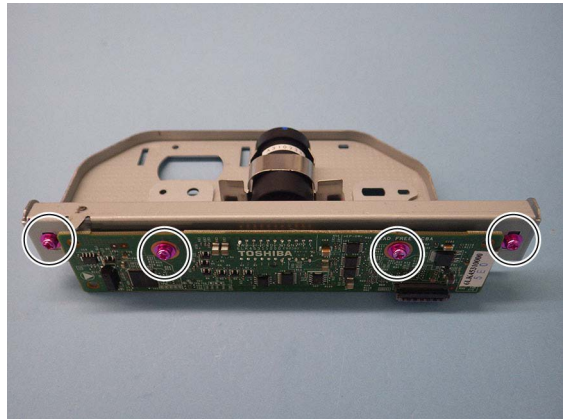

Fig. 4-75

4.3.6 Carriage home position sensor (S23)

- (1) Remove the original glass.
 ⓘ P. 4-23 "4.3.1 Original glass"
- (2) Remove the top rear cover.
 ⓘ P. 4-8 "4.1.15 Top rear cover"
- (3) Disconnect the 1 connector [1], and release 3 latches and remove carriage home position sensor [2].

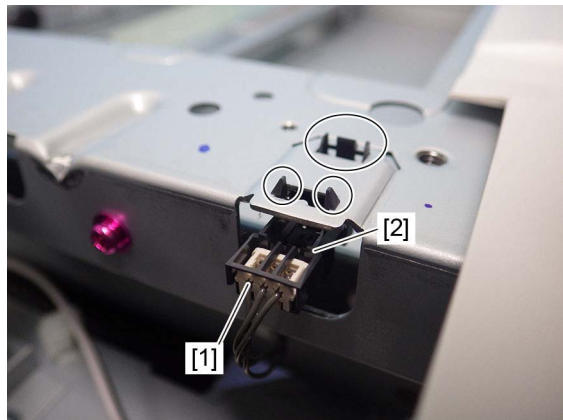

Fig. 4-76

4.3.7 Exposure lamp (EXP)

- (1) Remove the original glass and front top cover.
📖 P. 4-23 "4.3.1 Original glass"
📖 P. 4-6 "4.1.12 Front top cover"
- (2) Move carriage-1 [1] to a place where you can see the exposure lamp mounting screw through the frame hole.

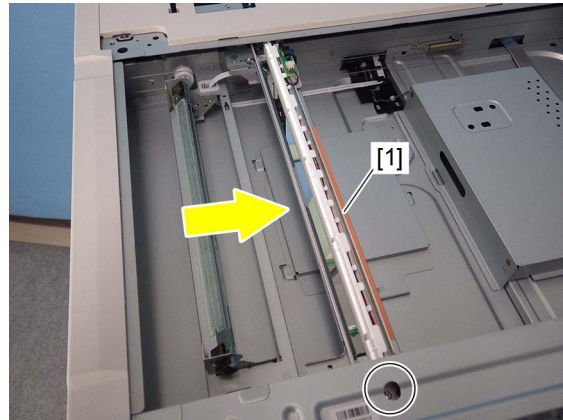

Fig. 4-77

Notes:

To move the carriage, manually rotate the drive pulley.



Fig. 4-78

- (3) Remove 1 screw.

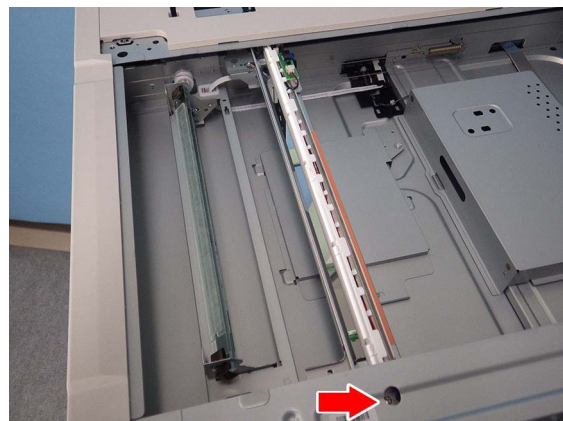

Fig. 4-79

- (4) Disconnect the connector [3] by sliding the front side of the exposure lamp [2] toward the direction of the arrow shown in the figure. Remove the exposure lamp [2] from the front side.

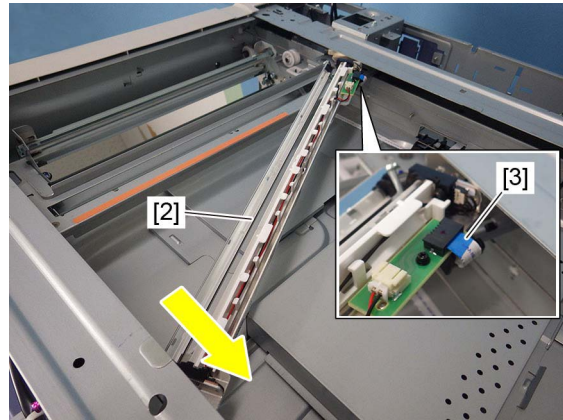

Fig. 4-80

Notes:

After replacing the exposure lamp, be sure to perform FS-05-3270.

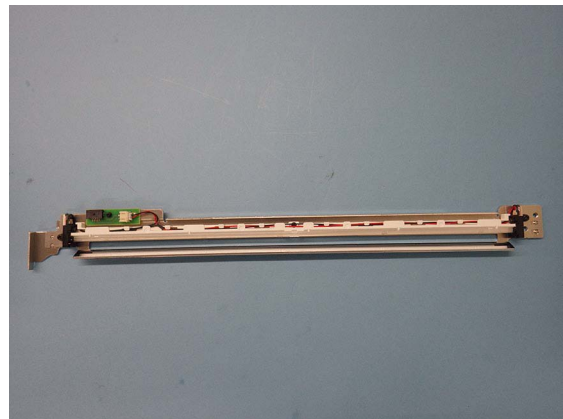

Fig. 4-81

4.3.8 Scan motor (M1)

- (1) Remove the top rear cover.
P. 4-8 "4.1.15 Top rear cover"
- (2) Remove the rear cover.
P. 4-10 "4.1.17 Rear cover"
- (3) Disconnect 1 connector.

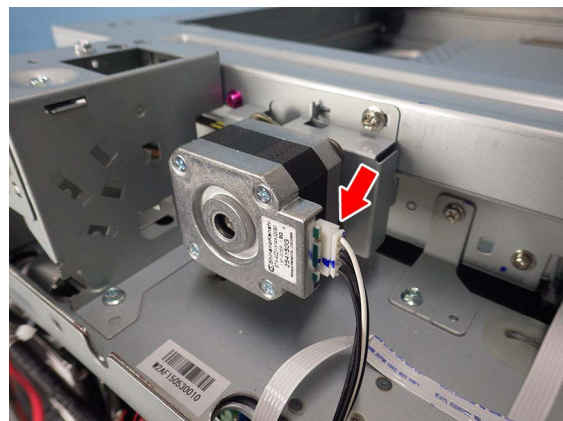

Fig. 4-82

(4) Remove 2 screws and take off the scan motor assembly [1].

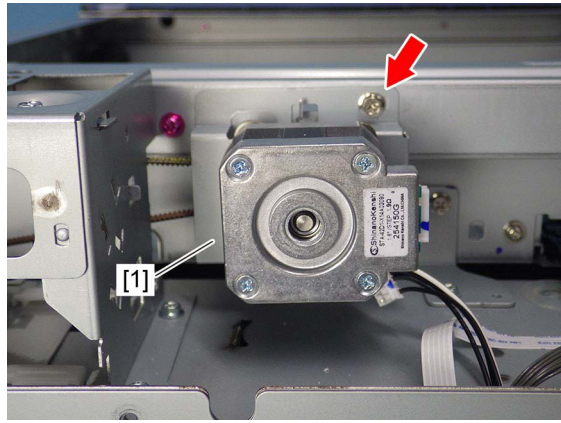

Fig. 4-83

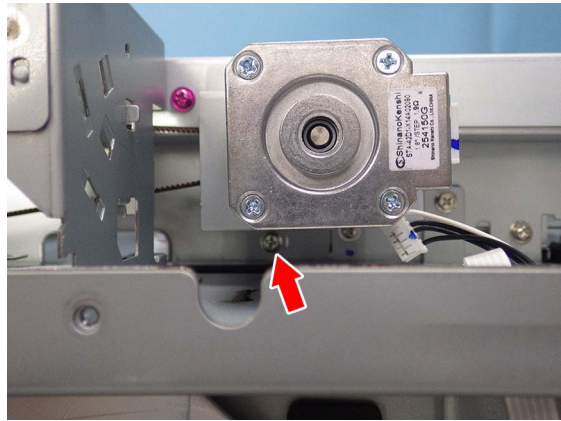



Fig. 4-84

Notes:

When installing the scan motor, use the belt tension jig.

 P. 6-87 "6.6.3 Belt tension adjustment of the scan motor"

(5) Remove 2 screws and take off the scan motor [2].

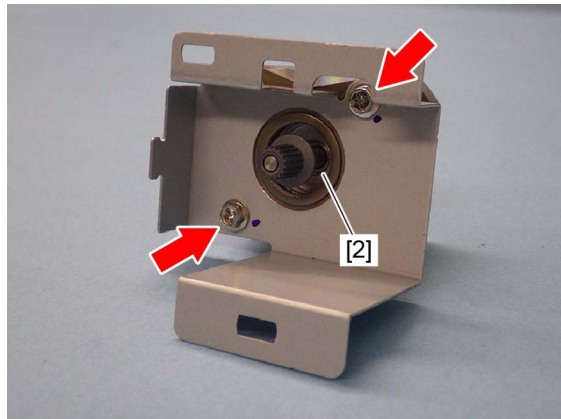



Fig. 4-85

4.3.9 Platen sensor (S21, S22)

- (1) Remove the top rear cover.
 P. 4-8 "4.1.15 Top rear cover"
- (2) Remove 5 screws.

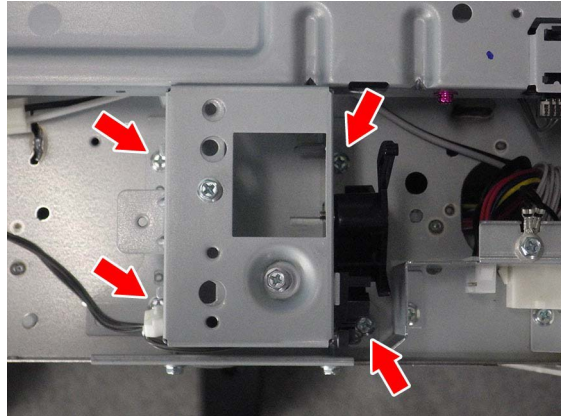

Fig. 4-86

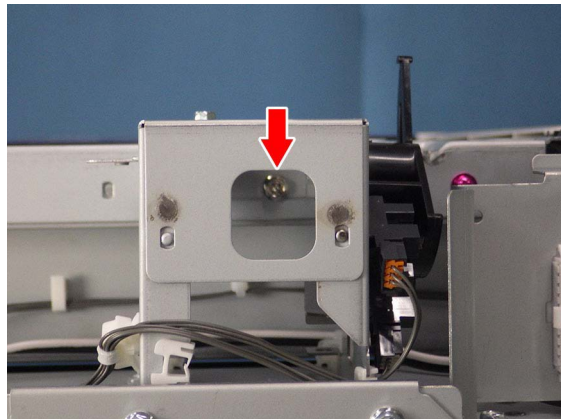

Fig. 4-87

- (3) Disconnect 2 connectors and take off the platen sensor assembly [1].

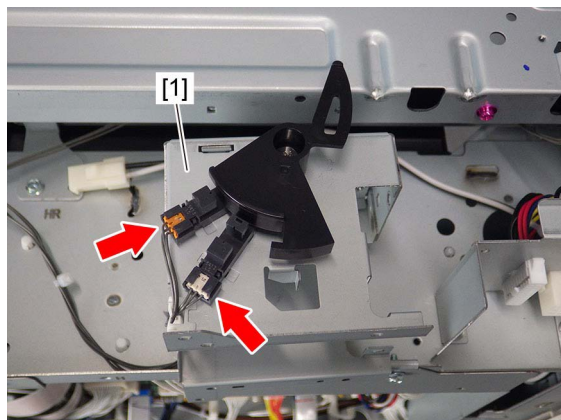

Fig. 4-88

Notes:

When installing, be careful not to connect each different connector.

- (4) Release each 3 latch and remove the platen sensor-1 [2] and -2 [3].

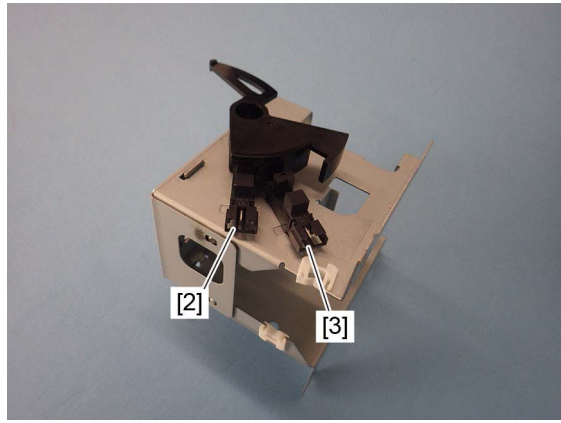

Fig. 4-89

4.3.10 Carriage-1

- (1) Remove the original glass.
P. 4-23 "4.3.1 Original glass"
- (2) Remove the top rear cover.
P. 4-8 "4.1.15 Top rear cover"
- (3) Remove the front top cover.
P. 4-6 "4.1.12 Front top cover"
- (4) Move carriage-1 [1] to the leftmost side, and make sure that the screws on carriage-1 are showing.

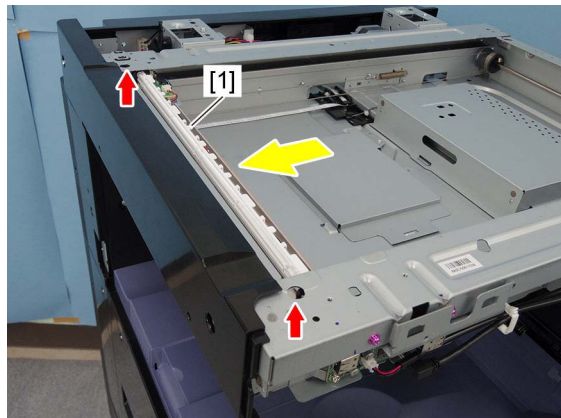

Fig. 4-90

Notes:

To move the carriage, manually rotate the drive pulley.

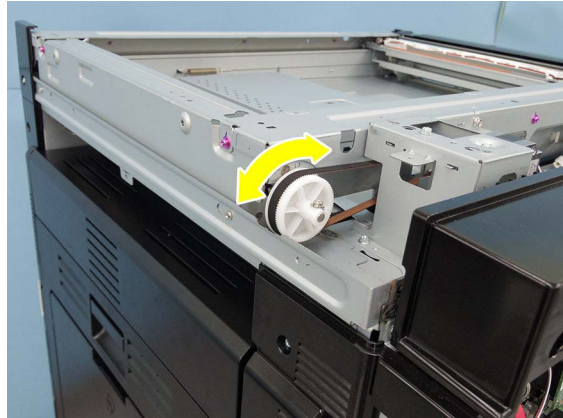

Fig. 4-91

- (5) Remove 2 screws.



Fig. 4-92

- (6) Slide the front of the carriage-1 [1] toward the direction of the arrow shown in the figure, while trying not to touch the mirror [2].

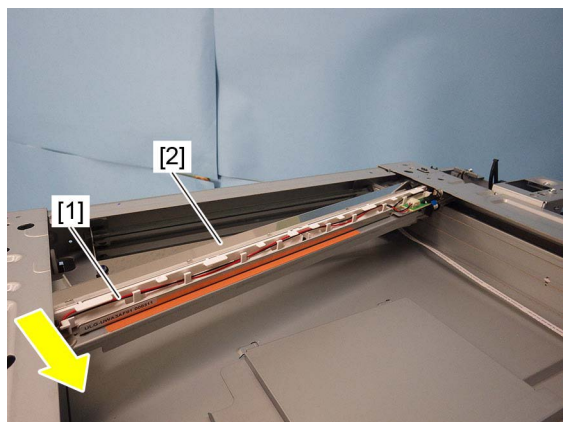

Fig. 4-93

(7) Release the harness from the harness guides [3] and disconnect the connector [4].

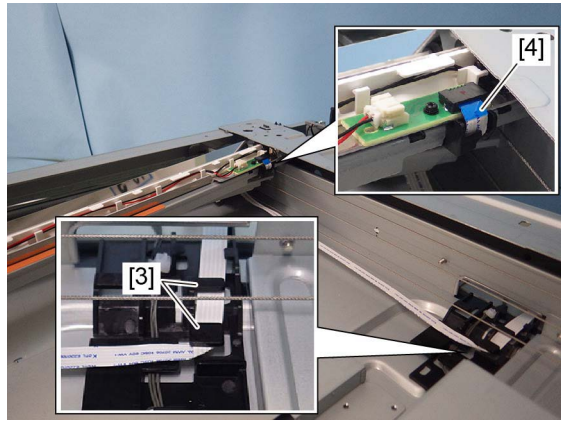

Fig. 4-94

(8) Remove the carriage-1 [1].

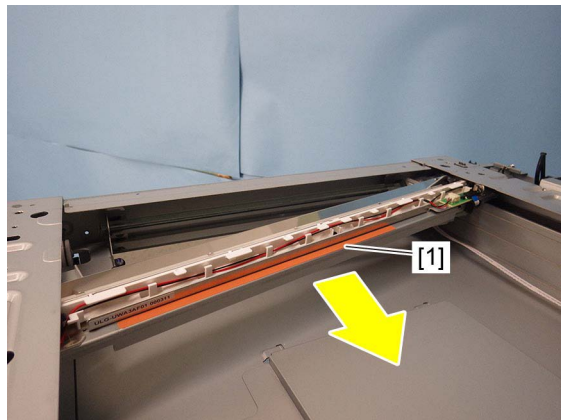

Fig. 4-95

Notes:

- After connecting the exposure lamp harness, move carriage-1 to the leftmost side and check the lamp harness for any twists.
- When installing carriage-1, make sure that the wires are placed on the front and rear notches of carriage-1 and fix them with screws.



Fig. 4-96



Fig. 4-97

4.3.11 Carriage wire, carriage-2

Notes:

When replacing the carriage wire with a new one, replace the front and rear at the same time.
 When replacing the carriage wire with a new one, set the value of FS-08-6123 to "0".

[A] Carriage wire, carriage-2

- (1) Remove carriage-1.
 📖 P. 4-36 "4.3.10 Carriage-1"
- (2) Move carriage-2 to the center.
- (3) Attach the wire holder jig [2] to the wire pulley [1] to prevent the wire from coming loose.

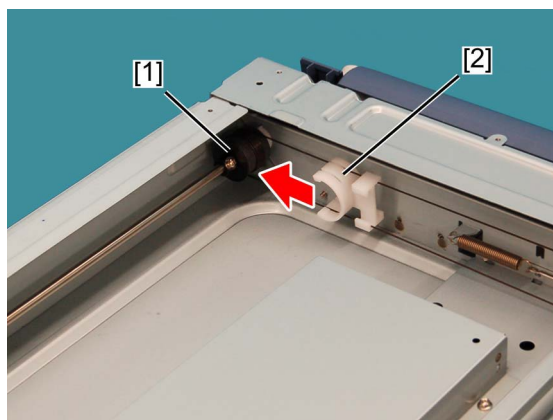

Fig. 4-98

Notes:

When attaching the wire holder jig [2], make sure that the wire has not shifted or become loose. The wire should come out of the slot of the wire holder jig [2] and be passed under the jig arm [3]. When installing the wire holder jig, be careful of the orientation.

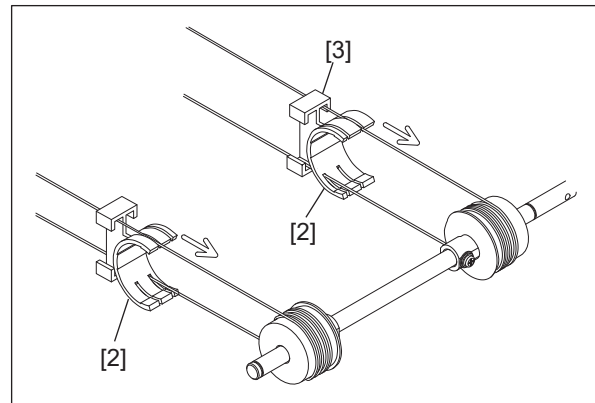

Fig. 4-99

- (4) Remove the tension springs [4] in the front and rear sides.
- (5) Remove the carriage wire [5].

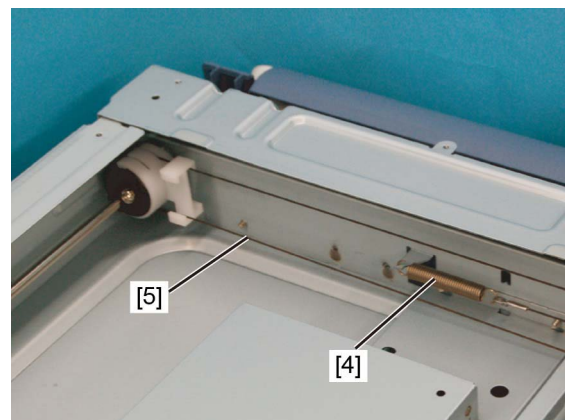

Fig. 4-100

- (6) Rotate carriage-2 [6] in the direction shown in the figure, while trying not to touch the mirror. Then remove carriage-2 [6].

Notes:

Replace mirror-2 and -3 together with carriage-2 [6]. Do not remove mirror-2 and -3.

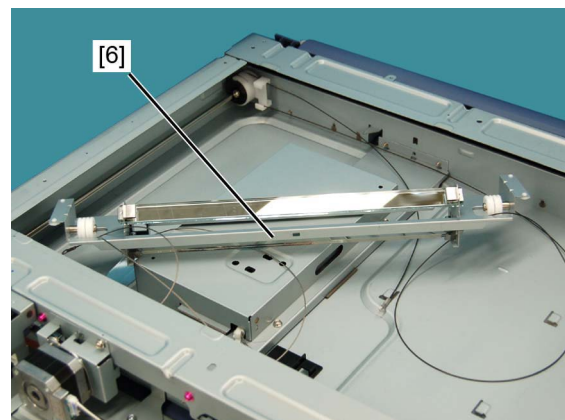

Fig. 4-101

[B] Installing the carriage wire

(1) As shown in the figure, replace the carriage wire and install a new wire.

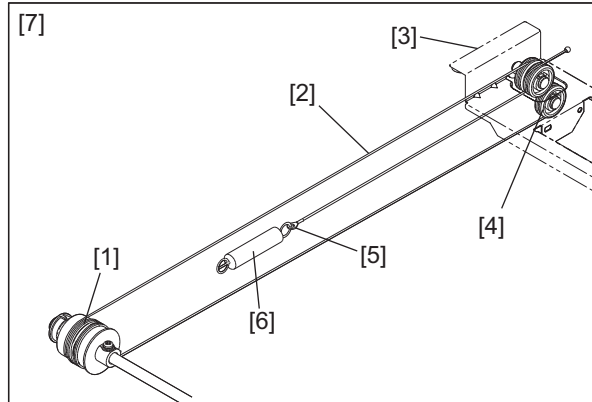

Fig. 4-102

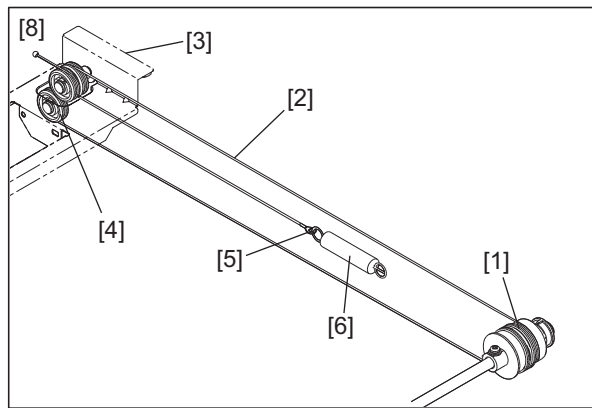

Fig. 4-103

- [1] Wire pulley
- [2] Carriage wire
- [3] Carriage-2
- [4] Idler pulley
- [5] Hook
- [6] Tension spring
- [7] Front side
- [8] Rear side

Notes:

It is not necessary to adjust the carriage wire tension since a certain tension is applied to the carriage wires through the tension springs. Make sure the tension applied to the wire is normal.

[C] Winding on the wire pulley

- (1) Pull the $\varnothing 3$ ball terminal [1] located at the center of the wire into a hole on the wire pulley. One end of the wire with the hook [2] attached comes to the outside.
 - (2) Wind the wires around the wire pulleys of the front side [3] and rear side [4]. The number of turns to be wound are as follows: 3 [5] toward the opposite side (outside) of the pulley boss, and 3 [6] toward the pulley boss side (inside).
- [7] Black
[8] Silver

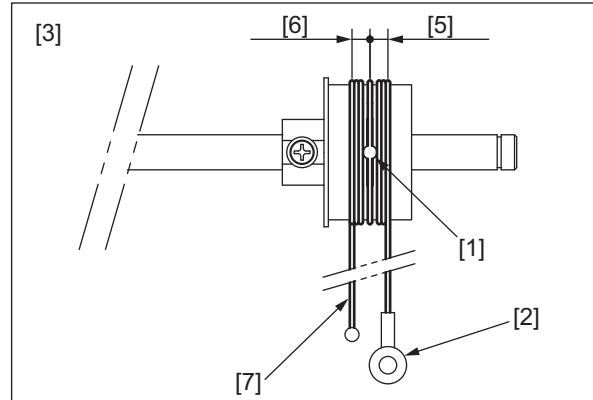

Fig. 4-104

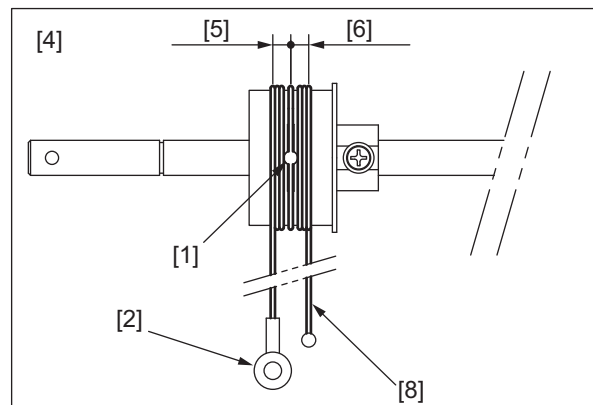

Fig. 4-105

Notes:

When winding the wire onto the pulley, be sure to note the following.

- Do not twist the wire.
- Wind the wires tightly so that they are in complete contact with the surface of the pulleys.
- Each turn should be pushed against the previously wound turn so that there is no space between them.

- (3) After winding the wires around the pulleys, attach the wire holder jigs to prevent the wire from coming loose.

Notes:

- When attaching the wire holder jig [9], make sure that the wire has not shifted or become loose.
- The wire should come out of the slot of the wire holder jig [9] and be passed under the jig arm [10].
- When installing the wire holder jig, be careful of the orientation.

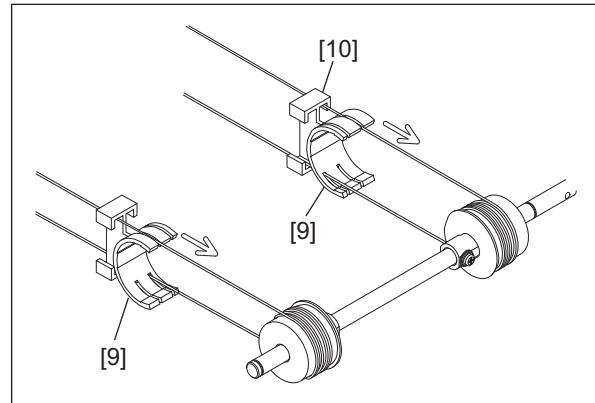

Fig. 4-106

4.3.12 Scanner damp heater (DH1)

- (1) Remove the rear cover.
P. 4-10 “4.1.17 Rear cover”
- (2) Remove the original glass.
P. 4-23 “4.3.1 Original glass”
- (3) Disconnect 1 connector.

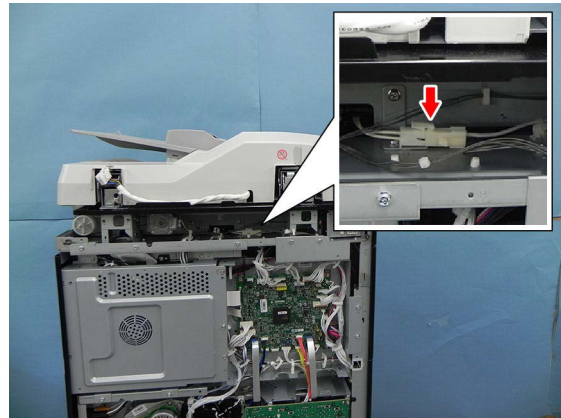

Fig. 4-107

(4) Remove the scanner damp heater [1].

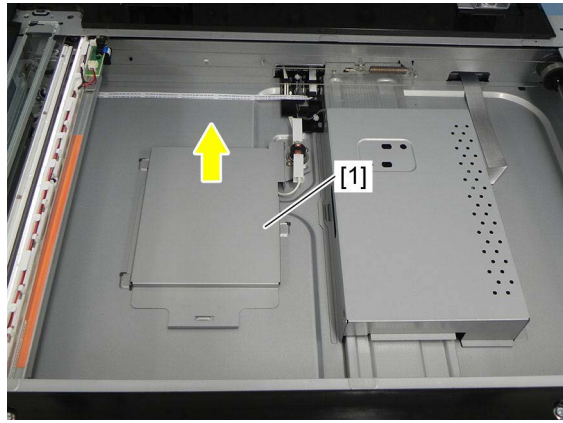

Fig. 4-108

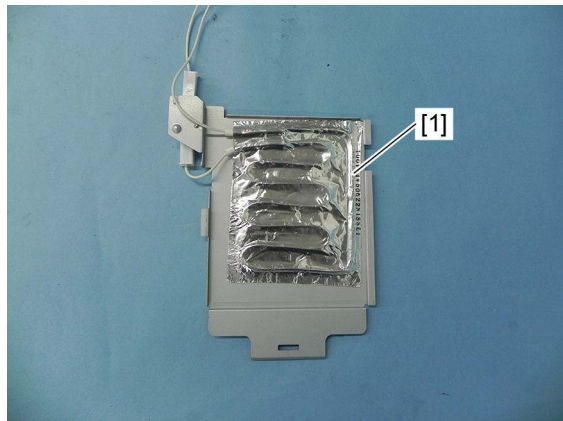

Fig. 4-109

Notes:

- Be sure that the fasten terminal of the thermostat is connected securely.
- Be sure that the thermostat is attached to the plate.

4.4 Writing Section

4.4.1 Laser optical unit cooling fan unit

- (1) Remove the left cover.
P. 4-1 “4.1.2 Left cover”
- (2) Disconnect 1 connector [1]. Push the lever [2] to release the latch and remove the laser optical unit cooling fan unit [3].

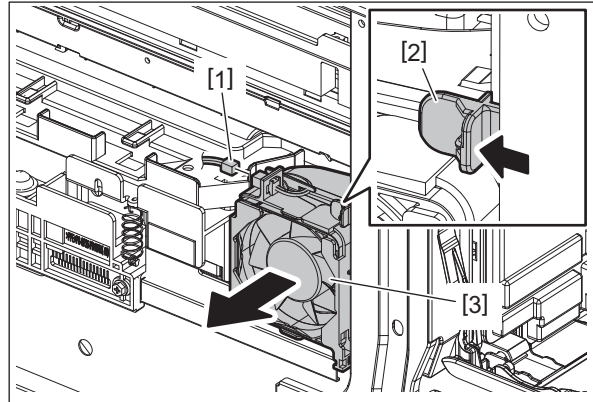

Fig. 4-110

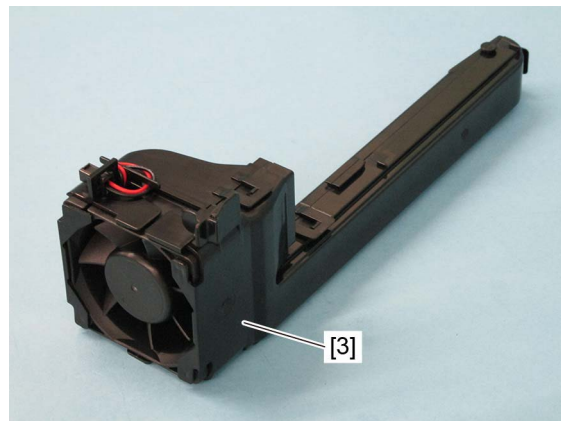

Fig. 4-111

4.4.2 Laser optical unit cooling fan

- (1) Remove the laser optical unit cooling fan unit.
P. 4-45 "4.4.1 Laser optical unit cooling fan unit"
- (2) Release 6 latches [1]. While removing 2 bosses [2], take off the LSU duct F [3].

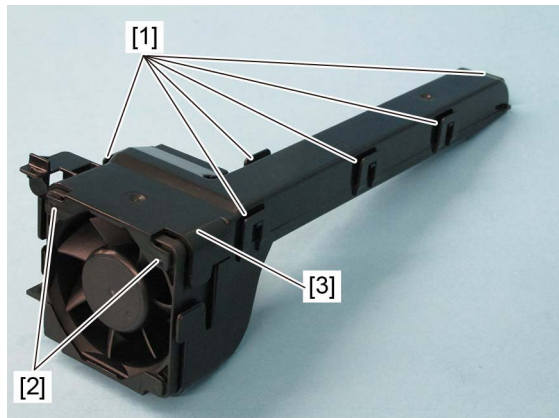

Fig. 4-112

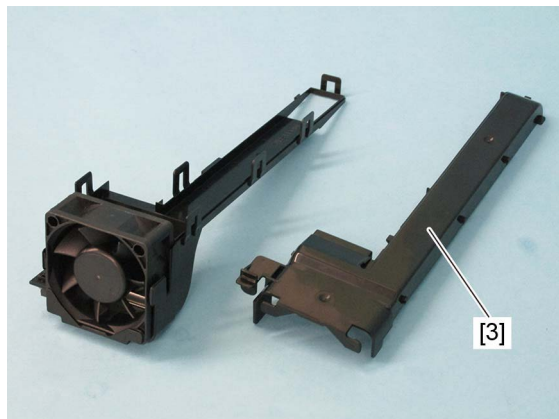

Fig. 4-113

- (3) Release 2 latches and disconnect the connector [4] from the LSU duct R [5]. Release the harness [6] from the LSU duct R [5].

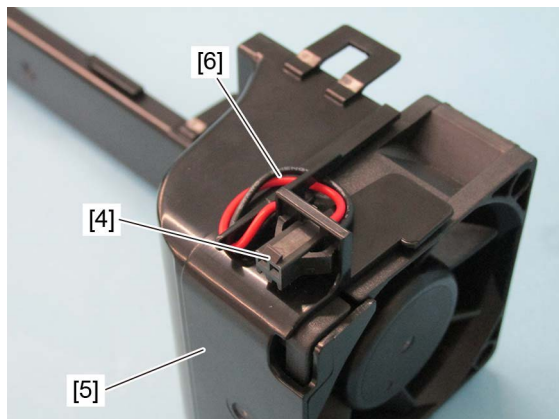

Fig. 4-114

- (4) Take off the laser optical unit cooling fan [7] from the LSU duct R [5].

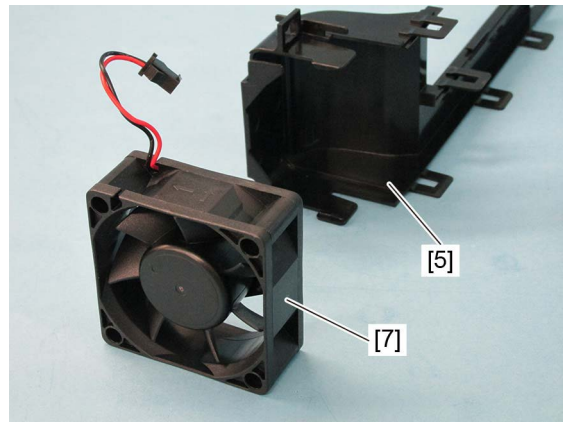

Fig. 4-115

4.4.3 Laser optical unit

- (1) Remove the laser optical unit cooling fan unit.
P. 4-45 "4.4.1 Laser optical unit cooling fan unit"
(2) Remove the flat cables [1].

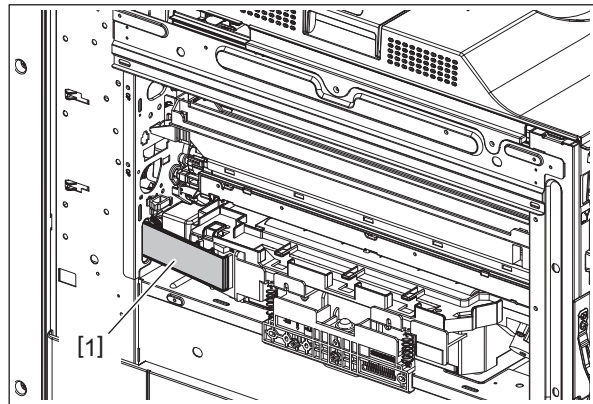

Fig. 4-116

Notes:

- When installing or removing, be careful not to damage the contact point of the flat cables.
- When installing, be sure to connect the connectors of the flat cables in the correct position.
- 45ppm/50ppm: 3 flat cables

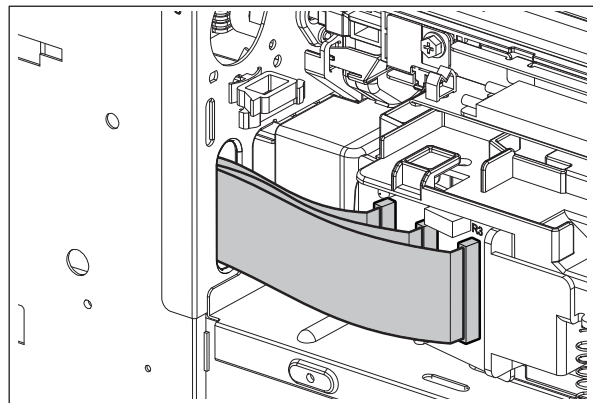

Fig. 4-117

- 25ppm/30ppm/35ppm: 2 flat cables

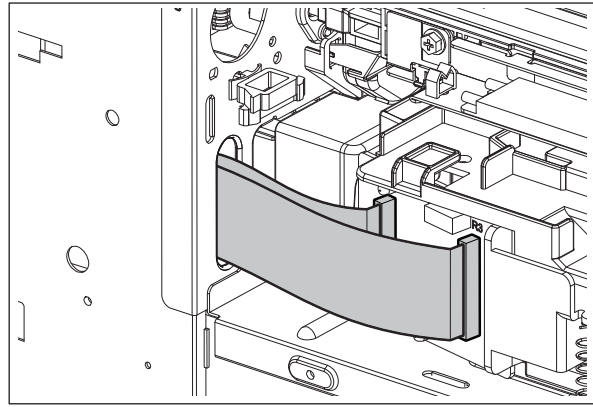

Fig. 4-118

- Be sure to confirm the position of the fixing screw of the laser optical unit.
- When the laser optical unit is installed, be sure to secure the screw in the same position in which it was removed.
- When the screw position is A: Adjustment of image tilting at the leading edge is not carried out (default).
- When the screw position is B: Adjustment of image tilting at the leading edge is carried out by +0.5 mm.
- When the screw position is C: Adjustment of image tilting at the leading edge is carried out by -0.5 mm.
- When the screw position is D: Adjustment of image tilting at the leading edge is carried out. In this case, confirm the position of the scale [2].

📖 P. 6-88 “6.7.2 Adjustment of image tilting at the leading edge”

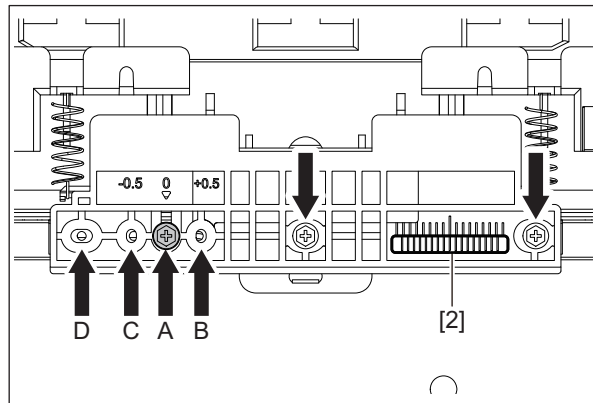

Fig. 4-119

- (3) Release the harness clamp [3] and disconnect 1 connector [4].

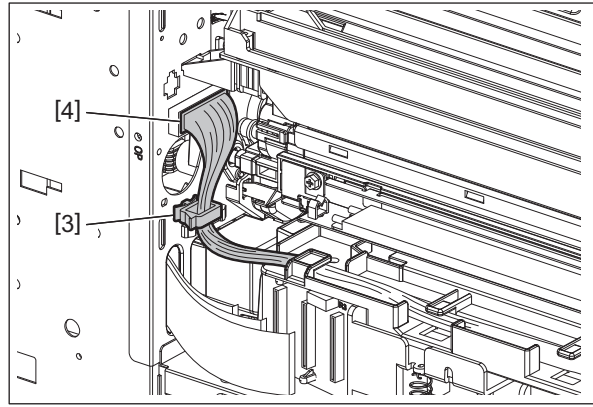

Fig. 4-120

- (4) Remove 3 screws.

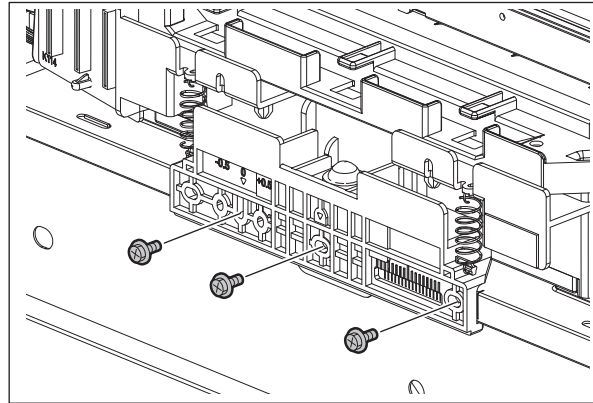

Fig. 4-121

- (5) Take off the LSU holder [5] from the frame.

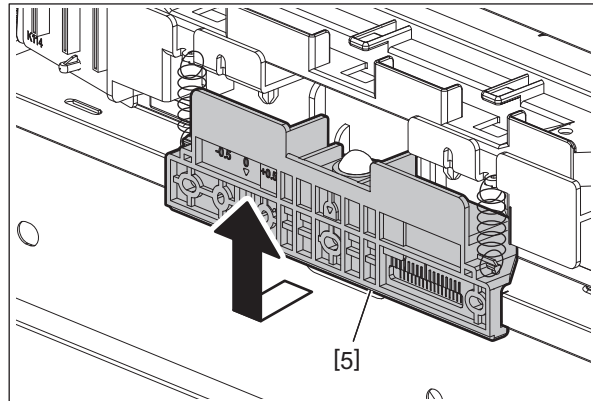

Fig. 4-122

Remarks:

LSU holder removed state

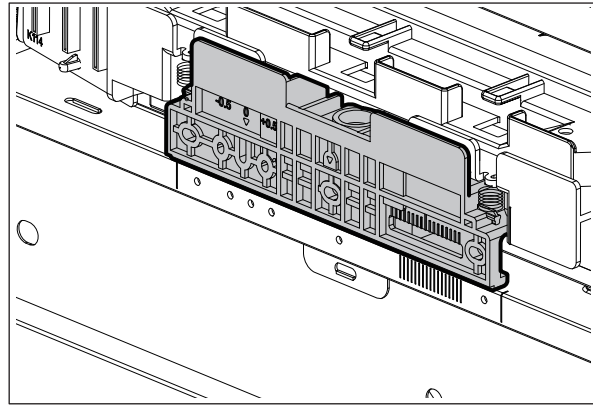

Fig. 4-123

- (6) While holding the handles [6] with your fingers, slowly pull out the laser optical unit [7] to the left.

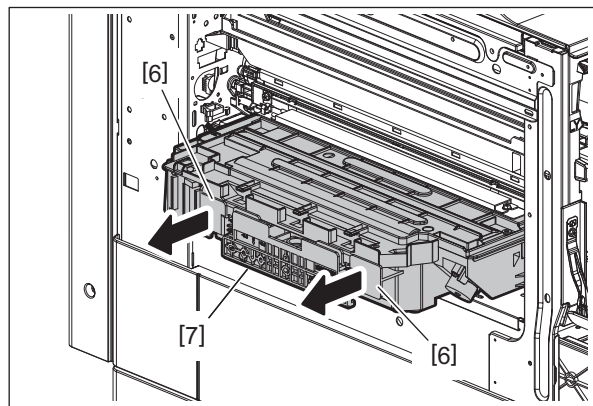

Fig. 4-124

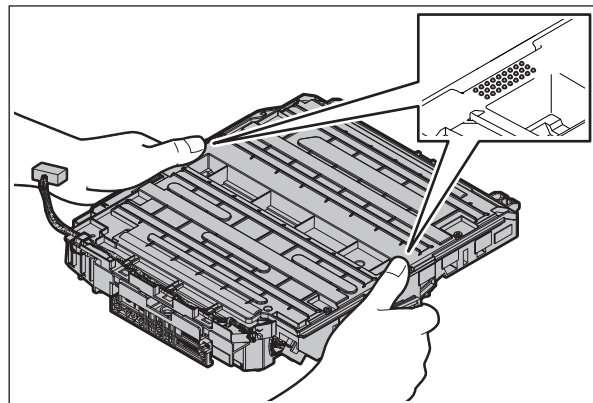

Fig. 4-125

Notes:

- When installing or removing, be careful not to damage the contact point of the flat cables.
- Do not touch the board with your bare hands since that is static-sensitive.
- Be sure to hold the center of the laser optical unit to do so.
- Do not leave fingerprints or stain on the slit glass of the laser optical unit.
- Pay close attention not to make an impact or vibration on the laser optical unit because it is a precise apparatus.
- Do not disassemble the laser optical unit in the field because it is precisely adjusted and very sensitive to dust and stain.
- Do not touch the LDR board directly with bare hands.

(7) Take off the laser optical unit [7].

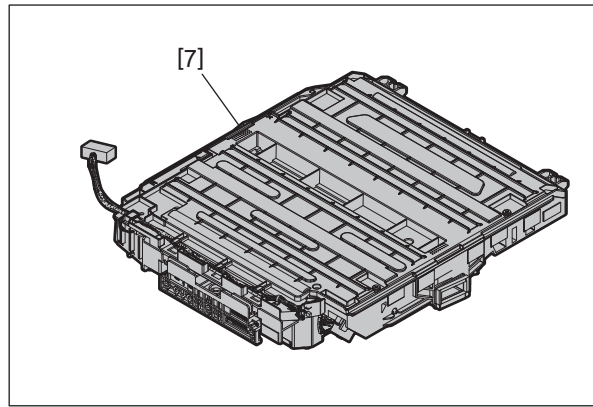

Fig. 4-126

Notes:

- When the laser optical unit is replaced, start the equipment in the 05 ADJUSTMENT MODE and perform the code FS-05-4721 before the normal start-up. After replacing the laser optical unit, be sure to perform FS-05-4719.
- When installing, be sure to place the flat cables inside the 6 cable holders [8].

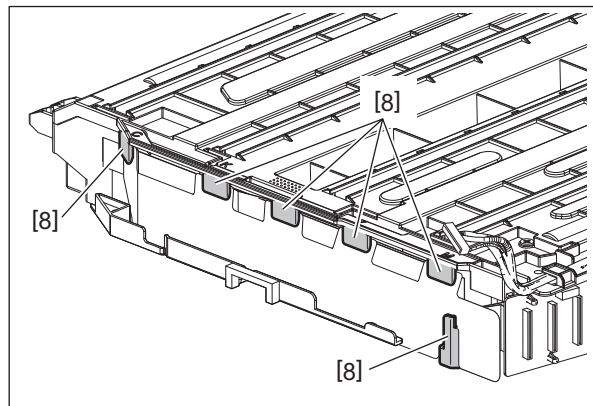

Fig. 4-127

- When installing, firmly insert the flat cable all the way in straight (up to the line on the cable). Confirm that the line on the cable and the connector are parallel and then carefully insert the cable straight.

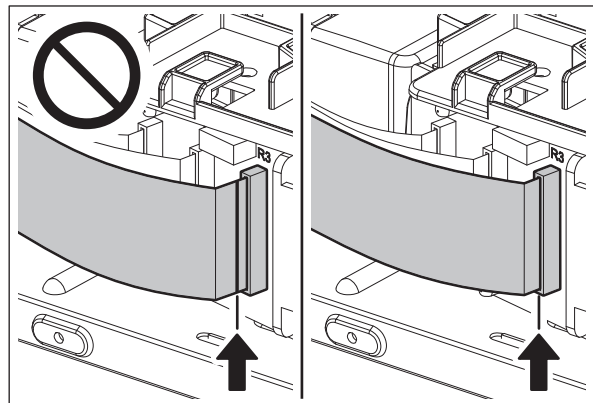

Fig. 4-128

4.4.4 Flat cables / LRL board

- (1) Remove the laser optical unit.
P. 4-47 "4.4.3 Laser optical unit"
- (2) Remove the protective film [2] from the cable holders [1].
- (3) Release the flat cables.

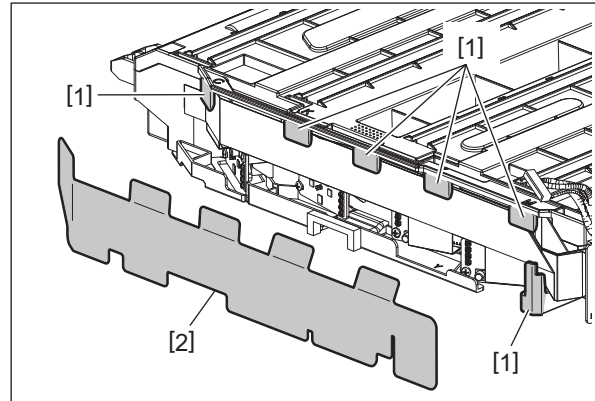

Fig. 4-129

- (4) Disconnect the flat cable [3] straight from the LRL board.

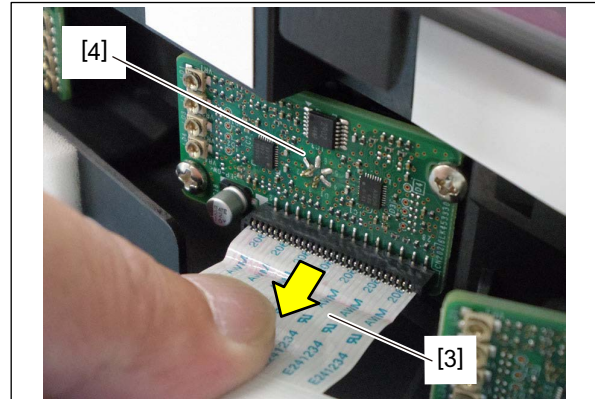

Fig. 4-130

Notes:

- Do not touch the board and laser diode with your bare hands since they are static-sensitive.
- Do not touch or deform the lead wire [4] of the laser diode.

- (5) Disconnect 1 connector [5] and take off the LRL board [6] from 2 locking supports.

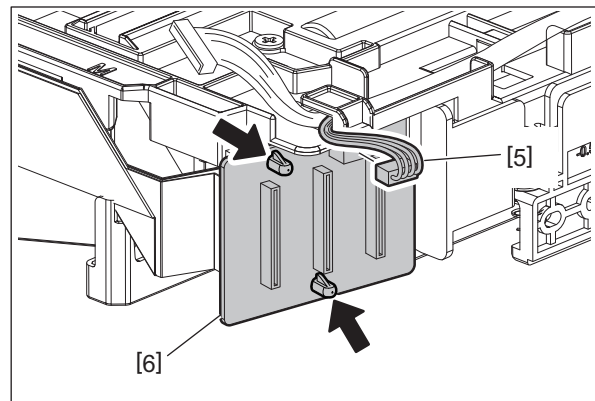

Fig. 4-131

(6) Pull out the flat cable straight from the LRL board.

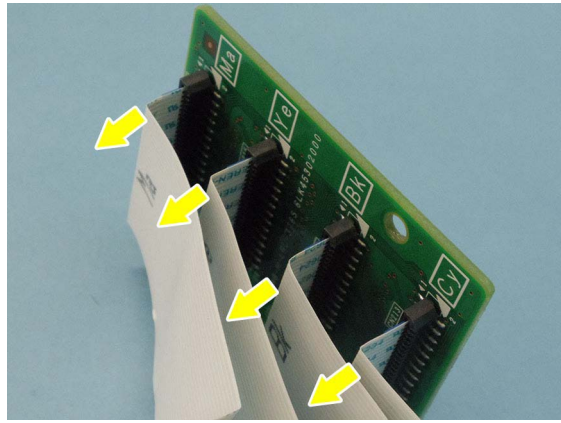

Fig. 4-132

Notes:

- When installing, be sure to connect the corresponding flat cable to the LRL board by matching the marks “Ma”, “Ye”, “Bk” and “Cy” given on it.
- When installing, firmly insert the flat cable all the way in straight (up to the line on the cable).
- When installing, confirm that the line on the cable and the connector are parallel and then carefully insert the cable straight.
- Do not use a damaged flat cable or one whose contact point has peeled off.
- When installing, be sure to connect the corresponding flat cable to the laser optical unit by matching the marks “C”, “K”, “Y” and “M” given on it.

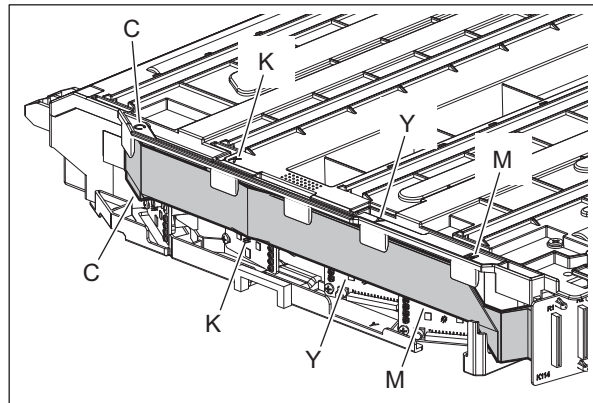

Fig. 4-133

- The installation directions of the LDR board for “C” and “K” and the one for “Y” and “M” differ (their upper and bottom directions are opposite). Therefore, the installation directions of the flat cable also differ accordingly. Pay attention to install them appropriately.



Fig. 4-134

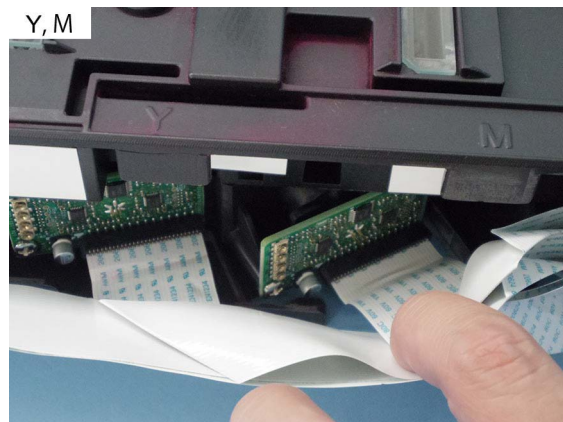

Fig. 4-135

- Be sure to attach the protective film [2] firmly after the flat cable is installed.

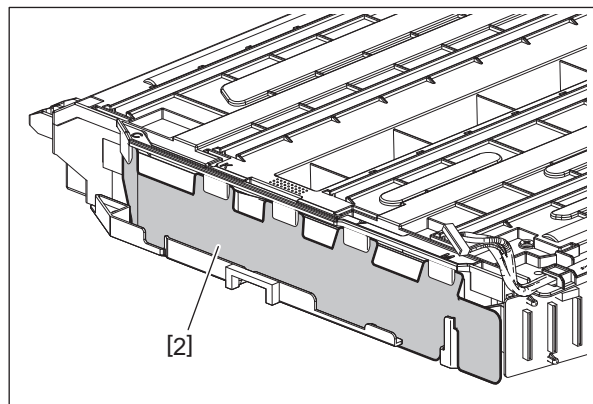

Fig. 4-136

4.5 Paper Feeding System

4.5.1 Bypass unit

- (1) Remove the right front cover.
📖 P. 4-5 “4.1.10 Right front cover”
- (2) Remove the right rear cover.
📖 P. 4-5 “4.1.11 Right rear cover”
- (3) Remove 4 screws and take off the stay [1].

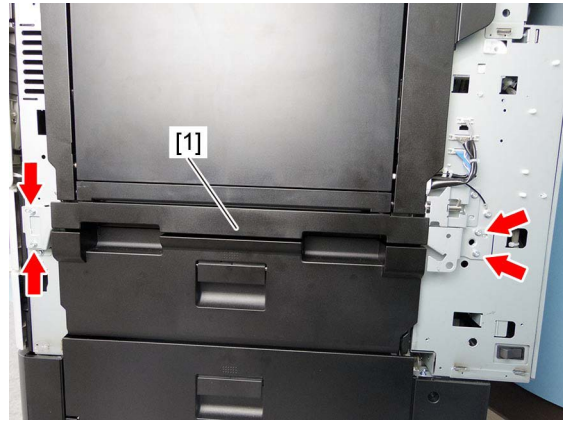

Fig. 4-137

- (4) To release the bypass unit [2], move the projection portion [3] on the front side and the rear side of the bypass unit [2] to the wider part [5] of the groove of the hinge stoppers [4].

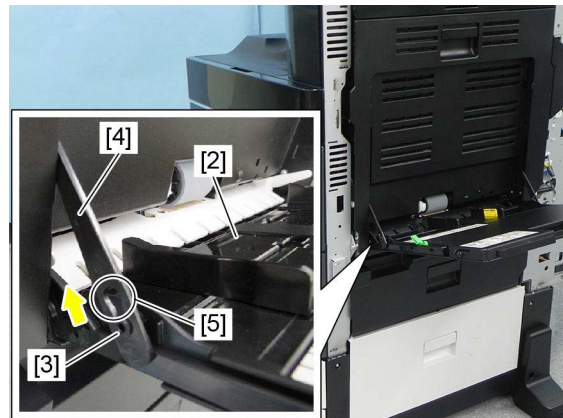

Fig. 4-138

- (5) Remove the arm [6] and paper holder lever [7].

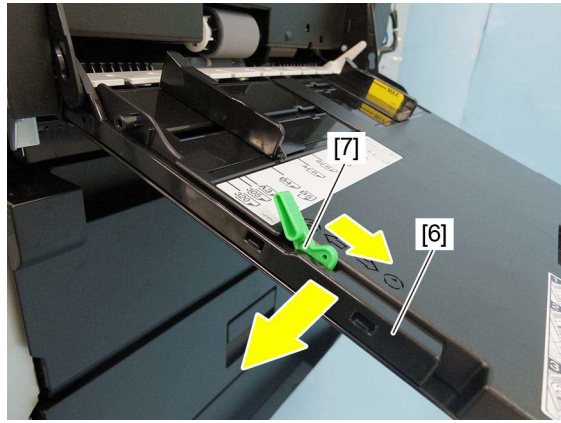

Fig. 4-139

- (6) Disconnect 1 connector and remove the bypass unit [8].

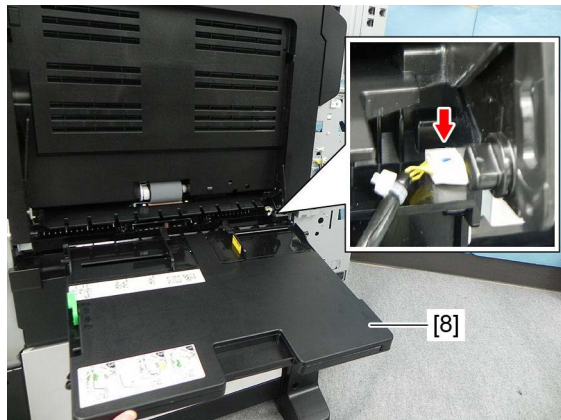

Fig. 4-140

4.5.2 Bypass feed roller

- (1) Open the bypass tray.
(2) Tip the paper holder release lever [1] outward to release the pressure.

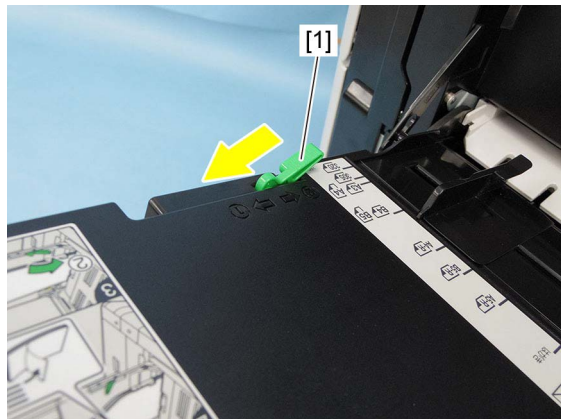

Fig. 4-141

(3) Remove the stopper [2].

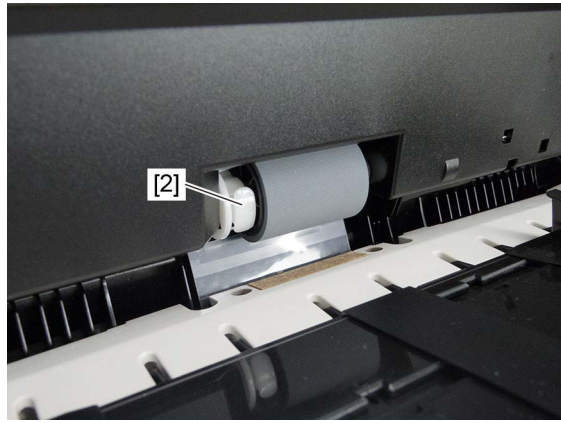

Fig. 4-142

(4) Press the collar [3] toward the rear side and release the lock.

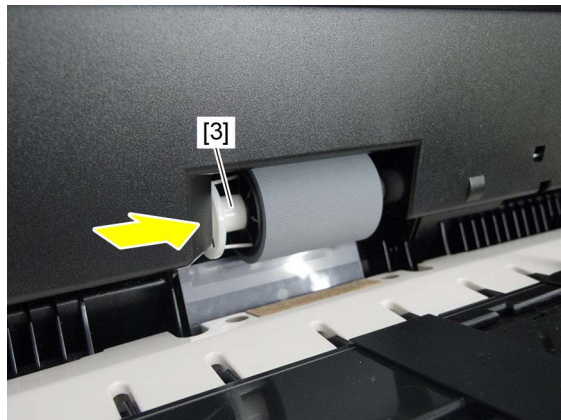

Fig. 4-143

(5) Remove the bypass feed roller [4] while pulling out it.

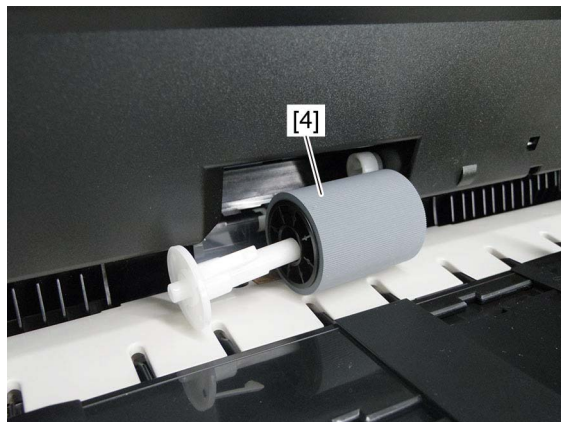

Fig. 4-144

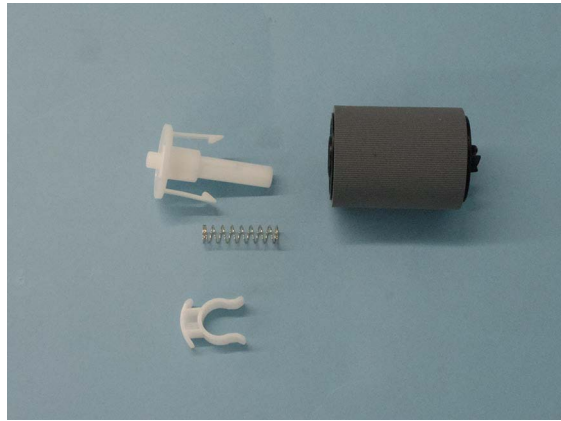

Fig. 4-145

Notes:

Make sure that the coupling is engaged when the bypass feed roller is replaced.

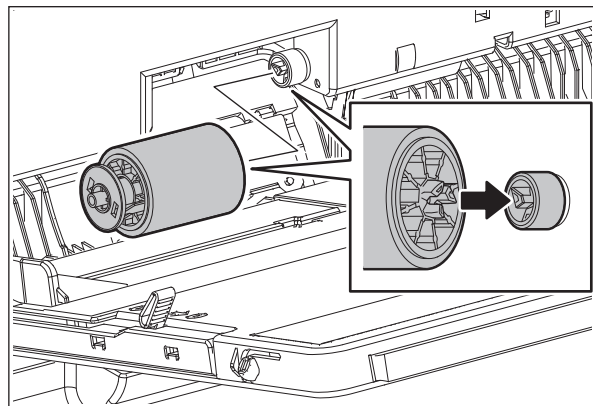



Fig. 4-146

4.5.3 Bypass separation roller

- (1) Remove the bypass feed roller.
 P. 4-56 “4.5.2 Bypass feed roller”
- (2) Lift the bypass separation roller [1] to remove it.

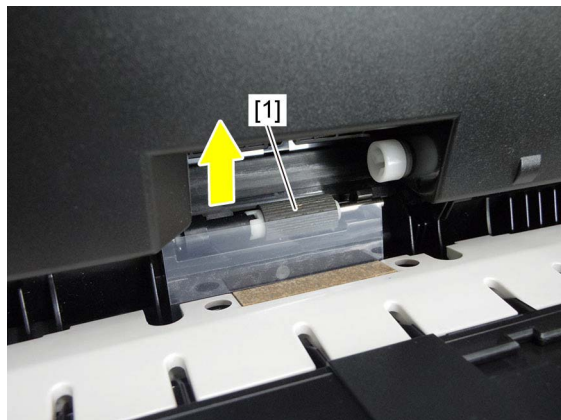

Fig. 4-147



Fig. 4-148



Fig. 4-149

Notes:

- When installing/removing, do not twist the film.
- Handle the bypass separation roller with care so that no dirt, oils or stains adhere.
- Be careful not to drop the parts inside the equipment.
- When replacing the parts or performing machine refreshment, apply 1 rice-sized grain of white grease (Molykote HP-300) to the bushings [2] of the bypass separation roller.

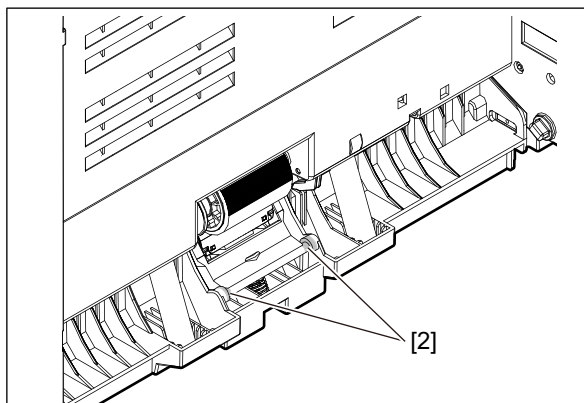

Fig. 4-150

4.5.4 Paper width detection PC board (SFB board) (S17)

- (1) Slide the slide tray [1] of the bypass unit.

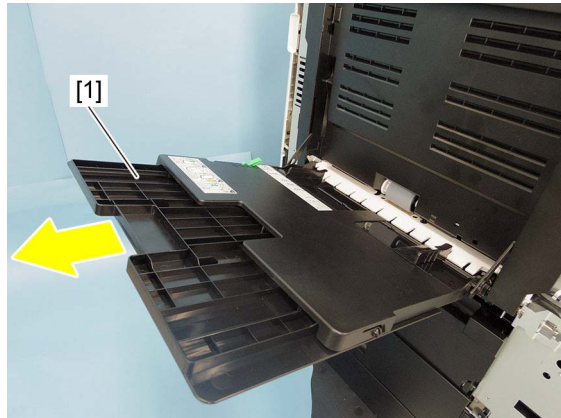

Fig. 4-151

- (2) Remove 1 screw and take off the paper width detection PC board (SFB board) cover [2].

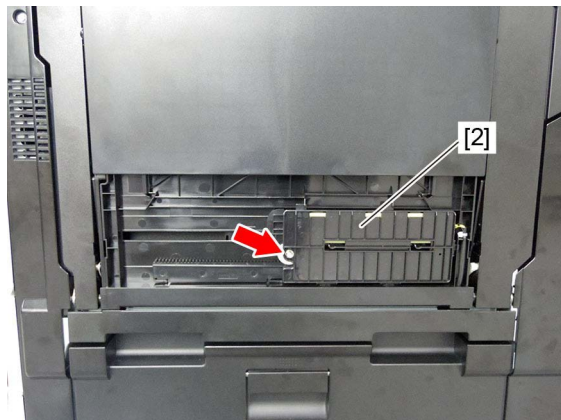

Fig. 4-152

Notes:

When removing the paper width detection PC board cover, be careful not to drop the gear.

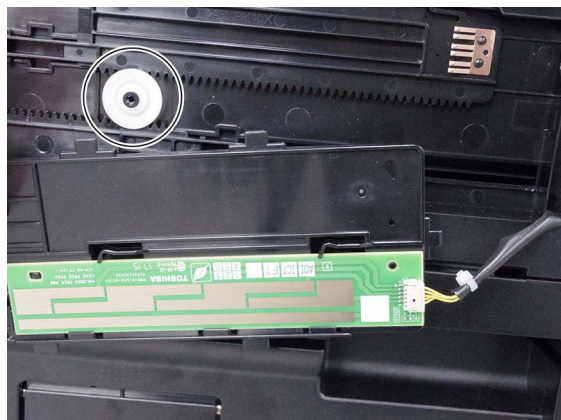

Fig. 4-153

- (3) Disconnect 1 connector [3] and remove the paper width detection PC board [4].

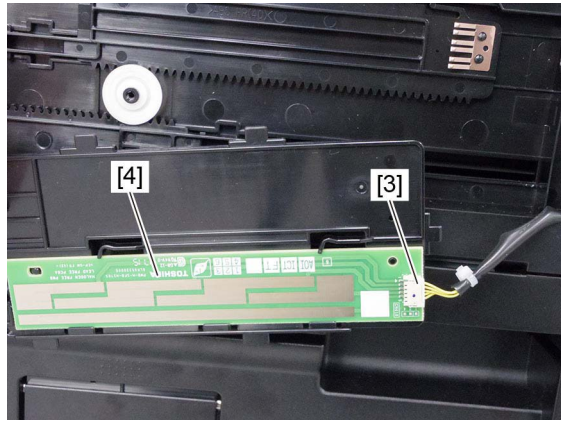

Fig. 4-154

4.5.5 Bypass feed sensor (S16)

- (1) Remove the transport unit.
P. 4-246 "4.11.3 Transport unit"
- (2) Remove the stopper [1].

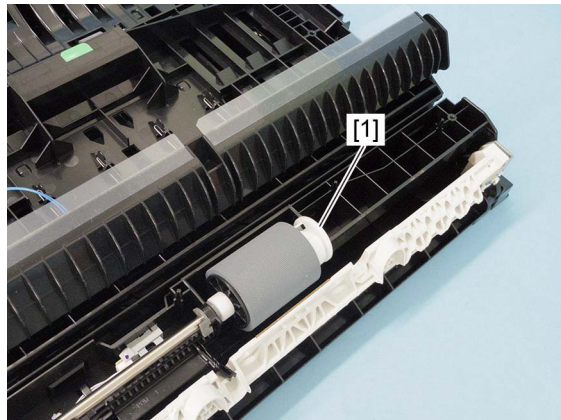

Fig. 4-155

- (3) Press the collar [1] toward the rear side and release the lock.
- (4) Remove the bypass feed roller [2] while pulling it out.

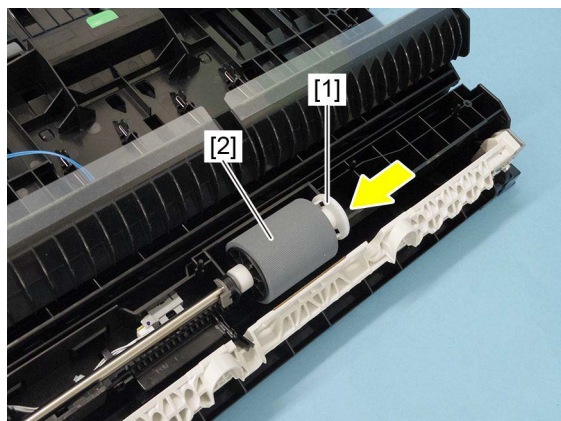

Fig. 4-156

- (5) Remove the clip [3]. Slide the shaft [4] toward the front side and remove the shaft [4]. Remove the collar [5].

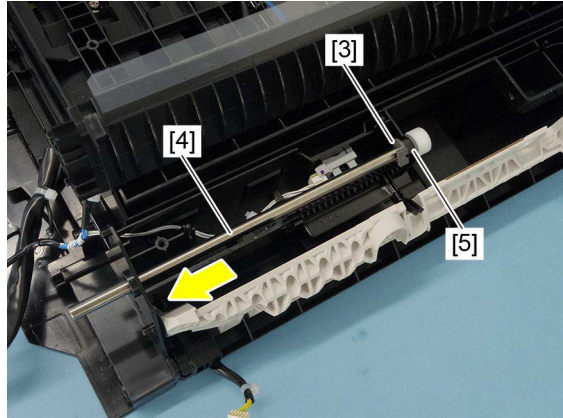

Fig. 4-157



Fig. 4-158

- (6) Release the harness from the harness guides, and disconnect 1 connector [6]. Remove the bypass feed sensor [7] and sensor arm [8].

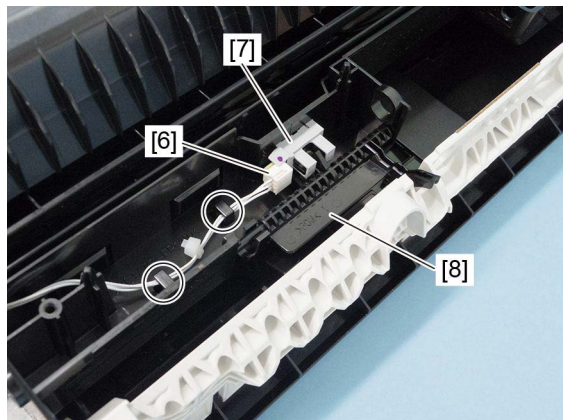

Fig. 4-159



Fig. 4-160

4.5.6 Side cover switch (SW5)

- (1) Open the side cover.
- (2) Release 2 hooks and pull out the side cover switch [1]. Disconnect 1 connector [2] and remove the side cover switch [1].

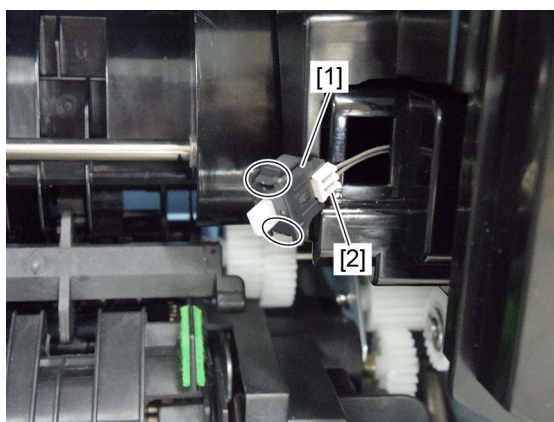

Fig. 4-161

4.5.7 Registration sensor (S19), Feed sensor (S20)

- (1) Remove the automatic duplexing unit (ADU).
 P. 4-243 "4.11.1 Automatic duplexing unit (ADU)"
- (2) Remove 4 screws, and then take off the stay [1].

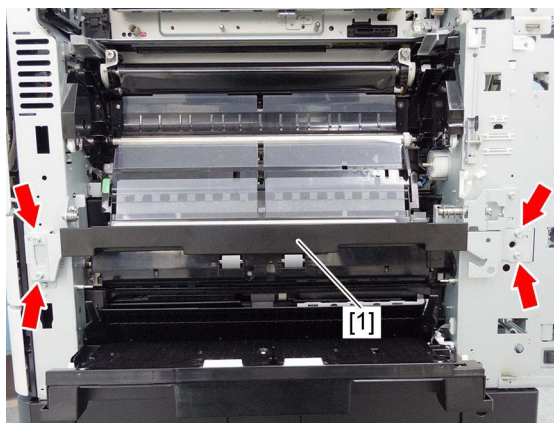

Fig. 4-162

- (3) Remove 1 screw.
- (4) Release 2 latches [2], and slide the transport guide [3] toward the front side, and then pull out the transport guide.

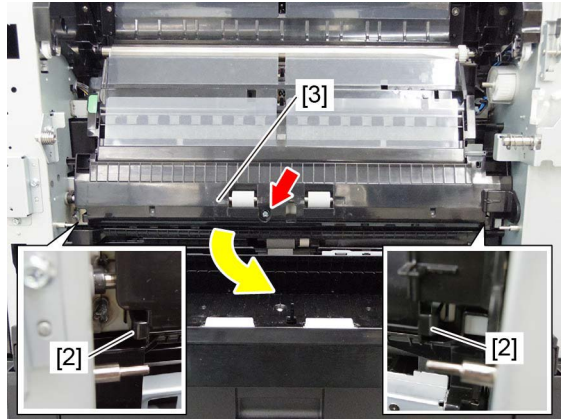

Fig. 4-163

- (5) Release the harness from the harness guides, and disconnect the 1 connector [4].

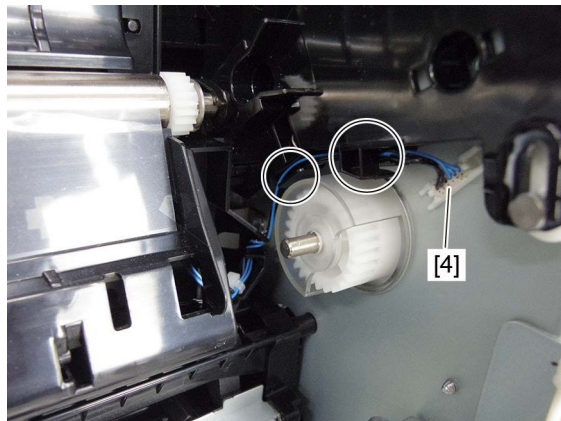

Fig. 4-164

- (6) Remove 1 screw.

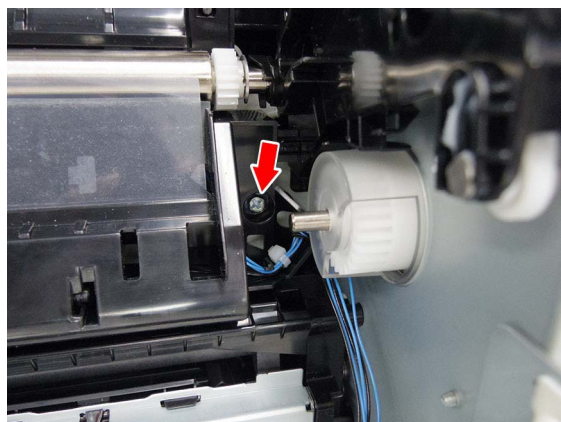

Fig. 4-165

- (7) Push the hook [5] and remove the paper guide [6] by sliding it toward the front side.

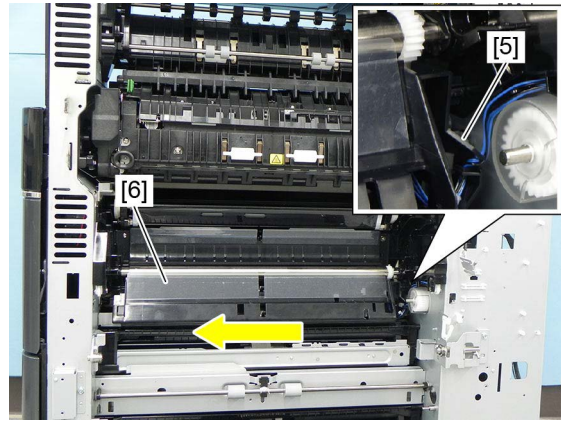

Fig. 4-166

- (8) Release 2 latches and remove the sensor bracket [7].

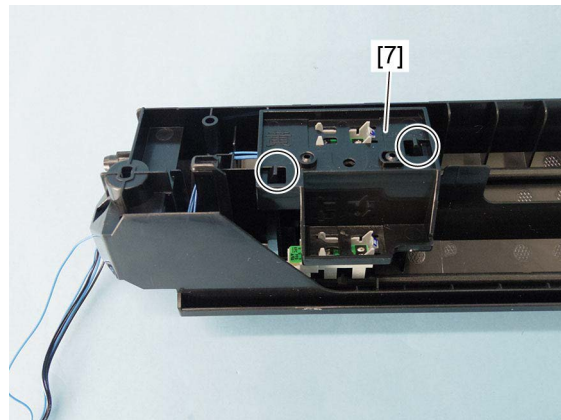

Fig. 4-167

- (9) Disconnect 2 connectors [8]. Remove the feed sensor [9] and registration sensor [10].

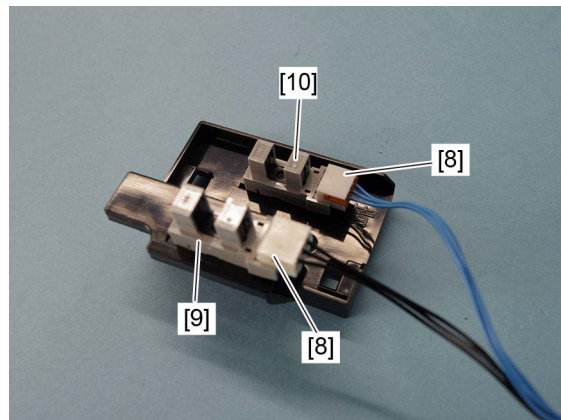



Fig. 4-168

Notes:

When installing connectors, connect the black wire harness to the feed sensor [9], and the blue wire harness to the registration sensor [10].

4.5.8 Registration roller (on the equipment side)

- (1) Remove the registration motor.
 P. 4-102 "4.5.36 Registration motor (M14)"
- (2) Remove the 1 bushing [1] and 1 gear [2].

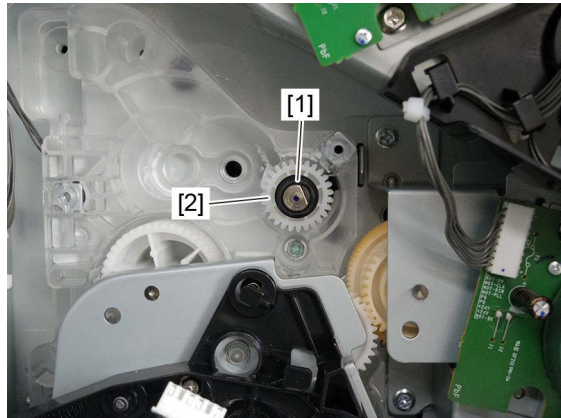

Fig. 4-169

- (3) Open the side cover.
- (4) Remove the clip [3]. Remove the front shaft by sliding it toward the rear side. Take off the registration roller shaft [4].

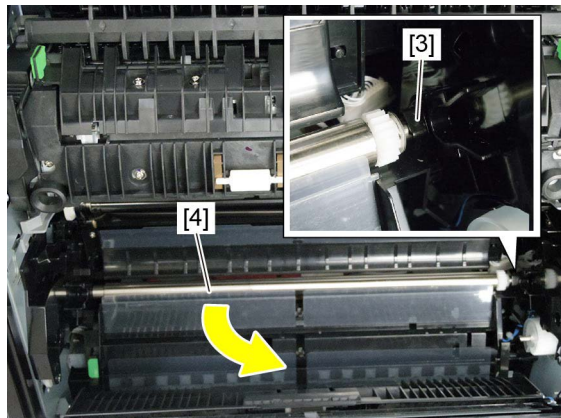

Fig. 4-170

- (5) Remove 2 bushings [5], 1 gear [6], 1 pin [7], 1 E-ring [8] and then take off the registration roller [9].

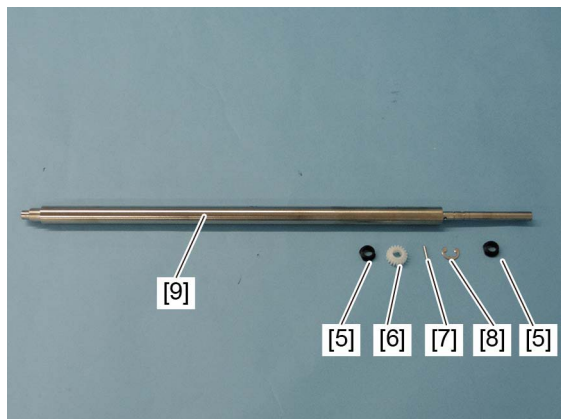

Fig. 4-171

Notes:

Apply conductive grease (FLOIL (GE-334C)) to the following portions.

- Application portion: Registration roller section
- Position: Leaf spring contact portion at the edge of SPG-GND-RGST-GRN_2
- Amount: Half a rice-sized grain

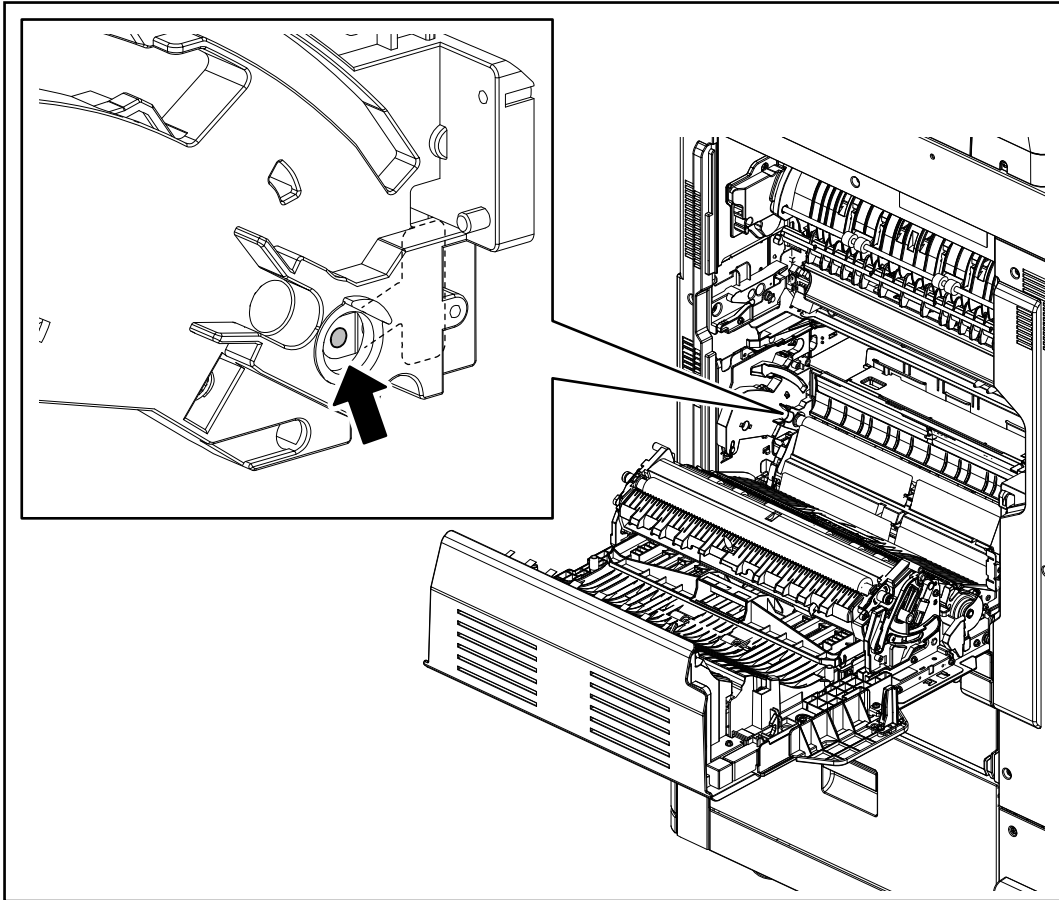

Fig. 4-172

4.5.9 Registration roller (on the ADU side)

- (1) Remove the 2nd transfer unit.
📖 P. 4-178 "4.7.9 2nd transfer unit (TRU)"
- (2) Remove 1 screw [11]. While compressing the spring, slide the holder [1] in the direction indicated by the arrow to align it with the notch [2]. Then take off the holder [1] and the spring.

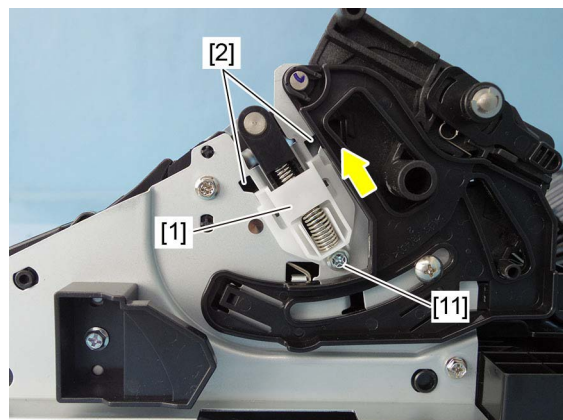

Fig. 4-173

- (3) Remove 1 screw [12]. While compressing the spring, slide the holder [3] in the direction indicated by the arrow to align it with the notch [4]. Then take off the holder [3] and the spring.

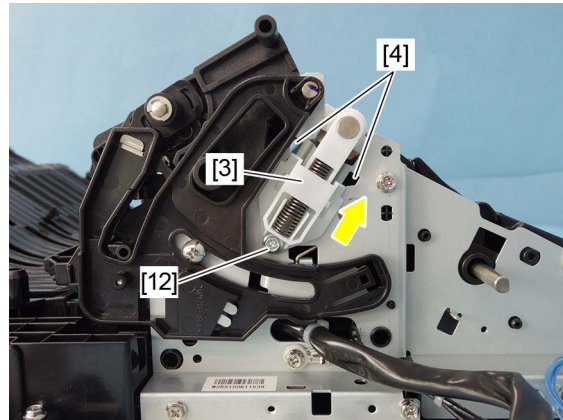

Fig. 4-174

- (4) Remove 2 bushing holders [5], 1 bushing [6], 1 leaf spring [7] and 1 gear [8] from the registration roller.

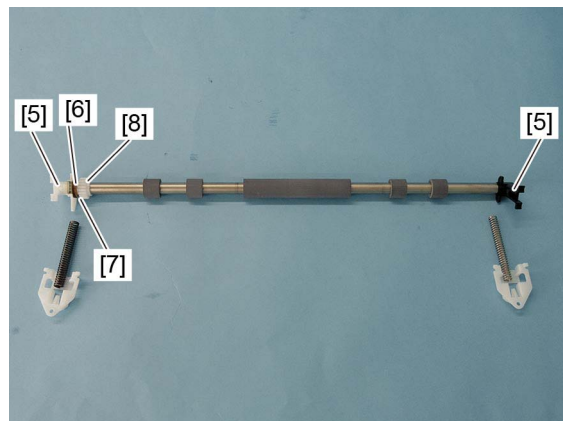

Fig. 4-175

Notes:

- When assembling, attach the black spring [9] on the rear side, and silver spring [10] on the front side.

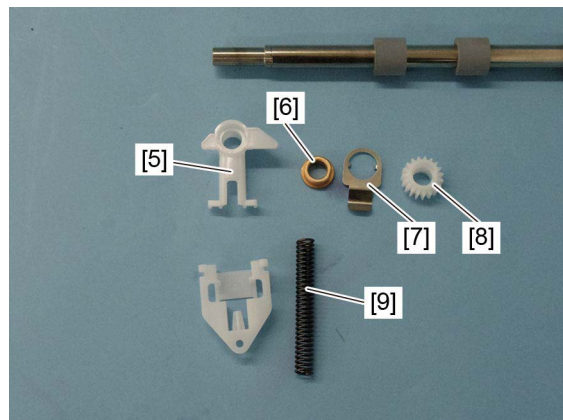

Fig. 4-176

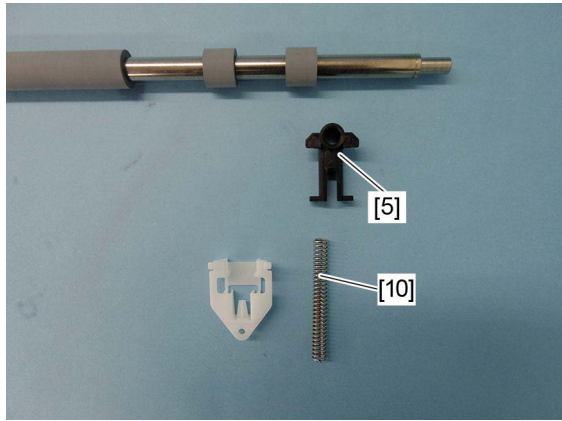

Fig. 4-177

- Install the gear [8], bushing [6], and leaf spring [7] in the orientation shown in the figure.

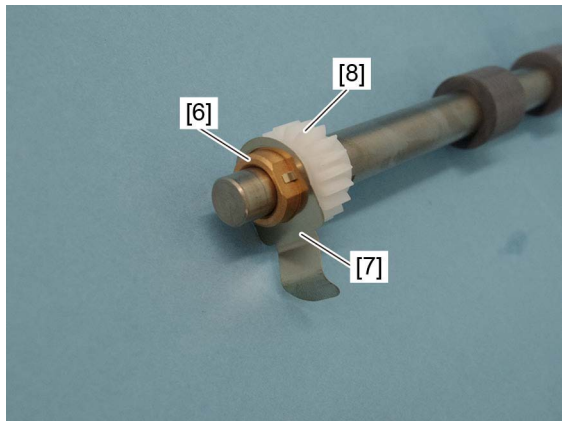

Fig. 4-178

4.5.10 Jam access cover

- (1) Open the jam access cover [1].

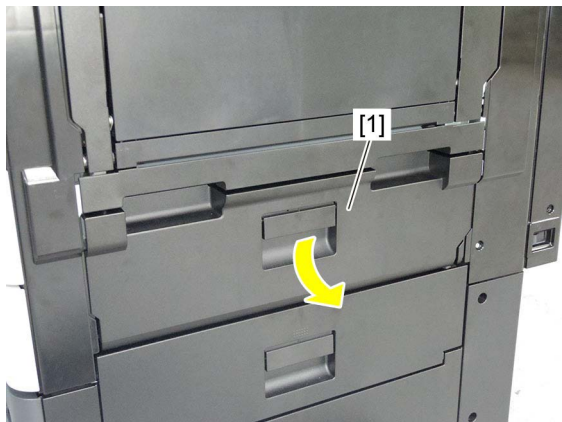

Fig. 4-179

- (2) Disconnect the 1 connector [2]. Take off the stopper [3].

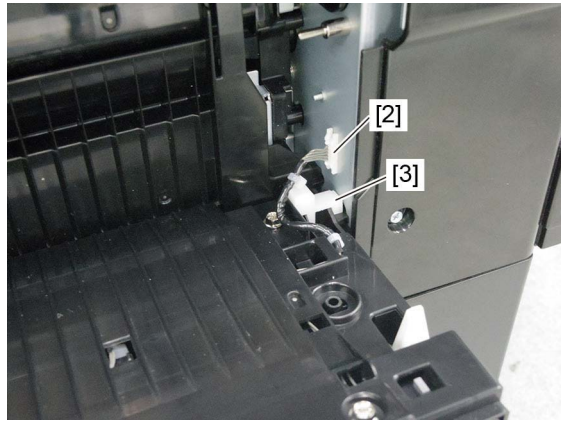

Fig. 4-180

- (3) While pressing the rear hinge [4] against the front side, remove the jam access cover [5] using the front hinge as a support.

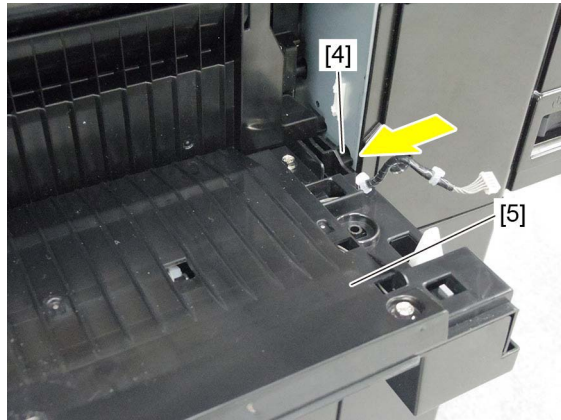

Fig. 4-181

4.5.11 Transport roller

- (1) Remove the transport clutch (L).
📖 P. 4-100 “4.5.33 Transport clutch (L) (CLT6)”
- (2) Remove the paper feed drive unit.
📖 P. 4-103 “4.5.37 Paper feed drive unit”
- (3) Remove the right front cover.
📖 P. 4-5 “4.1.10 Right front cover”
- (4) Remove the automatic duplexing unit.
📖 P. 4-243 “4.11.1 Automatic duplexing unit (ADU)”
- (5) Remove 4 screws and take off the stay [1].

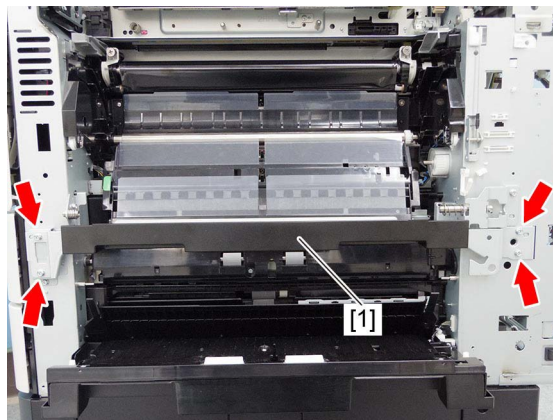

Fig. 4-182

- (6) Remove 1 screw.
- (7) Release 2 latches [2], and pull the transport guide [3] out toward you by sliding it toward the front side.

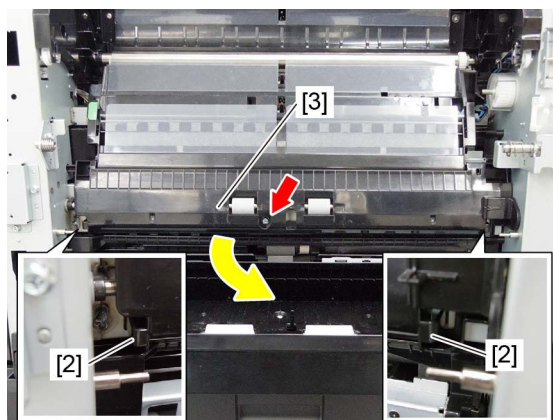

Fig. 4-183

(8) Remove the clip [4].

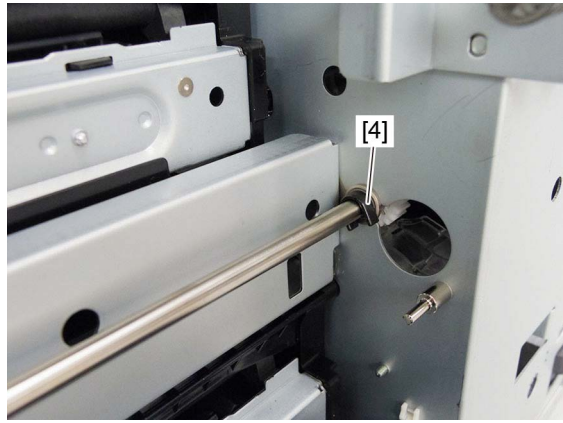

Fig. 4-184

(9) Remove the transport roller [6] by sliding the bushing [5] toward the front side.

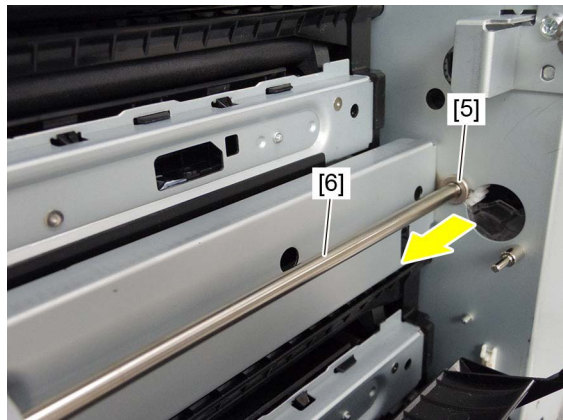

Fig. 4-185

(10) Remove the 2 bushings [7], 1 clip [8], 1 E-ring [9] and 1 gear [10].

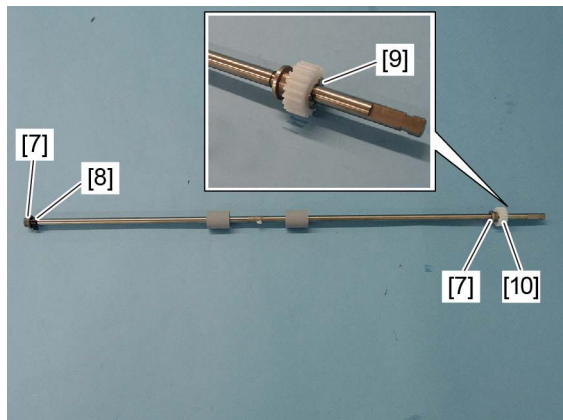

Fig. 4-186

4.5.12 Jam access cover opening/closing switch (SW20)

- (1) Remove the jam access cover.
P. 4-69 "4.5.10 Jam access cover"
- (2) Remove 4 screws. Release the engagement of 3 projections [1] on the lower side, and take off the cover [2].

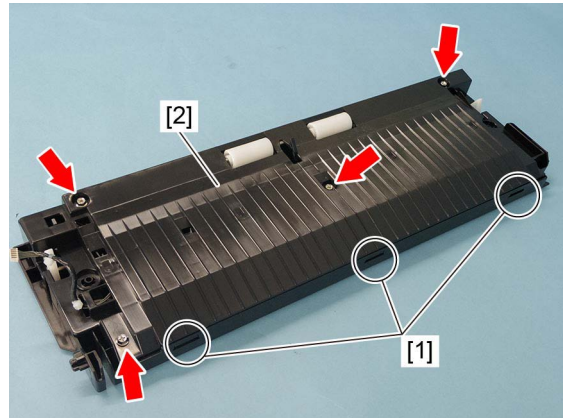

Fig. 4-187

- (3) Disconnect 1 connector [3]. Release the latch and remove the jam access cover opening/closing switch [4].

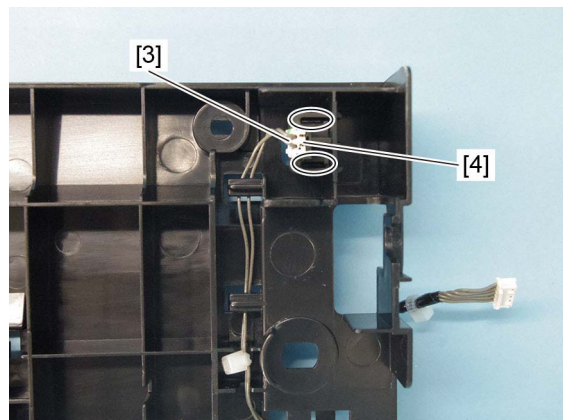

Fig. 4-188

4.5.13 2nd drawer paper feed sensor (S32)

- (1) Remove the jam access cover.
P. 4-69 "4.5.10 Jam access cover"
- (2) Remove 4 screws. Release the engagement of 3 projections [1] on the lower side, and take off the cover [2].

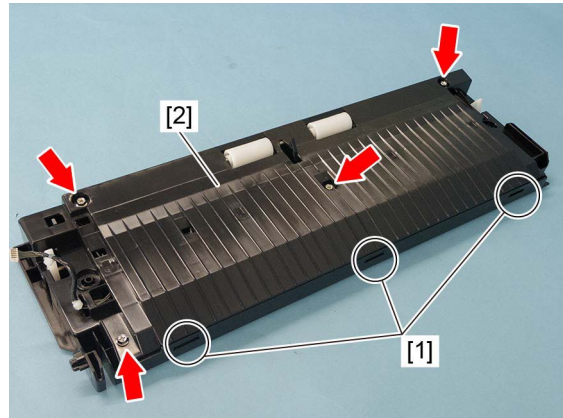

Fig. 4-189

- (3) Disconnect 1 connector [3]. Remove 2 screws and take off the cover [4].

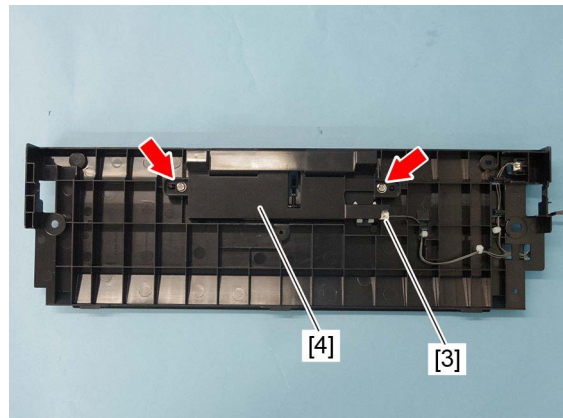

Fig. 4-190

- (4) Release the latch, and remove the 2nd drawer paper feed sensor [5].

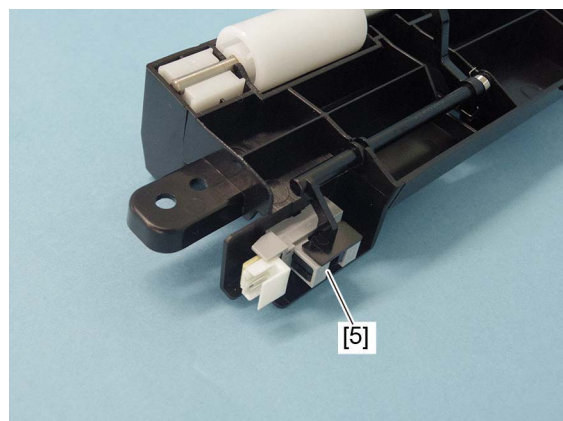



Fig. 4-191

4.5.14 1st drawer paper feed unit

- (1) Pull out the 1st drawer.
- (2) Remove the front cover.
 P. 4-1 "4.1.1 Front cover"
- (3) Turn the lock lever [1] clockwise. Pull out the 1st drawer paper feed unit [2] toward the front side to remove it.

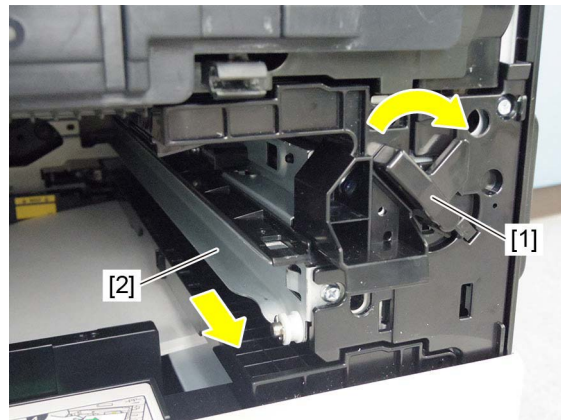



Fig. 4-192

Notes:

When installing, align the arrow of the 1st drawer paper feed unit with the guide before inserting horizontally.

4.5.15 1st drawer separation roller guide

- (1) Remove the 1st drawer paper feed unit.
 P. 4-75 "4.5.14 1st drawer paper feed unit"
- (2) Remove 2 screws from the separation roller [1].

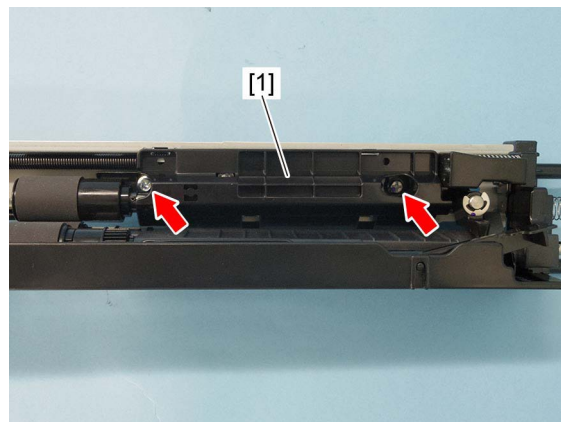

Fig. 4-193

(3) Release 2 latches [2] and remove the 1st drawer separation roller guide [1].

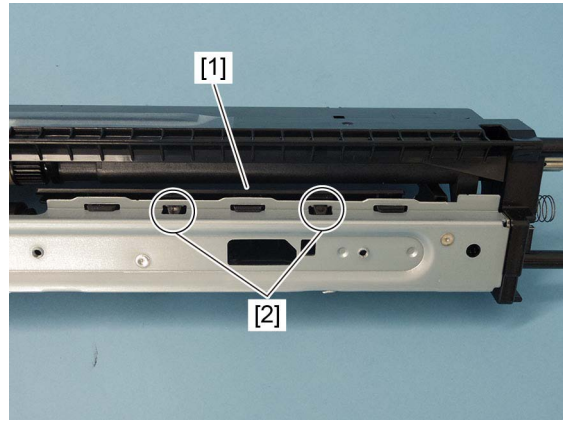

Fig. 4-194

(4) Remove the E-ring [3] and take off the shaft [4].

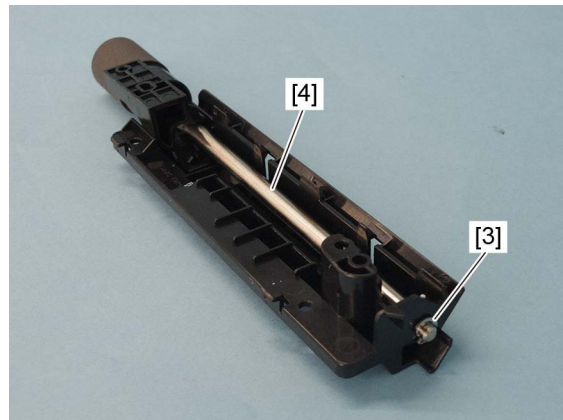

Fig. 4-195

(5) Remove the shaft cover [5].

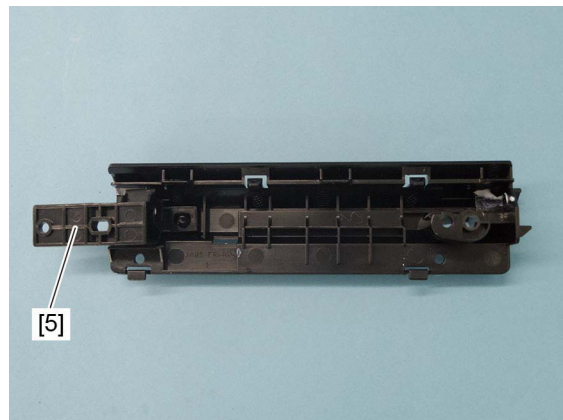

Fig. 4-196

Notes:

When replacing the parts or performing preventive maintenance, apply 1 rice-sized grain of white grease (Molykote HP-300) to the place [6] shown in the figure, and apply half a rice-sized grain of white grease (Molykote HP-300) to the 2 places [7] shown in the figure.

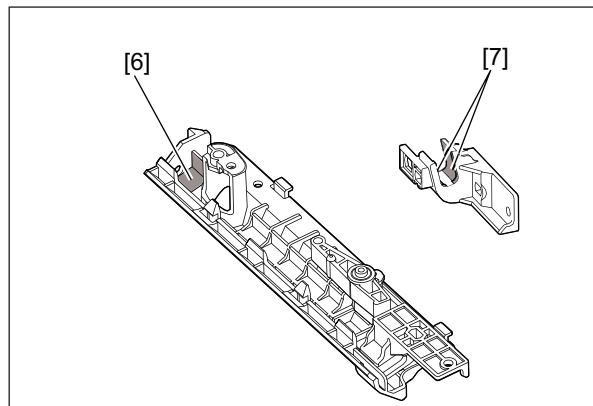

Fig. 4-197

4.5.16 2nd drawer paper feed unit

- (1) Pull out the 1st drawer.
- (2) Pull out the 2nd drawer.
- (3) Turn the lock lever [1] clockwise. Pull out the 2nd drawer paper feed unit [2] toward the front side to remove it.

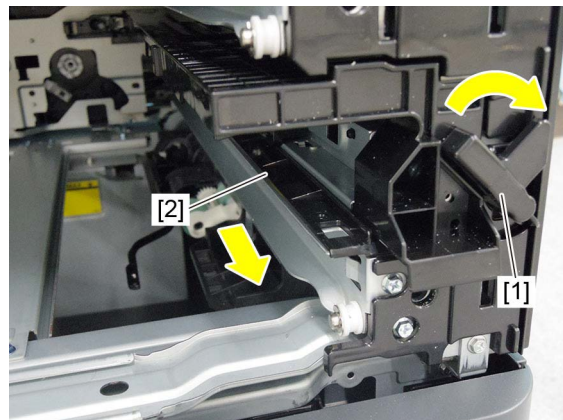

Fig. 4-198

Notes:

When installing, align the arrow of the 2nd drawer paper feed unit with the guide before inserting horizontally.

4.5.17 2nd drawer separation roller guide

- (1) Remove the 2nd drawer paper feed unit.
📖 P. 4-77 "4.5.16 2nd drawer paper feed unit"
- (2) Remove 2 screws from the separation roller guide [1].

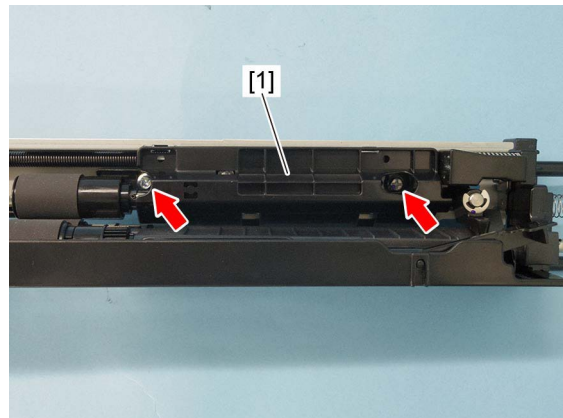

Fig. 4-199

- (3) Release 2 latches [2] and remove the 2nd drawer separation roller guide [1].

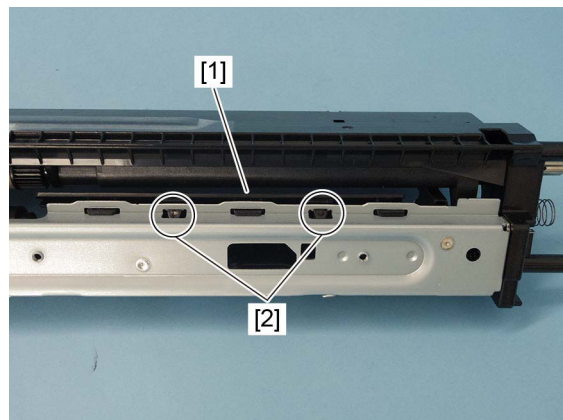

Fig. 4-200

- (4) Remove the E-ring [3] and take off the shaft [4].

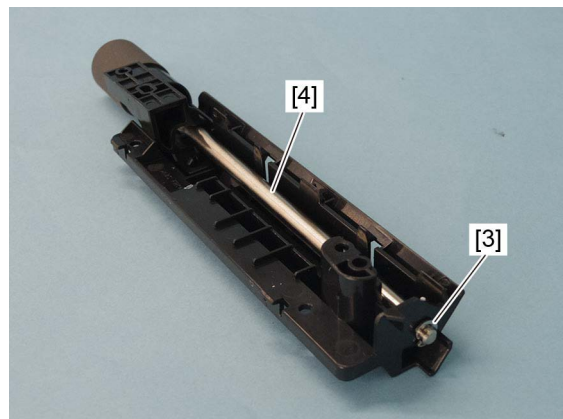

Fig. 4-201

- (5) Remove the shaft cover [5].

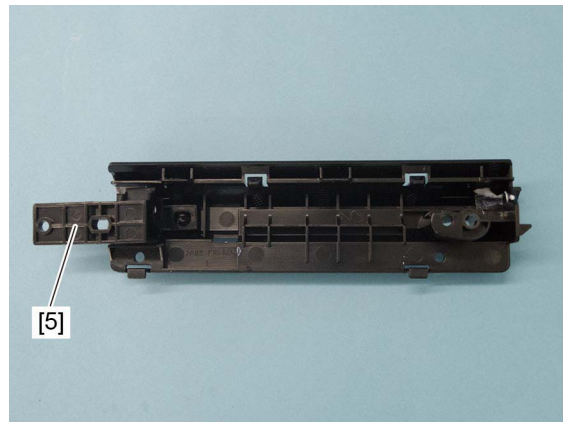

Fig. 4-202

Notes:

When replacing the parts or performing preventive maintenance, apply 1 rice-sized grain of white grease (Molykote HP-300) to the place [6] shown in the figure, and apply half a rice-sized grain of white grease (Molykote HP-300) to the 2 places [7] shown in the figure.

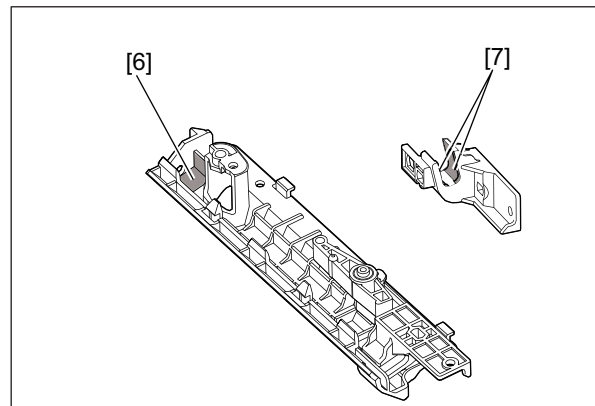

Fig. 4-203

4.5.18 1st drawer paper feed roller, separation roller, and pick-up roller

- (1) Pull out the 1st drawer paper feed unit.
P. 4-75 "4.5.14 1st drawer paper feed unit"
- (2) Slide the guide [1] to the front side.

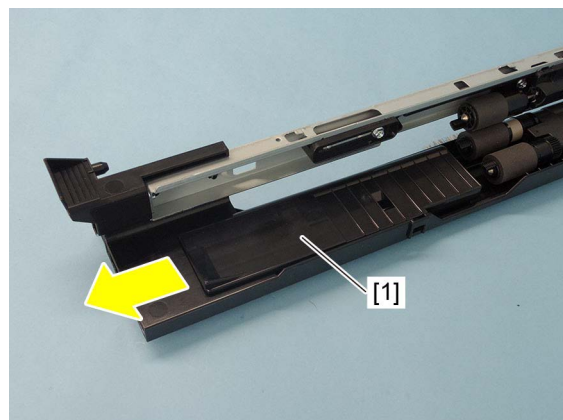

Fig. 4-204

- (3) Remove the clip [2] and take off the separation roller [3]. Remove the clip [4] and take off the feed roller [5]. Release the latch and take off the pickup roller [6].

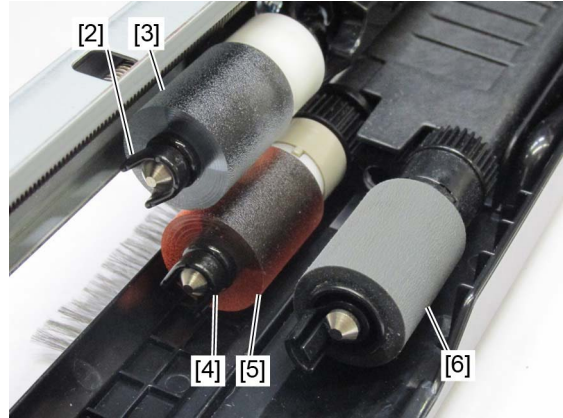

Fig. 4-205

Separation roller



Fig. 4-206

Feed roller



Fig. 4-207

Pick-up roller



Fig. 4-208

4.5.19 2nd drawer paper feed roller, separation roller, and pick-up roller

- (1) Pull out the 2nd drawer paper feed unit.
 P. 4-77 “4.5.16 2nd drawer paper feed unit”
- (2) Slide the guide [1] to the front side.

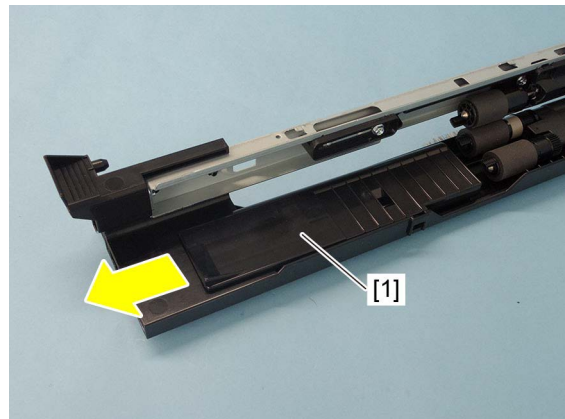

Fig. 4-209

- (3) Remove the clip [2] and take off the separation roller [3]. Remove the clip [4] and take off the feed roller [5]. Release the latch and take off the pickup roller [6].

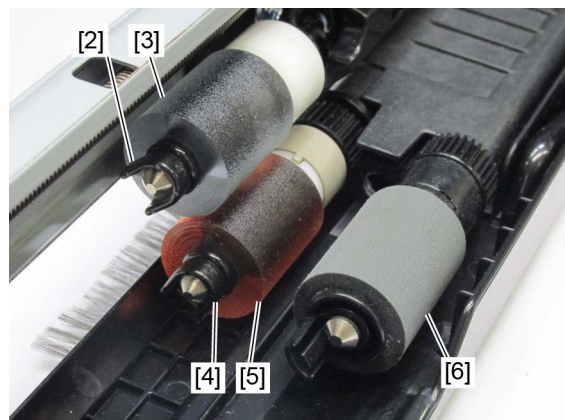

Fig. 4-210

Separation roller



Fig. 4-211

Feed roller





Fig. 4-212

Pick-up roller



Fig. 4-213

4.5.20 1st drawer detection switch (SW8)

- (1) Pull out the 1st drawer paper feed unit.
 P. 4-75 "4.5.14 1st drawer paper feed unit"
- (2) Pull out the 2nd drawer paper feed unit.
 P. 4-77 "4.5.16 2nd drawer paper feed unit"
- (3) Remove the 1st tray-up motor unit.
 P. 4-84 "4.5.22 1st tray-up motor unit"
- (4) Disconnect the 1 connector [1] from the rear side.
- (5) Release the latch from the rear side, and remove the 1st drawer detection switch [2] from the front side.

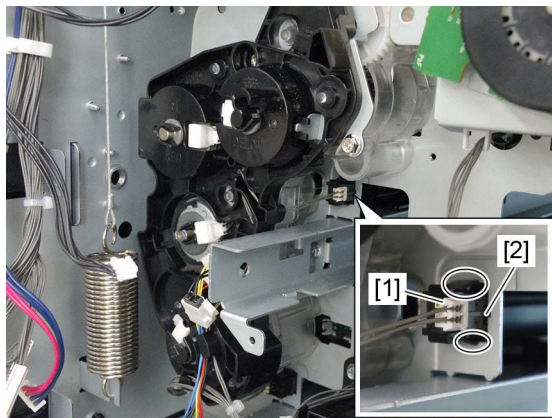





Fig. 4-214

4.5.21 2nd drawer detection switch (SW19)

- (1) Pull out the 1st drawer paper feed unit.
 P. 4-75 "4.5.14 1st drawer paper feed unit"
- (2) Pull out the 2nd drawer paper feed unit.
 P. 4-77 "4.5.16 2nd drawer paper feed unit"
- (3) Remove the 2nd tray-up motor unit.
 P. 4-86 "4.5.23 2nd tray-up motor unit"
- (4) Disconnect the 1 connector [1] from the rear side.
- (5) Release the latch from the rear side, and remove the 2nd drawer detection switch [2] from the front side.

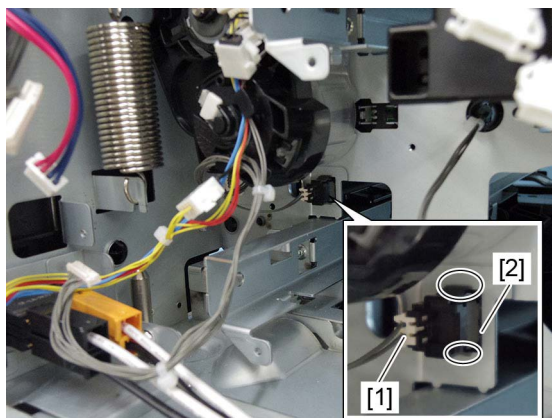

Fig. 4-215

4.5.22 1st tray-up motor unit

- (1) Remove the rear cover.
P. 4-10 "4.1.17 Rear cover"
- (2) Disconnect 13 connectors and 1 relay connector [5].
- (3) Release the harness from the harness clamp [6].
- (4) Remove 1 harness clamp [7].
- (5) Release the harness from the harness guides [8].

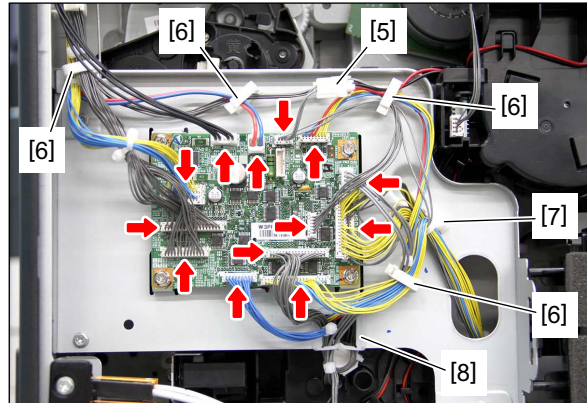

Fig. 4-216

- (6) Remove the hook [1] of the ozone exhaust fan duct.
- (7) Remove 3 screws and take off the bracket [2].

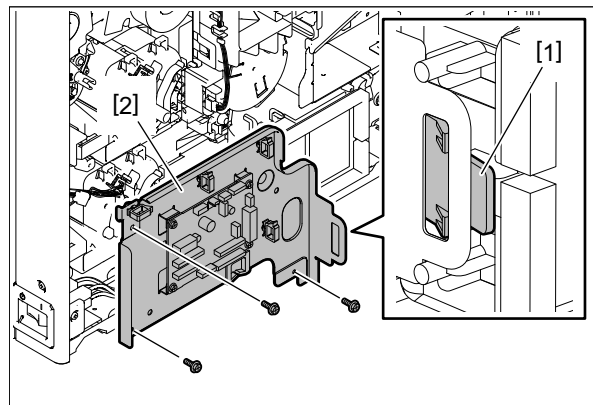

Fig. 4-217

- (8) Remove the developer unit cooling exhaust duct.
📖 P. 4-164 "4.6.35 Developer unit cooling exhaust duct"
- (9) Release the harness from the harness guides and disconnect 3 connectors [3].

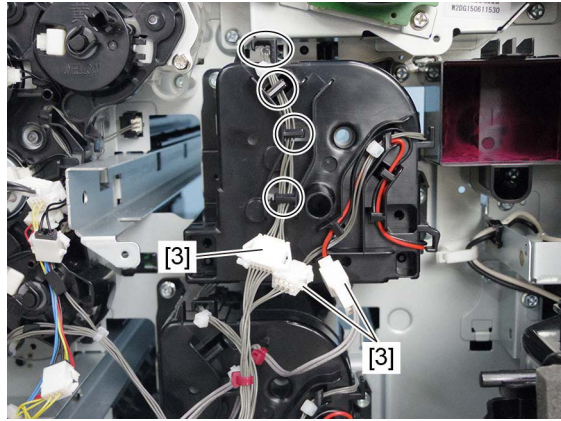

Fig. 4-218

- (10) Remove 3 screws and take off the 1st tray-up motor unit [4].

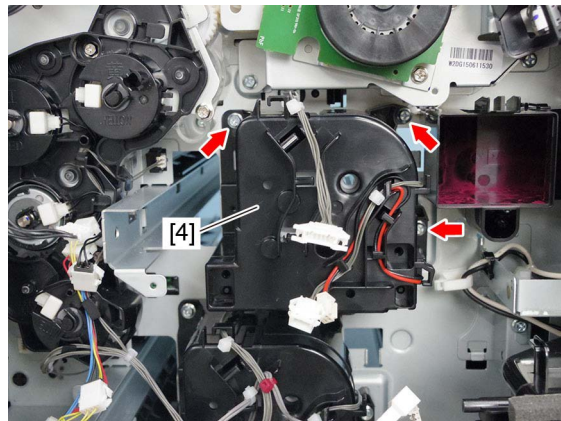

Fig. 4-219

4.5.23 2nd tray-up motor unit

- (1) Remove the rear cover.
P. 4-10 "4.1.17 Rear cover"
- (2) Disconnect 13 connectors and 1 relay connector [5].
- (3) Release the harness from the harness clamp [6].
- (4) Remove 1 harness clamp [7].
- (5) Release the harness from the harness guides [8].

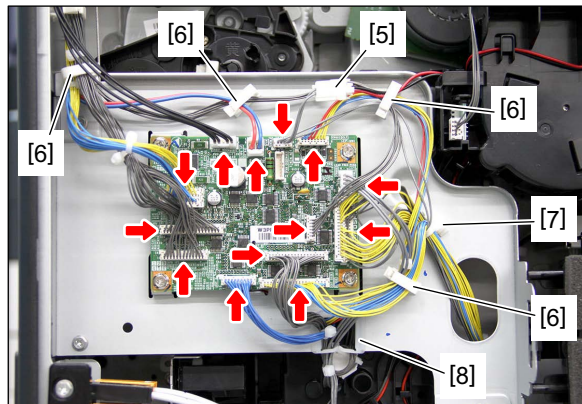

Fig. 4-220

- (6) Remove the hook [1] of the ozone exhaust fan duct.
- (7) Remove 3 screws and take off the bracket [2].

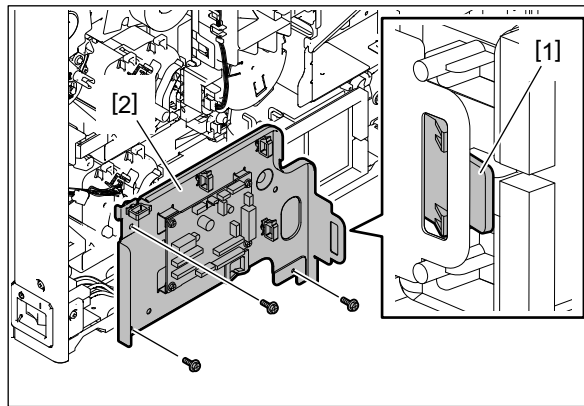

Fig. 4-221

- (8) Release the harness from the harness guides and disconnect 4 connectors [3].

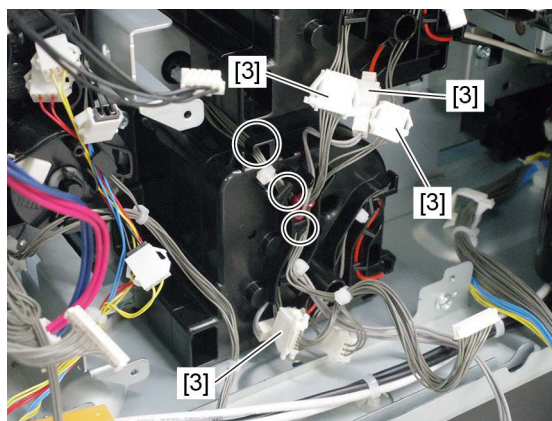

Fig. 4-222

- (9) Remove 3 screws and take off the 2nd tray-up motor unit [4].

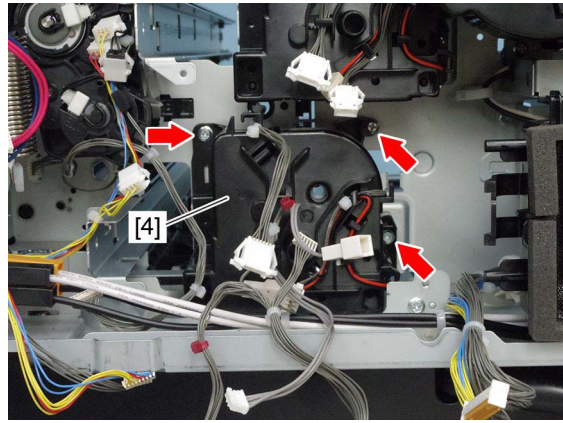

Fig. 4-223

4.5.24 Tray-up motor-1 (M15)

- (1) Remove the 1st tray-up motor unit.
P. 4-84 "4.5.22 1st tray-up motor unit"
- (2) Release the harness from the harness guides, and then disconnect 1 connector [1].

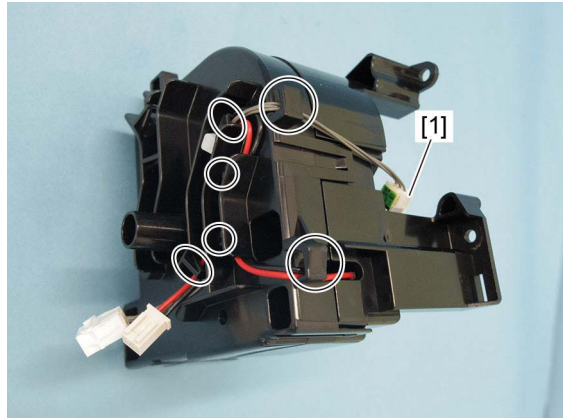

Fig. 4-224

- (3) Release 4 latches and remove the cover [2].

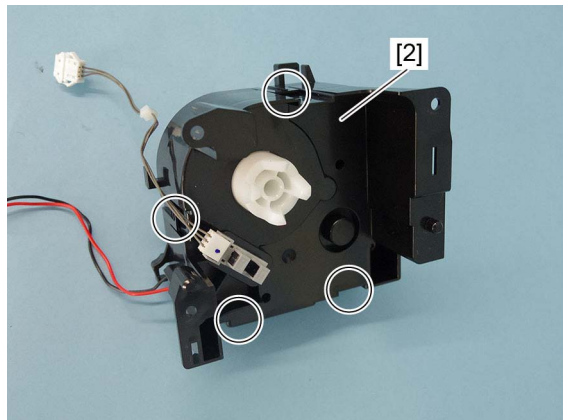

Fig. 4-225

- (4) Take off the tray-up motor-1 [3].

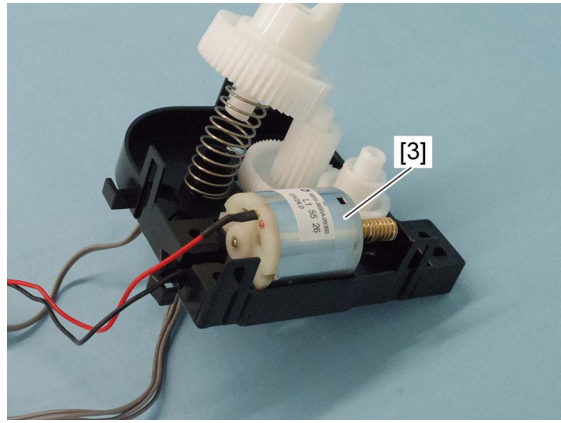

Fig. 4-226

4.5.25 Tray-up motor-2 (M16)

- (1) Remove the 2nd tray-up motor unit.
P. 4-86 "4.5.23 2nd tray-up motor unit"
- (2) Release the harness from the harness guides, and then disconnect 1 connector [1].

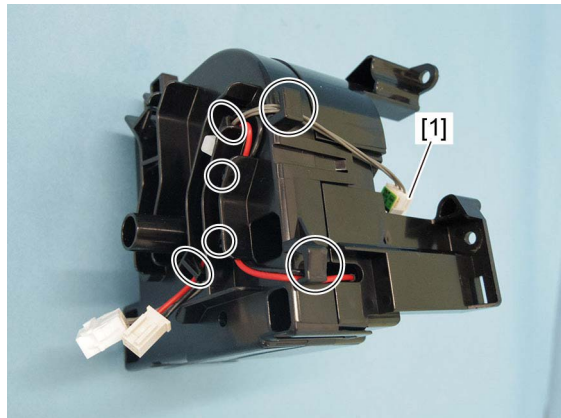

Fig. 4-227

- (3) Release 4 latches, and then remove the cover [2].

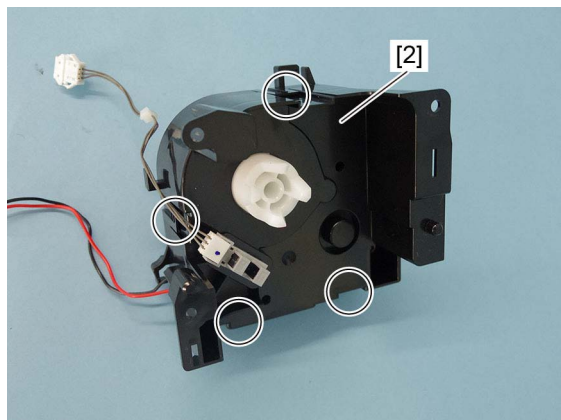

Fig. 4-228

- (4) Take off the tray-up motor-2 [3].

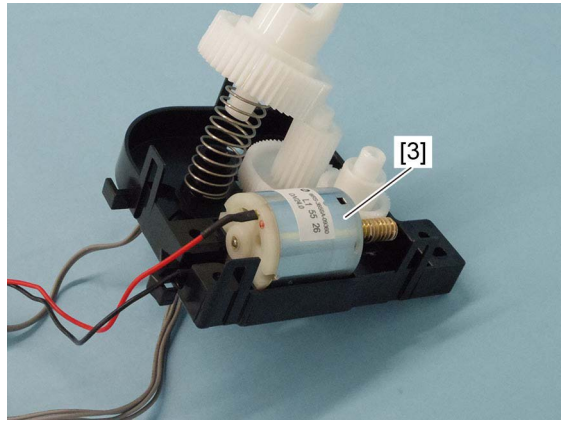

Fig. 4-229

4.5.26 1st drawer paper remaining sensor (S30)

- (1) Remove the 1st tray-up motor unit.
P. 4-84 "4.5.22 1st tray-up motor unit"
- (2) Release the harness from the harness guides, and then disconnect 1 connector [1].

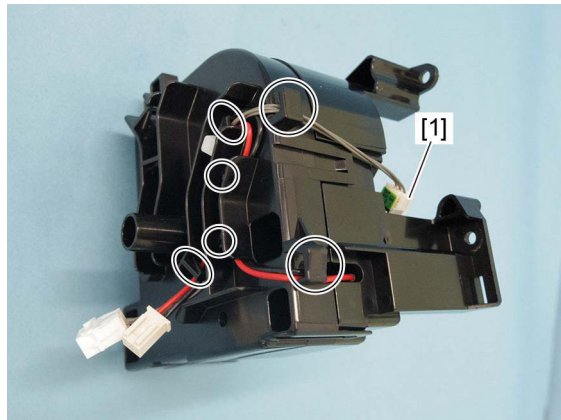

Fig. 4-230

- (3) Release 4 latches, and then remove the cover [2].

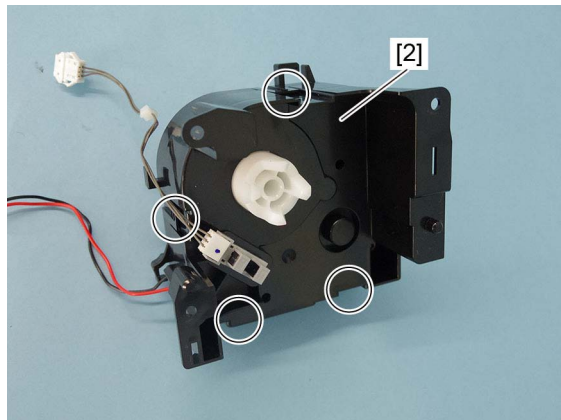

Fig. 4-231

- (4) Release 3 latches, and then remove the 1st drawer paper remaining sensor [3].

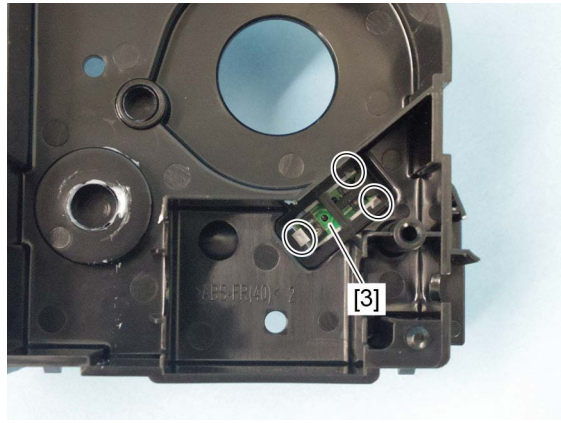

Fig. 4-232

4.5.27 2nd drawer paper remaining sensor (S33)

- (1) Remove the 2nd tray-up motor unit.
P. 4-86 “4.5.23 2nd tray-up motor unit”
- (2) Release the harness from the harness guides, and then disconnect 1 connector [1].

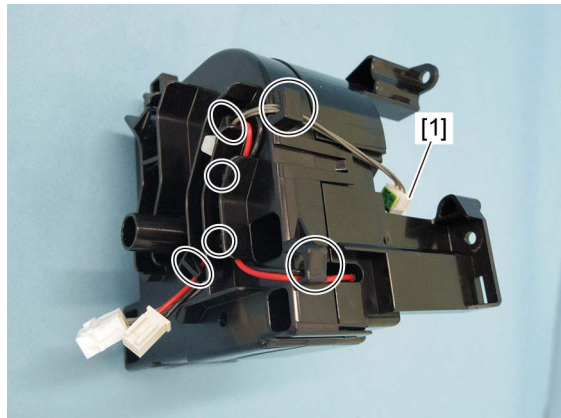

Fig. 4-233

- (3) Release 4 latches, and then remove the cover [2].

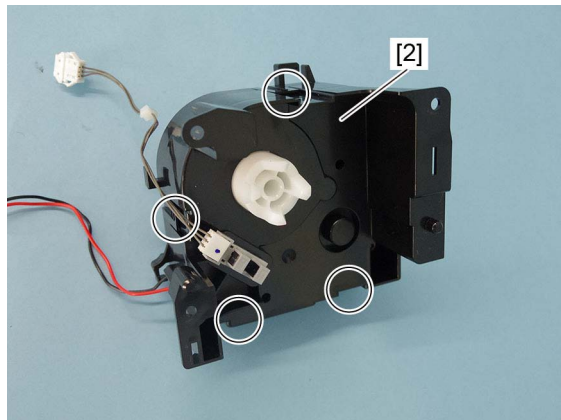

Fig. 4-234

- (4) Release 3 latches, and then remove the 2nd drawer paper remaining sensor [3].

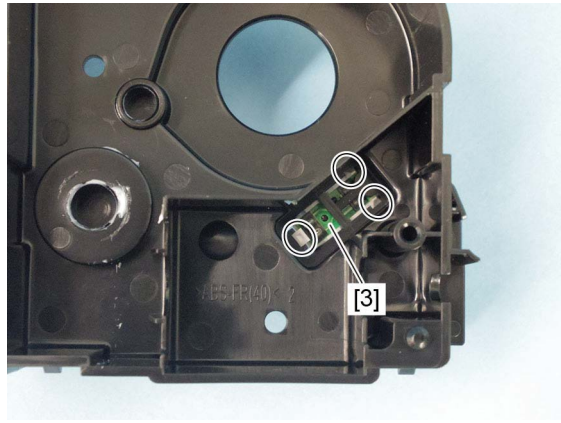

Fig. 4-235

4.5.28 1st drawer empty sensor (S5) and 1st drawer tray-up sensor (S31)

- (1) Pull out the 1st drawer paper feed unit.
P. 4-75 "4.5.14 1st drawer paper feed unit"
- (2) Pull out the 2nd drawer paper feed unit.
P. 4-77 "4.5.16 2nd drawer paper feed unit"
- (3) Remove the 1st tray-up motor unit.
P. 4-84 "4.5.22 1st tray-up motor unit"
- (4) Release the harness from the harness clamp [1]. Release the latch [2].

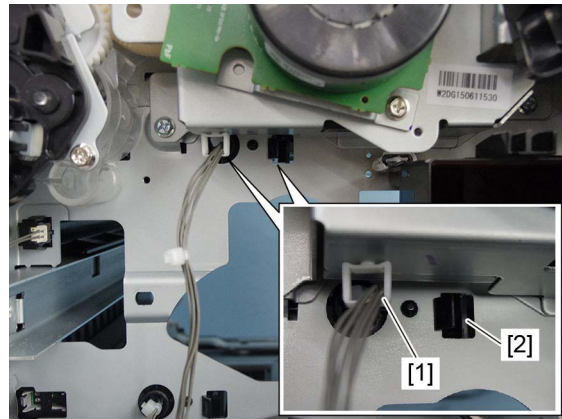

Fig. 4-236

- (5) Feed out the sensor holder [3] to the front side, and then remove it.

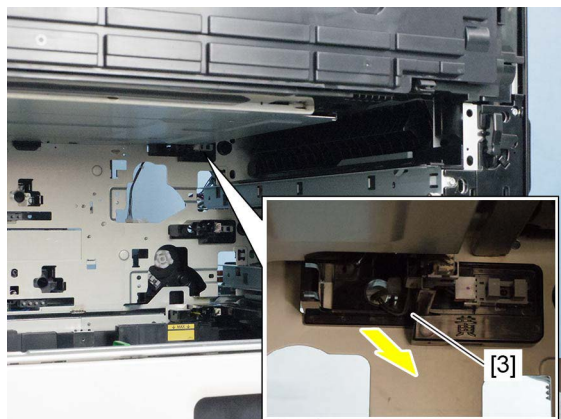

Fig. 4-237

Notes:

When installing, pass the connector through the hole [9], and fix it using the sensor holder projection [4] and latch [2].

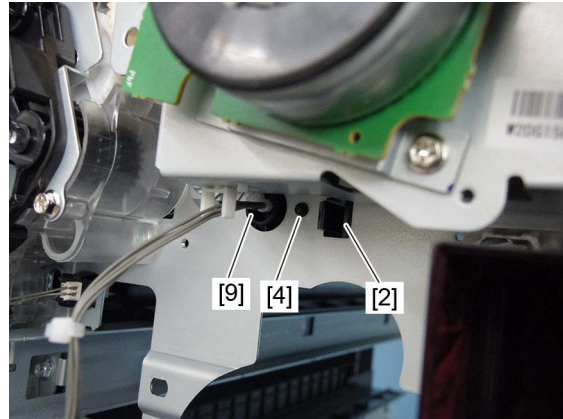

Fig. 4-238

- (6) Disconnect the 1 connector [5], and remove the 1st drawer empty sensor [6].
Disconnect the 1 connector [7], and remove the 1st drawer tray-up sensor [8].

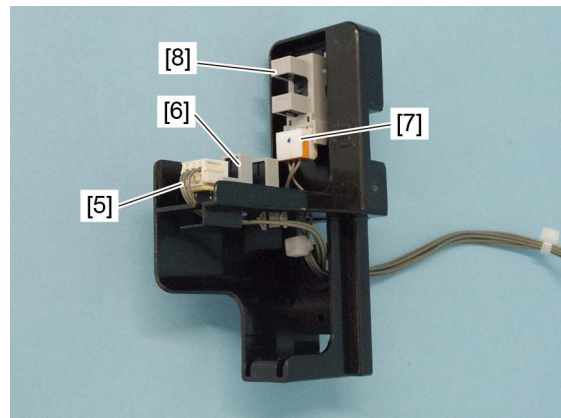

Fig. 4-239

Notes:

When installing connectors, connect the white connector to the 1st drawer empty sensor [6], and the yellow connector to the 1st drawer tray-up sensor [8].

4.5.29 2nd drawer empty sensor (S34) and 2nd drawer tray-up sensor (S35)

- (1) Pull out the 1st drawer paper feed unit.
📖 P. 4-75 “4.5.14 1st drawer paper feed unit”
- (2) Pull out the 2nd drawer paper feed unit.
📖 P. 4-77 “4.5.16 2nd drawer paper feed unit”
- (3) Remove the 1st tray-up motor unit.
📖 P. 4-84 “4.5.22 1st tray-up motor unit”
- (4) Release the harness from the harness clamp [1]. Release the latch [2].

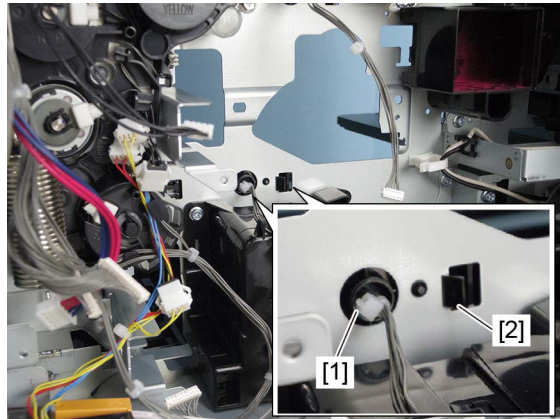

Fig. 4-240

- (5) Feed out the sensor holder [3] to the front side and then remove it.

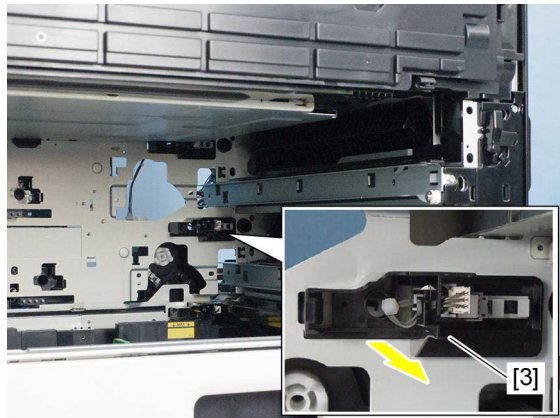

Fig. 4-241

Notes:

When installing, pass the connector through the hole [9], and fix it using the sensor holder projection [4] and latch [2].

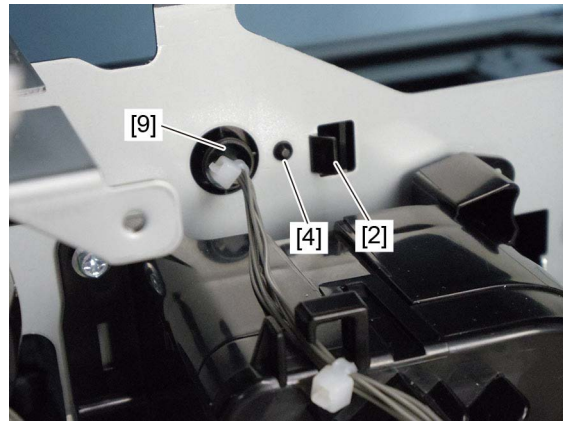

Fig. 4-242

- (6) Disconnect the 1 connector [5], and remove the 2nd drawer empty sensor [6].
Disconnect the 1 connector [7], and remove the 2nd drawer tray-up sensor [8].

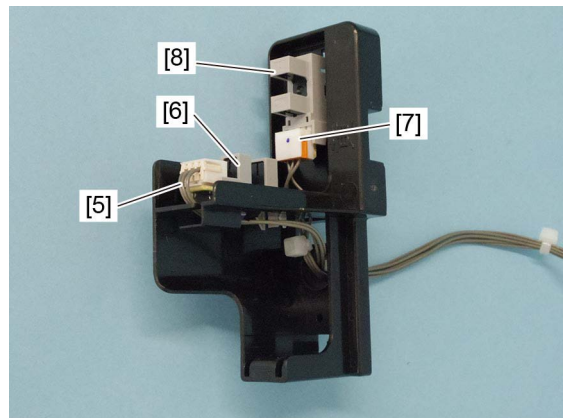

Fig. 4-243

Notes:

When installing connectors, connect the white connector to the 2nd drawer empty sensor [6], and the yellow connector to the 2nd drawer tray-up sensor [8].

4.5.30 1st drawer paper width detection switch (SW6) and 1st drawer paper length detection switch (SW7)

- (1) Remove the high-voltage transformer.
P. 9-15 “9.1.9 High-voltage transformer (HVT)”
- (2) Remove 1 spring [1] and disconnect the 2 connectors [2].

Notes:

Connect the yellow harness connector to the left side.

- (3) Release the latch, and remove the switch holder [3].

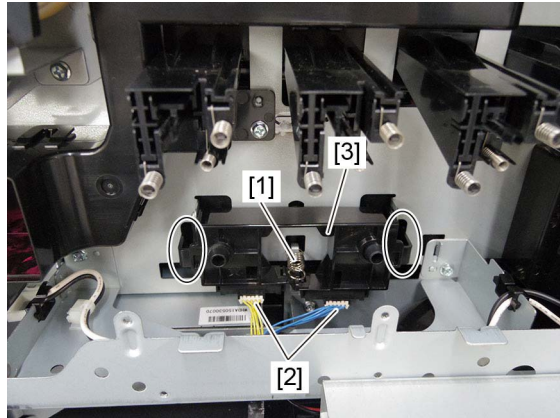

Fig. 4-244

- (4) Release the latch, and remove the 1st drawer paper width detection switch [4] and 1st drawer paper length detection switch [5].

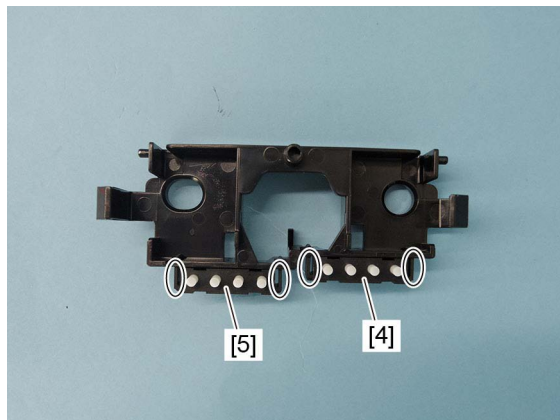



Fig. 4-245

4.5.31 2nd drawer paper width detection switch (SW17) and 2nd drawer paper length detection switch (SW18)

- (1) Remove the ozone exhaust fan duct.
 P. 4-151 "4.6.29 Ozone exhaust fan (F2)"
- (2) Remove 2 harness clamps [1].

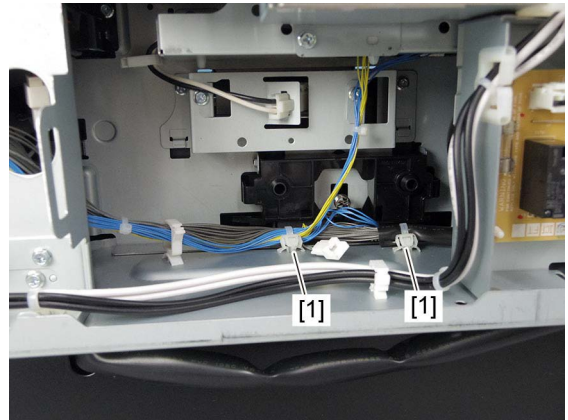

Fig. 4-246

- (3) Remove 1 spring [2] and disconnect 2 connectors [3].

Notes:

Connect the yellow harness connector to the left side.

- (4) Release the latch, and remove the switch holder [4].

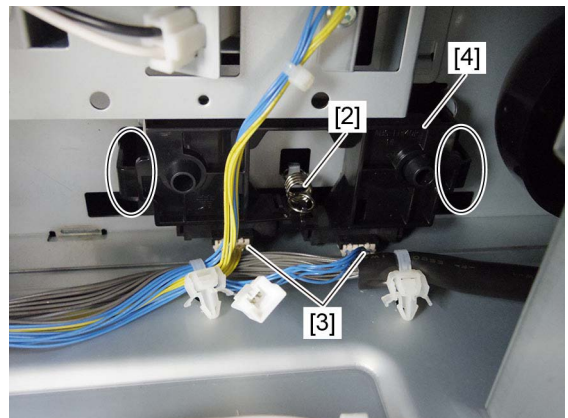

Fig. 4-247

- (5) Release the latch, and remove the 2nd drawer paper width detection switch [5] and 2nd drawer paper length detection switch [6].

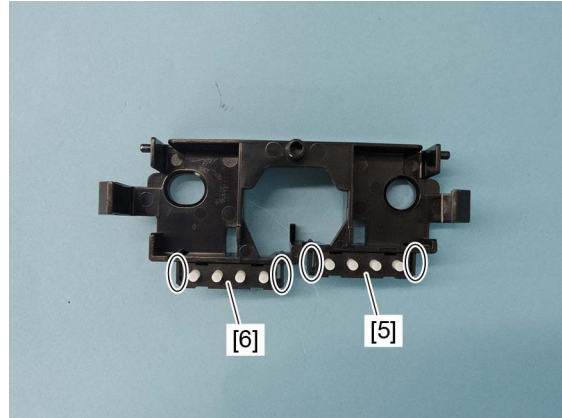

Fig. 4-248

4.5.32 Transport clutch (H) (CLT5)

- (1) Remove the rear cover.
P. 4-10 "4.1.17 Rear cover"
- (2) Disconnect 13 connectors and 1 relay connector [5].
- (3) Release the harness from the harness clamp [6].
- (4) Remove 1 harness clamp [7].
- (5) Release the harness from the harness guides [8].

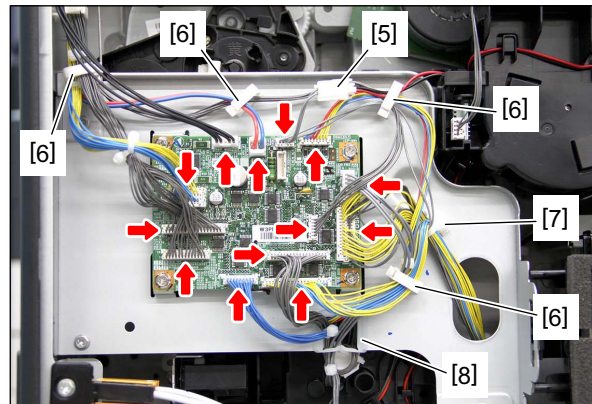

Fig. 4-249

- (6) Remove the hook [1] of the ozone exhaust fan duct.
- (7) Remove 3 screws and take off the bracket [2].

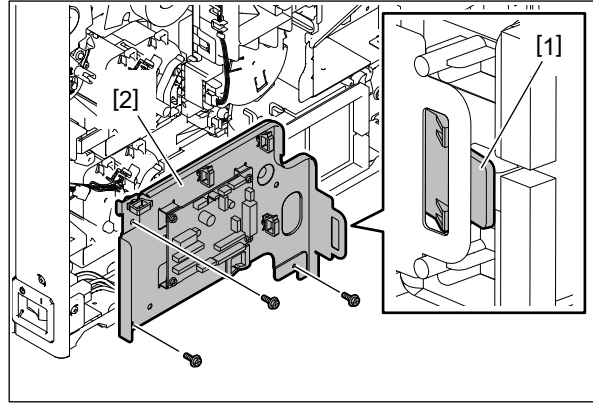

Fig. 4-250

- (8) Disconnect 3 connectors [9] and release the harness from the harness guides.

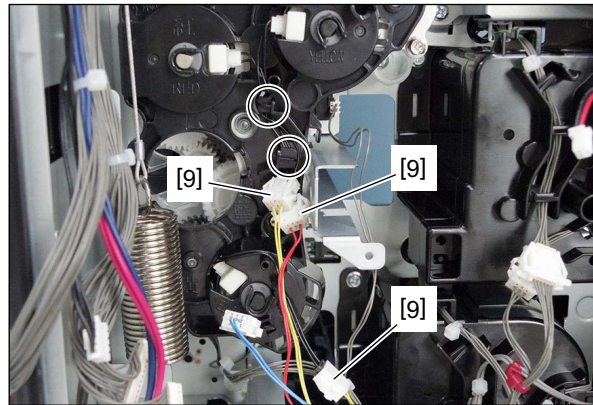

Fig. 4-251

- (9) Remove 3 clips [10] and take off 3 bushings [11].

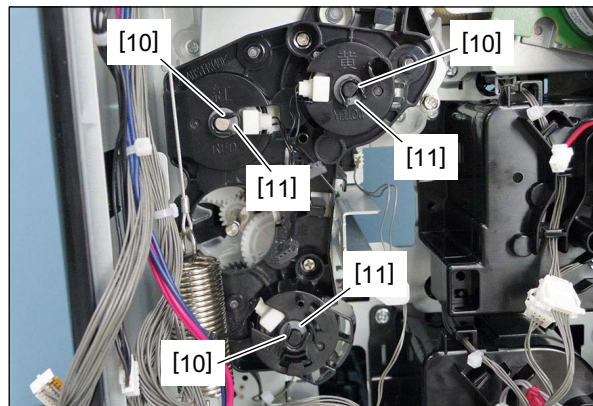

Fig. 4-252

(10) Remove 2 screws and take off the clutch cover [12].

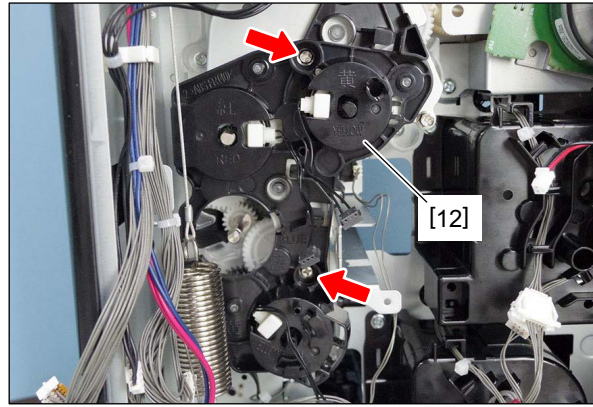

Fig. 4-253

(11) Remove the transport clutch (H) [13].

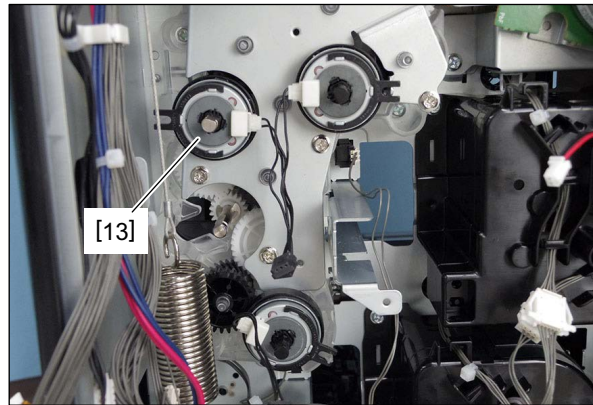

Fig. 4-254

Notes:

When installing the clutch, attach a rotation stopper.



Fig. 4-255

4.5.33 Transport clutch (L) (CLT6)

- (1) Remove the rear cover.
P. 4-10 "4.1.17 Rear cover"
- (2) Disconnect 13 connectors and 1 relay connector [5].
- (3) Release the harness from the harness clamp [6].
- (4) Remove 1 harness clamp [7].
- (5) Release the harness from the harness guides [8].

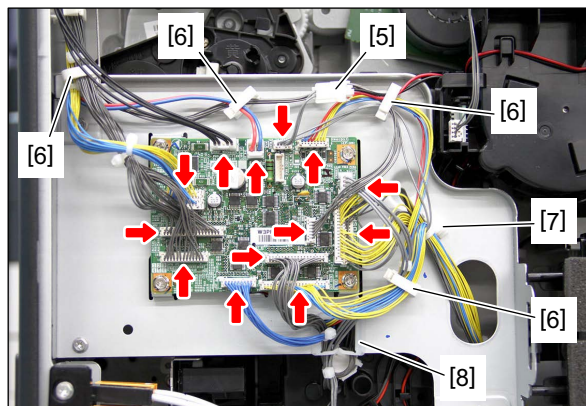

Fig. 4-256

- (6) Remove the hook [1] of the ozone exhaust fan duct.
- (7) Remove 3 screws and take off the bracket [2].

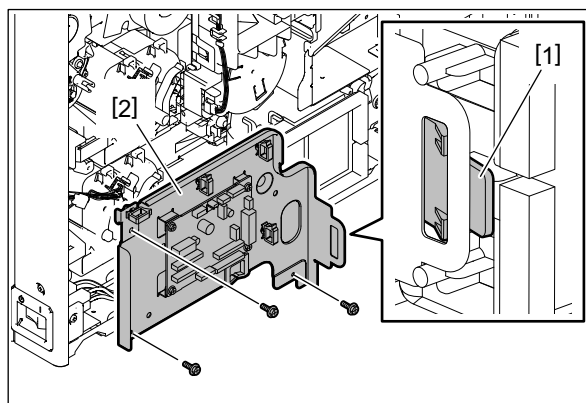

Fig. 4-257

- (8) Remove 1 clip [3] and disconnect 1 connector [4], and then take off the transport clutch (L) [9].

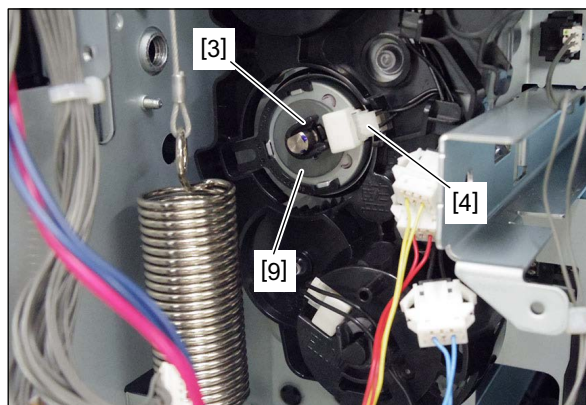

Fig. 4-258

Notes:

When installing the clutch, attach a rotation stopper.



Fig. 4-259

4.5.34 1st drawer feed clutch (CLT1)

- (1) Remove the transport clutch (L).
📖 P. 4-100 “4.5.33 Transport clutch (L) (CLT6)”
- (2) Remove the clutch cover.
📖 P. 4-97 “4.5.32 Transport clutch (H) (CLT5)”
- (3) Remove the 1st drawer feed clutch [1].

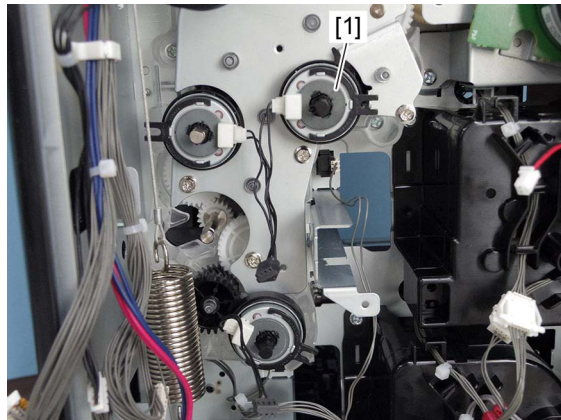

Fig. 4-260

Notes:

When installing the clutch, attach a rotation stopper.

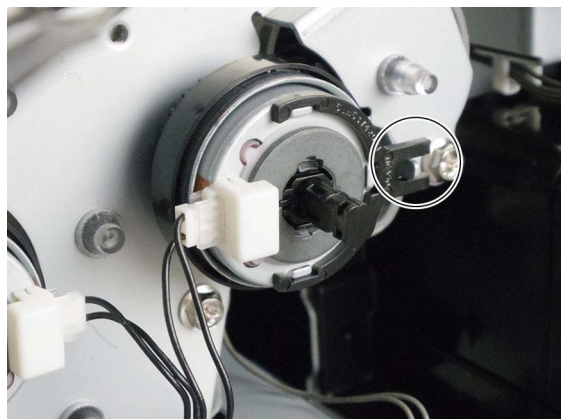



Fig. 4-261

4.5.35 2nd drawer feed clutch (CLT4)

- (1) Remove the clutch cover.
 P. 4-97 "4.5.32 Transport clutch (H) (CLT5)"
- (2) Remove the 2nd drawer feed clutch [1].

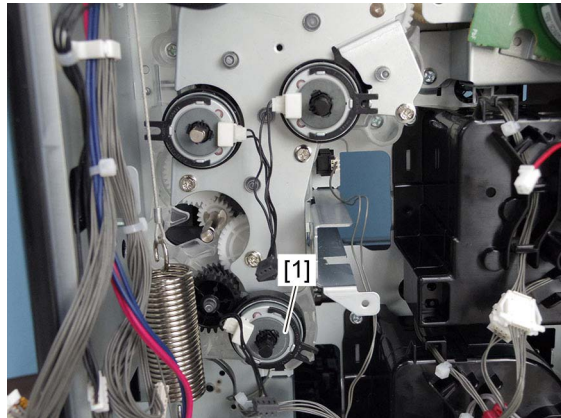

Fig. 4-262

Notes:

When installing the clutch, attach a rotation stopper.



Fig. 4-263

4.5.36 Registration motor (M14)

- (1) Remove the rear cover.
 P. 4-10 "4.1.17 Rear cover"
- (2) Remove 3 screws and disconnect the 1 connector [1], and take off the registration motor [2].

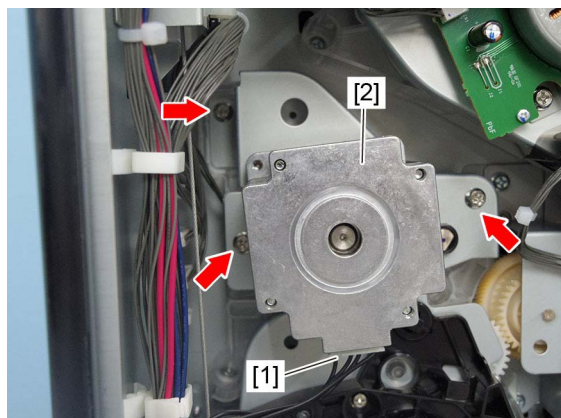

Fig. 4-264

- (3) Release the latch [3] and remove the gear [4].

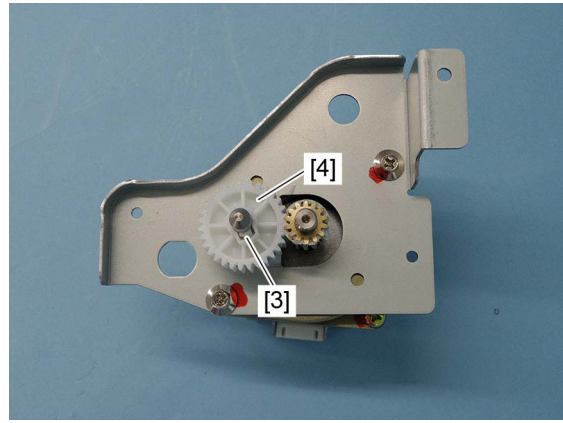

Fig. 4-265

Notes:

When replacing the parts or performing machine refreshment, apply 4 rice-sized grains of white grease (Molykote EM-30L) to the tooth surface of the gear and 1 or 2 rice-sized grains of white grease (Molykote EM-30L) to the shaft.

4.5.37 Paper feed drive unit

- (1) Remove the transport clutch (L).
📖 P. 4-100 “4.5.33 Transport clutch (L) (CLT6)”
- (2) Remove the registration motor.
📖 P. 4-102 “4.5.36 Registration motor (M14)”
- (3) Remove 1 bushing [1] and 1 gear [2].

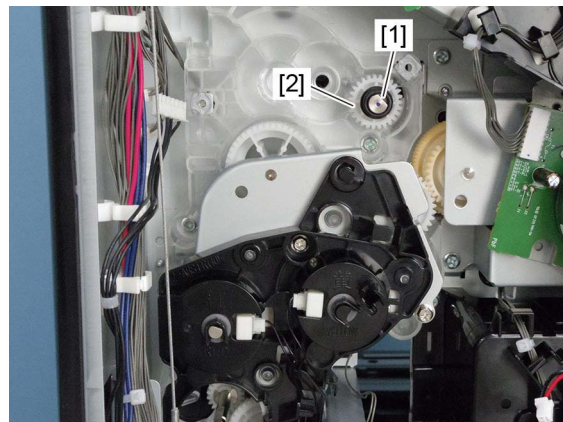

Fig. 4-266

- (4) Disconnect the 3 connectors [3].
- (5) Release the harness from the harness guides.

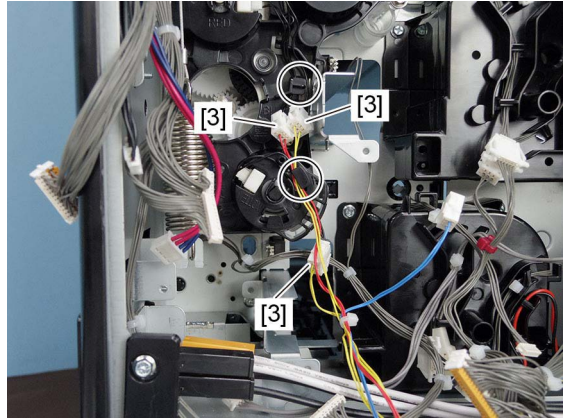

Fig. 4-267

- (6) Remove the spring [4].

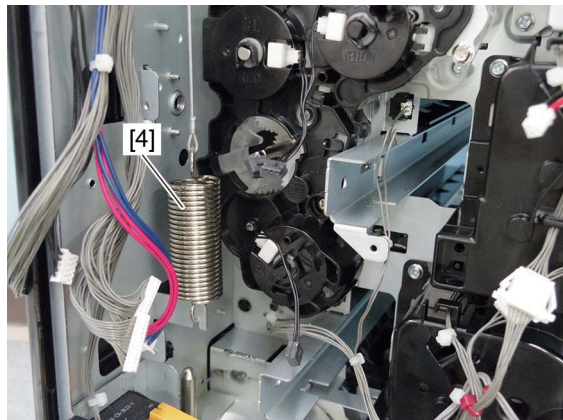

Fig. 4-268

- (7) Remove 4 screws, and take off the paper feed drive unit [5].

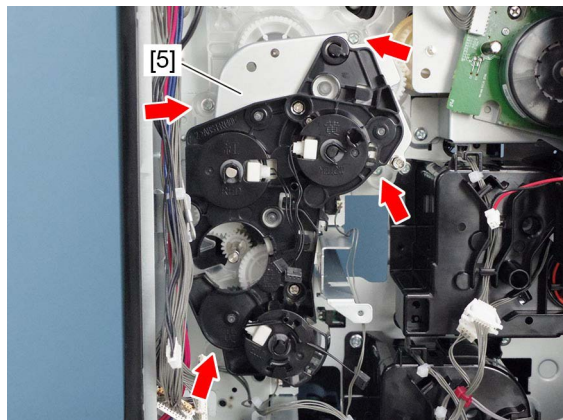

Fig. 4-269

4.5.38 Paper feed drive gear

- (1) Remove the paper feed drive unit.
☞ P. 4-103 "4.5.37 Paper feed drive unit"
- (2) Remove 3 clips [1], and take off 3 bushings [2].
- (3) Remove 2 screws and take off the clutch cover [3].

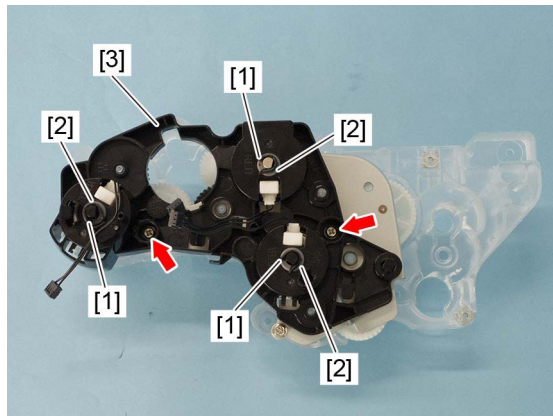

Fig. 4-270

- (4) Remove the 1st drawer paper feed clutch [4], 2nd drawer paper feed clutch [5], and transport clutch (H) [6].

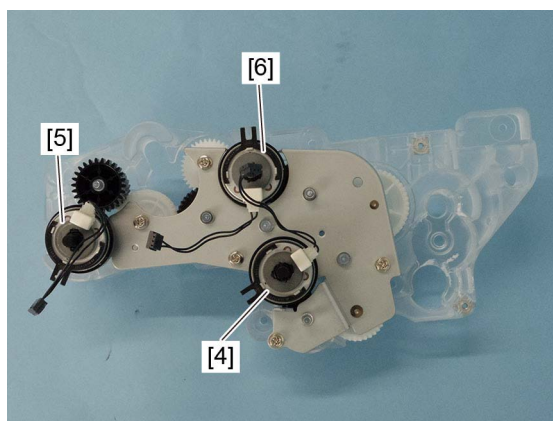

Fig. 4-271

Notes:

When installing the clutch, attach a rotation stopper.

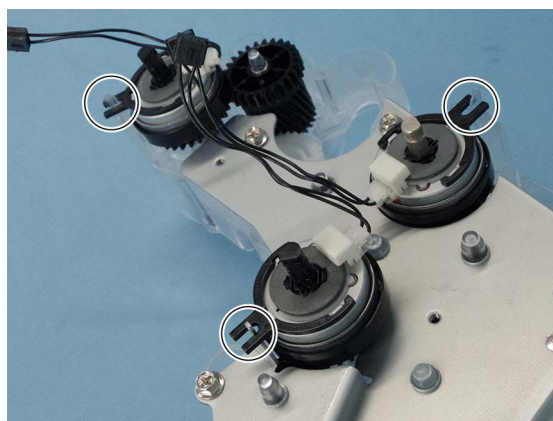

Fig. 4-272

- (5) Remove 5 screws and take off the paper feed drive gear cover [7].

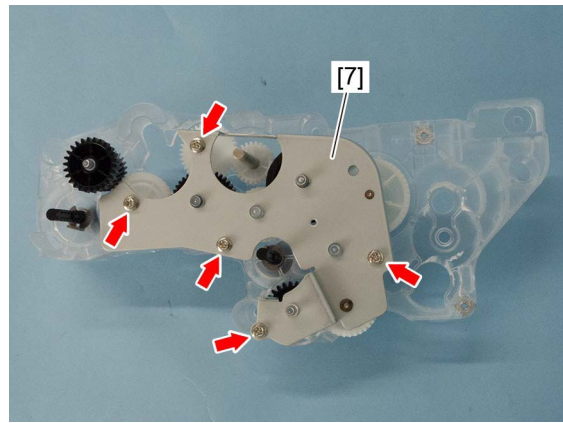

Fig. 4-273

Notes:

When replacing the parts or performing machine refreshment, apply 2 rice-sized grains of white grease (Molykote EM-30L) to the shaft [8].

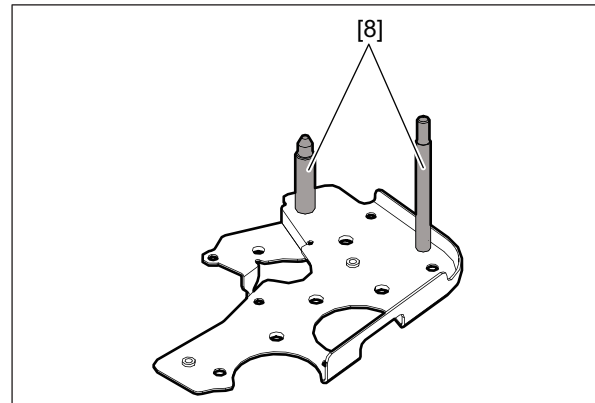

Fig. 4-274

- (6) Remove the paper feed drive gear.

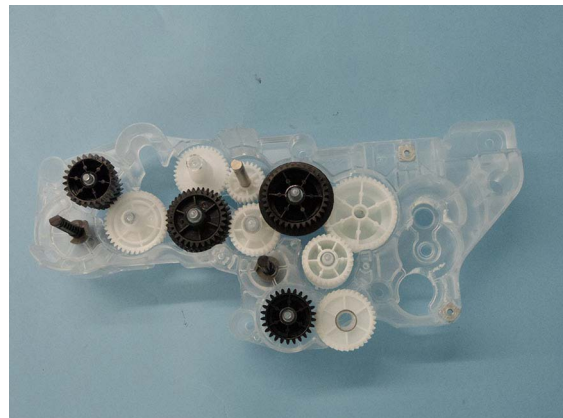

Fig. 4-275

Notes:

When replacing the parts or performing machine refreshment, apply 2 rice-sized grains of white grease (Molykote EM-30L) to the shaft [9] and also 4 rice-sized grains of white grease (Molykote EM-30L) to the tooth surface of the gear [10]. Do not apply grease to the black gears.

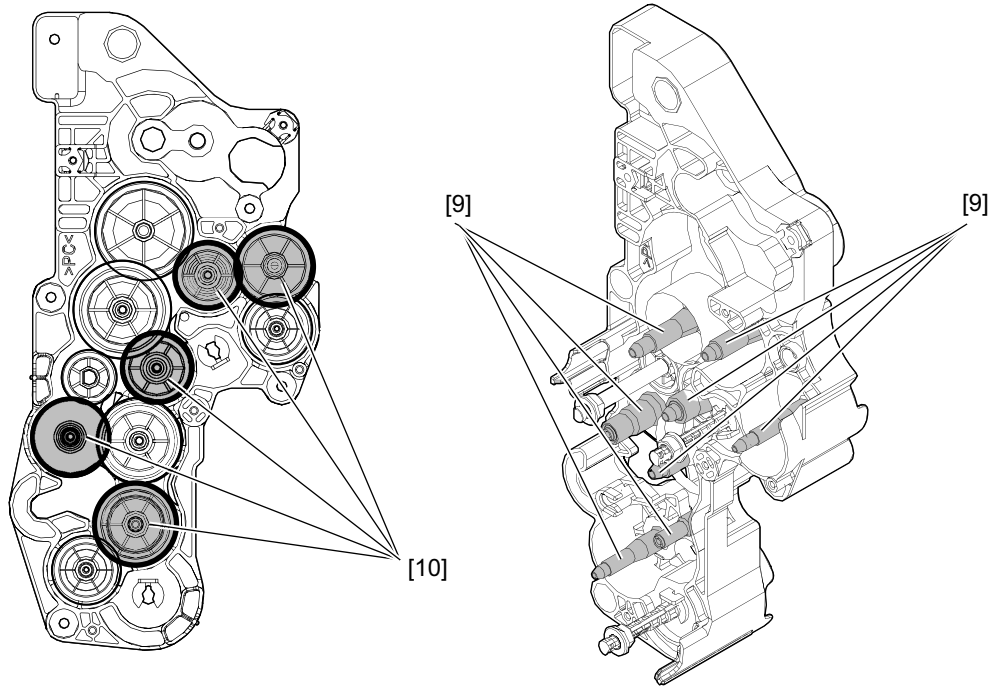

Fig. 4-276

4.6 Process Unit (Developer Unit, Cleaner)

4.6.1 Waste toner box

- (1) Open the front cover.
- (2) Press down 2 hooks and remove the waste toner box [1].

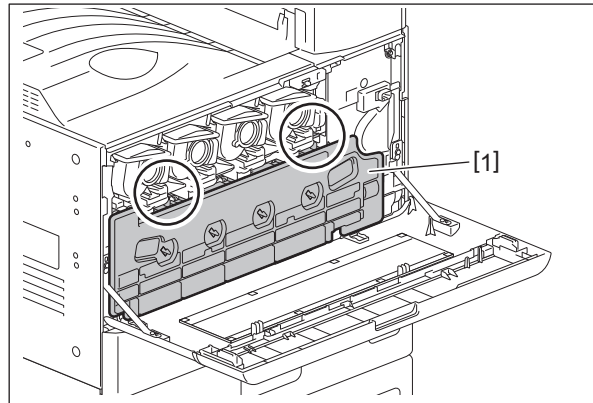

Fig. 4-277

Notes:

Put the waste toner box level.

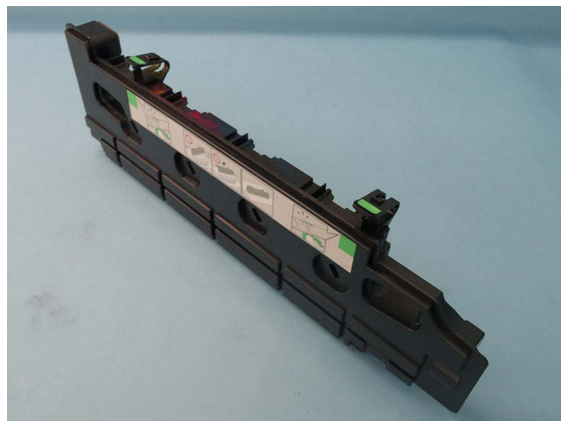
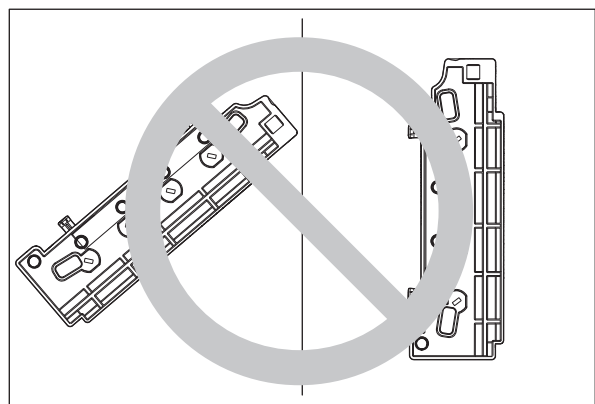

Fig. 4-278

Do not tilt the waste toner box.



4.6.2 Process unit (Developer unit, Cleaner)

- (1) Remove the waste toner box.
P. 4-108 "4.6.1 Waste toner box"

Notes:

To remove the process unit for black (K), pull the TBU release lever [1], turn it clockwise to release the lock, and then pull out the process unit.

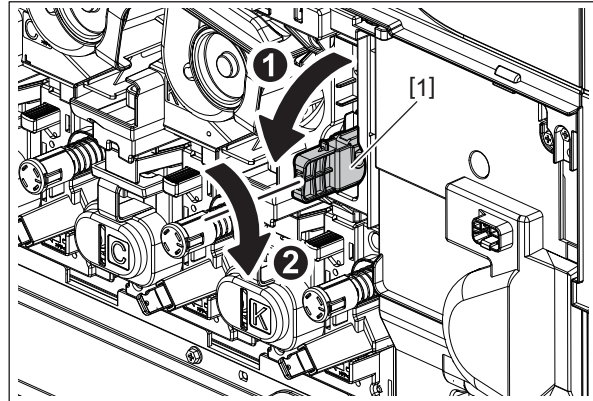

Fig. 4-279

- (2) Put your finger into the knob [2], and remove the process unit [3] carefully while pushing down the process unit cover lever [1].

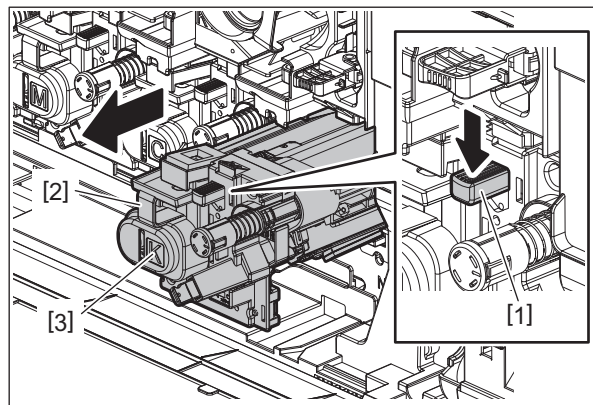

Fig. 4-280

Notes:

When installing the process unit [3], insert it carefully keeping it horizontal [5].

If it is tilted (especially if its leading edge is upward), the upper part of the unit will catch the edge of the transfer belt [6]. Pushing it will damage the belt.

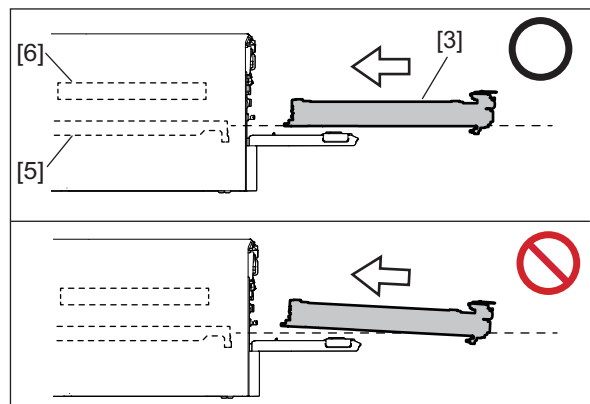

Fig. 4-281

(3) Release the 2 hooks.

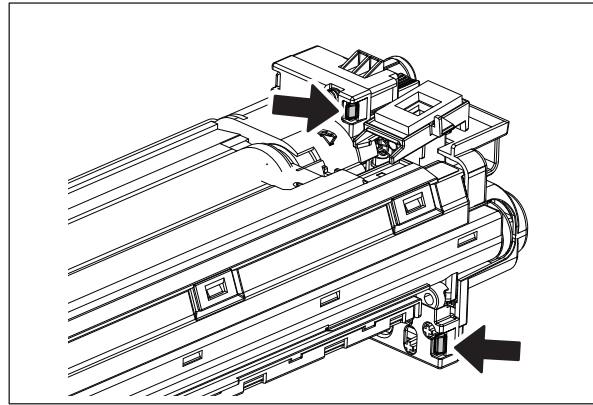

Fig. 4-282

(4) Release the 2 hooks and take off the process unit cover[7].

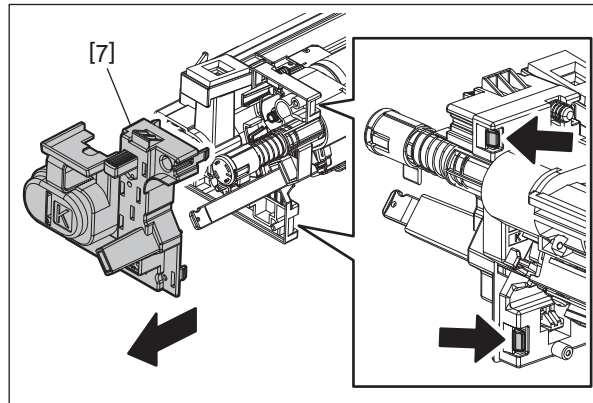

Fig. 4-283

(5) Hold the process unit while putting your thumbs at its arrow portions as shown in the figure.

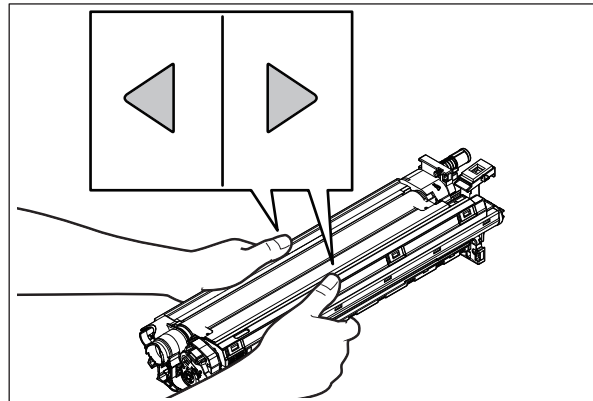

Fig. 4-284

Notes:

- Do not hold the edge of the process unit.
- Be careful not to touch the drum.

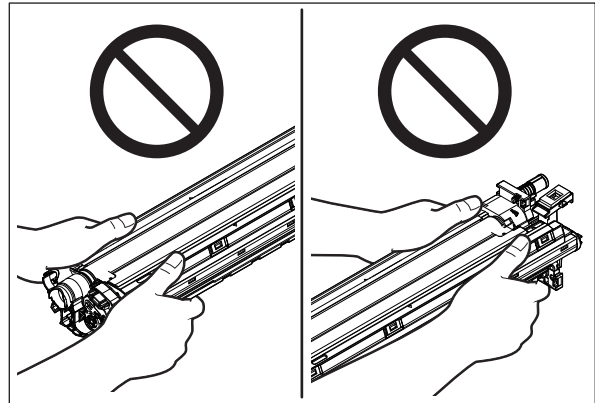

Fig. 4-285

- When handling or disassembling the developer unit, pay attention not to touch the folded portion (indicated by the arrows) of the pole position adjustment plate.

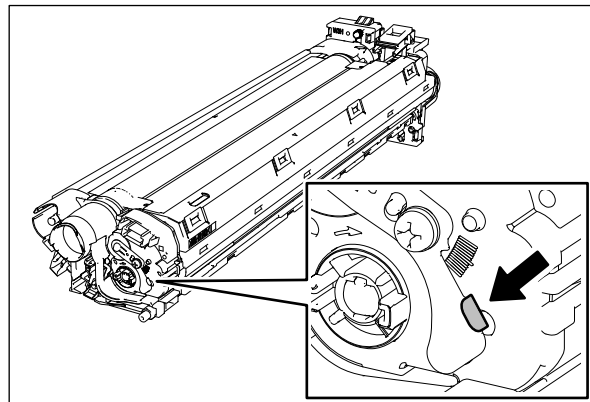

Fig. 4-286

(6) Put the developer unit [8] level, and open the cleaner unit [9].

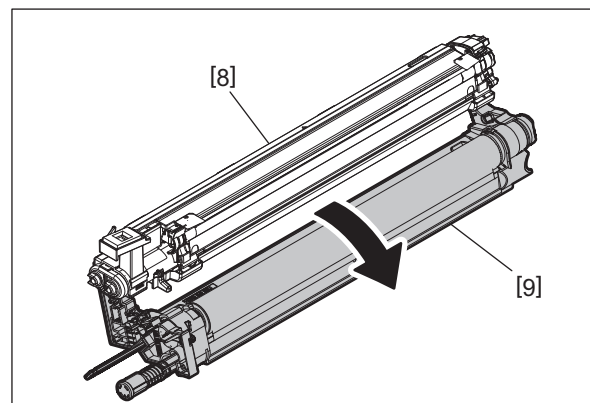

Fig. 4-287

Notes:

Do not tilt the developer unit.

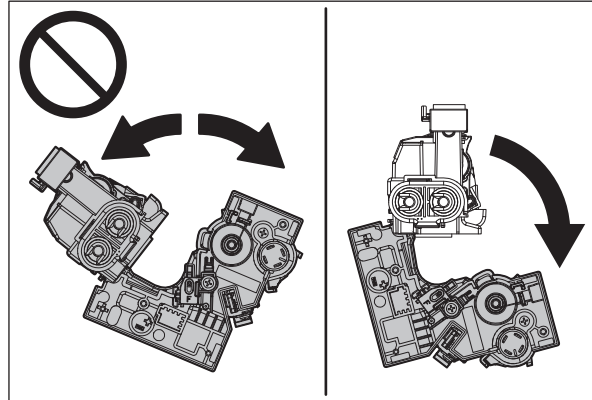

Fig. 4-288

(7) Slide the cleaner unit [10] and the developer unit [11] to release 2 bosses [12].

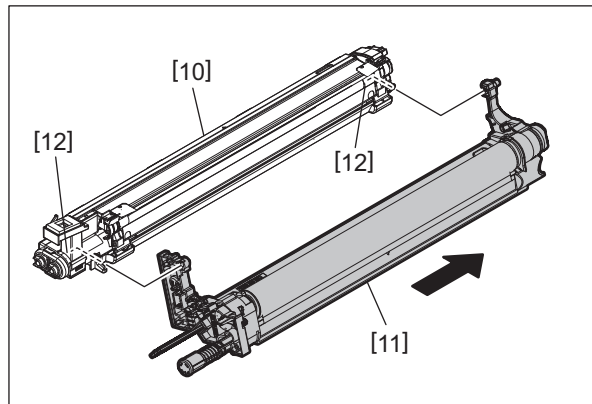

Fig. 4-289

Notes:

Apply conductive grease (FLOIL (GE-334C)) to the following portions.

- Application portion: Cleaner unit section
- Portion: Shaft of RTNR-EPU-FRT-H373-xxx (for each of the 4 colors)
- Amount: 2 rice-sized grains (for each)

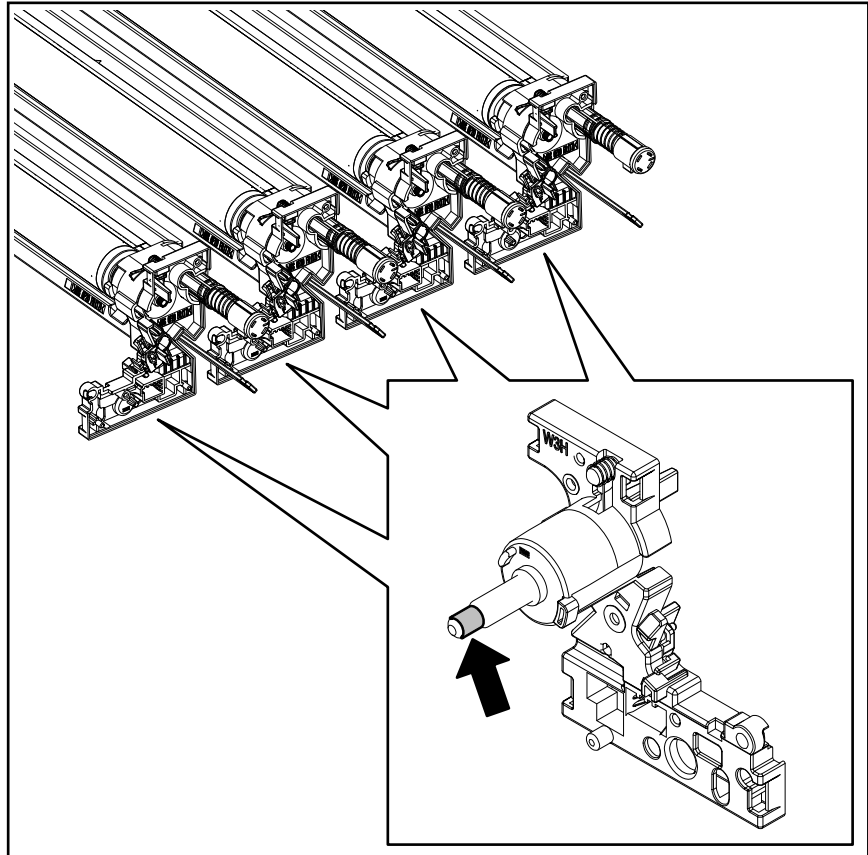



Fig. 4-290

4.6.3 Developer material

[A] Removing developer material

- (1) Remove the developer unit.
 P. 4-109 “4.6.2 Process unit (Developer unit, Cleaner)”
- (2) Release the latch [1] and the hook [2].

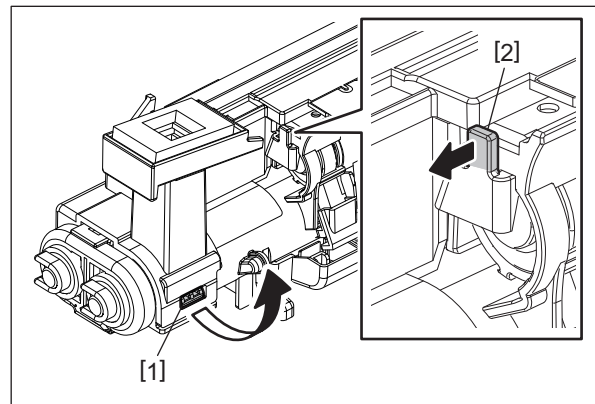

Fig. 4-291

- (3) Release 6 latches at the side of the upper cover.

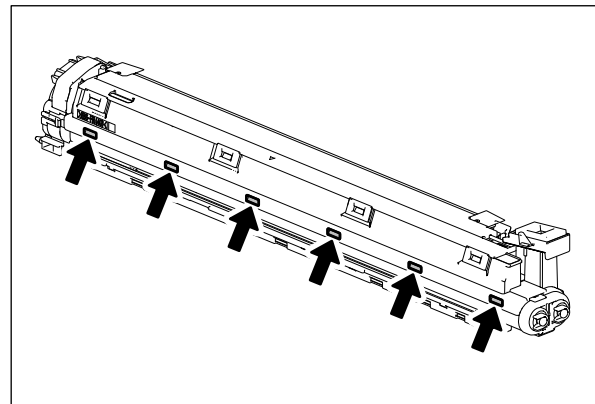

Fig. 4-292

- (4) Remove the upper cover [3].

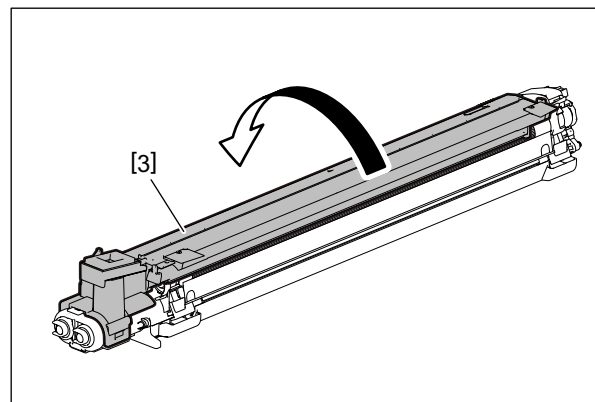

Fig. 4-293

(5) Discharge the developer material.

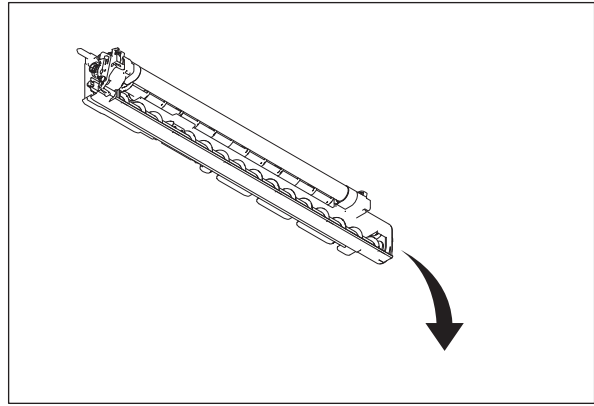

Fig. 4-294

Notes:

- Make sure not to have developer material adhering to the drive gears or bushings.
- If the developer material on the developer sleeve is hard to come off, use a brush (jig) to clean it off.

4407915710 BRUSH-33

[B] Filling developer unit with developer material

- (1) Shake the developer material bag and open it.
- (2) Pour in the developer until the mixer [1] under the developer sleeve is full.

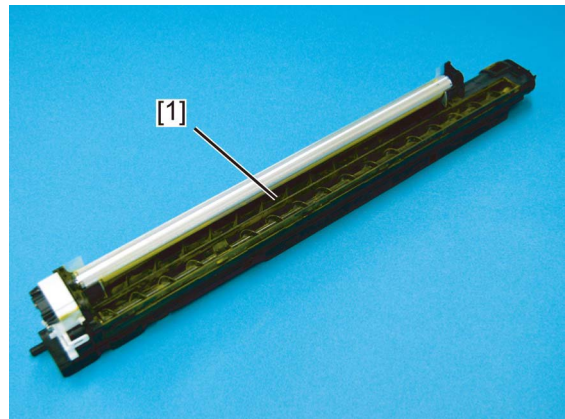

Fig. 4-295

- (3) Turn the knob [2] in the direction of the arrow shown on the cover until the developer material is evenly adhered to the surface of the developer sleeve.

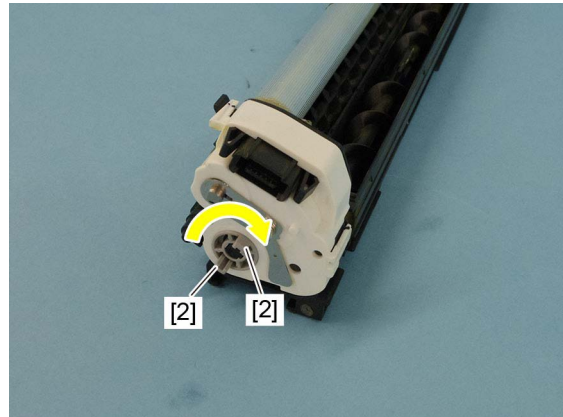

Fig. 4-296

- (4) Lift the rear side of the developer unit up and move the developer material to the front side of the mixer under the developer sleeve.



Fig. 4-297

- (5) Pour in more developer until the mixer [1] under the developer sleeve is full.

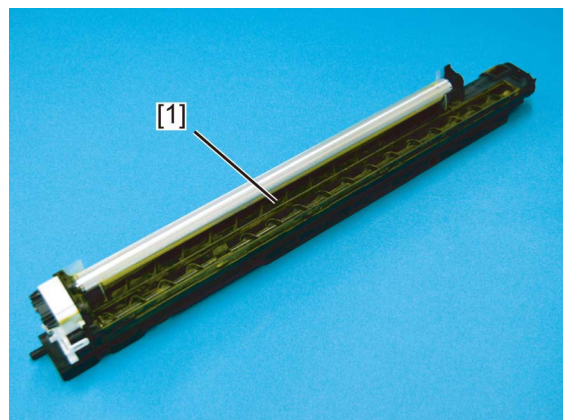

Fig. 4-298

(6) Pour all the remaining developer material into another mixer [3].

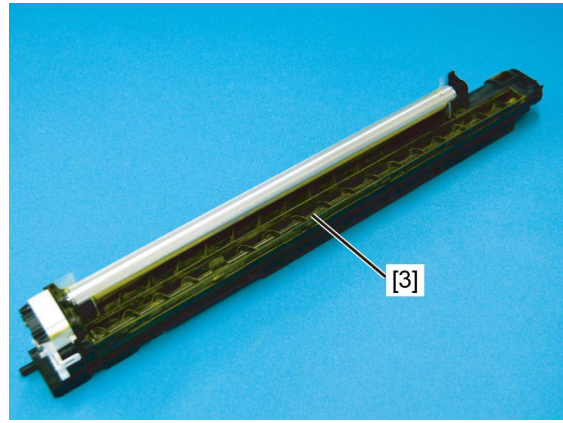

Fig. 4-299

Notes:

- Fill the developer material in the mixer section under the developer sleeve as much as possible.
- Check if the developer does not adhered to the joint of the upper cover.

(7) Install the upper cover.

Notes:

After the installation, check that all the protrusions and latches are fitted and locked securely.

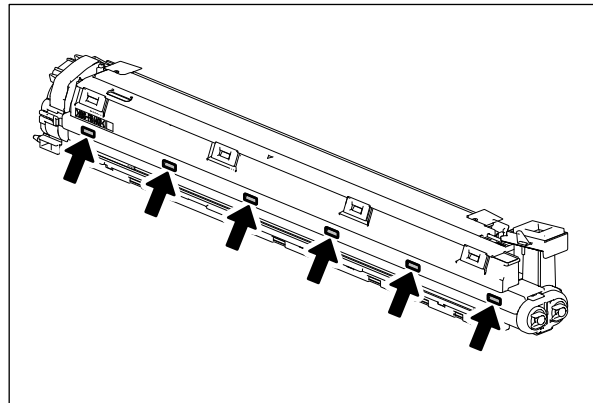

Fig. 4-300

4.6.4 Doctor blade

- (1) Discharge the developer material.
 P. 4-114 "4.6.3 Developer material"
- (2) Remove 2 screws.



Fig. 4-301

- (3) Peel off the side seal [1].

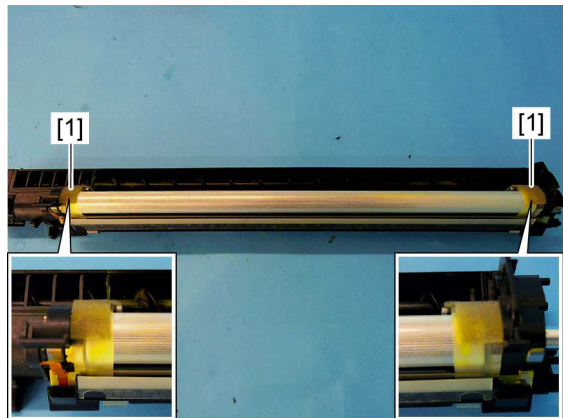

Fig. 4-302

- (4) Remove the doctor blade [2].



Fig. 4-303

4.6.5 Auto-toner sensor (S1, S2, S3, S4)

The auto-toner sensor is installed in the developer unit (Y, M, C, K).

- Auto-toner sensor (S1): Developer unit (K)
- Auto-toner sensor (S2): Developer unit (C)
- Auto-toner sensor (S3): Developer unit (M)
- Auto-toner sensor (S4): Developer unit (Y)

(1) Remove the corresponding the developer unit, and then discharge the developer material out of the unit.

📖 P. 4-109 “4.6.2 Process unit (Developer unit, Cleaner)”

📖 P. 4-114 “4.6.3 Developer material”

(2) Release the 2 hooks and take off the auto-toner sensor cover [1].

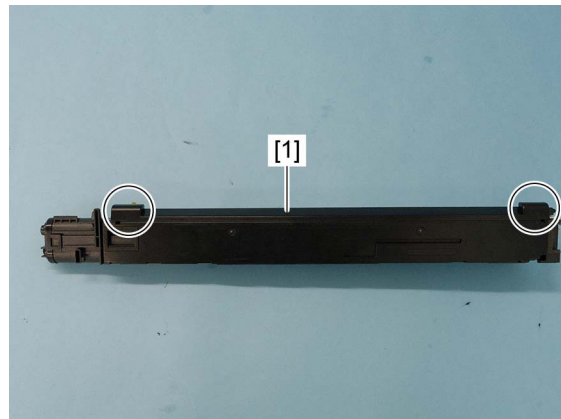

Fig. 4-304

(3) Disconnect the 1 connector [2].

(4) Remove the auto-toner sensor [3] by turning it counterclockwise.

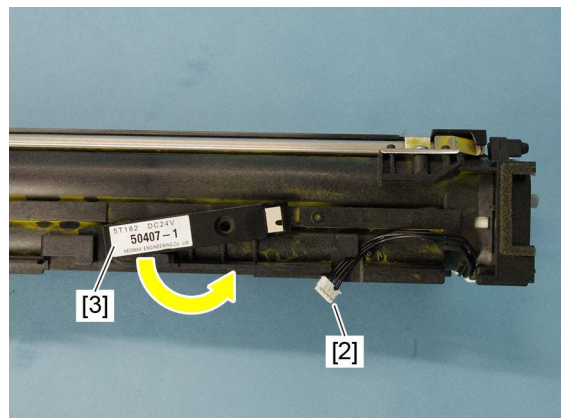



Fig. 4-305

4.6.6 Developer sleeve

- (1) Discharge the developer material.
 P. 4-114 “4.6.3 Developer material”
- (2) Before removing the pole position adjustment plate, record its scale position. (If necessary, add a marking.)
When the pole position adjustment plate is reattached, align it to the recorded scale position.

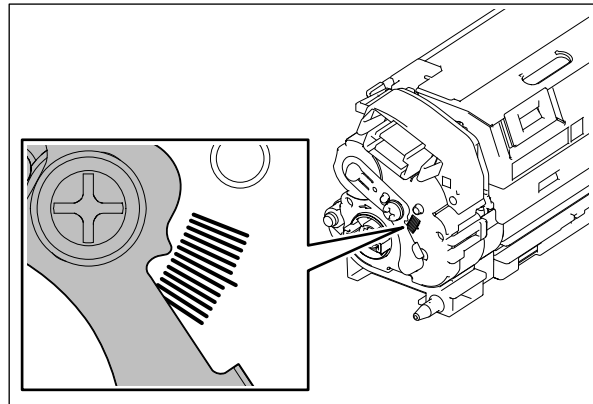

Fig. 4-306

- (3) Remove 1 screw and take off the pole position adjustment plate [1].

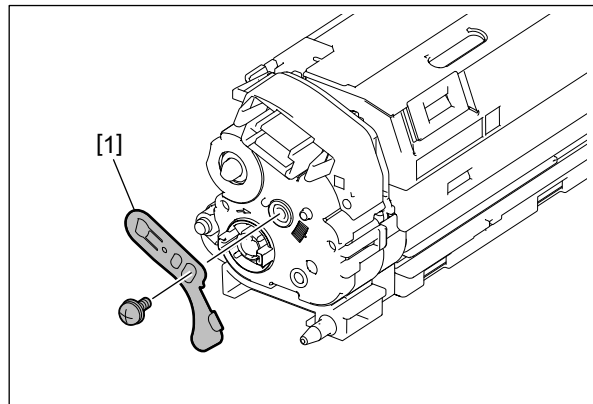

Fig. 4-307

- (4) Release 2 latches and remove the gear cover [2].

Notes:

When installing, align the idler gear shaft to the hole of the gear holder.

- (5) Disconnect the 1 connector [3] from the gear cover.

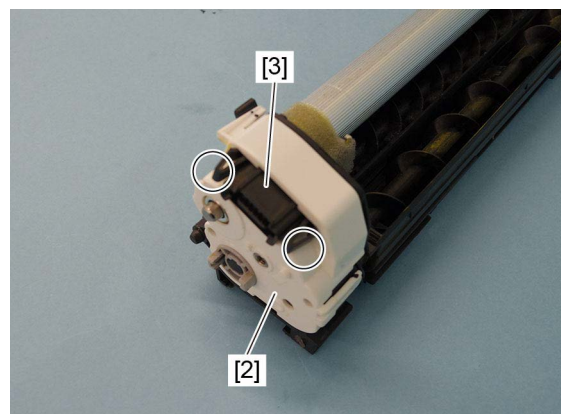

Fig. 4-308

(6) Remove the crescent ring [4], and take off the gear [5]. Remove the gear [6][7][8].

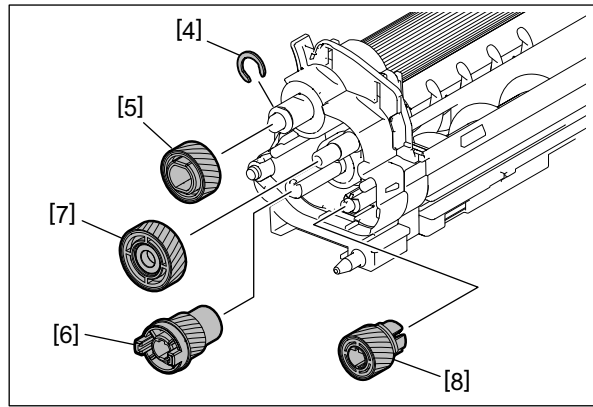

Fig. 4-309

Notes:

The color of the gear [7] differs between the 25/30/35ppm and 45/50ppm.

- 25/30/35ppm: White (A bearing is not inserted): Figure
- 45/50ppm: Gray (A bearing is inserted)

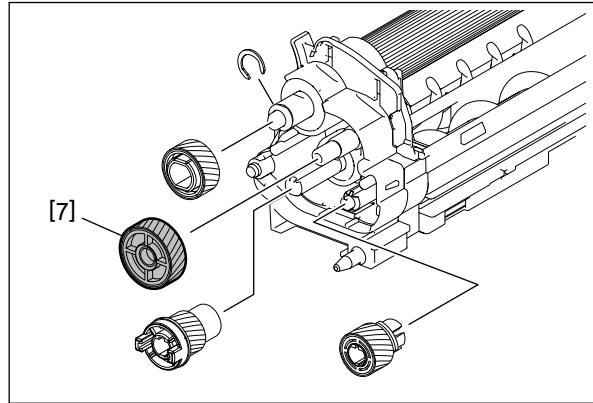

Fig. 4-310

(7) Remove the 2 bearings [5], 1 bearing holder [6], and developer sleeve [7].

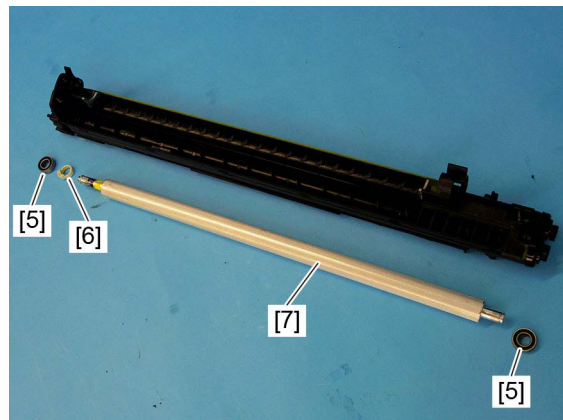

Fig. 4-311

4.6.7 Mixer

- (1) Remove the developer sleeve.
P. 4-120 "4.6.6 Developer sleeve"
- (2) Remove 2 clips [1], the front bushing holder [2] and 2 bearings [3].

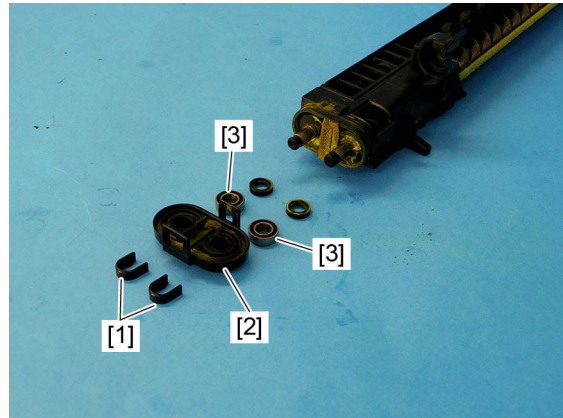

Fig. 4-312

Notes:

The parts [3] for the 25/35 ppm models are the bushings instead of the bearings.

- (3) Remove the separator [4], mixer [5], and bushing [6] from the front side.

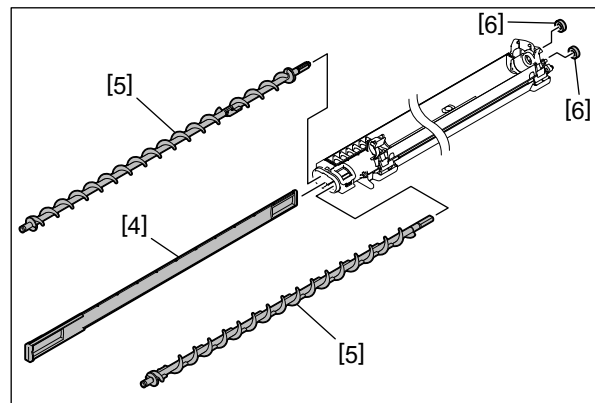

Fig. 4-313

Notes:

When installing a separator, turn the short collar [7] side to the left.

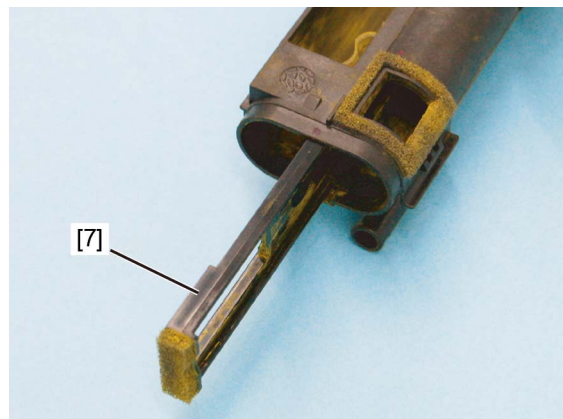

Fig. 4-314

4.6.8 Replacement of oil seal

- (1) Insert a fine screwdriver into the depression of the oil seal to take it out.
- (2) Push in a new oil seal parallel to the frame or bushing (shown figure).

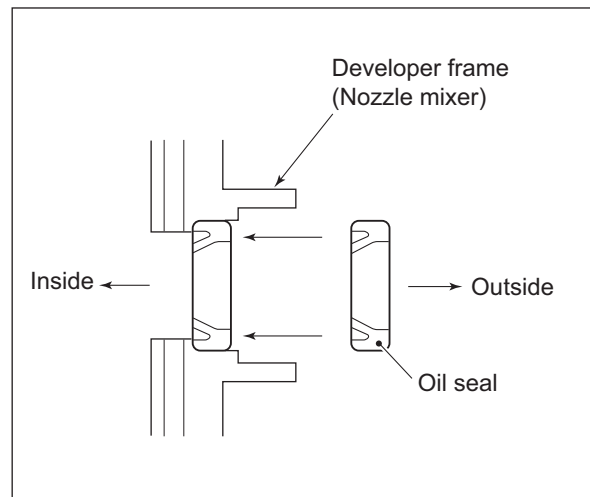



Fig. 4-315

4.6.9 Main charger

- (1) Remove the cleaner unit.
 P. 4-109 “4.6.2 Process unit (Developer unit, Cleaner)”
- (2) Lift the front side of the main charger [1] and lift it as shown in the figure.

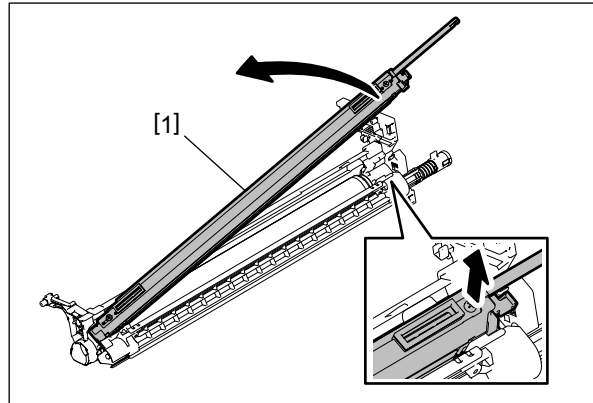

Fig. 4-316

- (3) Slide the main charger [1] toward the rear side and remove it.

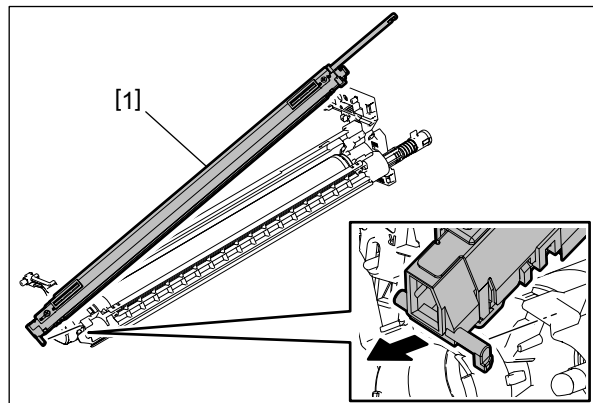



Fig. 4-317

4.6.10 Drum and bushing

- (1) Remove the main charger.
 P. 4-124 "4.6.9 Main charger"
- (2) Remove 2 screws and take off the holder [1].

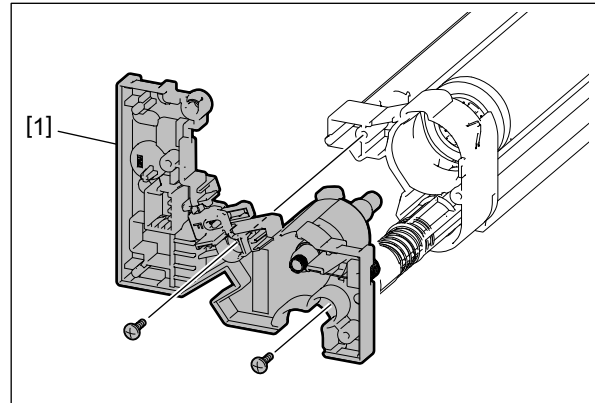

Fig. 4-318

- (3) Remove the drum [2] and bushing [3] from the cleaner.

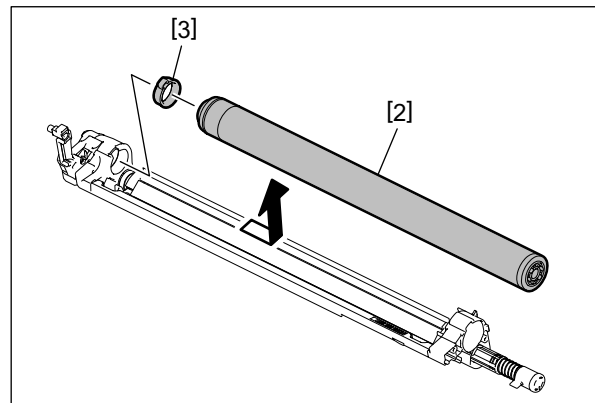

Fig. 4-319

Notes:

- Be sure not to touch, spit or scratch on the drum surface.
- Avoid a direct sunlight onto the drum. Move it to a dark place as soon as it is taken off.
- Be sure not to touch or scratch the edge of the drum cleaning blade.
- Flange on the front side of the K drum is black.



Fig. 4-320

- Flange on the front side of the YMC drum is white.

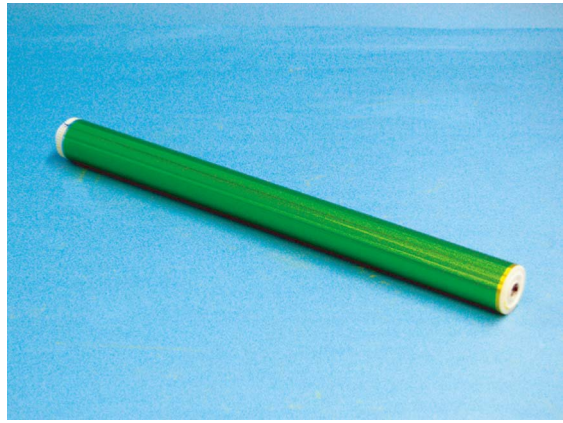

Fig. 4-321

4.6.11 Drum cleaning blade^{PM}

- (1) Remove the drum.
📖 P. 4-125 “4.6.10 Drum and bushing”
- (2) Remove the main charger.
📖 P. 4-124 “4.6.9 Main charger”
- (3) Remove 2 screws and take off the drum cleaning blade [1].

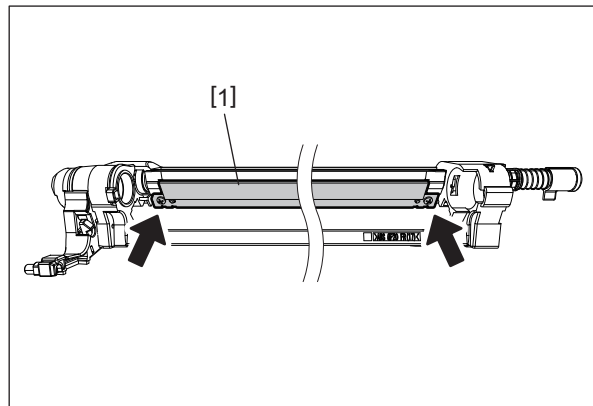

Fig. 4-322

Notes:

Be sure not to touch or scratch the edge of the cleaning blade.



Fig. 4-323

4.6.12 Side seal

- (1) Remove the drum cleaning blade.
P. 4-127 "4.6.11 Drum cleaning blade"
- (2) Remove the side seal [1].

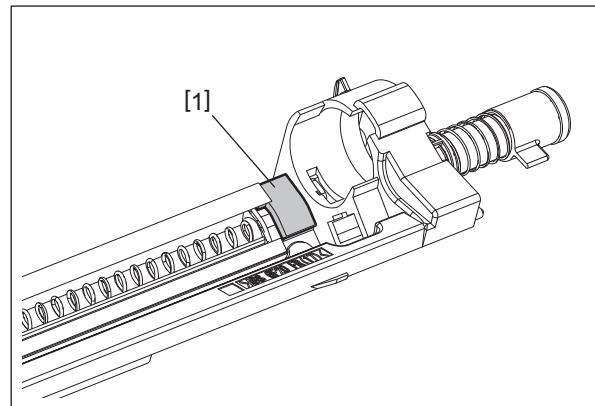

Fig. 4-324

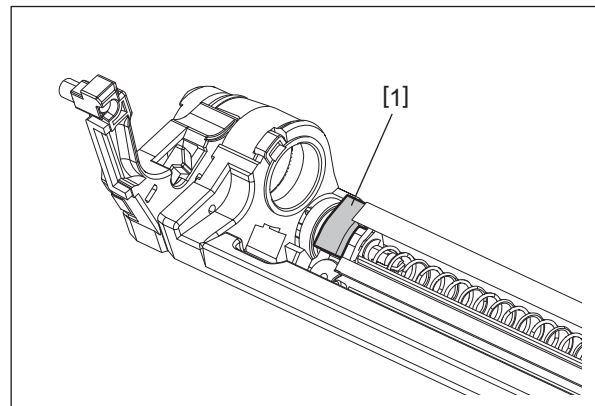

Fig. 4-325

Notes:

Make sure to attach the side seals as shown in the figure.

- From the case edge: 0 to 0.3 mm (Protruding from the case is unallowable.)
- Gap between the blade: 0 to 0.3 mm (Overlapping is unallowable.)

[1] Side seal

[2] Blade

[3] Case

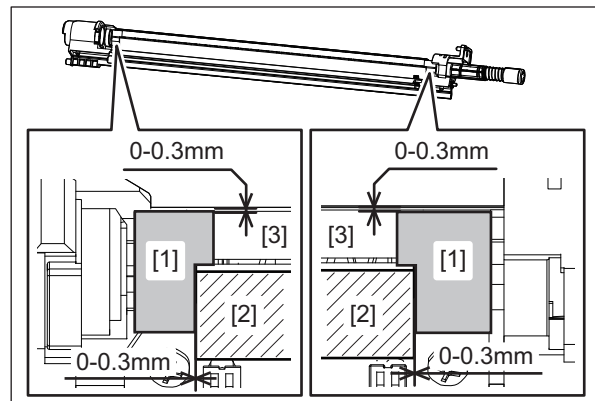

Fig. 4-326

4.6.13 Main charger grid

- (1) Remove the main charger.
P. 4-124 "4.6.9 Main charger"
- (2) Pull the lever [1].

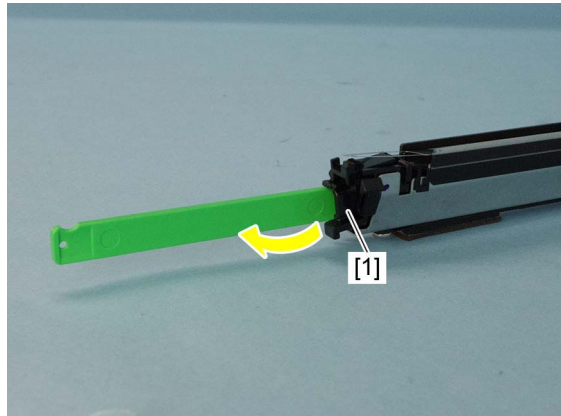

Fig. 4-327

- (3) Remove the main charger grid [2].

Notes:

- Do not touch the mesh area of the grid.
When installing the grid, be careful not to let the urethane sheet adhered to the charge case get caught in it.

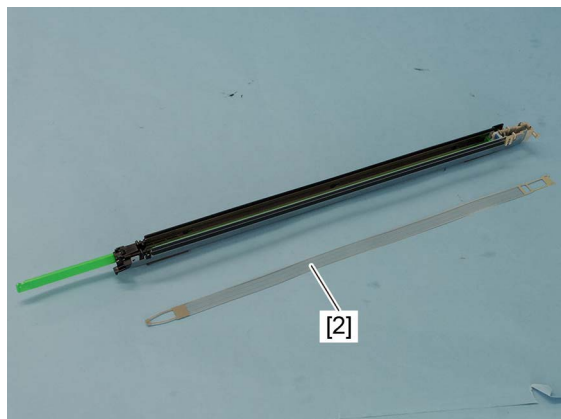

Fig. 4-328

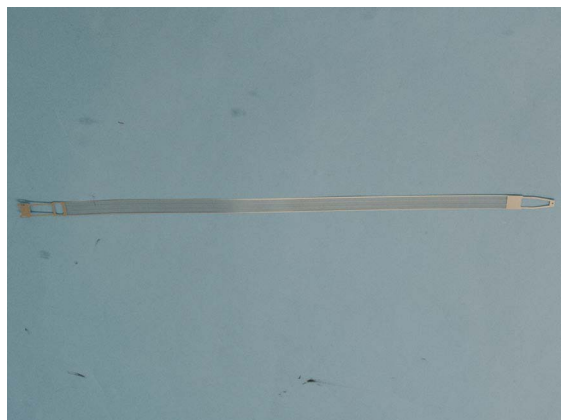

Fig. 4-329

- The shape of the main charger grid differs between the YMC and K.
 [1] YMC (lever: black)
 [2] K (lever: black)

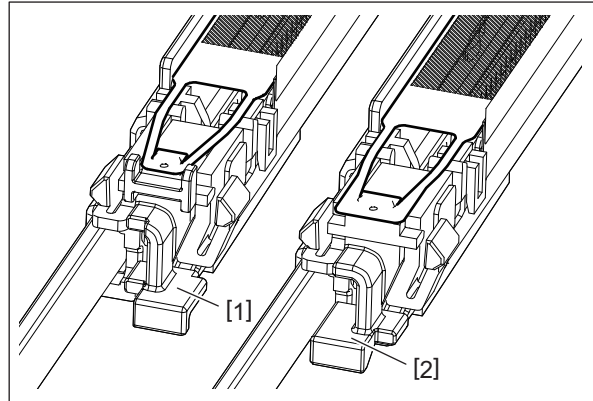



Fig. 4-330

4.6.14 Main charger cleaner

- (1) Remove the main charger grid.
 P. 4-129 “4.6.13 Main charger grid”
- (2) Remove the main charger cleaner [1].

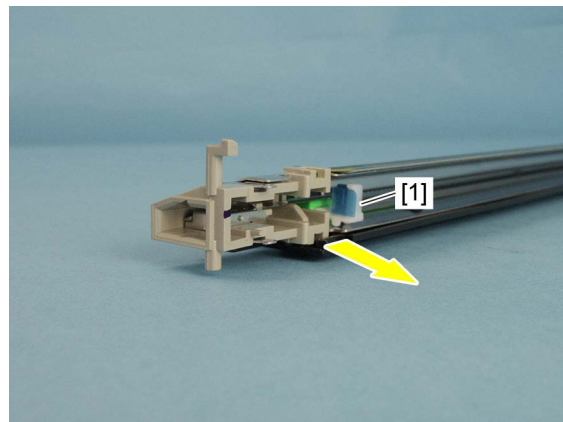

Fig. 4-331

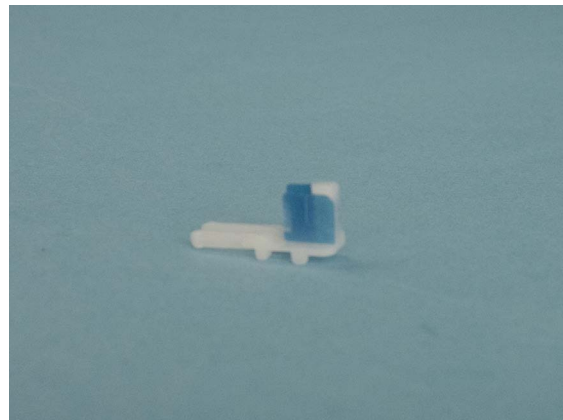



Fig. 4-332

4.6.15 Needle electrode

- (1) Remove the main charger cleaner.
 P. 4-130 “4.6.14 Main charger cleaner”
- (2) Pull out the lever [1] and remove the needle electrode [2] together with the lever [1].

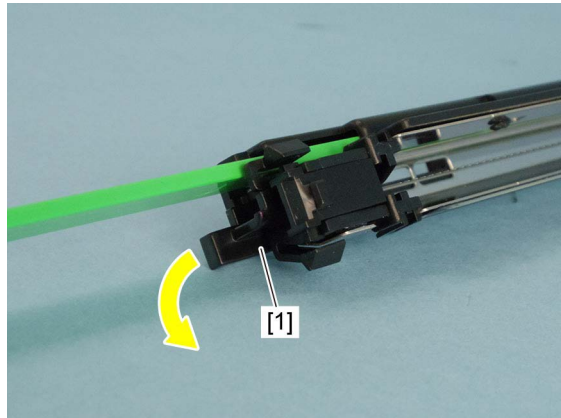

Fig. 4-333

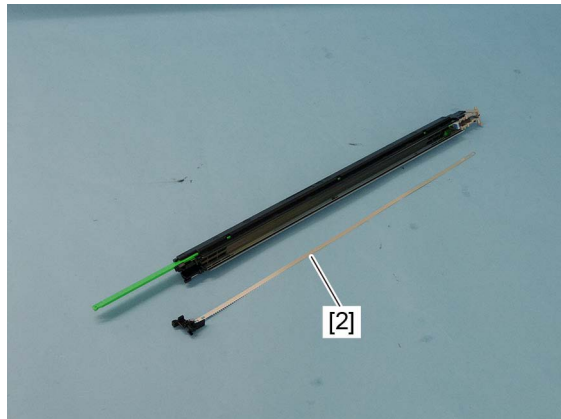

Fig. 4-334

Notes:

When installing the needle electrode, be sure of the following:

- Be sure that its needle comes at its top side.
- Hook the needle electrode and the spring on both front and rear terminals securely.
- Do not twist the needle electrode.
- Do not touch the needle electrode directly with bare hands.

4.6.16 EPU old/new detection switches (SW9, SW10, SW11, SW12)

- (1) Remove the transfer belt unit.
📖 P. 4-170 “4.7.3 Transfer belt unit (TBU)”
- (2) Remove the process unit.
📖 P. 4-109 “4.6.2 Process unit (Developer unit, Cleaner)”
- (3) Remove the toner motor assembly.
📖 P. 4-148 “4.6.26 Toner motor assembly”
- (4) Remove the drum and TBU drive unit.
📖 P. 4-184 “4.7.14 Drum and TBU drive unit”
- (5) Remove the front right cover.
📖 P. 4-7 “4.1.14 Front right cover”
- (6) Remove 1 screw and take off the switch bracket [1].

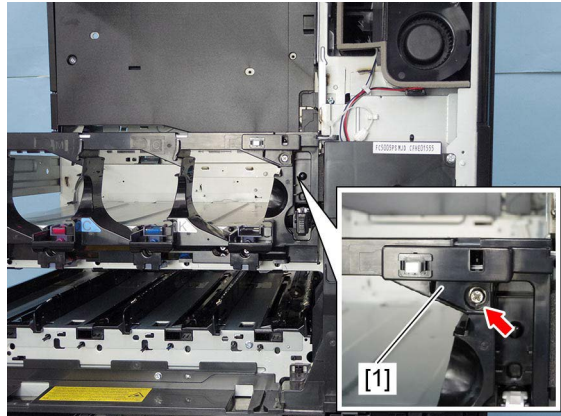

Fig. 4-335

- (7) Remove 3 screws.

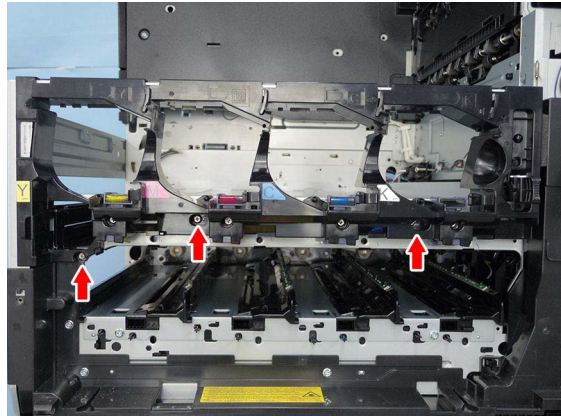

Fig. 4-336

(8) Release 5 upper latches [2], and then take off the toner cartridge holder [3].

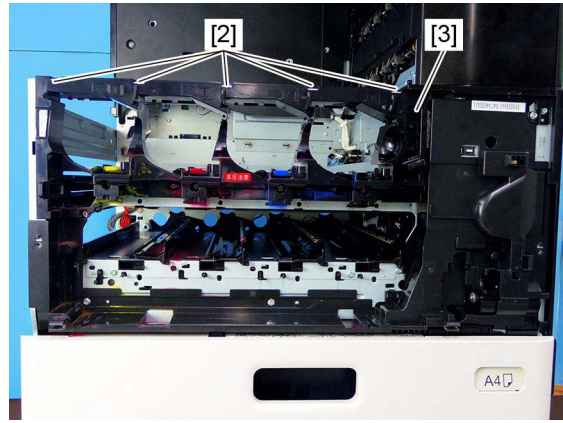

Fig. 4-337

(9) Remove 3 screws.

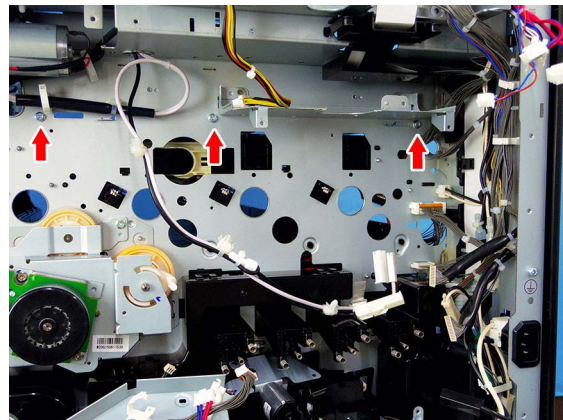

Fig. 4-338

(10) Release the harness from the harness clamp [4].

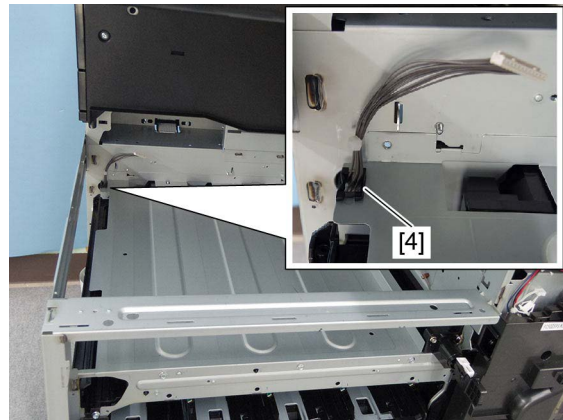

Fig. 4-339

(11) Remove 3 screws.

(12) Slide the toner cartridge top frame [5] toward the left side to remove it.

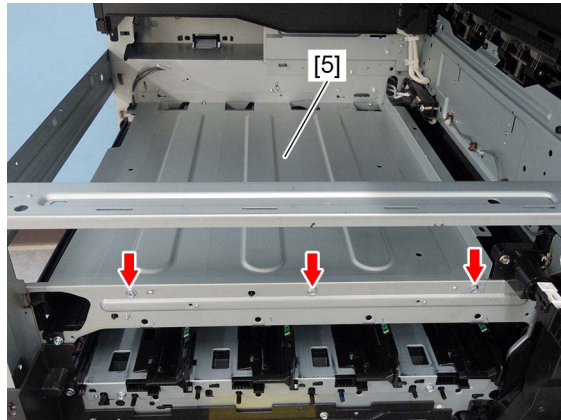

Fig. 4-340

(13) Remove 1 screw and take off the transfer belt cleaner guide [6].

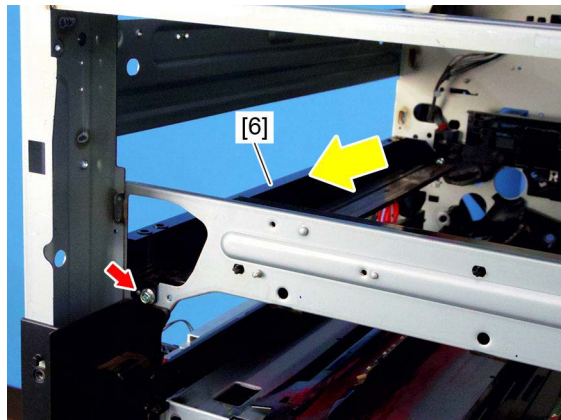

Fig. 4-341

(14) Remove 2 screws and take off the transfer belt rail (rear) [7].

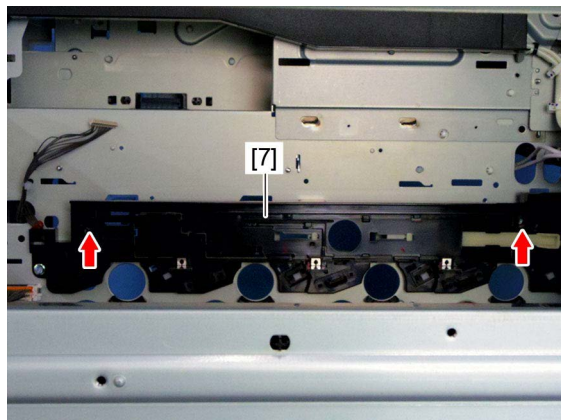

Fig. 4-342

(15) Remove 2 screws and take off the switch base [8].

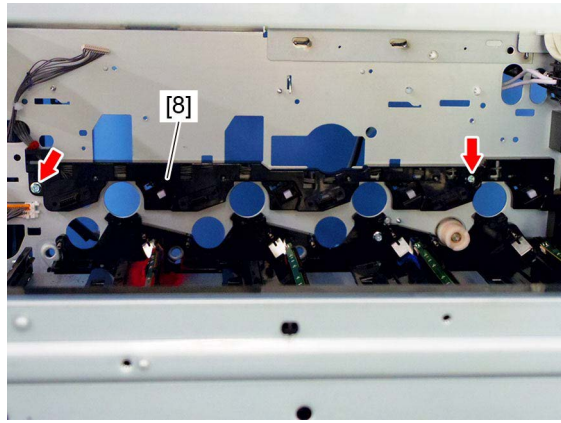

Fig. 4-343

(16) Release the latches, and remove the EPU old/new detection switch from the switch base.

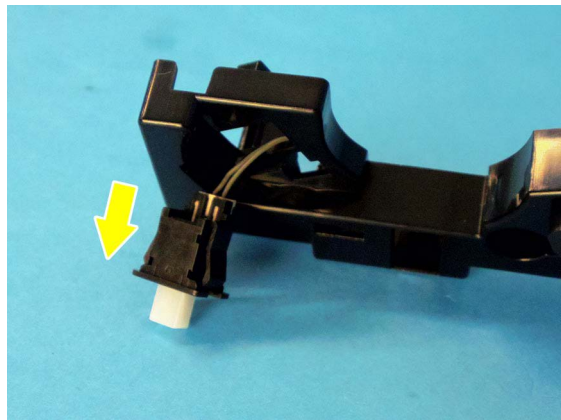

Fig. 4-344

EPU old/new detection switches

- SW9: Y
- SW10: M
- SW11: C
- SW12: K

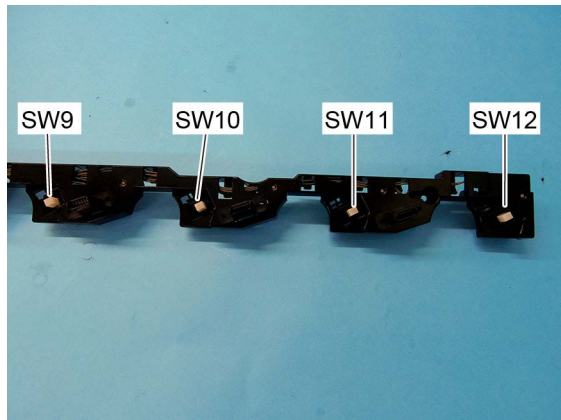

Fig. 4-345

4.6.17 Drum thermistor

- (1) Remove the discharge LED (C).
P. 4-137 "4.6.18 Discharge LED"
- (2) Disconnect the 1 connector [1].

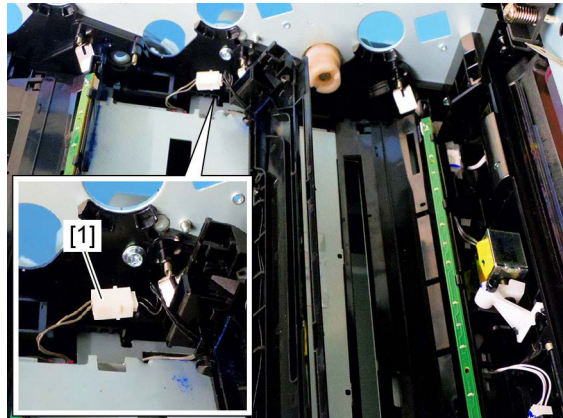

Fig. 4-346

- (3) Peel off the seal [2].

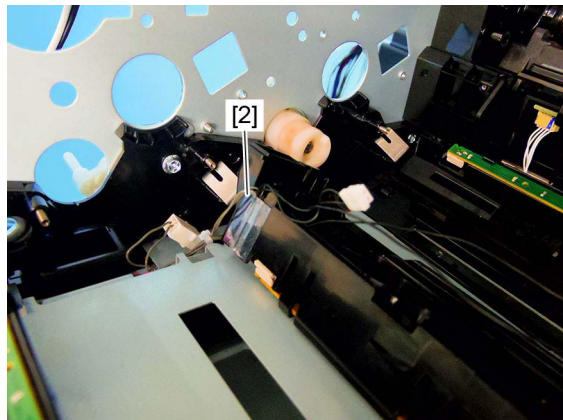

Fig. 4-347

- (4) Remove the harness and take off the thermistor [3].

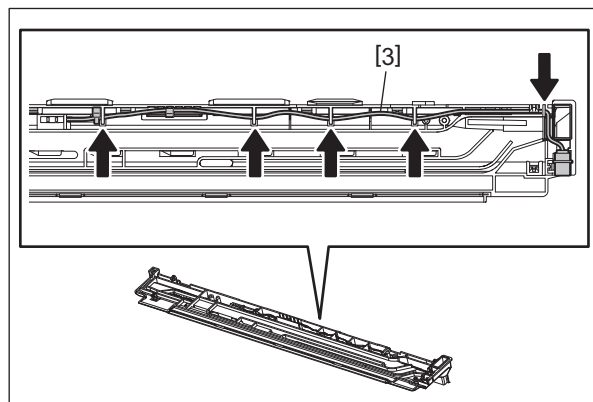

Fig. 4-348

4.6.18 Discharge LED

- (1) Remove the toner cartridge top frame.
P. 4-132 "4.6.16 EPU old/new detection switches (SW9, SW10, SW11, SW12)"
- (2) Slide the discharge LED [1] toward the left side.

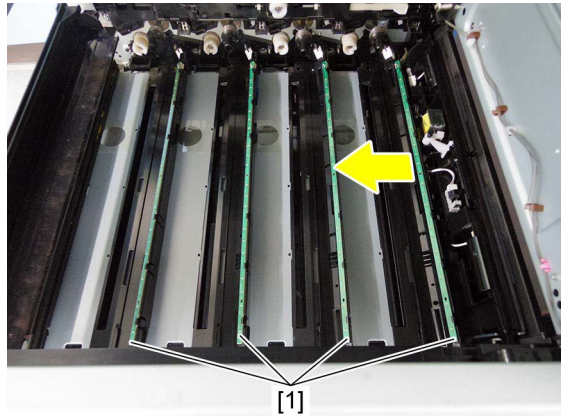

Fig. 4-349

- (3) Disconnect the 1 connector [2] and remove the discharge LED [1].

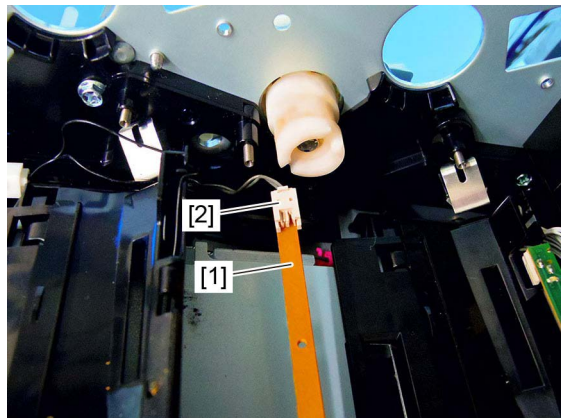

Fig. 4-350

4.6.19 Waste toner paddle rotation detection sensor (S9)

- (1) Remove the waste toner paddle motor unit.
P. 4-138 "4.6.20 Waste toner paddle motor (M7)"
- (2) Release 3 latches and disconnect 1 connector [1], and then remove the waste toner paddle rotation detection sensor [2].

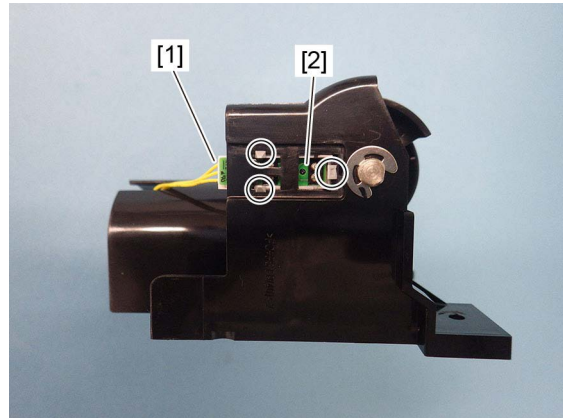

Fig. 4-351

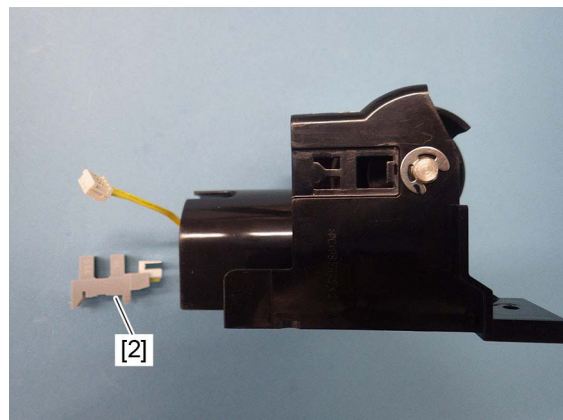

Fig. 4-352

4.6.20 Waste toner paddle motor (M7)

- (1) Remove the inner cover.
P. 4-11 "4.1.19 Front cover interlock switch (SW2)"
- (2) Remove 1 screw and release the duct [1].

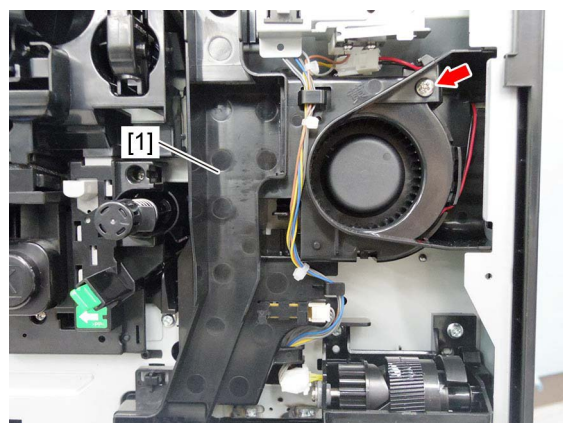

Fig. 4-353

- (3) Remove 3 screws and disconnect the 1 connector [2], and then remove the waste toner paddle motor unit [3].

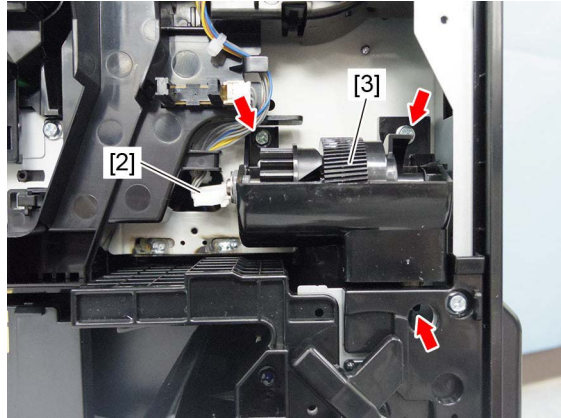

Fig. 4-354

- (4) Remove 1 E-ring [4] and gear [5].

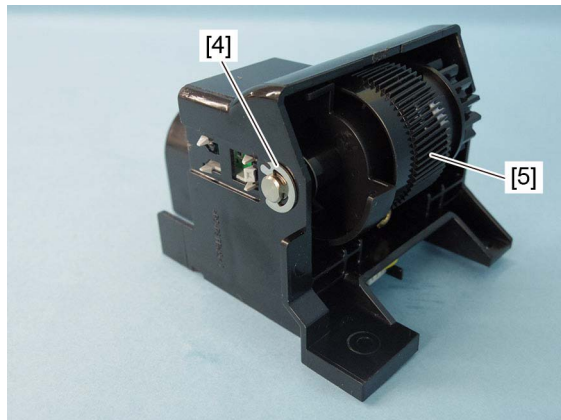

Fig. 4-355

- (5) Remove 2 screws and disconnect 1 connector [6].

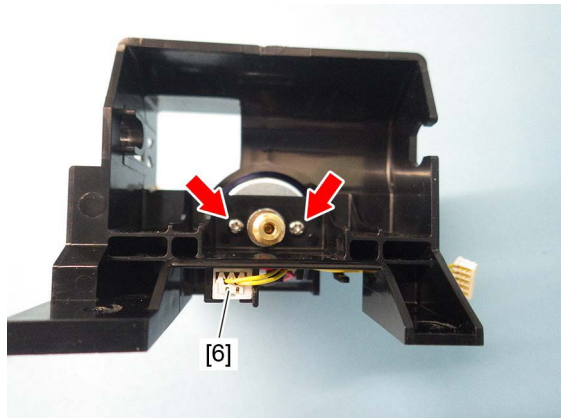

Fig. 4-356

- (6) Remove the waste toner paddle motor [7].

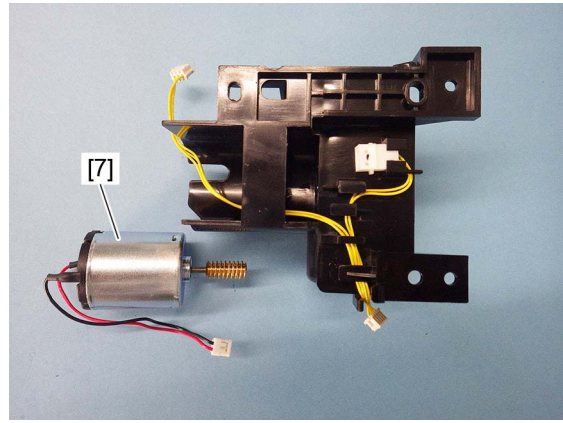

Fig. 4-357

Notes:

Wire the motor harness through hooks during assembly.

Make sure that the harness does not come up on the area in the red frame.

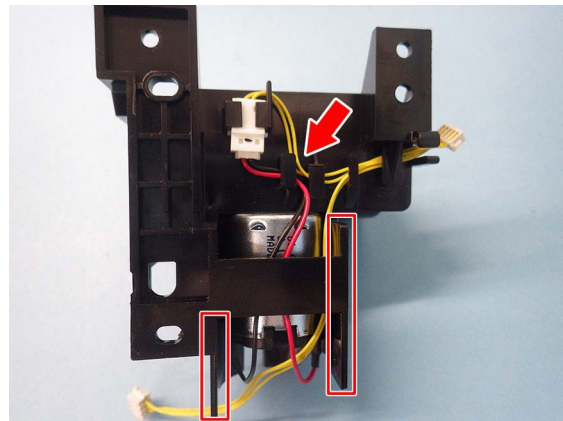

Fig. 4-358

4.6.21 Drum switching unit

- (1) Remove the high-voltage transformer.
P. 9-15 "9.1.9 High-voltage transformer (HVT)"
- (2) Release the harness from harness clamps [3], remove 2 screws, and take off the plate [1].

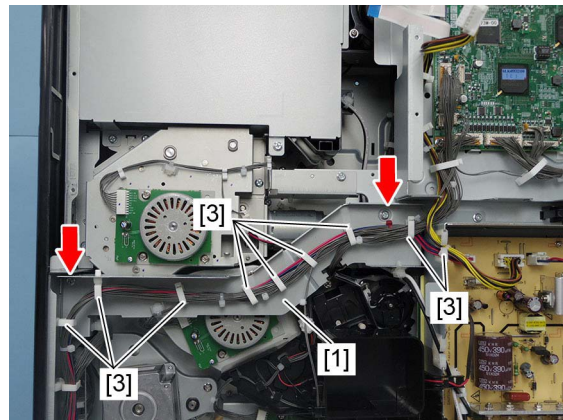

Fig. 4-359

- (3) Disconnect 4 connectors and release the harness from the harness guides [3].

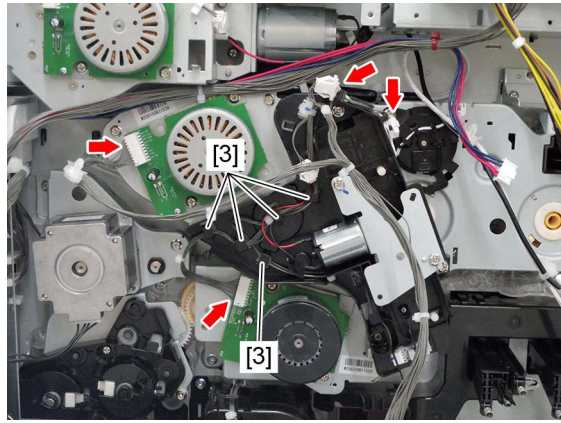

Fig. 4-360

- (4) Remove 3 screws and take off the drum switching unit [2].

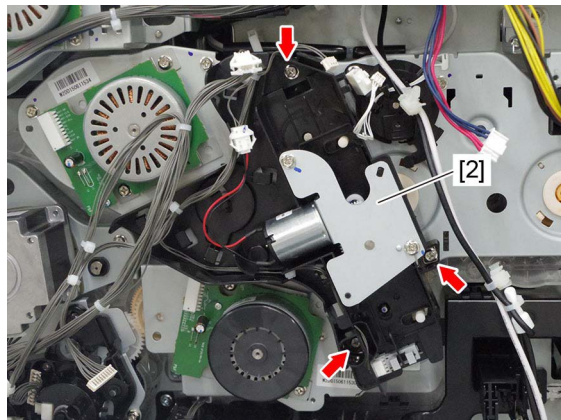

Fig. 4-361

4.6.22 Drum switching detection sensor (S11)

- (1) Remove the drum switching unit.
P. 4-140 "4.6.21 Drum switching unit"
- (2) Disconnect 1 connector [1], and take off the drum switching detection sensor [2].

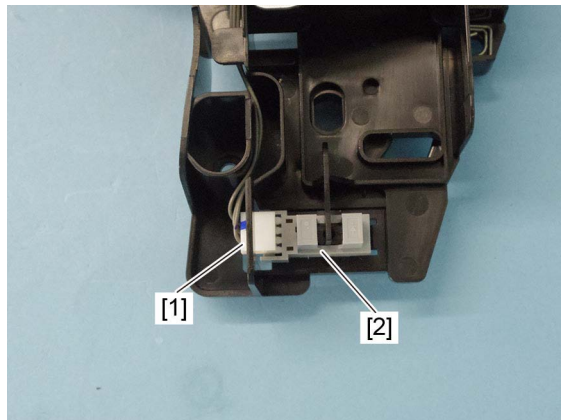

Fig. 4-362

4.6.23 Mono/color switching motor (M3)

- (1) Remove the rear cover.
P. 4-10 "4.1.17 Rear cover"
- (2) Disconnect the 1 connector [1], and release the harness from the harness guides [2].
- (3) Remove 2 screws and take off the mono/color switching motor bracket [3].

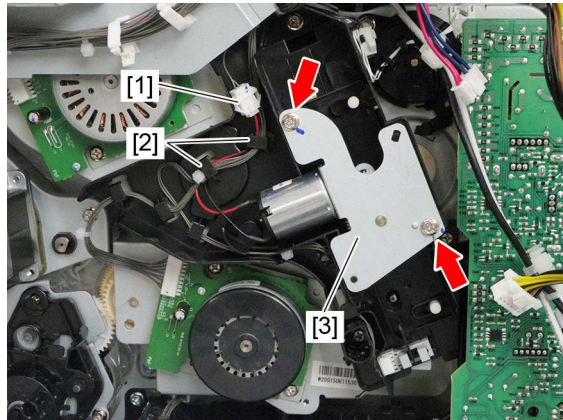

Fig. 4-363

- (4) Remove the arm [4].

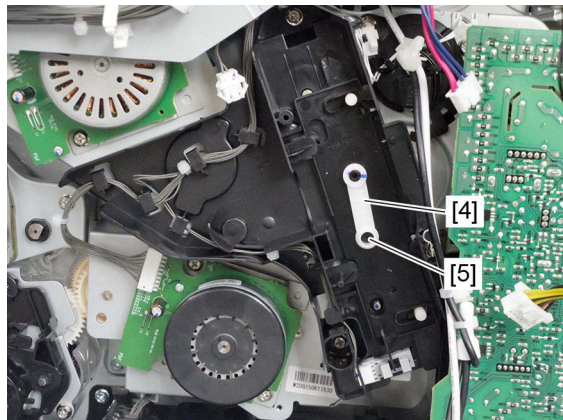

Fig. 4-364

Notes:

When installing the mono/color switching motor bracket, put the gear projection [6] into the arm hole [5].

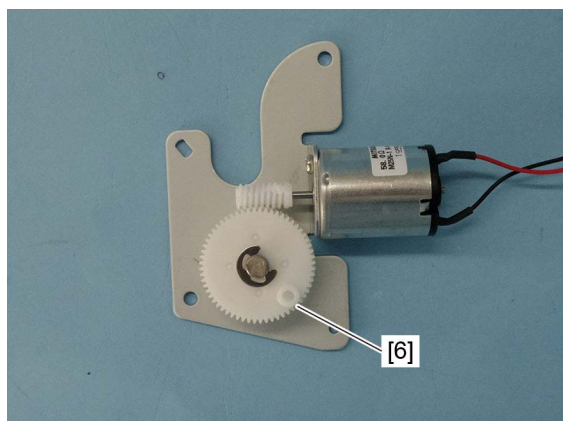

Fig. 4-365

- (5) Remove the E-ring [7] and gear [8].

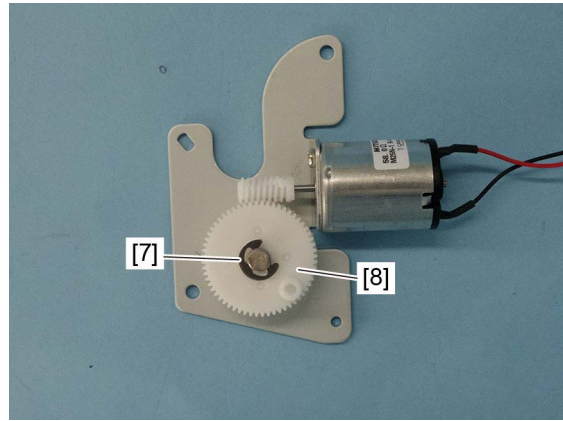

Fig. 4-366

Notes:

Before removing the gear, place a marking so that it can be re-assembled at the same position.

- (6) Remove 1 screw and take off the mono/color switching motor [9].

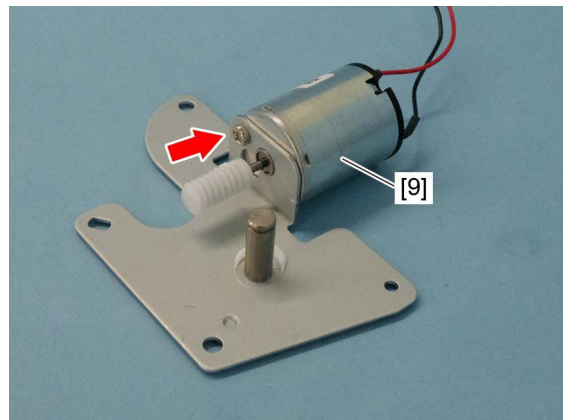

Fig. 4-367

Notes:

Pay attention to the size (length) of the screws. If incorrect ones are used, the motor could be damaged.

4.6.24 Paper feeding/developer unit drive motor (M2)

- (1) Remove the rear cover.
📖 P. 4-10 “4.1.17 Rear cover”
- (2) Remove the developer unit cooling exhaust duct.
📖 P. 4-164 “4.6.35 Developer unit cooling exhaust duct”
- (3) Disconnect 1 connector [2] and remove 2 screws, and then take off the paper feeding/developer unit drive motor [1].

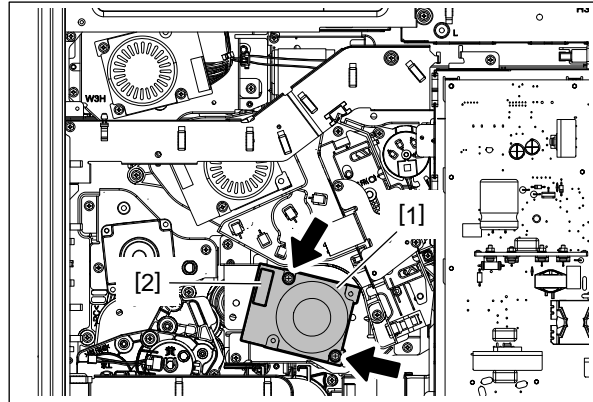

Fig. 4-368

4.6.25 Developer drive unit

- (1) Remove the drum TBU drive unit.
📖 P. 4-184 “4.7.14 Drum and TBU drive unit”
- (2) Remove the paper feed drive unit.
📖 P. 4-103 “4.5.37 Paper feed drive unit”
- (3) Release the harness from the harness clamp [1].

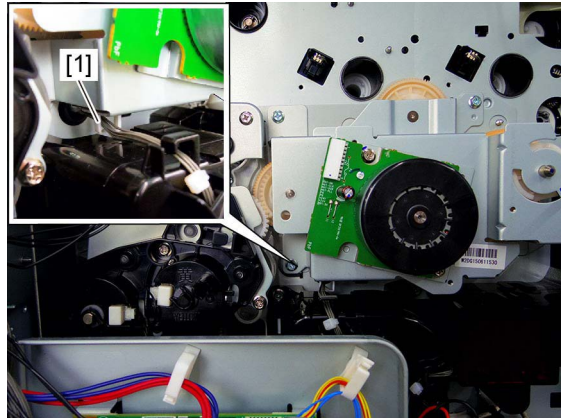

Fig. 4-369

(4) Remove 4 screws and take off the developer drive unit [2].

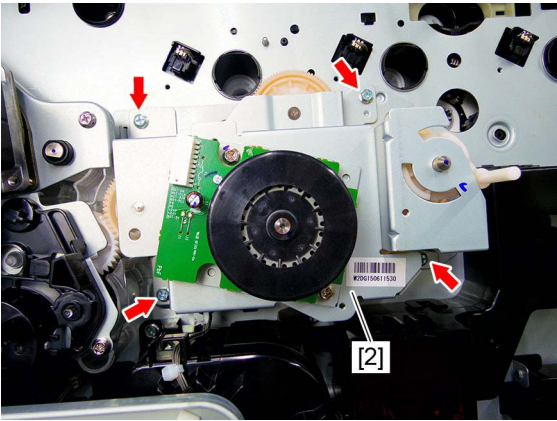

Fig. 4-370

Notes:

- When replacing the parts or performing preventive maintenance, apply white grease (Molykote EM-30L) to the following portions.
[3]: Apply a thin coat of the grease to whole outer circumference of each shaft.
[4]: Apply a thin coat of the grease to the tooth surface of each gear.
[5]: Apply a coat of the grease to the whole sliding surface of each coupling.
[6]: Apply a thin coat of the grease to whole outer circumference of each shaft.

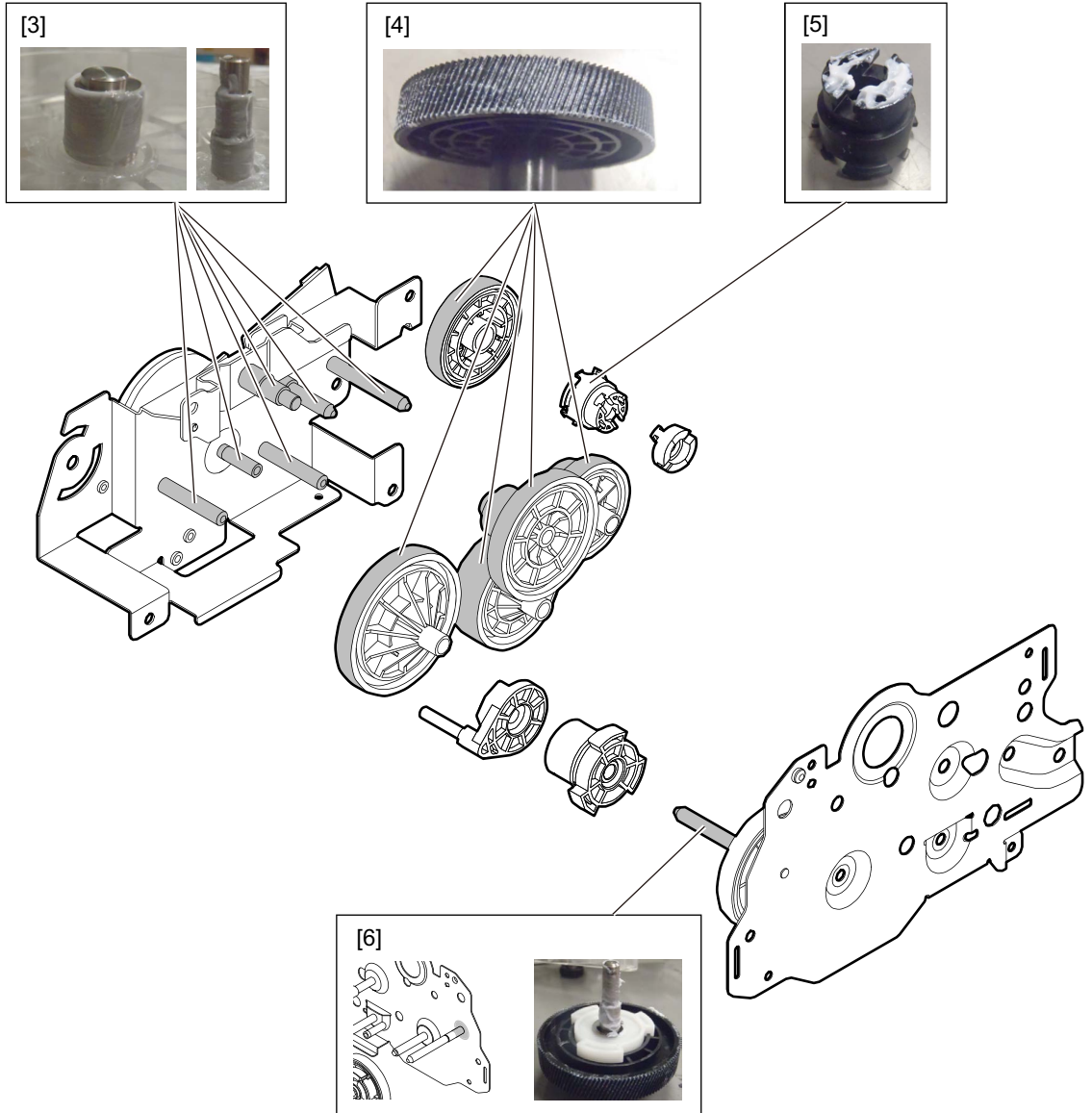

Fig. 4-371

- When replacing the parts or performing machine refreshment, apply 1 rice-sized grain of white grease (Molykote EM30-L) to the front side [7] and the rear side [8] of the cam.

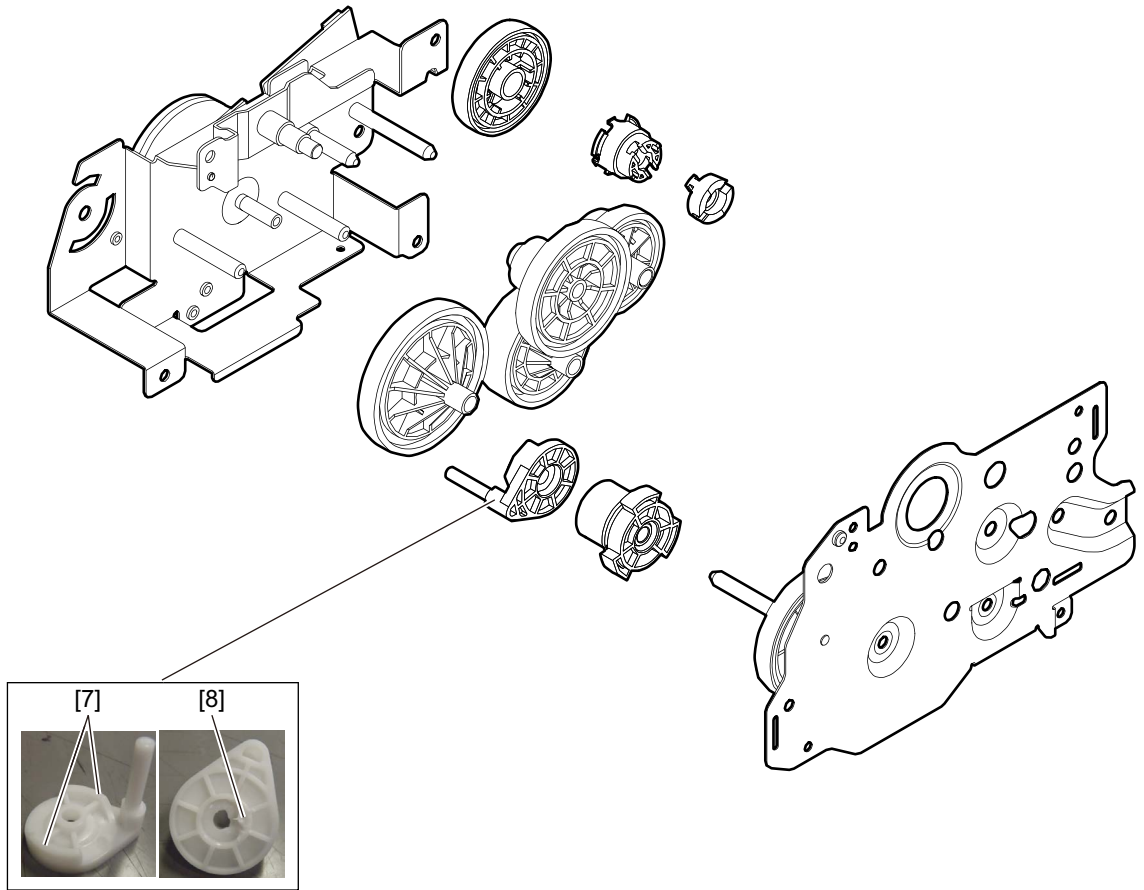

Fig. 4-372

4.6.26 Toner motor assembly

The toner motor is installed depending on toner cartridge (Y, M, C, K).

- Toner motor (M8): Toner cartridge (Y)
- Toner motor (M9): Toner cartridge (M)
- Toner motor (M10): Toner cartridge (C)
- Toner motor (M11): Toner cartridge (K)

- (1) Remove the receiving tray.
P. 4-2 "4.1.3 Receiving tray"
- (2) Pull out the toner cartridge.
- (3) Release the latch, and remove 4 toner cartridge rails [1] and 1 duct [2].

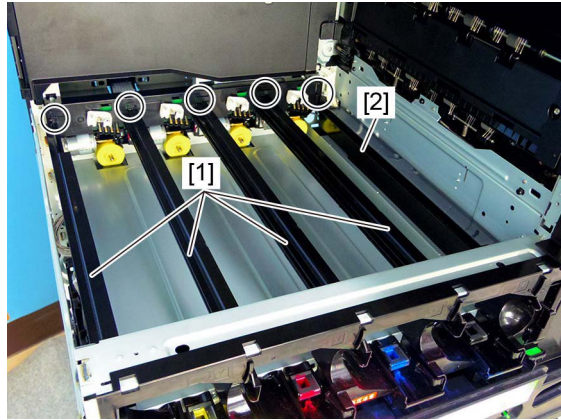

Fig. 4-373

Notes:

When installing the toner cartridge rail and duct, securely align them so that the rail and duct latch are aligned in the toner cartridge holder groove.



Fig. 4-374

- (4) Remove 2 screws and release 2 hooks [3], and then lift the toner motor assembly [4].

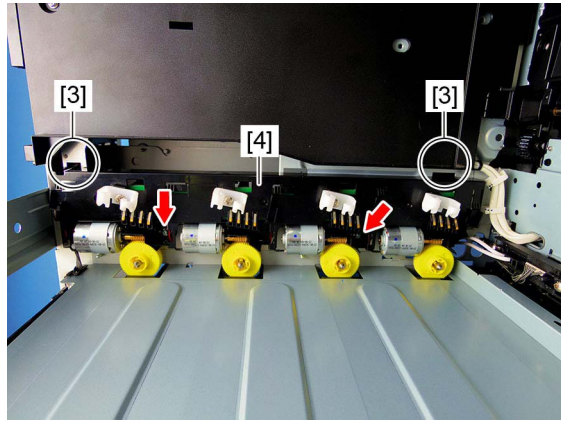

Fig. 4-375

- (5) Disconnect the connector [5] and remove the toner motor assembly [4].

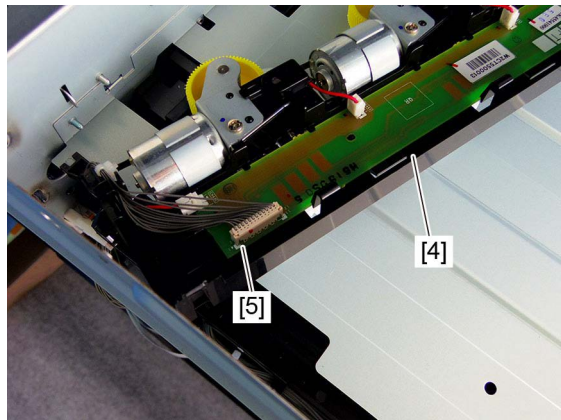

Fig. 4-376

4.6.27 Toner motor (M8, M9, M10, M11)

- (1) Remove the toner motor assembly.
📖 P. 4-148 “4.6.26 Toner motor assembly”
- (2) Release 2 latches.

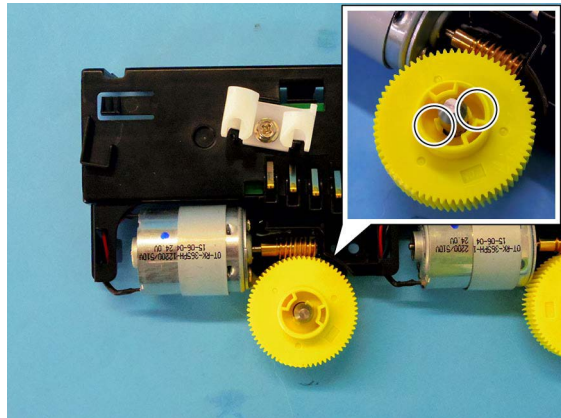

Fig. 4-377

(3) Remove the gear [1] and the spring [2].

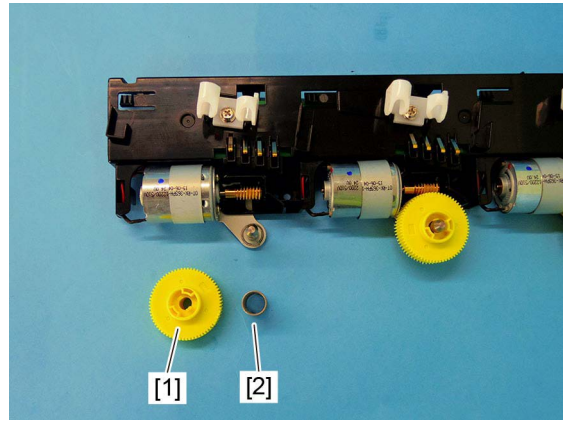

Fig. 4-378

(4) Remove 1 screw and disconnect the 1 connector [3], and then take off the motor bracket [4].

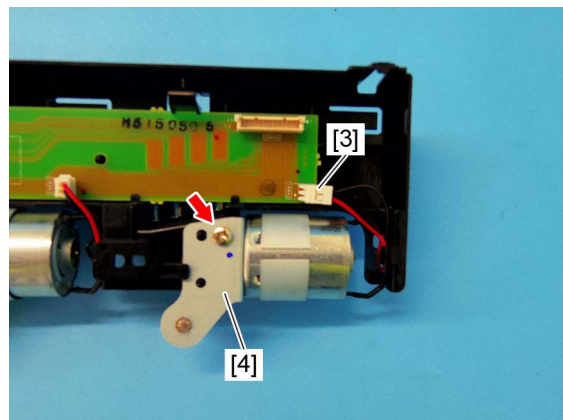

Fig. 4-379

(5) Remove 2 screws and take off the toner motor [5].

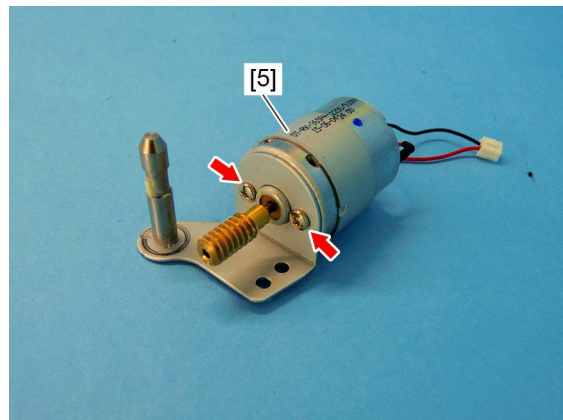

Fig. 4-380

4.6.28 Ozone filter

- (1) Remove the rear cover.
📖 P. 4-10 "4.1.17 Rear cover"
- (2) Remove the ozone filter [1].

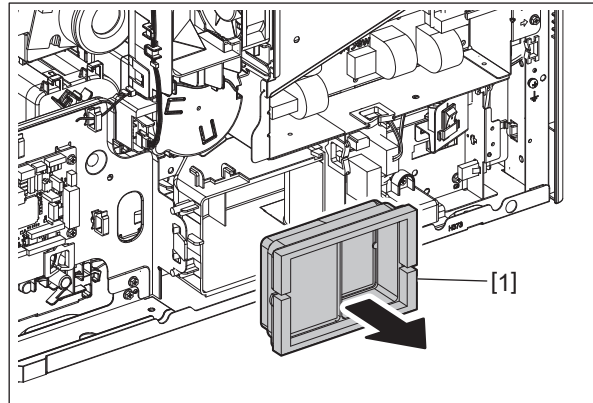

Fig. 4-381

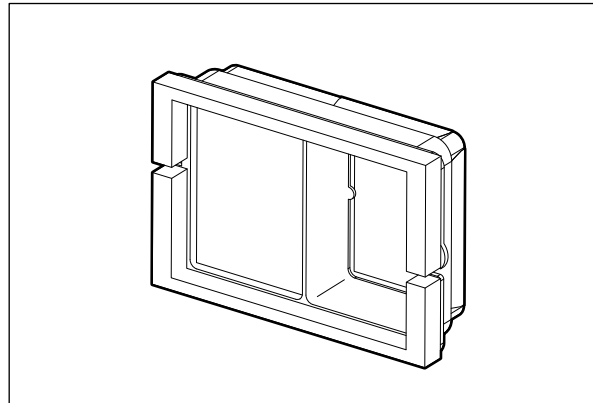

Fig. 4-382

4.6.29 Ozone exhaust fan (F2)

- (1) Remove the rear cover.
📖 P. 4-10 "4.1.17 Rear cover"
- (2) Disconnect 13 connectors and 1 relay connector [10].
- (3) Release the harness from the harness clamp [11].
- (4) Remove 1 harness clamp [12].
- (5) Release the harness from the harness guides [13].

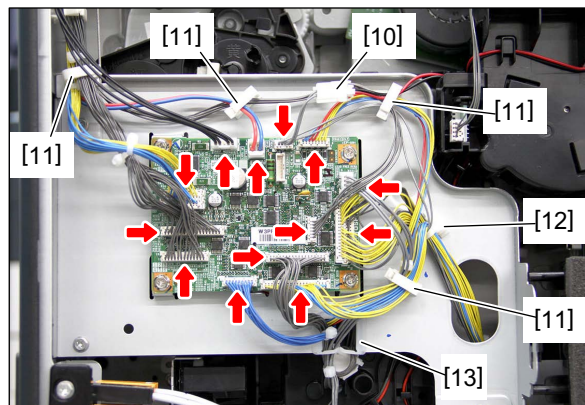

Fig. 4-383

- (6) Remove the hook [1] of the ozone exhaust fan duct.
- (7) Remove 3 screws and take off the bracket [2].

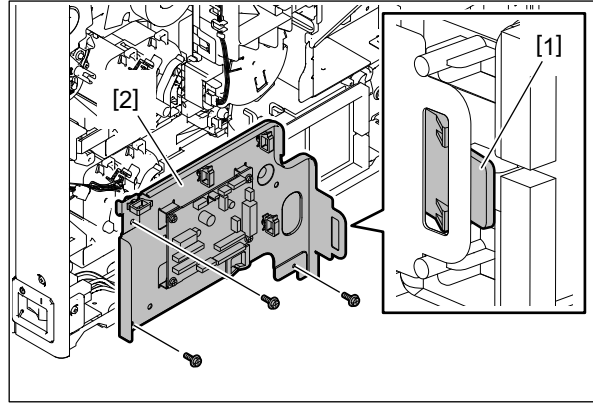

Fig. 4-384

- (8) Remove 1 screw and take off the cover [3].

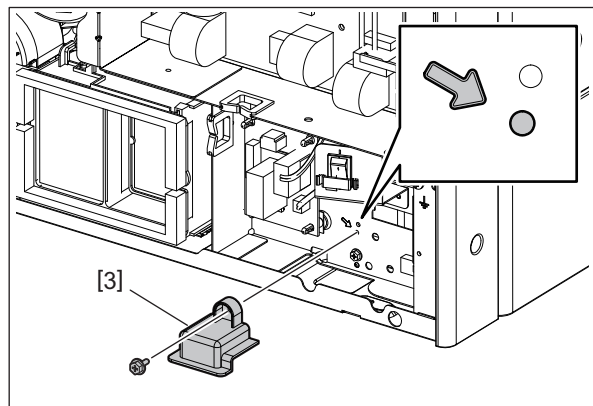

Fig. 4-385

Notes:

When installing, be sure that the screw is in the correct position.

- (9) Remove 3 screws and release the bracket [4].

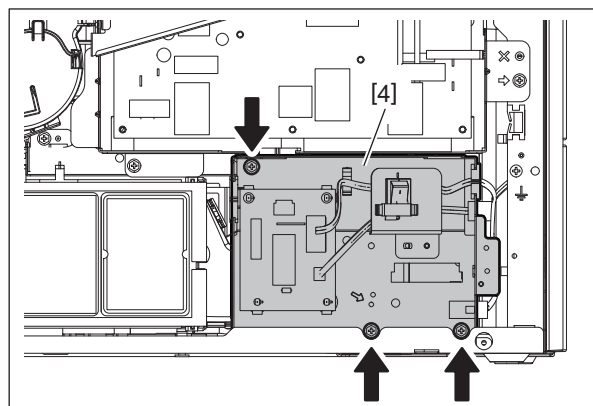

Fig. 4-386

(10) Slide the ozone exhaust fan duct [5] toward the left side.

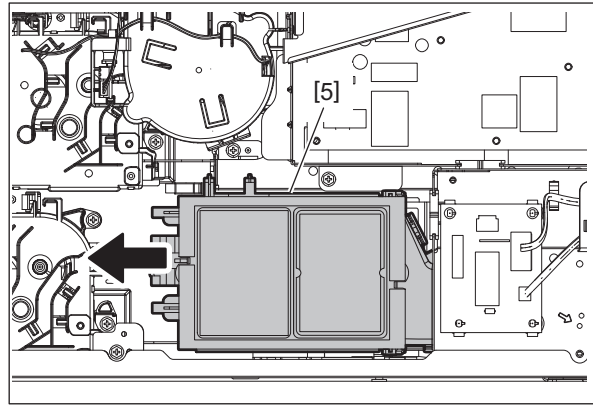

Fig. 4-387

(11) Disconnect 1 connector [6], and then remove the ozone exhaust fan duct [5].

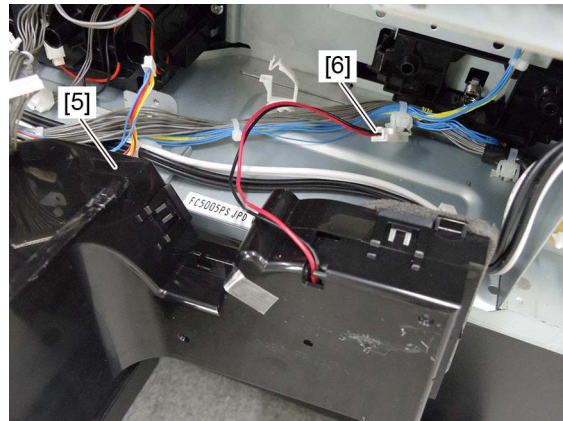

Fig. 4-388

(12) Remove the ozone filter [7].

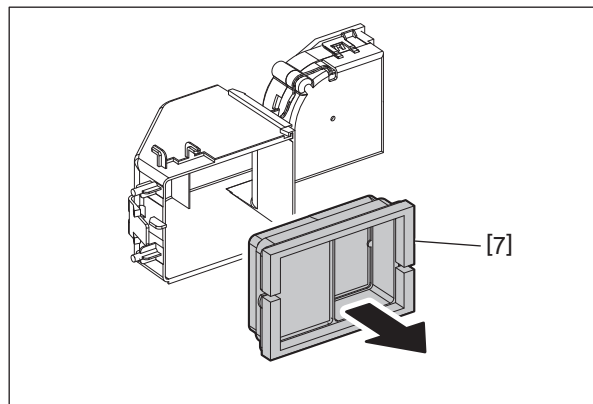

Fig. 4-389

(13) Release 4 latches and remove the ozone exhaust fan duct cover [8].

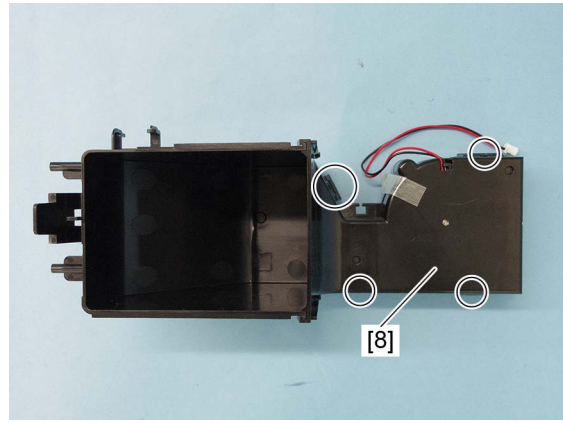

Fig. 4-390

(14) Remove the ozone exhaust fan [9].

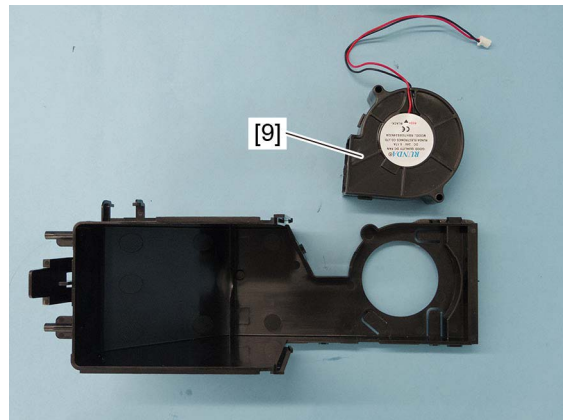

Fig. 4-391

4.6.30 Suctioning fan (F3)

- (1) Remove the inner cover and front cover switch bracket.
📖 P. 4-11 “4.1.19 Front cover interlock switch (SW2)”
- (2) Disconnect the 2 connectors [1], and release the harness from the harness guides [2].
- (3) Remove 1 screw. Release the latch [3] and take off the suctioning fan cover [4].

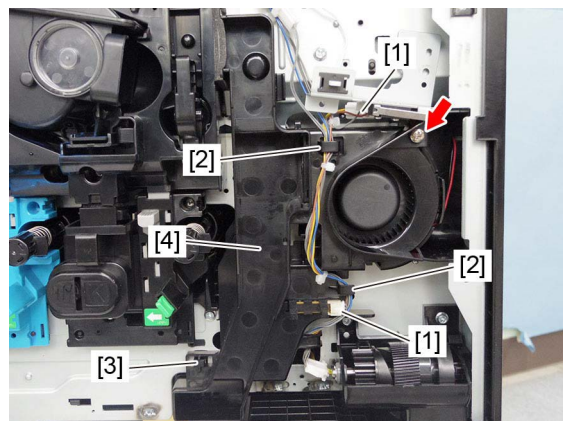

Fig. 4-392

- (4) Remove the suctioning fan [5].

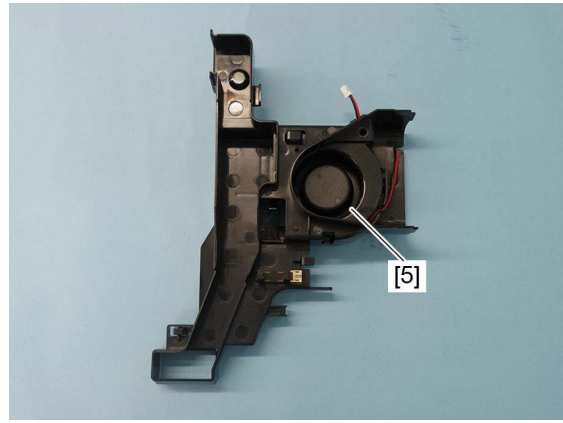

Fig. 4-393

4.6.31 Power supply unit cooling fan (F8)

- (1) Remove the developer unit cooling exhaust duct.
P. 4-164 "4.6.35 Developer unit cooling exhaust duct"
- (2) Release the harness from the harness guides. Release 3 latches [2] and take off the power supply unit cooling fan [1].

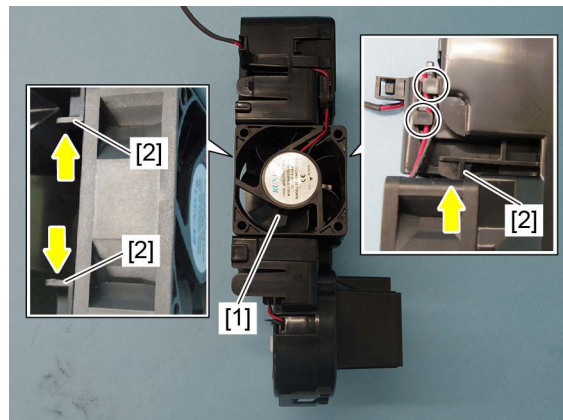



Fig. 4-394

4.6.32 Drum drive gear

- (1) Remove the drum and TBU drive unit.
 P. 4-184 "4.7.14 Drum and TBU drive unit"
- (2) Remove 2 screws.

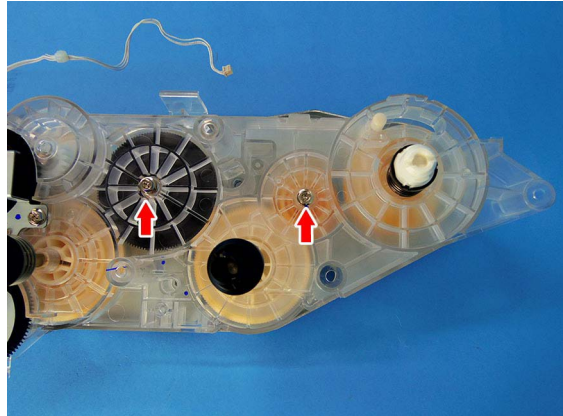

Fig. 4-395

- (3) Remove 2 screws and take off the drum motor [1].

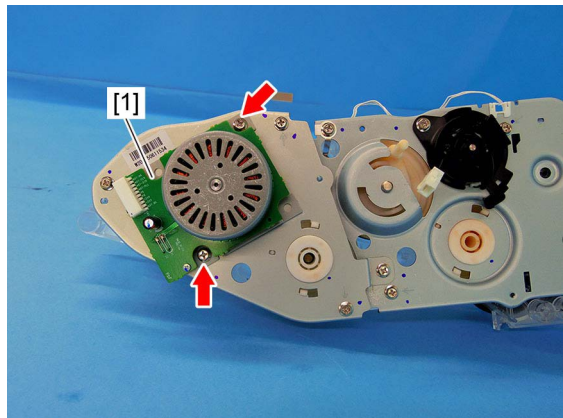



Fig. 4-396

- (4) Remove 1st transfer contact/release clutch (CLT2)[2].
 P. 4-181 "4.7.11 1st transfer contact/release clutch (CLT2)"

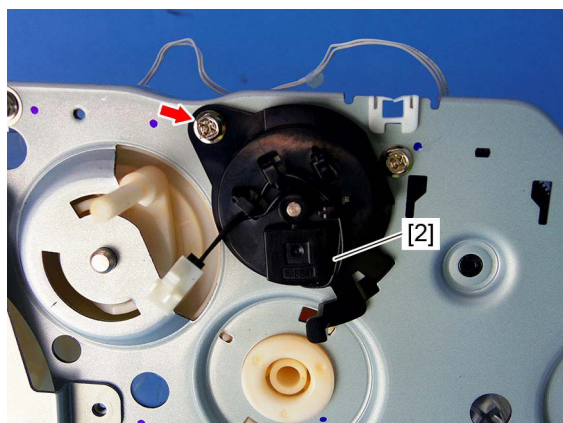

Fig. 4-397

- (5) Remove 4 screws and take off the K drum drive gear cover [3].

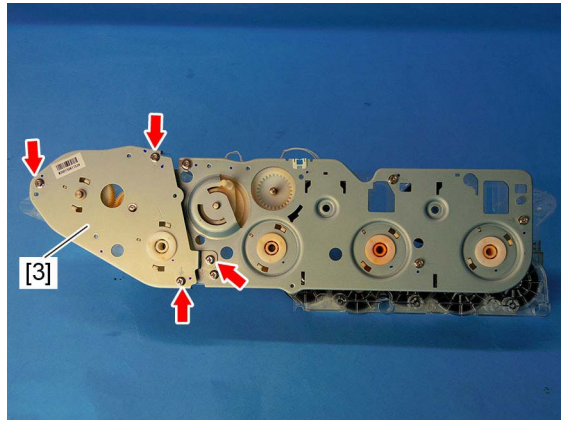

Fig. 4-398

Notes:

When installing the K drum drive gear cover, make sure that the spring [4] is engaged with the concave portion of the gear.

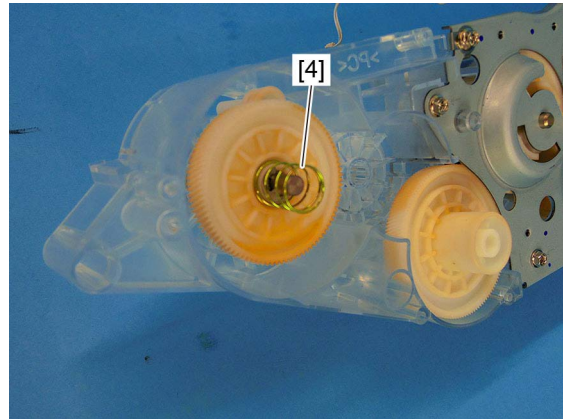

Fig. 4-399

- (6) Remove 6 screws and take off the YMC drum drive gear cover [5].

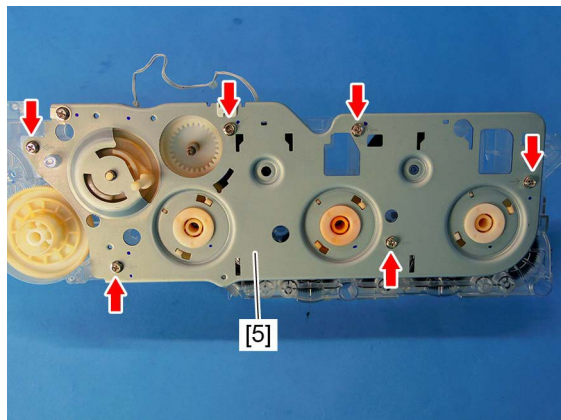

Fig. 4-400

(7) Remove the drum drive gear.

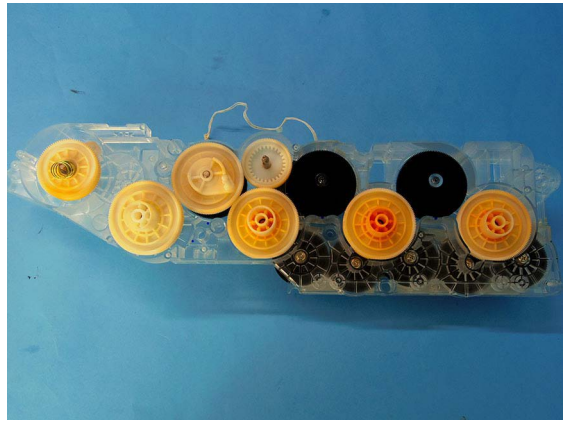

Fig. 4-401

Notes:

- When replacing the parts or performing machine refreshment, apply white grease (Molykote EM30-L) to the following portions.
[6]: Apply a thin coat of the grease to the tooth surface of each gear.
[7]: Apply a thin coat of the grease to whole outer circumference of each shaft.
[8]: Apply a thin coat of the grease to whole outer circumference of each shaft.
[9]: Apply a coat of the grease to the whole outer circumference of each shaft.
[10]: Apply a coat of the grease to the whole inner circumference of each shaft.
[11]: Apply 1 rice-sized grain of the grease to the whole outer circumference of each gear boss.
[12]: Apply 1 rice-sized grain of the grease to the front side [a] and the rear side [b] of the cam.
[13]: Apply a coat of the grease to the whole inner circumference of the bushing.

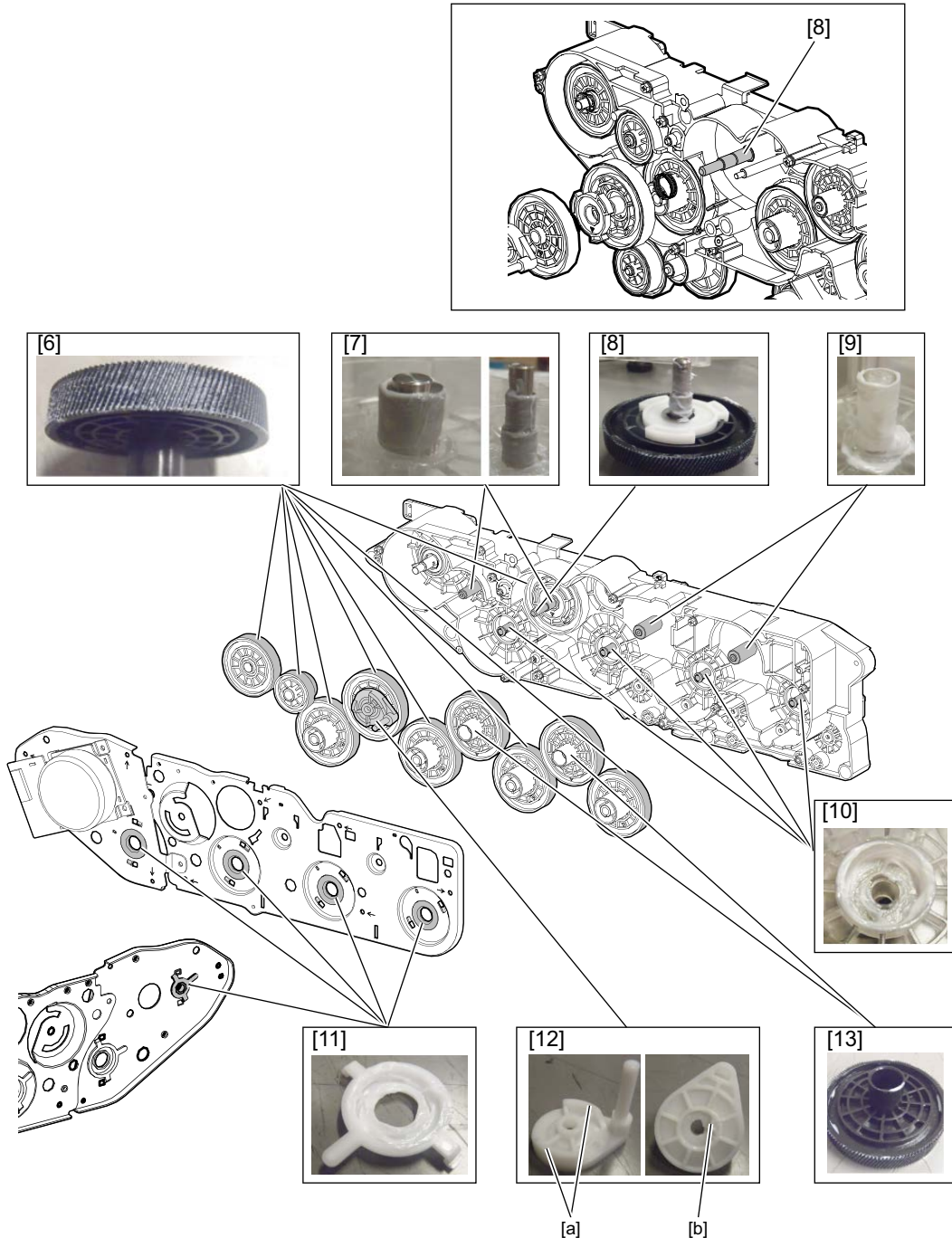

Fig. 4-402

- When replacing the parts or performing machine refreshment, do not apply grease to the shaft [14] and the tooth surface of the gear [15].

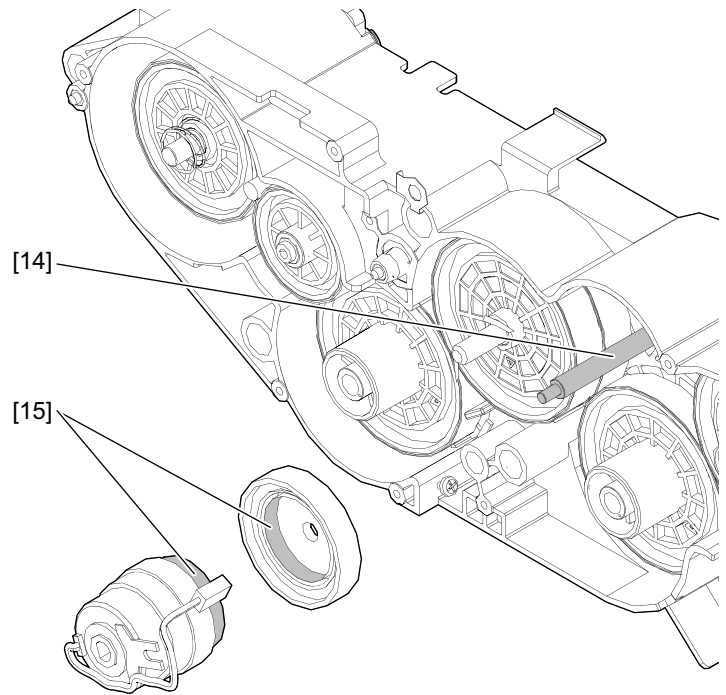

Fig. 4-403

- When reassembling, align arrows indicated on the gears [16] in the same direction as shown in the figure [17].

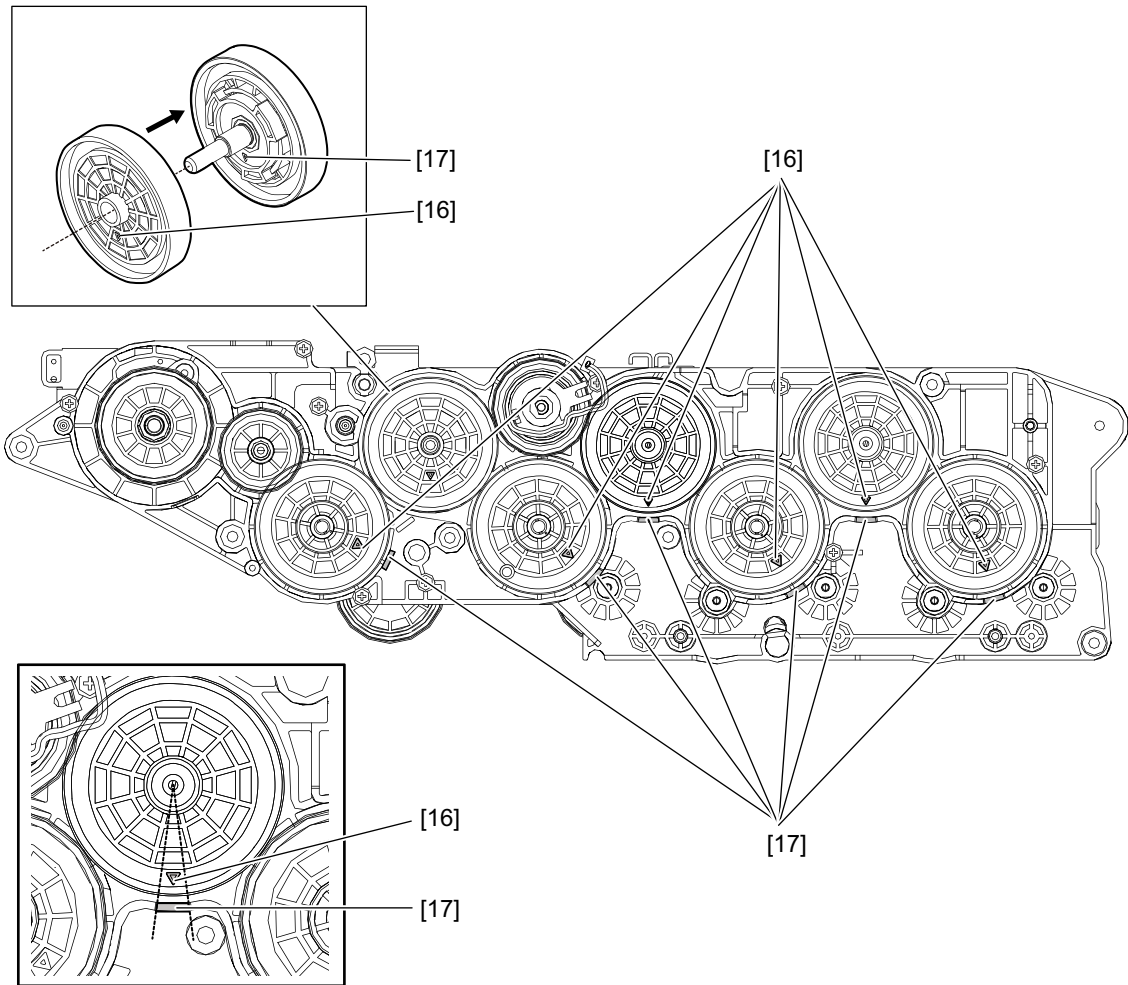

Fig. 4-404

4.6.33 Developer drive gear

- (1) Remove the drum and TBU drive unit.
 ☞ P. 4-184 “4.7.14 Drum and TBU drive unit”
- (2) Remove 3 screws and take off the developer drive gear cover [1].

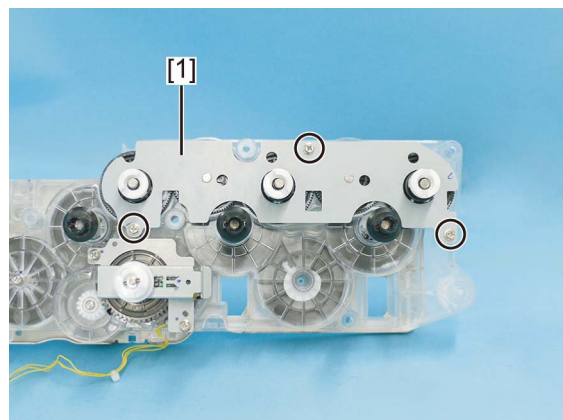

Fig. 4-405

(3) Remove the developer drive gear.



Fig. 4-406

Notes:

- When the gear has been replaced, grease its teeth surface and the shaft.
- When replacing the parts or performing preventive maintenance, apply an appropriate amount of white grease (Molykote EM-30L) to the shaft [2], the tooth surface of the gear [3] and the sliding surfaces of the coupling [4].

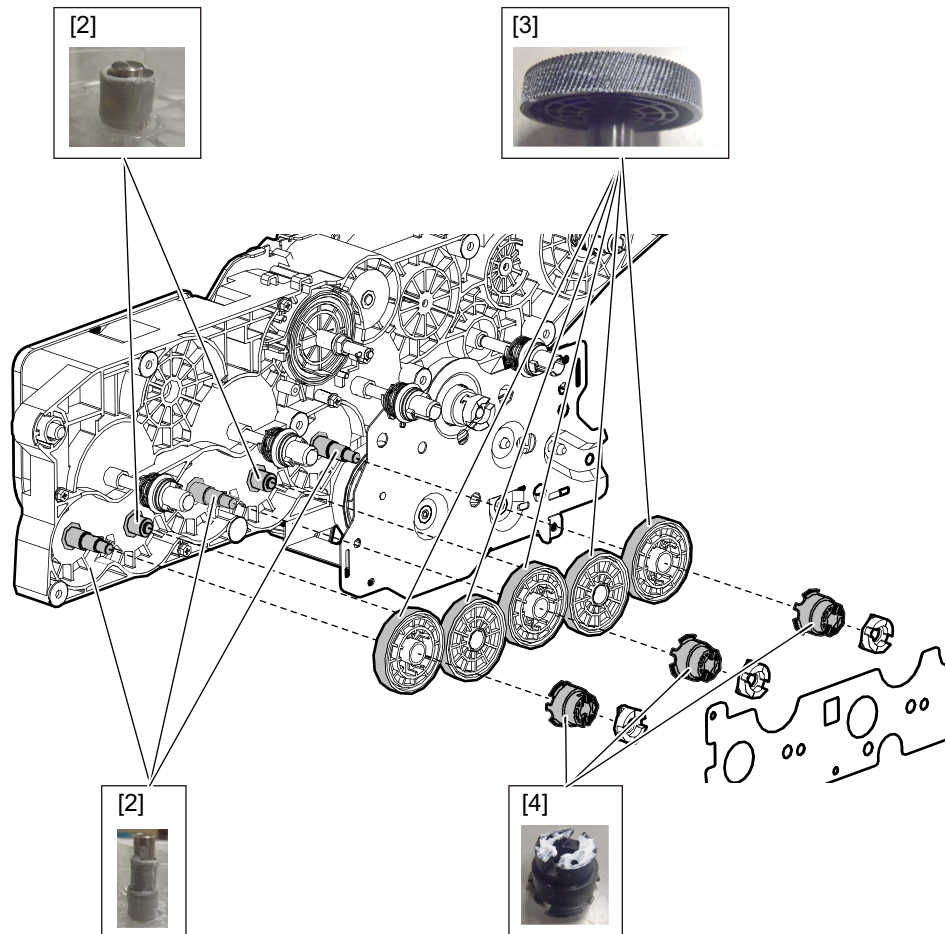

Fig. 4-407

4.6.34 Main power switch (SW4)

Notes:

Be sure to unplug the power cable before starting this work.

- (1) Remove the rear cover.
P. 4-10 "4.1.17 Rear cover"
- (2) Disconnect the 4 connectors [1].

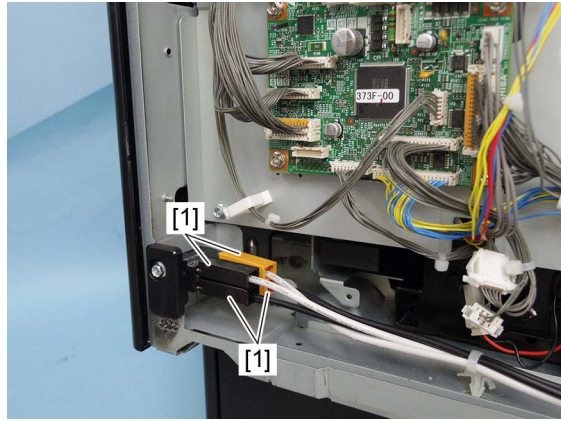

Fig. 4-408

- (3) Release the 2 latches [3] and remove the main power switch [2].

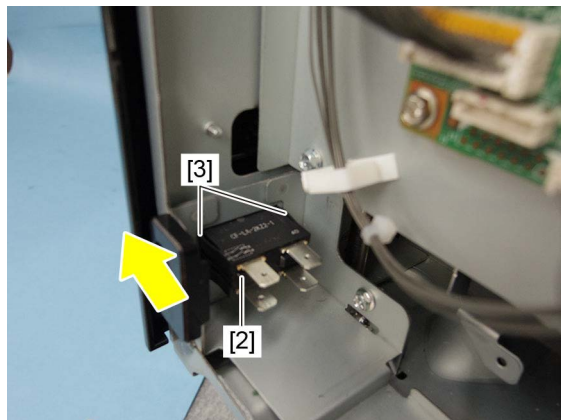



Fig. 4-409

4.6.35 Developer unit cooling exhaust duct

- (1) Remove the rear cover.
 P. 4-10 "4.1.17 Rear cover"
- (2) Remove 2 screws [2] and take off the power supply cover [1].

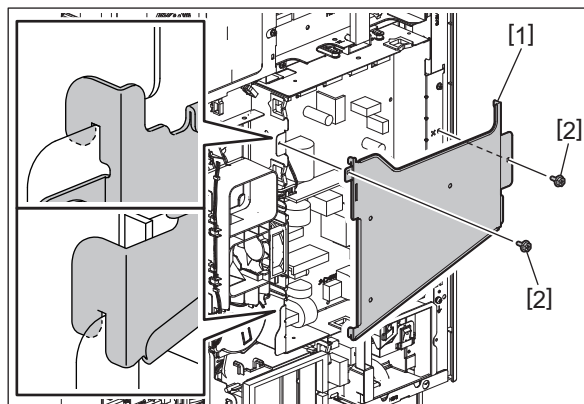

Fig. 4-410

- (3) Disconnect 2 connectors. Then release the harness from 1 clamp [3] and 4 hooks [4].

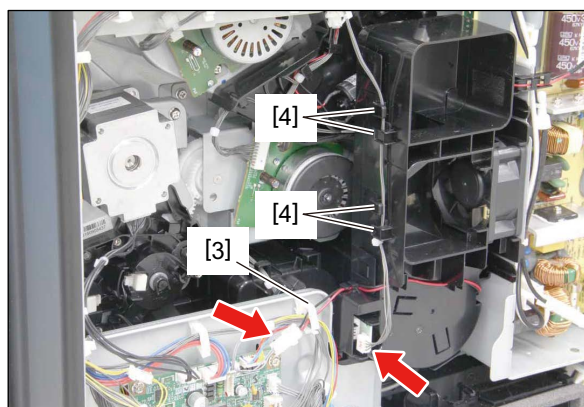

Fig. 4-411

- (4) Disconnect the connector [5] and release 2 latches [6]. Then remove the developer unit cooling exhaust duct [7] by pulling it toward you.

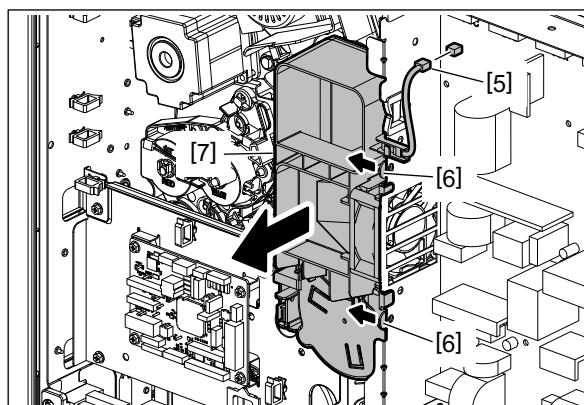

Fig. 4-412

4.6.36 Developer unit cooling fan (F5)

- (1) Remove the developer unit cooling exhaust duct.
📖 P. 4-164 "4.6.35 Developer unit cooling exhaust duct"
- (2) Remove the power supply unit cooling fan.
📖 P. 4-155 "4.6.31 Power supply unit cooling fan (F8)"
- (3) Release 2 latches.

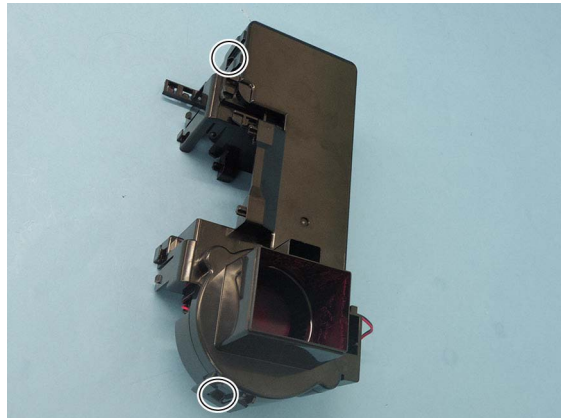

Fig. 4-413

- (4) Release 2 latches and remove the fan cover [1].

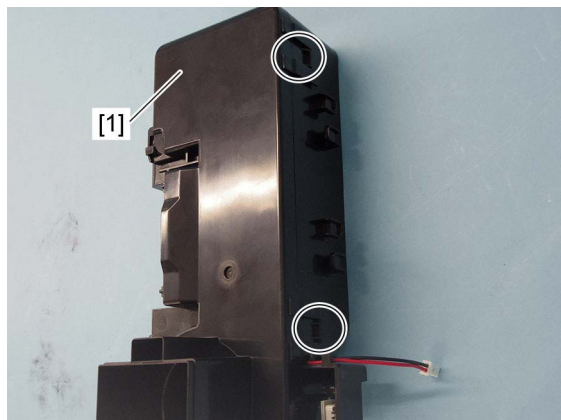

Fig. 4-414

- (5) Release the harness from the harness guides.

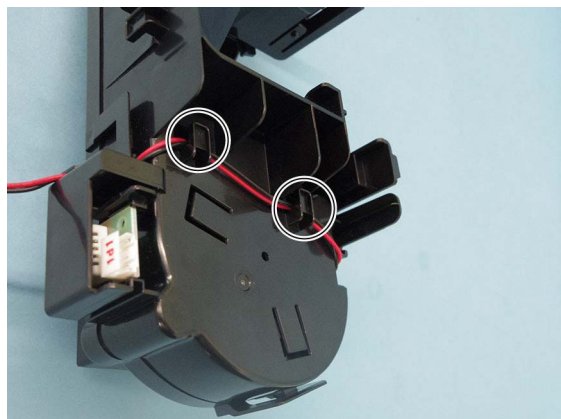

Fig. 4-415

- (6) Remove the developer unit cooling fan [2].

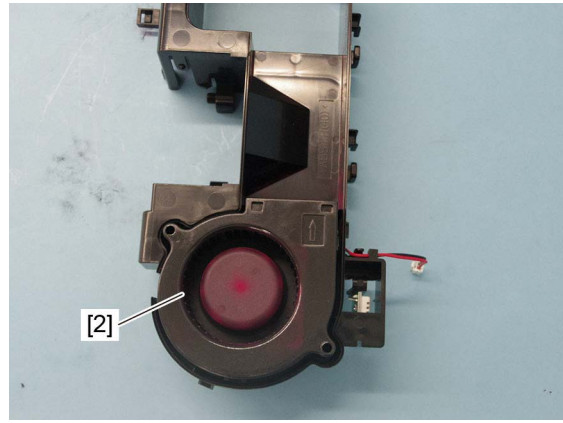

Fig. 4-416

4.6.37 Temperature/humidity sensor (S10)

- (1) Remove the developer unit cooling exhaust duct.
📖 P. 4-164 "4.6.35 Developer unit cooling exhaust duct"
- (2) Release the latch [2] by pushing it, and then remove the temperature/humidity sensor [1].

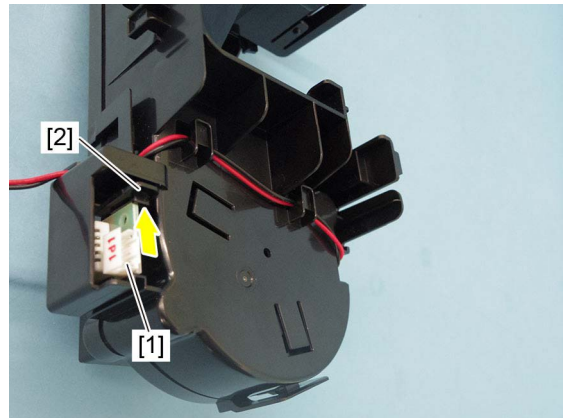

Fig. 4-417

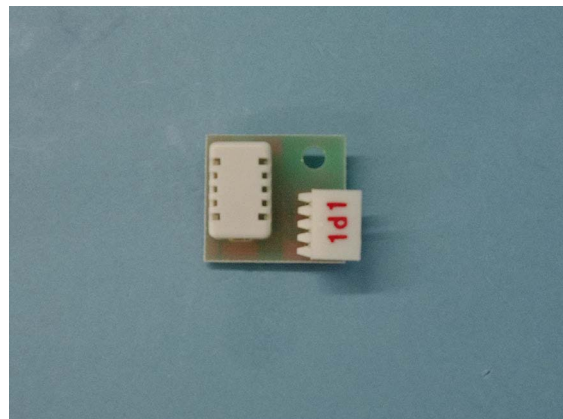

Fig. 4-418

4.7 Transfer Units (TBU, TRU)

4.7.1 Transfer belt cleaning unit

- (1) Remove the waste toner box.
P. 4-108 "4.6.1 Waste toner box"
- (2) Hold the lever [1] and pull the transfer belt cleaning unit [2] toward the front side to remove it.

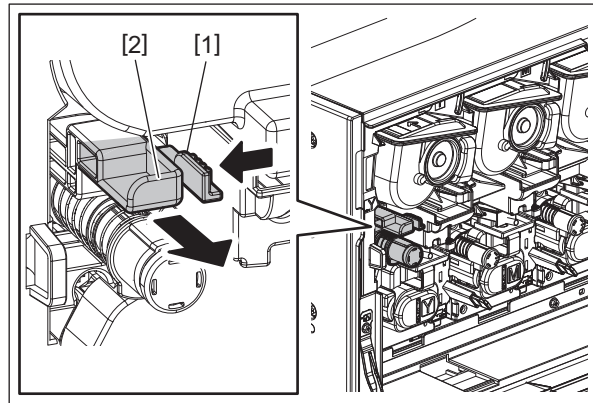

Fig. 4-419

4.7.2 Transfer belt cleaning blade/blade seal/recovery blade **PM**

- (1) Remove the transfer belt cleaning unit.
P. 4-167 "4.7.1 Transfer belt cleaning unit"
- (2) Remove 2 screws and take off the transfer belt cleaning blade [1].

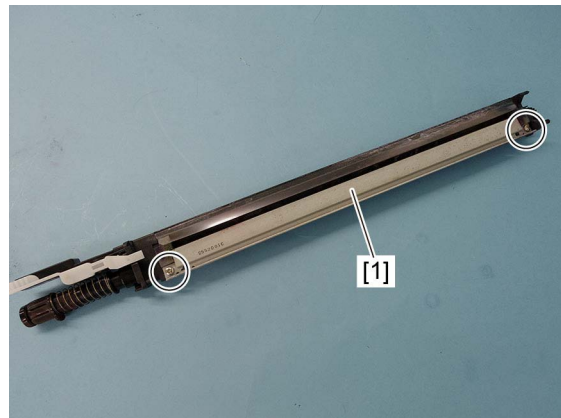

Fig. 4-420

(3) Remove the front and rear blade seals.



Fig. 4-421

Notes:

After the blade seals have been attached, be sure that no gap is left between the blade seals and the edge of the transfer belt cleaning blade.



Fig. 4-422

(4) Remove the recovery blade [2].

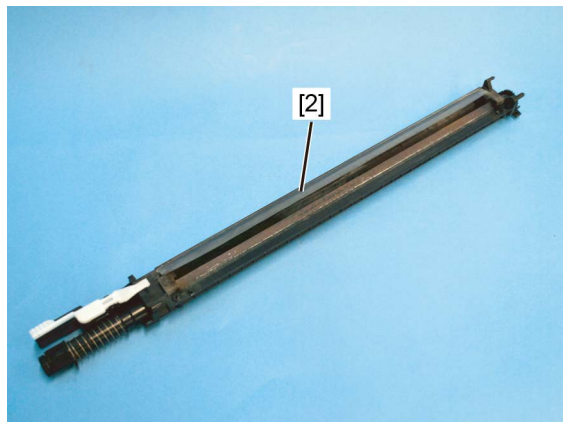

Fig. 4-423

Transfer belt cleaning blade

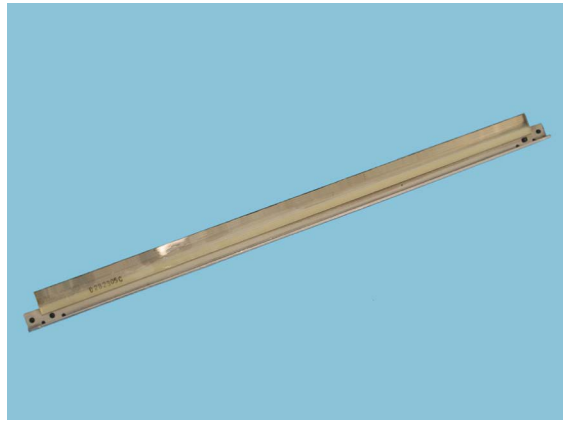

Fig. 4-424

Blade seal



Fig. 4-425

Recovery blade



Fig. 4-426

4.7.3 Transfer belt unit (TBU)

Notes:

You are recommended to wear gloves so that you do not touch the surface of the transfer belt with bare hands.

- (1) Remove the transfer belt cleaning unit.
P. 4-167 “4.7.1 Transfer belt cleaning unit”
- (2) Pull the TBU release lever [1] and turn it clockwise to release the 1st transfer roller.

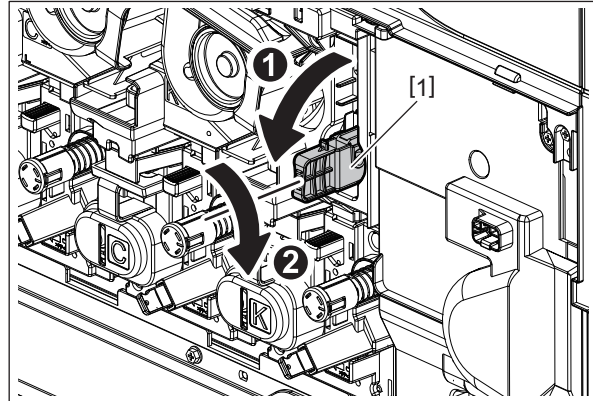

Fig. 4-427

- (3) Open the side cover and lower the 2nd transfer unit (TRU) [1].

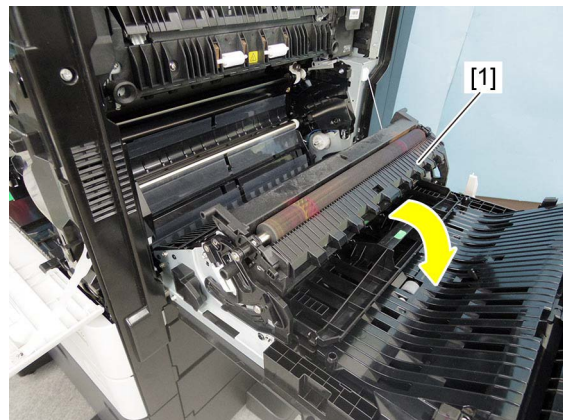

Fig. 4-428

- (4) Pull the lever [2]. Loosen 2 screws to lower them. Pull out the transfer belt unit [3].

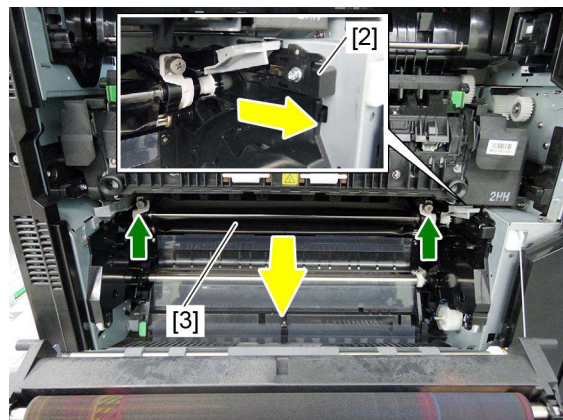

Fig. 4-429

Notes:

Be careful not to generate any friction between the transfer belt and the 2nd transfer unit when pulling out the transfer belt unit.

When installing the transfer belt unit, make sure that the lever [2] is pulled out.

When installing the transfer belt unit, push the handle unit [5] inside while the screw [4] is lowered.

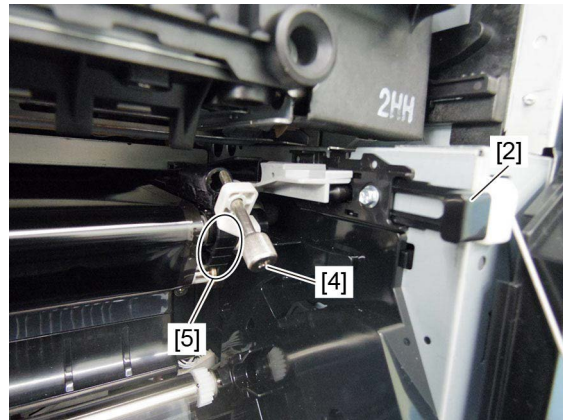

Fig. 4-430

4.7.4 Transfer belt

Notes:

You are recommended to wear gloves so that you do not touch the surface of the transfer belt with bare hands.

- (1) Remove the transfer belt unit.
P. 4-170 "4.7.3 Transfer belt unit (TBU)"
- (2) Remove the spring [2] and the front tensioner [1].

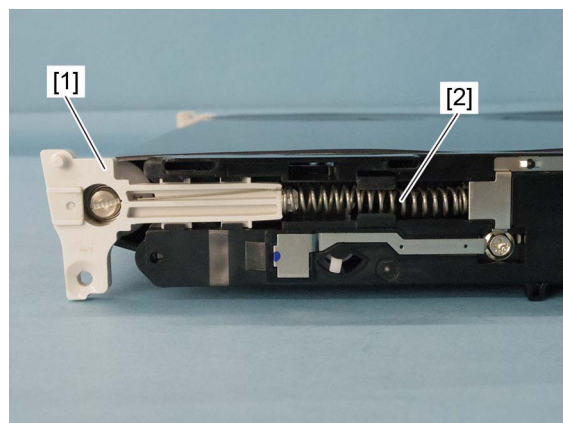

Fig. 4-431

(3) Remove the spring [3] in the rear side.

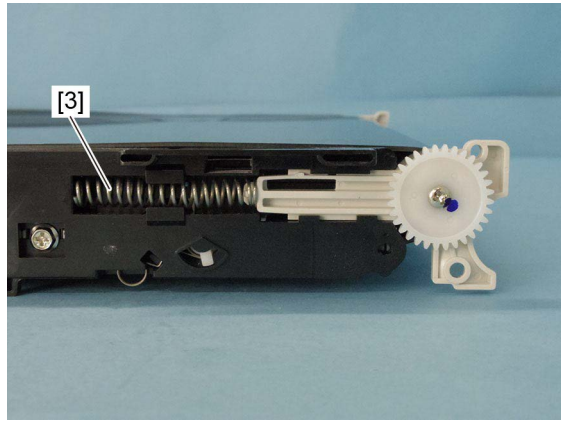

Fig. 4-432

(4) Remove 1 screw and take off the front drive roller bracket [4].

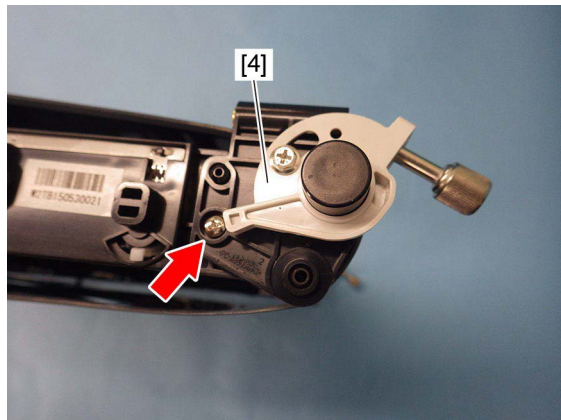

Fig. 4-433

(5) Using the material that is packed with the transfer belt (service part), stand the transfer belt unit [5] on the waste toner box [6].

Notes:

- Use 1 piece of white urethane foam (138 x 138 x 25 mm) with a 30 mm diameter hole.

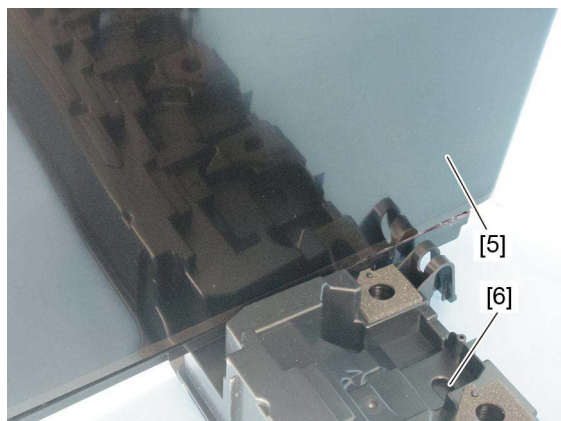

Fig. 4-434

- When installing, make sure that the \triangle mark [7] of the transfer belt unit is aligned with the \triangle mark [8] of the waste toner box.

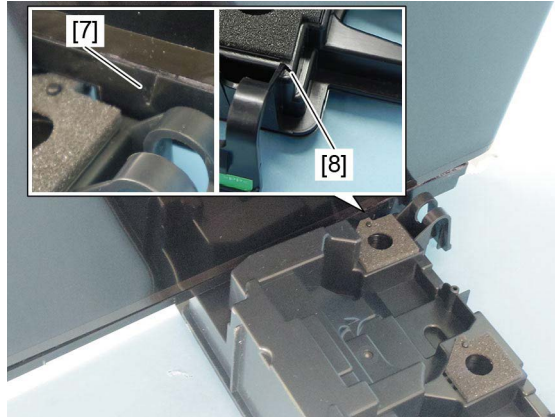

Fig. 4-435

- (6) Remove the transfer belt [9] upward.



Fig. 4-436

Notes:

- When installing the transfer belt, place the side with the serial number facing upward (front side).
- Install the transfer belt in the middle so that it does not move to one side.
- Do not touch the belt surface directly with bare hands.
- Be sure not to scratch the belt surface.
- Check if the rib on both ends of the transfer belt does not run on the rollers.



Fig. 4-437

4.7.5 Cleaner unit facing roller

- (1) Remove the transfer belt.
P. 4-171 "4.7.4 Transfer belt"
- (2) Remove 1 screw, 1 gear [1], 1 tensioner [2], 2 bearings [3], 2 guides [4], and then take off the cleaner unit facing roller [5].

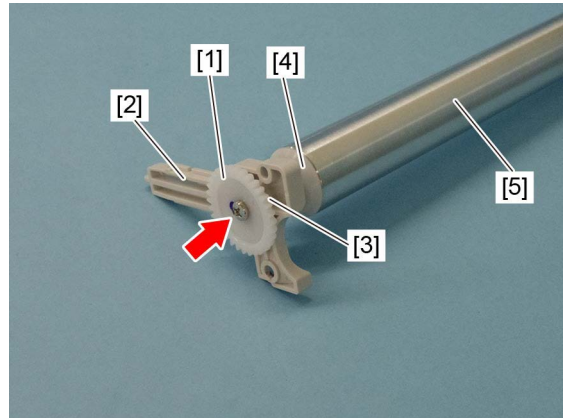

Fig. 4-438

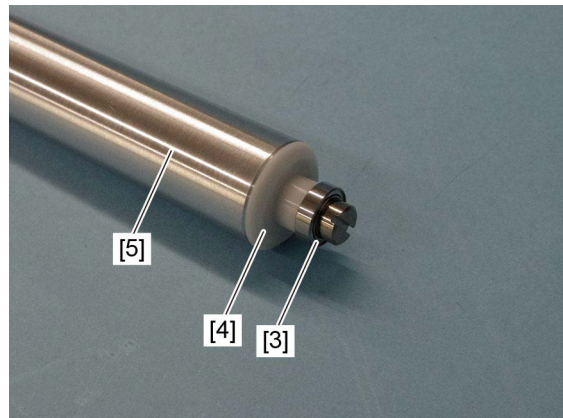

Fig. 4-439

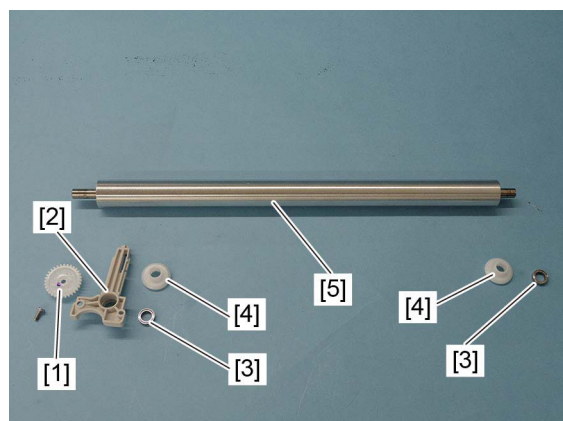

Fig. 4-440

4.7.6 Drive roller

- (1) Remove the transfer belt.
P. 4-171 "4.7.4 Transfer belt"
- (2) Remove the drive roller [1].

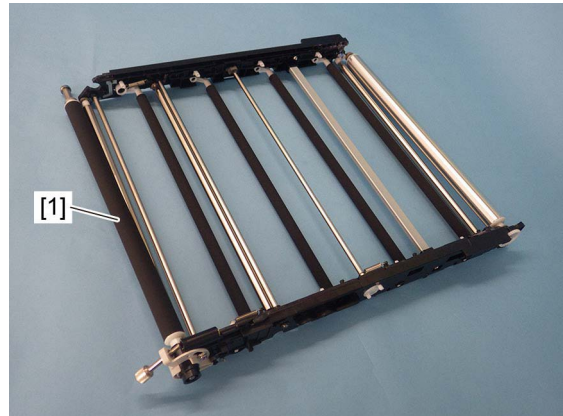

Fig. 4-441

Notes:

When installing the driver roller, correctly attach the spring [2] on the rear drive roller shaft.

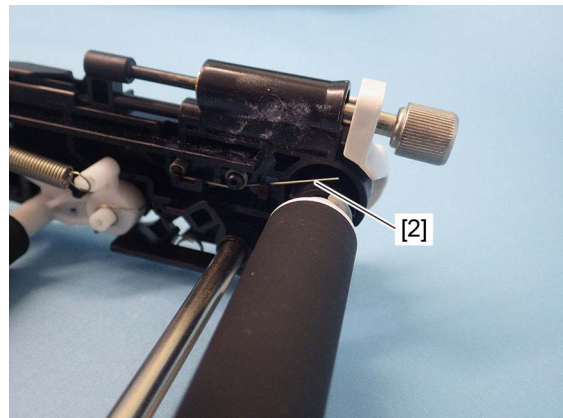

Fig. 4-442

4.7.7 1st transfer roller

- (1) Remove the transfer belt.
📖 P. 4-171 "4.7.4 Transfer belt"
- (2) Place the transfer belt frame upside down.
- (3) Turn the coupling to place the 1st transfer roller into the contact state.

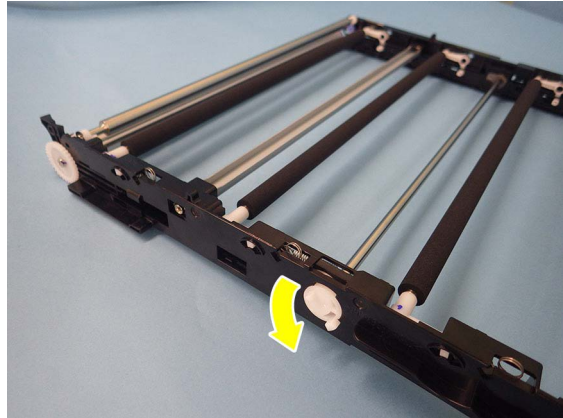

Fig. 4-443

- (4) Remove the rear shaft [2] on the 1st transfer roller.
- (5) Pull the 1st transfer roller [1] toward the rear side to remove it.

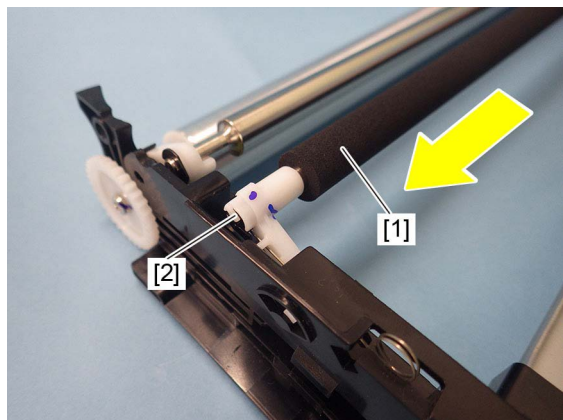

Fig. 4-444



Fig. 4-445

4.7.8 2nd transfer roller^{PM}

- (1) Open the side cover.
- (2) Raise the stopper and remove the 2nd transfer roller assembly [1].

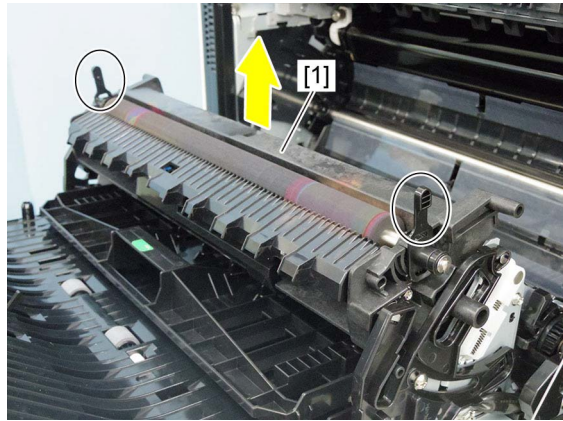

Fig. 4-446



Fig. 4-447

Notes:

- Be sure that the stopper is attached securely.

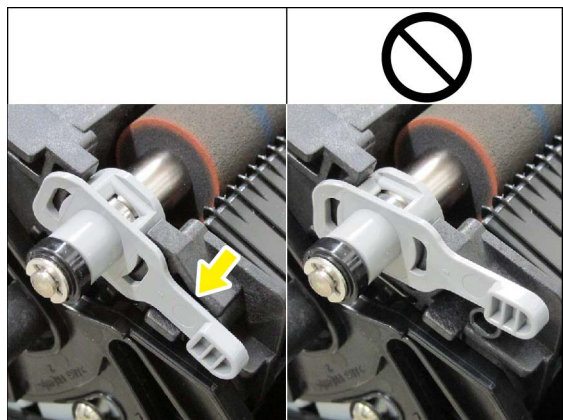

Fig. 4-448

- After the 2nd transfer roller has been replaced, check the conduction between the 2nd transfer roller shaft and the ADU rear frame (metal plate).

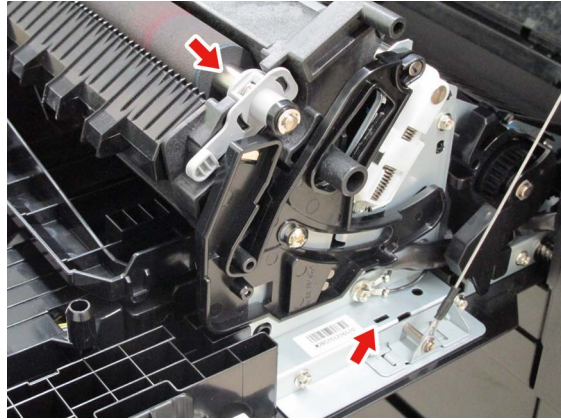

Fig. 4-449

4.7.9 2nd transfer unit (TRU)

- (1) Open the side cover.
- (2) Remove 1 screw and take off the harness cover [1].

Notes:

When installing the harness cover, be careful not to let the harness get caught in it.

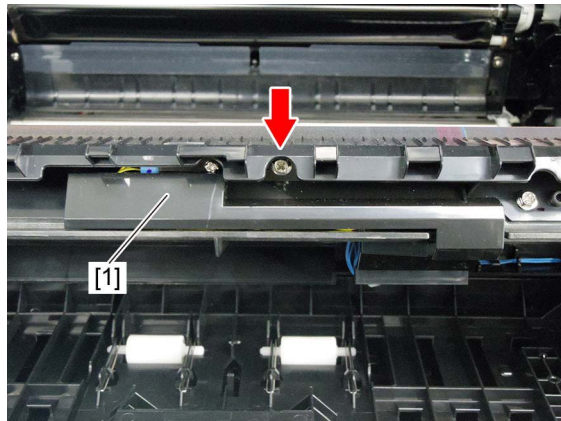

Fig. 4-450

- (3) Disconnect 1 connector [3], remove 1 screw [4] and 1 clip [5], and then remove the 2nd transfer roller unit [2].

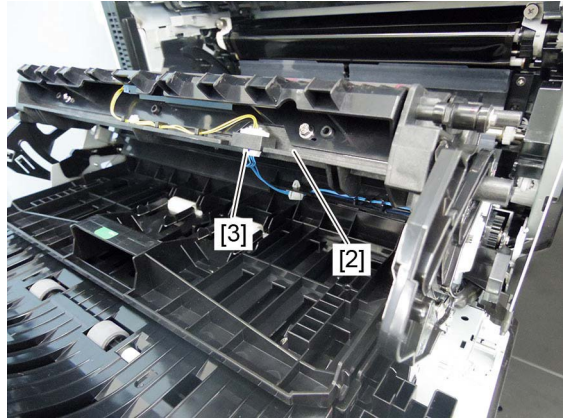

Fig. 4-451

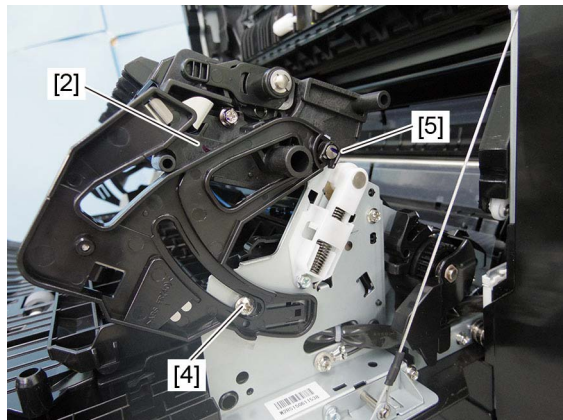

Fig. 4-452

Notes:

When removing the screw [4], be careful not to drop the washer.

4.7.10 Paper clinging detection sensor (S18)

- (1) Remove the 2nd transfer unit.
P. 4-178 "4.7.9 2nd transfer unit (TRU)"
- (2) Disconnect 1 connector [1] and remove 1 screw. Remove the paper clinging detection sensor [2].

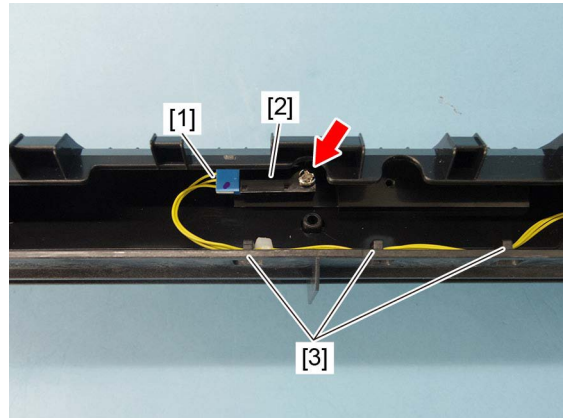

Fig. 4-453

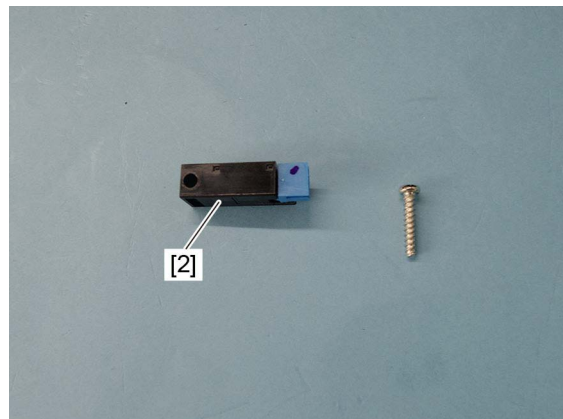

Fig. 4-454

Notes:

When installing, hook the harness to 3 hooks [3].

4.7.11 1st transfer contact/release clutch (CLT2)

- (1) Remove the high-voltage transformer.
P. 9-15 "9.1.9 High-voltage transformer (HVT)"
- (2) Release the harness from harness clamps [6], remove 2 screws, and take off the plate [1].

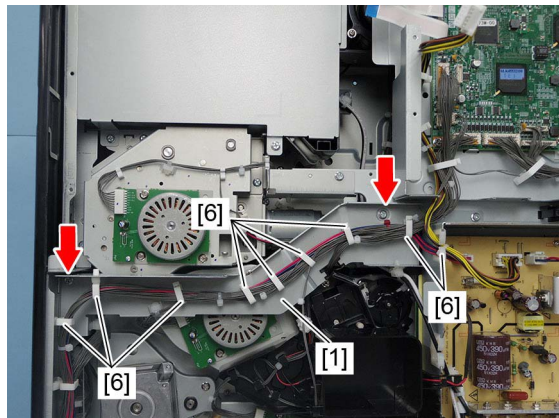

Fig. 4-455

- (3) Release the harness from the harness guides [7] and harness clamp [8].
- (4) Disconnect 2 connectors [9] and remove 1 screw. Then pull up the latch [10] toward the front side, rotate it clockwise, and remove the 1st transfer contact/release clutch cover [2].

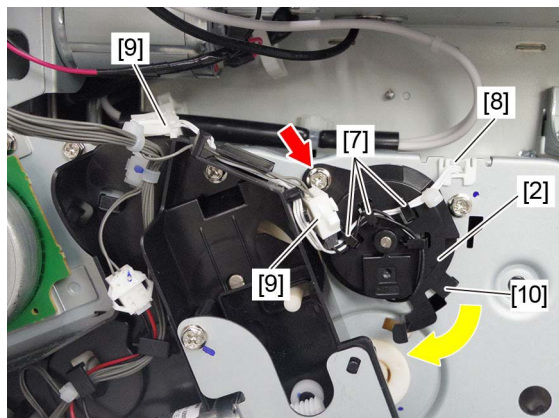

Fig. 4-456

- (5) Remove the 1st transfer contact/release clutch [3].

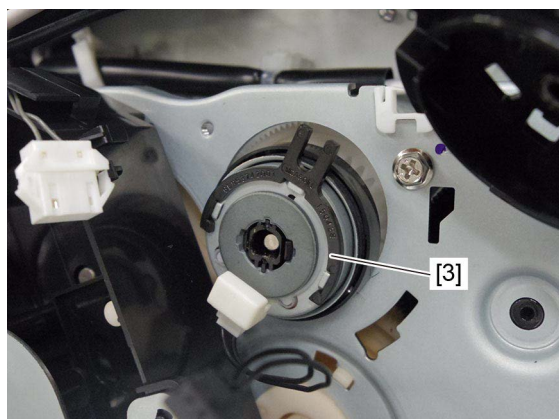

Fig. 4-457

Notes:

When installing, align the 1st transfer contact/release clutch stopper [4] to the 1st transfer contact/release clutch cover hole [5].

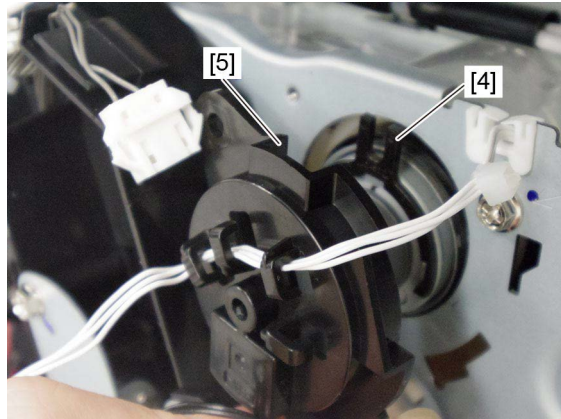

Fig. 4-458

4.7.12 1st transfer roller status detection sensor (S12)

- (1) Remove the drum and TBU drive unit.
P. 4-184 "4.7.14 Drum and TBU drive unit"
- (2) Release the harness from the harness clamp [1].

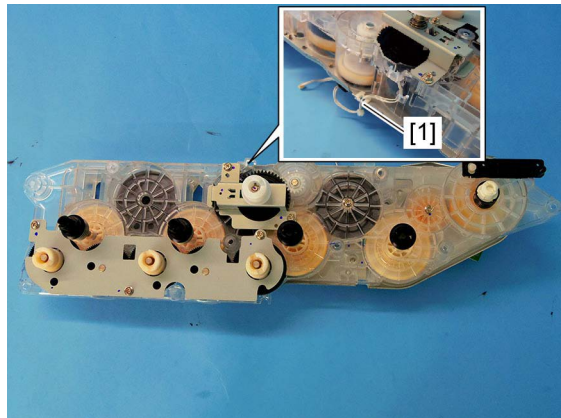

Fig. 4-459

- (3) Remove 2 screws and take off the 1st transfer contact/release gear unit [2].

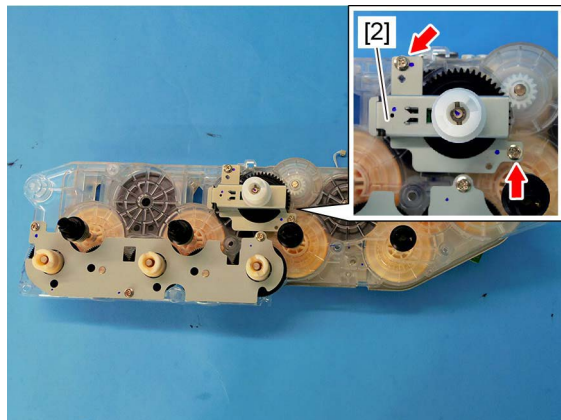

Fig. 4-460

- (4) Pull out the pin [3], and then remove the gear [4].

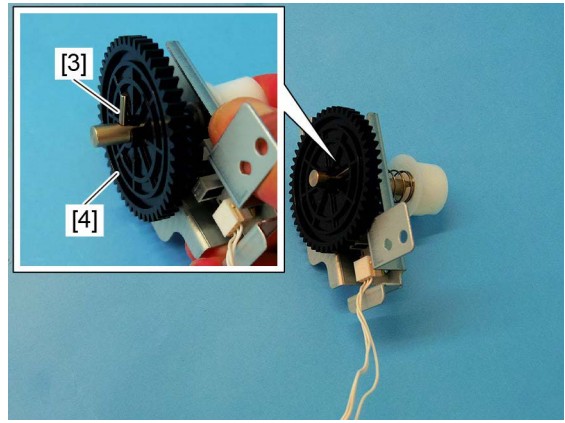

Fig. 4-461

- (5) Remove the 1st transfer roller status detection sensor [5] and disconnect the 1 connector [6].

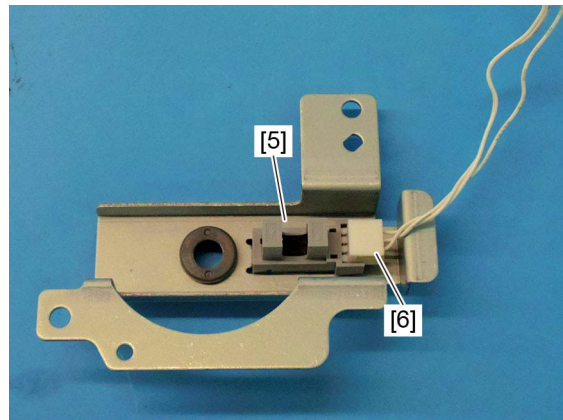

Fig. 4-462

4.7.13 Drum/TBU motor (M6)

- (1) Remove the rear cover.
P. 4-10 "4.1.17 Rear cover"
- (2) Release the harness from harness clamps [4], remove 2 screws, and take off the plate [1].

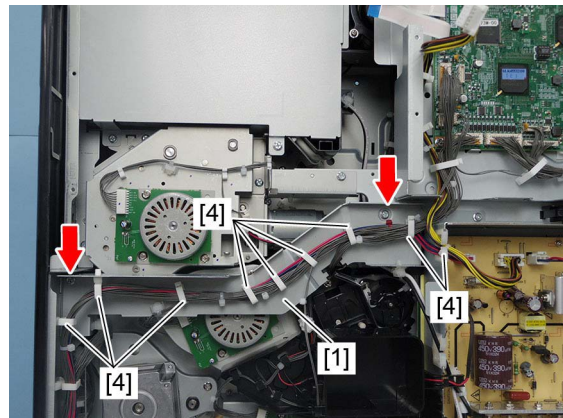

Fig. 4-463

- (3) Remove 2 screws and disconnect the 1 connector [3], and then take off the drum/TBU motor [2].

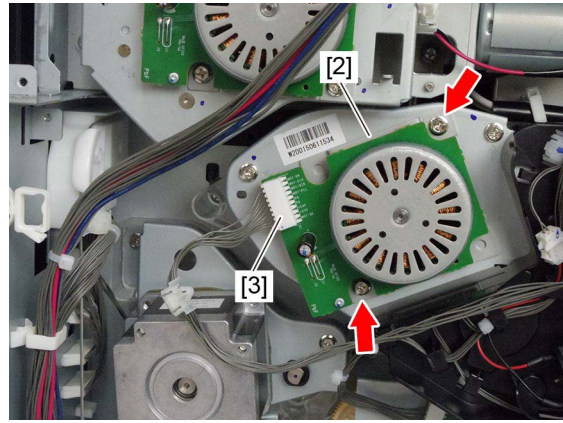

Fig. 4-464

4.7.14 Drum and TBU drive unit

- (1) Remove the switching regulator.
📖 P. 9-13 “9.1.8 Switching regulator”
- (2) Remove the high-voltage transformer.
📖 P. 9-15 “9.1.9 High-voltage transformer (HVT)”
- (3) Remove the drum switching unit.
📖 P. 4-140 “4.6.21 Drum switching unit”
- (4) Remove 2 power supply terminals [1].

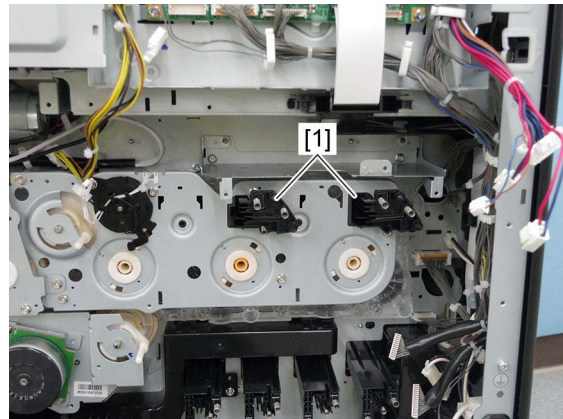

Fig. 4-465

Notes:

The number of the springs for the left side power supply terminal differs from the one for the right side power supply terminal.

- Left side (see from rear side): 3 springs
- Right side (see from rear side): 2 springs

- (5) Release the harness from the 3 harness guides [2] and the harness clamp [3].

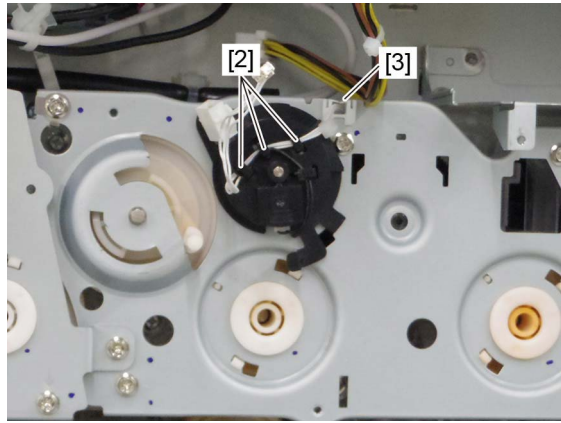

Fig. 4-466

- (6) Remove 7 screws and take off the drum and TBU drive unit [4].

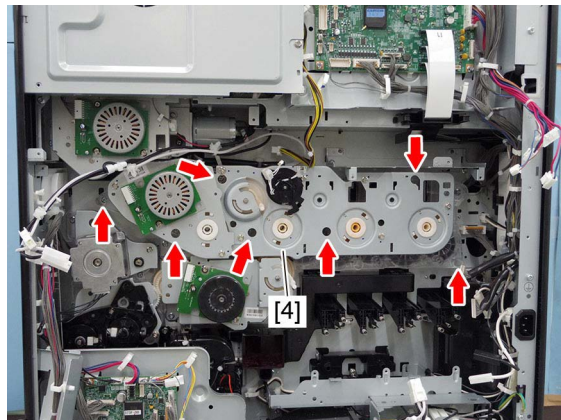

Fig. 4-467

Notes:

- When installing the drum and TBU drive unit, insert the protrusion of transfer belt drive shaft release arm [5] into the lever hole [6].

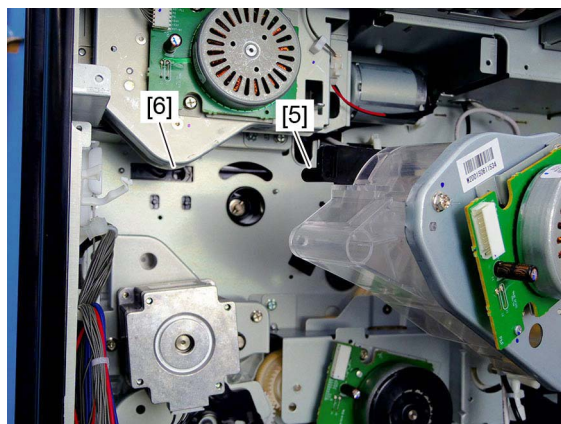

Fig. 4-468

- When installing the drum and TBU drive unit, put the drum and TBU drive unit hook [7] on the rear frame hole [8].

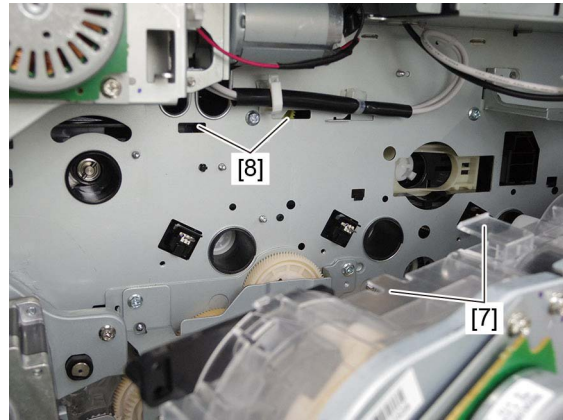

Fig. 4-469

- (7) Remove the transfer belt drive shaft release arm [9].

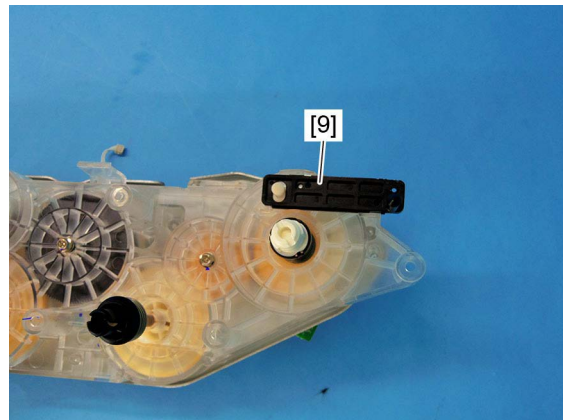

Fig. 4-470

4.8 Image Quality Control

4.8.1 Image quality control unit

- (1) Remove the transfer belt unit.
P. 4-170 “4.7.3 Transfer belt unit (TBU)”
- (2) Remove the Registration roller (on the equipment side).
P. 4-66 “4.5.8 Registration roller (on the equipment side)”
- (3) Remove 2 screws. Disconnect 1 connector [1] and take off the image quality control unit [2].

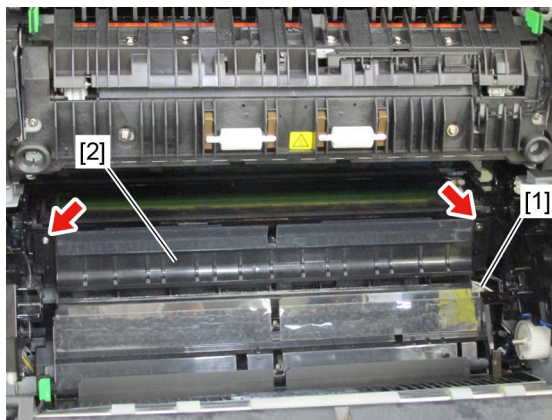

Fig. 4-471

Notes:

The attachment screw on the rear side is a shoulder screw, so exercise care when handling it during installation.

4.8.2 Paper dust holder

- (1) Remove the image quality control unit.
P. 4-187 “4.8.1 Image quality control unit”
- (2) Remove 4 screws.
- (3) Disconnect the connector and remove the paper dust holder [1].

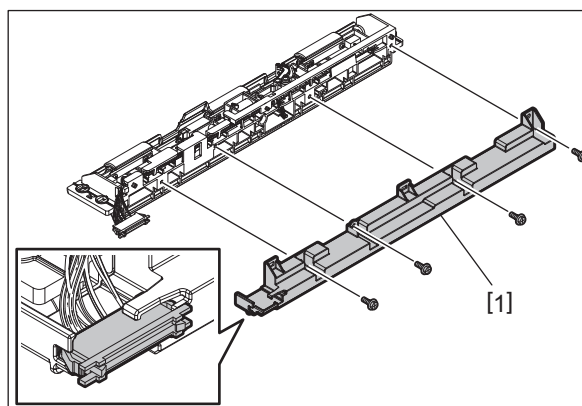

Fig. 4-472

4.8.3 Image position aligning sensor (Front) (S7)

- (1) Remove the image quality control unit.
📖 P. 4-187 "4.8.1 Image quality control unit"
- (2) Remove the paper dust holder.
📖 P. 4-187 "4.8.2 Paper dust holder"
- (3) Remove 2 screws and disconnect the 1 connector [1], and then take off the Image position aligning sensor (Front) [2].

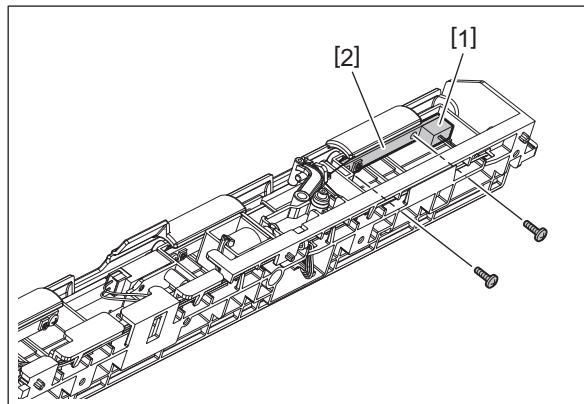

Fig. 4-473

4.8.4 Image position aligning sensor (Rear) (S8)

- (1) Remove the image quality control unit.
📖 P. 4-187 "4.8.1 Image quality control unit"
- (2) Remove the paper dust holder.
📖 P. 4-187 "4.8.2 Paper dust holder"
- (3) Remove 2 screws and disconnect the 1 connector [1], and then take off the image position aligning sensor (Rear) [2].

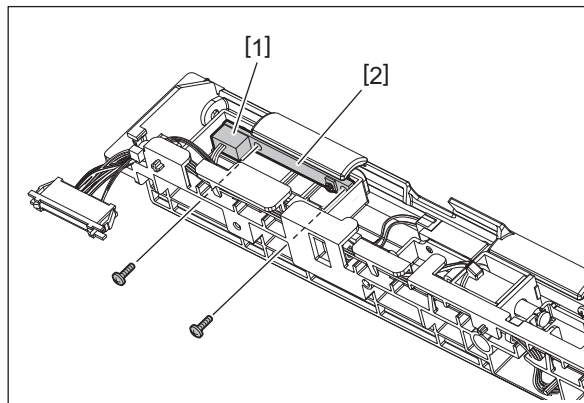

Fig. 4-474

4.8.5 Image position aligning sensor (Center)/Image quality sensor (S37)

- (1) Remove the image quality control unit.
📖 P. 4-187 “4.8.1 Image quality control unit”
- (2) Remove the paper dust holder.
📖 P. 4-187 “4.8.2 Paper dust holder”
- (3) Remove 2 screws, disconnect 1 connector [1] and then take off the image position aligning sensor (Center)/image quality sensor [2].

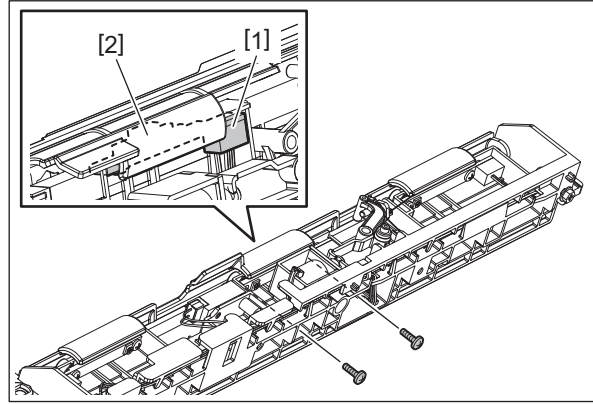

Fig. 4-475

4.8.6 Registration pass sensor (S6)

- (1) Remove the image quality control unit.
📖 P. 4-187 “4.8.1 Image quality control unit”
- (2) Disconnect the connector [1].

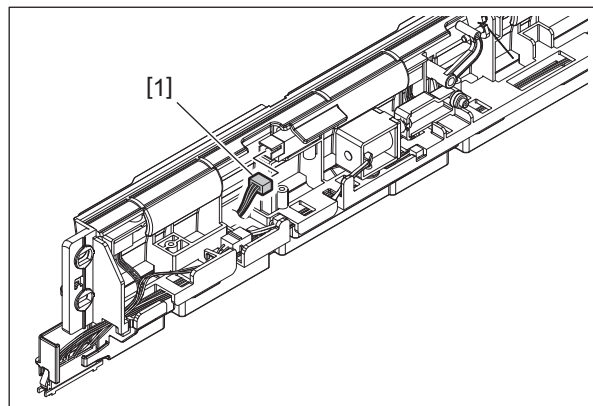

Fig. 4-476

- (3) Open the shutter [2] and remove 1 screw. Take off the registration pass sensor [3].

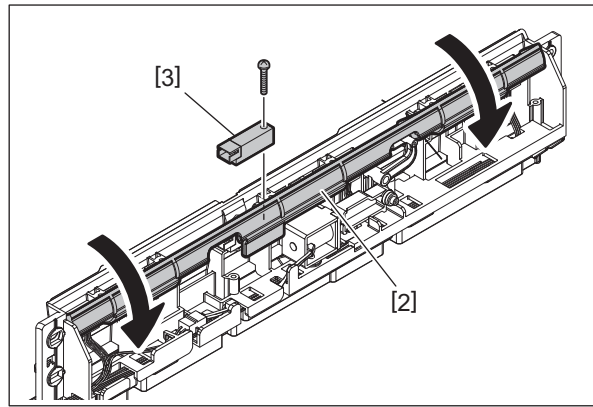

Fig. 4-477

4.8.7 Sensor shutter solenoid (SOL1)

- (1) Remove the image quality control unit.
📖 P. 4-187 "4.8.1 Image quality control unit"
- (2) Remove the paper dust holder.
📖 P. 4-187 "4.8.2 Paper dust holder"
- (3) Remove 1 screw and take off the sensor shutter solenoid [3].

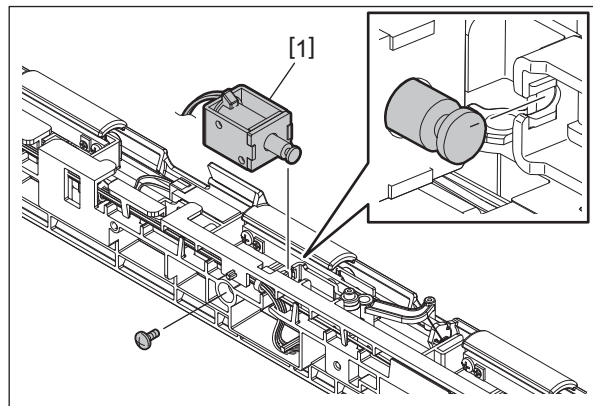

Fig. 4-478

4.9 Fuser Unit

4.9.1 Fuser unit

Notes:

- Be sure that the temperature of the fuser unit has lowered enough before removing it. If the unit still heated should be removed, wear a pair of gloves before working.
- When disassembling the fuser unit or replacing any parts in it, be sure that the wire harness is correctly set, and also be careful not to get it caught between other parts.

a. Be sure to wire the harness as shown below to prevent it from being caught by the cover.

b. Be sure to wire the harness along all the hooks of the harness holder as shown below.

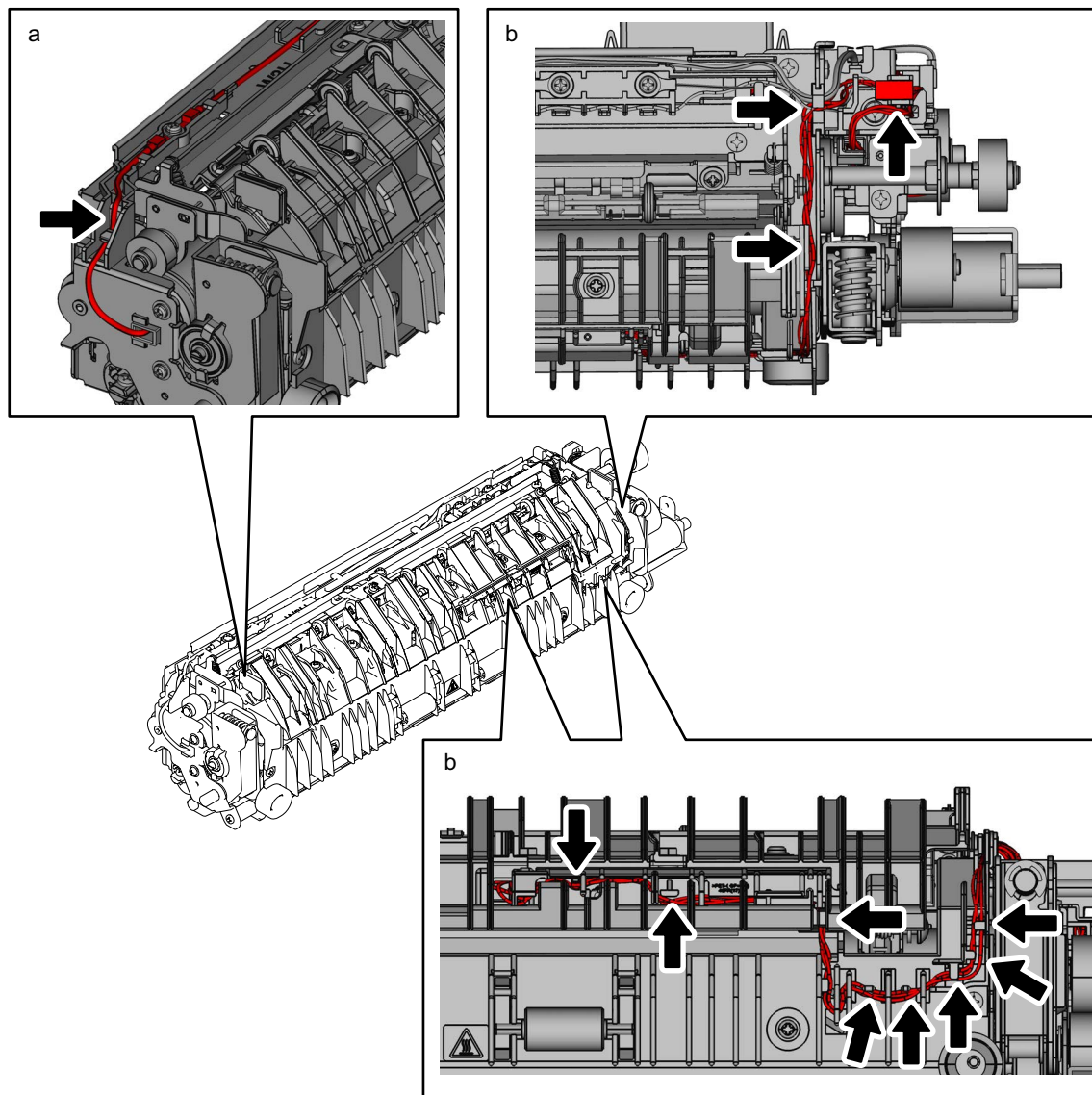

Fig. 4-479

- c. Be sure to wire the belt unit harness to the hooks [1] and [2] of the harness holder as shown below.
 d. Be sure to wire the harness as shown below to prevent it from being caught by the cover.

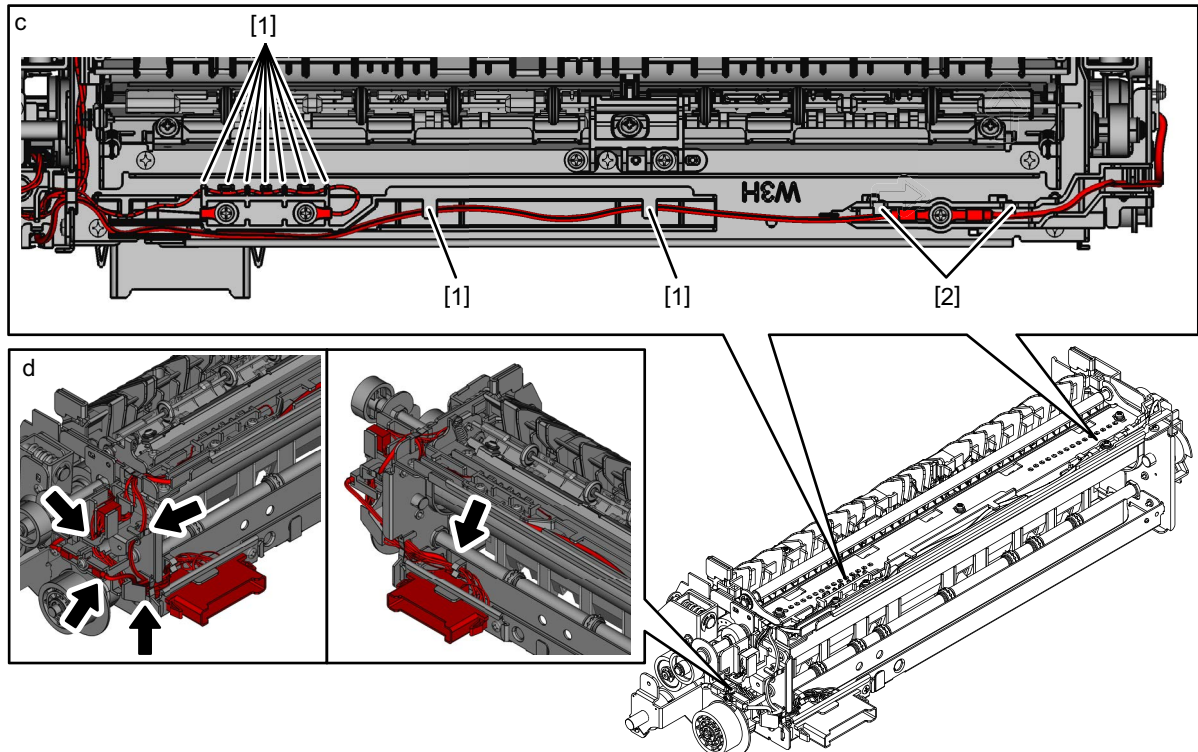

Fig. 4-480

- (1) Open the side cover.
- (2) Press down the lever [1] and remove the fuser unit [2].

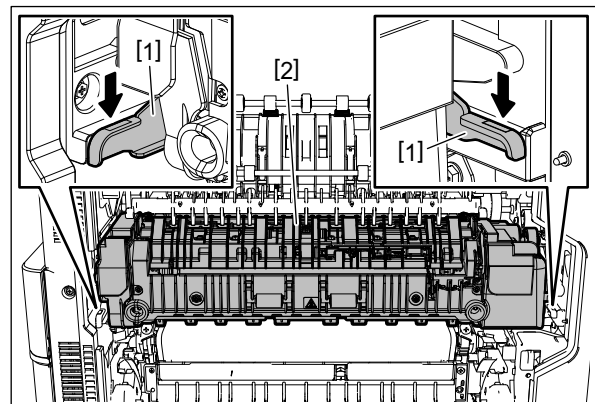

Fig. 4-481

Notes:

- The fuser unit is extremely hot. When removing the fuser unit, hold the handles of the unit to avoid a direct touch on the unit.

- When installing the fuser unit, be sure to press it in until the lever goes up. If the lever goes down, the fuser unit has not been correctly installed.

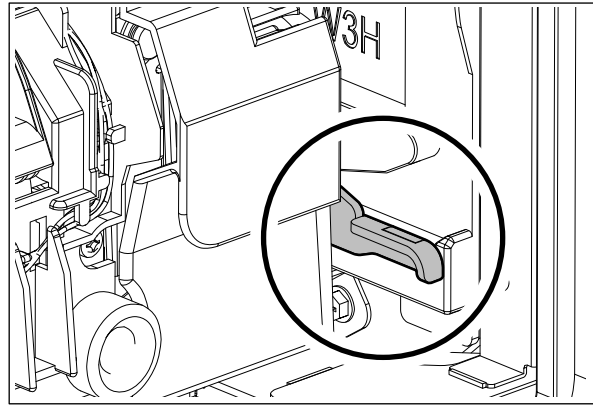

Fig. 4-482

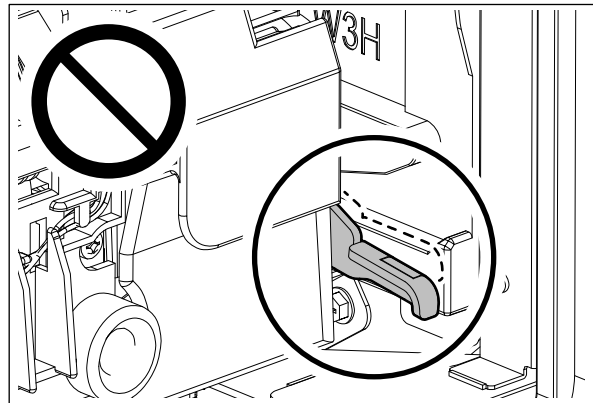

Fig. 4-483

- “3HH” is marked on the fuser unit for 45ppm/50ppm for identification. “3HL” is marked on the fuser unit for 25ppm/30ppm/35ppm.

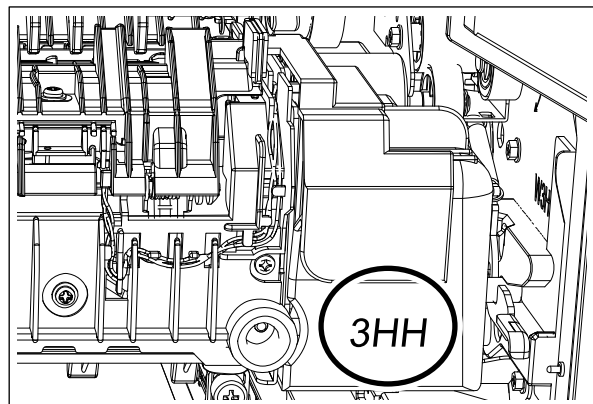

Fig. 4-484

- To avoid incorrect assembly, the fixing position of the bracket differs between the fuser units for 45ppm/50ppm and 25ppm/30ppm/35ppm.
45ppm/50ppm

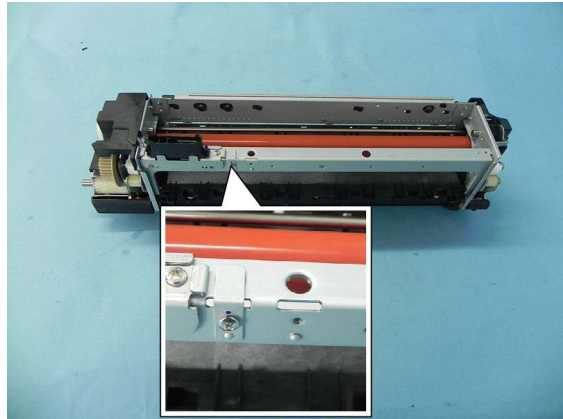

Fig. 4-485

25ppm/30ppm/35ppm

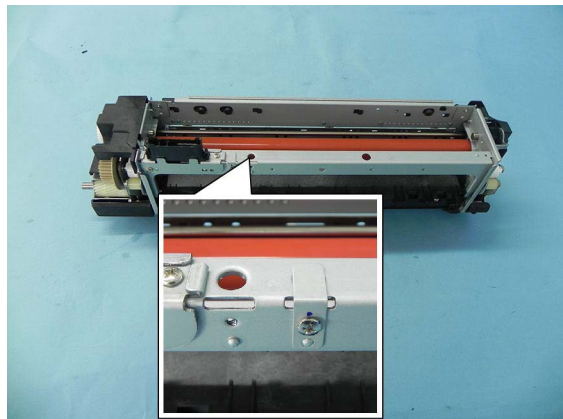



Fig. 4-486

4.9.2 Front side cover

- (1) Remove the fuser unit.
 P. 4-191 "4.9.1 Fuser unit"
- (2) Remove 2 screws and take off the front side cover [1].

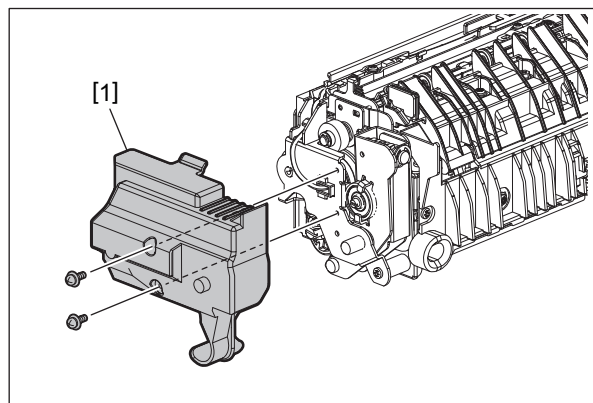

Fig. 4-487

4.9.3 Rear side cover

- (1) Remove the fuser unit.
P. 4-191 "4.9.1 Fuser unit"
- (2) Remove 2 screws and take off the rear side cover [1].

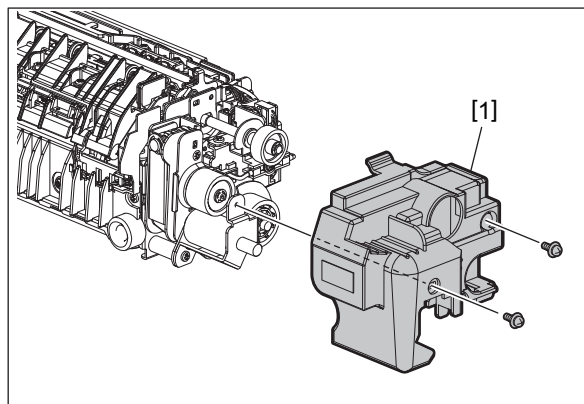

Fig. 4-488

Notes:

When installing the cover, put the harness into the harness guides so that it will not be pinched by the cover.

4.9.4 Separation finger^{PM}

- (1) Remove the fuser unit.
P. 4-191 "4.9.1 Fuser unit"
- (2) Remove 2 screws.

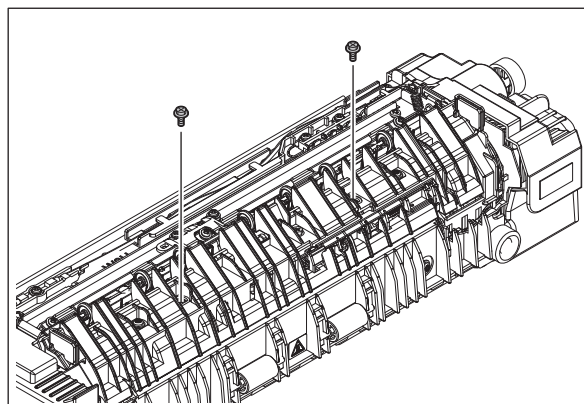

Fig. 4-489

(3) Open the guide [1].

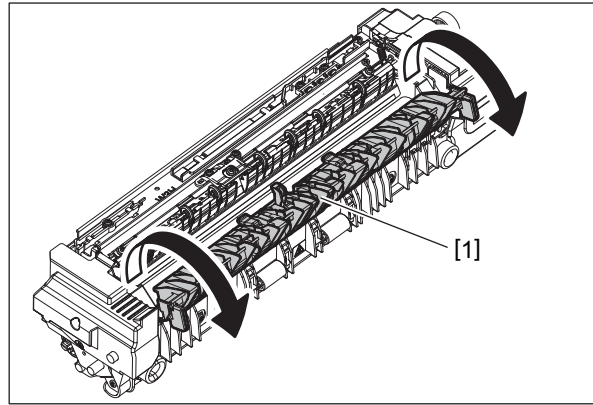

Fig. 4-490

(4) Release the latch [2] and take off the sensor cover [3].

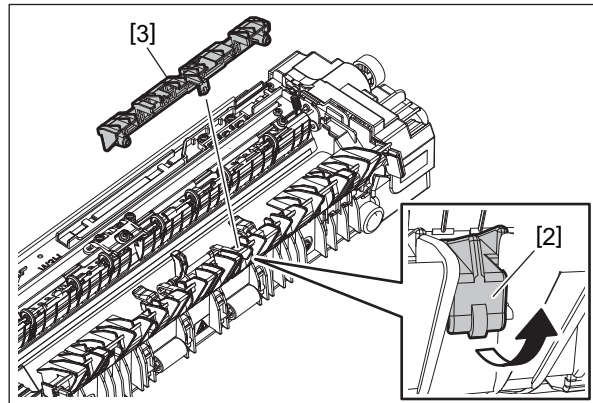

Fig. 4-491

(5) Remove 2 screws, and then take off the separation fingers [4] and springs [5].

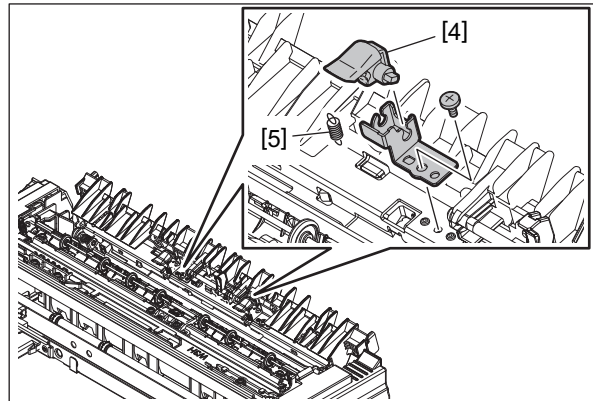

Fig. 4-492



Fig. 4-493

Notes:

Be careful not to pull springs out too far.

4.9.5 Separation guide <25ppm/30ppm/35ppm>

- (1) Remove the fuser unit.
 P. 4-191 "4.9.1 Fuser unit"
- (2) Remove the front side cover.
 P. 4-194 "4.9.2 Front side cover"
- (3) Remove the rear side cover.
 P. 4-195 "4.9.3 Rear side cover"
- (4) Remove 3 screws and take off the separation guide [1].

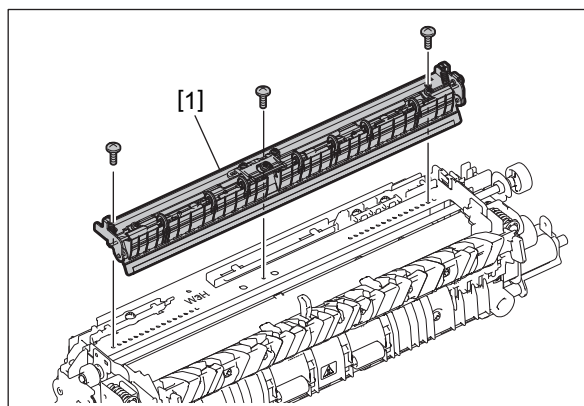



Fig. 4-494

4.9.6 Exit sensor (S13)

- (1) Remove the fuser unit.
 P. 4-191 "4.9.1 Fuser unit"
- (2) Remove 2 screws.

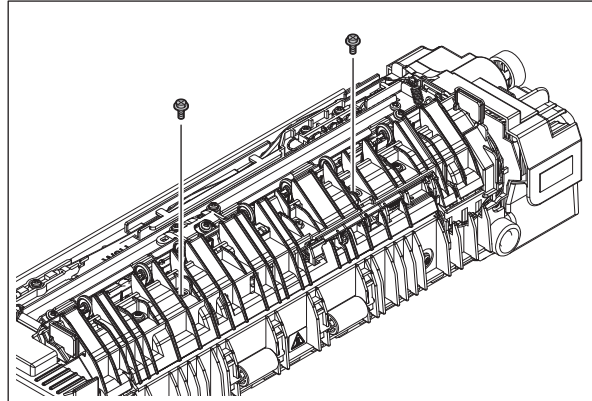

Fig. 4-495

- (3) Open the guide [1].

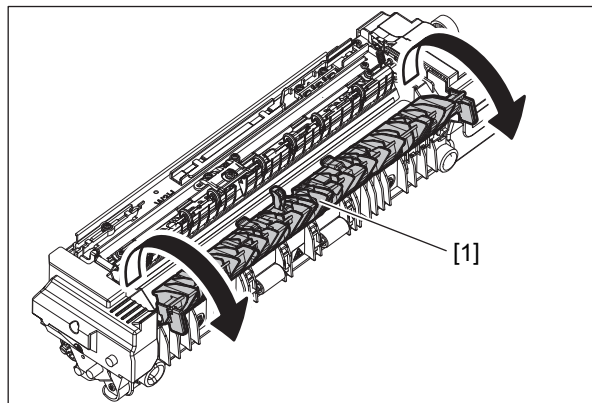

Fig. 4-496

- (4) Release the latch [2] and take off the sensor cover [3].

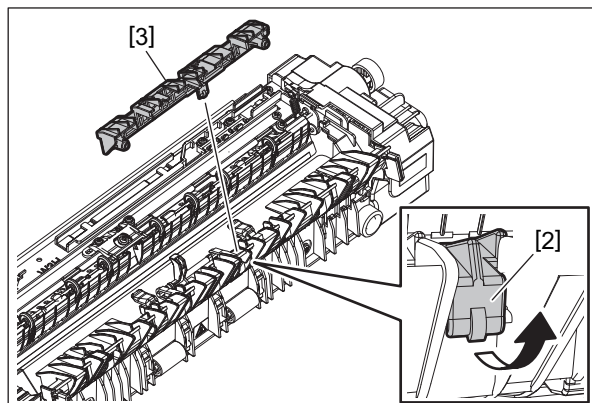

Fig. 4-497

- (5) Remove the actuator [4] and spring [5].

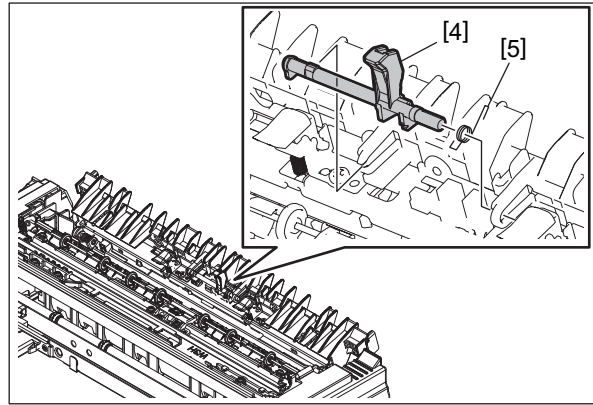

Fig. 4-498

- (6) Take off the exit sensor [5]. Disconnect 1 connector [7] from the exit sensor [6].

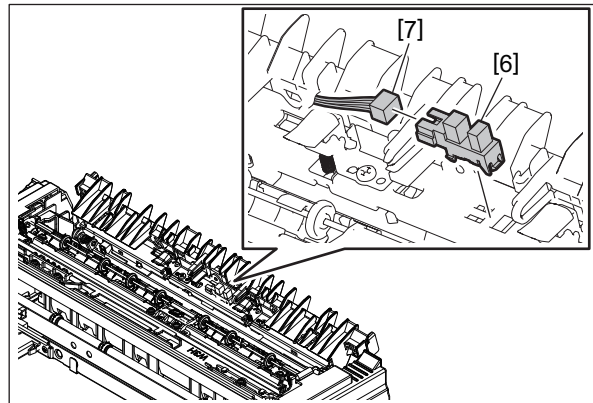

Fig. 4-499

4.9.7 Paper exit guide

- (1) Remove the fuser unit.
P. 4-191 "4.9.1 Fuser unit"
- (2) Remove the front side cover.
P. 4-194 "4.9.2 Front side cover"
- (3) Remove the rear side cover.
P. 4-195 "4.9.3 Rear side cover"
- (4) Disconnect 1 connector [1] and release the cable from the clamp.

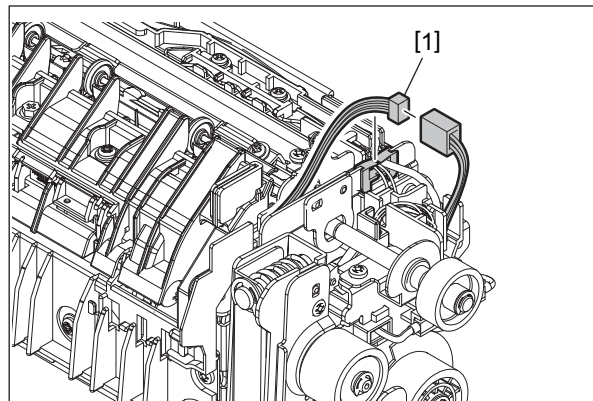

Fig. 4-500

- (5) Remove 2 screws and take off the paper exit guide [2].

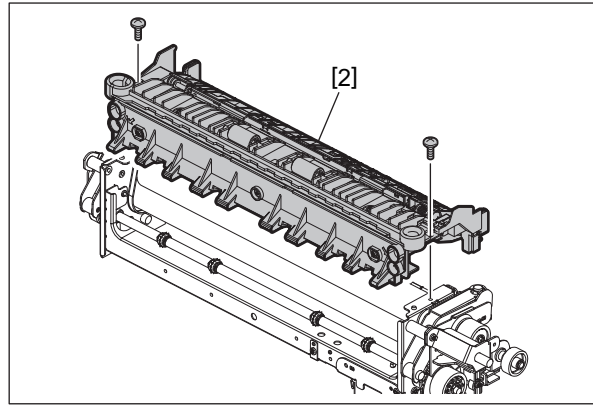

Fig. 4-501

4.9.8 Fuser belt

- (1) Remove the paper exit guide.
 P. 4-199 "4.9.7 Paper exit guide"
- (2) Remove 1 screw and 2 harnesses [2] from the harness holder [1]. Take off the harness holder [1].

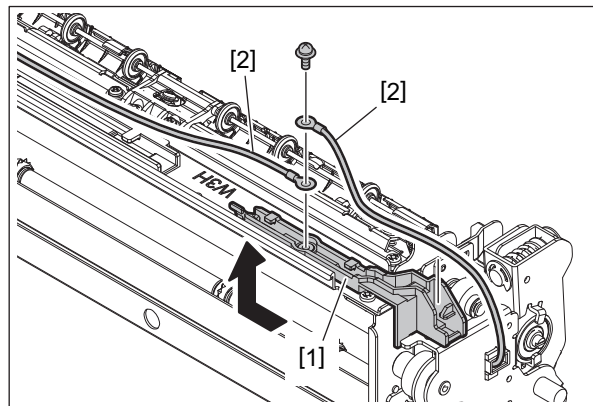

Fig. 4-502

- (3) Remove 2 screws and release 2 harnesses [4] from the harness holder [3].
 Remove the released harnesses from the clamp.

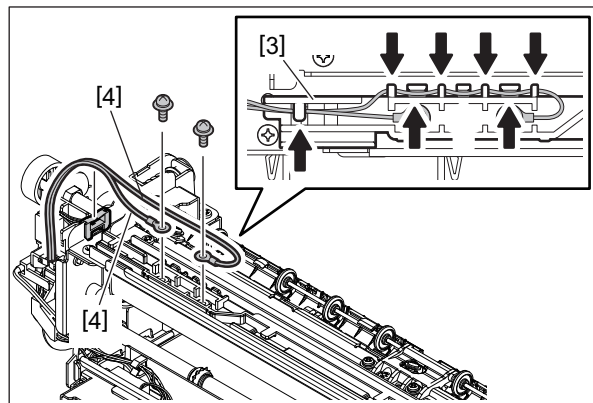

Fig. 4-503

Notes:

Connect the harnesses as shown in the figure.

(4) Remove 1 screw.

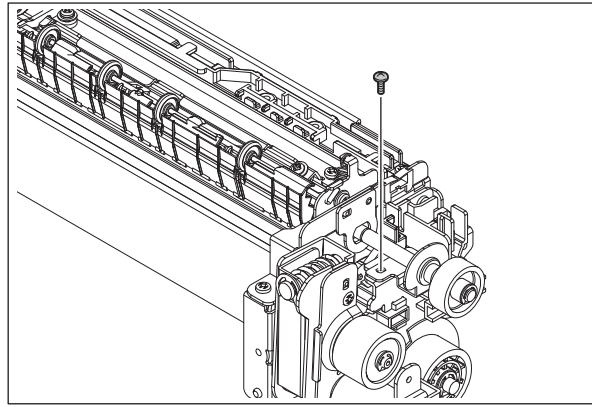

Fig. 4-504

(5) Remove 4 screws and the frame [5].

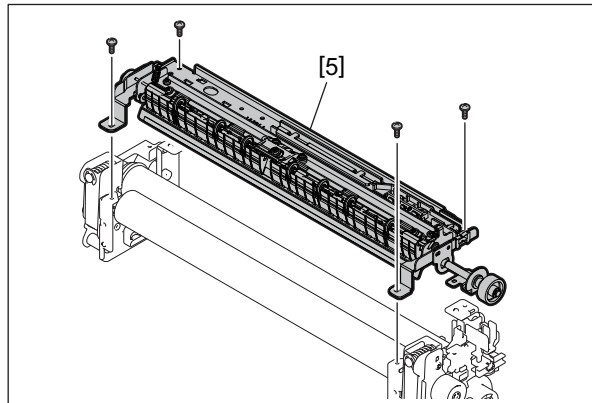

Fig. 4-505

(6) Remove 3 screws from the front side, and take off the plate [6].

(7) Remove the gear [7].

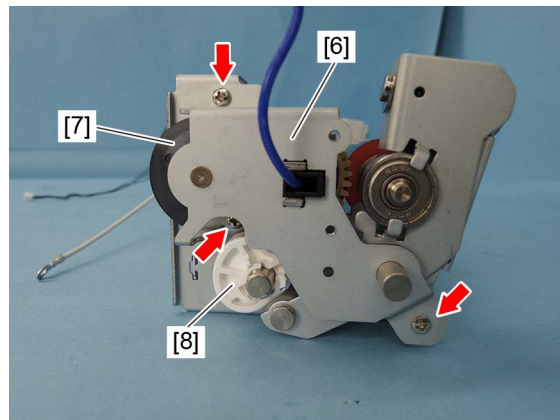

Fig. 4-506

Notes:

- When removing, check that the pressure roller contact/release cam [8] is located at the release position, and also that the fuser belt and pressure roller are released.

Contact position.



Fig. 4-507

Release position.

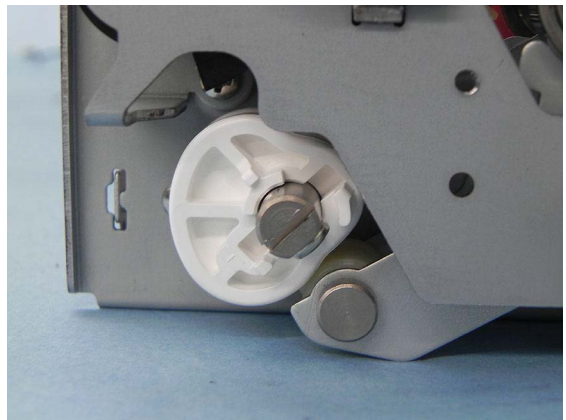

Fig. 4-508

- When replacing the parts or performing preventive maintenance, apply an appropriate amount of white grease (Molykote EM-30L) to the shaft [9] and the points [10] where the shaft [9] and the bracket contact.

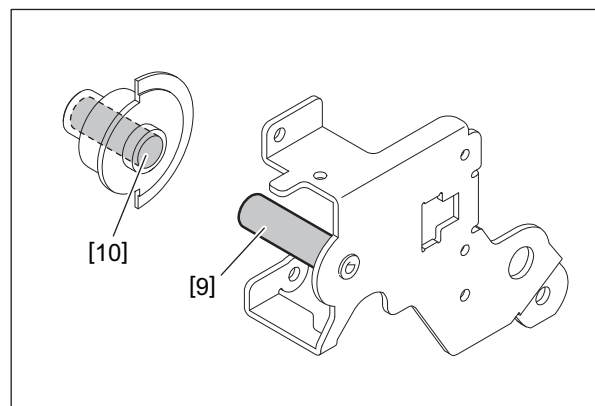

Fig. 4-509

(8) Remove 1 screw in the rear side.

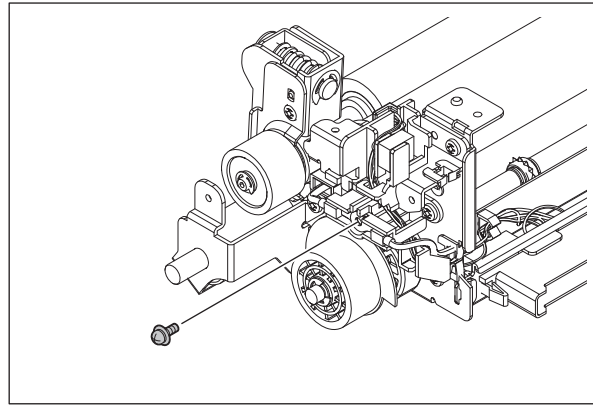

Fig. 4-510

(9) Remove 2 screws, and then disconnect the drawer connector [11].

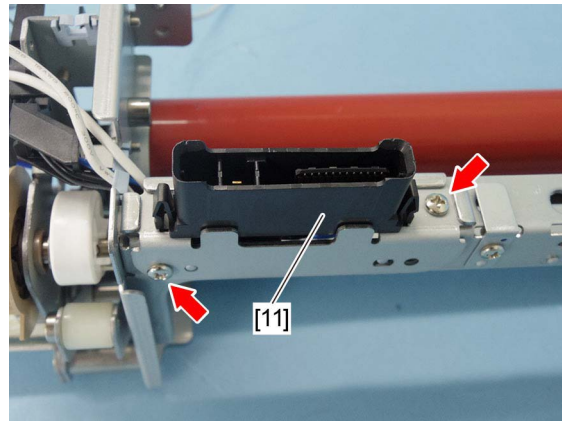

Fig. 4-511

(10) Disconnect 1 connector.

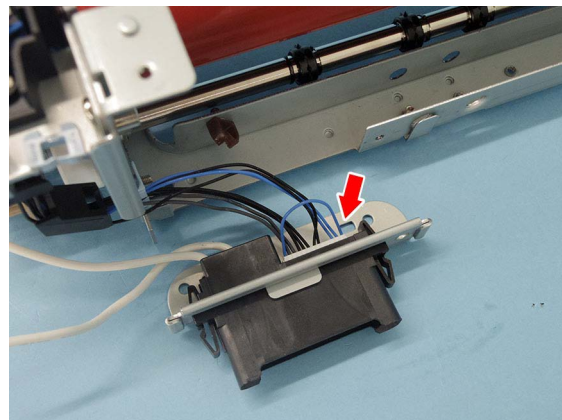

Fig. 4-512

(11) Release the harness [12] from the harness guides [18] and harness clamp [19].

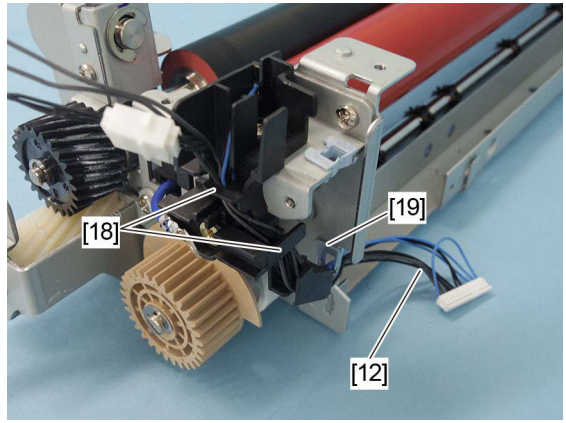

Fig. 4-513

(12) Remove the fuser belt unit [13].

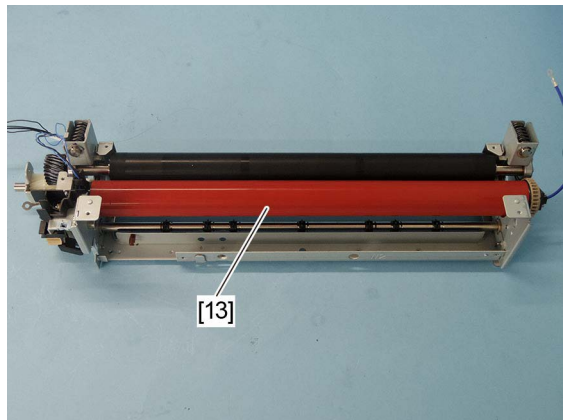

Fig. 4-514

(13) Remove the collar [14], and then take off the fuser belt [15] from the front side.

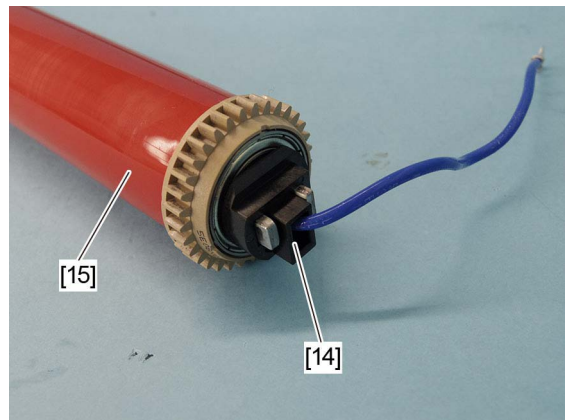

Fig. 4-515



Fig. 4-516

Notes: Replacing procedure

1. When replacing the fuser belt, pour the entire amount of oil into the fuser belt without spilling it. This should be done from the rear side where there is no gear.
2. Raise the fuser belt (front side: gear side down), and let the oil flow toward the front side. This should be done until around the center of the belt.
3. Hold the fuser belt holding unit with one hand, and insert the fuser belt into the unit, pressing the edge thermistor and the sliding sheet to the inside.
4. Slowly insert the fuser belt while turning it counterclockwise.

Notes:

- When installing the fuser belt, be careful not to let the silicon oil on the fuser belt lubricating sheet come in contact with the surface of the fuser belt. After installing, check that there is no silicon oil on the fuser belt. If silicon oil is running over more than 25 mm from the edge of the fuser belt, wipe it off using alcohol. If 25 mm or less, wipe it off with a dry cloth.
- Take care so that no damage or stains are detected on the fuser belt.
- After reassembling the fuser belt, check that there is no scratch on the surface and the edges of the belt, and check that the grease has not adhered on the belt surface.
- When installing the fuser belt, mount its center and edge thermistors inside of the belt by holding them with your fingers, paying attention not to deform them.
- Be sure to hold the thermistor lightly so as not to deform it when holding it.

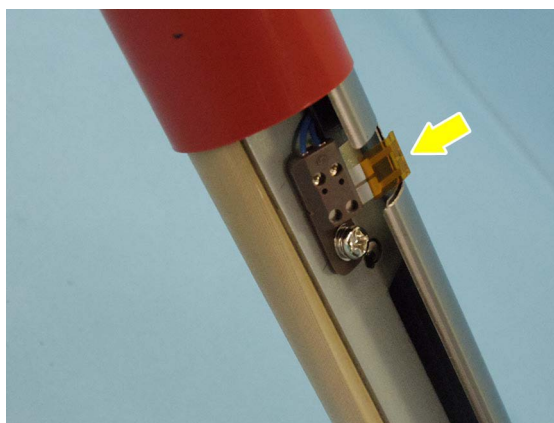

Fig. 4-517

- Handle the thermistor carefully so as not to deform and put it into the inside of fuser belt.
- When installing the fuser belt, pay attention that it is not caught with the harness.

- After a new fuser belt is installed in the frame of the fuser unit, be sure to remove the protection sheet [16] attached to the belt to avoid damaging or staining its surface.

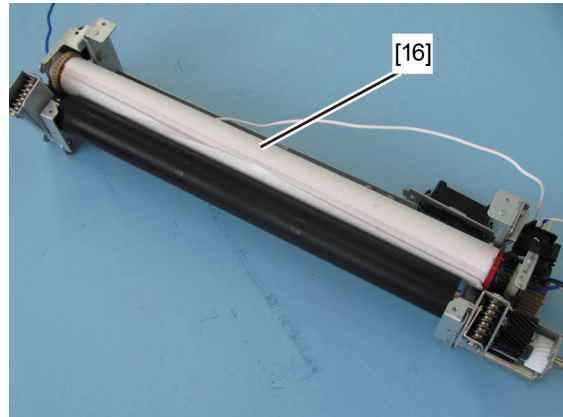

Fig. 4-518

- Be careful that the thermistor [17] of the fuser unit is not deformed when it is placed after the removal of the fuser belt. The thermistor may be deformed if it is made to come to the lower side by turning the fuser unit.

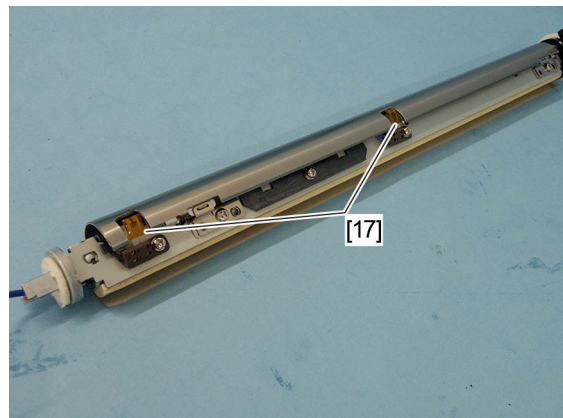

Fig. 4-519

4.9.9 Front fuser oil recovery sheet 2 / Front fuser oil recovery sheet 1

- (1) Remove the fuser belt unit.
P. 4-200 "4.9.8 Fuser belt"
- (2) Remove the front fuser oil recovery sheet 2 [1].

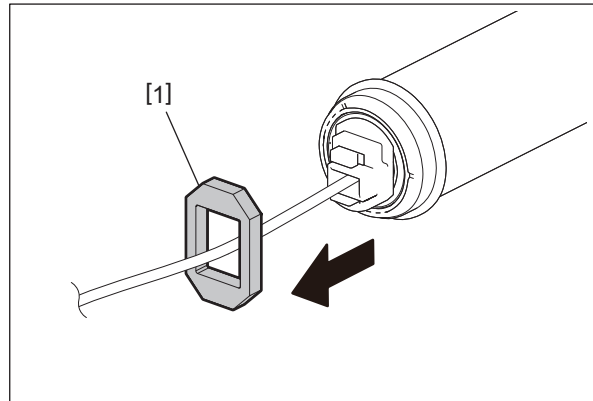

Fig. 4-520

- (3) Remove the bushing [2], and then take off the bearing [3].

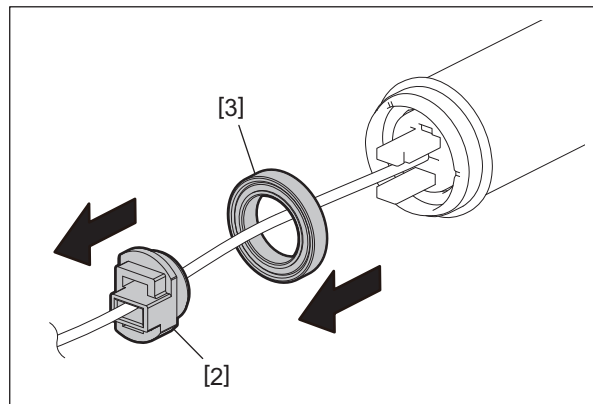

Fig. 4-521

- (4) Remove the front fuser oil recovery sheet 1 [4].

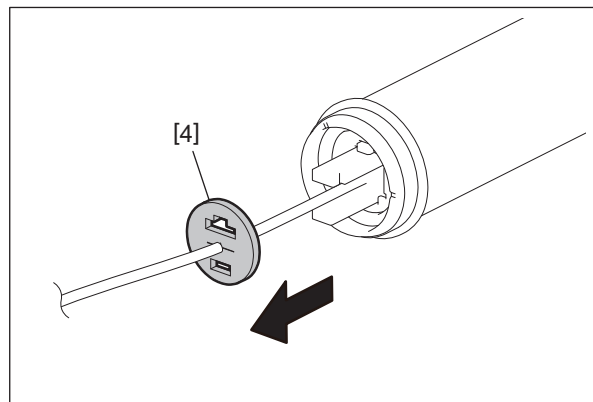



Fig. 4-522

4.9.10 Rear fuser oil recovery sheet

- (1) Remove the fuser belt unit.
 P. 4-200 "4.9.8 Fuser belt"
- (2) Remove the rear fuser oil recovery sheet [1].

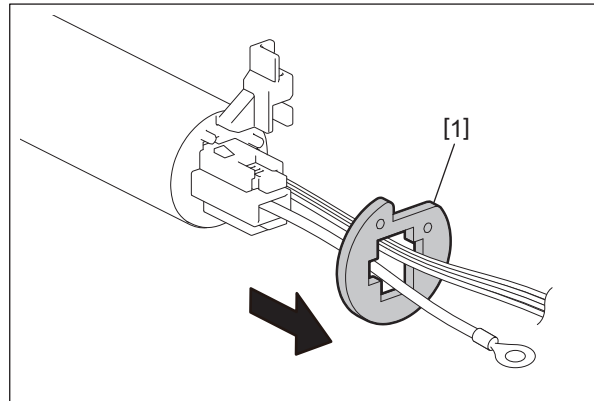

Fig. 4-523

Notes:

Be sure to insert the rear fuser oil recovery sheet [1] until it is securely hooked by the 2 latches as shown below. Otherwise, the oil in the fuser belt may leak.

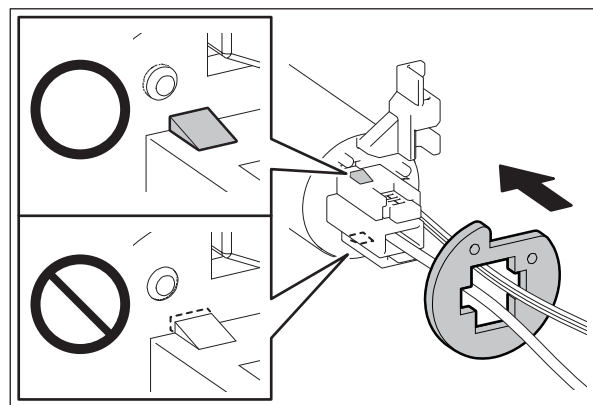

Fig. 4-524

4.9.11 Fuser belt lubricating sheet / Fuser belt pad

- (1) Remove the fuser belt.
P. 4-200 "4.9.8 Fuser belt"
- (2) Remove 3 screws (25ppm/30ppm/35ppm: M2.6, 45ppm/50ppm: M3).

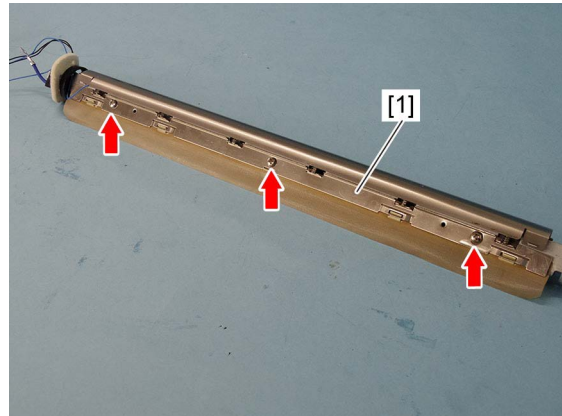

Fig. 4-525

Notes:

- When handling the inside of the fuser belt unit, position a towel or cushion so that no pressure is applied to the shield [1].
- Be sure to secure the 5 screws (M2.6/M3), otherwise they come off and this will cause the damage of the fuser belt.

- (3) Remove the fuser belt pad [2], and then take off the fuser belt lubricating sheet [3].

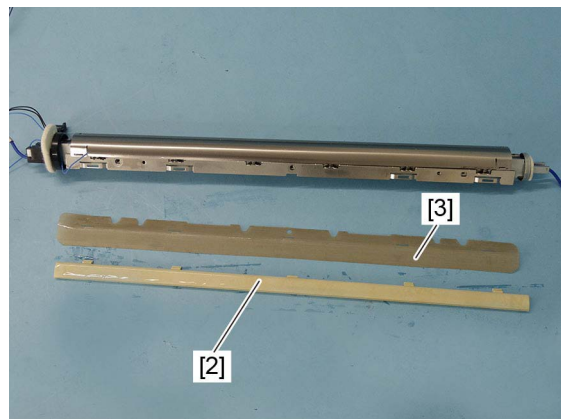

Fig. 4-526

Notes:

- When installing the fuser belt pad, align the 5 latches with the holes of fuser belt lubricating sheet.

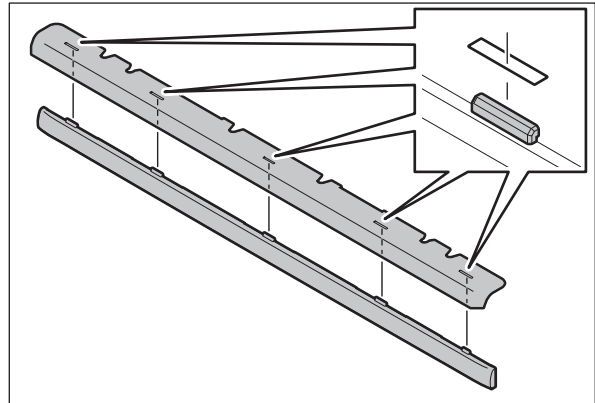

Fig. 4-527

- When installing the fuser belt lubricating sheet, align 5 latches with the notches of the fuser belt unit.



Fig. 4-528

- Check that there is no foreign matter adhering on the fuser belt lubricating sheet. Reassemble immediately to prevent any foreign matter from adhering. When reassembling, check that there is no foreign matter adhering on the fuser belt lubricating sheet, fuser belt pad, and fuser belt pad plate.



Fig. 4-529

4.9.12 Fuser belt center thermistor (THM1) / edge thermistor (THM2) / thermostat (THMO1)

Notes:

- If the thermistor/thermostat is not installed appropriately when it is replaced or installed, it may not work normally. If you carry out the maintenance of the equipment in such a situation, they may result in fatal accidents such as explosion or fire. Therefore, to avoid this, be sure to perform correct handling and installation.
- Replace the fuser belt unit with a new one for exchanging the fuser belt center thermistor, fuser belt edge thermistor and fuser belt unit thermostat.
- Do not disassemble in the field, since the installing dimensions of safety parts (thermistors/thermostats) cannot be secured.

(1) Remove the fuser belt pad and fuser belt lubricating sheet.

 P. 4-209 "4.9.11 Fuser belt lubricating sheet / Fuser belt pad"



Fig. 4-530

Notes:

- Be careful that the thermistor of the fuser unit is not deformed when it is placed after the removal of the fuser belt. The thermistor may be deformed if it is made to come to the lower side by turning the fuser unit.
 - The figure shows the 25ppm/30ppm/35ppm models.



Fig. 4-531

- The figure shows the 45ppm/50ppm models.
"50" is marked on the fuser belt unit for 45ppm/50ppm for identification.

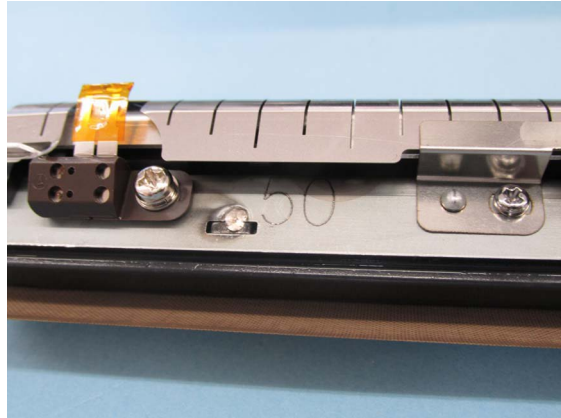

Fig. 4-532

4.9.13 Pressure roller

Notes:

The pressure spring differs between the 25ppm/30ppm/35ppm and 45ppm/50ppm models.

- 25ppm/30ppm/35ppm: Silver
- 45ppm/50ppm: Black

- (1) Remove the fuser belt.
P. 4-200 "4.9.8 Fuser belt"
- (2) Remove 2 screws and take off the bracket [1].

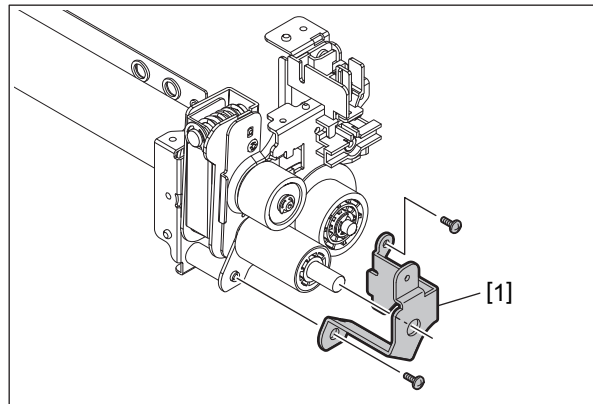

Fig. 4-533

- (3) Remove the 1 E-ring [2] and 2 gears [3].

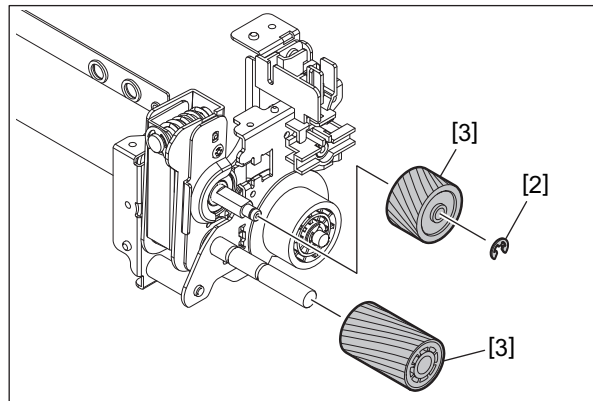

Fig. 4-534

Notes:

- When replacing the parts or performing preventive maintenance, apply an appropriate amount of white grease (HP-300) to the shaft [4] and the point [5] where the shaft [4] and the bracket contact.
- Apply 3 rice-sized grains of white grease (HP-300) to the tooth surface of the gear [6].

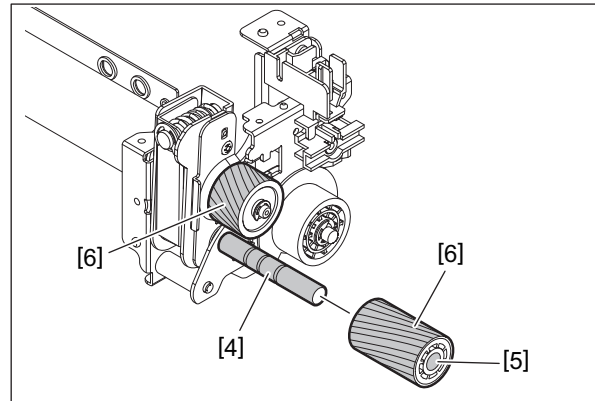

Fig. 4-535

- (4) Remove 1 screw on the rear side and take off the bracket.

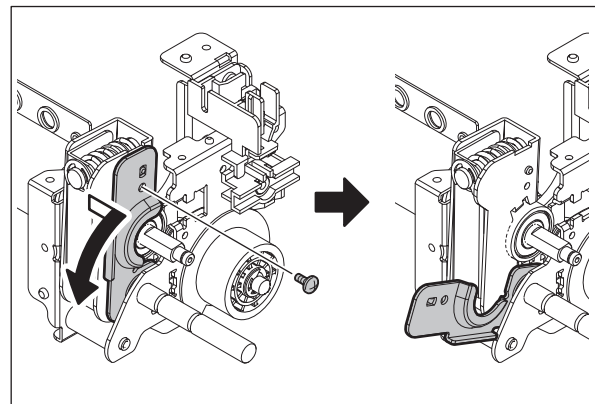

Fig. 4-536

- (5) Pull out the pressure roller [7] toward the rear side and remove it.

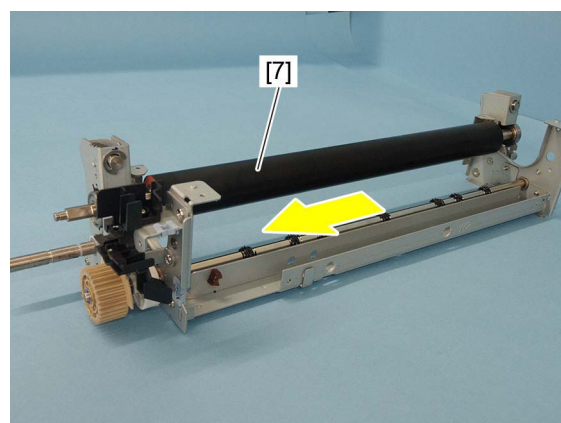

Fig. 4-537



Fig. 4-538

4.9.14 IH-COIL

Notes:

Be sure to unplug the power cable before starting this work.

- (1) Remove the fuser unit.
📖 P. 4-191 “4.9.1 Fuser unit”
- (2) Remove the tray rear cover.
📖 P. 4-2 “4.1.4 Tray rear cover”
- (3) Remove the IH board cover.
📖 P. 9-10 “9.1.7 IH board”
- (4) Remove 2 screws, and release 2 harnesses [1] from the harness holder [2].

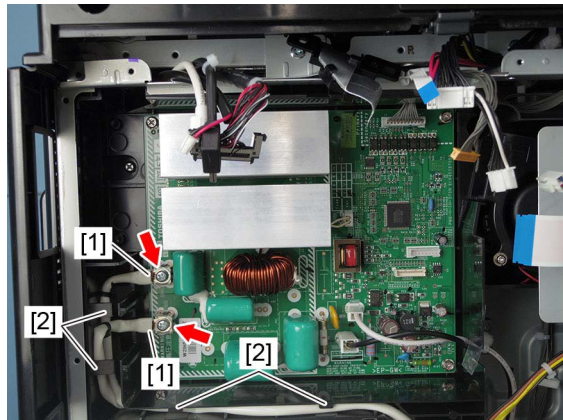

Fig. 4-539

Notes:

- Wire the IH harness as shown in the figure and secure the terminals horizontally.
- There is a risk of a fire resulting from the heat caused by the contact failure of the screws. To avoid this, confirm that the screws are not loosened.

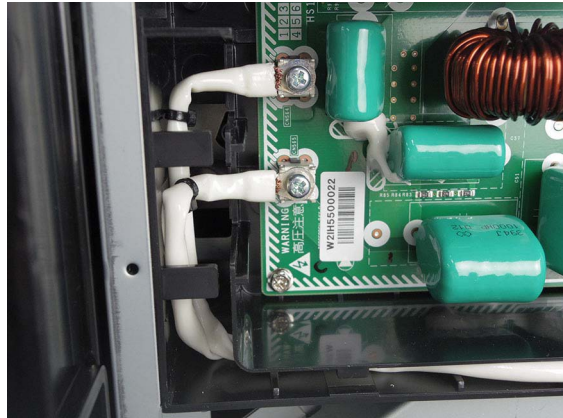

Fig. 4-540

- When assembling, wire the IH harness pulled out from the rear frame by aligning it to the inside of the harness holder as shown in the figure so that there is no warp.

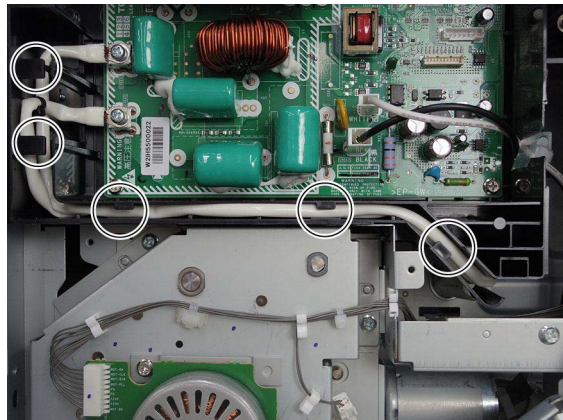

Fig. 4-541

(5) Release 2 harnesses from 3 harness clamps.

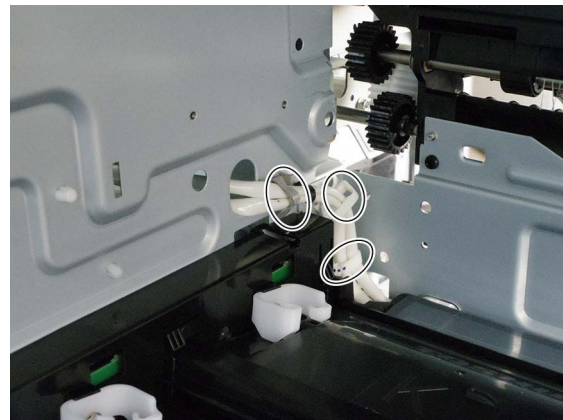

Fig. 4-542

(6) Remove 1 screw and take off the stopper [3].

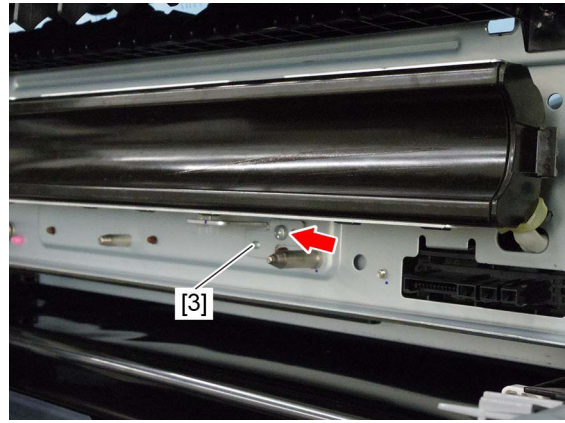

Fig. 4-543

Notes:

When the IH coil is installed, put its hook on the back side of the stopper.

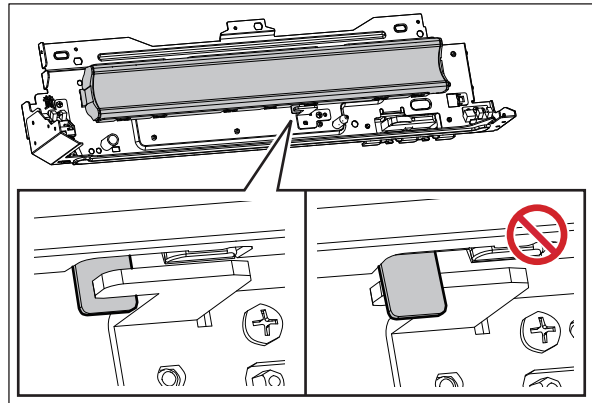

Fig. 4-544

(7) Lift the IH-COIL [4].

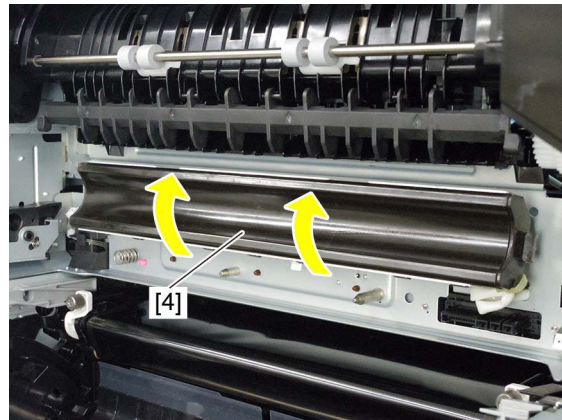

Fig. 4-545

(8) Remove 2 screws.

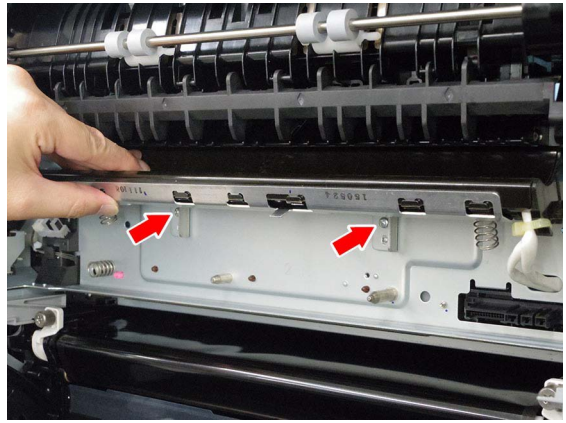

Fig. 4-546

(9) Pull out 2 harnesses and remove the IH-COIL [4].



Fig. 4-547

Notes:

The IH coil [4] differs between the 25ppm/30ppm/35ppm and 45ppm/50ppm models.
Refer to the mark indicated in the figure to identify the corresponding model.

25ppm/30ppm/35ppm: "2HL"

45ppm/50ppm: "2HH"

The figure shows 45ppm/50ppm.

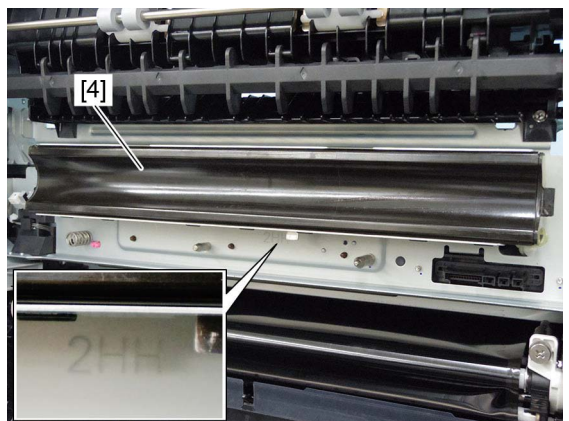

Fig. 4-548

4.9.15 Fuser belt rotation detection sensor (S27)

- (1) Remove the fuser unit.
P. 4-191 "4.9.1 Fuser unit"
- (2) Remove 1 screw, and take off the mold [1].
- (3) Disconnect the 1 connector [2], and remove the fuser belt rotation detection sensor [3].

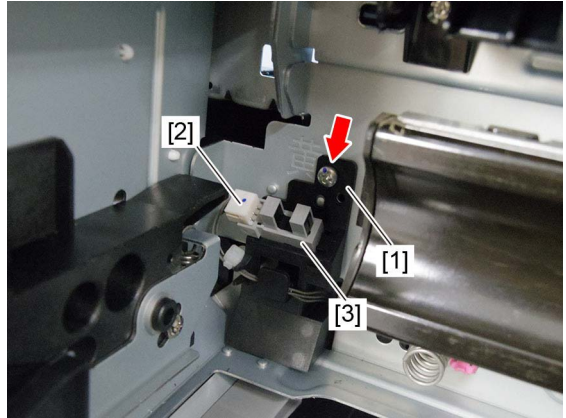

Fig. 4-549

Notes:

When installing, attach the mold projection [4] to the frame.



Fig. 4-550

4.9.16 Pressure roller contact/release detection sensor (S29)

- (1) Remove the fuser unit.
P. 4-191 "4.9.1 Fuser unit"
- (2) Remove 1 screw, and take off the plate [1].
- (3) Disconnect the 1 connector [2], and remove the pressure roller contact/release detection sensor [3].

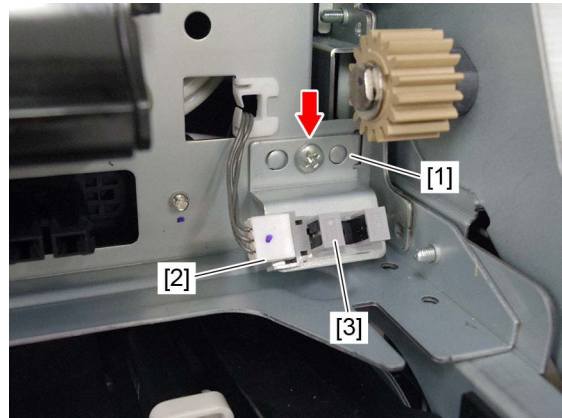

Fig. 4-551

4.9.17 Fuser motor (M4)

- (1) Remove the rear cover.
P. 4-10 "4.1.17 Rear cover"
- (2) Remove 3 screws, and take off the fuser motor [1].
- (3) Disconnect the 1 connector [2].

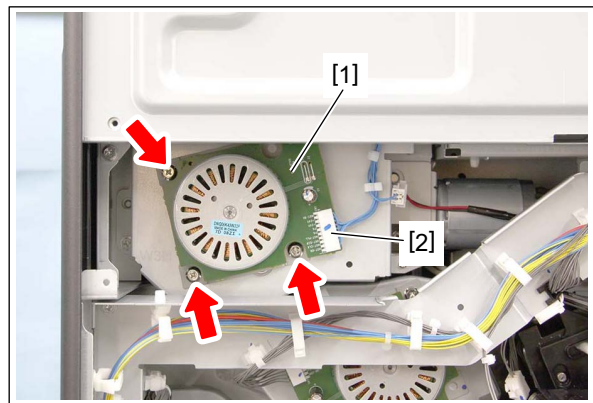

Fig. 4-552

4.9.18 Fuser drive unit

- (1) Remove the fuser unit.
P. 4-191 "4.9.1 Fuser unit"
- (2) Remove the SYS board case.
P. 9-5 "9.1.5 SYS board case"
- (3) Release the harnesses from the harness clamps [15]. Remove 2 screws and take off the plate [1].

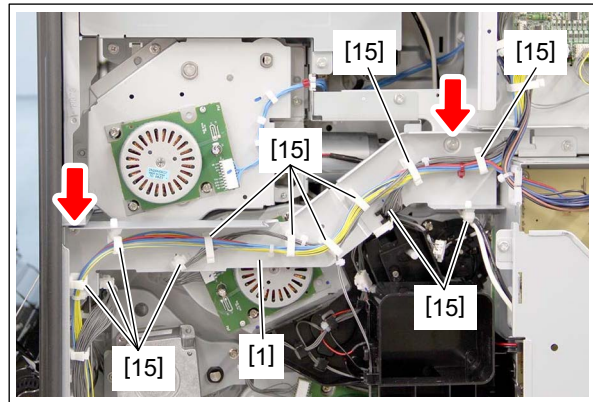

Fig. 4-553

- (4) Release the harness from harness clamps [16], and disconnect 2 connectors [2].

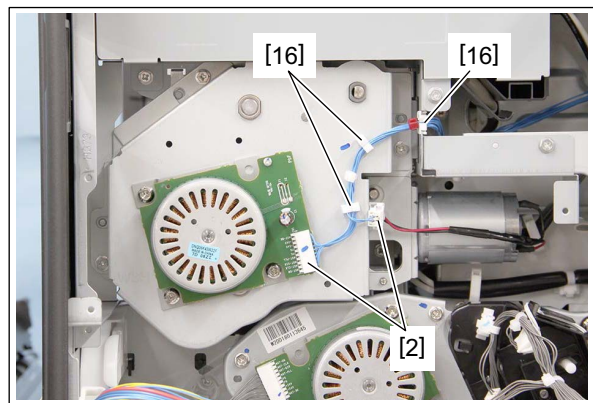

Fig. 4-554

- (5) Remove 4 screws, and take off the fuser drive unit [3].

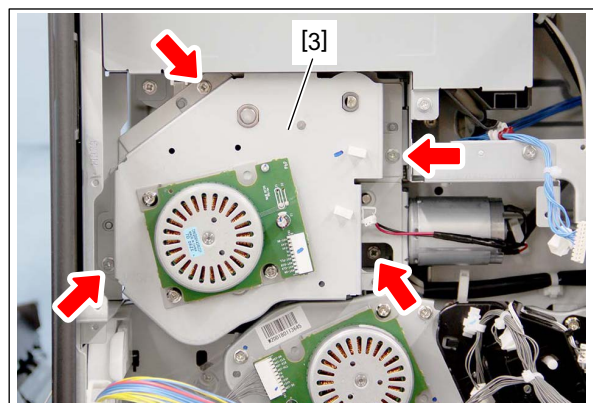

Fig. 4-555

(6) Remove the spring [4].

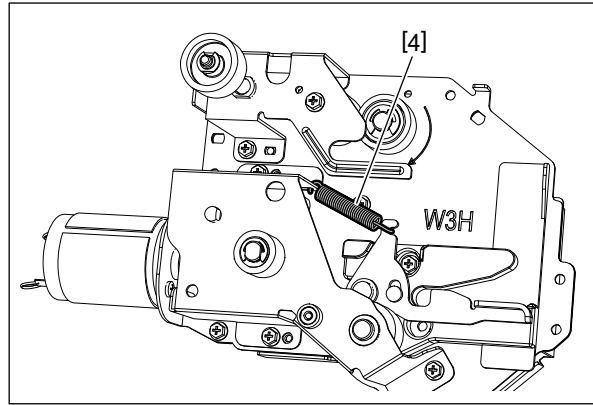

Fig. 4-556

(7) Remove 3 screws and take off the bracket [5].

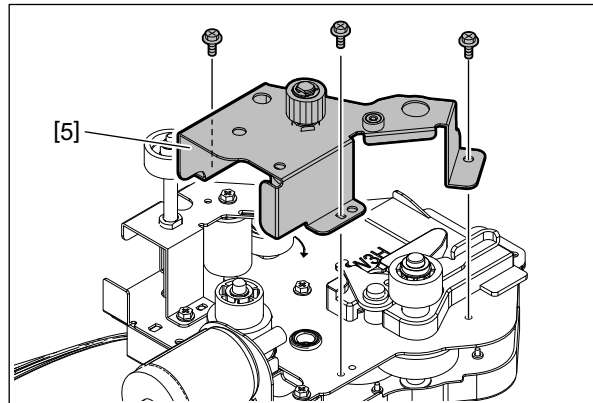

Fig. 4-557

(8) Remove the bearing [6], gear [7], and pin.

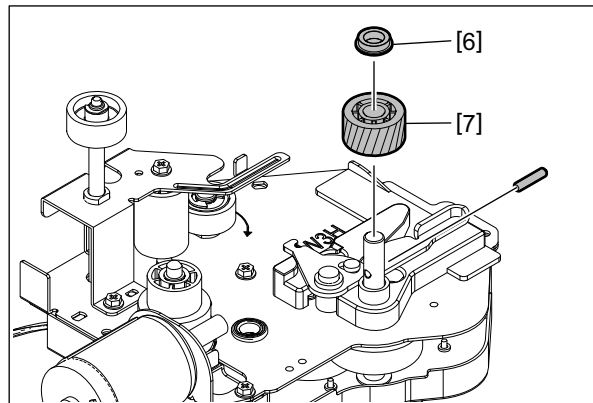

Fig. 4-558



Fig. 4-559

Notes:

For 25ppm/30ppm/35ppm models, the bearing [6] is replaced with the bushing.

- (9) Remove the clip [8] and gear [9].

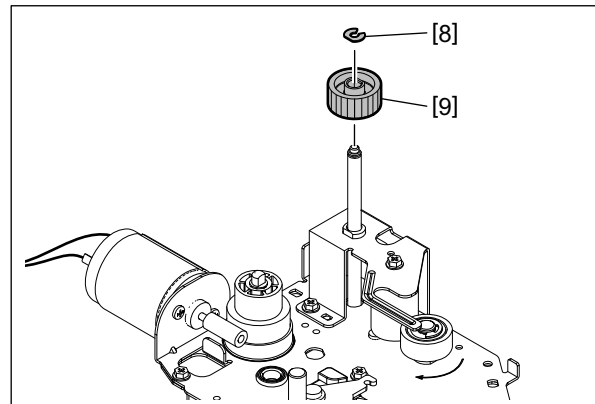

Fig. 4-560

- (10) Remove 3 screws and take off the bracket [10], bushing [11].

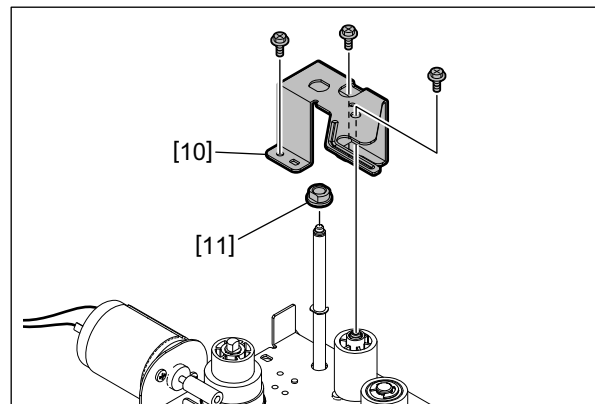

Fig. 4-561

(11) Remove the gear [12], E-ring [13] and one-way clutch [14].

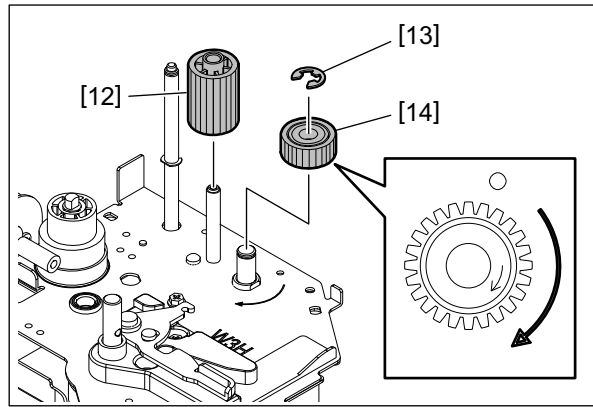

Fig. 4-562

Notes:

- When installing the one-way clutch [14], align the direction of the arrow shown on it to that on the plate.
- When replacing the parts or performing machine refreshment, apply an appropriate amount of white grease (Molykote EM-30L) to the shafts and the tooth surfaces of the gears.

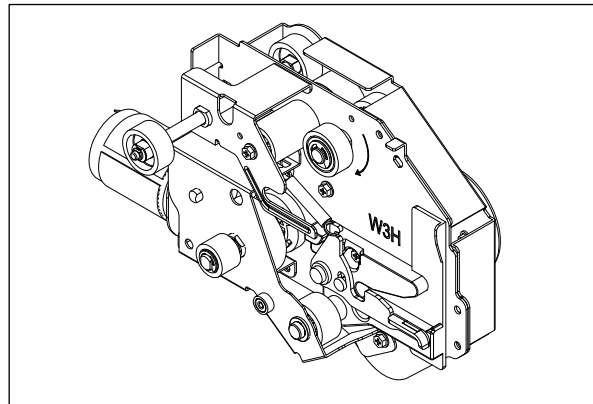

Fig. 4-563

4.9.19 Pressure roller contact/release motor (M13)

- (1) Remove the fuser drive unit.
P. 4-220 "4.9.18 Fuser drive unit"
- (2) Remove the spring [1].

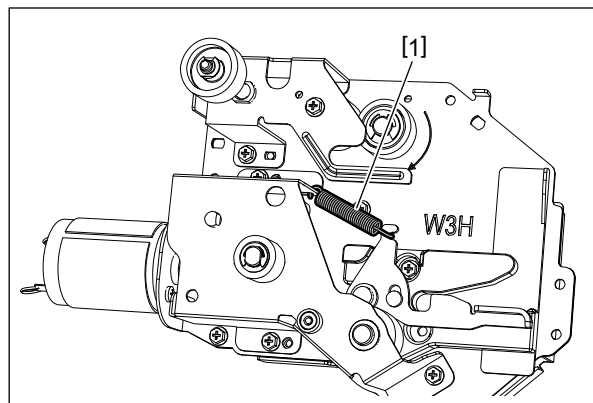

Fig. 4-564

(3) Remove 3 screws and take off the bracket [2].

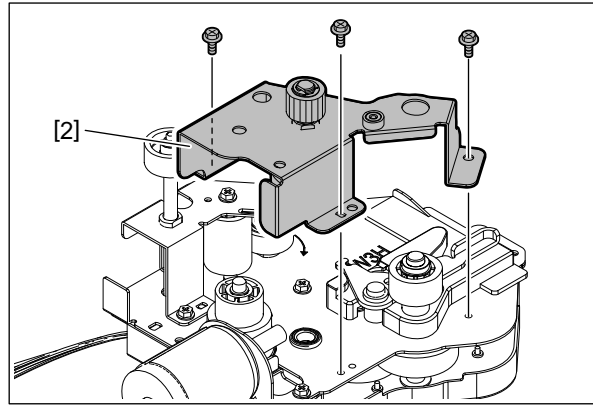

Fig. 4-565

(4) Remove the shaft [3] and gear [4].

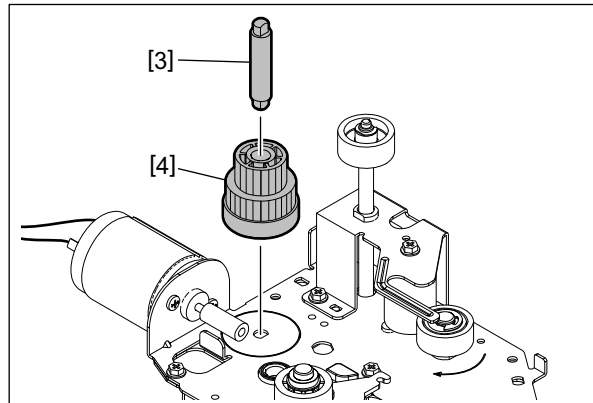

Fig. 4-566

(5) Remove the bearing [5], gear [6], and pin.

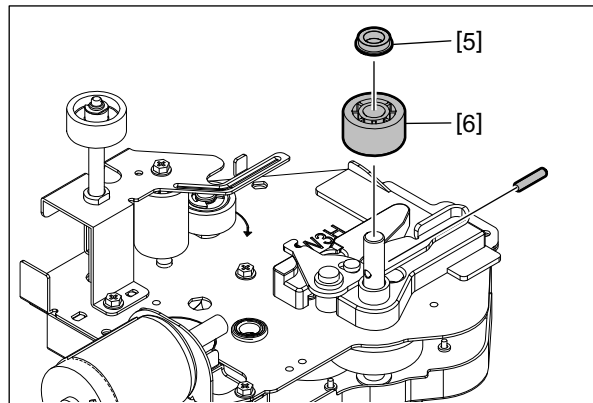

Fig. 4-567

(6) Remove the screw [7] and the lever [8].

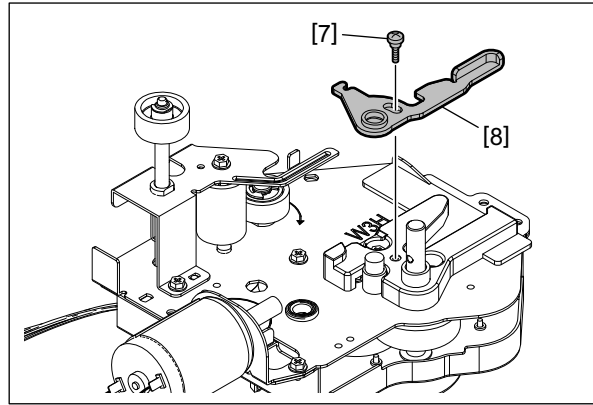

Fig. 4-568

(7) Remove 1 screw and take off the bracket [9].

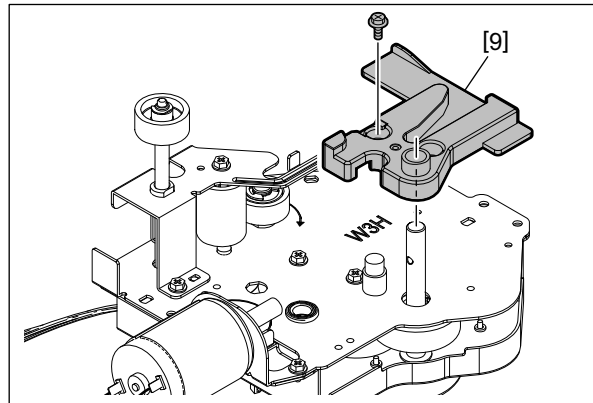

Fig. 4-569

(8) Remove 2 screws and take off the pressure roller contact/release motor [10].

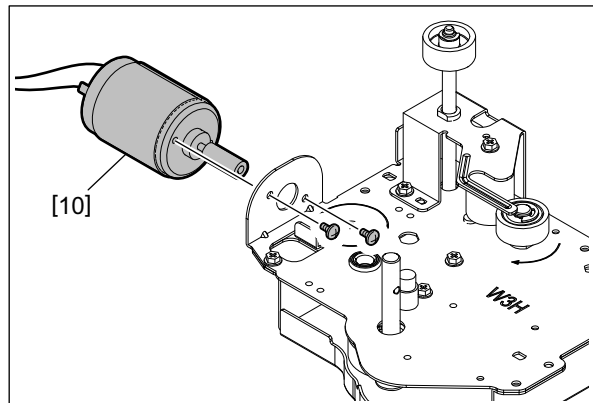



Fig. 4-570

4.9.20 IH board cooling fan (F6)

- (1) Remove the high-voltage transformer.
 P. 9-15 "9.1.9 High-voltage transformer (HVT)"
- (2) Remove the SYS board case.
 P. 9-5 "9.1.5 SYS board case"
- (3) Release the harness from harness clamps [6], remove 2 screws and take off the plate [1].

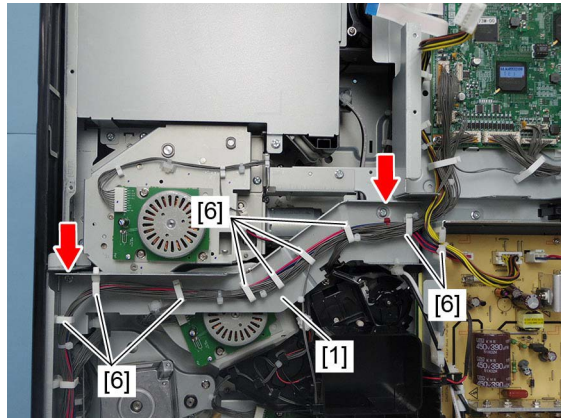

Fig. 4-571

- (4) Disconnect 19 connectors connected to the LGC board.

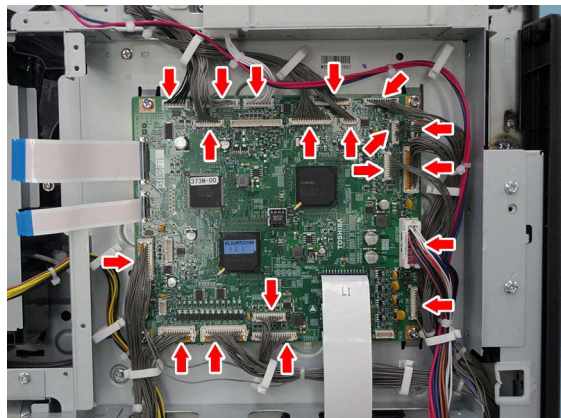

Fig. 4-572

(5) Remove 3 flat cables [2].

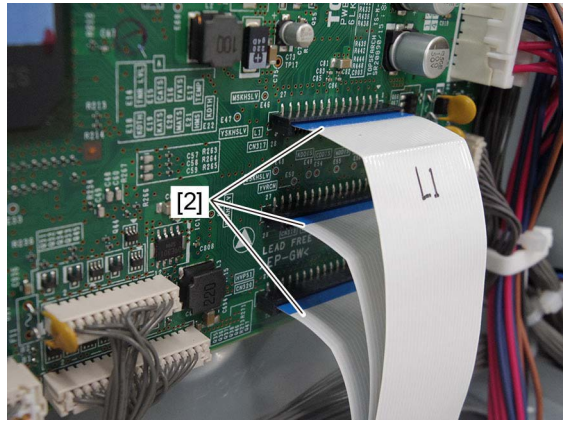

Fig. 4-573

Notes:

- When installing/removing, be careful not to damage the connection part of the flat cables [2].
- Do not use the flat cables [2] whose connection parts are peeled off or damaged.
- When installing, straightly insert the flat cables [2] to the innermost of the connectors (until the lines marked on the flat cables are concealed inside the connectors) securely.

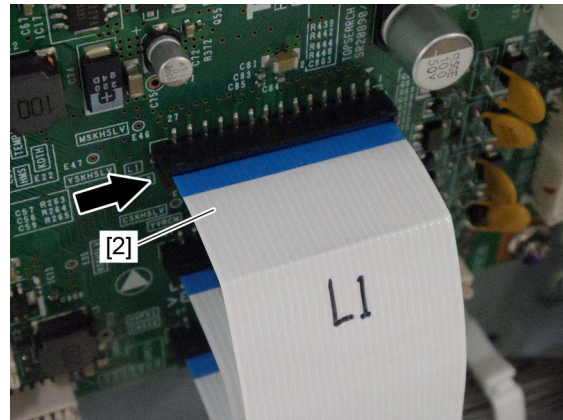

Fig. 4-574

- When installing, make sure that the line marked on the flat cables [2] and connectors are parallel to each other. Be careful not to insert them at an angle.

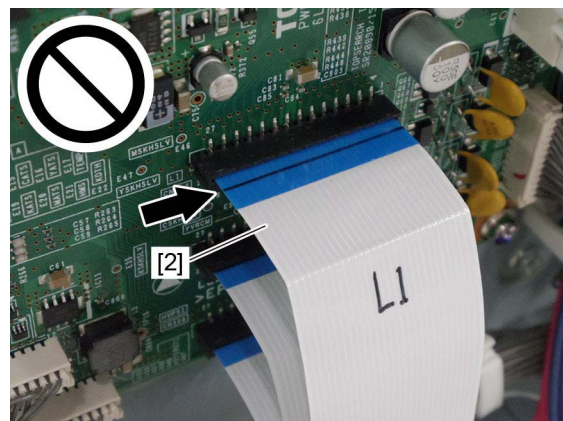

Fig. 4-575

(6) Remove 3 screws and take off the bracket [3].

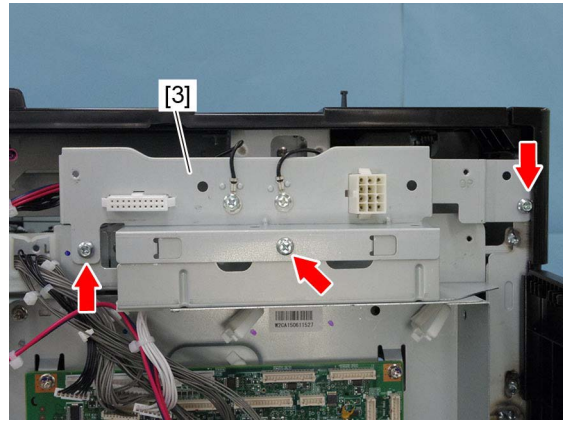

Fig. 4-576

(7) Remove 7 screws and take off the LGC board case [4] by sliding it toward the right side.

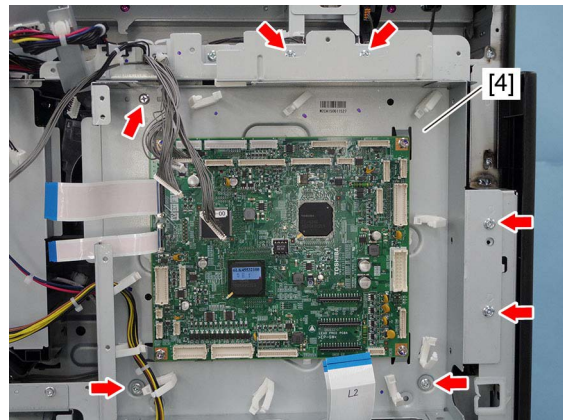

Fig. 4-577

Notes:

Hold the LGC board case and remove it.

(8) Remove 2 screws and release the harness from the harness clamps [6].

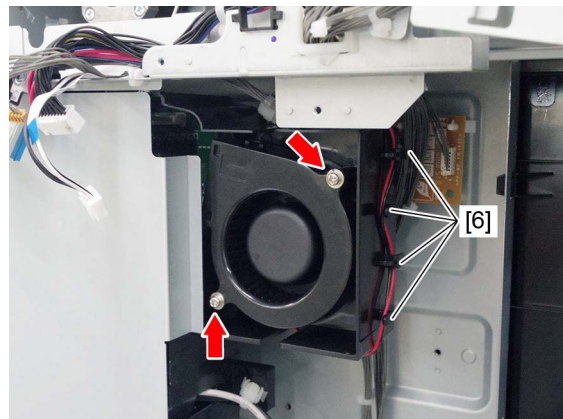

Fig. 4-578

(9) Disconnect 1 connector and remove the IH board cooling fan [5].

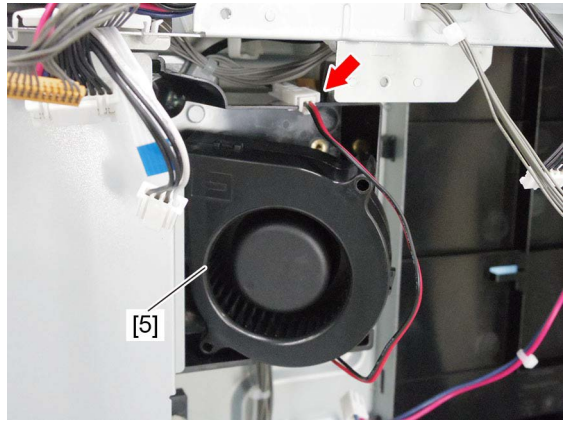

Fig. 4-579

4.10 Paper Exit and Reverse Sections

4.10.1 Reverse unit

- (1) Remove the right rear cover.
📖 P. 4-5 “4.1.11 Right rear cover”
- (2) Remove 1 screw, and take off the connector cover [1].

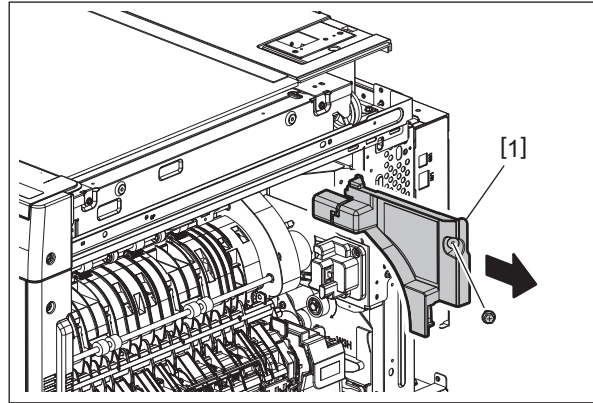

Fig. 4-580

- (3) Remove 2 screws.

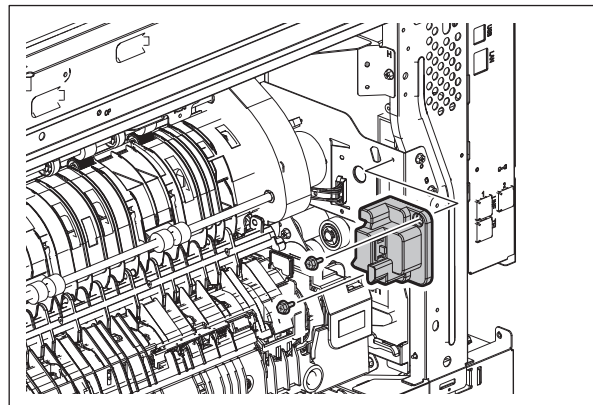

Fig. 4-581

- (4) Disconnect the 1 connector [2], and remove the switch unit [3].

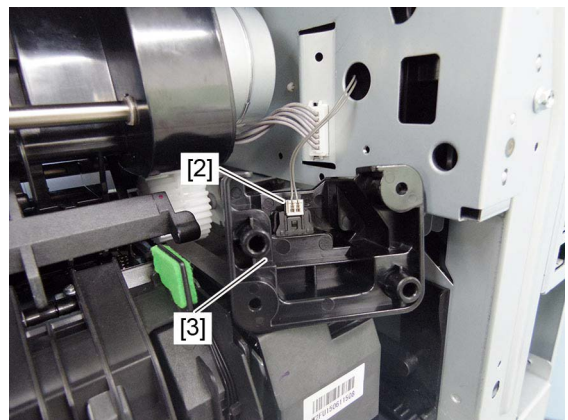

Fig. 4-582

- (5) Disconnect the 1 connector [4], remove 2 screws.

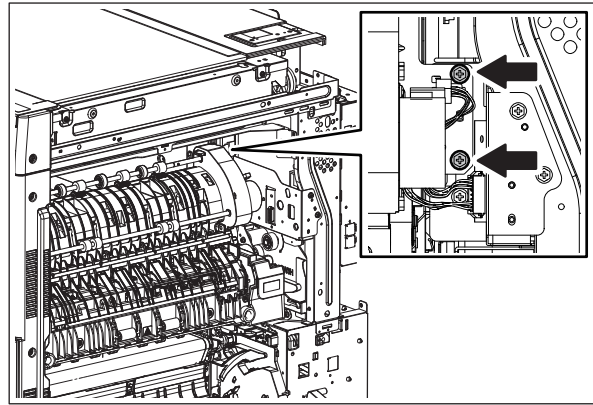

Fig. 4-583

- (6) Remove 1 screw.

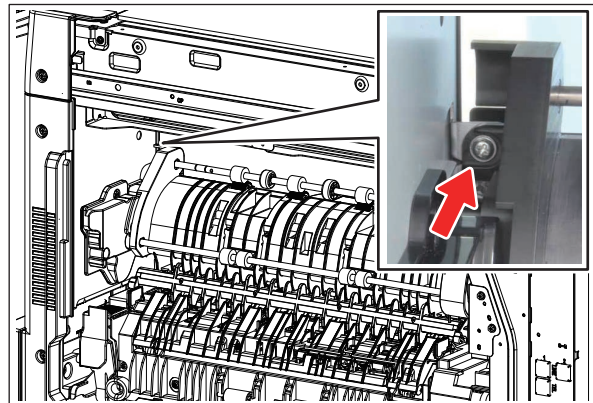

Fig. 4-584

Notes:

The screw on the front side is a shoulder screw. When installing, exercise care not to confuse it with other kinds of screws.

- (7) Lift the rear side [6] of the reverse unit [5] to release the rear side hook. Slide the reverse unit [5] to the rear side [7] and release the front side insertion. Pull out the reverse unit [5] by tilting it [8].

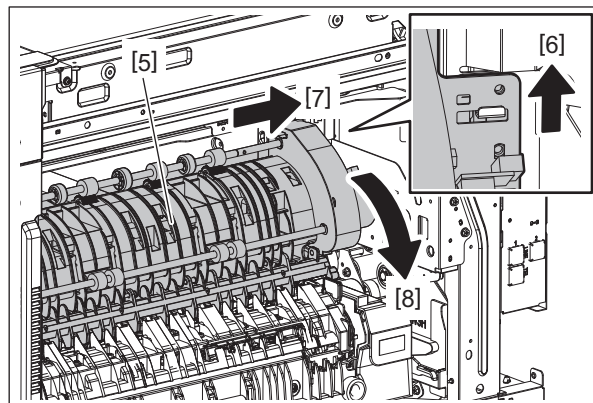

Fig. 4-585

Notes:

- When installing, align the duct [9] in the front side of the reverse unit with the projection [10] on the equipment side.

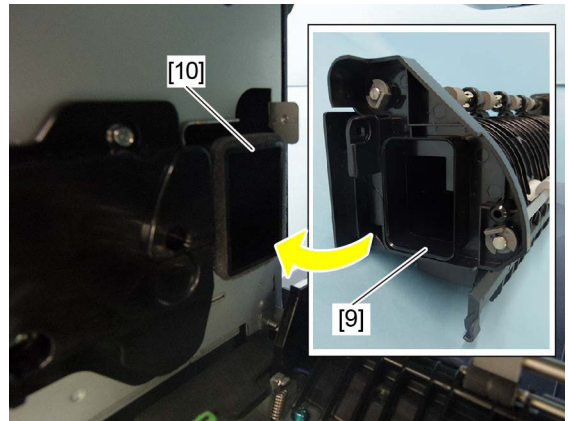

Fig. 4-586

- Pay attention to the attachment position of the screw.

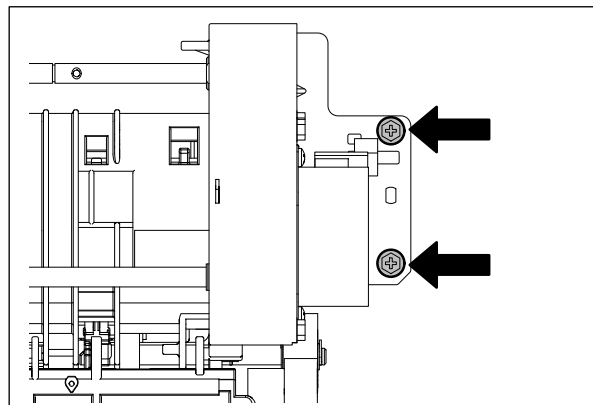

Fig. 4-587

4.10.2 Paper exit unit

- (1) Remove the fuser unit.
📖 P. 4-191 “4.9.1 Fuser unit”
- (2) Remove the reverse unit.
📖 P. 4-230 “4.10.1 Reverse unit”
- (3) Remove 3 screws and take off the paper exit unit [1].

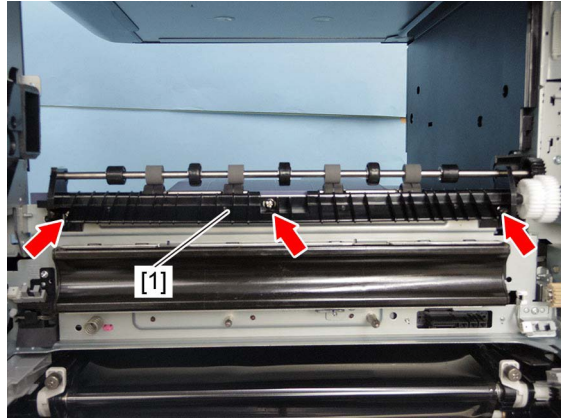

Fig. 4-588

Notes:

When installing the paper exit unit, align the protrusion [5] on the rear of the bottom of the screw hole with the frame hole, and fit the drive gear shaft into the bearing [4].

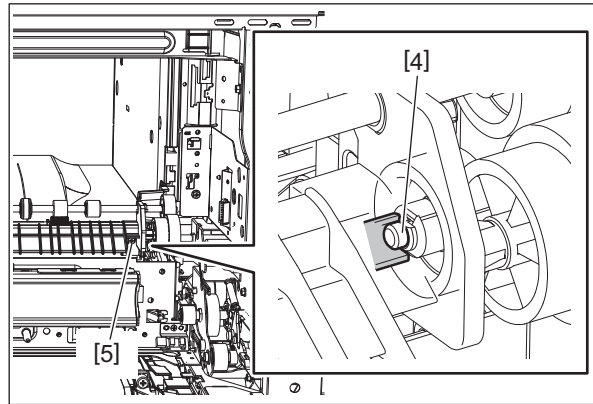

Fig. 4-589

4.10.3 Lower exit roller

- (1) Remove the paper exit unit.
📖 P. 4-233 "4.10.2 Paper exit unit"
- (2) Remove 2 E-rings [1], 1 gear [2], and 1 bushing [3].

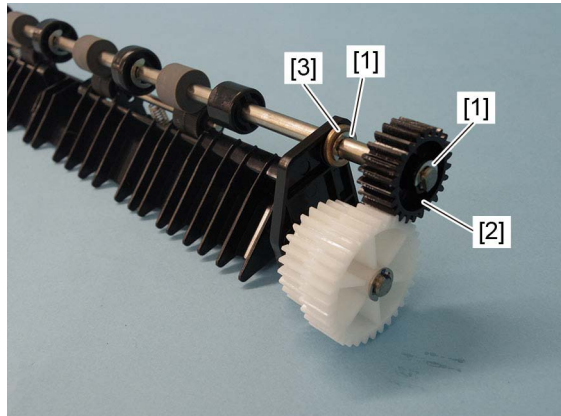

Fig. 4-590

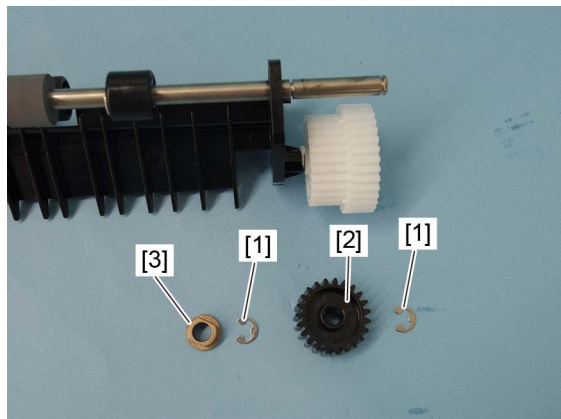

Fig. 4-591

(3) Remove 1 E-ring [4] and 1 bushing [5].

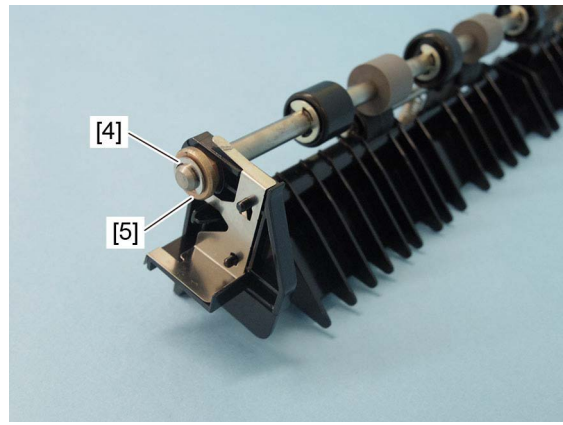

Fig. 4-592

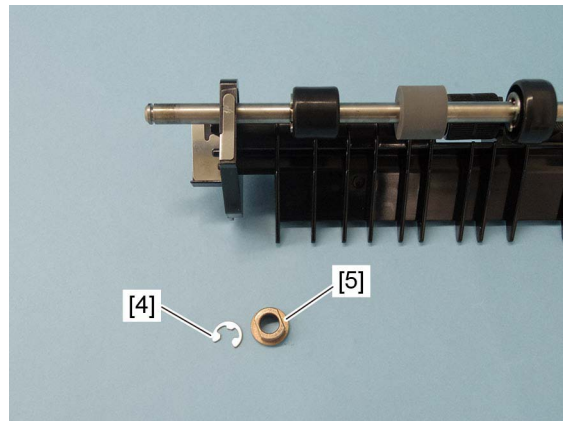

Fig. 4-593

(4) Remove the lower exit roller [6], and then take off the 2 idling rollers [7] and 2 springs [8].

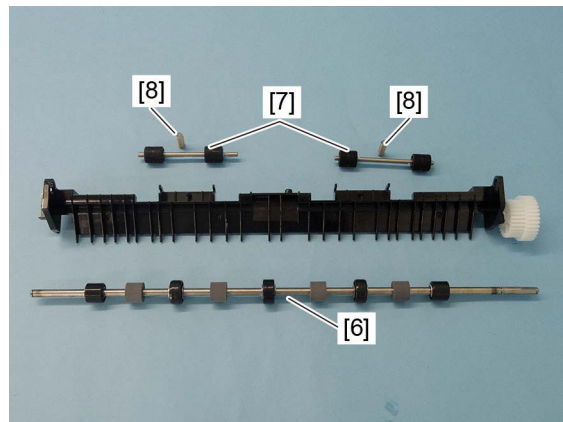

Fig. 4-594

Notes:

When replacing the idling roller or idling roller shaft, apply 1 rice sized grain of white grease (Molykote EM-30L) evenly around the 2 places [9] shown in the figure.

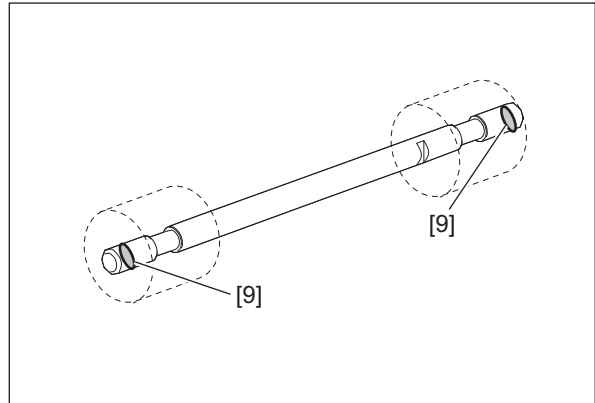

Fig. 4-595

4.10.4 Reverse motor (M5)

- (1) Remove the reverse unit.
P. 4-230 "4.10.1 Reverse unit"
- (2) Disconnect the 1 connector [1], remove 3 screws, and take off the reverse motor unit [2].

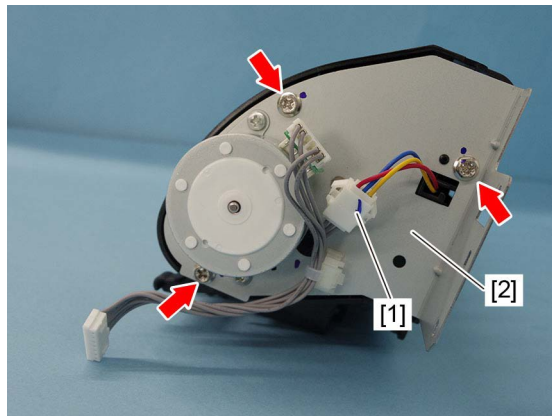

Fig. 4-596

Notes:

When installing the motor unit, exercise care not to forget to attach the timing belt [3].

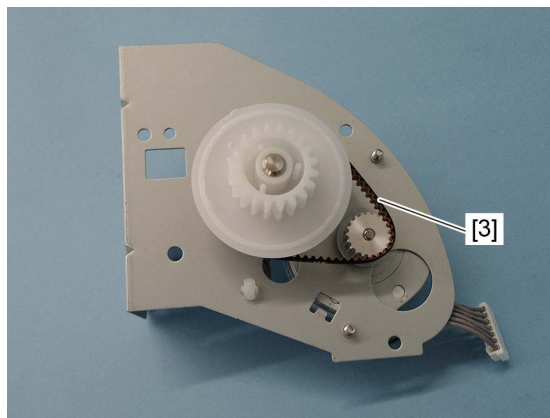

Fig. 4-597

- (3) Disconnect the 1 connector [4], remove 2 screws, and take off the reverse motor [5].

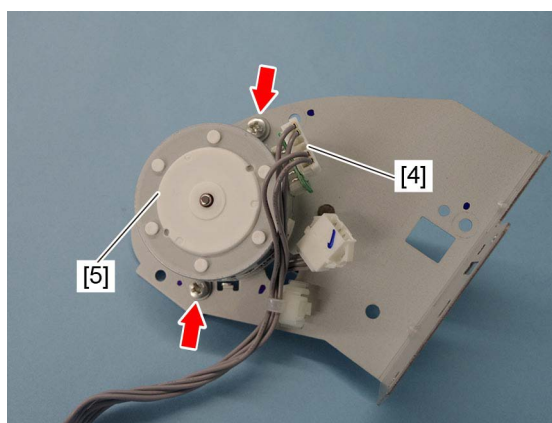

Fig. 4-598

4.10.5 Reverse gate solenoid (SOL2)

- (1) Remove the reverse motor unit.
P. 4-237 "4.10.4 Reverse motor (M5)"
- (2) Remove 2 screws and take off the cover [1].

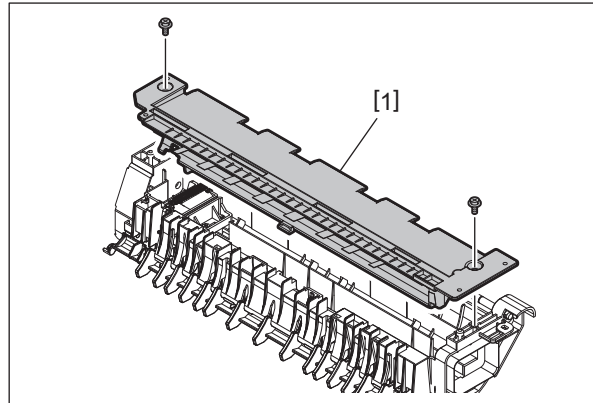

Fig. 4-599

- (3) Remove the harness from the harness guides.
- (4) Remove the 1 spring [2].

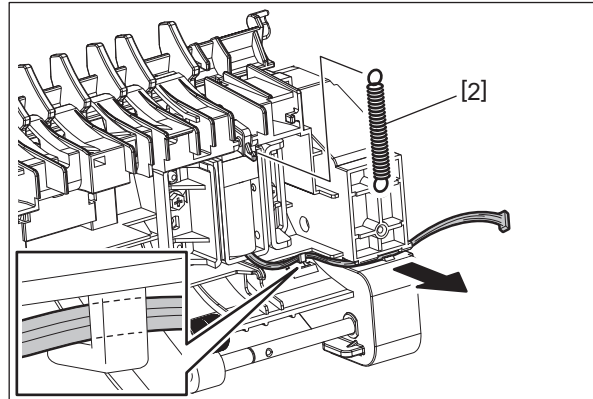

Fig. 4-600

- (5) Remove 2 screws.

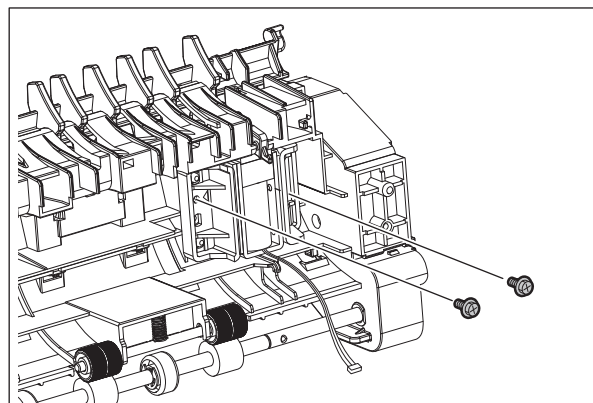

Fig. 4-601

- (6) Lift up the plunger [3] and take off the reverse gate solenoid [4] and 2 brackets [5] together.

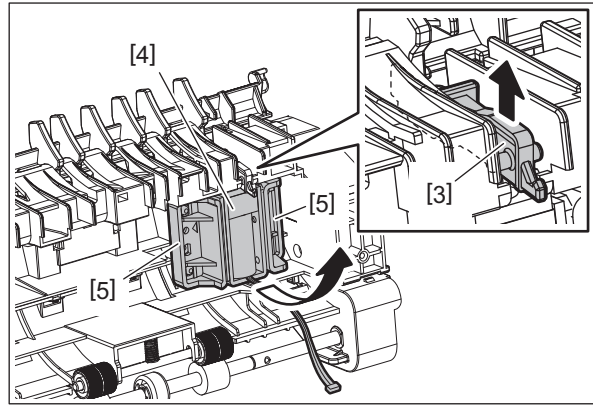

Fig. 4-602

- (7) Remove the plunger [3].

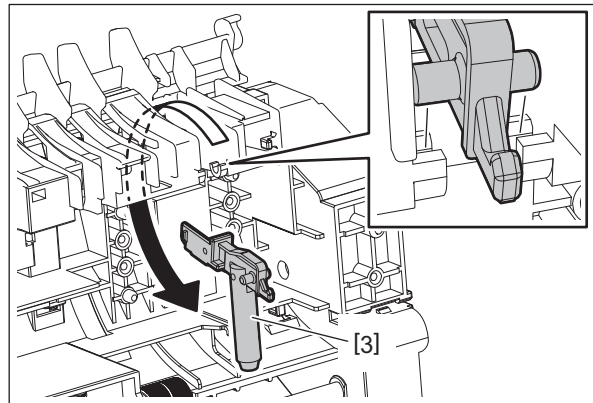

Fig. 4-603

Notes:

When installing, insert the mold at the edge of the plunger [3] into the groove of the reverse unit.

4.10.6 Upper exit roller

- (1) Remove the reverse motor unit.
P. 4-237 "4.10.4 Reverse motor (M5)"
(2) Remove 2 screws and take off the cover [1].

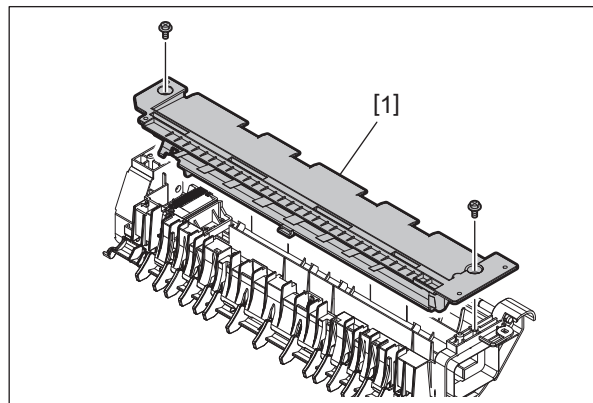

Fig. 4-604

(3) Remove the 2 springs [2] applying pressure to the idling roller.

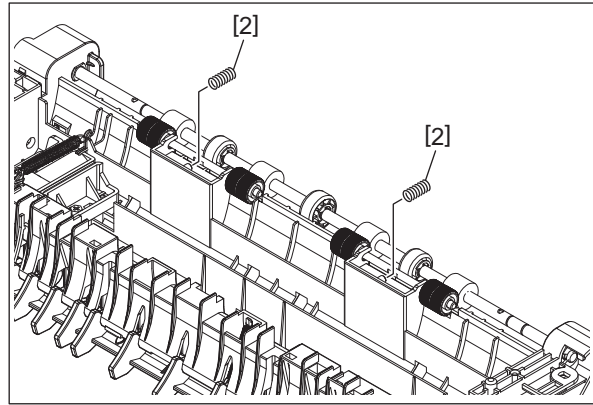

Fig. 4-605

(4) Remove the 1 gear [3], 1 clip [4], 1 bushing (metal) [5], and 1 bushing (resin) [6], then take off the upper exit roller [7].

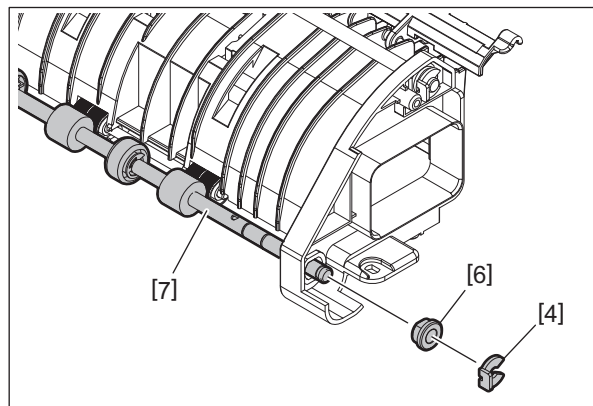

Fig. 4-606

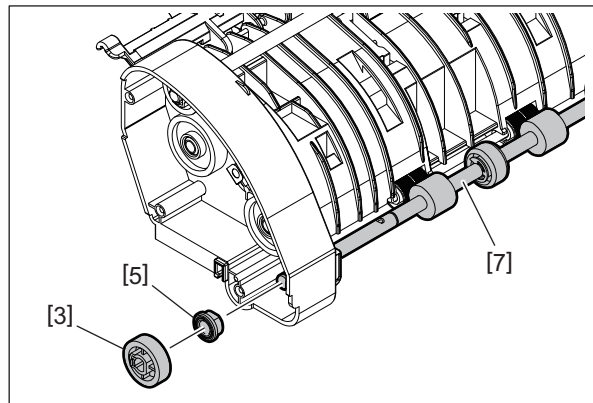

Fig. 4-607

Notes:

When replacing the idling roller or idling roller shaft, apply 1 rice sized grain of white grease (Molykote EM-30L) to the 2 place [8] shown in the figure 1 lap evenly.

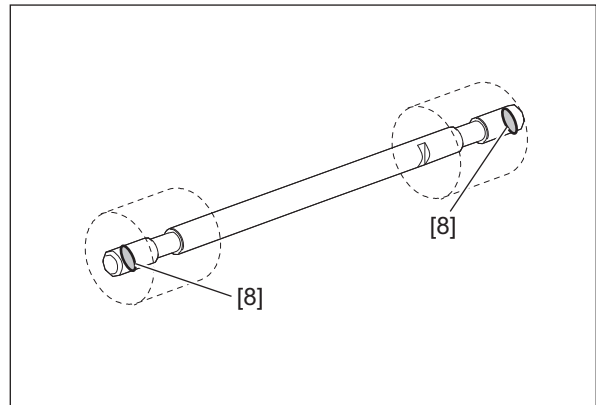

Fig. 4-608

4.10.7 Reverse roller

- (1) Remove the reverse motor unit.
P. 4-237 "4.10.4 Reverse motor (M5)"
- (2) Remove the 1 gear [1], 1 clip [2], 1 bushing (metal) [3], and 1 bushing (resin) [5], then take off the revers roller [4].

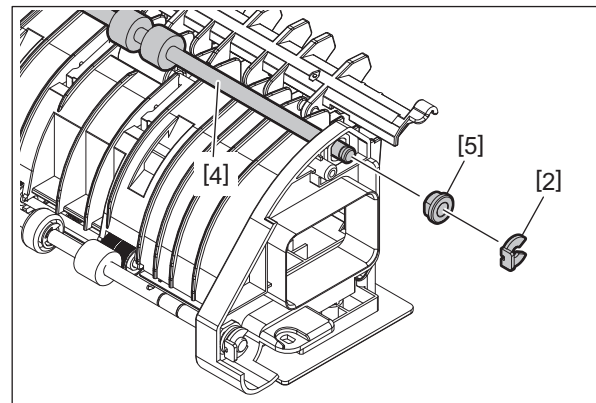

Fig. 4-609

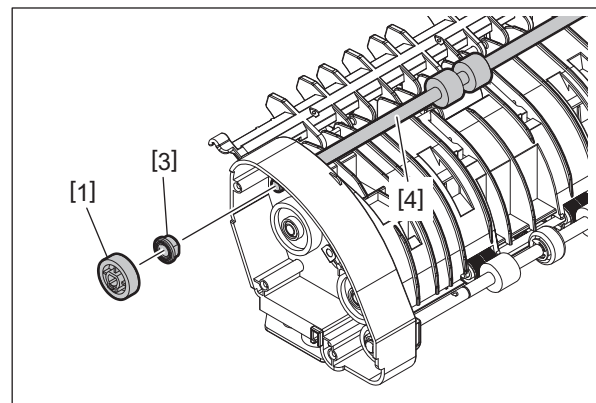



Fig. 4-610

4.10.8 Exit section cooling fan (F7)

- (1) Remove the inner cover.
 P. 4-11 "4.1.19 Front cover interlock switch (SW2)"
- (2) Remove the front right cover.
 P. 4-7 "4.1.14 Front right cover"
- (3) Disconnect 1 connector [1] and remove 1 screw, and then take off the duct [2].

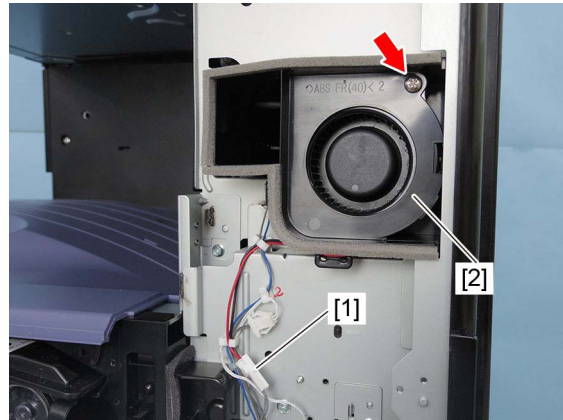

Fig. 4-611

- (4) Release the harness from the harness guides, and then remove the exit section cooling fan [3].

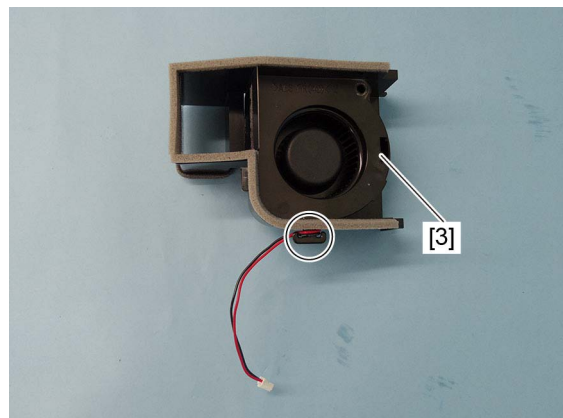

Fig. 4-612

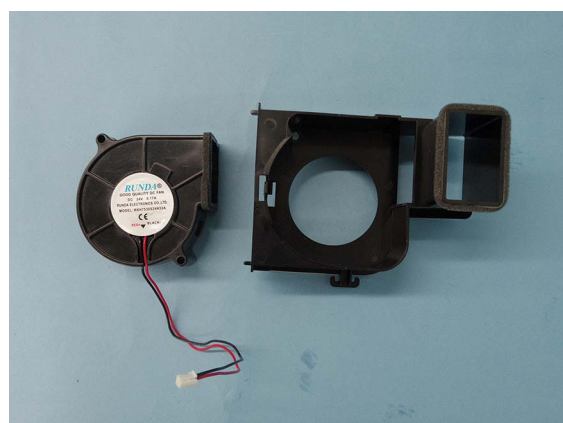

Fig. 4-613

4.11 Automatic Duplexing Unit (ADU)

4.11.1 Automatic duplexing unit (ADU)

- (1) Open the side cover.
- (2) Remove the right front cover.
P. 4-5 “4.1.10 Right front cover”
- (3) Remove the right rear cover.
P. 4-5 “4.1.11 Right rear cover”
- (4) Disconnect the 3 connectors [1], and release the harness from harness clamps [2]. Remove 1 screw and take off the ground wire [3].

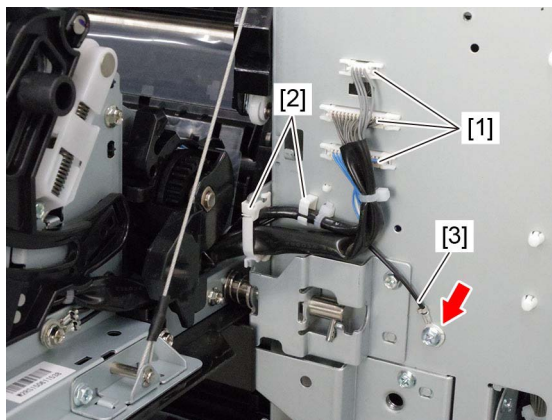

Fig. 4-614

- (5) Remove 1 screw and take off the wire end bracket [4] by holding up the automatic duplexing unit and sliding the bracket toward the rear side.

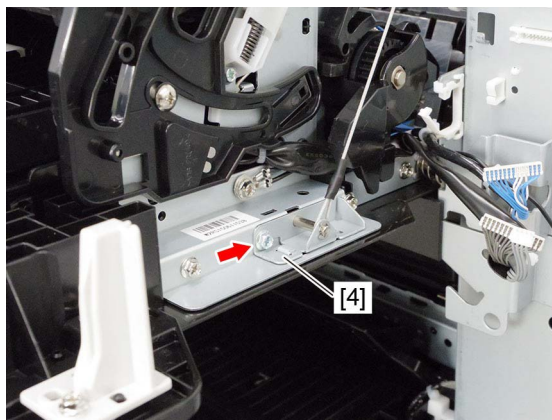

Fig. 4-615

Notes:

- When removing/attaching the wire end bracket, be sure to hold up the automatic duplexing unit so that the opening angle becomes smaller.

- After removing the wire end bracket, hang it on the hook of the frame so that the spring of the wire does not come off.

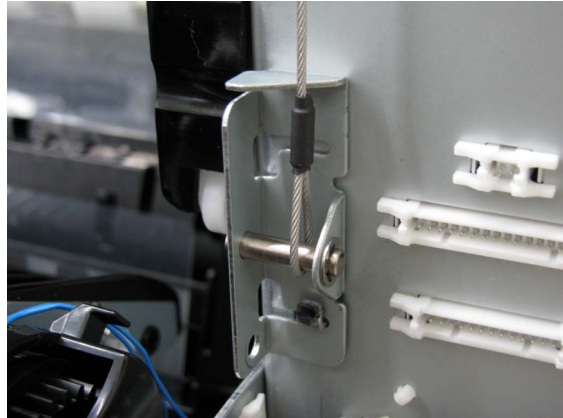

Fig. 4-616

- (6) Raise the rear hinge [5] and slide it outward, and then remove the rear shaft.

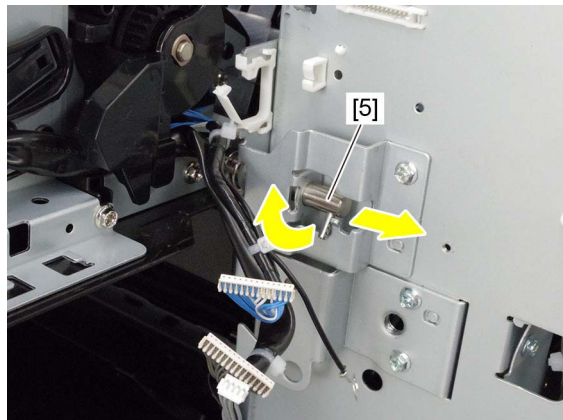

Fig. 4-617

Notes:

During installation, turn the rear hinge downward, and then install the right rear cover.

- (7) Slightly lift up the automatic duplexing unit [6] and slide it toward the rear side to remove it.

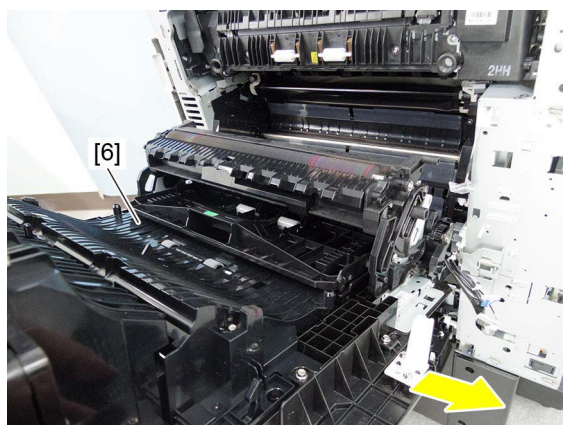

Fig. 4-618

Notes:

When installing the automatic duplexing unit, fit the boss to the hole in the front hinge.

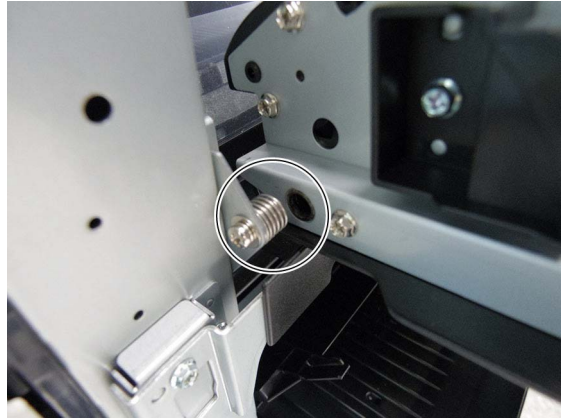

Fig. 4-619

4.11.2 Bypass feed clutch (CLT3)

- (1) Remove the automatic duplexing unit.
P. 4-243 "4.11.1 Automatic duplexing unit (ADU)"
- (2) Release the harness from the harness guides [1].
- (3) Remove 1 screw and take off the clutch cover [2].

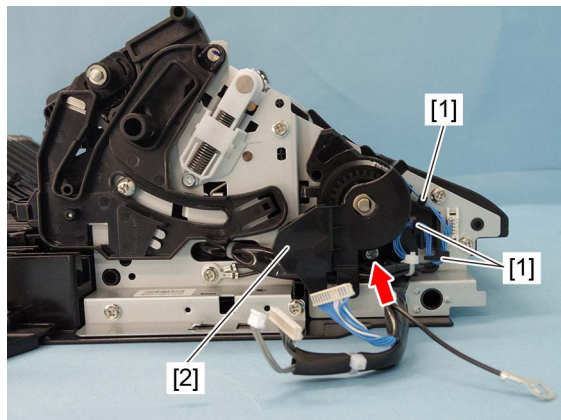

Fig. 4-620

- (4) Disconnect 1 connector [3] and take off the bypass feed clutch [4].

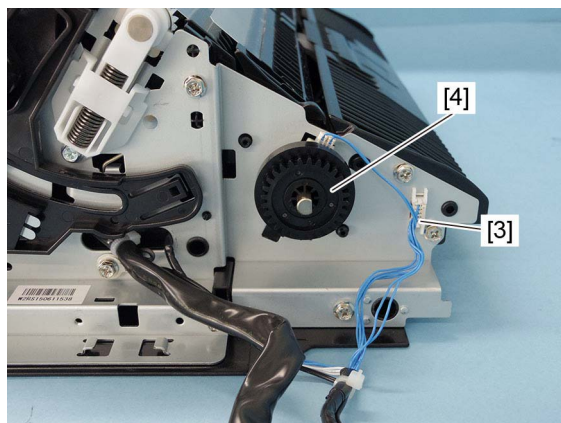

Fig. 4-621

Notes:

When installing the feed clutch, attach a rotation stopper.

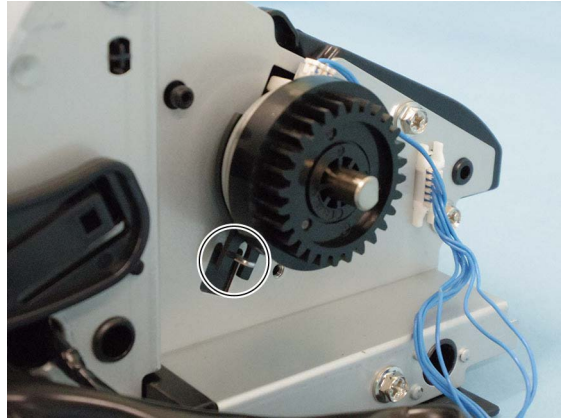

Fig. 4-622

4.11.3 Transport unit

- (1) Remove the 2nd transfer unit.
📖 P. 4-178 “4.7.9 2nd transfer unit (TRU)”
- (2) Remove the bypass feed clutch.
📖 P. 4-245 “4.11.2 Bypass feed clutch (CLT3)”
- (3) Remove the registration roller (Rubber).
📖 P. 4-67 “4.5.9 Registration roller (on the ADU side)”
- (4) Disconnect the 1 connector [1].

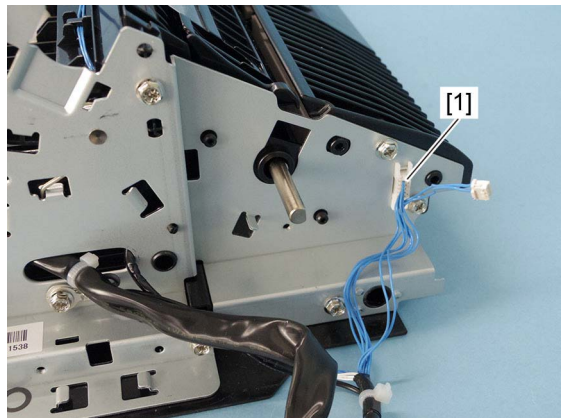

Fig. 4-623

(5) Remove 7 screws and take off the rear bracket [2] of the transport unit.

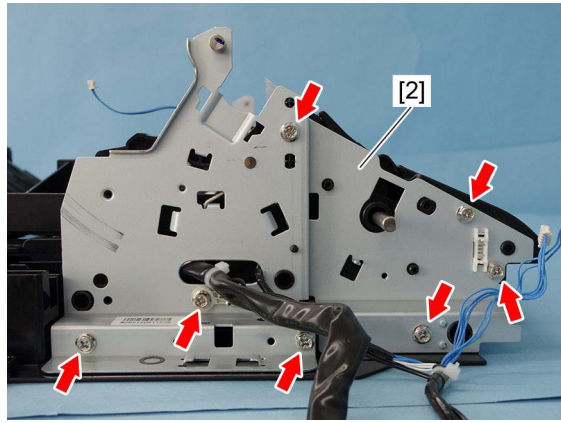

Fig. 4-624

(6) Disconnect the 1 connector [3].

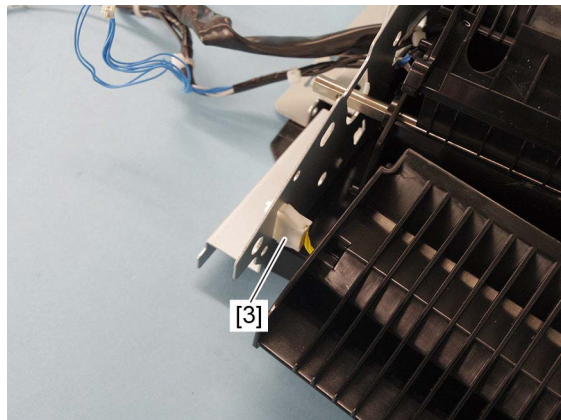

Fig. 4-625

(7) Remove 1 screw and take off the stopper [4].

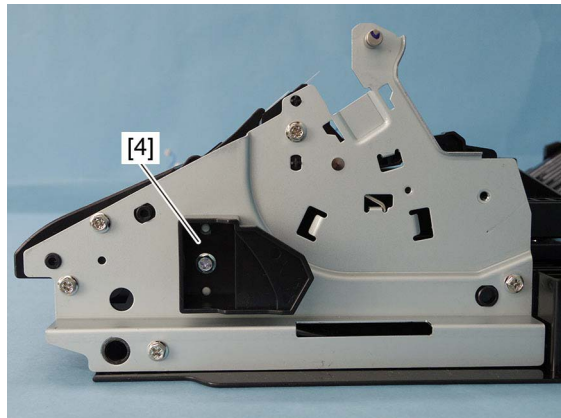

Fig. 4-626

(8) Remove 5 screws and take off the front bracket [5] of the transport unit.

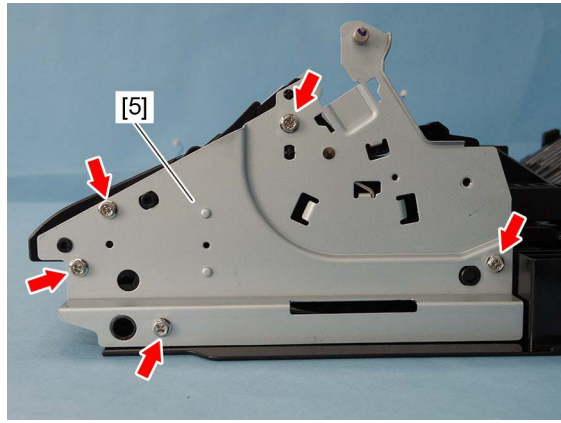

Fig. 4-627

(9) Remove the bypass separation roller [6], 3 springs [7], paper guide (lower) [8], and paper guide (upper) [9].

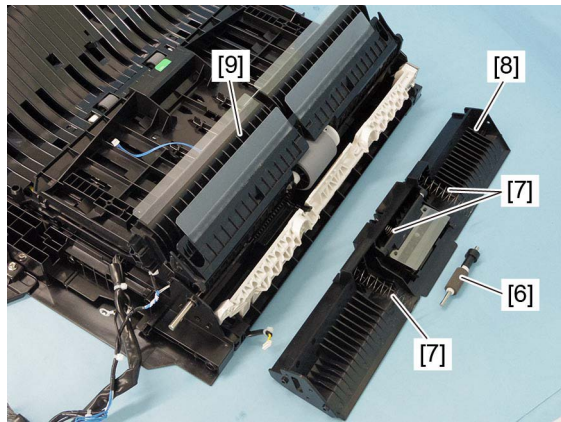

Fig. 4-628

(10) Remove 2 screws and take off the paper guide (middle) [10].

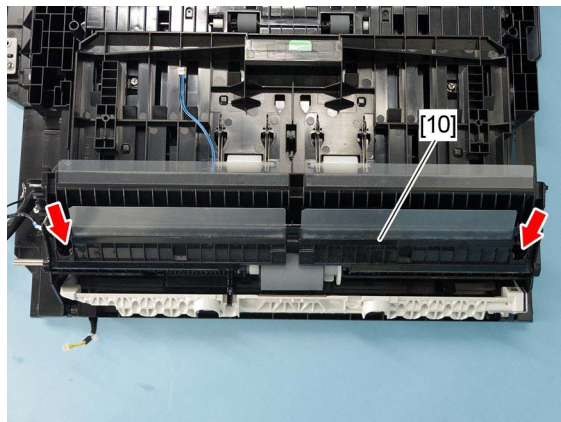

Fig. 4-629

4.11.4 ADU guide assembly

- (1) Remove the automatic duplexing unit.
📖 P. 4-243 “4.11.1 Automatic duplexing unit (ADU)”
- (2) Remove 2 screws and take off the cover [1].

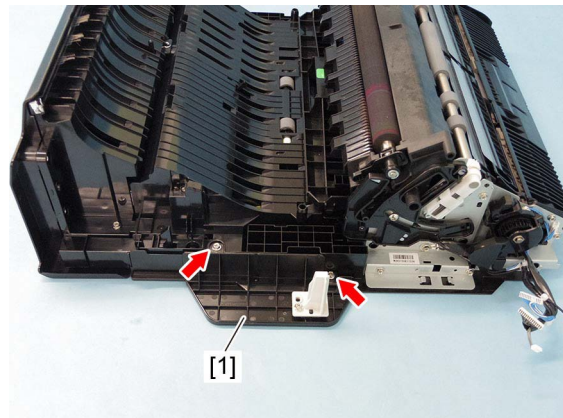

Fig. 4-630

- (3) Remove 6 screws.
- (4) Remove the bypass feed clutch.
📖 P. 4-245 “4.11.2 Bypass feed clutch (CLT3)”

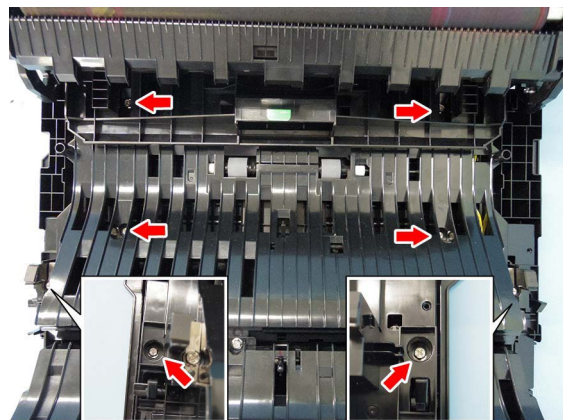

Fig. 4-631

- (5) Remove 1 screw for earth wire.

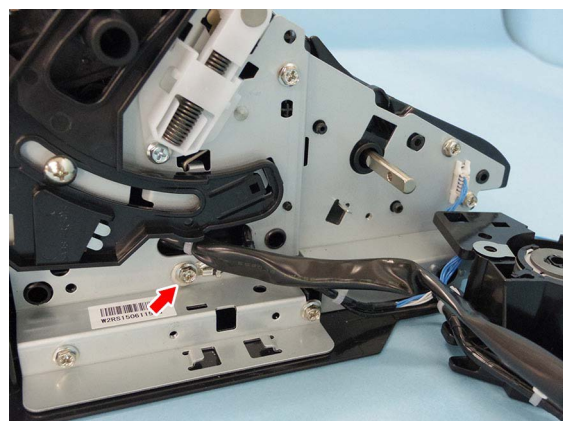

Fig. 4-632

- (6) Remove the ADU guide assembly [2] by sliding it toward you.

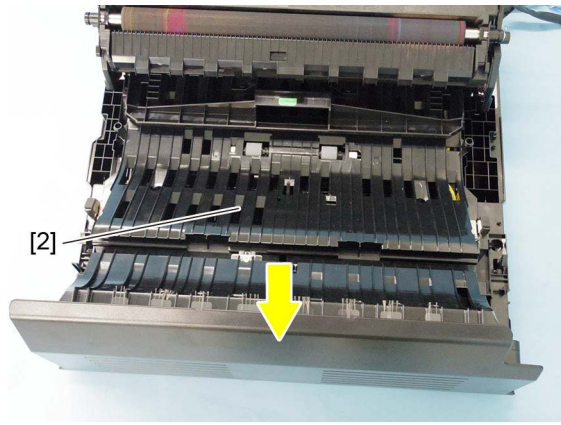

Fig. 4-633

4.11.5 ADU middle cover

- (1) Remove the ADU guide assembly.
📖 P. 4-249 “4.11.4 ADU guide assembly”
- (2) Remove 4 screws, and take off the ADU upper cover [1].

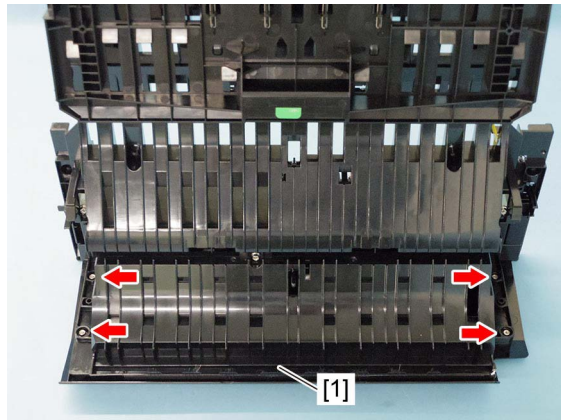

Fig. 4-634

- (3) Disconnect the 2 connectors [2].

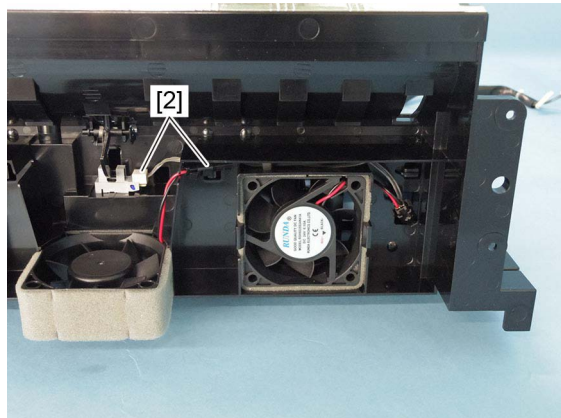

Fig. 4-635

Notes:

For 45/50ppm, disconnect the connector [3] of the fuser unit cooling fan 2.

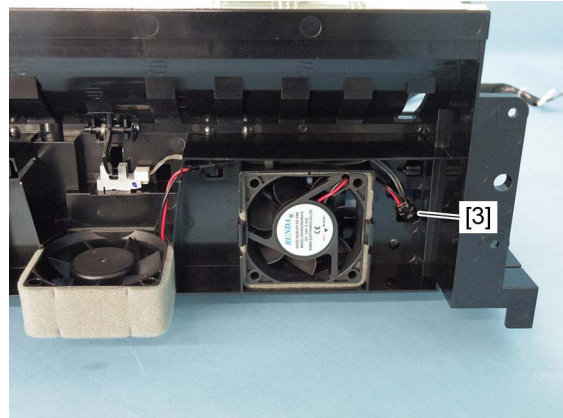

Fig. 4-636

- (4) Remove 3 screws, and take off the ADU middle cover [4].

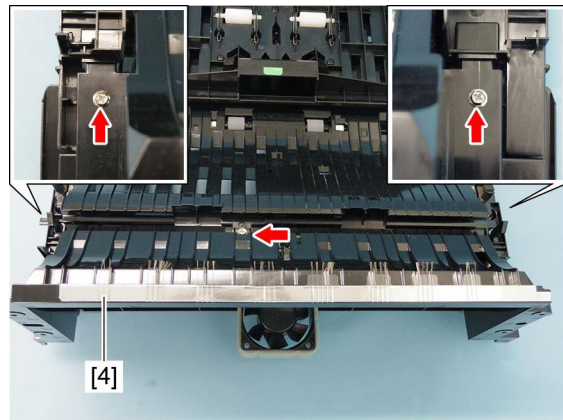

Fig. 4-637

Notes:

When taking off the ADU middle cover [4], hold the side of assembly [5].

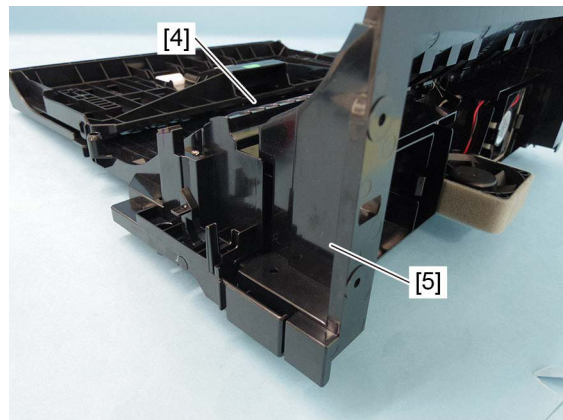



Fig. 4-638

4.11.6 ADU control PC board (ADU board) (ADU)

- (1) Remove the ADU guide assembly.
 P. 4-249 “4.11.4 ADU guide assembly”
- (2) Remove 2 springs, and take off the side cover release lever [1].

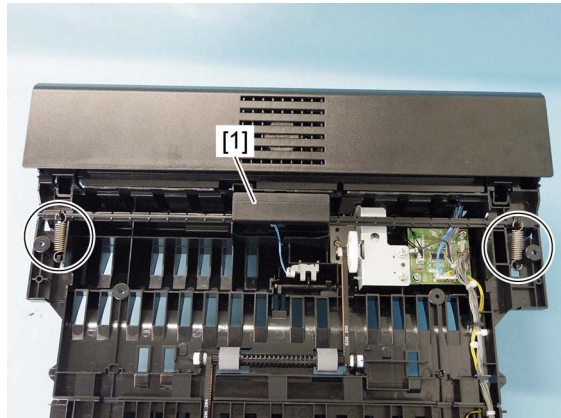

Fig. 4-639

- (3) Disconnect the 3 connectors [2] and remove 1 screw for ground cable [3].

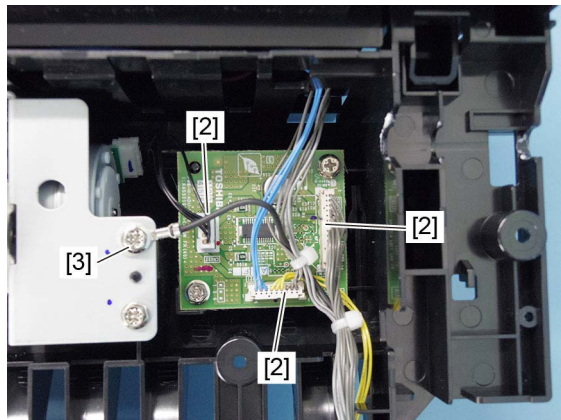

Fig. 4-640

- (4) Remove 2 screws, and take off the ADU control PC board (ADU board) [4].

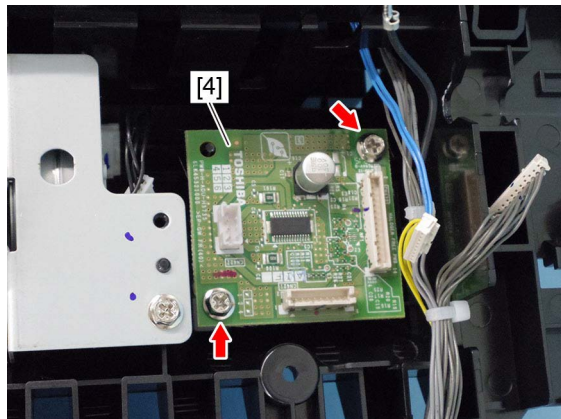

Fig. 4-641

4.11.7 ADU motor (M12)

- (1) Remove the ADU guide assembly.
P. 4-249 "4.11.4 ADU guide assembly"
- (2) Remove 2 springs, and take off the side cover release lever [1].

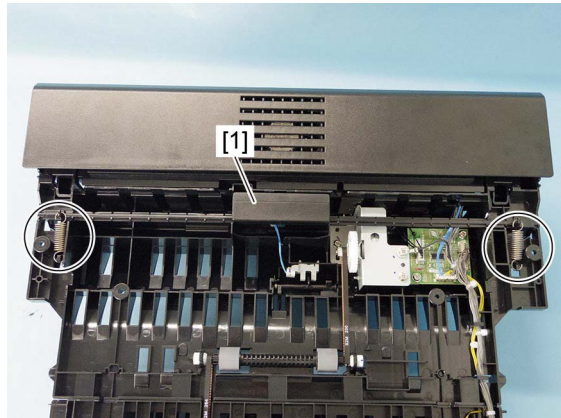

Fig. 4-642

- (3) Remove 3 screws.

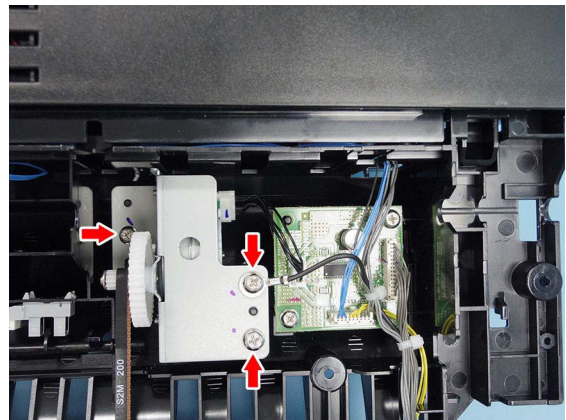

Fig. 4-643

- (4) Disconnect the 1 connector [2] and take off the ADU motor assembly [3].

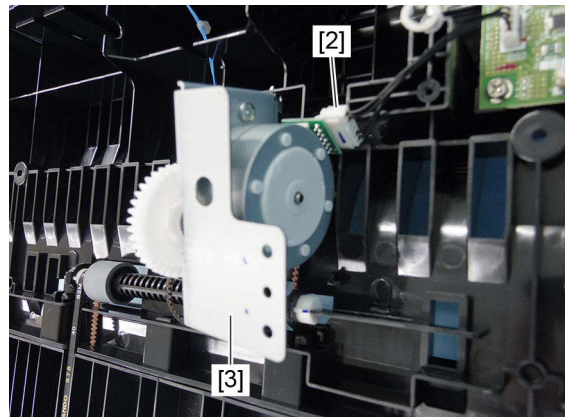

Fig. 4-644

- (5) Remove 2 screws, and take off the ADU motor [4].

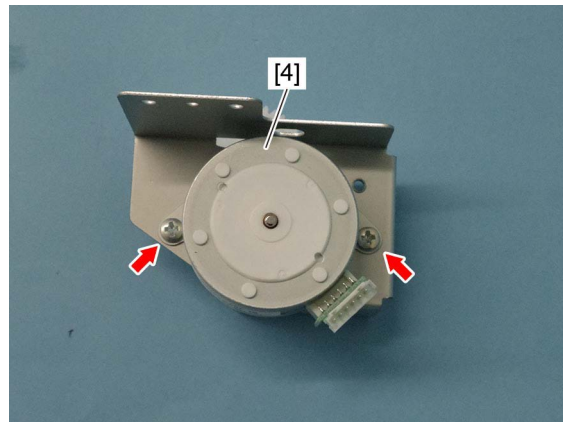

Fig. 4-645

4.11.8 ADU entrance sensor (S14)

- (1) Remove the ADU guide assembly.
P. 4-249 “4.11.4 ADU guide assembly”
- (2) Disconnect the 1 connector [1], release the latch, and take off the ADU entrance sensor [2].

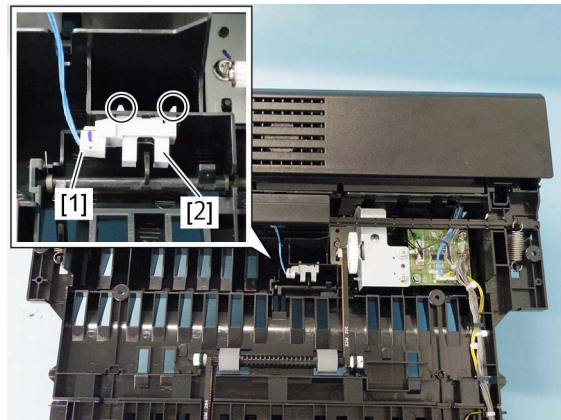

Fig. 4-646

4.11.9 ADU exit sensor (S15)

- (1) Remove the ADU guide assembly.
P. 4-249 “4.11.4 ADU guide assembly”
- (2) Disconnect the 1 connector [1], release the latch, and take off the ADU exit sensor [2].

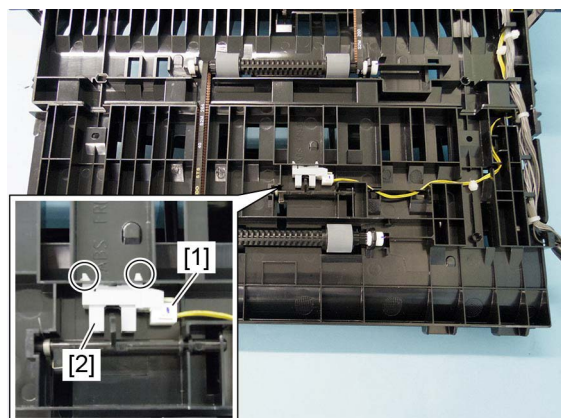

Fig. 4-647

4.11.10 Transport roller (Upper and lower)

- (1) Remove the ADU guide assembly.
P. 4-249 “4.11.4 ADU guide assembly”
- (2) Remove the transport roller [1] and drive belt [2].

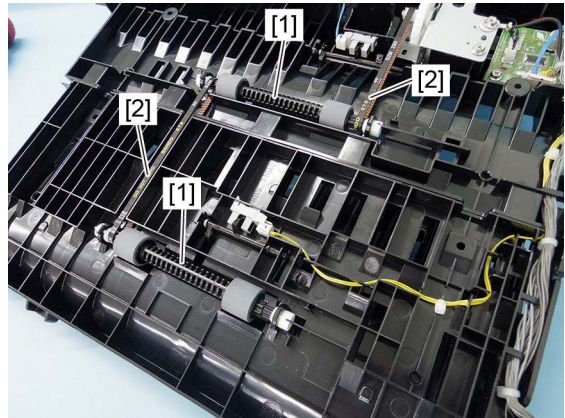

Fig. 4-648

Notes:

- Be sure to attach the belt when carrying out installation.
- When taking off the transport roller, bend the rib [3] to remove the collar [4], slide the shaft [5] onto the rib, and then take off the collar [6] on the opposite side to pull out the shaft.

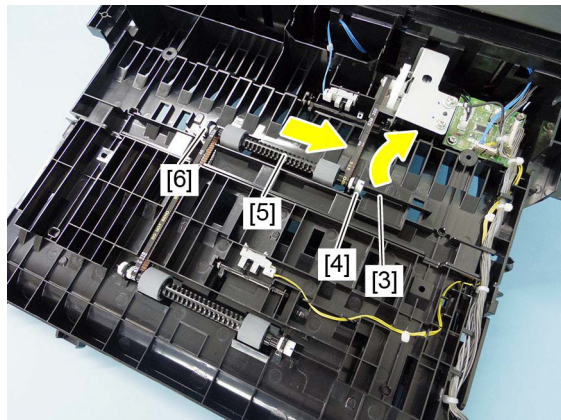

Fig. 4-649

- When replacing both the transport roller and the collar, or performing machine refreshment, apply an appropriate amount of white grease (Molykote EM-30L) inside of the collars [7]. When applying the grease, make sure that the grease is not running over. Grease might run out before the machine refreshment depending on frequency of use, apply an appropriate amount of grease as necessary.

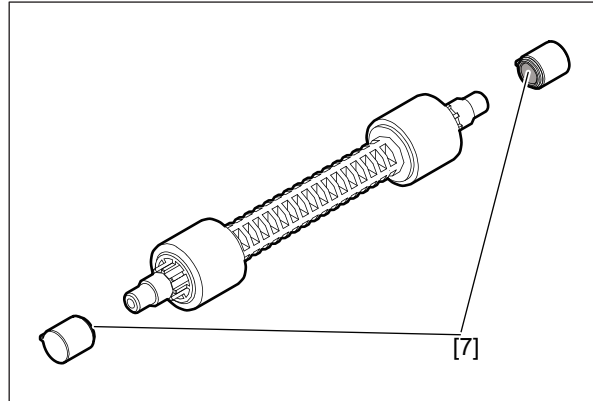

Fig. 4-650

4.11.11 Reverse sensor (S26)

- (1) Remove the ADU middle cover.
 📖 P. 4-250 "4.11.5 ADU middle cover"
- (2) Disconnect 1 connector [2], and release 2 latches, and take off the reverse sensor [1].

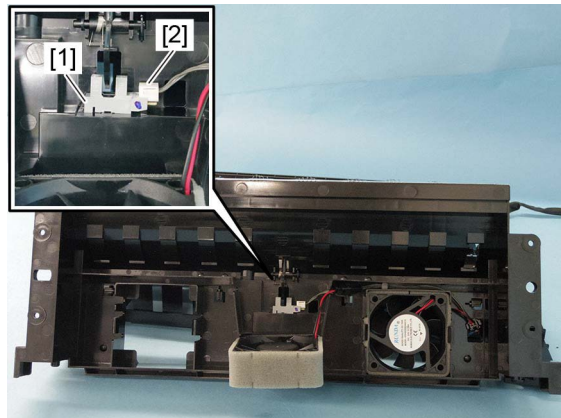

Fig. 4-651

4.11.12 Side cover interlock switch (SW3)

Notes:

If the interlock switch is not installed appropriately when it is replaced or installed, it may not work normally. If you carry out the maintenance of the equipment in such a situation, you could get an electric shock by touching live sections or be injured by touching moving sections. Therefore, to avoid this, be sure to perform correct handling and installation.

- (1) Remove the reverse unit.
 📖 P. 4-230 "4.10.1 Reverse unit"

- (2) Remove 2 screws and take off the side cover interlock switch cover [1].

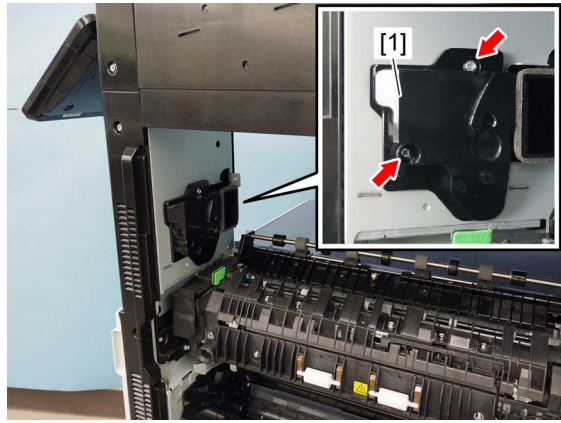

Fig. 4-652

- (3) Release the latches and take off the side cover interlock switch [2]. Disconnect 2 connectors [3].

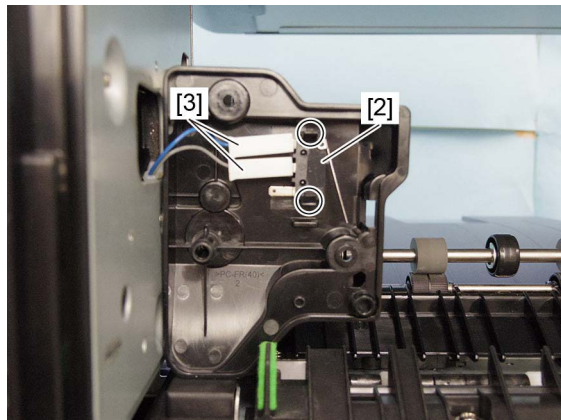

Fig. 4-653

4.11.13 Fuser unit cooling fan 1 (F4)

- (1) Remove the ADU guide assembly.
P. 4-249 "4.11.4 ADU guide assembly"
- (2) Remove 4 screws and take off the ADU front cover [1].

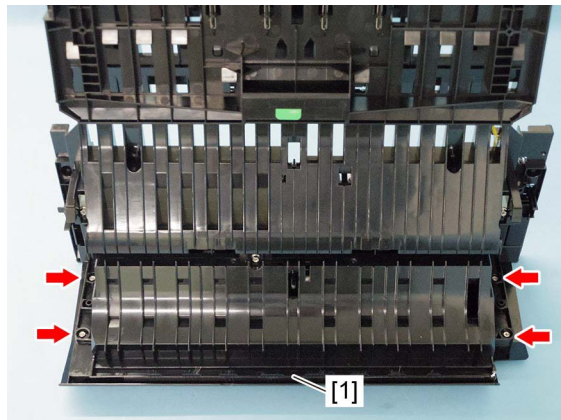

Fig. 4-654

- (3) Disconnect the 1 connector [2], and take off the fuser unit cooling fan [3].

Notes:

Install the fuser cooling fan so that the harness passes through the harness guides in the ADU middle cover.

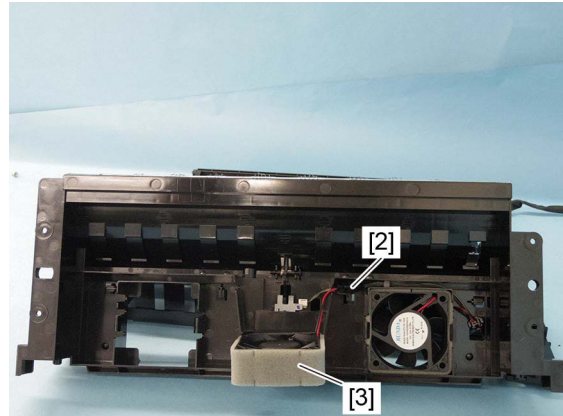

Fig. 4-655

4.11.14 Fuser unit cooling fan 2 (F9)

- (1) Remove the ADU guide assembly.
P. 4-249 “4.11.4 ADU guide assembly”
- (2) Remove 4 screws and take off the ADU front cover [1].

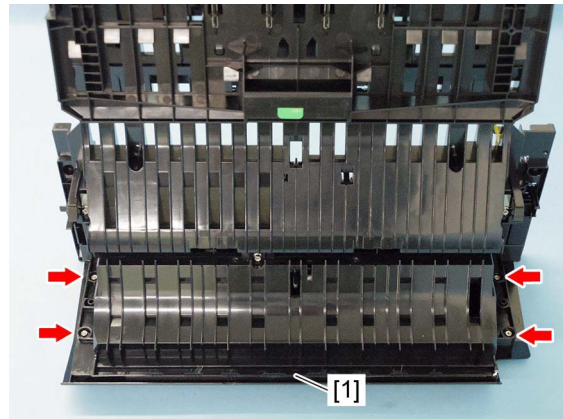

Fig. 4-656

- (3) Disconnect the 1 connector [2], and release 2 latches, and take off the fuser unit cooling fan 2 [3].

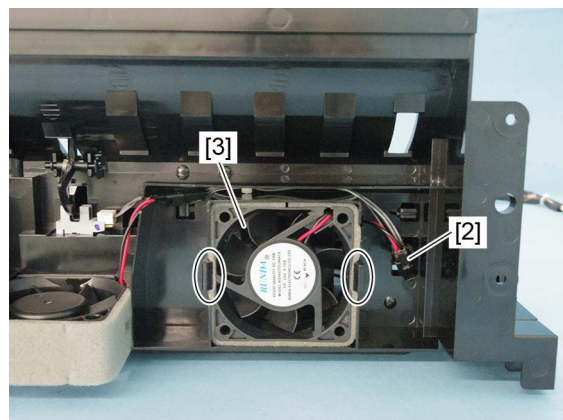



Fig. 4-657

4.12 Removal and Installation of Options

Important:

Before installing or removing options, turn the main power switch off and disconnect the power cable from the outlet.

4.12.1 Dual Scan Document Feeder

- (1) Press the [Power] button on the control panel to shut it down.
- (2) Turn the main power switch of the equipment off.
- (3) Disconnect the power cable.
- (4) Remove the rear cover.
 P. 4-10 "4.1.17 Rear cover"
- (5) Remove the SYS board cover.
 P. 9-1 "9.1.1 SYS board cover"
- (6) Take off the connector cover.

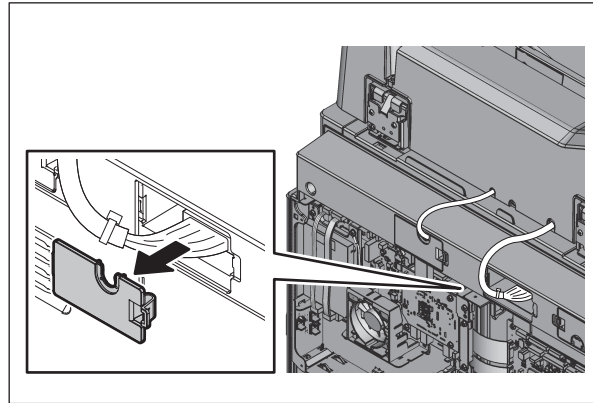

Fig. 4-658

- (7) Disconnect 1 connector.

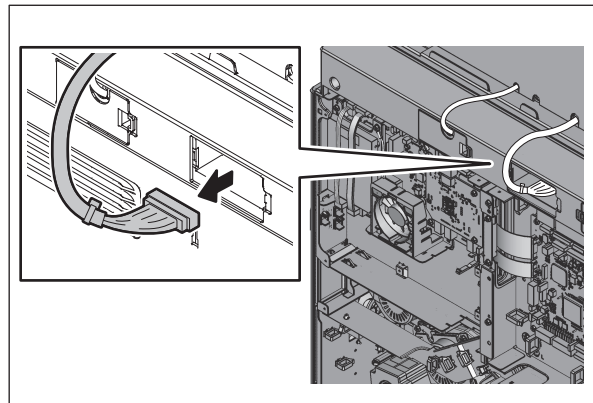

Fig. 4-659

(8) Remove 2 connector covers.

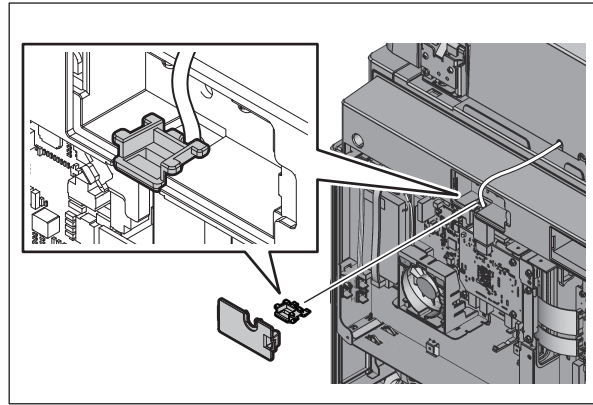

Fig. 4-660

(9) Disconnect 1 connector.

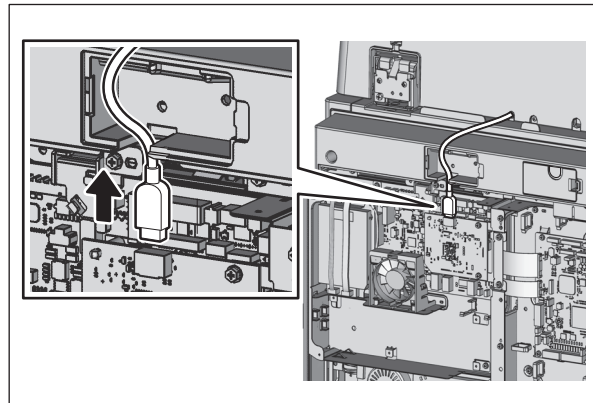

Fig. 4-661

(10) Remove 4 screws and take off 2 brackets.

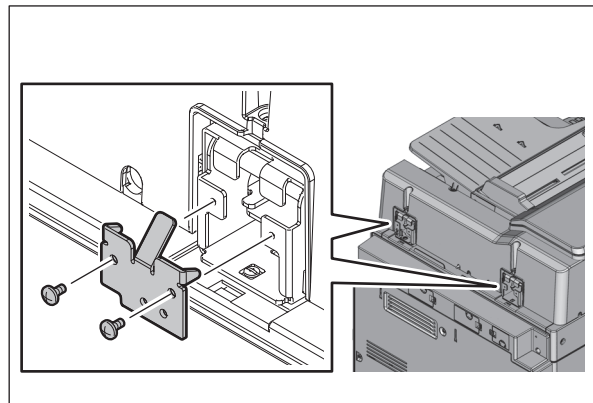

Fig. 4-662

(11) Remove 2 screws and 2 washers.

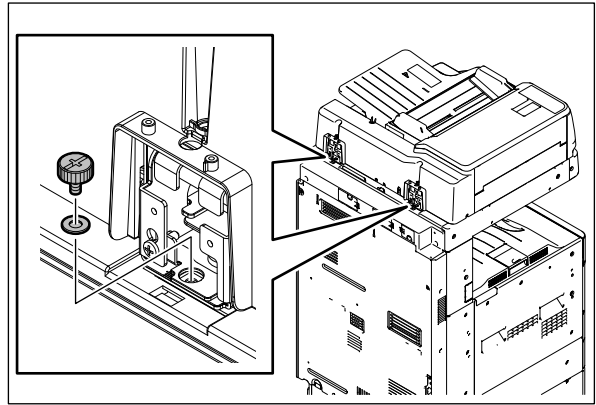

Fig. 4-663

(12) Remove the right hinge clearance cover.

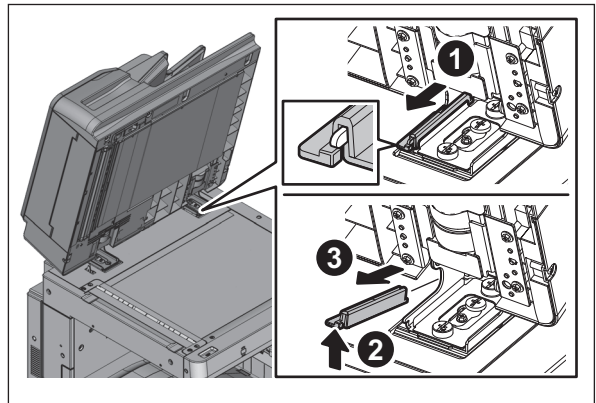

Fig. 4-664

(13) Open the dual scan document feeder. Remove 2 screws.

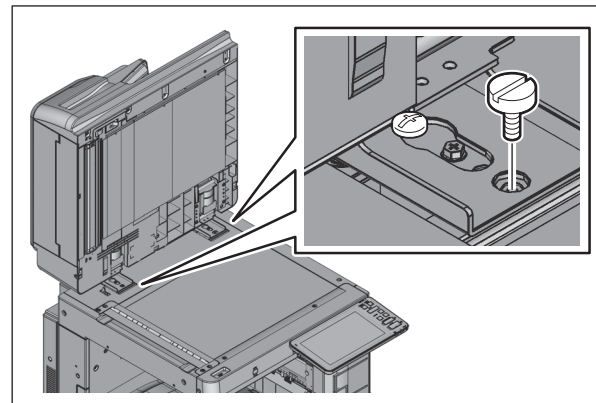

Fig. 4-665

(14) Remove the dual scan document feeder by sliding it toward the rear side.

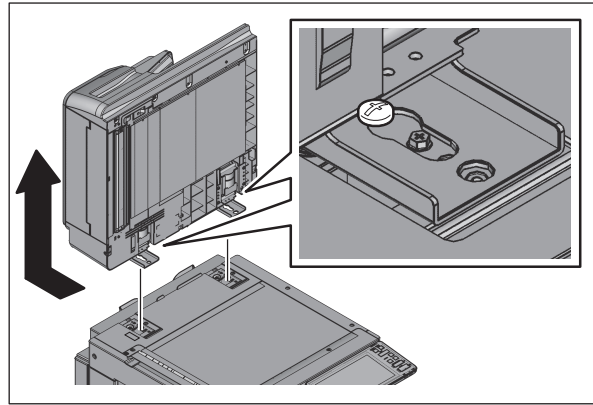

Fig. 4-666

4.12.2 Reversing Automatic Document Feeder

- (1) Press the [Power] button on the control panel to shut it down.
- (2) Turn the main power switch of the equipment off.
- (3) Disconnect the power cable.
- (4) Take off the connector cover.

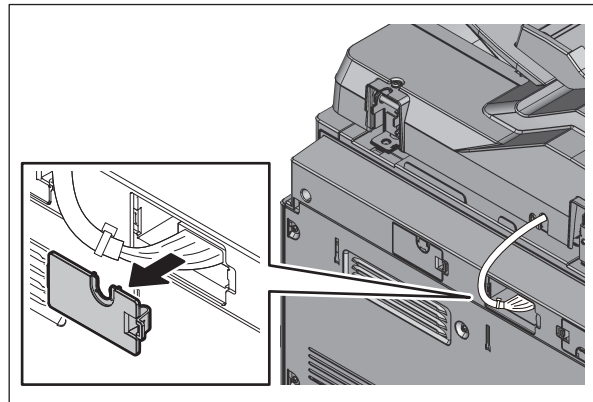

Fig. 4-667

(5) Disconnect 1 connector.

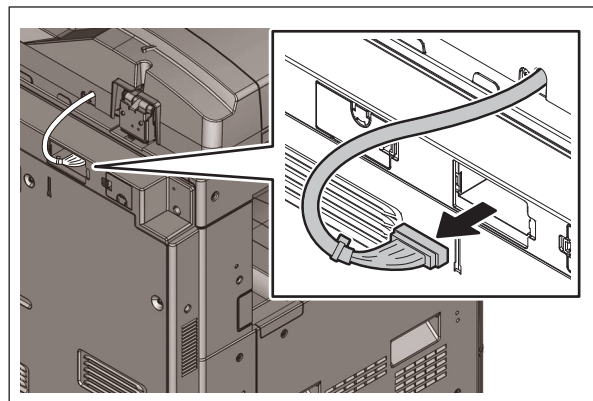

Fig. 4-668

(6) Install the connector cover.

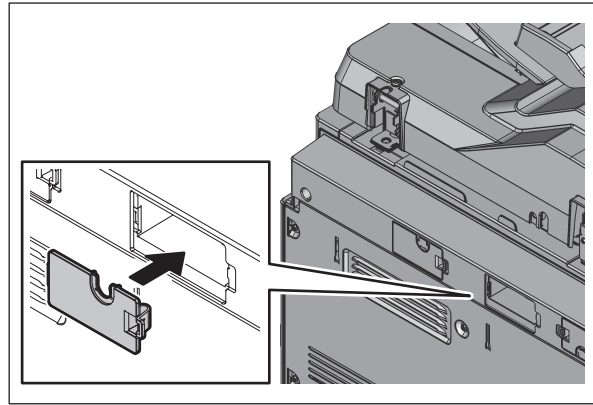

Fig. 4-669

(7) Remove 2 screws and take off 1 bracket.

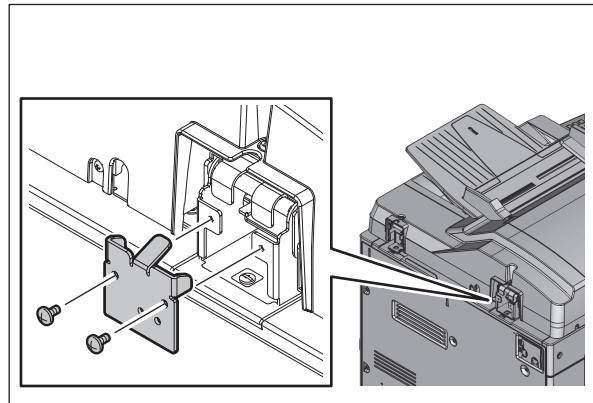

Fig. 4-670

(8) Remove the cover.

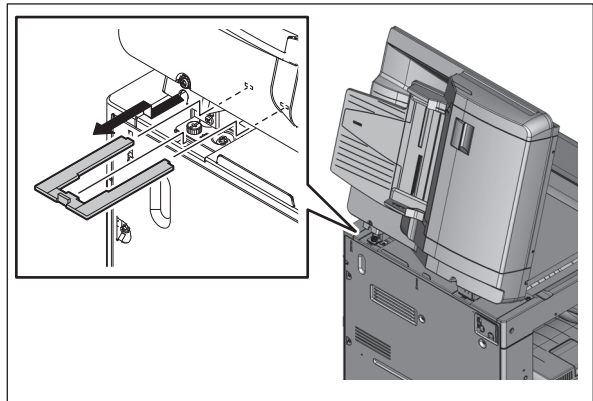

Fig. 4-671

(9) Remove 2 screws and 2 washers.

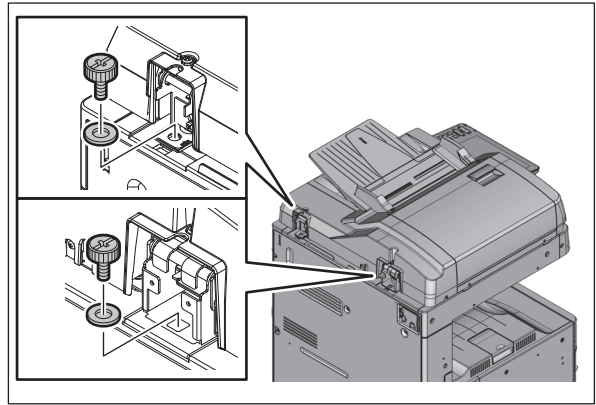

Fig. 4-673

(10) Open the reversing automatic document feeder. Remove 2 screws.

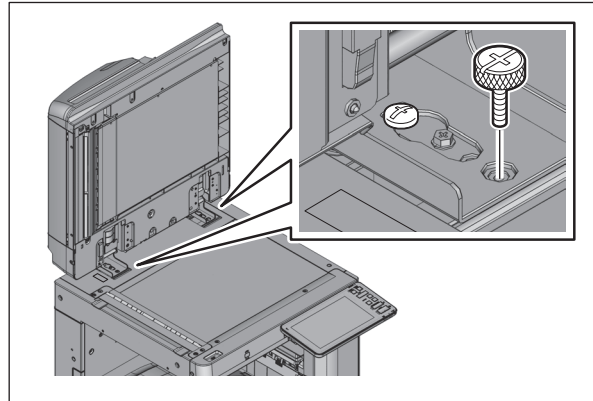

Fig. 4-673

(11) Remove the reversing automatic document feeder by sliding it toward the rear side.

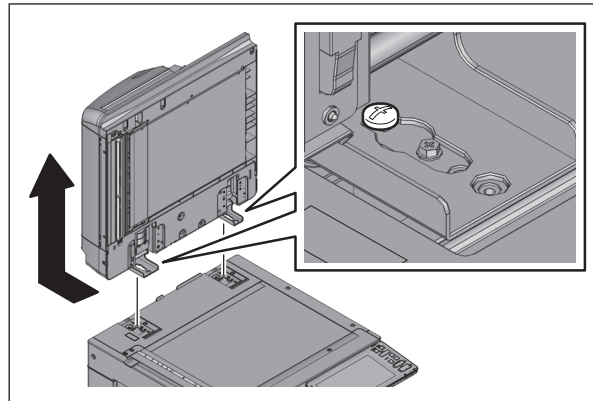

Fig. 4-674

4.12.3 Paper Feed Pedestal

- (1) Press the [Power] button on the control panel to shut it down.
- (2) Turn the main power switch of the equipment off.
- (3) Disconnect the power cable.
- (4) Remove 1 screw and take off the cover.

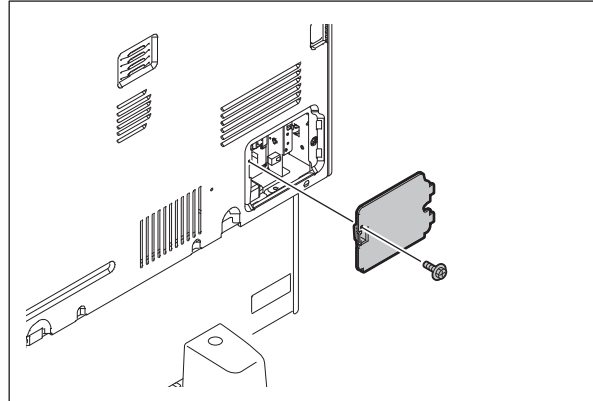

Fig. 4-675

- (5) Remove 1 screw and take off the harness holder.

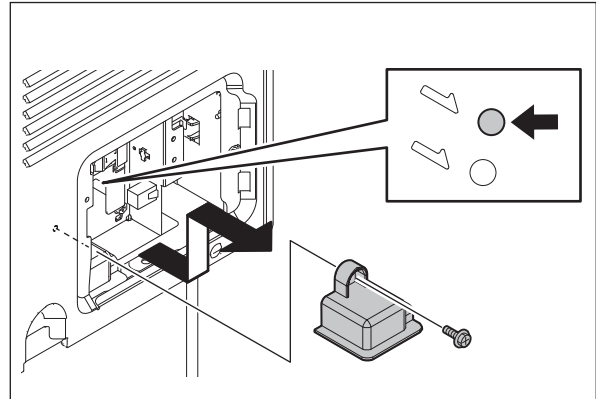

Fig. 4-676

- (6) Remove 1 screw and disconnect the ground cable. Disconnect 1 connector.

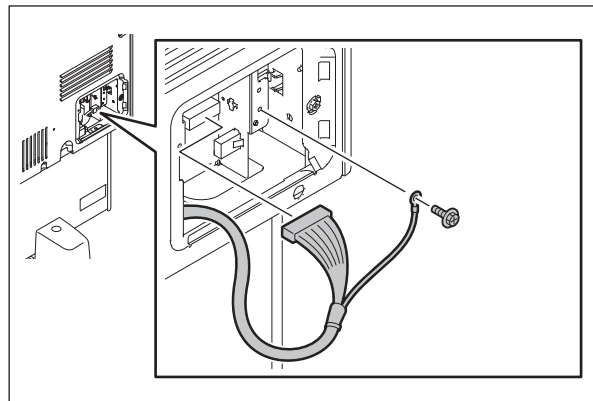

Fig. 4-677

(7) Install the harness holder with 1 screw.

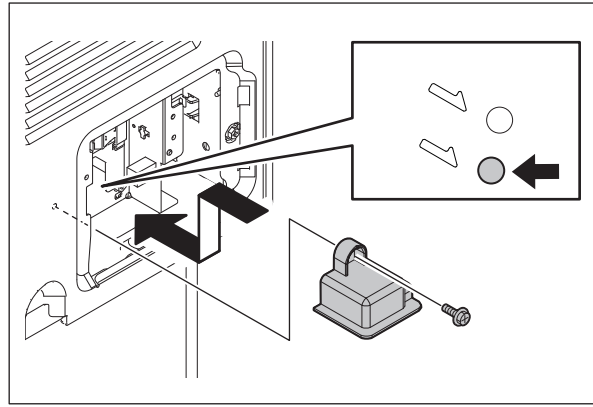

Fig. 4-678

(8) Remove 3 screws and take off 2 fixing brackets on the rear side.

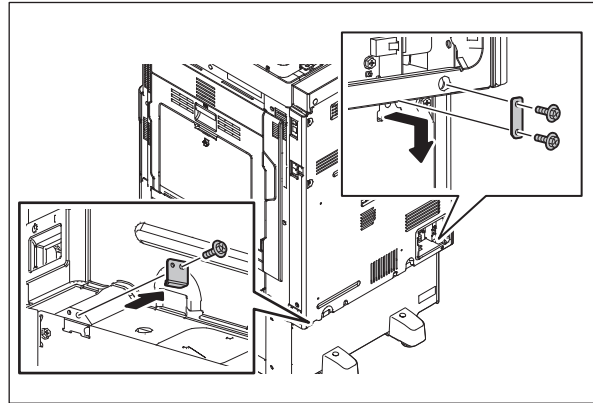

Fig. 4-679

(9) Install the cover.

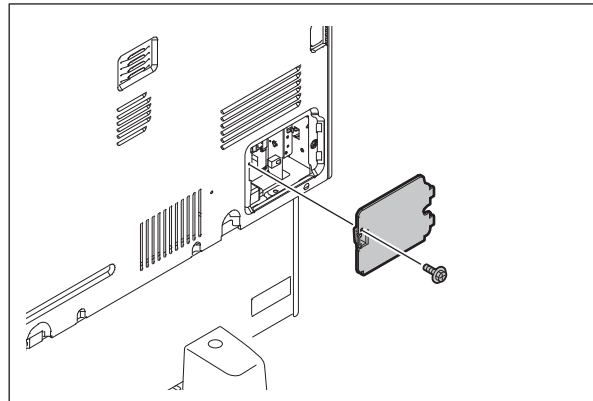

Fig. 4-680

(10) Pull out the drawer.

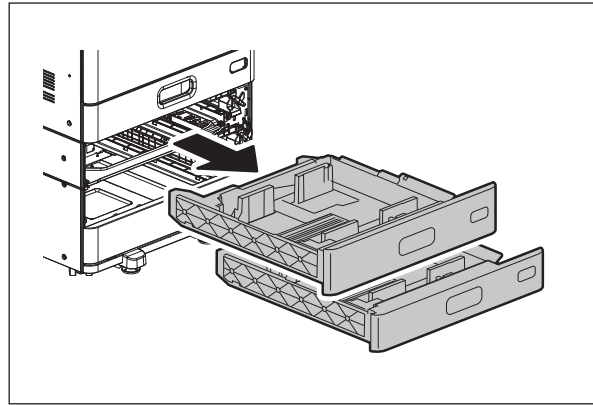

Fig. 4-681

(11) Remove 3 screws and take off 2 fixing brackets on the front side.

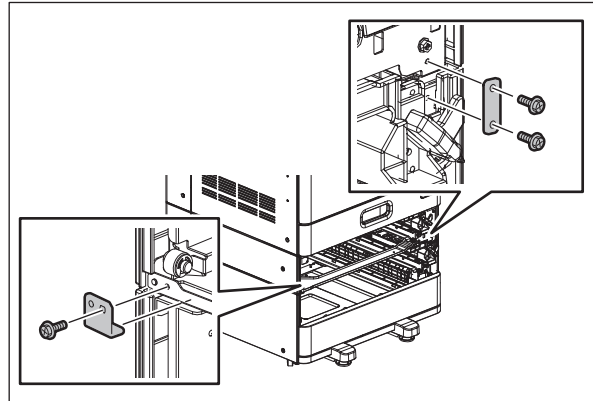

Fig. 4-682

(12) Install the drawer.

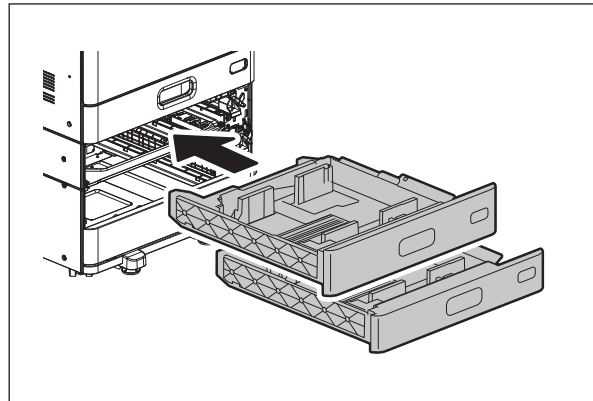

Fig. 4-683

(13) Lift the equipment up and remove the paper feed pedestal.

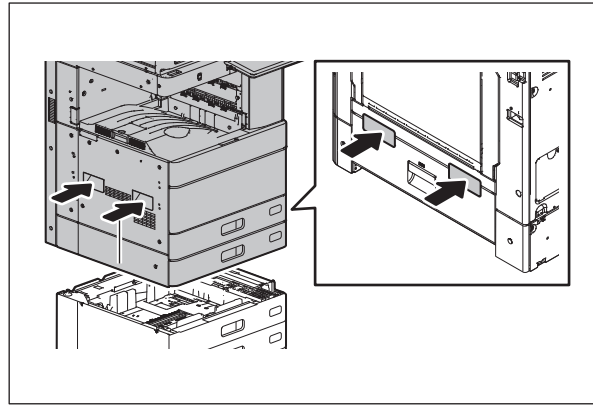

Fig. 4-684

4.12.4 Large Capacity Feeder

- (1) Press the [Power] button on the control panel to shut it down.
- (2) Turn the main power switch of the equipment off.
- (3) Disconnect the power cable.
- (4) Remove 1 screw and take off the cover.

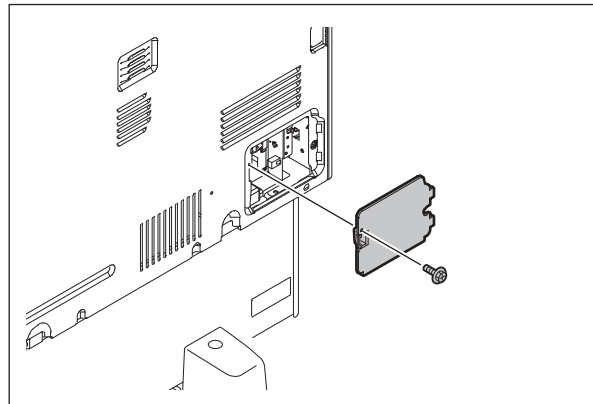

Fig. 4-685

- (5) Remove 1 screw and take off the harness holder.

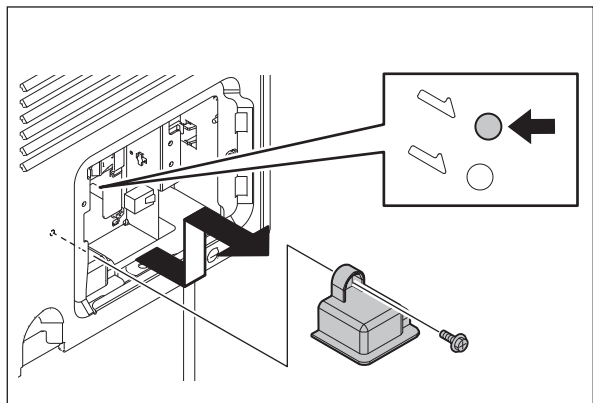

Fig. 4-686

- (6) Disconnect 2 connectors. Remove 1 screw and disconnect the ground cable.
[1] Damp heater harness
[2] Signal harness

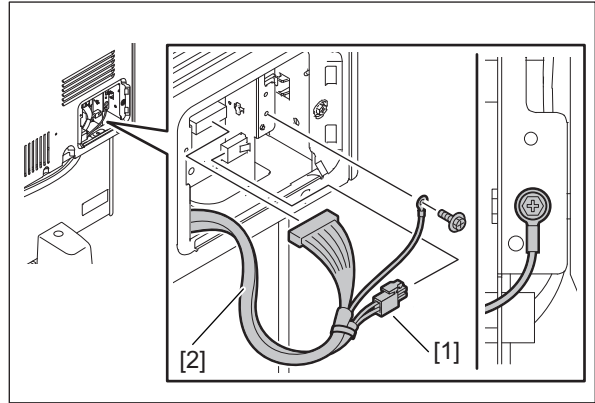

Fig. 4-687

- (7) Install the harness holder with 1 screw.

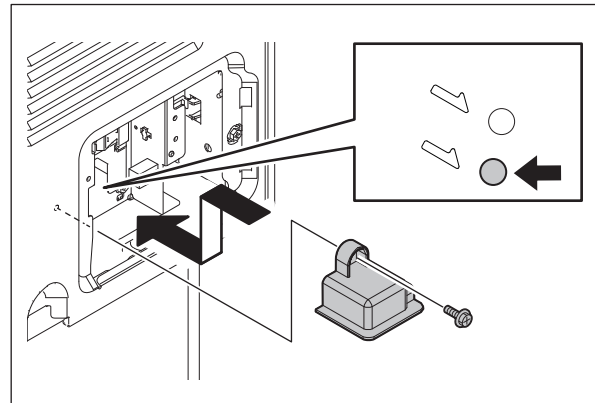

Fig. 4-688

- (8) Remove 3 screws and take off 2 fixing brackets on the rear side.

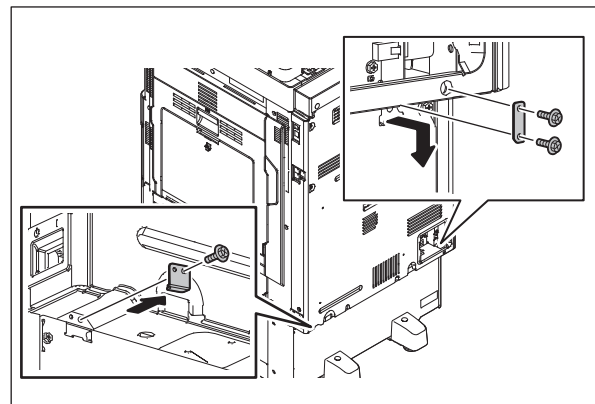

Fig. 4-689

(9) Install the cover.

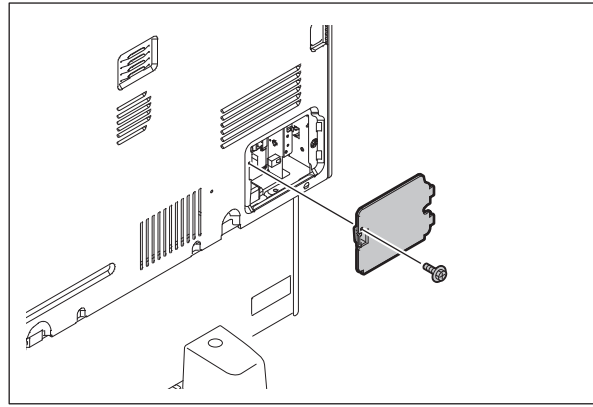

Fig. 4-690

(10) Pull out the drawer.

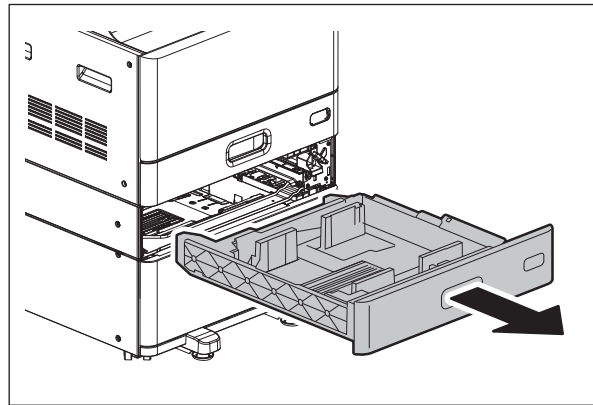

Fig. 4-691

(11) Pull out the large capacity feeder drawer.

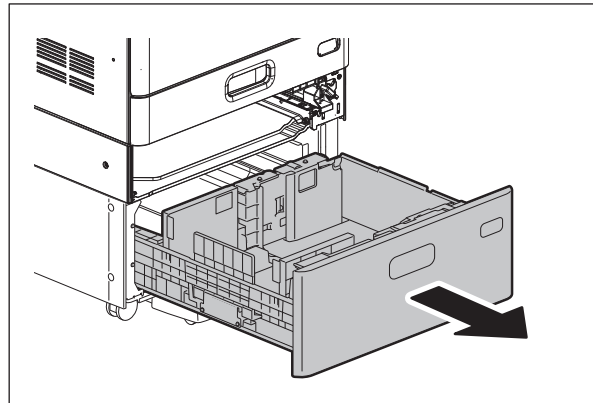

Fig. 4-692

(12) Install the right drawer.

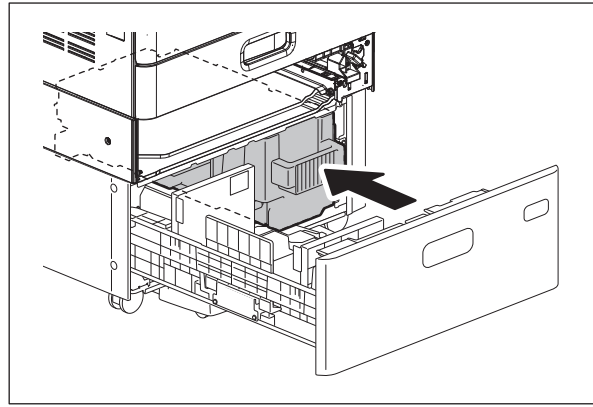

Fig. 4-693

(13) Remove 4 screws and take off 2 fixing brackets on the front side.

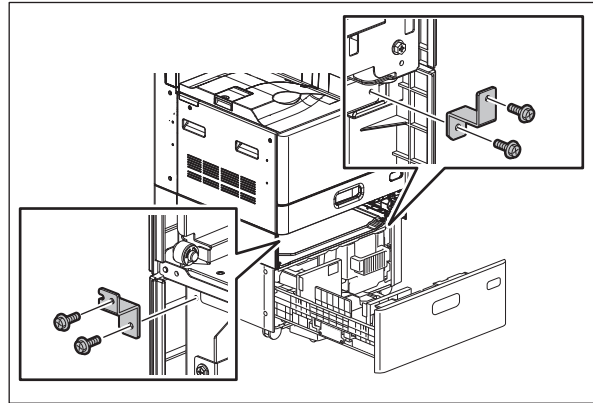

Fig. 4-694

(14) Install the large capacity feeder drawer.

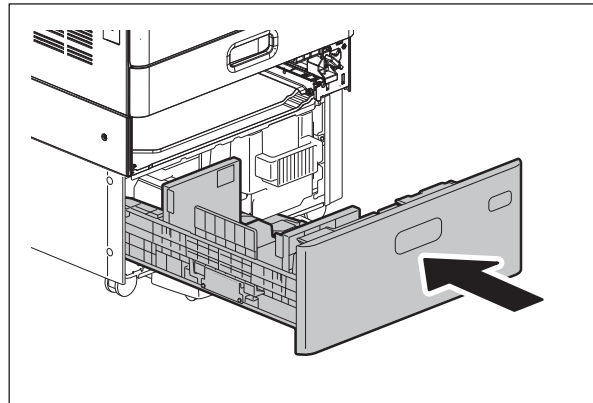

Fig. 4-695

(15) Install the drawer.

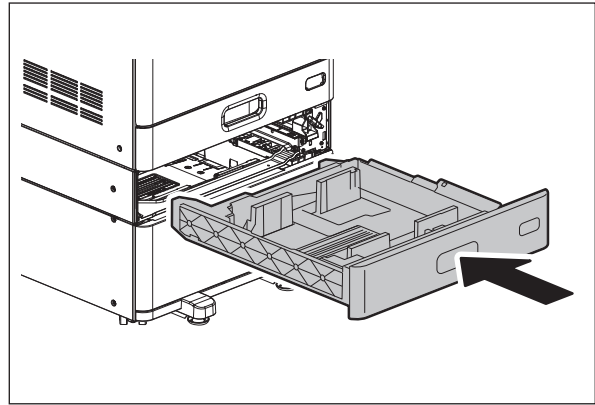

Fig. 4-696

(16) Lift the equipment up and remove the large capacity feeder.

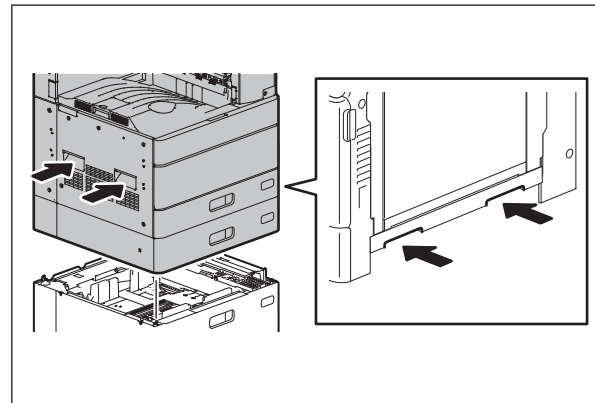

Fig. 4-697

4.12.5 Bridge kit

- (1) Press the [Power] button on the control panel to shut it down.
- (2) Turn the main power switch of the equipment off.
- (3) Disconnect the power cable.
- (4) Open the side cover. Remove 1 screw and take off the connector cover.

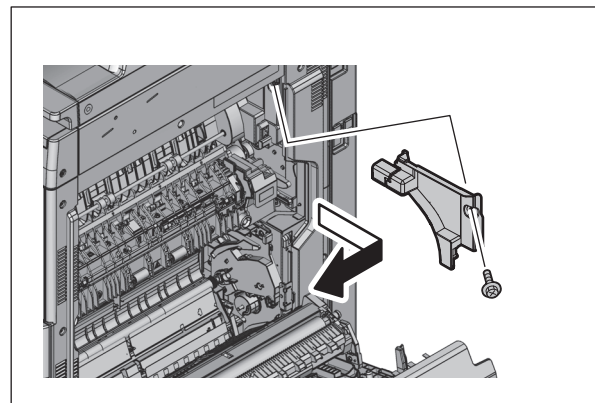

Fig. 4-698

(5) Disconnect 1 connector.

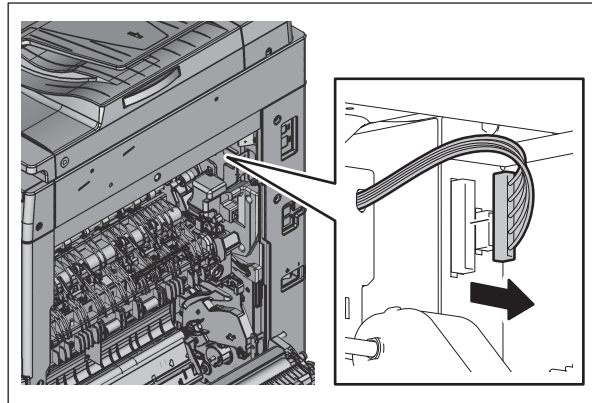

Fig. 4-699

(6) Remove 1 screw and take off the front cover of the bridge kit.

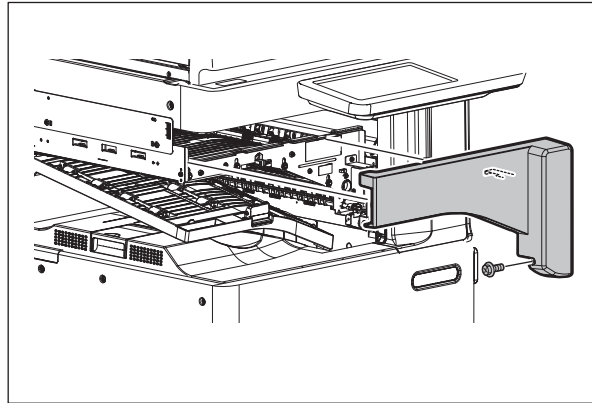

Fig. 4-700

(7) Remove 1 screw.

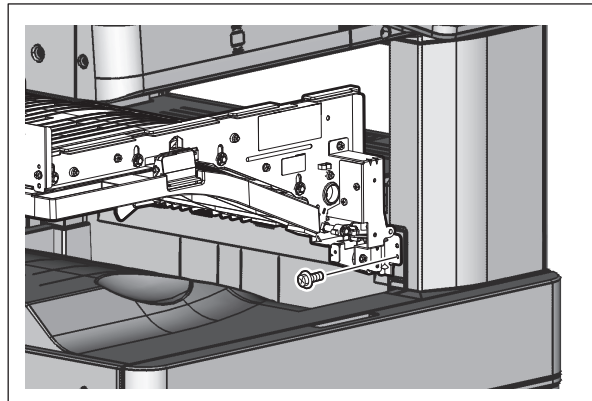

Fig. 4-701

- (8) Remove 2 screws and take off the fixing bracket.

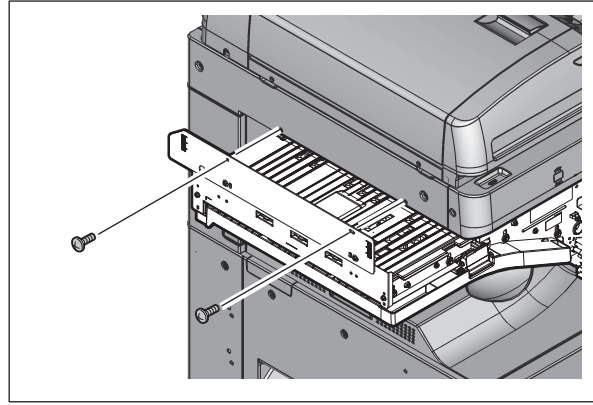

Fig. 4-702

- (9) Lift the bridge kit up to pull out the hook, and pull the bridge kit toward the front side to remove it.

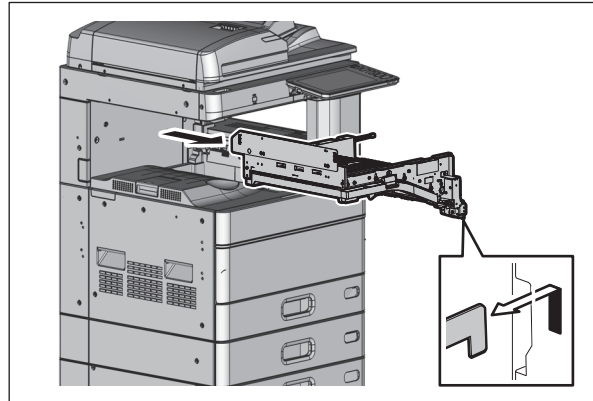

Fig. 4-703

4.12.6 Inner finisher

- (1) Press the [Power] button on the control panel to shut it down.
- (2) Turn the main power switch of the equipment off.
- (3) Disconnect the power cable.
- (4) Remove the connector cover.

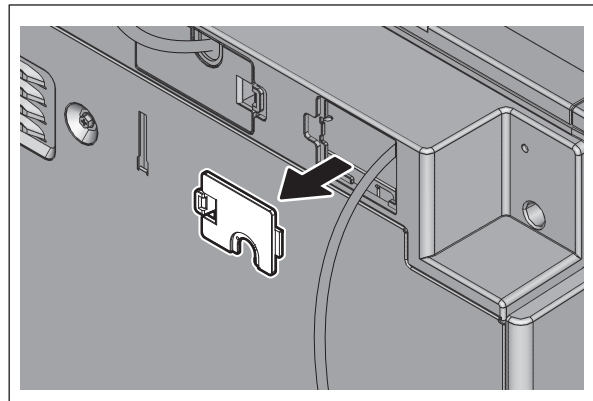

Fig. 4-704

(5) Disconnect the connector.

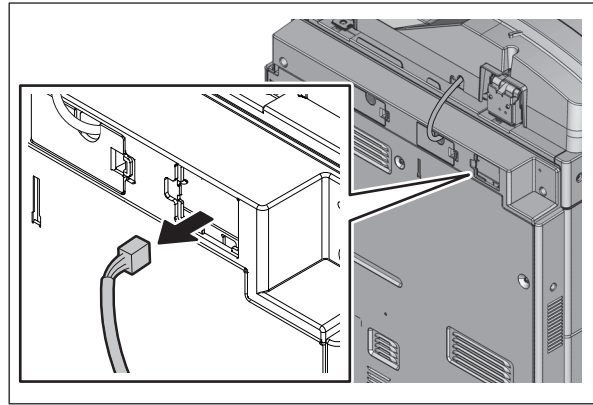

Fig. 4-705

(6) Install the connector cover.

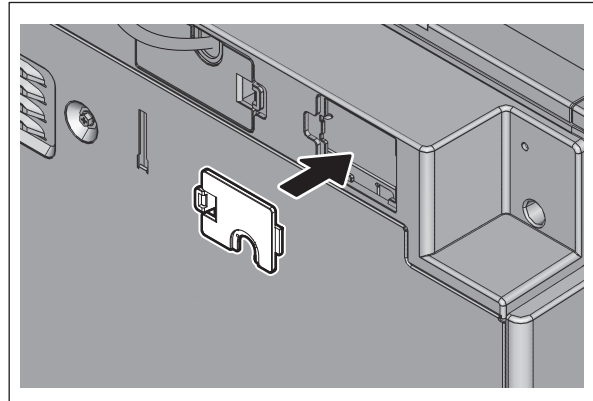

Fig. 4-706

(7) Open the finisher cover.

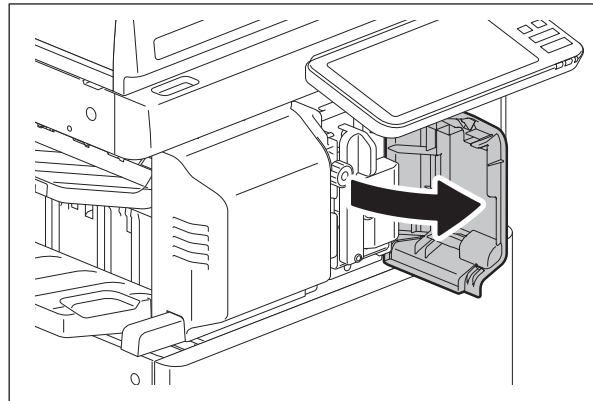

Fig. 4-707

(8) Press the button to release the lock. Pull out the finisher.

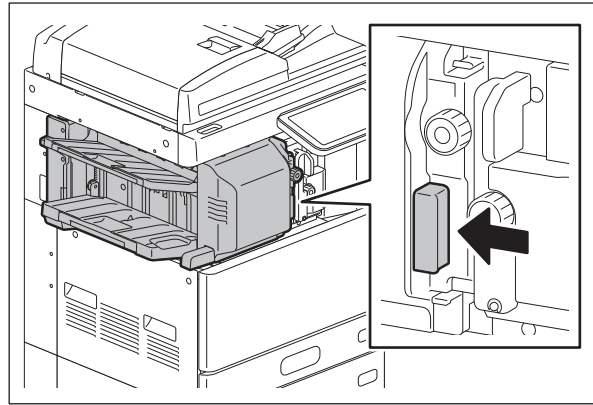

Fig. 4-708

(9) Remove 1 screw and take off 1 bracket.

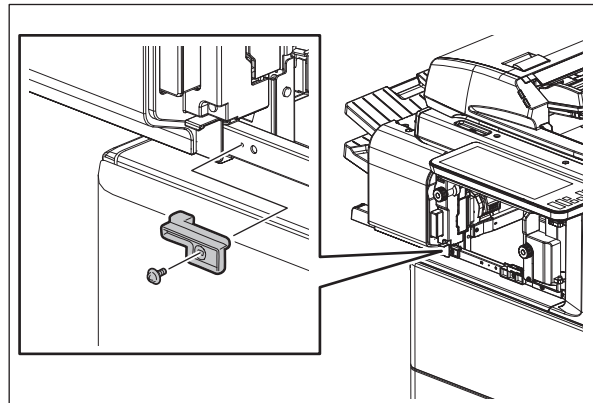

Fig. 4-709

(10) Return the finisher to the installation position temporarily by sliding it.

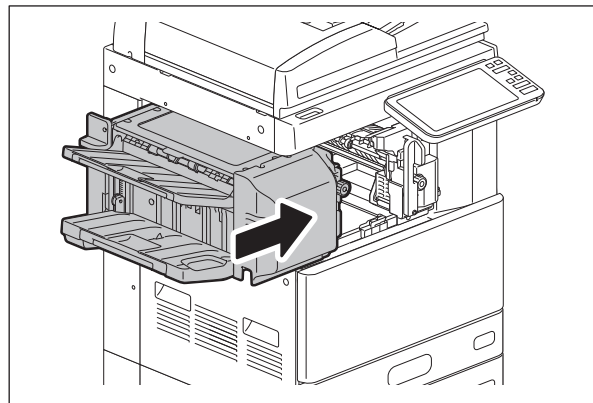

Fig. 4-710

(11) Remove 3 screws and take off the cover.

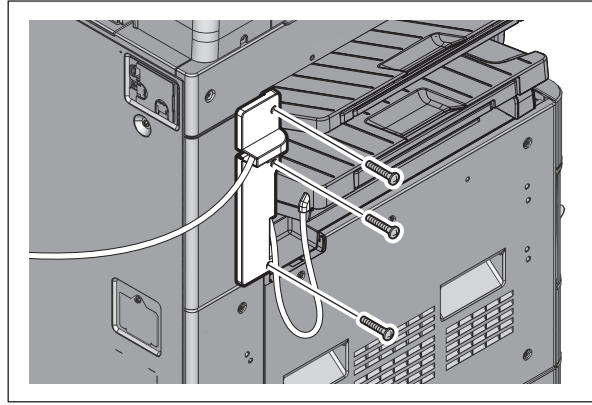

Fig. 4-711

(12) Remove 1 screw.

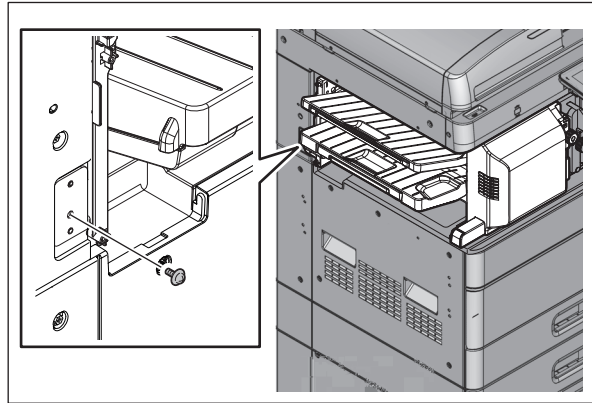

Fig. 4-712

(13) Remove the finisher.

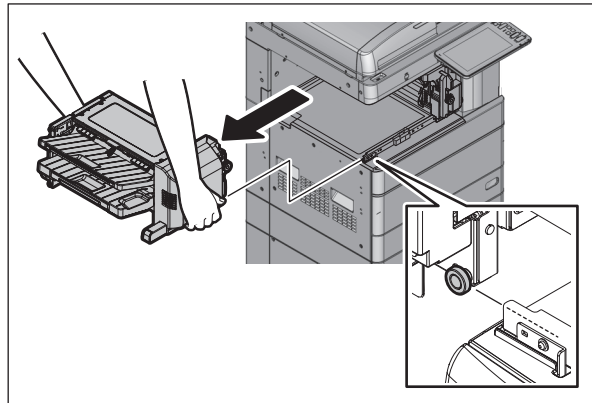

Fig. 4-713

4.12.7 Saddle stitch finisher

- (1) Press the [Power] button on the control panel to shut it down.
- (2) Turn the main power switch of the equipment off.
- (3) Disconnect the power cable.
- (4) Remove the connector cover.

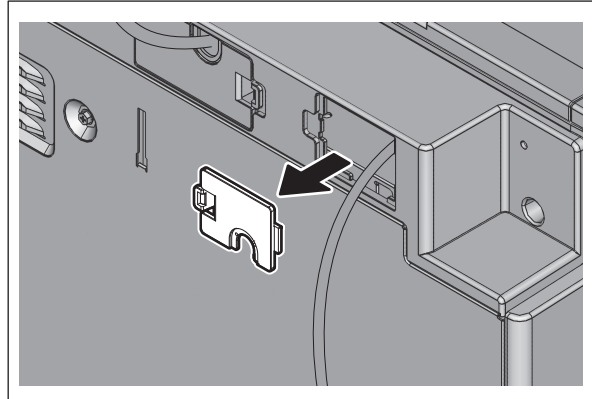

Fig. 4-714

- (5) Disconnect the connector.

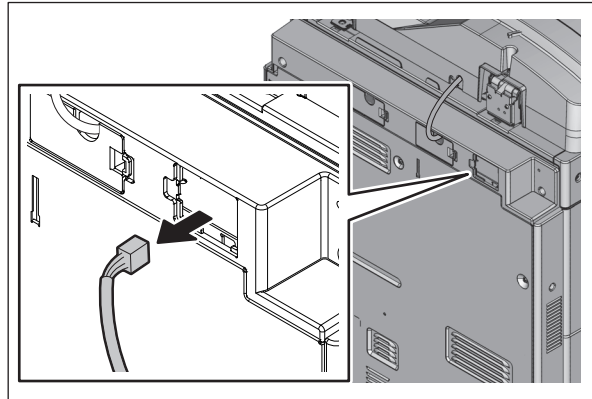

Fig. 4-715

- (6) Install the connector cover.

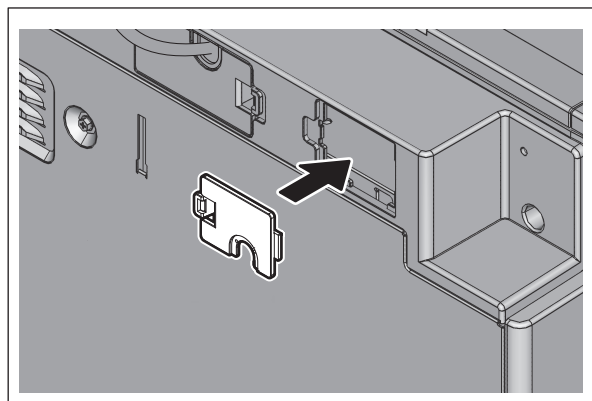

Fig. 4-716

- (7) Open the finisher cover and remove 1 fixing screw. Pull out the lever.

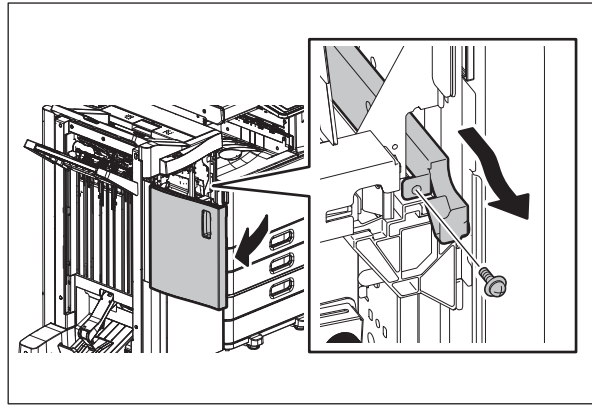

Fig. 4-717

- (8) Remove the finisher.

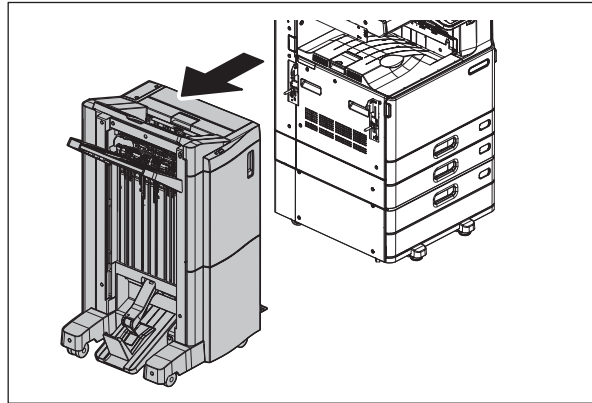

Fig. 4-718

4.12.8 Saddle stitch finisher (Hole punch unit)

- (1) Press the [Power] button on the control panel to shut it down.
- (2) Turn the main power switch of the equipment off.
- (3) Disconnect the power cable.
- (4) Remove the connector cover.

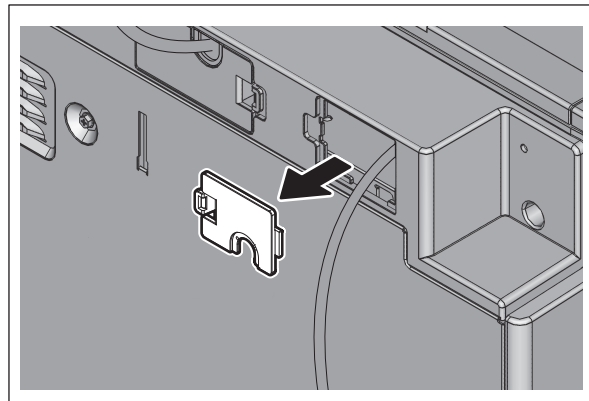

Fig. 4-719

(5) Disconnect the connector.

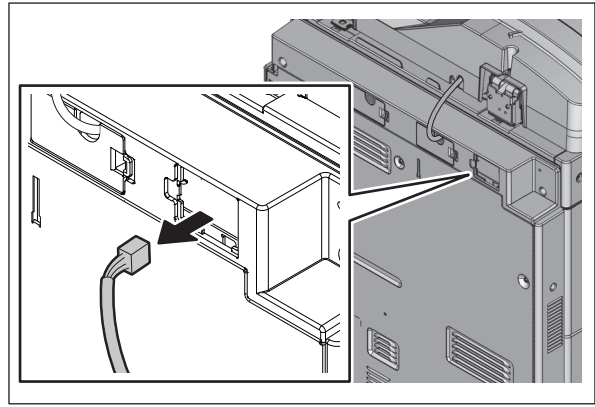

Fig. 4-720

(6) Install the connector cover.

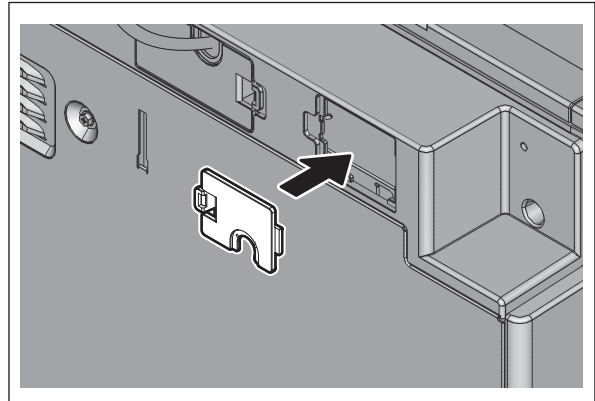

Fig. 4-721

(7) Take off the cover of the hole punch unit lower side.

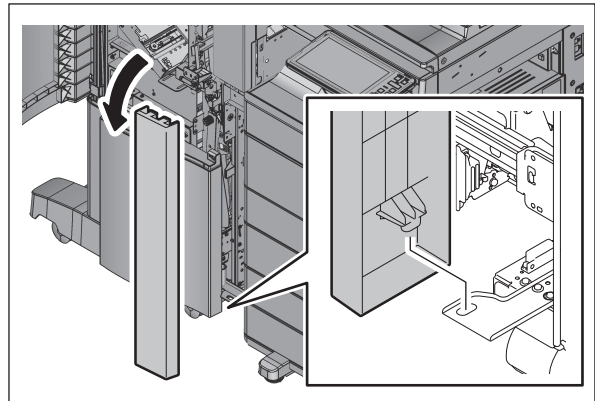

Fig. 4-722

- (8) Open the finisher cover and remove 1 fixing screw. Pull out the lever.

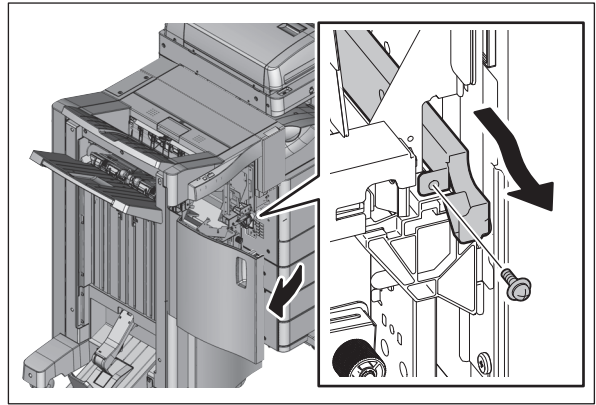

Fig. 4-723

- (9) Take off the finisher with the hole punch unit.

Notes:

Be careful not to fell the finisher when moving only the finisher unit.

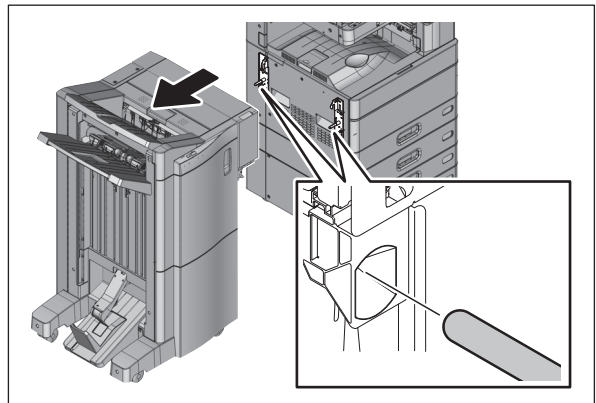

Fig. 4-724

4.12.9 Finisher

- (1) Press the [Power] button on the control panel to shut down the machine.
- (2) Turn the main power switch of the machine off.
- (3) Disconnect the power cable.
- (4) Remove the connector cover.

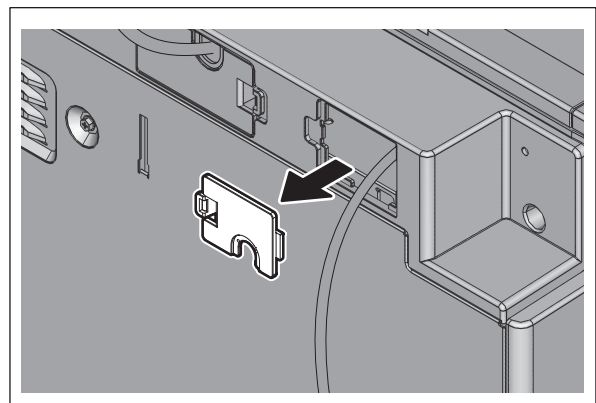

Fig. 4-725

(5) Disconnect the connector.

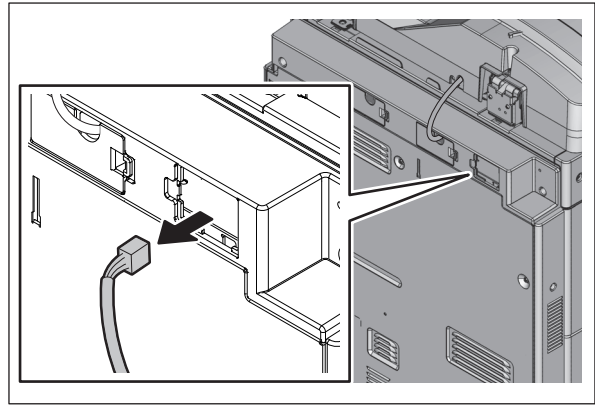

Fig. 4-726

(6) Install the connector cover.

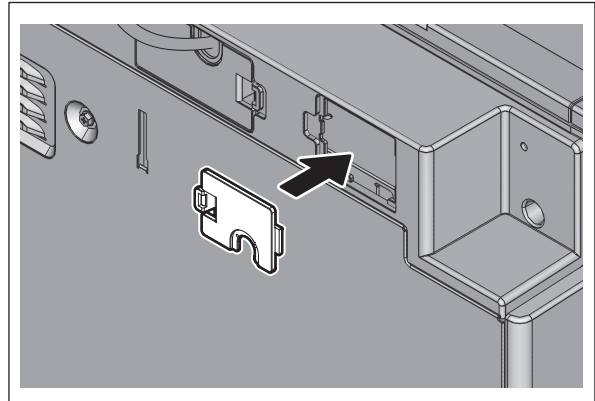

Fig. 4-727

(7) Open the finisher cover and remove 1 fixing screw. Pull out the lever.

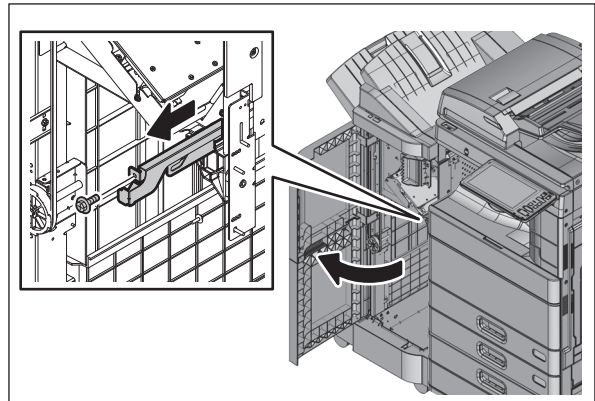

Fig. 4-728

- (8) Remove the finisher.

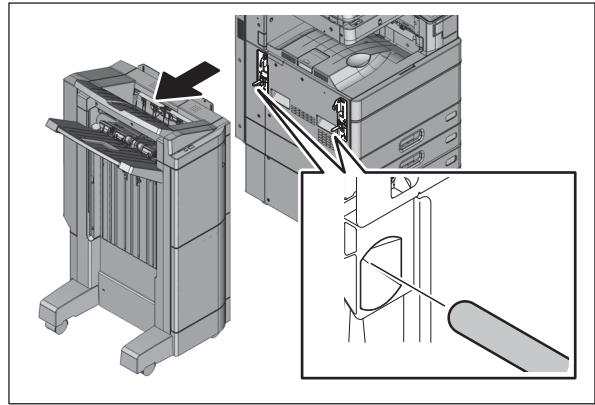

Fig. 4-729

4.12.10 Finisher (Hole punch unit)

- (1) Press the [Power] button on the control panel to shut down the machine.
- (2) Turn the main power switch of the machine off.
- (3) Disconnect the power cable.
- (4) Remove the connector cover.

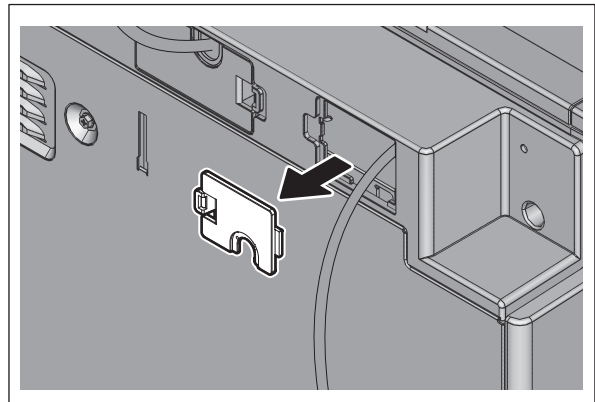

Fig. 4-730

- (5) Disconnect the connector.

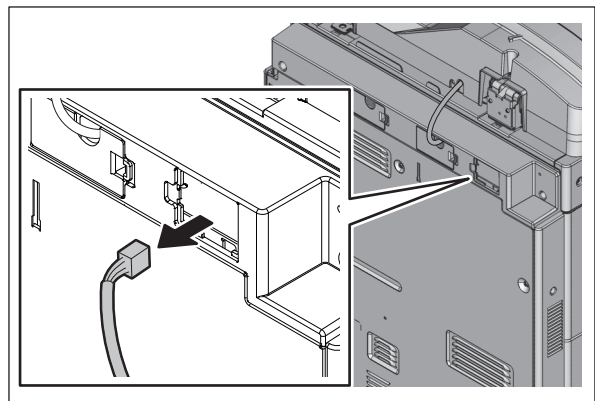

Fig. 4-731

(6) Install the connector cover.

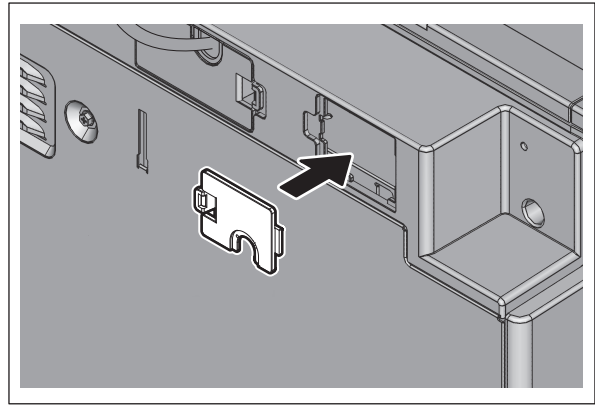

Fig. 4-732

(7) Take off the cover of the hole punch unit lower side.

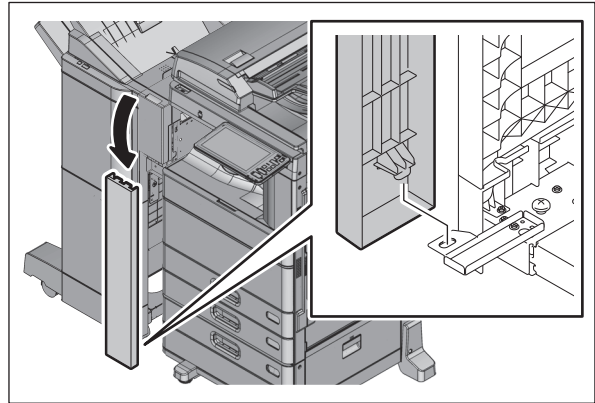

Fig. 4-733

(8) Remove 1 fixing screw and pull out the lever.

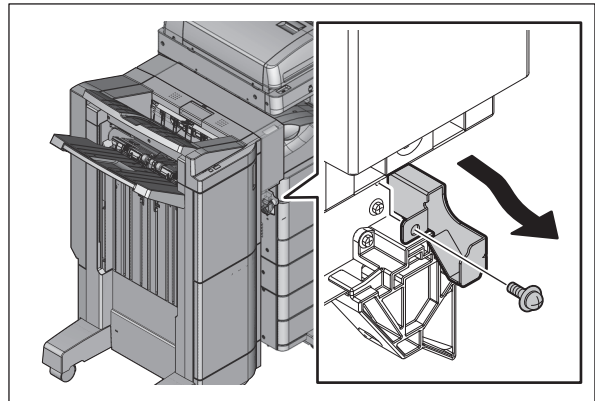

Fig. 4-734

- (9) Take off the finisher with the hole punch unit.

Notes:

Be careful not to fell the finisher when moving only the finisher unit.

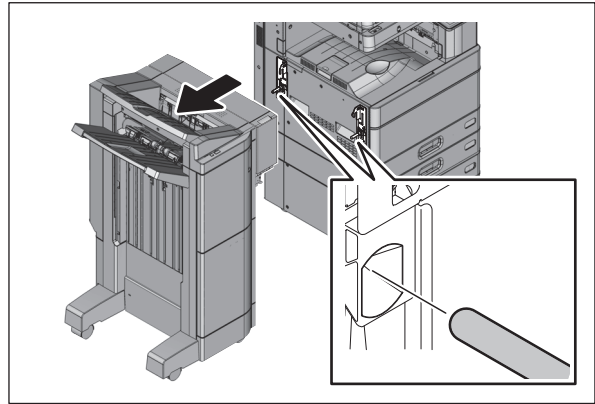

Fig. 4-735

4.12.11 Job separator

- (1) Press the [Power] button on the control panel to shut it down.
- (2) Turn the main power switch of the equipment off.
- (3) Disconnect the power cable.
- (4) Remove the tray.

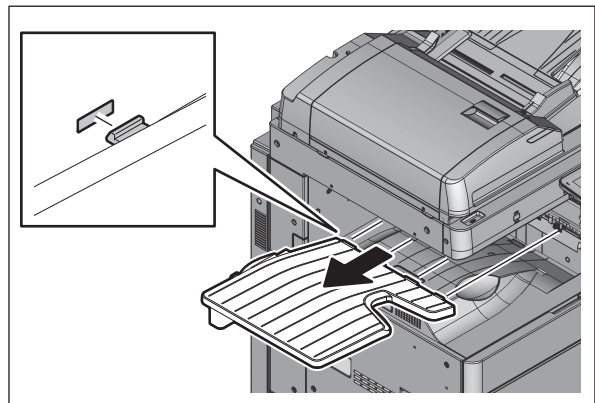

Fig. 4-736

- (5) Open the side cover. Remove 1 screw and take off the connector cover.

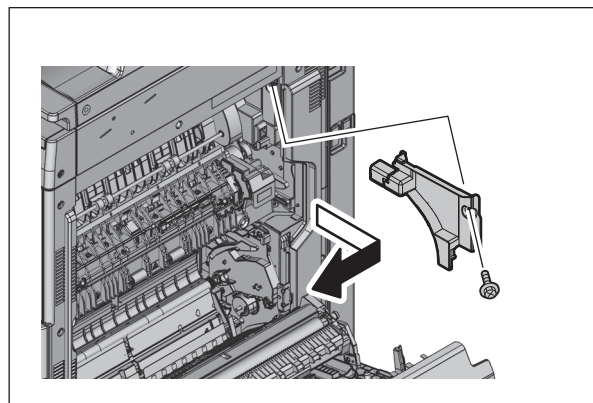

Fig. 4-737

(6) Disconnect 1 connector.

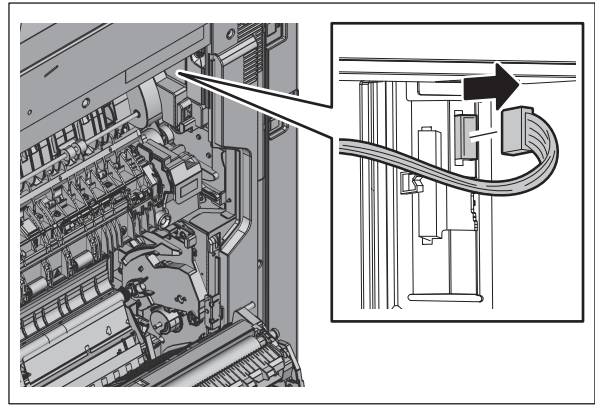

Fig. 4-738

(7) Remove 2 screws and take off the job separator.

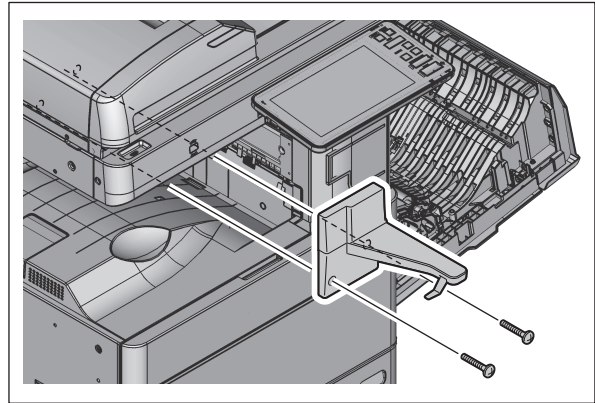

Fig. 4-739

5. SELF-DIAGNOSTIC MODE

5.1 Overview

This equipment consists of two servicing menus which have different start-up methods. Setting and adjustment can be performed by entering into a mode such as [05 ADJUSTMENT MODE] or [49 Firmware Update] from each menu.

- **FS Menu**

Mode		Contents
03 TEST MODE		Checks the status of input/output signals.
04 TEST PRINT MODE		Outputs the test patterns.
05 ADJUSTMENT MODE		Adjusts various items.
08 SETTING MODE		Sets various items.
20 PM SUPPORT MODE		Clears each counter.
30 LIST PRINT MODE		Prints various lists or outputs them in a CSV format.
31 CHART PRINT MODE		Prints the charts.
FAX	11 FAX CLEAR MODE	Sets the fax board.
	12 FAX LIST PRINT MODE	Outputs the contents set for the fax functions.
	13 FAX FUNCTION MODE	Sets the fax functions.
	19 RAM EDIT MODE	This is the mode for the special settings. (This is not used generally.)
35 DATA BACKUP/RESTORE MODE		Backs up or restores data.
36 CLONING		Creates and installs clone files.
37 LICENSE MANAGEMENT		Manages the license of applications.

- **HS Menu**

Mode		Contents
01 Control Panel Check		Checks various contents regarding the LCD, LED, hard keys and digital keys on the control panel.
49 Firmware Update		Performs firmware update with a USB storage device.
59 SRAM Data Cloning		Backs up the SRAM data to a USB storage device.
73 Firmware Assist		Clears error flags or SRAM, or safely deletes data in the HDD or SRAM to support the replacement of the SYS board, SRAM or HDD.
74 HDD Assist		Assists the Security HDD by checking the type of the mounted HDD or removing keys.
75 File System Recovery		Checks, recovers or initializes the file system (HDD).
76 SRAM Maintenance		Recovers the equipment from particular errors such as F800 or F900.

* Only the modes which are available for this equipment are displayed on each menu.

[A] Starting each Menu

Menu			Mode*1		Operation			
FS Menu [FUNCTION CLEAR] + [START] + [POWER ON]	→	Enter a service password and press [OK].	→	03 TEST MODE	→	SELF-DIAGNOSIS CODE		
				04 TEST PRINT MODE	→	SELF-DIAGNOSIS CODE		
				05 ADJUSTMENT MODE	→	CLASSIC*2	→	SELF-DIAGNOSIS CODE
				08 SETTING MODE	→	CLASSIC*2	→	SELF-DIAGNOSIS CODE
				20 PM SUPPORT MODE	→			5.8
				30 LIST PRINT MODE	→			5.9
				31 CHART PRINT MODE	→			5.10
				FAX • 11 FAX CLEAR MODE • 12 FAX LIST PRINT MODE • 13 FAX FUNCTION MODE • 19 RAM EDIT MODE*3	→			SELF-DIAGNOSIS CODE
				35 DATA BACKUP/RESTORE MODE	→			5.12
				36 CLONING	→			5.13
				37 LICENSE MANAGEMENT	→			5.14
HS Menu [HOME] + [START] + [POWER ON]	→	Enter a service password and press [OK].	→	01 Control Panel Check	→	5.15		
				49 Firmware Update	→	11.2.4		
				59 SRAM Data Cloning	→	12.1.4		
				73 Firmware Assist	→	5.16		
				74 HDD Assist	→	5.17		
				75 File System Recovery	→	5.18		
				76 SRAM Maintenance	→	5.19		

*1 FS menu: Select the mode and press [Next]. HS menu: Select the icon of the mode.

*2 Press [Classic] displayed at the upper right of the menu.

*3 This is not used generally.

[B] Cancellation of the self-diagnostic mode

The modes, which can be entered from [FS Menu], can be canceled by the following methods.

- When [FS Menu] is displayed on the screen:
Press [FS Menu] to return to the menu screen. Press [NORMAL].
The self-diagnostic mode finishes and the [HOME] screen appears. Rebooting/non-rebooting of the equipment will be performed depending on the mode worked and the code operated.
- When only [Return] is displayed on the screen:
Press [Return] for several times until [FS Menu] is displayed on the screen. When [FS Menu] appears, press it.
- When neither [Return] nor [FS Menu] are displayed on the screen:
Press the [ON/OFF] button and perform the shut-down operation on the screen displayed.

To cancel the modes which can be entered from [HS Menu], press the [ON/OFF] button for a few seconds to shut down the equipment.

[C] State transition diagram of self-diagnosis modes

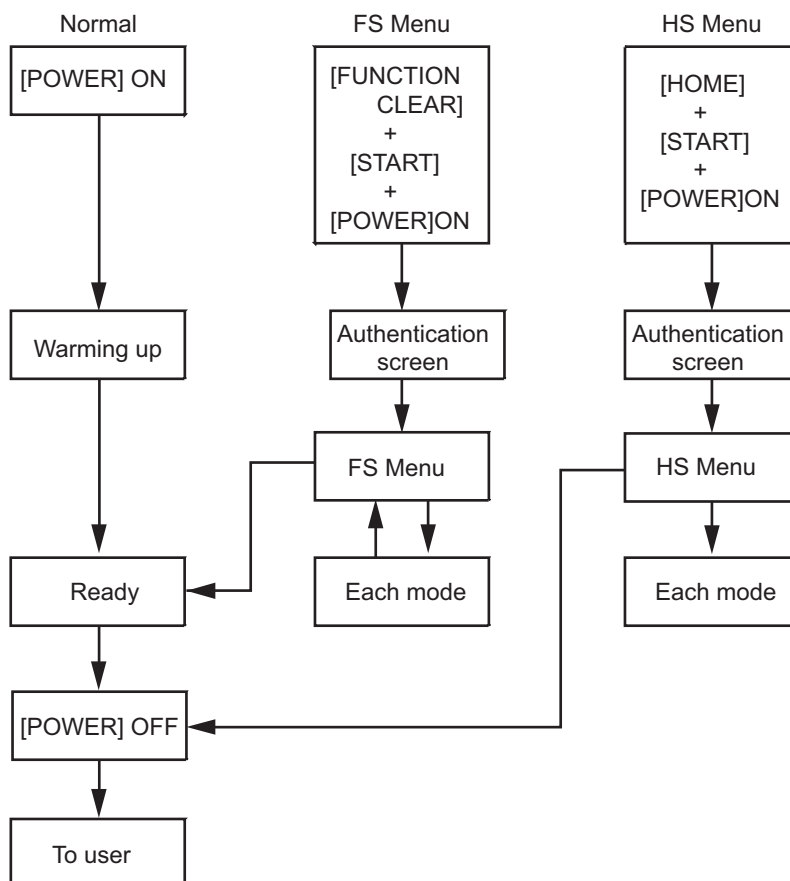

Fig.5-1

* Be sure to cancel the self-diagnostic mode before customers start using the equipment.

[D] Changing/setting of the service password

- (1) The [SETTINGS] screen is displayed by press [SETTINGS] on [FS Menu].
- (2) Press [Service Password] to change or reset the service password.

5.2 Description rule for each menu and mode

The description of the self-diagnostic code in this document complies with the rule below.

Example

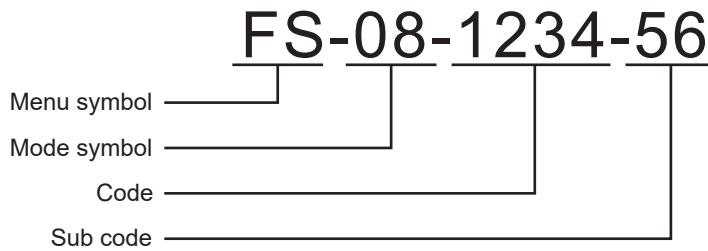

Fig.5-2

1. Symbol for the menu
FS: FS Menu (Starting by pressing the [ON/OFF] button while pushing the [FUNCTION CLEAR] and [START] buttons simultaneously.)
HS: HS Menu (Starting by pressing the [ON/OFF] button while pushing the [HOME] and [START] buttons simultaneously.)
2. Symbol for the mode
The first two digits of each mode
3. Code
The number of the code
4. Sub code
This will only be given when a sub code exists.

[A] FS Menu

[05 ADJUSTMENT MODE] or [08 SETTING MODE]:

[FS-05-1234-56] or [Perform FS-05-1234-56] is taken for explanation purposes.

- (1) Start FS Menu by pressing the [ON/OFF] button while pushing the [FUNCTION CLEAR] and [START] buttons simultaneously.

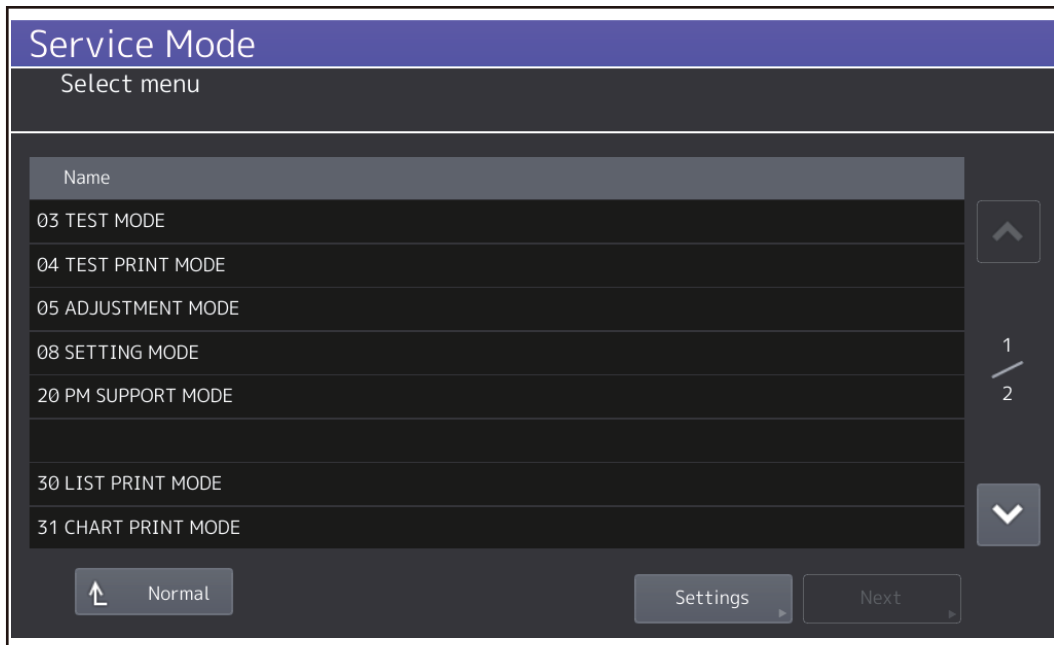

Fig.5-3

- (2) Select [05 ADJUSTMENT MODE] and press [Next].

- (3) Press [Classic] on the upper right of the menu to display the adjustment mode menu.

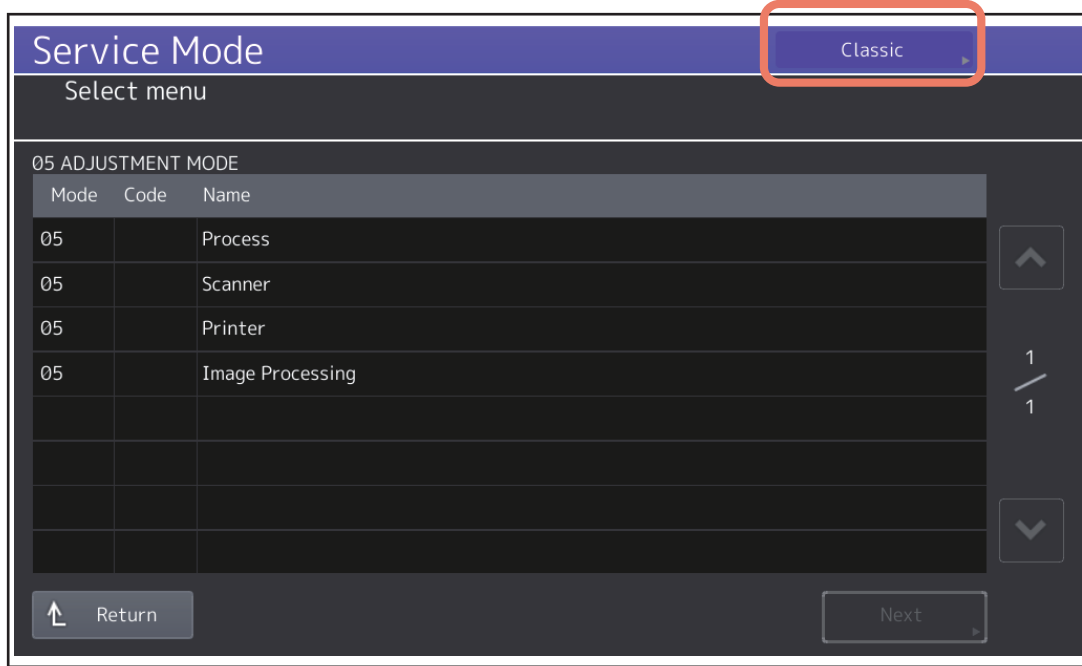

Fig.5-4

- (4) By using the digital keys displayed on the screen, enter [1], [2], [3], [4] and then press the [START] button. Enter the sub codes [5] and [6] and then press the [START] button.
- (5) Carry out the adjustment by following the instructions displayed on the screen or press the [START] button.

[03 TEST MODE]:

The key-pressing procedure for the modes, which are set by the combination of the [F1], [F2] and [F3] keys, are described as below.

[F1: ON]: Only F1 is turned ON.

[F1, 2: ON]: F1 and F2 are turned ON.

* The number of the [F] key, which is turned ON, is depicted by dividing with “,” (commas) as above.

[F1, 2, 3: ON]: All of the [F] keys are turned ON.

[F: OFF]: All of the [F] keys are turned OFF.

Example:

[FS-03-F:OFF-9-A]: Turn OFF all of the [F] keys in the FS-03 mode, select [9] and then [A].

[FS-03-F1:ON-9-A]: Turn ON the [F1] key in the FS-03 mode, select [9] and then [A].

[FAX]:

In case of [FS-11], [FS-12] or [FS-13] is given in the explanations, select [FAX] in the [FS Menu] and then press [Next] to choose each mode.

[B] HS Menu

- (1) Start HS Menu by pressing the [ON/OFF] button while pushing the [HOME] and [START] buttons simultaneously.

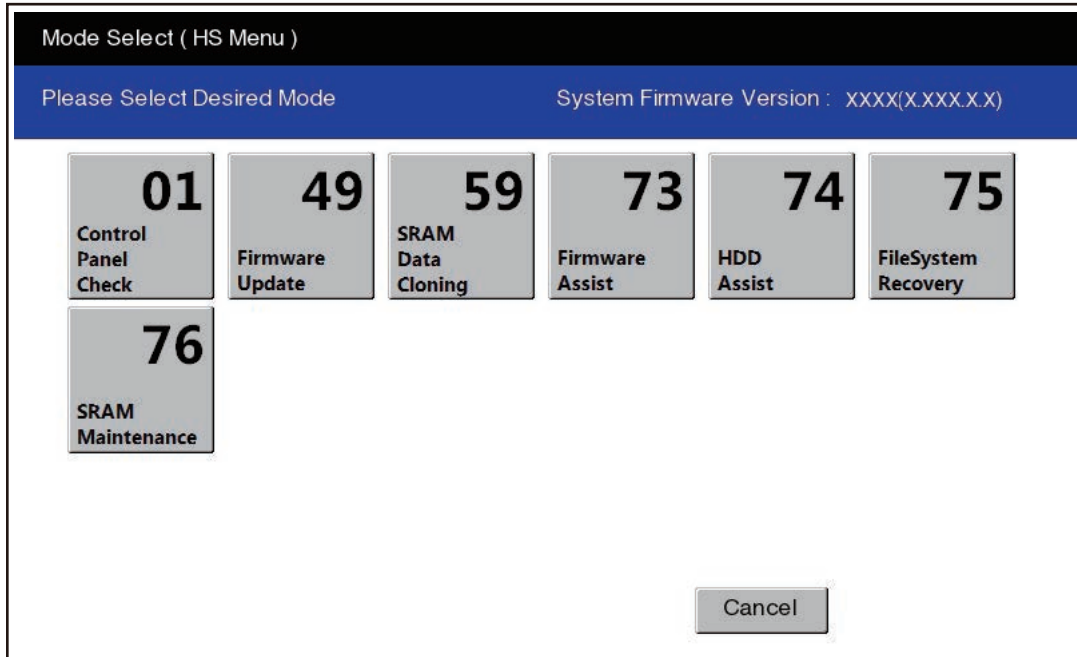

Fig.5-5

- (2) Press the icon to operate.
- (3) Follow the instructions displayed on the screen.

[C] When a particular setting condition is applied:

The setting value is given at the end of the description by dividing with “:” (colons).

Example:

[FS-08-8911:3]: “3” is set for FS-08-8911.

5.3 Service UI

5.3.1 Overview

Each mode of the self-diagnostic codes can be used by selecting the keyword of the screen in the Service UI.

The codes which are used frequently can be selected in the Service UI.

The Service UI can be used in the following modes in the FS Menu.

- 05 ADJUSTMENT MODE
- 08 SETTING MODE

Notes:

Not all codes can be used in the Service UI.

For the codes available with the Service UI, refer to the “Self-diagnostic code list” (separate document).

5.3.2 Operation procedure

- (1) Start the FS Menu. Select the mode of the above Service UI and press [Next].
- (2) Select the item whose setting is to be changed and press [Next] until the code number is displayed. The display shifts to the classic screen of the selected code.

5.3.3 Starting the FS Menu from the normal mode

If the [Gear] icon is displayed on the USER FUNCTIONS menu of the normal mode, the FS Menu can be started.

- (1) Turn the power ON.
- (2) Enter the user name and password if necessary. *
- (3) Press [USER FUNCTIONS] on the HOME screen.
- (4) Press the [Gear] icon on the upper left of the screen for at least 3 seconds.

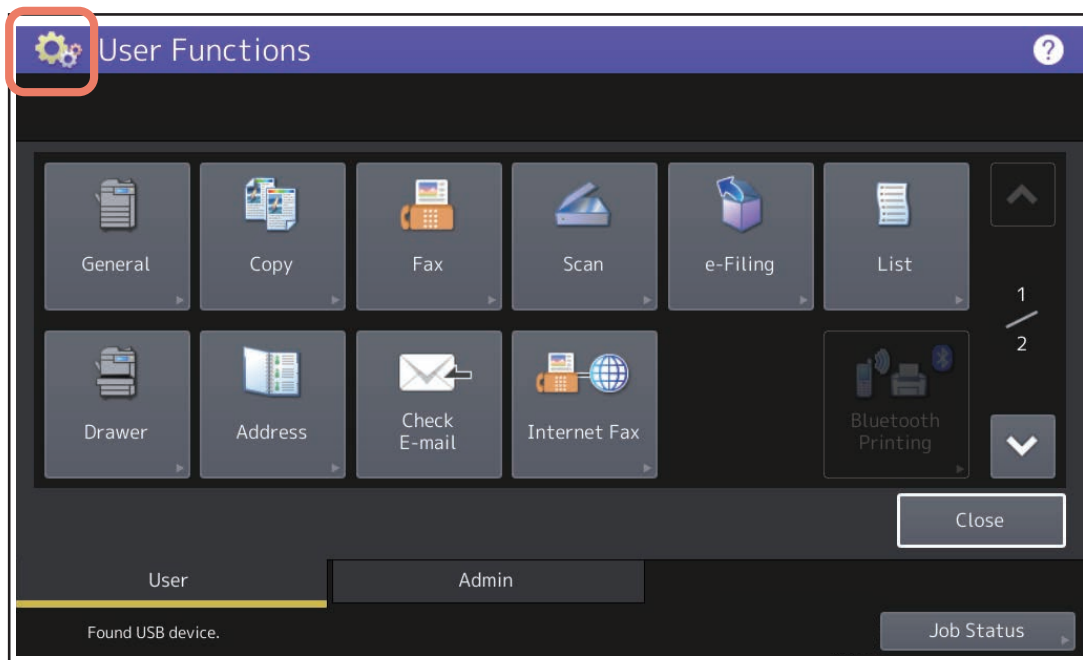

Fig.5-6

(5) Enter the service password and press [OK].
The FS Menu appears.

* When “3” is set for FS-08-8911 (security mode), the authentication screen is always displayed.

Notes:

- The service password needs to be changed to log in for the first time.
- In case the password is forgotten, ask the administrator to reset the service password.
- Note that the user data are deleted at that time.

5.4 03 TEST MODE

5.4.1 Output check

The status of the output signal can be checked.

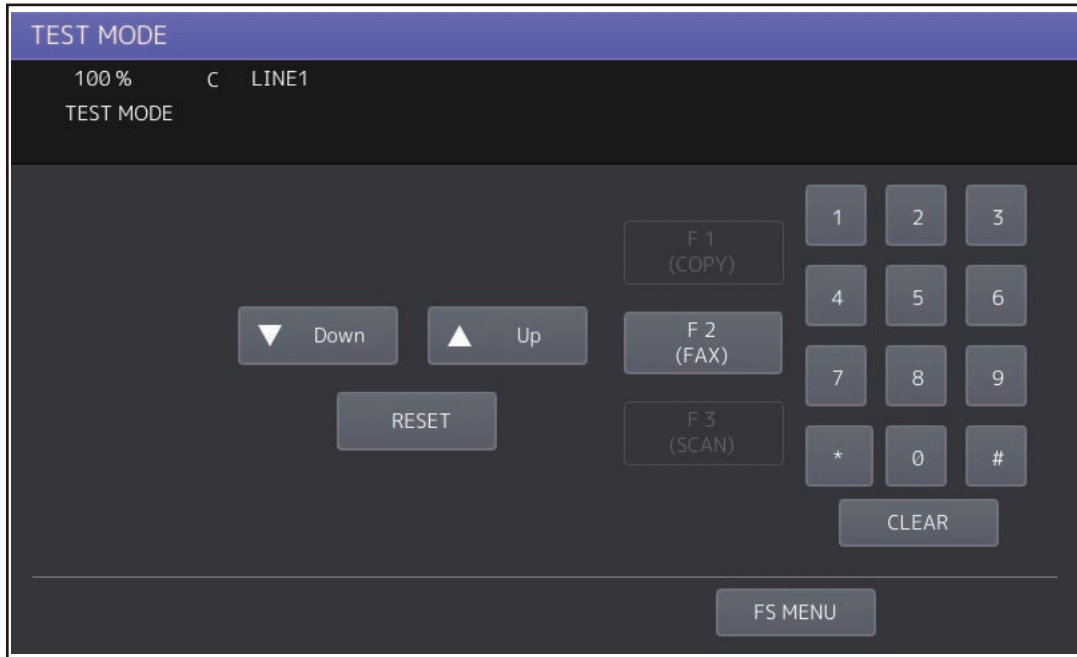

Fig.5-7

Operation procedure: Refer to SELF-DIAGNOSIS CODE.

5.4.2 Input check

The status of each input signal can be checked by operating the [F1], [F2], [F3] and the digital keys.

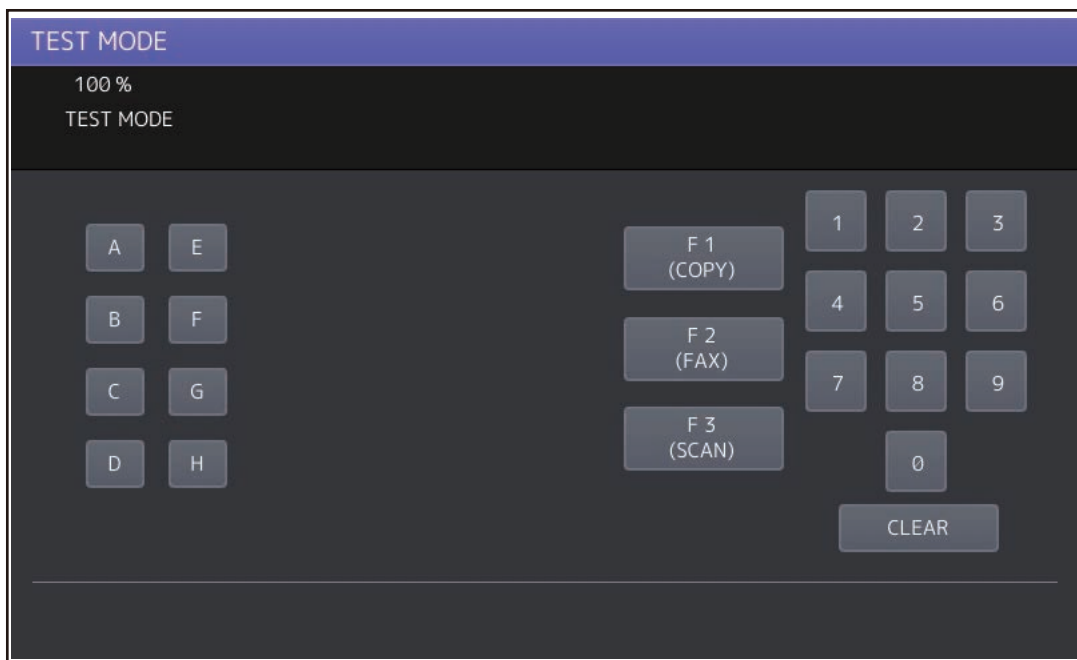

Fig.5-8

Operation procedure: Refer to SELF-DIAGNOSIS CODE.

5.5 04 TEST PRINT MODE

The embedded test pattern can be printed out.

Operation procedure: Refer to SELF-DIAGNOSIS CODE.

5.6 05 ADJUSTMENT MODE

Various adjustments and test printing can be performed.

Operation procedure: Refer to SELF-DIAGNOSIS CODE.

5.6.1 TEST PRINT

One sheet of the test print for various patterns can be printed out by entering 1 to 3-digit code and pressing [TEST PRINT] in the [Classic] Mode standby screen in the [05 ADJUSTMENT MODE].

Operation procedure: Refer to SELF-DIAGNOSIS CODE.

5.7 08 SETTING MODE

Various settings can be set.

Operation procedure: Refer to SELF-DIAGNOSIS CODE.

5.8 20 PM SUPPORT MODE

 P. 7-6 "7.4 PM Support Mode"

<Operation procedure>

[FS] → [20] → (Operation started) → Exit

5.9 30 LIST PRINT MODE

5.9.1 Operation procedure

[1] Print out

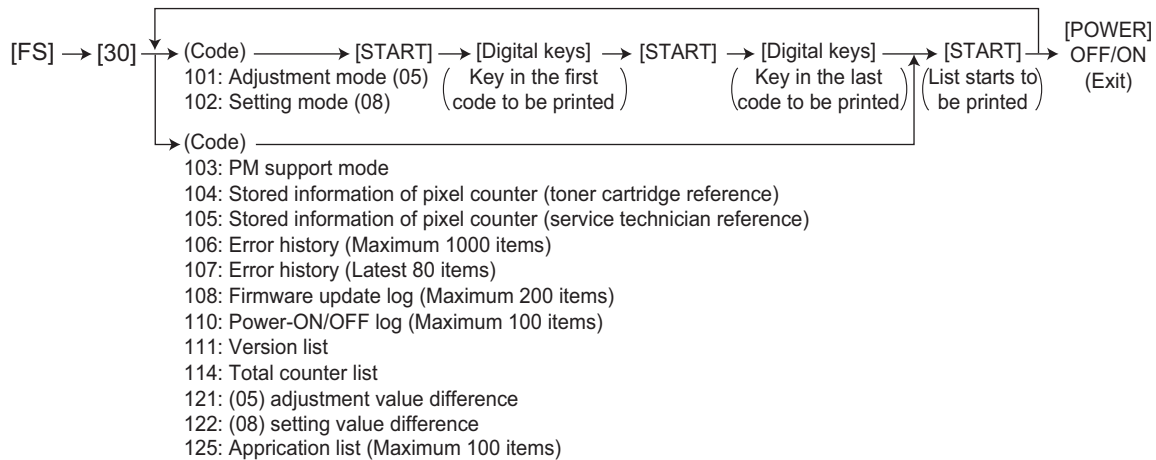

[2] CSV output (USB)

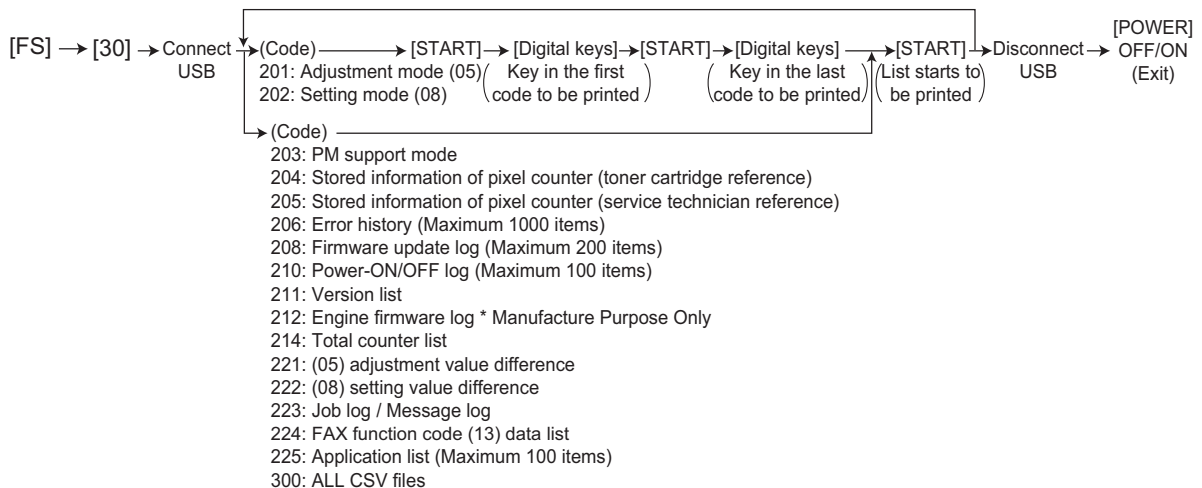

Notes:

Precautions when storing information into USB device

- When storing the setting information of the equipment into a USB device, be sure to obtain permission from a user in advance.
- When storing the setting information of the equipment into a USB device, the information is printed out in a CSV format. Handle and manage the information with extra care.
- Do not lose or leak the setting information of the equipment.
- Do not use the setting information of the equipment for purposes other than maintenance or product services.
- Provide the information promptly if a user requires so.
- The buttons on the control panel keep blinking while data are being stored in the USB device. Do not disconnect the USB device while data are being stored.

Remarks:

In the USB storage procedure above, lists are stored in a CSV format. The names of the CSV files are shown below.

201:ADJUSTMENT_LIST_serial_date and time(YYYYMMDDHHMMSS).csv
 202:SETTING_LIST_serial_date and time(YYYYMMDDHHMMSS).csv
 203:PM_LIST_serial_date and time(YYYYMMDDHHMMSS).csv
 204:PIXEL_TONER_LIST_serial_date and time(YYYYMMDDHHMMSS).csv
 205:PIXEL_SERVICE_LIST_serial_date and time(YYYYMMDDHHMMSS).csv
 206:ERROR_LOG_serial_date and time(YYYYMMDDHHMMSS).csv
 208:FW_UPGRADE_LOG_serial_date and time(YYYYMMDDHHMMSS).csv
 210:POWER_ONOFF_LOG_serial_date and time(YYYYMMDDHHMMSS).csv
 211:VERSION_LIST_serial_date and time(YYYYMMDDHHMMSS).csv
 212:ENG_FW_LOG_serial_date and time(YYYYMMDDHHMMSS).csv
 214:TOTAL_COUNTER_LIST_serial_date and time(YYYYMMDDHHMMSS).csv
 221:05DIFFERENCE_CODE_LIST_serial_date and time(YYYYMMDDHHMMSS).csv
 222:08DIFFERENCE_CODE_LIST_serial_date and time(YYYYMMDDHHMMSS).csv
 223:JOB_LOG_serial_date and time(YYYYMMDDHHMMSS) (encrypted file)/MESSAGE_LOG_serial_date and time(YYYYMMDDHHMMSS) (encrypted file)
 224:FAX_FUNCTION_LIST_serial_Date(YYYYMMDDHHMMSS).csv
 225:APPLICATION_LIST_serial_date and time(YYYYMMDDHHMMSS).csv

5.9.2 List printing

Lists below are output in the list print mode.

List data are printed out or output in a CSV format by storing them in a USB device. Paper sizes available for this printing are A4 or LT or larger. This section introduces a sample of each list.

Perform [FS-30] to start the list print mode.

Lists	List code	
	Printout	CSV file output
Adjustment mode (05) data list	101	201
Setting mode (08) data list	102	202
PM support mode data list	103	203
Pixel counter code list (toner cartridge reference)	104	204
Pixel counter code list (service technician reference)	105	205
Error history list	106 (Maximum 1000 items)	206 (Maximum 1000 items)
Error history list	107 (Latest 80 items)	-
Firmware upgrade log	108 (Maximum 200 items)	208 (Maximum 200 items)
Power ON/OFF log	110 (Maximum 100 items)	210 (Maximum 100 items)
Version list	111	211
Engine firmware log	-	212
Total counter list	114	214
(05) adjustment value difference	121	221
(08) setting value difference	122	222
Application list	125 (Maximum 100 items)	225 (Maximum 100 items)
Job log/Message log	-	223
FAX Function mode (13) data list	-	224
Output all CSV files	-	300 *

* (05) adjustment value difference and (08) setting value difference are not output.

- 05 ADJUSTMENT MODE

05 ADJUSTMENT MODE DATA LIST				S/N: xxxxxxxx		TOTAL: 9999999	
20xx-xx-xx xx:xx				TOSHIBA e-STUDIOxxx		DF TOTAL: 9999999	
CODE	DATA	CODE	DATA	CODE	DATA	CODE	DATA
2000	128	3860-0	88	4830	128	5920	128
.
.
.
.
.
.
.
.
.
.
.
.
.

Fig.5-9

The selected adjustment codes and the current adjustment value for each code are output in a list.

- 08 SETTING MODE

08 SETTING MODE		DATA LIST		S/N: xxxxxxxx		TOTAL: 9999999	
20xx-xx-xx xx:xx				TOSHIBA e-STUDIOxxx		DF TOTAL: 9999999	
CODE	DATA	CODE	DATA	CODE	DATA	CODE	DATA
2010	2	2880	12	3040	0	3070-3	0
.
.
.
.
.
.
.
.
.
.
.
.

Fig.5-10

The selected setting codes and the current setting value for each code are output in a list.

- 13 FAX FUNCTION MODE

```
13 FAX FUNCTION LIST FOR MAINTENANCE,VERSION x.x.x
20xx/xx/xx xx:xx:xx
TOSHIBA e-STUDIOxxxx
Cxxxxxxxx
FIN S/N-xxxxxxxx
TOTAL, 99999999, 99999999, 99999999, DF TOTAL, 99999999
CODE, SUB, DATA,
100, , 0
101, , 1
102, , 2
103, , 3
104, , 4
105, , 5
106, , 6
107, , 7
108, , 8
109, , 9
110, , 0
111, , 1
112, , 2
. .
. .
. .
. .
. .
. .
```

Fig.5-11

The selected setting codes and the current setting value for each code are output in a list.

- 20 PM SUPPORT MODE

PM SUPPORT CODE LIST				
		S/N: xxxxxxxx	TOTAL:	9999999
20xx-xx-xx xx:xx		TOSHIBA e-STUDIOxxx	DF TOTAL:	9999999
UNIT	OUTPUT PAGES/ DEVELOP COUNTS	PM OUTPUT PAGE/ DEVELOP COUNTS	DRIVE COUNTS	PM DRIVE COUNTS
DRUM (K)	2516	70000	11735	170000
DRUM BLADE (K)	2516	70000	11735	170000
GRID (K)	2516	70000	11735	170000
MAIN CHARGER NEEDLE (K)	2516	70000	11735	170000
CHARGER CLEANING PAD (K)	2516	70000	11735	170000
DRUM (Y)	411	70000	8625	170000
DRUM BLADE (Y)	411	70000	8625	170000
GRID (Y)	411	70000	8625	170000
MAIN CHARGER NEEDLE (Y)	411	70000	8625	170000
CHARGER CLEANING PAD (Y)	411	70000	8625	170000
DRUM (M)	411	70000	8625	170000
DRUM BLADE (M)	411	70000	8625	170000
GRID (M)	411	70000	8625	170000
MAIN CHARGER NEEDLE (M)	411	70000	8625	170000
CHARGER CLEANING PAD (M)	411	70000	8625	170000
.
.
.

Fig.5-12

The number of pages currently output (OUTPUT PAGES/DEVELOP COUNTS), the recommended number of output pages for PM (PM OUTPUT PAGES/DEVELOP COUNTS), the current drive count (DRIVE COUNTS) and the recommended drive count for PM (PM DRIVE COUNTS) are output together with PM units. Use this list for confirming the PM units to be replaced at each PM. See the following page for PM:

📖 P. 7-1 “7. PREVENTIVE MAINTENANCE (PM)”

- Pixel counter code list (toner cartridge reference)

PIXEL COUNTER CODE LIST							
		S/N: xxxxxxxx		TOTAL:		9999999	
		TOSHIBA e-STUDIOxxx		DF TOTAL:		9999999	
20xx-xx-xx xx:xx							
TONERCARTRIDGE							
No	DATE	COLOR		PPC	PRN	FAX	TOTAL
0	20xx-xx-xx	Y	Print Count[LT/A4]	181	45	---	226
1	20xx-xx-xx	Y	Average Pixel Count[%]	2.70	1.74	---	2.51
2	20xx-xx-xx	Y	Latest Pixel Count[%]	6.15	0.39	---	0.39
3	20xx-xx-xx	M	Print Count[LT/A4]	181	45	---	226
4	20xx-xx-xx	M	Average Pixel Count[%]	6.11	2	---	5.29
5	20xx-xx-xx	M	Latest Pixel Count[%]	6.82	2.15	---	2.15
6	20xx-xx-xx	C	Print Count[LT/A4]	181	45	---	226
7	20xx-xx-xx	C	Average Pixel Count[%]	5.46	2	---	4.81
8	20xx-xx-xx	C	Latest Pixel Count[%]	6.42	2.73	---	2.73
9	20xx-xx-xx	K	Print Count[LT/A4]	278	145	9	432
10	20xx-xx-xx	K	Average Pixel Count[%]	6.15	3.86	23.25	5.74
11	20xx-xx-xx	K	Latest Pixel Count[%]	7.32	2.19	6.25	2.19

Fig.5-13

Pixel counter data (toner cartridge reference) are output in a list. See the following page for the pixel counter:

 P. 5-55 "5.20 Pixel Counter"

- Pixel counter code list (service technician reference)

PIXEL COUNTER CODE LIST		S/N: xxxxxxxx	TOTAL:	9999999		
		TOSHIBA e-STUDIOxxx	DF TOTAL:	9999999		
20xx-xx-xx xx:xx						
SERVICEMAN						
No	DATE	COLOR	PPC	PRN	FAX	TOTAL
0	20xx-xx-xx	F Print Count[LT/A4]	181	45	---	226
1	20xx-xx-xx	F Average Pixel Count[%]	4.95	2.34	---	4.43
2	20xx-xx-xx	F Latest Pixel Count[%]	8.36	2.34	---	2.34
3	20xx-xx-xx	Y Print Count[LT/A4]	181	45	---	226
4	20xx-xx-xx	Y Average Pixel Count[%]	2.7	1.74	---	2.51
5	20xx-xx-xx	Y Latest Pixel Count[%]	6.15	0.39	---	0.39
6	20xx-xx-xx	M Print Count[LT/A4]	181	45	---	226
7	20xx-xx-xx	M Average Pixel Count[%]	6.11	2	---	5.29
8	20xx-xx-xx	M Latest Pixel Count[%]	6.82	2.15	---	2.15
9	20xx-xx-xx	C Print Count[LT/A4]	181	45	---	226
10	20xx-xx-xx	C Average Pixel Count[%]	5.46	2.18	---	4.81
11	20xx-xx-xx	C Latest Pixel Count[%]	6.42	2.73	---	2.73
12	20xx-xx-xx	K Print Count[LT/A4]	181	45	---	226
13	20xx-xx-xx	K Average Pixel Count[%]	5.51	3.43	---	5.10
14	20xx-xx-xx	K Latest Pixel Count[%]	14.05	4.10	---	4.10
15	20xx-xx-xx	K Print Count[LT/A4]	97	100	9	206
16	20xx-xx-xx	K Average Pixel Count[%]	7.36	4.06	23.25	6.45
17	20xx-xx-xx	K Latest Pixel Count[%]	7.32	2.19	6.25	2.19

Fig.5-14

Pixel counter data (service call reference) are output in a list. See the following page for the pixel counter:

 P. 5-55 "5.20 Pixel Counter"

- Error history

ERROR HISTORY LIST						
					S/N: xxxxxxxx	TOTAL: 9999999
					TOSHIBA e-STUDIOxxx	DF TOTAL: 9999999
20xx-xx-xx xx:xx						
CODE	COUNTER	DATE	TIME	ZOOM_XY	ABCD_EFGH_IJLOP_QR	
F110	00000000	xxxx-xx-xx	xx:xx:xx	000 000	0000_0000_0000_00_0000000000	
F110	00000000	xxxx-xx-xx	xx:xx:xx	000 000	0000_0000_0000_00_0000000000	
F110	00000000	xxxx-xx-xx	xx:xx:xx	000 000	0000_0000_0000_00_0000000000	
F110	00000000	xxxx-xx-xx	xx:xx:xx	000 000	0000_0000_0000_00_0000000000	
F110	00000000	xxxx-xx-xx	xx:xx:xx	000 000	0000_0000_0000_00_0000000000	
EAD0	00000000	xxxx-xx-xx	xx:xx:xx	000 000	0000_0000_0000_00_0000000000	
E860	00000000	xxxx-xx-xx	xx:xx:xx	000 000	0000_0000_0000_00_0000000000	
E731	00000000	xxxx-xx-xx	xx:xx:xx	000 000	0000_0000_0000_00_0000000000	
E090	00000000	xxxx-xx-xx	xx:xx:xx	000 000	0000_0000_0000_00_0000000000	
E870	00000000	xxxx-xx-xx	xx:xx:xx	000 000	0000_0000_0000_00_0000000000	
E724	00000000	xxxx-xx-xx	xx:xx:xx	000 000	0000_0000_0000_00_0000000000	

Fig.5-15

The error history is output. See the following page for the parameters for each error:

 P. 8-43 “8.2.4 Printer function error”

- Firmware update log

FW UPGRADE LOG													
											S/N: xxxxxxxx	TOTAL:	9999999
											TOSHIBA e-STUDIOxxx	DF TOTAL:	9999999
20xx-xx-xx xx:xx													
MANUFACTURE DATE 20xx-xx-xx													
UNPACKING DATE 20xx-xx-xx													
USER	ROM/VERSION	DATE	TOTAL	COPY(B)	COPY(2)	COPY(C)	PRINT(B)	PRINT(2)	PRINT(C)	LIST	FAX	STATUS	
Service Txxxxxxx	xxxx	20xx-xx-xx	99999999	99999999	99999999	99999999	99999999	99999999	99999999	99999999	99999999	OK	
Service Txxxxxxx	xxxx	20xx-xx-xx	99999999	99999999	99999999	99999999	99999999	99999999	99999999	99999999	99999999	OK	
Service Txxxxxxx	xxxx	20xx-xx-xx	99999999	99999999	99999999	99999999	99999999	99999999	99999999	99999999	99999999	OK	
.	
.	
.	
.	
.	
.	

Fig.5-16

Firmware update logs are output.

- MANUFACTURE DATE: the date of manufacture / UNPACKING DATE: the date that the equipment was unpacked.
- Only the versions of ROMs updated with USB device are output.

Item	Content
USER	User who updated firmware
ROM/VERSION	Version of firmware
DATE	Date that firmware was updated
TOTAL	Total counter data when firmware was updated
COPY (B)	Copier counter data (black) when firmware was updated
COPY (2)	Copier counter data (twin color) when firmware was updated
COPY (C)	Copier counter data (full color) when firmware was updated
PRINT (B)	Printer counter data (black) when firmware was updated
PRINT (2)	Printer counter data (twin color) when firmware was updated
PRINT (C)	Printer counter data (full color) when firmware was updated
LIST	List print counter data when firmware was updated
FAX	Fax print counter data when firmware was updated
STATUS	Result of update

- Power-ON/OFF log

POWER ON_OFF LOG							
				S/N: xxxxxxxx	TOTAL:	9999999	
				TOSHIBA e-STUDIOxxx	DF TOTAL:	9999999	
20xx-xx-xx xx:xx							
DATE	TIME	FUNCTION	TOTAL	DATE	TIME	FUNCTION	TOTAL
xxxx-xx-xx	xx:xx:xx	ON	99999999	xxxx-xx-xx	xx:xx:xx	ON	99999999
xxxx-xx-xx	xx:xx:xx	OFF	99999999	xxxx-xx-xx	xx:xx:xx	OFF	99999999
xxxx-xx-xx	xx:xx:xx	ON	99999999	xxxx-xx-xx	xx:xx:xx	ON	99999999
xxxx-xx-xx	xx:xx:xx	OFF	99999999	xxxx-xx-xx	xx:xx:xx	OFF	99999999
xxxx-xx-xx	xx:xx:xx	ON	99999999	xxxx-xx-xx	xx:xx:xx	RMT_OFF	99999999
xxxx-xx-xx	xx:xx:xx	OFF	99999999				
xxxx-xx-xx	xx:xx:xx	ON	99999999				
xxxx-xx-xx	xx:xx:xx	OFF	99999999				
xxxx-xx-xx	xx:xx:xx	RMT_OFF	99999999				
xxxx-xx-xx	xx:xx:xx	OFF	99999999				
.	.	.	.				
.	.	.	.				
.	.	.	.				

Fig.5-17

Power ON/OFF logs are output.

- Note that cases that the power was turned OFF with the main switch (not with the [ON/OFF] button on the control panel) will not be displayed.

Item	Content
DATE	Date that the power was turned ON or OFF
TIME	Time that the power was turned ON or OFF
FUNCTION	Whether the power was turned ON or OFF, or if it was turned ON or OFF with a remote reset function
TOTAL	Total counter data when the power was turned OFF and then back ON

- Version list

```

VERSION LIST
S/N: xxxxxxxx          TOTAL:          9999999
TOSHIBA e-STUDIOxxx   DF TOTAL:         9999999

20xx-xx-xx xx:xx

SYSTEM FIRMWARE ROM VERSION      : Txxxxxxxxxxx
SYSTEM FIRMWARE INTERNAL ROM VERSION: Vx.x.x.xx.xx
PRINTER ROM VERSION              : xxxM-xxx
SCANNER ROM VERSION              : xxxS-xxx
PFC ROM VERSION                  : xxxF-xxx
RADF/DSDF ROM VERSION           : DF-xxx
FINISHER STACKER ROM VERSION    : FIN-
FINISHER PUNCH ROM VERSION      : PUN-
FAX BOARD FIRMWARE ROM VERSION  : Fxx-xxx
SYSTEM FIRMWARE INTERNAL OS VERSION : Vx.xxx.x.x
HDD DATA VERSION               : Txxxxxxxxxxx
SYSTEM FIRMWARE OS VERSION      : Txxxxxxxxxxx
NIC FIRMWARE ROM VERSION        : XXXXXXXXXXXX
LANGUAGE VERSION
  English(US)                   : xxx.xxx  xxx xxx xx xx:xx:xx xxxx
  .                               .
  .                               .
  .                               .

CAPACITY OF HDD                  : xx.x GB
DEVICE INFORMATION OF HDD       : xxx xxxxxx-xxxxxx
SERIAL NUMBER OF HDD            : xx-xxxxxxxxxxxx
MEMORY SIZE                      : xxxx MB / xxxx MB
INSTALLED ELK NAME              : Data overwrite enabler
                                IPsec enabler
                                Meta scan enabler
                                External interface enabler
                                .
                                .
                                .

```

Fig.5-18

The list of versions is output.

Notes:

Some of the characters in the fonts that are used to print the version list are not supported. As a result, the language names under LANGUAGE VERSION may not be printed correctly when printing the version list.

- Engine firmware log

```
ENGINE FW LOG
20xx/xx/xx xx:xx
TOSHIBA e-STUDIOxxxx
Cxxxxxxxx
FIN S/N-xxxxxxxx
TOTAL, 9999999, DF TOTAL, 9999999
CODE      SUB   DATA
4624      0     0
4624      1     0
4624      2     58
4624      3     3
4624      4     58
4624      5     3
4624      6     0
4624      7     56
4624      8     3
4624      9     0
4624     10    41
4624     11     1
4624     12    29
4624     13     7
4624     14     0
4624     15     0
4624     16     0
4624     17     0
4624     18     0
4624     19     0
4624     20     0
.         .     .
.         .     .
.         .     .
.         .     .
.         .     .
```

Fig.5-19

The file of the engine firmware log is output (but it is not printed out).

- Total counter list

TOTAL COUNTER LIST		S/N: xxxxxxxx	TOTAL:	9999999	
20xx-xx-xx xx:xx		TOSHIBA e-STUDIOxxx	DF TOTAL:	9999999	
PRINT COUNTER					
TOTAL					
		FULL COLOR	TWIN/MONO	COLOR BLACK	TOTAL
COPY	37	0	1	38	
FAX	0	0	0	0	
PRINTER	122	0	60	182	
LIST	0	0	0	0	
TOTAL	159	0	61	220	
COPY					
		FULL COLOR	TWIN/MONO	COLOR BLACK	TOTAL
SMALL	37	0	1	38	
LARGE	0	0	0	0	
TOTAL	37	0	1	38	
FAX					
		FULL COLOR	TWIN/MONO	COLOR BLACK	TOTAL
SMALL	0	0	0	0	
LARGE	0	0	0	0	
TOTAL	0	0	0	0	
PRINTER					
		FULL COLOR	TWIN/MONO	COLOR BLACK	TOTAL
SMALL	118	0	60	178	
LARGE	4	0	0	4	
TOTAL	122	0	60	182	
LIST					
		FULL COLOR	TWIN/MONO	COLOR BLACK	TOTAL
SMALL	0	0	0	0	
LARGE	0	0	0	0	
TOTAL	0	0	0	0	
CALIBRATION COUNTER : 0					
SCAN COUNTER					
TOTAL					
		FULL COLOR	TWIN/MONO	COLOR BLACK	TOTAL
COPY	7	0	1	8	
FAX	0	0	0	0	
NETWOF	0	0	0	0	
TOTAL	7	0	1	8	
COPY					
		FULL COLOR	TWIN/MONO	COLOR BLACK	TOTAL
SMALL	7	0	1	8	
LARGE	0	0	0	0	
TOTAL	7	0	1	8	
FAX					
		FULL COLOR	TWIN/MONO	COLOR BLACK	TOTAL
SMALL	0	0	0	0	
LARGE	0	0	0	0	
TOTAL	0	0	0	0	
NETWORK					
		FULL COLOR	TWIN/MONO	COLOR BLACK	TOTAL
SMALL	0	0	0	0	
LARGE	0	0	0	0	
TOTAL	0	0	0	0	

Fig.5-20

The list of total counter is output.

Remarks:

By performing FS-08-3667, a QR code is added to the total counter list.

- (05) adjustment value/(08) setting value difference

05 DIFFERENCE LIST			S/N: xxxxxxxx TOTAL: 9999999		
xx-xx-xx xx:xx			TOSHIBA e-STUDIOxxxx DF TOTAL: 9999999		
CODE	BACKUP	CURRENT	CODE	BACKUP	CURRENT
* 2400	128	160			
.	.	.			
.	.	.			
.	.	.			
.	.	.			
.	.	.			
.	.	.			
.	.	.			
.	.	.			
.	.	.			
.	.	.			
.	.	.			

Fig.5-21

The value differences between the factory default and the current value of [05 Adjustment mode] and [08 Setting mode] in the FS Menu can be printed or output with a CSV file.

The mark "*" or "+" will be added to the left side of the code in the following cases.

- * : If there is a difference
- + : If there is no backed up value

Notes:

- Back-up data of the factory default are automatically created when the automatic gamma adjustment of the easy set-up mode has been completed during the unpacking and setting up of the equipment. The back-up file will be retained even if the system firmware is upgraded. However, the file will be deleted when the HDD is formatted or replaced.
- When the easy set-up mode is restarted while a specified value such as 4 through 9 is set for FS-08-9022 (Production process management status for easy setup), the back-up file stored during unpacking and setting-up is deleted after the completion of the automatic gamma adjustment and a new one is created while the value as of then is stored.
- When no back-up file exists
 When FS-30-121 (122) is performed, the equipment returns to the ready state of the 30 LIST PRINT MODE without performing printing.
 When FS-30-221 (222) is performed, the equipment returns to the ready state of the 30 LIST PRINT MODE and the error message "The file cannot be saved" appears on the panel.

5.10 31 CHART OUTPUT MODE

Various charts can be output.

- (1) Select [31 CHART OUTPUT MODE] in the FS Menu and press [Next].

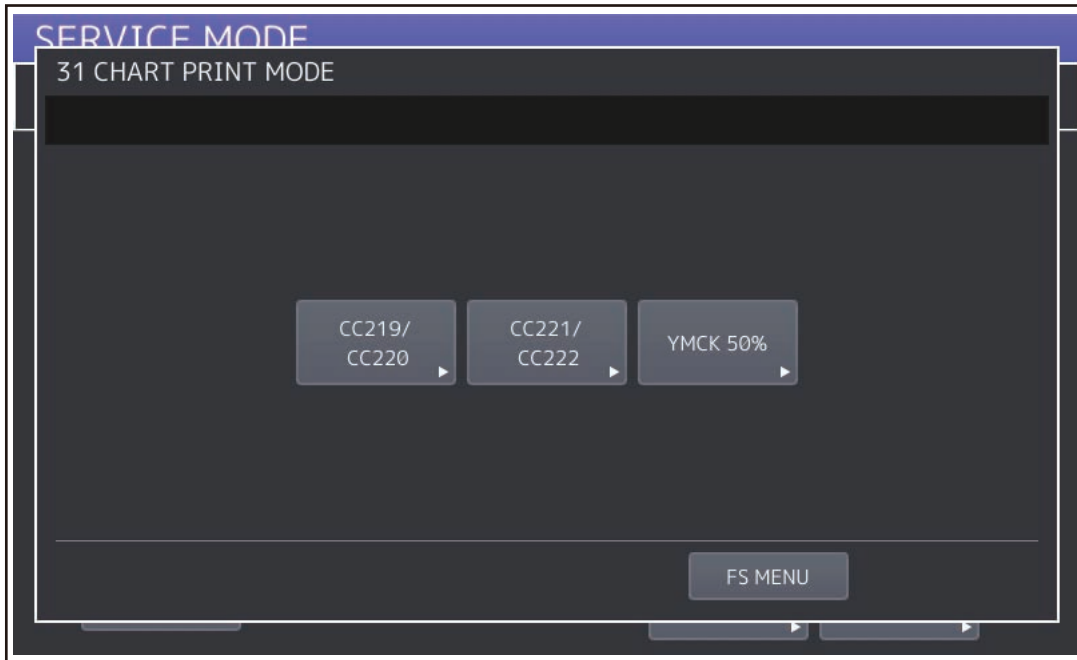

Fig.5-22

- (2) Press the type of the chart to be output.
- (3) Specify the output settings and press [PRINT].

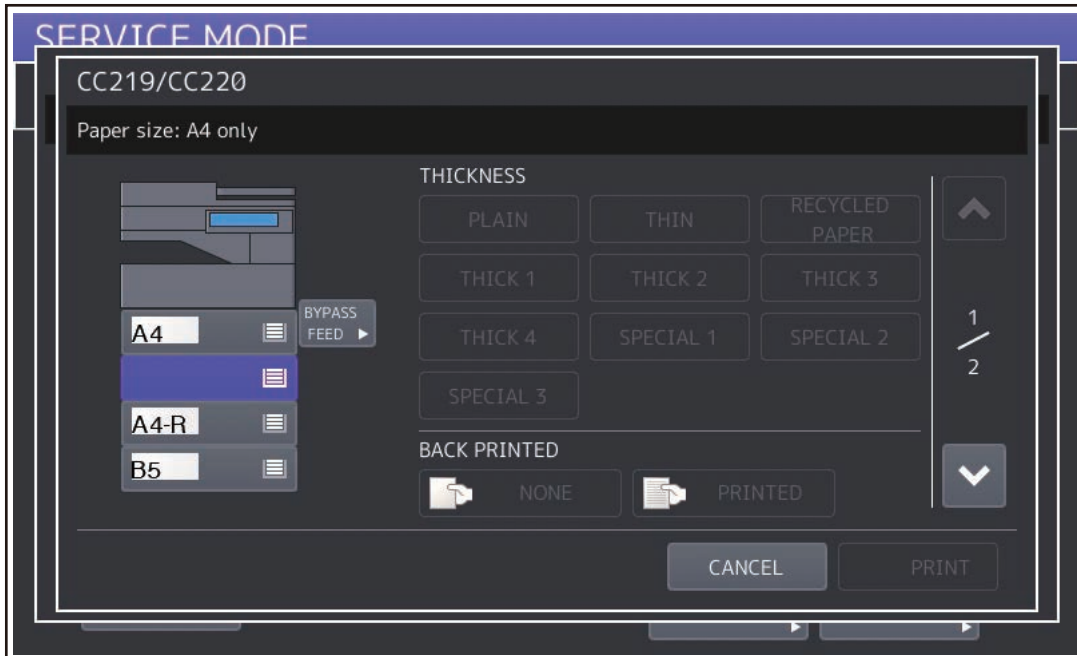

Fig.5-23

5.11 FAX

Adjustment and setting of the fax functions can be performed.

Select [FAX] in the FS Menu and press [Next]. The following modes are displayed.

11 FAX CLEAR MODE

12 FAX LIST PRINT MODE

13 FAX FUNCTION MODE

19 RAM EDIT MODE

Notes:

The data automatically received during the self-diagnostic mode are sometimes not printed.

Therefore, be sure to disconnect the modular code form the line connector (LINE1, LINE2) of the equipment before starting the self-diagnostic mode. After the equipment is released from the self-diagnostic mode, reconnect the modular code.

5.11.1 11 FAX CLEAR MODE

- (1) Select [FAX] in the FS Menu and press [Next]. Select [11 FAX CLEAR MODE] and press [Next].

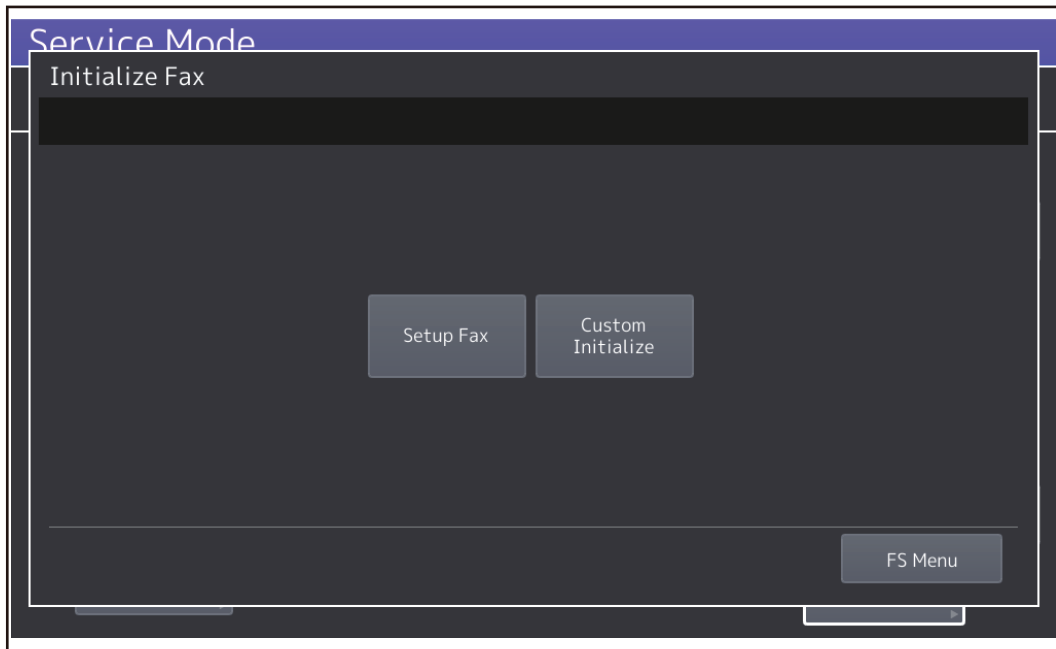

Fig.5-24

[Setup Fax] and [Custom Initialize] are displayed.

[A] Setup Fax

The destination of the fax can be set.

- (1) Press [Setup Fax].
- (2) Select the destination and press [OK].

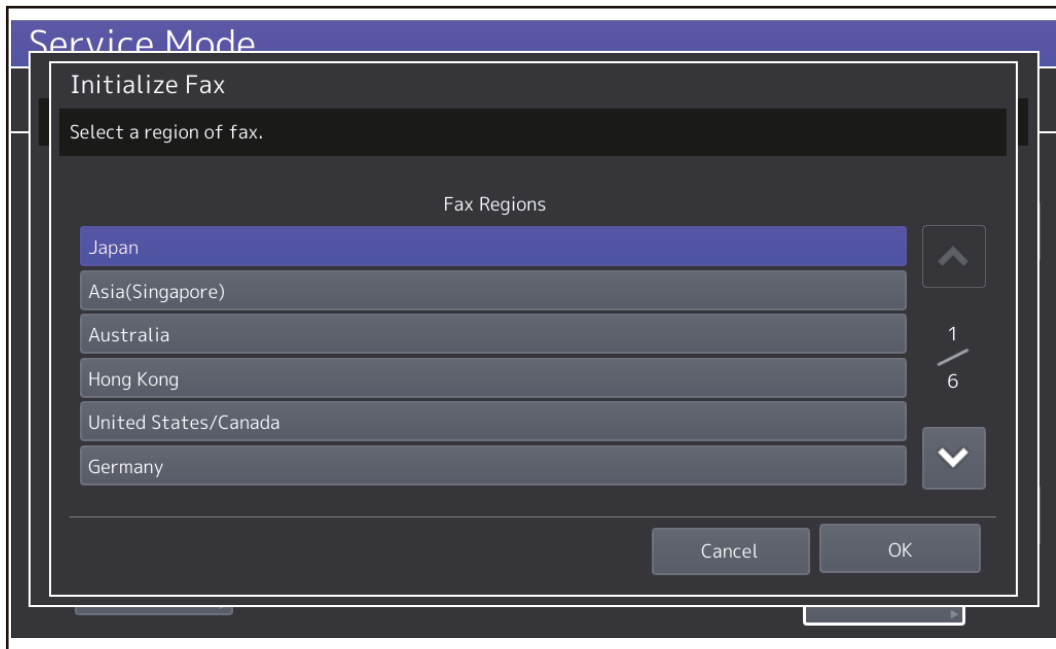

Fig.5-25

[B] Custom Initialize

Various FAX memories are initialized in the FAX clearing mode.

- Memory Areas
 - User registration area (SRAM)
 - ID registration area
 - Home position
 - Image data area (HDD, SRAM)
 - Transmission file
 - Reception file
 - Image data file management area
 - F-code box information
 - System setting area (NVRAM)
 - Settings in the [13 FAX FUNCTION MODE] Areas 100 - 999

<Operation procedure>

- (1) Press [Custom Initialize].

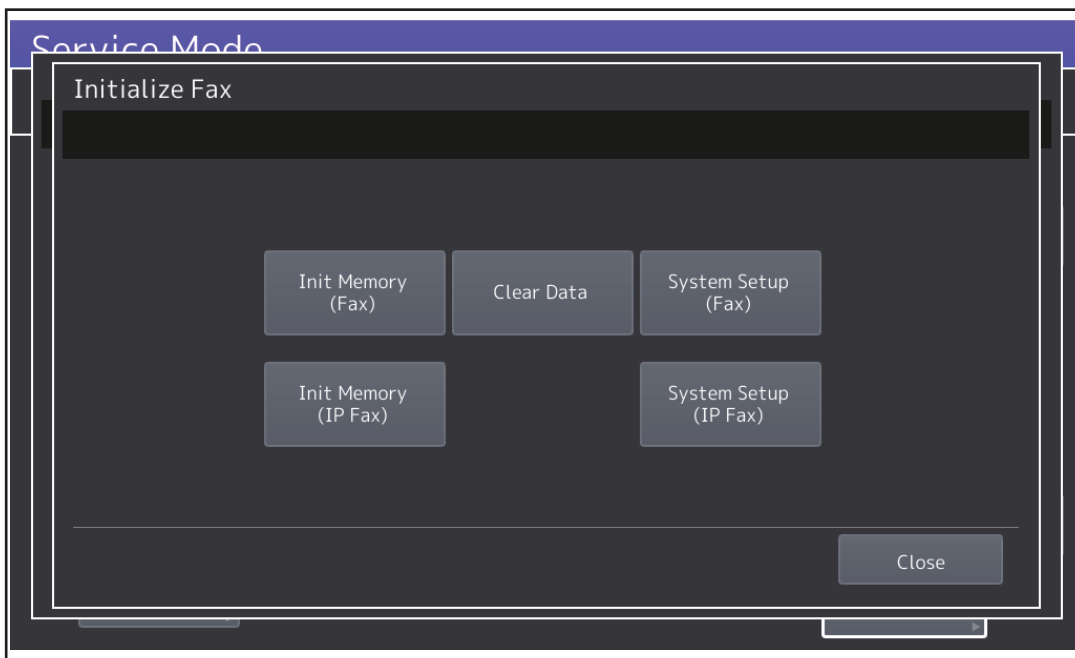

Fig.5-26

- (2) Select the mode.
 - [Init Memory (Fax)], [Init Memory (IP Fax)]: Initializes the user registration area (SRAM) so that there are no data stored. Initializes the system setting area (NVRAM) so that its value is reset to the default setting.
 - [Clear Data]: Initializes the image data area (HDD, SRAM) so that there are no data stored.
 - [System Setup (Fax)], [System Setup (IP Fax)]: Initializes the system setting area (NVRAM) so that its value is reset to the default setting.

5.11.2 12 FAX LIST PRINT MODE

The setting contents of the fax function can be output.

- (1) Select [FAX] in the FS Menu and press [Next]. Select [12 FAX LIST PRINT MODE] and press [Next].

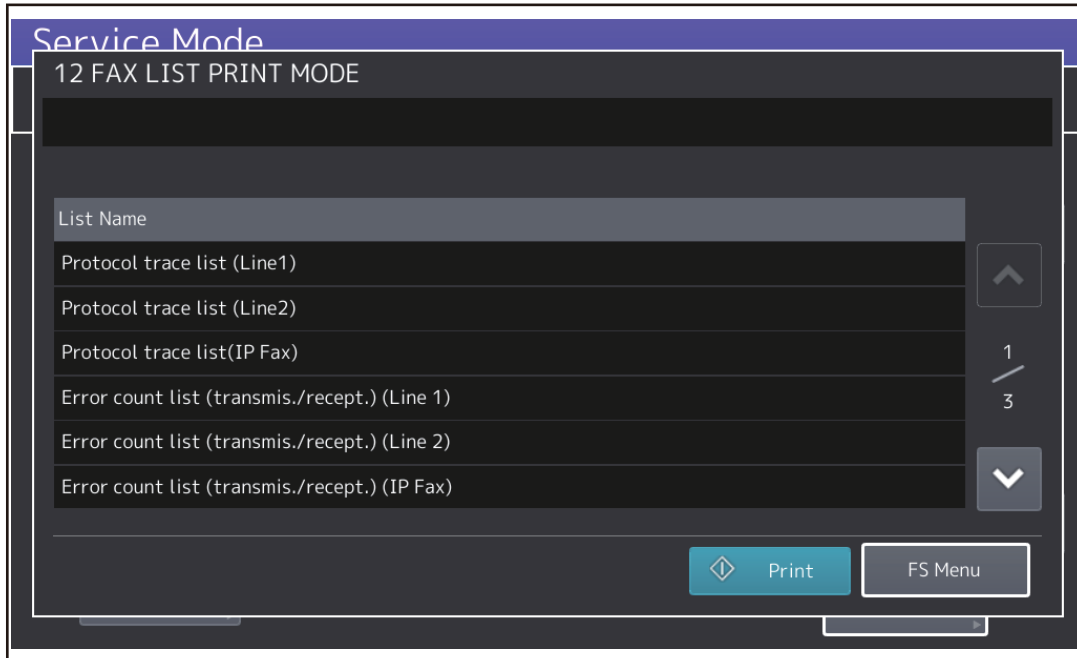

Fig.5-27

- (2) Select the list and press [Print].
The names of the lists in [12 FAX LIST PRINT MODE] are shown below.
 - Protocol trace list (Line1)
 - Protocol trace list (Line2)
 - Protocol trace list (IP Fax)
 - Error count list (transmis./recept.) (Line 1)
 - Error count list (transmis./recept.) (Line 2)
 - Error count list (transmis./recept.) (IP Fax)
 - ERROR COUNT LIST (IFAX)
 - ERROR COUNT LIST (SCAN)
 - Function List for Maintenance
 - Memory dump list (system)
 - Memory dump list (FAX/LINE1)
 - Memory dump list (FAX/LINE2)
 - SUPPLY ORDER LIST

5.11.3 13 FAX FUNCTION MODE

Various fax functions can be set.

Operation procedure: Refer to SELF-DIAGNOSIS CODE.

5.11.4 19 RAM EDIT MODE

This is a mode for the special adjustments and settings. (This is not used generally.)

5.12 35 DATA BACKUP/RESTORE MODE

This function can save (back up) a back-up file of the MFP setting data in a USB media or external server, or can restore the stored (backed up) file into the equipment.

- (1) Select [35 DATA BACKUP/RESTORE MODE] in the FS Menu and press [Next].

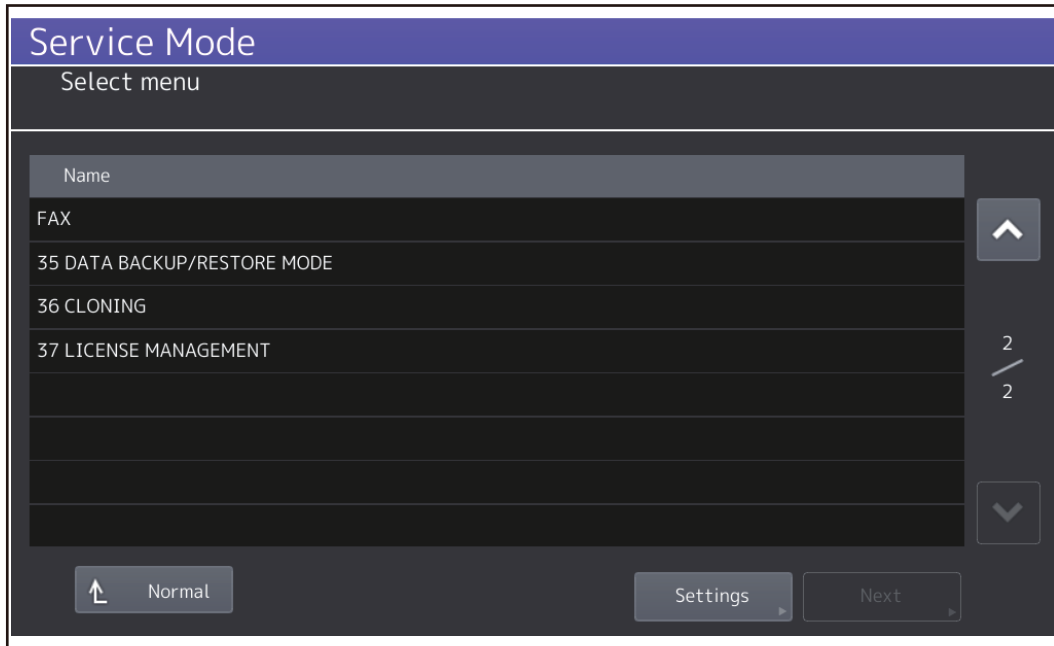

Fig.5-28

- (2) [Data Backup] and [Data Restore] are displayed.

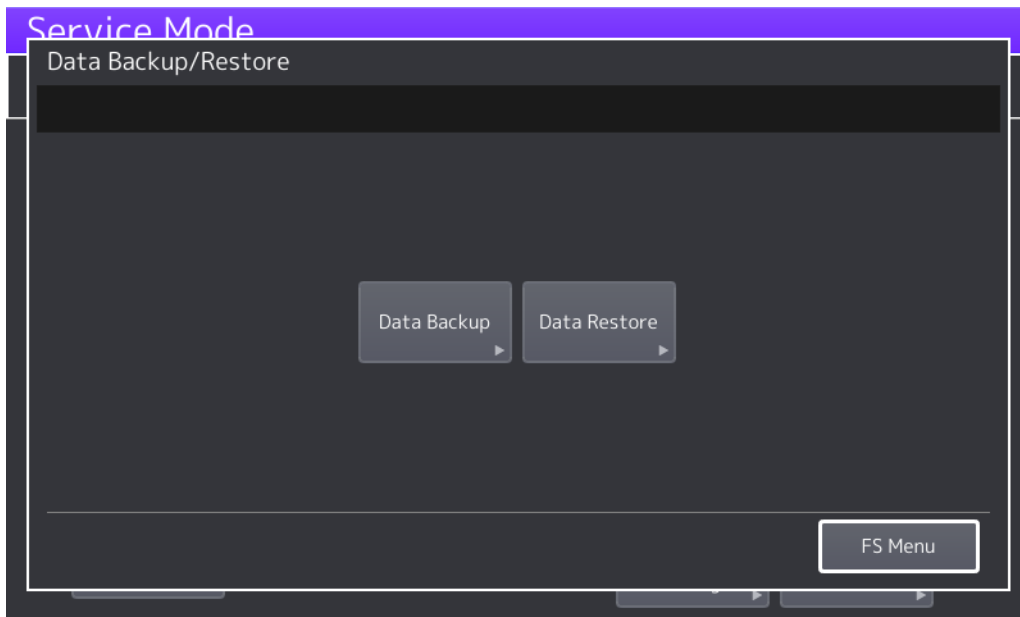

Fig.5-29

- (3) Select [Data Backup] or [Data Restore] and press [Next]. Press [USB Media].
- (4) Insert a USB storage device into the equipment and press [OK]. Backing up or restoring of the data starts.

Remarks:

For details, refer to the “HDD Data Back-up/Restore Instruction Manual” (separate document).

5.13 36 CLONING

This function can create a clone file including the MFP setting data and user information or can install the clone file in this equipment.

For details, see  P. 12-5 “12.2 Cloning (FS menu)”

5.14 37 LICENSE MANAGEMENT

This function can register or delete the application license.

For details, refer to the “License Management MANUAL” (separate document).

5.15 01 Control Panel Check Mode

The following items can be checked with this mode.

- LCD backlight on/off and brightness
- LCD display
- Confirmation of hard keys (buttons on the control panel) performance
- LEDs on/off
- Performance of digital keys (ten key option)
- LCD touch sensor
- USB storage device connection

Notes:

To check the performance of the digital keys, connect the ten key option before starting this mode.

5.15.1 Screen transition

Notes:

It is not possible to return to the HS Menu from [01 Control Panel Check]. To quit [01 Control Panel Check], display the LCD backlight check screen (Fig. A) and then press the [ON/OFF] button for a few seconds to shut down.

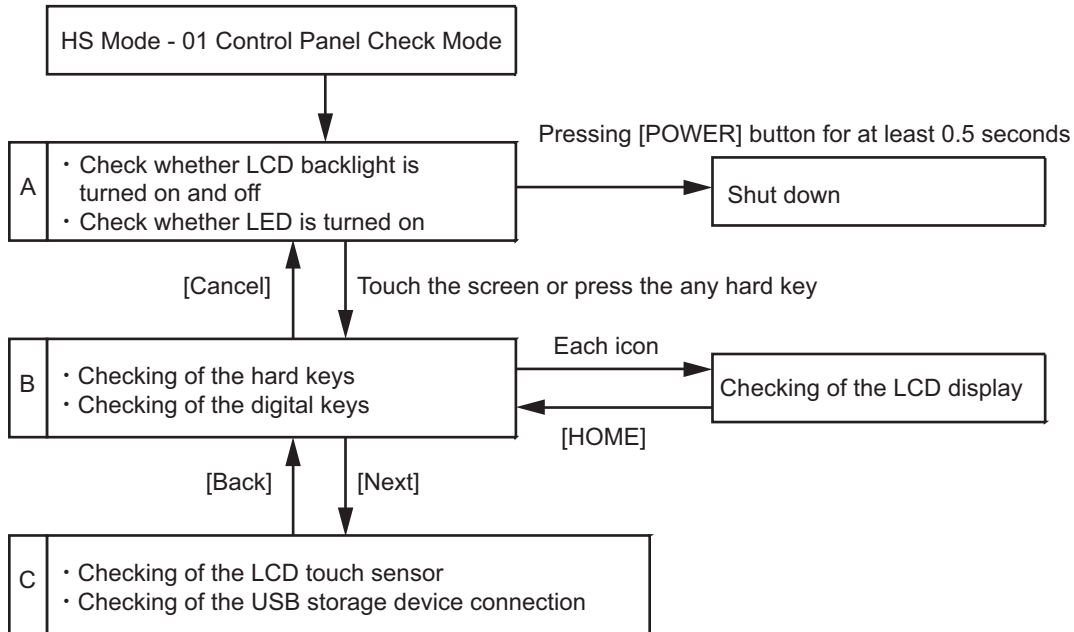

Fig.5-30

5.15.2 Checking of the LCD backlight and LEDs

By pressing [01 Control Panel Check], the LCD backlight blinks in 3-second intervals. Moreover, all LEDs are lit.

Remarks:

By touching the screen or pressing any hard key, the screen is shifted to the hard key confirmation screen.

5.15.3 Checking of the LCD display, hard keys and digital keys

[A] Checking of the LCD display

By pressing the icon on the touch panel, the LCD display (Picture 1-15) confirmation screen is displayed.

Remarks:

The screen is returned to this one when the [HOME] button is pressed on each screen.

[B] Checking of the hard keys

By pressing each hard key, a particular text is displayed and the lighting condition of the LED is changed.

The following table shows each text and performance when the key is pressed.

Hard key	Text	Performance
ON/OFF (Pressing for at least 0.5 seconds)	MAIN POWER	The [MEMORY RX] LED is turned OFF.
ENERGY SAVER	ENERGY SAVER	The [ENERGY SAVER] LED is turned OFF.
ACCESS	ACCESS	The [PRINT DATA] LED is turned OFF.
HOME	HOME	The [!] LED is turned OFF.
Programable key 1	P-1	The LCD backlight is made darker by each pressing. (10 levels)
Programable key 2	P-2	The LCD backlight is made lighter by each pressing. (10 levels)
FUNCTION CLEAR	FUNCTION CLEAR	The [FUNCTION CLEAR] LED is turned OFF.
START	START	The [START] LED is turned OFF.

The text is displayed only while the key is being pressed. Each LED is turned OFF only while the key is being pressed.

[C] Checking of the digital keys for Ten Key option

By pressing each digital key, a particular text is displayed. The following table shows each text when the key is pressed.

digital key	Text
1	OP-1
2	OP-2
3	OP-3
4	OP-4
5	OP-5
6	OP-6
7	OP-7
8	OP-8
9	OP-9
0	OP-0
*	OP-*
#	OP-#
C	OP-CLEAR

Remarks:

By pressing each icon on screen, the LCD display confirmation screen is displayed. The screen is shifted to the LCD touch sensor and USB storage device confirmation screen by pressing [Next] in the LCD display confirmation screen.

5.15.4 Checking of the LCD touch sensor and USB storage device connection

The screen is shifted to the LCD touch sensor and USB storage device confirmation screen by pressing [Next].

[A] Checking of the LCD touch sensor

It can be checked whether the operations of swipe, pinch-out (enlargement) and pinch-in (reduction) are correctly detected on the screen. When the above operation is performed on the screen, an arrow which indicates the one detected by the touch sensor and a message are displayed. Moreover, when any of [LH], [LL], [RH] or [RL] located on each corner of the screen is pressed, the calibration condition of the touched position can be checked.

[B] Checking of the USB storage device connection

It can be checked whether a USB storage device inserted into the USB port is connected properly. Install a USB storage device and press the [START] button. When a USB storage device is connected properly, [USB Connection Success] is displayed. If not, [USB Connection Failed] is displayed.

Remarks :

It is not possible to return to the HS Menu from [01 Control Panel Check]. Return to the LCD backlight check screen to shut down the equipment by pressing the [ON/OFF] button for a few seconds.

5.16 73 Firmware Assist Mode

5.16.1 Overview

This mode enables you to operate the HDD partition, formatting SRAM data, delete the HDD/SRAM data and backup/restore the encryption key and license.

The Functions in this mode are below.

Functions	Content
Clear Software Update Error Flag	Clearing update error flag
Format Root Partition	Formatting data storage partition
Format HDD	Creating HDD partition
Key Backup/Restore	Backing up/restoring encryption key and license
Erase HDD Securely	Erasing HDD securely
Clear Service Tech Password	Clearing service password
Disable Fast boot	Disabling faster start
Clear SRAM	Formatting SRAM data
Erase SRAM Securely	Erasing SRAM securely
Format HDD Without Key Generation	Creating HDD partition without having upgraded the key
HDD Data Restore	Performing formatting, backup data restoring and firmware upgrading in series

5.16.2 Operation procedure

- (1) Perform [HS-73] by pressing [73 Firmware Assist].
The following screen is displayed.

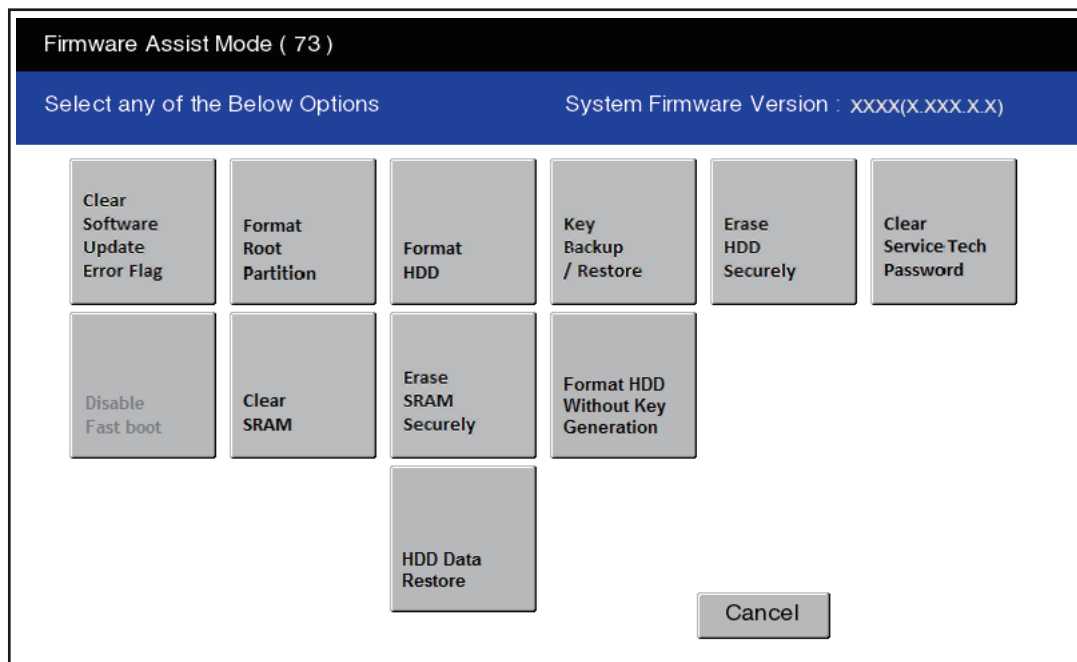

Fig.5-31

- (2) Press the icon to operate.

5.16.3 Functions

[A] Clearing update error flag (Clear Software Update Error Flag)

Even if the firmware downloading has been completed normally, the Recovery Mode may accidentally start up and an F600 error occurs when the power is turned ON again. In this case, clear the Update Error flags used in the download process with this function. (Normally, the flags are automatically cleared in the download process.)

Also in the case the Recovery Mode accidentally starts up after the replacement of SRAM, the flags are cleared with this function.

[B] Formatting data storage partition (Format Root Partition)

When a defect occurs on the UI data, etc. which are stored in the HDD, the partition with the stored UI data, etc. is formatted with this function.

Do not use this function since it is not normally necessary. HDD data must be installed after performing this function.

[C] Creating HDD partition (Format HDD)

When the HDD is replaced or UI data, etc. are downloaded using the USB storage, it is necessary to format a partition in the HDD before downloading. In this case, the partition is created in the HDD with this function.

Notes:

Perform the HDD partition formatting only when a new HDD is installed since all data in the current HDD are erased by this operation.

When this operation has been done, do not perform SRAM data formatting (Clear SRAM) before the normal start-up.

[D] Backing up/restoring encryption key and license (Key Backup Restore)

When the SRAM or the SYS board is replaced or initialized, the encryption key and license are erased. Therefore, they need to be backed up or restored with this function.

Configuration and function for key backup restore

		SRAM	FROM
Key	SRAM	-	-
	FROM	-	-
Licence	SRAM	-	-
	FROM	-	-
ADKey	SRAM	-	-
	FROM	-	-

HDDENCKEY[F100_1/2]	:	OK	OK
HDDDECKEY[F100_1/2]	:	OK	OK
SIGKEY[F109_2]	:	OK	OK
EncParam[F109_3]	:	OK	OK
LICENCE[F109_4]	:	OK	OK
MachineInfo[F900]	:	OK	OK
AGLENCKEY[F109_5]	:	OK	OK
AGLDECKEY[F109_5]	:	OK	OK
AdminPassword[F109_6]	:	OK	OK

Buttons: State, Back, Execute

Fig.5-32

The following table shows the relationship between each Key or License and icon.

Key or License name	Icon
HDDENCKEY [F100_1/2]	Key
HDDDECKEY [F100_1/2]	Key
SIGKEY [F109_2]	Key
EncParam [F109_3]	Key
LICENSE [F109_4]	License
MachineInfo [F900]	Key
AGLENCKEY [F109_5]	ADIKey
AGLDECKEY [F109_5]	ADIKey
AdminPassword [F109_6]	ADIKey

- * When “KeyBroken” or “KeyNull” is displayed on the SRAM row:
Backs up the encryption Key or License in SRAM when the icon is pressed
- * When “KeyBroken” or “KeyNull” is displayed on the FROM row:
Recovers the encryption Key or License in SRAM when the icon is pressed

[E] Erasing HDD securely (Erase HDD Securely)

This function is used when installing Data Overwrite Enabler (GP-1070) or before discarding the HDD. It overwrites all the used areas on the HDD with the selected data, and makes it unusable.

After selecting this function, specify the level below to be overwritten. This setting is the overwriting method complying with DoD 5220.22-M.

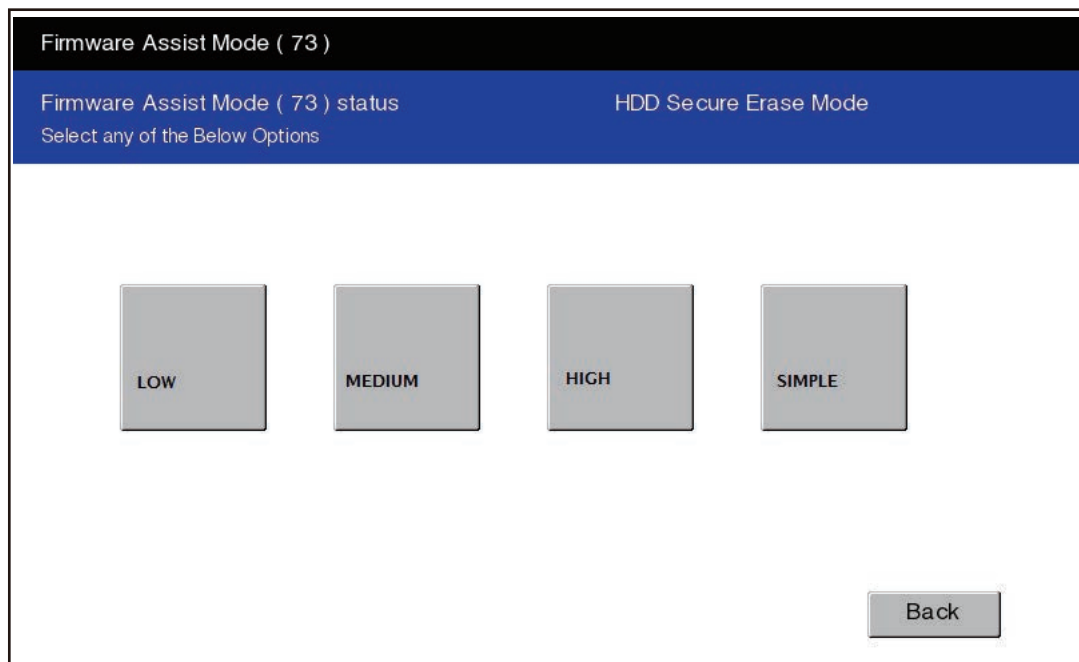

Fig.5-33

- LOW (Normally use this setting.)
This is the standard overwriting method.
“00-FF-Random-Verify” Once
- MEDIUM
This overwriting method is more secure than LOW. The erasing time is between LOW and HIGH.
“00-FF-Random” three times repeatedly -Verify
- HIGH
This is the most secure overwriting method. It takes the longest time to erase data.
“00-FF-Random” five times repeatedly -Verify

- **SIMPLE**

This is the simple overwriting method. It takes the shortest time to erase data.
Overwrite the Random data once

The reconfirmation screen is displayed when the icon is pressed.

Press [OK]: Processing starts.

Press [Back]: The screen returns to the previous one.

Notes:

When this operation has been done, do not perform SRAM data formatting (Clear SRAM) before the normal start-up.

[F] Formatting SRAM data (Clear SRAM)

When SRAM is replaced with a new one, abnormal values may be written in the new SRAM. SRAM data must be formatted with this function for such case.

Notes:

- This function is required only when a new SRAM is installed.
- Do not perform this function in cases other than the installation of a new SRAM because all data in the SRAM will be deleted with this function.
- When this operation has been done, do not perform HDD partition creation (Format HDD) before the normal start-up.

[G] Erasing SRAM securely (Erase SRAM Securely)

This function is used before discarding the SRAM.

It overwrites all the used areas on the SRAM with the selected data, and makes it unusable.

Immediately after selecting this function, the processing starts and is completed.

[H] Clearing service password (Clear Service Tech Password)

This function is needed after the HDD is replaced.

When the HDD is replaced, the service password stored in the new one is set as a blank. Therefore, its service password is copied to the SRAM so that both passwords become the same with this function.

The setting is enabled when the equipment is started up in the normal mode after performing this function.

[I] Disable Faster boot

This function disables faster start (*). Therefore, this can be operated while faster start is enabled.

- * Faster start: A start-up method which shortens the time for normal and FS menu startups by approx. 5 seconds by starting up the equipment from a dedicated file. (There is no effect on recovery from hibernation.)

Once the power is turned ON while the [HOME], [RESET] and [START] buttons are pressed simultaneously, a file for faster start is created and it becomes available. It will take approx. 3 minutes to create a file for faster start. When the file creation is completed, the equipment will automatically start in the normal mode.

- * Faster start can also be disabled by the following operations.

- Firmware update
- HS-73 → [Format HDD]
- Data Overwrite Enabler (GP-1070) installation or settings change
- Security level change
- HS-75 → [Initialize HDD]
- HS-59 → [Restore SRAM Data from USB]

[J] Restoring HDD Data (HDD Data Restore)

This function performs formatting, backup data restoring and firmware upgrading in series.

Notes:

- Perform this function only after the HDD is replaced or when there will be no problem even if all the information in the HDD is erased.
- Perform this function only when a USB storage device (*) in which the backup data and the firmware standard package are stored is prepared.
 - * It is available even if these 2 files are stored in different USB storage devices separately.

(1) Install the USB storage device with the backup data stored in the equipment.

(2) Perform this function.

- Format the HDD and restore the backup data.
- If the firmware standard package is stored in this USB storage device, continuously upgrade the firmware.
- If the firmware standard package is not stored in this USB storage device, an error appears. In such a case, install the USB storage device with the firmware standard package stored in the equipment and press [OK]. Firmware upgrading will start.
- After upgrading is completed, reboot the equipment.

5.17 74 HDD Assist Mode

5.17.1 Overview

This mode is available only when the security HDD (Secure HDD) is mounted in the equipment. It enables you to check the type of the mounted HDD, revert the Secure HDD to the factory default.

Functions of 74 HDD Assist mode

- Checks the type (Secure/Normal) of the mounted HDD.
- Disposes of Secure HDD data safely without any of leakage.
- Deletes image data when reusing a used Secure HDD.

5.17.2 Operation procedure

- (1) Perform [HS-74] by pressing [74 HDD Assist].
Then, the type of the mounted HDD appears on the screen.

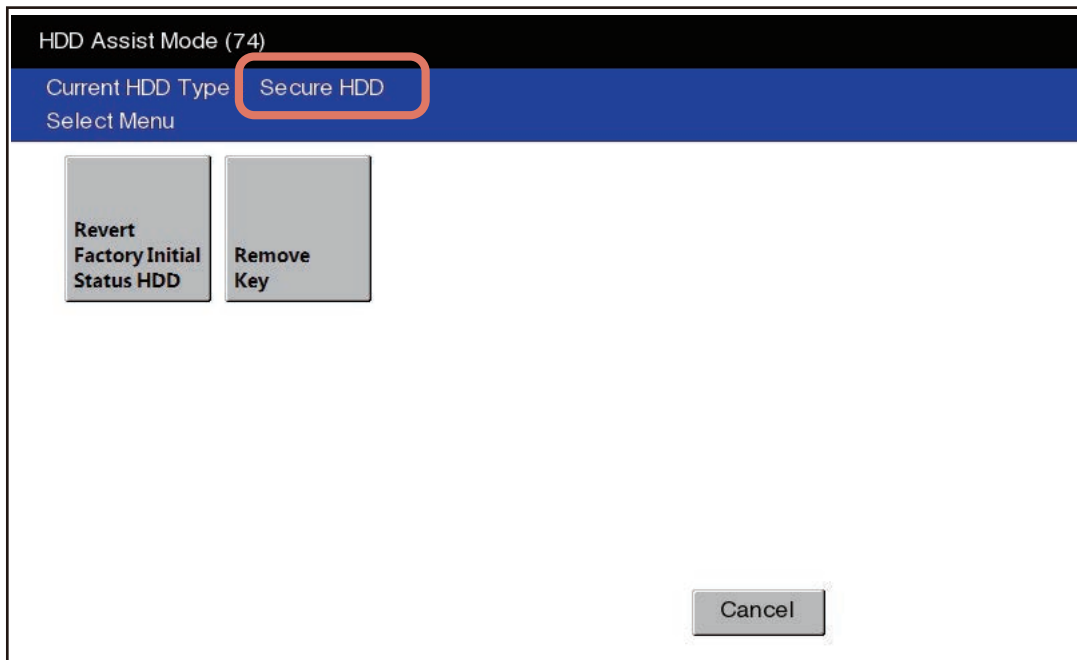



Fig.5-34

When a security HDD is mounted: Secure HDD
When a normal HDD is mounted: Normal HDD

(2) Press the icon to operate.

Remarks:

If the HDD type cannot be identified, "Unknown HDD" may appear on the screen.
Refer to  P. 8-287 "[F106_1] HDD error (HDD type detection error)".

Notes:

When "Normal HDD" is displayed, items 1 and 2 are not selectable.
If you select any of 1 and 2 and press the [START] button, the error message "Operation Failed. Press SoftPower Key to Switch Off." appears.

5.17.3 Functions

[A] Revert Factory Initial Status HDD

Select this to dispose of the Secure HDD as well as the equipment.

When this item is selected, all data in the HDD are deleted and the HDD is reverted to its initial status at the factory shipment. This operation requires only a few seconds; however, in order to make the HDD usable again, you need to perform [Format HDD] (creating HDD partition) in HS-73 and reinstall the HDD data with HS-49.

The following screen is displayed when [Revert Factory Initial Status HDD] is pressed.

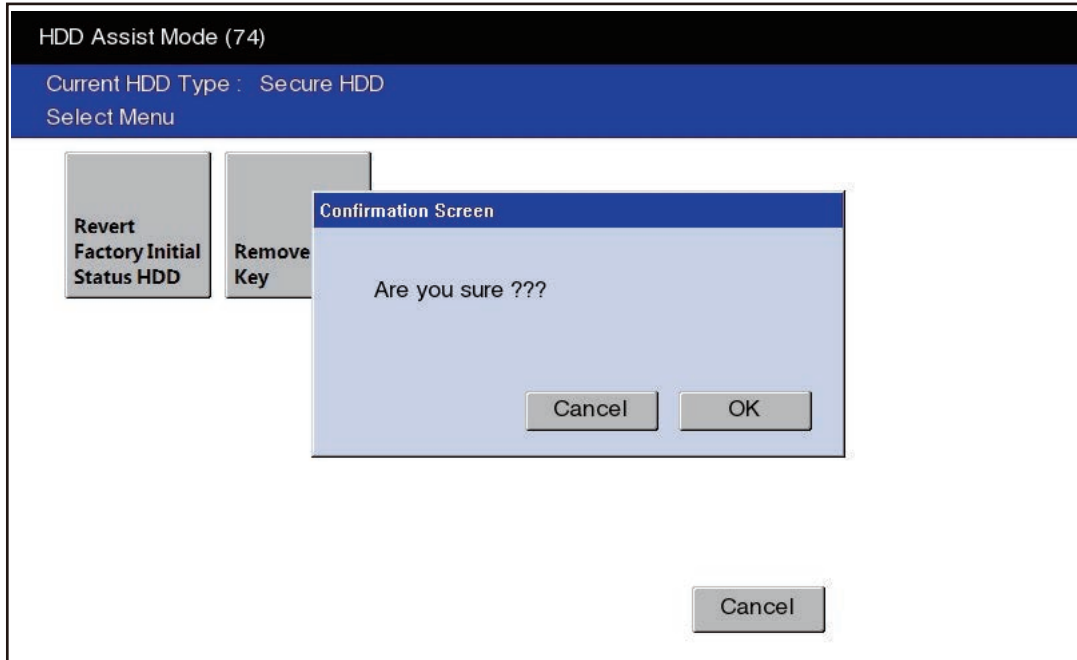

Fig.5-35

Press [OK] to carry out the operation.

When the operation is finished, the result appears on the menu.

Notes:

- If the equipment is started up in the normal mode under this condition, a service call (HDD mount error) will occur.
- After this has been performed, formatting of the HDD and reinstallation of applications are necessary.

[B] Remove Key

Select this to reuse the Secure HDD as well as the equipment.

When this item is selected, image data in the HDD are deleted.

This operation requires approx. 20 minutes since the partition must be rebuilt.

The following screen is displayed when [Remove Key] is pressed.

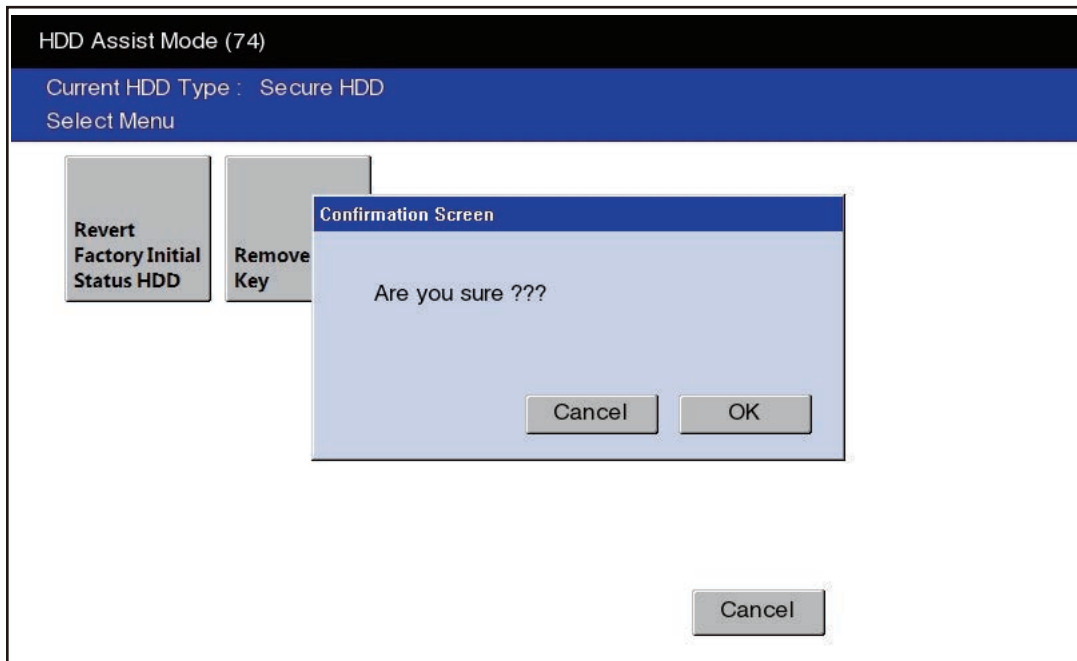

Fig.5-36

Press [OK] to carry out the operation.

When the operation is finished, the result appears on the menu.

Remarks:

- After this operation, the equipment becomes reusable without reinstalling the firmware.
- After this has been performed, formatting of the HDD and reinstallation of applications are necessary.

5.18 75 File System Recovery Mode

5.18.1 Overview

This is a mode to check if there is any damage to the file system (HDD) and recover it if necessary. Use this mode only in the following cases.

- There is a possibility of damage to the file system (HDD).
- There is an apparent damage to the file system (HDD), requiring recovery or initialization.

This mode enables you to have the following functions.

Functions	Content
Check F/S	Checks the file system.
Recovery F/S	Recovers the file system.
Initialize HDD	Initializes partitions in the HDD.
Initialize DB	Initializes database (LDAP DB / log DB / language DB / AppMgmt DB / HomeScreen DB / JobHistory DB / AppLicense DB).
SMART Info	Displays the various information in the HDD.
DISK Info	Displays the usage rate of each partition.
HDD Utility	Initializes log files.

5.18.2 Operation procedure

- (1) Perform [HS-75] by pressing [75 File System Recovery].
The following screen appears.

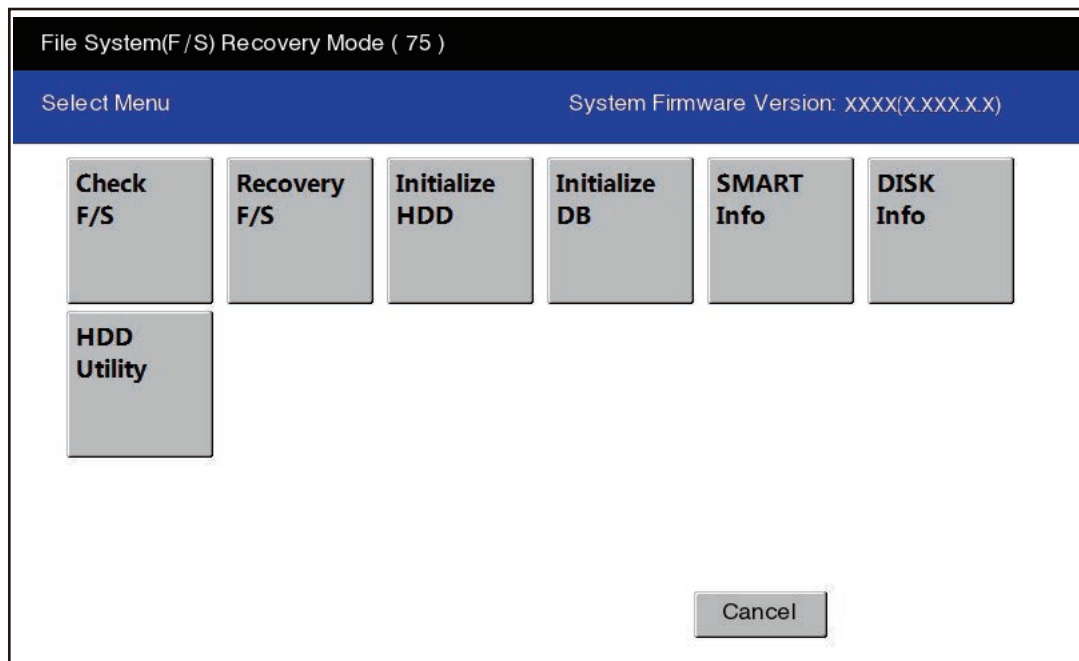

Fig.5-37

- (2) Press the icon to operate.

Notes:

- Do not turn the power OFF with the [MAIN POWER] button after the processing has started (while the processing is being performed).
- After the processing is completed, a beep sounds 4 times and either “Completed” or “Failed” appears on the screen.

5.18.3 Functions

[A] Check of the File System (Check F/S)

In case that particular service calls occur or there is a possibility of damage to the file system, the status of each partition in the HDD can be checked.

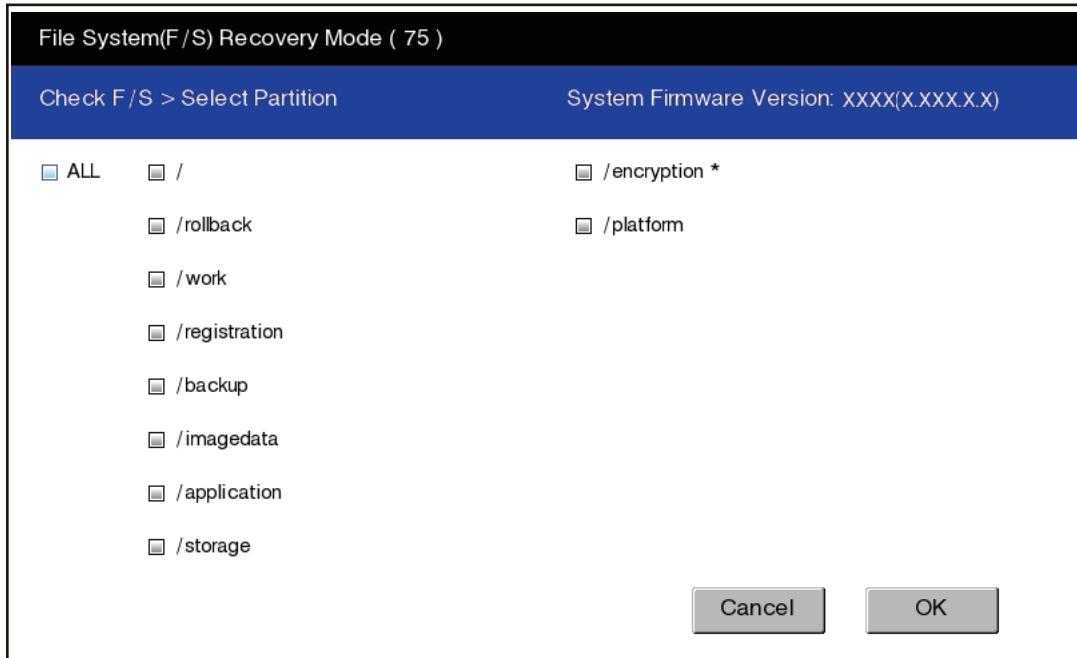

Fig.5-38

Explanation for each item

ALL: Checks all partitions.

/: Checks root partition only.

Others: Checks each partition shown above.

Remarks:

More than one partition can be selected. (A check mark is displayed at the selected item.)

* If damage is discovered, recover or initialize the file system (HDD).

[B] Recovery of the File System (Recovery F/S)

In case that an error occurs during the file system check, each partition can be recovered.

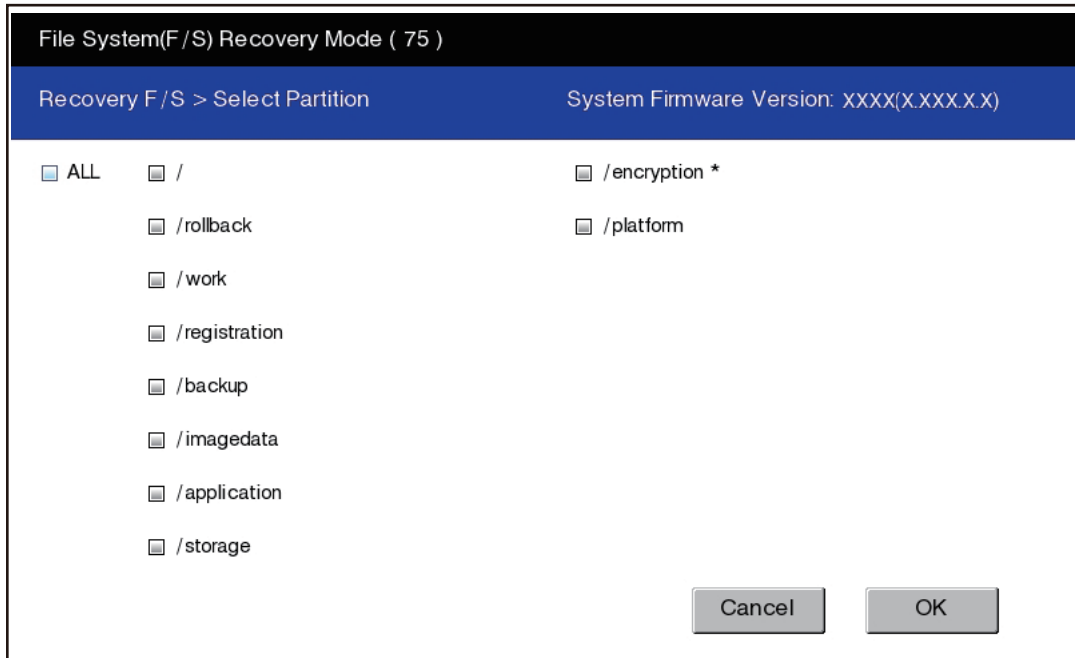

Fig.5-39

Explanation for each item

ALL: Recovers all partitions.

/: Recovers root partition only.

Others: Recovers each partition shown above.

Remarks:

More than one partition can be selected. (A check mark is displayed at the selected item.)

* If an error occurs during recovery, initialize the file system (HDD).

[C] Initialize the File System (Initialize HDD)

In case that an error occurs during the file system check and the partition cannot be recovered with the recovery, each partition can be initialized.

It is recommended to export the user information such as address book before performing this function.

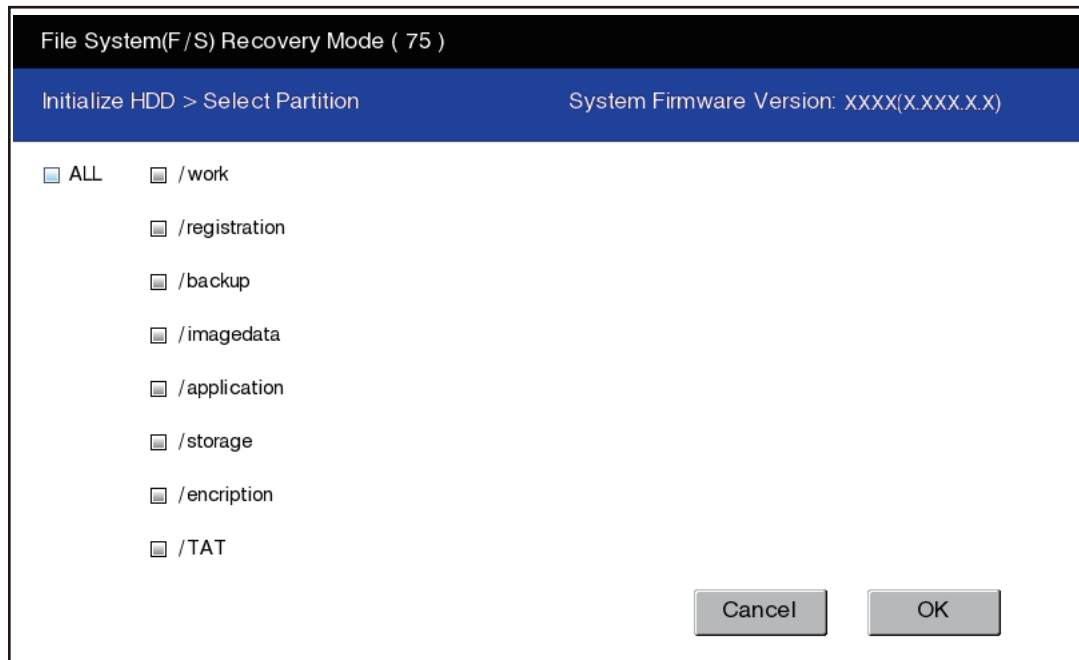

Fig.5-40

Explanation for each item

ALL: Initializes partitions other than root one and creates initial files.

Others: Initializes each partition.

Remarks:

More than one partition can be selected. (A check mark is displayed at the selected item.)

Notes:

If initialization is carried out by selecting [ALL] or [/encription], applications and OS data in the equipment are also initialized. In this case, the applications and the file system must be reinstalled. Install the system software (HDD DATA) with HS-49 after initialization.

If [ALL] is selected, minimal data necessary for normal startup are automatically recovered.

If initialization is carried out by selecting [ALL], the log database is also initialized. Back up the data before initializing if necessary.

If [ALL] is selected, do not perform SRAM data formatting (Clear SRAM) before the normal start-up.

[D] Initialize the DB (Initialize DB)

In case that particular service calls occur or there is a possibility of damage to the databases, each one can be initialized.

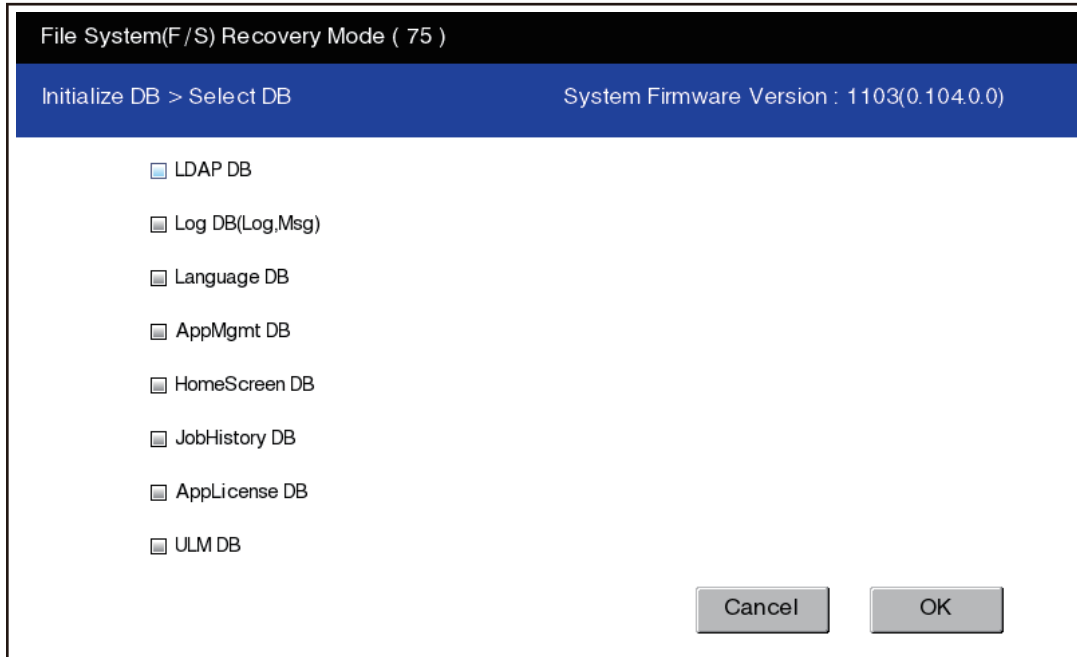

Fig.5-41

Explanation for each item

LDAP DB: Initializes address book data and the user information database.

Log DB (Log,Msg): Initializes job log data and the message database.

Language DB: Initializes the language database.

AppMgmt DB: Initializes the application database.

HomeScreen DB: Initializes the home screen database.

JobHistory DB: Initializes the job history database.

AppLicense DB: Initializes the application license database.

ULM DB: Initializes the license manager database.

Remarks:

Once the databases are selected, they are initialized.

[E] Displaying various data in the HDD (SMART Info)

Various data in the HDD can be displayed. (Data equivalent to the setting contents of FS-08-9065 are displayed.)

When this item is selected, data in the HDD embedded in the equipment are displayed. “---” is displayed for the items not supported.

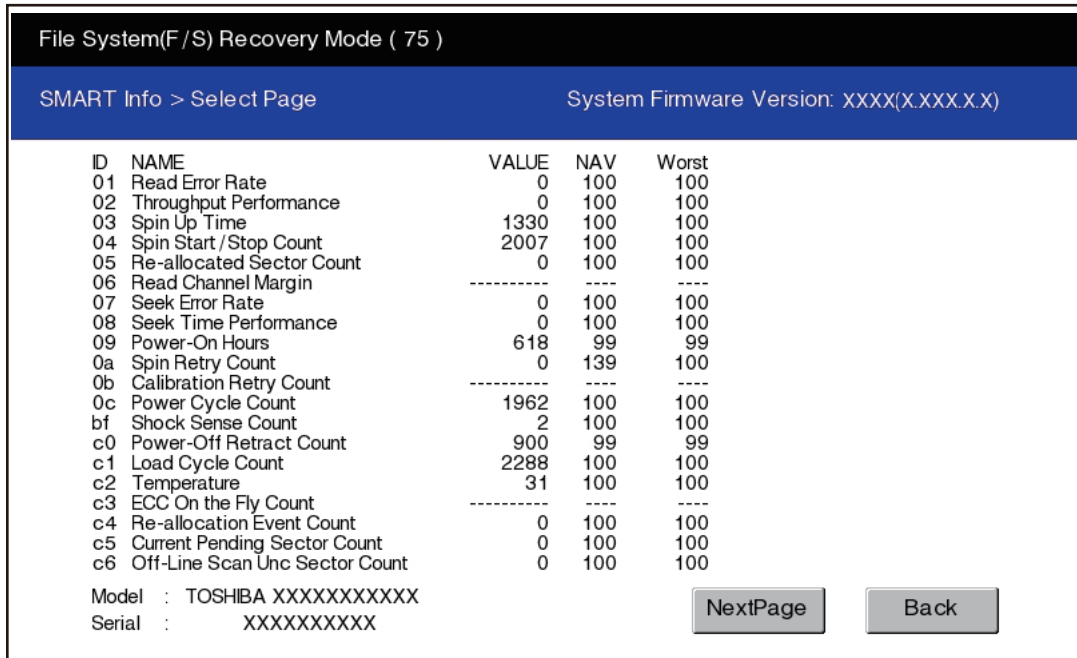

File System(F/S) Recovery Mode (75)

SMART Info > Select Page System Firmware Version: XXXX(X.XXX.X.X)

ID	NAME	VALUE	NAV	Worst
01	Read Error Rate	0	100	100
02	Throughput Performance	0	100	100
03	Spin Up Time	1330	100	100
04	Spin Start /Stop Count	2007	100	100
05	Re-allocated Sector Count	0	100	100
06	Read Channel Margin	-----	----	----
07	Seek Error Rate	0	100	100
08	Seek Time Performance	0	100	100
09	Power-On Hours	618	99	99
0a	Spin Retry Count	0	139	100
0b	Calibration Retry Count	-----	----	----
0c	Power Cycle Count	1962	100	100
bf	Shock Sense Count	2	100	100
c0	Power-Off Retract Count	900	99	99
c1	Load Cycle Count	2288	100	100
c2	Temperature	31	100	100
c3	ECC On the Fly Count	-----	----	----
c4	Re-allocation Event Count	0	100	100
c5	Current Pending Sector Count	0	100	100
c6	Off-Line Scan Unc Sector Count	0	100	100

Model : TOSHIBA XXXXXXXXXXXX
Serial : XXXXXXXXXXXX

NextPage Back

Fig.5-42

Remarks:

NAV: Normalized Attribute Value

Indicates the value of the specified HDD condition as compared to the manufacturer's optimum value.

Worst: Worst Ever Normalized Attribute Value

Indicates the worst value of NAV permitted by the manufacturer.

Notes:

The values of NAV and Worst should be treated as a rough reference since their basis may differ depending on the specification of HDD manufacturers.

[F] Displaying usage rate of each partition (DISK Info)

The usage rate of each partition can be checked.

When this item is selected, the usage rate of each partition is displayed.

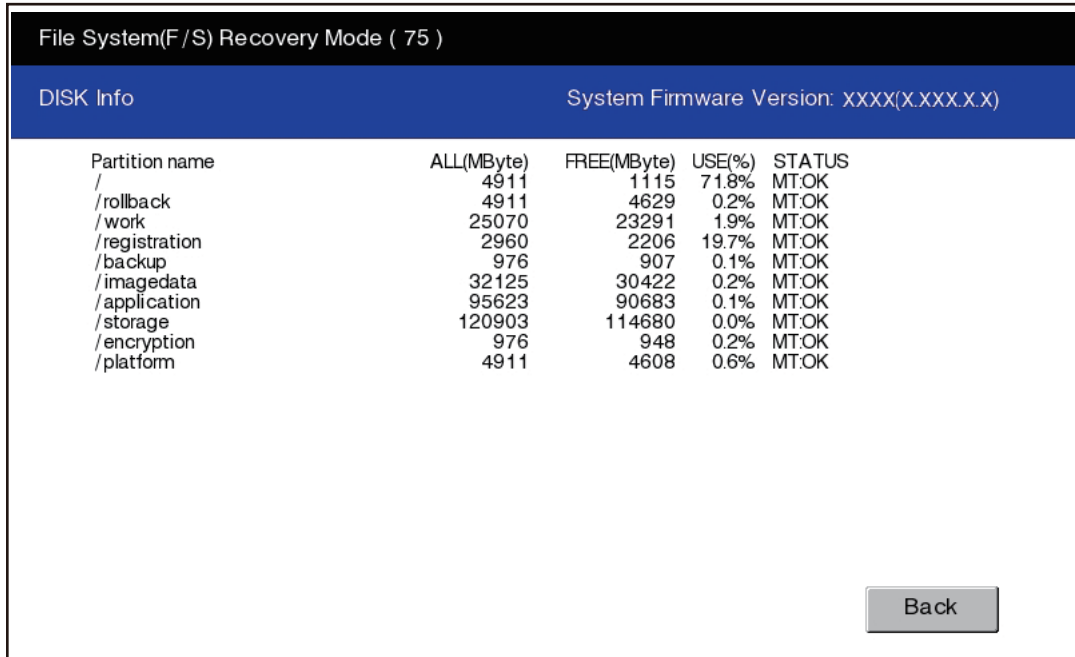

Partition name	ALL(MByte)	FREE(MByte)	USE(%)	STATUS
/	4911	1115	71.8%	MT:OK
/rollback	4911	4629	0.2%	MT:OK
/work	25070	23291	1.9%	MT:OK
/registration	2960	2206	19.7%	MT:OK
/backup	976	907	0.1%	MT:OK
/imagedata	32125	30422	0.2%	MT:OK
/application	95623	90683	0.1%	MT:OK
/storage	120903	114680	0.0%	MT:OK
/encryption	976	948	0.2%	MT:OK
/platform	4911	4608	0.6%	MT:OK

Fig.5-43

[G] Initialization of log file (HDD Utility)

Log files for researching can be deleted. Since only a certain amount of log files for researching is usually stored in the work area of an HDD, the use of this mode is not necessary. In case the performance level of the equipment is lowered (e.g.: the response of the control panel becomes extremely slow), make use of this mode. This phenomenon may be resolved.

5.19 76 SRAM Maintenance Mode

5.19.1 Overview

This is a mode in which you can clear particular errors such as F800 or F900.
The processing contents of this mode are the same as those for [Clear SRAM] in [HS-73].

Functions of 76 SRAM Maintenance mode

- Sets the serial number of this equipment.
- Clears F800 error.
- Clears F900 error.

5.19.2 Operation procedure

- (1) Perform [HS-76] by pressing [76 SRAM Maintenance].
Then the following screen is displayed.

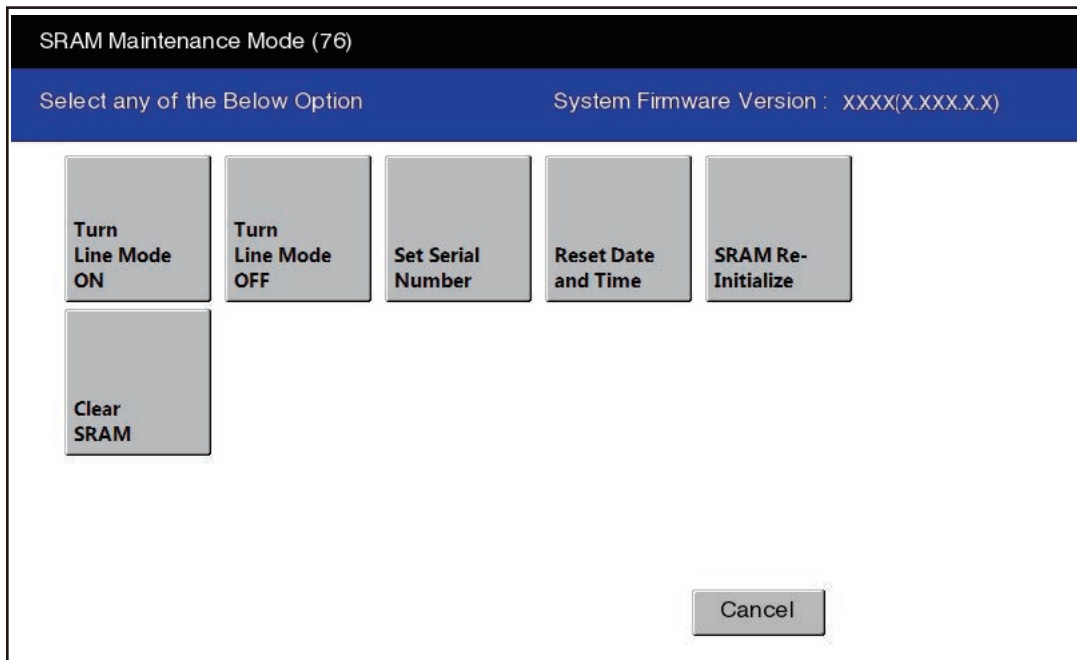

Fig.5-44

- (2) Press the icon to operate.

Notes:

[Turn Line Mode ON] or [Turn Line Mode OFF] starts once each icon is pressed.
When [Set Serial Number], [Reset Date and Time], [SRAM Re-Initialize] or [Clear SRAM] is pressed, the confirmation screen appears.

5.19.3 Functions

[A] Turn Line Mode ON (Manufacturing mode ON)

The equipment enters into the manufacturing mode.

[B] Turn Line Mode OFF (Manufacturing mode OFF)

The equipment enters into the service mode.

[C] Set Serial Number

When replacing SYS-SRAM, select this to set the serial number of the equipment since it must be done in advance of recovery from SRAM backup data.

- Clear SRAM first and then set the serial number in this mode.
- Recover from SRAM backup data after setting the serial number.
Refer to  P. 12-2 “12.1.4 Cloning procedure”

Key in the serial number of this equipment and press [OK].

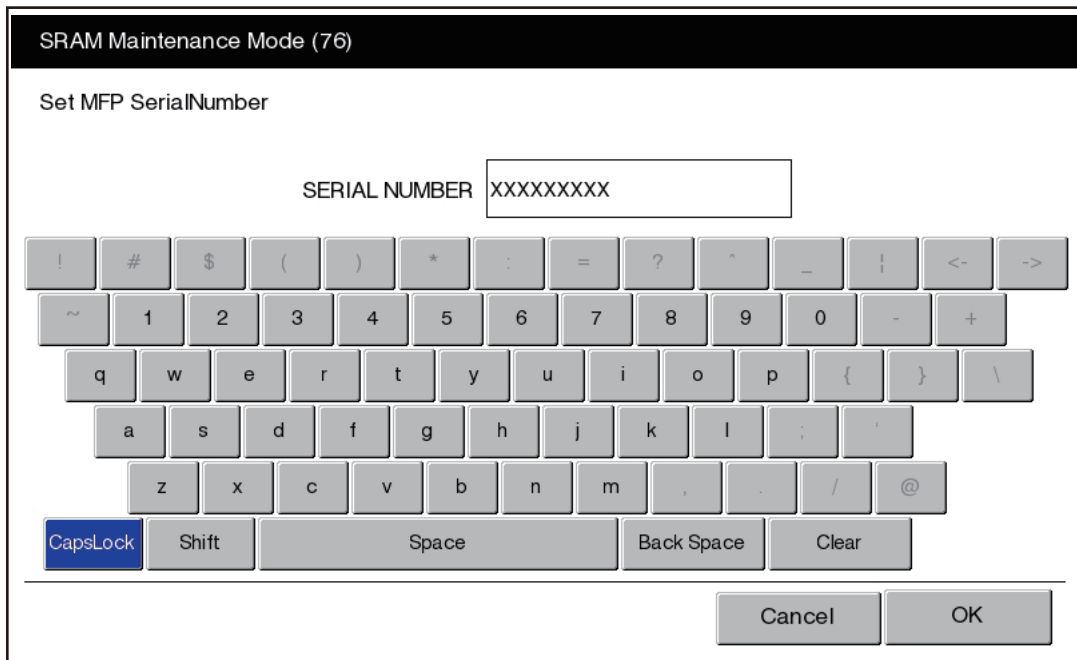

Fig.5-45

[D] Reset Date and Time

Select this to clear an F800 error which occurred when the date and time were set as after the end of the year 2037 or when the actual end of the year 2037 has come.

- After selecting this, start the equipment in the normal mode to reset the date and time.

[E] SRAM Re-Initialize

Since an F900 error cannot be cleared in the 73 Firmware Assist mode, use this function to clear the error in the following cases:

- When the SRAM and the SYS board are replaced at the same time
- When the SRAM is initialized with wrong destination at the replacement of the SRAM
Refer to  P. 9-34 “9.2.5 Precautions and procedure when replacing the SRAM”.

[F] Clear SRAM

Select this to clear all SRAM data when replacing SRAM.

Replace the SRAM and then clear the SRAM data.

After clearing the SRAM data, initialize SRAM following its replacement procedure.

Refer to  P. 9-34 “9.2.5 Precautions and procedure when replacing the SRAM”.

Notes:

When this operation has been done, do not perform HDD partition creation (Format HDD) before the normal start-up.

5.20 Pixel Counter

5.20.1 Outline

[1] Outline

Pixel counter is a function that counts the number of dots emitted by writing light source and converts it into the print ratio (%) per standard paper size. This "Print ratio (%) per standard paper size" is called Pixel count (%).

This function enables you to know how each user uses the equipment and to grasp the tendency of toner consumption (number of output pages per cartridge).

However, since some of the factors in "2" below are not taken into account by the pixel counter, its accuracy does sometimes not match the actual toner consumption.

[2] Factors affecting toner consumption

Standard number of output pages per cartridge shows the average number of output pages under the condition that the data of print ratio 5% is printed on the standard paper size (A4/LT) at a normal temperature and humidity.

However, users do not always print under the above condition. As for the type of original, copy/print mode and environment, each user has different tendency, and as a result, the number of output pages per cartridge becomes different depending on the user.

The major factors affecting toner consumption are as follows:

- Original/Data coverage
- Original/Data density
- Original/Print mode
- Density setting
- Print Pattern
Character images (e.g. Text) consume more toner than solid images even though they may have the same density.
- Number of pages per job
More toner is required when printing in the non-continuous running mode.
- Number of execution times of image quality control
Image quality control is performed automatically when the device is switched on, when it returns from sleep mode, and also during continuous running. Toner consumption may vary depending on the number of image quality adjustments performed during operation.
- Paper
The size, feeding direction and type of paper influence toner consumption.
- Environmental conditions
Temperature and Humidity affect toner consumption.
- Others
In addition to the above, there are other factors that may influence toner consumption. These include variations between individual products, life of consumable, bias voltages, Drum surface potential, etc.

The general relations between the above 4 factors and toner consumption per output page in the copy function are as follows:

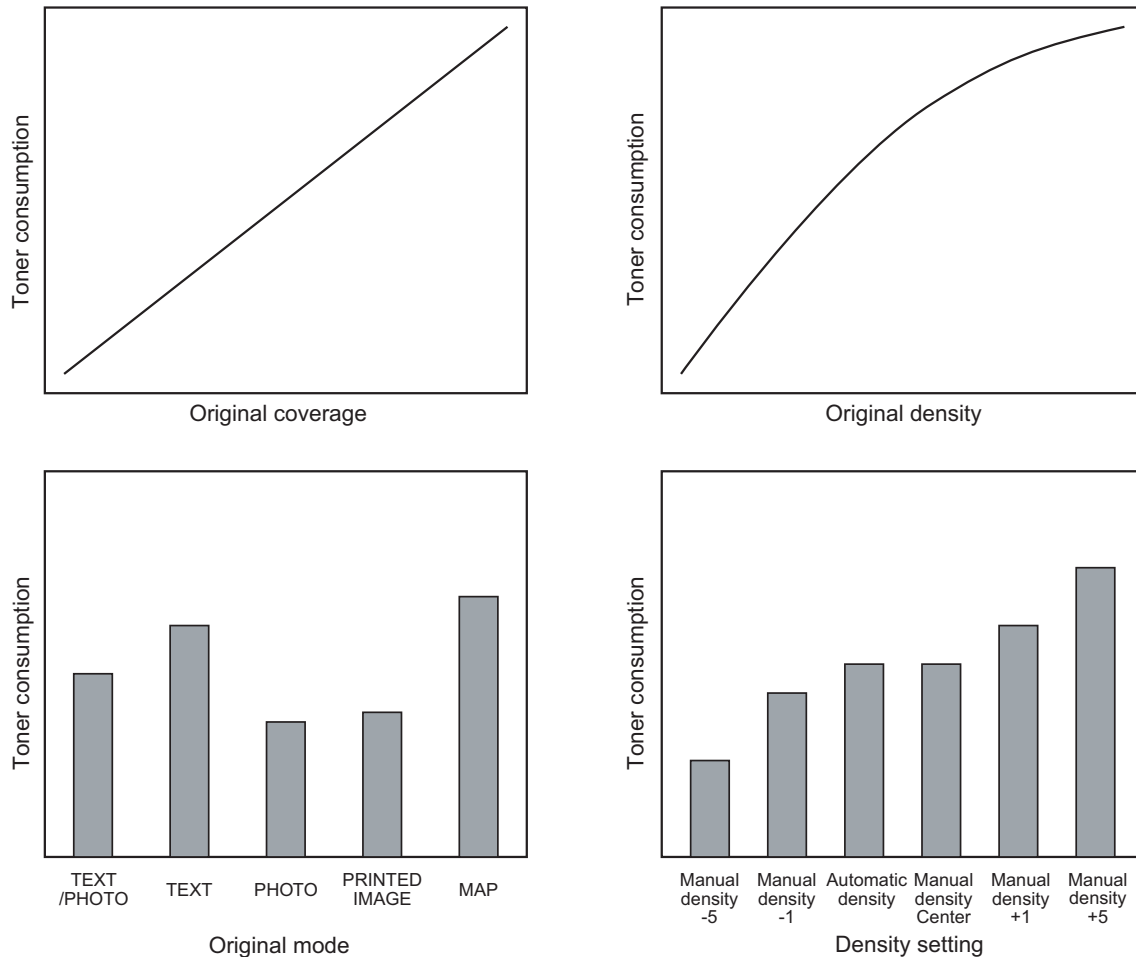

Fig.5-46 Factors affecting toner consumption and the tendency

[3] Details of pixel counter

- Toner cartridge reference and service technician reference
The pixel counter function in this equipment has 2 references, toner cartridge reference and service technician reference.

Toner cartridge reference

This is a system that accumulates data for each color between the installation of a new toner cartridge and the next installation.

The installation of new toner cartridge is judged when the total number of pixel count or output pages after the detection of toner cartridge empty has exceeded the threshold.

The threshold to be used is selectable in the FS-08-6506 between the pixel count and output pages (0: Output pages 1: Pixel counter). The threshold of pixel count is set in the FS-08-6508 and that of output pages is set in the FS-08-6507. When the new toner cartridge is judged as installed, the data related with the previous cartridge is cleared and replaced with the data after the installation of new cartridge. Clearing of the counter of the toner cartridge reference is performed in the FS-08-6503.

Service technician reference

This is a system that accumulates data between clearing the counter of the service technician reference by service technician and subsequently clearing the same counter.

Clearing of the counter of the service technician reference is performed in the FS-08-6502.

- **Print count (number of output pages)**
The number of output pages shown at the pixel counter is counted after converting all paper sizes to the standard paper size (A4/LT). Printing on other than the standard size is converted by paper area ratio. The standard paper size is set in the FS-08-6500.

The examples of conversion are as follows:

Ex.)

When printing on A4/LT size:

Counts the number of output pages as the print count.

When printing on A3/LD size:

Counts the number of output pages multiplied by 2 as the print count. (Area ratio to A4/LT: 200%)

When printing on B4 size:

Counts the number of output pages multiplied by 1.49 as the print count. (Area ratio to A4: 149%)

When printing on LG size:

Counts the number of output pages multiplied by 1.27 as the print count. (Area ratio to LT: 127%)

- **Pixel count (%)**
Pixel count (%) shows the ratio of the emitting pixels of the writing light source to all pixels on standard paper.
The examples of pixel count are as follows:

Notes:

In the following examples, 'solid copy' is considered to be 100%. But since the image has 4 margins, it never becomes 100% actually.

Ex.)

Printing 5 pages on A4/LT size with solid copy (writing light source emits to all pixels.)

→ Pixel count: 100%, Print count: 5

Printing 5 pages on A4/LT size with blank copy (writing light source never emits.)

→ Pixel count: 0%, Print count: 5

Printing 2 pages on A4/LT size with solid copy (writing light source emits to all pixels.)

Printing 2 pages on A4/LT size with blank copy (writing light source never emits.)

→ Pixel count: 50%, Print count: 4

Printing 3 pages on A4/LT size with 6% of writing light source emission

Printing 1 page on A4/LT size with 2% of writing light source emission

→ Pixel count: 5%, Print count: 4

Printing 2 pages on A3/LD size with solid copy (writing light source emits to all pixels.)

→ Pixel count: 100%, Print count: 4

Printing 2 pages on A3/LD size with 6% of writing light source emission

→ Pixel count: 6%, Print count: 4

- **Average pixel count (%) and latest pixel count (%)**
There are 2 types of the value calculated as the pixel count, average pixel count (%) and latest pixel count (%).

Average pixel count (%)

The average value of all pixel count data after each reference data is cleared is calculated and displayed.

Latest pixel count (%)

The value is displayed for printing just before the pixel counter is confirmed.

- Type of calculated data
 Since this is multifunctional and color equipment, the data of pixel count is calculated for each function and color.
 The following list is the information that can be confirmed by LCD screen. But actually, more information can be confirmed by the FS-08.
 See after-mentioned "5)-Display in the FS-08 for details.

Type of calculated data

	Toner cartridge reference				Service technician reference					
	Yellow	Magenta	Cyan	Black	Full color/Twin color					Black
					Total	Yellow	Magenta	Cyan	Black	
Copier function	Yes	Yes	Yes	Yes	Yes	Yes	Yes	Yes	Yes	Yes
Printer function	Yes	Yes	Yes	Yes	Yes	Yes	Yes	Yes	Yes	Yes
FAX function	No	No	No	Yes	No	No	No	No	No	Yes
Total	Yes	Yes	Yes	Yes	Yes	Yes	Yes	Yes	Yes	Yes

Yes: With data
 No: Without data

- Setting related with the pixel counter function
Standard paper size setting
 The standard paper size (A4 or LT) to convert it into the pixel count is selected (FS-08-6500).

Pixel counter display setting
 Whether or not to display the pixel counter on the LCD screen is selected (FS-08-6504).

Display reference setting
 The reference when displaying the pixel counter on the LCD screen (toner cartridge reference or service technician reference) is selected (FS-08-6505).

Determination counter of toner empty
 This is the counter to determine the replacement of new toner cartridge after the toner empty is detected.
 After the toner empty is detected by the auto-toner sensor, this counter checks if toner empty is not detected one more time while the specified number of pixel count or output pages is counted.
 When the toner empty is not detected, the installation of a new toner cartridge is judged.

Pixel counter clearing
 There are 3 types for the pixel count clear as follows:
 FS-08-6501: All information related to the pixel count is cleared.
 FS-08-6502: All information related to the service technician reference pixel count is cleared.
 FS-08-6503: All information related to the toner cartridge reference pixel count is cleared.

[4] Relation between pixel count and toner consumption

The user's printing out the image with large coverage or high density may cause the large value of pixel count. And the setting that toner consumption becomes high in the original mode or density setting may cause it as well.

In this case, the replacement cycle of toner cartridge is faster than the standard number of output pages. Therefore, this trend needs to be grasped for the service.

The relation between pixel count and number of output pages per cartridge is as follows:

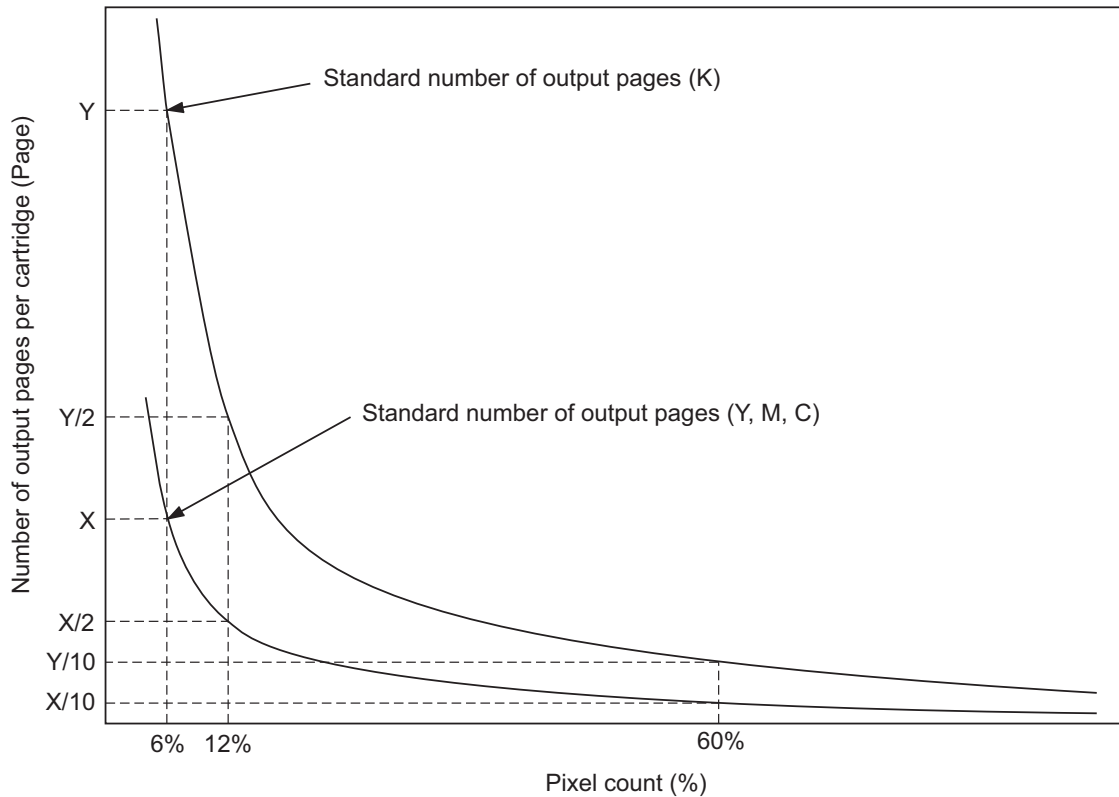

Fig.5-47 Pixel count and number of output pages per cartridge

[5] Pixel counter confirmation

- Display on LCD screen

Whether or not to display the pixel counter on the LCD screen is selected (0: Displayed, 1: Not displayed) in the setting mode (FS-08-6504), and whether or not to display it at the service technician reference or toner cartridge reference is selected (0: Service technician reference, 1: Toner cartridge reference) in the FS-08-6505.

The following screen is displayed when the buttons, [COUNTER] and [PIXEL COUNTER] are pressed in this order after "Displayed" is selected with the code above and the power is, as usual, turned ON. (The displayed buttons are depending on the FS-08-6505.)

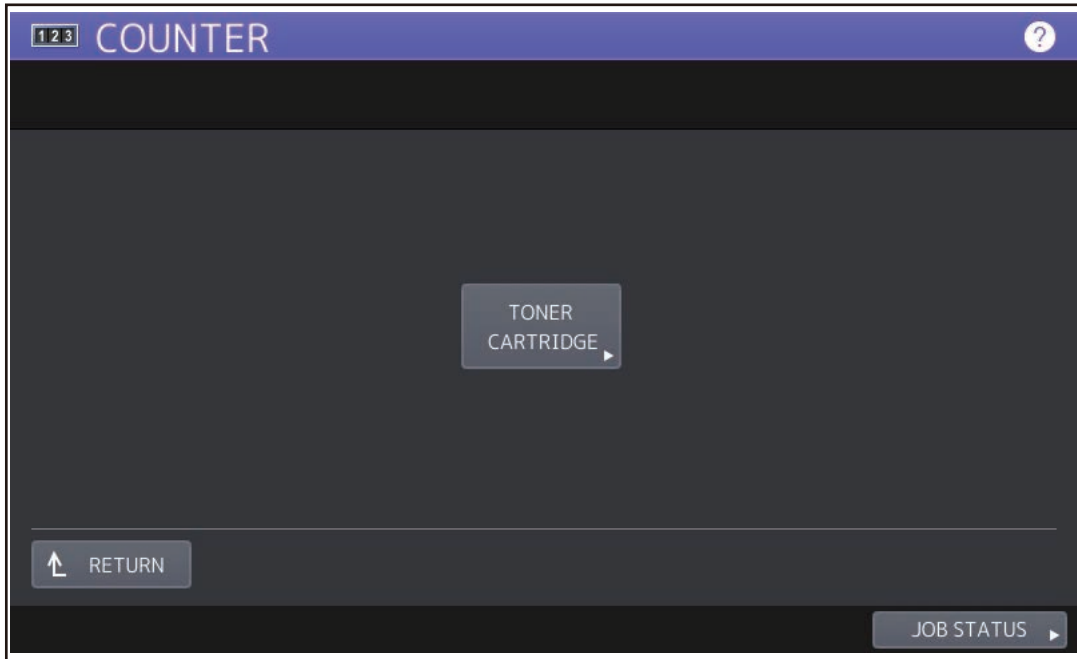

Fig.5-48

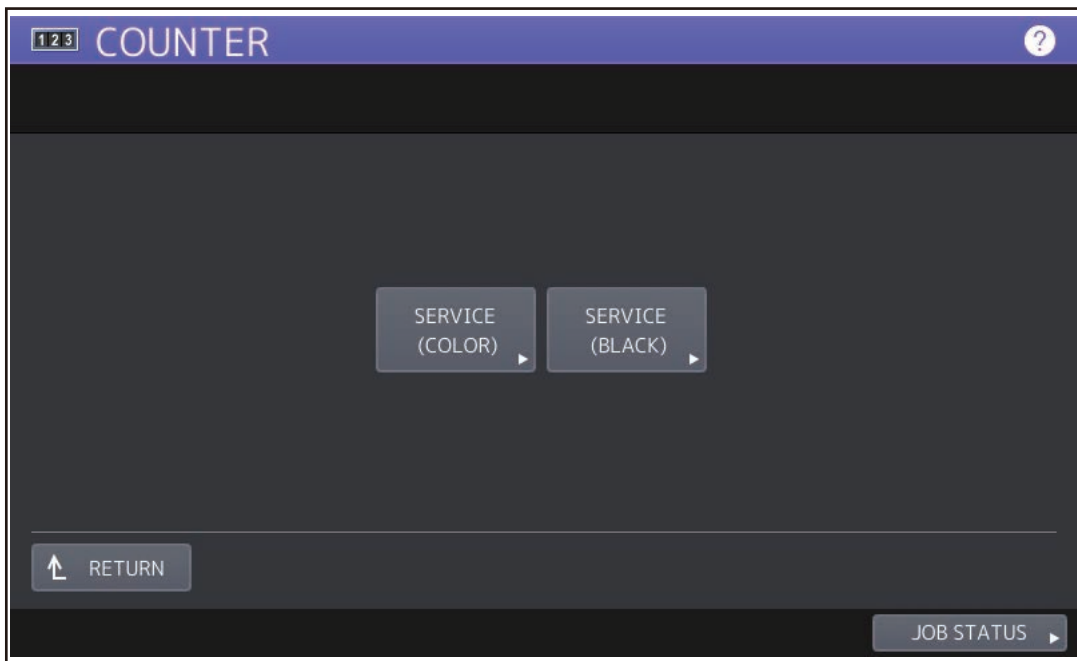

Fig.5-49 Reference selection screen

When selecting and pressing the button in the above screen, each pixel counter screen is displayed.
 [TONER CARTRIDGE]: Information screen of toner cartridge reference is displayed.
 [SERVICE (COLOR)]: Information screen of service technician reference (full color) is displayed.
 [SERVICE (BLACK)]: Information screen of service technician reference (black) is displayed.

The following screen is displayed when pressing [TONER CARTRIDGE].

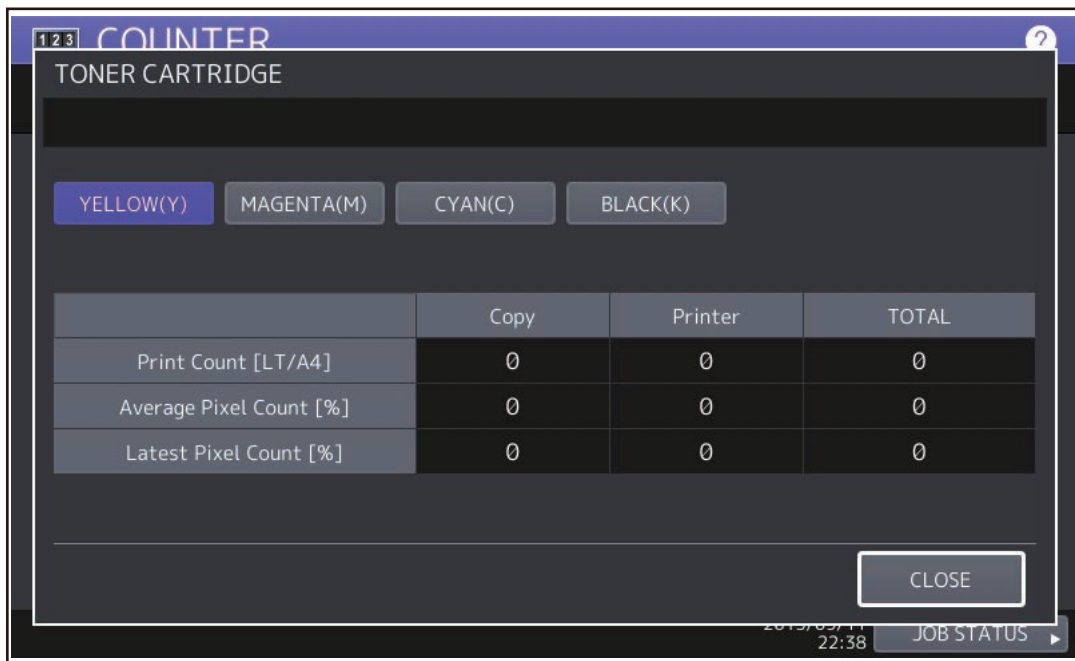

Fig.5-50 Information screen of toner cartridge reference

The following screen is displayed when pressing [SERVICE (COLOR)].

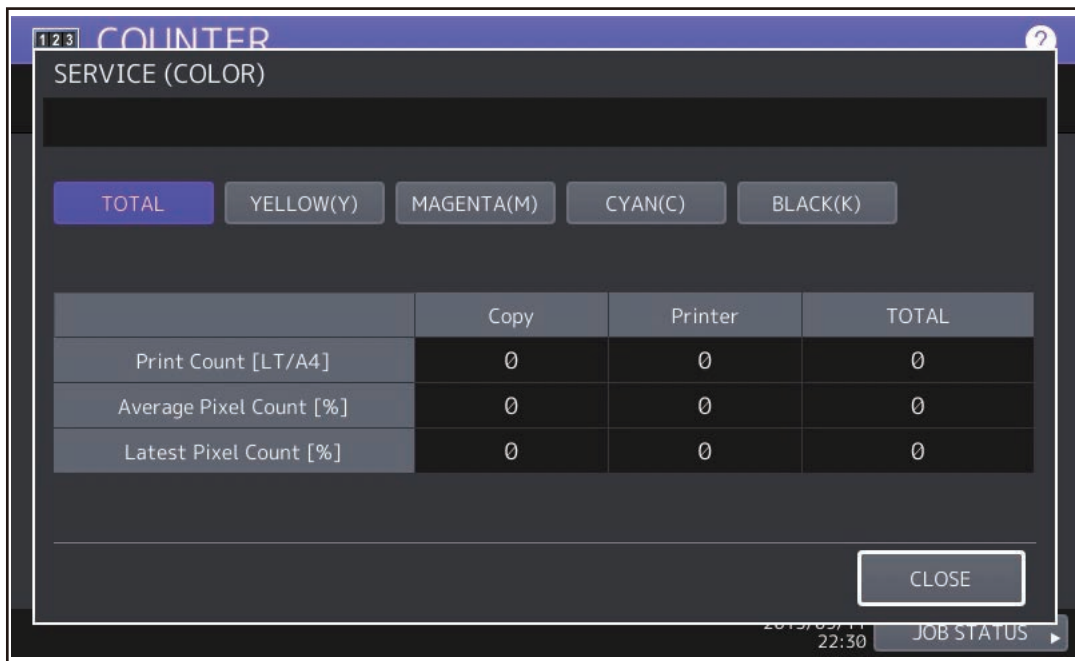

Fig.5-51 Information screen of service technician reference (full color)

The following screen is displayed when pressing the [SERVICE (BLACK)] button.

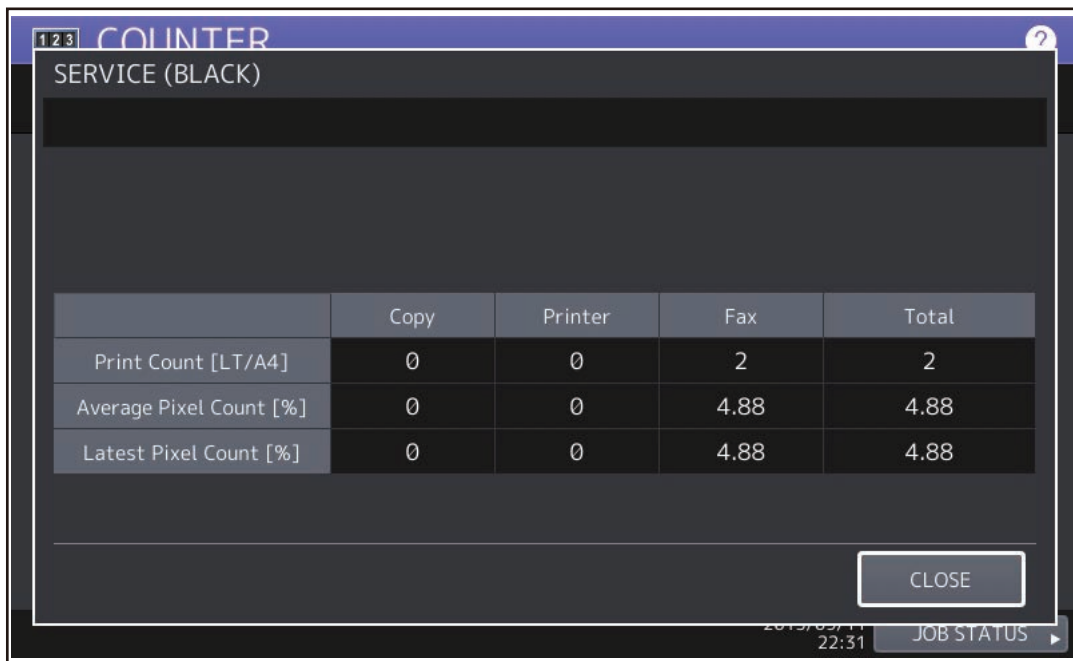

Fig.5-52 Information screen of service technician reference (black)

- Data list printing

The data for pixel counter can be printed in FS-30 LIST PRINT MODE.

FS-30-104: The data of the toner cartridge reference is printed.

FS-30-105: The data of service technician reference is printed.

PIXEL COUNTER CODE LIST

S/N: xxxxxxxx TOTAL: 9999999
TOSHIBA e-STUDIOxxx DF COUNTER: 9999999

'08-02-08 20:13

TONERCARTRIDGE

No	DATE	COL.	PPC	PRN	FAX	TOTAL
0	20080208	Y Print Count[LT/A4]	181	45	---	226
1	20080208	Y Average Pixel Count[%]	2.70	1.74	---	2.51
2	20080208	Y Latest Pixel Count[%]	6.15	0.39	---	0.39
3	20080208	M Print Count[LT/A4]	181	45	---	226
4	20080208	M Average Pixel Count[%]	6.11	2	---	5.29
5	20080208	M Latest Pixel Count[%]	6.82	2.15	---	2.15
6	20080208	C Print Count[LT/A4]	181	45	---	226
7	20080208	C Average Pixel Count[%]	5.46	2	---	4.81
8	20080208	C Latest Pixel Count[%]	6.42	2.73	---	2.73
9	20080208	K Print Count[LT/A4]	278	145	9	432
10	20080208	K Average Pixel Count[%]	6.15	3.86	23.25	5.74
11	20080208	K Latest Pixel Count[%]	7.32	2.19	6.25	2.19

Fig.5-53 Data list of toner cartridge reference

PIXEL COUNTER CODE LIST

S/N: xxxxxxxx

TOTAL: 9999999

TOSHIBA e-STUDIOxxx

DF COUNTER: 9999999

'08-02-08 20:13

SERVICEMAN

No	DATE	COL.		PPC	PRN	FAX	TOTAL
0	20080208	F	Print Count[LT/A4]	181	45	---	226
1	20080208	F	Average Pixel Count[%]	4.95	2.34	---	4.43
2	20080208	F	Latest Pixel Count[%]	8.36	2.34	---	2.34
3	20080208	Y	Print Count[LT/A4]	181	45	---	226
4	20080208	Y	Average Pixel Count[%]	2.7	1.74	---	2.51
5	20080208	Y	Latest Pixel Count[%]	6.15	0.39	---	0.39
6	20080208	M	Print Count[LT/A4]	181	45	---	226
7	20080208	M	Average Pixel Count[%]	6.11	2	---	5.29
8	20080208	M	Latest Pixel Count[%]	6.82	2.15	---	2.15
9	20080208	C	Print Count[LT/A4]	181	45	---	226
10	20080208	C	Average Pixel Count[%]	5.46	2.18	---	4.81
11	20080208	C	Latest Pixel Count[%]	6.42	2.73	---	2.73
12	20080208	K	Print Count[LT/A4]	181	45	---	226
13	20080208	K	Average Pixel Count[%]	5.51	3.43	---	5.10
14	20080208	K	Latest Pixel Count[%]	14.05	4.10	---	4.10
15	20080208	K	Print Count[LT/A4]	97	100	9	206
16	20080208	K	Average Pixel Count[%]	7.36	4.06	23.25	6.45
17	20080208	K	Latest Pixel Count[%]	7.32	2.19	6.25	2.19

Fig.5-54 Data list of service technician reference

- Display in the FS-08 SETTING MODE
Information of pixel count can be also checked in the 08 SETTING MODE.
For details, refer to the “Self-diagnostic code list” (separate document).

Print count, pixel count

Pixel count code table (toner cartridge reference)

		Full color/Twin color				Black	Black (at color) + Black
		Yellow	Magenta	Cyan	Black		
Copier function	Print count (page)	6567	6569	6571	6562	6563	-
	Average pixel count (%)	6619	6620	6621	6622	6623	6624
	Latest pixel count (%)	6636	6637	6638	6639	6724	-
Printer function	Print count (page)	6568	6570	6572	6564	6565	-
	Average pixel count (%)	6625	6626	6627	6628	6629	6630
	Latest pixel count (%)	6640	6641	6642	6643	6725	-
FAX function	Print count (page)	-	-	-	-	6566	-
	Average pixel count (%)	-	-	-	-	6635	-
	Latest pixel count (%)	-	-	-	-	6644	-
Total	Average pixel count (%)	6631	6632	6633	-	-	6634

Pixel count code table (service technician reference)

		Full color/Twin color					Black
		Total	Yellow	Magenta	Cyan	Black	
Copier function	Print count (page)	6557	-	-	-	-	6558
	Average pixel count (%)	6587	6588	6589	6590	6591	6602
	Latest pixel count (%)	6606	6607	6608	6609	6610	6616
Printer function	Print count (page)	6559	-	-	-	-	6560
	Average pixel count (%)	6592	6593	6594	6595	6596	6603
	Latest pixel count (%)	6611	6612	6613	6614	6615	6617
FAX function	Print count (page)	-	-	-	-	-	6561
	Average pixel count (%)	-	-	-	-	-	6604
	Latest pixel count (%)	-	-	-	-	-	6618
Total	Average pixel count (%)	6597	6598	6599	6600	6601	6605

Other information

Toner cartridge replacement counter.

The toner cartridge replacement count is displayed.

- FS-08-6573: Toner cartridge Y
- FS-08-6574: Toner cartridge M
- FS-08-6575: Toner cartridge C
- FS-08-6576: Toner cartridge K

Toner cartridge reference count started date

The toner cartridge reference count started date is displayed.

- FS-08-6519: Toner cartridge Y
- FS-08-6520: Toner cartridge M
- FS-08-6521: Toner cartridge C
- FS-08-6522: Toner cartridge K

Service technician reference cleared date

The service technician reference cleared date is displayed.

FS-08-6510: The date (FS-08-6502 was performed) is stored.

Toner cartridge reference cleared date

The toner cartridge reference cleared date is displayed.

The date (FS-08-6503 was performed) is stored.

- FS-08-6511: Toner cartridge Y
- FS-08-6512: Toner cartridge M
- FS-08-6513: Toner cartridge C
- FS-08-6514: Toner cartridge K

5.21 Batch Setting for Self-Diagnostic Codes

5.21.1 General description

The setting files encrypted in which each setting value has been written can be stored in a USB storage device. Installing this USB storage device in the equipment and reading a setting file enables the batch setting for the self-diagnostic codes.

- After the batch setting is performed, a result file is stored in the USB storage device.
- A maximum of 100 codes can be set in one file. If a code has sub codes, each of them is counted as one code.

Notes:

This function is not available if an automatic execution script such as a log collection is stored in a USB storage device.

5.21.2 Applicable codes

This function is available for the codes, whose values can be set by the service technicians, FS-05/08/13.

Notes:

- The codes only displaying the values and the ones acquiring or clearing the values by automatic execution are not included.
- When a value of the code which exchanges another one sequentially is changed, another one is altered in conjunction with it.
- Setting of the codes FS-08-8911 and FS-08-9000 is not possible.

5.21.3 Setting files

[1] Setting files

An encrypted file in which the setting values for each code to be changed is written in an XML format. A maximum of 100 codes can be set in one file. If a code has sub codes, each of them is counted as one code.

File name: Apply a name by employing the usable characters for an FAT32 format (extension: .diag).

File format: xml format

Notes:

- A setting file has to be encrypted by a dedicated encryption tool and then is stored in a USB storage device.
- A setting file has to be located in the 1st or 2nd layer of the root folder of a USB storage device.
- No other automatic execution script has to be located in the same layer in which a setting file is stored.

[2] Example

```
<Policy>
  <Data>
    <Category-05/>
    <Category-08>
      <Code>
        <MainCode>8724</MainCode>
        <Value>1</Value>
      </Code>
      <Code>
        <MainCode>9240</MainCode>
```

```

        <Value>2</Value>
    </Code>
    <Code>
        <MainCode>9264</MainCode>
        <SubCode>1</SubCode>
        <Value>1</Value>
    </Code>
</Category-08>
<Category-13/>
</Data>
</Policy>

```

Notes:

- The setting value of the code in procedure 10 is written by inserting a comma to divide the values.
E.g.: 08-4106 <Value>128,128</Value>
- Setting is carried out in order of written.
- The read-only codes and the execution codes are skipped to continue the processing if they are included.
- Even if writing of the setting value has failed, the processing will not stop and writing into the setting file will continue to its end.
After the processing has been completed, the result of writing of all codes is stored in a result file and then a message indicating partial success will be displayed.
- If the storing of a result file is not desired, add “<ResultFile>>false</ResultFile>” under “<Policy>”.

Example

```

<Policy>
    <ResultFile>>false</ResultFile>
    <Data>
        <Category-05/>
        <Category-08>
            <Code>
                <MainCode>8724</MainCode>
                <Value>1</Value>
            </Code>

```

5.21.4 Result files

[1] Result files

A file in which success or failure of the replacement of the setting values for each code included in the setting files is written. A result file is stored in a USB storage device after this code is performed.

File name: DIG_RESULT_XXXX_yymmddhhmmss.xml (XXXX: Serial No.)

File format: xml format

[2] Example

```
<Policy>
  <Data>
    <Category-05/>
    <Category-08>
      <Code>
        <MainCode>8724</MainCode>
        <RESULT>SUCCESS</RESULT>
      </Code>
      <Code>
        <MainCode>9240</MainCode>
        <RESULT>FAILED</RESULT>
      </Code>
      <Code>
        <MainCode>9264</MainCode>
        <SubCode>1</SubCode>
        <RESULT>UNSPECIFIED</RESULT>
      </Code>
    </Category-08>
    <Category-13/>
  </Data>
</Policy>
```

- * SUCCESS: Values are updated successfully.
- * FAILED: Update of values fails.
- * UNSPECIFIED: No codes written exist. A value to be set is outside the assignable range.

Notes:

- As for the codes whose values have been altered caused by batch setting of another one, their items, such as the code number, value changed and success/failure of the change, are not described in a result file.
- In case an unavailable code for writing is included in the setting file, the processing will continue and then a message indicating partial success will be displayed after the setting of all codes has been completed. Unavailable codes for writing are displayed in the list by pressing [View]. When [OK] is pressed on the screen of the message indicating partial success or the list screen, the display is returned to the BASIC screen.

5.21.5 Operation procedure

1. Enter into the Classic mode with [FS-08].
2. Install a USB storage device, in which setting files are stored, in the MFP.
3. Key in [3673] and then press the [START] button.
4. Select a setting file.

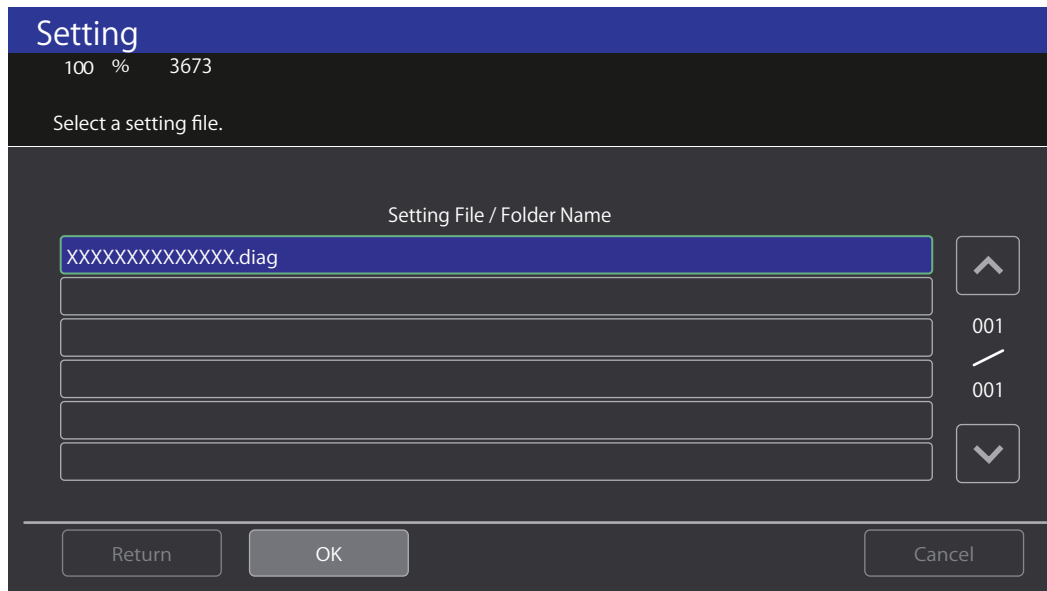

Fig.5-55

5. Press [OK].
6. When settings for all codes included in the setting file are completed, the BASIC screen of the 08 mode appears.
7. Remove the USB storage device.

6. SETTING / ADJUSTMENT

6.1 Image Related Adjustment

6.1.1 Adjustment order

This chapter mainly explains the procedures for image related adjustment. When replacing components which have other specified instructions for adjustment, those specified instructions are to be obeyed in priority.

In the following diagram, the solid lines with arrow lead to essential adjustments, while the dotted lines lead to adjustments to be performed if necessary.

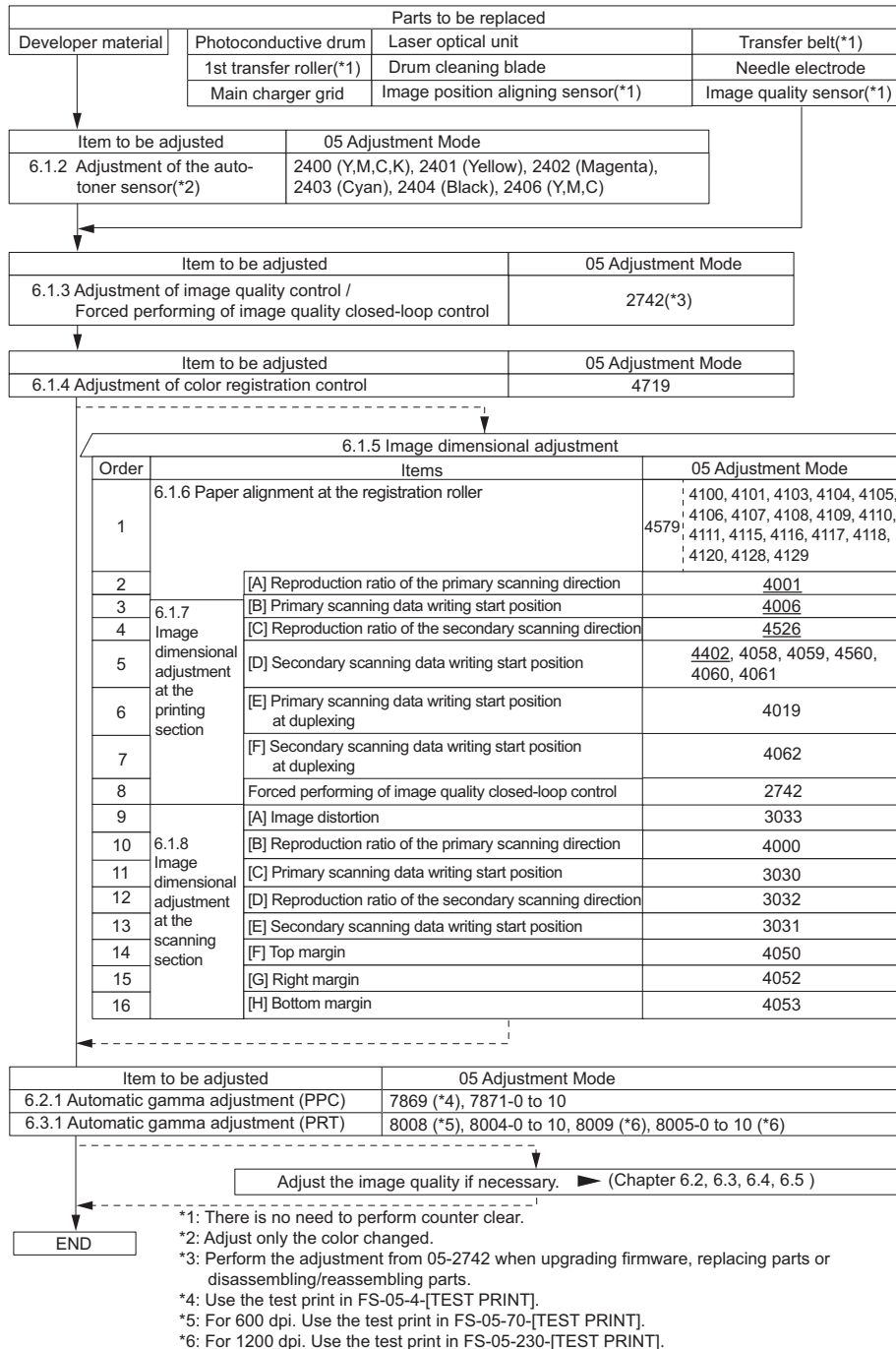

Fig.6-1

6.1.2 Adjustment of the auto-toner sensor

When the developer material is replaced, adjust the auto-toner sensor in the following procedure. If the value of FS-08-2707 (toner density ratio manual offset control) of the replacing developer material has been changed from "0" (default), return the sub code value of the corresponding color to "0".

- (1) Install the cleaner unit and developer unit.

Notes:

Do not install the toner cartridge.

- (2) Perform FS-05. The following message will be displayed.

FS → 05 →

100%	A	A3
TEST MODE		

Fig.6-2

- (3) Key in a code and press the [START] button.

Code		
2400: All developer materials	2401: Developer material Y	2402: Developer material M
2403: Developer material C	2404: Developer material K	2406: Developer material YMC

(Code)
↓

(B) →

100%	2400	A3
TEST MODE		

 → [START]

Fig.6-3

- (4) The message below will be displayed approx. 2 minutes later and the adjustment starts:
 - During the adjustment, "Current sensor voltage (V)" shown in (B) automatically changes and gradually approaches to "Target value (V) for adjustment reference voltage" shown in (A).

(B) →

Y: x.xxV	M: x.xxV	C: x.xxV	K: x.xxV
----------	----------	----------	----------

(C) → Y:***** M:***** C:***** K:***** ww%

(A) →

Y: z.zzV	M: z.zzV	C: z.zzV	K: z.zzV
----------	----------	----------	----------

(B): Current sensor voltage (V)

(C): Adjustment value, Humidity (%)

(A): Target value (V) for adjustment reference voltage

Fig.6-4

- (5) When the “Current sensor voltage (V)” in (B) is converged and the “Sensor output control value (bit value)” corresponding to the value for initial developer material is displayed in (C), the adjustment is completed.
- When the adjustment is completed, [OK] is displayed on the screen.

(B) →	Y: x.xxV	M: x.xxV	C: x.xxV	K: x.xxV
(C) →	Y: yyy	M: yyy	C: yyy	K: yyy
(A) →	Y: z.zzV	M: z.zzV	C: z.zzV	K: z.zzV

(B): Current sensor voltage (V)

(C): Sensor output control value (bit value)

(A): Target value (V) for adjustment reference voltage

Fig.6-5

Notes:

The values in (A), (B) and (C) vary with humidity.

- (6) Press [OK] to store the adjustment result in the memory.
- (7) Turn the power OFF and install the toner cartridges.

Notes:

When “Waste toner box replacement” is displayed at adjustment, follow the steps below.

<When “Waste toner box replacement” is displayed>

1. Replace the waste toner box with a new one and close the front cover.
2. Key in [4833] (Recovery from toner empty/waste toner full).
3. Check that “WAIT” is displayed.

6.1.3 Performing image quality control

- (1) When unpacking
Prior to image dimensional adjustment, perform the “Forced performing of image quality closed-loop control (FS-05-2742)” procedure.
- (2) When any of the following parts is replaced, be sure to perform the “Forced performing of image quality closed-loop control (FS-05-2742)” procedure.
 - Photoconductive drum
 - Developer material Y, M, C, K
 - Laser optical unit
 - Transfer belt
 - 1st transfer roller
 - Drum cleaning blade
 - Needle electrode
 - Main charger grid
 - Image position aligning sensor (Front)
 - Image position aligning sensor (Rear)/Image quality sensor

Notes:

Check that there is no problem in the secondary scanning data writing start position (e.g.: the void at the leading edge is too small or too wide) after “Forced performing of image quality closed-loop control (FS-05-2742)” has been performed.

When performing “Automatic gamma adjustment” in addition, “Forced performing of image quality closed-loop control (FS-05-2742)” should be done first.

- (3) When performing “Automatic gamma adjustment” in cases no parts written above are replaced, do the “Forced performing of image quality closed-loop control (FS-05-2742)” procedure before “Automatic gamma adjustment”.

Code	Item to be adjusted	Contents
2742	Forced performing of image quality closed-loop control	<p><Procedure></p> <ol style="list-style-type: none"> 1. Perform FS-05-2742. 2. “WAIT” is displayed. 3. When the adjustment finishes normally, the equipment returns to the initial state of Adjustment Mode. <p>When an error occurs</p> <p><When “Waste toner box replacement” is displayed></p> <ol style="list-style-type: none"> 1. Replace the waste toner box with a new one and close the front cover. 2. Key in [4833] (Recovery from toner empty/waste toner full). 3. Check that “WAIT” is displayed. <p><When toner empty is displayed></p> <ol style="list-style-type: none"> 1. Replace the empty toner cartridge with a new one and close the front cover. 2. Key in [4833] (Recovery from toner empty/waste toner full). 3. Check that “WAIT” is displayed. <p><Other abnormalities></p> <p>Take the appropriate action described in Troubleshooting.  P. 8-1 “8. ERROR CODE AND TROUBLESHOOTING”</p>

6.1.4 Adjustment of color registration control

After having finished the “Forced performing of image quality closed-loop control (FS-05-2742)” procedure, perform the “Forced performing of color registration control adjustment (FS-05-4719)” procedure.

Code	Item to be adjusted	Contents
4719	Forced performing of color registration control	<p><Procedure></p> <ol style="list-style-type: none"> 1. Perform FS-05-4719. 2. When the adjustment finishes normally, the equipment returns to the initial state of Adjustment Mode. <p>If the following errors are displayed after performing FS-05-4719, clear the error by following the steps below, and then perform FS-05-4719 again.</p> <p><When “Waste toner box replacement” is displayed></p> <ol style="list-style-type: none"> 1. Replace the waste toner box with a new one and close the front cover. 2. Key in [4833] (Recovery from toner empty/waste toner full). 3. Check that “WAIT” is displayed. <p><When toner empty is displayed></p> <ol style="list-style-type: none"> 1. Replace the empty toner cartridge with a new one and close the front cover. 2. Key in [4833] (Recovery from toner empty/waste toner full). 3. Check that “WAIT” is displayed. <p><Other abnormalities></p> <p>Take the appropriate action described in Troubleshooting.  P. 8-1 “8. ERROR CODE AND TROUBLESHOOTING”</p>

6.1.5 Image dimensional adjustment

There are several adjustment items in the image dimensional adjustment, as listed below. Prior to this image dimensional adjustment, perform “Forced performing of image quality closed-loop control (FS-05-2742)” and “Forced performing of color registration control (FS-05-4719)”.

In this equipment, it is necessary to perform “Forced performing of image quality closed-loop control (FS-05-2742)” in order to adjust the dislocation at the data writing start position in the primary scanning direction even after the image dimensional adjustment.

When adjusting these items, the following adjustment order should strictly be observed.

Item to be adjusted		Code in 05 Adjustment Mode
1. Paper alignment at the registration roller		4579 4100, 4101, 4103, 4104, 4105, 4106, 4107, 4108, 4109, 4110, 4111, 4115, 4116, 4117, 4118, 4120, 4128, 4129
2. Printer-related image dimensional adjustment	Reproduction ratio of the primary scanning direction	4001
	Primary scanning data writing start position	4006
	Reproduction ratio of the secondary scanning direction (Fine adjustment of transfer belt motor rotation speed)	4526
	Secondary scanning data writing start position	4402, 4058, 4059, 4060, 4061, 4560
	Primary scanning data writing start position at duplexing	4019
	Secondary scanning data writing start position at duplexing	4062
	Forced performing of image quality closed-loop control	2742
3. Scanner-related image dimensional adjustment	Image distortion	3033
	Reproduction ratio of the primary scanning direction	4000
	Primary scanning data writing start position	3030
	Reproduction ratio of the secondary scanning direction	3032
	Secondary scanning data writing start position	3031
	Top margin	4050
	Right margin	4052
	Bottom margin	4053

Notes:

Once the adjustment of the following codes has been performed, when image adjustment has been done by other codes and then adjustment of any of the following codes has been made again, recheck the images by outputting them from all drawers. In addition, retry the image dimensional adjustment from the beginning, if necessary.

05-4001, 4006, 4526-0, 4402

Remarks:

By entering the paper size used in the field in FS-05-4922 and then performing FS-05-4920, the differential in the paper size between the one used at the adjustment before factory shipment and the one used in the field is reflected to the equipment. Due to this, the margin around the image can be corrected easily.

[Procedure to key in adjustment values]

In accordance with the procedure described below, adjust the value of each item so that the measured values obtained from test copies satisfy the specification.

By pressing [TEST COPY] in the ready state of 05 Adjustment Mode, single sided test copying in the normal copy mode can be performed.

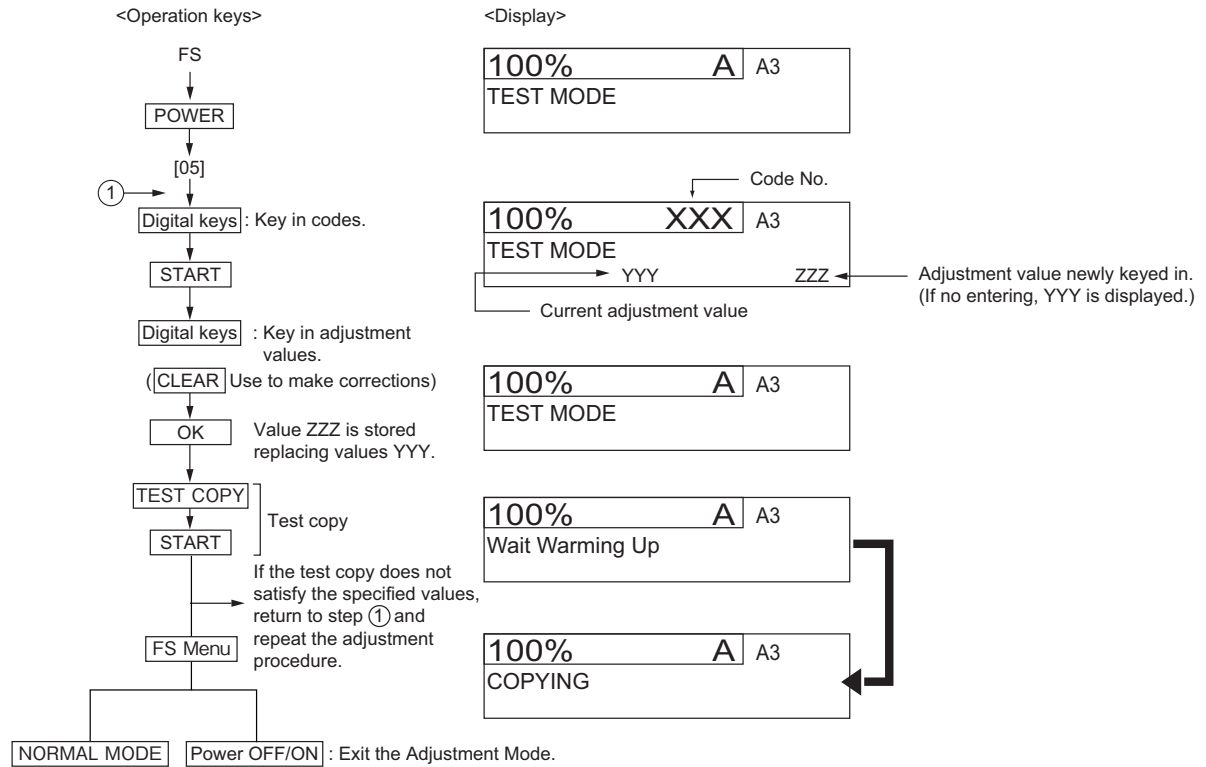

Fig.6-6

6.1.6 Paper alignment at the registration roller

[A] Adjustment with control panel

Paper alignment at the registration roller can be adjusted in the following procedure by performing the code FS-05-4579.

- 1. Select the drawer.

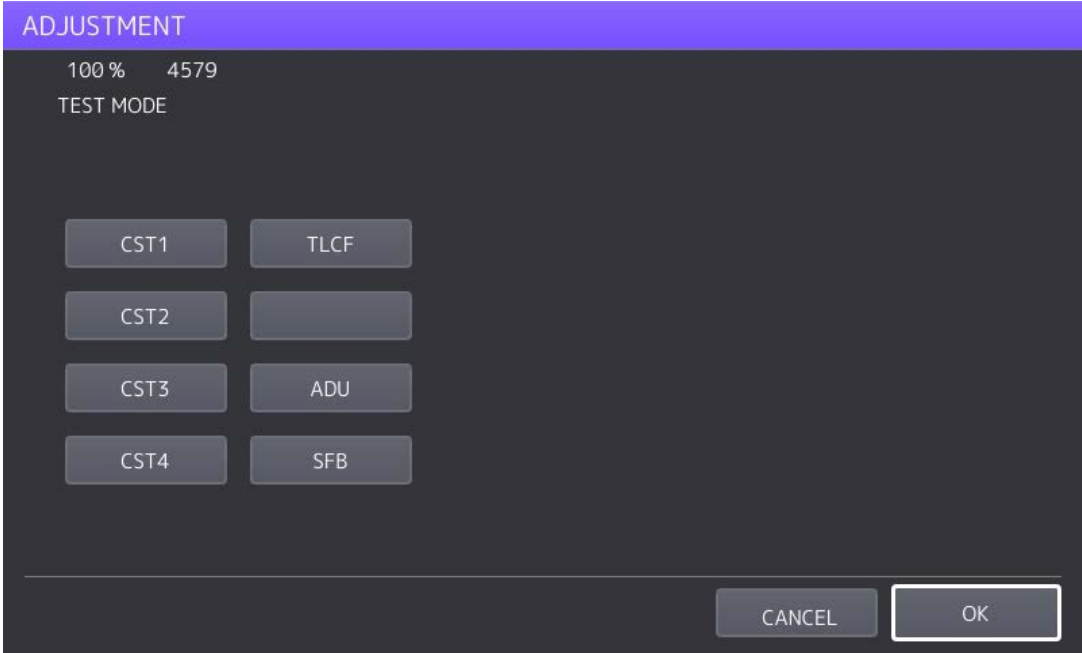

Fig.6-7

- 2. Select the paper size.

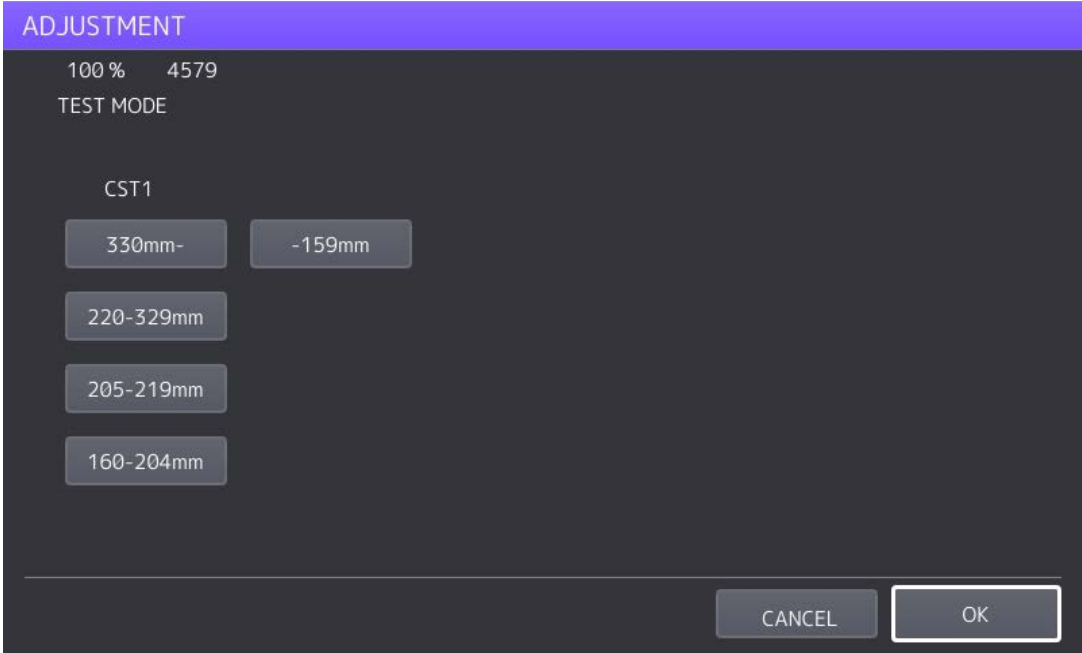

Fig.6-8

3. Select the media type.

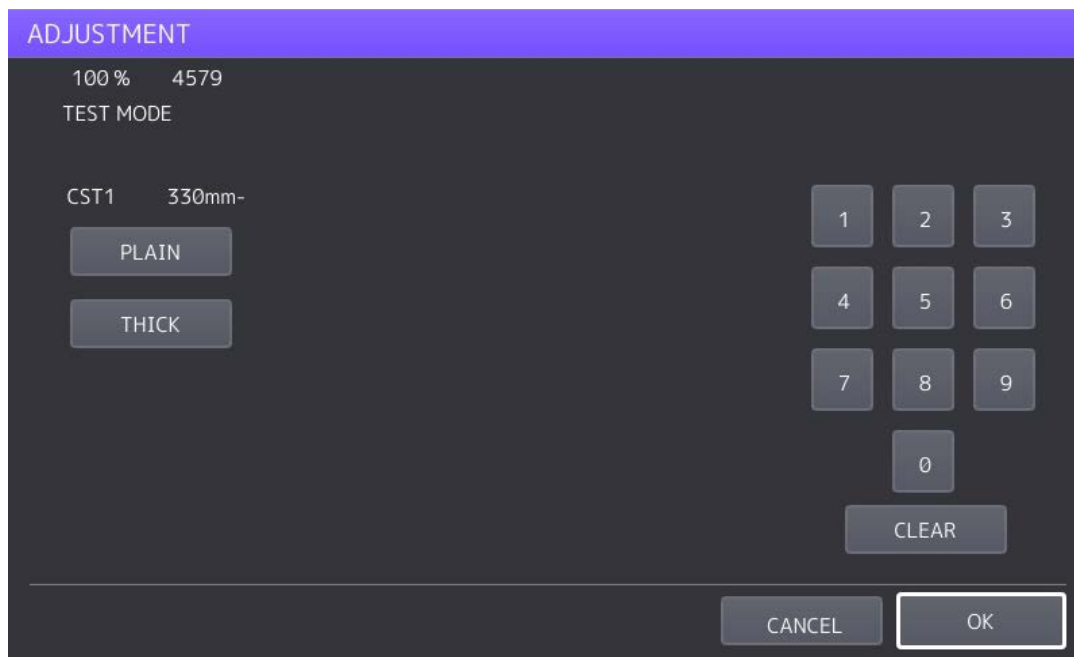

Fig.6-9

4. Key in the adjustment value.

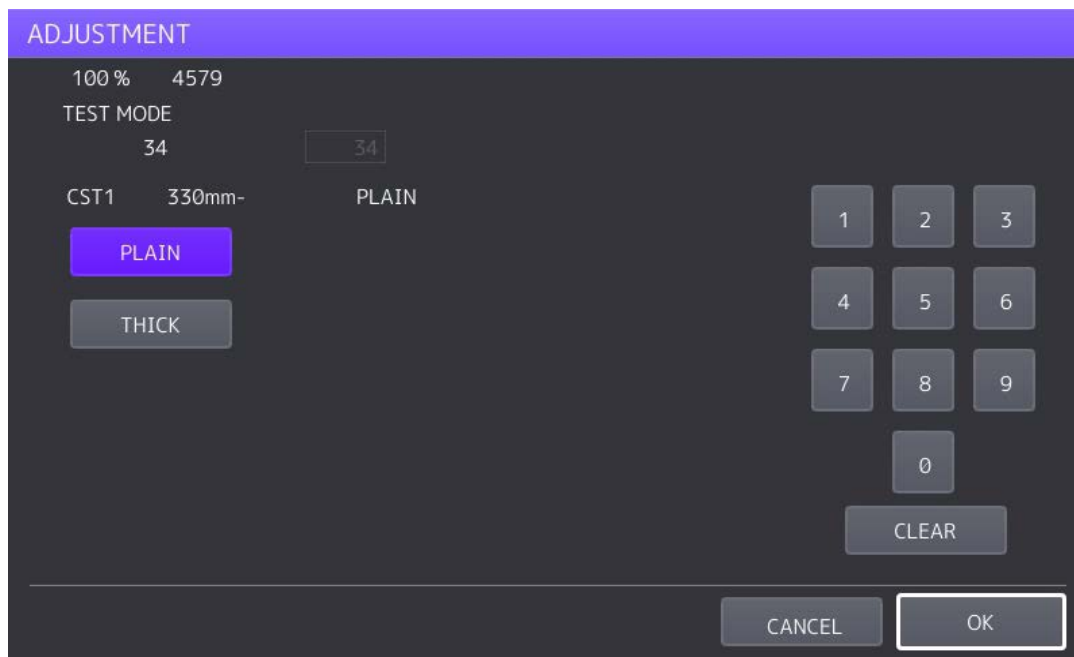

Fig.6-10

5. Press [OK] to finish the adjustment.

* Press the [FUNCTION CLEAR] button to return to the previous menu.

[B] Adjustment by direct code entry

The aligning amount is adjusted by using the following codes in 05 Adjustment Mode.

Drawer	Code	Sub code	Paper size (Select the paper size with the sub code.)	Paper type*
1st drawer (CST1)	4100	0,1,2,3,4	0: 330 mm or longer (13.0 inches or longer) 1: 220–329 mm (8.7–12.9 inches) 2: 205–219 mm (8.1–8.6 inches) 3: 160–204 mm (6.3–8.0 inches) 4: 159 mm or shorter (6.26 inches or shorter)	Plain/Recycled/Thick
	4115	0,1,2,3,4		Thick1/Thick2/Thick3
2nd drawer (CST2)	4101	0,1,2,3,4		Plain/Recycled/Thick
	4116	0,1,2,3,4		Thick1/Thick2/Thick3/ Envelope
3rd drawer (CST3)	4108	0,1,2,3,4		Plain/Recycled/Thick
	4117	0,1,2,3,4		Thick1/Thick2/Thick3/ Envelope
4th drawer (CST4)	4109	0,1,2,3,4		Plain/Recycled/Thick
	4118	0,1,2,3,4		Thick1/Thick2/Thick3/ Envelope
Bypass feed	4103	0,1,2,3,4		Plain/Recycled/Thick/Thin
	4104	0,1,2,3,4		Thick1
	4105	0,1,2,3,4		Thick2/Envelope
	4106	0,1,2,3,4		Thick3/Thick4
	4107	0,1,2,3,4		OHP
	4128	0,1,2,3,4		Special1
	4129	0,1,2,3,4		Special2/Special3
ADU	4110	0,1,2,3,4		0: 330 mm or longer (13.0 inches or longer) 1: 220–329 mm (8.7–12.9 inches) 2: 205–219 mm (8.1–8.6 inches) 3: 160–204 mm (6.3–8.0 inches) 4: 159 mm or shorter (6.26 inches or shorter)
	4120	0,1,2,3,4	Thick1/Thick2/Thick3/ Special1/Special2	
LCF	4111	-	-	Plain

* Weight:

Thin: 52 to 59 g/m² (14 lb. Bond to 16 lb. Bond)

Plain: 60 to 80 g/m² (16 lb. Bond to 22 lb. Bond)

Thick: 81 to 105 g/m² (22 lb. Bond to 28 lb. Bond)

Thick 1: 106 to 163 g/m² (28 lb. Bond to 60 lb. Cover (90 lb. Index))

Thick 2: 164 to 209 g/m² (61 lb. Cover to 77.3 lb. Cover (115.7 lb. Index))

Thick 3: 210 to 256 g/m² (140 lb. Index)

Thick 4: 257 to 280 g/m² (150 lb. Index)

<Procedure>

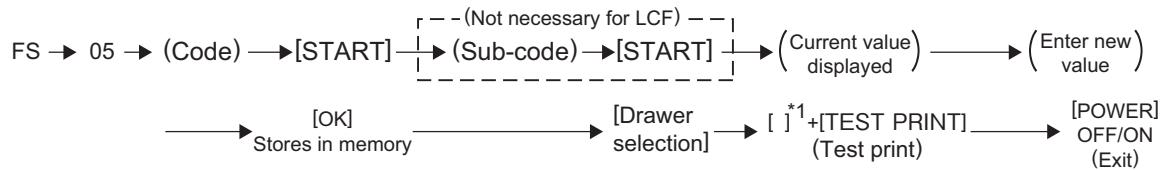

Fig.6-11

- (*1) 1: Single-sided grid pattern in Black Mode
- 3: Double-sided grid pattern in Black Mode
- 55: Grid pattern of thick paper 2 in Full Color Mode
- 56: Grid pattern of thick paper 3 in Full Color Mode
- 57: Grid pattern of OHP film in Full Color Mode
- 58: Single-sided grid pattern of thick paper 2 in Black Mode
- 59: Single-sided grid pattern of thick paper 3 in Black Mode
- 60: Single-sided grid pattern of OHP film in Black Mode
- 98: Single-sided grid pattern in K(4)* Mode

K(4)*: System in which the test pattern is printed only in the black mode, though the four color developers (Y, M, C, K) are contacted to the transfer belt.

Notes:

If the aligning amount is too large, abnormal noise (paper-folding noise) or actual paper folding may occur during paper feeding. If the aligning amount is too small, on the other hand, a skew, an image dislocation in feeding direction, E010 (Jam not reaching the exit sensor), E011 (Transfer belt paper-clinging jam), or E013 (The paper jam occurred between the registration pass sensor and the paper clinging detection sensor) may occur. Pay attention to the above and select the appropriate value.

6.1.7 Image dimensional adjustment at the printing section

This adjustment is performed by using the chart output from the equipment. There are two ways of the image dimensional adjustment; Type 1 and Type 2.

- Type 1: Adjusts the image position and the ratio by using the front side of the leading edge as a reference.

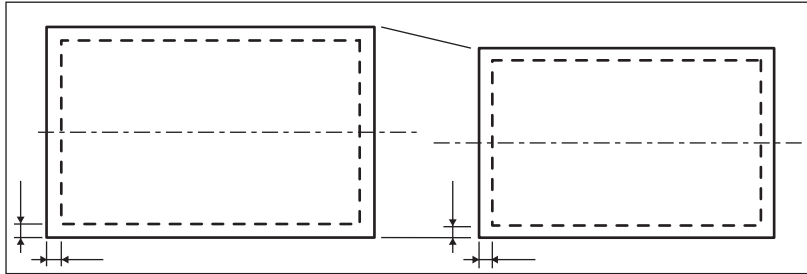

Fig.6-12

- Adjustment can be made with a high degree of accuracy.
 - The reference is given to the front side of the leading edge. Therefore, when the paper size is changed, the margin around the paper tends to be altered accordingly.
- Type 2: Adjusts the image position and the ratio by using the center of the paper path and that for the image.

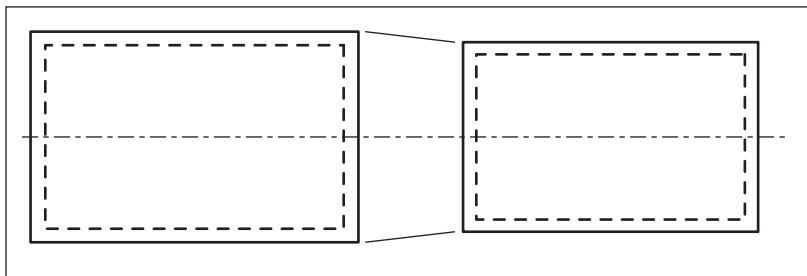

Fig.6-13

- The image position at the front and the back sides can make to be aligned easily.
- The margin around the paper can make to be evenly aligned easily.

Use the appropriate chart corresponding to the adjustment instruction. After the image dimensional adjustment, perform “Forced performing of image quality closed-loop control (FS-05-2742)”.

In addition, check that no gap has occurred in the following adjustments.

Scanner: P. 6-16 “[C] Reproduction ratio of the secondary scanning direction (Fine adjustment of transfer belt motor rotation speed)”

RADF: P. 6-140 “6.15.6 Adjustment of copy ratio”

Type 1: Adjustment to make the size of an image match

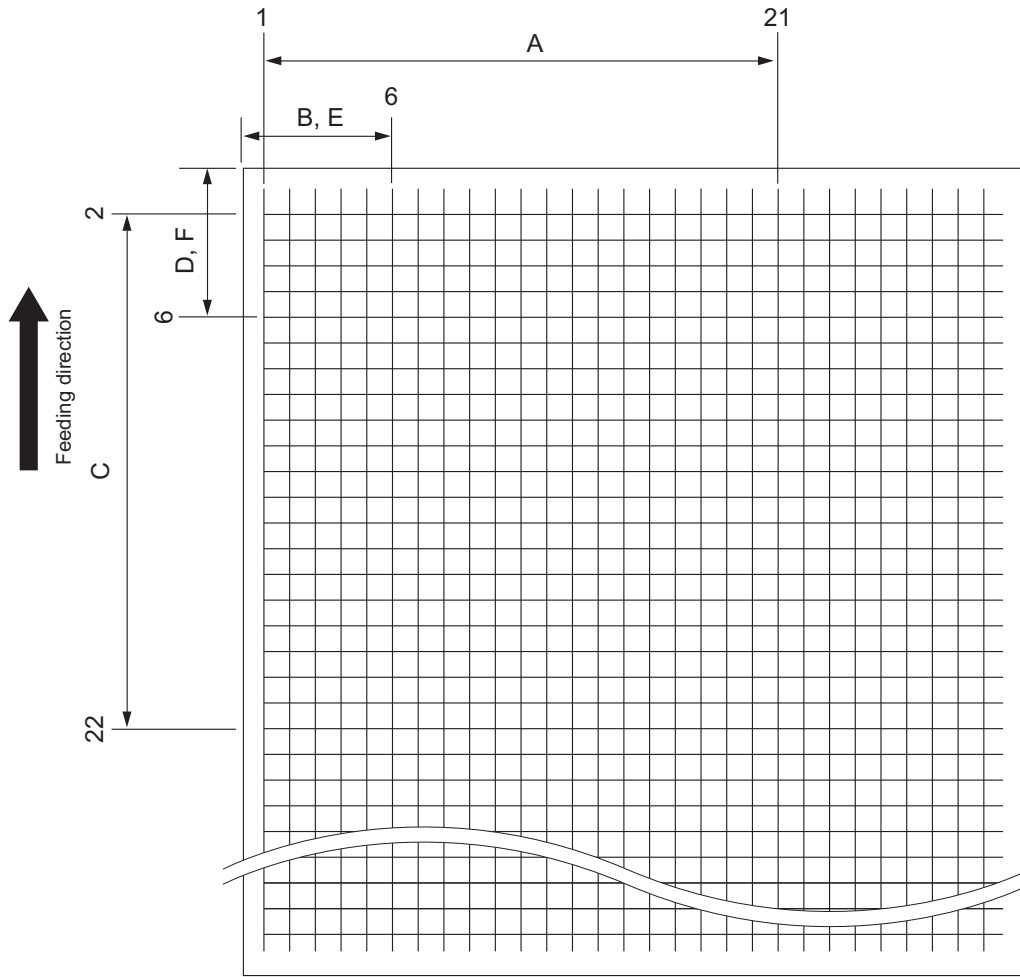

* E, F : Measure on the top side of the chart.

Fig.6-14

	Adjustment Tolerance	Detail of adjustment	Chart
A	200 ± 0.5mm	📖 P. 6-15 "[A] Reproduction ratio of the primary scanning direction"	05-98
B	52 ± 0.5mm	📖 P. 6-15 "[B] Primary scanning data writing start position"	
C	200 ± 0.5mm	📖 P. 6-16 "[C] Reproduction ratio of the secondary scanning direction (Fine adjustment of transfer belt motor rotation speed)"	
D	52 ± 0.5mm	📖 P. 6-17 "[D] Secondary scanning data writing start position"	05-3
E	52 ± 0.5mm	📖 P. 6-18 "[E] Primary scanning data writing start position at duplexing"	
F	52 ± 0.5mm	📖 P. 6-19 "[F] Secondary scanning data writing start position at duplexing"	

Type 2: Adjustment to make the void width match

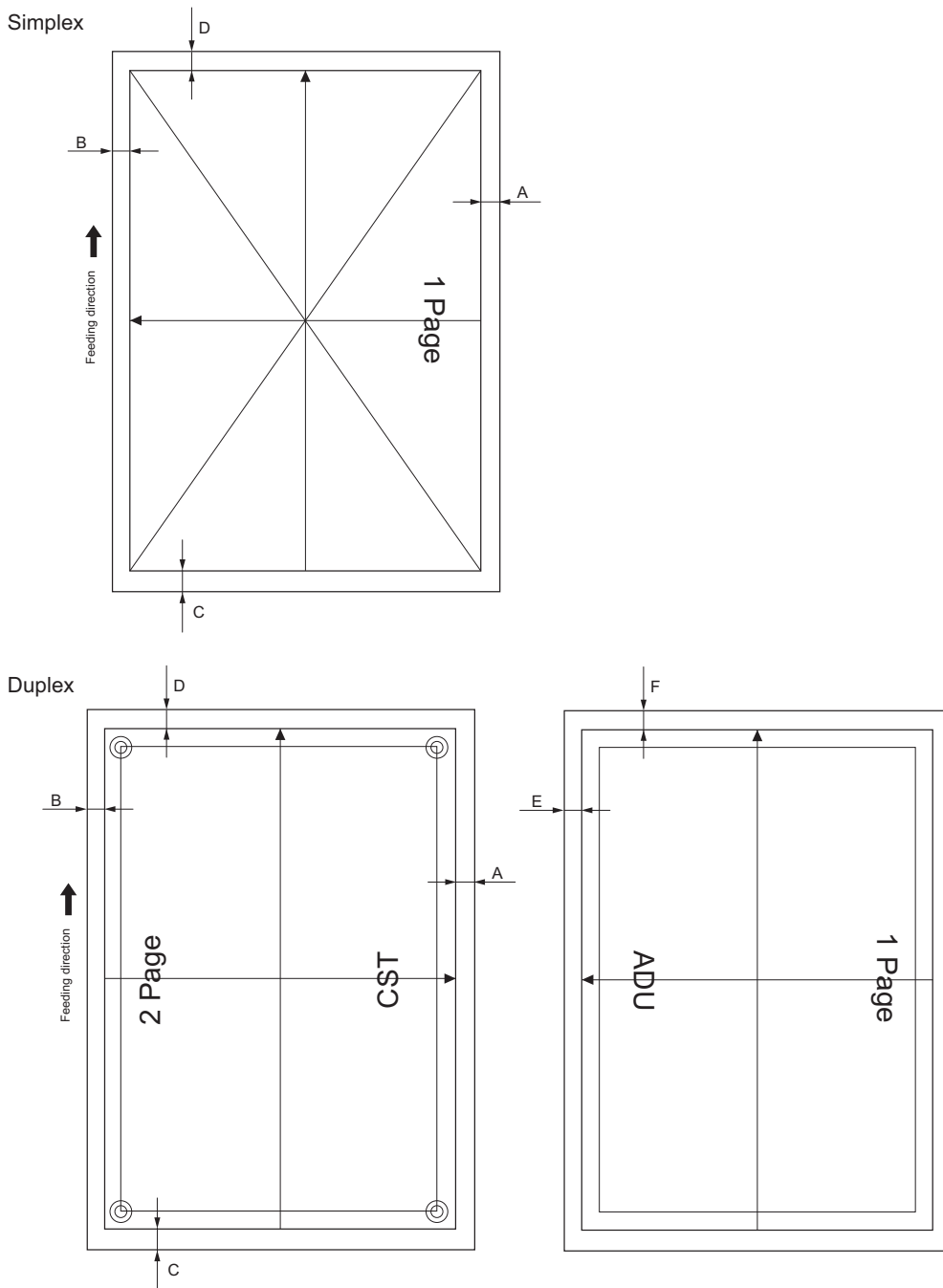

Fig.6-15

	Adjustment Tolerance	Detail of adjustment	Chart
A	$4.2 \pm 0.5\text{mm}$	P. 6-15 "[A] Reproduction ratio of the primary scanning direction"	05-315
B	$4.2 \pm 0.5\text{mm}$	P. 6-15 "[B] Primary scanning data writing start position"	
C	$4.2 \pm 0.5\text{mm}$	P. 6-16 "[C] Reproduction ratio of the secondary scanning direction (Fine adjustment of transfer belt motor rotation speed)"	
D	$4.2 \pm 0.5\text{mm}$	P. 6-17 "[D] Secondary scanning data writing start position"	
E	$4.2 \pm 0.5\text{mm}$	P. 6-18 "[E] Primary scanning data writing start position at duplexing"	05-316
F	$4.2 \pm 0.5\text{mm}$	P. 6-19 "[F] Secondary scanning data writing start position at duplexing"	

[A] Reproduction ratio of the primary scanning direction

1. Print out the chart in the ready state of FS-05 (Classic mode).
Press FS-05-98 or FS-05-315 → [TEST PRINT].
* Use A3/LD from the 2nd drawer.
2. Check that the distance A of each chart is within the acceptable range.
05-98: 200 ± 0.5 mm*
05-315: 4.2 ± 0.5 mm
* When A3/LD is used, the margin at the trailing edge of the paper will be deleted. Due to this, it is recommended to adjust between 199.5 to 200 mm.
3. If not, use the following procedure to change the values and measure the distance A again.
<Procedure>
FS-05-4001 → [START].
→ Key in a value (acceptable values: 0 to 255) → [OK] (Stored in the memory)
→ "100% A" is displayed → Key in the chart number → [TEST PRINT] → (A chart is printed out.)
* The larger the adjustment value is, the longer the distance A becomes (approx. 0.10 mm/step).

Notes:

Make sure the first line of the grid pattern is printed properly since it occasionally vanishes.

[B] Primary scanning data writing start position

1. Print out the chart in the ready state of FS-05 (Classic mode).
Press FS-05-98 or FS-05-315 → [TEST PRINT].
* Use A3/LD from the 2nd drawer.
2. Check that the distance B of each chart is within the acceptable range.
05-98: 52 ± 0.5 mm
05-315: 4.2 ± 0.5 mm
3. If not, use the following procedure to change the values and measure the distance B.
<Procedure>
FS-05-4006 → [START]
→ (Key in a value (acceptable values: 0 to 255)) → [OK] (Stored in the memory)
→ "100% A" is displayed → Key in the chart number → [TEST PRINT] → (A chart is printed out.)
* The larger the adjustment value is, the longer the distance B becomes (approx. 0.04 mm/step).

Notes:

Make sure the first line of the grid pattern is printed out since the line is occasionally vanished.

[C] Reproduction ratio of the secondary scanning direction (Fine adjustment of transfer belt motor rotation speed)

Code	Sub code	Function	Remarks
4526	0	PRT/PPC (Normal speed)	When the value increases, the reproduction ratio in the secondary scanning direction becomes larger. 0.056%/step
	4	PRT/PPC (Reduced speed)	

If the sub code "0" of FS-05-4526 is adjusted, the adjustment value of sub code 4 is also automatically changed in conjunction with the adjusted value, according to the proper parameter.

[C-1] Confirmation of FS-05-4526-0

1. Print out the chart in the ready state of FS-05 (Classic mode).
Press FS-05-98 or FS-05-315 → [TEST PRINT].
* Use A3/LD from the 2nd drawer.
2. Check that the distance C of each chart is within the acceptable range.
05-98: 200 ± 0.5 mm*
05-315: 4.2 ± 0.5 mm
* For A3/LD, it is recommended to adjust the distance C above within the range of 199.5 mm and 200 mm otherwise the margin of the trailing edge may be deleted.
3. If not, perform the procedure in "[C-2] Adjustment of FS-05-4526-0" to change the values and measure the distance C again.
4. Perform the color registration (4719) after the adjustment.

Notes:

Make sure the first line of the grid pattern(05-98) is printed out since the line is occasionally vanished.

[C-2] Adjustment of FS-05-4526-0

- FS-05-4526 → [START] → (Key in the sub-code [0]) → [START]
→ (Key in a value (acceptable values: 0 to 255)) → [OK] (Stored in the memory)
- * When the measured value is not within the acceptable range, the trailing edge area of the image may be out of position for the paper length or the density at the trailing edge area of the image may become lower. To avoid this, perform the adjustment while checking the image.
- "100% A" is displayed → Key in the chart number → [TEST PRINT] → (A chart is printed out.)
- * The larger the adjustment value is, the longer the distance C becomes (0.056%/step).
- (Key in the code [4719]) → [START] → (Enforced color registration)

Notes:

The setting value specified in FS-05-4526-0 is reflected to the charts printed out by FS-05-98, FS-05-3, FS-05-315 and FS-05-316. The adjustment result of FS-05-4526-4 cannot be confirmed by means of these charts.

When "FS-05-4526-0" is performed, a proper value is automatically calculated for the size of an image in each function mode (copy/printer/Fax) or at each speed (normal speed/reduced speed). The speed of the transfer belt motor is also adjusted. Therefore, use the above default value other than the sub code "0," unless otherwise required.

[D] Secondary scanning data writing start position

Performing the code FS-05-4402 covers this adjustment for all paper sources.
The adjustment for each paper source is also available.

For all paper sources

Code	Paper size	Acceptable value	Remarks
4402	A3/LD	0 to 200	Perform the adjustment for all paper sources.

For each paper source

Order for adjustment	Paper source	Code	Paper size	Acceptable value	Remarks
1	2nd drawer	4059	A3/LD	0 to 100	
2	1st drawer	4058	A4/LT	0 to 100	
3	LCF*	4561	A4/LT	0 to 100	
4	3rd drawer	4060	A4/LT	0 to 100	
5	4th drawer	4560	A4/LT	0 to 100	
6	Bypass feed	4061	A4/LT	0 to 100	

* When the LCF is installed, adjustment of the PFP (the 3rd and 4th drawers) is unnecessary.
When the PFP is installed, adjustment of the LCF is unnecessary.

1. Print out the chart in the ready state of FS-05 (Classic mode).
Press FS-05-98 or FS-05-315 → [TEST PRINT].
* Use A3/LD from the 2nd drawer.
2. Check that the distance D of each chart is within the acceptable range.
05-98: 52 ± 0.5 mm
05-315: 4.2 ± 0.5 mm
3. If not, use the following procedure to change the values and measure the distance D again.
<Procedure>
FS-05 → (Key in the code shown above) → [START]
→ (Key in an acceptable value shown above) → [OK] (Stored in the memory)
→ "100% A" is displayed → Key in the chart number → [TEST PRINT] → (A chart is printed out.)
* The larger the adjustment value is, the longer the distance D becomes (approx. 0.10 mm/step).

Notes:

Make sure the first line of the grid pattern(05-98) is printed out since the line is occasionally vanished.

[E] Primary scanning data writing start position at duplexing

Notes:

Make sure the first line of the grid pattern (05-3) is printed out since the line is occasionally vanished.

[E-1] Adjustment for long-sized paper

1. Print out the chart in the ready state of FS-05 (Classic mode).
Press FS-05-3 or FS-05-316 → [TEST PRINT].
* Use A3/LD from the 2nd drawer.
2. Check that the distance E of each chart is within the acceptable range.
05-3: 52 ± 0.5 mm
05-316: 4.2 ± 0.5 mm
3. If not, use the following procedure to change the values and measure the distance E again.
<Procedure>
FS-05-4019 → [START] → [0] → [START]
→ (Key in a value (acceptable values: 0 to 255)) → [OK] (Stored in the memory)
→ "100% A" is displayed → Key in the chart number → [TEST PRINT] → (A chart is printed out.)
* The larger the adjustment value is, the longer the distance E becomes (approx. 0.04 mm/step).

[E-2] Adjustment for short-sized paper

1. Print out the chart in the ready state of FS-05 (Classic mode).
Press FS-05-3 or FS-05-316 → [TEST PRINT].
* Use A4/LT from the 1st drawer.
2. Check that the distance E of each chart is within the acceptable range.
05-3: 52 ± 0.5 mm
05-316: 4.2 ± 0.5 mm
3. If not, use the following procedure to change the values and measure the distance E again.
<Procedure>
FS-05-4019 → [START] → [1] → [START]
→ (Key in a value (acceptable values: 0 to 255)) → [OK] (Stored in the memory)
→ "100% A" is displayed → Key in the chart number → [TEST PRINT] → (A chart is printed out.)
* The larger the adjustment value is, the longer the distance E becomes (approx. 0.04 mm/step).

[E-3] Adjustment for medium-sized paper (Length: 220 mm to 329 mm)

1. Print out the chart in the ready state of FS-05 (Classic mode).
Press FS-05-3 or FS-05-316 → [TEST PRINT].
* Use A4-R/LT-R
2. Check that the distance E of each chart is within the acceptable range.
05-3: 52 ± 0.5 mm
05-316: 4.2 ± 0.5 mm
3. If not, use the following procedure to change the values and measure the distance E again.
<Procedure>
Press FS-05-4019 → [START] → [2] → [START]
→ (Key in a value (acceptable values: 0 to 255)) → [OK] (Stored in the memory)
→ "100% A" is displayed → Key in the chart number → [TEST PRINT] → (A chart is printed out.)
* The larger the adjustment value is, the longer the distance E becomes (approx. 0.04 mm/step).

[F] Secondary scanning data writing start position at duplexing

- Print out the chart in the ready state of FS-05 (Classic mode).
Press FS-05-3 or FS-05-316 → [TEST PRINT].
* Use A3/LD from the 2nd drawer.
- Check that the distance F of each chart is within the acceptable range.
05-3: 52 ± 0.5 mm
05-316: 4.2 ± 0.5 mm
- If not, use the following procedure to change the values and measure the distance F again.
<Procedure>
Press FS-05-4062 → [START]
→ Key in a value (acceptable values: 0 to 255) → [OK] (Stored in the memory)
→ "100% A" is displayed → Key in the chart number → [TEST PRINT] → (A chart is printed out.)
* The larger the adjustment value is, the longer the distance F becomes (approx. 0.10 mm/step).

Notes:

Make sure the first line of the grid pattern is printed out since the line is occasionally vanished.

<Adjustment procedure summarization for A to F>		
Type 1: Adjustment to make the size of an image match FS-05-98 (3 for duplexing) → [TEST PRINT]		
A:	FS-05-4001 (2nd drawer, A3/LD)	→ 200 ± 0.5 mm (0.1 mm/step)
B:	FS-05-4006 (2nd drawer, A3/LD)	→ 52 ± 0.5 mm (0.04 mm/step)
C:	FS-05-4526-0 (2nd drawer, A3/LD)	→ 200 ± 0.5 mm (0.1 mm/step)
D:	FS-05-4402 (2nd drawer, A3/LD) → 52 ± 0.5 mm (0.1 mm/step) FS-05-4058 (1st drawer, A4/LT) FS-05-4059 (2nd drawer, A3/LD) FS-05-4060 (3rd drawer, A4/LT) FS-05-4560 (4th drawer, A4/LT) FS-05-4061 (Bypass feed, A4/LT)	
E:	FS-05-4019-0 (2nd drawer, A3/LD) FS-05-4019-1 (1st drawer, A4/LT) FS-05-4019-2 (A4-R/LT-R)	→ 52 ± 0.5 mm (0.04 mm/step)
F:	FS-05-4062 (2nd drawer, A3/LD)	→ 52 ± 0.5 mm (0.1 mm/step)

Type 2: Adjustment to make the void width match FS-05 → 315(316 for duplexing) → [TEST PRINT]		
A:	FS-05-4001 (2nd drawer, A3/LD)	→ 4.2 ± 0.5 mm (0.1 mm/step)
B:	FS-05-4006 (2nd drawer, A3/LD)	→ 4.2 ± 0.5 mm (0.04 mm/step)
C:	FS-05-4526-0 (2nd drawer, A3/LD)	→ 4.2 ± 0.5 mm (0.1 mm/step)
D:	FS-05-4402 (2nd drawer, A3/LD) → 4.2 ± 0.5 mm (0.1 mm/step) FS-05-4058 (1st drawer, A4/LT) FS-05-4059 (2nd drawer, A3/LD) FS-05-4060 (3rd drawer, A4/LT) FS-05-4560 (4th drawer, A4/LT) FS-05-4061 (Bypass feed, A4/LT)	
E:	FS-05-4019-0 (2nd drawer, A3/LD) FS-05-4019-1 (1st drawer, A4/LT) FS-05-4019-2 (A4-R/LT-R)	→ 4.2 ± 0.5 mm (0.04 mm/step)
F:	FS-05-4062 (2nd drawer, A3/LD)	→ 4.2 ± 0.5 mm (0.1 mm/step)

6.1.8 Image dimensional adjustment at the scanning section

[A] Image distortion

Notes:

The specification of the distortion is 1 mm to 200 mm when a drawer equipped as standard is used, and is 3 mm to 200 mm when an optional drawer (PFP and LCF) is used.

Do not perform this adjustment when the distortion is within the above value. If the adjustment has failed, fogging or a C260 error will occur.

This adjustment is for the distortion in the scanning section. Therefore, do not use this to correct paper skew at paper feeding.

When performing the adjustment, marginally rotate the screw by approximately one quarter while checking the image.

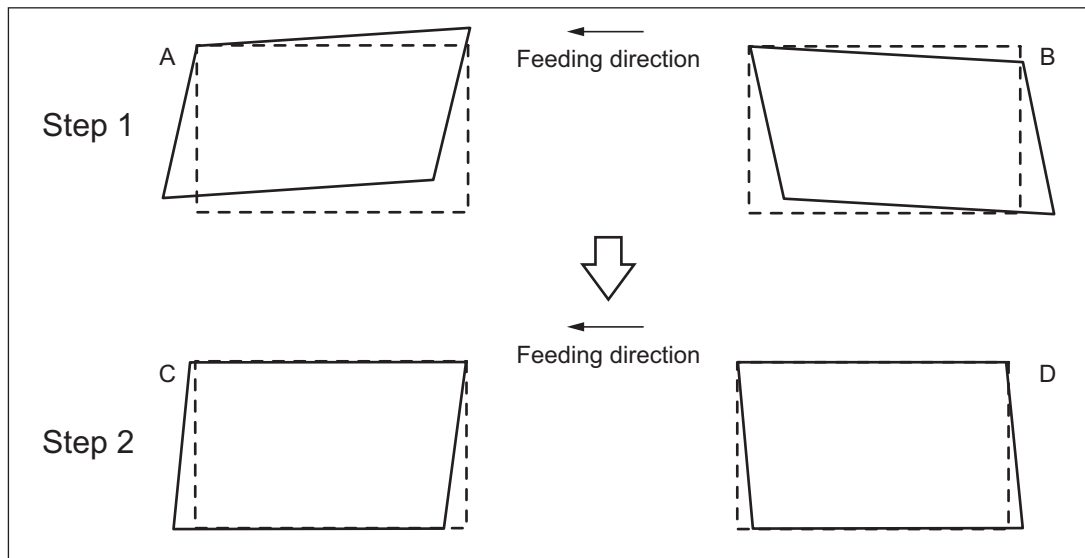

Fig.6-16

- (1) Perform FS-05.
- (2) Press [TEST COPY] → [START] button to make a copy of any image on a sheet of A3/LD paper.
- (3) Key in [3033] and press the [START] to move the carriage to the adjustment position.
- (4) Make an adjustment in the order of step 1 and 2.

Step 1

In case of A:

Tighten the mirror-3 adjustment screw (Rear) [1] (CW).

In case of B:

Loosen the mirror-3 adjustment screw (Rear) [1] (CCW).

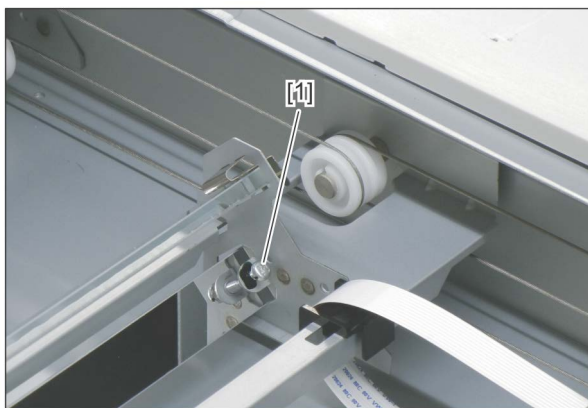

Fig.6-17

Step 2

In case of C:

Tighten the mirror-1 adjustment screw (Rear) [1] (CW).

In case of D:

Loosen the mirror-1 adjustment screw (Rear) [1] (CCW).

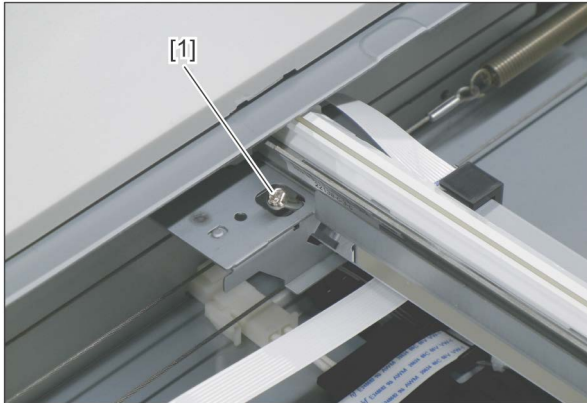

Fig.6-18

- (5) Apply the screw locking agents to the adjustment screws. (2 areas)
 - Recommended screw lock agent
Manufacturer: Three Bond
Product name: 1401E

The following adjustments (B) to (E) should be performed with Test Chart No. TCC-1/TCC-2.

 P. 6-26 “ Adjustments and Checks using Test Chart No. TCC-1/TCC-2”

[B] Reproduction ratio of the primary scanning direction

- (1) Perform FS-05.
- (2) Place Test Chart No. TCC-1/TCC-2 on the original glass (with the arrow positioned at the left rear side).
- (3) Press [TEST COPY] → [START] to make a copy at the mode of A4/LT, 100%, Full color and Text/Photo.
- (4) Measure the distance B between M1 and M2 on the copy with a ruler.
- (5) Check if the distance B is within 200 ± 0.5 mm.
- (6) If not, use the following procedure to change values and repeat step (3) to (5) above.
<Procedure>
FS-05-4000 → [START]
→ (Key in a value (acceptable values: 0 to 255) with digital keys)
→ [OK] (Stored in the memory)
* The larger the adjustment value is, the longer the distance B becomes (approx. 0.1 mm/step).

[C] Primary scanning position

- (1) Perform FS-05.
- (2) Place Test Chart No. TCC-1/TCC-2 on the original glass (with the arrow positioned at the left rear side).
- (3) Press [TEST COPY] → [START] to make a copy at the mode of A4/LT, 100%, Full color and Text/Photo.
- (4) Measure the distance C from the left paper edge to the 5 mm line of left grid pattern on the copy with a ruler.
- (5) Check if the distance C is within 5 ± 0.5 mm.

- (6) If not, use the following procedure to change values and repeat step (3) to (5) above.
- <Procedure>
FS-05-3030 → [START]
→ (Key in a value (acceptable values: 0 to 255))
→ [OK] (Stored in the memory)
* The larger the adjustment value is, the longer the distance C becomes (approx. 0.04 mm/step).

[D] Reproduction ratio of the secondary scanning direction

- (1) Perform FS-05.
(2) Place Test Chart No. TCC-1/TCC-2 on the original glass (with the arrow positioned at the left rear side).
(3) Press [TEST COPY] → [START] to make a copy at the mode of A4/LT, 100%, Full color and Text/Photo.
(4) Measure the distance D between M3 and M4 on the copy with a ruler.
(5) Check if the distance D is within 150 ± 0.5 mm.
(6) If not, use the following procedure to change values and repeat step (3) to (5) above.
- <Procedure>
FS-05-3032 → [START]
→ (Key in a value (acceptable values: 69 to 193))
→ [OK] (Stored in the memory)
* The smaller the adjustment value is, the smaller the ratio becomes (approx. 0.018%/step).

[E] Secondary scanning position

- (1) Perform FS-05.
(2) Place Test Chart No. TCC-1/TCC-2 on the original glass (with the arrow positioned at the left rear side).
(3) Press [TEST COPY] → [START] to make a copy at the mode of A4/LT, 100%, Full color and Text/Photo.
(4) Measure the distance E from the top paper edge to the 10 mm line of top grid pattern on the copy with a ruler.
(5) Check if the distance E is within 10 ± 0.5 mm.
(6) If not, use the following procedure to change values and repeat step (3) to (5) above.
- <Procedure>
FS-05-3031 → [START]
→ (Key in a value (acceptable values: 90 to 166))
→ [OK] (Stored in the memory)
* The larger the adjustment value is, the longer the distance E becomes (approx. 0.08 mm/step).

[F] Top margin

- (1) Perform FS-05.
- (2) Open the platen cover or DF.
- (3) Press [TEST COPY] → [START] to make a copy at the mode of A3/LD, 100%, Full color, Text/Photo and 2nd drawer.
- (4) Measure the blank area F at the leading edge of the copied image.
- (5) Check if the blank area F is within the range.

Function	Black	Color
Copy	4.2 mm + 2.8 mm / -1.2 mm	5 - 1.0 mm, 5 + 2.0 mm (4.0 to 7.0 mm)

- (6) If not, use the following procedure to change values and repeat the steps (3) to (5) above.

<Procedure>

FS-05-4050 → [START]

→ (Key in a value (acceptable values: 0 to 255))

→ [OK] (Stored in the memory)

→ (“100% A” is displayed.)

* The larger the adjustment value is, the wider the blank area at the leading edge becomes (approx. 0.04 mm/step).

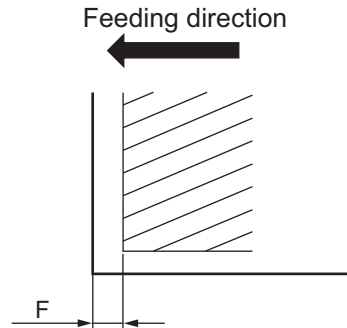

Fig.6-19

Notes:

Paper jams tend to occur in equipment in which thin paper such as 64g/m² (17lb. Bond) paper is used or a large amount of high density images such as pictures are output. For this equipment, we recommend that you adjust the top margin “in the plus direction” in order to prevent paper jamming.

Range of top margin adjustment (e.g.)

Function	Black	Color
Copy	4.2 - 7.0 mm	5.0 - 7.0 mm

[G] Right margin

- (1) Perform FS-05.
- (2) Open the platen cover or DF.
- (3) Press [TEST COPY] → [START] to make a copy at the mode of A3/LD, 100%, Full color, Text/Photo and 2nd drawer.
- (4) Measure the blank area G at the right side of the copied image.
- (5) Check if the blank area G is within the range.

Function	Black	Color
Copy	2±2.0 mm	2±2.0 mm

- (6) If not, use the following procedure to change values and repeat the steps (3) to (5) above.

<Procedure>

FS-05-4052 → [START]

→ (Key in a value (acceptable values: 0 to 255))

→ [OK] (Stored in the memory).

→ ("100% A" is displayed.)

* The larger the adjustment value is, the wider the blank area at the right side becomes (approx. 0.04 mm/step).

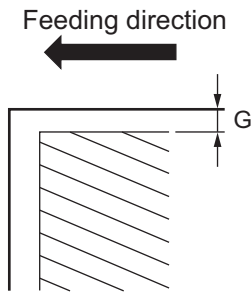

Fig.6-20

[H] Bottom margin

- (1) Perform FS-05.
- (2) Open platen cover or DF.
- (3) Press the [TEST COPY] → [START] to make a copy at the mode of A3/LD, 100%, Full color, Text/Photo and 2nd drawer.
- (4) Measure the blank area H at the trailing edge of the copied image.
- (5) Check if the blank area H is within the range.

Function	Black	Color
Copy	3±2.0 mm	3±2.0 mm

- (6) If not, use the following procedure to change values and repeat the steps (3) to (5) above.
<Procedure>
FS-05-4053 → [START]
→ (Key in a value (acceptable values: 0 to 255))
→ [OK] (stored in the memory)
→ ("100% A" is displayed.)
* The larger the adjustment value is, the wider the blank area at the trailing edge becomes (approx. 0.04 mm/step).

Feeding direction

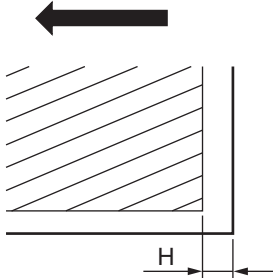

Fig.6-21

Adjustments and Checks using Test Chart No. TCC-1/TCC-2

Following items can be checked with the Test Chart No. TCC-1/TCC-2.

1. Points to be measured in the chart

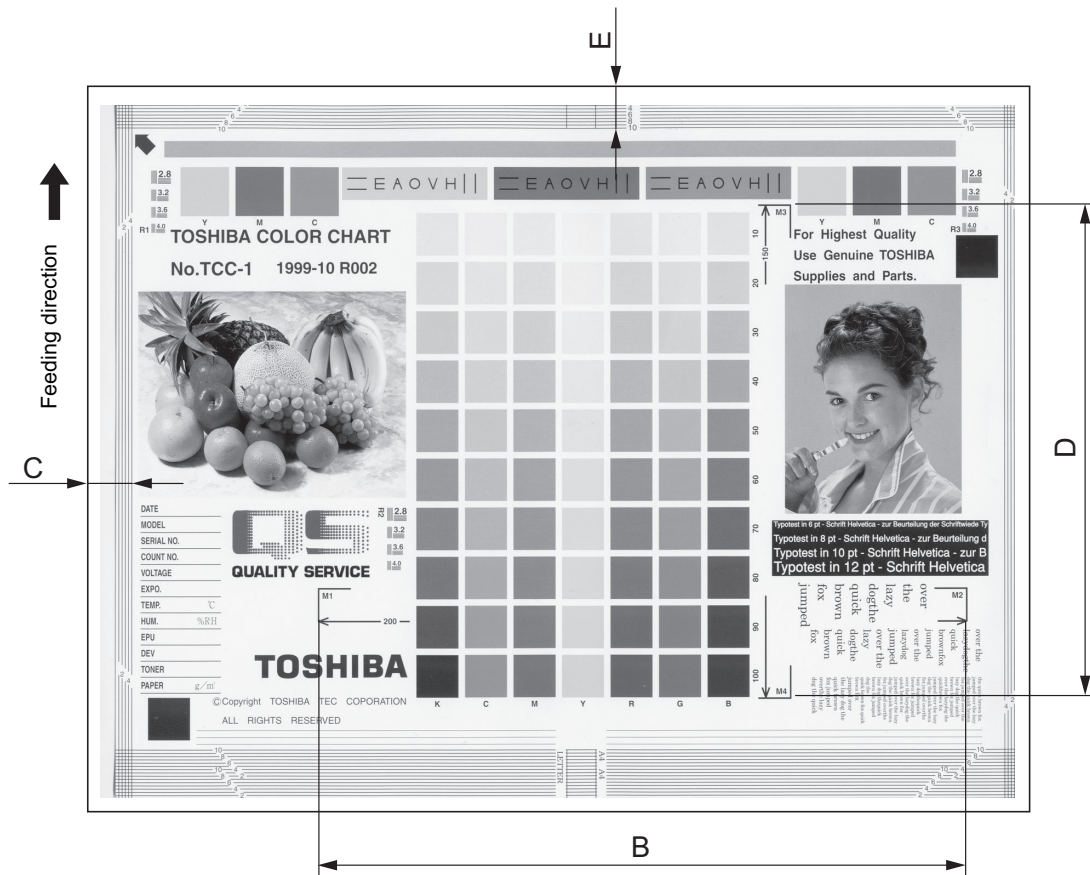

Fig.6-22

<Adjustment order>

FS-05 → (Chart TCC-1/TCC-2) → [TEST COPY] → [START] (A3/LD, 100%, Full color and Text/Photo)

- B: FS-05-4000 → 200 ± 0.5 mm (0.1 mm/step)
- C: FS-05-3030 → 5 ± 0.5 mm (0.04 mm/step)
- D: FS-05-3032 → 150 ± 0.5 mm (0.03 mm/step)
- E: FS-05-3031 → 10 ± 0.5 mm (0.08 mm/step)

2. Checking areas of the chart

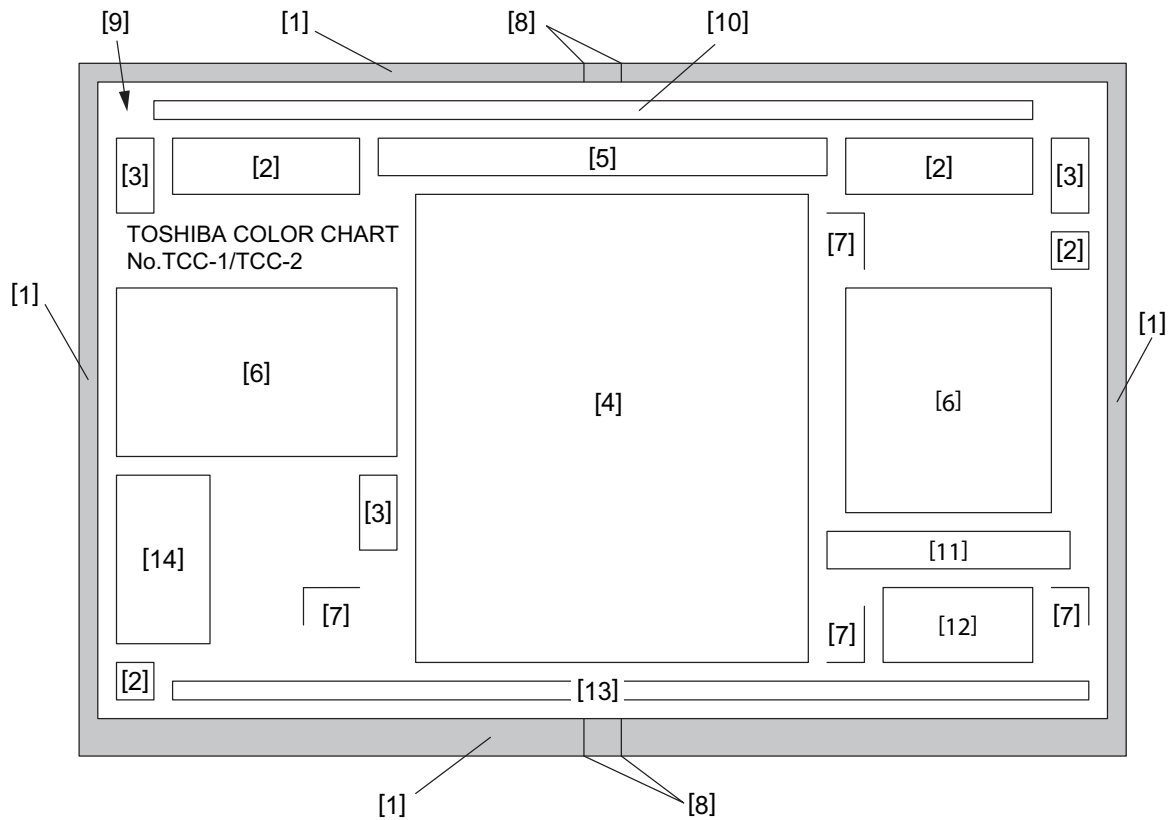

Fig.6-23

- | | | |
|------|-------------------------------|---|
| [1] | Grid patterns | : For adjusting margin (void) and scanner section |
| [2] | YMCK patches | : For checking uniformity |
| [3] | Resolution patterns | : For checking resolution |
| [4] | Gradation pattern | : Gradation pattern of seven colors (Y, M, C, R, G, B and K)
Coverage: 10-100%
For adjusting the halftone reproduction and gray balance |
| [5] | Color registration pattern | : For checking color registration |
| [6] | Pictures | : For checking color reproduction and moire |
| [7] | Magnification lines | : For checking the magnification error of primary and secondary scanning directions |
| [8] | Center lines | : Center lines for A4/LT sizes |
| [9] | Arrow | : A mark for placing the chart properly onto the original glass (place it to the left rear corner of the original glass.) |
| [10] | Halftone band | : For checking uniformity |
| [11] | White text on the black solid | : For checking the reproduction of white text on black solid |
| [12] | Text | : For checking reproduction of text |
| [13] | Thin lines | : For checking reproduction of the thin lines (line width: 100µm) |
| [14] | Note area | : For recording the date, conditions, etc. |

6.2 Image Quality Adjustment (Copying Function)

6.2.1 Automatic gamma adjustment

When the reproduction of gradation is not appropriate, the gradation reproducibility of all colors Y, M, C and K can be corrected by performing this automatic gamma adjustment. In case the gradation reproduction of the image checked is not satisfactory, make this adjustment as described below at parts replacement.



(1) When unpacking or any of the following parts has been replaced, be sure to make this adjustment:

- Photoconductive drum
- Developer material Y, M, C, K
- Laser optical unit
- Transfer belt
- 1st transfer roller
- Drum cleaning blade
- Needle electrode
- Main charger grid
- Image position aligning sensor (Front)
- Image position aligning sensor (Rear)/Image quality sensor
- SRAM
- EEPROM (LGC board)
- HDD

(2) When any of the following parts are replaced or adjusted, make a copy and check the image to determine if adjustment is necessary:

- 2nd transfer roller

Notes:

Be sure that this adjustment be made after performing the image adjustment in  P. 6-4 “6.1.3 Performing image quality control” and  P. 6-6 “6.1.5 Image dimensional adjustment”.

<Procedure>

- (1) Perform FS-05. → 05 Adjustment Mode
- (2) Select the A4/LT/A3/LD drawer. Key in the pattern number and press [TEST PRINT] to output a “Patch chart for gamma adjustment”.

<Adjustment Mode (05)>

Pattern No.	Pattern No.	Remark	Paper type
4	Color/black integrated	When performing code FS-05-7869	All paper types
200	Color/black integrated	When performing code FS-05-7871-0	Plain paper
202	Color/black integrated	When performing code FS-05-7871-1	Thick paper
204	Color/black integrated	When performing code FS-05-7871-2	Recycled paper
206	Color/black integrated	When performing code FS-05-7871-3	Thick paper 1
208	Color/black integrated	When performing code FS-05-7871-4	Thick paper 2
210	Color/black integrated	When performing code FS-05-7871-5	Thick paper 3
212	Color/black integrated	When performing code FS-05-7871-6	Thick paper 4
214	Color/black integrated	When performing code FS-05-7871-7	Special paper 1
216	Color/black integrated	When performing code FS-05-7871-8	Special paper 2
218	Color/black integrated	When performing code FS-05-7871-9	Special paper 3
220	Color/black integrated	When performing code FS-05-7871-10	Thin paper

- (3) Place the patch chart for adjustment printed in step (2) face down on the original glass. Place the chart aligning its side with 2 black squares against the original scale.
- (4) Key in a code and press the [START] button.
→ The scanner reads the chart automatically and performs automatic gamma adjustment calculation (approx.30 sec.).

<05 Adjustment Mode>

Code	Item to be adjusted	Contents
7869 (7871)	Automatic gamma adjustment	When the reproduction of gradation is not appropriate, the gradation reproducibility of all colors Y, M, C and K can be corrected by performing this automatic gamma adjustment. The result of 7869 is applied to all paper types. The result of 7871 is applied to the specified paper type.

- (5) When the adjustment has finished normally, press [OK] to have the adjustment results reflected. (To cancel the reflection of adjustment results, press [CANCEL].)
In the case of an abnormal ending, "ADJUSTMENT ERROR" is shown.
Press [CANCEL] to clear the error display. When it is cleared, the control panel display will return to the ready state. Then, check if the patch chart on the original glass is placed in the wrong direction or if it is placed inclined on the original glass, and then repeat step (3) and afterward.

Remarks:

To select the paper type for the automatic gamma adjustment in user calibration, change the code below to "1". (copy/print)

Code	Remarks
FS-08-9059	0: No paper selecting buttons displayed 1: Paper selecting buttons displayed. (For both Copy and Printer)

6.2.2 Density adjustment

Adjusts the center density.

<05 Adjustment Mode>

Color mode	Original mode							Item to be adjusted	Remarks
	Text/Photo	Text	Printed Image	Photo	Map	Custom Mode	Red Seal Color Mode		
Full color	7713	7714	7715	7716	7717	7718	7719	Manual density mode center value	The larger the value is, the darker the image becomes. Acceptable values: 0 to 255 (Default: 128)
	7720	7721	7722	7723	7724	7725	7726	Automatic density	
Twin color	7733	7734	7735	-	-	-	-	Manual density mode center value	
	7736	7737	7738	-	-	-	-	Automatic density	
Mono color	7727	7728	7729	-	-	-	-	Manual density mode center value	
	7730	7731	7732	-	-	-	-	Automatic density	

<05 Adjustment Mode>

Color mode	Original mode					Drop out color	Item to be adjusted	Remarks
	Text/Photo	Text	Photo	Gray scale	Custom Mode			
Black	7114	7115	7116	7138	7134	7160	Manual density mode center value	The larger the value is, the darker the image becomes. Acceptable values: 0 to 255 (Default: 128)
	7123	7124	7125	7141	7137	-	Automatic density mode	

Make a test copy and compare the image obtained with the current settings; if necessary, make adjustments according to the following procedure.

Notes:

Be sure that this adjustment is made after performing  P. 6-28 "6.2.1 Automatic gamma adjustment".

<Procedure>

- (1) Perform FS-05.
- (2) Key in a code and press the [START] button.
- (3) Key in an adjustment value.
(To correct the value once keyed in, press [CLEAR].)
- (4) Press [OK] to store the value. → The equipment goes back to the ready state.
- (5) Press [TEST COPY] and then press the [START] button to make a test copy.
- (6) If the desired image quality has not been attained, repeat step (2) to (5).

Notes:

To check an image of [User Custom], [Red Seal] and [Drop out color], use the one copied in the normal startup.

6.2.3 Gamma balance adjustment

The density adjustment at the Black Mode is performed by selecting its density area from the following: low density, medium density and high density.

<05 Adjustment Mode>

Color mode	Original mode					Drop out color	Item to be adjusted	Remarks
	Text/Photo	Text	Photo	Gray scale	Custom mode			
Black	7190-0	7191-0	7192-0	7193-0	7189-0	7187-0	Low density	The larger the value is, the density of the item to be adjusted becomes darker. Acceptable values: 0 to 255 (Default: 128)
	7190-1	7191-1	7192-1	7193-1	7189-1	7187-1	Medium density	
	7190-2	7191-2	7192-2	7193-2	7189-2	7187-2	High density	

Make a test copy and compare the image obtained with the current settings; if necessary, make adjustments according to the following procedure.

Notes:

Be sure that this adjustment is made after performing  P. 6-28 “6.2.1 Automatic gamma adjustment”.

<Procedure>

The procedure is the same as that of  P. 6-33 “6.2.5 Color balance adjustment”.

Notes:

To check an image of [User Custom] and [Drop out color], use the one copied in the normal startup.

6.2.4 Text gamma balance adjustment

The density of the text is adjusted for each color at the Full Color Mode. The adjustment is performed by selecting its density area from the following: low density, medium density and high density.

<05 Adjustment Mode>

Color mode	Original mode		Item to be adjusted	Remarks
	Text/Photo	Custom		
Yellow	7988-0	7992-0	Low density	The larger the value is, the density of the item to be adjusted becomes darker. Acceptable values: 0 to 255 (Default: 128)
	7988-1	7992-1	Medium density	
	7988-2	7992-2	High density	
Magenta	7989-0	7993-0	Low density	
	7989-1	7993-1	Medium density	
	7989-2	7993-2	High density	
Cyan	7999-0	7994-0	Low density	
	7999-1	7994-1	Medium density	
	7999-2	7994-2	High density	
Black	7991-0	7995-0	Low density	
	7991-1	7995-1	Medium density	
	7991-2	7995-2	High density	

Perform adjustment in accordance with the following procedure while comparing the test copy image and the setting values currently entered.

Notes:

Be sure to perform this adjustment after performing the following one.

 P. 6-28 "6.2.1 Automatic gamma adjustment"

Changing the adjustment setting influences the adjacent density area slightly.

E.g.: When the value of the medium density is larger, the adjacent areas in the low density and high density range will become slightly darker.

<Procedure>

- (1) Perform FS-05.
- (2) Key in the code of the mode to be adjusted (color and original mode) and press the [START] button.
- (3) Key in the value corresponding to the density area to be adjusted (0, 1 or 2) and then press the [START] button.
0: Low density
1: Medium density
2: High density
- (4) Key in the adjustment value.
(To correct the value once keyed in, press [CLEAR].)
- (5) Press [OK] to store the value.
-> The equipment returns to the ready state.
- (6) For resetting the value, repeat steps (2) to (5).
- (7) Press [TEST COPY] -> [START] button to make a test copy.
- (8) If the desired image density has not been attained, repeat steps (2) to (7).

Notes:

To check an image of [Custom], use the one copied in the normal startup.

6.2.5 Color balance adjustment

The color balance is adjusted by adjusting the density of each color at the Full Color Mode. The adjustment is performed by selecting its density area from the following: low density, medium density and high density.

<05 Adjustment Mode>

Color	Original mode							Item to be adjusted	Remarks
	Text/Photo	Text	Printed Image	Photo	Map	Custom mode	Red Seal Color		
Yellow	7960-0	7961-0	7962-0	7963-0	7964-0	7980-0	7984-0	Low density	The larger the value is, the darker the color to be adjusted becomes. Acceptable values: 0 to 255 (Default: 128)
	7960-1	7961-1	7962-1	7963-1	7964-1	7980-1	7984-1	Medium density	
	7960-2	7961-2	7962-2	7963-2	7964-2	7980-2	7984-2	High density	
Magenta	7965-0	7966-0	7967-0	7968-0	7969-0	7981-0	7985-0	Low density	
	7965-1	7966-1	7967-1	7968-1	7969-1	7981-1	7985-1	Medium density	
	7965-2	7966-2	7967-2	7968-2	7969-2	7981-2	7985-2	High density	
Cyan	7970-0	7971-0	7972-0	7973-0	7974-0	7982-0	7986-0	Low density	
	7970-1	7971-1	7972-1	7973-1	7974-1	7982-1	7986-1	Medium density	
	7970-2	7971-2	7972-2	7973-2	7974-2	7982-2	7986-2	High density	
Black	7975-0	7976-0	7977-0	7978-0	7979-0	7983-0	7987-0	Low density	
	7975-1	7976-1	7977-1	7978-1	7979-1	7983-1	7987-1	Medium density	
	7975-2	7976-2	7977-2	7978-2	7979-2	7983-2	7987-2	High density	

Make a test copy and compare the image obtained with the current settings; if necessary, make adjustments according to the following procedure.

Notes:

- Be sure that this adjustment is made after performing  P. 6-28 “6.2.1 Automatic gamma adjustment”.
- Changing the adjustment setting influences the adjacent density area slightly.
E.g.: When the value of the medium density is larger, the adjacent areas in the low density and high density range will become slightly darker.

<Procedure>

- (1) Perform FS-05.
- (2) Key in the code of the mode to be adjusted (color and original mode) and press the [START] button.
- (3) Select the density area to be adjusted with digital keys (0, 1 or 2), and press the [START] button.
0: Low density
1: Medium density
2: High density
- (4) Key in an adjustment value. (To correct the value once keyed in, press [CLEAR].)
- (5) Press [OK] to store the value in memory.
→ The equipment goes back to the ready state.
- (6) For resetting the value, repeat step (2) to (5).
- (7) Press [TEST COPY] and then press the [START] button to make a test copy.

(8) If the desired image quality has not been attained, repeat step (2) to (7).

Notes:

To check an image of [User Custom] and [Red Seal], use the one copied in the normal startup.

<Range of the density area (low density, medium density, high density)>

The color from 10 to 30 (low density), from 40 to 70 (medium density) and from 80 to 100 (high density) in No. TCC-1/TCC-2 chart can be used as a guide for the range of the density area influenced by the change of the adjustment value (low density, medium density, high density).

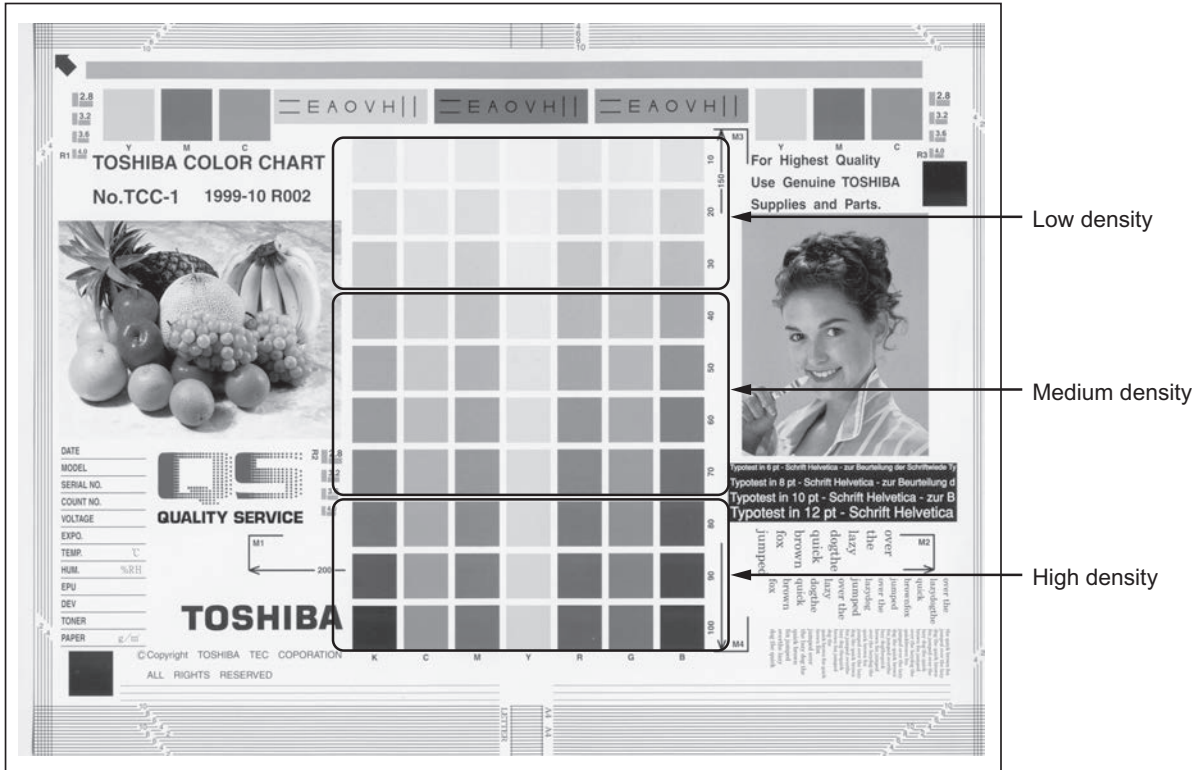

Fig.6-24

6.2.6 Background adjustment

The density of the background can be adjusted as follows.

<05 Adjustment Mode>

Color mode	Original mode								Drop out color	Remarks
	Text/Photo	Text	Printed Image	Photo	Map	Custom mode	Gray scale	Red Seal Color Mode		
Full color	7656	7657	7658	7659	7660	7661	---	7662	---	The larger the value is, the darker the background becomes. Acceptable values: 0 to 255 (Default: 128)
Mono color	7707	7708	7709	---	---	---	---	---	---	
Twin color	7710	7711	7712	---	---	---	---	---	---	
Black (Auto/Manual)	7100	7101	---	7102	---	7106	7105	---	7107	
Black (Manual)	7086	---	---	---	---	---	---	---	---	

Make a test copy and compare the image obtained with the current settings; if necessary, make adjustment using the following procedure.

<Procedure>

The procedure is the same as that of  P. 6-30 “6.2.2 Density adjustment”.

Notes:

To check an image of [User Custom], [Red Seal] and [Drop out color], use the one copied in the normal startup.

6.2.7 Judgment threshold for ACS (common for copy and scan)

Judgment levels for automatically identifying whether an original is color or black are adjusted. This adjustment is for judgment levels when “Auto Color” is selected as a color mode. The same adjustment value is simultaneously applied to all cases of originals on the original glass for copier functions and network scanning functions, and those placed on the DF.

<05 Adjustment Mode>

Code	Item to be adjusted	Contents
7630	Judgment threshold for ACS	The larger the value is, the more an original tends to be judged as black even at the Auto Color Mode. The smaller value is, the more it tends to be judged as color. Acceptable values: 0 to 255 (Default: 70)

Make a test copy and compare the image obtained with the current settings; if necessary and make adjustment.

<Procedure>

The procedure is the same as that of  P. 6-30 “6.2.2 Density adjustment”.

6.2.8 Judgment threshold adjustment for blank originals (common for copy and scan)

The judgment level is adjusted for automatic identification of whether the original set is blank or not. This adjustment is made when "OMIT BLANK PAGE" is selected on the control panel. The adjustment value is simultaneously applied to all modes at PPC and scanning.

<05 Adjustment Mode>

Code	Item to be adjusted	Remarks
7618	Judgment threshold adjustment for blank original	The larger the value is, the more an original tends to be judged as a blank sheet. Acceptable values: 0 to 255 (Default: 128)

<Procedure>

The procedure is the same as that of  P. 6-30 "6.2.2 Density adjustment".

6.2.9 Image area adjustment for blank original judgment and ACS judgment when an Image Repeat is used

The surrounding void amount of an image is adjusted when blank original judgment and ACS judgment are performed.

<05 Adjustment Mode>

Code	Item to be adjusted	Contents
7616-2	Void amount adjustment for blank page judgment (when an Image Repeat is used)	When a larger value is set, the image area to be used for the judgment is decreased. When a smaller value is set, the image area to be used for the judgment is increased. Acceptable value: 0 to 255 (Default: 200)
7616-3	Void amount adjustment for ACS judgment (when an Image Repeat is used)	When a larger value is set, the image area to be used for the judgment is decreased. When a smaller value is set, the image area to be used for the judgment is increased. Acceptable value: 0 to 255 (Default: 0)

Notes:

If a value, which is too smaller, is set, the shadow of the original may be used for the judgment and this may become the cause of a misjudgment.

<Procedure>

- (1) Perform FS-05.
- (2) Key in a code and press the [START] button.
- (3) Key in the adjustment value.
(To correct the value once keyed in, press [CLEAR].)
- (4) Press [OK] to store the value. -> The equipment returns to the ready state.
- (5) Start up the equipment in the normal mode and make a copy.
- (6) If the desired image density has not been attained, repeat steps (1) to (5).

6.2.10 Image area adjustment for blank original judgment and ACS judgment (common for copying and scanning)

The surrounding void amount of an image is adjusted when blank original judgment and ACS judgment are performed.

<05 Adjustment Mode>

Code	Item to be adjusted	Contents
7616-0	Void amount adjustment for blank page judgment	When a larger value is set, the image area to be used for the judgment is decreased.
7616-1	Void amount adjustment for ACS judgment	When a smaller value is set, the image area to be used for the judgment is increased. Acceptable value: 0 to 255 (Default: 200)

Notes:

If a value, which is too smaller, is set, the shadow of the original may be used for the judgment and this may become the cause of a misjudgment.

<Procedure>

- (1) Perform FS-05.
- (2) Key in a code and press the [START] button.
- (3) Key in the adjustment value.
(To correct the value once keyed in, press [CLEAR].)
- (4) Press [OK] to store the value. -> The equipment returns to the ready state.
- (5) Start up the equipment in the normal mode and make a copy.
- (6) If the desired image density has not been attained, repeat steps (1) to (5).

6.2.11 Sharpness adjustment

If you want to make copy images look softer or sharper, perform the following adjustment.
The adjustment can be made for each of the color modes and original modes independently.

<05 Adjustment Mode>

Code	Color mode	Original mode	Contents
7796	Full Color	Text/Photo	The larger the value is, the sharper the image becomes; while the smaller the value is, the softer the image becomes. The smaller the value is, the less moire tends to appear. Acceptable values: 0 to 255 (Default: 128)
7797		Text	
7798		Printed Image	
7799		Photo	
7800		Map	
7795		User custom	
7794		Red Seal Color Mode	
7801		Mono color	
7802	Text		
7803	Printed Image		
7804	Twin color	Text/Photo	
7805		Text	
7806		Printed Image	
7056	Black	Text/Photo	
7057		Text	
7058		Photo	
7249		User custom	
7061		Gray scale	
7062	Drop out color		

Make a test copy and compare the image obtained with the current settings; if necessary, make adjustment.

Notes:

You have to make adjustment by balancing between moire and sharpness.

<Procedure>

The procedure is the same as that of  P. 6-30 "6.2.2 Density adjustment".

Notes:

To check an image of [User Custom], [Red Seal Color Mode] and [Drop out color], use the one copied in the normal startup.

6.2.12 Setting range correction

The values of the background peak/text peak in the range correction at the Black Mode can be switched to “varied” or “fixed” in the following codes.

If they are fixed, the range correction is performed with standard values.

The values of the background peak affects the reproduction of the background density, and the values of the text peak affects that of the text density.

<05 Adjustment Mode>

Original mode	Original mode			Item to be adjusted	Remarks
	Text/Photo	Text	User Custom		
Black	7286	7287	7237	Manual density mode	0: Background peak / fixed 1: Background peak / varied

Make a test copy and compare the image obtained with the current settings; if necessary, make adjustment.

<Procedure>

The procedure is the same as that of  P. 6-30 “6.2.2 Density adjustment”.

Notes:

To check an image of [User Custom], use the one copied in the normal startup.

6.2.13 Adjustment of smudged/faint text

The smudge/faint text at a Black Mode can be set at the following codes.

<05 Adjustment Mode>

Color mode	Original mode			Item to be adjusted	Remarks
	Text/Photo	Text	Custom mode		
Black	7097	7098	7252	Adjustment of smudged/ faint text	When the value decreases, the faint text is improved. When the value increases, the smudged text is improved. Acceptable values: 0 to 4 (Default: 2)

Make a test copy and compare the image obtained with the current settings; if necessary, make adjustment.

Notes:

Remember the image specifications and life span of the replacing parts may not meet the standard when the setting value is changed from the default value.

<Procedure>

The procedure is the same as that of  P. 6-30 “6.2.2 Density adjustment”.

Notes:

To check an image of [User Custom], use the one copied in the normal startup.

6.2.14 Color adjustment of marker

The color of the one touch adjustment “MARKER” can be adjusted so that any marker colors already on the original can be distinguished.

<05 Adjustment Mode>

Code	Item to be adjusted	Relation between the adjustment value and the color (Acceptable values: 0 to 6)		
		0 to 2	3 (Default)	4 to 6
7850-0	Yellow	The smaller the value is, the more reddish the color becomes.	Yellow	The larger the value is, the more greenish the color becomes.
7850-1	Magenta	The smaller the value is, the more bluish the color becomes.	Magenta	The larger the value is, the more reddish the color becomes.
7850-2	Cyan	The smaller the value is, the more greenish the color becomes.	Cyan	The larger the value is, the more bluish the color becomes.
7850-3	Red	The smaller the value is, the closer to Magenta the color becomes.	Red	The larger the value is, the more yellowish the color becomes.
7850-4	Green	The smaller the value is, the more yellowish the color becomes.	Green	The larger the value is, the closer to Cyan the color becomes.
7850-5	Blue	The smaller the value is, the closer to Cyan the color becomes.	Blue	The larger the value is, the closer to Magenta the color becomes.

Notes:

The color may not always be reproduced precisely due to the characteristics of the fluorescent ink.

<Procedure>

- (1) Perform FS-05.
- (2) Key in a code and press the [START] button.
- (3) Key in a sub-code and press the [START] button.
- (4) Key in an adjustment value.
(To correct a value once keyed in, press [CLEAR].)
- (5) Press [OK] to store the value. → The equipment goes back to the ready state.
- (6) Turn the power OFF and back ON in the normal mode. Then make a copy in the one touch adjustment “MARKER” mode.
- (7) If the desired image quality has not been attained, repeat step (1) to (6).

6.2.15 Emission level adjustment

The emission level in the black mode can be adjusted as follows. This adjustment adjusts the dot size.

<05 Adjustment Mode>

Text/Photo	Text	Item to be adjusted	Remarks
7218-0	7219-0	Emission level 0/4	The smaller the value is, the smaller the emission level becomes. Therefore, the smaller dot is reproduced accordingly. Acceptable values: 0 to 255 (Default: Level 0/4: 0, Level 1/4: 63, Level 2/4: 127, Level 3/4: 191, Level 4/4: 255)
7218-1	7219-1	Emission level 1/4	
7218-2	7219-2	Emission level 2/4	
7218-3	7219-3	Emission level 3/4	
7218-4	7219-4	Emission level 4/4	

Make a test copy and compare the image obtained with the current settings; if necessary, make adjustments according to the following procedure.

<Procedure>

- (1) Perform FS-05.
- (2) Key in a code and press the [START] button.
- (3) Key in a sub-code and press the [START] button.
- (4) Key in an adjustment value.
(To correct a value once keyed in, press [CLEAR].)
- (5) Press [OK] to store the value. → The equipment goes back to the ready state.
- (6) Press [TEST COPY] and then press the [START] button to make a test copy.
- (7) If the desired image quality has not been attained, repeat step (2) to (6).

Notes:

- Change the setting value increment of 8 as a guide.
- Be sure to confirm the image when the setting value is changed.
- The setting value must increase as the emission level number (0 to 4) becomes higher. Do not increase this order when setting the values.
- Usually, emission level 4 / 4 is most effective in the black mode.

6.2.16 Maximum toner density adjustment to paper type

The maximum toner adhesion amount can be adjusted for each paper type.
It is used when offsetting occurs.

<05 Adjustment Mode>

Code	Paper type	Remarks
7913-0	Plain paper	The smaller the value is, the toner amount adhered decreases of the high density area (ex. prevention of fusing offsetting, jam in the fuser unit, etc.). Acceptable values: 0 to 255 <Default value> Thin paper: 64 Others: 128
7913-1	Thick paper	
7913-2	Recycled paper	
7913-3	Thick paper 1	
7913-4	Thick paper 2	
7913-5	Thick paper 3	
7913-6	Thick paper 4	
7913-7	Special paper 1	
7913-8	Special paper 2	
7913-9	Special paper 3	
7913-10	Thin paper	
7913-11	Envelop	
7913-12	OHP film	

Notes:

Even if a large value is set, the image does not drastically appear dark (the amount of toner adhering is not increased).

<Procedure>

The procedure is the same as that of  P. 6-30 "6.2.2 Density adjustment".

6.2.17 Maximum text density adjustment

The maximum text density in each color in the full color mode (Text/Photo, Text, Map mode) can be adjusted.

<05 Adjustment Mode>

Color	Code	Item to be adjusted	Remarks
Yellow	7889	Maximum text density	The larger the value is, the darker the maximum text density of each color to be adjusted becomes. Acceptable values: 0 to 10 (Default: 5)
Magenta	7890		
Cyan	7891		
Black	7892		

Make a test copy and compare the image obtained with the current settings; if necessary, make adjustments according to the following procedure.

Notes:

Be sure that this adjustment is made after performing  P. 6-28 "6.2.1 Automatic gamma adjustment".

<Procedure>

The procedure is the same as that of  P. 6-30 "6.2.2 Density adjustment".

6.2.18 Text/Photo reproduction level adjustment

Text/Photo reproduction level at the Full color mode and Auto color mode can be adjusted. Text/Photo reproduction level adjustment can be switched to “Photo oriented 1”, “Photo oriented 2”, “Text oriented 1” or “Text oriented 2” in the following codes.

<05 Adjustment Mode>

Mode			Item to be adjusted	Contents
Text/Photo	Custom mode (Text/Photo base)	Red Seal Color Mode		
7840	7841	7842	Text/Photo reproduction level adjustment	0, 5: Default The smaller the value, the higher the printed image reproduction level becomes (Photo oriented). The larger the value, the higher the text reproduction level becomes (Text oriented).

Notes:

- The text reproduction level is lower when the mode is switched from the default value to the Photo oriented.
- When you change the setting from the default value to Text oriented, noise occurs in a printed photo with a few lines.
- The codes for the user custom setting are enabled only when the base original mode of the user custom mode is Text/Photo.

<Procedure>

The procedure is the same as that of  P. 6-30 “6.2.2 Density adjustment”.

Notes:

To check an image of [User Custom] and [Red Seal], use the one copied in the normal startup.

6.2.19 Black header density level adjustment

The density level of black headers is adjusted.

<05 Adjustment Mode>

Mode	Code	Original mode	Remarks
Full Color	7811	Text/Photo	The larger the value is, the darker the black headers become but the dark areas in a photo become easily smudged. The smaller the value is, the lighter the black headers become but the dark areas in a photo do not smudge easily. Acceptable values: 0 to 8 (Default: 0) If the value is set to “0”, the settings will become to the equivalent ones to the following setting values. <ul style="list-style-type: none"> • Text/Photo mode: 3 • Text mode: 4 • User custom setting (in the Text mode base): 4 • User custom setting (in the Text/Photo, Photo, Printed image or Map mode base): 3
	7812	Text	
	7816	Custom mode	
	7817	Red Seal Color Mode	

Make a test copy and compare the image obtained with the current settings; if necessary, make adjustment.

<Procedure>

The procedure is the same as that of  P. 6-30 “6.2.2 Density adjustment”.

Notes:

To check an image of [User Custom] and [Red Seal], use the one copied in the normal startup.

6.2.20 Black area adjustment in twin color copy mode

<05 Adjustment Mode>

Mode	Code	Item to be adjusted	Remarks
Twin color mode with selected colors	7641-0	High density	The larger the value is, the larger the area recognized as black in the original becomes. The smaller the value is, the larger the area recognized as the color other than black becomes. Acceptable values: 0 to 255 (Default: 128)
	7641-1	Medium density	
	7641-2	Low density	
Twin color mode (Black and red)	7642-0	High density	The larger the value is, the larger the black area becomes. The smaller the value is, the larger the red area becomes. Acceptable values: 0 to 255 (Default: 128)
	7642-1	Medium density	
	7642-2	Low density	

<Procedure>

The procedure is the same as that of  P. 6-33 “6.2.5 Color balance adjustment”.

6.2.21 Background offsetting adjustment for DF (common for copy, scan and fax)

The background level for scanning originals with the DF is adjusted when the background fogging at the scanning of a manually-set original and an original used with the DF is different. This is to adjust the level of the background image removed when the scanning of the originals with the DF is performed. The adjustment value is applied to both the front and back sides.

<05 Adjustment Mode>

Color mode	Code	Remarks
Color	7026	The larger the value is, the darker the background density becomes. Acceptable values: 0 to 255 (Default: 128)
Black	7025	

<Procedure>

The procedure is the same as that of  P. 6-30 “6.2.2 Density adjustment”.

6.2.22 Background offsetting adjustment in back side for DSDF (common for copy, scan and fax)

The background level for scanning the back side of originals with the DSDF can be adjusted when there is a different background fogging level at the scanning of the back and front sides with the DSDF. This is to adjust the level of the background image removed when the scanning of the back side of the original with the DSDF is performed.

<05 Adjustment Mode>

Color mode	Code	Remarks
Color	7024	The larger the adjustment value, the darker the background becomes. Acceptable values: 0 to 255 (Default: 128)
Black	7023	

<Procedure>

The procedure is the same as that of  P. 6-30 “6.2.2 Density adjustment”.

6.2.23 Mono color copy / twin color copy adjustment

The density of the color specified on the touch panel is adjusted in the mono color copy or twin color copy mode. This adjustment is reflected to both mono color and twin color copying.

<05 Adjustment Mode>

Code	Subcode				Remarks
	Y	M	C	K	
Magenta	7644-0	7644-1	7644-2	7644-3	<p>The larger the value is, the darker the density becomes, and the smaller the value is, the lighter the density becomes. When "255" is set, the specified solid color is used for printing. When "0" is set, nothing is printed.</p> <p>For example, in case of "Red", the color when "Red" is specified becomes blue if you set as follows: (Y) 7649-0=0 (M) 7649-1=128 (C) 7649-2=255 Acceptable value: 0 to 255 (Default: 128)</p> <p>Notes: If a large value is set for all of YMCK, offsetting may occur. Make an adjustment while checking the image. If "0" is set for all four colors of YMCK, when a color is specified for the adjustment item, nothing is printed.</p>
Yellow	7645-0	7645-1	7645-2	7645-3	
YellowGreen	7646-0	7646-1	7646-2	7646-3	
Cyan	7647-0	7647-1	7647-2	7647-3	
Pink	7648-0	7648-1	7648-2	7648-3	
Red	7649-0	7649-1	7649-2	7649-3	
Orange	7650-0	7650-1	7650-2	7650-3	
Green	7651-0	7651-1	7651-2	7651-3	
Blue	7652-0	7652-1	7652-2	7652-3	
Purple	7653-0	7653-1	7653-2	7653-3	

<Procedure>

- (1) Perform FS-05.
- (2) Key in the code of the mode to be adjusted (color and original mode) and press the [START] button.
- (3) Select the density area to be adjusted with digital keys (0, 1, 2 or 3), and press the [START] button.
 0: Y
 1: M
 2: C
 3: K
- (4) Key in an adjustment value. (To correct the value once keyed in, press [CLEAR].)
- (5) Press [OK] to store the value in memory.
 → The equipment goes back to the ready state.
- (6) For resetting the value, repeat step (2) to (5).
- (7) Turn ON the power of the equipment and make a copy.
- (8) If the desired image quality has not been attained, repeat step (1) to (7).

6.2.24 Maximum density adjustment for each paper type

The maximum density for each paper type can be adjusted collectively.

<05 Adjustment Mode>

Code	Paper type	Remarks
7902	Plain paper	The smaller the value is, the lower the density of the whole image becomes. Acceptable values: 0 to 255 (Default: Plain paper: 255, Thick paper: 255, Recycled paper: 255, Thick paper 1: 255, Thick paper 2: 255, Thick paper 3: 255, Thick paper 4: 255, Special paper 1: 255, Special paper 2: 255, Special paper 3: 255, Thin paper: 255, Envelope: 255, OHP film: 240, User Media Type1 to 10: 255)
7903	Thick paper	
7904	Recycled paper	
7905	Thick paper 1	
7906	Thick paper 2	
7907	Thick paper 3	
7908	Thick paper 4	
7909	Special paper 1	
7910	Special paper 2	
7899	Special paper 3	
7900	Thin paper	
7901	Envelope	
7911	OHP film	
7912-0	User Media Type1	
7912-1	User Media Type2	
7912-2	User Media Type3	
7912-3	User Media Type4	
7912-4	User Media Type5	
7912-5	User Media Type6	
7912-6	User Media Type7	
7912-7	User Media Type8	
7912-8	User Media Type9	
7912-9	User Media Type10	

Notes:

Be aware that if too small a value is set, a faint image occurs.

<Procedure>

The procedure is the same as that of  P. 6-30 "6.2.2 Density adjustment".

6.2.25 Color reproduction selection

When the custom mode is selected, the color reproduction can be adjusted as follows.

<05 Adjustment Mode>

Code	Original mode	Remarks
7690	Custom mode	0: Same as Text/Photo, printed image, text, map mode 1: Same as Photo mode 2: Same as Red seal color mode 3: The gray level becomes a more bluish one than the one specified in the setting value "0". 4: The highlight reproduction becomes more emphasized than the one specified in the setting value "0". 5: Same as Text/Photo, printed image, text, map (photo priority) mode 6: Text/Photo, printed image, text, map mode (equivalent to "0" of the base model parameter) (Default value: 0)

Notes:

Be sure that this adjustment is made after performing  P. 6-28 "6.2.1 Automatic gamma adjustment".

When fine adjustment of the highlight is carried out while the setting value "4" is selected, perform  P. 6-35 "6.2.6 Background adjustment".

<Procedure>

- (1) Perform FS-05.
- (2) Key in a code and press the [START] button.
- (3) Key in an adjustment value.
(To correct a value once keyed in, press [CLEAR].)
- (4) Press [OK] to store the value. → The equipment goes back to the ready state.
- (5) Start up the equipment in the normal mode and make a copy.
- (6) If the desired image quality has not been attained, repeat step (1) to (5).

6.2.26 Reproducibility adjustment of dark-color text and gray print pattern

Black objects sometimes appear or uneven density (becomes lighter) may occur in dark-color text, such as dark-blue text, and gray print pattern. In such a case, change the setting of the priority by selecting "1" (Color text priority). However, when "1" is set, color objects sometimes appear in black text or black lines may be cut. Therefore, ask your users whether priority should be given to "Black text" or "Color text" before changing the setting.

<05 Adjustment Mode>

Code	Original mode	Remarks
7843-0	Text/Photo	0: Black text priority (default) 1: Color text priority
7843-1	Text	
7843-2	Map	
7843-3	Custom	
7843-4	Red seal color	

<Procedure>

- (1) Perform FS-05.
- (2) Key in a code and press the [START] button.
- (3) Key in a sub code and press the [START] button.
- (4) Key in the adjustment value.
(To correct a value once keyed in, press [CLEAR].)
- (5) Press [OK] to store the value. -> The equipment returns to the ready state.
- (6) Press [TEST COPY] > [START] button to make a test copy.

Notes:

To check an image of [Custom] and [Red seal color], use the one copied in the normal startup.

6.2.27 Hue adjustment

The hue in the full color mode can be adjusted as follows.

<05 Adjustment Mode>

Code	Original mode	Item to be adjusted	Description	Remarks
7665-0	Text/Photo	Red	The larger the value, the darker the yellow becomes. The smaller the value, the darker the magenta becomes.	Acceptable value: 0 to 255 Default value: 128
7665-1	Text/Photo	Yellow	The larger the value, the darker the green becomes. The smaller the value, the darker the red becomes.	
7665-2	Text/Photo	Green	The larger the value, the darker the cyan becomes. The smaller the value, the darker the yellow becomes.	
7665-3	Text/Photo	Cyan	The larger the value, the darker the blue becomes. The smaller the value, the darker the green becomes.	
7665-4	Text/Photo	Blue	The larger the value, the darker the magenta becomes. The smaller the value, the darker the cyan becomes.	
7665-5	Text/Photo	Magenta	The larger the value, the darker the red becomes. The smaller the value, the darker the blue becomes.	
7666-0	Text	Red	The larger the value, the darker the yellow becomes. The smaller the value, the darker the magenta becomes.	
7666-1	Text	Yellow	The larger the value, the darker the green becomes. The smaller the value, the darker the red becomes.	
7666-2	Text	Green	The larger the value, the darker the cyan becomes. The smaller the value, the darker the yellow becomes.	
7666-3	Text	Cyan	The larger the value, the darker the blue becomes. The smaller the value, the darker the green becomes.	
7666-4	Text	Blue	The larger the value, the darker the magenta becomes. The smaller the value, the darker the cyan becomes.	
7666-5	Text	Magenta	The larger the value, the darker the red becomes. The smaller the value, the darker the blue becomes.	
7667-0	Printed image	Red	The larger the value, the darker the yellow becomes. The smaller the value, the darker the magenta becomes.	
7667-1	Printed image	Yellow	The larger the value, the darker the green becomes. The smaller the value, the darker the red becomes.	
7667-2	Printed image	Green	The larger the value, the darker the cyan becomes. The smaller the value, the darker the yellow becomes.	
7667-3	Printed image	Cyan	The larger the value, the darker the blue becomes. The smaller the value, the darker the green becomes.	
7667-4	Printed image	Blue	The larger the value, the darker the magenta becomes. The smaller the value, the darker the cyan becomes.	
7667-5	Printed image	Magenta	The larger the value, the darker the red becomes. The smaller the value, the darker the blue becomes.	

Code	Original mode	Item to be adjusted	Description	Remarks
7668-0	Photo	Red	The larger the value, the darker the yellow becomes. The smaller the value, the darker the magenta becomes.	Acceptable value: 0 to 255 Default value: 128
7668-1	Photo	Yellow	The larger the value, the darker the green becomes. The smaller the value, the darker the red becomes.	
7668-2	Photo	Green	The larger the value, the darker the cyan becomes. The smaller the value, the darker the yellow becomes.	
7668-3	Photo	Cyan	The larger the value, the darker the blue becomes. The smaller the value, the darker the green becomes.	
7668-4	Photo	Blue	The larger the value, the darker the magenta becomes. The smaller the value, the darker the cyan becomes.	
7668-5	Photo	Magenta	The larger the value, the darker the red becomes. The smaller the value, the darker the blue becomes.	
7669-0	Map	Red	The larger the value, the darker the yellow becomes. The smaller the value, the darker the magenta becomes.	
7669-1	Map	Yellow	The larger the value, the darker the green becomes. The smaller the value, the darker the red becomes.	
7669-2	Map	Green	The larger the value, the darker the cyan becomes. The smaller the value, the darker the yellow becomes.	
7669-3	Map	Cyan	The larger the value, the darker the blue becomes. The smaller the value, the darker the green becomes.	
7669-4	Map	Blue	The larger the value, the darker the magenta becomes. The smaller the value, the darker the cyan becomes.	
7669-5	Map	Magenta	The larger the value, the darker the red becomes. The smaller the value, the darker the blue becomes.	
7670-0	Custom	Red	The larger the value, the darker the yellow becomes. The smaller the value, the darker the magenta becomes.	
7670-1	Custom	Yellow	The larger the value, the darker the green becomes. The smaller the value, the darker the red becomes.	
7670-2	Custom	Green	The larger the value, the darker the cyan becomes. The smaller the value, the darker the yellow becomes.	
7670-3	Custom	Cyan	The larger the value, the darker the blue becomes. The smaller the value, the darker the green becomes.	
7670-4	Custom	Blue	The larger the value, the darker the magenta becomes. The smaller the value, the darker the cyan becomes.	
7670-5	Custom	Magenta	The larger the value, the darker the red becomes. The smaller the value, the darker the blue becomes.	
7671-0	Red seal color	Red	The larger the value, the darker the yellow becomes. The smaller the value, the darker the magenta becomes.	
7671-1	Red seal color	Yellow	The larger the value, the darker the green becomes. The smaller the value, the darker the red becomes.	

Code	Original mode	Item to be adjusted	Description	Remarks
7671-2	Red seal color	Green	The larger the value, the darker the cyan becomes. The smaller the value, the darker the yellow becomes.	Acceptable value: 0 to 255 Default value: 128
7671-3	Red seal color	Cyan	The larger the value, the darker the blue becomes. The smaller the value, the darker the green becomes.	
7671-4	Red seal color	Blue	The larger the value, the darker the magenta becomes. The smaller the value, the darker the cyan becomes.	
7671-5	Red seal color	Magenta	The larger the value, the darker the red becomes. The smaller the value, the darker the blue becomes.	

Notes:

Be sure that this adjustment is made after performing  P. 6-28 “6.2.1 Automatic gamma adjustment”.

<Procedure>

- (1) Perform FS-05.
- (2) Key in a code and press the [START] button. (e.g. 7665)
- (3) Key in a value to adjust the color.
 - 0: Red
 - 1: Yellow
 - 2: Green
 - 3: Cyan
 - 4: Blue
 - 5: Magenta
 (To correct a value once keyed in, press [CLEAR].)
- (4) Press [OK] to store the value. → The equipment goes back to the ready state.
- (5) Repeat step (2) to (4) to make the setting again.
- (6) Press [TEST COPY] and then press the [START] button to make a test copy.
- (7) If the desired image quality has not been attained, repeat step (2) to (6).

Notes:

To check an image of [User Custom] and [Red Seal], use the one copied in the normal startup.

6.2.28 Saturation adjustment

The saturation of the copied image in the color copying function can be adjusted as follows.

<05 Adjustment Mode>

Code	Original mode	Item to be adjusted	Description	Remarks
7675-0	Text/Photo	Red	Input the larger value to increase the saturation, and input the smaller value to decrease the saturation.	Acceptable value: 0 to 255 Default value: 128
7675-1	Text/Photo	Yellow		
7675-2	Text/Photo	Green		
7675-3	Text/Photo	Cyan		
7675-4	Text/Photo	Blue		
7675-5	Text/Photo	Magenta		
7676-0	Text	Red		
7676-1	Text	Yellow		
7676-2	Text	Green		
7676-3	Text	Cyan		
7676-4	Text	Blue		
7676-5	Text	Magenta		
7677-0	Printed image	Red		
7677-1	Printed image	Yellow		
7677-2	Printed image	Green		
7677-3	Printed image	Cyan		
7677-4	Printed image	Blue		
7677-5	Printed image	Magenta		
7678-0	Photo	Red		
7678-1	Photo	Yellow		
7678-2	Photo	Green		
7678-3	Photo	Cyan		
7678-4	Photo	Blue		
7678-5	Photo	Magenta		
7679-0	Map	Red		
7679-1	Map	Yellow		
7679-2	Map	Green		
7679-3	Map	Cyan		
7679-4	Map	Blue		
7679-5	Map	Magenta		
7680-0	Custom	Red		
7680-1	Custom	Yellow		
7680-2	Custom	Green		
7680-3	Custom	Cyan		
7680-4	Custom	Blue		
7680-5	Custom	Magenta		
7681-0	Red seal color	Red		
7681-1	Red seal color	Yellow		
7681-2	Red seal color	Green		
7681-3	Red seal color	Cyan		
7681-4	Red seal color	Blue		
7681-5	Red seal color	Magenta		

Notes:

Be sure that this adjustment is made after performing  P. 6-28 "6.2.1 Automatic gamma adjustment".

<Procedure>

- (1) Perform FS-05.
- (2) Key in a code and press the [START] button. (e.g. 7675)
- (3) Key in a value to adjust the color.
 - 0: Red
 - 1: Yellow
 - 2: Green
 - 3: Cyan
 - 4: Blue
 - 5: Magenta

(To correct a value once keyed in, press [CLEAR].)
- (4) Press [OK] to store the value. → The equipment goes back to the ready state.
- (5) Repeat step (2) to (4) to make the setting again.
- (6) Press [TEST COPY] and then press the [START] button to make a test copy.
- (7) If the desired image quality has not been attained, repeat step (2) to (6).

6.2.29 Drop out color adjustment

The density level to be dropped out can be adjusted when copying is performed while selecting [Drop out color].

<05 Adjustment Mode>

Color mode	Code	Item to be adjusted	Remarks
Black	7066	Drop out color adjustment	When a larger value is set, a gray-like color in an original tends to be dropped out. When a smaller value is set, a gray-like color in an original tends to be remaining. Acceptable value: 20 to 80 (Default: 50)

Notes:

Perform the adjustment in accordance with the procedure below.

 P. 6-28 “6.2.1 Automatic gamma adjustment”

<Procedure>

The procedure is the same as that of  P. 6-30 “6.2.2 Density adjustment”.

Notes:

To check an image, use the one copied in the normal startup.

6.2.30 ADF noise reduction

The noise reduction level for streaks can be adjusted with the following codes when a scan job is performed using the ADF.

<05 Adjustment Mode>

Color mode	Original mode			Item to be adjusted	Remarks
	Text/Photo	Text	Custom mode		
Black	7151	7152	7150	ADF noise reduction level setting	When the value decreases, the effect of reducing streaks (set with FS-08-7617) becomes larger. When the value increases, the effect of reducing streaks (set with FS-08-7617) becomes smaller. When “0” is set, this function is disabled. Acceptable values: 0 to 200 (Default: 100)

When [FULL COLOR] or [AUTO COLOR] is selected for the color mode, the ADF noise reduction function for streaks can be set to enable or disable with the following codes.

Color mode	Original mode			Item to be adjusted	Remarks
	Text/Photo	Text	Custom mode		
Color	7694	-	7693	ADF noise reduction	Enable/Disable setting 0: Disabled 1: Enabled (Default: 1) FS-05-7693 is available only when “1” (TEXT/PHOTO) is set for FS-08-7614.

Notes:

Remember the image specifications and life span of the replacing parts may not meet the standard when the setting value is changed from the default value.

If too small a value is set, the text may not be printed clearly.

<Procedure>

The procedure is the same as that of  P. 6-30 “6.2.2 Density adjustment”.

Notes:

To check an image of [User Custom], use the one copied in the normal startup.

6.3 Image Quality Adjustment (Printing Function)

6.3.1 Automatic gamma adjustment

When the reproduction of gradation is not appropriate, the gradation reproducibility of all colors Y, M, C and K can be corrected by performing this automatic gamma adjustment. In case the gradation reproduction of the image checked is not satisfactory, make this adjustment as described below at parts replacement.

1. When unpacking or any of the following parts has been replaced, be sure to make this adjustment:
 - Photoconductive drum
 - Developer material Y, M, C, K
 - Laser optical unit
 - Transfer belt
 - 1st transfer roller
 - Drum cleaning blade
 - Needle electrode
 - Main charger grid
 - Image position aligning sensor (Front)
 - Image position aligning sensor (Rear)/Image quality sensor
 - SRAM board
 - EEPROM (LGC board)
 - HDD

2. When any of the following parts are replaced or adjusted, make a print and check the image to determine if adjustment is necessary:
 - 2nd transfer roller
 - Screen switchover (for color: FS-08-8110, for black: FS-08-7310)

Notes:

Be sure to perform this adjustment after performing  P. 6-4 “6.1.3 Performing image quality control”.

<Procedure>

- (1) Perform FS-05. → 05 Adjustment Mode
- (2) Select the A4/LT/A3/LD drawer. Key in the pattern number and press [TEST PRINT] to output a "Patch chart for adjustment".

600dpi

Pattern No.	Paper type	Remarks
70	Plain paper	Used when the code 8004-0 is performed
72	Thick paper	Used when the code 8004-1 is performed
74	Recycled paper	Used when the code 8004-2 is performed
76	Thick paper 1	Used when the code 8004-3 is performed
78	Thick paper 2	Used when the code 8004-4 is performed
80	Thick paper 3	Used when the code 8004-5 is performed
82	Thick paper 4	Used when the code 8004-6 is performed
84	Special paper 1	Used when the code 8004-7 is performed
86	Special paper 2	Used when the code 8004-8 is performed
88	Special paper 3	Used when the code 8004-9 is performed
90	Thin paper	Used when the code 8004-10 is performed

1200dpi

Pattern No.	Paper type	Remarks
230	Plain paper	Used when the code 8005-0 is performed
232	Thick paper	Used when the code 8005-1 is performed
234	Recycled paper	Used when the code 8005-2 is performed
236	Thick paper 1	Used when the code 8005-3 is performed
238	Thick paper 2	Used when the code 8005-4 is performed
240	Thick paper 3	Used when the code 8005-5 is performed
242	Thick paper 4	Used when the code 8005-6 is performed
244	Special paper 1	Used when the code 8005-7 is performed
246	Special paper 2	Used when the code 8005-8 is performed
248	Special paper 3	Used when the code 8005-9 is performed
250	Thin paper	Used when the code 8005-10 is performed

- (3) Place the patch chart for adjustment printed in step (2) face down on the original glass, with its side, on which two black squares are present, aligned against the original scale.
- (4) Key in a code and press the [START] button. → The scanner reads the chart automatically and performs automatic gamma adjustment calculation (approx. 30 sec.).

600dpi

Code	Paper type	Remarks
8004-0	Plain paper	When the reproduction of gradation is not appropriate, the gradation reproducibility of all colors Y, M, C and K can be corrected by performing this automatic gamma adjustment.
8004-1	Thick paper	
8004-2	Recycled paper	
8004-3	Thick paper 1	
8004-4	Thick paper 2	
8004-5	Thick paper 3	
8004-6	Thick paper 4	
8004-7	Special paper 1	
8004-8	Special paper 2	
8004-9	Special paper 3	
8004-10	Thin paper	
8008	All paper types*	

* If the code FS-05-8008 is performed, the adjustment will be applied to all paper types.

1200dpi

Code	Paper type	Remarks
8005-0	Plain paper	When the reproduction of gradation is not appropriate, the gradation reproducibility of all colors Y, M, C and K can be corrected by performing this automatic gamma adjustment.
8005-1	Thick paper	
8005-2	Recycled paper	
8005-3	Thick paper 1	
8005-4	Thick paper 2	
8005-5	Thick paper 3	
8005-6	Thick paper 4	
8005-7	Special paper 1	
8005-8	Special paper 2	
8005-9	Special paper 3	
8005-10	Thin paper	
8009	All paper types*	

* If the code FS-05-8009 is performed, the adjustment will be applied to all paper types.

- (5) When the adjustment has finished normally, press [OK] to have the adjustment results reflected. (To cancel the reflection of adjustment results, press [CANCEL].)
In the case of an abnormal ending, "ADJUSTMENT ERROR" is shown. Press [CANCEL] to clear the error display.
When it is cleared, the control panel display will return to the ready state. Then, check if the patch chart on the original glass is placed in the wrong direction or if it is placed inclined on the original glass, and then repeat step (3) and afterward.

To select the paper type for the automatic gamma adjustment in user calibration, change the code below to "1". (copy/print)

Code	Remarks
FS-08-9059	0: No paper selecting buttons displayed 1: Paper selecting buttons displayed. (For both Copy and Printer)

6.3.2 Gamma balance adjustment

The gamma balance is adjusted by adjusting the density at the Black Mode. The adjustment is performed by selecting its density area from the following: low density, medium density, and high density.

When “Black” (600 dpi) is set for the color mode and “Auto” is selected for the halftone setting, the gamma balance can be adjusted in each area of Text, Graphics and Image.

<05 Adjustment Mode>

Color mode	PS		PCL		XPS		Item to be adjusted	Remarks
	Smooth	Detail	Smooth	Detail	Smooth	Detail		
Black (600dpi)	7315-0	7316-0	7317-0	7318-0	7319-0	7320-0	Low density	The larger the value is, the density of the item to be adjusted becomes darker. Acceptable values: 0 to 255 (Default: 128)
	7315-1	7316-1	7317-1	7318-1	7319-1	7320-1	Medium density	
	7315-2	7316-2	7317-2	7318-2	7319-2	7320-2	High density	
Black (1200dpi)	7309-0	7310-0	---	---	---	---	Low density	The larger the value is, the density of the item to be adjusted becomes darker. Acceptable values: 0 to 255 (Default: 128)
	7309-1	7310-1	---	---	---	---	Medium density	
	7309-2	7310-2	---	---	---	---	High density	

Color mode	Auto (PS)			Auto (PCL)			Item to be adjusted	Remarks
	Text	Graphics	Image	Text	Graphics	Image		
Black (600dpi)	7360-0	7361-0	7362-0	7363-0	7364-0	7365-0	Low density	The larger the value is, the density of the item to be adjusted becomes darker. Acceptable values: 0 to 255 (Default: 128)
	7360-1	7361-1	7362-1	7363-1	7364-1	7365-1	Medium density	
	7360-2	7361-2	7362-2	7363-2	7364-2	7365-2	High density	

Color mode	Auto (PS)			Item to be adjusted	Remarks
	Text	Graphics	Image		
Black (1200dpi)	7357-0	7358-0	7359-0	Low density	The larger the value is, the density of the item to be adjusted becomes darker. Acceptable values: 0 to 255 (Default: 128)
	7357-1	7358-1	7359-1	Medium density	
	7357-2	7358-2	7359-2	High density	

Color mode	Auto (XPS)			Item to be adjusted	Remarks
	Text	Graphics	Image		
Black (600dpi)	7366-0	7367-0	7368-0	Low density	The larger the value is, the density of the item to be adjusted becomes darker. Acceptable values: 0 to 255 (Default: 128)
	7366-1	7367-1	7368-1	Medium density	
	7366-2	7367-2	7368-2	High density	

Notes:

- Be sure that this adjustment be made after performing  P. 6-55 “6.3.1 Automatic gamma adjustment”.
- Changing the adjustment setting influences the adjacent density area slightly.

E.g.: When the value of the medium density is larger, the adjacent areas in the low density and high density range will become slightly darker.

<Procedure>

- (1) Perform FS-05.
- (2) Key in the codes to be adjusted (language and screen) and press the [START] button.
- (3) Key in the value corresponding to the density area to be adjusted (0, 1 or 2) and press the [START] button.
0: Low density 1: Medium density 2: High density/Highest density
- (4) Key in the adjustment value. (To correct the value once keyed in, press [CLEAR].)
- (5) Press [OK] to store the value in memory. → The equipment goes back to the ready state.
- (6) For resetting the value, repeat step (2) to (5).
- (7) Let the equipment restart and perform the printing job.
- (8) If the image density has not been attained, repeat step (1) to (7)

<Range of the density area (low density, medium density, high density)>

The color from the 1st to the 7th stage (low density), from the 8th to the 11th stage (medium density) and from the 12th to the 13th stage (high density) in "Patch chart for gamma adjustment ([71] [TEST PRINT])" output as a confirmation in  P. 6-55 "6.3.1 Automatic gamma adjustment" can be used as a guide for the range of the density area (low density, medium density, high density) influenced by the change of the adjustment value.

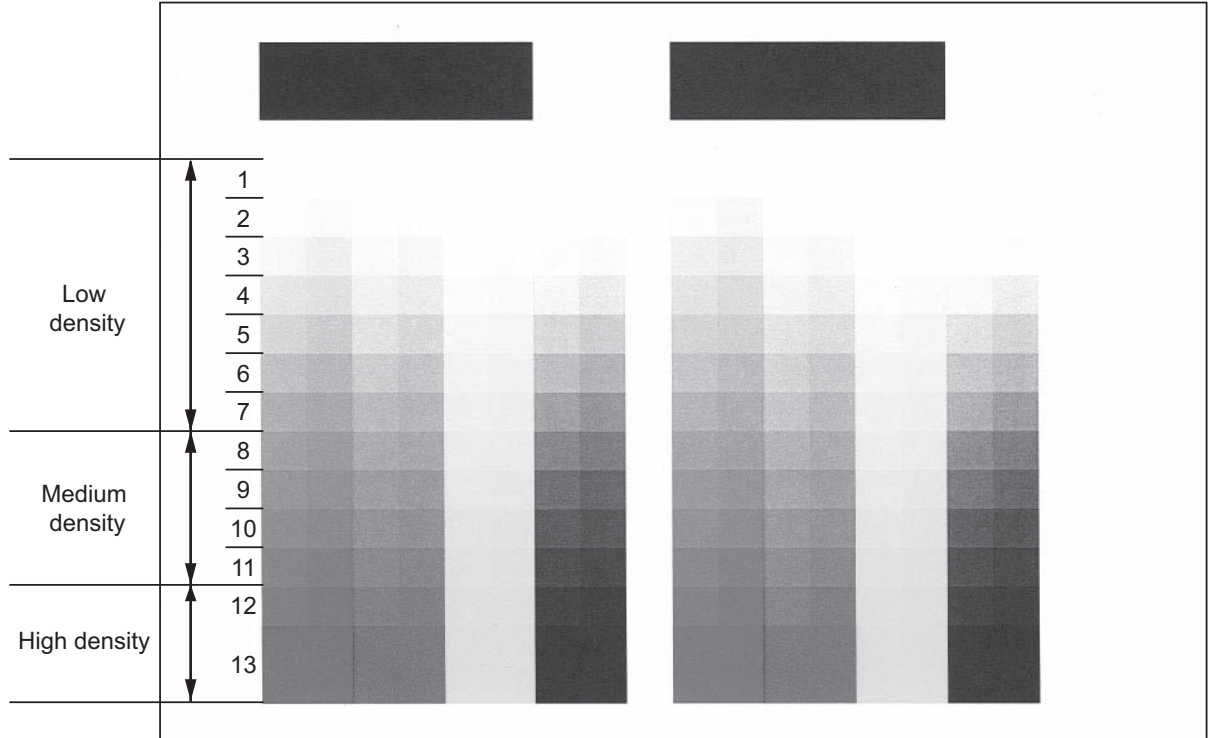

Fig.6-25

6.3.3 Color balance adjustment

The color balance is adjusted by adjusting the density of each color. The adjustment is performed by selecting its density area from the following: low density, medium density, and high density.

<05 Adjustment Mode>

For color printing

Color	PS		PCL		XPS		Auto (PS)			Remarks
	Smooth	Detail	Smooth	Detail	Smooth	Detail	Text	Graphics	Image	
Yellow (600dpi)	8050-0	8054-0	8058-0	8062-0	8042-0	8046-0	---	---	---	The larger the value is, the darker the color to be adjusted becomes. Acceptable values: 0 to 255 (Default: 128)
	8050-1	8054-1	8058-1	8062-1	8042-1	8046-1	---	---	---	
	8050-2	8054-2	8058-2	8062-2	8042-2	8046-2	---	---	---	
Magenta (600dpi)	8051-0	8055-0	8059-0	8063-0	8043-0	8047-0	---	---	---	
	8051-1	8055-1	8059-1	8063-1	8043-1	8047-1	---	---	---	
	8051-2	8055-2	8059-2	8063-2	8043-2	8047-2	---	---	---	
Cyan (600dpi)	8052-0	8056-0	8060-0	8064-0	8044-0	8048-0	---	---	---	
	8052-1	8056-1	8060-1	8064-1	8044-1	8048-1	---	---	---	
	8052-2	8056-2	8060-2	8064-2	8044-2	8048-2	---	---	---	
Black (600dpi)	8053-0	8057-0	8061-0	8065-0	8045-0	8049-0	---	---	---	
	8053-1	8057-1	8061-1	8065-1	8045-1	8049-1	---	---	---	
	8053-2	8057-2	8061-2	8065-2	8045-2	8049-2	---	---	---	
Yellow (1200dpi)	8268-0	8272-0	---	---	---	---	8164-0	8168-0	8172-0	
	8268-1	8272-1	---	---	---	---	8164-1	8168-1	8172-1	
	8268-2	8272-2	---	---	---	---	8164-2	8168-2	8172-2	
Magenta (1200dpi)	8269-0	8273-0	---	---	---	---	8165-0	8169-0	8173-0	
	8269-1	8273-1	---	---	---	---	8165-1	8169-1	8173-1	
	8269-2	8273-2	---	---	---	---	8165-2	8169-2	8173-2	
Cyan (1200dpi)	8270-0	8274-0	---	---	---	---	8166-0	8170-0	8174-0	
	8270-1	8274-1	---	---	---	---	8166-1	8170-1	8174-1	
	8270-2	8274-2	---	---	---	---	8166-2	8170-2	8174-2	
Black (1200dpi)	8271-0	8275-0	---	---	---	---	8167-0	8171-0	8175-0	
	8271-1	8275-1	---	---	---	---	8167-1	8171-1	8175-1	
	8271-2	8275-2	---	---	---	---	8167-2	8171-2	8175-2	

Color specified for twin color print	Item to be adjusted				Remarks
	Black	Yellow	Magenta	Cyan	
Black	8023-0	-	-	-	The larger the value is, the darker the color to be adjusted becomes. Acceptable values: 0 to 255 (Default: 128) Sub code 0: low density Sub code 1: medium density Sub code 2: high density
	8023-1	-	-	-	
	8023-2	-	-	-	
Cyan	-	8024-0	8025-0	8026-0	
	-	8024-1	8025-1	8026-1	
	-	8024-2	8025-2	8026-2	
Magenta	-	8027-0	8028-0	8029-0	
	-	8027-1	8028-1	8029-1	
	-	8027-2	8028-2	8029-2	
Yellow	-	8030-0	8031-0	8032-0	
	-	8030-1	8031-1	8032-1	
	-	8030-2	8031-2	8032-2	
Red	-	8033-0	8034-0	8035-0	
	-	8033-1	8034-1	8035-1	
	-	8033-2	8034-2	8035-2	
Green	-	8036-0	8037-0	8038-0	
	-	8036-1	8037-1	8038-1	
	-	8036-2	8037-2	8038-2	
Blue	-	8039-0	8040-0	8041-0	
	-	8039-1	8040-1	8041-1	
	-	8039-2	8040-2	8041-2	



Notes:

- Be sure that this adjustment is made after performing  P. 6-55 “6.3.1 Automatic gamma adjustment”.
- Changing the adjustment setting influences the adjacent density area slightly.
E.g.: When the value of the medium density is larger, the adjacent areas in the low density and high density range will become slightly darker.

<Procedure>

The procedure is the same as that of  P. 6-58 “6.3.2 Gamma balance adjustment”.

<Range of the density area (low density, medium density, high density)>

The color from the 1st to the 7th stage (low density), from the 8th to the 11th stage (medium density), from the 12th to the 13th stage (high density) in “Patch chart for gamma adjustment ([71] [TEST PRINT])” output in  P. 6-55 “6.3.1 Automatic gamma adjustment” can be used as a guide for the range of the density area influenced by the adjustment with the printer driver and the change of the adjustment value (low density, medium density, and high density (Refer to  P. 6-59 “Fig.6-25 ”).

6.3.4 Fine line/text density adjustment

The density of fine lines and small characters can be adjusted in the following codes.

<05 Adjustment Mode>

Printer Driver	General	Photographic	Presentation	Line art	Twin color	Monochrome	Remarks
PS	8130-0	8130-1	8130-2	8130-3	8133	7340	The larger the value is, the darker the density of the fine lines and small characters becomes. The smaller the value is, the lighter the density of the fine lines and small characters becomes. Acceptable values: 0 to 8 (Default: 0)
PCL	8131-0	8131-1	8131-2	8131-3	8134	7341	
XPS	8132-0	8132-1	8132-2	8132-3	8135	7342	

<Procedure>

- (1) Perform FS-05.
- (2) Key in the codes to be adjusted and press the [START] button.
- (3) Key in the adjustment value. (To correct the value once keyed in, press [CLEAR].)
- (4) Press [OK] to store the value in memory. → The equipment goes back to the ready state.
- (5) For resetting the value, repeat step (2) to (4).
- (6) Let the equipment restart and perform the printing job.
- (7) If the desired image has not been attained, repeat step (1) to (6).

6.3.5 Upper limit value in the toner saving mode

The upper limit value of the density when “Toner save” is selected in the Custom tab of the printer driver can be adjusted.

<05 Adjustment Mode>

Color	PS	PCL	XPS	1200dpi	Remarks
Monochrome	7307-0	7307-1	7307-2	7302	The smaller the value is, the lighter the density of image becomes. Acceptable values: 0 to 255 (Default: 176)
Except monochrome	8160-0	8160-1	8160-2	8161	

<Procedure>

The procedure is the same as that of  P. 6-58 “6.3.2 Gamma balance adjustment”.

6.3.6 Maximum toner density adjustment

The maximum toner amount adhering to the OHP and the User Media Type1 to 10 can be controlled.

<05 Adjustment Mode>

Color	Code	Media Type	Remarks
Color (600dpi)	8144-0	User Media Type1	The smaller the value is, the toner amount adhered decreases of the high density area (ex. prevention of fusing offsetting, etc.). Acceptable values: 0 to 255 (Default: OHP: 200, Others: 255)
	8144-1	User Media Type2	
	8144-2	User Media Type3	
	8144-3	User Media Type4	
	8144-4	User Media Type5	
	8144-5	User Media Type6	
	8144-6	User Media Type7	
	8144-7	User Media Type8	
	8144-8	User Media Type9	
	8144-9	User Media Type10	
	8145	OHP	
Color (1200dpi)	8148-0	User Media Type1	
	8148-1	User Media Type2	
	8148-2	User Media Type3	
	8148-3	User Media Type4	
	8148-4	User Media Type5	
	8148-5	User Media Type6	
	8148-6	User Media Type7	
	8148-7	User Media Type8	
	8148-8	User Media Type9	
	8148-9	User Media Type10	
		8149	OHP

<Procedure>

The procedure is the same as that of  P. 6-62 “6.3.4 Fine line/text density adjustment”.

Notes:

The larger the value is, the more frequently fusing offsetting occurs.

6.3.7 Fine line enhancement switchover

The setting of the thin line enhancement is changed.

<05 Adjustment Mode>

Printer Driver	Monochrome	Full Color	Twin color	Remarks
PS	7322-0	8102-0	8101-0	Whether fine lines are enhanced or not can be switched. 0: OFF 1: ON Acceptable values: 0 to 1 (Default: 1)
PCL	7322-1	8102-1	8101-1	
XPS	7322-2	8102-2	8101-2	

<Procedure>

The procedure is the same as that of  P. 6-58 “6.3.2 Gamma balance adjustment”.

6.3.8 “PureBlack/PureGray” threshold adjustment (PCL)

<05 Adjustment Mode>

Original mode				Item to be adjusted	Remarks
General	Photographic	Presentation	Line art		
8210-0	8210-1	8210-2	8210-3	Text	The larger the value is, the wider the color range to be printed only with the black toner becomes. The smaller the value is, the narrower this color range becomes. Acceptable values: 1 to 255
8211-0	8211-1	8211-2	8211-3	Graphics	
8212-0	8212-1	8212-2	8212-3	Image	

<Procedure>

The procedure is the same as that of  P. 6-58 “6.3.2 Gamma balance adjustment”.

6.3.9 “PureBlack/PureGray” threshold adjustment (Twin color mode)

<05 Adjustment Mode>

Code	Item to be adjusted	Remarks
8213	Text	The larger the value is, the wider the color range to be printed only with the black toner becomes. The smaller the value is, the narrower this color range becomes. Acceptable values: 1 to 255
8214	Graphics	
8215	Image	

<Procedure>

The procedure is the same as that of  P. 6-62 “6.3.4 Fine line/text density adjustment”.

6.3.10 “PureBlack/PureGray” threshold adjustment (PS)

<05 Adjustment Mode>

Original mode					Item to be adjusted	Remarks
General	Photographic	Presentation	Line art	Color profile		
8252-0	8252-1	8252-2	8252-3	8252-4	Text	The larger the value is, the wider the color range to be printed only with the black toner becomes. The smaller the value is, the narrower this color range becomes. Acceptable values: 1 to 255
8253-0	8253-1	8253-2	8253-3	8253-4	Graphics	
8254-0	8254-1	8254-2	8254-3	8254-4	Image	

<Procedure>

The procedure is the same as that of  P. 6-58 “6.3.2 Gamma balance adjustment”.

6.3.11 “PureBlack/PureGray” threshold adjustment (XPS)

<05 Adjustment Mode>

Original mode					Item to be adjusted	Remarks
General	Photographic	Presentation	Line art	Color profile		
8249-0	8249-1	8249-2	8249-3	8249-4	Text	The larger the value is, the wider the color range to be printed only with the black toner becomes. The smaller the value is, the narrower this color range becomes. Acceptable values: 1 to 255
8250-0	8250-1	8250-2	8250-3	8250-4	Graphics	
8251-0	8251-1	8251-2	8251-3	8251-4	Image	

<Procedure>

The procedure is the same as that of  P. 6-58 “6.3.2 Gamma balance adjustment”.

6.3.12 Toner limit threshold adjustment

<05 Adjustment Mode>

Smooth/Auto (PS/PCL/XPS)	Detail (PS/PCL/XPS)	Smooth (1200dpi)	Detail (1200dpi)	Paper type	Remarks
8071-0	8070-0	8090-0	8089-0	Plain paper	When you set a larger value, the density becomes high in some parts of the high density area since the maximum amount of toner adhering increases. When you set a smaller value, the reproduction of the gradation tends to be reduced since the maximum amount of toner adhering decreases and the maximum density becomes low. Note that if the value is too large, offsetting or jam in the fuser unit might occur. Acceptable values: 0 to 255 <Default value> Thin paper: 64 Others: 128
8071-1	8070-1	8090-1	8089-1	Thick paper	
8071-2	8070-2	8090-2	8089-2	Recycled paper	
8071-3	8070-3	8090-3	8089-3	Thick paper 1	
8071-4	8070-4	8090-4	8089-4	Thick paper 2	
8071-5	8070-5	8090-5	8089-5	Thick paper 3	
8071-6	8070-6	8090-6	8089-6	Thick paper 4	
8071-7	8070-7	8090-7	8089-7	Special paper 1	
8071-8	8070-8	8090-8	8089-8	Special paper 2	
8071-9	8070-9	8090-9	8089-9	Special paper 3	
8071-10	8070-10	8090-10	8089-10	Thin paper	
8071-11	8070-11	8090-11	8089-11	Envelope	
8071-12	8070-12	8090-12	8089-12	OHP film	

<Procedure>

The procedure is the same as that of  P. 6-58 “6.3.2 Gamma balance adjustment”.

6.3.13 Sharpness adjustment

This adjustment is applied when images need to be softer or sharper.
The adjustment for each original mode is available.

<05 Adjustment Mode>

Item to be adjusted	Monochrome*1	Color					Twin color	Remarks
		General*2	Photo	Presentation	Line art*2	Red Seal Color*2		
Text	8118-0	8110-0	8111-0	8112-0	8113-0	8109-0	8108-0	The larger the value is, the sharper the image becomes. The smaller the value is, the softer the image becomes. Acceptable values: 0 to 255 (Default: 128)
Graphics	8118-1	8110-1	8111-1	8112-1	8113-1	8109-1	8108-1	
Image	8118-2	8110-2	8111-2	8112-2	8113-2	8109-2	8108-2	

*1: Items which are adjusted when the value of FS-05-7322 is "0".

The items which are adjusted when the value of FS-05-7322 is "1" are as below.

Item to be adjusted	Monochrome
Text/Others	8118-0
Thin text	8118-1
Image	8118-2

*2: Items which are adjusted when the value of FS-05-8102 is "0".

The items which are adjusted when the value of FS-05-8102 is "1" are as below.

Item to be adjusted	General	Line art	Red Seal Color
Text/Others	8110-0	8113-0	8109-0
Thin text	8110-1	8113-1	8109-1
Image	8110-2	8113-2	8109-2

<Procedure>

The procedure is the same as that of  P. 6-58 "6.3.2 Gamma balance adjustment".

Notes:

To check an image of [Red Seal], use the one copied in the normal startup.

6.3.14 Thin line width lower limit adjustment

<05 Adjustment Mode>

Mode	Code	Remarks
600dpi	8240	Sets the lower limit value of the thin line width when "Distinguish Thin Lines" is selected in the screen selecting menu of the printer driver. The larger the value is, the thicker (darker) the thin line becomes. Acceptable values: 1 to 9 (Default: 2)
1200dpi	8241	

<Procedure>

The procedure is the same as that of  P. 6-62 "6.3.4 Fine line/text density adjustment".

6.3.15 Background adjustment

The density of background can be adjusted as follows.

<05 Adjustment Mode>

Mode	PS		PCL		XPS		1200dpi		Remarks
	Smooth	Detail	Smooth	Detail	Smooth	Detail	Smooth	Detail	
Color	8010-0	8013-0	8010-1	8013-1	8010-2	8013-2	8016	8017	The larger the value is, the darker the background becomes. The smaller the value is, the lighter the background becomes. Acceptable values: 0 to 255 (default: 128)
Twin Color	8011-0	8014-0	8011-1	8014-1	8011-2	8014-2	-	-	
Black	8012-0	8015-0	8012-1	8015-1	8012-2	8015-2	8018	8019	

<Procedure>

The procedure is the same as that of  P. 6-58 "6.3.2 Gamma balance adjustment".

6.3.16 Color/black judgment setting for twin color printing images

The color reproduction of the image object is specified in the twin color mode.

<05 Adjustment Mode>

Code	Remarks
8218	0: Reproduced with black and the specified color 1: Reproduced with black only Acceptable values: 0 to 1 (Default: 0)

<Procedure>

The procedure is the same as that of  P. 6-62 "6.3.4 Fine line/text density adjustment".

6.3.17 Emission level adjustment

The emission level in the e-Filing printing (Monochrome/binary), the Network FAX and the Internet FAX can be adjusted as follows. This adjustment adjusts the dot size.

<05 Adjustment Mode>

Code	Item to be adjusted	Function	Remarks
7350-0	Emission level 0/4	Network FAX, Internet FAX	The smaller the value is, the smaller the primary scanning direction emission level becomes. Therefore, the smaller dot is reproduced accordingly. Acceptable values: 0 to 255 (Default Level 0/4: 0, Level 1/4: 63, Level 2/4: 127, Level 3/4: 191, Level 4/4: 255)
7350-1	Emission level 1/4		
7350-2	Emission level 2/4		
7350-3	Emission level 3/4		
7350-4	Emission level 4/4		
7356-0	Emission level 0/4	e-Filing printing (Monochrome/binary)	
7356-1	Emission level 1/4		
7356-2	Emission level 2/4		
7356-3	Emission level 3/4		
7356-4	Emission level 4/4		

<Procedure>

The procedure is the same as that of  P. 6-41 "6.2.15 Emission level adjustment".

Notes:

- Change the setting value increment of 8 as a guide.
- Be sure to confirm the image when the setting value is changed.
- The setting value must increase as the emission level number (0 to 4) becomes higher. Do not increase this order when setting the values.
- Usually, emission level 4/4 is most effective in the black mode.
- It is not applied to the images printed in the black mode by the printer driver.

6.3.18 Density adjustment of graphic lines (1200 dpi)

This adjustment is available regardless of whether “Distinguish Thin Lines” of the printer driver is selected or not.

<05 Adjustment Mode>

Density adjustment

Color mode	Code	Remarks
Color/Black	8242-0	The density of the line in Black in the line density range specified by “FS-05-8243-0” or “FS-05-8243-1” can be adjusted. The larger the value is, the darker the line density becomes. Acceptable value: 0 to 5 (Default: 3)
	8242-1	The density of the line in Yellow, Magenta, Cyan, and Black in the line density range specified by “FS-05-8243-2” or “FS-05-8243-3” can be adjusted. The larger the value is, the darker the line density becomes. Acceptable value: 0 to 5 (Default: 1)

Effective range

Color mode	Code	Remarks
Color/Black	8243-0	The effective range (lower limit) of the density adjustment for the line in Black can be set. Acceptable value: 0 to 255 (Default: 1)
	8243-1	The effective range (upper limit) of the density adjustment for the line in Black can be set. Acceptable value: 0 to 255 (Default: 200)
	8243-2	The effective range (lower limit) of the density adjustment for the line in Yellow, Magenta, Cyan, and Black can be set. Acceptable value: 0 to 255 (Default: 1)
	8243-3	The effective range (upper limit) of the density adjustment for the line in Yellow, Magenta, Cyan, and Black can be set. Acceptable value: 0 to 255 (Default: 255)

Notes:

Be sure to set the values of the upper and lower limit properly so that they are not set in reverse.
The line density adjustment codes with black (8242-0, 8243-0 and 8243-1) are in common for both the color and black modes.

<Procedure>

The procedure is the same as that of  P. 6-58 “6.3.2 Gamma balance adjustment”.

6.3.19 Gradation switching for black mode printing text

The gradation level of the TEXT object in black mode printing can be switched.

<05 Adjustment Mode>

Mode	PS	PCL	XPS	Remarks
Black (600dpi)	7386-0	7386-1	7386-2	0: Text reproduction priority (Text with medium density will be reproduced darker.)
Black (1200dpi)	7387	-	-	1: Gradation reproduction priority (Text with medium density will be reproduced lighter.) Acceptable values: 0 to 1 (Default: 0)

<Procedure>

The procedure is the same as that of  P. 6-62 “6.3.4 Fine line/text density adjustment”.

6.3.20 Color reproduction switching (Twin color printing)

The color reproduction level in twin color printing can be switched.

<05 Adjustment Mode>

Code	Item to be adjusted	Remarks
8002	Color reproduction switching (Twin color printing)	0: Gradation priority Printing is performed in a natural gradation. This setting is suitable for printing an original such as a leaflet including photos. 1: Text reproduction priority Colored lines and text are printed in a clear shape. This setting is suitable for printing an original such as a form. Acceptable values: 0 to 1 (Default: 0)

<Procedure>

The procedure is the same as that of  P. 6-62 “6.3.4 Fine line/text density adjustment”.

6.3.21 Auto Trapping adjustment

White voids in the background caused by an off registration of text or graphics can be reduced.

<05 Adjustment Mode>

Code	Item to be adjusted	Remarks
8244-0	Number of pixels to perform trapping (dot)	When a larger value is set, it will get stronger against a wider gap (off registration); however, overlapped areas will become more conspicuous. Acceptable values: 1 to 3 (Default: 2)
8244-1	Color brightness of trapped areas (%)	The smaller the value is, the darker the color becomes. In this case, gaps will not become conspicuous; however, overlapped areas will become more conspicuous. Acceptable values: 0 to 255 (Default: 128)
8245	Enable/disable switching of trapping process at direct printing	Acceptable values: 0 to 1 (Default: 0)

Notes:

- This is available only in full color printing.
- The settings of 05-8244 are reflected when AutoTrapping is enabled in a printer driver.
- The settings of 05-8244 are common for PCL, PS and XPS (excluding 1200dpi printing at PS).
- Direct printing: Printing process which does not use (pass through) a printer driver.

<Procedure>

The procedure is the same as that of  P. 6-58 “6.3.2 Gamma balance adjustment”.

6.3.22 Adjustment of smudged text in black (600dpi)

Smudged text in black can be adjusted.

<05 Adjustment Mode>

Mode	PS	PCL	XPS	Remarks
Color	8121	8122	8123	When a larger value is set, black text becomes thinner. When a smaller value is set, it becomes thicker. Acceptable values: 0 to 9 (Default PS: 2, PCL/XPS: 5)
Twin Color	8124	8125	8126	
Black	7325	7326	7327	

<Procedure>

The procedure is the same as that of  P. 6-62 “6.3.4 Fine line/text density adjustment”.

6.3.23 Adjustment of smudged text in black (1200dpi)

Smudged text in black can be adjusted.

<05 Adjustment Mode>

Mode	Code	Remarks
Black	7305	When a larger value is set, black text becomes thinner. When a smaller value is set, it becomes thicker. Acceptable values: 0 to 9 (Default: 5)

<Procedure>

The procedure is the same as that of  P. 6-62 “6.3.4 Fine line/text density adjustment”.

6.3.24 Halftone setting

The halftone mode to be used is set when [Auto] is selected in Halftone of a printer driver.

<05 Adjustment Mode>

Mode	Item to be adjusted			Remarks
	Text	Graphics	Image	
1200 dpi	7383-0	7383-1	7383-2	0: Smooth 1: Detail Acceptable values: 0 to 1 (Default: Text:1, Graphics/Image: 0)

Notes:

Be sure to perform this adjustment after performing the following one.

 P. 6-55 "6.3.1 Automatic gamma adjustment"

<Procedure>

- (1) Perform FS-05.
- (2) Key in a code and press the [START] button.
- (3) Key in the code to be adjusted (0, 1 or 2) and press the [START] button.
- (4) Key in the adjustment value.
(To correct the value once keyed in, press [CLEAR].)
- (5) Press [OK] to store the value. -> The equipment returns to the ready state.
- (6) Start up the equipment in the normal mode and make a print.
- (7) If the desired image density has not been attained, repeat steps (1) to (6).

6.4 Image Quality Adjustment (Scanning Function)

6.4.1 Gamma balance adjustment

The gamma balance at the Black Mode is adjusted by adjusting the density. The adjustment is performed by selecting its density area from the following: low density, medium density and high density.

<05 Adjustment Mode>

Black			Gray Scale	Item to be adjusted	Remarks
Original mode					
Text/Photo	Photo	Custom mode			
7485-0	7487-0	7480-0	7488-0	Low density	The larger the value is, the density of the item to be adjusted becomes darker. Acceptable values: 0 to 255 (Default: 128)
7485-1	7487-1	7480-1	7488-1	Medium density	
7485-2	7487-2	7480-2	7488-2	High density	

<Procedure>

- (1) Perform FS-05.
- (2) Key in the code corresponding to the desired original mode and press the [START] button.
- (3) Key in the value corresponding to the density area to be adjusted (0, 1 or 2) and press the [START] button.
0: Low density (L), 1: Medium density (M), 2: High density (H)
- (4) Key in the adjustment value. (To correct the value once keyed in, press [CLEAR].)
- (5) Press [OK] to store the value in memory.
→ The equipment goes back to the ready state.
- (6) For resetting the value, repeat step (2) to (5).
- (7) Let the equipment restart and perform the scanning job.
- (8) If the desired image has not been attained, repeat step (1) to (7).

6.4.2 RGB Color balance adjustment

The color balance of the images scanned in the color mode can be adjusted.

<05 Adjustment Mode>

Original mode	Item to be adjusted			Remarks
	Red	Green	Blue	
Text/Photo	8425-0	8425-1	8425-2	When a larger value is set, red becomes darker. When a smaller value is set, it becomes lighter. Acceptable values: 0 to 255 (Default: 128)
Text	8426-0	8426-1	8426-2	
Photo	8427-0	8427-1	8427-2	
Custom	8428-0	8428-1	8428-2	

<Procedure>

- (1) Perform FS-05.
- (2) Key in the code corresponding to the desired original mode and press the [START] button.
- (3) Key in the value corresponding to the sub code to be adjusted (0, 1 or 2) and press the [START] button.
0: Red, 1: Green, 2: Blue
- (4) Key in the adjustment value. (Acceptable values: 0 to 255)
(To correct the value once keyed in, press [CLEAR].)
- (5) Press [OK] to store the value in a memory.
→ The equipment goes back to the ready state.
- (6) Turn the power ON again. Scan an original and check the images.
- (7) If the desired image has not been attained, repeat step (1) to (6).

6.4.3 Density adjustment

Adjusts the center density.

<05 Adjustment Mode>

Color Mode	Original mode				Item to be adjusted	Remarks
	Text/Photo	Text	Photo	Custom mode		
Color	8339	8340	8341	8380	Manual density center value/ Automatic density	The larger the value is, the darker the image becomes. Acceptable values: 0 to 255 (Default: 128)

<05 Adjustment Mode>

Mode	Original mode				Gray Scale	Item to be adjusted	Remarks
	Text/Photo	Text	Photo	Custom mode			
Black	7444	7445	7446	7475	7447	Manual density center value	The larger the value is, the darker the image becomes. Acceptable values: 0 to 255 (Default: 128)
	7456	7457	7458	7478	7459	Automatic density	

<Procedure>

- (1) Perform FS-05.
- (2) Key in a code and press the [START] button.
- (3) Key in an adjustment value (acceptable values: 0 to 255).
(To correct a value once keyed in, press [CLEAR].)
- (4) Press [OK] to store the value in memory.
→ The equipment goes back to the ready state.
- (5) Let the equipment restart and perform the scanning.
- (6) If the desired image quality has not been attained, repeat step (1) to (5).

6.4.4 Background adjustment (Color)

The adjustment level of background center value is adjusted.

<05 Adjustment Mode>

Code	Original mode	Remarks
8309	Text/Photo	The smaller the value is, the background becomes lighter. Acceptable values: 0 to 255 (Default: 128)
8310	Text	
8311	Photo	
8370	Custom mode	

<Procedure>

- (1) Perform FS-05.
- (2) Key in the codes and press the [START] button.
- (3) Key in the adjustment values. Acceptable values: 0 to 255. (To correct the value once keyed in, press [CLEAR].)
- (4) Press [OK] to store the value in memory. → The equipment goes back to the ready state.
- (5) Let the equipment restart and perform the scanning job.
- (6) If the desired image has not been attained, repeat step (1) to (5).

6.4.5 Background adjustment (Black/Grayscale)

The density of background can be adjusted as follows.

<05 Adjustment Mode>

Code	Color mode	Original mode	Remarks
7436	Black	Text/Photo	The smaller the value is, the background becomes lighter. Acceptable values: 0 to 255 (Default: 128)
7437		Text	
7438		Photo	
7441		Custom mode	
7439	Grayscale	-	

<Procedure>

The procedure is the same as that of  P. 6-74 "6.4.3 Density adjustment".

6.4.6 Judgment for ACS adjustment

The judgment level is adjusted for the automatic identification of whether the original set on the glass is black or color. Namely, this is to adjust the judgment level used when "Auto Color" is selected at color modes. The same adjustment value is simultaneously applied to all cases of originals on the original glass for copier functions and network scanning functions, and those placed on the DF.

<05 Adjustment Mode>

Code	Item to be adjusted	Contents
7630	Judgment for ACS adjustment	The larger the value is, the more an original tends to be judged as black even at the Auto Color Mode. The smaller the value is, the more it tends to be judged as color. Acceptable values: 0 to 255 (Default: 70)

<Procedure>:

The procedure is the same as that of  P. 6-74 "6.4.3 Density adjustment".

6.4.7 Sharpness adjustment

If you want to make scan images look softer or sharper, perform the following adjustment. The adjustment can be made for each of the color modes and original modes independently.

<05 Adjustment Mode>

Code	Color mode	Original mode	Contents
8354	Full Color	Text/Photo	The larger the value is, the sharper the image becomes; while the smaller the value is, the softer the image becomes. The smaller the value is, the less moire tends to appear. The acceptable values are 0 to 255. The center value is 128.
8335		Text	
8336		Photo	
8375		Custom mode	
7430	Black	Text/Photo	
7431		Text	
7432		Photo	
7470		Custom mode	
7433	Gray Scale	-	

Notes:

You have to make adjustment by balancing between moire and sharpness.

<Procedure>

The procedure is the same as that of  P. 6-74 “6.4.3 Density adjustment”.

6.4.8 Contrast adjustment

The contrast of the images scanned in the color mode can be adjusted.

<05 Adjustment Mode>

Original mode	Code	Remarks
Text/Photo	8419	When a larger value is set, the contrast becomes higher. When a smaller value is set, it becomes lower. Acceptable values: 0 to 255 (Default: 128)
Text	8420	
Photo	8421	
Custom	8422	

<Procedure>

- (1) Perform FS-05.
- (2) Key in the code corresponding to the desired original mode and press the [START] button.
- (3) Key in the adjustment value. (Acceptable values: 0 to 255)
(To correct the value once keyed in, press [CLEAR].)
- (4) Press [OK] to store the value in a memory.
→ The equipment goes back to the ready state.
- (5) Turn the power ON again. Scan an original and check the images.
- (6) If the desired image has not been attained, repeat step (1) to (5).

6.4.9 Fine adjustment of black density

The density of black side on scanned image is adjusted at color-scanning.

<05 Adjustment Mode>

Code	Original mode	Remarks
8314	Text/Photo	The larger the value is, the black side of the image becomes darker. Acceptable values: 0 to 4 (Default: 1)
8315	Text	The larger the value is, the black side of the image becomes darker. Acceptable values: 0 to 4 (Default: 0)
8316	Photo	
8371	Custom mode	

Notes:

Be careful for the value not to be too large since the gradation is reproduced worse in darker side.

<Procedure>

- (1) Perform FS-05.
- (2) Key in the codes and press the [START].
- (3) Key in the adjustment values. Acceptable values: 0 to 4. (To correct the value once keyed in, press [CLEAR].)
- (4) Press [OK] to store the value in memory. → The equipment goes back to the ready state.
- (5) Let the equipment restart and perform the scanning job.
- (6) If the desired image has not been attained, repeat step (1) to (5).

6.4.10 RGB conversion method selection

The color space conversion method of image is decided at color-scanning.

<05 Adjustment Mode>

Code	Original mode	Remarks
8319	Text/Photo	0: sRGB, 1: AppleRGB, 2: ROMMRGB, 3: AdobeRGB (Default: 0)
8320	Text	
8321	Photo	
8372	Custom mode	

<Procedure>

- (1) Perform FS-05.
- (2) Key in the codes and press the [START] button.
- (3) Key in the adjustment values. Acceptable values: 0 to 3. (To correct the value once keyed in, press [CLEAR].)
- (4) Press [OK] to store the value in memory. → The equipment goes back to the ready state.
- (5) Let the equipment restart and perform the scanning job.
- (6) If the desired image has not been attained, repeat step (1) to (5).

6.4.11 Adjustment of saturation

The saturation of the scanned image is adjusted for color-scanning.

<05 Adjustment Mode>

Code	Original mode	Remarks
8324	Text/Photo	The larger the value is, the brighter the image becomes. The smaller the value is, the duller the image becomes. Acceptable values: 0 to 255 (Default: 128)
8325	Text	
8326	Photo	
8373	Custom mode	

<Procedure>

- (1) Perform FS-05.
- (2) Key in the codes and press the [START] button.
- (3) Key in the adjustment values. Acceptable values: 0 to 255.
(To correct the value once keyed in, press [CLEAR].)
- (4) Press [OK] to store the value in the memory. → The equipment goes back to the ready state.
- (5) Let the equipment restart and perform the scanning job.
- (6) If the desired image has not been attained, repeat step (1) to (5).

6.4.12 Background offsetting adjustment for DF (common for copy, scan and fax)

The background level for scanning originals with the DF is adjusted when the background fogging at the scanning of a manually-set original and an original used with the DF is different. This is to adjust the level of the background image removed when the scanning of the originals with the DF is performed. The adjustment value is applied to both the front and back sides.

<05 Adjustment Mode>

Color mode	Code	Remarks
Color	7026	The larger the value is, the darker the background density becomes. Acceptable values: 0 to 255 (Default: 128)
Black	7025	

<Procedure>

The procedure is the same as that of  P. 6-74 "6.4.3 Density adjustment".

6.4.13 Background offsetting adjustment in back side for DSDF (common for copy, scan and fax)

The background level for scanning the back side of originals with the DSDF can be adjusted when there is a different background fogging level at the scanning of the back and front sides with the DSDF. This is to adjust the level of the background image removed when the scanning of the back side of the original with the DSDF is performed.

<05 Adjustment Mode>

Color mode	Code	Remarks
Color	7024	The larger the adjustment value, the darker the background becomes. Acceptable values: 0 to 255 (Default: 128)
Black	7023	

<Procedure>

The procedure is the same as that of  P. 6-30 "6.2.2 Density adjustment".

6.4.14 Adjustment of the capacity and image quality of SlimPDF

A SlimPDF is saved using different compression ratios and resolutions by being divided into the text and other portions.

The file size and the image quality can be adjusted by changing the compression ratio and resolution for areas other than text (e.g.: background).

<05 Adjustment Mode>

Code	Item to be adjusted	Remarks
9104	Compression quality of SlimPDF background processing	The compression ratio can be adjusted. This code is used to improve the image quality of the background. When a larger value is set, mosquito noise in the outline or boundary will be decreased and better image quality can be obtained; however, the file size will become larger. When a smaller value is set, the file size will be reduced; however, the noise in the outline or boundary will be increased and thus the image quality will become worse. Especially, the noise in the boundary between the white and color portions will become conspicuous. Change the setting value by 2 steps from the default as a target. Acceptable value: 0 to 10 (Default: 5)
9105	Sharpening of SlimPDF background processing	The sharpness can be adjusted. This code is used to improve the image quality of the background. The larger the value is, the better the sharpness of the outline and boundary becomes. However, if the value is too large, the noise will be enhanced or the moire will occur. The smaller the value is, the lower the noise or moire will occur. However, if the value is too small, blurred images will occur. Change the setting value by 2 steps from the default as a target. Acceptable value: 0 to 10 (Default: 5) Recommended value: 3 to 7
9107	Resolution of SlimPDF background processing	The resolution can be adjusted. This code is used to improve the image quality of the background. When a larger value is set, the image quality becomes sharper; however, the file size becomes larger. When a smaller value is set, the file size will be reduced; however, blurred images will occur. 0: 75dpi 1: 100dpi 2: 150dpi 3: 200dpi Acceptable value: 0 to 3 (Default: 1)

<Procedure>

- (1) Perform FS-05.
- (2) Key in the codes to be adjusted and press the [START] button.
- (3) Key in the adjustment value. (To correct a value once keyed in, press [CLEAR].)
- (4) Press [OK] to store the value in memory. → The equipment goes back to the ready state.
- (5) Turn the power OFF and then back ON. Then obtain a SlimPDF and check the images.
- (6) If the desired image quality has not been attained, repeat step (1) to (5).

Notes:

The image quality of the portions which are not recognized as text will be improved by setting the value "2" or larger in 05-9107.

In such a case; however, the file size will become larger. Therefore, to make the file size smaller, set the value "4" or smaller in 05-9104.

6.4.15 Surrounding void amount adjustment

The void amount around the network scanned image is adjusted.

In network scanning, since the void amount is very small in stored images, a shadow may appear around the scanned image due to the subtle difference in the original sizes. This shadow can be eliminated by adjusting the setting value.

The setting value is applied to all resolutions and color modes.

<05 Adjustment Mode>

Code	Item to be adjusted	Remarks
7489	Surrounding void amount adjustment	When the value increases, the blank area around the scanned image becomes wider and is replaced with white data. Acceptable value: 0 to 255 (Default: 0) A setting value of 24 is equivalent to 1 mm.

<Procedure>

The procedure is the same as that of  P. 6-74 “6.4.3 Density adjustment”.

6.4.16 Surrounding void amount adjustment (custom size scan)

When the custom size is specified during original size setting for network scanning, the void amount around the network scanned image is adjusted. A shadow may appear around the scanned image and this can be eliminated by means of the setting.

The adjustable types of the custom size are [Registered Size] and [Auto Detected] only.

The setting value is applied to all resolutions and color modes.

<05 Adjustment Mode>

Code	Item to be adjusted	Remarks
7090	Surrounding void amount adjustment of [Registered Size]	When the value increases, the blank area around the image scanned while [Registered Size] is set becomes wider and is replaced with white data. Acceptable value: 0 to 255 (Default: 0) Approx. 1 mm void is attached by the setting value “24”.
7091	Surrounding void amount adjustment of [Auto Detected]	When the value increases, the blank area around the image scanned while [Auto Detected] is set becomes wider and is replaced with white data. Acceptable value: 0 to 255 (Default: 0) Approx. 1 mm void is attached by the setting value “24”.

<Procedure>

The procedure is the same as that of  P. 6-74 “6.4.3 Density adjustment”.

6.4.17 Judgment threshold adjustment for blank originals (common for copy and scan)

The judgment level is adjusted for automatic identification of whether the original set is blank or not.

This adjustment is made when “OMIT BLANK PAGE” is selected on the control panel.

The adjustment value is simultaneously applied to all modes at PPC and scanning.

<05 Adjustment Mode>

Code	Item to be adjusted	Remarks
7618	Judgment threshold adjustment for blank original	The larger the value is, the more an original tends to be judged as a blank sheet. Acceptable values: 0 to 255 (Default: 128)

<Procedure>

The procedure is the same as that of  P. 6-30 “6.2.2 Density adjustment”.

6.4.18 JPEG compression level adjustment

The compression level for saving the scanned data in the JPEG format can be adjusted as follows.

<05 Adjustment Mode>

Code	Item to be adjusted	Remarks
8304-0	High quality	The larger the value is, the better the quality becomes, and the larger the size of file becomes. Acceptable values: 0 to 255 (Default: 128)
8304-1	Standard	
8304-2	Low quality	

<Procedure>

The procedure is the same as that of  P. 6-30 "6.2.2 Density adjustment".

6.4.19 ADF noise reduction

The noise reduction level for streaks can be adjusted with the following codes when a scan job is performed using the ADF.

<05 Adjustment Mode>

Color				Item to be adjusted	Remarks
Original mode					
Text/Photo	Text	Photo	Custom mode		
8413	8414	8415	8412	ADF noise reduction level setting	When the value decreases, the effect of reducing streaks becomes larger. When the value increases, the effect of reducing streaks becomes smaller. When "0" is set, this function is disabled. Acceptable values: 0 to 200 (Default: 100)

Black					Item to be adjusted	Remarks
Original mode				Gray scale		
Text/Photo	Text	Photo	Custom mode			
7401	7402	7403	7400	7404	ADF noise reduction level setting	When the value decreases, the effect of reducing streaks becomes larger. When the value increases, the effect of reducing streaks becomes smaller. When "0" is set, this function is disabled. Acceptable values: 0 to 200 (Default: 100)

Notes:

Remember the image specifications and life span of the replacing parts may not meet the standard when the setting value is changed from the default value.

If too small a value is set, the text may not be printed clearly.

<Procedure>

The procedure is the same as that of  P. 6-74 "6.4.3 Density adjustment".

6.5 Image Quality Adjustment (FAX Function)

6.5.1 Density adjustment

Adjusts the center density.

<05 Adjustment Mode>

Color mode	Original mode			Item to be adjusted	Remarks
	Text/Photo	Text *	Photo		
Black	7533	7534	7535	Manual density center value	[TEXT/PHOTO], [PHOTO]: The larger the value is, the darker the image becomes. [Text]: The larger the value is, the lighter the image becomes. Acceptable values: 0 to 255 (Default: 128)
	7542	-	7543	Automatic density mode	The larger the value is, the darker the image becomes. Acceptable values: 0 to 255 (Default: 128)

* Since the gradation in this mode is reproduced in a binary image (black and white), this adjustment should be a simple binary threshold adjustment.

<Procedure>

- (1) Perform FS-05.
- (2) Key in a code and press the [START] button.
- (3) Key in an adjustment value.
(To correct the value once keyed in, press [CLEAR].)
- (4) Press [OK] to store the value. → The equipment goes back to the ready state.
- (5) Turn the power OFF.

<Confirmation>

If possible, perform a Fax transmission and check the adjusted density with the image on the recipient's side.

6.5.2 Emission level adjustment

The emission level in the fax function can be set. In this setting the size of dots is adjusted.

<05 Adjustment Mode>

Code	Item to be adjusted	Remarks
7595-0	Emission level 0/4	The smaller the value is, the smaller the emission level becomes. Therefore, the smaller dot is reproduced accordingly. Acceptable values: 0 to 255 (Default: Level 0/4: 0, Level 1/4: 63, Level 2/4: 127, Level 3/4: 191, Level 4/4: 255)
7595-1	Emission level 1/4	
7595-2	Emission level 2/4	
7595-3	Emission level 3/4	
7595-4	Emission level 4/4	

<Procedure>

The procedure is the same as that of  P. 6-41 “6.2.15 Emission level adjustment”.

<Confirmation>

Check the emission level setting with the actual fax data received, if possible.

Notes:

- Change the setting value increment of 8 as a guide.
- Be sure to confirm the image when the setting value is changed.
- The setting value must increase as the emission level number (0 to 4) becomes higher. Do not increase this order when setting the values.
- Usually, emission level 4 / 4 is the most effective in the black mode.

6.5.3 Background offsetting adjustment for DF (common for copy, scan and fax)

The background level for scanning originals with the DF is adjusted when the background fogging at the scanning of a manually-set original and an original used with the DF is different. This is to adjust the level of the background image removed when the scanning of the originals with the DF is performed. The adjustment value is applied to both the front and back sides.

<05 Adjustment Mode>

Color mode	Code	Remarks
Black	7025	The larger the value is, the darker the background density becomes. Acceptable values: 0 to 255 (Default: 128)

<Procedure>

The procedure is the same as that of  P. 6-30 “6.2.2 Density adjustment”.

6.5.4 Background offsetting adjustment in back side for DSDF (common for copy, scan and fax)

The background level for scanning the back side of originals with the DSDF can be adjusted when there is a different background fogging level at the scanning of the back and front sides with the DSDF. This is to adjust the level of the background image removed when the scanning of the back side of the original with the DSDF is performed.

<05 Adjustment Mode>





Color mode	Code	Remarks
Black	7023	The larger the adjustment value, the darker the background becomes. Acceptable values: 0 to 255 (Default: 128)

<Procedure>

The procedure is the same as that of  P. 6-30 "6.2.2 Density adjustment".

6.6 Scanner

6.6.1 Adjustment carriages-1 positions

- (1) Take off the RADF/DSDF.
 P. 4-262 “4.12.2 Reversing Automatic Document Feeder”
- (2) Take off the right top cover.
 P. 4-4 “4.1.9 Right top cover”
- (3) Take off the original glass.
 P. 4-23 “4.3.1 Original glass”
- (4) Take off the left top cover.
 P. 4-3 “4.1.5 Left top cover”
- (5) Move the carriage-1[1] toward the exit side.

Notes:

Rotate the drive pulley to move the carriage.

- (6) Loosen the 2 fixing screws of the wire. Tighten the screws by aligning the sections [5] and [6] of the carriage-1 with the inside of the exit side frame [2].

Notes:

Confirm that they are aligned properly through the windows [3] and [4] of the exit side frame [2].

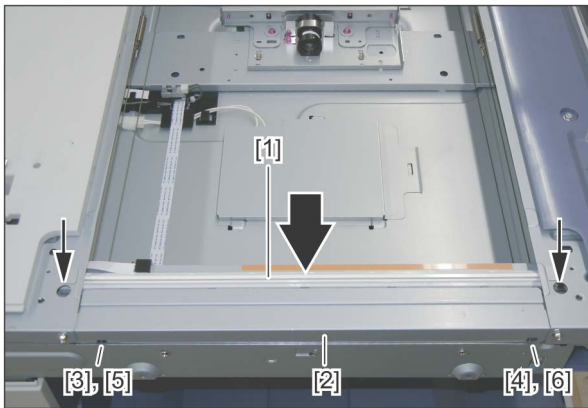

Fig.6-26

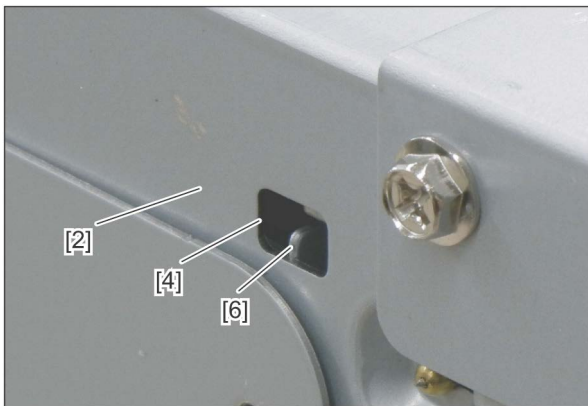

Fig.6-27

6.6.2 Position adjustment of CCD lens unit

Count the number of lines and write it down for later reference before removing the CCD lens unit. When installing the CCD lens unit, the same number of lines needs to be visible.

📖 P. 4-29 “4.3.5 Lens unit/CCD driving PC board”

6.6.3 Belt tension adjustment of the scan motor

- (1) Take off the rear cover.
📖 P. 4-10 “4.1.17 Rear cover”
- (2) Hook the belt tension jig[1] to the motor bracket[2] and hook section of the flame[3].
- (3) Loosen the screws [4] and [5].
- (4) The scan motor [6] is pulled by the belt tension jig [1]. When it is stopped, tighten the screws in order of [4] and [5].
- (5) Remove the belt tension jig[1].

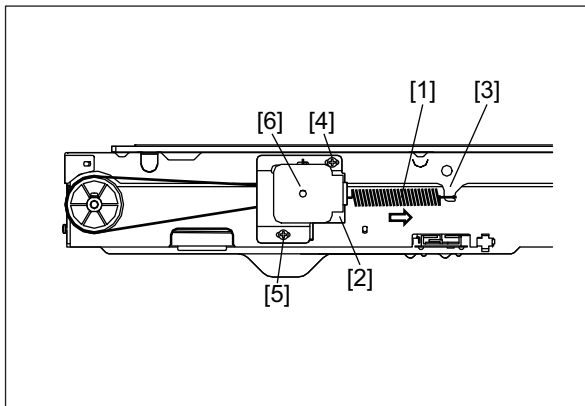

Fig.6-28

6.7 Writing Section

6.7.1 Image adjustment in the writing section

- Refer to the following pages for details.
- 📖 P. 6-15 “[B] Primary scanning data writing start position”
- 📖 P. 6-17 “[D] Secondary scanning data writing start position”
- 📖 P. 6-18 “[E] Primary scanning data writing start position at duplexing”

6.7.2 Adjustment of image tilting at the leading edge

When a printed image at the leading edge of paper is tilted as shown below, correct this by tilting the laser optical unit (LSU).

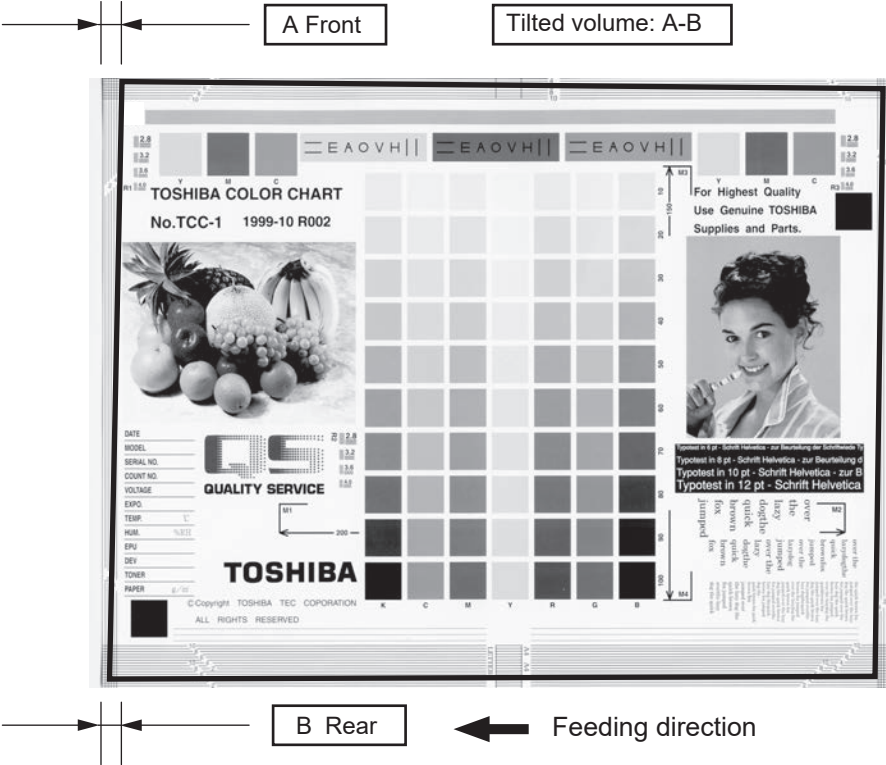

Fig.6-29

Remarks:

Explanation of the portions used for adjustment

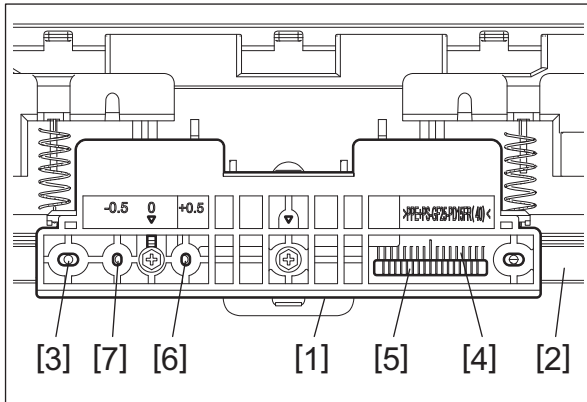



Fig.6-30

- [1] LSU holder
- [2] Frame
- [3] The screw hole to use when adjusting the tilted volume
- [4] The scale to use when adjusting the tilted volume (LSU holder side)
- [5] The scale to use when adjusting the tilted volume (frame side)
- [6] The screw hole to use when the value of "A-B" is +0.5 mm (" +0.5" is marked)
- [7] The screw hole to use when the value of "A-B" is -0.5 mm (" -0.5" is marked)

[1] Adjustment of the tilted volume

Notes:

The final adjustment is recommended to be made during installation at a user's site.
Check that paper is not skewed in the side guides of the drawer in advance.

- (1) Output a grid pattern of A3/LD size and check the tilted volume of an image (the value of "A-B").
- (2) Remove 5 screws and take off the left cover (Refer to  P. 4-1 "4.1.2 Left cover").

Notes:

Be sure to check the scale positions before carrying out the adjustment. Take a memo of the scale positions where the LSU holder [4] and the frame [5] ones are aligned.

Fig. C: The scale positions are aligned at the center.

Fig. D: The scale positions are aligned at the fifth one on the front side from the center.

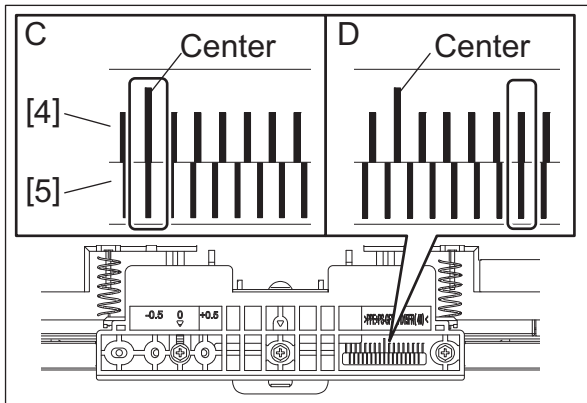

Fig.6-31

(3) Loosen 2 screws [8].

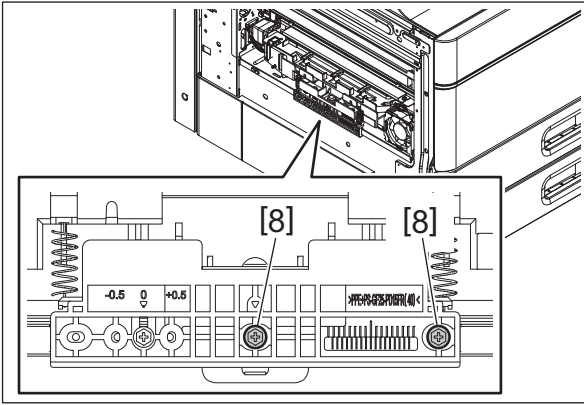

Fig.6-32

(4) Remove 1 screw [9].

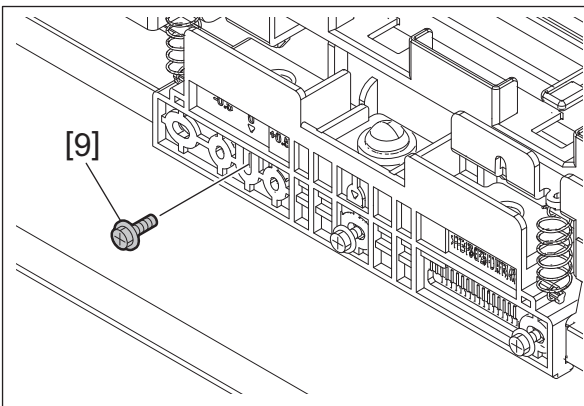

Fig.6-33

(5) Temporarily tighten the screw [9] removed in step (4) into the screw hole [3].

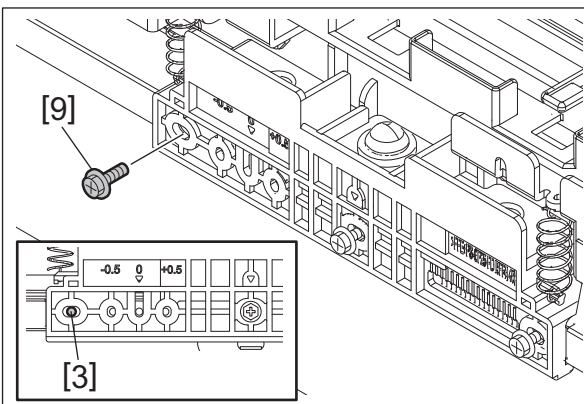

Fig.6-34

(6) Check the value of “A-B” and select the closest one from the following table.

	Scale position to be aligned		Tilted volume (A-B): [Unit: mm]	
	Frame	LSU holder	297 mm (A3)	279 mm (LD)
Front	8th	8th	1.12	1.04
	7th	7th	0.98	0.91
	6th	6th	0.84	0.78
	5th	5th	0.7	0.65
	4th	4th	0.56	0.52
	3rd	3rd	0.42	0.39
	2nd	2nd	0.28	0.26
	1st	1st	0.14	0.13
Center	0	0	0	0
Rear	1st	1st	-0.14	-0.13
	2nd	2nd	-0.28	-0.26
	3rd	3rd	-0.42	-0.39
	4th	4th	-0.56	-0.52
	5th	5th	-0.7	-0.65
	6th	6th	-0.84	-0.78
	7th	7th	-0.98	-0.91
	8th	8th	-1.12	-1.04
Remarks			Moving approx. 0.14 mm per 1 scale	Moving approx. 0.13 mm per 1 scale

(7) Align the scale position which corresponds to the value selected by referring to the above table.

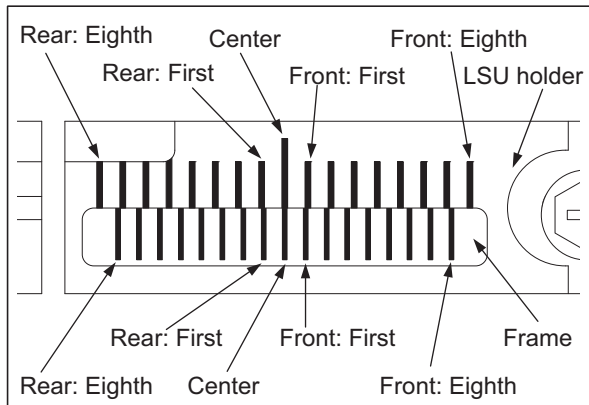

Fig.6-35

E.g.: When the width of the paper is 297 mm
If the value of "A-B" is approx. -0.6 mm, select -0.56 from the table. In this case, the scale position is located at the fourth one on the rear side. Move the LSU holder [1] to the front side so that its scale position of the fourth one on the rear side is aligned to that for the frame [2].

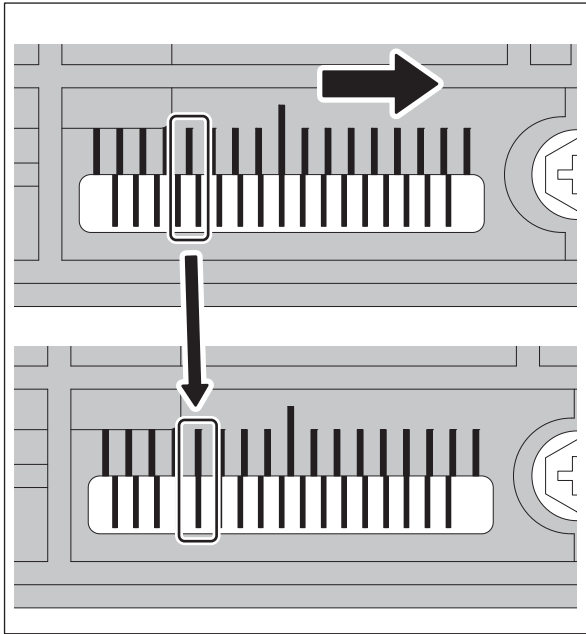

Fig.6-36

E.g.: When the width of the paper is 297 mm and the value of "A-B" is approx. 0.3 mm
Move the LSU holder [1] to the rear side so that its scale position of the second one on the front side is aligned to that for the frame [2].

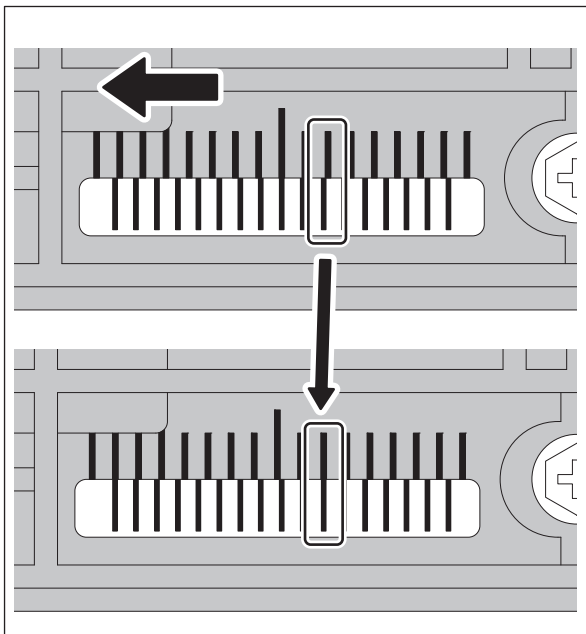

Fig.6-37

Notes:

This describes the adjustment procedure in the standard operation; however, adjustment of tilting in the laser optical unit has sometimes been carried out on the manufacturing line. In this case, move the scale position only by the required volume to be tilted since the ones of the frame and the LSU holder have been aligned.

If the paper width is 297 mm, the position is moved by approx. 0.14 mm per 1 scale. If the paper width is 279 mm, the position is moved by approx. 0.13 mm per 1 scale. When the value of "A-B" becomes a minus one, use the scale at the rear side. When the value of "A-B" becomes a plus one, use the scale at the front side.

E.g.: When the leading edge of the rear side is made approx. 0.5 mm wider (the front side made narrower) from the current adjusted position (the scale positions are aligned at the second one on the front side)

Move the LSU holder by 4 scales to the rear side so that the sixth ones are aligned.

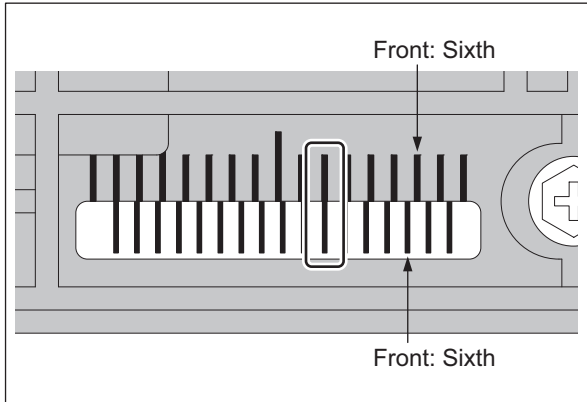

Fig.6-38

- (8) Secure the screw temporarily tightened in step (4).
- (9) Tighten the screws [8] loosened in step (3).
- (10) Output a grid pattern of A3/LD size and check whether image tilting has occurred or not. If this problem still persists, return to step (3) and perform the adjustment again.
- (11) Install the left cover.

[2] Adjustment of the tilted volume by 0.5 mm with a simplified method

If the value of "A-B" is +0.5 mm or -0.5 mm, the tilted volume can be adjusted by +/-0.5 mm with a simplified method in accordance with this procedure.

Notes:

The final adjustment is recommended to be made during installation at a user's site. Check that paper is not skewed in the side guides of the drawer in advance.

- (1) Output a grid pattern of A3/LD size and check the image tilting.
- (2) Remove 5 screws and take off the left cover (Refer to  P. 4-1 "4.1.2 Left cover".)

(3) Loosen 2 screws [8].

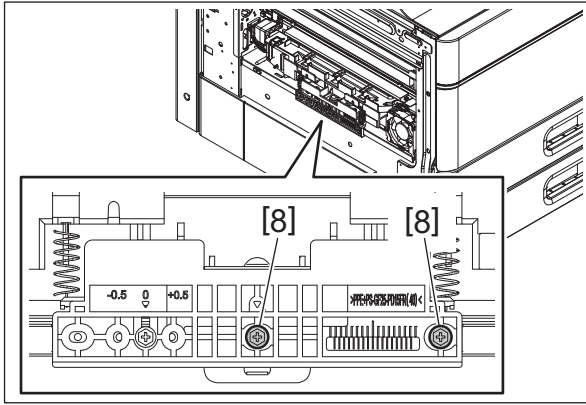

Fig.6-39

(4) Remove 1 screw [9].

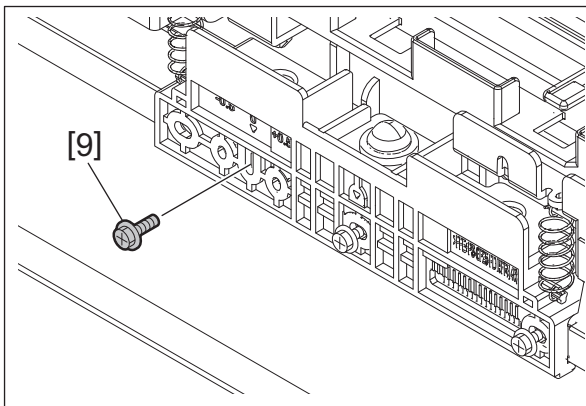

Fig.6-40

(5) Slide the LSU holder [1] and tighten the screw hole ([6] or [7]) to be corrected with the screw [9] removed in step (4).

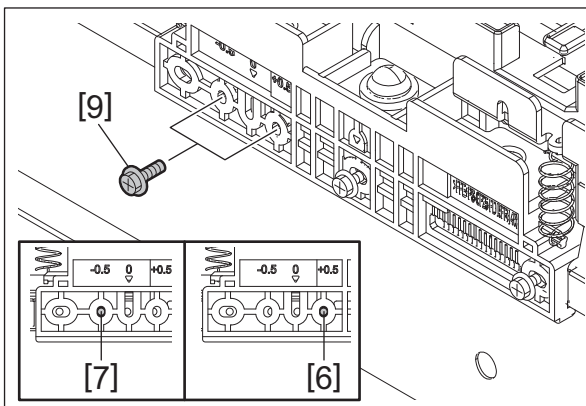

Fig.6-41

Remarks:

- [6] The screw hole to use when the value of "A-B" is approx. +0.5 mm (" +0.5" is marked)
- [7] The screw hole to use when the value of "A-B" is approx. -0.5 mm (" -0.5" is marked)

If the value of “A-B” is approx. +0.5 mm, slide the LSU holder [1] to the rear side and tighten the screw hole [6] with the screw.

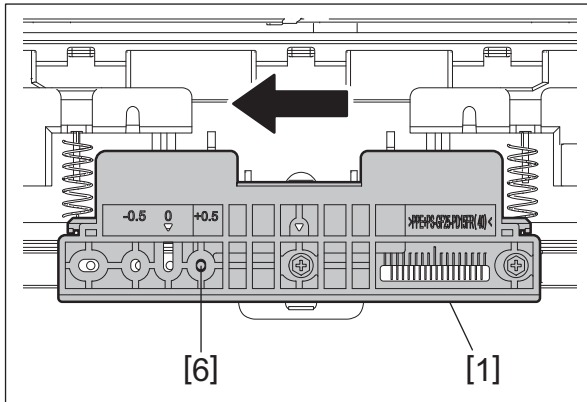

Fig.6-42

If the value of “A-B” is approx. -0.5 mm, slide the LSU holder [1] to the front side and tighten the screw hole [7] with the screw.

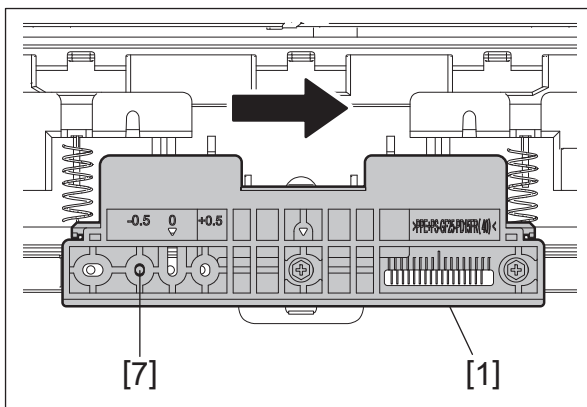

Fig.6-43

- (6) Tighten the screws [8] loosened in step (3).
- (7) Output a grid pattern of A3/LD size and check whether image tilting has occurred or not. If this problem still persists, return to step (3) or perform the procedure “[1] Adjustment of the tilted volume” to carry out the adjustment again.
- (8) Install the left cover.

6.8 Paper Feeding System

6.8.1 Adjusting the clearance of the paper and side guides

If the clearance between the paper and the side guides is too wide, it can be adjusted to between 0 and 1 mm using the following procedure (the clearance between the paper and the guides is 1 to 2 mm including both front and rear sides).

<Procedure>

- (1) Take out the drawer.
- (2) Move the side guide[1]. Loosen 2 screws.

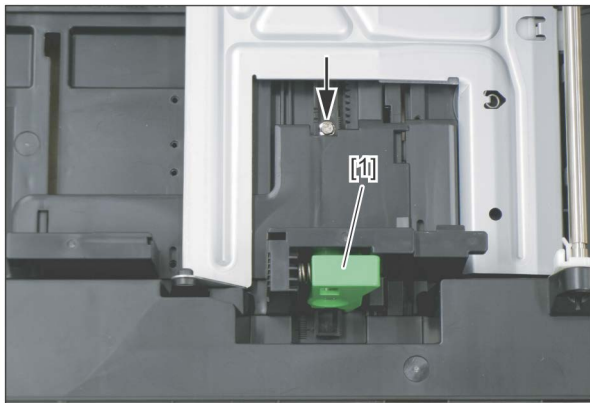

Fig.6-44

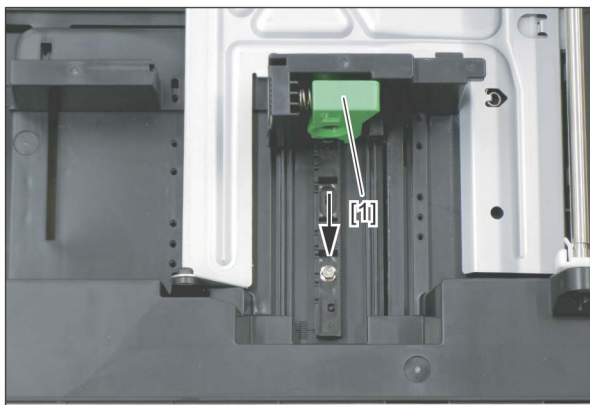

Fig.6-45

- (3) Move the side guide adjustment piece[1] to the front and tighten the screws (by 0.5 mm).

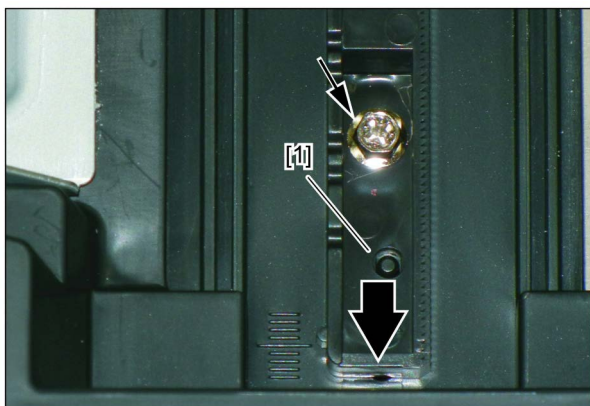

Fig.6-46

6.8.2 Separation roller pressure force adjustment

Generally, paper jams and multiple feeding often occur as the life end of the roller approaches. However, if they often occur even though its life has not yet reached its replacement timing, or if the life end comes much earlier than the scheduled replacement timing, paper jams, multiple feeding or shortened life can be improved by adjusting the pressure force of the separation roller. In this method, however, when the roller life becomes longer, jams and multiple feeding may occur frequently, and when the jams and multiple feeding are suppressed, the roller life may become shorter. Therefore, perform this adjustment while checking the status carefully, and if necessary, give a sufficient explanation to users.

<Adjustment procedure>

- (1) Take off the drawer feeding unit.
📖 P. 4-75 "4.5.14 1st drawer paper feed unit"
📖 P. 4-77 "4.5.16 2nd drawer paper feed unit"
- (2) Remove 1 screw, and then screw it temporarily into the oblong hole which is located next to it.

Notes:

Make a mark for the installation position of the holder [1] in advance.

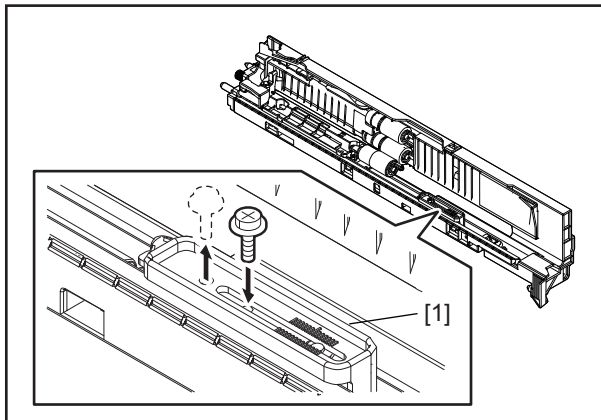

Fig.6-47

- (3) Move the holder [1].

Remarks:

Moving in the direction of A: The roller life will become longer (but multiple feeding may occur frequently).

Moving in the direction of B: Multiple feeding will be suppressed (but the roller life may become shorter).

Notes:

The recommended moving distance of the holder [1] is within 1 or 2 scale marks.

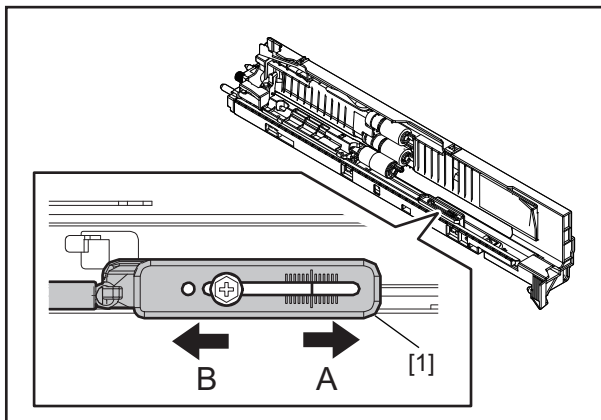

Fig.6-48

6.9 Process Unit Related Section

6.9.1 High-voltage transformer setting

The high-voltage transformers (PS-HVT) supply high-voltage to the parts related to charging, development, transfer and Discharging blade.

The high-voltage transformer has the following high-voltage outputs.

CH1	1	Main charger bias (Y)
	2	Main charger bias (M)
	3	Main charger bias (C)
	4	Main charger bias (K)
CH2	1	Main charger grid bias (Y)
	2	Main charger grid bias (M)
	3	Main charger grid bias (C)
	4	Main charger grid bias (K)
CH3	1	Developer bias (Y)
	2	Developer bias (M)
	3	Developer bias (C)
	4	Developer bias (K)
CH4	1	1st transfer roller bias (Y)
	2	1st transfer roller bias (M)
	3	1st transfer roller bias (C)
	4	1st transfer roller bias (K)
CH5	-	2nd transfer roller bias

Notes:

Never move the variable resistance on the board since the output adjustment has been performed at the shipment for the high-voltage transformer supplied as a service part. Also do not perform the setting change when the high-voltage power supply is replaced.

6.10 Developer Unit

6.10.1 Adjustment of the auto-toner sensor

When the developer material is replaced, adjust the auto-toner sensor.

📖 P. 6-2 “6.1.2 Adjustment of the auto-toner sensor”

6.10.2 Pole position adjustment

Adjust the pole position adjustment plate

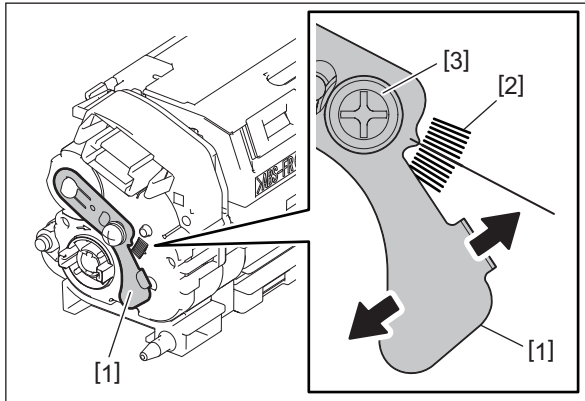

Fig.6-49

- (1) Record or mark the scale position [2] indicated by the pole position adjustment plate [1].
- (2) Loosen 1 screw [3] and adjust the pole position adjustment plate [1].
- (3) Tighten the screw [3].

6.11 Image Quality Control

6.11.1 Performing image quality control

When the image position aligning sensor (front) or image position aligning sensor (rear) or image position aligning sensor (center)/image quality sensor is replaced, perform the image quality control and adjustment of color registration control.

📖 P. 6-4 “6.1.3 Performing image quality control”

📖 P. 6-5 “6.1.4 Adjustment of color registration control”

6.12 Fuser Unit

6.12.1 Adjustment of the separation guide gap

Perform this adjustment when the following parts are replaced or disassembled.

- Separation guide
- Fixing plate of separation guide

Confirm the gap when the following parts are replaced or disassembled.

- Fuser belt
- Thermistor
- Thermostat
- Fuser belt lubricating sheet
- Fuser belt pad

Notes:

- Wait until the fuser unit is completely cooled down, and then start the adjustment.
- Place the fuser unit on a flat surface.
- Be sure not to damage the fuser belt with the gap adjustment jig.
- Adjust the gap while the pressure roller is contacted to the fuser belt.
- If the fuser unit is not installed to the equipment after the replacement or adjustment but must be stored as a unit for a long time, be sure to leave the pressure roller released from the fuser belt.
- To switch the contacted/released state, rotate the pressure roller contacting/releasing cam with a flathead screwdriver.

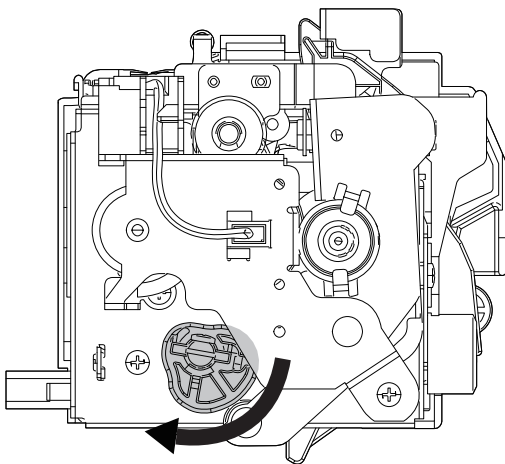

Fig.6-50

<Gap to be confirmed>

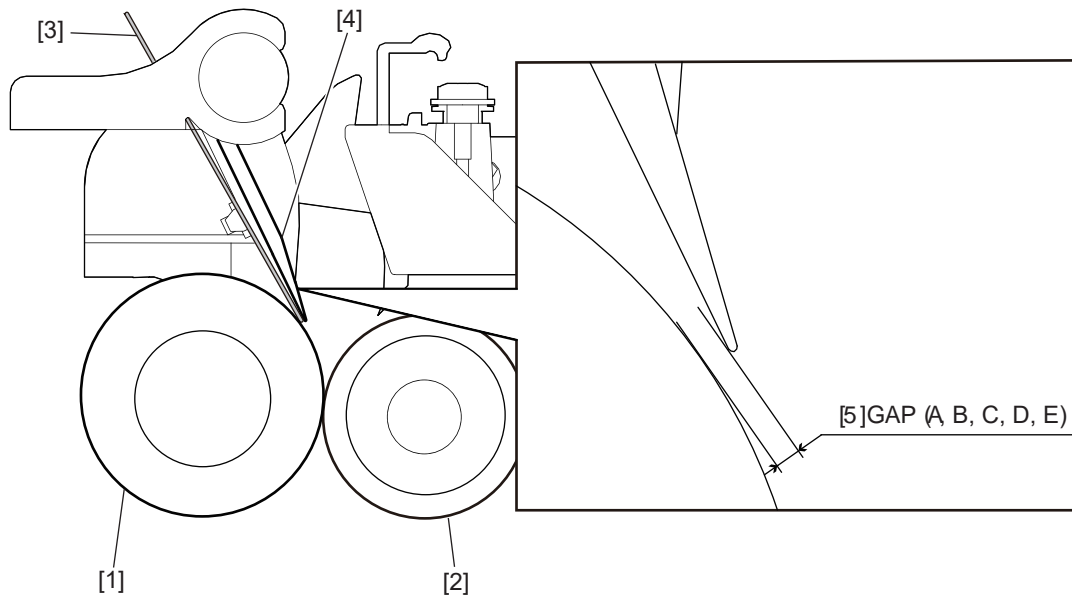

Fig.6-51

- [1] Fuser belt
- [2] Pressure roller
- [3] Separation guide gap adjustment jig
- [4] Separation guide
- [5] Gap

<Jig to be used>

Separation guide gap adjustment jig



Fig.6-52

<Adjustment procedure>

- (1) Insert the jig into the windows [A] and [E], and then adjust the gap to 0.5 to 0.55 mm.
- (2) Confirm the gaps of the window [B], [C] and [D]. When the gap is 0.55 to 0.8mm, adjustment is completed.
- (3) If the gaps [B], [C] and [D] is narrower than 0.55mm, adjust with center screw fasten.
- (4) If the gaps [B], [C] and [D] is wider than 0.8mm, loosen the front, center and rear screw, and then readjust from step (1).

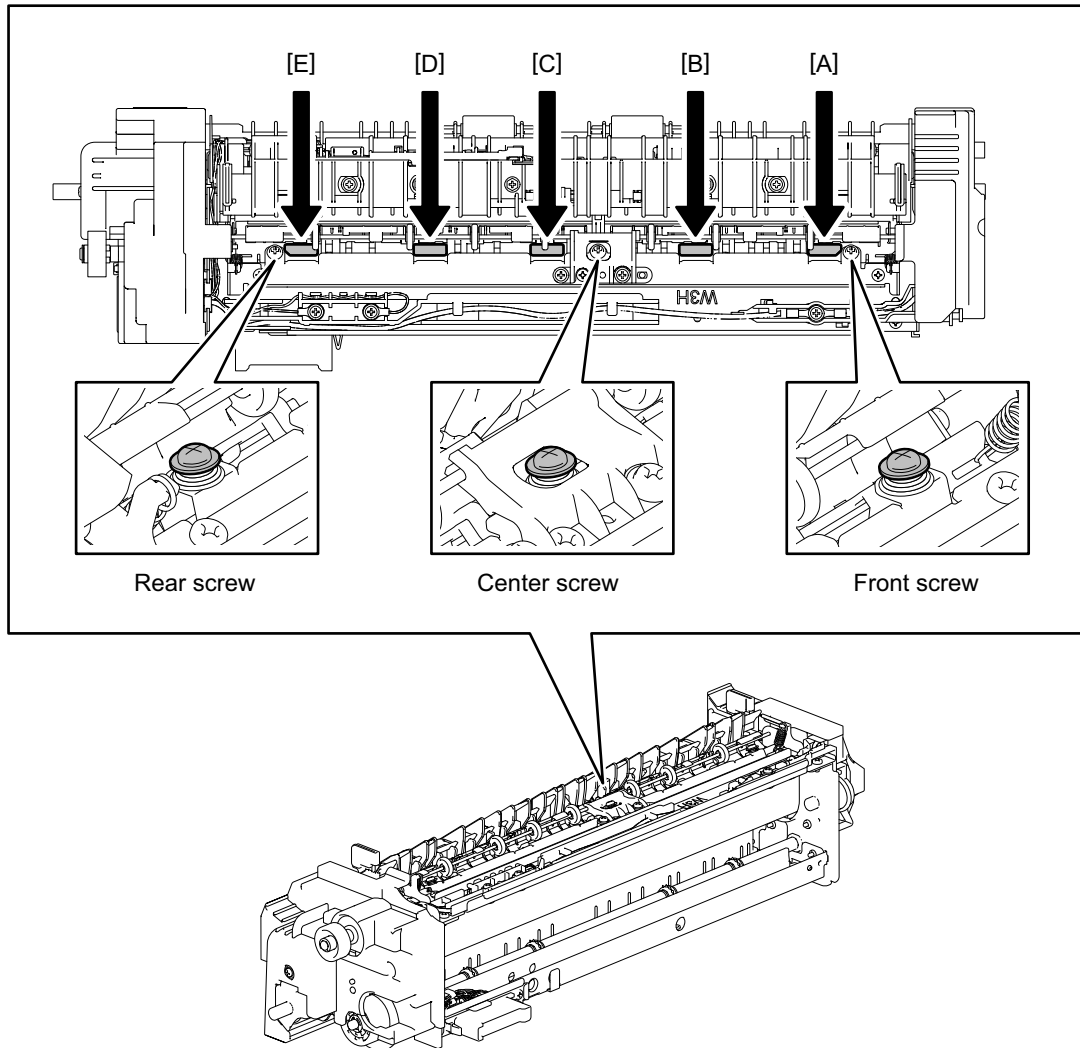

Fig.6-53

Remarks: Adjustable range of the gaps

[A][E] 0.45 to 0.8 mm

[B][C][D] 0.55 to 0.8 mm

- Adjustable range in the manufacturing process:

[A] and [E]: 0.45 to 0.8 mm

[B], [C] and [D]: 0.55 to 0.8 mm

- Adjustable range in the field:

[A] and [E]: 0.5 to 0.8 mm

[B], [C] and [D]: 0.55 to 0.8 mm

6.13 Control Panel Calibration

6.13.1 General description

Due to disassembling and replacing of the control panel or its temporary change, the touched position on the control panel sometimes cannot be detected properly, such as touch-and-response position mismatch or slow response. This function corrects this phenomenon.

Remarks:

If the control panel is replaced in a unit base, performing this function is not necessary.

6.13.2 Operation procedure

- (1) Perform FS-08-9050.
The calibration screen appears and a plus mark is displayed on the upper left of the screen.
- (2) Touch the center of the plus mark in the following order.
The plus mark is displayed in the order of 2 -> 3 -> 4, when it is touched and recognized.

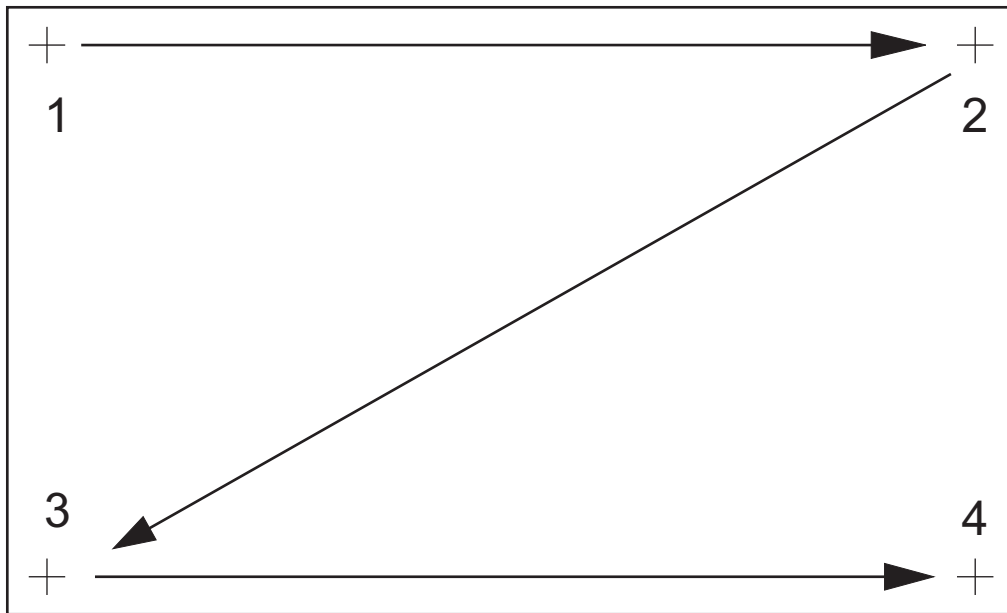

Fig.6-54

Notes:

- It is recommended to touch the plus mark using a touch pen with a fine tip.
- Calibration is performed at the touched position. Therefore, touch the center of the plus mark properly.

- (3) When circle marks are displayed, keep touching the center of the marks with your fingers in the following order.
After a few seconds have passed, the next circle marks are displayed.

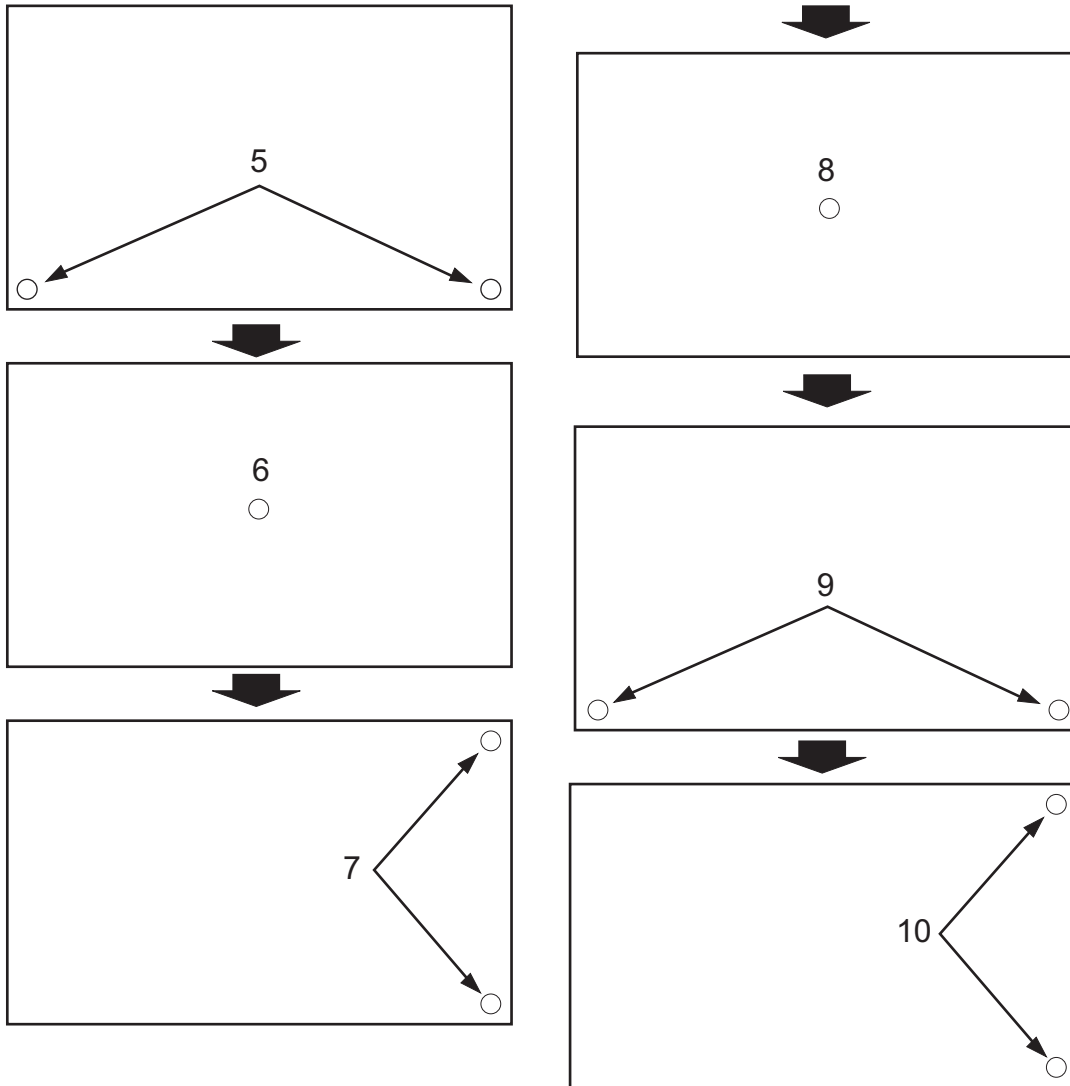

Fig.6-55

Notes:

- When two circle marks are displayed, touch them simultaneously.
- Calibration is performed at the touched position. Therefore, touch the circle marks properly.

(4) After all the marks are touched, the following screen appears and then calibration is completed.

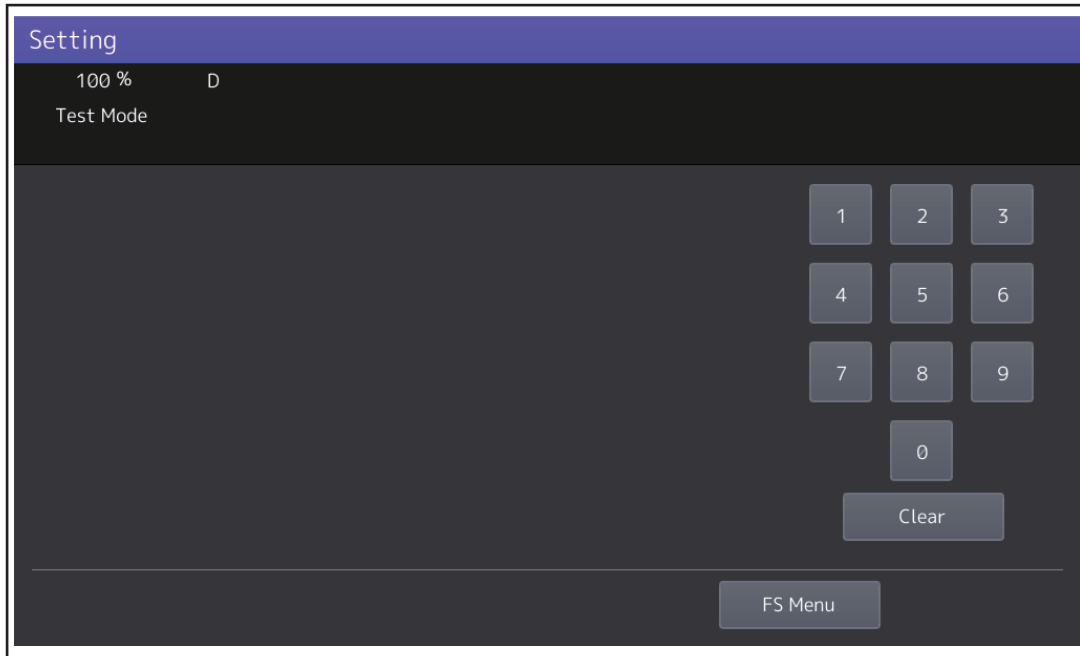

Fig.6-56

6.14 Adjustment of the DSDF

6.14.1 Adjustment of position

Perform this adjustment when the DSDF is not installed in the correct position.

Notes:

Check if the image adjustment for the equipment is performed properly before this adjustment of the DSDF. (See the Service Manual of the applicable equipment.)

[A] Checking

- (1) Open the DSDF and install 2 positioning pins.

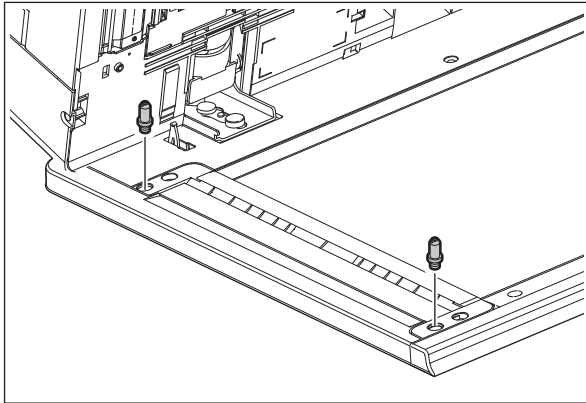

Fig.6-57

- (2) Remove the platen sheet.

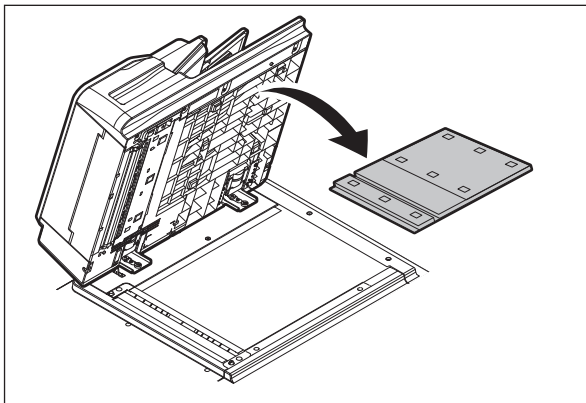



Fig.6-58

- (3) Close the DSDF and check if the positioning pins fit the holes on the DSDF.

Notes:

If the positioning pins cannot be fitted into the holes on the DSDF properly, go to  P. 6-108 “[B] Adjustment” to adjust the position of the DSDF and then install it.

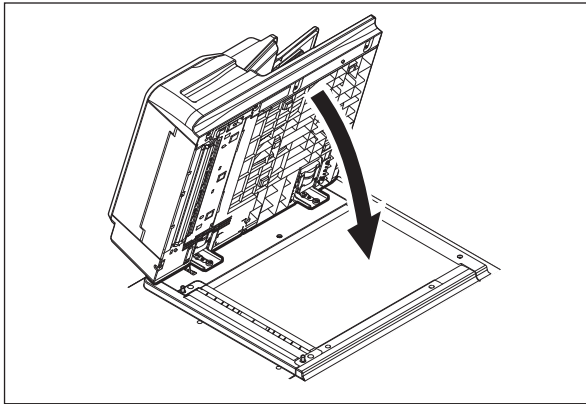

Fig.6-59

- (4) Place the platen sheet on the original glass and align it to the top left corner.
Close the DSDF gently and open it to check if the platen sheet is attached properly.

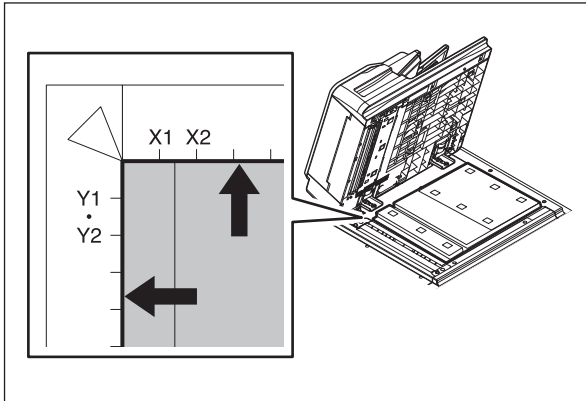

Fig.6-60

[B] Adjustment

If the pins cannot be fitted into the holes, perform the adjustment according to the following procedure.

- (1) Remove the brackets on the hinges.

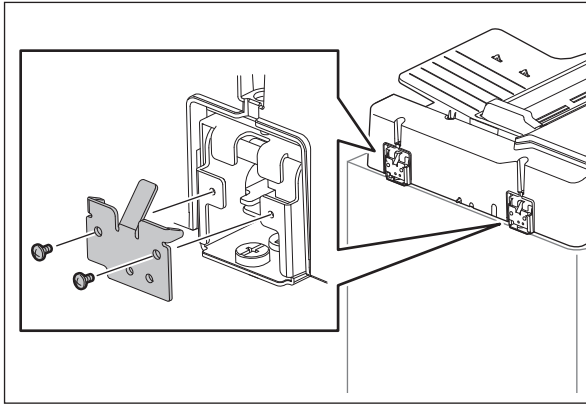

Fig.6-61

- (2) Loosen fixing screws.

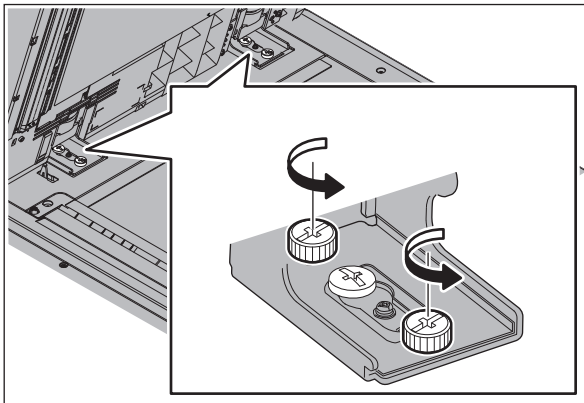

Fig.6-62

- (3) Position the pins with the holes on the DSDF by moving it so that the pins fit into the holes when the DSDF is closed.

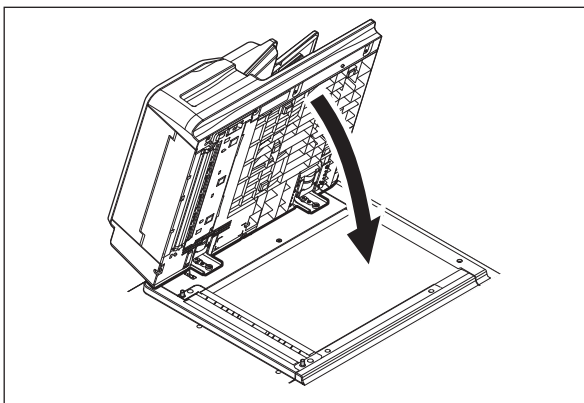

Fig.6-63

(4) Tighten the fixing screws of the rear side.

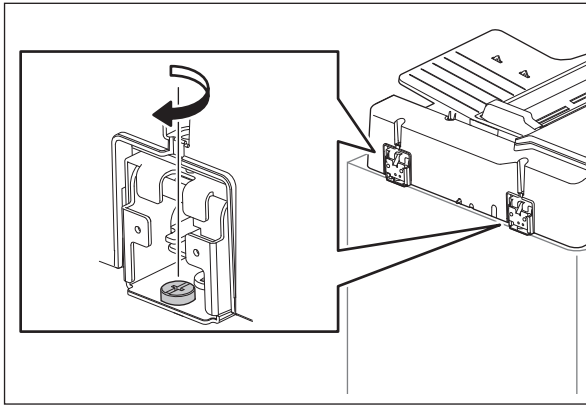

Fig.6-64

(5) Tighten the fixing screws of the front side.

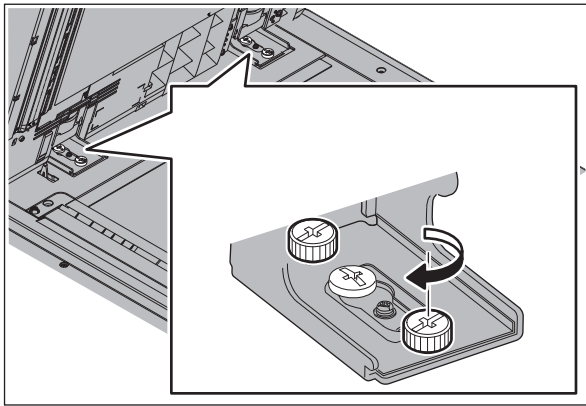

Fig.6-65

(6) Install the brackets on the hinges.

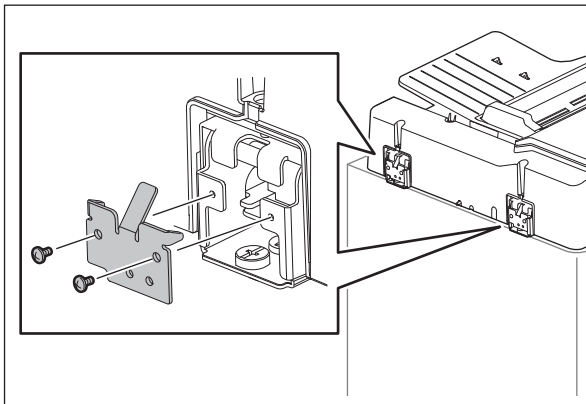

Fig.6-66

- (7) Place the platen sheet on the original glass and align it to the top left corner.
Close the DSDF gently and open it to check if the platen sheet is attached properly.

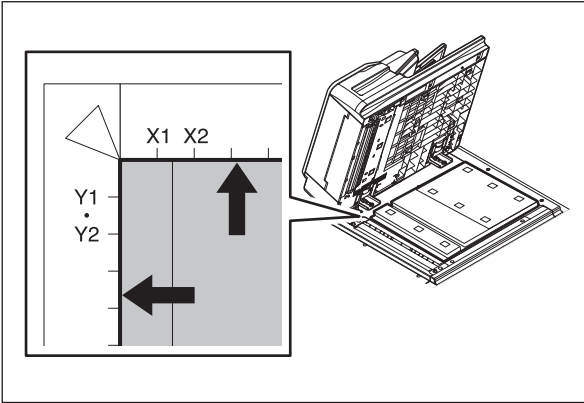

Fig.6-67

6.14.2 Adjustment of height

Notes:

Check if the image adjustment for the equipment is performed properly before this adjustment of the DSDF. (See the Service Manual of the applicable equipment.)

[A] Checking

- (1) Close the DSDF.
- (2) Light the exposure lamp.
 - Perform FS-03-267.
- (3) Visually check the gap between platen guide holder "A" and upper surface of the cover "B" from the left hand side of the equipment. If the value is not within the tolerance, perform the adjustment according to the following procedure.

[Tolerance of the gap]

Rear side: 0 - 0.5 mm

Front side: 0 mm

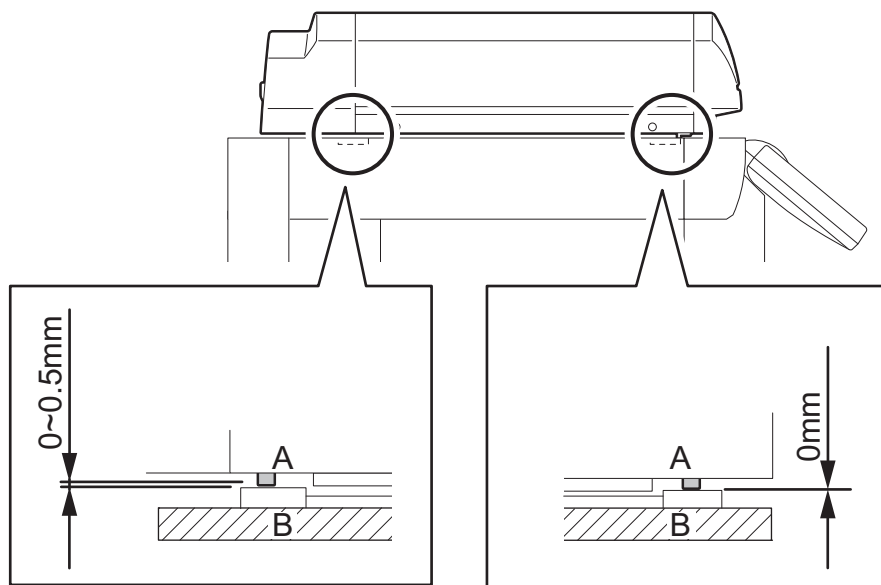

Fig.6-68

[B] Adjustment

- (1) Close the DSDF.
- (2) Adjust it by turning the adjustment screws on the hinges.
 - Adjust the height on the rear side by means of the screw on the hinge on the feed side of the DSDF.

Turn it clockwise: Heightened

Turn it counterclockwise: Lowered

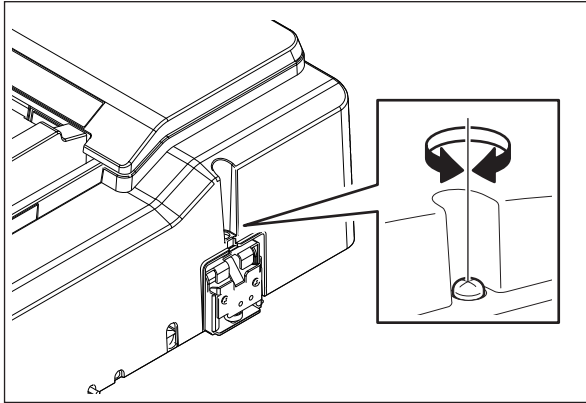

Fig.6-69

- Adjust the gap on the front side by means of the screw on the hinge on the exit side of the DSDF.

Turn it clockwise: Lowered

Turn it counterclockwise: Heightened

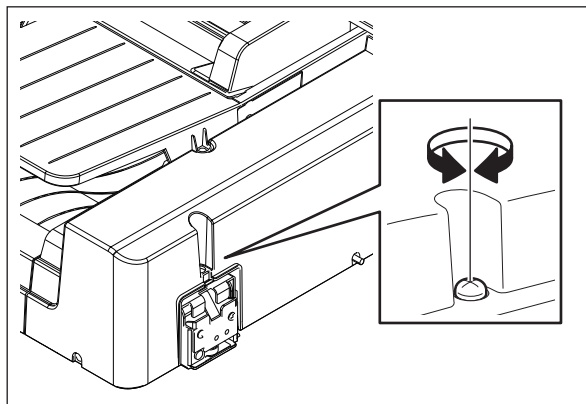

Fig.6-70

6.14.3 Adjustment of skew

Notes:

- Check if the image adjustment for the equipment is performed properly before this adjustment of the DSDF. (See the Service Manual of the applicable equipment.)
- The DSDF position adjustment shall be adjusted properly.

[A] Checking

Check the image using the chart (original) with vertical and horizontal lines in the following procedure.

Simplex (front side) copying

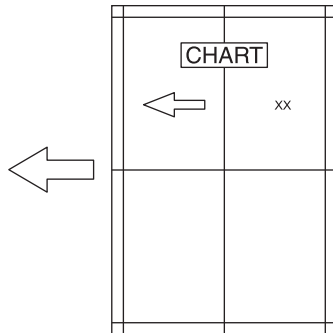

Fig.6-71

- (1) Place the chart provided as an original with its face up on the original tray of the DSDF, select [Sort mode] and [1 -> 1 Simplex] and then press the [START] button.
- (2) Superimpose the chart on the copy and check the inclination of the copy image.

Duplex (back side) copying

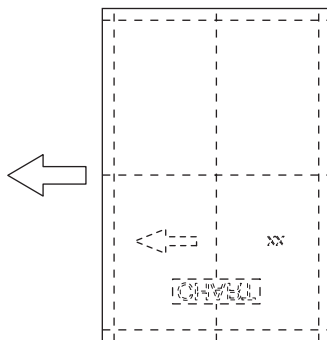

Fig.6-72

- (1) Place the chart provided as an original with its face down on the original tray of the DSDF, select [Sort mode] and [2 -> 2 Duplex] and then press the [START] button.
- (2) Superimpose the chart on the copy and check the inclination of the copy image.

[B] Adjustment

Simplex (front side) copying

- (1) Change the fixing screws of the front side to the shoulder head screw (service parts).

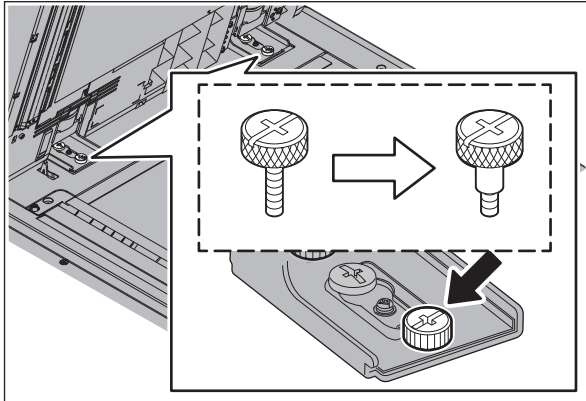

Fig.6-73

- (2) Turn the adjustment screw while checking the scale of the hinge.

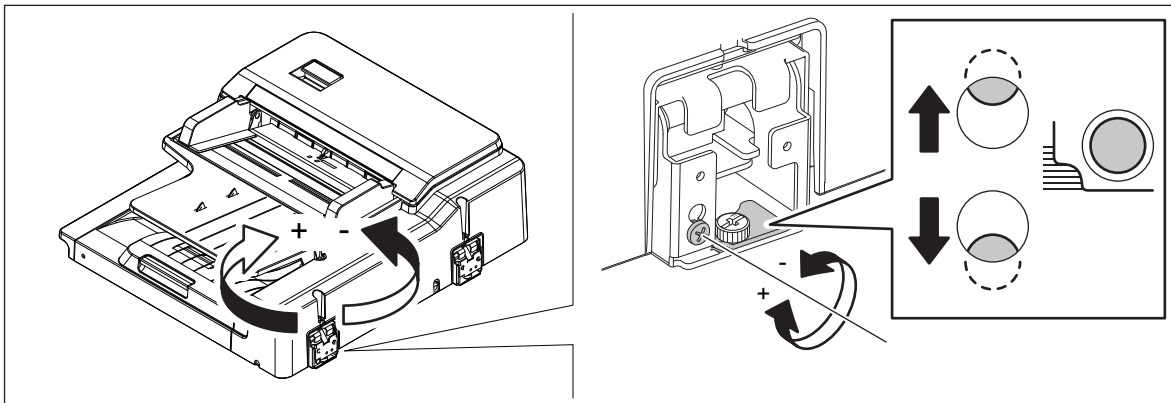

Fig.6-74

- (3) If the image skew is "C" as shown in the figure below, shift the aligning plate in the direction of "-", and if "D", shift it to "+".

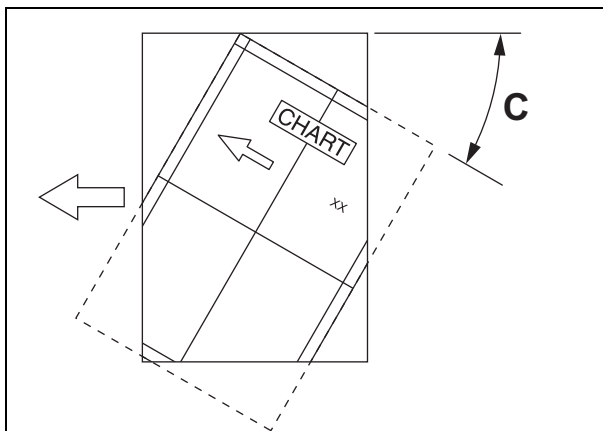

Fig.6-75

Shift the aligning plate in the direction of "-".

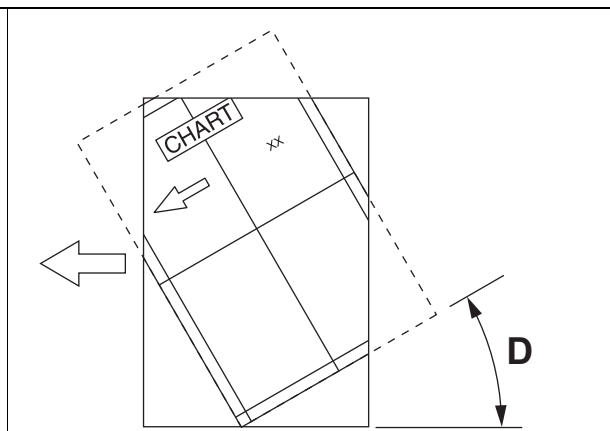

Fig.6-76

Shift the aligning plate in the direction of "+".

- (4) Check the skew of the copy image by using a chart.

Duplex (back side) copying

- (1) Remove the DSDF front side cover. (Refer to the service manual of applicable model.)
- (2) Clarify the attachment position of the plate by drawing a marking-off line.

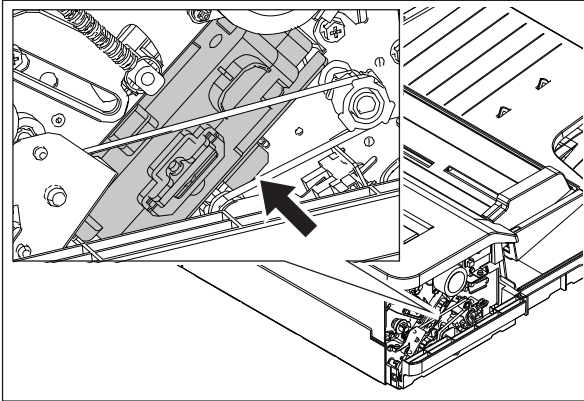

Fig.6-77

- (3) Loosen 1 screw.

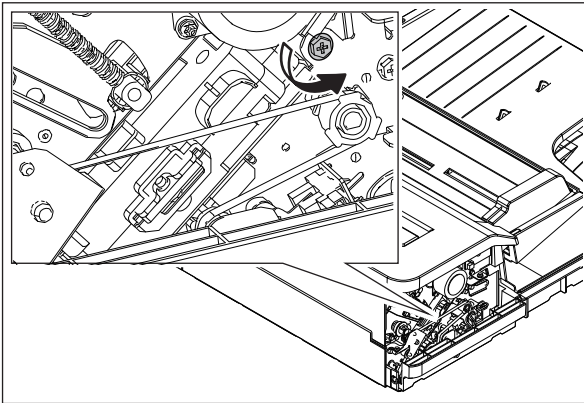
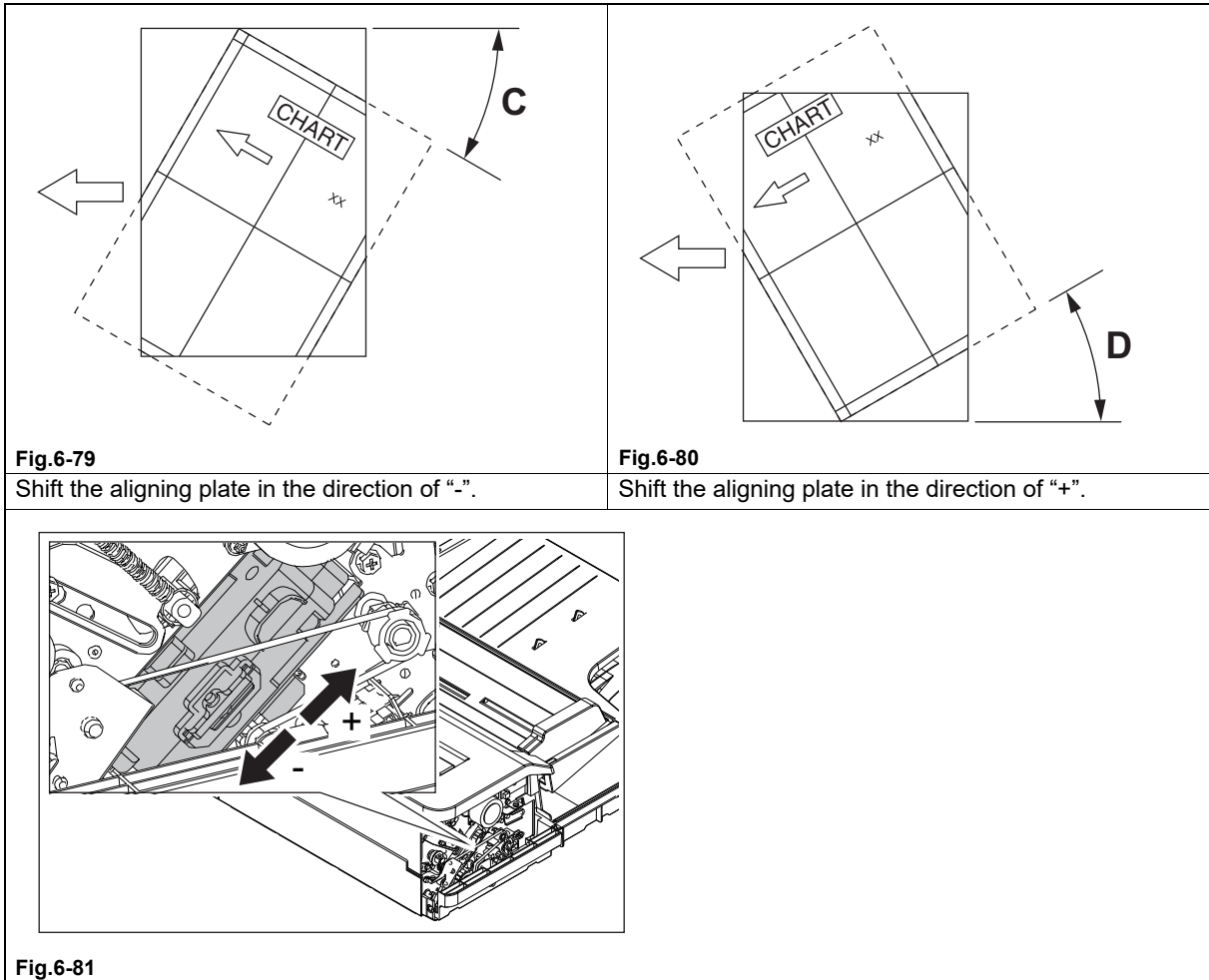

Fig.6-78

- (4) If the image skew is "C" as shown in the figure below, shift the aligning plate in the direction of "-", and if "D", shift it to "+".



- (5) Tighten the screw loosened in step (3). Check the skew of the copy image by using a chart.
 (6) Install the DSDF front side cover.

6.14.4 Adjustment of the leading edge position

Notes:

Check if the image adjustment for the equipment is performed properly before this adjustment of the DSDF. (See the Service Manual of the applicable equipment.)
Also, the DSDF position and height shall be adjusted properly.

[A] Checking

Check the image using the chart (original) with vertical and horizontal lines in the following procedure.

Simplex (front side) copying

- (1) Place the chart provided as an original with its face up on the original tray of the DSDF, select [Sort mode] and [1 -> 1 Simplex] and then press the [START] button.
- (2) Superimpose the chart on the copy and check the leading edge E of the chart and F of the copy.

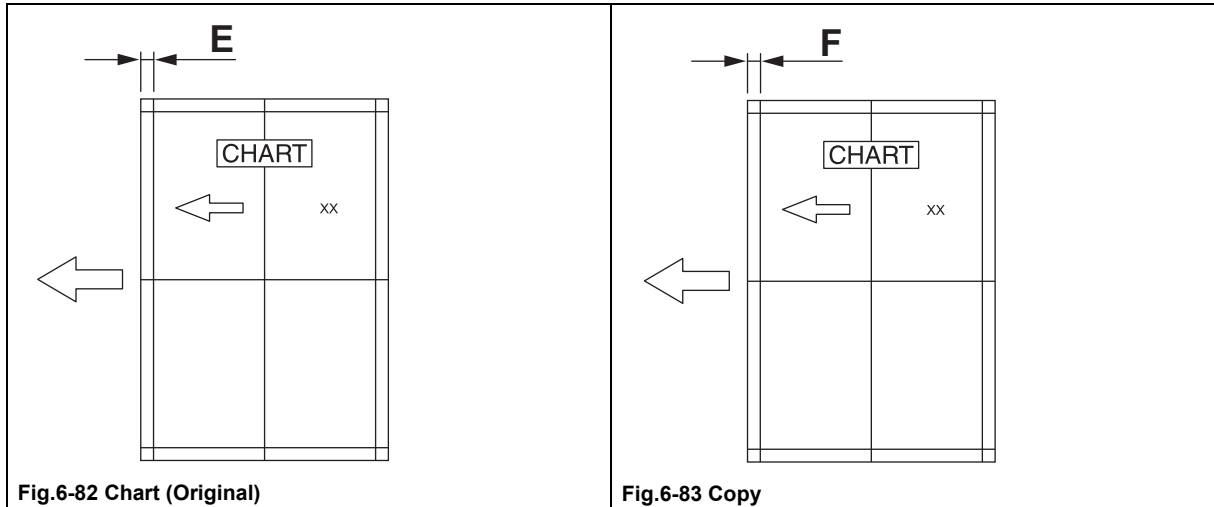

Duplex (back side) copying

- (1) Place the chart provided as an original with its face down on the original tray of the DSDF, select [Sort mode] and [2 -> 2 Duplex] and then press the [START] button.
- (2) Superimpose the chart on the copy and check the leading edge E of the chart and F of the copy.

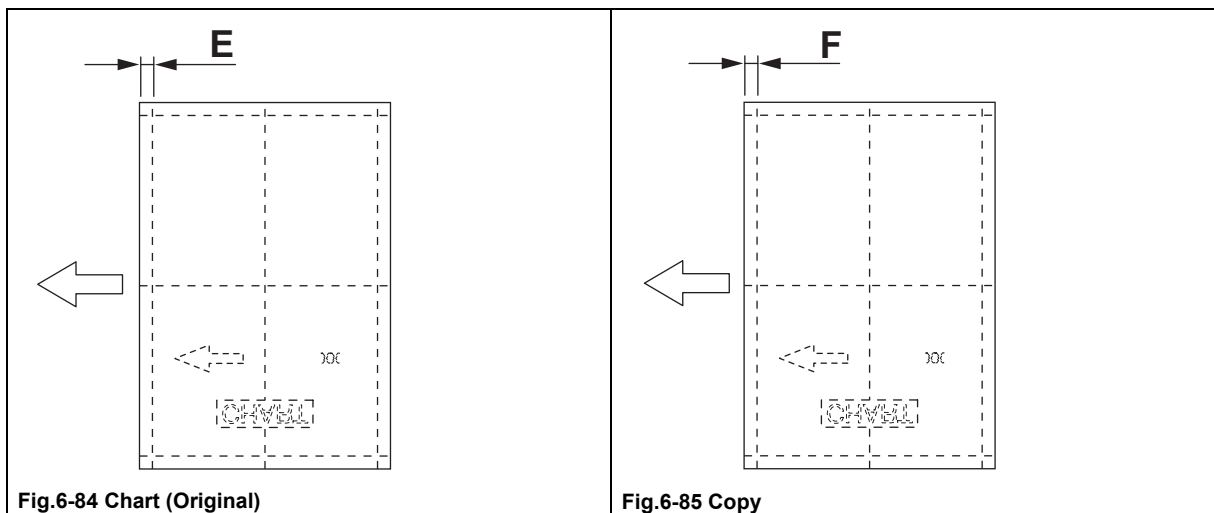

[B] Adjustment

Simplex (front side) copying

- (1) Perform FS-05-3044.
- (2) Enter the value.

Notes:

Changing one value shifts the copy image by 0.1 mm.

- If the leading edge (F) margin of the copy image is larger than the (E) margin of the chart, enter a value smaller than the current one.
- If the leading edge (F) margin of the copy image is smaller than the (E) margin of the chart, enter a value larger than the current one.

- (3) Press [OK].

Duplex (back side) copying

- (1) Perform FS-05-3045.

- (2) Enter the value.

- If the leading edge (F) margin of the copy image is larger than the (E) margin of the chart, enter a value smaller than the current one.
- If the leading edge (F) margin of the copy image is smaller than the (E) margin of the chart, enter a value larger than the current one.

Notes:

Changing one value shifts the copy image by 0.1 mm.

- (3) Press [OK].

6.14.5 Adjustment of horizontal position

Notes:

Check if the image adjustment for the equipment is performed properly before this adjustment of the DSDF.

(See the Service Manual of the applicable equipment.)

Also, the DSDF position and height shall be adjusted properly.

[1] Front side

[A] Checking (Front side)

Check the image using the chart (original) with a center line in the following procedure.

- (1) Place the chart provided as an original with its face up on the original tray of the DSDF.
- (2) Select the [Sort mode] and press the [START] button.
- (3) Fold the copy in half and check if the center line is misaligned.

[B] Adjustment (Front side)

- (1) Perform FS-05-3043.
 - If the center line of the copy image is shifted to the front side of the equipment, enter a value larger than the current one.

Notes:

Changing one value shifts the copy image by 0.0423 mm.

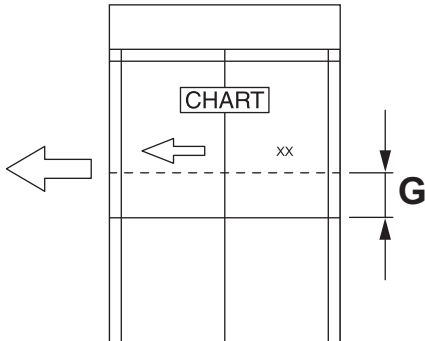

Fig.6-86

- If the center line of the copy image is shifted to the rear side of the equipment, enter a value smaller than the current one.

Notes:

Changing one value shifts the copy image by 0.0423 mm.

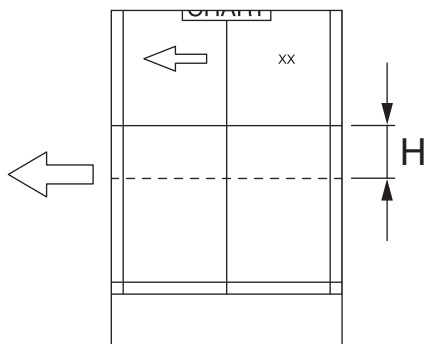

Fig.6-87

- (2) Press [OK].

[2] Back side

[A] Checking (back side)

Check the image using the chart (original) with a center line in the following procedure.

- (1) Place the chart provided as an original with its face down on the original tray of the DSDF.

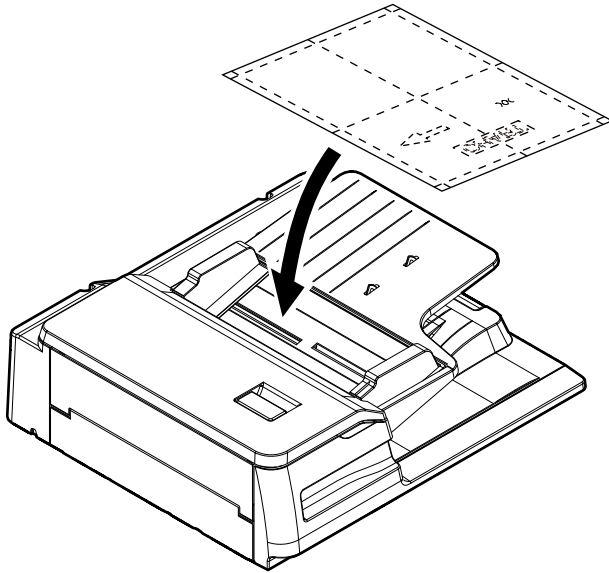

Fig.6-88

- (2) Select [2 Sided -> 1 Sided] and press the [START] button.
- (3) Fold the copy in half and check if the center line is misaligned.

[B] Adjustment (Back side)

- (1) Perform FS-05-3049.

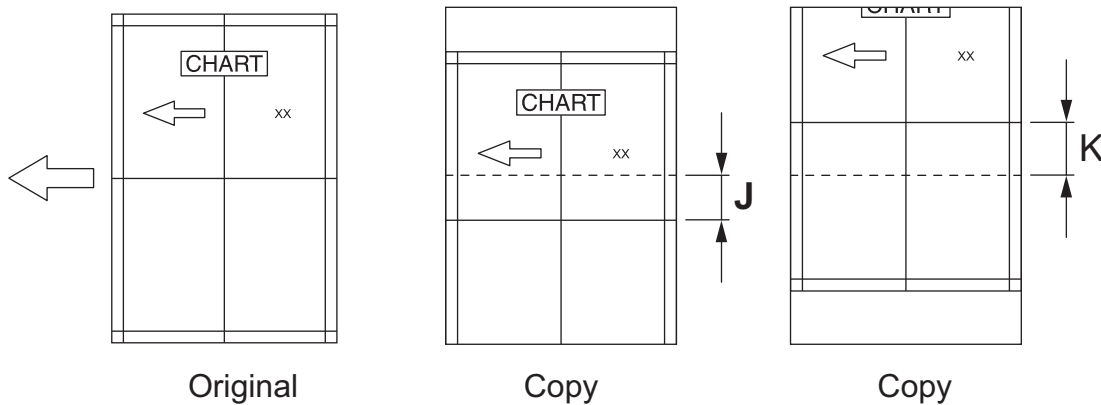

Fig.6-89

- If the center line of the copy image is shifted to the right side to the feeding direction (J), enter a value larger than the current one.
- If the center line of the copy image is shifted to the left side to the feeding direction (K), enter a value smaller than the current one.

Notes:

Changing one value shifts the copy image by 0.0423mm.

- (2) Press [OK].

6.14.6 Adjustment of copy ratio

Notes:

Check if the image adjustment for the equipment is performed properly before this adjustment of the DSDF.

(See the Service Manual of the applicable equipment.)

Also, the DSDF position and height shall be adjusted properly.

[A] Checking

Check the image using the chart (original) with vertical and horizontal lines in the following procedure.

- (1) Place the chart provided as an original with its face up on the original tray of the DSDF.
- (2) Select the [Sort mode] and press the [START] button.
- (3) Superimpose the chart on the copy and check the image dimension "l".

[B] Adjustment

- (1) Perform FS-05-3042.
 - If the copy image dimension "l" is larger than the chart dimension, enter a value smaller than the current one.
 - If the copy image dimension "l" is smaller than the chart dimension, enter a value larger than the current one.

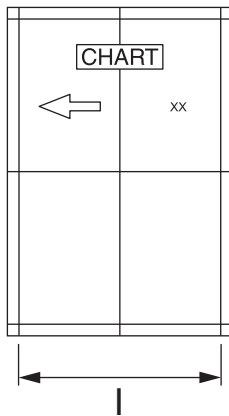

Fig.6-90

- (2) Press [OK].

6.14.7 DSDF read-in sensor-1 adjustment

[A] DSDF read-in sensor-1 automatic adjustment

Notes:

When the DSDF control PC board or the DSDF read-in sensor-1 is replaced, be sure to perform this adjustment.

If not, paper jams (E721, E725, E774) or operational problems may occur.

- (1) Perform FS-05-3210.

Notes:

- Be sure to close all of the DSDF cover before the adjustment is performed.
- Check that there is no paper on the DSDF read-in sensor-1 so that the light is not shielded.

[B] DSDF read-in sensor-1 manual adjustment

Notes:

When the DSDF read-in sensor-1 is replaced or re-installed, perform this manual adjustment.

- (1) Take off the DSDF left cover. (Refer to the service manual of applicable model.)
- (2) Close the original jam access cover and the DSDF.
- (3) Perform FS-05-3221.

Notes:

Be sure not to close or open the original jam access cover and the DSDF until step (5) is finished. If you do so, the adjustment value will be reset. In this case, repeat the adjustment from step (2).

- (4) Loosen 1 prism adjustment screw.

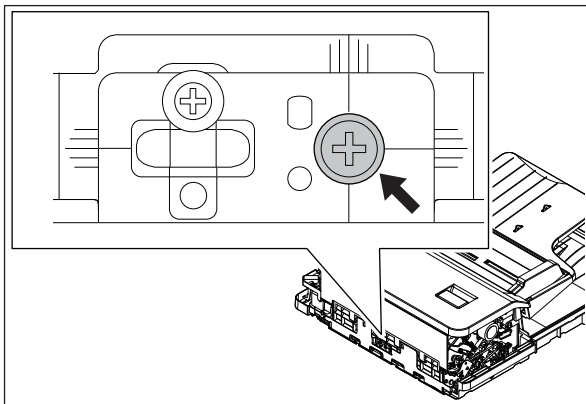

Fig.6-91

- (5) Slide the prism vertically. When the prism comes to the proper adjustment position, LED1 on the DSDF control PC board lights. At this position, tighten 1 prism adjustment screw.

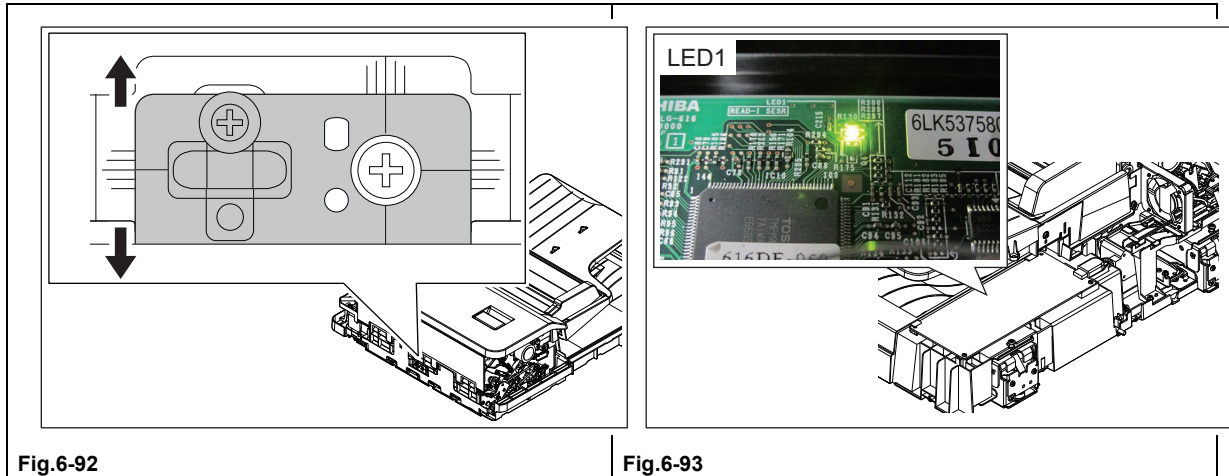

Fig.6-92

Fig.6-93

- (6) Perform automatic adjustment (FS-05-3210).

Notes:

After the manual adjustment is performed, be sure to do the automatic one.

- (7) Turn the power OFF and install the cover.

6.14.8 Platen sheet

If a shadow-like dark area appears on the edge of the image, reset the platen sheet.

- (1) Open the RADF and remove the platen sheet.

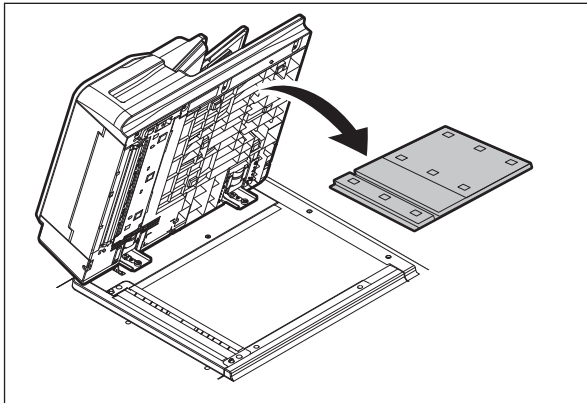

Fig.6-94

- (2) Place the platen sheet on the original glass and align it to the top left corner. Close the DSDF gently and open it to check if the platen sheet is attached properly.

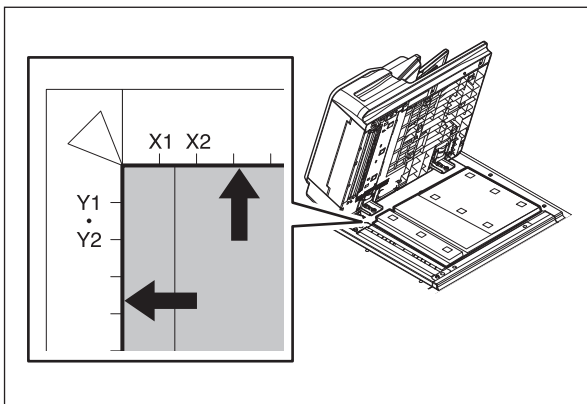

Fig.6-95

6.14.9 DSDF separation roller pressure force adjustment

In some cases the life of the separation roller may be shortened or paper jams (E712, E721) and multiple feeding (E724) may occur regardless of the operation frequency of the DSDF. This comes from the weight or edge status of paper used and the amount of paper dust.

Generally paper jams and multiple feeding often occur as the life end of the roller approaches.

However, if they often occur even though its life has not yet reached its replacement timing, or if the life end comes much earlier than the scheduled replacement timing, the jams and multiple feeding can be suppressed by adjusting the pressure force of the separation roller.

In this method; however, when the roller life becomes longer, jams and multiple feeding may occur frequently, and when the jams and multiple feeding are suppressed, the roller life may become shorter. Therefore, perform this adjustment while checking the status carefully, and if necessary, give a sufficient explanation to users.

- (1) Remove the DSDF pickup unit [1].
- (2) Open the DSDF separation roller cover [1].

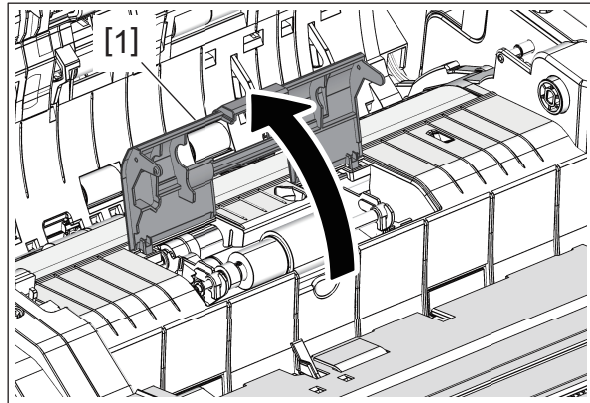

Fig.6-96

- (3) Turn the arm [2] to release the lock.

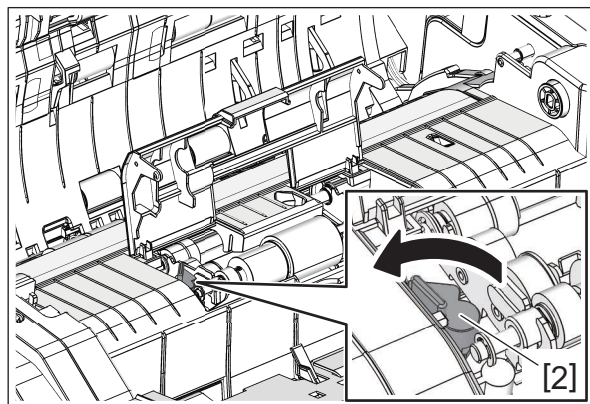

Fig.6-97

- (4) Lift up the DSDF separation roller unit [3].

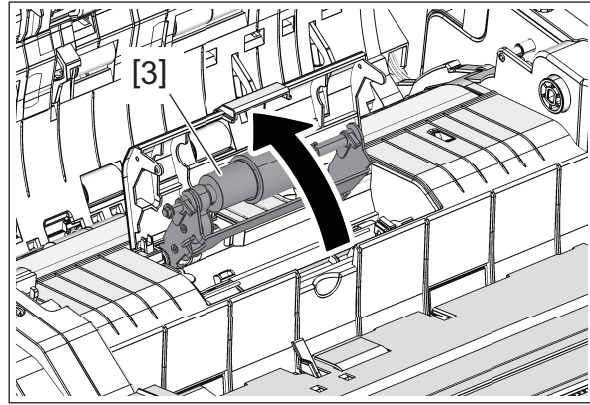

Fig.6-98

- (5) Move the adjustment plate [4] in the direction of F or R by 1 scale.
- Move to the direction F: Paper jams (E712, E721) will be suppressed. The roller life will become longer (but multiple feeding may occur frequently).
 - Move to the direction R: Multiple feeding will be suppressed (but the roller life may become shorter).

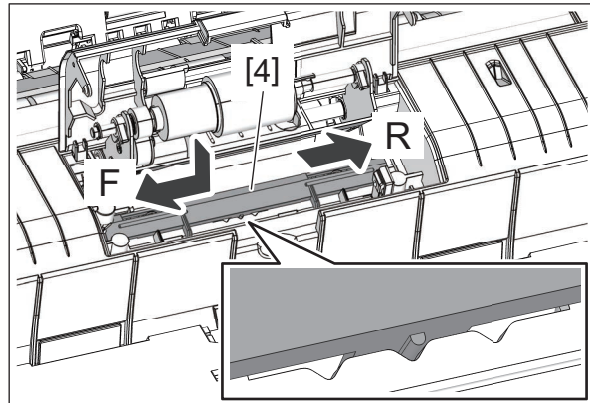

Fig.6-99

6.15 Adjustment of the RADF

6.15.1 Adjustment of RADF position

Perform this adjustment when the RADF is not installed in the correct position.

Notes:

Check if the image adjustment for the equipment is performed properly before this adjustment of the RADF.

[A] Checking

- (1) Open the RADF and install 2 positioning pins (the positioning pins are installed to the back side of the hinge which is on the left side of the RADF).

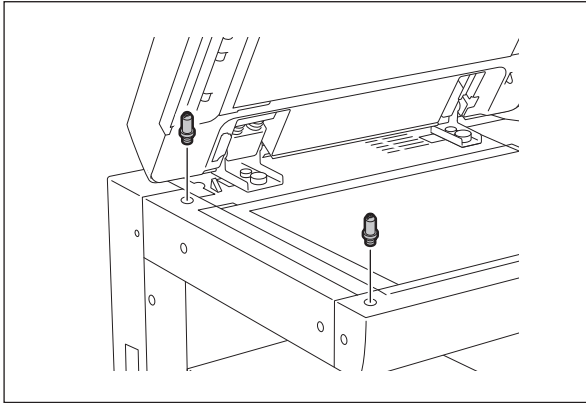

Fig.6-100

- (2) Remove the platen sheet.

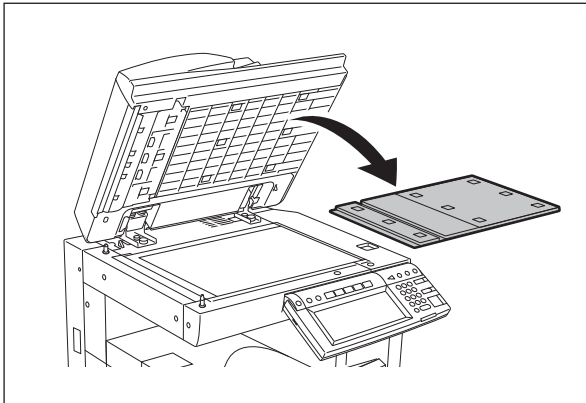

Fig.6-101

(3) Close the RADF and check if the positioning pins fit the holes on the RADF.

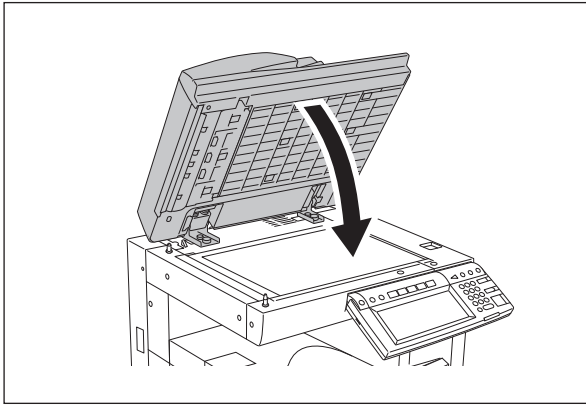

Fig.6-102

[B] Adjustment

If the pins cannot be fitted into the holes, perform the adjustment according to the following procedure.

(1) Remove the right-hand hinge screw at the rear side.

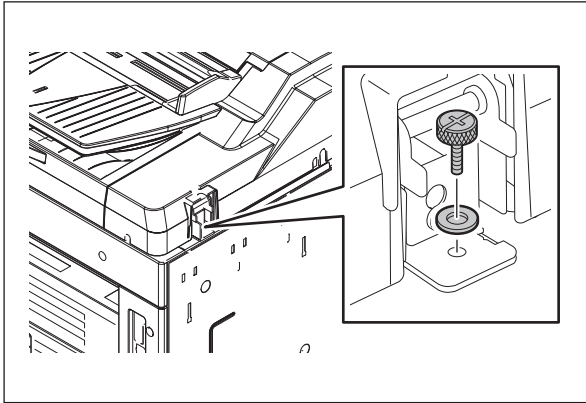

Fig.6-103

(2) Remove the bracket on the left-hand hinge.

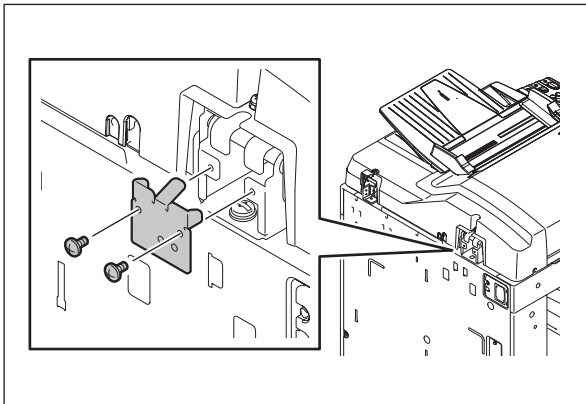

Fig.6-104

- (3) Loosen the left-hand hinge screw at the rear side.

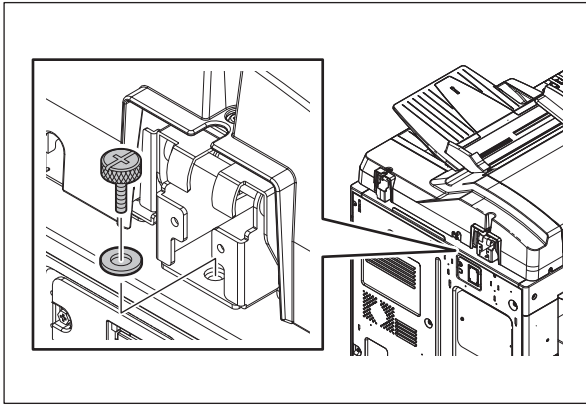

Fig.6-105

- (4) Tighten the hinge screws at the front side.

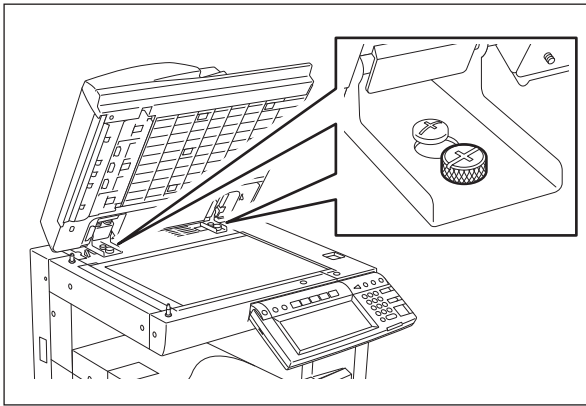

Fig.6-106

- (5) Position the pins with the holes on the RADF by moving it so that the pins fit into the holes when the RADF is closed.

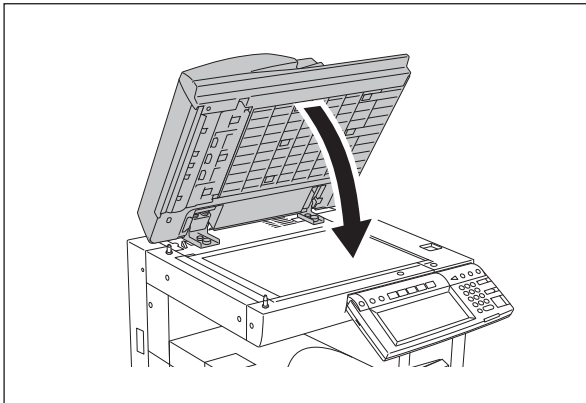

Fig.6-107

(6) Tighten the left-hand hinge screw at the rear side.

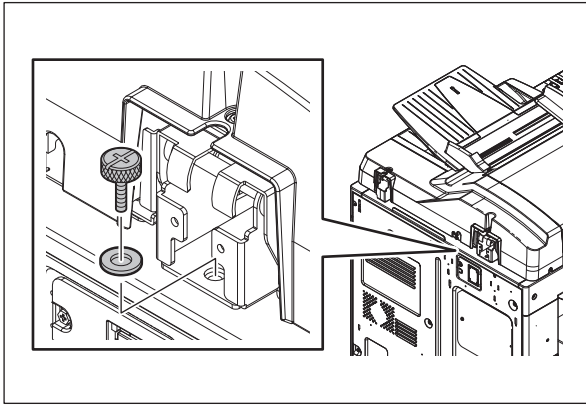

Fig.6-108

(7) Match the screw hole positions.

Notes:

Turn it clockwise: It moves toward the rear side.

Turn it counterclockwise: It moves toward the front side.

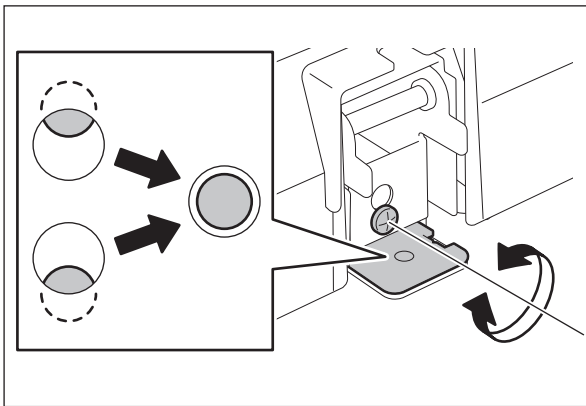

Fig.6-109

(8) Install the right-hand hinge screw at the rear side.

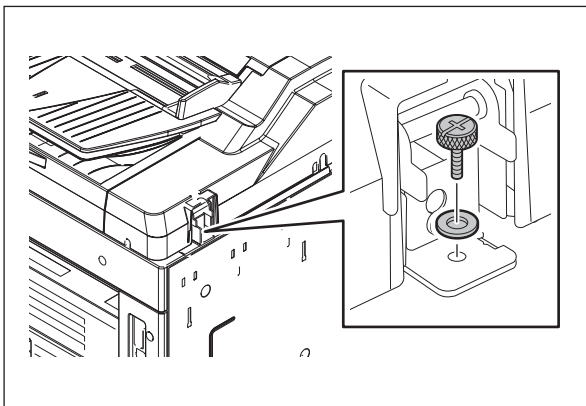

Fig.6-110

(9) Install the bracket on the left-hand hinge.

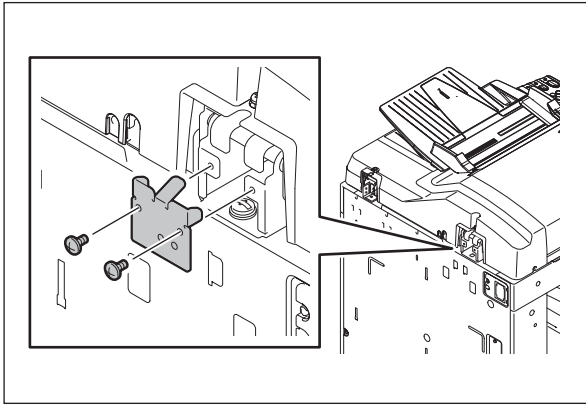

Fig.6-111

(10) Loosen the hinge screws at the front side.

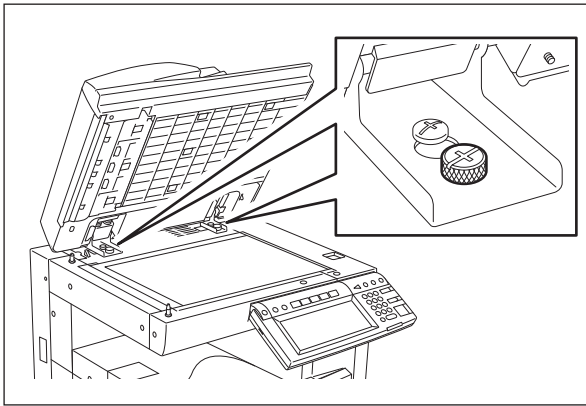

Fig.6-112

(11) Place the platen sheet on the original glass and align it to the top left corner. Close the RADF gently and open it to check if the platen sheet is attached properly.

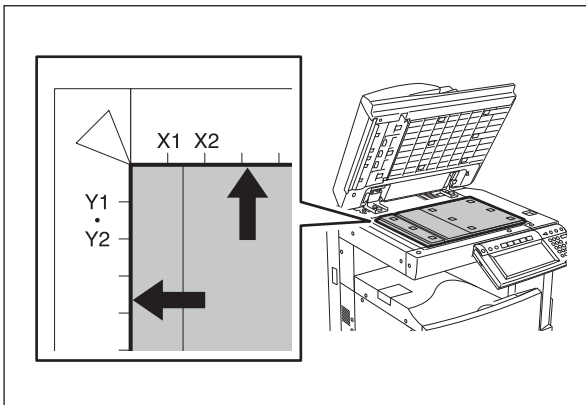

Fig.6-113

6.15.2 Adjustment of RADF height

Notes:

Check if the image adjustment for the equipment is performed properly before this adjustment of the RADF.

[A] Checking

- (1) Close the RADF.
- (2) Light the exposure lamp.
 - Perform FS-03.
 - Key in [267] and then press the [START] button. The exposure lamp is turned ON for a given length of time.
- (3) Visually check the gap between platen guide holder "A" and upper surface of the original glass "B" from the left hand side of the equipment. If the value is not within the tolerance, perform the adjustment according to the following procedure.

[Tolerance of the gap]

Rear side: 0 - 0.5 mm

Front side: 0 mm

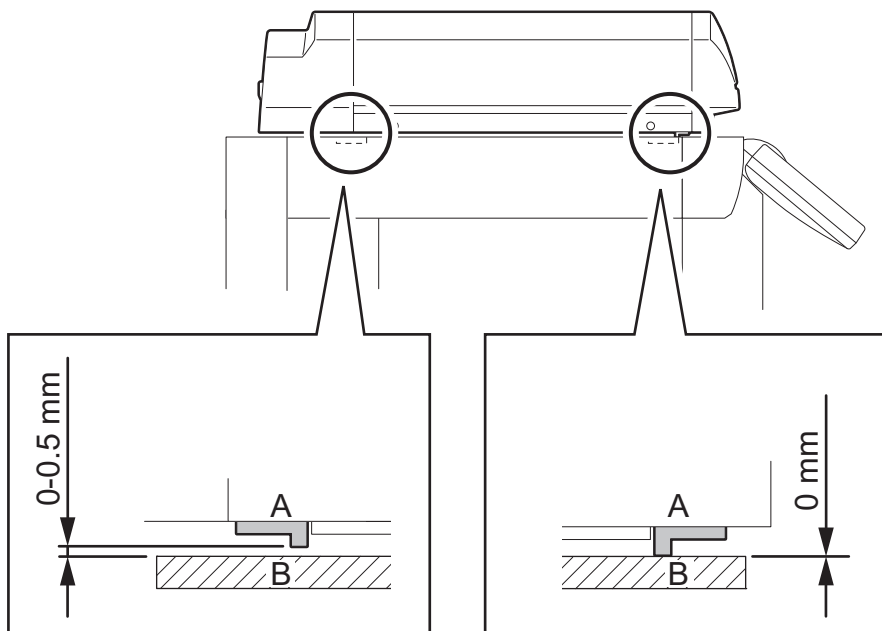

Fig.6-114

[B] Adjustment

- (1) Close the RADF.
- (2) Adjust it by turning the adjustment screws on the hinges.
 - Adjust the height on the rear side by means of the screw on the hinge on the exit side of the RADF.

Turn it clockwise: Heightened
Turn it counterclockwise: Lowered

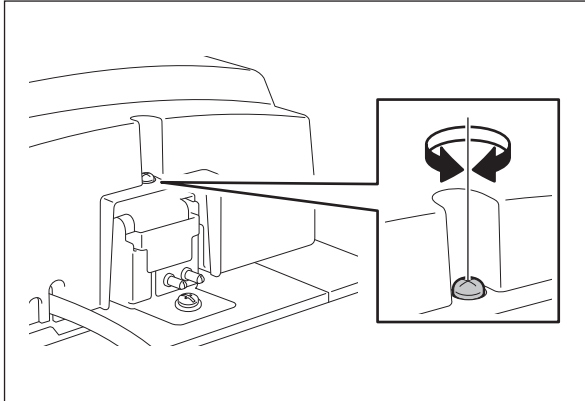

Fig.6-115

- Adjust the gap on the rear side by means of the screw on the hinge on the feed side of the RADF.

Turn it clockwise: Lowered
Turn it counterclockwise: Heightened

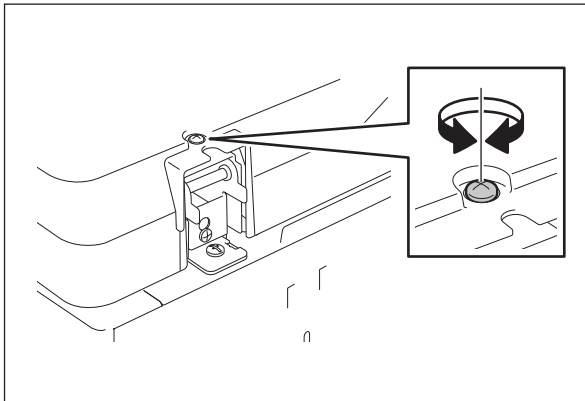

Fig.6-116

6.15.3 Adjustment of skew

Notes:

Check if the image adjustment for the equipment is performed properly before this adjustment of the RADF. Also, the RADF position and height shall be adjusted properly.

[A] Checking

Check the image using the chart (original) with vertical and horizontal lines in the following procedure.

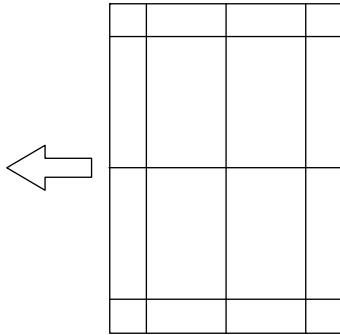

Fig.6-117 Chart (Original)

Simplex copying:

- (1) Place the chart provided as an original with its face up on the original tray of the RADF, select [Sort] and [1 → 1 Simplex] and then press the [START] button.
- (2) Superimpose the chart on the copy and check the inclination of the copy image.

Duplex copying:

- (1) Place the chart provided as an original with its face down on the original tray of the RADF, select [Sort] and [2 → 2 Duplex] and then press the [START] button.
- (2) Superimpose the chart on the copy and check the inclination of the copy image.

[B] Adjustment

Simplex copying:

- (1) Shift the aligning plate with the scale as the guide shown in the figure below to adjust the skew.

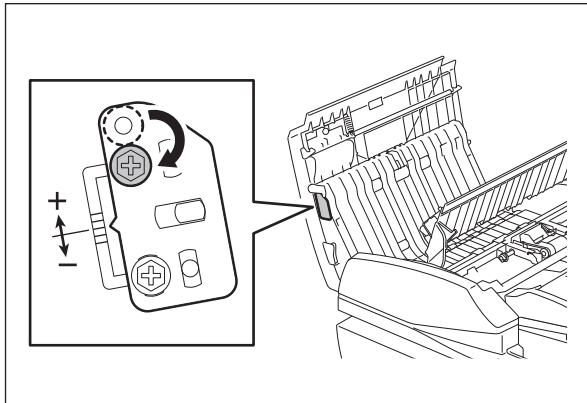

Fig.6-118

- (2) If the image skew is "C" as shown in the figure below, shift the aligning plate in the direction of "+", and if "D", shift it to "-".

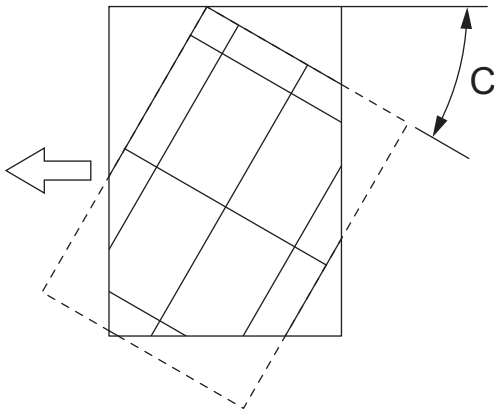

Fig.6-119

Shift the aligning plate in the direction of "+".

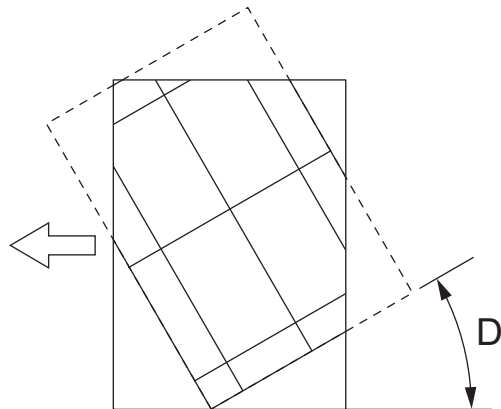

Fig.6-120

Shift the aligning plate in the direction of "-".

Duplex copying:

- (1) Shift the aligning plate with the scale as the guide shown in the figure below to adjust the skew.

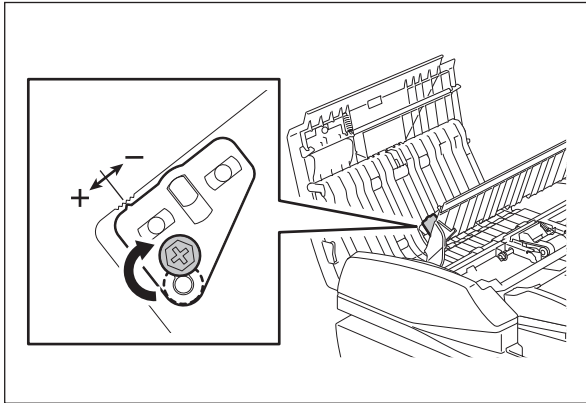

Fig.6-121

- (2) If the image skew is "C" as shown in the figure below, shift the aligning plate in the direction of "-", and if "D", shift it to "+".

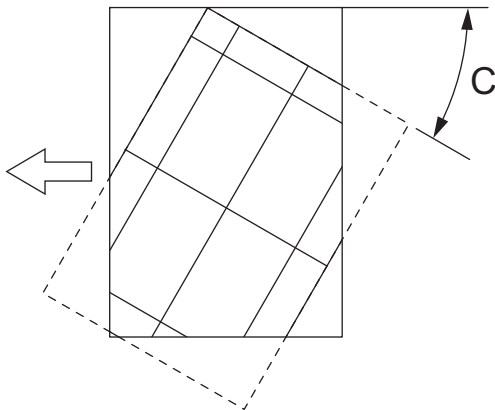

Fig.6-122

Shift the aligning plate in the direction of "-".

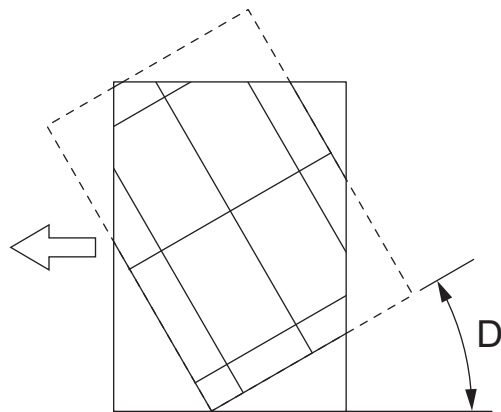

Fig.6-123

Shift the aligning plate in the direction of "+".

6.15.4 Adjustment of the leading edge position

Notes:

Check if the image adjustment for the equipment is performed properly before this adjustment of the RADF. Also, the RADF position and height shall be adjusted properly.

[A] Checking

Check the image using the chart (original) with vertical and horizontal lines in the following procedure.

Simplex copying:

- (1) Place the chart provided as an original with its face up on the original tray of the RADF, select [Sort] and [1 → 1 Simplex] and then press the [START] button.
- (2) Superimpose the chart on the copy and check the leading edge E of the chart and F of the copy.

Duplex copying:

- (1) Place the chart provided as an original with its face down on the original tray of the RADF, select [Sort] and [2 → 2 Duplex] and then press the [START] button.
- (2) Superimpose the chart on the copy and check the leading edge E of the chart and F of the copy.

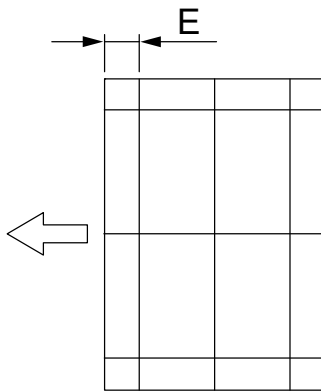

Fig.6-124 Chart (Original)

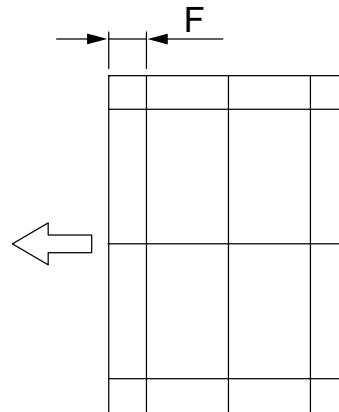

Fig.6-125 Copy

[B] Adjustment

Simplex copying:

- (1) Perform FS-05-3044.
- (2) Enter the value.
 - If the leading edge (F) margin of the copy image is larger than the (E) margin of the chart, enter a value smaller than the current one.

Notes:

Changing one value shifts the copy image by 0.1 mm.

- If the leading edge (F) margin of the copy image is smaller than the (E) margin of the chart, enter a value larger than the current one.

Notes:

Changing one value shifts the copy image by 0.1 mm.

- (3) Press [OK].

Duplex copying:

- (1) Perform FS-05-3045.
- (2) Enter the value.
 - If the leading edge (F) margin of the copy image is larger than the (E) margin of the chart, enter a value smaller than the current one.

Notes:

Changing one value shifts the copy image by 0.1 mm.

- If the leading edge (F) margin of the copy image is smaller than the (E) margin of the chart, enter a value larger than the current one.

Notes:

Changing one value shifts the copy image by 0.1 mm.

- (3) Press [OK].

6.15.5 Adjustment of horizontal position

Notes:

Check if the image adjustment for the equipment is performed properly before this adjustment of the RADF. Also, the RADF position and height shall be adjusted properly.

[A] Checking

Check the image using the chart (original) with a center line in the following procedure.

- (1) Place the chart provided as an original with its face up on the original tray of the RADF.
- (2) Select the [Sort] and then press the [START] button.
- (3) Fold the copy in half and check if the center line is misaligned.

[B] Adjustment

- (1) Perform FS-05-3043.
 - If the center line of the copy image is shifted to the front side of the equipment, enter a value larger than the current one.

Notes:

Changing one value shifts the copy image by 0.042 mm.

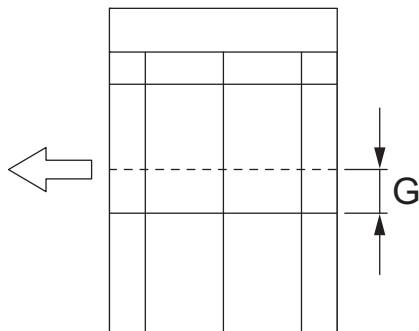

Fig.6-126

- If the center line of the copy image is shifted to the rear side of the equipment, enter a value smaller than the current one.

Notes:

Changing one value shifts the copy image by 0.042 mm.

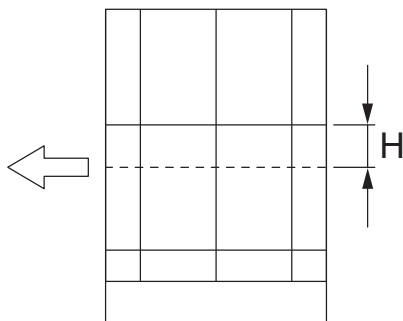

Fig.6-127

- (2) Press [OK].

6.15.6 Adjustment of copy ratio

Notes:

Check if the image adjustment for the equipment is performed properly before this adjustment of the RADF. Also, the RADF position and height shall be adjusted properly.

[A] Checking

Check the image using the chart (original) with vertical and horizontal lines in the following procedure.

- (1) Place the chart provided as an original with its face up on the original tray of the RADF.
- (2) Select the [Sort] and then press the [START] button.
- (3) Superimpose the chart on the copy and check the image dimension "l".

[B] Adjustment

- (1) Perform FS-05-3042.
 - If the copy image dimension "l" is larger than the chart dimension, enter a value smaller than the current one.
 - If the copy image dimension "l" is smaller than the chart dimension, enter a value larger than the current one.

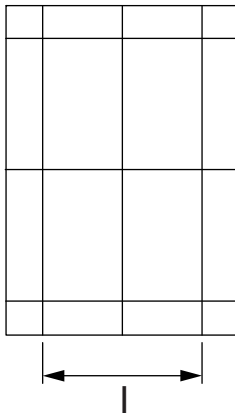

Fig.6-128

Notes:

When the value increases by "1", the reproduction ratio of the secondary scanning direction when using the RADF increases by approx. 0.1%.

- (2) Press [OK].

6.15.7 RADF Separation roller pressure force adjustment

In some cases the life of the separation roller may be shortened or paper jams (E712, E721) and multiple feeding (E724) may occur regardless of the operation frequency of the equipment. This comes from the weight or edge status of paper used and the amount of paper dust.

Generally, paper jams and multiple feeding often occur as the life end of the roller approaches.

However, if they often occur even though its life has not yet reached its replacement timing, or if the life end comes much earlier than the scheduled replacement timing, paper jams, multiple feeding or shortened life can be improved by adjusting the pressure force of the separation roller.

In this method, however, when the roller life becomes longer, jams and multiple feeding may occur frequently, and when the jams and multiple feeding are suppressed, the roller life may become shorter. Therefore, perform this adjustment while checking the status carefully, and if necessary, give a sufficient explanation to users.

[A] Adjustment procedure

- (1) Open the jam access cover.
- (2) Take off the paper feeder unit [1].

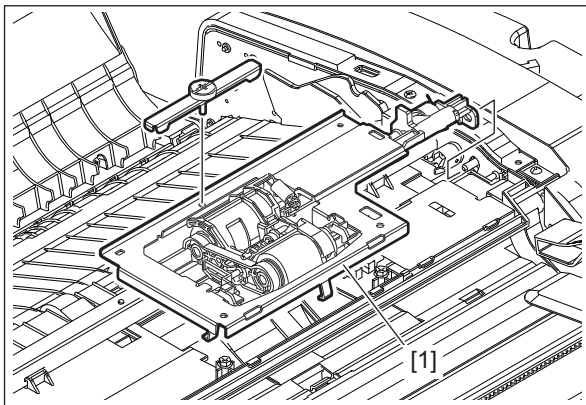

Fig.6-129

- (3) Remove 2 screws. Lift up the feeder upper guide [2] by sliding it to the right.

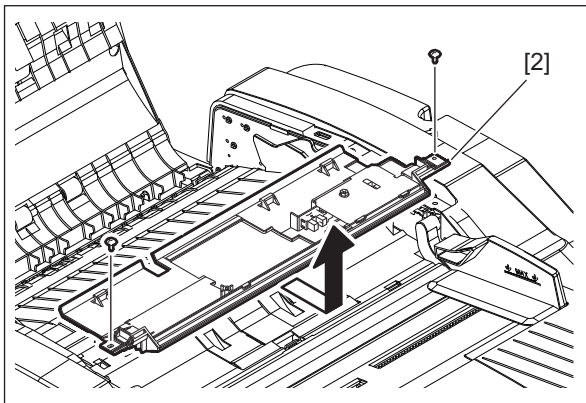

Fig.6-130

Notes:

Do not pull the harness too strong.

- (4) Take off the separation roller holder [3].

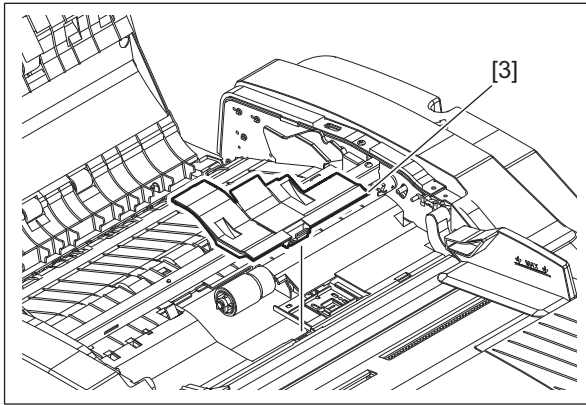

Fig.6-131

- (5) While holding the bracket [5] with your hand, remove the screw [4].

Notes:

When installing or taking off the bracket [5], keep it setting up because it is tensed with a spring to L direction.

- (6) Move the bracket [5].

- Move to the direction R: Paper jams (E712, E721) will be suppressed. The roller life will become longer (but multiple feeding may occur frequently).
- Move to the direction L: Multiple feeding will be suppressed (but the roller life may become shorter).
- The upper limit of the movement of the bracket for the adjustment is 1 scale. If the bracket is moved by 2 scales, deterioration of the pressure spring may occur.

- (7) Tighten the screw [4].

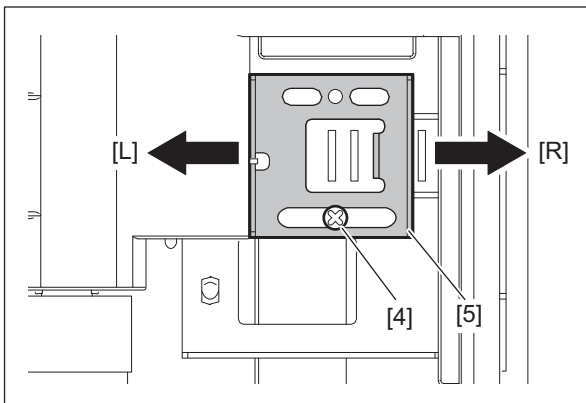

Fig.6-132

6.16 Adjustment of the Inner Finisher

Notes:

Before performing each adjustment, make sure that all covers (incl. those of the finisher and equipment) are closed. Otherwise, no power is supplied to the Finisher and the adjustment may not be performed properly.

Do not enter a value which exceeds the range of the adjustment value. Although such value can be entered depending on the models, adjustment will be performed with the default value.

6.16.1 Alignment position adjustment

[A] Alignment position adjustment (front)

This adjustment is performed in the Adjustment Mode (FS-05-4822-0) of the equipment.

Adjustment scale	0.2mm	
Adjustable range	-3.4 mm to 3.4 mm	
Adjustment value	-17 to 17 (Default value: 0)	
Adjustment direction	Increasing the value	The alignment plate moves to the center.
	Decreasing the value	The alignment plate moves to the edge of paper.

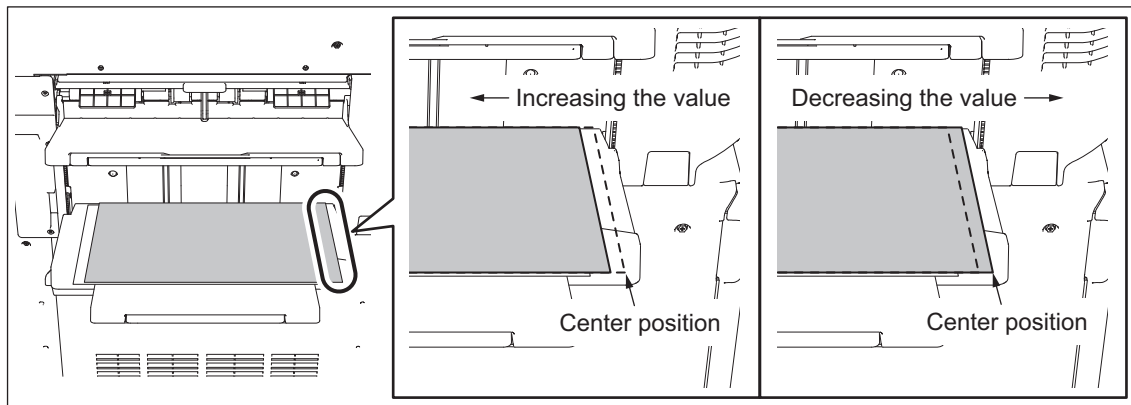

Fig.6-133

[B] Alignment position adjustment (rear)

This adjustment is performed in the Adjustment Mode (FS-05-4822-1) of the equipment.

Adjustment scale	0.2mm	
Adjustable range	-3.4 mm to 3.4 mm	
Adjustment value	-17 to 17 (Default value: 0)	
Adjustment direction	Increasing the value	The alignment plate moves to the center.
	Decreasing the value	The alignment plate moves to the edge of paper.

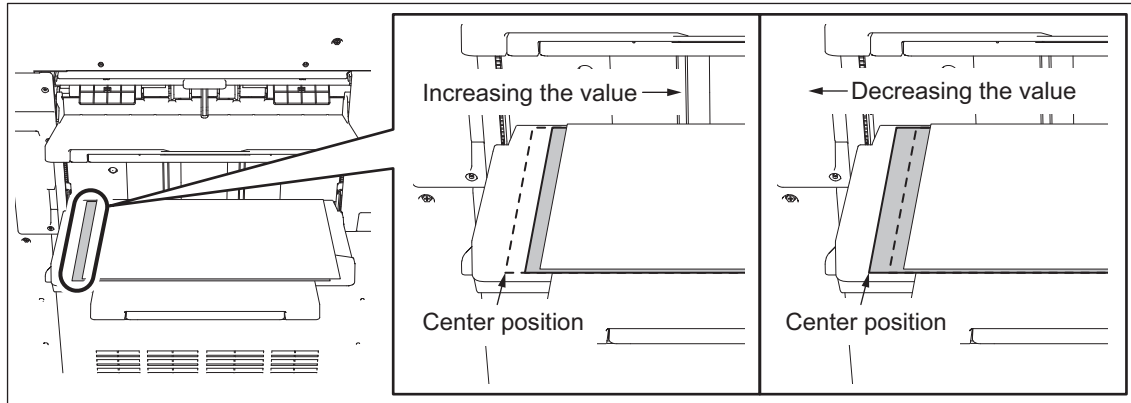

Fig.6-134

6.16.2 Stapling position adjustment

[A] Stapling position adjustment (rear 1-point / paper output direction: portrait)

This adjustment is performed in the Adjustment Mode (FS-05-4823-0) of the equipment.

Adjustment scale	0.2mm	
Adjustable range	-3.4 mm to 3.4 mm	
Adjustment value	-17 to 17 (Default value: 0)	
Adjustment direction	Increasing the value	The distance between the stapling position and the edge of the paper becomes longer
	Decreasing the value	The distance between the stapling position and the edge of the paper becomes shorter.

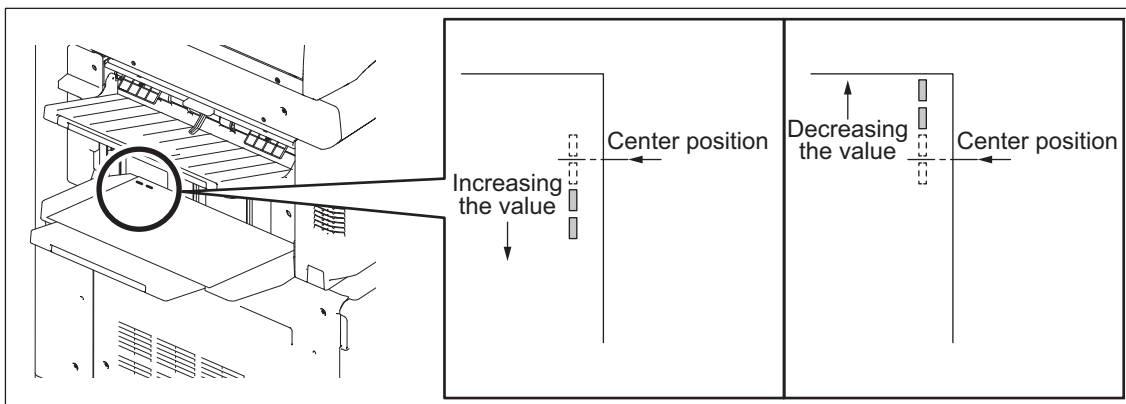

Fig.6-135

[B] Stapling position adjustment (rear 1-point / paper output direction: landscape)

This adjustment is performed in the Adjustment Mode (FS-05-4823-1) of the equipment.

Adjustment scale	0.2mm	
Adjustable range	-3.4mm to 3.4 mm	
Adjustment value	-17 to 17 (Default value: 0)	
Adjustment direction	Increasing the value	The distance between the stapling position and the edge of the paper becomes longer
	Decreasing the value	The distance between the stapling position and the edge of the paper becomes shorter.

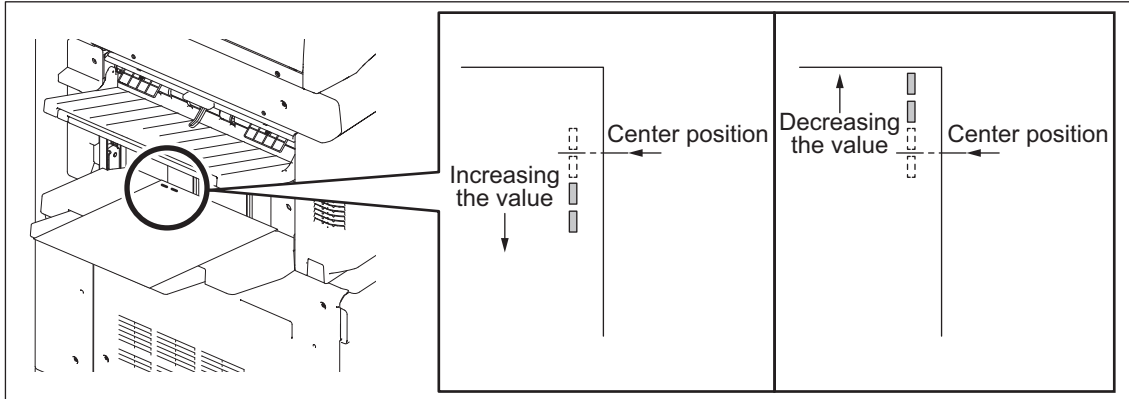

Fig.6-136

[C] Stapling position adjustment (front 1-point / paper output direction: portrait)

This adjustment is performed in the Adjustment Mode (FS-05-4823-2) of the equipment.

Adjustment scale	0.2mm	
Adjustable range	-3.4 mm to 3.4 mm	
Adjustment value	-17 to 17 (Default value: 0)	
Adjustment direction	Increasing the value	The distance between the stapling position and the edge of the paper becomes shorter.
	Decreasing the value	The distance between the stapling position and the edge of the paper becomes longer.

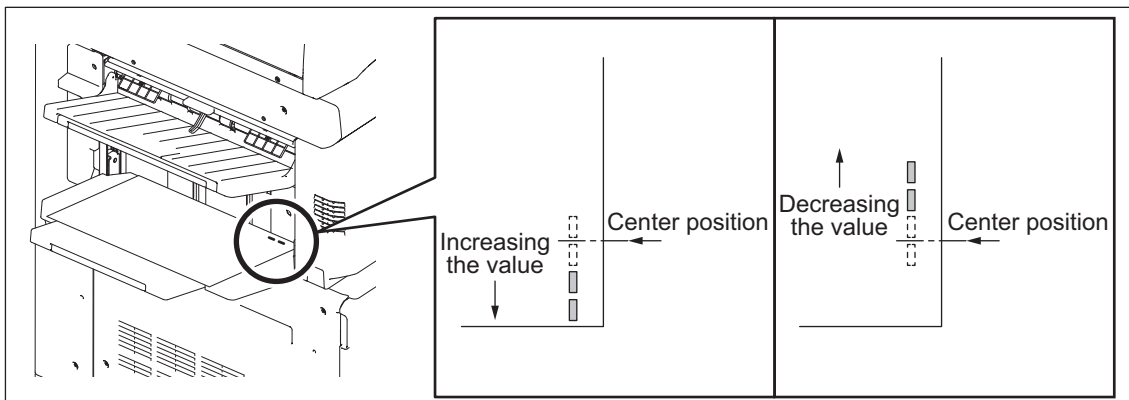

Fig.6-137

[D] Stapling position adjustment (front 1-point / paper output direction: landscape)

This adjustment is performed in the Adjustment Mode (FS-05-4823-3) of the equipment.

Adjustment scale	0.2mm	
Adjustable range	-3.4 mm to 3.4 mm	
Adjustment value	-17 to 17 (Default value: 0)	
Adjustment direction	Increasing the value	The distance between the stapling position and the edge of the paper becomes shorter.
	Decreasing the value	The distance between the stapling position and the edge of the paper becomes longer.

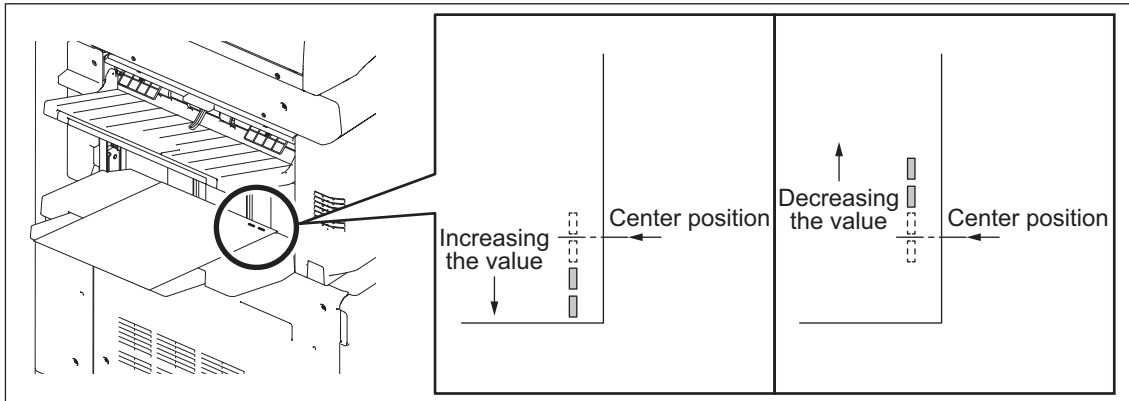

Fig.6-138

[E] Stapling position adjustment (center 2-point)

This adjustment is performed in the Adjustment Mode (FS-05-4823-4) of the equipment.

Adjustment scale	0.2mm	
Adjustable range	-3.4 mm to 3.4 mm	
Adjustment value	-17 to 17 (Default value: 0)	
Adjustment direction	Increasing the value	The stapling position moves farther to the front side from the center position.
	Decreasing the value	The stapling position moves farther to the rear side from the center position.

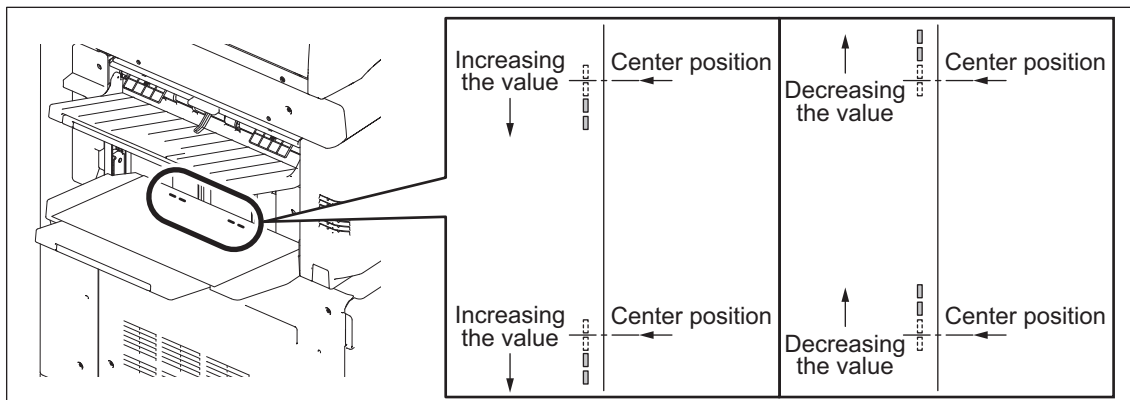

Fig.6-139

6.16.3 Punch hole position adjustment

This adjustment is performed in the Adjustment Mode (FS-05-4825) of the equipment.

Adjustment scale	0.2mm	
Adjustable range	-3.4 mm to 2.4 mm	
Adjustment value	-17 to 12 (Default value: 0)	
Adjustment direction	Increasing the value	The distance between the punch hole and the trailing edge of the paper becomes shorter.
	Decreasing the value	The distance between the punch hole and the trailing edge of the paper becomes longer.

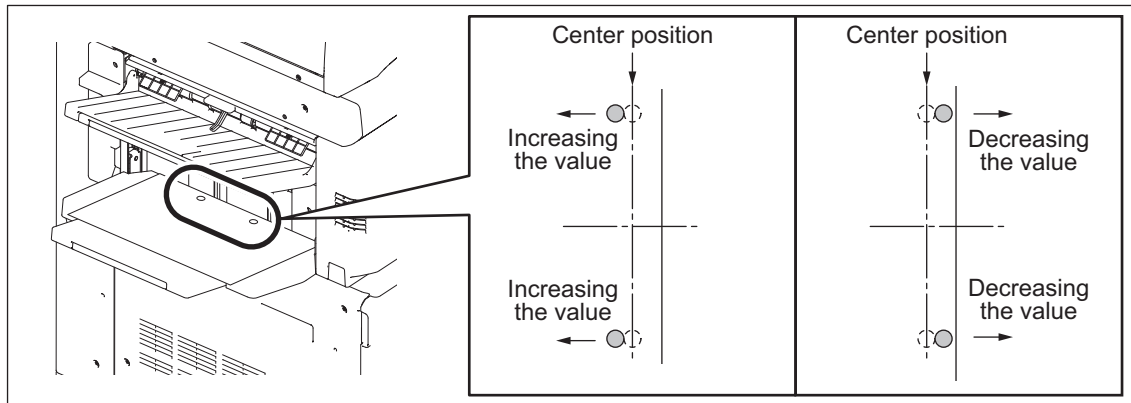

Fig.6-140

6.17 Adjustment of the Console Finisher

Notes:

Before performing each adjustment, make sure that all covers (incl. those of the finisher and host machine) are closed. Otherwise, the power is not supplied to the finisher and the adjustment may not be performed properly.

6.17.1 Adjusting the alignment position

Perform this adjustment after replacing the Finisher control board or when the alignment position must be changed for some reason.

[A] Reading/writing of the adjustment value with the self-diagnostic mode

If the adjustment values can be confirmed from the pre-change board, check them from the connected equipment and then set them into the post-change board.

A4-size adjustment value check: Perform FS-05-4838-1.

LT-size adjustment value check: Perform FS-05-4838-2.

Item to be adjusted		Code	Remarks
Horizontal position of the paper	A-series paper	FS-05-4838-1	Adjusts the horizontal position of the paper. When a positive value is set, the pitch of the alignment plate becomes smaller. When a negative value is set, the pitch of the alignment plate becomes larger. 0: Finisher not installed 1: -2.10mm, 2: -1.68mm, 3: -1.26mm, 4: -0.84mm, 5: -0.42mm, 6: 0.00mm, 7: +0.42mm, 8: +0.84mm, 9: +1.26mm, 10: +1.68mm, 11: +2.10mm
	LT-series paper	FS-05-4838-2	

If the adjustment values cannot be confirmed, perform the adjustment in the following procedure.

[B] Adjustment with DIP-SW

Adjustment must be performed with 2 types of adjustment sheets for the A4 and LT series.

The adjustment value of A4 will be applied to the operation with A3, A4, A4-R, B4, B5, FOLIO, 8K, 16K. The adjustment value of LT will be applied to the operation with LD, LG, LT, LT-R, COMP, 13 LG, 8.5" SQ.

- (1) Turn OFF the power of the equipment.
- (2) Remove 1 screw and take off the board access cover [1].
- (3) Set the SW1 [2] on the Finisher control board as shown in the figures below.

Adjusting for A4 size paper: Turn ON pin 2 and 4.

Adjusting for LT size paper: Turn ON pin 1, 2, and 4.

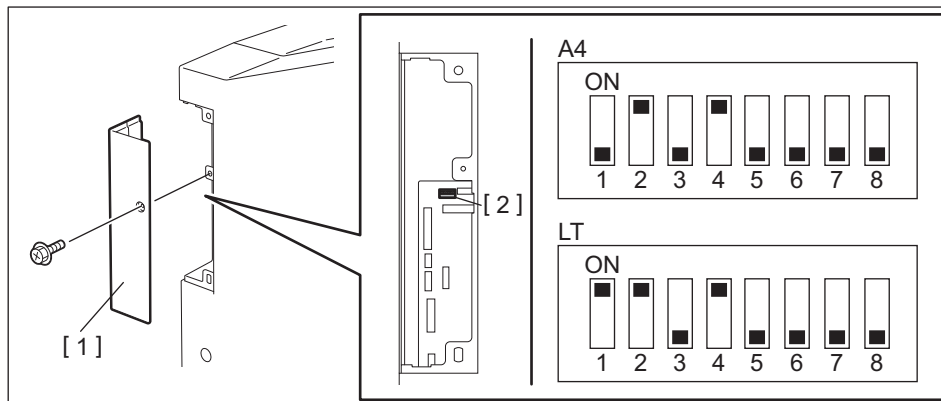

Fig.6-141

- (4) Start the equipment in the HS mode.
The alignment plate moves to the SW1 set position and then stops.

- (5) Press the [Button1] to adjust the alignment position.
 Every time [Button1] is pressed, the alignment plate shifts by 0.42 mm. (The gap between the alignment plates becomes narrower.)

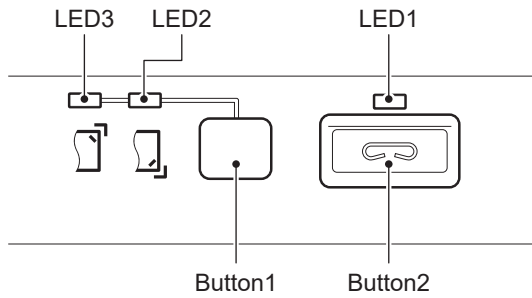

Fig.6-142

- (6) Place the adjustment sheet [1] on the process tray and adjust the position to make the gap between paper and the alignment plate [2] "0".
 Then setting is performed at a value that is one smaller than the adjustment value.

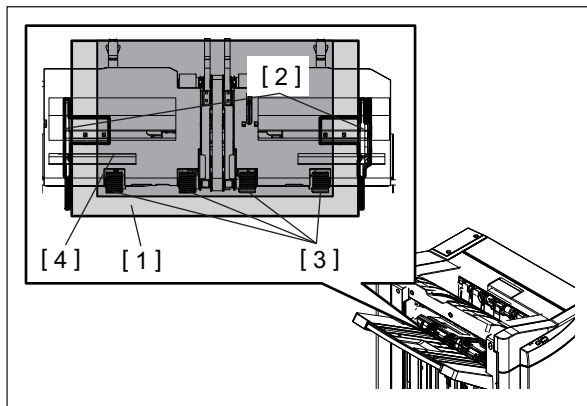

Fig.6-143

Remarks:

Use an adjustment sheet [1] made of plastic resin which is light and accurate in measurement (e.g. OHP film).
 To reduce frictional resistance with the vertical alignment roller [3] on the process tray, place a sheet of B5 paper [4] beneath the adjustment sheet [1] on the vertical alignment roller [3].
 Confirm the gap between paper and the alignment plate [2] by moving the adjustment sheet [1] forward and backward.

- (7) When the adjustment is completed, press the [Button2] on the finisher control panel to store the adjustment value in memory.
 When the value is stored normally, [LED1] on the finisher control panel will blink a certain number of times that corresponds to the adjustment value set for the equipment.
 See the following table for the number of times the [LED1] blinks and its corresponding moved amount (mm).

Number of Blinking	Distance from the center value (mm)
1	-2.10
2	-1.68
3	-1.26
4	-0.84
5	-0.42
6	Center value (0.00)
7	+0.42
8	+0.84
9	+1.26
10	+1.68
11	+2.10

- (8) Turn OFF the power of the equipment.
 (9) Turn OFF all bits of the SW1 on the Finisher control board.
 (10) Install the board access cover.

6.17.2 Adjusting the stapling position

Perform this adjustment after replacing the Finisher control board or when the stapling position must be changed for some reason.

[A] Reading/writing of the adjustment value with the self-diagnostic mode

If the adjustment values can be confirmed from the pre-change board, check them from the connected equipment and then set them into the post-change board.

Adjustment value check (common for A4-size and LT-size): Perform FS-05-4838-3.

Item to be adjusted	Code	Remarks
Stapling position	FS-05-4838-3	Adjusts the stapling position. When a positive value is set, it shifts toward the rear side. When a negative value is set, it shifts toward the front side. 0: Finisher not installed 1: -2.16mm, 2: -1.89mm, 3: -1.62mm, 4: -1.35mm, 5: -1.08mm, 6: -0.81mm, 7: -0.54mm, 8: -0.27mm, 9: ±0.00mm, 10: +0.27mm, 11: +0.54mm, 12: +0.81mm, 13: +1.08mm, 14: +1.35mm, 15: +1.62mm, 16: +1.89mm, 17: +2.16mm

If the adjustment values cannot be confirmed, perform the adjustment in the following procedure.

[B] Adjustment with DIP-SW

- (1) Turn OFF the power of the equipment.
- (2) Remove 1 screw and take off the board access cover [1].
- (3) Set the SW1 [2] on the Finisher control board as shown in the figures below.

When adjusting the rear side for A4 size paper: Turn ON pin 1, 3, and 4.	When adjusting the rear side for LT size paper: Turn ON pin 1, 2, 3, and 4.
When adjusting the front side for A4 size paper: Turn ON pin 3 and 4.	When adjusting the front side for LT size paper: Turn ON pin 2, 3, and 4.

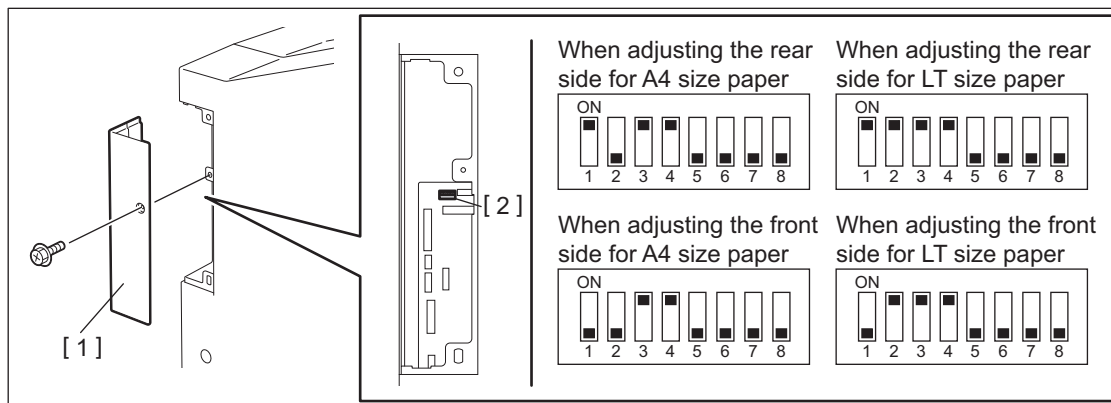

Fig.6-144

Remarks:

Although there are four setting types for the SW1 as shown above, perform only one of them since the adjustment values are used in common.

- (4) Start the equipment in the HS mode.
The staple unit moves to the rear or front side stapling position and stops. (It stops at the position of -2.16 mm (at the front side) from the center value of the adjustment range.)

- (5) Press [Button 1] to adjust the stapling position.
 Every time [Button 1] is pressed, the staple unit shifts by +0.27 mm (toward the rear side).
 Adjustment range is from -2.16 to +2.16 mm. If [Button 1] is pressed when the alignment position is at +2.16 mm, the unit will return to -2.16 mm.

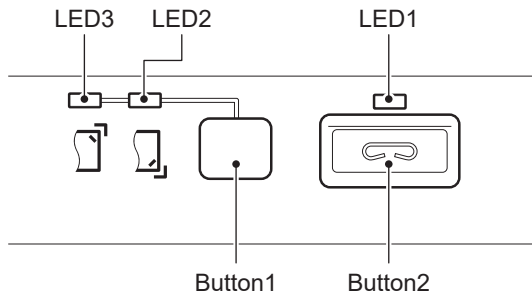

Fig.6-145

- (6) When the adjustment is completed, press [Button 2] on the finisher control panel to store the adjustment value in memory without sheets on the finishing tray.
 When the value is stored normally, [LED 1] on the control panel will blink for a number of times that corresponds to the adjustment value set for the equipment.
 See the following table for the number of times [LED 1] blinks and its corresponding adjustment value.

Number of blinking	Distance from the center value (mm)
1	-2.16
2	-1.89
3	-1.62
4	-1.35
5	-1.08
6	-0.81
7	-0.54
8	-0.27
9	Center value (0.00)
10	+0.27
11	+0.54
12	+0.81
13	+1.08
14	+1.35
15	+1.62
16	+1.89
17	+2.16

- (7) Turn OFF the power of the equipment.
- (8) Turn OFF all bits of the SW1 on the Finisher control board.
- (9) Install the board access cover.

6.18 Adjustment of the Saddle Stitch Finisher

Notes:

Before performing each adjustment, make sure that all covers (incl. those of the finisher and host machine) are closed. Otherwise, the power is not supplied to the finisher and the adjustment may not be performed properly.

6.18.1 Adjusting the alignment position

Perform this adjustment after replacing the Finisher control board or when the alignment position must be changed for some reason.

[A] Reading/writing of the adjustment value with the self-diagnostic mode

If the adjustment values can be confirmed from the pre-change board, check them from the connected equipment and then set them into the post-change board.

A4-size adjustment value check: Perform FS-05-4838-1.

LT-size adjustment value check: Perform FS-05-4838-2.

Item to be adjusted		Code	Remarks
Horizontal position of the paper	A-series paper	FS-05-4838-1	Adjusts the horizontal position of the paper. When a positive value is set, the pitch of the alignment plate becomes smaller. When a negative value is set, the pitch of the alignment plate becomes larger. 0: Finisher not installed 1: -2.10mm, 2: -1.68mm, 3: -1.26mm, 4: -0.84mm, 5: -0.42mm, 6: 0.00mm, 7: +0.42mm, 8: +0.84mm, 9: +1.26mm, 10: +1.68mm, 11: +2.10mm
	LT-series paper	FS-05-4838-2	

If the adjustment values cannot be confirmed, perform the adjustment in the following procedure.

[B] Adjustment with DIP-SW

Adjustment must be performed with 2 types of adjustment sheets for the A4 and LT series.

The adjustment value of A4 will be applied to the operation with A3, A4, A4-R, B4, B5, FOLIO, 8K, 16K. The adjustment value of LT will be applied to the operation with LD, LG, LT, LT-R, COMP, 13 LG, 8.5" SQ.

- (1) Turn OFF the power of the equipment.
- (2) Remove 2 screws and take off the board access cover [1].
- (3) Set the SW1 on the Finisher control board as shown in the figures below.

Adjusting for A4 size paper:
Turn ON pin 2 and 4.

Adjusting for LT size paper:
Turn ON pin 1, 2, and 4.

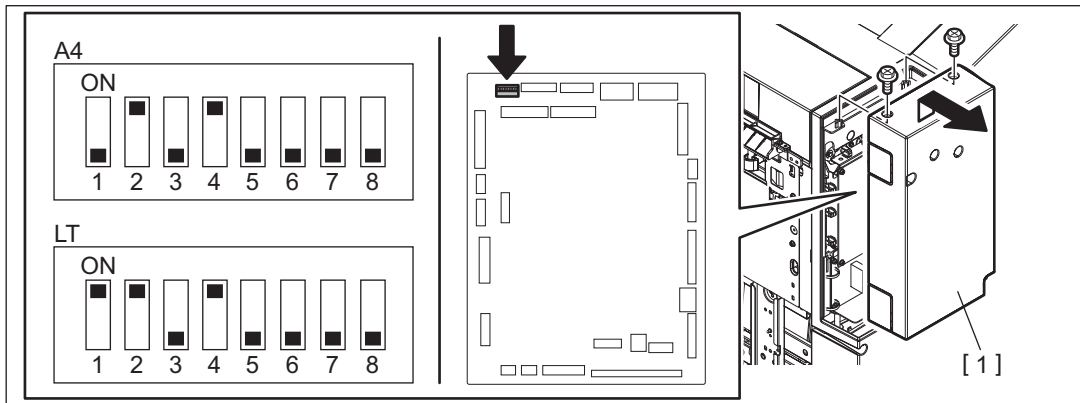

Fig.6-146

- (4) Start the equipment in the HS mode.
The alignment plate moves to the SW1 set position and then stops.
- (5) Press [Button1] to adjust the alignment position.
Every time [Button1] is pressed, the alignment plate shifts by 0.42 mm. (The gap between the alignment plates becomes narrower.)

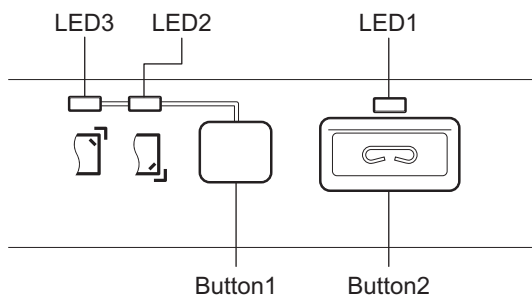

Fig.6-147

- (6) Place the adjustment sheet [1] on the process tray and adjust the position to make the gap between paper and the alignment plate [2] "0".
Then setting is performed at a value that is one smaller than the adjustment value.

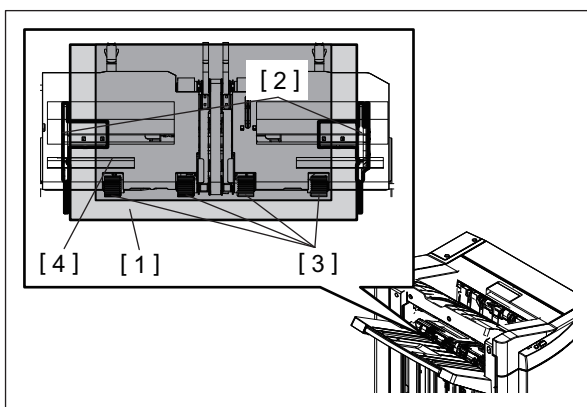

Fig.6-148

Remarks:

Use an adjustment sheet [1] made of plastic resin which is light and accurate in measurement (e.g. OHP film).

To reduce frictional resistance with the vertical alignment roller [3] on the process tray, place a sheet of B5 paper [4] beneath the adjustment sheet [1] on the vertical alignment roller [3].

Confirm the gap between paper and the alignment plate [2] by moving the adjustment sheet [1] forward and backward.

- (7) When the adjustment is completed, press the [Button2] on the finisher control panel to store the adjustment value in memory.
When the value is stored normally, the [LED1] on the control panel will blink for a number of times that corresponds to the adjustment value set for the equipment.
See the following table for the number of times [LED1] blinks and its corresponding moved amount (mm).

Number of Blinking	Distance from the center value (mm)
1	-2.10
2	-1.68
3	-1.26
4	-0.84
5	-0.42
6	Center value (0.00)
7	+0.42
8	+0.84
9	+1.26
10	+1.68
11	+2.10

- (8) Turn OFF the power of the equipment.
(9) Turn OFF all bits of the SW1 on the Finisher control board.
(10) Install the board access cover.

6.18.2 Adjusting the stapling position

Perform this adjustment after replacing the Finisher control board or when the stapling position must be changed for some reason.

[A] Reading/writing of the adjustment value with the self-diagnostic mode

If the adjustment values can be confirmed from the pre-change board, check them from the connected equipment and then set them into the post-change board.

Adjustment value check (common for A4-size and LT-size): Perform FS-05-4838-3.

Item to be adjusted	Code	Remarks
Stapling position	FS-05-4838-3	Adjusts the stapling position. When a positive value is set, it shifts toward the rear side. When a negative value is set, it shifts toward the front side. 0: Finisher not installed 1: -2.16mm, 2: -1.89mm, 3: -1.62mm, 4: -1.35mm, 5: -1.08mm, 6: -0.81mm, 7: -0.54mm, 8: -0.27mm, 9: ±0.00mm, 10: +0.27mm, 11: +0.54mm, 12: +0.81mm, 13: +1.08mm, 14: +1.35mm, 15: +1.62mm, 16: +1.89mm, 17: +2.16mm

If the adjustment values cannot be confirmed, perform the adjustment in the following procedure.

[B] Adjustment with DIP-SW

- (1) Turn OFF the power of the equipment.
- (2) Remove 2 screws and take off the board access cover [1].
- (3) Set the SW1 on the Finisher control board as shown in the figures below.

When adjusting the rear side for A4 size paper: Turn ON pin 1, 3, and 4.	When adjusting the rear side for LT size paper: Turn ON pin 1, 2, 3, and 4.
When adjusting the front side for A4 size paper: Turn ON pin 3 and 4.	When adjusting the front side for LT size paper: Turn ON pin 2, 3, and 4.

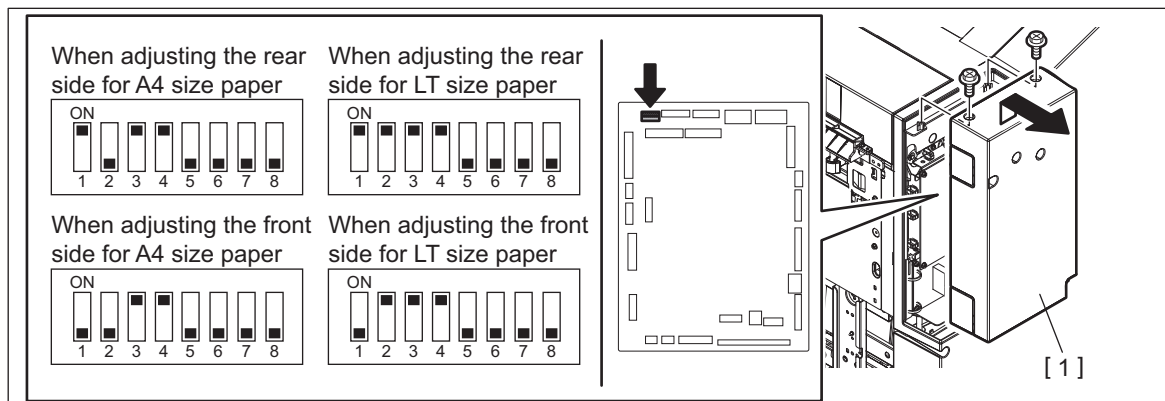

Fig.6-149

Remarks:

Although there are four setting types for the SW1 as shown above, perform only one of them since the adjustment values are used in common.

- (4) Start the equipment in the HS mode.
The staple unit moves to the rear or front side stapling position and stops. (It stops at the position of -2.16 mm (at the front side) from the center value of the adjustment range.)
- (5) Press [Button 1] to adjust the stapling position.
Every time [Button 1] is pressed, the staple unit shifts by +0.27 mm (toward the rear side).
Adjustment range is from -2.16 to +2.16 mm. If [Button 1] is pressed when the alignment position is at +2.16 mm, the unit will return to -2.16 mm.

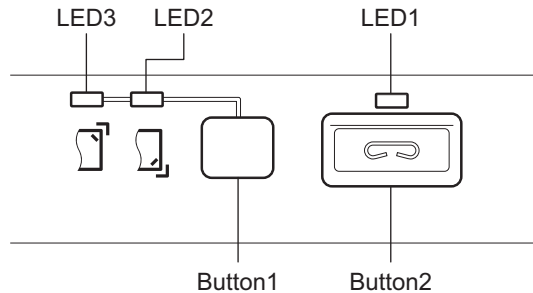

Fig.6-150

- (6) When the adjustment is completed, press [Button 2] on the finisher control panel to store the adjustment value in memory without sheets on the finishing tray.
When the value is stored normally, [LED 1] on the control panel will blink for a number of times that corresponds to the adjustment value set for the equipment.
See the following table for the number of times [LED 1] blinks and its corresponding adjustment value.

Number of blinking	Distance from the center value (mm)
1	-2.16
2	-1.89
3	-1.62
4	-1.35
5	-1.08
6	-0.81
7	-0.54
8	-0.27
9	Center value (0.00)
10	+0.27
11	+0.54
12	+0.81
13	+1.08
14	+1.35
15	+1.62
16	+1.89
17	+2.16

- (7) Turn OFF the power of the equipment.
- (8) Turn OFF all bits of the SW1 on the Finisher control board.
- (9) Install the board access cover.

6.18.3 Stapling/folding position adjustment in saddle stitch unit

Perform this adjustment when the saddle control PC board was replaced or the stapling/folding position must be changed for some reason.

Prepare 2 types of booklet samples using the main unit and use them for adjustment accordingly.

- (1) Create 2 types of booklet samples (1 set each) using the main unit.

	Sample 1	Sample 2
Media type	Recommended paper	Recommended paper
Paper size	A4	A3
Number of sheet	5 sheets	5 sheets

- (2) Measure the stapling and folding positions of the samples, and then perform adjustment accordingly.
For stapling and folding, paper on the stacker of the stacker unit is moved to an exclusive mechanism for stapling or folding. Therefore adjustment must be performed individually for the folding stopping position of the stacker and the stapling stopping position.

*Check the folding position at the centerfold page of the sample.

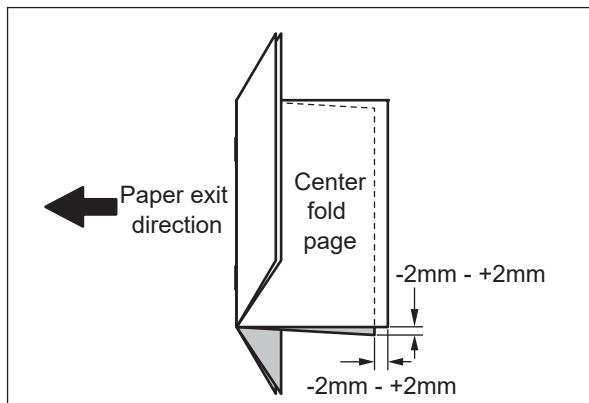

Fig.6-151

* Check the stapling position at the centerfold page of the sample.

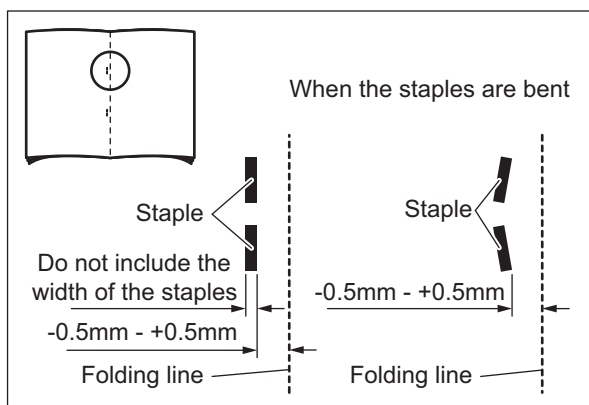
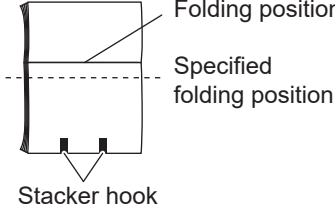
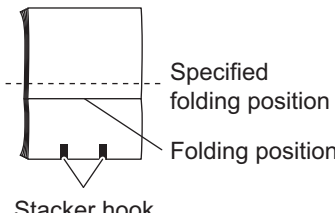
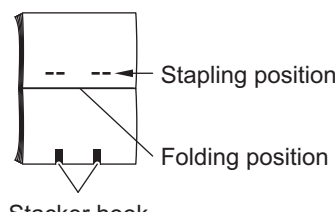
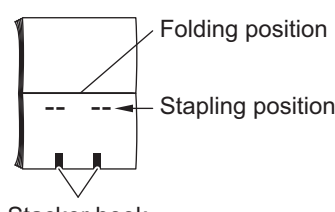

Fig.6-152

Notes:

Perform adjustment for the folding position first because the stapling position must be adjusted referring to the folding line.

Phenomenon	Contents	Adjustment
 <p>Folding position</p> <p>Specified folding position</p> <p>Stacker hook</p> <p>Fig.6-153</p>	<p>When the folding position is deviated from the specified one by more than -2.0 mm</p>	<p>Increase the value of the folding position adjustment in order to move the folding stopping position (the position of the stacker hooks) of the stacker upward.</p> <p>📖 P. 6-160 "[A] Adjustment with self-diagnostic mode"</p>
 <p>Specified folding position</p> <p>Folding position</p> <p>Stacker hook</p> <p>Fig.6-154</p>	<p>When the folding position is deviated from the specified one by more than 2.0 mm</p>	<p>Decrease the value of the folding position adjustment in order to move the folding stopping position (the position of the stacker hooks) of the stacker downward.</p> <p>📖 P. 6-160 "[A] Adjustment with self-diagnostic mode"</p>
 <p>Stapling position</p> <p>Folding position</p> <p>Stacker hook</p> <p>Fig.6-155</p>	<p>When the stapling position is deviated from the specified one more than -0.50 mm</p>	<p>Decrease the value of the stapling position adjustment in order to move the stapling stopping position (the position of the stacker hooks) of the stacker downward.</p> <p>📖 P. 6-160 "[A] Adjustment with self-diagnostic mode"</p>
 <p>Folding position</p> <p>Stapling position</p> <p>Stacker hook</p> <p>Fig.6-156</p>	<p>When the stapling position is deviated from the specified one more than 0.50 mm</p>	<p>Increase the value of the stapling position adjustment in order to move the stapling stopping position (the position of the stacker hooks) of the stacker upward.</p> <p>📖 P. 6-160 "[A] Adjustment with self-diagnostic mode"</p>

6.18.4 Folding position adjustment

[A] Adjustment with self-diagnostic mode

Perform the adjustment from the connected equipment.

If the adjustment values can be confirmed from the pre-change board, check them from the connected equipment and then set them into the post-change board.

LD-size and A3-size adjustment value check: Perform FS-05-4838-6.

LG-size, B4-size, A4R-size, and 8K-size adjustment value check: Perform FS-05-4838-7.

Item to be adjusted		Code	Remarks
Saddle stitch folding position	A3,LD	FS-05-4838-6	Adjusts the saddle stitch folding position in the paper feeding direction. When a positive value is set, it shifts toward the trailing edge of the paper (stacker hook side). When a negative value is set, it shifts toward the leading edge of the paper. 0: Finisher not installed 1: -1.4mm, 2: -1.2mm, 3: -1.0mm, 4: -0.8mm, 5: -0.6mm, 6: -0.4mm, 7: -0.2mm, 8: 0.0mm, 9: +0.2mm, 10: +0.4mm, 11: +0.6mm, 12: +0.8mm, 13: +1.0mm, 14: +1.2mm, 15: +1.4mm
	Other than A3 and LD	FS-05-4838-7	

6.18.5 Stapling position adjustment

[A] Adjustment with self-diagnostic mode

Perform the adjustment from the connected equipment.

If the adjustment values can be confirmed from the pre-change board, check them from the connected equipment and then set them into the post-change board.

LD-size and A3-size adjustment value check: Perform FS-05-4838-4.

LG-size, B4-size, A4R-size, and 8K-size adjustment value check: Perform FS-05-4838-5.

Item to be adjusted		Code	Remarks
Saddle stitch stapling position	A3,LD	FS-05-4838-4	Adjusts the saddle stitch stapling position in the paper feeding direction. When a positive value is set, it shifts toward the trailing edge of the paper (stacker hook side). When a negative value is set, it shifts toward the leading edge of the paper. 0: Finisher not installed 1: -2.8mm, 2: -2.4mm, 3: -2.0mm, 4: -1.8mm, 5: -1.2mm, 6: -0.8mm, 7: -0.4mm, 8: 0.0mm, 9: +0.4mm, 10: +0.8mm, 11: +1.2mm, 12: +1.6mm, 13: +2.0mm, 14: +2.4mm, 15: +2.8mm
	Other than A3 and LD	FS-05-4838-5	

6.18.6 Saddle stitch skew adjustment

Perform this adjustment when the folding position for saddle stitching is tilted.

- (1) Turn OFF the power of the equipment.
- (2) Open the cover, pull out the saddle stitch section, and then loosen the 2 screws.

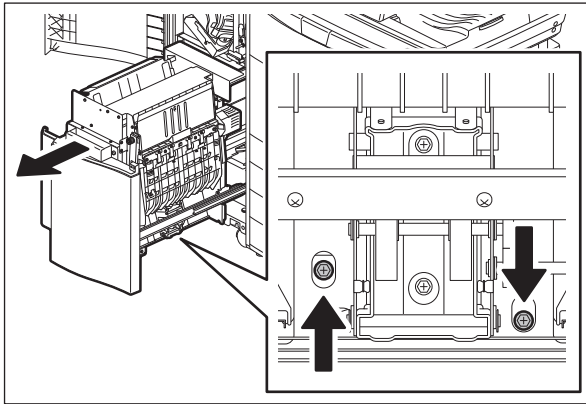

Fig.6-157

- (3) Rotate the adjustment screw slightly.

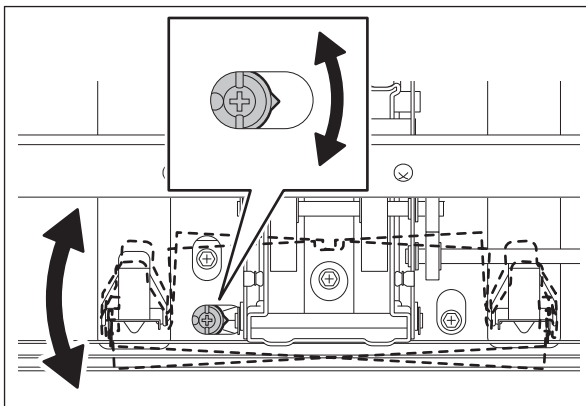

Fig.6-158

- (4) Tighten the 2 screws, return the saddle stitch section, and then close the cover.

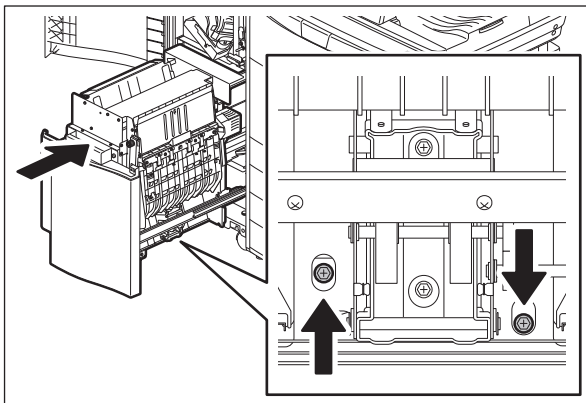

Fig.6-159

6.19 Adjustment of Hole punch unit

6.19.1 Destination setting of hole punch control PC board

This setting is performed when the hole punch control PC board (HP) [1] is replaced with a DIP switch [2] on it.

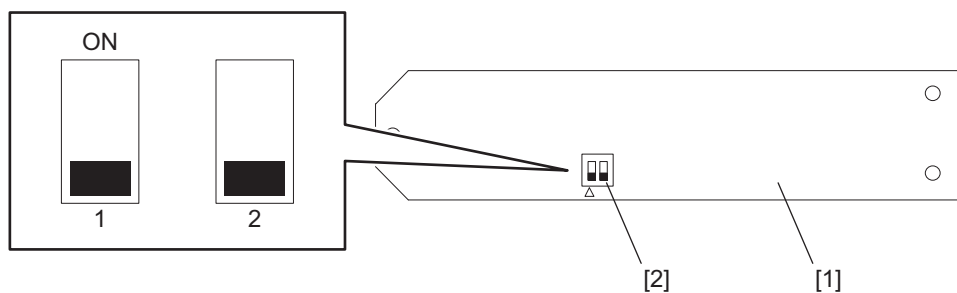

Fig.6-160

Refer to the table below for the destination settings.

Destination	Number of punch holes	DIP switch	
		1	2
MJ-6011E (Europe/Japan/China)	2 holes	OFF	OFF
MJ-6011N (North America)	2/3 holes	ON	OFF
MJ-6011F (France)	4 holes	OFF	ON
MJ-6011S (Sweden)	4 holes	ON	ON

6.19.2 Stopping position adjustment (MJ-6105)

This adjustment can change the position where paper transport stops during the punching operation. Perform this adjustment when you adjust the punching position on the paper in the transporting direction.

[A] Adjustment with self-diagnostic mode

Item to be adjusted	Code	Remarks
Hole punch position	FS-05-4838-0	Adjusts the hole punch position in the paper feeding direction. When a positive value is set, it shifts toward the feeding side. When a negative value is set, it shifts toward the exit side. 0: Finisher not installed 1: -1.10mm, 2: -0.88mm, 3: -0.66mm, 4: -0.44mm, 5: -0.22mm, 6: 0.00mm, 7: +0.22mm, 8: +0.44mm, 9: +0.66mm, 10: +0.88mm, 11: +1.10mm

[B] Adjustment with DIP-SW

If the adjustment values can be confirmed from the pre-change board, check them from the connected equipment and then set them into the post-change board.

Adjustment value check: Perform FS-05-4838-0.

If the adjustment values cannot be confirmed, perform the adjustment in the following procedure.

- (1) Turn the power of the equipment OFF.
- (2) Take off the board access cover [1] of the Finisher. Then set SW1 (DIP-SW) [2] on the finisher control PC board as shown below.

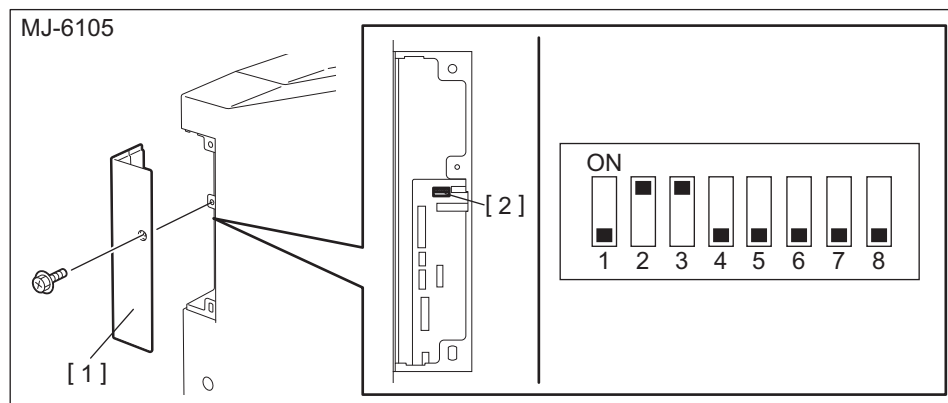

Fig.6-161

- (3) Turn the power of the equipment ON. The finisher enters into the stopping position adjustment mode.
- (4) LED1 on the finisher control panel blinks. The number of times it blinks indicates the current adjustment value.

- (5) Press Button1 on the finisher control panel to change the adjustment value. The number of times LED1 blinks changes in ascending order (e.g. 1, 2, 3... 11) each time you press Button1.

Number of LED1's blinking	Adjustment Value (Steps from the center value)	Distance from the center value
1	-5	1.10 mm
2	-4	0.88 mm
3	-3	0.66 mm
4	-2	0.44 mm
5	-1	0.22 mm
6	0	0 mm (Center value)
7	+1	0.22 mm
8	+2	0.44 mm
9	+3	0.66 mm
10	+4	0.88 mm
11	+5	1.10 mm

Notes:

When the adjustment value goes further in minus numbers in the table above, the distance between the paper edge and the holes becomes wider. When it goes further in plus numbers, this distance becomes narrower.

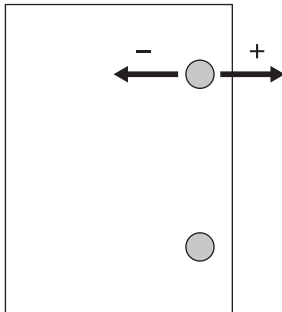

- (6) When the value change is completed, press Button2 on the finisher control panel to determine the adjustment value. (The adjustment value is written into the flash ROM.)
- (7) Turn the power of the equipment OFF.
- (8) Turn all the bits of SW1 (DIP-SW) on the finisher control PC board OFF.
- (9) Install the board access cover of the Finisher.

7. PREVENTIVE MAINTENANCE (PM)

7.1 General Description

The purpose of preventive maintenance (PM) is to maintain the quality level of this equipment by periodically inspecting and cleaning this equipment and also replacing the parts whose replacement timing has come according to the maintenance contract. There are PM kits packaged for each unit or a group of parts with the same replacement number of output pages, allowing you to carry out efficient parts replacement.

7.2 PM Display

7.2.1 General description

The maintenance timing for the PM parts of the process unit, such as the drum and developer material, and the PM parts of the units other than the process unit, such as the 2nd transfer roller varies depending on the conditions of the use, such as the ratio of color/black printing. Therefore, this equipment shows the appropriate maintenance timing of each part on the control panel LCD.

7.2.2 PM display conditions

The conditions of the PM display consist of the codes of the 08 SETTING MODE for “the setting value treated as a threshold of the PM display”, “the counter indicating the current number of prints and driving time” and “the setting value which determines the display conditions”.

The PM timing is displayed when the counter exceeds the setting value according to the display condition based on “the setting value which determines the display conditions”.

- Setting value treated as a threshold of the PM display

Notes:

When “0” is entered as the setting value, PM timing is not displayed.

FS-08-6190: Setting value of PM counter [process unit (K)]

FS-08-6191: Setting value of PM time counter [process unit (K)]

FS-08-6192: Setting value of PM counter [process unit (Y)]

FS-08-6193: Setting value of PM time counter [process unit (Y)]

FS-08-5550: Setting value of PM counter [process unit (M)]

FS-08-5551: Setting value of PM time counter [process unit (M)]

FS-08-5552: Setting value of PM counter [process unit (C)]

FS-08-5553: Setting value of PM time counter [process unit (C)]

FS-08-5554: Setting value of PM counter [developer material (K)]

FS-08-5555: Setting value of PM time counter [developer material (K)]

FS-08-5556: Setting value of PM counter [developer material (Y)]

FS-08-5557: Setting value of PM time counter [developer material (Y)]

FS-08-5558: Setting value of PM counter [developer material (M)]

FS-08-5559: Setting value of PM time counter [developer material (M)]

FS-08-5560: Setting value of PM counter [developer material (C)]

FS-08-5561: Setting value of PM time counter [developer material (C)]

FS-08-5562: Setting value of PM counter [parts other than the PM parts of the process unit]

FS-08-5563: Setting value of PM time counter [parts other than the PM parts of the process unit]

- Counter indicating the current number of prints and driving time

FS-08-6194: Current value of PM counter [process unit (K)]

FS-08-6195: Current value of PM time counter [process unit (K)]

FS-08-6196: Current value of PM counter [process unit (Y)]

FS-08-6197: Current value of PM time counter [process unit (Y)]

FS-08-5564: Current value of PM counter [process unit (M)]

FS-08-5565: Current value of PM time counter [process unit (M)]

FS-08-5566: Current value of PM counter [process unit (C)]
FS-08-5567: Current value of PM time counter [process unit (C)]
FS-08-5568: Current value of PM counter [developer material (K)]
FS-08-5569: Current value of PM time counter [developer material (K)]
FS-08-5570: Current value of PM counter [developer material (Y)]
FS-08-5571: Current value of PM time counter [developer material (Y)]
FS-08-5572: Current value of PM counter [developer material (M)]
FS-08-5573: Current value of PM time counter [developer material (M)]
FS-08-5574: Current value of PM counter [developer material (C)]
FS-08-5575: Current value of PM time counter [developer material (C)]
FS-08-5576: Current value of PM counter [parts other than the PM parts of the process unit]
FS-08-5577: Current value of PM time counter [parts other than the PM parts of the process unit]

- Setting value which determines the display conditions

FS-08-6198: Switching of output pages/driving counts at PM [process unit (K)]
FS-08-5578: Switching of output pages/driving counts at PM [process unit (Y)]
FS-08-5579: Switching of output pages/driving counts at PM [process unit (M)]
FS-08-5580: Switching of output pages/driving counts at PM [process unit (C)]
FS-08-5581: Switching of output pages/driving counts at PM [developer material (K)]
FS-08-5582: Switching of output pages/driving counts at PM [developer material (Y)]
FS-08-5583: Switching of output pages/driving counts at PM [developer material (M)]
FS-08-5584: Switching of output pages/driving counts at PM [developer material (C)]
FS-08-5585: Switching of output pages/driving counts at PM [parts other than the PM parts of the process unit]

7.2.3 PM display contents

When the counter value exceeds the setting value, the equipment notifies you that the maintenance time has arrived by displaying the message “Time for periodic maintenance ****” on the control panel LCD. “****” in the message is a 4-digit hexadecimal number code. This number is allocated in the following manner, therefore the parts needing maintenance can be identified.

PM parts of the process unit (K): 0008
 PM parts of the process unit (Y): 0001
 PM parts of the process unit (M): 0002
 PM parts of the process unit (C): 0004
 Developer material (K): 0080
 Developer material (Y): 0010
 Developer material (M): 0020
 Developer material (C): 0040
 Parts other than the PM parts of the process unit: 0100

If multiple parts have reached the maintenance time, the sum of the corresponding code values listed above is displayed in hexadecimal numbers.

For example, if the PM parts of the process units (K) and (C) and the developer materials (K) and (C) reach the maintenance time, the 4-digit hexadecimal number code will be “00CC” in hexadecimal numbers: 0008+0004+0080+0040=00CC.

4th digit	3rd digit		2nd digit		1st digit	
None	Part (2nd transfer roller)		Developer material		Photoconductive drum	
	Hexadecimal number code	Explanation	Hexadecimal number code	Explanation	Hexadecimal number code	Explanation
Always “0”	0	No maintenance required	0	No maintenance required	0	No maintenance required
	1	Maintenance required	1	Y	1	Y
			2	M	2	M
			3	M+Y	3	M+Y
			4	C	4	C
			5	Y+C	5	Y+C
			6	C+M	6	C+M
			7	Y+M+C	7	Y+M+C
			8	K	8	K
			9	K+Y	9	K+Y
			A	K+M	A	K+M
			B	K+M+Y	B	K+M+Y
			C	K+C	C	K+C
			D	K+Y+C	D	K+Y+C
			E	K+C+M	E	K+C+M
		F	K+Y+M+C	F	K+Y+M+C	

7.2.4 Counter clearing

The counter indicating “current number of prints and driving time” used for the PM display function is reset by entering “0” in it or clearing it in the 20 PM support mode.

Notes:

Even if “0” is entered in the PM management setting value of the 08 SETTING MODE, the corresponding counter for the PM display is not reset. Be sure to clear the counter in the 20 PM support mode when the maintenance is finished.

The reset condition of each counter is as follows:

- FS-08-6194: Current value of PM counter [process unit (K)]
- FS-08-6195: Current value of PM time counter [process unit (K)]
When the current value of “CLEANER/DRUM/CHARGER (K)” on the main screen or “DRUM (K)” on the sub-screen in the 20 PM support mode is cleared, the counter is reset.
In addition, when the K-EPU is recognized as a new one by the K-EPU old/new detection switch, the counter is also reset.
- FS-08-6196: Current value of PM counter [process unit (Y)]
- FS-08-6197: Current value of PM time counter [process unit (Y)]
When the current value of “CLEANER/DRUM/CHARGER (Y)” on the main screen or “DRUM (Y)” on the sub-screen in the 20 PM support mode is cleared, the counter is reset.
In addition, when the Y-EPU is recognized as a new one by the Y-EPU old/new detection switch, the counter is also reset.
- FS-08-5564: Current value of PM counter [process unit (M)]
- FS-08-5565: Current value of PM time counter [process unit (M)]
When the current value of “CLEANER/DRUM/CHARGER (M)” on the main screen or “DRUM (M)” on the sub-screen in the 20 PM support mode is cleared, the counter is reset.
In addition, when the M-EPU is recognized as a new one by the M-EPU old/new detection switch, the counter is also reset.
- FS-08-5566: Current value of PM counter [process unit (C)]
- FS-08-5567: Current value of PM time counter [process unit (C)]
When the current value of “CLEANER/DRUM/CHARGER (C)” on the main screen or “DRUM (C)” on the sub-screen in the 20 PM support mode is cleared, the counter is reset.
In addition, when the C-EPU is recognized as a new one by the C-EPU old/new detection switch, the counter is also reset.
- FS-08-5568: Current value of PM counter [developer material (K)]
- FS-08-5569: Current value of PM time counter [developer material (K)]
When the current value of “DEVELOPMENT UNIT” on the main screen or “BLACK DEVELOPER (K)” on the sub-screen in the 20 PM support mode is cleared, the counter is reset.
In addition, when the K-EPU is recognized as a new one by the K-EPU old/new detection switch, or the auto-toner sensor adjustment is performed, the counter is also reset.
- FS-08-5570: Current value of PM counter [developer material (Y)]
- FS-08-5571: Current value of PM time counter [developer material (Y)]
When the current value of “DEVELOPMENT UNIT” on the main screen or “YELLOW DEVELOPER (Y)” on the sub-screen in the 20 PM support mode is cleared, the counter is reset.
In addition, when the Y-EPU is recognized as a new one by the Y-EPU old/new detection switch, or the auto-toner sensor adjustment is performed, the counter is also reset.

- FS-08-5572: Current value of PM counter [developer material (M)]
- FS-08-5573: Current value of PM time counter [developer material (M)]
When the current value of “DEVELOPMENT UNIT (M)” on the main screen or “MAGENTA DEVELOPER (M)” on the sub-screen in the 20 PM support mode is cleared, the counter is reset.
In addition, when the M-EPU is recognized as a new one by the M-EPU old/new detection switch, or the auto-toner sensor adjustment is performed, the counter is also reset.
- FS-08-5574: Current value of PM counter [developer material (C)]
- FS-08-5575: Current value of PM time counter [developer material (C)]
When the current value of “DEVELOPMENT UNIT” on the main screen or “CYAN DEVELOPER (C)” on the sub-screen in the 20 PM support mode is cleared, the counter is reset.
In addition, when the C-EPU is recognized as a new one by the C-EPU old/new detection switch, or the auto-toner sensor adjustment is performed, the counter is also reset.
- FS-08-5576: Current value of PM counter [parts other than the PM parts of the process unit]
- FS-08-5577: Current value of PM time counter [parts other than the PM parts of the process unit]
When the current value of “2nd TRANSFER” on the main screen or “2nd TRANSFER ROLLER” on the sub screen in the 20 PM support mode is cleared, the counter is reset.

7.3 General Descriptions for PM Procedure

(1) Preparation

- Ask the user about the current conditions of the equipment and note them down.
- Before starting maintenance, make some sample copies and store them.
- See the replacement record and check the parts to be replaced in the 20 PM SUPPORT MODE or 30 LIST PRINT MODE.
 - 20 PM SUPPORT MODE (FS-20)
 - 30 LIST PRINT MODE (FS-30-103)

UNIT	OUTPUT PAGES DEVELOP COUNTS	PM OUTPUT PAGES DEVELOP COUNTS	DRIVE COUNTS	PM DRIVE COUNTS
DRUM(K)	1957	1957	3940	170000
DRUM BLADE(K)	1957	1957	10870	170000
GRID(K)	1957	1957	10870	170000
MAIN CHARGER NEEDLE(K)	1957	1957	10870	170000
CHARGER CLEANING PAD(K)	1957	1957	10870	170000
DRUM(Y)	1077	1077	3766	170000
DRUM BLADE(Y)	1077	1077	3766	170000
GRID(Y)	1077	1077	3766	170000
MAIN CHARGER NEEDLE(Y)	1077	1077	3766	170000
CHARGER CLEANING PAD(Y)	1077	1077	3766	170000
DRUM(M)	1077	1077	9547	170000
DRUM BLADE(M)	1077	1077	9547	170000
GRID(M)	1077	1077	9547	170000
MAIN CHARGER NEEDLE(M)	1077	1077	9547	170000
CHARGER CLEANING PAD(M)	1077	1077	9547	170000
DRUM(C)	1077	1077	9547	170000
DRUM BLADE(C)	1077	1077	9547	170000
GRID(C)	1077	1077	9547	170000
MAIN CHARGER	1077	1077	9547	170000

Fig. 7-1

- Turn OFF the power and make sure to unplug the equipment.
- (2) Perform a preventive maintenance using the checklist.
 - (3) Plug in the equipment after the maintenance has been finished. Then turn ON the power and make some copies to confirm that the equipment is working properly.

7.4 PM Support Mode

7.4.1 General description

This equipment has a 20 PM support mode which enables you to confirm the use status of each part (the number of output pages or developed pages, and drive counts) requiring periodic replacement and also the replacement record, as well as resetting counter values efficiently. This record can be printed out in the list print mode.

7.4.2 Operational flow

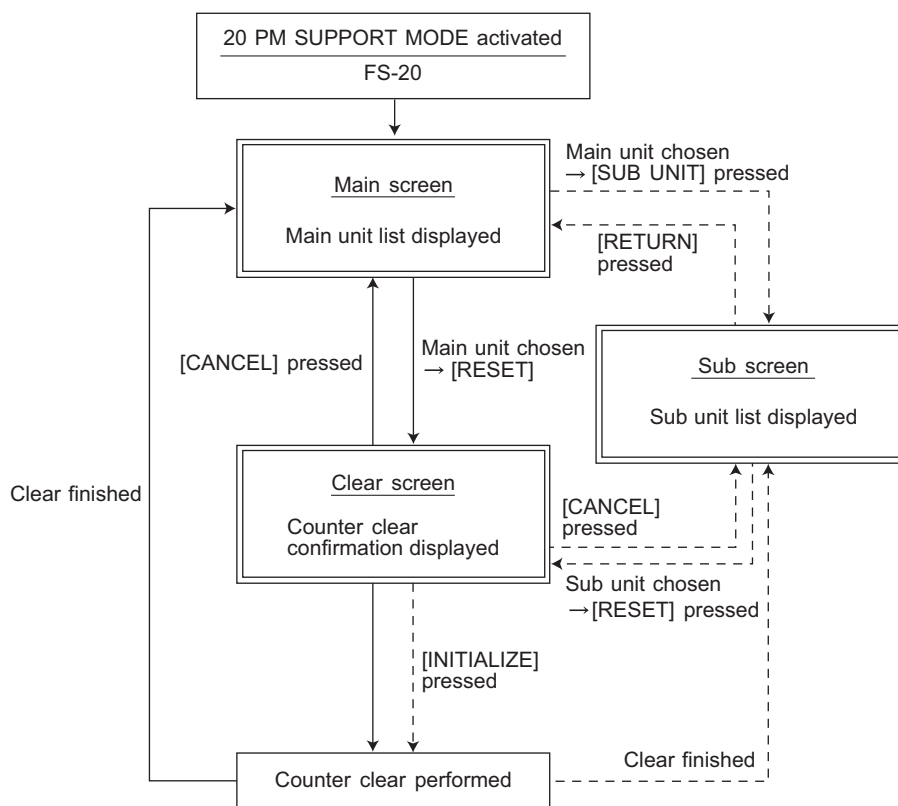

Fig. 7-2

- * When the authentication screen appears, press [OK]. (Enter the password, if one has been set.)
- * The screen goes back to the main screen when the counter clear is performed or the [CANCEL] button is pressed after moving from the main screen, while it goes back to the sub screen after moving from the sub screen.

7.4.3 Operational screen

The description of the display (including the function of each button) on the LCD screen is shown below.

[1] Main screen

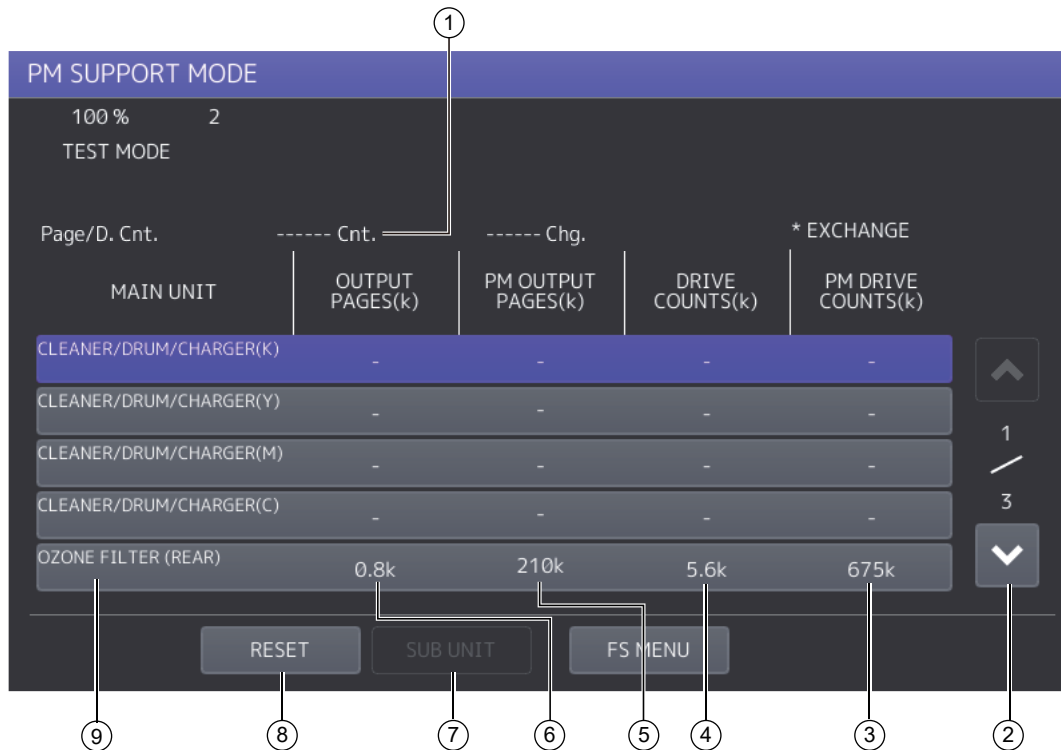

Fig. 7-3

1. Displaying of the number of print / develop pages (Page/D. cnt), drive counts (Cnt.) and previous replacement date (Chg.) for a chosen unit
When the replacement date for the sub unit is different, press the [SUB UNIT] button to move to the sub screen and see each information, otherwise information is not displayed
2. Moving to the next/previous page
3. Displaying of the standard number of drive counts to replace the unit parts
4. Displaying of the present drive counts
“*” is displayed next to the present number when the number of drive counts has exceeded its PM standard number.
5. Displaying of the standard number of print / develop pages to replace the unit parts
6. Displaying of the present number of print / develop pages
When there are differences among the sub units (parts), “_” is displayed and “CHECK SUBUNIT” is displayed at the top
“*” is displayed next to the present number when the number of print / develop pages has exceeded its PM standard number.
7. Moving to the sub screen of the selected unit
8. Moving to the clear screen to clear the selected unit counters 4 and 6, including all sub unit (parts) counters belonging to that unit. When the unit is not selected, all counters are cleared.
9. Displaying of the main unit name

Notes:

- “_” is always displayed at the drive counts section for the reversing automatic document feeder (RADF) and feed unit.
- “_” is displayed at the numeric section for the paper source which is not installed since the paper source is different depending on the structure of options.

[2] Sub screen

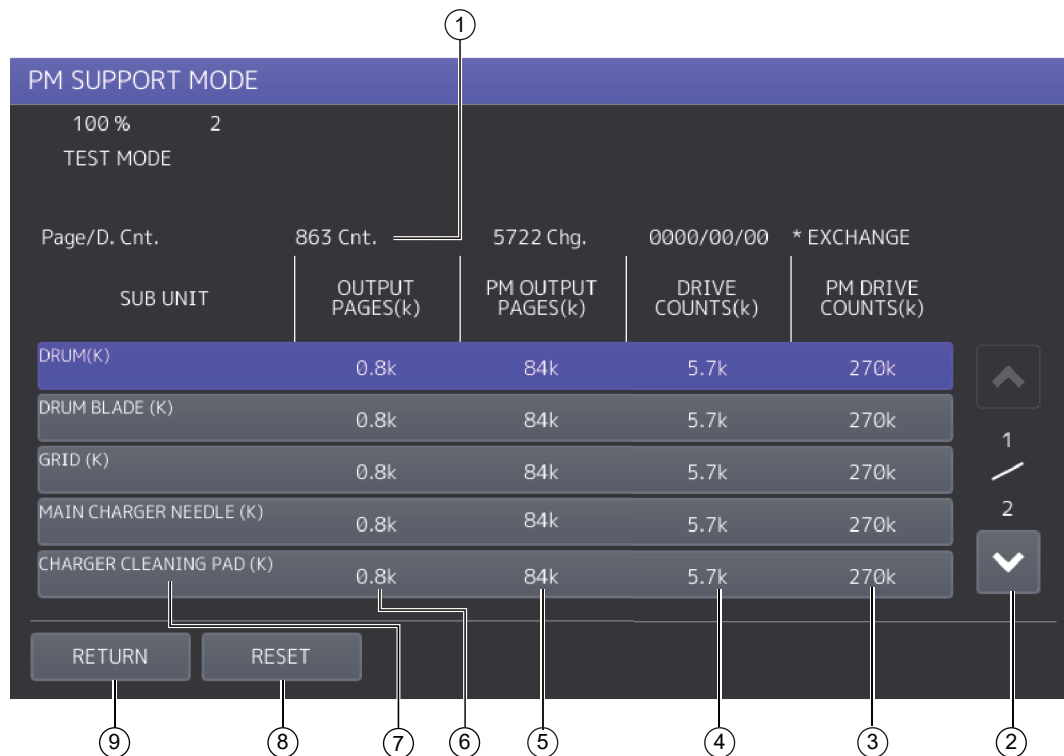

Fig. 7-4

1. Displaying of the number of print / develop pages and drive counts and previous replacement date for a chosen sub unit
2. Moving to the next/previous page
3. Displaying of the standard number of drive counts to replace the sub unit (parts)
4. Displaying of the present drive counts
 “*” is displayed next to the present number when the number of drive counts has exceeded its PM standard number.
5. Displaying of the standard number of print / develop pages to replace the sub unit (parts)
6. Displaying of the present number of print / develop pages
 “*” is displayed next to the present number when the number of print / develop pages has exceeded its PM standard number.
7. Displaying of the sub unit (parts) name
8. Moving to the clear screen to clear the selected unit (parts) counters
9. Back to the main screen

[3] Clear screen

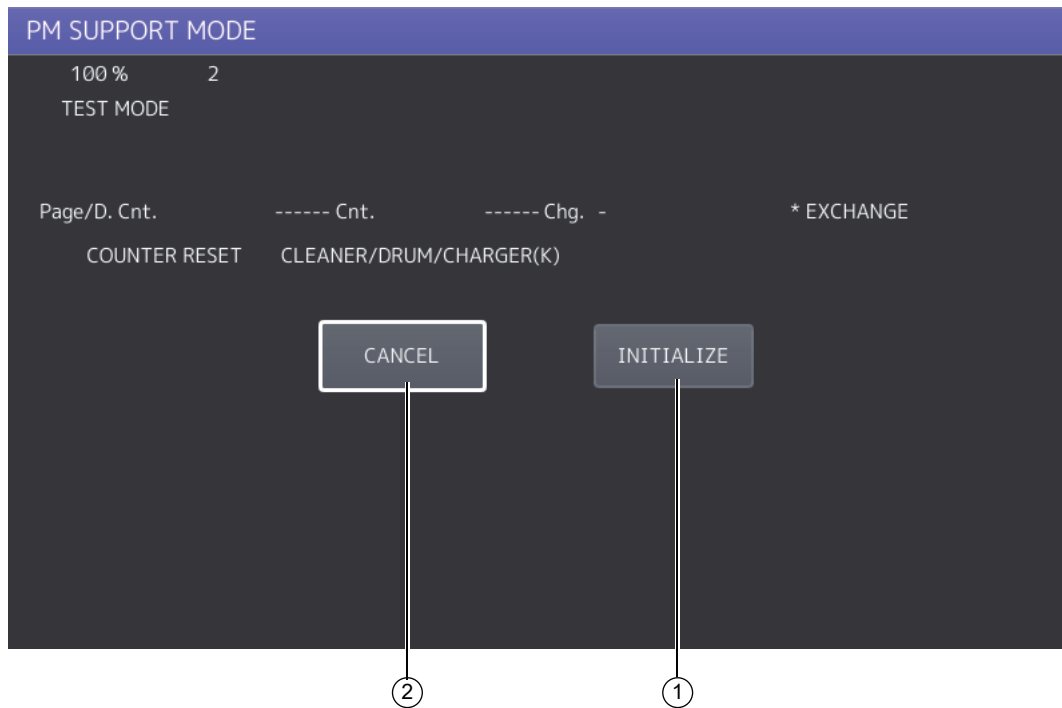

Fig. 7-5

1. When the [INITIALIZE] button is pressed, "Present number of print / develop pages" and Present driving counts" are cleared and "Previous replacement date" is updated.
2. When the [CANCEL] button is pressed, the counter is not cleared and the display returns to the main or sub screen.

7.4.4 Access tree

The relation between the main unit and the sub unit is shown below.

Notes:

Some parts in this manual are described with different names on the LCD screen. In this case, the name in this manual is indicated in square brackets [].

Main screen	Sub-screen
CLEANER/DRUM/CHARGER (K) [Process unit (K)]	DRUM (K) DRUM BLADE (K) [Drum cleaning blade] GRID (K) [Main charger grid] MAIN CHARGER NEEDLE (K) [Needle electrode] CHARGER CLEANING PAD (K) [Main charger cleaner] DRUM GAP SPACER (K)
CLEANER/DRUM/CHARGER (Y) [Process unit (Y)]	DRUM (Y) DRUM BLADE (Y) [Drum cleaning blade] GRID (Y) [Main charger grid] MAIN CHARGER NEEDLE (Y) [Needle electrode] CHARGER CLEANING PAD (Y) [Main charger cleaner] DRUM GAP SPACER (Y)
CLEANER/DRUM/CHARGER (M) [Process unit (M)]	DRUM (M) DRUM BLADE (M) [Drum cleaning blade] GRID (M) [Main charger grid] MAIN CHARGER NEEDLE (M) [Needle electrode] CHARGER CLEANING PAD (M) [Main charger cleaner] DRUM GAP SPACER (M)
CLEANER/DRUM/CHARGER (C) [Process unit (C)]	DRUM (C) DRUM BLADE (C) [Drum cleaning blade] GRID (C) [Main charger grid] MAIN CHARGER NEEDLE (C) [Needle electrode] CHARGER CLEANING PAD (C) [Main charger cleaner] DRUM GAP SPACER (C)
OZONE FILTER [Ozone filter-1]	OZONE FILTER [Ozone filter-1]
DEVELOPMENT UNIT	BLACK DEVELOPER [Developer material K] YELLOW DEVELOPER [Developer material Y] MAGENTA DEVELOPER [Developer material M] CYAN DEVELOPER [Developer material C]
TRANSFER BELT CLEANER	BLET BLADE
2nd TRANSFER	2nd TRANSFER ROLLER
FUSER	FUSER BELT PRESS ROLLER PRESS ROLLER FINGER FUSER PAD SLIDE SHEET
1st CST. [1st drawer]	PICK UP ROLLER (1st CST.) FEED ROLLER (1st CST.) SEP ROLLER (1st CST.) [Separation roller]
2nd CST. [2nd drawer]	PICK UP ROLLER (2nd CST.) FEED ROLLER (2nd CST.) SEP ROLLER (2nd CST.) [Separation roller]
SFB [Bypass unit]	FEED ROLLER (SFB) SEP PAD (SFB) [Separation roller]
Document feeder [DF]	PICK UP ROLLER (DF) FEED ROLLER (DF) SEP ROLLER (DF) [Separation roller]
LCF	PICK UP ROLLER (LCF) FEED ROLLER (LCF) SEP ROLLER (LCF) [Separation roller]
3rd CST. [PPF upper drawer]	PICK UP ROLLER (3rd CST.) FEED ROLLER (3rd CST.) SEP ROLLER (3rd CST.) [Separation roller]

Main screen	Sub-screen
4th CST. [PFP lower drawer]	PICK UP ROLLER (4th CST.) FEED ROLLER (4th CST.) SEP ROLLER (4th CST.) [Separation roller]

Notes:

When the counter value of any of the pickup roller, feed roller and separation roller in each unit is reset, the value of the feeding retry counter is also reset simultaneously. When the [RESET] button is pressed after selecting the feed unit in the Main Screen, the value of the feeding retry counter is also reset simultaneously.

The feeding retry counter:

- 1st drawer: Reset the feeding retry counter (FS-08-6230)
- 2nd drawer: Reset the feeding retry counter (FS-08-6231)
- PFP upper drawer: Reset the feeding retry counter (FS-08-6232)
- PFP lower drawer: Reset the feeding retry counter (FS-08-6233)
- Bypass unit: Reset the feeding retry counter (FS-08-6234)
- LCF: Reset the feeding retry counter (FS-08-6235)

7.5 Work Flow of Parts Replacement

The life span of the parts changes depending on their general use, such as the ratio of the color/black printing or the adjustment for keeping the printing quality. Therefore, it is necessary to consider not only the number of print / develop pages but also the drive counts when deciding the timing for parts replacement. Even if the number of print / develop pages has reached the level of replacement, for instance, the part may still be usable with its drive counts not reaching the specified drive counts. On the other hand, the part may need replacement even if the number of print / develop pages has not reached the level of replacement with its driving time exceeding the specified drive counts. The life span of some parts such as feed roller is heavily dependent on the number of output pages rather than the drive counts.

The following work flow diagram shows how to judge the timing of replacement with the number of print / develop pages.

Example 1:

When the number of print / develop pages has reached the specified level

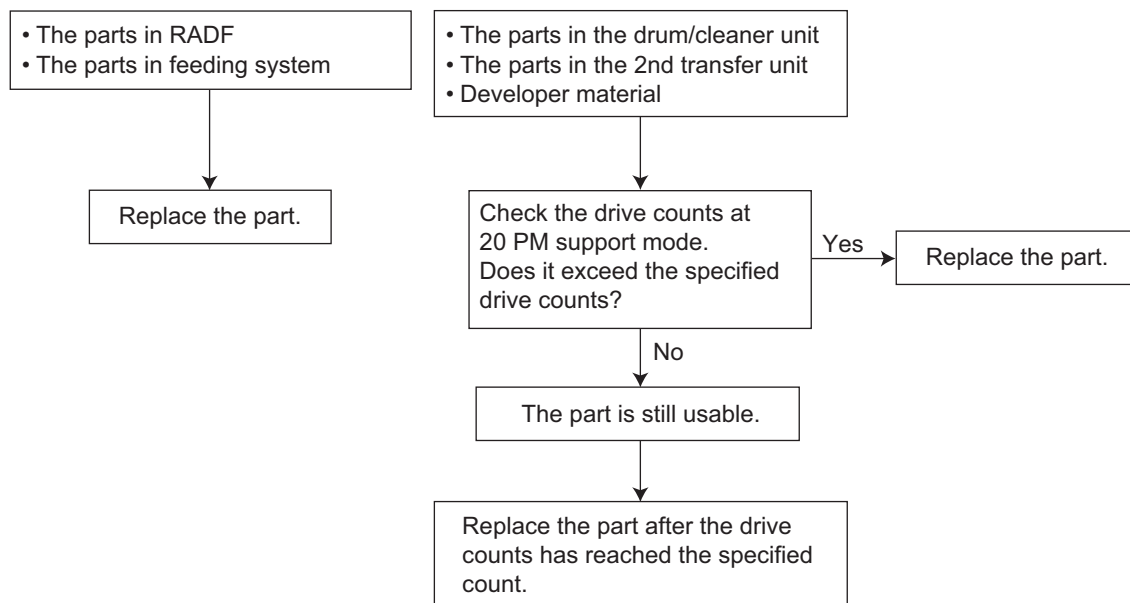

Fig. 7-6

Example 2:

When the image failure occurred before the number of print / develop pages has reached the specified level

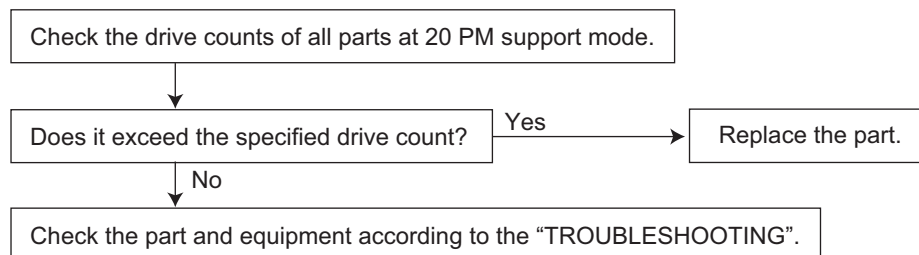

Fig. 7-7

7.6 Preventive Maintenance Checklist

The items to be checked in each unit at the time of preventive maintenance are as below.

Symbols/value used in the checklist

Item	Description
Cleaning	A: Clean with alcohol B: Clean with soft pad, cloth or vacuum cleaner
Lubrication/Coating	L: Launa 40 W1: White grease (Molykote EM-30L) W2: White grease (Molykote HP-300) AV: Alvania No.2 FL: FLOIL (GE-334C) C: Coating material (SANKOL CFD-409M)
Replacement	Value: Replacement cycle R1: Replacement R3: Replace if deformed or damaged.
Operation check	O: After cleaning or replacement, confirm there is no problem.

Notes:

- Perform cleaning and lubricating in the following timing. Lubricate the replacement parts according to the replacement cycle.

Model	Color	Black/white
25ppm	Every 75,000 sheets	Every 150,000 sheets
30ppm	Every 90,000 sheets	Every 180,000 sheets
35ppm	Every 105,000 sheets	Every 210,000 sheets
45ppm	Every 105,000 sheets	Every 210,000 sheets
50ppm	Every 105,000 sheets	Every 210,000 sheets

- The value in the “Replacement” field of the table in APPENDIX indicates the replacement number of output pages when those are all printed in either the black or the full color mode.
- The replacement cycle of the parts in the feeding section is determined by the number of sheets fed from each paper source.
- Be careful not to put oil on the rollers, belts and belt pulleys when lubricating.
- Parts list <P-I> represents the page item in “e-STUDIO2515AC/3015AC/3515AC/4515AC/5015AC Service Parts List”.

7.6.1 Scanner

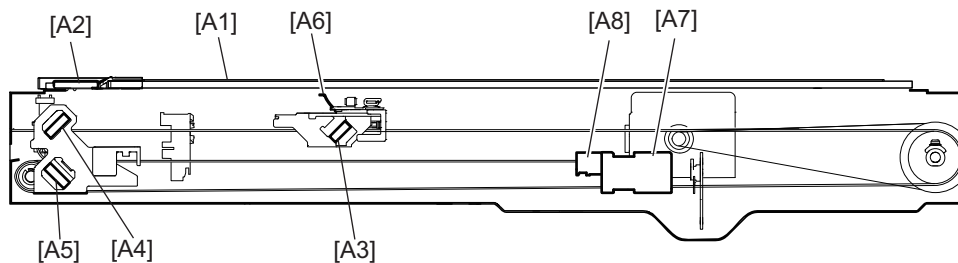

Fig. 7-8

For the items to check at the preventive maintenance, refer to “Appendix” - “Preventive Maintenance Checklist”.

- * A1: Original glass, A2: ADF original glass

Clean both sides of the original glass and ADF original glass. Also clean the film attached to the DF original glass in order to wipe off any dirt or paper dust. Make sure that there is no dust on the mirrors-1, -2, -3 and lens after cleaning. Then install the original glass and ADF original glass.

Notes:

Make sure that there is no fingerprints or oil staining on the glass surface underneath the original scale since it is the reading part of the shading correction plate.

Do not use such solvents as alcohol when cleaning the surface of the ADF original glass, because it is coated so as not to be scratched by originals.

When cleaning the original glass with alcohol, do so only for the stained areas because fog may appear.

7.6.2 Laser optical unit

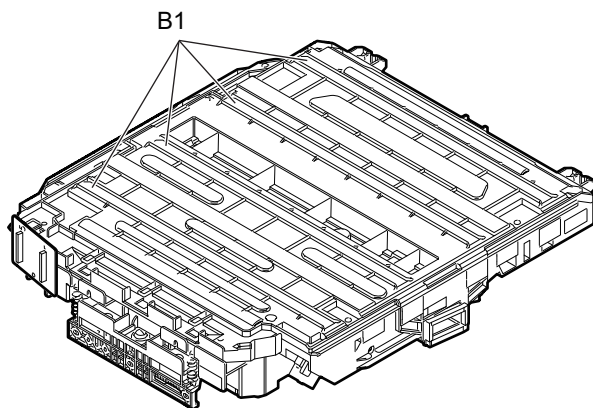

Fig. 7-9

For the items to check at the preventive maintenance, refer to “Appendix” - “Preventive Maintenance Checklist”.

- * B1: LSU slit glass

Clean the LSU slit glass with the LSU cleaner (green cleaner inside the front cover).

If dirt adheres to the LSU slit glass, clean it with alcohol, a soft pad, cloth or electric vacuum cleaner.

7.6.3 Feed unit

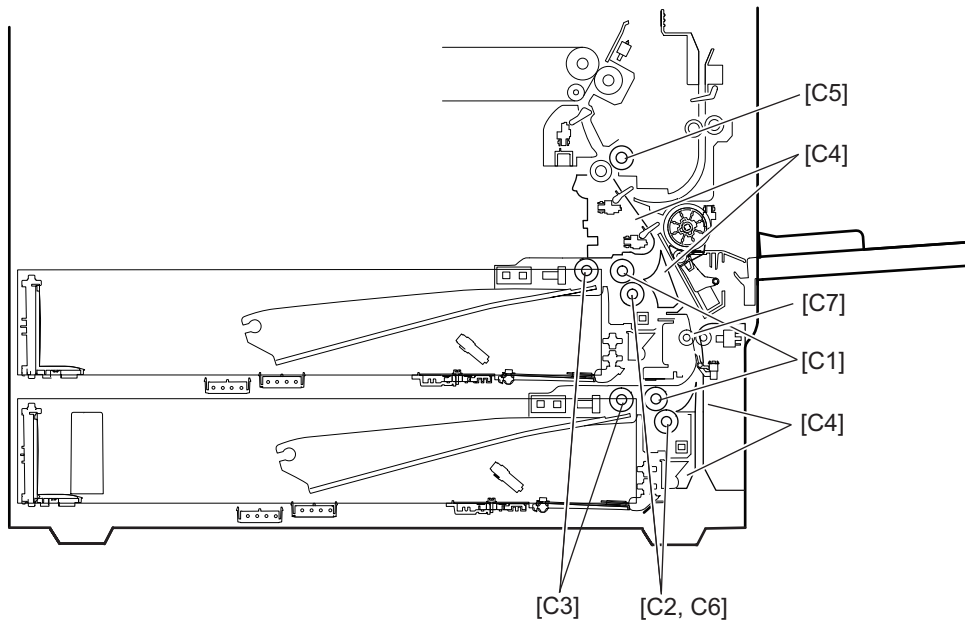

Fig. 7-10

For the items to check at the preventive maintenance, refer to “Appendix” - “Preventive Maintenance Checklist”.

- * C6: Separation roller guide
For lubrication, refer to the following.
 - 📖 P. 4-75 “4.5.15 1st drawer separation roller guide”
 - 📖 P. 4-78 “4.5.17 2nd drawer separation roller guide”

7.6.4 Automatic duplexing unit

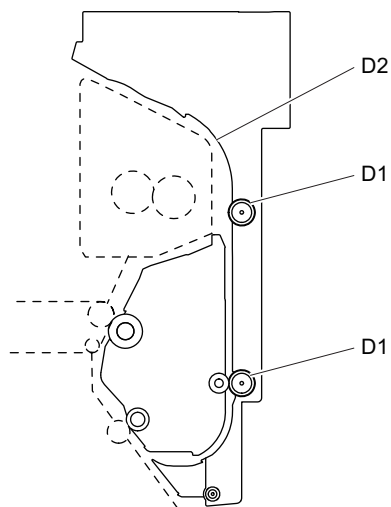

Fig. 7-11

For the items to check at the preventive maintenance, refer to “Appendix” - “Preventive Maintenance Checklist”.

7.6.5 Bypass feed unit

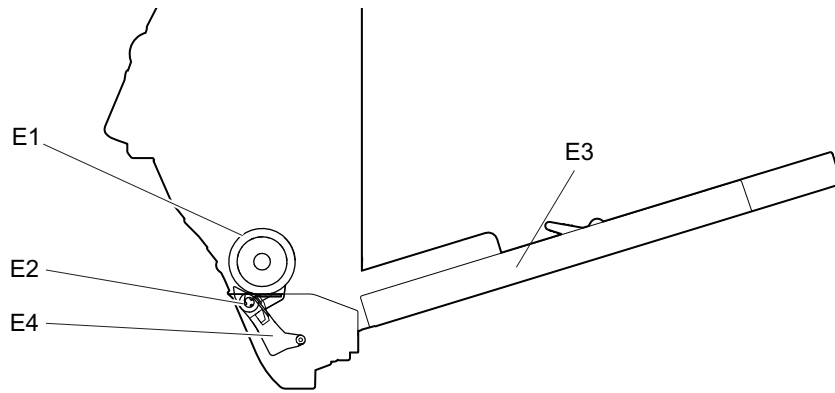

Fig. 7-12

For the items to check at the preventive maintenance, refer to “Appendix” - “Preventive Maintenance Checklist”.

7.6.6 Main charger

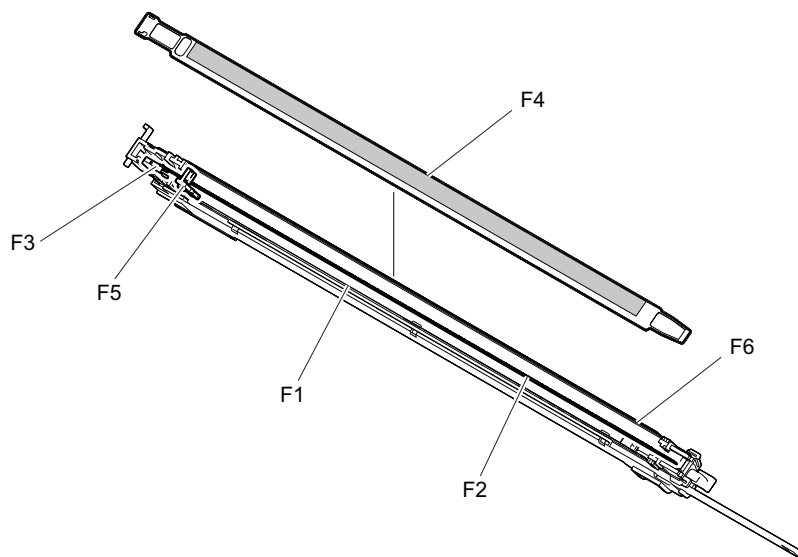

Fig. 7-13

For the items to check at the preventive maintenance, refer to “Appendix” - “Preventive Maintenance Checklist”.

* F1: Main charger case

Clean the main charger case and seal section of main charger duct with a cloth soaked in water and squeezed tightly, and then wipe them with a dry cloth.

7.6.7 Cleaner unit

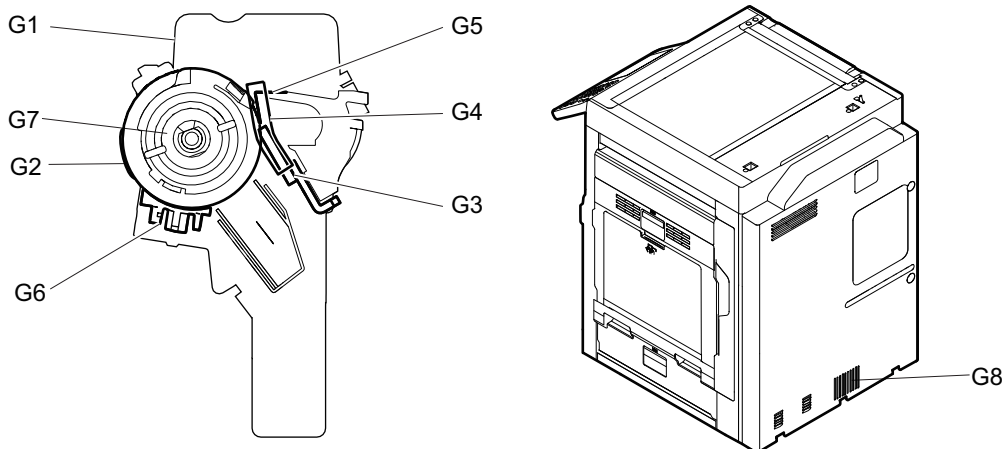

Fig. 7-14

For the items to check at the preventive maintenance, refer to “Appendix” - “Preventive Maintenance Checklist”.

* G2: Drum

• Handling precautions

If fingerprints or oil adhere to the surface of the drum, its properties may degrade, affecting the quality of the copy image. So, wear gloves to avoid touching the drum surface with your bare hands. Be sure to handle the drum carefully when installing and removing it so as not to damage its surface.

• Do not use “patting powder” (lubricant)

Since “patting powder” may affect the initial image if it adheres to the OPC surface, do not apply it. The friction between the drum and cleaning blade is sufficiently small without it and no problem would occur even if it is not applied.

• Clearing the drum counter

When the drum has been replaced with a new one, the drum counter “for the new drum (K, Y, M, C) must be cleared to 0 (zero). This clearing can be performed in PM support mode.

- Drum counter

Drum (K): FS-08-6250-0, 3, 6, 7

Drum (Y): FS-08-6252-0, 3, 6, 7

Drum (M): FS-08-6254-0, 3, 6, 7

Drum (C): FS-08-6256-0, 3, 6, 7

• Storage location of photoconductive drums

The drum should be stored in a dark place where the ambient temperature is between 10°C to 35°C (no condensation). Be sure to avoid places where drums may be subjected to high humidity, chemicals and/or their fumes.

Do not place the drum in a location where it is exposed to direct sunlight or high intensity light such as near a window. Otherwise the drum will fatigue, and will not produce sufficient image density immediately after being installed in the equipment.

• Cleaning the drum

At periodic maintenance calls, wipe the entire surface of the drum clean using the designated cleaning cotton. Note that there is no need to clean the surface of the new drum unless there is a problem. Use sufficiently thick cleaning cotton (dry soft pad) so as not to scratch the drum surface inadvertently with your fingertips or nails. Also, remove your rings and wristwatch before starting cleaning work to prevent accidental damage to the drum.

Do not use alcohol, selenium refresher and other organic solvents or silicon oil as they will have an adverse effect on the drum.

- Scratches on drum surface
If the surface is scratched in such a way that the aluminum substrate is exposed, no copy image will be produced on this area. In addition, the cleaning blade will be damaged so replacement with a new drum will be necessary.
- Collecting used drums
Regarding the recovery and disposal of used drums, follow the relevant local regulations or rules.

* G3: Drum cleaning blade

- Handling precautions
Pay attention to the following points as the cleaning blade life is determined by the condition of its edge. Replace the cleaning blade with new ones if poor images are copied due to the damaged blade regardless of the number of output pages which have been made.
 - Do not allow hard objects to hit or rub against blade edge.
 - Do not rub the edge with a cloth or soft pad.
 - Do not leave oil (or fingerprints, etc.) on the edge.
 - Do not apply solvents such as paint thinner to the blade.
 - Do not allow paper fibers or dirt to contact the blade edge.
 - Do not place the blade near a heat source.
- Cleaning procedure
Clean the blade edge with a cloth moistened with water and squeezed lightly.
Since the edge of the blade is vulnerable and can be easily damaged by factors such as the adherence of paper dust.

* G4: Side seal

When replacing the drum cleaning unit, check that there is no gap between the blade and side seals on both ends. If there is, or when the side seals put pressure to the cleaning blade, reattach the side seals on the position shown in the figure (by slightly pushing them to the direction of the arrows).



Fig. 7-15

- * G5: Recovery blade
Clean the surface of the recovery blade with a soft pad or cloth, if dirt cannot be removed with a vacuum cleaner. If the edge of recovery blade is damaged, replace the blade regardless of the number of output pages.

Notes:

Never use water or alcohol for cleaning the recovery blade.

- * G6: Drum gap spacer
When replacing the drum gap spacer, apply FLOIL (GE-334C) on the shaft of drum gap spacer.

7.6.8 Developer unit (K, Y, M, and C)

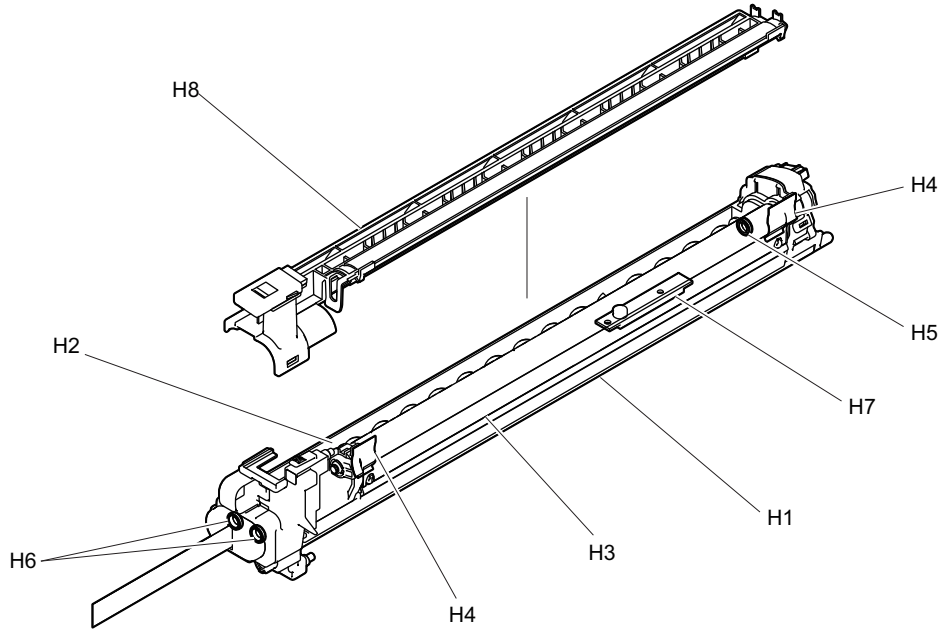

Fig. 7-16

For the items to check at the preventive maintenance, refer to “Appendix” - “Preventive Maintenance Checklist”.

- * H9: Developer drive unit
For lubrication, refer to the following.
 - 📖 P. 4-144 “4.6.25 Developer drive unit”
 - 📖 P. 4-161 “4.6.33 Developer drive gear”

* H1: Developer unit, H3: Front seal (unified with the doctor blade)

1. Cleaning

Clean the doctor blade so as to prevent developer material from adhering to it when the drum is being replaced.

Space the front seal from the developer sleeve and then insert a doctor blade cleaning jig into the doctor sleeve gap. Then clean the doctor blade by running the jig from one end to the other 3 times along with the edge of the blade.

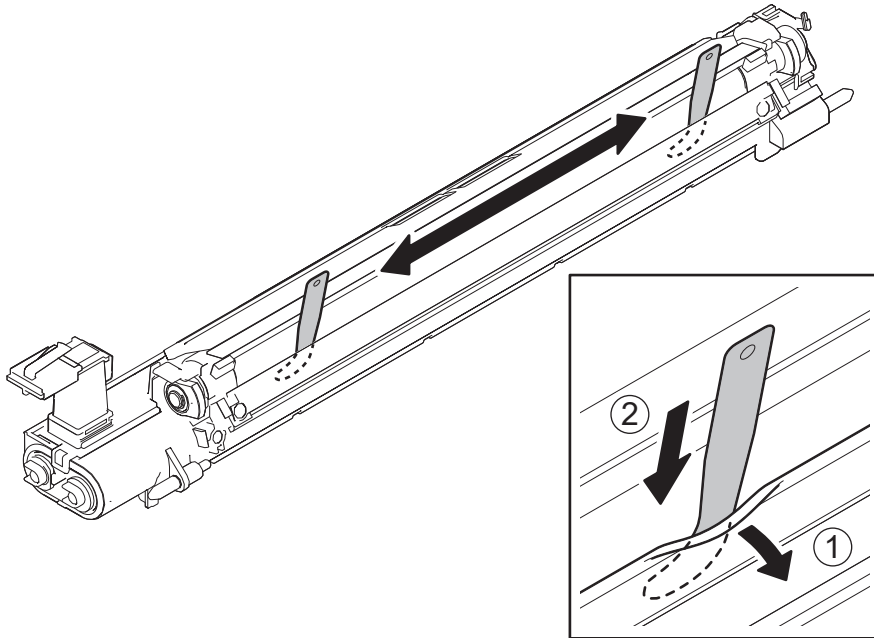

Fig. 7-17

2. Removal of foreign matter in the developer unit

(1) Take off the developer unit.

(2) Space the front seal.

(3) Insert the cleaning jig all the way in the developer unit at a position approx. 30 mm away from the white streak.

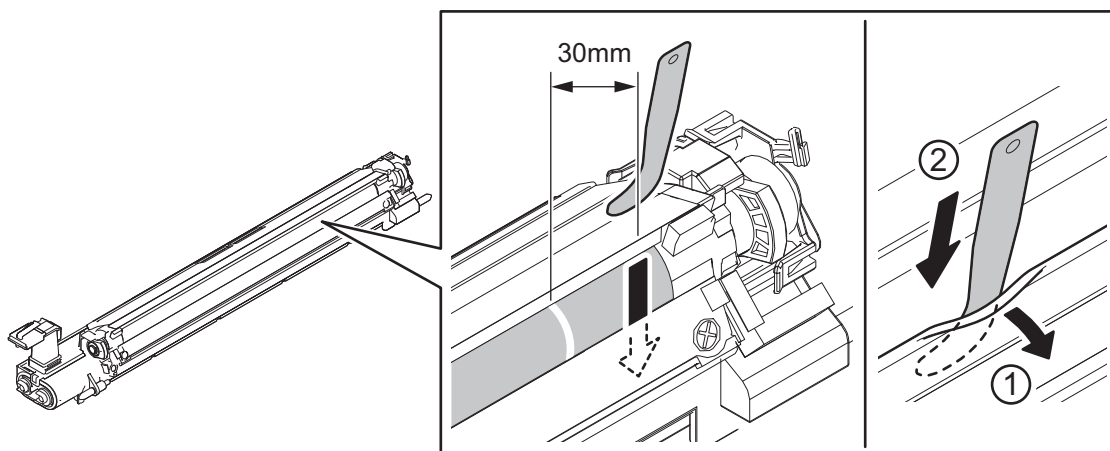

Fig. 7-18

- (4) Slide the cleaning jig to where the white streak appears.
- (5) Pull out the cleaning jig while manually turning the gear to rotate the developer sleeve.

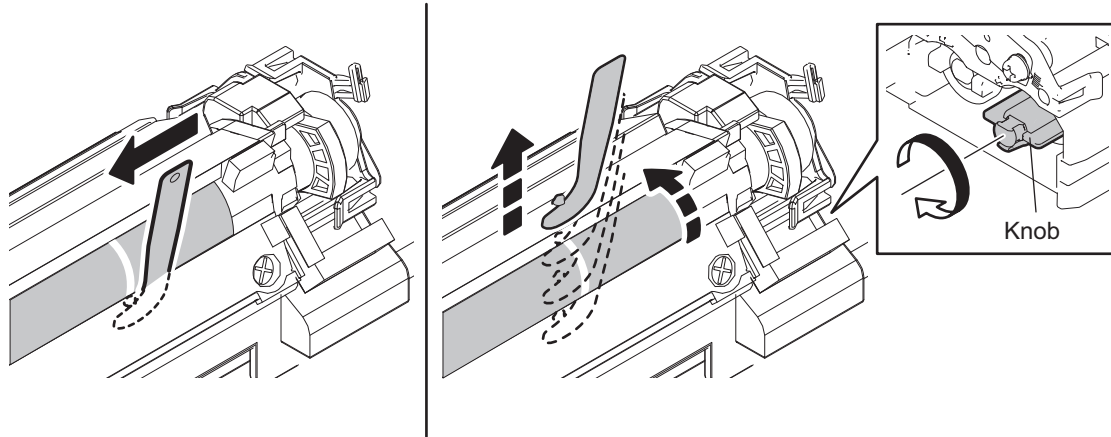

Fig. 7-19

Remarks:

If foreign matter is not removed by the above procedure, take off the developer unit, discharge the developer material on to a sheet of clean paper and then remove any foreign matter found. If you cannot find any foreign matter, exchange the developer material.

3. Removal of foreign matter on the developer sleeve

- (1) Apply a sheet of paper to the developer sleeve.
- (2) Scrape off foreign matter and developer material on the developer sleeve using the jig.

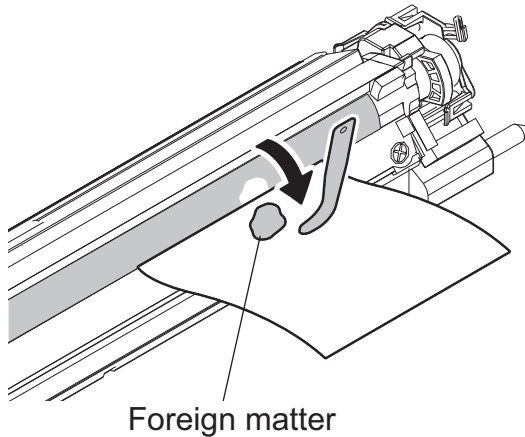

Fig. 7-20

4. Cleaning method by the doctor blade cleaning jig (PM) (during preventative maintenance)
- (1) Take off the developer unit.
📖 P. 4-109 “4.6.2 Process unit (Developer unit, Cleaner)”
 - (2) Discharge the developer material.
📖 P. 4-114 “4.6.3 Developer material”
 - (3) Insert A4 or LT plain paper between the developer sleeve (magnetic roller) [2] and the doctor blade [3]. Insert the paper until it is visible from the opposite side.

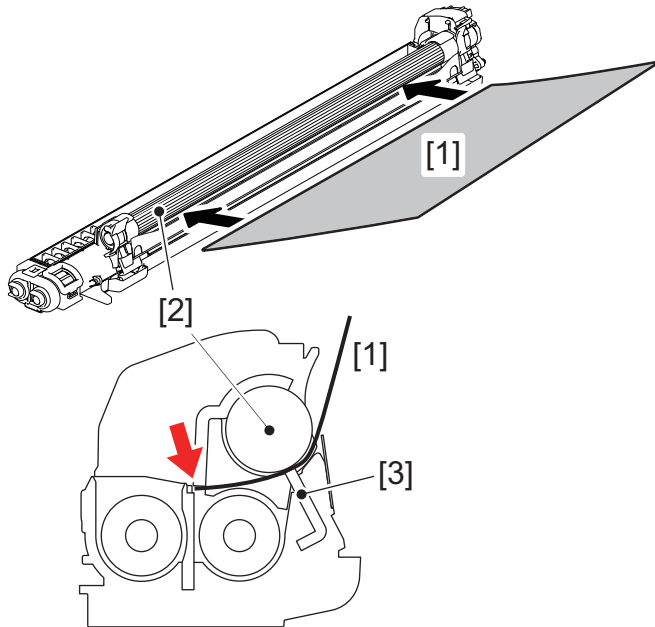

Fig. 7-21

Notes:

The paper must be inserted to protect the developer sleeve (magnetic roller). In addition, align the paper to the center of the developer sleeve (magnetic roller).

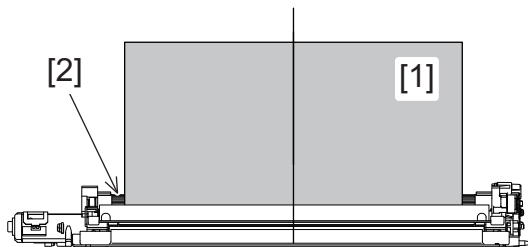

Fig. 7-22

(4) Put the paper over the developer sleeve (magnetic roller).

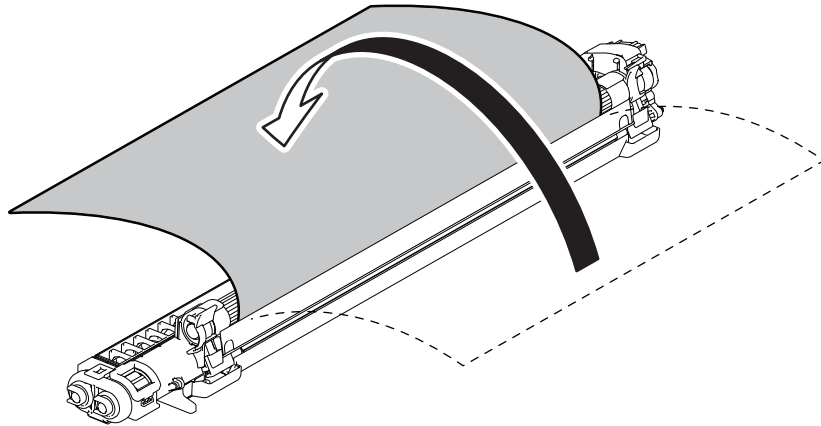

Fig. 7-23

(5) Raise the front seal and insert the doctor blade cleaning jig (PM) between the paper and the doctor blade.

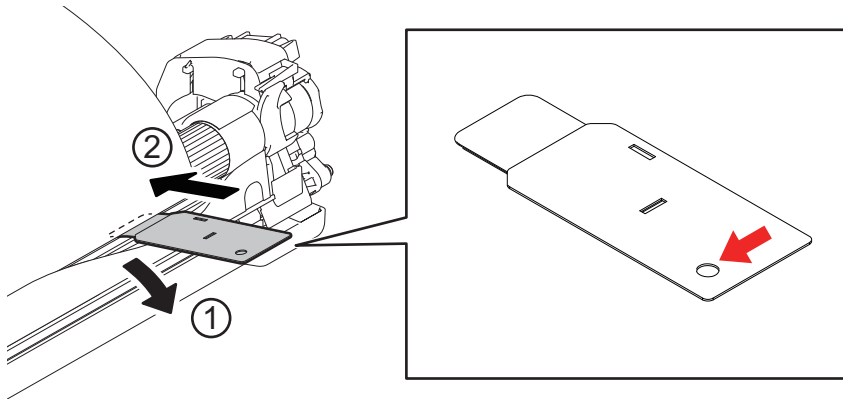

Fig. 7-24

Notes:

Be sure to make the cleaning surface downward at the doctor blade side. When the cleaning surface is downward, the hole position becomes on the left side as shown in the figure.

(6) While the jig is being inserted, it is hard to do so around the doctor blade. However, be sure to insert it until it reaches the end.

Insert reference: Until the narrow portion of the jig hides.

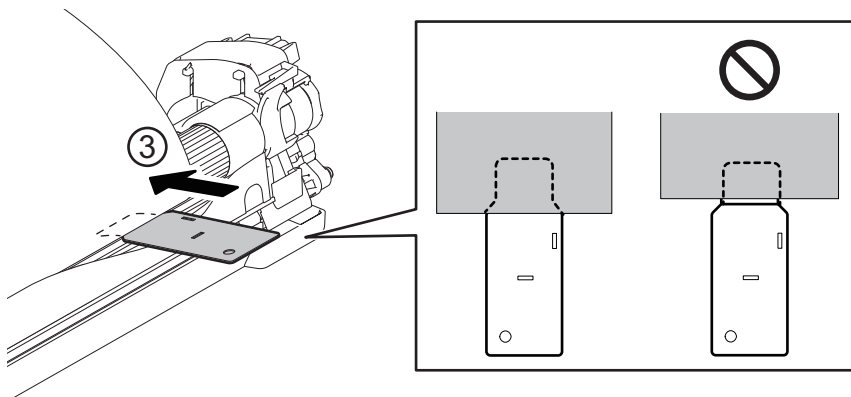

Fig. 7-25

(7) Slide the doctor blade cleaning jig (PM) from side to side once.

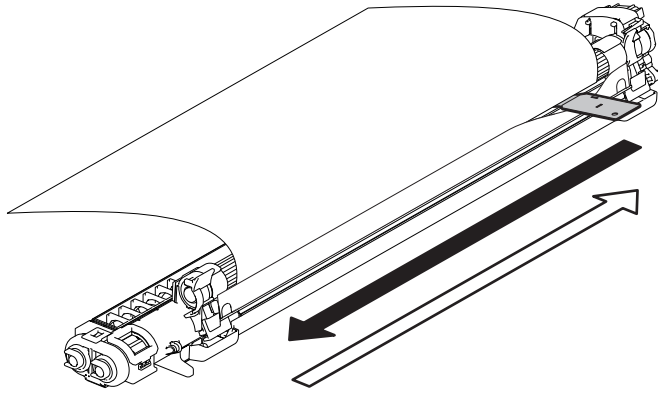

Fig. 7-26

Notes:

The slide range of the jig is within the width of the inserted paper.

(8) Remove the doctor blade cleaning jig (PM) and the paper.

* H2: Developer material

After replacing the developer material, be sure to perform the auto-toner adjustment and then image quality control initialization.

📖 P. 6-2 "6.1.2 Adjustment of the auto-toner sensor"

📖 P. 6-4 "6.1.3 Performing image quality control"

* H7: Auto-toner sensor

Clean the surface of the auto-toner sensor with a cotton swab or soft cloth with sufficient alcohol filled in.

7.6.9 Transfer belt unit / Transfer belt cleaning unit

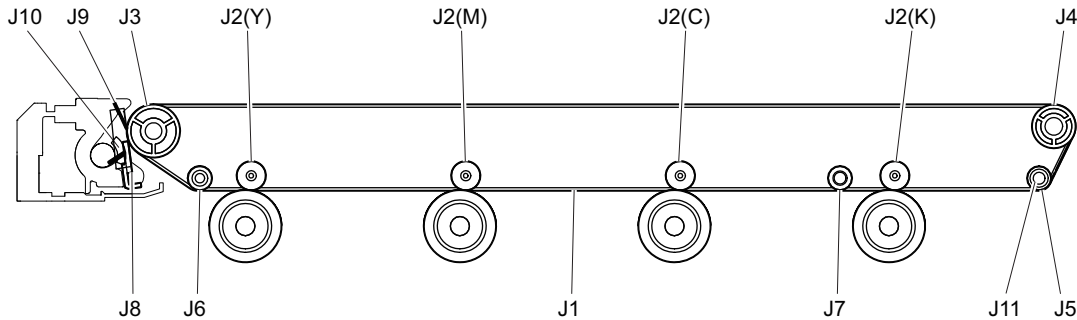

Fig. 7-27

For the items to check at the preventive maintenance, refer to “Appendix” - “Preventive Maintenance Checklist”.

- * J1: Transfer belt
 - Handling precautions
 - Do not touch the front and rear surfaces of the transfer belt surface with bare hands.
 - Prevent oil or other foreign matter from adhering to both surfaces of the transfer belt.
 - Do not apply external pressure that might scratch the transfer belt.
 - When replacing the belt and transfer belt cleaning unit, apply patting powder sufficiently and evenly. Otherwise, it may reduce the cleaning efficiency.
 - When replacing the transfer belt, clean J3, J4, J5, J6, and J7 with a solvent such as alcohol, and then attach the transfer belt.
 - Cleaning procedure

Fully clean up the toner and such adhering to the roller with alcohol, and then wipe it with a dry cloth until no trace remains. Take care not to have the transfer belt surface being damaged or dented. Replace the transfer belt with a new one regardless of the number of output pages, if any crack or major scar is found.
- * J2: 1st transfer roller

Since the sponge may be damaged, do not clean the surface of the roller. Clean the toner adhering to the power supplying part including springs with a solvent such as alcohol. When cleaning the spring, be careful not to deform it.
- * J3: Cleaning unit facing roller, J5: Belt clinging roller before 2nd transfer, J6: Lift roller, J7: Winding roller (K)

Fully clean up the toner and such adhering to the roller with alcohol since an image failure may occur if there is any dirt remaining on the roller. Also, remove dust and toner scattering adhering to the inside of the transfer belt unit in order to keep rollers clean.
- * J4: TBU drive roller

Clean up the toner adhering to the roller with alcohol.
- * J8: Transfer belt cleaning blade
 - Handling precautions

Pay attention to the following points as the cleaning blade life is determined by the condition of its edge.

- Do not allow hard objects to hit or rub against blade edge.
 - Do not rub the edge with a cloth or soft pad.
 - Do not leave oil (or fingerprints, etc.) on the edge.
 - Do not apply solvents such as paint thinner to the blade.
 - Do not allow paper fibers or dirt to contact the blade edge.
 - Do not place the blade near a heat source.
- Cleaning procedure
Clean the blade edge with a cloth moistened with water and squeezed lightly.

7.6.10 Image quality control unit

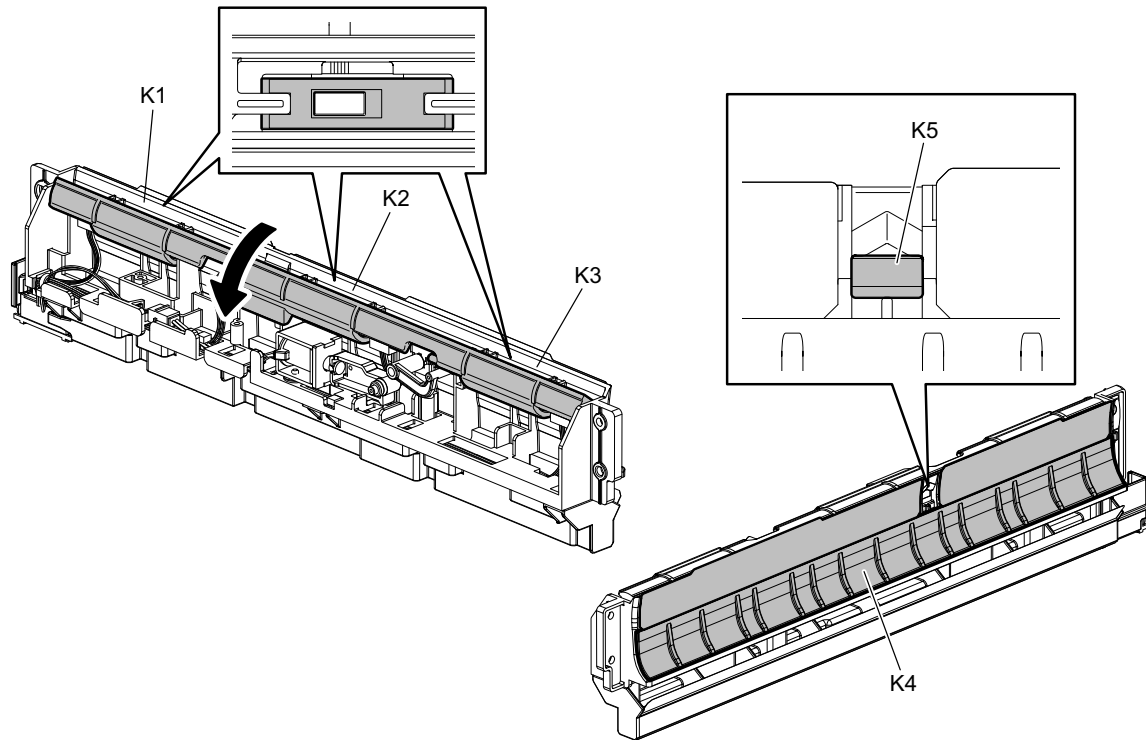

Fig. 7-28

For the items to check at the preventive maintenance, refer to “Appendix” - “Preventive Maintenance Checklist”.

- * K5: Registration pass sensor
If toner adheres to the registration pass sensor (paper contact side), clean it with a soft pad, cotton swab, cloth or electric vacuum cleaner.
Be careful not to touch the TBU during cleaning.

7.6.11 2nd transfer unit

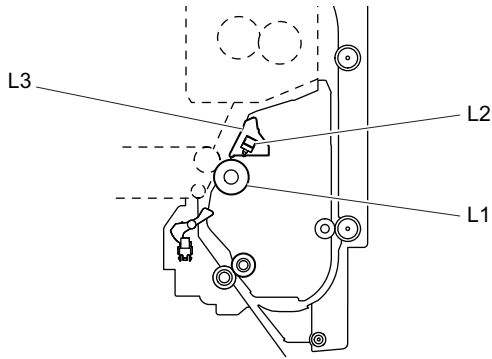

Fig. 7-29

For the items to check at the preventive maintenance, refer to “Appendix” - “Preventive Maintenance Checklist”.

- * L2: Paper clinging detection sensor
Open the 2nd transfer unit and clean the paper clinging detection sensor with a cotton swab.

Notes:

Be sure to clean the entire surface of the sensor.

- * L3: 2nd transfer roller paper guide
If toner adheres to the ribs of the 2nd transfer roller paper guide, clean it with a soft pad, cloth or electric vacuum cleaner.

7.6.12 Fuser unit

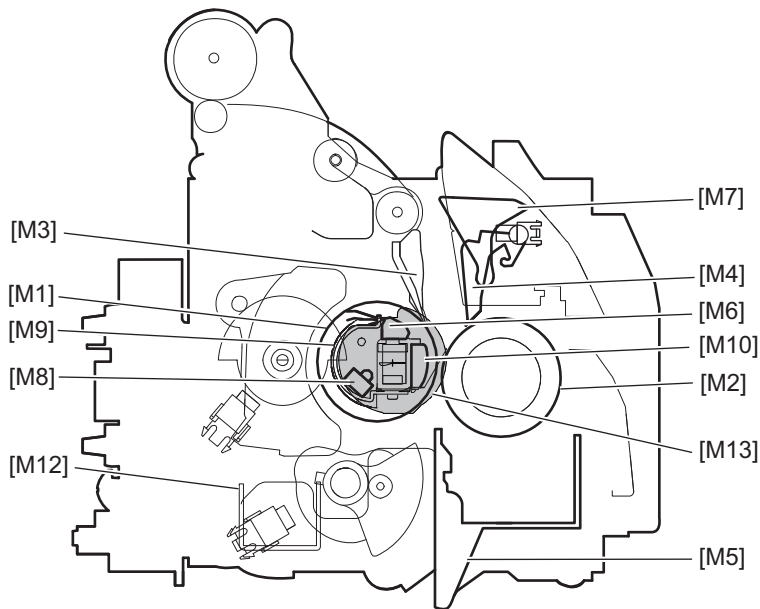

Fig. 7-30

For the items to check at the preventive maintenance, refer to “Appendix” - “Preventive Maintenance Checklist”.

- * M3: Separation guide
If toner adheres to the separation guide, wipe it off with a dry cloth.
Do not take off the separation guide unless otherwise required.
- * M4: Separation finger
The paper jam may be caused if the tip of the finger is damaged or deformed, or a dirt image caused by the finger occurs. If there is any problem with it, replace the finger with a new one regardless of the number of output pages which have been made. Do not damage the tip of the finger during the cleaning. The finger may be damaged if the toner adhering to the tip of it is scraped off forcibly. Replace the finger if the toner is sticking to it heavily.
- * M6, M8: Thermistor, Thermostat
Replace the thermistor or thermostat with a new one if it is damaged or deformed regardless of degree.
- * M7: Exit sensor actuator, M12: Fuser unit lower stay
If toner has adhered, wipe it off with alcohol.
- * M9: Fuser belt lubricating sheet
When replacing the sheet, apply grease on the entire surface of the sheet evenly. For lubrication, refer to P. 4-209 “4.9.11 Fuser belt lubricating sheet / Fuser belt pad”.
- * M11: Drive gear
For lubrication, refer to the following.
 P. 4-200 “4.9.8 Fuser belt”
 P. 4-212 “4.9.13 Pressure roller”

7.6.13 Paper exit section / Reverse section

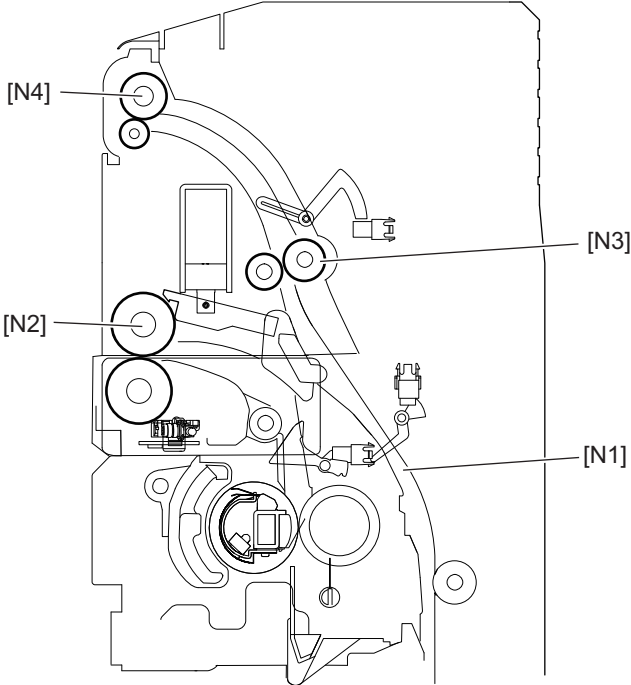

Fig. 7-31

For the items to check at the preventive maintenance, refer to “Appendix” - “Preventive Maintenance Checklist”.

7.6.14 DSDF

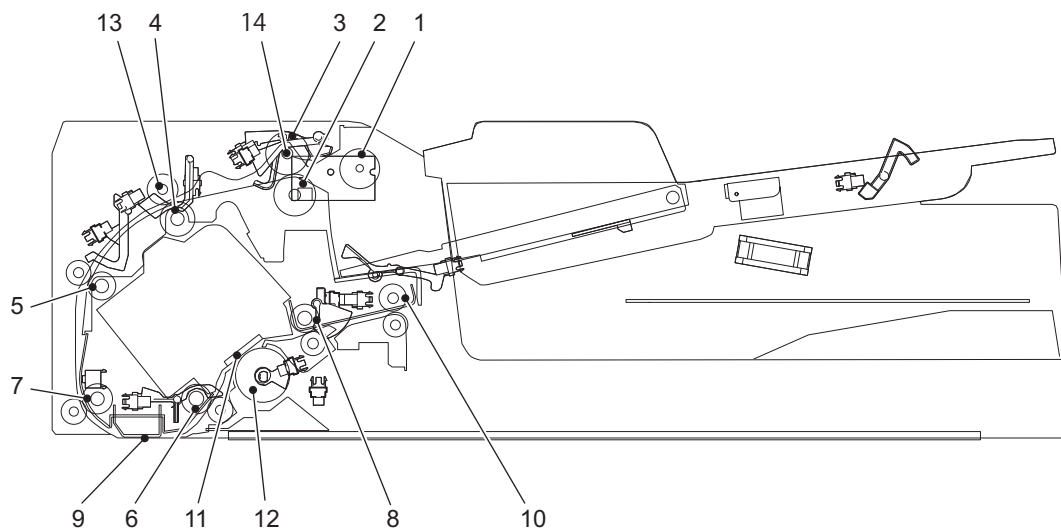

Fig. 7-32

	Items to check	Cleaning *1	Lubrication/ Coating *1	Replacement (x 1,000)	Operation check	Parts list <P-I>	Remarks
1	DSDF pickup roller	A		R1 120		1-18	*2
2	DSDF separation roller	A		R1 120		5-21	
3	DSDF feed roller	A		R1 120		1-14	
4	DSDF registration roller	A				7-14	
5	Pre-read roller-1	A				7-13	
6	Pre-read roller-2	A				7-21	
7	Post-read roller-1	A				14-12	
8	Post-read roller-2	A				11-15	
9	Reading guide	A				15-3	
10	DSDF exit roller	A				11-12	
11	DSDF-CCD original glass	B				5-22	
12	Shading plate	A				12-14	
13	Registration pinch roller shaft		W			4-2	
14	DSDF feed roller shaft		W			1-21	*3

* Page-Item (P-I) is described in the column of the Parts list.

*1: Perform cleaning / lubrication for the DSDF at the same interval as for the main equipment to which the DSDF is connected.

*2: When the DSDF pickup roller is replaced, clean its shaft holes in the DSDF pickup unit.

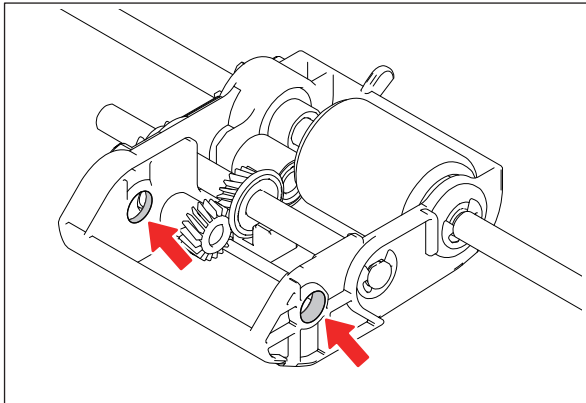

Fig. 7-33

*3: Remove the DSDF pickup unit. Release the hook. Remove the lever from the DSDF pickup unit. Apply grease (Molykote EM-30L) by 0.01 cc to the edge of the shaft. (See the figure below.)

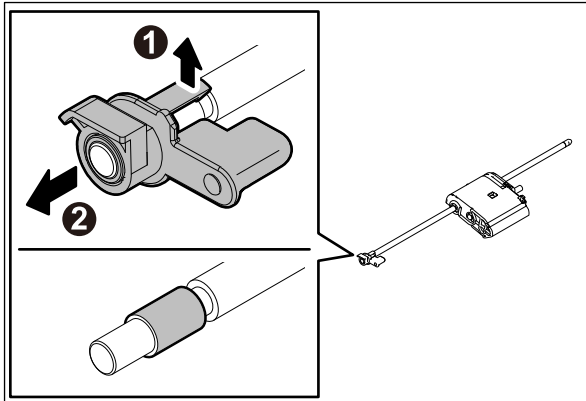

Fig. 7-34

7.6.15 RADF

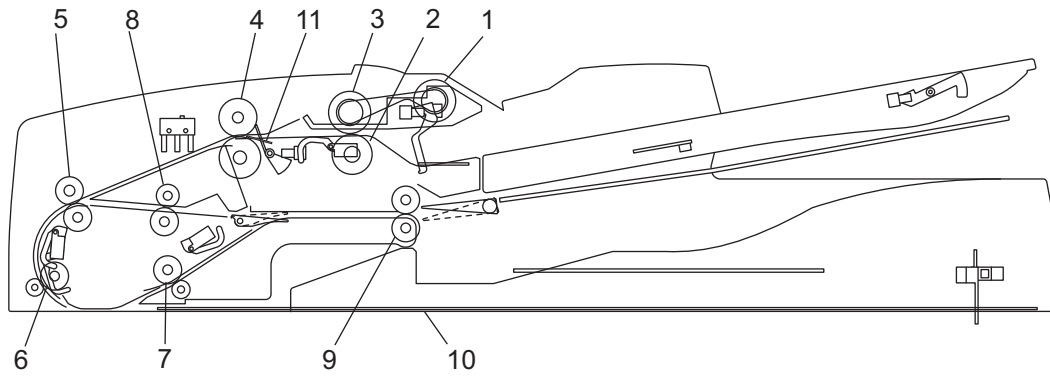

Fig. 7-35

Items to check		Cleaning	Lubrication/ Coating	Replacement		Operation check	Parts list <P-I>
				(x 1,000 sheets)	(x 1,000 drive counts)		
1	Pickup roller	A		R1 120	-		5-27
2	Separation roller	A		R1 120	-		4-10
3	Feed roller	A		R1 120	-		5-27
4	Registration roller	A					4-30
5	Intermediate transfer roller	A					3-13
6	Front read roller	A					3-14
7	Rear read roller	A					3-1
8	Reverse registration roller	A					3-10
9	Exit/reverse roller	A					4-25
10	Platen sheet	B or A					1-25
11	Registration roller front sheet*			R1 120			

* Registration roller front sheet: Attached on the feeder lower guide.

7.6.16 PFP

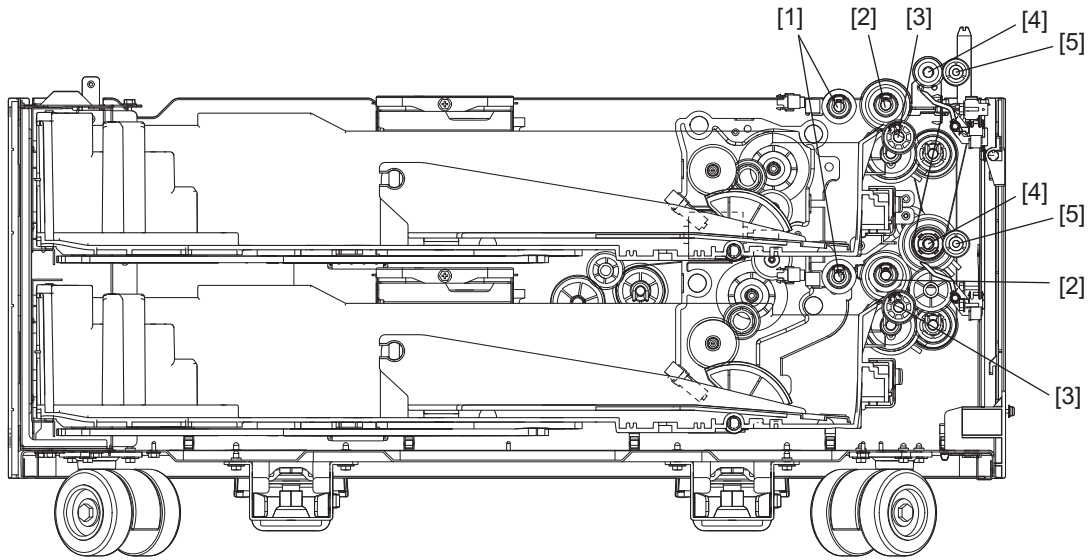

Fig. 7-36

Items to check		Cleaning	Lubrication/ Coating	Replacement		Operation check	Parts list <P-I>
				(x 1,000 sheets)	(x 1,000 drive counts)		
1	Pickup roller (upper/lower)	A		80 or every 2.5 years, whichever comes first			5-26
2	Feed roller (upper/lower)	A		80 or every 2.5 years, whichever comes first			5-26
3	Separation roller (upper/lower)	A		80 or every 2.5 years, whichever comes first			5-30
4	Transport roller (tooth face)	A		R			2-35 2-40
5	Idling roller (upper/lower) Clean the inner diameter of the idling roller and the shaft.	A	W1				4-2
6	Paper guide	B					4-1 4-11

7.6.17 LCF

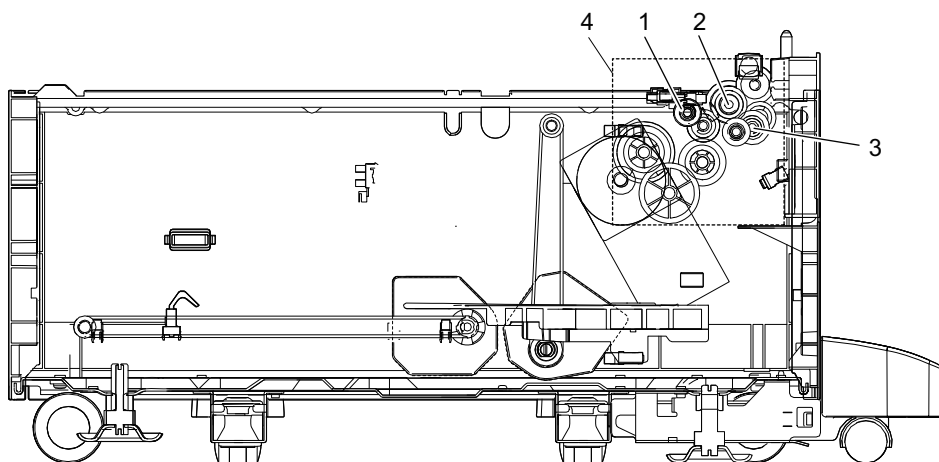

Fig. 7-37

Items to check		Cleaning	Lubrication/ Coating	Replacement		Operation check	Parts list <P-I>
				(x 1,000 sheets)	(x 1,000 drive counts)		
1	Pickup roller	A		160			4-4
2	Feed roller	A		160			4-3
3	Separation roller	A		160			5-8
4	Drive gear (tooth face)		W1				-

7.6.18 Inner finisher

Item	Interval	Description	Remarks
Transport roller	Every 30,000 of paper feeding times	Cleaning	Wipe with a cloth soaked in water and then tightly squeezed.
Small roller in the paper transport section			
Transport path and guides			
Transport path sensor			Wipe with a dry cloth.
Grease application to drive unit	As needed	Applying grease	EM-50L
Paper detection sensor	Minimum maintenance interval set for the equipment	Cleaning	Wipe with a dry cloth or alcohol

7.6.19 Saddle stitch finisher / Finisher

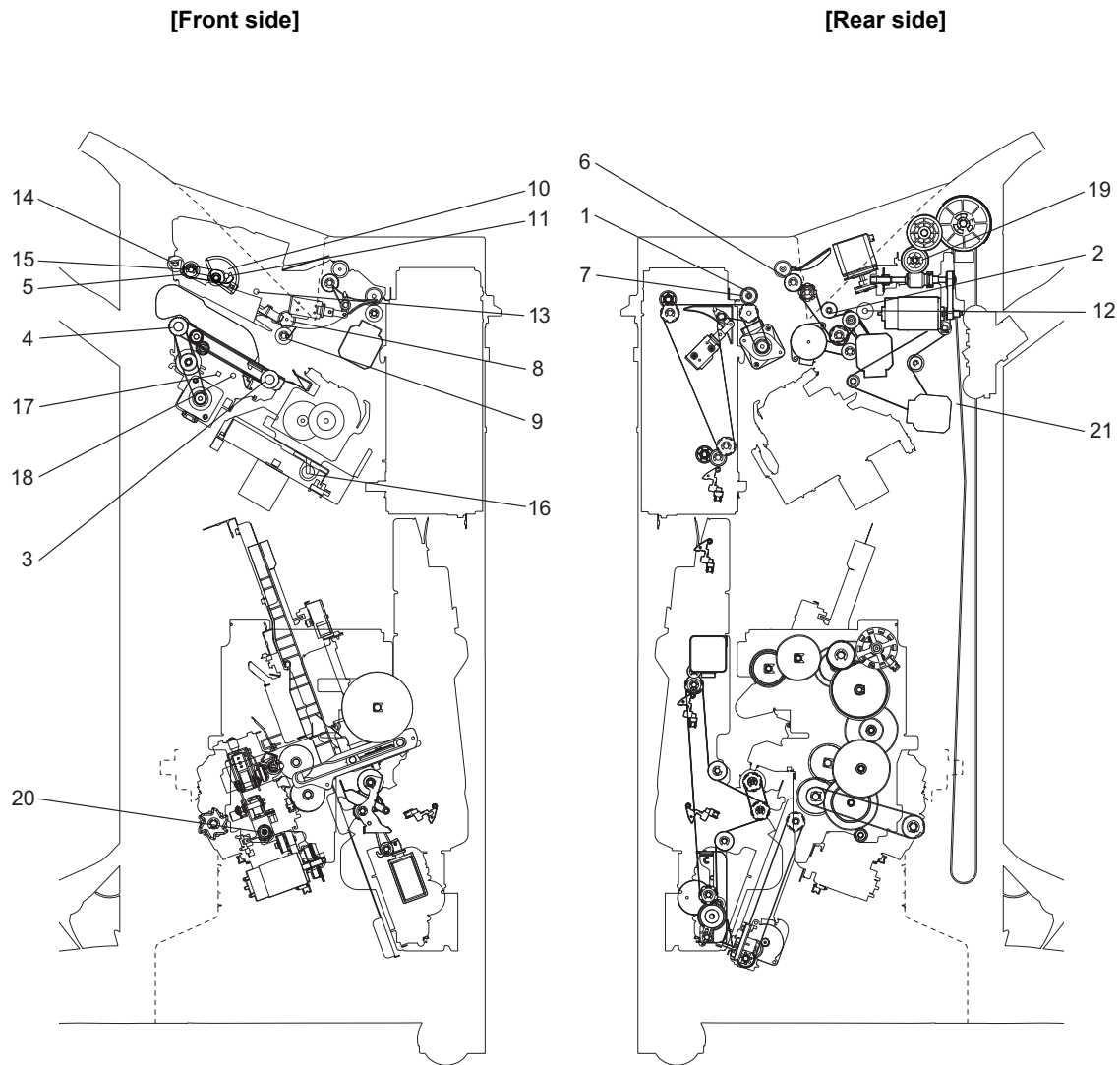

Fig. 7-38

Items to check		Cleaning	Lubrication/ Coating	Replacement (x 1,000)	Operation check	Parts list (P-I)	Remarks
1	Entrance sensor (S1)	A					
2	Transport sensor (S2)	A					
3	Stack transport roller-1	A					
4	Stack transport roller-2	A					
5	Buffer roller	A					
6	Exit roller	A					
7	Entrance roller	A					
8	Transport roller	A					
9	Paddle	A		1,000			
10	Front assist guide cam / Rear assist guide cam		C				*a
11	Buffer roller link		W3				*b
12	Shaft		W3				*c
13	Buffer tray shaft		W3				*d

Items to check		Cleaning	Lubrication/ Coating	Replacement (x 1,000)	Operation check	Parts list (P-I)	Remarks
14	Pinch roller shaft		W3				*e
15	Buffer roller shaft		W3				*f
16	Stapler carrier shaft		W3				*g
17	Rack gear (Aligning plate)		W3				*h
18	Finishing tray shaft		W3				*i
19	Movable tray drive gear		W3				*j
20	Additional folding unit carrier shaft		W3				*k
21	Grate-shaped guide	A	C				*l

***a Front assist guide cam/Rear assist guide cam**

With a cleaning brush, apply an adequate amount of coating material (SANKOL CFD-409M) all around the front and rear assist guide cams [1].

- * Use a cleaning brush (4407915710 BRUSH-33) because cloth contaminated with the coating material shall be treated as industrial waste.
- * Do not apply coating material to the rubber section.
- * When coating material adheres to the skin, rinse it well with water.
- * The brush with which the coating agent (SANKOL CFD-409M) was applied must be exclusive for coating. Do not use it to clean other areas.

***b. Buffer roller link**

Apply an adequate amount of white grease (Molykote EM-30L) to the entire buffer roller link [2].

***c. Shaft**

Apply an adequate amount of white grease (Molykote EM-30L) to the entire shaft [3].

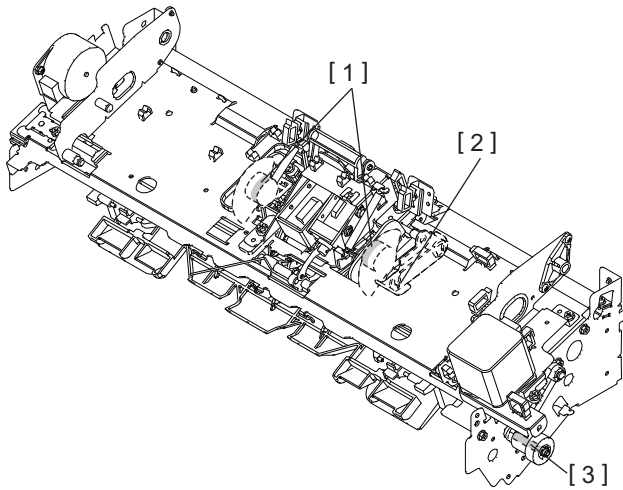

Fig. 7-39

*d. Buffer tray shaft

Apply an adequate amount of white grease (Molykote EM-30L) to the entire buffer tray shaft [1].

*e. Pinch roller shaft

Apply an adequate amount of white grease (Molykote EM-30L) to the entire pinch roller shaft [2].

*f. Buffer roller shaft

Apply an adequate amount of white grease (Molykote EM-30L) to the entire buffer roller shaft [3].

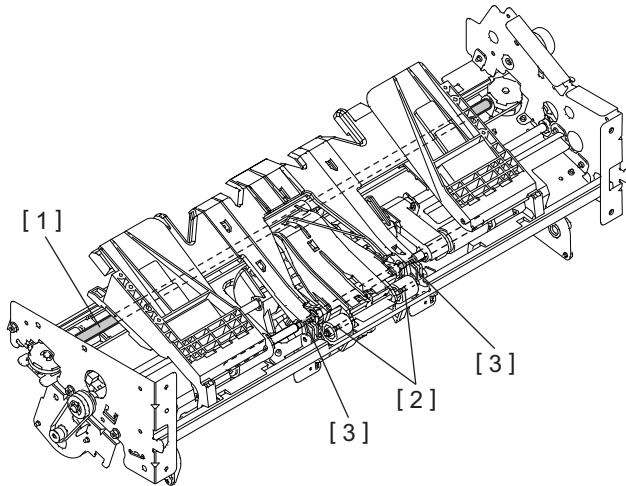

Fig. 7-40

*g. Stapler carrier shaft

Apply an adequate amount of white grease (Molykote EM-30L) to the entire stapler carrier shaft [1].

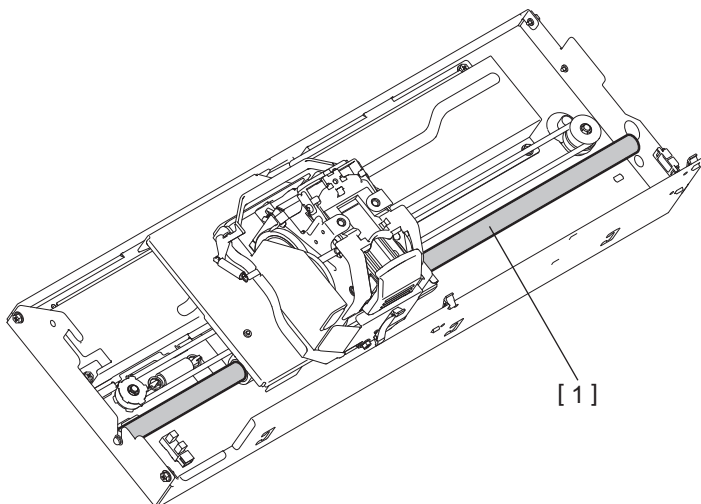

Fig. 7-41

*h. Rack gear (Aligning plate)

*i. Finishing tray shaft

1. Take off the junction box unit.

* If the hole punch unit is installed, take it off beforehand.

2. Apply oil as follows through the opening which shows up when the junction box unit has been removed.

Apply an adequate amount of white grease (Molykote EM-30L) to the gear teeth of the rack gear [1] which drive the aligning plate, and the entire finishing tray shaft [2].

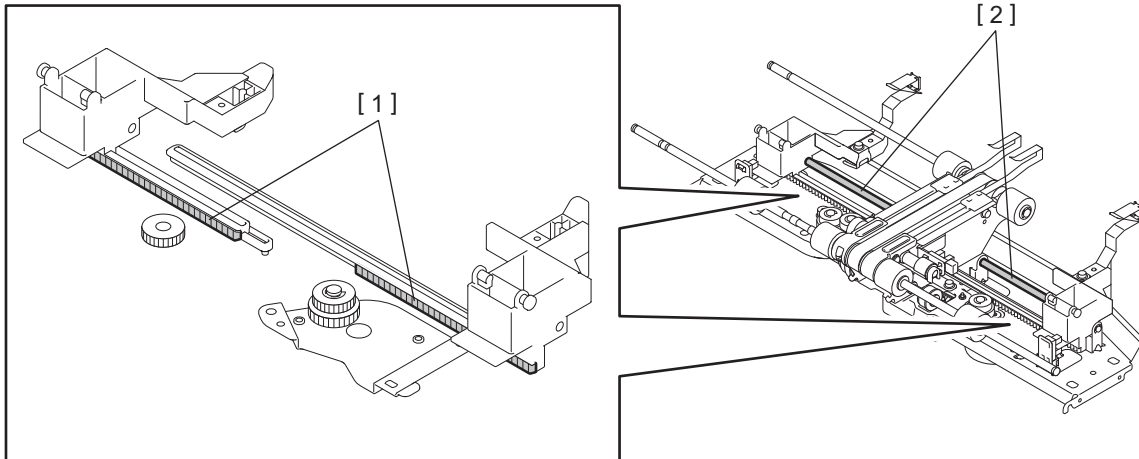

Fig. 7-42

*j. Movable tray drive gear

Apply an adequate amount of white grease (Molykote HP-300) to the gear teeth of the movable tray drive gear [1].

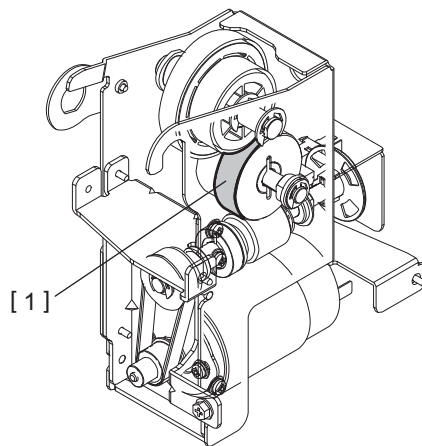

Fig. 7-43

*k Additional folding unit carrier shaft

Apply an adequate amount of white grease (Molykote EM-30L) to the entire Additional folding unit carrier shaft [1].

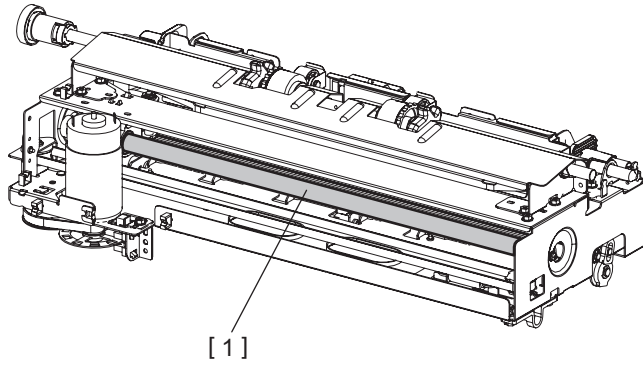

Fig. 7-44

*1 Grate-shaped guide

When an abnormal noise occurs in the grate-shaped guide or the trailing edge of the paper stacked on the tray is dirty, apply coating material (SANKOL CFD-409M) by using a cleaning brush to the portion on the guide with which the paper edge is in contact.

- * Use a cleaning brush (4407915710 BRUSH-33) because cloth contaminated with the coating material shall be treated as industrial waste.
- * Do not apply coating material (Molykote PD-910) to the rubber section of the grate-shaped tray.
- * When coating material adheres to the skin, rinse it well with water.
- * The brush with which the coating agent (SANKOL CFD-409M) was applied must be exclusive for coating. Do not use it to clean other areas.

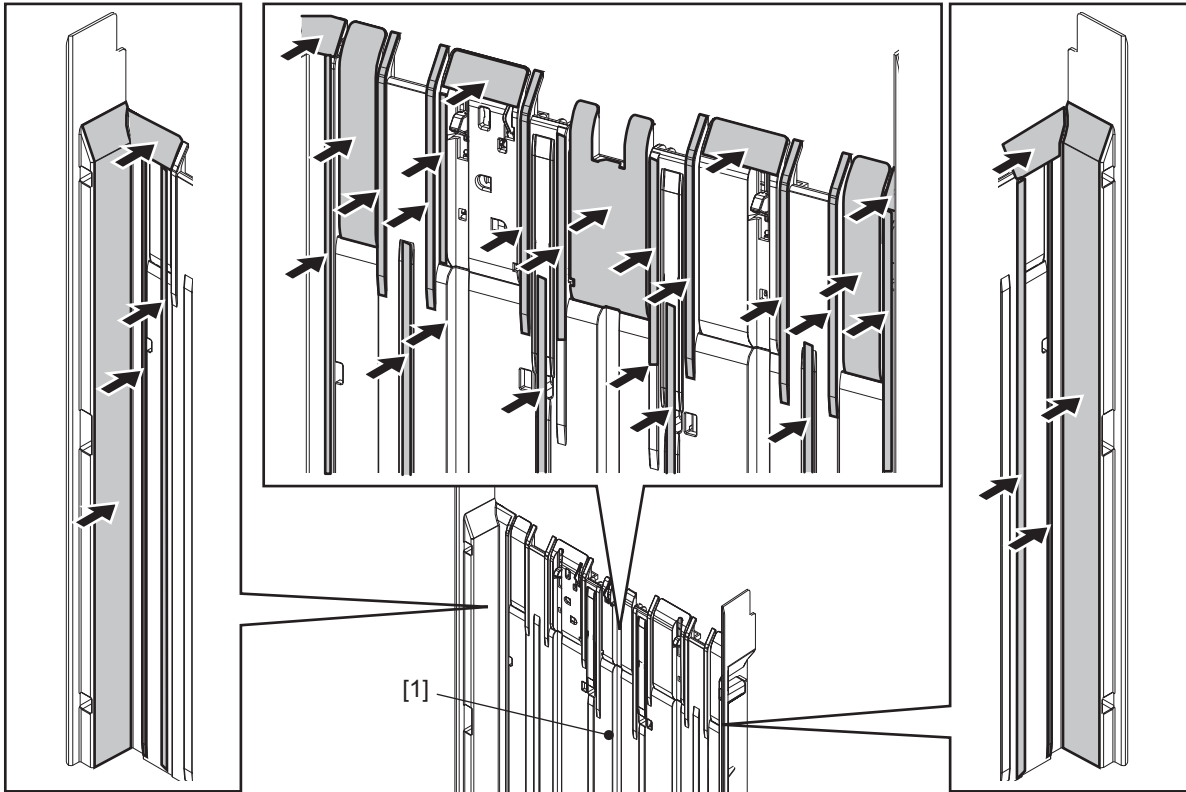

Fig. 7-45

7.6.20 Hole punch unit (MJ-6105)

Items to check*1		Cleaning	Lubrication *2	Replacement (x1,000)	Operation check	Parts list (P-I) *3
1	Transport roller	A			O	
2	Sensors	B				
3	Drive gears		W1		O	
4	Punched scrap container	Dispose of the punched paper bits.				
5	Punching unit *4			R1 1000		

*1 Perform maintenance in the timing of preventive maintenance of the equipment.

*2 Be careful not to put oil on the rollers, belts and belt pulleys when lubricating.

*3 This column indicates the page and item numbers of the Parts List.

*4 This unit may require replacement once or more over the period of machine warranty because of deterioration or damage. Replace them as needed.

7.7 Machine Refreshing Checklist

The check items for each unit at the machine refreshment are shown below.

Symbols/value used in the checklist

Item	Description
Cleaning	A: Clean with alcohol B: Clean with soft pad, cloth or vacuum cleaner
Lubrication/Coating	W1: White grease (Molykote EM-30L) W2: White grease (Molykote HP-300)
Replacement	Value: Replacement cycle R1: Replacement R2: For preventive maintenance, check if the parts are damaged and replace them as required. If the parts are not replaced at the machine refreshing interval, inspect them at the subsequent PM. R3: Replace if deformed or damaged. If the parts are not replaced at the machine refreshing interval, inspect them at the subsequent PM. R4: Lubrication recommended: If the parts are not lubricated at the machine refreshing interval, inspect their lubrication status at the subsequent PM.
Operation check	O: After cleaning or replacement, confirm there is no problem.







Notes:

- When performing machine refreshment, check the items in the preventive maintenance checklist in addition to the items in the machine refreshing checklist.
- Perform cleaning and lubricating in the following timing. Lubricate the replacement parts according to the replacement cycle.

Model	Replacement cycle
25ppm	450,000 sheets
30ppm	540,000 sheets
35ppm	630,000 sheets
45ppm	680,400 sheets
50ppm	756,000 sheets

- The value in the “Replacement” field of the table in APPENDIX indicates the replacement number of output pages when those are all printed in either the Black or the Full Color mode.
- The replacement cycle of the parts in the feeding section equals to the number of sheets fed from each paper source.
- Be careful not to put oil on the rollers, belts and belt pulleys when lubricating.
- Parts list <P-I> represents the page item in “e-STUDIO2515AC/3015AC/3515AC/4515AC/5015AC Service Parts List”.

Items to check	Cleaning	Lubrication/ Coating	Replacement		Operation check	Parts list <P-I>
			(x 1,000 sheets)	(x 1,000 drive counts)		
1		W1	R4	R4		-
2		W1	R4	R4		-
3		W1	R4	R4		-
4		W1	R4	R4		-
5		W1	R4	R4		46-1
D1		W1	R4	R4		41-10
E2		W2	R4	R4		21-24
G8			R1	R1		-
J1	A		R2	R2		26-14
J2	A		R2	R2		27-9
J4	B		R2	R2		26-27

- * Replacing transfer belt unit is also available.
- * 1: Paper feeding drive unit
For lubrication, refer to  P. 4-105 “4.5.38 Paper feed drive gear”.
- * 2: Drum TBU drive unit
For lubrication, refer to  P. 4-156 “4.6.32 Drum drive gear”.
- * 3: Development drive unit
For lubrication, refer to  P. 4-144 “4.6.25 Developer drive unit”.
- * 4: Fuser unit drive gear
For lubrication, refer to  P. 4-220 “4.9.18 Fuser drive unit”.
- * 5: Gear of registration motor
For lubrication, refer to  P. 4-102 “4.5.36 Registration motor (M14)”.
- * D1: ADU transport roller
For lubrication, refer to  P. 4-255 “4.11.10 Transport roller (Upper and lower)”.
- * E2: Bypass separation roller
For lubrication, refer to  P. 4-58 “4.5.3 Bypass separation roller”.

7.8 Storage of Supplies and Replacement Parts

Precautions for storing supplies and replacement parts are shown below.

1. Toner/Developer
Toner and developer should be stored in a place where the ambient temperature is between 10°C to 35°C (no condensation), and should also be protected against direct sunlight during transportation.
2. Photoconductive drum
Like the toner and developer, photoconductive drum should be stored in a dark place where the ambient temperature is between 10°C to 35°C (no condensation). Be sure to avoid places where drums may be subjected to high humidity, chemicals and/or their fumes.
If drums are left near a window exposed to direct sunlight or intense light, they will be worn out. Due to this, fogging may occur immediately after installing in the equipment.
3. Drum cleaning blade / Transfer belt cleaning blade
This item should be stored in a flat place where the ambient temperature is between 10°C to 35°C, and should also be protected against high humidity, chemicals and/or their fumes.
4. Transfer belt / Transfer roller / Fuser belt / Pressure roller
Avoid places where the rollers may be subjected to high humidity, chemicals and/or their fumes.
5. Fuser belt
Oil co-packed with the fuser belt and PM kits should be stored in a special container to keep it in a stable condition. Do not transfer oil into another container.
6. Paper
Avoid storing copy paper in places where it may be subjected to high humidity.
After a package is opened, be sure to place and store it in a storage bag.

7.9 PM KIT

A PM kit is a package for each unit of replacement parts requiring PM.

KIT name	Component	Qty.	P-I
DEV-KIT-FC505K	Developer material (K)	1	-
	Drum cleaning blade	1	34-35
	Needle electrode	1	35-8
	Main charger grid	1	35-6
	Main charger cleaner	2	35-7
	Drum gap spacer (White) *3	1	-
	Drum gap spacer (Black) *1,*2	1	34-12
EPU-KIT-FC505CLR	Drum cleaning blade	3	34-35
	Needle electrode	3	35-8
	Main charger grid	3	35-6
	Main charger cleaner	6	35-7
	Drum gap spacer (White) *3	3	-
	Drum gap spacer (Black) *1, *2	3	34-12
FR-KIT-FC505 *1	Pressure roller	1	38-34
	Fuser belt	1	38-13B
	Fuser belt pad	1	38-26
	Fuser belt lubricating sheet	1	38-26
	Separation finger	2	39-5
	Silicon oil	1	108-28
	Harness clamp	1	-
	Front fuser oil recovery sheet1	1	38-13B
	Front fuser oil recovery sheet2	1	38-13B
	Rear fuser oil recovery sheet	1	38-13B
FR-KIT-FC505H *2	Pressure roller	1	38-34
	Fuser belt	1	38-13A
	Fuser belt pad	1	38-26
	Fuser belt lubricating sheet	1	38-26
	Separation finger	2	39-5
	Silicon oil	1	108-28
	Front fuser oil recovery sheet1	1	38-13A
	Front fuser oil recovery sheet2	1	38-13A
	Rear fuser oil recovery sheet	1	38-13A
TBU-KIT-FC50	Transfer belt cleaning blade	1	30-19
	Blade seal (front)	1	30-20
	Blade seal (rear)	1	30-21
	Blade seal (back)	2	30-17
ROL-KIT-FC30-U (1st drawer/2nd drawer/PFP)	Pick up roller	1	23-29
	Feed roller	1	23-29
	Separation roller	1	23-30
ROL-KIT-1026 (LCF)	Pick up roller	1	4-4
	Feed roller	1	4-3
	Separation roller	1	5-8
DF-KIT-3031 (RADF)	Pick up roller	1	5-13
	Feed roller	1	5-13
	Separation roller	1	4-10
	Registration roller front sheet	3	4-38 4-39

KIT name	Component	Qty.	P-I
KIT-ROL-DSDF (DSDF)	DSDF pickup roller	1	1-18
	DSDF feed roller	1	1-14
	DSDF separation roller	1	5-21

*1 For e-STUDIO2515AC/3015AC/3515AC

*2 For e-STUDIO4515AC/5015AC

*3 For e-STUDIO2505AC/3005AC/3505AC/4505AC/5005AC

7.10 Maintenance Part List

The parts used for the maintenance of this equipment are as follows.

No.	Item	Purpose	P-I
1	Cleaning brush	Cleaning inside of the equipment	101-2
2	Doctor blade cleaning jig	Cleaning the doctor blade	101-3
3	Wire holder jig	Fixing the wire at the assembly of the carriage wire	101-4
4	Belt tension jig	Adjusting the belt tension at the installation of the scan motor	101-7
5	Drum bag	Storing the drum	101-9
6	Patting powder	For transfer belt	101-25
7	Door-switch jig	Lock of door switch	101-1
8	Color test chart (TCC-2)	For test print (A4/LT)	101-10
9	Color test chart	For test print (A3/LD)	101-11
10	Separation guide gap adjustment jig	For adjusting the gap between the fuser belt and separation guide	101-27
11	Doctor blade cleaning jig (PM)	In order to avoid the occurrence of defective images by removing adhering stains by cleaning the doctor blade during preventative maintenance.	101-29

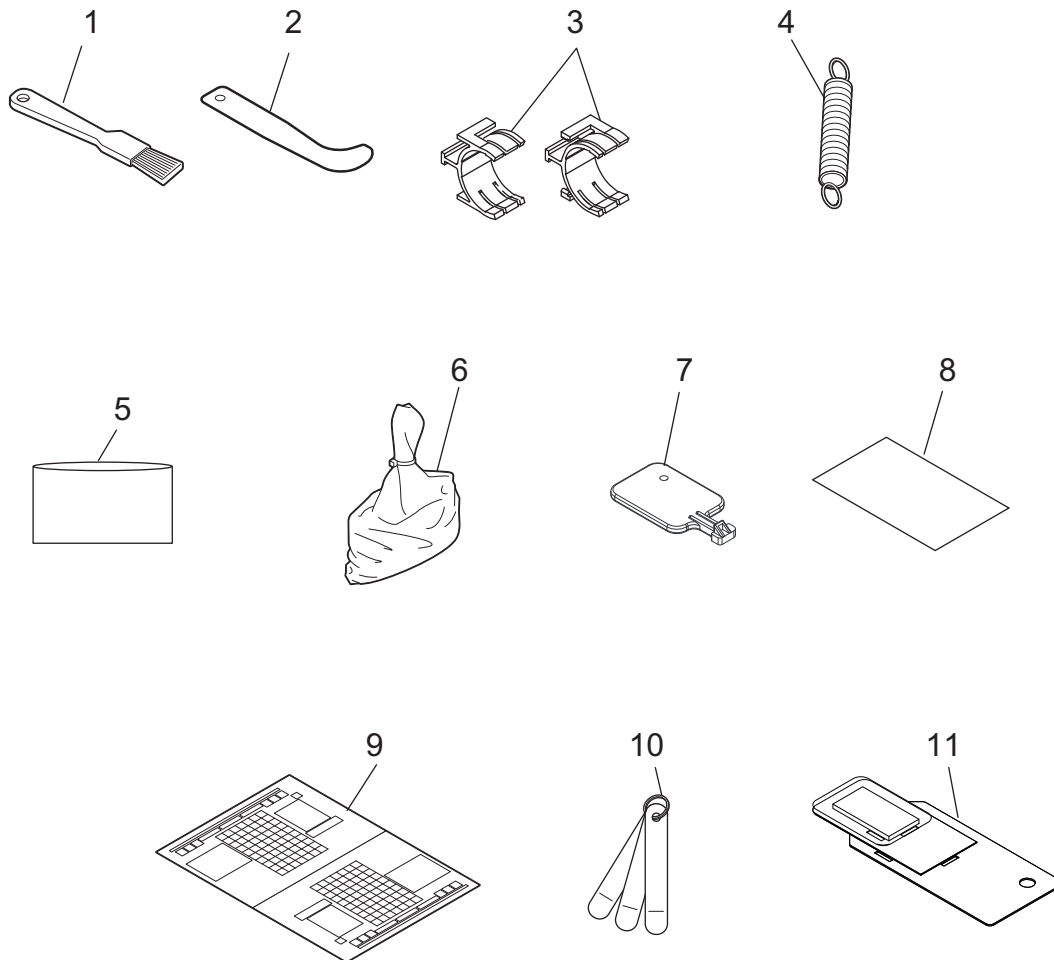

Fig. 7-46

7.11 Grease List

The parts used for the maintenance of this equipment are as follows.

Symbol	Grease name	Type	Color	Volume	Container	Parts list <P-I>*
L	Launa 40	Lubricating oil	Yellow or transparent	100 cc	Oiler	101-21
W1	White grease (Molykote EM-30L)	Grease	White	100 g	Bottle	101-24
W2	White grease (Molykote HP-300)	Heat-resisting grease	White	10 g	Bottle	101-22
AV	Alvania No.2	Grease	Amber	100 g	Tube	101-23
FL	FLOIL (GE-334C)	Conductive grease	Black	20 g	Bottle	101-26

* Part list <P-I> represents the page item in “e-STUDIO2515AC/3015AC/3515AC/4515AC/5015AC Service Parts List”.

8. ERROR CODE AND TROUBLESHOOTING

8.1 General Descriptions

This chapter explains the procedures for solving troubles occurring in the equipment.

When a trouble occurs, check if an error code is displayed on the LCD screen of the control panel first. If displayed, refer to “8.2 Error Code List” to figure out the classification and contents of the error, and then refer to “8.3 Diagnosis and Prescription for Each Error Code” to remove its cause.

When no error is displayed but the equipment does not operate properly or images are not printed properly, refer to “8.4 Other Errors” or “8.5 Troubleshooting for the Image” to remove its cause.

When troubles have occurred in the equipment, various causes can be considered. Check the items below first.

- Is there any problem with the power cable or an outlet?
Check if the power cable is inserted securely. When it is almost removed or not inserted securely, power voltage may become unstable, causing a trouble in the equipment.
- Are the connectors connected securely?
Reconnect them securely. Even if they are apparently inserted, there may be a contact failure. Carefully check if the connection is secured especially after the disassembly or replacement of parts.
- Are there any abnormalities in the setting value of the self-diagnostic code?
If an abnormal value has been entered in the self-diagnostic code related to the problem, an operation failure may occur. If an abnormal value has been entered in the self-diagnostic code related to the image quality adjustment, defective images may occur. Therefore, check that the proper value has been entered in the self-diagnostic code.
- Are there any similar cases?
Check if there have been any similar problems in the troubleshooting in the Service Manual. If there are similar cases, refer to their troubleshooting.

Notes:

If unusual odor is detected or if smoke or fire comes out of the equipment, immediately turn the power OFF. Even in the cases other than the above, fully observe safety precautions.

If any PC board or HDD shall be replaced, refer to “9.2 Precautions, Procedures and Settings for Replacing PC Boards and HDD”.

8.1.1 If a problem continues even after performing all troubleshooting

If a problem continues even after performing all troubleshooting and technical tips, report the problem to the appropriate Toshiba service center along with the following information. This information will help the service center understand your problem and take quick action to find the solution.

1. Serial Number

2. List Print

Refer to the appropriate Service Manual for the detailed procedure to obtain a List Print.

A. Enter the value given below to obtain a List Print by CSV file.

FS-30-300: All CSV files

B. Enter the value given below to obtain a List Print by printing it out.

FS-30-101: 05 ADJUSTMENT MODE

FS-30-102: 08 SETTING MODE

FS-30-104: Pixel counter data (Toner cartridge standard)

FS-30-106: Error history (1000 cases max)

FS-30-108: Firmware update log (200 cases max)

FS-30-110: Power on/off log (100 cases max)

3. For an image-related problem, refer to the following sections.

 P. 8-514 “8.5.45 If an image-related problem continues after performing all troubleshooting”

If a problem nevertheless continues to persist, collect image samples with the problem areas and the feeding direction marked first. Then provide information about the type, size, and weight of the paper along with a copy of the print data / spool file causing the problem.

4. For abnormal acoustic noise, describe the situation in as much detail as possible.

5. For hardware-related problems, provide photos of any broken parts, paper jams, etc.

In case of paper jams, include the type of paper and its manufacturer.

6. For software-related problems, provide list prints, TopAccess Logs and the detailed procedure needed to duplicate the problem.

* This is the minimum information required to report a complaint. It would be appreciated if you could obtain additional information.

* Follow the directions of the service center if they request additional information as each issue is unique to some degree.

8.1.2 Collection of debug logs with a USB device

[1] General description

The purpose of collecting the debug logs is to acquire the information for analyzing problems which occurred during the MFP's operation. In such a case, you can collect the debug logs by inserting a USB device containing the dedicated script file into the MFP. Even if the power has to be turned OFF with the main power switch after a problem occurs, the debug logs will be saved in the MFP (up to 3 logs). If the debug logs have already been saved in the MFP, they also can be collected.

The following information is included in the USB debug logs.

Internal operation, Job history, HDD/memory usage status, etc. (Personal/Corporate information (address book) not included)

When the debug logs are collected, also do so for the following information. since it may be difficult to investigate only using the debug log.

- List print mode [FS-30-300: All CSV files]
- Job logs below in TopAccess > [Logs] > [Export Logs]
 - Print Job Log Export
 - Fax Transmission Journal Export
 - Fax Reception Journal Export
 - Scan Log Export
 - Messages Log Export
- Problem occurrence time
Or the time when the customer called if it is difficult to work out when it occurred
- Status of when you collected the debug log
As in the example below, check the status to know if the problem occurred at the debug log collection or how the customer recovered it.
E.g.
 - You checked the problem and connected a USB device to the equipment.
 - No problem occurred when an attempt to collect the debug log was made; however the customer did turn the main power switch OFF when the problem occurred, so the log can be collected.

[2] Collection procedure

1. Note
When collecting a log, be sure to obtain consent from the user in advance and get the dedicated script file from the service center.
2. About USB devices
Be sure to format the USB device with FAT16/32 beforehand. (Recommend size: 2GB or more)
3. Advance preparation of collection
Store the dedicated script file to the root directory of the USB device.
4. Procedure for collecting debug logs
 - (1) Insert the USB device, in which the dedicated script file is stored, into the MFP while the power is ON.
 - After the USB device is inserted into the MFP, the screen will change.
 - (2) Select [Basic Debug Logs], [All Debug Logs] or [9S-300CSV Print Job List] and then press the [START] button.
 - [9S-300CSV Print Job List] can be selected together with [Basic Debug Logs] or [All Debug Logs].
 - The log collection of [All Debug Logs] will start automatically if no operation is made for 30 seconds after the screen has been changed.
 - The LED of the MFP starts blinking when the log collection has begun.
 - The panel display will be changed during the log collection depending on the conditions of the MFP. However, the log collection will continue as long as the LED is blinking.

- (3) When the log collection is finished, the beeping is heard. After the beeping has stopped, remove the USB device.
- The MFP will reboot automatically in 10 seconds after a beeping sound.
 - If this has not been done automatically after 30 seconds have passed, reboot the MFP manually.

Notes:

- Do not remove the USB device while the LED in the MFP is blinking.
- If the LED does not start blinking after the USB device is inserted and a few minutes have passed, try the procedure from step (1) again.
- If there is no beeping after the LED starts blinking (about 20 minutes), try procedure from step (1) again.
- If the USB device is inserted when the MFP is not ready, the debug logs cannot be collected.

5. Collected debug logs

- When the collection of the debug logs is completed, the compressed file of the collected logs is stored in the root directory of the USB device.

File name:

XXXX.YYYYMMDDHHmmSS	(for basic version and all version)
XXXX.YYYYMMDDHHmmSS.Defunct	(for all version)
XXXX.YYYYMMDDHHmmSS.PowerOff	(for all version)
XXXX.YYYYMMDDHHmmSS_9S300	(for "9S300 csv files, Print job list")
XXXX.YYYYMMDDHHmmSS_JobList	(for "9S300 csv files, Print job list")
XXXX.YYYYMMDDHHmmSS.USBLog	(for basic version, all version and "9S300 csv files, Print job list")
md5sum.txt	(for basic version, all version and "9S300 csv files, Print job list")

(XXXX= Serial number of the equipment, YYYY= year, MM= month, DD= day, HH= hour, mm= minute, SS= second)

- After the debug logs have been collected, be sure to send them to the service center together with a report.

8.1.3 Traceability label

A traceability label on which a management No. at the manufacturing has been printed is attached to some units. If a problem occurs in a unit, report it to the appropriate Toshiba service center along with the traceability label information to help them to understand it.

[1] Management No.

A management No. consists of 13 digits with letters of the alphabet and numbers. The following shows the meaning of each block.

- From the 1st to 4th digits: Classification
- From the 5th to 10th digits: Production date
- From the 11th to 13th digits: Sequential numbers

Classification				Production date						Sequential numbers			
1	2	3	4	5	6	7	8	9	10	11	12	13	(digits)
1	2	3	4	1	2	3	4	5	6	1	2	3	

[2] Applicable units

A traceability label is attached to the following units.

No.	Unit	Remarks
1	High-voltage transformer	
2	Automatic duplexing unit (ADU)	
3	Process unit (EPU)	
4	Scanner frame	
5	CCD driving PC board (CCD board)	
6	Toner cartridge PC board (CTRG board)	
7	Switching regulator	
8	System control PC board (SYS board)	
9	Logic PC board (LGC board)	
10	Heater control PC board (IH board)	
11	Laser optical unit (LSU)	
12	Control panel	
13	DAMP board	
14	USB-Hub (HUB board)	
15	Hard disk (HDD)	
16	Paper feed control PC board (PFC board)	

8.2 Error Code List

The following error codes is displayed at the upper right of the screen when the “CLEAR PAPER” or “CALL SERVICE” symbol is blinking.

Remarks:

Elision character of the “Error code display media”

Panl: Control panel

JLog: JobLog (TopAccess Print Log - Scan Log)

ML: Message Log (TopAccess Message Log)

Noti: Notification

CSV: CSV output (List print)

Y: Yes

2nd: An error status has been detected twice (= error code has been determined)

5th: An error status has been detected five times (= error code has been determined)

8.2.1 Jam

Error code	Classification	Message	Contents	Error code display media					Troubleshooting
				Panl	JL	ML	Noti	CSV	
E010	Paper exit jam	Paper Ejection Misfeed - Please Clear Paper Path.	Jam not reaching the exit sensor	-	-	Y	Y	Y	P. 8-105
E011	Other paper jam	Paper Misfeed in Printer - Please Clear Paper Path.	Transfer belt paper-clinging jam	-	-	Y	Y	Y	P. 8-121
E013	Other paper jam		Paper not reaching the registration pass sensor jam	Y	-	-	-	Y	P. 8-122
E020	Paper exit jam	Paper Ejection Misfeed - Please Clear Paper Path.	Stop jam at the exit sensor	-	-	Y	Y	Y	P. 8-106
E030	Other paper jam	Paper Misfeed in Printer - Please Clear Paper Path.	Power-ON jam	-	-	Y	Y	Y	P. 8-124
E061	Other paper jam	Paper Misfeed in Printer - Please Clear Paper Path.	Incorrect paper size setting for 1st drawer	-	-	Y	Y	Y	P. 8-125
E062	Other paper jam	Paper Misfeed in Printer - Please Clear Paper Path.	Incorrect paper size setting for 2nd drawer	-	-	Y	Y	Y	P. 8-125
E063	Other paper jam	Paper Misfeed in Printer - Please Clear Paper Path.	Incorrect paper size setting for PFP upper drawer	-	-	Y	Y	Y	P. 8-125
E064	Other paper jam	Paper Misfeed in Printer - Please Clear Paper Path.	Incorrect paper size setting for PFP lower drawer	-	-	Y	Y	Y	P. 8-125
E065	Other paper jam	Paper Misfeed in Printer - Please Clear Paper Path.	Incorrect paper size setting for bypass tray	-	-	Y	Y	Y	P. 8-125
E090	Other paper jam	Paper Misfeed in Printer - Please Clear Paper Path.	Image data delay jam	-	-	Y	Y	Y	P. 8-125
E091	Other paper jam	Paper Misfeed in Printer - Please Clear Paper Path.	Motor-ON time-out jam	-	-	Y	Y	Y	P. 8-125
E0A0	Other paper jam	Paper Misfeed in Printer - Please Clear Paper Path.	Image transport ready time-out jam	-	-	Y	Y	Y	P. 8-126

Error code	Classification	Message	Contents	Error code display media					Troubleshooting
				Panl	JL	ML	Noti	CSV	
E110	Paper misfeeding	Paper Insertion Misfeed - Please Clear Paper Path.	ADU misfeeding (paper not reaching the registration sensor)	-	-	Y	Y	Y	P. 8-108
E120	Paper misfeeding	Paper Insertion Misfeed - Please Clear Paper Path.	Bypass misfeeding (paper not reaching the bypass feed sensor)	-	-	Y	Y	Y	P. 8-108
E130	Paper misfeeding	Paper Insertion Misfeed - Please Clear Paper Path.	1st drawer misfeeding (paper not reaching the 1st drawer feed sensor)	-	-	Y	Y	Y	P. 8-109
E140	Paper misfeeding	Paper Insertion Misfeed - Please Clear Paper Path.	2nd drawer misfeeding (paper not reaching the 2nd drawer feed sensor)	-	-	Y	Y	Y	P. 8-109
E150	Paper misfeeding	Paper Insertion Misfeed - Please Clear Paper Path.	PFP upper drawer misfeeding (paper not reaching the PFP upper drawer feed sensor)	-	-	Y	Y	Y	P. 8-110
E160	Paper misfeeding	Paper Insertion Misfeed - Please Clear Paper Path.	PFP lower drawer misfeeding (paper not reaching the PFP lower drawer feed sensor)	-	-	Y	Y	Y	P. 8-110
E190	Paper misfeeding	Paper Insertion Misfeed - Please Clear Paper Path.	T-LCF misfeeding (paper not reaching the T-LCF transport sensor)	-	-	Y	Y	Y	P. 8-111
E200	Paper transport jam	Paper Misfeed in Printer - Please Clear Paper Path.	1st drawer transport jam (paper not reaching the registration sensor)	-	-	Y	Y	Y	P. 8-112
E210	Paper transport jam	Paper Misfeed in Printer - Please Clear Paper Path.	2nd drawer transport jam (paper not reaching the registration sensor)	-	-	Y	Y	Y	P. 8-112
E220	Paper transport jam	Paper Misfeed in Printer - Please Clear Paper Path.	2nd drawer transport jam (paper not reaching the feed sensor)	-	-	Y	Y	Y	P. 8-113
E270	Paper transport jam	Paper Insertion Misfeed - Please Clear Paper Path.	Bypass transport jam (paper not reaching the registration sensor)	-	-	Y	Y	Y	P. 8-112
E300	Paper transport jam	Paper Misfeed in Printer - Please Clear Paper Path.	PFP upper drawer transport jam (paper not reaching the registration sensor)	-	-	Y	Y	Y	P. 8-112
E310	Paper transport jam	Paper Misfeed in Printer - Please Clear Paper Path.	PFP upper drawer transport jam (paper not reaching the feed sensor)	-	-	Y	Y	Y	P. 8-113

Error code	Classification	Message	Contents	Error code display media					Troubleshooting
				Panl	JL	ML	Noti	CSV	
E320	Paper transport jam	Paper Misfeed in Printer - Please Clear Paper Path.	PFP upper drawer transport jam (paper not reaching the 2nd drawer paper feed sensor)	-	-	Y	Y	Y	P. 8-114
E330	Paper transport jam	Paper Misfeed in Printer - Please Clear Paper Path.	PFP lower drawer transport jam (paper not reaching the registration sensor)	-	-	Y	Y	Y	P. 8-112
E340	Paper transport jam	Paper Misfeed in Printer - Please Clear Paper Path.	PFP lower drawer transport jam (paper not reaching the feed sensor)	-	-	Y	Y	Y	P. 8-113
E350	Paper transport jam	Paper Misfeed in Printer - Please Clear Paper Path.	PFP lower drawer transport jam (paper not reaching the 2nd drawer feed sensor)	-	-	Y	Y	Y	P. 8-114
E360	Paper transport jam	Paper Misfeed in Printer - Please Clear Paper Path.	PFP lower drawer transport jam (paper not reaching the PFP upper drawer feed sensor)	-	-	Y	Y	Y	P. 8-114
E3C0	Paper transport jam	Paper Misfeed in Printer - Please Clear Paper Path.	LCF transport jam (paper not reaching the registration sensor)	-	-	Y	Y	Y	P. 8-112
E3D0	Paper transport jam	Paper Misfeed in Printer - Please Clear Paper Path.	LCF transport jam (paper not reaching the feed sensor)	-	-	Y	Y	Y	P. 8-113
E3E0	Paper transport jam	Paper Misfeed in Printer - Please Clear Paper Path.	LCF transport jam (paper not reaching the 2nd drawer paper feed sensor)	-	-	Y	Y	Y	P. 8-114
E410	Cover open jam	Paper Misfeed in Printer - Please Clear Paper Path.	Front cover open jam	-	-	Y	Y	Y	P. 8-129
E420	Cover open jam	Paper Misfeed in Printer - Please Clear Paper Path.	PFP side cover open jam	-	-	Y	Y	Y	P. 8-129
E430	Cover open jam	Paper Misfeed in Printer - Please Clear Paper Path.	Duplexing unit cover open jam	-	-	Y	Y	Y	P. 8-130
E440	Cover open jam	Paper Misfeed in Printer - Please Clear Paper Path.	Jam access cover open jam	-	-	Y	Y	Y	P. 8-130
E450	Cover open jam	Paper Misfeed in Printer - Please Clear Paper Path.	LCF side cover open jam	-	-	Y	Y	Y	P. 8-130
E480	Cover open jam	Paper Misfeed in Printer - Please Clear Paper Path.	Bridge unit open jam	-	-	Y	Y	Y	P. 8-131
E490	Cover open jam	Paper Misfeed in Printer - Please Clear Paper Path.	Job separator cover open jam	Y	-	Y	Y	Y	P. 8-131

Error code	Classification	Message	Contents	Error code display media					Troubleshooting
				Panl	JL	ML	Noti	CSV	
E510	Paper transport jam	Paper Misfeed in Automatic Duplexing Unit - Please Clear Paper Path.	Paper not reaching the ADU entrance sensor jam	-	-	Y	Y	Y	P. 8-115
E520	Paper transport jam	Paper Misfeed in Automatic Duplexing Unit - Please Clear Paper Path.	Stop jam in the ADU	-	-	Y	Y	Y	P. 8-116
E550	Other paper jam	Paper Misfeed in Printer - Please Clear Paper Path.	Paper remaining jam on the transport path	-	-	Y	Y	Y	P. 8-126
E551	Other paper jam	[Error] Paper Misfeed in the engine. Please clear paper path	Paper remaining jam on the transport path (when a service call occurs)	-	-	Y	Y	Y	P. 8-127
E552	Other paper jam	[Error] Paper Misfeed in the engine. Please clear paper path	Paper remaining jam on the transport path (when the cover is closed)	-	-	Y	Y	Y	P. 8-127
E570	Paper transport jam	Paper Misfeed in Printer - Please Clear Paper Path.	Jam not reaching the reverse sensor	-	-	Y	Y	Y	P. 8-116
E580	Paper transport jam	Paper Misfeed in Printer - Please Clear Paper Path.	Stop jam at the reverse sensor	-	-	Y	Y	Y	P. 8-117
E712	DSDF jam	Paper Misfeed in Automatic Document Feeder - Please Clear Paper Path.	Jam not reaching the DSDF registration sensor	-	-	Y	-	Y	P. 8-132
	RADF jam		Jam not reaching the original registration sensor	-	-	Y	-	Y	P. 8-132
E714	DSDF jam	Paper Misfeed in Automatic Document Feeder - Please Clear Paper Path.	DSDF feed signal reception jam	-	-	Y	-	Y	P. 8-132
	RADF jam		Feed signal reception jam	-	-	Y	-	Y	P. 8-133
E717	DSDF jam	Paper Misfeed in Automatic Document Feeder - Please Clear Paper Path.	Original not reaching the DSDF original feed sensor jam	-	-	Y	-	Y	P. 8-133
E718	DSDF jam	Paper Misfeed in Automatic Document Feeder - Please Clear Paper Path.	Original setting jam / Original tray lift abnormality	-	-	Y	-	Y	P. 8-134
E721	DSDF jam	Paper Misfeed in Automatic Document Feeder - Please Clear Paper Path.	Original not reaching the DSDF read-in sensor-1 jam	-	-	Y	-	Y	P. 8-135
	RADF jam		Jam not reaching the read sensor	-	-	Y	-	Y	P. 8-135

Error code	Classification	Message	Contents	Error code display media					Troubleshooting
				Panl	JL	ML	Noti	CSV	
E722	DSDF jam	Paper Misfeed in Automatic Document Feeder - Please Clear Paper Path.	Original not reaching the DSDF exit sensor jam	-	-	Y	-	Y	P. 8-136
	RADF jam		Jam not reaching the original exit / reverse sensor (during scanning)	-	-	Y	-	Y	P. 8-136
E724	DSDF jam	Paper Misfeed in Automatic Document Feeder - Please Clear Paper Path.	Original stopping at the DSDF registration sensor jam	-	-	Y	-	Y	P. 8-137
	RADF jam		Stop jam at the registration sensor	-	-	Y	-	Y	P. 8-137
E725	DSDF jam	Paper Misfeed in Automatic Document Feeder - Please Clear Paper Path.	Original stopping at the DSDF read-in sensor-1 jam	-	-	Y	-	Y	P. 8-138
	RADF jam		Stop jam at the read sensor	-	-	Y	-	Y	P. 8-138
E726	DSDF jam	Paper Misfeed in Automatic Document Feeder - Please Clear Paper Path.	Transport / exit signal reception jam	-	-	Y	-	Y	P. 8-139
	RADF jam		Transport / exit signal reception jam	-	-	Y	-	Y	P. 8-139
E727	DSDF jam	Paper Misfeed in Automatic Document Feeder - Please Clear Paper Path.	Original not reaching the DSDF read-in sensor-2 jam	-	-	Y	-	Y	P. 8-140
E729	DSDF jam	Paper Misfeed in Automatic Document Feeder - Please Clear Paper Path.	Original stopping at the DSDF read-in sensor-2 jam	-	-	Y	-	Y	P. 8-141
E731	DSDF jam	Paper Misfeed in Automatic Document Feeder - Please Clear Paper Path.	Original stopping at the DSDF exit sensor jam	-	-	Y	-	Y	P. 8-141
	RADF jam		Stop jam at the original exit / reverse sensor	-	-	Y	-	Y	P. 8-142
E762	DSDF jam	Paper Misfeed in Automatic Document Feeder - Please Clear Paper Path.	Original remaining at the DSDF registration sensor jam	-	-	Y	-	Y	P. 8-142
E769	DSDF jam	Paper Misfeed in Automatic Document Feeder - Please Clear Paper Path.	Original remaining at the DSDF feed sensor jam	-	-	Y	-	Y	P. 8-143
E770	DSDF jam	Paper Misfeed in Automatic Document Feeder - Please Clear Paper Path.	Original remaining at the DSDF original width detection sensor-1 jam	-	-	Y	-	Y	P. 8-143
E771	DSDF jam	Paper Misfeed in Automatic Document Feeder - Please Clear Paper Path.	Original remaining at the DSDF original width detection sensor-2 jam	-	-	Y	-	Y	P. 8-144

Error code	Classification	Message	Contents	Error code display media					Troubleshooting
				Panl	JL	ML	Noti	CSV	
E774	DSDF jam	Paper Misfeed in Automatic Document Feeder - Please Clear Paper Path.	Original remaining at the DSDF read-in sensor-1 jam	-	-	Y	-	Y	P. 8-144
E775	DSDF jam	Paper Misfeed in Automatic Document Feeder - Please Clear Paper Path.	Original remaining at the DSDF read-in sensor-2 jam	-	-	Y	-	Y	P. 8-145
E777	DSDF jam	Paper Misfeed in Automatic Document Feeder - Please Clear Paper Path.	Original remaining at the DSDF exit sensor jam	-	-	Y	-	Y	P. 8-145
E860	RADF jam	Paper Misfeed in Automatic Document Feeder - Please Clear Paper Path.	RADF jam access cover open jam	-	-	Y	-	Y	P. 8-145
E860	DSDF jam	Paper Misfeed in Automatic Document Feeder - Please Clear Paper Path.	DSDF original jam access cover open jam / DSDF shading sheet HP sensor abnormal	-	-	Y	-	Y	P. 8-146
E870	RADF jam	Paper Misfeed in Automatic Document Feeder - Please Clear Paper Path.	RADF open jam	-	-	Y	-	Y	P. 8-147
E910	Finisher jam (Bridge unit)	Paper Misfeed in Printer - Please Clear Paper Path.	Paper not reaching the bridge unit transport sensor-1	Y	-	Y	Y	Y	P. 8-148
E920	Finisher jam (Bridge unit)	Paper Misfeed in Printer - Please Clear Paper Path.	Paper stopping at the bridge unit transport sensor-1	Y	-	Y	Y	Y	P. 8-148
E930	Finisher jam (Bridge unit)	Paper Misfeed in Printer - Please Clear Paper Path.	Paper not reaching the bridge unit transport sensor-2	Y	-	Y	Y	Y	P. 8-149
E940	Finisher jam (Bridge unit)	Paper Misfeed in Printer - Please Clear Paper Path.	Paper stopping at the bridge unit transport sensor-2	Y	-	Y	Y	Y	P. 8-149
E950	Job separator jam	Paper Misfeed in Printer - Please Clear Paper Path.	Jam not reaching the JSP feed sensor	Y	-	Y	Y	Y	P. 8-151
E951	Job separator jam	Paper Misfeed in Printer - Please Clear Paper Path.	Stop jam at the JSP feed sensor	Y	-	Y	Y	Y	P. 8-151
E9F0	Finisher jam Hole punch unit	Hole Punch Unit Misfeed in Finisher - Please Clear Hole Punch.	Punching jam	Y	-	Y	Y	Y	P. 8-171
EA10	Finisher jam (Finisher section)	Paper Misfeed in Finisher - Please Clear Paper Path.	Paper transport delay jam	Y	-	Y	Y	Y	P. 8-152
EA20	Finisher jam (Finisher section)	Paper Misfeed in Finisher - Please Clear Paper Path.	Paper transport stop jam	Y	-	Y	Y	Y	P. 8-153
EA21	Finisher jam (Finisher section)	Paper Misfeed in Finisher - Please Clear Paper Path.	Paper size error jam (transport sensor)	Y	-	Y	Y	Y	P. 8-154

Error code	Classification	Message	Contents	Error code display media					Troubleshooting
				Panl	JL	ML	Noti	CSV	
EA22	Finisher jam Hole punch unit	Paper Misfeed in Finisher - Please Clear Paper Path.	Paper size error jam (Paper position sensor)	-	-	Y	Y	Y	P. 8-154
EA23	Finisher jam (Finisher section)	Paper Misfeed in Finisher - Please Clear Paper Path.	Paper stopping jam (transport sensor)	-	-	Y	Y	Y	P. 8-155
EA24	Finisher jam (Finisher section)	Paper Misfeed in Finisher - Please Clear Paper Path.	Paper transport delay jam (between entrance and transport sensor)	-	-	Y	Y	Y	P. 8-155
EA25	Finisher jam (Finisher section)	Paper Misfeed in Finisher - Please Clear Paper Path.	Paper transport jam in Finisher (after paper stack was exited)	-	-	Y	Y	Y	P. 8-156
EA26	Finisher jam (Finisher section)	Paper Misfeed in Finisher - Please Clear Paper Path.	Paper transport stop jam (stop command request)	-	-	Y	Y	Y	P. 8-157 P. 8-157
EA27	Finisher jam (Finisher section)	Paper Misfeed in Finisher - Please Clear Paper Path.	Paper transport jam in Finisher	-	-	Y	Y	Y	P. 8-157
EA28	Finisher jam (Finisher section)	Paper Misfeed in Finisher - Please Clear Paper Path.	Paper transport jam (paper holder plate operation delay)	-	-	Y	Y	Y	P. 8-158
EA29	Finisher jam (Finisher section)	Paper Misfeed in Finisher - Please Clear Paper Path.	Paper transport jam (stack transport delay)	-	-	Y	Y	Y	P. 8-158
EA2A	Finisher jam (Finisher section)	Paper Misfeed in Finisher - Please Clear Paper Path.	Paper transport jam in the Finisher (between the entrance path and middle path sensor)	-	-	Y	Y	Y	P. 8-159
EA2B	Finisher jam (Finisher section)	Paper Misfeed in Finisher - Please Clear Paper Path.	Paper transport jam in the Finisher (middle path sensor)	-	-	Y	Y	Y	P. 8-159
EA2C	Finisher jam (Finisher section)	Paper Misfeed in Finisher - Please Clear Paper Path.	Paper transport jam in the Finisher (between the entrance path and sub-path sensor)	-	-	Y	Y	Y	P. 8-160
EA2D	Finisher jam (Finisher section)	Paper Misfeed in Finisher - Please Clear Paper Path.	Paper transport jam in the Finisher (sub-path sensor)	-	-	Y	Y	Y	P. 8-160
EA2E	Finisher jam (Finisher section)	Paper Misfeed in Finisher - Please Clear Paper Path.	Paper transport remaining jam in the Finisher (sub- path sensor)	-	-	Y	Y	Y	P. 8-161
EA31	Finisher jam (Finisher section)	Paper Misfeed in Finisher - Please Clear Paper Path.	Transport path paper remaining jam	Y	-	Y	Y	Y	P. 8-161
EA32	Finisher jam (Finisher section)	Paper Misfeed in Finisher - Please Clear Paper Path.	Exit paper remaining jam	Y	-	Y	Y	Y	P. 8-162
EA40	Finisher jam (Finisher section)	Paper Misfeed in Finisher - Please Clear Paper Path.	Cover open jam	Y	-	Y	Y	Y	P. 8-163

Error code	Classification	Message	Contents	Error code display media					Troubleshooting
				Panl	JL	ML	Noti	CSV	
EA50	Finisher jam (Finisher section)	Staple Jam in Finisher - Please Clear Staple.	Stapling jam	Y	-	Y	Y	Y	P. 8-164
EA60	Finisher jam (Finisher section)	Paper Misfeed in Finisher - Please Clear Paper Path.	Early arrival jam	Y	-	Y	Y	Y	P. 8-164
EA70	Finisher jam (Finisher section)	Paper Misfeed in Finisher - Please Clear Paper Path.	Stack exit belt home position error	Y	-	Y	Y	Y	P. 8-165
EA90	Finisher jam (Saddle stitch section)	Paper Misfeed in Finisher - Please Clear Paper Path.	Cover open jam	Y	-	Y	Y	Y	P. 8-167
EAA0	Finisher jam (Saddle stitch section)	Paper Misfeed in Finisher - Please Clear Paper Path.	Paper remaining jam in Saddle Stitch Unit	Y	-	Y	Y	Y	P. 8-167
EAB0	Finisher jam (Saddle stitch section)	Paper Misfeed in Finisher - Please Clear Paper Path.	Paper transport jam in Saddle Stitch Unit	Y	-	Y	Y	Y	P. 8-168
EAB1	Finisher jam (Saddle stitch section)	Paper Misfeed in Finisher - Please Clear Paper Path.	Paper size error jam	Y	-	Y	Y	Y	P. 8-169
EAD0	Other paper jam	Paper Misfeed in Printer - Please Clear Paper Path.	Print end command time-out jam	-	-	Y	Y	Y	P. 8-172
EAE0	Finisher jam	Paper Misfeed in Printer - Please Clear Paper Path.	Receiving time-out jam	-	-	Y	Y	Y	P. 8-172
EAFA	Finisher jam (Finisher section)	Paper Misfeed in Finisher - Please Clear Paper Path.	Stack exit roller home position sensor detection error	Y	-	Y	Y	Y	P. 8-166
EAFA	Finisher jam (Finisher section)	Paper Misfeed in Finisher - Please Clear Paper Path.	Stapler unit sliding motor home position detection error	Y	-	Y	Y	Y	-
EAFB	Finisher jam (Finisher section)	Paper Misfeed in Finisher - Please Clear Paper Path.	Stapler movement error	Y	-	Y	Y	Y	P. 8-231
EAFD	Finisher jam (Finisher section)	Paper Misfeed in Finisher - Please Clear Paper Path.	Movable tray height error	Y	-	Y	Y	Y	P. 8-227
EAFD	Finisher jam (Finisher section)	Paper Misfeed in Finisher - Please Clear Paper Path.	Movable tray movement error	Y	-	Y	Y	Y	P. 8-228
EAFE	Finisher jam (Finisher section)	Paper Misfeed in Finisher - Please Clear Paper Path.	Assist guide cam position error	Y	-	Y	Y	Y	P. 8-225
EB30	Other paper jams	Paper Misfeed in Printer - Please Clear Paper Path.	Ready time-out jam	-	-	Y	Y	Y	P. 8-172
EB50	Paper transport jam	Paper Misfeed in Printer - Please Clear Paper Path.	Paper remaining on the transport path due to multiple feeding	-	-	Y	Y	Y	P. 8-118

Error code	Classification	Message	Contents	Error code display media					Troubleshooting
				Panl	JL	ML	Noti	CSV	
EB60	Paper transport jam	Paper Misfeed in Printer - Please Clear Paper Path.	Paper remaining on the transport path due to multiple feeding	-	-	Y	Y	Y	P. 8-120
ED10	Finisher jam (Hole Punch section)	Paper Misfeed in Finisher - Please Clear Paper Path.	Skew adjustment motor home position detection error	Y	-	Y	Y	Y	P. 8-173
ED11	Finisher jam (Hole Punch section)	Paper Misfeed in Finisher - Please Clear Paper Path.	Sideways adjustment motor home position detection error	Y	-	Y	Y	Y	P. 8-173
ED13	Finisher jam (Finisher section)	Paper Misfeed in Finisher - Please Clear Paper Path.	Front alignment plate home position error	Y	-	Y	Y	Y	P. 8-174
ED14	Finisher jam (Finisher section)	Paper Misfeed in Finisher - Please Clear Paper Path.	Rear alignment plate home position error	Y	-	Y	Y	Y	P. 8-177
ED15	Finisher jam (Finisher section)	Paper Misfeed in Finisher - Please Clear Paper Path.	Paddle home position error	Y	-	Y	Y	Y	P. 8-175
ED16	Finisher jam	Paper Misfeed in Finisher - Please Clear Paper Path.	Buffer tray home position error	Y	-	Y	Y	Y	P. 8-175
EF10	Finisher jam (Saddle stitch section)	Paper Misfeed in Finisher - Please Clear Paper Path.	Paper not supported for saddle stitch finisher	Y	-	Y	Y	Y	P. 8-176
EF11	Finisher jam (Saddle stitch section)	Paper Misfeed in Finisher - Please Clear Paper Path.	Saddle stitch finisher stapling error (front)	Y	-	Y	Y	Y	P. 8-176
EF12	Finisher jam (Saddle stitch section)	Paper Misfeed in Finisher - Please Clear Paper Path.	Saddle stitch finisher stapling error (rear)	Y	-	Y	Y	Y	P. 8-176
EF13	Finisher jam (Saddle stitch section)	Paper Misfeed in Finisher - Please Clear Paper Path.	Saddle stitch unit paper holding home position detection error	Y	-	Y	Y	Y	P. 8-177
EF14	Finisher jam (Saddle stitch section)	Paper Misfeed in Finisher - Please Clear Paper Path.	Saddle stitch unit paper exit jam	Y	-	Y	Y	Y	P. 8-177
EF15	Finisher jam (Saddle stitch section)	Paper Misfeed in Finisher - Please Clear Paper Path.	Saddle stitch finisher side alignment motor home position detection abnormality	Y	-	Y	Y	Y	P. 8-184
EF16	Finisher jam (Saddle stitch section)	Paper Misfeed in Finisher - Please Clear Paper Path.	Saddle stitch finisher stacker motor home position detection abnormality	Y	-	Y	Y	Y	P. 8-185
EF17	Finisher jam (Saddle stitch section)	Paper Misfeed in Finisher - Please Clear Paper Path.	Saddle stitch finisher folding blade home position detection abnormality	Y	-	Y	Y	Y	P. 8-185

Error code	Classification	Message	Contents	Error code display media					Troubleshooting
				Panl	JL	ML	Noti	CSV	
EF18	Finisher jam (Saddle stitch section)	Paper Misfeed in Finisher - Please Clear Paper Path.	Saddle stitch finisher additional folding roller home position detection abnormality	Y	-	Y	Y	Y	P. 8-186
EF19	Finisher jam (Saddle stitch section)	Paper Misfeed in Finisher - Please Clear Paper Path.	Saddle stitch unit paper folding jam	Y	-	Y	Y	Y	P. 8-186
EF20	Finisher jam (Saddle stitch section)	Paper Misfeed in Finisher - Please Clear Paper Path.	Saddle stitch unit stacker jam	-	-	Y	Y	Y	P. 8-188

8.2.2 Service call

Error code	Classification	Message	Contents	Error code display media					Troubleshooting
				Panl	JL	ML	Noti	CSV	
C020	Drive system related service call	Fatal Error - Please Contact Service Technician.	Developer drive motor abnormality	2nd	-	Y	Y	Y	P. 8-189
C040	Paper feeding system related service call	Printer Input Error.	PFP motor abnormality	Y	-	Y	Y	Y	P. 8-190
C130	Paper feeding system related service call	Printer Input Error.	1st drawer tray abnormality	Y	-	Y	Y	Y	P. 8-191
C140	Paper feeding system related service call	Printer Input Error.	2nd drawer tray abnormality	Y	-	Y	Y	Y	P. 8-191
C150	Paper feeding system related service call	Printer Input Error.	PFP upper drawer tray abnormality	Y	-	Y	Y	Y	P. 8-192
C160	Paper feeding system related service call	Printer Input Error.	PFP lower drawer tray abnormality	Y	-	Y	Y	Y	P. 8-192
C180	Paper feeding system related service call	Printer Input Error.	LCF tray-up motor abnormality	Y	-	Y	Y	Y	P. 8-193
C1A0	Paper feeding system related service call	Printer Input Error.	LCF end fence motor abnormality	Y	-	Y	Y	Y	P. 8-194
C1B0	Paper feeding system related service call	Printer Input Error.	LCF transport motor abnormality	Y	-	Y	Y	Y	P. 8-195
C260	Scanning system related service call	Fatal Error - Please Contact Service Technician.	Peak detection error	2nd	-	Y	Y	Y	P. 8-196
C262	Scanning system related service call	Fatal Error - Please Contact Service Technician.	Communication error	2nd	-	Y	Y	Y	P. 8-197
C270	Scanning system related service call	Fatal Error - Please Contact Service Technician.	Carriage home position sensor not turning OFF within a specified period of time / Downloading firmware with an incorrect model	Y	-	Y	Y	Y	P. 8-197
C280	Scanning system related service call	Fatal Error - Please Contact Service Technician.	Carriage home position sensor not turning ON within a specified period of time	Y	-	Y	Y	Y	P. 8-198
C290	Scanning system related service call	Fatal Error - Please Contact Service Technician.	Scanner fuse blowout	2nd	-	Y	Y	Y	P. 8-199
C370	Copy process related service call	Fatal Error - Please Contact Service Technician.	Transfer belt abnormality	2nd	-	Y	Y	Y	P. 8-263

Error code	Classification	Message	Contents	Error code display media					Troubleshooting
				Panl	JL	ML	Noti	CSV	
C380	Copy process related service call	Fatal Error - Please Contact Service Technician.	Auto-toner sensor-K abnormality (upper limit)	2nd	-	Y	Y	Y	P. 8-263
C381	Copy process related service call	Fatal Error - Please Contact Service Technician.	Auto-toner sensor-K abnormality (lower limit)	2nd	-	Y	Y	Y	P. 8-264
C390	Copy process related service call	Fatal Error - Please Contact Service Technician.	Auto-toner sensor-C abnormality (upper limit)	2nd	-	Y	Y	Y	P. 8-265
C391	Copy process related service call	Fatal Error - Please Contact Service Technician.	Auto-toner sensor-C abnormality (lower limit)	2nd	-	Y	Y	Y	P. 8-266
C3A0	Copy process related service call	Fatal Error - Please Contact Service Technician.	Auto-toner sensor-M abnormality (upper limit)	2nd	-	Y	Y	Y	P. 8-266
C3A1	Copy process related service call	Fatal Error - Please Contact Service Technician.	Auto-toner sensor-M abnormality (lower limit)	2nd	-	Y	Y	Y	P. 8-267
C3B0	Copy process related service call	Fatal Error - Please Contact Service Technician.	Auto-toner sensor-Y abnormality (upper limit)	2nd	-	Y	Y	Y	P. 8-268
C3B1	Copy process related service call	Fatal Error - Please Contact Service Technician.	Auto-toner sensor-Y abnormality (lower limit)	2nd	-	Y	Y	Y	P. 8-269
C3E1	Copy process related service call	Fatal Error - Please Contact Service Technician.	Drum / cleaner / charger unit replacement (old-new) detection abnormality	2nd	-	Y	Y	Y	P. 8-269
C440	Fuser unit related service call	Fatal Error - Please Contact Service Technician.	Heater abnormality after abnormality judgment (temperature abnormality at printing status)	Y	-	Y	Y	Y	P. 8-200
C445	Fuser unit related service call	Fatal Error - Please Contact Service Technician.	Fusing temperature abnormality after abnormality judgment (pre-running end temperature abnormality)	Y	-	Y	Y	Y	P. 8-200
C446	Fuser unit related service call	Fatal Error - Please Contact Service Technician.	Fusing temperature abnormality after abnormality judgment (pre-running end temperature abnormality)	Y	-	Y	Y	Y	P. 8-200

Error code	Classification	Message	Contents	Error code display media					Troubleshooting
				Panl	JL	ML	Noti	CSV	
C447	Fuser unit related service call	Fatal Error - Please Contact Service Technician.	Fusing temperature abnormality after abnormality judgment (temperature abnormality at ready status / during printing)	Y	-	Y	Y	Y	P. 8-200
C449	Fuser unit related service call	Fatal Error - Please Contact Service Technician.	Fusing temperature abnormality after abnormality judgment (high temperature abnormality)	Y	-	Y	Y	Y	P. 8-200
C471	Fuser unit related service call	Fatal Error - Please Contact Service Technician.	IH board initialization abnormality	2nd	-	Y	Y	Y	P. 8-201
C472	Fuser unit related service call	Fatal Error - Please Contact Service Technician.	Power supply abnormality	Y	-	Y	Y	Y	P. 8-201
C473	Fuser unit related service call	Fatal Error - Please Contact Service Technician.	Power voltage upper limit abnormality	2nd	-	Y	Y	Y	P. 8-202
C474	Fuser unit related service call	Fatal Error - Please Contact Service Technician.	Power voltage lower limit abnormality	2nd	-	Y	Y	Y	P. 8-202
C480	Fuser unit related service call	Fatal Error - Please Contact Service Technician.	IGBT high temperature abnormality	2nd	-	Y	Y	Y	P. 8-202
C4B0	Fuser unit related service call	Fatal Error - Please Contact Service Technician.	Status counter abnormality	Y	-	Y	Y	Y	P. 8-203
C4B1	Fuser unit related service call	Fatal Error - Please Contact Service Technician.	Fuser unit voltage judgment abnormality	2nd	-	Y	Y	Y	P. 8-203
C4B2	Fuser unit related service call	Fatal Error - Please Contact Service Technician.	IH firmware combination error	2nd	-	Y	Y	Y	P. 8-203
C4C0	Fuser unit related service call	Fatal Error - Please Contact Service Technician.	Fuser unit old / new detection fuse abnormality	2nd	-	Y	Y	Y	P. 8-204
C4E0	Fuser unit related service call	Fatal Error - Please Contact Service Technician.	Pressure roller release abnormality	2nd	-	Y	Y	Y	P. 8-204
C4E1	Fuser unit related service call	Fatal Error - Please Contact Service Technician.	Pressure roller contact / semi-contact abnormality	2nd	-	Y	Y	Y	P. 8-204

Error code	Classification	Message	Contents	Error code display media					Troubleshooting
				Panl	JL	ML	Noti	CSV	
C4E2	Fuser unit related service call	Fatal Error - Please Contact Service Technician.	Fuser belt rotation detection sensor abnormality	2nd	-	Y	Y	Y	P. 8-205
C550	DSDf service call	Fatal Error - Please Contact Service Technician.	Communication error between the scanner and DF	5th	-	Y	Y	Y	P. 8-207
	RADF service call			5th	-	Y	Y	Y	P. 8-207
C551	DSDf / RADf service call	Fatal Error - Please Contact Service Technician.	DF model detection error	2nd	-	Y	Y	Y	P. 8-211
C552	DSDf / RADf service call	Fatal Error - Please Contact Service Technician.	DF abnormality	5th	-	Y	Y	Y	P. 8-211
C553	DSDf service call	Fatal Error - Please Contact Service Technician.	DSDf CCD-module Peak detection error	5th	-	Y	Y	Y	P. 8-211
C554	DSDf service call	Fatal Error - Please Contact Service Technician.	AfE communication error	5th	-	Y	Y	Y	P. 8-212
C560	Communication related service call	Fatal Error - Please Contact Service Technician.	Communication error between Engine-CPU and PFC board	5th	-	Y	Y	Y	P. 8-208
C580	Option related service call	Printer Output Error.	Communication error between the LGC board and the finisher	5th	-	Y	Y	Y	P. 8-208
C5A0	Circuit related service call	Fatal Error - Please Contact Service Technician.	EEPROM abnormality (LGC board)	Y	-	Y	Y	Y	P. 8-216
C5A1	Circuit related service call	Fatal Error - Please Contact Service Technician.	EEPROM data abnormality (LGC board)	Y	-	Y	Y	Y	P. 8-216
C730	DSDf service call	Automatic Document Feeder Error - Please Contact Service Technician.	DSDf EEPROM writing error	2nd	-	Y	Y	Y	P. 8-213
C7B0	DSDf service call	Automatic Document Feeder Error - Please Contact Service Technician.	Initial time-out error	5th	-	Y	Y	Y	P. 8-213
C8C0	DSDf service call	Automatic Document Feeder Error - Please Contact Service Technician.	DSDf read-in sensor-1 automatic adjustment error	2nd	-	Y	Y	Y	P. 8-213
C8E0	DSDf / RADf service call	Automatic Document Feeder Error - Please Contact Service Technician.	DF control abnormality (communication protocol abnormality)	5th	-	Y	Y	Y	P. 8-214

Error code	Classification	Message	Contents	Error code display media					Troubleshooting
				Panl	JL	ML	Noti	CSV	
C900	Circuit related service call	Fatal Error - Please Contact Service Technician.	Connection error between the SYS board and the LGC board	2nd	-	Y	Y	Y	P. 8-216
C911	Toner cartridge related service call	Failed to access to the toner IC chip	Toner cartridge PC board access abnormality (K)	-	-	Y	Y	Y	P. 8-217
C912	Toner cartridge related service call	Failed to access to the toner IC chip	Toner cartridge PC board access abnormality (C)	-	-	Y	Y	Y	P. 8-217
C913	Toner cartridge related service call	Failed to access to the toner IC chip	Toner cartridge PC board access abnormality (M)	-	-	Y	Y	Y	P. 8-217
C914	Toner cartridge related service call	Failed to access to the toner IC chip	Toner cartridge PC board access abnormality (Y)	-	-	Y	Y	Y	P. 8-217
C916	Circuit related service call	Fatal Error - Please Contact Service Technician.	Sub-CPU access abnormality	2nd	-	Y	Y	Y	P. 8-217
C940	Circuit related service call	Fatal Error - Please Contact Service Technician.	Engine-CPU abnormality	2nd	-	Y	Y	Y	P. 8-218
C962	Circuit related service call	Fatal Error - Please Contact Service Technician.	LGC board ID abnormality	Y	-	Y	Y	Y	P. 8-218
C963	Circuit related service call	[Error] Printer Needs Attention: Call for service	Connection detection error between the SYS board and the LGC board	2nd	-	Y	Y	Y	P. 8-218
C964	Circuit related service call	Fatal Error - Please Contact Service Technician.	LGC board boot process abnormality	2nd	-	Y	Y	Y	P. 8-219
C970	Process related service call	Fatal Error - Please Contact Service Technician.	High-voltage transformer abnormality	2nd	-	Y	Y	Y	P. 8-270
C9E0	Circuit related service call	Scanner Error - Please Contact Service Technician.	Connection error between the scanner CPU and the system CPU	Y	-	Y	Y	Y	P. 8-219
CA00	Image control related service call	Fatal Error - Please Contact Service Technician.	Color registration abnormality	2nd	-	Y	Y	Y	P. 8-247
CA10	Laser optical unit related service call	Fatal Error - Please Contact Service Technician.	Polygonal motor abnormality	2nd	-	Y	Y	Y	P. 8-221
CA20	Laser optical unit related service call	Fatal Error - Please Contact Service Technician.	H-Sync detection error (K, Y)	2nd	-	Y	Y	Y	P. 8-221
CA21	Laser optical unit related service call	Fatal Error - Please Contact Service Technician.	H-Sync detection error (K)	2nd	-	Y	Y	Y	P. 8-221

Error code	Classification	Message	Contents	Error code display media					Troubleshooting
				Panl	JL	ML	Noti	CSV	
CA22	Laser optical unit related service call	Fatal Error - Please Contact Service Technician.	H-Sync detection error (Y)	2nd	-	Y	Y	Y	P. 8-221
CA60	Laser optical unit related service call	Fatal Error - Please Contact Service Technician.	LSU thermistor-1 abnormality	2nd	-	Y	Y	Y	P. 8-222
CA61	Laser optical unit related service call	Fatal Error - Please Contact Service Technician.	LSU thermistor-2 abnormality	2nd	-	Y	Y	Y	P. 8-223
CB00	Finisher related service call	Fatal Error - Please Contact Service Technician.	Finisher communication error	5th	-	Y	Y	Y	P. 8-224
CB10	Finisher related service call	Printer Output Error.	Entrance motor abnormality	2nd	-	Y	Y	Y	P. 8-224
CB11	Finisher related service call	Fatal Error - Please Contact Service Technician.	Buffer tray guide motor abnormality	5th	-	Y	Y	Y	P. 8-224
CB13	Finisher related service call	Fatal Error - Please Contact Service Technician.	Finisher exit motor abnormality	2nd	-	Y	Y	Y	P. 8-225
CB14	Finisher related service call	Fatal Error - Please Contact Service Technician.	Finisher assist guide motor abnormality	5th	-	Y	Y	Y	P. 8-225
CB15	Finisher related service call	Fatal Error - Please Contact Service Technician.	Catching motor abnormality	5th	-	Y	Y	Y	P. 8-226
CB30	Finisher related service call	Printer Output Error.	[MJ-1042] Movable tray shift motor abnormality [MJ-1109/1110] Movable tray shift motor abnormality	2nd	-	Y	Y	Y	P. 8-226 P. 8-227
CB31	Finisher related service call	Fatal Error - Please Contact Service Technician.	Movable tray paper-full detection error	5th	-	Y	Y	Y	P. 8-228
CB40	Finisher related service call	Printer Output Error.	[MJ-1042] Front alignment plate home position detection error [MJ-1109/1110] Front alignment motor abnormality	5th	-	Y	Y	Y	P. 8-229 P. 8-229
CB50	Finisher related service call	Printer Output Error.	[MJ-1042] Stapler home position detection error [MJ-1109/1110] Stapler home position error	5th	-	Y	Y	Y	P. 8-230 P. 8-230

Error code	Classification	Message	Contents	Error code display media					Troubleshooting
				Panl	JL	ML	Noti	CSV	
CB51	Finisher related service call	Fatal Error - Please Contact Service Technician.	[MJ-1042] Stapler unit sliding home position detection error [MJ-1109/1110] Stapler shift home position error	5th	-	Y	Y	Y	P. 8-231 P. 8-231
CB60	Finisher related service call	Printer Output Error.	Stapler unit shift motor abnormality	5th	-	Y	Y	Y	P. 8-232
CB80	Finisher related service call	Printer Output Error.	[MJ-1042] Finisher control PC board backup RAM error [MJ-1109/1110] Backup RAM data abnormality	2nd	-	Y	Y	Y	P. 8-232 P. 8-232
CB81	Finisher related service call	Fatal Error - Please Contact Service Technician.	Flash ROM abnormality	2nd	-	Y	Y	Y	P. 8-233
CB82	Finisher related service call (Finisher section)	Fatal Error - Please Contact Service Technician.	Finisher - Main program error	2nd	-	Y	Y	Y	P. 8-233
CB83	Finisher related service call (Saddle stitch unit)	Fatal Error - Please Contact Service Technician.	Saddle stitch finisher - Main program error	2nd	-	Y	Y	Y	P. 8-233
CB84	Finisher related service call (Hole punch unit)	Hole punch unit - Main program error	Hole punch unit - Main program error	2nd	-	Y	Y	Y	P. 8-234
CB92	Finisher related service call (Saddle stitch unit)	Fatal Error - Please Contact Service Technician.	Saddle stitch finisher RAM abnormality	2nd	-	Y	Y	Y	P. 8-234
CB93	Finisher related service call (Saddle stitch unit)	Fatal Error - Please Contact Service Technician.	Saddle stitch finisher additional folding motor abnormality	5th	-	Y	Y	Y	P. 8-234
CB94	Finisher related service call (Saddle stitch unit)	Fatal Error - Please Contact Service Technician.	Saddle transport motor abnormality	5th	-	Y	Y	Y	P. 8-235
CB95	Finisher related service call (Saddle stitch unit)	Fatal Error - Please Contact Service Technician.	Saddle stitch finisher stacker motor abnormality	5th	-	Y	Y	Y	P. 8-235
CBA0	Finisher related service call (Saddle stitch unit)	Fatal Error - Please Contact Service Technician.	Front saddle stapler home position error	5th	-	Y	Y	Y	P. 8-235
CBB0	Finisher related service call (Saddle stitch unit)	Fatal Error - Please Contact Service Technician.	Rear saddle stapler home position error	5th	-	Y	Y	Y	P. 8-236
CBC0	Finisher related service call (Saddle stitch unit)	Fatal Error - Please Contact Service Technician.	Saddle stitch finisher side alignment motor abnormality	5th	-	Y	Y	Y	P. 8-236

Error code	Classification	Message	Contents	Error code display media					Troubleshooting
				Panl	JL	ML	Noti	CSV	
CBE0	Finisher related service call (Saddle stitch unit)	Fatal Error - Please Contact Service Technician.	Saddle stitch finisher folding motor abnormality	5th	-	Y	Y	Y	P. 8-237
CC02	Finisher related service call (Finisher section)	Fatal Error - Please Contact Service Technician.	Stack exit roller nip home position detection error	2nd	-	Y	Y	Y	P. 8-237
CC20	Finisher related service call	Fatal Error - Please Contact Service Technician.	Saddle stitch communication error	2nd	-	Y	Y	Y	P. 8-237
CC30	Finisher related service call (Finisher section)	Fatal Error - Please Contact Service Technician.	Stack transport motor abnormality	5th	-	Y	Y	Y	P. 8-238
CC31	Finisher related service call (Finisher section)	Fatal Error - Please Contact Service Technician.	Transport motor abnormality	2nd	-	Y	Y	Y	P. 8-238
CC41	Finisher related service call (Finisher section)	Fatal Error - Please Contact Service Technician.	Assist guide cam home position abnormality	2nd	-	Y	Y	Y	P. 8-239
CC51	Finisher related service call (Hole punch unit)	Fatal Error - Please Contact Service Technician.	[MJ-1042] (When MJ-6011 is installed) Punch unit sliding motor abnormality [MJ-1109/1110] (When MJ-6105 is installed) Sideways adjustment motor abnormality	2nd	-	Y	Y	Y	P. 8-239 P. 8-240
CC52	Finisher related service call (Hole punch unit)	Fatal Error - Please Contact Service Technician.	Skew adjustment motor abnormality	5th	-	Y	Y	Y	P. 8-240
CC54	Finisher related service call (Hole punch unit)	Fatal Error - Please Contact Service Technician.	Paper detection sensors abnormality	2nd	-	Y	Y	Y	P. 8-241
CC60	Finisher related service call (Hole punch unit)	Fatal Error - Please Contact Service Technician.	Punch motor abnormality	2nd	-	Y	Y	Y	P. 8-241
CC61	Finisher related service call (Hole punch unit)	Fatal Error - Please Contact Service Technician.	[MJ-1042] (When MJ-6011 is installed) Punch motor abnormality [MJ-1109/1110] (When MJ-6105 is installed) Punch motor home position detection error	5th	-	Y	Y	Y	P. 8-241 P. 8-242
CC71	Finisher related service call (Hole punch unit)	Fatal Error - Please Contact Service Technician.	Punch ROM checksum error	Y	-	Y	Y	Y	P. 8-242

Error code	Classification	Message	Contents	Error code display media					Troubleshooting
				Panl	JL	ML	Noti	CSV	
CC72	Finisher related service call (Hole punch unit)	Fatal Error - Please Contact Service Technician.	Punch RAM read / write error	Y	-	Y	Y	Y	P. 8-243
CC80	Finisher related service call (Finisher section)	Fatal Error - Please Contact Service Technician.	[MJ-1042] Front alignment motor abnormality [MJ-1109/1110] Rear alignment motor abnormality	2nd	-	Y	Y	Y	P. 8-243 P. 8-243
CC93	Finisher related service call (Finisher section)	Fatal Error - Please Contact Service Technician.	Knurled roller shift solenoid abnormality	2nd	-	Y	Y	Y	P. 8-244
CC94	Finisher related service call (Finisher section)	Fatal Error - Please Contact Service Technician.	Fan motor abnormality	2nd	-	Y	Y	Y	P. 8-245
CCF1	Finisher related service call (Finisher section)	Fatal Error - Please Contact Service Technician.	Tray safety switch abnormality	2nd	-	Y	Y	Y	P. 8-245
CD40	Copy process related service call	Fatal Error - Please Contact Service Technician.	Waste toner box full error	-	-	Y	Y	Y	P. 8-271
CDE0	Finisher related service call (Finisher section)	Printer Output Error.	Paddle motor abnormality	5th	-	Y	Y	Y	P. 8-245
CE00	Finisher related service call	Fatal Error - Please Contact Service Technician.	Communication error between the finisher and the punch unit	5th	-	Y	Y	Y	P. 8-246
CE10	Image control related service call	Fatal Error - Please Contact Service Technician.	Image quality sensor abnormality (OFF level)	2nd	-	Y	Y	Y	P. 8-253
CE20	Image control related service call	Fatal Error - Please Contact Service Technician.	Image quality sensor abnormality (no pattern level)	2nd	-	Y	Y	Y	P. 8-254
CE40	Image control related service call	Fatal Error - Please Contact Service Technician.	Image quality control test pattern abnormality	2nd	-	Y	Y	Y	P. 8-256
CE41	Image control related service call	Fatal Error - Please Contact Service Technician.	Image quality TRC control test pattern abnormality	2nd	-	Y	Y	Y	P. 8-259
CE50	Image control related service call	Fatal Error - Please Contact Service Technician.	Temperature / humidity sensor abnormality	2nd	-	Y	Y	Y	P. 8-260
CE70	Image control related service call	Fatal Error - Please Contact Service Technician.	Drum drive switching abnormality	2nd	-	Y	Y	Y	P. 8-260
CE90	Image control related service call	Fatal Error - Please Contact Service Technician.	Drum thermistor abnormality	2nd	-	Y	Y	Y	P. 8-262

Error code	Classification	Message	Contents	Error code display media					Troubleshooting
				Panl	JL	ML	Noti	CSV	
CF10	Finisher related service call	Printer Output Error.	Communication module writing failure	2nd	-	Y	Y	Y	P. 8-246
F070	Communication related service call	Fatal Error - Please Contact Service Technician.	Communication error between the system-CPU and the engine-CPU	5th	-	Y	Y	Y	P. 8-208
F071	Communication related service call	Fatal Error - Please Contact Service Technician.	Communication initialization error between the system-CPU and the engine-CPU	2nd	-	Y	Y	-	P. 8-209
F074		Fatal Error - Please Contact Service Technician.	Communication error between the system-CPU and the engine-CPU (engine-CPU response abnormality)	5th	-	Y	Y	Y	P. 8-209
F090	Circuit related service call	Fatal Error - Please Contact Service Technician.	SRAM abnormality on the SYS board	Y	-	Y	Y	-	P. 8-220
F100_0	Other service call	Fatal Error - Please Contact Service Technician.	HDD format error (Operation failure of key data)	Y	-	Y	Y	-	P. 8-272
F100_1	Other service call	Fatal Error - Please Contact Service Technician.	HDD format error (HDD encryption key data damaged - one board)	Y	-	Y	Y	-	P. 8-272
F100_2	Other service call	Fatal Error - Please Contact Service Technician.	HDD format error (HDD encryption key data damaged - both boards)	Y	-	Y	Y	-	P. 8-273
F100_3	Other service call	Fatal Error - Please Contact Service Technician.	Serial number value error	Y	-	Y	Y	-	P. 8-274
F100_4	Other service call	Fatal Error - Please Contact Service Technician.	Hash check error of encryption partition key	Y	-	Y	Y	-	P. 8-274
F101_0	Other service call	Fatal Error - Please Contact Service Technician.	HDD connection error (HDD connection cannot be detected)	Y	-	Y	Y	-	P. 8-275
F101_1	Other service call	Fatal Error - Please Contact Service Technician.	Root partition mount error (HDD formatting fails)	Y	-	Y	Y	-	P. 8-275
F101_2	Other service call	Fatal Error - Please Contact Service Technician.	Partition mount error	Y	-	Y	Y	-	P. 8-275
F101_3	Other service call	Fatal Error - Please Contact Service Technician.	Partition mount error	Y	-	Y	Y	-	P. 8-275

Error code	Classification	Message	Contents	Error code display media					Troubleshooting
				Panl	JL	ML	Noti	CSV	
F101_4	Other service call	Fatal Error - Please Contact Service Technician.	Partition mount error	-	-	-	-	-	P. 8-276
F101_5	Other service call	Fatal Error - Please Contact Service Technician.	Partition mount error	-	-	-	-	-	P. 8-277
F101_6	Other service call	Fatal Error - Please Contact Service Technician.	Partition mount error	-	-	-	-	-	P. 8-278
F101_7	Other service call	Fatal Error - Please Contact Service Technician.	Partition mount error	-	-	-	-	-	P. 8-279
F101_8	Other service call	Fatal Error - Please Contact Service Technician.	Partition mount error	-	-	-	-	-	P. 8-280
F101_9	Other service call	Fatal Error - Please Contact Service Technician.	Partition mount error	-	-	-	-	-	P. 8-281
F101_10	Other service call	Fatal Error - Please Contact Service Technician.	Partition mount error	-	-	-	-	-	P. 8-282
F101_11	Other service call	Fatal Error - Please Contact Service Technician.	Partition mount error	-	-	-	-	-	P. 8-283
F101_12	Other service call	Fatal Error - Please Contact Service Technician.	Partition mount error	-	-	-	-	-	P. 8-276
F101_13	Other service call	Fatal Error - Please Contact Service Technician.	Error due to damage to file	-	-	-	-	-	P. 8-284
F101_14	Other service call	Fatal Error - Please Contact Service Technician.	Partition mount error	-	-	-	-	-	P. 8-285
F102	Other service call	Fatal Error - Please Contact Service Technician.	HDD start error	Y	-	Y	Y	-	P. 8-286
F103	Other service call	Fatal Error - Please Contact Service Technician.	HDD transfer time-out	5th	-	Y	Y	-	P. 8-286
F104	Other service call	Fatal Error - Please Contact Service Technician.	HDD data error	5th	-	Y	Y	-	P. 8-286
F105	Other service call	Fatal Error - Please Contact Service Technician.	HDD other error	5th	-	Y	Y	-	P. 8-286

Error code	Classification	Message	Contents	Error code display media					Troubleshooting
				Panl	JL	ML	Noti	CSV	
F106_0	Other service call		HDD error (Illegal disk replacement detected)	2nd	-	-	-	-	P. 8-286
F106_1	Other service call		HDD error (HDD type detection error)	2nd	-	-	-	-	P. 8-287
F106_2	Other service call		HDD error (Secure HDD encryption key download operation error)	2nd	-	-	-	-	P. 8-287
F106_3	Other service call		HDD error (Secure HDD authentication Admin Password generation error)	2nd	-	-	-	-	P. 8-288
F106_4	Other service call		HDD error (Authentication random number generation error)	2nd	-	-	-	-	P. 8-289
F106_5	Other service call		HDD error (Authentication data transmission error)	2nd	-	-	-	-	P. 8-289
F106_6	Other service call		HDD error (Error caused by reason other than F106_0 to 5 errors)	2nd	-	-	-	-	P. 8-290
F106_7	Other service call		HDD error (Error caused by reason other than F106_0 to 5 errors)	2nd	-	-	-	-	P. 8-290
F106_8	Other service call		HDD error (Error caused by reason other than F106_0 to 5 errors)	2nd	-	-	-	-	P. 8-290
F106_10	Other service call		HDD error (Error caused by reason other than F106_0 to 5 errors)	2nd	-	-	-	-	P. 8-290
F106_11	License Management		License damaged (HDD and SRAM)	2nd	-	-	-	-	P. 8-290
F106_12	License Management		License damaged (SRAM)	2nd	-	-	-	-	P. 8-291
F106_UNDEF	Other service call		HDD error (Error caused by reason other than F106_0 to 5 errors)	2nd	-	-	-	-	P. 8-290
F109_0	Other service call		Key consistency error (Consistency check operation error)	Y	-	-	-	-	P. 8-291
F109_1	Other service call		Key consistency error (SRAM encryption AES key data damage)	Y	-	-	-	-	P. 8-292
F109_2	Other service call		Key consistency error (Signature Check public key damage)	Y	-	-	-	-	P. 8-292

Error code	Classification	Message	Contents	Error code display media					Troubleshooting
				Panl	JL	ML	Noti	CSV	
F109_3	Other service call		Key consistency error (HDD encryption parameter damage)	Y	-	-	-	-	P. 8-293
F109_4	Other service call		Key consistency error (license data damage)	Y	-	-	-	-	P. 8-294
F109_5	Other service call		Key consistency error (encryption key for HDD is damaged)	Y	-	-	-	-	P. 8-295
F109_6	Other service call		Key consistency error (administrator password error for HDD authentication)	Y	-	-	-	-	P. 8-296
F109_7	Other service call		Hash check error of ADI-HDD authentication key	Y	-	-	-	-	P. 8-297
F110	Communication related service call	Fatal Error - Please Contact Service Technician.	Communication error between the system-CPU and the scanner-CPU	5th	-	-	-	Y	P. 8-298
F111	Communication related service call	Fatal Error - Please Contact Service Technician.	Communication error between the system-CPU and the scanner-CPU	5th	-	-	-	Y	P. 8-298
F115	Scanning system related service call	Fatal Error - Please Contact Service Technician.	S-VDEN ON signal time-out error	2nd	-	Y	Y	Y	P. 8-214
F116	Scanning system related service call	Fatal Error - Please Contact Service Technician.	S-VDEN OFF signal time-out error	2nd	-	Y	Y	Y	P. 8-214
F117	Scanning system related service call (DSDF)	Fatal Error - Please Contact Service Technician.	S-VDEN ON (back side) signal time-out error	2nd	-	Y	Y	Y	P. 8-214
F118	Scanning system related service call (DSDF)	Fatal Error - Please Contact Service Technician.	S-VDEN OFF (back side) signal time-out error	2nd	-	Y	Y	Y	P. 8-214
F119	Scanning system related service call	Fatal Error - Please Contact Service Technician.	Scanner abnormality detection	5th	-	Y	Y	Y	P. 8-298
F11A	Scanning system related service call	Fatal Error - Please Contact Service Technician.	Communication error between the SYS board and the CCD board	2nd	-	Y	Y	Y	P. 8-215
F11B	Scanning system related service call	Fatal Error - Please Contact Service Technician.	Communication error between the SYS board and the DSDF-CCD module	2nd	-	Y	Y	Y	P. 8-215
F120	Other service call	Fatal Error - Please Contact Service Technician.	Database abnormality	Y	-	Y	Y	-	P. 8-299

Error code	Classification	Message	Contents	Error code display media					Troubleshooting
				Panl	JL	ML	Noti	CSV	
F121	Other service call	User Management DB corrupted.	Database abnormality (user information management database error)	2nd	-	Y	Y	-	P. 8-299
F122	Other service call	Log Management DB corrupted.	Database abnormality (message / job log management database error)	Y	-	Y	Y	-	P. 8-300
F124	Other service call	AppManagement DB corrupted.	Database abnormality (application management database damage error)	Y	-	Y	Y	-	P. 8-300
F125	Other service call	HomeScreen DB corrupted.	Database abnormality (Home screen database damage error)	Y	-	Y	Y	-	P. 8-300
F126	Other service call	JobHistory DB corrupted.	Database abnormality (Job history database damage error)	Y	-	Y	Y	-	P. 8-301
F127	Other service call	AppLicense DB corrupted.	Database abnormality (application license management database damage error)	Y	-	Y	Y	-	P. 8-301
F128	License Management	LMDB ERROR	License management database damage	-	-	Y	Y	-	P. 8-301
F130	Other service call		Invalid MAC address	2nd	-	-	-	-	P. 8-302
F131	Other service call	Fatal Error - Please Contact Service Technician.	Filtering setting file damage error	Y	-	Y	Y	-	P. 8-302
F140	Other service call	Fatal Error - Please Contact Service Technician.	ASIC format abnormality	2nd	-	Y	Y	Y	P. 8-302
F150	Other service call	-	Power failure during the manufacturing mode	Y	-	Y	Y	-	P. 8-303
F200	Other service call	Fatal Error - Please Contact Service Technician.	Data Overwrite option (GP-1070) disabled	Y	-	Y	Y	-	P. 8-303
F350	Circuit related service call	Fatal Error - Please Contact Service Technician.	SYS board abnormality	Y	-	Y	Y	Y	P. 8-220
F400	Circuit related service call	Fatal Error - Please Contact Service Technician.	SYS board cooling fan abnormality	Y	-	Y	Y	-	P. 8-304

Error code	Classification	Message	Contents	Error code display media					Troubleshooting
				Panl	JL	ML	Noti	CSV	
F410	Circuit related service call	Fatal Error - Please Contact Service Technician.	Power abnormality	2nd	-	Y	Y	-	P. 8-304
F510	Other service call		Application start error	5th	-	-	-	-	P. 8-304
F520	Other service call		Operating system start error	Y	-	-	-	-	P. 8-305
F521	Other service call		Integrity check error	Y	-	-	-	-	P. 8-305
F523	Other service call		Security check error at the startup	Y	-	-	-	-	P. 8-305
F550	Other service call	Fatal Error - Please Contact Service Technician.	Encryption partition error	-	-	Y	Y	-	P. 8-305
F600	Other service call	Fatal Error - Please Contact Service Technician.	Firmware update error	Y	-	-	-	-	P. 8-306
F700	Other service call	Fatal Error - Please Contact Service Technician.	Overwrite error	-	-	Y	Y	-	P. 8-306
F800	Other service call	Fatal Error - Please Contact Service Technician.	Date error	2nd	-	-	-	-	P. 8-306
F900	Other service call		Model information alignment error	Y	-	-	-	-	P. 8-307
F902_1	Other service call		System firmware / system software model information consistency error	Y	-	-	-	-	P. 8-307
F902_2	Other service call		A model-unmatched SYS board is installed or the SRAM is cleared	Y	-	-	-	-	P. 8-307
F902_3	Other service call		SRAM abnormality on the SYS board	Y	-	-	-	-	P. 8-308
F902_4	Other service call		SYS board model information consistency error	Y	-	-	-	-	P. 8-309

8.2.3 Error in Internet FAX / Scanning function

1. Internet FAX related error

Error code	Classification	Message	Contents	Error code display media					Troubleshooting
				Panl	JL	ML	Noti	CSV	
1C10	Internet FAX related error	Illegal Job status	System access abnormality	-	Y	-	Y	-	P. 8-310
1C11	Internet FAX related error	Not enough memory	Insufficient memory	-	Y	-	Y	-	P. 8-310
1C12	Internet FAX related error	Illegal Job status	Message reception error	-	Y	-	Y	-	P. 8-311
1C13	Internet FAX related error	Illegal Job status	Message transmission error	-	Y	-	Y	-	P. 8-311
1C14	Internet FAX related error	Invalid parameter specified	Invalid parameter	-	Y	-	Y	-	P. 8-311
1C15	Internet FAX related error	Message size exceeded limit or maximum size	Exceeding file capacity	-	Y	-	Y	-	P. 8-311
1C30	Internet FAX related error	Failed to create directory	Directory creation failure	-	Y	-	Y	-	P. 8-311
1C31	Internet FAX related error	Failed to create file	File creation failure	-	Y	-	Y	-	P. 8-311
1C32	Internet FAX related error	Failed to delete file	File deletion failure	-	Y	-	Y	-	P. 8-310
1C33	Internet FAX related error	Failed to create file	File access failure	-	Y	-	Y	-	P. 8-311
1C40	Internet FAX related error	Failed to convert image file format	Image conversion abnormality	-	Y	-	Y	-	P. 8-312
1C60	Internet FAX related error	Failed To Process your Job. Insufficient Storage space.	HDD full failure during processing	-	Y	-	Y	-	P. 8-312
1C61	Internet FAX related error	Failed to read AddressBook	AddressBook reading failure	-	Y	-	Y	-	P. 8-312
1C63	Internet FAX related error	Invalid Domain Address	Terminal IP address unset	-	Y	-	Y	-	P. 8-313
1C64	Internet FAX related error	Invalid Domain Address	Terminal mail address unset	-	Y	-	Y	-	P. 8-313
1C65	Internet FAX related error	Failed to connect to SMTP server	SMTP mail address unset	-	Y	-	Y	-	P. 8-313
1C66	Internet FAX related error	Failed to connect to SMTP server	Server time-out error	-	Y	-	Y	-	P. 8-313
1C69	Internet FAX related error	Failed to connect to SMTP server	SMTP server connection error	-	Y	-	Y	-	P. 8-314
1C6B	Internet FAX related error	Invalid address specified in To: field	Terminal mail address error	-	Y	-	Y	-	P. 8-314
1C6C	Internet FAX related error	Invalid address specified in To: field	Destination mail address error	-	Y	-	Y	-	P. 8-314
1C6D	Internet FAX related error	NIC system error	System error	-	Y	-	Y	-	P. 8-314
1C70	Internet FAX related error	SMTP service is not available	SMTP client OFF	-	Y	-	Y	-	P. 8-315
1C71	Internet FAX related error	Failed SMTP Authentication	SMTP authentication error	-	Y	-	Y	-	P. 8-315

Error code	Classification	Message	Contents	Error code display media					Troubleshooting
				Panl	JL	ML	Noti	CSV	
1C72	Internet FAX related error	POP Before SMTP Authentication Failed	POP before SMTP error	-	Y	-	Y	-	P. 8-315
1CC0	Internet FAX related error	Job canceled	Job canceling	-	Y	-	Y	-	-
1CC1	Internet FAX related error	Power failure occurred	Power failure	-	Y	-	Y	-	P. 8-315

2. RFC related error

Error code	Classification	Message	Contents	Error code display media					Troubleshooting
				Panl	JL	ML	Noti	CSV	
2500	RFC related error	Syntax error, command unrecognized	HOST NAME error (RFC: 500) / Destination mail address error (RFC: 500) / Terminal mail address error (RFC: 500)	-	Y	-	Y	-	P. 8-316
2501	RFC related error	Syntax error in parameters or arguments	HOST NAME error (RFC: 501) / Destination mail address error (RFC: 501) / Terminal mail address error (RFC: 501)	-	Y	-	Y	-	P. 8-316
2503	RFC related error	Bad sequence of commands	Destination mail address error (RFC: 503)	-	Y	-	Y	-	P. 8-316
2504	RFC related error	Command parameter not implemented	HOST NAME error (RFC: 504)	-	Y	-	Y	-	P. 8-316
2550	RFC related error	Mailbox unavailable	Destination mail address error (RFC: 550)	-	Y	-	Y	-	P. 8-316
2551	RFC related error	User not local	Destination mail address error (RFC: 551)	-	Y	-	Y	-	P. 8-316
2552	RFC related error	Insufficient system storage	Terminal / Destination address error (RFC: 552)	-	Y	-	Y	-	P. 8-317
2553	RFC related error	Mailbox name not allowed	Destination mail address error (RFC: 553)	-	Y	-	Y	-	P. 8-317

3. Remote scanning related error

Error code	Classification	Message	Contents	Error code display media					Troubleshooting
				Panl	JL	ML	Noti	CSV	
2A00	Remote scanning related error	Successfully stored document	Successful completion (BoxInTA)	-	Y	-	-	-	-
2A20	Remote scanning related error	Failed to acquire resource	System management module resource acquiring failure	-	Y	-	-	-	P. 8-317

Error code	Classification	Message	Contents	Error code display media					Troubleshooting
				Panl	JL	ML	Noti	CSV	
2A31	Remote scanning related error	WS Scan function is not available	WS Scan disabled	-	Y	-	-	-	P. 8-317
2A40	Remote scanning related error	System fatal error	System error	-	Y	-	-	-	P. 8-318
2A50	Remote scanning related error	Job canceled	Job canceled	-	Y	-	-	-	-
2A51	Remote scanning related error	Power failure occurred	Power failure	-	Y	-	-	-	P. 8-318
2A60	Remote scanning related error	Authentication for WS Scan failed	WS Scan user authentication failure	-	Y	-	-	-	P. 8-318
2A70	Remote scanning related error	Insufficient permission to execute RemoteScan	Remote Scan privilege check error	-	-	Y	-	-	P. 8-319
2A71	Remote scanning related error	Insufficient permission to execute WS Scan	WS Scan privilege check error	-	Y	-	-	-	P. 8-319
2A72	Remote scanning related error	Insufficient permission to access e-Filing box using scan utility.	e-Filing box data access privilege check error (Scan Utility)	-	-	Y	-	-	P. 8-319
2A73	Remote scanning related error	Insufficient permission to execute Addressbook Export/Import operation.	Error in the AddressBook operation privilege check	-	-	Y	-	-	P. 8-319
2AD0	Remote scanning related error	Backup operation of e-Filing data from Backup/Restore Utility is done	e-Filing box data backing up	-	-	Y	-	-	-
2AD1	Remote scanning related error	Restore operation of e-Filing data from Backup/Restore Utility is done	e-Filing box data restoring	-	-	Y	-	-	-
2AD2	Remote scanning related error	Archive operation of e-Filing data is done	e-Filing box data archiving	-	-	Y	-	-	-
2AD3	Remote scanning related error	Restore operation of e-Filing data is done	Archived e-Filing box data restoring	-	-	Y	-	-	-
2AD4	Remote scanning related error	Download e-Filing data by scan utility	e-Filing box data downloading (Scan Utility)	-	-	Y	-	-	-

4. e-Filing related error

Error code	Classification	Message	Contents	Error code display media					Troubleshooting
				Panl	JL	ML	Noti	CSV	
2B00	e-Filing box related error	Successfully stored document	Doc saving successful	-	Y	-	Y	-	-

Error code	Classification	Message	Contents	Error code display media					Troubleshooting
				Panl	JL	ML	Noti	CSV	
2B01	e-Filing box related error	Successfully sent document to print queue	Successful completion (BoxPrnTA)	-	-	-	-	-	-
2B02	e-Filing box related error	-	Successful completion (BoxEmailTA)	-	-	-	-	-	-
2B11	e-Filing box related error	Job status failed	Job status abnormality	-	Y	-	Y	-	P. 8-320
2B20	e-Filing box related error	Failed to access file	File library function error	-	Y	-	Y	-	P. 8-320
2B30	e-Filing box related error	Insufficient disk space	Insufficient disk space in BOX partition	-	Y	-	Y	-	P. 8-320
2B31	e-Filing box related error	Failed to access Electronic Filing	Status of the specified e-Filing box or folder is undefined or being created / deleted	-	Y	-	Y	-	P. 8-320
2B50	e-Filing box related error	Failed to process image	Image library error	-	Y	-	Y	-	P. 8-320
2B51	e-Filing box related error	Failed to print images from the document box	List library error	-	Y	-	Y	-	P. 8-321
2B71	e-Filing box related error	Document(s) expire(s) in a few days.	There are documents which will expire in a few days	-	-	Y	Y	-	-
2B80	e-Filing box related error	Hard Disk space for Electronic Filing nearly full.	Hard disk space in BOX partition is nearly full (90%)	-	-	Y	Y	-	-
2B90	e-Filing box related error	Insufficient Memory	Insufficient memory capacity	-	Y	-	Y	-	P. 8-320
2BA0	e-Filing box related error	Invalid Box password specified	Invalid Box password	-	Y	-	Y	-	P. 8-321
2BA1	e-Filing box related error	Incorrect paper size / invalid color mode / invalid resolution	The specified paper size, color mode or resolution is not available	-	-	-	Y	-	P. 8-321
2BB0	e-Filing box related error	Job canceled	Job canceling	-	Y	-	Y	-	-
2BB1	e-Filing box related error	Power failure occurred	Power failure	-	Y	-	Y	-	P. 8-322
2BC0	e-Filing box related error	System fatal error	Fatal failure occurred	-	Y	-	Y	-	P. 8-320
2BD0	e-Filing box related error	Power failure occurred during e-Filing restore.	Power failure during restoring of e-Filing box	-	-	Y	Y	-	P. 8-322
2BD1	e-Filing box related error	e-Filing Box Storage is initialized.	e-Filing box is initialized	-	-	Y	Y	-	-
2BE0	e-Filing box related error	Failed to get machine parameter	Machine parameter reading error	-	Y	-	Y	-	P. 8-322
2BF0	e-Filing box related error	Maximum number of page range is reached	Exceeding the maximum number of pages	-	Y	-	Y	-	P. 8-322
2BF1	e-Filing box related error	Maximum number of document range is reached	Exceeding the maximum number of documents	-	Y	-	Y	-	P. 8-322

Error code	Classification	Message	Contents	Error code display media					Troubleshooting
				Panl	JL	ML	Noti	CSV	
2BF2	e-Filing box related error	Maximum number of folder range is reached	Exceeding the maximum number of folders	-	Y	-	Y	-	P. 8-323

5. E-mail related error

Error code	Classification	Message	Contents	Error code display media					Troubleshooting
				Panl	JL	ML	Noti	CSV	
2C00	E-mail related error	Sent scanned image(s) by email	Communication successful completion	-	Y	-	Y	-	-
2C01	E-mail related error	Sent scanned image(s) by email	Transferring completion (Fax reception)	-	Y	-	Y	-	-
2C02	E-mail related error	Sent scanned image(s) by email	Transferring completion (E-mail reception)	-	Y	-	Y	-	-
2C04	E-mail related error	Service information was sent by E-mail	Notification transmission successful completion	-	Y	-	Y	-	-
2C10	E-mail related error	Illegal Job status	System access abnormality	-	Y	-	Y	-	P. 8-323
2C11	E-mail related error	Not enough memory	Insufficient memory	-	Y	-	Y	-	P. 8-323
2C12	E-mail related error	Illegal Job status	Message reception error	-	Y	-	Y	-	P. 8-324
2C13	E-mail related error	Illegal Job status	Message transmission error	-	Y	-	Y	-	P. 8-324
2C14	E-mail related error	Invalid parameter specified	Invalid parameter	-	Y	-	Y	-	P. 8-324
2C15	E-mail related error	Message size exceeded limit or maximum size	Exceeding file capacity	-	Y	-	Y	-	P. 8-324
2C20	E-mail related error	Illegal Job status	System management module access abnormality	-	Y	-	Y	-	P. 8-325
2C21	E-mail related error	Illegal Job status	Job control module access abnormality	-	Y	-	Y	-	P. 8-325
2C22	E-mail related error	Illegal Job status	Job control module access abnormality	-	Y	-	Y	-	P. 8-325
2C30	E-mail related error	Failed to create directory	Directory creation failure	-	Y	-	Y	-	P. 8-325
2C31	E-mail related error	Failed to create file	File creation failure	-	Y	-	Y	-	P. 8-325
2C32	E-mail related error	Failed to delete file	File deletion failure	-	Y	-	Y	-	P. 8-323
2C33	E-mail related error	Failed to create file	File access failure	-	Y	-	Y	-	P. 8-325
2C40	E-mail related error	Failed to convert image file format	Image conversion abnormality	-	Y	-	Y	-	P. 8-325
2C43	E-mail related error	Encryption error. Failed to create file	Encryption error	-	Y	-	Y	-	P. 8-326
2C44	E-mail related error	Creating the image file was not permitted	Encryption PDF enforced mode error	-	Y	-	Y	-	P. 8-326

Error code	Classification	Message	Contents	Error code display media					Troubleshooting
				Panl	JL	ML	Noti	CSV	
2C45	E-mail related error	Failed in making meta data	Meta data creation error (Scan to Email)	-	Y	-	Y	-	P. 8-326
2C50	E-mail related error	Insufficient permission to execute Scan job	Authentication failure at job execution	-	Y	-	Y	-	P. 8-326
2C60	E-mail related error	Failed To Process your Job. Insufficient Storage space	HDD full failure during processing	-	Y	-	Y	-	P. 8-327
2C61	E-mail related error	Failed to read AddressBook	AddressBook reading failure	-	Y	-	Y	-	P. 8-327
2C62	E-mail related error	Not enough memory	Memory acquiring failure	-	Y	-	Y	-	P. 8-325
2C63	E-mail related error	Invalid Domain Address	Terminal IP address unset	-	Y	-	Y	-	P. 8-327
2C64	E-mail related error	Invalid Domain Address	Terminal mail address unset	-	Y	-	Y	-	P. 8-327
2C65	E-mail related error	Failed to connect to SMTP server	SMTP address unset	-	Y	-	Y	-	P. 8-328
2C66	E-mail related error	Failed to connect to SMTP server	Server time-out error	-	Y	-	Y	-	P. 8-328
2C69	E-mail related error	Failed to connect to SMTP server	SMTP server connection error	-	Y	-	Y	-	P. 8-328
2C6A	E-mail related error	Failed to send E-mail message	HOST NAME error (No RFC error)	-	Y	-	Y	-	P. 8-328
2C6B	E-mail related error	Invalid address specified in From: field	Terminal mail address error	-	Y	-	Y	-	P. 8-329
2C6C	E-mail related error	Invalid address specified in To: field	Destination mail address error (No RFC error)	-	Y	-	Y	-	P. 8-329
2C70	E-mail related error	SMTP service is not available	SMTP client OFF	-	Y	-	Y	-	P. 8-329
2C71	E-mail related error	Failed SMTP Authentication	SMTP authentication error	-	Y	-	Y	-	P. 8-329
2C72	E-mail related error	POP Before SMTP Authentication Failed	POP before SMTP error	-	Y	-	Y	-	P. 8-330
2CC0	E-mail related error	Job canceled	Job canceling	-	Y	-	Y	-	-
2CC1	E-mail related error	Power failure occurred	Power failure	-	Y	-	Y	-	P. 8-330

6. File sharing related error

Error code	Classification	Message	Contents	Error code display media					Troubleshooting
				Panl	JL	ML	Noti	CSV	
2D00	File sharing related error	Stored document in controller shared folder	Successful completion (saving in a local directory)	-	Y	-	Y	-	-
2D01	File sharing related error	Stored document in network folder	Successful completion (saving in remote)	-	Y	-	Y	-	-

Error code	Classification	Message	Contents	Error code display media					Troubleshooting
				Panl	JL	ML	Noti	CSV	
2D02	File sharing related error	Stored document in controller shared folder	Successful completion (saving of a received FaxtoFile / &File in a local directory)	-	Y	-	Y	-	-
2D03	File sharing related error	Stored document in network folder	Successful completion (saving of a received FaxtoFile / &File in remote)	-	Y	-	Y	-	-
2D04	File sharing related error	Stored document in controller shared folder	Successful completion (saving of a received EmailtoFile / &File in a local directory)	-	Y	-	Y	-	-
2D05	File sharing related error	Stored document in network folder	Successful completion (saving of a received EmailtoFile / &File in remote)	-	Y	-	Y	-	-
2D10	File sharing related error	Illegal Job status	System access abnormality	-	Y	-	Y	-	P. 8-330
2D11	File sharing related error	Not enough memory	Insufficient memory	-	Y	-	Y	-	P. 8-331
2D12	File sharing related error	Illegal Job status	Message reception error	-	Y	-	Y	-	P. 8-331
2D13	File sharing related error	Illegal Job status	Message transmission error	-	Y	-	Y	-	P. 8-331
2D14	File sharing related error	Invalid parameter specified	Invalid parameter	-	Y	-	Y	-	P. 8-331
2D15	File sharing related error	Document size exceeded limit or maximum size	Exceeding the maximum size for file sharing	-	Y	-	Y	-	P. 8-331
2D30	File sharing related error	Failed to create directory	Directory creation failure	-	Y	-	Y	-	P. 8-332
2D31	File sharing related error	Failed to create file	File creation failure	-	Y	-	Y	-	P. 8-332
2D32	File sharing related error	Failed to delete file	File deletion failure	-	Y	-	Y	-	P. 8-330
2D33	File sharing related error	Failed to create file	File access failure	-	Y	-	Y	-	P. 8-332
2D40	File sharing related error	Failed to convert image file format	Image conversion abnormality	-	Y	-	Y	-	P. 8-332
2D43	File sharing related error	Encryption error. Failed to create file	Encryption error	-	Y	-	Y	-	P. 8-332
2D44	File sharing related error	Creating the image file was not permitted	Encryption PDF enforced mode error	-	Y	-	Y	-	P. 8-333
2D45	File sharing related error	Failed in making meta data	Meta data creation error (Scan to File)	-	Y	-	Y	-	P. 8-333
2D50	File sharing related error	Insufficient permission to execute Scan job	Authentication failure at job execution	-	Y	-	Y	-	P. 8-333
2D62	File sharing related error	Failed to connect to network destination. Check destination path	File server connection failure	-	Y	-	Y	-	P. 8-333

Error code	Classification	Message	Contents	Error code display media					Troubleshooting
				Panl	JL	ML	Noti	CSV	
2D63	File sharing related error	Specified network path is invalid. Check destination path	Invalid network path	-	Y	-	Y	-	P. 8-334
2D64	File sharing related error	Logon to file server failed. Check username and password	Login failure	-	Y	-	Y	-	P. 8-334
2D65	File sharing related error	There are too many documents in the folder. Failed in creating new document.	New document creation failure caused by an excess of documents in a folder	-	Y	-	Y	-	P. 8-334
2D66	File sharing related error	Failed To Process your Job. Insufficient Storage space.	Storage capacity full failure during processing	-	Y	-	Y	-	P. 8-334
2D67	File sharing related error	FTP service is not available	FTP service not available	-	Y	-	Y	-	P. 8-335
2D68	File sharing related error	File Sharing service is not available	File sharing service not available	-	Y	-	Y	-	P. 8-335
2D69	File sharing related error	NetWare service is not available	NetWare service not available	-	Y	-	Y	-	P. 8-335
2DA0	File sharing related error	Expired scan documents deleted from share folder.	Periodical deletion of scanned documents has been completed properly	-	Y	-	Y	-	-
2DA1	File sharing related error	Expired Sent Fax documents deleted from shared folder.	Periodical deletion of transmitted Fax documents has been completed properly	-	-	Y	Y	-	-
2DA2	File sharing related error	Expired Received Fax documents deleted from shared folder.	Periodical deletion of received Fax documents has been completed properly	-	-	Y	Y	-	-
2DA3	File sharing related error	Scanned documents in shared folder deleted upon user's request.	Manual deletion of scanned documents has been completed properly	-	-	Y	Y	-	-
2DA4	File sharing related error	Sent Fax Documents in shared folder deleted upon user's request.	Manual deletion of transmitted Fax documents has been completed properly	-	-	Y	Y	-	-
2DA5	File sharing related error	Received Fax Documents in shared folder deleted upon user's request.	Manual deletion of received Fax documents has been completed properly	-	-	Y	Y	-	-
2DA6	File sharing related error	Failed to delete file.	File deletion failure	-	-	Y	Y	-	P. 8-330
2DA7	File sharing related error	Failed to acquire resource.	Resource acquiring failure	-	-	Y	Y	-	P. 8-330
2DC0	File sharing related error	Job canceled	Job canceling	-	Y	-	Y	-	-

Error code	Classification	Message	Contents	Error code display media					Troubleshooting
				Panl	JL	ML	Noti	CSV	
2DC1	File sharing related error	Power failure occurred	Power failure	-	Y	-	Y	-	P. 8-335
2E00	File sharing related error	Stored document in controller USB Media	Successful completion (saving in a USB storage)	-	Y	-	Y	-	-
2E01	File sharing related error	Stored document in controller USB Media	Successful completion (saving of a received FaxtoFile / &File in a USB storage)	-	Y	-	Y	-	-
2E02	File sharing related error	Stored document in controller USB Media	Successful completion (saving of a received EmailtoFile / &File in a USB storage)	-	Y	-	Y	-	-
2E10	File sharing related error	Illegal Job status	System access abnormality in USB storage	-	Y	-	Y	-	P. 8-336
2E11	File sharing related error	Not enough memory	Insufficient memory capacity for USB storage	-	Y	-	Y	-	P. 8-336
2E12	File sharing related error	Illegal Job status	Message reception error in USB storage	-	Y	-	Y	-	P. 8-336
2E13	File sharing related error	Illegal Job status	Message transmission error in USB storage	-	Y	-	Y	-	P. 8-336
2E14	File sharing related error	Invalid parameter specified	Invalid parameter for USB storage	-	Y	-	Y	-	P. 8-336
2E15	File sharing related error	Document size exceeded limit or maximum size	Exceeding the maximum size for file sharing	-	Y	-	Y	-	P. 8-337
2E30	File sharing related error	Failed to create directory	Directory creation failure in USB storage	-	Y	-	Y	-	P. 8-337
2E31	File sharing related error	Failed to create file	File creation failure in USB storage	-	Y	-	Y	-	P. 8-337
2E32	File sharing related error	Failed to delete file	File deletion failure in USB storage	-	Y	-	Y	-	P. 8-337
2E33	File sharing related error	Failed to create file	File access failure in USB storage	-	Y	-	Y	-	P. 8-339
2E40	File sharing related error	Failed to convert image file format	Image conversion abnormality in USB storage	-	Y	-	Y	-	P. 8-339
2E43	File sharing related error	Encryption error. Failed to create file.	Encryption failure in USB storage	-	Y	-	Y	-	P. 8-339
2E44	File sharing related error	Creating the image file was not permitted	Encryption PDF enforced mode error in USB storage	-	-	-	Y	-	P. 8-339
2E45	File sharing related error	Failed in making meta data	Meta data creation error in USB storage (Scan to File)	-	Y	-	Y	-	P. 8-340
2E50	File sharing related error	Insufficient permission to execute Scan job	Authentication failure at job execution	-	Y	-	Y	-	P. 8-340

Error code	Classification	Message	Contents	Error code display media					Troubleshooting
				Panl	JL	ML	Noti	CSV	
2E65	File sharing related error	There are too many documents in folder. Failed in creating new document.	File creation error due to insufficient USB folder capacity	-	Y	-	Y	-	P. 8-340
2E66	File sharing related error	Failed To Process your Job. Insufficient Storage space.	HDD full failure during USB storage process	-	Y	-	Y	-	P. 8-340
2EC0	File sharing related error	Job canceled	Job canceling	-	Y	-	Y	-	-
2EC1	File sharing related error	Power Failure Job Aborted	Power failure in USB storage	-	Y	-	Y	-	P. 8-341

7. E-mail reception related error

Error code	Classification	Message	Contents	Error code display media					Troubleshooting
				Panl	JL	ML	Noti	CSV	
3000	E-mail reception related error	Received E-mail Job was successfully completed.	E-mail reception is completed properly	-	Y	-	Y	-	-
3A10	E-mail reception related error	MIME Error has been detected in the received mail.	E-mail MIME error	-	Y	-	Y	-	P. 8-342
3A20	E-mail reception related error	Analyze Error has been detected in the received mail.	E-mail analysis error	-	Y	-	Y	-	P. 8-342
3A30	E-mail reception related error	Whole partial mails were not reached by timeout.	Partial mail time-out error	-	Y	-	Y	-	P. 8-342
3A40	E-mail reception related error	Partial Mail Error has been detected in the received mail.	Partial mail related error	-	Y	-	Y	-	P. 8-342
3A50	E-mail reception related error	HDD Full Error has been occurred in this mail.	Insufficient HDD capacity error	-	Y	-	Y	-	P. 8-343
3A70	E-mail reception related error	Receiving partial mail was aborted since the partial mail setting has been changed to Disable.	Error of partial mail interruption	-	Y	-	Y	-	P. 8-343
3A80	E-mail reception related error	Partial mail was received during the partial mail setting is disabled.	Partial mail reception setting OFF	-	Y	-	Y	-	P. 8-343
3B10	E-mail reception related error	Format Error has been detected in the received mail.	E-mail format error	-	Y	-	Y	-	P. 8-342
3B20	E-mail reception related error	Content-Type Error has been detected in the received mail.	Content-Type error	-	Y	-	Y	-	P. 8-343
3B40	E-mail reception related error	Decode Error has been detected in the received mail.	E-mail decode error	-	Y	-	Y	-	P. 8-342

Error code	Classification	Message	Contents	Error code display media					Troubleshooting
				Panl	JL	ML	Noti	CSV	
3B50	E-mail reception related error	Received Email data was broken. It was deleted from mail server.	Received mail data deletion	-	-	Y	Y	-	P. 8-344
3C10	E-mail reception related error	Tiff Analyze Error has been detected in the received mail.	TIFF analysis error	-	Y	-	Y	-	P. 8-344
3C13	E-mail reception related error	Tiff Analyze Error has been detected in the received mail.	TIFF analysis error	-	Y	-	Y	-	P. 8-344
3C20	E-mail reception related error	Tiff Compression Error has been detected in the received mail.	TIFF compression error	-	Y	-	Y	-	P. 8-345
3C30	E-mail reception related error	Tiff Resolution Error has been detected in the received mail.	TIFF resolution error	-	Y	-	Y	-	P. 8-345
3C40	E-mail reception related error	Tiff Paper Size Error has been detected in the received mail.	TIFF paper size error	-	Y	-	Y	-	P. 8-345
3C50	E-mail reception related error	Offramp Destination Error has been detected in the received mail.	Offramp destination error	-	Y	-	Y	-	P. 8-345
3C60	E-mail reception related error	Offramp Security Error has been detected in the received mail.	Offramp security error	-	Y	-	Y	-	P. 8-346
3C70	E-mail reception related error	Power Failure has been occurred in E-mail receiving.	Power failure error	-	Y	-	Y	-	P. 8-346
3C90	E-mail reception related error	OffRamp Fax transmission disable error has been detected in the received mail.	Offramp Fax transmission disable error	-	Y	-	Y	-	P. 8-346
3D10	E-mail reception related error	SMTP Destination Error has been detected in the received mail. This mail was deleted.	Destination address error	-	-	Y	Y	-	P. 8-346
3D20	E-mail reception related error	OffRamp Destination limitation Error has been detected in the received mail.	Offramp destination limitation error	-	-	Y	Y	-	P. 8-347
3D30	E-mail reception related error	Fax unit Error has occurred because the OffRamp mail was received but it has no Fax unit.	FAX Unit error	-	-	Y	Y	-	P. 8-347
3E10	E-mail reception related error	POP3 Connection Error has occurred in the received mail.	POP3 server connection error	-	-	Y	Y	-	P. 8-347

Error code	Classification	Message	Contents	Error code display media					Troubleshooting
				Panl	JL	ML	Noti	CSV	
3E20	E-mail reception related error	POP3 Connection Timeout Error has occurred in the received mail.	POP3 server connection time-out error	-	-	Y	Y	-	P. 8-348
3E30	E-mail reception related error	POP3 Login Error has occurred in the received mail.	POP3 login error	-	-	Y	Y	-	P. 8-348
3E40	E-mail reception related error	POP3 Login Error occurred in the received mail	POP3 login type error	-	-	Y	Y	-	P. 8-348
3F10	E-mail reception related error	File I/O Error has occurred in this mail. The mail can not be received until File I/O is recovered.	File I/O error	-	-	Y	Y	-	P. 8-348
3F20	E-mail reception related error	File I/O Error has been occurred in this mail. The mail could not be received until File I/O is recovered.	File I/O error	-	Y	-	Y	-	P. 8-348

8.2.4 Printer function error

Following codes are displayed at the end of the user name on the print job log screen.

Error code	Classification	Message	Contents	Error code display media					Troubleshooting
				Panl	JL	ML	Noti	CSV	
4000	Printer error	-	Successful completion	-	Y	-	-	-	-
4011	Printer error	-	Print job cancellation	-	-	-	-	-	P. 8-349
4021	Printer error	-	Print job power failure	-	Y	-	-	-	P. 8-349
4031	Printer error	-	HDD full during print	-	Y	-	-	-	P. 8-349
4032	Printer error	-	Exceeding the upper limit of the registration number for the sharing jobs	-	Y	-	-	-	P. 8-349
4033	Printer error	-	Network setting error	-	Y	-	-	-	P. 8-349
4041	Printer error	-	User authentication error	-	Y	-	-	-	P. 8-350
4042	Printer error	-	Department authentication error	-	Y	-	-	-	P. 8-350
4043	Printer error	-	Project authentication error	-	Y	-	-	-	P. 8-350
4045	Printer error	-	Problem in LDAP server connection or LDAP server authorization settings	-	Y	-	-	-	P. 8-350
4111	Printer error	-	Quota over error (no quota in a department and user)	-	Y	-	-	-	P. 8-350
4112	Printer error	-	Quota over error (no quota in a user)	-	Y	-	-	-	P. 8-351
4113	Printer error	-	Quota over error (no quota in a department)	-	Y	-	-	-	P. 8-351
4121	Printer error	-	Job canceling due to external counter error	-	Y	-	-	-	P. 8-351
4211	Printer error	-	Printing data storing limitation error	-	Y	-	-	-	P. 8-351
4212	Printer error	-	e-Filing box storing limitation error	-	Y	-	-	-	P. 8-352
4213	Printer error	-	File storing limitation error	-	Y	-	-	-	P. 8-352
4214	Printer error	-	Fax / Internet Fax transmission limitation error	-	Y	-	-	-	P. 8-352
4221	Printer error	-	Private-print-only error	-	Y	-	-	-	P. 8-352
4222	Printer error	-	Hold-print-only error	-	Y	-	-	-	P. 8-352

Error code	Classification	Message	Contents	Error code display media					Troubleshooting
				Panl	JL	ML	Noti	CSV	
4223	Printer error	-	Private-print-only / Hold-print-only error	-	Y	-	-	-	P. 8-352
4231	Printer error	-	Hardcopy security printing error	-	Y	-	-	-	P. 8-353
4243	Printer error	-	Sharing job - An error caused by not having a license	-	Y	-	-	-	P. 8-353
4244	Printer error	-	Sharing job - An error caused by function disabled	-	Y	-	-	-	P. 8-353
4245	Printer error	-	OCR functions not available	-	Y	-	-	-	P. 8-353
4311	Printer error	-	No privilege to perform a job	-	Y	-	-	-	P. 8-353
4312	Printer error	-	Not authorized to store a file	-	Y	-	-	-	P. 8-354
4313	Printer error	-	No privilege for e-Filing box storage	-	Y	-	-	-	P. 8-354
4314	Printer error	-	No privilege for Fax / Internet Fax transmission	-	Y	-	-	-	P. 8-354
4321	Printer error	-	No privilege for the print settings	-	Y	-	-	-	P. 8-354
4411	Printer error	-	Image data creation failure	-	Y	-	-	-	P. 8-354
4412	Printer error	-	Double-sign encoding error	-	Y	-	-	-	P. 8-354
4511	Printer error	Print failure due to connection timeout	Connection timeout	-	-	Y	-	-	P. 8-355
4521	Printer error	Cannot print due to connection limit	Reaching the maximum number of connections	-	-	Y	-	-	P. 8-355
4522	Printer error	Registered print job number reached to limit during printing	Exceeding the upper limit of the registration number of jobs during data reception	-	-	Y	-	-	P. 8-355
4523	Printer error	Storage full occurred during printing	HDD full during data reception	-	-	Y	-	-	P. 8-355
4611	Printer error	-	Font download failure (exceeding the maximum number of registrations)	-	Y	-	-	-	P. 8-356
4612	Printer error	-	Font download failure (HDD full)	-	Y	-	-	-	P. 8-356
4613	Printer error	-	Font download failure (others)	-	Y	-	-	-	P. 8-356
4621	Printer error	-	Downloaded font deletion failure	-	Y	-	-	-	P. 8-356
4721	Printer error	Cannot connect MFP due to unexpected combination of Multi Station Print	Connection failure of Multi Station Print because of an unexpected ROM version combination	-	-	Y	-	-	P. 8-356

Error code	Classification	Message	Contents	Error code display media					Troubleshooting
				Panl	JL	ML	Noti	CSV	
4F10	Printer error	-	System abnormality	-	Y	-	-	-	P. 8-357

8.2.5 TopAccess related error/Communication error with external application

Error code	Classification	Message	Contents	Error code display media					Troubleshooting
				Panl	JL	ML	Noti	CSV	
5012	Communication error	Remote monitoring system error	Authentication error	-	-	Y	Y	-	P. 8-358
5013	Communication error	Remote monitoring system error	Communication error between eBR	-	-	Y	-	-	P. 8-358
5014	Communication error	Remote monitoring system error	No SSL certificate	-	-	Y	-	-	P. 8-358
5015	Communication error	Remote monitoring system error	Invalid SSL certificate error	-	-	Y	-	-	P. 8-358
5016	Communication error	Remote monitoring system error	Expired SSL certificate error	-	-	Y	-	-	P. 8-362
5017	Communication error	Remote monitoring system error	Other SSL certificate related error	-	-	Y	-	-	P. 8-359
5018	Communication error	Remote monitoring system error	Invalid DNS error	-	-	Y	-	-	P. 8-359
5019	Communication error	Remote monitoring system error	Connection error	-	-	Y	-	-	P. 8-359
501A	Communication error	Remote monitoring system error	Proxy error	-	-	Y	-	-	P. 8-359
501B	Communication error	Remote monitoring system error	No URL (host / port) or invalid path	-	-	Y	-	-	P. 8-359
501C	Communication error	-	Toner-K remaining amount notification	-	-	-	-	-	-
501D	Communication error	-	Toner-C remaining amount notification	-	-	-	-	-	-
501E	Communication error	-	Toner-M remaining amount notification	-	-	-	-	-	-
501F	Communication error	-	Toner-Y remaining amount notification	-	-	-	-	-	-
5020	Communication error	The first registration was completed.	Initial registration completion	-	-	Y	-	-	-
5021	Communication error	Communication with Remote monitoring system succeeded	Successful communication with an eBR2 server	-	-	Y	-	-	-
5030	Communication error	Remote monitoring system error	An error has occurred in the HTTP communication	-	-	Y	-	-	P. 8-360
50FF	Communication error	Remote monitoring system error	eBR2 internal error	-	-	Y	-	-	P. 8-360
5110	Communication error	-	Toner cartridge detection error	-	-	-	-	-	P. 8-360
5211	Communication error	-	PM counter excess	-	-	-	-	-	-
5212	Communication error	Open the front cover, and clean the slit glass and main charger.	Time for cleaning of the main charger	-	-	Y	Y	-	P. 8-360
5310	Communication error	-	Toner-K empty	-	-	-	-	-	P. 8-360
5311	Communication error	-	Toner-Y empty	-	-	-	-	-	P. 8-360

Error code	Classification	Message	Contents	Error code display media					Troubleshooting
				Panl	JL	ML	Noti	CSV	
5312	Communication error	-	Toner-M empty	-	-	-	-	-	P. 8-360
5313	Communication error	-	Toner-C empty	-	-	-	-	-	P. 8-360
5400	Communication error	Succeeded in MFP registration	MFP registration success	-	-	Y	Y	-	-
5401	Information	Immediate connection to the global remote maintenance service has been executed.	Immediate connection execution to an eCC server	-	-	Y	Y	-	-
5410	Communication error	Remote maintenance service error	MFP registration error	-	-	Y	Y	-	P. 8-361
5411	Communication error	Remote maintenance service error	MFP registration lock error	-	-	Y	Y	-	P. 8-361
5412	Communication error	Remote maintenance service error	Server busy error	-	-	Y	Y	-	P. 8-361
5413	Communication error	Remote maintenance service error	Server error	-	-	Y	Y	-	P. 8-361
5414	Communication error	Remote maintenance service error	Invalid device file error	-	-	Y	Y	-	P. 8-362
5415	Communication error	Remote maintenance service error	Communication error	-	-	Y	Y	-	P. 8-362
5416	Communication error	Remote maintenance service error	Update failure of system software / setting files of the equipment	-	-	Y	Y	-	P. 8-362
5417	Communication error	Remote maintenance service error	Invalid setting files of the equipment or system software	-	-	Y	Y	-	P. 8-362
5BD0	Communication error	Power failure occurred during restore	Power failure during restoration	-	-	Y	Y	-	P. 8-363
5C10	Communication error	FAX Unit is not attached.	FAX Unit attachment error	-	-	Y	Y	-	P. 8-363
5C11	Communication error	Security error on Address Book.	Network Fax transmission error	-	-	Y	Y	-	P. 8-363

8.2.6 MFP access error

Error code	Classification	Message	Contents	Error code display media					Troubleshooting
				Panl	JL	ML	Noti	CSV	
6000	MFP access error	Successful user login	User login success to an MFP	-	-	Y	Y	-	-
6001	MFP access error	Failed user login	User login failure to an MFP	-	-	Y	Y	-	-
6002	MFP access error	Successful user logout	User logout success from an MFP: Manual logout	-	-	Y	Y	-	-
6003	MFP access error	Successful user logout (Session Time Out)	User logout success from an MFP: Automatic logout	-	-	Y	Y	-	-
6004	MFP access error	Successful User Box Authentication	Authentication success of a user box password	-	-	Y	Y	-	-
6005	MFP access error	Failed User Box Authentication	Authentication failure of a user box password	-	-	Y	Y	-	-
6006	MFP access error	User login information was broken	UserToken binding failure	-	-	Y	Y	-	-
6007	MFP access error	Failed user login	Unsuccessful User Login to MFP	-	-	Y	Y	-	P. 8-364
6008	MFP access error	Failed to connect on External LDAP server for Role Based Access Control	Connection failure to an external Role Base Access Control (LDAP) server	-	-	Y	Y	-	P. 8-364
6009	MFP access error	Failed user login (Authentication server connection error)	User login failure to an MFP (during NIC initialization)	-	-	Y	Y	-	P. 8-364
600A	MFP access error	Department code has not been assigned to the user	Department code not assigned to a user	-	-	Y	Y	-	P. 8-364
6010	MFP access error	Cannot find the Home Directory.	Home directory not found	-	-	Y	Y	-	-
6011	MFP access error	Failed to register the user by automatically (Maximum number of registered users)	User automatic registration failure (due to an upper limit of the user registration number)	-	-	Y	Y	-	P. 8-364
6012	MFP access error	Successful user login by cache information	User login success with cache information	-	-	Y	Y	-	-
6013	MFP access error	Failed to connect on the authentication server	Connection failure to the authentication server	-	-	Y	Y	-	P. 8-364
6014	MFP access error	Server is not responding. Authentication is conducted skipping the server for a certain period of time.	Inaccessible authentication server detection	-	-	Y	Y	-	P. 8-365

Error code	Classification	Message	Contents	Error code display media					Troubleshooting
				Panl	JL	ML	Noti	CSV	
6031	MFP access error	Illegal CL code.	Invalid setting: Invalid CL code	-	-	Y	Y	-	P. 8-365
6032	MFP access error	Illegal period.	Card related error: Expired card	-	-	Y	Y	-	P. 8-365
6033	MFP access error	No entering record.	Card related error: Invalid flag data (no room-entry data)	-	-	Y	Y	-	P. 8-365
6034	MFP access error	Illegal entering record.	Card related error: Invalid flag data (invalid card data)	-	-	Y	Y	-	P. 8-365
6035	MFP access error	Illegal SSFC settings of MFP.	Invalid setting: Invalid flag information (not set in an MFP)	-	-	Y	Y	-	P. 8-366
6036	MFP access error	Unmatched settings and card info.	Invalid setting: Invalid flag information (Information between an MFP and card does not match)	-	-	Y	Y	-	P. 8-366
6037	MFP access error	You cannot be used.	Permission flag for use not available	-	-	Y	Y	-	P. 8-366
6040	MFP access error	Failed to read the card	Card authentication: Read error	-	-	Y	Y	-	P. 8-366
6041	MFP access error	Card Authentication Failed because of Card Reading Error	Card authentication: Card related error	-	-	Y	Y	-	P. 8-366
6042	MFP access error	Card Authentication Failed because of Setting Error	Card authentication: Card setting error	-	-	Y	Y	-	P. 8-367
6043	MFP access error	Card Authentication Failed because the card information was duplicated on the card server.	Card authentication failure (duplication of card information)	-	-	Y	Y	-	-
6044	MFP access error	Card Notification Communication Error	Card notification failure (Stage2)	-	-	Y	Y	-	-
6050	MFP access error	Successful print authentication	Print job authentication success	-	-	Y	Y	-	-
6051	MFP access error	Failed print authentication	Print job authentication failure	-	-	Y	Y	-	-
6052	MFP access error	Failed to connect on External LDAP server for Role Based Access Control	Connection failure to an external Role Base Access Control (LDAP) server	-	-	Y	Y	-	P. 8-367
6053	MFP access error	Failed print authentication (Authentication server connection error)	Print job authentication failure due to NIC initialization	-	-	Y	Y	-	-

Error code	Classification	Message	Contents	Error code display media					Troubleshooting
				Panl	JL	ML	Noti	CSV	
6054	MFP access error	Failed to register the user by automatically (Maximum number of registered users)	Print job authentication failure due to upper limit excess of user automatic registration	-	-	Y	Y	-	-
6055	MFP access error	Successful print authentication by cache information	Print job authentication success with cache information	-	-	Y	Y	-	-
6060	MFP access error	Successful user login	(PIN authentication) User login success to an MFP	-	-	Y	Y	-	-
6061	MFP access error	Successful user logout	(PIN authentication) User logout success from an MFP: Manual logout	-	-	Y	Y	-	-
6062	MFP access error	Successful user logout (Session Time Out)	(PIN authentication) User logout success from an MFP: Automatic logout	-	-	Y	Y	-	-
6063	MFP access error	Department code has not been assigned to the user	(PIN authentication) Department code not assigned to a user	-	-	Y	Y	-	-
6064	MFP access error	Cannot find the Home Directory.	(PIN authentication) Home directory not found	-	-	Y	Y	-	-
6065	MFP access error	Failed to register the user by automatically (Maximum number of registered users)	(PIN authentication) User automatic registration failure (due to a upper limit of the user registration number)	-	-	Y	Y	-	-
6066	MFP access error	PIN Authentication Failed because the PIN code was duplicated on the PIN server.	PIN authentication failure (duplication of a PIN code)	-	-	Y	Y	-	-
6067	MFP access error	Successful user login by cache information	(PIN authentication) User login success to an MFP with cache information	-	-	Y	Y	-	-
6100	MFP access error	User account is locked	User account locking out	-	-	Y	Y	-	-
6101	MFP access error	Box is locked	e-Filing box locking out	-	-	Y	Y	-	P. 8-367
6102	MFP access error	Failed to login because the user account had been locked out.	User account being locking out	-	-	Y	Y	-	P. 8-367

Error code	Classification	Message	Contents	Error code display media					Troubleshooting
				Panl	JL	ML	Noti	CSV	
6103	MFP access error	Failed to access Box because the Box had been locked out.	e-Filing box being locking out	-	-	Y	Y	-	P. 8-367
6121	MFP access error	Failed to Secure Erase	Automatic secure erase failure	-	-	Y	Y	-	P. 8-368
6130	MFP access error	Successfully verified clock with Time Server	Synchronization success to a time server	-	-	Y	Y	-	-
6131	MFP access error	MFP fail to verify clock with Time Server	Synchronization with a time server has failed	-	-	Y	Y	-	P. 8-368
6150	MFP access error	Print Log full (100% Used) Log OverWrite will be start	Print log database full	-	-	Y	Y	-	-
6151	MFP access error	Print Log near full (95% Used)	Print log database nearly full (95%)	-	-	Y	Y	-	-
6152	MFP access error	Print Log near full (90% Used)	Print log database nearly full (90%)	-	-	Y	Y	-	-
6153	MFP access error	Print Log near full (80% Used)	Print log database nearly full (80%)	-	-	Y	Y	-	-
6154	MFP access error	Print Log near full (70% Used)	Print log database nearly full (70%)	-	-	Y	Y	-	-
6160	MFP access error	Scan Log full (100% Used) Log OverWrite will be start	Scan log database full	-	-	Y	Y	-	-
6161	MFP access error	Scan Log near full (95% Used)	Scan log database nearly full (95%)	-	-	Y	Y	-	-
6162	MFP access error	Scan Log near full (90% Used)	Scan log database nearly full (90%)	-	-	Y	Y	-	-
6163	MFP access error	Scan Log near full (80% Used)	Scan log database nearly full (80%)	-	-	Y	Y	-	-
6164	MFP access error	Scan Log near full (70% Used)	Scan log database nearly full (70%)	-	-	Y	Y	-	-
6170	MFP access error	FAX_Transmission Log full (100% Used) Log OverWrite will be started	Fax transmission database full	-	-	Y	Y	-	-
6171	MFP access error	FAX_Transmission Log near full (95% Used)	Fax transmission database nearly full (95%)	-	-	Y	Y	-	-
6172	MFP access error	FAX_Transmission Log near full (90% Used)	Fax transmission database nearly full (90%)	-	-	Y	Y	-	-
6173	MFP access error	FAX_Transmission Log near full (80% Used)	Fax transmission database nearly full (80%)	-	-	Y	Y	-	-
6174	MFP access error	FAX_Transmission Log near full (70% Used)	Fax transmission database nearly full (70%)	-	-	Y	Y	-	-
6180	MFP access error	FAX_Receive Log full (100% Used) Log OverWrite will be start	Fax reception database full	-	-	Y	Y	-	-
6181	MFP access error	FAX_Receive Log near full (95% Used)	Fax reception database nearly full (95%)	-	-	Y	Y	-	-

Error code	Classification	Message	Contents	Error code display media					Troubleshooting
				Panl	JL	ML	Noti	CSV	
6182	MFP access error	FAX_Receive Log near full (90% Used)	Fax reception database nearly full (90%)	-	-	Y	Y	-	-
6183	MFP access error	FAX_Receive Log near full (80% Used)	Fax reception database nearly full (80%)	-	-	Y	Y	-	-
6184	MFP access error	FAX_Receive Log near full (70% Used)	Fax reception database nearly full (70%)	-	-	Y	Y	-	-
6190	MFP access error	Message Log full (100% Used) Log OverWrite will be start	Message log database full	-	-	Y	Y	-	-
6191	MFP access error	Message Log near full (95% Used)	Message log database nearly full (95%)	-	-	Y	Y	-	-
6192	MFP access error	Message Log near full (90% Used)	Message log database nearly full (90%)	-	-	Y	Y	-	-
6193	MFP access error	Message Log near full (80% Used)	Message log database nearly full (80%)	-	-	Y	Y	-	-
6194	MFP access error	Message Log near full (70% Used)	Message log database nearly full (70%)	-	-	Y	Y	-	-
61B0	MFP access error	Failed to save Image Log data	Image log saving failure to an MFP local storage	-	-	Y	Y	-	P. 8-368
61C0	MFP access error	Application Log full (100% Used) Log OverWrite will be start	Application log database full	-	-	Y	Y	-	-
61C1	MFP access error	Application Log near full (95% Used)	Application log database nearly full (95%)	-	-	Y	Y	-	-
61C2	MFP access error	Application Log near full (90% Used)	Application log database nearly full (90%)	-	-	Y	Y	-	-
61C3	MFP access error	Application Log near full (80% Used)	Application log database nearly full (80%)	-	-	Y	Y	-	-
61C4	MFP access error	Application Log near full (70% Used)	Application log database nearly full (70%)	-	-	Y	Y	-	-
61D0	Data Backup / Data Restore	Please make a backup of HDD data.	Backup is required since an HDD may be damaged	-	-	Y	Y	-	-
61D1	Data Backup / Data Restore	Exchange of the HDD is required. Please contact service.	Replacement is required since an HDD is likely to fail in the near future	-	-	Y	Y	-	-
6200	MFP access error	Service Technician changed Security Level	Security level change of an MFP by a service technician	-	-	Y	Y	-	-
6220	MFP access error	Administrator's setting wizard is finished	Execution of the administrator setting wizard	-	-	-	-	-	-

Error code	Classification	Message	Contents	Error code display media					Troubleshooting
				Panl	JL	ML	Noti	CSV	
6221	MFP access error	Security settings are changed by Administrator	Security setting items change by an administrator	-	-	-	-	-	-
6240	MFP access error	User account password is not pursuant to Security Policy	A user password is outside the security policy.	-	-	-	-	-	-
6241	MFP access error	e-Filing Box password is not pursuant to Security Policy	An e-Filing box password is outside the security policy.	-	-	-	-	-	-
6260	MFP access error	User Information updated	User information change	-	-	-	-	-	-
6261	MFP access error	Role Information updated	Role information change	-	-	-	-	-	-
6262	MFP access error	Role in Group is edited	Group role information change	-	-	-	-	-	-
6263	MFP access error	Failed to add the new build-in user or role	New build-in user and role update failure	-	-	-	-	-	P. 8-368
6280	MFP access error	Selfsigned Certificate generated	Self-signed certification generation	-	-	-	-	-	-
6281	MFP access error	Server Certificate generated	Server certification generation	-	-	-	-	-	-
6282	MFP access error	Failed to add certificate	Certification addition failure	-	-	-	-	-	-
6283	MFP access error	Cryptographic key generated	Encryption key generation	-	-	-	-	-	-

8.2.7 Maintenance error

Error code	Classification	Message	Contents	Error code display media					Troubleshooting
				Panl	JL	ML	Noti	CSV	
7100	Maintenance error	Successfully updated Copier Firmware	System firmware installation success	-	Y	Y	-	-	-
711A	Maintenance error	Cleared License Key	Electronic key clear	-	-	Y	Y	-	-
711C	Maintenance error	Successfully removed License Key	Electronic key returning success	-	-	Y	Y	-	-
711D	Maintenance error	Failed to remove License Key	License key returning failure	-	-	Y	Y	-	P. 8-369
711E	Maintenance error	Successfully installed License Key	Electronic key installation success	-	-	Y	Y	-	-
711F	Maintenance error	Failed to install License Key	License key installation failure	-	-	Y	Y	-	P. 8-369
7136	Maintenance error	Successfully imported EWB error screen file	EWB error screen file importing success	-	-	Y	Y	-	-
7137	Maintenance error	Failed to imported EWB error screen file	EWB error screen file importing failure	-	-	Y	Y	-	-
7154	Maintenance error	Rebuilt the Log DB by Log DB corruption	Log database rebuilding caused by damage on it	-	-	Y	Y	-	-
7155	Maintenance error	Rebuilt the Image Log DB by Image Log DB corruption	Image log database rebuilding caused by damage on it	-	-	Y	Y	-	-
7156	Maintenance error	Rebuilt the AppManagement DB due to AppManagement DB corruption.	App Management database rebuilding has been performed automatically since it was damaged	-	-	Y	Y	-	-
7157	Maintenance error	Rebuilt the HomeScreen DB due to HomeScreen DB corruption.	HomeScreen database rebuilding has been performed automatically since it was damaged	-	-	Y	Y	-	-
7158	Maintenance error	Rebuilt the JobHistory DB due to JobHistory DB corruption.	JobHistory database rebuilding has been performed automatically since it was damage	-	-	Y	Y	-	-
7159	Maintenance error	Rebuilt the AppLicense DB by AppLicense DB corruption	AppLicense database rebuilding has been performed automatically since it was damaged	-	-	Y	Y	-	-
718A	Maintenance error	Edited Date & Time Setting	The time set in the MFP has been changed	-	-	Y	Y	-	-
718B	Maintenance error	Started the Daylight Savings Time	Summer time has started	-	-	Y	Y	-	-

Error code	Classification	Message	Contents	Error code display media					Troubleshooting
				Panl	JL	ML	Noti	CSV	
718C	Maintenance error	Ended the Daylight Savings Time	Summer time has ended	-	-	Y	Y	-	-
71B0	Maintenance error	Failed to decrypt Software Package	Software package file decryption failure	-	-	Y	Y	-	P. 8-369
71B2	Maintenance error	Successfully updated Laser ROM	Laser firmware installation success	-	-	Y	Y	-	-
71B3	Maintenance error	Failed to update Laser ROM	Laser firmware installation failure	-	-	Y	Y	-	-
71B4	Maintenance error	Successfully updated Finisher ROM	Finisher firmware installation success	-	-	Y	Y	-	-
71B5	Maintenance error	Failed to update Finisher ROM	Finisher firmware installation failure	-	-	Y	Y	-	P. 8-369
71B6	Maintenance error	Successfully updated Saddle ROM	Saddle firmware installation success	-	-	Y	Y	-	-
71B7	Maintenance error	Failed to update Saddle ROM	Saddle firmware installation failure	-	-	Y	Y	-	P. 8-369
71B8	Maintenance error	Successfully updated Punch ROM	Punch firmware installation success	-	-	Y	Y	-	-
71B9	Maintenance error	Failed to update Punch ROM	Punch firmware installation failure	-	-	Y	Y	-	P. 8-370
71BA	Maintenance error	Successfully updated UI Data	UI data installation success	-	-	Y	-	-	-
71BB	Maintenance error	Failed to update UI Data	UI data installation failure	-	-	Y	-	-	-
71BC	Maintenance error	UI Data successfully rolled back	UI data recovery success	-	-	Y	-	-	-
71BD	Maintenance error	Failed to rollback UI Data	UI data recovery failure	-	-	Y	-	-	-
71BE	Maintenance error	Failed to update UI Data (non-permitted machine)	UI data installation failure	-	-	Y	-	-	-
71BF	Maintenance error	Failed to update UI Data (non-permitted model)	UI data installation failure	-	-	Y	-	-	-
71E0	License Management	LMDB Recovery	License abnormality due to damage on the license manager database	-	-	Y	Y	-	P. 8-370
7200	Maintenance error	Successful transfer of Image Log to the external server	Image log saving success to an external server	-	-	Y	Y	-	-
7201	Maintenance error	Failed to transfer of Image Log to the external server	Image log saving failure to an external server	-	-	Y	Y	-	-
7202	Maintenance error	Image Log was deleted	Image log deletion	-	-	Y	Y	-	-
7203	Maintenance error	Image Log was deleted automatically	Image log automatic deletion	-	-	Y	Y	-	-
7204	Maintenance error	Image log was downloaded	Image log downloading	-	-	Y	Y	-	-

Error code	Classification	Message	Contents	Error code display media					Troubleshooting
				Panl	JL	ML	Noti	CSV	
7210	Maintenance error	Successful synchronization of User Management information	User management information synchronization success	-	-	Y	Y	-	-
7211	Maintenance error	Failed to synchronize User Management information	User management information synchronization failure	-	-	Y	Y	-	-
7212	Maintenance error	Failed to synchronize User Management information (setting mistake)	User management information synchronization failure (incorrect setting)	-	-	Y	Y	-	-
7213	Maintenance error	Failed to synchronize User Management information for some Slave MFPs	Some user management information synchronization failure	-	-	Y	Y	-	-
7220	Maintenance error	Successful synchronization of AddressBook	AddressBook delivery success	-	-	Y	Y	-	-
7221	Maintenance error	Failed to synchronize Address Book	AddressBook delivery failure	-	-	Y	Y	-	-
7222	Maintenance error	Failed to synchronize Address Book for some Slave MFPs	Some AddressBook delivery failure	-	-	Y	Y	-	-
7230	Maintenance error	Added new Project Code	Project creation	-	-	Y	Y	-	-
7231	Maintenance error	Edited Project Code	Project edition	-	-	Y	Y	-	-
7232	Maintenance error	Removed a Project Code	Project deletion	-	-	Y	Y	-	-
7233	Maintenance error	Successfully exported Project Code	Project export success	-	-	Y	Y	-	-
7234	Maintenance error	Failed to export Project Code	Project export failure	-	-	Y	Y	-	-
7235	Maintenance error	Download Project Code.	Exported project downloading	-	-	Y	Y	-	-
7236	Maintenance error	Successfully imported Project Code	Project import success	-	-	Y	Y	-	-
7237	Maintenance error	Failed to import Project Code	Project import failure	-	-	Y	Y	-	-
7238	Maintenance error	Failed to import some Project Codes	Some project import failure	-	-	Y	Y	-	-
7272	Maintenance error	Successfully updated FAX FIRMWARE1	Fax firmware1 installation success	-	-	Y	Y	-	-
7273	Maintenance error	Failed to update FAX FIRMWARE1	Fax firmware1 installation failure	-	-	Y	Y	-	-
7274	Maintenance error	Successfully updated FAX FIRMWARE2	Fax firmware2 installation success	-	-	Y	Y	-	-
7275	Maintenance error	Failed to update FAX FIRMWARE2	Fax firmware2 installation failure	-	-	Y	Y	-	-

Error code	Classification	Message	Contents	Error code display media					Troubleshooting
				Panl	JL	ML	Noti	CSV	
7276	Maintenance error	Successfully updated NIC FIRMWARE	NIC firmware installation success	-	-	Y	Y	-	-
7277	Maintenance error	Failed to update NIC FIRMWARE	NIC firmware installation failure	-	-	Y	Y	-	-
7278	Maintenance error	Successfully installed Monotype RIP Font	Monotype RIP font installation success	-	-	Y	Y	-	-
7279	Maintenance error	Failed to install Monotype RIP Font	Monotype RIP font installation failure	-	-	Y	Y	-	-
7280	Data Backup / Data Restore	Data Backup file storage was completed successfully	Storing of the data backup file has succeeded	-	-	Y	Y	-	-
7281	Data Backup / Data Restore	Data Backup file storage was cancelled	Storing of the data backup file has been canceled	-	-	Y	Y	-	-
7282	Data Backup / Data Restore	Regular Data Backup was not performed	Periodical data backing up has not been executed	-	-	Y	Y	-	-
7283	Data Backup / Data Restore	Data Backup file storage failed (USB media was not inserted)	Storing of the data backup file has failed (A USB storage has not been inserted)	-	-	Y	Y	-	-
7284	Data Backup / Data Restore	Data Backup file storage failed (Failed to save the file to USB media)	Storing of the data backup file has failed (Storing of a file into a USB storage has failed)	-	-	Y	Y	-	-
7285	Data Backup / Data Restore	Data Backup file storage failed (Failed to connect to the external server)	Storing of the data backup file has failed (Connection to an external server is not possible)	-	-	Y	Y	-	-
7286	Data Backup / Data Restore	Data Backup file storage failed (Failed to save the file to the external server)	Storing of the data backup file has failed (Storing of a file into an external server has failed)	-	-	Y	Y	-	-
7287	Data Backup / Data Restore	Data Backup file storage failed	Storing of the data backup file has failed	-	-	Y	Y	-	-
7290	Data Backup / Data Restore	Data Restore process was completed successfully	Restoring of the data has succeeded	-	-	Y	Y	-	-
7291	Data Backup / Data Restore	Data Restore from USB media or the external server was cancelled	Job cancel of data restore processing	-	-	Y	Y	-	-
7292	Data Backup / Data Restore	Data Restore process failed (USB media was not inserted)	Data restore processing failure (A USB storage is not inserted)	-	-	Y	Y	-	-
7293	Data Backup / Data Restore	Data Restore process failed (Failed to connect to the external server)	Data restore processing failure (Connection to an external server is not possible)	-	-	Y	Y	-	-

Error code	Classification	Message	Contents	Error code display media					Troubleshooting
				Panl	JL	ML	Noti	CSV	
7294	Data Backup / Data Restore	Data Restore process failed (Failed to get the Data Backup file from USB media)	Data restore processing failure (Obtaining a file from a USB storage has failed)	-	-	Y	Y	-	-
7295	Data Backup / Data Restore	Data Restore process failed (Failed to get the Data Backup file from external server)	Data restore processing failure (Obtaining a file from an external server has failed)	-	-	Y	Y	-	-
7296	Data Backup / Data Restore	Data Restore process failed (Data Backup file is corrupted)	Data restore processing failure (Data backup file invalid)	-	-	Y	Y	-	-
7297	Data Backup / Data Restore	Data Restore process failed	Data restore processing failure	-	-	Y	Y	-	-
72A0	Maintenance error	Notification events that were registered from an application were deleted.	Deletion of event notification destination information registered from an application	-	-	Y	Y	-	-
72D0	Maintenance error	Failed to update UI Data (compatibility check error)	UI data installation failure	-	-	Y	-	-	-
72D1	Maintenance error	Failed to update Copier Firmware (compatibility check error)	System firmware installation failure	-	-	Y	-	-	-
72D2	Maintenance error	Successfully updated plugin of printer driver.	Upgrading of the plug-in for printer drivers has succeeded	-	-	Y	Y	-	-
72D3	Maintenance error	Failed to update plugin of printer driver.	Upgrading of the plug-in for printer drivers has failed	-	-	Y	Y	-	-
72D4	Maintenance error	Successfully deleted plugin of printer driver.	Deletion of the plug-in for printer drivers has succeeded	-	-	Y	Y	-	-
72D5	Maintenance error	Failed to delete plugin of printer driver.	Deletion of the plug-in for printer drivers has failed	-	-	Y	Y	-	-
72D6	Maintenance error	Failed to update UI Data (License check error)	UI data installation failure	-	-	Y	-	-	-
7300	Maintenance error	Successfully installed Application	An application is installed	-	-	Y	Y	-	-
7301	Maintenance error	Failed to install Application	Installation of an application fails	-	-	Y	Y	-	P. 8-370
7302	Maintenance error	Successfully uninstalled Application	An application is uninstalled	-	-	Y	Y	-	-
7303	Maintenance error	Failed to uninstall Application	Uninstallation of an application fails	-	-	Y	Y	-	-
7304	Maintenance error	Successfully updated Application	An application is updated	-	-	Y	Y	-	-

Error code	Classification	Message	Contents	Error code display media					Troubleshooting
				Panl	JL	ML	Noti	CSV	
7305	Maintenance error	Failed to update Application	Updating of an application fails	-	-	Y	Y	-	-
7306	Maintenance error	Application removal completed	Deletion of all the applications has succeeded	-	-	Y	Y	-	-
7307	Maintenance error	Failed to completely delete application.	Deletion of all the applications has failed	-	-	Y	Y	-	-
7308	Maintenance error	Automatically stopped the application.	Applications have automatically stopped	-	-	Y	Y	-	-
7309	Maintenance error	Automatically started the application.	Applications have automatically started	-	-	Y	Y	-	-
7311	Maintenance error	Failed to start Application	Start of an application fails	-	-	Y	Y	-	-
7313	Maintenance error	Application was terminated abnormally	An application ends abnormally	-	-	Y	Y	-	-
7315	Maintenance error	App start duplicated error. Please retry later.	App start duplicated error	-	-	Y	Y	-	-
7316	Maintenance error	Application license is Fraud error.	Application license is invalid	-	-	Y	Y	-	-
7320	Maintenance error	Application license was activated.	The license of an application is enabled	-	-	Y	Y	-	-
7321	Maintenance error	Failed to activation of application license	Enabling of the license for an application fails	-	-	Y	Y	-	-
7322	Maintenance error	Application license was inactivated.	The license of an application is disabled	-	-	Y	Y	-	-
7323	Maintenance error	Failed to inactivation of application license	Disabling of the license for an application fails	-	-	Y	Y	-	-
7324	Maintenance error	Installed the application license.	Installation of the application license has succeeded	-	-	Y	Y	-	-
7325	Maintenance error	Failed to install the application license.	Installation of the application license has failed	-	-	Y	Y	-	-
7326	Maintenance error	Application license uninstalled.	Application license has been uninstalled	-	-	Y	Y	-	-
7327	Maintenance error	Failed to uninstall the application license.	Uninstallation of the application license has failed	-	-	Y	Y	-	-
7328	Maintenance error	Application license removal completed	Deletion of all the application licenses has succeeded	-	-	Y	Y	-	-
7329	Maintenance error	Failed to completely delete application license.	Deletion of all the application licenses has failed	-	-	Y	Y	-	-
7330	Maintenance error	The expiration date of the license of the application approaches.	The validated date of the license for an application will nearly have expired	-	-	Y	Y	-	-

Error code	Classification	Message	Contents	Error code display media					Troubleshooting
				Panl	JL	ML	Noti	CSV	
7331	Maintenance error	The time limit of the application license expired.	The validity date of the license for an application has expired	-	-	Y	Y	-	-
7332	Maintenance error	Failed to install Application. Please install the latest Application.	Application installation error	-	-	Y	Y	-	-
7333	Maintenance error	Failed to start Application. Please update the Application.	Application start error	-	-	Y	Y	-	-
7334	Maintenance error	Successfully installed Application Localization.	Installation of the application localization data has succeeded	-	-	Y	Y	-	-
7335	Maintenance error	Failed to install Application Localization.	Installation of the application localization data has failed	-	-	Y	Y	-	-
7336	Maintenance error	Application install error. The application is not supported for this MFP.	Application install error	-	-	Y	Y	-	-
7337	Maintenance error	Failed to add application button automatically.	Automatic addition of application icons has failed since the Home screen to which they are automatically added had already become full	-	-	Y	Y	-	-
7400	License Management	License Activation Success(Online)	License activation success (Online)	-	-	Y	Y	-	-
7401	License Management	License Activation Success(Offline)	License activation success (Offline)	-	-	Y	Y	-	-
7402	License Management	License Activation failed	License activation failure (Online)	-	-	Y	Y	-	P. 8-370
7403	License Management	License Activation failed, NW timeout	License activation failure (network timeout)	-	-	Y	Y	-	P. 8-370
7404	License Management	License Activation failed, NW error	License activation failure (network error)	-	-	Y	Y	-	P. 8-370
7410	License Management	License Deactivate Success(Online)	License deactivation success (Online)	-	-	Y	Y	-	-
7411	License Management	License Deactivate Success(Offline)	License deletion success (Offline)	-	-	Y	Y	-	-
7412	License Management	License Deactivation failed	License deactivation failure (Online)	-	-	Y	Y	-	P. 8-371
7423	License Management	License Deactivation failed, NW timeout	License deactivation failure (network timeout)	-	-	Y	Y	-	P. 8-371
7424	License Management	License Deactivation failed, NW error	License deactivation failure (network error)	-	-	Y	Y	-	P. 8-371

Error code	Classification	Message	Contents	Error code display media					Troubleshooting
				Panl	JL	ML	Noti	CSV	
7430	License Management	License Activation failed, Invalid serial number	Serial number mismatching	-	-	Y	Y	-	P. 8-371
7431	License Management	License Activation failed, Invalid subnet	Subnet mismatching	-	-	Y	Y	-	P. 8-372
7432	License Management	License Activation failed, Invalid Domain	Domain mismatching	-	-	Y	Y	-	P. 8-372
7433	License management	License Activation failed (Invalid input)	License certificate ID invalid	-	-	Y	Y	Y	P. 8-372
7434	License management	License Activation failed (Same license)	License duplicating installation	-	-	Y	Y	Y	P. 8-372
7435	License management	License Activation failed (unsupported license)	Unsupported license activation	-	-	Y	Y	Y	P. 8-373
7440	License Management	License file Signature mismatch error	Signature mismatching	-	-	Y	Y	-	P. 8-373
7441	License Management	Trial License expired	End of the trial period	-	-	Y	Y	-	-
7442	License Management	License period expired	End of the valid period	-	-	Y	Y	-	-
7443	License Management	License Expired	License use period expired	-	-	Y	Y	-	P. 8-373
7444	License Management	License Not Found	No license exists	-	-	Y	Y	-	P. 8-373
7445	License Management	License Full	Full of the license	-	-	Y	Y	-	P. 8-373

8.2.8 Network error

Error code	Classification	Message	Contents	Error code display media					Troubleshooting
				Panl	JL	ML	Noti	CSV	
8000	Network error	Static address of IPv4 was duplicated.	IPv4 address conflict	-	-	Y	Y	-	P. 8-374
8011	Network error	Link Local address of IPv6 was duplicated.	IPv6 link local address conflict	-	-	Y	Y	-	P. 8-374
8012	Network error	Manual address of IPv6 was duplicated.	IPv6 manual address conflict	-	-	Y	Y	-	P. 8-374
8013	Network error	Stateless address of IPv6 was duplicated.	IPv6 stateless address conflict	-	-	Y	Y	-	P. 8-374
8014	Network error	Stateful address of IPv6 was duplicated.	IPv6 stateful address conflict	-	-	Y	Y	-	P. 8-374
8021	Network error	N/A	Authentication success	-	-	Y	Y	-	-
8022	Network error	Authentication Failure	802.1X authentication failure	-	-	Y	Y	-	P. 8-374
8023	Network error	Can not contact Authentication Server/Switch	Connection failure to an authentication server and a switch	-	-	Y	Y	-	P. 8-375
8024	Network error	Certificate verification Failure	Failure in verification of certification	-	-	Y	Y	-	P. 8-375
8031	Network error	No IKE proposal chosen	IPsec error for IKEv1 certification failure	-	-	Y	Y	-	P. 8-375
8032	Network error	IKE Certificate Authentication failed	IPsec error for wrong proposal selection	-	-	Y	Y	-	P. 8-375
8033	Network error	IKE Pre-shared key Authentication failed	IPsec error for shared key authentication failure	-	-	Y	Y	-	P. 8-375
8034	Network error	Invalid Certificate	IPsec error for invalid certificate upload	-	-	Y	Y	-	P. 8-376
8035	Network error	Certificate Type unsupported	IPsec error for non-supported certification	-	-	Y	Y	-	P. 8-376
8036	Network error	Invalid certificate authority	IPsec error for invalid certification of authentication	-	-	Y	Y	-	P. 8-376
8037	Network error	Certificate unavailable	IPsec error for certification disable	-	-	Y	Y	-	P. 8-376
8038	Network error	No ISAKMP SA established	IPsec error for SA is not present	-	-	Y	Y	-	P. 8-376
8039	Network error	Invalid Signature	IPsec error for invalid signature for certification	-	-	Y	Y	-	P. 8-377
803A	Network error	No IKEv2 proposal chosen	IPsec error for wrong selection of proposal	-	-	Y	Y	-	P. 8-377

Error code	Classification	Message	Contents	Error code display media					Troubleshooting
				Panl	JL	ML	Noti	CSV	
803B	Network error	IKEv2 Certificate Authentication failed	IPsec error for IKEv2 certification failure	-	-	Y	Y	-	P. 8-377
803C	Network error	IKEv2 Secret key Authentication failed	IKEv2 error for IKEv2 if secret key authentication failed	-	-	Y	Y	-	P. 8-377
803D	Network error	Falling Back to IKEv1	IPsec error if peer does not support IKEv2 and falling back to IKEv1	-	-	Y	Y	-	P. 8-377
803E	Network error	ISAKMP SA unusable (deleted)	IPsec error if ISAKMP SA is uncreated or destroyed due to some uncertain conditions	-	-	Y	Y	-	P. 8-378
803F	Network error	Crypto operation failed	IPsec error for IKEv2 if crypto operation failed	-	-	Y	Y	-	P. 8-378
8040	Network error	Invalid key information	IPsec error for IKEv2 if key info is invalid	-	-	Y	Y	-	P. 8-378
8041	Network error	CA not trusted	IPsec error for IKEv2 if CA is not trusted	-	-	Y	Y	-	P. 8-378
8042	Network error	Authentication Method mismatch	IPsec error for authentication method inconsistency	-	-	Y	Y	-	P. 8-378
8043	Network error	IKE Version mismatch	IPsec error for version inconsistency	-	-	Y	Y	-	P. 8-378
8044	Network error	Encapsulation mode mismatch	IPsec error for encapsulation inconsistency	-	-	Y	Y	-	P. 8-379
8045	Network error	Peer IP Address mismatch	IPsec error for peer IP inconsistency	-	-	Y	Y	-	P. 8-379
8046	Network error	Local IP Address mismatch	IPsec error for local IP inconsistency	-	-	Y	Y	-	P. 8-379
8047	Network error	Local ID mismatch	IPsec error for local ID inconsistency	-	-	Y	Y	-	P. 8-379
8048	Network error	Remote ID mismatch	IPsec error for remote ID inconsistency	-	-	Y	Y	-	P. 8-379
8049	Network error	IPsec Remote IP mismatch	IPsec error for remote IP inconsistency	-	-	Y	Y	-	P. 8-379
804A	Network error	IKEv1/IKEv2 Timed out	IPsec error for IKEv2 timeout	-	-	Y	Y	-	P. 8-380
804B	Network error	Invalid manual key data	IPsec error for invalid of ID manual key	-	-	Y	Y	-	P. 8-380
8061	Network error	Secure Update to Primary DDNS failed.	Update error for secure primary DDNS	-	-	Y	Y	-	P. 8-380

Error code	Classification	Message	Contents	Error code display media					Troubleshooting
				Panl	JL	ML	Noti	CSV	
8062	Network error	Secure Update to Secondary DDNS failed.	Update error for secure secondary DDNS	-	-	Y	Y	-	P. 8-380
8063	Network error	Secure update to primary IPv6 server failed	Update error for IPv6 secure primary DDNS	-	-	Y	Y	-	P. 8-380
8064	Network error	Secure update to secondary IPv6 server failed	Update error for IPv6 secure secondary DDNS	-	-	Y	Y	-	P. 8-380
8065	Network error	IPv6 Update to Primary DDNS failed.	Update error for IPv6 primary DDNS	-	-	Y	Y	-	P. 8-380
8066	Network error	IPv6 Update to Secondary DDNS failed.	Update error for IPv6 secondary DDNS	-	-	Y	Y	-	P. 8-380
8067	Network error	IPv4 Update to Primary DDNS failed.	Update error for IPv4 primary DDNS	-	-	Y	Y	-	P. 8-380
8068	Network error	IPv4 Update to Secondary DDNS failed.	Update error for IPv4 secondary DDNS	-	-	Y	Y	-	P. 8-380
8069	Network error	Invalid TSIG/ SIG(0) Key file uploaded	This message is displayed when the key file for SIG(0) or TSIG is invalid	-	-	Y	Y	-	P. 8-380
80B1	Network error	Bluetooth Disconnected	Bluetooth connection failure	-	-	Y	Y	-	P. 8-381
80B2	Network error	Bluetooth Print error	Bluetooth print error	-	-	Y	Y	-	-
80B3	Network error	Bluetooth Fatal error	Bluetooth fatal error	-	-	Y	Y	-	-
80B4	Network error	Bluetooth Storage Near Full	Bluetooth storage near full	-	-	Y	Y	-	-
80B5	Network error	Bluetooth Storage Full	Bluetooth storage full	-	-	Y	Y	-	-
80C0	Network error	Failed to establish the TLS session (unexpected message)	TLS session establishment failure (invalid message)	-	-	Y	Y	-	P. 8-381
80C1	Network error	Failed to establish the TLS session (bad record mac)	TLS session establishment failure (invalid MAC data)	-	-	Y	Y	-	P. 8-381
80C2	Network error	Failed to establish the TLS session (decryption failed)	TLS session establishment failure (decoding failure)	-	-	Y	Y	-	P. 8-381
80C3	Network error	Failed to establish the TLS session (record overflow)	TLS session establishment failure (recording length abnormality)	-	-	Y	Y	-	P. 8-381
80C4	Network error	Failed to establish the TLS session (decompression failure)	TLS session establishment failure (data decompression failure)	-	-	Y	Y	-	P. 8-382
80C5	Network error	Failed to establish the TLS session (handshake failure)	TLS session establishment failure (handshake failure)	-	-	Y	Y	-	P. 8-382

Error code	Classification	Message	Contents	Error code display media					Troubleshooting
				Panl	JL	ML	Noti	CSV	
80C6	Network error	Failed to establish the TLS session (bad certificate)	TLS session establishment failure (certificate abnormality)	-	-	Y	Y	-	P. 8-382
80C7	Network error	Failed to establish the TLS session (unsupported certificate)	TLS session establishment failure (non-support certificate)	-	-	Y	Y	-	P. 8-382
80C8	Network error	Failed to establish the TLS session (certificate revoked)	TLS session establishment failure (invalid certificate)	-	-	Y	Y	-	P. 8-382
80C9	Network error	Failed to establish the TLS session (certificate expired)	TLS session establishment failure (certificate with validity date expired)	-	-	Y	Y	-	P. 8-382
80CA	Network error	Failed to establish the TLS session (certificate unknown)	TLS session establishment failure (certificate process error)	-	-	Y	Y	-	P. 8-383
80CB	Network error	Failed to establish the TLS session (illegal parameter)	TLS session establishment failure (invalid parameter)	-	-	Y	Y	-	P. 8-383
80CC	Network error	Failed to establish the TLS session (unknown ca)	TLS session establishment failure (unknown CA certificate)	-	-	Y	Y	-	P. 8-383
80CD	Network error	Failed to establish the TLS session (access denied)	TLS session establishment failure (access rejection)	-	-	Y	Y	-	P. 8-383
80CE	Network error	Failed to establish the TLS session (decode error)	TLS session establishment failure (decoding error)	-	-	Y	Y	-	P. 8-383
80CF	Network error	Failed to establish the TLS session (decrypt error)	TLS session establishment failure (decoding error)	-	-	Y	Y	-	P. 8-384
80D0	Network error	Failed to establish the TLS session (export restriction)	TLS session establishment failure (export restrictions)	-	-	Y	Y	-	P. 8-384
80D1	Network error	Failed to establish the TLS session (protocol version)	TLS session establishment failure (non-support protocol version)	-	-	Y	Y	-	P. 8-384
80D2	Network error	Failed to establish the TLS session (internal error)	TLS session establishment failure (internal error)	-	-	Y	Y	-	P. 8-384
80D3	Network error	Failed to establish the TLS session (user canceled)	TLS session establishment failure (cancellation by a user)	-	-	Y	Y	-	P. 8-384

Error code	Classification	Message	Contents	Error code display media					Troubleshooting
				Panl	JL	ML	Noti	CSV	
80D4	Network error	Failed to establish the TLS session (no renegotiation)	TLS session establishment failure (invalid renegotiation)	-	-	Y	Y	-	P. 8-385
8101	Network error	Wireless association with Access point failure	Wireless connection in the Access point failure	-	-	Y	Y	-	P. 8-385
8102	Network error	MFP not able to contact the Access point with the specified SSID	Connection of MFP to the Access point with a specified SSID failure	-	-	Y	Y	-	P. 8-385
8103	Network error	Wireless Certificate verification failure	Wireless certificate verification failure	-	-	Y	Y	-	P. 8-385
8104	Network error	Cannot connect to the access point due to H/W abnormality of wireless LAN	Wireless LAN / Bluetooth module hardware error	-	-	Y	Y	-	P. 8-385
8106	Network error	Wi-Fi Direct Session MAX	The number of connection sessions of Wi-Fi Direct has reached the maximum.	-	-	Y	Y	-	-
8121	Network error	Domain - General Failure during Authentication	Domain: Authentication failure	-	-	Y	Y	-	P. 8-386
8122	Network error	Domain - Invalid Username or Password	Domain: Invalid user name or password	-	-	Y	Y	-	P. 8-386
8123	Network error	Domain - Server not present in Network	Domain: Invalid server	-	-	Y	Y	-	P. 8-386
8124	Network error	Domain - User account is disabled on Server	Domain: Invalid user account	-	-	Y	Y	-	P. 8-386
8125	Network error	Domain - User account has expired and cannot be used for logon	Domain: Expired user account (cannot be used for logon)	-	-	Y	Y	-	P. 8-386
8126	Network error	Domain - User account is locked and cannot be used for logon	Domain: Locked user account (cannot be used for logon)	-	-	Y	Y	-	P. 8-387
8127	Network error	Domain - Invalid logon hours for the User	Domain: Invalid logon time	-	-	Y	Y	-	P. 8-387
8128	Network error	Active Directory Domain - Clock Skew error due to difference in Time between Server and MFP	Active directory domain: Clock skew error (due to difference in time between the server and the MFP)	-	-	Y	Y	-	P. 8-387
8129	Network error	Active Directory Domain - Kerberos Ticket has expired and cannot be used for Authentication	Active directory domain: Expired Kerberos ticket (cannot be used for authentication)	-	-	Y	Y	-	P. 8-387

Error code	Classification	Message	Contents	Error code display media					Troubleshooting
				Panl	JL	ML	Noti	CSV	
812A	Network error	Active Directory Domain - Verification of the Ticket has failed	Active directory domain: Kerberos ticket authentication failure	-	-	Y	Y	-	P. 8-387
812B	Network error	Active Directory Domain-The Domain specified could not be found	Active directory domain: Invalid realm name	-	-	Y	Y	-	P. 8-388

8.2.9 Notification

Error code	Classification	Message	Contents	Error code display media					Troubleshooting
				Panl	JL	ML	Noti	CSV	
D101	Information	Paper Empty - Large Capacity Feeder (LCF)	Paper presence / absence in the LCF	-	-	Y	Y	-	-
D102	Information		Paper presence / absence in the SFB	-	-	-	-	-	-
D103	Information	Paper Empty in Drawer 1 - Please Add Paper.	Paper presence / absence in the 1st drawer	-	-	Y	Y	-	-
D104	Information	Paper Empty in Drawer 2 - Please Add Paper.	Paper presence / absence in the 2nd drawer	-	-	Y	Y	-	-
D105	Information	Paper Empty in Drawer 3 - Please Add Paper.	Paper presence / absence in the PFP1	-	-	Y	Y	-	-
D106	Information	Paper Empty in Drawer 4 - Please Add Paper.	Paper presence / absence in the PFP2	-	-	Y	Y	-	-
D201	Information	Front Cover Open - Please Close Cover.	Front cover	-	-	Y	Y	-	-
D202	Information	Paper Feeding Cover Open - Please Close Cover.	Paper feed cover of the equipment	-	-	Y	Y	-	-
D204	Information	Lower Side Cover Open - Please Close Cover.	T-LCF cover (taking off of the LCF (large capacitor feeder))	-	-	Y	Y	-	-
D205	Information	Lower Side Cover Open - Please Close Cover.	Paper feed cover of the PFP (side cover)	-	-	Y	Y	-	-
D206	Information	Automatic Duplexing Unit Cover Open - Please Close Cover.	ADU cover / unit	-	-	Y	Y	-	-
D207	Information	Relay Unit Cover Open - Please Close Cover.	Bridge unit transport cover	-	-	Y	Y	-	-
D209	Information	Finisher Joint Cover Open - Please Close Cover.	Finisher joint (when a hanging finisher is taken off)	-	-	Y	Y	-	-
D20A	Information	Finisher Door Open - Please Close Door.	Finisher door	-	-	Y	Y	-	-
D20E	Information	Lower Tray Delivery Cover Open - Please Close Cover	Saddle stitch stapler connection	-	-	Y	Y	-	-
D20F	Information	Punch Unit Front Cover Open - Please Close Cover.	Front cover of the punch unit	-	-	Y	Y	-	-

Error code	Classification	Message	Contents	Error code display media					Troubleshooting
				Panl	JL	ML	Noti	CSV	
D211	Information	Job Separator Cover Open - Please Close Cover.	Job separator cover	-	-	Y	Y	-	-
D217	Information	Finisher Door Open - Please Close Door.	Upper cover of the finisher	-	-	Y	Y	-	-
D301	Information	Black Toner Empty - Please Refill.	Toner-K empty	-	-	Y	Y	-	-
D302	Information	Cyan Toner Empty - Please Refill.	Toner-C empty	-	-	Y	Y	-	-
D303	Information	Magenta Toner Empty - Please Refill.	Toner-M empty	-	-	Y	Y	-	-
D304	Information	Yellow Toner Empty - Please Refill.	Toner-Y empty	-	-	Y	Y	-	-
D30F	Information	Waste Toner Box Full - Please Replace.	Waste toner box full	-	-	Y	Y	-	-
D311	Information		Non-genuine toner-K	-	-	-	-	-	-
D312	Information		Non-genuine toner-C	-	-	-	-	-	-
D313	Information		Non-genuine toner-M	-	-	-	-	-	-
D314	Information		Non-genuine toner-Y	-	-	-	-	-	-
D321	Information		Toner-K nearly empty	Y	-	-	-	-	-
D322	Information		Toner-C nearly empty	Y	-	-	-	-	-
D323	Information		Toner-M nearly empty	Y	-	-	-	-	-
D324	Information		Toner-Y nearly empty	Y	-	-	-	-	-
D32E	Information		Waste toner box nearly full	-	-	-	Y	-	-
D341	Information	Black Toner Empty - Please Refill.	Cartridge-K empty	-	-	Y	-	-	-
D342	Information	Cyan Toner Empty - Please Refill.	Cartridge-C empty	-	-	Y	-	-	-
D343	Information	Magenta Toner Empty - Please Refill.	Cartridge-M empty	-	-	Y	-	-	-
D344	Information	Yellow Toner Empty - Please Refill.	Cartridge-Y empty	-	-	Y	-	-	-
D361	Information	New unit was installed	Fuser unit replacement completion	-	-	Y	-	-	-
D362	Information	New unit was installed	EPU-K replacement completion	-	-	Y	-	-	-
D363	Information	New unit was installed	EPU-C replacement completion	-	-	Y	-	-	-

Error code	Classification	Message	Contents	Error code display media					Troubleshooting
				Panl	JL	ML	Noti	CSV	
D364	Information	New unit was installed	EPU-M replacement completion	-	-	Y	-	-	-
D365	Information	New unit was installed	EPU-Y replacement completion	-	-	Y	-	-	-
D366	Information	New unit was installed	EPU2-K replacement completion	-	-	Y	-	-	-
D367	Information	New unit was installed	EPU2-C replacement completion	-	-	Y	-	-	-
D368	Information	New unit was installed	EPU2-M replacement completion	-	-	Y	-	-	-
D369	Information	New unit was installed	EPU2-Y replacement completion	-	-	Y	-	-	-
D401	Information	Close Drawer 1	1st drawer	-	-	Y	Y	-	-
D402	Information	Close Drawer 2	2nd drawer	-	-	Y	Y	-	-
D403	Information	Close Drawer 3	3rd drawer	-	-	Y	Y	-	-
D404	Information	Close Drawer 4	4th drawer	-	-	Y	Y	-	-
D405	Information	Close large capacity feeder (LCF)	Paper supply door of the T-LCF	-	-	Y	Y	-	-
D407	Information	Close large capacity feeder (LCF)	Paper supply door of the T-LCF (left side)	-	-	Y	Y	-	-
D711	Information	Add/Remove Drawer 2	2nd drawer installation / removal	-	-	Y	Y	-	-
D712	Information	Add/Remove Drawer 3	3rd drawer installation / removal	-	-	Y	Y	-	-
D713	Information	Add/Remove Drawer 4	4th drawer installation / removal	-	-	Y	Y	-	-
D718	Information	Add/Remove Large Capacity Feeder	LCF installation / removal	-	-	Y	Y	-	-
D730	Information	Add/Remove Finisher	Finisher installation / removal	-	-	Y	Y	-	-
D731	Information	Add/Remove Saddle Finisher	Saddle stitch unit installation / removal	-	-	Y	Y	-	-
D732	Information	Add/Remove Hole Punch Unit	Hole punch unit installation / removal	-	-	Y	Y	-	-
D750	Information	Add/Remove Automatic Duplexing Unit	ADU installation / removal	-	-	Y	Y	-	-
D751	Information	Add/Remove Relay Unit	Bridge unit installation / removal	-	-	Y	Y	-	-
D770	Information	Add/Remove Automatic Document Feeder	ADF installation / removal	-	-	Y	Y	-	-

Error code	Classification	Message	Contents	Error code display media					Troubleshooting
				Panl	JL	ML	Noti	CSV	
D7B0	Information	Add/Remove Fax Unit(Line1)	FAX Unit line 1 installation / removal	-	-	Y	Y	-	-
D7B1	Information	Add/Remove Fax Unit(Line2)	FAX Unit line 2 installation / removal	-	-	Y	Y	-	-
D7E0	Information	Add/Remove Coin Controller	Coin controller installation / removal	-	-	Y	Y	-	-
D7E1	Information	Add/Remove Key Copy Counter	Key counter installation / removal	-	-	Y	Y	-	-
D800	Information	The machine was shut down	Shutdown	-	-	Y	Y	-	-
D801	Information	Turned on the power	Power ON	-	-	Y	Y	-	-
D802	Information	Gone into the energy save mode	Move low power	-	-	Y	Y	-	-
D803	Information	Gone into the sleep mode	Move sleep	-	-	Y	-	-	-
D804	Information	The machine was rebooted	Execute reboot	-	-	Y	Y	-	-
D805	Information		Silent reboot	-	-	-	-	-	-
D806	Information	Reboot By Service Call	Rebooting for recovering from an internal error (service call)	Y	-	Y	-	-	-

8.2.10 FAX error

Error code	Classification	Message	Contents	Error code display media					Troubleshooting
				PanI	JL	ML	Noti	CSV	
0000	Fax	-	Information: The Fax transmission has succeeded.	-	Y	-	Y	-	-
	Fax	-	Information: The Fax reception has succeeded.	-	Y	-	Y	-	
	IP Fax	-	Information: The IP Fax transmission has succeeded.	-	Y	-	Y	-	
	IP Fax	-	Information: The IP Fax reception has succeeded.	-	Y	-	Y	-	
0012	Fax	-	Original jam: The Fax transmission has failed since an original was misfed in the DF while a Fax job was being sent.	-	Y	-	Y	-	P. 8-389
0013	Fax	-	Cover is open: The Fax transmission has failed since the cover of the equipment or options that process paper was opened.	-	Y	-	Y	-	P. 8-389
0020	Fax	-	Power failure: The Fax transmission has failed due to a power failure.	-	Y	-	Y	-	P. 8-389
	Fax	-	Power failure: The Fax reception has failed due to a power failure.	-	Y	-	Y	-	
	IP Fax	-	Power failure: The IP Fax transmission has failed due to a power failure.	-	Y	-	Y	-	
	IP Fax	-	Power failure: The IP Fax reception has failed due to a power failure.	-	Y	-	Y	-	

Error code	Classification	Message	Contents	Error code display media					Troubleshooting
				Panl	JL	ML	Noti	CSV	
0030	Fax	-	Recording paper jam: The Fax transmission has been stopped due to the following reason. <ul style="list-style-type: none"> Paper misfeeding occurred with another job. A Fax job was canceled. 	-	Y	-	Y	-	P. 8-390
0033	Fax	-	Polling error: The polling reception has failed due to the following reason. <ul style="list-style-type: none"> A polling original was not set on the other side's device. The security setting between this equipment and the other side's device did not match. 	-	Y	-	Y	-	P. 8-390
0040	Fax	-	Modem communication error: The Fax transmission has failed since the modem could not send the signal properly.	-	Y	-	Y	-	P. 8-390
	Fax	-	Modem communication error: The Fax reception has failed since the modem could not receive the signal properly.	-	Y	-	Y	-	

Error code	Classification	Message	Contents	Error code display media					Troubleshooting
				Panl	JL	ML	Noti	CSV	
0042	Fax	-	Memory full: The Fax reception has been canceled since the capacity shortage or an abnormality occurred in the storage while a Fax job was being received. (Pages which are received successfully will be printed out.)	-	Y	-	Y	-	P. 8-391
	IP Fax	-	Memory full: The IP Fax reception has been canceled since the capacity shortage or an abnormality occurred in the storage while an IP Fax job was being received. (Pages which are received successfully will be printed out.)	-	Y	-	Y	-	
0050	Fax	-	Line is busy: Since the line of the other side's device was busy, the Fax transmission has failed even though the redialing was carried out by the maximum number of specified times.	-	Y	-	Y	-	P. 8-391
0051	Fax	Please confirm the cable or connection equipment for Line1.	No cable connected for Fax line: The Fax transmission has failed since no cable for the Fax line was connected.	Y	Y	-	Y	-	P. 8-391
		Please confirm the cable or connection equipment for Line2.							
0052	Fax	-	T1 time-out: The Fax transmission has failed since NSF / DIS could not be detected. (Memory transmission)	-	Y	-	Y	-	P. 8-392
	IP Fax	-	T1 time-out: The IP Fax transmission has failed since NSF / DIS could not be detected. (Memory transmission)	-	Y	-	Y	-	

Error code	Classification	Message	Contents	Error code display media					Troubleshooting
				Panl	JL	ML	Noti	CSV	
00B0	Fax	-	Initial signal not detected: The Fax transmission has failed since NSF / DIS could not be detected. (Direct transmission)	-	Y	-	Y	-	P. 8-392
00B1	Fax	-	Terminal constants not compatible: The Fax transmission has failed since the other side's device did not have the capability which was transferred by NSF / DIS on this equipment.	-	Y	-	Y	-	P. 8-392
	Fax	-	Terminal constants not compatible: The Fax reception has failed since NSS / DCS, which was a capability other than the ones transferred by NSF / DIS on this equipment, was received.	-	Y	-	Y	-	
	IP Fax	-	Terminal constants not compatible: The IP Fax transmission has failed since the other side's device did not have the capability which was transferred by NSF / DIS on this equipment.	-	Y	-	Y	-	
	IP Fax	-	Terminal constants not compatible: The IP Fax job reception has failed since NSS / DCS, which was a capability other than the ones transferred by NSF / DIS on this equipment, was received.	-	Y	-	Y	-	

Error code	Classification	Message	Contents	Error code display media					Troubleshooting
				Panl	JL	ML	Noti	CSV	
00B2	Fax	-	Reception of DCN (Phase B): The Fax transmission has failed since DCN was sent in Phase B.	-	Y	-	Y	-	P. 8-393
	Fax	-	Reception of DCN (Phase B): The Fax reception has failed since DCN was received in Phase B.	-	Y	-	Y	-	
	IP Fax	-	Reception of DCN (Phase B): The IP Fax transmission has failed since DCN was sent in Phase B.	-	Y	-	Y	-	
	IP Fax	-	Reception of DCN (Phase B): The IP Fax reception has failed since DCN was received in Phase B.	-	Y	-	Y	-	
00B3	Fax	-	DCS / DTC not detected: The Fax reception has failed since DCS / DTC could not be detected.	-	Y	-	Y	-	P. 8-394
	IP Fax	-	DCS / DTC not detected: The IP Fax transmission has failed since DCS / DTC could not be detected.	-	Y	-	Y	-	
	IP Fax	-	DCS / DTC not detected: The IP Fax reception has failed since DCS / DTC could not be detected.	-	Y	-	Y	-	

Error code	Classification	Message	Contents	Error code display media					Troubleshooting
				Panl	JL	ML	Noti	CSV	
00B4	Fax	-	Training error: This equipment has performed fall-back but the Fax transmission has failed.	-	Y	-	Y	-	P. 8-394
	Fax	-	Training error: The Fax reception has failed since after receiving FTT, the receiver has received a timeout or DCN.	-	Y	-	Y	-	
	IP Fax	-	Training error: This equipment has performed fall-back but the IP Fax transmission has failed.	-	Y	-	Y	-	
	IP Fax	-	Training error: The IP Fax reception has failed since after receiving FTT, the receiver has received a timeout or DCN.	-	Y	-	Y	-	
00B5	Fax	-	CFR not detected: The Fax transmission has failed since a training signal has been sent out but CFR could not be detected.	-	Y	-	Y	-	P. 8-395
	IP Fax	-	CFR not detected: The IP Fax transmission has failed since a training signal has been sent out but CFR could not be detected.	-	Y	-	Y	-	

Error code	Classification	Message	Contents	Error code display media					Troubleshooting
				Panl	JL	ML	Noti	CSV	
00B6	Fax	-	No response made to CTC: The Fax transmission has failed since no response was made to CTC.	-	Y	-	Y	-	P. 8-395
	IP Fax	-	No response made to CTC: The IP Fax transmission has failed since no response was made to CTC.	-	Y	-	Y	-	
	IP Fax	-	No response made to CTC: The IP Fax reception has failed since DCN was received during ECM transmission.	-	Y	-	Y	-	
00B7	Fax	-	Phase B cannot be completed: The Fax transmission has failed since a modem error or a sequence error in the FAX Unit occurred.	-	Y	-	Y	-	P. 8-396
	Fax	-	Phase B cannot be completed: The Fax reception has failed since a modem error or a sequence error in the FAX Unit occurred.	-	Y	-	Y	-	
	IP Fax	-	Phase B cannot be completed: The IP Fax transmission has failed since an error occurred in the system.	-	Y	-	Y	-	
	IP Fax	-	Phase B cannot be completed: The IP Fax reception has failed since an error occurred in the system.	-	Y	-	Y	-	
00C0	Fax	-	Image signal carrier not detected: The Fax reception has failed since this equipment has failed to detect a carrier.	-	Y	-	Y	-	P. 8-397

Error code	Classification	Message	Contents	Error code display media					Troubleshooting
				Panl	JL	ML	Noti	CSV	
00C1	Fax	-	High-speed signal not detected: The Fax reception has failed since this equipment has failed to detect a high-speed signal.	-	Y	-	Y	-	P. 8-397
	IP Fax	-	High-speed signal not detected: The IP Fax reception has failed since this equipment has failed to detect a high-speed signal.	-	Y	-	Y	-	
00C2	Fax	-	Image signal carrier disconnected: The Fax transmission has failed since a carrier disconnection was detected after the image signal was picked up by the other side's device.	-	Y	-	Y	-	P. 8-397
	Fax	-	Image signal carrier disconnected: The Fax reception has failed since a carrier disconnection was detected after the image signal was picked up by this equipment.	-	Y	-	Y	-	
	IP Fax	-	Image signal carrier disconnected: The IP Fax reception has failed since a carrier disconnection was detected after the image signal was picked up by this equipment.	-	Y	-	Y	-	
00C4	Fax	-	EOL time-out: The Fax reception has failed since this equipment could not detect EOL or not decode with MMR.	-	Y	-	Y	-	P. 8-398

Error code	Classification	Message	Contents	Error code display media					Troubleshooting
				Panl	JL	ML	Noti	CSV	
00C5	Fax	-	Excess length of data received: The Fax reception has failed due to the disconnection of the communication since the length of the received original exceeded 2 m.	-	Y	-	Y	-	P. 8-398
	IP Fax	-	Excess length of data received: The IP Fax reception has failed due to the disconnection of the communication since the length of the received original exceeded 2 m.	-	Y	-	Y	-	
00C6	Fax	-	Image code conversion error: The Fax reception has failed since the conversion of the received image went wrong.	-	Y	-	Y	-	P. 8-398
	IP Fax	-	Image code conversion error: The IP Fax reception has failed since the conversion of the received image went wrong.	-	Y	-	Y	-	

Error code	Classification	Message	Contents	Error code display media					Troubleshooting
				Panl	JL	ML	Noti	CSV	
00C7	Fax	-	Phase C cannot be completed: The Fax transmission has failed since a modem error or a sequence error in the FAX Unit occurred.	-	Y	-	Y	-	P. 8-399
	Fax	-	Phase C cannot be completed: The Fax reception has failed since a modem error or a sequence error in the FAX Unit occurred.	-	Y	-	Y	-	
	IP Fax	-	Phase C cannot be completed: The IP Fax transmission has failed since a system error or a sequence error occurred.	-	Y	-	Y	-	
	IP Fax	-	Phase C cannot be completed: The IP Fax reception has failed since a system error or a sequence error occurred.	-	Y	-	Y	-	
00C8	IP Fax	-	Transmitted image was not made in time: The IP Fax transmission has failed due to the disconnection of the communication from the other side's device since the notification of the transmitted image was not made in time.	-	Y	-	Y	-	P. 8-399

Error code	Classification	Message	Contents	Error code display media					Troubleshooting
				Panl	JL	ML	Noti	CSV	
00D0	Fax	-	Post message not detected: The Fax transmission has failed since this equipment could not detect an MCF, RTP, RTN, PIN or PIP or the other side's device could not detect MPS, EOM or EOP.	-	Y	-	Y	-	P. 8-400
	Fax	-	Post message not detected: The Fax reception has failed since the other side's device could not detect an MCF, RTP, RTN, PIN or PIP or this equipment could not detect MPS, EOM or EOP.	-	Y	-	Y	-	
	IP Fax	-	Post message not detected: The IP Fax transmission has failed since this equipment could not detect an MCF, RTP, RTN, PIN or PIP or the other side's device could not detect MPS, EOM or EOP.	-	Y	-	Y	-	
	IP Fax	-	Post message not detected: The IP Fax reception has failed since the other side's device could not detect an MCF, RTP, RTN, PIN or PIP or this equipment could not detect MPS, EOM or EOP.	-	Y	-	Y	-	
00D1	Fax	-	Reception of DCN: The Fax reception has failed since DCN was received.	-	Y	-	Y	-	P. 8-400
	IP Fax	-	Reception of DCN: The IP Fax transmission has failed since DCN was received.	-	Y	-	Y	-	
	IP Fax	-	Reception of DCN: The IP Fax reception has failed since DCN was received.	-	Y	-	Y	-	

Error code	Classification	Message	Contents	Error code display media					Troubleshooting
				Panl	JL	ML	Noti	CSV	
00D2	Fax	-	Poor image quality: The Fax transmission has failed since the quality of the received image was poor in the other side's device.	-	Y	-	Y	-	P. 8-401
	Fax	-	Poor image quality: The Fax reception has failed since the quality of the received image was poor.	-	Y	-	Y	-	
	IP Fax	-	Poor image quality: The IP Fax transmission has failed since the quality of the received image was poor in the other side's device.	-	Y	-	Y	-	
	IP Fax	-	Poor image quality: The IP Fax reception has failed since the quality of the received image was poor.	-	Y	-	Y	-	
00D3	Fax	-	No response made to EOR: The Fax transmission has failed since no response was made to EOR or DCN was received during ECM transmission.	-	Y	-	Y	-	P. 8-402
	IP Fax	-	No response made to EOR: The IP Fax transmission has failed since no response was made to EOR or DCN was received during ECM transmission.	-	Y	-	Y	-	

Error code	Classification	Message	Contents	Error code display media					Troubleshooting
				Panl	JL	ML	Noti	CSV	
00D4	Fax	-	No response made to RR: The Fax transmission has failed since no response was made to RR or DCN was received during ECM transmission.	-	Y	-	Y	-	P. 8-402
	IP Fax	-	No response made to RR: The IP Fax transmission has failed since no response was made to RR or DCN was received during ECM transmission.	-	Y	-	Y	-	
00D5	Fax	-	T5 time-out: The Fax transmission has failed since RNR-RR was repeated and the line was disconnected due to timeout during ECM transmission.	-	Y	-	Y	-	P. 8-402
00D6	Fax	-	ERR returned to EOR: The Fax reception has failed due to the bad condition of the communication.	-	Y	-	Y	-	P. 8-403
	IP Fax	-	ERR returned to EOR: The IP Fax reception has failed due to the bad condition of the communication.	-	Y	-	Y	-	

Error code	Classification	Message	Contents	Error code display media					Troubleshooting
				Panl	JL	ML	Noti	CSV	
00D7	Fax	-	Line disconnected by transmission of EOR: The Fax transmission has failed since the line was disconnected after EOR was sent by this equipment during ECM transmission.	-	Y	-	Y	-	P. 8-403
	IP Fax	-	Line disconnected by transmission of EOR: The IP Fax transmission has failed since the line was disconnected after EOR was sent by this equipment during ECM transmission.	-	Y	-	Y	-	
00D8	Fax	-	Time-out between FCD frames: The Fax reception has failed since a time-out occurred between the FCD frames.	-	Y	-	Y	-	P. 8-403
00DA	Fax	-	MCF not returned: The Fax reception has failed since MCF could not be returned from this equipment.	-	Y	-	Y	-	P. 8-404
	IP Fax	-	MCF not returned: The IP Fax reception has failed since MCF could not be returned from this equipment.	-	Y	-	Y	-	
00E8	Fax	-	HDD error: The Fax transmission has failed due to a defective HDD.	-	Y	-	Y	-	P. 8-404
	Fax	-	HDD error: The Fax reception has failed due to a defective HDD.	-	Y	-	Y	-	
	IP Fax	-	HDD error: The IP Fax transmission has failed due to a defective HDD.	-	Y	-	Y	-	
	IP Fax	-	HDD error: The IP Fax reception has failed due to a defective HDD.	-	Y	-	Y	-	

Error code	Classification	Message	Contents	Error code display media					Troubleshooting
				Panl	JL	ML	Noti	CSV	
00F0	Fax	-	Software trouble: The Fax transmission has failed due to defective software.	-	Y	-	Y	-	P. 8-405
	Fax	-	Software trouble: The Fax reception has failed due to defective software.	-	Y	-	Y	-	
	IP Fax	-	Software trouble: The IP Fax transmission has failed due to defective software.	-	Y	-	Y	-	
	IP Fax	-	Software trouble: The IP Fax reception has failed due to defective software.	-	Y	-	Y	-	
00F1	Fax	-	Hardware noise: The Fax transmission has failed due to defective hardware.	-	Y	-	Y	-	P. 8-405
	Fax	-	Hardware noise: The Fax reception has failed due to defective hardware.	-	Y	-	Y	-	
00F4	Fax	-	Software trouble (FAX Unit): The Fax transmission has failed due to defective software.	-	Y	-	Y	-	P. 8-406
	Fax	-	Software trouble (FAX Unit): The Fax reception has failed due to defective software.	-	Y	-	Y	-	
0100	IP Fax	Registration to SIP server Success.	Registration Success: The registration to an SIP server has succeeded.	-	-	Y	-	-	-
0101	IP Fax	Registration to SIP server failed.	Response TimeOut (Registration): A time-out has occurred since there was no response from an SIP server. (Register)	Y	-	Y	Y	-	P. 8-406
0102	IP Fax	-	Response TimeOut (Invite): The IP Fax transmission has failed due to a time-out since there was no response from an SIP server. (Invite)	-	Y	-	Y	-	P. 8-406

Error code	Classification	Message	Contents	Error code display media					Troubleshooting
				Panl	JL	ML	Noti	CSV	
0103	IP Fax	Registration to SIP server failed.	"Multiple Choices" Received: The registration to an SIP server has failed due to an error. (Multiple Choices)	Y	-	Y	Y	-	P. 8-406
0104	IP Fax	Registration to SIP server failed.	"Moved Permanently" Received: The registration to an SIP server has failed due to an error. (Moved Permanently)	Y	-	Y	Y	-	P. 8-407
0105	IP Fax	Registration to SIP server failed.	"Moved Temporarily" Received: The registration to an SIP server has failed due to an error. (Moved Temporarily)	Y	-	Y	Y	-	P. 8-407
0106	IP Fax	Registration to SIP server failed.	"Use Proxy" Received: The registration to an SIP server has failed due to an error. (Use Proxy)	Y	-	Y	Y	-	P. 8-407
0107	IP Fax	Registration to SIP server failed.	"Alternative Service" Received: The registration to an SIP server has failed due to an error. (Alternative Service)	Y	-	Y	Y	-	P. 8-407
0109	IP Fax	Registration to SIP server failed.	"Bad Request" Received: The registration to an SIP server has failed due to an error. (Bad Request)	Y	-	Y	Y	-	P. 8-407
010A	IP Fax	Registration to SIP server failed.	"Unauthorized" Received: The registration to an SIP server has failed due to an error. (Unauthorized)	Y	-	Y	Y	-	P. 8-408
010B	IP Fax	Registration to SIP server failed.	"Payment Required" Received: The registration to an SIP server has failed due to an error. (Payment Required)	Y	-	Y	Y	-	P. 8-408
010C	IP Fax	Registration to SIP server failed.	"Forbidden" Received: The registration to an SIP server has failed due to an error. (Forbidden)	Y	-	Y	Y	-	P. 8-408

Error code	Classification	Message	Contents	Error code display media					Troubleshooting
				Panl	JL	ML	Noti	CSV	
010D	IP Fax	Registration to SIP server failed.	"Not Found" Received: The registration to an SIP server has failed due to an error. (Not Found)	Y	-	Y	Y	-	P. 8-408
010E	IP Fax	Registration to SIP server failed.	"Method Not Allowed" Received: The registration to an SIP server has failed due to an error. (Method Not Allowed)	Y	-	Y	Y	-	P. 8-408
010F	IP Fax	Registration to SIP server failed.	"Not Acceptable" Received: The registration to an SIP server has failed due to an error. (Not Acceptable)	Y	-	Y	Y	-	P. 8-409
0110	IP Fax	Registration to SIP server failed.	"Proxy Authentication Required" Received: The registration to an SIP server has failed due to an error. (Proxy Authentication Required)	Y	-	Y	Y	-	P. 8-409
0111	IP Fax	Registration to SIP server failed.	"Request Timeout" Received: The registration to an SIP server has failed due to an error. (Request Timeout)	Y	-	Y	Y	-	P. 8-409
0113	IP Fax	Registration to SIP server failed.	"Gone" Received: The registration to an SIP server has failed due to an error. (Gone)	Y	-	Y	Y	-	P. 8-409
0115	IP Fax	Registration to SIP server failed.	"Precondition Failed" Received: The registration to an SIP server has failed due to an error. (Precondition Failed)	Y	-	Y	Y	-	P. 8-409
0116	IP Fax	Registration to SIP server failed.	"Request Entity Too Large" Received: The registration to an SIP server has failed due to an error. (Request Entity Too Large)	Y	-	Y	Y	-	P. 8-410
0117	IP Fax	Registration to SIP server failed.	"Request-URI Too Long" Received: The registration to an SIP server has failed due to an error. (Request-URI Too Long)	Y	-	Y	Y	-	P. 8-410

Error code	Classification	Message	Contents	Error code display media					Troubleshooting
				Panl	JL	ML	Noti	CSV	
0118	IP Fax	Registration to SIP server failed.	“Unsupported Media Type” Received: The registration to an SIP server has failed due to an error. (Unsupported Media Type)	Y	-	Y	Y	-	P. 8-410
0119	IP Fax	Registration to SIP server failed.	“Unsupported URI Scheme” Received: The registration to an SIP server has failed due to an error. (Unsupported URI Scheme)	Y	-	Y	Y	-	P. 8-410
011A	IP Fax	Registration to SIP server failed.	“Unknown Resource-Priority” Received: The registration to an SIP server has failed due to an error. (Unknown Resource-Priority)	Y	-	Y	Y	-	P. 8-410
011B	IP Fax	Registration to SIP server failed.	“Bad Extension” Received: The registration to an SIP server has failed due to an error. (Bad Extension)	Y	-	Y	Y	-	P. 8-411
011C	IP Fax	Registration to SIP server failed.	“Extension Required” Received: The registration to an SIP server has failed due to an error. (Extension Required)	Y	-	Y	Y	-	P. 8-411
011D	IP Fax	Registration to SIP server failed.	“Session Timer Too Small” Received: The registration to an SIP server has failed due to an error. (Session Timer Too Small)	Y	-	Y	Y	-	P. 8-411
011E	IP Fax	Registration to SIP server failed.	“Interval Too Brief” Received: The registration to an SIP server has failed due to an error. (Interval Too Brief)	Y	-	Y	Y	-	P. 8-411
011F	IP Fax	Registration to SIP server failed.	“Anonymity disallowed” Received: The registration to an SIP server has failed due to an error. (Anonymity disallowed)	Y	-	Y	Y	-	P. 8-411

Error code	Classification	Message	Contents	Error code display media					Troubleshooting
				Panl	JL	ML	Noti	CSV	
0120	IP Fax	Registration to SIP server failed.	“Temporarily Unavailable” Received: The registration to an SIP server has failed due to an error. (Temporarily Unavailable)	Y	-	Y	Y	-	P. 8-412
0121	IP Fax	Registration to SIP server failed.	“Call/Transaction Does Not Exist” Received: The registration to an SIP server has failed due to an error. (Call/Transaction Does Not Exist)	Y	-	Y	Y	-	P. 8-412
0122	IP Fax	Registration to SIP server failed.	“Loop Detected” Received: The registration to an SIP server has failed due to an error. (Loop Detected)	Y	-	Y	Y	-	P. 8-412
0123	IP Fax	Registration to SIP server failed.	“Too Many Hops” Received: The registration to an SIP server has failed due to an error. (Too Many Hops)	Y	-	Y	Y	-	P. 8-412
0124	IP Fax	Registration to SIP server failed.	“Address Incomplete” Received: The registration to an SIP server has failed due to an error. (Address Incomplete)	Y	-	Y	Y	-	P. 8-412
0125	IP Fax	Registration to SIP server failed.	“Ambiguous” Received: The registration to an SIP server has failed due to an error. (Ambiguous)	Y	-	Y	Y	-	P. 8-413
0126	IP Fax	Registration to SIP server failed.	“Busy Here” Received: The registration to an SIP server has failed due to an error. (Busy Here)	Y	-	Y	Y	-	P. 8-413
0127	IP Fax	Registration to SIP server failed.	“Request Terminated” Received: The registration to an SIP server has failed due to an error. (Request Terminated)	Y	-	Y	Y	-	P. 8-413

Error code	Classification	Message	Contents	Error code display media					Troubleshooting
				Panl	JL	ML	Noti	CSV	
0128	IP Fax	Registration to SIP server failed.	"Not acceptable here" Received: The registration to an SIP server has failed due to an error. (Not acceptable here)	Y	-	Y	Y	-	P. 8-413
0129	IP Fax	Registration to SIP server failed.	"Bad Event" Received: The registration to an SIP server has failed due to an error. (Bad Event)	Y	-	Y	Y	-	P. 8-413
012A	IP Fax	Registration to SIP server failed.	"Request Updated" Received: The registration to an SIP server has failed due to an error. (Request Updated)	Y	-	Y	Y	-	P. 8-414
012B	IP Fax	Registration to SIP server failed.	"Request Pending" Received: The registration to an SIP server has failed due to an error. (Request Pending)	Y	-	Y	Y	-	P. 8-414
012C	IP Fax	Registration to SIP server failed.	"Undecipherable" Received: The registration to an SIP server has failed due to an error. (Undecipherable)	Y	-	Y	Y	-	P. 8-414
012D	IP Fax	Registration to SIP server failed.	"Security Agreement Required" Received: The registration to an SIP server has failed due to an error. (Security Agreement Required)	Y	-	Y	Y	-	P. 8-414
012E	IP Fax	Registration to SIP server failed.	"Internal Server Error" Received: The registration to an SIP server has failed due to an error. (Internal Server Error)	Y	-	Y	Y	-	P. 8-414
012F	IP Fax	Registration to SIP server failed.	"Not Implemented" Received: The registration to an SIP server has failed due to an error. (Not Implemented)	Y	-	Y	Y	-	P. 8-415

Error code	Classification	Message	Contents	Error code display media					Troubleshooting
				Panl	JL	ML	Noti	CSV	
0130	IP Fax	Registration to SIP server failed.	“Bad Gateway” Received: The registration to an SIP server has failed due to an error. (Bad Gateway)	Y	-	Y	Y	-	P. 8-415
0131	IP Fax	(Panl) Due to IP line traffic,It may take time to send. (ML) ITransmission takes time because IP line is crowded.	“Service Unavailable” Received: The IP Fax transmission took time since the IP line was busy.	Y	-	Y	Y	-	P. 8-415
0132	IP Fax	Registration to SIP server failed.	“Gateway Time-out” Received: The registration to an SIP server has failed due to an error. (Gateway Time-out)	Y	-	Y	Y	-	P. 8-415
0133	IP Fax	Registration to SIP server failed.	“Version Not Supported” Received: The registration to an SIP server has failed due to an error. (Version Not Supported)	Y	-	Y	Y	-	P. 8-415
0134	IP Fax	Registration to SIP server failed.	“Message Too Large” Received: The registration to an SIP server has failed due to an error. (Message Too Large)	Y	-	Y	Y	-	P. 8-416
0135	IP Fax	Registration to SIP server failed.	“Precondition Failure” Received: The registration to an SIP server has failed due to an error. (Precondition Failure)	Y	-	Y	Y	-	P. 8-416
0136	IP Fax	Registration to SIP server failed.	“Busy Everywhere” Received: The registration to an SIP server has failed due to an error. (Busy Everywhere)	Y	-	Y	Y	-	P. 8-416
0137	IP Fax	Registration to SIP server failed.	“Decline” Received: The registration to an SIP server has failed due to an error. (Decline)	Y	-	Y	Y	-	P. 8-416
0138	IP Fax	Registration to SIP server failed.	“Does Not Exist Anywhere” Received: The registration to an SIP server has failed due to an error. (Does Not Exist Anywhere)	Y	-	Y	Y	-	P. 8-416

Error code	Classification	Message	Contents	Error code display media					Troubleshooting
				Panl	JL	ML	Noti	CSV	
0139	IP Fax	Registration to SIP server failed.	“Not Acceptable” Received: The registration to an SIP server has failed due to an error. (Not Acceptable)	Y	-	Y	Y	-	P. 8-417
013D	IP Fax	Registration to SIP server failed.	Registration failed: The registration to an SIP server has failed due to an error. (Other errors)	Y	-	Y	Y	-	P. 8-417
013E	IP Fax	-	Invite failed: The IP Fax transmission / reception has failed due to a communication error. (Other errors)	-	-	-	Y	-	P. 8-417
0140	IP Fax	(Panl) Reboot machine due to IP Fax initializing error. (ML) Failed to start IP Fax.	Failed to start: The starting of the IP Fax function has failed.	Y	-	Y	Y	-	P. 8-417
0141	IP Fax	-	Job interruption due to setting change occurred: The implementation of an IP Fax job has been stopped since the settings were changed.	-	Y	-	Y	-	P. 8-417
0142	IP Fax	-	Irregal address: The IP Fax transmission has failed due to a communication error. (Recipient entry error)	-	-	-	Y	-	P. 8-418
0143	IP Fax	-	SIP server is unavailable: The IP Fax transmission / reception has failed due to a communication error. (SIP server unusable)	-	Y	-	Y	-	P. 8-418
0144	IP Fax	-	Under congestion: The IP Fax transmission has failed due to a communication error. (Under congestion)	-	-	-	Y	-	P. 8-418

Error code	Classification	Message	Contents	Error code display media					Troubleshooting
				PanI	JL	ML	Noti	CSV	
0150	IP Fax	-	Disconnected by communication partner: The IP Fax transmission has failed due to a communication error. (Communication disconnection from the other side's device)	-	Y	-	Y	-	P. 8-418
	IP Fax	-	Disconnected by communication partner: The IP Fax reception has failed due to a communication error. (Communication disconnection from the other side's device)	-	Y	-	Y	-	
0200	IP Fax	-	Success: The IP Fax transmission has been completed.	-	Y	-	Y	-	-
0300	IP Fax	-	"Multiple Choices" Received: The IP Fax transmission / reception has failed due to a communication error. (Multiple Choices)	-	Y	-	Y	-	P. 8-419
0301	IP Fax	-	"Moved Permanently" Received: The IP Fax transmission / reception has failed due to a communication error. (Moved Permanently)	-	Y	-	Y	-	P. 8-419
0302	IP Fax	-	"Moved Temporarily" Received: The IP Fax transmission / reception has failed due to a communication error. (Moved Temporarily)	-	Y	-	Y	-	P. 8-419
0305	IP Fax	-	"Use Proxy" Received: The IP Fax transmission / reception has failed due to a communication error. (Use Proxy)	-	Y	-	Y	-	P. 8-419

Error code	Classification	Message	Contents	Error code display media					Troubleshooting
				Panl	JL	ML	Noti	CSV	
0380	IP Fax	-	"Alternative Service" Received: The IP Fax transmission / reception has failed due to a communication error. (Alternative Service)	-	Y	-	Y	-	P. 8-419
0400	IP Fax	-	"Bad Request" Received: The IP Fax transmission / reception has failed due to a communication error. (Bad Request)	-	Y	-	Y	-	P. 8-420
0401	IP Fax	-	"Unauthorized" Received: The IP Fax transmission / reception has failed due to a communication error. (Unauthorized)	-	Y	-	Y	-	P. 8-420
0402	IP Fax	-	"Payment Required" Received: The IP Fax transmission / reception has failed due to a communication error. (Payment Required)	-	Y	-	Y	-	P. 8-420
0403	IP Fax	-	"Forbidden" Received: The IP Fax transmission / reception has failed due to a communication error. (Forbidden)	-	Y	-	Y	-	P. 8-420
0404	IP Fax	-	"Not Found" Received: The IP Fax transmission / reception has failed due to a communication error. (Not Found)	-	Y	-	Y	-	P. 8-420
0405	IP Fax	-	"Method Not Allowed" Received: The IP Fax transmission / reception has failed due to a communication error. (Method Not Allowed)	-	Y	-	Y	-	P. 8-421

Error code	Classification	Message	Contents	Error code display media					Troubleshooting
				Panl	JL	ML	Noti	CSV	
0406	IP Fax	-	"Not Acceptable" Received: The IP Fax transmission / reception has failed due to a communication error. (Not Acceptable)	-	Y	-	Y	-	P. 8-421
0407	IP Fax	-	"Proxy Authentication Required" Received: The IP Fax transmission / reception has failed due to a communication error. (Proxy Authentication Required)	-	Y	-	Y	-	P. 8-421
0408	IP Fax	-	"Request Timeout" Received: The IP Fax transmission / reception has failed due to a communication error. (Request Timeout)	-	Y	-	Y	-	P. 8-421
0410	IP Fax	-	"Gone" Received: The IP Fax transmission / reception has failed due to a communication error. (Gone)	-	Y	-	Y	-	P. 8-421
0412	IP Fax	-	"Precondition Failed" Received: The IP Fax transmission / reception has failed due to a communication error. (Precondition Failed)	-	Y	-	Y	-	P. 8-422
0413	IP Fax	-	"Request Entity Too Large" Received: The IP Fax transmission / reception has failed due to a communication error. (Request Entity Too Large)	-	Y	-	Y	-	P. 8-422
0414	IP Fax	-	"Request-URI Too Long" Received: The IP Fax transmission / reception has failed due to a communication error. (Request-URI Too Long)	-	Y	-	Y	-	P. 8-422

Error code	Classification	Message	Contents	Error code display media					Troubleshooting
				Panl	JL	ML	Noti	CSV	
0415	IP Fax	-	“Unsupported Media Type” Received: The IP Fax transmission / reception has failed due to a communication error. (Unsupported Media Type)	-	Y	-	Y	-	P. 8-422
0416	IP Fax	-	“Unsupported URI Scheme” Received: The IP Fax transmission / reception has failed due to a communication error. (Unsupported URI Scheme)	-	Y	-	Y	-	P. 8-422
0417	IP Fax	-	“Unknown Resource-Priority” Received: The IP Fax transmission / reception has failed due to a communication error. (Unknown Resource-Priority)	-	Y	-	Y	-	P. 8-423
0420	IP Fax	-	“Bad Extension” Received: The IP Fax transmission / reception has failed due to a communication error. (Bad Extension)	-	Y	-	Y	-	P. 8-423
0421	IP Fax	-	“Extension Required” Received: The IP Fax transmission / reception has failed due to a communication error. (Extension Required)	-	Y	-	Y	-	P. 8-423
0422	IP Fax	-	“Session Timer Too Small” Received: The IP Fax transmission / reception has failed due to a communication error. (Session Timer Too Small)	-	Y	-	Y	-	P. 8-423

Error code	Classification	Message	Contents	Error code display media					Troubleshooting
				Panl	JL	ML	Noti	CSV	
0423	IP Fax	-	"Interval Too Brief" Received: The IP Fax transmission / reception has failed due to a communication error. (Interval Too Brief)	-	Y	-	Y	-	P. 8-423
0433	IP Fax	-	"Anonymity disallowed" Received: The IP Fax transmission / reception has failed due to a communication error. (Anonymity disallowed)	-	Y	-	Y	-	P. 8-424
0480	IP Fax	-	"Temporarily Unavailable" Received: The IP Fax transmission / reception has failed due to a communication error. (Temporarily Unavailable)	-	Y	-	Y	-	P. 8-424
0481	IP Fax	-	"Call/Transaction Does Not Exist" Received: The IP Fax transmission / reception has failed due to a communication error. (Call/Transaction Does Not Exist)	-	Y	-	Y	-	P. 8-424
0482	IP Fax	-	"Loop Detected" Received: The IP Fax transmission / reception has failed due to a communication error. (Loop Detected)	-	Y	-	Y	-	P. 8-424
0483	IP Fax	-	"Too Many Hops" Received: The IP Fax transmission / reception has failed due to a communication error. (Too Many Hops)	-	Y	-	Y	-	P. 8-424

Error code	Classification	Message	Contents	Error code display media					Troubleshooting
				Panl	JL	ML	Noti	CSV	
0484	IP Fax	-	"Address Incomplete" Received: The IP Fax transmission / reception has failed due to a communication error. (Address Incomplete)	-	Y	-	Y	-	P. 8-425
0485	IP Fax	-	"Ambiguous" Received: The IP Fax transmission / reception has failed due to a communication error. (Ambiguous)	-	Y	-	Y	-	P. 8-425
0486	IP Fax	-	"Busy Here" Received: The IP Fax transmission / reception has failed due to a communication error. (Busy Here)	-	Y	-	Y	-	P. 8-425
0487	IP Fax	-	"Request Terminated" Received: The IP Fax transmission / reception has failed due to a communication error. (Request Terminated)	-	Y	-	Y	-	P. 8-425
0488	IP Fax	-	"Not acceptable here" Received: The IP Fax transmission / reception has failed due to a communication error. (Not acceptable here)	-	Y	-	Y	-	P. 8-425
0489	IP Fax	-	"Bad Event" Received: The IP Fax transmission / reception has failed due to a communication error. (Bad Event)	-	Y	-	Y	-	P. 8-426
0490	IP Fax	-	"Request Updated" Received: The IP Fax transmission / reception has failed due to a communication error. (Request Updated)	-	Y	-	Y	-	P. 8-426

Error code	Classification	Message	Contents	Error code display media					Troubleshooting
				Panl	JL	ML	Noti	CSV	
0491	IP Fax	-	"Request Pending" Received: The IP Fax transmission / reception has failed due to a communication error. (Request Pending)	-	Y	-	Y	-	P. 8-426
0493	IP Fax	-	"Undecipherable" Received: The IP Fax transmission / reception has failed due to a communication error. (Undecipherable)	-	Y	-	Y	-	P. 8-426
0494	IP Fax	-	"Security Agreement Required" Received: The IP Fax transmission / reception has failed due to a communication error. (Security Agreement Required)	-	Y	-	Y	-	P. 8-426
0500	IP Fax	-	"Internal Server Error" Received: The IP Fax transmission / reception has failed due to a communication error. (Internal Server Error)	-	Y	-	Y	-	P. 8-427
0501	IP Fax	-	"Not Implemented" Received: The IP Fax transmission / reception has failed due to a communication error. (Not Implemented)	-	Y	-	Y	-	P. 8-427
0502	IP Fax	-	"Bad Gateway" Received: The IP Fax transmission / reception has failed due to a communication error. (Bad Gateway)	-	Y	-	Y	-	P. 8-427

Error code	Classification	Message	Contents	Error code display media					Troubleshooting
				Panl	JL	ML	Noti	CSV	
0503	IP Fax	(Panl) Due to IP line traffic,It may take time to send. (ML) ITransmission takes time because IP line is crowded.	“Service Unavailable” Received: The IP Fax transmission / reception has failed due to a communication error. (Service Unavailable)	Y	Y	-	Y	-	P. 8-427
0504	IP Fax	-	“Gateway Time-out” Received: The IP Fax transmission / reception has failed due to a communication error. (Gateway Time-out)	-	Y	-	Y	-	P. 8-427
0505	IP Fax	-	“Version Not Supported” Received: The IP Fax transmission / reception has failed due to a communication error. (Version Not Supported)	-	Y	-	Y	-	P. 8-428
0513	IP Fax	-	“Message Too Large” Received: The IP Fax transmission / reception has failed due to a communication error. (Message Too Large)	-	Y	-	Y	-	P. 8-428
0580	IP Fax	-	“Precondition Failure” Received: The IP Fax transmission / reception has failed due to a communication error. (Precondition Failure)	-	Y	-	Y	-	P. 8-428
0600	IP Fax	-	“Busy Everywhere” Received: The IP Fax transmission / reception has failed due to a communication error. (Busy Everywhere)	-	Y	-	Y	-	P. 8-428
0603	IP Fax	-	“Decline” Received: The IP Fax transmission / reception has failed due to a communication error. (Decline)	-	Y	-	Y	-	P. 8-428

Error code	Classification	Message	Contents	Error code display media					Troubleshooting
				Panl	JL	ML	Noti	CSV	
0604	IP Fax	-	"Does Not Exist Anywhere" Received: The IP Fax transmission / reception has failed due to a communication error. (Does Not Exist Anywhere)	-	Y	-	Y	-	P. 8-429
0606	IP Fax	-	"Not Acceptable" Received: The IP Fax transmission / reception has failed due to a communication error. (Not Acceptable)	-	Y	-	Y	-	P. 8-429
4246	IP Fax	IP Fax license is not installed	IP Fax license is not installed: The license of the IP Fax has not been installed.	-	-	Y	-	-	P. 8-429
DA01	Fax	(Panl) Fax line1 is out of order. Reboot the machine. (ML) FAX Unit Line1 is broken. Please Contact Service Technician.	The FAX Unit of line 1 has been damaged: The FAX Unit of line 1 has been damaged or an abnormality has occurred in the interface between the systems.	Y	-	Y	-	-	P. 8-429
DA02	Fax	(Panl) Fax line2 is out of order. Reboot the machine. (ML) FAX Unit Line2 is broken. Please Contact Service Technician.	The FAX Unit of line 2 has been damaged: The FAX Unit of line 2 has been damaged or an abnormality has occurred in the interface between the systems.	Y	-	Y	-	-	P. 8-429

8.2.11 Error history

In the setting mode (08-9703), the latest twenty groups of error data will be displayed.

Display example

EA10	99999999	2013-07-11 17:05:32	064	064	2362_1000_0000_0_X XXXXXXXXXX
Error code	Total counter	YYYY-MM-DD HH:MM:SS	MMM	NNN	ABCD_EFHI_JLOP_Q _R
4 digits	8 digits	14 digits	3 digits	3 digits	23 digits

A	Paper source
	0: Not selected 1: Bypass feed 2: LCF 3: 1st drawer 4: 2nd drawer 5: PFP upper drawer 6: PFP lower drawer 7: Unused 8: Unused
B	Paper size code
	0: A5/ST 1: A5-R 2: ST-R 3: LT 4: A4 5: B5-R 6: LT-R 7: A4-R 8: OTHER/UNIV 9: B5 A: FOLIO/COMP B: LG C: B4 D: LD E: A3 F: 13"LG G: Unused H: A6-R I: Post card J: 8.5"SQ K: A3-wide / LD wide L: Unused M: 8K N: 16K-R O: 16K P: COM10 Q: DL R: Monarch S: CHO-3 T: YOU-4 U: SRA3 (320x450) V: SRA3 (320x460) Z: Not selected a: Envelope Kaku-2
C	Sort mode/staple mode
	0: Non-sort/Non-staple 1: Group 2: Sort 7: Front staple 8: Double staple 9: Rear staple A: Saddle stitch B: Center fold C: Top Left D: Top Right E: Top Center F: Left Center
D	ADF mode
	0: Unused 1: AUTO FEED (SADF) 2: STACK FEED
E	APS/AMS mode
	0: Not selected 1: APS 2: AMS
F	Duplex mode
	Copy: 0: Single-sided/Single-sided 1: Book 2: Double-sided/Single-sided 4: Double-sided/Duplex copying 8: Single-sided/Duplex copying Printer: 0: Single-sided 8: Double-sided FAX: 0: Single-sided 8: Double-sided e-Filing: 0: Single-sided 8: Double-sided List printing: 0: Single-sided -
H	Image shift
	0: Unused 1: Book 2: Left 3: Right 4: Top 5: Bottom 6: Book+Top 7: Book+Bottom 8: Left+Top 9: Left+Bottom A: Right+Top B: Right+Bottom
I	Editing
	0: Unused 1: Masking 2: Trimming 3: Mirror image 4: Unused 5: NEG/POS
J	Edge erase/Dual-page
	0: Unused 1: Edge erase 2: Dual-page 3: Edge erase & Dual-page
K	Unused
L	Function
	0: Unused 1: Copying 2: FAX/Internet FAX transmission 3: FAX/Internet FAX/E-mail reception printing 4: Unused 5: Printing/List print 6: Scan/E-mail transmission
MMM	Primary scanning reproduction ratio (Display in hexadecimal)
	(Mx256)+(Mx16)+M
NNN	Secondary scanning reproduction ratio (Display in hexadecimal)
	(Nx256)+(Nx16)+N

O	Color mode
	0: Auto color 1: Full color 2: Black 3: Unused 4: Twin color copy 5: Gray scale 6: Unused 7: Image smoothing
P	Media type
	0: Plain paper 1: Thick 1 2: Thick 2 3: Thick 3 4: Thick 4 5: Special paper 1 6: Special paper 2 7: Recycled paper 8: Unused 9: Unused A: Thin paper B: OHP film C: Thick 1/ reverse D: Thick 2/ reverse E: Thick 3/ reverse F: Thick 4/ reverse G: Special paper 1/ reverse H: Special paper 2/ reverse I: Envelope J: Tab paper K: Plain paper/ reverse L: Recycled paper/ reverse M: Thin paper/ reverse N: Special paper 3/ reverse O: Special paper 3/ reverse P: Envelope/ reverse Q: Thick R: Thick/ reverse S to Z: Unused a: User type 1 b: User type 2 c: User type 3 d: User type 4 e: User type 5 f: User type 6 g: User type 7 h: User type 8 i: User type 9 j: User type 10
Q	RADF size mixed
	0: Unused 1: Size mixed 2: Single-size document
R	Workflow ID: 10-digit ID

8.3 Diagnosis and Prescription for Each Error Code



8.3.1 Check item

Check item	Contents
Sensor check	<ul style="list-style-type: none"> Check the sensor in the test mode. Check that there is no dust on the sensor. Check that the actuator is correctly operated.
Connector check	<ul style="list-style-type: none"> Check that the connector is not disconnected. Check that the pins are not deformed and do not come off. Disconnect and reconnect the connector. Even if the connector is not apparently disconnected, it may be connected loosely. Therefore check carefully that it is secure.
Harness check	<ul style="list-style-type: none"> Check if the harnesses are open circuited. Check that the harness is not caught.
Motor check	<ul style="list-style-type: none"> Check the motor in the test mode. Check that there is no abnormality in the driving section. Check that there is no abnormality in the roller.
Board check	<ul style="list-style-type: none"> Check if the board is short circuited or open circuited. Check that the boards are installed properly. Check if the boards are deformed due to a forcible installation.

8.3.2 Paper transport jam (paper exit section)

[E010] Jam not reaching the exit sensor

Classification	Error content
Paper exit jam	The paper which has passed through the fuser unit does not reach the exit sensor.

Phenomenon of paper jamming	Check item	Measures
Paper jamming immediately after the removal and installation of the transfer belt unit.	Transfer belt unit	Check if the transfer belt unit is installed properly.  P. 4-170 "4.7.3 Transfer belt unit (TBU)"
Paper separation failure at separation guide in the Fuser Unit	Fuser unit	<ul style="list-style-type: none"> Paper transport check Check the gap between the separation guide and fuser belt.  P. 6-100 "6.12.1 Adjustment of the separation guide gap"
	Drawer	Check that paper is not skewed in the side guides of the drawer.
	Leading edge margin	Adjust the margin with FS-05-4402 (Leading edge position adjustment) to "Color: 5.5 mm". Widen the margin if needed. (Specification Black: 4.2 mm / Color: 5 mm) <ul style="list-style-type: none"> Use A3/LD paper It is easy to check skew with a copy of a solid image (about 10 mm on its leading edge). Refer to  P. 6-17 "[D] Secondary scanning data writing start position".
Paper jamming at separation finger in the Fuser Unit.	Fuser unit	Clean the separation finger. Check if the fingers or springs of the separation finger are securely attached. Replace the separation finger.
The leading edge of paper has no scratches and the paper stops before being fused.	Fuser unit	Check that the pressure release screw of the pressure roller is securely tightened and pressure is properly applied.
	Transfer belt	Replace the transfer belt. Replace the transfer belt unit.

Phenomenon of paper jamming	Check item	Measures
Paper folded in one side and fused during duplex printing		Check if toner adheres to the fuser entry guide. Clean it if needed.
All	Exit sensor	<ul style="list-style-type: none"> • Sensor check (Perform the input check: FS-03-[ALL]OFF/[9]/[C]) • Actuator check • Connector check • Harness check
	LGC board	<ul style="list-style-type: none"> • Board check • Connector check (CN329, CN306, CN316, CN327, CN305) • Harness check
	PFC board	<ul style="list-style-type: none"> • Board check • Connector check (CN452, CN465) • Harness check
	Aligning amount	If the aligning amount is too small, a skew, an image dislocation in the feeding direction, E010 (a paper jam occurring between the registration pass sensor and the paper clinging detection sensor) may happen. If the aligning amount is too large, on the other hand, an abnormal noise (paper-folding noise) or actual paper folding may occur. Confirm that the value of the aligning amount is appropriate. Refer to  P. 6-8 "6.1.6 Paper alignment at the registration roller".

Parts to be replaced	Remark
Separation finger of the fuser unit	
Transfer belt	
Transfer belt unit	
Exit sensor	
LGC board	
PFC board	
Registration motor	

[E020] Stop jam at the exit sensor

Classification	Error content
Paper exit jam	The trailing edge of the paper does not pass the exit sensor after its leading edge has reached this sensor.

Phenomenon of paper jamming	Check item	Measures
Paper jamming at separation finger in the Fuser Unit.	Fuser unit	Clean the separation finger. Check if the fingers or springs of the separation finger are securely attached. Replace the separation finger.

Phenomenon of paper jamming	Check item	Measures
Paper separation failure at separation guide in the fuser unit	Fuser unit	<ul style="list-style-type: none"> Paper transport check Check the gap between the separation guide and fuser belt. P. 6-100 “6.12.1 Adjustment of the separation guide gap”
	Drawer	Check that paper is not skewed in the side guides of the drawer.
	Leading edge margin	Adjust the margin with FS-05-4402 (Leading edge position adjustment) to “Color: 5.5 mm”. (Specification Black: 4.2 mm / Color: 5 mm) <ul style="list-style-type: none"> Use A3/LD paper It is easy to check skew with a copy of a solid image (about 10 mm on its leading edge). Refer to P. 6-17 “[D] Secondary scanning data writing start position”.
Scratches on the leading edge of paper		Check if toner adheres to the exit gate. Clean it if needed.
Paper stopped in the reverse section	Reverse gate solenoid	<ul style="list-style-type: none"> Solenoid check (Perform the output check: FS-03-222, FS-03-223) Connector check (CN301, J609, J610) Harness check
All	Self-diagnosis code	Change the setting value of FS-08-4542 (Switching for incorrect size jam detection) from “1” (Disabled) to “0”(Enabled).
	Exit sensor	<ul style="list-style-type: none"> Sensor check (Perform the input check: FS-03-[ALL]OFF/[9]/[C]) Actuator check Connector check Harness check
	LGC board	<ul style="list-style-type: none"> Board check Connector check (CN329, CN306) Harness check

Parts to be replaced	Remark
Separation finger of the fuser unit	
Reverse gate solenoid	
Exit sensor	
LGC board	

8.3.3 Paper misfeeding

[E110] ADU misfeeding (paper not reaching the registration sensor)

Classification	Error content
Paper misfeeding	The paper which has passed through ADU does not reach the registration sensor during duplex printing.

Phenomenon of paper jamming	Check item	Measures
Paper stop jam at the registration roller position	Registration guide	Check the registration guide. Replace it if needed.
All	Registration sensor	<ul style="list-style-type: none"> • Sensor check (Perform the input check: FS-03-[ALL]OFF/[9]/[A]) • Connector check (J660, J659) • Harness check
	PFC board	<ul style="list-style-type: none"> • Board check • Connector check (CN450, CN452, CN458) • Harness check
	LGC board	<ul style="list-style-type: none"> • Board check • Connector check (CN323) • Harness check
	ADU	Check if the connector between the ADU and equipment is connected.

Parts to be replaced	Remark
Registration sensor	
PFC board	
LGC board	
Rollers in the ADU	Clean or replace it.

[E120] Bypass misfeeding (paper not reaching the bypass feed sensor)

Classification	Error content
Paper misfeeding	Paper fed from the bypass tray does not reach the bypass feed sensor.

Check item	Measures
Bypass feed clutch	<ul style="list-style-type: none"> • Clutch check (Perform the output check: FS-03-204) • Connector check (J696, J693, CN451) • Harness check
Feed sensor	<ul style="list-style-type: none"> • Sensor check (Perform the input check: FS-03-[ALL]OFF/[9]/[B]) • Connector check (J661, J659, CN458) • Harness check
PFC board	<ul style="list-style-type: none"> • Board check • Connector check (CN458, CN451, CN452) • Harness check
LGC board	<ul style="list-style-type: none"> • Board check • Connector check (CN323, CN451) • Harness check

Parts to be replaced	Remark
Bypass feed clutch	
Feed sensor	
PFC board	
LGC board	
Bypass feed roller	Replace it if it is worn out.
Bypass separation roller	Replace it if it is worn out.

[E130] 1st drawer misfeeding (paper not reaching the 1st drawer feed sensor)

Classification	Error content
Paper misfeeding	The paper fed from the 1st drawer does not reach the 1st drawer feed sensor.

Check item	Measures
Feed sensor	<ul style="list-style-type: none"> • Sensor check (Perform the input check: FS-03-[ALL]OFF/[9]/[B]) • Connector check (J661, J659, CN458) • Harness check
1st drawer feed clutch	<ul style="list-style-type: none"> • Clutch check (Perform the output check: FS-03-201) • Connector check (J666, CN461) • Harness check
PFC board	<ul style="list-style-type: none"> • Board check • Connector check (CN458, CN452, CN461) • Harness check
LGC board	<ul style="list-style-type: none"> • Board check • Connector check (CN323) • Harness check

Parts to be replaced	Remark
Feed sensor	
PFC board	
LGC board	
1st drawer feed clutch	
1st drawer feed roller	Replace it if it is worn out.
1st drawer separation roller	Replace it if it is worn out.
1st drawer pickup roller	Replace it if it is worn out.

[E140] 2nd drawer misfeeding (paper not reaching the 2nd drawer feed sensor)

Classification	Error content
Paper misfeeding	The paper fed from the 2nd drawer does not reach the 2nd drawer feed sensor.

Check item	Measures
2nd drawer feed sensor	<ul style="list-style-type: none"> • Sensor check (Perform the input check: FS-03-[F2]ON/[4]/[D]) • Connector check (J688, J686, CN455) • Harness check
2nd drawer feed clutch	<ul style="list-style-type: none"> • Clutch check (Perform the output check: FS-03-202) • Harness check • Connector check (J676, CN461)
PFC board	<ul style="list-style-type: none"> • Board check • Connector check (CN455, CN461, CN458, CN452) • Harness check
LGC board	<ul style="list-style-type: none"> • Board check • Connector check (CN323) • Harness check

Parts to be replaced	Remark
2nd drawer feed sensor	
PFC board	
LGC board	
2nd drawer feed clutch	

Parts to be replaced	Remark
2nd drawer feed roller	Replace it if it is worn out.
2nd drawer separation roller	Replace it if it is worn out.
2nd drawer pickup roller	Replace it if it is worn out.

[E150] PFP upper drawer misfeeding (paper not reaching the PFP upper drawer feed sensor)

Classification	Error content
Paper misfeeding	The paper fed from the PFP upper drawer does not reach the PFP upper drawer feed sensor.

Check item	Measures
PFP upper drawer feed sensor	<ul style="list-style-type: none"> • Sensor check (Perform the input check: FS-03-[F2]ON/[0]/[C]) • Connector check (CN247, J959, J975) • Harness check
PFP upper drawer feed clutch	<ul style="list-style-type: none"> • Clutch check (Perform the output check: FS-03-226) • Connector check (CN246, J960, J963) • Harness check
LGC board	<ul style="list-style-type: none"> • Board check • Connector check (CN323, J700) • Harness check
PFC board	<ul style="list-style-type: none"> • Board check • Connector check (CN459, CN464, CN455, J700) • Harness check
PFP board	<ul style="list-style-type: none"> • Board check • Connector check (J959, CN241, CN246, CN247) • Harness check

Parts to be replaced	Remark
PFP upper drawer feed sensor	
PFP upper drawer feed clutch	
LGC board	
PFC board	
PFP board	
PFP upper drawer feed roller	Replace it if it is worn out.
Separation roller	Replace it if it is worn out.
Pickup roller	Replace it if it is worn out.

[E160] PFP lower drawer misfeeding (paper not reaching the PFP lower drawer feed sensor)

Classification	Error content
Paper misfeeding	The paper fed from the PFP lower drawer does not reach the PFP lower drawer feed sensor.

Check item	Measures
PFP lower drawer feed sensor	<ul style="list-style-type: none"> • Sensor check (Perform the input check: FS-03-[F2]ON/[0]/[D]) • Connector check (CN247, J959, J976) • Harness check
PFP lower drawer feed clutch	<ul style="list-style-type: none"> • Clutch check (Perform the output check: FS-03-228) • Connector check (CN246, J960, J962) • Harness check
LGC board	<ul style="list-style-type: none"> • Board check • Connector check (CN323, J700) • Harness check

Check item	Measures
PFC board	<ul style="list-style-type: none"> Board check Connector check (CN459, CN464, CN455, J700) Harness check
PFP board	<ul style="list-style-type: none"> Board check Connector check (J959, CN241, CN246, CN247) Harness check

Parts to be replaced	Remark
PFP lower drawer feed sensor	
PFP lower drawer feed clutch	
LGC board	
PFC board	
PFP board	
PFP lower drawer feed roller	Replace it if it is worn out.
Separation roller	Replace it if it is worn out.
Pickup roller	Replace it if it is worn out.

[E190] T-LCF misfeeding (paper not reaching the T-LCF transport sensor)

Classification	Error content
Paper misfeeding	The paper fed from the T-LCF does not reach the T-LCF feed sensor.

Check item	Measures
LCF transport sensor	<ul style="list-style-type: none"> Sensor check (Perform the input check: FS-03-[F1]ON/[9]/[F]) Connector check (CN1, CN6, CN349) Harness check
LCF feed clutch	<ul style="list-style-type: none"> Clutch check (Perform the output check: 03-209) Connector check (CN1, CN6, CN349) Harness check
LGC board	<ul style="list-style-type: none"> Board check Connector check (CN323, J700) Harness check
PFC board	<ul style="list-style-type: none"> Board check Connector check (CN459, CN464, CN455, J700) Harness check
LCF board	<ul style="list-style-type: none"> Board check Connector check (CN1, CN6) Harness check

Parts to be replaced	Remark
LCF transport sensor	
LCF feed clutch	
PFC board	
PFC board	
LCF board	
LCF feed roller	Replace it if it is worn out.
Separation roller	Replace it if it is worn out.
Pickup roller	Replace it if it is worn out.

8.3.4 Paper transport jam

[E200] 1st drawer transport jam (paper not reaching the registration sensor)

[E210] 2nd drawer transport jam (paper not reaching the registration sensor)

[E270] Bypass transport jam (paper not reaching the registration sensor)

[E300] PFP upper drawer transport jam (paper not reaching the registration sensor)

[E330] PFP lower drawer transport jam (paper not reaching the registration sensor)

[E3C0] LCF transport jam (paper not reaching the registration sensor)

Classification	Error content
Paper transport jam	[E200] Paper transport jam in the 1st drawer (paper not reaching the registration sensor). [E210] Paper transport jam in the 2nd drawer (paper not reaching the registration sensor). [E270] Paper transport jam in the bypass tray (paper not reaching the registration sensor). [E300] Paper fed from the PFP upper drawer does not reach the registration sensor after it has passed through the transport sensor. [E330] Paper fed from the PFP lower drawer does not reach the registration sensor after it has passed through the transport sensor. [E3C0] Paper fed from the LCF does not reach the registration sensor after it has passed through the transport sensor.

Check item	Measures
Registration sensor	<ul style="list-style-type: none"> • Sensor check (Perform the input check: FS-03-[ALL]OFF/[9]/[A]) • Connector check (CN458, J659, J660) • Harness check
1st drawer feed clutch	<ul style="list-style-type: none"> • Clutch check (Perform the output check: FS-03-201) • Connector check (CN461, J666) • Harness check
2nd drawer feed clutch	<ul style="list-style-type: none"> • Clutch check (Perform the output check: FS-03-202) • Connector check (CN461, J676) • Harness check
Bypass feed clutch	<ul style="list-style-type: none"> • Clutch check (Perform the output check: FS-03-204) • Connector check (CN451, J696, J693) • Harness check
Transport clutch (H)	<ul style="list-style-type: none"> • Clutch check (Perform the output check: FS-03-230) • Connector check (CN461, J664) • Harness check
Transport clutch (L)	<ul style="list-style-type: none"> • Clutch check (Perform the output check: FS-03-233) • Connector check (CN461, J665) • Harness check
PFC board	<ul style="list-style-type: none"> • Board check • Connector check (CN458, CN461, CN451, CN452) • Harness check
LGC board	<ul style="list-style-type: none"> • Board check • Connector check (CN323) • Harness check

Parts to be replaced	Remark
Registration sensor	
1st drawer feed clutch	
2nd drawer feed clutch	
Bypass feed clutch	
Transport clutch (H)/(L)	
PFC board	
LGC board	
Feed roller	Replace it if it is worn out.
Separation roller	Replace it if it is worn out.

Parts to be replaced	Remark
Pickup roller	Replace it if it is worn out.
Transport roller	Replace it if it is worn out.

[E220] 2nd drawer transport jam (paper not reaching the feed sensor)

[E310] PFP upper drawer transport jam (paper not reaching the feed sensor)

[E340] PFP lower drawer transport jam (paper not reaching the feed sensor)

[E3D0] LCF transport jam (paper not reaching the feed sensor)

Classification	Error content
Paper transport jam	[E220] Paper transport jam in the 2nd drawer (paper not reaching the feed sensor). [E310] Paper fed from the PFP upper drawer does not reach the transport sensor after it has passed through the 2nd drawer paper feed sensor. [E340] PFP lower drawer transport jam (paper not reaching the feed sensor). [E3D0] LCF transport jam (paper not reaching the feed sensor).

Check item	Measures
Bypass paper guide	<ul style="list-style-type: none"> • Check if the bypass paper guide is warped. • Reassemble the bypass separation roller holder since it is possibly disengaged.
Feed sensor	<ul style="list-style-type: none"> • Sensor check (Perform the input check: FS-03-[ALL]OFF/[9]/[B]) • Connector check (CN458, J659, J661) • Harness check
Transport clutches (high speed)	<ul style="list-style-type: none"> • Clutch check (Perform the output check: FS-03-230) • Connector check (CN461, J664) • Harness check
Transport clutches (low speed)	<ul style="list-style-type: none"> • Clutch check (Perform the output check: FS-03-233) • Connector check (CN461, J665) • Harness check
PFC board	<ul style="list-style-type: none"> • Board check • Connector check (CN461, CN452, CN458) • Harness check
LGC board	<ul style="list-style-type: none"> • Board check • Connector check (CN323) • Harness check

Parts to be replaced	Remark
1st drawer feed sensor	
Transport clutches (high speed)	
Transport clutches (low speed)	
PFC board	
LGC board	
Feed roller	Replace it if it is worn out.
Separation roller	Replace it if it is worn out.
Pickup roller	Replace it if it is worn out.
Transport roller	Replace it if it is worn out.

[E320] PFP upper drawer transport jam (paper not reaching the 2nd drawer paper feed sensor)**[E350] PFP lower drawer transport jam (paper not reaching the 2nd drawer paper feed sensor)****[E3E0] LCF transport jam (paper not reaching the 2nd drawer paper feed sensor)**

Classification	Error content
Paper transport jam	[E320] Paper fed from the PFP upper drawer does not reach the 2nd drawer paper feed sensor after it has passed through the PFP upper drawer paper feed sensor. [E350] Paper fed from the PFP lower drawer does not reach the 2nd transport sensor after it has passed through the PFP upper drawer paper feed sensor. [E3E0] LCF transport jam (paper not reaching the 2nd drawer paper feed sensor).

Check item	Measures
2nd drawer paper feed sensor	<ul style="list-style-type: none"> • Sensor check (Perform the input check: FS-03-[F2]ON/[4]/[D]) • Connector check (CN455, J686, J688) • Harness check
PFC board	<ul style="list-style-type: none"> • Board check • Connector check (CN459, CN455, J700) • Harness check
LGC board	<ul style="list-style-type: none"> • Board check • Connector check (CN323) • Harness check

Parts to be replaced	Remark
2nd drawer paper feed sensor	
PFC board	
LGC board	
Feed roller	Replace it if it is worn out.
Separation roller	Replace it if it is worn out.
Pickup roller	Replace it if it is worn out.
Transport roller	Replace it if it is worn out.

[E360] PFP lower drawer transport jam (paper not reaching the PFP upper drawer feed sensor)

Classification	Error content
Paper transport jam	Paper fed from the PFP lower drawer does not reach the PFP upper drawer paper feed sensor after it has passed through the PFP lower drawer paper feed sensor.

Check item	Measures
PFP upper drawer feed sensor	<ul style="list-style-type: none"> • Sensor check (Perform the input check: FS-03-[F2]ON/[0]/[C]) • Connector check (CN247, J959, J975) • Harness check
PFP transport clutch	<ul style="list-style-type: none"> • Clutch check (Perform the output check: 03-225) • Connector check (CN241, CN247, J957) • Harness check
LGC board	<ul style="list-style-type: none"> • Board check • Connector check (CN323) • Harness check
PFC board	<ul style="list-style-type: none"> • Board check • Connector check (CN459, CN455, J700) • Harness check
PFP board	<ul style="list-style-type: none"> • Board check • Connector check (CN241, CN247) • Harness check

Parts to be replaced	Remark
PFP lower drawer feed sensor	
PFP transport clutches	
LGC board	
PFC board	
PFP board	
Feed roller	Replace it if it is worn out.
Separation roller	Replace it if it is worn out.
Pickup roller	Replace it if it is worn out.
PFP transport roller	Replace it if it is worn out.

[E510] Paper not reaching the ADU entrance sensor jam

Classification	Error content
Paper transport jam	The paper does not reach the ADU entrance sensor after it is switchbacked in the exit section.

Check item	Measures
Reverse sensor	<ul style="list-style-type: none"> • Sensor check (Perform the input check: FS-03-[ALL]OFF/[9]/[D]) • Connector check (J703, CN421) • Harness check
ADU entrance sensor	<ul style="list-style-type: none"> • Sensor check (Perform the input check: FS-03-[ALL]OFF/[9]/[G]) • Connector check (J692, CN421) • Harness check
Reverse motor	<ul style="list-style-type: none"> • Motor check (Perform the output check: FS-03-121/171) • Connector check (CN301, J609, J611) • Harness check
LGC board	<ul style="list-style-type: none"> • Connector check (CN323, CN301) • Harness check • Board check
PFC board	<ul style="list-style-type: none"> • Board check • Connector check (CN450, CN452) • Harness check
ADU board	<ul style="list-style-type: none"> • Connector check (CN420, CN421, CN422, J689) • Harness check • Board check
Reverse roller	Roller check (attrition, deformation, deterioration)
Upper exit roller	Roller check (attrition, deformation, deterioration)
Reverse gate solenoid / Reverse gate	<ul style="list-style-type: none"> • Solenoid check (Perform the output check: FS-03-222/223) • Connector check (CN301, J609, J610) • Harness check • Reverse gate check (Operation, installation, deformation)

Parts to be replaced	Remark
Reverse sensor	
ADU entrance sensor	
Reverse motor	
LGC board	
PFC board	
ADU board	
Reverse roller	Clean or replace it if it is worn out.
Upper exit roller	Clean or replace it if it is worn out.
Reverse gate solenoid	
Reverse gate	

[E520] Stop jam in the ADU

Classification	Error content
Paper transport jam	The paper does not reach the ADU exit sensor after it has passed the ADU entrance sensor.

Check item	Measures
ADU exit sensor	<ul style="list-style-type: none"> • Sensor check (Perform the input check: FS-03-[ALL]OFF/[9]/[H]) • Connector check (J693, CN421) • Harness check
LGC board	<ul style="list-style-type: none"> • Board check • Connector check (CN323) • Harness check
PFC board	<ul style="list-style-type: none"> • Board check • Connector check (CN450, CN452) • Harness check
ADU board	<ul style="list-style-type: none"> • Board check • Connector check (J689, CN420, CN421, CN422) • Harness check
ADU motor	<ul style="list-style-type: none"> • Motor check (Perform the output check: FS-03-110/160) • Connector check (J691, CN422) • Harness check • Bracket check

Parts to be replaced	Remark
ADU exit sensor	
ADU motor	
LGC board	
PFC board	
ADU board	
Rollers in the ADU	Replace it if it is worn out.
Pressure spring	Replace if pressurization is insufficient.

[E570] Jam not reaching the reverse sensor

Classification	Error content
Paper transport jam	The paper which has passed the exit sensor does not reach the reverse sensor.

Check item	Measures
Reverse sensor	<ul style="list-style-type: none"> • Sensor check (Perform the input check: FS-03-[ALL]OFF/[9]/[D]) • Connector check (CN421, J703) • Harness check
Fuser motor	<ul style="list-style-type: none"> • Motor check (Perform the output check: FS-03-113/163) • Connector check (J603) • Harness check
Reverse motor	<ul style="list-style-type: none"> • Motor check (Perform the output check: FS-03-121/171) • Connector check (CN301, J609, J611) • Harness check
Reverse unit	<ul style="list-style-type: none"> • Check the reverse unit is installed properly.  P. 4-230 "4.10 Paper Exit and Reverse Sections"
Reverse gate solenoid / Reverse gate	<ul style="list-style-type: none"> • Solenoid check (Perform the output check: FS-03-222/223) • Connector check (CN301, J609, J610) • Harness check • Reverse gate check (Operation, installation, deformation)

Check item	Measures
LGC board	<ul style="list-style-type: none"> Connector check (CN301, CN323) Harness check Board check
PFC board	<ul style="list-style-type: none"> Board check Connector check (CN450, CN452) Harness check
ADU board	<ul style="list-style-type: none"> Board check Connector check (J689, CN420, CN421, J703) Harness check
Reverse roller	Roller check (attrition, deformation, deterioration)
Fuser unit	Check if the adjustment value for the tilting of the fuser unit is aligned to the uppermost line of the scale. Refer to  P. 8-498 "8.5.36 Image skewing on paper trailing edge".

Parts to be replaced	Remark
Reverse sensor	
Fuser motor	
Reverse motor	
Reverse gate solenoid	
Reverse gate	
LGC board	
PFC board	
ADU board	
Reverse roller	

[E580] Stop jam at the reverse sensor

Classification	Error content
Paper transport jam	The trailing edge of the paper does not pass the reverse sensor after its leading edge has reached this sensor.

Check item	Measures
Reverse sensor	<ul style="list-style-type: none"> Sensor check (Perform the input check: FS-03-[ALL]OFF/[9]/[D]) Connector check (CN421, J703) Harness check
Reverse motor	<ul style="list-style-type: none"> Motor check (Perform the output check: FS-03-121/171) Connector check (CN301, J609, J611) Harness check
Reverse unit	<ul style="list-style-type: none"> Check the reverse unit is installed properly.  P. 4-230 "4.10 Paper Exit and Reverse Sections"
Reverse gate solenoid / Reverse gate	<ul style="list-style-type: none"> Solenoid check (Perform the output check: FS-03-222/223) Connector check (CN301, J609, J610) Harness check Reverse gate check (Operation, installation, deformation)
LGC board	<ul style="list-style-type: none"> Connector check (CN301, CN323) Harness check Board check
PFC board	<ul style="list-style-type: none"> Board check Connector check (CN450, CN452) Harness check
ADU board	<ul style="list-style-type: none"> Board check Connector check (J689, CN420, CN421, J703) Harness check
Reverse roller	Roller check (attrition, deformation, deterioration)
Upper exit roller	Roller check (attrition, deformation, deterioration)

Parts to be replaced	Remark
Reverse sensor	
Reverse motor	
Reverse gate solenoid	
Reverse gate	
LGC board	
PFC board	
ADU board	
Reverse roller	
Upper exit roller	

[EB50] Paper remaining on the transport path due to multiple feeding

Classification	Error content
Paper transport jam	The multiple feeding of preceding paper caused the misfeeding of upcoming paper.

When the paper is fed from any of the 1st drawer, bypass feed unit or ADU: (When the paper is fed from the 1st drawer:)

Check item	Measures
Feed sensor	<ul style="list-style-type: none"> • Sensor check (Perform the input check: FS-03-[ALL]OFF/[9]/[B]) • Connector check (CN458, J659, J661) • Harness check
PFC board	<ul style="list-style-type: none"> • Board check • Connector check (CN458, CN461, CN452) • Harness check
LGC board	<ul style="list-style-type: none"> • Board check • Connector check (CN323) • Harness check
1st drawer feed clutch	<ul style="list-style-type: none"> • Connector check (CN461, J666) • Harness check

Parts to be replaced	Remark
Feed sensor	
PFC board	
LGC board	
Separation roller	Replace it if it is worn out.
1st drawer feed clutch	

(When the paper is fed from the bypass feed unit:)

Check item	Measures
Feed sensor	<ul style="list-style-type: none"> • Sensor check (Perform the input check: FS-03-[ALL]OFF/[9]/[B]) • Connector check (CN458, J659, J661) • Harness check
PFC board	<ul style="list-style-type: none"> • Board check • Connector check (CN458, CN451, CN452) • Harness check
LGC board	<ul style="list-style-type: none"> • Board check • Connector check (CN323) • Harness check
Bypass feed clutch	<ul style="list-style-type: none"> • Connector check (CN451, J693, J696) • Harness check

Parts to be replaced	Remark
Feed sensor	
PFC board	
LGC board	
Separation roller, Separation pad	Replace it if it is worn out.
Bypass feed clutch	

(When the paper is fed from the ADU:)

Check item	Measures
ADU entrance sensor	<ul style="list-style-type: none"> • Sensor check (Perform the input check: FS-03-[ALL]OFF/[9]/[H]) • Connector check (CN421, J693) • Harness check
LGC board	<ul style="list-style-type: none"> • Board check • Connector check (CN323) • Harness check
ADU board	<ul style="list-style-type: none"> • Board check • Connector check (J689, CN420, CN421, CN422) • Harness check
Registration sensor	<ul style="list-style-type: none"> • Sensor check (Perform the input check: FS-03-[ALL]OFF/[9]/[A]) • Connector check (J1077, J1114, CN462, CN458, J659, J660) • Harness check
PFC board	<ul style="list-style-type: none"> • Board check • Connector check (CN458, CN452, CN450) • Harness check

Parts to be replaced	Remark
ADU entrance sensor	
LGC board	
ADU board	
PFC board	
Registration sensor	
Roller	Replace it if it is worn out.

When the paper is fed from any of the 2nd drawer, PFP or LCF:

Check item	Measures
Feed sensor	<ul style="list-style-type: none"> • Sensor check (Perform the input check: FS-03-[ALL]OFF/[9]/[B]) • Connector check (CN458, J659, J661) • Harness check
2nd drawer paper feed sensor	<ul style="list-style-type: none"> • Sensor check (Perform the input check: FS-03-[F2]ON/[4]/[D]) • Connector check (CN455, J686, J688) • Harness check
PFC board	<ul style="list-style-type: none"> • Board check • Connector check (CN458, CN455, CN452, CN461) • Harness check
LGC board	<ul style="list-style-type: none"> • Board check • Connector check (CN323) • Harness check
Transport clutch (H)	<ul style="list-style-type: none"> • Connector check (CN461, J664) • Harness check
Transport clutch (L)	<ul style="list-style-type: none"> • Connector check (CN461, J665) • Harness check

Parts to be replaced	Remark
Feed sensor	
Paper feed sensor	
LGC board	
PFC board	
Roller	Replace it if it is worn out.
Transport clutch (H)	
Transport clutch (L)	

[EB60] Paper remaining on the transport path due to multiple feeding

Classification	Error content
Paper transport jam	The multiple feeding of preceding paper caused the misfeeding of upcoming paper.

Check item	Measures
Registration sensor	<ul style="list-style-type: none"> • Clean the registration sensor. • Sensor check (Perform the input check: FS-03-[ALL]OFF/[9]/[A]) • Connector check (CN458, J659, J660) • Harness check
PFC board	<ul style="list-style-type: none"> • Board check • Connector check (CN458, CN452, CN461) • Harness check
LGC board	<ul style="list-style-type: none"> • Connector check (CN323) • Board check
Drive unit, Rollers	<ul style="list-style-type: none"> • Gear check (attrition, deformation) • Roller check (attrition, deformation)

Parts to be replaced	Remark
Registration sensor	
PFC board	
LGC board	
Rollers	Replace it if it is worn out.

8.3.5 Other paper jam

[E011] Transfer belt paper-clinging jam

Classification	Error content
Other paper jam	Paper not reached the paper clinging detection sensor.

Phenomenon of paper jamming	Check item	Measures
Paper jamming immediately after the removal and installation of the transfer belt unit.	Transfer belt unit	Check if the transfer belt unit is installed properly.  P. 4-170 "4.7.3 Transfer belt unit (TBU)"
Paper stop jam at transfer belt	Drawer	Check if paper is folded at the leading edge.
No scratches on the paper leading edge	Drawer	Check if paper is folded at the leading edge. Check that paper is not skewed in the side guides of the drawer.
	Process unit	Clean the process unit or replace it.
	Paper clinging detection sensor	Clean the sensor
All	PFC board	<ul style="list-style-type: none"> • Board check • Connector check (CN452, CN451, CN465) • Harness check
	LGC board	<ul style="list-style-type: none"> • Board check • Connector check (CN323) • Harness check
	Paper clinging detection sensor	<ul style="list-style-type: none"> • Sensor check (Perform the input check: FS-03-[ALL]OFF/[9]/[E]) • Connector check (CN451, J693, J698, J699) • Harness check
	Check of the 2nd transfer roller connection	Check that the 2nd transfer roller shaft is securely grounded via the ADU rear frame (metal plate). <ul style="list-style-type: none"> • Check if the spring is deformed. • Check if the bearing and the spring contact properly.
	Change of the 2nd transfer bias	<p>If the leading edge of paper clings to the 2nd transfer roller and causes paper jamming, change the 2nd transfer roller bias correction factor of the leading/trailing edge of the paper. (The larger the value, the smaller the transfer voltage of the leading/trailing edge of the paper.)</p> <p>Codes to be changed (Initial value of the transfer bias of the leading edge of the paper: 0)</p> <ul style="list-style-type: none"> • Color mode print (front side): FS-05-2938-* • Color mode print (back side): FS-05-2939-* • Black mode print (front side): FS-05-2940-* • Black mode print (back side): FS-05-2941-* <p>* (Sub-codes): Plain paper: 0, Thick paper 1: 1, Thick paper 2: 2, Thick paper 3: 3, Overhead transparencies: 4 (front side only), Special paper 1: 5, Special paper 2: 6, Recycled paper: 7, Thick paper 4: 8, Thin paper: 9, Envelope: 10, Special paper 3: 11</p> <p>Notes: After these codes are changed, perform solid duplex-printing and check that there is no faint or void image on the leading/trailing edge of the paper.</p>

Phenomenon of paper jamming	Check item	Measures
	Aligning amount	If the aligning amount is too small, a skew, an image dislocation in the feeding direction, E011 (a paper jam occurring between the registration pass sensor and the paper clinging detection sensor) may happen. If the aligning amount is too large, on the other hand, an abnormal noise (paper-folding noise) or actual paper folding may occur. Confirm that the value of the aligning amount is appropriate. Refer to  P. 6-8 "6.1.6 Paper alignment at the registration roller".
	Spring of the high-voltage supply contact point	<ul style="list-style-type: none"> Check if the spring of the high-voltage supply contact point [1] is deformed. If yes, replace it. Check if foreign matter adheres to the spring of the high-voltage supply contact point [1]. If yes, clean it. 
	Registration sensor	<ul style="list-style-type: none"> Check that the installation status of the registration sensor. If there is any abnormality, correct it. Check that the actuator is properly operated. If there is any abnormality, correct it.

Fig.8-1

Parts to be replaced	Remark
Process unit	
Registration motor	
PFC board	
LGC board	
Paper clinging detection sensor	
Registration roller	Replace it if it is worn out.
Spring of the high-voltage supply contact point	

[E013] Paper not reaching the registration pass sensor jam

Classification	Error content
Other paper jam	Paper not reaching the registration pass sensor jam.

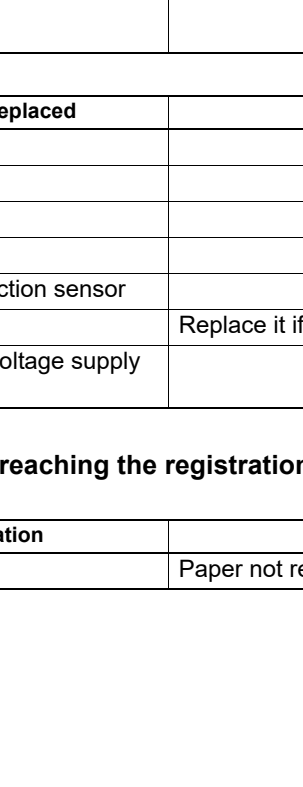
Phenomenon of paper jamming	Check item	Measures
Paper stop jam at Registration roller	Registration pass sensor	<ul style="list-style-type: none"> • Sensor check (Perform the input check: FS-03-[ALL]OFF/[9]/[F]) • Connector check (CN309, J620, J621) • Harness check
	Drawer	<ul style="list-style-type: none"> • Check if any damage is at the leading edge. • Check if paper is folded at the leading edge.
	Drive unit, Rollers	<ul style="list-style-type: none"> • Drive unit check • Gear check • Roller check • Registration motor check (Perform the output check: FS-03-108/158) • Harness check
	Developer unit	Replace the Developer unit.
	Aligning amount	If the aligning amount is too small, a skew, an image dislocation in the feeding direction, E013 (a paper jam occurring between the registration pass sensor and the paper clinging detection sensor) may happen. If the aligning amount is too large, on the other hand, an abnormal noise (paper-folding noise) or actual paper folding may occur. Confirm that the value of the aligning amount is appropriate. Refer to  P. 6-8 "6.1.6 Paper alignment at the registration roller".
	PFC board	<ul style="list-style-type: none"> • Board check • Connector check (CN465) • Harness check
	LGC board	<ul style="list-style-type: none"> • Board check • Connector check (CN309) • Harness check
	Registration sensor	<ul style="list-style-type: none"> • Sensor check (Perform the input check: FS-03-[ALL]OFF/[9]/[A]) • Connector check (CN458, J659, J660) • Harness check
	Spring of the high-voltage supply contact point	<ul style="list-style-type: none"> • Check if the spring of the high-voltage supply contact point [1] is deformed. If yes, replace it. • Check if foreign matter adheres to the spring of the high-voltage supply contact point [1]. If yes, clean it.

Fig.8-2

Parts to be replaced	Remark
Registration pass sensor	
Rollers	Replace it if it is worn out.
Developer unit	
PFC board	
LGC board	

Parts to be replaced	Remark
Registration motor	
Registration roller	Replace it if it is worn out.
Spring of the high-voltage supply contact point	

[E030] Power-ON jam

Classification	Error content
Other paper jam	The paper is remaining on the paper transport path when power is turned ON.

Check item	Measures
Sensor in the jamming area	<ul style="list-style-type: none"> • Sensor check (Refer to the table below) • Connector check • Harness check
LGC board	<ul style="list-style-type: none"> • Board check • Connector check • Harness check

Parts to be replaced	Remark
Sensor in the jamming area	Refer to the table below.
LGC board	

Relation between the jamming area and the corresponding sensors/covers.
(If a jam is occurring in the ADU, LCF or PFP, check the board in each unit.)

Jamming area	Cover	Sensor	Test Mode/Input check
Registration area	Jam access cover	Registration sensor	FS-03-[ALL]OFF/[9]/[A]
		Paper clinging detection sensor	FS-03-[ALL]OFF/[9]/[E]
		Registration pass sensor	FS-03-[ALL]OFF/[9]/[F]
		Feed sensor	FS-03-[ALL]OFF/[9]/[B]
Exit area	Fuser cover	Exit sensor	FS-03-[ALL]OFF/[9]/[C]
ADU	ADU	ADU entrance sensor	FS-03-[ALL]OFF/[9]/[G]
		ADU exit sensor	FS-03-[ALL]OFF/[9]/[H]
Bypass feed unit	Side cover	2nd drawer feed sensor	FS-03-[F2]ON/[4]/[D]
LCF	LCF side cover	LCF transport sensor	FS-03-[F1]ON/[9]/[F]
PFP	PFP side cover	PFP upper drawer feed sensor	FS-03-[F2]ON/[0]/[C]
		PFP lower drawer feed sensor	FS-03-[F2]ON/[0]/[D]
Bridge unit	Bridge unit	Bridge unit transport sensor-1 (Entrance sensor)	FS-03-[ALL]OFF/[0]/[A]
		Bridge unit transport sensor-2 (Exit sensor)	FS-03-[ALL]OFF/[0]/[B]
Finisher	Finisher door	Sensors in the finisher	-

- [E061] Incorrect paper size setting for 1st drawer**
- [E062] Incorrect paper size setting for 2nd drawer**
- [E063] Incorrect paper size setting for PFP upper drawer**
- [E064] Incorrect paper size setting for PFP lower drawer**
- [E065] Incorrect paper size setting for bypass tray**

Classification	Error item
Other paper jam	[E061], [E062], [E063], [E064] The size of paper in the drawer differs from size setting of the equipment. [E065] The size of paper in the bypass tray differs from size setting of the equipment.

Check item	Measures
Setting	If any paper remains in the equipment or drawer, remove it. Match the paper size of the drawer setting and the one in the drawer. * Paper size detection is performed at the first sheet of paper when the drawer is opened or closed, or when the power of the equipment is turned ON.

[E090] Image data delay jam

Classification	Error item
Other paper jam	Image data to be printed cannot be prepared.

Check item	Measures
Paper path	<ul style="list-style-type: none"> Remove the paper remained in front of the registration sensor. Check if the error is cleared by turning the power OFF and then back ON.
Power	<ul style="list-style-type: none"> Check if the error is cleared by turning the power OFF and then back ON.
SYS board	<ul style="list-style-type: none"> Connector check Main memory check Board check
LGC board	<ul style="list-style-type: none"> Connector check Board check
HDD	<ul style="list-style-type: none"> Connector check HDD check

Parts to be replaced	Remarks
SYS board	
LGC board	
HDD	
Main memory	

[E091] Motor-ON time-out jam

Classification	Error item
Other paper jam	The equipment does not operate normally because abnormality occurred on an interface between the SYS board and engine firmware.

Check item	Measures
Paper path	<ul style="list-style-type: none"> Check if there is any paper in the equipment. Remove it if there is. If the error still occurs, check the following.

Check item	Measures
Power	Check if the error is cleared by turning the power OFF and then back ON.
SYS board	<ul style="list-style-type: none"> • Connector check • Board check
LGC board	<ul style="list-style-type: none"> • Connector check • Board check
HDD	<ul style="list-style-type: none"> • Connector check • HDD check

Parts to be replaced	Remarks
SYS board	
LGC board	
HDD	

[E0A0] Image transport ready time-out jam

Classification	Error content
Other paper jam	Image data to be printed cannot be sent.

Check item	Measures
LGC board	<ul style="list-style-type: none"> • Flat cable check (SYS board - LGC board) • Connector check (CN330) • Board check
SYS board	<ul style="list-style-type: none"> • Flat cable check (SYS board - LGC board) • Connector check (CN133) • Board check

Parts to be replaced	Remark
LGC board	
SYS board	
Flat cable	

[E550] Paper remaining jam on the transport path

Classification	Error content
Other paper jam	Paper is remaining on the transport path when printing is finished (caused by a multiple paper feeding).

Step	Check Item	Result	Measures	Next Step
1	Jamming transport path		Open the cover of the unit/area whose picture is flashing on the control panel and remove any paper on the transport path.	
2	Feed or transport roller possibly causing multiple feeding		Check the feed roller.	
3	Sensor in the jamming area		<ul style="list-style-type: none"> • Sensor check (Refer to the table below) • Harness check • Connector check 	
4	LGC board		<ul style="list-style-type: none"> • Harness check • Connector check • Board check 	
	Notes: If the jam is occurring in the ADU, PFP, or LCF, check the board in each unit.			

Parts to be replaced	Remark
Feed or transport roller possibly causing multiple feeding	
Sensor in the jamming area	Refer to the table below.
LGC board	

Relation between the jamming area and the corresponding sensors/covers.

Jamming area	Cover	Sensor	Test Mode/Input check
Registration area	Jam access cover	Registration sensor	FS-03-[ALL]OFF/[9]/[A]
		Paper clinging detection sensor	FS-03-[ALL]OFF/[9]/[E]
		Registration pass sensor	FS-03-[ALL]OFF/[9]/[F]
		Feed sensor	FS-03-[ALL]OFF/[9]/[B]
Exit area	Fuser cover	Exit sensor	FS-03-[ALL]OFF/[9]/[C]
ADU	ADU	ADU entrance sensor	FS-03-[ALL]OFF/[9]/[G]
		ADU exit sensor	FS-03-[ALL]OFF/[9]/[H]
Bypass feed unit	Side cover	2nd drawer feed sensor	FS-03-[F2]ON/[4]/[D]
LCF	LCF side cover	LCF transport sensor	FS-03-[F1]ON/[9]/[F]
PFP	PFP side cover	PFP upper drawer feed sensor	FS-03-[F2]ON/[0]/[C]
		PFP lower drawer feed sensor	FS-03-[F2]ON/[0]/[D]
Bridge unit	Bridge unit	Bridge unit transport sensor-1 (Entrance sensor)	FS-03-[ALL]OFF/[0]/[A]
		Bridge unit transport sensor-2 (Exit sensor)	FS-03-[ALL]OFF/[0]/[B]
Finisher	Finisher door	Sensors in the finisher	-

[E551] Paper remaining jam on the transport path (when a service call occurs)

[E552] Paper remaining jam on the transport path (when the cover is closed)

Classification	Error content
Other paper jam	[E551] The paper is detected on the transport path when a service call occurs. [E552] The paper is detected on the transport path after the cover is opened and closed.

Step	Check Item	Result	Measures	Next Step
1	Jamming transport path		Open the cover of the unit/area whose picture is flashing on the control panel and remove any paper on the transport path.	
2	Sensor in the jamming area		<ul style="list-style-type: none"> • Sensor check (Refer to the table below) • Harness check • Connector check 	
3	LGC board		<ul style="list-style-type: none"> • Harness check • Connector check • Board check 	
	Notes: If the jam is occurring in the ADU, LCF or PFP, check the board in each unit.			

Parts to be replaced	Remark
Sensor in the jamming area	Refer to the table below.
LGC board	

Relation between the jamming area and the corresponding sensors/covers.

Jamming area	Cover	Sensor	Test Mode/Input check
Registration area	Jam access cover	Registration sensor	FS-03-[ALL]OFF/[9]/[A]
		Paper clinging detection sensor	FS-03-[ALL]OFF/[9]/[E]
		Registration pass sensor	FS-03-[ALL]OFF/[9]/[F]
		Feed sensor	FS-03-[ALL]OFF/[9]/[B]
Exit area	Fuser cover	Exit sensor	FS-03-[ALL]OFF/[9]/[C]
ADU	ADU	ADU entrance sensor	FS-03-[ALL]OFF/[9]/[G]
		ADU exit sensor	FS-03-[ALL]OFF/[9]/[H]
Bypass feed unit	Side cover	2nd drawer feed sensor	FS-03-[F2]ON/[4]/[D]
LCF	LCF side cover	LCF transport sensor	FS-03-[F1]ON/[9]/[F]
PFP	PFP side cover	PFP upper drawer feed sensor	FS-03-[F2]ON/[0]/[C]
		PFP lower drawer feed sensor	FS-03-[F2]ON/[0]/[D]
Bridge unit	Bridge unit	Bridge unit transport sensor-1 (Entrance sensor)	FS-03-[ALL]OFF/[0]/[A]
		Bridge unit transport sensor-2 (Exit sensor)	FS-03-[ALL]OFF/[0]/[B]
Finisher	Finisher door	Sensors in the finisher	-

8.3.6 Cover open jam

[E410] Front cover open jam

Classification	Error content
Cover open jam	The front cover has opened during printing.

Check item	Measures
Switching regulator	<ul style="list-style-type: none"> Is the voltage of 24V being supplied from the power supply unit? (Perform the input check: FS-03-[ALL]OFF/[7]/[D]) Connector check (CN512) Fuse check (F201, F202, F203)
High-voltage transformer	<ul style="list-style-type: none"> Check if the high-voltage transformer (HVT) is installed properly. Board check Connector check Harness check
LGC board	<ul style="list-style-type: none"> Board check Connector check (CN314, CN320, CN321, CN310) Harness check
Front cover switch	<ul style="list-style-type: none"> Switch check (Perform the input check: FS-03-[ALL]OFF/[7]/[C]) Connector check (CN310, J613, J713) Harness check

Parts to be replaced	Remark
Switching regulator	
LGC board	
High-voltage transformer	
Front cover switch	

[E420] PFP side cover open jam

Classification	Error content
Cover open jam	The PFP side cover has opened during printing.

Check item	Measures
PFP side cover opening/closing switch	<ul style="list-style-type: none"> Is the PFP side cover opening/closing switch working? (Perform the input check: FS-03-[F2]ON/[0]/[A]) Connector check (CN247, J959, J974) Harness check
PFP board	<ul style="list-style-type: none"> Board check Connector check (CN241, CN247) Harness check
PFC board	<ul style="list-style-type: none"> Board check Connector check (CN459, CN452, J700) Harness check
LGC board	<ul style="list-style-type: none"> Board check Connector check (CN323) Harness check

Parts to be replaced	Remark
PFP side cover opening/closing switch	
PFP board	
PFC board	
LGC board	

[E430] Duplexing unit cover open jam

Classification	Error content
Cover open jam	The duplexing unit cover has opened during printing.

Check item	Measures
Side cover switch	<ul style="list-style-type: none">Is the switch working? (Perform the input check: FS-03-[ALL]OFF[7]/[A])Connector check (CN307, J606)Harness check
LGC board	<ul style="list-style-type: none">Board checkConnector check (CN307)Harness check
Switching regulator	<ul style="list-style-type: none">Replace the switching regulator

Parts to be replaced	Remark
Side cover switch	
LGC board	
Switching regulator	

[E440] Jam access cover open jam

Classification	Error content
Cover open jam	The jam access cover has opened during printing.

Check item	Measures
Jam access cover opening/closing switch	<ul style="list-style-type: none">Is the jam access cover opening/closing switch working? (Perform the input check: FS-03-[F2]ON/[4]/[A])Connector check (CN455, J686, J687)Harness check
PFC board	<ul style="list-style-type: none">Board checkConnector check (CN455, CN452)Harness check
LGC board	<ul style="list-style-type: none">Board checkConnector check (CN323)Harness check

Parts to be replaced	Remark
Jam access cover opening/closing switch	
PFC board	
LGC board	

[E450] LCF side cover open jam

Classification	Error content
Cover open jam	The LCF side cover has opened during printing.

Check item	Measures
LCF side cover opening/closing switch	<ul style="list-style-type: none">Is the switch working? (Perform the input check: FS-03-[F1]ON/[9]/[A])Connector check (CN7, CN70)Harness check

Check item	Measures
LCF board	<ul style="list-style-type: none"> Board check Connector check (CN7, CN1) Harness check
PFC board	<ul style="list-style-type: none"> Board check Connector check (CN452, CN459, J700, CN464) Harness check
LGC board	<ul style="list-style-type: none"> Board check Connector check (CN323) Harness check

Parts to be replaced	Remark
LCF side cover opening/closing switch	
LCF board	
PFC board	
LGC board	

[E480] Bridge unit open jam

Classification	Error content
Cover open jam	The bridge unit has opened during printing.

Check item	Measures
Bridge unit cover opening/closing detection sensor	<ul style="list-style-type: none"> Is the sensor working? (Perform the input check: FS-03-[ALL]OFF/[7]/[B]) Connector check (J607) Harness check
LGC board	<ul style="list-style-type: none"> Board check Connector check (CN307) Harness check

Parts to be replaced	Remark
Bridge unit cover opening/closing detection sensor	
LGC board	

[E490] Job separator cover open jam

Classification	Error content
Cover open jam	The job separator cover has opened during printing.

Check item	Measures
JSP cover switch	<ul style="list-style-type: none"> Is the JSP cover switch working? (Perform the input check: FS-03-[ALL]OFF/[7]/[B]) Connector check (CN260, CN261) Harness check
LGC board	<ul style="list-style-type: none"> Board check Connector check (CN307, J607) Harness check

Parts to be replaced	Remark
JSP cover switch	
LGC board	

8.3.7 RADF/DSDF jam

[E712] Jam not reaching the DSDF registration sensor

Classification	Error content
DSDF jam	The original fed from the original tray does not reach the DSDF registration sensor.

Check item	Measures
Original	Flatten the original if it is folded or excessively curled and place it again.
Roller	<ul style="list-style-type: none"> Clean the DSF pickup roller, DSDF feed roller and DSDF separation roller if they are stained.
DSDF registration sensor	<ul style="list-style-type: none"> Check if the DSDF registration sensor is working properly. (Perform the input check: FS-03-[F2]ON/[7]/[H]) Replace the DSDF registration sensor.
Connector	Check if the connectors (J975, J950 and CN74) on the DSDF control PC board are disconnected from the DSDF registration sensor or the harnesses are open circuited. Correct if any.
DSDF control PC board	Replace the DSDF control PC board.

Parts to be replaced	Remark
Roller	DSF pickup roller, DSDF feed roller, DSDF separation roller
DSDF registration sensor	
DSDF control PC board	

[E712] Jam not reaching the original registration sensor

Classification	Error content
RADF jam	The original fed from the original feeding tray does not reach the registration sensor.

Check item	Measures
Pickup roller Feed roller Separation roller	<ul style="list-style-type: none"> Clean them if they are stained.
Original registration sensor	<ul style="list-style-type: none"> Sensor check (Perform the input check: FS-03-[F2]ON/[7]/[H]) Connector check (CN74, J88, J86) Harness check
RADF board	<ul style="list-style-type: none"> Board check Connector check (CN74) Harness check

Parts to be replaced	Remark
Original registration sensor	
RADF board	
Pickup roller	Replace it if it is worn out
Feed roller	Replace it if it is worn out.
Separation roller	Replace it if it is worn out.

[E714] DSDF feed signal reception jam

Classification	Error content
DSDF jam	The feed signal from the equipment is received even though there is no original on the original tray.

Check item	Measures
Reproducing ability	<ul style="list-style-type: none"> Release the paper jam and reattempt copying or scanning.
DSDF empty sensor	<ul style="list-style-type: none"> Check if the DSDF empty sensor is working properly. (Perform the input check: FS-03-[F2]ON/[7]/[B]) Check if the connector (CN75) on the DSDF control PC board is disconnected from the DSDF empty sensor or the harnesses are open circuited. Correct if any. Replace the DSDF empty sensor.
DSDF control PC board	Replace the DSDF control PC board.

Parts to be replaced	Remark
DSDF empty sensor	
DSDF control PC board	

[E714] Feed signal reception jam

Classification	Error content
RADF jam	The feed signal from the equipment is received even though there is no original on the original tray.

Check item	Measures
Empty sensor	<ul style="list-style-type: none"> Sensor check (Perform the input check: FS-03-[F2]ON/[7]/[B]) Lever check Connector check (CN75, J92, J96) Harness check
RADF board	<ul style="list-style-type: none"> Board check Connector check (CN75) Harness check

Parts to be replaced	Remark
Empty sensor	
RADF board	

[E717] Original not reaching the DSDF original feed sensor jam

Classification	Error content
DSDF jam	The original does not reach the DSDF feed sensor even though original feeding has started.

Check item	Measures
DSDF feed sensor	<ul style="list-style-type: none"> Check if the DSDF feed sensor is working properly. (Perform the input check: FS-03-[F2]ON/[8]/[E]) Replace the DSDF feed sensor.
Connector	<ul style="list-style-type: none"> Check if the connectors (J974, J950 and CN74) on the DSDF control PC board are disconnected from the DSDF feed sensor or the harnesses are open circuited. Correct if any.
DSDF feed motor	<ul style="list-style-type: none"> Check if the DSDF feed motor is working properly.
Connector	<ul style="list-style-type: none"> Check if the connectors (J990 and CN77) on the DSDF control PC board are disconnected from the DSDF feed motor or the harnesses are open circuited. Correct if any.
DSDF control PC board	Replace the DSDF control PC board.

Parts to be replaced	Remark
DSDF feed sensor	

Parts to be replaced	Remark
DSDf feed motor	
DSDf control PC board	

[E718] Original setting jam / Original tray lift abnormality

A paper jam which may occur when the original tray lift is working (before the original feeding operation)

Classification	Error content
DSDf jam	The original tray lift has been driven to raise or lower and the DSDf tray lift upper limit sensor / DSDf tray lift lower limit sensor have not been turned ON within a specified time.

Check item	Measures
<ul style="list-style-type: none"> When a paper jam has occurred after an original is set, during original feeding, during the initial operation or when an original is pulled out 	
Malfunction	<ul style="list-style-type: none"> Check whether an operation to apply a load to the original tray has been performed while it is being raised or lowered. Check if there is a foreign matter in the tray lifting section. If there is any, remove it, open and then close the cover to release the paper jam status. If there is none, take the following measure.
<ul style="list-style-type: none"> When the original tray lift is being rising (When a paper jam has occurred after the original placed or during original feeding) 	
DSDf tray lift upper limit sensor	<p>There will be an abnormality in the DSDf tray lift upper limit sensor when an error occurs while the tray is rising. (Perform the input check: FS-03-[F2]ON/[6]/[E])</p> <ul style="list-style-type: none"> Check if the sensor is damaged, the connector is disconnected or the harness is open circuited. If yes, replace any of them.
<ul style="list-style-type: none"> When the original tray lift is being lowering (When a paper jam has occurred if an original is pulled out during the initial operation or the operation itself) 	
DSDf tray lift lower limit sensor	<p>There will be an abnormality in the DSDf tray lift lower limit sensor when an error occurs while the tray is lowering. (Perform the input check: FS-03-[F2]ON/[6]/[F])</p> <ul style="list-style-type: none"> Check if the sensor is damaged, the connector is disconnected or the harness is open circuited. If yes, replace any of them.
<ul style="list-style-type: none"> When the rising or lowering of the original tray lift does not work 	
DSDf tray-up clutch	<p>There will be an abnormality in the DSDf tray-up clutch if it does not work.</p> <ul style="list-style-type: none"> Check if the clutch is damaged, the connector is disconnected or the harness is open circuited. If yes, replace any of them.
DSDf separation motor	<p>There will be an abnormality in the DSDf separation motor if it does not work. (Perform the output check: FS-03-291/292)</p> <ul style="list-style-type: none"> Check if the motor is damaged, the connector is disconnected or the harness is open circuited. If yes, replace any of them.
<ul style="list-style-type: none"> All 	
DSDf control PC board	<ul style="list-style-type: none"> Check that there is no abnormality on the DSDf control PC board when operation failure has occurred in the DSDf tray lift upper limit sensor, DSDf tray lift lower limit sensor, DSDf tray-up clutch or DSDf separation motor. If yes, replace any of them.

Parts to be replaced	Remark
DSDf tray lift upper limit sensor	
DSDf tray lift lower limit sensor	
DSDf tray-up clutch	
DSDf separation motor	
DSDf control PC board	

[E721] Original not reaching the DSDF read-in sensor-1 jam

Classification	Error content
DSDF jam	The original does not reach the DSDF read-in sensor-1 after it has passed through the DSDF registration sensor.

Check item	Measures
Roller	<ul style="list-style-type: none"> Clean the DSDF registration roller and pre-read rollers if they are stained.
DSDF read-in sensor-1	<ul style="list-style-type: none"> Check if the DSDF read-in sensor-1 is working properly. (Perform the input check: FS-03-[F2]ON/[7]/[G]) Perform the DSDF read-in sensor-1 automatic adjustment.
Aligning amount	Perform the aligning amount adjustment (FS-05-3040).
Connector	<ul style="list-style-type: none"> Check if the connectors (J983, J956 and CN75) on the DSDF control PC board are disconnected from the DSDF read-in sensor-1 or the harnesses are open circuited. Correct if any.
DSDF read motor	<ul style="list-style-type: none"> Check if the DSDF read motor is working properly. Check if the connectors (J992 and CN79) on the DSDF control PC board are disconnected from the DSDF read motor or the harnesses are open circuited. Correct if any.
DSDF registration motor	<ul style="list-style-type: none"> Check if the DSDF registration motor is working properly. Check if the connectors (J982 and CN79) on the DSDF control PC board are disconnected from the DSDF read motor or the harnesses are open circuited. Correct if any.
DSDF control PC board	<ul style="list-style-type: none"> Replace the DSDF control PC board.

Parts to be replaced	Remark
Roller	DSDF registration roller, Pre-read roller
DSDF read-in sensor-1	
DSDF read motor	
DSDF registration motor	
DSDF control PC board	

[E721] Jam not reaching the read sensor

Classification	Error content
RADF jam	The original does not reach the read sensor after it has passed the registration sensor (when scanning the front side) or the reverse sensor (when scanning the back side).

Phenomenon of paper jamming	Check item	Measures
All	Registration sensor Read roller	<ul style="list-style-type: none"> Clean the registration roller and the read roller if they are stained.
	Read sensor	<ul style="list-style-type: none"> Sensor check (Perform the input check: FS-03-[F2]ON/[7]/[G]) Connector check (CN75, J94) Harness check
	RADF board	<ul style="list-style-type: none"> Board check Connector check (CN75) Harness check

Parts to be replaced	Remark
Reading start guide of the RADF	
Paper guide of the RADF	

Parts to be replaced	Remark
Read sensor	
RADF board	
Registration roller	Clean or replace it.
Read roller	Clean or replace it.

[E722] Original not reaching the DSDF exit sensor jam

Classification	Error content
DSDF jam	The original does not reach the DSDF exit sensor after it has passed through the DSDF read-in sensor-2.

Check item	Measures
Roller	<ul style="list-style-type: none"> Clean the post-read roller-2 if it is stained.
DSDF exit sensor	<ul style="list-style-type: none"> Check if the DSDF exit sensor is working properly. (Perform the input check: FS-03-[F2]ON/[7]/[E]) Replace the DSDF exit sensor.
Connector	<ul style="list-style-type: none"> Check if the connectors (J985, J957 and CN75) on the DSDF control PC board are disconnected from the DSDF exit sensor or the harnesses are open circuited. Correct if any.
DSDF control PC board	<ul style="list-style-type: none"> Replace the DSDF control PC board.

Parts to be replaced	Remark
Roller	Post-read roller-2
DSDF exit sensor	
DSDF control PC board	

[E722] Jam not reaching the original exit / reverse sensor (during scanning)

Classification	Error content
RADF jam	The original which passed the read sensor does not reach the exit sensor when it is transported from the scanning section to exit section.

Check item	Measures
Read roller	<ul style="list-style-type: none"> Clean the read roller if it is stained.
Original exit/reverse sensor	<ul style="list-style-type: none"> Sensor check (Perform the input check: FS-03-[F2]ON/[7]/[E]) Connector check (CN75, J93) Harness check
RADF board	<ul style="list-style-type: none"> Board check Connector check (CN75) Harness check

Parts to be replaced	Remark
Original exit/reverse sensor	
RADF board	
Read roller	Replace it if it is worn out.

[E724] Original stopping at the DSDF registration sensor jam

Classification	Error content
DSDF jam	The trailing edge of the original does not pass through the DSDF registration sensor after its leading edge has passed through this sensor.

Check item	Measures
Roller	<ul style="list-style-type: none"> Clean the DSDF registration roller if it is stained.
DSDF registration sensor	<ul style="list-style-type: none"> Check if the DSDF registration sensor is working properly. (Perform the input check: FS-03-[F2]ON/[7]/[H]) Replace the DSDF registration sensor.
DSDF tray original length sensor-1, DSDF tray original length sensor-2 DSDF tray original width sensor-1, DSDF tray original width sensor-2	<ul style="list-style-type: none"> Check if these sensors can detect an original properly. Check if the DSDF tray original width sensor-1 and DSDF tray original width sensor-2 are working properly. (Perform the input check: FS-03-[F2]ON/[8]/[F], FS-03-[F2]ON/[8]/[G]) Check if the DSDF tray original length sensor-1 and DSDF tray original length sensor-2 are working properly. (Perform the input check: FS-03-[F2]ON/[8]/[D], FS-03-[F2]ON/[7]/[A]) Replace the DSDF tray original width sensor-1 and -2, DSDF tray original length sensor-1 and -2.
Connector	<ul style="list-style-type: none"> Check if the connectors (J975, J950 and CN74) on the DSDF control PC board are disconnected from the DSDF registration sensor or the harnesses are open circuited. Correct if any. Check if the connectors (J970, J971 and CN76) on the DSDF control PC board are disconnected from the DSDF tray original length sensor-1 and DSDF tray original length sensor-2 or the harnesses are open circuited. Correct if any.
DSDF control PC board	<ul style="list-style-type: none"> Replace the DSDF control PC board.

Parts to be replaced	Remark
DSDF registration sensor	
DSDF tray original length sensor-1, DSDF tray original length sensor-2	
DSDF tray original width sensor-1, DSDF tray original width sensor-2	
DSDF control PC board	

[E724] Stop jam at the registration sensor

Classification	Error content
RADF jam	The trailing edge of the original does not pass the registration sensor after its leading edge has reached this sensor.

Check item	Measures
Registration roller	<ul style="list-style-type: none"> Clean the registration roller if it is stained.
Registration sensor	<ul style="list-style-type: none"> Sensor check (Perform the input check: FS-03-[F2]ON/[7]/[H]) Connector check (CN74, J88, J86) Harness check
RADF board	<ul style="list-style-type: none"> Board check Connector check (CN74) Harness check
Original width detection sensor-1	<ul style="list-style-type: none"> Sensor check (Perform the input check: FS-03-[F2]ON/[8]/[F]) Connector check (CN74, J86, J89) Harness check
Original width detection sensor-2	<ul style="list-style-type: none"> Sensor check (Perform the input check: FS-03-[F2]ON/[8]/[G]) Connector check (CN74, J86, J90) Harness check

Parts to be replaced	Remark
Registration sensor	
RADF board	
Registration roller	Replace it if it is worn out.
Original width detection sensor-1	
Original width detection sensor-2	

[E725] Original stopping at the DSDF read-in sensor-1 jam

Classification	Error content
DSDF jam	The trailing edge of the original does not pass through the DSDF read-in sensor-1 after its leading edge has passed through this sensor.

Check item	Measures
Roller	<ul style="list-style-type: none"> Clean the post-read roller-1 if it is stained.
DSDF read-in sensor-1	<ul style="list-style-type: none"> Check if the DSDF read-in sensor-1 is working properly. (Perform the input check: FS-03-[F2]ON/[7]/[G]) Perform the DSDF read-in sensor-1 automatic adjustment.
Connector	<ul style="list-style-type: none"> Check if the connectors (J983, J956 and CN75) on the DSDF control PC board are disconnected from the DSDF read-in sensor-1 or the harnesses are open circuited. Correct if any.
DSDF control PC board	<ul style="list-style-type: none"> Replace the DSDF control PC board.

Parts to be replaced	Remark
DSDF read-in sensor-1	
DSDF control PC board	

[E725] Stop jam at the read sensor

Classification	Error content
RADF jam	The trailing edge of the original does not pass the read sensor after its leading edge has reached this sensor.

Check item	Measures
Read roller	<ul style="list-style-type: none"> Clean the read roller if it is stained.
Read sensor	<ul style="list-style-type: none"> Sensor check (Perform the input check: FS-03-[F2]ON/[7]/[G]) Connector check (CN75, J94) Harness check
Original intermediate transport sensor	<ul style="list-style-type: none"> Sensor check (Perform the input check: FS-03-[F2]ON/[7]/[F]) Connector check (CN75, J94) Harness check
RADF board	<ul style="list-style-type: none"> Board check Connector check (CN75) Harness check

Parts to be replaced	Remark
Read sensor	
RADF board	
Read roller	Replace it if it is worn out.
Original intermediate transport sensor	

[E726] Transport / exit signal reception jam

Classification	Error content
DSDF jam	The transport or exit signal has been received while no original is placed in the DSDF.

Check item	Measures
Reproducing ability	<ul style="list-style-type: none"> Turn the power OFF and then back ON to check the occurrence.

Parts to be replaced	Remark
-	

[E726] Transport / exit signal reception jam

Classification	Error content
RADF jam	RADF receives the transport / exit reception signal from the equipment when no original is at the exposure waiting position.

Check item	Measures
RADF board	<ul style="list-style-type: none"> Board check Connector check Harness check
SYS board	<ul style="list-style-type: none"> Board check Connector check Harness check
Switching power supply	<ul style="list-style-type: none"> Check if the 24V and 5V outputs of the switching power supply are normal. Board check Connector check Harness check

Parts to be replaced	Remark
RADF board	
SYS board	
Switching power supply	

[E727] Original not reaching the DSDF read-in sensor-2 jam

Classification	Error content
DSDF jam	The original does not reach the DSDF read-in sensor-2 after it has passed through the DSDF read-in sensor-1.

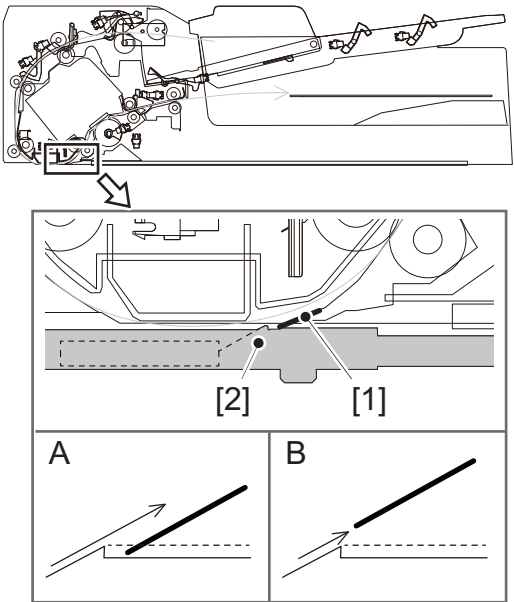
Check item	Measures
An original has stopped at the transparent film [1].	<p>Turn on the exposure lamp (output check: FS-03-267) and confirm the position between the transparent film [1] and the upper edge of the slope [2].</p>  <p>Fig.8-3</p> <ul style="list-style-type: none"> • State A (throughout the whole of the transparent film): OK (Go to the next step.) • State B: Perform the height adjustment. (P. 6-111 “6.14.2 Adjustment of height”) Replace the transparent film if the position between it and the upper edge of the slope cannot be adjusted as shown above [A].
Roller	<ul style="list-style-type: none"> • Clean the post-read roller-1 if it is stained.
Installation	<ul style="list-style-type: none"> • Check if the DSDF is installed properly.
DSDF read-in sensor-2	<ul style="list-style-type: none"> • Check if the DSDF read-in sensor-2 is working properly. (Perform the input check: FS-03-[F2]ON/[6]/[D]) • Replace the DSDF read-in sensor-2.
Connector	<ul style="list-style-type: none"> • Check if the connectors (J984, J956 and CN75) on the DSDF control PC board are disconnected from the DSDF read-in sensor-2 or the harnesses are open circuited. Correct if any.
DSDF control PC board	<ul style="list-style-type: none"> • Replace the DSDF control PC board.

Parts to be replaced	Remark
DSDF read-in sensor-2	
DSDF control PC board	

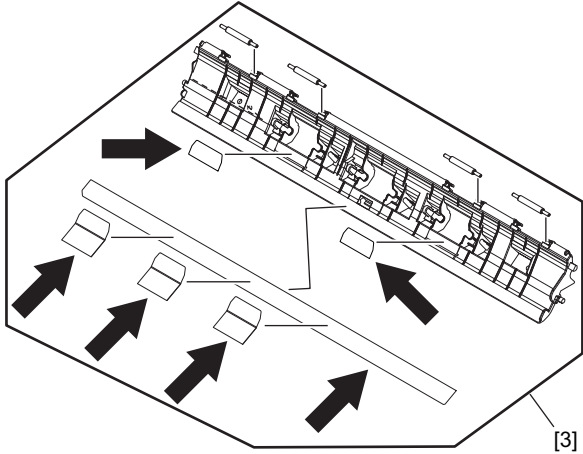
Parts to be replaced	Remark
Transparent film set	 <p data-bbox="619 644 687 666">Fig.8-4</p> <p data-bbox="619 704 1369 749">Perform the replacement with the transparent film set or with the guide [3].</p>

[E729] Original stopping at the DSDF read-in sensor-2 jam

Classification	Error content
DSDF jam	The trailing edge of the original does not pass through the DSDF read-in sensor-2 after its leading edge has passed through this sensor.

Check item	Measures
Roller	<ul style="list-style-type: none"> • Clean the pre-read roller-2 if it is stained.
DSDF read-in sensor-2	<ul style="list-style-type: none"> • Check if the DSDF read-in sensor-2 is working properly. (Perform the input check: FS-03-[F2]ON/[6]/[D]) • Replace the DSDF read-in sensor-2.
Connector	<ul style="list-style-type: none"> • Check if the connectors (J984, J956 and CN75) on the DSDF control PC board are disconnected from the DSDF read-in sensor-2 or the harnesses are open circuited. Correct if any.
DSDF exit motor	<ul style="list-style-type: none"> • Check if the DSDF exit motor is working properly. • Check if the connectors (J991 and CN77) on the DSDF control PC board are disconnected from the DSDF exit motor or the harnesses are open circuited. Correct if any.
DSDF control PC board	<ul style="list-style-type: none"> • Replace the DSDF control PC board.

Parts to be replaced	Remark
DSDF read-in sensor-2	
DSDF exit motor	
DSDF control PC board	

[E731] Original stopping at the DSDF exit sensor jam

Classification	Error content
DSDF jam	The trailing edge of the original does not pass through the DSDF exit sensor after its leading edge has passed through this sensor.

Check item	Measures
Roller	<ul style="list-style-type: none"> • Clean the DSDF exit roller if it is stained.

Check item	Measures
Transport path	<ul style="list-style-type: none"> Check if there is a paper or foreign matter in the exit section of the DSDF.
DSDF exit sensor	<ul style="list-style-type: none"> Check if the DSDF exit sensor is working properly. (Perform the input check: FS-03-[F2]ON/[7]/[E]) Replace the DSDF sensor.
Connector	<ul style="list-style-type: none"> Check if the connectors (J985, J957 and CN75) on the DSDF control PC board are disconnected from the DSDF exit sensor or the harnesses are open circuited. Correct if any.
DSDF control PC board	<ul style="list-style-type: none"> Replace the DSDF control PC board.

Parts to be replaced	Remark
DSDF exit sensor	
DSDF control PC board	

[E731] Stop jam at the original exit / reverse sensor

Classification	Error content
RADF jam	The trailing edge of the original does not pass the original exit / reverse sensor after its leading edge has reached this sensor.

Check item	Measures
Exit roller	<ul style="list-style-type: none"> Clean the exit roller if it is stained.
Stop jam at the original exit/ reverse sensor	<ul style="list-style-type: none"> Sensor check (Perform the input check: FS-03-[F2]ON/[7]/[E]) Connector check (J93, CN75) Harness check
RADF board	<ul style="list-style-type: none"> Board check Connector check (CN75) Harness check

Parts to be replaced	Remark
Exit sensor	
RADF board	
Exit roller	Replace it if it is worn out.

[E762] Original remaining at the DSDF registration sensor jam

Classification	Error content
DSDF jam	The DSDF registration sensor remains turned ON.

Check item	Measures
Transport path	<ul style="list-style-type: none"> Check if there is a paper or foreign matter in the transport path of the DSDF.
DSDF registration sensor	<ul style="list-style-type: none"> Check if the DSDF registration sensor is working properly. (Perform the input check: FS-03-[F2]ON/[7]/[H]) Replace the DSDF registration sensor.
Connector	<ul style="list-style-type: none"> Check if the connectors (J975, J950 and CN74) on the DSDF control PC board are disconnected from the DSDF registration sensor or the harnesses are open circuited. Correct if any.
DSDF control PC board	<ul style="list-style-type: none"> Replace the DSDF control PC board.

Parts to be replaced	Remark
DSDF registration sensor	
DSDF control PC board	

[E769] Original remaining at the DSDF feed sensor jam

Classification	Error content
DSDF jam	The DSDF feed sensor remains turned ON.

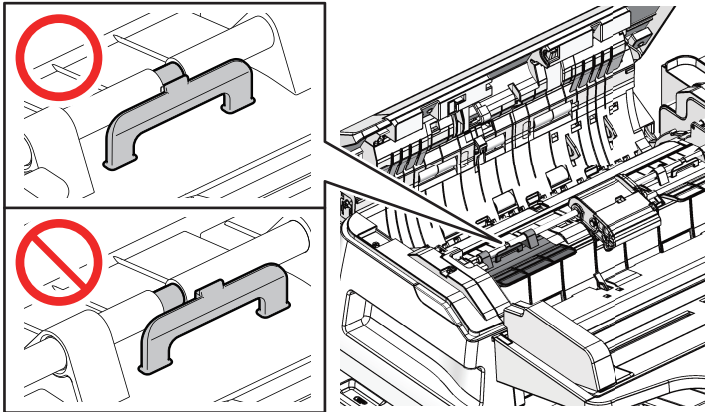
Check item	Measures
Corner folding prevention guide	<ul style="list-style-type: none"> Check if the corner folding prevention guide is installed properly. If the latch of the corner folding prevention guide has come off from the shaft groove, slide the guide to reinstall it. Replace the corner folding prevention guide if it is damaged.  <p>Fig.8-5</p>
Connector	<ul style="list-style-type: none"> Check if the connectors (J974, J950 and CN74) on the DSDF control PC board are disconnected from the DSDF feed sensor or the harnesses are open circuited. Correct if any.
DSDF feed sensor	<ul style="list-style-type: none"> Check if the DSDF feed sensor is working properly. (Perform the input check: FS-03-[F2]ON/[8]/[E]) Replace the DSDF feed sensor.
DSDF control PC board	<ul style="list-style-type: none"> Replace the DSDF control PC board.

Parts to be replaced	Remark
Corner folding prevention guide	
DSDF feed sensor	
DSDF control PC board	

[E770] Original remaining at the DSDF original width detection sensor-1 jam

Classification	Error content
DSDF jam	The DSDF original width detection sensor-1 remains turned ON.

Check item	Measures
Connector	<ul style="list-style-type: none"> Check if the connectors (J972, J950 and CN75) on the DSDF control PC board are disconnected from the DSDF original width detection sensor-1 or the harnesses are open circuited. Correct if any.
DSDF original width detection sensor-1	<ul style="list-style-type: none"> Check if the DSDF original width detection sensor-1 is working properly. (Perform the input check: FS-03-[F2]ON/[8]/[F]) Check that there is no paper dust on the DSDF original width detection sensor-1. If paper dust adheres to the DSDF original width detection sensor-1, clean it. Replace the DSDF original width detection sensor-1.
DSDF control PC board	<ul style="list-style-type: none"> Replace the DSDF control PC board.

Parts to be replaced	Remark
DSDF original width detection sensor-1	
DSDF control PC board	

[E771] Original remaining at the DSDF original width detection sensor-2 jam

Classification	Error content
DSDF jam	The DSDF original width detection sensor-2 remains turned ON.

Check item	Measures
Connector	<ul style="list-style-type: none"> Check if the connectors (J973, J950 and CN75) on the DSDF control PC board are disconnected from the DSDF original width detection sensor-2 or the harnesses are open circuited. Correct if any.
DSDF original width detection sensor-2	<ul style="list-style-type: none"> Check if the DSDF original width detection sensor-2 is working properly. (Perform the input check: FS-03-[F2]ON/[8]/[G]) Check that there is no paper dust on the DSDF original width detection sensor-2. If paper dust adheres to the DSDF original width detection sensor-2, clean it. Replace the DSDF original width detection sensor-2.
DSDF control PC board	<ul style="list-style-type: none"> Replace the DSDF control PC board.

Parts to be replaced	Remark
DSDF original width detection sensor-2	
DSDF control PC board	

[E774] Original remaining at the DSDF read-in sensor-1 jam

Classification	Error content
DSDF jam	The DSDF read-in sensor-1 remains turned ON.

Check item	Measures
Roller	<ul style="list-style-type: none"> Clean the post-read roller-1 if it is stained.
Connector	<ul style="list-style-type: none"> Check if the connectors (J983, J956 and CN75) on the DSDF control PC board are disconnected from the DSDF read-in sensor-1 or the harnesses are open circuited. Correct if any.
DSDF read-in sensor-1	<ul style="list-style-type: none"> Check if the DSDF read-in sensor-1 is working properly. (Perform the input check: FS-03-[F2]ON/[7]/[G]) Perform the DSDF read-in sensor-1 automatic adjustment.
DSDF control PC board	<ul style="list-style-type: none"> Replace the DSDF control PC board.

Parts to be replaced	Remark
DSDF read-in sensor-1	
DSDF control PC board	

[E775] Original remaining at the DSDF read-in sensor-2 jam

Classification	Error content
DSDF jam	The DSDF read-in sensor-2 remains turned ON.

Check item	Measures
Roller	<ul style="list-style-type: none"> Clean the pre-read roller-2 if it is stained.
Connector	<ul style="list-style-type: none"> Check if the connectors (J984, J956 and CN75) on the DSDF control PC board are disconnected from the DSDF read-in sensor-2 or the harnesses are open circuited. Correct if any.
DSDF read-in sensor-2	<ul style="list-style-type: none"> Check if the DSDF read-in sensor-2 is working properly. (Perform the input check: FS-03-[F2]ON/[6]/[D]) Replace the DSDF read-in sensor-2.
DSDF control PC board	<ul style="list-style-type: none"> Replace the DSDF control PC board.

Parts to be replaced	Remark
DSDF read-in sensor-2	
DSDF control PC board	

[E777] Original remaining at the DSDF exit sensor jam

Classification	Error content
DSDF jam	The DSDF exit sensor remains turned ON.

Check item	Measures
Roller	<ul style="list-style-type: none"> Clean the DSDF exit roller if it is stained.
Connector	<ul style="list-style-type: none"> Check if the connectors (J985, J957 and CN75) on the DSDF control PC board are disconnected from the DSDF exit sensor or the harnesses are open circuited. Correct if any.
DSDF exit sensor	<ul style="list-style-type: none"> Check if the DSDF exit sensor is working properly. (Perform the input check: FS-03-[F2]ON/[7]/[E]) Replace the DSDF sensor.
DSDF control PC board	<ul style="list-style-type: none"> Replace the DSDF control PC board.

Parts to be replaced	Remark
DSDF exit sensor	
DSDF control PC board	

[E860] RADF jam access cover open jam

Classification	Error content
RADF jam	The RADF jam access cover has opened during RADF operation.

Check item	Measures
RADF jam access cover sensor	<ul style="list-style-type: none"> Switch check (Perform the input check: FS-03-[F2]ON/[7]/[C]) Connector check (CN75, J92, J97) Harness check
RADF board	<ul style="list-style-type: none"> Board check Connector check (CN75) Harness check

Parts to be replaced	Remark
RADF jam access cover sensor	

Parts to be replaced	Remark
RADF board	

[E860] DSDF original jam access cover open jam / DSDF shading sheet HP sensor abnormal

Classification	Error content
DSDF jam	<ul style="list-style-type: none"> The jam access cover of the DSDF has become opened during its operation. The DSDF exit motor has been driven and the DSDF shading sheet HP sensor has not been turned ON within a specified time. <p>Details: If a paper jam has occurred at the start of a duplex copying or scanning job or at the end of a copying or scanning job, the cover may have opened as a result.</p> <p>The home position detection is carried out by the DSDF shading sheet HP sensor when the cover or DSDF is closed, the power is turned ON, during the initial operation or at the end of a job. This home position detection checks that the DSDF shading sheet HP sensor is turned ON within a specified time after the DSDF exit motor has started driving. If the home position cannot be detected when the cover or DSDF is closed or the power is turned ON, a cover open error will be displayed. If the home position cannot be detected during the initial operation or at the end of a job, a DSDF shading sheet HP sensor abnormality will occur and this error code will be displayed.</p>

Check item	Measures
<ul style="list-style-type: none"> When a paper jam has occurred at the start or end of the original transportation 	
DSDF lower cover	<ul style="list-style-type: none"> Check if the DSDF lower cover is closed appropriately.
DSDF lower cover opening/closing detection sensor	<ul style="list-style-type: none"> Check if the connectors (J980, J953 and CN75) on the DSDF control PC board are disconnected from the DSDF lower cover opening/closing detection sensor or the harnesses are open circuited. Correct if any. Check if the DSDF lower cover opening/closing detection sensor is working properly. (Perform the input check: FS-03-[F2]ON/[6]/[C]) Replace the DSDF lower cover opening/closing detection sensor.
DSDF lower cover interlock switch	<ul style="list-style-type: none"> Check if the DSDF lower cover interlock switch is working properly. Replace the DSDF lower cover interlock switch.
DSDF exit motor	<ul style="list-style-type: none"> Check if the DSDF exit motor rotates properly. (Perform the input check: FS-03-284) If yes, check the DSDF shading sheet HP sensor. Check if the connector of the DSDF exit motor is disconnected or the harnesses are open circuited. Replace the DSDF exit motor.
DSDF shading sheet HP sensor	<ul style="list-style-type: none"> Check if the DSDF shading sheet HP sensor is working properly. (Perform the input check: FS-03-[F2]ON/[6]/[A]) Check if the connector of the DSDF shading sheet HP sensor is disconnected or the harnesses are open circuited. Replace the DSDF shading sheet HP sensor.
DSDF control PC board	<ul style="list-style-type: none"> Check if the connector of the DSDF control PC board is disconnected or the harnesses are open circuited. Replace the DSDF control PC board.
<ul style="list-style-type: none"> When a paper jam has occurred during original transportation 	
Cover	<ul style="list-style-type: none"> Check if the DSDF upper cover is closed appropriately. Check if the DSDF lower cover is closed appropriately. Check if the front cover of the equipment is closed appropriately.
DSDF upper cover opening/closing detection sensor	<ul style="list-style-type: none"> Check if the connectors (J981, J954 and CN75) on the DSDF control PC board are disconnected from the DSDF upper cover opening/closing detection sensor or the harnesses are open circuited. Correct if any. Check if the DSDF upper cover opening/closing detection sensor is working properly. (Perform the input check: FS-03-[F2]ON/[7]/[C]) Replace the DSDF upper cover opening/closing detection sensor.

Check item	Measures
DSDF upper cover interlock switch	<ul style="list-style-type: none"> Check if the DSDF upper cover interlock switch is working properly. Replace the DSDF upper cover interlock switch.
DSDF lower cover opening/closing detection sensor	<ul style="list-style-type: none"> Check if the connectors (J980, J953 and CN75) on the DSDF control PC board are disconnected from the DSDF lower cover opening/closing detection sensor or the harnesses are open circuited. Correct if any. Check if the DSDF lower cover opening/closing detection sensor is working properly. (Perform the input check: FS-03-[F2]ON/[6]/[C]) Replace the DSDF lower cover opening/closing detection sensor.
DSDF lower cover interlock switch	<ul style="list-style-type: none"> Check if the DSDF lower cover interlock switch is working properly. Replace the DSDF lower cover interlock switch.
DSDF exit motor	<ul style="list-style-type: none"> Check if the DSDF exit motor rotates properly. (Perform the input check: FS-03-284) If yes, check the DSDF shading sheet HP sensor. Check if the connector of the DSDF exit motor is disconnected or the harnesses are open circuited. Replace the DSDF exit motor.
DSDF shading sheet HP sensor	<ul style="list-style-type: none"> Check if the DSDF shading sheet HP sensor is working properly. (Perform the input check: FS-03-[F2]ON/[6]/[A]) Check if the connector of the DSDF shading sheet HP sensor is disconnected or the harnesses are open circuited. Replace the DSDF shading sheet HP sensor.
DSDF control PC board	<ul style="list-style-type: none"> Check if the connector of the DSDF control PC board is disconnected or the harnesses are open circuited. Replace the DSDF control PC board.

Parts to be replaced	Remark
DSDF upper cover opening/closing detection sensor	
DSDF upper cover interlock switch	
DSDF lower cover opening/closing detection sensor	
DSDF lower cover interlock switch	
DSDF exit motor	
DSDF shading sheet HP sensor	
DSDF control PC board	

[E870] RADF open jam

Classification	Error content
RADF jam	The RADF has become opened during its operation.

Check item	Measures
Platen sensor	<ul style="list-style-type: none"> Sensor check (Perform the input check: Platen sensor-1: FS-03-[F2]ON[5]/[C], Platen sensor-2: FS-03-[F2]ON[5]/[G]) Connector check (CN121, J1003, J1004) Harness check
LGC board	<ul style="list-style-type: none"> Board check Connector check (CN121) Harness check



Parts to be replaced	Remark
Platen sensor	
LGC board	

8.3.8 Jam in bridge unit

[E910] Paper not reaching the bridge unit transport sensor-1

[E920] Paper stopping at the bridge unit transport sensor-1

Classification	Error content
Finisher jam (Bridge unit)	[E910] The paper does not reach the bridge unit transport sensor-1 after it has passed the exit sensor. [E920] The trailing edge of the paper does not pass the bridge unit transport sensor-1 after its leading edge has reached the sensor.

Phenomenon of paper jamming	Check item	Measures
Paper separation failure at separation guide in the fuser unit	Fuser unit	<ul style="list-style-type: none"> Check the gap between the separation guide and the fuser belt.  P. 6-100 "6.12.1 Adjustment of the separation guide gap" Paper transport check
	Drawer	Check that paper is not skewed in the side guides of the drawer.
	Leading edge margin	Adjust the margin with FS-05-4402 (Leading edge position adjustment) to "Color: 5.5 mm". Widen the margin if needed. (Specification Black: 4.2 mm / Color: 5 mm) <ul style="list-style-type: none"> Use A3/LD paper It is easy to check skew with a copy of a solid image (about 10 mm on its leading edge). Refer to  P. 6-1 "6.1 Image Related Adjustment".
There are scratches on the leading paper edge		Replace it if needed. Check if the guide is not deformed. Replace it if needed.
All	Bridge unit exit	Check that Mylar on the bridge unit exit is not deformed. Replace it if needed. (E920)
	Finisher	Check if paper jamming occurs in the finisher.
	Bridge unit transport sensor-1 (entrance sensor)	<ul style="list-style-type: none"> Sensor check (Perform the input check: FS-03-[ALL]OFF[0]/[A]) Connector check (CN307, J607, J801) Harness check
	Bridge unit gate solenoid	<ul style="list-style-type: none"> Solenoid check (Perform the output check: FS-03-232) Connector check (CN307, J607, J801) Harness check
	LGC board	<ul style="list-style-type: none"> Board check Connector check (CN307) Harness check
	Bridge unit	<ul style="list-style-type: none"> Does the transport roller of the bridge unit work when the fuser motor is rotated? (Perform the output check: FS-03-113/163) Check the drive system of the equipment and bridge unit. Check if the rollers in the lower exit roller, the pressure spring and the bridge unit are worn out.

Parts to be replaced	Remark
Bridge unit transport sensor-1 (entrance sensor)	
LGC board	
Bridge unit gate solenoid	

[E930] Paper not reaching the bridge unit transport sensor-2**[E940] Paper stopping at the bridge unit transport sensor-2**

Classification	Error content
Finisher jam (Bridge unit)	[E930] The trailing edge of the paper does not reach the bridge unit transport sensor-2 after its leading edge has reached the bridge unit transport sensor-1. [E940] The trailing edge of the paper does not reach the bridge unit transport sensor-2 after its leading edge has reached the bridge unit transport sensor-2.

Check item	Measures
Bridge unit transport sensor-2 (exit sensor)	<ul style="list-style-type: none">• Sensor check (Perform the input check: FS-03-[ALL]OFF[0]/[B])• Connector check (CN307, J607, J802)• Harness check
LGC board	<ul style="list-style-type: none">• Board check• Connector check (CN307)• Harness check
Bridge unit	<ul style="list-style-type: none">• Does the transport roller of the bridge unit work when the fuser motor is rotated? (Perform the output check: FS-03-113/163)• Check the drive system of the equipment and bridge unit.• Check if the rollers in the lower exit roller, the pressure spring and the bridge unit are worn out.

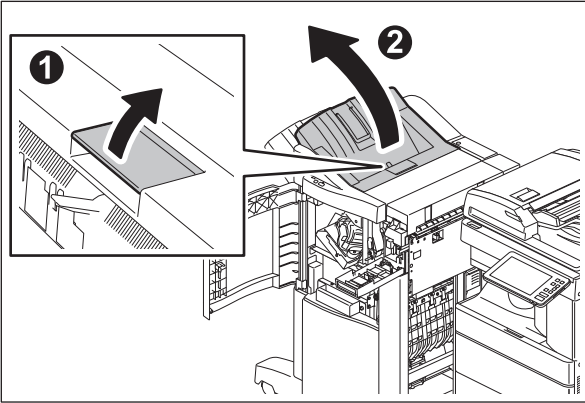
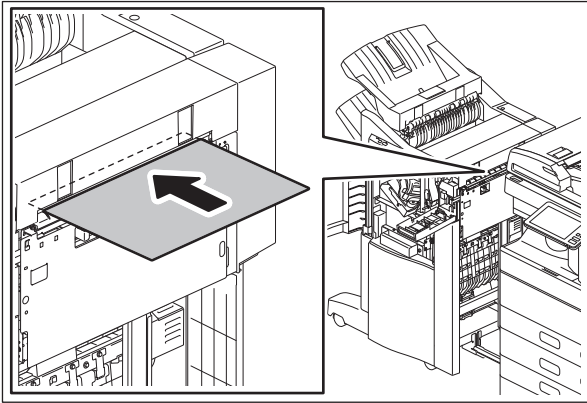
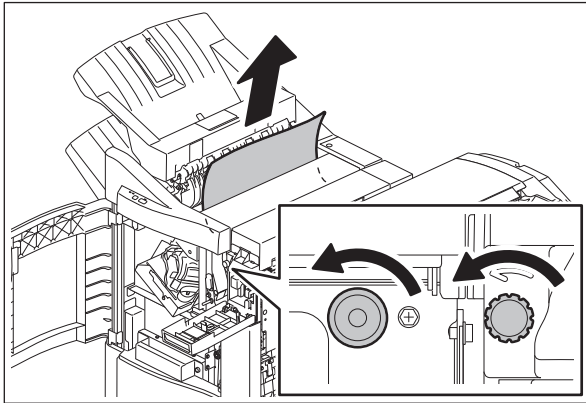
Check item	Measures
<p>Hole punch unit (When an error has occurred immediately after the time of unpacking and installation)</p>	<p>A sheet in the finisher (hole punch unit) may be deformed. Correct this.</p> <ol style="list-style-type: none"> 1. Separate the finisher (hole punch unit) from the equipment. 2. Open the stationary tray of the finisher (hole punch unit).  <ol style="list-style-type: none"> 3. Insert one sheet of A4/LT-size thick paper into the paper transport inlet of the finisher (hole punch unit).  <p>Remarks: Use the thick paper of A4-LT size and 216g/m² (80 lb. Bond) or equivalent.</p> <ol style="list-style-type: none"> 4. Open the front cover of the finisher (hole punch unit). Turn the 2 knobs simultaneously. Transport the thick paper by turning the knobs in the direction of the arrow to remove it. 

Parts to be replaced	Remark
Bridge unit transport sensor-2 (exit sensor)	
LGC board	

[E950] Jam not reaching the JSP feed sensor
[E951] Stop jam at the JSP feed sensor

Classification	Error content
Job separator jam	[E950] The paper has passed through the exit sensor does not reach the JSP feed sensor. [E951] The trailing edge of the paper does not pass the JSP feed sensor after its leading edge has reached this sensor.

Procedure	Check item	Result	Measures	Next Step
1	Open the JSP cover. Is there any paper on the transport path?	Yes	Remove the paper.	
		No		2
2	Is the JSP feed sensor working? (Perform the input check in the test mode: FS-03-[ALL]OFF/[0]/[A])	Yes		3
		No	<ul style="list-style-type: none"> • Check if the connector of the JSP feed sensor is disconnected. • Check if either of the connectors CN260 or CN262 on the JSP board is disconnected. • Check if the connector CN307 on the LGC board is disconnected. • Check if the relay connector J607 is disconnected. • Check if the connector pins are disconnected and the harnesses are open circuited. • Check if the conductor patterns on the JSP board and LGC board are short circuited or open circuited. • Replace the JSP feed sensor. • Replace the JSP board. • Replace the LGC board. 	
3	Replacing board		<ul style="list-style-type: none"> • Replace the JSP board. • Replace the LGC board. 	

Parts to be replaced	Remark
JSP feed sensor	
JSP board	
LGC board	

8.3.9 Paper jam in finisher section

[EA10] Paper transport delay jam

Classification	Error content
Finisher jam (Finisher section)	<ul style="list-style-type: none"> [MJ-1042] 1st transport motor (M8) fault / 2nd transport motor (M4) fault. [MJ-1109] Paper transport delay jam. [MJ-1110] Paper transport delay non-inserting jam.

MJ-1042

Probable cause	Checking and measures
1st transport motor (M8) abnormality	Check if the electrical continuity of the coil is normal. If electricity is not conducted, replace the motor.
Faulty cables and connectors	Check if the electrical continuity between the connector terminals is normal. If electricity is not conducted, replace the connector. (Finisher control PC board (FIN): CN22)
2nd transport motor (M4) abnormality	Check if the electrical continuity of the coil is normal. If electricity is not conducted, replace the motor.
Faulty cables and connectors	Check if the electrical continuity between the connector terminals is normal. If electricity is not conducted, replace the connector. (Finisher control PC board (FIN): CN14)
Finisher control PC board (FIN) abnormality	If the error still occurs after replacing the motor and the connector, exchange the finisher control PC board (FIN).

Parts to be replaced	Remark
1st transport motor (M8) abnormality	
2nd transport motor (M4) abnormality	
Finisher control PC board (FIN) abnormality	

MJ-1109/MJ-1110

Check item	Measures
Paper	Check if there is any paper in the finisher or on the transport path of the equipment and remove it if there is.
Feeding sensor (S22)	Check if there is a disconnection of the connector, incorrect installation or breakage of the feeding sensor (S22). If there is, reinstall the sensor correctly or replace it.
Transport path switching solenoid (SOL5)	Check that the gap between the transfer guide surface and the upper surface of the flapper tip is in the acceptable range according to the status of the transport path switching solenoid (SOL5) (solenoid OFF: 1.5 to 2.1 mm, solenoid ON: 2.3 to 2.9 mm). If it is not, adjust it. Check the harness between the transport path switching solenoid (SOL5) and the finisher control PC board (CN1). If there is any abnormality, correct it.
Entrance motor (M1)	Check the harness between the entrance motor (M1) and the finisher control PC board (CN17). If there is any abnormality, correct it.
Finisher control PC board (FIN)	<ul style="list-style-type: none"> Board check Connector check (CN1, CN17) Harness check

Parts to be replaced	Remark
Feeding sensor (S22)	

Parts to be replaced	Remark
Transport path switching solenoid (SOL5)	
Entrance motor (M1)	
Finisher control PC board (FIN)	

[EA20] Paper transport stop jam

Classification	Error content
Finisher jam (Finisher section)	<ul style="list-style-type: none"> [MJ-1042] 1st transport motor (M8) fault / 2nd transport motor (M4) fault. [MJ-1109/1110] Paper stopping jam.

MJ-1042

Probable cause	Checking and measures
1st transport motor (M8) abnormality	Check if the electrical continuity of the coil is normal. If electricity is not conducted, replace the motor.
Faulty cables and connectors	Check if the electrical continuity between the connector terminals is normal. If electricity is not conducted, replace the connector. (Finisher control PC board (FIN): CN22)
2nd transport motor (M4) abnormality	Check if the electrical continuity of the coil is normal. If electricity is not conducted, replace the motor.
Faulty cables and connectors	Check if the electrical continuity between the connector terminals is normal. If electricity is not conducted, replace the connector. (Finisher control PC board (FIN): CN14)
Finisher control PC board (FIN) abnormality	If the error still occurs after replacing the motor and the connector, exchange the finisher control PC board (FIN).

Parts to be replaced	Remark
1st transport motor (M8) abnormality	
2nd transport motor (M4) abnormality	
Finisher control PC board (FIN) abnormality	

MJ-1109/1110

Check item	Measures
Paper	Check if there is any paper in the finisher or on the transport path of the equipment and remove it if there is.
Entrance sensor (S1)	<ul style="list-style-type: none"> Sensor check Connector check Harness check
Finisher control PC board (FIN)	<ul style="list-style-type: none"> Board check Connector check (CN8) Harness check
Assist guide	Check that there is no abnormality in the adjustment for its height.

Parts to be replaced	Remark
Entrance sensor (S1)	
Finisher control PC board (FIN)	
Assist guide	

[EA21] Paper size error jam (transport sensor)

Classification	Error content
Finisher jam (Finisher section)	The transport sensor on the finisher transport path detects that the paper is shorter than the acceptable size.

MJ-1109/1110

Check item	Measures
Paper	<ul style="list-style-type: none"> Check if there is any paper in the finisher or on the transport path of the equipment and remove it if there is. Use paper accepted in the specifications.
Entrance sensor (S1)	<ul style="list-style-type: none"> Sensor check Connector check Harness check
Transport sensor (S2)	<ul style="list-style-type: none"> Sensor check Connector check Harness check
Finisher control PC board (FIN)	<ul style="list-style-type: none"> Board check Connector check (CN8) Harness check

Parts to be replaced	Remark
Entrance sensor (S1)	
Transport sensor (S2)	
Finisher control PC board (FIN)	

[EA22] Paper size error jam (Paper position sensor)

Classification	Error content
Finisher jam Hole punch unit	The paper position sensor on the hole punch unit detects that the paper is shorter than the acceptable size.

MJ-1109/1110

Check item	Measures
Paper	Check if there is any paper in the finisher or on the transport path of the equipment and remove it if there is.
Entrance sensor (S1)	<ul style="list-style-type: none"> Sensor check Connector check Harness check
Transport sensor (S2)	<ul style="list-style-type: none"> Sensor check Connector check Harness check
Paper position sensor (Hole punch unit)	<ul style="list-style-type: none"> Sensor check (S6-1, S6-2) Connector check (CN1, CN4, CN5) Harness check
Finisher control PC board (FIN)	<ul style="list-style-type: none"> Board check Connector check (CN8) Harness check

Parts to be replaced	Remark
Entrance sensor (S1)	
Transport sensor (S2)	

Parts to be replaced	Remark
Paper position sensor (S6-1, S6-2)	Hole punch unit
Finisher control PC board (FIN)	

[EA23] Paper stopping jam (transport sensor)

MJ-1109/MJ-1110

Classification	Error content
Finisher jam (Finisher section)	The trailing edge of the paper does not pass through the transport sensor after its leading edge has passed through this sensor on the finisher transport path.

Check item	Measures
Paper	Check if there is any paper in the finisher or on the transport path of the equipment and remove it if there is.
Transport sensor (S2)	<ul style="list-style-type: none"> • Sensor check • Connector check • Harness check
Finisher control PC board (FIN)	<ul style="list-style-type: none"> • Board check • Connector check (CN8) • Harness check

Parts to be replaced	Remark
Transport sensor (S2)	
Finisher control PC board (FIN)	

[EA24] Paper transport delay jam (between entrance and transport sensor)

MJ-1109/MJ-1110

Classification	Error content
Finisher jam (Finisher section)	The leading edge of paper which has passed the entrance sensor on the Finisher transport path does not reach the transport sensor.

Check item	Measures
Paper	Check if there is any paper in the finisher or on the transport path of the equipment and remove it if there is.
Pinch roller arm	Check the position of pinch roller arm. If it is down, fix its mechanism.
Transport path switching solenoid (SOL5)	<ul style="list-style-type: none"> • Check that the gap between the transfer guide surface and the upper surface of the flapper tip is in the acceptable range according to the status of the transport path switching solenoid (SOL5) (solenoid OFF: 1.5 to 2.1 mm, solenoid ON: 2.3 to 2.9 mm). If it is not, adjust it. • Check the harness between the transport path switching solenoid (SOL5) and the finisher control PC board (CN1). If there is any abnormality, correct it.
Entrance sensor (S1)	<ul style="list-style-type: none"> • Sensor check • Connector check (CN8) • Harness check
Transport sensor (S2)	<ul style="list-style-type: none"> • Sensor check • Connector check (CN8) • Harness check
Entrance motor (M1)	<ul style="list-style-type: none"> • Motor check • Connector check (CN17) • Harness check
Finisher control PC board (FIN)	<ul style="list-style-type: none"> • Board check • Connector check (CN8, CN17) • Harness check

Parts to be replaced	Remark
Transport path switching solenoid (SOL5)	
Entrance sensor (S1)	
Transport sensor (S2)	
Entrance motor (M1)	
Finisher control PC board (FIN)	

[EA25] Paper transport jam in Finisher (after paper stack was exited)

Classification	Error content
Finisher jam (Finisher section)	<ul style="list-style-type: none"> [MJ-1042] Stack exit motor (M5) abnormality. [MJ-1109/1110] The finishing tray paper detection sensor detects paper after a stack of paper exits from the finishing tray.

MJ-1042

Probable cause	Checking and measures
Stack exit motor (M5) abnormality	Check if the electrical continuity of the coil is normal. If electricity is not conducted, replace the motor.
Faulty cables and connectors	Check if the electrical continuity between the connector terminals is normal. If electricity is not conducted, replace the connectors. (Finisher control PC board (FIN): CN14)
Finisher control PC board (FIN) abnormality	If the error still occurs after replacing the motor, sensor and connectors, exchange the finisher control PC board (FIN).

Parts to be replaced	Remark
Stack exit motor (M5) abnormality	
Finisher control PC board (FIN) abnormality	

MJ-1109/MJ-1110

Check item	Measures
Paper	Check if there is any paper in the finisher or on the transport path of the equipment and remove it if there is.
Finishing tray paper detection sensor (S12)	<ul style="list-style-type: none"> Sensor check Connector check (CN25) Harness check
Finisher control PC board (FIN)	<ul style="list-style-type: none"> Board check Connector check (CN25) Harness check

Parts to be replaced	Remark
Finishing tray paper detection sensor (S12)	
Finisher control PC board (FIN)	

[EA26] Paper transport stop jam (stop command request)

MJ-1042

Classification	Error content
Finisher jam (Finisher section)	The equipment sends a stop signal during feeding.

Check item	Measures
Finisher	<ul style="list-style-type: none"> • Check if the harness connecting the equipment and the Finisher control PC board (FIN) is disconnected or open circuited. • Check if the conductor pattern on the finisher control PC board is open circuited or short circuited. • Update the finisher firmware. • Replace the Finisher control PC board (FIN).
LGC board	<ul style="list-style-type: none"> • Check if the harness connecting the finisher and the LGC board on the equipment is disconnected or open circuited. • Connector check • Check if the conductor pattern on the LGC board is open circuited or short circuited. • Replace the LGC board.

Parts to be replaced	Remark
Finisher control PC board (FIN)	
LGC board (LGC)	

[EA26] Paper transport stop jam (stop command request)**[EA27] Paper transport jam in Finisher**

MJ-1109/MJ-1110

Classification	Error content
Finisher jam (Finisher section)	[EA26] The equipment sends a stop signal during feeding. [EA27] The entrance sensor is turned ON later than the specified timing.

Check item	Measures
Paper	Check if there is any paper in the finisher or on the transport path of the equipment and remove it if there is.
Entrance sensor (S1)	<ul style="list-style-type: none"> • Sensor check • Connector check (CN8) • Harness check
Finisher control PC board (FIN)	<ul style="list-style-type: none"> • Board check • Connector check (CN8) • Harness check

Parts to be replaced	Remark
Entrance sensor (S1)	
Finisher control PC board (FIN)	

[EA28] Paper transport jam (paper holder plate operation delay)

MJ-1109/MJ-1110

Classification	Error content
Finisher jam (Finisher section)	An attempt to start the paper holder plate operation for dropping paper on the finishing tray is made, but the previous paper holder plate operation has not yet been finished.

Check item	Measures
Paper	Check if there is any paper in the finisher or on the transport path of the equipment and remove it if there is.
Assist guide	Is there any mechanical problem when the assist guide is rotated? If there is any mechanical problem, fix its mechanism.
Assist guide motor (M10)	<ul style="list-style-type: none"> • Motor check • Connector check (CN10) • Harness check
Finisher control PC board (FIN)	<ul style="list-style-type: none"> • Board check • Connector check (CN10) • Harness check

Parts to be replaced	Remark
Assist guide motor (M10)	
Finisher control PC board (FIN)	

[EA29] Paper transport jam (stack transport delay)

MJ-1109/MJ-1110

Classification	Error content
Finisher jam (Finisher section)	The buffer tray is extended to drop a stack of paper on the finishing tray but the previous stack has not yet exited.

Check item	Measures
Paper	Check if there is any paper in the finisher or on the transport path of the equipment and remove it if there is.
Buffer tray guide	Is there any mechanical problem when the buffer tray guide is opened and closed while the buffer roller is kept raised? If there is any mechanical problem, fix its mechanism.
Buffer tray guide motor (M2)	<ul style="list-style-type: none"> • Motor check • Connector check (CN10) • Harness check
Finisher control PC board (FIN)	<ul style="list-style-type: none"> • Board check • Connector check (CN8) • Harness check

Parts to be replaced	Remark
Buffer tray guide motor (M2)	
Finisher control PC board (FIN)	

[EA2A] Paper transport jam in the Finisher (between the entrance path and middle path sensor)
MJ-1042

Classification	Error content
Finisher jam (Finisher section)	The leading edge of the paper has passed the entrance path sensor, but does not reach the middle path sensor in the Finisher Unit transport path.

Probable cause	Checking and measures
1st transport motor (M8) abnormality	Check if the electrical continuity of the coil is normal. If electricity is not conducted, replace the motor.
2nd transport motor (M4) abnormality	Check if the electrical continuity of the coil is normal. If electricity is not conducted, replace the motor.
Entrance path sensor (S19) abnormality	Measure the voltage on TP86 on the finisher control PC board (FIN). Then check that the measured voltage is 1V or lower when not shielded and within the range of $3.3V \pm 5\%$ when shielded. If the voltage does not fall within the range mentioned, replace the sensor.
Middle path sensor (S7) abnormality	Measure the voltage on TP84 on the finisher control PC board (FIN). Then check that the measured voltage is 1V or lower when not shielded and within the range of $3.3V \pm 5\%$ when shielded. If the voltage does not fall within the range mentioned, replace the sensor.
Faulty cables and connectors	Check if the electrical continuity between the connector terminals is normal. If electricity is not conducted, replace the connector. (Finisher control PC board (FIN): CN6, CN14, CN22)
Finisher control PC board (FIN) abnormality	If the error still occurs after replacing the sensor and the connector, replace the finisher control PC board (FIN).

[EA2B] Paper transport jam in the Finisher (middle path sensor)
MJ-1042

Classification	Error content
Finisher jam (Finisher section)	The paper remains at the middle path sensor for a longer period than specified while being transported on the Finisher Unit transport path.

Probable cause	Checking and measures
2nd transport motor (M4) abnormality	Check if the electrical continuity of the coil is normal. If electricity is not conducted, replace the motor.
Entrance path sensor (S19) abnormality	Measure the voltage on TP86 on the finisher control PC board (FIN). Then check that the measured voltage is 1V or lower when not shielded and within the range of $3.3V \pm 5\%$ when shielded. If the voltage does not fall within the range mentioned, replace the sensor.
Middle path sensor (S7) abnormality	Measure the voltage on TP84 on the finisher control PC board (FIN). Then check that the measured voltage is 1V or lower when not shielded and within the range of $3.3V \pm 5\%$ when shielded. If the voltage does not fall within the range mentioned, replace the sensor.
Faulty cables and connectors	Check if the electrical continuity between the connector terminals is normal. If electricity is not conducted, replace the connector. (Finisher control PC board (FIN): CN6, CN14, CN22)
Finisher control PC board (FIN) abnormality	If the error still occurs after replacing the sensor and the connector, replace the finisher control PC board (FIN).

[EA2C] Paper transport jam in the Finisher (between the entrance path and sub-path sensor)

MJ-1042

Classification	Error content
Finisher jam (Finisher section)	The leading edge of the paper has passed the entrance sensor, but does not reach the sub-path sensor in the Finisher Unit transport path.

Probable cause	Checking and measures
1st transport motor (M8) abnormality	Check if the electrical continuity of the coil is normal. If electricity is not conducted, replace the motor.
2nd transport motor (M4) abnormality	Check if the electrical continuity of the coil is normal. If electricity is not conducted, replace the motor.
Entrance path sensor (S19) abnormality	Measure the voltage on TP86 on the finisher control PC board (FIN). Then check that the measured voltage is 1V or lower when not shielded and within the range of 3.3V±5% when shielded. If the voltage does not fall within the range mentioned, replace the sensor.
Sub-path sensor (S8) abnormality	Measure the voltage on TP85 on the finisher control PC board (FIN). Then check that the measured voltage is 1V or lower when not shielded and within the range of 3.3V±5% when shielded. If the voltage does not fall within the range mentioned, replace the sensor.
Stationary tray full detection sensor (S11) abnormality	Measure the voltage on TP26 on the finisher control PC board (FIN). Then check that the measured voltage is 1V or lower when not shielded and within the range of 3.3V±5% when shielded. If the voltage does not fall within the range mentioned, replace the sensor.
Faulty cables and connectors	Check if the electrical continuity between the connector terminals is normal. If electricity is not conducted, replace the connector. (Finisher control PC board (FIN): CN6, CN10, CN14, CN22)
Finisher control PC board (FIN) abnormality	If the error still occurs after replacing the sensor and the connector, replace the finisher control PC board (FIN).

[EA2D] Paper transport jam in the Finisher (sub-path sensor)

MJ-1042

Classification	Error content
Finisher jam (Finisher section)	The paper remains at the sub-path sensor for a longer period than specified while being transported on the Finisher Unit transport path.

Probable cause	Checking and measures
2nd transport motor (M4) abnormality	Check if the electrical continuity of the coil is normal. If electricity is not conducted, replace the motor.
Entrance path sensor (S19) abnormality	Measure the voltage on TP86 on the finisher control PC board (FIN). Then check that the measured voltage is 1V or lower when not shielded and within the range of 3.3V±5% when shielded. If the voltage does not fall within the range mentioned, replace the sensor.
Sub-path sensor (S8) abnormality	Measure the voltage on TP85 on the finisher control PC board (FIN). Then check that the measured voltage is 1V or lower when not shielded and within the range of 3.3V±5% when shielded. If the voltage does not fall within the range mentioned, replace the sensor.
Stationary tray full detection sensor (S11) abnormality	Measure the voltage on TP26 on the finisher control PC board (FIN). Then check that the measured voltage is 1V or lower when not shielded and within the range of 3.3V±5% when shielded. If the voltage does not fall within the range mentioned, replace the sensor.
Faulty cables and connectors	Check if the electrical continuity between the connector terminals is normal. If electricity is not conducted, replace the connector. (Finisher control PC board (FIN): CN6, CN10, CN14, CN22)
Finisher control PC board (FIN) abnormality	If the error still occurs after replacing the sensor and the connector, replace the finisher control PC board (FIN).

[EA2E] Paper transport remaining jam in the Finisher (sub-path sensor)

MJ-1042

Classification	Error content
Finisher jam (Finisher section)	Paper is detected in the sub-path sensor when the power is turned ON or the cover is closed.

Probable cause	Checking and measures
Entrance path sensor (S19) abnormality	Measure the voltage on TP86 on the finisher control PC board (FIN). Then check that the measured voltage is 1V or lower when not shielded and within the range of 3.3V±5% when shielded. If the voltage does not fall within the range mentioned, replace the sensor.
Sub-path sensor (S8) abnormality	Measure the voltage on TP85 on the finisher control PC board (FIN). Then check that the measured voltage is 1V or lower when not shielded and within the range of 3.3V±5% when shielded. If the voltage does not fall within the range mentioned, replace the sensor.
Stationary tray full detection sensor (S11) abnormality	Measure the voltage on TP26 on the finisher control PC board (FIN). Then check that the measured voltage is 1V or lower when not shielded and within the range of 3.3V±5% when shielded. If the voltage does not fall within the range mentioned, replace the sensor.
Faulty cables and connectors	Check if the electrical continuity between the connector terminals is normal. If electricity is not conducted, replace the connector. (Finisher control PC board (FIN): CN6, CN10, CN22)
Finisher control PC board (FIN) abnormality	If the error still occurs after replacing the sensor and the connector, replace the finisher control PC board (FIN).

[EA31] Transport path paper remaining jam

Classification	Error content
Finisher jam (Finisher section)	<ul style="list-style-type: none"> [MJ-1042] Paper is detected in the entrance path sensor or middle path sensor when the power is turned ON or the cover is closed. [MJ-1109/1110] Paper which has passed through the entrance sensor does not reach the transport sensor.

MJ-1042

Probable cause	Checking and measures
Entrance path sensor (S19) abnormality	Measure the voltage on TP86 on the finisher control PC board (FIN). Then check that the measured voltage is 1V or lower when not shielded and within the range of 3.3V±5% when shielded. If the voltage does not fall within the range mentioned, replace the sensor.
Middle path sensor (S7) abnormality	Measure the voltage on TP84 on the finisher control PC board (FIN). Then check that the measured voltage is 1V or lower when not shielded and within the range of 3.3V±5% when shielded. If the voltage does not fall within the range mentioned, replace the sensor.
Sub-path sensor (S8) abnormality	Measure the voltage on TP85 on the finisher control PC board (FIN). Then check that the measured voltage is 1V or lower when not shielded and within the range of 3.3V±5% when shielded. If the voltage does not fall within the range mentioned, replace the sensor.
Faulty cables and connectors	Check if the electrical continuity between the connector terminals is normal. If electricity is not conducted, replace the connector. (Finisher control PC board (FIN): CN6, CN22)
Finisher control PC board (FIN) abnormality	If the error still occurs after replacing the sensor and the connector, exchange the finisher control PC board (FIN).

Check item	Measures
Paper	Check if there is any paper in the finisher or on the transport path of the equipment and remove it if there is.
Entrance sensor (S1)	<ul style="list-style-type: none"> • Sensor check • Connector check (CN8) • Harness check
Feeding sensor (S22)	<ul style="list-style-type: none"> • Sensor check (S22) • Connector check (CN1) • Harness check
Paper position sensor (Hole punch unit: S6-1, S6-2)	<ul style="list-style-type: none"> • Remove any paper dust in and around the sensors (S6-1 and S6-2) and clean them.
	<ul style="list-style-type: none"> • Sensor check (S6-1, S6-2) • Connector check (CN1, CN4, CN5) • Harness check
Transport sensor (S2)	<ul style="list-style-type: none"> • Sensor check • Connector check (CN8) • Harness check
Finisher control PC board (FIN)	<ul style="list-style-type: none"> • Board check • Connector check (CN1, CN8) • Harness check

Parts to be replaced	Remark
Entrance sensor (S1)	
Feeding sensor (S22)	
Paper position sensor (S6-1, S6-2)	Hole punch unit
Transport sensor (S2)	
Finisher control PC board (FIN)	

[EA32] Exit paper remaining jam

Classification	Error content
Finisher jam (Finisher section)	<ul style="list-style-type: none"> • [MJ-1042] Paper is detected in the finishing tray sensors when the power is turned ON. • [MJ-1109/1110] Paper is detected in the finishing tray paper detection sensor when the power is turned ON.

MJ-1042

Probable cause	Checking and measures
Finishing tray sensor (S4) abnormality	Measure the voltage on TP14 on the finisher control PC board (FIN). Then check that the measured voltage is 1V or lower when not shielded and within the range of $3.3V \pm 5\%$ when shielded. If the voltage does not fall within the range mentioned, replace the sensor.
Faulty cables and connectors	Check if the electrical continuity between the connector terminals is normal. If electricity is not conducted, replace the connector. (Finisher control PC board (FIN): CN5)
Finisher control PC board (FIN) abnormality	If the error still occurs after replacing the sensor and the connector, exchange the finisher control PC board (FIN).

MJ-1109/1110

Check item	Measures
Paper	Check if there is any paper in the finisher or on the transport path of the equipment and remove it if there is.

Check item	Measures
Processing tray sensor (S12)	<ul style="list-style-type: none"> • Sensor check • Connector check • Harness check
Finisher control PC board (FIN)	<ul style="list-style-type: none"> • Board check • Connector check (CN25) • Harness check

Parts to be replaced	Remark
Processing tray sensor (S12)	
Finisher control PC board (FIN)	

[EA40] Cover open jam

Classification	Error content
Finisher jam (Finisher section)	The finisher cover has opened during paper transport.

MJ-1042

Probable cause	Checking and measures
Sub-path opening/closing sensor (S12) abnormality	Measure the voltage on TP12 on the finisher control PC board (FIN). Then check that the measured voltage is 1V or lower when not shielded and within the range of $3.3V \pm 5\%$ when shielded. If the voltage does not fall within the range mentioned, replace the sensor.
Front cover switch (SW1) abnormality	Measure the voltage on TP77 on the finisher control PC board (FIN). Then check that the measured voltage is 1V or lower when the switch is ON and within the range of $3.3V \pm 5\%$ when OFF. If the voltage does not fall within the range mentioned, replace the switch.
Faulty cables and connectors	Check if the electrical continuity between the connector terminals is normal. If electricity is not conducted, replace the connector. (Finisher control PC board (FIN): CN10, CN13)
Finisher control PC board (FIN) abnormality	If the error still occurs after replacing the switches, sensor and connector, exchange the finisher control PC board (FIN).

MJ-1109/1110

Check item	Measures
Cover / stationary tray	<ul style="list-style-type: none"> • Close the front cover or the stationary tray if they are opened.
Front cover switch (SW1)	<ul style="list-style-type: none"> • Switch check • Connector check • Harness check
Stationary tray opening/closing switch (SW2)	<ul style="list-style-type: none"> • Switch check • Connector check • Harness check
Finisher control PC board	<ul style="list-style-type: none"> • Connector check (CN14) • Board check • Harness check

Parts to be replaced	Remark
Cover locking bracket	If it is broken.
Front cover switch (SW1)	
Stationary tray opening/closing switch (SW2)	
Finisher control PC board (FIN)	

[EA50] Stapling jam

Classification	Error content
Finisher jam (Finisher section)	Stapling is not performed properly.

MJ-1042

Probable cause	Checking and measures
Staple unit stapling start position sensor (S17) abnormality	Measure the voltage on TP23 on the finisher control PC board (FIN). Then check that the measured voltage is 1V or lower when the sensor is ON and within the range of 3.3V±5% when OFF. If the voltage does not fall within the range mentioned, replace the staple unit.
Staple unit staple empty sensor (S18) abnormality	Measure the voltage on TP24 on the finisher control PC board (FIN). Then check that the measured voltage is 1V or lower when the sensor is ON and within the range of 3.3V±5% when OFF. If the voltage does not fall within the range mentioned, replace the staple unit.
Faulty cables and connectors	Check if the electrical continuity between the connector terminals is normal. If electricity is not conducted, replace the connectors. (Finisher control PC board (FIN): CN17)
Finisher control PC board (FIN) abnormality	If the error still occurs after replacing the staple unit and the connectors, exchange the finisher control PC board (FIN).

MJ-1109/1110

Check item	Measures
Stapler	<ul style="list-style-type: none"> • Check if there is any paper in the finisher or on the transport path of the equipment or on the finishing tray. Remove it if there is • Is the jam cleared by taking off the staple cartridge from the finisher and removing the staple sheet slid from the staple case? • If the actuator of the stapler safety sensor (S11) does not move smoothly, remove its clip from the side and then reattach it. • Connector check • Harness check
Finisher control PC board (FIN)	<ul style="list-style-type: none"> • Board check • Connector check (CN2) • Harness check

Parts to be replaced	Remark
Stapler	
Finisher control PC board (FIN)	

[EA60] Early arrival jam

Classification	Error content
Finisher jam (Finisher section)	A paper jam occurs because paper from the equipment arrives at the Finisher too early.

MJ-1042

Probable cause	Checking and measures
Entrance path sensor (S19) abnormality	Measure the voltage on TP86 on the finisher control PC board (FIN). Then check that the measured voltage is 1V or lower when not shielded and within the range of 3.3V±5% when shielded. If the voltage does not fall within the range mentioned, replace the sensor.
Faulty cables and connectors	Check if the electrical continuity between the connector terminals is normal. If electricity is not conducted, replace the connector. (Finisher control PC board (FIN): CN22)

Probable cause	Checking and measures
Finisher control PC board (FIN) abnormality	If the error still occurs after replacing the sensor and the connector, exchange the finisher control PC board (FIN).

MJ-1109/1110

Check item	Measures
Paper	Check if there is any paper in the finisher or on the transport path of the equipment and remove it if there is.
Feeding sensor (S22)	<ul style="list-style-type: none"> • Sensor check(S22) • Connector check (CN1) • Harness check
Finisher control PC board (FIN)	<ul style="list-style-type: none"> • Board check • Connector check (CN1) • Harness check

Parts to be replaced	Remark
Feeding sensor (S22)	
Finisher control PC board (FIN)	

[EA70] Stack exit belt home position error

MJ-1109/1110

Classification	Error content
Finisher jam (Finisher section)	The stack exit belt is not at the home position.

Check item	Measures
Stack belt exit home position sensor (S9)	<ul style="list-style-type: none"> • Check if there is a disconnection of the connector, incorrect installation or breakage of the stack belt exit home position sensor (S9). If there is, reinstall the sensor correctly or replace it. • Check if the connector (CN25) on the finisher control PC board is disconnected from the stack belt exit home position sensor (S9) and the harnesses are open circuited. Correct if any.
Stack transport motor (M8)	<ul style="list-style-type: none"> • Check if the connector (CN18) on the finisher control PC board is disconnected from the stack transport motor (M8) and the harnesses are open circuited. Correct if any.

Parts to be replaced	Remark
Stack belt exit home position sensor (S9)	
Stack transport motor (M8)	
Finisher control PC board (FIN)	

[EAF1] Stack exit roller home position sensor detection error

MJ-1042

Classification	Error content
Finisher jam (Finisher section)	The detection of the home position of the stack exit roller shift motor ends abnormally. This error may occur if paper is jammed while being transported, so it is treated as a paper jam.

Probable cause	Measures
Stack exit roller shift motor (M6) Stack exit roller home position sensor (S13)	The stack exit roller home position sensor (S13) does not detect that the exit roller is not at the upper position after the stack exit roller motor (M6) has been driven in the specified time when the exit roller is moved down.
	The stack exit roller home position sensor (S13) does not detect that the exit roller is at the upper position after the stack exit roller shift motor (M6) has been driven in the specified time when the exit roller is moved up.

[EAF2] Stapler unit sliding motor home position detection error

MJ-1042

Classification	Error content
Finisher jam (Finisher section)	The detection of the home position of the stapler unit sliding motor ends abnormally. This error may occur if paper is jammed while being transported, so it is treated as a paper jam.

Error	Timing of detection
Staple unit sliding motor (M7) Staple unit sliding home position sensor (S3)	The turning OFF of the staple unit sliding home position sensor (S3) is not detected when the staple unit is moved from a point where this sensor is turned ON to one point where this sensor is turned OFF after the staple unit sliding motor (M7) has been driven at the specified number of pulse.
	The turning ON of the staple unit sliding home position sensor (S3) is not detected when the staple unit is moved from a point where this sensor is turned OFF to one point where this sensor is turned ON after the staple unit sliding motor (M7) has been driven at the specified number of pulse.

Probable cause	Checking and measures
Staple unit sliding motor (M7) abnormality	Check if the electrical continuity of the coil is normal. If electricity is not conducted, replace the staple unit.
Staple unit sliding home position sensor (S3) abnormality	Measure the voltage on TP18 on the finisher control PC board (FIN). Then check that the measured voltage is 1V or lower when not shielded and within the range of 3.3V±5% when shielded. If the voltage does not fall within the range mentioned, replace the sensor.
Faulty cables and connectors	Check if the electrical continuity between the connector terminals is normal. If electricity is not conducted, replace the connectors. (Finisher control PC board (FIN): CN3, CN18)
Finisher control PC board (FIN) abnormality	If the error still occurs after replacing the staple unit, sensors and connectors, exchange the finisher control PC board (FIN).

8.3.10 Paper jam in saddle stitch section

[EA90] Cover open jam

MJ-1110

Classification	Error item
Finisher jam (Saddle stitch section)	The saddle stitch unit has opened during printing.

Check item	Measures
Saddle stitch unit	Close the saddle stitch unit if it is open.
Paper	Remove any paper on the stacker.
Saddle stitch unit opening/closing switch (SW5)	Check if there is a disconnection of the connector, incorrect installation or breakage of the saddle stitch unit opening/closing switch (SW5). If there is, reinstall the sensor correctly or replace it. Check if the harness between the saddle stitch unit opening/closing switch (SW5) and the CN26 of the finisher control PC board (FIN) is disconnected or open circuited. Correct if so.

Parts to be replaced	Remarks
Saddle stitch unit opening/closing switch (SW5)	
Finisher control PC board (FIN)	

[EAA0] Paper remaining jam in Saddle Stitch Unit

MJ-1110

Classification	Error item
Finisher jam (Saddle stitch section)	Paper remaining in Saddle Stitch Unit when the power is turned ON.

Check item	Measures
Paper	<ul style="list-style-type: none"> Check if there is any paper in the finisher, saddle stitch unit or the on the transport path of the equipment. Remove it if there is. Use paper accepted in the specifications. Do not use the paper shorter than the specification.
Junction box paper detection sensor (S26)	<ul style="list-style-type: none"> Sensor check(S26) Connector check(CN1) Harness check
Transport path-2 sensor (S27)	<ul style="list-style-type: none"> Sensor check(S27) Connector check(CN3) Harness check
Transport path-3 sensor (S28)	<ul style="list-style-type: none"> Sensor check(S28) Connector check(CN3) Harness check
Ejecting roller sensor(S29)	<ul style="list-style-type: none"> Sensor check(S29) Connector check(CN3) Harness check
Harness	Check if the flat cable between the finisher control PC board (FIN) and the saddle control PC board (SDL) is disconnected or open circuited. Correct if so. (Replace the harness if open circuited. Reconnect the connector securely if there is any disconnection.)
Finisher control PC board (FIN)	<ul style="list-style-type: none"> Board check Connector check(CN21) Harness check
Saddle control PC board (SDL)	<ul style="list-style-type: none"> Board check Connector check(CN3, CN6) Harness check

Parts to be replaced	Remarks
Junction box paper detection sensor (S26)	
Transport path-2 sensor (S27)	
Transport path-3 sensor (S28)	
Ejecting roller sensor (S29)	
Finisher control PC board (FIN)	
Saddle control PC board (SDL)	

[EAB0] Paper transport jam in Saddle Stitch Unit

MJ-1110

Classification	Error item
Finisher jam (Saddle stitch section)	Paper has remained in the transport path.

Check item	Measures
Paper	<ul style="list-style-type: none"> Check if there is any paper in the finisher, saddle stitch unit or the on the transport path of the equipment. Remove it if there is. Use paper accepted in the specifications. <p>Do not use the paper longer than the specification.</p>
Transport roller	Fix any mechanical problem occurring when the transfer roller is rotated.
Feeding sensor (S22)	<ul style="list-style-type: none"> Sensor check(S22) Connector check (CN1) Harness check
Junction box paper detection sensor (S26)	<ul style="list-style-type: none"> Sensor check(S26) Connector check(CN1) Harness check
Transport path-2 (S27)	<ul style="list-style-type: none"> Sensor check(S27) Connector check(CN3) Harness check
Transport path-3 (S28)	<ul style="list-style-type: none"> Sensor check(S28) Connector check(CN3) Harness check
Ejecting roller sensor(S29)	<ul style="list-style-type: none"> Sensor check(S29) Connector check(CN3) Harness check
Saddle transport motor (M16)	<ul style="list-style-type: none"> Motor check(M16) Connector check(CN5) Harness check
Transport path switching solenoid (SOL5)	<p>Check that the gap between the transfer guide surface and the upper surface of the flapper tip is in the acceptable range according to the status of the transport path switching solenoid (SOL5) (solenoid OFF: 1.5 to 2.1 mm, solenoid ON: 2.3 to 2.9 mm). If it is not, adjust it.</p> <p>Check if the harness between the transport path switching solenoid (SOL5) and the CN1 of the finisher control PC board (FIN) is disconnected or open circuited. Correct if so.</p>
Entrance motor (M1)	<ul style="list-style-type: none"> Motor check(M1) Connector check(CN17) Harness check
Harness	<p>Check if the flat cable between the finisher control PC board (FIN) and the saddle control PC board (SDL) is disconnected or open circuited. Correct if so. (Replace the harness if open circuited. Reconnect the connector securely if there is any disconnection.)</p>
Finisher control PC board (FIN)	<ul style="list-style-type: none"> Board check Connector check(CN21) Harness check

Check item	Measures
Saddle control PC board (SDL)	<ul style="list-style-type: none"> Board check Connector check(CN3, CN6) Harness check

Parts to be replaced	Remarks
Junction box paper detection sensor (S26)	
Feeding sensor (S22)	
Transport path-2 (S27)	
Transport path-3 (S28)	
Ejecting roller sensor (S29)	
Saddle transport motor (M16)	
Entrance motor (M1)	
Transport path switching solenoid (SOL5)	
Saddle control PC board (SDL)	
Finisher control PC board (FIN)	

[EAB1] Paper size error jam
MJ-1110

Classification	Error item
Finisher jam (Saddle stitch section)	Paper does not reach the sensor because the paper is shorter than spec.

Check item	Measures
Paper	<ul style="list-style-type: none"> Check if there is any paper in the finisher, saddle stitch unit or the on the transport path of the equipment. Remove it if there is. Use paper accepted in the specifications.
Feeding sensor (S22)	<ul style="list-style-type: none"> Sensor check (S22) Connector check (CN1) Harness check
Junction box paper detection sensor (S26)	<ul style="list-style-type: none"> Sensor check (S26) Connector check (CN1) Harness check
Transport path-2 sensor (S27)	<ul style="list-style-type: none"> Sensor check (S27) Connector check (CN3) Harness check
Transport path-3 sensor (S28)	<ul style="list-style-type: none"> Sensor check (S28) Connector check (CN3) Harness check
Ejecting roller sensor (S29)	<ul style="list-style-type: none"> Sensor check (S29) Connector check (CN3) Harness check
Harness	Check if the flat cable between the finisher control PC board (FIN) and the saddle control PC board (SDL) is disconnected or open circuited. Correct if so. (Replace the harness if open circuited. Reconnect the connector securely if there is any disconnection.)
Finisher control PC board (FIN)	<ul style="list-style-type: none"> Board check Connector check (CN1, CN21) Harness check
Saddle control PC board (SDL)	<ul style="list-style-type: none"> Connector check (CN3, CN6) Board check

Parts to be replaced	Remarks
Feeding sensor (S22)	

Parts to be replaced	Remarks
Junction box paper detection sensor (S26)	
Transport path-2 sensor (S27)	
Transport path-3 sensor (S28)	
Ejecting roller sensor (S29)	
Finisher control PC board (FIN)	
Saddle control PC board (SDL)	

8.3.11 Paper jam in puncher unit

[E9F0] Punching jam

Classification	Error content
Finisher jam Hole punch unit	Punching is not performed properly.

MJ-1042 (When MJ-6011 is installed)

Probable cause	Checking and measures
Punch unit sliding motor abnormality	Check if the electrical continuity of the coil is normal. If electricity is not conducted, replace the motor.
Punch sliding unit home position sensor abnormality	Measure the voltage on TP26 on the hole punch control PC board. Then check that the measured voltage is 1V or lower when not shielded and within the range of $5V \pm 5\%$ when shielded. If the voltage does not fall within the range mentioned, replace the sensor.
Paper detection sensor (light-receiving/light-emitting) (S24/S25)	Measure the voltage on 8-pin of CN6 on the hole punch control PC board. Then check that the measured voltage is 3.0V or higher when not shielded and 1.2 or lower when shielded. If the voltage does not fall within the range mentioned, replace the sensor.
Faulty cables and connectors	Check if the electrical continuity between the connector terminals is normal. If electricity is not conducted, replace the connector. (Hole punch control PC board: CN3, CN4, CN5, CN6, CN7)
Hole punch control PC board abnormality	If the error still occurs after replacing the sensor and the connector, replace the hole punch control PC board.
Finisher control PC board (FIN) abnormality	Replace the finisher control PC board (FIN).

MJ-1109/1110 (When MJ-6105 is installed)

Check item	Measures
Paper	Check if there is any paper on the transport path of the equipment and remove it if there is.
Punch motor (M3)	<ul style="list-style-type: none"> • Motor check • Connector check • Harness check
Punch HP sensor (S4)	<ul style="list-style-type: none"> • Sensor check • Connector check • Harness check
Punch sensor (S5)	<ul style="list-style-type: none"> • Sensor check • Connector check • Harness check
Hole punch control PC board (HP)	<ul style="list-style-type: none"> • Board check • Connector check • Harness check

Parts to be replaced	Remark
Punch HP sensor (S4)	
Punch sensor (S5)	
Punch motor (M3)	
Hole punch control PC board (HP)	

8.3.12 Other paper jam

[EAD0] Print end command time-out jam

Classification	Error content
Other paper jam	The printing has not finished normally because of the communication error between the SYS board and LGC board at the end of printing.

Check item	Measures
Power	<ul style="list-style-type: none"> Check if the error is cleared by turning the power OFF and then back ON.
SYS board	<ul style="list-style-type: none"> Connector check Board check
LGC board	<ul style="list-style-type: none"> Connector check Board check

Parts to be replaced	Remark
SYS board	
LGC board	

[EAE0] Receiving time-out jam

Classification	Error content
Finisher jam	The printing has been interrupted because of the communication error between the equipment and finisher when the paper is transported from the equipment to the finisher.

Check item	Measures
Finisher	<ul style="list-style-type: none"> Is the finisher working? Check if the voltage (24V) is being supplied to the finisher. Check if the harness connecting the I/F connector of the finisher side and LGC board is open circuited. Connector check
LGC board	<ul style="list-style-type: none"> Connector check(CN304, J612) Check if the harness connecting the finisher and LGC board is open circuited. Check if the conductor pattern on the LGC board is short circuited or open circuited.

Parts to be replaced	Remark
LGC board	
Harness	

[EB30] Ready time-out jam

Classification	Error content
Other paper jams	The equipment judges that the paper transport to the finisher is disabled because of the communication error between the equipment and finisher at the start of printing.

Check item	Measures
Finisher	<ul style="list-style-type: none"> Check if the connector on the equipment is disconnected from the finisher or the harnesses are open circuited. Correct if any. Check the finisher firmware version. Update the finisher firmware to the latest one.

Parts to be replaced	Remark
LGC board	

[ED10] Skew adjustment motor home position detection error

MJ-1109/1110 (when MJ-6105 is installed)

Classification	Error content
Finisher jam (Hole Punch section)	The skew adjustment motor is not at the home position.

Check item	Measures
Paper	<ul style="list-style-type: none"> Check if there is any paper in the hole punch unit, finisher or the on the transport path of the equipment. Remove it if there is. Use paper accepted in the specifications.
Skew adjustment motor (M1)	<ul style="list-style-type: none"> Rotate skew adjustment motor and fix its mechanism if it does not rotate smoothly.
Skew HP sensor (S2) Skew adjustment motor (M1) Hole punch control PC board	<ul style="list-style-type: none"> Check if the connectors on the hole punch control PC board (HP board) are disconnected from the skew HP sensor (S2) and the skew adjustment motor, or the harnesses are open circuited. Correct if any.

Parts to be replaced	Remark
Skew adjustment motor (M1)	
Skew HP sensor (S2)	
Hole punch control PC board (HP)	

[ED11] Sideways adjustment motor home position detection error

MJ-1109/1110 (when MJ-6105 is installed)

Classification	Error content
Finisher jam (Hole Punch section)	The sideways adjustment motor is not at the home position.

Check item	Measures
Paper	<ul style="list-style-type: none"> Check if there is any paper in the hole punch unit, finisher or the on the transport path of the equipment. Remove it if there is. Use paper accepted in the specifications.
Sideways adjustment motor (M2)	<ul style="list-style-type: none"> Rotate sideways adjustment motor and fix its mechanism if it does not rotate smoothly.
Sideways deviation HP sensor (S3) Sideways adjustment motor (M2) Hole punch control PC board (HP)	<ul style="list-style-type: none"> Check if the connectors on the hole punch control PC board (HP board) are disconnected from the sideways deviation HP sensor (S3) and the sideways adjustment motor, or the harnesses are open circuited. Correct if any.

Parts to be replaced	Remark
Sideways adjustment motor (M2)	
Sideways deviation HP sensor (S3)	
Hole punch control PC board (HP)	

[ED13] Front alignment plate home position error

MJ-1109/1110

Classification	Error content
Finisher jam (Finisher section)	The front alignment plate is not at the home position.

Check item	Measures
Front alignment plate	<ul style="list-style-type: none"> Move the front alignment plate. Fix any mechanical problem.
Front alignment plate home position sensor (S7)	<ul style="list-style-type: none"> Check if there is a disconnection of the connector, incorrect installation or breakage of the front alignment plate home position sensor (S7). If there is, reinstall the sensor correctly or replace it.
	<ul style="list-style-type: none"> Check if the connector (CN25) on the finisher control PC board is disconnected from the front alignment plate home position sensor (S7) and the harnesses are open circuited. Correct if so.
Front alignment motor (M5)	<ul style="list-style-type: none"> Check if the connector (CN18) on the finisher control PC board is disconnected from the front alignment motor (M5) and the harnesses are open circuited. Correct if so.

Parts to be replaced	Remark
Front alignment plate home position sensor (S7)	
Front alignment motor (M5)	
Finisher control PC board (FIN)	

[ED14] Rear alignment plate home position error

MJ-1109/1110

Classification	Error content
Finisher jam (Finisher section)	The rear alignment plate is not at the home position.

Check item	Measures
Rear alignment plate	<ul style="list-style-type: none"> Move the rear alignment plate. Fix any mechanical problem.
Rear alignment plate home position sensor (S8)	<ul style="list-style-type: none"> Check if there is a disconnection of the connector, incorrect installation or breakage of the rear alignment plate home position sensor (S8). If there is, reinstall the sensor correctly or replace it.
	<ul style="list-style-type: none"> Check if the connector (CN25) on the finisher control PC board is disconnected from the rear alignment plate home position sensor (S8) and the harnesses are open circuited. Correct if so.
Rear alignment motor (M6)	<ul style="list-style-type: none"> Check if the connector (CN18) on the finisher control PC board is disconnected from the rear alignment motor (M6) and the harnesses are open circuited. Correct if so.

Parts to be replaced	Remark
Rear alignment plate home position sensor (S8)	
Rear alignment motor (M6)	
Finisher control PC board (FIN)	

[ED15] Paddle home position error

MJ-1109/1110

Classification	Error content
Finisher jam (Finisher section)	The paddle is not at the home position.

Check item	Measures
Paddle	<ul style="list-style-type: none"> Rotate the paddle. If there is any mechanical problem, fix its mechanism.
Paddle home position sensor Paddle motor Finisher control PC board	<ul style="list-style-type: none"> Check if the connectors (CN15, CN16) on the Finisher control PC board (FIN) are disconnected from the paddle home position sensor (S3) and the paddle motor (M3), or the harnesses are open circuited. Correct if any.

Parts to be replaced	Remark
Paddle motor (M3)	
Paddle home position sensor (S3)	
Finisher control PC board (FIN)	

[ED16] Buffer tray home position error

MJ-1109/1110

Classification	Error content
Finisher jam	The buffer tray is not at the home position.

Check item	Measures
Buffer tray guide	<ul style="list-style-type: none"> Open and close the buffer tray guide. Fix any mechanical problem.
Buffer tray home position sensor (S5)	<ul style="list-style-type: none"> Check if there is a disconnection of the connector, incorrect installation or breakage of the buffer tray home position sensor (S5). If there is, reinstall the sensor correctly or replace it. Check if the connector (CN11) on the finisher control PC board is disconnected from the buffer tray home position sensor (S5) and the harnesses are open circuited. Correct if so.
Assist arm motor (M10)	<ul style="list-style-type: none"> Check if the connector (CN10) on the finisher control PC board is disconnected from the assist arm motor (M10) and the harnesses are open circuited. Correct if so.
Buffer tray guide motor (M2)	<ul style="list-style-type: none"> Check if the connector (CN10) on the finisher control PC board is disconnected from the buffer tray guide motor (M2) and the harnesses are open circuited. Correct if so.

Parts to be replaced	Remark
Buffer tray home position sensor (S5)	
Assist arm motor (M10)	
Buffer tray guide motor (M2)	
Finisher control PC board (FIN)	

[EF10] Paper not supported for saddle stitch finisher

MJ-1110

Classification	Error item
Finisher jam (Saddle stitch section)	Unsupported paper size, type and an excess number of pages for stapling are selected.

Check item	Measures
Paper	<ul style="list-style-type: none"> Check the paper size, paper type, or number of pages for stapling. Change them if they are unsupported.

[EF11] Saddle stitch finisher stapling error (front)

MJ-1110

Classification	Error item
Finisher jam (Saddle stitch section)	Front stapling is not correctly done.

Check item	Measures
Paper	<ul style="list-style-type: none"> Check if there is any paper in the hole punch unit, finisher or the on the transport path of the equipment. Remove it if there is. Use paper accepted in the specifications.
Staple cartridge (front side)	<ul style="list-style-type: none"> Is the jam released by taking off the front staple cartridge from the Finisher and removing the staple sheet slid from the staple case?
Front saddle stapler drive unit	<ul style="list-style-type: none"> Unit check Connector check Harness check
Saddle control PC board (SDL)	<ul style="list-style-type: none"> Connector check (CN2) Board check

Parts to be replaced	Remarks
Front saddle stapler drive unit	
Saddle control PC board (SDL)	

[EF12] Saddle stitch finisher stapling error (rear)

MJ-1110

Classification	Error item
Finisher jam (Saddle stitch section)	Rear stapling is not correctly done.

Check item	Measures
Paper	<ul style="list-style-type: none"> Check if there is any paper in the hole punch unit, finisher or the on the transport path of the equipment. Remove it if there is. Use paper accepted in the specifications.
Staple cartridge (rear side)	<ul style="list-style-type: none"> Is the jam released by taking off the rear staple cartridge from the Finisher and removing the staple sheet slid from the staple case?
Rear saddle stapler drive unit	<ul style="list-style-type: none"> Unit check Connector check Harness check
Saddle control PC board (SDL)	<ul style="list-style-type: none"> Connector check (CN1) Board check

Parts to be replaced	Remarks
Rear saddle stapler drive unit	

Parts to be replaced	Remarks
Saddle control PC board (SDL)	

[EF13] Saddle stitch unit paper holding home position detection error

MJ-1110

Classification	Error item
Finisher jam (Saddle stitch section)	The paper holder home position cannot be detected.

Check item	Measures
Paper holding cam	<ul style="list-style-type: none"> Is there any mechanical problem when the paper holding cam is rotated? Correct if so.
Paper holding home position sensor (S38)	<ul style="list-style-type: none"> Sensor check Connector check Harness check
Paper holding clutch (CLT4)	Check if the harness between the saddle control PC board (SDL) and the paper holding clutch (CLT4) is disconnected or open circuited. Correct if so. (Replace the harness if open circuited. Reconnect the connector securely if there is any disconnection.)
Saddle transport motor (M16)	Check if the harness between the saddle control PC board (SDL) and the saddle transport motor (M16) is disconnected or open circuited. Correct if so. (Replace the harness if open circuited. Reconnect the connector securely if there is any disconnection.)
Saddle control PC board (SDL)	<ul style="list-style-type: none"> Connector check (CN5) Board check

Parts to be replaced	Remarks
Paper holding home position sensor (S38)	
Paper holding clutch (CLT4)	
Saddle transport motor (M16)	
Saddle control PC board (SDL)	

[EF14] Saddle stitch unit paper exit jam

MJ-1110

Classification	Error item
Finisher jam (Saddle stitch section)	Outputting paper is not completed within a fixed time.

Check item	Measures
Paper	<ul style="list-style-type: none"> Is there any paper remaining in the paper transport path of the equipment or the saddle stitch section of the Finisher?
Exit sensor (S31)	<ul style="list-style-type: none"> Sensor check Connector check (CN7) Harness check
Harness	Check if the harness between the finisher control PC board (FIN) and the saddle control PC board (SDL) is disconnected or open circuited. Correct if so. (Replace the harness if open circuited. Reconnect the connector securely if there is any disconnection.)
Finisher control PC board (FIN)	<ul style="list-style-type: none"> Board check Connector check (CN21) Harness check
Saddle control PC board (SDL)	<ul style="list-style-type: none"> Connector check (CN6, CN7) Board check

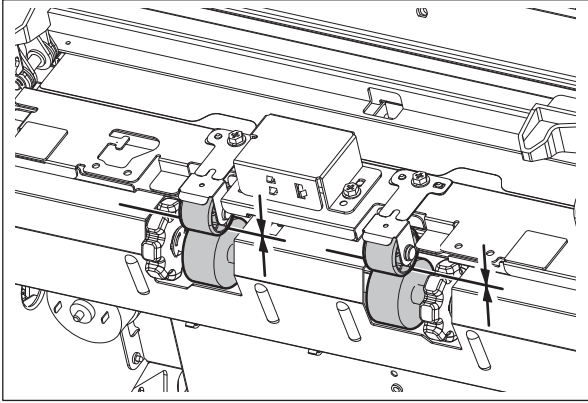
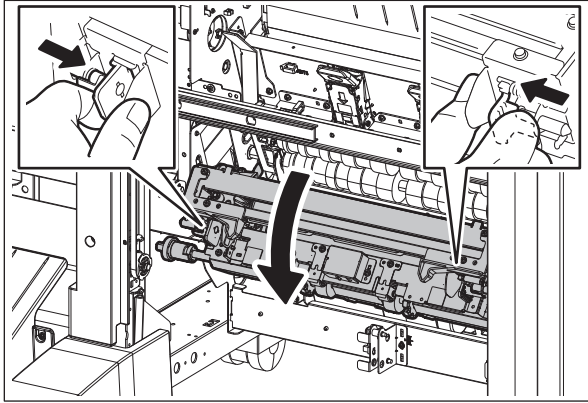
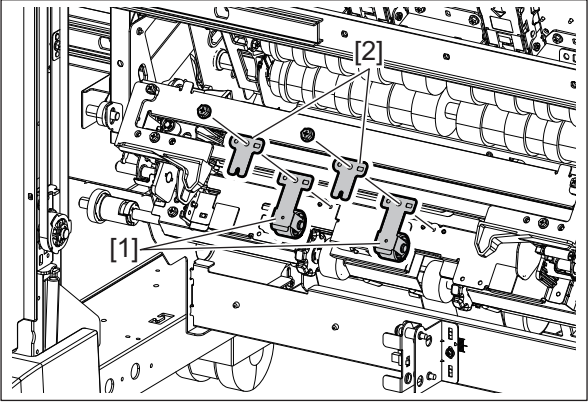
Check item	Measures
<p>Leaf springs and assist leaf springs of the transport pinch roller (for the saddle)</p>	<ul style="list-style-type: none"> Check if there is any gap between the exit roller (for the saddle) and the transport pinch roller (for the saddle). If there is, replace the leaf springs [1] and the assist leaf springs [2] of the transport pinch roller (for the saddle). 
	<p>Fig.8-6</p> <ul style="list-style-type: none"> Check if the leaf springs [1] and the assist leaf springs [2] of the transport pinch roller (for the saddle) are missshapen. If they are warped or deformed, replace them. For the removal procedure of the leaf springs [1] and the assist leaf springs [2], refer to the following figures. 
	 <p>Fig.8-8</p>

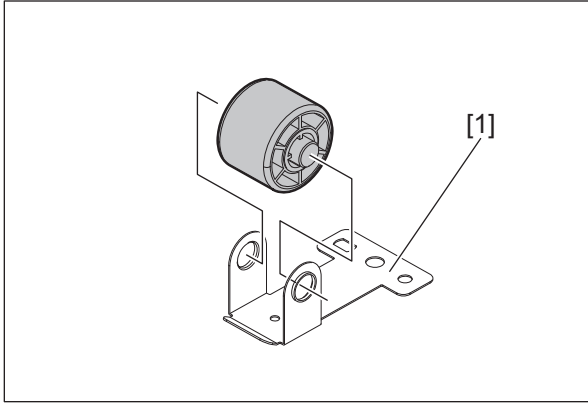
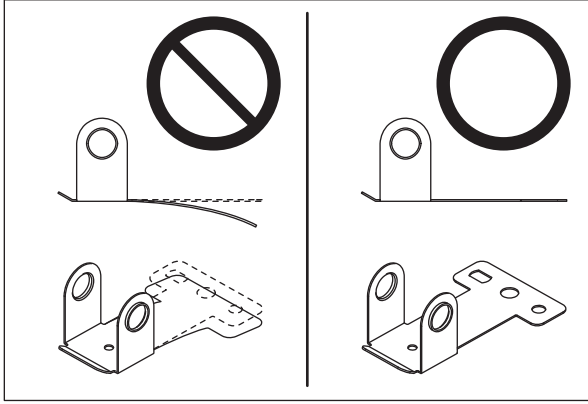
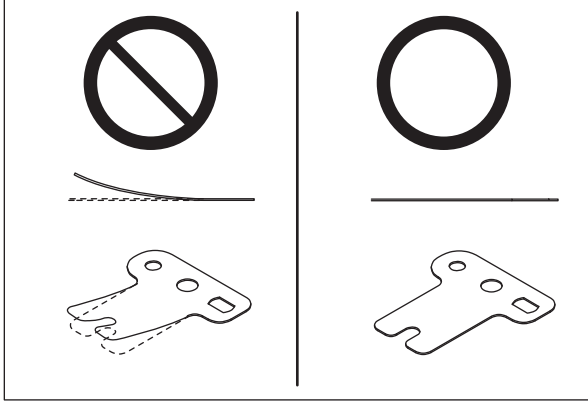
Check item	Measures
<p>Leaf springs and assist leaf springs of the transport pinch roller (for the saddle)</p>	<ul style="list-style-type: none"> Take off the leaf springs [1].  <p>Fig.8-9</p> <p>Notes: In order to confirm that there is no warpage or deformation on the leaf springs [1] and the assist leaf springs [2] of the transport pinch roller (for the saddle), remove them and put them on a flat place.</p>  <p>Fig.8-10</p>  <p>Fig.8-11</p>

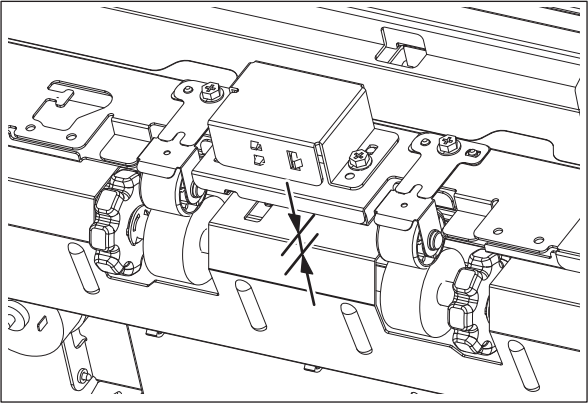
Check item	Measures
Lower transport guide	<p>Check that the gap of the lower transport guide is 15 mm or below. 15 mm or below: OK Larger than 15 mm: Not good</p>  <p>Fig.8-12</p> <p>If the gap is larger than 15 mm, check the attachment condition or replace the lower transport guide.</p>
Exit roller (for the saddle)	<ul style="list-style-type: none"> • Check the engagement status of the gear [4] by rotating the exit roller [3] (for the saddle) in the direction of the arrow (opposite direction of the exiting). <ul style="list-style-type: none"> - When not good: The gear [4] rotates without having been engaged. (The ratchet [5] does not rotate.) - When OK: The ratchet [5] rotates while sliding, but the gear [4] is stopped. (The gear [4] is engaged.)

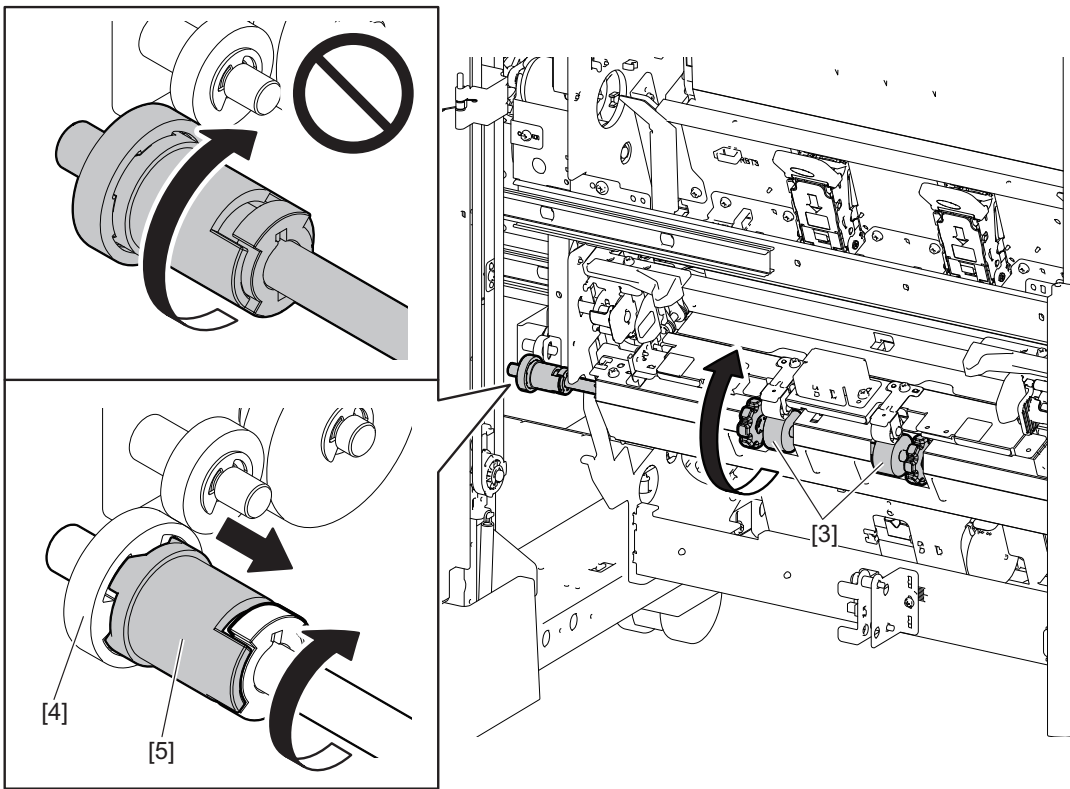
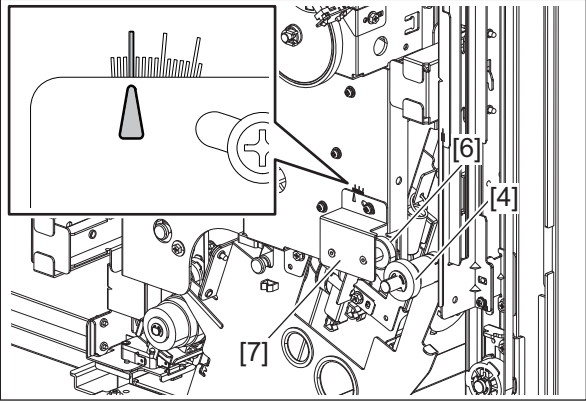
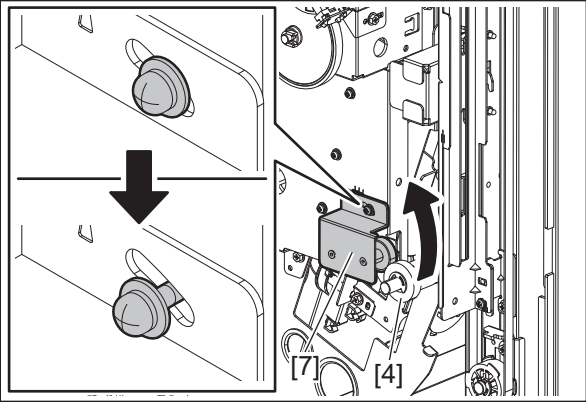
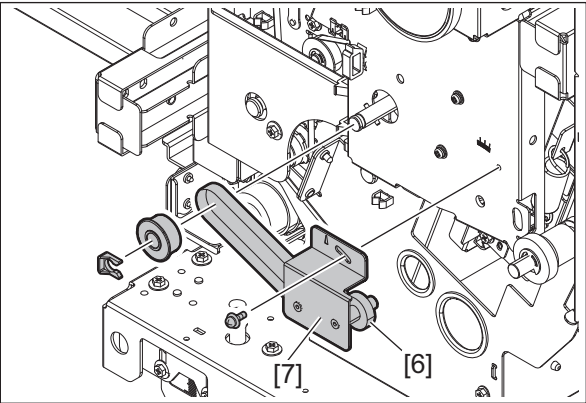
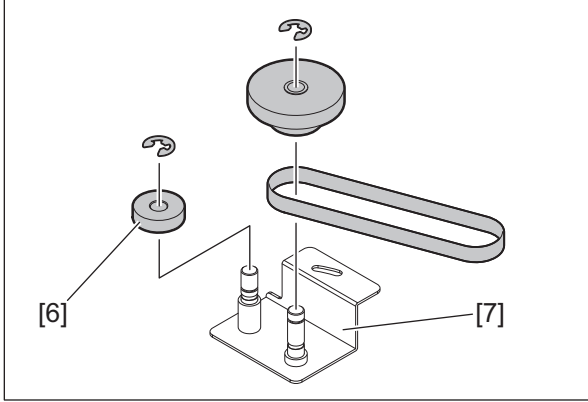
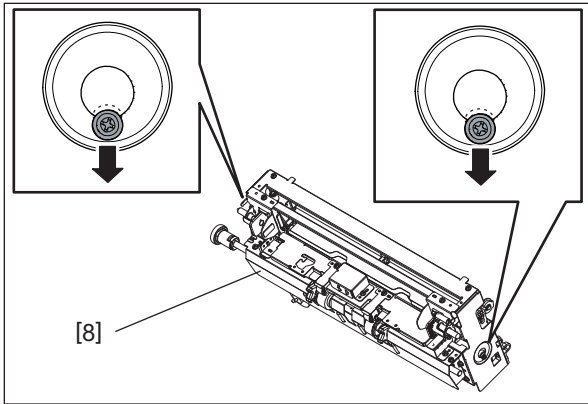
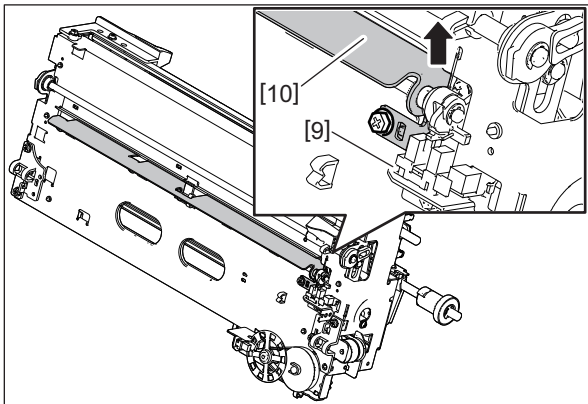

Fig.8-13

Check item	Measures
Exit roller (for the saddle)	<ul style="list-style-type: none"> In the case of “not good”, replace the bracket [7] at the idle gear [6] side. <p>Notes: When replacing, check the position where the pre-change bracket [7] is attached and add its marking in order to install the post-change one in the same place.</p>  <p>Fig.8-14</p> <ul style="list-style-type: none"> For the removal procedure of the bracket [7], refer to the following figures.  <p>Fig.8-15</p>  <p>Fig.8-16</p>

Check item	Measures
Exit roller (for the saddle)	 <p data-bbox="657 585 746 612">Fig.8-17</p>

Check item	Measures
EFS unit	<ul style="list-style-type: none"> • Correct the misalignment of the shaft of the EFS unit [8]. Move the screws in the direction of the arrow and secure them. (both the front and rear)  <p>[8]</p> <p>Fig.8-18</p> <ul style="list-style-type: none"> • Replace the following parts. <ul style="list-style-type: none"> - BRIR-ROD-EX-F-SDL-F5330 - PLT-BURR-ROD-EX-F-SDL - ASYS-PLT3-FILM3-EFS - FILM4-EFS - ACTR-EX-F-SDL - SPG-ACTR-EX-F-SDL - SHAFT-ACTR-EX-F-SDL - ACTR2-EFS - SPG-T-11R5XR55X5R5L-SDL3 • Check if there is a disconnection of the connector, incorrect installation or breakage of the exit transport sensor (S41) [9]. If there is, reinstall the sensor correctly or replace it. Move the bracket [10] in the direction of the arrow and secure it with the screw.  <p>[9]</p> <p>[10]</p> <p>Fig.8-19</p>

Parts to be replaced	Remarks
Exit sensor (S31)	
Saddle control PC board (SDL)	
Finisher control PC board (FIN)	
Leaf springs for the transport pinch roller (for the saddle)	Even if no abnormalities have been confirmed by the check items for the lower transport guide (for the saddle) and the transport pinch roller (for the saddle), replace the leaf springs and the assist leaf springs of the transport pinch roller (for the saddle) if an EF14 error has occurred.
Assist leaf springs for the transport pinch roller (for the saddle)	

Parts to be replaced	Remarks
Bracket at the idle gear side	
Lower transport guide (for the saddle)	
Exit roller (for the saddle)	
EFS unit	<ul style="list-style-type: none"> • BRIR-ROD-EX-F-SDL-F5330 • PLT-BURR-ROD-EX-F-SDL • ASYS-PLT3-FILM3-EFS • FILM4-EFS • ACTR-EX-F-SDL • SPG-ACTR-EX-F-SDL • SHAFT-ACTR-EX-F-SDL • ACTR2-EFS • SPG-T-11R5XR55X5R5L-SDL3 • Exit transport sensor (S41)

[EF15] Saddle stitch finisher side alignment motor home position detection abnormality
MJ-1110

Classification	Error item
Finisher jam (Saddle stitch section)	The side alignment motor home position cannot be detected.

Check item	Measures
Jog	<ul style="list-style-type: none"> • Is there any mechanical problem when the jog is moved? Correct if so.
Side alignment home position sensor (S36)	<ul style="list-style-type: none"> • Sensor check • Connector check • Harness check
Side alignment motor (M15)	<ul style="list-style-type: none"> • Motor check • Connector check • Harness check
Saddle control PC board (SDL)	<ul style="list-style-type: none"> • Connector check (CN4) • Board check

Parts to be replaced	Remarks
Side alignment home position sensor (S36)	
Side alignment motor (M15)	
Saddle control PC board (SDL)	

[EF16] Saddle stitch finisher stacker motor home position detection abnormality
MJ-1110

Classification	Error item
Finisher jam (Saddle stitch section)	The stacker motor home position cannot be detected.

Check item	Measures
Stacker carrier	<ul style="list-style-type: none"> Is there any mechanical problem when the stacker carrier is moved? Correct if so.
Stacker home position sensor (S33)	<ul style="list-style-type: none"> Sensor check Connector check Harness check
Stacker motor (M14)	<ul style="list-style-type: none"> Motor check Connector check Harness check
Saddle control PC board (SDL)	<ul style="list-style-type: none"> Connector check (CN8) Board check

Parts to be replaced	Remarks
Stacker home position sensor (S33)	
Stacker motor (M14)	
Saddle control PC board (SDL)	

[EF17] Saddle stitch finisher folding blade home position detection abnormality
MJ-1110

Classification	Error item
Finisher jam (Saddle stitch section)	The folding blade home position cannot be detected.

Check item	Measures
Folding blade cam	<ul style="list-style-type: none"> Is there any mechanical problem when the folding blade cam is rotated? Correct if so.
Folding blade home position sensor (S35)	<ul style="list-style-type: none"> Sensor check Connector check (CN12) Harness check
Folding blade clutch (CLT3)	<ul style="list-style-type: none"> Clutch check Connector check (CN13) Harness check
Saddle control PC board (SDL)	<ul style="list-style-type: none"> Connector check (CN12, CN13) Board check

Parts to be replaced	Remarks
Folding blade home position sensor (S35)	
Folding blade clutch (CLT3)	
Saddle control PC board (SDL)	

[EF18] Saddle stitch finisher additional folding roller home position detection abnormality
MJ-1110

Classification	Error item
Finisher jam (Saddle stitch section)	The additional folding roller home position cannot be detected.

Check item	Measures
Additional folding carrier	<ul style="list-style-type: none"> Is there any mechanical problem when the additional folding carrier is moved? Correct if so.
Additional folding home position sensor (S39) Additional folding motor encoder sensor (S42)	<ul style="list-style-type: none"> Sensor check Connector check (CN7) Harness check
Additional folding motor (M20)	<ul style="list-style-type: none"> Motor check. Check if the motor and timing belt is installed properly. Connector check (CN10) Harness check
Saddle control PC board (SDL)	<ul style="list-style-type: none"> Connector check (CN7, CN10) Board check

Parts to be replaced	Remarks
Additional folding home position sensor (S39)	
Additional folding motor encoder sensor (S42)	
Additional folding motor (M20)	
Saddle control PC board (SDL)	

[EF19] Saddle stitch unit paper folding jam
MJ-1110

Classification	Error item
Finisher jam (Saddle stitch section)	Fold processed paper cannot be transported to the additional folding roller.

Check item	Measures
Paper	<ul style="list-style-type: none"> Is there any paper remaining in the paper transport path in the equipment or the saddle stitch section of the Finisher? Use paper accepted in the specifications.
Exit transport sensor (S41)	<ul style="list-style-type: none"> Sensor check Connector check (CN7) Harness check
Stacker paper detection sensor (S30)	<ul style="list-style-type: none"> Sensor check Connector check (CN3) Harness check
Harness	<ul style="list-style-type: none"> Connector check Flat harness check
Finisher control PC board (FIN)	<ul style="list-style-type: none"> Board check Connector check (CN21) Harness check
Saddle control PC board (SDL)	<ul style="list-style-type: none"> Connector check (CN7) Board check

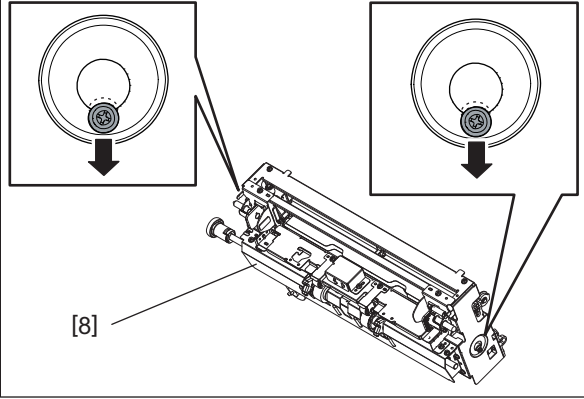
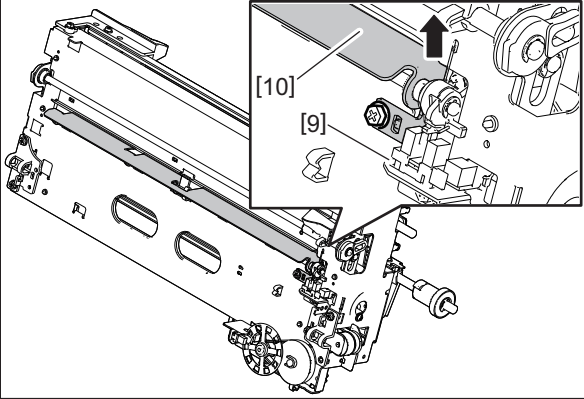
Check item	Measures
EFS unit	<ul style="list-style-type: none"> • Correct the misalignment of the shaft of the EFS unit [8]. Move the screws in the direction of the arrow and secure them. (both the front and rear)  <p>Fig.8-20</p> <ul style="list-style-type: none"> • Replace the following parts. <ul style="list-style-type: none"> - BRIR-ROD-EX-F-SDL-F5330 - PLT-BURR-ROD-EX-F-SDL - ASYS-PLT3-FILM3-EFS - FILM4-EFS - HLDR-P-SNSR-SDL - ACTR-P-SNSR-SDL - SPG-P-SNSR-SDL - ACTR2-EFS - SPG-T-11R5XR55X5R5L-SDL3 • Check if there is a disconnection of the connector, incorrect installation or breakage of the exit transport sensor (S41) [9]. If there is, reinstall the sensor correctly or replace it. Move the bracket [10] in the direction of the arrow and secure it with the screw.  <p>Fig.8-21</p>

Parts to be replaced	Remarks
Exit transport sensor (S41)	
Stacker paper detection sensor (S30)	
Saddle control PC board (SDL)	
Finisher control PC board (FIN)	

Parts to be replaced	Remarks
EFS unit	<ul style="list-style-type: none"> • BRIR-ROD-EX-F-SDL-F5330 • PLT-BURR-ROD-EX-F-SDL • ASYS-PLT3-FILM3-EFS • FILM4-EFS • HLDR-P-SNSR-SDL • ACTR-P-SNSR-SDL • SPG-P-SNSR-SDL • ACTR2-EFS • SPG-T-11R5XR55X5R5L-SDL3

[EF20] Saddle stitch unit stacker jam

MJ-1110

Classification	Error item
Finisher jam (Saddle stitch section)	Transported paper cannot be detected in the stacker paper detection sensor.

Check item	Measures
Paper	<ul style="list-style-type: none"> • Is there any paper remaining in the paper transport path in the equipment or the saddle stitch section of the Finisher? • Use paper accepted in the specifications.
Stacker paper detection sensor (S30)	<ul style="list-style-type: none"> • Sensor check • Connector check (CN3) • Harness check
Harness	<ul style="list-style-type: none"> • Connector check • Flat harness check
Finisher control PC board (FIN)	<ul style="list-style-type: none"> • Board check • Connector check (CN21) • Harness check
Saddle control PC board (SDL)	<ul style="list-style-type: none"> • Connector check (CN3) • Board check

Parts to be replaced	Remarks
Stacker paper detection sensor (S30)	
Saddle control PC board (SDL)	

8.3.13 Drive system related service call

[C020] Developer drive motor abnormality

Classification	Error content
Drive system related service call	The developer drive motor is not rotating normally.

Check item	Measures
Developer unit	<ul style="list-style-type: none"> Check if the developer material is caked. Check if there is any abnormality in the row of gears on the rear side of the developer unit. Check if the amount of developer material is proper.
Development drive unit/Paper feeding drive unit	<ul style="list-style-type: none"> Check if there is any foreign matter between the gears. Check if there is any damage on the gear tooth surface. Check if there is any scratch on the caliber or the shaft of each gear. Check if the proper amount of grease is applied to the caliber or the shaft of each gear. Check if there is any damage to the developer drive output coupling.
Paper feeding/developer unit drive motor	<ul style="list-style-type: none"> Check that the motor is rotated normally. (FS-03-112/162) Connector check Harness check
Drum TBU drive unit	<ul style="list-style-type: none"> Check if there is any foreign matter in the row of the color developer drive gears. Check if there is any damage on the tooth surface of the color developer drive gears. Check if there is any scratch on the caliber or the shaft of each color developer drive gear. Check if the proper amount of grease is applied to the caliber or the shaft of each color developer drive gear. Check if there is any damage to the developer drive output coupling.
LGC board	<ul style="list-style-type: none"> Board check Connector check (CN327) Harness check
1st/2nd drawer feed roller	<ul style="list-style-type: none"> Check if the 1st drawer feed roller is overloaded. Check if there is any damage to the roller coupling.
Bypass unit	<ul style="list-style-type: none"> Check if the bypass feed roller is overloaded. Check if there is any damage to the row of the bypass unit gears.
Paper feeding drive section	<ul style="list-style-type: none"> Check if there is any foreign matter between the gears. Check if there is any damage on the gear tooth surface. Check if there is any scratch on the caliber or the shaft of each gear.
Transport roller	<ul style="list-style-type: none"> Check if the PFU transport roller is overloaded.

Parts to be replaced	Remark
Developer unit	
Feeding/developing drive unit	
Paper feeding/developer unit drive motor	
Drum TBU drive unit	
LGC board	
1st/2nd drawer feed roller	
Bypass unit	
Paper feeding drive section	
Transport roller	

8.3.14 Paper feeding system related service call

[C040] PFP motor abnormality

Classification	Error content
Paper feeding system related service call	The PFP motor is not rotating normally.

Procedure	Check item	Result	Measures	Next Step
1	Is the PFP motor working? (Perform the output check: FS-03-109/159)	Yes		2
		No	<ul style="list-style-type: none"> • Check if the connector J952 of the PFP motor is disconnected. • Check if the connector CN245 on the PFP board is disconnected. • Check if the connector CN241 on the PFP board is • Check if the connector CN459 on the PFC board is disconnected. • Check if the connector pins are disconnected or the harnesses are open circuited. • Check if the conductor patterns on the PFP motor board, PFP board and PFC board are short circuited or open circuited. 	
2	Is the LED on the PFP motor board lit without flashing?	Yes		3
		No	<ul style="list-style-type: none"> • Check if the connector pins are disconnected or the harnesses are open circuited. • Check if the conductor patterns on the PFP motor board, PFP board and PFC board are short circuited or open circuited. 	
3	PFP board		<ul style="list-style-type: none"> • Board check • Connector check • Harness check • Replace the PFP board. 	
4	PFC board		<ul style="list-style-type: none"> • Board check • Connector check (CN459, J700) • Harness check 	

Parts to be replaced	Remark
PFP motor	
PFP board	
PFC board	

[C130] 1st drawer tray abnormality

[C140] 2nd drawer tray abnormality

Classification	Error content
Paper feeding system related service call	<ul style="list-style-type: none"> [C130] The tray-up motor-1 is not rotating or the 1st drawer tray is not moving normally. [C140] The tray-up motor-2 is not rotating or the 2nd drawer tray is not moving normally.

Procedure	Check item	Result	Measures	Next Step
1	Does the tray go up? (Perform the output check: FS-03-242, FS-03-243)	Yes		2
		No	<ul style="list-style-type: none"> Check if the connector of the tray-up motor-1 is disconnected (CN460, J667). Check if the connector of the tray-up motor-2 is disconnected (CN460, J677). Check if the connector on the PFC board is disconnected. (CN452, CN460) Check if the connector on the LGC board is disconnected (CN323). Check if the connector pins are disconnected or the harnesses are open circuited. Check if the conductor pattern on the LGC board is short circuited or open circuited. 	
2	Is the tray-up sensor working? (Perform the input check: FS-03-[ALL]OFF/[0]/[E], FS-03-[F2]ON/[4]/[E])	Yes		3
		No	<ul style="list-style-type: none"> Check if the connector of the 1st drawer tray-up sensor is disconnected (CN457, J673, J675). Check if the connector of the 2nd drawer tray-up sensor is disconnected (CN457, J683, J685). Check if the connector on the PFC board is disconnected. (CN452, CN457) Check if the connector on the LGC board is disconnected (CN323). Check if the slit reaches the sensor. Check if the connector pins are disconnected or the harnesses are open circuited. Check if the conductor pattern on the LGC board is short circuited or open circuited. 	
3	PFC board		<ul style="list-style-type: none"> Check if the conductor pattern on the PFC board is short circuited or open circuited. 	
4	LGC board		<ul style="list-style-type: none"> Check if the conductor pattern on the LGC board is short circuited or open circuited. 	

Parts to be replaced	Remark
Tray-up motor-1	
Tray-up motor-2	
PFC board	
LGC board	
1st drawer tray-up sensor	
2nd drawer tray-up sensor	

[C150] PFP upper drawer tray abnormality

[C160] PFP lower drawer tray abnormality

Classification	Error content
Paper feeding system related service call	<ul style="list-style-type: none"> • [C150] The PFP tray-up motor is not rotating or the PFP upper drawer tray is not moving normally. • [C160] The PFP tray-up motor is not rotating or the PFP lower drawer tray is not moving normally.

Procedure	Check item	Result	Measures	Next Step
1	Does the tray go up? (Perform the output check: FS-03-278, FS-03-280)	Yes		2
		No	<ul style="list-style-type: none"> • Check if the connector of the tray-up motor is disconnected. (J967, J961, CN244) • Check if any of the connectors CN241 and CN244 on the PFP board is disconnected. • Check if the connector CN459, J700 on the PFC board is disconnected. • Check if the connector pins are disconnected or the harnesses are open circuited. • Check if the conductor patterns on the PFP board and PFC board are short circuited or open circuited. 	
2	Is the tray-up sensor working? (Perform the input check: FS-03-[F1]ON/[5]/[A], FS-03-[F1]ON/[5]/[E])	Yes		3
		No	<ul style="list-style-type: none"> • Check if the connector of the sensor is disconnected. (CN246, J960, J965, J966, J970, J972) • Check if any of the connectors CN241 and CN246 on the PFP board is disconnected. • Check if the connector CN459, J700 on the PFC board is disconnected. • Check if the slit reaches the sensor. • Check if the connector pins are disconnected or the harnesses are open circuited. • Check if the conductor patterns on the PFP board and PFC board are short circuited or open circuited. 	
3	PFC board		<ul style="list-style-type: none"> • Check if the conductor pattern on the PFC board is short circuited or open circuited. 	

Parts to be replaced	Remark
Tray-up motor	
PFP board	
PFC board	
Tray-up sensor	

[C180] LCF tray-up motor abnormality

Classification	Error content
Paper feeding system related service call	The LCF tray-up motor is not rotating or the LCF tray is not moving normally.

Procedure	Check item	Result	Measures	Next Step
1	Does the tray move? (Perform the output check: FS-03-271)	Yes		2
		No	<ul style="list-style-type: none"> Check if the connector of the LCF tray-up motor is disconnected. (CN5, CN50) Check if any of the connectors CN100 and CN101 on the LCF board is disconnected. Check if the connector CN459, J700 on the PFC board is disconnected. Check if the connector pins are disconnected or the harnesses are open circuited. Check if the conductor patterns on the LCF board and PFC board are short circuited or open circuited. 	
2	Are the LCF tray-up sensor and LCF tray bottom sensor working? (Perform the input check: FS-03-[F1]ON/[8]/[A], FS-03-[F1]ON/[8]/[E])	Yes		3
		No	<ul style="list-style-type: none"> Check if the connectors of the sensors are disconnected. (CN2, CN20, CN200, CN205, CN6, CN64) Check if any of the connectors CN100 and CN101 on the LCF board is disconnected. Check if the connector CN459, J700 on the PFC board is disconnected. Check if the slit reaches the sensors. Check if the connector pins are disconnected or the harnesses are open circuited. Check if the conductor patterns on the LCF board and PFC board are short circuited or open circuited. 	
3	PFC board		<ul style="list-style-type: none"> Check if the conductor pattern on the PFC board is short circuited or open circuited. 	

Parts to be replaced	Remark
LCF tray-up motor	
LCF board	
PFC board	
LCF tray-up sensor	
LCF tray bottom sensor	

[C1A0] LCF end fence motor abnormality

Classification	Error content
Paper feeding system related service call	The LCF end fence motor is not rotating or the LCF end fence is not moving normally.

Procedure	Check item	Result	Measures	Next Step
1	Is the LCF end fence motor working? (Perform the output check: FS-03-207)	Yes		2
		No	<ul style="list-style-type: none"> Check if the connector of the LCF end fence motor is disconnected. (CN5, CN51) Check if any of the connectors CN100 and CN101 on the LCF board is disconnected. Check if the connector CN459, J700 on the PFC board is disconnected. Check if the connector pins are disconnected or the harnesses are open circuited. Check if the conductor patterns on the PFC board and LGC board are short circuited or open circuited. 	
2	Are the LCF end fence home/stop position sensors working? (Perform the input check: FS-03-[F1]ON/[8]/[H], FS-03-[F1]ON/[8]/[G])	Yes		3
		No	<ul style="list-style-type: none"> Check if the connectors of the sensors are disconnected. (CN4, CN40, CN400, CN402, CN403) Check if either of the connectors CN100 or CN107 on the LCF board is disconnected. Check if the connector CN459, J700 on the PFC board is disconnected. Check if the slit reaches the sensors. Check if the connector pins are disconnected or the harnesses are open circuited. Check if the conductor patterns on the LCF board and PFC board are short circuited or open circuited. 	
3	PFC board		<ul style="list-style-type: none"> Check if the conductor pattern on the PFC board is short circuited or open circuited. 	

Parts to be replaced	Remark
LCF end fence motor	
LCF board	
PFC board	
LCF end fence home position sensor	
LCF end fence stop position sensor	

[C1B0] LCF transport motor abnormality

Classification	Error content
Paper feeding system related service call	The LCF transport motor is not rotating normally (when paper can be fed from any drawer except the LCF).

Procedure	Check item	Result	Measures	Next Step
1	Is the LCF transport motor working? (Perform the output check: FS-03-122/172)	Yes		2
		No	<ul style="list-style-type: none"> • Check if the connector CN3, CN30 of the LCF transport motor is disconnected. • Check if the signal line connector CN100 on the LCF board is disconnected. • Check if the power line connector CN101 on the LCF board is disconnected. • Check if the connector CN459, J700 on the PFC board is disconnected. • Check if the connector pins are disconnected or the harnesses are open circuited. • Check if the conductor patterns on the LCF transport motor board, LCF board and PFC board are short circuited or open circuited. 	
2	LCF transport motor PFC board		<ul style="list-style-type: none"> • Check if the connector pins are disconnected or the harnesses are open circuited. • Check if the conductor patterns on the LCF transport motor board, LCF board and PFC board are short circuited or open circuited. • Replace the LCF transport motor. • Replace the PFC board. 	

Parts to be replaced	Remark
LCF transport motor	
LCF board	
PFC board	

8.3.15 Scanning system related service call

[C260] Peak detection error

Classification	Error content
Scanning system related service call	Lighting of the exposure lamp (white reference) is not detected when power is turned ON.

Procedure	Check item	Result	Measures	Next Step
1	Does the exposure lamp light? (Perform the output check: FS-03-267)	Yes	It is lit.	2
		No	It is not lit.	3
2	Shading correction plate		Check if there is any scratch or stain on the shading correction plate.	
	Mirror		Check if the mirror is tilted. 1. Check that the lens is reflected in the mirror looking at carriage-1 from the upper position. 2. Check that the mirror is secured at the leaf spring.	
	Carriage		1. Check if the carriage is tilted by moving it to the left stopping point. 2. Check if the wire fixing screw is loosened. 3. Check if the movement of the carriage is unstable due to disengagement of the carriage roller.	
	Exposure lamp		1. Check if the exposure lamp is correctly lit. 2. Check if the harness is connected properly to the exposure lamp connector. (CN123, CN010) 3. When the carriage is driven, check if the harness interferes with it or parts are caught in it.	
	CCD board / Lens unit		1. Check if the connector of the CCD board is connected properly. (CN120, CN001) 2. Check if the CCD board is installed properly. (Check that the lens unit is not tilted or the screw is securely tighten.)	
	SYS board		1. Check if the connector of the SYS board (CN120, CN123) is connected properly. 2. Check if the mounted parts on the SYS board are damaged or abnormal. 3. Check if the power is output from the SYS board for CCD. (CN122).	
3	SYS board		1. Check if the supply cable is connected properly to the connector (CN105). 2. Check if the mounted parts on the SYS board are damaged or abnormal.	
	Exposure lamp		1. Check if the harness of the exposure lamp is connected to the LED light source properly. (CN123, CN010) 2. Check if the exposure lamp is scratched or damaged. 3. Check if the exposure lamp harness comes off the board.	
	Power supply harness		1. Check if wiring of the power supply harness (CN105) is abnormal. 2. Check if the harness is scratched or open circuited.	

Parts to be replaced	Remark
Lens unit	
SYS board	
Exposure lamp	

Parts to be replaced	Remark
Power supply harness	
Carriage-1	
Carriage-2	

[C262] Communication error

Classification	Error content
Scanning system related service call	Communication error between the CCD board and the SYS board. CPU abnormality.

Procedure	Check item	Measure
1	RADF/DSDF	Turn the power OFF and disconnect the harness between the RADF/DSDF and the equipment from the SYS board. Then check if the error is reproduced under this situation. If the error is not reproduced, perform the following measures. 1. Check if the connectors between the RADF/DSDF and the equipment are connected properly. (CN122, CN71, CN70, J12) 2. If there is any abnormality in the harness and connectors, replace them. 3. Check if there is any abnormality in the appearance of the parts mounted on the RADF control PC board / DSDF control PC board. 4. Replace the RADF control PC board / DSDF control PC board. If the error is reproduced, perform the following measures after step 2.
2	Harness	Check if the connectors between the SYS board and the CCD board are connected properly. (CN120, CN001) If there is any abnormality in the harness and connectors between the SYS board and the CCD board, replace the harness and connectors.
3	Lens unit	1. Check if there is any abnormality in the appearance of the parts mounted on the CCD board. 2. Replace the lens unit.
4	SYS board	1. Check if the connectors of the SYS board are connected properly. (CN120, CN105) 2. Check if there is any abnormality in the appearance of the parts mounted on the SYS board. 3. Replace the SYS board.

Parts to be replaced	Remark
RADF control PC board / DSDF control PC board	
Harnesses	
Lens unit	
SYS board	

[C270] Carriage home position sensor not turning OFF within a specified period of time / Downloading firmware with an incorrect model

Classification	Error content
Scanning system related service call	The carriage does not shift from its home position in a specified time / Downloading firmware with an incorrect model.

Procedure	Check item	Result	Measures	Next Step
1	Carriage locking		Check if the carriage locking screw for packaging is attached.	

Procedure	Check item	Result	Measures	Next Step
2	Are the carriages slightly moved to the feeding direction?/Are the carriages staying at a position other than home position?	Yes	<ul style="list-style-type: none"> Check if the circuits of the CCD board are abnormal. 	3
		No		
3	CCD board		<ul style="list-style-type: none"> Check if the connector pin is disconnected or the harness is short circuited or open circuited. (CN001) Check if the conductor pattern on the CCD board is short circuited or open circuited. If the model of the firmware downloaded is incorrect, a C270 error (exposure lamp blinks twice) occurs. If the exposure lamp blinks twice, download the correct firmware. 	
4	Carriage home position sensor		<ol style="list-style-type: none"> Check if the harness of the carriage home position sensor is connected properly. (CN121, J002) Check if the harness is caught or open circuited. 	
5	SYS board		<ol style="list-style-type: none"> Check if the connector of the SYS board (CN120, CN121, CN124, CN125) is connected properly. Check if the mounted parts on the SYS board are damaged or abnormal. Check if 24 V (CN125) on the SYS board is short circuited. Check if 24 V is supplied to the SYS board (CN125). 	
6	Scan motor		<ol style="list-style-type: none"> Check if the belt tension is loosened. Check if the motor fixing screw is loosened. Check if the carriage wire and the timing belt come off. Check if the connector (CN124) is connected to the motor properly. Check if the harness of the motor is caught or open circuited. 	
7	Setting		Clear the SRAM data and initialize them. Refer to  P. 9-34 "9.2.5 Precautions and procedure when replacing the SRAM".	

Parts to be replaced	Remark
CCD board	
Carriage home position sensor	
Carriage home position sensor harness	
SYS board	
Scan motor	
Scan motor harness	

[C280] Carriage home position sensor not turning ON within a specified period of time

Classification	Error content
Scanning system related service call	Carriage home position sensor not turning ON within a specified time.

Procedure	Check item	Measures
1	Carriage locking	<ul style="list-style-type: none"> Check if the carriage locking screw for packaging is attached.
2	Carriage hole position sensor	<ol style="list-style-type: none"> Check if the harness is properly connected to the sensor. Check if the harness is caught or open circuited.

Procedure	Check item	Measures
3	SYS board	<ol style="list-style-type: none"> 1. Check if the harness (CN121, J002) of the carriage home position sensor is connected properly. 2. Check if the mounted parts on the SYS board are damaged or abnormal. 3. Check if 24 V (CN125) on the SYS board is short circuited. 4. Check if 24 V is supplied to the SYS board (CN125).
4	Scan motor	<ol style="list-style-type: none"> 1. Check if the belt tension is loosened (if the motor screw is loosened). 2. Check if the carriage wire and the timing belt come off. 3. Check if the connector (CN124) is connected to the motor properly. 4. Check if the harness of the motor is caught or open circuited.

Parts to be replaced	Remark
Carriage home position sensor	
Carriage home position sensor harness	
SYS board	
Scan motor	
Scan motor harness	

[C290] Scanner fuse blowout

Classification	Error content
Scanning system related service call	The scanning system does not operate due to a blowout of the fuse in the scanning system.

Check item	Result	Measures
Is 24V supplied to the SYS board?	Yes	<p>Check the following because the signal for checking 24V on the SYS board is abnormal.</p> <ol style="list-style-type: none"> 1. Check if the scanner CPU (IC26) is damaged or abnormal. 2. Check if the mounted parts on the SYS board are damaged or abnormal. 3. Check if 24V on the SYS board is short circuited. 4. Check if 24V is supplied to the SYS board (CN125).
	No	<ol style="list-style-type: none"> 1. Check if the 24V supply harness is properly connected to the connector (CN125). 2. Check if 24V and SG on the SYS board are short circuited. 3. Check if the power supply is short circuited by pulling out the supply harness on the SYS board (CN125). 4. Check if the fuse on the LVPS (F203) is open circuited. 5. Check if there is no abnormality on the LVPS.

Parts to be replaced	Remark
SYS board	
Fuse (F203)	
Power supply harness	
LVPS	

8.3.16 Fuser unit related service call

Notes:

Be sure to turn OFF the power and unplug the power cable beforehand when checking the power supply unit and fuser unit.

The fuser unit itself or the part of the unit remains heated and the capacitors are still charged after a while the power cable is unplugged. So make sure the unit is cooled down enough before checking.

[C440] Heater abnormality after abnormality judgment (temperature abnormality at printing status)

[C445/C446] Fusing temperature abnormality after abnormality judgment (pre-running end temperature abnormality)

[C447] Fusing temperature abnormality after abnormality judgment (temperature abnormality at ready status / during printing)

[C449] Fusing temperature abnormality after abnormality judgment (high temperature abnormality)

Classification	Error content
Fuser unit related service call	<ul style="list-style-type: none"> [C440], [C445], [C446], [C447] Abnormality of the thermistor is detected or the temperature of the fuser roller does not rise in a specified period of time. [C449] The temperature of the fuser roller has exceeded the range.

Procedure	Check item	Measures
1	Power voltage	<ul style="list-style-type: none"> Check if the power voltage is normal.(Is the voltage during the operation $\pm 10\%$ of the rated voltage?)
2	Thermistor	<ul style="list-style-type: none"> Check if the center and edge thermistor are installed properly. Check if the harnesses of the center and edge thermistor are open circuited. Check if the connectors of the center and edge thermistor are disconnected (CN306, J608).
3	Switching regulator and fuser unit	<ul style="list-style-type: none"> Is the fuser unit installed correctly? Check if the IH-COIL is broken. Check if the terminal of the IH-COIL is attached securely. Check if the thermostat is blown Check if the drawer connector is damaged or its connection is detected. Check if the connectors of the power supply unit are disconnected (CN504, CN505, CN512). Check if the harness is open circuited or short circuited. Check if the connectors of the IH board are disconnected (CN561, CN562, CN563, CN564, CN565). Check if the harness is open circuited or short circuited. Check if the power supply unit is abnormal.
4	LGC board	<ul style="list-style-type: none"> Check if the connectors CN306, CN302and CN323 are disconnected. Check if the harness is open circuited or short circuited. Check if the conductor pattern on the LGC board is short circuited or open circuited.
5	IH board	<ul style="list-style-type: none"> Check if the connectors CN561 is disconnected. Check if the conductor pattern on the IH board is short circuited or open circuited.

Procedure	Check item	Measures
6	Clear the status counter	<ol style="list-style-type: none"> Perform FS-08-2002. Change the current status counter value "5", "6", "7", "9", "10", "22", "23", "24", "25", "27", "29", or "63 to 70". Change the value to "0". <ul style="list-style-type: none"> The status counter value is as follows in the following cases. <ul style="list-style-type: none"> The error occurred during warming-up: "5" or "6" The error occurred after the equipment has become ready: "7". The temperature detected by the center thermistor is 220°C or higher, the temperature detected by the edge thermistor is 237°C or higher: "9", "10", "22", "23", "25", "27" or "29" The error occurred during printing: "24", "25", or "64 to 70". The error occurred during energy saving: "27". A paper jam occurred: "29".

Parts to be replaced	Remark
Fuser unit	
IH board	
Switching regulator	
LGC board	
Harness	Harness between the LGC board and switching regulator, LGC board and IH board, switching regulator and fuser unit.
IH-COIL	

[C471] IH board initialization abnormality

[C472] Power supply abnormality

Classification	Error item
Fuser unit related service call	Power is not supplied to the IH board. Or there is trouble in the power supply environment of the installation location.

Check item	Measures
Power supply	Check if the power voltage is normal. (Is the voltage during the operation $\pm 10\%$ of the rated voltage?)
Side cover interlock switch	<ul style="list-style-type: none"> Connector check (CN514, J519) Harness check
Fuser unit	<ul style="list-style-type: none"> Drawer connector check Thermostat check Unit check
LGC board	<ul style="list-style-type: none"> Connector check (CN302, CN306, CN314) Board check
Switching regulator	<ul style="list-style-type: none"> Connector check (CN504, CN505, CN512) Relay check (FS-03-[ALL]OFF/[6]/[D])
IH board	<ul style="list-style-type: none"> Connector check (CN561, CN562, CN563) Board check
Status counter	<ol style="list-style-type: none"> Perform FS-08-2002. Change the current status counter value "11" to "0". Turn the power OFF and then back ON. Make sure that the equipment enters the normal ready state.
Connector and harness	<ul style="list-style-type: none"> Check the connectors and harnesses of the parts replaced just before C471 occurred. Check the connectors which connect the equipment and LCF/ PFP.

Parts to be replaced	Remarks
Side cover interlock switch.	
LGC board	
FIL board	
IH board	
Power supply	

[C473] Power voltage upper limit abnormality

[C474] Power voltage lower limit abnormality

Classification	Error item
Fuser unit related service call	<ul style="list-style-type: none"> • [C473] The power voltage supplied to the IH board is higher than the rated voltage. • [C474] The power voltage supplied to the IH board is lower than the rated voltage.

Check item	Measures
Power supply	<ul style="list-style-type: none"> • Check if the power voltage is normal.(Is the voltage during the operation $\pm 10\%$ of the rated voltage?)
Fuser unit	<ul style="list-style-type: none"> • Drawer connector check • Thermostat check • Unit check
IH board	<ul style="list-style-type: none"> • Connector check (CN561, CN562, CN563) • Board check
LGC board	<ul style="list-style-type: none"> • Connector check (CN302, CN306) • Board check
Status counter	<ol style="list-style-type: none"> 1. Perform FS-08-2002. Change the current status counter value "13" or "16" to "0". 2. Turn the power OFF and then back ON. Make sure that the equipment enters the normal ready state.

Parts to be replaced	Remarks
Power supply	
IH board	
LGC board	

[C480] IGBT high temperature abnormality

Classification	Error item
Fuser unit related service call	IGBT (element of the IH board) is overheated.

Check item	Measures
IH board cooling fan	<ul style="list-style-type: none"> • Fan motor check (Perform the output check: FS-03-442) • Connector check (J601) • Harness check
LGC board	<ul style="list-style-type: none"> • Connector check (CN302) • Board check
IH board	<ul style="list-style-type: none"> • Connector check (CN561, CN562, CN563, CN564, CN565) • Board check
Status counter	<ol style="list-style-type: none"> 1. Perform FS-08-2002. Change the current status counter value "15" to "0". 2. Turn the power OFF and then back ON. Make sure that the equipment enters the normal ready state.

Parts to be replaced	Remarks
IH board cooling fan	
LGC board	
IH board	
Power supply	

[C4B0] Status counter abnormality

Classification	Error content
Fuser unit related service call	An abnormal value is entered in the status counter.

Check item	Measures
LGC board	<ul style="list-style-type: none"> Check if the conductor pattern on the board is short circuited or open circuited. Check if EEPROM is mounted.
Status counter	<ol style="list-style-type: none"> Perform FS-08-2002. Reset the displayed current status counter value "1 to 4", "8", "17 to 21", "26", "28", "30 to 62", or "67 or more" to "0". Turn the power OFF and then back ON. Make sure that the equipment enters the normal status.

Parts to be replaced	Remark
LGC board	

[C4B1] Fuser unit voltage judgment abnormality

Classification	Error item
Fuser unit related service call	Errors when there is no match between the destination selected in the IH board and the equipment.

Check item	Measures
LGC board	<ul style="list-style-type: none"> Connector check (CN302) Board check
IH board	<ul style="list-style-type: none"> Connector check (CN561, CN562, CN563) Board check

Parts to be replaced	Remarks
LGC board	
IH board	

[C4B2] IH firmware combination error

Classification	Error item
Fuser unit related service call	Abnormality due to a mismatch between the IH firmware and the IH board.

Check item	Measures
Combination of the firmware version	<ul style="list-style-type: none"> Check the combination of the firmware version of the IH firmware. Reinstall the firmware of correct combination.
IH board	<ul style="list-style-type: none"> Connector check Board check

Parts to be replaced	Remarks
IH board	

[C4C0] Fuser unit old / new detection fuse abnormality

Classification	Error content
Fuser unit related service call	Fuser unit old / new detection fuse abnormality.

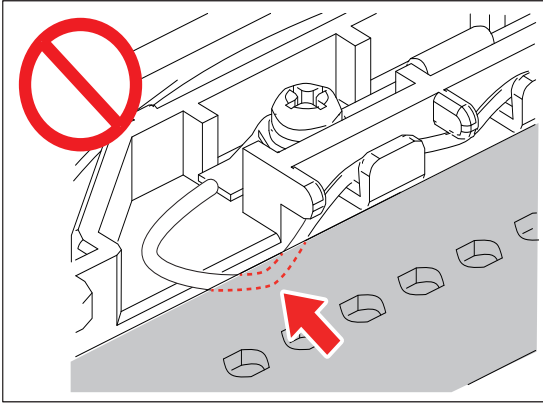
Check item	Measures
Fuser unit	<ul style="list-style-type: none"> Connector check (J608) Check if the harness of fuser unit new/old detection fuse is caught or open circuited / short circuited.  <p>The diagram shows a cross-section of a fuser unit. A red circle with a diagonal slash (a 'no' symbol) is positioned over a harness connection. A red arrow points to a specific point on the harness where it appears to be caught or improperly connected. The diagram is labeled Fig.8-22.</p>
LGC board	<ul style="list-style-type: none"> Replace the fuser unit. Connector check (CN306) Harness check Replace the LGC board.

Parts to be replaced	Remark
Fuser unit	
LGC board	

[C4E0] Pressure roller release abnormality

[C4E1] Pressure roller contact / semi-contact abnormality

Classification	Error item
Fuser unit related service call	<ul style="list-style-type: none"> [C4E0] The releasing behavior of the pressure roller cannot be detected. The abnormality of the pressure roller contact / release detection sensor. [C4E1] The contacting / semi-contacting behavior of the pressure roller cannot be detected.

Check item	Measures
Pressure roller contact/release detection sensor (S29)	<ul style="list-style-type: none"> Sensor check (Perform the input check: FS-03-[F2]ON/[2]/[H]) Connector check (CN306, J605) Harness check

Check item	Measures
Pressure roller contact/release motor (M13)	<ul style="list-style-type: none"> Motor check (Perform the output check: FS-03-272) Connector check (CN305, J602) Harness check
Fuser unit	<ul style="list-style-type: none"> Drawer connector check Thermostat check Unit check <p>Check if the adjustment value for the tilting of the fuser unit is aligned to the uppermost line of the scale. Refer to  P. 8-498 "8.5.36 Image skewing on paper trailing edge".</p>
LGC board	<ul style="list-style-type: none"> Connector check (CN305, CN306) Board check

Parts to be replaced	Remarks
Pressure roller contact/release detection sensor	
Pressure roller contact/release motor	
LGC board	

[C4E2] Fuser belt rotation detection sensor abnormality

Classification	Error item
Fuser unit related service call	The fuser belt does not rotate or incorrectly rotates.

Check item	Measures
Fuser unit	<ul style="list-style-type: none"> Fuser belt rotation detection sensor check (Input check: 03-[ALL]OFF/[6]/[A]) Connector check in the fuser belt rotation sensor Harness check in the fuser belt rotation sensor Rotation detection plate (rotor) check Grease check in the gear (shaft / tooth flank) Fuser belt check Check if the bushing of fuser belt drive shaft is worn. Fuser unit installation check (Check that the levers fixing the fuser unit are lifted up.)
Fuser belt rotation detection sensor	<ul style="list-style-type: none"> Sensor check (Input check: FS-03-[ALL]OFF/[6]/[A]) Connector check in the fuser belt rotation sensor (CN306, J604) Harness check in the fuser belt rotation sensor
Fuser drive unit	<ul style="list-style-type: none"> Bushing check Check that the drive unit is correctly installed (3 dowels). Check that the drive metal plate is not broken. Check that the gear is not damaged or worn. One-way clutch check Grease check in the gear (shaft / tooth flank)
LGC board	<ul style="list-style-type: none"> Connector check (CN305, CN306) Board check
Fuser motor	<ul style="list-style-type: none"> Motor check (Perform the output check: FS-03-113/163) Connector check (CN305, J603) Harness check

Parts to be replaced	Remarks
Fuser belt rotation detection sensor	
Detection plate (rotor)	Dirty/damaged
Fuser belt	Deformed/damaged
Bushing of fuser belt drive shaft	Worn
Bushing of fuser drive unit	Worn
Drive plate	Bend section broken

Parts to be replaced	Remarks
Gear	Teeth damaged, worn
LGC board	
Fuser motor	

8.3.17 Communication related service call

[C550] Communication error between the scanner and DF

Classification	Error content
DSDF service call	Communication error between the scanner and DF.

Check item	Measures
Connector	<ul style="list-style-type: none"> Check if the connectors (CN70, CN71 and J97) connected the DSDF and the equipment are connected properly.
HDMI cable	<ul style="list-style-type: none"> Check if the HDMI cables (CN78 and CN90) are connected properly.
DSDF I/F board	<ul style="list-style-type: none"> Check if the DSDF I/F board is installed in the SYS board properly.
Connector	<ul style="list-style-type: none"> Check if the connectors of the SYS board and the DSDF board are connected properly. Replace the harness.
DSDF board	<ul style="list-style-type: none"> Replace the DSDF control PC board.
SYS board	<ul style="list-style-type: none"> Check the connector (CN122) of the SYS board. Check if the connectors on the SYS board are disconnected from the DSDF board or the harnesses are open circuited. Correct if any. Check the SYS board (IC25, IC28). Replace the SYS board.

Parts to be replaced	Remark
HDMI cable / Harness	
DSDF I/F board	
DSDF board	
SYS board	

[C550] Communication error between the scanner and DF

Classification	Error content
RADF service call	Communication error between the scanner and DF.

Check item	Measures
RADF board	<ul style="list-style-type: none"> Check if the harness connecting the RADF board and SYS board is disconnected or open circuited. (CN122, J12, CN71) Check if the conductor pattern on the RADF board is short circuited or open circuited. Connector check
SYS board	<ul style="list-style-type: none"> Check if the conductor pattern on the SYS board is short circuited or open circuited. Check the connector (CN122) of the SYS board. Check if the connectors on the SYS board are disconnected from the RADF board or the harnesses are open circuited. Correct if any. Check the SYS board (IC25, IC28). Replace the SYS board.

Parts to be replaced	Remark
RADF board	
SYS board	

[C560] Communication error between Engine-CPU and PFC board

Classification	Error item
Communication related service call	Communication error between Engine-CPU and PFC board.

Check item	Measures
LGC board	<ul style="list-style-type: none"> • Turn the power OFF and then back ON using the main power switch. • Connector check (CN323) • Check if the conductor pattern on the LGC board is open circuited or short circuited. • Check if the harness between LGC-PFC has any scratch on it or is open circuited or caught anywhere. • If the same error occurs again, replace the LGC board.
PFC board	<ul style="list-style-type: none"> • Connector check (CN452) • Check if the conductor pattern on the PFC board is open circuited or short circuited. • Check if the harness between LGC-PFC has any scratch on it or is open circuited or caught anywhere. • If the same error occurs again, replace the PFC board.

Parts to be replaced	Remarks
LGC board	
PFC board	
Harness	

[C580] Communication error between the LGC board and the finisher

Classification	Error content
Option related service call	Communication error between the LGC board and the finisher.

Check item	Measures
Finisher	<ul style="list-style-type: none"> • Check if the specified finisher is attached.
LGC board	<ul style="list-style-type: none"> • Check if the harness connecting the LGC board and the Finisher control PC board (FIN) is disconnected or open circuited. • Check if the conductor pattern on the LGC board is open circuited or short circuited.
Finisher control PC board (FIN)	Check if the conductor pattern on the Finisher control PC board (FIN) is open circuited or short circuited.

Parts to be replaced	Remarks
LGC board	
Finisher control PC board (FIN)	

[F070] Communication error between the system-CPU and the engine-CPU

Classification	Error content
Communication related service call	Communication error between the system-CPU and the engine-CPU.

Check item	Measures
Error code	<ul style="list-style-type: none"> • Turn the power OFF and then back ON using the main power switch, and then check if the error code changes to another one. • If it changes to another one, follow the procedure for the changed error code.

Check item	Measures
Check firmware version	<ul style="list-style-type: none"> Check the version of the system firmware on the SYS board. Check the version of the engine firmware on the LGC board.
Board check	<ul style="list-style-type: none"> Check if the connector (CN133, CN132) on the SYS board and the connector (CN330, CN329) on the LGC board are completely inserted. Check if the connector pin between the SYS board connectors (CN133, CN132) and the LGC board connectors (CN330, CN329) is disconnected. Check if the connector CN314 on the LGC board and the connector CN512 on the PS-ACC are completely inserted. Check if the conductor patterns on the LGC board and SYS board are short circuited or open circuited
Harness	<ul style="list-style-type: none"> Connector check Harness check

Parts to be replaced	Remark
Harness	Be sure to exchange the parts in the order of the harness, LGC board and SYS board.
LGC board	Be sure to exchange the parts in the order of the harness, LGC board and SYS board.
SYS board	Be sure to exchange the parts in the order of the harness, LGC board and SYS board.

[F071] Communication initialization error between the system-CPU and the engine-CPU
[F074] Communication error between the system-CPU and the engine-CPU (engine-CPU response abnormality)

Classification	Error content
Communication related service call	<ul style="list-style-type: none"> [F071] Communication initialization error between the system-CPU and the engine-CPU. [F074] Communication error between the system-CPU and the engine-CPU (engine-CPU response abnormality).

Check item	Measures
Error code	<ul style="list-style-type: none"> Turn the power OFF and then back ON using the main power switch, and then check if the error code changes to another one. If it changes to another one, follow the procedure for the changed error code.
Check firmware version	<ul style="list-style-type: none"> Check the version of the system firmware on the SYS board. Check the version of the engine firmware on the LGC board.
Board check	<ul style="list-style-type: none"> Check if the connector (CN133, CN132) on the SYS board and the connector (CN330, CN329) on the LGC board are completely inserted. Check if the connector pin between the SYS board connectors (CN133, CN132) and the LGC board connectors (CN330, CN329) is disconnected. Check if the connector CN314 on the LGC board and the connector CN512 on the PS-ACC are completely inserted. Check if the conductor patterns on the LGC board and SYS board are short circuited or open circuited
Harness	<ul style="list-style-type: none"> Connector check Harness check
LGC board	<ul style="list-style-type: none"> 25/30/35 ppm: Measure the voltage on TP33 on the LGC board. Then check that the measured voltage is 3.3V. If the voltage does not output, replace the LGC board. 45/50 ppm: Measure the voltage on TP18 on the LGC board. Then check that the measured voltage is 3.3V. If the voltage does not output, replace the LGC board.

Parts to be replaced	Remark
Harness	Be sure to exchange the parts in the order of the harness, LGC board and SYS board.
LGC board	Be sure to exchange the parts in the order of the harness, LGC board and SYS board.
SYS board	Be sure to exchange the parts in the order of the harness, LGC board and SYS board.

8.3.18 RADF / DSDF related service call

[C551] DF model detection error

Classification	Error content
DSDF / RADF service call	Incorrect DF installed in the equipment.

Check item	Measures
RADF/DSDF	<ul style="list-style-type: none"> Check if the installed RADF / DSDF is an option exclusively set for the model. Replace the RADF / DSDF with the one exclusively set for the model.
DSDF I/F board	<ul style="list-style-type: none"> Check the DSDF I/F board installation. Check the connector (CN89) of the DSDF I/F board. Check if the connectors on the DSDF I/F board are disconnected from the DSDF control PC board or the harnesses are open circuited. Correct if any. Replace the DSDF I/F board.
SYS board	<ul style="list-style-type: none"> Check the connector (CN129) of the SYS board. Replace the SYS board.

Parts to be replaced	Remark
RADF / DSDF	
RADF board, DSDF I/F board	
SYS board	

[C552] DF abnormality

Classification	Error content
DSDF / RADF service call	DF abnormality.

Check item	Measures
Connector	<ul style="list-style-type: none"> Check if the connectors (CN70, CN71 and J97) connected the DSDF and the equipment are connected properly. Check if the connectors (CN70 and CN71) connected the RADF and the equipment are connected properly.
Firmware	<ul style="list-style-type: none"> Update the firmware of the DSDF/RADF.
Connector	<ul style="list-style-type: none"> Check if the connectors of the DSDF control PC board are connected properly. Replace the harness.
DSDF control PC board / RADF control PC board	<ul style="list-style-type: none"> Replace the DSDF control PC board / RADF control PC board.

Parts to be replaced	Remark
DSDF control PC board / RADF control PC board	

[C553] DSDF CCD-module Peak detection error

Classification	Error content
DSDF service call	The light source of the DSDF-CCD module does not light, or there is a detection error of the light source.

Check item	Measures
HDMI cable	<ul style="list-style-type: none"> Check if the HDMI cables (CN78 and CN90) are connected properly.

Check item	Measures
DSDF I/F board	<ul style="list-style-type: none"> Check if the DSDF I/F board is installed in the SYS board properly. Check the connector (CN89) of the DSDF I/F board. Check if the connectors on the DSDF I/F board are disconnected from the DSDF control PC board or the harnesses are open circuited. Correct if any. Replace the DSDF control board.
Connector	<ul style="list-style-type: none"> Check if the connectors of the SYS board and the DSDF control PC board are connected properly. Replace the harness.
Power supply	<p>Check if 24V is supplied to the DSDF control PC board properly.</p> <ul style="list-style-type: none"> Check the connector of the power supply of the DSDF control PC board: CN70 Pins 1 and 2. Check the connector of the power supply of the SYS board: CN122 Pins 19 and 20.
DSDF exit motor	<ul style="list-style-type: none"> Check if the DSDF exit motor is working properly. Check if the connectors (J991 and CN77) on the DSDF control PC board are disconnected from the DSDF exit motor or the harnesses are open circuited. Correct if any.
DSDF-CCD module	<ul style="list-style-type: none"> Check if the connectors of the DSDF-CCD module and the DSDF control PC board are connected properly. Check that there is no abnormality in the DSDF-CCD module.
SYS board	<ul style="list-style-type: none"> Check the connector (CN122) of the SYS board. Check the SYS board (IC31, IC32). Replace the SYS board.

Parts to be replaced	Remark
DSDF I/F board	
DSDF exit motor	
DSDF-CCD module	
SYS board	

[C554] AFE communication error

Classification	Error content
DSDF service call	Communication error between the DSDF-CCD module and SYS board.

Check item	Measures
HDMI cable	<ul style="list-style-type: none"> Check if the HDMI cables (CN78 and CN90) are connected properly.
DSDF I/F board	<ul style="list-style-type: none"> Check if the DSDF I/F board is installed in the SYS board properly. Check the connector (CN89) of the DSDF I/F board. Check if the connectors on the DSDF I/F board are disconnected from the DSDF control PC board or the harnesses are open circuited. Correct if any. Check the DSDF I/F board (IC6, IC9, IC204). Replace the DSDF I/F board.
Connector	<ul style="list-style-type: none"> Check if the connectors of the SYS board and the DSDF control PC board are connected properly. Replace the harness.
DSDF-CCD module	<ul style="list-style-type: none"> Check if the connectors of the DSDF-CCD module and the DSDF control PC board are connected properly. Check that there is no abnormality in the DSDF-CCD module.
SYS board	<ul style="list-style-type: none"> Check the connector (CN129) of the SYS board. Check the SYS board (IC26). Replace the SYS board.

Parts to be replaced	Remark
DSDF I/F board	
DSDF-CCD module	

Parts to be replaced	Remark
SYS board	

[C730] DSDF EEPROM writing error

Classification	Error content
DSDF service call	An abnormality occurs while the data are being written in the EEPROM of the DSDF.

Check item	Measures
Adjustment	<ul style="list-style-type: none"> Perform the DSDF read-in sensor-1 automatic adjustment.
DSDF control PC board	<ul style="list-style-type: none"> If this error still persists after the DSDF read-in sensor-1 automatic adjustment has been performed, replace the DSDF control PC board.

Parts to be replaced	Remark
DSDF control PC board	

[C7B0] Initial time-out error

Classification	Error content
DSDF service call	The initialization is not completed within the specified time.

Check item	Measures
Reproducing ability	<ul style="list-style-type: none"> Turn the power OFF and then back ON to check the occurrence.
DSDF shading sheet	<ul style="list-style-type: none"> Clean the DSDF shading sheet.

Parts to be replaced	Remark
DSDF shading sheet	

[C8C0] DSDF read-in sensor-1 automatic adjustment error

Classification	Error content
DSDF service call	An adjustment value becomes outside the specified one during DSDF read-in sensor-1 automatic adjustment.

Check item	Measures
DSDF read-in sensor-1	<ul style="list-style-type: none"> Perform the DSDF read-in sensor-1 adjustment manually. If the LED does not light even if the adjustment has been performed, check the DSDF read-1 sensor-1 and the DSDF control PC board. Check if the connector on the DSDF control PC board is disconnected from the DSDF read-in sensor-1 or the harnesses are open circuited. Correct if any. Replace the DSDF read-in sensor-1.
DSDF control PC board	<ul style="list-style-type: none"> Replace the DSDF control PC board.

Parts to be replaced	Remark
DSDF read-in sensor-1	
DSDF control PC board	

[C8E0] DF control abnormality (communication protocol abnormality)

Classification	Error content
DSDF / RADF service call	System stop is required due to the control abnormality.

Check item	Measures
Power	<ul style="list-style-type: none"> Turn the power OFF and then back ON to check if the equipment operates normally.
DSDF / RADF board	<ul style="list-style-type: none"> Connector check Board check

Parts to be replaced	Remark
DSDF/RADF board	

[F115] S-VDEN ON signal time-out error

[F116] S-VDEN OFF signal time-out error

[F117] S-VDEN ON (back side) signal time-out error

[F118] S-VDEN OFF (back side) signal time-out error

Classification	Error content
[F115], [F116] Scanning system related service call	The scanning job has not finished normally.
[F117], [F118] Scanning system related service call (DSDF)	The scanning job has not finished normally.

Check item	Measures
Reproducing ability	<ul style="list-style-type: none"> Turn the power OFF and then back ON to check the occurrence.
Connector / Harness	<ul style="list-style-type: none"> Check if the joint connector (J12) between the DF and the equipment is disconnected or its pin is deformed. Check if the SYS board connector (CN122) and the DSDF control PC board / RADF control PC board connector (CN71) are disconnected. Check if the harnesses between the SYS board and the joint connector and between the joint connector and the DSDF control PC board / RADF control PC board are normal. If the harnesses have any scratches on them, are open circuited, caught anywhere or their pin is deformed, replace them.
RADF control PC board / DSDF control PC board	<ul style="list-style-type: none"> Replace the board.
SYS board	<ul style="list-style-type: none"> Replace the board.

Parts to be replaced	Remark
Harness	Be sure to exchange the parts in the order of the harness, DSDF control PC board or RADF control PC board and SYS board.
DSDF control PC board	Be sure to exchange the parts in the order of the harness, DSDF control PC board or RADF control PC board and SYS board. After the DSDF control PC board has been replaced, perform FS-05-3210.
RADF control PC board	Be sure to exchange the parts in the order of the harness, DSDF control PC board or RADF control PC board and SYS board.
SYS board	Be sure to exchange the parts in the order of the harness, DSDF control PC board or RADF control PC board and SYS board.

[F11A] Communication error between the SYS board and the CCD board

Classification	Error content
Scanning system related service call	Communication error between the SYS board and the CCD board.

Check item	Measures
Reproducing ability	<ul style="list-style-type: none"> Turn the power OFF and then back ON to check the occurrence.
SYS board	<ul style="list-style-type: none"> Check if the connectors of the CCD board and SYS board are disconnected or the harnesses are open circuited. (CN120, CN001) Check if there is no abnormality in the SYS board.

Parts to be replaced	Remark
Harness	Be sure to exchange the parts in the order of the harness, CCD board and SYS board.
CCD board	Be sure to exchange the parts in the order of the harness, CCD board and SYS board.
SYS board	Be sure to exchange the parts in the order of the harness, CCD board and SYS board.

[F11B] Communication error between the SYS board and the DSDF-CCD module

Classification	Error content
Scanning system related service call (DSDF)	Communication error between the SYS board and the DSDF-CCD module.

Check item	Measures
Reproducing ability	<ul style="list-style-type: none"> Turn the power OFF and then back ON to check the occurrence.
SYS board	<ul style="list-style-type: none"> Check the connector (CN129) of the SYS board. Check the SYS board (IC26). Replace the SYS board.
HDMI cable	<ul style="list-style-type: none"> Check if the HDMI cables (CN78 and CN90) are connected properly.
DSDF I/F board	<ul style="list-style-type: none"> Check if the DSDF I/F board is installed in the SYS board properly. Check the connector (CN89) of the DSDF I/F board. Check if the connectors on the DSDF I/F board are disconnected from the DSDF control PC board or the harnesses are open circuited. Correct if any. Check the DSDF I/F board (IC6, IC9, IC204). Replace the DSDF I/F board.
Connector	<ul style="list-style-type: none"> Check if the connectors of the SYS board and the DSDF control PC board are connected properly. Replace the harness.
DSDF-CCD module	<ul style="list-style-type: none"> Check if the connectors of the DSDF-CCD module and the DSDF control PC board are connected properly. Check that there is no abnormality in the DSDF-CCD module.

Parts to be replaced	Remark
Harness	Be sure to exchange the parts in the order of the harness, DSDF I/F board, DSDF-CCD module and SYS board.
DSDF I/F board	Be sure to exchange the parts in the order of the harness, DSDF I/F board, DSDF-CCD module and SYS board.
DSDF-CCD module	Be sure to exchange the parts in the order of the harness, DSDF I/F board, DSDF-CCD module and SYS board.
SYS board	Be sure to exchange the parts in the order of the harness, DSDF I/F board, DSDF-CCD module and SYS board.

8.3.19 Circuit related service call

[C5A0] EEPROM abnormality (LGC board)

Classification	Contents
Circuit related service call	EEPROM abnormality (LGC board).

Check item	Measures
EEPROM	EEPROM check
LGC board	<ul style="list-style-type: none">IC socket check (25/30/35ppm: IC63, 45/50ppm: IC12)Board check

Parts to be replaced	Remark
EEPROM	
LGC board	

[C5A1] EEPROM data abnormality (LGC board)

Classification	Contents
Circuit related service call	EEPROM data abnormality (LGC board).

Check item	Measures
EEPROM	EEPROM check
LGC board	<ul style="list-style-type: none">IC socket check (25/30/35ppm: IC63, 45/50ppm: IC12)Board check

Parts to be replaced	Remark
EEPROM	
LGC board	

[C900] Connection error between the SYS board and the LGC board

Classification	Contents
Circuit related service call	Connection error between SYS board and LGC board.

Check item	Measures
LGC board	<ul style="list-style-type: none">Connector check (CN329)Board check
SYS board	<ul style="list-style-type: none">Connector check (CN132)Board check
Harness (Flat cable)	<ul style="list-style-type: none">Connector checkHarness check

Parts to be replaced	Remark
LGC board	If the problem is not corrected with the replacement of the LGC board, reinstall the removed LGC board and replace the SYS board.
SYS board	
Harness	

[C911] Toner cartridge PC board access abnormality (K)**[C912] Toner cartridge PC board access abnormality (C)****[C913] Toner cartridge PC board access abnormality (M)****[C914] Toner cartridge PC board access abnormality (Y)**

Classification	Contents
Toner cartridge related service call	Abnormal access to the toner cartridge IC chip.

Procedure	Check item	Result	Measures	Next Step
1	Does non-genuine toner cartridge display appear when the front cover is opened and closed?	Yes	Use the genuine toner cartridge.	
		No		2
2	Toner cartridge		<ul style="list-style-type: none"> Check the phenomenon by removing the toner cartridges (Y, M, C and K) and reinserting them. Check that the CTRG board of each cartridge (Y, M, C and K) is installed properly. Avoid touching the contact point. Wipe the contact point with a soft cloth if it's stained. 	
3	Contact point on the equipment side		Check that the spring of the contact point for each color (Y, M, C and K) is not deformed.	
4	Is the spring of the contact point returned when it is pushed lightly?	Yes		
		No	<ul style="list-style-type: none"> Check that the CTIF board is installed properly. Board check 	7
5	LGC board		<ul style="list-style-type: none"> Connector check (CN315) Board check 	
6	Harness		<ul style="list-style-type: none"> Connector check (CN315, CN440) Harness check 	
7	CTIF board for each color (Y, M, C and K)		<ul style="list-style-type: none"> Check that the board is installed properly. Board check 	
8	Perform the above troubleshooting and if the C911, C912, C913 or C914 error is cleared, set the following self-diagnostic codes to "0" (normal). <ul style="list-style-type: none"> FS-08-4689-0: Board information of toner cartridge (Y) FS-08-4689-1: Board information of toner cartridge (M) FS-08-4689-2: Board information of toner cartridge (C) FS-08-4689-3: Board information of toner cartridge (K) 			

Parts to be replaced	Remark
Toner cartridge	
LGC board	
Harness	
CTIF board	

[C916] Sub-CPU access abnormality

Classification	Contents
Circuit related service call	Sub-CPU access abnormality.

Check item	Measures
LGC board	<ol style="list-style-type: none"> Check if there is no abnormality in the LGC board. Check if the conductor pattern of the LGC board is short circuited or open circuited.

Parts to be replaced	Remark
LGC board	

[C940] Engine-CPU abnormality

Classification	Contents
Circuit related service call	Engine-CPU abnormality.

Check item	Measures
Main power switch	Turn OFF the main power switch, then back ON.
Engine-CPU	<ul style="list-style-type: none"> Check if the conductor pattern of the Engine-CPU is short circuited or open circuited. Update the engine firmware.
LGC board	Board check

Parts to be replaced	Remark
LGC board	

[C962] LGC board ID abnormality

Classification	Contents
Circuit related service call	LGC board ID abnormality.

Check item	Measures
Harness catching	<p>When C962 appears because of a change from another error code, check whether or not any of the harnesses, which are connected to the connectors below, are being caught up in their wiring. If this is indeed the case, correct their wiring or replace them.</p> <ul style="list-style-type: none"> - LGC board: CN306, CN307, CN310, CN322, CN323, CN327 - PFC board: CN450, CN451, CN455, CN457, CN458 - ADU board: CN421
Error code	<ul style="list-style-type: none"> Turn the power OFF and then back ON using the main power switch, and then check if the error code changes to another one. If it changes to another one, follow the procedure for the changed error code
LGC board	<ul style="list-style-type: none"> Connector check (CN330, CN329) Board check Check if the model of the equipment matches the color of the label on the LGC board.  P. 9-7 "9.1.6 LGC board"
SYS board	<ul style="list-style-type: none"> Connector check (CN133, CN132) Board check
Harness	<ul style="list-style-type: none"> Connector check Harness check

Parts to be replaced	Remark
LGC board	If the problem is still not corrected with the replacement of the LGC board, reinstall it and ask a specialist to repair it. (Abnormal ID)

[C963] Connection detection error between the SYS board and the LGC board

Classification	Error item
Circuit related service call	3.3V output from the SYS board not detected on the LGC board.

Check Item	Measures
LGC board	Connector check (CN329, CN330)
SYS board	Connector check (CN133, CN132)
Harness between the SYS board and the LGC board	Harness check

Check Item	Measures
Harness between the SYS board and the low-voltage power supply	Harness check

Check item	Measures
Harness between the SYS board and the LGC board	
LGC board	If the problem is not corrected by the replacement of the LGC board, reinstall the removed LGC board and replace the SYS board.
SYS board	
Harness between the SYS board and the low-voltage power supply	

[C964] LGC board boot process abnormality

Classification	Contents
Circuit related service call	LGC board boot process abnormality.

Check item	Measures
LGC board	<ul style="list-style-type: none"> Turn the power OFF and then back ON using the main power switch. If the same error occurs again, replace the LGC board.

Parts to be replaced	Remark
LGC board	

[C9E0] Connection error between the scanner CPU and the system CPU

Classification	Contents
Circuit related service call	Connection error between the scanner CPU and the system CPU.

Check item	Measures
SYS board	<ul style="list-style-type: none"> Board check

Parts to be replaced	Remark
SYS board	

[F090] SRAM abnormality on the SYS board

Classification	Contents
Circuit related service call	SRAM abnormality on the SYS board.

Check Item	Measures
SRAM	<ol style="list-style-type: none"> 1. Check that the SRAM is installed properly. 2. Shut down the equipment. 3. Perform [FS-08]. 4. Press [CLASSIC]. 5. When "SRAM REQUIRES INITIALIZATION" appears on the LCD screen, confirm the destination and press the [START] button. If the destination is incorrect, enter the number for the correct one and press the [START] button. 6. When the confirmation message appears on the LCD screen, press [INITIALIZE]. (SRAM initialization starts.) 7. Enter the serial number of the equipment correctly. (FS-08-9601) 8. Initialize the NIC information. (FS-08-9083) 9. Shut down the equipment. 10. Perform [FS-05]. 11. Press [CLASSIC]. 12. Perform "Data transfer of characteristic value of scanner". (FS-05-3203, FS-05-3240) 13. By using the [4] [TEST PRINT] test pattern, perform "Automatic gamma adjustment" <PPC>. (FS-05-7869) 14. By using the [70] [TEST PRINT] test pattern, perform "Automatic gamma adjustment" <PRT>. (FS-05-8008, FS-05-8009) 15. Reboot the equipment. 16. If the error still occurs, replace the SRAM.
SYS board	Board check

Parts to be replaced	Remark
SRAM	Be sure to exchange the parts in the order of the SRAM and SYS board.
SYS board	Be sure to exchange the parts in the order of the SRAM and SYS board.

[F350] SYS board abnormality

Classification	Contents
Circuit related service call	SYS board abnormality.

Check item	Measures
SYS board	Board check
Combination of the firmware version	<ul style="list-style-type: none"> • Check the combination of the firmware version of the system firmware, system software, engine firmware, and scanner firmware. • Reinstall the firmware of correct combination.

Parts to be replaced	Remark
SYS board	

8.3.20 Laser optical unit related service call

[CA10] Polygonal motor abnormality

Classification	Contents
Laser optical unit related service call	The polygonal motor does not work normally.

Check item	Measures
Polygonal motor	<ul style="list-style-type: none"> Motor check (Perform the output check: FS-03-103/153) Connector check (Relay connector J643) Harness check
LGC board	<ul style="list-style-type: none"> Connector check (CN322) LGC board check
Laser optical unit cooling fan	<ul style="list-style-type: none"> Fan motor check (Perform the output check: FS-03-437) Connector check (Relay connector J648) Harness check
Developer unit cooling fan	<ul style="list-style-type: none"> Fan motor check (Perform the output check: FS-03-451) Connector check (CN462, J662) Harness check

Parts to be replaced	Remark
Laser optical unit	
LGC board	
Laser optical unit cooling fan	
Developer unit cooling fan	
Harness	

[CA20] H-Sync detection error (K, Y)

[CA21] H-Sync detection error (K)

[CA22] H-Sync detection error (Y)

Classification	Contents
Laser optical unit related service call	H-Sync signal detection PC board cannot detect laser beams.

Check item	Measures
Laser optical unit	<ul style="list-style-type: none"> Connector check (Relay connector J643) Check the harness/connector between the LGC board and the laser optical unit. Flat cable/terminal check
LRL board	Connector check <ul style="list-style-type: none"> 25/30/35ppm: CN204 (K), CN205 (Y) 45/50ppm: CN210 (K), CN211 (K, Y), CN212 (Y)
LGC board	<ul style="list-style-type: none"> Connector check: CN322 (K, Y), CN317 (Y), CN318 (K, Y), CN319 (K) LGC board check
Grounding	Check that the equipment is grounded properly.

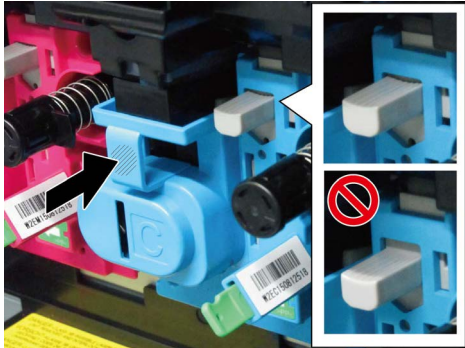
Check item	Measures
EPU	<p>Has the developer unit (Y, M, C, K) been installed securely? Press the slanted line portion of the developer unit until a click sound is heard.</p> 
Main charger	Check if the main charger is installed securely.
Spring of high-voltage supply contact point	Check if the spring of high-voltage supply contact point is deformed.
Needle electrode	<ul style="list-style-type: none"> Check if the needle electrode is broken or the main charger grid is deformed. Check if any foreign matter is on the needle electrode or main charger grid.

Parts to be replaced	Remark
Laser optical unit	Laser optical unit includes the H-Sync signal detection PC board.
LGC board	
Harness	
Flat cable	

[CA60] LSU thermistor-1 abnormality

Classification	Contents
Laser optical unit related service call	The LSU thermistor cannot detect the temperature. The LSU thermistor-1 is broken.

Check item	Measures
LRL board	<ul style="list-style-type: none"> Check if the flat cable is disconnected. Check if there is no abnormality on the contact surface of the connector terminal and the flat cable. Check if the flat cable is broken. 45/50 ppm: CN211 20/25/35 ppm: CN205 Check if the connector of the thermistor harness is disconnected. Check if the connector terminal and the harness are broken. CN222
LGC board	<ul style="list-style-type: none"> Check if the flat cable is disconnected. Check if there is no abnormality on the contact surface of the connector terminal and the flat cable. Check if the flat cable is broken. 45/50 ppm: CN318 20/25/35 ppm: CN317
Laser optical unit	<ul style="list-style-type: none"> Replace the laser optical unit. (Replace the thermistor and the LRL board.)
LGC board	<ul style="list-style-type: none"> Replace the LGC board.

Parts to be replaced	Remark
Laser optical unit	
LGC board	
Flat cable	

Remarks:

If a CA60 or CA61 error frequently occurs and the equipment does not operate, set “1” (Error not detected) in FS-08-4807. The equipment will be made to recover from the error.

However, color registration control will not be performed at an appropriate timing. Due to this, color deviation may occur. Therefore, this should be performed as a temporary measure.

After the troubleshooting for a CA60 or CA61 error has been performed properly, return the value to “0” (Error detected) of FS-08-4807.

[CA61] LSU thermistor-2 abnormality

Classification	Contents
Laser optical unit related service call	The LSU thermistor cannot detect the temperature. The LSU thermistor-2 is broken.

Check item	Measures
LRL board	<ul style="list-style-type: none"> Check if the flat cable is disconnected. Check if there is no abnormality on the contact surface of the connector terminal and the flat cable. Check if the flat cable is broken. 45/50 ppm: CN211 20/25/35 ppm: CN204 Check if the connector of the thermistor harness is disconnected. Check if the connector terminal and the harness are broken. CN222
LGC board	<ul style="list-style-type: none"> Check if the flat cable is disconnected. Check if there is no abnormality on the contact surface of the connector terminal and the flat cable. Check if the flat cable is broken. 45/50 ppm: CN318 20/25/35 ppm: CN319
Laser optical unit	<ul style="list-style-type: none"> Replace the laser optical unit. (Replace the thermistor and the LRL board.)
LGC board	<ul style="list-style-type: none"> Replace the LGC board.

Parts to be replaced	Remark
Laser optical unit	
LGC board	
Flat cable	

Remarks:

If a CA60 or CA61 error frequently occurs and the equipment does not operate, set “1” (Error not detected) in FS-08-4807. The equipment will be made to recover from the error.

However, color registration control will not be performed at an appropriate timing. Due to this, color deviation may occur. Therefore, this should be performed as a temporary measure.

After the troubleshooting for a CA60 or CA61 error has been performed properly, return the value to “0” (Error detected) of FS-08-4807.

8.3.21 Finisher related service call

[CB00] Finisher communication error

Classification	Error content
Finisher related service call	Communication error has occurred between the equipment and finisher.

Check item	Measures
Finisher	<ul style="list-style-type: none"> Check if the harness connecting the equipment and the Finisher control PC board (FIN) is disconnected or open circuited. Check if the conductor pattern on the finisher control PC board (FIN) is open circuited or short circuited. Update the finisher firmware. Replace the finisher control PC board (FIN).
LGC board	<ul style="list-style-type: none"> Check if the harness connecting the finisher and the LGC board on the equipment is disconnected or open circuited. Connector check (CN304) Check if the conductor pattern on the LGC board is open circuited or short circuited. Replace the LGC board.

Parts to be replaced	Remark
Finisher control PC board (FIN)	
LGC board (LGC)	

[CB10] Entrance motor abnormality

MJ-1109/1110

Classification	Contents
Finisher related service call	The entrance motor is not rotating normally.

Check Item	Measures
Feeding roller	Rotate the feeding roller. Fix any mechanical problem.
Entrance motor (M1)	Check if the connector (CN17) on the finisher control PC board is disconnected from the entrance motor (M1) and the harnesses are open circuited. Correct if so.

Parts to be replaced	Remark
Entrance motor (M1)	
Finisher control PC board (FIN)	

[CB11] Buffer tray guide motor abnormality

MJ-1109/1110

Classification	Contents
Finisher related service call	<p>The buffer tray guide motor is not rotating or the buffer tray guide is not moving normally.</p> <ul style="list-style-type: none"> A [CB11] error occurs if the [ED16] error occurs three times in succession or the [ED16] error occurs during the initialization.

Check Item	Measures
Buffer tray guide	Raise the buffer roller and open/close the buffer tray guide. Fix any mechanical problem.

Check Item	Measures
Buffer tray guide motor (M2)	Check if the connector (CN10) on the finisher control PC board (FIN) is disconnected from the buffer tray guide motor (M2) and the harnesses are open circuited. Correct if so.

Parts to be replaced	Remark
Buffer tray guide motor (M2)	
Finisher control PC board (FIN)	

[CB13] Finisher exit motor abnormality

MJ-1109/1110

Classification	Error item
Finisher related service call	The finisher exit motor is not rotating or the finisher exit roller is not moving normally.

Check item	Measures
Exit roller	<ul style="list-style-type: none"> Check if properly installed. Is there any mechanical problem when the exit roller is rotated? Correct if so.
Exit motor (M11).	<ul style="list-style-type: none"> Motor check Connector check (CN15) Harness check
Finisher control PC board (FIN)	<ul style="list-style-type: none"> Connector check (CN15) Board check

Parts to be replaced	Remarks
Exit motor (M11)	
Finisher control PC board (FIN)	

[CB14] Finisher assist guide motor abnormality

[EAFE] Assist guide cam position error

MJ-1109/1110

Classification	Error item
[CB14] Finisher related service call	The finisher assist guide motor is not rotating or the assist guide cam is not moving normally.
[EAFE] Finisher jam (Finisher section)	The assist guide motor is not rotating or the paper pusher cam is not moving normally.

Check item	Measures
Paper pusher cam	<ul style="list-style-type: none"> Check if properly installed. Is there any mechanical problem when the paper pusher cam is rotated?
Assist arm motor (M10)	<ul style="list-style-type: none"> Motor check Connector check (CN10) Harness check
Finisher control PC board (FIN)	<ul style="list-style-type: none"> Connector check (CN10) Board check

Parts to be replaced	Remarks
Assist arm motor (M10)	
Finisher control PC board (FIN)	

[CB15] Catching motor abnormality

MJ-1109/1110

Classification	Error item
Finisher related service call	Catching motor abnormality.

Check item	Measures
Catching motor (M21)	Is there any mechanical problem when the catching motor is rotated? If there is any mechanical problem, fix its mechanism.
Harness	Check if the connector on the finisher control PC board is disconnected from the Catching home position sensor and the harnesses are open circuited. Correct if any.
Finisher control PC board (FIN)	<ul style="list-style-type: none"> • Connector check (CN17) • Board check • Harness check

Parts to be replaced	Remarks
Catching motor (M21)	
Harness	
Finisher control PC board (FIN)	

[CB30] Movable tray shift motor abnormality

MJ-1042

Classification	Contents
Finisher related service call	The movable tray shift motor is not rotating or the movable tray is not moving normally.

Error	Timing of detection
Movable tray shift motor (M1) Stack top detection solenoid (SOL1) Stack top detection sensor-1 (S1) Stack top detection sensor-2 (S2) Movable tray lower limit sensor (S14)	<p>A locking signal is detected after the specified time *while the movable tray is moving.</p> <p>* A locking signal is not monitored from the start driving the motor until the specified time has passed.</p> <p>The stack top position of paper is not detected after the movable tray shift motor (M1) is driven in the specified time when the movable tray is moved up.</p> <p>The lower limit position of the stack top of paper is not detected after the movable tray shift motor (M1) has been driven in the specified time during the initial movement of the movable tray.</p> <p>The turning OFF of the movable tray lower limit sensor (S14) is not detected when the movable tray is moved from a point where this sensor is turned ON to one point where this sensor is turned OFF after the movable tray shift motor (M1) has been driven in the specified time.</p>

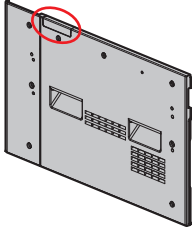
Probable cause	Checking and measures
Movable tray	<p>If there is mechanical problem when the movable tray is moved, fix the mechanism.</p> <ul style="list-style-type: none"> When installing the finisher, exercise care not to forget to remove the small left cover.  <ul style="list-style-type: none"> Check there is any obstacle which obstructs of operation under a movable tray. Remove any obstacles from the area of the movable tray operation.
Movable tray shift motor (M1) abnormality	Check if the electrical continuity of the coil is normal. If electricity is not conducted, replace the motor
Movable tray lower limit sensor (S14) abnormality	Measure the voltage on TP17 on the finisher control PC board (FIN). Then check that the measured voltage is 1V or lower when not shielded and within the range of 3.3V±5% when shielded. If the voltage does not fall within the range mentioned, replace the sensor.
Faulty cables and connectors	Check if the electrical continuity among the connector terminals is normal. If electricity is not conducted, replace the connectors. (Finisher control PC board (FIN): CN4, CN10)
Finisher control PC board (FIN) abnormality	If the error still occurs after replacing the motor, sensors and connectors, exchange the finisher control PC board (FIN).
Stack top detection solenoid (SOL1) abnormality	Check if the electrical continuity of the coil is normal. If electricity is not conducted, replace the solenoid.
Stack top detection sensor-1 (S1) abnormality	Measure the voltage on TP11 on the finisher control PC board (FIN). Then check that the measured voltage is 1V or lower when not shielded and within the range of 3.3V±5% when shielded. If the voltage does not fall within the range mentioned, replace the sensor.
Stack top detection sensor-2 (S2) abnormality	Measure the voltage on TP20 on the finisher control PC board (FIN). Then check that the measured voltage is 1V or lower when not shielded and within the range of 3.3V±5% when shielded. If the voltage does not fall within the range mentioned, replace the sensor.
Faulty cables and connectors	Check if the electrical continuity between the connector terminals is normal. If electricity is not conducted, replace the connector. (Finisher control PC board (FIN): CN3)
Finisher control PC board (FIN) abnormality	If the error still occurs after replacing the solenoid, sensors and connector, exchange the finisher control PC board (FIN).

[CB30] Movable tray shift motor abnormality

[EAFC] Movable tray height error

MJ-1109/1110

Classification	Contents
[CB30] Finisher related service call	The movable tray shift motor is not rotating or the movable tray is not moving normally.
[EAFC] Finisher jam (Finisher section)	Movable tray shift motor abnormality: The movable tray shift motor is not rotating or the movable tray is not moving normally.

Check item	Measures
Movable tray	If there is mechanical problem when the movable tray is moved, fix the mechanism.
Movable tray shift motor (M12)	Check the connectors and harnesses between the movable tray shift motor (M12) and the finisher control PC board (CN19).

Check item	Measures
Movable tray position A, B, and C sensors (S13, S14 and S15)	<ul style="list-style-type: none"> Connector check (CN20) Sensor check Harness check

Parts to be replaced	Remark
Movable tray shift motor (M12)	
Movable tray position A, B, and C sensors (S13, S14 and S15)	
Finisher control PC board (FIN)	

[CB31] Movable tray paper-full detection error

[EAFD] Movable tray movement error

MJ-1109/1110

Classification	Contents
[CB31] Finisher related service call	The actuator of the movable tray paper-full detection sensor does not move smoothly.
[EAFD] Finisher jam (Finisher section)	Movable tray paper-full detection error: The actuator of the movable tray paper-full detection sensor does not move smoothly.

Check item	Measures
Movable tray paper-full sensor (S16)	Fix any mechanical problem occurring when the actuator is moved.
	Check if there is a disconnection of the connector, incorrect installation or breakage of the movable tray paper-full sensor (S16). If there is, reinstall the sensor correctly or replace it.
	Check if the connector (CN22) on the finisher control PC board is disconnected from the movable tray paper-full sensor (S16) and the harnesses are open circuited. Correct if so.
Movable tray position A, B, and C sensors (S13, S14 and S15)	<ul style="list-style-type: none"> Connector check (CN20) Sensor check Harness check

Parts to be replaced	Remark
Movable tray paper-full sensor (S16)	
Movable tray position A, B, and C sensors (S13, S14 and S15)	
Finisher control PC board (FIN)	

[CB40] Front alignment plate home position detection error

MJ-1042

Classification	Contents
Finisher related service call	The front alignment motor is not rotating or the front alignment plate is not moving normally. <ul style="list-style-type: none"> You receive a [CB40] error when the [ED13] error occurs three times in succession.

Error	Timing of detection
Rear alignment motor (M3) Rear alignment plate home position sensor (S6)	The turning OFF of the rear alignment plate home position sensor (S6) is not detected when the rear alignment plate is moved from a point where this sensor is turned ON to one point where this sensor is turned OFF after the rear alignment motor (M3) has been driven at the specified number of pulse. The turning ON of the rear alignment plate home position sensor (S6) is not detected when the rear alignment plate is moved from a point where this sensor is turned OFF to one point where this sensor is turned ON after the rear alignment motor (M3) has been driven at the specified number of pulse.

Probable cause	Checking and measures
Rear alignment motor (M3) abnormality	Check if the electrical continuity of the coil is normal. If electricity is not conducted, replace the motor.
Rear alignment plate home position sensor (S6) abnormality	Measure the voltage on TP16 on the finisher control PC board (FIN). Then check that the measured voltage is 1V or lower when not shielded and within the range of 3.3V±5% when shielded. If the voltage does not fall within the range mentioned, replace the sensor.
Faulty cables and connectors	Check if the electrical continuity between the connector terminals is normal. If electricity is not conducted, replace the connectors. (Finisher control PC board (FIN): CN5, CN12)
Finisher control PC board (FIN) abnormality	If the error still occurs after replacing the motor, sensor and connectors, exchange the finisher control PC board (FIN).

[CB40] Front alignment motor abnormality

* You receive a [CB40] error when the [ED13] error occurs three times in succession.

MJ-1109/1110

Classification	Contents
Finisher related service call	The front alignment motor is not rotating or the front alignment plate is not moving normally. <ul style="list-style-type: none"> You receive a [CB40] error when the [ED13] error occurs three times in succession.

Check item	Measures
Front alignment plate	If there is mechanical problem when the front alignment plate is moved, fix the mechanism.
Front alignment motor (M5)	Check the connectors and harnesses between the front alignment motor (M5) and the finisher control PC board (CN18).

Parts to be replaced	Remark
Front alignment motor (M5)	
Finisher control PC board (FIN)	

[CB50] Stapler home position detection error

MJ-1042

Classification	Contents
Finisher related service call	Staple unit clinching home position sensor does not work. <ul style="list-style-type: none"> You receive a [CB50] error when the [EA50] error occurs three times in succession.

Error	Timing of detection
Stapler motor (M10) Staple unit clinching home position sensor (S16)	The staple unit clinching home position sensor (S16) does not detect the opening of the staple unit after the stapler motor (M10) has been driven reversely in the specified time from the closing during the initial movement of the staple unit.
	The staple unit clinching home position sensor (S16) does not detect the opening of the staple unit in the specified time from the closing during the clinching movement of the staple unit, and also this sensor does not detect the opening by the reverse rotation of the motor after the stapler is stopped.
	The staple unit clinching home position sensor (S16) does not detect the closing of the staple unit after the specified time during the clinching movement of the staple unit.
	The staple unit clinching home position sensor (S16) does not detect the opening of the staple unit at the start of the clinching.

Probable cause	Checking and measures
Staple motor (M10) abnormality	Check if the electrical continuity of the coil is normal. If electricity is not conducted, replace the staple unit.
Staple unit clinching home position sensor (S16) abnormality	Measure the voltage on CN16 on the finisher control PC board (FIN). Then check that the measured voltage is 1V or lower when the sensor is ON and within the range of $3.3V \pm 5\%$ when OFF. If the voltage does not fall within the range mentioned, replace the staple unit.
Staple unit improper clinching prevention sensor (S15) abnormality	Measure the voltage on TP25 on the finisher control PC board (FIN). Then check that the measured voltage is 1V or lower when not shielded and within the range of $3.3V \pm 5\%$ when shielded. If the voltage does not fall within the range mentioned, replace the sensor.
Faulty cables and connectors	Check if the electrical continuity between the connector terminals is normal. If electricity is not conducted, replace the connectors. (Finisher control PC board (FIN): CN16, CN17)
Finisher control PC board (FIN) abnormality	If the error still occurs after replacing the motor, sensors, switch and connectors, exchange the finisher control PC board (FIN).

[CB50] Stapler home position error

MJ-1109/1110

Classification	Contents
Finisher related service call	Stapler home position sensor does not work. <ul style="list-style-type: none"> You receive a [CB50] error when the [EA50] error occurs three times in succession.

Check item	Measures
Stapler	<ul style="list-style-type: none"> Check the connectors and harnesses between the stapler and finisher control PC board (CN2). Check the harnesses in the stapler.

Parts to be replaced	Remark
Stapler	

Parts to be replaced	Remark
Finisher control PC board (FIN)	

[CB51] Stapler unit sliding home position detection error

MJ-1042

Classification	Contents
Finisher related service call	The stapler is not at the home position.

Error	Timing of detection
Staple unit sliding motor (M7) Staple unit sliding home position sensor (S3)	The turning OFF of the staple unit sliding home position sensor (S3) is not detected when the staple unit is moved from a point where this sensor is turned ON to one point where this sensor is turned OFF after the staple unit sliding motor (M7) has been driven at the specified number of pulse.
	The turning ON of the staple unit sliding home position sensor (S3) is not detected when the staple unit is moved from a point where this sensor is turned OFF to one point where this sensor is turned ON after the staple unit sliding motor (M7) has been driven at the specified number of pulse.

Probable cause	Checking and measures
Staple unit sliding motor (M7) abnormality	Check if the electrical continuity of the coil is normal. If electricity is not conducted, replace the staple unit.
Staple unit sliding home position sensor (S3) abnormality	Measure the voltage on TP18 on the finisher control PC board (FIN). Then check that the measured voltage is 1V or lower when not shielded and within the range of $3.3 \pm 5\%$ when shielded. If the voltage does not fall within the range mentioned, replace the sensor.
Faulty cables and connectors	Check if the electrical continuity between the connector terminals is normal. If electricity is not conducted, replace the connectors. (Finisher control PC board (FIN): CN3, CN18)
Finisher control PC board (FIN) abnormality	If the error still occurs after replacing the staple unit, sensors and connectors, exchange the finisher control PC board (FIN).

[CB51] Stapler shift home position error

[EAFB] Stapler movement error

MJ-1109/1110

Classification	Contents
[CB51] Finisher related service call	The stapler is not at the home position.
[EAFB] Finisher jam (Finisher section)	Stapler shift home position error: The stapler is not at the home position.

Check item	Measures
Stapler	<ul style="list-style-type: none"> Move the stapler. Fix any mechanical problem.
Stapler unit home position sensor (S10)	<ul style="list-style-type: none"> Check if there is a disconnection of the connector, incorrect installation or breakage of the stapler unit home position sensor (S10). If there is, reinstall the sensor correctly or replace it.
	<ul style="list-style-type: none"> Check if the connector (CN27) on the finisher control PC board is disconnected from the stapler unit home position sensor (S10) and the harnesses are open circuited. Correct if so.
Stapler unit shift motor (M9)	<ul style="list-style-type: none"> Check if the connector (CN15) on the finisher control PC board (FIN) is disconnected from the stapler unit shift motor (M9) and the harnesses are open circuited. Correct if so.

Parts to be replaced	Remark
Stapler unit home position sensor (S10)	
Stapler unit shift motor (M9)	
Finisher control PC board (FIN)	

[CB60] Stapler unit shift motor abnormality

MJ-1109/1110

Classification	Contents
Finisher related service call	Stapler unit shift motor is not rotating or stapler unit is not moving normally.

Check Item	Measures
Stapler	If there is mechanical problem when the stapler is moved, fix the mechanism.
Stapler unit shift motor (M9)	Check the connectors and harnesses between the stapler unit shift motor (M9) and the finisher control PC board (CN15).

Parts to be replaced	Remark
Stapler unit shift motor (M9)	
Finisher control PC board (FIN)	

[CB80] Finisher control PC board backup RAM error

MJ-1042

Classification	Contents
Finisher related service call	Abnormality of checksum value on finisher control PC board is detected when the power is turned ON.

Error	Timing of detection
EEPROM	Data readout check is performed after data writing and the result of the data readout check does not conform to the written data. The equipment does not enter the ready status after the specified time has passed from data writing.

Probable cause	Checking and measures
Finisher control PC board (FIN) abnormality	Replace the finisher control PC board (FIN) as the cause is a fault in the IC of the backup RAM.

Parts to be replaced	Remark
Finisher control PC board (FIN)	

[CB80] Backup RAM data abnormality

MJ-1109/1110

Classification	Contents
Finisher related service call	Abnormality of checksum value on finisher control PC board is detected when the power is turned ON.

Check Item	Measures
Main power switch	Turn OFF the main power switch, then back ON.

Parts to be replaced	Remark
Finisher control PC board (FIN)	

[CB81] Flash ROM abnormality

MJ-1109/1110

Classification	Contents
Finisher related service call	Abnormality of checksum value on finisher control PC board is detected when the power is turned ON.

Check Item	Measures
Main power switch	Turn OFF the main power switch, then back ON.
Finisher control PC board (FIN)	Board check

Parts to be replaced	Remark
Finisher control PC board (FIN)	

[CB82] Finisher - Main program error

MJ-1109/1110

Classification	Error item
Finisher related service call (Finisher section)	Finisher - Main program error.

Check item	Measures
Finisher control PC board (FIN)	<ul style="list-style-type: none"> Update the firmware version of the finisher control PC board (FIN). Board check

Parts to be replaced	Remarks
Finisher control PC board (FIN)	

[CB83] Saddle stitch finisher - Main program error

MJ-1110

Classification	Error item
Finisher related service call (Saddle stitch unit)	Saddle stitch finisher - Main program error.

Check item	Measures
Saddle control PC board (SDL)	<ul style="list-style-type: none"> Update the firmware version of the saddle control PC board (SDL). Board check

Parts to be replaced	Remarks
Saddle control PC board (SDL)	

[CB84] Hole punch unit - Main program error

MJ-1109/1110 (When MJ-6105 is installed)

Classification	Error item
Finisher related service call (Hole punch unit)	Hole punch unit - Main program error.

Check item	Measures
Hole punch control PC board (HP)	<ul style="list-style-type: none"> Update the firmware version of the hole punch control PC board (HP). Board check

Parts to be replaced	Remarks
Hole punch control PC board (HP)	

[CB92] Saddle stitch finisher RAM abnormality

MJ-1110

Classification	Error item
Finisher related service call (Saddle stitch unit)	Saddle stitch finisher RAM abnormality.

Check item	Measures
Reproducibility	Turn the power OFF and then back ON.
Saddle control PC board (SDL)	<ul style="list-style-type: none"> Check if the conductor pattern on the saddle control PC board (SDL) is open circuited or short circuited. Board check

Parts to be replaced	Remarks
Saddle control PC board (SDL)	

[CB93] Saddle stitch finisher additional folding motor abnormality

MJ-1110

Classification	Error item
Finisher related service call (Saddle stitch unit)	<p>An abnormal interruption of the encoder pulse of the additional folding motor occurs.</p> <ul style="list-style-type: none"> The [CB93] error also occurs when the error [EF18] has occurred consecutively for 3 times.

Check item	Measures
Additional folding carrier	<ul style="list-style-type: none"> Check if properly installed. Is there any mechanical problem when the additional folding carrier is moved? Correct if so.
Additional folding motor (M20)	<ul style="list-style-type: none"> Motor check Connector check (CN10) Harness check
Saddle control PC board (SDL)	<ul style="list-style-type: none"> Connector check (CN10) Board check

Parts to be replaced	Remarks
Additional folding motor (M20)	
Saddle control PC board (SDL)	

[CB94] Saddle transport motor abnormality

MJ-1110

Classification	Error item
Finisher related service call (Saddle stitch unit)	Saddle transport motor abnormality or the motor is not moving normally. Paper holding mechanism or transport path switching solenoid abnormality. The [CB94] error also occurs when the error [EAB0] or [EF13] has occurred consecutively for 3 times.

Check item	Measures
Transport roller	<ul style="list-style-type: none"> • Check if properly installed. • Is there any mechanical problem when the transport rollers are rotated?
Saddle transport motor (M16)	<ul style="list-style-type: none"> • Motor check • Connector check (CN5) • Harness check
Saddle control PC board (SDL)	<ul style="list-style-type: none"> • Connector check (CN5) • Board check

Parts to be replaced	Remarks
Saddle transport motor (M16)	
Saddle control PC board (SDL)	

[CB95] Saddle stitch finisher stacker motor abnormality

MJ-1110

Classification	Error item
Finisher related service call (Saddle stitch unit)	An interruption error or rotation abnormality occurs in the saddle stitch finisher stacker motor. The [CB95] error also occurs when the error [EF16] has occurred consecutively for 3 times.

Check item	Measures
Stacker carrier	<ul style="list-style-type: none"> • Check if properly installed. • Is there any mechanical problem when the stacker carrier is moved?
Stacker motor (M14)	<ul style="list-style-type: none"> • Motor check • Connector check (CN8) • Harness check
Saddle control PC board (SDL)	<ul style="list-style-type: none"> • Connector check (CN8) • Board check

Parts to be replaced	Remarks
Stacker motor	
Saddle control PC board	

[CBA0] Front saddle stapler home position error

MJ-1110

Classification	Error item
Finisher related service call (Saddle stitch unit)	The detection of the home position of the stapler unit ends abnormally.

Check item	Measures
Front saddle stapler clinch unit	<ul style="list-style-type: none"> • Harness check • Connector check
Saddle control PC board (SDL)	<ul style="list-style-type: none"> • Connector check (CN2) • Board check

Parts to be replaced	Remarks
Front saddle stapler clinch unit	
Saddle control PC board (SDL)	

[CBB0] Rear saddle stapler home position error

MJ-1110

Classification	Error item
Finisher related service call (Saddle stitch unit)	The detection of the home position of the stapler unit ends abnormally.

Check item	Measures
Rear saddle stapler clinch unit	Harness check
Saddle control PC board (SDL)	<ul style="list-style-type: none"> • Connector check (CN1) • Board check

Parts to be replaced	Remarks
Rear saddle stapler clinch unit	
Saddle control PC board (SDL)	

[CBC0] Saddle stitch finisher side alignment motor abnormality

MJ-1110

Classification	Error item
Finisher related service call (Saddle stitch unit)	<p>The side alignment motor is not rotating or the jog is not moving normally.</p> <ul style="list-style-type: none"> • A [CBC0] error will occur when an [EF15] error has arisen consecutively for 3 times.

Check item	Measures
Saddle stitch unit	Is there any mechanical problem when the jog is moved? Correct if so.
Side alignment motor (M15)	<ul style="list-style-type: none"> • Harness check • Connector check (CN4)
Saddle control PC board (SDL)	<ul style="list-style-type: none"> • Connector check (CN4) • Board check

Parts to be replaced	Remarks
Side alignment motor (M15)	
Saddle control PC board (SDL)	

[CBE0] Saddle stitch finisher folding motor abnormality

MJ-1110

Classification	Contents
Finisher related service call (Saddle stitch unit)	An encoder pulse interruption error or rotation abnormality occurs in the saddle stitch finisher folding motor. <ul style="list-style-type: none"> You receive a [CBE0] error when the [EF17] error occurs three times in succession.

Check Item	Measures
Folding motor encoder sensor (S34)	<ul style="list-style-type: none"> Sensor check (S34) Connector check (CN13) Harness check
Folding motor (M17)	<ul style="list-style-type: none"> Harness check Connector check (CN19)
Saddle control PC board (SDL)	<ul style="list-style-type: none"> Connector check (CN13, CN19) Board check

Parts to be replaced	Measures
Folding motor encoder sensor (S34)	
Folding motor (M17)	
Saddle control PC board (SDL)	

[CC02] Stack exit roller nip home position detection error

MJ-1042

Classification	Contents
Finisher related service call (Finisher section)	The detection of the home position of the stack exit roller nip ends abnormally.

Check item	Measures
Stack exit roller shift motor (M6) Stack exit roller home position sensor (S13)	<p>The stack exit roller home position sensor (S13) does not detect that the exit roller is not at the upper position after the stack exit roller motor (M6) has been driven in the specified time when the exit roller is moved down.</p> <p>The stack exit roller home position sensor (S13) does not detect that the exit roller is at the upper position after the stack exit roller shift motor (M6) has been driven in the specified time when the exit roller is moved up.</p>

[CC20] Saddle stitch communication error

MJ-1110

Classification	Contents
Finisher related service call	Communication error between finisher controller PC board and saddle stitcher controller board.

Check Item	Measures
Finisher control PC board (FIN)	<ul style="list-style-type: none"> Connector check Harness check Board check
Saddle control PC board (SDL)	<ul style="list-style-type: none"> Connector check Harness check Board check
Finisher control PC board (FIN)	Update the firmware version of the finisher control PC board (FIN).

Check Item	Measures
Saddle control PC board (SDL)	Update the firmware version of the saddle control PC board (SDL).

Parts to be replaced	Remark
Finisher control PC board (FIN)	
Saddle control PC board (SDL)	

[CC30] Stack transport motor abnormality

* You receive a [CC30] error when the [EA70] error occurs three times in succession.

MJ-1109/1110

Classification	Contents
Finisher related service call (Finisher section)	The stack transport motor is not rotating or the paper exit belt is not moving normally. <ul style="list-style-type: none"> You receive a [CC30] error when the [EA70] error occurs three times in succession.

Check item	Measures
Stack transport belt	<ul style="list-style-type: none"> Move the stack transport belt. Fix any mechanical problem.
Stack transport motor (M8)	<ul style="list-style-type: none"> Check if the connector (CN18) on the finisher control PC board (FIN) is disconnected from the stack transport motor (M8) and the harnesses are open circuited. Correct if so.

Parts to be replaced	Remark
Stack transport motor (M8)	
Finisher control PC board (FIN)	

[CC31] Transport motor abnormality

MJ-1109/1110

Classification	Contents
Finisher related service call (Finisher section)	The transport motor is not rotating or the stack transport roller -1 and -2 is not rotating normally.

Check item	Measures
Stack transport roller -1 Stack transport roller -2	<ul style="list-style-type: none"> Rotate the stack transport roller -1 and -2. Fix any mechanical problem.
Transport motor	<ul style="list-style-type: none"> Check if the connector (CN15) on the finisher control PC board (FIN) is disconnected from the transport motor (M7) and the harnesses are open circuited. Correct if so.

Parts to be replaced	Remark
Transport motor (M7)	
Finisher control PC board (FIN)	

[CC41] Assist guide cam home position abnormality

MJ-1109/1110

Classification	Contents
Finisher related service call (Finisher section)	Assist guide cam home position abnormality.

Check item	Measures
Paper pusher cam	<ul style="list-style-type: none"> Rotate the paper pusher cam. Fix any mechanical problem.
Paper holder home position sensor (S6)	<ul style="list-style-type: none"> Check if the connector (CN11) on the finisher control PC board (FIN) is disconnected from the paper holder home position sensor (S6) and the harnesses are open circuited. Correct if so.

Parts to be replaced	Remark
Paper holder home position sensor (S6)	
Finisher control PC board (FIN)	

[CC51] Punch unit sliding motor abnormality

MJ-1042 (When MJ-6011 is installed)

Classification	Contents
Finisher related service call (Hole punch unit)	Punch unit sliding motor abnormality.

Error	Timing of detection
Punch unit sliding motor (M12) Punch sliding unit home position sensor (S23)	The punch sliding unit is not slid after sliding request is sent.
	The punch sliding unit home position sensor (S23) does not detect that the unit is at its home position after the specified time when the unit is returned to the home position, or this sensor does not detect that the unit is out of its home position after the specified time when the unit is released.
	The punch sliding unit home position sensor (S23) does not detect that the unit is at its home position after the specified time when the unit is moved, or this sensor does not detect that the unit is at its home position when the unit is released.

Probable cause	Checking and measures
Punch unit sliding motor (M12) abnormality	Check if the electrical continuity of the coil is normal. If electricity is not conducted, replace the motor.
Punch sliding unit home position sensor (S23) abnormality	Measure the voltage on TP26 on the hole punch control PC board (HP). Then check that the measured voltage is 1V or lower when not shielded and within the range of 5V±5% when shielded. If the voltage does not fall within the range mentioned, replace the sensor.
Faulty cables and connectors	Check if the electrical continuity between the connector terminals is normal. If electricity is not conducted, replace the connector. (Hole punch control PC board (HP): CN3, CN4, CN5, CN6, CN7)
Hole punch control PC board (HP) abnormality	If the error still occurs after replacing the motor, sensor and connectors, exchange the hole punch control PC board (HP).

[CC51] Sideways adjustment motor abnormality

MJ-1109/1110 (When MJ-6105 is installed)

Classification	Contents
Finisher related service call (Hole punch unit)	Sideways adjustment motor is not rotating or punching unit is not shifting normally. <ul style="list-style-type: none"> The [CC51] error will be displays when the [ED11] error occurs three times in succession or during the initial operation.

Check Item	Measures
Paper	If there is any paper remaining on the transport path, remove the paper.
Sideways adjustment motor (M2)	<ul style="list-style-type: none"> If there is mechanical problem when the sideways adjustment motor (M2) is rotated, fix the mechanism. Check the connector (CN10) and harnesses between the hole punch control PC board (HP) and sideways adjustment motor (M2).
Sideways deviation home position sensor (S3)	<ul style="list-style-type: none"> Sensor check Harness check Connector check (CN8)

Parts to be replaced	Remark
Sideways adjustment motor (M2)	
Sideways deviation home position sensor (S3)	
Hole punch control PC board (HP)	

[CC52] Skew adjustment motor abnormality

MJ-1109/1110 (When MJ-6105 is installed)

Classification	Contents
Finisher related service call (Hole punch unit)	Skew adjustment motor is not rotating or punching unit is not shifting normally. <ul style="list-style-type: none"> The [CC52] error will be displays when the [ED10] error occurs three times in succession or during the initial operation.

Check Item	Measures
Paper	If there is any paper remaining on the transport path, remove the paper.
Skew adjustment motor (M1)	<ul style="list-style-type: none"> If there is mechanical problem when the skew adjustment motor (M1) is rotated, fix the mechanism. Check the connector (CN10) and harnesses between the hole punch control PC board (HP) and skew adjustment motor (M1).
Skew home position sensor (S2)	<ul style="list-style-type: none"> Sensor check Harness check Connector check (CN10)

Parts to be replaced	Remark
Skew home position sensor (S2)	
Skew adjustment motor (M1)	
Hole punch control PC board (HP)	

[CC54] Paper detection sensors abnormality

MJ-1042

Error	Timing of detection
Finisher related service call (Hole punch unit)	The adjustment of the paper detection sensors has failed.

Probable cause	Checking and measures
Paper detection sensors (S24 and S25) abnormality	Measure the voltage on pin CN6.8 on the hole punch control PC board (HP). Then check that the measured voltage is 3.0V or higher when not shielded and 1.2V or lower when shielded. If the voltage does not fall within the range mentioned, replace a couple of PC boards on either the light-receiving side or the light-emitting side.
Faulty cables and connectors	Check if the electrical continuity between the connector terminals is normal. If electricity is not conducted, replace the connector. (Hole punch control PC board (HP): CN4, CN5, CN6)
Hole punch control PC board (HP) abnormality	If the error still occurs after replacing the sensors and the connectors, exchange the hole punch control PC board (HP).

[CC60] [CC61] Punch motor abnormality

MJ-1042

Error	Timing of detection
Finisher related service call (Hole punch unit)	[CC60] Punch motor is not rotating or punch unit is not shifting normally. [CC61] Punch motor abnormality. <ul style="list-style-type: none"> The [CC61] error occurs when the [E9F0] error occurs three times in succession or during the initial operation.

Error	Timing of detection
Punch motor (M11) Paper detection sensor (S24/S25) Punch shaft home position sensor (S26) Rear punch shaft home position sensor (S22)	The paper detection sensors (S24 and S25) do not emit light after specified time when they are selected
	The level of the light-receiving amount is not lowered after the light-emitting amount of the paper detection sensors (S24 and S25) is adjusted to the lower limit.
	Punching is not performed after punching request is sent, or the punching request is sent during the punching.
	The status of the punch shaft home position sensor (S26) or the rear punch shaft home position sensor (S22) is not changed after punching request is sent.
	A punching locking signal is detected consistently over the specified time.
	The punch shaft home position sensor (S26) or the rear punch shaft home position sensor (S22) does not detect that the shaft is not at its home position at the start of punching or punch waste full detection.

Probable cause	Checking and measures
Punch motor (M11) abnormality	Check if the electrical continuity of the coil is normal. If electricity is not conducted, replace the motor.
Rear punch shaft home position sensor (S22) abnormality	Measure the voltage on TP25 on the hole punch control PC board (HP). Then check that the measured voltage is 1V or lower when not shielded and within the range of 5V±5% when shielded. If the voltage does not fall within the range mentioned, replace the sensor.
Punch shaft home position sensor (S26) abnormality	Measure the voltage on TP24 on the hole punch control PC board (HP). Then check that the measured voltage is 1V or lower when not shielded and within the range of 5V±5% when shielded. If the voltage does not fall within the range mentioned, replace the sensor.

Probable cause	Checking and measures
Punch motor clock sensor (S20) abnormality	Measure the voltage on TP27 on the hole punch control PC board (HP). Then check that the measured voltage is 1V or lower when not shielded and within the range of 5V±5% when shielded. If the voltage does not fall within the range mentioned, replace the sensor.
Faulty cables and connectors	Check if the electrical continuity between the connector terminals is normal. If electricity is not conducted, replace the connector. (Hole punch control PC board (HP): CN2, CN5, CN6, CN7, CN8)
Hole punch control PC board (HP) abnormality	If the error still occurs after replacing the motor, sensors and connectors, exchange the hole punch control PC board (HP).

[CC61] Punch motor home position detection error

MJ-1109/1110 (When MJ-6105 is installed)

Classification	Contents
Finisher related service call (Hole punch unit)	Punch motor is not rotating or punch unit is not shifting normally. <ul style="list-style-type: none"> The [CC61] error occurs when the [E9F0] error occurs three times in succession or during the initial operation.

Check Item	Measures
Paper	If there is any paper remaining on the transport path, remove the paper.
Punch motor (M3)	<ul style="list-style-type: none"> If there is mechanical problem when the punch motor (M3) is rotated, fix the mechanism. Check the connector (CN2) and harnesses between the hole punch control PC board (HP) and punch motor (M3).
Punch home position sensor (S4)	<ul style="list-style-type: none"> Sensor check Harness check Connector check (CN3)

Parts to be replaced	Remark
Punch home position sensor (S4)	
Punch motor (M3)	
Hole punch control PC board (HP)	

[CC71] Punch ROM checksum error

MJ-1109/1110 (When MJ-6105 is installed)

Classification	Contents
Finisher related service call (Hole punch unit)	Abnormality of checksum value on Hole punch control PC board is detected when the power is turned on.

Check Item	Measures
Hole punch control PC board (HP)	Board check

Parts to be replaced	Remark
Hole punch control PC board (HP)	

[CC72] Punch RAM read / write error
 MJ-1109/1110 (When MJ-6105 is installed)

Classification	Contents
Finisher related service call (Hole punch unit)	Abnormality of checksum value on Hole punch control PC board is detected when the power is turned on.

Check Item	Measures
Hole punch control PC board (HP)	Board check

Parts to be replaced	Remark
Hole punch control PC board (HP)	

[CC80] Front alignment motor abnormality
 MJ-1042

Classification	Contents
Finisher related service call (Finisher section)	Front alignment motor abnormality.

Error	Timing of detection
Front alignment motor (M2) Front alignment plate home position sensor (S5)	The turning OFF of the front alignment plate home position sensor (S5) is not detected when the front alignment plate is moved from a point where this sensor is turned ON to one point where this sensor is turned OFF after the front alignment motor (M2) has been driven at the specified number of pulse.
	The turning ON of the front alignment plate home position sensor (S5) is not detected when the front alignment plate is moved from a point where this sensor is turned OFF to one point where this sensor is turned ON after the front alignment motor (M2) has been driven at the specified number of pulse.

Probable cause	Checking and measures
Front alignment motor (M2) abnormality	Check if the electrical continuity of the coil is normal. If electricity is not conducted, replace the motor.
Front alignment plate home position sensor (S5) abnormality	Measure the voltage on TP15 on the finisher control PC board (FIN). Then check that the measured voltage is 1V or lower when not shielded and within the range of 3.3V±5% when shielded. If the voltage does not fall within the range mentioned, replace the sensor.
Faulty cables and connectors	Check if the electrical continuity between the connector terminals is normal. If electricity is not conducted, replace the connectors. (Finisher control PC board (FIN): CN5, CN12)
Finisher control PC board (FIN) abnormality	If the error still occurs after replacing the motor, sensor and connectors, exchange the finisher control PC board (FIN).

[CC80] Rear alignment motor abnormality
 MJ-1109/1110

Classification	Contents
Finisher related service call (Finisher section)	The rear alignment motor is not rotating or the rear alignment plate is not moving normally. <ul style="list-style-type: none"> You receive a [CC80] error when the [ED14] error occurs three times in succession.

Check Item	Measures
Rear alignment plate	If there is mechanical problem when the rear alignment plate is moved, fix the mechanism.
Rear alignment motor (M6)	Check the connectors and harnesses between the rear alignment motor (M6) and the finisher control PC board (CN18).

Parts to be replaced	Remark
Rear alignment motor (M6)	
Finisher control PC board (FIN)	

[CC93] Knurled roller shift solenoid abnormality

MJ-1042

Classification	Contents
Finisher related service call (Finisher section)	An abnormality occurs in the knurled roller shift solenoid.

Error	Timing of detection
Knurled roller shift solenoid (SOL3) 2nd transport motor (M4) Knurled roller home position sensor (S10)	The knurled roller home position sensor (S10) does not detect that the knurled roller is at the upper position after the 2nd transport motor (M4) has been driven at the specified number of pulses during the initial rising movement of the knurled roller.
	The knurled roller home position sensor (S10) does not detect that the knurled roller is not at the upper position after the 2nd transport motor (M4) has been driven at the specified number of pulses during the initial lowering movement of the knurled roller.
	The knurled roller home position sensor (S10) does not detect that the knurled roller is at the upper position when the pressurization of stack exit movement is finished.
Gear	<p>Check the gear of transport unit in finishing section. When assembling the gear, align its rib to the protrusion as shown in the figure.</p> 

Fig.8-23

[CC94] Fan motor abnormality

MJ-1042

Classification	Contents
Finisher related service call (Finisher section)	Fan motor abnormality.

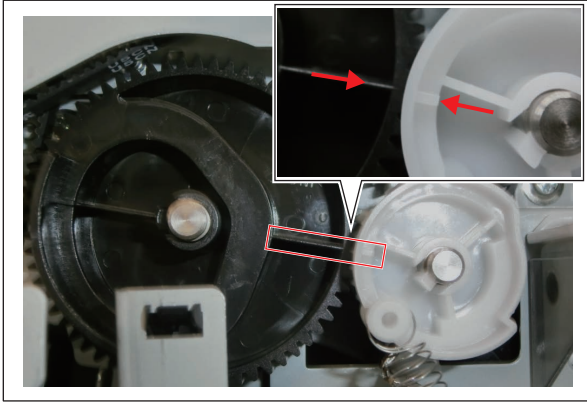
Error	Timing of detection
Fan motor (M9)	The turning ON of the fan locking signal is detected consistently after the specified time*. * A locking signal is not monitored from the start driving the motor until the specified time has passed.

[CCF1] Tray safety switch abnormality

MJ-1110

Classification	Error item
Finisher related service call (Finisher section)	<ul style="list-style-type: none"> The tray safety switch turned on during tray operation (moving up or down). The tray operated with the tray safety switch turned on.

Check item	Measures
Tray safety switch (SW2)	Check the connectors and harnesses between the tray safety switch (SW2) and the connector J110 on the finisher control PC board.
Stack tray shift motor (M2)	Check the connectors and harnesses between the stack tray shift motor (M2) and the connector J114 on the finisher control PC board.
Finisher control PC board (FIN)	<ul style="list-style-type: none"> Board check Connector check Harness check

Parts to be replaced	Remarks
Tray safety switch (SW2)	
Stack tray shift motor (M2)	
Finisher control PC board (FIN)	

[CDE0] Paddle motor abnormality

MJ-1109/1110

Classification	Contents
Finisher related service call (Finisher section)	The paddle motor is not rotating or the paddle is not rotating normally. <ul style="list-style-type: none"> You receive a [CDE0] error when the [ED15] error occurs three times in succession.

Check Item	Measures
Paddle	Rotate the paddle. Fix any mechanical problem.
Paddle motor (M3)	Check the connectors and harnesses between the paddle motor (M3) and the finisher control PC board (CN16).

Parts to be replaced	Remark
Paddle motor (M3)	
Finisher control PC board (FIN)	

[CE00] Communication error between the finisher and the punch unit

MJ-1109/1110 (When MJ-6105 is installed)

Classification	Contents
Finisher related service call	Communication error between finisher control PC board and hole punch control PC board.

Check item	Measures
Hole punch control PC board (HP)	<ul style="list-style-type: none"> • Check the connectors and harnesses between the hole punch control PC board (HP) and the finisher control PC board (FIN). • Board check

Parts to be replaced	Remark
Hole punch control PC board (HP)	
Finisher control PC board (FIN)	

[CF10] Communication module writing failure

MJ-1109/1110

Classification	Contents
Finisher related service call	Communication module writing failure.

Check item	Measures
Finisher	<ul style="list-style-type: none"> • Check if the harness connecting the equipment and the finisher control PC board (FIN) is disconnected or open circuited. • Check if the conductor pattern on the finisher control PC board (FIN) is open circuited or short circuited. • Update the finisher firmware.
LGC board	<ul style="list-style-type: none"> • Check if the harness connecting the finisher and the LGC board on the equipment is disconnected or open circuited. • Connector check • Check if the conductor pattern on the LGC board is open circuited or short circuited.

Parts to be replaced	Remark
Finisher control PC board (FIN)	
LGC board	

8.3.22 Image control related service call

- (1) Based on the procedure of [CE10], [CE20] and [CE40] described below, check the status and take appropriate actions. And then perform the forced performing of image quality closed-loop control according to the following procedure.
 1. Perform FS-05-2742.
 2. Confirm that the image quality control has finished normally.
- (2) After confirming the items in (1), clear the abnormal detection counter of image quality control.
 1. Perform FS-08-2528.
 2. Rewrite the displayed status counter from “1” - “16” to “0”.
 3. Perform FS-08-2529.
 4. Rewrite the displayed status counter from “1” - “16” to “0”.
 5. Perform FS-08-2530.
 6. Rewrite the displayed status counter from “1” - “16” to “0”.
 7. Perform FS-08-2531.
 8. Rewrite the displayed status counter from “1” - “16” to “0”.
 9. Turn the power OFF and then back ON. Make sure that the equipment enters the normal ready state.

[CA00] Color registration abnormality

Classification	Contents
Image control related service call	Color registration abnormality.

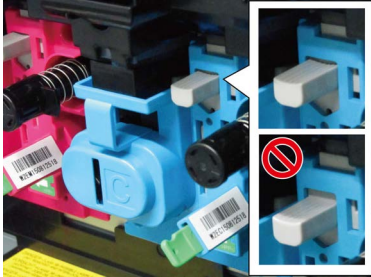
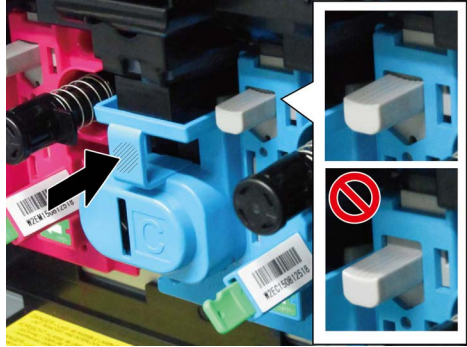
Step	Check Item	Result	Measures	Next Step
1	Has FS-05-2742 (Forced performing of image quality closed-loop control) been performed?	No Yes	Perform FS-05-4719 (Forced performing of color registration control). Remarks: The correction value of the secondary scanning data writing start position is obtained by FS-05-2742 (Forced performing of image quality closed-loop control). If a scanning abnormality has occurred at that time, CA00 appears. When a CA00 error has occurred during FS-05-2742, perform FS-05-4719 (Forced performing of color registration control adjustment) first. If a CA00 error still persists even after FS-05-4719 has been performed, carry out the following steps.	2
2	Has the developer unit (Y, M, C, K) been installed securely? 	No	Press the slanted line portion of the developer unit until a click sound is heard. 	

Step	Check Item	Result	Measures	Next Step
3	Check the printer output image. Remarks: Checking if images are generated on the transfer belt by taking the transfer belt unit off is an alternative check method for steps 3 and 4.		Output the test patterns and check them. Using FS-04-250 / FS-05-341-[TEST PRINT]	
4	Is the image abnormal (image void, Low density, etc.)?	No		8
		Yes		5
5	Check if there is any abnormality on the rods of the main charger cleaner. Correct if there is.			
6	Check if the drum is rotated properly by turning the coupling of the cleaner unit. Correct the auger and the surrounding hardware if not.			
7	Laser optical unit		<ul style="list-style-type: none"> • Check the connectors and harnesses <ul style="list-style-type: none"> - Mirror motor-Y/M/C: CN322, J643 - LGC board: CN317, CN319 (25/30/35ppm) CN317, CN318, CN319 (45/50ppm) - LRL board: CN205, CN204, 206, 207, 208, 209 (25/30/35ppm) CN210, CN211, CN212, 213, 214, 215, 216 (45/50ppm) - Image position aligning sensor (Front): CN309, J620, J624 - Image position aligning sensor (Rear): CN309, J620, J623 - Image position aligning sensor (Center) / Image quality sensor: CN309, J620, J720 - Sensor shutter solenoid: CN309, J620, J622 • Check if there is any stain or scratch on the laser optical unit. Clean or correct if there is. 	
8	Check if there is any stain on the image quality sensor (Front), image quality sensor (Rear) and image quality sensor (Center).			
9	Check if the sensor shutter is working properly.			
10	< Invalidating color registration control >		<ul style="list-style-type: none"> • Perform FS-08-4546. • Set the value to "0" (not performed automatically). 	
11	< Checking the abnormal status on color registration >		Perform FS-05-4720-0. (Displaying the cause of color registration detection error)	

Step	Check Item	Result	Measures	Next Step
12	Check the displayed value. When the error [CA00] occurs, the value between 1 and 255 is displayed. (0: Normal completion) (The statuses of total 8 sections (4 colors on the front and rear sides) are displayed.)		1: Y on the rear side detection abnormality (*1)	21
			2: Y on the front side detection abnormality (*1)	21
			3: Y on the front and rear sides detection abnormality	21
			4: M on the rear side detection abnormality (*1)	21
			8: M on the front side detection abnormality (*1)	21
			12: M on the front and rear sides detection abnormality	21
			16: C on the rear side detection abnormality (*1)	21
			32: C on the front side detection abnormality (*1)	21
			48: C on the front and rear sides detection abnormality	21
			64: K on the rear side detection abnormality (*1)	21
			85: All colors on the rear side detection abnormality	16
			128: K on the front side detection abnormality (*1)	21
			170: All colors on the front side detection abnormality	16
			192: K on the front and rear sides detection abnormality	21
			255: All colors on the front and rear sides detection abnormality	16
13	< Checking the abnormal status on color registration >		Other than the above: Multiple colors detection abnormality	21
			Remarks: The adjustment value is the sum of (*1), which, as in the example below, specifies the cause of the detection abnormality. (E.g. 1) FS-05-4720-0 --- in case of 72 $72 = 64 + 8$ > K on the rear side / M on the front side detection abnormality (E.g. 2) FS-05-4720-0 --- in case of 146 $146 = 128 + 18 = 128 + 16 + 2$ > K on the front side / C on the rear side / Y on the front side detection abnormality	
			Perform FS-05-4720-1. (Displaying the cause of color registration detection error)	

Step	Check Item	Result	Measures	Next Step
14	Check the displayed value. When the error [CA00] occurs, the value between 1 and 85 is displayed. (0: Normal completion) (The statuses of total 8 sections (4 colors on the center side) are displayed.)		1: Y on the center side detection abnormality (*2)	21
			4: M on the center side detection abnormality (*2)	21
			16: C on the center side detection abnormality (*2)	21
			64: K on the center side detection abnormality (*2)	21
			85: All colors on the center side detection abnormality	16
			Other than the above: Multiple colors detection abnormality Remarks: The adjustment value is the sum of (*2), which, as in the example below, specifies the cause of the detection abnormality. (E.g. 3) FS-05-4720-1 --- in case of 65 65 = 64 + 1 > K on the center side / Y on the center side detection abnormality	21
15	Checking the mirror motor moving amount Perform all the following self-diagnostic codes and check each value. FS-05-4730-0 FS-05-4730-1 FS-05-4730-2		If the value is not 32 or 992: Proceed to the next step. If the value of any code is 32 or 992: Perform FS-05-4721. After that, check that the value has been changed from 32 or 992.	16

Step	Check Item	Result	Measures	Next Step
16	< Checking the status of the image position aligning sensor >		<p>Check if the light emitting area of the image position aligning sensor emits LEDs and if the reflected lights on the transfer belt surface are detected by the light receiving area of the image position aligning sensor.</p> <ol style="list-style-type: none"> FS-03-[F2]ON/[1]/[B]: Check the image position aligning sensor (Front). FS-03-[F2]ON/[1]/[A]: Check the image position aligning sensor (Rear). FS-03-[F2]ON/[1]/[C]: Check the image position aligning sensor (Center) / Image quality sensor. FS-03-125: Sensor shutter is opened. FS-03-126: Image position aligning sensor / LED ON FS-03-[F2]ON/[1]/[B]: Check the image position aligning sensor (Front). FS-03-[F2]ON/[1]/[A]: Check the image position aligning sensor (Rear). FS-03-[F2]ON/[1]/[C]: Check the image position aligning sensor (Center) / Image quality sensor. Compare them (step 6, 7 and 8) with the statues of [A], [B] and [C] displayed in step 1, 2 and 3. <ul style="list-style-type: none"> All [A], [B] and [C] are changed - The image position aligning sensors on all sides are operating normally. [A] remains same - The image position aligning sensor on the rear side is not operating normally. [B] remains same - The image position aligning sensor on the front side is not operating normally. [C] remains same - The image position aligning sensor on the center side is not operating normally. FS-03-176: Image position aligning sensor / LED OFF FS-03-175: Sensor shutter is closed. Turn the power OFF. If the image position aligning sensors on both sides are operating normally, proceed to step (19). In other cases, proceed to step (17). 	
17	Image position aligning sensor		<ul style="list-style-type: none"> Check the connectors and harnesses (J620, J623, J624) between the image position aligning sensor and the LGC board (CN309). Check if the light emitting or receiving area of the image position aligning sensor stained with toner. 	
18	Are the sensor shutters of the image position aligning sensor opening or closing normally? Are they normal without any damage? 1. Take off the transfer belt unit so that the sensor unit can be seen. 2. Perform FS-03-125/175.	Yes		19
		No		20
19	Is the light emitting area of the image position aligning sensor emitting LEDs? 1. Perform FS-03-125. (Open the sensor shutter) 2. Perform FS-03-126. (The light emitting area of the sensor should emit LEDs)	Yes		21
		No		20

Step	Check Item	Result	Measures	Next Step
20	Image position aligning sensor		<ul style="list-style-type: none"> Connector and harness check Clean the light emitting and receiving areas of the image position aligning sensor. If the sensor shutter is damaged, replace it. If the sensor shutter solenoid is not operating normally, replace the solenoid. 	16
21	< Checking with test pattern >		<ul style="list-style-type: none"> Perform FS-04-286. Check if the printed image of the test pattern in each color contains difference in density on its front, center and rear sides, or if there is any image trouble in a whole image. 	
22	Is the image of the test pattern printed normally without any difference in density on its front and rear sides?	Yes		25
		No		23
23	Transfer belt and the photoconductive drum		Check the contacting status of the transfer belt and the photoconductive drum.	24
24	Developer material		Check the amount of the developer material. (Check if the developer material is supplied on the developer sleeve.)	25
25	Is the image printed normally without yellow, magenta, cyan or black streaks in the secondary scanning direction?	Yes		27
		No		26
26	Check if the main charger wire corresponding to the color of the streaks is stained.			27
27	Is the image printed normally without white streaks in the secondary scanning direction?	Yes		29
		No		28
28	Check if the slit glasses of laser optical unit is stained.			29
29	Is a certain color in the printed image turned to solid?	Yes		31
		No		30
30			<ul style="list-style-type: none"> Abnormality in the main high-voltage transformer corresponding to the color or abnormality in the laser optical unit. Switch one of 4 main high-voltage transformers which possibly contains abnormality with the one possibly normal. Then print the same test pattern. If the color which turned into solid changes along with the replacement of the main high-voltage transformer, this main high-voltage transformer is defined as abnormal. If the color which turned into solid does not change, check if the harness between the LGC board and the main high-voltage transformer is broken or if the power is sufficiently supplied to the main charger (breaking of the high-voltage harness or connection defect). If no problem is found, check the laser optical unit. 	31
31	If the density level is low on both front and rear sides, is the image printed normally in cases other than noted above?	Yes		33
		No		32

Step	Check Item	Result	Measures	Next Step
32			<ul style="list-style-type: none"> • Check if the photoconductive drum and the transfer belt are rotating. If not, correct their mechanism. • Check if there are abnormal stain, large breaking or scratches on the transfer belt surface. • Check if the connector of the transfer transformer is disconnected. • Check if the high-voltage harnesses of the main high-voltage transformer and the transfer transformer are disconnected. • Check if the harness between the LGC board and the transfer transformer is broken. • Check if the high-voltage joints of the transfer belt unit are securely contacted or if they are not stained. • Check if the high-voltage harness is broken. • Check if the connector of the main high-voltage transformer is disconnected. • Check if the harness between the LGC board and the main high-voltage transformer is broken. • Replace the transfer transformer. • Replace the main high-voltage transformer. 	21
33	< Checking with the enforced image position adjustment > Does the error [CA00] occur during the position adjustment control? Perform FS-05-4719. (Enforced position adjustment)	Yes		34
		No		16
34	< Validating the color registration control >		Check the operation and correct if necessary. Then be sure to perform the following: 1. Perform FS-08-4546. (Position adjustment control / Mode setting) 2. Set the value to "3" (default value). 3. Turn the power OFF.	
35	<Checking the image position aligning sensor>		Clean the image position aligning sensor (S7, S8).	
36	<Checking the power supply>		Check if any of the springs for supplying power to the transfer belt unit is deformed. Replace the spring if it is deformed.	
37	<Checking the power supply>		Check if any of the springs for supplying power to the EPU is deformed. Replace the spring if it is deformed.	

[CE10] Image quality sensor abnormality (OFF level)

Classification	Contents
Image control related service call	The output value of this sensor is out of a specified range when sensor light source is OFF.

Check Item	Measures
Image quality sensor	Connector check
LGC board	<ul style="list-style-type: none"> • Connector check (CN309, J620, J624) • Check the harnesses between the LGC board and the image quality sensor. • Check the harnesses between the LGC board and the switching power supply.

Parts to be replaced	Remark
Switching power supply	
Image quality sensor	
LGC board	
High-voltage transformer	

[CE20] Image quality sensor abnormality (no pattern level)

Classification	Contents
Image control related service call	The output value of this sensor is out of a specified range when the image quality control test pattern is not formed.

Step	Check Item	Result	Measures	Next Step
1	<ul style="list-style-type: none"> Check the image quality sensor detection value (FS-05-2757). Is the value of FS-05-2757-0 "0", and is the value of FS-05-2757-1 "255"? 	Yes		9
		No		2
2	<ul style="list-style-type: none"> Is the transfer belt or the transfer belt unit securely installed? Are there any abnormal stains (cleaning defects), large scratches or breaking on the transfer belt surface? Are the drum and the transfer belt rotating smoothly? Is the transfer belt tight? 	Yes		6
		No		3
3	Transfer belt unit		Check if the transfer belt unit is securely installed. Correct it if not.	4
4	Transfer belt		Check if any toner image remains on the transfer belt surface. If any, check the installation status of the TBU cleaner unit. If there is any abnormality, correct it, and clean the transfer belt.	5
5	Drum and transfer belt		Check if the drum and the transfer belt are properly operated.(ON: FS-03-101 / OFF: FS-03-151) If the transfer belt rotates normally, check if any abnormal stains (cleaning defects), large scratches or breaking are on the surface of transfer belt by making full rotation of transfer belt. Replace the transfer belt if any. Check if the transfer belt is loose or heaving, and correct it if needed. If they are not rotating normally, check if their drive gears are damaged or if they contact the equipment. Correct it if needed.	18*
6	<ul style="list-style-type: none"> Is the sensor shutter of the image quality sensor opening or closing normally? Or is it normal without any damage? Is the sensor surface of the image quality sensor clean? 	Yes		9
		No		7
7	Sensor unit		Take off the transfer belt unit so that you can see the sensor unit.	

Step	Check Item	Result	Measures	Next Step
8	Sensor shutter		<ul style="list-style-type: none"> Check if the sensor shutter is opening or closing normally. (Opening: FS-03-125 / Closing: FS-03-175) If the sensor shutter is not opening or closing, check if it is damaged or there is any abnormality in the sensor shutter solenoid. <p>Notes: If the shutter is opened (FS-03-125), close the shutter (FS-03-175).</p> <ul style="list-style-type: none"> Check the connector and the harness between the sensor shutter solenoid and the LGC board. (LGC CN309 9-10 pin, J620, J622) Slide the sensor shutter so that the sensor surface can be seen. Clean the sensor surface with a cotton swab or a soft cloth. Clean the area around the sensor (e.g.: sensor shutter) if it is stained, so that the sensor surface does not become dirty. 	18*
9	Image quality sensor		Check the connectors and harnesses between the LGC board (CN309) and the image quality sensor.	*
10	<ul style="list-style-type: none"> Is +5V power supply voltage normally supplied to the image quality sensor? Is +5V voltage normally output by the CN309 5-pin on the LGC board? 			11
11	LGC board		<ul style="list-style-type: none"> Check if +5V voltage is output by the terminal (25/30/35ppm: TP32, 45/50ppm: TP13) on the LGC board. Check if the supply harness between the switching power supply and the LGC board is open circuited, damaged or disconnected. 	18*
12	Set the values of "Image quality closed-loop control / Contrast voltage (FS-08-2486)" to "0" (Invalid).			
13	Perform "Enforced performing of image quality open-loop control (FS-05-2740)".			
14	Output the image quality control test pattern (FS-04-270) more than one time and the list print (FS-30-101). Is the image normal?	Yes		16
		No		15
15	Abnormal image Correct the abnormal image.		Blank print, Solid print, White banding, Color banding, White spots, Poor transfer, Uneven image density, Faded image (low density), Uneven light distribution, Blotched image. Notes: Blank print: including when one of the YMCK colors is not printed.	17
16	Replace the image quality sensor or the LGC board.			
17	Set the values of "Image quality closed-loop control / Contrast voltage (FS-08-2486)" to "1" (Valid).			

Step	Check Item	Result	Measures	Next Step
18	Perform "Forced performing of image quality closed-loop control (FS-05-2742)" and make sure it is completed normally. (Error [CE10], [CE20] and [CE40] do not appear.)	Yes		20
		No		19
19	Check and correct it accordingly.			
20	Perform "Automatic gamma adjustment".			
21	Reset all of the values in the codes "Abnormality detection count (Y/M/C/K) Display/0 clearing (FS-08-2528 to FS-08-2531)".			
22	High-voltage transformer		Check if the high-voltage transformer is damaged or abnormal.	

* Go to step 12 for the second time.

[CE40] Image quality control test pattern abnormality

Classification	Contents
Image control related service call	The test pattern is not formed normally.

Step	Check Item	Result	Measures	Next Step
1	Check if there is any abnormality on the hand grips and rods of the main charger cleaner. Correct if there is.			
2	Check if the drum is rotated properly by turning the gear of the drum cleaner unit. Correct the auger and the surrounding hardware if not.			
3	Laser optical unit		<ul style="list-style-type: none"> Check the connectors and harnesses between the LGC board and the laser optical unit. (25/30/35ppm: CN317, CN319, CN204, CN205, CN206, CN207, CN208, CN209, 45/50ppm: CN317, CN318, CN319, CN210, CN211, CN212, CN213, CN214, CN215, CN216, CN202) Check if there is any stain or scratch on the laser optical unit. Clean or correct if there is. 	
4	Check if there is any stain on the image quality sensor (Rear).			
5	Check if the sensor shutter is working properly.			

Step	Check Item	Result	Measures	Next Step
6	Transfer belt		<p>Check if the transfer belt is installed in the transfer belt unit properly. Check if the transfer belt is loose or heaving, and correct it if needed.</p> <p>Check if the transfer belt unit is installed in the equipment properly.</p> <p>Check if the transfer belt is properly operated. (ON: FS-03-101 / OFF: FS-03-151)</p> <p>If the transfer belt rotates normally, check if any abnormal stains (cleaning defects), large scratches or breaking are on the surface of transfer belt by making full rotation of transfer belt. Replace the transfer belt if any.</p> <p>If the transfer belt is not rotating normally, check if the drive gears are damaged or if it contacts the equipment or if the transfer belt cleaning unit is normal. Correct it if needed.</p>	17*
7	Check if any of the springs for supplying power to the transfer belt unit is deformed. Replace the spring if it is deformed.			
8	Use "Image quality control abnormal detection counter Y to K display/0 clearing (FS-08-2528 to 2531)" to check the abnormal occurring condition for each color.			
9	Check the first pattern detection value for each color of image quality sensor detection value (FS-05-2758-2 to 5), and identify the color of unit which causing test pattern abnormality. Identify the color of unit by check the value which exceeds "600". (Sub-code 2: Y, 3: M, 4: C, 5: K)		<p>If the detected value of K is normal but that for only Y, those for Y and M, or those for Y, M and C is abnormal, perform the following procedure.</p> <p>> Check that the phenomenon can be recovered by replacing the 1st transfer contact/release clutch or the 1st transfer roller status detection sensor.</p>	
10	Check if the developer unit identified in step 9 has been installed properly.		Visually check the installation and assembly status of the developer unit, and correct it if there is any abnormality.	17*
11	Set the values of "Image quality closed-loop control / Contrast voltage (FS-08-2486)" to "0" (Invalid).			
12	Perform "Enforced performing of image quality open-loop control (FS-05-2740)".			
13	Output several number of sheets of the image quality control test pattern (FS-04-270) and the list print (FS-30-101), and check the pattern of the color identified in step 9. Is the image normal?	Yes		15
		No		14
14	Abnormal image Correct the abnormal image.		<p>Blank print, Solid print, White banding, Color banding, White spots, Poor transfer, Uneven image density, Faded image (low density), Uneven light distribution, Blotched image.</p> <p>Notes: Refer to the each troubleshooting for the image. Blank print: including when one of the YMCK colors is not printed.</p>	16

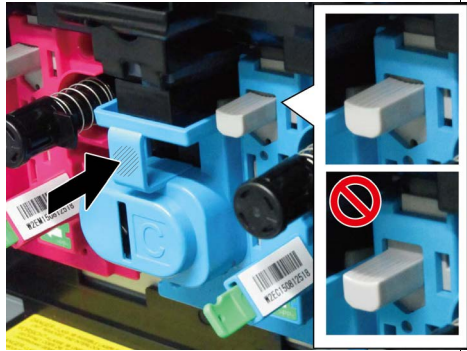
Step	Check Item	Result	Measures	Next Step
15	Replace the image quality sensor or LGC board.			
16	Set the values of "Image quality closed-loop control / Contrast voltage (FS-08-2486)" to "1" (Valid).			
17	Perform "Forced performing of image quality closed-loop control (FS-05-2742)." Is it completed normally?	Yes		19
		No		18
18	Check and correct it accordingly.			
19	Perform "Automatic gamma adjustment".			
20	Clear all "Image quality control abnormal detection counter Y to K display/0 clearing (FS-08-2528 to 2531)".			
21	EPU		<p>Has the developer unit (Y, M, C, K) been installed securely? Press the slanted line portion of the developer unit until a click sound is heard.</p> 	

* If you have already performed this checking cycle once, proceed to step (11).

Parts to be replaced	Remarks
Main charger cleaner	
Drum cleaner unit	
Laser optical unit	
Image quality sensor (Rear)	
Transfer belt	
Spring for supplying power	
1st transfer contact/release clutch	
1st transfer roller status detection sensor	
Image quality sensor	
LGC board	
High-voltage transformer (HVT)	

[CE41] Image quality TRC control test pattern abnormality

Classification	Error item
Image control related service call	The image quality TRC control test pattern is not printed normally.

Step	Check item	Result	Measures	Next step
1	Change the setting of the image quality TRC control to "Disabled". Set the values of FS-08-2600 and FS-08-8103 to "0".			2
2	Output several number of sheets of the image quality control test pattern (FS-04-270) and the list print (FS-30-101), and check the pattern of each color. Is the image normal?	YES NO	<ul style="list-style-type: none"> • Check if process units and developer units are properly installed. • Check if there is any scattered toner or developer material around the laser optical unit, clean it if there is any. • Correct the problem by referring to "Troubleshooting for the Image".  P. 8-442 "8.5 Troubleshooting for the Image" 	3
3	Change the setting of the image quality TRC control to "Enabled". Set the values of FS-08-2600 and FS-08-8103 to "1".			4
4	Perform the automatic gamma adjustment. If the adjustment is normally finished, this is the end of the procedure. If the error CE41 still occurs, proceed to step 5.			
5	Check if the harness between the connector CN133 on the SYS board and the connector CN330 on the LGC board is disconnected or open circuited. Correct if so.			6
6	Check if the conductor patterns on the SYS board and the LGC board are short circuited or open circuited.			7
7	If no abnormality is found in steps 5 to 6 above, replace the SYS board.			8
8	Perform automatic gamma adjustment. If the adjustment is normally finished, this is the end of the procedure. If the error CE41 still occurs, proceed to step 9.			
9	Reinstall the removed SYS board and then replace the LGC board. Perform automatic gamma adjustment after the board is replaced.			

Parts to be replaced	Remarks
LGC board	
SYS board	
High-voltage transformer	

[CE50] Temperature / humidity sensor abnormality

Classification	Contents
Image control related service call	The output value of temperature / humidity sensor is out of a specified range.

Check Item	Measures
Temperature/humidity sensor	Check the connectors and harnesses between the temperature/humidity sensor and LGC board (CN325).

Parts to be replaced	Remark
Temperature/humidity sensor	
LGC board	

[CE70] Drum drive switching abnormality

Classification	Contents
Image control related service call	The drum switching detection sensor is not turned ON after the mono / color switching motor was rotated for a specified period of time.

Step	Check Item	Result	Measures	Next Step
1	Is the drum switching motor (M3) operating properly? (Perform the output check: FS-03-240)	Yes		7
		No		2
2	Drum switching motor (M3)		Check the connector of the motor. (J653)	
3	Drum switching detection sensor (S11)		Sensor check	
4	LGC board		<ul style="list-style-type: none"> Connector check (CN327) Board check 	
5	Is the drum TBU drive unit [1] installed properly? P. 8-261"Fig.8-24"		<ul style="list-style-type: none"> Install the drum TBU drive unit [1] properly. P. 8-261"Fig.8-24" 	
6	Check that there is no friction or abnormality by pushing the protrusion [2] of the drive switching cam and the one [3] for the developer/paper feeding drive switching cam while the drum TBU drive unit [1] is removed. P. 8-261"Fig.8-24"		<ul style="list-style-type: none"> If there is any foreign matter in the unit, remove it. If the slide area spring [4] in the unit is deformed or is not attached properly, correct it. Apply grease (Molykote EM-30L) to the slide area of the switching cam [5]. P. 8-261"Fig.8-25" P. 8-261"Fig.8-26" 	
7	Is the drum switching detection sensor (S11) working? (Perform the input check: FS-03-[ALL]OFF/[8]/[G] (Highlighted in the black mode))	Yes		10
		No		8
8	Drum switching detection sensor (S11)		<ul style="list-style-type: none"> Sensor, connector, joint connector check Check if there is any foreign matter such as grease in the detection area of the drum switching detection sensor. 	
9	LGC board		<ul style="list-style-type: none"> Connector check (CN327) Board check 	
10	Is the drum switching motor assembled in the drum drive unit able to be rotated smoothly by hand?	Yes		12
		No		11

Step	Check Item	Result	Measures	Next Step
11	Drum switching motor (M3)		<ul style="list-style-type: none"> While reinstalling the drum switching motor, push it so that its gear will slightly move away from the engaging gear. Check the bracket in which the drum switching motor is installed. If it is deformed, replace it. 	
12	Is the drum switching guide able to be moved smoothly by hand after the drum switching motor has been removed?	Yes		14
		No		13
13	Drum switching motor (M3)		Check if the slide area (guide, plate) of the drum switching guide is deformed or any foreign matter is attached to it. (Replace it if there is.)	
14	LGC board		Board check	

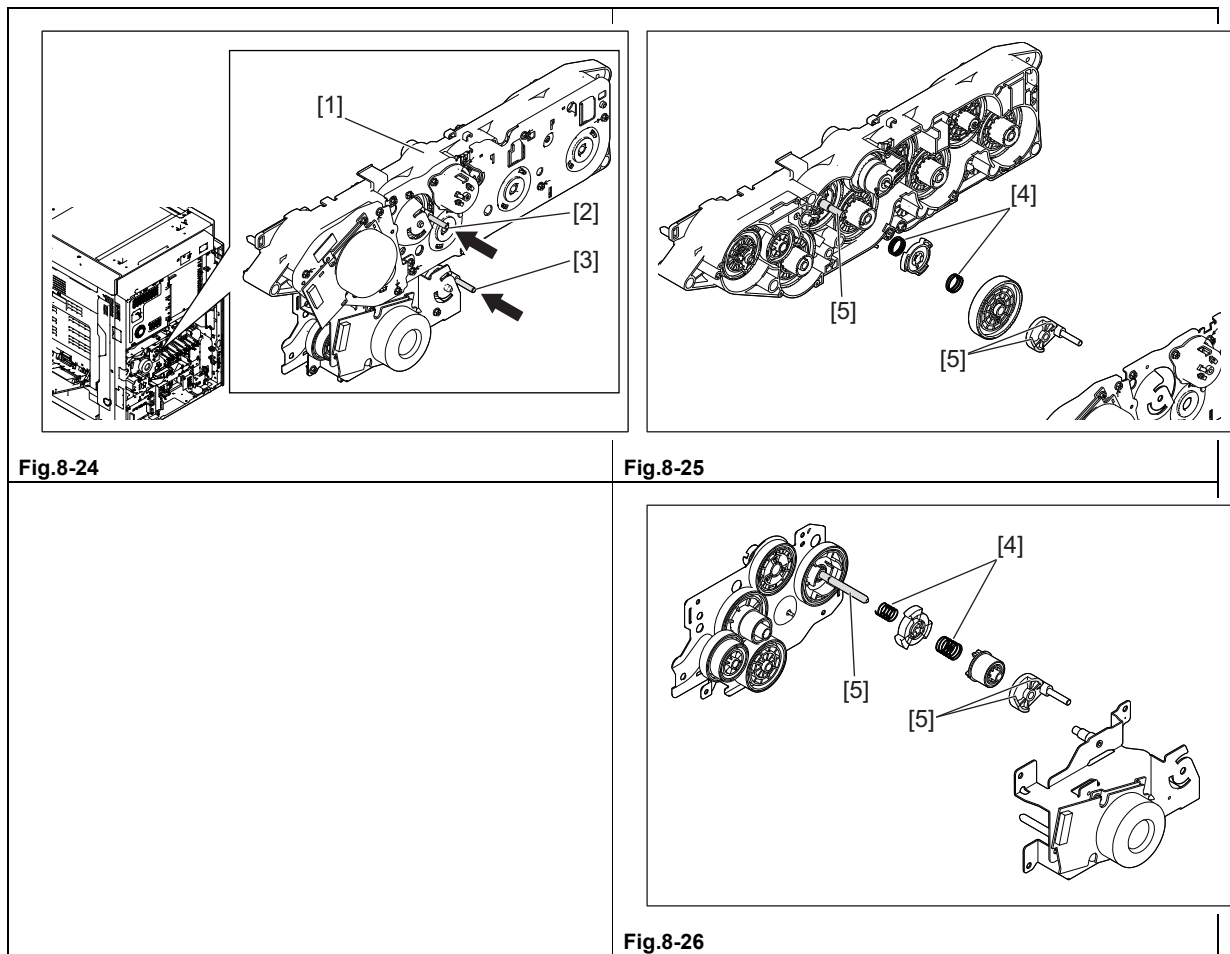

Parts to be replaced	Remark
Drum switching motor (M3)	
Drum switching detection sensor (S11)	
LGC board	

[CE90] Drum thermistor abnormality

Classification	Contents
Image control related service call	The output value of the drum thermistor is out of a specified range.

Check Item	Measures
Drum thermistor	<ul style="list-style-type: none">• Thermistor check (Perform the input check: FS-03-[F1]ON/[3])• Connector check (J638, J637)• Harness check
LGC board	<ul style="list-style-type: none">• Connector check (CN312)

Parts to be replaced	Remark
Drum thermistor	
LGC board	

8.3.23 Copy process related service call

[C370] Transfer belt abnormality

Classification	Contents
Copy process related service call	The transfer belt is not moved normally.

Check Item	Measures
Transfer belt unit	<ul style="list-style-type: none"> Check if the transport belt unit is working normally.
Drum TBU drive unit	Connector check (J651, J656)
Drum TBU motor	Connector check (CN327, J651)
Drum cleaner unit	Check if the drum is overloaded.
Transfer belt cleaning unit	Check that there is no abnormality in the cleaning blade. Check if the waste toner auger is overloaded.
LGC board	Connector check (CN327)
Transfer belt	Check if it's normal.
1st transfer roller status detection sensor (S12)	Sensor check
1st transfer contact/release clutch (CLT2)	Clutch check

Parts to be replaced	Remark
Drum TBU motor	
LGC board	
1st transfer roller status detection sensor (S12)	
1st transfer contact/release clutch (CLT2)	

[C380] Auto-toner sensor-K abnormality (upper limit)

Classification	Contents
Copy process related service call	An output of the auto-toner sensor cannot be detected correctly.

Step	Check Item	Result	Measures	Next Step
1	Developer unit		<ul style="list-style-type: none"> Check if the developer unit is installed properly. Check that the developer unit and coupling on the equipment side are properly engaged. Check that the mixer of the developer unit is rotated. Check if the developer material is too light visually. Check if the amount of the developer material is too large or too small. Remove any toner or dust on the auto-toner sensor connector and the drawer connector of the process cover. Remove any toner or dust on the EPU sensor connector and the drawer connector on the equipment side. 	
2	Auto toner sensor LGC board		<ul style="list-style-type: none"> Check the connectors and harnesses between the auto toner sensor and LGC board (CN313, J635, J636). Remove any foreign matter such as toner in the connector of the auto toner sensor. 	

Parts to be replaced	Remark
Auto toner sensor	
Harness	
LGC board	
Developer material	
High-voltage transformer	

[C381] Auto-toner sensor-K abnormality (lower limit)

Classification	Contents
Copy process related service call	An output of the auto-toner sensor cannot be detected correctly.

Step	Check Item	Result	Measures	Next Step
1	Developer unit		<ul style="list-style-type: none"> Check if the developer unit is installed properly. Check that the developer unit and coupling on the equipment side are properly engaged. Check that the mixer of the developer unit is rotated. Check if the amount of the developer material is too large or too small. Remove any toner or dust on the auto-toner sensor connector and the drawer connector of the process cover. Remove any toner or dust on the EPU sensor connector and the drawer connector on the equipment side. 	
2	Auto toner sensor LGC board		<ul style="list-style-type: none"> Check the connectors and harnesses between the auto toner sensor and LGC board (CN313, J635, J636). Check if there is any foreign matter such as toner in the connector of the auto toner sensor. Remove if there is and reconnect it. 	

Parts to be replaced	Remark
Auto toner sensor	
Harness	
LGC board	
Developer material	

[C390] Auto-toner sensor-C abnormality (upper limit)

Classification	Contents
Copy process related service call	An output of the auto-toner sensor cannot be detected correctly.

Step	Check Item	Result	Measures	Next Step
1	Developer unit		<ul style="list-style-type: none"> • Check if the developer unit is installed properly. • Check that the developer unit and coupling on the equipment side are properly engaged. • Check that the mixer of the developer unit is rotated. • Check if the developer material is too light visually. • Check if the amount of the developer material is too large or too small. • Remove any toner or dust on the auto-toner sensor connector and the drawer connector of the process cover. • Remove any toner or dust on the EPU sensor connector and the drawer connector on the equipment side. 	
2	Auto toner sensor LGC board		<ul style="list-style-type: none"> • Check the connectors and harnesses between the auto toner sensor and LGC board (CN313, J633, J634). • Check if there is any foreign matter such as toner in the connector of the auto toner sensor. Remove if there is and reconnect it. 	

Parts to be replaced	Remark
Auto toner sensor	
Harness	
LGC board	
Developer material	
High-voltage transformer	

[C391] Auto-toner sensor-C abnormality (lower limit)

Classification	Contents
Copy process related service call	An output of the auto-toner sensor cannot be detected correctly.

Step	Check Item	Result	Measures	Next Step
1	Developer unit		<ul style="list-style-type: none"> • Check if the developer unit is installed properly. • Check that the developer unit and coupling on the equipment side are properly engaged. • Check that the mixer of the developer unit is rotated. • Check if the amount of the developer material is too large or too small. • Remove any toner or dust on the auto-toner sensor connector and the drawer connector of the process cover. • Remove any toner or dust on the EPU sensor connector and the drawer connector on the equipment side. 	
2	Auto toner sensor LGC board		<ul style="list-style-type: none"> • Check the connectors and harnesses between the auto toner sensor and LGC board (CN313, J633, J634). • Check if there is any foreign matter such as toner in the connector of the auto toner sensor. Remove if there is and reconnect it. 	

Parts to be replaced	Remark
Auto toner sensor	
Harness	
LGC board	
Developer material	

[C3A0] Auto-toner sensor-M abnormality (upper limit)

Classification	Contents
Copy process related service call	An output of the auto-toner sensor cannot be detected correctly.

Step	Check Item	Result	Measures	Next Step
1	Developer unit		<ul style="list-style-type: none"> • Check if the developer unit is installed properly. • Check that the developer unit and coupling on the equipment side are properly engaged. • Check that the mixer of the developer unit is rotated. • Check if the developer material is too light visually. • Check if the amount of the developer material is too large or too small. • Remove any toner or dust on the auto-toner sensor connector and the drawer connector of the process cover. • Remove any toner or dust on the EPU sensor connector and the drawer connector on the equipment side. 	

Step	Check Item	Result	Measures	Next Step
2	Auto toner sensor LGC board		<ul style="list-style-type: none"> Check the connectors and harnesses between the auto toner sensor and LGC board (CN313, J631, J632). Check if there is any foreign matter such as toner in the connector of the auto toner sensor. Remove if there is and reconnect it. 	

Parts to be replaced	Remark
Auto toner sensor	
Harness	
LGC board	
Developer material	
High-voltage transformer	

[C3A1] Auto-toner sensor-M abnormality (lower limit)

Classification	Contents
Copy process related service call	An output of the auto-toner sensor cannot be detected correctly.

Step	Check Item	Result	Measures	Next Step
1	Developer unit		<ul style="list-style-type: none"> Check if the developer unit is installed properly. Check that the developer unit and coupling on the equipment side are properly engaged. Check that the mixer of the developer unit is rotated. Check if the amount of the developer material is too large or too small. Remove any toner or dust on the auto-toner sensor connector and the drawer connector of the process cover. Remove any toner or dust on the EPU sensor connector and the drawer connector on the equipment side. 	
2	Auto toner sensor LGC board		<ul style="list-style-type: none"> Check the connectors and harnesses between the auto toner sensor and LGC board (CN313, J631, J632). Check if there is any foreign matter such as toner in the connector of the auto toner sensor. Remove if there is and reconnect it. 	

Parts to be replaced	Remark
Auto toner sensor	
Harness	
LGC board	
Developer material	

[C3B0] Auto-toner sensor-Y abnormality (upper limit)

Classification	Contents
Copy process related service call	An output of the auto-toner sensor cannot be detected correctly.

Step	Check Item	Result	Measures	Next Step
1	Developer unit		<ul style="list-style-type: none"> • Check if the developer unit is installed properly. • Check that the developer unit and coupling on the equipment side are properly engaged. • Check that the mixer of the developer unit is rotated. • Check if the developer material is too light visually. • Check if the amount of the developer material is too large or too small. • Remove any toner or dust on the auto-toner sensor connector and the drawer connector of the process cover. • Remove any toner or dust on the EPU sensor connector and the drawer connector on the equipment side. 	
2	Auto toner sensor LGC board		<ul style="list-style-type: none"> • Check the connectors and harnesses between the auto toner sensor and LGC board (CN313, J629, J630). • Check if there is any foreign matter such as toner in the connector of the auto toner sensor. Remove if there is and reconnect it. 	

Parts to be replaced	Remark
Auto toner sensor	
Harness	
LGC board	
Developer material	
High-voltage transformer	

[C3B1] Auto-toner sensor-Y abnormality (lower limit)

Classification	Contents
Copy process related service call	An output of the auto-toner sensor cannot be detected correctly.

Step	Check Item	Result	Measures	Next Step
1	Developer unit		<ul style="list-style-type: none"> Check if the developer unit is installed properly. Check that the developer unit and coupling on the equipment side are properly engaged. Check that the mixer of the developer unit is rotated. Check if the amount of the developer material is too large or too small. Remove any toner or dust on the auto-toner sensor connector and the drawer connector of the process cover. Remove any toner or dust on the EPU sensor connector and the drawer connector on the equipment side. 	
2	Auto toner sensor LGC board		<ul style="list-style-type: none"> Check the connectors and harnesses between the auto toner sensor and LGC board (CN313, J629, J630). Check if there is any foreign matter such as toner in the connector of the auto toner sensor. Remove if there is and reconnect it. 	

Parts to be replaced	Remark
Auto toner sensor	
Harness	
LGC board	
Developer material	

[C3E1] Drum / cleaner / charger unit replacement (old-new) detection abnormality

Classification	Contents
Copy process related service call	Drum / cleaner / charger unit replacement (old-new) detection abnormality.

Step	Check Item	Result	Measures	Next Step
1	Check if the old/new detection pusher of the drum cleaner unit is being ejected.	Yes		4
		No		2
2	Check if the harness of the drum old/new detection switch in the drum cleaner unit is open circuited.	Yes		3
		No	Replace the harness.	
3	Is the drum old/new detection switch of the drum cleaner unit normal?	Yes		4
		No	Replace the drum old/new detection switch.	
4	Check if the drum old/new detection pusher is moved to the escape position while the coupling of the drum cleaner unit is rotated by hand. (Is a driving in the old/new detection pusher section transmitted?)	Yes		3
		No	Correct the drum old/new detection pusher so that it is moved to the escape position.	

Step	Check Item	Result	Measures	Next Step
5	Check that the coupling of the drum TBU drive unit is driven properly.	Yes	Correct the engagement of the couplings in the drum TBU drive unit and the drum cleaner unit.	9
		No		6
6	Check that the drum TBU drive motor rotates properly. (Output check: FS-03-101/151)	Yes		9
		No		7
7	Check that the connector of the drum TBU drive motor is connected properly. (CN327, J651)	Yes		9
		No		8
8	Check if the harness of the drum TBU drive motor is open circuited.	Yes		9
		No	Replace the drum TBU drive motor.	
9	Check that the connector of the LGC board (CN313, CN327) is connected properly.	Yes		11
		No	Reconnect the connector.	
10	Is the harness of the LGC board normal?	Yes		11
		No	Replace the harness.	
11	Is the LGC board normal?		Replace the LGC board.	

Parts to be replaced	Remark
Drum old/new detection switches	
Drum TBU motor	
LGC board	
Harness	

[C970] High-voltage transformer abnormality

Classification	Contents
Copy Process related service call	Leakage of the main charger is detected.

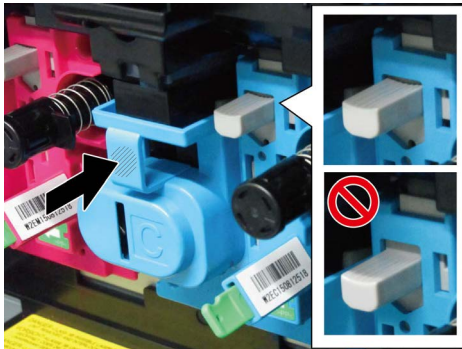
Check Item	Measures
EPU	<p>Has the developer unit (Y, M, C, K) been installed securely? Press the slanted line portion of the developer unit until a click sound is heard.</p> 
Main charger	Check if the main charger is installed securely.
Spring of high-voltage supply contact point	Check if the spring of high-voltage supply contact point is deformed.
Needle electrode	<ul style="list-style-type: none"> Check if the needle electrode is broken or the main charger grid is deformed. Check if any foreign matter is on the needle electrode or main charger grid.

[CD40] Waste toner box full error

Classification	Contents
Copy Process related service call	Waste toner box full is detected.

Check Item	Measures
Waste toner box	<ol style="list-style-type: none">1. Replace the waste toner box with a new one.2. Turn the power OFF and then back ON.
Clear the counter	<ol style="list-style-type: none">1. Set the value of FS-08-4541 to "0".2. Turn the power OFF and then back ON.

Parts to be replaced	Remark
Waste toner box	

8.3.24 Other service call

[F100_0] HDD format error (Operation failure of key data)

Classification	Contents
Other service call	Operation of HDD key data fails.

Check item	Measures
Setting	Reboot the equipment. If it cannot be recovered, reinstall the software in the following procedure. 1. Install the system firmware. 📖 P. 11-2 "11.2 Firmware Updating with USB Device"
SRAM	Replace the SRAM.
SYS board	Replace the SYS board.

Parts to be replaced	Remark
SRAM	Be sure to exchange the parts in the order of the SRAM and SYS board.
SYS board	Be sure to exchange the parts in the order of the SRAM and SYS board.

[F100_1] HDD format error (HDD encryption key data damaged - one board)

Classification	Contents
Other service call	Encryption key data of either the SYS board or the SRAM are damaged.

Check item	Measures
Encryption key status	Check the displayed message. (HS-73 Firmware Assist mode > Key Backup/Restore)

Take appropriate countermeasures shown in the table below according to the messages displayed in "SRAM" and "FROM".

Remarks:

If the error is not cleared, reinstallation of the system firmware and system software is needed. (HS-49 Firmware Update mode)

📖 P. 11-2 "11.2 Firmware Updating with USB Device"

SRAM	FROM	Measures
OK	AccessFailed	Replace the SYS board. 📖 P. 9-30 "9.2.4 Precautions and procedures when replacing the SYS board"(all steps)
OK	KeyNull KeyBroken	Recover the encryption key on the SYS board. 📖 P. 9-30 "9.2.4 Precautions and procedures when replacing the SYS board"(📖 P. 9-32 "[D] Restore encryption key")
AccessFailed	OK	Replace the SRAM. (USB backup data are not used) 📖 P. 9-30 "9.2.4 Precautions and procedures when replacing the SYS board"(all steps)
KeyNull KeyBroken	OK	Recover the encryption key on the SRAM. 📖 P. 9-34 "9.2.5 Precautions and procedure when replacing the SRAM"(📖 P. 9-37 "[H] Backup encryption key (FROM > SRAM)")

SRAM	FROM	Measures
Keymismatch	Keymismatch	<p><The error occurs when the SYS board is replaced> Recover the encryption key on the SYS board. 📖 P. 9-30 "9.2.4 Precautions and procedures when replacing the SYS board"(📖 P. 9-32 "[D] Restore encryption key")</p> <p><The error occurs except when the SYS board is replaced> Replace the SRAM. 📖 P. 9-34 "9.2.5 Precautions and procedure when replacing the SRAM"(all steps)</p>

Parts to be replaced	Remark
SRAM	Be sure to exchange the parts in the order of the SRAM and SYS board.
SYS board	Be sure to exchange the parts in the order of the SRAM and SYS board.

[F100_2] HDD format error (HDD encryption key data damaged - both boards)

Classification	Contents
Other service call	Encryption key data of both the SYS board and the SRAM are damaged.







Check item	Measures
Encryption key status	Check the displayed message. (HS-73 Firmware Assist mode > Key Backup/Restore)

Take appropriate countermeasures shown in the table below according to the messages displayed in "SRAM" and "FROM".

Remarks:

If the error is not cleared, reinstallation of the system firmware / system software and application is needed. (HS-49 Firmware Update mode)

SRAM	FROM	Measures
*	AccessFailed	<p>Replace the SYS board. 📖 P. 9-30 "9.2.4 Precautions and procedures when replacing the SYS board"(all steps)</p> <p><With USB backup data: All key data recovery></p> <ol style="list-style-type: none"> 1. Recover all the data on the SRAM. HS-59 SRAM Data Cloning mode > Restore SRAM Data from USB (For details, see 📖 P. 12-2 "12.1.4 Cloning procedure"[B]Restore procedure.) 2. Recover the encryption key/license on the SYS board. Follow the procedures below noted in 📖 P. 9-30 "9.2.4 Precautions and procedures when replacing the SYS board". 📖 P. 9-32 "[C] Restore ADI key"(only when Secure HDD is installed) 📖 P. 9-32 "[D] Restore encryption key" 📖 P. 9-32 "[E] Restore license"
AccessFailed	*	<p>Replace the SRAM. 📖 P. 9-34 "9.2.5 Precautions and procedure when replacing the SRAM"(for the SYS board, all steps)</p>

SRAM	FROM	Measures
KeyNull/ KeyBroken	KeyNull/ KeyBroken	<p><No USB backup data></p> <p>1. Reinstall the system software.  P. 11-2 "11.2 Firmware Updating with USB Device"</p> <p><With USB backup data: All key data recovery></p> <p>1. Recover all the data on the SRAM. HS-59 SRAM Data Cloning mode > Restore SRAM Data from USB (For details, see  P. 12-2 "12.1.4 Cloning procedure"[B]Restore procedure.)</p> <p>2. Recover the encryption key/license on the SYS board. Follow the procedures below noted in  P. 9-30 "9.2.4 Precautions and procedures when replacing the SYS board".  P. 9-32 "[C] Restore ADI key"(only when Secure HDD is installed)  P. 9-32 "[D] Restore encryption key"  P. 9-32 "[E] Restore license"</p>

* AccessFailed, KeyNull or KeyBroken

Parts to be replaced	Remark
SRAM	Be sure to exchange the parts in the order of the SRAM and SYS board.
SYS board	Be sure to exchange the parts in the order of the SRAM and SYS board.

[F100_3] Serial number value error

Classification	Contents
Other service call	Only the first two characters of the serial number are entered. (The serial number is not completely entered.)

Check item	Measures
Serial number	Enter the serial number with [FS-08-9601]. If an F100_3 error occurs at the FS Menu startup, select HS-76 SRAM clear mode > Set Serial Number and enter the serial number.

[F100_4] Hash check error of encryption partition key

Classification	Contents
Other service call	Hash check error of encryption partition key.

Check item	Measures
SYS board	Replace the SYS board.  P. 9-30 "9.2.4 Precautions and procedures when replacing the SYS board"

Parts to be replaced	Remark
SYS board	

[F101_0] HDD connection error (HDD connection cannot be detected)

[F101_1] Root partition mount error (HDD formatting fails)

[F101_2][F101_3] Partition mount error

Classification	Contents
Other service call	Sub-code 0: HDD connection error (HDD connection cannot be detected).Sub-code 1: The HDD cannot be connected (mounted) caused by damage to the areas in which the program is mainly stored. Sub-code 2, 3: The areas other than those described in the F101_1 and F101_4 to F101_10 errors are damaged.

Check item	Measures
HDD, SYS board, Setting	<ol style="list-style-type: none"> 1. Turn the power of the equipment OFF and check the connection of the HDD. <ul style="list-style-type: none"> - Connector and harness check - Check if the connector pins of the HDD are bent. - Check if HDD for other equipment is not installed. - Check if SRAM for other equipment is not installed. 2. If the error still occurs after step 1, perform the following. <ul style="list-style-type: none"> - Perform HS-73 Firmware Assist mode > Key Backup/Restore and check that each Key Status is "OK". - If not, recover the key (press [Key] and select the menu, and then press [Execute]). 3. If the error still persists after step 2, perform the following. <ul style="list-style-type: none"> - Perform HS-73 Firmware Assist mode > Format HDD, and then install "System Software (HD data)" with HS-49 Firmware Update mode. <p>Notes: The following items will be deleted by HS-73 Firmware Assist mode > Format HDD.</p> <ul style="list-style-type: none"> • Message Log • Job Log • Spool Data (Print, Email reception) • Template <p>If F101_1 occurs with secure HDD or the error persists after performing step 3, perform step 3 after performing the following.</p> <ul style="list-style-type: none"> - HS-74 HDD Assist mode > Revert Factory Initial Status HDD. 4. If the error persists even after step 3, replace the HDD harness. 5. If the error persists even after step 4, replace the HDD. 6. If the error persists even after step 5, replace the SYS board.

Parts to be replaced	Remark
HDD harness	Be sure to exchange the parts in the order of the HDD harness, HDD and SYS board.
HDD	Be sure to exchange the parts in the order of the HDD harness, HDD and SYS board.
SYS board	Be sure to exchange the parts in the order of the HDD harness, HDD and SYS board.

[F101_4] Partition mount error
[F101_12] Partition mount error

Classification	Contents
Other service call	Sub-code 4: The "/work" partition is damaged. Sub-code 12: File link error in the "/work" partition.

Check item	Measures
HDD, SYS board, Setting	<ol style="list-style-type: none"> 1. Turn the power of the equipment OFF and check the connection of the HDD. <ul style="list-style-type: none"> - Connector and harness check - Check if the connector pins of the HDD are bent. - Check if HDD for other equipment is not installed. - Check if SRAM for other equipment is not installed. 2. If the error still occurs after step 1, perform the following. <ul style="list-style-type: none"> - Perform HS-73 Firmware Assist mode > Key Backup/Restore and check that each Key Status is "OK". - If not, recover the key (press [Key] and select the menu, and then press [Execute]). 3. If the error persists after step 2, perform HS-75 File System Recovery mode > Recovery F/S > /work, and then restart the equipment. 4. If the error persists after step 3, perform HS-75 File System Recovery mode > Initialize HDD > /work, and then restart the equipment. 5. If the error still persists after step 4, perform the following. <ul style="list-style-type: none"> - Perform HS-73 Firmware Assist mode > Format HDD, and then install "System Software (HD data)" with HS-49 Firmware Update mode. <p>Notes: The following items will be deleted by performing HS-73 Firmware Assist mode > Format HDD.</p> <ul style="list-style-type: none"> • Message Log • Job Log • Spool Data (Print, Email reception) • Template <p>If the error still persists even after step 5, perform the following and then reattempt step 5.</p> <ul style="list-style-type: none"> - HS-74 HDD Assist mode > Revert Factory Initial Status HDD. 6. If the error persists even after step 5, replace the HDD harness. 7. If the error persists even after step 6, replace the HDD. 8. If the error persists even after step 7, replace the SYS board.

Parts to be replaced	Remark
HDD harness	Be sure to exchange the parts in the order of the HDD harness, HDD and SYS board.
HDD	Be sure to exchange the parts in the order of the HDD harness, HDD and SYS board.
SYS board	Be sure to exchange the parts in the order of the HDD harness, HDD and SYS board.

[F101_5] Partition mount error

Classification	Contents
Other service call	Sub-code 5: The "/registration" partition is damaged.

Check item	Measures
HDD, SYS board, Setting	<ol style="list-style-type: none"> 1. Turn the power of the equipment OFF and check the connection of the HDD. <ul style="list-style-type: none"> - Connector and harness check - Check if the connector pins of the HDD are bent. - Check if HDD for other equipment is not installed. - Check if SRAM for other equipment is not installed. 2. If the error still occurs after step 1, perform the following. <ul style="list-style-type: none"> - Perform HS-73 Firmware Assist mode > Key Backup/Restore and check that each Key Status is "OK". - If not, recover the key (press [Key] and select the menu, and then press [Execute]). 3. If the error persists after step 2, perform HS-75 File System Recovery mode > Recovery F/S > /registration, and then restart the equipment. 4. If the error persists after step 3, perform HS-75 File System Recovery mode > Initialize HDD > /registration, and then restart the equipment. 5. If the error still persists after step 4, perform the following. <ul style="list-style-type: none"> - Perform HS-73 Firmware Assist mode > Format HDD, and then install "System Software (HD data)" with HS-49 Firmware Update mode. <p>Notes: The following items will be deleted by performing HS-73 Firmware Assist mode > Format HDD.</p> <ul style="list-style-type: none"> • Message Log • Job Log • Spool Data (Print, Email reception) • Template <p>If the error still persists even after step 5, perform the following and then reattempt step 5.</p> <ul style="list-style-type: none"> - HS-74 HDD Assist mode > Revert Factory Initial Status HDD. 6. If the error persists even after step 5, replace the HDD harness. 7. If the error persists even after step 6, replace the HDD. 8. If the error persists even after step 7, replace the SYS board.

Parts to be replaced	Remark
HDD harness	Be sure to exchange the parts in the order of the HDD harness, HDD and SYS board.
HDD	Be sure to exchange the parts in the order of the HDD harness, HDD and SYS board.
SYS board	Be sure to exchange the parts in the order of the HDD harness, HDD and SYS board.

[F101_6] Partition mount error

Classification	Contents
Other service call	Sub-code 6: The “/backup” partition is damaged.

Check item	Measures
HDD, SYS board, Setting	<ol style="list-style-type: none"> 1. Turn the power of the equipment OFF and check the connection of the HDD. <ul style="list-style-type: none"> - Connector and harness check - Check if the connector pins of the HDD are bent. - Check if HDD for other equipment is not installed. - Check if SRAM for other equipment is not installed. 2. If the error still occurs after step 1, perform the following. <ul style="list-style-type: none"> - Perform HS-73 Firmware Assist mode > Key Backup / Restore and check that each Key Status is “OK”. - If not, recover the key (press [Key] and select the menu, and then press [Execute]). 3. If the error persists after step 2, perform HS-75 File System Recovery mode > Recovery F/S > /backup, and then restart the equipment. 4. If the error persists after step 3, perform HS-75 File System Recovery mode > Initialize HDD > /backup, and then restart the equipment. 5. If the error still persists after step 4, perform the following. <ul style="list-style-type: none"> - Perform HS-73 Firmware Assist mode > Format HDD, and then install “System Software (HD data)” with HS-49 Firmware Update mode. <p>Notes: The following items will be deleted by performing HS-73 Firmware Assist mode > Format HDD.</p> <ul style="list-style-type: none"> • Message Log • Job Log • Spool Data (Print, Email reception) • Template <p>If the error still persists even after step 5, perform the following and then reattempt step 5.</p> <ul style="list-style-type: none"> - HS-74 HDD Assist mode > Revert Factory Initial Status HDD. 6. If the error persists even after step 5, replace the HDD harness. 7. If the error persists even after step 6, replace the HDD. 8. If the error persists even after step 7, replace the SYS board.

Parts to be replaced	Remark
HDD harness	Be sure to exchange the parts in the order of the HDD harness, HDD and SYS board.
HDD	Be sure to exchange the parts in the order of the HDD harness, HDD and SYS board.
SYS board	Be sure to exchange the parts in the order of the HDD harness, HDD and SYS board.

[F101_7] Partition mount error

Classification	Contents
Other service call	Sub-code 7: The "/imagedata" partition is damaged.

Check item	Measures
HDD, SYS board, Setting	<ol style="list-style-type: none"> 1. Turn the power of the equipment OFF and check the connection of the HDD. <ul style="list-style-type: none"> - Connector and harness check - Check if the connector pins of the HDD are bent. - Check if HDD for other equipment is not installed. - Check if SRAM for other equipment is not installed. 2. If the error still occurs after step 1, perform the following. <ul style="list-style-type: none"> - Perform HS-73 Firmware Assist mode > Key Backup/Restore and check that each Key Status is "OK". - If not, recover the key (press [Key] and select the menu, and then press [Execute]). 3. If the error persists after step 2, perform HS-75 File System Recovery mode > Recovery F/S > /imagedata, and then restart the equipment. 4. If the error persists after step 3, perform HS-75 File System Recovery mode > Initialize HDD > /imagedata, and then restart the equipment. 5. If the error still persists after step 4, perform the following. <ul style="list-style-type: none"> - Perform HS-73 Firmware Assist mode > Format HDD, and then install "System Software (HD data)" with HS-49 Firmware Update mode. <p>Notes: The following items will be deleted by performing HS-73 Firmware Assist mode > Format HDD.</p> <ul style="list-style-type: none"> • Message Log • Job Log • Spool Data (Print, Email reception) • Template <p>If the error still persists even after step 5, perform the following and then reattempt step 5.</p> <ul style="list-style-type: none"> - HS-74 HDD Assist mode > Revert Factory Initial Status HDD. 6. If the error persists even after step 5, replace the HDD harness. 7. If the error persists even after step 6, replace the HDD. 8. If the error persists even after step 7, replace the SYS board.

Parts to be replaced	Remark
HDD harness	Be sure to exchange the parts in the order of the HDD harness, HDD and SYS board.
HDD	Be sure to exchange the parts in the order of the HDD harness, HDD and SYS board.
SYS board	Be sure to exchange the parts in the order of the HDD harness, HDD and SYS board.

[F101_8] Partition mount error

Classification	Contents
Other service call	Sub-code 8: The "/storage" partition is damaged.

Check item	Measures
HDD, SYS board, Setting	<ol style="list-style-type: none"> 1. Turn the power of the equipment OFF and check the connection of the HDD. <ul style="list-style-type: none"> - Connector and harness check - Check if the connector pins of the HDD are bent. - Check if HDD for other equipment is not installed. - Check if SRAM for other equipment is not installed. 2. If the error still occurs after step 1, perform the following. <ul style="list-style-type: none"> - Perform HS-73 Firmware Assist mode > Key Backup/Restore and check that each Key Status is "OK". - If not, recover the key (press [Key] and select the menu, and then press [Execute]). 3. If the error persists after step 2, perform HS-75 File System Recovery mode > Recovery F/S > /storage, and then restart the equipment. 4. If the error persists after step 3, perform HS-75 File System Recovery mode > Initialize HDD > /storage, and then restart the equipment. 5. If the error still persists after step 4, perform the following. <ul style="list-style-type: none"> - Perform HS-73 Firmware Assist mode > Format HDD, and then install "System Software (HD data)" with HS-49 Firmware Update mode. <p>Notes: The following items will be deleted by performing HS-73 Firmware Assist mode > Format HDD.</p> <ul style="list-style-type: none"> • Message Log • Job Log • Spool Data (Print, Email reception) • Template <p>If the error still persists even after step 5, perform the following and then reattempt step 5.</p> <ul style="list-style-type: none"> - HS-74 HDD Assist mode > Revert Factory Initial Status HDD. 6. If the error persists even after step 5, replace the HDD harness. 7. If the error persists even after step 6, replace the HDD. 8. If the error persists even after step 7, replace the SYS board.

Parts to be replaced	Remark
HDD harness	Be sure to exchange the parts in the order of the HDD harness, HDD and SYS board.
HDD	Be sure to exchange the parts in the order of the HDD harness, HDD and SYS board.
SYS board	Be sure to exchange the parts in the order of the HDD harness, HDD and SYS board.

[F101_9] Partition mount error

Classification	Contents
Other service call	Sub-code 9: The "/encryption" partition is damaged.

Check item	Measures
HDD, SYS board, Setting	<ol style="list-style-type: none"> 1. Turn the power of the equipment OFF and check the connection of the HDD. <ul style="list-style-type: none"> - Connector and harness check - Check if the connector pins of the HDD are bent. - Check if HDD for other equipment is not installed. - Check if SRAM for other equipment is not installed. 2. If the error still occurs after step 1, perform the following. <ul style="list-style-type: none"> - Perform HS-73 Firmware Assist mode > Key Backup/Restore and check that each Key Status is "OK". - If not, recover the key (press [Key] and select the menu, and then press [Execute]). 3. If the error persists after step 2, perform HS-75 File System Recovery mode > Recovery F/S > /encryption, and then restart the equipment. 4. If the error persists after step 3, perform HS-75 File System Recovery mode > Initialize HDD > /encryption, and then restart the equipment. 5. If the error still persists after step 4, perform the following. <ul style="list-style-type: none"> - Perform HS-73 Firmware Assist mode > Format HDD, and then install "System Software (HD data)" with HS-49 Firmware Update mode. <p>Notes: The following items will be deleted by performing HS-73 Firmware Assist mode > Format HDD.</p> <ul style="list-style-type: none"> • Message Log • Job Log • Spool Data (Print, Email reception) • Template <p>If the error still persists even after step 5, perform the following and then reattempt step 5.</p> <ul style="list-style-type: none"> - HS-74 HDD Assist mode > Revert Factory Initial Status HDD. 6. If the error persists even after step 5, replace the HDD harness. 7. If the error persists even after step 6, replace the HDD. 8. If the error persists even after step 7, replace the SYS board.

Parts to be replaced	Remark
HDD harness	Be sure to exchange the parts in the order of the HDD harness, HDD and SYS board.
HDD	Be sure to exchange the parts in the order of the HDD harness, HDD and SYS board.
SYS board	Be sure to exchange the parts in the order of the HDD harness, HDD and SYS board.

[F101_10] Partition mount error

Classification	Contents
Other service call	Sub-code 10: The "/application" partition is damaged.

Check item	Measures
HDD, SYS board, Setting	<ol style="list-style-type: none"> 1. Turn the power of the equipment OFF and check the connection of the HDD. <ul style="list-style-type: none"> - Connector and harness check - Check if the connector pins of the HDD are bent. - Check if HDD for other equipment is not installed. - Check if SRAM for other equipment is not installed. 2. If the error still occurs after step 1, perform the following. <ul style="list-style-type: none"> - Perform HS-73 Firmware Assist mode > Key Backup/Restore and check that each Key Status is "OK". - If not, recover the key (press [Key] and select the menu, and then press [Execute]). 3. If the error persists after step 2, perform HS-75 File System Recovery mode > Recovery F/S > /application, and then restart the equipment. 4. If the error persists after step 3, perform HS-75 File System Recovery mode > Initialize HDD > /application, and then restart the equipment. 5. If the error still persists after step 4, perform the following. <ul style="list-style-type: none"> - Perform HS-73 Firmware Assist mode > Format HDD, and then install "System Software (HD data)" with HS-49 Firmware Update mode. <p>Notes: The following items will be deleted by performing HS-73 Firmware Assist mode > Format HDD.</p> <ul style="list-style-type: none"> • Message Log • Job Log • Spool Data (Print, Email reception) • Template <p>If the error still persists even after step 5, perform the following and then reattempt step 5.</p> <ul style="list-style-type: none"> - HS-74 HDD Assist mode > Revert Factory Initial Status HDD. 6. If the error persists even after step 5, replace the HDD harness. 7. If the error persists even after step 6, replace the HDD. 8. If the error persists even after step 7, replace the SYS board.

Parts to be replaced	Remark
HDD harness	Be sure to exchange the parts in the order of the HDD harness, HDD and SYS board.
HDD	Be sure to exchange the parts in the order of the HDD harness, HDD and SYS board.
SYS board	Be sure to exchange the parts in the order of the HDD harness, HDD and SYS board.

[F101_11] Partition mount error

Classification	Contents
Other service call	HDD unmounted: Connection of HDD cannot be detected. Sub-code 11: A file in the "/platform" partition is damaged.

Check item	Measures
HDD, SYS board, Setting	<ol style="list-style-type: none"> 1. Turn the power of the equipment OFF and check the connection of the HDD. <ul style="list-style-type: none"> - Connector and harness check - Check if the connector pins of the HDD are bent. - Check if HDD for other equipment is not installed. - Check if SRAM for other equipment is not installed. 2. If the error persists after step 1, perform the following. <ul style="list-style-type: none"> - Perform HS-73 Firmware Assist mode > Format HDD, and then install "System Software (HD data)" with HS-49 Firmware Update mode. <p>Notes: The following items will be deleted by performing HS-73 Firmware Assist mode > Format HDD.</p> <ul style="list-style-type: none"> • Message Log • Job Log • Spool Data (Print, Email reception) • Template 3. If the error persists even after step 2, perform the following and then reattempt step 2. <ul style="list-style-type: none"> - HS-74 HDD Assist mode > Revert Factory Initial Status HDD. 4. If the error persists even after step 3, replace the HDD harness. 5. If the error persists even after step 4, replace the HDD. 6. If the error persists even after step 5, replace the SYS board.

Parts to be replaced	Remark
HDD harness	Be sure to exchange the parts in the order of the HDD harness, HDD and SYS board.
HDD	Be sure to exchange the parts in the order of the HDD harness, HDD and SYS board.
SYS board	Be sure to exchange the parts in the order of the HDD harness, HDD and SYS board.

[F101_13] Error due to damage to file

Classification	Contents
Other service call	HDD not mounted - The detection of the HDD has failed. Sub-code 13: The files under the "/imagedata" are corrupted.

Check item	Measures
HDD, SYS board, Setting	<ol style="list-style-type: none"> 1. Turn the power of the equipment OFF and check the connection of the HDD. <ul style="list-style-type: none"> - Check the connectors and harnesses. - Check if the connector pins of the HDD are bent. - Check if an HDD for other equipment is installed. - Check if a SRAM for other equipment is installed. 2. If the error still persists after step 1, perform the following items. <ul style="list-style-type: none"> - Perform HS-75 File System Recovery mode > Recovery F/S > /imagedata and reboot the equipment. 3. If the error still persists after step 2, perform the following items. <ul style="list-style-type: none"> - Perform HS-73 Firmware Assist mode > [Format HDD], and then reinstall "System Software (HD data)" with HS-49 Firmware Update mode. <p>Notes: The following items will be deleted by performing HS-73 Firmware Assist mode > [Format HDD].</p> <ul style="list-style-type: none"> • Message Log • Job Log • Spool Data (Print, Email reception) • Template 4. If the error still persists even after step 3, perform the following and then reattempt step 3. <ul style="list-style-type: none"> - HS-74 > [Revert Factory Initial Status HDD] 5. If the error still persists even after step 4, replace the HDD harness. 6. If the error still persists even after step 5, replace the HDD. 7. If the error still persists even after step 6, replace the SYS board.

Parts to be replaced	Remark
HDD harness	Be sure to exchange the parts in the order of the HDD harness, HDD and SYS board.
HDD	Be sure to exchange the parts in the order of the HDD harness, HDD and SYS board.
SYS board	Be sure to exchange the parts in the order of the HDD harness, HDD and SYS board.

[F101_14] Partition mount error

Classification	Contents
Other service call	Sub-code 14: HDD cannot be connected (mounted) due to damage to the "/rollback" partition.

Check item	Measures
HDD, SYS board, Setting	<ol style="list-style-type: none"> 1. Reboot the equipment. If the error still persists, perform the following steps. 2. Turn the power of the equipment OFF and check the connection of the HDD. <ul style="list-style-type: none"> - Connector and harness check - Check if the connector pins of the HDD are bent. - Check if an HDD for other equipment is installed. - Check if a SRAM for other equipment is installed. 3. If the error still persists after step 2, perform the following items. <ul style="list-style-type: none"> - Perform HS-73 Firmware Assist mode > [Format HDD], and then install "System Software (HD data)" with HS-49 Firmware Update mode. <p>Notes: The following items will be deleted by performing HS-73 Firmware Assist mode > [Format HDD].</p> <ul style="list-style-type: none"> • Message Log • Job Log • Spool Data (Print, Email reception) • Template 4. If the error still persists even after step 3, perform the following and then reattempt step 3. <ul style="list-style-type: none"> - HS-74 > [Revert Factory Initial Status HDD] 5. If the error still persists even after step 4, replace the HDD harness. 6. If the error still persists even after step 5, replace the HDD. 7. If the error still persists even after step 6, replace the SYS board.

Parts to be replaced	Remark
HDD harness	Be sure to exchange the parts in the order of the HDD harness, HDD and SYS board.
HDD	Be sure to exchange the parts in the order of the HDD harness, HDD and SYS board.
SYS board	Be sure to exchange the parts in the order of the HDD harness, HDD and SYS board.

- [F102] HDD start error
- [F103] HDD transfer time-out
- [F104] HDD data error
- [F105] HDD other error

Classification	Contents
Other service call	[F102] HDD cannot become "Ready" state. [F103] Reading / writing cannot be performed in the specified period of time. [F104] Abnormality is detected in the data of HDD. [F105] HDD other error.

Check item	Measures
HDD	<ul style="list-style-type: none"> Connector and harness check Check if the connector pins of the HDD are bent. Perform the bad sector check (FS-08-9072). If the check result is OK, recover the data in the HDD. If the check result is failed, replace the HDD.

Parts to be replaced	Remark
HDD harness	Be sure to exchange the parts in the order of the HDD harness, HDD and SYS board.
HDD	Be sure to exchange the parts in the order of the HDD harness, HDD and SYS board.
SYS board	Be sure to exchange the parts in the order of the HDD harness, HDD and SYS board.

[F106_0] HDD error (Illegal disk replacement detected)

Classification	Error item
Other service call	The Secure HDD has been replaced illegally to Normal HDD.

Check item	Measures
Setting	Check if the HDD has been replaced with a Normal HDD. 1. Start the equipment in the 4C mode: Perform HS-74 HDD assist mode. 2. Check the type of the HDD shown on the top left of the control panel display "Current HDD type". <ul style="list-style-type: none"> In case of Normal HDD, replace it with the original Secure HDD or a new Secure HDD. <p>Notes:</p> <ul style="list-style-type: none"> To replace with the original Secure HDD, start the equipment in the normal mode and then reinstall system software only if any abnormality occurs. In case of "Secure HDD" Check each item in the Measures field for the HDD below. If the error still occurs, reinstall the system software.
HDD	<ul style="list-style-type: none"> Connector check Harness check Follow the procedure below if no abnormality is found in the check items above. <ol style="list-style-type: none"> 1. Perform HS-74 HDD assist mode. > Revert Factory Initial Status HDD 2. Reinstall the system software. If the error persists even after above step, replace the HDD. If the equipment operation disabled after above step, replace the HDD.

Parts to be replaced	Remark
HDD harness	Be sure to exchange the parts in the order of the HDD harness, HDD and SYS board.
HDD	Be sure to exchange the parts in the order of the HDD harness, HDD and SYS board.
SYS board	Be sure to exchange the parts in the order of the HDD harness, HDD and SYS board.

[F106_1] HDD error (HDD type detection error)

Classification	Error item
Other service call	HDD type detection fails.

Check item	Measures
Setting	<ul style="list-style-type: none"> If the error is not recovered after rebooting the equipment or no abnormality is found on any check items for the HDD, reinstall the system software.
HDD	<ul style="list-style-type: none"> Connector check Harness check Perform HS-75 File system recovery mode. Check the file system and recover it if necessary. If the recovery fails, replace the HDD. If the equipment does not start in the HS-75 File system recovery mode, also replace the HDD. Check that either the Secure HDD or Normal HDD is mounted. <ol style="list-style-type: none"> Perform HS-74 HDD assist mode. Check the type of the HDD shown on the control panel display "Current HDD type". Normal status: Secure HDD or Normal HDD Abnormal status: Unknown HDD If "Unknown HDD" is displayed, reinstall the system software. If the error persists even after above step, replace the HDD. If the above step cannot be performed, replace the HDD.

Parts to be replaced	Remark
HDD harness	Be sure to exchange the parts in the order of the HDD harness, HDD and SYS board.
HDD	Be sure to exchange the parts in the order of the HDD harness, HDD and SYS board.
SYS board	Be sure to exchange the parts in the order of the HDD harness, HDD and SYS board.

[F106_2] HDD error (Secure HDD encryption key download operation error)

Classification	Error item
Other service call	Downloading of or consistency check for Secure HDD encryption key fails.

Check item	Measures
Setting	Checking of Secure HDD encryption key status 1. Perform HS-73 Assist mode. 2. Perform "Key Backup / Restore". 3. Check the status of the Secure HDD encryption key on the Key Backup / Restore menu. 4. After the operation is completed, shut down the equipment. <ul style="list-style-type: none"> • In case both the ADIKey SRAM/FROM status are OK Reinstall the system firmware. • In case either the ADIKey SRAM/FROM status is other than OK Restore the Secure HDD encryption key. • In case both of the ADIKey SRAM/FROM status are other than OK Reinstall the system software.
HDD	If the error persists even after above step, replace the HDD. If the equipment operation disabled after above step, replace the HDD.

Parts to be replaced	Remark
HDD harness	Be sure to exchange the parts in the order of the HDD harness, HDD and SYS board.
HDD	Be sure to exchange the parts in the order of the HDD harness, HDD and SYS board.
SYS board	Be sure to exchange the parts in the order of the HDD harness, HDD and SYS board.

[F106_3] HDD error (Secure HDD authentication Admin Password generation error)

Classification	Error item
Other service call	The generation of Secure HDD authentication Admin Password fails.

Check item	Measures
Setting	Perform HS-73 Assist mode > Format HDD, and then install the system software by performing HS-49 Firmware update mode > SYSTEM SOFTWARE (HD Data). Notes: The following items will be deleted by performing HS-73 Assist mode > Format HDD. <ul style="list-style-type: none"> • Message Log • Job Log • Spool Data (Print, Email reception) • Template
HDD	If the error persists even after above step, replace the HDD. If the equipment operation disabled after above step, replace the HDD.

Parts to be replaced	Remark
HDD harness	Be sure to exchange the parts in the order of the HDD harness, HDD and SYS board.
HDD	Be sure to exchange the parts in the order of the HDD harness, HDD and SYS board.
SYS board	Be sure to exchange the parts in the order of the HDD harness, HDD and SYS board.

[F106_4] HDD error (Authentication random number generation error)

Classification	Error item
Other service call	The generation of a random number for authentication data fails.

Check item	Measures
Setting	<p>Perform HS-73 Assist mode > Format HDD, and then install the system software by performing HS-49 Firmware update mode > SYSTEM SOFTWARE (HD Data).</p> <p>Notes: The following items will be deleted by performing HS-73 Assist mode > Format HDD.</p> <ul style="list-style-type: none"> • Message Log • Job Log • Spool Data (Print, Email reception) • Template
HDD	If the error persists even after above step, replace the HDD. If the equipment operation disabled after above step, replace the HDD.

Parts to be replaced	Remark
HDD harness	Be sure to exchange the parts in the order of the HDD harness, HDD and SYS board.
HDD	Be sure to exchange the parts in the order of the HDD harness, HDD and SYS board.
SYS board	Be sure to exchange the parts in the order of the HDD harness, HDD and SYS board.

[F106_5] HDD error (Authentication data transmission error)

Classification	Error item
Other service call	The transmission of authentication data fails.

Check item	Measures
Setting	<p>Perform HS-73 Assist mode > Format HDD, and then install the system software by performing HS-49 Firmware update mode > SYSTEM SOFTWARE (HD Data).</p> <p>Notes: The following items will be deleted by performing HS-73 Assist mode > Format HDD.</p> <ul style="list-style-type: none"> • Message Log • Job Log • Spool Data (Print, Email reception) • Template <ul style="list-style-type: none"> • In case this error occurred after returning SRAM data for SRAM cloning: Copy the Secure HDD key from FROM to SRAM. <ol style="list-style-type: none"> 1. Perform HS-73 Assist mode. 2. Select "Key Backup / Restore". 3. Check the status of the Secure HDD key on the Key/Backup Restore menu. 4. Select [ADiKey] twice. 5. Check that copying of the Secure HDD key from the FROM to SRAM is selected. 6. Press [Execute]. 7. When the restoring of the encryption key is completed, "Success" appears to the right-hand side of [ADiKey] FROM. 8. After the operation has been completed, shut down the equipment.

Check item	Measures
HDD	If the error persists even after above step, replace the HDD. If the equipment operation disabled after above step, replace the HDD.

Parts to be replaced	Remark
HDD harness	Be sure to exchange the parts in the order of the HDD harness, HDD and SYS board.
HDD	Be sure to exchange the parts in the order of the HDD harness, HDD and SYS board.
SYS board	Be sure to exchange the parts in the order of the HDD harness, HDD and SYS board.

[F106_6] [F106_7] [F106_8] [F106_10] [F106_UNDEF] HDD error (Error caused by reason other than F106_0 to 5 errors)

Classification	Error item
Other service call	Error caused by reason other than F106_0 to 5 errors.

Check item	Measures
Setting	Perform HS-73 Assist mode > Format HDD, and then install the system software by performing HS-49 Firmware update mode > SYSTEM SOFTWARE (HD Data). Notes: The following items will be deleted by performing HS-73 Assist mode > Format HDD. <ul style="list-style-type: none"> • Message Log • Job Log • Spool Data (Print, Email reception) • Template
HDD	If the error persists even after above step, replace the HDD. If the equipment operation disabled after above step, replace the HDD.

Parts to be replaced	Remark
HDD harness	Be sure to exchange the parts in the order of the HDD harness, HDD and SYS board.
HDD	Be sure to exchange the parts in the order of the HDD harness, HDD and SYS board.
SYS board	Be sure to exchange the parts in the order of the HDD harness, HDD and SYS board.

[F106_11] License damaged (HDD and SRAM)

Classification	Error content
License management	Both licenses registered in the HDD and SRAM are damaged.

Check item	Measures
Backup data	Restore the backup data in which all the activated licenses with the latest status are stored. Remarks: Applications with the trial license cannot be recovered from the backup data. If necessary, reinstall the applications.

Check item	Measures
License	<ul style="list-style-type: none"> If there are no backup data as above, reactivate all the licenses which have been activated in this equipment. If the functions have been activated by the export license file, import the license exported from the host unit of the equipment.

Parts to be replaced	Remark
HDD harness	Be sure to exchange the parts in the order of the HDD harness, HDD, SRAM and SYS board.
HDD	Be sure to exchange the parts in the order of the HDD harness, HDD, SRAM and SYS board.
SRAM	Be sure to exchange the parts in the order of the HDD harness, HDD, SRAM and SYS board.
SYS board	Be sure to exchange the parts in the order of the HDD harness, HDD, SRAM and SYS board.

[F106_12] License damaged (SRAM)



Classification	Error content
License management	The license registered in the SRAM is damaged.

Check item	Measures
-	<ol style="list-style-type: none"> Reboot the equipment. If the problem still persists, perform FS-08-9053 and reboot the equipment again. If the problem still occurs after performing step 2, replace the SRAM.

Parts to be replaced	Remark
SRAM	Be sure to exchange the parts in the order of the SRAM and SYS board.
SYS board	Be sure to exchange the parts in the order of the SRAM and SYS board.

[F109_0] Key consistency error (Consistency check operation error)

Classification	Contents
Other service call	Key consistency check on each key data fails.

Check item	Measures
Setting	Reboot the equipment. If it cannot be recovered, reinstall the software in the following procedure. <ol style="list-style-type: none"> Install the system firmware. If the error cannot be solved after installing the system firmware, reinstall the system software and application program.  P. 11-2 "11.2 Firmware Updating with USB Device"
SRAM	If the error is not cleared after the software reinstallation, replace the SRAM.  P. 9-34 "9.2.5 Precautions and procedure when replacing the SRAM"
SYS board	If the error is not cleared after this (see above), replace the SYS board.  P. 9-30 "9.2.4 Precautions and procedures when replacing the SYS board"

Parts to be replaced	Remark
SRAM	Be sure to exchange the parts in the order of the SRAM and SYS board.
SYS board	Be sure to exchange the parts in the order of the SRAM and SYS board.

[F109_1] Key consistency error (SRAM encryption AES key data damage)

Classification	Contents
Other service call	AES key data used for SRAM encryption are damaged.

Check item	Measures
Setting	Reboot the equipment. If it cannot be recovered, reinstall the software in the following procedure. 1. Install the system firmware. 2. If the error cannot be solved after installing the system firmware, reinstall the system software and application program. ⓘ P. 11-2 “11.2 Firmware Updating with USB Device”
SRAM	If the error is not cleared after the software reinstallation, replace the SRAM.
SYS board	If the error is not cleared after this (see above), replace the SYS board.

Parts to be replaced	Remark
SRAM	Be sure to exchange the parts in the order of the SRAM and SYS board.
SYS board	Be sure to exchange the parts in the order of the SRAM and SYS board.

[F109_2] Key consistency error (Signature Check public key damage)

Classification	Contents
Other service call	Public key data used for Integrity Check are damaged.

Check item	Measures
Setting	Reboot the equipment. If it cannot be recovered, reinstall the software in the following procedure. 1. Install the system firmware. 2. If the error cannot be solved after installing the system firmware, reinstall the system software and application program. ⓘ P. 11-2 “11.2 Firmware Updating with USB Device”
SRAM	If the error is not cleared after the software reinstallation, replace the SRAM.
SYS board	If the error is not cleared after this (see above), replace the SYS board.

Parts to be replaced	Remark
SRAM	Be sure to exchange the parts in the order of the SRAM and SYS board.
SYS board	Be sure to exchange the parts in the order of the SRAM and SYS board.

[F109_3] Key consistency error (HDD encryption parameter damage)

Classification	Contents
Other service call	Parameter used for HDD partition encryption are damaged.

Check item	Measures
Encryption key status confirmation	Check the message displayed by HS-73 Assist mode > Key Backup / Restore.

Take measures given in the following table according to the messages displayed in the SRAM and FROM fields.

Remarks:

If the error is not cleared, it is required to reinstall the system firmware and system software. (HS-49 Firmware update mode)

SRAM	FROM	Measures
*	AccessFailed	Replace the SYS board. ☞ P. 9-30 “9.2.4 Precautions and procedures when replacing the SYS board”(all steps) <With USB backup data: All key data recovery> 1. Recover all the data on the SRAM. HS-59 SRAM data cloning mode > Restore SRAM Data from USB (For details, see ☞ P. 12-2 “12.1.4 Cloning procedure”[B]Restore procedure.) 2. Recover the encryption key/license on the SYS board. Follow the procedures below noted in ☞ P. 9-30 “9.2.4 Precautions and procedures when replacing the SYS board”. ☞ P. 9-32 “[C] Restore ADI key”(only when Secure HDD is installed) ☞ P. 9-32 “[D] Restore encryption key” ☞ P. 9-32 “[E] Restore license”
AccessFailed	*	Replace the SYS board. ☞ P. 9-34 “9.2.5 Precautions and procedure when replacing the SRAM”(for the SYS board, all steps)
OK	KeyNull/ KeyBroken	Recover the encryption key on the SYS board. ☞ P. 9-30 “9.2.4 Precautions and procedures when replacing the SYS board”(☞ P. 9-32 “[D] Restore encryption key”)
AccessFailed	OK	Replace the SRAM. ☞ P. 9-34 “9.2.5 Precautions and procedure when replacing the SRAM”(all steps)
KeyNull/ KeyBroken	OK	Recover the encryption key on the SRAM. ☞ P. 9-34 “9.2.5 Precautions and procedure when replacing the SRAM”(☞ P. 9-37 “[H] Backup encryption key (FROM > SRAM)”)
KeyNull/ KeyBroken	KeyNull/ KeyBroken	<No USB backup data> 1. Reinstall the system software. ☞ P. 11-2 “11.2 Firmware Updating with USB Device” <With USB backup data: All key data recovery> 1. Recover all the data on the SRAM. HS-59 SRAM data cloning mode > Restore SRAM Data from USB (For details, see ☞ P. 12-2 “12.1.4 Cloning procedure”[B]Restore procedure.) 2. Recover the encryption key/license on the SYS board. Follow the procedures below noted in ☞ P. 9-30 “9.2.4 Precautions and procedures when replacing the SYS board”. ☞ P. 9-32 “[C] Restore ADI key”(only when Secure HDD is installed) ☞ P. 9-32 “[D] Restore encryption key” ☞ P. 9-32 “[E] Restore license”

* AccessFailed, KeyNull or KeyBroken

Parts to be replaced	Remark
SRAM	Be sure to exchange the parts in the order of the SRAM and SYS board.
SYS board	Be sure to exchange the parts in the order of the SRAM and SYS board.

[F109_4] Key consistency error (license data damage)

Classification	Contents
Other service call	The license data are damaged.

Check item	Measures
Encryption key status confirmation	Check the message displayed by HS-73 Assist mode > Key Backup / Restore.

Take appropriate countermeasures shown in the table below according to the messages displayed in the SRAM and FROM fields of LICENCE [F109_4].

Remarks:

If the error is not cleared, reinstallation of the system firmware and system software is needed. (HS-49 Firmware update mode)

SRAM License Status	FROM License Status	Measures
*	AccessFailed	Replace the SYS board. ☞ P. 9-30 "9.2.4 Precautions and procedures when replacing the SYS board"(all steps) <With USB backup data: All key data recovery> 1. Recover all the data on the board. HS-59 SRAM data cloning mode > Restore SRAM Data from USB (For details, see ☞ P. 12-2 "12.1.4 Cloning procedure"[B]Restore procedure.) 2. Recover the encryption key/license on the SYS board. Follow the procedures below noted in ☞ P. 9-30 "9.2.4 Precautions and procedures when replacing the SYS board". ☞ P. 9-32 "[C] Restore ADI key"(only when Secure HDD is installed) ☞ P. 9-32 "[D] Restore encryption key" ☞ P. 9-32 "[E] Restore license"
AccessFailed	*	Replace the SRAM. ☞ P. 9-34 "9.2.5 Precautions and procedure when replacing the SRAM"(all steps)
KeyMismatch	KeyMismatch	<The error occurs when the SYS board is replaced> Recover the license on the SYS board. (Transfer the license from SRAM to FROM.) ☞ P. 9-30 "9.2.4 Precautions and procedures when replacing the SYS board"(☞ P. 9-32 "[E] Restore license") <The error occurs except when the SYS board is replaced> Recover the license on the SRAM. (Transfer the license from FROM to SRAM.) ☞ P. 9-34 "9.2.5 Precautions and procedure when replacing the SRAM"(☞ P. 9-37 "[I] Backup license (FROM > SRAM)")

* AccessFailed or KeyMismatch

Parts to be replaced	Remark
SRAM	Be sure to exchange the parts in the order of the SRAM and SYS board.
SYS board	Be sure to exchange the parts in the order of the SRAM and SYS board.

[F109_5] Key consistency error (encryption key for HDD is damaged)

Classification	Contents
Other service call	Encryption key for HDD is damaged.

Check item	Measures
Encryption key status confirmation	Check the message displayed by HS-73 Assist mode > Key Backup Restore.

Take appropriate countermeasures shown in the table below according to the messages displayed in the SRAM and FROM fields of AGLNCKEY [F109_5] / AGLDECKEY [F109_5].

Remarks:

If the error is not cleared, reinstallation of the system firmware and system software is needed. (HS-49 Firmware update mode)

SRAM	FROM	Measures
*	AccessFailed	Replace the SYS board. ☞ P. 9-30 “9.2.4 Precautions and procedures when replacing the SYS board”(all steps) <With USB backup data: All key data recovery> 1. Recover all the data on the SRAM. HS-59 SRAM data cloning mode > Restore SRAM Data from USB (For details, see ☞ P. 12-2 “12.1.4 Cloning procedure”[B]Restore procedure.) 2. Recover the encryption key/license on the SYS board. Follow the procedures below noted in ☞ P. 9-30 “9.2.4 Precautions and procedures when replacing the SYS board”. ☞ P. 9-32 “[C] Restore ADI key”(only when Secure HDD is installed) ☞ P. 9-32 “[D] Restore encryption key” ☞ P. 9-32 “[E] Restore license”
AccessFailed	*	Replace the SRAM. ☞ P. 9-34 “9.2.5 Precautions and procedure when replacing the SRAM”(all steps)
OK	KeyNull/ KeyBroken	Recover the ADI key on the SYS board. ☞ P. 9-30 “9.2.4 Precautions and procedures when replacing the SYS board”(☞ P. 9-32 “[C] Restore ADI key”)
KeyNull/ KeyBroken	OK	Recover the ADI key on the SRAM. ☞ P. 9-34 “9.2.5 Precautions and procedure when replacing the SRAM”(☞ P. 9-36 “[G] Backup ADI key (FROM > SRAM)”)
KeyNull/ KeyBroken	KeyNull/ KeyBroken	<No USB backup data> 1. Create the partition in the HDD, and reinstall the system software. ☞ P. 9-25 “9.2.3 Precautions and procedures when replacing the HDD”(Perform step 3 or later in “[E]Replace / Format HDD”) <With USB backup data: All key data recovery> 1. Recover all the data on the SRAM. HS-59 SRAM data cloning mode > Restore SRAM Data from USB (For details, see ☞ P. 12-2 “12.1.4 Cloning procedure”[B]Restore procedure.) 2. Recover the encryption key/license on the SYS board. Follow the procedures below noted in ☞ P. 9-30 “9.2.4 Precautions and procedures when replacing the SYS board”. ☞ P. 9-32 “[C] Restore ADI key”(only when Secure HDD is installed) ☞ P. 9-32 “[D] Restore encryption key” ☞ P. 9-32 “[E] Restore license”

SRAM	FROM	Measures
KeyMismatch	KeyMismatch	<p><The error occurs when the SYS board is replaced> Recover the ADI key on the SYS board. (Transfer the ADI key from SRAM to FROM.) P. 9-30 "9.2.4 Precautions and procedures when replacing the SYS board" (P. 9-32 "[C] Restore ADI key")</p> <p><The error occurs except when the SYS board is replaced> Recover the ADI key on the SRAM. (Transfer the ADI key from FROM to SRAM.) P. 9-34 "9.2.5 Precautions and procedure when replacing the SRAM" (P. 9-36 "[G] Backup ADI key (FROM > SRAM)")</p>

* AccessFailed or KeyMismatch

Parts to be replaced	Remark
SRAM	Be sure to exchange the parts in the order of the SRAM and SYS board.
SYS board	Be sure to exchange the parts in the order of the SRAM and SYS board.

[F109_6] Key consistency error (administrator password error for HDD authentication)

Classification	Contents
Other service call	Administrator password error for HDD authentication.

Check item	Measures
Encryption key status confirmation	Check the message displayed by HS-73 Assist mode > Key Backup Restore.

Take appropriate countermeasures shown in the table below according to the messages displayed in the SRAM and FROM fields of AdminPassword [F109_6].

Remarks:

If the error is not cleared, reinstallation of the system firmware and system software is needed. (HS-49 Firmware update mode)

SRAM	FROM	Measures
*	AccessFailed	<p>Replace the SYS board. P. 9-30 "9.2.4 Precautions and procedures when replacing the SYS board"(all steps) <With USB backup data: All key data recovery> 1. Recover all the data on the SRAM. HS-59 SRAM data cloning mode > Restore SRAM Data from USB (For details, see P. 12-2 "12.1.4 Cloning procedure"[B]Restore procedure.) 2. Recover the encryption key/license on the SYS board. Follow the procedures below noted in P. 9-30 "9.2.4 Precautions and procedures when replacing the SYS board". P. 9-32 "[C] Restore ADI key"(only when Secure HDD is installed) P. 9-32 "[D] Restore encryption key" P. 9-32 "[E] Restore license"</p>
AccessFailed	*	<p>Replace the SRAM. P. 9-34 "9.2.5 Precautions and procedure when replacing the SRAM"(all steps)</p>
OK	KeyNull/ KeyBroken	<p>Recover the ADI key on the SYS board. P. 9-30 "9.2.4 Precautions and procedures when replacing the SYS board" (P. 9-32 "[C] Restore ADI key")</p>
KeyNull/ KeyBroken	OK	<p>Recover the ADI key on the SRAM. P. 9-34 "9.2.5 Precautions and procedure when replacing the SRAM" (P. 9-36 "[G] Backup ADI key (FROM > SRAM)")</p>

SRAM	FROM	Measures
KeyNull/ KeyBroken	KeyNull/ KeyBroken	<p><No USB backup data></p> <p>1. Create the partition in the HDD, and reinstall the system software. 9.2.3Precautions and procedures when replacing the HDD(Perform step 3 or later in “[E]Replace / Format HDD”)</p> <p><With USB backup data: All key data recovery></p> <p>1. Recover all the data on the SRAM. HS-59 SRAM data cloning mode > Restore SRAM Data from USB (For details, see P. 12-2 “12.1.4 Cloning procedure”[B]Restore procedure.)</p> <p>2. Recover the encryption key/license on the SYS board. Follow the procedures below noted in P. 9-30 “9.2.4 Precautions and procedures when replacing the SYS board”. P. 9-32 “[C] Restore ADI key”(only when Secure HDD is installed) P. 9-32 “[D] Restore encryption key” P. 9-32 “[E] Restore license”</p>
KeyMismatch	KeyMismatch	<p><The error occurs when the SYS board is replaced> Recover the ADI Key on the SYS board. (Transfer the ADI Key from SRAM to FROM.) P. 9-30 “9.2.4 Precautions and procedures when replacing the SYS board”(P. 9-32 “[C] Restore ADI key”)</p> <p><The error occurs except when the SYS board is replaced> Recover the ADI key on the SRAM. (Transfer the ADI Key from FROM to SRAM.) P. 9-34 “9.2.5 Precautions and procedure when replacing the SRAM”(P. 9-36 “[G] Backup ADI key (FROM > SRAM)”)</p>

* AccessFailed or KeyMismatch

Parts to be replaced	Remark
SRAM	Be sure to exchange the parts in the order of the SRAM and SYS board.
SYS board	Be sure to exchange the parts in the order of the SRAM and SYS board.

[F109_7] Hash check error of ADI-HDD authentication key

Classification	Contents
Other service call	Hash check error of ADI-HDD authentication key.



Check item	Measures
Setting	<p>Install the system software in the following procedure: HS-73 Assist mode > Format HDD > HS-49 Firmware update mode > SYSTEM SOFTWARE (HD Data)</p> <p>Notes: Once HS-73 Assist mode > Format HDD has been carried out, the user data are deleted.</p>
SRAM	If the error is not cleared after the software reinstallation, replace the SRAM.
SYS board	If the error is not cleared after this (see above), replace the SYS board.

Parts to be replaced	Remark
SRAM	Be sure to exchange the parts in the order of the SRAM and SYS board.
SYS board	Be sure to exchange the parts in the order of the SRAM and SYS board.

[F110] Communication error between the system-CPU and the scanner-CPU**[F111] Communication error between the system-CPU and the scanner-CPU**

Classification	Error content
Communication related service call	[F110] Communication error between the system-CPU and the scanner-CPU. [F111] Communication error between the system-CPU and the scanner-CPU.

Check item	Measures
Reproducibility	Turn the power OFF and then back ON using the main power switch.
Setting	<ul style="list-style-type: none"> • Check if the value of 08-9000 (Destination setting of the equipment) is set correctly. • Perform "Data transfer of characteristic value of scanner" (FS-05-3203) • Update the scanner firmware.
SYS board	<ul style="list-style-type: none"> • Check if the conductor pattern on the SYS board is short circuited or open circuited. • Connector check (CN122) • Harness check (CN122)

Parts to be replaced	Remark
SYS board	Refer to the following sections: <ul style="list-style-type: none"> •  P. 9-3 "9.1.4 SYS board" •  P. 9-30 "9.2.4 Precautions and procedures when replacing the SYS board"

[F119] Scanner abnormality detection

Classification	Error item
Scanning system related service call	Connection error between scanner CPU and system CPU.

Check item	Measures
SYS board	<ul style="list-style-type: none"> • Check if there is any abnormality in the appearance of parts mounted on the SYS board. • Replace the SYS board.

Parts to be replaced	Remarks
SYS board	

[F120] Database abnormality

Classification	Error item
Other service call	Database is not operating normally.

Check item	Measures
Setting	<ol style="list-style-type: none"> 1. Check that no jobs remain and rebuild the databases. <ul style="list-style-type: none"> - HS-75 File system recovery mode > Initialize database > LDAP DB and Log DB (Job,Msg). 2. If the error is not recovered, reinstall the system software. <ul style="list-style-type: none"> - HS-49 Firmware update mode > System Software(HD data) <p>Notes:</p> <ul style="list-style-type: none"> • If you rebuild the databases with a job remaining, delete it after finishing. • When "Rebuilding all databases" is performed, all data including log/user/role/group/department information and address book data are deleted. If you back up the data in advance, they will be recovered by restoring them after rebuilding the database.

Parts to be replaced	Remark
HDD	

[F121] Database abnormality (user information management database error)

Classification	Error item
Other service call	Login after the startup fails in any starting mode because user management database is corrupted.

Check item	Measures
Setting	<ol style="list-style-type: none"> 1. Check that no jobs remain and rebuild the databases. 2. Delete the data in the following procedure: <ul style="list-style-type: none"> - HS-75 File system recovery mode > Initialize database > LDAP database (Note that all user, role, group and accounting data will be deleted.) 3. If the error is not recovered, reinstall the system software. <ul style="list-style-type: none"> - HS-49 Firmware update mode > System Software(HD data) <p>Notes:</p> <ul style="list-style-type: none"> • If you rebuild the databases with a job remaining, delete it after finishing. • When "Rebuilding all databases" is performed, all data including log/user/role/group/department information and address book data are deleted. If you back up the data in advance, they will be recovered by restoring them after rebuilding the database.

Parts to be replaced	Remark
HDD	

[F122] Database abnormality (message / job log management database error)

Classification	Error item
Other service call	Login after the startup fails in any starting mode because log management database is corrupted.

Check item	Measures
Setting	<ol style="list-style-type: none"> 1. Check that no jobs remain and rebuild the databases. 2. Delete the data in the following procedure: <ul style="list-style-type: none"> - HS-75 File system recovery mode > Initialize database > Log database (jobs and messages) (Note that all job and message logs will be deleted.) 3. If the error is not recovered, reinstall the system software. <ul style="list-style-type: none"> - HS-49 Firmware update mode > System Software(HD data) <p>Notes:</p> <ul style="list-style-type: none"> • If you rebuild the databases with a job remaining, delete it after finishing. • When "Rebuilding all databases" is performed, all data including log/user/role/group/department information and address book data are deleted. If you back up the data in advance, they will be recovered by restoring them after rebuilding the database.

Parts to be replaced	Remark
HDD	

[F124] Database abnormality (application management database damage error)

Classification	Error item
Other service call	Application management database is damaged.

Check item	Measures
Setting	<ol style="list-style-type: none"> 1. Delete the journal file by the following procedure. <ul style="list-style-type: none"> - HS-75 File System recovery mode > Initialize DB > AppMgmt DB <p>Notes:</p> <p>All of the application information will be deleted.</p> <ol style="list-style-type: none"> 2. If the error is not recovered, reinstall the system software. <ul style="list-style-type: none"> - HS-49 Firmware update mode > System Software(HD data)

Parts to be replaced	Remark
HDD	

[F125] Database abnormality (Home screen database damage error)

Classification	Error item
Other service call	Home screen database is damaged.

Check item	Measures
Setting	<ol style="list-style-type: none"> 1. Delete the journal file by the following procedure. <ul style="list-style-type: none"> - HS-75 File System recovery mode > Initialize DB > HomeScreen DB 2. If the error is not recovered, reinstall the system software. <ul style="list-style-type: none"> - HS-49 Firmware update mode > System Software(HD data)

Parts to be replaced	Remark
HDD	

[F126] Database abnormality (Job history database damage error)

Classification	Error item
Other service call	Job history database is damaged.

Check item	Measures
Setting	<ol style="list-style-type: none"> Delete the journal file by the following procedure. <ul style="list-style-type: none"> HS-75 File System recovery mode > Initialize DB > JobHistory DB If the error is not recovered, reinstall the system software. <ul style="list-style-type: none"> HS-49 Firmware update mode > System Software(HD data)

Parts to be replaced	Remark
HDD	

[F127] Database abnormality (application license management database damage error)

Classification	Error item
Other service call	Application license management database is damaged.

Check item	Measures
Setting	<ol style="list-style-type: none"> Delete the journal file by the following procedure. <ul style="list-style-type: none"> HS-75 File System recovery mode > Initialize DB > AppLicense DB If the error is not recovered, reinstall the system software. <ul style="list-style-type: none"> HS-49 Firmware update mode > System Software(HD data)

Parts to be replaced	Remark
HDD	

[F128] License management database damage

Classification	Error content
License management	The license management database stored in the HDD has been damaged.

Check item	Measures
-	<p>Reboot the equipment.</p> <p>When a 71E0 error has appeared, perform its troubleshooting.</p> <p>If an F128 error has appeared again, perform the following procedure.</p> <ol style="list-style-type: none"> Open HS-[75 File System Recovery]-[Initialize DB]. Select [ULM DB] only and press [OK]. Reboot the equipment. When a 71E0 error has appeared, perform its troubleshooting.

Parts to be replaced	Remark
HDD	Be sure to exchange the parts in the order of the HDD and SRAM.
SRAM	Be sure to exchange the parts in the order of the HDD and SRAM.

[F130] Invalid MAC address

Classification	Contents
Other service call	This error occurs when the top 3 bytes of the MAC address is not "00", "80", "91".

Check item	Measures
Setting	This error occurs when the top 3 bytes of the MAC address is not "00", "80", "91".
SYS board	Replace the SYS board

Parts to be replaced	Remark
SYS board	

[F131] Filtering setting file damage error

Classification	Contents
Other service call	The filtering function is not working properly due to the damage to the file for the filtering setting.

Check item	Measures
Setting	<ol style="list-style-type: none"> 1. Check the bad sector of the HDD (FS-08-9072). If the result is "NG", replace the HDD. Notes: It may take more than 30 minutes to finish the checking. 2. Perform HS-73 Assist mode > Format HDD, and then reinstall the HDD software. Notes: User data will be deleted when HS-73 Assist mode > Format HDD is performed.

Parts to be replaced	Remarks
HDD	

[F140] ASIC format abnormality

Classification	Contents
Other service call	ASIC format abnormality.

Check item	Measures
SYS board	<ul style="list-style-type: none"> Connector check (CN129) Check if the connector is disconnected, the terminals are folded or there is any foreign matter. (When the DSDF I/F board installed, take it off to perform the check.) Board check Check both front and back side of the board if there is an abnormality such as staining, foreign matter or scratches around IC29 (indicated in the figure below). <div data-bbox="660 442 1251 846" style="text-align: center;"> </div> <p data-bbox="635 868 719 895">Fig.8-27</p>

Parts to be replaced	Remarks
SYS board	

[F150] Power failure during the manufacturing mode

Classification	Contents
Other service call	When a power failure occurred during the manufacturing mode, this error code appears at the next startup.

Check item	Measures
Power supply	<ul style="list-style-type: none"> Turn the power OFF and then back ON. Set the value of FS-08-9010 to "0". If it changes to another error code, follow the procedure for the changed error code.

[F200] Data Overwrite option (GP-1070) disabled

Classification	Contents
Other service call	Data Overwrite option (GP-1070) disabled.

Check item	Measures
Setting	Perform FS-08-3840 to install the Data Overwrite Enabler (GP-1070).

[F400] SYS board cooling fan abnormality

Classification	Contents
Circuit related service call	SYS board cooling fan abnormality.

Check item	Measures
SYS cooling fan	Check if the fan is rotating properly. If not, check if any foreign object is adhered.
SYS board	Check the connector (CN117) and relay connector.

Parts to be replaced	Remark
SYS cooling fan	Be sure to exchange the parts in the order of the SYS cooling fan and SYS board.
SYS board	Be sure to exchange the parts in the order of the SYS cooling fan and SYS board.

[F410] Power abnormality

Classification	Contents
Circuit related service call	This error occurs when the status of the LSI mounted on the SYS board has become an error due to a power abnormality. The equipment will be automatically rebooted at the first-time occurrence; however, the error history will not remain when rebooting is done automatically. This error code appears if an error has occurred continuously.

Check item	Measures
Power cable	Check that the power cable is inserted securely or it is not damaged.
User's site	<ul style="list-style-type: none">Do not plug any cables for other devices in the outlet to which that for the equipment is connected.The power cable co-packed with the equipment must be used without employing any extension cables.Be sure to use an outlet which is far from the one to which a device, such as an air conditioner or a printer, which uses a large amount of power is connected.
Board	<ol style="list-style-type: none">Power supply unitSYS board

Parts to be replaced	Remark
<ol style="list-style-type: none">Power supply unitSYS board	Be sure to exchange the power supply unit and the SYS board in the order described on the left-hand side.

[F510] Application start error

Classification	Error item
Other service call	The application fails to start.

Check item	Measures
Setting	<ol style="list-style-type: none">Reboot.If it has still not recovered, reinstall the system software.If it still persists after step 2, perform HS-73 Assist mode > Format HDD, and then reinstall the system software. <p>Notes: User data will be deleted when HS-73 Assist mode > Format HDD is performed.</p>

[F520] Operating system start error

Classification	Error item
Other service call	The operating system fails to start.

Check item	Measures
Setting	<ol style="list-style-type: none"> 1. Reboot. 2. If it has still not recovered, reinstall the system software. 3. If it still persists after step 2, perform HS-75 File System Recovery > Check F/S. If there is a partition in error, recover it in Recovery F/S. If the partition is not recovered, format it by Initialize HDD. 4. Reboot the equipment. Confirm that the equipment has started normally. If not, perform HS-73 Assist mode > Format HDD, and then reinstall the system software. <p>Notes:</p> <ul style="list-style-type: none"> • User data will be deleted when HS-73 Assist mode > Format HDD is performed. • User data will be deleted when HS-73 Assist mode > Format HDD is performed.

[F521] Integrity check error

Classification	Error item
Other service call	The program data fails to be authenticated.

Check item	Measures
Setting	<p>Restart the equipment.</p> <p>If the error is not recovered after restarting the equipment, reinstall software following.</p> <ul style="list-style-type: none"> • System software, application program, Engine firmware, Scanner firmware, FAX firmware (GD-1370)

[F523] Security check error at the startup

Classification	Error item
Other service call	An abnormality has been detected during the security condition check at the startup.

Check item	Measures
Setting	<p>Restart the equipment.</p> <p>If the error is not recovered after restarting the equipment, reinstall software following.</p> <ul style="list-style-type: none"> • System software, application program, Engine firmware, Scanner firmware, FAX firmware (GD-1370)

[F550] Encryption partition error

Classification	Error item
Other service call	The encryption partition fails to be read and written.

Check item	Measures
Setting	<ul style="list-style-type: none"> • Recover the encryption key with HS-73 Assist mode > Key Backup/Restore.

[F600] Firmware update error

Classification	Error item
Other service call	The firmware fails to be updated.

Check item	Measures
Setting	<ol style="list-style-type: none">1. Perform HS-73 Assist mode > Clear Error Flag in Software Installation.2. Reinstall the firmware in error displayed on the F600 error screen.

[F700] Overwrite error

Classification	Error item
Other service call	Overwriting fails.

Check item	Measures
Setting	<ul style="list-style-type: none">• If a service call occurs again after the reboot, replace the HDD.

Parts to be replaced	Remark
HDD	

[F800] Date error

Classification	Error item
Other service call	The year 2038 problem.

Check item	Measures
Setting	Reset the date, and request the administrator to set the date and time. <ol style="list-style-type: none">1. Perform HS-76 SRAM clear mode > Reset Date and Time.2. Request the administrator to set the date and time.

Parts to be replaced	Remark
SYS board	

[F900] Model information alignment error

Classification	Error item
Other service call	The model information is damaged.

Check item	Measures
Setting	<p>Recover the machine information by means of the following procedure.</p> <p><Machine information recovery></p> <ol style="list-style-type: none"> 1. Perform HS-76 SRAM clear mode > SRAM Re-Initialize. 2. After the operation is completed, shut down the equipment. * If it is not recovered, perform the following procedure. 3. Perform HS-73 Assist mode > Key Backup/Restore. 4. Press [Key] twice. 5. Check that copying of the key from the FROM to SRAM is selected. 6. Press [Execute]. 7. When the restoring of the key is completed, "Success" appears to the right-hand side of [Key] FROM. 8. After the operation is completed, shut down the equipment.

[F902_1] System firmware / system software model information consistency error

Classification	Error item
Other service call	Invalid system firmware / system software is installed.

Check item	Measures
Setting	<ol style="list-style-type: none"> 1. Confirm the model of the equipment. 2. Install the system firmware corresponding to the model. 📖 P. 11-2 "11.2 Firmware Updating with USB Device" 3. Install the system software corresponding to the model. 📖 P. 11-6 "11.2.4 Update procedure"
SYS board	Replace the SYS board.

Parts to be replaced	Remark
SYS board	

[F902_2] A model-unmatched SYS board is installed or the SRAM is cleared

Classification	Error item
Other service call	<ul style="list-style-type: none"> • The SYS board for e-STUDIO2010AC/2510AC is installed in 25/30/35/45/50 ppm. Or the opposite combination. • The SRAM is cleared.

Check item	Measures
SYS board	<ul style="list-style-type: none"> • Check if the model of the equipment matches the part number of the SYS board.

Check item	Measures
Setting	<p>Perform the following procedure if an error occurs when the SRAM is cleared.</p> <ol style="list-style-type: none"> 1. Perform FS-08 SETTING MODE. 2. When "SRAM REQUIRES INITIALIZATION" is displayed on the display, check the destination and then press the [START] button. If the destination is not correct, key in the correct one and then press the [START] button. 3. After the confirmation message is displayed, press the [Initialize] button. (SRAM is initialized.) 4. Enter the serial number (FS-08-9601). Match it with the serial number on the label attached to the rear cover of the equipment. 5. Initialize the NIC information (FS-08-9083). 6. Perform 05 ADJUSTMENT MODE. 7. Perform "Data transfer of characteristic value of scanner" (FS-05-3203, FS-05-3240). 8. Perform "Automatic gamma adjustment" <PPC> (FS-05-7869). 9. Perform "Automatic gamma adjustment" <PRT> (FS-05-8008, FS-05-8009). 10. Turn the power OFF and then back ON.

Parts to be replaced	Remark
SYS board	

[F902_3] SRAM abnormality on the SYS board



Classification	Contents
Other service call	SRAM abnormality on the SYS board.

Check Item	Measures
SRAM	<ol style="list-style-type: none"> 1. Check that the SRAM is installed properly. 2. Shut down the equipment. 3. Perform [FS-08]. 4. Press [CLASSIC]. 5. When "SRAM REQUIRES INITIALIZATION" appears on the LCD screen, confirm the destination and press the [START] button. If the destination is incorrect, enter the number for the correct one and press the [START] button. 6. When the confirmation message appears on the LCD screen, press [INITIALIZE]. (SRAM initialization starts.) 7. Enter the serial number of the equipment correctly. (FS-08-9601) 8. Initialize the NIC information. (FS-08-9083) 9. Shut down the equipment. 10. Perform [FS-05]. 11. Press [CLASSIC]. 12. Perform "Data transfer of characteristic value of scanner". (FS-05-3203, FS-05-3240) 13. By using the [4] [TEST PRINT] test pattern, perform "Automatic gamma adjustment" <PPC>. (FS-05-7869) 14. By using the [70] [TEST PRINT] test pattern, perform "Automatic gamma adjustment" <PRT>. (FS-05-8008, FS-05-8009) 15. Reboot the equipment. 16. If the error still occurs, replace the SRAM.
SYS board	Board check

Parts to be replaced	Remark
SRAM	Be sure to exchange the parts in the order of the SRAM and SYS board.
SYS board	Be sure to exchange the parts in the order of the SRAM and SYS board.

[F902_4] SYS board model information consistency error

Classification	Error item
Other service call	Invalid SYS board is installed to the equipment.

Check item	Measures
SYS board	Check if the model of the equipment matches the color of the label on the SYS board.  P. 9-3 "9.1.4 SYS board"
Setting	1. Install the system firmware. 2. If the error cannot be solved after installing the system firmware, reinstall the system software and application program.  P. 11-2 "11.2 Firmware Updating with USB Device"

Parts to be replaced	Remark
SYS board	

8.3.25 Error in Internet FAX / Scanning function

Notes:

When formatting the HDD (HS-75 > Initialize HDD > Clear Error Flag in Software Installation), all data in the shared folder, Electronic Filing, Address Book, template, etc. are erased. Back up these data before the initialization. Note that some of data cannot be backed up.

 P. 9-25 “9.2.3 Precautions and procedures when replacing the HDD”

[1] Internet FAX related error

[1C10] System access abnormality

Classification	Error item
Internet FAX related error	System access abnormality.

Check item	Measures
Setting	<ul style="list-style-type: none"> • Turn the power OFF and then back ON. Perform the job in error again. • If the error still persists, check if the settings of SSL/TLS and the authentication are specified properly in the SMTP client setting. • If the error nevertheless continues to persist, check if there are no jobs existing and then perform HDD formatting.

Parts to be replaced	Remarks

[1C32] File deletion failure

Classification	Error item
Internet FAX related error	File deletion failure.

Check item	Measures
Setting	<ul style="list-style-type: none"> • Turn the power OFF and then back ON. Perform the job in error again. • If the error still occurs, first, check if there are no jobs existing and then perform the HDD formatting (HS-75 File System Recovery mode > Initialize HDD > ALL).

Parts to be replaced	Remarks

[1C11] Insufficient memory

Classification	Error item
Internet FAX related error	Insufficient memory.

Check item	Measures
Setting	<ul style="list-style-type: none"> • When there are running jobs, perform the job in error again after the completion of the running jobs. • If the error still occurs, turn the power OFF and then back ON, and perform the job again.

Parts to be replaced	Remarks

[1C12] Message reception error**[1C13] Message transmission error**

Classification	Error item
Internet FAX related error	[1C12] Message reception error. [1C13] Message transmission error.

Check item	Measures
Setting	<ul style="list-style-type: none"> Turn the power OFF and then back ON. Perform the job in error again.

Parts to be replaced	Remarks

[1C14] Invalid parameter

Classification	Error item
Internet FAX related error	Invalid parameter.

Check item	Measures
Setting	<ul style="list-style-type: none"> When a template is used, form the template again. If the error still occurs, turn the power OFF and then back ON, and perform the job again.

Parts to be replaced	Remarks

[1C15] Exceeding file capacity

Classification	Error item
Internet FAX related error	Exceeding file capacity.

Check item	Measures
Setting	<ul style="list-style-type: none"> Reset and extend the "Maximum send to E-mail/iFAX size" or reduce the number of pages and perform the job again.

Parts to be replaced	Remarks

[1C30] Directory creation failure**[1C31] File creation failure****[1C33] File access failure**

Classification	Error item
Internet FAX related error	[1C30] Directory creation failure. [1C31] File creation failure. [1C33] File access failure.

Check item	Measures
Setting	<ul style="list-style-type: none"> Check if the access privilege to the storage directory is writable. Check if the server or local disk has a sufficient space in disk capacity.

Parts to be replaced	Remarks

[1C40] Image conversion abnormality

Classification	Error item
Internet FAX related error	Image conversion abnormality.

Check item	Measures
Setting	<ul style="list-style-type: none"> • Turn the power OFF and then back ON. Perform the job in error again. • Replace the main memory and perform the job again.

Parts to be replaced	Remarks
Main memory	

[1C60] HDD full failure during processing

Classification	Error item
Internet FAX related error	HDD full failure during processing.

Check item	Measures
Setting	<ul style="list-style-type: none"> • Delete the job in progress or being set or in the HOLD/PRIVATE/PROOF/INVALID, and perform it again. • Check if the server or local disk has a sufficient space in disk capacity.

Parts to be replaced	Remarks

[1C61] AddressBook reading failure

Classification	Error item
Internet FAX related error	AddressBook reading failure.

Check item	Measures
Setting	<ul style="list-style-type: none"> • Turn the power OFF and then back ON. Perform the job in error again. • Reset the data in the AddressBook and perform the job again.

Parts to be replaced	Remarks

[1C63] Terminal IP address unset

Classification	Error item
Internet FAX related error	Terminal IP address unset.

Check item	Measures
Setting	<ul style="list-style-type: none">Reset the Terminal IP address.Turn the power OFF and then back ON. Perform the job in error again.

Parts to be replaced	Remarks

[1C64] Terminal mail address unset

Classification	Error item
Internet FAX related error	Terminal mail address unset.

Check item	Measures
Setting	<ul style="list-style-type: none">Reset the Terminal mail address.Turn the power OFF and then back ON. Perform the job in error again.

Parts to be replaced	Remarks

[1C65] SMTP mail address unset

Classification	Error item
Internet FAX related error	SMTP mail address unset.

Check item	Measures
Setting	<ul style="list-style-type: none">Reset the SMTP address and perform the job.Turn the power OFF and then back ON. Perform the job in error again.

Parts to be replaced	Remarks

[1C66] Server time-out error

Classification	Error item
Internet FAX related error	Server time-out error.

Check item	Measures
Setting	<ul style="list-style-type: none">Check if the SMTP server is operating properly.

Parts to be replaced	Remarks

[1C69] SMTP server connection error

Classification	Error item
Internet FAX related error	SMTP server connection error.

Check item	Measures
Setting	<ul style="list-style-type: none">Reset the login name or password of SMTP server and perform the job again.Check if the SMTP server is operating properly.

Parts to be replaced	Remarks

[1C6B] Terminal mail address error

Classification	Error item
Internet FAX related error	Terminal mail address error.

Check item	Measures
Setting	<ul style="list-style-type: none">Check the SMTP Authentication method.Check if there is an illegal character in the Terminal mail address.Set the correct SMTP Authentication method or delete the illegal character and reset the appropriate Terminal mail address, then perform the job again.

Parts to be replaced	Remarks

[1C6C] Destination mail address error

Classification	Error item
Internet FAX related error	Destination mail address error.

Check item	Measures
Setting	<ul style="list-style-type: none">Check if there is an illegal character in the Destination mail address.Delete the illegal character and reset the appropriate Destination mail address, then perform the job again.

Parts to be replaced	Remarks

[1C6D] System error

Classification	Error item
Internet FAX related error	System error.

Check item	Measures
Setting	<ul style="list-style-type: none">Turn the power OFF and then back ON. Perform the job in error again.If the error still occurs, replace the SYS board.

Parts to be replaced	Remarks
SYS board	

[1C70] SMTP client OFF

Classification	Error item
Internet FAX related error	SMTP client OFF.

Check item	Measures
Setting	<ul style="list-style-type: none"> Set the SMTP valid and perform the job again.

Parts to be replaced	Remarks

[1C71] SMTP authentication error

Classification	Error item
Internet FAX related error	SMTP authentication error.

Check item	Measures
Setting	<ul style="list-style-type: none"> Check that SMTP authentication method, login name and password are correct, then perform authentication again.

Parts to be replaced	Remarks

[1C72] POP before SMTP error

Classification	Error item
Internet FAX related error	POP before SMTP error.

Check item	Measures
Setting	<ul style="list-style-type: none"> Check that both the POP Before SMTP setting and POP3 setting are correct, then perform authentication again.

Parts to be replaced	Remarks

[1CC1] Power failure

Classification	Error item
Internet FAX related error	Power failure.

Check item	Measures
Setting	<ul style="list-style-type: none"> Check if the power cable is connected properly and it is inserted securely. Check if the power voltage is unstable.

Parts to be replaced	Remarks

[2] RFC related error

[2500] HOST NAME error (RFC: 500) / Destination mail address error (RFC: 500) / Terminal mail address error (RFC: 500)

[2501] HOST NAME error (RFC: 501) / Destination mail address error (RFC: 501) / Terminal mail address error (RFC: 501)

Classification	Error item
RFC related error	[2500] HOST NAME error (RFC: 500) / Destination mail address error (RFC: 500) / Terminal mail address error (RFC: 500) [2501] HOST NAME error (RFC: 501) / Destination mail address error (RFC: 501) / Terminal mail address error (RFC: 501)

Check item	Measures
Setting	<ul style="list-style-type: none"> • Check if the Terminal mail address and Destination mail address are correct. • Check if the mail server is operating properly. • Turn the power OFF and then back ON. Perform the job in error again.

Parts to be replaced	Remarks

[2503] Destination mail address error (RFC: 503)

[2504] HOST NAME error (RFC: 504)

[2551] Destination mail address error (RFC: 551)

Classification	Error item
RFC related error	[2503] Destination mail address error (RFC: 503) [2504] HOST NAME error (RFC: 504) [2551] Destination mail address error (RFC: 551)

Check item	Measures
Setting	<ul style="list-style-type: none"> • Check if the mail server is operating properly. • Turn the power OFF and then back ON. Perform the job in error again. • If the error still occurs, replace the SYS board.

Parts to be replaced	Remarks

[2550] Destination mail address error (RFC: 550)

Classification	Error item
RFC related error	Destination mail address error (RFC: 550)

Check item	Measures
Setting	<ul style="list-style-type: none"> • Check the state of the mail box in the mail server.

Parts to be replaced	Remarks

[2552] Terminal / Destination mail address error (RFC: 552)

Classification	Error item
RFC related error	Terminal / Destination mail address error (RFC: 552)

Check item	Measures
Setting	<ul style="list-style-type: none"> • Confirm the size on the mail server. • Transmit again in text mode or with lower resolution or divide the document and transmit again. • If the error still occurs, turn the power OFF and then back ON. Perform the job in error again.

Parts to be replaced	Remarks

[2553] Destination mail address error (RFC: 553)

Classification	Error item
RFC related error	Destination mail address error (RFC: 553)

Check item	Measures
Setting	<ul style="list-style-type: none"> • Check if there is an illegal character in the mail box in the mail server.

Parts to be replaced	Remarks

[3] Remote scanning related error

[2A20] System management module resource acquiring failure

Classification	Error item
Remote scanning related error	System management module resource acquiring failure.

Check item	Measures
Setting	<ul style="list-style-type: none"> • Retry the job in error. • If the error still occurs, turn the power OFF and then back ON, then retry the job in error.

Parts to be replaced	Remarks

[2A31] WS Scan disabled

Classification	Error item
Remote scanning related error	A job is performed while WS Scan function is disabled.

Check item	Measures
Setting	<ul style="list-style-type: none"> • Check if WS Scan (Web Scanning Services) function is disabled on the TopAccess screen. If it is disabled, enable it. • Or, check if the forcible encryption setting of the secure PDF is enabled.

Parts to be replaced	Remarks

[2A40] System error

Classification	Error item
Remote scanning related error	System error.

Check item	Measures
Setting	<ul style="list-style-type: none"> • Turn the power OFF and then back ON, then retry the job in error.

Parts to be replaced	Remarks

[2A51] Power failure

Classification	Error item
Remote scanning related error	Power failure.

Check item	Measures
Setting	<ul style="list-style-type: none"> • Check if the power cable is properly connected. • Check if the power supply voltage is inconstant.

Parts to be replaced	Remarks

[2A60] WS Scan user authentication failure

Classification	Error item
Remote scanning related error	WS Scan for job authentication failed.

Check item	Measures
Setting	<ul style="list-style-type: none"> • When "1" (TTEC's WIA driver) is set for FS-08-9749 and also Windows Fax&Scan is used Check if the user name that you used to log in Windows is a name registered as a user. • When MFP panel or EWB Scan is used Check if the login user name is a name registered as a user.

Parts to be replaced	Remarks

[2A70] Remote Scan privilege check error

Classification	Error item
Remote scanning related error	A job is performed by a user without Remote Scan privilege.

Check item	Measures
Setting	Check if correct privilege is given to the user.

Parts to be replaced	Remarks

[2A71] WS Scan privilege check error

Classification	Error item
Remote scanning related error	A job is performed by a user without WS Scan privilege.

Check item	Measures
Setting	Check if correct privilege is given to the user.

Parts to be replaced	Remarks

[2A72] e-Filing box data access privilege check error (Scan Utility)

Classification	Error item
Remote scanning related error	A user without e-Filing box data access privilege tried to use Scan utility.

Check item	Measures
Setting	Check if correct privilege is given to the user.

Parts to be replaced	Remarks

[2A73] Error in the AddressBook operation privilege check

Classification	Error item
Remote scanning related error	Error in the AddressBook operation privilege check.

Check item	Measures
Setting	A user, who does not have the Address book Remote Access privilege, has performed export/import of the address book. Check if the correct privilege is given to a user.

[4] e-Filing box related error
[2B11] Job status abnormality
[2B20] File library function error
[2B30] Insufficient disk space in BOX partition
[2BC0] Fatal failure occurred

Classification	Error item
e-Filing box related error	[2B11] Job status abnormality. [2B20] File library function error. [2B30] Insufficient disk space in BOX partition. [2BC0] Fatal failure occurred.

Check item	Measures
Setting	<ul style="list-style-type: none"> • Erase some data in the Electronic Filing or the shared folder and perform the job in error again (in case of [2B30]). Ask the administrator if e-Filing has been disabled. • Turn the power OFF and then back ON. Perform the job in error again. • Check if there are no other running jobs and perform the HDD formatting (HS-75 File System Recovery mode > Initialize HDD > ALL). • If the recovery is still not completed, replace the SYS board.

Parts to be replaced	Remarks
SYS board	

[2B31] Status of the specified e-Filing box or folder is undefined or being created / deleted

Classification	Error item
e-Filing box related error	Status of the specified e-Filing box or folder is undefined or being created / deleted.

Check item	Measures
Setting	<ul style="list-style-type: none"> • Check if the specified Electronic Filing or folder exists. (If no, this error would not occur.) • Delete the specified Electronic Filing or folder. • Change the name of folder to be created. • Perform the job in error again.

Parts to be replaced	Remarks

[2B50] Image library error
[2B90] Insufficient memory capacity

Classification	Error item
e-Filing box related error	[2B50] Image library error. [2B90] Insufficient memory capacity.

Check item	Measures
Setting	<ul style="list-style-type: none"> • Turn the power OFF and then back ON. Perform the job in error again. • If the error still occurs, replace the main memory. • Delete the job in progress or being set or in the HOLD/PRIVATE/PROOF/INVALID, and retry the job in error.

Parts to be replaced	Remarks

[2B51] List library error

Classification	Error item
e-Filing box related error	List library error.

Check item	Measures
Setting	<ul style="list-style-type: none"> • Check if the Function list can be printed. • If it can be printed, retry the job which was in error. • If it cannot be printed, replace the main memory. • If it still cannot be printed, initialize the HDD (HS-75 File System Recovery mode > Initialize HDD > ALL).

Parts to be replaced	Remarks

[2BA0] Invalid Box password

Classification	Error item
e-Filing box related error	Invalid Box password.

Check item	Measures
Setting	<ul style="list-style-type: none"> • Check if the password is correct. • Reset the password. • When this error occurs when printing the data in the Electronic Filing, perform the printing with the administrator's password.

Parts to be replaced	Remarks

[2BA1] The specified paper size, color mode or resolution is not available

Classification	Error item
e-Filing box related error	Invalid paper size / color mode / resolution.

Check item	Measures
Setting	<ul style="list-style-type: none"> • The specified paper size, color mode or resolution cannot be used. Check the setting.

Parts to be replaced	Remarks

[2BB1] Power failure**[2BD0] Power failure during restoring of e-Filing box**

Classification	Error item
e-Filing box related error	[2BB1] Power failure. [2BD0] Power failure during restoring of e-Filing box.

Check item	Measures
Setting	<ul style="list-style-type: none"> • Check if the power cable is connected properly and it is inserted securely. • Check if the power voltage is unstable.

Parts to be replaced	Remarks

[2BE0] Machine parameter reading error

Classification	Error item
e-Filing box related error	Machine parameter reading error.

Check item	Measures
Setting	<ul style="list-style-type: none"> • Turn the power OFF and then back ON. Perform the job in error again.

Parts to be replaced	Remarks

[2BF0] Exceeding the maximum number of pages

Classification	Error item
e-Filing box related error	Exceeding the maximum number of pages.

Check item	Measures
Setting	<ul style="list-style-type: none"> • Reduce the number of inserting pages and perform the job again.

Parts to be replaced	Remarks

[2BF1] Exceeding the maximum number of documents

Classification	Error item
e-Filing box related error	Exceeding the maximum number of documents.

Check item	Measures
Setting	<ul style="list-style-type: none"> • Backup the documents in the box or folder to PC or delete them.

Parts to be replaced	Remarks

[2BF2] Exceeding the maximum number of folders

Classification	Error item
e-Filing box related error	Exceeding the maximum number of folders.

Check item	Measures
Setting	<ul style="list-style-type: none"> • Backup the folders in the box or folder to PC or delete them.

Parts to be replaced	Remarks

[5] E-mail related error**[2C10] System access abnormality**

Classification	Error item
E-mail related error	System access abnormality.

Check item	Measures
Setting	<ul style="list-style-type: none"> • Turn the power OFF and then back ON. Perform the job in error again. • If the error still persists, check if the settings of SSL/TLS and the authentication are specified properly in the SMTP client setting. • If the error nevertheless continues to persist, check if there are no jobs existing and then perform HDD formatting.

Parts to be replaced	Remarks

[2C32] File deletion failure

Classification	Error item
E-mail related error	File deletion failure.

Check item	Measures
Setting	<ul style="list-style-type: none"> • Turn the power OFF and then back ON. Perform the job in error again. • If the error still occurs, first, check if there are no jobs existing and then perform the HDD formatting (HS-75 File System Recovery mode > Initialize HDD > ALL).

Parts to be replaced	Remarks

[2C11] Insufficient memory

Classification	Error item
E-mail related error	Insufficient memory.

Check item	Measures
Setting	<ul style="list-style-type: none"> When there are running jobs, perform the job in error again after the completion of the running jobs. If the error still occurs, turn the power OFF and then back ON, and perform the job again.

Parts to be replaced	Remarks

[2C12] Message reception error
[2C13] Message transmission error

Classification	Error item
E-mail related error	[2C12] Message reception error. [2C13] Message transmission error.

Check item	Measures
Setting	<ul style="list-style-type: none"> Turn the power OFF and then back ON. Perform the job in error again.

Parts to be replaced	Remarks

[2C14] Invalid parameter

Classification	Error item
E-mail related error	Invalid parameter.

Check item	Measures
Setting	<ul style="list-style-type: none"> When a template is used, form the template again. If the error still occurs, turn the power OFF and then back ON, and perform the job again.

Parts to be replaced	Remarks

[2C15] Exceeding file capacity

Classification	Error item
E-mail related error	Exceeding file capacity.

Check item	Measures
Setting	<ul style="list-style-type: none"> Reset and extend the "Maximum send to E-mail/iFAX size" or reduce the number of pages and perform the job again.

Parts to be replaced	Remarks

[2C20] System management module access abnormality**[2C21] Job control module access abnormality****[2C22] Job control module access abnormality**

Classification	Error item
E-mail related error	[2C20] System management module access abnormality. [2C21], [2C22] Job control module access abnormality.

Check item	Measures
Setting	<ul style="list-style-type: none"> • Turn the power OFF and then back ON. Perform the job in error again. • Check if there are no other running jobs and perform the HDD formatting (HS-75 File System Recovery mode > Initialize HDD > ALL). • If the recovery is still not completed, replace the SYS board.

Parts to be replaced	Remarks

[2C30] Directory creation failure**[2C31] File creation failure****[2C33] File access failure**

Classification	Error item
E-mail related error	[2C30] Directory creation failure. [2C31] File creation failure. [2C33] File access failure.

Check item	Measures
Setting	<ul style="list-style-type: none"> • Check if the access privilege to the storage directory is writable. • Check if the server or local disk has a sufficient space in disk capacity.

Parts to be replaced	Remarks

[2C40] Image conversion abnormality**[2C62] Memory acquiring failure**

Classification	Error item
E-mail related error	[2C40] Image conversion abnormality. [2C62] Memory acquiring failure.

Check item	Measures
Setting	<ul style="list-style-type: none"> • Turn the power OFF and then back ON. Perform the job in error again. • Replace the main memory and perform the job again.

Parts to be replaced	Remarks
Main memory	

[2C43] Encryption error

Classification	Error item
E-mail related error	Encryption error.

Check item	Measures
Setting	<ul style="list-style-type: none">Turn the power OFF and then back ON. Perform the job in error again.

Parts to be replaced	Remarks

[2C44] Encryption PDF enforced mode error

Classification	Error item
E-mail related error	Encryption PDF enforced mode error.

Check item	Measures
Setting	<ul style="list-style-type: none">Reset the encryption and perform the job in error again.If an image file not encrypted is created, consult your administrators.

Parts to be replaced	Remarks

[2C45] Meta data creation error (Scan to Email)

Classification	Error item
E-mail related error	Creation of meta data failed when a user tried to perform meta scan for Scan to Email.

Check item	Measures
Setting	Check the template settings. Perform the job in error again. If the error still occurs, turn the power OFF and then back ON, and then perform the job in error again.

Parts to be replaced	Remarks

[2C50] Authentication failure at job execution

Classification	Error item
E-mail related error	A Scan To File job is carried out while user authentication or department authentication has not been done.

Check item	Measures
Setting	Retry the job after user authentication or department authentication has been done.

[2C60] HDD full failure during processing

Classification	Error item
E-mail related error	HDD full failure during processing.

Check item	Measures
Setting	<ul style="list-style-type: none">• Delete the job in progress or being set or in the HOLD/PRIVATE/PROOF/INVALID, and perform it again.• Check if the server or local disk has a sufficient space in disk capacity.• Check that there is enough space in the server or local disk.

Parts to be replaced	Remarks

[2C61] AddressBook reading failure

Classification	Error item
E-mail related error	AddressBook reading failure.

Check item	Measures
Setting	<ul style="list-style-type: none">• Turn the power OFF and then back ON. Perform the job in error again.• Reset the data in the Address Book and perform the job again.

Parts to be replaced	Remarks

[2C63] Terminal IP address unset

Classification	Error item
E-mail related error	Terminal IP address unset.

Check item	Measures
Setting	<ul style="list-style-type: none">• Reset the Terminal IP address.• Turn the power OFF and then back ON. Perform the job in error again.

Parts to be replaced	Remarks

[2C64] Terminal mail address unset

Classification	Error item
E-mail related error	Terminal mail address unset.

Check item	Measures
Setting	<ul style="list-style-type: none">• Reset the Terminal mail address.• Turn the power OFF and then back ON. Perform the job in error again.

Parts to be replaced	Remarks

[2C65] SMTP address unset

Classification	Error item
E-mail related error	SMTP address unset.

Check item	Measures
Setting	<ul style="list-style-type: none"> Reset the SMTP address and perform the job. Turn the power OFF and then back ON. Perform the job in error again.

Parts to be replaced	Remarks

[2C66] Server time-out error

Classification	Error item
E-mail related error	Server time-out error.

Check item	Measures
Setting	<ul style="list-style-type: none"> Check if the SMTP server is operating properly.

Parts to be replaced	Remarks

[2C69] SMTP server connection error

Classification	Error item
E-mail related error	SMTP server connection error.

Check item	Measures
Setting	<ul style="list-style-type: none"> Reset the login name and password of SMTP server and perform the job again. Check if the SMTP server is operating properly.

Parts to be replaced	Remarks

[2C6A] HOST NAME error (No RFC error)

Classification	Error item
E-mail related error	HOST NAME error (No RFC error).

Check item	Measures
Setting	<ul style="list-style-type: none"> Check if there is an illegal character in the device name. Delete the illegal character and reset the appropriate device name.

Parts to be replaced	Remarks

[2C6B] Terminal mail address error

Classification	Error item
E-mail related error	Terminal mail address error.

Check item	Measures
Setting	<ul style="list-style-type: none"> • Check the SMTP Authentication method. • Check if there is an illegal character in the Terminal mail address. • Set the correct SMTP Authentication method or delete the illegal character and reset the appropriate Terminal mail address, then perform the job again.

Parts to be replaced	Remarks

[2C6C] Destination mail address error (No RFC error)

Classification	Error item
E-mail related error	Destination mail address error (No RFC error).

Check item	Measures
Setting	<ul style="list-style-type: none"> • Check if there is an illegal character in the Destination mail address. • Delete the illegal character and reset the appropriate Destination mail address, then perform the job again.

Parts to be replaced	Remarks

[2C70] SMTP client OFF

Classification	Error item
E-mail related error	SMTP client OFF.

Check item	Measures
Setting	<ul style="list-style-type: none"> • Set the SMTP valid and perform the job again.

Parts to be replaced	Remarks

[2C71] SMTP authentication error

Classification	Error item
E-mail related error	SMTP authentication error.

Check item	Measures
Setting	<ul style="list-style-type: none"> • Check that SMTP authentication method, login name and password are correct, then perform authentication again.

Parts to be replaced	Remarks

[2C72] POP before SMTP error

Classification	Error item
E-mail related error	POP before SMTP error.

Check item	Measures
Setting	<ul style="list-style-type: none"> Check that both the POP Before SMTP setting and POP3 setting are correct, then perform authentication again.

Parts to be replaced	Remarks

[2CC1] Power failure

Classification	Error item
E-mail related error	Power failure.

Check item	Measures
Setting	<ul style="list-style-type: none"> Check if the power cable is connected properly and it is inserted securely. Check if the power voltage is unstable.

Parts to be replaced	Remarks

[6] File sharing related error

[2D10] System access abnormality

[2D32] File deletion failure

[2DA6] File deletion failure

[2DA7] Resource acquiring failure

Classification	Error item
File sharing related error	[2D10] System access abnormality. [2D32] [2DA6] File deletion failure. [2DA7] Resource acquiring failure.

Check item	Measures
Setting	<ul style="list-style-type: none"> Delete some files in the shared folder by using Explorer because of automatic/manual file deletion failure (in case of [2DA6]) Turn the power OFF and then back ON. Perform the job in error again. If the error still occurs, first, check if there are no jobs existing and then perform HDD formatting (HS-75 File System Recovery mode > Initialize HDD > ALL).

Parts to be replaced	Remarks

[2D11] Insufficient memory

Classification	Error item
File sharing related error	Insufficient memory.

Check item	Measures
Setting	<ul style="list-style-type: none">When there are running jobs, perform the job in error again after the completion of the running jobs.If the error still occurs, turn the power OFF and then back ON, and perform the job again.

Parts to be replaced	Remarks

[2D12] Message reception error

[2D13] Message transmission error

Classification	Error item
File sharing related error	[2D12] Message reception error. [2D13] Message transmission error.

Check item	Measures
Setting	<ul style="list-style-type: none">Turn the power OFF and then back ON. Perform the job in error again.

Parts to be replaced	Remarks

[2D14] Invalid parameter

Classification	Error item
File sharing related error	Invalid parameter.

Check item	Measures
Setting	<ul style="list-style-type: none">When a template is used, form the template again.If the error still occurs, turn the power OFF and then back ON, and perform the job again.

Parts to be replaced	Remarks

[2D15] Exceeding the maximum size for file sharing

Classification	Error item
File sharing related error	Exceeding the maximum size for file sharing.

Check item	Measures
Setting	<ul style="list-style-type: none">Divide the file in error into several files and retry. Or retry the job in a single-page format.Delete the documents in the folder, and reattempt the job in error.

Parts to be replaced	Remarks

[2D30] Directory creation failure

[2D31] File creation failure

[2D33] File access failure

Classification	Error item
File sharing related error	[2D30] Directory creation failure. [2D31] File creation failure. [2D33] File access failure.

Check item	Measures
Setting	<ul style="list-style-type: none"> • Check if the access privilege to the storage directory is writable. • Check if the server or local disk has a sufficient space in disk capacity.

Parts to be replaced	Remarks

[2D40] Image conversion abnormality

Classification	Error item
File sharing related error	Image conversion abnormality.

Check item	Measures
Setting	<ul style="list-style-type: none"> • Turn the power OFF and then back ON. Perform the job in error again. • Replace the main memory and perform the job again.

Parts to be replaced	Remarks

[2D43] Encryption error

Classification	Error item
File sharing related error	Encryption error.

Check item	Measures
Setting	<ul style="list-style-type: none"> • Turn the power OFF and then back ON. Perform the job in error again.

Parts to be replaced	Remarks

[2D44] Encryption PDF enforced mode error

Classification	Error item
File sharing related error	Encryption PDF enforced mode error.

Check item	Measures
Setting	<ul style="list-style-type: none"> Reset the encryption and perform the job in error again. If an image file not encrypted is created, consult your administrators.

Parts to be replaced	Remarks

[2D45] Meta data creation error (Scan to File)

Classification	Error item
File sharing related error	Creation of meta data failed when a user tried to perform meta scan for Scan to File.

Check item	Measures
Setting	Check the template settings. Perform the job in error again. If the error still occurs, turn the power OFF and then back ON, and then perform the job in error again.

Parts to be replaced	Remarks

[2D50] Authentication failure at job execution

Classification	Error item
File sharing related error	A Scan To File job is carried out while user authentication or department authentication has not been done.

Check item	Measures
Setting	Retry the job after user authentication or department authentication has been done.

[2D62] File server connection failure

Classification	Error item
File sharing related error	File server connection failure.

Check item	Measures
Setting	<ul style="list-style-type: none"> Check the IP address or path of the server. Check if the server is operating properly.

Parts to be replaced	Remarks

[2D63] Invalid network path

Classification	Error item
File sharing related error	Invalid network path.

Check item	Measures
Setting	<ul style="list-style-type: none">• Check the network path.• If the path is correct, turn the power OFF and then back ON, and perform the job again.

Parts to be replaced	Remarks

[2D64] Login failure

Classification	Error item
File sharing related error	Login failure.

Check item	Measures
Setting	<ul style="list-style-type: none">• Reset the login name and password. Perform the job.• Check if the account of the server is properly set up.

Parts to be replaced	Remarks

[2D65] New document creation failure caused by an excess of documents in a folder

Classification	Error item
File sharing related error	New document creation failure caused by an excess of documents in a folder.

Check item	Measures
Setting	<ul style="list-style-type: none">• Delete some documents in the folder.

Parts to be replaced	Remarks

[2D66] Storage capacity full failure during processing

Classification	Error item
File sharing related error	Storage capacity full failure during processing.

Check item	Measures
Setting	<ul style="list-style-type: none">• Delete the job in progress or being set or in the HOLD/PRIVATE/PROOF/INVALID, and perform it again.• Check if the server or local disk has a sufficient space in disk capacity.• Check that there is enough space in the server or local disk.

Parts to be replaced	Remarks

[2D67] FTP service not available

Classification	Error item
File sharing related error	FTP service not available.

Check item	Measures
Setting	<ul style="list-style-type: none">• Check if the setting of FTP service is valid.

Parts to be replaced	Remarks

[2D68] File sharing service not available

Classification	Error item
File sharing related error	File sharing service not available.

Check item	Measures
Setting	<ul style="list-style-type: none">• Check if the setting of SMB is valid.

Parts to be replaced	Remarks

[2D69] NetWare service not available

Classification	Error item
File sharing related error	When a user tried to perform Scan to File with NetWare protocol even though the NetWare setting is disabled, a message notifies the user that NetWare service is disabled.

Check item	Measures
Setting	Check if the Netware setting is enabled.

Parts to be replaced	Remarks

[2DC1] Power failure

Classification	Error item
File sharing related error	Power failure.

Check item	Measures
Setting	<ul style="list-style-type: none">• Check if the power cable is connected properly and it is inserted securely.• Check if the power voltage is unstable.

Parts to be replaced	Remarks

[2E10] System access abnormality in USB storage

Classification	Error item
File sharing related error	Job status is invalid.

Check item	Measures
Setting	Turn the power OFF and then back ON. Perform the job in error again. If the error still occurs, first, check if there are no jobs existing and then perform HDD formatting (HS-75 File System Recovery mode > Initialize HDD > ALL).

Parts to be replaced	Remarks

[2E11] Insufficient memory capacity for USB storage

Classification	Error item
File sharing related error	Insufficient memory capacity for USB storage.

Check item	Measures
Setting	If there is a job in progress, perform the job in error again after the job in progress is finished. If the error still occurs, turn the power OFF and then back ON, and then perform the job in error again.

Parts to be replaced	Remarks

[2E12] Message reception error in USB storage

[2E13] Message transmission error in USB storage

Classification	Error item
File sharing related error	Job status is invalid.

Check item	Measures
Setting	Turn the power OFF and then back ON. Perform the job in error again.

Parts to be replaced	Remarks

[2E14] Invalid parameter for USB storage

Classification	Error item
File sharing related error	The specified parameter is invalid.

Check item	Measures
Setting	If a template is being used, recreate the template. If the error still occurs, turn the power OFF and then back ON. Perform the job in error again.

Parts to be replaced	Remarks

[2E15] Exceeding the maximum size for file sharing

Classification	Error item
File sharing related error	There are too many files in the folder. Creation of a document failed.

Check item	Measures
Setting	Delete some files in the folder. Perform the job in error again.

Parts to be replaced	Remarks

[2E30] Directory creation failure in USB storage

Classification	Error item
File sharing related error	Creation of a directory failed.

Check item	Measures
Setting	Check if access privilege to the storage directory is writable. Check if the server or local disk has sufficient space in its disk capacity.

Parts to be replaced	Remarks

[2E31] File creation failure in USB storage

Classification	Error item
File sharing related error	Creation of a file failed.

Check item	Measures
Setting	Check if access privilege to the storage directory is writable. Check if the server or local disk has sufficient space in its disk capacity.

Parts to be replaced	Remarks

[2E32] File deletion failure in USB storage

Classification	Error item
File sharing related error	Deletion of a file failed.

Check item	Measures
Setting	Turn the power OFF and then back ON. Perform the job in error again. If the error still occurs, first, check if there are no jobs existing and then perform HDD formatting (HS-75 > Initialize HDD > Clear Error Flag in Software Installation).

Parts to be replaced	Remarks

[2E33] File access failure in USB storage

Classification	Error item
File sharing related error	Access to a file failed.

Check item	Measures
Setting	Check if access privilege to the storage directory is writable. Check if the server or local disk has sufficient space in its disk capacity.

Parts to be replaced	Remarks

[2E40] Image conversion abnormality in USB storage

Classification	Error item
File sharing related error	Conversion of image file format failed.

Check item	Measures
Setting	Turn the power OFF and then back ON. Perform the job in error again. Replace the main memory and then perform the job in error again.

Parts to be replaced	Remarks

[2E43] Encryption failure in USB storage

Classification	Error item
File sharing related error	Creation of a file failed due to PDF encryption error.

Check item	Measures
Setting	Turn the power OFF and then back ON. Perform the job in error again.

Parts to be replaced	Remarks

[2E44] Encryption PDF enforced mode error in USB storage

Classification	Error item
File sharing related error	Creation of an image file is not permitted.

Check item	Measures
Setting	Reset the encryption and perform the job in error again. To create an image file not encrypted, consult your administrator.

Parts to be replaced	Remarks

[2E45] Meta data creation error in USB storage (Scan to File)

Classification	Error item
File sharing related error	Creation of meta data failed.

Check item	Measures
Setting	Check the template settings. Perform the job in error again. If the error still occurs, turn the power OFF and then back ON, and then perform the job in error again.

Parts to be replaced	Remarks

[2E50] Authentication failure at job execution

Classification	Error item
File sharing related error	A Scan To USB job is carried out while user authentication or department authentication has not been done.

Check item	Measures
Setting	A Scan To USB job is carried out while user authentication or department authentication has not been done. Retry the job after user authentication or department authentication has been done.

Parts to be replaced	Remarks

[2E65] File creation error due to insufficient USB folder capacity

Classification	Error item
File sharing related error	Creation of a new file failed because there were too many files in the USB folder.

Check item	Measures
Setting	Delete unnecessary files in the folder.

Parts to be replaced	Remarks

[2E66] HDD full failure during USB storage process

Classification	Error item
File sharing related error	HDD became full while storing data in HDD.

Check item	Measures
Setting	Delete the job in progress or being set or in the HOLD/PRIVATE/PROOF/INVALID, and perform it again. Check if the server or local disk has a sufficient space in disk capacity. Check that there is enough space in the USB memory.

Parts to be replaced	Remarks

[2EC1] Power failure in USB storage

Classification	Error item
File sharing related error	A job was interrupted due to a power failure.

Check item	Measures
Setting	Check if the power cable is connected properly and inserted securely. Check if the power voltage is unstable.

Parts to be replaced	Remarks

[7] E-mail reception related error

[3A10] E-mail MIME error

Classification	Error item
E-mail reception related error	E-mail MIME error.

Check item	Measures
Setting	<ul style="list-style-type: none">• The format of the mail is not corresponding to MIME 1.0.• Request the sender to retransmit the mail in the format corresponding to MIME 1.0.

Parts to be replaced	Remarks

[3A20] E-mail analysis error

[3B10] E-mail format error

[3B40] E-mail decode error

Classification	Error item
E-mail reception related error	[3A20] E-mail analysis error. [3B10] E-mail format error. [3B40] E-mail decode error.

Check item	Measures
Setting	<ul style="list-style-type: none">• These errors occur when the mail data is damaged from the transmission to the reception of the mail.• Request the sender to retransmit the mail.

Parts to be replaced	Remarks

[3A30] Partial mail time-out error

Classification	Error item
E-mail reception related error	Partial mail time-out error.

Check item	Measures
Setting	<ul style="list-style-type: none">• The partial mail is not received in a specified period of time.• Request the sender to retransmit the partial mail, or set the time-out period of the partial mail longer.

Parts to be replaced	Remarks

[3A40] Partial mail related error

Classification	Error item
E-mail reception related error	Partial mail related error.

Check item	Measures
Setting	<ul style="list-style-type: none">• The format of the partial mail is not compatible to this equipment.• Request the sender to remake and retransmit the partial mail in RFC2046 format.

Parts to be replaced	Remarks

[3A50] Insufficient HDD capacity error

Classification	Error item
E-mail reception related error	Insufficient HDD capacity error.

Check item	Measures
Setting	<ul style="list-style-type: none"> • This error occurs when the HDD capacity is not sufficient for a temporary concentration of the jobs, etc. • Request the sender to retransmit after a certain period of time, or divide the mail into more than one. • Insufficient HDD capacity error also occurs when printing cannot be performed for reasons such as lack of printing paper. • In this case, supply the printing paper.

Parts to be replaced	Remarks

[3A70] Error of partial mail interruption

Classification	Error item
E-mail reception related error	Error of partial mail interruption.

Check item	Measures
Setting	<ul style="list-style-type: none"> • This error occurs when the partial mail reception setting becomes OFF during the partial mail reception. • Reset the partial mail reception setting ON and then request the sender to retransmit the mail.

Parts to be replaced	Remarks

[3A80] Partial mail reception setting OFF

Classification	Error item
E-mail reception related error	Partial mail reception setting OFF.

Check item	Measures
Setting	Reset the partial mail reception setting ON and then request the sender to retransmit the mail.

Parts to be replaced	Remarks

[3B20] Content-Type error

Classification	Error item
E-mail reception related error	Content-Type error.

Check item	Measures
Setting	The file format attached to the e-mail is not supported by this equipment (TIFF-FX/PDF/JPEG/XPS). Or the combination of the file formats attached to the e-mail is not available to be received together by this equipment. (The file format TIFF-FX cannot be received together PDF, JPEG and XPS ones.) Request the sender to retransmit the file by modifying the file format which is supported by this equipment. Or request the sender to retransmit the e-mail by attaching only TIFF-FX format files or by attaching PDF, JPEG and XPS format files (a mixture of the formats is available).

Parts to be replaced	Remarks

[3B50] Received mail data deletion

Classification	Error item
E-mail reception related error	Received mail data deletion.

Check item	Measures
Setting	<ul style="list-style-type: none"> Mail data received have been deleted from a server as their reception process could not be carried out since they were broken. Check that the address of the mail sent immediately before the error was correct. Request the transmitter of the deleted mail to reattempt the transmission.

Parts to be replaced	Remarks

[3C10] TIFF analysis error

[3C13] TIFF analysis error

Classification	Error item
E-mail reception related error	TIFF analysis error.

Check item	Measures
Setting	<ul style="list-style-type: none"> These errors occur when the mail data is damaged from the transmission to the reception of the mail, or when the format of the attached file is not supported by this equipment (TIFF-FX). Request the sender to retransmit the mail.

Parts to be replaced	Remarks

[3C20] TIFF compression error

Classification	Error item
E-mail reception related error	TIFF compression error.

Check item	Measures
Setting	<ul style="list-style-type: none">The compression method of the TIFF file is not acceptable for this equipment. (Acceptable: MH/MR/MMR/JBIG)Request the sender to retransmit the file in the acceptable compression method.

Parts to be replaced	Remarks

[3C30] TIFF resolution error

Classification	Error item
E-mail reception related error	TIFF resolution error.

Check item	Measures
Setting	<ul style="list-style-type: none">The resolution of the TIFF file is not acceptable for this equipment. (Acceptable: 200 x 100, 200 x 200, 200 x 400, 400 x 400, 300 x 300 or equivalent)Request the sender to retransmit the file in the acceptable resolution.

Parts to be replaced	Remarks

[3C40] TIFF paper size error

Classification	Error item
E-mail reception related error	TIFF paper size error.

Check item	Measures
Setting	<ul style="list-style-type: none">The paper size of the TIFF file is not acceptable for this equipment. (Acceptable: A4, B4, A3, B5, LT, LG, LD or ST)Request the sender to retransmit the file in the acceptable paper size.

Parts to be replaced	Remarks

[3C50] Offramp destination error

Classification	Error item
E-mail reception related error	Offramp destination error.

Check item	Measures
Setting	<ul style="list-style-type: none"> • These errors occur when the FAX number of the offramp destination is incorrect. • Request the sender to correct the FAX number of offramp destination and then retransmit the mail.

Parts to be replaced	Remarks

[3C60] Offramp security error

Classification	Error item
E-mail reception related error	Offramp security error.

Check item	Measures
Setting	<ul style="list-style-type: none"> • These errors occur when the FAX number of the offramp destination is not on the Address Book. • Check if the FAX number of the offramp destination is correctly entered or the number has not been changed.

Parts to be replaced	Remarks

[3C70] Power failure error

Classification	Error item
E-mail reception related error	Power failure error.

Check item	Measures
Setting	<ul style="list-style-type: none"> • Check if the mail is recovered after turning ON the power again. • Request the sender to retransmit the mail if it is not recovered.

Parts to be replaced	Remarks

[3C90] Offramp Fax transmission disable error

Classification	Error item
E-mail reception related error	Offramp Fax transmission disable error.

Check item	Measures
Setting	This error is displayed when a Fax/Internet Fax transmission limitation error has occurred during OffRamp gateway function. Confirm if the Fax Send Function of MFP setting is disable or not.

[3D10] Destination address error

Classification	Error item
E-mail reception related error	Destination address error.

Check item	Measures
Setting	<ul style="list-style-type: none"> • Check if the setting of the server or DNS is correct. Correct if any of the setting is incorrect. • When the content of the setting is correct, confirm the sender if the destination is correct.

Parts to be replaced	Remarks

[3D20] Offramp destination limitation error

Classification	Error item
E-mail reception related error	Offramp destination limitation error.

Check item	Measures
Setting	Inform the sender that the transfer of the FAX data over 40 is not supported.

Parts to be replaced	Remarks

[3D30] FAX Unit error

Classification	Error item
E-mail reception related error	FAX Unit error.

Check item	Measures
Setting	<ul style="list-style-type: none"> • This error occurs when the FAX board is not installed or the FAX board has an abnormality. • Check if the FAX board is correctly connected.

Parts to be replaced	Remarks

[3E10] POP3 server connection error

Classification	Error item
E-mail reception related error	POP3 server connection error.

Check item	Measures
Setting	Check if the IP address or domain name of the POP3 server set for this equipment is correct, or check if POP3 server to be connected is operating properly.

Parts to be replaced	Remarks

[3E20] POP3 server connection time-out error

Classification	Error item
E-mail reception related error	POP3 server connection time-out error.

Check item	Measures
Setting	<ul style="list-style-type: none">• Check if POP3 server to be connected is operating properly.• Check if the LAN cable is correctly connected.

Parts to be replaced	Remarks

[3E30] POP3 login error

Classification	Error item
E-mail reception related error	POP3 login error.

Check item	Measures
Setting	Check if the POP3 server login name and password set for this equipment are correct.

Parts to be replaced	Remarks

[3E40] POP3 login type error

Classification	Error item
E-mail reception related error	POP3 login type error.

Check item	Measures
Setting	Check that the login type (Auto, POP3 or APOP) to the POP3 server is correct.

Parts to be replaced	Remarks

[3F10] File I/O error

[3F20] File I/O error

Classification	Error item
E-mail reception related error	File I/O error.

Check item	Measures
Setting	<ul style="list-style-type: none">• These errors occur when the mail data is not transferred properly to the HDD.• Request the sender to retransmit the mail.• Replace the HDD if the error still occurs after retransmission.

Parts to be replaced	Remarks

8.3.26 Printer function error

[4011] Print job cancellation

Classification	Error item
Printer function error	A print job (copy, list print, network print) is deleted from the print job screen.

Check item	Measures
Setting	This message appears when deleting the job on the screen.

[4021] Print job power failure

Classification	Error item
Printer function error	The power of the equipment is turned OFF during a print job (copy, list print, network print) process.

Check item	Measures
Setting	<ul style="list-style-type: none">When there are running jobs, perform the job in error again after the completion of the running jobs.If the error still occurs, turn the power OFF and then back ON, and perform the job again.

[4031] HDD full during print

Classification	Error item
Printer function error	A large amount of image data is saved in an HDD at private print or invalid network print.

Check item	Measures
Setting	Delete unnecessary private print jobs and invalid department print jobs. Check if the server or local disk has sufficient space in its disk capacity.

[4032] Exceeding the upper limit of the registration number for the sharing jobs

Classification	Error item
Printer function error	No more sharing jobs can be registered because its registration number as a personal or functional has reached the upper limit. (A specific error for the Serverless Location Free Print function)

Check item	Measures
Setting	Check that no unnecessary shared jobs yet to be printed are remaining. If there are such jobs, delete them.

[4033] Network setting error

Classification	Error item
Printer function error	A sharing job cannot be registered since the applicable address has not been found from the list used for the Serverless Location Free Print function. (A specific error for the Serverless Location Free Print function)

Check item	Measures
Setting	The address applicable to this equipment has not been registered in the cooperating machine list. Add the address applicable to this equipment.

[4041] User authentication error

Classification	Error item
Printer function error	The user who intended to print a document is not registered as a user.

Check item	Measures
Setting	Perform the authentication or register as a user, and then perform the printing again.

[4042] Department authentication error

Classification	Error item
Printer function error	The department whose code is specified for a print job is not registered.

Check item	Measures
Setting	Check department information registered in this equipment.

[4043] Project authentication error

Classification	Error item
Printer function error	The project whose code is specified for a print job is not registered.

Check item	Measures
Setting	Check project information registered in this equipment.

[4045] Problem in LDAP server connection or LDAP server authorization settings

Classification	Error item
Printer function error	Problem in LDAP server connection or LDAP server authorization settings.

Check item	Measures
Setting	Confirm the administrator for the LDAP server connection or LDAP server authorization settings.

[4111] Quota over error (no quota in a department and user)

Classification	Error item
Printer function error	The number of the assigned pages set by the department and user management has reached 0.

Check item	Measures
Setting	The number of the assigned pages set by the department and the number of those assigned by user management have both reached 0. Assign the number of the pages again or perform initialization.

[4112] Quota over error (no quota in a user)

Classification	Error item
Printer function error	The number of the assigned pages set by the user management has reached 0.

Check item	Measures
Setting	The number of the assigned pages set by the user management has reached 0. Assign the number of the pages again or perform initialization.

[4113] Quota over error (no quota in a department)

Classification	Error item
Printer function error	The number of the assigned pages set by the department management has reached 0.

Check item	Measures
Setting	The number of the assigned pages set by the department management has reached 0. Assign the number of the pages again or perform initialization.

[4121] Job canceling due to external counter error

Classification	Error item
Printer function error	Job canceling due to external counter error.

Check item	Measures
Setting	<ol style="list-style-type: none"> 1. Drop a coin in. Perform the print job in error again. 2. Insert a key card and then perform the print job in error again, or consult your administrator. 3. Insert a key copy counter and then perform the print job in error again. 4. Reset the scheduled print job and then perform the print job in error again.

[4211] Printing data storing limitation error

Classification	Error item
Printer function error	Printing with its data being stored to the HDD temporarily (Proof print, Private print, Scheduled print, etc.) has been performed.

Check item	Measures
Setting	Select "Normal Print", and then perform the printing again.

[4212] e-Filing box storing limitation error

Classification	Error item
Printer function error	Printing with its data being stored to the HDD (print and e-Filing, print to e-Filing, etc.) has been performed.

Check item	Measures
Setting	Select "Normal Print", and then perform the printing again.

[4213] File storing limitation error

Classification	Error item
Printer function error	The file storing function is set to "disabled".

Check item	Measures
Setting	The file storing function is set to "disabled". Check the settings of the equipment.

[4214] Fax / Internet Fax transmission limitation error

Classification	Error item
Printer function error	The Fax / Internet Fax transmission function or the Network Fax / Internet Fax function is set to "disabled".

Check item	Measures
Setting	Check the settings of this equipment.

[4221] Private-print-only error

Classification	Error item
Printer function error	Jobs other than Private print ones have been performed.

Check item	Measures
Setting	Select "Private print", and then perform the printing again.

[4222] Hold-print-only error

Classification	Error item
Printer function error	Hold-print-only error.

Check item	Measures
Setting	Email direct printing cannot be performed since Hold printing is not selectable for it.

[4223] Private-print-only / Hold-print-only error

Classification	Error item
Printer function error	Private-print-only / Hold-print-only error.

Check item	Measures
Setting	Email direct printing cannot be performed since Private printing and Hold printing are not selectable for it.

[4231] Hardcopy security printing error

Classification	Error item
Printer function error	A hardcopy security printing job has been performed when the function is restricted.

Check item	Measures
Setting	Hardcopy security printing cannot be performed because the function is restricted in the self-diagnosis mode. Check the settings of the equipment.

[4243] Sharing job - An error caused by not having a license

Classification	Error item
Printer function error	Sharing job - An error caused by not having a license.

Check item	Measures
Setting	Check that the license of the multi station print option is installed. If it is not, install it.

[4244] Sharing job - An error caused by function disabled

Classification	Error item
Printer function error	Sharing job - An error caused by function disabled.

Check item	Measures
Setting	Check from TopAccess whether the function of the multi station print option is disabled. If it is disabled, enable it.

[4245] OCR functions not available

Classification	Error item
Printer function error	OCR functions not available.

Check item	Measures
Setting	Check whether the OCR license or an extended memory is installed.

[4311] No privilege to perform a job

Classification	Error item
Printer function error	No privilege to perform a job.

Check item	Measures
Setting	Confirm the administrator for the JOB authorization.

[4312] Not authorized to store a file

Classification	Error item
Printer function error	Not authorized to store a file.

Check item	Measures
Setting	The user has not been authorized to perform this operation. Ask your administrator.

[4313] No privilege for e-Filing box storage**[4314] No privilege for Fax / Internet Fax transmission****[4321] No privilege for the print settings**

Classification	Error item
Printer function error	[4313] No privilege to store e-Filing box data is given. (e-Filing box storage permission) [4314] No privilege to send a Fax or Internet Fax jobs is given. (Fax / Internet Fax transmission permission) [4321] No privilege to the print with the specified settings is given. (Print setting permission)

Check item	Measures
Setting	Check the privilege given, or request the administrator to add the necessary privilege.

[4411] Image data creation failure

Classification	Error item
Printer function error	Image data creation failure.

Check item	Measures
Setting	Check if the file to be printed is broken. Perform printing again or use another printer driver. <ul style="list-style-type: none"> • Network print: Perform the print job in error again, or use another printer driver (e.g.; PS3, Universal). • Direct print: Check if the file is corrupted (e.g. checking if the file is displayed on your PC monitor), or check if the file format is supported by this equipment.

[4412] Double-sign encoding error

Classification	Error item
Printer function error	A double-sign encoding error has occurred because the PDF file is encrypted in a forbidden language or in a language not supported.

Check item	Measures
Setting	Printing using this function cannot be performed due to a decoding process error which occurs because the PDF file is encrypted incorrectly or encrypted in a language not supported.

[4511] Connection timeout

Classification	Error item
Printer function error	In the case the print data is not sent from the client PC during printing and print ends in error, or connection is not disconnected from the PC, timeout error is detected.

Check item	Measures
Setting	<ul style="list-style-type: none">• Check that the Ethernet setting of the MFP is the same as that for the hub to which the MFP is being connected.• Check that the Ethernet cable is connected properly.

[4521] Reaching the maximum number of connections

Classification	Error item
Printer function error	In the case the MFP reaches the max. number of connections and cannot receive a job.

Check item	Measures
Setting	<ul style="list-style-type: none">• Perform printing again after a certain period of time.• If this frequently occurs due to the network environment or the number of the client PCs, change the setting of the following self-diagnostic codes. FS-08-3727, FS-08-3731, FS-08-3732, FS-08-3765, FS-08-9561

[4522] Exceeding the upper limit of the registration number of jobs during data reception

Classification	Error item
Printer function error	Since the MFP nears the Workflow Full, reception of the jobs is limited.

Check item	Measures
Setting	<ul style="list-style-type: none">• Wait until the printing of the jobs which are being processed or are waiting is completed and then perform printing again.• Delete unnecessary private print jobs and invalid department print jobs and then perform printing again.

[4523] HDD full during data reception

Classification	Error item
Printer function error	Since the MFP nears the HDD Full, reception of the jobs is limited.

Check item	Measures
Setting	<ul style="list-style-type: none">• Delete unnecessary private print jobs and invalid department print jobs and then perform printing again.• Check if the server or local disk has sufficient space in its disk capacity.

[4611] Font download failure (exceeding the maximum number of registrations)**[4612] Font download failure (HDD full)**

Classification	Error item
Printer function error	[4611] A new font cannot be registered because the number of fonts registered in this equipment has already reached the limit. [4612] A new font cannot be registered because there is insufficient space in the font storage area of this equipment.

Check item	Measures
Setting	Delete one or more fonts already registered.

[4613] Font download failure (others)

Classification	Error item
Printer function error	A new font cannot be registered due to other abnormalities.

Check item	Measures
Setting	Reattempt the downloading. Recreate font data and reattempt the downloading.

[4621] Downloaded font deletion failure

Classification	Error item
Printer function error	The specified font cannot be deleted because it does not exist, it is undeletable or any another abnormality has occurred.

Check item	Measures
Setting	Check if the font to be deleted is registered (or pre-registered) in this equipment.

[4721] Connection Error of Multi Station Print (Unexpected combination of ROM version)

Classification	Error item
Printer function error	Connection failure of Multi Station Print because of an unexpected ROM version combination.

Check item	Measures
Check the version of the connected equipment.	Check the version of the equipment to connect and then update the version of the unconnectable equipment to become the same as that for the connected one.

[4F10] System abnormality

Classification	Error item
Printer function error	Printing was not performed successfully due to other abnormalities.

Check item	Measures
Setting	<ol style="list-style-type: none">1. Perform the job in error again. If the error still occurs, turn the power OFF and then back ON, and perform the job again.2. Collect the debug log with USB device. 📖 P. 8-3 "8.1.2 Collection of debug logs with a USB device"3. Initialize HDD. Refer to step 3 and later in *** 'Replace / Format HDD' on page 27 *** in 📖 P. 9-25 "9.2.3 Precautions and procedures when replacing the HDD".

8.3.27 TopAccess related error/Communication error with external application

[5012] Authentication error

Classification	Error item
Communication error with external application	A temporary password entered in this equipment by downloading from e-Bridge is invalid, or the permanent password set in e-Bridge is invalid.

Check item	Measures
Setting	Confirm the user name and temporary password.

[5013] Communication error between eBR

Classification	Error item
Communication error with external application	Communication is attempted while the eBR is enabled for some reason such as version upgrade.

Check item	Measures
Setting	Check if the MFP is connected to the eBR2 server.

[5014] No SSL certificate

Classification	Error item
Communication error with external application	There is no SSL certificate or the certificate is not in a correct file format.

Check item	Measures
Setting	Install the correct SSL certificate.

[5015] Invalid SSL certificate error

Classification	Error item
Communication error with external application	The SSL certificate is incorrect.

Check item	Measures
Setting	Install the correct SSL certificate.

[5016] Expired SSL certificate error

Classification	Error item
Communication error with external application	The SSL certificate is expired.

Check item	Measures
Setting	Set the correct time.

[5017] Other SSL certificate related error

Classification	Error item
Communication error with external application	The SSL certificate is invalid.

Check item	Measures
Setting	Install the correct SSL certificate.

[5018] Invalid DNS error

Classification	Error item
Communication error with external application	The DNS address is incorrect.

Check item	Measures
Setting	Set the correct DNS address. If any setting is needed in DNS, consult your administrators.

[5019] Connection error

Classification	Error item
Communication error with external application	Settings for the initial URL and proxy are incorrect.

Check item	Measures
Setting	Perform the correct settings for initial URL and proxy.

[501A] Proxy error

Classification	Error item
Communication error with external application	Settings for the IP address or port are incorrect.

Check item	Measures
Setting	Set the correct IP address or port for the proxy setting. If any setting is needed in proxy, consult your administrators.

[501B] No URL (host / port) or invalid path

Classification	Error item
Communication error with external application	The initial URL is incorrect.

Check item	Measures
Setting	Set the correct initial URL.

[5030] An error has occurred in the HTTP communication

Classification	Error item
Communication error with external application	An error in the HTTP communication.

Check item	Measures
Setting	Check the URL for communication. Check that the valid IP address is assigned to connect to the server.

[50FF] eBR2 internal error

Classification	Error item
Communication error with external application	A fatal error occurred in the MFP.

Check item	Measures
Setting	Restart the MFP, and then try again.

[5110] Toner cartridge detection error

Classification	Error item
TopAccess related error	Toner cartridge detection error.

Check item	Measures
Toner cartridge	<ul style="list-style-type: none"> Refer to the troubleshooting for C911/C912/C913/C914 error.  P. 8-217 "[C911] Toner cartridge PC board access abnormality (K)"

[5212] Time for cleaning of the main charger

Classification	Error item
TopAccess related error	Appears when the time for main charger cleaning comes (at the output of approx. every 10,000 sheets).

Check item	Measures
Main charger	<ul style="list-style-type: none"> Clean the main charger. If the message is not cleared after the cleaning, check if there is any detection error, breakage or poor connection of the needle electrode cleaner detection sensor.

[5310] Toner-K empty**[5311] Toner-Y empty****[5312] Toner-M empty****[5313] Toner-C empty**

Classification	Error item
TopAccess related error	The toner cartridge has become empty.

Check item	Measures
Toner cartridge	Replace the toner cartridges corresponding to the errors. If the errors still persist after replacement, check that the toner cartridge interface board (CTIF board) or the toner cartridge board (CTRG board) is connected properly.

[5410] MFP registration error

Classification	Error item
Communication error with external application	The serial number of the equipment is not registered in the Remote maintenance service. The registration processing from the equipment to the Remote maintenance service has failed.

Check item	Measures
Remote maintenance service setting	Contact the administrator of the Remote maintenance service to confirm that the serial number and model name of the equipment have been correctly imported to the Remote maintenance server. (Be sure the serial number of the equipment is CAPITALIZED.)

[5411] MFP registration lock error

Classification	Error item
Communication error with external application	Data to send to the Remote maintenance server from the equipment have been damaged or incorrect authentication data have been sent.

Check item	Measures
Setting of a remote maintenance service	Check that the local date and time are correctly set in the equipment. If not, enter the correct ones. If an error continues to be recorded for several days even though the date and time have been correctly set, contact the administrator of the Remote Maintenance service.

[5412] Server busy error

Classification	Error item
Communication error with external application	The Remote maintenance service cannot handle the periodic communication from the equipment due to overloading in the Remote maintenance service.

Check item	Measures
None	The equipment performs the periodic communication automatically. Therefore, check that no error will occur at the next periodic communication. If an error continues to be recorded for several days, contact the administrator of the Remote Maintenance service.

[5413] Server error

Classification	Error item
Communication error with external application	The server of the Remote maintenance service cannot make response to the equipment. A temporary power failure has occurred.

Check item	Measures
Remote maintenance service setting	Contact the administrator of the Remote maintenance service to confirm that the serial number and model name of the equipment have been correctly imported to the Remote maintenance server. (Be sure the serial number of the equipment is CAPITALIZED.) If an error continues to be recorded for several days, contact the administrator of the Remote Maintenance service.

[5414] Invalid device file error

Classification	Error item
Communication error with external application	A device file to sent to the Remote maintenance service from the equipment has been damaged.

Check item	Measures
Communication environment	The equipment performs the periodic communication automatically. Therefore, check that no error will occur at the next periodic communication. If an error continues to be recorded for several days, contact the administrator of the Remote Maintenance service.

[5415] Communication error

Classification	Error item
Communication error with external application	The equipment cannot communicate the Remote maintenance service.

Check item	Measures
Setting	Check that there is no problem in the wiring connection between the equipment and the Remote maintenance service as well as in the connection and setting of network devices.

[5416] Update failure of system software / setting files of the equipment

Classification	Error item
Communication error with external application	The setting files and the system software of the equipment cannot be updated because there is an ongoing job. There are too many printing and fax jobs which are ongoing.

Check item	Measures
Communication environment	Have the customer clear pending jobs in the equipment job queues and retry the update by the Remote maintenance service.

[5417] Invalid setting files of the equipment or system software

Classification	Error item
Communication error with external application	Upgrading has failed since the setting files of the equipment or the system software that has been downloaded from the Remote maintenance server has been incorrect or has been damaged.

Check item	Measures
Communication environment	Contact the administrator of the Remote maintenance service to check that the setting files of the equipment or the system software that has been downloaded is applicable to the model.

[5BD0] Power failure during restoration

Classification	Error item
TopAccess related error	Power supply has been cut off during the restoration of the database sent from TopAccess.

Check item	Measures
Power	<ul style="list-style-type: none">• Check if the power cable is connected properly and is inserted securely.• Check if the power voltage is unstable.• Reattempt the restoration of the database (Address Book, templates, F-code (Mailbox) or user information).

[5C10] FAX Unit attachment error

Classification	Error item
TopAccess related error	Network Fax is disabled because no FAX Unit is installed.

Check item	Measures
FAX unit	<ul style="list-style-type: none">• Check if the FAX Unit is attached.• Check if there is any damage or abnormality on the FAX Unit.• Check if the connector on the FAX Unit is connected properly.

[5C11] Network Fax transmission error

Classification	Error item
TopAccess related error	A Network Fax job has failed because the specified address is not registered in the AddressBook.

Check item	Measures
Setting	The address specified for the Network Fax is not registered on the AddressBook. Register it.

8.3.28 MFP access error

[6007] Unsuccessful User Login to MFP

Classification	Error item
MFP access error	User authentication cannot be done because connection to the authentication server has failed.

Check item	Measures
Setting	Check if the operating status of the server and connection from an MFP have been confirmed.

[6008] Connection failure to an external Role Base Access Control (LDAP) server

Classification	Error item
MFP access error	User authentication cannot be done because connection to an external RBAC server has failed.

Check item	Measures
Setting	Check if the operating status of the server and connection from the MFP have been confirmed.

[6009] User login failure to an MFP (during NIC initialization)

Classification	Error item
MFP access error	Connection to an authentication server failed since NIC initialization is being performed.

Check item	Measures
Setting	Perform the user log-in after NIC initialization has been completed.

[600A] Department code not assigned to a user

Classification	Error item
MFP access error	Authentication failed since the department code has not been assigned to the user.

Check item	Measures
Setting	Assign the department code to the user.

[6011] User automatic registration failure (due to an upper limit of the user registration number)

Classification	Error item
MFP access error	User automatic registration failed since the user registration number has reached the upper limit.

Check item	Measures
Setting	Delete unnecessary registered users.

[6013] Connection failure to the authentication server

Classification	Error item
MFP access error	Failed to connect to the authentication server.

Check item	Measures
Setting	Check that the server setting is proper by accessing [TopAccess] > [Administration] > [Maintenance] > [Directory Service]. When "Auto" is selected as the authentication method, this error may output to the log depending on the environment.

[6014] Inaccessible authentication server detection

Classification	Error item
MFP access error	The authentication server that cannot be accessed is detected.

Check item	Measures
Setting	There is an inaccessible authentication server. Make sure no authentication server is down. Access to the inaccessible server will be attempted again when the time set in FS-08-8788 has passed since the inaccessibility detection or when the equipment is turned off and on.

[6031] Invalid setting: Invalid CL code

Classification	Error item
MFP access error	A card is not usable as its CL code does not match.

Check item	Measures
Setting	Use an available card.

[6032] Card related error: Expired card

Classification	Error item
MFP access error	The card cannot be used because it has expired.

Check item	Measures
Setting	Use a card with a valid expiration.

[6033] Card related error: Invalid flag data (no room-entry data)

Classification	Error item
MFP access error	The card cannot be used because no room-entry data are recorded in it.

Check item	Measures
Setting	Use a correct card that has been used for entering the room.

[6034] Card related error: Invalid flag data (invalid card data)

Classification	Error item
MFP access error	The card cannot be used because the data required for the use of the card are not correctly set.

Check item	Measures
Setting	Use a valid card.

[6035] Invalid setting: Invalid flag information (not set in an MFP)

Classification	Error item
MFP access error	The necessary information in order to use a card is not set in the equipment.

Check item	Measures
Setting	Use an available card or ask the administrator to register the information.

[6036] Invalid setting: Invalid flag information (Information between an MFP and card does not match)

Classification	Error item
MFP access error	A card is not usable since its information and the value set in the equipment do not match.

Check item	Measures
Setting	Use an available card or ask the administrator to register the information.

[6037] Permission flag for use not available

Classification	Error item
MFP access error	A card is not usable since the privilege to use the device or equipment is not applied.

Check item	Measures
Setting	Use an available card or request the administrator to give the privilege.

[6040] Card authentication: Read error

Classification	Error item
MFP access error	Card information could not be obtained correctly.

Check item	Measures
Setting	Reattempt card scanning. If the error persists even though the card scanning is attempted several times, the card information may be broken or the card reader may be damaged.

[6041] Card authentication: Card related error

Classification	Error item
MFP access error	Card data cannot be obtained correctly.

Check item	Measures
Setting	Reattempt scanning. If the error still occurs after reattempting scanning several times, card data may be corrupted or the card reader may be out of order.

[6042] Card authentication: Card setting error

Classification	Error item
MFP access error	The self-diagnostic code required for card authentication is not set in this equipment correctly.

Check item	Measures
Setting	Set the correct self-diagnostic code.

[6052] Connection failure to an external Role Base Access Control (LDAP) server

Classification	Error item
MFP access error	User authentication for print job cannot be done because connection to an external RBAC server has failed.

Check item	Measures
Setting	Check if the operating status of the server and connection from the MFP have been confirmed.

[6101] e-Filing box locking out

Classification	Error item
MFP access error	An e-Filing box becomes unusable since the entry of a password has failed for a specified number of times.

Check item	Measures
Setting	Reattempt to access the e-Filing box after a while. Contact the administrator to check this.

[6102] User account being locking out

Classification	Error item
MFP access error	Failed to login because the user account had been locked out.

Check item	Measures
Setting	Log into TopAccess as an administrator, and release the locked user account.

[6103] e-Filing box being locking out

Classification	Error item
MFP access error	The e-Filing box became inaccessible because an incorrect password has been entered for the specified number of times.

Check item	Measures
Setting	Retry access after a few minutes. For the locking period, ask your administrator.

[6121] Automatic secure erase failure

Classification	Error item
MFP access error	The automatic secure erase fails.

Check item	Measures
Setting	Data overwriting failed for some reason. If the error still occurs after rebooting the equipment, start up using the following procedure: HS-73 Assist mode > Format HDD > Reinstallation of software or HDD replacement

[6131] MFP fail to verify clock with time server

Classification	Error item
MFP access error	The MFP is not synchronized with the SNTP server.

Check item	Measures
Setting	Check that the SNTP server is operating correctly. Check that the path to the SNTP server is operating correctly. Check that the settings are correct in TopAccess > [Administrator] > [Setup] > [General] > [SNTP Service].

[61B0] Image log saving failure to an MFP local storage

Classification	Error item
MFP access error	Saving of an image log failed.

Check item	Measures
Setting	Confirm that a local folder has a sufficient space in the disk capacity. If not, delete image logs, data in the e-Filing box and shared files.

[6263] New build-in user and role update failure

Classification	Error item
MFP access error	Updating of new built-in user and role failed.

Check item	Measures
Setting	When updating is performed, Remote-access-service and Remote-service-technician are added. However, updating failed since a user or role with the same names already existed. Change the name of the user or the role and reboot the equipment.

8.3.29 Maintenance error

[711D] License key returning failure

Classification	Error item
Maintenance error	The one-time dongle license fails to be returned to USB storage.

Check item	Measures
Setting	Return the license to the USB device used for installing the license. Check that the USB device is correctly installed. Notes: The GP-1080 IPsec Enabler cannot return to the USB device due to license problem. The GP-1070 Overwrite Enabler cannot return to the USB device in the high security (08-8911: 3).

[711F] License key installation failure

Classification	Error item
Maintenance error	The one-time dongle license fails to be installed.

Check item	Measures
Setting	Check that the USB device is correctly installed.

[71B0] Software package file decryption failure

Classification	Error item
Maintenance error	Software package file decryption failed.

Check item	Measures
Setting	Software package file may have a problem or may be corrupted. Check the software package file and then reattempt the installation.

[71B5] Finisher firmware installation failure

Classification	Error item
Maintenance error	Finisher firmware installation failure.

Check item	Measures
Setting	Finisher firmware installation failed. Reinstall the firmware.

[71B7] Saddle firmware installation failure

Classification	Error item
Maintenance error	Saddle firmware installation failure.

Check item	Measures
Setting	Saddle firmware installation failed. Reinstall the firmware.

[71B9] Punch firmware installation failure

Classification	Error item
Maintenance error	Punch firmware installation failure.

Check item	Measures
Setting	Punch firmware installation failed. Reinstall the firmware.

[71E0] License abnormality due to damage on the license manager database

Classification	Error content
License management	A message which notifies that the license manager database has been restored and the recovery of the license has become possible.

Check item	Measures
Backup data	Restore the backup data with the latest status, including all the activated licenses, are stored. Remarks: Applications with the trial license cannot be recovered from the backup data. If necessary, reinstall the applications.
License	<ul style="list-style-type: none">• If there are no backup data as above, reactivate all the licenses which have been activated in this equipment.• If the functions have been activated by the export license file, import the license exported from the host unit of the equipment.

[7301] Failed to install application

Classification	Error content
Maintenance error	Failed to install application

Check item	Measures
When you install the application, you will see the "The version of framework is old." Did you see the message?	<ul style="list-style-type: none">• Updating System firmware.• After updating the system firmware, reinstall the application.

[7402] License activation failure (Online)

Classification	Error content
License management	License activation by means of "Online" has failed.

Check item	Measures
License	Ask the license provider whether the license is correct or not. If the license is not correct, ask the license provider to issue the correct license authentication ID.

[7403] License activation failure (network timeout)

[7404] License activation failure (network error)

Classification	Error content
License management	License activation by means of "Online" has failed due to a network problem.

Check item	Measures
Network setting	<ul style="list-style-type: none"> Check that the URL for the license server has not been changed. If the URL for the license server has been changed, enter the post-change URL into FS-08-3634 and then reattempt the activation. Ask a user (a network administrator) to check that the value entered in the following code is correct. FS-08-8693~8696
Network environment	<p>Ask a user (a network administrator) to check whether the following settings are correct.</p> <ul style="list-style-type: none"> The proxy is not filtered. The firewall is set properly.
License server	<p>Ask the license provider that both servers are working. If they are not working, reattempt the activation after recovering.</p>

[7412] License deactivation failure (Online)

Classification	Error content
License management	License deactivation by means of "Online" has failed.

Check item	Measures
License server	Ask the license provider whether the license information exists in the server.

[7423] License deactivation failure (network timeout)

[7424] License deactivation failure (network error)

Classification	Error content
License management	License deactivation by means of "Online" has failed due to a network problem.

Check item	Measures
Network setting	<ul style="list-style-type: none"> Check that the URL for the license server has not been changed. If the URL for the license server has been changed, enter the post-change URL into FS-08-3634 and then reattempt the activation. Ask a user (a network administrator) to check that the value entered in the following code is correct. FS-08-8693~8696
Network environment	<p>Ask a user (a network administrator) to check whether the following settings are correct.</p> <ul style="list-style-type: none"> The proxy is not filtered. The firewall is set properly.
License server	<p>Ask the license provider that both servers are working. If they are not working, reattempt the deactivation after recovering.</p>

[7430] Serial number mismatching

Classification	Error content
License management	The serial number registered in the license does not match that for the activated equipment while the license has been activated by means of "Offline".

Check item	Measures
Serial number	<p>Check whether the serial number for the equipment matches the one included in the file name of the license file. If the serial number does not match, perform the activation in the equipment which has a serial number which is included in the file name of the license file.</p>

[7431] Subnet mismatching

Classification	Error content
License management	The values of the 1st to 3rd octet registered in the license do not match those for the IP address of the equipment in which activation is being performed while the license has been activated by means of "Offline".

Check item	Measures
IP address	If this error has occurred during the activation in the host unit of the equipment, ask the license provider to rerelease the license with the correct information. If this error has occurred during the activation by means of the export license file, check that the values of the 1st to 3rd octet for the IP address of the equipment in which activation is being performed match those for the host unit.

[7432] Domain mismatching

Classification	Error content
License management	The domain registered in the license does not match that for the equipment while the license has been activated by means of "Offline".

Check item	Measures
IP address	If this error has occurred during the activation in the host unit of the equipment, ask the license provider to rerelease the license with the correct domain. If this error has occurred during the activation by means of the export license file, check that the domain of the equipment in which activation is being performed matches that for the host unit.

[7433] License certificate ID invalid

Classification	Error content
License management	The license certificate ID format does not match.

Check item	Measures
License	<ul style="list-style-type: none">• If the certificate ID was manually entered, check it. If it is incorrect, enter the correct one.• If the certificate ID was selected from the file, check which is correct, the file or the certificate ID. If the file or the certificate file is incorrect, enter the correct one.

[7434] License duplicating installation

Classification	Error content
License management	The license to be installed has already been installed.

Check item	Measures
License	<ul style="list-style-type: none">• Check that the license to be installed is correct. If not, install the correct one.• Check that the equipment in which the license is installed is correct. Check if the equipment is the one in which the license has already been installed.

[7435] Unsupported license activation

Classification	Error content
License management	The license cannot be installed since it is not supported for the equipment.

Check item	Measures
License	Check that the equipment in which the license is installed is correct. Check if the equipment is supported.

[7440] Signature mismatching

Classification	Error content
License management	The license file is broken.

Check item	Measures
License server	Ask the license provider to rerelease the license.

[7443] License use period expired

Classification	Error content
License management	More than 30 days have passed after the license file or the export license file was created.

Check item	Measures
License created date	If this error has occurred in the host unit of the equipment of the node license or the subnet/domain license, ask the license provider to release the reusable license. If this error has occurred in the export license file, export the license from the host unit again. * The license created date can be checked by the time stamp on the license file.

[7444] No license exists

Classification	Error content
License management	License not found.

Check item	Measures
License status	Wait for a while and then reattempt the same operation. If this error has occurred repeatedly and the license is used continuously, deactivate or delete the license and then perform reactivation with the reusable license.

[7445] Full of the license

Classification	Error content
License management	Since the number of the licenses registered in this equipment has reached the maximum, new ones cannot be activated.

Check item	Measures
License	Deactivate or delete the licenses which are not being used.

8.3.30 Network error

[8000] IPv4 address conflict

Classification	Error item
Network error	IPv4 address conflict.

Check item	Measures
Setting	Check if the same IP address is not used by another machine.

[8011] IPv6 link local address conflict

Classification	Error item
Network error	IPv6 link local address conflict.

Check item	Measures
Setting	Check if the same IP address is not used by other machine.

[8012] IPv6 manual address conflict

Classification	Error item
Network error	IPv6 manual address conflict.

Check item	Measures
Setting	Check if the same IP address is not used by other machine.

[8013] IPv6 stateless address conflict

Classification	Error item
Network error	IPv6 stateless address conflict.

Check item	Measures
Setting	Check if the same IP address is not used by other machine.

[8014] IPv6 stateful address conflict

Classification	Error item
Network error	IPv6 stateful address conflict.

Check item	Measures
Setting	Check if the same IP address is not used by other machine.

[8022] 802.1X authentication failure

Classification	Error item
Network error	Failed in 802.1X authentication.

Check item	Measures
Setting	Check the user credential.

[8023] Connection failure to an authentication server and a switch

Classification	Error item
Network error	Failed in connection to authentication server and switch.

Check item	Measures
Setting	Check connectivity to switch or server.

[8024] Failure in verification of certification

Classification	Error item
Network error	Failed in verification of certificate.

Check item	Measures
Setting	Check if a valid certificate is installed.

[8031] IPsec error for IKEv1 certification failure

Classification	Error item
Network error	IKEv1 certification failed.

Check item	Measures
Setting	Check <ol style="list-style-type: none"> 1. CA and user certificate in both MFP and remote peer - certificate timestamp and IPsec Certificate template should be valid. 2. CRL DP server name is mapped in MFP's host table or DNS entry. 3. Certificate against CRL.

[8032] IPsec error for wrong proposal selection

Classification	Error item
Network error	IKEv1 wrong proposal chosen.

Check item	Measures
Setting	Check the IKEv1 IPsec proposal parameters (like encryption/ authentication algorithms, DH group, authentication methods) in the MFP and peer machine.

[8033] IPsec error for shared key authentication failure

Classification	Error item
Network error	IKEv1 shared key authentication failed.

Check item	Measures
Setting	Mismatch in IKEv1 Pre Shared Key. Check the PSK in MFP and remote machine.

[8034] IPsec error for invalid certificate upload

Classification	Error item
Network error	IKEv1 invalid certificate.

Check item	Measures
Setting	Check the CA and User certificate in MFP and peer machine.

[8035] IPsec error for non-supported certification

Classification	Error item
Network error	IKEv1 certificate not supported.

Check item	Measures
Setting	Check the User certificate type.

[8036] IPsec error for invalid certification of authentication

Classification	Error item
Network error	IKEv1 invalid certificate authentication.

Check item	Measures
Setting	Check the CA certificate in MFP and Peer machine.

[8037] IPsec error for certification disable

Classification	Error item
Network error	IKEv1 certificate unavailable.

Check item	Measures
Setting	Certificate has been deleted from Certificate store. Re-upload the corresponding certificates.

[8038] IPsec error for SA is not present

Classification	Error item
Network error	IKEv1 no SA established.

Check item	Measures
Setting	Check the IKEv1/IPsec proposal parameters (like encryption/ authentication algorithms, DH group, authentication methods) in MFP and peer machine. Check <ol style="list-style-type: none"> 1. CA and user certificate in both MFP and remote peer - certificate timestamp and IPsec Certificate template should be valid. 2. CRL DP server name is mapped in MFP's host table or DNS entry. 3. Certificate against CRL.

[8039] IPsec error for invalid signature for certification

Classification	Error item
Network error	IKEv1 invalid signature.

Check item	Measures
Setting	Mismatch in Signature payload (MAC or IV). Check the CA and user certificate in MFP and peer machine.

[803A] IPsec error for wrong selection of proposal

Classification	Error item
Network error	IKEv2 wrong proposal chosen.

Check item	Measures
Setting	Check the IKEv2/IPsec proposal parameters (encryption/ authentication algorithms, DH group, authentication methods) in MFP and peer machine.

[803B] IPsec error for IKEv2 certification failure

Classification	Error item
Network error	IKEv2 Certificate failed.

Check item	Measures
Setting	Check 1. CA and user certificate in both MFP and remote peer - certificate timestamp and IPsec Certificate template should be valid. 2. CRL DP server name is mapped in MFP's host table or DNS entry. 3. Certificate against CRL.

[803C] IKEv2 error for IKEv2 if secret key authentication failed

Classification	Error item
Network error	IKEv2 secret key authentication failed.

Check item	Measures
Setting	Mismatch in IKEv2 Pre Shared Key. Check the PSK in MFP and peer machine.

[803D] IPsec error if peer does not support IKEv2 and falling back to IKEv1

Classification	Error item
Network error	IKEv2 falling back to IKEv1.

Check item	Measures
Setting	Remote machine does not support IKEv2. Downgrade and use IKEv1.

[803E] IPsec error if ISAKMP SA is uncreated or destroyed due to some uncertain conditions

Classification	Error item
Network error	IKEv2 ISAKMP SA unavailable.

Check item	Measures
Setting	Restart IPsec service on Peer and retry.

[803F] IPsec error for IKEv2 if crypto operation failed

Classification	Error item
Network error	IKEv2 cryptographic operation failed.

Check item	Measures
Setting	If Certificates are being used, re-upload the corresponding certificates using Security Services. Restart IPsec Service on MFP.

[8040] IPsec error for IKEv2 if key info is invalid

Classification	Error item
Network error	IKEv2 invalid key information.

Check item	Measures
Setting	Check IKE settings in MFP and peer.

[8041] IPsec error for IKEv2 if CA is not trusted

Classification	Error item
Network error	IKEv2 CA not trusted.

Check item	Measures
Setting	Check the CA certificate in MFP and peer machine. Check the CA certificate timestamp.

[8042] IPsec error for authentication method inconsistency

Classification	Error item
Network error	IKEv2 Authentication method mismatch.

Check item	Measures
Setting	Mismatch in IKE authentication type. Check the Authentication type in MFP and peer.

[8043] IPsec error for version inconsistency

Classification	Error item
Network error	IPsec IKE version mismatch.

Check item	Measures
Setting	Mismatch in IKE version. Check the IKE version in MFP and peer.

[8044] IPsec error for encapsulation inconsistency

Classification	Error item
Network error	IPsec encapsulation mismatch.

Check item	Measures
Setting	Check the IPsec mode (Transport/Tunnel) in MFP and peer.

[8045] IPsec error for peer IP inconsistency

Classification	Error item
Network error	IPsec peer IP mismatch.

Check item	Measures
Setting	Remote Traffic selector mismatch. Check the destination address/port in IPsec filter.

[8046] IPsec error for local IP inconsistency

Classification	Error item
Network error	IPsec local IP mismatch.

Check item	Measures
Setting	Local traffic selector mismatch. Check the source address/port in IPsec filter.

[8047] IPsec error for local ID inconsistency

Classification	Error item
Network error	IPsec local ID mismatch.

Check item	Measures
Setting	Check the user certificate in MFP

[8048] IPsec error for remote ID inconsistency

Classification	Error item
Network error	IPsec remote ID mismatch.

Check item	Measures
Setting	Check the user certificate in peer machine.

[8049] IPsec error for remote IP inconsistency

Classification	Error item
Network error	IPsec remote IP mismatch.

Check item	Measures
Setting	Remote traffic selector mismatch. Check the source address/port in IPsec filter.

[804A] IPsec error for IKEv2 timeout

Classification	Error item
Network error	IPsec IKEv1 / IKEv2 timeout.

Check item	Measures
Setting	Check the network connectivity between MFP and peer machine. Select the Flush Connections Option and retry.

[804B] IPsec error for invalid of ID manual key

Classification	Error item
Network error	IPsec invalid manual key.

Check item	Measures
Setting	Check the Inbound and Outbound (ESP Encryption/Authentication and AH Authentication) keys in MFP and Remote PC.

[8061] Update error for secure primary DDNS

[8062] Update error for secure secondary DDNS

[8063] Update error for IPv6 secure primary DDNS

[8064] Update error for IPv6 secure secondary DDNS

[8065] Update error for IPv6 primary DDNS

[8066] Update error for IPv6 secondary DDNS

[8067] Update error for IPv4 primary DDNS

[8068] Update error for IPv4 secondary DDNS

Classification	Error item
Network error	[8061] Secure update to primary IPv4 server failed. [8062] Secure update to secondary IPv4 server failed. [8063] Secure update to primary IPv6 server failed. [8064] Secure update to secondary IPv6 server failed. [8065] IPv6 primary DDNS update error. [8066] IPv6 secondary DDNS update error. [8067] IPv4 primary DDNS update error. [8068] IPv4 secondary DDNS update error.

Check item	Measures
Setting	Check if there is any problem with DNS or DDNS settings.

[8069] This message is displayed when the key file for SIG(0) or TSIG is invalid

Classification	Error item
Network error	This message is displayed when the key file for SIG(0) or TSIG is invalid.

Check item	Measures
Setting	Verify the TSIG/SIG(0) key files used.

[80B1] Bluetooth connection failure

Classification	Error item
Network error	Bluetooth connection failure.

Check item	Measures
Wireless LAN/Bluetooth module connection status	Check the connection of the wireless LAN/Bluetooth module.

[80C0] TLS session establishment failure (invalid message)

Classification	Error item
Network error	An inappropriate message has been received.

Check item	Measures
Setting	Check the SSL/TLS settings of a connect-to server. Check the SSL certificate installed in the equipment.

[80C1] TLS session establishment failure (invalid MAC data)

Classification	Error item
Network error	Invalid MAC data have been received.

Check item	Measures
Setting	Check the SSL/TLS settings of a connect-to server. Check the SSL certificate installed in the equipment.

[80C2] TLS session establishment failure (decoding failure)

Classification	Error item
Network error	TLSCiphertext data structure has been encoded by an invalid method.

Check item	Measures
Setting	Check the SSL/TLS settings of a connect-to server. Check the SSL certificate installed in the equipment.

[80C3] TLS session establishment failure (recording length abnormality)

Classification	Error item
Network error	A TLSCiphertext record whose size is $2^{14}+2048$ bytes or more has been received. Or, decoding to a TLSCompressed record whose size is $2^{14}+2048$ bytes or more has been carried out.

Check item	Measures
Setting	Check the SSL/TLS settings of a connect-to server. Check the SSL certificate installed in the equipment.

[80C4] TLS session establishment failure (data decompression failure)

Classification	Error item
Network error	Data (output) with an invalid expansion function have been received. (E.g.: Data with length exceeded)

Check item	Measures
Setting	Check the SSL/TLS settings of a connect-to server. Check the SSL certificate installed in the equipment.

[80C5] TLS session establishment failure (handshake failure)

Classification	Error item
Network error	A handshake_failure alert message has been received.

Check item	Measures
Setting	Check the SSL/TLS settings of a connect-to server. Check the SSL certificate installed in the equipment.

[80C6] TLS session establishment failure (certificate abnormality)

Classification	Error item
Network error	A certificate has been broken. Or, a signature which cannot be verified properly has been included.

Check item	Measures
Setting	Check the SSL certificate installed in the equipment.

[80C7] TLS session establishment failure (non-support certificate)

Classification	Error item
Network error	The type of the certificate has not been supported.

Check item	Measures
Setting	Check the SSL certificate installed in the equipment.

[80C8] TLS session establishment failure (invalid certificate)

Classification	Error item
Network error	The certificate has been disabled by its signer.

Check item	Measures
Setting	Check the SSL certificate installed in the equipment.

[80C9] TLS session establishment failure (certificate with validity date expired)

Classification	Error item
Network error	The validity date of the certificate has expired.

Check item	Measures
Setting	Check the SSL certificate installed in the equipment.

[80CA] TLS session establishment failure (certificate process error)

Classification	Error item
Network error	Since a non-specified problem has occurred, the certification process has failed.

Check item	Measures
Setting	Check the SSL certificate installed in the equipment.

[80CB] TLS session establishment failure (invalid parameter)

Classification	Error item
Network error	The acceptable range of the field for handshake has been exceeded. Or, an inconsistency between another field has occurred.

Check item	Measures
Setting	Check the SSL/TLS settings of a connect-to server. Check the SSL certificate installed in the equipment.

[80CC] TLS session establishment failure (unknown CA certificate)

Classification	Error item
Network error	A valid certificate chain or a part of the chain has been received; however, there is no CA certificate. Or, a certificate could not be received since it does not match the already-known relied CA.

Check item	Measures
Setting	Check the SSL certificate installed in the equipment.

[80CD] TLS session establishment failure (access rejection)

Classification	Error item
Network error	Although a valid certificate has been received, a connect-to server has rejected the access when access control was applied.

Check item	Measures
Setting	Check the SSL/TLS settings of a connect-to server.

[80CE] TLS session establishment failure (decoding error)

Classification	Error item
Network error	A value in the field is outside of the range. Or, a message could be decoded since its length was inappropriate.

Check item	Measures
Setting	Check the SSL/TLS settings of a connect-to server. Check the SSL certificate installed in the equipment.

[80CF] TLS session establishment failure (decoding error)

Classification	Error item
Network error	A handshake encryption process has failed.

Check item	Measures
Setting	Check the SSL/TLS settings of a connect-to server. Check the SSL certificate installed in the equipment.

[80D0] TLS session establishment failure (export restrictions)

Classification	Error item
Network error	A negotiation which does not comply with the export restrictions of the regulation has been detected.

Check item	Measures
Setting	Check the SSL/TLS settings of a connect-to server. Check the SSL certificate installed in the equipment.

[80D1] TLS session establishment failure (non-support protocol version)

Classification	Error item
Network error	Unsupported versions of the TLS protocol have been recognized.

Check item	Measures
Setting	Check that the communication with a client, server or external applications is made using the supported TLS protocol (only TLS1.2 available as of 2020) in the SSL/TLS settings. Check the SSL/TLS certificate installed in the equipment.

[80D2] TLS session establishment failure (internal error)

Classification	Error item
Network error	A process cannot be continued due to an internal error.

Check item	Measures
Setting	Check the SSL/TLS settings of a connect-to server. Check the SSL certificate installed in the equipment.

[80D3] TLS session establishment failure (cancellation by a user)

Classification	Error item
Network error	A handshake has been canceled for a reason other than a protocol error.

Check item	Measures
Setting	Check the SSL/TLS settings of a connect-to server. Check the SSL certificate installed in the equipment.

[80D4] TLS session establishment failure (invalid renegotiation)

Classification	Error item
Network error	The following items are improper. - A client response to a HelloRequest message. - A server response to a ClientHello message received after the first handshake. - Renegotiation performed later.

Check item	Measures
Setting	Check the SSL/TLS settings of a connect-to server. Check the SSL certificate installed in the equipment.

[8101] Wireless connection in the Access point failure

Classification	Error item
Network error	Wireless connection in the Access point failure.

Check item	Measures
Setting	Verify the credentials used for association with Access point.

[8102] Connection of MFP to the Access point with a specified SSID failure

Classification	Error item
Network error	Connection of MFP to the Access point with a specified SSID failure.

Check item	Measures
Setting	Verify the access point name setting and mechanism used for association same as Access Point setting.

[8103] Wireless certificate verification failure

Classification	Error item
Network error	Wireless certificate verification failure.

Check item	Measures
Setting	Verify the certificate settings used for association.

[8104] Wireless LAN / Bluetooth module hardware error

Classification	Error item
Network error	Wireless LAN / Bluetooth module hardware error.

Check item	Measures
Wireless LAN/Bluetooth module	Check the connection of the wireless LAN/Bluetooth module. Replace the wireless LAN/Bluetooth module.

[8121] Domain: Authentication failure

Classification	Error item
Network error	An unknown domain authentication error occurs when connecting to the domain controller.

Check item	Measures
Setting	Check the network settings of the equipment, and retry connecting to the domain controller.

[8122] Domain: Invalid user name or password

Classification	Error item
Network error	The user name or password of the domain authentication is not valid and the user cannot log on.

Check item	Measures
Setting	Check if the user name or password is correctly entered. Enter them by specifying the upper and lower case letters correctly.

[8123] Domain: Invalid server

Classification	Error item
Network error	The server cannot be detected at domain authentication.

Check item	Measures
Setting	Check if the server fails. Check the network settings of the equipment. If name resolution is used, check the settings of the DNS and DDNS.

[8124] Domain: Invalid user account

Classification	Error item
Network error	The user account is invalid at domain authentication and it cannot be used to log on.

Check item	Measures
Setting	Check if the setting of the user account in "Active Directory User and Computer" is disabled.

[8125] Domain: Expired user account (cannot be used for logon)

Classification	Error item
Network error	The user account has expired at domain authentication and it cannot be used to log on.

Check item	Measures
Setting	Check if the setting of the user account in "Active Directory User and Computer" has expired.

[8126] Domain: Locked user account (cannot be used for logon)

Classification	Error item
Network error	The user account is locked at domain authentication and it cannot be used to log on.

Check item	Measures
Setting	Check the setting of the account lock-out on the server.

[8127] Domain: Invalid logon time

Classification	Error item
Network error	The user logon time is invalid at domain authentication and the user cannot logon.

Check item	Measures
Setting	Check the log-on time setting of the user account in "Active Directory User and Computer".

[8128] Active directory domain: Clock skew error (due to difference in time between the server and the MFP)

Classification	Error item
Network error	The difference between the time set in the equipment and that set in the server is more than five minutes at domain authentication of the Active Directory and the user cannot log on.

Check item	Measures
Setting	Match the time of the equipment and domain controller, or if an SNTP server is in the network, recommend the use of SNTP.

[8129] Active directory domain: Expired Kerberos ticket (cannot be used for authentication)

Classification	Error item
Network error	A Kerberos ticket has expired at the domain authentication of the Active Directory and the user cannot log on.

Check item	Measures
Setting	Check if the Kerberos ticket on the Kerberos server has expired.

[812A] Active directory domain: Kerberos ticket authentication failure

Classification	Error item
Network error	A Kerberos ticket authentication error of the Active Directory domain authentication occurs and the user cannot log on.

Check item	Measures
Setting	Check if the user name or password is correctly entered. If this problem still persists, contact your Window server administrator.

[812B] Active directory domain: Invalid realm name

Classification	Error item
Network error	The realm name for the domain authentication of the Active Directory is invalid and the user cannot log on.

Check item	Measures
Setting	Check if the Realm name of the Active Directory server of the equipment is wrong. If this problem still persists, contact your Window server administrator.

8.3.31 FAX error

[0012] Original jam

Classification	Error item
Fax	The Fax transmission has failed since an original was misfed in the DF while a Fax job was being sent.

Check item	Measures
Setting	Remove the misfed original and reattempt the Fax transmission.

[0013] Cover is open

Classification	Error item
Fax	The Fax transmission has failed since the cover of the equipment or options that process paper was opened.

Check item	Measures
Setting	Close the cover and reattempt the Fax transmission.

[0020] Power failure Transmission

Classification	Error item
Fax	The Fax transmission has failed due to a power failure.

Check item	Measures
Setting	Reattempt the Fax transmission.

Reception

Classification	Error item
Fax	The Fax reception has failed due to a power failure.

Check item	Measures
Setting	Reattempt the Fax reception.

Transmission

Classification	Error item
IP Fax	The IP Fax transmission has failed due to a power failure.

Check item	Measures
Setting	Reattempt the IP Fax transmission.

Reception

Classification	Error item
IP Fax	The IP Fax reception has failed due to a power failure.

Check item	Measures
Setting	Reattempt the IP Fax reception.

[0030] Recording paper jam

Classification	Error item
Fax	The Fax transmission has been stopped due to the following reason. <ul style="list-style-type: none">• Paper misfeeding occurred with another job.• A Fax job was canceled.

Check item	Measures
Setting	In the case of paper misfeeding, remove it and reattempt the Fax transmission.

[0033] Polling error

Classification	Error item
Fax	The polling reception has failed due to the following reason. <ul style="list-style-type: none">• A polling original was not set on the other side's device.• The security setting between this equipment and the other side's device did not match.

Check item	Measures
Setting	Take the following action and reattempt the polling reception. <ul style="list-style-type: none">• Ask to set the polling original on the other side's device.• Make the security setting matched between this equipment and the other side's device.

[0040] Modem communication error Transmission

Classification	Error item
Fax	The Fax transmission has failed since the modem could not send the signal properly.

Check item	Measures
Setting	Reattempt the Fax transmission.

Reception

Classification	Error item
Fax	The Fax reception has failed since the modem could not receive the signal properly.

Check item	Measures
Setting	Reattempt the Fax reception.

[0042] Memory full

Classification	Error item
Fax	The Fax reception has been canceled since the capacity shortage or an abnormality occurred in the storage while a Fax job was being received. (Pages which are received successfully will be printed out.)

Check item	Measures
Setting	Take the following action and reattempt the Fax reception. <ul style="list-style-type: none">• In the case of a capacity shortage, free up the memory space.• In the case of an abnormality, replace the storage.

Classification	Error item
IP Fax	The IP Fax reception has been canceled since the capacity shortage or an abnormality occurred in the storage while an IP Fax job was being received. (Pages which are received successfully will be printed out.)

Check item	Measures
Setting	Take the following action and reattempt the IP Fax reception. <ul style="list-style-type: none">• In the case of a capacity shortage, free up the memory space.• In the case of an abnormality, replace the storage.

[0050] Line is busy

Classification	Error item
Fax	Since the line of the other side's device was busy, the Fax transmission has failed even though the redialing was carried out by the maximum number of specified times.

Check item	Measures
Setting	Reattempt the Fax transmission. Increase the number of redialing times if required.

[0051] No cable connected for Fax line

Classification	Error item
Fax	The Fax transmission has failed since no cable for the Fax line was connected.

Check item	Measures
Setting	Connect a cable for the Fax line and reattempt the Fax transmission.

[0052] T1 time-out

Classification	Error item
Fax	The Fax transmission has failed since NSF / DIS could not be detected. (Memory transmission)

Check item	Measures
Setting	Check that the other side's device is answering in the Fax mode and reattempt the Fax transmission.

Classification	Error item
IP Fax	The IP Fax transmission has failed since NSF / DIS could not be detected. (Memory transmission)

Check item	Measures
Setting	Check that the other side's device is answering in the Fax mode and reattempt the IP Fax transmission.

[00B0] Initial signal not detected

Classification	Error item
Fax	The Fax transmission has failed since NSF / DIS could not be detected. (Direct transmission)

Check item	Measures
Setting	Check that the other side's device is answering in the Fax mode and reattempt the Fax transmission.

[00B1] Terminal constants not compatible

Transmission

Classification	Error item
Fax	The Fax transmission has failed since the other side's device did not have the capability which was transferred by NSF / DIS on this equipment.

Check item	Measures
Setting	Check the capability of the other side's device and reattempt the Fax transmission by using a receivable mode for it.

Reception

Classification	Error item
Fax	The Fax reception has failed since NSS / DCS, which was a capability other than the ones transferred by NSF / DIS on this equipment, was received.

Check item	Measures
Setting	Check the capability of this equipment and reattempt the Fax reception by using a receivable mode for it.

Transmission

Classification	Error item
IP Fax	The IP Fax transmission has failed since the other side's device did not have the capability which was transferred by NSF / DIS on this equipment.

Check item	Measures
Setting	Check the capability of the other side's device and reattempt the IP Fax transmission by using a receivable mode for it.

Reception

Classification	Error item
IP Fax	The IP Fax job reception has failed since NSS / DCS, which was a capability other than the ones transferred by NSF / DIS on this equipment, was received.

Check item	Measures
Setting	Check the capability of this equipment and reattempt the IP Fax reception by using a receivable mode for it.

[00B2] Reception of DCN (Phase B) Transmission

Classification	Error item
Fax	The Fax transmission has failed since DCN was sent in Phase B.

Check item	Measures
Setting	Reattempt the Fax transmission.

Reception

Classification	Error item
Fax	The Fax reception has failed since DCN was received in Phase B.

Check item	Measures
Setting	Reattempt the Fax reception.

Transmission

Classification	Error item
IP Fax	The IP Fax transmission has failed since DCN was sent in Phase B.

Check item	Measures
Setting	Reattempt the IP Fax transmission.

Reception

Classification	Error item
IP Fax	The IP Fax reception has failed since DCN was received in Phase B.

Check item	Measures
Setting	Reattempt the IP Fax reception.

[00B3] DCS / DTC not detected

Classification	Error item
Fax	The Fax reception has failed since DCS / DTC could not be detected.

Check item	Measures
Setting	Reattempt the Fax reception.

Transmission

Classification	Error item
IP Fax	The IP Fax transmission has failed since DCS / DTC could not be detected.

Check item	Measures
Setting	Reattempt the IP Fax transmission.

Reception

Classification	Error item
IP Fax	The IP Fax reception has failed since DCS / DTC could not be detected.

Check item	Measures
Setting	Reattempt the IP Fax reception.

[00B4] Training error**Transmission**

Classification	Error item
Fax	This equipment has performed fall-back but the Fax transmission has failed.

Check item	Measures
Setting	Adjust the attenuator and link equalizer of this equipment and the other side's device and reattempt the Fax transmission.

Reception

Classification	Error item
Fax	The Fax reception has failed since after receiving FTT, the receiver has received a timeout or DCN.

Check item	Measures
Setting	Adjust the attenuator and link equalizer of this equipment and the other side's device and reattempt the Fax reception.

Transmission

Classification	Error item
IP Fax	This equipment has performed fall-back but the IP Fax transmission has failed.

Check item	Measures
Setting	Check the following items and reattempt the IP Fax transmission. <ul style="list-style-type: none"> This equipment and the other side's device are connected to a network properly. If the other side's device is in the Fax mode, its attenuator and link equalizer are adjusted properly.

Reception

Classification	Error item
IP Fax	The IP Fax reception has failed since after receiving FTT, the receiver has received a timeout or DCN.

Check item	Measures
Setting	Check the following items and reattempt the IP Fax reception. <ul style="list-style-type: none"> This equipment and the other side's device are connected to a network properly. If the other side's device is in the Fax mode, its attenuator and link equalizer are adjusted properly.

[00B5] CFR not detected

Classification	Error item
Fax	The Fax transmission has failed since a training signal has been sent out but CFR could not be detected.

Check item	Measures
Setting	Adjust the attenuator and link equalizer of this equipment and the other side's device and reattempt the Fax transmission.

Classification	Error item
IP Fax	The IP Fax transmission has failed since a training signal has been sent out but CFR could not be detected.

Check item	Measures
Setting	Check the following items and reattempt the IP Fax transmission. <ul style="list-style-type: none"> The network of this equipment is functioning properly. The IP Fax function of this equipment is set properly. If the other side's device is in the Fax mode, its attenuator and link equalizer are adjusted properly.

[00B6] No response made to CTC

Classification	Error item
Fax	The Fax transmission has failed since no response was made to CTC.

Check item	Measures
Setting	Adjust the attenuator and link equalizer of this equipment and the other side's device and reattempt the Fax transmission.

Transmission

Classification	Error item
IP Fax	The IP Fax transmission has failed since no response was made to CTC.

Check item	Measures
Setting	Check the following items and reattempt the IP Fax transmission. <ul style="list-style-type: none"> • The network of this equipment is functioning properly. • The IP Fax function of this equipment is set properly. • If the other side's device is in the Fax mode, its attenuator and link equalizer are adjusted properly.

Reception

Classification	Error item
IP Fax	The IP Fax reception has failed since DCN was received during ECM transmission.

Check item	Measures
Setting	Check the following items and reattempt the IP Fax reception. <ul style="list-style-type: none"> • The network of this equipment is functioning properly. • The IP Fax function of this equipment is set properly. • If the other side's device is in the Fax mode, its attenuator and link equalizer are adjusted properly.

[00B7] Phase B cannot be completed Transmission

Classification	Error item
Fax	The Fax transmission has failed since a modem error or a sequence error in the FAX Unit occurred.

Check item	Measures
Setting	Reattempt the Fax transmission. If the error persists, replace the FAX Unit.

Reception

Classification	Error item
Fax	The Fax reception has failed since a modem error or a sequence error in the FAX Unit occurred.

Check item	Measures
Setting	Reattempt the Fax reception. If the error persists, replace the FAX Unit.

Transmission

Classification	Error item
IP Fax	The IP Fax transmission has failed since an error occurred in the system.

Check item	Measures
Setting	Reboot this equipment and reattempt the IP Fax transmission.

Reception

Classification	Error item
IP Fax	The IP Fax reception has failed since an error occurred in the system.

Check item	Measures
Setting	Reboot this equipment and reattempt the IP Fax reception.

[00C0] Image signal carrier not detected

Classification	Error item
Fax	The Fax reception has failed since this equipment has failed to detect a carrier.

Check item	Measures
Setting	Adjust the attenuator and link equalizer of this equipment and the other side's device and reattempt the Fax reception.

[00C1] High-speed signal not detected

Classification	Error item
Fax	The Fax reception has failed since this equipment has failed to detect a high-speed signal.

Check item	Measures
Setting	Adjust the attenuator and link equalizer of this equipment and the other side's device and reattempt the Fax reception.

Classification	Error item
IP Fax	The IP Fax reception has failed since this equipment has failed to detect a high-speed signal.

Check item	Measures
Setting	Check the following items and reattempt the IP Fax reception. <ul style="list-style-type: none">• The network of this equipment and the other side's device is functioning properly.• The IP Fax function of this equipment is set properly.• If the other side's device is in the Fax mode, its attenuator and link equalizer are adjusted properly.

[00C2] Image signal carrier disconnected

Transmission

Classification	Error item
Fax	The Fax transmission has failed since a carrier disconnection was detected after the image signal was picked up by the other side's device.

Check item	Measures
Setting	Reattempt the Fax transmission.

Reception

Classification	Error item
Fax	The Fax reception has failed since a carrier disconnection was detected after the image signal was picked up by this equipment.

Check item	Measures
Setting	Reattempt the Fax reception.

Classification	Error item
IP Fax	The IP Fax reception has failed since a carrier disconnection was detected after the image signal was picked up by this equipment.

Check item	Measures
Setting	Reattempt the IP Fax reception.

[00C4] EOL time-out

Classification	Error item
Fax	The Fax reception has failed since this equipment could not detect EOL or not decode with MMR.

Check item	Measures
Setting	Reattempt the Fax reception.

[00C5] Excess length of data received

Classification	Error item
Fax	The Fax reception has failed due to the disconnection of the communication since the length of the received original exceeded 2 m.

Check item	Measures
Setting	Ask to make the length of the original 2 m or less and reattempt the Fax reception.

Classification	Error item
IP Fax	The IP Fax reception has failed due to the disconnection of the communication since the length of the received original exceeded 2 m.

Check item	Measures
Setting	Ask to make the length of the original 2 m or less and reattempt the IP Fax reception.

[00C6] Image code conversion error

Classification	Error item
Fax	The Fax reception has failed since the conversion of the received image went wrong.

Check item	Measures
Setting	Reattempt the Fax reception.

Classification	Error item
IP Fax	The IP Fax reception has failed since the conversion of the received image went wrong.

Check item	Measures
Setting	Reattempt the IP Fax reception.

[00C7] Phase C cannot be completed**Transmission**

Classification	Error item
Fax	The Fax transmission has failed since a modem error or a sequence error in the FAX Unit occurred.

Check item	Measures
Setting	Reattempt the Fax transmission. If the error persists, replace the FAX Unit.

Reception

Classification	Error item
Fax	The Fax reception has failed since a modem error or a sequence error in the FAX Unit occurred.

Check item	Measures
Setting	Reattempt the Fax reception. If the error persists, replace the FAX Unit.

Transmission

Classification	Error item
IP Fax	The IP Fax transmission has failed since a system error or a sequence error occurred.

Check item	Measures
Setting	Reboot this equipment and reattempt the IP Fax transmission.

Reception

Classification	Error item
IP Fax	The IP Fax reception has failed since a system error or a sequence error occurred.

Check item	Measures
Setting	Reboot this equipment and reattempt the IP Fax reception.

[00C8] Transmitted image was not made in time

Classification	Error item
IP Fax	The IP Fax transmission has failed due to the disconnection of the communication from the other side's device since the notification of the transmitted image was not made in time.

Check item	Measures
Setting	Reattempt the IP Fax transmission.

[00D0] Post message not detected**Transmission**

Classification	Error item
Fax	The Fax transmission has failed since this equipment could not detect an MCF, RTP, RTN, PIN or PIP or the other side's device could not detect MPS, EOM or EOP.

Check item	Measures
Setting	Reattempt the Fax transmission.

Reception

Classification	Error item
Fax	The Fax reception has failed since the other side's device could not detect an MCF, RTP, RTN, PIN or PIP or this equipment could not detect MPS, EOM or EOP.

Check item	Measures
Setting	Reattempt the Fax reception.

Transmission

Classification	Error item
IP Fax	The IP Fax transmission has failed since this equipment could not detect an MCF, RTP, RTN, PIN or PIP or the other side's device could not detect MPS, EOM or EOP.

Check item	Measures
Setting	Reattempt the IP Fax transmission.

Reception

Classification	Error item
IP Fax	The IP Fax reception has failed since the other side's device could not detect an MCF, RTP, RTN, PIN or PIP or this equipment could not detect MPS, EOM or EOP.

Check item	Measures
Setting	Reattempt the IP Fax reception.

[00D1] Reception of DCN

Classification	Error item
Fax	The Fax reception has failed since DCN was received.

Check item	Measures
Setting	Reattempt the Fax reception.

Transmission

Classification	Error item
IP Fax	The IP Fax transmission has failed since DCN was received.

Check item	Measures
Setting	Reattempt the IP Fax transmission.

Reception

Classification	Error item
IP Fax	The IP Fax reception has failed since DCN was received.

Check item	Measures
Setting	Reattempt the IP Fax reception.

[00D2] Poor image quality

Transmission

Classification	Error item
Fax	The Fax transmission has failed since the quality of the received image was poor in the other side's device.

Check item	Measures
Setting	Reattempt the Fax transmission.

Reception

Classification	Error item
Fax	The Fax reception has failed since the quality of the received image was poor.

Check item	Measures
Setting	Reattempt the Fax reception.

Transmission

Classification	Error item
IP Fax	The IP Fax transmission has failed since the quality of the received image was poor in the other side's device.

Check item	Measures
Setting	Check the following items and reattempt the IP Fax transmission. <ul style="list-style-type: none">• The network of this equipment and the other side's device is functioning properly.• The IP Fax function of this equipment is set properly.

Reception

Classification	Error item
IP Fax	The IP Fax reception has failed since the quality of the received image was poor.

Check item	Measures
Setting	Check the following items and reattempt the IP Fax reception. <ul style="list-style-type: none">• The network of this equipment and the other side's device is functioning properly.• The IP Fax function of this equipment is set properly.

[00D3] No response made to EOR

Classification	Error item
Fax	The Fax transmission has failed since no response was made to EOR or DCN was received during ECM transmission.

Check item	Measures
Setting	Ask to adjust the attenuator and link equalizer of the other side's device and reattempt the Fax transmission.

Classification	Error item
IP Fax	The IP Fax transmission has failed since no response was made to EOR or DCN was received during ECM transmission.

Check item	Measures
Setting	Check the following items and reattempt the IP Fax transmission. <ul style="list-style-type: none">• The network of this equipment device is functioning properly.• The IP Fax function of this equipment is set properly.• If the other side's device is in the Fax mode, its attenuator and link equalizer are adjusted properly.

[00D4] No response made to RR

Classification	Error item
Fax	The Fax transmission has failed since no response was made to RR or DCN was received during ECM transmission.

Check item	Measures
Setting	Ask to adjust the attenuator and link equalizer of the other side's device and reattempt the Fax transmission.

Classification	Error item
IP Fax	The IP Fax transmission has failed since no response was made to RR or DCN was received during ECM transmission.

Check item	Measures
Setting	Check the following items and reattempt the IP Fax transmission. <ul style="list-style-type: none">• The network of this equipment device is functioning properly.• The IP Fax function of this equipment is set properly.• If the other side's device is in the Fax mode, its attenuator and link equalizer are adjusted properly.

[00D5] T5 time-out

Classification	Error item
Fax	The Fax transmission has failed since RNR-RR was repeated and the line was disconnected due to timeout during ECM transmission.

Check item	Measures
Setting	Reattempt the Fax transmission. If the error persists, check whether the other side's device can output MCF or not.

[00D6] ERR returned to EOR

Classification	Error item
Fax	The Fax reception has failed due to the bad condition of the communication.

Check item	Measures
Setting	Reattempt the Fax reception.

Classification	Error item
IP Fax	The IP Fax reception has failed due to the bad condition of the communication.

Check item	Measures
Setting	Check the following items and reattempt the IP Fax reception. <ul style="list-style-type: none">• The network of this equipment and the other side's device is functioning properly.• The IP Fax function of this equipment is set properly.

[00D7] Line disconnected by transmission of EOR

Classification	Error item
Fax	The Fax transmission has failed since the line was disconnected after EOR was sent by this equipment during ECM transmission.

Check item	Measures
Setting	Adjust the attenuator and link equalizer of this equipment and reattempt the Fax transmission.

Classification	Error item
IP Fax	The IP Fax transmission has failed since the line was disconnected after EOR was sent by this equipment during ECM transmission.

Check item	Measures
Setting	Check the following items and reattempt the IP Fax transmission. <ul style="list-style-type: none">• The network of this equipment and the other side's device is functioning properly.• The IP Fax function of this equipment is set properly.

[00D8] Time-out between FCD frame

Classification	Error item
Fax	The Fax reception has failed since a time-out occurred between the FCD frames.

Check item	Measures
Setting	Reattempt the Fax reception.

[00DA] MCF not returned

Classification	Error item
Fax	The Fax reception has failed since MCF could not be returned from this equipment.

Check item	Measures
Setting	Reattempt the Fax reception.

Classification	Error item
IP Fax	The IP Fax reception has failed since MCF could not be returned from this equipment.

Check item	Measures
Setting	Reattempt the IP Fax reception.

**[00E8] HDD error
Transmission**

Classification	Error item
Fax	The Fax transmission has failed due to a defective HDD.

Check item	Measures
Setting	Reattempt the Fax transmission. If the error persists, replace the HDD.

Reception

Classification	Error item
Fax	The Fax reception has failed due to a defective HDD.

Check item	Measures
Setting	Reattempt the Fax reception. If the error persists, replace the HDD.

Transmission

Classification	Error item
IP Fax	The IP Fax transmission has failed due to a defective HDD.

Check item	Measures
Setting	Reattempt the IP Fax transmission. If the error persists, replace the HDD.

Reception

Classification	Error item
IP Fax	The IP Fax reception has failed due to a defective HDD.

Check item	Measures
Setting	Reattempt the IP Fax reception. If the error persists, replace the HDD.

[00F0] Software trouble**Transmission**

Classification	Error item
Fax	The Fax transmission has failed due to defective software.

Check item	Measures
Setting	Reinstall the Fax firmware. If the error persists, replace the Fax unit.

Reception

Classification	Error item
Fax	The Fax reception has failed due to defective software.

Check item	Measures
Setting	Reinstall the Fax firmware. If the error persists, replace the Fax unit.

Transmission

Classification	Error item
IP Fax	The IP Fax transmission has failed due to defective software.

Check item	Measures
Setting	Check that the IP Fax function of this equipment is set properly. Reboot this equipment and reattempt the IP Fax transmission.

Reception

Classification	Error item
IP Fax	The IP Fax reception has failed due to defective software.

Check item	Measures
Setting	Check that the IP Fax function of this equipment is set properly. Reboot this equipment and reattempt the IP Fax reception.

[00F1] Hardware noise**Transmission**

Classification	Error item
Fax	The Fax transmission has failed due to defective hardware.

Check item	Measures
Setting	<ul style="list-style-type: none"> • Reboot this equipment and reattempt the Fax transmission. • Reinstall the Fax firmware. • If the error persists, replace the Fax unit.

Reception

Classification	Error item
Fax	The Fax reception has failed due to defective hardware.

Check item	Measures
Setting	<ul style="list-style-type: none"> • Reboot this equipment and reattempt the Fax reception. • Reinstall the Fax firmware. • If the error persists, replace the Fax unit.

[00F4] Software trouble (FAX Unit)

Transmission

Classification	Error item
Fax	The Fax transmission has failed due to defective software.

Check item	Measures
Setting	<ul style="list-style-type: none">• Reboot this equipment and reattempt the Fax transmission.• Reinstall the Fax firmware.• If the error persists, replace the FAX Unit.

Reception

Classification	Error item
Fax	The Fax reception has failed due to defective software.

Check item	Measures
Setting	<ul style="list-style-type: none">• Reboot this equipment and reattempt the Fax reception.• Reinstall the Fax firmware.• If the error persists, replace the Fax unit.

[0101] Response TimeOut (Registration)

Classification	Error item
IP Fax	A time-out has occurred since there was no response from an SIP server. (Register)

Check item	Measures
Setting	Check the setting of the network or the SIP server.

[0102] Response TimeOut (Invite)

Classification	Error item
IP Fax	The IP Fax transmission has failed due to a time-out since there was no response from an SIP server. (Invite)

Check item	Measures
Setting	Reattempt the IP Fax transmission. If the error persists, check the network or the server setting and recipient information.

[0103] "Multiple Choices" Received

Classification	Error item
IP Fax	The registration to an SIP server has failed due to an error. (Multiple Choices)

Check item	Measures
Setting	Check the setting of the network or the SIP server.

[0104] “Moved Permanently” Received

Classification	Error item
IP Fax	The registration to an SIP server has failed due to an error. (Moved Permanently)

Check item	Measures
Setting	Check the setting of the network or the SIP server.

[0105] “Moved Temporarily” Received

Classification	Error item
IP Fax	The registration to an SIP server has failed due to an error. (Moved Temporarily)

Check item	Measures
Setting	Check the setting of the network or the SIP server.

[0106] “Use Proxy” Received

Classification	Error item
IP Fax	The registration to an SIP server has failed due to an error. (Use Proxy)

Check item	Measures
Setting	Check the setting of the network or the SIP server.

[0107] “Alternative Service” Received

Classification	Error item
IP Fax	The registration to an SIP server has failed due to an error. (Alternative Service)

Check item	Measures
Setting	Check the setting of the network or the SIP server.

[0109] “Bad Request” Received

Classification	Error item
IP Fax	The registration to an SIP server has failed due to an error. (Bad Request)

Check item	Measures
Setting	Check the setting of the network or the SIP server.

[010A] “Unauthorized” Received

Classification	Error item
IP Fax	The registration to an SIP server has failed due to an error. (Unauthorized)

Check item	Measures
Setting	Check the setting of the network or the SIP server.

[010B] “Payment Required” Received

Classification	Error item
IP Fax	The registration to an SIP server has failed due to an error. (Payment Required)

Check item	Measures
Setting	Check the setting of the network or the SIP server.

[010C] “Forbidden” Received

Classification	Error item
IP Fax	The registration to an SIP server has failed due to an error. (Forbidden)

Check item	Measures
Setting	Check the setting of the network or the SIP server.

[010D] “Not Found” Received

Classification	Error item
IP Fax	The registration to an SIP server has failed due to an error. (Not Found)

Check item	Measures
Setting	Check the setting of the network or the SIP server.

[010E] “Method Not Allowed” Received

Classification	Error item
IP Fax	The registration to an SIP server has failed due to an error. (Method Not Allowed)

Check item	Measures
Setting	Check the setting of the network or the SIP server.

[010F] “Not Acceptable” Received

Classification	Error item
IP Fax	The registration to an SIP server has failed due to an error. (Not Acceptable)

Check item	Measures
Setting	Check the setting of the network or the SIP server.

[0110] “Proxy Authentication Required” Received

Classification	Error item
IP Fax	The registration to an SIP server has failed due to an error. (Proxy Authentication Required)

Check item	Measures
Setting	Check the setting of the network or the SIP server.

[0111] “Request Timeout” Received

Classification	Error item
IP Fax	The registration to an SIP server has failed due to an error. (Request Timeout)

Check item	Measures
Setting	Check the setting of the network or the SIP server.

[0113] “Gone” Received

Classification	Error item
IP Fax	The registration to an SIP server has failed due to an error. (Gone)

Check item	Measures
Setting	Check the setting of the network or the SIP server.

[0115] “Precondition Failed” Received

Classification	Error item
IP Fax	The registration to an SIP server has failed due to an error. (Precondition Failed)

Check item	Measures
Setting	Check the setting of the network or the SIP server.

[0116] “Request Entity Too Large” Received

Classification	Error item
IP Fax	The registration to an SIP server has failed due to an error. (Request Entity Too Large)

Check item	Measures
Setting	Check the setting of the network or the SIP server.

[0117] “Request-URI Too Long” Received

Classification	Error item
IP Fax	The registration to an SIP server has failed due to an error. (Request-URI Too Long)

Check item	Measures
Setting	Check the setting of the network or the SIP server.

[0118] “Unsupported Media Type” Received

Classification	Error item
IP Fax	The registration to an SIP server has failed due to an error. (Unsupported Media Type)

Check item	Measures
Setting	Check the setting of the network or the SIP server.

[0119] “Unsupported URI Scheme” Received

Classification	Error item
IP Fax	The registration to an SIP server has failed due to an error. (Unsupported URI Scheme)

Check item	Measures
Setting	Check the setting of the network or the SIP server.

[011A] “Unknown Resource-Priority” Received

Classification	Error item
IP Fax	The registration to an SIP server has failed due to an error. (Unknown Resource-Priority)

Check item	Measures
Setting	Check the setting of the network or the SIP server.

[011B] “Bad Extension” Received

Classification	Error item
IP Fax	The registration to an SIP server has failed due to an error. (Bad Extension)

Check item	Measures
Setting	Check the setting of the network or the SIP server.

[011C] “Extension Required” Received

Classification	Error item
IP Fax	The registration to an SIP server has failed due to an error. (Extension Required)

Check item	Measures
Setting	Check the setting of the network or the SIP server.

[011D] “Session Timer Too Small” Received

Classification	Error item
IP Fax	The registration to an SIP server has failed due to an error. (Session Timer Too Small)

Check item	Measures
Setting	Check the setting of the network or the SIP server.

[011E] “Interval Too Brief” Received

Classification	Error item
IP Fax	The registration to an SIP server has failed due to an error. (Interval Too Brief)

Check item	Measures
Setting	Check the setting of the network or the SIP server.

[011F] “Anonymity disallowed” Received

Classification	Error item
IP Fax	The registration to an SIP server has failed due to an error. (Anonymity disallowed)

Check item	Measures
Setting	Check the setting of the network or the SIP server.

[0120] “Temporarily Unavailable” Received

Classification	Error item
IP Fax	The registration to an SIP server has failed due to an error. (Temporarily Unavailable)

Check item	Measures
Setting	Check the setting of the network or the SIP server.

[0121] “Call/Transaction Does Not Exist” Received

Classification	Error item
IP Fax	The registration to an SIP server has failed due to an error. (Call/Transaction Does Not Exist)

Check item	Measures
Setting	Check the setting of the network or the SIP server.

[0122] “Loop Detected” Received

Classification	Error item
IP Fax	The registration to an SIP server has failed due to an error. (Loop Detected)

Check item	Measures
Setting	Check the setting of the network or the SIP server.

[0123] “Too Many Hops” Received

Classification	Error item
IP Fax	The registration to an SIP server has failed due to an error. (Too Many Hops)

Check item	Measures
Setting	Check the setting of the network or the SIP server.

[0124] “Address Incomplete” Received

Classification	Error item
IP Fax	The registration to an SIP server has failed due to an error. (Address Incomplete)

Check item	Measures
Setting	Check the setting of the network or the SIP server.

[0125] “Ambiguous” Received

Classification	Error item
IP Fax	The registration to an SIP server has failed due to an error. (Ambiguous)

Check item	Measures
Setting	Check the setting of the network or the SIP server.

[0126] “Busy Here” Received

Classification	Error item
IP Fax	The registration to an SIP server has failed due to an error. (Busy Here)

Check item	Measures
Setting	Check the setting of the network or the SIP server.

[0127] “Request Terminated” Received

Classification	Error item
IP Fax	The registration to an SIP server has failed due to an error. (Request Terminated)

Check item	Measures
Setting	Check the setting of the network or the SIP server.

[0128] “Not acceptable here” Received

Classification	Error item
IP Fax	The registration to an SIP server has failed due to an error. (Not acceptable here)

Check item	Measures
Setting	Check the setting of the network or the SIP server.

[0129] “Bad Event” Received

Classification	Error item
IP Fax	The registration to an SIP server has failed due to an error. (Bad Event)

Check item	Measures
Setting	Check the setting of the network or the SIP server.

[012A] “Request Updated” Received

Classification	Error item
IP Fax	The registration to an SIP server has failed due to an error. (Request Updated)

Check item	Measures
Setting	Check the setting of the network or the SIP server.

[012B] “Request Pending” Received

Classification	Error item
IP Fax	The registration to an SIP server has failed due to an error. (Request Pending)

Check item	Measures
Setting	Check the setting of the network or the SIP server.

[012C] “Undecipherable” Received

Classification	Error item
IP Fax	The registration to an SIP server has failed due to an error. (Undecipherable)

Check item	Measures
Setting	Check the setting of the network or the SIP server.

[012D] “Security Agreement Required” Received

Classification	Error item
IP Fax	The registration to an SIP server has failed due to an error. (Security Agreement Required)

Check item	Measures
Setting	Check the setting of the network or the SIP server.

[012E] “Internal Server Error” Received

Classification	Error item
IP Fax	The registration to an SIP server has failed due to an error. (Internal Server Error)

Check item	Measures
Setting	Check the setting of the network or the SIP server.

[012F] “Not Implemented” Received

Classification	Error item
IP Fax	The registration to an SIP server has failed due to an error. (Not Implemented)

Check item	Measures
Setting	Check the setting of the network or the SIP server.

[0130] “Bad Gateway” Received

Classification	Error item
IP Fax	The registration to an SIP server has failed due to an error. (Bad Gateway)

Check item	Measures
Setting	Check the setting of the network or the SIP server.

[0131] “Service Unavailable” Received

Classification	Error item
IP Fax	The IP Fax transmission took time since the IP line was busy.

Check item	Measures
Setting	Wait for a while and then reattempt the IP Fax transmission. If this still persists, check the setting of the SIP server.

[0132] “Gateway Time-out” Received

Classification	Error item
IP Fax	The registration to an SIP server has failed due to an error. (Gateway Time-out)

Check item	Measures
Setting	Check the setting of the network or the SIP server.

[0133] “Version Not Supported” Received

Classification	Error item
IP Fax	The registration to an SIP server has failed due to an error. (Version Not Supported)

Check item	Measures
Setting	Check the setting of the network or the SIP server.

[0134] “Message Too Large” Received

Classification	Error item
IP Fax	The registration to an SIP server has failed due to an error. (Message Too Large)

Check item	Measures
Setting	Check the setting of the network or the SIP server.

[0135] “Precondition Failure” Received

Classification	Error item
IP Fax	The registration to an SIP server has failed due to an error. (Precondition Failure)

Check item	Measures
Setting	Check the setting of the network or the SIP server.

[0136] “Busy Everywhere” Received

Classification	Error item
IP Fax	The registration to an SIP server has failed due to an error. (Busy Everywhere)

Check item	Measures
Setting	Check the setting of the network or the SIP server.

[0137] “Decline” Received

Classification	Error item
IP Fax	The registration to an SIP server has failed due to an error. (Decline)

Check item	Measures
Setting	Check the setting of the network or the SIP server.

[0138] “Does Not Exist Anywhere” Received

Classification	Error item
IP Fax	The registration to an SIP server has failed due to an error. (Does Not Exist Anywhere)

Check item	Measures
Setting	Check the setting of the network or the SIP server.

[0139] “Not Acceptable” Received

Classification	Error item
IP Fax	The registration to an SIP server has failed due to an error. (Not Acceptable)

Check item	Measures
Setting	Check the setting of the network or the SIP server.

[013D] Registration failed

Classification	Error item
IP Fax	The registration to an SIP server has failed due to an error. (Other errors)

Check item	Measures
Setting	Check the setting of the network or the SIP server.

[013E] Invite failed

Classification	Error item
IP Fax	The IP Fax transmission / reception has failed due to a communication error. (Other errors)

Check item	Measures
Setting	Check the setting of the network or the SIP server.

[0140] Failed to start

Classification	Error item
IP Fax	The starting of the IP Fax function has failed.

Check item	Measures
Setting	Reboot the equipment.

[0141] Job interruption due to setting change occurred

Classification	Error item
IP Fax	The implementation of an IP Fax job has been stopped since the settings were changed.

Check item	Measures
Setting	Reattempt the IP Fax transmission / reception.

[0142] Irregal address

Classification	Error item
IP Fax	The IP Fax transmission has failed due to a communication error. (Recipient entry error)

Check item	Measures
Setting	Correct the recipient and reattempt the IP Fax transmission.

[0143] SIP server is unavailable

Classification	Error item
IP Fax	The IP Fax transmission / reception has failed due to a communication error. (SIP server unusable)

Check item	Measures
Setting	Check the setting of the network or the SIP server.

[0144] Under congestion

Classification	Error item
IP Fax	The IP Fax transmission has failed due to a communication error. (Under congestion)

Check item	Measures
Setting	Wait for a while and then reattempt the IP Fax transmission.

[0150] Disconnected by communication partner Transmission

Classification	Error item
IP Fax	The IP Fax transmission has failed due to a communication error. (Communication disconnection from the other side's device)

Check item	Measures
Setting	Wait for a while and then reattempt the IP Fax transmission.

Reception

Classification	Error item
IP Fax	The IP Fax reception has failed due to a communication error. (Communication disconnection from the other side's device)

Check item	Measures
Setting	Reattempt the IP Fax reception.

[0300] “Multiple Choices” Received

Classification	Error item
IP Fax	The IP Fax transmission / reception has failed due to a communication error. (Multiple Choices)

Check item	Measures
Setting	Check the setting of the network or the SIP server.

[0301] “Moved Permanently” Received

Classification	Error item
IP Fax	The IP Fax transmission / reception has failed due to a communication error. (Moved Permanently)

Check item	Measures
Setting	Check the setting of the network or the SIP server.

[0302] “Moved Temporarily” Received

Classification	Error item
IP Fax	The IP Fax transmission / reception has failed due to a communication error. (Moved Temporarily)

Check item	Measures
Setting	Check the setting of the network or the SIP server.

[0305] “Use Proxy” Received

Classification	Error item
IP Fax	The IP Fax transmission / reception has failed due to a communication error. (Use Proxy)

Check item	Measures
Setting	Check the setting of the network or the SIP server.

[0380] “Alternative Service” Received

Classification	Error item
IP Fax	The IP Fax transmission / reception has failed due to a communication error. (Alternative Service)

Check item	Measures
Setting	Check the setting of the network or the SIP server.

[0400] “Bad Request” Received

Classification	Error item
IP Fax	The IP Fax transmission / reception has failed due to a communication error. (Bad Request)

Check item	Measures
Setting	Wait for a while and then reattempt the IP Fax transmission.

[0401] “Unauthorized” Received

Classification	Error item
IP Fax	The IP Fax transmission / reception has failed due to a communication error. (Unauthorized)

Check item	Measures
Setting	Wait for a while and then reattempt the IP Fax transmission.

[0402] “Payment Required” Received

Classification	Error item
IP Fax	The IP Fax transmission / reception has failed due to a communication error. (Payment Required)

Check item	Measures
Setting	Wait for a while and then reattempt the IP Fax transmission.

[0403] “Forbidden” Received

Classification	Error item
IP Fax	The IP Fax transmission / reception has failed due to a communication error. (Forbidden)

Check item	Measures
Setting	Wait for a while and then reattempt the IP Fax transmission.

[0404] “Not Found” Received

Classification	Error item
IP Fax	The IP Fax transmission / reception has failed due to a communication error. (Not Found)

Check item	Measures
Setting	Wait for a while and then reattempt the IP Fax transmission.

[0405] “Method Not Allowed” Received

Classification	Error item
IP Fax	The IP Fax transmission / reception has failed due to a communication error. (Method Not Allowed)

Check item	Measures
Setting	Wait for a while and then reattempt the IP Fax transmission.

[0406] “Not Acceptable” Received

Classification	Error item
IP Fax	The IP Fax transmission / reception has failed due to a communication error. (Not Acceptable)

Check item	Measures
Setting	Wait for a while and then reattempt the IP Fax transmission.

[0407] “Proxy Authentication Required” Received

Classification	Error item
IP Fax	The IP Fax transmission / reception has failed due to a communication error. (Proxy Authentication Required)

Check item	Measures
Setting	Wait for a while and then reattempt the IP Fax transmission.

[0408] “Request Timeout” Received

Classification	Error item
IP Fax	The IP Fax transmission / reception has failed due to a communication error. (Request Timeout)

Check item	Measures
Setting	Wait for a while and then reattempt the IP Fax transmission.

[0410] “Gone” Received

Classification	Error item
IP Fax	The IP Fax transmission / reception has failed due to a communication error. (Gone)

Check item	Measures
Setting	Wait for a while and then reattempt the IP Fax transmission.

[0412] “Precondition Failed” Received

Classification	Error item
IP Fax	The IP Fax transmission / reception has failed due to a communication error. (Precondition Failed)

Check item	Measures
Setting	Wait for a while and then reattempt the IP Fax transmission.

[0413] “Request Entity Too Large” Received

Classification	Error item
IP Fax	The IP Fax transmission / reception has failed due to a communication error. (Request Entity Too Large)

Check item	Measures
Setting	Wait for a while and then reattempt the IP Fax transmission.

[0414] “Request-URI Too Long” Received

Classification	Error item
IP Fax	The IP Fax transmission / reception has failed due to a communication error. (Request-URI Too Long)

Check item	Measures
Setting	Wait for a while and then reattempt the IP Fax transmission.

[0415] “Unsupported Media Type” Received

Classification	Error item
IP Fax	The IP Fax transmission / reception has failed due to a communication error. (Unsupported Media Type)

Check item	Measures
Setting	Wait for a while and then reattempt the IP Fax transmission.

[0416] “Unsupported URI Scheme” Received

Classification	Error item
IP Fax	The IP Fax transmission / reception has failed due to a communication error. (Unsupported URI Scheme)

Check item	Measures
Setting	Wait for a while and then reattempt the IP Fax transmission.

[0417] “Unknown Resource-Priority” Received

Classification	Error item
IP Fax	The IP Fax transmission / reception has failed due to a communication error. (Unknown Resource-Priority)

Check item	Measures
Setting	Wait for a while and then reattempt the IP Fax transmission.

[0420] “Bad Extension” Received

Classification	Error item
IP Fax	The IP Fax transmission / reception has failed due to a communication error. (Bad Extension)

Check item	Measures
Setting	Wait for a while and then reattempt the IP Fax transmission.

[0421] “Extension Required” Received

Classification	Error item
IP Fax	The IP Fax transmission / reception has failed due to a communication error. (Extension Required)

Check item	Measures
Setting	Wait for a while and then reattempt the IP Fax transmission.

[0422] “Session Timer Too Small” Received

Classification	Error item
IP Fax	The IP Fax transmission / reception has failed due to a communication error. (Session Timer Too Small)

Check item	Measures
Setting	Wait for a while and then reattempt the IP Fax transmission.

[0423] “Interval Too Brief” Received

Classification	Error item
IP Fax	The IP Fax transmission / reception has failed due to a communication error. (Interval Too Brief)

Check item	Measures
Setting	Wait for a while and then reattempt the IP Fax transmission.

[0433] “Anonymity disallowed” Received

Classification	Error item
IP Fax	The IP Fax transmission / reception has failed due to a communication error. (Anonymity disallowed)

Check item	Measures
Setting	Wait for a while and then reattempt the IP Fax transmission.

[0480] “Temporarily Unavailable” Received

Classification	Error item
IP Fax	The IP Fax transmission / reception has failed due to a communication error. (Temporarily Unavailable)

Check item	Measures
Setting	Wait for a while and then reattempt the IP Fax transmission.

[0481] “Call/Transaction Does Not Exist” Received

Classification	Error item
IP Fax	The IP Fax transmission / reception has failed due to a communication error. (Call/Transaction Does Not Exist)

Check item	Measures
Setting	Wait for a while and then reattempt the IP Fax transmission.

[0482] “Loop Detected” Received

Classification	Error item
IP Fax	The IP Fax transmission / reception has failed due to a communication error. (Loop Detected)

Check item	Measures
Setting	Wait for a while and then reattempt the IP Fax transmission.

[0483] “Too Many Hops” Received

Classification	Error item
IP Fax	The IP Fax transmission / reception has failed due to a communication error. (Too Many Hops)

Check item	Measures
Setting	Wait for a while and then reattempt the IP Fax transmission.

[0484] “Address Incomplete” Received

Classification	Error item
IP Fax	The IP Fax transmission / reception has failed due to a communication error. (Address Incomplete)

Check item	Measures
Setting	Wait for a while and then reattempt the IP Fax transmission.

[0485] “Ambiguous” Received

Classification	Error item
IP Fax	The IP Fax transmission / reception has failed due to a communication error. (Ambiguous)

Check item	Measures
Setting	Wait for a while and then reattempt the IP Fax transmission.

[0486] “Busy Here” Received

Classification	Error item
IP Fax	The IP Fax transmission / reception has failed due to a communication error. (Busy Here)

Check item	Measures
Setting	Wait for a while and then reattempt the IP Fax transmission.

[0487] “Request Terminated” Received

Classification	Error item
IP Fax	The IP Fax transmission / reception has failed due to a communication error. (Request Terminated)

Check item	Measures
Setting	Wait for a while and then reattempt the IP Fax transmission.

[0488] “Not acceptable here” Received

Classification	Error item
IP Fax	The IP Fax transmission / reception has failed due to a communication error. (Not acceptable here)

Check item	Measures
Setting	Wait for a while and then reattempt the IP Fax transmission.

[0489] “Bad Event” Received

Classification	Error item
IP Fax	The IP Fax transmission / reception has failed due to a communication error. (Bad Event)

Check item	Measures
Setting	Wait for a while and then reattempt the IP Fax transmission.

[0490] “Request Updated” Received

Classification	Error item
IP Fax	The IP Fax transmission / reception has failed due to a communication error. (Request Updated)

Check item	Measures
Setting	Wait for a while and then reattempt the IP Fax transmission.

[0491] “Request Pending” Received

Classification	Error item
IP Fax	The IP Fax transmission / reception has failed due to a communication error. (Request Pending)

Check item	Measures
Setting	Wait for a while and then reattempt the IP Fax transmission.

[0493] “Undecipherable” Received

Classification	Error item
IP Fax	The IP Fax transmission / reception has failed due to a communication error. (Undecipherable)

Check item	Measures
Setting	Wait for a while and then reattempt the IP Fax transmission.

[0494] “Security Agreement Required” Received

Classification	Error item
IP Fax	The IP Fax transmission / reception has failed due to a communication error. (Security Agreement Required)

Check item	Measures
Setting	Wait for a while and then reattempt the IP Fax transmission.

[0500] “Internal Server Error” Received

Classification	Error item
IP Fax	The IP Fax transmission / reception has failed due to a communication error. (Internal Server Error)

Check item	Measures
Setting	Check the setting of the SIP server.

[0501] “Not Implemented” Received

Classification	Error item
IP Fax	The IP Fax transmission / reception has failed due to a communication error. (Not Implemented)

Check item	Measures
Setting	Check the setting of the SIP server.

[0502] “Bad Gateway” Received

Classification	Error item
IP Fax	The IP Fax transmission / reception has failed due to a communication error. (Bad Gateway)

Check item	Measures
Setting	Check the setting of the SIP server.

[0503] “Service Unavailable” Received

Classification	Error item
IP Fax	The IP Fax transmission / reception has failed due to a communication error. (Service Unavailable)

Check item	Measures
Setting	Wait for a while and then reattempt the IP Fax transmission.

[0504] “Gateway Time-out” Received

Classification	Error item
IP Fax	The IP Fax transmission / reception has failed due to a communication error. (Gateway Time-out)

Check item	Measures
Setting	Check the setting of the SIP server.

[0505] “Version Not Supported” Received

Classification	Error item
IP Fax	The IP Fax transmission / reception has failed due to a communication error. (Version Not Supported)

Check item	Measures
Setting	Check the setting of the SIP server.

[0513] “Message Too Large” Received

Classification	Error item
IP Fax	The IP Fax transmission / reception has failed due to a communication error. (Message Too Large)

Check item	Measures
Setting	Check the setting of the SIP server.

[0580] “Precondition Failure” Received

Classification	Error item
IP Fax	The IP Fax transmission / reception has failed due to a communication error. (Precondition Failure)

Check item	Measures
Setting	Check the setting of the SIP server.

[0600] “Busy Everywhere” Received

Classification	Error item
IP Fax	The IP Fax transmission / reception has failed due to a communication error. (Busy Everywhere)

Check item	Measures
Setting	Check the setting of the network or the SIP server.

[0603] “Decline” Received

Classification	Error item
IP Fax	The IP Fax transmission / reception has failed due to a communication error. (Decline)

Check item	Measures
Setting	Check the setting of the network or the SIP server.

[0604] “Does Not Exist Anywhere” Received

Classification	Error item
IP Fax	The IP Fax transmission / reception has failed due to a communication error. (Does Not Exist Anywhere)

Check item	Measures
Setting	Check the setting of the network or the SIP server.

[0606] “Not Acceptable” Received

Classification	Error item
IP Fax	The IP Fax transmission / reception has failed due to a communication error. (Not Acceptable)

Check item	Measures
Setting	Check the setting of the network or the SIP server.

[4246] IP Fax license is not installed

Classification	Error item
IP Fax	The license of the IP Fax has not been installed.

Check item	Measures
Setting	Check that the license of the IP Fax has been installed.

[DA01] The FAX Unit of line 1 has been damaged

Classification	Error item
Fax	The FAX Unit of line 1 has been damaged or an abnormality has occurred in the interface between the systems.

Check item	Measures
Setting	Reboot the equipment. If the error still persists, replace the FAX Unit of line 1.

[DA02] The FAX Unit of line 2 has been damaged

Classification	Error item
Fax	The FAX Unit of line 2 has been damaged or an abnormality has occurred in the interface between the systems.

Check item	Measures
Setting	Reboot the equipment. If the error still persists, replace the FAX Unit of line 2.

8.4 Other Errors

8.4.1 Equipment operation disabled after the installation of option(s)

Check if the optional board is installed properly.

8.4.2 Wireless LAN connection disabled

The connection state and settings of the Wireless LAN can be checked with [USER FUNCTIONS]→[ADMIN]→[WIRELESS LAN]→[SETTING CHECK].

Confirm the settings with the administrator.

- “NIC INITIALIZING” does not disappear at the time of the power being turned ON and it disappears after 6 minutes with the NIC initializing time-out. In this case, the connection to the Wireless LAN does not succeed even though “NIC INITIALIZING” disappears.
- The connection to the Wireless LAN cannot be made if the Access Point to be connected is not found or security settings are not correct.

8.4.3 “Invalid Department Code” is displayed

Log in to TopAccess as an administrator, select [Authentication] on the [User Management] tab, and then check whether Department Setting is enabled or disabled.

Department Setting is enabled:

- Log in to TopAccess as an administrator, select [Authentication] on the [User Management] tab, and then check User Management Setting.
- Confirm the settings of FS-08-3805 in the setting mode.

Department Setting is disabled:

- Log in to TopAccess as an administrator, select [Authentication] on the [User Management] tab, and then check User Management Setting.

8.4.4 Paper folded on the leading edge

If the leading edge of B4, B5 or B5-R paper is folded when it exits, check the following items.

- Check if the rear and side guides of the drawer or the side guide of the bypass tray correspond to the paper size.

8.4.5 Toner cartridge unrecognized

If the toner cartridge is not recognized, check the following.

- Check that there is no access abnormality to the toner cartridge IC chip.
- Check the setting of FS-08-4689 in the setting mode. If the value is “1” to “5”, perform the C911/C912/C913/C914 troubleshooting.

 P. 8-217 “ [C911] Toner cartridge PC board access abnormality (K)”

8.4.6 Ethernet disabled in half-duplex communication

The Ethernet of this equipment does not support half-duplex communication.

When the port setting of the switch is fixed at half-duplex communication, use any of 10/100/1000 Mbps, full-duplex fixed communication mode or auto-negotiation function.

In addition, select the setting of the equipment corresponding to that of the switch.

([ADMIN] > [NETWORK] > [ETHERNET])

Check the set communication speed as follows if required:

[ADMIN] > [NETWORK] > [ETHERNET]

8.4.7 The equipment does not start after the power has been turned ON.

[1] The LCD screen does not display after the power has been turned ON.

1. General description

When the lamps on the control panel do not light or error codes are not displayed on the LCD screen after the power has been turned ON, perform this troubleshooting.

2. Status LED / Power LED

After the power is turned ON, the status of the equipment from the startup until the end of system device initialization (the LCD screen works) is displayed by the status LED (8-bit) on the SYS board. When the equipment does not start or the LCD screen does not display after the power is turned ON, check this status LED on the SYS board in order to judge the corresponding troubleshooting. In addition to this, the power LED is lit when 12 VA power is being supplied to the SYS board.

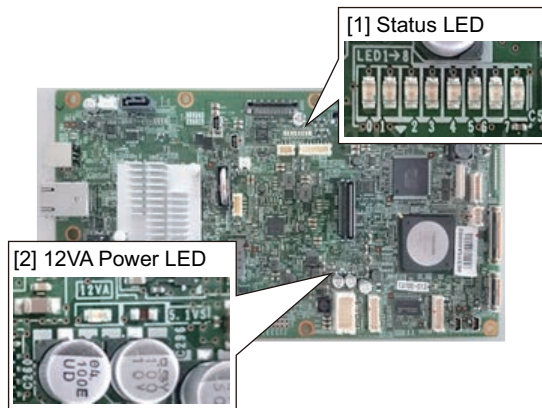

Fig.8-28

3. Measures

When an error code is displayed, perform its troubleshooting.

If the LCD screen is turned OFF and an error code cannot be confirmed as a result, check the lighting condition of each LED and perform the troubleshooting according to the status below.

Main Power LED / Energy Saver LED (on Control panel)

LED	Lighting condition	SYS power LED	Troubleshooting
Main Power LED	ON	ON	<p>The control panel does not operate normally.</p> <ul style="list-style-type: none"> • Check the connection of the harness (41-pin) of the control panel. Check if there is no abnormality in the harness. • Check if there is no abnormality in the parts of the control panel. • Download the system software again. • Check if there is no abnormality in the SYS board. • Replace the main memory (DIMM). • Replace the control panel. • Replace the SYS board.
		OFF	<p>The 12 VA power is not supplied to the SYS board.</p> <ul style="list-style-type: none"> • Check the connection of the power harness of the SYS board. Check if there is no abnormality in the harness. • Check if there is no abnormality in the switching regulator. • Check if there is no abnormality in the SYS board. • Replace the power harness of the SYS board. • Replace the switching regulator. • Replace the SYS board. <p>The 12 VA power supply is stopped due to an overcurrent.</p> <ul style="list-style-type: none"> • Turn OFF the main power switch and open the front cover. While keeping this status, press the main power switch to check that the SYS power LED is turned ON. <p>[If the SYS power LED is turned ON]</p> <ul style="list-style-type: none"> • Check if there is no abnormality in all harnesses with the 24 V power supplied. • Check if there is no abnormality in all boards with the 24 V power supplied. • Replace all boards with the 24 V power supplied. <p>[If the SYS power LED is not turned ON]</p> <ul style="list-style-type: none"> • Check if there is no abnormality in all harnesses with the 12 VA power supplied. • Check if there is no abnormality in all boards with the 12 VA power supplied. • Replace all boards with the 12 VA power supplied.
	OFF	ON	<p>The 5 VS power is not supplied to the control panel.</p> <ul style="list-style-type: none"> • Check the connection of the harness of the control panel. • Check if there is no abnormality in the parts of the control panel.
		OFF	<p>The power is not supplied to the SYS board.</p> <ul style="list-style-type: none"> • Check the connection of the power harness of the SYS board. • Check if there is no abnormality in the switching regulator. • Check if there is no abnormality in the SYS board.

LED	Lighting condition	SYS power LED	Troubleshooting
Energy Saver LED	ON	-	-
	Blinking	-	When the Energy Saver LED is turned OFF after a certain time has passed: Initialization between the control panel and the SYS board is not completed. <ul style="list-style-type: none"> • Check the connection of the harness of the control panel. • SYS board abnormality (Check the lighting condition of the SYS power LED and the SYS status LED, and perform the measures described in the next table.)
		-	When the Energy Saver LED blinks even if some times have passed: The LCD is not turned ON after initialization between the control panel and the SYS board is completed. <ul style="list-style-type: none"> • Check the connection of the harness of the control panel. • Check if there is no abnormality in the parts of the control panel. • SYS board abnormality (Check the lighting condition of the SYS power LED and the SYS status LED, and perform the measures described in the next table.)
OFF	ON	The 12 VA power is not supplied to the control panel. <ul style="list-style-type: none"> • Check the connection of the harness of the control panel. • Check if there is no abnormality in the parts of the control panel. 	

Power LED / Status LED (on SYS board)

LED		Lighting condition	SYS board status	Troubleshooting
Power LED		OFF	Waiting for the power supply	Check the connection of the switching regulator harness and the power supply harness.  P. 8-435 "[2] The equipment does not start after the power has been turned ON."
Status LED	Bit7	ON	Main memory abnormality	<ul style="list-style-type: none"> • Check the installation status of the main memory, and reinstall it if necessary. • Perform calibration of the main memory at the startup. • Replace the main memory or the SYS board.
	Bit4	ON	Network IC communication error	Replace the SYS board.
	Bit3	ON	ASIC detection error	Replace the SYS board.
	Bit2	ON	HDD/SSD detection error	<ul style="list-style-type: none"> • When the error code is from F100 to F109, perform the HDD/SSD fault diagnosis by following each troubleshooting. • If the LCD screen does not display, check the connection of the HDD harness.
	Bit1	ON	Control panel communication error	<ul style="list-style-type: none"> • Check the connection of the harness of the control panel. • Check if there is no abnormality in the parts of the control panel.
	Bit0	ON	Errors other than the above	Replace the SYS board.

Remarks:

- When Bit1 or Bit7 of the status LED is ON and an error code is displayed on the LCD screen, perform the troubleshooting for each error code.
- The lighting condition of the status LED is determined while Bit0 is turned OFF. Due to this, be sure to check the condition from Bit1 to Bit7 while Bit0 is turned OFF.

[2] The equipment does not start after the power has been turned ON.

Check the following items when the equipment does not start due to an abnormality in the power supply side even if the power has been turned ON.

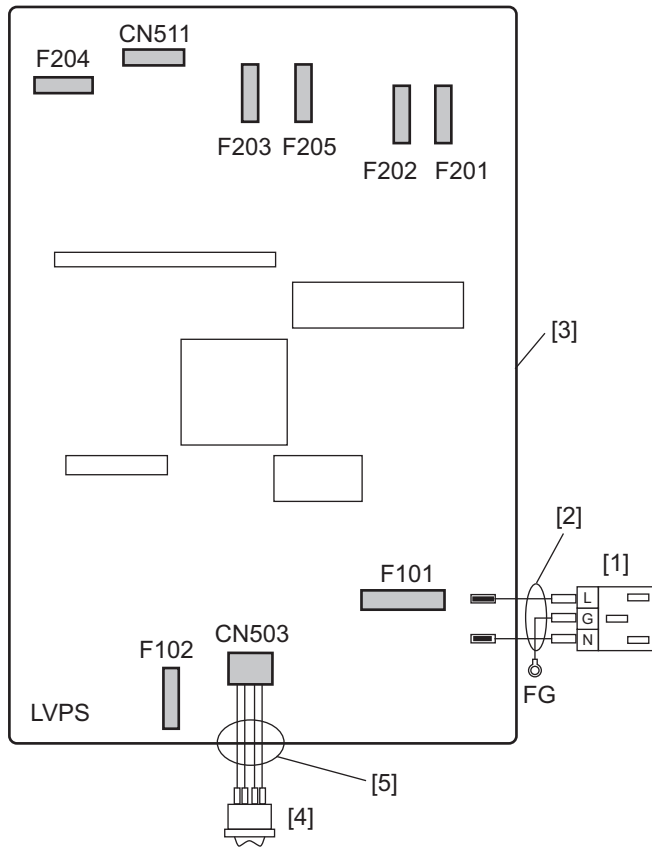

Fig.8-29

1. When the [Power] LED on the control panel does not light. / When the fan on the SYS board does not work. / The LCD screen does not display.

Check item	Measures
Power voltage	Is the power voltage within +/- 10% of the rated voltage?
Power cable	Check if the harnesses are open circuited or if contact failure occurs in the connector.
Inlet [1][2]	Check if the inlet [1] and its harness [2] are open circuited or disconnected.
Main power switch [4]	Check if the main power switch [4] and its harness [5] are open circuited or disconnected.

Check item	Measures
Switching regulator (LVPS) [3]	<p>Check if the harness [2] is inserted into the connectors (CN501, CN502) of the switching regulator [3] properly.</p> <p>Check if the harness [5] is inserted into the connector (CN503) of the switching regulator [3] properly.</p>
	<p>Check if the fuse (F101) has melted.</p> <ul style="list-style-type: none"> If the fuse (F101) cannot be blown out even when it has been replaced and the damp heater switch has been turned OFF (in the equipment with the damp heater installed) and then the main power switch is turned ON, exchange the damp heater in question. <p>Remarks:</p> <p>If the resistance value of the damp heater is as below, there will be an abnormality in the damp heater in question.</p> <ul style="list-style-type: none"> Scanner damp heater: 714Ω -10% or below Drum damp heater (right): 830Ω -10% or below Drum damp heater (left): 830Ω -10% or below Drawer damp heater: 2KΩ -10% or below <ul style="list-style-type: none"> If the fuse (F101) cannot be blown out even when it has been replaced and the fuser unit has been taken off and then the main power switch is turned ON, exchange the fuser unit. If the IH board cooling fan does not work after the fuse (F101) has been replaced, exchange the IH board. If the problem still persists even though the above steps have been carried out, replace the switching regulator [3].
	<p>Check if the fuse (F102) has melted.</p> <ul style="list-style-type: none"> Replace the switching regulator [3].
	<p>Check if the CN511 5-pin and 6-pin of the switching regulator output 5V +/- 5%.</p> <ul style="list-style-type: none"> Output when the connectors of the control panel are disconnected: Replace the control panel. Output when all of the connectors of the SYS board are disconnected: Replace the SYS board. Output when all of the connectors of the LGC board are disconnected: Replace the LGC board. If the problem still persists even though the above steps have been carried out, replace the switching regulator [3].
IH board	<p>If the problem still persists even though all the above steps have been checked, replace the IH board.</p>

2. When the [Power] LED on the control panel lights. / When the fan on the SYS board does not work.
/ The LCD screen does not display.

Check item	Measures
Options	<p>Check if this problem can be resolved when the connectors of the paper handling options are disconnected and then the power is turned OFF and then back ON. (Does the LCD screen display?)</p> <ul style="list-style-type: none"> Check if there is abnormality such as catching in the harnesses of the applicable options.

Check item	Measures
LGC board	<p>Check if this problem can be resolved when the ADU is opened. (Does the LCD screen display?)</p> <p>If the problem is resolved (the LCD screen displays), close all covers and check the following items.</p> <ul style="list-style-type: none"> • The LCD screen displays when CN301 is disconnected: Check or replace the reverse gate solenoid and the harness. • The LCD screen displays when CN301 is disconnected: Check or replace the paper feeding/developer unit drive motor and the harness. Check or replace the drum/TBU motor and the harness. Check or replace the 1st transfer contact/release clutch and the harness. (25ppm/30ppm/35ppm) • The LCD screen displays when CN327 is disconnected: Check or replace the paper feeding/developer unit drive motor and the harness. Check or replace the drum/TBU motor and the harness. Check or replace the 1st transfer contact/release clutch and the harness. (45ppm/50ppm) • The LCD screen displays when CN302 is disconnected: Check or replace the IH board cooling fan and the harness. • The LCD screen displays when CN305 is disconnected: Check or replace the fuser motor and the harness. • The LCD screen displays when CN309 is disconnected: Check or replace the sensor shutter solenoid and the harness • The LCD screen displays when CN311 is disconnected: Check or replace the suctioning fan and the harness. Check or replace the exit section cooling fan and the harness. • The LCD screen displays when CN312 is disconnected: Check or replace the discharge LED (Y, M, C and K) and the harness. • The LCD screen displays when CN320 and CN321 are disconnected: Check or replace the high-voltage transformer and the harness. • The LCD screen displays when CN322 is disconnected: Check or replace the laser optical unit and the harness. • If the problem still persists even though the above items have been done, replace the LGC board.
PFC board	<ul style="list-style-type: none"> • The LCD screen displays when CN450 is disconnected: Check or replace the ADU board and the harness. • The LCD screen displays when CN451 is disconnected: Check or replace the bypass feed clutch and the harness. • The LCD screen displays when CN461 is disconnected: Check or replace the 1st drawer feed clutch, 2nd drawer feed clutch, transport clutch (L), transport clutch (H) and harness. • The LCD screen displays when CN462 is disconnected: Check or replace the ozone exhaust fan and the harness. Check or replace the developer unit cooling fan and the harness.
SYS board	The LCD screen displays when CN125 is disconnected: Replace the SYS board.
Switching regulator (LVPS) [3]	When the problem is not resolved (the LCD screen does not display) even if the front cover or the side cover is opened, replace the switching regulator.
Power supply unit cooling fan	<p>Check if the power supply unit cooling fan rotates.</p> <ul style="list-style-type: none"> • Check the connector of the power supply unit cooling fan. • Replace the LGC board. • Replace the switching regulator.



8.4.8 Countermeasure to sudden power failure

	Phenomenon	Check item	Measures
1	The [ENERGY SAVER] button is lit. The power supply is recovered by pressing the [ENERGY SAVER] button.	<ul style="list-style-type: none"> The mode is at the Sleep mode. 	Turn off the Sleep mode setting. Or change the setting.
2	The power supply is recovered by pressing the [ON/OFF] button.	<ul style="list-style-type: none"> The weekly timer has run. 	<ul style="list-style-type: none"> Turn off the setting of the weekly timer. Or change the setting. Check if the time is set correctly.
3	The power supply is not recovered even if the [ON/OFF] button is pressed.	<p>The harnesses of 12V or 24V are short circuited.</p> <ul style="list-style-type: none"> Check if there is any abnormality, such as scratches or being caught on the harnesses of each board, and damage on the connector pins. 	<ul style="list-style-type: none"> Replace the harness. Replace the switching regulator.
4	The LED of the main power is not lit.	<ul style="list-style-type: none"> Check if there is any abnormality in the power cable. Check if there is any abnormality such as scratches or being caught on the harnesses for the inlet or the main power switch. Check if the fuses (F101/102) for the main power switch are cut. Check if the harness for the switching regulator is properly connected. 	<ul style="list-style-type: none"> Replace the power cable. Replace the harnesses for the inlet, the main power switch and the switching regulator. Replace the switching regulator.
5	The LED of the main power is lit.	<p>Check the voltage of the power connector (CN105) on the SYS board.</p> <ul style="list-style-type: none"> The voltage of 5-pin is lower than 4.8V. The voltage of 9-pin is lower than 10.8V. The voltage of 5-pin is 4.8V or more, that for 9-pin is 0V and that for 1-pin is 0V. 	<ul style="list-style-type: none"> Replace the switching regulator.
		<p>Check the voltage of the power connector (CN105) on the SYS board.</p> <ul style="list-style-type: none"> The voltage of 5-pin is 4.8V or more, that for 9-pin is 0V and that for 1-pin is 4.8V or more. 	<ul style="list-style-type: none"> Replace the SYS board.
6	Power supply failed at warming up. (The LED of the main power is lit.)	<p>Check if there is any abnormality in the fuser unit.</p> <ul style="list-style-type: none"> Check if there is any abnormality in the terminal of the connector. Check if there is any abnormality in the installation of the thermistor and no dust on it. 	<ul style="list-style-type: none"> Repair the defective portions of the fuser unit. Replace the fuser unit.
		<p>Check if there is any abnormality in the LGC board.</p> <ul style="list-style-type: none"> Check if the connectors of LGC board are disconnected, installed properly or their pins are damaged. 	<ul style="list-style-type: none"> Replace the harness. Replace the LGC board.
		<ul style="list-style-type: none"> Check if there is any abnormality in the switching regulator. 	<ul style="list-style-type: none"> Replace the switching regulator.

	Phenomenon	Check item	Measures
7	Power supply failed when the motor rotates. Power supply failed when the cover is closed.	Check if there is any abnormality in the motor. <ul style="list-style-type: none"> Check if there is any abnormality which makes the motor disable to rotate. Check if there is any abnormality such as scratches or being caught on the harness of the motor. 	<ul style="list-style-type: none"> Release the problems or replace the motor and harness.
		Check if there is any abnormality in the options. <ul style="list-style-type: none"> Check if the problem is released when disconnecting the option. 	<ul style="list-style-type: none"> Check if there is any abnormality in the disconnected option and release the problems.
8	Power supply failed when the ADU is opened and closed.	<ul style="list-style-type: none"> Check if there is any abnormality such as scratches or being caught on the harness for the ADU hinge. 	<ul style="list-style-type: none"> Replace the harness.
9	Power supply failed when the DF is opened and closed.	<ul style="list-style-type: none"> Check if there is any abnormality such as scratches or being caught on the harness for the DF and the scanner. Check if there is any abnormality such as scratches or being caught on the harness between the SYS board and the scanner. Check if there is any abnormality on the connector pins. 	<ul style="list-style-type: none"> Replace the harness.
10	The equipment is rebooted.	<ul style="list-style-type: none"> An error occurred. (Depending on the error, the equipment will reboot at its first time and then a service call will happen at its second time.) 	<ul style="list-style-type: none"> Check the error code and solve the problem. Check the installation status of the main memory, and reinstall it if necessary. Replace the main memory.

Parts to be replaced	Remarks
Power cable	
Switching regulator	
Fuser unit	
SYS board	
LGC board	
Harnesses in question	
Main memory	

8.4.9 “Authentication Failed” is displayed

- Reset the service password
Reset the service password by accessing [USER FUNCTIONS] > [ADMIN] > [GENERAL] > [PASSWORD SETUP] > [RESET SERVICE PASSWORD].
- Initialize the SRAM
Refer to  P. 9-34 “9.2.5 Precautions and procedure when replacing the SRAM”, and perform “[D] Initialize SRAM system storage area” and following steps.
- Replace the SRAM
Refer to  P. 9-34 “9.2.5 Precautions and procedure when replacing the SRAM”, and replace the SRAM board.

8.4.10 Error code “M00” is displayed while updating firmware

Check item	Measures
SYS board	<ul style="list-style-type: none"> • Connector check (CN133, CN132) • Harness check • Short circuited or open circuited check
LGC board	<ul style="list-style-type: none"> • Connector check (CN330, CN329, CN314) • Harness check • Short circuited or open circuited check
LVPS board	<ul style="list-style-type: none"> • Connector check (CN512)

Parts to be replaced	Remarks
SYS board	
LGC board	
LVPS board	
Harness	

8.4.11 “Fax line1 is out of order.” or “Fax line2 is out of order.” is displayed

1. Turn the power OFF and then back ON.
2. Replace the fax board.

8.4.12 “Close the cover on the right” is repeatedly displayed at intervals of a few seconds

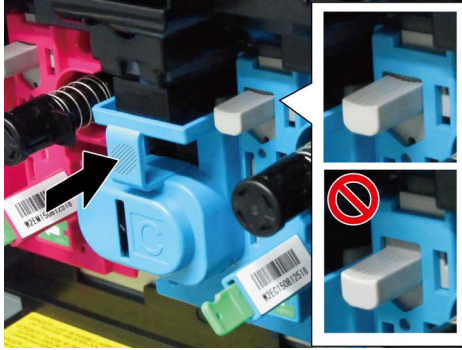
Check item	Measures
EPU (C, K)	<p>Has the developer unit (C, K) been installed securely? Press the slanted line portion of the developer unit until a click sound is heard.</p> 
Switching regulator (PS)	Replace the switching regulator.

8.4.13 “Latch the developer unit (Yellow, Magenta, Cyan, Black)” remains displayed

After the power is turned ON, “Latch the developer unit (Yellow, Magenta, Cyan, Black)” is displayed on the panel. This display is not changed even if the developer unit is removed and then installed.

Step	Check item	Measures
1	<ul style="list-style-type: none"> Installation state of the developer unit (Y, M, C, K) 	<ul style="list-style-type: none"> Remove and install the developer unit. Close the front cover. Make sure the drawer connector is connected securely and there is no deformed connector pins.
		<ul style="list-style-type: none"> If the display for all colors is not changed even if step 1 has been carried out, perform steps 2 to 5. If the display for any of the colors is changed, perform steps 6 and 7.
2	Change in the display	<ul style="list-style-type: none"> Check if the display is changed when the power is turned OFF and then back ON. If an error indication is displayed, perform its troubleshooting in accordance with its procedure.
3	SYS board	<ul style="list-style-type: none"> Connector check (CN132) Harness check Short circuited or open circuited check
4	LGC board	<ul style="list-style-type: none"> Connector check (CN329) Harness check Short circuited or open circuited check
5	Flat cable	<ul style="list-style-type: none"> Check if there is any abnormality in the terminal of the flat cable between the SYS and LGC boards. Check if the flat cable is open circuited.
6	Harness	<ul style="list-style-type: none"> Check if there is a short circuit or open circuit in the harness (CN313) for connecting the LGC board and the developer unit whose display is not changed.
7	LGC board	<ul style="list-style-type: none"> Connector check (CN313) Harness check Short circuited or open circuited check



Parts to be replaced	Remark
Flat cable	
SYS board	
LGC board	
Developer unit	

8.5 Troubleshooting for the Image

8.5.1 Color deviation

1) Color deviation

<Symptoms>

Original mode	Location	Phenomena	
All modes	Color blurred in outline of white text or illustration on a colored background	Color deviation	 <p>Fig.8-30</p>
Text Mode Text/Photo Mode	Outline in black text on a colored background	White void	 <p>Fig.8-31</p>
Photo Mode Map Mode	Color blurred in outline of line or text	Color deviation	 <p>Fig.8-32</p>

Cause/Section	Step	Check Item	Measures	Remark
	1	Perform the Forced performing of color registration control adjustment (FS-05-4719).	Has it ended normally? When CA00 occurs: → Proceed to [CA00] troubleshooting.	
	2	Test printing (A3/LD)	Output the built-in grid pattern	For the following checks
Drum rotation abnormality	3	Check the drum motor operation in the test mode (FS-03 TEST MODE) to see if there is any rotation abnormality of the drum.	Replace the drum TBU motor.	
	4	Check the drum TBU motor operation in the test mode (FS-03 TEST MODE) to see if there is any rotation abnormality of the drum.	Reconnect the connectors. Replace the harnesses. Replace the LGC board.	
Inadequate drum TBU motor rotation speed	5	Check the value set for drum TBU motor rotation speed. (Is the value significantly different from the default value?)	Reset drum TBU motor speed to 128.	
Drum coupling and coupling on the equipment side	6	Loose coupling, damage, deformation	Check if they are installed properly or replace the couplings.	

Cause/Section	Step	Check Item	Measures	Remark
Transfer belt	7	Deformation or damage of the transfer belt or stains on the transfer belt.	Clean or replace the transfer belt.	
	8	Are the gears on the transfer belt side loosen, damaged or deformed?	Tighten the screws if they loosen, or replace the gears.	
	9	Stain or damage of the drive roller	Clean or replace the drive roller.	
	10	Does the rib of the transfer belt overlap the collar on both edge of the drive roller?	Adjust the position of the transfer belt.	
	11	Is the belt edge damaged or stained?	Clean or replace the transfer belt.	
	12	Peeling of the cleaning blade (Large driving load)	Replace the cleaning blade.	
	13	Is the transfer belt unit installed normally? (Is the unit properly grounded?)	Check and correct the installing.	
High-voltage transformer	14	Check the connection of the high-voltage supply terminal of the 1st or 2nd transfer rollers.	Correct or replace the terminal if it is loosened or damaged.	

8.5.2 Uneven pitch and jitter image

<Symptoms>

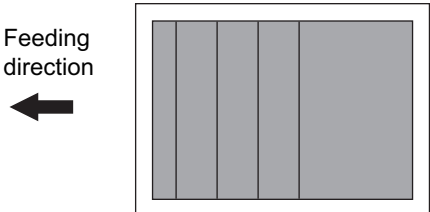
Original mode	Location	Phenomena	
All modes	Occurs cyclically at right angles to paper feeding direction	Uneven pitch	 <p>Feeding direction</p> <p>←</p> <p>Fig.8-33</p>

Cause/Section	Step	Check Item	Measures	Remark
	1	Test printing (A3/LD)	Output the built-in halftone and grid patterns.	For the following checks
Drum	2	Are there uneven pitches of approx. 94 mm?	Replace the drum.	
	3	Is there any damage on the drum surface?	Clean or replace the drum.	
Drum drive	4	Is there any dent, damage or deformation on the gears of the drum drive unit?	Replace the gears of the drum drive unit.	
Drum rotation abnormality	5	Check the drum TBU motor operation in the test mode (FS-03 TEST MODE) to see if there is any rotation abnormality of the drum.	Reconnect the connectors. Replace the harnesses. Replace the LGC board. Replace the drum TBU motor.	
Developer sleeve	6	Are there uneven pitches of approx. 28 mm?	Replace the developer sleeve.	
Inadequate drum TBU motor rotation speed	7	Check the value set for drum TBU motor rotation speed. (Is the value significantly different from the default value?)	Reset drum TBU motor speed to 128.	
Drum coupling	8	Loose coupling, damage, deformation	Replace the couplings.	
Transfer belt	9	Deformation or damage of the transfer belt	Replace the transfer belt.	Check the halftone pattern. (Uneven pitch: approx. 56 mm)
	10	Stain or damage of the drive roller	Clean or replace the drive roller.	Check the halftone pattern. (Uneven pitch: approx. 56 mm)
	11	Large driving load due to the peeling of the cleaning blade	Replace the cleaning blade.	
Transfer belt drive	12	Are there uneven pitches of 0.63 mm?	Replace the TBU gears.	
Feeding drive	13	Are there uneven pitches of approx 2.0 mm or 0.79 mm, 1.25 mm?	Replace the gears of the feed/transport gear unit and the first drawer transport clutches.	
	14	Is there any dent, damage or deformation on the gear of the feed/transport gear unit and the first drawer transport clutch (CLT5 or CLT6)?		

Cause/Section	Step	Check Item	Measures	Remark
Fusing drive	15	Are there uneven pitches of approx. 94 mm?	Perform "Fine adjustment of fuser belt rotational speed" (FS-05-4529-0, 3, 4, 7).	
	16	Is the fuser unit properly installed in the equipment?	Check if the fuser unit is installed correctly.	
	17	Is there any dent, damage or deformation on the drive gears of the pressure roller?	Replace the drive gear of the pressure roller.	
EPU drive	18	Are there uneven pitches of approx. 0.78 mm?	Replace the developer drive unit, developer sleeve and drive gears of the mixer.	
	19	Is there any dent, damage or deformation on the developer drive unit, developer sleeve and drive gears of the mixer?		
2nd transfer roller	20	Are there uneven pitches of approx. 75 mm? Is there any deformation to the 2nd transfer roller? Since the 2nd transfer roller is always in contact with the transfer belt, the roller may creep if the power has not been turned on and the equipment left unused for a long time (1 month or more), causing an uneven pitch.	Replace the 2nd transfer roller.	This problem may occur on thick paper or the image on the back side of the paper in duplex printing.

8.5.3 Poor image density, color reproduction and gray balance

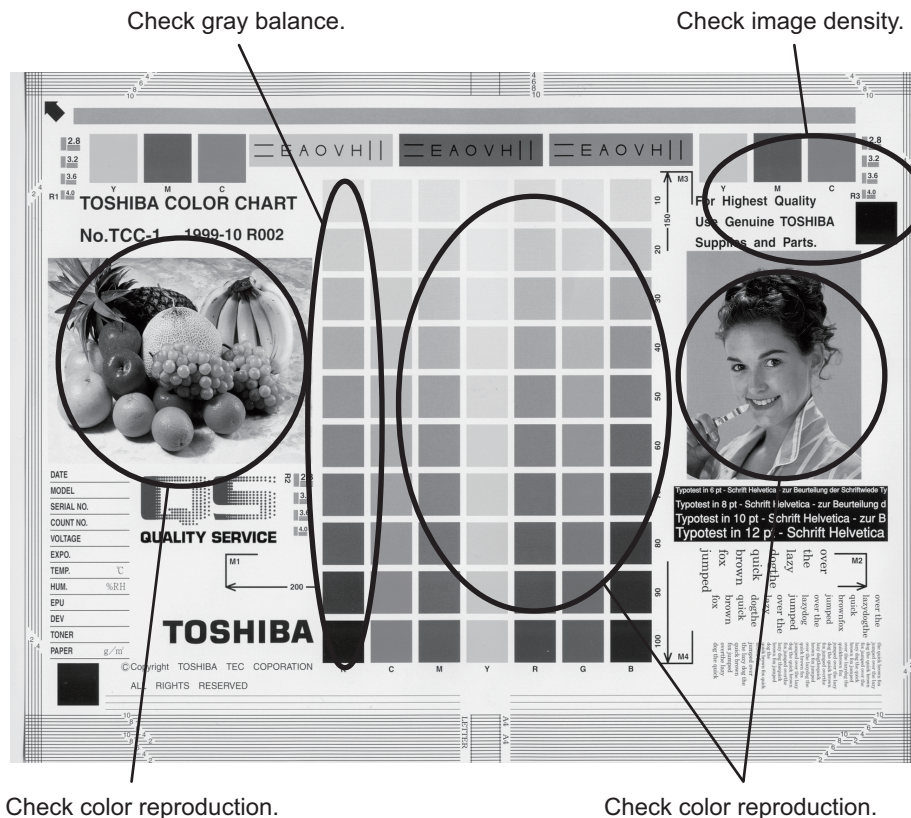

Fig.8-34

Cause/Section	Step	Check item	Measures	Remarks
Density / Color reproduction / Gray balance	1	Check the image density / color reproduction / gray balance.	Perform FS-05-2742 (Enforced performing of image quality control (closed-loop)) and then automatic gamma adjustment.	
Printer density	2	Check the density of printed images.	Repeatedly perform CC219/ CC220 outputs and FS-05-2742 (Enforced performing of image quality control (closed-loop)) for 2 or 3 times.	If the density and color reproduction vary, go to step 6.
	3	Check the density of printer output image.	Output the test patterns and check them. Using FS-04-36 for each color	Go to step 7 if defect occurs.
Scanner	4	Check if the original glass, mirrors or lens is dirty.	Clean it.	
Parameter adjustment value	5	Check the image processing parameters.	Adjust the color balance (color). Adjust the image density.	

Cause/Section	Step	Check item	Measures	Remarks
Image quality control abnormality	6	Check if the connector of the Image position aligning sensor (Center) / Image quality sensor is connected properly.	Reconnect the connector properly.	
		Check if the harness of the Image position aligning sensor (Center) / Image quality sensor is open circuited.	Replace the harness.	
		Does the sensor shutter operate properly?	Correct the installation of the shutter or replace it.	
		Image position aligning sensor (Center) / Image quality sensor	Replace the image position aligning sensor (Center) / Image quality sensor.	
Printed images abnormality	7	Is there any faded image (low density)?	Perform the troubleshooting procedures against the faded image.	
		Is there any fog in the background?	Perform the troubleshooting procedures against the background fogging.	
		Is there any blotch image?	Perform the troubleshooting procedures against the blotch image.	
		Is the transfer belt slackened?	Correct the installation of the parts around the transfer belt unit. Replace the transfer belt unit.	
		Is the frame of the transfer belt unit conducted to the equipment?	Check if the grounding leaf spring contacts securely. Replace the grounding leaf spring.	
		Is there any poor transfer?	Perform the troubleshooting procedures against the poor transfer.	
		Is there any poor cleaning of the transfer belt? (Check inside the equipment.)	Correct the transfer belt area.	

* If the trouble is not solved at the step 1 and the step 2 or followings (excluding the parameter adjustment) are performed, make sure to perform “Enforced performing of image quality closed-loop control” and then “Automatic gamma adjustment” after taking a measure.

8.5.4 Background fogging 1

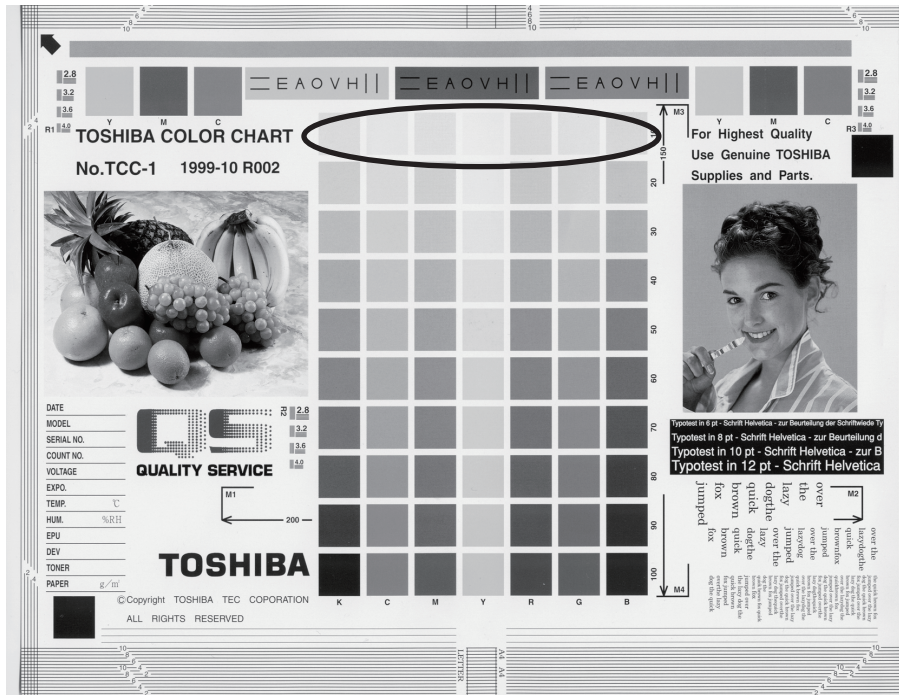

Fig.8-35

Cause/Section	Step	Check item	Measures	Remarks
Adjustment	1	Perform the shading correction.	Perform FS-05-3218.If an error occurs, retry it. If the error still persists, clean the original glass covering the shading correction plate and perform FS-05-3218 again.	
Density reproduction	2	Check the gradation reproduction.	Perform the forced performing of image quality closed-loop control (FS-05-2742) and then automatic gamma adjustment.	
Printer section	3	Check the printer output image.	Output the test patterns and check them. Using FS-04-36 for each color	See step 7 if defects occur.
Scanner	4	Check if the original glass, DF original glass, mirrors or lens is dirty.	Clean it.	
Parameter adjustment value	5	Check the image processing parameters.	Check the value of offsetting adjustment for background adjustment.	
	6	Adjust the image processing parameters.	While checking the above encircled image, adjust the reproduction level by the offsetting adjustment for background adjustment.	
Cover	7	Is the cover installed properly? (Is the drum exposed to the external light?)	Correct it.	
Auto-toner	8	Is the auto-toner sensor normal?	Check the operation of auto-toner sensor and readjust.	
	9	Is the toner supply operating constantly?	Check the motor and circuits.	

Cause/Section	Step	Check item	Measures	Remarks
High-voltage transformer (main charger unit output, developer unit bias)	10	Is the harness between the LGC board (CN320, CN321) and the high-voltage transformer (CN530, CN531) open circuited? Are the connectors connected securely?	Reconnect the connectors securely. Replace the harness.	
	11	Do the springs for supplying power contact the high-voltage transformer output portions (OUT-1 to OUT-3)?	Make the springs for supplying power contact the high-voltage transformer output portions securely.	
	12	Does the high-voltage transformer work properly?	Replace the high-voltage transformer.	
Developer unit	13	Is the contact between the drum and developer material proper?	<ul style="list-style-type: none"> Check the pole position. Confirm that they are aligned properly through the doctor blade and the bearing. If there is any abnormality, replace the developer unit. 	
Developer material/Toner/ Drum	14	Using the specified developer material, toner and drum?	Use the specified developer material, toner and drum.	
	15	Have the developer material and drum reached their PM life?	Replace the developer material and drum.	
	16	Is the storage environment of the toner cartridge 35°C or less without dew?	Use the toner cartridge stored in the environment within specification.	
Drum cleaning blade	17	Is the drum cleaned properly?	Check the drum cleaning blade pressure.	
Transfer belt cleaning blade	18	Is the transfer belt cleaning blade in proper contact with the transfer belt?	Take off the transfer belt and check if the transfer belt cleaning blade pressure spring and pressure hook are installed properly.	
Toner dusting	19	Is the toner accumulated on the seals of the developer unit?	Remove the toner and clean the seals.	

* If the trouble is not solved at the step 1 and the step 2 or followings (excluding the parameter adjustment) are performed, make sure to perform “Enforced performing of image quality closed-loop control” and then “Automatic gamma adjustment” after taking a measure.

8.5.5 Background fogging 2 (1200 dpi printing)

<Symptoms>

The stripe pattern is printed on the whole area of paper at 1200 dpi printing, it looks like background fogging.

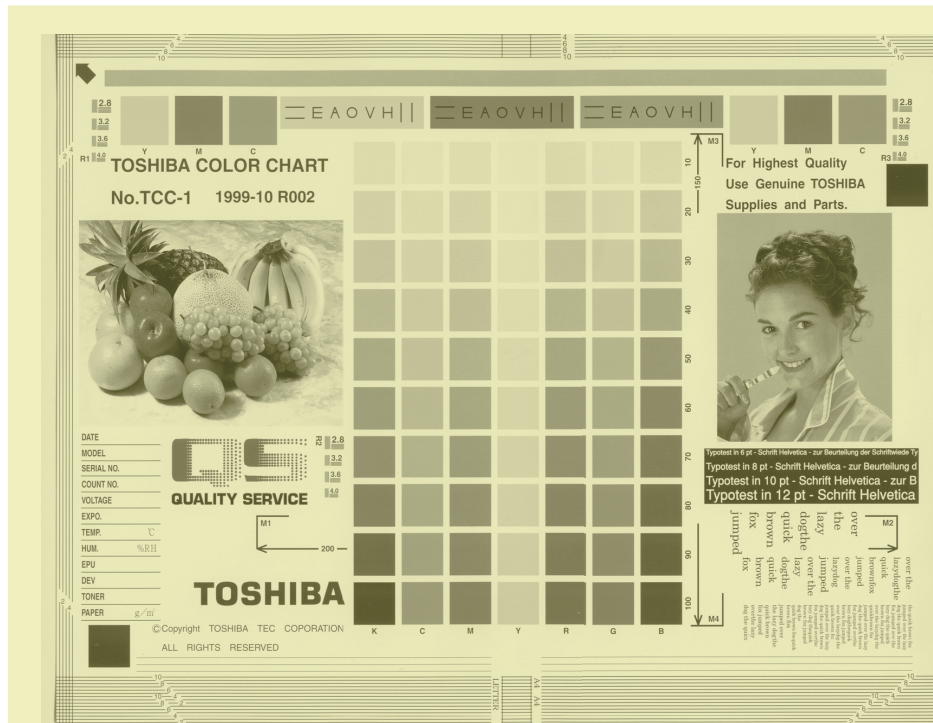

Fig.8-36

Cause/Section	Step	Check item	Measures	Remarks
Connectors which connect the LGC board and SYS board	1	Check if there is foreign matter or dust on the terminals of connectors (CN133, CN330).	Remove the foreign matter or clean the connectors if there is dust.	
	2	Check if the harness and connectors (CN133, CN330) are inserted at an angle.	Insert the harness properly.	
LGC board and SYS board	3	Check if the board is short circuited or open circuited.	Replace the LGC board or SYS board.	

8.5.6 Moire /lack of sharpness

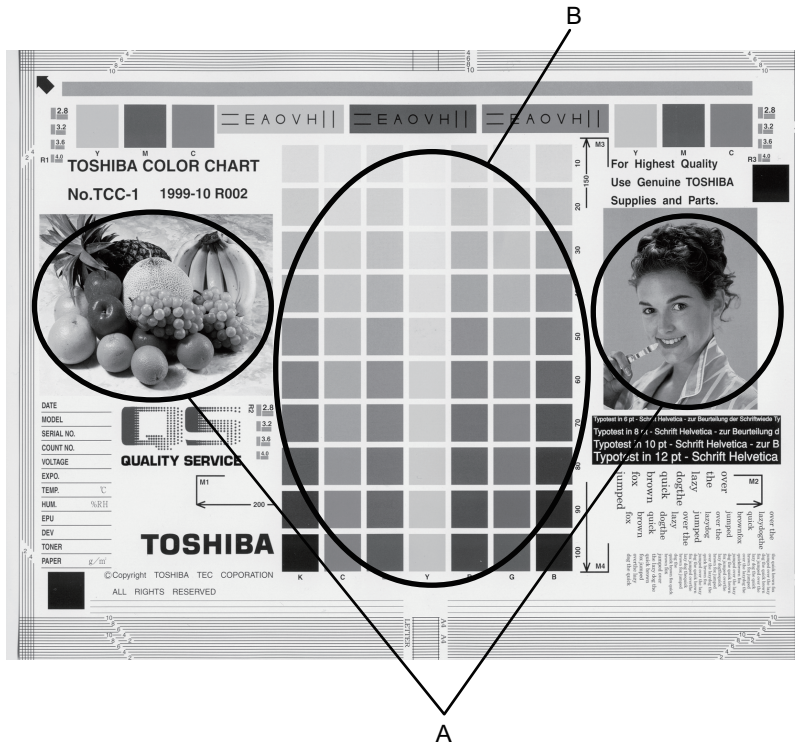

Fig.8-37

Moire

Cause/Section	Step	Check item	Measures	Remarks
Density reproduction	1	Check the gradation reproduction.	Perform the forced performing of image quality closed-loop control (FS-05-2742) and then automatic gamma adjustment.	
Parameter adjustment value	2	Check the image processing parameters.	Check the sharpness adjustment value.	
	3	Adjust the image processing parameters.	While checking the above encircled images A and B, decrease moire by sharpness adjustment.	
Printer section	4	Check the printer output image.	Output the test patterns and check them. Using FS-04-36 for each color	When defects occur, perform the corresponding troubleshooting procedures.

Lack of sharpness

Cause/Section	Step	Check item	Measures	Remarks
Density reproduction	1	Check the gradation reproduction.	Perform the forced performing of image quality closed-loop control (FS-05-2742) and then automatic gamma adjustment.	
Parameter adjustment value	2	Check the image processing parameters.	Check the sharpness adjustment value.	
	3	Adjust the image processing parameters.	While checking the above encircled image A, increase sharpness by sharpness adjustment.	

- * If the trouble is not solved at the step 1 and the step 2 or followings (excluding the parameter adjustment) are performed, make sure to perform “Enforced performing of image quality closed-loop control” and then “Automatic gamma adjustment” after taking a measure.

8.5.7 Toner offset

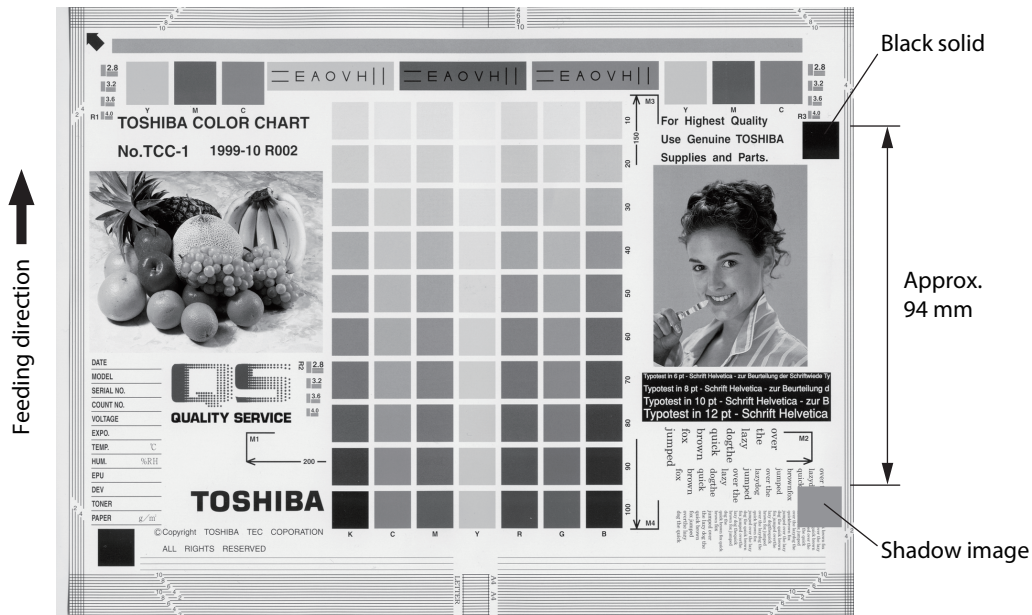

Fig.8-38

Toner offset (Shadow image appears approx. 94 mm behind the high density image.)

Cause/Section	Step	Check item	Measures	Remarks
Fuser unit	1	Is the pressure between the fuser belt and pressure roller proper?	Check the pressure removal parts and pressure mechanism.	
	2	Is there scratch on the fuser belt or pressure roller surface?	Replace the fuser belt or the pressure roller.	
	3	Has the fuser belt or pressure roller reached its PM life?	Replace the fuser belt or the pressure roller.	
	4	Is the fuser belt temperature proper?	Check and correct the control circuit.	
	5	<ul style="list-style-type: none"> Is there any deformation to the thermistors? Are the thermistors contacted with the fuser belt? (Take out the thermistors from the fuser belt, and then check that there is recoil by spring force.)	Replace the thermistor.	
Paper	6	Is the paper type corresponding to its mode?	Use the proper type of paper or select the proper mode.	
	7	Using recommended paper?	Use the recommended paper.	
Developer material	8	Is the specified developer used?	Use the specified developer and toner.	
Scanner	9	Are the mirrors, original glass or lens dirty?	Clean them.	
Image quality control	10	Is the control activated?	Check the image quality control related codes.	
Density	11	Is the density too high?	Perform the forced performing of image quality closed-loop control (FS-05-2742) and then automatic gamma adjustment.	

Cause/Section	Step	Check item	Measures	Remarks
Printer density	12	Check the density of printer output image.	Output the test patterns and check them using FS-04-36 for each color	When defects occur, perform the corresponding troubleshooting procedures.

8.5.8 Toner offset (shadow image) at the edges

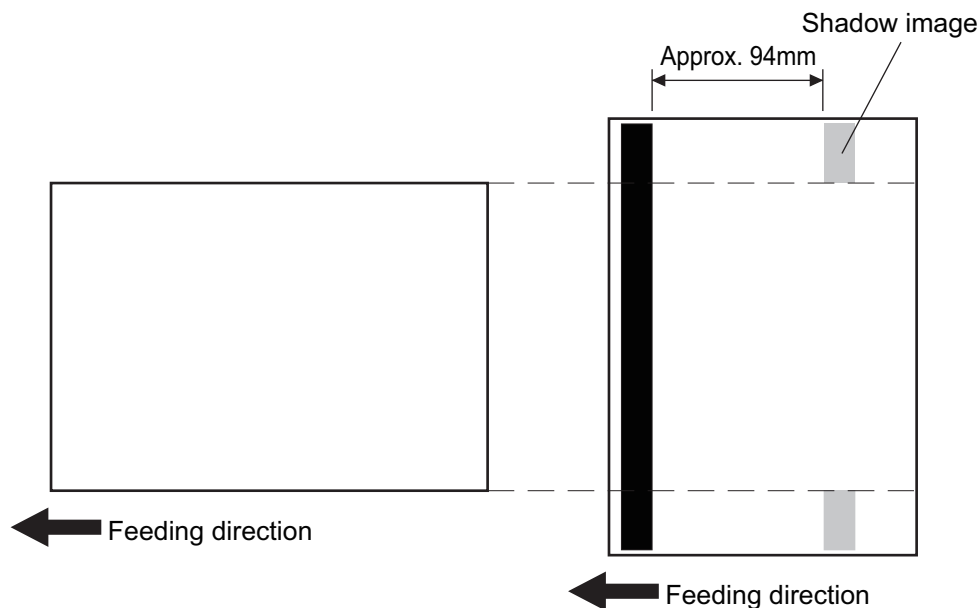

Fig.8-39

Toner offset (shadow image) sometimes appears at both edges of the paper when a wide-size sheet is printed following the continuous printing of narrow-size ones or rotate sort-printing. In such a case, change the setting of Wait between the printings of narrow-size and wide-size paper.

Notes:

- When the setting is changed, toner offset can be reduced; however, the performance (printing speed) will also be lowered accordingly. Therefore, the setting should only be changed depending on the occurrence frequency or corresponding to users' requests.
- The values below are the recommended ones. Therefore, adjust the values according to the situation.
- Set the number of the sheets for FS-08-5455 so that the value is within the below ones.
08-5455-0 < 08-5455-1 < 08-5455-2
- Set the number of the sheets for FS-08-5355 so that the value is within the below ones.
08-5355-0 < 08-5355-4 < 08-5355-8, 08-5355-1 < 08-5355-5 < 08-5355-9,
08-5355-2 < 08-5355-6 < 08-5355-10, 08-5355-3 < 08-5355-7 < 08-5355-11

1. Combined job

Code	Recommended setting value		Remarks
	25/30/35 ppm	45/50 ppm	
FS-08-5455-0	Default value	12	Wait is carried out with a small number of sheets.
FS-08-5455-1	Default value	14	
FS-08-5455-2	Default value	0	
FS-08-5456-0	1	3	The Wait period is extended.
FS-08-5456-1	Default value	7	
FS-08-5456-2	7	11	
FS-08-5457-0	1	Default value	
FS-08-5457-1	1	Default value	

2. When Ready is inserted between jobs

Code	Recommended setting value		Remarks
	25/30/35 ppm	45/50 ppm	
FS-08-5354-0	0	Default value	
FS-08-5354-1	0	Default value	
FS-08-5354-2	0	Default value	
FS-08-5354-3	0	Default value	
FS-08-5355-0	Default value	22	Wait is carried out with a small number of sheets.
FS-08-5355-1	Default value	22	
FS-08-5355-2	Default value	22	
FS-08-5355-3	Default value	22	
FS-08-5355-4	Default value	0	
FS-08-5355-5	Default value	0	
FS-08-5355-6	Default value	0	
FS-08-5355-7	Default value	0	
FS-08-5355-8	Default value	1	
FS-08-5355-9	Default value	1	
FS-08-5355-10	Default value	1	
FS-08-5355-11	Default value	1	The Wait period is extended.
FS-08-5357-0	1	3	
FS-08-5357-1	1	3	
FS-08-5357-2	1	3	
FS-08-5357-3	1	3	
FS-08-5357-4	Default value	7	
FS-08-5357-5	Default value	7	
FS-08-5357-6	Default value	7	
FS-08-5357-7	Default value	7	
FS-08-5357-8	7	11	
FS-08-5357-9	7	11	
FS-08-5357-10	7	11	A paper size which is judged as narrow-size is selected.
FS-08-5357-11	7	11	
FS-08-5358-0	Default value	12	
FS-08-5358-1	Default value	12	
FS-08-5358-2	Default value	12	
FS-08-5358-3	Default value	12	

8.5.9 Blurred image

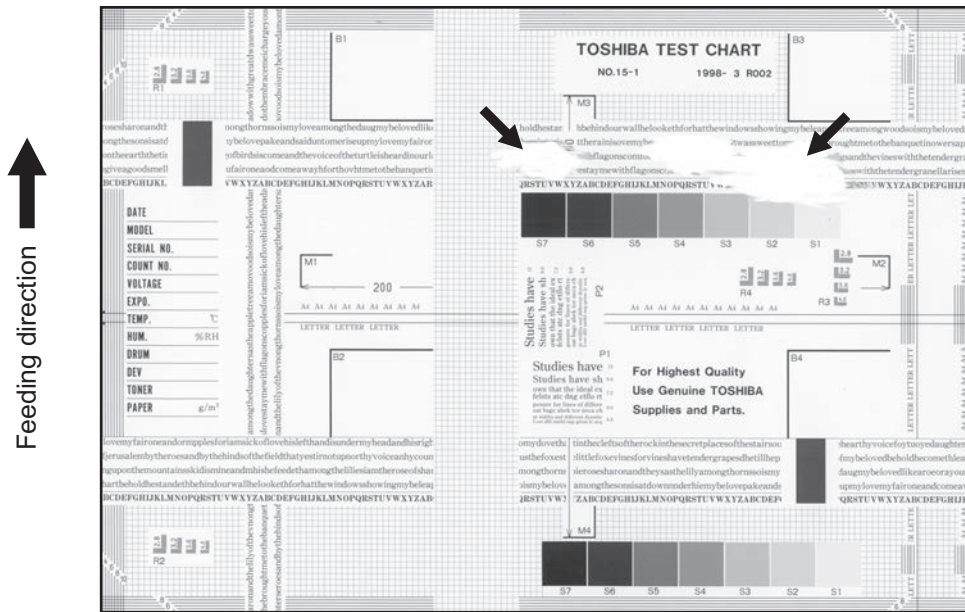

Fig.8-40

Cause/Section	Step	Check item	Measures
Scanner	1	Is the scanner bedewed?	Clean it.
Drum	2	Is the drum bedewed or dirty?	Wipe the drum with dry cloth. * Be sure not to use alcohol or other organic solvents because they have bad effect on the drum.
Ozone exhaust	3	Is the ozone exhaust fan operating properly?	Check the connection of the connector. Replace the fan.
	4	Is the ozone filter stained or damaged?	Replace it.
Laser optical unit (LSU)	5	Is the slit glass of the laser optical unit (LSU) dirty?	Clean the slit glass of the laser optical unit (LSU).
Main charger	6	Is the charger grid dirty or deformed?	Clean or replace the charger grid.
Main charger	7	Is there foreign matter on the charger grid?	Remove foreign matter. Clean or replace the charger grid.

8.5.10 Poor fusing

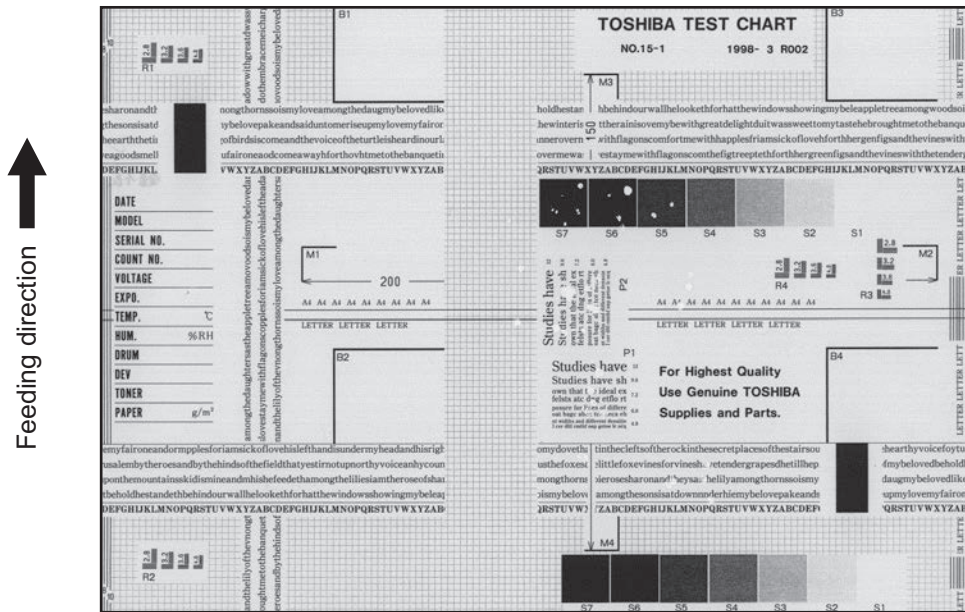

Fig.8-41

Cause/Section	Step	Check item	Measures
Electric power/ control abnormal	1	Is the connector in proper contact with the equipment?	Correct it.
	2	Is the IH drive circuit (switching power supply) working properly?	Replace the switching power supply.
	3	Are the connectors on the LGC board and joint connectors connected properly?	Reconnect them.
	4	Is the LGC board normal?	Replace the LGC board.
	5	Is the harness connected with the LGC board short circuited or open circuited?	Replace the harness.
	6	<ul style="list-style-type: none"> Is there any deformation to the thermistors? Are the thermistors contacted with the fuser belt? (Take out the thermistors from the fuser belt, and then check that there is recoil by spring force.) 	Replace the thermistor.
Insufficient pressure between fuser belt and pressure roller	7	Is the pressure between the fuser belt and pressure roller proper?	Check the pressure removal parts and pressure mechanism.
Fuser belt temperature	8	Is the temperature of fuser belt too low?	Check/correct the setting value of fuser belt temperature. Clean or replace the thermistor. Check/correct the related circuit.
Developer material and toner	9	Using the specified developer material and toner?	Use the specified developer material and toner.

Cause/Section	Step	Check item	Measures
Paper	10	Is the paper damp?	Change the paper.
	11	Is the paper type corresponding to its mode?	Use the proper type of paper or select the proper mode.
	12	Using the recommended paper?	Use the recommended paper.

8.5.11 Blank print



Fig.8-42

Cause/Section	Step	Check item	Measures
High-voltage transformer (main charger unit output, 1st and 2nd transferrollers, developer unit, and main charger grid bias)	1	Is the harness between the LGC board (CN320, CN321) and the high-voltage transformer (CN530, CN531) open circuited? Are the connectors connected securely?	Reconnect the connectors securely. Replace the harness.
	2	Do the springs for supplying power contact the high-voltage transformer output portions (OUT-1 to OUT-5)?	Make the springs for supplying power contact the high-voltage transformer output portions securely.
	3	Does the high-voltage transformer work properly?	Replace the high-voltage transformer.
Developer unit	4	Is the developer unit installed securely?	Check/correct the developer sleeve coupling engaging.
	5	Do the developer sleeve and mixer rotate?	Check/correct the developer drive system.
	6	Is the developer unit filled up with the developer material?	Check that the charger grid is not dirty. (The developer material may be reduced due to the carrier offset.)
	7	Is the developer material properly transported?	Remove foreign matter from the developer material, if any.
	8	Is there any magnetic brush phase error?	Check the developer pole position.
	9	Is the doctor sleeve gap incorrect?	Check that the doctor blade firmly contacts the bearing. If there is any abnormality, replace the developer unit.
Drum	10	Is the drum rotating?	Check/correct the drum coupling engaging. Check the drum drive system.
	11	Is the drum grounded?	Check the contact of the grounding plate.
Transfer unit	12	Is the transfer belt in proper contact with the drum?	Check if the contact releasing lever is at releasing position. Check the installation of the transfer belt.
	13	Is the transport of the transfer belt normal?	Check the installation of the transfer belt or transport mechanism.

Cause/Section	Step	Check item	Measures
Harnesses for CCD, SYS and LGC boards	14	Are the connectors securely connected? Is any harness between the boards open circuited?	Reconnect the connectors securely. Replace the harness.

8.5.12 Solid print



Fig.8-43

When there is a void on the solid image

Cause/Section	Step	Check item	Measures
Exposure lamp	1	Does the exposure lamp light?	If the lamp does not work, replace it.
Harnesses for CCD, SYS and LGC boards	2	Are the connectors securely connected? Is any harness between the boards open circuited? Is the harness between the SYS and LGC boards not disconnected?	Reconnect the connectors securely. Replace the harness.
Scanner	3	Is there foreign matter in the optical path?	Remove it.
Bedewing of scanner	4	Is the scanner bedewed?	Clean the mirrors and lens. Keep the power cord plugged so that the damp heater can work.

When there is no void on the solid image

Cause/Section	Step	Check item	Measures
Main charger	1	Is the main charger securely installed?	Reinstall it securely.
	2	Does the needle electrode not come off?	Reinstall it securely.
High-voltage transformer (main charger unit output, main charger grid bias)	3	Is the harness between the LGC board (CN320, CN321) and the high-voltage transformer (CN530, CN531) open circuited? Are the connectors connected securely?	Reconnect the connectors securely. Replace the harness.
	4	Do the springs for supplying power contact the high-voltage transformer output portions (OUT-1 to OUT-2)?	Make the springs for supplying power contact the high-voltage transformer output portions securely.
	5	Does the high-voltage transformer work properly?	Replace the high-voltage transformer.
Bedewing of drum	6	Is the drum bedewed?	Clean the drum. Keep the power cord plugged so that the damp heater can work.

8.5.13 White banding (in feeding direction)

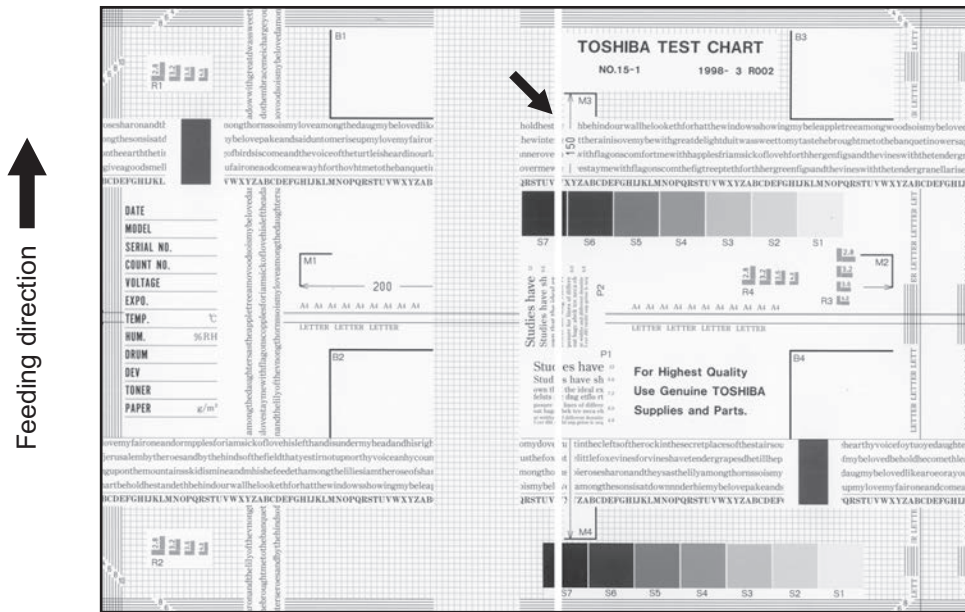

Fig.8-44

Cause/Section	Step	Check item	Measures	Phenomenon	
-	0	Check whether this phenomenon occurs in the same place of the paper in all four colors (Y, M, C and K) or a particular one.	Perform the measures by referring to "Y" described in the Phenomenon column, depending on the occurrence state of each color.	One color	Four colors
Laser optical unit (LSU)	1	Is the slit glass of the laser optical unit (LSU) dirty?	Clean the slit glass of the laser optical unit (LSU).	Y	-
Main charger grid	2	Is there foreign matter on the charger grid?	Remove foreign matter.	Y	-
Developer unit	3	Is there foreign matter inside the doctor blade?	Remove foreign matter.	Y	-
	4	Is there foreign matter on the drum seal?	Remove foreign matter.	Y	-
	5	Do any paper fibers or dirt adhere to the developer unit and contact with the drum?	Remove the paper fibers or dirt.	Y	-
	6	Check if the developer material layer on the developer sleeve corresponding to the white banding is thin.	Clean the doctor blade. See "1. Cleaning" in P. 7-19 "7.6.8 Developer unit (K, Y, M, and C)".	Y	-
Drum	7	Is there scratch or foreign matter on the drum surface?	Replace the drum.	Y	-

Cause/Section	Step	Check item	Measures	Phenomenon	
Transfer unit	8	Is there scratch or foreign matter on the transfer belt surface?	Replace the transfer belt.	-	Y
	9	Are the harness or foreign matters in contact with the transfer belt surface?	Correct or remove them.	-	Y
	10	Is there any scratch or hole on the 1st transfer roller?	Replace the 1st transfer roller.	Y	-
	11	Is there any scratch or hole on the 2nd transfer roller?	Replace the 2nd transfer roller.	-	Y
	12	Is there any foreign matter on the TBU drive roller?	Remove foreign matter or clean the roller.	-	Y
Transport path	13	Does the toner image touch foreign matter after transfer, before entering the fuser unit?	Remove foreign matter.	-	Y
Discharge LED	14	Has any LED of discharge LED gone out?	Replace the discharge LED.	Y	-
Scanner	15	Is there foreign matter or dust in the optical path?	Clean the lens and mirrors.	-	Y

8.5.14 White banding (at right angles to feeding direction)

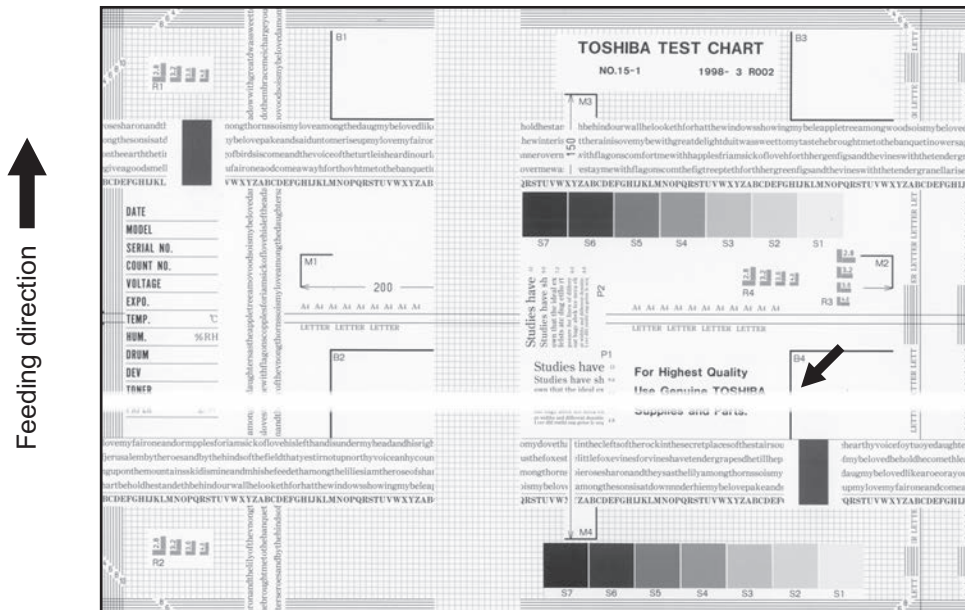

Fig.8-45

Cause/Section	Step	Check item	Measures
Main charger	1	Is the terminal contact poor?	Clean or adjust the terminals.
Drum	2	Is there any abnormalities on the drum surface?	Replace the drum.
	3	Is the drum grounded?	Check the contact of the grounding plate.
Discharge LED	4	Is the discharge LED lighting properly?	Replace the discharge LED or clean terminals.
Developer unit	5	Is the developer sleeve rotating correctly? Is there any abnormalities on the sleeve surface?	Check the developer drive system, or clean the sleeve surface.
	6	Is the connection of developer bias supply terminal normal?	Correct it.
Drive systems	7	Is the drum, scanner or transfer belt jittery?	Check each drive system.
High-voltage transformer (main charger needle electrode/grid, 1st/2nd transfer roller and developer bias)	8	Is the high-voltage transformer output defective?	Check/correct any electric leakage and related circuits. If the high-voltage transformer does not work, replace it.
Main charger	9	Is the charger grid dirty or deformed?	Clean or replace the charger grid.
Main charger	10	Is there foreign matter on the charger grid?	Remove foreign matter. Clean or replace the charger grid.
Fuser unit	11	Is white banding intermittent and does appear by approx. 10 mm from the trailing edge of paper?	Perform "Fine adjustment of fuser belt rotational speed" (FS- 05-4529-0, 3, 4, 7). Guide for the adjustment: Increase by 5 to 10 from the current value. If the value is increased too much, the margin at the trailing edge of the paper will be deleted.

8.5.15 Skew (slantwise copying)

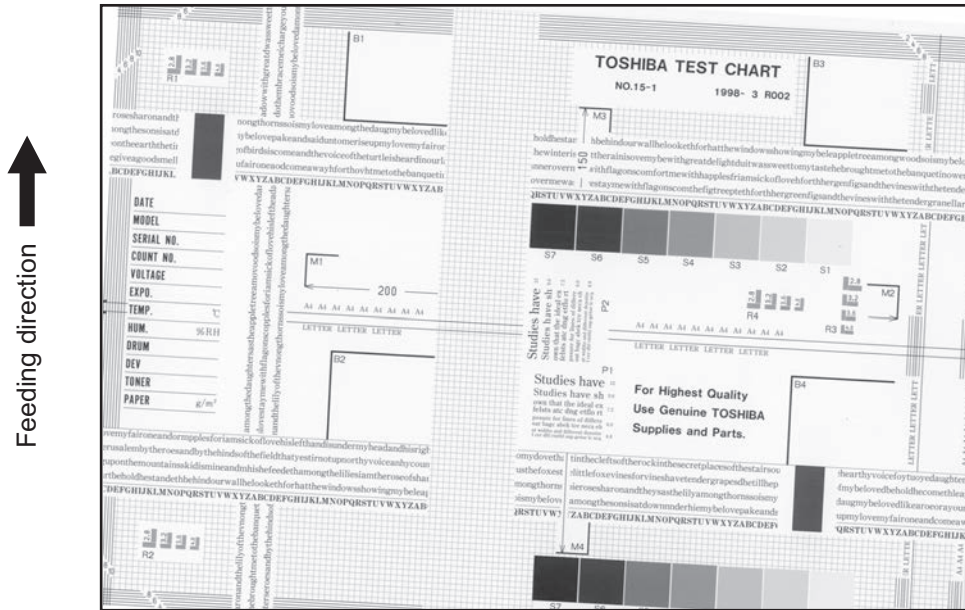

Fig.8-46

Cause/Section	Step	Check item	Measures
Drawer/LCF	1	Is the drawer or LCF properly installed?	Reinstall the drawer or LCF properly.
	2	Is too much paper loaded in the drawer or LCF?	Reload paper within the acceptable range of paper weight. <Acceptable paper weight> 1st/2nd drawer: 60.5 mm PFP upper/lower drawer: 60.5 mm LCF: 137.8 mm x 2 places
	3	Is the paper corner folded?	Change the paper direction and reinsert it.
	4	Are the drawer or LCF side guides properly set?	Adjust the side guides.
Paper feed roller	5	Is the surface of paper feed roller dirty?	Clean the roller surface with alcohol, or replace the roller.
Rollers	6	Is each roller improperly fixed to the shaft?	Check E-rings, pins and clips.
2nd transfer roller	7	Install the roller by reversing its back and front sides.	Output with the rollers exchanged and check the printed image.
Aligning amount	8	Is the aligning amount proper?	Increase or decrease the aligning amount.
Registration roller	9	Is the registration roller spring removed?	Mount the spring correctly. Clean the roller if it is dirty.
Registration guide	10	Is the registration guide improperly installed?	Correct it.
2nd transfer front guide	11	Is the 2nd transfer front guide installed properly?	Correct it.
RADF/DSDF	12	Is the RADF/DSDF installed and adjusted properly?	Reinstall and readjust it.
Transfer unit	13	Is the transfer belt unit installed properly?	Correct it.

8.5.16 Color banding (in feeding direction)

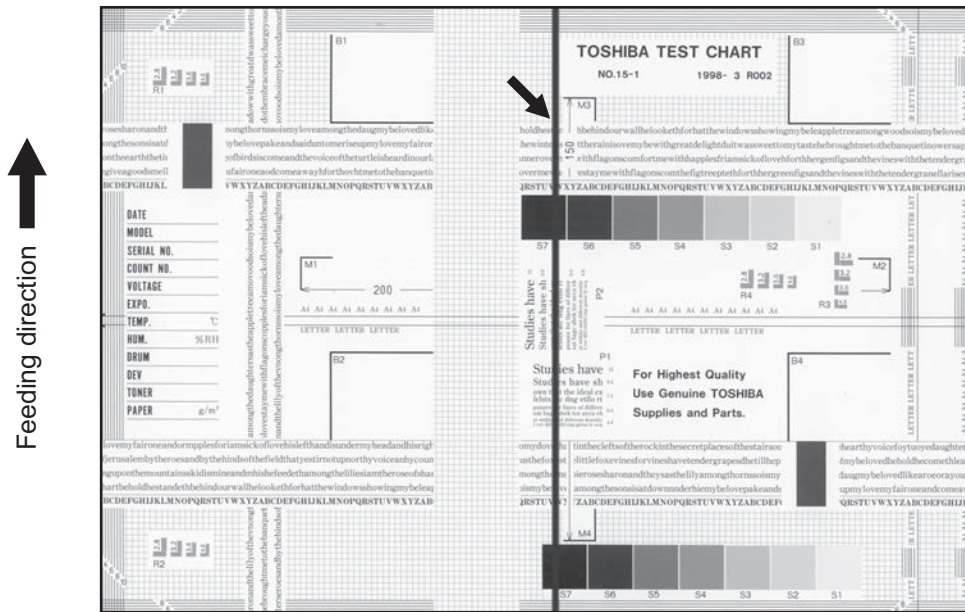

Fig.8-47

Cause/Section	Step	Check item	Measures
Scanner	1	Is there foreign matter in the optical path?	Clean the slit, lens and mirrors.
	2	Is there dust or stain on the shading correction plate or ADF original glass?	Clean it.
	3	Disconnect the harness from the connector at the CCD board to confirm that no foreign matter is adhering to the connector and the terminal of the harness.	Clean the terminals of the connector and the harness with an air blower or brush.
Main charger	4	Is there foreign matter on the charger grid?	Remove foreign matter.
	5	Is the charger grid dirty or deformed?	Clean or replace the charger grid.
	6	Is there foreign matter on the main charger?	Remove foreign matter.
	7	Is the needle electrode dirty or deformed?	Clean or replace the needle electrode.
	8	Is there foreign matter inside the charger case?	Remove foreign matter.
	9	Is the inner surface of charger case dirty?	Clean inside.
Drum cleaner	10	Is there any foreign matter on the edge of the drum cleaning blade?	Clean the drum cleaning blade.
	11	Are there any scratches on the edge of the drum cleaning blade?	Replace the drum cleaning blade.
	12	Is there any foreign matter on the drum?	Clean or replace the drum.
	13	Are there any scratches on the drum?	Replace the drum.
	14	Is toner recovery defective?	Clean the toner recovery auger section.
	15	Are there any scratches on the front holder?	Replace the front holder.
	16	Are there any scratches on the rear bushing?	Replace the rear bushing.

Cause/Section	Step	Check item	Measures
Developer unit	17	Does the developer material continue to be used even though its 1-PM cycle has already exceeded?	If yes, replace the developer material.
	18	Is the doctor blade installed properly?	If not, reinstall the doctor blade properly.
	19	Is there foreign matter or stain on the doctor blade and the developer sleeve?	Clean or replace the doctor blade and the developer sleeve.
	20	Are there any dents or scratches on the developer sleeve?	Replace the developer sleeve.
Transfer unit	21	Are the harness or foreign matters in contact with the transfer belt surface?	Correct or remove them.
	22	Is there any foreign matter (such as paper dust or the adhesive paste of a sticker label) on the edge of the transfer belt cleaning blade?	Clean or replace the transfer belt cleaning blade.
	23	Are there any scratches on the edge of the transfer belt cleaning blade?	Replace the transfer belt cleaning blade.
	24	Is there any foreign matter (such as the adhesive paste of a sticker label) on the transfer belt?	Clean or replace the transfer belt.
	25	Are there any scratches on the transfer belt?	Replace the transfer belt.
	26	Check the feeding retry counter to confirm whether a feeding retry has frequently occurred or not. FS-08-6230: 1st drawer FS-08-6231: 2nd drawer FS-08-6232: PFP upper drawer FS-08-6233: PFP lower drawer FS-08-6234: Bypass feed FS-08-6235: LCF	If a feeding retry has frequently occurred, clean the transfer belt cleaning blade and then set "1" (Enabled) to FS-08-2374.
Fuser unit	27	a. Is there dirt or scratches on the fuser belt and pressure roller surface? b. Is the gap between the separation guide and fuser belt proper?	a. Clean or replace them. b. Correct the gap.
Laser optical unit (LSU)	28	Is the slit glass of the laser optical unit (LSU) dirty?	Clean the slit glass of the laser optical unit (LSU).
SYS board	29	Disconnect the harness (between the CCD and the SYS board) from the connector at the SYS board to confirm that no foreign matter is adhering to the connector and the terminal of the harness.	Clean the terminals of the connector and the harness with an air blower or brush.

8.5.17 Color banding (at right angles to feeding direction)

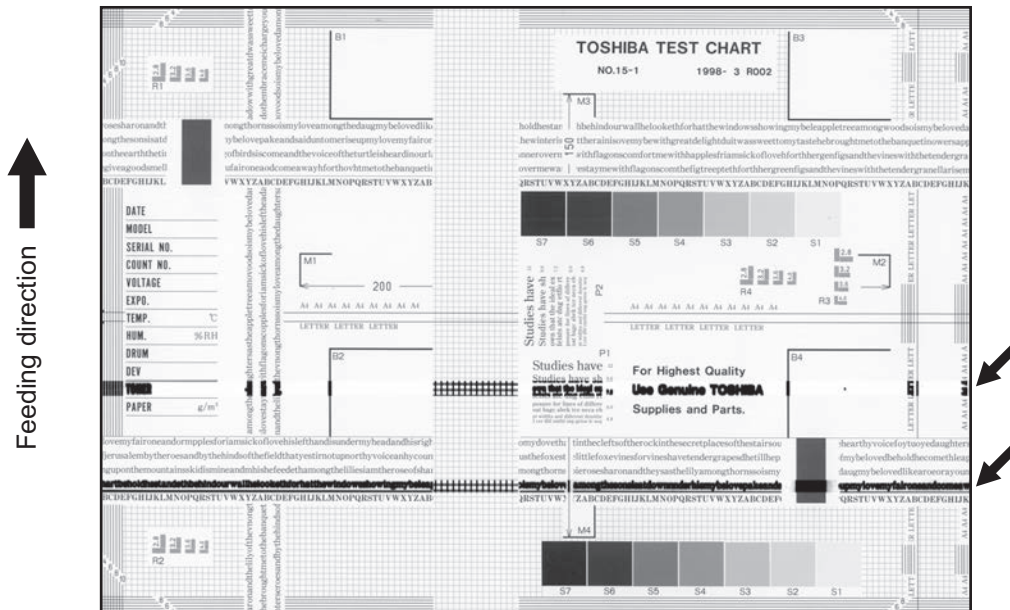

Fig.8-48

Cause/Section	Step	Check item	Measures
Main charger	1	Is the needle electrode dirty or deformed?	Clean or replace the needle electrode.
Fuser unit	2	Is the fuser belt or pressure roller dirty?	Clean them.
High-voltage transformer (main charger needle electrode/grid and transfer roller bias)	3	Is the high-voltage transformer output defective?	Check the circuit and replace the high-voltage transformer if not working.
	4	Is each joint of high-voltage output loosened? (Check if any electric leakage is causing noise.)	Reconnect each joint.
Drum	5	Is there deep scratch on the drum surface?	Replace the drum, especially if the scratch has reached the aluminum base.
	6	Are there fine scratches on the drum surface (drum pitting)?	Check and correct the contact of cleaning blade and recovery blade.
	7	Is the drum grounded?	Check the contact of the grounding plate.
2nd transfer roller	8	Is the 2nd transfer roller rotating normally?	Clean the roller area or replace the roller.
Scanner	9	Is there foreign matter on the carriage rail?	Remove foreign matter.
Main charger	10	Is the charger grid dirty or deformed?	Clean or replace the charger grid.
Main charger	11	Is there foreign matter on the charger grid?	Remove foreign matter. Clean or replace the charger grid.
Fuser unit	12	Is color banding intermittent and does appear by approx. 10 mm from the trailing edge of paper?	Perform "Fine adjustment of fuser belt rotational speed" (FS- 05-4529-0, 3, 4, 7). Guide for the adjustment: Increase by 5 to 10 from the current value. If the value is increased too much, the margin at the trailing edge of the paper will be deleted.

Cause/Section	Step	Check item	Measures
Transfer unit	13	Check the feeding retry counter to confirm whether a feeding retry has frequently occurred or not. FS-08-6230: 1st drawer FS-08-6231: 2nd drawer FS-08-6232: PFP upper drawer FS-08-6233: PFP lower drawer FS-08-6234: Bypass feed FS-08-6235: LCF	If a feeding retry has frequently occurred, clean the transfer belt cleaning blade and then set "1" (Enabled) to FS-08-2374.

8.5.18 White spots



Fig.8-49

Cause/Section	Step	Check item	Measures
Developer unit/ Toner cartridge	1	Is the toner density of developer material proper?	Check and correct the auto-toner sensor and toner supply operation. Check if the amount of toner is sufficient in the toner cartridge.
	2	Is the doctor-sleeve gap proper?	Check that the doctor blade firmly contacts the bearing. If there is any abnormality, replace the developer unit.
Developer material/Toner/ Drum	3	Using the specified developer material, toner and drum?	Use the specified developer material, toner and drum.
	4	Have the developer material and drum reached their PM life?	Replace the developer material and drum.
	5	Is the storage environment of the toner cartridge 35°C or less without dew?	Use the toner cartridge stored in the environment within specification.
	6	Is there any dent on the surface of the drum?	Replace the drum.
	7	Is there any film forming on the drum?	Clean or replace the drum.
	8	Is the drum bedewed?	Wipe the drum surface with a piece of dry cloth.
Transfer unit	9	Is there foreign matter on the transfer belt surface?	Remove foreign matter.
	10	Is there foreign matter on the transfer belt TBU drive roller?	Clean the transfer belt unit.
Main charger	11	Is there foreign matter on the charger?	Remove it.
	12	Is the needle electrode dirty or deformed?	Clean or replace the needle electrode.

Cause/Section	Step	Check item	Measures
High-voltage transformer (main charger needle electrode/grid, developer 1st/2nd transfer roller bias)	13	Is the high-voltage transformer output defective?	Adjust the output.
Paper	14	Is the paper type corresponding to its mode?	Use the proper type of paper or select the proper mode.

8.5.19 Poor transfer

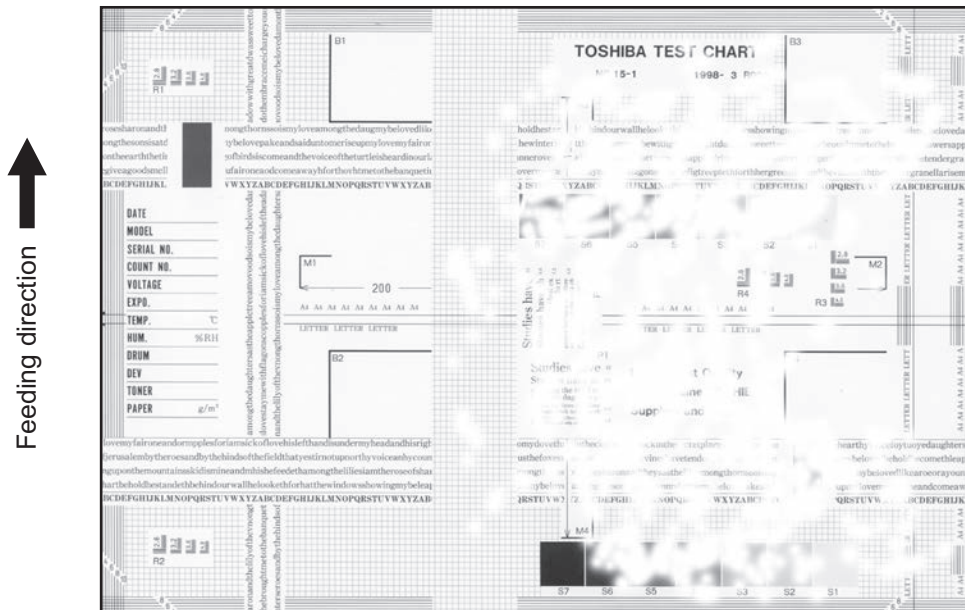

Fig.8-50

Cause/Section	Step	Check item	Measures
Transfer unit	1	Is the transfer belt or 1st/2nd transfer rollers dirty?	Clean it.
	2	Is the transfer belt in proper contact with the drum?	Correct it.
	3	Is the 2nd transfer roller in proper contact with the transfer belt?	Correct it.
	4	Is there any deformation or abnormalities on the transfer belt?	Replace the belt.
	5	Is the TBU drive roller dirty?	Clean the roller and replace the cleaning pad.
Paper	6	Is the high-voltage fed to the 2nd transfer roller correctly?	If any contact failure occurs in the feeding area (e.g. the conductive bushing and spring come off), correct it.
	7	Is paper in the drawer or LCF curled?	Reinsert paper with reverse side up or change paper.
	8	Is paper in the drawer or LCF damp?	Change paper. * Avoid storing paper in damp place.
Registration roller	9	Is the registration roller malfunctioning?	Clean the roller, remount the spring, or replace defective motor-related parts.
Aligning amount	10	Is the aligning amount proper?	Decrease the aligning amount
High-voltage transformer (1st/2nd transfer roller bias)	11	Is the harness between the LGC board (CN320, CN321) and the high-voltage transformer (CN530, CN531) open circuited? Are the connectors connected securely?	Reconnect the connectors securely. Replace the harness.
	12	Do the springs for supplying power contact the high-voltage transformer output portions (OUT-4 to OUT-5)?	Make the springs for supplying power contact the high-voltage transformer output portions securely.
	13	Does the high-voltage transformer work properly?	Replace the high-voltage transformer.

8.5.20 Uneven image density 1 (in feeding direction)

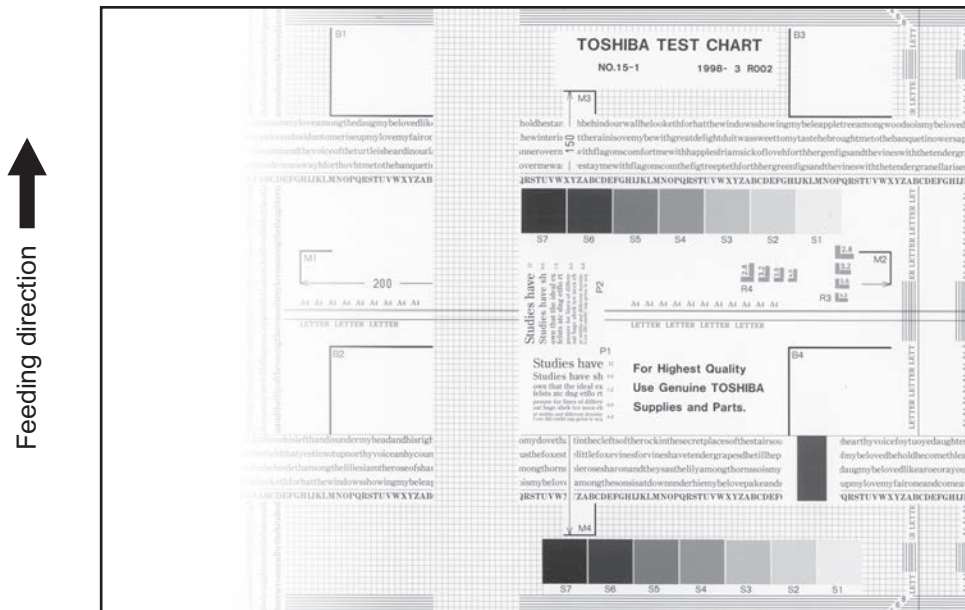

Fig.8-51

Cause/Section	Step	Check item	Measures
Main charger	1	Is the main charger dirty?	Clean it or replace the needle electrode.
	2	Is the main charger grid color tarnish (black, red or green etc.)?	Replace the main charger grid.
Transfer unit	3	Is the transfer belt or 1st/2nd transfer rollers dirty?	Clean the belt.
	4	Is the transfer belt in proper contact with the drum?	Correct it.
	5	Is 2nd transfer roller in proper contact with the transfer belt? (Is the roller tilted?)	Open and close the jam access cover. Check if there is any abnormality in the movement of the 2nd transfer roller pressure mechanism.
	6	Is there any abnormalities or deformation on the transfer belt?	Replace the transfer belt.
Laser optical unit (LSU)	7	Is the slit glass of the laser optical unit (LSU) dirty?	Clean the slit glass of the laser optical unit (LSU).
Discharge LED	8	Is the discharge LED dirty?	Clean it.
	9	Has any LED of discharge LED gone out?	Replace it.
Developer unit	10	Is the magnetic brush in proper contact with the drum?	Check that the doctor blade firmly contacts the bearing. If there is any abnormality, replace the developer unit.
	11	Is the developer unit pressure spring applying properly?	Check the pressure spring.
	12	Is the transport of developer material poor?	Remove foreign matter if any.
	13	Is Kapton tape peeled off or deformed?	Attach new Kapton tape.
Scanner section	14	a. Is the platen cover or RADF/DSDF open? b. Is the original glass, mirrors, or lens dirty?	a. Close the platen cover or RADF/DSDF. b. Clean them.

Cause/Section	Step	Check item	Measures
Drum cleaner unit	15	Is there any abnormalities or deformation on the gap spacer?	Replace the gap spacer.

8.5.21 Uneven image density 1 (at right angles to feeding direction)

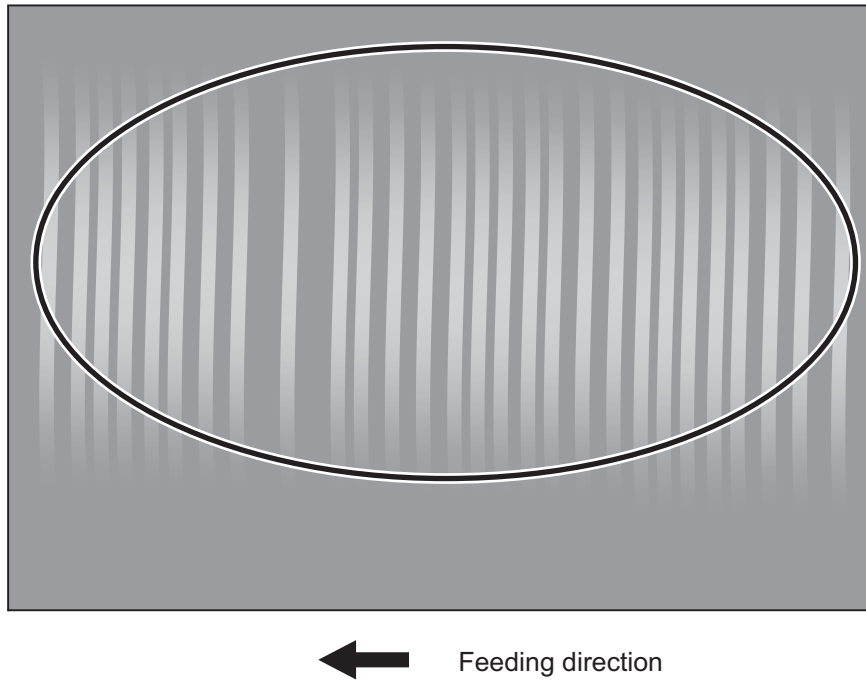

Fig.8-52

Cause/Section	Step	Check item	Measures
Developer unit	1	Is the magnetic brush in proper contact with the drum?	Check that the doctor blade firmly contacts the bearing. If there is any abnormality, replace the developer unit.

8.5.22 Uneven image density 2



Fig.8-53

← Feeding direction

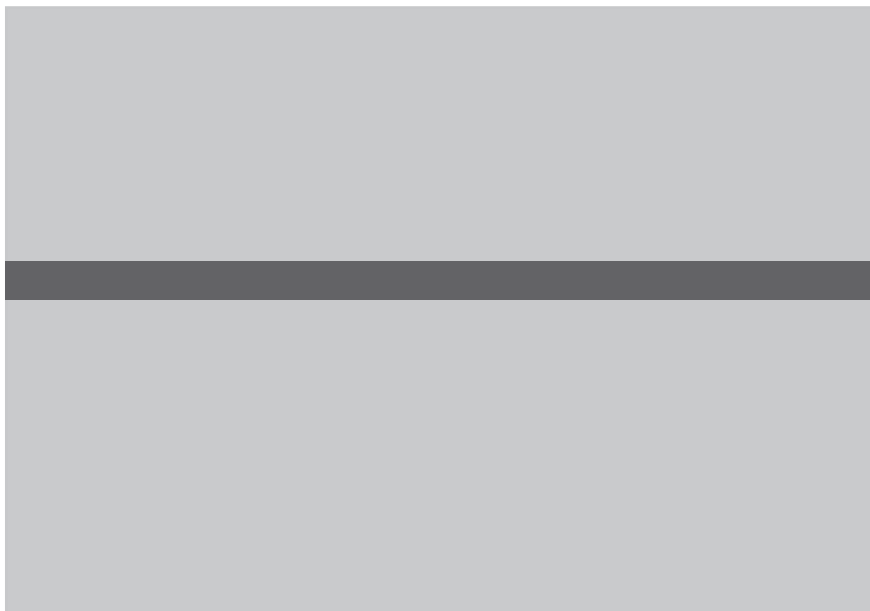





Fig.8-54

← Feeding direction

Cause/Section	Step	Check item	Measures
Developer unit	1	Is the layer of the developer material on the developer sleeve where the density is uneven thin or lacking?	<ul style="list-style-type: none"> Remove the foreign matter in the developer unit. See "2. Removal of foreign matter in the developer unit" in  P. 7-19 "7.6.8 Developer unit (K, Y, M, and C)". Clean the developer unit. See "1. Cleaning" in  P. 7-19 "7.6.8 Developer unit (K, Y, M, and C)".
	2	If there is no uneven thickness in the developer material layer confirmed in step 1	Clean the doctor blade. See "1. Cleaning" in  P. 7-19 "7.6.8 Developer unit (K, Y, M, and C)".
	3	Does uneven image density occur again?	See work flow diagram in  P. 7-12 "7.5 Work Flow of Parts Replacement".

8.5.23 Faded image (low density, roughness)

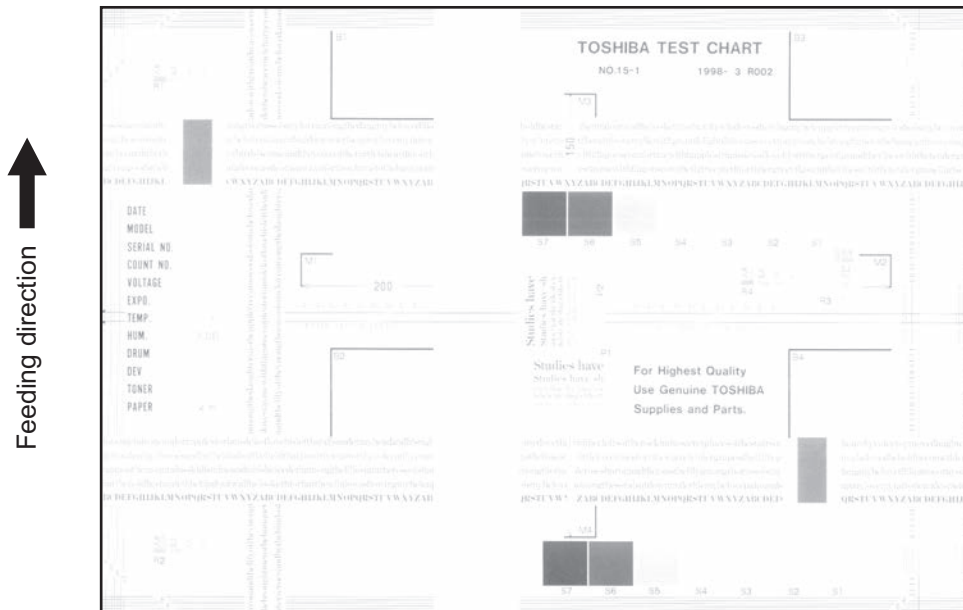

Fig.8-55

Cause/Section	Step	Check item	Measures
Toner empty Auto-toner circuit	1	Is the "ADD TONER" symbol blinking?	Replace the toner cartridge.
	2	Is there enough toner in the cartridge?	Check the auto-toner circuit function.
	3	Is the toner density of developer material too low?	
Toner motor	4	Is the toner motor malfunctioning?	Check the motor drive circuit.
Toner cartridge	5	Are there any abnormalities in the toner cartridge?	Replace the toner cartridge.
Developer material	6	Has the developer material reached its PM life?	Replace developer material.
Developer unit	7	Is the magnetic brush in proper contact with the drum?	<ul style="list-style-type: none"> • Check the developer unit installation. • Check the pole position. • Check that the doctor blade firmly contacts the bearing. If there is any abnormality, replace the developer unit.
Main charger	8	Is the main charger dirty?	Clean it or replace the needle electrode.
Drum	9	Is there film forming on the drum surface?	Clean or replace the drum.
	10	Has the drum reached its PM life?	Replace the drum.
Transfer unit	11	Has the transfer belt, 1st or 2nd transfer roller reached its PM life?	Replace the transfer belt, 1st or 2nd transfer roller.
High-voltage transformer (main charger unit output, developer unit and main charger grid bias)	12	Is the harness between the LGC board (CN320, CN321) and the high-voltage transformer (CN530, CN531) open circuited? Are the connectors connected securely?	Reconnect the connectors securely. Replace the harness.
	13	Do the springs for supplying power contact the high-voltage transformer output portions (OUT-1 to OUT-3)?	Make the springs for supplying power contact the high-voltage transformer output portions securely.
	14	Does the high-voltage transformer work properly?	Replace the high-voltage transformer.

Cause/Section	Step	Check item	Measures
2nd transfer	15	Is the recommended paper used?	<p>If not, change the values of FS-05-2934 to FS-05-2937 to adjust the 2nd transfer bias offset.</p> <p>Check the mode (color or monochrome) and the side (front or back). Set the value for each paper type so that the density of the image quality becomes the darkest.</p> <p>Notes:</p> <ul style="list-style-type: none"> • After the setting has been changed, perform automatic gamma adjustment. • When the value is increased close to 10, white spots may occur. To avoid this, perform the adjustment while checking the image. • When the value is reduced close to 0, poor transfer may occur. To avoid this, perform the adjustment while checking the image.

8.5.24 Image dislocation in leading edge

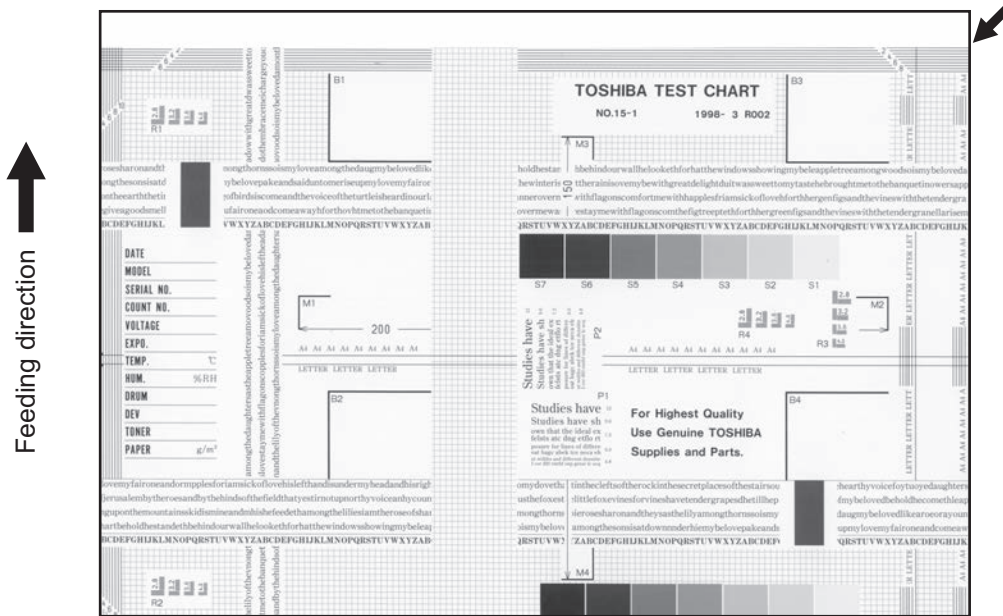

Fig.8-56

Cause/Section	Step	Check item	Measures
Adjustment error of scanner or printer section	1	Is the same dislocation on every copy?	Adjust the scanner/printer using the Adjustment Mode.
Registration roller	2	Is the registration roller dirty, or is the spring removed?	Clean the roller with alcohol. Reinstall the spring.
	3	Is the registration motor malfunctioning?	Adjust or replace the gears, etc. if they are not engaged properly.
	4	Is the registration motor operating normally? (Is the timing of operation delaying?)	Replace the registration motor.
Paper feed clutch	5	Is the paper feed clutch malfunctioning?	Check the circuit or the clutch and replace them if necessary.
Aligning amount	6	Is the aligning amount proper?	Increase or decrease the aligning amount.
Paper pushing amount	7	Is the paper pushing amount proper?	Increase or decrease the paper pushing amount.
Each roller	8	Are the roller and shaft not fixed securely?	Check the E-ring, pin and clip.
	9	Is the roller surface dirty?	Clean the roller surface with alcohol or replace it.
Registration guide	10	Is the registration guide improperly installed?	Reinstall the guide.

8.5.25 Image jittering

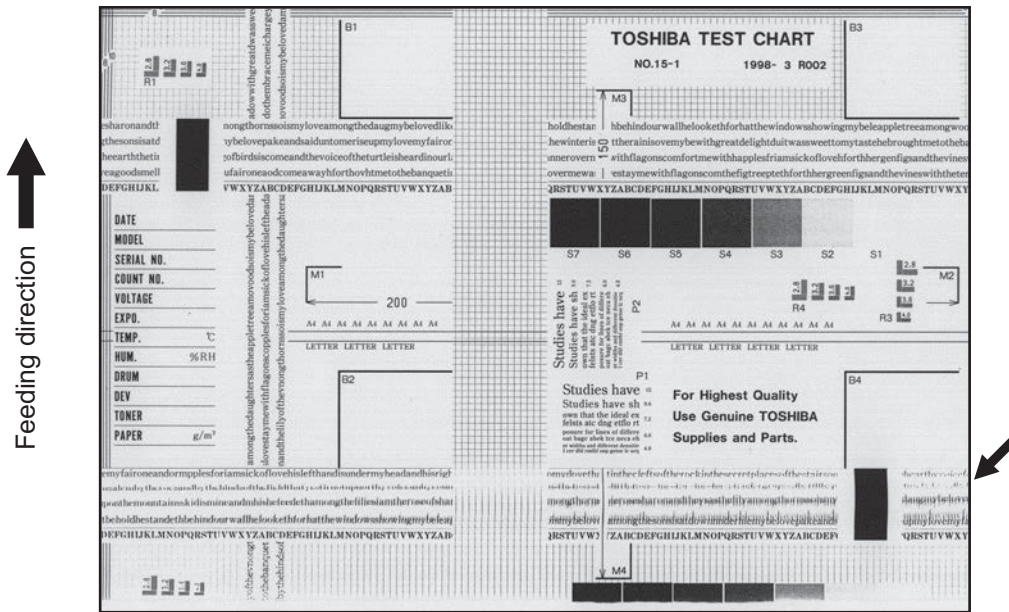

Fig.8-57

Cause/Section	Step	Check item	Measures
-	1	Is the toner image on the drum proper?	If proper, perform steps 1 to 3; otherwise perform step 4 and after.
Registration roller	2	Is the registration roller rotating normally?	Check the registration roller section and its springs.
Transfer unit	3	Is the transfer belt or 2nd transfer roller operating normally?	Check the drive system and replace the transfer belt or 2nd transfer roller if necessary.
Fuser unit	4	Are the fuser belt and pressure roller rotation proper? Is the fuser belt transportation proper?	Check the drive system. Replace the fuser belt and pressure roller if necessary.
Drum	5	Is there large scratch on the drum?	Replace the drum.
Scanner	6	Are there any abnormalities on the carriage feet?	Replace the feet.
	7	Is the tension of timing belt inappropriate?	Correct the tension.
	8	Is the carriage drive system malfunctioning?	Check the carriage drive system.
	9	Are any mirrors loosely installed?	Install them properly.
Drum drive system	10	Is the drum drive system malfunctioning?	Check the drum drive system. Clean or replace the belts, pulleys, bushings if they have dirt or scratches.

8.5.26 Poor cleaning

Notes:

Poor cleaning may occur in feeding direction.

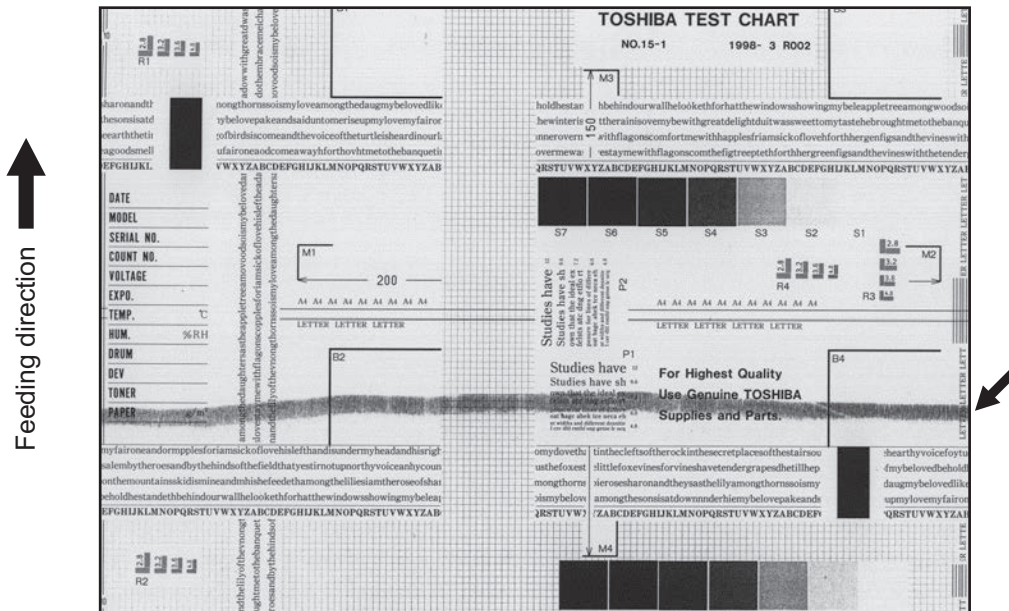

Fig.8-58

Cause/Section	Step	Check item	Measures
Developer material	1	Is the specified developer material used?	Use the specified developer material and toner.
Drum cleaner	2	Is there dust on the drum cleaning blade edge?	Clean or replace it.
	3	Is the drum cleaning blade peeled?	Replace the blade.
Transfer belt cleaner	4	Is there paper dust on the edge of transfer belt cleaning blade?	Clean or replace it.
	5	Is the transfer belt cleaning blade peeled?	Replace the blade.
	6	Is the transfer belt cleaning blade in proper contact with the transfer belt?	<ul style="list-style-type: none"> Check if the transfer belt cleaning blade is installed in the transfer belt cleaning unit properly. Check if the transfer belt cleaning unit is installed in the transfer belt unit properly.
Toner recovery auger	7	Is the toner recovery defective?	Clean the toner recovery auger. Check the cleaning blade pressure.
Fuser unit	8	Is there any bubble-like defect on the fuser belt (approx. 94 mm pitch on the image)?	Replace the fuser belt. Check and modify the IH drive circuit.
	9	Have the fuser belt and pressure roller reached their PM life?	Replace them.
	10	Is the pressure between the fuser belt and pressure roller proper?	Check and adjust the pressure mechanism.
	11	Is the temperature of fuser belt proper?	Check/correct the setting value of fuser belt temperature. Clean or replace the thermistors. Check and correct the circuit.

Remarks:

Depending on the paper to be used, image staining tends to occur due to the poor cleaning of the transfer belt.

Conditions in which poor cleaning of the transfer belt caused by the paper easily occurs:

- Paper generating a lot of paper dust is used.
- Labels, coating paper or ink-jet paper is frequently used.
- The number of the continuous paper feeding times is large.
- Paper whose width is narrow, such as A4-R, LT-R or B5, is frequently used.

Sample of image staining due to poor cleaning caused by the paper:

- Streak-like image staining, which is parallel to the paper feeding direction, occurs in the both areas approx. 90 mm or more outside from the center of the paper.
- If the width of the paper is 180 mm or less, streak-like image staining may occur around both its edges.

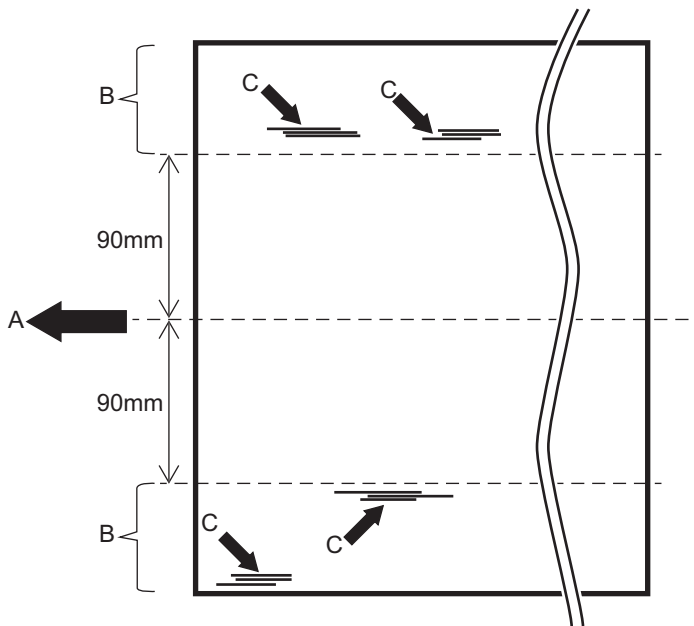

Fig.8-59

A: Paper feeding direction

B: Areas where the poor cleaning (image staining) frequently occurs

C: Image staining

Countermeasure:

1. Change the setting of FS-08-9199 (Automatic interruption page number setting for printing). (Recommended value: 80)
2. Recommend the users to feed the paper in the A4 or LT direction if they frequently use paper of a narrow width, such as A4-R, LT-R or B5

Notes:

When a smaller value is set in FS-08-9199 (Automatic interruption page number setting for printing), a better cleaning effect can be obtained. However, the performance ability will be reduced since the number of the printing interruption times is increased. The interruption time of the printing is approx. 3 to 4 seconds per one time. However, this will vary depending on the models, environment and use status.

8.5.27 Uneven light distribution



Fig.8-60

Cause/Section	Step	Check item	Measures
Original glass	1	Is the original glass dirty?	Clean the glass.
Main charger	2	Are the needle electrode, grid and case dirty?	Clean or replace them.
Discharge LED	3	Is the discharge LED dirty?	Clean it.
Scanner exposure lamp	4	Are the reflector, exposure lamp, mirrors, lens, etc. dirty?	Clean them.
	5	Is the exposure lamp tilted?	Adjust the installed position of the lamp.
	6	Is the lamp discolored or degraded?	Replace it.

8.5.28 Blotched image

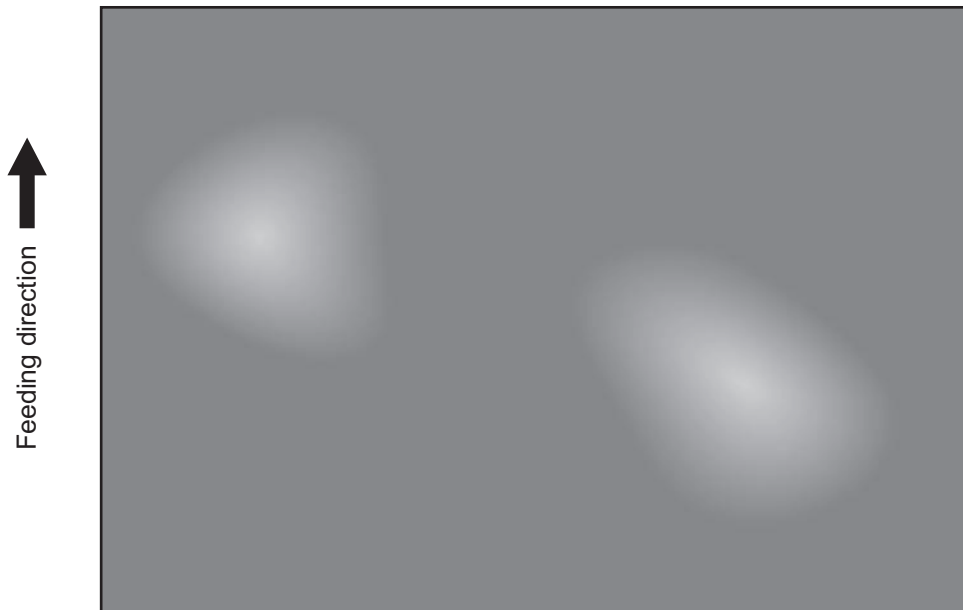

Fig.8-61

Cause/Section	Step	Check item	Measures
Paper	1	Is the paper type corresponding to its mode?	Check the paper type and mode.
	2	Is paper too dry?	Change paper.
Transfer unit	3	Is the transfer belt in proper contact with the drum?	Contact and release the transfer belt unit several times with the TBU release lever. Check that the 1st transfer roller is rotated smoothly upward and downward.
	4	Is the 2nd transfer roller in proper contact with the transfer belt?	Open and close the jam access cover. Check if there is any abnormality in the movement of the 2nd transfer roller pressure mechanism.
	5	Are there any abnormalities on the transfer belt?	Clean or replace the transfer belt.
High-voltage transformer (1st and 2nd transfer rollers bias)	6	Is the harness between the LGC board (CN320, CN321) and the high-voltage transformer (CN530, CN531) open circuited? Are the connectors connected securely?	Reconnect the connectors securely. Replace the harness.
	7	Do the springs for supplying power contact the high-voltage transformer output portions (OUT-4 to OUT-5)?	Make the springs for supplying power contact the high-voltage transformer output portions securely.
	8	Does the high-voltage transformer work properly?	Replace the high-voltage transformer.

8.5.29 Stain on the paper back side

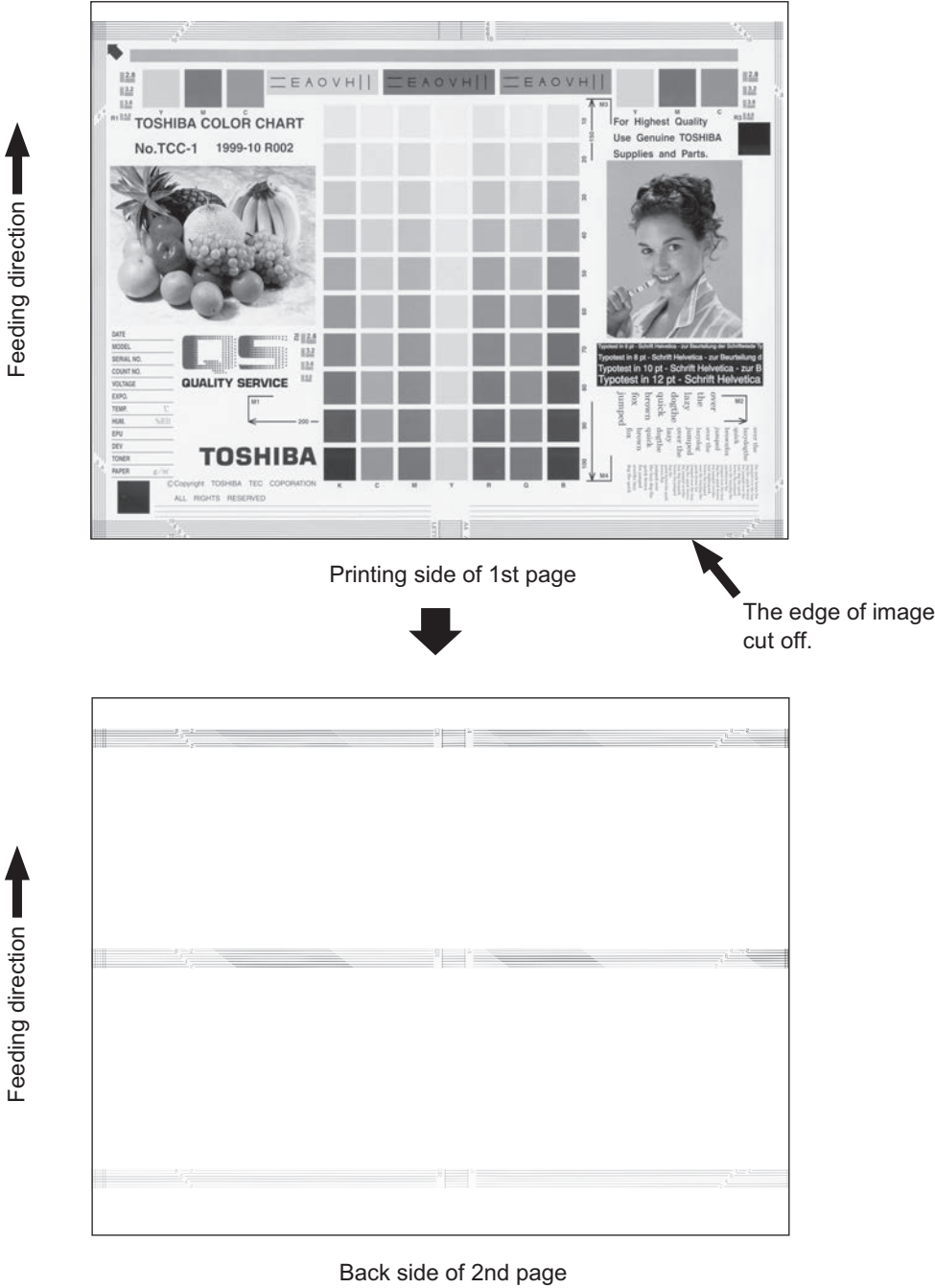

Fig.8-62

Cause/Section	Step	Check item	Measures
Image adjustment/ setting	1	Is the margin adjustment of image correct?	Adjust the margin.
	2	Is the margin adjustment of image correct when the paper size is not selected in bypass feeding?	Adjust the margin.
	3	Is the margin adjustment of image at duplexing correct?	Adjust the margin. (FS-05-4064-0 to 5)
	4	Is the image location in primary/ secondary scanning direction correct?	Adjust the location.
	5	Is the reproduction ratio of image in primary/secondary scanning direction correct?	Adjust the reproduction ratio.
	6	Is the tab setting correct?	Correct the setting.
Paper feeding / Transport area	7	Does the size of paper in the drawer or LCF correspond to the setting?	Use the appropriate paper size or correct the size setting.
	8	Is the width between the slides in the drawer correct (too wide)?	Correct the position of the slides.
	9	Is the width between the slides of the bypass tray correct (too wide)?	Correct the width.
	10	Is the paper aligning amount sufficient?	Adjust the aligning amount.
	11	Are the feed roller and transport roller dirty or worn out?	Clean or replace the rollers.
	12	Does the paper mode correspond to the paper type?	Use the appropriate paper type or paper mode.
	13	Using the recommended paper?	Use the recommended paper.
Transfer unit	14	Is there any stain caused by a poor cleaning, etc. on the transfer belt?	Clean the transfer belt.
	15	Is the transfer belt cleaning blade in proper contact with the transfer belt?	Take off the transfer belt and check if the transfer belt cleaning blade pressure spring and the pressure hook are installed properly.
	16	Is the 2nd transfer roller rotating properly?	Clean the area around the roller. Otherwise replace the roller.
	17	Is there any foreign matter or stain on the 2nd transfer roller?	Clean or replace the roller.
	18	Has the 2nd transfer roller reached to its PM life?	Replace the 2nd transfer roller.
Fuser unit	19	Are the fuser belt and pressure roller dirty?	Clean the fuser belt and pressure roller.
	20	Is the back side of the paper stained?	Clean the fuser belt and pressure roller.
	21	Is the separation finger dirty?	Clean the separation finger.
	22	Is the rib of transport guide dirty?	Clean the rib.

8.5.30 White void in the halftone

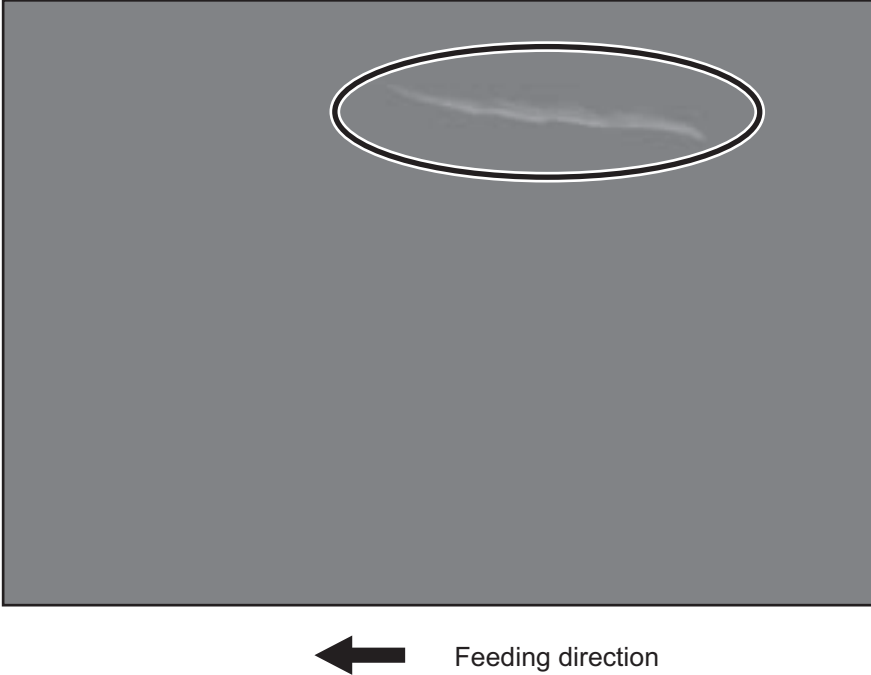

Fig.8-63

Cause/Section	Step	Check item	Measures
Fuser unit	1	Installed position of the fuser unit	Loosen the 1 screw [1] on the fuser unit guide rail (front). Remove 1 screw [2]. Change its position to the adjustment hole [3] and move the fuser unit guide rail (front) up or down (one step). (Fig.8-64) * There is a 1-mm scale [4].
	2	The installation position of the fuser unit paper entrance guide	Following are the adjustment procedure of the fuser unit paper inlet guide. (Fig.8-65) Notes: <ul style="list-style-type: none"> • Confirm the positions of the screws before removing the inlet guide. • Check if the inlet guide is attached horizontally by checking the scales for the inlet guide. (1) Take off the fuser unit. (2) Remove the 2 screws of the paper entrance guide [1], and then secure them to the holes next to the original ones. (3) Vertically move the paper entrance guide to the upper direction of the figure so that it is separated by approx. 0.5 mm from the fuser belt. (4) In the condition of step (3), check whether white void occurs or not. (5) If white void still persists, move the paper entrance guide by 0.1 to 0.2 mm upward or downward. Notes: <ol style="list-style-type: none"> 1. Be careful not to move the paper entrance guide too much, since this could cause paper wrinkling. 2. If paper wrinkling does occur, return the paper entrance guide to the position described in step (3).

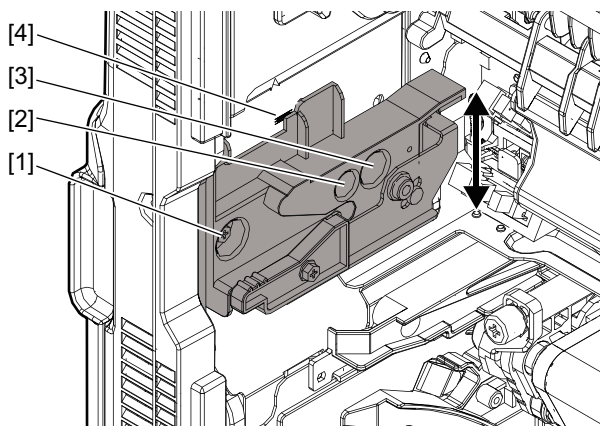

Fig.8-64

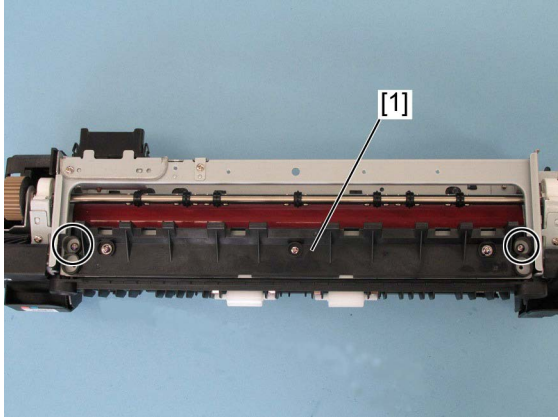

Fig.8-65

8.5.31 Paper wrinkle

There are 2 locations where the paper wrinkle occurs: before the fusing stage and in the fuser unit. See below to determine the case.



Smooth out the wrinkled paper. When there is no image in the wrinkled area

→See (1) "Paper wrinkle before fusing".

Smooth out the wrinkled paper. When there is a copied image in the wrinkled area

→See (2) "Paper wrinkle in the fuser unit".

(1) Paper wrinkle before fusing

<u>Is paper properly set?</u>		
 ↓	NO →	Set paper properly.
YES		
<u>Is there any abnormality such as scratch or wear on the transport roller?</u>		
 ↓	YES →	Replace the transport roller.
NO		
<u>Is flexible paper such as recycled paper used?</u>		
 ↓	YES →	Switch to the recycled paper mode. (Select "RECYCLED PAPER" in MEDIA TYPE.) If the paper wrinkle still appears, proceed to NO.
NO		
Decrease the adjustment value for the paper alignment. ( P. 6-8 "6.1.6 Paper alignment at the registration roller") If the paper wrinkle still appears, proceed to next.		
 ↓		
1. Increase the adjustment value for the paper alignment. ( P. 6-8 "6.1.6 Paper alignment at the registration roller") 2. Increase the transport motor speed. (Adjust it at the code FS-05-4532-0, 3, 4, 7.)		

(2) Paper wrinkle in the fuser unit

<u>Is the paper properly set?</u>		
 ↓	NO →	Set the paper properly.
YES		
<u>Has the paper absorbed moisture?</u>		
 ↓	YES →	Use paper that has not absorbed moisture.
NO		
<u>Is flexible paper such as recycled paper used?</u>		
 ↓	YES →	Switch to the recycled paper mode. (Select "RECYCLED PAPER" in MEDIA TYPE.) If the paper wrinkle still appears, proceed to NO.
NO		
1. Adjust the installed position of the fuser unit up or down and check if the paper wrinkle disappears. ( P. 8-489 "8.5.30 White void in the halftone") 2. Adjust the inlet guide[1] of the fuser unit and check if the paper wrinkle disappears. (Fig.8-66)		
Notes:		
<ul style="list-style-type: none"> • Confirm the positions of the screws before removing the inlet guide. • Check if the inlet guide is attached horizontally by checking the scales for the inlet guide. 		

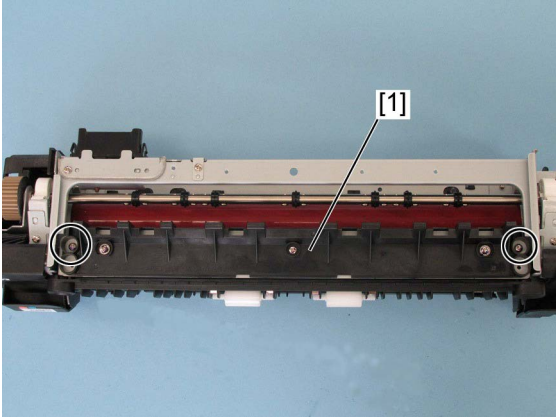

Fig.8-66

8.5.32 Staining at the leading/trailing edge

Staining may occur at the leading/trailing edge of the paper.

If a large amount of printing is carried out, staining may be seen as streaks as shown below.

Example: Leading edge of paper

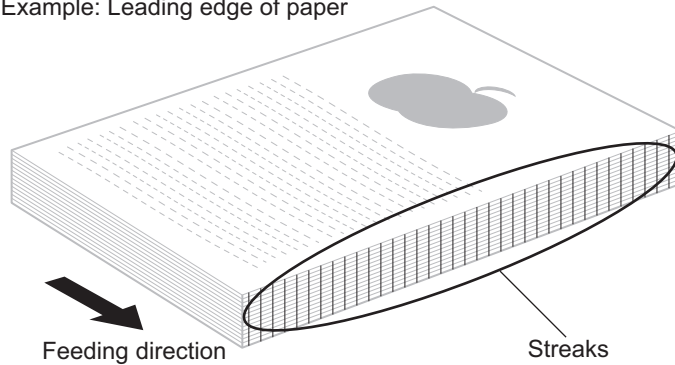

Fig.8-67

Cause/Section	Step	Check item	Measures
2nd transfer unit	1	Is there any toner adhering to the ribs of the transfer guide [1]?	Clean the ribs of the transfer guide [1].
Image quality control unit	2	Is there any toner adhering to the ribs of the transfer guide [1]?	Clean the ribs of the transfer guide [1].
Fuser unit	3	Is there any toner adhering to the fuser unit lower stay [2]?	Clean the fuser unit lower stay [2] with alcohol.
	4	Is there any toner adhering to the ribs of the transfer guide?	Clean the ribs of the transfer guide.
	5	Is there any toner adhering to the frame or shaft of the fuser unit entrance side?	Clean the frame or shaft of the fuser unit entrance side with alcohol.
Paper exit unit	6	Is there any toner adhering to the ribs of the paper exit guide?	Clean the ribs of the paper exit guide.
Finisher	7	The coating material is applied to the grate-shaped guide?	Apply an adequate amount of coating material (SANKOL CFD-409M) to the grate-shaped guide.

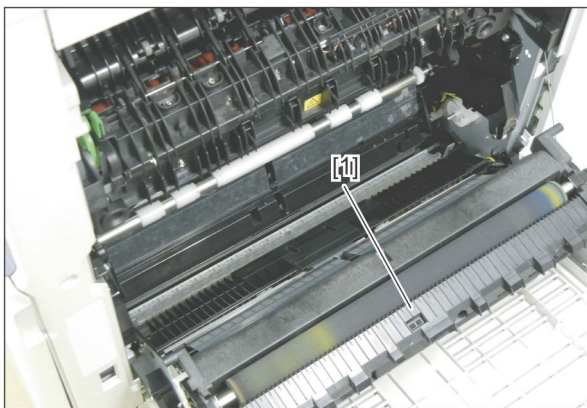

Fig.8-68

Notes:

Clean them with a soft pad, cloth or electric vacuum cleaner.

8.5.33 Faint image

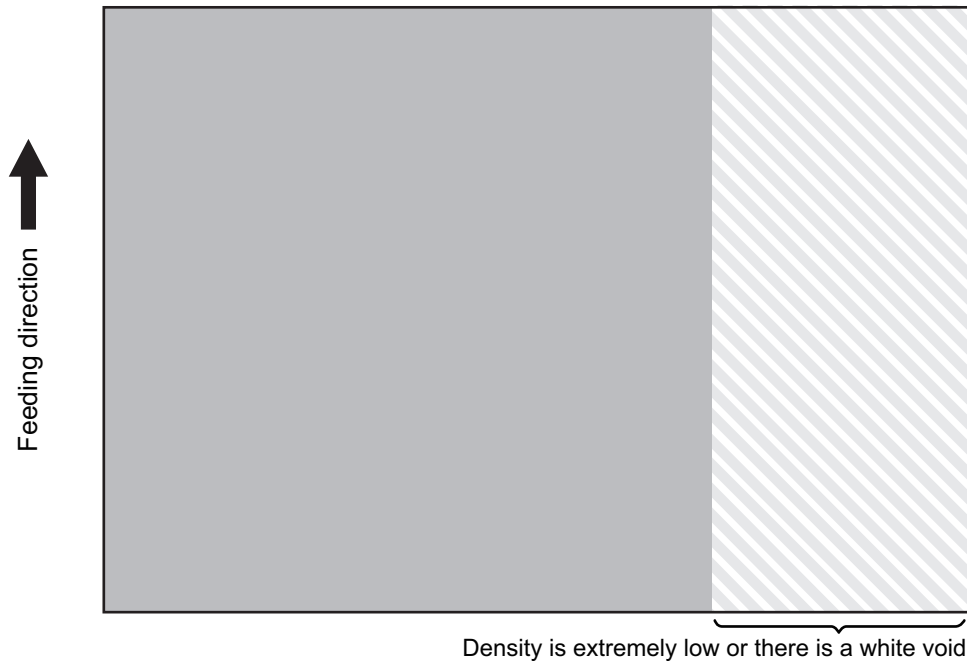

Fig.8-69

* Checking is easier with a halftone (Y) test chart.

Cause/Section	Step	Check item	Measures
Transfer belt unit (TBU)	1	Are the drum and the transfer belt contacted?	Contact and release the transfer belt unit several times with the TBU release lever. Check that the 1st transfer roller is rotated smoothly upward and downward.
Process unit (EPU)	2	Is the contact between the drum and developer material proper?	<ul style="list-style-type: none"> • Check the pole position. • Check that the doctor blade firmly contacts the bearing. If there is any abnormality, replace the developer unit.
Laser optical unit (LSU)	3	Is the slit glass of the laser optical unit (LSU) dirty?	Clean the slit glass of the laser optical unit (LSU).
	4	Is the problem resolved if you replace the laser optical unit (LSU) ?	Replace the laser optical unit (LSU).
Transfer unit (TRU)	5	Is 2nd transfer roller in proper contact with the transfer belt? (Is the roller tilted?)	Open and close the jam access cover. Check if there is any abnormality in the movement of the 2nd transfer roller pressure mechanism.

8.5.34 Toner scattering

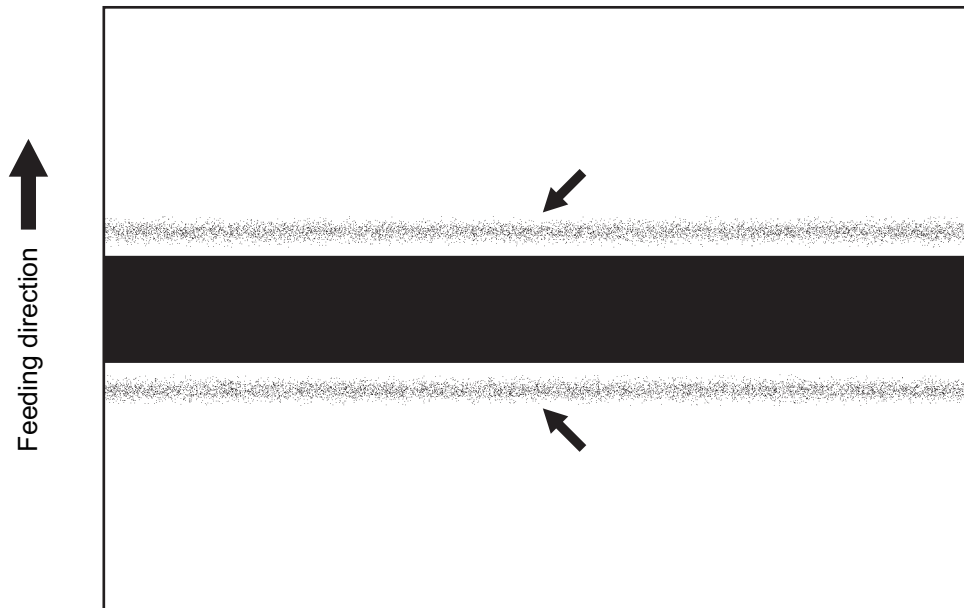
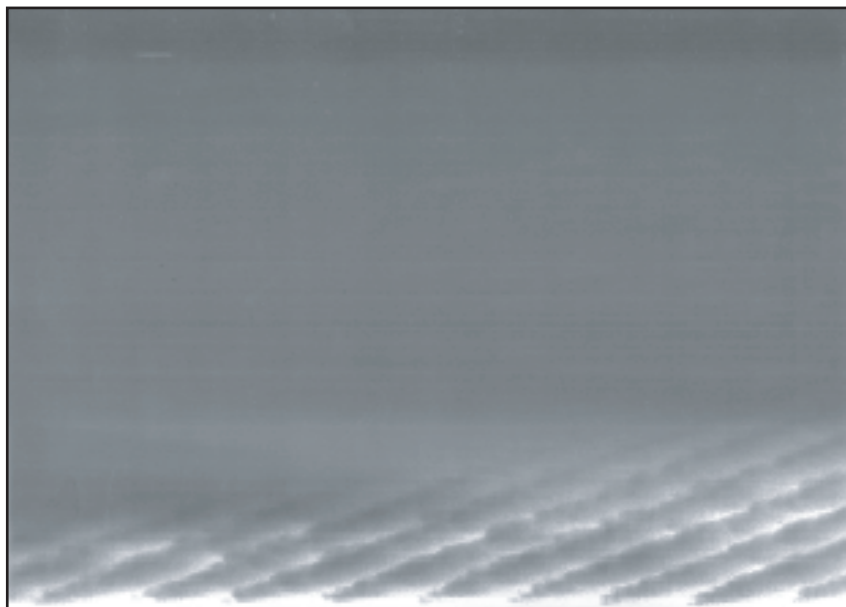

Fig.8-70

Cause/Section	Step	Check Item	Measures
Paper	1	Check if the paper type is set properly.	Set the paper type to be used properly.
Drawer / bypass tray	2	Is toner scattered when printing is performed on the back side of which front side has been printed?	When printing on the back side is performed, place the paper on the bypass tray and select the paper type and [Printed] in "Back Printed".
2nd transfer	3	Is the recommended paper used?	<p>If not, change the values of FS-05-2934 to FS-05-2937 to adjust the 2nd transfer bias offset.</p> <p>Check the mode (color or monochrome) and the side (front or back). Set the value for each paper type so that the density of the image quality becomes the darkest.</p> <p>Notes:</p> <ul style="list-style-type: none"> • After the setting has been changed, perform automatic gamma adjustment. • When the value is increased close to 10, white spots may occur. To avoid this, perform the adjustment while checking the image. • When the value is reduced close to 0, poor transfer may occur. To avoid this, perform the adjustment while checking the image.

8.5.35 Feathered image



← Feeding direction

Fig.8-71

Cause/Section	Step	Check Item	Measures
Developer unit	1	Pole position adjustment plate	Adjust the pole position adjustment plate. (Fig.8-72) 1. Record or mark the scale position [2] indicated by the pole position adjustment plate [1]. 2. Loosen 1 screw [3] and move the pole position adjustment plate [1]. 3. Turn the pole position adjustment plate [1] counterclockwise (in the direction of the black arrow) by 3 scales.

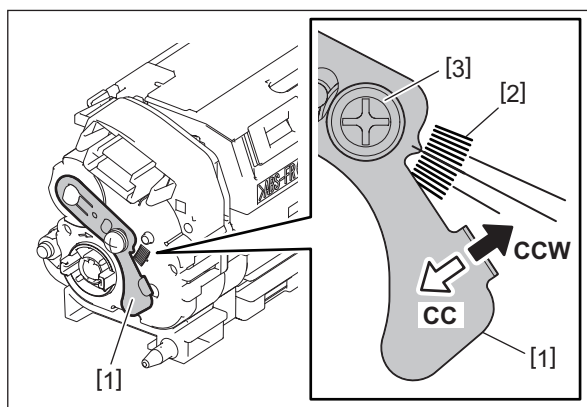

Fig.8-72

Notes:

Check the image after the pole position is adjusted.

8.5.36 Image skewing on paper trailing edge

When a grid pattern is output, follow the procedure below if the image on the paper trailing edge is skewed by 1.0 mm or more.

[A] The rear side in the secondary scanning direction is longer than the front side. (Front < Rear)

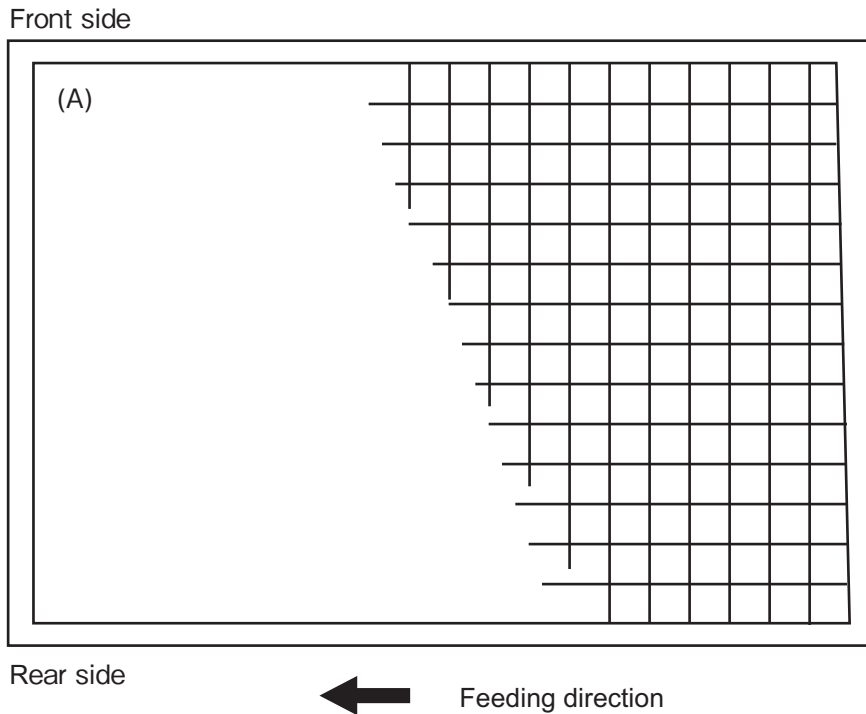

Fig.8-73

Cause/Section	Step	Check Item	Measures
Fuser unit	1	Fuser unit guide rail	Adjust the fuser unit guide rail (Fig.8-74) <ol style="list-style-type: none"> 1. Take off the fuser unit. 2. Loosen the 1 screw [1] of the front guide rail in the fuser unit. 3. Remove 1 screw [2] and attach it to the screw hole for adjustment [3]. 4. Move the guide rail upward by 1 mm. <ul style="list-style-type: none"> - Moving it by 1 mm changes the screw in the trailing edge by 0.65 mm. - There is a 0.5-mm scale on the part marked with [4]. 5. Tighten the 1 screw [1] of the front guide rail in the fuser unit. 6. Install the fuser unit. <ul style="list-style-type: none"> - Check that the image on the paper trailing edge is skewed by 1 mm or less after the adjustment.

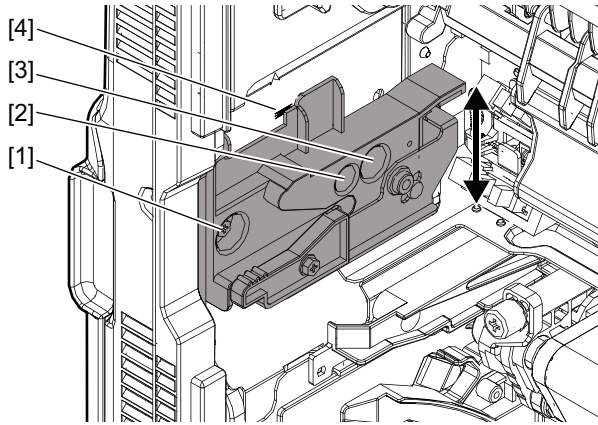

Fig.8-74

Notes:

Adjust the fuser unit installation position within the range “A” as shown in the figure below.

- Upper limit: The first line from the center
- Lower limit: The second line from the center

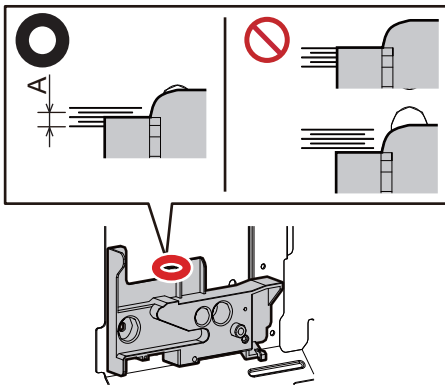

Fig.8-75

[B] The front side in the secondary scanning direction is longer than the rear side. (Front > Rear)

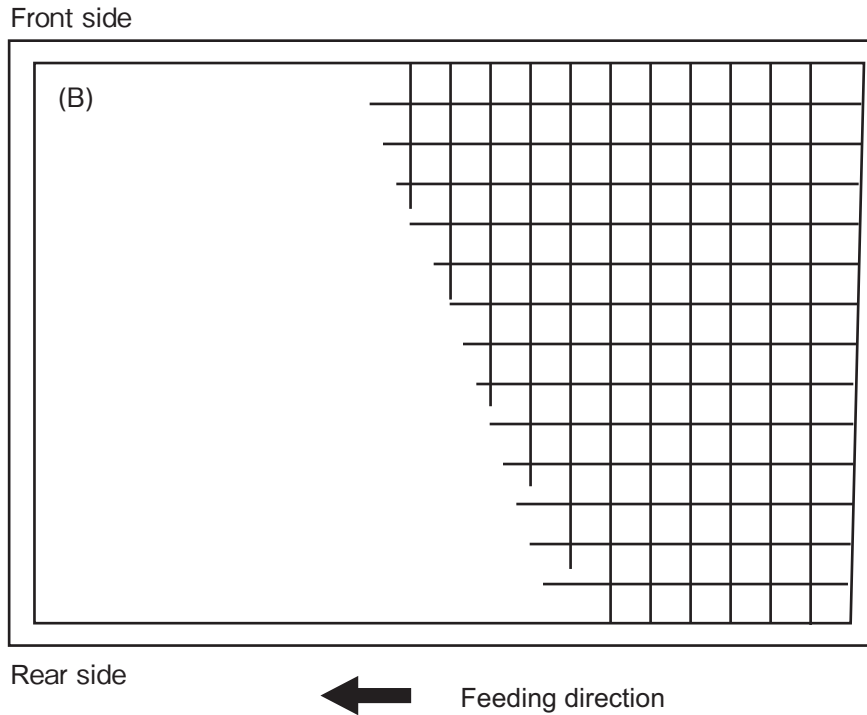

Fig.8-76

Cause/Section	Step	Check Item	Measures
Fuser unit	1	Fuser unit guide rail	Adjust the fuser unit guide rail (Fig.8-77) <ol style="list-style-type: none"> 1. Take off the fuser unit. 2. Loosen the 1 screw [1] of the front guide rail in the fuser unit. 3. Remove 1 screw [2] and attach it to the screw hole for adjustment [3]. 4. Move the guide rail downward by 1 mm. <ul style="list-style-type: none"> - Moving it by 1 mm changes the screw in the trailing edge by 0.65 mm. - There is a 0.5-mm scale on the part marked with [4]. 5. Tighten the 1 screw [1] of the front guide rail in the fuser unit. 6. Install the fuser unit. <ul style="list-style-type: none"> - Check that the image on the paper trailing edge is skewed by 1 mm or less after the adjustment.

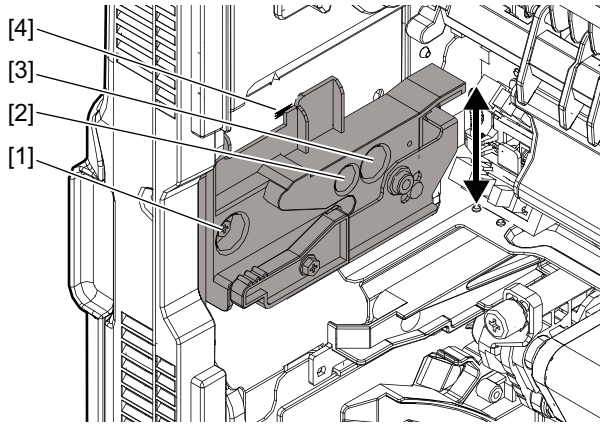

Fig.8-77

8.5.37 Staining on both edges of paper

The streaks may appear on both sides of paper when printing the wide-sized paper (SRA3/320 x 450 mm, 320 x 460 mm).



Fig.8-78

Cause/Section	Step	Check item	Measures
Transfer belt unit	1	Are there any stains on both sides of the transfer belt?	Clean both sides of the transfer belt with alcohol. (Approx. 10 mm from the edge)
	2		Replace the blade seals of the transfer belt cleaning unit.

8.5.38 Roller trace



Fig.8-79

Cause/Section	Step	Check item	Measures
Lower exit roller (idling roller)	1	Is the surface of the lower exit roller and idling roller stained?	Clean the lower exit roller and idling roller surface with alcohol, or replace the roller.

8.5.39 Staining at the leading edge

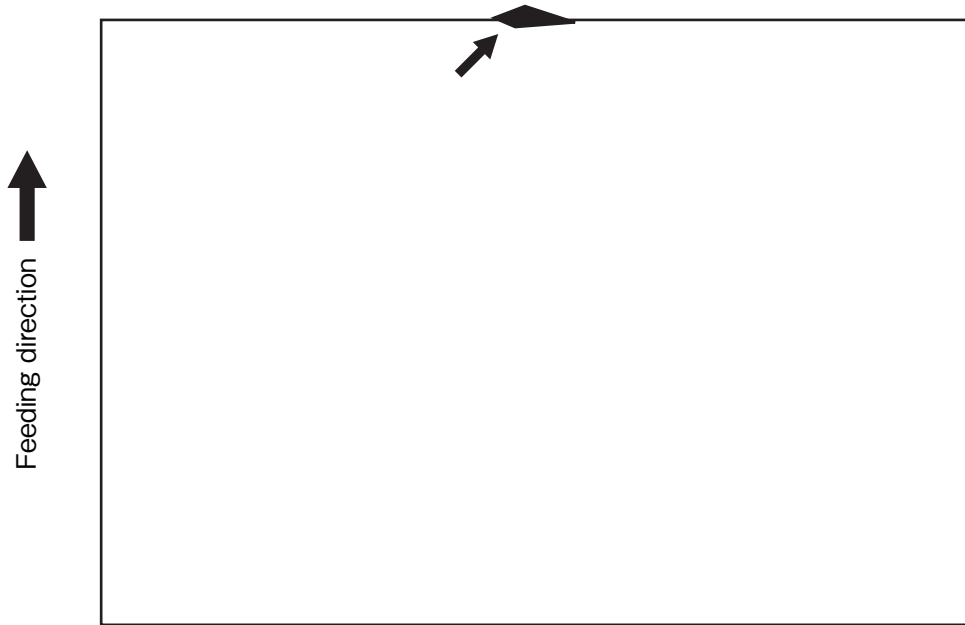

Fig.8-80

Cause/Section	Step	Check item	Measures
Exit sensor	1	Is the actuator of the exit sensor stained?	Clean the actuator with alcohol, or replace the actuator.

8.5.40 Image distortion (dogleg image)

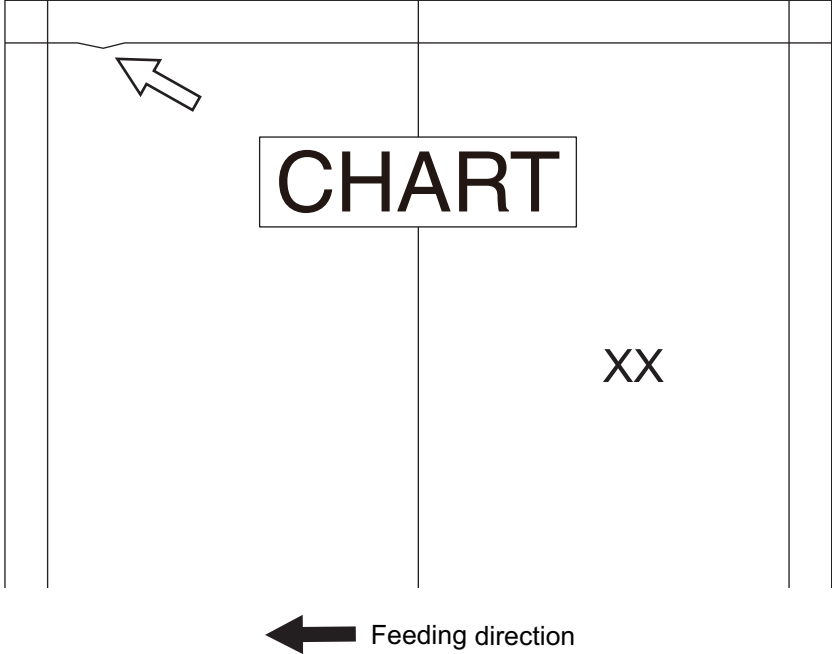

Fig.8-81

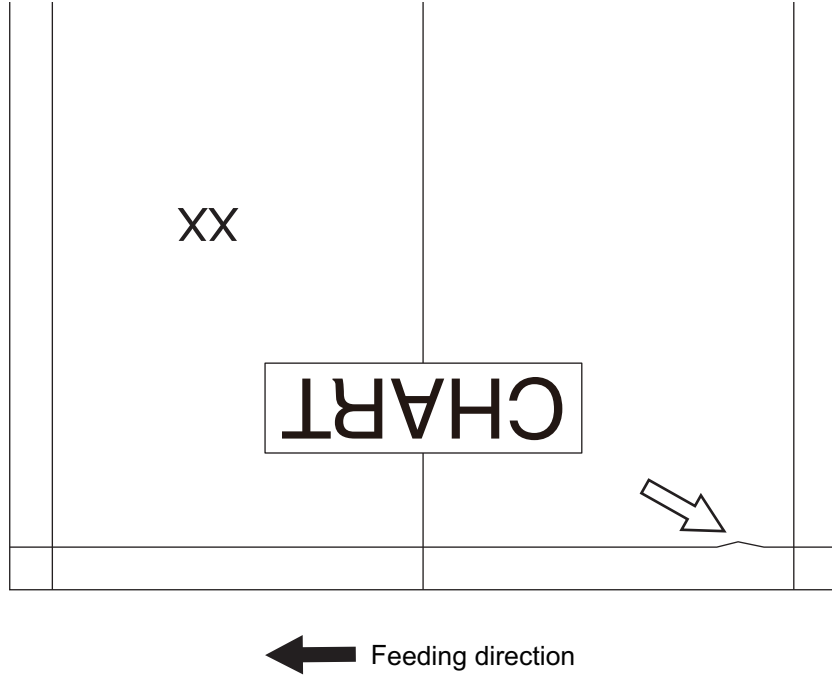

Fig.8-82

The image distortion (dogleg image) shown upper occur on the leading or trailing edge at the back side of the copied or scanned paper while the DSDF was used.

Cause/Section	Step	Check item	Measures
DSDF	1	Adjustment of position / Adjustment of height	<p>Check the installation condition of the DSDF and confirm that there are no abnormalities in the adjustment for its position and height.</p> <p>📖 P. 6-106 "6.14.1 Adjustment of position"</p> <p>📖 P. 6-111 "6.14.2 Adjustment of height"</p>
	2	Adjustment of skew	<p>Perform the adjustment of image tilting at the back side.</p> <p>📖 P. 6-113 "6.14.3 Adjustment of skew"</p> <p>Remarks:</p> <p>The phenomenon tends to be reduced if the CCD module is moved in the "+" direction.</p> <p>Perform the adjustment of image tilting at the front side corresponding to the tilted amount of the back side.</p> <p>Notes:</p> <ul style="list-style-type: none"> • When this adjustment is performed, the entire image may be tilted. • Even if this adjustment is performed, a dogleg image will not be resolved completely.

8.5.41 Low density level in halftone around a text or line

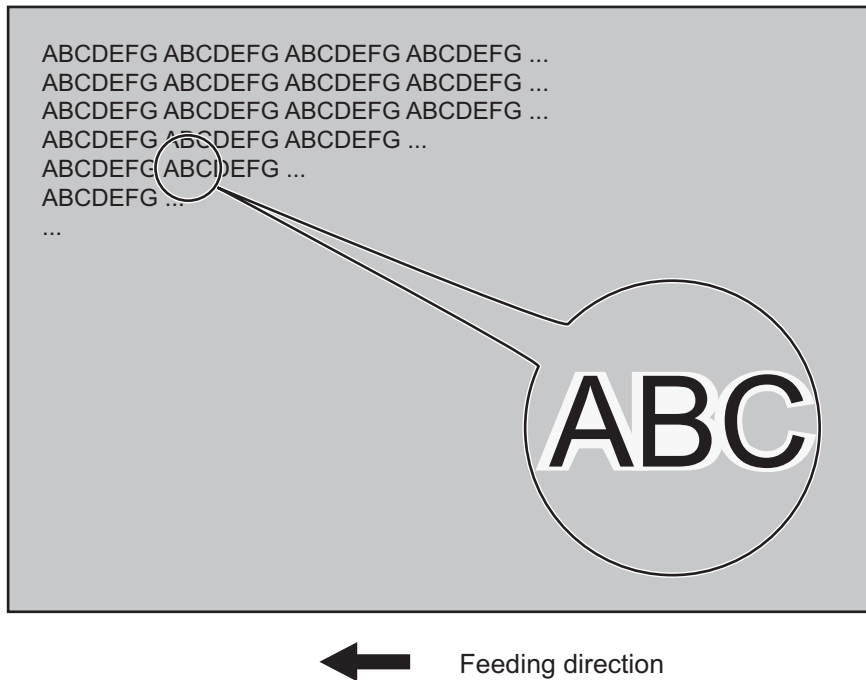

Fig.8-83

Cause/Section	Step	Check item	Measures
Laser optical unit	1	Image quality closed-loop control	Perform the enforced performing of image quality closed-loop control (FS-05-2742).
Main charger / Charger grid	2	Are the needle electrode, grid and case dirty?	Clean or replace it.
Discharger LED	3	Is the discharger LED dirty?	Clean it.
Screen	4	-	<p>Change the setting of the screen to the low screen ruling value by the following codes.</p> <ul style="list-style-type: none"> • Color: Set "1" (Low screen ruling value) in FS-08-8110. • Color: Set "0" (Low screen ruling to reduce unevenness of the printed image) in FS-08-8111. • Black: Set "1" (Low screen ruling value) in FS-08-7310. <p>Notes:</p> <ul style="list-style-type: none"> • After the setting value has been changed, be sure to perform automatic gamma adjustment. • When the low screen ruling value is set, jaggies may become more conspicuous in diagonal lines depending on the original. Set this setting while checking the image.

8.5.42 Shadow in copied/scanned images when using the DSDF



← Feeding direction

Fig.8-84

Cause/Section	Step	Check item	Measures	Remarks
Prior confirmation (MFP/DSDF adjustment condition check)	1	Check that the image dimensional adjustment of the MFP is performed properly.	If the adjustment is insufficient, perform the following items. 1. Image dimensional adjustment at the printing section 2. Image dimensional adjustment at the scanning section	If there is no problem in the adjustment condition, start the adjustment from step 3.
	2	Check that the image related adjustment of the DSDF is performed properly.	If the adjustment is insufficient, perform the following items. 1. Adjustment of the leading edge position 2. Adjustment of the horizontal position 3. Adjustment of the copy ratio	

Cause/Section	Step	Check item	Measures	Remarks
Image related adjustment of the MFP/DSDF	3	Perform scanning from the DSDF and check whether a shadow or an image void has appeared at the leading or trailing edge in the feeding direction.	If any defects occur, perform the following items. <ol style="list-style-type: none"> Image dimensional adjustment at the printing section (Secondary scanning data writing start position adjustment, Reproduction ratio of the secondary scanning direction adjustment) Image dimensional adjustment at the scanning section (Secondary scanning data writing start position adjustment) Image related adjustment of the DSDF (Adjustment of the leading edge position, Adjustment of the copy ratio) 	
	4	Perform scanning from the DSDF and check whether a shadow or an image void has appeared at the left or right edge in the feeding and vertical direction.	If any defects occur, perform the following items. <ol style="list-style-type: none"> Image dimensional adjustment at the printing section (Primary scanning data writing start position adjustment) Image dimensional adjustment at the scanning section (Primary scanning data writing start position adjustment) Image related adjustment of the DSDF (Adjustment of the horizontal position) 	
Copying	5	<ul style="list-style-type: none"> Check whether a trailing edge shadow of an original has appeared at copying only. Check whether a trailing edge shadow of an original has appeared when copying is made by selecting a larger size of paper than that for an original or by reducing the size. 	If any defects occur, perform the following items. <ol style="list-style-type: none"> Change the value of FS-08-3075 (Allowing of trailing edge adjustment of scanning) to "1" (Allowed). Decrease the value of FS-05-3350 (Scan trailing edge adjustment for the front side) and FS-05-3351 (Scan trailing edge adjustment for the back side) from 50 until the trailing edge shadow of an original has disappeared. <p>Remarks: When the value is decreased by "1", the image will be cut (become shorter) by 0.3 mm.</p>	This adjustment is available only for the copying function. (This adjustment cannot be performed in the scanning function.)

8.5.43 The exit paper surface feels rough like sand is adhering to it (carrier offset)

Cause/Section	Step	Check item	Measures
Developer material / Drum	1	Has the developer material and the drum reached their PM life?	Replace the developer material and the drum.
Main charger	2	Is there foreign matter on the main charger?	Clean or replace the main charger.
Developer unit	3	<ul style="list-style-type: none"> Are the connectors of the auto-toner sensor connected properly? (CN313A, CN313B, J629, J631, J633, J635, J630, J632, J634, J636) Is the auto-toner sensor installed correctly? 	<ul style="list-style-type: none"> Connect the connectors and perform auto-toner sensor adjustment. Install the auto-toner sensor correctly and perform auto-toner sensor adjustment.
Discharge LED	4	<p>Are the discharge LEDs lit? Check this by the following steps.</p> <ol style="list-style-type: none"> Start the equipment with [03 TEST MODE]. Open the front cover and install the door-switch jig. Remove the waste toner box. Perform 03-235 and 03-236 to check that the discharge LEDs for each color are lit. <p>Notes: Be sure to perform this in a short time.</p>	<ul style="list-style-type: none"> If discharge LEDs are not lit, check that the connectors are connected securely. (CN312, J637, J639, J640, J642, J641) Replace the discharge LED.
Toner motor	5	<p>Are the toner motors working properly? Perform 03-410, 03-411, 03-412 and 03-413 to check that the toner motors for each color are working properly.</p>	<ul style="list-style-type: none"> Check that the connectors for each toner motor are connected securely. (CN315, CN440, CN441, CN442, CN443, CN444) If the harness of the toner motor is broken, replace the harness. Replace the toner motor. Replace the CTIF board. Replace the LGC board.
High-voltage transformer	6	<ul style="list-style-type: none"> Check that the connectors of the high-voltage transformer are connected securely. (CN530, CN531 and each Faston terminal) Is the harness of the high-voltage transformer broken? Is there any abnormality in the high-voltage transformer? 	<ul style="list-style-type: none"> Connect the connectors securely. If the harness is broken, replace it. Replace the high-voltage transformer.
LGC board	7	<ul style="list-style-type: none"> Are the connectors of the LGC board connected securely? Is the harness of the LGC board broken? Is there any abnormality in the LGC board? 	<ul style="list-style-type: none"> Connect the connectors securely. If the harness is broken, replace it. Replace the LGC board.
Process unit (EPU)	8	Is there any abnormality in the process units (EPU)?	Replace all the process units (EPU) for YMCK and perform auto-toner sensor adjustment.

Notes:

The carrier may be adhering to each transport guide, each transfer roller and the fuser belt. Therefore, perform cleaning after this troubleshooting has been carried out.

Parts to be replaced	Remark
Developer material	
Drum	
Main charger	
Discharge LED	
Toner motor	
Process unit (EPU)	Developer unit, Cleaner
High-voltage transformer	
LGC board	

8.5.44 Scanned image abnormality

When the following abnormality has appeared on images in the scanning and copying functions even if there is no abnormality in the output images in the printing function, there will be an abnormality in the scanner. In such a case, perform this countermeasure.

Example of abnormal images

- (1) The entire image has become lighter or darker.
- (2) The entire image has been colored.
- (3) The color of the image does not match that of the original.



Fig.8-85

- Abnormality in the scanner of the equipment
 - When an abnormality in the images has occurred in scanning using the original glass
 - When an abnormality in the images has occurred in scanning using the RADF
 - When an abnormality in the images only on the front side has occurred in scanning using the DADF

Cause/Section	Step	Check item	Measures
Connector	1	Are the connectors securely connected?	<ul style="list-style-type: none"> • Reconnect the connector (CN120) of the SYS board and then check the image. • Reconnect the connector (CN001) of the CCD board and then check the image.
SYS board	2	Is there any abnormality in the SYS board?	<ul style="list-style-type: none"> • If this problem still persists even after step 1 was performed, replace the SYS board and then check the image. Do not perform 05-3203 (Data transfer of characteristic value) at this time. • If the image condition has become better, finish this troubleshooting without carrying out 05-3203. (It is not necessary to continue to perform the subsequent steps.)
CCD board	3	Is there any abnormality in the CCD board?	<ul style="list-style-type: none"> • If this problem still persists even after step 2 was performed, replace the CCD board. Do not perform 05-3209 (Data transfer of characteristic value of scanner: SYS board > CCD board) at this time. After replacing, check the image. • If the image condition has become better, finish this troubleshooting without carrying out 05-3209. (It is not necessary to continue to perform the subsequent steps.)

Cause/Section	Step	Check item	Measures
SRAM	4	Is there any abnormality in the SRAM data?	<ul style="list-style-type: none"> If this problem still persists even after step 3 was performed, return the CCD board to an removed one. Perform 05-3203 (Data transfer of characteristic value) and check the image. If the image condition has become better, finish this troubleshooting.
CCD board / SRAM	5	Is there any abnormality in both the CCD board and the SRAM?	<ul style="list-style-type: none"> If this problem still persists even after step 4 was performed, replace the CCD board with the one used in step 3. Perform 05-3203 (Data transfer of characteristic value) and check the image. If the image condition has become better, finish this troubleshooting.

- Abnormality in the scanner (DSDF-CCD module) of the DSDF
 - When an abnormality in the images only on the back side has occurred in scanning using the DSDF

Cause/Section	Step	Check item	Measures
Connector	1	Are the connectors securely connected?	<ul style="list-style-type: none"> Reinstall the DSDF-I/F board and check the image. If this problem still persists even after step 1 was performed, replace the DSDF-I/F board and then check the image. If the image condition has become better, finish this troubleshooting.
DSDF-I/F board	2	Is there any abnormality in the DSDF-I/F board?	<ul style="list-style-type: none"> If this problem still persists even after step 1 was performed, replace the DSDF-I/F board and then check the image. If the image condition has become better, finish this troubleshooting.
SYS board	3	Is there any abnormality in the SYS board?	<ul style="list-style-type: none"> If this problem still persists even after step 2 was performed, replace the SYS board and then check the image. Do not perform 05-3203 (Data transfer of characteristic value) at this time. If the image condition has become better, finish this troubleshooting without carrying out 05-3203. (It is not necessary to continue to perform the subsequent steps.)
CCD module	4	Is there any abnormality in the DSDF-CCD module?	<ul style="list-style-type: none"> If this problem still persists even after step 3 was performed, replace the DSDF-CCD module. Perform 05-3240 (Data transfer of characteristic value of the scanner) and check the image. If the image condition has become better, finish this troubleshooting.

8.5.45 If an image-related problem continues after performing all troubleshooting

If an image-related problem continues even after performing all the troubleshooting, an abnormal value may have been entered in the self-diagnostic code. In such a case, attempt the initialization of the self-diagnostic code in accordance with the table below.

Notes:

- Perform the list print before the initialization.
- Initialization should be performed only for the function in which the image-related problem has occurred.
- The self-diagnostic code which will be initialized is related to the image adjustment. Therefore, only problems which have occurred during the image processing can be solved. If a cause of the problem is related to the hardware or other system issues, it will not be able to be solved even if the initialization of the self-diagnostic code is performed.

Function	Self-diagnostic code to be initialized	Precautions
Copying	FS-08-7000	After the initialization has been carried out, perform automatic gamma adjustment.
Printing	FS-08-7300	After the initialization has been carried out, perform automatic gamma adjustment (600 dpi and 1200 dpi).
Scanning	FS-08-7400	None
Fax	FS-08-7500	None

9. REPLACEMENT OF PC BOARDS/HDD

9.1 Removal and Installation of PC Boards/HDD

Notes:

When the PC board/HDD is replaced, refer to the respective Notes and Cautions of “Replacement of PC boards and HDD” in  P. 9-22 “9.2 Precautions, Procedures and Settings for Replacing PC Boards and HDD”.

9.1.1 SYS board cover

- (1) Remove the rear cover.
 P. 4-10 “4.1.17 Rear cover”
- (2) Remove 1 screw and take off the SYS board cover [1] by sliding it toward the right side.

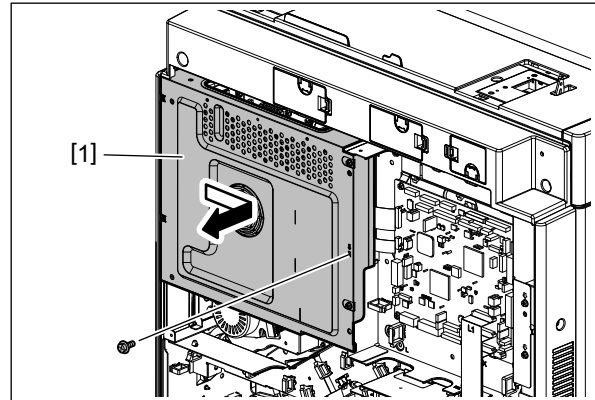



Fig. 9-1

9.1.2 SYS board cooling fan (F1)

- (1) Remove the SYS board cover.
 P. 9-1 “9.1.1 SYS board cover”
- (2) Disconnect the 1 connector [1].
- (3) Lift the 2 latches up, and remove the SYS board cooling fan [2] by sliding it toward you.

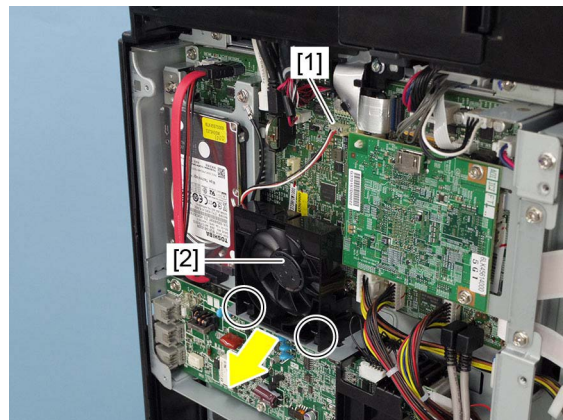



Fig. 9-2

9.1.3 Hard disk (HDD)

- (1) Take off the SYS board cover.
 P. 9-1 "9.1.1 SYS board cover"
- (2) Remove 4 screws and disconnect 2 connectors [1], and then take off the HDD unit [2].

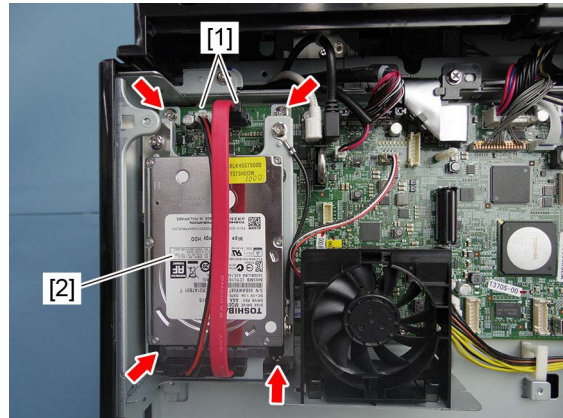

Fig. 9-3

- (3) Loosen 4 screws.

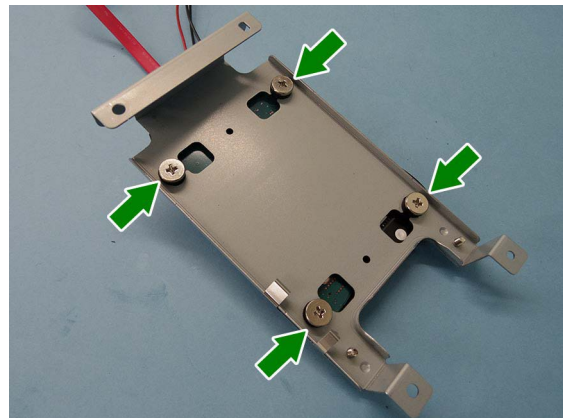

Fig. 9-4

- (4) Remove 2 screws and disconnect the ground cable [3]. Take off the hard disk [4] from the bracket.

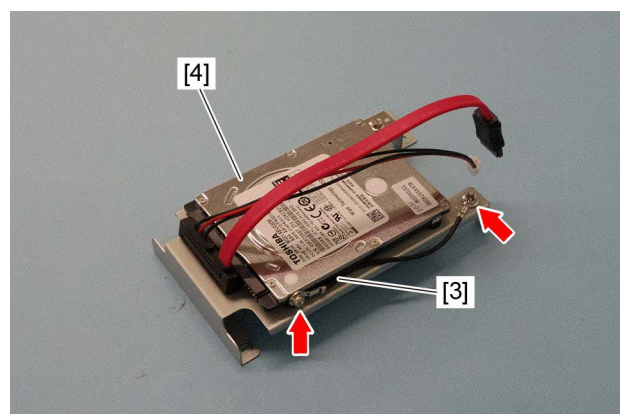

Fig. 9-5

9.1.4 SYS board

Notes:

When the SYS board or main memory has been replaced, be sure to perform the calibration of memory.

When performing the calibration of memory, turn the power ON while pressing the [ENERGY SAVER] button.

When the equipment is started up normally, the calibration has been completed.

If the calibration is not performed, the equipment may be not started up normally.

- (1) Remove the SYS board cover.
📖 P. 9-1 “9.1.1 SYS board cover”
- (2) If the DSDF is installed, remove the DSDF I/F board.
📖 P. 9-21 “9.1.16 DSDF I/F board”
- (3) Remove the SYS board cooling fan.
📖 P. 9-1 “9.1.2 SYS board cooling fan (F1)”
- (4) Remove the HDD unit.
📖 P. 9-2 “9.1.3 Hard disk (HDD)”
- (5) Disconnect 11 connectors that connected to the SYS board. Release the lock by raising the flap and remove 2 flat cables [1].

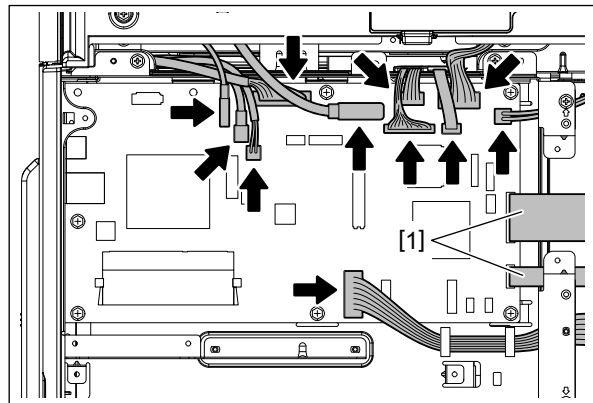

Fig. 9-6

Notes:

When installing the harnesses, be sure to connect each USB harness correctly.

CN112: Gray USB connector
(The harness of the control panel)

CN113: Black USB connector
(The harness of the USB Hub board)

Notes:

- When removing the flat cable [1], release the lock by raising the flap [2] and pull out the cable.
- When installing the flat cable [1], attach the cable to the connector and lock the cable by tilting the flap [2].
- When installing the flat cable [1], do not push it in strongly.
- When installing the flat cable [1], be careful not to insert it at an angle.
- Do not apply pressure to or damage the edge of the flat cable [1].

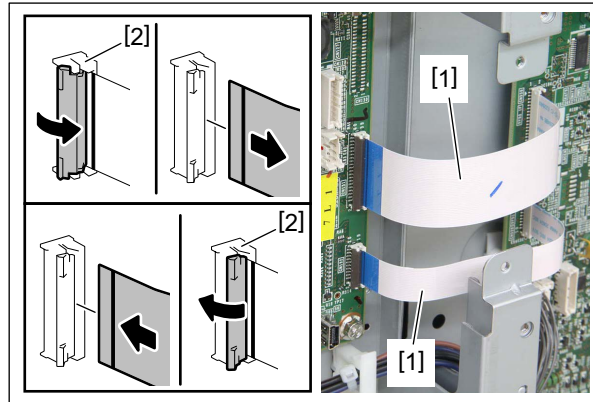

Fig. 9-7

- (6) Remove 6 screws and take off the SYS board [3].

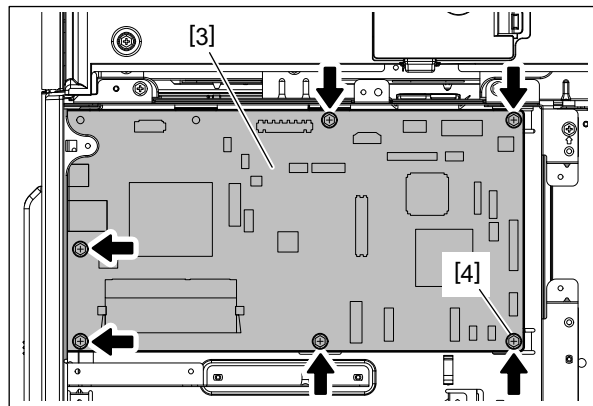

Fig. 9-8

Notes:

- When installing the SYS board, fasten the screw [4] at first.

- The SYS board to be installed differs depending on the models. Due to this, before replacing, be sure to check the color of the identification label on the SYS board to install the corresponding one in the equipment.
Label color: Yellow

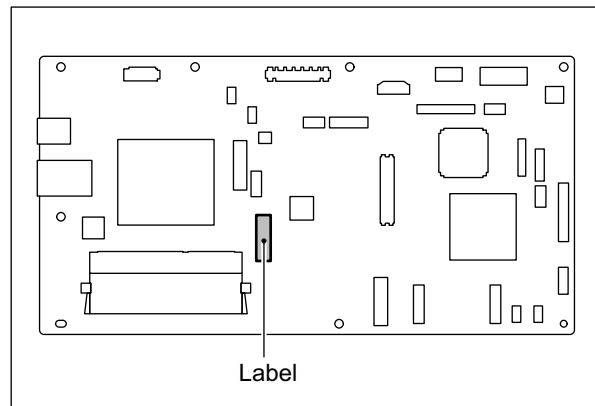

Fig. 9-9

9.1.5 SYS board case

- (1) Remove the SYS board cover.
P. 9-1 "9.1.1 SYS board cover"
- (2) Disconnect 11 connectors from the SYS board. Release the lock by raising the flap and remove 2 flat cables [1].

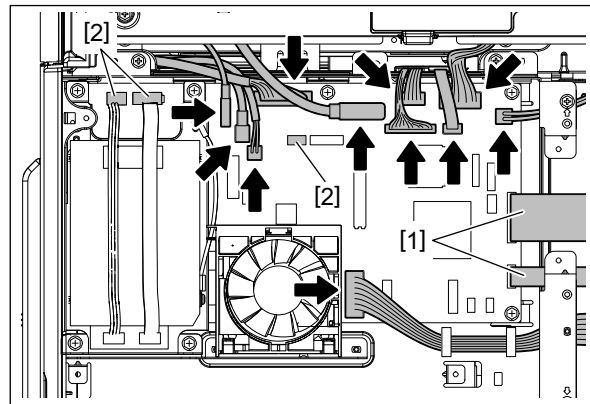

Fig. 9-10

Notes:

- Do not disconnect 3 connectors [2] connected to the HDD and SYS board cooling fan. When installing the harnesses, be sure to connect each USB harness correctly.
CN112: Gray USB connector (The harness of the control panel)
CN113: Black USB connector (The harness of the USB Hub board)

- When removing the flat cable [1], release the lock by raising the flap [2] and pull out the cable. When installing the flat cable [1], attach the cable to the connector and lock the cable by tilting the flap [2].
When installing the flat cable [1], do not push it in strongly.
When installing the flat cable [1], be careful not to insert it at an angle.
Do not apply pressure to or damage the edge of the flat cable [1].

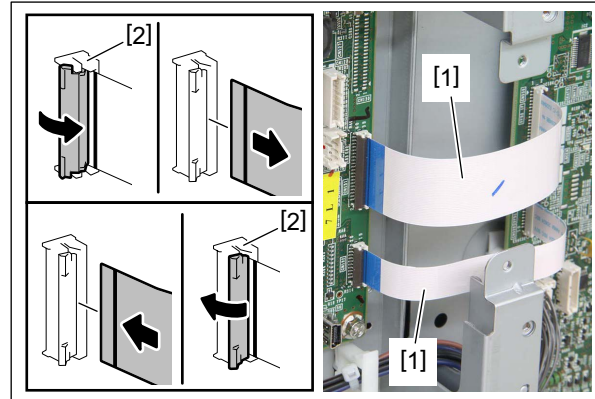

Fig. 9-11

- (3) Remove 6 screws and release the harness from the harness clamps [4]. Remove 6 screws and take off the SYS board case [5].

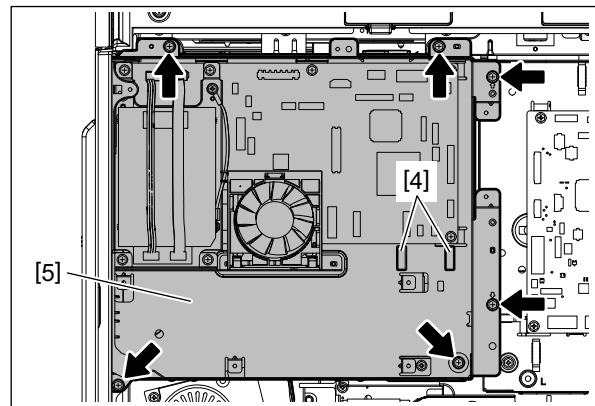

Fig. 9-12

Notes:

Hold the SYS board case to remove it.

9.1.6 LGC board

- (1) Disconnect 22 connectors connected to the LGC board.

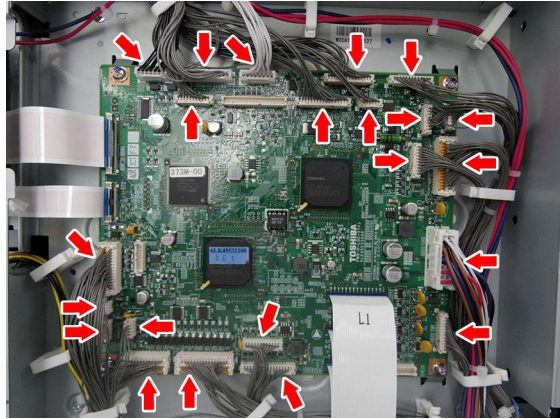

Fig. 9-13

Notes:

Disconnect 26 connectors for the 45/50ppm models.

- (2) Release the lock of the flap and then remove 2 flat cables [1].

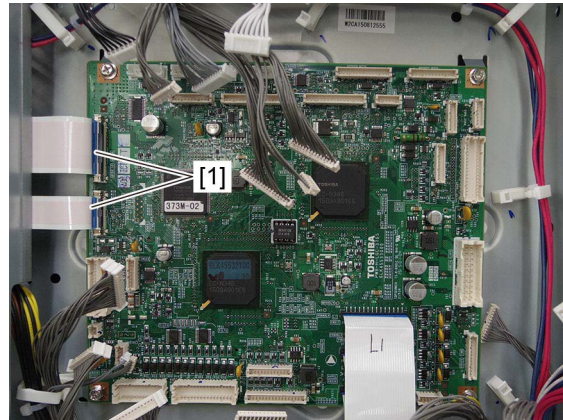

Fig. 9-14

Notes:

- When removing the flat cable [1], release the lock by raising the flap [2] and pull out the cable. When installing the flat cable [1], attach the cable to the connector and lock the cable by tilting the flap [2].

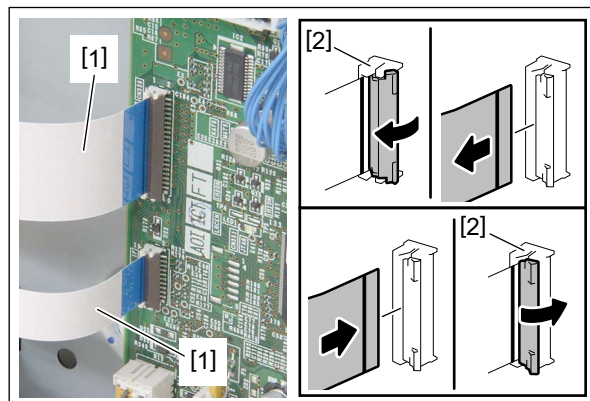

Fig. 9-15

- When installing the flat cable [1], do not push it in strongly.
When installing the flat cable [1], be careful not to insert it at an angle.
Do not apply pressure to or damage the edge of the flat cable [1].

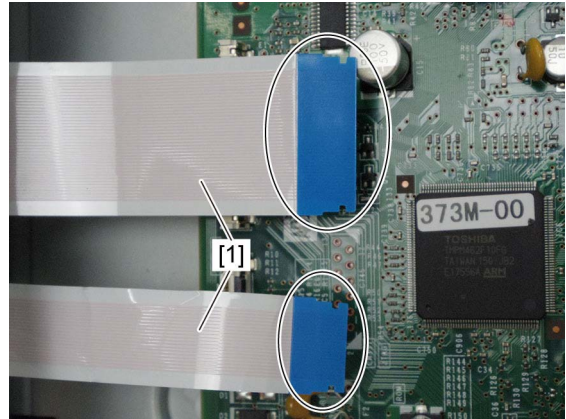

Fig. 9-16

- (3) Remove 3 flat cables [2].

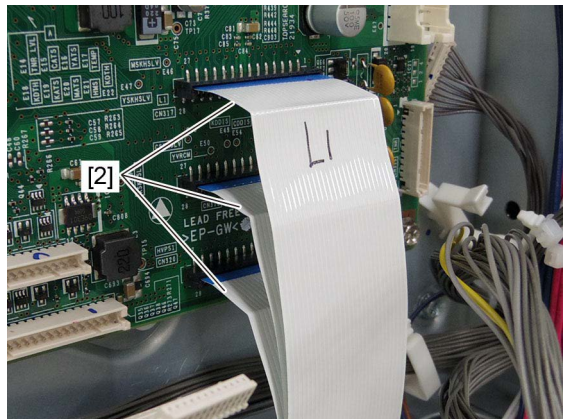

Fig. 9-17

Notes:

- When installing/removing, be careful not to damage the connection part of the flat cables [2].
When installing, be careful not to connect the flat cables [2] to the wrong connectors.
Do not use the flat cables [2] which connection parts are peeled off or damaged.

- When installing, straightly insert the flat cables [2] to the innermost of the connectors (until the lines marked on the flat cables are concealed inside the connectors) securely. When installing, make sure that the line marked on the flat cables [2] and connectors are parallel to each other. Be careful not to insert them at an angle.

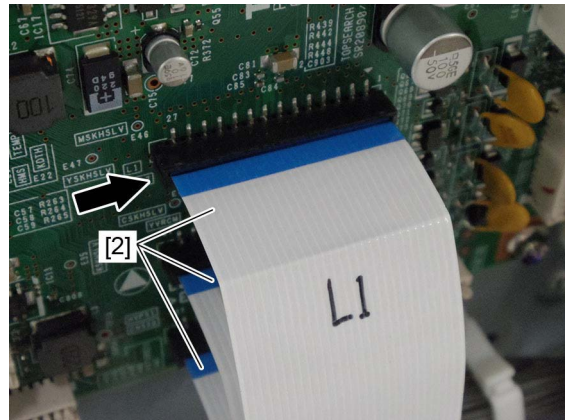

Fig. 9-18

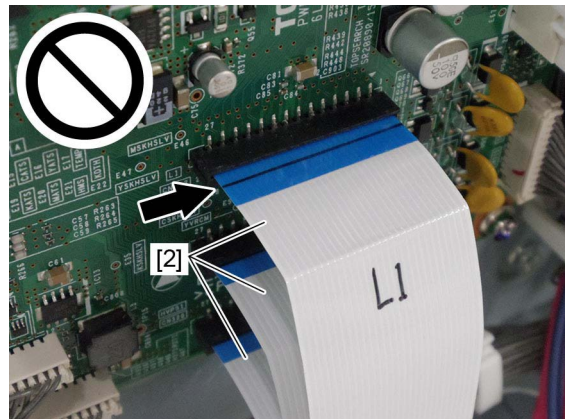

Fig. 9-19

- (4) Remove 4 screws and take off the LGC board [4].

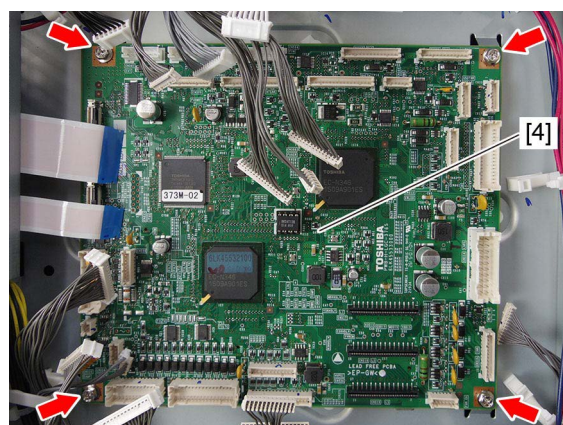

Fig. 9-20

Notes:

The LGC board to be installed differs depending on the models. Due to this, before replacing, be sure to check the color of the identification label on the LGC board to install the corresponding one in the equipment.

- 25ppm: Brown
- 30ppm: White / Red
- 35ppm: Yellow
- 45ppm: Pink
- 50ppm: Blue / Red

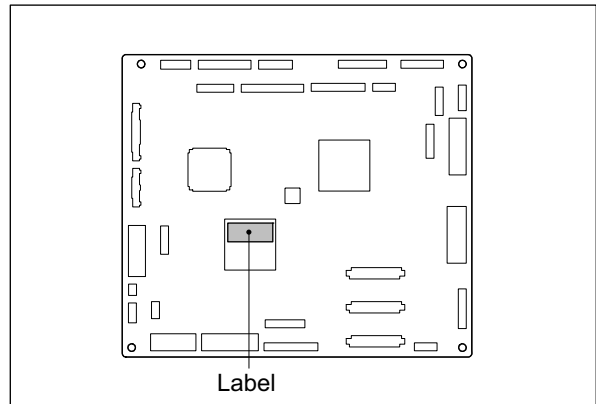

Fig. 9-21

9.1.7 IH board

Notes:

Be sure to unplug the power cable before starting this work.

- (1) Remove the SYS board case.
📖 P. 9-5 "9.1.5 SYS board case"
- (2) Remove 3 screws and take off the IH board cover [1] by sliding it downward.

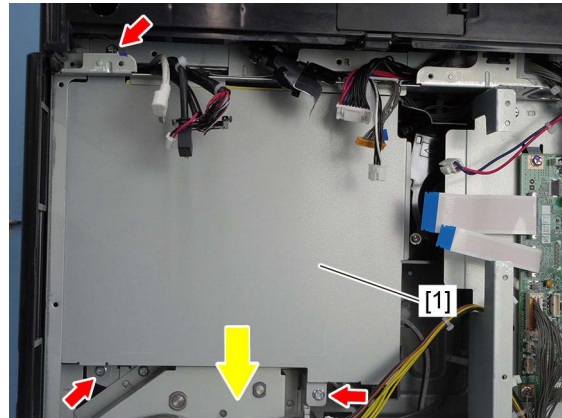

Fig. 9-22

- (3) Disconnect the 3 connectors [2].
- (4) Remove 1 screw for each, and take off 2 IH feed terminals [3].

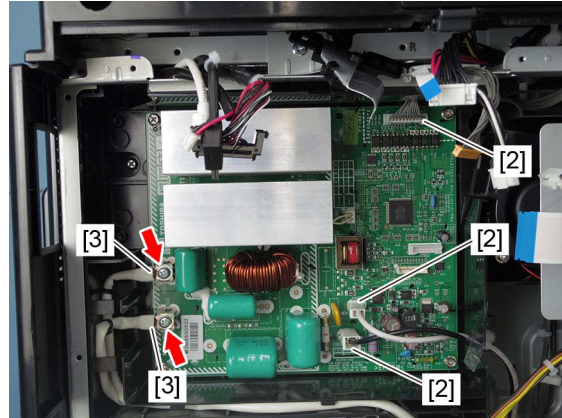

Fig. 9-23

Notes:

- When connecting connectors, be careful not to confuse the white connector location with the black connector location.
When installing, securely tighten the fixing screw of the IH feed terminal [3] so that it does not become loose.
- Wire the IH harness as shown in the figure and secure the terminals horizontally.

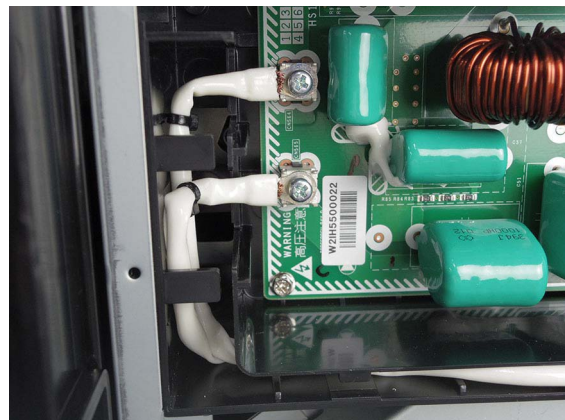

Fig. 9-24

- When assembling, wire the IH harness pulled out from the rear frame by aligning it to the inside of the harness holder as shown in the figure so that there is no warp.

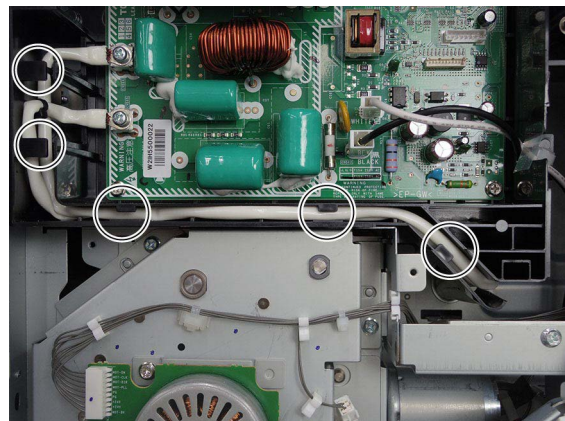

Fig. 9-25

(5) Remove 4 screws and take off the IH board [4].

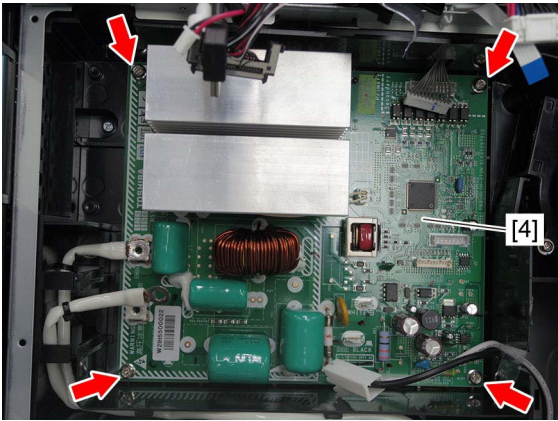

Fig. 9-26

9.1.8 Switching regulator

Notes:

- Be sure to unplug the power cable before starting this work.
- Electric charge may remain in the capacitors on the switching regulator even if the main power is turned off and the plug is disconnected.
- Since there is a risk of an electric shock, pay full attention not to touch the board and mounted parts while handling the switching regulator.

- (1) Remove the rear cover.
P. 4-10 “4.1.17 Rear cover”
- (2) Remove 2 screws [2] and take off the power supply cover [1].

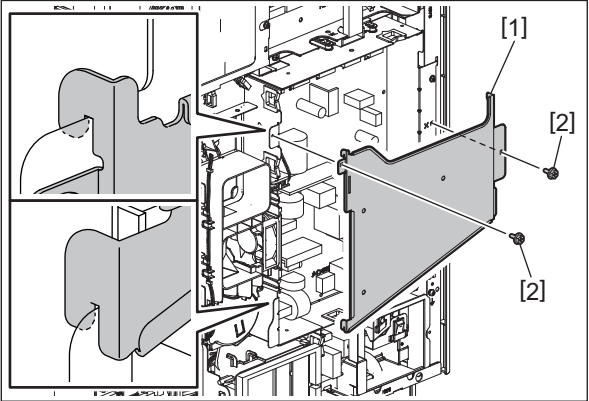

Fig. 9-27

- (3) Disconnect 12 connectors from the switching regulator.

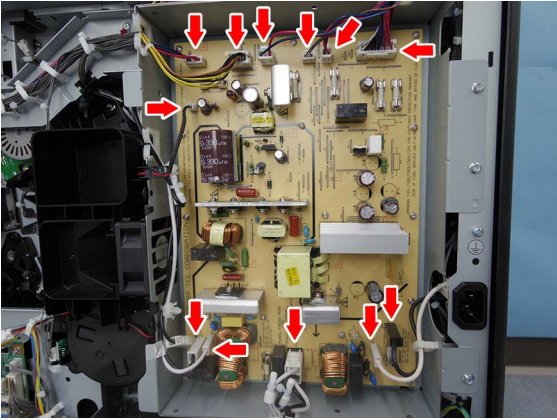

Fig. 9-28

(4) Remove 4 screws and take off the switching regulator [1].

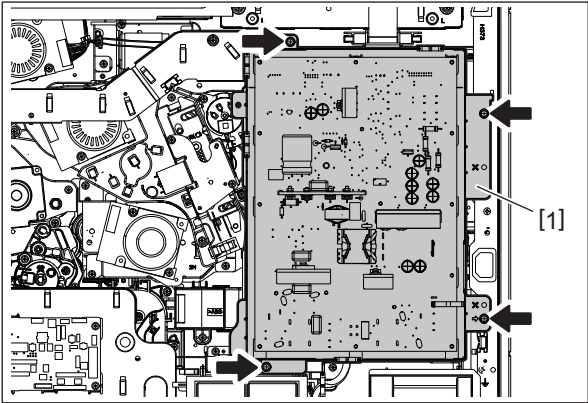

Fig. 9-29

9.1.9 High-voltage transformer (HVT)

Notes:

Be sure to unplug the power cable before starting this work.

- (1) Remove the developer unit cooling exhaust duct.
📖 P. 4-164 “4.6.35 Developer unit cooling exhaust duct”
- (2) Disconnect 10 connectors from the switching regulator.
- (3) Release 6 clamps.

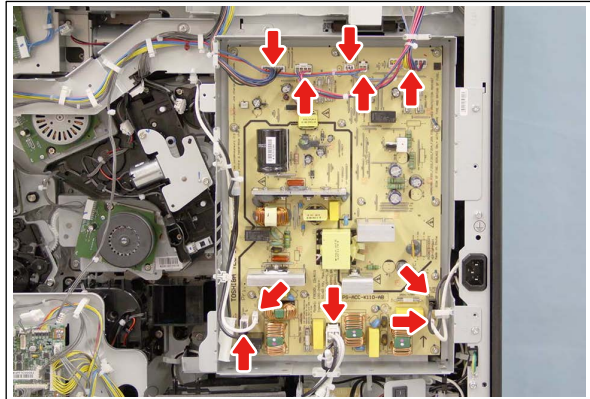

Fig. 9-30

- (4) Remove 4 screws and take off the switching regulator [1].

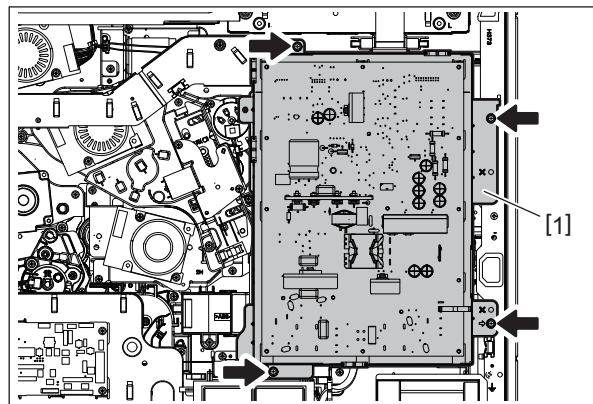

Fig. 9-31

- (5) Unlock 2 locking supports and remove the film [2].

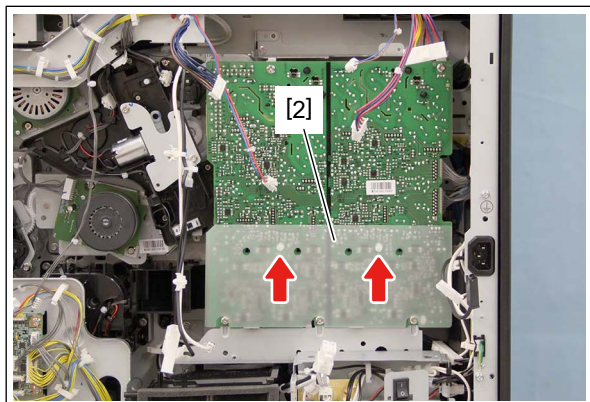

Fig. 9-32

- (6) Remove 5 screws and release 4 locking supports [3].

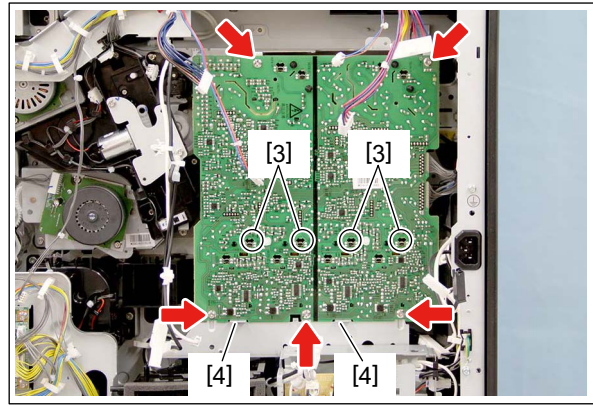

Fig. 9-33

Notes:

When installing, match the frame with the concave portion [4] of the high-voltage transformer, and then push it until the supports [3] are locked.

- (7) Disconnect 2 connectors and take off the high-voltage transformer [3].

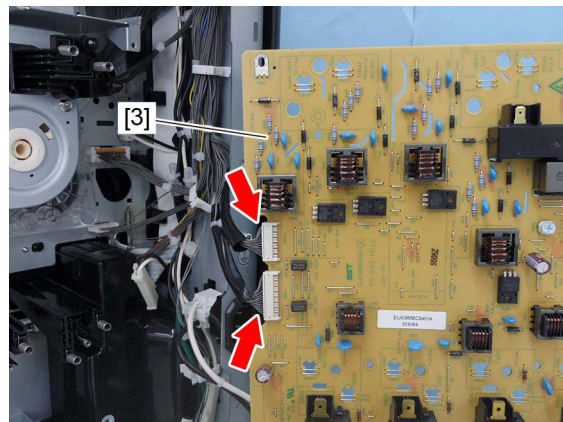

Fig. 9-34

Notes:

When installing the high-voltage transformer, make sure the feed springs contact the plastic (locator) pins as shown in the figure.

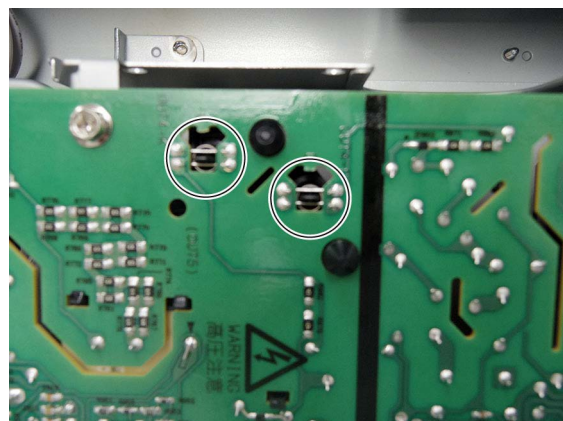

Fig. 9-35

9.1.10 SRAM

- (1) Remove the rear cover.
📖 P. 4-10 "4.1.17 Rear cover"
- (2) Take off the HDD unit.
📖 P. 9-2 "9.1.3 Hard disk (HDD)"
- (3) Remove the SRAM [1] from the SYS board.

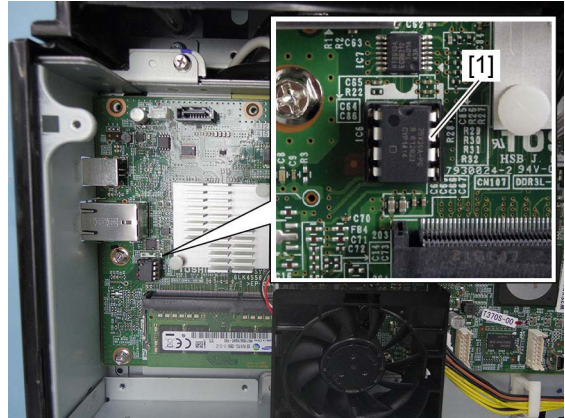

Fig. 9-36

Notes:

Be careful not to damage the SRAM when removing the SRAM from the SYS board.
When installing the SRAM, pay attention to the orientation. Install the SRAM with its concave portion up.

9.1.11 Main memory (DIMM)

Notes:

When the SYS board or main memory has been replaced, be sure to perform the calibration of memory.
When performing the calibration of memory, turn the power ON while pressing the [ENERGY SAVER] button.
When the equipment is started up normally, the calibration has been completed.
If the calibration is not performed, the equipment may be not started up normally.

- (1) Remove the SYS board cooling fan.
📖 P. 9-1 "9.1.2 SYS board cooling fan (F1)"
- (2) Take off the HDD unit.
📖 P. 9-2 "9.1.3 Hard disk (HDD)"
- (3) Release 2 latches and remove the main memory [1].

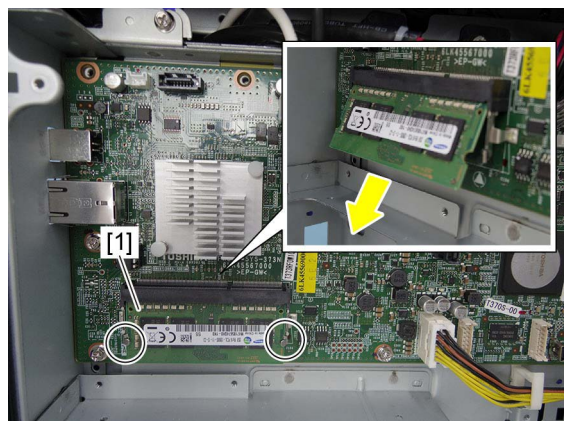



Fig. 9-37

9.1.12 EEPROM

- (1) Remove the rear cover.
 P. 4-10 "4.1.17 Rear cover"
- (2) Remove the EEPROM [1] from the LGC board.

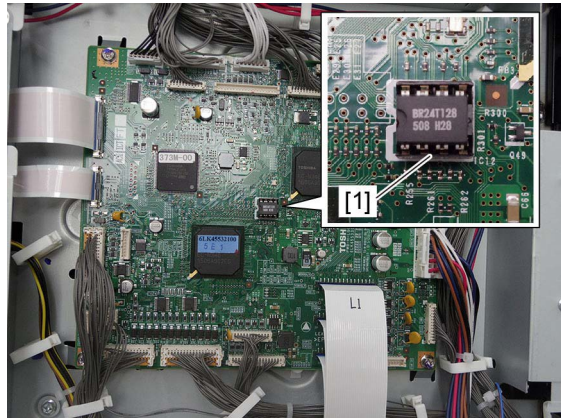



Fig. 9-38

Notes:

Be careful not to damage the EEPROM when removing it from the LGC board.
When installing the EEPROM, pay attention to the orientation. Install the EEPROM with its concave portion left.

9.1.13 PFC board

- (1) Remove the rear cover.
 P. 4-10 "4.1.17 Rear cover"
- (2) Disconnect 13 connectors from the PFC board.

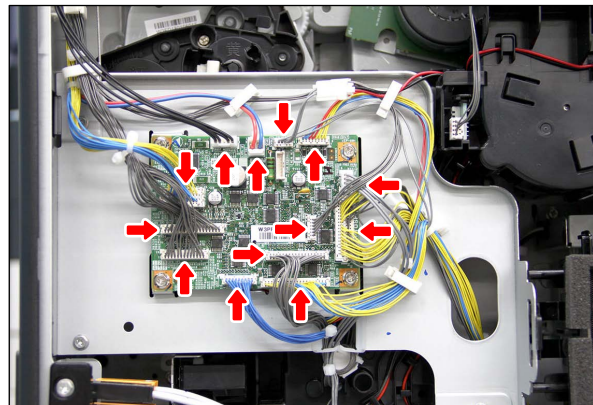

Fig. 9-39

- (3) Remove 4 screws and take off the PFC board [1].

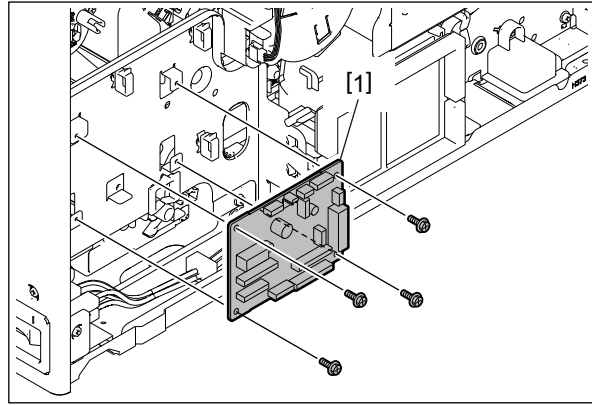

Fig. 9-40

9.1.14 DAMP board

Notes:

Be sure to unplug the power cable before starting this work.

If the DAMP board is not installed appropriately, a serious accident such as an electric shock may occur. Therefore, to avoid this, be sure to perform correct handling and installation.

- (1) Remove the rear cover.
P. 4-10 "4.1.17 Rear cover"
- (2) Disconnect 3 connectors from the DAMP board.

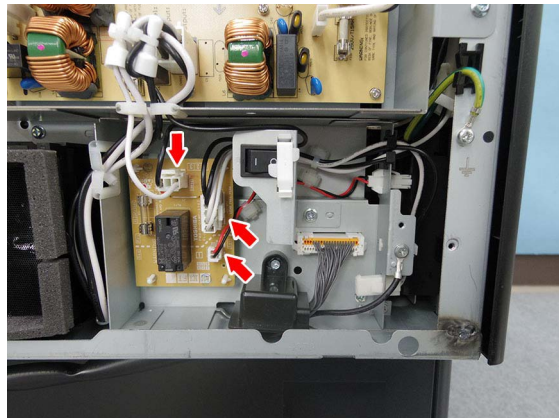

Fig. 9-41

- (3) Release 4 locking supports and remove the DAMP board [1].

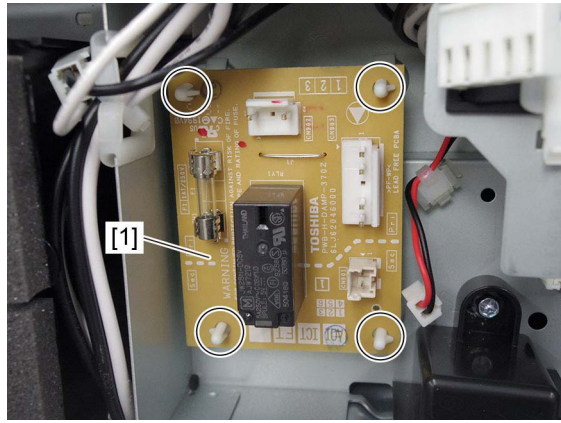

Fig. 9-42

9.1.15 CTIF board

- (1) Remove the toner motor assembly.
P. 4-148 “4.6.26 Toner motor assembly”
- (2) Disconnect 4 connectors [1], release 4 latches and then remove the CTIF board [2].

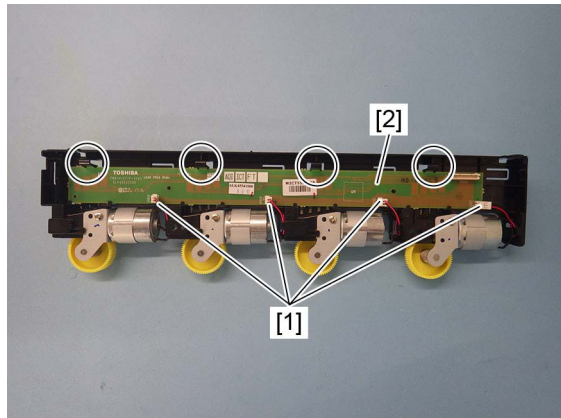

Fig. 9-43

9.1.16 DSDF I/F board

- (1) Remove the rear cover.
P. 4-10 "4.1.17 Rear cover"
- (2) Remove the SYS board cover.
P. 9-1 "9.1.1 SYS board cover"
- (3) Disconnect 1 connector.

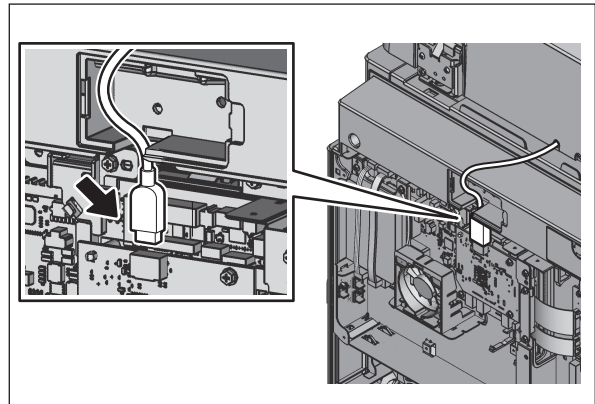

Fig. 9-44

- (4) Remove 2 screws and take off the DSDF I/F board.

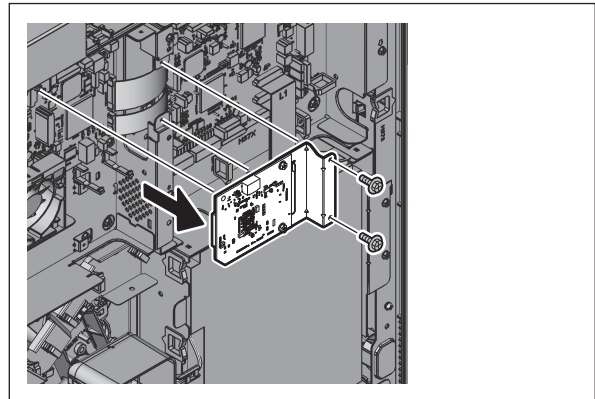







Fig. 9-45

9.2 Precautions, Procedures and Settings for Replacing PC Boards and HDD

9.2.1 Precautions when replacing PC boards

- The ID for each equipment is registered on the LGC board, the SYS board and Lens unit. So, if their replacement is required, be sure to replace only one board at a time. Do not replace the SYS board and the SRAM together.
- If both the LGC board and SYS board require replacement, replace them in the following procedure.
 1. First, replace one of the board to be replaced.
 2. Turn the power ON and confirm that “READY” is displayed.
 3. Turn the power OFF.
 4. Replace another board that requires replacement.
- When replacing the LGC board, remove the EEPROM on the old board, and then attach it to the new board.
- When the HDD requires replacement, see  P. 9-25 “9.2.3 Precautions and procedures when replacing the HDD”.
- When the SYS board requires replacement, see  P. 9-30 “9.2.4 Precautions and procedures when replacing the SYS board”.
- When the Lens unit requires replacement, see  P. 9-44 “9.2.8 Procedures and settings when replacing the lens unit”.
- When SRAM requires replacement, see  P. 9-34 “9.2.5 Precautions and procedure when replacing the SRAM”.
- When the DSP board requires replacement, see  P. 6-103 “6.13 Control Panel Calibration”.

9.2.2 HDD fault diagnosis

This code displays the HDD operation history, which is recorded in the HDD, on the control panel. HDD failure can be diagnosed or predicted with the information displayed.

1. Display

The following screen is displayed with setting code FS-08-9065. You can also refer to the same information by perform HS-75 > [SMART Info]

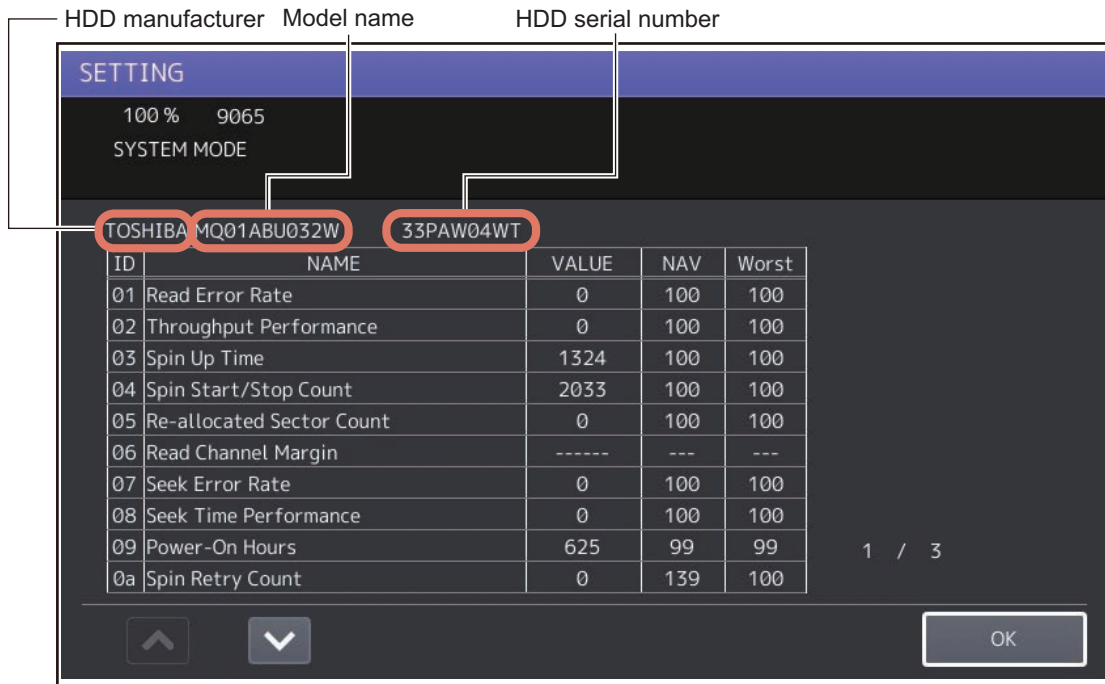

Fig. 9-46

- Items supported differ depending on the HDD manufacturer.
- "----" is displayed on the VALUE, NAV and Worst columns if items are not supported.

2. Usage

The combination of the values of ID=05 and c5 is used to diagnose whether or not the HDD has a physical failure when HDD failure is suspected (service call F100 to F109 or F120 to F122 or F124 occurred).

Result		Description	Diagnosis
ID	VALUE		
05	0	Low possibility of physical failure	HDD replacement is not required.
c5	0		
05	From 1 to 999	Defective sector has been reassigned and HDD is recovered.	HDD replacement is not required.
c5	0		
05	Any value	High possibility of defective sector existence. (There will be a possibility of physical failure depending on the use of HDD.)	HDD replacement is recommended.
c5	1 or more		
05	Either one is at least 1000.	High possibility of physical failure	HDD replacement is recommended.
c5			
05	All values are displayed as "-----".	High possibility of physical failure (A HDD connector, harness or SYS board may be one of the causes.)	HDD replacement is recommended.
c5			

3. ID=05 and c5

ID	Name	Description	Remarks
05	Re-allocated Sector Count	The number of sectors reassigned	This value tends to increase at HDD failure.
c5	Current Pending Sector Count	The number of candidate sectors to be reassigned	This value tends to increase at HDD failure.

4. Description of each ID

ID	Name	Meaning
01	Read Error Rate	This attribute is a measure of the read error rate.
02	Throughput Performance	This attribute is a measure of the throughput performance.
03	Spin Up Time	This attribute is a measure of how quickly the drive is able to spin up from a spun down condition.
04	Spin Start/Stop Count	This attribute is a measure of the total number of spin ups from a spun down condition.
05	Re-allocated Sector Count	This attribute is a measure of the total number of reallocated sectors.
07	Seek Error Rate	This is a measure of the seek error rate.
08	Seek Time Performance	This attribute is a measure of a drive's seek performance during normal online operations.
09	Power-On Hours	This attribute is a measure of the total time (hours or minutes depending on disk manufacturer) the drive has been on.
0a	Spin Retry Count	This attribute is a measure of the total number of spin retries.
0c	Power Cycle Count	This attribute is a measure of the number of times the drive has been turned on.
c0	Power off Retract Count	This attribute is a measure of the total number of emergency unloads.
c1	Load Cycle Count	This attribute is a measure of the total number of load/unloads.
c2	Temperature	This attribute is a measure of the temperature in the HDD.
c3	ECC On the Fly Count	This attribute is a measure of the total number of the ECC On the Fly.
c4	Reallocation Event Count	This attribute is a measure of the total number of the reallocation events.
c5	Current Pending Sector Count	This attribute is a measure of the total number of candidate sectors to be reallocated.
c6	Off-Line Scan Uncorrectable Sector Count	This attribute is a measure of the total number of uncorrectable sectors found during the off-line scan.
c7	Ultra DMA CRC Error Count (Rate)	This attribute is a measure of the total number of errors found in data transfer in the Ultra-DMA mode.
c8	Write Error Rate	This attribute is a measure of the write error rate.

Notes:

“Over-range” is displayed if the number of digits acquired from the HDD exceeds the maximum digits which can be displayed on the control panel; however, this does not indicate an error.

9.2.3 Precautions and procedures when replacing the HDD

Notes:

When the HDD is replaced, it is necessary to back up the data in the HDD before replacing and to recover them after replacing.
To maintain the security, ask users to perform the backup/restore for users' data/information in the HDD. The service technician can perform them only when users permit it.
Some data in the HDD cannot be backed up and can be kept only on the paper.
Do not replace the HDD and the SRAM together.
When the HDD is replaced, do not perform SRAM data formatting (Clear SRAM) before the normal start-up.
When the HDD is replaced, do not restore the back-up file before the normal start-up.

A procedure for replacing the HDD is shown below.

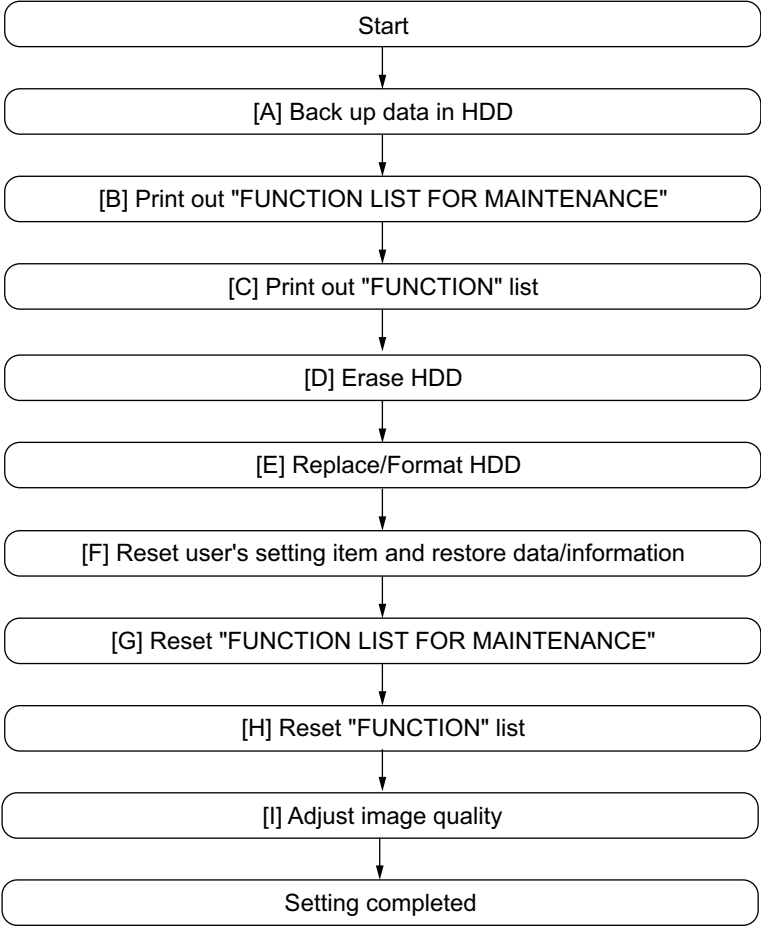

Fig. 9-47

[A] Back up in HDD

Ask the user (machine administrator) to back up the data in the HDD. Refer to the table below for the type of data, availability and method of backup.

Type of data in HDD	Availability	Backup method
Image data in the e-Filing	Available	Archive them in the "e-Filing" of TopAccess. As for the backup in Box data, all data (selectable by the box) can be backed up / restored in one go by using "e-Filing Backup/Restore Utility".
F-code information, Template registration information, Address book data	Available	Export them in the [Administration] tab - [Maintenance] - [Export] of TopAccess.
User information, Combined information (User information + Role + Group), LDAP Role, Department information, Project code	Available	Export them in the [Administration] tab - [Export/Import] - [Export] of TopAccess.
Log data (Print, Scan, FAX (Transmission/Reception))	Available	Export them in the "Administrator" menu of TopAccess. (Import cannot be performed.)
Data in the shared folder (Scanned data, Saved data of copy / FAX transmission)	Available	Copy them to the client computer via the network. (The data which have been copied to the client computer cannot be copied to the shared folder.)
Print waiting data (Copying data and FAX reception data that are waiting to be printed due to the paper run-out and jam, etc.)	Not available	Finish printing them after supplying paper or releasing the jam, etc. (The data cannot be left.)
Print job (Private print data, Schedule print data)	Not available	If any jobs are left, print them. (The data cannot be backed up.)
FAX saved data (Confidential / Bulletin board data)	Not available	Print them. (The data cannot be backed up.)
Registration data for FAX transmission (Delayed transmission / Recovery transmission)	Not available	The data cannot be backed up.

[B] Print out "FUNCTION LIST FOR MAINTENANCE"

- (1) Perform FS-12 (12 FAX LIST PRINT MODE).
- (2) Select "Function list for Maintenance" and then press [PRINT].

[C] Print out "FUNCTION" list

- (1) Press [USER FUNCTIONS] on the [HOME] screen.
- (2) Enter the password in [Administrator] tab and press [OK].

Notes:

Explain the procedure to the user (machine administrator) and ask him/her to enter his/her password.

- (3) Press [LIST/REPORT] and then [LIST].
- (4) Press [FUNCTION]. The "FUNCTION LIST" is printed out.

[D] Erase HDD

In case of the Secure HDD:

- (1) Perform HS-74 > [Revert Factory Initial Status HDD] and then press [OK].
- (2) Turn the power OFF.

In case of Normal HDD:

- (1) Perform HS-73 > [Erase HDD Security] and then press [OK].
- (2) Select any of "LOW", "MEDIUM", "HIGH" or "SIMPLE" and then press [OK].
- (3) Turn the power OFF.

[E] Replace / Format HDD

- (1) Confirm that the power is turned OFF.
- (2) Replace the HDD.
(Refer to  P. 9-2 "9.1.3 Hard disk (HDD)".)
- (3) Create the partitions on the HDD.
 1. Perform HS-73 > [Format HDD] and then press [OK].
 2. When "Operation Complete" is displayed on the LCD, creating of the partitions is completed.

Remarks:

When HS-[73 Firmware Assist]-[HDD Data Restore] is carried out instead of step (3), perform [HDD Data Restore] and then the following steps in [E].

(4) > (5) > (6) > (9) > (10) > (11) > (12)

In addition, skip [F] and perform the procedure from [G].

- (4) Turn the power OFF.
- (5) Format the service password.
 1. Perform HS-73 > [Clear Service Tech Password] and then press [OK].
 2. When "Reset Complete" is displayed on the LCD, formatting of the service tech password is completed.
- (6) Turn the power OFF.
- (7) Update the system software using the USB device.
See " P. 11-2 "11.2 Firmware Updating with USB Device"" for details.
- (8) Turn the power OFF.
- (9) When the Fax Board (GD-1370) is installed, perform [CUSTOM INITIALIZE] > [INIT MEMORY(FAX)] and [CLEAR DATA] in the FS-11 FAX CLEAR MODE. Then turn the power OFF.
- (10) Check the system software version (08-8952).
Confirm the version displayed on the LCD, and then press [OK].
- (11) Initialization of NIC information (08-9083).
- (12) Turn the power OFF.

[F] Reset user's setting items and restore data/information

Ask the user (machine administrator) to reset the user's setting items and to restore data or information. Refer to the following for the reset and restore:

Items to reset/restore	Method
Printer driver	Upload them in the "Administrator" menu of TopAccess.
F-code information, Template registering information, Address book data	Import them in the [Administration] tab - [Maintenance] - [Import] of TopAccess.
User information, Combined information (User information + Role + Group), LDAP Role, Department information, Project code	Import them in the [Administration] tab - [Export/Import] - [Import] of TopAccess.
Image data in the e-Filing	Upload them in the "e-Filing" of TopAccess.

Notes:

- When the SSL is enabled, perform the setting of the following items again with "Self-signed certificate" of TopAccess.
 - Country/Region Name
 - State or Province Name
 - Locality Name
 - Organization Name
 - Organizational Unit Name
 - Common Name
 - Email Address
- When the wireless LAN is used, recreate its setting. (only when security with a certificate is used) Also, upload the following certificate file with "Install Certificate for Wireless LAN" of TopAccess.
 - CA certificate (PEM)
 - CA certificate (DER)

[G] Reset "FUNCTION LIST FOR MAINTENANCE"

- (1) Print out the "FUNCTION LIST FOR MAINTENANCE" list before formatting the HDD. For how to print it out, refer to [B]Print out "FUNCTION LIST FOR MAINTENANCE".
- (2) Perform FS-13 (13 FAX FUNCTION MODE).
- (3) Compare the lists which were printed before and after the formatting to check the setting items having the different setting values. Set the value which was set before the formatting.
- (4) Turn the power OFF.

[H] Reset "FUNCTION" list

Reset the fax function by referring to the "function list" that was printed out in [C]Print out "FUNCTION" list.



- (1) Press [USER FUNCTIONS] on the [HOME] screen.
- (2) Press [ADMIN], enter the password, and then press [OK].

Notes:

Explain the user (machine administrator) about the next operation and ask him/her to enter his/her password.

- (3) Press [FAX] and then [TERMINAL ID] to set each item.
- (4) Press [INITIAL SETUP] to set each item.

[I] Adjust image quality

- (1) Perform “Automatic gamma adjustment (PPC)” (FS-05-7869).
 P. 6-28 “6.2.1 Automatic gamma adjustment”
- (2) Perform “Automatic gamma adjustment (PRT)” (FS-05-8008, 8009).
 P. 6-55 “6.3.1 Automatic gamma adjustment”
- (3) Turn the power OFF.

9.2.4 Precautions and procedures when replacing the SYS board

A procedure for SYS board replacement is shown below.

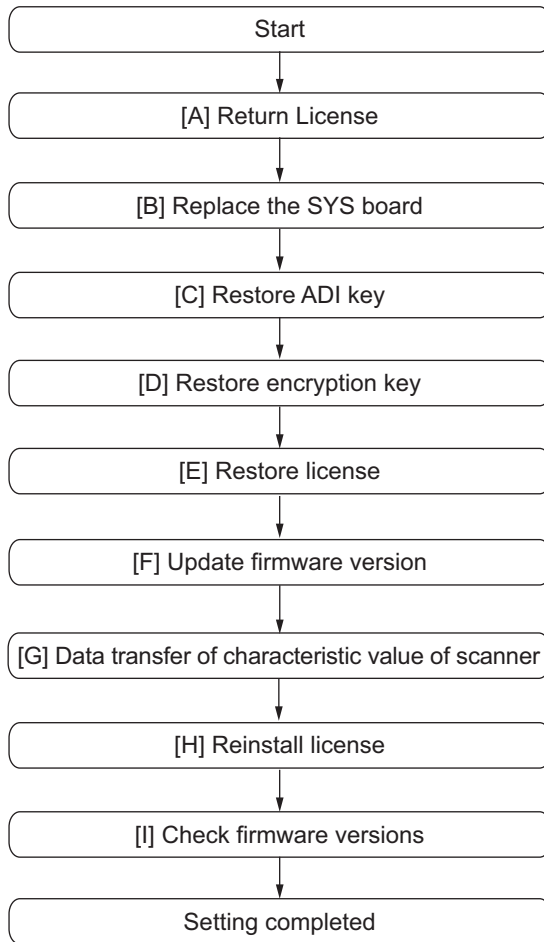

Fig. 9-48

Notes:

- [C] is required only for the equipment in which the Secure HDD has been installed.
- It is required to perform HDD formatting in equipment with the High Security Mode enabled. Therefore, perform the following items which are carried out at the HDD replacement in advance.
 - 📖 P. 9-26 “[A] Back up in HDD”
 - 📖 P. 9-26 “[B] Print out “FUNCTION LIST FOR MAINTENANCE””
 - 📖 P. 9-26 “[C] Print out “FUNCTION” list”
- Do not perform the following steps in [C] in the equipment with the High Security Mode enabled.

[A] Return License

Notes:

- If the 08 Setting Mode is not started up, “[A]Return License” can be omitted. In that case, reinstall the license with “[1]Re-registration when the board is replaced” if it is cleared since “[H] Reinstallation of License” cannot be performed.
- When installing the Data Overwrite Enabler (GP-1070) and security mode is setting High Security, set the security mode level to “1” (Low level). Then restart the equipment.

- (1) Perform FS-08-3840.
- (2) Select the license to be returned, and then press [REMOVE].
- (3) Install the one-time dongle, which you used for uploading the selected license, in the equipment, and then press [OK].
- (4) The Remove screen is displayed, then press [YES]. If this screen is not displayed, check whether the one-time dongle is installed in the equipment properly.
- (5) After 10 to 40 seconds passes, the screen for notifying the success of performance is displayed. Then press [OK]. If this screen is not displayed or the screen for notifying the failure of performance is displayed, quit this operation by pressing [NO]/[CLOSE]. Then, check whether the one-time dongle, which you used for uploading the selected license, is installed in the equipment.
- (6) Check that the returned license is not displayed on the screen.

Remarks:

- If there are any other licenses to be returned, repeat from step (2).
- If there is no more licenses to be returned, press [CLOSE], and then turn the power OFF.

[B] Replace the SYS board

Notes:

Before replacing the SYS board, perform the following procedure.

 P. 9-22 “9.2.1 Precautions when replacing PC boards”

- (1) Confirm that the power is turned OFF.
- (2) Replace the SYS board.
- (3) Install main memory (DIMM) to the new SYS board (from the old SYS board).
- (4) Install SRAM to the new SYS board (from the old SYS board).

Notes:

When the combination of the main memory and the SYS board has been changed by replacing either of them, it is necessary to perform the calibration of the main memory at the next startup. To perform the calibration of the main memory, start up the equipment while pressing the [ENERGY SAVER] button.

E.g.:

To start up HS Menu, turn the power ON by pressing the [ON/OFF] button while pushing the [HOME], [START] and [ENERGY SAVER] buttons simultaneously.

[C] Restore ADI key

If the Secure HDD is installed, follow the steps below. To confirm the type of device, start up the equipment in the HS-74.

Notes:

Do not perform the following steps in  P. 9-32 “[C] Restore ADI key” in the equipment with the High Security Mode enabled.

- (1) Perform HS-73.
- (2) Press [Key Backup/Restore].
- (3) Press [ADIKey], and then press [Execute].
- (4) Wait until the restoring of the ADI key is completed. “Success” is displayed.
- (5) Turn the power OFF.

[D] Restore encryption key

- (1) Perform HS-73.
- (2) Press [Key Backup/Restore].
- (3) Press [Key], and then press [Execute].
- (4) Wait until the restoring of the encryption key is completed. “Success” is displayed.
- (5) Restart the equipment after the restoring is completed. If you want to perform the restoring of the license, do not restart the equipment but perform from (2) in “[E] Restore license”.

[E] Restore license

- (1) Perform HS-73.
- (2) Press [Key Backup/Restore].
- (3) Press [License] and then [Execute].
- (4) Wait until the restoring of the license is completed. “Success” is displayed.
* Confirm that “OK” is indicated in all of the FROM column and then reboot the equipment.



Notes:

For equipment with the High Security Mode enabled, continue by performing the following steps.

1. Create the partitions on the HDD.
 1. Perform HS-73 > [Format HDD] and then press [OK].
 2. When “Operation Complete” is displayed on the LCD, creating of the partitions is completed.
2. Turn the power OFF.
3. Format the service password.
 1. Perform HS-73 > [Clear Service Tech Password] and then press [OK].
 2. When “Reset Complete” is displayed on the LCD, formatting of the service tech password is completed.
4. Turn the power OFF.
5. Update the system software using a USB device.
6. Turn the power
7. When the Fax Board (GD-1370) is installed, perform [CUSTOM INITIALIZE] > [INIT MEMORY(FAX)] and [CLEAR DATA] in the FS-11 FAX CLEAR MODE. Then turn the power OFF.
8. Check the system software version (FS-08-8952).
Confirm the version displayed on the LCD and then press [OK].

9. Format the NIC information (FS-08-9083).
10. Turn the power OFF.
11. Perform the procedure in “12.4.3 Procedure for entering the High Security Mode”.

[F] Update firmware version

- (1) Update the version of system firmware using the USB device.
 P. 11-2 “11.2 Firmware Updating with USB Device”
- (2) Update the version of scanner firmware with the USB device.
 P. 11-2 “11.2 Firmware Updating with USB Device”

[G] Data transfer of characteristic value of scanner

- (1) Perform FS-05-3203.
- (2) Turn the power OFF.

[H] Reinstall license

If the license was returned “[A]Return License”, reinstall it with the following procedure.

- (1) Perform FS-08-3840.
- (2) Press [INSTALL].
- (3) Install the one-time dongle in the equipment (the one which you used for returning the selected license before replacing the equipment). Then press [OK].
- (4) Select the license to be installed, and then press [INSTALL].
- (5) The screen for notifying that the installation will be started is displayed. Then press [YES].
- (6) After 10 to 40 seconds have passed, the screen for notifying the success of the performance is displayed. Then press [OK]. If the screen for notifying a failure of the performance is displayed, quit this operation by pressing [NO]. Then check that the one-time dongle is installed properly in the equipment.
- (7) Check that the installed license is displayed on the license list.

Remarks:

If there are any other licenses to be installed, repeat from step (2). If there are no other licenses to be installed, press [CLOSE], and then turn the power OFF.

[I] Check firmware versions

- System firmware version (FS-08-9930)
- Scanner firmware version (FS-08-9902)

Notes:

If the security mode is changed from High Security to Low Security in the step “[A] Return License”, set the value of FS-08-8911 to “3” (High Security).

9.2.5 Precautions and procedure when replacing the SRAM

Notes:

Do not replace the HDD and the SRAM together.

Be careful not to damage the board when replacing the SRAM.

When the SRAM is replaced, do not perform HDD partition creation (Format HDD) before the normal start-up.

A procedure for replacing the SRAM is shown below.

When disposing of the SRAM, perform the items in [P. 9-47](#) “9.3.4 Precautions when disposing of the SRAM”.

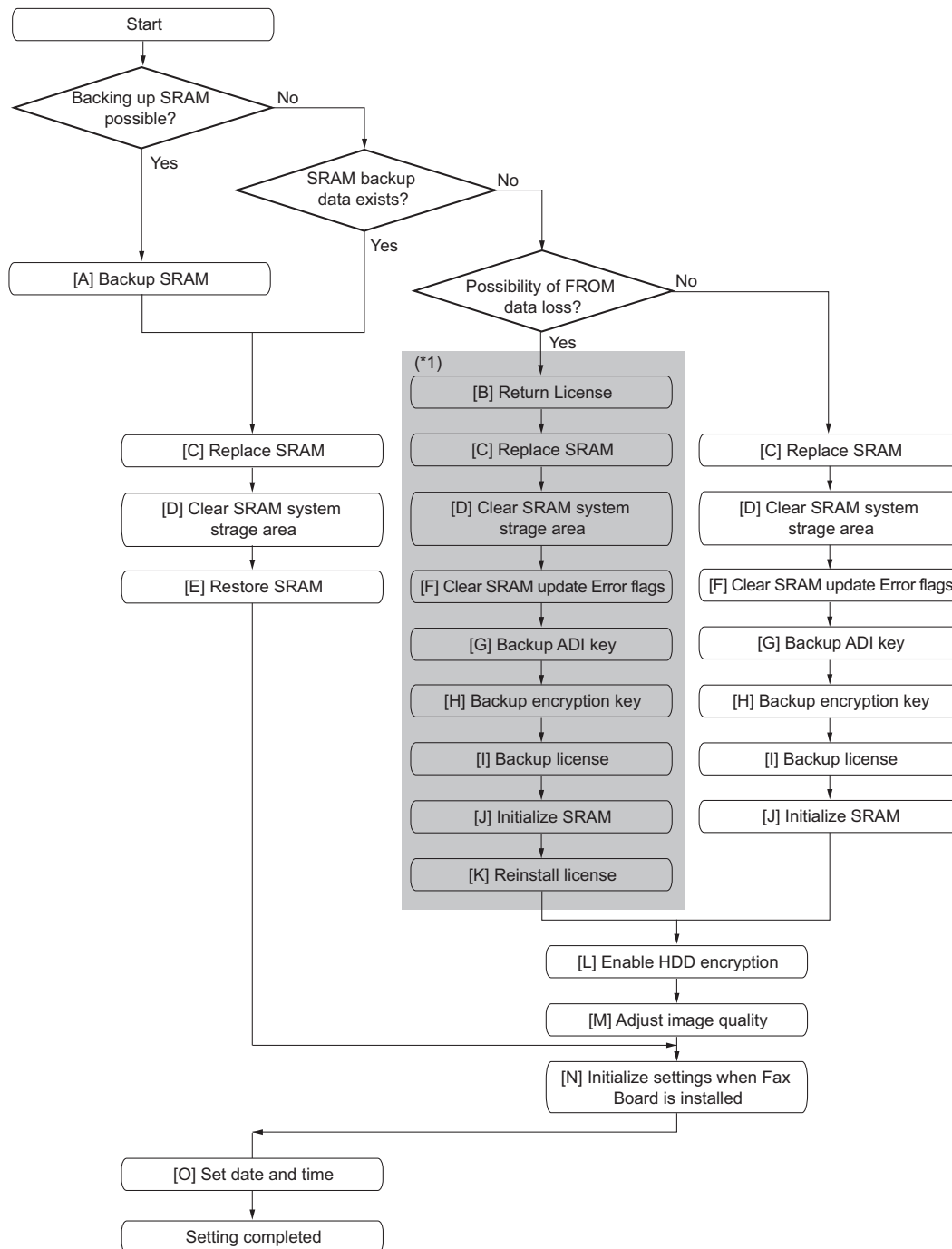



Fig. 9-49

Notes:

- [G], [H] and [I] are required only for the equipment in which the Secure HDD has been installed.
- [H] and [I] are required only for the equipment in which a Normal HDD has been installed.
- Use the flow (*1) when securely returning and reinstalling the license. Returning and reinstalling the license is required when it has been lost. The examples are as below.
 - E.g. 1: When SRAM data are overwritten on the FROM mistakenly due to an incorrect operation during the backup of the license
 - E.g. 2: When the SYS board (SRAM) is damaged or the license data in the FROM are broken

[A] Backup SRAM

Perform a backup before replacing the SRAM.

 P. 12-2 “[A] Backup procedure”

Notes:

- If “[A]Backup SRAM” fails, proceed to “[B]Return License”.
- If “[A]Backup SRAM” succeeds, proceed to “[C]Replace SRAM”.

[B] Return License**Notes:**

When installing the Data Overwrite Enabler (GP-1070) and the security mode is set to High Security, set the security mode level to “1” (Low level). Then restart the equipment.

- (1) Perform FS-08-3840.
- (2) Select the license to be returned, and then press [REMOVE].
- (3) Install the one-time dongle, which you used for uploading the selected license, in the equipment, and then press [OK].
- (4) The Remove screen is displayed, then press [YES]. If this screen is not displayed, check whether the one-time dongle is installed in the equipment properly.
- (5) After 10 to 40 seconds passes, the screen for notifying the success of performance is displayed. Then press [OK]. If this screen is not displayed or the screen for notifying the failure of performance is displayed, quit this operation by pressing [NO]/[CLOSE]. Then, check whether the one-time dongle, which you used for uploading the selected license, is installed in the equipment.
- (6) Check that the returned license is not displayed on the screen.

Remarks:

- If there are any other licenses to be returned, repeat from step (2).
- If there is no more licenses to be returned, press [CLOSE], and then turn the power OFF.

[C] Replace SRAM

- (1) Confirm that the power is turned OFF.
- (2) Take off the Fax Board (GD-1370) if it is installed.
- (3) Replace the SRAM.
 P. 9-17 “9.1.10 SRAM”

[D] Clear SRAM system storage area

- (1) Perform HS-76.
The authentication screen appears. Press [OK]. (Entry of a password is unnecessary.)
- (2) When “SRAM Clear Mode” appears on the LCD, press the [Clear SRAM].
- (3) When “SRAM Format Completed” is displayed on the LCD, initializing is completed.
- (4) Turn the power OFF.

[E] Restore SRAM

- (1) Perform HS-76.
- (2) When “SRAM Clear Mode” appears on the LCD screen, press [Set Serial Number].
- (3) Key in the serial number printed on the label attached to the rear cover of the equipment and then press [OK].
- (4) “Set Serial Number was completed.” is displayed.
- (5) Turn the power OFF.
- (6) If there are SRAM backup data, perform restoring.
 P. 12-3 “[B] Restore procedure”
- (7) Turn the power OFF after the restoring of SRAM is completed.

Remarks:

When the restoration is completed successfully, proceed to “ P. 9-39 “[N] Initialize settings when FAX Board (GD-1370) is installed””.

[F] Clear Software Update Error Flag

- (1) Perform HS-73.
- (2) Press [Clear Software Update Error Flag].
- (3) When “Operation Complete” is displayed on the LCD, clearing the flag is completed.
- (4) Turn the power OFF.

[G] Backup ADI key (FROM > SRAM)

If the Secure HDD is installed, follow the steps below.

- (1) Perform HS-73.
- (2) Press [Key Backup/Restore].
- (3) Press [ADIKey] twice and then [Execute].
- (4) Wait until the backup of the ADI key is completed. “Success” is displayed.
- (5) Restart the equipment after the backup is completed.
If you want to perform the backup of the encryption key, do not restart the equipment but perform from (2) in “ P. 9-37 “[H] Backup encryption key (FROM > SRAM)””.
- (6) Turn the power OFF.

[H] Backup encryption key (FROM > SRAM)

- (1) Perform HS-73.
- (2) Press [Key Backup/Restore].
- (3) Press [Key] twice and then [Execute].
- (4) Wait until the backup of the encryption key is completed. "Success" is displayed.
- (5) Restart the equipment after the backup is completed. If you want to perform the backup of the license, do not restart the equipment but perform from (3) in  P. 9-37 "[I] Backup license (FROM > SRAM)".
- (6) Turn the power OFF.

[I] Backup license (FROM > SRAM)**Notes:**

If "License SRAM to FROM" is performed by mistake, carry out the following procedure.
 P. 9-45 "[1] Re-registration when the board is replaced"

- (1) Perform HS-73.
- (2) Press [Key Backup/Restore].
- (3) Press [License] twice and then [Execute].
- (4) Wait until the backup of the license is completed. "Success" is displayed.
- (5) Restart the equipment after the backup is completed.
- (6) Turn the power OFF.
* After the restoring is completed, check that "OK" is indicated in SRAM column. Then, restart the equipment.

[J] Initialize SRAM

- (1) Perform FS-08.
- (2) Initialize the SRAM.
 1. When "SRAM REQUIRES INITIALIZATION" is displayed on the LCD, check the destination and then press the [START] button.
If the destination is not correct, key in the correct one and then press the [START] button.
 2. After the confirmation message is displayed, press [OK].
- (3) Perform the initialization at the software version upgrade (FS-08-9030).
- (4) Initialize the NIC information (FS-08-9083).
- (5) Enter the serial number (FS-08-9601).
Key in the serial number on the label attached to the rear cover of the equipment, and then press [OK].
- (6) Turn the power off.

[K] Reinstall license

If the license was returned in “[B]Return License”, reinstall it with the following procedure.

- (1) Perform FS-08-3840.
- (2) Press [INSTALL].
- (3) Install the one-time dongle in the equipment (the one which you used for returning the selected license before replacing the equipment). Then press [OK].
- (4) Select the license to be installed, and then press [INSTALL].
- (5) The screen for notifying that the installation will be started is displayed. Then press [YES].
- (6) After 10 to 40 seconds have passed, the screen for notifying the success of the performance is displayed. Then press [OK]. If the screen for notifying a failure of the performance is displayed, quit this operation by pressing [NO]. Then check that the one-time dongle is installed properly in the equipment.
- (7) Check that the installed license is displayed on the license list.

Remarks:

- If there are any other licenses to be installed, repeat from step (2).
- If there are no other licenses to be installed, press [CLOSE], and then turn the power OFF.

[L] Enable HDD encryption



If the HDD encryption function is used, follow the procedure below.

Notes:

When the installation of the license of the Data Overwrite Enabler (GP-1070) is required, be sure to do this before HDD encryption is performed. However, it is not necessary to do so for the models (NAD) in which the Data Overwrite Enabler (GP-1070) is installed as a standard.

- (1) Perform FS-08-8911.
- (2) Enable the encryption function.
 - For enabling HDD encryption only
Set the value of FS-08-8911 to “1”, and then set the value of FS-08-9379 to “1” (Security priority) or “2” (Performance priority).
 - For high security mode
Set the value of FS-08-8911 to “3”.
- (3) Turn the power OFF.

[M] Adjust image quality

- (1) Perform “Data transfer of characteristic value of scanner” (FS-05-3203).
- (2) Perform “Automatic gamma adjustment” <PPC> (FS-05-7869).
 P. 6-28 “6.2.1 Automatic gamma adjustment”
- (3) Perform “Automatic gamma adjustment” <PRT> (FS-05-8008/8009).
 P. 6-55 “6.3.1 Automatic gamma adjustment”
- (4) Turn the power OFF.

[N] Initialize settings when FAX Board (GD-1370) is installed

- (1) Reinstall the FAX Board (GD-1370).
- (2) Set the destination of FAX (FS-08-9001).
- (3) Turn the power OFF.
- (4) Perform FS-11 > CUSTOM INITIALIZE > INIT MEMORY(FAX).
- (5) Turn the power OFF and then back ON.
- (6) Set the dial type according to these buttons: [HOME] > [USER FUNCTIONS] > [ADMIN] > [FAX] > [INITIAL SETUP]

[O] Set date and time

Set the date and time according to these buttons.

[HOME] > [USER FUNCTIONS] > [ADMIN] > [GENERAL] > [CLOCK] > [DATE/TIME]

9.2.6 Procedures when replacing the LGC board

Be sure to follow the procedure below when replacing the LGC board.

- (1) Turn the power OFF.
- (2) Remove the LGC board.
 P. 9-7 "9.1.6 LGC board"
- (3) Install the removed LGC board's EEPROM into the new LGC board.
- (4) Attach the new LGC board.

9.2.7 Procedures and settings when replacing EEPROM (for LGC board)

Notes:

Be careful not to damage the EEPROM when replacing the EEPROM.

A procedure for replacing the EEPROM is shown below.

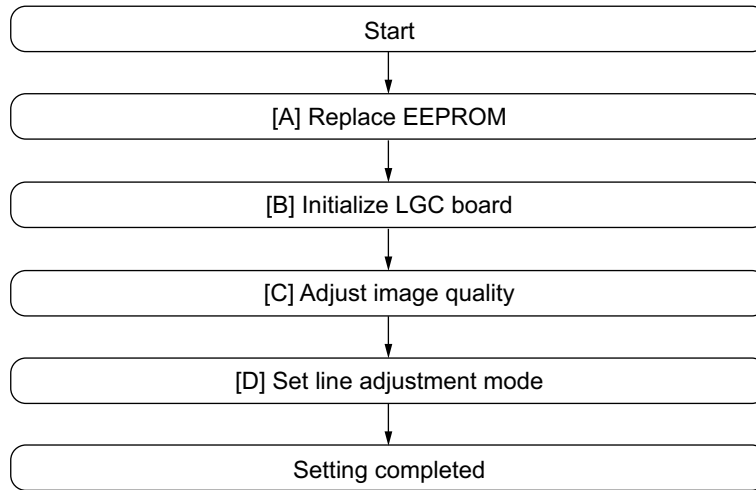



Fig. 9-50

[A] Replace SRAM

- (1) Confirm that the power is turned OFF.
- (2) Replace the EEPROM.
 P. 9-18 "9.1.12 EEPROM"

[B] Initialize LGC board

- (1) Open the front cover, and check the destination printed on the white tape stuck on the equipment.
- (2) Perform "Destination display at SRAM initialization" (FS-08-9060).

- (3) Check whether the displayed destination (see the below figure) of the SRAM is the same as the one in step (1).

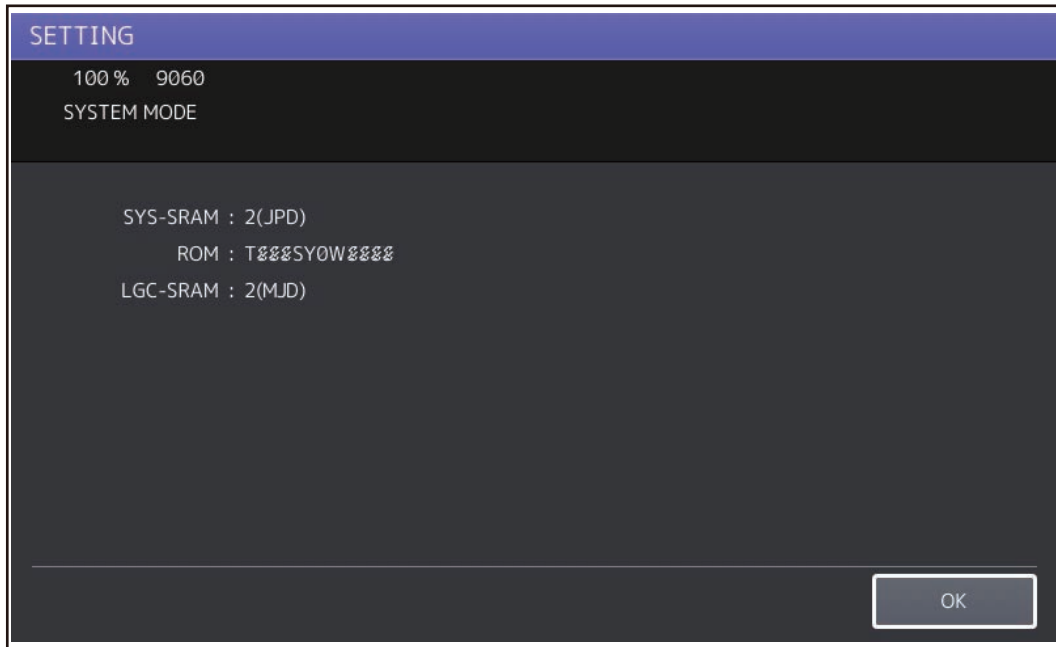

Fig. 9-51

Remarks:

If the destinations are different, initialize the SRAM with reference to the following procedure.
📖 P. 9-34 “9.2.5 Precautions and procedure when replacing the SRAM”

- (4) Perform “Printer all clear” (FS-08-9090).

Notes:

Perform FS-08-9090 only when the EEPROM on the LGC board is replaced. Do not perform this code in other cases.

- (5) Press [INITIALIZE] to perform the initialization of the EEPROM.

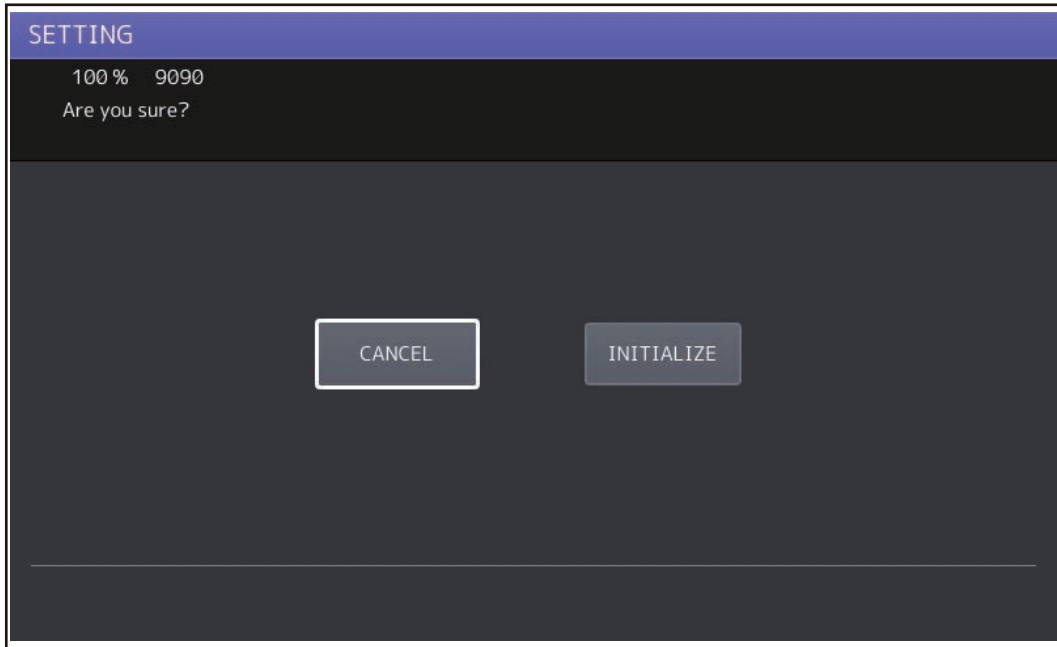

Fig. 9-52

- (6) Perform “Destination display at SRAM initialization” (FS-08-9060), and check whether the same destinations are displayed for the SRAM and the LGC board.

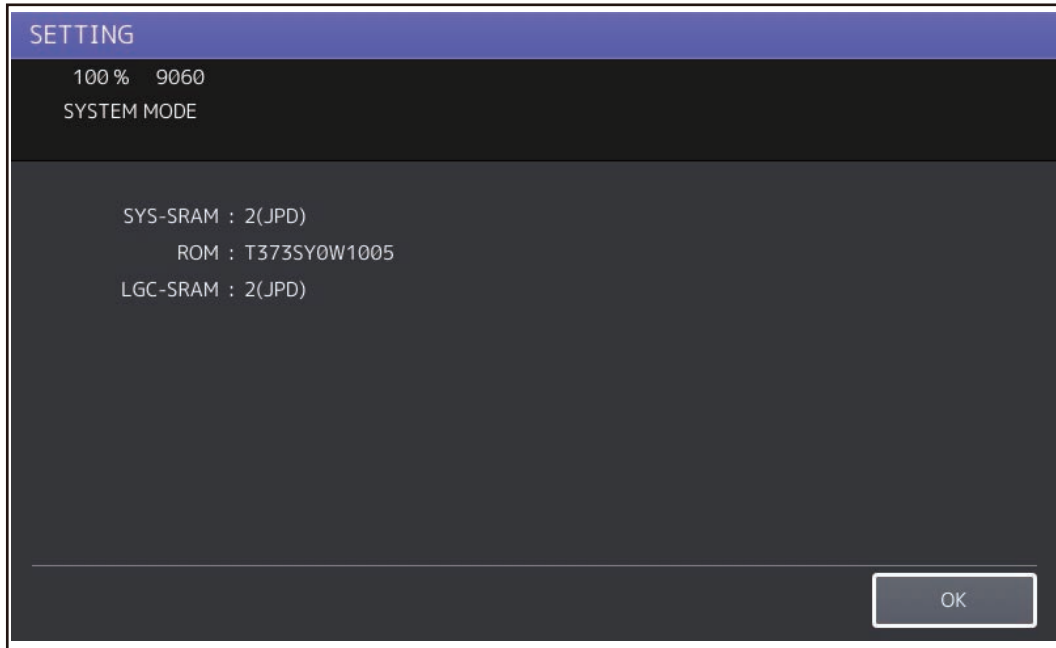

Fig. 9-53

Remarks:

If an error occurs during the initialization of the LGC board and the initialization fails, error messages are displayed on the touch panel. The error messages and the corresponding troubleshooting methods are shown below.

Error message	Troubleshooting
UNDEFINED MODEL	Since the LGC board probably has a problem, replace it with a new one by following the procedure below. 📖 P. 9-7 “9.1.6 LGC board”
UNDEFINED VERSION	Recheck the destination of the SRAM. Since the SRAM probably has a problem, replace it with a new one by following the procedure below. 📖 P. 9-17 “9.1.10 SRAM”
VERIFY ERROR	Check whether the EEPROM (for the LGC board) is connected properly.

[C] Adjust image quality

- (1) Write down the adjustment values of the following code attached to the rear side of the front cover.





	L (0)	H (1)
FS-05-2627		
FS-05-2628		
FS-05-2629		
FS-05-2630		

- (2) Perform FS-05-2627 ~ 2630 and then enter all the adjustment values written down in step (1).

- (3) Reset the auto toner sensor.
 1. Turn the power OFF.
 2. Replace the developer materials for four colors (YMCK).
 3. Perform automatic adjustment of auto-toner sensor (FS-05-2400).

Notes:

- You can reset the auto-toner sensor by directly entering the adjustment values for FS-05-2405-0 to 3 with the Adjustment mode data list, which has been printed during normal operation of equipment such as when it is setup, when preventive maintenance (PM) is performed or when developer material is replaced, etc.
- If you perform automatic adjustment (FS-05-2400) of the auto-toner sensor without replacing the developer materials for four colors (YMCK), image quality is not guaranteed.

- (4) Perform the “Forced performing of image quality closed-loop control (FS-05-2742)”.
- (5) Perform the enforced position adjustment (FS-05-4719).
- (6) Perform printer related adjustment and scanner related adjustment.
 -  P. 6-12 “6.1.7 Image dimensional adjustment at the printing section”
 -  P. 6-20 “6.1.8 Image dimensional adjustment at the scanning section”
- (7) Perform “Automatic gamma adjustment” <PPC> (FS-05-7869).
 -  P. 6-28 “6.2.1 Automatic gamma adjustment”
- (8) Perform “Automatic gamma adjustment” <PRT> (FS-05-8008/8009).
 -  P. 6-55 “6.3.1 Automatic gamma adjustment”

Notes:

Usually, it is only necessary to perform automatic gamma adjustment for [Plain paper]; however if other paper is used, perform automatic gamma adjustment per paper type.

[D] Set line adjustment mode

- (1) Turn the power OFF.
- (2) Perform FS-08-9010.
- (3) Set “Line adjustment mode” to “0: For factory shipment”.

Notes:

Since “1: For line” is set for “Line adjustment mode” in [B] Initialize LGC board in EEPROM (for LGC board) supplied as a service part, number of prints is not counted unless it is changed.

9.2.8 Procedures and settings when replacing the lens unit

When replacing the lens unit, follow the procedure below.

- (1) Confirm that the power is turned OFF.
- (2) Replace the lens unit.
 -  P. 4-29 “4.3.5 Lens unit/CCD driving PC board”
- (3) Perform “Data transfer of characteristic value of scanner / SYS board > Lens unit (FS-05-3209)”.
- (4) Perform “Shading correction plate Automatic dust detection adjustment (FS-05-3218)”.
- (5) Turn the power OFF.

9.2.9 Firmware confirmation after the PC board/HDD replacement

After replacing the PC board/HDD, check the firmware version in the 08 Setting Mode and confirm if the firmware combination is correct.

Firmware	Code
System software	9900
System firmware	9930
Engine firmware	9901
Scanner firmware	9902
NIC firmware	9990
DF firmware	9903
Finisher firmware	9904
Hole punch firmware	9944
FAX board firmware(Line1)	9905
FAX board firmware(Line2)	9969

The installed ROM versions and the registered optional Electronic License Keys can be confirmed in the list print mode following the procedure below.

- (1) Perform [FS-30-111] to print out VERSION LIST.
* It is recommended to keep this list for future reinstallation such as the replacement of the SYS board.
- (2) Shut down the equipment.

9.2.10 License re-registration using the one-time dongle

[1] Re-registration when the board is replaced

The license registered using the one-time dongle can be re-registered only in the same equipment. When the SYS board or SRAM is replaced, follow the procedures for re-registration given below.

- (1) Perform FS-08-3840.
- (2) Press [INSTALL].
- (3) Install the one-time dongle in the equipment (the one which you used for registering the selected license), and then press [OK].
- (4) Select the license to be installed, and then press [INSTALL].
- (5) The screen for notifying that the installation will be started is displayed. Then press [YES].
- (6) After 10 to 40 seconds have passed, the screen for notifying the success of the performance is displayed. Then press [OK]. If the screen for notifying a failure of the performance is displayed, quit this operation by pressing [NO]. Then check that the one-time dongle, which you used for uploading the selected license, is installed in the equipment.
- (7) Check that the installed license is displayed on the license list.

Remarks:

If there are any other licenses to be returned, repeat from step (2). If there are no other licenses to be returned, press [CLOSE], and then turn the power OFF.

Notes:

This procedure is available only with the one-time dongle used for the previous registration, since the model information registered in it is utilized. Use the same one-time dongle and the equipment when registering the license.

[2] Re-registration when the equipment is replaced due to malfunction

When the equipment has to be replaced due to a malfunction, return the license registered in the equipment to the one-time dongle and register it to the new equipment following the procedure below.

Notes:

It is not possible to re-register the license for the IPsec Enabler (GP-1080) into other equipment.

- (1) Perform FS-08-3840.
- (2) Select the license to be returned, and then press [REMOVE].
- (3) Install the one-time dongle in the equipment (the one which you used for uploading the selected license), and then press [OK].
- (4) The Remove screen is displayed. Then press [YES].
If this screen is not displayed, check that the one-time dongle is installed in the equipment properly.
- (5) After 10 to 40 seconds have passed, the screen for notifying the success of the performance is displayed. Then press [OK].
If the screen for notifying a failure of the performance is displayed, quit this operation by pressing [NO]. Then check that the one-time dongle, which you used for uploading the selected license, is installed in the equipment.
- (6) Check that the returned license is not displayed on the screen.

Remarks:

If there are any other licenses to be returned, repeat from step (2).

If there are no other licenses to be returned, press [CLOSE], and then turn the power OFF.

- (7) Replace the equipment.
- (8) Perform FS-08-3840.
- (9) Press [INSTALL].
- (10) Install the one-time dongle in the equipment (the one which you used for returning the selected license before replacing the equipment). Then press [OK].
- (11) Select the license to be installed, and then press [INSTALL].
- (12) The screen for notifying that the installation will be started is displayed. Then press [YES].
- (13) After 10 to 40 seconds have passed, the screen for notifying the success of the performance is displayed. Then press [OK]. If the screen for notifying a failure of the performance is displayed, quit this operation by pressing [NO]. Then check that the one-time dongle is installed properly in the equipment.
- (14) Check that the installed license is displayed on the license list.

Remarks:

If there are any other licenses to be installed, repeat from step (9). If there are no other licenses to be installed, press [CLOSE], and then turn the power OFF.

9.3 Precautions for Installation of GP-1070 and Disposal of HDD/ Board

9.3.1 Precautions for Installation of GP-1070

When installing the Data Overwrite Enabler (GP-1070), perform the following setting:

HS-73> [Erase HDD Securely]: HDD securely erasing

This setting is the overwriting method complying with DoD 5220.22-M.

1. LOW: This is the normal overwriting method. (This setting is used normally.)
"00-FF-Random-Verify" Once
2. MEDIUM: This overwriting method is more secure than LOW. The erasing time is between LOW and HIGH.
"00-FF-Random" three times repeatedly -Verify
3. HIGH: This is the most secure overwriting method. It takes the longest time to erase data
"00-FF-Random" five times repeatedly -Verify
4. SIMPLE: This is the simple overwriting method. It takes the shortest time to erase data.
Overwrite the Random data once

9.3.2 Precautions when disposing of HDD

[1] When disposing of Secure HDD

When disposing of Secure HDD, perform the following setting:

HS-74 > [Revert factory initial status HDD]

[2] When disposing of Normal HDD

When disposing of Normal HDD, perform the following setting:

HS-73 > [Erase HDD Securely]: HDD securely erasing

This setting is the overwriting method complying with DoD 5220.22-M.

1. LOW: This is the normal overwriting method. (This setting is used normally.)
"00-FF-Random-Verify" Once
2. MEDIUM: This overwriting method is more secure than LOW. The erasing time is between LOW and HIGH.
"00-FF-Random" three times repeatedly -Verify
3. HIGH: This is the most secure overwriting method. It takes the longest time to erase data
"00-FF-Random" five times repeatedly -Verify
4. SIMPLE: This is the simple overwriting method. It takes the shortest time to erase data.
Overwrite the Random data once

9.3.3 Precautions when disposing of the SYS board

When disposing of the SYS board, data clearing is not required since important data, such as user information, etc. are stored in the SRAM.

9.3.4 Precautions when disposing of the SRAM

When disposing of the SRAM, perform HS-73 > Erase SRAM Securely (SRAM securely erasing) for security reasons.

Notes:

If this is performed, the equipment cannot be started up.

10. REMOTE SERVICE

There are following functions as Remote Service.

1. Auto Supply Order
Automatically orders the toner and used waste toner box by FAX or E-mail.
2. Service Notification
Notifies the status of the equipment to the service technician by FAX or E-mail.

10.1 Auto Supply Order

10.1.1 Outline

Automatically orders the toner and used waste toner box.

(1) Placing an Order

There are two ways to place an order.

- FAX
Installation of the FAX board is required.
If the FAX board has not been installed, it is regarded as OFF setting.
- E-mail (E-mail body + TIFF image)

(2) Order Intervals

The Auto Supply Order is sent as indicated in the following steps.

- Toner cartridge
 1. Toner empty occurs.
 2. The toner cartridge is replaced.
 3. The toner empty counter is incremented when the total number of prints or the pixel counter value exceeds the threshold set in the following self-diagnostic code.

Items	Code	Contents
Toner empty determination counter	FS-08-6506	Selects the counter to determine toner empty. 0: Output pages 1: Pixel counter
Threshold setting for toner empty determination (output pages)	FS-08-6507	Sets the number of output pages to determine toner empty. This setting is valid when "0" is set at FS-08-6506.
Threshold setting for toner empty determination (pixel counter)	FS-08-6508	Sets the number of the pixel counter value to determine toner empty. This setting is valid when "1" is set at FS-08-6506.

e.g.) When "0" is set for FS-08-6506 and "50" is set for FS-08-6507

The toner empty counter is incremented when 50 sheets are printed after the toner cartridge has been replaced.

4. When the accumulated number of toner empty times reaches the set condition, an order is placed automatically.

- Waste toner box
When the number of the waste toner full detection times reaches the set condition, an order is placed automatically.

The order condition for the toner cartridge and the waste toner box can be set individually.

(3) If Order Failure Occurs

If some problems occur and the order cannot be placed after registering an order as a job, refer to the standard countermeasure for the FAX/E-mail transmission failure.

10.1.2 Setting item

To enable Auto Supply Order, the following settings are required.

Notes:

When selecting E-mail to place an order, it is required that sending and receiving E-mails are available. Confirm the details to the administrator.

(1) Self-diagnosis (08 Setting Mode)

As the default setting, the Auto Supply Order setting screen is not displayed on the touch panel. To display it, switching the Valid/Invalid setting (FS-08-9783) is required.

0: Valid (FAX/Internet FAX)

1: Valid (FAX/Internet FAX/HTTP)*

2: Invalid (Default)

When changing the setting value from "2" (default) to "0", the Auto Supply Order setting screen is displayed. (* HTTP has not been supported yet.)

(2) Touch Panel Setting

Each item is set from the Auto Supply Order screen on the touch panel.

Entering the password and customer information is required because the setting is made from the ADMIN screen. Setting it with the administrator is a must.

- Basic setting

[ADMIN] > [SERVICE] > [SUPPLY ORDER SETUP] > [ORDER INFORMATION]

AUTO SUPPLY ORDER	Ordered by: [FAX], [MAIL], [HTTP] (*1)
FAX NUMBER	FAX number of supplier (*2)
E-MAIL	E-mail address of supplier (*3)
CUSTOMER	Customer information
NAME	
TEL NUMBER	
E-MAIL	
ADDRESS	
SUPPLIER	Supplier information
NAME	
ADDRESS	
SERVICE TECHNICIAN	Service technician information
NUMBER	
NAME	
TEL NUMBER	
E-MAIL	

*1 HTTP has not been supported yet.

*2 The fax number of the supplier must be entered when an order is made by means of a fax.

*3 The e-mail address of the supplier must be entered when an order is made by means of an e-mail.

- Detailed setting for the order
[ADMIN] > [SERVICE] > [SUPPLY ORDER SETUP] > [TONER ORDERING]

**** TONER ORDER	Order information (TONER /USED TONER CONTAINER)
PART NUMBER	Part number to be ordered
CONDITIOIN	The number of conditions (*)
QUANTITY	The quantity to be ordered
AUTO ORDER	ON/OFF setting of order for each part

- * The order is placed when the number of replacement reaches the number specified for the CONDITION.
- FAX number of this equipment (common information)
[ADMIN] > [FAX] > [TERMINAL ID]

ID NAME	ID name of this equipment
FAX NUMBER	FAX number of this equipment

- E-mail information of this equipment (common information)
[ADMIN] > [E-MAIL]

FROM ADDRESS	E-mail address of this equipment (*)
FROM NAME	E-mail username of this equipment

- * When sending an E-mail, validity of the address is checked. If the address is invalid, it is not sent.

- (3) Output of setting list of the Auto Supply Order.
1. Perform FS-12 (12 FAX LIST PRINT MODE).
 2. Select "SUPPLY ORDER LIST" and then press [PRINT].

10.1.3 Setting procedure

- (1) Perform FS-08-9783 and set the setting value to "0".
- (2) Turn the power OFF and then back ON.
- (3) Press [USER FUNCTIONS] on the HOME screen.
- (4) Press the [ADMIN] tab.
When the Administrator Password has been set, the ADMINISTRATOR PASSWORD screen is displayed.

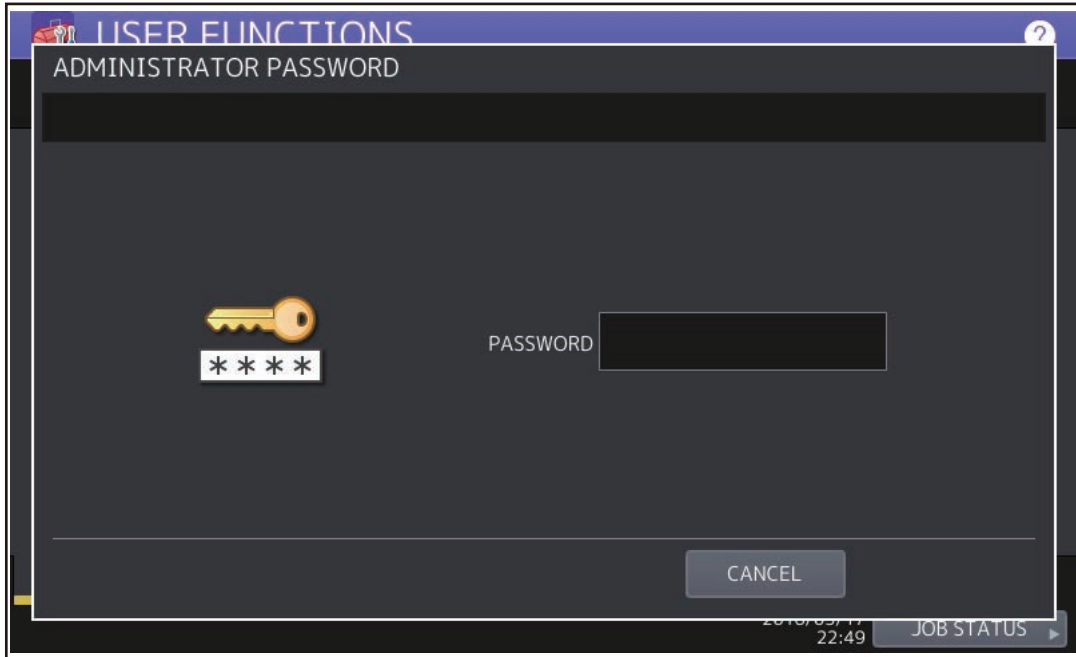

Fig.10-1

- (5) The keyboard appears upon your touching the entry box for a password. Enter the administrator password and then press [OK] or [CLOSE].
 - * Confirm the password to the administrator.

(6) Press [SERVICE] in the ADMIN screen.

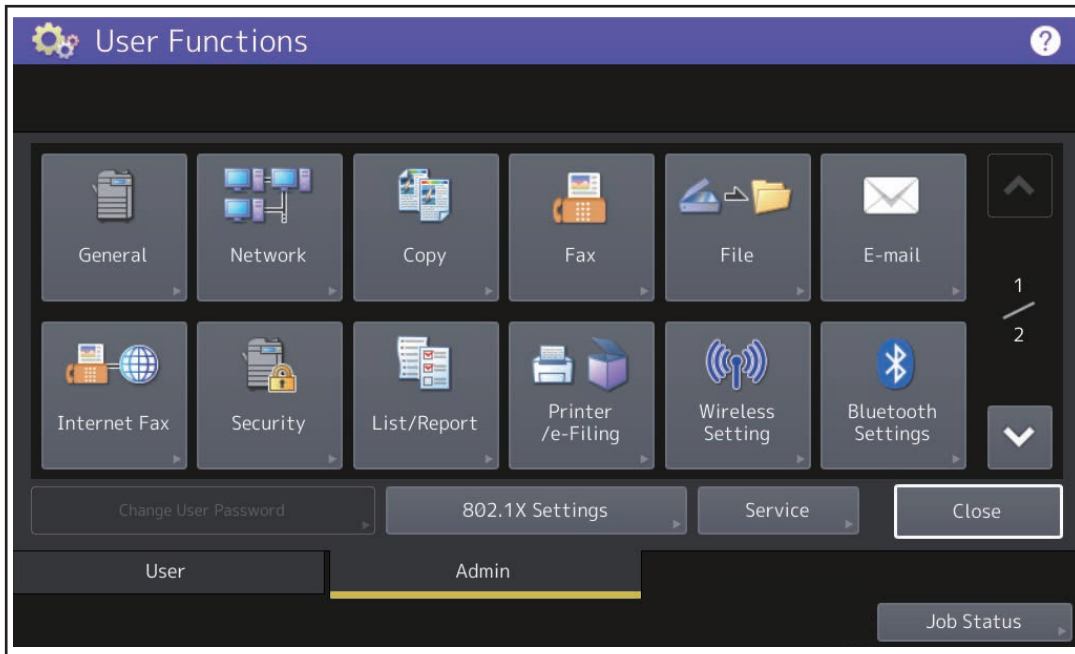

Fig.10-2

(7) The SERVICE screen is displayed.

(8) Press [SUPPLY ORDER SETUP].

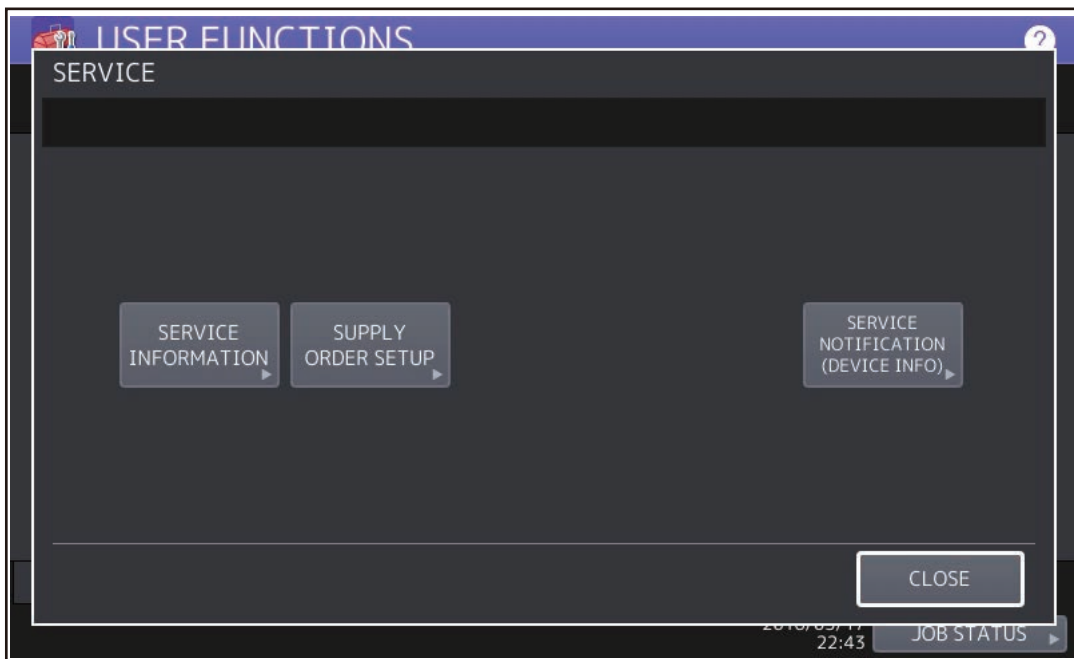

Fig.10-3

(9) Press [ORDER INFORMATION].

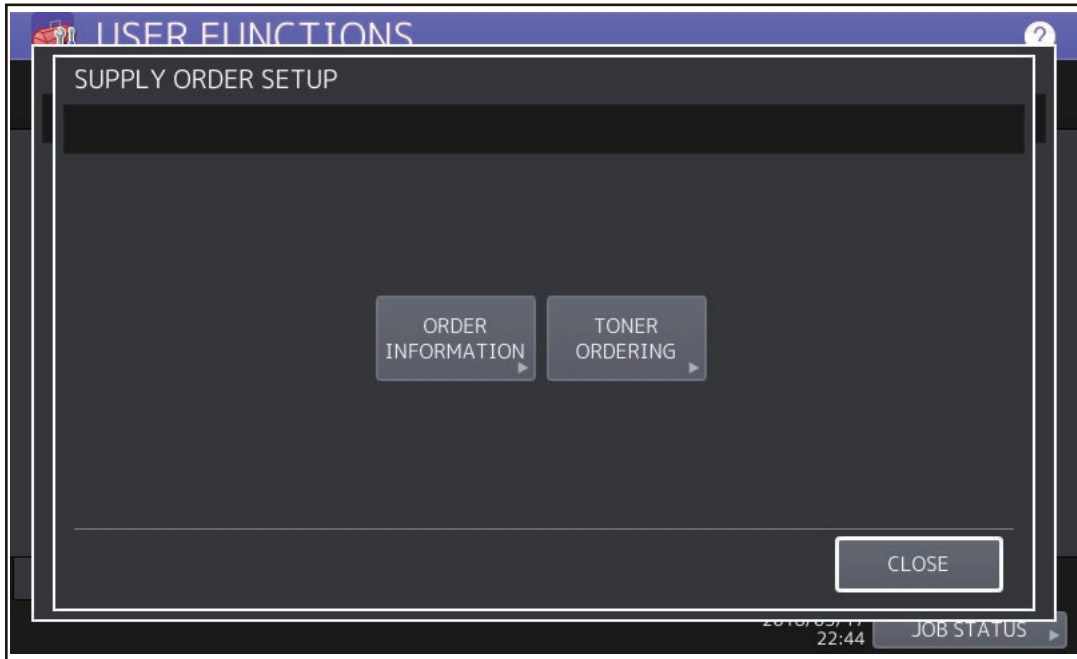

Fig.10-4

(10) The ORDER INFORMATION screen is displayed.

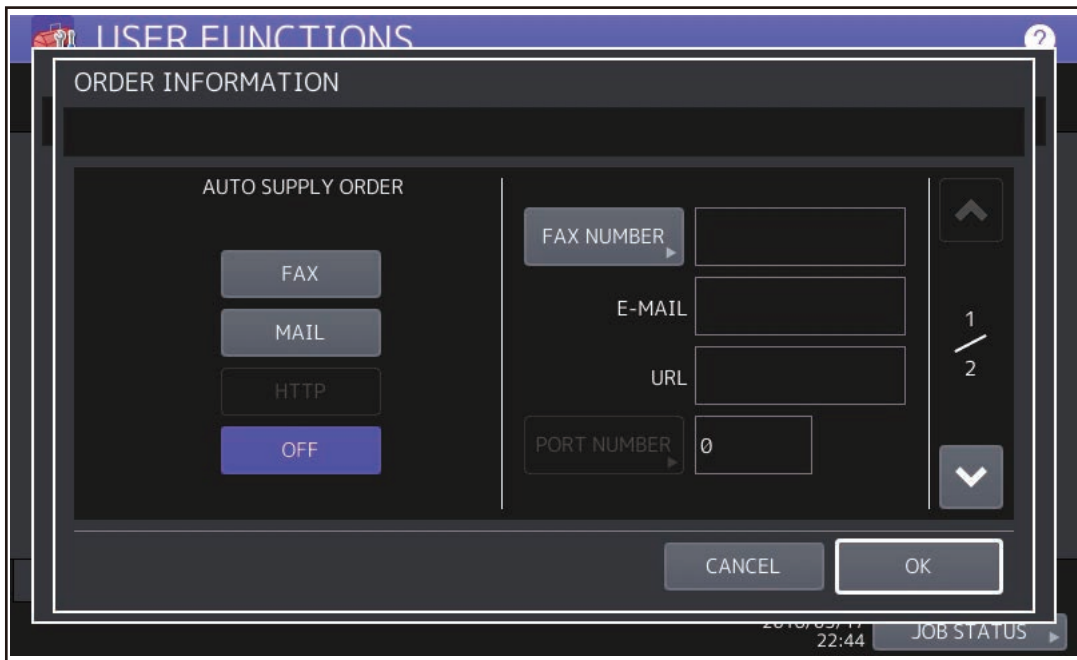

Fig.10-5

(11) Press the buttons on the screen of ORDER INFORMATION to set the required item.

- [FAX]/[MAIL]/
[OFF] Select [FAX] or [MAIL] for the transmitting way of order.
 (HTTP has not been supported yet.)
 [OFF]: Turn off the AUTO SUPPLY ORDER function.
- [FAX NUMBER] Input the FAX number of supplier.
 (This must be entered when an order is transmitted by means of a fax.)
- [E-MAIL] Input the E-mail address of supplier.
 (This must be entered when an order is transmitted by means of an e-mail.)

(12) Press the scroll button.

(13) The SUPPLIER screen is displayed.

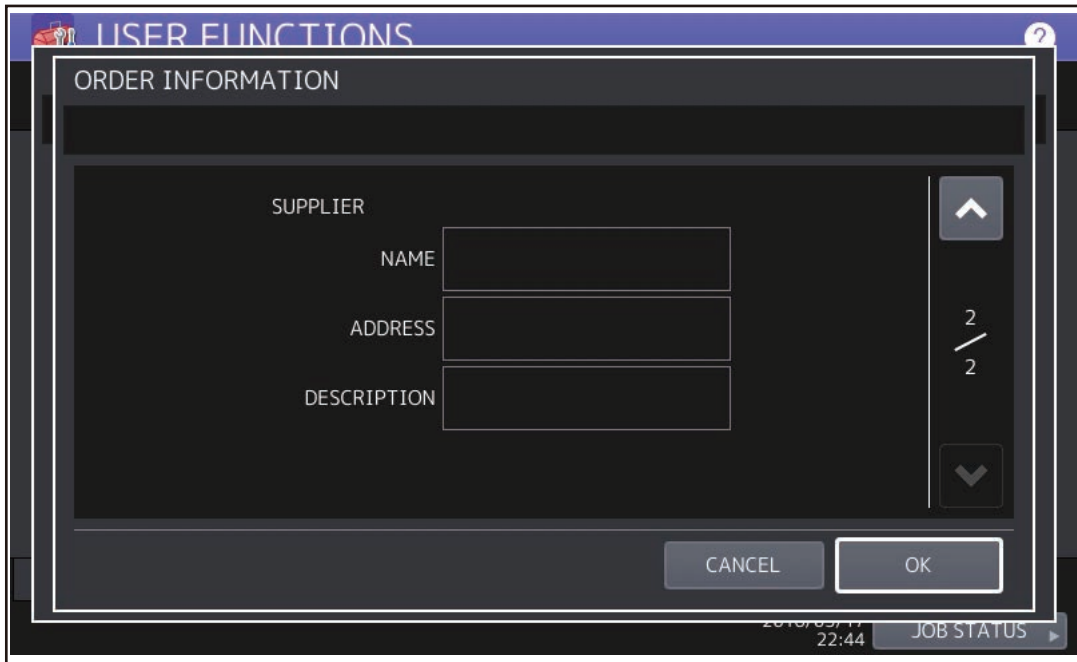

Fig.10-6

(14) Press the buttons of the screen of SUPPLIER to set the required item.

- [NAME] Input the name of supplier.
- [ADDRESS] Input the address of supplier.
- [DESCRIPTION] Input the remarks if necessary.

(15) Press [OK].
Press [OK] to register the entered information and then the screen returns to the (7) SERVICE screen.
Press [CANCEL] to cancel the entered information and then the screen returns to the (7) SERVICE screen.

(16) The SERVICE screen is displayed.

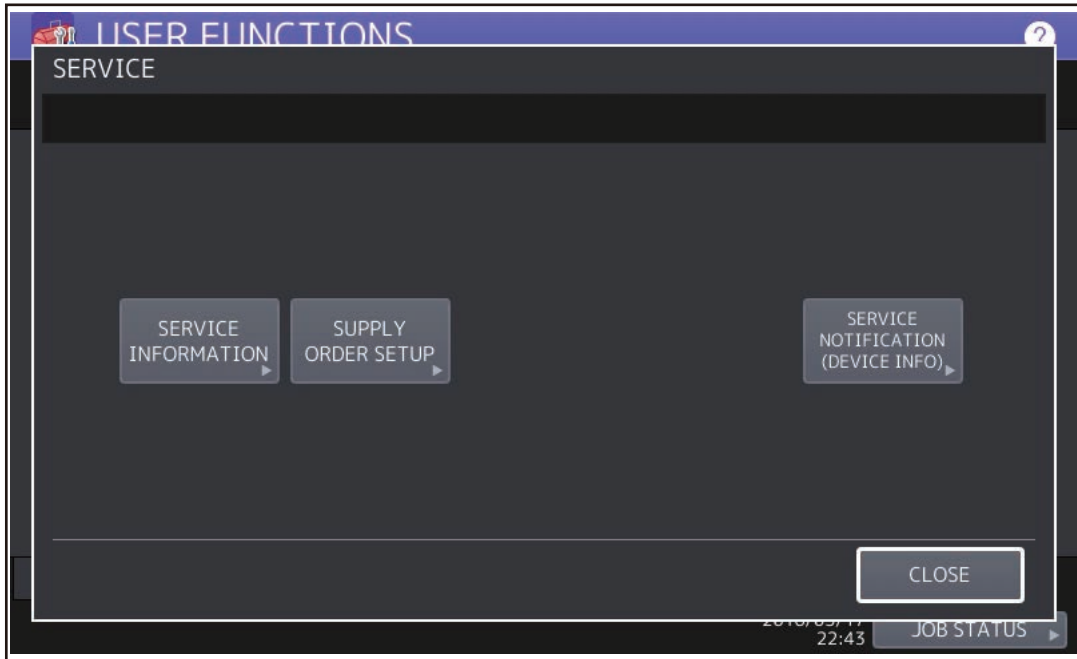

Fig.10-7

(17) Press [SERVICE INFORMATION].

(18) The SERVICE INFORMATION screen is displayed.

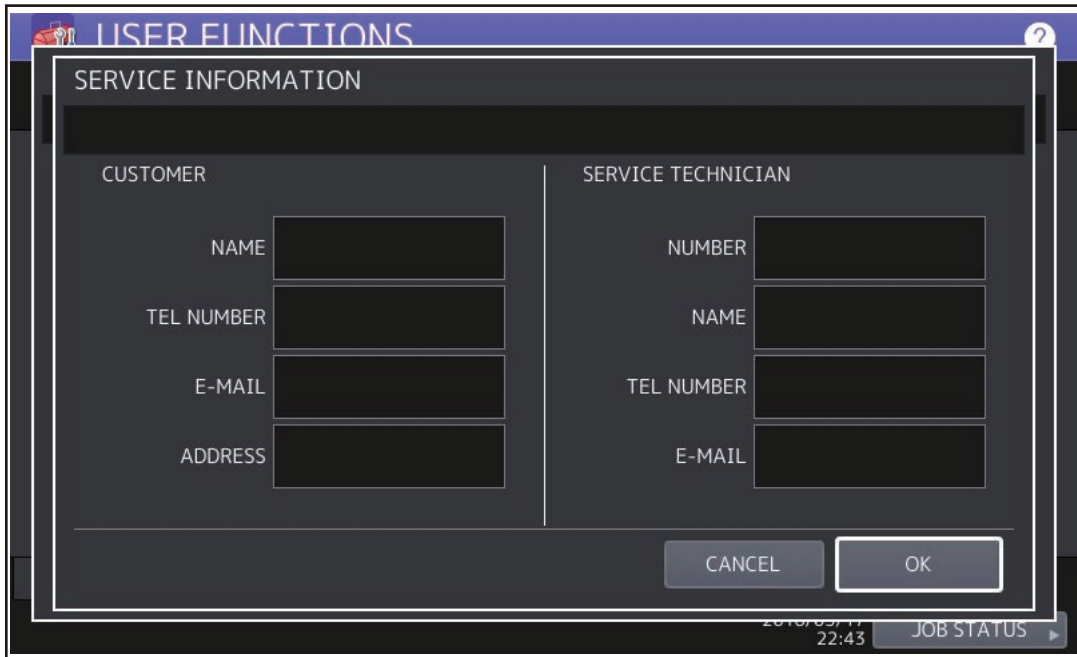

Fig.10-8

(19) Press the buttons of the screen of SERVICE INFORMATION to set the required item.
CUSTOMER

- [NAME] Input the name of customer.
- [TEL NUMBER] Input the telephone number of customer.
- [E-MAIL] Input the E-mail address of customer.
- [ADDRESS] Input the address of customer.

SERVICE TECHNICIAN

- [NUMBER] Input the number of SERVICE TECHNICIAN.
- [NAME] Input the name of SERVICE TECHNICIAN.
- [TEL NUMBER] Input the telephone number of SERVICE TECHNICIAN.
- [E-MAIL] Input the E-mail address of SERVICE TECHNICIAN.

(20) Press [OK] to register and complete the order information setting.

(21) The SERVICE screen is returned.

(22) Press [SUPPLY ORDER SETUP].



Fig.10-9

(23) Press [TONER ORDERING].



Fig.10-10

(24) The TONER ORDERING screen is displayed.

(25) Select the part to be ordered. (Press [YELLOW])

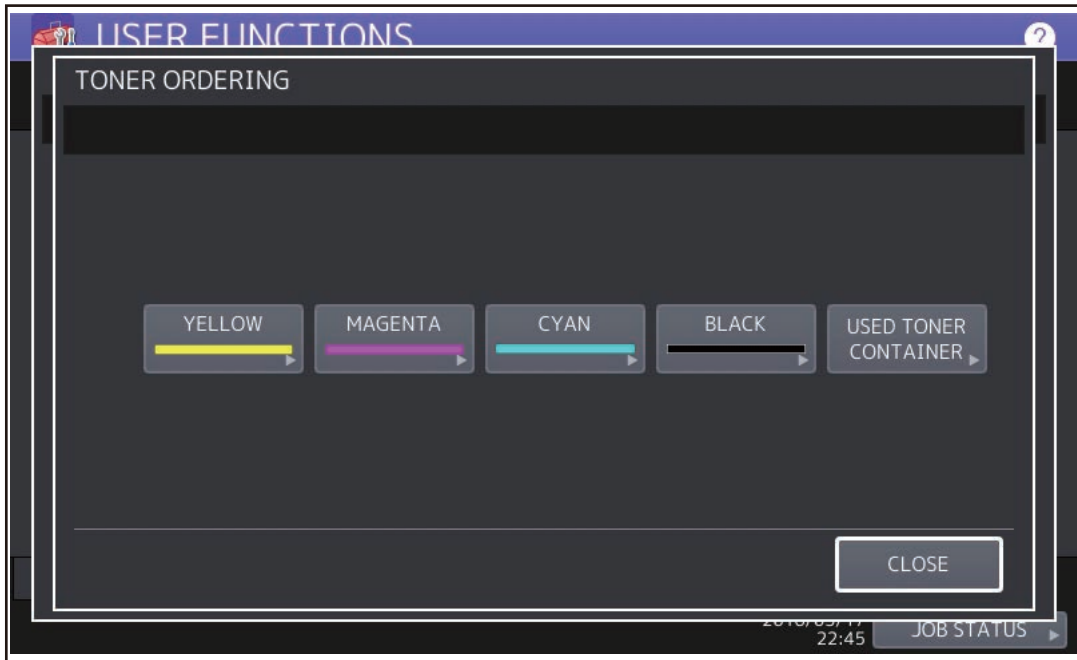

Fig.10-11

(26) Input the order information of TONER.

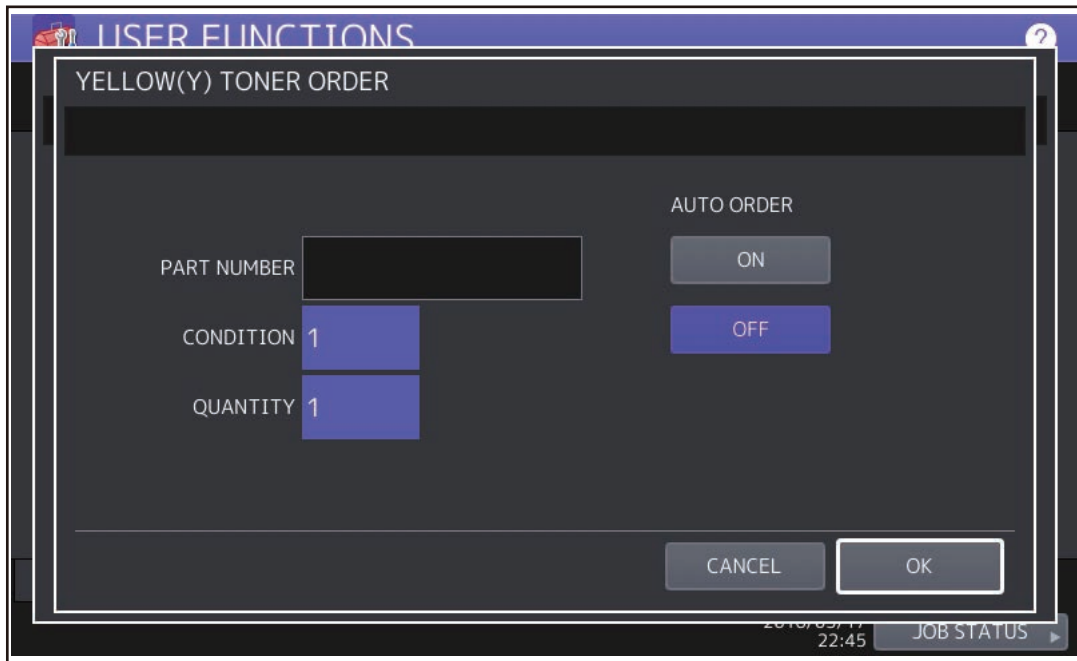

Fig.10-12

- [PART NUMBER] Toner number
- [CONDITION] The order is placed when the accumulated number of toner empty times reaches the value set in here.
- [QUANTITY] Quantity to be ordered

AUTO ORDER

- [ON]/[OFF] Allows you to select whether each part is ordered automatically or not.

(27) Press [OK] to register the setting of toner order.

(28) The TONER ORDERING screen is displayed.

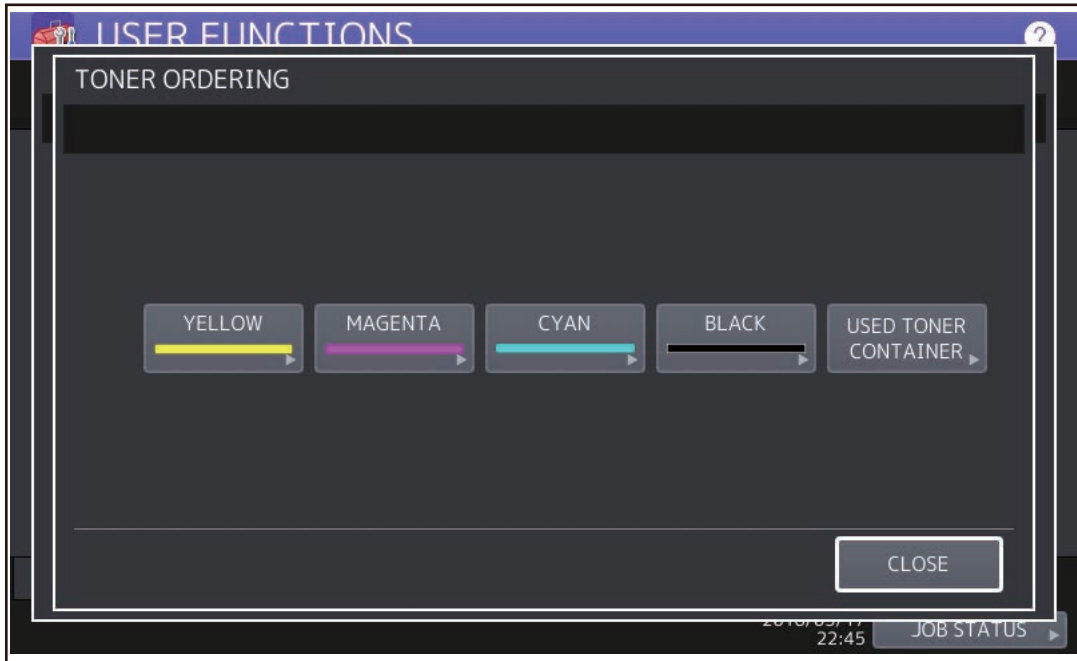

Fig.10-13

(29) Press [MAGENTA] / [CYAN] / [BLACK] / [USED TONER CONTAINER], and then input the order information in the same way.

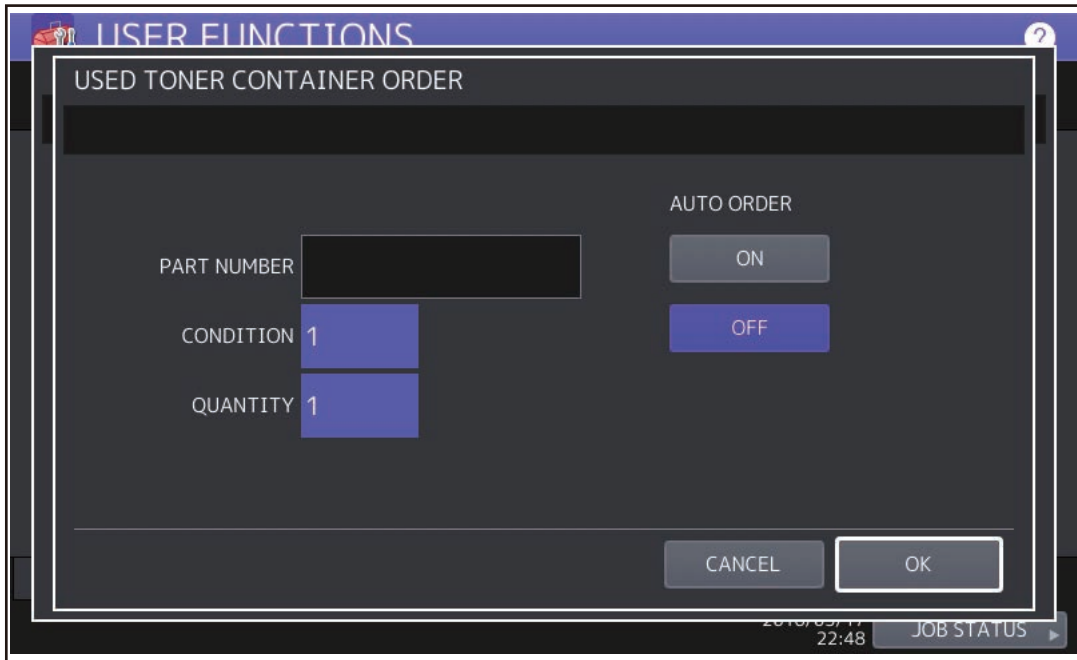

Fig.10-14

(30) Press [OK] to register the order information.

Notes:

Auto Supply Order setting is also available from the following 08 Setting Mode.

Items	Code	Contents
The transmitting way of order [FAX]/[MAIL] /[OFF]	FS-08-9750	0: Ordered by FAX 1: Ordered by E-mail 2: Ordered by HTTP 3: OFF
SUPPLIER [FAX NUMBER]	FS-08-9751	Maximum 32 digits
SUPPLIER [E-MAIL]	FS-08-9752	Maximum 192 letters
CUSTOMER [NAME]	FS-08-9756	Maximum 50 letters
CUSTOMER [TEL NUMBER]	FS-08-9757	Maximum 32 digits
CUSTOMER [E-MAIL]	FS-08-9758	Maximum 192 letters
CUSTOMER [ADDRESS]	FS-08-9759	Maximum 100 letters
SUPPLIER [NAME]	FS-08-9764	Maximum 50 letters
SUPPLIER [ADDRESS]	FS-08-9765	Maximum 100 letters
SERVICE TECHNICIAN [NUMBER]	FS-08-9760	Maximum 5 digits
SERVICE TECHNICIAN [NAME]	FS-08-9761	Maximum 50 letters
SERVICE TECHNICIAN [TEL NUMBER]	FS-08-9762	Maximum 32 digits
SERVICE TECHNICIAN [E-MAIL]	FS-08-9763	Maximum 192 letters
Remarks [DESCRIPTION]	FS-08-9766	Maximum 128 letters
YELLOW(Y) TONER [PART NUMBER]	FS-08-9773	Maximum 20 digits
YELLOW(Y) TONER [CONDITION]	FS-08-9775	1-99
YELLOW(Y) TONER [QUANTITY]	FS-08-9774	1-99
MAGENTA(M) TONER [PART NUMBER]	FS-08-9770	Maximum 20 digits
MAGENTA(M) TONER [CONDITION]	FS-08-9772	1-99
MAGENTA(M) TONER [QUANTITY]	FS-08-9771	1-99
CYAN(C) TONER [PART NUMBER]	FS-08-9767	Maximum 20 digits
CYAN(C) TONER [CONDITION]	FS-08-9769	1-99
CYAN(C) TONER [QUANTITY]	FS-08-9768	1-99
BLACK(K) TONER [PART NUMBER]	FS-08-9776	Maximum 20 digits
BLACK(K) TONER [CONDITION]	FS-08-9778	1-99

Items	Code	Contents
BLACK(K) TONER [QUANTITY]	FS-08-9777	1-99
USED TONER CONTAINER [PART NUMBER]	FS-08-9779	Maximum 20 digits
USED TONER CONTAINER [CONDITION]	FS-08-9781	1-99
USED TONER CONTAINER [QUANTITY]	FS-08-9780	1-99

(31) The SERVICE screen is returned.

(32) Press [SERVICE NOTIFICATION (DEVICE INFO)].

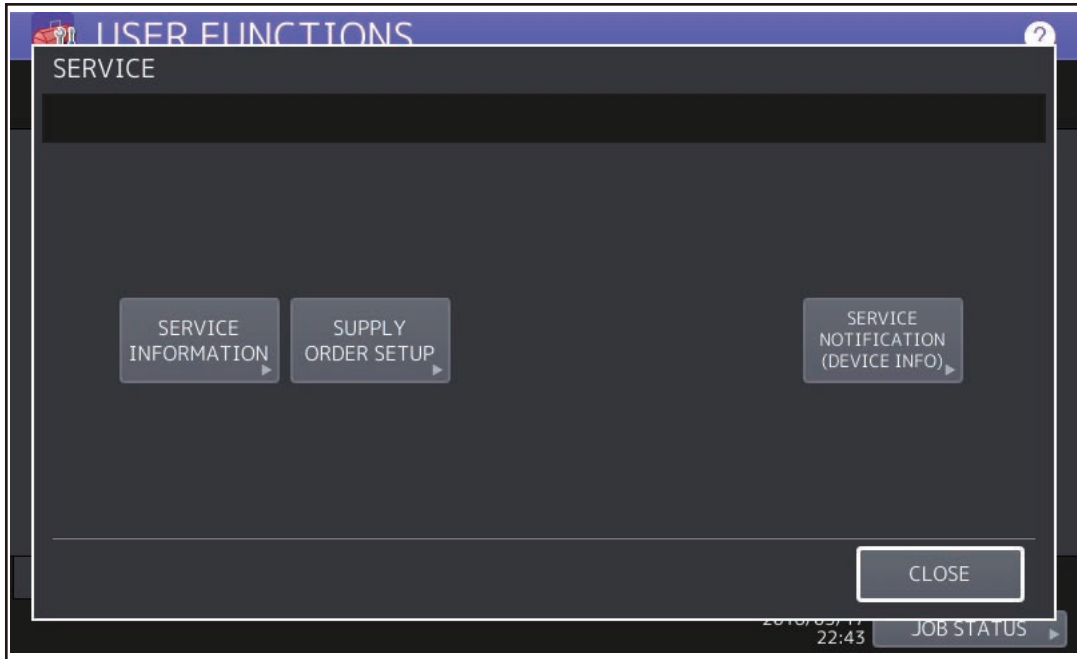

Fig.10-15

- (33) Press [ON] or [OFF] in SERVICE NOTIFICATION (DEVICE INFO).
When [OFF] is pressed, all functions related SERVICE NOTIFICATION (DEVICE INFO) become ineffective.

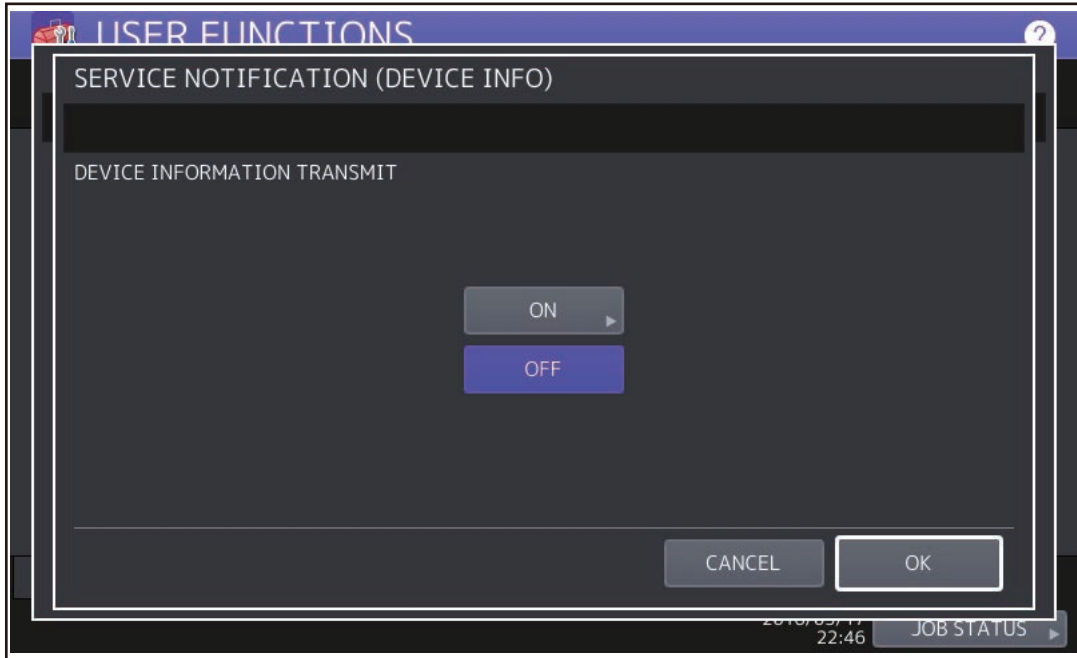

Fig.10-16

- (34) When SERVICE NOTIFICATION (DEVICE INFO) is set to ON, the screen to set the notification date is displayed.
Then set the notification date with the following procedure.

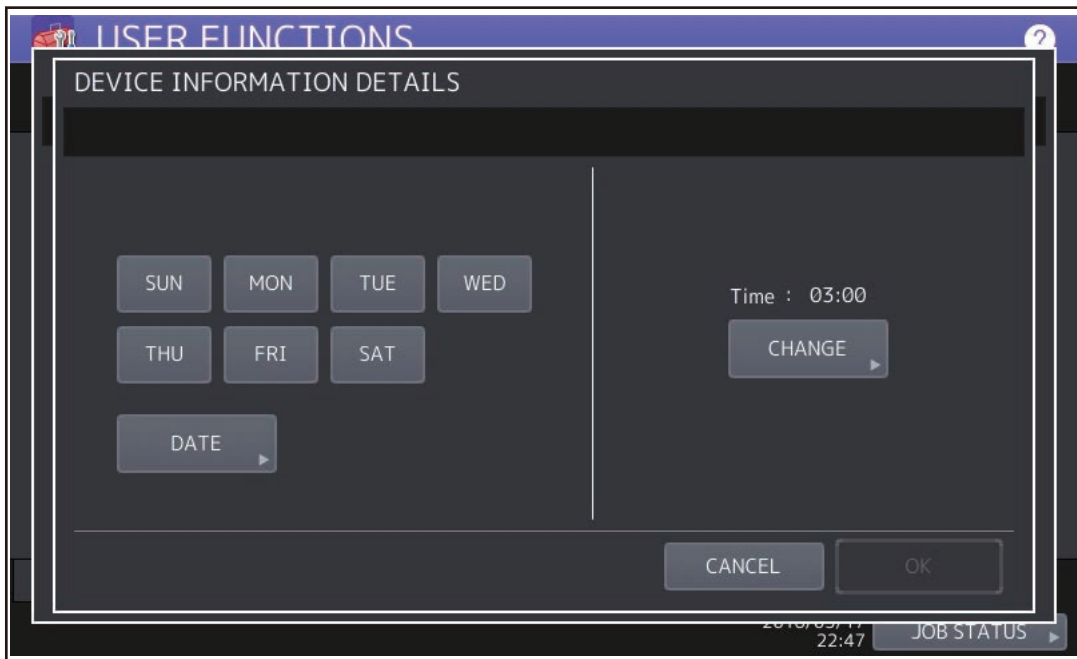

Fig.10-17

Set the date and time of the “DEVICE INFORMATION DETAILS”.

The following 3 items can be specified for the date setting, and more than one day of the week also can be selected.

- Day of the week (More than one day can be selected.)
- Notify Date 1

- Notify Date 2
- **Day of the week ([SUN] to [SAT])**
Pressing [SUN] to [SAT] of the desired day makes transmission on every specified day. More than one day can be selected.
- * This does not affect the settings of “Notify Date 1” and “Notify Date 2”.
- **Notify Date 1 and Notify Date 2 ([DATE])**
Pressing [DATE] sets up to 2 dates on which you want to send data.
- * This is not affected by the specified day of the week.

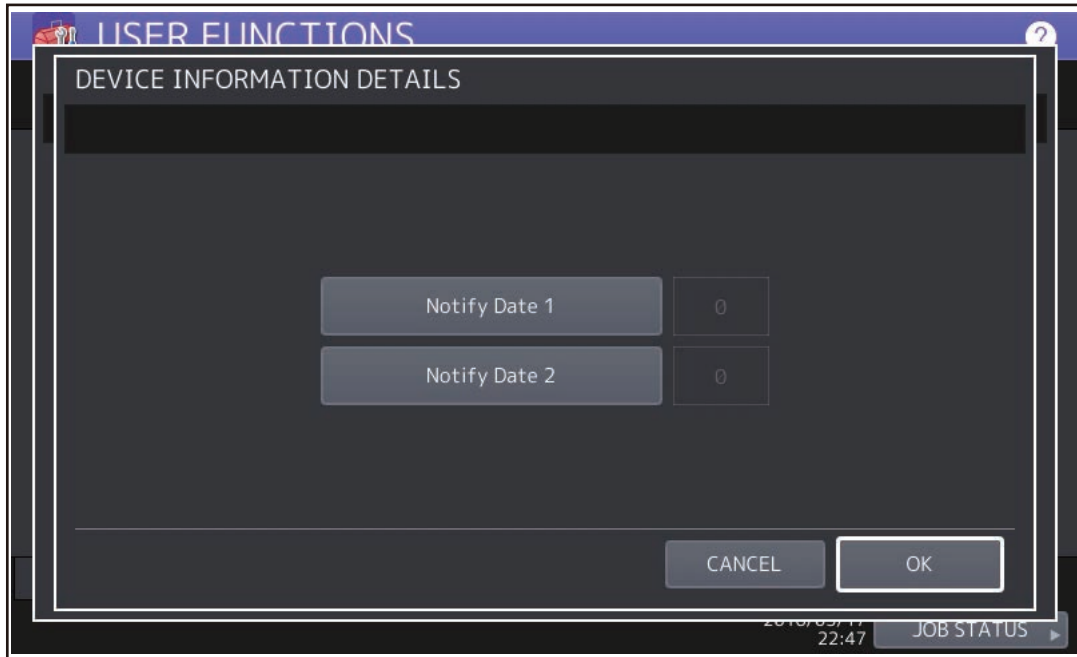

Fig.10-18

Key in the date (acceptable values: 0-31) in “Notify Date 1” or “Notify Date 2” and press [OK].

- **Time setting ([CHANGE])**

Pressing [CHANGE] sets the time at which you want to send data.

This is the time when data are sent with “Day of the week”, “Notify Date 1” and “Notify Date 2”.

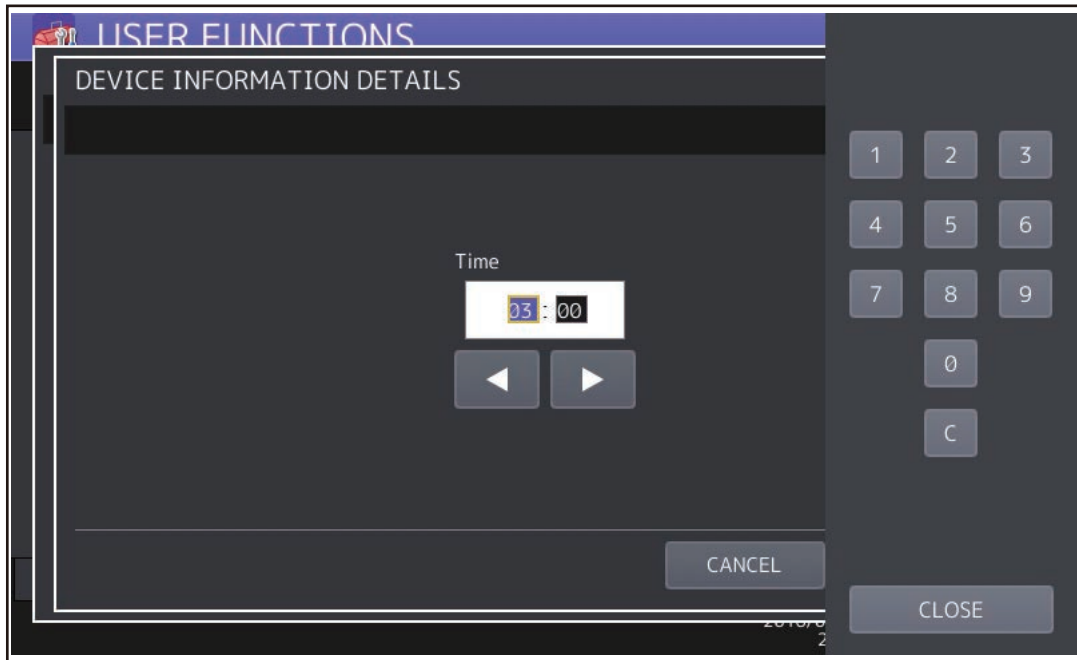

Fig.10-19

Key in the time (acceptable values: 00:00-23:59) in “Time”.

Key in the time in the hour column of “Time”, press the scroll button, key in the time in the minute column of “Time”.

After all the settings are completed, press [OK].

(35) Press [CLOSE]. The setting completes.

10.1.4 Order sheet format

The sample of order sheet is as follows.

- (1) FAX (This format is the same as that of TIFF image attached E-mail.)
 - *1 Part not to be ordered is not output. (Less space between the lines)

DATE & TIME	:99-99-'99 99:99			
CUSTOMER NUMBER	:XXX			
CUSTOMER NAME	:XX			
CUSTOMER ADDRESS	:XX			
CUSTOMER TEL NUMBER	:XX			
CUSTOMER E-MAIL ADDRESS	:XX			
SERVICE TECHNICIAN TEL NUMBER	:XX			
SERVICE TECHNICIAN E-MAIL	:XX			
SUPPLIER NAME	:XX			
SUPPLIER ADDRESS	:XX			

	PART NUMBER	QUANTITY	
TONER CARTRIDGE			
CYAN	:XXXXXXXXXXXX	99	} (*1)
MAGENTA	:XXXXXXXXXXXX	99	
YELLOW	:XXXXXXXXXXXX	99	
BLACK	:XXXXXXXXXXXX	99	
USED TONER CONTAINER	:XXXXXXXXXXXX	99	

DESCRIPTION AREA

.....

DEVICE DESCRIPTION	:XXXXXXXXXXXXXXXXXXXXXXXXXXXX			
SERIAL NUMBER	:XXXXXXXXXXXXXXXXXXXXXXXXXXXX			
DEVICE FAX NUMBER	:XXXXXXXXXXXXXXXXXXXXXXXXXXXX			
DEVICE E-MAIL ADDRESS	:XXXXXXXXXXXXXXXXXXXXXXXXXXXX			

	TOTAL	BLACK	TWIN COLOR	FULL COLOR
PRINT COUNTER	999999999	999999999	999999999	999999999
SCAN COUNTER	999999999	999999999	999999999	999999999

TONER INFORMATION

YELLOW REMAINING QUANTITY (%)	: 0000059
MAGENTA REMAINING QUANTITY (%)	: 0000060
CYAN REMAINING QUANTITY (%)	: 0000061
BLACK REMAINING QUANTITY (%)	: 0000062

Fig.10-20

DESCRIPTION AREA:	Remarks
DEVICE DESCRIPTION:	Model name
SERIAL NUMBER:	Serial number
DEVICE FAX NUMBER:	Fax number
DEVICE E-MAIL ADDRESS:	E-mail address

(2) E-MAIL (TIFF image attached with the E-mail is the same format with that of the FAX order sheet.)

SUBJECT: SUPPLY ORDER REQUEST

*1 Part not to be ordered is not output. (Less space between the lines)

```
Date&Time: '12-04-14 00:17
Customer Number: a1 MachineName: TOSHIBA e-STUDIOxxxx
SerialNumber: 1234567890
Device FAX Number: 456
Device Email: aaa@linux.nam1.local
OrderInformation:
CYAN PartNumber: CYAN-01 Quantity: 15
MAGENTA PartNumber: MAGENTA-02 Quantity: 16 } (*1)
BLACK PartNumber: BLACK-04 Quantity: 18
CounterInformation:
PrintCounter(Small) FullColor: 0 TwinColor: 0 Black: 150
PrintCounter(Large) FullColor: 0 TwinColor: 0 Black: 0
ScanCounter FullColor: 0 TwinColor: 0 Black: 7
```

Fig.10-21

Date&Time:	Order date and time
Customer Number:	Customer number
MachineName:	Model name (MFP model name)
SerialNumber:	Serial number
Device FAX Number:	Fax number
Device Email:	E-mail address
OrderInformation:	Order information
CYAN PartNumber:	Cyan toner cartridge part number
MAGENTA PartNumber:	Magenta toner cartridge part number
BLACK PartNumber:	Black toner cartridge part number
Quantity:	Order quantity
CounterInformation:	Counter information
PrintCounter (Small) FullColor: 0 TwinColor: 0 Black:	Print count (Small size) for Full color, Twin color and Black
PrintCounter (Large) FullColor: 0 TwinColor: 0 Black:	Print count (Large size) for Full color, Twin color and Black
ScanCounter FullColor: 0 TwinColor: 0 Black:	Scan count
	Scan count for Full color, Twin color and Black

(3) Result list

*1 Part not to be ordered is not output. (Less space between the lines)

```
ORDER XXXXXXXXXX
DATE & TIME          :99-99-'99 99:99
CUSTOMER NUMBER     :XXX
CUSTOMER NAME       :XXXXXXXXXXXXXXXXXXXXXXXXXXXXXXXXXXXX
CUSTOMER ADDRESS    :XXXXXXXXXXXXXXXXXXXXXXXXXXXXXXXXXXXX
CUSTOMER TEL NUMBER :XXXXXXXXXXXXXXXXXXXXXXXXXXXXXXXXXXXX
CUSTOMER E-MAIL ADDRESS :XXXXXXXXXXXXXXXXXXXXXXXXXXXXXXXXXXXX
SERVICE TECHNICIAN
TEL NUMBER          :XXXXXXXXXXXXXXXXXXXXXXXXXXXXXXXXXXXX
SERVICE TECHNICIAN E-MAIL :XXXXXXXXXXXXXXXXXXXXXXXXXXXXXXXXXXXX
SUPPLIER NAME       :XXXXXXXXXXXXXXXXXXXXXXXXXXXXXXXXXXXX
SUPPLIER ADDRESS    :XXXXXXXXXXXXXXXXXXXXXXXXXXXXXXXXXXXX

-----
TONER CARTRIDGE    PART NUMBER      QUANTITY
CYAN                :XXXXXXXXXXXXX      99
MAGENTA             :XXXXXXXXXXXXX      99
YELLOW              :XXXXXXXXXXXXX      99 (*1)
BLACK               :XXXXXXXXXXXXX      99
USED TONER CONTAINER :XXXXXXXXXXXXX      99
-----
DESCRIPTION AREA .....
.....
DEVICE DESCRIPTION  :XXXXXXXXXXXXXXXXXXXX
SERIAL NUMBER       :XXXXXXXXXXXXXXXXXXXX
DEVICE FAX NUMBER   :XXXXXXXXXXXXXXXXXXXX
DEVICE E-MAIL ADDRESS :XXXXXXXXXXXXXXXXXXXX

PRINT COUNTER      TOTAL      BLACK      TWIN COLOR      FULL COLOR
999999999          999999999  999999999  999999999      999999999
SCAN COUNTER       999999999  999999999  999999999      999999999

TONER INFORMATION

YELLOW REMAINING QUANTITY (%) : 00000059
MAGENTA REMAINING QUANTITY (%) : 00000059
CYAN REMAINING QUANTITY (%) : 00000059
BLACK REMAINING QUANTITY (%) : 00000059
```

Fig.10-22

ORDER SUCCESSFUL/FAILURE:	Automatic supply ordering: transmission success or failure
DATE & TIME:	Order date and time
CUSTOMER NUMBER:	Customer number
CUSTOMER NAME:	Customer name
CUSTOMER ADDRESS:	Customer address
CUSTOMER TEL NUMBER:	Customer telephone number
CUSTOMER E-MAIL ADDRESS:	Customer E-mail address
SERVICE TECHNICIAN TEL NUMBER:	Service technician telephone number
SERVICE TECHNICIAN E-MAIL:	Service technician E-mail address
SUPPLIER NAME:	Supplier name
SUPPLIER ADDRESS:	Supplier address
PART NUMBER:	Order part number

QUANTITY:	Order quantity
TONER CARTRIDGE:	Toner cartridge
	CYAN: Cyan
	MAGENTA: Magenta
	YELLOW: Yellow
	BLACK: Black
USED TONER CONTAINER:	Used toner container (waste toner box)
DESCRIPTION AREA:	Remarks
DEVICE DESCRIPTION:	Model name (MFP model name)
SERIAL NUMBER:	Serial number
DEVICE FAX NUMBER:	Fax number
DEVICE E-MAIL ADDRESS:	E-mail address
PRINT COUNTER:	Print count
SCAN COUNTER:	Scan count
TOTAL:	Total
BLACK:	Black
TWIN COLOR:	Twin color
FULL COLOR:	Full color
TONER INFORMATION:	Toner information
YELLOW REMAINING QUANTITY (%)	Toner remaining quantity (Yellow)
MAGENTA REMAINING QUANTITY (%)	Toner remaining quantity (Magenta)
CYAN REMAINING QUANTITY (%)	Toner remaining quantity (Cyan)
BLACK REMAINING QUANTITY (%)	Toner remaining quantity (Black)

10.2 Service Notification

10.2.1 Outline

This function automatically notifies the status of the equipment to the service technician by E-mail or FAX. The following 6 are the items to be notified.

- Total counter transmit
When this function is effective, it notifies each counter information periodically (on the set date and time every month).
- Service call transmit (E-mail only)
When this function is effective, it notifies the corresponding error code and such at a service call error.
- PM counter transmit
When this function is effective, it notifies that the PM timing has come when the present PM count has reached to its setting value, or the present PM driving count has reached to its setting value.
- Toner near empty transmit
When this function is effective, it notifies each counter information and toner cartridge information if toner near empty occurs.
- Waste toner near full transmit
When this function is effective, it notifies each counter information and toner cartridge information if toner near empty occurs.
- HDD alert notification
When this function is effective, it notifies an alert for backing up or replacing the HDD.

10.2.2 Setting

Notes:

When using this function, it is required that sending and receiving E-mails or FAXes are available. Confirm the details to the administrator.

[1] Preparation

If the menu display of this function is disabled (not displayed), set it to be enabled (displayed) with the following code.

FS-08-9604 Display set of the [Service Notification] button
 0: Not displayed
 1: Displayed

[2] Setting procedure

- (1) Press [USER FUNCTIONS] on the HOME screen and select the [ADMIN] tab. Then, enter the password and press [OK].
Confirm the password to the administrator.

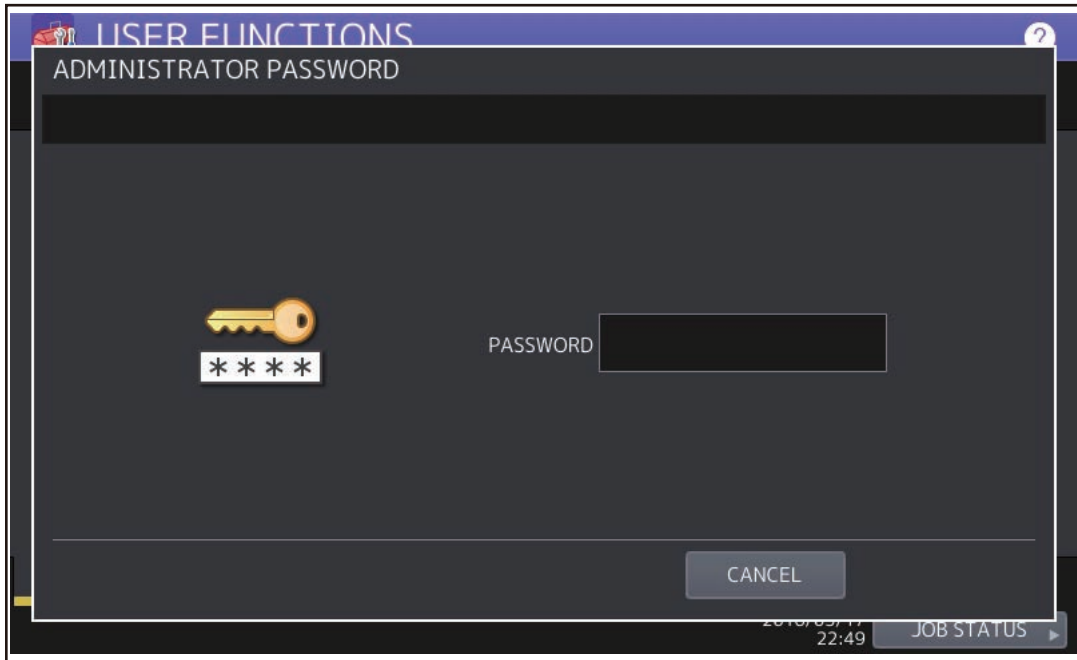

Fig.10-23

- (2) Press [SERVICE].



Fig.10-24

(3) Press [SERVICE NOTIFICATION].

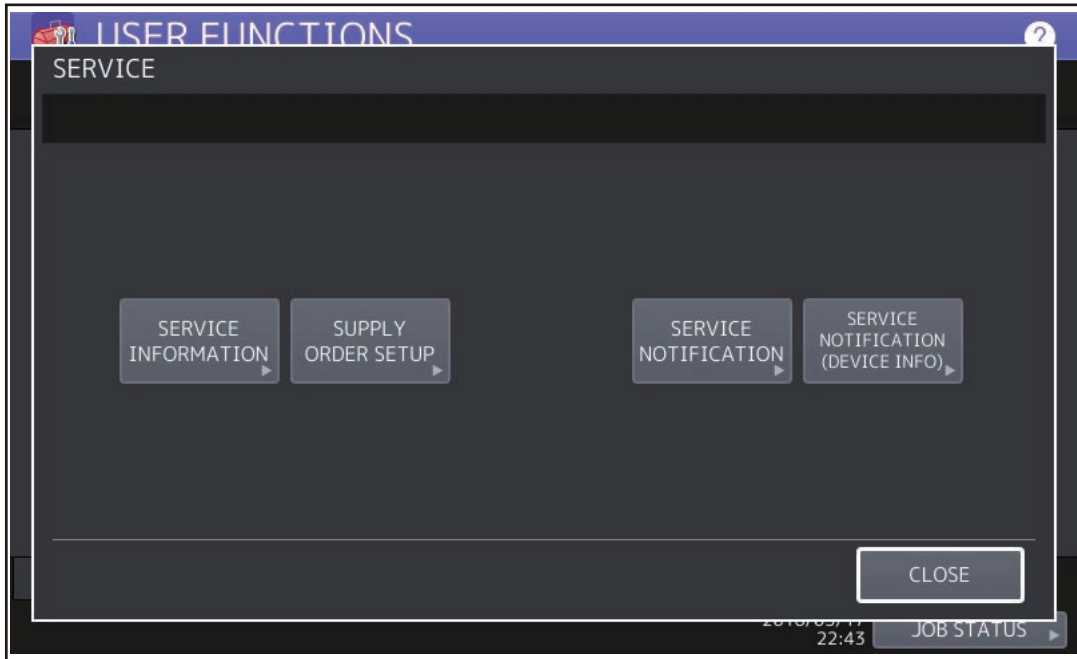

Fig.10-25

(4) Press [E-MAIL] or [FAX].
When [OFF] is pressed, all functions related Service Notification become ineffective.

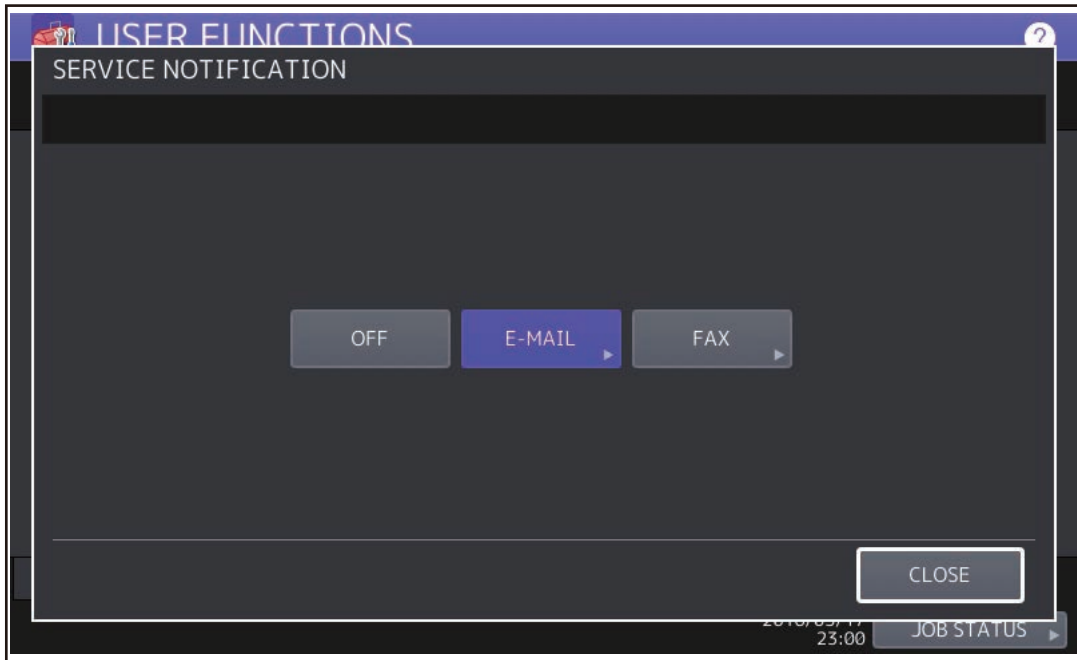

Fig.10-26

- (5) Enter the e-mail address or fax number of the destination and press [OK]. A maximum of 3 addresses can be set. (The keyboard appears upon your touching the entry box for an e-mail address.)



Fig.10-27

Press [FAX NUMBER], key in the FAX number and then press [OK].

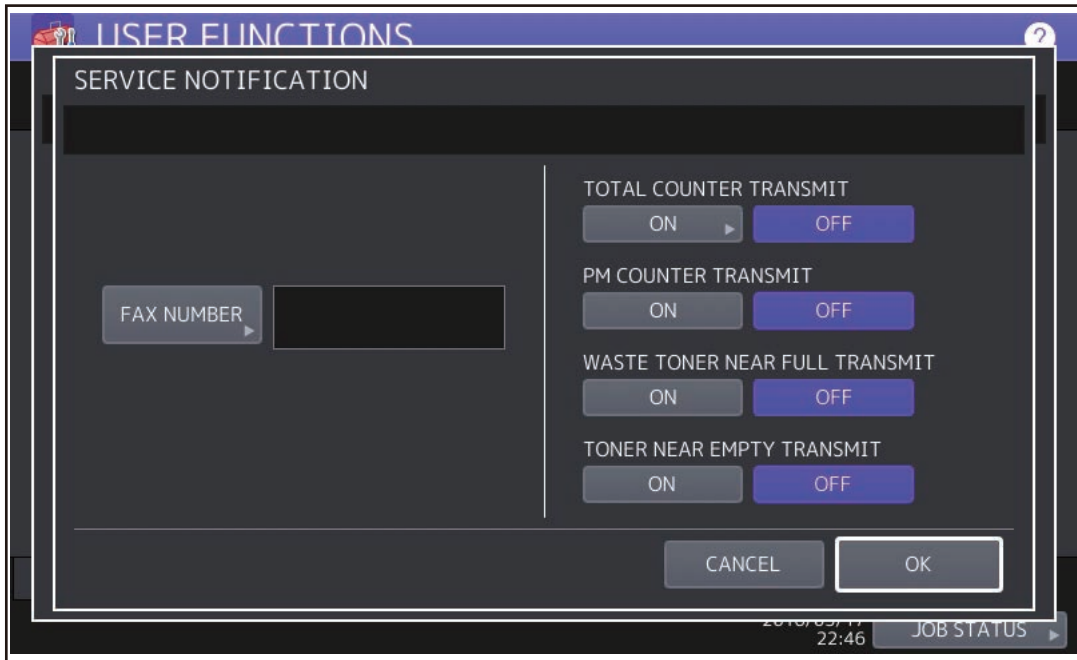

Fig.10-28

- (6) Press [ON] to notify or [OFF] not to notify each item for E-mail and FAX.
When Total Count Transmit is set to ON, the screen to set the notification date is displayed.
Then set the notification date with the following procedure.

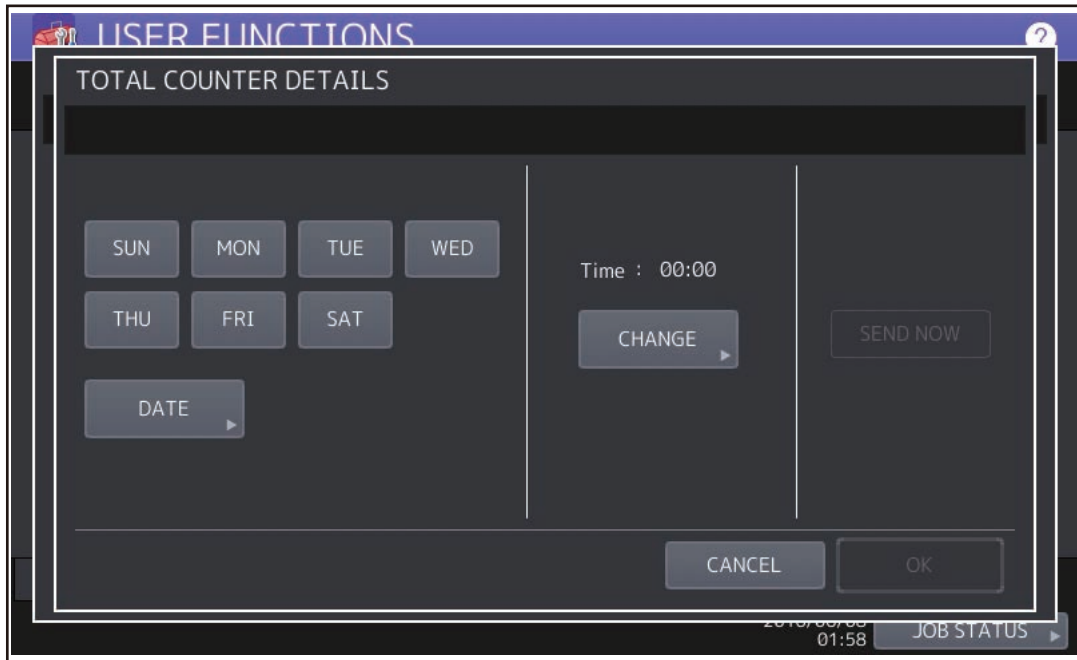

Fig.10-29

Set the date and time of the Total Counter.

The following 3 items can be specified for the date setting, and more than one day of the week also can be selected.

- Day of the week (More than one day can be selected.)
- Notify Date 1
- Notify Date 2

You can send the Total Counter immediately without the above settings by pressing [SEND NOW].

- **Day of the week ([SUN] to [SAT])**
Pressing [SUN] to [SAT] of the desired day makes transmission on every specified day. More than one day can be selected.
- * This does not affect the settings of “Notify Date 1” and “Notify Date 2”.

- **Notify Date 1 and Notify Date 2 ([DATE])**
Pressing [DATE] sets up to 2 dates on which you want to send data.
- * This is not affected by the specified day of the week.

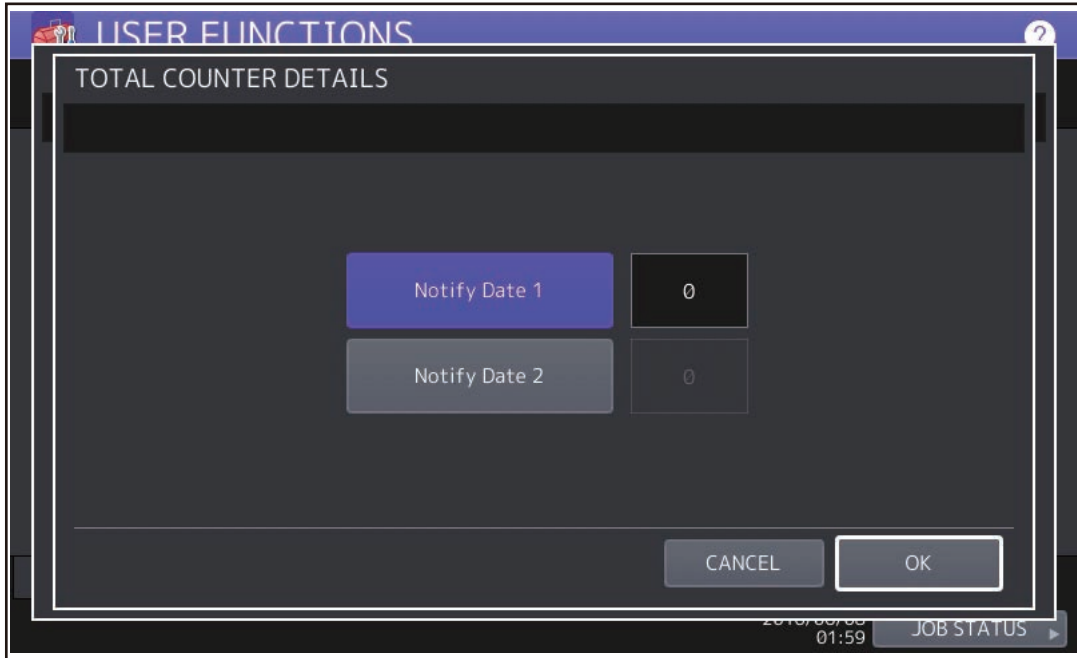

Fig.10-30

Key in the date (acceptable values: 0-31) in “Notify Date 1” or “Notify Date 2” and press [OK].

- **Time setting ([CHANGE])**
Pressing [CHANGE] sets the time at which you want to send data.
This is the time when data are sent with “Day of the week”, “Notify Date 1” and “Notify Date 2”.

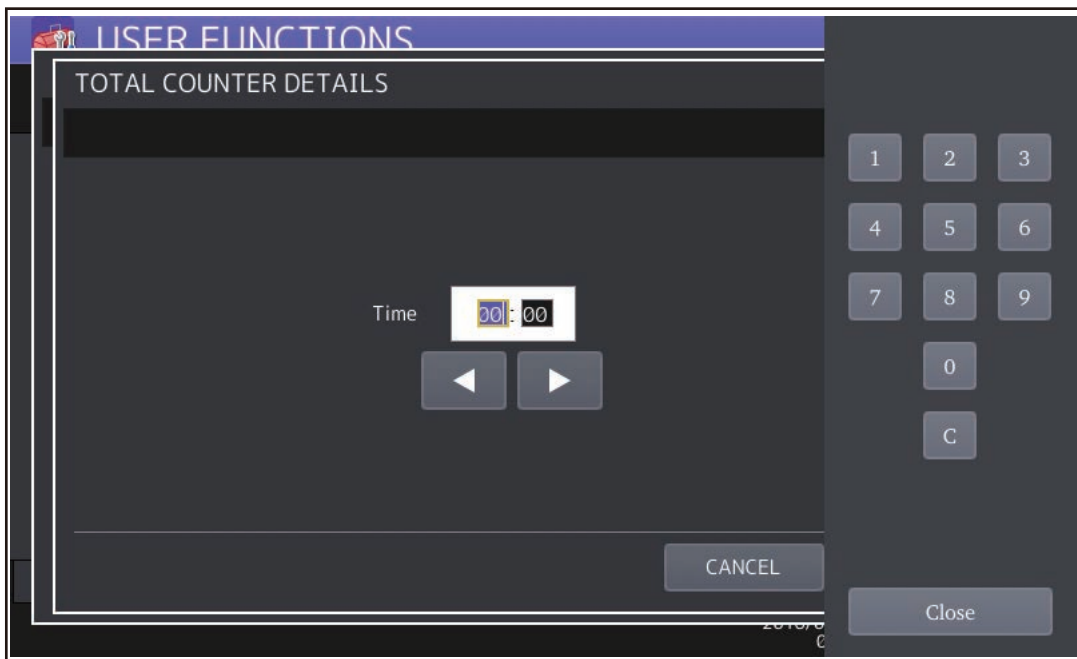

Fig.10-31

Key in the time (acceptable values: 00:00-23:59) in “Time”.

Key in the time in the hour column of “Time”, press the scroll button, key in the time in the minute column of “Time”.

After all the settings are completed, press [CLOSE].

(7) Press [OK]. The setting completes.

Notes:

Service Notification setting is also available from the following 08 Setting Mode.

Set the service notification setting (FS-08-9793) to "1" or "2". Then sets the items (self-diagnostic code) which you want to transmit to ON.

Items	Code	Contents
Service Notification setting	FS-08-9793	0: Invalid 1: Valid (E-mail) 2: Valid (Fax)
E-mail address 1	FS-08-9794	Maximum 192 letters
E-mail address 2	FS-08-9607	Maximum 192 letters
E-mail address 3	FS-08-9608	Maximum 192 letters
FAX number	FS-08-9784	Maximum 32 digits
Total Counter Transmit setting	FS-08-9795	0: OFF (Invalid) 1: ON (Valid)
Total counter transmission date setting	FS-08-9796	0 to 31
Total counter transmission date setting(2)	FS-08-9880	0 to 31
Day of total counter data transmission	FS-08-9881	1 byte 00000000(0)-01111111(127) From the 2nd bit - Sunday, Monday, Tuesday, Wednesday, Thursday, Friday, Saturday
Total counter transmission interval setting (Hour/Minute/Minute)	FS-08-9606	00:00-23:59 (Hour/Minute/Minute)
Service Call Transmit setting	FS-08-9605	0: OFF (Invalid) 1: ON (Valid)
PM Counter Transmit setting	FS-08-9797	0: OFF (Invalid) 1: ON (Valid)
Toner near empty Transmit setting	FS-08-8538	0: OFF (Invalid) 1: ON (Valid)
Waste toner near full Transmit setting	FS-08-3699	0: OFF (Invalid) 1: ON (Valid)

10.2.3 Items to be notified

The items to be notified are shown below.

[1] Total Counter Transmit / PM Counter Transmit by E-mail

Subject: COUNTER NOTIFICATION

(In case of the PM Counter Transmit, it is shown as "PERIODICAL MAINTENANCE NOTIFICATION".)

①	Date	:	04/26/2012 12:34
②	Machine Model	:	TOSHIBA e-STUDIOxxxx
③	SerialNumber	:	1234567890
④	Total Counter	:	00004787
⑤	Supplier:		
	Name	:	SUPPLIER_NAME
	Tel Number	:	1122334455
	E-Mail	:	Supplier_emailaddress@cccc.xxx
	Address	:	SUPPLIER_ADDRESS
⑥	Customer:		
	Name	:	CUSTOMER_NAME
	Tel Number	:	1234567890
	E-Mail	:	customer_emailaddress@dddd.xxx
	Address	:	CUSTOMER_ADDRESS
⑦	Service Technician:		
	Number	:	svc12
	Name	:	SERVICE_TECHNICIAN_NAME
	Tel Number	:	0987654321
	E-Mail	:	svc@toshibatec.co.jp
	ChargeCounterFormat:		
⑧	LargeSizeChargeCount		1
⑨	LargeSizeChargePaperDefinition		1
	PMCounterFormat:		
⑩	LargeSizePMCount		1
⑪	LargeSizePMPaperDefinition		0
	Charge Counter:		
		Large	Small
	<Print Counter>		
	Full Color	-----	
⑫	Copy	00000000	00000000
⑬	Print	00000000	00000000
	Twin Color	-----	
⑭	Copy	00000000	00000000
	Black	-----	
⑮	Copy	00000000	00000000
⑯	Print	00000000	00000000
⑰	List	00000000	00000000
⑱	FAX	00000000	00000000
	<Scan Counter>		
	Full Color	-----	
⑲	Copy Scan	00000000	00000000
⑳	Net Scan	00000000	00000000
	Twin Color	-----	
㉑	Copy Scan	00000000	00000000
	Black	-----	
㉒	Copy Scan	00000000	00000000
㉓	FAX Scan	00000000	00000000
㉔	Net Scan	00000000	00000000
	<FAX Counter>		
㉕	Transmit	00000000	00000000
㉖	Receive	00000000	00000000

Fig.10-32

Periodical Maintenance Counter:			
		Pages	Drive Counts
27	K-EPU		
	Setting	00000000	00000000
28	Current	00000000	00000000
29	Y-EPU		
	Setting	00000000	00000000
30	Current	00000000	00000000
31	M-EPU		
	Setting	00000000	00000000
32	Current	00000000	00000000
33	C-EPU		
	Setting	00000000	00000000
34	Current	00000000	00000000
35	K-Dev		
	Setting	00000000	00000000
36	Current	00000000	00000000
37	Y-Dev		
	Setting	00000000	00000000
38	Current	00000000	00000000
39	M-Dev		
	Setting	00000000	00000000
40	Current	00000000	00000000
41	C-Dev		
	Setting	00000000	00000000
42	Current	00000000	00000000
43	Others		
	Setting	00000000	00000000
44	Current	00000000	00000000
45	Printer Error History:		
	Date	Time	ErrorCode Counter
	04/13/2008	16:44	F110 00000000
	04/12/2008	22:28	F110 00000000
	04/12/2008	22:23	F110 00000000
	03/15/2008	22:23	F110 00000000
	02/25/2008	11:12	F110 00000000
	Toner Information		
	Toner	Remaining Quantity (%)	
46	Yellow	00000000	
47	Magenta	00000000	
48	Cyan	00000000	
49	Black	00000000	

Fig.10-33

1. Date
2. Machine model name
3. Serial number
4. Total counter value
5. Supplier information
6. Customer information
7. Service technician information
8. Count setting of large-sized paper (Fee charging system counter)
9. Definition setting of large-sized paper (Fee charging system counter)
- 10.Count setting of large-sized paper (PM)
- 11.Definition setting of large-sized paper (PM)
- 12.Number of output pages in the Copier Function (FULL COLOR)
- 13.Number of output pages in the Printer Function (FULL COLOR)
- 14.Number of output pages in the Copier Function (TWIN COLOR)
- 15.Number of output pages in the Copier Function (BLACK)
- 16.Number of output pages in the Printer Function (BLACK)
- 17.Number of output pages at the List Print Mode (BLACK)
- 18.Number of output pages in the FAX Function (BLACK)
- 19.Number of scanning pages in the Copier Function (FULL COLOR)
- 20.Number of scanning pages in the Network Scanning Function (FULL COLOR)
- 21.Number of scanning pages in the Copier Function (TWIN COLOR)
- 22.Number of scanning pages in the Copier Function (BLACK)
- 23.Number of scanning pages in the FAX Function (BLACK)
- 24.Number of scanning pages in the Network Scanning Function (BLACK)

- 25.Number of transmitted pages in the FAX Function (BLACK)
- 26.Number of received pages in the FAX Function (BLACK)
- 27.PM count setting value / PM driving count setting value [EPU (K)]
- 28.PM count present value / PM driving count present value [EPU (K)]
- 29.PM count setting value / PM driving count setting value [EPU (Y)]
- 30.PM count present value / PM driving count present value [EPU (Y)]
- 31.PM count setting value / PM driving count setting value [EPU (M)]
- 32.PM count present value / PM driving count present value [EPU (M)]
- 33.PM count setting value / PM driving count setting value [EPU (C)]
- 34.PM count present value / PM driving count present value [EPU (C)]
- 35.PM count setting value / PM driving count setting value [Developer material (K)]
- 36.PM count present value / PM driving count present value [Developer material (K)]
- 37.PM count setting value / PM driving count setting value [Developer material (Y)]
- 38.PM count present value / PM driving count present value [Developer material (Y)]
- 39.PM count setting value / PM driving count setting value [Developer material (M)]
- 40.PM count present value / PM driving count present value [Developer material (M)]
- 41.PM count setting value / PM driving count setting value [Developer material (C)]
- 42.PM count present value / PM driving count present value [Developer material (C)]
- 43.PM count setting value / PM driving count setting value [Other parts]
- 44.PM count present value / PM driving count present value [Other parts]
- 45.History error
 - *1 The latest 20 errors are displayed.
- 46.Toner remaining quantity (Yellow)
- 47.Toner remaining quantity (Magenta)
- 48.Toner remaining quantity (Cyan)
- 49.Toner remaining quantity (Black)

[2] Total Counter Transmit / PM Counter Transmit by FAX

*1 In case of the PM Counter Transmit, the title is replaced to "PERIODICAL MAINTENANCE NOTIFICATION".

Sheet 1

COUNTER NOTIFICATION (*1)	
①	DATE : 12/04/14 13:47
②	MACHINE MODEL : TOSHIBA e-STUDIOxxxx
③	SERIAL NUMBER : 1234567890
④	TOTAL COUNTER : 00004787
[
⑤	CUSTOMER NAME : CUSTOMER_NAME
	CUSTOMER ADDRESS : CUSTOMER_ADDRESS
	CUSTOMER TEL NUMBER : 1234567890
	CUSTOMER E-MAIL ADDRESS : customer_emailaddress@dddd.xxx
[
⑥	SERVICE TECHNICIAN NUMBER : svc12
	SERVICE TECHNICIAN NAME : SERVICE_TECHNICIAN_NAME
	SERVICE TECHNICIAN TEL NUMBER : 0987654321
	SERVICE TECHNICIAN E-MAIL : svc@toshibatec.co.jp
[
⑦	SUPPLIER NAME : SUPPLIER_NAME
	SUPPLIER ADDRESS : SUPPLIER_ADDRESS
	SUPPLIER FAX NUMBER : 5544332211
	SUPPLIER E-MAIL : supplier_emailaddress@ccccc.xxx

Fig.10-34

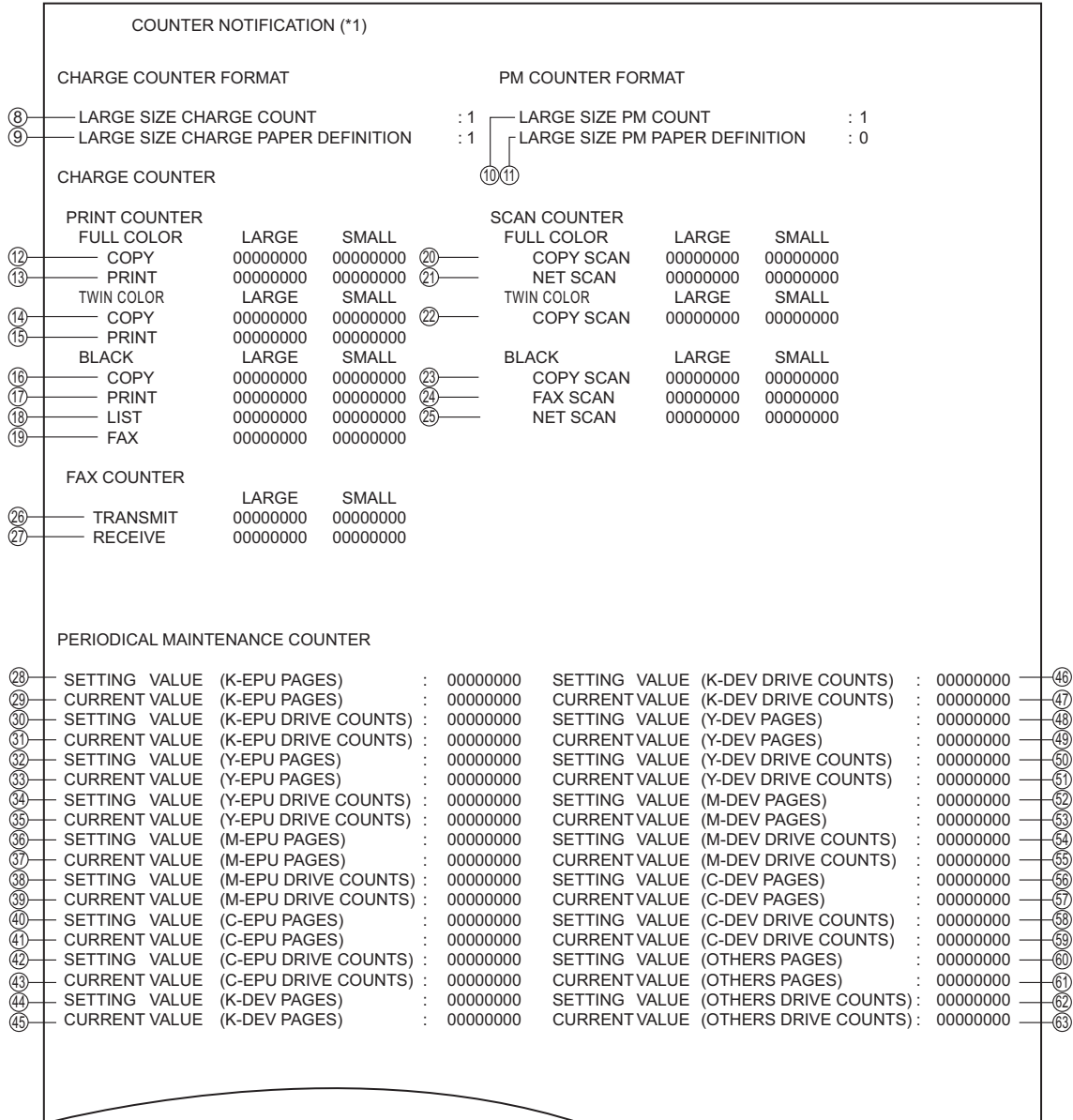

Fig.10-35

COUNTER NOTIFICATION (*1)								
PRINTER ERROR HISTORY								
DATE	TIME	ERROR CODE	COUNTER	DATE	TIME	ERROR CODE	COUNTER	
08/04/13	16:44	F110	00000000	08/04/13	16:44	F110	00000000	(*2)
08/04/12	22:28	F110	00000000	08/04/13	16:44	F110	00000000	
08/04/12	22:23	F110	00000000	08/04/13	16:44	F110	00000000	
08/03/15	22:23	F110	00000000	08/04/13	16:44	F110	00000000	
08/02/25	11:12	F110	00000000	08/04/13	16:44	F110	00000000	
TONER INFORMATION								
YELLOW REMAINING QUANTITY (%)			:	00000059				
MAGENTA REMAINING QUANTITY (%)			:	00000059				
CYAN REMAINING QUANTITY (%)			:	00000059				
BLACK REMAINING QUANTITY (%)			:	00000059				

Fig.10-36

1. Date
2. Machine model name
3. Serial number
4. Total counter value
5. Customer information
6. Service technician information
7. Supplier information
8. Count setting of large-sized paper (Fee charging system counter)
9. Definition setting of large-sized paper (Fee charging system counter)
- 10.Count setting of large-sized paper (PM)
- 11.Definition setting of large-sized paper (PM)
- 12.Number of output pages in the Copier Function (FULL COLOR)
- 13.Number of output pages in the Printer Function (FULL COLOR)
- 14.Number of output pages in the Copier Function (TWIN COLOR)
- 15.Number of output pages in the Printer Function (TWIN COLOR)
- 16.Number of output pages in the Copier Function (BLACK)
- 17.Number of output pages in the Printer Function (BLACK)
- 18.Number of output pages at the List Print Mode (BLACK)
- 19.Number of output pages in the FAX Function (BLACK)
- 20.Number of scanning pages in the Copier Function (FULL COLOR)
- 21.Number of scanning pages in the Network Scanning Function (FULL COLOR)
- 22.Number of scanning pages in the Copier Function (TWIN COLOR)
- 23.Number of scanning pages in the Copier Function (BLACK)
- 24.Number of scanning pages in the FAX Function (BLACK)
- 25.Number of scanning pages in the Network Scanning Function (BLACK)
- 26.Number of transmitted pages in the FAX Function (BLACK)
- 27.Number of received pages in the FAX Function (BLACK)
- 28.PM count setting value [EPU (K)]
- 29.PM count present value [EPU (K)]
- 30.PM driving count setting value [EPU (K)]
- 31.PM driving count present value [EPU (K)]
- 32.PM count setting value [EPU (Y)]
- 33.PM count present value [EPU (Y)]
- 34.PM driving count setting value [EPU (Y)]
- 35.PM driving count present value [EPU (Y)]

- 36.PM count setting value [EPU (M)]
- 37.PM count present value [EPU (M)]
- 38.PM driving count setting value [EPU (M)]
- 39.PM driving count present value [EPU (M)]
- 40.PM count setting value [EPU (C)]
- 41.PM count present value [EPU (C)]
- 42.PM driving count setting value [EPU (C)]
- 43.PM driving count present value [EPU (C)]
- 44.PM count setting value [Developer material (K)]
- 45.PM count present value [Developer material (K)]
- 46.PM driving count setting value [Developer material (K)]
- 47.PM driving count present value [Developer material (K)]
- 48.PM count setting value [Developer material (Y)]
- 49.PM count present value [Developer material (Y)]
- 50.PM driving count setting value [Developer material (Y)]
- 51.PM driving count present value [Developer material (Y)]
- 52.PM count setting value [Developer material (M)]
- 53.PM driving count present value [Developer material (M)]
- 54.PM driving count setting value [Developer material (M)]
- 55.PM driving count present value [Developer material (M)]
- 56.PM count setting value [Developer material (C)]
- 57.PM count present value [Developer material (C)]
- 58.PM driving count setting value [Developer material (C)]
- 59.PM driving count present value [Developer material (C)]
- 60.PM count setting value (Other parts)
- 61.PM count present value (Other parts)
- 62.PM driving count setting value (Other parts)
- 63.PM driving count present value (Other parts)
- 64.History of error
 - *2 The latest 20 errors are displayed.
- 65.Toner remaining quantity (Yellow)
- 66.Toner remaining quantity (Magenta)
- 67.Toner remaining quantity (Cyan)
- 68.Toner remaining quantity (Black)

[3] Toner near-empty notification by e-mail

Subject: Toner Near-Empty Notification

```
1  Date       : 04/26/2012 12:34
2  Machine Model : TOSHIBA e-STUDIOxxxx
3  SerialNumber : 1234567890
4  Total Counter : 00004787
5  Supplier:
   Name       : SUPPLIER_NAME
   Fax Number : 1122334455
   E-Mail     : Supplier_emailaddress@cccc.xxx
   Address    : SUPPLIER_ADDRESS
6  Customer:
   Name       : CUSTOMER_NAME
   Tel Number : 1234567890
   E-Mail     : customer_emailaddress@ddd.xxx
   Address    : CUSTOMER_ADDRESS
7  Service Technician:
   Number     : svc12
   Name       : SERVICE_TECHNICIAN_NAME
   Tel Number : 0987654321
   E-Mail     : svc@toshibatec.co.jp
8  ChargeCounterFormat:
   LargeSizeChargeCount      1
9  LargeSizeChargePaperDefinition  1
10 PMCounterFormat:
   LargeSizePMCount          1
11 LargeSizePMPaperDefinition  0
   Charge Counter:
       Large Small
   <Print Counter>
   Black -----
12 Copy      00000000 00000000
13 Print     00000000 00000000
14 List      00000000 00000000
15 FAX       00000000 00000000
   <Scan Counter>
   Full Color -----
16 Net Scan  00000000 00000000
   Black -----
17 Copy Scan 00000000 00000000
18 FAX Scan  00000000 00000000
19 Net Scan  00000000 00000000
   <FAX Counter>
20 Transmit  00000000 00000000
21 Receive   00000000 00000000
```

Fig.10-37

Periodical Maintenance Counter:			
	Pages	Drive Counts	
K-EPU			
22	Setting	00000000	00000000
23	Current	00000000	00000000
K-EPU			
24	Setting	00000000	00000000
25	Current	00000000	00000000
Others			
26	Setting	00000000	00000000
27	Current	00000000	00000000
Printer Error History:			
Date	Time	ErrorCode	Counter
04/13/2008	16:44	F110	00000000
04/12/2008	22:28	F110	00000000
04/12/2008	22:23	F110	00000000
03/15/2008	22:23	F110	00000000
02/25/2008	11:12	F110	00000000
Toner Information:			
Toner			
29	Yellow	00000000	
30	Magenta	00000000	
31	Cyan	00000000	
32	Black	00000000	

Fig.10-38

1. Date
2. Machine model name
3. Serial number
4. Total counter value
5. Supplier information
6. Customer information
7. Service technician information
8. Count setting of large-sized paper (Fee charging system counter)
9. Definition setting of large-sized paper (Fee charging system counter)
- 10.Count setting of large-sized paper (PM)
- 11.Definition setting of large-sized paper (PM)
- 12.Number of output pages in the Copier Function (BLACK)
- 13.Number of output pages in the Printer Function (BLACK)
- 14.Number of output pages at the List Print Mode (BLACK)
- 15.Number of output pages in the FAX Function (BLACK)
- 16.Number of scanning pages in the Network Scanning Function (Full color)
- 17.Number of scanning pages in the Copier Function (BLACK)
- 18.Number of scanning pages in the FAX Function (BLACK)
- 19.Number of scanning pages in the Network Scanning Function (BLACK)
- 20.Number of transmitted pages in the FAX Function (BLACK)
- 21.Number of received pages in the FAX Function (BLACK)
- 22.PM count setting value / PM driving count setting value [EPU (K)]
- 23.PM count present value / PM driving count present value [EPU (K)]
- 24.PM count setting value / PM driving count setting value [Developer material (K)]
- 25.PM count present value / PM driving count present value [Developer material (K)]
- 26.PM count setting value / PM driving count setting value [Other parts]

- 27. PM count present value / PM driving count present value [Other parts]
- 28. History error
- 29. Toner remaining quantity (Yellow)
- 30. Toner remaining quantity (Magenta)
- 31. Toner remaining quantity (Cyan)
- 32. Toner remaining quantity (Black)

[4] Toner near-empty notification by FAX

Sheet 1

TONER NEAR-EMPTY NOTIFICATION (*1)	
1	DATE : 12/04/14 13:47
2	MACHINE MODEL : TOSHIBA e-STUDIOxxxx
3	SERIAL NUMBER : 1234567890
4	TOTAL COUNTER : 00004787
[
5	CUSTOMER NAME : CUSTOMER_NAME
	CUSTOMER ADDRESS : CUSTOMER_ADDRESS
	CUSTOMER TEL NUMBER : 1234567890
	CUSTOMER E-MAIL ADDRESS : customer_emailaddress@dddd.xxx
[
6	SERVICE TECHNICIAN NUMBER : svc12
	SERVICE TECHNICIAN NAME : SERVICE_TECHNICIAN_NAME
	SERVICE TECHNICIAN TEL NUMBER : 0987654321
	SERVICE TECHNICIAN E-MAIL : svc@toshibatec.co.jp
[
7	SUPPLIER NAME : SUPPLIER_NAME
	SUPPLIER ADDRESS : SUPPLIER_ADDRESS
	SUPPLIER FAX NUMBER : 5544332211
	SUPPLIER E-MAIL : supplier_emailaddress@cccc.xxx

Fig.10-39

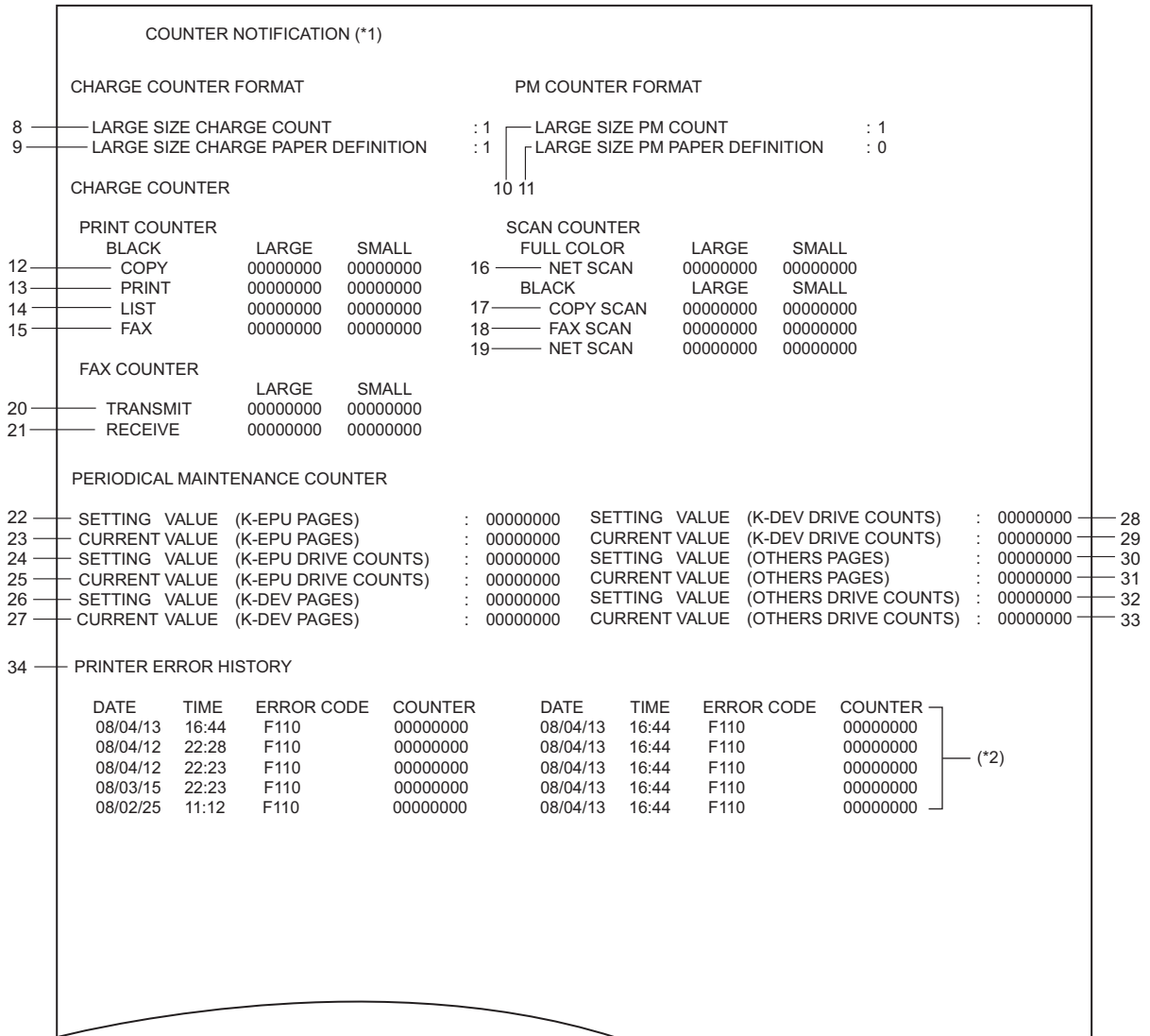

Fig.10-40

COUNTER NOTIFICATION (*1)		
35	Toner Cartridge Information:	
36	Toner Near-Empty Counter	
37	Setting	00000000
38	Current	00000000
39	Color code	1
40	Toner Near-Empty Sensed	1
41	Point Of Destination	0
	Used History	
	Developer Counter	00000056
	Developer Driving Time	00000057
	Drum Driving Time	00000058
	Toner Information	
42	Yellow Remaining Quantity (%)	: 00000059
43	Magenta Remaining Quantity (%)	: 00000060
44	Cyan Remaining Quantity (%)	: 00000061
45	Black Remaining Quantity (%)	: 00000062

Fig.10-41

1. Date
2. Machine model name
3. Serial number
4. Total counter value
5. Customer information
6. Service technician information
7. Supplier information
8. Count setting of large-sized paper (Fee charging system counter)
9. Definition setting of large-sized paper (Fee charging system counter)
10. Count setting of large-sized paper (PM)
11. Definition setting of large-sized paper (PM)
12. Number of output pages in the Copier Function (BLACK)
13. Number of output pages in the Printer Function (BLACK)
14. Number of output pages at the List Print Mode (BLACK)
15. Number of output pages in the FAX Function (BLACK)
16. Number of scanning pages in the Network Scanning Function (Full color)
17. Number of scanning pages in the Copier Function (BLACK)
18. Number of scanning pages in the FAX Function (BLACK)
19. Number of scanning pages in the Network Scanning Function (BLACK)
20. Number of transmitted pages in the FAX Function (BLACK)
21. Number of received pages in the FAX Function (BLACK)
22. PM count setting value [EPU (K)]
23. PM count present value [EPU (K)]
24. PM driving count setting value [EPU (K)]
25. PM driving count present value [EPU (K)]
26. PM count setting value [Developer material (K)]
27. PM driving count present value [Developer material (K)]
28. PM driving count setting value [Developer material (K)]
29. PM driving count present value [Developer material (K)]
30. PM count setting value (Other parts)
31. PM driving count present value (Other parts)
32. PM driving count setting value (Other parts)
33. PM driving count present value (Other parts)

- 34. History of error
- 35. Toner cartridge information
- 36. Toner near-empty counter
- 37. Setting value of toner cartridge rotation time counter
- 38. Current value of toner cartridge rotation time counter
- 39. Color of toner cartridge
 - 1: Black
 - 2: Yellow
 - 3: Magenta
 - 4: Cyan
- 40. Value of "toner near empty threshold setting (FS-08-5155)"
- 41. Destination setting of toner cartridge
 - *2 The latest 20 errors are displayed.
- 42. Toner remaining quantity (Yellow)
- 43. Toner remaining quantity (Magenta)
- 44. Toner remaining quantity (Cyan)
- 45. Toner remaining quantity (Black)

[5] Service Call Transmit
 Subject: Service Call Notification

① Date: 04/14/2012 13:47
 Machine Name: e-STUDIOxxxx SerialNumber:1234567890
 ② ③

④ Function: Printer
 ⑤ Severity: Error
 ⑥ Error Code: XXXX
 ⑦ Message:
 XXX

⑧ Supplier:
 Name : SUPPLIER_NAME
 Tel Number : 1122334455
 E-Mail : supplier_emailaddress@cccc.xxx
 Address : SUPPLIER_ADDRESS

⑨ Customer:
 Name : CUSTOMER_NAME
 Tel Number : 1234567890
 E-Mail : customer_emailaddress@dddd.xxx
 Address : CUSTOMER_ADDRESS

⑩ Service Technician:
 Number : svc12
 Name : SERVICE_TECHNICIAN_NAME
 Tel Number : 0987654321
 E-Mail : svc@toshibatec.co.jp

⑪ Printer Error History:

Date	Time	ErrorCode	Counter
04/13/2012	16:44	F110	} (*1)
04/12/2012	22:28	F110	
04/12/2012	22:23	F110	
03/15/2012	22:23	F110	
02/25/2012	11:12	F110	

Toner Information

Toner	Remaining Quantity(%)
⑫ Yellow	00000000
⑬ Magenta	00000000
⑭ Cyan	00000000
⑮ Black	00000000

Fig.10-42

1. Date (When an error occurs)
2. Machine model name
3. Serial number
4. Function: Fixed at "Printer"
5. Severity: Fixed at "Error"
6. Error code
7. Error message: The content of error is displayed.
8. Supplier information
9. Customer information
10. Service technician information
11. History of error
 - *1 The latest 20 errors are displayed.
12. Toner remaining quantity (Yellow)
13. Toner remaining quantity (Magenta)
14. Toner remaining quantity (Cyan)
15. Toner remaining quantity (Black)

[6] HDD alert notification by E-mail

Subject: HDD ALERT NOTIFICATION

Date	: 99-99-'99 99:99
Machine Model	: TOSHIBA e-STUDIOxxxx
Serial Number	: 1234567890
F/W Ver.	: XXXXXXXXXXXXXXXX
Total Counter	: 00000000
Supplier:	
Name	: XXX
Tel Number	: XXX
E-Mail	: XXX
Address	: XXX
Customer:	
Name	: XXX
Tel Number	: XXX
E-Mail	: XXX
Address	: XXX
Service Technician:	
Number	: XXX
Name	: XXX
Tel Number	: XXX
E-Mail	: XXX
HDD Model Number	: TOSHIBAXXXXXXXXXXXXXXXXXXXXXXXXXXXXX
HDD Serial Number	: XXXXXXXXXXXXXXXXXXXXXXX
SMART Information	
Start/Stop Count	: 0
Reallocated Sector Count	: 0
Power-On hours count	: 0
Drive Power Cycle Count	: 0
Shock Sense Count	: 0
Power-Off Retract Count	: 0
Load Cycle Count	: 0
Temperature(Minimum)	: 0
Temperature(Maximum)	: 0
Reallocated Sector Event	: 0
Current Pending Sector Count	: 0
CRC Error Count	: 0
Loaded Hours	: 0
HDD Check Result	: Please make a backup of HDD data.

Fig.10-43

[7] HDD alert notification by Fax

Sheet 1

```
HDD ALERT NOTIFICATION
DATE : 99-99-'99 99:99
MACHINE MODEL : TOSHIBA e-STUDIOxxxx
SERIAL NUMBER : 1234567890
TOTAL COUNTER : 00000000
CUSTOMER NAME : XXXXXXXXXXXXXXXXXXXXXXXXXXXXXXXXXXXXXXXXXXXX
CUSTOMER ADDRESS : XXXXXXXXXXXXXXXXXXXXXXXXXXXXXXXXXXXXXXXXXXXX
CUSTOMER TEL NUMBER : XXXXXXXXXXXXXXXXXXXXXXXXXXXXXXXXXXXXXXXXXXXX
CUSTOMER E-MAIL ADDRESS : XXXXXXXXXXXXXXXXXXXXXXXXXXXXXXXXXXXXXXXXXXXX
SERVICE TECHNICIAN NUMBER : XXXXXXXXXXXXXXXXXXXXXXXXXXXXXXXXXXXXXXXXXXXX
SERVICE TECHNICIAN NAME : XXXXXXXXXXXXXXXXXXXXXXXXXXXXXXXXXXXXXXXXXXXX
SERVICE TECHNICIAN TEL NUMBER : XXXXXXXXXXXXXXXXXXXXXXXXXXXXXXXXXXXXXXXXXXXX
SERVICE TECHNICIAN E-MAIL : XXXXXXXXXXXXXXXXXXXXXXXXXXXXXXXXXXXXXXXXXXXX
SUPPLIER NAME : XXXXXXXXXXXXXXXXXXXXXXXXXXXXXXXXXXXXXXXXXXXX
SUPPLIER ADDRESS : XXXXXXXXXXXXXXXXXXXXXXXXXXXXXXXXXXXXXXXXXXXX
SUPPLIER FAX NUMBER : XXXXXXXXXXXXXXXXXXXXXXXXXXXXXXXXXXXXXXXXXXXX
SUPPLIER E-MAIL ADDRESS : XXXXXXXXXXXXXXXXXXXXXXXXXXXXXXXXXXXXXXXXXXXX
```

Fig.10-44

Sheet 2

```
HDD ALERT NOTIFICATION
HDD MODEL NUMBER : TOSHIBAXXXXXXXXXXXXXXXXXXXXXXXXXX
HDD SERIAL NUMBER : XXXXXXXXXXXXXXXXXXXX
SMART INFORMATION
START/STOP COUNT : 0
REALLOCATED SECTOR COUNT : 0
POWER-ON HOURS COUNT : 0
DRIVE POWER CYCLE COUNT : 0
SHOCK SENSE COUNT : 0
POWER-OFF RETRACT COUNT : 0
LOAD CYCLE COUNT : 0
TEMPERATURE(MINIMUM) : 0
TEMPERATURE(MAXIMUM) : 0
REALLOCATED SECTOR EVENT : 0
CURRENT PENDING SECTOR COUNT : 0
CRC ERROR COUNT : 0
LOADED HOURS : 0
HDD CHECK RESULT : PLEASE MAKE A BACKUP OF HDD DATA.
```

Fig.10-45

10.3 Remote Panel (VNC)

10.3.1 Outline

By using the Remote Panel (VNC: Virtual Network Computing) function, the control panel of equipment (*) which is located in a remote place can be operated by a client computer or tablet.

* Equipment whose IP address can be confirmed from a client computer or tablet to be operated

Notes:

- The VNC function is available with the SYS version TC01HD0W1500 or later.
- Be sure to obtain permission from the user beforehand to enable and use this function.
- If the user's permission can be obtained, ask that the equipment be operated with this function enabled and not disabled.
- The VNC client software needs to be installed in a client computer or tablet in order for you to perform the VNC connection with the equipment. (Recommended VNC client software: "UltraVNC")

The following items become operable in the VNC function.

- All the operations which are available on the control panel (operations of icons in the touch panel and hard keys)

Notes:

The pinch operation on the touch panel, [ON/OFF] button operation, LED lamp performance and Ten Key (option) operation are not supported.

- Shifting to the FS Menu from the normal mode
- Browsing and setting self-diagnostic codes in the FS Menu

10.3.2 Setting

[1] Setting the equipment

Set this function from TopAccess or [08 SETTING MODE].

[A] Setting from TopAccess

Access from TopAccess > [Administration] > [Setup] > [Network] and specify the items in VNC Setting as below.

Item name	Setting
Enable VNC Function	Select [Enable].
Old Password	Enter the old password for the VNC function.
New Password	Enter a new password for the VNC function.
Retype Password	Retype the new password for the VNC function.
Enable SSL/TLS	Select [Enable] or [Disable].

[B] Setting from [08 SETTING MODE]

Code	Description	Setting
FS-08-8794	VNC connection of control panel	Set "1" (Allowed to connect).
FS-08-8559	Password at VNC connection	Enter a password for the VNC function.
FS-08-8699	SSL function setting	Set "1" (Enabled) or "2" (Disabled).

Notes:

- "d9kvgn" has been given for the default password. Be sure to change this at the time of the first setting.
- To use "UltraVNC" for the VNC client software, set [Disable] in the [Enable SSL/TLS] option. To perform the VNC function by selecting [Enable] for the [Enable SSL/TLS] option, use a VNC client software which supports SSL/TLS.
- Specify a password with six or more and eight or less alphanumeric letters.
- When the "Enable" is selected for Enable VNC Function (FS-08-8794: 1), the equipment cannot shift to the Super Sleep mode.

[2] Setting a client computer or tablet

Install the VNC client software.

10.3.3 Operation

[1] VNC connection between the equipment and a client computer or tablet

- (1) Start the VNC client software in the client computer or tablet.
- (2) Enter the IP address of the equipment to connect in the VNC Server field and press [Connect].

Remarks:

Select "Auto" for Quick Options.

- (3) Enter the password for the VNC connection and press [Log On].
The control panel of the connected equipment is displayed.

Notes:

Only one client computer or tablet can be connected to one equipment unit.

[2] Operation of the equipment on the remote panel

The equipment can be operated by mouse clicking the button or icon on the control panel displayed on the client computer or tablet.

Notes:

- The pinch operation on the touch panel, [ON/OFF] button operation, LED lamp performance and Ten Key (option) operation are not supported.
- Operation on the control panel of the equipment is possible even during the VNC connection.
- The equipment does not shift to the Energy Saving mode or Sleep mode during the VNC connection.

[3] Shifting to the FS Menu

- (1) Press the [Gear] icon with the mouse for at least 3 seconds.
- (2) Enter the service password on the login screen and press [OK].

Important:

Be sure to shift the equipment to the normal mode before quitting the VNC connection.

Notes:

- While the equipment is shifting to the FS Menu, jobs such as network printing, fax, internet fax and remote scanning are not accepted.
- If the equipment is rebooted when it is returned from the FS menu to the normal mode, the VNC connection is disconnected. To continue the operation, perform the VNC connection again.

10.4 Remote Service

10.4.1 Outline

When the remote management of the equipment is performed by e-BRIDGE CloudConnect, carry out the updating or setting change once a day or at the time of the rebooting of the equipment. Using the Remote Service function can immediately reflect the updating or setting change to the equipment, and thus the period to solve the problem can be shortened.

10.4.2 Setting

Set "1" (Enabled) for FS-08-3820 (e-BRIDGE CloudConnect function setting).

[Remote Service] is displayed in [User Functions -User-] > [Admin] > [General] on the touch panel.

10.4.3 Operation

After the setting, such as a policy, has been specified to the target equipment by means of e-BRIDGE CloudConnect, ask your user to press [Remote Service] and then press [Yes] on the connection confirmation screen.

Notes:

- During the connecting of the Remote Service function, an hourglass mark is displayed on the screen and the operation of other functions becomes impossible.
- When the Remote Service function is finished, the equipment will reboot.
- When this operation has been completed successfully, "Communication success" is displayed on the bottom left of the Home screen.
- If an error has occurred, check the message log of TopAccess and take an appropriate measure.

11. FIRMWARE UPDATING

11.1 Overview

When you want to update the firmware to the latest one or the equipment becomes inoperable due to some defect in the firmware, updating can be performed as follows.

Equipment

Firmware	Updating method
System firmware	USB device
Engine firmware	
Scanner firmware	
System software	
NIC firmware	

Options

Model name	Firmware	Updating method
Reversing Automatic Document Feeder (RADF) (MR-3031)	RADF firmware	USB device
Dual Scan Document Feeder (DSDF) (MR-4000)	DSDF firmware	
Finisher (MJ-1042)	Finisher firmware	
Finisher (MJ-1109)	Finisher firmware	
Finisher (MJ-1110)	Finisher firmware	
Hole Punch Unit (MJ-6105)	Hole punch unit firmware	
FAX Board (GD-1370)	FAX board firmware (Line1)	
	FAX board firmware (Line2)	

Notes:

- Written firmware varies depending on the kinds of the boards provided as service parts. For updating, only the minimum firmware is installed on the system control PC board, logic PC board, scanning section control PC board and FAX board. The latest version of the firmware at the time of delivery is written on the RADF control PC board and finisher control PC board. When any of above boards is replaced with a new one in the field, check the other firmware version used and then update with a corresponding suitable version.
- “Can’t fetch Ver” is displayed in the Installed Version field when the version of the installed firmware cannot be acquired properly. For example, if [HS-49] is carried out without your performing the normal startup after updating, this message will appear for some firmware.

11.2 Firmware Updating with USB Device

The software and firmware can be updated by means of a USB device in which an update package is stored. All necessary files for updating are stored in the package provided, so be sure to save all of them in the model specific folder.

For the data file for each firmware, refer to the following tables.

Notes:

When performing the update, use the latest program.

11.2.1 Updating methods

There are three types of updating methods by means of a USB device. The table below explains the differences.

Method	File	Explanation
Normal update	Standard package	Updating the file of a base version.
Differential items update	Differential items package	Updating the version by means of the package of only the files which have been changed from the base. This method is applied to the system firmware and the system software. Since only the files which have been changed are packaged, the data size is smaller than that for the standard package. This method cannot be used for the equipment whose HDD has been formatted.
Patch update	Patch	Updating can be done in a shorter time than the standard one. This method is applied to the system firmware and the system software only.

11.2.2 Firmware type and data file for updating

[A] Normal update

Equipment

Firmware	Stored	Data file name	Display
System firmware	System control PC board (SYS board)	TC01SF0Wxxxx.tar * xxxx is version.	SYSTEM FIRMWARE (OS DATA)
System software	HDD	TC01HD0Wxxxx.tar * xxxx is version.	SYSTEM SOFTWARE (HDD DATA)
Engine firmware	Logic PC board (LGC board)	TK110MWW.xxx * xxx is version.	ENGINE FIRMWARE
Scanner firmware	System control PC board (SYS board)	TK100SLGWV.xxx * xxx is version.	SCANNER FIRMWARE
NIC firmware	System control PC board (SYS board)	T370NIC0Wxxxx.tar * xxxx is version.	NIC FIRMWARE

Option

Firmware	Stored	Data file name	Display
RADF firmware	DLG board (MR-3031)	H617DFWW.0xxx * xxx is version.	RADF FIRMWARE
DSDf firmware	DLG board (MR-4000)	H616DFWW.xxx * xxx is version.	DSDf FIRMWARE
Finisher firmware (MJ-1042)	Finisher control PC board	FIN1042T.xxx * xxx is version.	FINISHER FIRMWARE
Finisher firmware (MJ-1109)	Finisher control PC board	FIN1109T.xxx * xxx is version.	FINISHER FIRMWARE
Finisher firmware (MJ-1110)	Finisher control PC board	FIN1110T.xxx * xxx is version.	FINISHER FIRMWARE
Hole punch unit firmware (MJ-6105)	Punch control PC board	PUN6105T.xxx * xxx is version.	PUNCH FIRMWARE
FAX firmware (GD-1370)	System control PC board (SYS board)	FAXH625T.xxx * xxx is version.	FAX FIRMWARE1, FAX FIRMWARE2

[B] Patch update

Firmware	Stored	Data file name	Display
System firmware	System control PC board (SYS board)	TC01SFPWxxxx.tar * xxxx is version.	SYSTEM FIRMWARE (OS DATA)
System software	HDD	TC01HDPWxxxx.tar * xxxx is version.	SYSTEM SOFTWARE (HDD DATA)

[C] Differential items update

Firmware	Stored	Data file name	Display
System firmware	System control PC board (SYS board)	TC01SFdWxxxx.tar * xxxx is version.	SYSTEM FIRMWARE (OS DATA)
System software	HDD	TC01HDdWxxxx.tar * xxxx is version.	SYSTEM SOFTWARE (HDD DATA)

11.2.3 Folder configuration of a USB device

[A] Normal update

Store the data file for updating in the model specific folder. This configuration is an example. The number of files differs depending on the installed option.

Model specific folder name	2015AC_5015AC
----------------------------	---------------

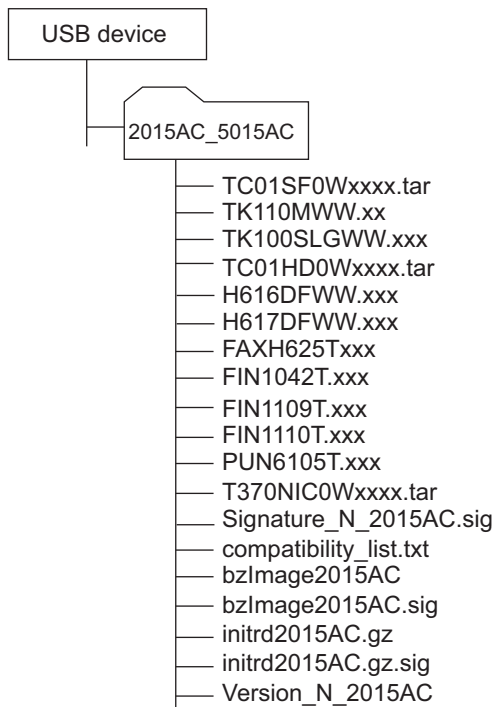

Fig.11-1

[B] Patch update

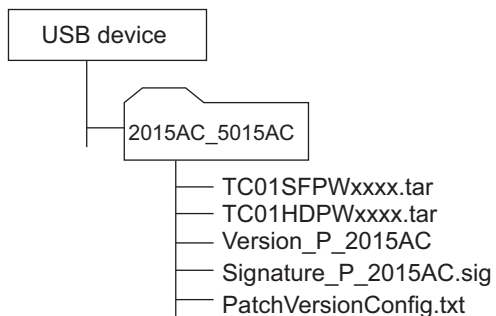

Fig.11-2

[C] Differential items update

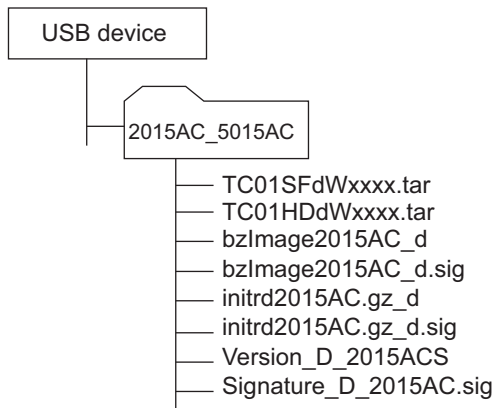

Fig.11-3

Notes:

- Since the date and time set in the equipment are recorded in the firmware update log, make sure that they are correct before updating the firmware.
- Never change the model specific folder name, since it is used for identifying the data file when the data files used for updating multiple models are stored in the USB device.

Important:

- Only the USB devices which meet the following conditions should be used for updating. Be careful since updating with any device other than the above is never guaranteed.
 - A combination USB device with a flash memory (to be connected directly to the USB port) and its capacity is 2GB or more.
 - Operation of the USB device used for updating has been confirmed at the input check of this equipment (03 Test mode). (P. 5-9 “5.4.2 Input check”)
 - USB devices which comply with the following standards regulated by USB-IF (USB Implementers Forum)
 - Class number: 8 (=08h) (Mass-storage class)
 - Sub-class number: 6 (=06h) (SCSI transfer command set)
 - Protocol number: 80 (=50h) (Bulk-Only)
- * Most common USB devices comply with the specification above and can be used for updating. However, the operation in all the Multi Functional Digital Color Systems and Multi Functional Digital Systems is not necessarily guaranteed since the most of these devices are developed based on use in a PC environment (Windows or Macintosh). Therefore, check thoroughly that the device is operational in the equipment for which the updating will be performed when purchasing it.
- The USB devices complying with USB2.0 can be used for updating.
- Do not update the firmware by any storage device other than a flash memory (such as a USB connection type memory card reader, CD/DVD drive or hard disk), since it is never guaranteed.
- It is possible to store the model specific update program and the data file for updating directly in the root directory when you store the updating data file for one specific model in the USB device. However, if the model specific folder for the same model as that of the data file stored in the root directory already exists, this will have priority.

11.2.4 Update procedure

Important:

- The file system of a USB device should be formatted in the FAT16 or FAT32 format. USB devices formatted in an NTFS or another format will not be able to be operated. The file system of a USB device can be confirmed by opening its property using Windows Explorer or such.
- Never shut down the equipment during the update. Firmware data and the following option data (if installed) could be damaged and may not be able to be operated properly.
 - Data Overwrite Enabler (GP-1070)
 - Meta Scan Enabler (GS-1010)
 - External Interface Enabler (GS-1020)
 - IPsec Enabler (GP-1080)
 - Hardcopy Security kit (GP-1190A)
 - OCR Enabler (GS-1080/1085)
 - Multi Station Print Enabler (GS-1090/1095)

[1] Updating firmware

- (1) Connect the USB device to the PC and write the model specific folder in which the data file is stored.
Store the data file for updating in the model specific folder.
- (2) Press the [ON/OFF] button to shut down the equipment.
- (3) Connect the USB device [1] to the USB port [2].

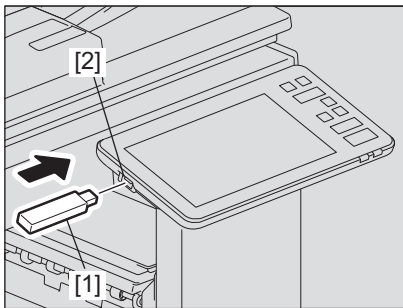

Fig.11-4

- (4) Start the HS Menu.

(5) Press [49 Firmware Update].

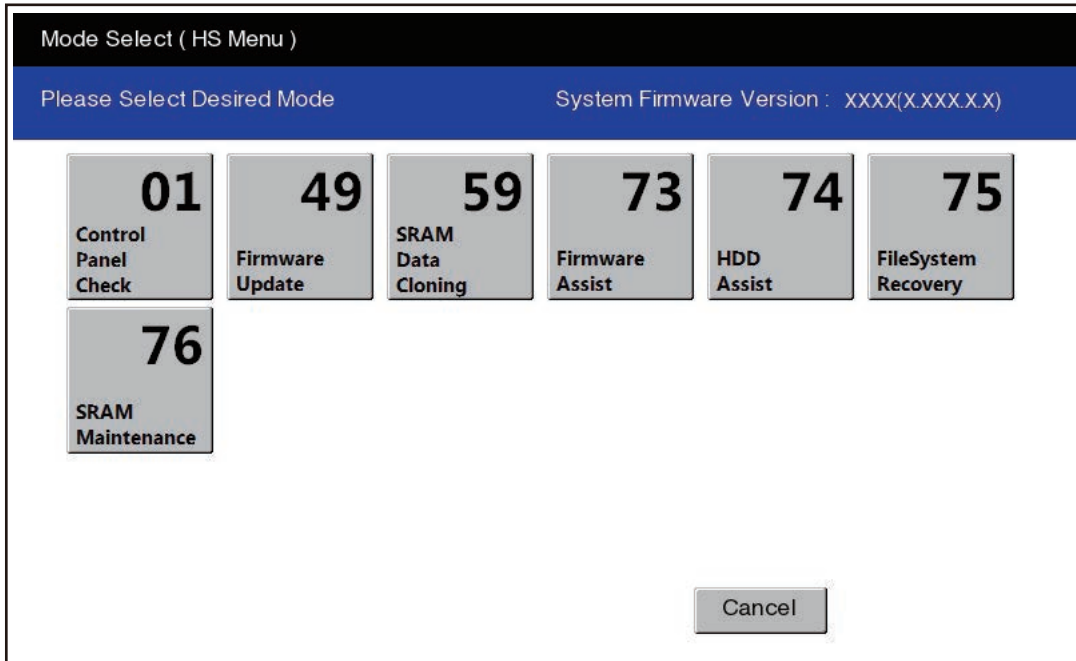

Fig.11-5

(6) Select the update type.
Normal Update
Patch Update
Diff Update

Notes:

The update file which is selected must be included in the model specific folder. There is no problem if updated files of different types are mixed.

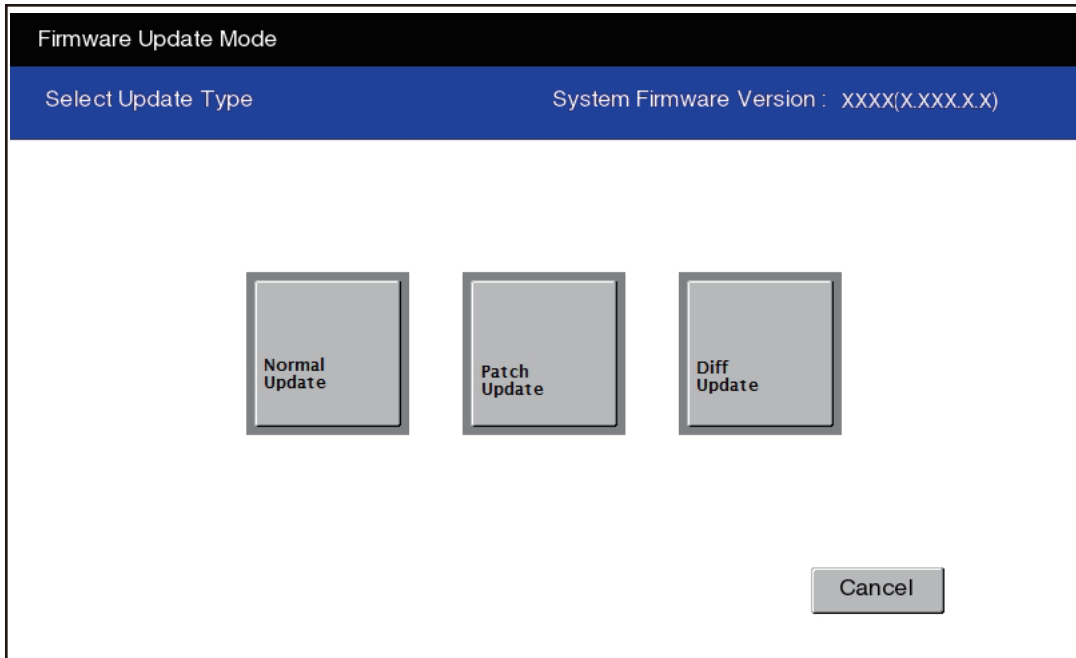

Fig.11-6

The screen for selecting items to be updated is displayed.

- Only the firmware which is included in the update file is displayed.
- The firmware whose version is later than the current one is being selected to be updated if there is such in the update file.

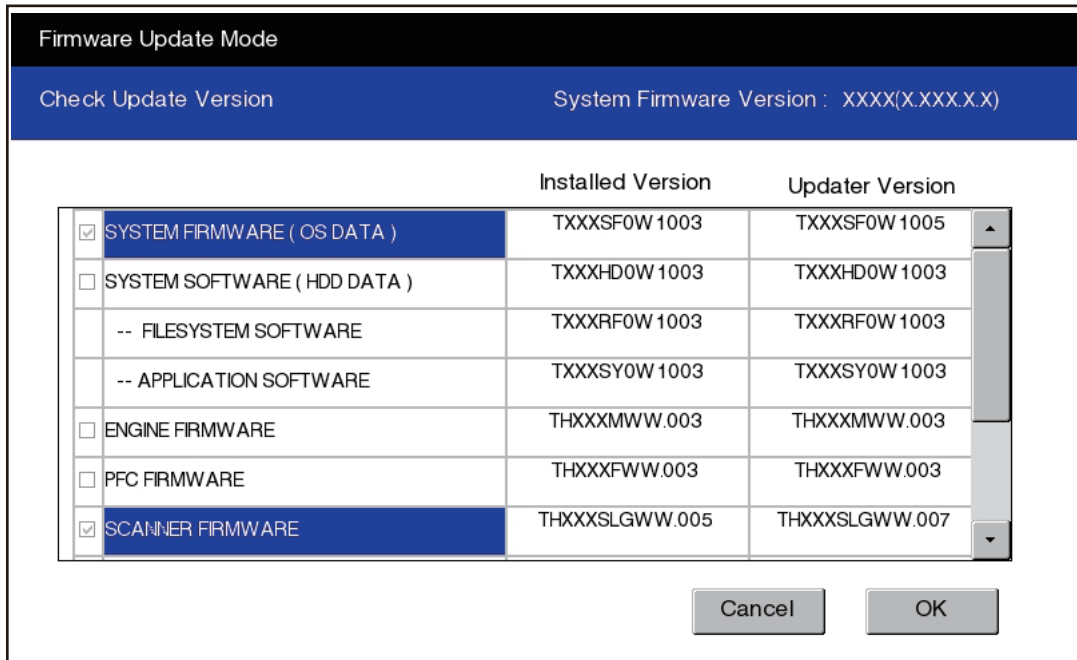

Fig.11-7

Notes:

- The display of items on this screen varies depending on the types of data written on the USB device. Each item is displayed only when each data file is written on the USB device in the following conditions.

[A] Normal update

Item	Condition (xxx is version)
SYSTEM FIRMWARE (OS DATA)	TC01SF0Wxxxx.tar is written.
SYSTEM SOFTWARE (HDD DATA)	TC01HD0Wxxxx.tar is written.
ENGINE FIRMWARE	TK110MWW.xxx is written.
SCANNER FIRMWARE	TK100SLGWW.xxx is written.
RADF FIRMWARE	H617DFWW.0xxx is written. (When MR-3031 is connected)
DSDL FIRMWARE	H616DFWW.xxx is written. (When MR-4000 is connected)
NIC FIRMWARE	T370NIC0Wxxxx.tar is written.
FAX FIRMWARE	FAXH625TZxx is written. (When GD-1370 is connected.)
FINISHER FIRMWARE	FIN1042T.xxx is written. (When MJ-1042 is connected.) FIN1109T.xxx is written. (When MJ-1109 is connected.) FIN1110T.xxx is written. (When MJ-1110 is connected.)
PUNCH FIRMWARE	PUN6105T.xxx is written. (When MJ-6105 is connected.)

[B] Patch update

Item	Condition (xxx is version)
SYSTEM FIRMWARE (OS DATA)	TC01SFPWxxxx.tar is written.
SYSTEM SOFTWARE (HDD DATA)	TC01HDPWxxxx.tar is written.

[C] Differential items update

Item	Condition (xxx is version)
SYSTEM FIRMWARE (OS DATA)	TC01SFdWxxxx.tar is written.
SYSTEM SOFTWARE (HDD DATA)	TC01HDdWxxxx.tar is written.

- If the USB device is not recognized properly, “USB device Not detected” message is displayed. In this case, disconnect the USB device and connect again within 3 minutes, or shut down the equipment and connect the device properly. Then repeat the procedure from (5).
- If any of the error messages below is displayed, confirm if the data file in the USB device is correct. Then repeat the procedure from (5).

Error number	Error message	Cause
01	Model specific update program XXXXXXXXXXXXX is not stored.	No update file of this equipment exists in the USB storage.

- (7) Select the item.
The item selected is highlighted and a check is marked at its left side. If you press the item once again, its selection is released.

Item	Remarks
SYSTEM FIRMWARE(OS DATA)	Updating System firmware
SYSTEM SOFTWARE (HDD DATA)	Updating System software
ENGINE FIRMWARE	Updating Engine firmware
SCANNER FIRMWARE	Updating Scanner firmware
RADF FIRMWARE	Updating RADF firmware
DSDF FIRMWARE	Updating DSDF firmware
NIC FIRMWARE	Updating NIC firmware
FAX FIRMWARE	Updating FAX firmware
FINISHER FIRMWARE	Updating Finisher firmware
PUNCH FIRMWARE	Updating Punch firmware

- (8) Press [OK].
Updating starts and the processing status is displayed on the screen.

Status display during update	Status display when update is completed
SYSTEM FIRMWARE(OS DATA) update in progress	SYSTEM FIRMWARE(OS DATA) Completed
SYSTEM SOFTWARE (HDD DATA) update in progress	SYSTEM SOFTWARE (HDD DATA) Completed
ENGINE FIRMWARE update in progress	ENGINE FIRMWARE Completed
SCANNER FIRMWARE update in progress	SCANNER FIRMWARE Completed
RADF FIRMWARE update in progress	RADF FIRMWARE Completed
DSDF FIRMWARE update in progress	DSDF FIRMWARE Completed
NIC FIRMWARE update in progress	NIC FIRMWARE Completed
FAX FIRMWARE update in progress	FAX FIRMWARE Completed
FINISHER FIRMWARE update in progress	FINISHER FIRMWARE Completed
PUNCH FIRMWARE update in progress	PUNCH FIRMWARE Completed

- (9) When updating is completed properly, the following message is displayed at the bottom of the LCD screen.

Normal update: Update successfully completed Restart the MFP

Patch update: Patch Update Successfully Restart the MFP

Differential items update: Differential Update Successfully Restart the MFP

Notes: Troubleshooting when “Customized UI version is not compatible!” is displayed

In the equipment with the customized UI installed, when its version is not compatible with that for the HDD DATA to be installed, “Customized UI version is not compatible!” is displayed and the updating will fail. To continue the updating, perform FS-08-3512 (Customized UI uninstallation).

Notes: Troubleshooting when “Update Failed” is displayed

- Even though an update fails, do not turn the power OFF until other updates are finished.
- “Update Failed.” is displayed at the bottom of the screen when the updating is not completed properly. “Failed” appears next to the failed item on the status display. If “Update Failed” appears at the bottom of the screen, turn OFF the power and then check the following items. After confirming and clearing the problems, restart updating from the beginning.
 - Does the USB device meet the conditions to be used for updating?
 - Is the data file written properly on the USB device?
 - Is the USB device installed properly?
 - Do the USB device and equipment operate properly?
 - When H05 error occurs and it does not clear after a USB media check, replace the main memory (DIMM).
- The integrity check system is automatically operated before firmware updating. During this operation, “Verifying Signature...” and “Progress: **%” are displayed on the control panel. When the check is completed properly, no message for notifying the success will appear and the firmware updating will start. If it fails, “Invalid Signature” and “Copy Data with >valid signature in USB” will be shown. In that case, firmware updating cannot be performed, so turn the power OFF and disconnect the USB device. Check that there is no abnormality in the firmware data, and reperform the update.
- When a system firmware (OS Data) update error or system software (HD Data) update error occurs, “Update Failed” or “Failed” appears on the screen and the error number appears next to the message.

For details of each error, refer to the following tables.

System firmware update Error	
Error number	Error content
O01	FROM writing failed
O02	FROM verification error
O03	File operation error
O04	SRAM flag set error
O05	Electronic key data backup error
O06	Device error
O07	Signature Check Failed error
O08	Signature not present error

System software update Error	
Error number	Error content
H01	File creation error
H02	File decompression error (Out of free disk space on the HDD at file extraction)
H03	Partition mount error
H04	Other errors
H05	Signature Check Failed error
H06	Signature not present error
H07	Hard Disk Full Error

- When an Engine firmware update error, Scanner firmware update error, RADF/DSDF firmware update error, Punch firmware update error, Finisher firmware update error or FAX firmware update error occurs, “Update Failed” or “Failed” appears on the screen and the error number and error message appear next to the message. For details of each error, refer to the following tables.

Engine firmware update Error		
Error number	Error message	Error content
M01	Time out (When the download is requested)	Communication timeout (When the download is requested)
M02	Time out (When the download is written)	Communication timeout (When the download is written)
M03	Time out (When the download is finished)	Communication timeout (When the download is finished)
M04	Reception failed (When the download is requested)	Downloading request was denied. (When the download is requested)
M05	Deletion error (When the download is written)	Deletion error (When the download is written)
M06	Writing error (When the download is written)	Writing error (When the download is written)
M07	Checksum error (When the download is finished)	Checksum error (When the download is finished)
M08	Reception status code abnormality (When the download is requested)	Reception status code abnormality (When the download is requested)
M09	Reception status code abnormality (When the download is written)	Reception status code abnormality (When the download is written)
M10	Reception status code abnormality (When the download is finished)	Reception status code abnormality (When the download is finished)
M00	Other error	Other error

Scanner firmware update Error		
Error number	Error message	Error content
S01	Time out (When the download is requested)	Communication timeout (When the download is requested)
S02	Time out (When the download is written)	Communication timeout (When the download is written)
S03	Time out (When the download is finished)	Communication timeout (When the download is finished)
S05	Deletion error (When the download is written)	Deletion error (When the download is written)
S06	Writing error (When the download is written)	Writing error (When the download is written)
S08	Reception status code abnormality (When the download is requested)	Reception status code abnormality (When the download is requested)
S09	Reception status code abnormality (When the download is written)	Reception status code abnormality (When the download is written)
S10	Reception status code abnormality (When the download is finished)	Reception status code abnormality (When the download is finished)
S00	Other error	Other error

NIC firmware update Error		
Error number	Error message	Error content
N01	Connection Failure	Communication timeout
N02	No Update Files	No Update Files
N03	Flash Write Error	Writing error
N04	File decompression error	File decompression error

NIC firmware update Error		
Error number	Error message	Error content
N05	Other Errors	Other error

RADF/DSDF firmware update Error		
Error number	Error message	Error content
R01	Time out (When the download is requested)	Communication timeout (When the download is requested)
R02	Time out (When the download is written)	Communication timeout (When the download is written)
R03	Time out (When the download is finished)	Communication timeout (When the download is finished)
R05	Deletion error (When the download is written)	Deletion error (When the download is written)
R06	Writing error (When the download is written)	Writing error (When the download is written)
R08	Reception status code abnormality (When the download is requested)	Reception status code abnormality (When the download is requested)
R09	Reception status code abnormality (When the download is written)	Reception status code abnormality (When the download is written)
R10	Reception status code abnormality (When the download is finished)	Reception status code abnormality (When the download is finished)
R11	ADF not connected	RADF/DSDF not installed
R12	ADF download error	Firmware for different model data connected
R13	RADF/DSDF Mismatch error	Firmware for different model data connected
R00	Other error	Other error

Punch firmware update Error		
Error number	Error message	Error content
U01	Time out (When the download is requested)	Communication timeout (When the download is requested)
U02	Time out (When the download is written)	Communication timeout (When the download is written)
U03	Time out (When the download is finished)	Communication timeout (When the download is finished)
U04	Reception failed (When the download is requested)	Downloading request was denied. (When the download is requested)
U05	Deletion error (When the download is written)	Deletion error (When the download is written)
U06	Writing error (When the download is written)	Writing error (When the download is written)
U07	Checksum error (When the download is finished)	Checksum error (When the download is finished)
U08	Reception status code abnormality (When the download is requested)	Reception status code abnormality (When the download is requested)
U09	Reception status code abnormality (When the download is written)	Reception status code abnormality (When the download is written)
U10	Reception status code abnormality (When the download is finished)	Reception status code abnormality (When the download is finished)
U00	Other error	Other error

Finisher firmware update Error		
Error number	Error message	Error content
F01	Time out (When the download is requested)	Communication timeout (When the download is requested)

Finisher firmware update Error		
Error number	Error message	Error content
F02	Time out (When the download is written)	Communication timeout (When the download is written)
F03	Time out (When the download is finished)	Communication timeout (When the download is finished)
F04	Reception failed (When the download is requested)	Downloading request was denied. (When the download is requested)
F05	Deletion error (When the download is written)	Deletion error (When the download is written)
F06	Writing error (When the download is written)	Writing error (When the download is written)
F07	Checksum error (When the download is finished)	Checksum error (When the download is finished)
F08	Reception status code abnormality (When the download is requested)	Reception status code abnormality (When the download is requested)
F09	Reception status code abnormality (When the download is written)	Reception status code abnormality (When the download is written)
F10	Reception status code abnormality (When the download is finished)	Reception status code abnormality (When the download is finished)
F00	Other error	Other error

FAX firmware update Error		
Error number	Error message	Error content
FX01	Communication Timeout (when download is requested)	Communication timeout (When the download is requested)
FX02	Communication Timeout (when data is downloaded)	Communication timeout (When the download is finished)
FX03	Download request Failed	Downloading request was denied. (When the download is requested)
FX04	Received failure during download request	Reception Error (When the download is requested)
FX05	Received failure during data download	Reception error (During data download)
FX06	File decompression error	File decompression error
FX07	Other Errors	Other error

(10) Check that [Automatic Initialization] is displayed and then remove the USB device.

(11) Press [Automatic Initialization].

The equipment is rebooted and the initialization of the updating data is carried out.

[2] Confirmation of the updated data

After the updating is completed, check each data version in the 08 Setting Mode to confirm that the data were overwritten properly.

 P. 11-14 “11.3 Confirmation of the updated data”

[3] Adjustment

Perform the adjustment of the equipment.

- Performing Image Quality Control (FS-05-2742):
 📖 P. 6-4 “6.1.3 Performing image quality control”
- Adjustment of Color Registration Control (FS-05-4719):
 📖 P. 6-5 “6.1.4 Adjustment of color registration control”
- Automatic gamma adjustment <PPC> (FS-05-7869) (using FS-05-4 → [TEST PRINT] test pattern):
 📖 P. 6-28 “6.2.1 Automatic gamma adjustment”
- Automatic gamma adjustment <PRT> (FS-05-8008) (using FS-05-70 → [TEST PRINT] test pattern):
 📖 P. 6-55 “6.3.1 Automatic gamma adjustment”
- Automatic gamma adjustment <PRT> (FS-05-8009) (using FS-05-230 → [TEST PRINT] test pattern):
 📖 P. 6-55 “6.3.1 Automatic gamma adjustment”

11.3 Confirmation of the updated data

After the updating is completed, check each data version in 08 Setting Mode to confirm that the data were overwritten properly.

Firmware	Code
System software	9900
System firmware	9930
Engine firmware	9901
Scanner firmware	9902
NIC firmware	9990
DF firmware	9903
Finisher firmware	9904
Hole punch firmware	9944
FAX board firmware(Line1)	9905
FAX board firmware(Line2)	9969

12. BACKUP FUNCTION

12.1 Cloning (HS menu)

12.1.1 General description

Cloning (HS menu) is a function that backs up user data, setting data and SRAM data into a USB storage device and also restores these data into the equipment.

This function backs up or restores the data of the same equipment (same serial number), and is performed when the SRAM is replaced.

Notes:

The SYS board and SRAM should never be replaced together.

12.1.2 Precautions

- When the Security HDD is initialized or replaced, back up the SRAM data afterwards.
- It is assumed that cloning (HS menu) is to be performed when equipment is installed or options are installed. If the address book has been registered, do not perform restoring. Otherwise, registered or set data are lost.
- The USB storage device for the cloning (HS menu) must meet the following conditions. A cloning (HS menu) operation with any devices other than the following will not be guaranteed.
 - A combination USB storage device with a flash memory (to be connected directly to the USB port) and its capacity is 1GB or more.
 - A device compliant with the following specifications established by USB-IF (USB Implementers Forum)

Class number:	8 (=08h)	(Mass storage class)
Sub-Class number:	6 (=06h)	(SCSI transfer command set)
Protocol number:	80 (=50h)	(Bulk-only)

The USB storage device should be formatted in the FAT16 or FAT32. (Correct operation cannot be guaranteed if it is formatted in NTFS/exFAT.)
 - Most of the common USB storage device are compliant with the above specifications and are therefore applicable to this cloning (HS menu). However, most of these devices were originally developed to be used in an environment for PCs (e.g. Windows or Macintosh) and thus operations exclusively with this equipment have not been fully guaranteed. Therefore, the user must thoroughly check in advance whether there will be any problem in operating with this equipment when one of these devices is adopted.
- The USB storage device compliant with both USB 1.1 and USB 2.0 can be used for this cloning (HS menu).
- Cloning (HS menu) with any storage devices other than a flash memory (e.g. USB-connectable memory card reader, CD/DVD drive, hard disk) will never be guaranteed. Therefore, never use them for this operation.
- Be sure to unplug the LAN cable and Fax line before data are backed up / restored. Also, do not use the RADF and open the cover, drawer, etc. during the cloning (HS menu).
- Data can be backed up / restored only for the same model and version. If the version is different, update the firmware and back up / restore data in the same version.
- Restore data to equipment which has the same options as when the data are backed up.
- Delete the backed up data in the USB storage device after the cloning (HS menu).

12.1.3 Backup files

The following files are saved in the root directory of the USB storage device by backing up.

Filename	Remark
Modelname_MFPSerialNo_yyyy-MM-dd_hh-mm	E.g.: When backup was performed at 13:59 on October 1st, 2016. Txxx_CUK911379_2016-10-01_13-59

12.1.4 Cloning procedure

[A] Backup procedure

- (1) Shut down the equipment.
- (2) Connect the USB storage device [1] to the USB port [2].

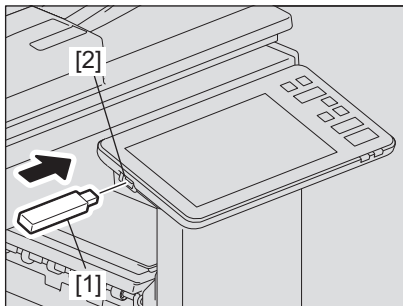

Fig.12-1

- (3) Perform HS-59→[Backup SRAM Data to USB].

Notes:

When “Operation Failed” is displayed, turn the power OFF and then reattempt the steps from (1).

- (4) Enter the password and press [OK].

Remarks:

- Maximum 15 characters
- This password will be used when the backed-up clone data are restored in the equipment.

- (5) “Backup successfully done” is displayed on the LCD when the backup has been properly completed.
- (6) Turn the power OFF.

[B] Restore procedure

- (1) Press the [ON/OFF] button to shut down the equipment.
- (2) Connect the USB storage device [1] to the USB port [2].

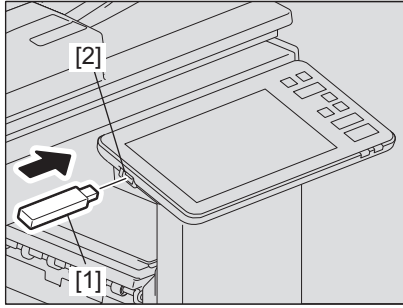

Fig.12-2

- (3) Perform HS-59→Restore SRAM Data from USB.
- (4) Enter the password which has been set in (4) of “[A]Backup procedure”, and press [OK].
- (5) Enter the serial number of the equipment and press [OK].

Notes:

Use the serial number given on the label attached to the rear cover for the entry.

- (6) “Restore successfully done Restart the MFP” is displayed on the LCD when the restoring has been properly completed.
- (7) Then turn the power OFF.

Notes:

- When the back-up file is restored, do not perform HDD partition creation (Format HDD) before the normal start-up.
- When the backup data, which were created before the HDD has been initialized or replaced, are restored, do so also for ADIKey. (Only for a secure HDD)
📖 P. 9-32 “[C] Restore ADI key”

[C] Confirmation of the error

“Operation Failed” is displayed on the lower left part of the LCD when the data have not been properly backed up or restored.

Moreover, details of an error are displayed under the above message.

(The following is an example screen when “USB Memory not detected” is displayed.)

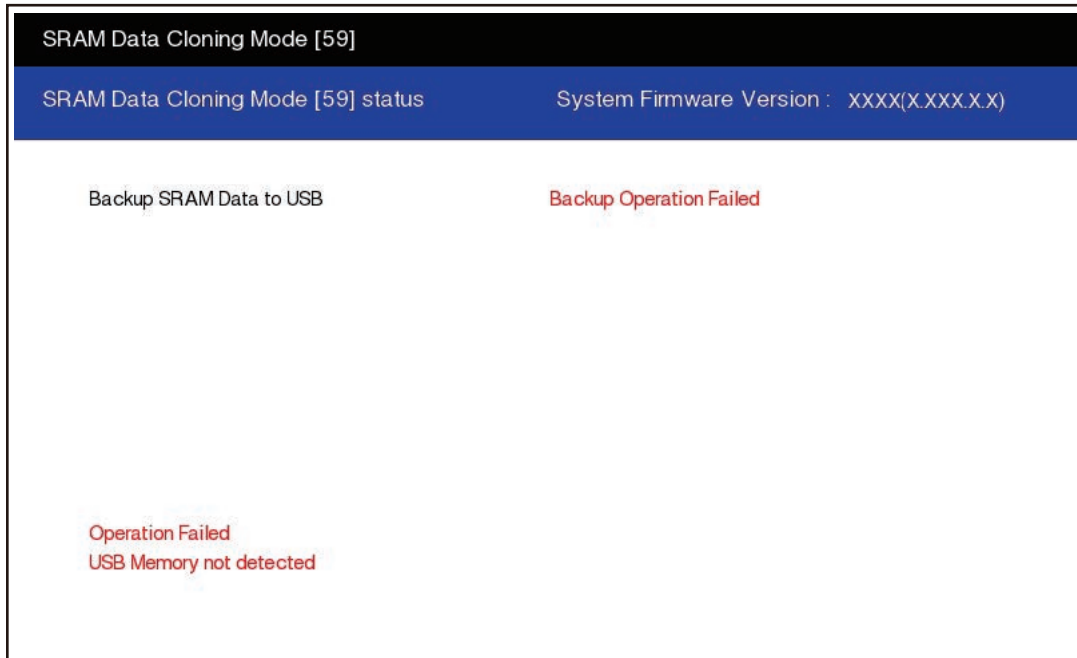

Fig.12-3

In this case, turn the power OFF and then check the following items. After confirming and solving the problem, back up / restore the data again from the beginning.

- Does the USB storage device meet the conditions being used for this cloning?
- Is the updated program file written on the USB storage device properly?
- Is the USB storage device installed properly?
- Is the USB storage device or the equipment damaged?

Backup	
Display content	Error content
USB device not detected	The USB storage device has not been installed.
SRAM Device Not Connected	The SRAM has not been installed.
Backup not created	Creation of the Backup file of data of the SRAM has failed.
Encryption Failed	An encryption of the backup file has failed.
password Not Appended to Backup	Addition of the encryption password has failed.
MFP Serial Number Not Set	Acquisition of the MFP Serial No. has failed.

Restore	
Display content	Error content
USB device not detected	The USB storage device has not been installed.
SRAM Device Not Connected	The SRAM has not been installed.
Invalid Backup File	The SYS board has not been recognized.
No Backup File Exists	Backup file has not existed in the USB storage device.
Invalid password	An incorrect password has been entered.
Decryption Failed	Decoding of the backup file has failed.
Invalid MFP Serial Number: xxxxxxxx	An incorrect MFP Serial No. has been entered.
MFP Serial Number Not Set	Acquisition of the MFP Serial No. has failed.
Backup File Corrupted	A backup file has been damaged.

12.2 Cloning (FS menu)

12.2.1 General description

By means of cloning (FS menu) can store the MFP setting data and user information as a clone file into a USB storage device. In addition, the clone file created by another unit of the equipment can be installed in this one, resulting in making of the same conditions.

12.2.2 Precautions

- A clone file created by the following MFPs can be installed in this equipment.
 - e-STUDIO2010AC/2510AC
 - e-STUDIO2515AC/3015AC/3515AC/4515AC/5015AC
 - e-STUDIO5516AC/6516AC/7516AC
 - e-STUDIO2018A/2518A/3018A/3518A/4518A/5018A
 - e-STUDIO5518A/6518A/7518A/8518A
 - e-STUDIO2000AC/2500AC
 - e-STUDIO2505AC/3005AC/3505AC/4505AC/5005AC
 - e-STUDIO5506AC/6506AC/7506AC
 - e-STUDIO2008A/2508A/3008A/3508A/4508A/5008A
 - e-STUDIO5508A/6508A/7508A/8508A
 - e-STUDIO3508LP/4508LP/5008LP
 - e-STUDIO2050C/2550C
 - e-STUDIO2555C/3055C/3555C/4555C/5055C
 - e-STUDIO2555CSE/3055CSE/3555CSE/4555CSE/5055CSE
 - e-STUDIO5560C/6560C/6570C
 - e-STUDIO207L/257/307/357/457/507
 - e-STUDIO557/657/757/857
 - e-STUDIO307LP
 - e-STUDIO287CS/347CS/407CS
 - e-STUDIO287CSL/347CSL
 - e-STUDIO477S/527S
 - e-STUDIO477SL
 - e-STUDIO2040C/2540C/3040C/3540C/4540C
 - e-STUDIO5540C/6540C/6550C
 - e-STUDIO206L/256/306/356/456/506
 - e-STUDIO256SE/306SE/356SE/456SE/506SE
 - e-STUDIO556/656/756/856
 - e-STUDIO556SE/656SE/756SE/856SE
 - e-STUDIO306LP
- When a clone file created by this equipment is installed in another one, confirm the installation ability by referring to the Service Manual for the target model.
- When a clone file created by another unit of the equipment is installed in this one, settings and information about the functions which are not supported by this equipment will be disregarded.
- When cloning of user information is carried out by means of this function, ask your users to change the setting to [Enable] of [User Information Cloning] from [Administration] - [Setup] - [General settings] - [Device Information] via TopAccess.
- When cloning of the administrator password is carried out by means of this function, ask your users to change the setting to [Enable] of [Administrator's Password Cloning] from [Administration] - [Setup] - [General settings] - [Device Information] via TopAccess.
- Be sure to use a USB storage device which satisfies the conditions described in  P. 12-1 "12.1.2 Precautions".
- Delete a clone file stored in the USB storage device after the cloning.

- Notes for cloning
 - Cloning of the service password is achieved when it is carried out with an administrator setting from TopAccess or the control panel.
For example, the service password is set in blank when cloning is carried out using a clone file of the equipment whose service password is blank.
 - When cloning is carried out from the FS menu, its performance is changed as below by setting to [Enable] or [Disable] in [Data Cloning Function] from [Administration] - [Setup] - [General Setting] - [Device Information] via TopAccess.
[Disable] (default): Cloning of the service password is not achieved.
[Enable]: Cloning of the service password is achieved.

12.2.3 Clone file creation procedure

- (1) Press [36 CLONING] in the FS menu.
- (2) Press [Create Clone File].
- (3) Select the categories to be included in the clone file.

Notes:

- If the following categories cannot be selected, ask your users to change the setting to [Enable] of [User Information Cloning] from [Administration] - [Setup] - [General settings] - [Device Information] via TopAccess.
 - User Management
 - Address Book
 - Address Book + Template + MailBoxes
- If Administrator's Password cannot be selected, ask your users to change the setting to [Enable] of [Administrator's Password Cloning] from [Administration] - [Setup] - [General settings] - [Device Information] via TopAccess.

- (4) Press [Save].
- (5) Enter a file name. Set a password if necessary.
Once a password has been set, its entry is required when this clone file is installed in the equipment.
- (6) Press [Save].
The clone file is stored by a file name with the extension ".enc" applied.

Notes:

Be sure to disconnect the USB storage device after the completion screen is displayed.

12.2.4 Clone file installation procedure

- (1) Press [36 CLONING] in the FS menu.
- (2) Press [Install Clone File].
- (3) Connect the USB storage device with the store clone file and press [OK].
- (4) Select the clone file to be installed.
Enter the password if one has been set.
- (5) Press [Install].

Notes:

Be sure to disconnect the USB storage device after the completion screen is displayed.

12.3 AES Data Encryption Function Setting

12.3.1 General description

Data encryption is a function that encrypts data in the HDD to enhance the security. Note that this function may affect the equipment performance.

12.3.2 Precautions

When the data encryption function is set to be enabled, the data saved in the HDD before the encryption has been performed cannot be retrieved. Therefore when data encryption function needs to be enabled after the installation of the equipment, it is necessary to back up the data in the HDD before setting this function and then recover them after the setting.

- To ensure security, ask the user (machine administrator) to back up or restore the user's data and information in the HDD. A service technician can back up or restore them only when the user (machine administrator) permits it.
- Some data in the HDD cannot be backed up and can be left only on printouts.

When the data encryption function is enabled, FS-08-9113 (Screen setting for automatic energy saver/automatic power OFF) is automatically set to "0: OFF".

12.3.3 Setting procedure

A procedure for setting the data encryption function is shown below.

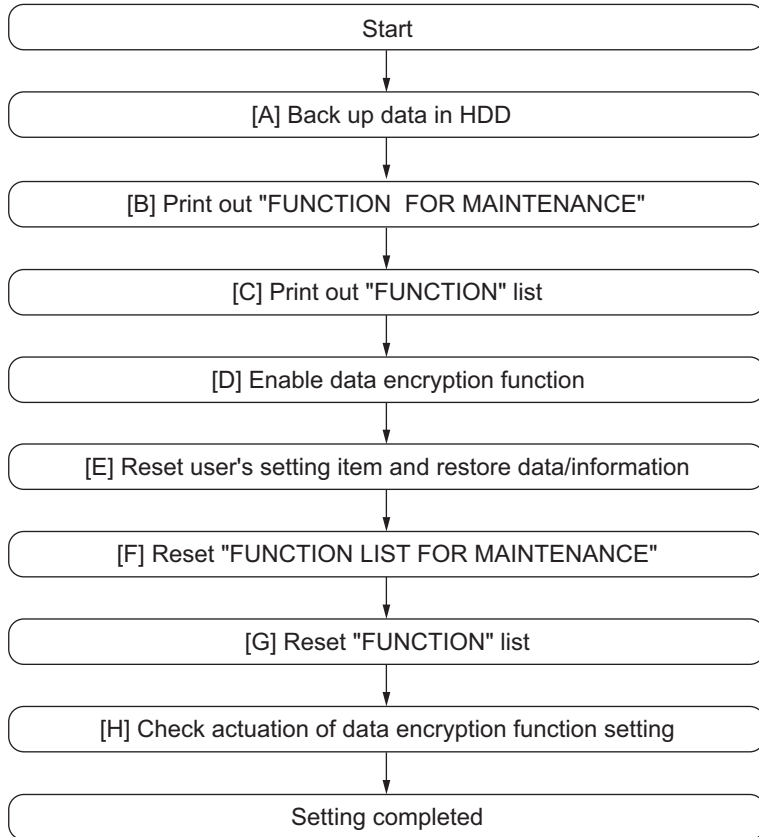

Fig.12-4

[A] Back up in HDD

Ask the user (machine administrator) to back up the data in the HDD. Refer to the table below for the type of data, availability and method of backup.

Type of data in HDD	Availability	Backup method
Image data in the e-Filing	Available	Archive them in the "e-Filing" of TopAccess. As for the backup in Box data, all data (selectable by the box) can be backed up / restored in one go by using "e-Filing Backup/Restore Utility".
F-code information, Template registration information, Address book data	Available	Export them up in the "Administrator" menu of TopAccess.
Department management data	Available	Export them in "Administrator" menu of TopAccess.
Log data (Print, Scan, FAX (Transmission/Reception)) / Message Log	Available	Export them in the "Log" menu of TopAccess. (Import cannot be performed.)
Data in the shared folder (Scanned data, Saved data of copy / FAX transmission)	Available	Copy them to the client computer via the network. (The data which have been copied to the client computer cannot be copied to the shared folder.)
Role information	Available	Export role information on the TopAccess menus. [User Management] tab >[Export]
Print waiting data (Copying data and FAX reception data that are waiting to be printed due to the paper run-out and jam, etc.)	Not available	Finish printing them after the paper supply and the jam release, etc. (The data cannot be kept.)
Print job (Private print data, Schedule print data)	Not available	If any jobs are left, print them. (The data cannot be backed up.)
FAX saved data (Confidential / Bulletin board data)	Not available	Print them. (The data cannot be backed up.)
Registration data for FAX transmission (Delayed transmission / Recovery transmission)	Not available	Print them. (The data cannot be backed up.)

[B] Print out "FUNCTION LIST FOR MAINTENANCE"

- (1) Select "FAX LIST PRINT MODE" and then press [NEXT].
- (2) Select "Function list for Maintenance" and then press [PRINT].

[C] Print out “FUNCTION” list

- (1) Press [USER FUNCTIONS] on the HOME screen.
- (2) Press [ADMIN], enter the password, and then press [ENTER].
- (3) Press [LIST/REPORT] and then [LIST].
- (4) Press [FUNCTION]. The “FUNCTION” list is printed out.

Notes:

Explain the procedure to the user (machine administrator) and ask him/her to enter his/her password.

[D] Enable data encryption function

Perform the setting of the data encryption function in the code FS-08-9379. The setting values are shown below.

- 0: Encryption disabled
- 1: Encryption enabled (Security priority)
- 2: Encryption enabled (Performance priority)

Security priority: All user data are encrypted.

Performance priority: Encryption data are generated only in a copying or a printing process temporarily. All user data except files which are deleted in a corresponding process are encrypted.

[E] Reset user’s setting items and restore data/information

Ask the user (machine administrator) to reset the user’s setting items and to restore data or information. Refer to the following for the reset and restore:

Items to reset/restore	Method
Printer driver	Upload them in the “Administrator” menu of TopAccess.
F-code information, Template registering information, Address book data	Restore them in the “Administrator” menu of TopAccess.
Department management data	Import them in the “Administrator” menu of TopAccess.
Image data in the e-Filing	Restore them in the “e-Filing” of the TopAccess.
Role information	Import role information on the TopAccess menus. [User Management] tab > [User Confirm/Create/Modify] > [Role Information]

Notes:

- When the SSL is enabled, perform the setting of the following items again with “Create self-signed certificate” of TopAccess.
 - Country/Region Name
 - State or Province Name
 - Locality Name
 - Organization Name
 - Organizational Unit Name
 - Common Name
 - Email Address
- When the wireless LAN is used, recreate its setting. (only when security with a certificate is used) Also, upload the following certificate file with “Security” of TopAccess.
 - CA certificate
 - Device certificate

[F] Reset “FUNCTION LIST FOR MAINTENANCE”

- (1) Print out the “FUNCTION LIST FOR MAINTENANCE” list before formatting the HDD. For how to print it out, refer to [B] Print out “FUNCTION LIST FOR MAINTENANCE”.
- (2) Perform FS→13 FAX FUNCTION MODE.
- (3) Compare the lists which were printed before and after the formatting to check the setting items having the different setting values. Set the value which was set before the formatting.
- (4) Turn the power OFF.

[G] Reset “FUNCTION” list

Reset the fax function by referring to the “function list” that was printed out in  P. 12-11 “[C] Print out “FUNCTION” list”.

- (1) Press [USER FUNCTIONS].
- (2) Press [ADMIN], enter the password, and then press [ENTER].
- (3) Press [FAX] and then [TERMINAL ID] to set each item.
- (4) Press [INITIAL SETUP] to set each item.

Notes:

Explain to the user (machine administrator) about the next operation and ask him/her to enter his/her password.

[H] Check actuation of data encryption function setting

Check if the data encryption function is in operation.

Press [COUNTER] on the control panel. If a key-shaped icon is displayed at the top right of the screen, the data encryption function is in operation.

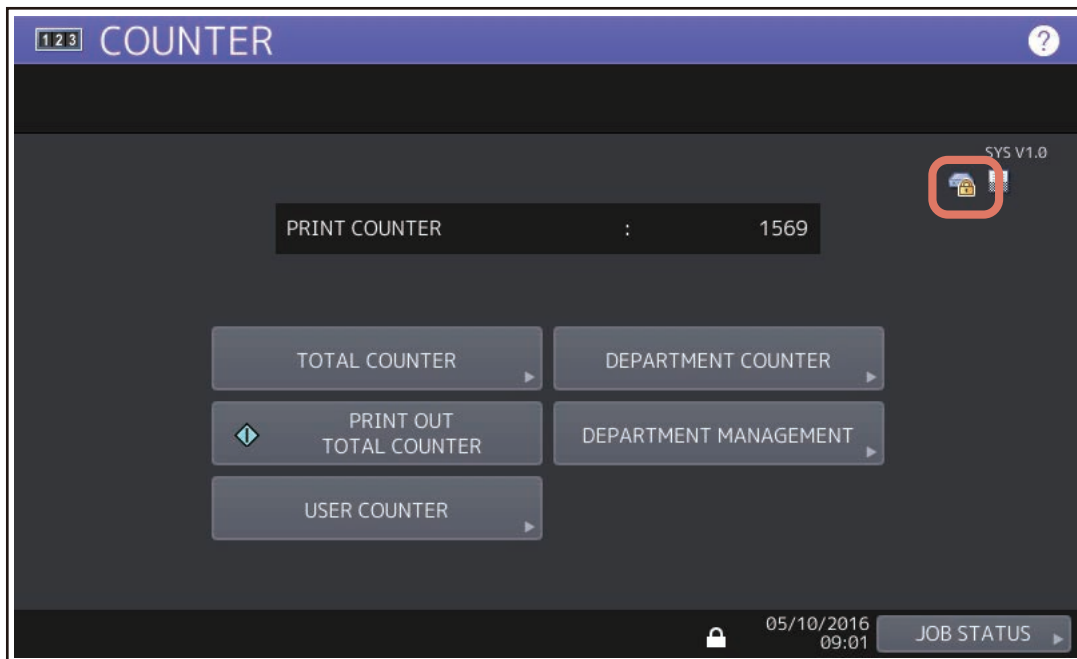



Fig.12-5

12.3.4 Procedure for disabling data encryption function

The basic procedure is the same as the one for enabling this function. To disable it, set “0 (Invalid)” in the code FS-08-9379 at step  P. 12-11 “[D] Enable data encryption function”.

12.3.5 Procedure for discarding HDD when data encryption function is enabled

Set the data encryption function disabled following the procedure shown in  P. 12-13 “12.3.4 Procedure for disabling data encryption function”. Then perform the code HS-73→[Erase HDD Securely] to completely erase the data in the HDD.

12.4 High Security Mode

12.4.1 General description

The High Security Mode is a security mode complying with CC certification which is suitable for HCD-PP. To have the equipment enter this mode, follow the procedure and the precautions below.

12.4.2 Prior confirmation

- Confirm that the administrator for the equipment is authorized and ask him/her to observe the installation.
- To have the equipment enter the High Security Mode complying with CC certification which is suitable for HCD-PP, the Fax Unit (GD-1370) is required. Confirm that this unit is installed in advance. Follow the Unpacking Instructions to install it. It is possible to have the equipment enter the High Security Mode without installing the Fax Unit. However, in such a case, the equipment is not judged as a digital MFP and thus it does not comply with the CC certification.
- To avoid physical security problems, such as hardware removal or inappropriate disassembly at the installation site, take all necessary measures, such as checking who enters and leaves the site.
- Confirm that no received fax data or print jobs in progress exist. If there are any, be sure to print them all out before entering the High Security Mode.
- The HDD is initialized in the High Security Mode. Be sure first to back up user data such as documents, Address Book, templates or fax settings using the export function or the backup/restore utility of the TopAccess. Refer to items noted in  P. 12-8 “12.3 AES Data Encryption Function Setting”.
- Make a note of the settings on the Administration tab page of the TopAccess in advance.
- Compatibility of cloning data is lost between the High Security Mode and the normal mode; therefore, cloning data cannot be imported.

Downloaded from	Downloaded to	Compatibility of cloning data
Normal mode	Normal mode	Yes
Normal mode	High Security Mode	No
High Security Mode	Normal mode	No
High Security Mode	High Security Mode	Yes

12.4.3 Procedure for entering the High Security Mode

- (1) Set the value of the code FS-08-8911 (Security mode level setting) to “3” (High). Then restart the equipment.
- (2) A key-shaped icon appears at the bottom of the touch panel, indicating that it is now in the High Security Mode.
- (3) Press [COUNTER] button on the control panel. If a key-shaped icon, indicating that the HDD data are being encrypted, a paper-shaped icon indicating that the Data Overwrite Enabler is operating normally and the version name of the installed system ROM (SYS V1.0) are displayed on the top right of the counter menu, this means the mode is operating normally.
- (4) Reset the user data backed up in advance.

12.4.4 Precautions

- In the High Security Mode, an integrity check system is operated at every restart. If F521 (integrity check error) is displayed, take the necessary measures following the troubleshooting procedure.
- When a self-diagnostic mode is started in the High Security Mode, an authentication screen appears. Enter the default user name and password as follows:
Default user name: service
Default password: #1048#
- If a password change screen appears, reset the password according to the rules below.
 - It must not include the user name.
 - It must be a combination of letters of the alphabet and numbers.
 - It must be 6 characters or more. (Maximum 64 characters)
 - The same character must not be repeated 4 times within the new password.
 - The old and the new passwords must not be the same.
- When the equipment is shifted to the High Security Mode, the contents for some codes will be changed as below.
 - The default value is changed.
 - The settings cannot be changed.
 - Some setting values cannot be selected.For details, refer to the “Self-diagnostic code list” (separate document).
- The HDD is initialized (and the saved user data are deleted) when the equipment returns to the normal mode from the High Security Mode. Be sure to back up user data before having it do so.
- In the above case, the password is not reset. The password setting can be changed with the code FS-08-8919.
- After the equipment enters the High Security Mode, ask the administrator for the equipment to select [FULL] and perform the Integrity check manually.

12.5 Decommissioning

12.5.1 General description

Decommissioning is the function which performs automatic batch processing of the user data deletion and settings formatting. This is used when the equipment is removed.

12.5.2 Functions

By performing decommissioning, automatic batch processing of the user data deletion and settings formatting can be carried out.

There are two ways for decommissioning; one is performed from the control panel on the equipment and the other is performed by remote operation using a remote maintenance service. In this manual, the way used for decommissioning from the control panel on the equipment is explained.

12.5.3 Precautions

- Deleted data and formatted setting values subjected to decommissioning cannot be returned to the original ones.
- The equipment cannot be operated while performing decommissioning.

Remarks:

- The firmware update log and the power ON/OFF log are not deleted.
- Installed licenses and applications are not deleted.
- The data of the NIC Config List and the Function List which a remote maintenance service obtains are formatted.

12.5.4 Procedures of decommissioning

[1] Performing of decommissioning

- (1) Confirm that no paper jams and errors have occurred and the equipment is not being operated.
- (2) Perform FS-08-8615.
- (3) Press [EXECUTION].

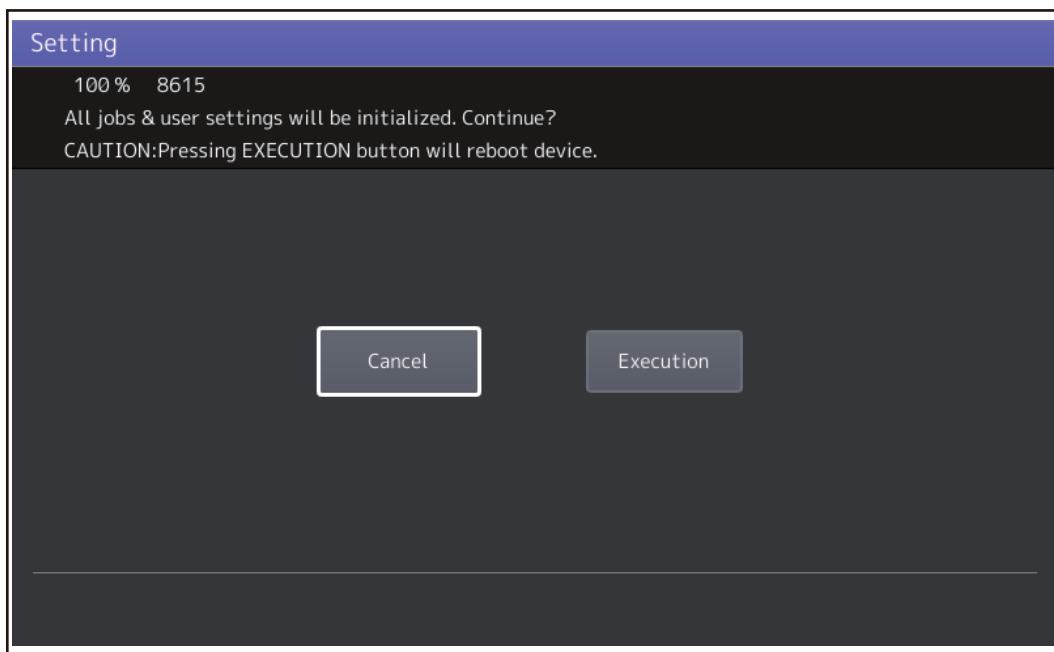

Fig.12-6

The equipment is rebooted. After this has happened, the state is changed to the decommissioning mode and the processing starts.

The equipment carries out the following items while performing decommissioning.

- Stopping the network function
- Prohibiting job reception and job execution
- Deleting pending jobs
- Returning the settings to the factory default ones
- Deleting users information, etc.

(4) When the processing is completed, “Success” or “Failed” is displayed.

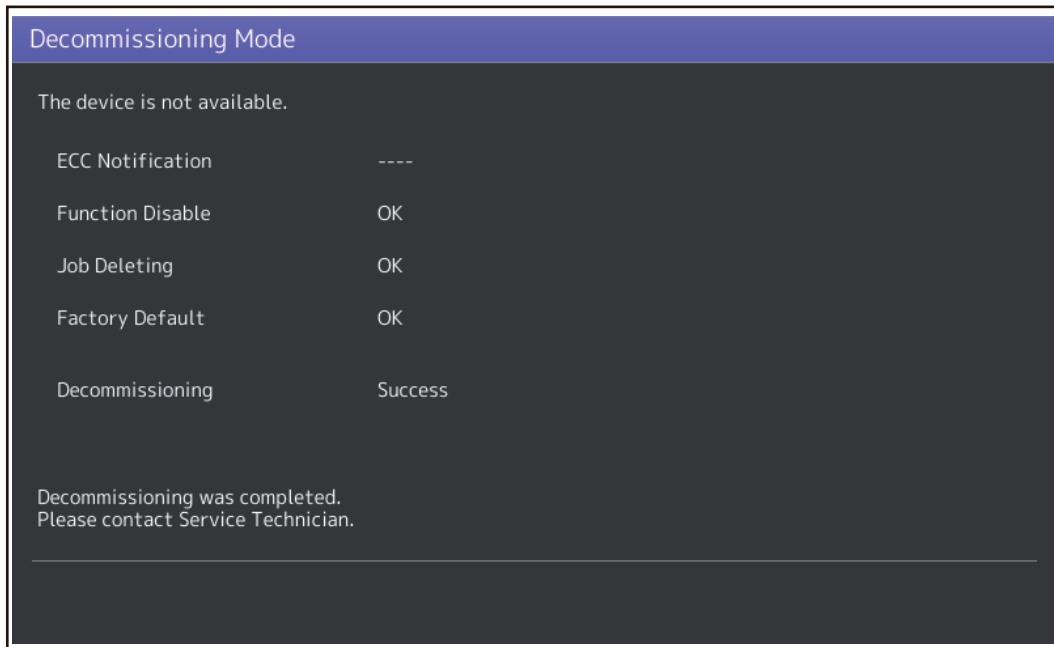

Fig.12-7

Notes:

When “Failed” is displayed, manually delete or format the data.

(5) After the processing is completed, the equipment is kept in the decommissioning mode state.

Remarks:

- The equipment will keep retaining the decommissioning mode until it is canceled.
- While the decommissioning mode is retained, the processing result keeps being displayed and receiving and executing of jobs are stopped. Only the [ON/OFF] button is operable.

(6) To cancel the decommissioning mode, perform the procedure of [2].

[2] Cancellation of decommissioning

(1) Perform FS-08-8616.

(2) Press [EXECUTION].

The equipment is rebooted. After this has happened, the state is changed to the normal mode.

Remarks:

If the decommissioning mode cannot be canceled even though the procedure of [2] has been carried out, perform the following steps.

1. Perform FS-49.
2. Install the system software (HDD data).
3. The equipment is rebooted. Confirm that the state of the equipment is changed to the normal mode.

13. EXTERNAL COUNTERS

13.1 Outline

This chapter describes the interface between external counters, such as Coin Controller and Key copy counter.

13.2 Signal

13.2.1 Connector

- Connector on the LGC board: CN303 (JST-made B20B-CZHK-B-1(LF)(SN)(V)) (Coin Controller)
- Connector on the SYS board: CN118 (JST-made B7B-PH-SM4) (Coin Controller)

13.2.2 Coin controller

[1] Settings

1. Set the value of FS-08-9016 to “1” or “5”.
2. Harness kit: GQ-1280

[2] Pin Layout

Notes:

Do not connect inductive loads to CTRON, such as a mechanical counter or a relay coil.

1. LGC Board

Pin No.	I/O	Signal name	Function	Voltage level	Remarks
1 - 4	-	-	-	-	Not connect
5	Power	+24V	24V line	DC24V+10%, -5%	
6	Out	CTRON	Total Counter On Signal	Open Collector	L: ON IO (Max): 500mA
7	In	CTRCNT	Copy permission Signal 1	L=0V, H=DC3.3V	L: Allowed *1
8	Out	MCRUN	Ready to Copy Signal	Open Collector	L: Operating IO (Max): 40mA
9	Out	EXTCTR	Exit Sensor On Signal	Open Collector	L: ON IO (Max): 40mA
10	GND	PG	Power ground	0V	
11 - 18	-	-	-	-	Not connect
19	Power	+5V (Sleep)	5V line	DC5.1V	At the sleep mode: OFF
20	-	-	-	-	Not connect

*1 When the coin controller outputs the CTRCNT signal, the controller should be driven by means of an open collector or open drain to prevent the inflow of current to the equipment.

2. SYS board

Pin No.	I/O	Signal name	Function	Voltage level	Remarks
1	Out	LARGE / SMALL	Paper size Signal	Open Collector	L: Large size IO (Max): 20mA
2	Out	FULL COLOR	Full color mode Signal	Open Collector	L: Full color IO (Max): 20mA
3	Out	TWN/MON COLOR	Twin color / Mono color Mode Signal	Open Collector	L: Twin colors IO (Max): 20mA
4	Out	B/W	Black mode Signal	Open Collector	L: Black IO (Max): 20mA
5	-	-	-	-	Not connect
6	GND	GND	Signal Ground	0V	
7	-	-	-	-	Not connect

[3] Details of the signals

1. CTRON signal (output signal)

The CTRON signal is synchronized with an electronic counter of the equipment and it becomes "Low" when one sheet of paper is counted up. This signal is output from the LGC board.



Fig.13-1

2. CTCNT signal (input signal)

The CTCNT signal enables to accept copies when the coin controller is connected, and copies can be accepted with "Low". In case of "High", "Set Key Counter" appears and copies cannot be made.

3. MCRUN signal (output signal)

The MCRUN signal is changed to "Low" during copying. It becomes "Low" at 30 ms or more before the CTRON signal is turned ON, and "High" at 50 ms or more after the EXTCTR signal goes OFF. However, if copying is interrupted due to forced toner supply or similar, this signal is "High" until copying is made possible again.

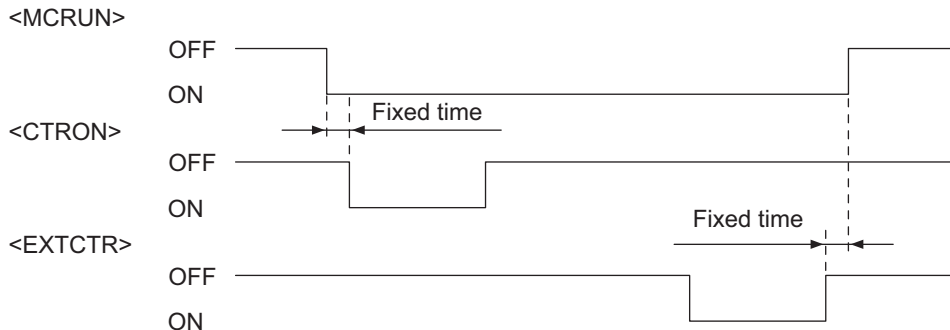

Fig.13-2

4. EXTCTR signal (output signal)

The EXTCTR signal is synchronized with “Exit sensor ON” and becomes “Low” (ON) for 200 ms. The coin controller counts the number of times with this signal. This is the signal only for the coin controller.

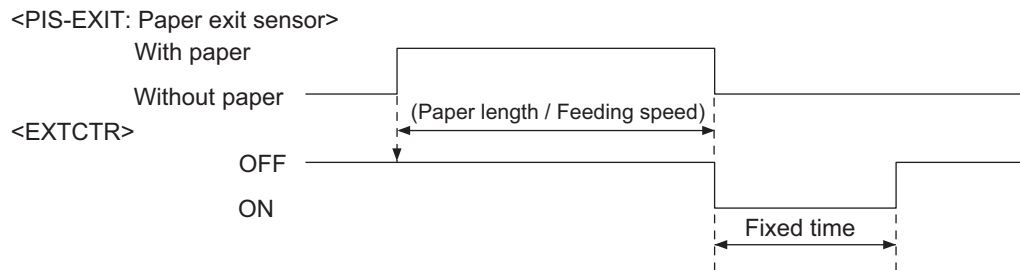

Fig.13-3

5. LARGE/SMALL signal (output signal)

When large size paper (A3 / A3 wide / LD) is selected or paper size is not specified with the manual feeding, it outputs “Low” in real time. In other cases, it outputs “High”. The setting change for large size paper is performed with F/W. This is the signal only for the coin controller.

6. FULL COLOR signal (output signal)

If the full color mode is selected, it outputs “Low” in real time. In other cases, it outputs “High”. By default, it outputs “Low” since it is set as full color mode. This is the signal only for the coin controller.

7. TWN / MON COLOR signal (output signal)

If the twin color or mono color mode is selected, it outputs “Low” in real time. In other cases, it outputs “High”. This is the signal only for the coin controller.

8. B/W signal (output signal)

If the black mode is selected, it outputs “Low” in real time. In other cases, it outputs “High”. This is the signal only for the coin controller.

[4] Harness (GQ-1280)

Board	Connector	Pin No.	Signal name	Pin No.	Connector
SYS board (CN118)	Connector-2	1	LARGE / SMALL	7	Connector-3 (Coin controller)
		2	FULL COLOR	8	
		3	TWN/MON COLOR	9	
		4	B/W	10	
		5	-	-	
		6	SG	12	
		7	-	-	
LGC board (CN303)	Connector-1	1	-	-	
		2	-	-	
		3	-	-	
		4	-	-	
		5	+24V	1	
		6	CTRON	2	
		7	CTRCNT	3	
		8	MCRUN	4	
		9	EXTCTR	5	
		10	PG	6	
		11	-	-	
		12	-	-	
		13	-	-	
14	-	-			
15	-	-			
16	-	-			
17	-	-			
18	-	-			
19	+5VL	11			
20	-	-			

13.2.3 Key copy counter

[1] Settings

1. Set the value of FS-08-9016 to "3".
2. Harness kit: -

[2] Pin Layout

Notes:

Use 24V supplied from the equipment as power for the output signals (KCTRON) from the transistor.

1. LGC Board

Pin No.	I/O	Signal name	Function	Voltage level	Remarks
1	GND	SG	Signal Ground	0V	
2	In	CTRCNT	Copy permission Signal 1	L=0V, H=DC3.3V	L: Allowed *1
3	Power	+24V	24V line	DC24V+10%, -5%	
4	Out	KCTRON	Mechanical Counter On Signal	Open Collector	L: ON IO (Max): 500mA
5 - 20	-	-	-	-	Not connect

*1 When the coin controller outputs the CTRCNT signal, the controller should be driven by means of an open collector or open drain to prevent the inflow of current to the equipment.

2. SYS board

Do not connect to the SYS board.

[3] Details of the signals

1. CTRCNT signal (input signal)

The CTRCNT signal enables to accept copies when the coin controller is connected, and copies can be accepted with "Low". In case of "High", "Set Key Counter" appears and copies cannot be made.

2. KCTRON signal (output signal)

These signals are synchronized with the electronic counter of the equipment and they become "Low" when the counter is turned ON. They are the signals for driving a mechanical counter, and output from the LGC board.

They can drive inductive loads, such as a solenoid, using 24V supplied from the equipment. The interval between when they are turned ON and when this happens next must be at least 100 ms. "Single count" or "Double count" can be switched according to the paper size by setting "1" or "2" for FS-08-6010.

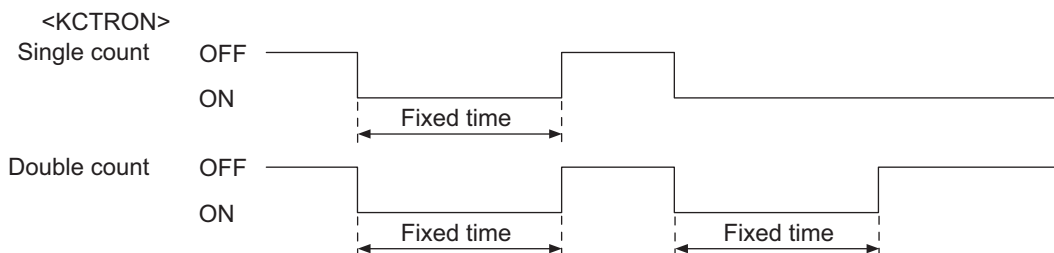

Fig.13-4

13.3 Notices

13.3.1 Setting code

Each signal will be enabled by configuring the setting code "FS-08-9016" (Externally installed counter).

FS-08-9016

- 0: No external counter (Default)
- 1: Coin controller
- 2: Copy key card (For Japan only)
- 3: Key copy counter
- 5: Coin controller supporting ACS/mixed-size

13.3.2 Setting value change and restrictions when using the card controller

1. Setting value

- FS-08-9016 (Externally installed counter): Set to "2" (Copy key card).
- FS-08-9017 (Setting for counter installed externally): It should be charged precisely according to the usage.
Example: To charge only when copies are made, set to "1".
- FS-08-6011 (Definition setting of large sized paper): Set to "0" if only A3 and LD are regarded as large size. Set to "1" if B4, LG, FOLIO and COMP are done so as well.

13.3.3 Setting value change and restrictions when using the coin controller

FS-08-9016 (Externally installed counter): Set to "1" (Coin controller) or "5" (Coin controller supporting ACS/mixed-size).

Notes:

- A coin controller supporting ACS (Auto Color Selection) can be connected by setting to "5" (Coin controller supporting ACS/mixed-size). However, operation is not guaranteed unless the specification for the ACS timing is met.
- Mixed-size jobs will be supported by setting to "5". The switching process of the size signal is carried out for each page.
- Be sure to make the following charge settings appropriately according to the usage.
 - FS-08-9017 (Setting for counter installed externally): To charge only when copies are made, set to "1".
 - FS-08-6011 (Definition setting of large sized paper): Set to "0" if only A3 and LD are regarded as large size. Set to "1" if B4, LG, FOLIO and COMP are to be so as well.

13.3.4 Installation of external counter

It is not allowed to install more than one external counter (Key copy counter and Coin Controller) at the same time.

13.3.5 Setting value change and restrictions when using the key counter

The Key copy counter used for current models is not supported in this equipment, but the circuit for driving the counter has been mounted. The mechanical counter can be used by setting as below, however the harness for connecting it has not been provided as an option.

1. Setting value

- FS-08-9016 (Externally installed counter): Set to "3" (Key copy counter).
- FS-08-9017 (Setting for counter installed externally): It should be charged precisely according to the usage.
Example: To charge only when copies are made, set to "1".
- FS-08-6011 (Definition setting of large sized paper): Set to "0" if only A3 and LD are regarded as large size. Set to "1" if B4, LG, FOLIO and COMP are done so as well.

13.3.6 Restrictions when using the external counter

The Job Skip function will be disabled when an external counter is installed (when a value other than "0" is set for FS-08-9016).

Therefore, if printing is attempted while a counter or a coin controller is used, all jobs stored in the HDD may be printed.

14. NOTES FOR THE INSTALLATION OF A CARD READER

- (1) The card reader to use in this equipment needs to satisfy all of the following conditions. However, the operation cannot be guaranteed even if all of these conditions are satisfied.
 1. Complying with the USB HID class and satisfying the following class codes
 - Class code: 0x03
 - Sub Class code: 0x00
 - Protocol code: 0x01
 2. An interface descriptor for the USB HID class needs to be single. (A card reader which consists of multiple HID classes, such as card reader and keyboard functions, cannot be used.)
 3. The USB VID/PID of the card reader has been registered in this equipment. For details about the registration of VID/PID, ask your service contact center.
- (2) When any problems concerning to a card reader have occurred, ask your service contact center to confirm whether the card reader satisfies the above conditions or not.

15. WIRE HARNESS CONNECTION

15.1 AC Wire Harness

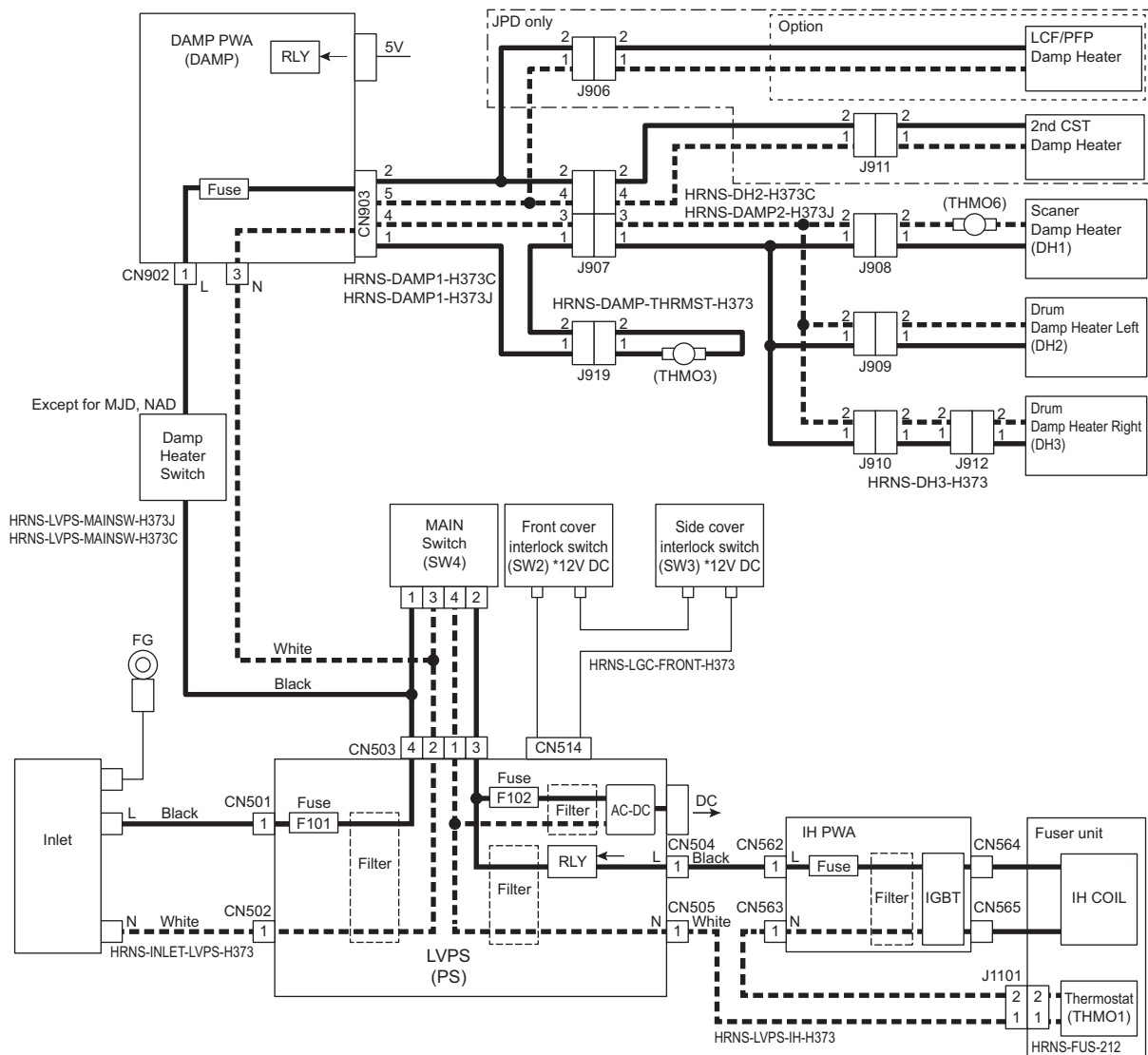
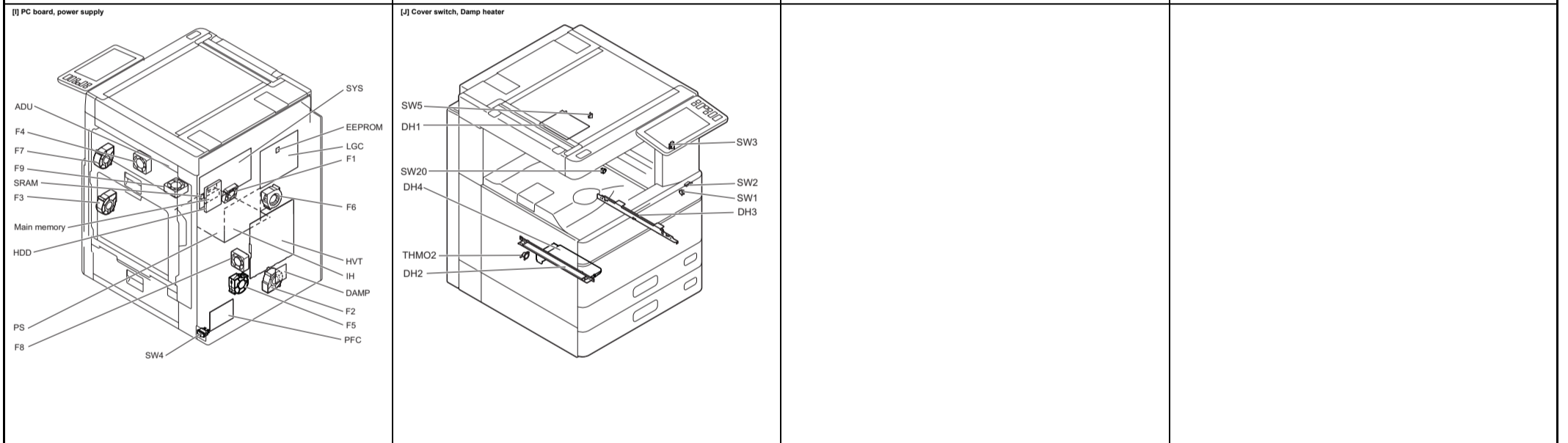
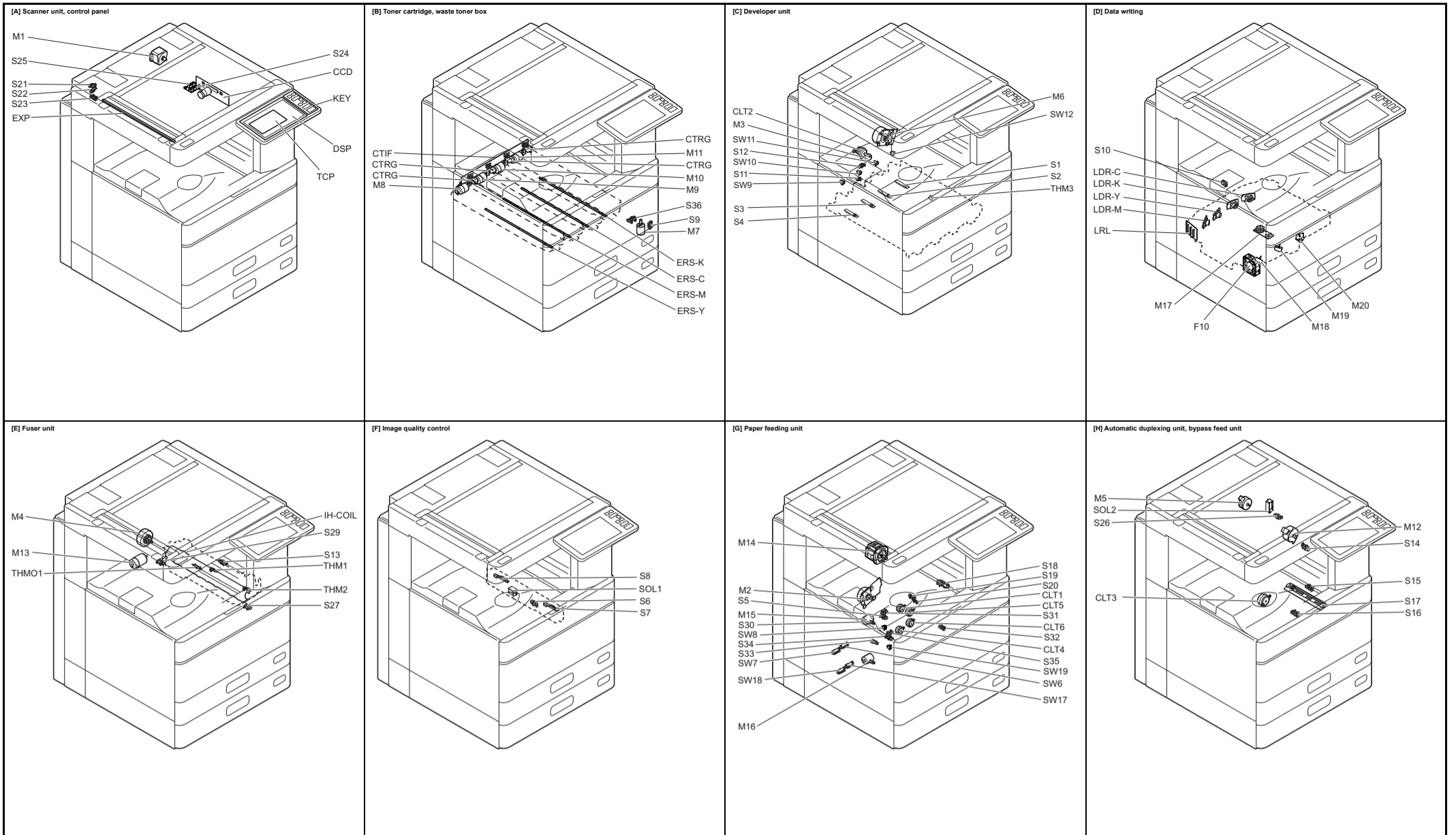

Fig.15-1

Notes:

- Front cover interlock switch (SW2) and side cover interlock switch (SW3) are the interlock switches with 12V DC.
- When the front cover interlock switch (SW2) or side cover interlock switch (SW3) is turned OFF, 24VD output will stop.

15.2.3 Electric Parts Layout



Symbol	Name	Figure	Wire harness location
M1	SCAN-MOT Scan motor	[A]	5-A
M2	FEEDDEV-MOT Paper feeding/developer unit drive motor	[G]	6-G
M3	DRM-SW-MOT Microcolor switching motor	[C]	6-G
M4	FUS-MOT Fuser motor	[E]	8-G
M5	REV-MOT Reverse motor	[H]	8-H
M6	DRM/TBU-MOT Drum/TBU motor	[C]	6-G
M7	USD-TNR-MOT Waste toner paddle motor	[B]	8-D
M8	TNR-MOT-Y Toner motor-Y	[B]	8-F
M9	TNR-MOT-M Toner motor-M	[B]	8-F
M10	TNR-MOT-C Toner motor-C	[B]	8-G
M11	TNR-MOT-K Toner motor-K	[B]	8-G
M12	ADU-MOT ADU motor	[H]	1-D
M13	FUS-CR-MOT Pressure roller contact/release motor	[E]	8-H
M14	RGST-MOT Registration motor	[G]	1-F
M15	TUP-MOT1 Tray-up motor-1	[G]	1-F
M16	TUP-MOT2 Tray-up motor-2	[G]	1-F
M17	POL-MOT Polygonal motor	[D]	7-E
M18	MIR-MOT-Y Mirror motor-Y	[D]	7-F
M19	MIR-MOT-M Mirror motor-M	[D]	7-E
M20	MIR-MOT-C Mirror motor-C	[D]	7-F
F1	SYS-FAN SYS cooling fan	[I]	3-E
F2	OZN-FAN Ozone exhaust fan	[I]	1-G
F3	SCT-FAN Suctioning fan	[I]	8-C
F4	FUS-FAN1 Fuser unit cooling fan-1	[I]	1-E
F5	DVP-FAN Developer unit cooling fan	[I]	1-G
F6	IH-FAN IH board cooling fan	[I]	7-H
F7	EXT-FAN Exit section cooling fan	[I]	8-C
F8	PS-FAN Power supply unit cooling fan	[I]	5-H
F9	FUS-FAN2 Fuser unit cooling fan-2	[I]	1-E
F10	LSU-FAN Laser optical unit cooling fan	[D]	7-E

Symbol	Name	Figure	Wire harness location
S1	ATTNR-SNR-K Auto-toner sensor-K	[C]	8-B
S2	ATTNR-SNR-C Auto-toner sensor-C	[C]	8-B
S3	ATTNR-SNR-M Auto-toner sensor-M	[C]	8-A
S4	ATTNR-SNR-Y Auto-toner sensor-Y	[C]	8-A
S5	CST1-EMP-SNR 1st drawer empty sensor	[G]	2-H
S6	RGST-PASS-SNR Registration pass sensor	[F]	8-D
S7	IMG-POS-SNR-F Image position aligning sensor (Front)	[F]	8-D
S8	IMG-POS-SNR-R Image position aligning sensor (Rear)/Image quality sensor	[F]	8-D
S9	USD-TNR-PDL-SNR Waste toner paddle rotation detection sensor	[B]	8-D
S10	TEMPHUMI-SNR Temperature/humidity sensor	[D]	8-D
S11	DRM-SW-SNR Drum switching detection sensor	[C]	6-G
S12	1ST-TRNS-SW-SNR 1st transfer roller status detection sensor	[C]	6-H
S13	EXIT-SNR Exit sensor	[E]	7-G
S14	ADU-LSNR ADU entrance sensor	[H]	1-D
S15	ADU-LSNR ADU exit sensor	[H]	1-D
S16	SFB-FEED-SNR Bypass feed sensor	[H]	1-C
S17	PWA-F-SFB Paper width detection PC board (SFB board)	[H]	1-C
S18	CLNG-SNR Paper clinging detection sensor	[G]	1-D
S19	RGST-SNR Registration sensor	[G]	1-E
S20	TRANS-SNR Feed sensor	[G]	1-E
S21	PLTN-SNR1 Platen sensor-1	[A]	5-B
S22	PLTN-SNR2 Platen sensor-2	[A]	5-B
S23	HOME-SNR Carriage home position sensor	[A]	5-B
S24	APS1 Automatic original detection sensor-1	[A]	5-A
S25	APS2 Automatic original detection sensor-2	[A]	5-A
S26	REV-SNR Reverse sensor	[H]	1-D
S27	FR-RD-SNR Fuser roller rotation detection sensor	[E]	7-F
S29	PR-CR-SNR Pressure roller contact/release detection sensor 2	[E]	2-H
S30	CST1-FR-SNR 1st drawer paper remaining sensor	[G]	2-H
S31	CST1-TRY-SNR 1st drawer tray-up sensor	[G]	2-F
S32	CST2-FEED-SNR 2nd drawer paper feed sensor	[G]	2-G
S33	CST2-FR-SNR 2nd drawer paper remaining sensor	[G]	2-G
S34	CST2-EMP-SNR 2nd drawer empty sensor	[G]	2-G
S35	CST2-TRY-SNR 2nd drawer tray-up sensor	[G]	8-C
S36	WTNR-NFL-SNR Waste toner amount detection sensor	[B]	-
SW1	FRT-COV-SW Front cover switch	[J]	8-C

Symbol	Name	Figure	Wire harness location
SW2	F-COV-INTLCK-SW Front cover interlock switch	[J]	AC Wire Harness
SW3	S-COV-INTLCK-SW Side cover interlock switch	[J]	AC Wire Harness
SW4	MAIN-SW Main power switch	[I]	5-H
SW5	SIDE-COV-SW Side cover switch	[J]	6-G
SW6	CST1-WDT-SW 1st drawer paper width detection switch	[G]	4-C
SW7	CST1-LGT-SW 1st drawer paper length detection switch	[G]	2-E
SW8	CST1-SW 1st drawer detection switch	[G]	2-G
SW9	Y-EPU-SW Y EPU old/new detection switch	[C]	8-A
SW10	M-EPU-SW M EPU old/new detection switch	[C]	8-A
SW11	C-EPU-SW C EPU old/new detection switch	[C]	8-B
SW12	K-EPU-SW K EPU old/new detection switch	[C]	8-B
SW17	CST2-WDT-SW 2nd drawer paper width detection switch	[G]	2-F
SW18	CST2-LGT-SW 2nd drawer paper length detection switch	[G]	2-F
SW19	CST2-SW 2nd drawer detection switch	[G]	2-G
SW20	JAM-CVR-SW Jam access cover opening/closing switch	[J]	2-F

Symbol	Name	Figure	Wire harness location
CLT1	CST1-FEED-CLT 1st drawer feed clutch	[G]	1-F
CLT2	1ST-TRNS-CLT 1st transfer roller contact/release clutch	[C]	6-H
CLT3	SFB-FEED-CLT Bypass feed clutch	[H]	1-C
CLT4	CST2-FEED-CLT 2nd drawer feed clutch	[G]	1-F
CLT5	FEED-CLT-H Transport clutch (H)	[G]	1-F
CLT6	FEED-CLT-L Transport clutch (L)	[G]	1-F

Symbol	Name	Figure	Wire harness location
SOL1	SNR-SHUT-SOL Sensor shutter solenoid	[F]	8-D
SOL2	REV-SOL Reverse gate solenoid	[H]	8-H

Symbol	Name	Figure	Wire harness location
CCD	PWA-F-CCD CCD driving PC board (CCD board)	[A]	5-C
DSP	PWA-F-DSP Display PC board (DSP board)	[A]	4-D
KEY	PWA-F-KEY Key PC board (KEY board)	[A]	4-D
CTIF	PWA-F-CTIF Toner cartridge interface PC board (CTIF board)	[B]	8-G
CTRIG	PWA-F-CTRIG Toner cartridge PC board (CTRIG board)	[B]	8-G
ADU	PWA-F-ADU ADU control PC board (ADU board)	[H]	1-D
SYS	PWA-H-SYS System control PC board (SYS board)	[I]	5-D 2-C
LGC	PWA-F-LGC Logic PC board (LGC board)	[I]	5-A 6-D 7-D
PFC	PWA-PFC Paper feed control PC board (PFC board)	[I]	2-D
IH	PWA-H-IH Heater control PC board (H board)	[I]	7-G 7-H
LDR-Y	LDR-Y Laser driving PC board-Y (LDR-Y board)	[D]	6-A
LDR-M	LDR-M Laser driving PC board-M (LDR-M board)	[D]	6-B
LDR-C	LDR-C Laser driving PC board-C (LDR-C board)	[D]	6-C
LDR-K	LDR-K Laser driving PC board-K (LDR-K board)	[D]	6-D
LRL	LRL Laser control signal relay board (LRL board)	[D]	7-B 7-C
DAMP	PWA-H-DAMP Scanner heater control PC board	[I]	AC Wire harness

Symbol	Name	Figure	Wire harness location
EXP	LP-EXPO Exposure lamp	[A]	5-B
ERS-Y	LP-ERS-Y Discharge LED-Y	[B]	8-B
ERS-M	LP-ERS-M Discharge LED-M	[B]	8-C
ERS-C	LP-ERS-C Discharge LED-C	[B]	8-C
ERS-K	LP-ERS-K Discharge LED-K	[B]	8-C
DH1	SCN-DHL Scanner damp heater	[J]	AC Wire Harness
DH2	DRM-DHL Drum damp heater (Left)	[J]	AC Wire Harness
DH3	DRM-DHR Drum damp heater (Right)	[J]	AC Wire Harness
IH-COIL	IH-COIL IH-COIL	[E]	AC Wire harness

Symbol	Name	Figure	Wire harness location
THM1	THMS-FR-C Fuser roller center thermistor	[E]	7-F 7-G
THM2	THMS-FR-S Fuser roller side thermistor	[E]	7-F 7-G
THM3	THMS-FR-E Fuser roller edge thermistor	[E]	7-F 7-G
THMO1	THERMO-FR Fuser roller thermostat	[E]	AC Wire harness
THMO2	THERMO-DRM-DHL Drum damp heater thermostat (Left)	[J]	AC Wire harness

Symbol	Name	Figure	Wire harness location
TCP	TCP panel	[A]	4-D
EEPROM	Electrically Erasable Programmable Read Only Memory	[I]	-
SRAM	SRAM	[I]	-
HDD	HDD hard disk	[I]	4-G
Main memory	Main memory	[I]	2-D
PS	PS-ACC Switching regulator	[I]	4-G
HVT	PS-HVT High-voltage transformer	[I]	8-E

Scanner
25ppm

Items to check	Black		150				225				300				375				450				Operation check	P-I	
	Color		75		150		225		300		375		450		450		450								
	Cleaning	Lubrication /Coating	(x 1,000 sheets)	(x 1,000 drive counts)	Cleaning	Lubrication /Coating	(x 1,000 sheets)	(x 1,000 drive counts)	Cleaning	Lubrication /Coating	(x 1,000 sheets)	(x 1,000 drive counts)	Cleaning	Lubrication /Coating	(x 1,000 sheets)	(x 1,000 drive counts)	Cleaning	Lubrication /Coating	(x 1,000 sheets)	(x 1,000 drive counts)					
A1	Original glass							B or A										B or A							25-2
A2	ADF original glass							B										B							25-3
A3	Mirror-1							B										B							11-1
A4	Mirror-2							B										B							12-1
A5	Mirror-3							B										B							12-1
A6	Reflector							B										B							11-3
A7	Lens							B										B							10-9
A8	Automatic original detection sensor							B										B						○	10-12

30ppm

Items to check	Black		180				270				360				450				540				Operation check	P-I		
	Color		90		180		270		360		450		540		540		540									
	Cleaning	Lubrication /Coating	(x 1,000 sheets)	(x 1,000 drive counts)	Cleaning	Lubrication /Coating	(x 1,000 sheets)	(x 1,000 drive counts)	Cleaning	Lubrication /Coating	(x 1,000 sheets)	(x 1,000 drive counts)	Cleaning	Lubrication /Coating	(x 1,000 sheets)	(x 1,000 drive counts)	Cleaning	Lubrication /Coating	(x 1,000 sheets)	(x 1,000 drive counts)						
A1	Original glass							B or A										B or A								25-2
A2	ADF original glass							B										B								25-3
A3	Mirror-1							B										B								11-1
A4	Mirror-2							B										B								12-1
A5	Mirror-3							B										B								12-1
A6	Reflector							B										B								11-3
A7	Lens							B										B								10-9
A8	Automatic original detection sensor							B										B						○	10-12	

35ppm

Items to check	Black		210				315				420				525				630				Operation check	P-I		
	Color		105		210		315		420		525		630		630		630									
	Cleaning	Lubrication /Coating	(x 1,000 sheets)	(x 1,000 drive counts)	Cleaning	Lubrication /Coating	(x 1,000 sheets)	(x 1,000 drive counts)	Cleaning	Lubrication /Coating	(x 1,000 sheets)	(x 1,000 drive counts)	Cleaning	Lubrication /Coating	(x 1,000 sheets)	(x 1,000 drive counts)	Cleaning	Lubrication /Coating	(x 1,000 sheets)	(x 1,000 drive counts)						
A1	Original glass							B or A										B or A								25-2
A2	ADF original glass							B										B								25-3
A3	Mirror-1							B										B								11-1
A4	Mirror-2							B										B								12-1
A5	Mirror-3							B										B								12-1
A6	Reflector							B										B								11-3
A7	Lens							B										B								10-9
A8	Automatic original detection sensor							B										B						○	10-12	

45ppm

Items to check	Black		226.8				340.2				453.6				680.4				Operatio n check	P-I					
	Color		113.4		226.8		226.8		340.2		453.6		453.6		567		680.4								
	Cleaning	Lubrication /Coating	Replacement (x 1,000 sheets) (x 1,000 drive counts)		Cleaning	Lubrication /Coating	Replacement (x 1,000 sheets) (x 1,000 drive counts)		Cleaning	Lubrication /Coating	Replacement (x 1,000 sheets) (x 1,000 drive counts)		Cleaning	Lubrication /Coating	Replacement (x 1,000 sheets) (x 1,000 drive counts)		Cleaning	Lubrication /Coating			Replacement (x 1,000 sheets) (x 1,000 drive counts)				
A1	Original glass									B or A									B or A						25-2
A2	ADF original glass									B									B						25-3
A3	Mirror-1									B									B						11-1
A4	Mirror-2									B									B						12-1
A5	Mirror-3									B									B						12-1
A6	Reflector									B									B						11-3
A7	Lens									B									B						10-9
A8	Automatic original detection sensor									B									B					○	10-12

50ppm

Items to check	Black		252				378				504				756				Operatio n check	P-I					
	Color		126		252		252		378		504		504		630		756								
	Cleaning	Lubrication /Coating	Replacement (x 1,000 sheets) (x 1,000 drive counts)		Cleaning	Lubrication /Coating	Replacement (x 1,000 sheets) (x 1,000 drive counts)		Cleaning	Lubrication /Coating	Replacement (x 1,000 sheets) (x 1,000 drive counts)		Cleaning	Lubrication /Coating	Replacement (x 1,000 sheets) (x 1,000 drive counts)		Cleaning	Lubrication /Coating			Replacement (x 1,000 sheets) (x 1,000 drive counts)				
A1	Original glass									B or A									B or A						25-2
A2	ADF original glass									B									B						25-3
A3	Mirror-1									B									B						11-1
A4	Mirror-2									B									B						12-1
A5	Mirror-3									B									B						12-1
A6	Reflector									B									B						11-3
A7	Lens									B									B						10-9
A8	Automatic original detection sensor									B									B					○	10-12

50ppm

		Black		252		252		378		504		504		630		756		Operatio n check	P-I				
		Color		126		252		378		504		504		630		756							
Items to check		Cleaning	Lubrication /Coating	Replacement (x 1,000 sheets	Replacement (x 1,000 drive counts)	Cleaning	Lubrication /Coating	Replacement (x 1,000 sheets	Replacement (x 1,000 drive counts)	Cleaning	Lubrication /Coating	Replacement (x 1,000 sheets)	Replacement (x 1,000 drive counts)	Cleaning	Lubrication /Coating	Replacement (x 1,000 sheets	Replacement (x 1,000 drive counts)			Cleaning	Lubrication /Coating	Replacement (x 1,000 sheets	Replacement (x 1,000 drive counts)
C1	Paper feed roller			80	-			80	-			80	-			80	-			80	-		23-43
C2	Separation roller			80	-			80	-			80	-			80	-			80	-		23-30
C3	Pickup roller			80	-			80	-			80	-			80	-			80	-		23-29
C4	Paper guide																	B					13-12
C5	Registration roller																	A		R3	R3		22-11
C6	Separation roller guide																		W2				23-19
C7	Transport roller																	A		R3	R3		23-35

Automatic duplexing unit

25ppm

Items to check	Black		150				225				300				375				450				Operatio n check	P-I
	Color		150				225				300				375				450					
	Cleaning	Lubrication /Coating	Replacement (x 1,000 sheets (x 1,000 drive counts)		Cleaning	Lubrication /Coating	Replacement (x 1,000 sheets (x 1,000 drive counts)		Cleaning	Lubrication /Coating	Replacement (x 1,000 sheets (x 1,000 drive counts)		Cleaning	Lubrication /Coating	Replacement (x 1,000 sheets (x 1,000 drive counts)		Cleaning	Lubrication /Coating	Replacement (x 1,000 sheets (x 1,000 drive counts)					
D1	Transport roller																		A		R3	R3		41-10
D2	Paper guide																		B					41-5/ 41-20

30ppm

Items to check	Black		180				270				360				450				540				Operatio n check	P-I
	Color		180				270				360				450				540					
	Cleaning	Lubrication /Coating	Replacement (x 1,000 sheets (x 1,000 drive counts)		Cleaning	Lubrication /Coating	Replacement (x 1,000 sheets (x 1,000 drive counts)		Cleaning	Lubrication /Coating	Replacement (x 1,000 sheets (x 1,000 drive counts)		Cleaning	Lubrication /Coating	Replacement (x 1,000 sheets (x 1,000 drive counts)		Cleaning	Lubrication /Coating	Replacement (x 1,000 sheets (x 1,000 drive counts)					
D1	Transport roller																		A		R3	R3		41-10
D2	Paper guide																		B					41-5/ 41-20

35ppm

Items to check	Black		210				315				420				525				630				Operatio n check	P-I
	Color		210				315				420				525				630					
	Cleaning	Lubrication /Coating	Replacement (x 1,000 sheets (x 1,000 drive counts)		Cleaning	Lubrication /Coating	Replacement (x 1,000 sheets (x 1,000 drive counts)		Cleaning	Lubrication /Coating	Replacement (x 1,000 sheets (x 1,000 drive counts)		Cleaning	Lubrication /Coating	Replacement (x 1,000 sheets (x 1,000 drive counts)		Cleaning	Lubrication /Coating	Replacement (x 1,000 sheets (x 1,000 drive counts)					
D1	Transport roller																		A		R3	R3		41-10
D2	Paper guide																		B					41-5/ 41-20

45ppm

Items to check	Black		226.8				340.2				453.6				567				680.4				Operatio n check	P-I
	Color		226.8				340.2				453.6				567				680.4					
	Cleaning	Lubrication /Coating	Replacement (x 1,000 sheets (x 1,000 drive counts)		Cleaning	Lubrication /Coating	Replacement (x 1,000 sheets (x 1,000 drive counts)		Cleaning	Lubrication /Coating	Replacement (x 1,000 sheets (x 1,000 drive counts)		Cleaning	Lubrication /Coating	Replacement (x 1,000 sheets (x 1,000 drive counts)		Cleaning	Lubrication /Coating	Replacement (x 1,000 sheets (x 1,000 drive counts)					
D1	Transport roller																		A		R3	R3		41-10
D2	Paper guide																		B					41-5/ 41-20

50ppm

Items to check	Black		252				378				504				630				756				Operatio n check	P-I
	Color		252				378				504				630				756					
	Cleaning	Lubrication /Coating	Replacement (x 1,000 sheets (x 1,000 drive counts)		Cleaning	Lubrication /Coating	Replacement (x 1,000 sheets (x 1,000 drive counts)		Cleaning	Lubrication /Coating	Replacement (x 1,000 sheets (x 1,000 drive counts)		Cleaning	Lubrication /Coating	Replacement (x 1,000 sheets (x 1,000 drive counts)		Cleaning	Lubrication /Coating	Replacement (x 1,000 sheets (x 1,000 drive counts)					
D1	Transport roller																		A		R3	R3		41-10
D2	Paper guide																		B					41-5/ 41-20

Cleaner unit

25ppm

Items to check	Black		75 (337)				150 (675)				225 (1011)				300 (1350)				375 (1685)				450 (2025)				Operatio n check	P-I
	Color		75 (337)		150 (674)		225 (1011)		300 (1348)		375 (1685)		450 (2022)		450 (2022)													
	Cleaning	Lubrication /Coating	Replacement (x 1,000 sheets)	Replacement (x 1,000 drive counts)	Cleaning	Lubrication /Coating	Replacement (x 1,000 sheets)	Replacement (x 1,000 drive counts)	Cleaning	Lubrication /Coating	Replacement (x 1,000 sheets)	Replacement (x 1,000 drive counts)	Cleaning	Lubrication /Coating	Replacement (x 1,000 sheets)	Replacement (x 1,000 drive counts)	Cleaning	Lubrication /Coating	Replacement (x 1,000 sheets)	Replacement (x 1,000 drive counts)								
G1 Whole cleaner unit (K)					B								B							B						-		
G2 Drum (K)							R1	R1							R1	R1								R1	R1	34-28		
G3 Drum cleaning blade (K)							R1	R1							R1	R1								R1	R1	34-35		
G4 Side seal (K)					B		R3	R3					B		R3	R3				B				R3	R3	34-6/ 34-7		
G5 Recovery blade (K)					B								B							B						34-9		
G6 Drum gap spacer (K)															R1	R1										34-12/ 34-15		
G1 Whole cleaner unit (YMC)	B				B				B				B				B			B						-		
G2 Drum (YMC)			R1	R1			R1	R1			R1	R1			R1	R1			R1	R1				R1	R1	34-28		
G3 Drum cleaning blade (YMC)			R1	R1			R1	R1			R1	R1			R1	R1			R1	R1				R1	R1	34-35		
G4 Side seal (YMC)	B		R3	R3	B		R3	R3	B		R3	R3	B		R3	R3	B		R3	R3	B			R3	R3	34-6/ 34-7		
G5 Recovery blade (YMC)	B				B				B				B				B			B						34-9		
G6 Drum gap spacer (YMC)											R1	R1														34-12/ 34-15		
G7 Ozone filter																								R1	R1	7-41		

*: Drive counts

30ppm

Items to check	Black		90 (337)				180 (675)				270 (1011)				360 (1350)				450 (1685)				540 (2025)				Operatio n check	P-I
	Color		90 (337)		180 (674)		270 (1011)		360 (1348)		450 (1685)		540 (2022)		540 (2022)													
	Cleaning	Lubrication /Coating	Replacement (x 1,000 sheets)	Replacement (x 1,000 drive counts)	Cleaning	Lubrication /Coating	Replacement (x 1,000 sheets)	Replacement (x 1,000 drive counts)	Cleaning	Lubrication /Coating	Replacement (x 1,000 sheets)	Replacement (x 1,000 drive counts)	Cleaning	Lubrication /Coating	Replacement (x 1,000 sheets)	Replacement (x 1,000 drive counts)	Cleaning	Lubrication /Coating	Replacement (x 1,000 sheets)	Replacement (x 1,000 drive counts)								
G1 Whole cleaner unit (K)					B										B					B							-	
G2 Drum (K)							R1	R1							R1	R1								R1	R1	34-28		
G3 Drum cleaning blade (K)							R1	R1							R1	R1								R1	R1	34-35		
G4 Side seal (K)					B		R3	R3					B		R3	R3				B				R3	R3	34-6/ 34-7		
G5 Recovery blade (K)					B								B							B						34-9		
G6 Drum gap spacer (K)															R1	R1										34-12/ 34-15		
G1 Whole cleaner unit (YMC)	B				B				B				B				B			B						-		
G2 Drum (YMC)			R1	R1			R1	R1			R1	R1			R1	R1			R1	R1				R1	R1	34-28		
G3 Drum cleaning blade (YMC)			R1	R1			R1	R1			R1	R1			R1	R1			R1	R1				R1	R1	34-35		
G4 Side seal (YMC)	B		R3	R3	B		R3	R3	B		R3	R3	B		R3	R3	B		R3	R3	B			R3	R3	34-6/ 34-7		
G5 Recovery blade (YMC)	B				B				B				B				B			B						34-9		
G6 Drum gap spacer (YMC)											R1	R1														34-12/ 34-15		
G7 Ozone filter																								R1	R1	7-41		

*: Drive counts

35ppm

Items to check	Black Color		105 (337)				210 (675)				315 (1011)				420 (1350)				525 (1685)				630 (2025)				Operation check	P-I
	Cleaning	Lubrication /Coating	Replacement		Cleaning	Lubrication /Coating	Replacement		Cleaning	Lubrication /Coating	Replacement		Cleaning	Lubrication /Coating	Replacement		Cleaning	Lubrication /Coating	Replacement		Cleaning	Lubrication /Coating	Replacement					
			(x 1,000 sheets)	(x 1,000 drive counts)			(x 1,000 sheets)	(x 1,000 drive counts)			(x 1,000 sheets)	(x 1,000 drive counts)			(x 1,000 sheets)	(x 1,000 drive counts)			(x 1,000 sheets)	(x 1,000 drive counts)			(x 1,000 sheets)	(x 1,000 drive counts)	(x 1,000 sheets)	(x 1,000 drive counts)		
G1 Whole cleaner unit (K)					B									B							B					-		
G2 Drum (K)							R1	R1							R1	R1							R1	R1		34-28		
G3 Drum cleaning blade (K)							R1	R1							R1	R1							R1	R1		34-35		
G4 Side seal (K)					B		R3	R3						B		R3	R3					B		R3	R3	34-6/ 34-7		
G5 Recovery blade (K)					B									B								B				34-9		
G6 Drum gap spacer (K)															R1	R1										34-12/ 34-15		
G1 Whole cleaner unit (YMC)	B				B				B					B							B					-		
G2 Drum (YMC)			R1	R1			R1	R1			R1	R1			R1	R1							R1	R1		34-28		
G3 Drum cleaning blade (YMC)			R1	R1			R1	R1			R1	R1			R1	R1							R1	R1		34-35		
G4 Side seal (YMC)	B		R3	R3	B		R3	R3	B		R3	R3	B		R3	R3	B				R3		R3	R3		34-6/ 34-7		
G5 Recovery blade (YMC)	B				B				B				B				B				B					34-9		
G6 Drum gap spacer (YMC)											R1	R1														34-12/ 34-15		
G7 Ozone filter																							R1	R1		7-41		

*: Drive counts

45ppm

Items to check	Black Color		105 (312)				210 (625)				315 (936)				420 (1250)				525 (1560)				630 (1875)				Operation check	P-I
	Cleaning	Lubrication /Coating	Replacement		Cleaning	Lubrication /Coating	Replacement		Cleaning	Lubrication /Coating	Replacement		Cleaning	Lubrication /Coating	Replacement		Cleaning	Lubrication /Coating	Replacement		Cleaning	Lubrication /Coating	Replacement					
			(x 1,000 sheets)	(x 1,000 drive counts)			(x 1,000 sheets)	(x 1,000 drive counts)			(x 1,000 sheets)	(x 1,000 drive counts)			(x 1,000 sheets)	(x 1,000 drive counts)			(x 1,000 sheets)	(x 1,000 drive counts)			(x 1,000 sheets)	(x 1,000 drive counts)	(x 1,000 sheets)	(x 1,000 drive counts)		
G1 Whole cleaner unit (K)					B									B							B					-		
G2 Drum (K)							R1	R1							R1	R1							R1	R1		34-28		
G3 Drum cleaning blade (K)							R1	R1							R1	R1							R1	R1		34-35		
G4 Side seal (K)					B		R3	R3						B		R3	R3					B		R3	R3	34-6/ 34-7		
G5 Recovery blade (K)					B									B								B				34-9		
G6 Drum gap spacer (K)															R1	R1										34-12/ 34-15		
G1 Whole cleaner unit (YMC)	B				B				B					B							B					-		
G2 Drum (YMC)			R1	R1			R1	R1			R1	R1			R1	R1							R1	R1		34-28		
G3 Drum cleaning blade (YMC)			R1	R1			R1	R1			R1	R1			R1	R1							R1	R1		34-35		
G4 Side seal (YMC)	B		R3	R3	B		R3	R3	B		R3	R3	B		R3	R3	B				R3		R3	R3		34-6/ 34-7		
G5 Recovery blade (YMC)	B				B				B				B				B				B					34-9		
G6 Drum gap spacer (YMC)											R1	R1														34-12/ 34-15		
G7 Ozone filter																							R1	R1		7-41		

*: Drive counts

50ppm

Items to check	Black Color				210 (562)				315 (843)				420 (1124)				525 (1405)				630 (1872)				Operation check	P-I
	105 (281)		210 (562)		315 (843)		420 (1124)		525 (1405)		630 (1872)		630 (1872)		630 (1872)		630 (1872)									
	Cleaning	Lubrication /Coating	Replacement (x 1,000 sheets)	Replacement (x 1,000 drive counts)	Cleaning	Lubrication /Coating	Replacement (x 1,000 sheets)	Replacement (x 1,000 drive counts)	Cleaning	Lubrication /Coating	Replacement (x 1,000 sheets)	Replacement (x 1,000 drive counts)	Cleaning	Lubrication /Coating	Replacement (x 1,000 sheets)	Replacement (x 1,000 drive counts)	Cleaning	Lubrication /Coating	Replacement (x 1,000 sheets)	Replacement (x 1,000 drive counts)						
G1 Whole cleaner unit (K)					B								B							B					-	
G2 Drum (K)							R1	R1							R1	R1							R1	R1	34-28	
G3 Drum cleaning blade (K)							R1	R1							R1	R1							R1	R1	34-35	
G4 Side seal (K)					B		R3	R3					B		R3	R3				B			R3	R3	34-6/ 34-7	
G5 Recovery blade (K)					B								B							B					34-9	
G6 Drum gap spacer (K)															R1	R1									34-12/ 34-15	
G1 Whole cleaner unit (YMC)	B				B				B				B				B			B					-	
G2 Drum (YMC)			R1	R1			R1	R1			R1	R1			R1	R1			R1	R1			R1	R1	34-28	
G3 Drum cleaning blade (YMC)			R1	R1			R1	R1			R1	R1			R1	R1			R1	R1			R1	R1	34-35	
G4 Side seal (YMC)	B		R3	R3	B		R3	R3	B		R3	R3	B		R3	R3	B		R3	R3	B		R3	R3	34-6/ 34-7	
G5 Recovery blade (YMC)	B				B				B				B				B			B					34-9	
G6 Drum gap spacer (YMC)											R1	R1													34-12/ 34-15	
G7 Ozone filter																							R1	R1	7-41	

*: Drive counts

Developer unit (K, Y, M, and C)

25ppm

Items to check	Black		75 (240)				150 (480)				225 (720)				300 (960)				375 (1200)				450 (1440)				Operation check	P-I
	Color		75 (240)				150 (480)				225 (720)				300 (960)				375 (1200)				450 (1440)					
	Cleaning	Lubrication /Coating	Replacement		Cleaning	Lubrication /Coating	Replacement		Cleaning	Lubrication /Coating	Replacement		Cleaning	Lubrication /Coating	Replacement		Cleaning	Lubrication /Coating	Replacement		Cleaning	Lubrication /Coating	Replacement					
(x 1,000 sheets)			(x 1,000 drive counts)	(x 1,000 sheets)			(x 1,000 drive counts)	(x 1,000 sheets)			(x 1,000 drive counts)	(x 1,000 sheets)			(x 1,000 drive counts)	(x 1,000 sheets)			(x 1,000 drive counts)	(x 1,000 sheets)			(x 1,000 drive counts)	(x 1,000 sheets)	(x 1,000 drive counts)	(x 1,000 sheets)	(x 1,000 drive counts)	
H1	Whole developer unit				B							B								B						-		
H2	Developer material						R1	R1							R1	R1							R1	R1		-		
H3	Front seal (unified with the doctor blade)				B		R3	R3					B		R3	R3					B		R3	R3		33-37		
H4	Side seal (front, rear)				B		R3	R3					B		R3	R3					B		R3	R3		33-6/ 33-7		
H5	Oil seal (Rear side)						R3	R3							R3	R3							R3	R3		33-25		
H6	Oil seal (Front side)						R3	R3							R3	R3							R3	R3		33-25		
H7	Auto-toner sensor				B								B								B					33-4		
H8	Development drive unit													W1												-		
H9	Used toner container						120					120											120					
							30					30											30					

*: Drive counts

30ppm

Items to check	Black		90 (240)				180 (480)				270 (720)				360 (960)				450 (1200)				540 (1440)				Operation check	P-I
	Color		90 (240)				180 (480)				270 (720)				360 (960)				450 (1200)				540 (1440)					
	Cleaning	Lubrication /Coating	Replacement		Cleaning	Lubrication /Coating	Replacement		Cleaning	Lubrication /Coating	Replacement		Cleaning	Lubrication /Coating	Replacement		Cleaning	Lubrication /Coating	Replacement		Cleaning	Lubrication /Coating	Replacement					
(x 1,000 sheets)			(x 1,000 drive counts)	(x 1,000 sheets)			(x 1,000 drive counts)	(x 1,000 sheets)			(x 1,000 drive counts)	(x 1,000 sheets)			(x 1,000 drive counts)	(x 1,000 sheets)			(x 1,000 drive counts)	(x 1,000 sheets)			(x 1,000 drive counts)	(x 1,000 sheets)	(x 1,000 drive counts)	(x 1,000 sheets)	(x 1,000 drive counts)	
H1	Whole developer unit				B							B								B						-		
H2	Developer material						R1	R1							R1	R1							R1	R1		-		
H3	Front seal (unified with the doctor blade)				B		R3	R3					B		R3	R3					B		R3	R3		33-37		
H4	Side seal (front, rear)				B		R3	R3					B		R3	R3					B		R3	R3		33-6/ 33-7		
H5	Oil seal (Rear side)						R3	R3							R3	R3							R3	R3		33-25		
H6	Oil seal (Front side)						R3	R3							R3	R3							R3	R3		33-25		
H7	Auto-toner sensor				B								B								B					33-4		
H8	Development drive unit													W1												-		
H9	Used toner container						120					120											120					
							30					30											30					

*: Drive counts

35ppm

Items to check	Black		105 (240)				210 (480)				315 (720)				420 (960)				525 (1200)				630 (1440)				Operation check	P-I
	Color		105 (240)				210 (480)				315 (720)				420 (960)				525 (1200)				630 (1440)					
	Cleaning	Lubrication /Coating	Replacement		Cleaning	Lubrication /Coating	Replacement		Cleaning	Lubrication /Coating	Replacement		Cleaning	Lubrication /Coating	Replacement		Cleaning	Lubrication /Coating	Replacement		Cleaning	Lubrication /Coating	Replacement					
(x 1,000 sheets)			(x 1,000 drive counts)	(x 1,000 sheets)			(x 1,000 drive counts)	(x 1,000 sheets)			(x 1,000 drive counts)	(x 1,000 sheets)			(x 1,000 drive counts)	(x 1,000 sheets)			(x 1,000 drive counts)	(x 1,000 sheets)			(x 1,000 drive counts)	(x 1,000 sheets)	(x 1,000 drive counts)			
H1	Whole developer unit				B							B								B						-		
H2	Developer material						R1	R1							R1	R1							R1	R1		-		
H3	Front seal (unified with the doctor blade)				B		R3	R3					B		R3	R3					B		R3	R3		33-37		
H4	Side seal (front, rear)				B		R3	R3					B		R3	R3					B		R3	R3		33-6/ 33-7		
H5	Oil seal (Rear side)						R3	R3							R3	R3							R3	R3		33-25		
H6	Oil seal (Front side)						R3	R3							R3	R3							R3	R3		33-25		
H7	Auto-toner sensor				B								B								B					33-4		
H8	Development drive unit													W1												-		
H9	Used toner container						120					120											120					
							30					30											30					

*: Drive counts

Transfer belt unit

25ppm

Items to check	75 (337.5)				150 (675)				225 (1012.5)				300 (1350)				375 (1687.5)				450 (2025)				Operatio n check	P-I
	Cleaning	Lubrication /Coating	Replacement (x 1,000 sheets) (x 1,000 drive counts)		Cleaning	Lubrication /Coating	Replacement (x 1,000 sheets) (x 1,000 drive counts)		Cleaning	Lubrication /Coating	Replacement (x 1,000 sheets) (x 1,000 drive counts)		Cleaning	Lubrication /Coating	Replacement (x 1,000 sheets) (x 1,000 drive counts)		Cleaning	Lubrication /Coating	Replacement (x 1,000 sheets) (x 1,000 drive counts)		Cleaning	Lubrication /Coating	Replacement (x 1,000 sheets) (x 1,000 drive counts)			
J1	Transfer belt																				A		R3	R3		26-14
J2	1st transfer roller																				A		R3	R3		27-9
J3	Cleaning unit facing																				A					26-10
J4	TBU drive roller																				B		R3	R3		26-27
J5	Belt clinging roller before 2nd transfer																				A		R3	R3		27-2
J6	Lift roller																				A		R3	R3		26-8
J7	Winding roller (K)																				A		R3	R3		27-4
J8	Transfer belt cleaning blade							150	675						150	675							150	675		30-19
J9	Recovery blade																				B					30-22
J10	Blade seal							150	675						150	675							150	675		30-17, 30-20, 30-21
J11	Belt clinging roller bushing before 2nd transfer																				B		R3	R3		27-1

30ppm

Items to check	90 (337.5)				180 (675)				270 (1012.5)				360 (1350)				450 (1687.5)				540 (2025)				Operatio n check	P-I
	Cleaning	Lubrication /Coating	Replacement (x 1,000 sheets) (x 1,000 drive counts)		Cleaning	Lubrication /Coating	Replacement (x 1,000 sheets) (x 1,000 drive counts)		Cleaning	Lubrication /Coating	Replacement (x 1,000 sheets) (x 1,000 drive counts)		Cleaning	Lubrication /Coating	Replacement (x 1,000 sheets) (x 1,000 drive counts)		Cleaning	Lubrication /Coating	Replacement (x 1,000 sheets) (x 1,000 drive counts)		Cleaning	Lubrication /Coating	Replacement (x 1,000 sheets) (x 1,000 drive counts)			
J1	Transfer belt																				A		R3	R3		26-14
J2	1st transfer roller																				A		R3	R3		27-9
J3	Cleaning unit facing																				A					26-10
J4	TBU drive roller																				B		R3	R3		26-27
J5	Belt clinging roller before 2nd transfer																				A		R3	R3		27-2
J6	Lift roller																				A		R3	R3		26-8
J7	Winding roller (K)																				A		R3	R3		27-4
J8	Transfer belt cleaning blade							180	675						180	675							180	675		30-19
J9	Recovery blade																				B					30-22
J10	Blade seal							180	675						180	675							180	675		30-17, 30-20, 30-21
J11	Belt clinging roller bushing before 2nd transfer																				B		R3	R3		27-1

35ppm

Items to check	105 (337.5)				210 (675)				315 (1012.5)				420 (1350)				525 (1687.5)				630 (2025)				Operatio n check	P-I
	Cleaning	Lubrication /Coating	Replacement		Cleaning	Lubrication /Coating	Replacement		Cleaning	Lubrication /Coating	Replacement		Cleaning	Lubrication /Coating	Replacement		Cleaning	Lubrication /Coating	Replacement		Cleaning	Lubrication /Coating	Replacement			
			(x 1,000 sheets)	(x 1,000 drive counts)			(x 1,000 sheets)	(x 1,000 drive counts)			(x 1,000 sheets)	(x 1,000 drive counts)			(x 1,000 sheets)	(x 1,000 drive counts)			(x 1,000 sheets)	(x 1,000 drive counts)			(x 1,000 sheets)	(x 1,000 drive counts)		
J1	Transfer belt																				A		R3	R3		26-14
J2	1st transfer roller																				A		R3	R3		27-9
J3	Cleaning unit facing																				A					26-10
J4	TBU drive roller																				B		R3	R3		26-27
J5	Belt clinging roller before 2nd transfer																				A		R3	R3		27-2
J6	Lift roller																				A		R3	R3		26-8
J7	Winding roller (K)																				A		R3	R3		27-4
J8	Transfer belt cleaning blade						210	675							210	675							210	675		30-19
J9	Recovery blade																				B					30-22
J10	Blade seal						210	675							210	675							210	675		30-17, 30-20, 30-21
J11	Belt clinging roller bushing before 2nd transfer																				B		R3	R3		27-1

45ppm

Items to check	105 (312.5)				210 (625)				315 (937.5)				420 (1250)				525 (1562.5)				630 (1875)				Operatio n check	P-I
	Cleaning	Lubrication /Coating	Replacement		Cleaning	Lubrication /Coating	Replacement		Cleaning	Lubrication /Coating	Replacement		Cleaning	Lubrication /Coating	Replacement		Cleaning	Lubrication /Coating	Replacement		Cleaning	Lubrication /Coating	Replacement			
			(x 1,000 sheets)	(x 1,000 drive counts)			(x 1,000 sheets)	(x 1,000 drive counts)			(x 1,000 sheets)	(x 1,000 drive counts)			(x 1,000 sheets)	(x 1,000 drive counts)			(x 1,000 sheets)	(x 1,000 drive counts)			(x 1,000 sheets)	(x 1,000 drive counts)		
J1	Transfer belt																				A		R3	R3		26-14
J2	1st transfer roller																				A		R3	R3		27-9
J3	Cleaning unit facing																				A					26-10
J4	TBU drive roller																				B		R3	R3		26-27
J5	Belt clinging roller before 2nd transfer																				A		R3	R3		27-2
J6	Lift roller																				A		R3	R3		26-8
J7	Winding roller (K)																				A		R3	R3		27-4
J8	Transfer belt cleaning blade						210	625							210	625							210	625		30-19
J9	Recovery blade																				B					30-22
J10	Blade seal						210	625							210	625							210	625		30-17, 30-20, 30-21
J11	Belt clinging roller bushing before 2nd transfer																				B		R3	R3		27-1

Items to check	105 (281)				210 (562)				315 (843)				420 (1124)				525 (1405)				630 (1686)				Operatio n check	P-I
	Cleaning	Lubrication /Coating	Replacement		Cleaning	Lubrication /Coating	Replacement		Cleaning	Lubrication /Coating	Replacement		Cleaning	Lubrication /Coating	Replacement		Cleaning	Lubrication /Coating	Replacement		Cleaning	Lubrication /Coating	Replacement			
			(x 1,000 sheets)	(x 1,000 drive counts)			(x 1,000 sheets)	(x 1,000 drive counts)			(x 1,000 sheets)	(x 1,000 drive counts)			(x 1,000 sheets)	(x 1,000 drive counts)			(x 1,000 sheets)	(x 1,000 drive counts)			(x 1,000 sheets)	(x 1,000 drive counts)		
J1	Transfer belt																				A				26-14	
J2	1st transfer roller																				A				27-9	
J3	Cleaning unit facing																				A		R3	R3	26-10	
J4	TBU drive roller																				B				26-27	
J5	Belt clinging roller before 2nd transfer																				A		R3	R3	27-2	
J6	Lift roller																				A		R3	R3	26-8	
J7	Winding roller (K)																				A		R3	R3	27-4	
J8	Transfer belt cleaning blade						210	562						210	562								210	562	30-19	
J9	Recovery blade																				B				30-22	
J10	Blade seal						210	562						210	562								210	562	30-17, 30-20, 30-21	
J11	Belt clinging roller bushing before 2nd transfer																				B		R3	R3	27-1	

50ppm

Items to check	126				252				378				504				630				756				Operatio n check	P-I
	Cleaning	Lubrication /Coating	Replacement (x 1,000 drive sheets)		Cleaning	Lubrication /Coating	Replacement (x 1,000 drive sheets)		Cleaning	Lubrication /Coating	Replacement (x 1,000 drive sheets)		Cleaning	Lubrication /Coating	Replacement (x 1,000 drive sheets)		Cleaning	Lubrication /Coating	Replacement (x 1,000 drive sheets)		Cleaning	Lubrication /Coating	Replacement (x 1,000 drive sheets)			
K1	Image position aligning sensor (Front)				A								A								A					14-6
K2	Image position aligning sensor (Center) / Image quality sensor				A								A								A					14-6
K3	Image position aligning sensor (Rear) / Image quality sensor				A								A								A					14-6
K4	Transport guide				B								B								B					14-8
K5	Registration pass sensor				B								B								B					14-9

Fuser unit
25ppm

Items to check	100				200				300				400				500				600				Operation check	P-I			
	Cleaning	Lubrication /Coating	Replacement (x 1,000 sheets) (x 1,000 drive counts)		Cleaning	Lubrication /Coating	Replacement (x 1,000 sheets) (x 1,000 drive counts)		Cleaning	Lubrication /Coating	Replacement (x 1,000 sheets) (x 1,000 drive counts)		Cleaning	Lubrication /Coating	Replacement (x 1,000 sheets) (x 1,000 drive counts)		Cleaning	Lubrication /Coating	Replacement (x 1,000 sheets) (x 1,000 drive counts)		Cleaning	Lubrication /Coating	Replacement (x 1,000 sheets) (x 1,000 drive counts)						
M1 Fuser belt							R1	R1							R1	R1										R1	R1		38-13
M2 Pressure roller							R1	R1							R1	R1										R1	R1		38-34
M3 Separation guide							R3	R3							R3	R3										R3	R3		37-14
M4 Separation finger							R1	R1							R1	R1										R1	R1		39-5
M5 Fuser unit entrance					A		R3	R3					A		R3	R3				A						R3	R3		37-1
M6 Thermistor							R3	R3							R3	R3										R3	R3		38-1
M7 Exit sensor actuator					A		R3	R3					A		R3	R3				A						R3	R3		39-15
M8 Thermostat							R3	R3							R3	R3										R3	R3		38-1
M9 Fuser belt lubricating sheet						SI	R1	R1						SI	R1	R1								SI	R1	R1		38-70	
M10 Fuser belt pad							R1	R1							R1	R1										R1	R1		38-26
M11 Drive gear						W1								W1										W1				38-47/ 38-48	
M12 Fuser unit lower stay					A								A							A								37-24	
M13 Fuser oil recovery sheet (3pcs.)							R1	R1							R1	R1										R1	R1		38-13

30ppm

Items to check	120				240				360				480				600				720				Operation check	P-I				
	Cleaning	Lubrication /Coating	Replacement (x 1,000 sheets) (x 1,000 drive counts)		Cleaning	Lubrication /Coating	Replacement (x 1,000 sheets) (x 1,000 drive counts)		Cleaning	Lubrication /Coating	Replacement (x 1,000 sheets) (x 1,000 drive counts)		Cleaning	Lubrication /Coating	Replacement (x 1,000 sheets) (x 1,000 drive counts)		Cleaning	Lubrication /Coating	Replacement (x 1,000 sheets) (x 1,000 drive counts)		Cleaning	Lubrication /Coating	Replacement (x 1,000 sheets) (x 1,000 drive counts)							
M1 Fuser belt							R1	R1							R1	R1											R1	R1		38-13
M2 Pressure roller							R1	R1							R1	R1											R1	R1		38-34
M3 Separation guide							R3	R3							R3	R3											R3	R3		37-14
M4 Separation finger							R1	R1							R1	R1											R1	R1		39-5
M5 Fuser unit entrance					A		R3	R3					A		R3	R3				A							R3	R3		37-1
M6 Thermistor							R3	R3							R3	R3											R3	R3		38-1
M7 Exit sensor actuator					A		R3	R3					A		R3	R3				A							R3	R3		39-15
M8 Thermostat							R3	R3							R3	R3											R3	R3		38-1
M9 Fuser belt lubricating sheet						SI	R1	R1						SI	R1	R1								SI	R1	R1		38-70		
M10 Fuser belt pad							R1	R1							R1	R1											R1	R1		38-26
M11 Drive gear						W1								W1										W1				38-47/ 38-48		
M12 Fuser unit lower stay					A								A							A								37-24		
M13 Fuser oil recovery sheet (3pcs.)							R1	R1							R1	R1											R1	R1		38-13

35ppm

Items to check	140				280				420				560				700				840				Operation check	P-I				
	Cleaning	Lubrication /Coating	Replacement (x 1,000 sheets) (x 1,000 drive counts)		Cleaning	Lubrication /Coating	Replacement (x 1,000 sheets) (x 1,000 drive counts)		Cleaning	Lubrication /Coating	Replacement (x 1,000 sheets) (x 1,000 drive counts)		Cleaning	Lubrication /Coating	Replacement (x 1,000 sheets) (x 1,000 drive counts)		Cleaning	Lubrication /Coating	Replacement (x 1,000 sheets) (x 1,000 drive counts)		Cleaning	Lubrication /Coating	Replacement (x 1,000 sheets) (x 1,000 drive counts)							
M1 Fuser belt							R1	R1							R1	R1											R1	R1		38-13
M2 Pressure roller							R1	R1							R1	R1											R1	R1		38-34
M3 Separation guide							R3	R3							R3	R3											R3	R3		37-14
M4 Separation finger							R1	R1							R1	R1											R1	R1		39-5
M5 Fuser unit entrance					A		R3	R3					A		R3	R3				A							R3	R3		37-1
M6 Thermistor							R3	R3							R3	R3											R3	R3		38-1
M7 Exit sensor actuator					A		R3	R3					A		R3	R3				A							R3	R3		39-15
M8 Thermostat							R3	R3							R3	R3											R3	R3		38-1
M9 Fuser belt lubricating sheet						SI	R1	R1						SI	R1	R1								SI	R1	R1		38-70		
M10 Fuser belt pad							R1	R1							R1	R1											R1	R1		38-26
M11 Drive gear						W1								W1										W1				38-47/ 38-48		
M12 Fuser unit lower stay					A								A							A								37-24		
M13 Fuser oil recovery sheet (3pcs.)							R1	R1							R1	R1											R1	R1		38-13

REVISION RECORD

Ver02

Ver.02 <2020.09.18>	
Page	Contents
2-2	The description has been added. (Using a printer driver)
2-9	The description has been added. (Paper size of bypass feeding for using a printer driver)
5-29	The illustration has been changed. (Initialized display for FAX clear mode)
6-78	The mistake has been corrected. ([6.4] Background offsetting adjustment for DF)
6-78	The color mode "monochrome" has been renamed to "black". ([6.4] Background offsetting adjustment in back side for DSDF)
6-78	The error code "05-7023" has been added and the mistake has been corrected. ([6.4] Background offsetting adjustment for DSDF)
6-84	The mistake has been corrected. ([6.5] Background offsetting adjustment for DF)
6-85	The error code "05-7023" has been added and the mistake has been corrected. ([6.5] Background offsetting adjustment in back side for DSDF)
6-122	The notes has been added. (DSDF read-in sensor-1 adjustment)
6-125	The item has been added. (DSDF separation roller pressure force adjustment)
7-48	The mistake has been corrected. (Separation guide gap adjustment jig)
8-1	The overview description of the troubleshooting have been changed.
8-26	The item has been added. (F101-14)
8-47	The item has been added. (5401 error) The error messages have been changed. (5410 to 5417)
8-61	The error items have been added. (7433 to 7435)
8-122	The procedure of the troubleshooting for E011 have been added.
8-123	The procedure of the troubleshooting for E013 have been added.
8-143	The procedure of the troubleshooting for E769 have been added.
8-183	The procedure of the troubleshooting for EF14 have been added.
8-187	The procedure of the troubleshooting for EF19 have been added.
8-197	The replacement parts of the troubleshooting for C260 have been added.
8-197	The description of the troubleshooting for C262 has been changed.
8-209	The instructions of the replacement parts for E070 have been added.
8-210	The instructions of the replacement parts for E071 and E074 have been added.
8-214	The instructions of the replacement parts for F115 to F118 have been added.
8-215	The instructions of the replacement parts for F11A have been added.
8-215	The instructions of the replacement parts for F11B have been added.
8-220	The instructions of the replacement parts for F090 have been added.
8-250	The description of the troubleshooting for CA00 has been changed.
8-272	The instructions of the replacement parts for F100_0 have been added.
8-273	The instructions of the replacement parts for F100_1 have been added.
8-274	The instructions of the replacement parts for F100_2 have been added.
8-275	The instructions of the replacement parts for F101_0 to F101_3 have been added.
8-276	The instructions of the replacement parts for F101_4 and F101_12 have been added.
8-277	The instructions of the replacement parts for F101_5 have been added.
8-278	The instructions of the replacement parts for F101_6 have been added.
8-279	The instructions of the replacement parts for F101_7 have been added.
8-280	The instructions of the replacement parts for F101_8 have been added.
8-281	The instructions of the replacement parts for F101_9 have been added.
8-282	The instructions of the replacement parts for F101_10 have been added.
8-283	The instructions of the replacement parts for F101_11 have been added.
8-284	The description of the troubleshooting for F101_13 has been corrected.
8-285	The item has been added. (F101_14)
8-286	The instructions of the replacement parts for F102 to F105 have been added.

Page	Contents
8-287	The instructions of the replacement parts for F106_0 have been added.
8-287	The instructions of the replacement parts for F106_1 have been added.
8-288	The instructions of the replacement parts for F106_2 have been added.
8-288	The instructions of the replacement parts for F106_3 have been added.
8-289	The instructions of the replacement parts for F106_4 have been added.
8-290	The instructions of the replacement parts for F106_5 have been added.
8-290	The instructions of the replacement parts for F106_6 to F106_UNDEF have been added.
8-291	The instructions of the replacement parts for F106_11 have been added.
8-291	The instructions of the replacement parts for F106_12 have been added.
8-292	The instructions of the replacement parts for F109_0 have been added.
8-292	The instructions of the replacement parts for F109_1 have been added.
8-292	The instructions of the replacement parts for F109_2 have been added.
8-294	The instructions of the replacement parts for F109_3 have been added.
8-294	The instructions of the replacement parts for F109_4 have been added.
8-296	The instructions of the replacement parts for F109_5 have been added.
8-297	The instructions of the replacement parts for F109_6 have been added.
8-297	The instructions of the replacement parts for F109_7 have been added.
8-299	The instructions of the replacement parts for F120 have been added.
8-299	The instructions of the replacement parts for F121 have been added.
8-300	The instructions of the replacement parts for F122 have been added.
8-300	The mistake of the troubleshooting for F124 has been corrected. The instructions of the replacement parts for F124 have been added.
8-300	The mistake of the troubleshooting for F125 has been corrected.
8-301	The instructions of the replacement parts for F125 have been added.
8-301	The mistake of the troubleshooting for F126 has been corrected. The instructions of the replacement parts for F126 have been added.
8-301	The mistake of the troubleshooting for F127 has been corrected. The instructions of the replacement parts for F127 have been added.
8-301	The instructions of the replacement parts for F128 have been added.
8-302	The instructions of the replacement parts for F130 have been added.
8-304	The instructions of the replacement parts for F400 have been added.
8-306	The instructions of the replacement parts for F700 have been added.
8-306	The instructions of the replacement parts for F800 have been added.
8-308	The instructions of the replacement parts for F902_3 have been added.
8-309	The instructions of the replacement parts for F902_4 have been added.
8-361	The error item and the measures have been changed. (5410)
8-361	The error item and the measures have been changed. (5411)
8-361	The error item and the measures have been changed. (5412)
8-361	The error item and the measures have been changed. (5413)
8-362	The error item and the measures have been changed. (5414)
8-362	The error item and the measures have been changed. (5415)
8-362	The error item and the measures have been changed. (5416)
8-362	The error item and the measures have been changed. (5417)
8-372	The description of the troubleshooting has been added. (7433)
8-372	The description of the troubleshooting has been added. (7434)
8-373	The description of the troubleshooting has been added. (7435)
8-384	The description of the troubleshooting for 80D1 has been corrected.
8-446	The description of the troubleshooting have been changed. (Poor image density, color reproduction and gray balance)
8-449	The mistake of the doctor blade adjustment have been corrected. The description of the troubleshooting has been corrected. (Background fogging 1)

Ver.02 <2020.09.18>	
Page	Contents
8-460	The mistake of the doctor blade adjustment have been corrected. The description of the troubleshooting has been corrected. (Blank print)
8-471	The mistake of the doctor blade adjustment have been corrected. The description of the troubleshooting has been corrected. (White spots)
8-474	The mistake of the doctor blade adjustment have been corrected. The description of the troubleshooting has been corrected. (Uneven image density 1)
8-476	The mistake of the doctor blade adjustment have been corrected. The description of the troubleshooting has been corrected. (Uneven image density 1)
8-479	The mistake of the doctor blade adjustment have been corrected. The description of the troubleshooting has been corrected. (Faded image)
8-495	The mistake of the doctor blade adjustment have been corrected. The description of the troubleshooting has been corrected. (Faint image)
8-514	The item has been added. (If an image-related problem continues after performing all troubleshooting)
10-47	The item has been added. (Remote Panel VNC)
10-49	The item has been added. (Remote Service)

Ver.01 <2019.09.10>	
Page	Contents
General precautions	A note has been added.
2-9	The mistake has been corrected. (Supported Client OS)
2-12	The description has been corrected.
2-13	The illustration has been corrected.
2-14	The illustration has been changed. (Add option)
2-15	Note has been added.
2-16	The description has been added. (Add option)
2-17	The description has been added.
3-5	The illustration has been corrected.
3-21	The description has been corrected. (LRL board)
3-23	The numbers for P-I have been added. (SRAM)
3-26	The description has been added. (Toner CND)
3-46 to 3-47	The illustration has been corrected.
3-78	The description has been corrected.
4-29	The illustration have been corrected.
4-48	The description has been corrected.
4-207	The procedure has been added. (Front fuser oil recovery sheet 2 / Front fuser oil recovery sheet 1)
4-208	The procedure has been added. (Rear fuser oil recovery sheet)
4-233	The description has been corrected. (Paper exit unit)
5-1	The description has been corrected. (HS Menu)
5-4	The illustration has been corrected. (Fig.5-3)
5-5	The illustration has been corrected. (Fig.5-4)
5-7	The illustration has been corrected. (Fig.5-6)
5-27	The illustration has been corrected. (Fig.5-24)
5-28	The illustration has been corrected. (Fig.5-25)
5-29	The illustration has been corrected. (Fig.5-26)
5-30	The illustration has been corrected. (Fig.5-27) The description of step (2) has been added.
5-31	The illustration has been corrected. (Fig.5-28)
5-32	The notes has been deleted.
5-33	The notes has been added.
5-43	The description has been corrected.
5-49	The illustration has been corrected. (Fig.5-41) The description has been added.
6-79	The description has been changed. (Adjustment of the capacity and image quality of SlimPDF)
6-103 to 6-105	The procedure has been added. (Control Panel Calibration)
7-14	The illustration has been corrected. (Fig.7-8)
7-22 to 7-24	The procedure has been added.
7-31 to 7-32	The description has been added. (DSDf)
7-48 to 7-49	The description has been changed. (Maintenance Part List)
8-5 to 8-69	The description has been changed. (Error Code List)
8-70 to 8-100	The description has been added. (FAX error)
8-120	The description of the troubleshooting for E011 has been deleted.
8-147 to 8-148	The description of the troubleshooting for E930 and E940 have been changed.
8-153	The description of the troubleshooting for EA23 has been changed.
8-155	The description of the troubleshooting for EA27 has been changed.
8-178	The description of the troubleshooting for C040 has been changed.
8-190	The description of the troubleshooting for C1B0 has been changed.
8-192	The description of the troubleshooting for C262 has been changed.

Ver.01 <2019.09.10>	
Page	Contents
8-193	The description of the troubleshooting for C270 has been changed.
8-194	The description of the troubleshooting for C280 has been changed.
8-194	The description of the troubleshooting for C290 has been changed.
8-195	The procedure have been changed. (E440/E445/E446/E447/E449)
8-203	The description of the troubleshooting for C580 has been changed.
8-219	The description of the troubleshooting for CB01 has been deleted.
8-278	The description of the troubleshooting for F101_11 has been added.
8-284	The description of the troubleshooting for F106_12 has been changed.
8-290	The description of the troubleshooting for F110 and F111 have been changed.
8-295	The description of the troubleshooting for F150 has been changed.
8-317	The description of the troubleshooting for 2C50 has been changed.
8-324	The description of the troubleshooting for 2D50 has been added.
8-351	The description of the troubleshooting have been changed. (5410 and 5411)
8-352	The description of the troubleshooting have been changed. (5413 to 5417)
8-360	The description of the troubleshooting for 7301 has been added.
8-379 to 8-419	The troubleshooting have been added. (FAX error)
8-422	The troubleshooting has been changed. (The equipment does not start after the power has been turned ON.)
8-438	The description of the troubleshooting has been changed. (Background fogging 1)
8-450	The description of the troubleshooting has been changed. (Blank print)
8-451	The description of the troubleshooting has been changed. (Solid print)
8-452 to 8-453	The description of the troubleshooting has been changed. (White banding (in feeding direction))
8-456 to 8-457	The description of the troubleshooting has been changed. (Color banding (in feeding direction))
8-462	The description of the troubleshooting has been changed. (Poor transfer)
8-466	The description of the troubleshooting has been changed. (Uneven image density 2)
8-467	The description of the troubleshooting has been changed. (Faded image (low density, roughness))
8-470	The procedure has been deleted. (Image jittering)
8-474	The description of the troubleshooting has been changed. (Blotched image)
8-485	The description of the troubleshooting has been changed. (Feathered image)
8-498	The description of the troubleshooting has been added. (The exit paper surface feels rough like sand is adhering to it)
8-500 to 8-501	The description of the troubleshooting has been added. (Scanned image abnormality)
9-10	The description has been added. (The color of the identification label on the LGC board)
9-13 to 9-14	The notes has been added. The description has been corrected.
9-15	The illustration has been corrected. (Fig.9-31)
12-6	The notes has been added.
12-16	The description has been corrected.
14-1	The description has been corrected. (NOTES FOR THE INSTALLATION OF A CARD READER)
15-1	The illustration has been corrected. (Fig.15-1) The notes has been added. (AC Wire Harness)

Ver00

Ver.00 <2018.06.20>	
Page	Contents
All	Initial release

TOSHIBA

Toshiba Tec Corporation

1-11-1, OSAKI, SHINAGAWA-KU, TOKYO, 141-8562, JAPAN