

TOSHIBA

SERVICE PARTS LIST

MULTIFUNCTIONAL DIGITAL SYSTEMS

**e-STUDIO2040c/2540c/3040c/
3540c/4540c**

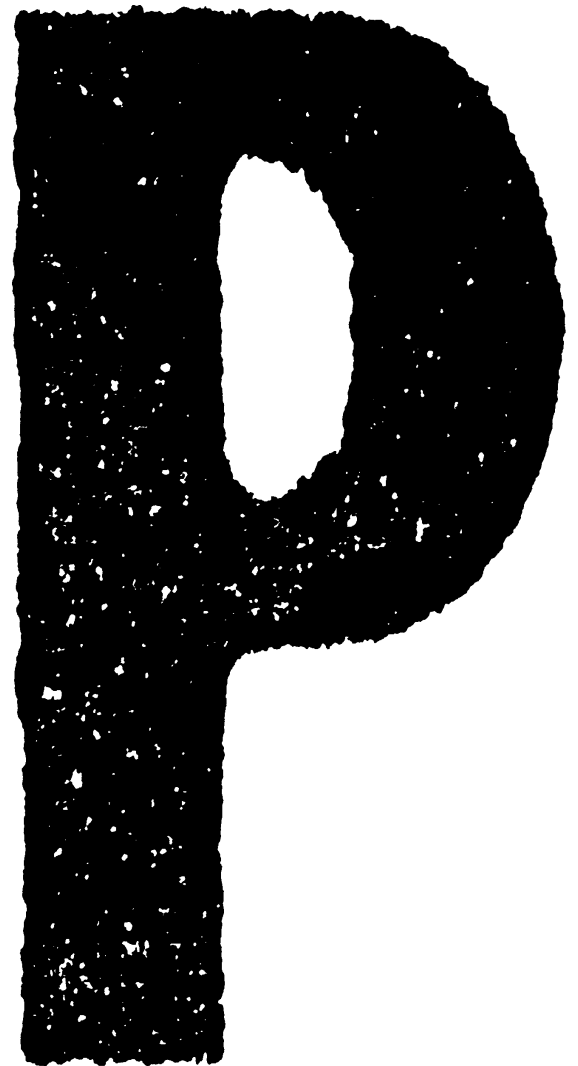

© 2011 TOSHIBA TEC CORPORATION All rights reserved

Under the copyright laws, this manual cannot be reproduced in any form without prior written permission of TOSHIBA TEC CORPORATION. No patent liability is assumed, however, with respect to the use of the information contained herein.

CONTENTS

COVER-1-ASY	1	MAIN-CHARGER-ASY	40
COVER-2-ASY	2	TONER-1-ASY	41
CONTROL-PANEL-ASY	3	TONER-2-ASY	42
BASE-FRAME-ASY	4	FUSER-1-ASY	43
FRONT-FRAME-ASY	5	FUSER-2-ASY	44
REAR-FRAME-ASY-1	6	FUSER-3-ASY	45
REAR-FRAME-ASY-2	7	FUSER SATY&GUIDE EXIT-ASY	46
POWER-SUPPLY-ASY	8	INNER-COVER-ASY	47
CASE-PCB-ASY	9	ADU-ASY-1	48
COV_STAY-PCB-ASY	10	ADU-ASY-2	49
LASER-OPTICAL-UNIT	11	DRAWER-ASY	50
OPTICAL-FRAME-ASY	12	JIGS & GREASE	101
TRU-UNIT-1	13	DOWNLOAD JIGS	102
TRU-UNIT-2	14	SUPPLIES	103
DEV_TBU-DRIVE-ASY	15	REPLACE UNIT	104
DRUM-DRIVE-ASY	16	PM-KIT	105
REGIST&TR1-DRIVE-ASY	17		
FUSER&EXIT-DRIVE-ASY	18		
OPTICAL-DRIVE-ASY	19		
FEEDER-1-ASY	20		
FEEDER-2-ASY	21		
BYPASS-ASY	22		
BYPASS-FEEDER-1-ASY	23		
BYPASS-FEEDER-2-ASY	24		
ALIGNING-ASY	25		
COV&GUIDE-FEED-ASY	26		
LIFT-TRU&SNR-POS-ASY	27		
PLATEN-ASY	28		
CRG-1-ASY	29		
CRG-2-ASY	30		
TRANSPORT-BELT-UNIT-1	31		
TRANSPORT-BELT-UNIT-2	32		
TRANSPORT-BELT-UNIT-3	33		
TRANSPORT-BELT-UNIT-4	34		
BELT-CLEAN-UNIT-ASY	35		
SHUTTER-ASY	36		
EPU-SUB-ASY	37		
DEVELOPER-ASY	38		
CLN-DRUM-ASY	39		

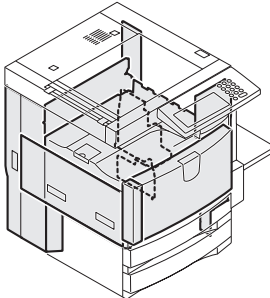
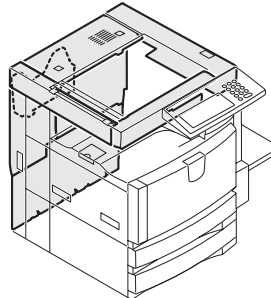
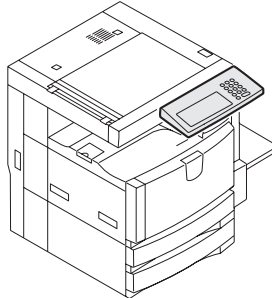
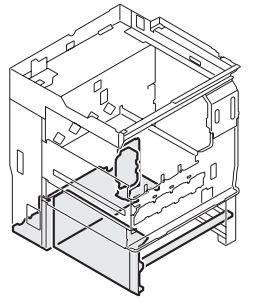
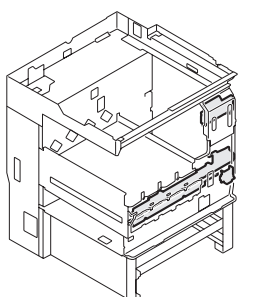
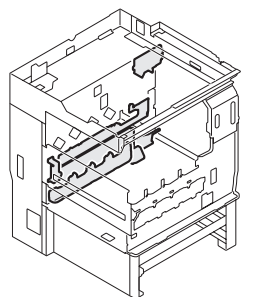
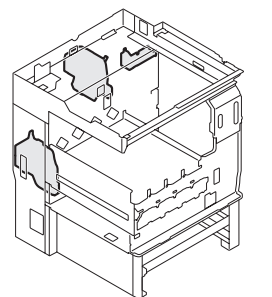
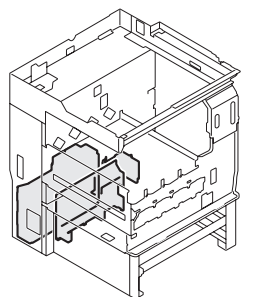
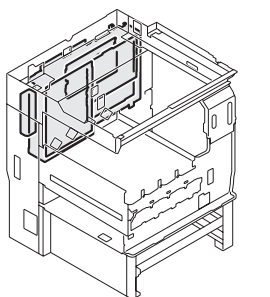
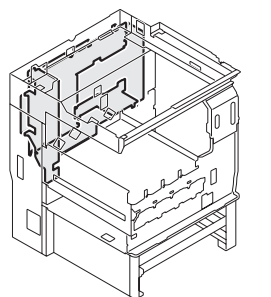
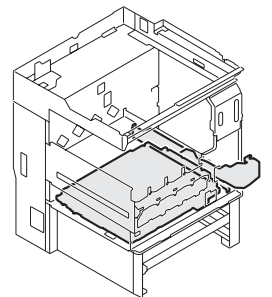
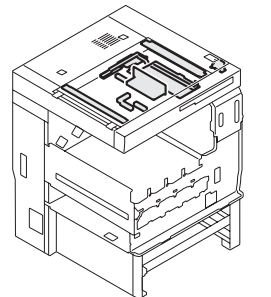
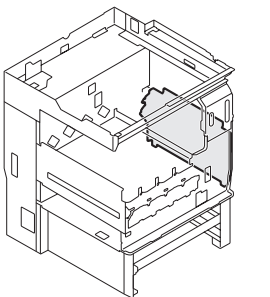
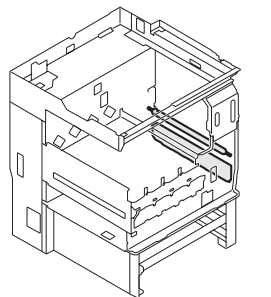
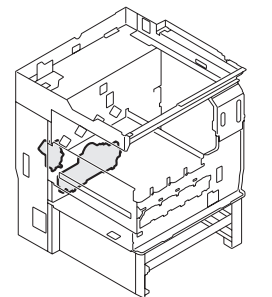
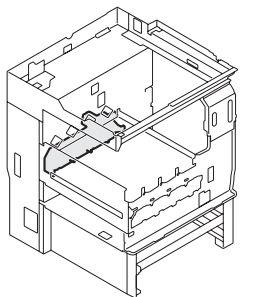
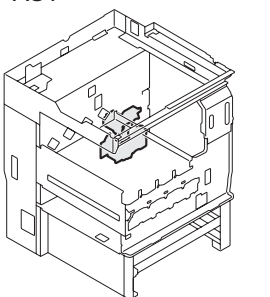
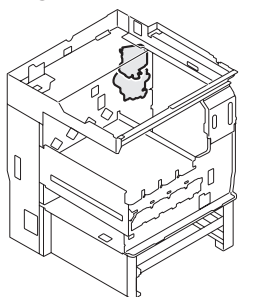
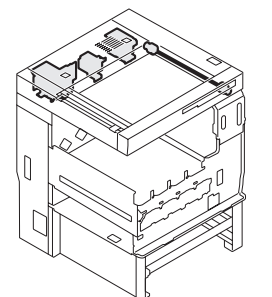
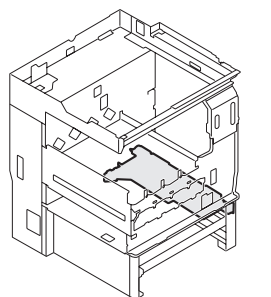
<p>1. COVER-1-ASY</p> 	<p>2. COVER-2-ASY</p> 	<p>3. CONTROL-PANEL-ASY</p> 	<p>4. BASE-FRAME-ASY</p> 
<p>5. FRONT-FRAME-ASY</p> 	<p>6. REAR-FRAME-ASY-1</p> 	<p>7. REAR-FRAME-ASY-2</p> 	<p>8. POWER-SUPPLY-ASY</p> 
<p>9. CASE-PCB-ASY</p> 	<p>10. COV_STAY-PCB-ASY</p> 	<p>11. LASER-OPTICAL-UNIT</p> 	<p>12. OPTICAL-FRAME-ASY</p> 
<p>13. TRU-UNIT-1</p> 	<p>14. TRU-UNIT-2</p> 	<p>15. DEV_TBU-DRIVE-ASY</p> 	<p>16. DRUM-DRIVE-ASY</p> 
<p>17. REGIST&TR1-DRIVE-ASY</p> 	<p>18. FUSER&EXIT-DRIVE-ASY</p> 	<p>19. OPTICAL-DRIVE-ASY</p> 	<p>20. FEEDER-1-ASY</p> 

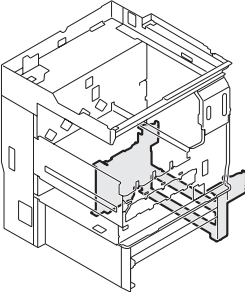
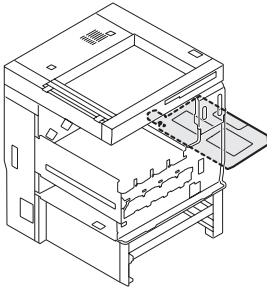
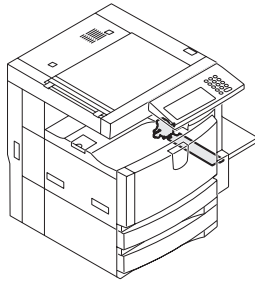
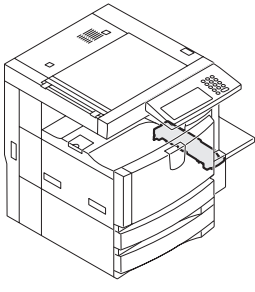
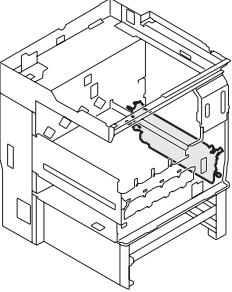
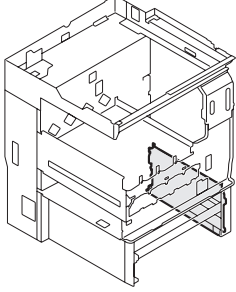
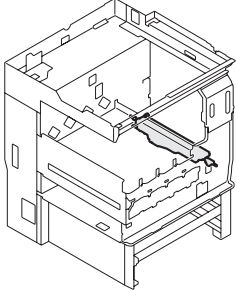
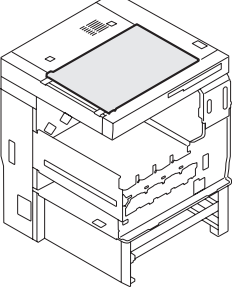
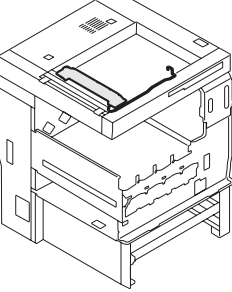
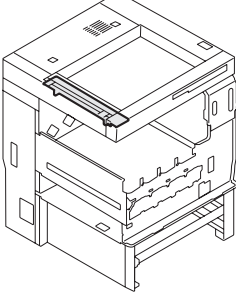
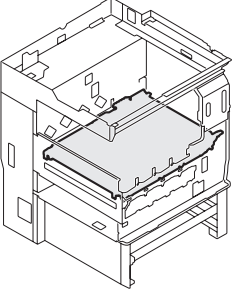
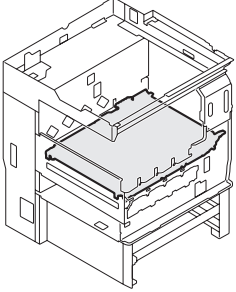
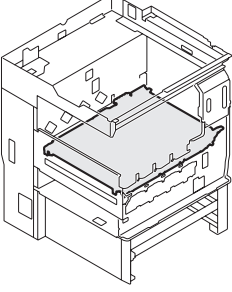
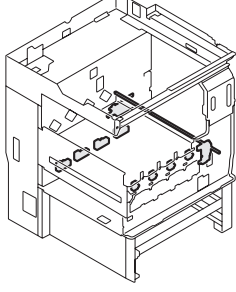
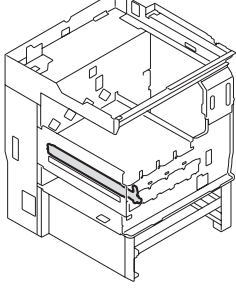
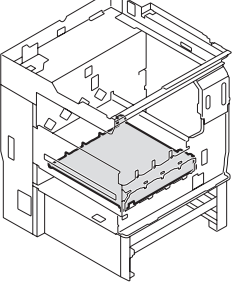
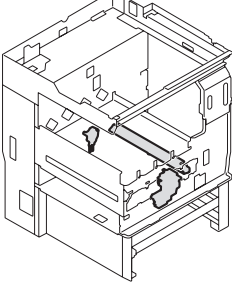
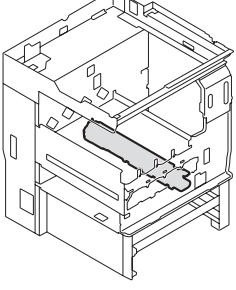
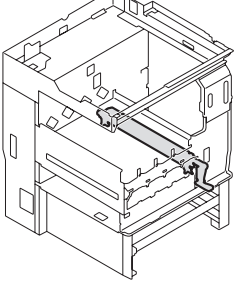
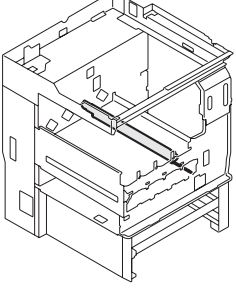
<p>21. FEEDER-2-ASY</p> 	<p>22. BYPASS-ASY</p> 	<p>23. BYPASS-FEEDER-1-ASY</p> 	<p>24. BYPASS-FEEDER-2-ASY</p> 
<p>25. ALIGNING-ASY</p> 	<p>26. COV&GUIDE-FEED-ASY</p> 	<p>27. LIFT-TRU&SNR-POS-ASY</p> 	<p>28. PLATEN-ASY</p> 
<p>29. CRG-1-ASY</p> 	<p>30. CRG-2-ASY</p> 	<p>31. TRANSPORT-BELT-UNIT-1</p> 	<p>32. TRANSPORT-BELT-UNIT-2</p> 
<p>33. TRANSPORT-BELT-UNIT-3</p> 	<p>34. TRANSPORT-BELT-UNIT-4</p> 	<p>35. BELT-CLEAN-UNIT-ASY</p> 	<p>36. SHUTTER-ASY</p> 
<p>37. EPU-SUB-ASY</p> 	<p>38. DEVELOPER-ASY</p> 	<p>39. CLN-DRUM-ASY</p> 	<p>40. MAIN-CHARGER-ASY</p> 

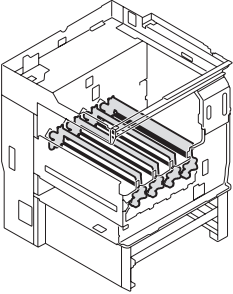
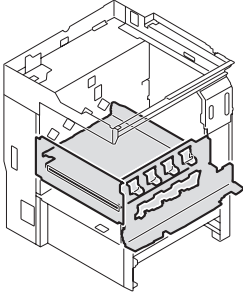
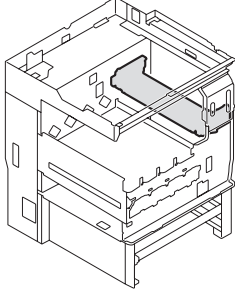
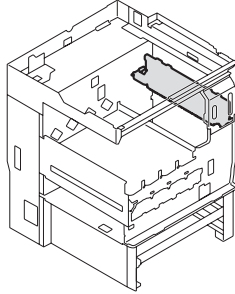
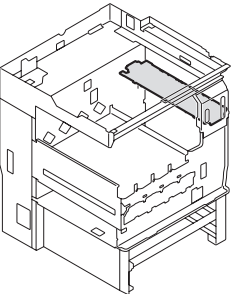
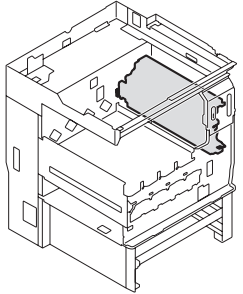
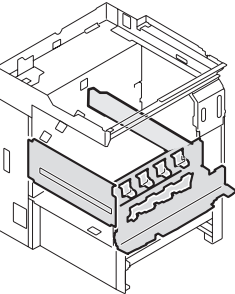
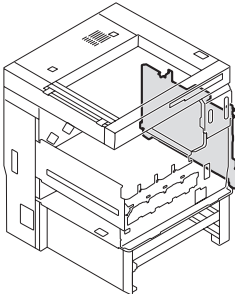
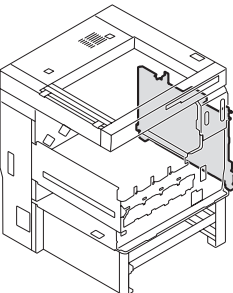
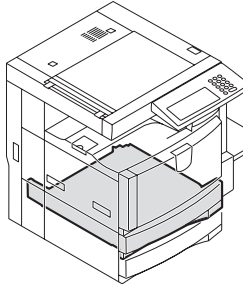
<p>41. TONER-1-ASY</p> 	<p>42. TONER-2-ASY</p> 	<p>43. FUSER-1-ASY</p> 	<p>44. FUSER-2-ASY</p> 
<p>45. FUSER-3-ASY</p> 	<p>46. FUSER SATY&GUIDE EXIT-ASY</p> 	<p>47. INNER-COVER-ASY</p> 	<p>48. ADU-ASY-1</p> 
<p>49. ADU-ASY-2</p> 	<p>50. DRAWER-ASY</p> 		

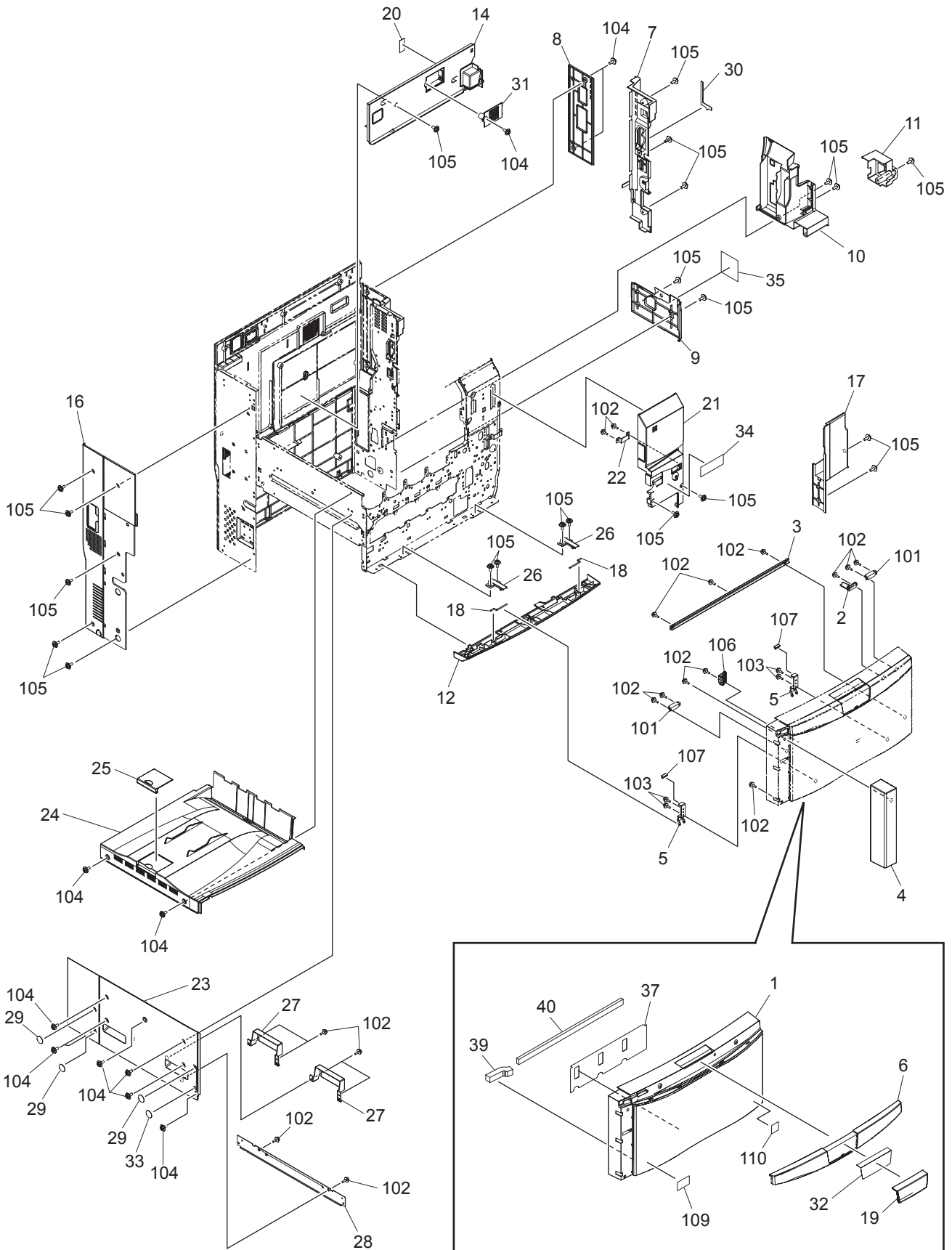

ITEM No.	PART No.	PART NAME	Q'TY / PAGE	Q'TY / PACK	REMARKS
1	6LJ00604000	COV-FRT-450-D	1	1/PP	
2	6LE22838000	PUSHER-SW-380	1	1/P	
3	6LE21715000	BRKT-COV-FRT	1	1/P	
4	6LH32103200	COV-FRT-LFT-SIDE-H14XD	1	1/PP	
5	6LH32104000	BRKT-LEVER-450	2	1/P	
6	6LH32102000	COV-FRT-TOP-450	1	1/PP	
7	6LE21745200	ASYS-COV-RGT-UPR-H14XD	1	1/PP	
8	6LH32111200	COV-RGT-SYS-H14XD	1	1/P	
9	6LE21709400	COV-RGT-LWR-H14XN	1	1/P	
10	6LH32149200	COV-HINGE-R-H14XD	1	1/PP	
11	6LE21708200	COV-BYPS-RER-H14XD	1	1/P	
12	6LH32121200	COV-FRT-LW-H14XD	1	1/PP	
14	6LE21764200	ASYS-COV-TRAY-BCK-H14XD	1	1/PP	
16	6LH32124200	COV-LFT-RER-H14XD	1	1/PP	
17	6LE21700200	COV-HINGE-F-H14XD	1	1/P	
18	6LH32146000	PIN-HINGE	2	1/P	
19	6LH32101000	COV-EMBLEM-450	1	1/P	
20	6LE21763000	SHEET-COV-TRAY-BCK	1	1/P	
21	6LE21751100	ASYS-COV-FRM-FRT-H14X	1	1/PP	
22	6LE21710000	PLATE-MG	1	1/P	
23	6LE21759200	COV-LFT-H14XD	1	1/PP	
24	6LH32130100	ASYS-COV-TRAY-H14X	1	1/PP	
25	6LE21719200	COV-STOP-PAPER-H14XD	1	1/P	
26	6LJ00603000	BRKT-ARM	2	1/P	
27	6LE21736000	COV-HANDLE-BACK-380D	2	1/P	
28	6LE21742000	BRKT-FIN-LFT	1	1/P	
29	6LJ04029000	LBL-MASK-D_V_GRAY-H14X	3	1/P	
30	6LJ02542000	LBL-INST-3-H14X	1	1/P	
31	6LE21756200	COV-TRAY-BCK-OZ-H14XD	1	1/P	
32 A	6LJ00606000	SHEET-EMBLEM-2040C	1	1/C	e-STUDIO2040C
32 B	6LJ00606100	SHEET-EMBLEM-2540C	1	1/C	e-STUDIO2540C
32 C	6LJ00606200	SHEET-EMBLEM-3040C	1	1/C	e-STUDIO3040C
32 D	6LJ00606300	SHEET-EMBLEM-3540C	1	1/C	e-STUDIO3540C
32 E	6LJ00606400	SHEET-EMBLEM-4540C	1	1/C	e-STUDIO4540C
33	6LH59926000	LBL-MASK-D_V_GRAY	1	5/P	
34	6LA47644000	LBL-CAU-LSR-350	1	1/KP	
35 A	44204604000	LBL-SERVICE-45	1	5/P	NAD,AUD,ASD,ARD
35 E	6LH45852000	LBL-SERVICE-CABLE	1	1/KP	MJD
37	6LH39290000	SHEET-CLNFRT-450	1	1/KP	
39 B	6LH39279000	SEAL-COV-FRT-2	1	1/KP	e-STUDIO4540C
40 B	6LH39278000	SEAL-COV-FRT-1	1	1/KP	e-STUDIO4540C
101	FO-01564000	CA-0168C	2	5/P	
102	X0-02247000	S/TPP/FHEXM-3X8-NI	19	10/P	
103	X0-02249000	S/TPP/FHEXM-3X12-NI	4	10/P	
104	X0-02235000	S/FHEXM-M4X8-NI	12	10/P	
105	X0-02421000	S/TPS/FHEXM/R-4X8-ZU3	22	10/P	
106	6LJ00600000	PUSHER-SW-FRT-H14X	1	1/P	
107	6LJ01212000	GSKT-STGL-5-6-12	2	1/P	
108	6LE21762000	COV-SUB-TRAY-380	1	1/PP	
109	6LH45830000	LBL-E-BRIDGE2	1	1/P	
110	6LE84761000	LBL-ENERGY-T-PS-N	1	5/KP	

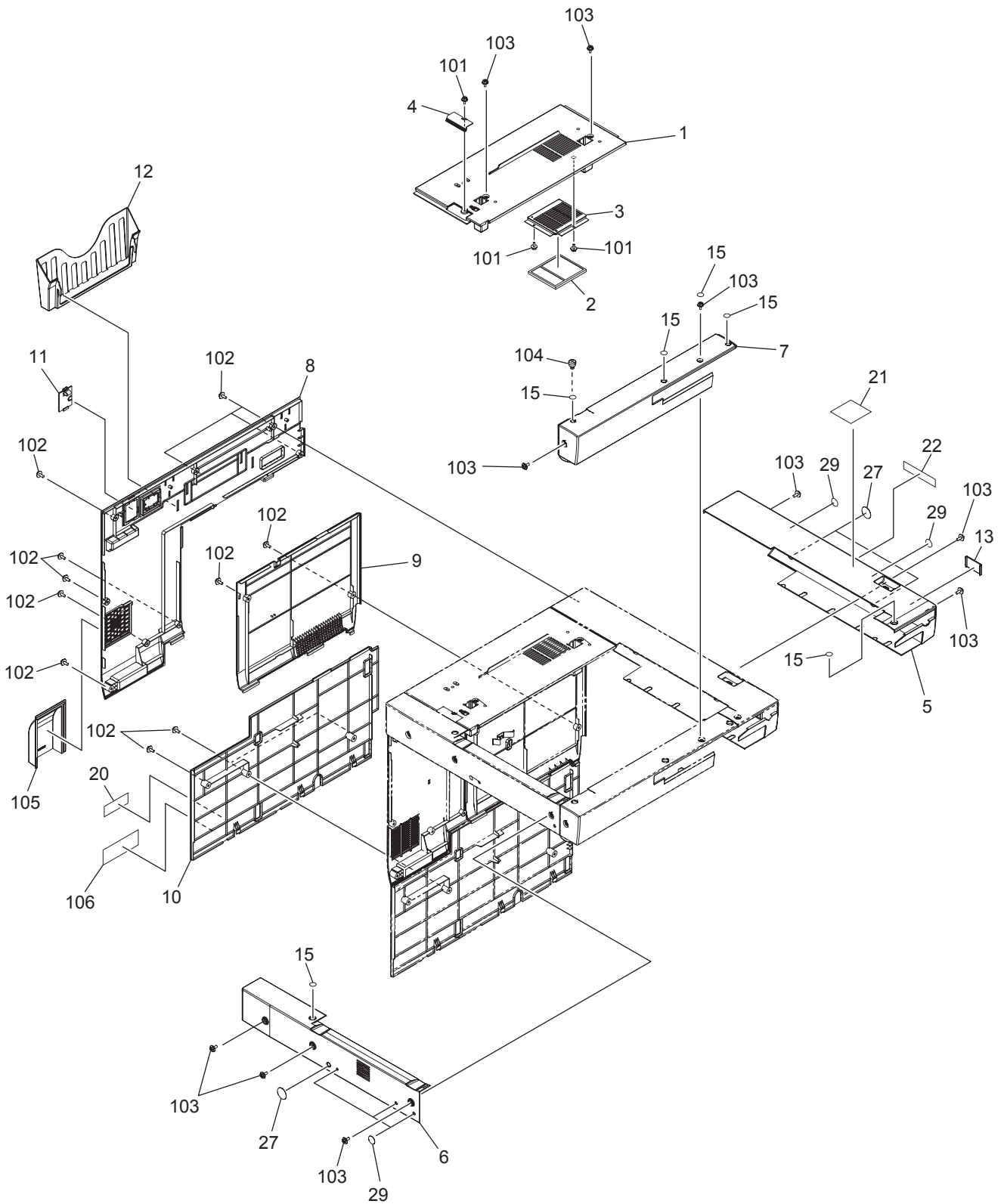

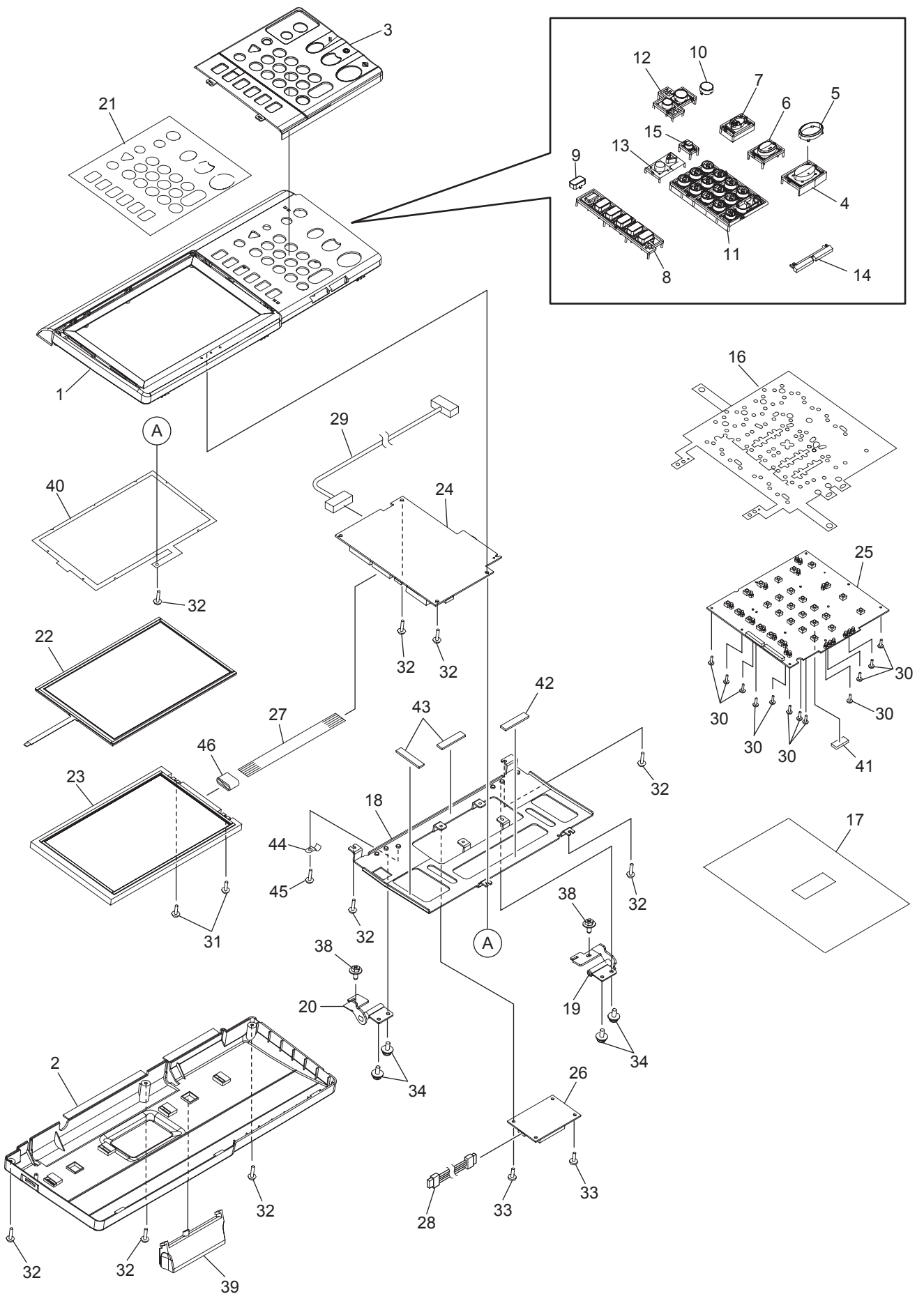

ITEM No.	PART No.	PART NAME	Q'TY / PAGE	Q'TY / PACK	REMARKS
1	6LH37303200	COV-CONP-UPR-H14XN	1	1/PP	
2	6LH37304200	COV-CONP-LWR-H14XN	1	1/PP	
3	6LH37305000	COV-CONP-CLEAR-45X	1	1/PP	
4	6LH02005000	KEY-START	1	1/C	
5	6LH02006000	KEY-START-RING	1	1/D	
6	6LH02007000	KEY-STOP	1	1/C	
7	6LH02008100	KEY-RESET-U	1	1/C	
8	6LH02009000	KEY-FUNCTION	1	1/C	
9	6LH02010000	KEY-MENU	1	1/P	
10	6LH02011000	KEY-POWER	1	1/D	
11	6LH37308000	KEY-TEN-45X	1	1/C	
12	6LH37306000	KEY-ENERGY-45X	1	1/C	
13	6LH37307000	KEY-USER-FUNC-45X	1	1/C	
14	6LH37309000	LID-LED-45X	1	1/D	
15	6LH02012000	KEY-COUNT	1	1/C	
16	6LH37310000	MYLAR-SHIELD-45X	1	1/KP	
17	6LH52204000	SHIELD-SHEET-470	1	1/KP	
18	6LJ02903000	SHIELD-CONPANE-45X	1	1/P	
19	6LH37332000	ASYS-HINGE-R-45X	1	1/P	
20	6LH37333000	ASYS-HINGE-L-45X	1	1/P	
21	6LH37331000	SHEET-PANEL-45X-U	1	1/KP	
22	6LH37335000	ASYS-PNL-TOUCH-450	1	1/C	
23	6LH70012000	ASYS-DSP-LCD-H100	1	1/C	
24	6LH62845000	PWA-F-DSP-470	1	1/SB	
25	6LH40335000	PWA-F-KEY-450N	1	1/SB	
26	6LH62505000	INV-DSP-470	1	1/C	
27	6LH61431000	HRNS-LCD-DSP-470	1	1/P	
28	6LH39826000	HRNS-INV-DSP-450	1	1/P	
29	6LJ05181000	HRNS-SYS-DSP-140	1	1/P	
30	X0-02094000	S/TPB/BID-2X6-NI	12	10/P	
31	X0-02096000	S/TPP/BRZ-3X8-NI	2	10/P	
32	X0-02095000	S/TPP/BRZ-3X10-NI	9	10/P	
33	X0-00434000	S/BID-M3X8-NI	2	10/P	
34	X0-02217000	S/PAN/SWWP-M4X8-ZU3	4	10/P	
38	X0-02421000	S/TPS/FHEXM/R-4X8-ZU3	2	10/P	
39	6LH37319000	STOPPER-OPE-45X	1	1/PP	
40	6LH37337000	MYLAR-SHIELD-LCD	1	1/KP	
41	6LH37330000	SPACER	1	1/P	
42	6LJ02901000	GSKT-CONP-H14X-1	1	1/P	
43	6LJ02902000	GSKT-CONP-H14X-2	2	1/P	
44	6LH70095000	CLMP-MGC-3	1	1/P	
45	X0-02093000	S/PAN/SWWWS-M4X6-NI	1	10/P	
46	D0-29877000	FRC-31-12-5	1	1/P	

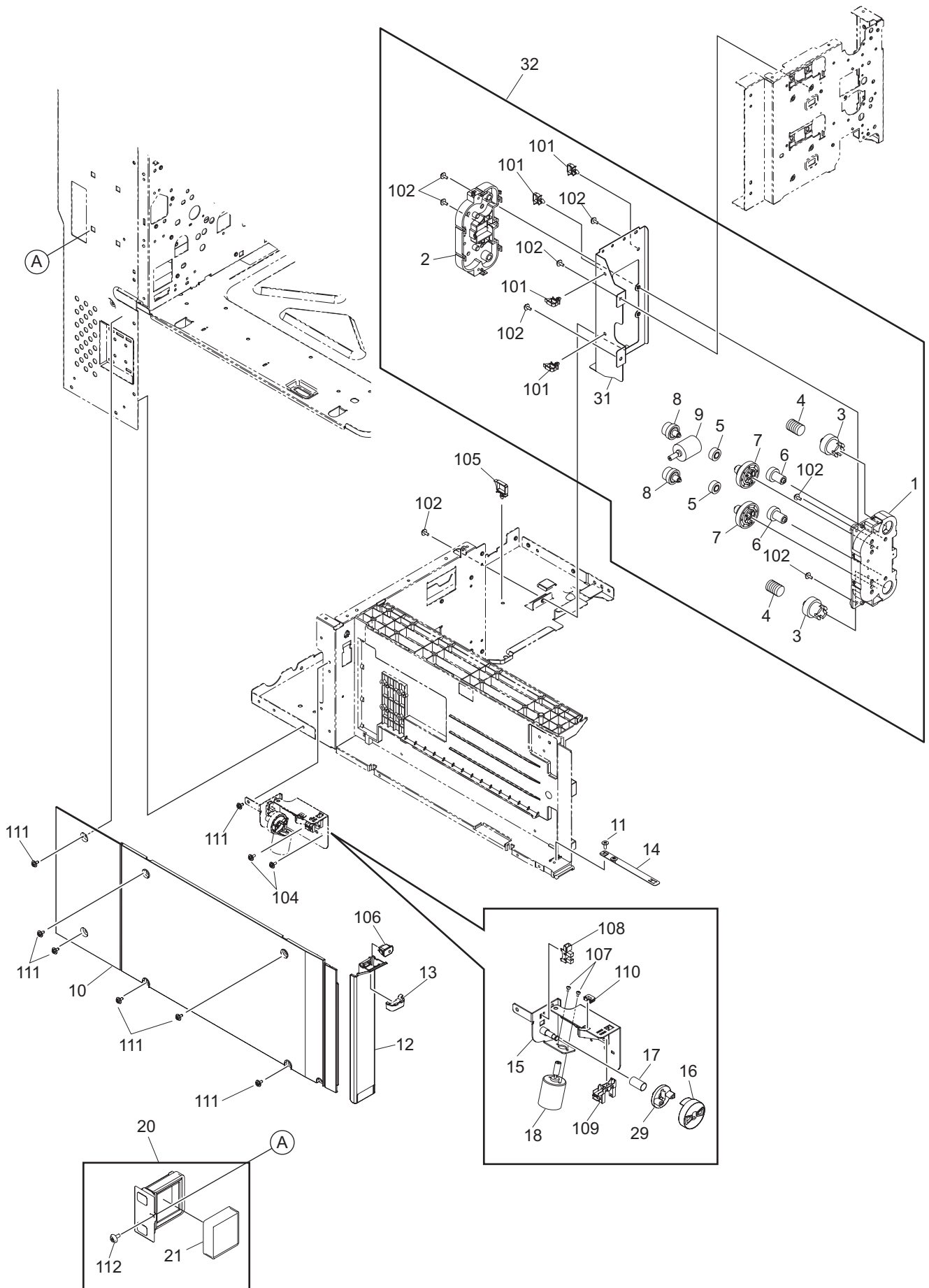

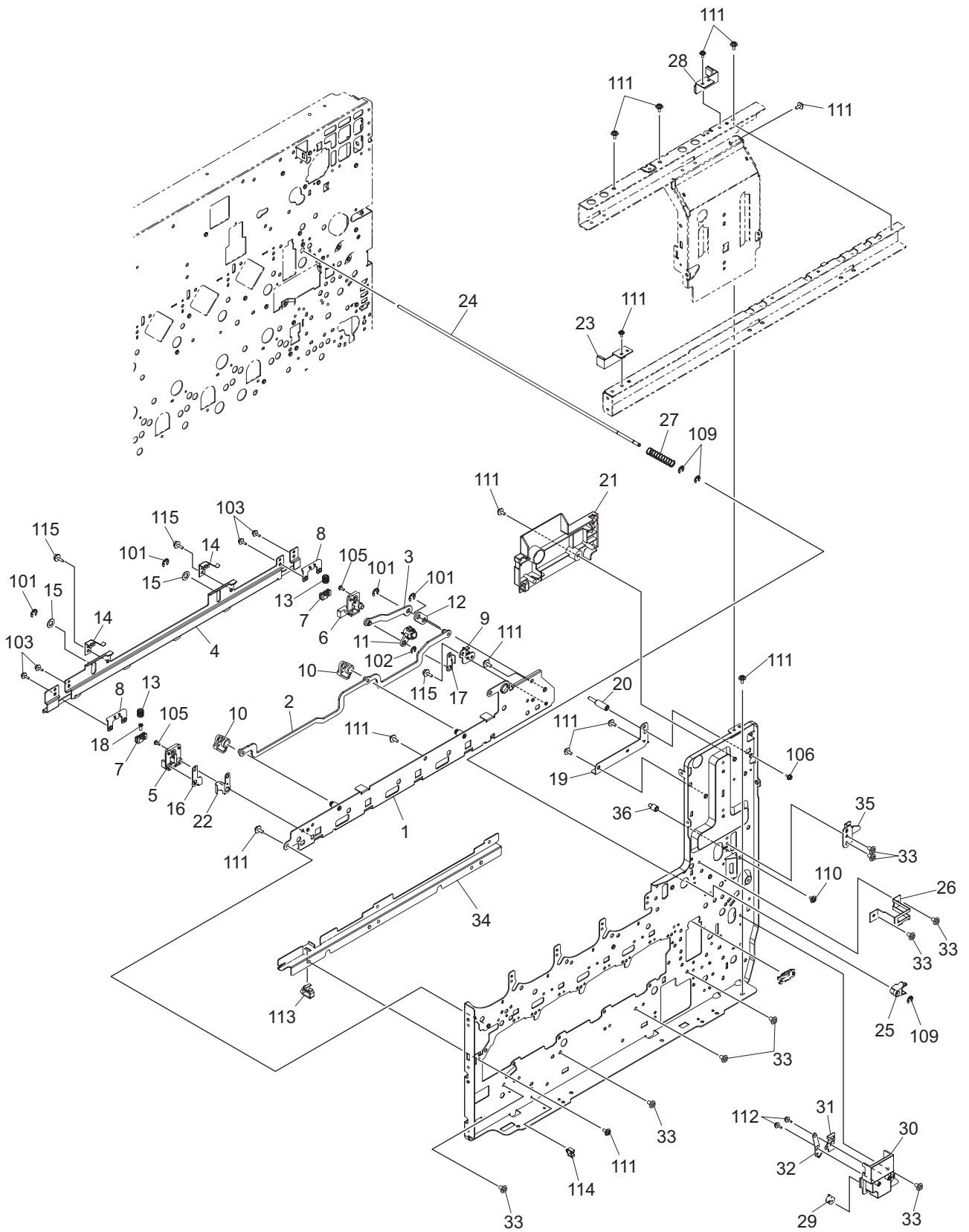

ITEM No.	PART No.	PART NAME	Q'TY / PAGE	Q'TY / PACK	REMARKS
1	6LJ03372000	ASYS-PLATE-CRU-F	1	1/P	
2	6LJ03345000	ASYS-LINK-TBU-CRU-F	1	1/P	
3	6LJ03346000	ASYS-LINK-LIFT-CRU-F	1	1/P	
4	6LE28313000	RAIL-GUIDE-TBU-F	1	1/P	
5	6LJ03352000	HLDR-TBU-F-CL	1	1/P	
6	6LJ03351000	HLDR-TBU-F-TR	1	1/P	
7	6LE28419000	HLDR-RAIL-TBU	2	1/P	
8	6LE28421000	BRKT-HLDR-TBU	2	1/P	
9	6LE28286000	HOLDER-GUIDE-MID-L-F	1	1/P	
10	6LE28250000	CAM-LIFT-TBU-F	2	1/P	
11	6LE28246000	CAM-LIFT-CRU-F	1	1/P	
12	6LE28294000	LINK-LIFT-PLATE-CRU	1	1/P	
13	6LE28420000	SPG-HLDR-RAIL-TBU	2	5/P	
14	6LE28338000	SPG-F-DPM-TBU-F	2	1/P	
15	6LE28372000	WSHR-6R2X12XR5-APS	2	5/P	
16	6LE28508000	SPG-F-FIX-TBU-CL	1	1/P	
17	6LE28340000	SPG-F-FIX-TBU	1	1/P	
18	6LE28392000	SCREW-TBU-F380-2	1	5/P	
19	6LE25897000	BRKT-SLIDE-F	1	1/P	
20	6LE23953000	STUD-LEVER-ADU-F	1	1/P	
21	6LE21701000	COV-FRM-TOP-BCK-380D	1	1/P	
22	6LE28509000	SPG-TBU-F-CLN	1	1/P	
23	6LJ03121000	ASYS-BRKT-GEL-L-F-H140	1	1/P	
24	6LE22822000	SHAFT-DOOR-SW	1	1/P	
25	6LH33241000	PUSHER-COVF-45X	1	1/P	
26	6LH33240000	BRKT-SWCOV-45X	1	1/P	
27	6LE22904000	SPG-C-5R75XR55X40	1	1/P	
28	6LJ03123000	ASYS-BRKT-GEL-R-F-H140	1	1/P	
29	6LA37732000	ASYS-ERZV10D821-350	1	1/D	
30	6LA37611000	HLDR-ERTH-RGST	1	1/P	
31	6LA37612000	SPG-F-RGST-R	1	1/P	
32	6LA37613000	SPG-F-RGST-L	1	1/P	
33	X0-02421000	S/TPS/FHEXM/R-4X8-ZU3	9	10/P	
34	6LH32964000	BRKT-BASE-SHUT-FRT-450	1	1/P	
35	6LJ02513000	BRKT-FUS-FRM-F2	1	1/P	
36	6LE29029000	STUD-HOOK-TRU	1	1/P	
101	X0-00966000	RR/E-5-SS	4	10/P	
102	X0-00965000	RR/E-4-SS	1	10/P	
103	X0-02231000	S/FHEXM-M3X8-NI	4	10/P	
105	X0-02069000	S/TPS/BID-3X6-ZU3	2	10/P	
106	X0-02230000	S/FHEXM-M3X6-NI	1	10/P	
109	X0-00964000	RR/E-3-SS	3	10/P	
110	X0-02234000	S/FHEXM-M4X6-NI	1	10/P	
111	X0-02589000	S/TPD3/FHEXM-4X8-ZU3	14	10/P	
112	X0-02247000	S/TPP/FHEXM-3X8-NI	2	10/P	
113	F0-01647000	RLWT-1V0	1	5/P	
114	F0-01250000	MSB-1207	1	5/P	
115	X0-02592000	S/TPD3/FHEXM-3X6-ZU3	3	10/P	

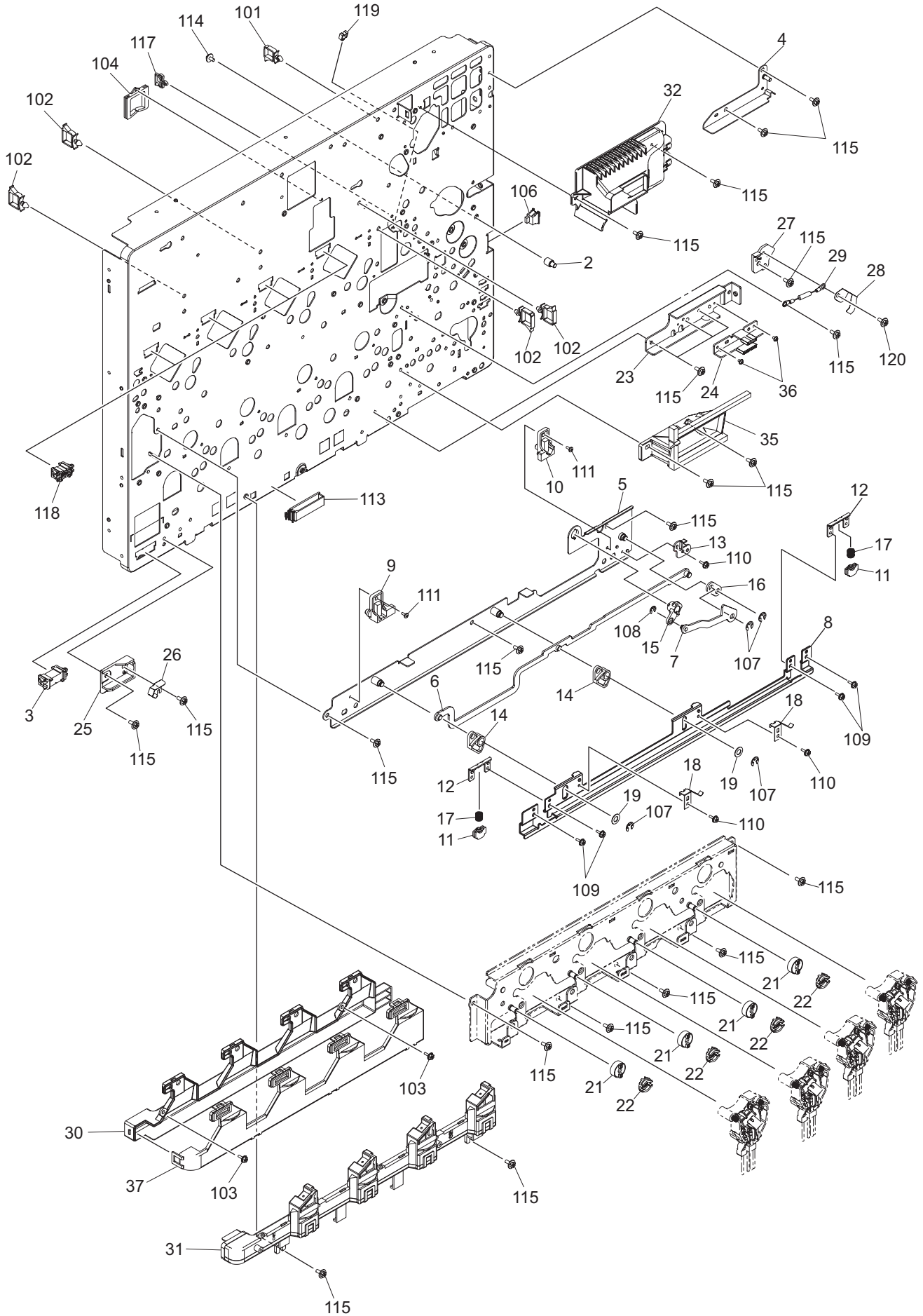

ITEM No.	PART No.	PART NAME	Q'TY / PAGE	Q'TY / PACK	REMARKS
2	6LE29029000	STUD-HOOK-TRU	1	1/P	
3	E0-09967000	BU28P-TZW-S (LF)(SN)	1	1/P	
4	6LE25903000	ASYS-BKT-SLD-R	1	1/P	
5	6LJ03360000	ASYS-PLATE-CRU-R	1	1/P	
6	6LJ03359000	ASYS-LINK-TBU-CRU-R	1	1/P	
7	6LJ03358000	ASYS-LINK-LIFT-CRU-R	1	1/P	
8	6LE28314000	RAIL-GUIDE-TBU-R	1	1/P	
9	6LJ03354000	HLDR-TBU-R-CL	1	1/P	
10	6LJ03353000	HLDR-TBU-R-TR	1	1/P	
11	6LE28419000	HLDR-RAIL-TBU	2	1/P	
12	6LE28421000	BRKT-HLDR-TBU	2	1/P	
13	6LE28287000	HOLDER-GUIDE-MID-L-R	1	1/P	
14	6LE28251000	CAM-LIFT-TBU-R	2	1/P	
15	6LE28248000	CAM-LIFT-CRU-R	1	1/P	
16	6LE28294000	LINK-LIFT-PLATE-CRU	1	1/P	
17	6LE28420000	SPG-HLDR-RAIL-TBU	2	5/P	
18	6LE28339000	SPG-F-DPM-TBU-R	2	1/P	
19	6LE28372000	WSHR-6R2X12XR5-APS	2	5/P	
21	6LJ01600000	ASYS-GEAR-6H24-BRG-F14X	4	1/P	
22	6LE23715000	COUPL-DRIVE-DEV-MID	4	1/P	
23	6LE26518000	ASYS-BASE-LSU-RER-RGT	1	1/P	
24	6LE25243000	BRKT-REINF-FRM-R	1	1/P	
25	6LE26418000	BASE-LSU-RER-LFT	1	1/P	
26	6LE26419000	SPG-F-HLDR-LSU-LFT	1	1/P	
27	6LE29004000	TERM-GUIDE-MID	1	1/P	
28	6LE29003000	SPG-F-TERM-GUIDE	1	1/P	
29	6LE29002000	ASYS-RESIST-380	1	1/D	
30 A	6LH32933000	ASYS-DUCT-EPU-COOL-TOP	1	1/PP	e-STUDIO4540C
31	6LH32907000	ASYS-DUCT-OZN	1	1/PP	
32	6LE23922000	DUCT-EXIT-REAR	1	1/P	
35	6LE22588000	ASYS-DUCT-LSU-REAR	1	1/P	
36	6LA37949000	S/PAN/WP-M3X5-NI	2	10/P	
37 A	6LH32912000	DUCT-EPU-COOL-BTM-F45X	1	1/D	e-STUDIO4540C
101	F0-01243000	LWS-1211Z	1	5/P	
102	F0-01245000	LWS-1316Z	4	5/P	
103 A	X0-02247000	S/TPP/FHEXM-3X8-NI	2	10/P	e-STUDIO4540C
104	F0-00034000	EDS-2323U	1	5/P	
106	E0-01853000	CS1A-B2CA	1	1/D	
107	X0-00966000	RR/E-5-SS	4	10/P	
108	X0-00965000	RR/E-4-SS	1	10/P	
109	X0-02231000	S/FHEXM-M3X8-NI	4	10/P	
110	X0-02592000	S/TPD3/FHEXM-3X6-ZU3	3	10/P	
111	X0-02069000	S/TPS/BID-3X6-ZU3	2	10/P	
113	F0-01556000	RFCC-525S	1	1/P	
114	X0-02234000	S/FHEXM-M4X6-NI	1	10/P	
115	X0-02589000	S/TPD3/FHEXM-4X8-ZU3	23	10/P	
117	F0-01749000	RLMS-2V0	1	1/P	
118	E0-10456000	BU16P-TZW-S (LF)(SN)	4	1/P	
119	F0-01250000	MSB-1207	1	5/P	
120	X0-02251000	S/TPP/FHEXM-4X8-NI	1	10/P	

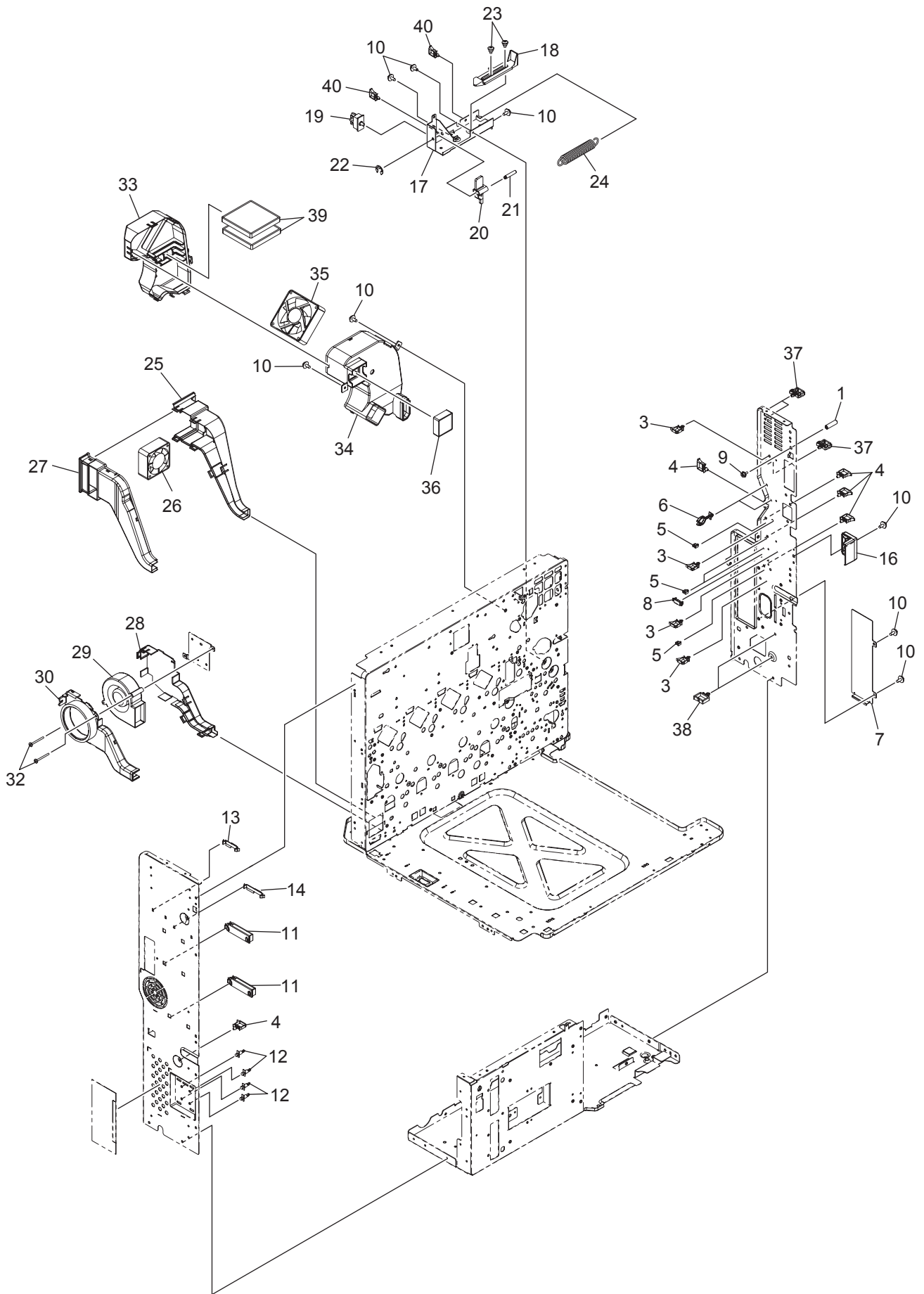

ITEM No.	PART No.	PART NAME	Q'TY / PAGE	Q'TY / PACK	REMARKS
1	6LE21005000	STUD-ADU-380	1	1/P	
3	F0-01243000	LWS-1211Z	4	5/P	
4	F0-01245000	LWS-1316Z	5	5/P	
5	F0-01250000	MSB-1207	4	5/P	
6	F0-00505000	HL-18-0	2	5/P	
7	6LE22883000	PLATE-COVER-FAX	1	1/P	
8	F0-01451000	RFC-16V0	1	1/P	
9	X0-02230000	S/FHEXM-M3X6-NI	1	10/P	
10	X0-02421000	S/TPS/FHEXM/R-4X8-ZU3	8	10/P	
11	F0-01556000	RFCC-525S	2	1/P	
12	F0-00342000	SPLSN-6U	4	5/P	
13	F0-01418000	RFC-33V0	1	1/P	
14	F0-01858000	RFC-45V0	1	1/P	
16	6LE29018200	COVER-HNS-H14XD	1	1/P	
17	6LE22817000	BRKT-DOOR-SW-380	1	1/P	
18	6LE22823000	SLIDE-SW-ADU	1	1/P	
19	E0-08442000	FA1L-AA22	1	1/D	
20	6LE22819000	GUIDE-SW-DOOR-380	1	1/P	
21	6LE22824000	STUD-DOOR-SW	1	1/P	
22	X0-00965000	RR/E-4-SS	1	10/P	
23	6LE06406000	SCREW-CH-M	2	10/P	
24	6LE22836000	SPG-E-6R5XR45X31R9	1	1/P	
25	6LH32920000	DUCT-OZN-FAN-B	1	1/PP	
26	6LJ01024000	ASYS-DUCT-FAN-60-H140	1	1/D	
27	6LH32941000	ASYS-DUCT-OZN-A	1	1/PP	
28 A	6LH32929000	ASYS-DUCT-EPU-COOL-B	1	1/PP	e-STUDIO4540C
29 A	6LE09187000	FAND-DEV-390	1	1/D	e-STUDIO4540C
30 A	6LH32926000	ASYS-DUCT-EPU-COOL-A	1	1/PP	e-STUDIO4540C
32 A	X0-00461000	S/BID-M4X35-NI	2	10/P	e-STUDIO4540C
33	6LJ01011000	DUCT-TNR-EXIT-U-H140	1	1/PP	
34	6LJ01012000	ASYS-DUCT-TNR-EXIT-L-H140	1	1/PP	
35	6LE22571000	ASYS-DUCT-FAN	1	1/D	
36	6LH32949000	FLTR-OZ-50-TNR-EX-450	1	1/C	
37	F0-01609000	RLWC-2SV0	3	5/P	
38	F0-01252000	WS-4W	2	5/P	
39	6LJ01021000	FLTR-OZN-H140	2	1/P	
40	F0-00736000	LWS-0711Z	2	5/P	

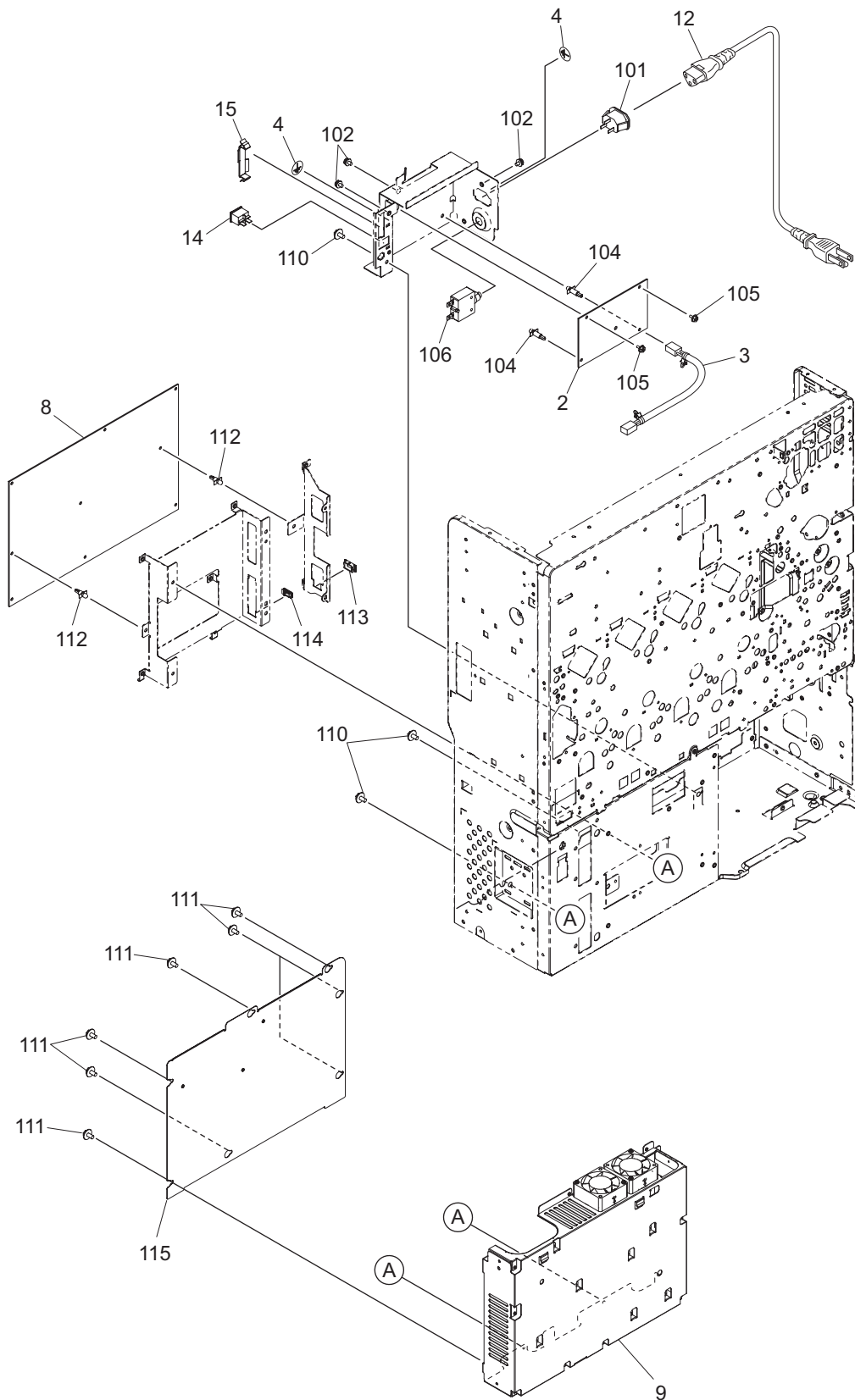

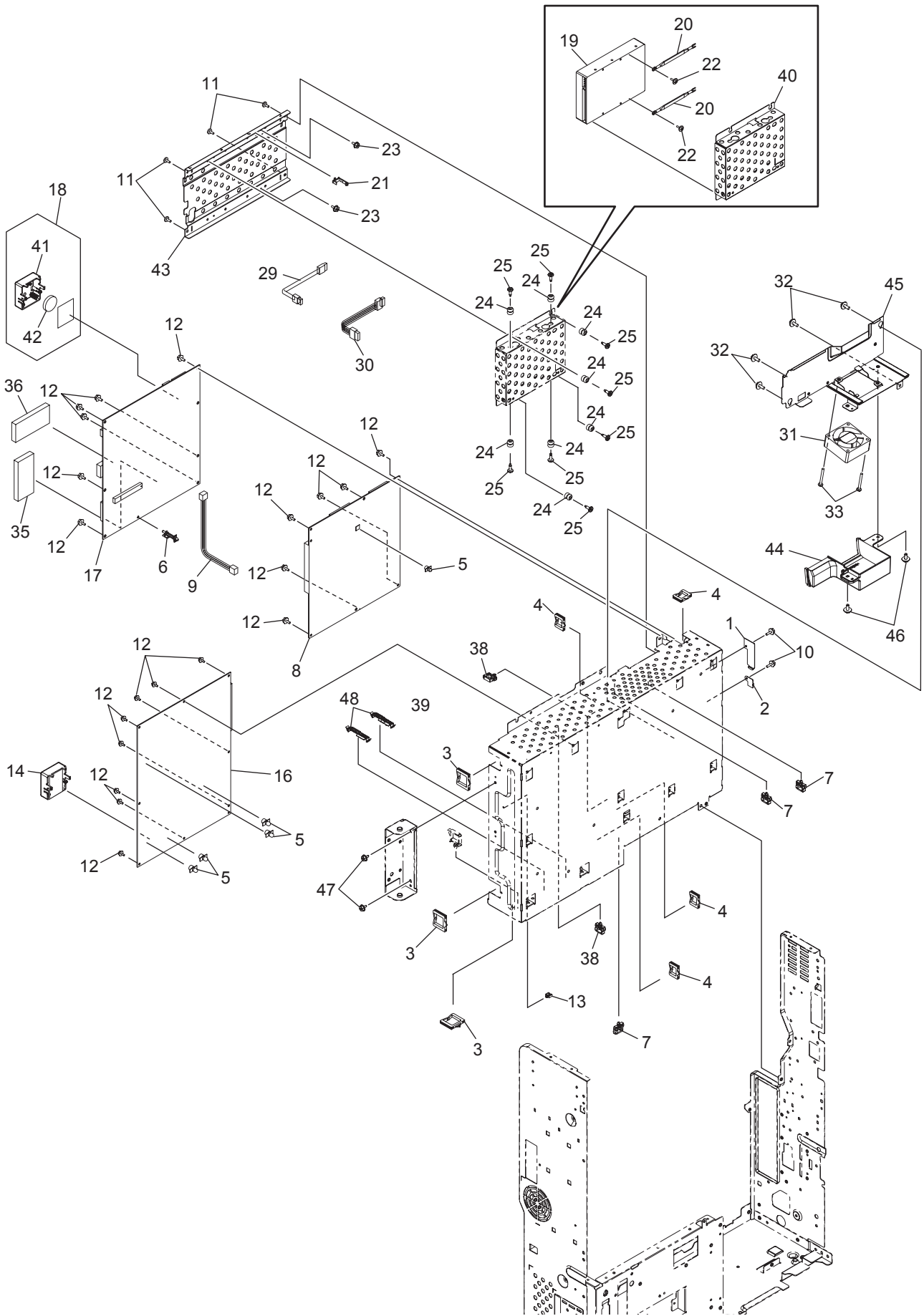

ITEM No.	PART No.	PART NAME	Q'TY / PAGE	Q'TY / PACK	REMARKS
1	6LA34629000	COV-CNCT-DWN	1	1/P	
2	6LA34648000	COV-CNCT-USB-H	1	1/P	
3	F0-00034000	EDS-2323U	3	5/P	
4	F0-00047000	EDS-1717U	4	10/P	
5	F0-00331000	SPSN-4U	5	5/P	
6	F0-01756000	SHCBS-14	1	1/P	
7	F0-01609000	RLWC-2SV0	3	5/P	
8	6LH39833000	PWA-F-IMG-450	1	1/SB	
9	6LH39761000	HRNS-SYS-FAN-450	1	1/P	
10	X0-02593000	S/TPD3/FHEXM-3X8-ZU3	2	10/P	
11	X0-00430000	S/BID-M3X6-NI	4	10/P	
12	X0-02230000	S/FHEXM-M3X6-NI	20	10/P	
13	F0-01250000	MSB-1207	1	5/P	
14	6LJ09476000	ASYB-SRAM-T130MS	1	1/C	
16 A	6LJ05197000	ASYB-LGC-140S	1	1/SB	e-STUDIO2040C
16 B	6LJ05197100	ASYB-LGC-141S	1	1/SB	e-STUDIO2540C
16 C	6LJ05197200	ASYB-LGC-142S	1	1/SB	e-STUDIO3040C
16 D	6LJ05197300	ASYB-LGC-143S	1	1/SB	e-STUDIO3540C
16 E	6LJ05197400	ASYB-LGC-144S	1	1/SB	e-STUDIO4540C
17	6LJ05213000	ASYB-PWA-SYS-140S	1	1/SB	
18	6LH09585000	ASYB-SRAM-430S	1	1/C	
19	G0-00633000	WD1600AVJS-63N9A0	1	1/S	
20	E0-05933000	GST-100-RFM4	2	1/P	
21	F0-00367000	RLWS-1TV0	1	10/P	
22	6LE82485000	SCREW-#6-32X1/4	2	10/P	
23	X0-02592000	S/TPD3/FHEXM-3X6-ZU3	2	10/P	
24	F0-01327000	HED-1111-ALS20ABK	8	1/P	
25	6LA56769000	SCREW-HDD-CASE	8	1/P	
29	6LJ05169000	HRNS-SATA-SIG-140	1	1/P	
30	6LJ05175000	HRNS-SATA-POW-140	1	1/P	
31	6LH08778000	FAN_D-SYS-6025-430	1	1/D	
32	X0-02235000	S/FHEXM-M4X8-NI	4	10/P	
33	X0-02114000	S/TPS/PAN-4X32-ZU3	2	10/P	
35	C0-16868000	HYMP112S64CP6-S6	1	1/C	DDR2 SO-DIMM 1GB
36	C0-16877000	MT4HTF6464HZ-800H1	1	1/C	DDR2 SO-DIMM 512MB
38	F0-01943000	RLWC-3SV0	3	5/P	
40	6LE22806000	BRKT-HDD-380	1	1/P	
41	6LH01123000	COVER-SRAM-BOARD	1	1/P	
42	6LE90510000	LI-BAT-CR-2450	1	1/S	
43	6LH33234000	STAY-HDD-380	1	1/P	
44	6LJ01007000	ASYS-DUCT-SYS-FAN-H140	1	1/PP	
45	6LJ01019000	COVER-FAX-CNCT-H140	1	1/PP	
46	X0-02421000	S/TPS/FHEXM/R-4X8-ZU3	2	10/P	
47	X0-02419000	S/TPS/FHEXM/R-3X6-ZU3	2	10/P	
48	F0-01858000	RFC-45V0	2	1/P	

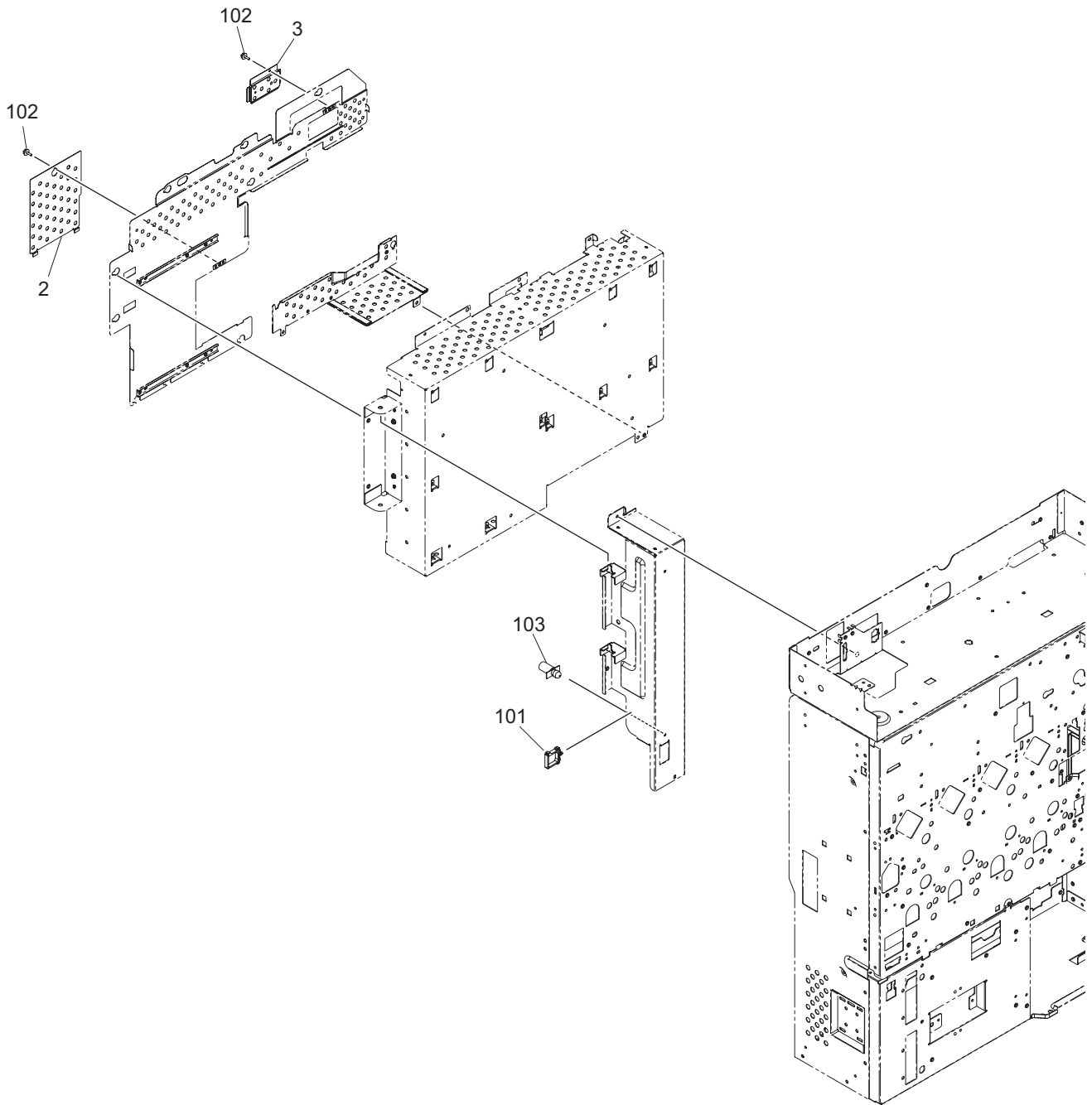

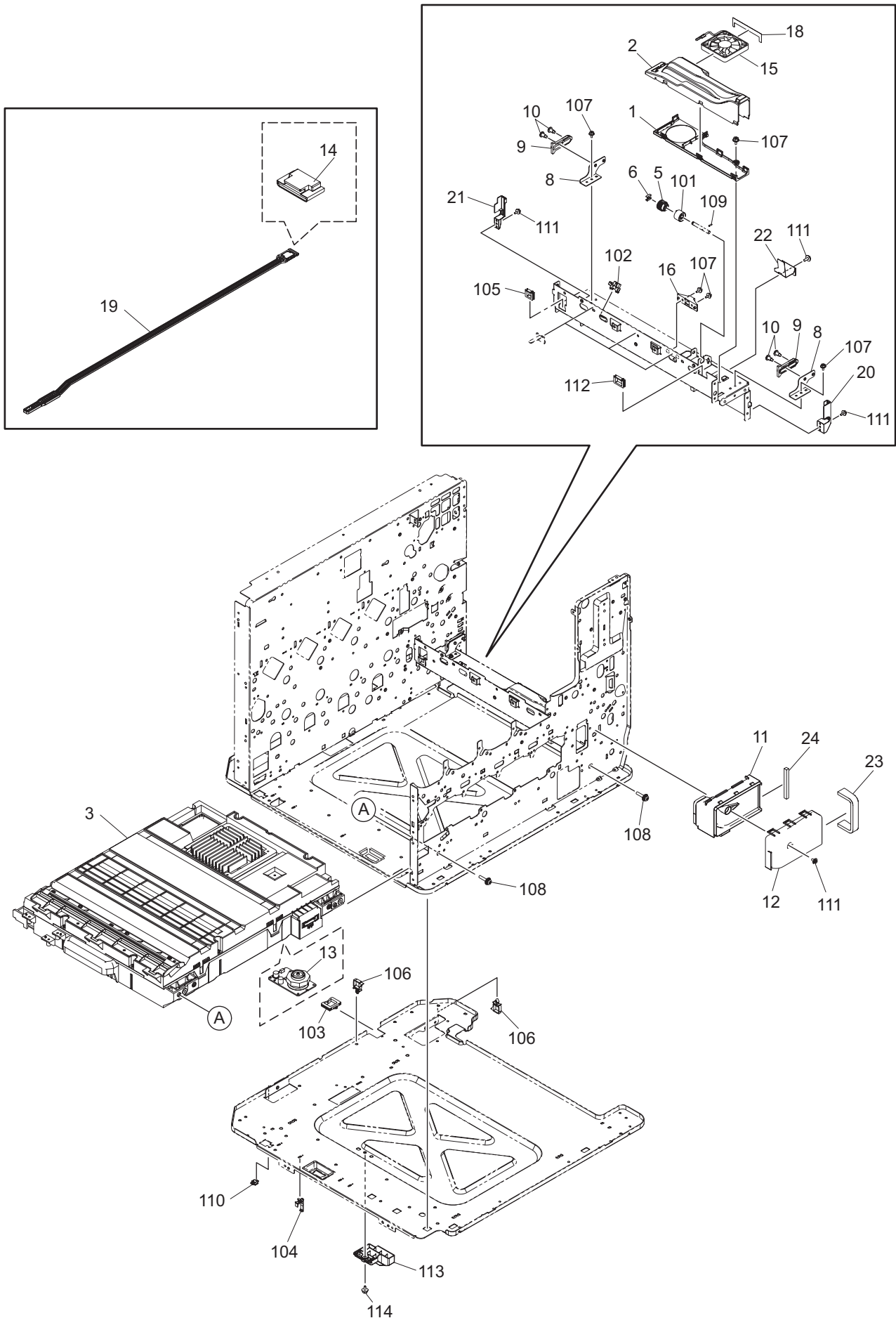

ITEM No.	PART No.	PART NAME	Q'TY / PAGE	Q'TY / PACK	REMARKS
1	6LE22625000	DUCT-LSU-R-D-LWR	1	1/D	e-STUDIO2040C/2540C/3040C/3540C e-STUDIO4540C
2	6LE22626000	DUCT-LSU-R-D-UPR	1	1/D	
3 A	6LJ02704000	LASER-UNIT-H140	1	1/S	
3 B	6LJ02704100	LASER-UNIT-H144	1	1/S	
5	6LE29011000	GEAR-08S21-TRU-S	1	1/P	
6	4408358930	STOP-RING-6-4	1	5/P	
8	6LE29013000	PLT-PUSH-TRU	2	1/P	
9	6LE29009000	PUSHER-TRU	2	1/P	
10	6LA67469000	SCREW-SCAN-DF	4	5/P	
11	6LE22646000	ASYS-DUCT-LSU-LWR	1	1/PP	
12	6LE22645000	DUCT-LSU-FN-UPR	1	1/P	
13 A	6LH08048000	MOTR_D-POL-380-ZS	1	1/S	
13 B	6LE26556000	MOTR_D-POL-382-S	1	1/S	
14	6LE26465000	ASYS-CLNR-GLASS	1	1/P	
15	6LE22631000	ASYS-FAN-LSU-380	1	1/D	
16	6LE24251000	HLDR-MID-ROLLER	1	1/P	
18	6LE26505000	SEAL-DUCT-LSU	1	1/KP	
19	6LH36836000	ASYB-CLNLSU-45X	1	1/KP	
20	6LE24342100	COVER-SPG-CAM-F-H	1	1/P	
21	6LE24343100	COVER-SPG-CAM-R-H	1	1/P	
22	6LE29015000	SPG-DETENT-TRU	1	1/P	
23	6LE26535000	SEAL-DUCT-LSU-F-A	1	1/KP	
24	6LE26536000	SEAL-DUCT-LSU-F-B	1	1/KP	
101	F0-01560000	OTLV6-500B	1	5/P	
102	C0-10813000	GP1A73ARJ00F	1	1/P	
103	F0-00047000	EDS-1717U	1	10/P	
104	F0-00367000	RLWS-1TV0	1	10/P	
105	F0-00542000	LES-1010	1	5/P	
106	F0-01243000	LWS-1211Z	2	5/P	
107	X0-02592000	S/TPD3/FHEXM-3X6-ZU3	5	10/P	
108	X0-00198000	S/PAN/SWWP-M4X16-N1	2	10/P	
109	X0-00979000	P/PRL/AH7-2X8-SS	1	10/P	
110	F0-00671000	EDS-0607M	1	5/P	
111	X0-02421000	S/TPS/FHEXM/R-4X8-ZU3	4	10/P	
112	F0-01897000	LES-1017	1	1/P	
113	6LJ00500000	SLOPE-LOCK-CST1	1	1/P	
114	X0-02419000	S/TPS/FHEXM/R-3X6-ZU3	1	10/P	

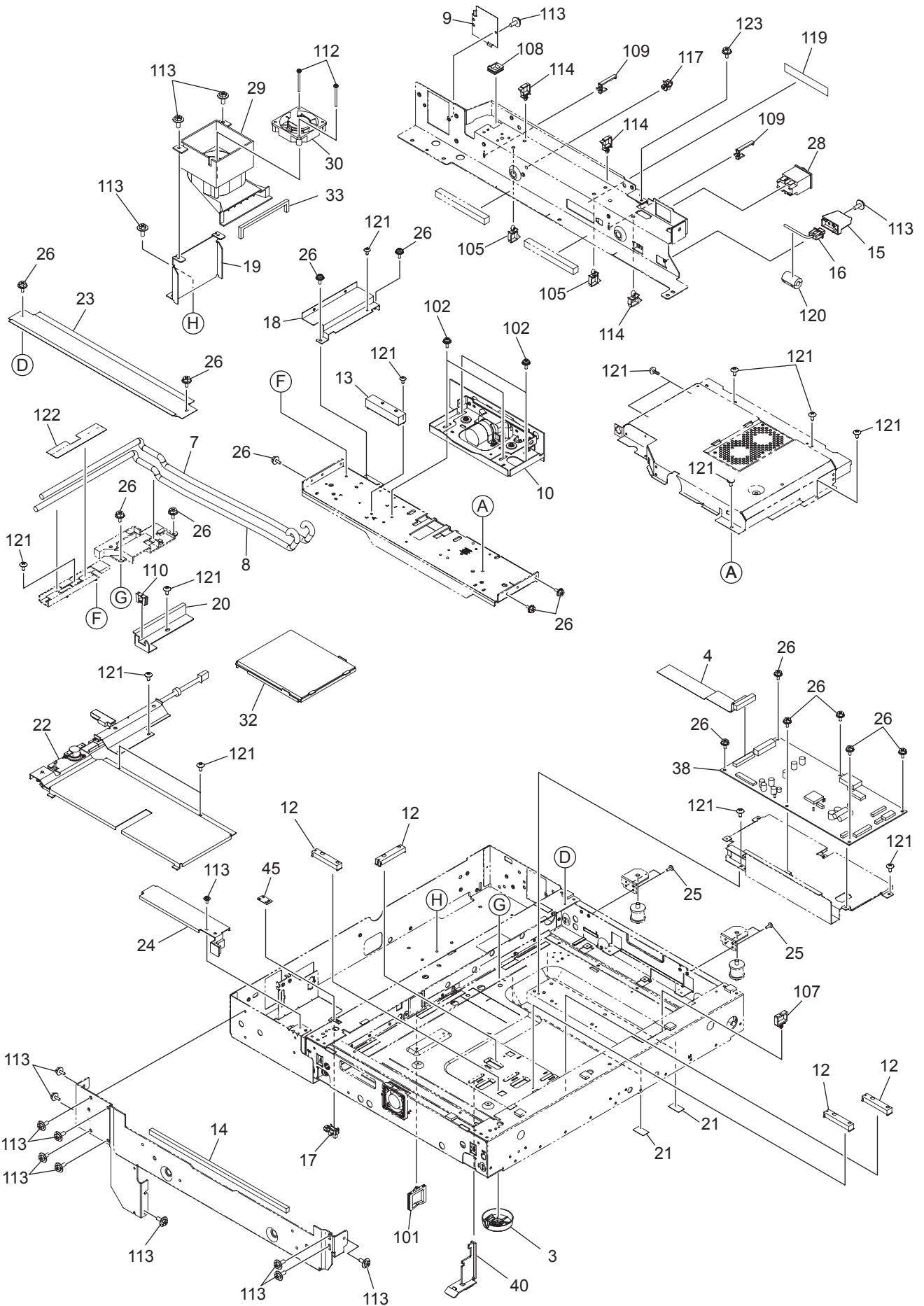

ITEM No.	PART No.	PART NAME	Q'TY / PAGE	Q'TY / PACK	REMARKS
3	6LE27445000	COVER-FOOT-SCAN-380	1	1/P	
4	6LH39754000	HRNS-SCN-SYS-450	1	1/P	
7	6LH39892000	HRNS-SCN-SNSR-450	1	1/P	
8	6LH39750000	HRNS-SCN-PS-450	1	1/P	
9	6LE27449000	COVER-KEY	1	1/P	
10	6LJ03119000	LENS-UNIT-H140	1	1/S	
12 A	6LH08819000	SNSR-PS-182EL1	3	1/C	NAD
12 B	6LH08819000	SNSR-PS-182EL1	4	1/C	MJD,AUD,ASD,ARD
13	6LE09478000	SNSR-PS-TY1CH56	1	1/C	
14	6LA39926000	CUSH-STAY-TP-LFT	1	1/KP	
15	6LH33222000	HOLDER-USB-45X	1	1/P	
16	6LH39790000	CABLE-USB-450	1	1/P	
17	C0-10813000	GP1A73ARJ00F	1	1/P	
18	6LA39453000	COVER-HRNS-SLG	1	1/P	
19	6LE27450000	BRKT-FAN-RER-380	1	1/P	
20 B	6LA39898000	BRKT-D_H-LENS	1	1/P	AUD,ASD,ARD
21	6LA39908000	MYLAR-BASE-SCAN	4	5/KP	
22 A	6LA86520000	ASY-D-H-SCAN-L-E-371	1	1/C	AUD,ASD,ARD
23	6LA39866000	STAY-TP-RGT-SCAN	1	1/P	
24	6LJ03122000	ASYS-BRKT-COV-GEL-LR-H140	1	1/P	
25	X0-02069000	S/TPS/BID-3X6-ZU3	4	10/P	
26	X0-02592000	S/TPD3/FHEXM-3X6-ZU3	15	10/P	
28	E0-08497000	AJ8W200WWF	1	1/D	
29	6LA39673000	DUCT-SCAN-RER	1	1/P	
30	6LE09967000	FAND-6015-39X	1	1/D	
32 A	6LA86523000	ASY-D_H-SCAN-R-E-371	1	1/C	AUD,ASD,ARD
33	6LA39675000	CUSH-DUCT-SCAN-RER	1	1/KP	
38	6LJ05198000	ASYB-PWA-SLG-140S	1	1/SB	
40	6LH37829000	LOCK-CRG-450	1	1/P	
45	6LA29902000	COVER-SNSR-LIFT	1	1/P	
101	F0-00034000	EDS-2323U	1	5/P	
102	X0-00077000	S/PAN/SWWP-M3X8-NI	4	10/P	
105	F0-01243000	LWS-1211Z	2	5/P	
107	F0-01179000	WWS-2U	1	5/P	
108	F0-00542000	LES-1010	1	5/P	
109	F0-00036000	RLWS3TV0	2	5/P	
110 B	F0-00120000	ES-0505	1	5/P	AUD,ASD,ARD
112	X0-02344000	S/TPP/PAN-3X20-NI	2	10/P	
113	X0-02421000	S/TPS/FHEXM/R-4X8-ZU3	16	10/P	
114	F0-00736000	LWS-0711Z	3	5/P	
117	F0-01859000	FGCS-5	1	1/P	
119	6LH37828000	MYLAR-FRAME-R-L	1	1/KP	
120	D0-24725000	SFT-36SN	1	1/P	
121	6LA08935000	SCR-M3X6BISR-NI	15	10/P	
122	6LE27416000	MYLAR-GUIDE-HNS-380	1	1/KP	
123	X0-02419000	S/TPS/FHEXM/R-3X6-ZU3	1	10/P	

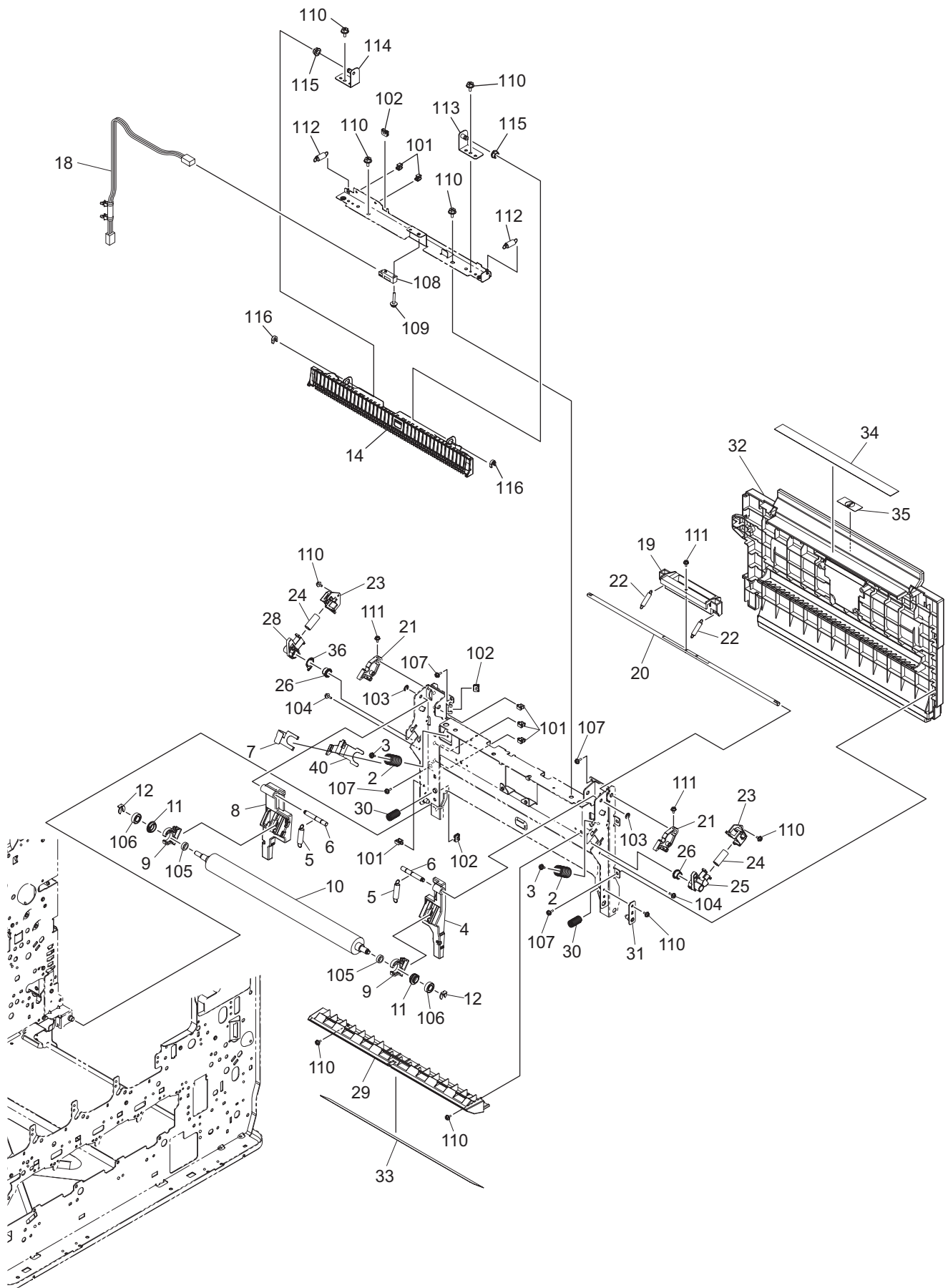

ITEM No.	PART No.	PART NAME	Q'TY / PAGE	Q'TY / PACK	REMARKS
2	6LH39400000	SPG-C-16R5X1R4X56R2-TR2	2	1/P	
3	6LE46468000	SCREW-SPG-TR2	2	5/P	
4	6LH39403000	ARM-TRU-F	1	1/P	
5	6LJ03810000	SPG-E-8R2XR9X31R5-TRU-ROL	2	1/P	
6	6LE29035000	STUD-PIVOT-TRU	2	1/P	
7	6LE29067000	SPG-F-ARM-R-TRU	1	1/P	
8	6LH39402000	ARM-TRU-R	1	1/P	
9	6LJ03803000	HOLDER-ROL-TRU-H14X	2	1/P	
10	6LE39057000	CR-FC35TR2	1	1/S	
11	6LE29040000	BUSH-TRU-ROL	2	1/P	
12	44201801000	STOP-RING-6-1.5	2	5/P	
14	6LJ03816000	ASYS-TRU-GUIDE-H14X	1	1/C	
18	6LJ05075000	HRNS-TRUFAN-140	1	1/P	
19	6LE29027000	LEVER-LOCK-TRU-380	1	1/P	
20	6LE29039000	SHAFT-HOOK-TRU	1	1/P	
21	6LE29038000	HOOK-TRU-380	2	1/P	
22	6LE29061000	SPG-E-6R1XR6X25R4-TRU	2	1/P	
23	6LE24244000	HOLDER-RGST-SPE	2	1/P	
24	6LE24299000	SPG-C-10R1X1X48R4	2	1/P	
25	6LE24272000	BUSH-ROL-RGST-F	1	1/P	
26	6LH23442000	BUSH-8X12X8F-NU4	2	5/P	
28	6LE24249000	BUSH-ROL-RGST-R	1	1/P	
29	6LJ01919000	ASYS-GUIDE-RGST-R-H14X	1	1/PP	
30	6LE24330000	SPG-C-10R8X1X38R5	2	1/P	
31	6LE24376000	ASYS-BRKT-GUIDE-TR1	1	1/P	
32	6LE29014200	COVER-TRU-H14XD	1	1/PP	
33	6LE29001000	SHEET-GUIDE-ADU	1	1/KP	
34	6LE46498000	LBL-CAU-BLT-410	1	1/KP	
35	6LA36367000	LBL-FUS-1	1	5/P	
36	6LE24323000	SPL-EARTH-RGST-R	1	1/P	
40	6LH39409000	SPG-F-EARTH-TRU-ROL	1	1/C	
101	F0-01048000	UAMS-05-0	6	5/P	
102	F0-00120000	ES-0505	3	5/P	
103	X0-00965000	RR/E-4-SS	2	10/P	
104	X0-02593000	S/TPD3/FHEXM-3X8-ZU3	2	10/P	
105	F0-01872000	L-1280ZZHP0P25LY551	2	1/P	
106	F0-01550000	DDL-1680HHRPOP25LY349	2	1/P	
107	X0-02247000	S/TPP/FHEXM-3X8-NI	4	10/P	
108	C0-15007000	PS119ED1	1	1/C	
109	X0-02135000	S/PAN/SWWP-M3X14-NI	1	10/P	
110	X0-02592000	S/TPD3/FHEXM-3X6-ZU3	9	10/P	
111	X0-02230000	S/FHEXM-M3X6-NI	3	10/P	
112	6LJ03811000	SPG-E-5R1XR45X13R35-GUIDE	2	1/P	
113	6LJ03804000	ASYS-HLDR-GUIDE-F	1	1/P	
114	6LJ03807000	ASYS-HLDR-GUIDE-R	1	1/P	
115	44201492000	BUSH-6-POM	2	5/P	
116	4407972860	STOP-RING-6-5	2	5/P	

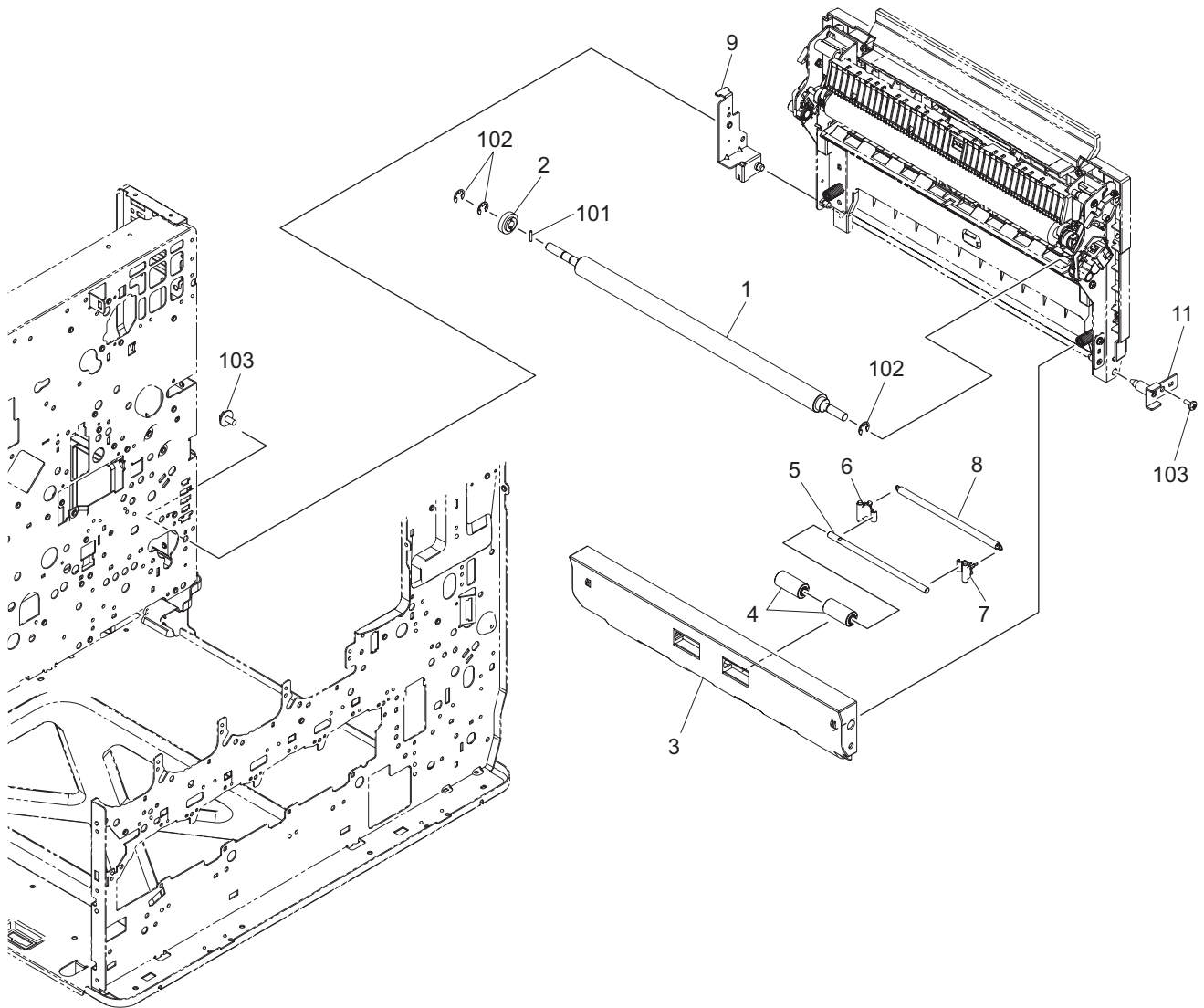

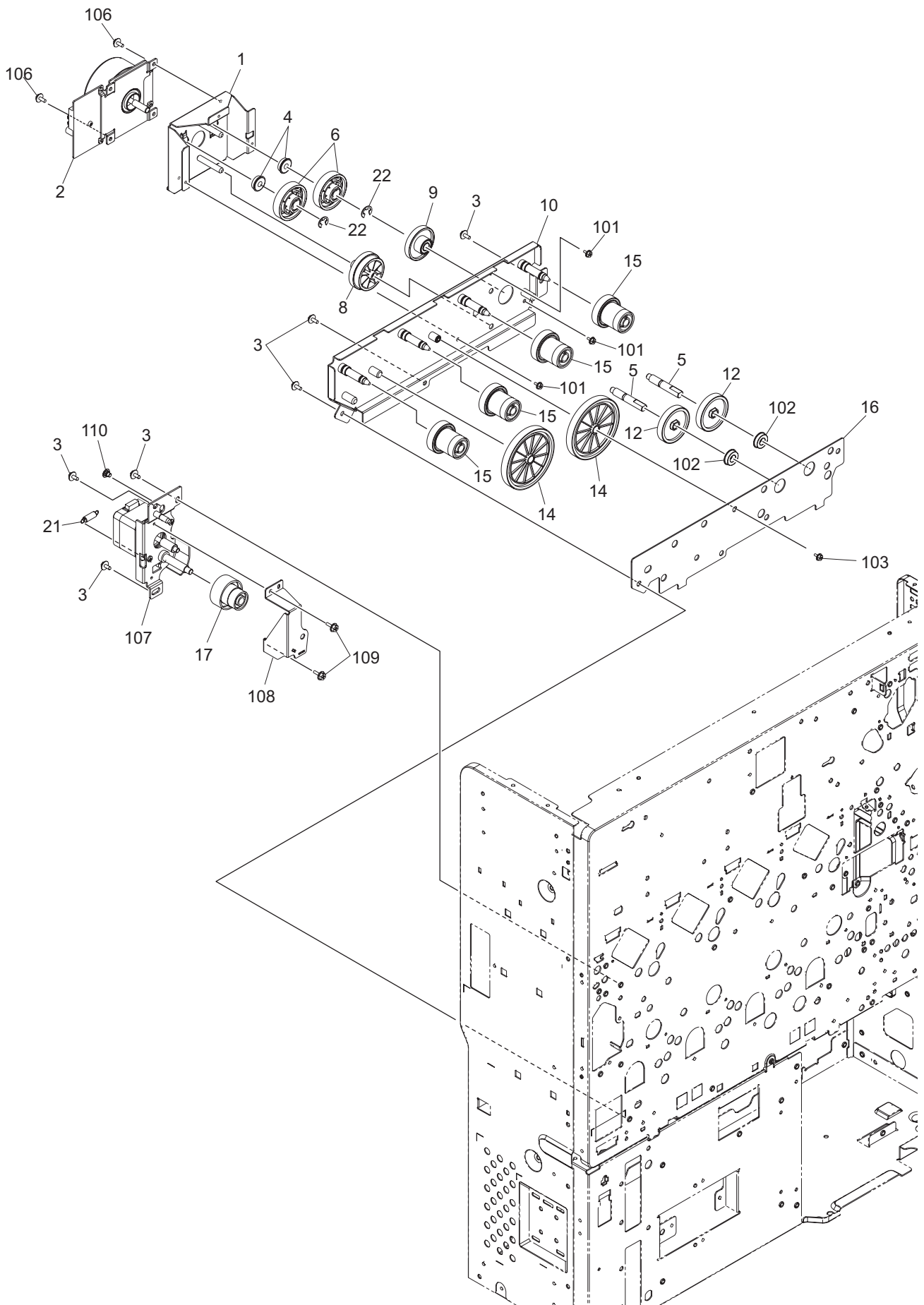

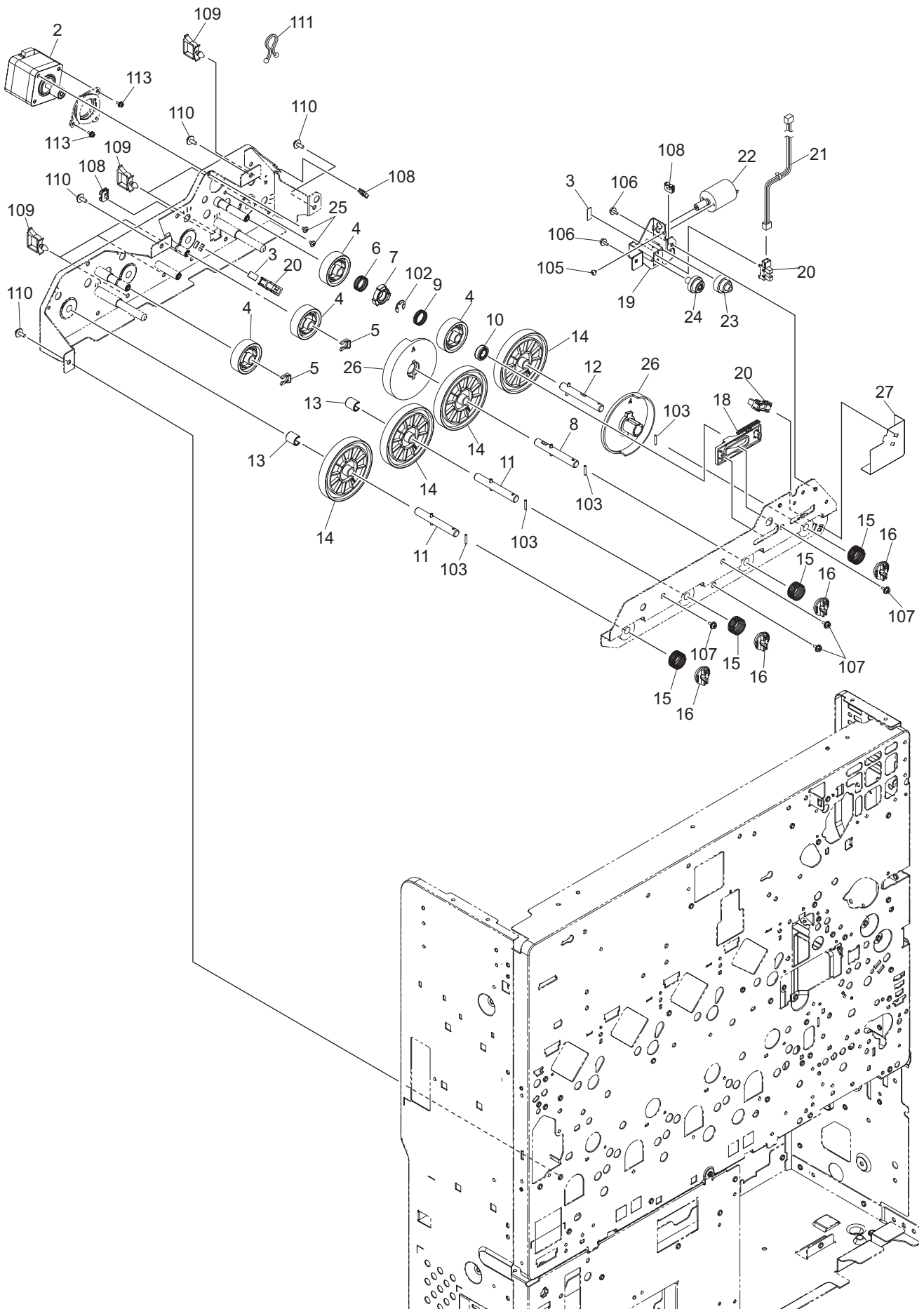

ITEM No.	PART No.	PART NAME	Q'TY / PAGE	Q'TY / PACK	REMARKS
2	6LJ00819000	MOTR_S-DRUM-H14X	1	1/C	
3	44201543000	MYLAR-SW-RGST-2	2	5/P	
4	6LE22115000	GEAR-5H66-8-IDLER-DRUM	4	1/P	
5	41306265000	STOP RING	2	1/P	
6	6LE22213000	SPG-C-IDL-RER-N	1	1/P	
7	6LE22121000	COUPL-IDL-DRUM	1	1/P	
8	6LH32507000	ASYS-SHAFT-DRV-DRUM-C-450	1	1/P	
9	6LE22128000	SPG-C-IDL-FRT	1	1/P	
10	6LE22107000	COLAR-IDL-DRUM	1	1/P	
11	6LJ00838000	ASYS-SHAFT-DRIVE-DRUM-YMC	2	1/P	
12	6LH32506000	ASYS-SHAFT-DRV-DRUM-K-450	1	1/P	
13	6LE22133000	COLAR-DRIVE-DRUM	2	1/P	
14	6LE22114000	GEAR-5H132-8-DRUM	4	1/P	
15	6LE22135000	SPG-C-DRIVE-DRUM	4	1/P	
16	6LE22209000	COUPL-DRIVE-DRUM-380	4	1/P	
18	6LE22211000	GUIDE-SEP-GEAR-IDL	1	1/P	
19	6LJ00839000	ASYS-BRKT-MOTR-SEP-IDL	1	1/P	
20	C0-10813000	GP1A73ARJ00F	3	1/P	
21	6LE29389000	HRNS-SNS-DRM-380	1	1/P	
22	6LH38646000	ASYS-MOTR-SW-DRIVE-DRUM	1	1/D	
23	6LE22124000	GEAR-5H35_5S25-6	1	1/P	
24	6LE22125000	GEAR-5S35_5S25-6	1	1/P	
25	6LE22138000	S/BID-M3X4-ZC3-RED	2	5/P	
26	6LH32508000	DISK-DRIVE-DRUM	2	1/P	
27	6LH32520000	MYLAR-COV-SNSR	1	1/C	
102	X0-00968000	RR/E-7-SS	1	10/P	
103	X0-01526000	P/PRL/AH7-2X12-SS	4	10/P	
105	X0-02112000	S/PAN-M3X3-NI	1	10/P	
106	X0-02592000	S/TPD3/FHEXM-3X6-ZU3	2	10/P	
107	X0-02230000	S/FHEXM-M3X6-NI	4	10/P	
108	F0-00120000	ES-0505	3	5/P	
109	F0-01245000	LWS-1316Z	6	5/P	
110	X0-02421000	S/TPS/FHEXM/R-4X8-ZU3	4	10/P	
111	F0-02033000	OLS-115	1	5/P	
113	X0-00059000	S/PAN/SVWS-M3X6-NI	2	10/P	

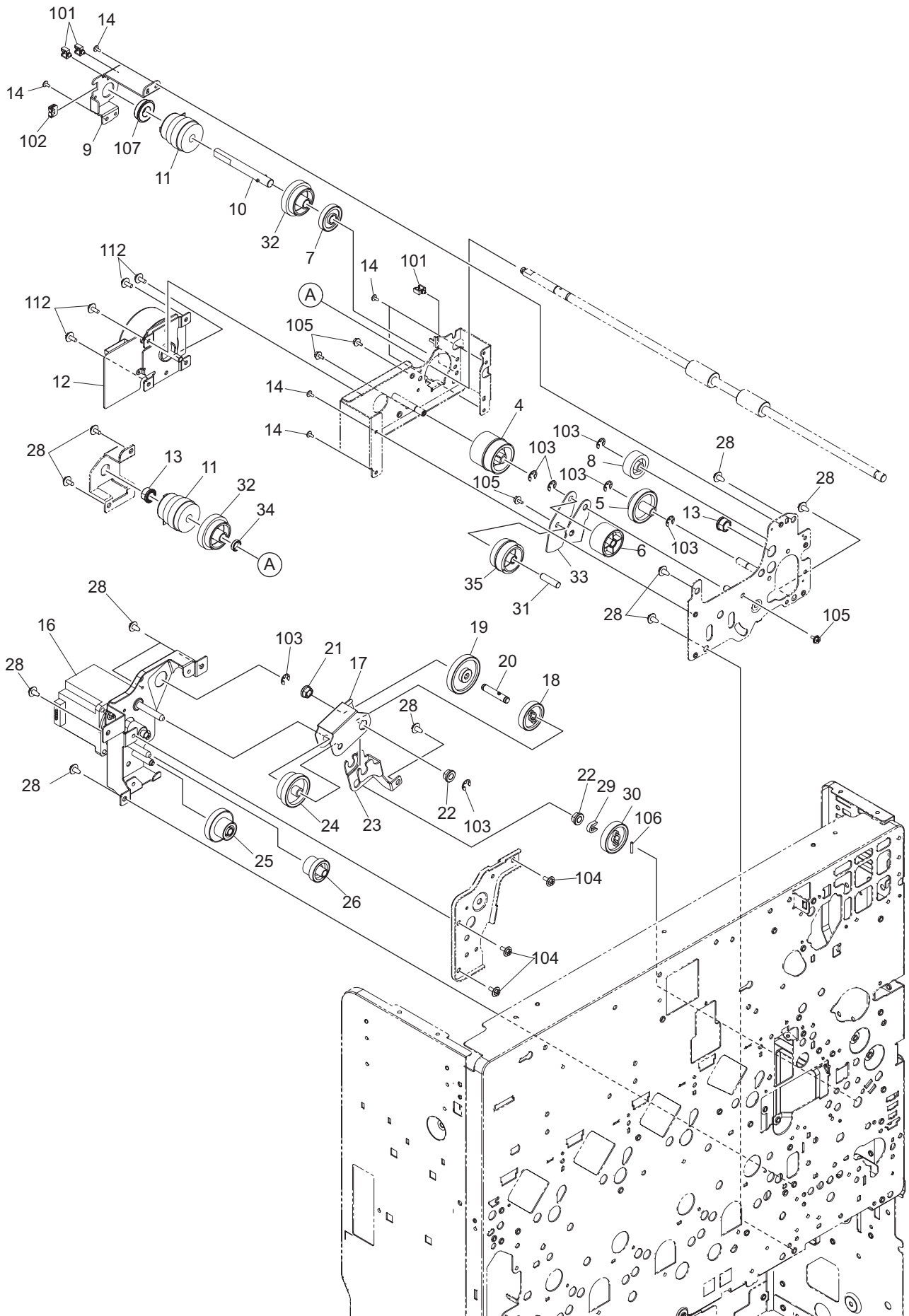

ITEM No.	PART No.	PART NAME	Q'TY / PAGE	Q'TY / PACK	REMARKS
4	6LE22174000	GEAR-05S60-05H60-06	1	1/P	
5	6LE22168000	GEAR-05S40-05S64-06	1	1/P	
6	6LE22173000	GEAR-05S54-06	1	1/P	
7	6LE24365000	GEAR-05S50-8N	1	1/P	
8	6LE24367000	GEAR-05S46-6N	1	1/P	
9	6LE24355000	BRKT-DRV-TR1-CL	1	1/P	
10	6LH34600000	ASYS-SHAFT-DRV-TR1-CLT-N	1	1/P	
11	6LH34604000	CLUTCH-G28-08D-30A	2	1/D	
12	6LH09053000	MOTRD-FEED-430	1	1/C	
13	6LH23442000	BUSH-8X12X8F-NU4	2	5/P	
14	6LA08935000	SCR-M3X6BISR-NI	6	10/P	
16 A	6LJ01918000	ASYB-MOTOR-RGST-H140	1	1/C	e-STUDIO2040C/2540C/3040C/3540C
16 B	6LE29083000	ASYB-MOTOR-RGST	1	1/C	e-STUDIO4540C
17	6LE29048000	PLT-ARM-RGST	1	1/P	
18	6LE29091000	GEAR-4H68-6	1	1/P	
19	6LE29090000	GEAR-4H94-CLT	1	1/P	
20	6LE29106000	ASYS-SHAFT-DRV-RGST	1	1/P	
21	4407734980	BUSH-6-GCB	1	5/P	
22	44201492000	BUSH-6-POM	2	5/P	
23	6LH39412000	PLT-ARM-RGST-DRV	1	1/P	
24	6LE29089000	GEAR-8S40-4H68-6	1	1/P	
25	6LE29052000	GEAR-10S17_10S31-6	1	1/P	
26	6LE29051000	GEAR-10S16_8S27-6	1	1/P	
28	X0-02421000	S/TPS/FHEXM/R-4X8-ZU3	11	10/P	
29	4407972860	STOP-RING-6-5	1	5/P	
30	6LE29092000	GEAR-4H72-6	1	1/P	
31	6LE24255000	STUD-PLANET-GEAR	1	1/P	
32	6LE24357000	GEAR-05S56-08	2	1/P	
33	6LE24239000	BRKT-PLANET-GEAR	1	1/P	
34	6LE24356000	COLLAR-ROLL-MID-380	1	5/P	
35	6LE22175000	GEAR-10S29-05S58-06	1	1/P	
101	F0-01251000	MSB-1607	4	1/P	
102	F0-00120000	ES-0505	1	5/P	
103	X0-00966000	RR/E-5-SS	7	10/P	
104	X0-02589000	S/TPD3/FHEXM-4X8-ZU3	3	10/P	
105	X0-02230000	S/FHEXM-M3X6-NI	4	10/P	
106	X0-01526000	P/PRL/AH7-2X12-SS	1	10/P	
107	F0-01390000	LNR-1680HHRP0P15LY13	1	1/P	
112	X0-02593000	S/TPD3/FHEXM-3X8-ZU3	4	10/P	

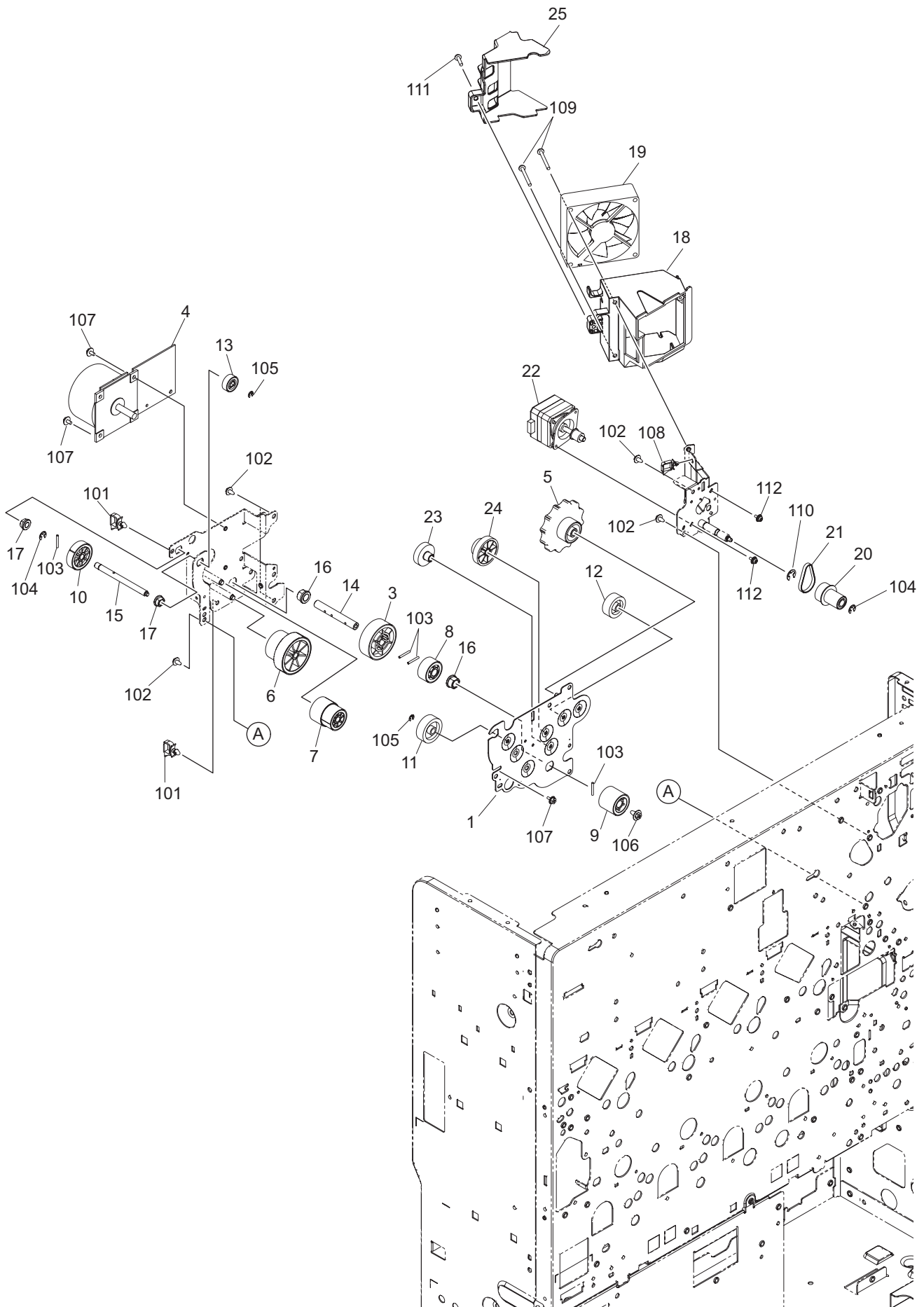

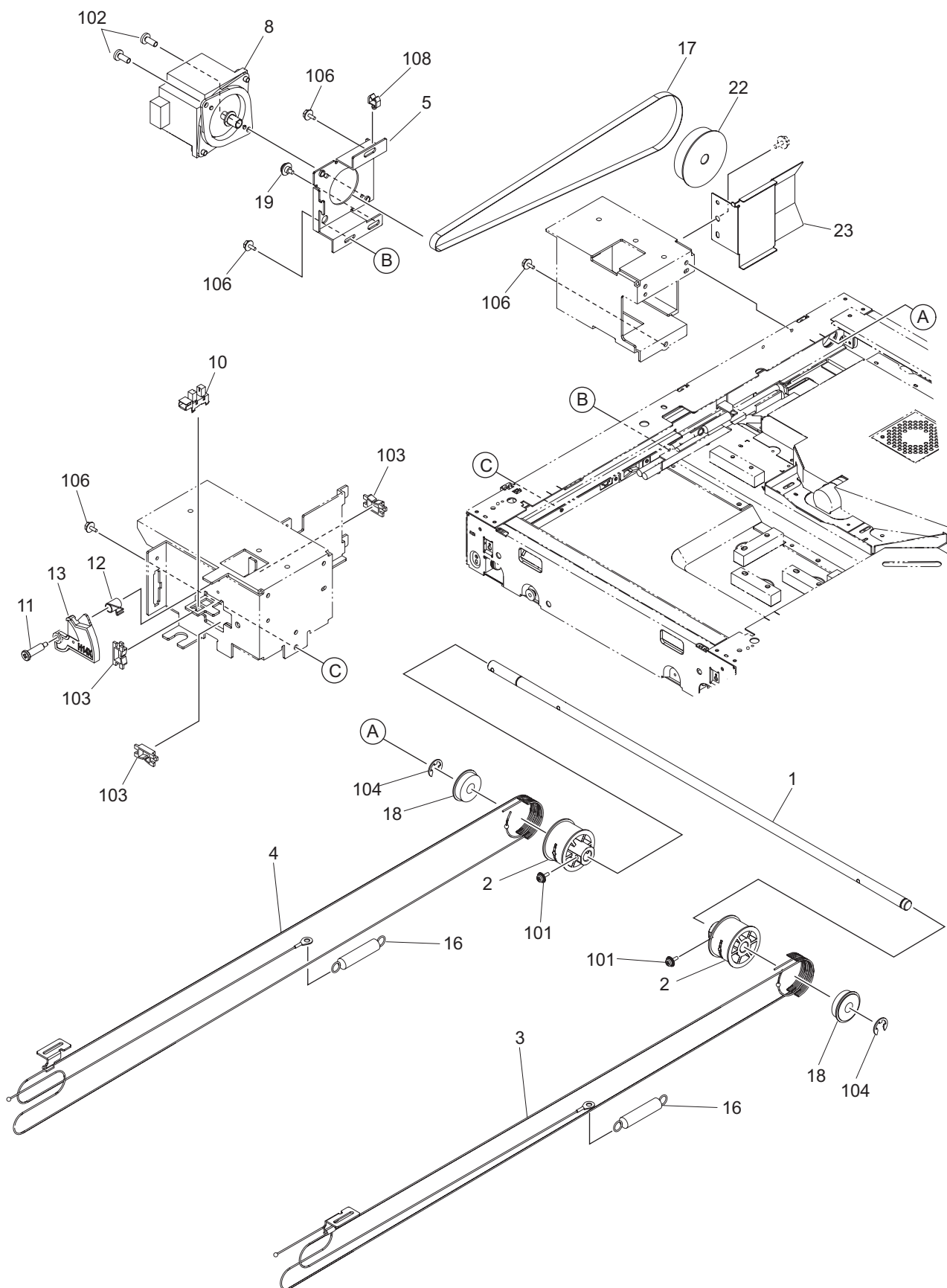

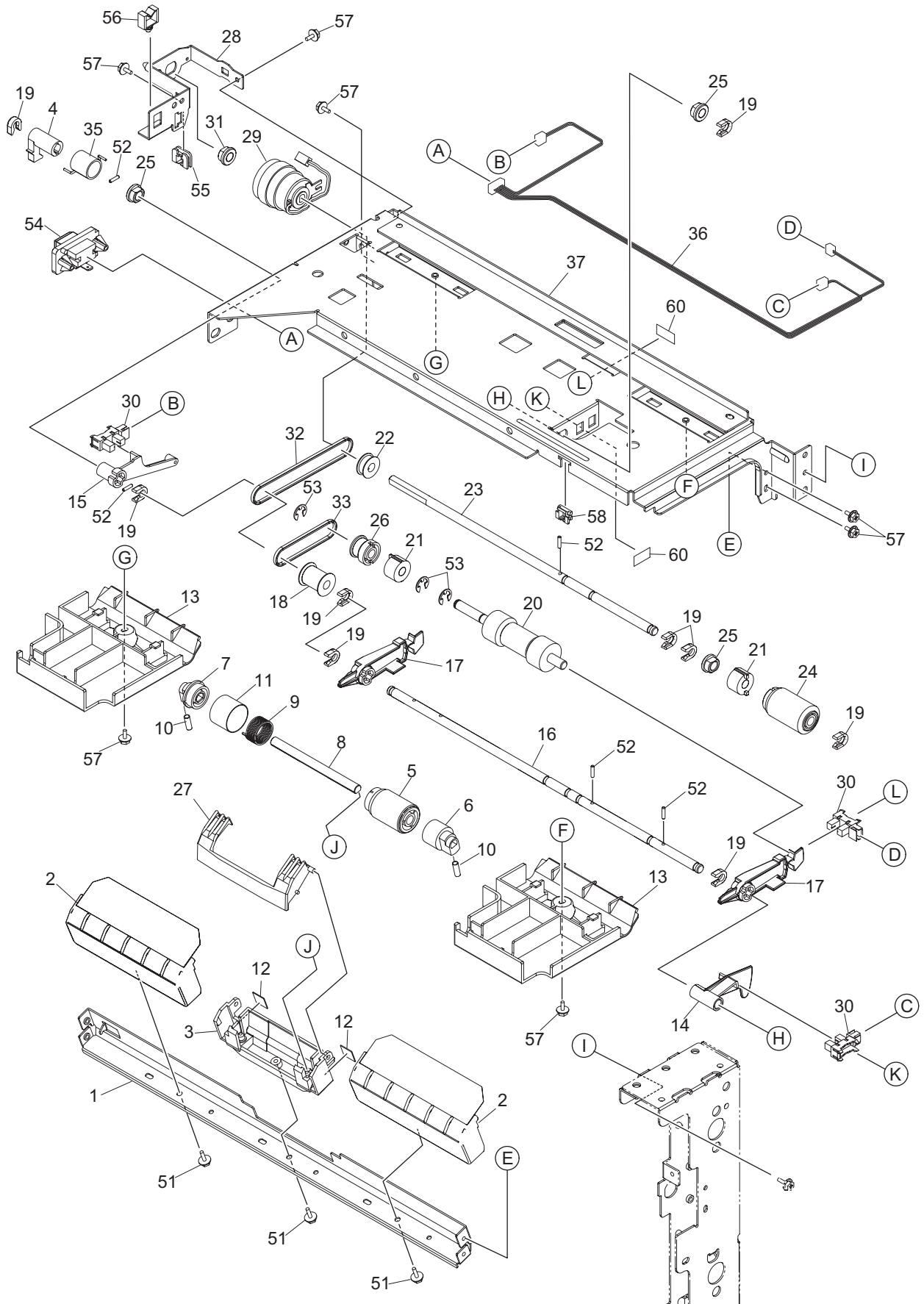

ITEM No.	PART No.	PART NAME	Q'TY / PAGE	Q'TY / PACK	REMARKS
1	6LA47898000	BRKT-ROL-SEP	1	1/P	
2	6LJ01906000	ASYS-GUIDE-P-SEP-N	2	1/KP	
3	44201805000	HLDR-SEP-ROL-DM	1	1/P	
4	6LA47910000	LEVER-RLR-PICK	1	1/P	
5	6LH46302000	ASYS-ROLL-SPT	1	1/P	
6	4401964360	ARBOR-SPT-F	1	1/P	
7	4401964270	ARBOR-SPT-R	1	1/P	
8	41304506000	SFT-SEP-AT	1	1/P	
9	44201817000	SPR-1.0-15.60RF	1	5/P	
10	6LA47909000	SPC055-045-01525	2	5/P	
11	44201773000	COV-SPE/ARBOR	1	1/P	
12	41319491000	CHIP-HLDR-SEP	2	1/P	
13	6LA47908000	GUIDE-P-FEED	2	1/P	
14	41306012000	ACTR-EMPTY-PPR	1	1/P	
15	41318603000	ARM-FEED-UNIT	1	1/P	
16	41318604000	SFT-DRV-PICK	1	1/P	
17	6LE24295000	ARM-RLR-PICK-380	2	1/P	
18	41306002000	PLY/T-PICK-20	1	1/P	
19	4407972860	STOP-RING-6-5	9	5/P	
20	6LE77312000	ROLLER-PICK-N	1	1/P	
21	6LE69842000	CLUTCH-6-L	2	1/P	
22	4402231780	PLY-20-2M	1	1/P	
23	6LE24306000	SHAFT-ROL-FEED-380	1	1/P	
24	6LE69833000	K-ROLL-FEED	1	1/P	
25	44201492000	BUSH-6-POM	3	5/P	
26	41306274000	PLY/T-20-ROL-2G	1	1/P	
27	44201810000	LEV-ROL-SEP-DM	1	1/P	
28	6LE24258000	ASYS-BRKT-CLT-380	1	1/P	
29	6LH34603000	CLUTCH-G28-06D-30AK	1	1/D	
30	C0-10813000	GP1A73ARJ00F	3	1/P	
31	6LH53768000	BUSH-6-NU4	1	1/P	
32	41306504000	BLT/T-194-2GT-2	1	1/P	
33	41306502000	BLT/T-124-2GT-2	1	1/P	
35	41305501000	SPR-LVR-PICK	1	1/P	
36	6LE29399000	HRNS-PFP-FED-380	1	1/P	
37	6LA47892000	ASYS-BRKT-FEED-UNIT	1	1/PP	
51	X0-02247000	S/TPP/FHEXM-3X8-NI	3	10/P	
52	X0-00979000	P/PRL/AH7-2X8-SS	5	10/P	
53	X0-00966000	RR/E-5-SS	3	10/P	
54	E0-08732000	54702-1219	1	5/P	
55	F0-00120000	ES-0505	1	5/P	
56	F0-01250000	MSB-1207	1	5/P	
57	X0-02592000	S/TPD3/FHEXM-3X6-ZU3	7	10/P	
58	F0-00671000	EDS-0607M	1	5/P	
60	44201543000	MYLAR-SW-RGST-2	2	5/P	

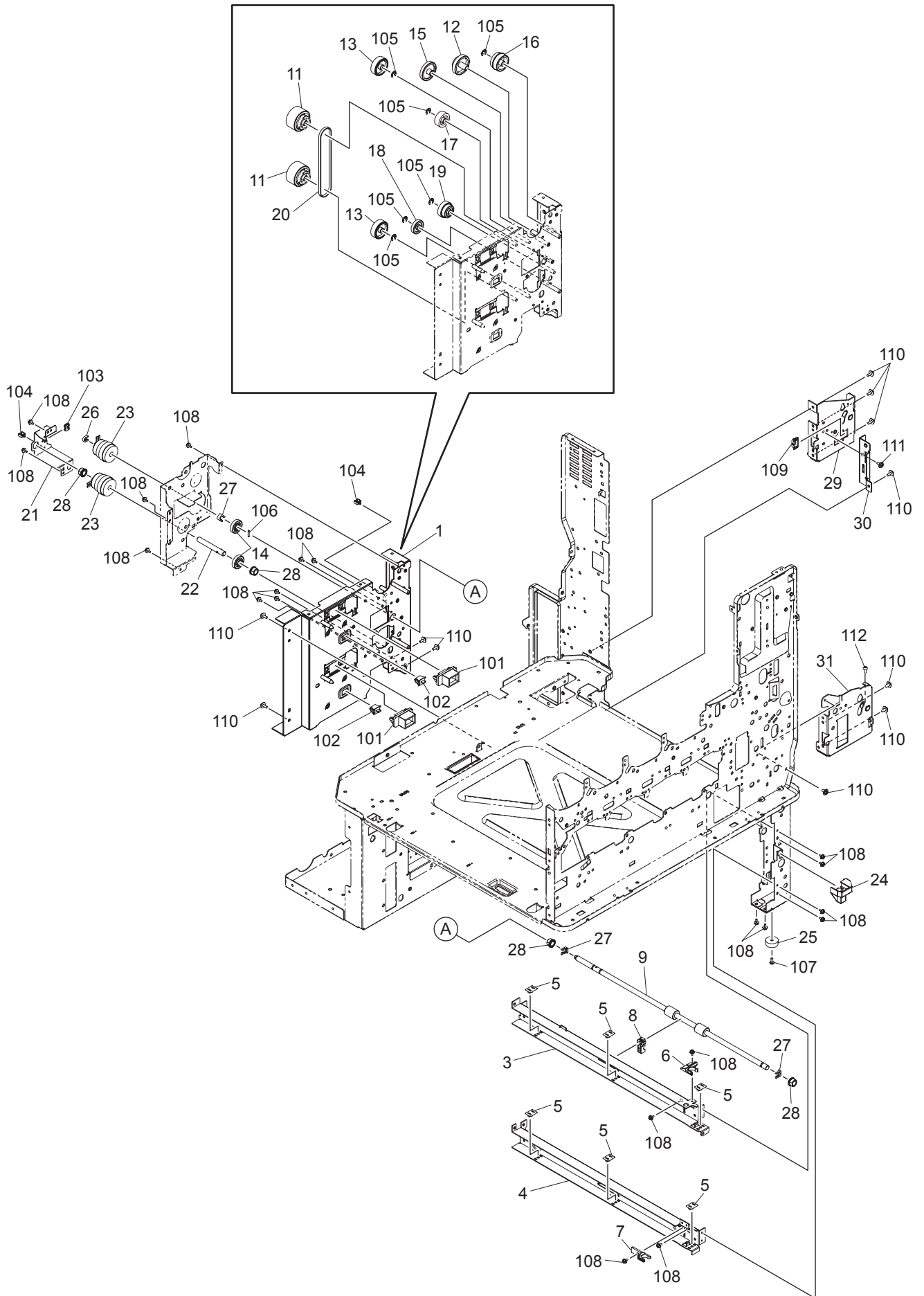

ITEM No.	PART No.	PART NAME	Q'TY / PAGE	Q'TY / PACK	REMARKS
1	6LE24223000	ASYS-FRM-FEEDER-R	1	1/P	
3	6LE24209000	RAIL-CST-RGT-380	1	1/P	
4	6LA64841000	RAIL-CSSTT-RGT	1	1/P	
5	41306007000	SLIDER-CST	6	1/P	
6	6LE24257000	CATCH-CST-380	1	1/P	
7	44201601000	CATCH-CST-320	1	1/P	
8	44201613000	BUSH-ROL-FEEDER	1	1/P	
9	6LE24203000	ROLLER-FEEDER-380	1	1/KP	
11	6LE24242000	GEAR-10S35_P3GT25-6	2	1/P	
12	6LE24243000	GEAR-10S20_10S32-6	1	1/P	
13	6LE24254000	GEAR-10S29-6	2	1/P	
14	6LE24265000	GEAR-10S21-8	2	1/P	
15	6LE24266000	GEAR-10S31-6	1	1/P	
16	6LE24292000	GEAR-10S25_10S27-6	1	1/P	
17	44201367000	GEAR-10S023-06	1	1/P	
18	6LA41184000	GEAR-10S22-6-TR2	1	1/P	
19	6LA64833000	GEAR-10S20_10S25-6	1	1/P	
20	6LA04271000	BLT/T-297-3GT-4	1	1/P	
21	6LE24263000	BRKT-DRV-FEEDER-CL	1	1/P	
22	6LJ01934000	ASYS-SHAFT-DRV-TR1-CL	1	1/P	
23	6LH34604000	CLUTCH-G28-08D-30A	2	1/D	
24	6LH34710000	COVER-RAIL-CST	1	1/P	
25	41306501000	FOOT-MAIN-AT	1	1/P	
26	4407972860	STOP-RING-6-5	1	5/P	
27	41306265000	STOP RING	3	1/P	
28	6LH23442000	BUSH-8X12X8F-NU4	4	5/P	
29	6LH31404000	ASYS-BRKT-ADU-R-450	1	1/P	
30	6LE21204000	BRKT-HOLD-BYP-R	1	1/P	
31	6LE21216000	ASYS-BRKT-ADU-FRT	1	1/P	
101	E0-08733000	55533-1219	2	5/P	
102	E0-01853000	CS1A-B2CA	2	1/D	
103	F0-00120000	ES-0505	1	5/P	
104	F0-01250000	MSB-1207	2	5/P	
105	X0-00966000	RR/E-5-SS	6	10/P	
106	X0-01526000	P/PRL/AH7-2X12-SS	1	10/P	
107	X0-02074000	S/TPS/BID-4X8-ZU3	1	10/P	
108	X0-02592000	S/TPD3/FHEXM-3X6-ZU3	20	10/P	
109	F0-01248000	ESC-0912	1	10/P	
110	X0-02421000	S/TPS/FHEXM/R-4X8-ZU3	11	10/P	
111	X0-02589000	S/TPD3/FHEXM-4X8-ZU3	1	10/P	
112	X0-02070000	S/TPS/BID-3X8-ZU3	1	10/P	

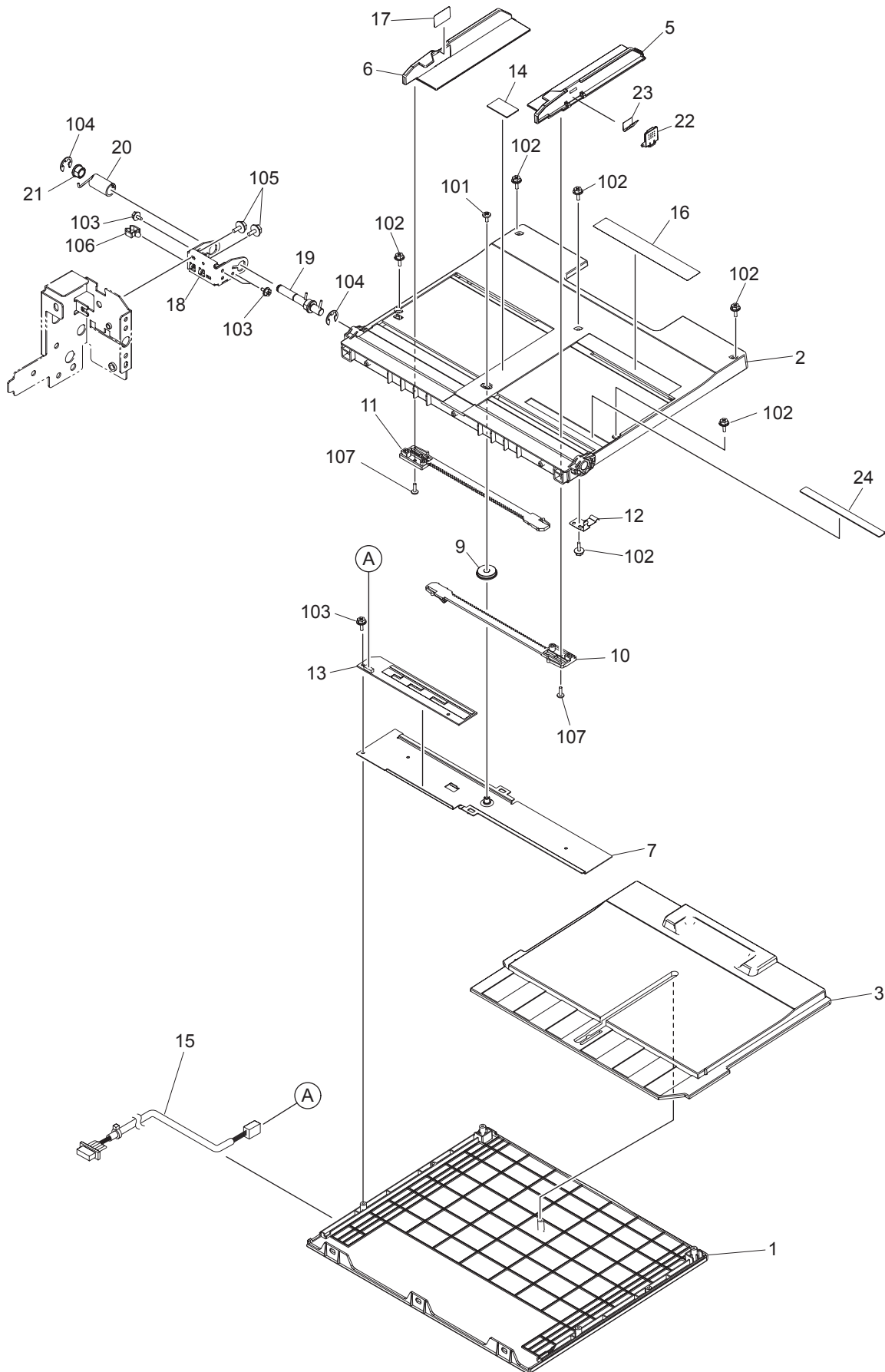

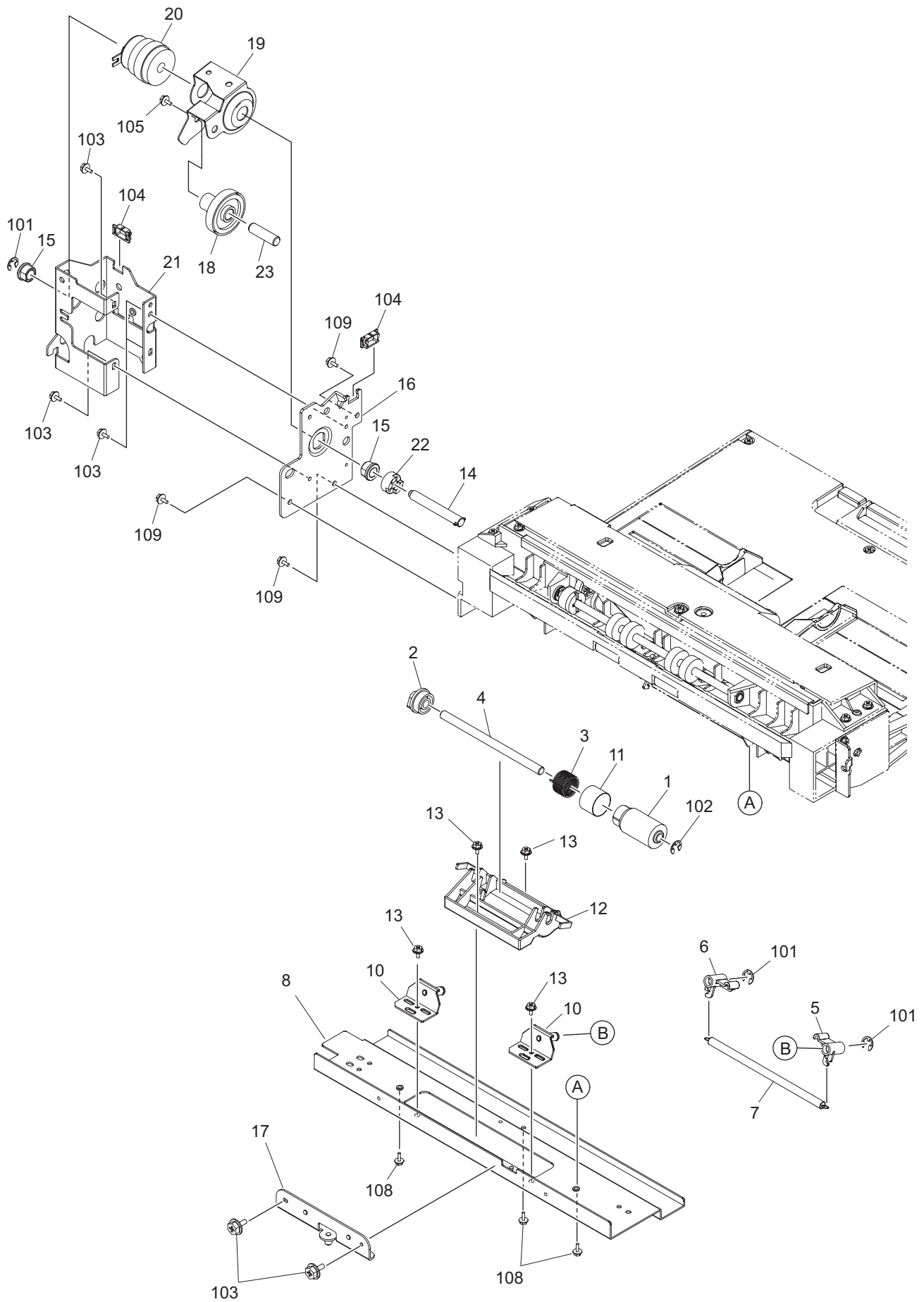

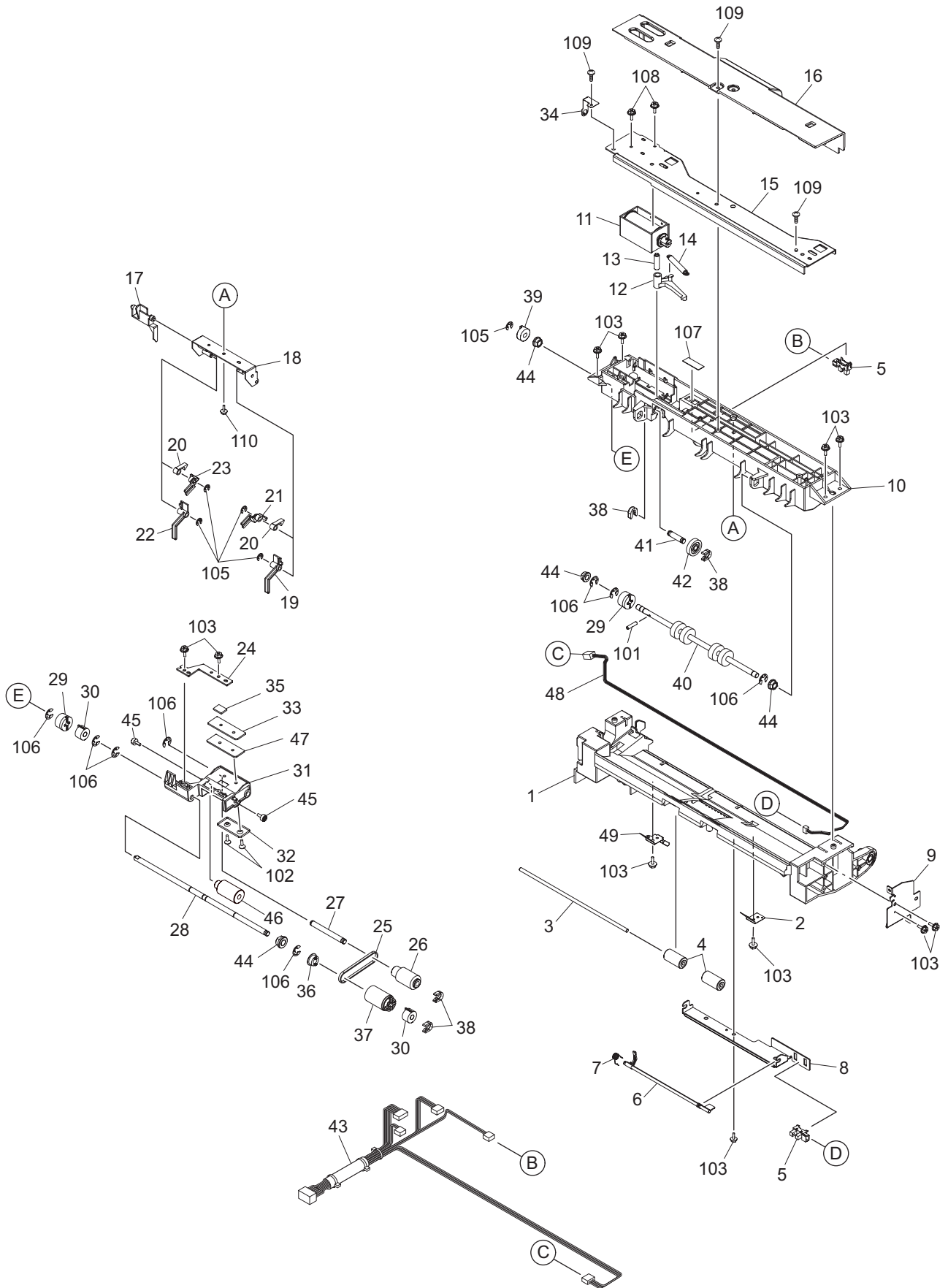

ITEM No.	PART No.	PART NAME	Q'TY / PAGE	Q'TY / PACK	REMARKS
1	6LE21223200	ASYS-FRM-BYPASS-H14XD	1	1/PP	
2	6LE21254000	SPL-IDLR-TR-BYPS-N	1	1/P	
3	6LA28966000	SHAFT-IDLR-TR-BYPS	1	1/P	
4	6LE40416000	IDLER-TR-BYPASS-K	2	1/P	
5	C0-10813000	GP1A73ARJ00F	2	1/P	
6	6LE40422000	ACTUATOR-BYP	1	1/P	
7	6LA28960000	SPG-T-SNSR-LOW-T	1	1/P	
8	6LA28952000	BRKT-ACT-BYP	1	1/P	
9	6LE21225000	ASYS-BRKT-FRM-BYPS-FRT	1	1/P	
10	6LE40440000	GUIDE-BYPASS-U	1	1/PP	
11	6LA15259000	SOL-SFB-340	1	1/D	
12	6LA28767000	LEVER-PICK	1	1/P	
13	6LE40435000	STUD-LVR-PIC-BP	1	1/P	
14	6LA28769000	SPG-E-6R5XR7X28R5L	1	1/P	
15	6LA28827000	STAY-BYPASS-U	1	1/P	
16	6LE40442300	ASYS-COVER-BYPASS-H14XT	1	1/PP	
17	6LA28768000	ACTR-EMP-SW-BYP	1	1/P	
18	6LH31603000	ASYS-BRKT-STOPPER	1	1/P	
19	6LA28821000	STPR-BYP-F-350	1	1/P	
20	4401965270	ARM-STOPPER	2	5/P	
21	4401965250	LEVER-STOPPER-F	1	1/P	
22	6LA28822000	STPR-BYP-R-350	1	1/P	
23	4401965260	LEVER-STOPPER-R	1	1/P	
24	6LA28819000	PLATE-ARM-PICK	1	1/P	
25	6LA28835000	BLT-SY-138-2GT-2.8	1	1/P	
26	44218398000	K-ROLL-PICK-BYP	1	1/P	
27	6LE40436000	SFT-ROL-PIC-BYP-350	1	1/P	
28	6LA28807000	SHAFT-ROL-FEED-BYPS	1	1/P	
29	6LA28811000	GEAR-06S-027-06	2	1/P	
30	6LE69842000	CLUTCH-6-L	2	1/P	
31	6LA28756000	ARM-PICK-350	1	1/P	
32	6LA28832000	WEIGHT-PICK-BYP-LOW	1	1/P	
33	6LA28834000	WEIGHT-PICK-BYP-UP	1	1/P	
34	6LA28817000	SPL-ROL-FEED-BYP	1	1/P	
35	6LA28758000	CUSHION-PAD	1	5/P	
36	4401966400	PLY/T-2GT020-06	1	1/P	
37	44218389000	K-RLR-FEED-SFB	1	1/P	
38	4407972860	STOP-RING-6-5	4	5/P	
39	6LA28812000	CPG-DRVN-BYP-350	1	1/P	
40	6LE40425000	ROLLER-TR-BYPASS-18.5	1	1/KP	
41	6LE40439000	STUD-G032-BYPS	1	1/P	
42	44201789000	GEAR-06S-032-06	1	1/P	
43	6LE29398000	HRNS-SFB-380	1	1/P	
44	6LH53768000	BUSH-6-NU4	4	1/P	
45	6LE40407000	SCREW-WEIGHT-3*6	2	5/P	
46	6LE40412000	WEIGHT-PICK-BYP-T	1	1/P	
47	6LA28833000	WEIGHT-PICK-BYP-MID	1	1/P	
48	6LA71421000	HRNS-SFB-PIS-360	1	1/P	
49	6LE21252000	SPL-IDLR-TR-BYP-R	1	1/C	
101	X0-00979000	P/PRL/AH7-2X8-SS	1	10/P	
102	X0-02011000	S/CTS-M3X8-NI	2	10/P	
103	X0-02247000	S/TPP/FHEXM-3X8-NI	11	10/P	
105	X0-00964000	RR/E-3-SS	5	10/P	
106	X0-00966000	RR/E-5-SS	8	10/P	
107	44201543000	MYLAR-SW-RGST-2	1	5/P	
108	X0-02230000	S/FHEXM-M3X6-NI	2	10/P	
109	X0-01989000	S/TPP/BID-3X8-NI	3	10/P	
110	X0-00595000	S/TPP/PAN-3X6-NI	1	10/P	

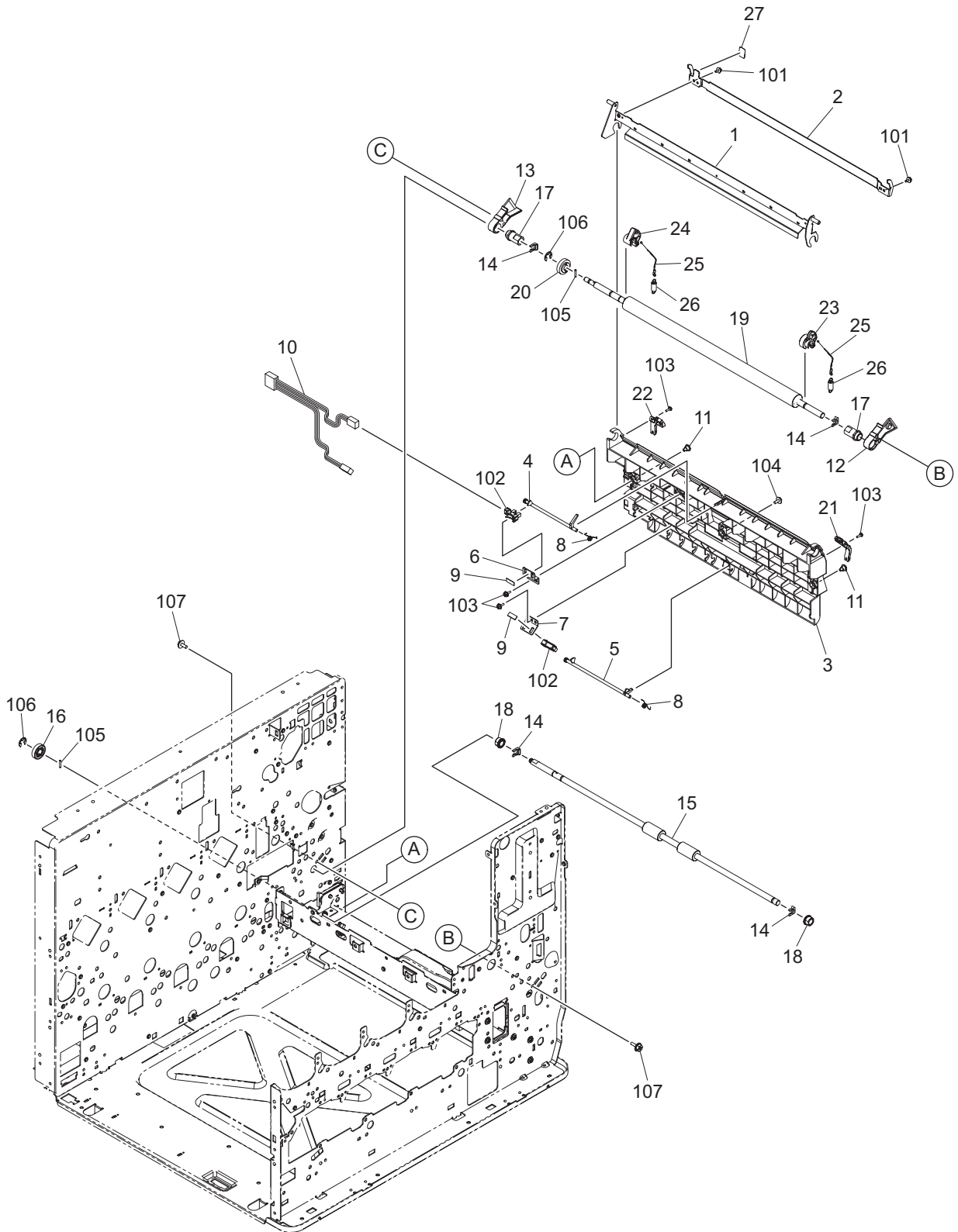

ITEM No.	PART No.	PART NAME	Q'TY / PAGE	Q'TY / PACK	REMARKS
1	6LJ03827000	ASYS-GUIDE-MID-L	1	1/PP	
2	6LH39426000	GUIDE-MID-R	1	1/P	
3	6LE24275000	ASYS-GUIDE-RGST-L-380	1	1/PP	
4	6LE24231000	ACTR-RGST-380	1	1/P	
5	6LE24229000	ACTR-MID-380	1	1/P	
6	6LA37626000	HLDR-REG-SENSOR	1	1/P	
7	6LE24232000	BRKT-SENS-MID	1	1/P	
8	6LE24277000	SPG-ACT-380	2	1/P	
9	44201543000	MYLAR-SW-RGST-2	2	5/P	
10	6LE29386000	HRNS-FEED1-380	1	1/P	
11	6LA37669000	SCREW-LOCK-ARM	2	5/P	
12	6LE24326000	HLDR-ROL-RGST-F-AL	1	1/P	
13	6LE24327000	HLDR-ROL-RGST-R-AL	1	1/P	
14	41306265000	STOP RING	4	1/P	
15	6LJ01915000	RLR-MID-H14X	1	1/KP	
16	6LE24366000	GEAR-05S40-8N	1	1/P	
17	6LE24328000	BUSH-ROL-RGST-L	2	5/P	
18	6LH23442000	BUSH-8X12X8F-NU4	2	5/P	
19	6LJ01910000	ROLLER-RGST-L-H140-0.05	1	1/KP	
20	6LJ01911000	GEAR-RGST-H140	1	1/P	
21	6LE24337000	GUIDE-RAIL-WIRE-F	1	1/P	
22	6LE24338000	GUIDE-RAIL-WIRE-R	1	1/P	
23	6LH34712000	CAM-RGST-STOP-F	1	1/P	
24	6LH34713000	CAM-RGST-STOP-R	1	1/P	
25	6LE24339000	WIRE-CAM-RGST	2	1/P	
26	6LE24340000	SPG-E-CAM-RGST	2	1/P	
27	6LE29099000	LBL-GUIDE-MID	1	1/P	
101	X0-02551000	S/PAN/SWWP-M3X6-ZU3	2	10/P	
102	C0-10813000	GP1A73ARJ00F	2	1/P	
103	X0-01989000	S/TPP/BID-3X8-NI	4	10/P	
104	X0-02421000	S/TPS/FHEXM/R-4X8-ZU3	1	10/P	
105	X0-01526000	P/PRL/AH7-2X12-SS	2	10/P	
106	X0-00968000	RR/E-7-SS	2	10/P	
107	X0-02234000	S/FHEXM-M4X6-NI	2	10/P	

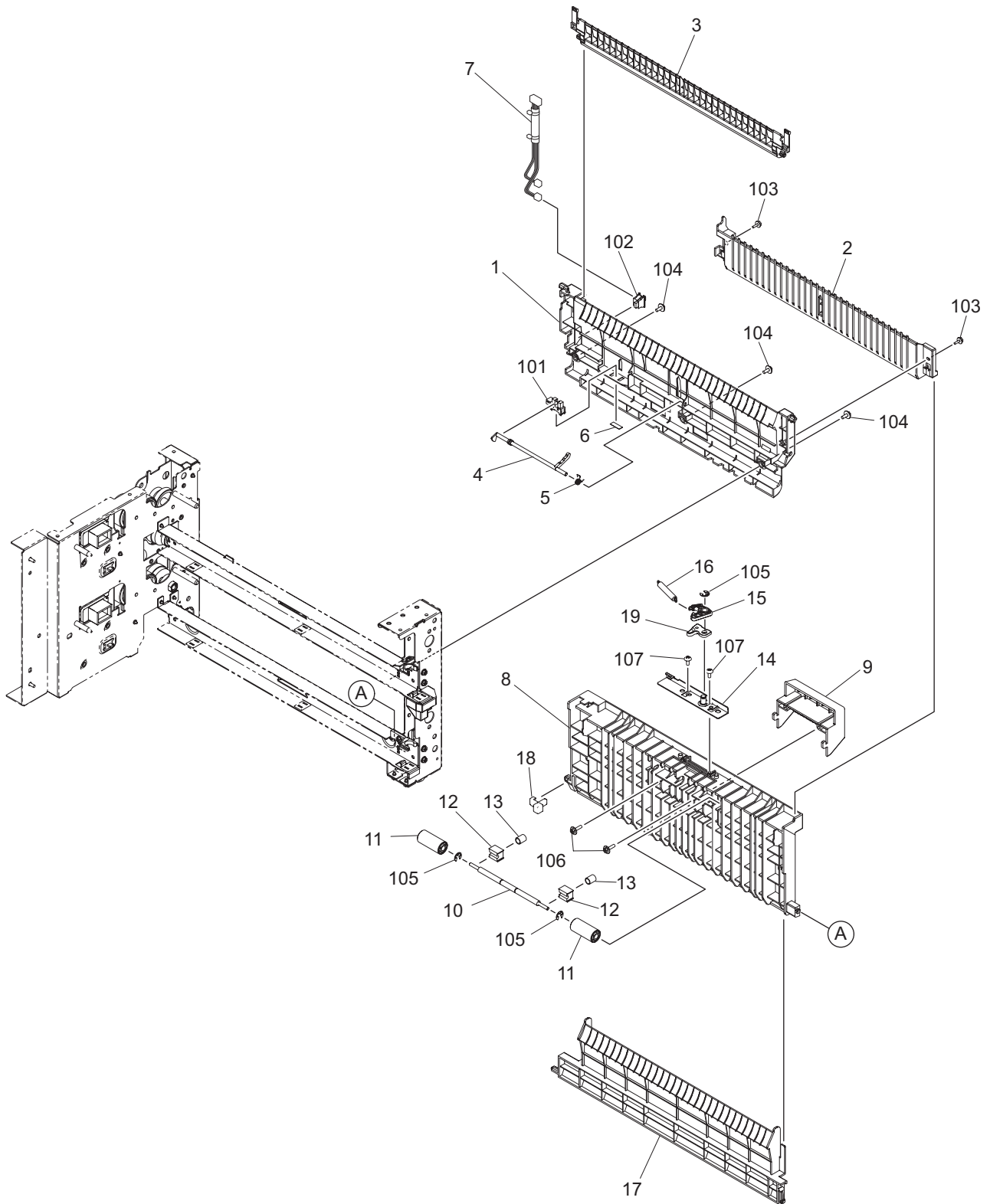

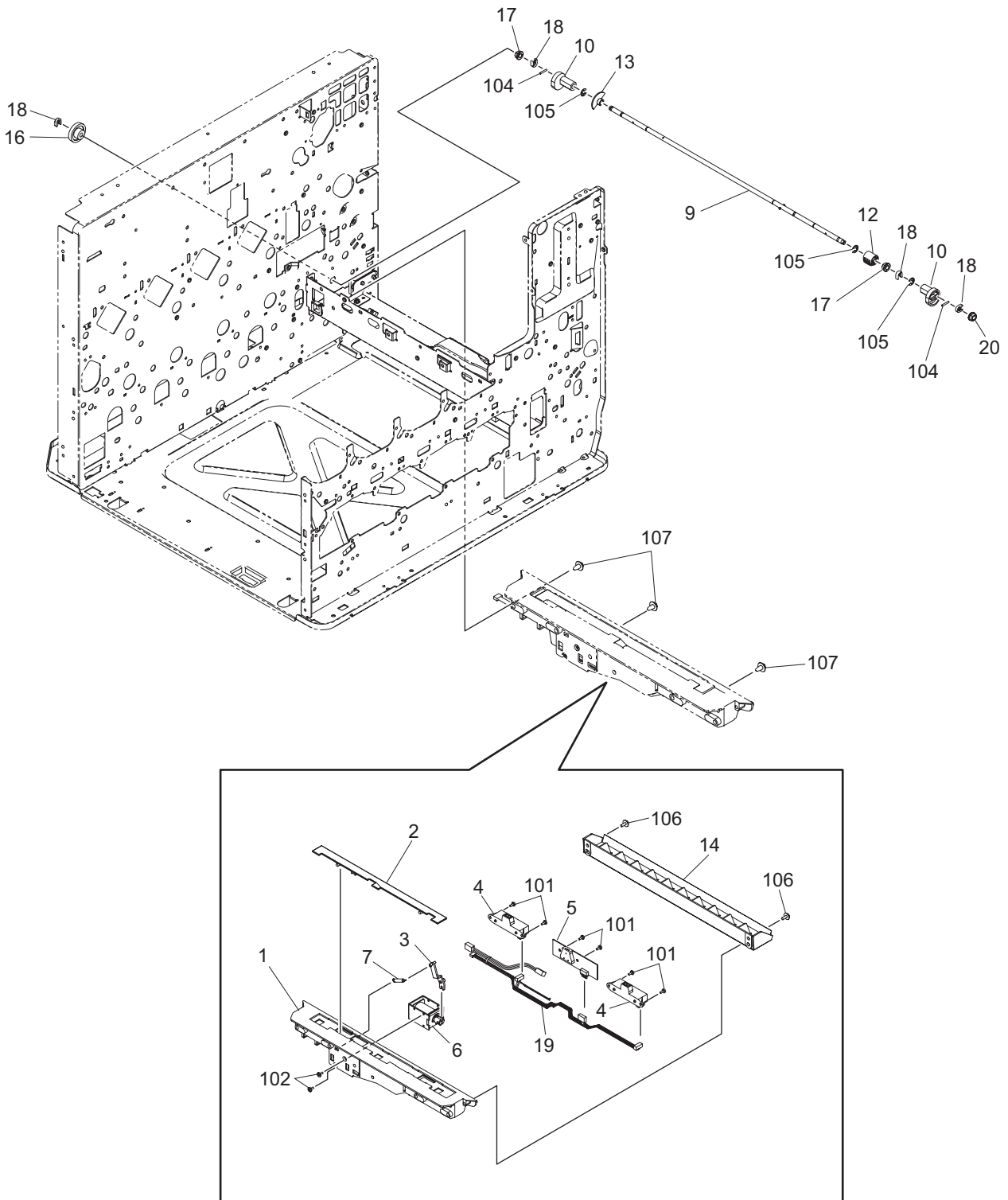

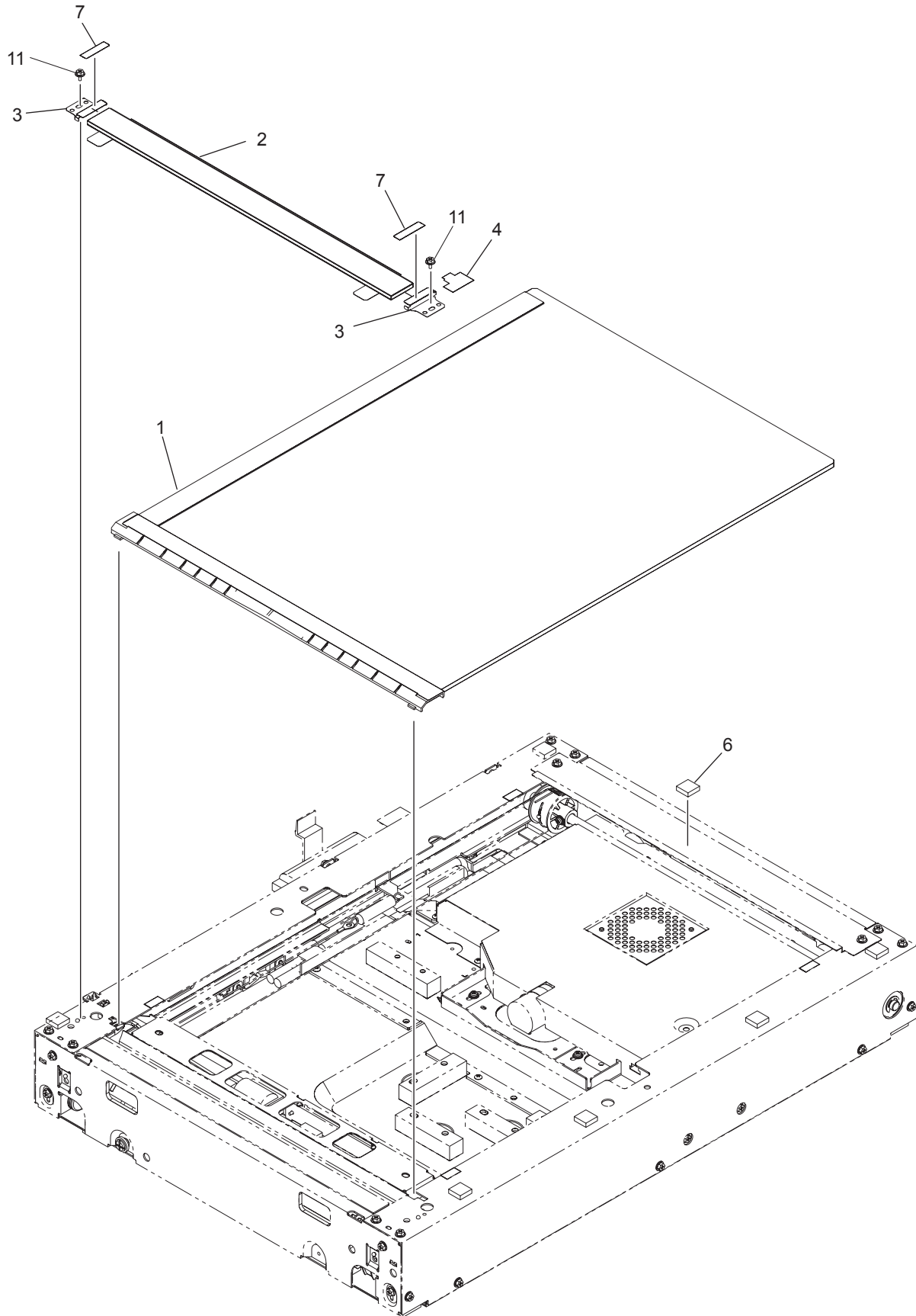

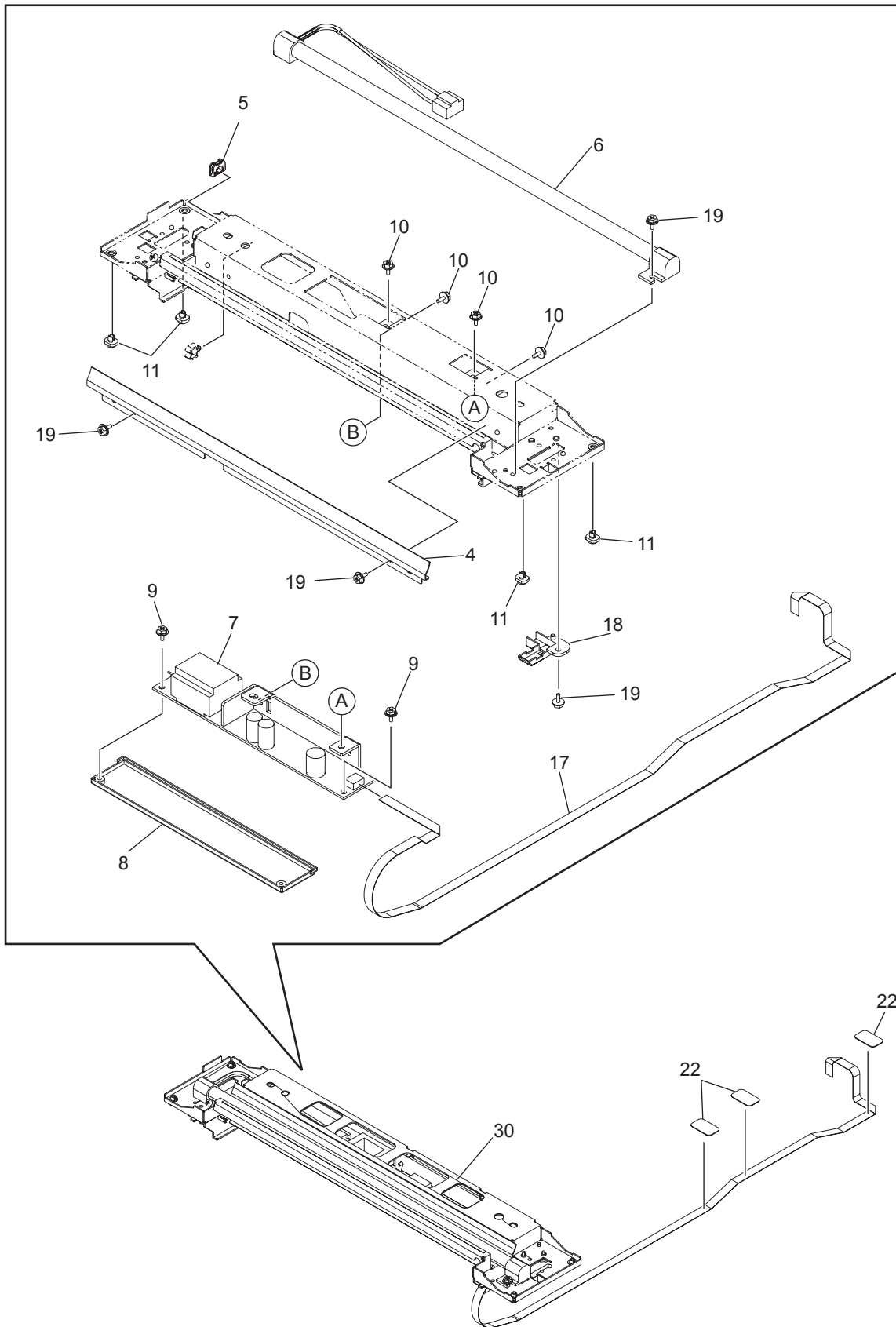

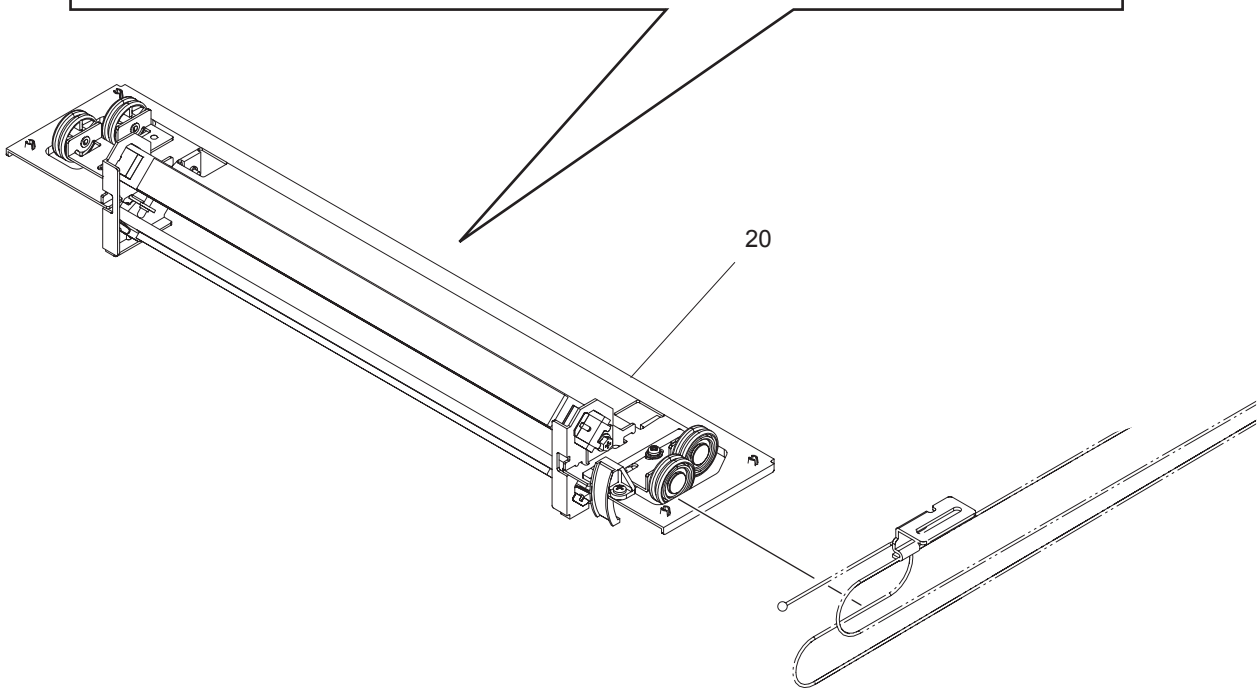
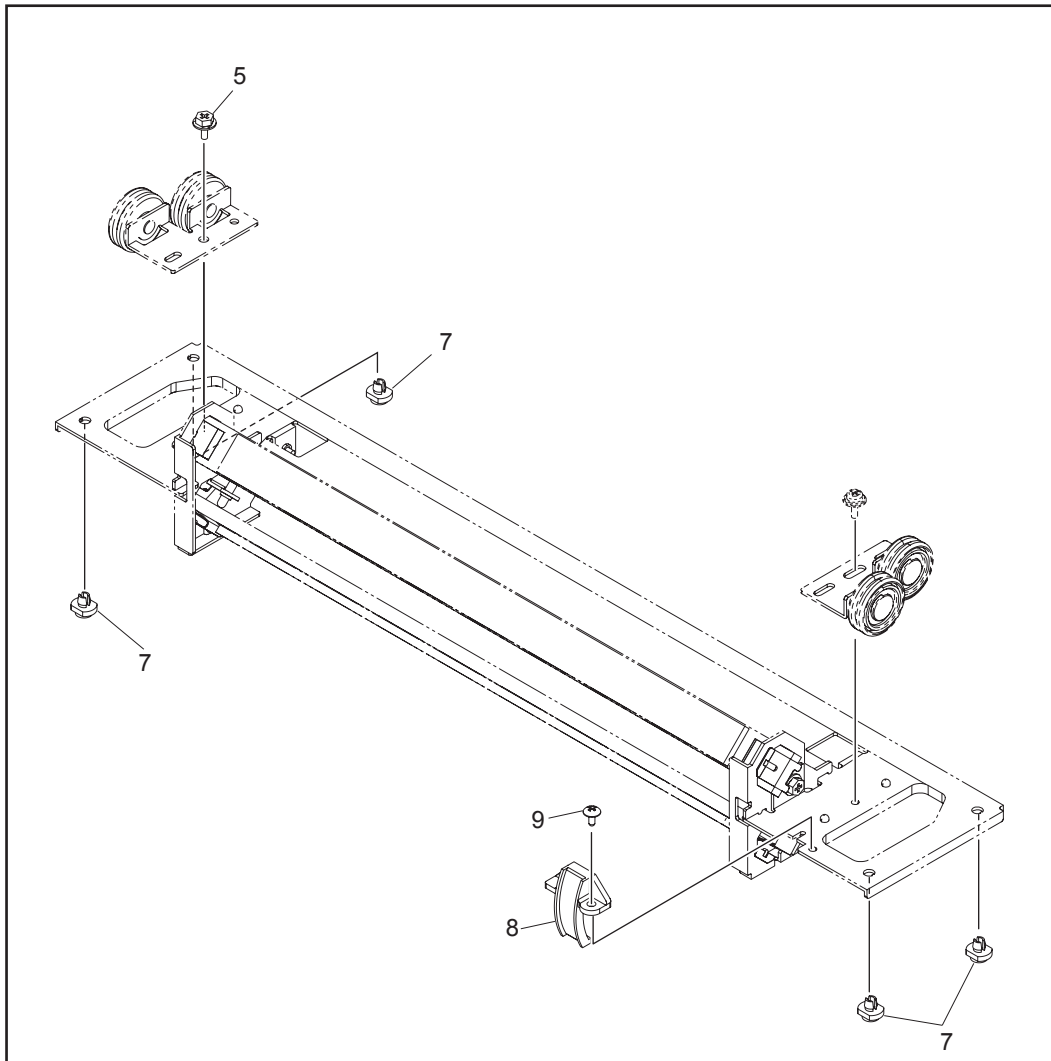

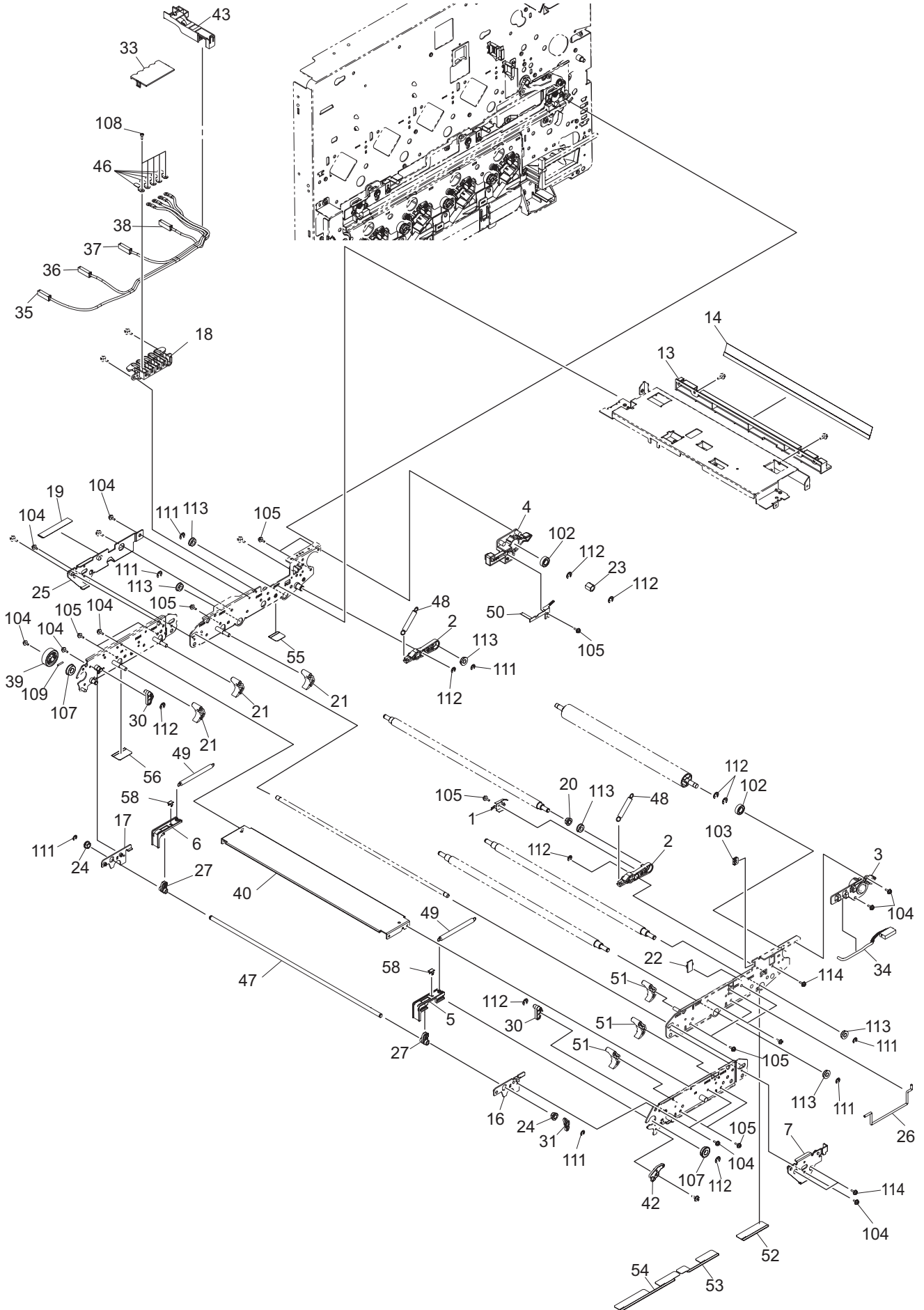

ITEM No.	PART No.	PART NAME	Q'TY / PAGE	Q'TY / PACK	REMARKS
1	6LH38610000	SPG-TBU-TNS-GND	1	1/P	
2	6LE28204000	ARM-TENSION-MOLD	2	1/P	
3	6LH38601000	HLDR-BRG-F-450	1	1/P	
4	6LH38600000	HLDR-BRG-R-450	1	1/P	
5	6LE28288000	HOOK-CLN-TBU-F	1	1/P	
6	6LJ03304000	HOOK-CLN-TBU-R-EX	1	1/P	
7	6LJ03368000	FRAME-TBU-HINGE-F-H14X	1	1/P	
13	6LH38623000	HLDR-PAD-CLN-TR2-N	1	1/P	
14	6LH38622000	MYLAR-CLN-TR2-WP-450	1	1/KP	
16	6LE28229000	ASYS-PLATE-CLN-F	1	1/P	
17	6LJ03302000	ASYS-PLATE-CLN-R-EX	1	1/P	
18	6LE28236000	BASE-TERMINAL-TBU	1	1/P	
19	6LE28431000	LBL-HANDL-TBU	1	5/P	
20	6LH23444000	BUSH-GCB-6-4-NU4	1	1/P	
21	6LE28442000	LVR-LIFT-TR1-R	3	1/P	
22	4407685930	HOLDER-WH	1	5/P	
23	6LE28475000	BUSH-TR2-TBU	1	5/P	
24	44201492000	BUSH-6-POM	2	5/P	
25	6LJ03369000	FRAME-TBU-HINGE-R-H14X	1	1/P	
26	6LE28487000	LVR-TBU-F380	1	1/P	
27	6LE28245000	CAM-LIFT-CLN-TBU	2	1/P	
30	6LE28252000	CAM-LIFT-TNS	2	1/P	
31	6LJ03321000	CAM-SIDE-PLATE-CLN	1	1/P	
33	6LE28258000	COVER-TERMINAL-TBU	1	1/P	
34	6LJ05091000	HRNS-TBU-140	1	1/P	
35	6LE29418000	HRNS-TBUHV-C-380	1	1/P	
36	6LE29419000	HRNS-TBUHV-K-380	1	1/P	
37	6LE29417000	HRNS-TBUHV-M-380	1	1/P	
38	6LE29416000	HRNS-TBUHV-Y-380	1	1/P	
39	6LJ03301000	GEAR-3H106-TBU-H14X	1	1/P	
40	6LE28481000	PLATE-TBU-CL	1	1/P	
42	6LJ03322000	GUIDE-STUD-CLN-TBU	1	1/P	
43	6LE28277000	GUIDE-WH-TR	1	1/P	
46	6LE28308000	PLATE-TERMINAL-TBU	5	1/P	
47	6LE28325000	SHAFT-CAM-LVR-CLN	1	1/P	
48	6LE28531000	SPG-E-TNS-9N	2	1/P	
49	6LE28478000	SPG-E-CLN-TBU	2	1/P	
50	6LH38648000	PLATE-TR2-TBU	1	1/C	
51	6LE28301000	LVR-LIFT-TR1	3	1/P	
52	6LJ03324000	MYLAR-TBU-H14X-F-1	1	1/P	
53	6LJ03325000	MYLAR-TBU-H14X-F-2	1	1/P	
54	6LJ03328000	MYLAR-TBU-H14X-F-3	1	1/P	
55	6LJ03326000	MYLAR-TBU-H14X-R-1	1	5/P	
56	6LJ03327000	MYLAR-TBU-H14X-R-2	1	5/P	
58	6LE28486000	SPG-F-HOOK-STOP	2	1/P	
102	F0-01973000	L-1680HHRP0P25LY551	2	5/P	
103	F0-00120000	ES-0505	1	5/P	
104	X0-02230000	S/FHEXM-M3X6-NI	10	10/P	
105	X0-02247000	S/TPP/FHEXM-3X8-NI	10	10/P	
107	F0-01390000	LNR-1680HHRP0P15LY13	2	1/P	
108	X0-00602000	S/TPP/PAN-3X8-NI	5	10/P	
109	X0-01526000	P/PRL/AH7-2X12-SS	1	10/P	
111	X0-00965000	RR/E-4-SS	7	10/P	
112	X0-00966000	RR/E-5-SS	9	10/P	
113	F0-01966000	F126ZZ-DF30ELC-GV22	6	1/P	

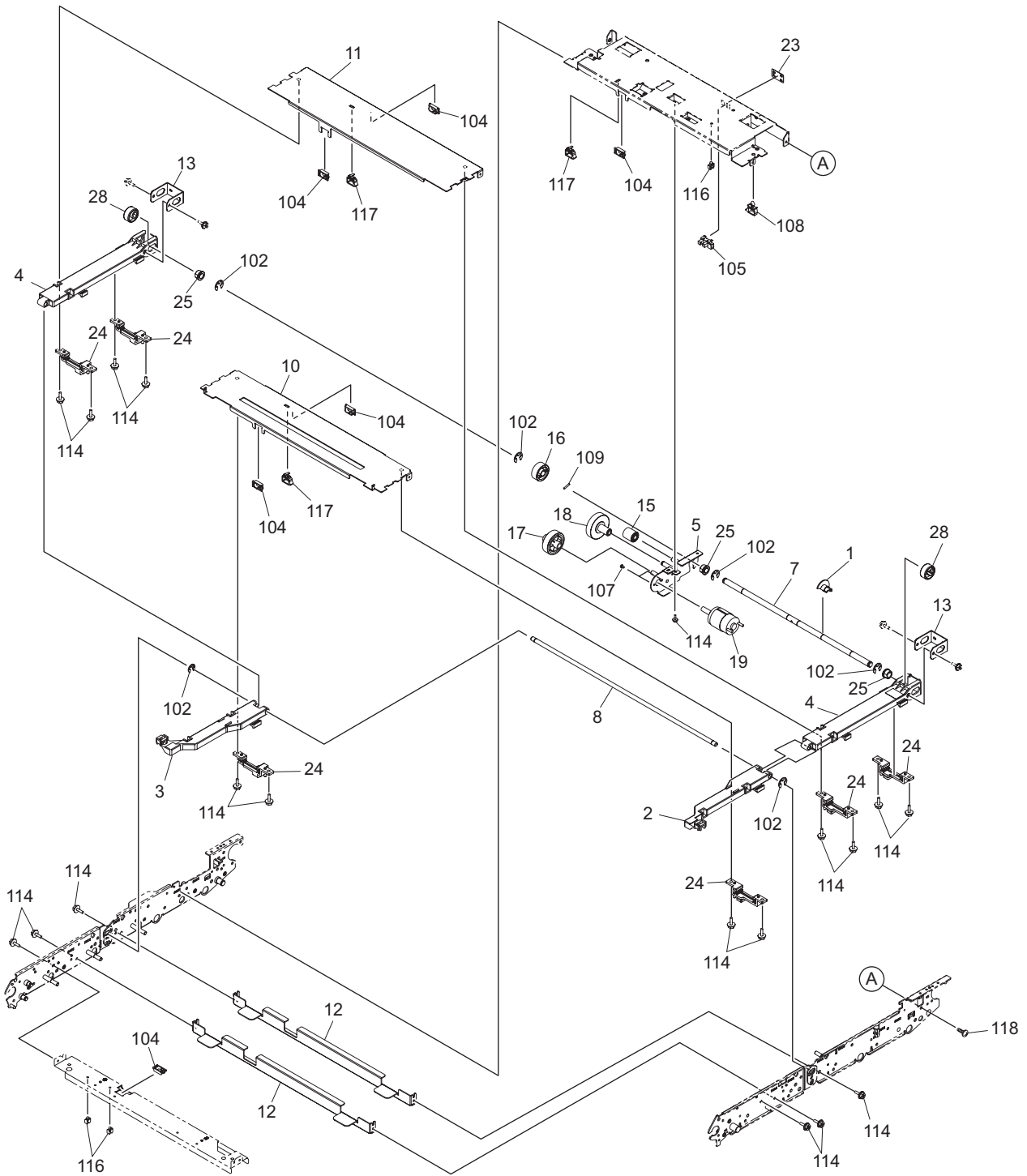

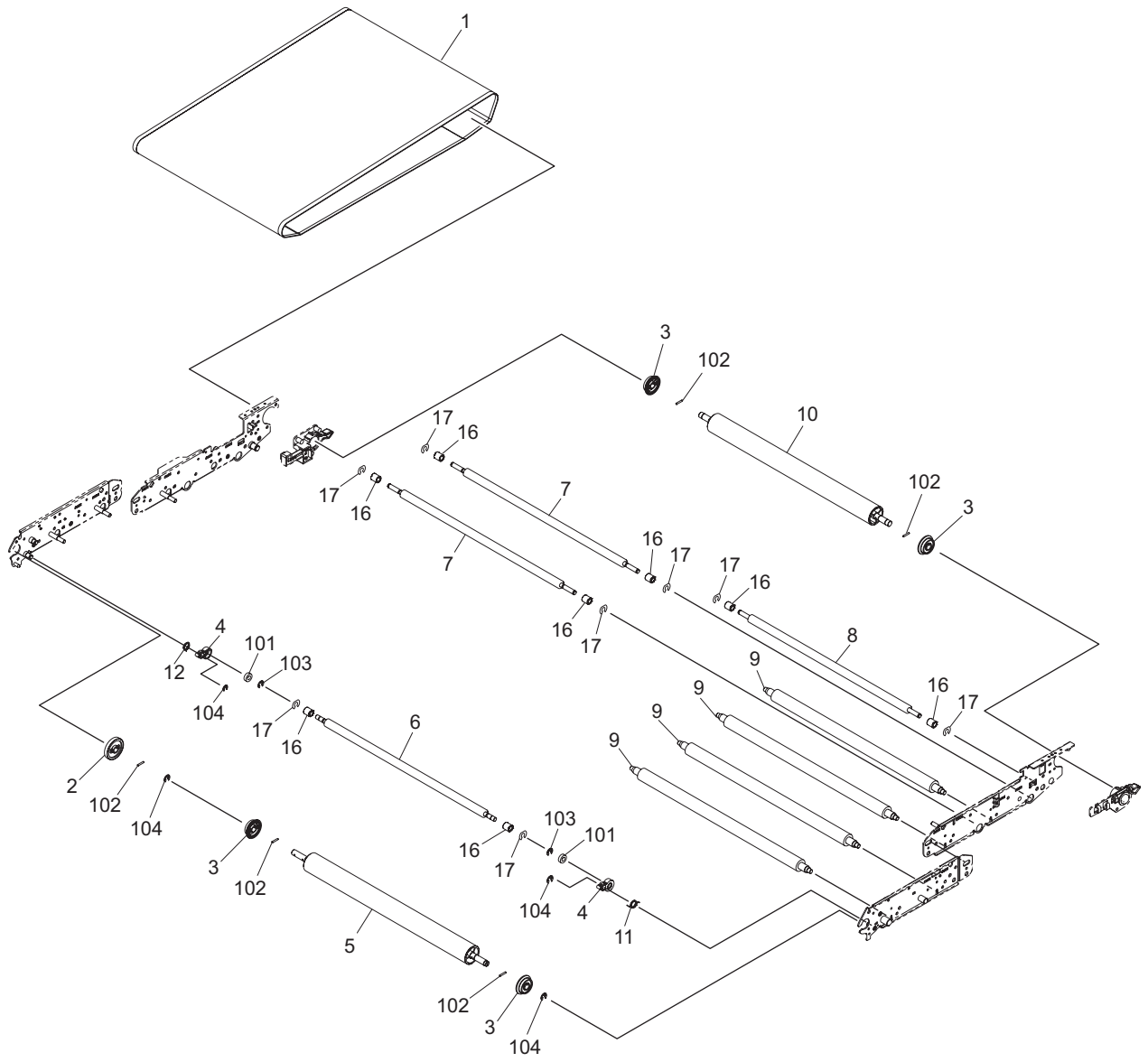

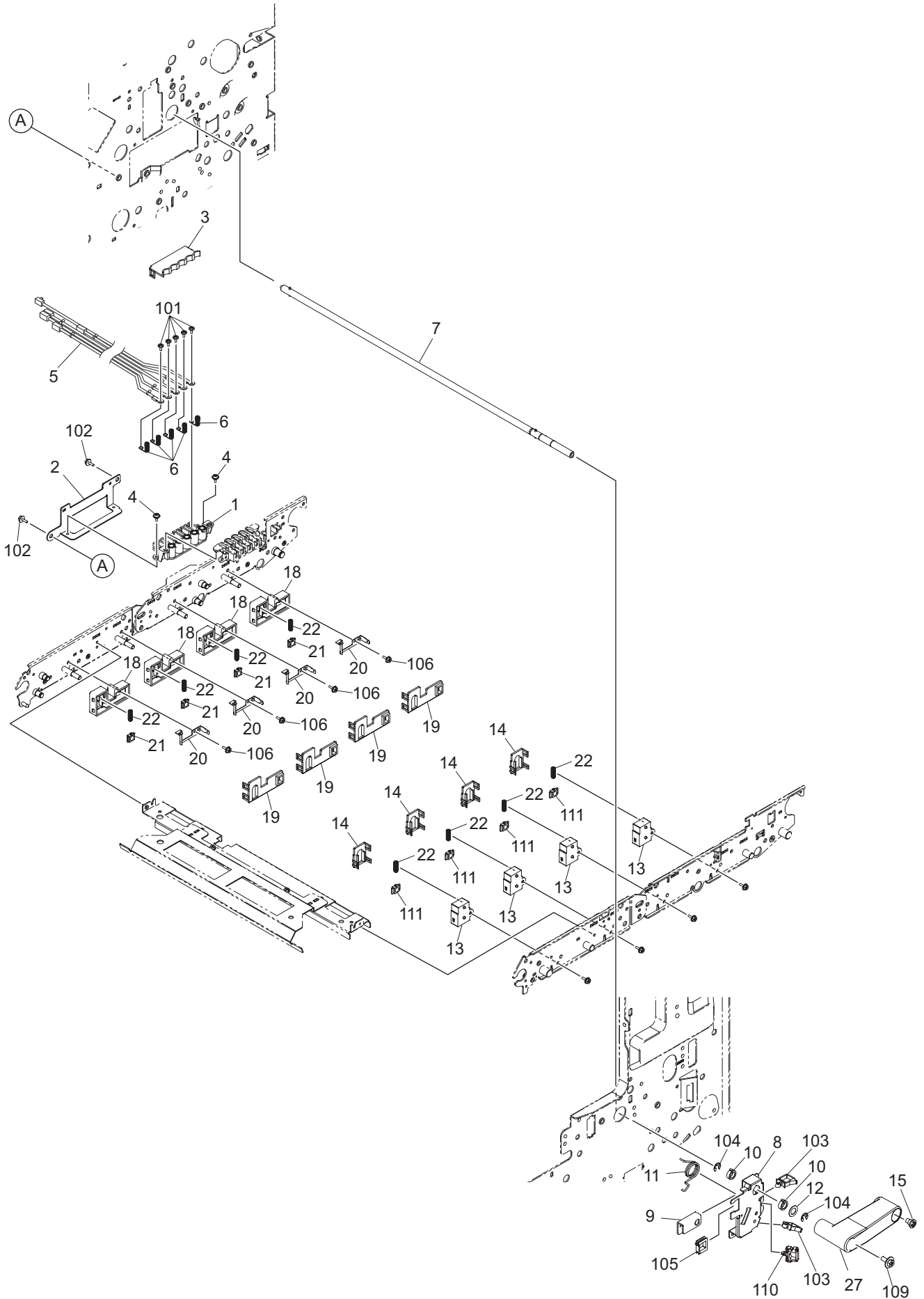

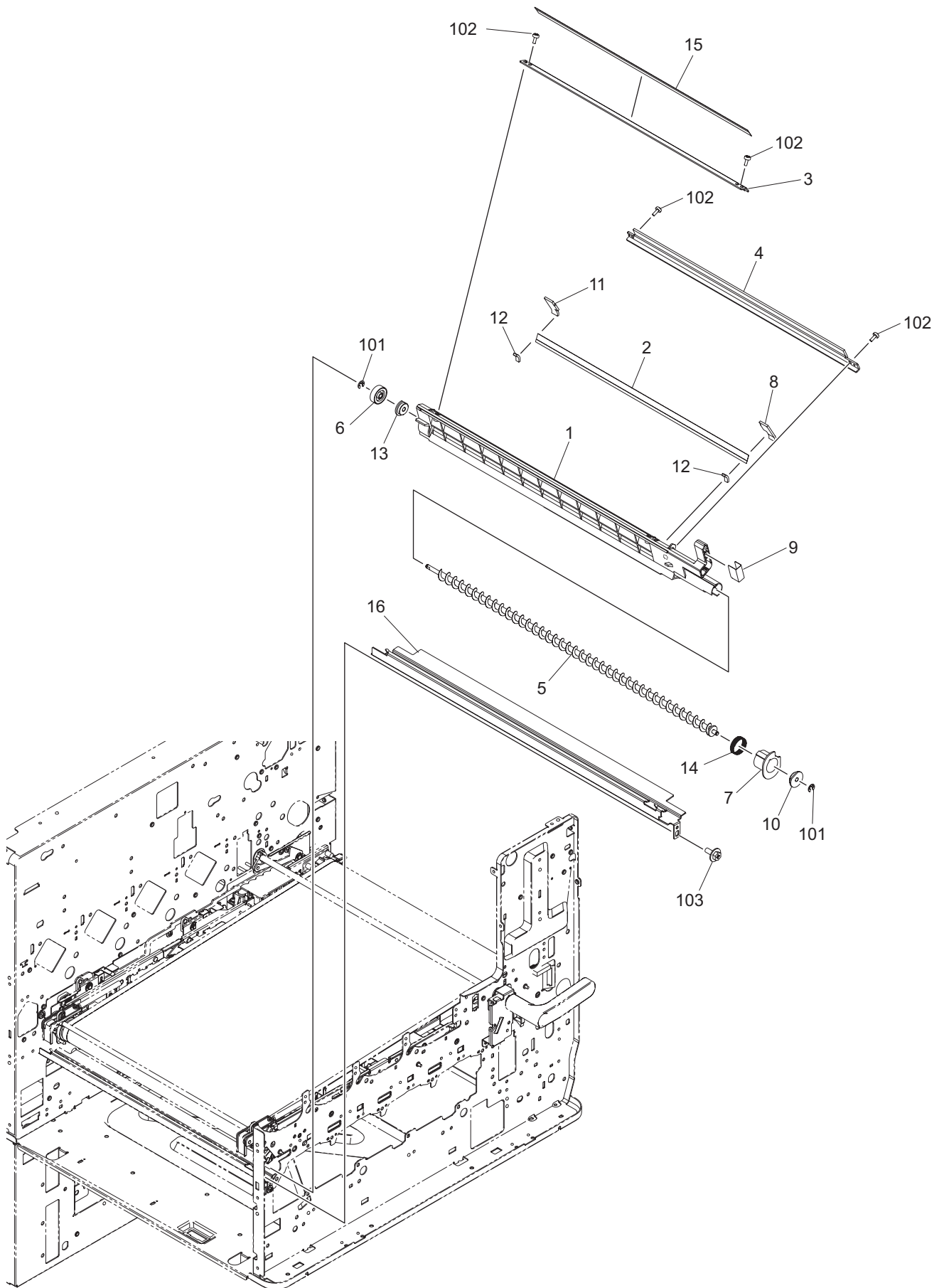

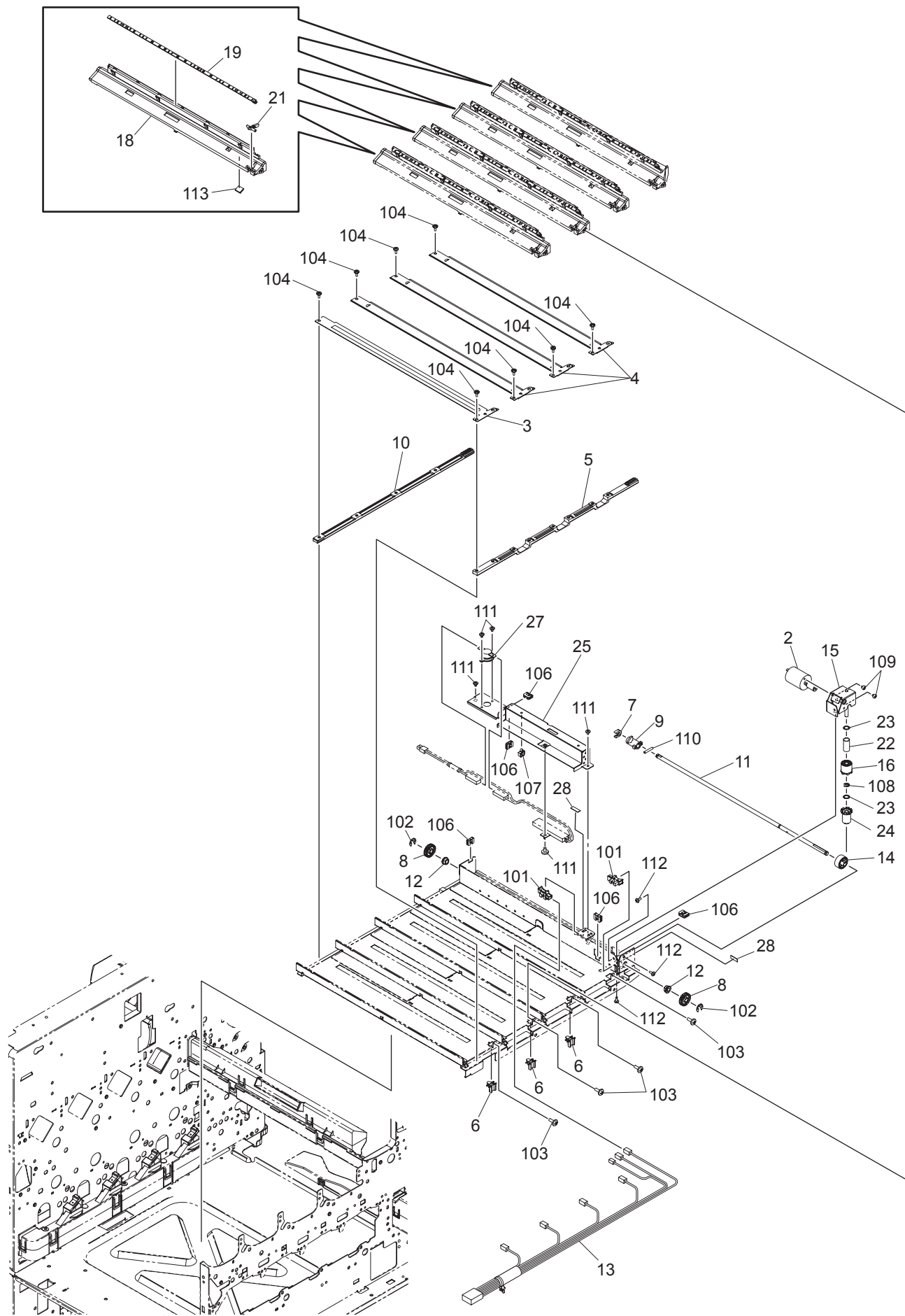

ITEM No.	PART No.	PART NAME	Q'TY / PAGE	Q'TY / PACK	REMARKS
2	6LE22603000	ASYS-MOTR-SHUT-380	1	1/D	
3	6LH32902000	PLATE-SHUT-TNR-Y-45X	1	1/KP	
4	6LH32901000	PLATE-SHUT-TNR-45X	3	1/KP	
5	6LH32984000	RACK-SHUT-FRT-45X	1	1/KP	
6	6LH33257000	GUIDE-HARNESS	3	1/P	
7	4407972860	STOP-RING-6-5	1	5/P	
8	6LE22530000	GEAR-SHUT-FRT	2	1/P	
9	6LH32980000	ACTR-SHUT-C	1	1/P	
10	6LH32985000	RACK-SHUT-RER-45X	1	1/KP	
11	6LE22534000	SHAFT-SHUTTER	1	1/P	
12	44201492000	BUSH-6-POM	2	5/P	
13	6LJ05170000	HRNS-LSHTU-140	1	1/P	
14	6LE22596000	GEAR-IDLER-08H17	1	1/P	
15	6LH32963000	ASYS-PLTSH-45X	1	1/P	
16	6LE22611000	GEAR-IDLER-08H18-U-A	1	1/P	
18	6LH32969000	DUCT-OZN-CHA-F45X	1	1/PP	
19	6LH39940000	LAMP-ERASE-450	1	1/S	
21	6LE22563000	ACTR-CHARGR-MAIN	1	1/P	
22	6LE22614000	SPG-SHUT-D-160	1	1/P	
23	6LA78907000	WASHER-6R2X9R5XR13-PL	2	5/P	
24	6LE22612000	GEAR-IDLER-08H9-L-A	1	1/P	
25	6LE22881000	BRKT-DH-380	1	1/P	
27	6LE71198000	THRMST-CS-7SA	1	1/C	
28	44201543000	MYLAR-SW-RGST-2	2	5/P	
101	C0-10813000	GP1A73ARJ00F	2	1/P	
102	X0-00966000	RR/E-5-SS	2	10/P	
103	X0-02069000	S/TPS/BID-3X6-ZU3	4	10/P	
104	X0-01414000	S/TPP/BID-3X6-NC	8	10/P	
106	F0-00120000	ES-0505	5	5/P	
107	F0-01640000	UAMS-05SN 142SH BLK	1	5/P	
108	X0-00965000	RR/E-4-SS	1	10/P	
109	X0-02112000	S/PAN-M3X3-NI	2	10/P	
110	X0-01526000	P/PRL/AH7-2X12-SS	1	10/P	
111	X0-00426000	S/BID-M3X4-NI	5	10/P	
112	X0-00430000	S/BID-M3X6-NI	3	10/P	
113	F0-02042000	MN-1	1	5/P	

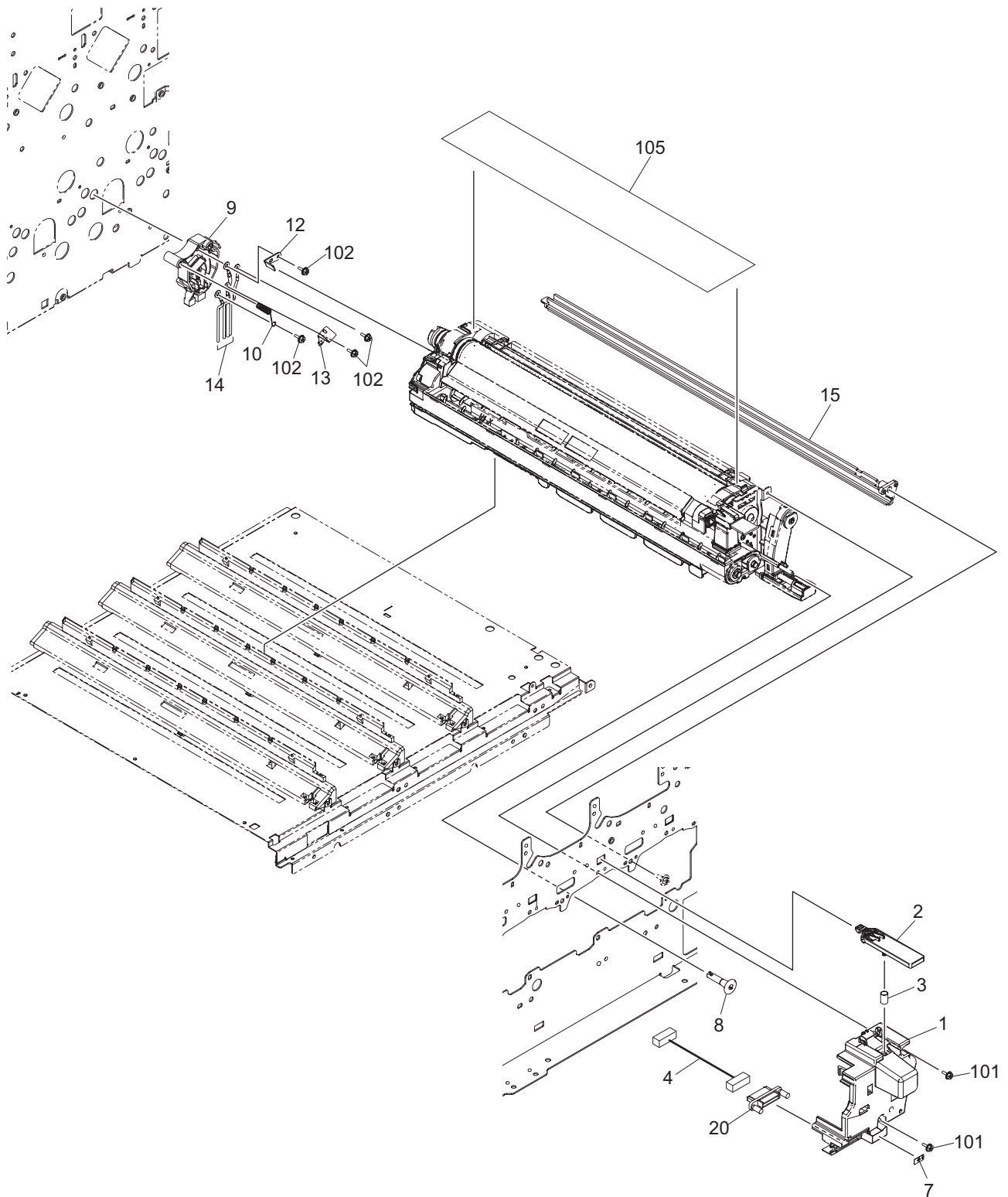

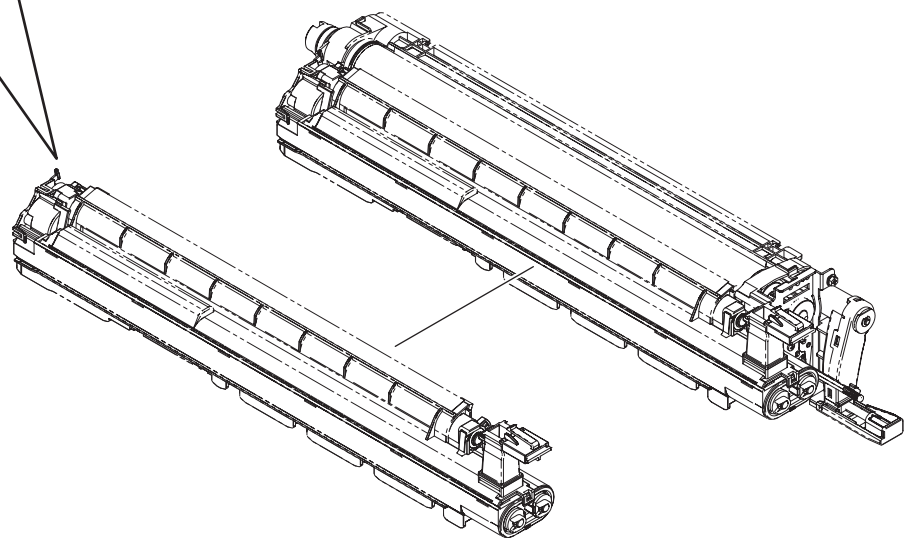
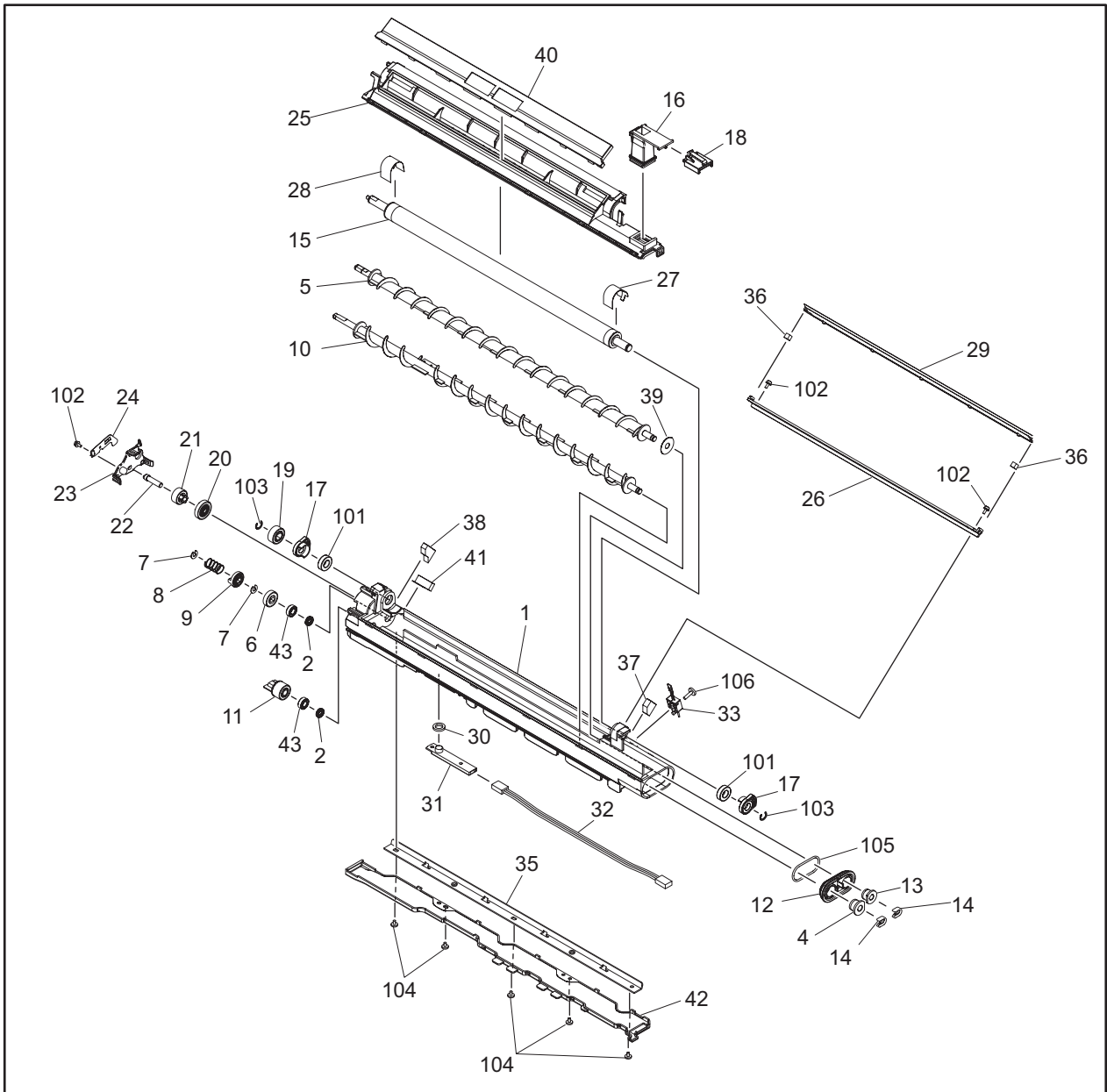

ITEM No.	PART No.	PART NAME	Q'TY / PAGE	Q'TY / PACK	REMARKS
1	6LJ01337000	ASYS-CASE-DEV-SEAL-H14X	1	1/C	
2	4401949290	SEAL-VC6-10-2.5	2	1/P	
4	6LJ01358000	ASYS-BUSH-6X12X10F-H14X	1	1/P	
5	6LE23152000	MIXER-1-380-25	1	1/KP	
6	6LE23185000	GEAR-8H18-DEV	1	1/P	
7	4406527980	WAS-POLY-4	2	10/P	
8	6LE23186000	SPG-C-CPG-DEV	1	1/P	
9	6LE23184000	CPG-DRV-DEV	1	1/P	
10	6LH33552000	ASYS-MIXER-2-F45X	1	1/PP	
11	6LE23155000	GEAR-8H18-6-R	1	1/P	
12	6LH33639000	HLDR-BUSH-DEV-F-45X	1	1/P	
13	6LA30779000	BUSH-SEAL-6-M	1	1/P	
14	4407972860	STOP-RING-6-5	2	5/P	
15	6LH33598000	RLR-MAGT-F45X-R	1	1/KP	
16	6LH33621000	ASYS-SEAL-DUCT-DEV-2	1	1/P	
17	6LE23156000	RLR-GUIDE-DEV-035	2	1/P	
18	6LE23610000	ASYS-SEAL-SHUT-DEV	1	1/P	
19	6LE23157000	GEAR-8H19-8-L	1	1/P	
20	6LJ01349000	ASYS-GEAR-8H22-5-L-BR	1	1/P	
21	6LJ01348000	ASYS-GEAR-8H17-5-R-BR-M	1	1/P	
22	6LE23161000	STUD-GEAR-DEV	1	1/P	
23	6LE23239000	ASYS-HLDR-GEAR-DEV	1	1/P	
24	6LE23162000	ADJSTR-MG-2	1	1/P	
25	6LJ01335000	ASYS-COVER-DEV-H14X	1	1/PP	
26	6LH33548000	ASYS-DOCTOR-F45X	1	1/KP	
27	6LE23163000	SEAL-MG-SIDE-F	1	1/P	
28	6LE23164000	SEAL-MG-SIDE-R	1	1/P	
29	6LE23605000	ASYS-HLDR-SHIELD-DEV	1	1/C	
30	6LA29904000	SEAL-ATC-BLK	1	5/P	
31	6LE29460000	SNSR-ATC-380	1	1/C	
32 A	6LH39908000	HRNS-MCEPU-450	1	1/P	M,C
32 B	6LH39907000	HRNS-YKEPU-450	1	1/P	Y,K
33	6LE29461000	THMS-DRM-380	1	1/C	Y,K
35	6LH33523000	PLATE-DEV-COOLER	1	1/P	
36	6LE23212000	SEAL-MG-DOC-L	2	5/P	
37	6LE23218000	SEAL-DOC-SIDE-F	1	5/P	
38	6LE23219000	SEAL-DOC-SIDE-R	1	5/P	
39	6LE23233000	SEAL-MIXER-380	1	5/P	
40	6LH33564000	ASYS-DUCT-DEV-COV	1	1/P	
41	6LH33574000	ASYS-SEAL-DOC-SIDE-R	1	1/P	
42	6LH33597000	DUCT-DEV-COOLER	1	1/PP	
43	F0-01959000	L1260 2RS-SH44M-GV22	2	1/P	
101	F0-01868000	6882RSSH44M	2	1/P	
102	X0-01973000	S/PAN/SWWS-M3X6-BS	3	10/P	
103	F0-01499000	S5103-31 3BC	2	10/P	
104	X0-00426000	S/BID-M3X4-NI	5	10/P	
105	F0-02053000	CO0523A	1	1/P	
106	X0-00434000	S/BID-M3X8-NI	1	10/P	

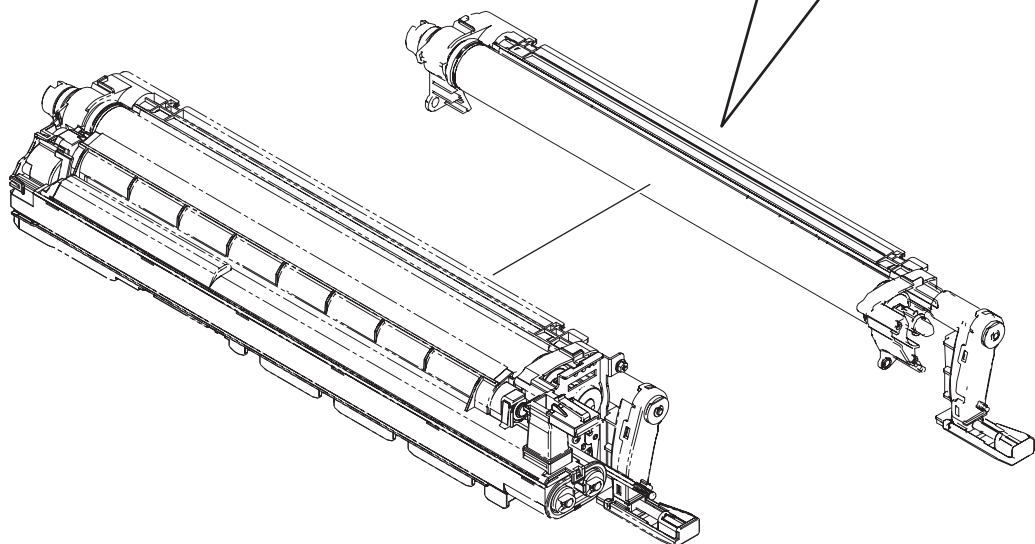
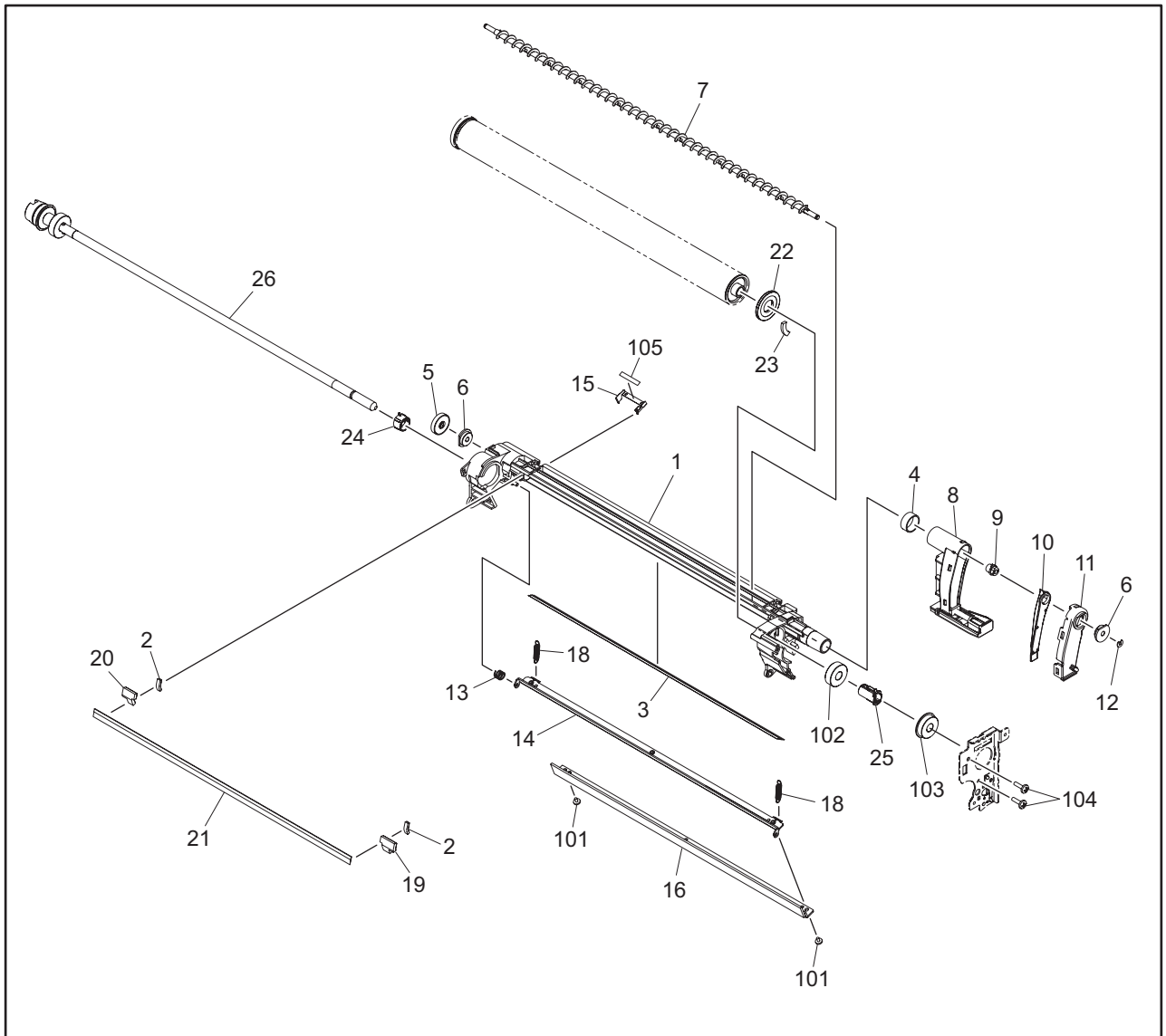

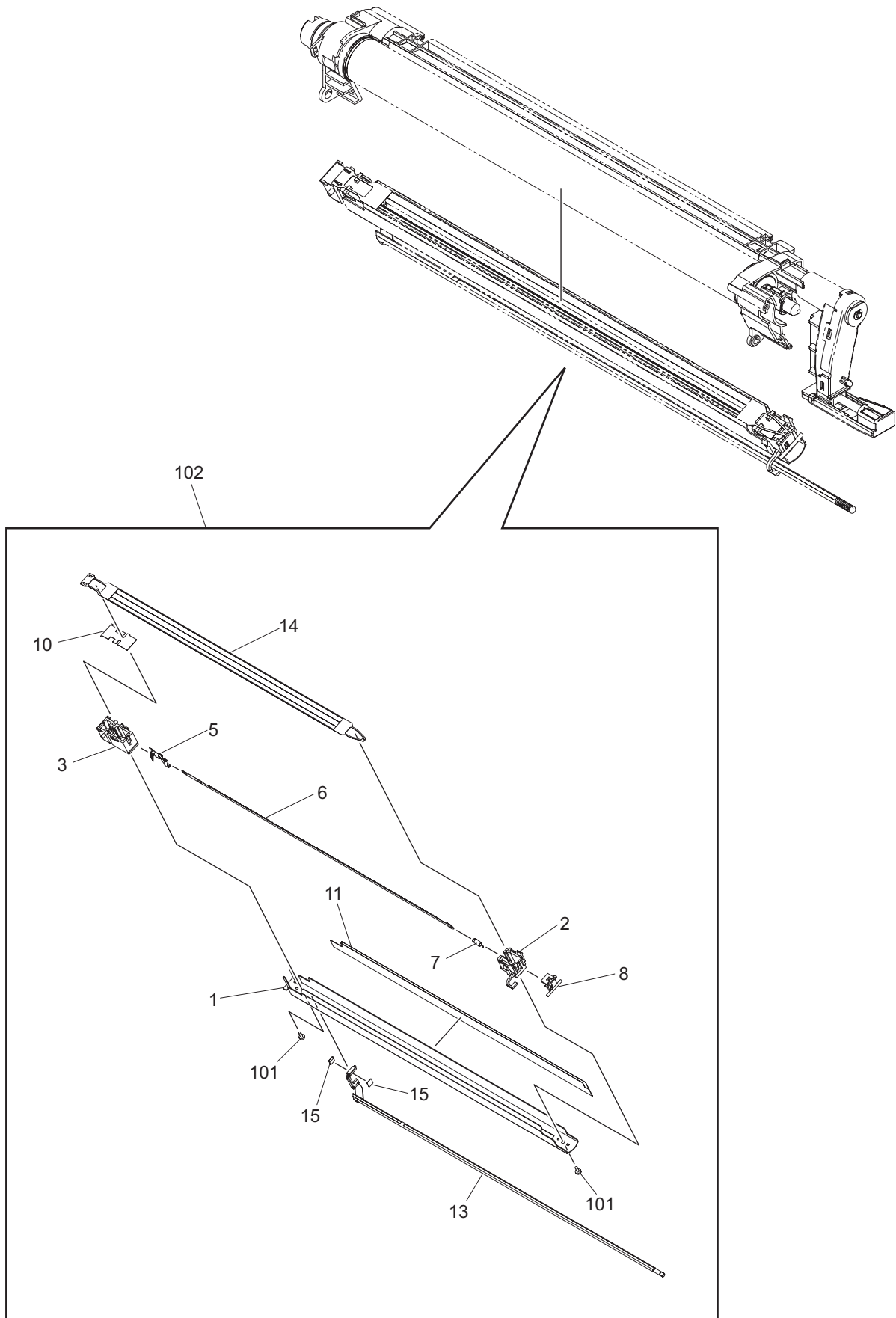

ITEM No.	PART No.	PART NAME	Q'TY / PAGE	Q'TY / PACK	REMARKS
1	6LJ03508000	COVER-INNR-DRW-H14X	1	1/P	
2	6LH40207000	HRNS-EPU-450	1	1/P	
3	X0-02421000	S/TPS/FHEXM/R-4X8-ZU3	6	10/P	
4	6LH39112000	ASYS-CASE-DUCT-TOP	1	1/PP	
5	6LH39292000	CASE-DUCT-AUG-WTNR	1	1/PP	
6	6LH04280000	ASYS-BUSH-6X12X6F-M	2	1/P	
7	6LH39119000	COUPL-AUG-WTNR	1	1/P	
8	6LH39120000	CLNR-WTNR-DUCT-2	1	1/P	
9	6LH39291000	AUGER-WTNR-FRT	1	1/KP	
10	44204339000	BUSH-0612*06F-M	2	5/P	
11	6LH39128000	PULLY-2GT19-6	1	1/P	
12	6LH39215000	ASYS-LID-WTNR	1	1/P	
13	6LH39201000	ASYS-GEAR-PLT	1	1/P	
14	6LH39205000	ASYS-WPIPE-45X	1	1/PP	
15	6LH39212000	GEAR-10S33-6D	1	1/P	
16	6LH39213000	GEAR-10S33-P2GT19-6	1	1/P	
17	6LH39214000	BLT_SY-176-2GT-2	1	1/P	
18	6LH39125000	ASYS-SHUT-WTNR	1	1/P	
19	6LH39123000	SPG-E-SHUT-WTNR	1	1/P	
20	4407972860	STOP-RING-6-5	1	5/P	
21	6LE28832000	ACTR-U-PADL-SNR	1	1/P	
22	6LH39211000	LID-DUCT-F45X	1	1/P	
23	6LH39209000	AUGER-WTNR-F45X	1	1/PP	
24	6LH39210000	DUCT-VT-F45X	1	1/P	
25	6LH39798000	HRNS-AUGLCK-450	1	1/P	
26	E0-01853000	CS1A-B2CA	1	1/D	
27	C0-10813000	GP1A73ARJ00F	1	1/P	
28	X0-01989000	S/TPP/BID-3X8-NI	3	10/P	
29	6LH39217000	ACTR-COV-OPEN	1	1/P	
30	6LA08937000	SCREW-BKT-DEV	1	10/P	
33	6LH39221000	ASYS-BRKT-DRV-WTNR	1	1/P	
34	6LH39233000	GEAR-5H49-CPL	1	1/P	
35	6LH39231000	GEAR-5H21_P2GT60-6	1	1/P	
36	6LH39805000	MOTRD-AUG-450CW	1	1/D	
37	6LH39234000	BLT_SY-202-2GT-4	1	1/P	
38	6LH39225000	ASYS-BRKT-DRV-WTNR-SUB	1	1/P	
39	6LH39232000	GEAR-5H47-6	1	1/P	
40	6LH39797000	HRNS-AUGMTR-450	1	1/P	
41	6LH39237000	HLDR-SENS-THERM	1	1/P	
42	D0-27874000	CHS-CSC-20	1	1/C	
43	X0-00966000	RR/E-5-SS	1	10/P	
44	X0-02270000	S/PAN-M2.6X2.5-NI	2	10/P	
45	X0-02247000	S/TPP/FHEXM-3X8-NI	1	10/P	
46	X0-02230000	S/FHEXM-M3X6-NI	1	10/P	
47	X0-02593000	S/TPD3/FHEXM-3X8-ZU3	1	10/P	
48	F0-00120000	ES-0505	1	5/P	
50	F0-01250000	MSB-1207	1	5/P	
51	6LH39228000	ASYS-BRKT-DRV-TENS	1	1/P	
52	4401950980	COLLAR-DEV-TENS	1	5/P	
53	6LH39235000	SPG-E-5XR35X20R3	1	1/P	
54	6LA08936000	SCREW-M3-TENS	1	10/P	
55	44201543000	MYLAR-SW-RGST-2	1	5/P	

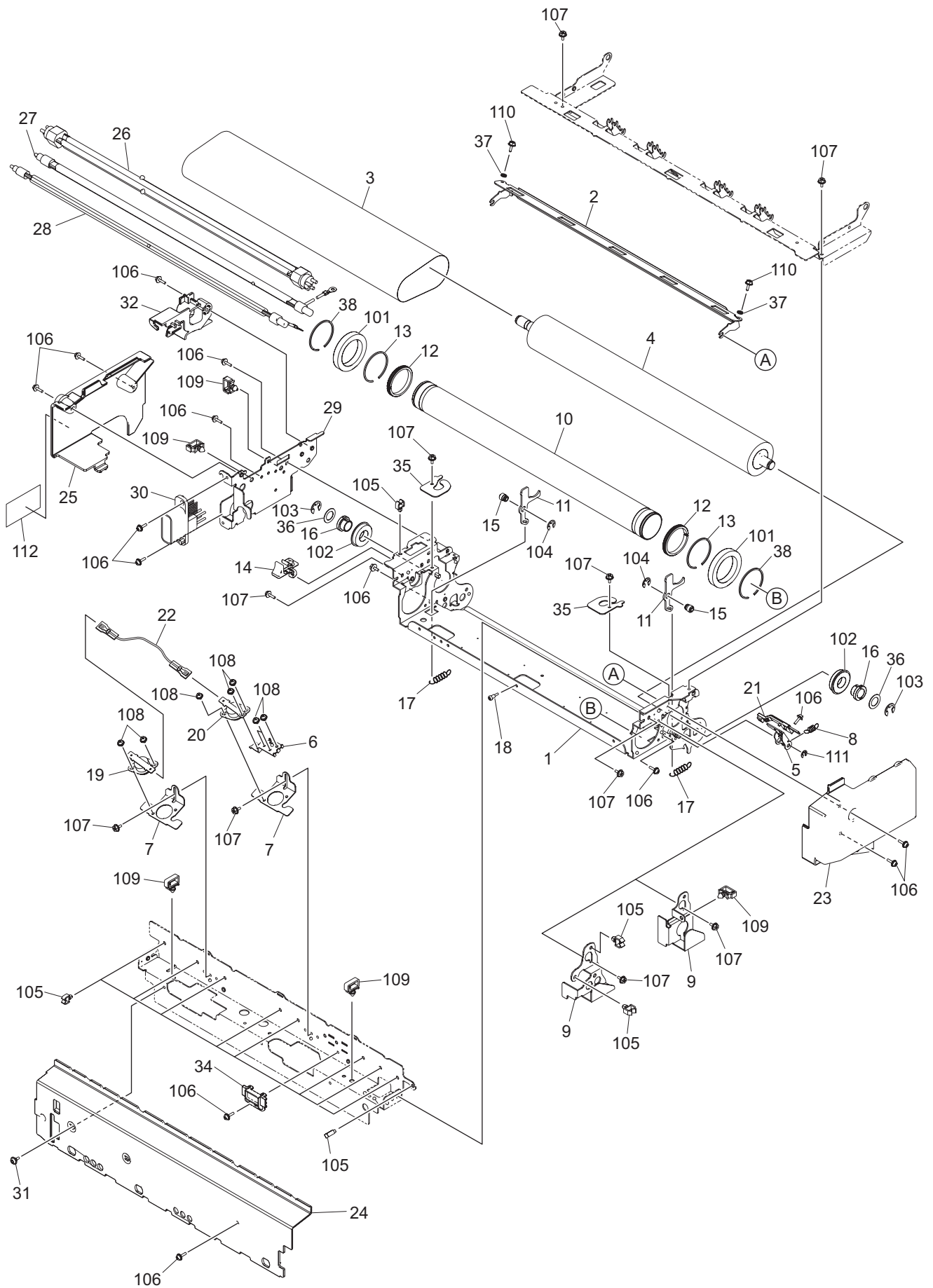

ITEM No.	PART No.	PART NAME	Q'TY / PAGE	Q'TY / PACK	REMARKS
1	6LH36283000	ASYS-FRM-FUS-450	1	1/PP	
2	6LH36336000	ASYS-SEP-AJ6-7A	1	1/P	
3	6LE94751000	BT-FC35-FU	1	1/S	
4	6LE98369000	FR-FC28-U	1	1/S	
5	6LH36299000	BRKT-FUS-SEN-IN-45X	1	1/P	
6	6LH36229000	BRKT-THRM-LAMP-454	1	1/P	
7	6LE25887000	BRKT-HR-TMS	2	1/P	
8	6LH36262000	SPG-E-FUS-SEN-45X	1	1/P	
9 A	6LH36201000	BRKT-LAMP-F-454T	1	1/P	e-STUDIO4540C
9 B	6LH36276000	BRKT-LAMP-F-450-S	1	1/P	e-STUDIO2040C/2540C/3040C/3540C
10	6LJ02529000	ROLL-HT-14X	1	1/C	
11	6LE25809000	BRKT-TEN-SP	2	1/P	
12	6LE25801000	COLLAR-HR-T1	2	1/P	
13	6LE25846000	CRR-HR-CLR-K2	2	1/P	
14	6LH36308000	COV-HNS-R-45X	1	1/P	
15	6LE25834000	STUD-TEN-SP	2	1/P	
16	6LH36378000	BUSH-FUS-FR2	2	1/P	
17	6LE25853000	SPG-E-FUS-HR	2	1/P	
18	6LH36358000	SCREW-M3-D3.5X5.5	1	10/P	
19	6LE29440000	THRMST-HTR2-380	1	1/C	
20	6LE29439000	THRMST-HTR1-380	1	1/C	
21	6LH39783000	THMS-FUS-BELT-E-450	1	1/C	
22	6LE29346000	HRNS-FUS-HTR-C-380	1	1/P	
23	6LH36316000	COVER-FUS-F-FC	1	1/P	
24	6LH36315000	COVER-FUS-B-FC	1	1/P	
25	6LH36317000	COVER-FUS-R-FC	1	1/P	
26 A	6LH36249000	LAMP-TRIPLE-115-454	1	1/C	e-STUDIO4540C
26 B	6LH36250000	LAMP-TRIPLE-230-454	1	1/C	e-STUDIO4540C
27 A	6LE25860000	LAMP-C-115-K2	1	1/C	e-STUDIO2040C/2540C/3040C/3540C
27 B	6LE25863000	LAMP-C-230-K2	1	1/C	e-STUDIO2040C/2540C/3040C/3540C
28 A	6LE25861000	LAMP-S-115-K2	1	1/C	e-STUDIO2040C/2540C/3040C/3540C
28 B	6LE25864000	LAMP-S-230-K2	1	1/C	e-STUDIO2040C/2540C/3040C/3540C
29 A	6LH36202000	BRKT-LAMP-R-454T	1	1/P	e-STUDIO4540C
29 B	6LH36256000	BRKT-LAMP-R-450	1	1/P	e-STUDIO2040C/2540C/3040C/3540C
30 A	6LH39776000	HRNS-DRW1-AC-450	1	1/P	e-STUDIO2040C/2540C/3040C/3540C
30 B	6LH39777000	HRNS-DRW1B-AC-450	1	1/P	e-STUDIO2040C/2540C/3040C/3540C
30 C	6LH39706000	HRNS-DRW2-AC-450	1	1/P	e-STUDIO4540C
30 D	6LH39801000	HRNS-DRW2B-AC-450	1	1/P	e-STUDIO4540C
31	6LH36359000	SCREW-M3-D4X2.3	1	10/P	
32	6LH36314000	COV-FUS-HNS-R-FC	1	1/P	
34	6LH36341000	COVER-HRNS-B	1	1/P	
35	6LH36374000	SPG-F-PLT-FUS	2	1/P	
36	6LE25970000	WASHER-FUSER	2	5/P	
37	6LE25967000	SPG-C-SEP-ADJ	2	5/P	
38	6LH24640000	CRR-HT/RLR	2	1/P	
101	F0-01362000	6806ZZS1C4KZ	2	1/P	
102	F0-01976000	6802ZZNRS1C4KZ	2	1/P	
103	X0-00968000	RR/E-7-SS	2	10/P	
104	X0-00966000	RR/E-5-SS	2	10/P	
105 A	F0-00270000	UAMS-05L-0-46	10	10/P	e-STUDIO4540C
105 B	F0-00270000	UAMS-05L-0-46	12	10/P	e-STUDIO2040C/2540C/3040C/3540C
106	X0-00094000	S/PAN/SWWP-M3X10-NI	14	10/P	
107	X0-02230000	S/FHEXM-M3X6-NI	9	10/P	
108	6LH55301000	USUITA-SEMS-3X5-6	8	5/P	
109	F0-00032000	PLWS-1-46B	5	5/P	
110	X0-02420000	S/TPS/FHEXM/R-3X8-ZU3	2	10/P	
111	X0-00964000	RR/E-3-SS	1	10/P	
112	6LJ02548000	LBL-CAU-GREASE-FUS	1	1/KP	

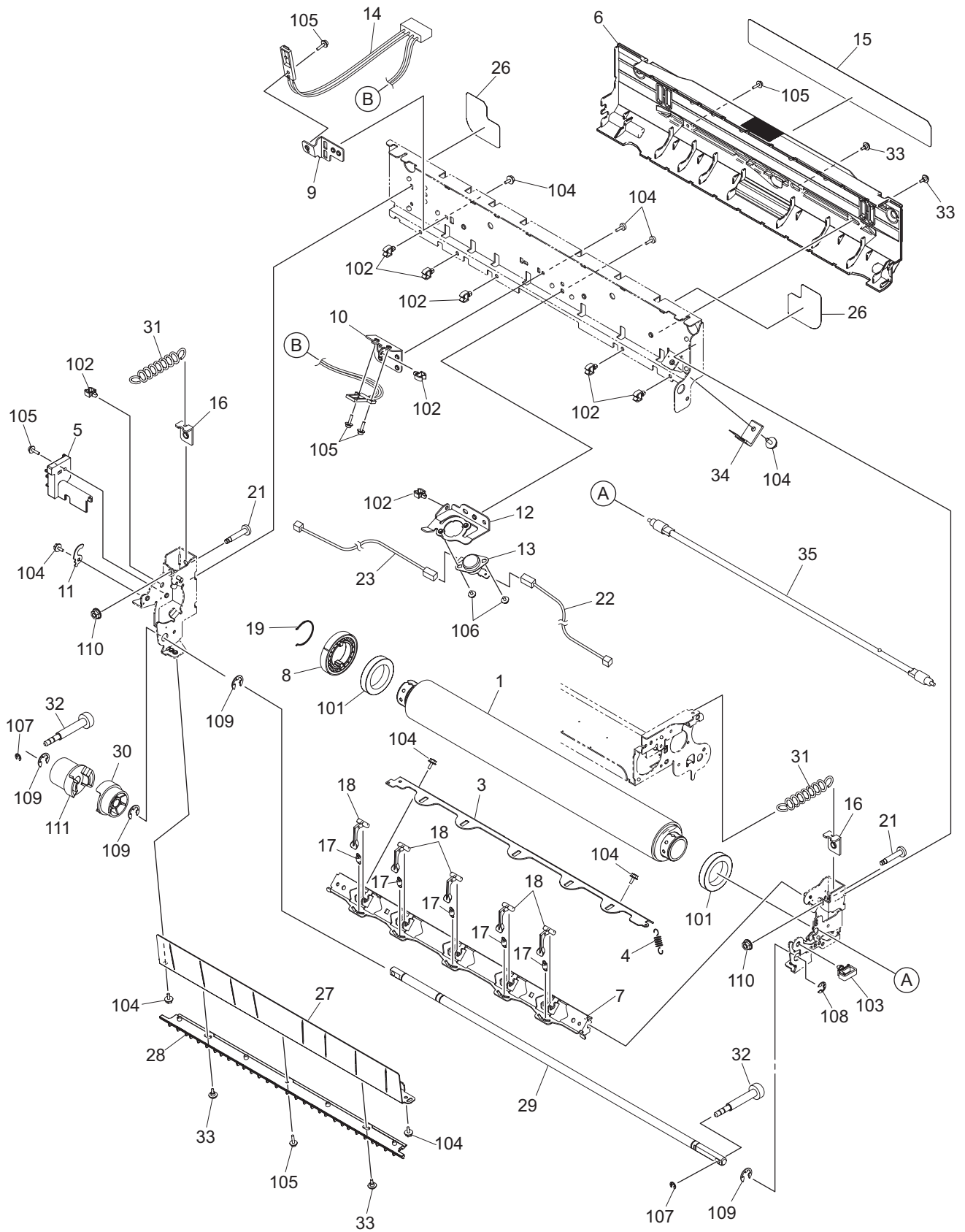

ITEM No.	PART No.	PART NAME	Q'TY / PAGE	Q'TY / PACK	REMARKS
1	6LH49563000	HR-FC28-L	1	1/S	
3	6LH36233100	COV-PR-SCR-450-T	1	1/P	
4	6LH36230000	SPG-E-FUS-SCR-45X	1	1/P	
5	6LH36320000	COVER-PR-HNS-R-FC	1	1/P	
6	6LH36319000	COVER-PR-450M-FC	1	1/PP	
7	6LH36213000	BRKT-SCRPR-PR-450	1	1/P	
8	6LJ02510000	GEAR-10S40-FUS-EX	1	1/P	
9	6LH36242000	BRKT-PR-THM-450-E	1	1/P	
10	6LE25891000	BRKT-PR-SEN-NT	1	1/P	
11	6LE25885000	BRKT-LAMP-HLD	1	1/P	
12	6LE25883000	BRKT-PR-ELEC-K2	1	1/P	
13	6LE29433000	THRMST-PRS-380	1	1/C	
14 A	6LH39784000	THMS-PRS-450	1	1/C	e-STUDIO2040C/2540C/3040C/3540C
14 B	6LH39785000	THMS-PRS-454	1	1/C	e-STUDIO4540C
15 A	6LH36303000	LBL-HOT-45X	1	1/KP	NAD,MJD,AUD,ASD,ARD
16	6LH36222000	BRKT-PR-SPR-450	2	1/P	
17	6LH36375000	SPG-E-SCRPR-F450	5	1/P	
18	6LA36256000	SCRAPR-FUS-350	5	5/P	
19	44217749000	SPR-PRESS-BRG	1	5/P	
21	6LJ02512000	SCREW-PR-H14X	2	1/P	
22	6LE29349000	HRNS-FUS-PRS-F-380	1	1/P	
23	6LE29348000	HRNS-FUS-PRS-R-380	1	1/P	
26	6LH36305000	SHEET-COV-PR	2	1/P	
27	6LH36385000	GUIDE-ENT-PR-450-V	1	1/P	
28	6LH36322000	GUIDE-ENT-FUS-FC	1	1/KP	
29	6LJ02516000	SHAFT-FUS-EX	1	1/P	
30	6LJ02525000	GEAR-10S29-PR	1	1/P	
31	6LE25852000	SPG-E-FUS-PR	2	1/P	
32	6LJ02544000	SCREW-SFT-8-V-H14X	2	1/P	
33	6LH36359000	SCREW-M3-D4X2.3	4	10/P	
34	6LE06670000	BRUSH-FUSER	1	1/C	
35 A	6LH36259000	LAMP-PR-115-45X	1	1/C	NAD
35 B	6LH36257000	LAMP-PR-230-45X	1	1/C	MJD,AUD,ASD,ARD
101	F0-01361000	6805ZZS1C4KZ	2	1/P	
102	F0-00270000	UAMS-05L-0-46	8	10/P	
103	F0-00032000	PLWS-1-46B	1	5/P	
104	X0-02230000	S/FHEXM-M3X6-NI	9	10/P	
105	X0-00094000	S/PAN/SWWP-M3X10-NI	6	10/P	
106	6LH55301000	USUITA-SEMS-3X5-6	2	5/P	
107	X0-00964000	RR/E-3-SS	2	10/P	
108	X0-00966000	RR/E-5-SS	1	10/P	
109	X0-00968000	RR/E-7-SS	4	10/P	
110	6LJ02527000	NUT-FUS-PR-LEFT-H14X	2	5/P	
111	6LJ02524000	GEAR-10S29-IDL	1	1/P	

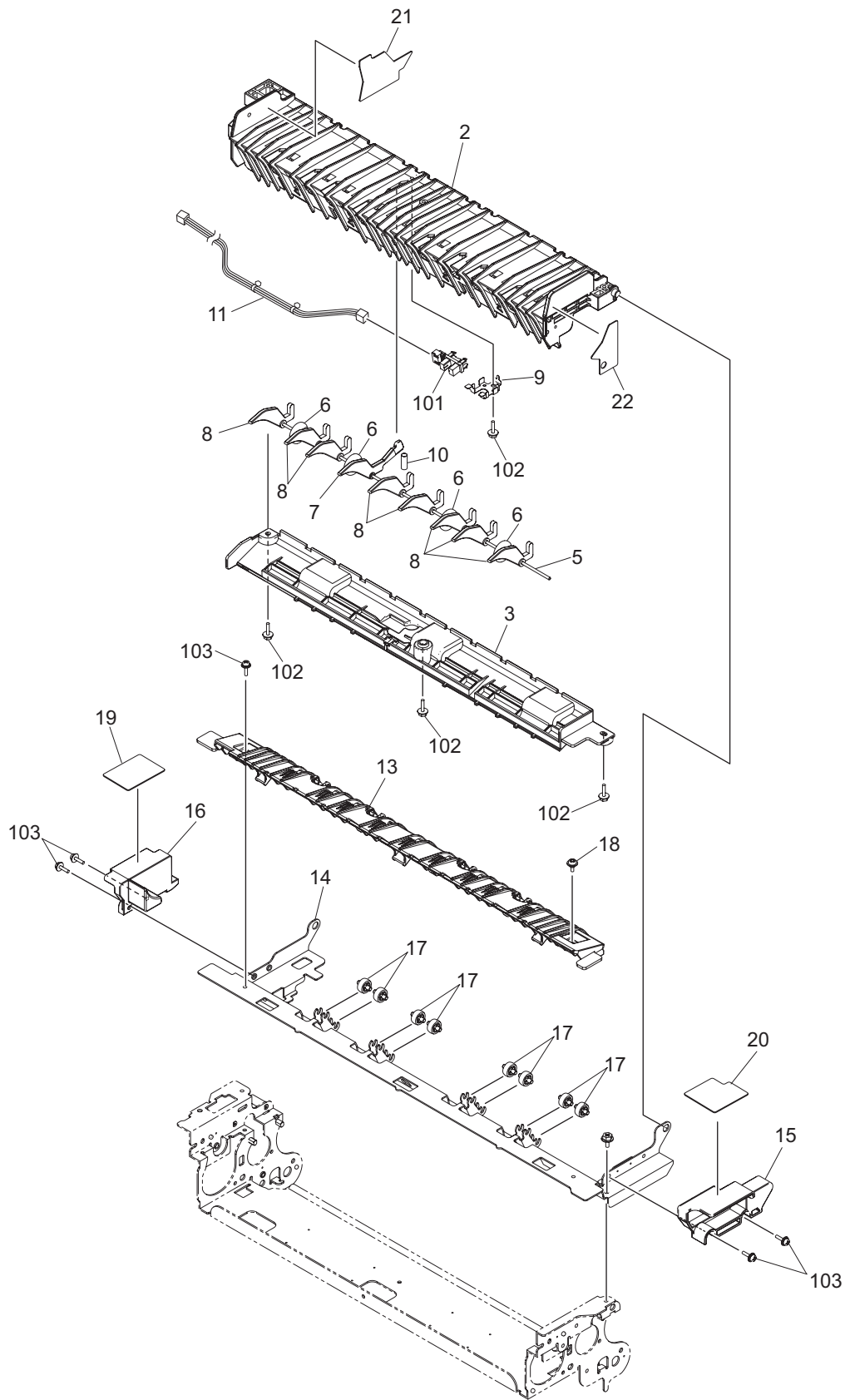

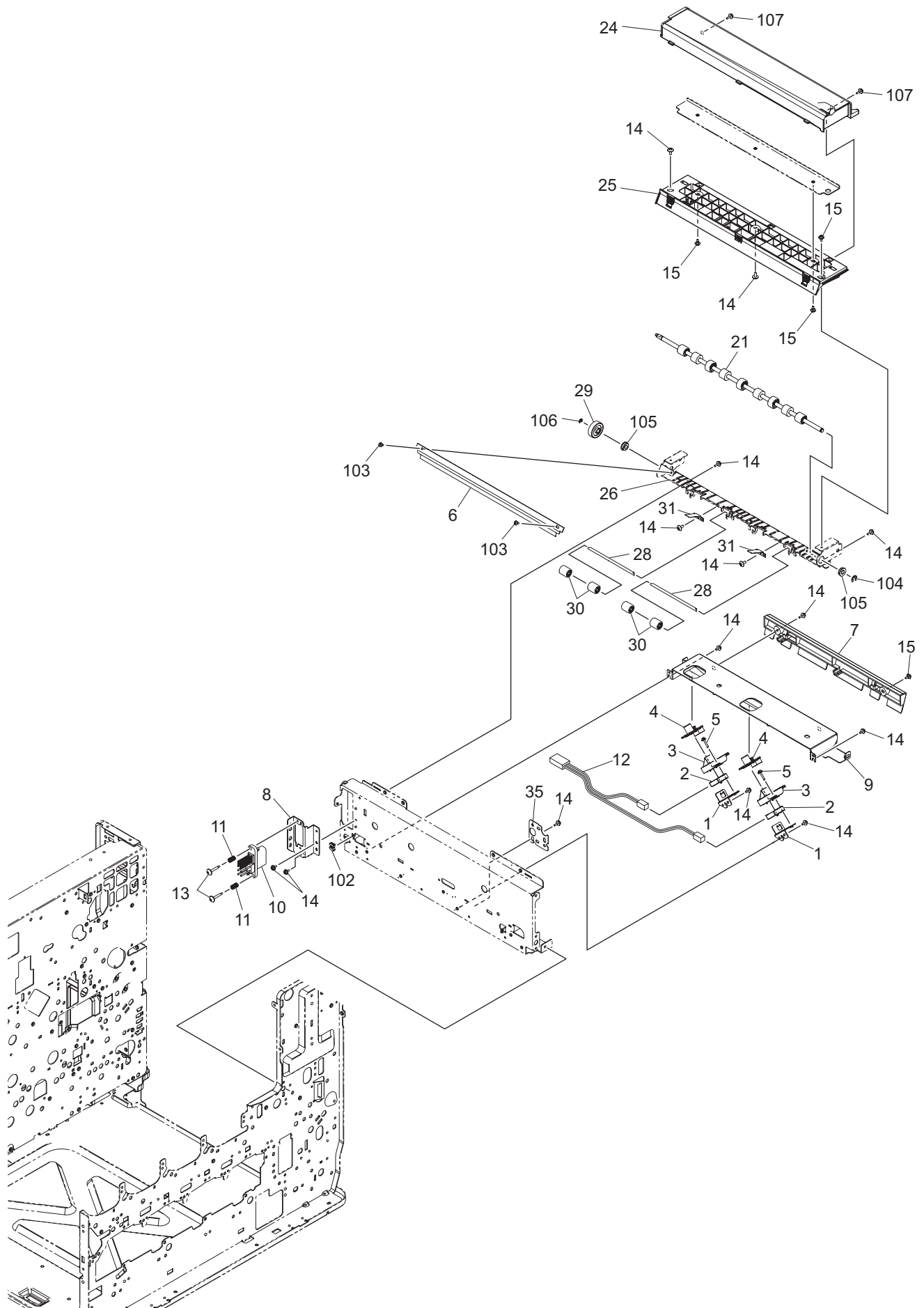

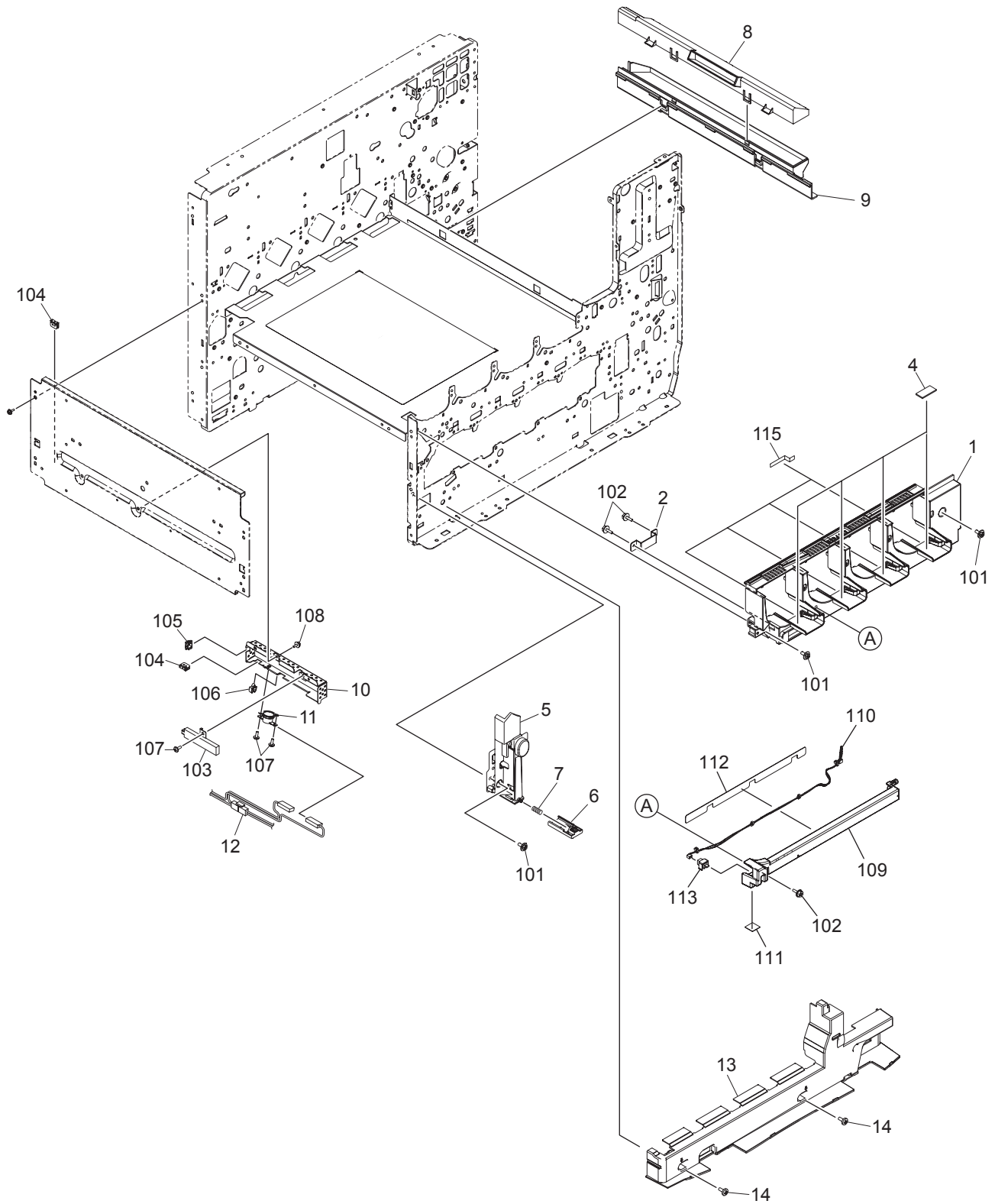

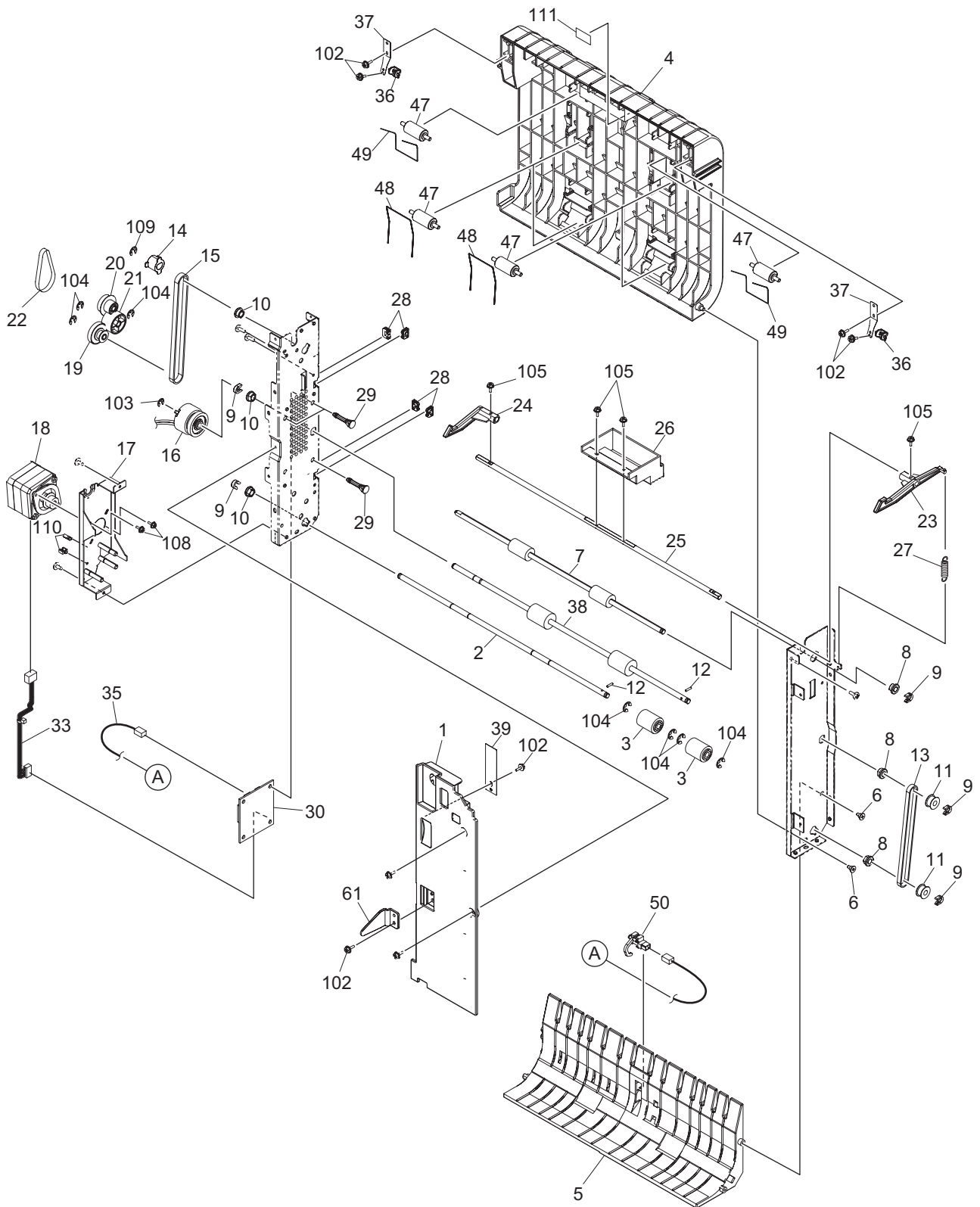

ITEM No.	PART No.	PART NAME	Q'TY / PAGE	Q'TY / PACK	REMARKS
1	6LE21008000	COV-IN-R-380	1	1/PP	
2	6LE40307000	SFT-TR-L-20	1	1/P	
3	6LE40306000	ROL-TR-CLT-ADU-DK	2	1/P	
4	6LE40309200	GUIDE-P-IN-DK-B2	1	1/PP	
5	6LE40313000	GUIDE-PAPER-L32D	1	1/P	
6	6LA28608000	SCREW-CASET	2	5/P	
7	6LE40304000	ROLL-TR-U-16	1	1/KP	
8	6LH53768000	BUSH-6-NU4	3	1/P	
9	4407972860	STOP-RING-6-5	5	5/P	
10	44201492000	BUSH-6-POM	3	5/P	
11	41317051000	PLY/T-2GT020-6F	2	1/P	
12	X0-00979000	P/PRL/AH7-2X8-SS	2	10/P	
13	6LE40312000	BLT/T-286-2GT-5	1	1/P	
14	6LE40308000	PLY/T-2GT016-6F	1	1/P	
15	6LA78706000	BLT/T-258-2GT-5	1	1/P	
16	6LH53742000	CLUTCH-50R-G28-6	1	1/D	
17	6LJ00103000	ASYS-BKT-MOT-ADU-H14X	1	1/P	
18	6LJ00101000	ASYS-MOTR-S-ADU-H14X	1	1/C	
19	6LA78452000	GEAR-10S28-P2GT20-6	1	1/P	
20	6LA78772000	GEAR-10S15-PS2M39-6	1	1/P	
21	6LA78496000	GEAR-10S28-06	1	1/P	
22	6LA78447000	BLT-SY-S2M-120-4	1	1/P	
23	41316054000	LEVER-LATCH-F	1	1/P	
24	44203255000	LEVER-LATCH-R32	1	1/P	
25	6LA28625000	SHAFT-OPEN-350	1	1/P	
26	6LE40317100	LEVER-OPEN-H14X	1	1/P	
27	41316064000	SPE-068-070-241	1	1/P	
28	F0-00120000	ES-0505	4	5/P	
29	F0-00221000	KGLS-24RTV0	3	5/P	
30	6LJ05079000	PWA-H-ADU-140	1	1/SB	
33	6LJ05031000	HRNS-ADU-MOT-140	1	1/P	
35	6LJ05032000	HRNS-ADU-FED-U-140	1	1/P	
36	6LE21012000	SPCR-SPL-GUIDE-380	2	1/P	
37	6LE21017000	SPL-GUIDE-IN-380	2	1/P	
38	6LJ00112000	ROLL-TRANS-C-H140	1	1/KP	
39	6LJ00111000	SPL-ADU-H14X	1	1/P	
47	6LA78742000	ROLL-TRANS-IDLE-371	6	1/P	
48	41316103000	SPR-IDLE	4	1/C	
49	6LE40310000	SPR-IDLE-U	2	1/D	
50	6LE09239000	SNSR-FED-390	1	1/P	
61	6LE21007000	PLATE-PUSH-INT	1	1/P	
102	X0-02247000	S/TPP/FHEXM-3X8-NI	6	10/P	
103	X0-00965000	RR/E-4-SS	1	10/P	
104	X0-00966000	RR/E-5-SS	7	10/P	
105	X0-02231000	S/FHEXM-M3X8-NI	4	10/P	
108	X0-02230000	S/FHEXM-M3X6-NI	2	10/P	
109	X0-00964000	RR/E-3-SS	1	10/P	
110	F0-01250000	MSB-1207	2	5/P	
111	6LJ00116000	LBL-JAMOP-ADU	1	1/KP	

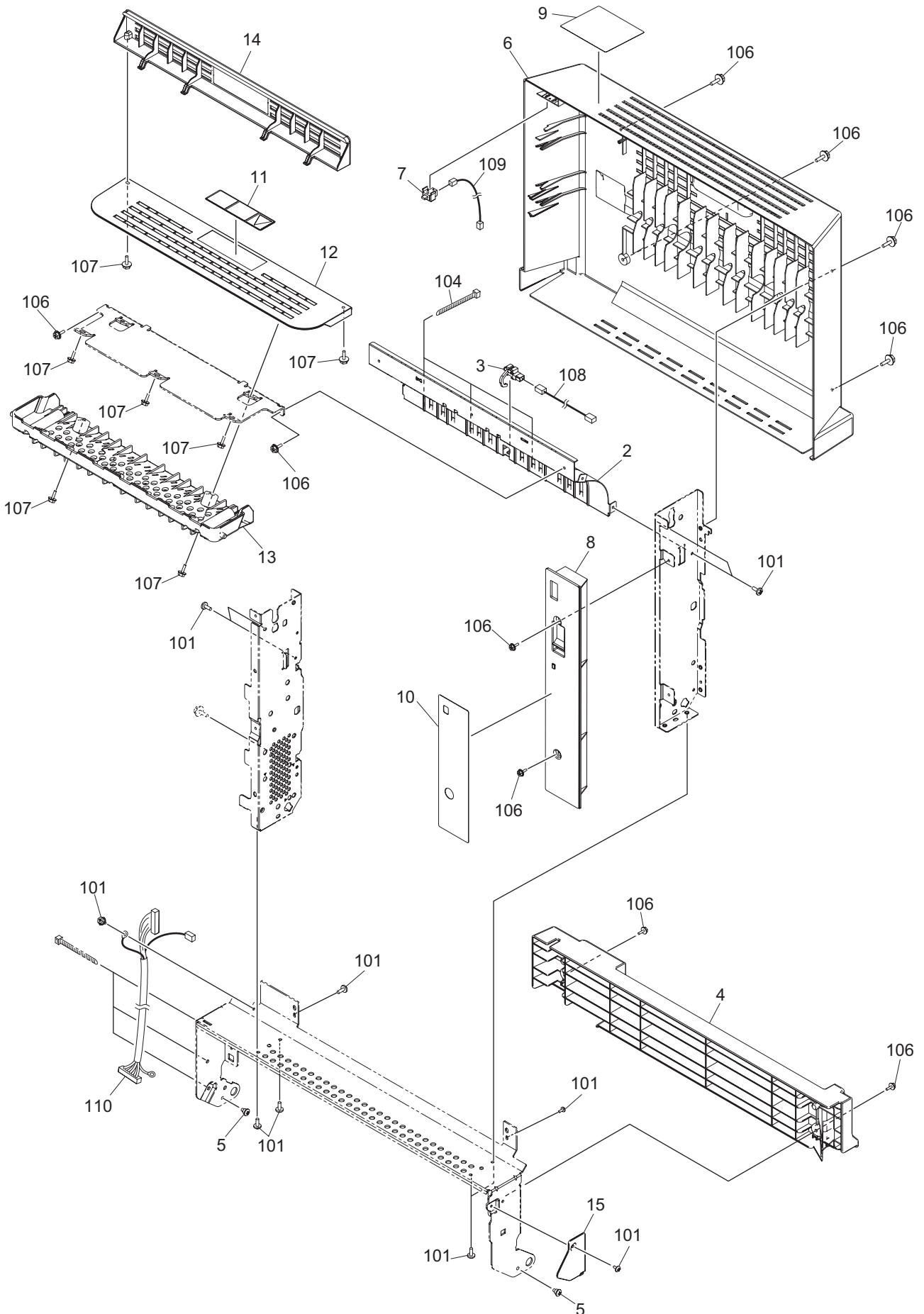

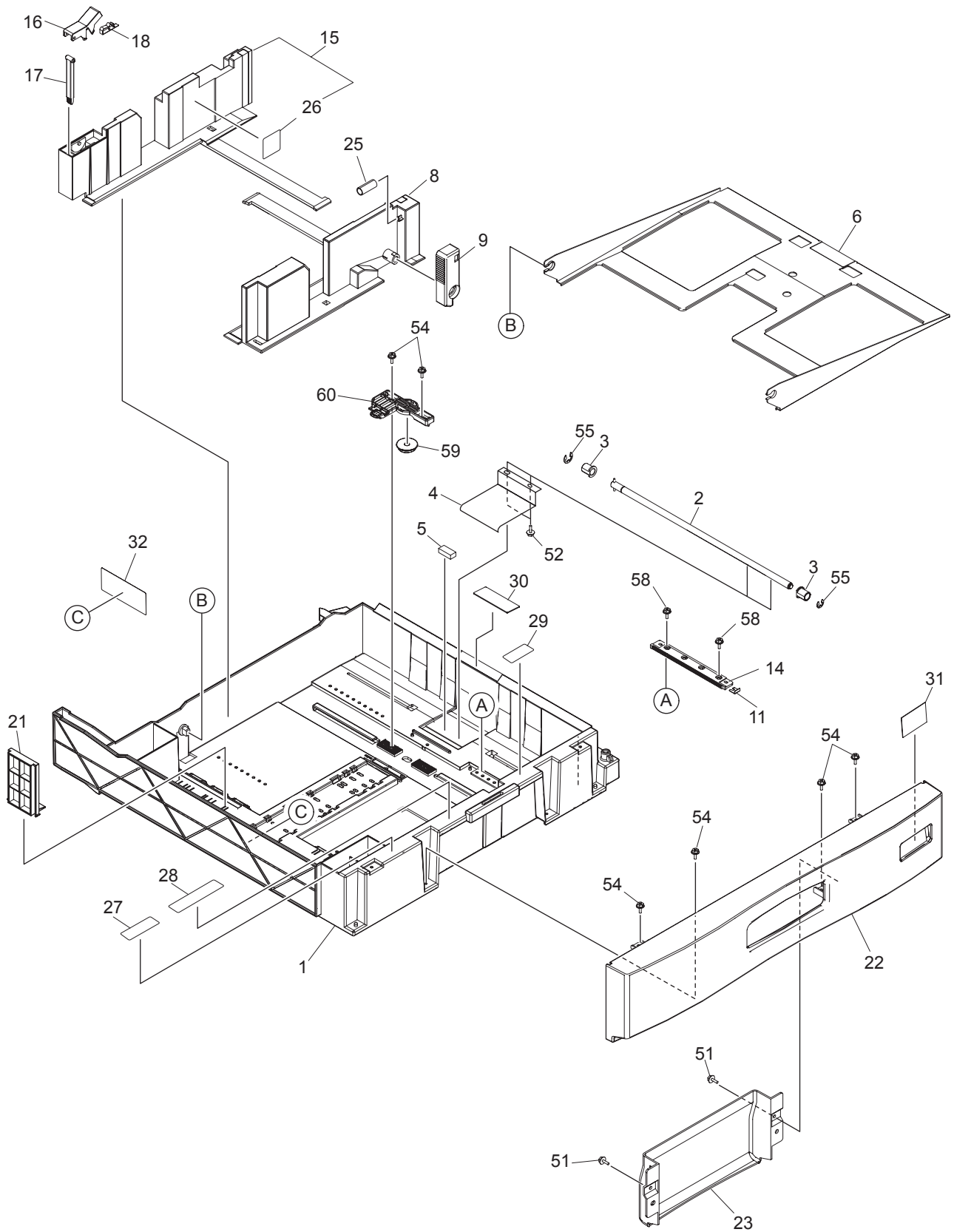

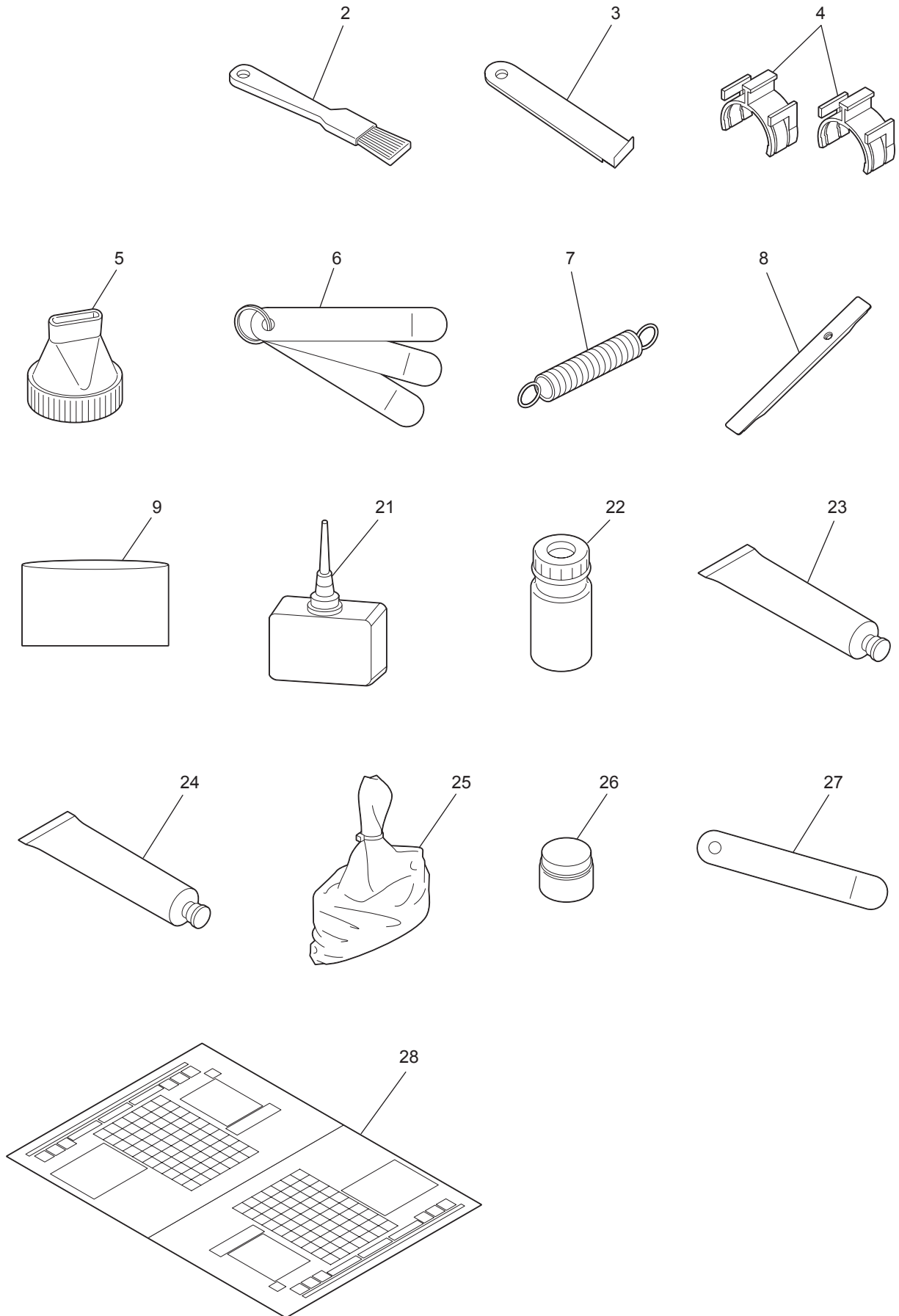

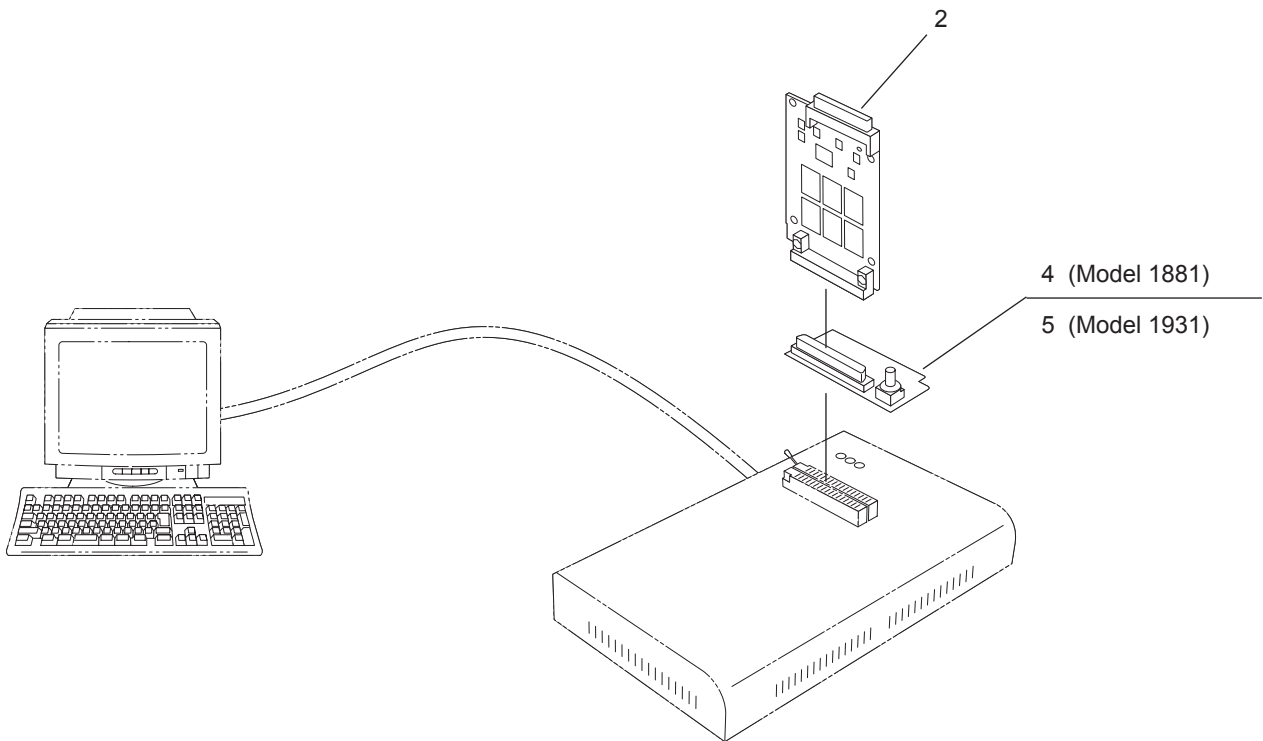
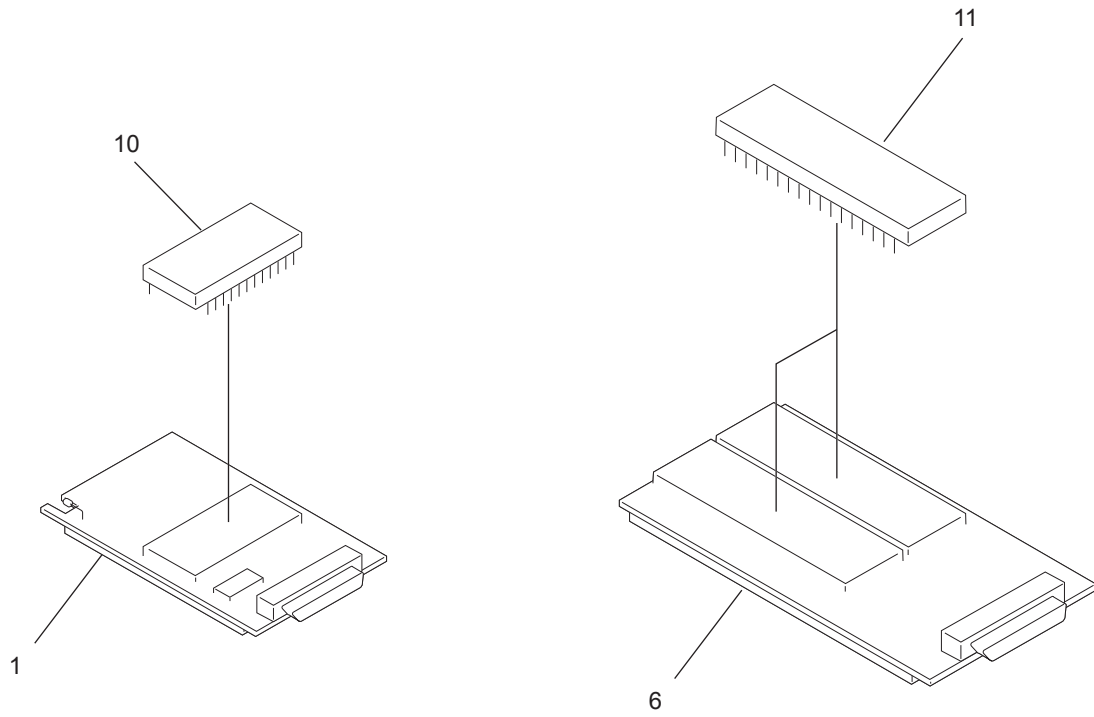

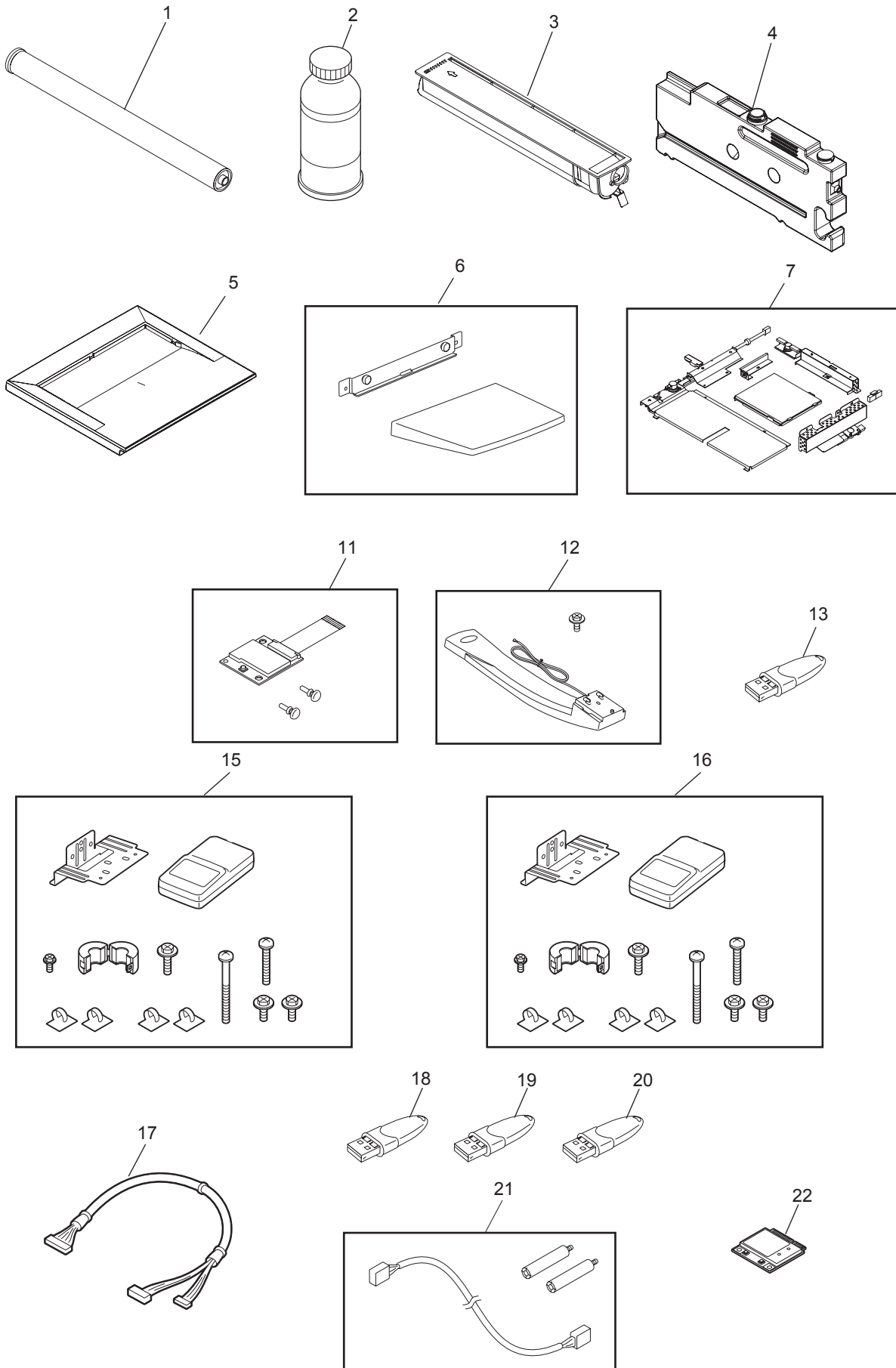

ITEM No.	PART No.	PART NAME	Q'TY / PAGE	Q'TY / PACK	REMARKS
1 A	6LJ04446000	OD-FC25	1	1/S	
1 B	6LJ04446100	OD-FC25C	1	1/S	
2 A	6LJ04811300	D-FC25-K	1	1/S	DEVELOPER (K)
2 B	6LJ04811000	D-FC25-Y	1	1/S	DEVELOPER (Y)
2 C	6LJ04811100	D-FC25-M	1	1/S	DEVELOPER (M)
2 D	6LJ04811200	D-FC25-C	1	1/S	DEVELOPER (C)
3 A	6AK00000160	PS-ZTFC25K(1)	1	SUPPLY	Toner (K) for TABS/TCL
3 B	6AG00003580	PS-ZTFC25K(1)	1	SUPPLY	Toner (K) for STI
3 C	6AK00000148	PS-ZTFC25AK(1)	1	SUPPLY	Toner (K) for Argentina
3 D	6AJ00000075	PS-ZTFC25EK(1)	1	SUPPLY	Toner (K) for EUROPE
3 E	6AG00003480	PS-ZTFC25DK(1)	1	SUPPLY	Toner (K) for TAP, TSP
3 F	6AG00003468	PS-ZTFC25CK(1)	1	SUPPLY	Toner (K) for China
3 G	6AK00000166	PS-ZTFC25Y(1)	1	SUPPLY	Toner (Y) for TABS/TCL
3 H	6AG00003575	PS-ZTFC25Y(1)	1	SUPPLY	Toner (Y) for STI
3 I	6AK00000154	PS-ZTFC25AY(1)	1	SUPPLY	Toner (Y) for Argentina
3 J	6AJ00000081	PS-ZTFC25EY(1)	1	SUPPLY	Toner (Y) for EUROPE
3 K	6AG00003486	PS-ZTFC25DY(1)	1	SUPPLY	Toner (Y) for TAP, TSP
3 L	6AG00003474	PS-ZTFC25CY(1)	1	SUPPLY	Toner (Y) for China
3 M	6AK00000163	PS-ZTFC25M(1)	1	SUPPLY	Toner (M) for TABS/TCL
3 N	6AG00003583	PS-ZTFC25M(1)	1	SUPPLY	Toner (M) for STI
3 O	6AK00000151	PS-ZTFC25AM(1)	1	SUPPLY	Toner (M) for Argentina
3 P	6AJ00000078	PS-ZTFC25EM(1)	1	SUPPLY	Toner (M) for EUROPE
3 Q	6AG00003483	PS-ZTFC25DM(1)	1	SUPPLY	Toner (M) for TAP, TSP
3 R	6AG00003471	PS-ZTFC25CM(1)	1	SUPPLY	Toner (M) for China
3 S	6AK00000157	PS-ZTFC25C(1)	1	SUPPLY	Toner (C) for TABS/TCL
3 T	6AG00003572	PS-ZTFC25C(1)	1	SUPPLY	Toner (C) for STI
3 U	6AK00000145	PS-ZTFC25AC(1)	1	SUPPLY	Toner (C) for Argentina
3 V	6AJ00000072	PS-ZTFC25EC(1)	1	SUPPLY	Toner (C) for EUROPE
3 W	6AG00003477	PS-ZTFC25DC(1)	1	SUPPLY	Toner (C) for TAP, TSP
3 X	6AG00003465	PS-ZTFC25CC(1)	1	SUPPLY	Toner (C) for China
4 A	6AG00002037	PS-TBFC28	1	SUPPLY	for TABS, TCL, TAP, TSP, Asia, Latin(TABS)
4 B	6AG00002039	PS-TBFC28E	1	SUPPLY	for EUROPE,
4 C	6AG00002038	PS-TBFC28C	1	SUPPLY	for CND
5 A	6AG00000825	KA-3511PC	1	SUPPLY	Except for CND
5 B	6AG00000826	KA-3511PC-C	1	SUPPLY	CND
6 A	6AR00000755	KK-4550	1	SUPPLY	Except for CND
6 B	6AR00000756	KK-4550C	1	SUPPLY	CND
7 A	6AG00001654	MF-3500CU	1	SUPPLY	NAD
7 B	6AG00001652	MF-3500CE	1	SUPPLY	MJD
11	6A000000766	GN-2010	1	SUPPLY	Bluetooth Module
12 A	6A000000459	GN-3010	1	SUPPLY	Antenna :All except CND
12 B	6AR00000579	GN-3010C	1	SUPPLY	Antenna :CND
13	6A000001051	GP-1070	1	SUPPLY	Data Overwrite kit
15	6A000000878	KP-2004	1	SUPPLY	HID card reader
16 A	6A000000925	KP-2005	1	SUPPLY	Mifare card reader
16 B	6A000001016	KP-2005C	1	SUPPLY	Mifare card reader CND
17	6A000000880	GQ-1110	1	SUPPLY	Harness kit for coin controller
18	6A000001055	GS-1010	1	SUPPLY	Scan Connector kit
19	6A000001057	GS-1020	1	SUPPLY	External interface kit
20	6A000001053	GP-1080	1	SUPPLY	IPSec kit (except China)
21	6LE27469000	KIT-KEY-COUNTER-380S	1	1/P	
22 A	6A000001221	GN-1060	1	SUPPLY	All except CND
22 B	6A000001223	GN-1060C	1	SUPPLY	CND

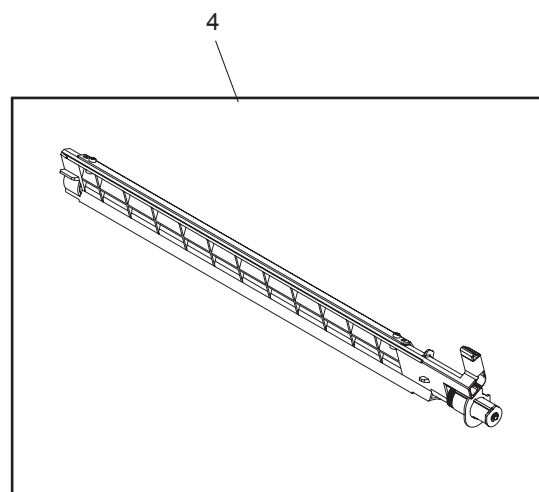
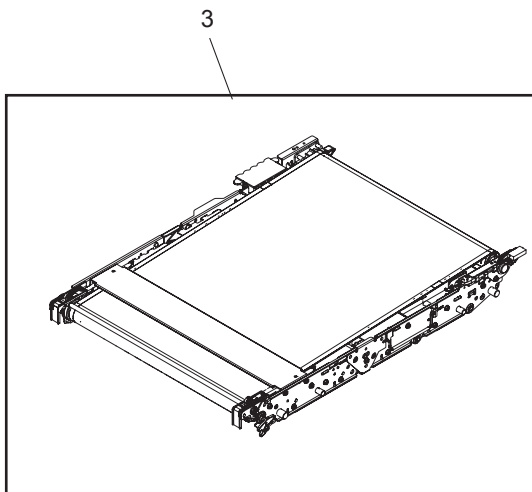
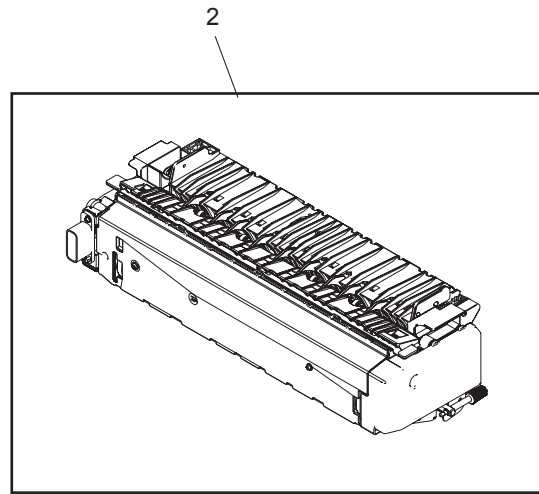
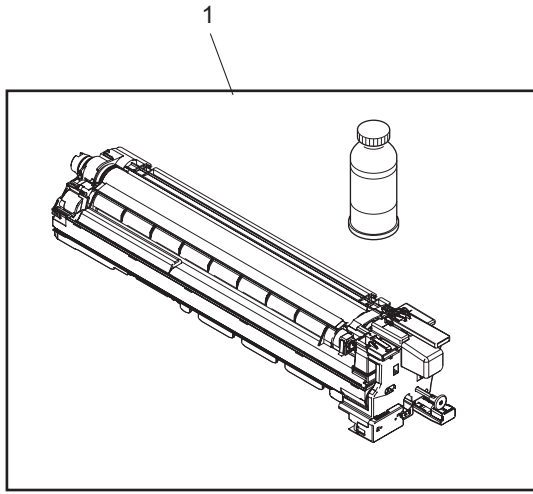

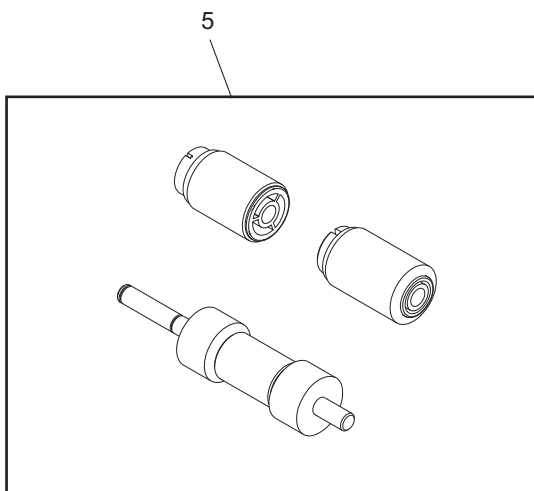
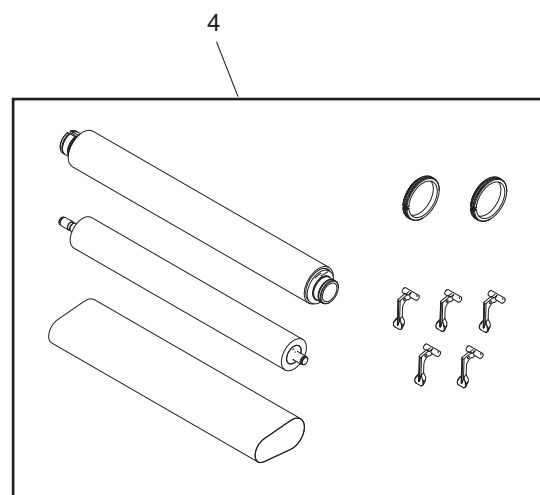
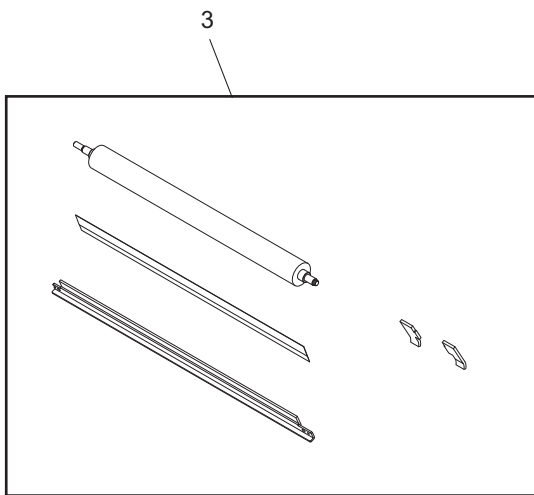
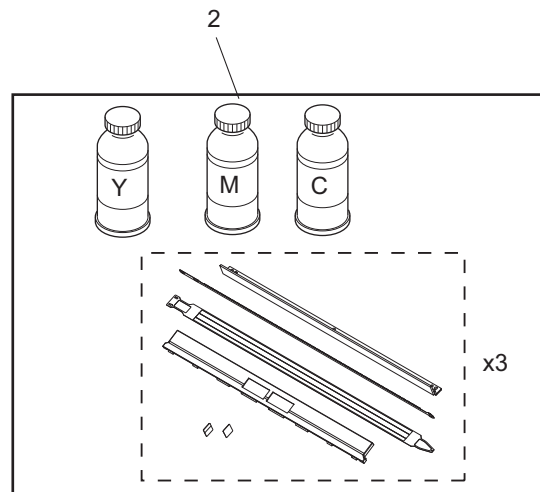
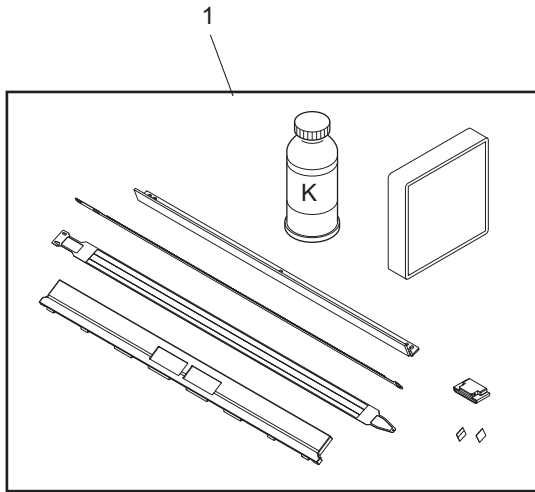

TOSHIBA

TOSHIBA TEC CORPORATION

2-17-2, HIGASHIGOTANDA, SHINAGAWA-KU, TOKYO, 141-8664, JAPAN

WWW.SERVICE-MANUAL.NET