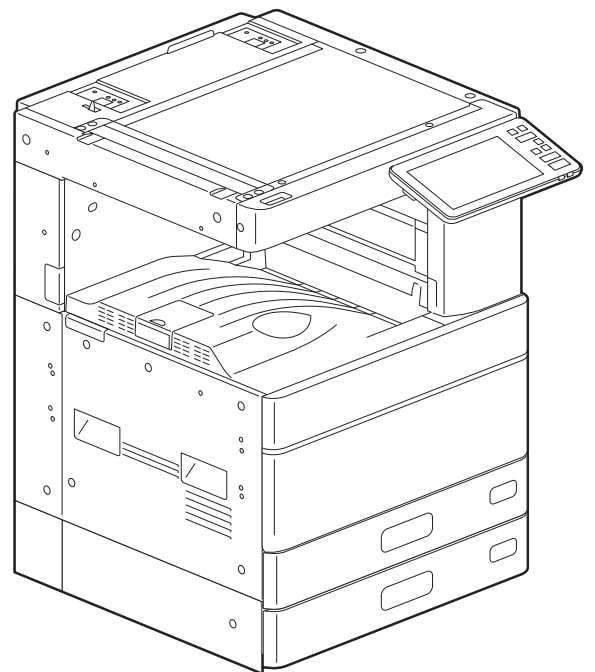


**TOSHIBA**

# **SERVICE MANUAL**

**MULTIFUNCTIONAL DIGITAL SYSTEMS**  
**e-STUDIO2018A/2518A/3018A/3518A/**  
**4518A/5018A/**  
**3018AG/3518AG/4518AG**



Model: DP-2018A/2518A/3018A/3518A/4518A/5018A  
Publish Date: June 2018  
File No. SME180009B0  
R180221U4902-TTEC  
Ver02 F\_2020-09

## Trademarks

- The official name of Windows<sup>®</sup> 7 is Microsoft Windows 7 Operating System.
- The official name of Windows<sup>®</sup> 8.1 is Microsoft Windows 8.1 Operating System.
- The official name of Windows<sup>®</sup> 10 is Microsoft Windows 10 Operating System.
- The official name of Windows Server<sup>®</sup> 2008 is Microsoft Windows Server 2008 Operating System.
- The official name of Windows Server<sup>®</sup> 2012 is Microsoft Windows Server 2012 Operating System.
- The official name of Windows Server<sup>®</sup> 2016 is Microsoft Windows Server 2016 Operating System.
- Microsoft, Windows, Windows NT, and the brand names and product names of other Microsoft products are trademarks of Microsoft Corporation in the US and other countries.
- Apple, AppleTalk, Macintosh, Mac, Mac OS, Safari, iPhone, iPod touch, TrueType, AirPrint, AirPrint logo, and iPad are trademarks of Apple Inc.
- IOS is a trademark or registered trademark of Cisco in the U.S. and other countries and is used under license.
- Adobe, Acrobat, Reader, and PostScript are trademarks of Adobe Systems Incorporated.
- Mozilla<sup>®</sup>, Firefox<sup>®</sup> and the Firefox logo<sup>®</sup> are trademarks or registered trademarks of Mozilla Foundation in the U.S. and other countries.
- IBM, AT and AIX are trademarks of International Business Machines Corporation.
- NOVELL<sup>®</sup>, NetWare<sup>®</sup>, and NDS<sup>®</sup> are trademarks of Novell, Inc.
- FLOIL<sup>®</sup> is a registered trademark of Kanto Kasei Ltd.
- MOLYKOTE<sup>®</sup> is a registered trademark of Dow Corning Corporation.
- KAPTON<sup>®</sup> is registered trademarks of E.I.du Pont de Nemours and Company.
- Sankol<sup>®</sup> is a registered trademark of SANKEIKAGAKU CO.,Ltd.
- e-STUDIO, e-BRIDGE, and TopAccess are trademarks of Toshiba TEC Corporation.
- Other company names and product names in this manual are the trademarks of their respective companies.

© 2018-2020 Toshiba Tec Corporation All rights reserved

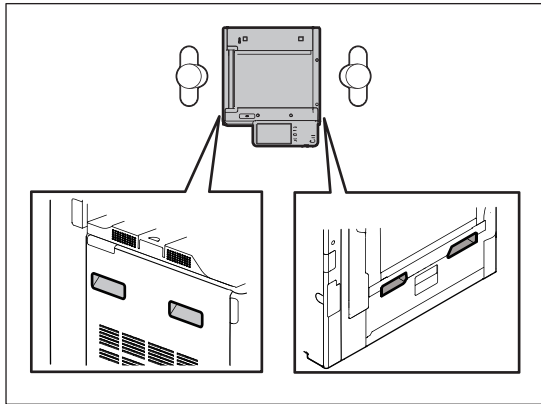
Under the copyright laws, this manual cannot be reproduced in any form without prior written permission of Toshiba Tec Corporation.

# GENERAL PRECAUTIONS REGARDING THE SERVICE FOR THIS EQUIPMENT

**The installation and service shall be done by a qualified service technician.**

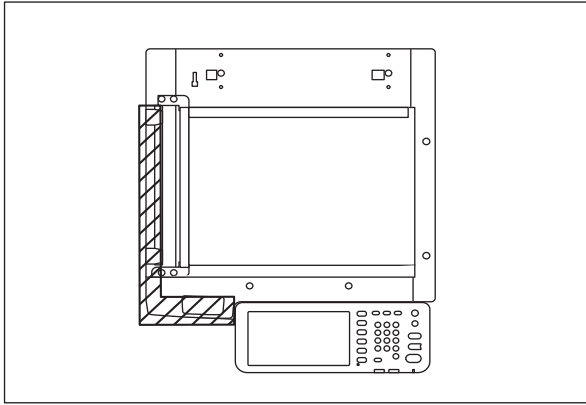
## 1. Transportation/Installation

- When transporting/installing the equipment, employ two persons and be sure to hold the positions as shown in the figure.  
The equipment is quite heavy, and weighs approximately 58 kg (134.48 lb.), therefore pay full attention when handling it.



- Be sure not to hold the movable parts or units (e.g. the control panel, ADU or RADF) when transporting the equipment.
- Be sure to use a dedicated outlet with AC 110 V / 13.2 A, 120 V or 127 V / 12 A, 220-240 V or 240 V / 8 A for its power source.
- The equipment must be grounded for safety.
- Select a suitable place for installation. Avoid excessive heat, high humidity, dust, vibration and direct sunlight.
- Provide proper ventilation since the equipment emits a slight amount of ozone.
- To insure adequate working space for the copying operation, keep a minimum clearance of 30 cm (12") on the left, 80 cm (32") on the right and 10 cm (4") on the rear.
- The equipment shall be installed near the socket outlet and shall be easily accessible.
- Be sure to fix and plug in the power cable securely after the installation so that no one trips over it.
- When the equipment is used after the option is removed, be sure to install the parts or the covers which have been taken off so that the inside of the equipment is not exposed.
- Do not use an ultrasonic humidifier near the MFP.  
Components such as chlorinate and mineral will be atomized by an ultrasonic humidifier and they will adhere to electric parts in the MFP. This could cause malfunctions.

- Do not lift the machine by the areas in the figure that are shaded when lifting it.



- Do not use an ozone generator near the MFP. Or, place any ozone generator as far away from the MFP as possible.

## 2. General Precautions at Service

- Be sure to turn the power OFF and unplug the power cable during service (except for the service should be done with the power turned ON).
- After the power cable is disconnected, an electric charge may remain in the boards of the equipment. Therefore, be sure to disconnect or connect the connectors when about 1 minute (e.g.: the time for taking off the rear cover) has passed after the power cable is disconnected.
- The fuse could be in the neutral. The mains shall be disconnected to de-energize the phase conductors.
- Unplug the power cable and clean the area around the prongs of the plug and socket outlet once a year or more. A fire may occur when dust lies on this area.
- When the parts are disassembled, reassembly is the reverse of disassembly unless otherwise noted in this manual or other related documents. Be careful not to install small parts such as screws, washers, pins, E-rings, star washers in the wrong places.
- Basically, the equipment should not be operated with any parts removed or disassembled.
- The PC board must be stored in an anti-electrostatic bag and handled carefully using a antistatic wristband since the ICs on it may be damaged due to static electricity.

**Caution: Before using the wristband, unplug the power cable of the equipment and make sure that there are no charged objects which are not insulated in the vicinity.**

- Avoid expose to laser beam during service. This equipment uses a laser diode. Be sure not to expose your eyes to the laser beam. Do not insert reflecting parts or tools such as a screwdriver on the laser beam path. Remove all reflecting metals such as watches, rings, etc. before starting service.
- Be sure not to touch high-temperature sections such as the exposure lamp, fuser unit, damp heater and areas around them.
- Be sure not to touch high-voltage sections such as the chargers, transfer roller, developer, high-voltage transformer, inverter for the LCD backlight and power supply unit. Especially, the board of these components should not be touched since the electric charge may remain in the capacitors, etc. on them even after the power is turned OFF.
- Make sure that the equipment will not operate before touching potentially dangerous places (e.g. rotating/operating sections such as gears, belts pulleys, fans and laser beam exit of the laser optical unit).
- Be careful when removing the covers since there might be the parts with very sharp edges underneath.
- When servicing the equipment with the power turned ON, be sure not to touch live sections and rotating/operating sections. Avoid exposing your eyes to laser beam.
- Use designated jigs and tools.
- Use recommended measuring instruments or equivalents.
- Return the equipment to the original state and check the operation when the service is finished.
- Be very careful to treat the touch panel gently and never hit it. Breaking the surface could cause malfunctions.
- Do not leave plastic bags where children can get at them. This may cause an accident such as suffocation if a child puts his/her head into a bag. Plastic bags of options or service parts must be brought back.
- There is a risk of an electric shock or fire resulting from the damage to the harness covering or conduction blockage. To avoid this, be sure to wire the harness in the same way as that before disassembling when the equipment is assembled/disassembled.

### **3. General operations**

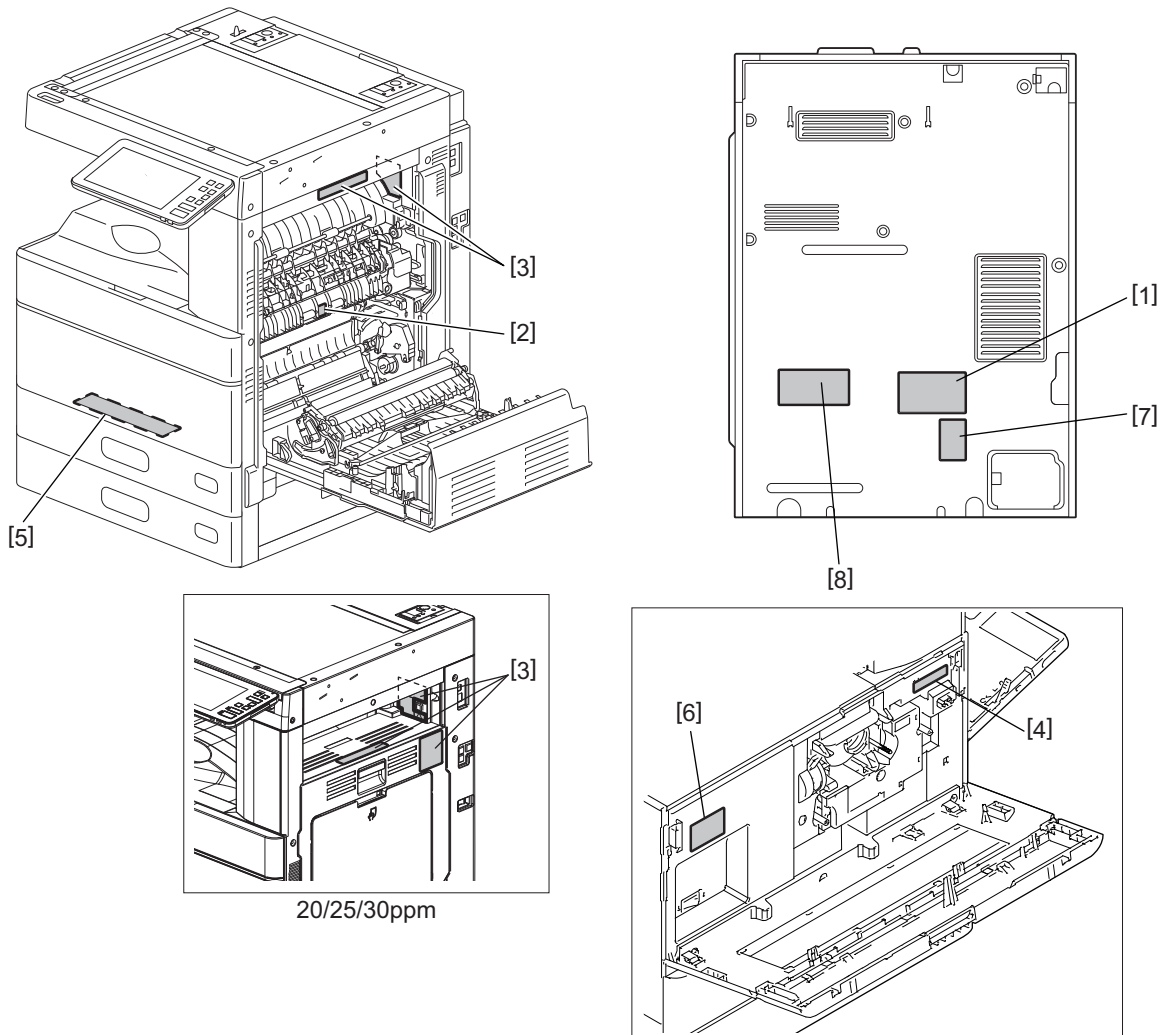
- Check the procedures and perform as described in the Service Manual.
- Make sure you do not lose your balance.
- Avoid exposure to your skin and wear protective gloves as needed.

### **4. Important Service Parts for Safety**

The breaker, door switch, fuse, thermostat, thermofuse, thermistor, batteries, IC-RAMs including lithium batteries, etc. are particularly important for safety. Be sure to handle/install them properly. If these parts are short-circuited and their functions become ineffective, they may result in fatal accidents such as explosion or fire. Do not allow a short-circuit and do not use the parts not recommended by Toshiba Tec Corporation.

### **5. Cautionary Labels**

During servicing, be sure to check the rating label and cautionary labels such as "Unplug the power cable during service", "CAUTION. HOT", "CAUTION. HIGH VOLTAGE", "CAUTION. LASER BEAM", etc. to see if there is any dirt on their surface and if they are properly stuck to the equipment.



- [1] Rating label
- [2] Warning for high temperature area (fuser unit)
- [3] Warning for high temperature area (fuser unit)
- [4] Machine serial number label
- [5] Warning for high temperature area (damp heater)
- [6] Warning for laser
- [7] Warning for service
- [8] Warning for laser

## 6. Disposal of the Equipment, Supplies and Packing Materials

Regarding the recovery and disposal of the equipment, supplies, packing materials, follow the relevant local regulations or rules.

## 7. Batteries and IC RAMs including lithium batteries etc.

### CAUTION:

RISK OF EXPLOSION IF BATTERY IS REPLACED BY AN INCORRECT TYPE.

DISPOSE OF USED BATTERIES ACCORDING TO THE RELEVANT LOCAL REGULATIONS OR RULES.

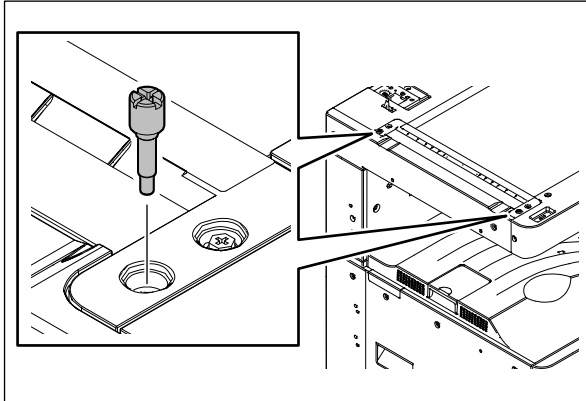
## Precautions for Transporting Equipment Once Unpacked

### General Description

It is recommended to follow the procedure below when you transport equipment that has already been unpacked but has not been packed again. Note that the following procedure cannot guarantee the operation of the transported equipment.

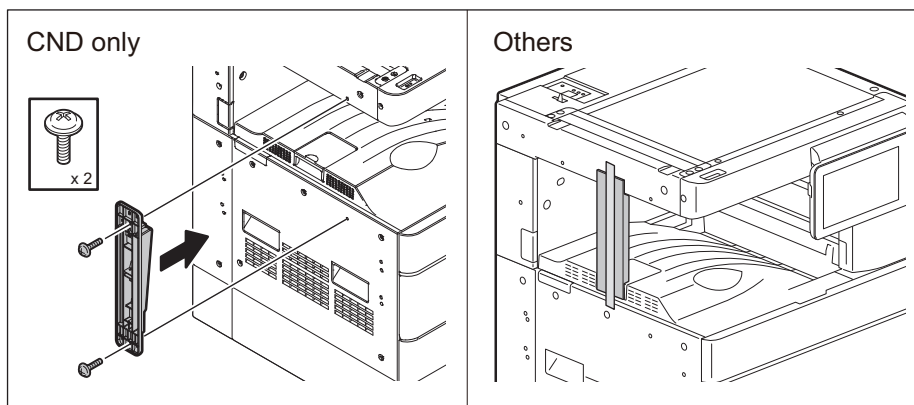
### [A] Fixing the carriage

1. Perform the PM code: FS-03-261 (Scan motor ON Automatically stops at limit position) so that the carriage is moved to the fixing position.
2. Tighten the 2 screws to fix the carriage.



### [B] Attach the packing material (scanner supporting member)

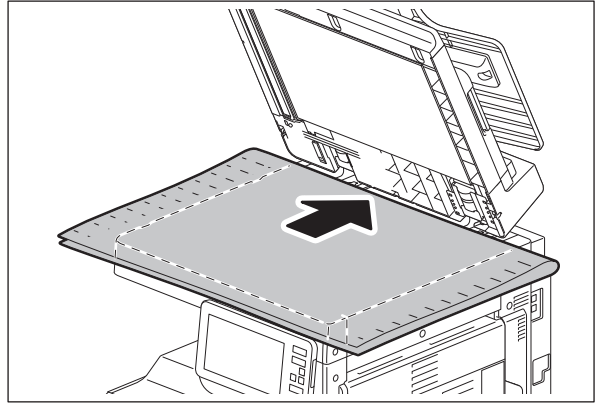
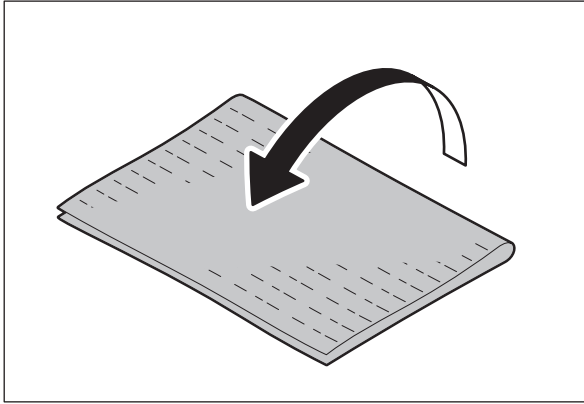
1. Attach the packing material under the scanner (if it is still kept immediately after the setup).



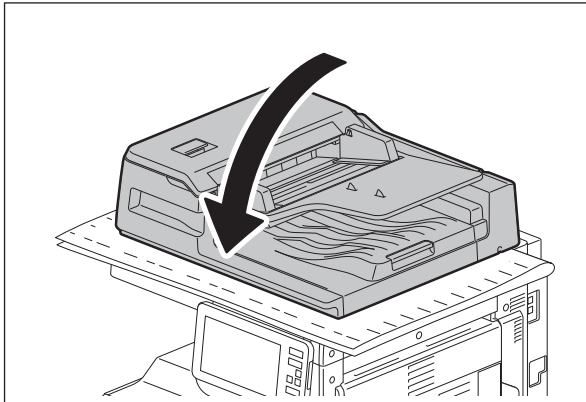
**[C] Attach the cushioning material**

When transporting the equipment with the DSDF installed, be sure to attach the cushioning material as below to prevent the cover in the scanner section from being scratched by the protrusion of the DSDF cover.

1. Fold the cushioning material (packing material) in two. (Utilize the packing material used in the scanner section, if available.) Place it on the upper surface of the scanner section so that it is covered.



2. While paying attention to ensure that the cushioning material is not moved, slowly close the DSDF.



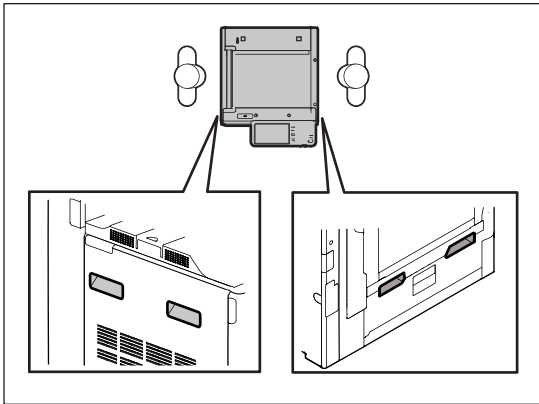


# ALLGEMEINE SICHERHEITSMASSNAHMEN IN BEZUG AUF DIE WARTUNG

**Die Installation und die Wartung sind von einem qualifizierten Service-Techniker durchzuführen.**

## 1. Transport/Installation

- Zum Transportieren/Installieren des Gerätes werden 2 Personen benötigt. Nur an den in der Abbildung gezeigten Stellen tragen.  
Das Gerät ist sehr schwer und wiegt etwa 58 kg; deshalb muss bei der Handhabung des Geräts besonders aufgepasst werden.



- Beim Transportieren des Gerätes nicht an den beweglichen Teilen oder Einheiten (z.B. das Bedienungsfeld, die Duplexeinheit oder die automatische Dokumentenzuführung) halten.
- Eine spezielle Steckdose mit Stromversorgung von AC 110 V / 13.2 A, 120 V oder 127 V / 12 A, 220-240 V / 8 A als Stromquelle verwenden.
- Das Gerät ist aus Sicherheitsgründen zu erden.
- Einen geeigneten Standort für die Installation wählen. Standorte mit zuviel Hitze, hoher Luftfeuchtigkeit, Staub, Vibrieren und direkter Sonneneinstrahlung sind zu vermeiden.
- Für ausreichende Belüftung sorgen, da das Gerät etwas Ozon abgibt.
- Um einen optimalen Kopierbetrieb zu gewährleisten, muss ein Abstand von mindestens 30 cm links, 80 cm rechts und 10 cm dahinter eingehalten werden.
- Das Gerät ist in der Nähe der Steckdose zu installieren; diese muss leicht zu erreichen sein.
- Nach der Installation muss das Netzkabel richtig hineingesteckt und befestigt werden, damit niemand darüber stolpern kann.
- Falls der Auspackungsstandort und der Installationsstandort des Gerätes verschieden sind, die Bildqualitätsjustierung (automatische Gammajustierung) je nach der Temperatur und Luftfeuchtigkeit des Installationsstandorts und der Papiersorte, die verwendet wird, durchführen.
- Betreiben Sie keinen Ultraschall-Luftbefeuchter in der Nähe des MFP.  
Chlorat- und mineralhaltige Komponenten werden von einem Ultraschallbefeuchter zerstäubt und die Partikel können sich an den elektrischen Teilen innerhalb des MFP anlagern. Dies kann zu Fehlfunktionen führen.

## 2. Allgemeine Sicherheitsmassnahmen in bezug auf die Wartung

- Während der Wartung das Gerät ausschalten und das Netzkabel herausziehen (ausser Wartung, die bei einem eingeschalteten Gerät, durchgeführt werden muss).
- Das Netzkabel herausziehen und den Bereich um die Steckerpole und die Steckdose die Umgebung in der Nähe von den Steckerzacken und der Steckdose wenigstens einmal im Jahr reinigen. Wenn Staub sich in dieser Gegend ansammelt, kann dies ein Feuer verursachen.
- Die Sicherung kann eingeschaltet bleiben. Der Stromstecker sollte jedoch gezogen werden, damit die internen Leiter von der Phase getrennt sind.
- Wenn die Teile auseinandergenommen werden, wenn nicht anders in diesem Handbuch usw erklärt, ist das Zusammenbauen in umgekehrter Reihenfolge durchzuführen. Aufpassen, dass kleine Teile wie Schrauben, Dichtungsringe, Bolzen, E-Ringe, Stern-Dichtungsringe, Kabelbäume nicht an den verkehrten Stellen eingebaut werden.
- Grundsätzlich darf das Gerät mit entfernten oder auseinandergenommenen Teilen nicht in Betrieb genommen werden.
- Das PC-Board muss in einer Anti-elektrostatischen Hülle gelagert werden. Nur Mit einer Manschette bei Betätigung eines Armbandes anfassen, sonst könnte es sein, dass die integrierten Schaltkreise durch statische Elektrizität beschädigt werden.

**Vorsicht: Vor Benutzung der Manschette der Betätigung des Armbandes, das Netzkabel des Gerätes herausziehen und prüfen, dass es in der Nähe keine geladenen Gegenstände, die nicht isoliert sind, gibt.**

- Setzen Sie sich während der Wartungsarbeiten nicht dem Laserstrahl aus. Dieses Gerät ist mit einer Laserdiode ausgestattet. Es ist unbedingt zu vermeiden, direkt in den Laserstrahl zu blicken. Keine reflektierenden Teile oder Werkzeuge, wie z. B. Schraubendreher, in den Pfad des Laserstrahls halten. Vor den Wartungsarbeiten sämtliche reflektierenden Metallgegenstände, wie Uhren, Ringe usw., entfernen.
- Auf keinen Fall Hochtemperaturbereiche, wie die Belichtungslampe, die Fixiereinheit, die Heizquelle und die umliegenden Bereiche, berühren.
- Auf keinen Fall Hochspannungsbereiche, wie die Ladeeinheiten, die Transferwalze, die Entwicklereinheit, den Hochspannungstransformator, den Umrichter für die LCD-Hintergrundbeleuchtung und das Netzgerät, berühren. Insbesondere sollten die Platinen dieser Komponenten nicht berührt werden, da die Kondensatoren usw. auch nach dem Ausschalten des Geräts noch elektrisch geladen sein können.
- Vor dem Berühren potenziell gefährlicher Bereiche (z. B. drehbare oder betriebsrelevante Bereiche, wie Zahnräder, Riemen, Riemenscheiben, Lüfter und die Laseraustrittsöffnung der optischen Lasereinheit) sicherstellen, dass das Gerät sich nicht bedienen lässt.
- Beim Entfernen von Abdeckungen vorsichtig vorgehen, da sich darunter scharfkantige Komponenten befinden können.
- Bei Wartungsarbeiten am eingeschalteten Gerät dürfen keine unter Strom stehenden, drehbaren oder betriebsrelevanten Bereiche berührt werden. Nicht direkt in den Laserstrahl blicken.
- Ausschließlich vorgesehene Werkzeuge und Hilfsmittel verwenden.
- Empfohlene oder gleichwertige Messgeräte verwenden.
- Nach Abschluss der Wartungsarbeiten das Gerät in den ursprünglichen Zustand zurück versetzen und den einwandfreien Betrieb überprüfen.
- Das berührungsempfindliche Bedienungsfeld stets vorsichtig handhaben und keinen Stößen aussetzen. Wenn die Oberfläche beschädigt wird, kann dies zu Funktionsstörungen führen.
- Bewahren Sie Kunststofftüten kindersicher auf. Es besteht Erstickungsgefahr, wenn sich Kinder beim Spielen eine Kunststofftüte über den Kopf ziehen. Bitte nehmen Sie die Kunststofftüten von Optionen oder Serviceparts wieder zurück.
- Wenn der Schutzmantel eines Kabels oder die Steckerisolierung beschädigt werden, besteht Brandgefahr oder die Gefahr eines elektrischen Schlags. Um dies zu vermeiden, sollten Kabel in der gleichen Weise verlegt werden, wie sie vor der Demontage/dem Transport verlegt waren.

## 3. Allgemeine Sicherheitsmassnahmen

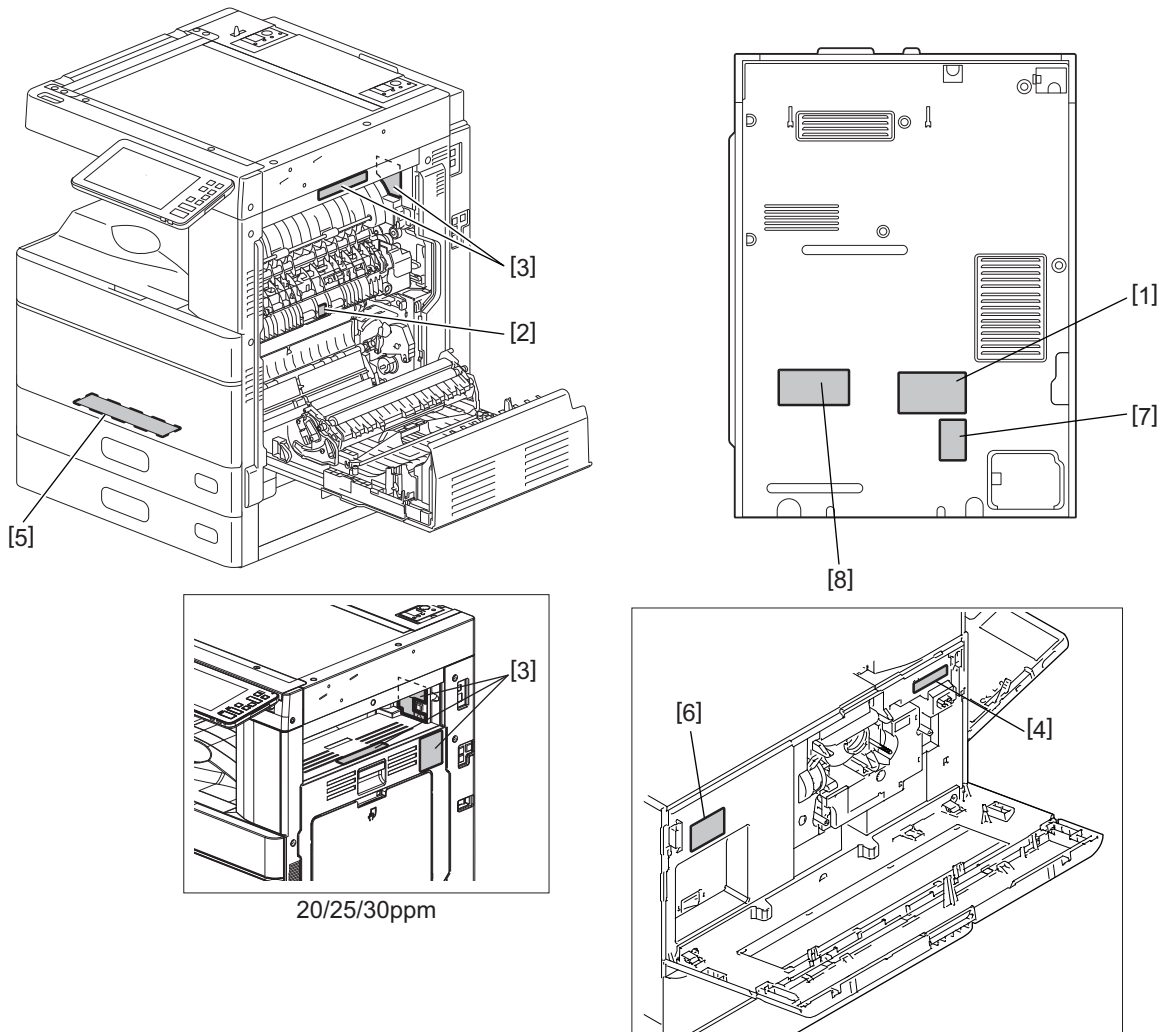
- Die Verfahren sind zu überprüfen und wie im Wartungshandbuch beschrieben durchzuführen.
- Vorsichtig, dass Sie nicht umfallen.
- Um Aussetzung zur Haut zu vermeiden, tragen Sie wenn nötig Schutzhandschuhe.

#### 4. Sicherheitsrelevante Wartungsteile

- Der Leistungsschutzschalter, der Türschalter, die Sicherung, der Thermostat, die Thermosicherung, der Thermistor, der Akku, die IC-RAMs einschließlich der Lithiumakkus usw. sind besonders sicherheitsrelevant. Sie müssen unbedingt korrekt gehandhabt und installiert werden. Wenn diese Teile kurzgeschlossen und funktionsunfähig werden, kann dies zu schwerwiegenden Schäden, wie einer Explosion oder einer Explosion oder einem Abbrand, führen. Kurzschlüsse sind zu vermeiden, und es sind ausschließlich Teile zu verwenden, die von der Toshiba TEC Corporation empfohlen sind.

#### 5. Warnetiketten

- Im Rahmen der Wartung unbedingt das Leistungsschild und die Etiketten mit Warnhinweisen überprüfen [z. B. „Unplug the power cable during service“ („Netz Kabel vor Beginn der Wartungsarbeiten abziehen“), „CAUTION. HOT“ („VORSICHT, HEISS“), „CAUTION. HIGH VOLTAGE“ („VORSICHT, HOCHSPANNUNG“), „CAUTION. LASER BEAM“ („VORSICHT, LASER“) usw.], um sicherzustellen, dass sie nicht verschmutzt sind und korrekt am Gerät angebracht sind.



- [1] Erkennungsetikett
- [2] Warnung für Bereiche mit hohen Temperaturen
- [3] Warnung für Bereiche mit hohen Temperaturen
- [4] Produktionszahlsetikett
- [5] Warnung für Bereiche mit hohen Temperaturen
- [6] Laser-Warnetikett
- [7] Erklärungsetikett
- [8] Laser-Warnetikett

## **6. Entsorgung des Geräts, der Verbrauchs- und Verpackungsmaterialien**

- In Bezug auf die Entsorgung und Wiederverwertung des Geräts, der Verbrauchs- und Verpackungsmaterialien, sind die einschlägigen nationalen oder regionalen Vorschriften zu befolgen.

## **7. Akkus und IC RAMs einschließlich Lithiumakkus etc.**

### **VORSICHT:**

ES BESTEHT EXPLOSIONSGEFAHR; WENN DER AKKU DURCH DEN FALSCHEN TYP ERSETZT WIRD.

ENTSORGEN SIE GEBRAUCHTE AKKUS ENTSPRECHEND DER EINSCHLÄGIGEN REGIONALEN BESTIMMUNGEN UND VORSCHRIFTEN.

- **Laseremissionseinheit**

Diese Einheit besteht aus der Laserdiode, dem Fokussierungsobjektiv, der Blende und dem Zylinderobjektiv.

- Laserdiode

Diese Laserdiode zeichnet sich durch eine geringe Regeldifferenz, eine kleine Laservariation und einen niedrigen Schwellenstrom aus.

Die Blende der Laseremissionseinheit ist unter dem Fokussierobjektiv angeordnet, um die Form der Laserstrahlen in der primären und sekundären Scanrichtung festzulegen.

Die Laserdiode gibt Laserstrahlen als Reaktion auf die Signale der Laseremissionssteuerung (ein/aus) von der Lasertreiber-PC-Platine (LDR) aus. Die durch das Fokussierobjektiv geführten Laserstrahlen werden auf die Trommeloberfläche fokussiert.

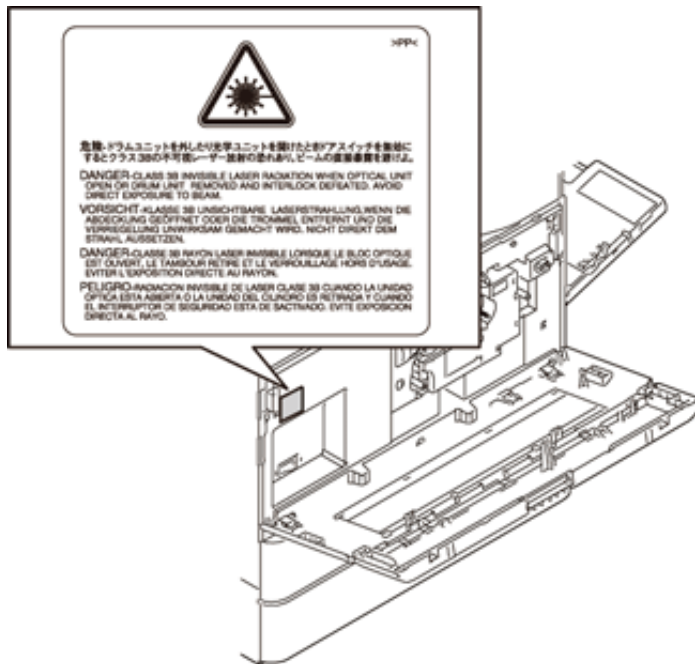
- Vorsichtsmaßnahmen im Zusammenhang mit Lasern

Dieses Gerät enthält eine Laserdiode, die einen unsichtbaren Laserstrahl emittiert.

Da man diesen Laserstrahl nicht sehen kann, ist bei der Handhabung der Komponenten der optischen Lasereinheit, bei der Durchführung von Arbeiten und bei der Justierung des Laserstrahls äußerste Vorsicht geboten. Arbeiten dürfen niemals anhand anderer als den vorgeschriebenen Anleitungen durchgeführt werden; andernfalls kann es zu einer Schädigung Exposition durch Laserstrahlung kommen.

Die Lasereinheit ist vollständig mit einer Schutzabdeckung versiegelt. Solange ausschließlich die Arbeitsschritte der vorgeschriebenen Anleitungen durchgeführt werden, tritt der Laserstrahl nicht aus, und es besteht keine Gefahr, der Laserstrahlung ausgesetzt zu werden.

Das folgende Laser-Warnetikett ist an der Abdeckung vorne rechts angebracht.



- **Warnhinweise:**

- Setzen Sie sich während der Wartungsarbeiten nicht dem Laserstrahl aus.  
Dieses Gerät ist mit einer Laserdiode ausgestattet. Es ist unbedingt zu vermeiden, direkt in den Laserstrahl zu blicken. Keine reflektierenden Teile oder Werkzeuge, wie z. B. Schraubendreher, in den Pfad des Laserstrahls halten. Vor den Wartungsarbeiten sämtliche reflektierenden Metallgegenstände, wie Uhren, Ringe usw., entfernen.
- Bei Wartungsarbeiten am eingeschalteten Gerät dürfen keine unter Strom stehenden, drehbaren oder betriebsrelevanten Bereiche berührt werden. Nicht direkt in den Laserstrahl blicken.
- Im Rahmen der Wartung unbedingt das Leistungsschild und die Etiketten mit Warnhinweisen überprüfen [z. B. „Unplug the power cable during service“ („Netzkabel vor Beginn der Wartungsarbeiten abziehen“), „CAUTION. HOT“ („VORSICHT, HEISS“), „CAUTION. HIGH VOLTAGE“ („VORSICHT, HOCHSPANNUNG“), „CAUTION. LASER BEAM“ („VORSICHT, LASER“) usw.], um sicherzustellen, dass sie nicht verschmutzt sind und korrekt am Gerät angebracht sind.

# CONTENTS

<b>1. FEATURES .....</b>	<b>1-1</b>
1.1 Main Features of this Equipment .....	1-1
<b>2. SPECIFICATIONS / ACCESSORIES / OPTIONS / SUPPLIES .....</b>	<b>2-1</b>
2.1 Specifications .....	2-1
2.1.1 General .....	2-1
2.1.2 Copy .....	2-4
2.1.3 Print .....	2-11
2.1.4 Scan .....	2-11
2.1.5 Internet Fax .....	2-12
2.1.6 Network Fax (Option) .....	2-13
2.2 Accessories .....	2-14
2.3 System List .....	2-15
2.4 Options .....	2-18
2.5 Supplies .....	2-20
<b>3. OUTLINE OF THE MACHINE .....</b>	<b>3-1</b>
3.1 Sectional View .....	3-1
3.2 Electric Parts Layout .....	3-4
3.3 Symbols and Functions of Various Components .....	3-12
3.3.1 Motors .....	3-12
3.3.2 Sensors and switches .....	3-13
3.3.3 Electromagnetic clutches .....	3-15
3.3.4 Solenoids .....	3-15
3.3.5 PC boards .....	3-16
3.3.6 Lamps and heaters .....	3-17
3.3.7 Thermistors and thermostats .....	3-17
3.3.8 Transformer .....	3-18
3.3.9 Others .....	3-18
3.4 Copy Process .....	3-19
3.4.1 General Description of Copying Process .....	3-19
3.5 Comparison with e-STUDIO2008A/2508A/3008A/3508A/4508A/5008A .....	3-20
3.6 General Operation .....	3-22
3.6.1 Overview of operation .....	3-22
3.6.2 Description of operation .....	3-22
3.6.3 Detection of abnormality .....	3-25
3.6.4 Hibernation function .....	3-30
3.7 Control Panel .....	3-31
3.7.1 General description .....	3-31
3.8 Scanner .....	3-32
3.8.1 General description .....	3-32
3.8.2 Construction .....	3-33
3.8.3 Functions .....	3-34
3.8.4 Description of operation .....	3-36
3.8.5 Process of detection of original size .....	3-37
3.9 Laser Optical Unit .....	3-39
3.9.1 General description .....	3-39
3.9.2 Laser precautions .....	3-40
3.10 Paper Feeding System .....	3-41
3.10.1 General descriptions .....	3-41
3.10.2 Composition .....	3-42
3.10.3 Functions .....	3-43
3.10.4 Description of operation .....	3-44
3.11 Drive System .....	3-50
3.11.1 General description .....	3-50
3.11.2 Functions .....	3-51

3.12	Drum Related Section .....	3-52
3.12.1	Configuration .....	3-52
3.12.2	Composition .....	3-52
3.12.3	Functions .....	3-53
3.13	Development System .....	3-55
3.13.1	Configuration .....	3-55
3.13.2	Construction .....	3-55
3.13.3	Functions .....	3-56
3.13.4	Functions of the toner cartridge PC board (CTRG) .....	3-59
3.14	Fuser Unit .....	3-62
3.14.1	General description .....	3-62
3.14.2	Composition .....	3-63
3.14.3	Functions .....	3-63
3.14.4	Operation .....	3-64
3.14.5	Heater control circuit .....	3-65
3.15	Paper Exit Section / Reverse Section .....	3-70
3.15.1	General description .....	3-70
3.15.2	Functions .....	3-71
3.15.3	Exit motor / Reverse motor / Main motor drive .....	3-72
3.16	Automatic Duplexing Unit (ADU) .....	3-73
3.16.1	General description .....	3-73
3.16.2	Composition .....	3-74
3.16.3	Functions .....	3-75
3.16.4	Description of operations .....	3-75
3.16.5	Drive of ADU .....	3-76
3.17	Power Supply Unit .....	3-77
3.17.1	Construction .....	3-77
3.17.2	Explanation of functions .....	3-77
3.17.3	Operation of DC output circuits .....	3-78
3.17.4	Output channel .....	3-80
3.17.5	Fuse .....	3-81
<b>4.</b>	<b>DISASSEMBLY AND REPLACEMENT .....</b>	<b>4-1</b>
4.1	Covers .....	4-1
4.1.1	Front cover .....	4-1
4.1.2	Left cover .....	4-1
4.1.3	Receiving tray .....	4-2
4.1.4	Tray rear cover .....	4-2
4.1.5	Left top cover .....	4-3
4.1.6	Left rear cover .....	4-3
4.1.7	Exit back cover .....	4-4
4.1.8	Right top cover .....	4-4
4.1.9	Right front cover .....	4-4
4.1.10	Right rear cover .....	4-5
4.1.11	Front top cover .....	4-5
4.1.12	Control panel lower cover .....	4-6
4.1.13	Front right cover .....	4-7
4.1.14	Rear top cover .....	4-7
4.1.15	Rear cover .....	4-8
4.1.16	Front cover switch (SW4) .....	4-8
4.1.17	Front cover interlock switch (SW2) .....	4-8
4.2	Control Panel .....	4-10
4.2.1	Control panel unit .....	4-10
4.2.2	KEY board/button .....	4-13
4.2.3	DSP board .....	4-14
4.3	Scanner Unit .....	4-16
4.3.1	Precautions for the scanner fixing screws .....	4-16
4.3.2	Original glass .....	4-20
4.3.3	Lens cover .....	4-25



4.3.4	Automatic original detection sensor-1 (S1)	4-25
4.3.5	Automatic original detection sensor-2 (S2)	4-26
4.3.6	Lens unit/CCD driving PC board	4-26
4.3.7	Carriage home position sensor (S3)	4-28
4.3.8	Exposure lamp (EXP)	4-28
4.3.9	Scan motor (M1)	4-30
4.3.10	Platen sensor (S20, S21)	4-32
4.3.11	Carriage-1	4-33
4.3.12	Carriage wire, carriage-2	4-36
4.3.13	Scanner damp heater (DH2)	4-41
4.4	Writing Section	4-42
4.4.1	Laser optical unit	4-42
4.5	Paper Feeding System	4-45
4.5.1	Bypass unit	4-45
4.5.2	Bypass feed roller	4-46
4.5.3	Bypass separation roller	4-49
4.5.4	Paper size detection board	4-50
4.5.5	Bypass paper sensor (S8)	4-51
4.5.6	ADU opening/closing switch (SW5)	4-54
4.5.7	Registration sensor (S17), 1st transport sensor (S16)	4-55
4.5.8	Paper dust holder	4-58
4.5.9	Registration roller (on the equipment side)	4-58
4.5.10	Registration roller (on the ADU side)	4-59
4.5.11	Feed cover	4-61
4.5.12	Transport roller	4-62
4.5.13	Feed cover opening/closing switch (SW10)	4-64
4.5.14	2nd transport sensor (S9)	4-65
4.5.15	1st drawer paper feed unit	4-66
4.5.16	1st drawer separation roller guide	4-67
4.5.17	2nd drawer paper feed unit	4-69
4.5.18	2nd drawer separation roller guide	4-70
4.5.19	1st drawer paper feed roller, separation roller, and pick-up roller	4-71
4.5.20	2nd drawer paper feed roller, separation roller, and pick-up roller	4-73
4.5.21	1st drawer detection switch (SW11)	4-75
4.5.22	2nd drawer detection switch (SW12)	4-76
4.5.23	Upper tray-up motor unit	4-77
4.5.24	Lower tray-up motor unit	4-77
4.5.25	Upper tray-up motor (M11)	4-78
4.5.26	Lower tray-up motor (M12)	4-79
4.5.27	1st drawer paper stock sensor (S10)	4-79
4.5.28	2nd drawer paper stock sensor (S13)	4-80
4.5.29	1st drawer empty sensor (S12) and 1st drawer tray-up sensor (S11)	4-81
4.5.30	2nd drawer empty sensor (S15) and 2nd drawer tray-up sensor (S14)	4-82
4.5.31	1st drawer paper width detection switch (SW6) and 1st drawer paper length detection switch (SW7)	4-84
4.5.32	2nd drawer paper width detection switch (SW8) and 2nd drawer paper length detection switch (SW9)	4-85
4.5.33	High speed transport clutch (CLT5)	4-86
4.5.34	Low speed transport clutch (CLT6)	4-88
4.5.35	1st drawer feed clutch (CLT3)	4-89
4.5.36	2nd drawer feed clutch (CLT4)	4-90
4.5.37	Flywheel	4-91
4.5.38	Registration roller clutch (CLT1)	4-91
4.5.39	Paper feed drive unit	4-92
4.5.40	Paper feed drive gear	4-94
4.6	Driving Section	4-97
4.6.1	Main motor (M8) <35ppm/45ppm/50ppm>	4-97
4.6.2	Main motor (M8) <20ppm/25ppm/30ppm>	4-97

4.7	Drum Related Section .....	4-99
4.7.1	Process unit .....	4-99
4.7.2	Drum cleaner unit .....	4-100
4.7.3	Discharge LED .....	4-102
4.7.4	Main charger .....	4-103
4.7.5	Main charger grid .....	4-104
4.7.6	Main charger cleaner .....	4-104
4.7.7	Needle electrode .....	4-105
4.7.8	Drum .....	4-106
4.7.9	Drum cleaning blade .....	4-108
4.7.10	Drum separation finger .....	4-108
4.7.11	Recovery blade .....	4-109
4.7.12	Temperature/humidity sensor (S19) .....	4-110
4.7.13	Toner motor (M4) .....	4-111
4.7.14	Process unit fan (M2) .....	4-112
4.7.15	Main power switch (SW1) .....	4-113
4.8	Developer Unit .....	4-114
4.8.1	Developer unit .....	4-114
4.8.2	Removing developer material .....	4-116
4.8.3	Filling developer unit with developer material .....	4-117
4.8.4	Auto-toner sensor (S4) .....	4-118
4.8.5	Drum thermistor (THMS4) .....	4-118
4.8.6	Guide roller / Developer sleeve .....	4-119
4.8.7	Mixer .....	4-124
4.8.8	Replacement of oil seal .....	4-126
4.9	Transfer Unit .....	4-127
4.9.1	Transfer unit .....	4-127
4.9.2	TRU fan (M9) .....	4-128
4.9.3	Transfer roller unit .....	4-129
4.9.4	Transfer roller .....	4-129
4.9.5	Separation needle .....	4-131
4.9.6	Ozone filter .....	4-132
4.10	Fuser Unit .....	4-134
4.10.1	Fuser unit .....	4-134
4.10.2	Front side cover .....	4-137
4.10.3	Rear side cover .....	4-137
4.10.4	Fuser roller cover .....	4-138
4.10.5	Paper entrance guide .....	4-138
4.10.6	Separation finger .....	4-139
4.10.7	Exit sensor (S5) .....	4-141
4.10.8	Fuser center thermostat (THMO1)/fuser front thermostat (THMO2) .....	4-142
4.10.9	Center thermistor (THMS1)/side thermistor (THMS2)/ edge thermistor (THMS3) .....	4-143
4.10.10	Center heater lamp (LAMP1)/side heater lamp (LAMP2) .....	4-147
4.10.11	Pressure roller .....	4-149
4.10.12	Fuser roller .....	4-151
4.11	Paper Exit and Reverse Sections .....	4-153
4.11.1	Reverse unit <35ppm/45ppm/50ppm> .....	4-153
4.11.2	Paper exit unit <35ppm/45ppm/50ppm> .....	4-155
4.11.3	Paper exit unit <20ppm/25ppm/30ppm> .....	4-156
4.11.4	Exit roller / Lower exit roller .....	4-157
4.11.5	Exit motor (M10) .....	4-158
4.11.6	Reverse motor (M13) <35ppm/45ppm/50ppm> .....	4-160
4.11.7	Reverse gate solenoid (SOL1) <35ppm/45ppm/50ppm> .....	4-161
4.11.8	Upper exit roller <35ppm/45ppm/50ppm> .....	4-163
4.11.9	Reverse roller <35ppm/45ppm/50ppm> .....	4-165
4.12	Automatic Duplexing Unit (ADU) .....	4-166
4.12.1	Automatic duplexing unit (ADU) .....	4-166

4.12.2	Bypass feed clutch (CLT2) .....	4-168
4.12.3	ADU guide assembly <35ppm/45ppm/50ppm> .....	4-170
4.12.4	ADU guide assembly <20ppm/25ppm/30ppm> .....	4-171
4.12.5	ADU middle cover <35ppm/45ppm/50ppm> .....	4-173
4.12.6	ADU middle cover <20ppm/25ppm/30ppm> .....	4-175
4.12.7	ADU control PC board (ADU) <35ppm/45ppm/50ppm> .....	4-176
4.12.8	ADU control PC board (ADU board) (ADU) <20ppm/25ppm/30ppm> .....	4-177
4.12.9	ADU motor (M5) <35ppm/45ppm/50ppm> .....	4-178
4.12.10	ADU motor (M5) <20ppm/25ppm/30ppm> .....	4-179
4.12.11	ADU entrance sensor (S7) .....	4-180
4.12.12	ADU exit sensor (S6) .....	4-180
4.12.13	Transport roller (Upper and lower) .....	4-181
4.12.14	Reverse sensor (S18) <35ppm/45ppm/50ppm> .....	4-183
4.12.15	ADU interlock switch (SW3) <35ppm/45ppm/50ppm> .....	4-184
4.12.16	ADU interlock switch (SW3) <20ppm/25ppm/30ppm> .....	4-185
4.12.17	Exit section cooling fan (M14) <35ppm/45ppm/50ppm> .....	4-186
4.13	Removal and Installation of Options .....	4-187
4.13.1	Dual Scan Document Feeder .....	4-187
4.13.2	Reversing Automatic Document Feeder .....	4-192
4.13.3	Paper Feed Pedestal .....	4-195
4.13.4	Large Capacity Feeder .....	4-197
4.13.5	Bridge kit .....	4-201
4.13.6	Inner finisher .....	4-203
4.13.7	Saddle stitch finisher .....	4-206
4.13.8	Saddle stitch finisher (with Hole punch unit) .....	4-208
4.13.9	Finisher (with Hole punch unit) .....	4-210
4.13.10	Finisher .....	4-212
4.13.11	Job Separator <20ppm/25ppm/30ppm> .....	4-213
4.13.12	Job separator <35ppm/45ppm/50ppm> .....	4-215

## 5. SELF-DIAGNOSTIC MODE ..... 5-1

5.1	Overview .....	5-1
5.2	Description Rule for Each Menu and Mode .....	5-4
5.3	Service UI .....	5-7
5.3.1	Overview .....	5-7
5.3.2	Operation procedure .....	5-7
5.3.3	Starting the FS Menu from the normal mode .....	5-7
5.4	03 TEST MODE .....	5-9
5.4.1	Output check .....	5-9
5.4.2	Input check .....	5-9
5.5	04 TEST PRINT MODE .....	5-10
5.6	05 ADJUSTMENT MODE .....	5-10
5.6.1	TEST PRINT .....	5-10
5.7	08 SETTING MODE .....	5-10
5.8	20 PM SUPPORT MODE .....	5-10
5.9	21 EPU REPLACE MODE .....	5-10
5.10	30 LIST PRINT MODE .....	5-11
5.10.1	Operation procedure .....	5-11
5.10.2	List printing .....	5-12
5.11	FAX .....	5-26
5.11.1	11 FAX CLEAR MODE .....	5-26
5.11.2	12 FAX LIST PRINT MODE .....	5-29
5.11.3	13 FAX FUNCTION MODE .....	5-29
5.11.4	19 RAM EDIT MODE .....	5-29
5.12	35 DATA BACKUP/RESTORE MODE .....	5-30
5.13	36 CLONING .....	5-31
5.14	37 LICENSE MANAGEMENT .....	5-31
5.15	01 Control Panel Check Mode .....	5-31
5.15.1	Screen transition .....	5-31

5.15.2	Checking of the LCD back light and LEDs.....	5-32
5.15.3	Checking of the LCD display, hard keys and digital keys.....	5-32
5.15.4	Checking of the LCD touch sensor and USB storage device connection.....	5-33
5.16	73 Firmware Assist Mode.....	5-34
5.16.1	Overview.....	5-34
5.16.2	Operation procedure.....	5-34
5.16.3	Functions.....	5-35
5.17	74 HDD Assist Mode.....	5-39
5.17.1	Overview.....	5-39
5.17.2	Operation procedure.....	5-39
5.17.3	Functions.....	5-40
5.18	75 File System Recovery Mode.....	5-42
5.18.1	Overview.....	5-42
5.18.2	Operation procedure.....	5-42
5.18.3	Functions.....	5-43
5.19	76 SRAM Maintenance Mode.....	5-49
5.19.1	Overview.....	5-49
5.19.2	Operation procedure.....	5-49
5.19.3	Functions.....	5-50
5.20	Pixel Counter.....	5-52
5.20.1	Outline.....	5-52
5.21	Batch Setting for Self-Diagnostic Codes.....	5-60
5.21.1	General description.....	5-60
5.21.2	Applicable codes.....	5-60
5.21.3	Setting files.....	5-60
5.21.4	Result files.....	5-61
5.21.5	Operation procedure.....	5-62

## 6. SETTING / ADJUSTMENT..... 6-1

6.1	Image Related Adjustment.....	6-1
6.1.1	Adjustment order.....	6-1
6.1.2	Adjustment of auto-toner sensor.....	6-2
6.1.3	Image dimensional adjustment.....	6-4
6.1.4	Paper alignment at the registration roller.....	6-6
6.1.5	Image dimensional adjustment at the printing section.....	6-10
6.1.6	Scanner related adjustment.....	6-17
6.2	Image Quality Adjustment (Copying Function).....	6-26
6.2.1	Automatic gamma adjustment (600dpi).....	6-26
6.2.2	Density adjustment.....	6-27
6.2.3	Gamma balance adjustment.....	6-28
6.2.4	Background adjustment.....	6-29
6.2.5	Sharpness adjustment.....	6-29
6.2.6	Setting range correction.....	6-30
6.2.7	Adjustment of smudged text in black.....	6-30
6.2.8	Emission level adjustment.....	6-31
6.2.9	Judgment threshold adjustment for blank originals (common for copy and scan).....	6-31
6.2.10	Image area adjustment for blank original judgment (common for copying and scanning).....	6-32
6.2.11	Drop out color adjustment.....	6-32
6.2.12	Background offsetting adjustment for DF (common for copy, scan and fax) ...	6-33
6.2.13	Background offsetting adjustment in back side for DSDF (common for copy, scan and fax).....	6-33
6.2.14	RADF scan noise reduction.....	6-33
6.3	Image Quality Adjustment (Printing Function).....	6-34
6.3.1	Automatic gamma adjustment.....	6-34
6.3.2	Gamma balance adjustment.....	6-35
6.3.3	Upper limit value in the toner saving mode (1200dpi).....	6-36
6.3.4	Thin line width lower limit adjustment.....	6-36

6.3.5	Emission level adjustment .....	6-36
6.3.6	Density adjustment of graphic lines (1200dpi).....	6-37
6.3.7	Gradation switching for black mode printing text .....	6-37
6.3.8	Adjustment of smudged text in black .....	6-38
6.4	Image Quality Adjustment (Scanning Function).....	6-39
6.4.1	Gamma balance adjustment.....	6-39
6.4.2	RGB Color balance adjustment .....	6-39
6.4.3	Density adjustment .....	6-40
6.4.4	Background adjustment (Color).....	6-41
6.4.5	Background adjustment (Black/Grayscale).....	6-41
6.4.6	Judgment for ACS adjustment .....	6-41
6.4.7	Sharpness adjustment .....	6-42
6.4.8	Contrast adjustment.....	6-43
6.4.9	Fine adjustment of black density .....	6-43
6.4.10	RGB conversion method selection .....	6-43
6.4.11	Adjustment of saturation .....	6-44
6.4.12	Background offsetting adjustment for DF (common for copy, scan and fax) ...	6-44
6.4.13	Background offsetting adjustment in back side for DSDF (common for copy, scan and fax) .....	6-44
6.4.14	Adjustment of the capacity and image quality of SlimPDF .....	6-45
6.4.15	Surrounding void amount adjustment .....	6-46
6.4.16	Surrounding void amount adjustment (custom size scan) .....	6-46
6.4.17	Judgment threshold adjustment for blank originals (common for copy and fax) .....	6-46
6.4.18	Image area adjustment for blank original judgment and ACS judgment (for scanning).....	6-47
6.4.19	JPEG compression level adjustment .....	6-47
6.4.20	DF scan noise reduction .....	6-48
6.5	Image Quality Adjustment (FAX Function).....	6-49
6.5.1	Density adjustment .....	6-49
6.5.2	Emission level adjustment .....	6-49
6.5.3	Background offsetting adjustment for DF (common for copy, scan and fax) ...	6-50
6.5.4	Background offsetting adjustment in back side for DSDF (common for copy, scan and fax) .....	6-50
6.6	Adjustment of High-Voltage Transformer.....	6-51
6.6.1	Adjustment .....	6-51
6.6.2	Precautions .....	6-57
6.7	Scanner.....	6-59
6.7.1	Adjustment carriages-1 positions.....	6-59
6.7.2	Position adjustment of CCD lens unit .....	6-60
6.7.3	Belt tension adjustment of the scan motor.....	6-60
6.8	Paper Feeding System.....	6-61
6.8.1	Adjusting the clearance of the paper and side guides .....	6-61
6.8.2	Separation roller pressure force adjustment.....	6-62
6.9	Adjustment of Developer Unit .....	6-64
6.9.1	Doctor-to-sleeve gap .....	6-64
6.10	Fuser Unit.....	6-67
6.10.1	Adjustment of the thermostat gap .....	6-67
6.11	Control Panel Calibration .....	6-69
6.11.1	General description.....	6-69
6.11.2	Operation procedure .....	6-69
6.12	Adjustment of the DSDF .....	6-72
6.12.1	Adjustment of position .....	6-72
6.12.2	Adjustment of height .....	6-77
6.12.3	Adjustment of skew.....	6-79
6.12.4	Adjustment of the leading edge position .....	6-83
6.12.5	Adjustment of horizontal position.....	6-85
6.12.6	Adjustment of copy ratio .....	6-87

6.12.7	DSDF read-in sensor-1 adjustment .....	6-88
6.12.8	Platen sheet.....	6-90
6.12.9	DSDF separation roller pressure force adjustment.....	6-91
6.13	Adjustment of the RADF .....	6-93
6.13.1	Adjustment of RADF position.....	6-93
6.13.2	Adjustment of RADF height .....	6-98
6.13.3	Adjustment of skew.....	6-100
6.13.4	Adjustment of the leading edge position.....	6-103
6.13.5	Adjustment of horizontal position.....	6-105
6.13.6	Adjustment of copy ratio .....	6-106
6.13.7	RADF Separation roller pressure force adjustment .....	6-107
6.14	Adjustment of the Inner Finisher .....	6-109
6.14.1	Alignment position adjustment.....	6-109
6.14.2	Stapling position adjustment.....	6-110
6.14.3	Punch hole position adjustment.....	6-113
6.15	Adjustment of the Console Finisher .....	6-114
6.15.1	Adjusting the alignment position .....	6-114
6.15.2	Adjusting the stapling position .....	6-117
6.16	Adjustment of the Saddle Stitch Finisher .....	6-119
6.16.1	Adjusting the alignment position .....	6-119
6.16.2	Adjusting the stapling position .....	6-122
6.16.3	Stapling/folding position adjustment in saddle stitch unit.....	6-124
6.16.4	Folding position adjustment.....	6-126
6.16.5	Stapling position adjustment.....	6-126
6.16.6	Saddle stitch skew adjustment .....	6-127
6.17	Adjustment of Hole Punch Unit .....	6-128
6.17.1	Destination setting of hole punch control PC board.....	6-128
6.17.2	Stopping position adjustment (MJ-6105) .....	6-129
<b>7.</b>	<b>PREVENTIVE MAINTENANCE (PM).....</b>	<b>7-1</b>
7.1	General Description .....	7-1
7.2	PM Display .....	7-1
7.2.1	General description.....	7-1
7.2.2	PM display conditions .....	7-1
7.2.3	PM display contents.....	7-3
7.2.4	Clearing counter .....	7-3
7.3	General Descriptions for PM Procedure .....	7-4
7.4	PM Support Mode .....	7-5
7.4.1	General description.....	7-5
7.4.2	Operational flow and operational screen .....	7-5
7.5	Work flow of parts replacement.....	7-10
7.6	21 EPU Replacement Mode.....	7-11
7.6.1	General description.....	7-11
7.6.2	Operation flow.....	7-11
7.6.3	Counters to be cleared .....	7-13
7.6.4	Precautions.....	7-13
7.6.5	To allow the equipment to detect a recycled unit as a new one after replacement.....	7-14
7.7	Fuser Unit Status Detection Mode .....	7-15
7.7.1	General description.....	7-15
7.7.2	Operational flow.....	7-15
7.7.3	Counters to be cleared .....	7-15
7.7.4	Precautions.....	7-15
7.8	Preventive Maintenance Checklist.....	7-16
7.8.1	Scanner .....	7-17
7.8.2	Laser optical unit.....	7-18
7.8.3	Paper feeding section .....	7-19
7.8.4	Drum related section.....	7-21
7.8.5	Developer section .....	7-24

7.8.6	Fuser unit.....	7-26
7.8.7	Paper exit section / Reverse section .....	7-28
7.8.8	Automatic duplexing unit.....	7-29
7.8.9	DSDF .....	7-30
7.8.10	RADF .....	7-32
7.8.11	PPF .....	7-33
7.8.12	LCF .....	7-34
7.8.13	Job separator (MJ-5014) .....	7-35
7.8.14	Inner Finisher .....	7-36
7.8.15	Saddle stitch finisher / Finisher .....	7-37
7.8.16	Hole punch unit (MJ-6105) .....	7-42
7.9	Machine Refreshing Checklist.....	7-43
7.10	Precautions for Storing and Handling Supplies.....	7-44
7.10.1	Precautions for storing TOSHIBA supplies .....	7-44
7.10.2	Checking and cleaning of photoconductive drum .....	7-45
7.10.3	Checking and cleaning of drum cleaning blade .....	7-46
7.10.4	Checking and cleaning of fuser roller and pressure roller .....	7-46
7.10.5	Checking and replacing the transfer roller .....	7-47
7.11	PM KIT .....	7-48
7.12	Maintenance Part List .....	7-49
7.13	Grease List.....	7-51
<b>8.</b>	<b>ERROR CODE AND TROUBLESHOOTING .....</b>	<b>8-1</b>
8.1	General Descriptions.....	8-1
8.1.1	If a problem continues even after performing all troubleshooting. ....	8-2
8.1.2	Collection of debug logs with a USB device .....	8-3
8.1.3	Traceability label.....	8-5
8.2	Error Code List.....	8-6
8.2.1	Jam .....	8-6
8.2.2	Service call .....	8-16
8.2.3	Error in Internet FAX / Scanning function .....	8-29
8.2.4	Printer function error .....	8-42
8.2.5	TopAccess related error/Communication error with external application .....	8-45
8.2.6	MFP access error .....	8-47
8.2.7	Maintenance error.....	8-52
8.2.8	Network error .....	8-66
8.2.9	Notification .....	8-72
8.2.10	FAX error .....	8-76
8.2.11	Error history .....	8-107
8.3	Diagnosis and Prescription for Each Error Code .....	8-109
8.3.1	Check item.....	8-109
8.3.2	Paper exit jam.....	8-110
8.3.3	Paper transport jam .....	8-111
8.3.4	Paper misfeeding.....	8-122
8.3.5	Cover open jam .....	8-128
8.3.6	Other jam .....	8-133
8.3.7	RADF jam .....	8-138
8.3.8	Finisher jam .....	8-155
8.3.9	Drive system related service call .....	8-195
8.3.10	Paper feeding system related service call .....	8-197
8.3.11	Scanning system related service call.....	8-203
8.3.12	Process related service call .....	8-207
8.3.13	Fuser unit related service call .....	8-210
8.3.14	Optional communication related service call .....	8-213
8.3.15	Circuit related service call.....	8-220
8.3.16	Communication related service call .....	8-223
8.3.17	Laser optical unit related service call.....	8-226
8.3.18	Finisher related service call .....	8-227
8.3.19	Service call for others .....	8-250

8.3.20	Error in Internet FAX / Scanning function .....	8-285
8.3.21	Printer function error .....	8-314
8.3.22	TopAccess related error .....	8-322
8.3.23	MFP access error .....	8-328
8.3.24	Maintenance error.....	8-336
8.3.25	Network error .....	8-349
8.3.26	FAX error .....	8-363
8.4	Other Errors .....	8-404
8.4.1	Wireless LAN connection disabled .....	8-404
8.4.2	“Invalid Department Code” is displayed .....	8-404
8.4.3	When “SET FUSER UNIT” is displayed.....	8-404
8.4.4	Toner cartridge unrecognized .....	8-404
8.4.5	“Authentication Failed” is displayed .....	8-404
8.4.6	Error code “M00” is displayed while updating firmware .....	8-405
8.4.7	“COVER OPEN” continues to be displayed .....	8-405
8.4.8	The equipment does not start after the power has been turned ON.....	8-406
8.4.9	Countermeasure to sudden power failure.....	8-410
8.4.10	“Latch the developer unit” remains displayed .....	8-412
8.5	Troubleshooting for the Image .....	8-413
8.5.1	Abnormality of image density / Gray balance .....	8-413
8.5.2	Background fogging.....	8-414
8.5.3	Moire/lack of sharpness .....	8-415
8.5.4	Toner offset.....	8-416
8.5.5	Toner offset (shadow image) at the edges .....	8-418
8.5.6	Blurred image .....	8-419
8.5.7	Poor fusing.....	8-420
8.5.8	Blank copy .....	8-421
8.5.9	Solid copy .....	8-422
8.5.10	White banding or white void (in the feeding direction) .....	8-423
8.5.11	White banding (at right angle with the feeding direction).....	8-425
8.5.12	Skew (inclined image).....	8-426
8.5.13	Black banding (in the feeding direction).....	8-427
8.5.14	Black banding (at right angle with the feeding direction) .....	8-429
8.5.15	White spots .....	8-430
8.5.16	Poor image transfer .....	8-431
8.5.17	Uneven image density .....	8-432
8.5.18	Faded image (low density, abnormal gray balance) .....	8-433
8.5.19	Image dislocation in feeding direction.....	8-434
8.5.20	Jittering image .....	8-435
8.5.21	Poor cleaning .....	8-436
8.5.22	Uneven light distribution .....	8-437
8.5.23	Blotched image .....	8-438
8.5.24	Black streaks on image leading edge during scanning.....	8-439
8.5.25	Image distortion (dogleg image) .....	8-440
8.5.26	Image skewing on paper trailing edge .....	8-442
8.5.27	Shadow in copied/scanned images when using the DSDF .....	8-446
8.5.28	Scanned image abnormality .....	8-448
8.5.29	Drum pitch fogging.....	8-450
8.5.30	If an image-related problem continues after performing all troubleshooting ..	8-451

## 9. REPLACEMENT OF PC BOARDS/HDD ..... 9-1

9.1	Removal and Installation of PC Boards/HDD.....	9-1
9.1.1	SYS board cover.....	9-1
9.1.2	SYS board cooling fan (M6).....	9-1
9.1.3	Hard disk (HDD) .....	9-2
9.1.4	SYS board .....	9-3
9.1.5	SYS board case.....	9-5
9.1.6	LGC board .....	9-7
9.1.7	Switching regulator .....	9-9



9.1.8	High-voltage transformer (HVT)	9-10
9.1.9	SRAM	9-11
9.1.10	Main memory (DIMM)	9-11
9.1.11	EEPROM	9-12
9.1.12	Switching regulator cooling fan (M7)	9-12
9.1.13	DSDF I/F board	9-13
9.2	Precautions and Procedures for Replacing PC Boards and HDD/SSD	9-14
9.2.1	Precautions when replacing PC boards	9-14
9.2.2	HDD/SSD fault diagnosis	9-15
9.2.3	Precautions and procedures when replacing the HDD/SSD	9-18
9.2.4	Precautions and procedures when replacing the SYS board	9-22
9.2.5	Precautions and procedure when replacing the SRAM	9-26
9.2.6	Procedures when replacing the LGC board	9-31
9.2.7	Procedures and settings when replacing EEPROM (for LGC board)	9-31
9.2.8	Procedures and settings when replacing the lens unit	9-35
9.2.9	Firmware confirmation after the PC board/HDD/SSD replacement	9-35
9.2.10	License re-registration using the one-time dongle	9-36
9.3	Precautions for Installation of GP-1070 and Disposal of HDD/SSD/Board	9-38
9.3.1	Precautions for Installation of GP-1070	9-38
9.3.2	Precautions when disposing of the HDD/SSD	9-38
9.3.3	Precautions when disposing of the SYS board	9-38
9.3.4	Precautions when disposing of the SRAM	9-38
<b>10.</b>	<b>REMOTE SERVICE</b>	<b>10-1</b>
10.1	Auto Supply Order	10-1
10.1.1	Outline	10-1
10.1.2	Setting item	10-2
10.1.3	Setting procedure	10-4
10.1.4	Order sheet format	10-16
10.2	Service Notification	10-20
10.2.1	Outline	10-20
10.2.2	Setting	10-21
10.2.3	Items to be notified	10-27
10.3	Remote Panel (VNC)	10-43
10.3.1	Outline	10-43
10.3.2	Setting	10-43
10.3.3	Operation	10-44
10.4	Remote Service	10-45
10.4.1	Outline	10-45
10.4.2	Setting	10-45
10.4.3	Operation	10-45
<b>11.</b>	<b>FIRMWARE UPDATING</b>	<b>11-1</b>
11.1	Overview	11-1
11.2	Firmware Updating with USB Device	11-2
11.2.1	Updating methods	11-2
11.2.2	Firmware type and data file for updating	11-2
11.2.3	Folder configuration of a USB device	11-4
11.2.4	Update procedure	11-6
11.3	Confirmation of the updated data	11-14
<b>12.</b>	<b>BACKUP FUNCTION</b>	<b>12-1</b>
12.1	Cloning (HS menu)	12-1
12.1.1	General description	12-1
12.1.2	Precautions	12-1
12.1.3	Backup files	12-2
12.1.4	Cloning procedure	12-2
12.2	Cloning (FS menu)	12-5
12.2.1	General description	12-5
12.2.2	Precautions	12-5

12.2.3	Clone file creation procedure .....	12-7
12.2.4	Clone file installation procedure .....	12-7
12.3	AES Data Encryption Function Setting .....	12-8
12.3.1	General description .....	12-8
12.3.2	Precautions .....	12-8
12.3.3	Setting procedure .....	12-9
12.3.4	Procedure for disabling data encryption function .....	12-13
12.3.5	Procedure for discarding HDD when data encryption function is enabled ....	12-13
12.4	High Security Mode .....	12-14
12.4.1	General description .....	12-14
12.4.2	Prior confirmation .....	12-14
12.4.3	Procedure for entering the High Security Mode .....	12-14
12.4.4	Precautions .....	12-15
12.5	Decommissioning .....	12-16
12.5.1	General description .....	12-16
12.5.2	Functions .....	12-16
12.5.3	Precautions .....	12-16
12.5.4	Procedures of decommissioning .....	12-16
<b>13.</b>	<b>EXTERNAL COUNTERS .....</b>	<b>13-1</b>
13.1	Outline .....	13-1
13.2	Signal .....	13-1
13.2.1	Connector .....	13-1
13.2.2	Coin controller .....	13-1
13.2.3	Key copy counter .....	13-4
13.3	Notices .....	13-5
13.3.1	Setting code .....	13-5
13.3.2	Setting value change and restrictions when using the card controller .....	13-5
13.3.3	Setting value change and restrictions when using the coin controller .....	13-5
13.3.4	Installation of external counter .....	13-5
13.3.5	Setting value change and restrictions when using the key counter .....	13-6
13.3.6	Restrictions when using the external counter .....	13-6
<b>14.</b>	<b>NOTES FOR THE INSTALLATION OF A CARD READER .....</b>	<b>14-1</b>
<b>15.</b>	<b>WIRE HARNESS CONNECTION DIAGRAMS .....</b>	<b>15-1</b>
15.1	AC Wire Harness .....	15-1
15.2	DC Wire Harness (20ppm/25ppm/30ppm) .....	15-3
15.3	Electric Parts Layout (20ppm/25ppm/30ppm) .....	15-4
15.4	DC Wire Harness (35ppm/45ppm/50ppm) .....	15-5
15.5	Electric Parts Layout (35ppm/45ppm/50ppm) .....	15-6
<b>APPENDIX .....</b>	<b>1</b>	
<b>REVISION RECORD .....</b>	<b>1</b>	

# 1. FEATURES

## 1.1 Main Features of this Equipment

- **Resistive touch panel**  
In order to improve the operability, a 10.1-inch resistive touch panel is adopted.
- **PC board**  
Each PC board is downsize.
- **Image related adjustment**  
The standard of the image quality adjustment which performs before factory shipment has been changed to the one used the center as a reference. When the image dimensional adjustment is performed in the field, utilize Type 2 which uses the center as a reference (the same adjustment performed before factory shipment). The correction can be applied easily.



## 2. SPECIFICATIONS / ACCESSORIES / OPTIONS / SUPPLIES

In this document, a model name is replaced with an alias as follows:

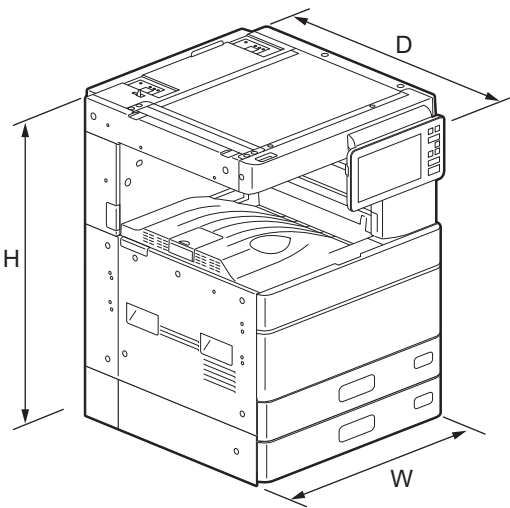
Model name	Alias
e-STUDIO2018A	20ppm
e-STUDIO2518A	25ppm
e-STUDIO3018A	30ppm
e-STUDIO3518A	35ppm
e-STUDIO4518A	45ppm
e-STUDIO5018A	50ppm

### 2.1 Specifications

#### 2.1.1 General

Type	Desktop type (Console type: when optional Paper Feed Pedestal (PFP) or optional Large Capacity Feeder (LCF) is installed.)	
Original glass	Fixed	
Copy process	Indirect electrophotographic method (dry)	
Developing system	2-component magnetic brush developing	
Fixing method	20ppm/25ppm/30ppm: Halogen lamp (2 pieces) 35ppm/45ppm/50ppm: Halogen lamp (3 pieces)	
Photosensor type	OPC	
Original scanning sensor	CCD sensor	
Scanning light source	LED	
Resolution	Scanning	600 dpi x 600 dpi
	Writing	600 dpi x 600 dpi 1200dpi x 1200dpi (PS only)
Gradation	256	
Paper feeding	2 drawer + Bypass feeding 2 drawer + Bypass feeding+ PFP 1 drawer (optional) 2 drawer + Bypass feeding+ PFP 2 drawers (optional) 2 drawer + Bypass feeding+ LCF (optional)	
Paper supply	Drawer/PFP (optional)	Stack height 60.5 mm, Approx. 550 sheets (80 g/m <sup>2</sup> , 21.3 lb. Bond), Approx. 500 sheets (105 g/m <sup>2</sup> , 28 lb. Bond)
	Bypass feeding	Stack height 11 mm, Approx. 100 sheets (80 g/m <sup>2</sup> , 21.3 lb. Bond), Approx. 80 sheets (105 g/m <sup>2</sup> , 28 lb. Bond)
	LCF (optional)	Stack height 110 mm, Approx. 2000 sheets (80 g/m <sup>2</sup> , 21.3 lb. Bond), Approx. 1660 sheets (105 g/m <sup>2</sup> , 28 lb. Bond)
	Envelope Drawer (optional)	Plain paper: Approx. 550 sheets (80 g/m <sup>2</sup> , 21.3 lb. Bond), Approx. 500 sheets (105 g/m <sup>2</sup> , 28 lb. Bond) Envelope: Stack height 505 mm (Approx. 60 envelopes)

Paper size	1st drawer	A3, A4, A4-R, A5-R, B4, B5, B5-R, FOLIO, 8K, 16K, 16K-R, LD, LG, LT, LT-R, ST-R, COMPUTER, 13"LG, 8.5" x 8.5", Non-standard
	2nd drawer/PFP (optional)	A3, A4, A4-R, A5-R, B4, B5, B5-R, FOLIO, 8K, 16K, 16K-R, LD, LG, LT, LT-R, ST-R, COMPUTER, 13"LG, 8.5" x 8.5", Envelope (DL, COM10, Monarch, CHO-3, YOU-4)
	Bypass feeding	A3, A4, A4-R, A6-R (*1), A5-R, B4, B5, B5-R, FOLIO, 8K, 16K, 16K-R, LD, LG, LT, LT-R, ST-R, COMPUTER, 13"LG, 8.5" x 8.5" Non-standard (*2) (*3) (*4): Paper size within 100 - 297 mm (3.9 - 11.7") (Width), 148 - 432 mm (5.8 - 17") (Length)  (*1) A6-R size paper: Thick 2 or larger is available. (*2) Non-standard size paper: Corner folding, paper wrinkling or skewing may occur. (*3) Thick 1 or smaller size paper: Skewing may occur in paper whose size is 140 (Width) x 210 (Length) mm or smaller. (*4) When printing is performed by using a printer driver, the available paper size may differ from the above one depending on the specifications of the printer driver.
	LCF (optional)	A4, LT
	Envelope Drawer (optional)	Plain paper: A4-R, A5-R, B5-R, 16K-R, LG, LT-R, ST-R, 13"LG, Envelope DL (110 x 220 mm), Envelope Com10 (4 1/8 x 9 1/2"), Envelope Monarch (3 7/8 x 7 1/2"), Envelope Cho-3 (120 x 235 mm), Envelope You-4 (105 x 235 mm), Envelope Kaku-2 (240 x 332 mm) Non-standard envelope: Paper size within 100 - 240 mm (3.9 - 9.45") (Width), 162 - 380 mm (6.38 - 14.9") (Length)
Paper type	Drawer / PFP (optional)	Plain paper, Recycled paper, Thick, Thick 1, Thick 2, Thick 3
	Bypass feeding	Plain paper, Recycled paper, Thick, Thick 1, Thick 2, Thick 3, Thin paper, Sticker labels, OHP film, Tab paper
	LCF (optional)	Plain paper, Recycled paper
	Envelope Drawer (optional)	Plain paper, Envelope, Thick 1
Paper weight	Drawer / PFP (optional)	60g/m <sup>2</sup> to 256 g/m <sup>2</sup> (16 lb. Bond to 140 lb. Index)
	Bypass feeding	52 g/m <sup>2</sup> to 256 g/m <sup>2</sup> (16 lb. Bond to 100 lb. Cover)
	LCF (optional)	64 g/m <sup>2</sup> to 105 g/m <sup>2</sup> (17 lb. Bond to 28 lb. Bond)
	Envelope Drawer (optional)	60 g/m <sup>2</sup> to 163 g/m <sup>2</sup> (16 lb. Bond to 90 lb. Index)
Automatic duplexing unit	Type	Stackless, Switchback type
	Acceptable paper size	A3, A4, A4-R, A5-R, B4, B5, B5-R, FOLIO, 8K, 16K, 16K-R, LD, LG, LT, ST-R, COMPUTER, 13"LG, 8.5" x 8.5", Non-standard
	Acceptable paper weight	60 g/m <sup>2</sup> to 256 g/m <sup>2</sup> (17 lb. Bond to 80 lb. Cover)
Toner supply		Automatic toner density detection/supply (There is a recovered toner supply mechanism.) Toner cartridge exchange type
Density control		Automatic density mode and manual density mode selectable in 11 steps
Total counter		Electronic counter
Memory (RAM)	Main memory (including page memory)	20/25/30 ppm: 2 GB (except CND), 4 GB (CND) 35/45/50 ppm: 4 GB
	Page Memory	Included in main memory
HDD (SSD)		320 GB (32 GB)
Account Codes		10000 codes
Department Codes		1000 codes

Machine version	<p>NAD: North America, Brazil  MJD: Europe  AUD: Australia  ASD: Asia, Hong Kong, Latin America  TWD: Taiwan  CND: China  CNS: China (SSD)  ARD: Argentina  JPD: Japan</p>
Warm-up time	<p>Normal start-up: Approx. 20 sec. (100 V/200 V series) &lt;Stand-alone, temperature: 20°C&gt;  Start-up without hibernation: Approx. 70 sec. (100 V/200 V series) &lt;Stand-alone, temperature: 20°C&gt;  *Varies depending on the settings, use conditions, and quality maintenance behavior such as toner refill.</p>
Recovery from sleep	<p>20ppm/25ppm/30ppm: Approx. 14 sec. &lt;Stand-alone, temperature: 20°C&gt;  35ppm/45ppm/50ppm: Approx. 16 sec. &lt;Stand-alone, temperature: 20°C&gt;  * Varies depending on the settings, use conditions, and quality maintenance behavior such as toner refill.</p>
Power requirements	<p>AC 110 V / 13.2 A, 120 V / 12 A  220-240 V / 8 A (50/60 Hz)  * The acceptable value of each voltage is ± 10%.</p>
Power consumption	<p>1.5 kW or less (100 V, 120 V)  1.6 kW or less (200 V series)  * The electric power is supplied to the RADF, Finisher, PFP and LCF through the equipment.</p>
Weight	<p>20ppm/25ppm/30ppm: Approx. 55 kg (127.87 lb.)  35ppm/45ppm/50ppm: Approx. 58 kg (134.48 lb.)</p>
Dimensions of the equipment	<p>W 586 x D 603 x H 787 (mm)  * When the tilt angle of the control panel is 90 degrees.</p> 

## 2.1.2 Copy

### [ 1 ] Copy specifications

Storage capacity		Max. 1000 sheets or until the memory is full
Original glass	Original scanning system	Flat surface scanning system (the left rear corner used as guide to place originals)
	Original type	Sheets, books
	Original size	Max. A3/LD
Reversing Automatic Document Feeder (optional)	Original scanning system	Fixed scanning system by feeding the original (the center used as guide to place originals)
	Original type	Sheets (carbon, bounded or stapled originals cannot be accepted)
	Original size	A3, A4, A4-R, A5-R, B4, B5, B5-R, FOLIO, LD, LG, LT, LT-R, ST-R, COMPUTER
	Original paper weight	Single-sided copy: 35-157g/m <sup>2</sup> (9.3 lb. Bond - 58 lb. Cover) Double-sided copy: 50-157g/m <sup>2</sup> (13.3 lb. Bond - 58 lb. Cover)
	Original capacity	Max. 100 sheets (80 g/m <sup>2</sup> ) (Stack height 16 mm)
Dual scan document feeder (optional)	Original scanning system	Fixed scanning system by feeding the original (the center used as guide to place originals)
	Original type	Sheets (carbon, bounded or stapled originals cannot be accepted)
	Original size	A3, A4, A4-R, A5-R, B4, B5, B5-R, FOLIO, LD, LG, LT, LT-R, ST-R, COMPUTER
	Original paper weight	35-209g/m <sup>2</sup> (9.3 lb. Bond - 77.3 lb. Cover) (Bleed-through will occur when a 2-sided original with thin paper such as 35 g/m <sup>2</sup> (9.3 lb.) is scanned.)
	Original capacity	Max. 300 sheets (80 g/m <sup>2</sup> ) (Stack height 38 mm)
Eliminated portion *		Leading edges: 3.0 ± 2.0 mm, Trailing edges Side edges: 2.0 ± 2.0 mm
Multiple copying		Up to 999 copies

\* Paper size: A3/LD or smaller.

### [ 2 ] First copy time

20ppm/25ppm/30ppm	Approx. 4.3 sec. or less
35ppm/45ppm/50ppm	Approx. 3.6 sec. or less



### [ 3 ] Copy speed (Copies/min.)

#### [ 3-1 ] Plain paper

Drawer, Bypass feeding: 60 g/m<sup>2</sup> to 80 g/m<sup>2</sup>

LCF: 64 g/m<sup>2</sup> to 80 g/m<sup>2</sup>

- \* "-" means "Not acceptable".
- \* When originals are manually placed for single-sided, continuous copying.
- \* Plain paper is selected for the paper type.
- \* Acceptable range of output sheets:
  - Drawers for A4, LT, B5, A5-R, ST-R, 8.5", SQ paper, PFP and LCF: within  $\pm 0.5$  sheets
  - Bypass tray: within  $\pm 2.0$  sheets
  - Others: within  $\pm 1.0$  sheet
- \* "Wait" may be displayed or the print speed may decrease depending on the usage environment or print settings.

#### 20ppm

Paper supply Paper size	Drawer	Bypass feed		PFP	LCF (A4/LT only)
		Size specified	Size not specified		
A4, LT, B5, A5-R, ST-R, 8.5", SQ	20.3	20.3	13.2	20.3	20.3
A4-R, B5-R, LT-R	16.9	16.9	13.2	16.9	-
B4, LG, FOLIO, COMPUTER	14.8	14.8	13.2	14.8	-
A3, LD	13.2	13.2	13.2	13.2	-

#### 25ppm

Paper supply Paper size	Drawer	Bypass feed		PFP	LCF (A4/LT only)
		Size specified	Size not specified		
A4, LT, B5, A5-R, ST-R, 8.5", SQ	25.3	25.3	16.8	25.3	25.3
A4-R, B5-R, LT-R	23.3	23.3	16.8	23.3	-
B4, LG, FOLIO, COMPUTER	19.5	19.5	16.8	19.5	-
A3, LD	16.8	16.8	16.8	16.8	-

#### 30ppm

Paper supply Paper size	Drawer	Bypass feed		PFP	LCF (A4/LT only)
		Size specified	Size not specified		
A4, LT, B5, A5-R, ST-R, 8.5", SQ	30.3	30.3	16.8	30.3	30.3
A4-R, B5-R, LT-R	23.3	23.3	16.8	23.3	-
B4, LG, FOLIO, COMPUTER	19.5	19.5	16.8	19.5	-
A3, LD	16.8	16.8	16.8	16.8	-

#### 35ppm

Paper supply Paper size	Drawer	Bypass feed		PFP	LCF (A4/LT only)
		Size specified	Size not specified		
A4, LT, B5, A5-R, ST-R, 8.5", SQ	35.3	35.3	25.4	35.3	35.3
A4-R, B5-R, LT-R	35	35	25.4	35	-

Paper supply Paper size	Drawer	Bypass feed		PFP	LCF (A4/LT only)
		Size specified	Size not specified		
B4, LG, FOLIO, COMPUTER	29.5	29.5	25.4	29.5	-
A3, LD	25.4	25.4	25.4	25.4	-

#### 45ppm

Paper supply Paper size	Drawer	Bypass feed		PFP	LCF (A4/LT only)
		Size specified	Size not specified		
A4, LT, B5, A5-R, ST- R, 8.5", SQ	45.3	45.3	25.4	45.3	45.3
A4-R, B5-R, LT-R	35	35	25.4	35	-
B4, LG, FOLIO, COMPUTER	29.5	29.5	25.4	29.5	-
A3, LD	25.4	25.4	25.4	25.4	-

#### 50ppm

Paper supply Paper size	Drawer	Bypass feed		PFP	LCF (A4/LT only)
		Size specified	Size not specified		
A4, LT, B5, A5-R, ST- R, 8.5", SQ	50.3	50.3	25.4	50.3	50.3
A4-R, B5-R, LT-R	35	35	25.4	35	-
B4, LG, FOLIO, COMPUTER	29.5	29.5	25.4	29.5	-
A3, LD	25.4	25.4	25.4	25.4	-

#### [ 3-2 ] Thick/Thick 1/Thick 2/Thick 3

- \* "-" means "Not acceptable".
- \* When originals are manually placed for single-sided, continuous copying.
- \* The acceptable range of output sheets is within  $\pm 2.0$ .

#### Thick: 81 to 105 g/m<sup>2</sup> (28 lb. Bond)

##### 20ppm

Paper supply Paper size	Drawer	Bypass feed		PFP	LCF (A4/LT only)
		Size specified	Size not specified		
A4, LT, B5, A5-R, ST- R, 8.5", SQ	20.3	20.3	13.2	20.3	20.3
A4-R, B5-R, LT-R	16.5	16.5	13.2	16.5	-
B4, LG, FOLIO, COMPUTER	14.7	14.7	13.2	14.7	-
A3, LD	13.2	13.2	13.2	13.2	-

##### 25ppm

Paper supply Paper size	Drawer	Bypass feed		PFP	LCF (A4/LT only)
		Size specified	Size not specified		
A4, LT, B5, A5-R, ST- R, 8.5", SQ	25.3	25.3	16.4	25.3	25.3
A4-R, B5-R, LT-R	22.5	22.5	16.4	22.5	-
B4, LG, FOLIO, COMPUTER	19.0	19.0	16.4	19.0	-
A3, LD	16.4	16.4	16.4	16.4	-

**30ppm**

Paper supply Paper size	Drawer	Bypass feed		PFP	LCF (A4/LT only)
		Size specified	Size not specified		
A4, LT, B5, A5-R, ST-R, 8.5", SQ	29	29	16.4	29	29
A4-R, B5-R, LT-R	22.5	22.5	16.4	22.5	-
B4, LG, FOLIO, COMPUTER	19	19	16.4	19	-
A3, LD	16.4	16.4	16.4	16.4	-

**35ppm**

Paper supply Paper size	Drawer	Bypass feed		PFP	LCF (A4/LT only)
		Size specified	Size not specified		
A4, LT, B5, A5-R, ST-R, 8.5", SQ	35.3	35.3	24.8	35.3	35.3
A4-R, B5-R, LT-R	33.9	33.9	24.8	33.9	-
B4, LG, FOLIO, COMPUTER	28.7	28.7	24.8	28.7	-
A3, LD	24.8	24.8	24.8	24.8	-

**45ppm/50ppm**

Paper supply Paper size	Drawer	Bypass feed		PFP	LCF (A4/LT only)
		Size specified	Size not specified		
A4, LT, B5, A5-R, ST-R, 8.5", SQ	43.4	43.4	24.8	43.4	43.4
A4-R, B5-R, LT-R	33.9	33.9	24.8	33.9	-
B4, LG, FOLIO, COMPUTER	28.7	28.7	24.8	28.7	-
A3, LD	24.8	24.8	24.8	24.8	-

**Thick 1: 106 to 163 g/m<sup>2</sup> (90 lb. Index)****20ppm**

Paper supply Paper size	Drawer	Bypass feed		PFP	LCF (A4/LT only)
		Size specified	Size not specified		
A4, LT, B5, A5-R, ST-R, 8.5", SQ	20	20	12	20	-
A4-R, B5-R, LT-R	16	16	12	16	-
B4, LG, FOLIO, COMPUTER	14	14	12	14	-
A3, LD	12	12	12	12	-

**25ppm**

Paper supply Paper size	Drawer	Bypass feed		PFP	LCF (A4/LT only)
		Size specified	Size not specified		
A4, LT, B5, A5-R, ST-R, 8.5", SQ	25.3	25.3	16	25.3	-
A4-R, B5-R, LT-R	22.5	22.5	16	22.5	-
B4, LG, FOLIO, COMPUTER	18	18	16	18	-
A3, LD	16	16	16	16	-

**30ppm**

Paper supply Paper size	Drawer	Bypass feed		PFP	LCF (A4/LT only)
		Size specified	Size not specified		
A4, LT, B5, A5-R, ST-R, 8.5", SQ	29	29	16	29	-
A4-R, B5-R, LT-R	22.5	22.5	16	22.5	-
B4, LG, FOLIO, COMPUTER	18	18	16	18	-
A3, LD	16	16	16	16	-

**35ppm**

Paper supply Paper size	Drawer	Bypass feed		PFP	LCF (A4/LT only)
		Size specified	Size not specified		
A4, LT, B5, A5-R, ST-R, 8.5", SQ	35.3	35.3	20	35.3	-
A4-R, B5-R, LT-R	29	29	20	29	-
B4, LG, FOLIO, COMPUTER	23	23	20	23	-
A3, LD	20	20	20	20	-

**45ppm/50ppm**

Paper supply Paper size	Drawer	Bypass feed		PFP	LCF (A4/LT only)
		Size specified	Size not specified		
A4, LT, B5, A5-R, ST-R, 8.5", SQ	40	40	20	40	-
A4-R, B5-R, LT-R	29	29	20	29	-
B4, LG, FOLIO, COMPUTER	23	23	20	23	-
A3, LD	20	20	20	20	-

**Thick 2: 164 to 209 g/m<sup>2</sup> (110 lb. Index)****20ppm**

Paper supply Paper size	Drawer	Bypass feed		PFP	LCF (A4/LT only)
		Size specified	Size not specified		
A4, LT, B5, A5-R, ST-R, 8.5", SQ	20	20	12	20	-
A4-R, B5-R, LT-R	16	16	12	16	-
B4, LG, FOLIO, COMPUTER	14	14	12	14	-
A3, LD	12	12	12	12	-

**25ppm**

Paper supply Paper size	Drawer	Bypass feed		PFP	LCF (A4/LT only)
		Size specified	Size not specified		
A4, LT, B5, A5-R, ST-R, 8.5", SQ	25	25	14	25	-
A4-R, B5-R, LT-R	20	20	14	20	-
B4, LG, FOLIO, COMPUTER	16	16	14	16	-
A3, LD	14	14	14	14	-

**30ppm**

Paper supply Paper size	Drawer	Bypass feed		PFP	LCF (A4/LT only)
		Size specified	Size not specified		
A4, LT, B5, A5-R, ST-R, 8.5", SQ	28	28	14	28	-
A4-R, B5-R, LT-R	20	20	14	20	-
B4, LG, FOLIO, COMPUTER	16	16	14	16	-
A3, LD	14	14	14	14	-

**35ppm/45ppm/50ppm**

Paper supply Paper size	Drawer	Bypass feed		PFP	LCF (A4/LT only)
		Size specified	Size not specified		
A4, LT, B5, A5-R, ST-R, 8.5", SQ	32	32	16	32	-
A4-R, B5-R, LT-R	23	23	16	23	-
B4, LG, FOLIO, COMPUTER	18	18	16	18	-
A3, LD	20	20	20	20	-

**Thick 3: 210 to 256 g/m<sup>2</sup> (140 lb. Index)****20ppm**

Paper supply Paper size	Drawer	Bypass feed		PFP	LCF (A4/LT only)
		Size specified	Size not specified		
A4, LT, B5, A5-R, ST-R, 8.5", SQ	20	20	12	20	-
A4-R, B5-R, LT-R	16	16	12	16	-
B4, LG, FOLIO, COMPUTER	14	14	12	14	-
A3, LD	12	12	12	12	-

**25ppm/30ppm/35ppm/45ppm/50ppm**

Paper supply Paper size	Drawer	Bypass feed		PFP	LCF (A4/LT only)
		Size specified	Size not specified		
A4, LT, B5, A5-R, ST-R, 8.5", SQ	24	24	12	24	-
A4-R, B5-R, LT-R	17	17	12	17	-
B4, LG, FOLIO, COMPUTER	14	14	12	14	-
A3, LD	12	12	12	12	-

**[ 3-3 ] Envelope****20ppm/25ppm/30ppm/35ppm/45ppm/50ppm**

Paper supply Paper size	2nd drawer	PFP
COM10, Monarch, CHO-3, YOU-4	10	10

## [ 4 ] System copy speed

Copy mode		Sec.					
		20ppm	25ppm	30ppm	35ppm	45ppm	50ppm
Single-sided originals ↓ Single-sided copies	1 set	34.46	29.48	26.74	21.84	18.84	17.68
	3 sets	96.83	78.93	68.21	57.77	47.80	42.80
Single-sided originals ↓ Double-sided copies	5 sets	155.58	129.92	107.69	91.02	72.96	66.91
	1 set	37.86	33.28	31.60	24.79	22.60	23.03
	3 sets	97.97	80.81	75.40	59.46	49.12	49.37
Double-sided originals ↓ Double-sided copies	5 sets	156.54	129.68	120.15	93.92	75.98	75.56
	1 set	69.12	58.52	56.89	52.82	52.71	53.09
	3 sets	186.13	154.64	144.82	120.39	105.76	106.13
Double-sided originals ↓ Single-sided copies	5 sets	304.50	250.54	232.86	188.53	158.65	159.08
	1 set	66.30	55.33	52.23	49.52	50.60	49.63
	3 sets	184.35	150.03	131.61	117.36	102.27	97.36
Single-sided originals ↓ Single-sided copies	5 sets	302.51	245.37	210.03	185.38	155.71	145.00

- \* Shows the period of time from when the [START] button is pressed until the message "Ready" is displayed. (10 sheets of A4/LT size original are set on the RADF and one of the copy modes above is selected.)
- \* Setting: when in the Text/Photo mode with Automatic density and APS/AMS set to OFF, or when in the sort mode with paper fed from the 1st drawer.
- \* The finisher, saddle stitch finisher, and hole punch unit not installed.

## 2.1.3 Print

Supported Page Description Language (Printer Driver)		PCL6, PostScript 3 emulation, XPS
Supported Page Description Language (MFP)		PCL6, PostScript 3 emulation, XPS, PCL5e, PCL5c, PDF (emulation)
Supported Client OS		Windows 10 / Windows 7 / Windows 8.1 / Windows Server 2008 / Windows Server 2012 / Windows Server 2016 Mac OS X 10.6.8 or later Solaris v11.2 or later HP-UX ver.11iv3, HP-UX64 ver.11iv3 AIX 7.x Red Hat Enterprise Linux 5.x/6.x/7.x, SuSE Linux 11.2/11.3, CUPS
Resolution		600 dpi x 600 dpi, 1 bit 2400 dpi (Equivalence) x 600 dpi (Smoothing process) 1200 dpi x 1200 dpi, 2 bit (3600 dpi (Equivalence) x 1200 dpi) PS only
Eliminated portion *		Leading edges, Trailing edges, Side edges: 4.2 ± 2.0 mm
Interface	Standard	Ethernet (1000BASE-T/100BASE-TX/10BASE-T), USB 2.0 (High speed)
	Optional	Wireless LAN (IEEE 802.11b/g/n) Bluetooth V3.0 (HCRP/BIP/OPP/FTP/HID)
Paper size	Bypass feeding	Paper size within 100.0 - 297.0 mm (3.94 - 11.69") (Width), 148.0 - 431.8 mm (5.83 - 17.00") (Length)

## 2.1.4 Scan

Scanning speed (A4/LT)	Color / Black / Gray scale	RADF: 73 spm (200 dpi / 300 dpi) 50 spm (600 dpi) DSDF: Simplex: 120 spm, Duplex: 240 spm (200 dpi / 300 dpi) Simplex: 70 spm, Duplex: 140 spm (600 dpi)
Resolution		100, 150, 200, 300, 400 and 600 dpi
Scan mode		Black, Gray scale, Color and ACS (Auto color Selection)
File formats		JPEG, Multi/Single page TIFF, Multi/Single page PDF, Slim PDF, Multi/Single page XPS

\* When scanning single-sided A4/LT landscape originals using RADF/DSDF

## 2.1.5 Internet Fax

### [ 1 ] Internet FAX transmission

Resolution	TX Resolution < dots/mm >	Standard (8 x 3.85), Fine (8 x 7.7),
Scanning	Original Document Size	A3, B4, A4, A4-R, A5, B5, B5-R, A5-R, LT, LT-R, LG, LD, ST, ST-R, Computer, Folio
	Speed	0.7 sec. (per page/A4) Max. 50 spm (ITU-T No.1, A4, 8 x 3.85, Text mode)
	Gray scale	256 levels (Error Diffusion)
Address book	Address Book	400 stations
	Group	Max. 40 stations
Transmission Features	Broadcast transmission	Max. 80 destinations/job (Fax number and E-mail address are available to be registered in same job.)
	Message size limitation	Max. 100MB
	Message division	Page by page

### [ 2 ] Internet FAX receiving

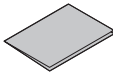

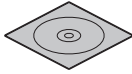
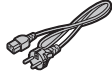


Format of receive attachment	TIFF-FX (Profile S, F, J)
------------------------------	---------------------------



## 2.1.6 Network Fax (Option)

Compatibility		Super G3, G3 (ITU-T.30) Internet Fax (Simple mode) (ITU-T.37)
TX Resolution	PSTN	Standard: 200 x 100 dpi, Fine: 200 x 200 dpi, Super Fine: 200 x 400 dpi, Ultra Fine: 400 x 400 dpi
	Internet Fax	200 dpi x 200 dpi
Original Document Size		A3, A4, A5, B4, B5, FOLIO, LD, LG, LT, ST, COMPUTER
Mail Box	User defined	Max. 300 boxes
Routed document format	Send to e-Filing	MMR
	Send to File (SMB)	Single TIFF, Multi-TIFF, Single PDF, Multi PDF
	Send to FTP	Single TIFF, Multi-TIFF, Single PDF, Multi PDF
	Send to E-mail	Single TIFF, Multi-TIFF, Single PDF, Multi PDF
	Send to I-Fax	TIFF-S
	Send to PSTN-FAX	MMR

## 2.2 Accessories

Unpacking/Setup instruction		1 set
Operator's manual		1 set <ul style="list-style-type: none"> <li>• Quick Start Guide: 1 manual</li> <li>• Safety Information: 1 manual</li> </ul>
DVD		1 pc. Client Utilities / User Documentation DVD (Except NAD, AUD)
Power cable		1 pc.
Warranty sheet		1 pc. (for NAD)
Setup report		1 set (for NAD, ARD and MJD)
Rubber plug		2 pcs.
Developer material		1 pc. (except for NAD and MJD)
Toner		1 pc. (except for NAD and MJD)
Approval sheet		1 set (for CND and CNS)
Right lower cover		1 pc.
Screw (M3x8)		1 pc.

\* Machine version

NAD: North America, Brazil

MJD: Europe

AUD: Australia

ASD: Asia, Hong Kong, Latin America, Saudi Arabia, others

TWD: Taiwan

CND: China

CNS: China

ARD: Argentina

JPD: Japan

**Notes:**

Check that the above accessories are correctly co-packed at the time of unpacking.

## 2.3 System List

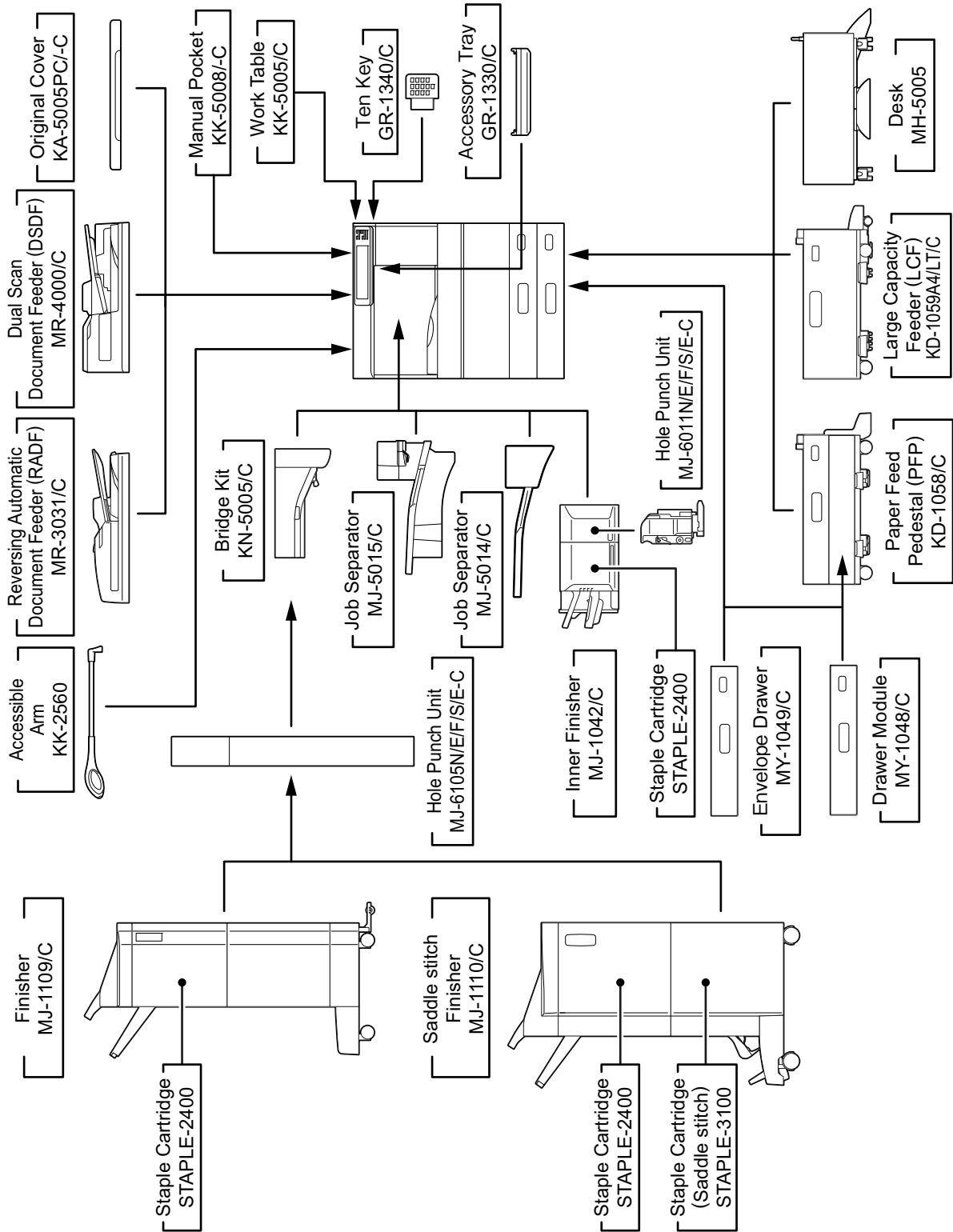


Fig. 2-1

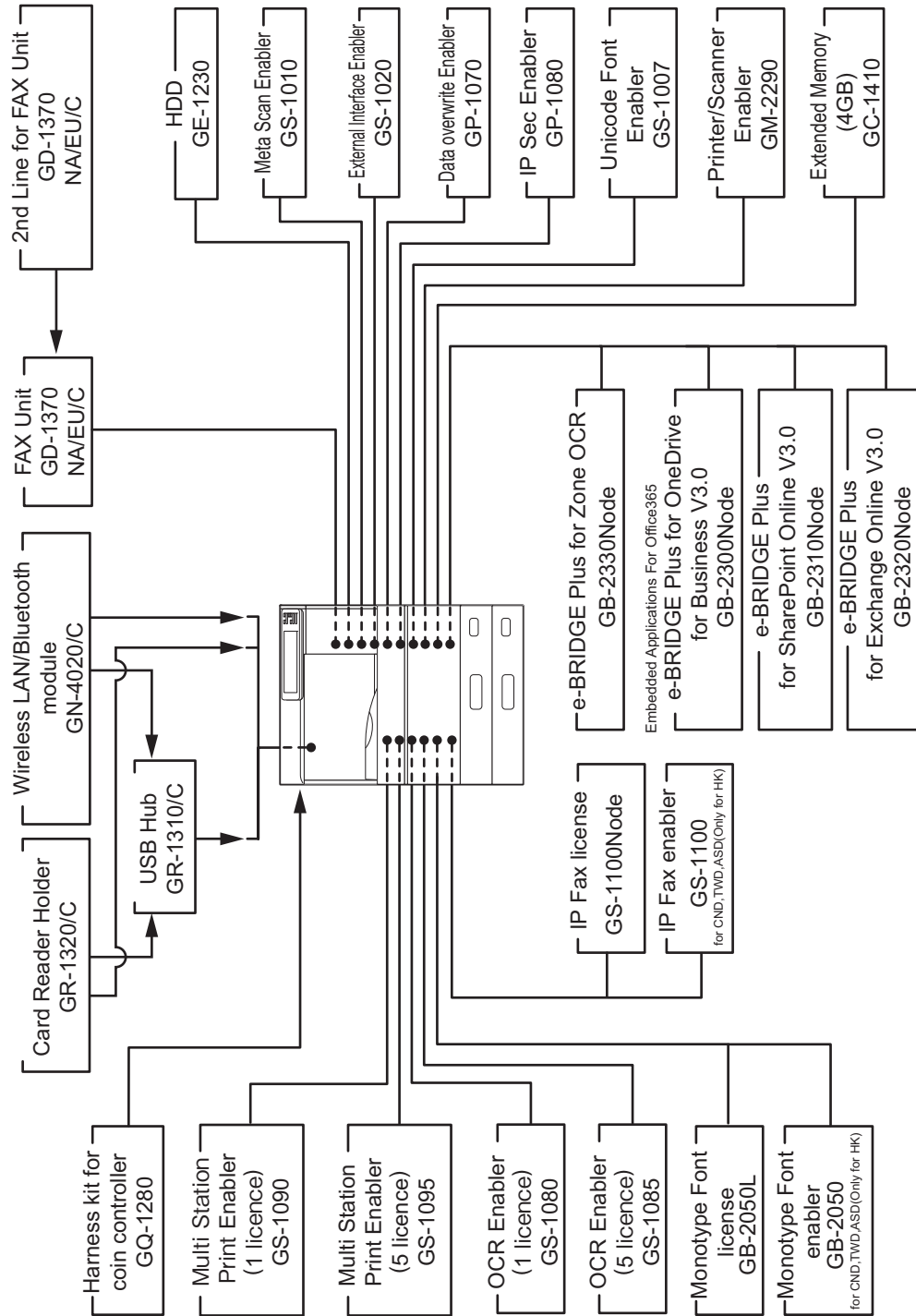


Fig. 2-2

**Notes:**

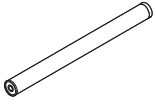

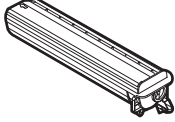
- The bridge kit (KN-5005/C) is necessary for installation of the finisher (MJ-1109/C or MJ-1110/C).
- The finisher (MJ-1042/C) is necessary for installation of the hole punch unit (MJ-6011E/N/F/S/E-C).
- The finisher (MJ-1109/C or MJ-1110/C) is necessary for installation of the hole punch unit (MJ-6105/E/N/F/S/E-C).
- GE-1230 is FIPS SED.
- The Extended Memory (4GB) (GC-1410) is necessary for the installation of the DSDF (MR-4000) to 20/25/30 ppm model (except CND).
- The Extended Memory (4GB) (GC-1410) is necessary for the installation of the OCR Enabler (GS-1080/GS-1085) to 20/25/30 ppm model (except CND).
- The Extended Memory (4GB) (GC-1410) is necessary for the installation of the IP-FAX (GS-1100) to 20/25/30 ppm model (except CND).
- Install the Ten Key (GR-1340) first when it is done together with the Accessory Tray (GR-1330).
- 20/25/30 ppm model: The USB Hub (GR-1310/C) is necessary for installation of the Wireless LAN / Bluetooth module (GN-4020/C).
- 20/25/30 ppm model: The USB Hub (GR-1310/C) is necessary for installation of the Card Reader Holder (GR-1290/C).
- 35/45/50 ppm model: The USB Hub (GR-1310/C) is necessary for installation of the Card Reader Holder (GR-1320/C) and Wireless LAN/Bluetooth module (GN-4020/C) together.
- Reversing Automatic Document Feeder (RADF): MR-3031-B and MR-3031C-B are used.
- Paper Feed Pedestal (PFP): KD-1058-B and KD-1058C-B are used.
- Large Capacity Feeder (LCF): KD-1059LT-B, KD-1059A4-B and KD-1059C-B are used.
- Drawer Module: MY-1048-B and MY-1048C-B are used.
- Enveloper Drawer: MY-1049-B and MY-1049C-B are used.
- Inner Finisher: MJ-1042-B and MJ-1042C-B are used.
- Finisher: MJ-1109-B and MJ-1109C-B are used.
- Saddle Stitch Finisher: MJ-1110-B and MJ-1110C-B are used.
- The envelope drawer (MY-1049/C) can be installed as the 2nd drawer or as the 3rd or 4th drawer of the paper feed pedestal (KD-1058/C).
- When the main memory with 2 GB is replaced with a 4 GB one, set the value of this code to "1".

## 2.4 Options

Model	Option
MR-3031/C	Reversing Automatic Document Feeder (RADF)
MR-4000/C	Dual Scan Document Feeder (DSDF)
KA-5005PC/PCC	Original Cover
KD-1058/C	Paper Feed Pedestal (PFP)
MY-1048/C	Drawer Module
MY-1049/C/J	Envelope Drawer
KD-1059LT/A4/C	Large Capacity Feeder (LCF)
MH-5005	Desk
KK-5008/C	Operator's manual pocket
KK-5005/C	Work Table
KK-2560	Accessible Arm
MJ-5014/C	Job Separator (for 20/25/30 ppm)
MJ-5015/C	Job Separator (for 35/45/50 ppm)
KN-5005/C	Bridge Kit
MJ-1042/C	Inner Finisher
MJ-6011E/N/F/S/E-C	Hole Punch Unit (for MJ-1042)
MJ-1109/C	Finisher
MJ-1110/C	Saddle Stitch Finisher
MJ-6105/E/N/F/S/E-C	Hole Punch Unit (for MJ-1109/1110)
STAPLE-2400	Staple Cartridge (for MJ-1042/1109/1110)
STAPLE-3100	Staple Cartridge (MJ-1110 saddle stitch)
GD-1370NA/EU/C	Fax Unit / 2nd Line for FAX Unit
GR-1310/C	USB Hub
GR-1320/C	Card Reader Holder
GR-1330/C	Accessory Tray
GR-1340/C	Ten Key
GN-4020/C	Wireless LAN / Bluetooth Module
GQ-1280	Harness Kit (for coin controller)
GE-1230	HDD (FIPS Hard Disk)
GC-1410	Extended Memory (4GB) (for 20/25/30 ppm)
MF-5018CE	Damp Heater
GS-1010	Meta Scan Enabler
GS-1020	External Interface Enabler
GP-1080	IPsec Enabler
GP-1070	Data Overwrite Enabler
GS-1007	Unicode Font Enabler
GB-2050L	Monotype Font license
GB-2050	Monotype Font enabler for CND, TWD, ASD (Only for HK)
GS-1100Node	IP Fax license
GS-1100	IP Fax enabler for CND, TWD, ASD (Only for HK)
GS-1080	OCR Enabler (1 license)
GS-1085	OCR Enabler (5 licenses)
GS-1090	Multi Station Print Enabler (1 license)
GS-1095	Multi Station Print Enabler (5 licenses)
GM-2290	Printer/Scanner Enabler (for ASD)
GB-2330Node	e-BRIDGE Plus for Zone OCR
GB-2300Node	Embedded Applications For Office365 <ul style="list-style-type: none"> <li>e-BRIDGE Plus for OneDrive for Business V3.0 (Node)</li> </ul>

Model	Option
GB-2310Node	Embedded Applications For Office365 • e-BRIDGE Plus for SharePoint Online V3.0 (Node)
GB-2320Node	Embedded Applications For Office365 • e-BRIDGE Plus for Exchange Online V3.0 (Node)

## 2.5 Supplies

<p>Drum</p> 	<p>PS-OD-4530 (except for China) OD-4530C (for China)</p>
<p>Developer material</p> 	<p>PS-ZD5070 (except for China) D4530C (for China)</p>
<p>Toner cartridge</p> 	<p>PS-ZT5018U(1) (for North America, Central and South America) PS-ZT5018E(1) (for Europe) PS-ZT5018C(1) (for China) PS-ZT5018C(8) (for China) PS-ZT5018CM(1) (for China) PS-ZT5018CM(8) (for China) PS-ZT5018P(1) (for Asia) PS-ZT5018T(1) (for Taiwan)</p>



# 3. OUTLINE OF THE MACHINE

## 3.1 Sectional View

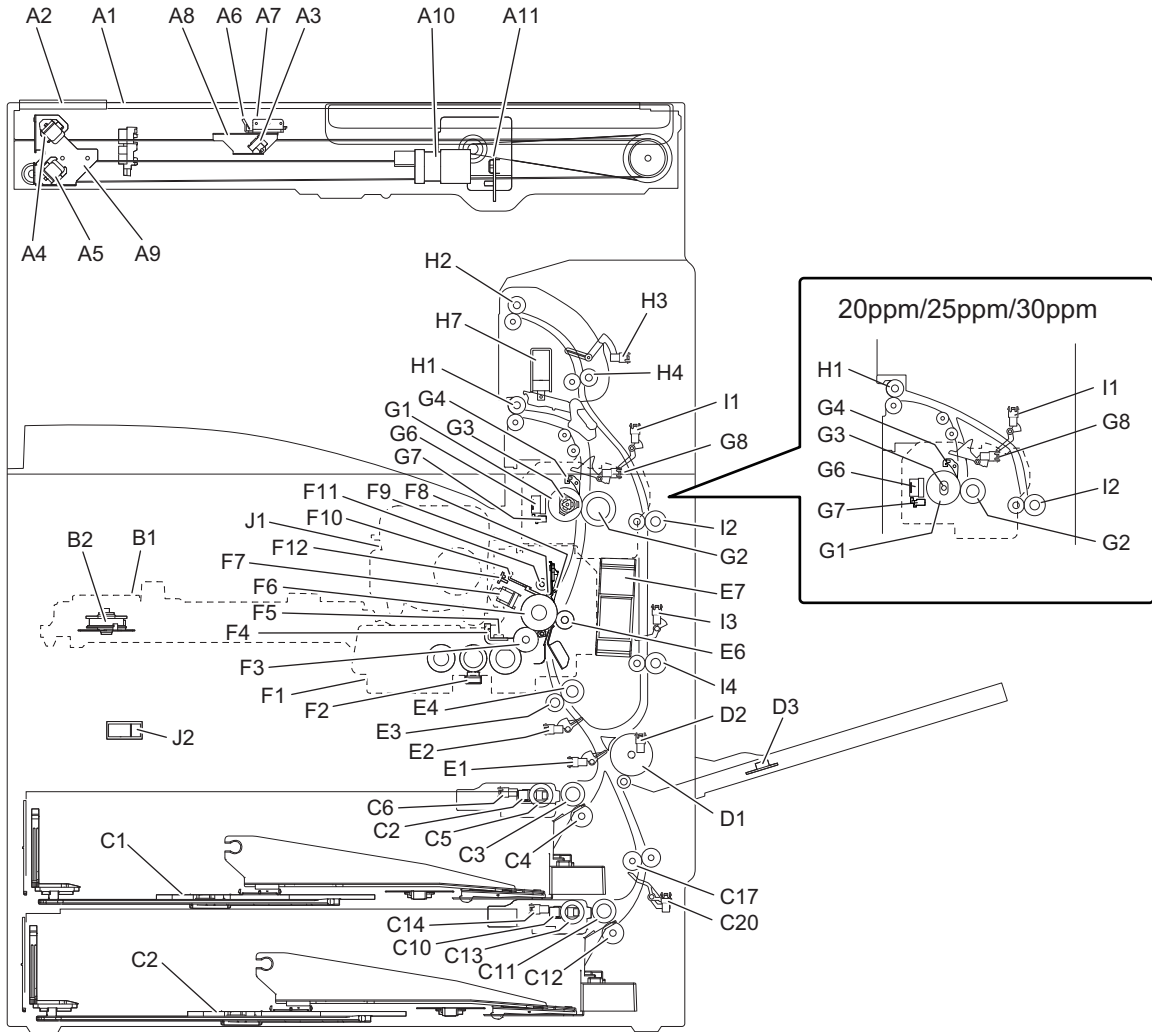


Fig. 3-1

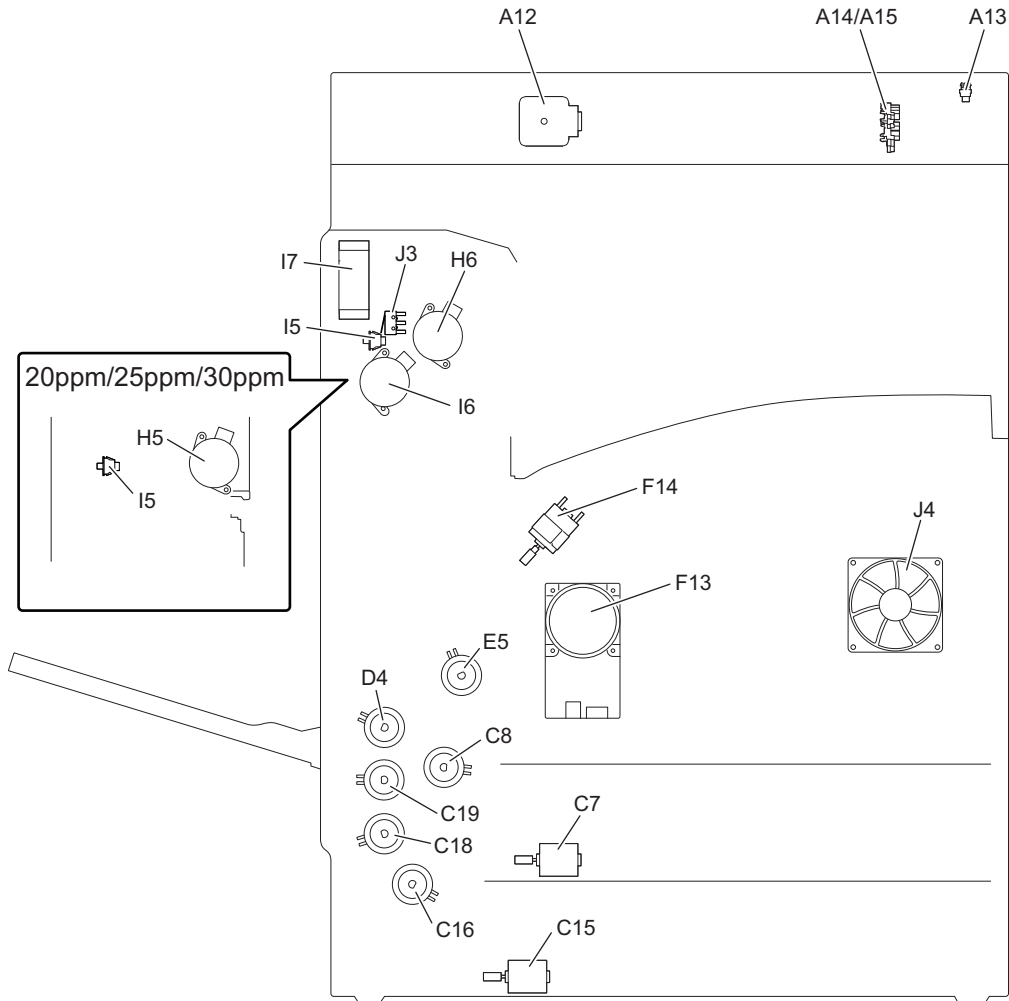


Fig. 3-2

A1	Original glass	E4	Registration roller (rubber)
A2	RADF original glass	E5	Registration roller clutch
A3	Mirror-1	E6	Transfer roller
A4	Mirror-2	E7	TRU fan
A5	Mirror-3	F1	Developer unit
A6	Reflector	F2	Auto-toner sensor
A7	Exposure lamp	F3	Developer sleeve (magnetic roller)
A8	Carriage-1	F4	Doctor blade
A9	Carriage-2	F5	Drum thermistor
A10	Lens	F6	Drum
A11	CCD driving PC board (CCD board)	F7	Main charger
A12	Scan motor	F8	Separation finger for drum
A13	Carriage home position sensor	F9	Recovery blade
A14	Platen sensor-1	F10	Cleaning blade
A15	Platen sensor-2	F11	Toner recovery auger
B1	Laser optical unit	F12	Discharge LED
B2	Polygonal motor	F13	Main motor
C1	1st drawer	F14	Toner motor
C2	1st drawer pick-up roller	G1	Fuser roller
C3	1st drawer feed roller	G2	Pressure roller
C4	1st drawer separation roller	G3	Heater lamp
C5	1st drawer tray-up sensor	G4	Separation finger for fuser roller
C6	1st drawer empty sensor	G5	Fuser center thermostat
C7	1st tray-up motor	G6	Fuser front thermostat
C8	1st drawer feed clutch	G7	Center/side/edge thermistor
C9	2nd drawer	G8	Exit sensor
C10	2nd drawer pick-up roller	H1	Exit roller (20ppm/25ppm/30ppm) / Lower exit roller (35ppm/45ppm/50ppm)
C11	2nd drawer feed roller	H2	Upper exit roller
C12	2nd drawer separation roller	H3	Reverse sensor
C13	2nd drawer tray-up sensor	H4	Reverse roller
C14	2nd drawer empty sensor	H5	Exit motor
C15	2nd tray-up motor	H6	Reverse motor
C16	2nd drawer feed clutch	H7	Reverse gate solenoid
C17	Transport roller	I1	ADU entrance sensor
C18	Low speed transport clutch	I2	ADU upper transport roller
C19	High speed transport clutch	I3	ADU exit sensor
C20	2nd transport sensor	I4	ADU lower transport roller
D1	Bypass feed roller	I5	ADU opening/closing switch
D2	Bypass paper sensor	I6	ADU motor
D3	Paper size detection board	I7	Exit section cooling fan
D4	Bypass feed clutch	J1	Toner cartridge
E1	1st transport sensor	J2	Main power switch
E2	Registration sensor	J3	ADU interlock switch
E3	Registration roller (metal)	J4	Switching regulator cooling fan

# 3.2 Electric Parts Layout

## [A] Scanner unit, control panel

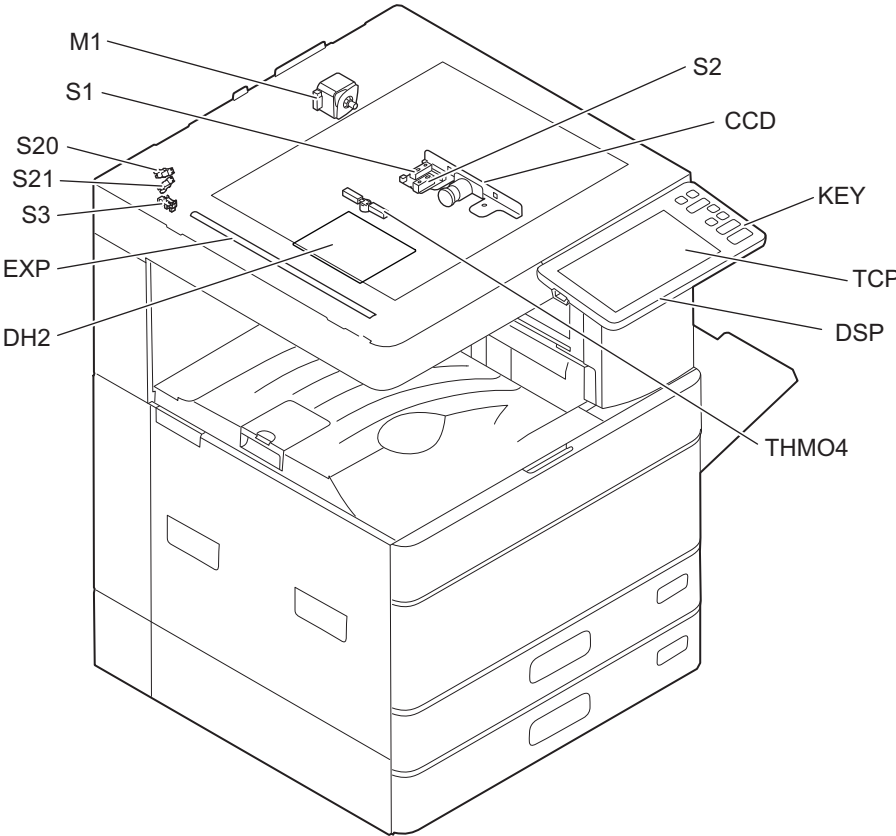


Fig. 3-3

[B] Power supply, switch, developer unit

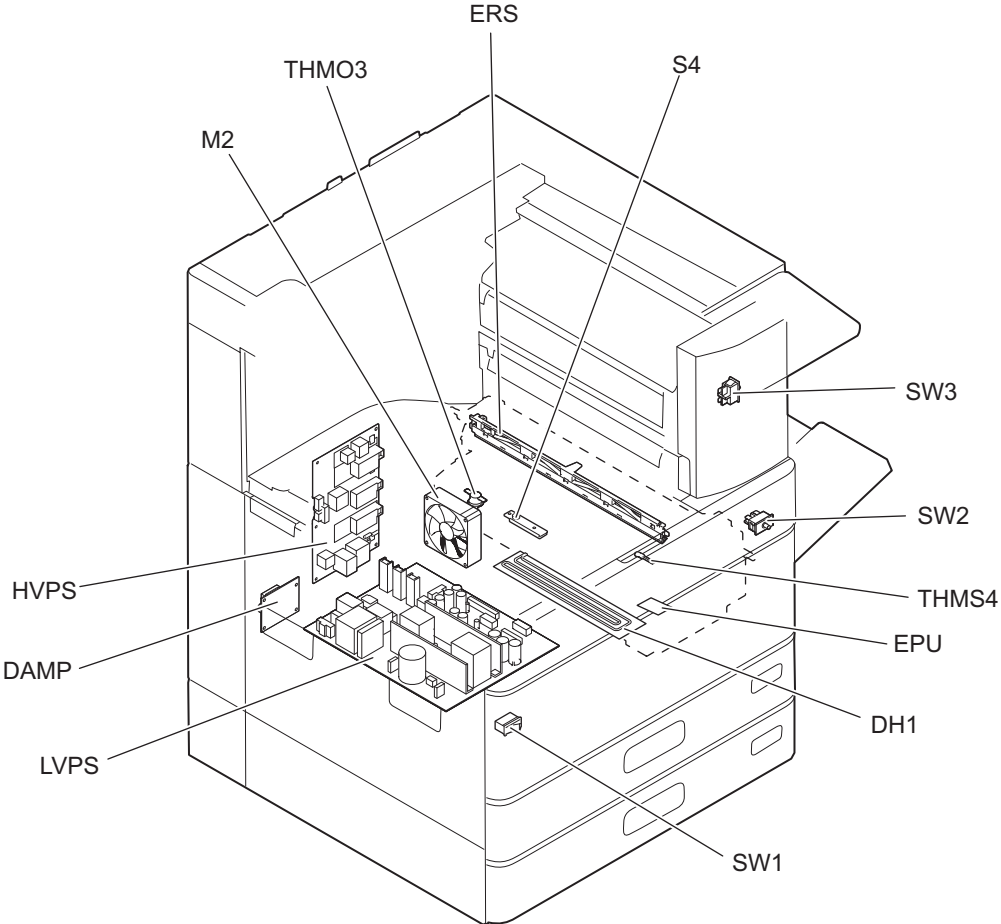


Fig. 3-4

[C] Laser unit, fuser unit, toner cartridge

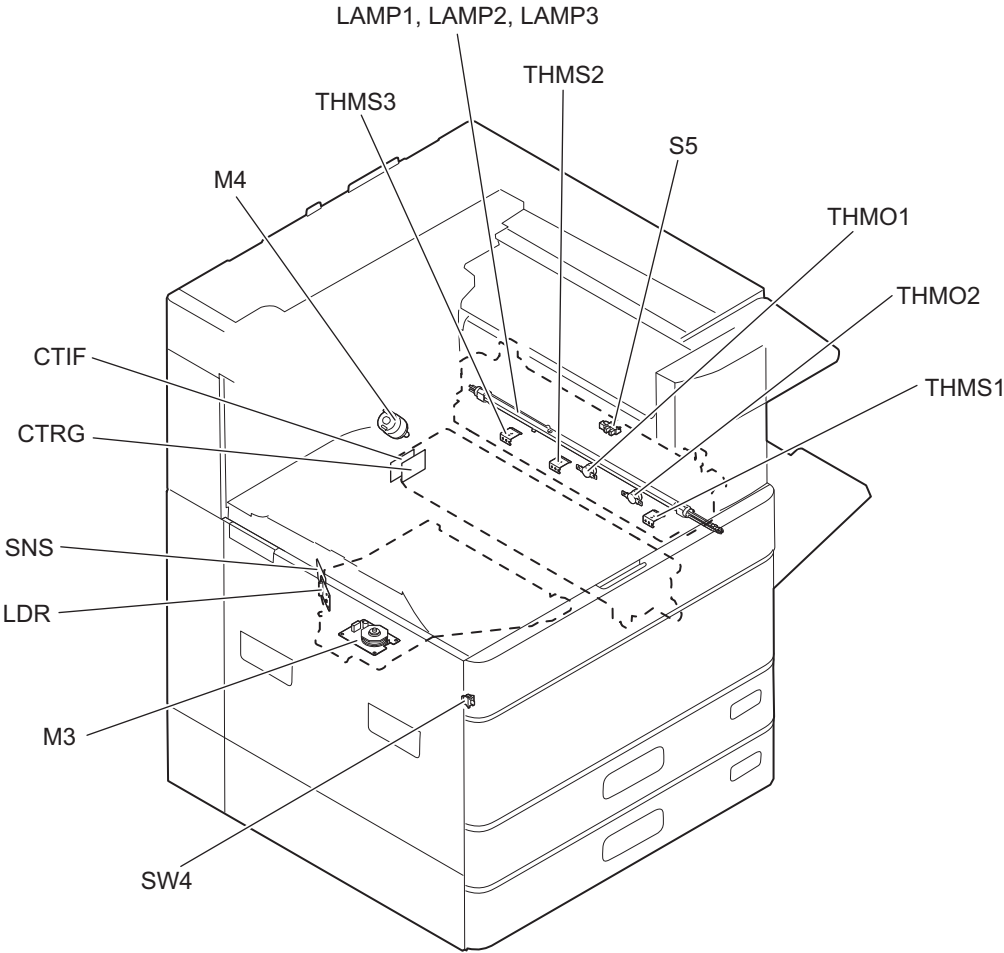


Fig. 3-5

[D] Drive unit

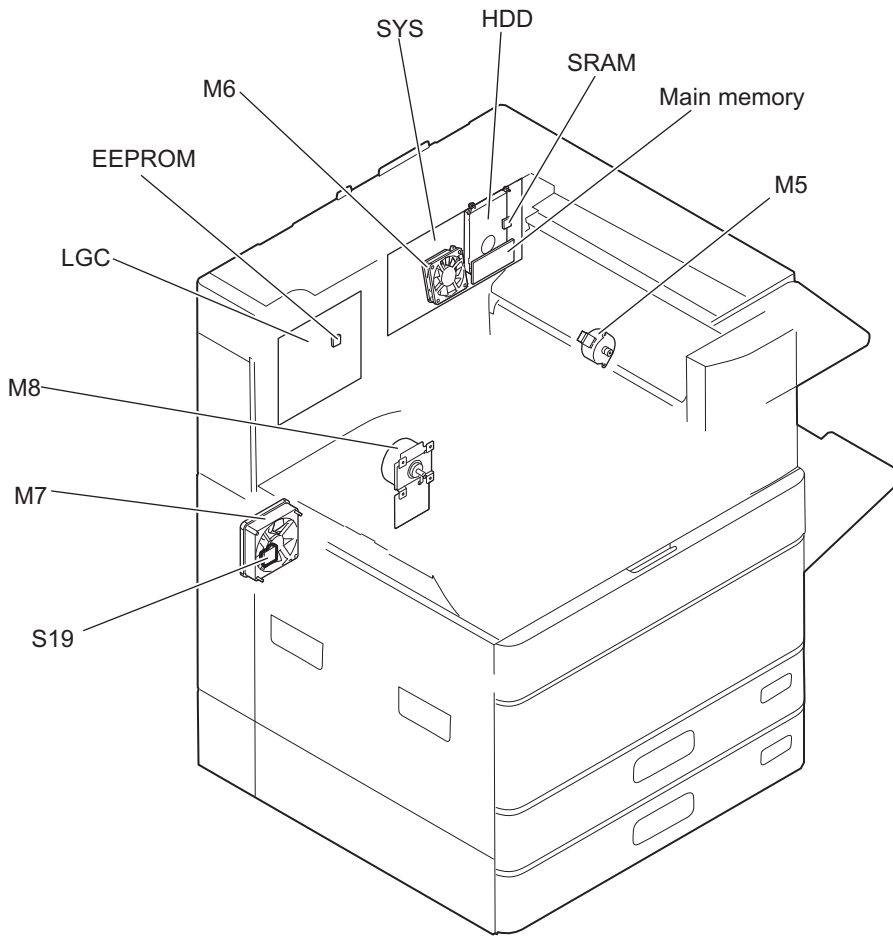
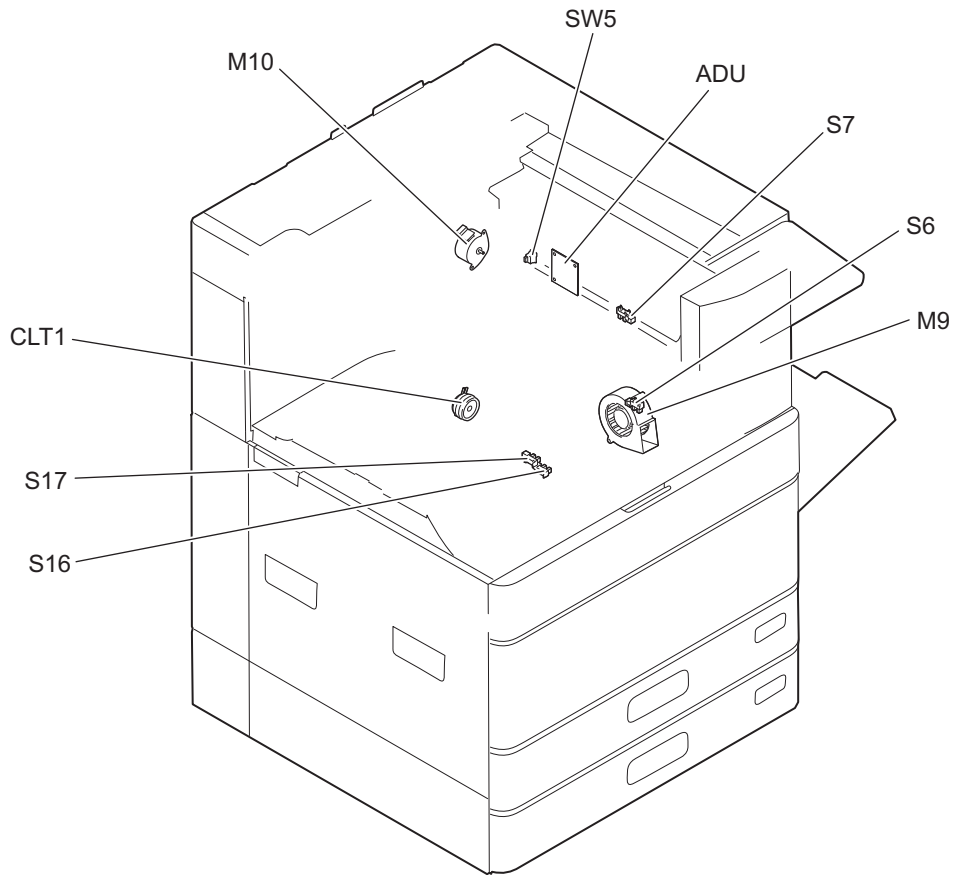


Fig. 3-6

**[E] Automatic duplexing unit, transfer unit, exit unit**  
20ppm/25ppm/30ppm



**Fig. 3-7**



35ppm/45ppm/50ppm

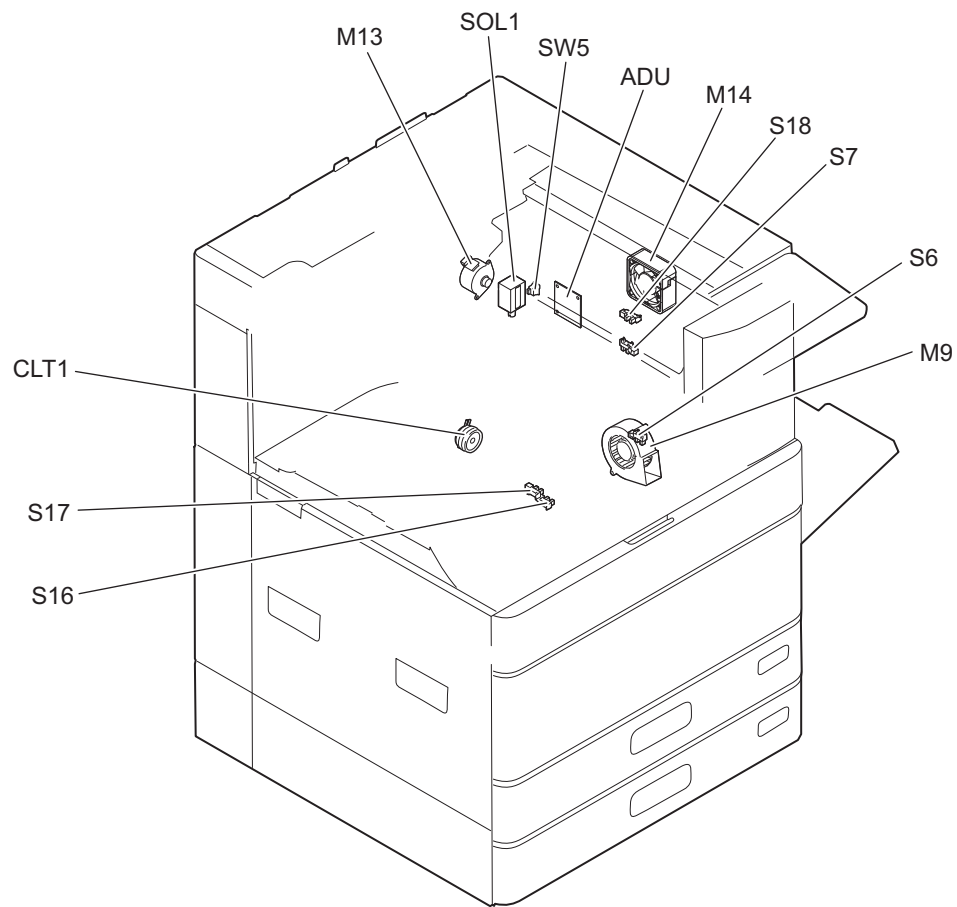
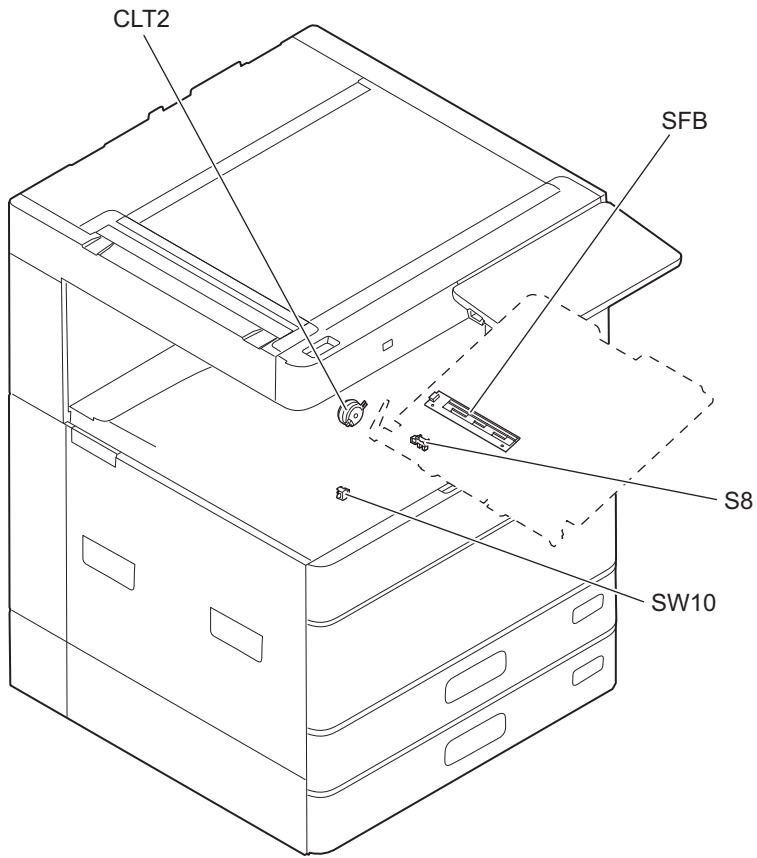


Fig. 3-8

**[F] Bypass feed unit**



**Fig. 3-9**

[G] Drawer unit

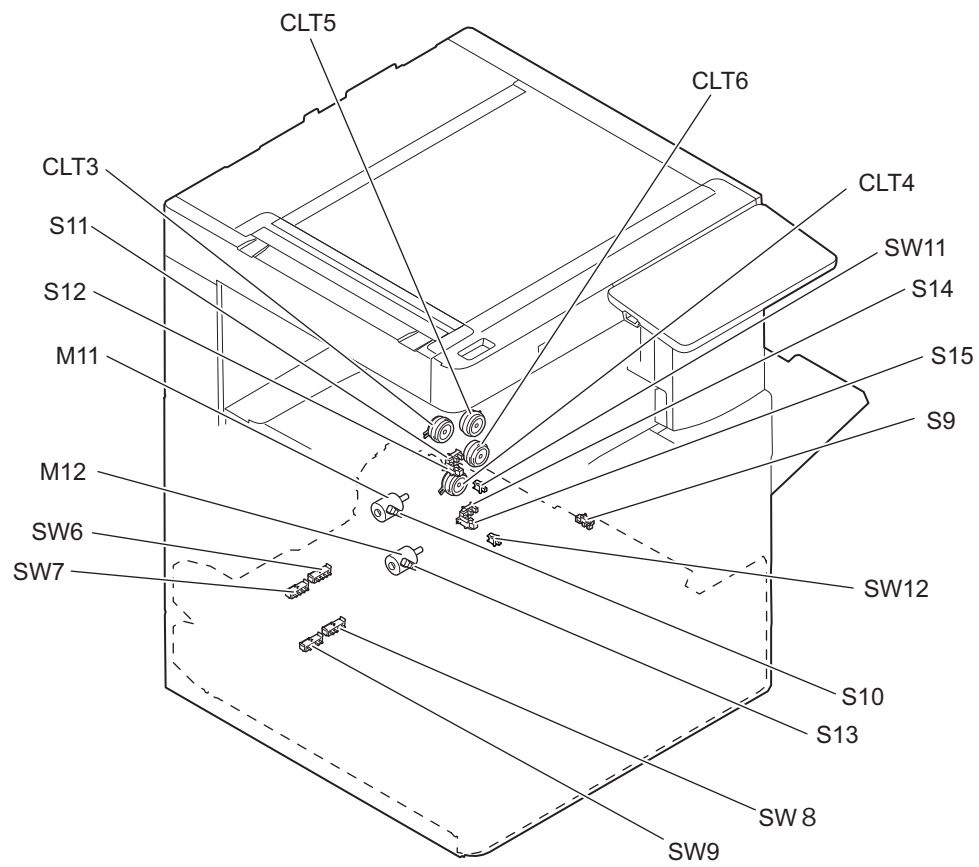


Fig. 3-10

### 3.3 Symbols and Functions of Various Components

The column "P-I" shows the page and item number in the parts list.

#### 3.3.1 Motors

Symbol	Name	Function	Remarks		P-I
M1	SCAN-MOT Scan motor	Driving the carriages	[A] Scanner unit, control panel	Fig. 3-3	14-8
M2	PU-FAN Process unit fan	Cooling down the process unit	[B] Power supply, switch, developer unit	Fig. 3-4	4-14
M3	POL-MOT Polygonal motor	Driving the polygonal mirror	[C] Laser unit, fuser unit, toner cartridge	Fig. 3-5	10-1
M4	TNR-MOT Toner motor	Transporting toner from the toner cartridge to the developer unit	[C] Laser unit, fuser unit, toner cartridge	Fig. 3-5	13-29
M5	ADU-MOT ADU motor	Driving the automatic duplexing unit	[D] Drive unit	Fig. 3-6	33-16
M6	SYS-FAN-MOT SYS board cooling fan	Cooling down the SYS board	[D] Drive unit	Fig. 3-6	8-27
M7	POW-FAN Switching regulator cooling fan	Cooling down the switching regulator	[D] Drive unit	Fig. 3-6	4-14
M8	MAIN-MOT Main motor	Driving the drum, developer unit, fuser unit, registration roller, transport rollers, feed rollers and pick-up rollers. Driving the lower exit roller (35ppm/45ppm/50ppm)	[D] Drive unit	Fig. 3-6	13-21
M9	TRU-FAN TRU fan	Assisting the paper separation process	[E] Automatic duplexing unit, transfer unit, exit unit	Fig. 3-7 Fig. 3-8	12-7
M10	EXIT-MOT Exit motor	Driving the exit roller * 20ppm/25ppm/30ppm only	[E] Automatic duplexing unit, transfer unit, exit unit	Fig. 3-7	39-34
M11	TRAY-U-MOT Upper tray-up motor	Driving the lifting movement of trays in upper drawer	[G] Drawer unit	Fig. 3-10	37-12
M12	TRAY-L-MOT Lower tray-up motor	Driving the lifting movement of trays in lower drawer	[G] Drawer unit	Fig. 3-10	37-12
M13	REV-MOT Reverse motor	Driving the reverse roller and upper exit roller * 35ppm/45ppm/50ppm only	[E] Automatic duplexing unit, transfer unit, exit unit	Fig. 3-8	39-34
M14	EXIT-FAN Exit section cooling fan	Cooling down the exit section * 35ppm/45ppm/50ppm only	[E] Automatic duplexing unit, transfer unit, exit unit	Fig. 3-8	34-25

### 3.3.2 Sensors and switches

Symbol	Name	Function	Remarks	P-I
S1	APS1 Automatic original detection sensor-1	Detecting original size (for LT size)	[A] Scanner unit, control panel	Fig. 3-3 11-12
S2	APS2 Automatic original detection sensor-2	Detecting original size	[A] Scanner unit, control panel	Fig. 3-3 11-12
S3	HOME-SNR Carriage home position sensor	Carriage home position detection	[A] Scanner unit, control panel	Fig. 3-3 15-5
S4	ATTNR-SNR Auto-toner sensor	Detecting the density of toner in the developer unit	[B] Power supply, switch, developer unit	Fig. 3-4 27-20
S5	EXIT-SNR Exit sensor	Detecting the transporting paper at the exit section	[C] Laser unit, fuser unit, toner cartridge	Fig. 3-5 32-25
S6	ADU-TR1-SNR ADU exit sensor	Detecting the transporting paper in automatic duplexing unit	[E] Automatic duplexing unit, transfer unit, exit unit	Fig. 3-7 Fig. 3-8 33-19
S7	ADU-TR2-SNR ADU entrance sensor	Detecting the transporting paper at automatic duplexing unit entrance section	[E] Automatic duplexing unit, transfer unit, exit unit	Fig. 3-7 Fig. 3-8 33-19
S8	SFB-EMP-SNR Bypass paper sensor	Detecting presence/absence of paper on the bypass tray	[F] Bypass feed unit	Fig. 3-9 19-36
S9	2ND-FEED-SNR 2nd transport sensor	Detecting the transport paper and jamming fed from the 2nd drawer or PFP/LCF	[G] Drawer unit	Fig. 3-10 20-5
S10	CST1-NEAR-EMP-SNR 1st drawer paper stock sensor	Paper amount detection in the 1st drawer	[G] Drawer unit	Fig. 3-10 37-7
S11	CST1-TRY-SNR 1st drawer tray-up sensor	Position detection of the lifting tray of the 1st drawer	[G] Drawer unit	Fig. 3-10 6-56
S12	CST1-EMP-SNR 1st drawer empty sensor	Paper presence/absence detection in the 1st drawer	[G] Drawer unit	Fig. 3-10 6-56
S13	CST2-NEAR-EMP-SNR 2nd drawer paper stock sensor	Paper amount detection in the lower drawer	[G] Drawer unit	Fig. 3-10 37-7
S14	CST2-TRY-SNR 2nd drawer tray-up sensor	Position detection of the lifting tray of the 2nd drawer	[G] Drawer unit	Fig. 3-10 6-56
S15	CST2-EMP-SNR 2nd drawer empty sensor	Paper presence/absence detection in the 2nd drawer	[G] Drawer unit	Fig. 3-10 6-56
S16	1ST-FEED-SNR 1st transport sensor	Detecting the transporting paper and jamming fed from the bypass, drawer, ADU	[E] Automatic duplexing unit, transfer unit, exit unit	Fig. 3-7 Fig. 3-8 20-5
S17	RGST-SNR Registration sensor	Detecting the paper transport at the registration roller section	[E] Automatic duplexing unit, transfer unit, exit unit	Fig. 3-7 Fig. 3-8 20-5

Symbol	Name	Function	Remarks	P-I	
S18	REV-SNR Reverse sensor	Detecting the transporting paper at the reverse section * 35ppm/45ppm/50ppm only	[E] Automatic duplexing unit, transfer unit, exit unit	Fig. 3-8	34-9
S19	TEMP/HUMI-SNR Temperature/humidity sensor	Detecting the temperature and humidity of the outside air taken into the equipment	[D] Drive unit	Fig. 3-6	4-16
S20	PLTN-SNR1 Platen sensor-1	Detecting the opening/closing status of the platen cover or RADF	[A] Scanner unit, control panel	Fig. 3-3	14-13
S21	PLTN-SNR2 Platen sensor-2	Detecting the opening/closing status of the platen cover or RADF	[A] Scanner unit, control panel	Fig. 3-3	14-13
SW1	MAIN-SW Main power switch	Turning ON/OFF of the equipment	[B] Power supply, switch, developer unit	Fig. 3-4	5-18
SW2	FRNT-COV-INTLCK-SW Front cover interlock switch	Supplying or shutting off AC power to the switching regulator (voltage generating circuit interlocked with these covers) according to the opening/closing status of the front cover (Cover open: Shut off)	[B] Power supply, switch, developer unit	Fig. 3-4	5-41
SW3	ADU-INTLCK-SW ADU interlock switch	Supplying or shutting off AC power to the switching regulator (voltage generating circuit interlocked with these covers) according to the opening/closing status of the automatic duplexing unit (Cover open: Shut off)	[B] Power supply, switch, developer unit	Fig. 3-4	5-41
SW4	FRONT-COV-SW Front cover switch	Detecting opening/closing of the front cover	[C] Laser unit, fuser unit, toner cartridge	Fig. 3-5	5-42
SW5	ADU-COV-SW ADU opening/closing switch	Detecting opening/closing of the automatic duplexing unit	[E] Automatic duplexing unit, transfer unit, exit unit	Fig. 3-7 Fig. 3-8	7-6
SW6	CST1-WDT-SW 1st drawer paper width detection switch	Detecting the width of paper in the 1st drawer	[G] Drawer unit	Fig. 3-10	37-16
SW7	CST1-LGT-SW 1st drawer paper length detection switch	Detecting the length of paper in the 1st drawer	[G] Drawer unit	Fig. 3-10	37-16
SW8	CST2-WDT-SW 2nd drawer paper width detection switch	Detecting the width of paper in the 2nd drawer	[G] Drawer unit	Fig. 3-10	37-16
SW9	CST2-LGT-SW 2nd drawer paper length detection switch	Detecting the length of paper in the 2nd drawer	[G] Drawer unit	Fig. 3-10	37-16
SW10	FEED-COV-SW Feed cover opening/closing switch	Feed cover opening/closing detection	[F] Bypass feed unit	Fig. 3-9	20-27
SW11	CST1-SW 1st drawer detection switch	Detecting the presence of the 1st drawer	[G] Drawer unit	Fig. 3-10	6-54

Symbol	Name	Function	Remarks	P-I
SW12	CST2-SW 2nd drawer detection switch	Detecting the presence of the 2nd drawer	[G] Drawer unit Fig. 3-10	6-54

### 3.3.3 Electromagnetic clutches

Symbol	Name	Function	Remarks	P-I
CLT1	RGST-CLT Registration roller clutch	Driving the registration roller	[E] Automatic duplexing unit, transfer unit, exit unit Fig. 3-7 Fig. 3-8	38-31
CLT2	SFB-CLT Bypass feed clutch	Driving the bypass feed roller	[F] Bypass feed unit Fig. 3-9	19-13
CLT3	CST1-FEED-CLT 1st drawer feed clutch	Driving the 1st drawer pick-up roller	[G] Drawer unit Fig. 3-10	38-10
CLT4	CST2-FEED-CLT 2nd drawer feed clutch	Driving the 2nd drawer pick-up roller	[G] Drawer unit Fig. 3-10	38-10
CLT5	TR-U-CLT High speed transport clutch	Driving with high speed for the transport roller	[G] Drawer unit Fig. 3-10	38-30
CLT6	TR-M-CLT Low speed transport clutch	Driving with low speed for the transport roller	[G] Drawer unit Fig. 3-10	38-10

### 3.3.4 Solenoids

Symbol	Name	Function	Remarks	P-I
SOL1	REV-SOL Reverse gate solenoid	Changing the paper transport route at the exit section * 35ppm/45ppm/50ppm only	[E] Automatic duplexing unit, transfer unit, exit unit Fig. 3-8	39-30

### 3.3.5 PC boards

Symbol	Name	Function	Remarks	P-I	
CCD	PWA-F-CCD CCD driving PC board (CCD board)	Controlling CCD and outputting the analog signal	[A] Scanner unit, control panel	Fig. 3-3	11-9
CTIF	PWA-H-CTIF Toner cartridge interface PC board (CTIF board)	Interface for detecting the toner cartridge (Detecting the CTRG board)	[C] Laser unit, fuser unit, toner cartridge	Fig. 3-5	6-60
CTRG	PWA-H-CTRG Toner cartridge PC board (CTRG board)	Storing the status of the toner cartridge	[C] Laser unit, fuser unit, toner cartridge	Fig. 3-5	---
DSP	PWA-F-DSP Display PC board (DSP board)	Controlling the whole control panel	[A] Scanner unit, control panel	Fig. 3-3	3-15
EPU	PWA-F-EPU EPU memory board (EPU board)	Determining the used status of the developer unit (EPU) (Determining whether a unit is new or used) (Service management required)	[B] Power supply, switch, developer unit	Fig. 3-4	27-21
KEY	PWA-F-KEY Key control PC board (KEY board)	Controlling the key switches and LEDs	[A] Scanner unit, control panel	Fig. 3-3	3-14
LDR	PWA-H-LDR Laser driving PC board (LDR board)	Driving the laser diode	[C] Laser unit, fuser unit, toner cartridge	Fig. 3-5	10-1
LGC	PWA-H-LGC Logic PC board (LGC board)	Controlling the print engine section	[D] Drive unit	Fig. 3-6	8-7
SFB	PWA-H-SFB Paper size detection board	Detecting the width of paper on the bypass tray	[F] Bypass feed unit	Fig. 3-9	18-6
SNS	PWA-H-SNS H-sync signal detection PC board (SNS board)	Detection of the laser beam position	[C] Laser unit, fuser unit, toner cartridge	Fig. 3-5	10-1
SYS	PWA-H-SYS System control PC board (SYS board)	Controlling the whole system and image processing	[D] Drive unit	Fig. 3-6	8-29
ADU	PWA-H-ADU ADU board (ADU board)	Driving the ADU motor	[E] Automatic duplexing unit, transfer unit, exit unit	Fig. 3-7 Fig. 3-8	33-1



### 3.3.6 Lamps and heaters

Symbol	Name	Function	Remarks	P-I	
DH1	DRM-DH Drum damp heater	Preventing condensation of the drum	[B] Power supply, switch, developer unit	Fig. 3-4	5-20
DH2	SCN-DH Scanner damp heater	Preventing condensation of the carriages	[A] Scanner unit, control panel	Fig. 3-3	11-17
ERS	LP-ERS Discharge LED	Removing the residual charge from the drum surface	[B] Power supply, switch, developer unit	Fig. 3-4	26-32
EXP	LP-EXPO Exposure lamp	Exposing the original to the light (LED)	[A] Scanner unit, control panel	Fig. 3-3	22-3
LAMP1	CNTR-LAMP Center heater lamp	Heating the center section of fuser roller	[C] Laser unit, fuser unit, toner cartridge	Fig. 3-5	30-8
LAMP2	SIDE-LAMP Side heater lamp	Heating the section of both sides of fuser roller	[C] Laser unit, fuser unit, toner cartridge	Fig. 3-5	30-8
LAMP3	LAMP-TRIPLE Sub heater lamp	Sub heating of the fuser roller * 35ppm/45ppm/50ppm only	[C] Laser unit, fuser unit, toner cartridge	Fig. 3-5	30-8

### 3.3.7 Thermistors and thermostats

Symbol	Name	Function	Remarks	P-I	
THMO1	THERMO-FSR-C Fuser center thermostat	Preventing overheating in the fuser unit	[C] Laser unit, fuser unit, toner cartridge	Fig. 3-5	30-6
THMO2	THERMO-FSR-F Fuser front thermostat	Preventing overheating in the fuser unit	[C] Laser unit, fuser unit, toner cartridge	Fig. 3-5	30-6
THMO3	THERMO-DRM-DH Drum damp heater thermostat	Controlling the temperature of the drum damp heater	[B] Power supply, switch, developer unit	Fig. 3-4	5-21
THMO4	THERMO-SCN-DH Scanner damp heater thermostat	Controlling the temperature of the scanner damp heater	[A] Scanner unit, control panel	Fig. 3-3	11-17
THMS1	THMS-C-HTR Center thermistor	Detecting the surface temperature at fuser roller center (for controlling the temperature of the center heater lamp)	[C] Laser unit, fuser unit, toner cartridge	Fig. 3-5	31-5
THMS2	THMS-S-HTR Side thermistor	Detecting the surface temperature at the rear side of the fuser roller (for controlling the temperature of the side heater lamp)	[C] Laser unit, fuser unit, toner cartridge	Fig. 3-5	31-5
THMS3	THMS-EDG-HTR Edge thermistor	Detecting the surface temperature at the edge of the fuser roller (for preventing overheating)	[C] Laser unit, fuser unit, toner cartridge	Fig. 3-5	31-5

Symbol	Name	Function	Remarks	P-I
THMS4	THMS-DRM Drum thermistor	Detecting the temperature at the drum surface	[B] Power supply, switch, developer unit	Fig. 3-4 27-22

### 3.3.8 Transformer

Symbol	Name	Function	Remarks	P-I
HVPS	PS-HVT High-voltage transformer	Generating high-voltage and supplying it to the following sections <ul style="list-style-type: none"> <li>• Needle electrode</li> <li>• Main charger grid</li> <li>• Developer bias</li> <li>• Transfer bias</li> </ul>	[B] Power supply, switch, developer unit	Fig. 3-4 9-6

### 3.3.9 Others

Symbol	Name	Function	Remarks	P-I
TCP	TCP Touch panel	Displaying and entering various kinds of information	[A] Scanner unit, control panel	Fig. 3-3 3-1
HDD	HDD Hard disk	Storing the program data and image data	[D] Drive unit	Fig. 3-6 8-16
LVPS	PS-ACC Switching regulator	Generating DC voltage and supplying it to each section of the equipment	[B] Power supply, switch, developer unit	Fig. 3-4 9-5
DAMP	PWA-H-DAMP DAMP board	Power supplying to each damp heater	[B] Power supply, switch, developer unit	Fig. 3-4 9-11
Main memory	Main memory	Saving data and programs temporarily (Also used as page memory in this equipment.)	[D] Drive unit	Fig. 3-6 8-25
SRAM	SRAM	Storing the setting or program, etc. used for the control by the system PC board	[D] Drive unit	Fig. 3-6 8-26
EEPROM	EEPROM Electrically Erasable Programmable Read Only Memory	Storing the setting or adjustment value, etc. used for the control by the logic PC board	[D] Drive unit	Fig. 3-6 8-23

## 3.4 Copy Process

### 3.4.1 General Description of Copying Process

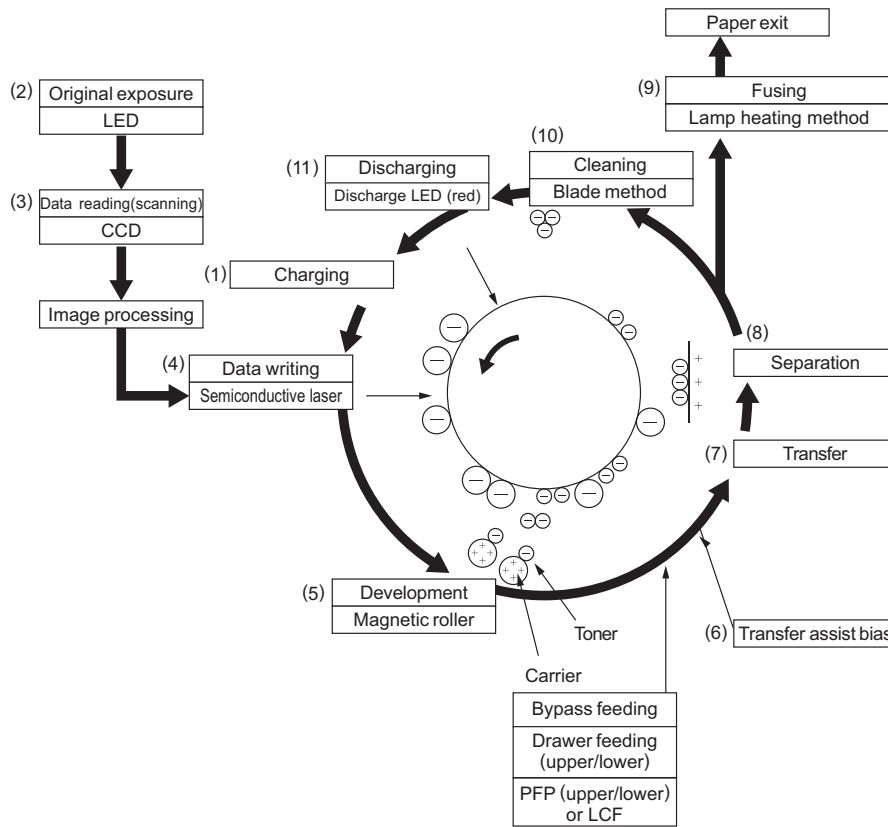


Fig. 3-11

- |  |   |
|--|---|
| (1) Charging: Applies negative charge on the surface of the photoconductive drum.  | (7) Transfer: Transfers the visible toner image on the photoconductive drum onto paper.                 |
| ↓  | ↓   |
| (2) Original exposure: Converts images on the original into optical signals.   | (8) Separation: Separates paper with the toner image from the photoconductive drum.                     |
| ↓  | ↓   |
| (3) Data reading: The optical signals are converted into electrical signals.   | (9) Fusing: Fuses the toner image onto the paper by applying heat and pressure.                         |
| ↓  | ↓   |
| (4) Data writing: The electrical signals are converted into light signal (laser emission) which exposes the surface of the photoconductive drum. | (10) Cleaning: Scrapes off the residual toner from the drum.  |
| ↓  | ↓   |
| (5) Development: Negatively-charged toner adheres to the photoconductive drum and forms visible image.   | (11) Discharging: Eliminates the residual negative charge from the surface of the photoconductive drum. |
| ↓  |   |
| (6) Transfer assist bias: Improves transfer efficiency.  |   |
| ↓  |   |

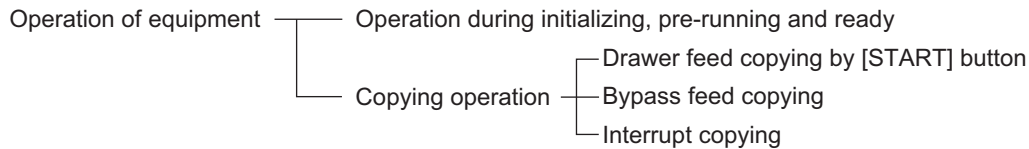
### 3.5 Comparison with e-STUDIO2008A/2508A/3008A/3508A/4508A/5008A

Process	e-STUDIO2008A/2508A/3008A/3508A/4508A/5008A		e-STUDIO2018A/2518A/3018A/3518A/4518A/5018A	
	e-STUDIO2008A/2508A/3008A	e-STUDIO3508A/4508A/5008A	e-STUDIO2018A/2518A/3018A	e-STUDIO3518A/4518A/5018A
1. Photoconductive drum	PS-OD-4530, OD-4530C (OPC $\phi$ 30)	←	←	←
• Sensitivity	Highly sensitized/durable drum	←	←	←
• Surface potential	-391V (Adjustable)	←	←	←
2. Charging	Scorotron method (Needle electrode)	←	←	←
• Grid voltage	-407V (Adjustable output)	-429V (Adjustable output)	-407V (Adjustable output)	-429V (Adjustable output)
3. Data writing	Semiconductor laser (Adjustable output)	←	←	←
• Light source	Semiconductor laser (Adjustable output)	←	←	←
• Light amount	-3.50nJ/mm <sup>2</sup> (Adjustable output)	-3.75nJ/mm <sup>2</sup> (Adjustable output)	-3.50nJ/mm <sup>2</sup> (Adjustable output)	-3.75nJ/mm <sup>2</sup> (Adjustable output)
4. Development	One magnetic roller	←	←	←
• Magnetic roller	One magnetic roller	←	←	←
• Auto-toner	Magnetic bridgecircuit method	←	←	←
• Toner supply	Toner cartridge	←	←	←
• Toner-empty detection	Density detection method	←	←	←
• Toner	PS-ZT3008U(1) PS-ZT3008C(1) PS-ZT3008C(8) PS-ZT5070T(1) PS-ZT3008E(1) PS-ZT3008P(1) PS-ZT3008CM(1) PS-ZT3008CM(8)	←	PS-ZT5018U(1) PS-ZT5018C(1) PS-ZT5018C(8) PS-ZT5018T(1) PS-ZT5018E(1) PS-ZT5018P(1) PS-ZT5018CM(1) PS-ZT5018CM(8)	←
• Developer material	PS-ZD5070 D4530C	←	←	←
• Developer bias	DC-268V Adjustable output AC 1100 V No reverse bias output	←	←	←
5. Transfer	Transfer roller output	←	←	←
• Transfer method	Transfer roller output	←	←	←
• Transfer output	Adjustable output (Constant current)	←	←	←
• Transfer assist bias	+475V	←	←	←

Process	e-STUDIO2008A/2508A/3008A/3508A/4508A/5008A		e-STUDIO2018A/2518A/3018A/3518A/4518A/5018A	
	e-STUDIO2008A/2508A/3008A	e-STUDIO3508A/4508A/5008A	e-STUDIO2018A/2518A/3018A	e-STUDIO3518A/4518A/5018A
6. Separation • Separation method  • Separation output	Needle separation method  Adjustable output (Constant current)	←  ←	←  ←	←  ←
7. Discharge • Discharging position  • Discharge LED	Exposure after cleaning  10 red LED's	←  14 red LED's	←  10 red LED's	←  14 red LED's
8. Cleaning • Method  • Recovered toner	Cleaning blade  Reuse (There is the recovered toner supply mechanism.)	←  ←	←  ←	←  ←
9. Fusing • Method    • Cleaning  • Heater	Long-life fuser roller method  • Fuser roller: Thin roller coated with fluoroplastic (ø30)  • Pressure roller: PFA tube roller (ø22)  -  Heater lamp (600W x 2)  Turned ON/OFF by thermistor	←  ← ←  • Pressure roller: PFA tube roller (ø30)  -  ← (600W x 2 + 300W x 1)  ←	←  ← Thin roller coated with fluoroplastic (ø30)  • Pressure roller: PFA tube roller (ø22)  -  ← (600W x 2)  ←	←  ← Thin roller coated with fluoroplastic (ø30)  • Pressure roller: PFA tube roller (ø30)  -  ← (600W x 2 + 300W x 1)  ←

## 3.6 General Operation

### 3.6.1 Overview of operation



### 3.6.2 Description of operation

#### [ 1 ] Warming-up

##### 1. Initialization

Power ON

- Heater lamp ON
- “WAIT WARMING UP” is displayed
- Fan motors ON
- Initialization of scanning system
  - The carriage moves to the home position.
  - The carriage moves to the peak detection position.
  - The exposure lamp is turned ON.
  - Peak detection (white color is detected by the shading correction plate)
  - The exposure lamp is turned OFF.
- “READY (WARMING UP)” is displayed

##### 2. Pre-running operation

The pre-running operation is started when the temperature of the fuser roller surface reaches a certain temperature.

- The main motor is turned ON.
  - Fuser roller rotated
  - Drum rotated
- Initialization of feeding system
  - Each drawer tray goes up.
- Pre-running operation stops after three seconds.

##### 3. When the surface temperature of the fuser roller becomes sufficient for fusing,

- “READY” is displayed.

#### [ 2 ] Ready state (ready for copying)


Buttons on the control panel enabled

- When no button is pressed for a certain period of time,
  - Set number “1” and reproduction ratio “100%” are displayed. Equipment returns to the normal ready state.

### [ 3 ] Drawer feed copying (1st drawer paper feeding)

1. Press the [START] button
  - “READY” changes to “COPYING”
  - Exposure lamp ON
  - Scan motor ON → carriages -1 and -2 move forward
  - Polygonal motor rotates in high speed
  - Main motor and exit motor ON
  - The drum, fuser unit, developer unit and exit roller / lower exit roller are driven.
2. Drawer paper feeding
  - Main charger, developer bias and discharge LED ON. Fans are rotated in high speed. Drawer feed clutch ON.
  - The pick-up roller, feed roller and separation roller start to rotate.
  - Paper reaches the 1st transport sensor
  - The 1st transport sensor is turned ON.
  - Paper reaches the registration roller.
  - The registration sensor is turned ON and aligning is performed.
  - Drawer feed clutch OFF after a certain period of time
3. After the carriage operation:
  - Registration clutch ON after a certain period of time → paper is transported to the transfer area.
  - Copy counter operates
4. After the registration clutch is turned ON:
  - Transfer charger ON after a certain period of time
  - Copy counter operates
5. Completion of scanning
  - Scan motor OFF
  - Exposure lamp OFF
  - Registration clutch OFF (after the trailing edge of the paper passed the registration roller)
  - “READY (PRINTING)” is displayed
  - “WAIT” is displayed
6. Paper exit
  - Exit sensor detects the trailing edge of the paper
  - Main charger, developer bias and discharge LED OFF
  - Polygonal motor, main motor and exit motor OFF
  - Drum, fuser unit and developer unit stop
  - Fans return to the ready rotation
  - “READY” is displayed and the equipment enters the ready mode

#### **[ 4 ] Bypass feed copying**

1. Insert a sheet of paper into the bypass tray.
  - Bypass paper sensor ON
  - “Ready for bypass feeding” is displayed.
2. Press the [START] button
  - “Ready for bypass feeding” changes to “COPYING”
  - Exposure lamp ON
  - Scan motor ON → Carriages -1 and -2 move forward
  - Polygonal motor rotates in high speed
  - Main motor and exit motor ON
  - The drum, fuser unit, developer unit and exit roller / lower exit roller are driven.
3. Bypass feeding
  - Main charger, developer bias and discharge LED ON. Fans are rotated in high speed.
  - Bypass feed clutch ON
  - The bypass feed roller start to rotate.
  - Aligning operation
  - Paper reaches the registration roller
  - After a certain period of time, the bypass feed clutch OFF
4. Hereafter, the operation 3) through 6) of  P. 3-23 “[ 3 ] Drawer feed copying (1st drawer paper feeding)” is repeated.

#### **[ 5 ] Interruption copying**

1. Press the [INTERRUPT] button
  - Copying operation in progress is temporarily stopped. Carriages -1 and -2 return to appropriate positions.
  - “Job interrupted job 1 saved” is displayed.
  - Automatic density and reproduction ratio 100% are set (The set number remains the same)
2. Select the desired copy condition
3. After the interruption copying is finished:
  - The equipment returns to the status before the interruption by pressing the [INTERRUPT] button.
4. Press the [START] button
  - The copying operation before the interruption is resumed.



### 3.6.3 Detection of abnormality

When something abnormal has occurred in the equipment, the symbols corresponding to the type of abnormality are displayed.

#### [ 1 ] Types of abnormality

1. Abnormality cleared without turning OFF the door switch
  - (A) Add paper
  - (B) Pick-up failure in bypass
  - (C) Set key copy counter
  
2. Abnormality not cleared without turning OFF the door switch
  - (D) Misfeed in equipment
  - (E) Replace the toner cartridge
  - (F) EPU not installed properly
  
3. Abnormality not cleared without turning OFF the [ON/OFF] button
  - (G) Call for service

#### [ 2 ] Description of abnormality

(A) Add paper

- Drawer empty sensor detects the presence or absence of paper.

[When drawer is not installed]

No drawer detected

↓

Tray not going up (drawer empty sensor OFF)

↓

“Add paper” displayed

↓

[START] button disabled

[When drawer is installed]

↓

Drawer detected

↓

Tray going up (drawer empty sensor OFF)

↓

“Add paper” displayed

↓

[START] button disabled

- When the power is turned ON or the LCF drawer is inserted (when the power is turned ON or equipment drawer / PFP drawers are inserted), LCF (PFP/equipment) performs initialization.

↓

Detects the presence of paper

Tray-up motor ON – The tray goes up

- When the tray-up sensor is not turned ON in a fixed period of time, it means that the tray is in abnormal condition.
  - “Add paper” is displayed regardless of presence/absence of paper.
    - Cleared by turning the drawer open/close

- Tray-up sensor is turned ON in a fixed period of time.
  - The tray motor stops.

At this time, if the empty sensor is ON: It is judged that there is paper.

OFF: It is judged that there is no paper.

↓

Drawer area of the LCD panel blinks (When the drawer is selected)

- When the paper in the drawer runs out during copying,

- The tray-up sensor turned OFF
- The tray-up motor turned ON → Tray goes up
- The tray-up sensor turned ON → Tray-up motor stopped.

- Empty sensor turned OFF during the copying in spite of the tray-up sensor is ON

↓

It is judged that there is no paper.

↓

Drawer area of the LCD panel blinks (When the drawer is selected)

↓

The copying operation is stopped.


#### (B) Paper misfeed in bypass ( )

- During bypass feeding  
Bypass feed clutch ON

↓

1st transport sensor is not turned ON in a fixed period of time

↓

Clear paper symbol is displayed (  ): E120

↓


Copying operation is disabled

↓

Solution: The bypass paper sensor is turned OFF by removing the paper from the bypass tray.

(C) Set key copy counter

- When the key copy counter (optional) is pulled out from the equipment which installs it:  
 “Set key copy counter” displayed  
 ↓  
 Copying operation disabled
- When the counter is pulled out during copying:  
 Copying is stopped when the key copy counter is pulled out.  
 ↓  
 “Set key copy counter” displayed  
 ↓  
 Copying operation disabled

(D) Misfeed in equipment (  )

- Exit sensor detects jamming of the leading edge of paper.  
 ↓  
 Registration clutch ON  
 ↓ Less than regulation time  
 Exit sensor ON  
 If the exit sensor is not turned ON after the regulation time  
 ↓  
 Paper jam (E010)→ The copying operation is stopped

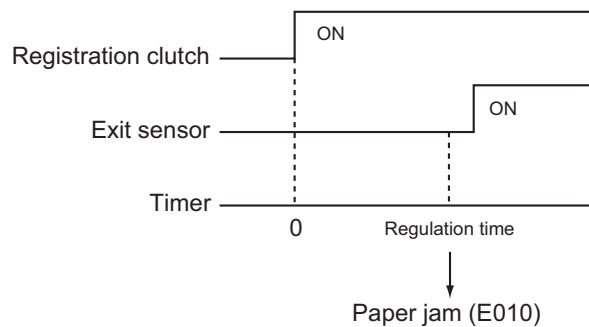


Fig. 3-12

- Exit sensor detects jamming of the tailing edge of paper  
 ↓  
 Registration clutch OFF  
 ↓ Less than regulation time  
 Exit sensor OFF  
 If the exit sensor is not turned OFF after the regulation time  
 ↓  
 Paper jam (E020)→ The copying operation is stopped

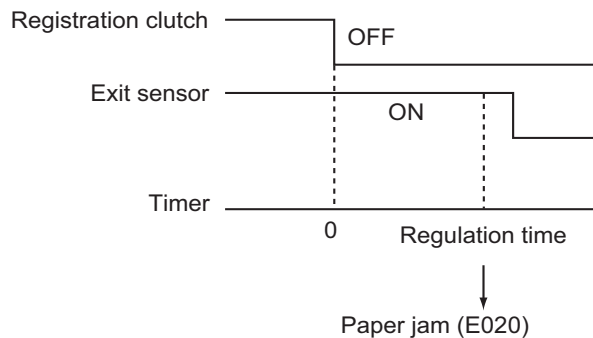


Fig. 3-13

- Reverse sensor detects jamming of the leading edge of paper: 35ppm/45ppm/50ppm  
 Exit sensor ON  
 ↓ Less than regulation time

Reverse sensor ON  
If the reverse sensor is not turned ON after the regulation time



Paper jam (E570)→ The copying operation is stopped.

- Reverse sensor detects jamming of the tailing edge of paper: 35ppm/45ppm/50ppm



Exit sensor OFF



Less than regulation time

Reverse sensor OFF  
If the reverse sensor is not turned OFF after the regulation time



Paper jam (E580)→ The copying operation is stopped.

- Immediately after the power ON



Any of all sensors on paper transport path detects paper (ON)



Paper jam (E030)

- Front cover is opened during copying



Paper jam (E410)

- Registration sensor detects jamming of the leading edge of paper:  
Registration sensor is not turned ON in a fixed period of time after the leading edge of paper passed the 1st transport sensor.



Paper jam (E200, E210, E270, E300, E330 and E3C0)

- During paper feeding from ADU:  
Registration sensor is not turned ON in a fixed period of time after the ADU motor is turned ON.



Paper jam (E110)

- During paper transporting from ADU:  
ADU entrance/exit sensors do not detect the paper at the fixed timing




Paper jam (E510 or E520)

- The 1st/2nd transport sensor and each sensors of PFP/LCF are not turned ON in a fixed period of time after the feed clutch is turned ON



Paper jam (E220, E310, E320, E340–E360, E3D0 and E3E0: Error code differs depending on the paper source.)

(E) Replace the toner cartridge (  )

- Toner density becomes low



Auto-toner sensor detects the absence of the toner



Control circuit → “Install new toner cartridge” displayed: the copying operation disabled

Solution: Open the front cover and replace the toner cartridge with a new one.  
Toner is supplied → copying operation enabled.

(F) EPU not installed properly

- EPU not installed properly



“EPU not installed” is displayed.

Solution: Check if the connector between the EPU drawer and the developer unit is connected.  
Then check if the EPU is installed in the equipment properly and close the front cover.


(G) Call for service

Check the error code displayed on the control panel when “Call for service” appears, and handle the abnormality in reference to the error code table.

 P. 8-6 “8.2 Error Code List”

### 3.6.4 Hibernation function

A hibernation function is embedded in this equipment. This function allows the equipment to store the last status of the system in the HDD immediately before the power is turned OFF, and to restart from this stored status at the next boot-up.

For warming-up time, refer to  P. 2-1 “2.1.1 General”

If hibernation is not performed when the power is turned OFF or the equipment boots up immediately after the settings, warming-up takes longer. It differs depending on the usage conditions; warming-up will take approx. 30 to 150 sec.

The following are the conditions which necessitate a longer warming-up time.

- Rebooting from TopAccess
- First booting after power interruption
- First booting after a self-diagnosis code is changed in the Service UI
- First booting after the power is turned OFF with the main power switch during the super sleep mode
- Installing options or finishers
- First booting after an option or a finisher is removed
- During toner supply
- Operating while “READY (WARMING UP)” is still on the control panel
- Shutting down during network initialization
- First booting after the power is turned OFF in a procedure other than the correct one described in the Quick Start Guide

## 3.7 Control Panel

### 3.7.1 General description

The control panel consists of button switches and touch-panel to operate the equipment and select various modes, and LEDs to display the state of the equipment.

When the operator's attention is required, graphic symbols light or blink with messages explaining the condition of the equipment in the LCD panel. When paper jams and "Call for service" occur, error codes are also displayed to notify users of the problem.

A 10.1-inch resistance film touch panel is used in this equipment, resulting in the improvement of operability.

The [ON/OFF] button is placed on the control panel, and this button is used instead of the main power switch to turn the power ON/OFF.

The digital keys are displayed on the touch panel instead of being located on the control panel. In addition to this, a digital key pad can be installed optionally for a user who wants to carry out the button operation by means of the actual keys.

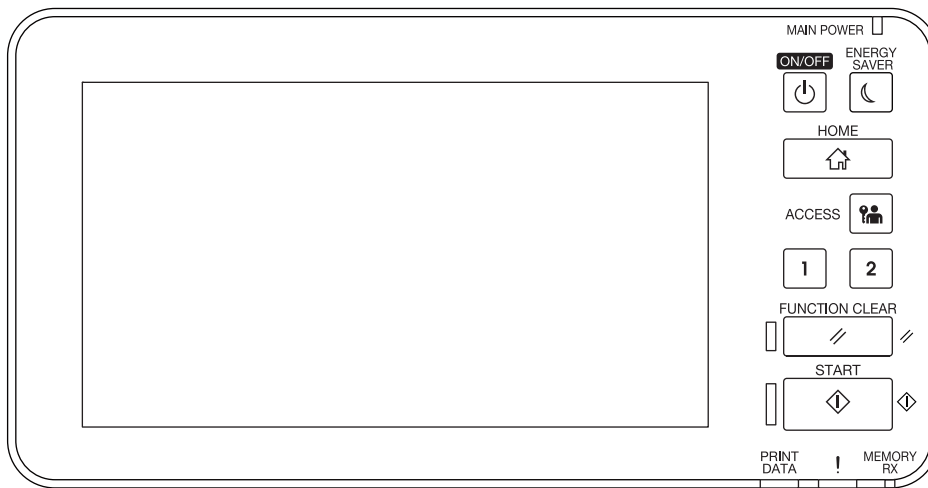


Fig. 3-14

## 3.8 Scanner

### 3.8.1 General description

In the scanning section of this equipment, the surface of an original is irradiated with a direct light and the reflected light is led through mirrors, a lens and a slit to CCD where optical-to-electrical conversion is performed, converting the optical image data into an electrical (analog) signal. This analog signal is changed to a digital signal, which then undertakes various corrective processes necessary for image formation. After that, arithmetic operation is performed on the digital signal, which is then transmitted to the data writing section.

In this equipment, a reduction-type CCD for color processing is used. What this CCD differs from black-and-white CCDs is that its devices are arranged in 3 lines and covered with color filters (Red, Green, and Blue). These lines are composed with 3-line color devices and black-and-white device with no filter.

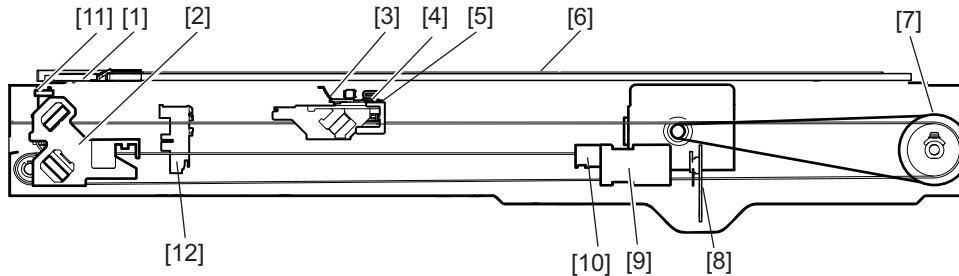


Fig. 3-15

- [1] ADF original glass
- [2] Carriage-2
- [3] Reflector
- [4] Exposure lamp
- [5] Carriage-1
- [6] Original glass
- [7] Drive pulley
- [8] CCD board
- [9] Lens
- [10] Automatic original detection sensor
- [11] Carriage home position sensor
- [12] Platen sensor



### 3.8.2 Construction

Scanner		
Original glass	Original glass	
	ADF original glass	
Carriage-1	Exposure lamp (EXP)	
	Reflector	
	Mirror-1	
Carriage-2	Mirror-2	
	Mirror-3	
Lens unit	Lens	
	CCD driving PC board (CCD)	
Automatic original detection sensor (S1)		
Driving section	Scan motor (M1)	<ul style="list-style-type: none"> <li>• 2-phase stepping motor</li> <li>• Driving the carriage-1 and carriage-2</li> </ul>
Other	Carriage home position sensor (S3)	
	Platen sensor-1 (S20)	
	Platen sensor-2 (S21)	

### 3.8.3 Functions

The following shows the construction and purpose of the scanning system:

#### 1. Original glass

This is a glass for placing original. The light from the exposure lamp (EXP) is irradiated to the original through this glass.

The ADF original glass is used when original is read with the Automatic Document Feeder. Original is transported on the ADF original glass by the Automatic Document Feeder, and the transported original is read under the ADF original glass by the carriage. Do not use such solvents as alcohol when cleaning the surface of the ADF original glass, because it is coated so as not to be scratched by originals.

#### 2. Carriage-1

Carriage-1 consists of the exposure lamp (EXP), reflector, mirror-1, etc. It is driven by the scan motor (M1) and scans an original on the glass.

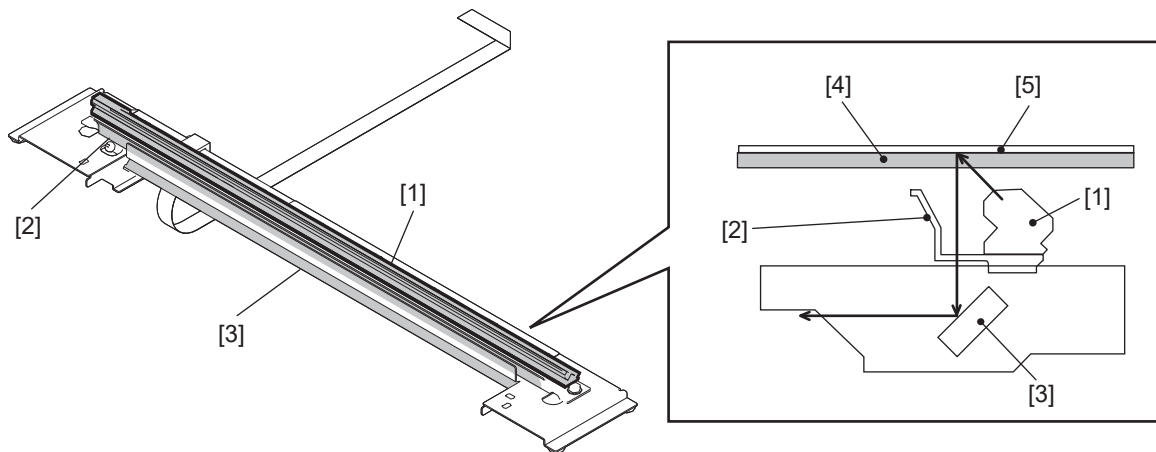


Fig. 3-16

- [1] Exposure lamp
- [2] Reflector
- [3] Mirror-1
- [4] Original glass
- [5] Original

- Exposure lamp (EXP)  
This lamp is the light source to irradiate the original on the glass. (LED lamp)
- Reflector  
This is a plate to efficiently direct the light from the exposure lamp (EXP) to the surface of the original on the glass.
- Mirror-1  
This mirror directs the light reflected from the original to the mirror-2 described later.

3. Carriage-2

Carriage-2 mainly consists of the mirror-2, mirror-3, etc. and directs the reflected light from the mirror-1 through the mirrors-2 and -3 to the lens.

This carriage is driven by the same scan motor (M1) as that for the carriage-1 at half the scanning speed of the carriage-1 (The scanning distance is also half that of the carriage-1).

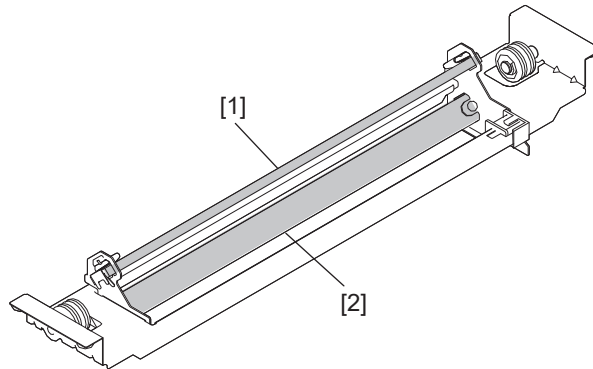


Fig. 3-17

- [1] Mirror-2
- [2] Mirror-3

4. Lens unit

The light reflected from the mirror-3 is led to the CCD placed at the focal point of the lens which is fixed in a position.

5. CCD driving PC board (CCD)

Processes such as signal amplification, signal integration and A/D conversion are applied on the electrical signal which was converted by CCD.

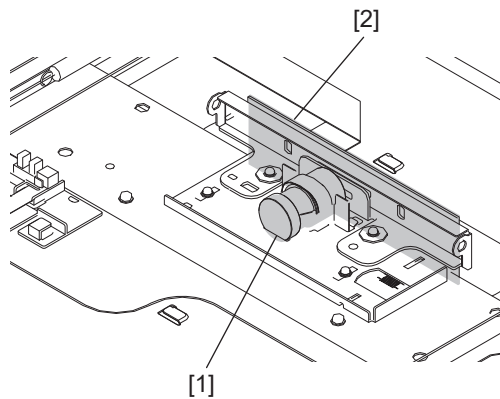


Fig. 3-18

- [1] Lens
- [2] CCD board

6. Automatic original detection sensor (S1, S2)

The size of an original placed on the glass is instantly detected using the automatic original detection sensors (S1, S2) fixed on the base frame without moving the carriage-1.

## 3.8.4 Description of operation

### [ 1 ] Scanning operation

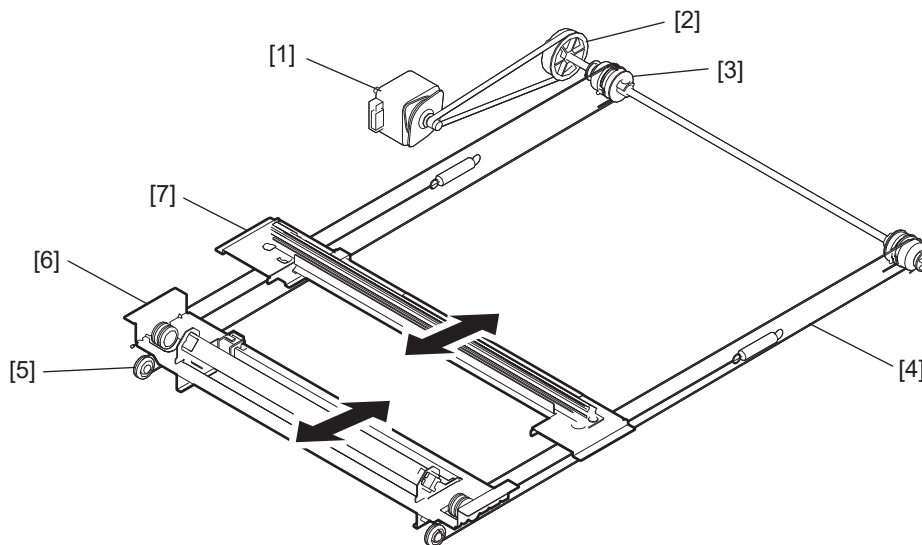


Fig. 3-19

- [1] Scan motor
- [2] Drive pulley
- [3] Wire pulley
- [4] Wire
- [5] Idler pulley
- [6] Carriage-2
- [7] Carriage-1

- Scanning of an original placed on the original glass  
This motor drives the carriages-1 and -2 through the timing belt and carriage wire. First, the scan motor drives the carriages-1 and -2 to their respective home positions. The home positions are detected when the carriage-1 passes the home position sensor (S3). When the [START] button is pressed, both carriages start to move and scan the original on the glass.
- Scanning of an original placed on the RADF  
The carriage-1 stays at the shading position during shading correction, and at the scanning position during scanning operation.
- Carriage speed  
The Carriage speed of the original placed on the original glass in the color mode is the same as that in the black mode.

### 3.8.5 Process of detection of original size

In this equipment, detection of original sizes is performed with the combination of a CCD and the automatic original detection sensors-1 and -2 (S1 and S2).

A size in the primary scanning direction is detected by the CCD while that in the secondary scanning direction is detected by the sensors.

#### [ 1 ] Original size detection procedure

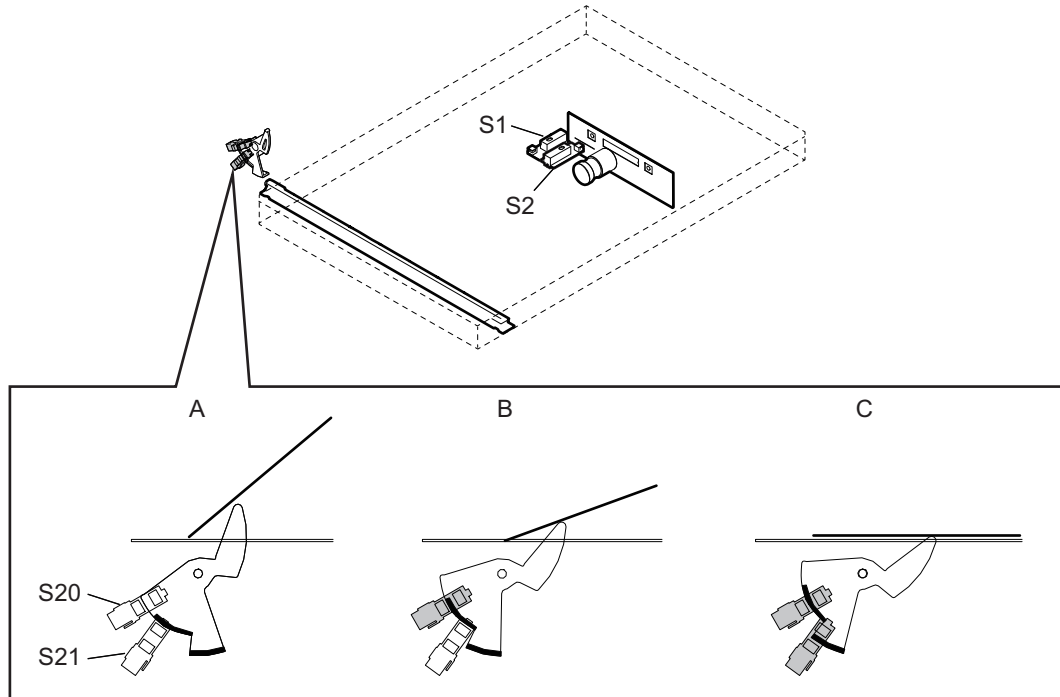


Fig. 3-20

A: Platen cover (or DF) fully opened

When the platen cover is fully opened, the original size is not detected.

B: Platen cover (or DF) opened by 25 degrees - Detected by the platen sensor-1 (S21)

When this status is detected, the exposure lamp of the scanner emits light and the presence/absence of the original in the secondary scanning direction and the paper size of the original in the primary scanning direction are detected by the automatic original detection sensor. (As for the LT series, two automatic original detection sensors are used.

C: Platen cover (or DF) closed - Detected by the platen sensors-1 and -2 (S21 and S22)

This status is detected by the platen sensors-1 and -2. The exposure lamp of the scanner emits light for a short time and the sensors detect the length of the original in the primary scanning direction again.

#### Remarks:

When the platen cover (or the DF) is fully closed or closed by 25 degrees or less, the exposure lamp emits light as follows. Light emitted -> OFF -> light emitted -> OFF -> carriage moved. If the connectors are connected to the platen sensor-1 (S21) and -2 (S22) in reverse, the exposure lamp emits light as follows. Light emitted -> OFF -> carriage moved -> light emitted.

When the following phenomena have occurred, the platen sensor-1 (S21) may be damaged. In such a case, check the sensors and harnesses.

- The exposure lamp does not emit light even when the platen cover is opened by 25 degrees.
- The detected paper size of the original is not correct.

## [ 2 ] Detection points

### Sensor detection points [A4, K Series]

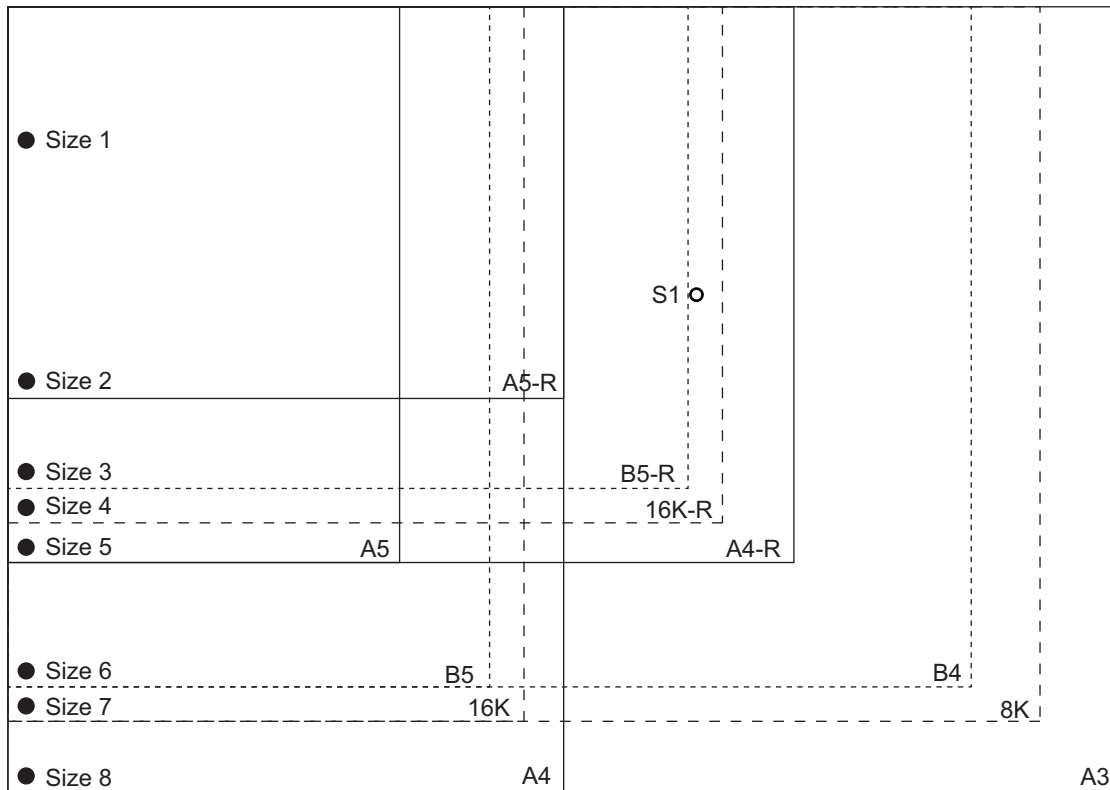


Fig. 3-21

### Sensor detection points [LT Series]

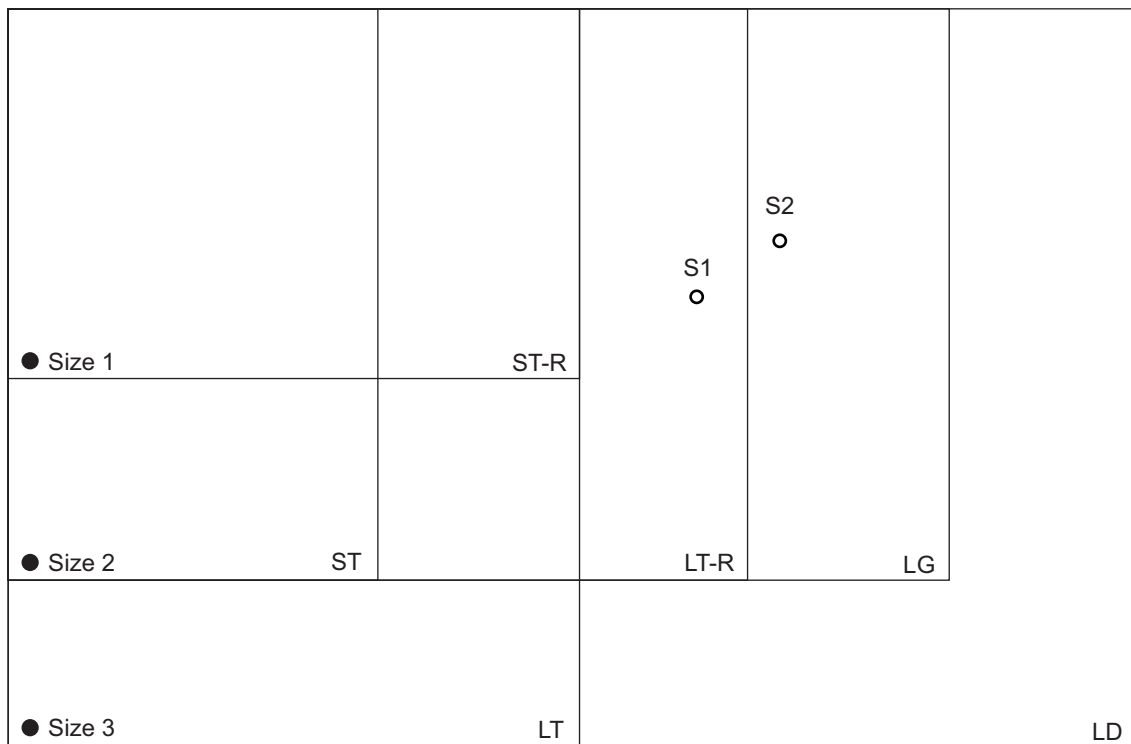


Fig. 3-22

# 3.9 Laser Optical Unit

## 3.9.1 General description

The laser optical unit radiates the laser beam onto the photoconductive drum responding to the digital image signals transmitted from the LGC board to create the latent image. Image signal is converted into the light emission signal of the laser diode on the laser driving PC board (LDR), then radiated on the drum through the optical elements such as cylinder lenses, polygonal mirror and f $\theta$  lens.

The unit must not be disassembled in the field as they are very sensitive to dust and finely adjusted at the factory.

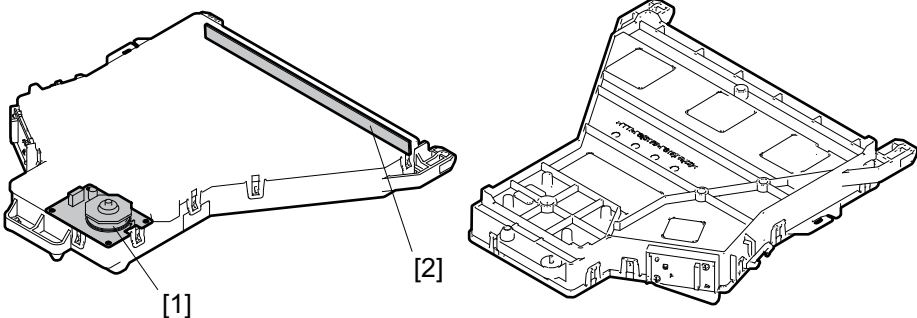
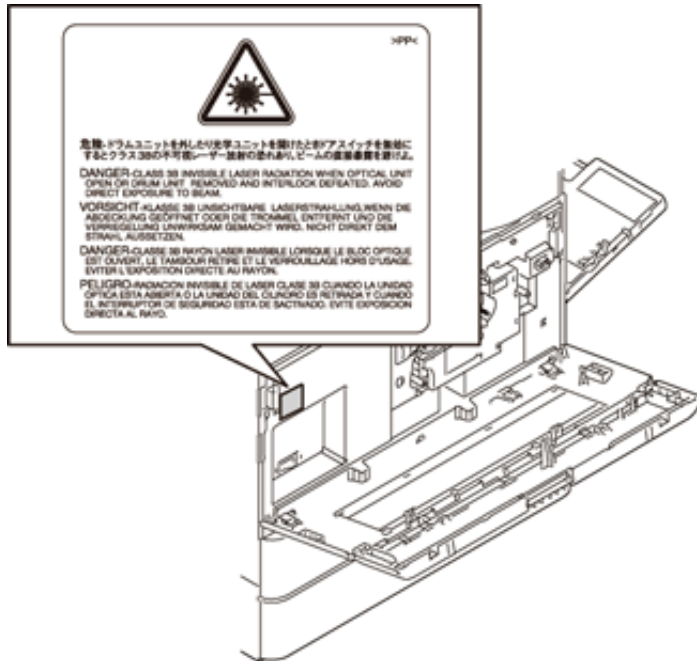


Fig. 3-23

- [1] Polygonal motor
- [2] Slit glass

### 3.9.2 Laser precautions

A laser diode is used for this equipment and radiates an invisible laser beam. Since it is not visible, be extremely careful when handling the laser optical unit components, performing operations or adjusting the laser beam. Also never perform the procedure with other than the specified manuals because you could be exposed to the laser radiation. The laser optical unit is completely sealed with a protective cover. As long as only the operations of specified manuals are performed, the laser beam is not leaked and you are in no danger of being exposed to laser radiation. The following cautionary label for the laser is attached to the inner cover.



#### Cautions:

- Avoid expose to laser beam during service. This equipment uses a laser diode. Be sure not to expose your eyes to the laser beam. Do not insert reflecting parts or tools such as a screwdriver on the laser beam path. Remove all reflecting metals such as watches, rings, etc. before starting service.
- When servicing the equipment with the power turned ON, be sure not to touch live sections and rotating/operating sections. Avoid exposing your eyes to laser beam.
- During servicing, be sure to check the rating label and cautionary labels such as “Unplug the power cable during service”, “CAUTION. HOT”, “CAUTION. HIGH VOLTAGE”, “CAUTION. LASER BEAM”, etc. to see if there is any dirt on their surface and if they are properly stuck to the equipment.



## 3.10 Paper Feeding System

### 3.10.1 General descriptions

The purpose of this system is to pick up a sheet of paper from the drawer or bypass tray and transport it to the transfer position. The paper feeding system mainly consists of the pick-up roller, feed roller, separation roller, transport roller, registration roller, bypass paper sensor, drawer empty sensor, drawer paper stock sensor, registration sensor and the drive system for these components.

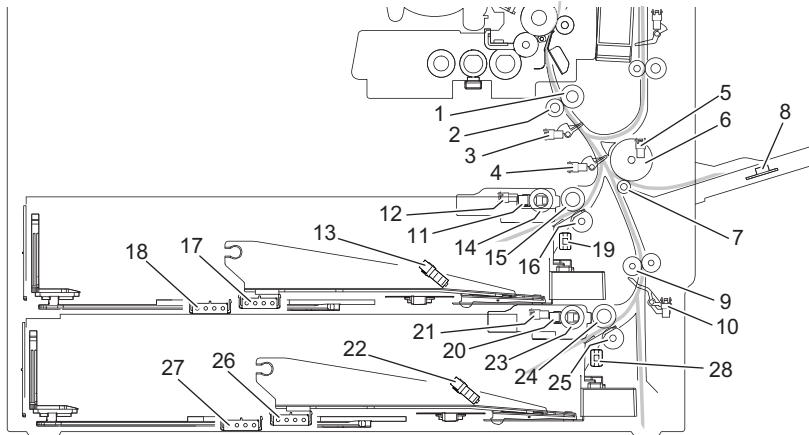


Fig. 3-24

No.	Name	No.	Name
1	Registration roller (rubber)	15	1st drawer feed roller
2	Registration roller (metal)	16	1st drawer separation roller
3	Registration sensor (S17)	17	1st drawer paper width detection switch
4	1st transport sensor (S16)	18	1st drawer paper length detection switch
5	Bypass paper sensor (S8)	19	1st drawer detection switch
6	Bypass feed roller	20	2nd drawer tray-up sensor (S14)
7	Bypass separation roller	21	2nd drawer empty sensor (S15)
8	Paper width detection PC board (SFB)	22	2nd drawer paper stock sensor (S13)
9	Transport roller	23	2nd drawer pick-up roller
10	2nd transport sensor (S9)	24	2nd drawer feed roller
11	1st drawer tray-up sensor (S11)	25	2nd drawer separation roller
12	1st drawer empty sensor (S12)	26	2nd drawer paper width detection switch
13	1st drawer paper stock sensor (S10)	27	2nd drawer paper length detection switch
14	1st drawer pick-up roller	28	2nd drawer detection switch

### 3.10.2 Composition

Paper feed		
1st/2nd drawer feed unit	1st/2nd drawer pick-up roller	PM parts
	1st/2nd drawer feed roller	PM parts
	1st/2nd drawer separation roller	PM parts
	1st/2nd drawer paper stock sensor	S10/S13
	1st/2nd drawer tray-up sensor	S11/S14
	1st/2nd drawer empty sensor	S12/S15
	1st/2nd drawer feed clutch	CLT3/CLT4
Bypass unit	Bypass feed roller	PM parts
	Bypass separation pad	PM parts
	Bypass paper sensor	S8
	Bypass feed clutch	CLT2
	Paper width detection PC board	SFB
Transport section, other	1st/2nd drawer tray-up motor	M11/M12
	Registration sensor	S17
	Registration roller (rubber)	
	Registration roller (metal)	
	1st/2nd transport sensor	S16/S9
	Transport roller	
	Registration roller clutch	CLT1
	Hi-speed clutch	CLT5
	Low-speed clutch	CLT6
Feed cover opening/closing switch	SW10	

### 3.10.3 Functions

1. Pick-up roller  
This roller moves up and down to draw out a sheet of paper from the drawer, and transport it to the feed roller.
2. Feed roller  
This roller transports the paper from the pick-up roller to the registration roller.
3. Separation roller  
This roller is mounted against the feed roller. When two sheets of paper or more are transported from the pick-up roller, the load of the torque limiter (spring) of the separation roller is greater than the frictional force between the sheets. As the result, the separation roller is stopped and the lower sheet of paper is not transported any further. When only one sheet of paper is transported from the pick-up roller, the separation roller is forced to rotate following the feed roller.
4. Transport roller  
This roller transports the paper from the lower drawer or PFP/LCF to the 1st transport roller.
5. Registration roller  
Paper transported from the 1st transport roller is pushed against the registration roller, which aligns the leading edge of paper. The registration roller then rotates to transport the paper to the transfer section.
6. Bypass feed roller  
This roller picks up and feeds paper from the bypass unit.
7. Bypass separation roller  
This roller is mounted against the feed roller. When two sheets of paper or more are transported, the load of the torque limiter (spring) of the bypass separation roller is greater than the frictional force between the sheets. As a result, the bypass separation roller is stopped and the lower sheet of paper is not transported any further. When only one sheet of paper is transported, the bypass separation roller is forced to rotate the feed roller.
8. Bypass paper sensor(S8)  
This sensor detects whether paper is set in the bypass tray or not. If it is, bypass feeding is performed in preference to drawer feeding. And also detects whether paper has been transported from the bypass tray or not. In other words, whether the leading/trailing edge of paper has passed the feed sensor or not. This sensor is utilized to detect the jams such as paper misfeeding in the bypass unit.
9. Upper/Lower drawer empty sensor (S12/S15)  
This is a transmissive-type sensor which detects the presence/absence of paper in the drawer using an actuator. When there is no paper in the drawer, the actuator blocks the light path of the sensor. Then the sensor determines that there is no paper.
10. Upper/Lower drawer paper stock sensor (S10/S13)  
This is a transmissive-type sensor which detects the amount of paper remaining in the drawer using an actuator. When the remaining paper has become around 100 sheets, the actuator blocks the light path of the sensor to notify that the paper quantity is getting less.
11. Registration sensor (S17)  
This sensor detects whether the leading edge of the paper has reached the registration roller or not, and the trailing edge of paper has passed the registration roller or not.
12. 1st transport sensor (S16)  
This sensor detects whether paper from each paper source is being transported or not.

13.2nd transport sensor (S9)

This sensor detects whether paper from the 2nd drawer, PFP or LCF (both optional) is being transported or not.

14.1st/2nd drawer feed clutch (CLT3/CLT4)

These clutches drive the upper and lower drawer pick-up rollers. When these clutches are turned ON while the main motor (M8) is being rotated, the drive from these clutches rotates the pick-up rollers so as to pick up paper.

15.Hi-speed clutch (CLT5)

Drives the Transport roller at high speed by transmitting the drive from the main motor.

16.Low-speed clutch (CLT6)

Drives the Transport roller at low speed by transmitting the drive from the main motor.

17.Registration roller clutch (CLT1)

Drives the registration roller.

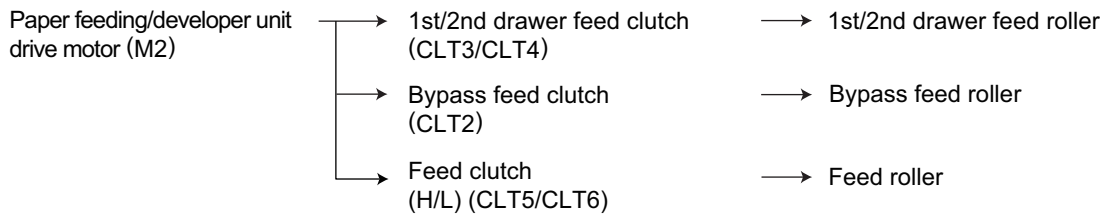
18.Bypass feed clutch (CLT2)

This clutch drives the rotation of the bypass feed roller. When this clutch is turned ON while the main motor (M8) is being rotated, the drive from this clutch feeds and transports paper on the bypass tray to the inside of this equipment.

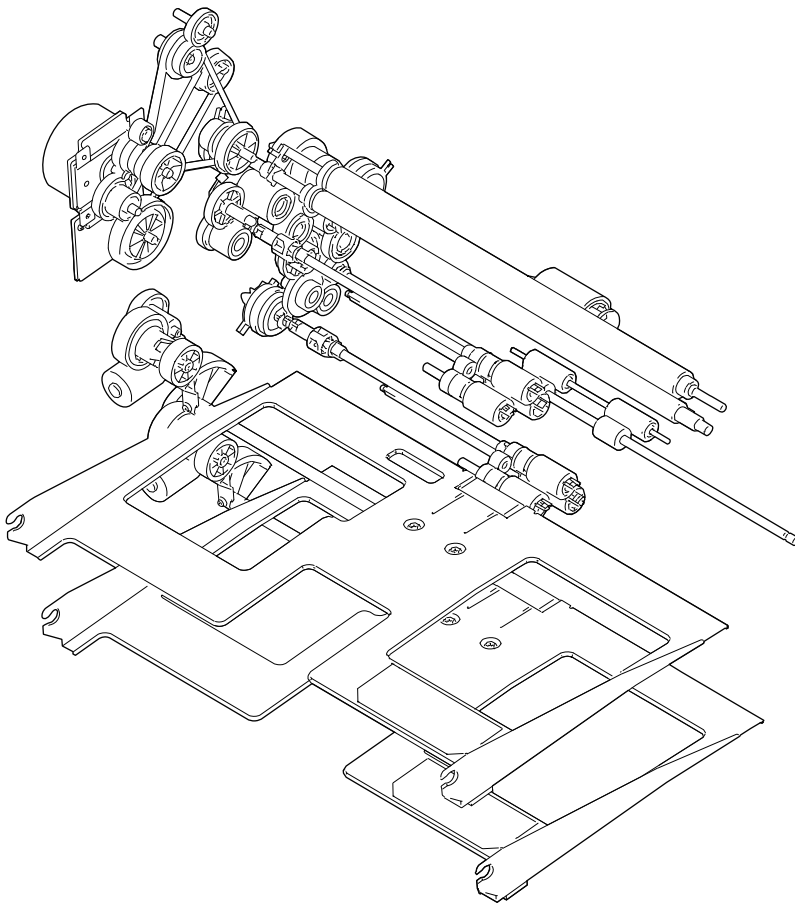
### 3.10.4 Description of operation

#### [ 1 ] Drive of rollers

The drive of each motor in the paper feeding area activates the paper transfer roller as follows.



## [ 2 ] Picking up System



**Fig. 3-25**

When the drawer is inserted into the equipment, the drawer tray is raised by the tray-up motor and paper can be fed.

When the driving force from the main motor is transmitted to the pick-up roller, feed roller and transport roller through the gears and clutches, the paper is fed and transported.

Paper is picked up by the movement of the feed clutch. When the feed clutch is turned ON, the pick-up roller and feed roller rotate, and the paper is picked up from the drawer.

The paper is separated by the separation roller.

### [ 3 ] Paper Feed System

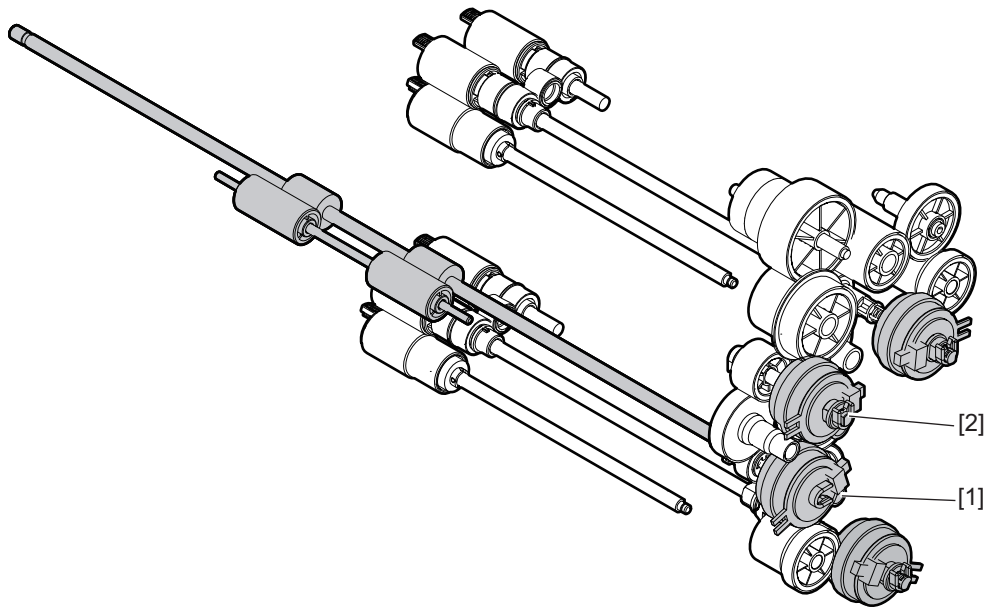


Fig. 3-26

[1] Low speed transport clutch

[2] High speed transport clutch

The low-speed/high-speed clutches transmit the driving force from the main motor to the transport roller. When transporting paper, they are turned ON.

The Low speed transport clutch is turned ON when the low speed transportation is performed for printing. The High speed transport clutch is turned ON when high speed transportation is performed to transport the paper which has passed through the paper feed sensor to the registration position. High speed transportation is also performed when the paper is transported from the PFP to the registration position (When the PFP is connected).

### [ 4 ] Operation of bypass feed roller

The driving force transmitted through the bypass feed clutch (CLT2) is transmitted to the bypass feed roller through the shaft. The roller is rotated by this driving force.

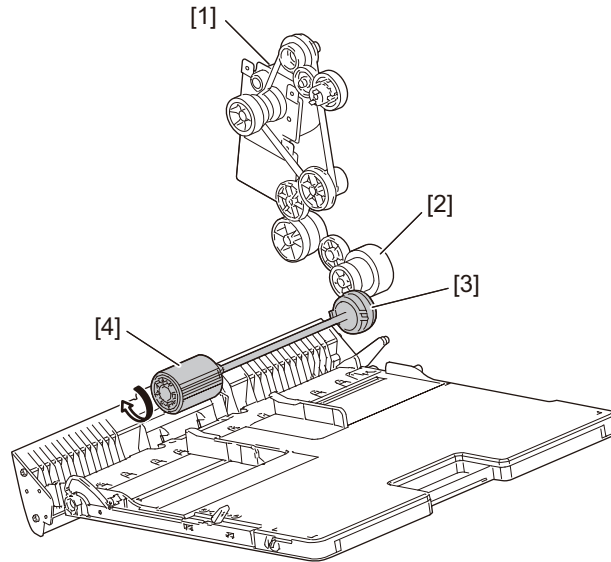


Fig. 3-27

- [1] Main motor
- [2] Gear
- [3] Bypass feed clutch
- [4] Bypass feed roller

### [ 5 ] Separation of paper

The separation roller is pushed to the paper feed roller by the spring force.

When two or more sheets of paper are fed, since the friction between two sheets of paper is smaller than that between a sheet and the separation roller, the lower sheets are not transported any further while the uppermost one is transported by the paper feed roller.

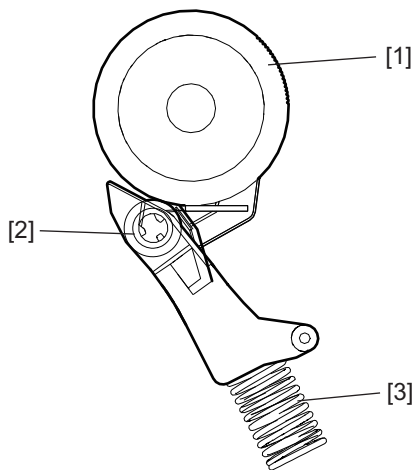


Fig. 3-28

- [1] Bypass feed roller
- [2] Bypass separation roller
- [3] Spring

## [ 6 ] Paper size detection

This equipment automatically detects the size of the paper placed in each drawer.

The end and side guides in each drawer are moved according to the paper size and a pusher moves together with the end and side guides.

Then the protrusion of the pusher pushes each button of the drawer paper size detection sensors-1 and -2.

Thus the paper size is detected with the combination of the pushing statuses of the drawer paper size detection sensors-1 and -2.

The drawer paper size detection sensor-1 detects the movement of the side guides while the drawer paper size detection sensor-2 detects that of the end guide.

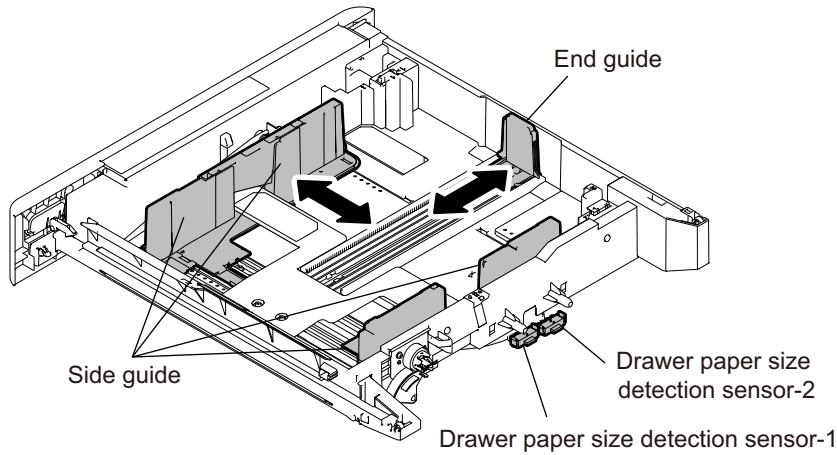


Fig. 3-29

[Example]

The positions of the guides and the pusher in cases of A3 and A4-R are shown below as examples.

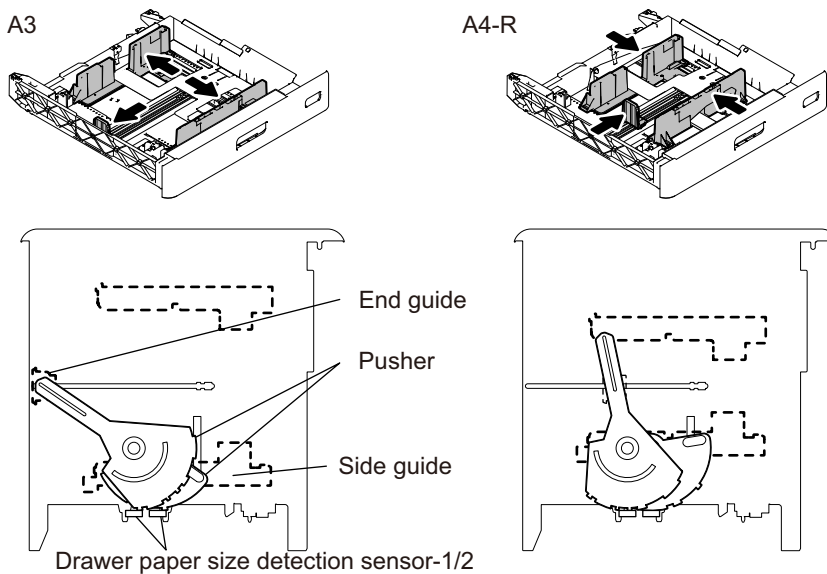


Fig. 3-30



## [ 7 ] General operation

### [A] From power-ON to ready status

If either of the sensors on the transport path is ON (means there is paper on the transport path) when the equipment is turned ON, it is determined that a paper jam has occurred and no operation is enabled until the paper is removed.

### [B] Ready status

When a drawer is inserted or pulled out at ready status, to check the availability of paper.

### [C] Bypass feeding

- The bypass feed sensor detects the absent of paper.
- The bypass feed clutch is turned ON, and the bypass feed roller is rotated to start feeding.
- The leading edge of the paper turns the registration sensor ON, and the paper is aligned with the registration roller.
- The bypass feed clutch is turned OFF, and the bypass feed roller is stopped.
- The registration motor is turned ON, and the paper is transported to the transfer unit.

### [D] Paper feeding

- Lower drawer
  - The feed clutch and high speed clutch is turned ON, and the pick-up roller, feed roller and transport roller rotate to start paper feeding.
  - The leading edge of paper turns the paper feed sensor ON, and the feed clutch is turned OFF. (Pick-up roller and feed roller stop rotating.)
  - The leading edge of paper turns the registration sensor ON and the paper is aligned by the registration roller.
  - The high speed clutch is turned OFF, and the transport roller stop rotating.
  - The registration motor and low speed clutch are turned ON, and the paper is transported to the transfer unit.
- Upper drawer
  - The feed clutch is turned ON and the pick-up roller and feed roller rotate to start paper feeding.
  - The leading edge of paper turns the registration sensor ON, and the paper is aligned by the registration roller.
  - The feed clutch is turned OFF and the pick-up roller and feed roller stop rotating.
  - The registration motor is turned ON, and the paper is transported to the transfer unit.

## [ 8 ] Envelope drawer

The envelope drawer is an option to allow a standard envelope to be fed from the drawer. Different side walls compared to those of the current drawers are adopted. These side walls are positioned by being aligned to the width of an envelope and they have the function of holding envelopes.

By using the drawer paper size detection sensors 1 and 2, the level where the envelope drawer is installed is detected. Since the size of the paper in the envelope drawer is not detected automatically, it is necessary to set it manually.

## 3.11 Drive System

### 3.11.1 General description

The drive system drives the drum, developer unit, cleaner unit, fuser unit, transport roller, feed roller (upper/lower drawer and bypass unit) and registration roller.  
The drive system is driven by the rotation of the main motor.

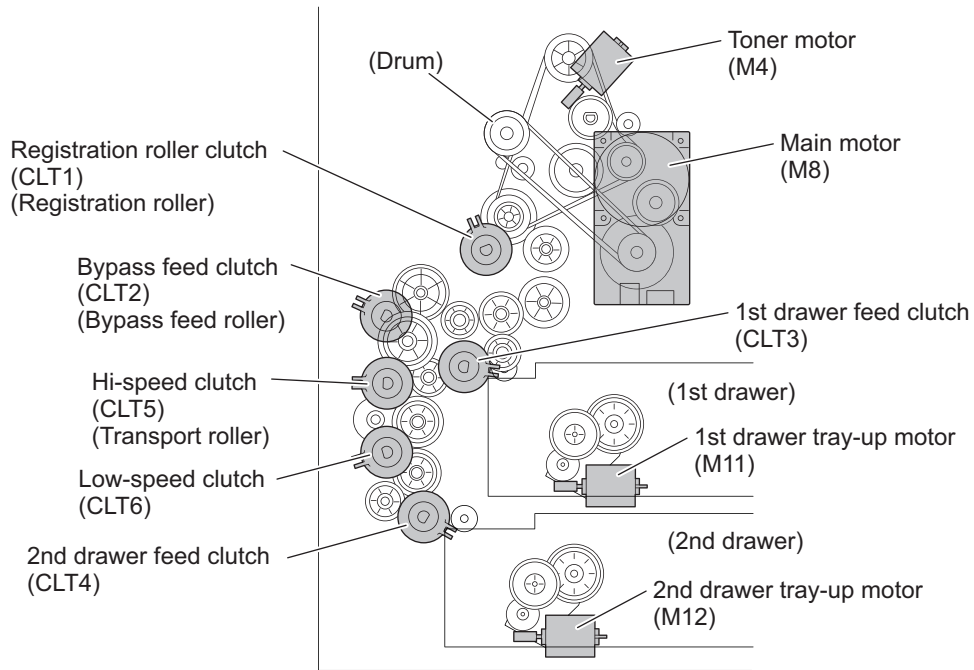


Fig. 3-31

## 3.11.2 Functions

1. Drum cleaner unit drive  
Drives the drum by transmitting the rotation of the main motor through the gears and the timing belt to the drum flange gear. Also drives the toner recovery auger to transport the used toner to the developer unit.
2. Developer unit drive  
Drives the developer unit by transmitting the rotation of the main motor through the gears to the developer unit gears.
3. Fuser unit drive  
Drives the fuser unit by transmitting the rotation of the main motor through the gears and timing belt to the fuser unit gears.
4. Registration roller drive  
Drives the registration roller by transmitting the rotation of the main motor through the gears, timing belt and clutches.
5. Transport roller drive  
Drives the transport roller by transmitting the rotation of the main motor through the gears, timing belt and clutches.
6. Feed roller drive  
Drives the cassette feed roller by transmitting the rotation of the main motor through the gears and clutches.
7. Drives the paper exit options  
Drives the Bridge Kit and Job Separator by transmitting the rotation of the main motor through the gears and the timing belt to their gears.

## 3.12 Drum Related Section

### 3.12.1 Configuration

This chapter explains about the area around the drum, drum itself, image processing, their parts and control circuits.

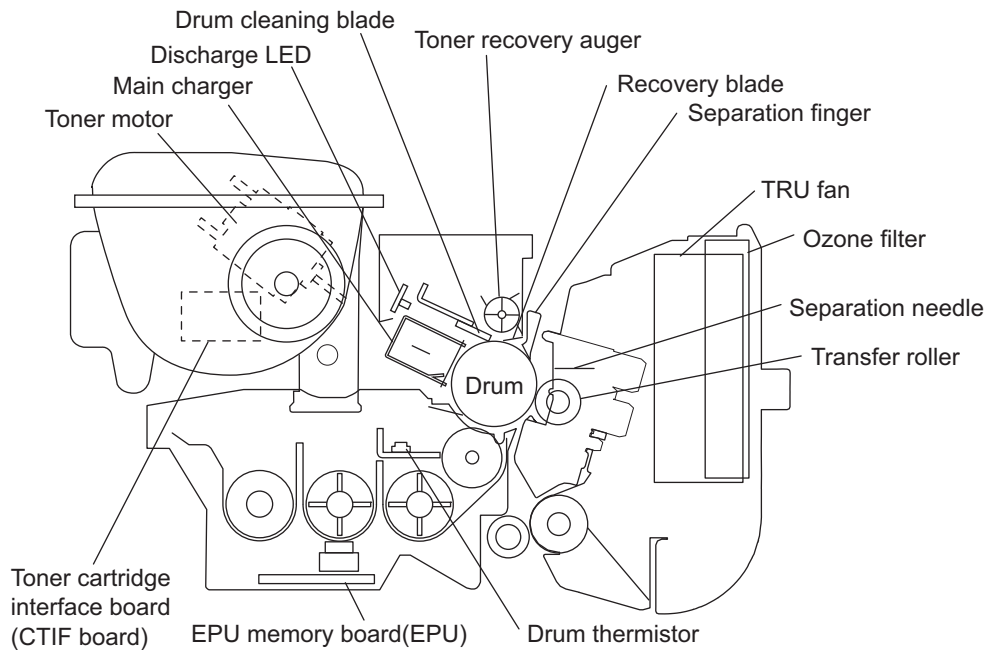


Fig. 3-32

### 3.12.2 Composition

Drum related section		
Drum cleaner unit	Drum	PM parts
	Main charger	PM parts
	Cleaner	
	Drum cleaning blade	PM parts
	Recovery blade	PM parts
	Needle electrode	PM parts
	Discharge LED	ERS
Transfer roller unit	Transfer roller	PM parts
	Separation needle	
Other	Drum thermistor	THMS4
	High-voltage transformer	HVPS
	TRU fan	M9
	Process unit fan	M2
	Ozone filter	PM parts

### 3.12.3 Functions

#### 1. Drum

The drum is made of a cylindrical aluminum base coated with thin film of organic photoconductive substance.

The photoconductive object becomes insulative (the electrical resistance is high) when it is not exposed to the light and electrically conductive (the electrical resistance is low) when it is exposed to the light. This object is called a photoconductor.

#### 2. Main charger

The main charger in this equipment consists of a metal rod with U-shaped section, insulated blocks at both ends of the rod and a needle electrode attached between them.

When a high voltage is applied to the needle electrode, the air around it is charged (ionized). The ionized air then flows into the drum causing it to be charged. This phenomenon is called "corona discharge". At the same time, a control bias is applied to the main charger grid to control the charging amount.

In a dark place, negative charge is evenly applied onto the drum surface by the corona discharge and this grid. In addition, a cleaner is installed to clean up the dust attached on the needle electrode.

##### - Needle electrode

The needle electrode has aligned needles and their points perform the corona discharge. These points (electrodes) discharge toward the drum in one direction to realize the more efficient discharging comparing to the charger wire which discharges in a radial direction. Therefore, the needle electrode enables to reduce the ozone amount.

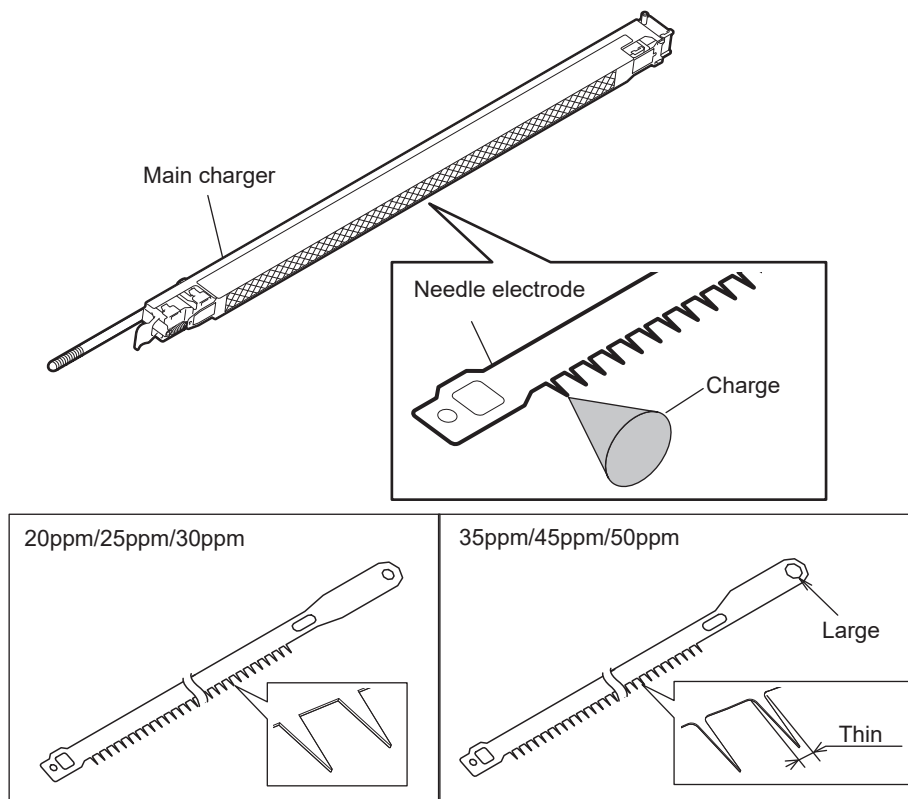


Fig. 3-33

#### 3. Drum cleaner

##### - Drum cleaning blade

This blade is pressed against the drum surface and scrapes off the residual toner from the drum surface.

##### - Recovery blade

This blade catches the toner scraped off by the cleaning blade.

- Toner recovery auger  
This auger carries the residual toner scraped off to the developer unit and reuses the toner.
4. Transfer roller unit
    - Transfer supporting bias  
Positive bias is applied to the registration roller, the pre-transfer guide and the fuser unit entrance guide so as to prevent the transfer ability from lowering under high humidity environments.
    - Transfer roller (transfer charger)  
A transfer roller is used as the transfer charger for this equipment.  
With the transfer roller, dots are reproduced more clearly because the electric charge is concentrated on a contact point between the paper and the drum surface, and thus toner is less scattered at the time of transfer.
    - Separation needle (separation charger)  
This needle requires a smaller capacity of the high-voltage transformer than the existing charger wire does. This needs to be cleaned with a brush at PM.
  5. Discharge LED  
Discharging is a process to decrease or eliminate the electrical potential of the drum surface. The electrical resistance of the photosensitive layer is decreased by the light irradiation, and the residual charge on the drum surface is neutralized and eliminated. The electrical potential of the drum surface is fixed to a certain amount before the drum is charged.  
The number of the discharge LEDs for the 20ppm/25ppm/30ppm differs from that for the 35ppm/45ppm/50ppm because the discharging amount differs depending on the copy speed.  
Therefore, be sure to install discharge LEDs in a correct model.  
20ppm/25ppm/30ppm: 10 LEDs  
35ppm/45ppm/50ppm: 14 LEDs
  6. Drum thermistor  
The drum thermistor detects the drum surface temperature, and thus each rotation speed of the exhaust fan and internal cooling fan-1 is controlled when the equipment is in the ready status.
  7. High-voltage transformer  
This is a board to generate the output control voltage of the main charger, main charger grid, transfer charger, separation charger, developer bias and transfer supporting bias.
  8. Temperature/Humidity sensor (S19)  
This sensor and drum thermistor detect the temperature and humidity inside of the equipment since the drum, developer material and paper are affected by environmental elements such as temperature or humidity. Thus the main charger grid, transfer/separation output, transfer guide bias, developer bias, laser output and auto-toner output are controlled to be at their optimum states.
  9. Process unit fan (M2)  
This fan cools down the inside of the equipment, drum cleaning unit and developer unit.
  10. TRU fan (M9)  
The TRU fan cools down the inside of the equipment. The air to exhaust includes the ozone generated by the corona discharge, and this ozone is removed by the ozone filter. The exhaust fan also helps the paper separation by absorbing the paper to post-transfer guide.

### 3.13 Development System

#### 3.13.1 Configuration

The developer unit in this equipment has a recovered toner supply mechanism which recovers the recovered toner scraped off by the drum cleaning blade and recycles the recovered toner. The developer unit is driven by the main motor to rotate the mixers and developer sleeve.

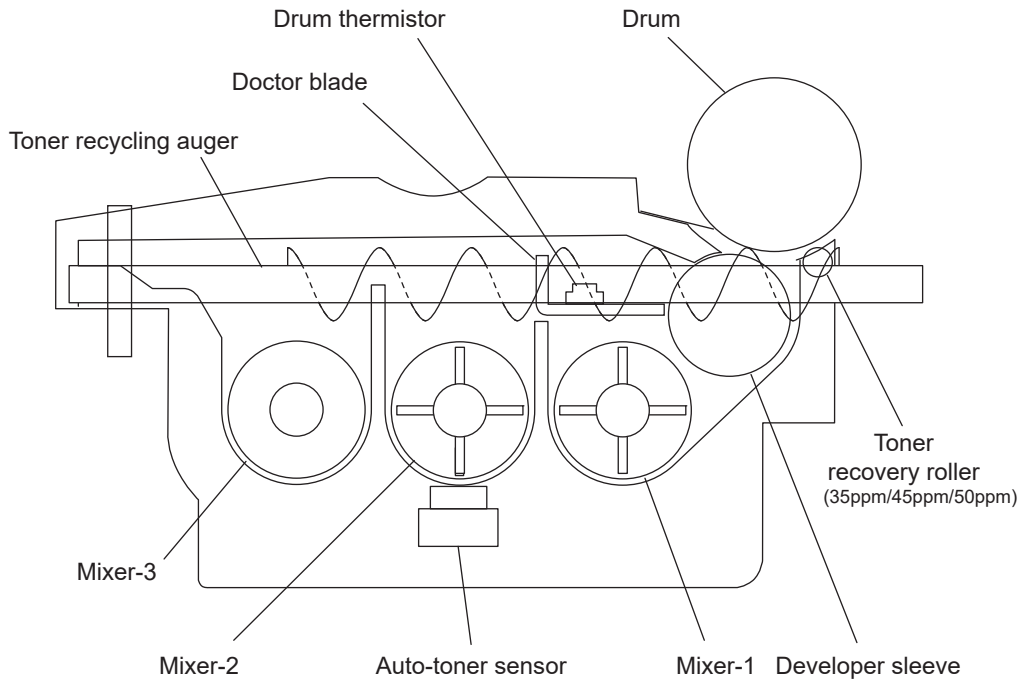


Fig. 3-34

#### 3.13.2 Construction

Developer unit	Developer material	PM parts
	Mixers-1, -2 and -3	
	Developer sleeve (Magnet roller)	
	Doctor blade	
	Auto-toner sensor	S4
	Drum thermistor	THMS4
	EPU memory board	EPU
	Recovered toner supply mechanism (Toner recycling auger)	
Toner cartridge	Toner cartridge PC board	CTRG
	Toner cartridge interface PC board	CTIF
Toner motor		M4

### 3.13.3 Functions

#### [ 1 ] General description

1. Toner cartridge drive unit / Toner cartridge installation detection mechanism (IC chip)  
The toner cartridge is filled with toner. The toner motor drives the cartridge to supply the toner to the developer unit.  
The IC chip detects whether a toner cartridge is installed.
2. Developer unit
  - Developer material  
The developer material is made of a mixture of the carrier and toner.  
The carrier is an electrical conductive ferrite whose size is approx 44  $\mu\text{m}$ . The toner is a resin particle whose size is approx 8.5  $\mu\text{m}$ .  
The developer material needs periodic replacement since its quality is deteriorated by long use.
  - Mixers-1, -2 and -3  
Friction is generated by mixing the developer material. The carrier is charged to (+) and the toner to (-), and the image is formed on the drum surface by the static electricity caused by the friction. The mixer-3 is mounted exclusively for the recovered toner to mix it with sufficient time.
  - Magnetic roller (Developer sleeve)  
This is an aluminum roller with a magnet inside. The magnet works to absorb the developer material and forms the magnetic brush. The magnet is fixed and only the sleeve around is rotated. This rotation makes the magnetic brush of the developer sleeve sweep over the drum surface and perform development.
  - Doctor blade  
Doctor blade controls the amount of the developer material transported by the developer sleeve so that the magnetic brush of the developer material contacts with the drum surface properly.
  - Auto-toner sensor  
The carrier and the toner (toner density) in the developer material should be always fixed to a certain ratio to output normal images. The auto-toner sensor detects the inclusion ratio of the toner in the developer material by using a magnetic bridge circuit. When the quantity of toner becomes insufficient, the toner motor is driven to supply the toner from the toner cartridge.
  - Recovered toner supply mechanism  
The recovered toner transported from the drum cleaner is transported into the developer unit by the toner recycling auger on the front side of the developer unit. The drive of the toner recycling auger is transmitted by the mixer-3.



**[ 2 ] Process unit mechanism (differences between 20ppm/25ppm/30ppm and 35ppm/45ppm/50ppm)**

The process unit of this equipment has two types; one is for the 20ppm/25ppm/30ppm and another is for the 35ppm/45ppm/50ppm.

The differences between two are shown below.

Be sure not to install the process unit to a wrong model when replacing them because they are incompatible each other.

To distinguish them, check the position of the bracket hole seen from the back side.

Parts	20ppm/25ppm/30ppm	35ppm/45ppm/50ppm
Toner recovery roller	Not installed	Installed
Gear, belt	For low speed	For high speed
Discharge LED	10 LEDs	14 LEDs
Needle electrode	For low speed	For high speed
Position of bracket hole (seen from the back side)	Bottom	Top

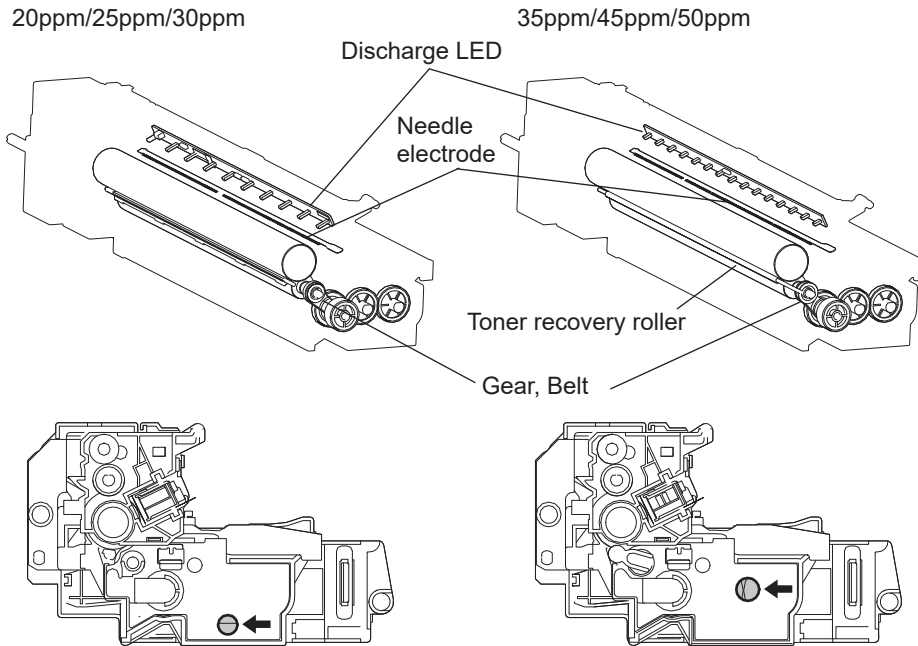


Fig. 3-35

### [ 3 ] Recovered toner supply mechanism

The toner scraped off by the drum cleaning blade is transported by the toner recovery auger, toner recycling auger to be recycled, and then returned to the developer unit. Then the recovered toner in the developer unit is mixed with developer material by the mixer-3. The mixer-3 is mounted exclusively for the recovered toner to mix it with sufficient time.

On the other hand, the toner (fresh) transported into the developer unit from the toner cartridge is mixed by the mixer-2. Then the toner (fresh) and recovered toner are mixed together and further transported to the mixer-1. They are further mixed and transported to the developer sleeve by the mixer-1.

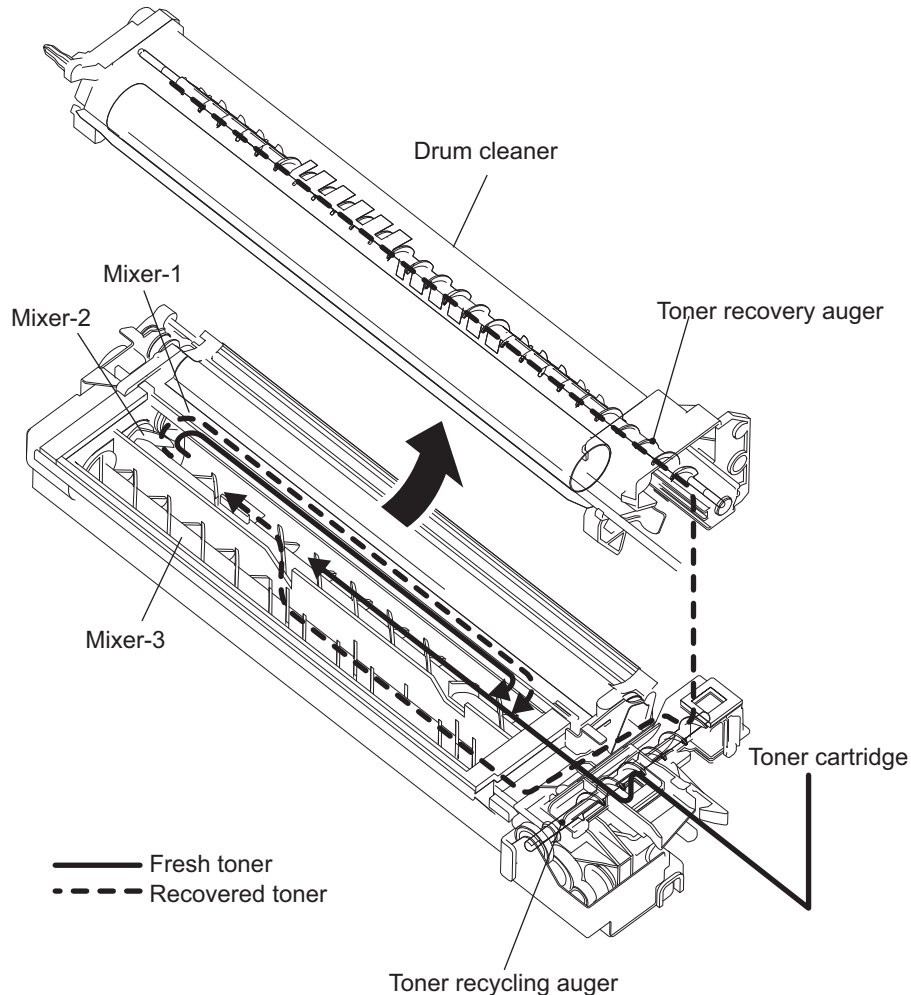


Fig. 3-36

### 3.13.4 Functions of the toner cartridge PC board (CTRG)

An IC chip is embedded in this board. Data such as identification information for the recommended TOSHIBA toner cartridge, thresholds to determine if the cartridge is nearly empty, and controlling data for the image quality to be optimal according to the toner characteristics are written in this chip. To measure the amount of toner remaining in the cartridge, when the value of the counter for the period of the toner cartridge rotation time is updated, this equipment writes the updated value into the toner cartridge PC board (CTRG).

These data written in the toner cartridge PC board (CTRG) enable the functions below, and accordingly this equipment operates as shown below.

Data reading is performed every time when the power is turned ON, the front cover is closed, a job is finished and the equipment has recovered from the sleep mode.

#### [ 1 ] Data read by the toner cartridge PC board (CTRG)

- Data to identify recommended TOSHIBA toner cartridges
- Thresholds to determine if the toner cartridge is nearly empty
- Value of the counter for the period of the toner cartridge rotation time
- Data for optimizing image quality
- Threshold of toner remaining displays

#### [ 2 ] Functions

- Cartridge detecting function  
This function checks whether the toner cartridge is inserted correctly or not, and whether the recommended toner cartridge is used or not.
- Toner remaining check function  
This function notifies the user of the near-empty status of toner. Normally, the message (Toner is low) is displayed when the toner is running out, and (Toner empty) when the toner cartridge is empty.
- Toner remaining check notification function  
Upon detecting the near-empty status of toner, this function automatically notifies your service representative.
- Image optimization function  
This function controls the quality of images to be optimal according to the characteristics of the toner used.
- Toner remaining display function  
This function displays the remaining toner amount from 0% to 100%.

#### [ 3 ] Operations

A sign indicating that the toner cartridge is nearly empty appears in the following cases:

- The counter value for the toner cartridge rotation time has exceeded the threshold previously written in the toner cartridge PC board (CTRG). (Related code: FS-08-5155)
- The remaining amount of toner is equal to or less than the set amount (percentage or number of sheets). (Related code: FS-08-5155, FS-08-5810, FS-08-5811)

When a used cartridge refilled with new toner is used, a sign indicating that the toner cartridge is empty appears because information for determining the empty status is already written in the toner cartridge PC board (CTRG).

When a non-recommended toner cartridge is used, "Toner not recognized" appears on the control panel, and then the equipment may stop normal operations. The toner remaining display function, the toner remaining check function, the automatic remote supply order to TOSHIBA sales representatives and the image optimization function may also be disabled.

The self-diagnosis codes to adjust the timing for displaying the toner near-empty status are as follows.

- Toner near empty threshold setting (FS-08-5155)  
<Setting value>

0: The period from the appearance of the toner near-empty sign to the actual complete consumption of the toner is set to long.

1: Normal (Default)

2: The period from the appearance of the toner near-empty sign to the actual complete consumption of the toner is set to short.

4: Toner near-empty status threshold value: (%)

5: Toner near-empty status threshold value: (Number of sheets)

- Toner near-empty status threshold value setting (%) (FS-08-5810)  
Use this code to specify the threshold value (unit: %) for displaying the toner near-empty status. This code is used when the value of FS-08-5155 is set to "4".
- Toner near-empty status threshold value setting (number of sheets) (FS-08-5811)  
Use this code to specify the threshold value (unit: number of sheets) for displaying the toner near-empty status. This code is used when the value of FS-08-5155 is set to "5".
- Fine adjustment of threshold value for displaying the toner remaining amount / toner near-empty (FS-08-5156)  
Performs fine adjustment of the threshold value for displaying the toner remaining amount and toner near-empty.  
Display threshold value = Default threshold value x setting value/100 (Unit: %)

#### [ 4 ] Toner near-empty / toner empty display adjustment

The toner empty appears when the auto-toner sensor in the developer unit detects that the level amount of toner in the developer unit has actually become low. The toner remaining amount is displayed by means of calculating it by counting the value of the counter for the period of the toner motor rotation time. Then the toner near-empty appears when the calculated toner remaining amount has reached the specified value (the toner amount which can print approx. 1,000 sheets of paper when an image whose print ratio is 6% is printed with the A4/LT equivalent paper size).

The relationship between the period of the toner motor rotation time and the actual toner consumption amount varies depending on the printed images and usage conditions. Therefore, the displaying of the toner remaining amount can be adjusted by the codes shown below. However, it is recommended to handle the toner remaining amount as the reference since the printed images and usage conditions are always unstable and there will be variations in the systems.

##### 1. Fine adjustment of the toner remaining amount display

When the displayed toner remaining amount is decreased more quickly than that for the actual toner (when "1%" is being displayed for a long time), set a value in FS-08-5156 larger than the default one. When the displayed toner remaining amount is decreased more slowly than that for the actual toner (when the toner near-empty appears before "1%" is displayed), set a value in FS-08-5156 than smaller the default one.

##### 2. Toner near-empty setting change

- Setting change of the period from the toner near-empty to the toner empty

When the period is made longer, set "0" in FS-08-5155. When the period is made shorter, set "2" in FS-08-5155.

- Setting change of the toner near-empty threshold value

When the threshold value (default: printing approx. 1,000 sheets of paper is available when an image whose print ratio is 6% is printed with the A4/LT equivalent paper size) used to designate toner near-empty is changed, perform the following setting change.

When the change is made by using the toner remaining amount (%), set "4" in FS-08-5155 and exchange the value of FS-08-5810. In order to designate the toner near-empty while the toner remaining amount is greater than the default value, set a larger value in FS-08-5810.

When the change is made by using the available remaining number of print sheets, set "5" in FS-08-5155 and exchange the value of FS-08-5811. In order to designate the toner near-empty while the available remaining number of print sheets is greater than the default value (printing approx. 1,000 sheets of paper is available when an image whose print ratio is 6% is printed with the A4/LT equivalent paper size), set a larger value in FS-08-5811.

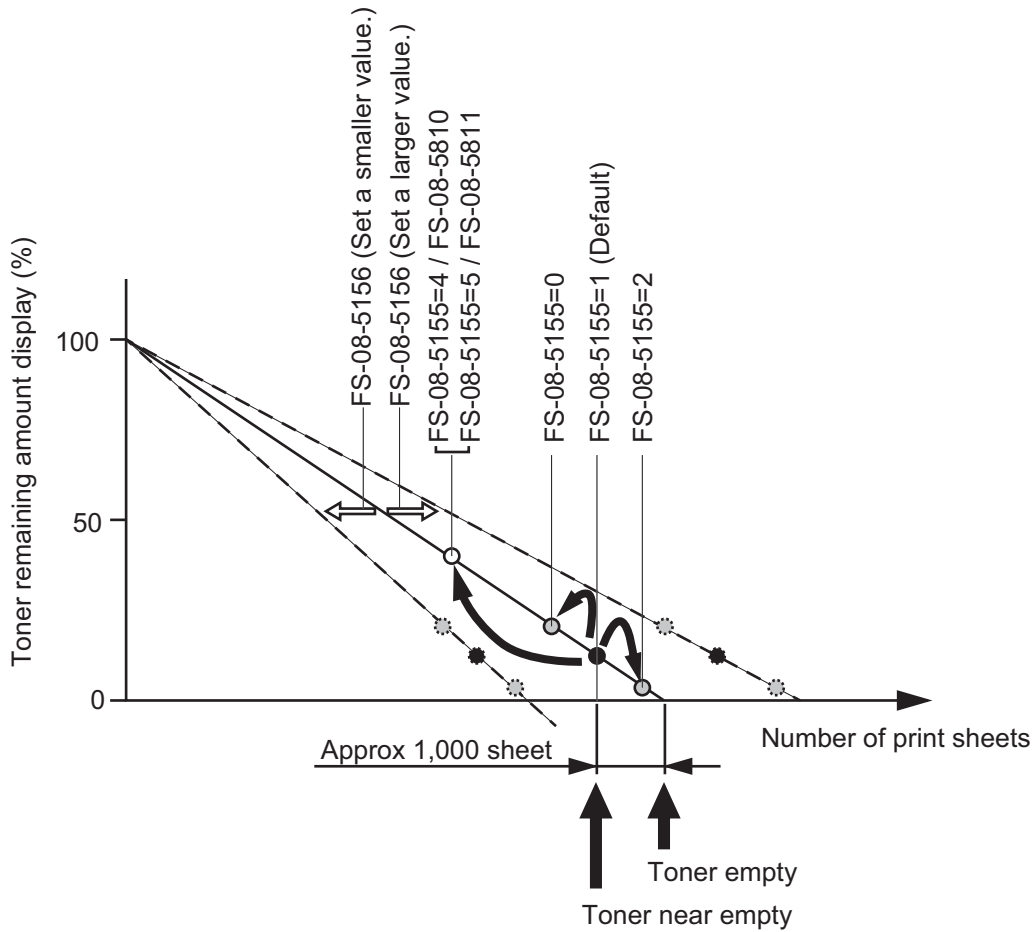


Fig. 3-37

**Notes:**

- Do not perform the change operations 1 (Fine adjustment of the toner remaining amount display) and 2 (Toner near-empty setting change) simultaneously. Otherwise, the desired results may not be obtained. If the change is required by the combination of the operations 1 (Fine adjustment of the toner remaining amount display) and 2 (Toner near-empty setting change), only perform either of them first. Then change the setting for another one while checking the results.
- The values of the toner remaining amount and the number of print sheets are the reference. They will vary depending on the printed images and usage conditions.

## 3.14 Fuser Unit

### 3.14.1 General description

In the fuser unit, toner is fused by applying heat and pressure on the transferred image on the transported paper. The paper is then transported to the paper exit section after completion of fusing. The fuser unit consists of the heater lamps, fuser roller, pressure roller, separation fingers, thermistors, thermostat, etc.

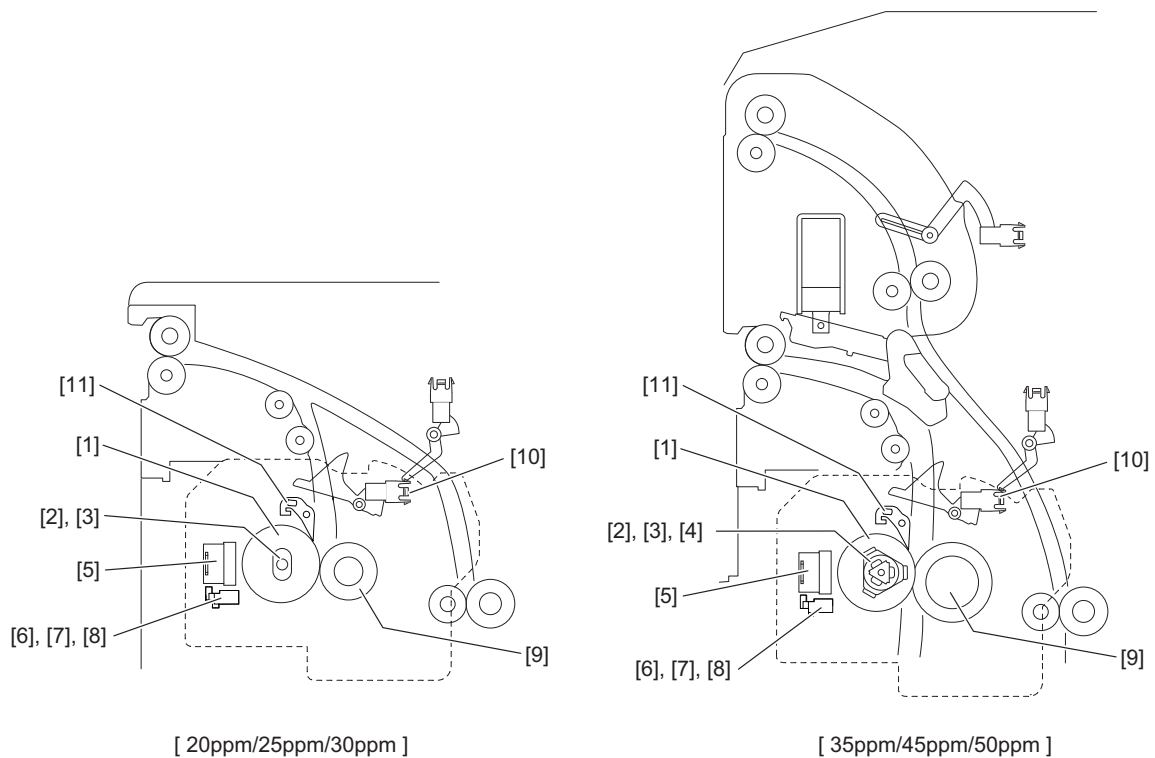


Fig. 3-38

- [1] Fuser roller
- [2] Side heater lamp
- [3] Center heater lamp
- [4] Sub heater lamp
- [5] Fuser roller center thermostat, Fuser roller front thermostat
- [6] Fuser roller edge thermistor
- [7] Fuser roller center thermistor
- [8] Fuser roller side thermistor
- [9] Pressure roller
- [10] Exit sensor
- [11] Fuser roller separation finger

### 3.14.2 Composition

Fuser roller	
Center heater lamp	LAMP1 (600 W)
Side heater lamp	LAMP2 (600 W)
Sub heater lamp	LAMP3 (300 W)
Fuser roller center thermistor	THM1
Fuser roller side thermistor	THM2
Fuser roller edge thermistor	THM3
Fuser roller center thermostat	THMO1
Fuser roller front thermostat	THMO2
Pressure roller	
Separation finger	

### 3.14.3 Functions

#### 1. Heater lamp

The heater lamps are halogen lamps to apply heat to the fuser roller. The fuser unit in this equipment has 3 heater lamps with different functions each other.

3 heater lamps having different functions are called the center heater lamp, the side heater lamp and the sub heater lamp. The center heater lamp has a coil wound up on its center and this part generates heat. The side heater lamp has coils wound up on its both ends and these parts generate heat. The sub heater lamp has a coil wound up in whole and generates heat to assist the center heater lamp and the side heater lamp.

For 20ppm/25ppm/35ppm, the sub heater lamp is not installed.

The following is the output of each heater lamp.

Center heater lamp: 600W

Side heater lamp: 600W

Sub heater lamp: 300W

#### 2. Fuser roller

The fuser roller applies heat onto the paper and is heated by the heater lamps installed inside of the fuser roller. The heat from this roller fuses toner onto the paper. The fuser roller in this equipment is a thin roller and the warming-up time is shortened.

#### 3. Pressure roller

The pressure roller is a sponge roller which assures the nip amount of the fuser roller. The pressure from the spring presses the paper onto the fuser roller to fuse the toner onto the paper efficiently.

The pressure roller is electrical conductive, and to improve the transferability and prevent offset, positive (+) bias is applied to the pressure roller and the entrance guide. A sponge roller with a lower hardness is adopted for the pressure roller in this fuser unit to enable envelopes to pass through.

The outside diameter of the pressure roller is  $\varnothing 22$  (mm) for 20ppm/25ppm/30ppm and  $\varnothing 30$  (mm) for 35ppm/45ppm/50ppm.

#### 4. Separation fingers

The separation fingers are installed, five above the pressure roller and five above the fuser roller, in order to separate the paper adhered on each roller.

#### 5. Center thermistor / Side thermistor

This thermistor detects the temperature of the fuser roller to maintain it in a certain temperature range between the lower limit causing the poor fusing and the upper limit causing the high temperature offsetting. When the temperature of the fuser roller is lower than the preset temperature, it turns ON the power supply to the heater lamps, and when it is higher than the preset temperature, it cuts off the supply.

The center thermistor detects the temperature of the center part of the fuser roller, and the side thermistor detects the temperature of one side of fuser roller and control the both sides.

#### 6. Edge thermistor

It detects the temperature abnormality at the both ends of the fuser roller. This area may be overheated without heat absorption by paper since paper does not pass through this area. This thermistor is not related to the temperature control of the fuser roller.

#### 7. Thermostat

The thermostat cuts off the power supply to the heater lamps by opening itself if the fuser roller becomes abnormally hot as a result of the problem such as thermistor malfunction. The thermostat for this equipment is used to prevent abnormal operation. When the thermostat detects any abnormality, it must be replaced as well as the other damaged parts in the fuser unit.

#### 8. Exit sensor

The exit sensor detects if the leading edge of the paper or the paper has passed through the fuser unit. This sensor is also used for the detection of a paper jam in the fuser unit and paper exit section.

### 3.14.4 Operation

The fuser roller is pressed with the spring force from the pressure roller side, and is rotated by the main motor drive. Then the paper transported to the fuser unit is hold between the fuser roller and pressure roller and the toner is fused on the paper with heat and pressure. After this, the separation fingers separate the paper from the fuser roller or pressure roller. Then the paper is transported to the inner tray, paper exiting options through the exit roller / lower exit roller. In addition, the heater lamps in the fuser roller do not structurally rotate.

3 heater lamps having different functions each other are installed; the center heater lamp applies heat to the center part of the fuser roller, the side heater lamp applies heat to both ends of the roller, and the sub heater lamp applies heat to the whole roller and assists the heater lamp and the side heater lamp. For 20ppm/25ppm/30ppm, the sub heater lamp is not installed.

The thermistors control the temperature of fuser roller and detect temperature abnormalities. If the temperature becomes excessively high, the thermostat is opened to stop the power supply to the heater lamps.



### 3.14.5 Heater control circuit

#### [ 1 ] Configuration

In this equipment, the surface temperature of the fuser roller is controlled by turning ON/OFF 3 heater lamps (center, side and sub) which have different heat-generating positions with the command from the engine-CPU on the LGC board.

The surface temperature of the fuser roller is detected by 3 thermistors (center, side and edge) and then the information of the temperature is transmitted to the engine-CPU and each control circuit. Based on the detected temperature, the engine-CPU transmits the control signal of the heater lamp to the control circuit (TRC: Triac) of each heater lamp on the switching regulator via the temperature control circuit. The power supply to the fuser roller is thus controlled by driving TRC. The temperature control circuit detects the overheating of the fuser roller. In case that the surface temperature of the fuser roller has exceeded the specified temperature, the temperature control circuit turns the heater lamp OFF. If the temperature control circuit does not function for some reason and the fuser roller is abnormally overheated as the result, a relay OFF circuit transmits a relay OFF signal to turn off the relay, and to turn the power OFF forcibly.

If the temperature control circuit does not function for some reason and the fuser roller is abnormally overheated as the result, a forcible power-OFF circuit transmits a reset signal to the power switch to turn the power OFF forcibly. In addition, if these control circuits do not function with thermistor abnormality or other reasons and the fuser roller is abnormally overheated as the result, 2 thermostats (front and center ones in the fuser unit) shut off the power supply to the heater lamps to protect the equipment.

A sub-heater lamp, installed only for MJD, is turned ON only when the fuser unit is started, and supports other lamps.

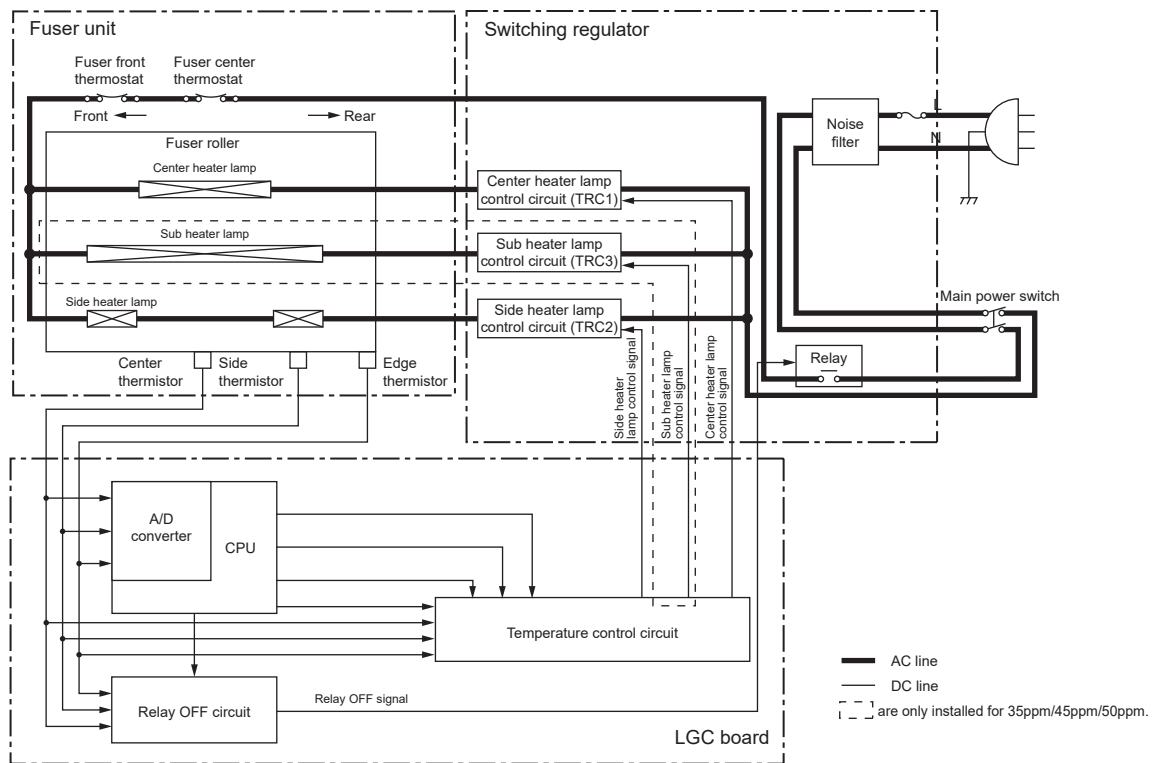


Fig. 3-39

## [ 2 ] Temperature detection section

### [ 2-1 ] Fuser unit error status counter control

- If the error codes [C411] to [C4B0] are displayed and still not cleared even though the thermistor, thermostat and heater lamp have been repaired (and the power ON/OFF does not clear the error), check the fuser unit error status counter (FS-08-2002) to clear the value to "0".

#### Remarks:

The fuser unit error status counter (Setting Mode (FS-08-2002)) never has values other than 0 to 68.

- If the heater lamps do not turn ON and the service call [C411] or [C412] is displayed immediately after the power is ON, ensure the fuser unit error status counter is "2" or over. If it is "62" or over, be sure to check the thermistor, thermostat and heater lamp. Reset the counter to "0" after repairing them, then turn ON the power.
- If the fuser unit error status counter is "undefined value", EEPROM or its data may have been ruined due to leakage from the chargers.  
Check the bias, high-voltage transformers and needle electrodes for defects, and also look through all the data in EEPROM.
- When the thermistors detect overheating, the engine CPU decides the error code and counter value of the fuser unit error status. After turning OFF each output (the heater lamp, exposure lamp, control panel display, motors and so on), the engine CPU turns OFF the power to protect the fuser unit.

Error code: C449

Fuser unit error status counter (FS-08-2002): 9, 19, 21, 22, 23, 25, 27, 29, 45, 59, 60, 61, 63, 64, 65, 66, 67 to 68

Thermistors continue detecting the abnormal temperature even after the error codes and counter values are decided. Even if the power is turned ON immediately, it is automatically turned OFF again when the surface temperature of the fuser belt is still higher than the abnormal temperature detected.

Wait until the surface temperature of the fuser belt is lowered enough, and turn ON the power to check the counter value while it is turned OFF again. After confirming that it is the fuser unit abnormality, correct the abnormality and reset the counter value (08-2002) to "0" to start up the equipment normally.

### [ 2-2 ] Temperature detection circuit

The thermistor is a device whose resistance varies according to the detected temperature. The ASIC detects voltages output from this devices, and judges whether the operation of the fuser unit is normal or abnormal from the changes in voltages.

If one of the thermistors is broken, the control circuit judges that the temperature of the fuser belt or pressure roller is extremely low and keeps turning the heater lamps ON. As a result, the temperature of the fuser belt or pressure roller rises, and possibly activates the thermostat which is a safety protection device. To prevent this in advance, the ASIC works to detect whether each thermistor is broken or not. Also, the control circuit constantly checks the temperature of the fuser roller and the pressure roller to prevent them from excessive heating by circuit abnormality or thermistor abnormality, and automatically shuts OFF the power when one of these temperatures exceeds the specified temperature.

### [ 2-3 ] Abnormality detection by the thermistors

The following table shows the conditions for judging the temperature abnormality of the fuser roller, and the detecting timing.

Check timing	Error code	Counter	Temperature judged			Error judging timing	
			Fuser roller thermistor				
			Center	Side	Edge		
Power ON	C449	9	240°C or above	---	---	Power ON	
			---	240°C or above	---		
			---	---	240°C or above		
		59	Thermistor (HTERR signal: L)				
Detecting 40°C	C449	19	240°C or above	---	---	On usual	
			---	240°C or above	---		
			---	---	240°C or above		
		60	Thermistor (HTERR signal: L)				
	C411	(1)	40°C or below	---	---	Center: 40°C Side: 40°C	
			---	40°C or below	---		
	C412	2	40°C or below	---	---	Center: 40°C Side: 40°C	
			---	40°C or below	---		
	Detecting 100°C	C449	21	240°C or above	---	---	On usual
				---	240°C or above	---	
---				---	240°C or above		
61			Thermistor (HTERR signal: L)				
C443		3	100°C or below	---	---	Center: 100°C Side: 100°C	
			---	100°C or below	---		

Check timing	Error code	Counter	Temperature judged			Error judging timing
			Fuser roller thermistor			
			Center	Side	Edge	
Ready temperature is detected	C449	22	240°C or above	---	---	On usual
			---	240°C or above	---	
			---	---	240°C or above	
		63	Thermistor (HTERR signal: L)			
	C452	62	Ready temperature or above	100°C or below	---	Center: Ready temperature
			100°C or below	Ready temperature or above	---	Side: Ready temperature
C455	5	Ready temperature or above	---	---		
		---	Ready temperature or above	---		
During ready	C449	23	240°C or above	---	---	On usual
			---	240°C or above	---	
			---	---	240°C or above	
		64	Thermistor (HTERR signal: L)			
	C447	7	40°C or below	---	---	On usual
			---	40°C or below	---	
---			---	40°C or below		
During printing	C449	25	240°C or above	---	---	On usual
			---	240°C or above	---	
			---	---	240°C or above	
		65	Thermistor (HTERR signal: L)			
	C447	8	40°C or below	---	---	On usual
			---	40°C or below	---	
			---	---	40°C or below	
	C450	6	---	The WAIT control according to low temperatures is 1 minute or more.	---	On usual
---				---		

Check timing	Error code	Counter	Temperature judged			Error judging timing
			Fuser roller thermistor			
			Center	Side	Edge	
At energy saving mode	C449	27	240°C or above	---	---	On usual
			---	240°C or above	---	
			---	---	240°C or above	
		66	Thermistor (HTERR signal: L)			
At paper jam	C449	29	240°C or above	---	---	On usual
			---	240°C or above	---	
			---	---	240°C or above	
		67	Thermistor (HTERR signal: L)			
At self-diagnostic mode	C449	45	240°C or above	---	---	On usual
			---	240°C or above	---	
			---	---	240°C or above	
		68	Thermistor (HTERR signal: L)			

\* The figures in the “Error code” and “Counter” fields with parentheses denote that an error status has not yet been determined (= error status is detected only once).

## 3.15 Paper Exit Section / Reverse Section

### 3.15.1 General description

For 20ppm/25ppm/30ppm, a sheet of paper with the toner fused on is transported to the inner tray or Automatic Duplexing Unit (ADU) by switchbacking in the paper exit section.

For 35ppm/45ppm/50ppm, a sheet of paper with the toner fused on is transported to the inner tray, but the lower exit roller does not switchback.

The reverse section is only installed for 35ppm/45ppm/50ppm.

It is a path only for switchbacking to the ADU to enhance the high-speed printing.

The reverse section has the reverse gate which switches the transport path to the paper exit section or the reverse section. The reverse roller and upper exit roller switchbacks to transport the paper to the ADU.

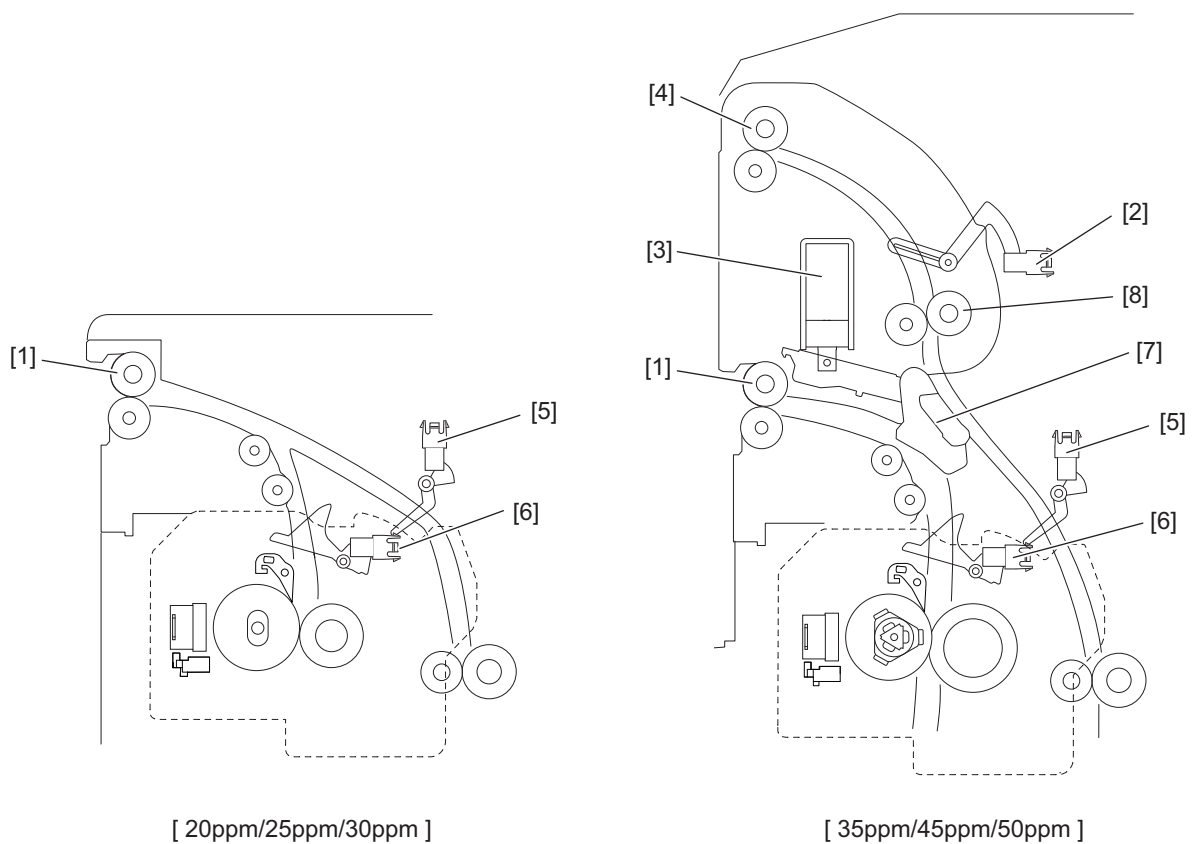


Fig. 3-40

[1] Exit roller (20ppm/25ppm/30ppm) / Lower exit roller (35ppm/45ppm/50ppm)

[2] Reverse sensor

[3] Reverse gate solenoid

[4] Upper exit roller

[5] ADU entrance sensor

[6] Exit sensor

[7] Reverse gate

[8] Reverse roller

item	20ppm/25ppm/30ppm	35ppm/45ppm/50ppm
Reverse section (Switchback mechanism) <ul style="list-style-type: none"> <li>• Reverse motor</li> <li>• Reverse sensor</li> <li>• Upper exit roller</li> <li>• Reverse roller</li> <li>• Reverse gate solenoid</li> <li>• Reverse gate</li> </ul>	Not installed	Installed

### 3.15.2 Functions

1. Exit motor (M10)  
 The exit motor is a stepping motor which drives the exit roller (20ppm/25ppm/30ppm). For 20ppm/25ppm/30ppm, this motor rotates exit roller reversely to switchback when the paper is transported to the ADU.
2. Exit roller (20ppm/25ppm/30ppm)  
 The exit roller transports the paper from the fuser unit to the inner tray. This roller is driven by the exit motor.  
 For 20ppm/25ppm/30ppm, this roller switchbacks to transport the paper to the ADU.
3. Lower exit roller (35ppm/45ppm/50ppm)  
 The lower exit roller transports the paper from the fuser unit to the inner tray. This roller is driven by the main motor.
4. Reverse sensor (S18) (only installed for 35ppm/45ppm/50ppm)  
 The reverse sensor detects if the leading edge of the paper from the paper exit section has reached to the reverse roller. This sensor is also used for the detection of a paper jam in the reverse section, and the detection of the trailing edge of the reversed paper at duplex printing as well.
5. Reverse motor (M13) (only installed for 35ppm/45ppm/50ppm)  
 The reverse motor is a stepping motor which drives the reverse roller and upper exit roller, however, this motor rotates reversely to switchback when the paper is transported to the ADU.
6. Reverse roller / Upper exit roller (only installed for 35ppm/45ppm/50ppm)  
 The reverse roller and upper exit roller transports the paper from the paper exit section to the job separator (MJ-5014/C: 20ppm/25ppm/30ppm, MJ-5015/C: 35ppm/45ppm/50ppm) or ADU. This roller is driven by the reverse motor.
7. Reverse gate solenoid (SOL1) (only installed for 35ppm/45ppm/50ppm)  
 This reverse gate solenoid drives the reverse gate and switches the paper transport path (exit section of reverse section).

### 3.15.3 Exit motor / Reverse motor / Main motor drive

1. Exit Motor

The figure shown below is the layout of the driving gears of the exit roller.

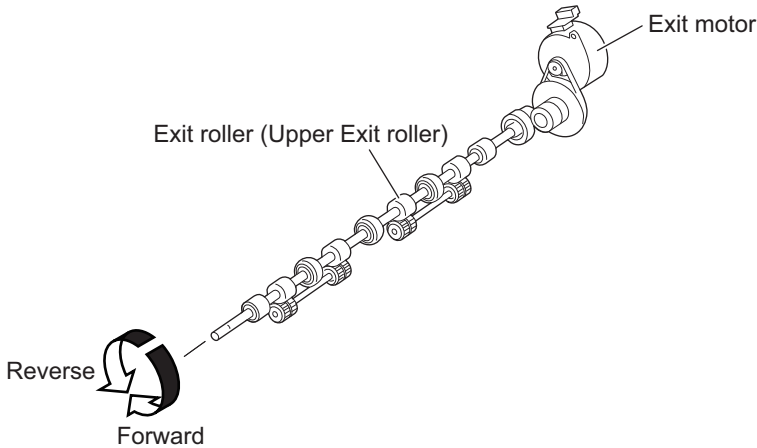


Fig. 3-41

2. Reverse Motor (only installed for 35ppm/45ppm/50ppm)

The figure shown below is the layout of the driving gears of the reverse roller and upper exit roller.

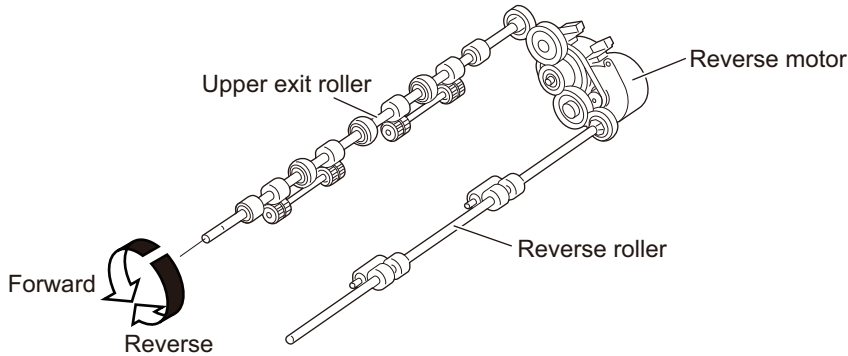


Fig. 3-42

3. Main Motor

The figure shown below is the layout of the driving gears of the lower exit roller. (35ppm/45ppm/50ppm)

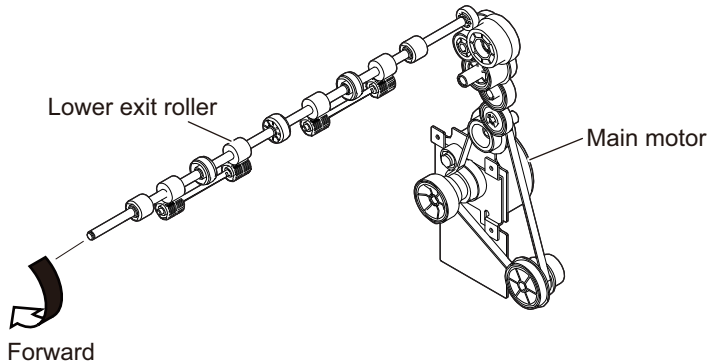


Fig. 3-43



## 3.16 Automatic Duplexing Unit (ADU)

### 3.16.1 General description

The Automatic Duplexing Unit (ADU) of this equipment is a unit to reverse the paper when duplex printing is performed. The ADU mainly consists of the transport roller and its driving section, paper guide and ADU entrance/exit sensors.

The ADU for the 20/25/30 ppm models adopts the switchback method to transport the paper through the exit roller. Immediately after printing on one side of the paper (completing the fusion process), the exit roller switchbacks to transport the reversed paper to the registration section to print on the other side.

The ADU for the 35/45/50 ppm models adopts the switchback method to transport the paper through the reverse section. Immediately after printing on one side of the paper (completing the fusion process), the reverse section switchbacks to transport the reversed paper to the registration section to print on the other side.

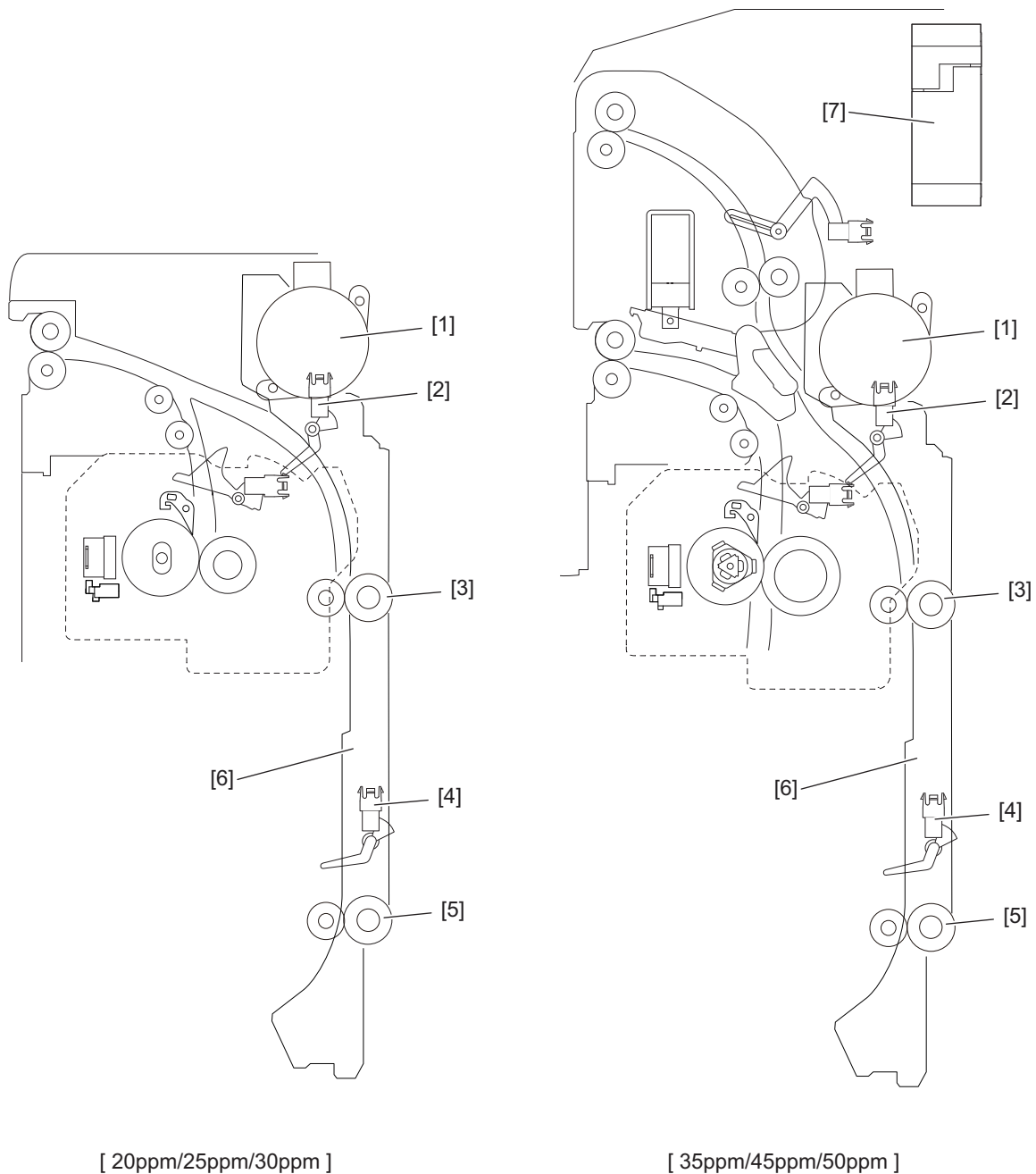


Fig. 3-44

- [1] ADU motor
- [2] ADU entrance sensor
- [3] Upper transport roller
- [4] ADU exit sensor
- [5] Lower transport roller
- [6] Paper guide
- [7] Exit section cooling fan (35ppm/45ppm/50ppm only)

### 3.16.2 Composition

ADU motor	M5: Stepping motor
ADU entrance sensor	S7
ADU exit sensor	S6
Reverse sensor	S18
ADU driving PC board	ADU
Upper transport roller	
Lower transport roller	

### 3.16.3 Functions

1. ADU motor (M5)  
Drives the ADU upper transport roller and the ADU lower transport roller. The ADU motor is installed to the rear frame of the equipment.
2. ADU entrance sensor (S7)  
Detects the paper transported in the ADU.
3. ADU exit sensor (S6)  
Detects the paper transported in the ADU.
4. ADU opening/closing switch (SW5)  
Detects opening/closing of the ADU.
5. Transport roller (Upper/Lower)  
Transports the paper inside the ADU.

### 3.16.4 Description of operations

For the 20/25/30 ppm models, when the trailing edge of the paper passes through the exit gate, the exit roller switchbacks to transport it into the ADU (the exit gate is switched on its own weight). The switchbacked paper is transported as the transport speed increases. When the ADU exit sensor detects the paper, the speed starts to decrease.

After the paper is transported to the registration section, the printing of the front side (recording data on the front side of paper) is performed.

The paper passes through the exit gate again and exits to the exit tray to complete duplex printing.

For the 35/45/50 ppm models, when the paper passes through the reserve sensor, the reverse gate solenoid switches the reverse gate, and the reverse roller / upper exit roller switchbacks to transport the paper into the ADU. The switchbacked paper is transported as its transport speed increases. When it is transported to the ADU exit sensor, the speed decreases.

After the paper is transported to the registration section, the printing of the front side (recording data on the front side of paper) is performed.

The paper passes through the lower exit roller and exits to the exit tray to complete duplex printing.

There are three methods of judging a paper jam: (1) whether the ADU entrance sensor is turned ON or not in a specified period of time after the switchback to the ADU started (E510). (2) whether the ADU exit sensor is turned ON or not in a specified period of time after the ADU entrance sensor is turned ON (E520). (3) whether the registration sensor is turned ON or not in a specified period of time after the paper feeding from the ADU to the equipment (E110).

If the ADU is opened during duplex printing, the ADU motor is stopped, namely, ADU open jam occurs (E430).

The equipment is never to be stopped during printing by interruption in any case except paper jam or service call.

For the 20/25/30 ppm models, the duplex printing operation varies depending on the size of the paper, single-paper circulation and alternateness circulation.

### 3.16.5 Drive of ADU

When the ADU motor (M5) rotates, the upper transport roller and lower transport roller are rotated driven by the gears and belt.

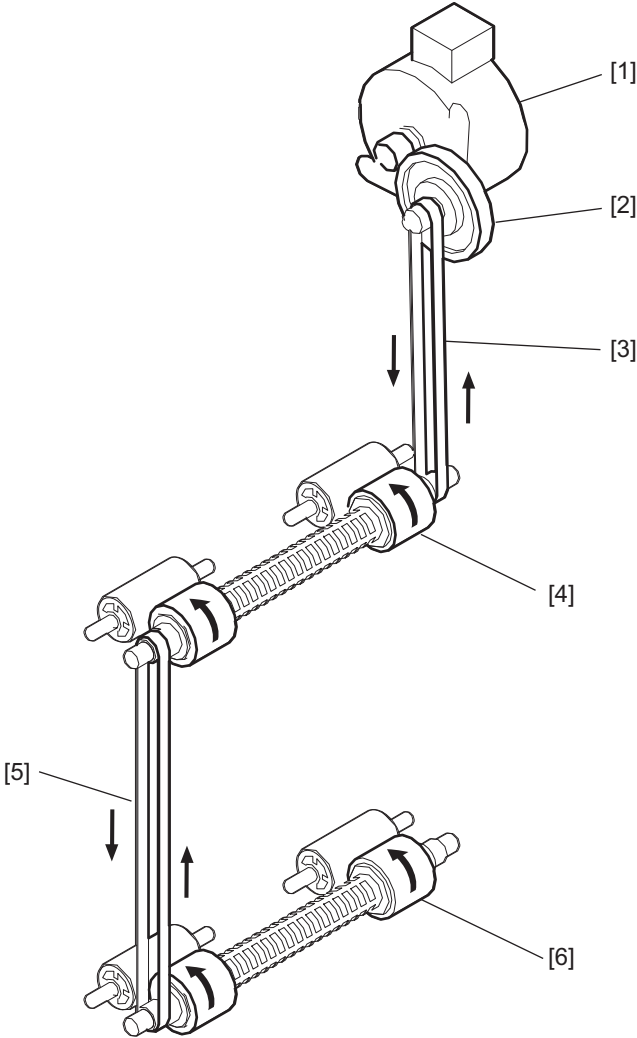


Fig. 3-45

- [1] ADU motor
- [2] Gear
- [3] Timing belt
- [4] Upper transport roller
- [5] Timing belt
- [6] Lower transport roller

## 3.17 Power Supply Unit

### 3.17.1 Construction

The power supply unit consists of the AC filter, insulation type DC output circuit, heater lamp control circuit and damp heater power supply circuit.

### 3.17.2 Explanation of functions

The functions of each component of the power supply unit are described here

1. AC filter  
Eliminates noise from the outside and prevents the noise generated by the equipment from leaking to the outside.
2. DC output circuits  
Converts AC voltage input from outside to DC voltage and supplies it to each electric part. The DC voltage is divided into the following two lines.
  - a. Main power switch line:  
Power supply used in the entire equipment during image forming process.  
Two kinds of voltage (+5V, +12V) are output when the main power switch of the equipment is turned ON.
  - b. Door switch line:  
Power supply used in the entire equipment during image forming process, being supplied via the interlock switch. Two kinds of voltage (+5VD and +24VD) are output only when the main power switch of the equipment is turned ON and two doors (front cover and ADU unit) are closed.
3. Heater lamp control circuit  
TRC (Triac) is driven by the heater control signal (HTR1ON/HTR2ON/HTRASTON) from the LGC board and then AC power is supplied to each heater lamp (center, side and sub) in the fuser unit. For 20ppm/25ppm/30ppm, the sub heater lamp is not installed and the HTRASTON signal is not supplied.
4. Damp heater power supply circuit  
AC power input from outside is output directly to the DAMP board and then supplied to the damp heater in each section in the equipment. The damp heater switch is set to OFF as initial setting for shutting off the power to the damp heater. When using the damp heater, the damp heater switch needs to be turn ON after installing the equipment. The damp heater (including the DAMP board) is an option in NAD/MJD model, and is installed as standard device in other models.

### 3.17.3 Operation of DC output circuits

#### 1. Starting line output

When the main power switch of the equipment is turned ON, power starts supplying to all the lines only when two doors (front cover and ADU) are closed.

#### 2. Stopping line output

When the main power switch of the equipment is turned OFF, PWR-DN signal is output after the instantaneous outage insurance time elapses and then the supply of each voltage stops. If the supply of voltage of the main line (+5VS, +12VA) stops earlier than the 24V line does, it may cause the damage of the electron device on each control circuit. To prevent this, the supply of these voltages stops after the PWR-DN signal is output and the minimum retaining time elapses.

#### 3. Output protection

Each output system includes an overcurrent and overvoltage protection circuits (a fuse and internal protection circuit). This is to prevent the defectives (damage or abnormal operation of the secondary circuit) which may be caused by an overcurrent due to a short circuit or an overvoltage due to a short circuit between different voltages. If the protection circuit is activated (except the case the fuse is blown out), remove the causes such as short-circuit. Turn ON the power again to clear the overcurrent protection.

#### 4. Recovering from super sleep mode (normal starting)

When the [ENERGY SAVER] button on the control panel is pressed during the super sleep mode, a super sleep mode shifting/recovering signal (SYS-EN) is output from the SYS board and then voltage starts being supplied to all the lines, if no error was detected.

#### 5. Recovering from super sleep mode (when receiving a packet)

When a packet from a network is received during the super sleep mode, the mode is shifted to the sleep mode.

When packets are received frequently, a control is performed to keep the sleep mode for a specified period. It will be cleared when the power is turned OFF and then back ON.

#### 6. Shifting to super sleep mode (normal stopping)

When the [ENERGY SAVER] button on the control panel is pressed while the main power switch of the equipment is toggled ON, a super sleep mode shifting/recovering signal (SYS-EN) is stop after the initialization is finished and then all lines for output voltage except +5VS are closed.

The Super sleep mode is disabled under the following conditions.

- When the Super sleep mode is set to be disabled on the control panel, TopAccess and with the code FS-08-8543
- When the Wireless LAN Module, Bluetooth Module, e-BRIDGE ID Gate or Data Overwrite Enabler is installed, or when the IPsec Enabler is installed and its function is set to be enabled
- When the dial-in function is set to be enabled
- When operation is being performed in the self-diagnosis mode (Disabled until the main power switch is turned OFF)

## 7. State of the power supply

### - Power OFF

The main power switch of the equipment is turned OFF. Since DC voltage is not supplied to each board, the equipment is not operable.

### - Normal state (including Energy saving mode)

The main power switch of the equipment is turned ON and DC voltage is supplied to each board. When the cover of the equipment is closed, 24V DC voltage is supplied and the equipment enters into the ready/printing state.

### - Sleep mode

Since +24V DC voltages are not supplied but +12VA, and +5VS DC voltages only, the equipment does not enter into the ready state.

### - Super Sleep mode

Only DC voltage and +5VS are output from the power supply unit. The [ENERGY SAVER] button is monitored and the LED of the main power switch is lit.

### 3.17.4 Output channel

The following are output channels for the main power switch line.

main power switch line

Connector	Pin No.	Voltage	Destination
CN511	2	+12VA	SYS board DF (via SYS board)
	4	+5VS	
CN512	6	+12VA	LGC board
CN514	1	+12VA	Cover switch

The following are output channels for the cover switch line.

Cover switch line

Connector	Pin No.	Voltage	Destination
CN512	15	+24VD1	LGC board
	16		
CN513	3	+24VD3	SYS board
CN516	2	+24VD5	Finisher



### 3.17.5 Fuse

When the power supply secondary fuse is blown out, confirm that there is no abnormality with each part using the following table.

Voltage	Board/Unit	Part	Fuse type
+24VD1	LGC	Process unit fan	F201:8A (Time-lag)
		Toner motor	
		Polygonal motor	
		Upper Tray-up motor	
		Lower Tray-up motor	
		TRU fan	
		Switching regulator cooling fan	
		Auto-toner sensor	
		1st drawer feed clutch	
		2nd drawer feed clutch	
		Registration roller clutch	
		High speed transport clutch	
		Low speed transport clutch	
		ADU clutch	
		Discharge LED	
		Main power switch	
		High-voltage transformer	
		Bypass feed clutch	
		ADU motor	
		Exit motor	
	Reverse motor (35ppm/45ppm/50ppm only)		
	REV gate solenoid (35ppm/45ppm/50ppm only)		
	Main motor		
SYS	Scan motor		
	Exposure lamp (Lamp inverter board / LED board)		
	Key copy counter / Coin controller		
	Bridge unit / Job separator		
	PFP/LCF		
+24VD3	RADF		F203:4A (Time-lag)
+24VD4	Finisher		F204:5A (Time-lag)

#### Primary fuse

Part		Fuse type
MFP	-	F101
Switching regulator	PS	F102



## 4. DISASSEMBLY AND REPLACEMENT

### 4.1 Covers

#### 4.1.1 Front cover

- (1) Open the front cover.
- (2) Loosen 2 screws and pull out the front cover [1] at an angle toward the lower-front side.

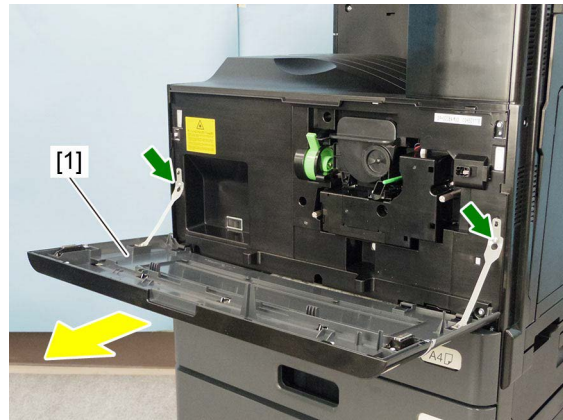


Fig. 4-1

#### 4.1.2 Left cover

- (1) Open the front cover and pull out the 1st drawer.
- (2) Remove 8 screws and take off the left cover [1].
  - [2] M4 x 8
  - [3] M3 x 8

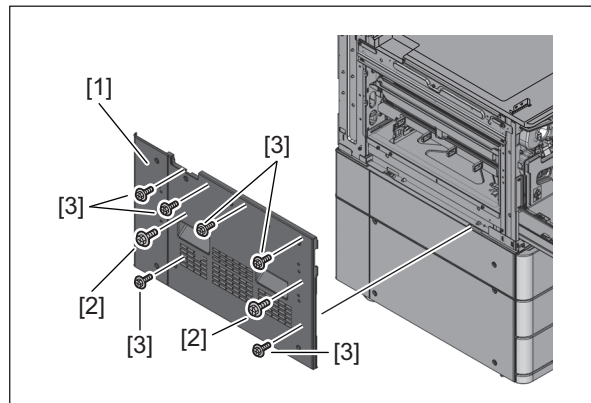


Fig. 4-2

### 4.1.3 Receiving tray

- (1) Remove the left cover.  
📖 P. 4-1 "4.1.2 Left cover"
- (2) Remove the receiving tray [1].

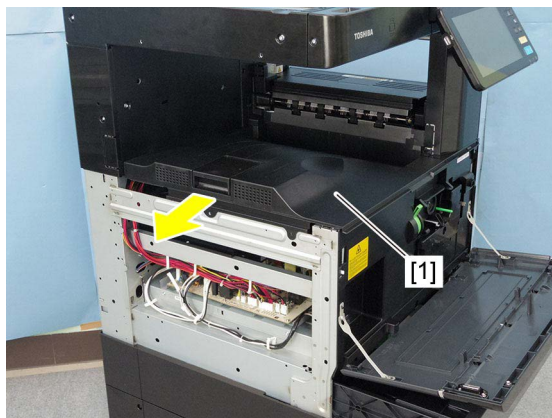


Fig. 4-3

### 4.1.4 Tray rear cover

- (1) Remove the receiving tray.  
📖 P. 4-2 "4.1.3 Receiving tray"
- (2) Remove the left rear cover.  
📖 P. 4-3 "4.1.6 Left rear cover"
- (3) Remove the exit back cover.  
📖 P. 4-4 "4.1.7 Exit back cover"
- (4) Remove 1 screw and take off the tray rear cover [1] by sliding it to the left.

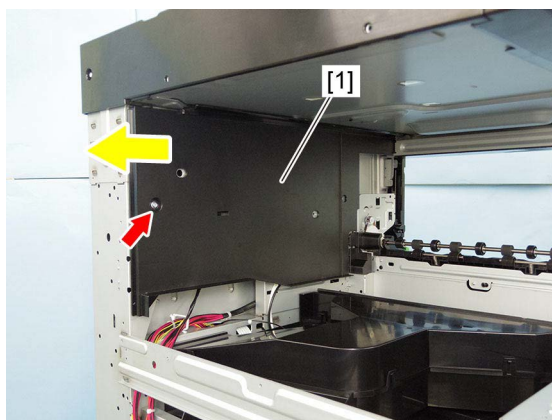


Fig. 4-4

**Notes:**

When installing, insert the latch [2] into the hole in the frame.

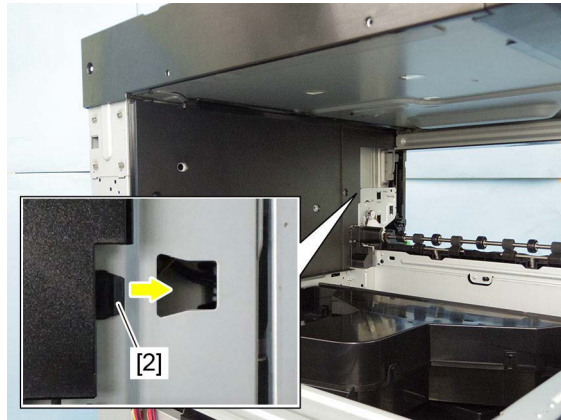


Fig. 4-5

### 4.1.5 Left top cover

(1) Remove 2 screws and take off the left top cover [1].

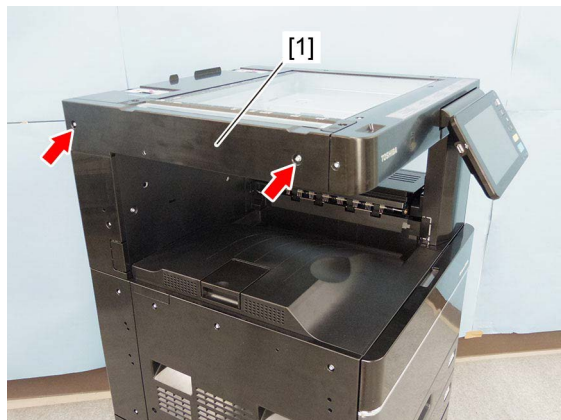


Fig. 4-6

### 4.1.6 Left rear cover

(1) Remove 1 screw and take off the left rear cover [1] by lifting it up.



Fig. 4-7

### 4.1.7 Exit back cover

- (1) Open the side cover.
- (2) Remove 1 screw and take off the exit back cover [1].



Fig. 4-8

### 4.1.8 Right top cover

- (1) Remove 3 screws and take off the top right cover [1] by lifting it up.

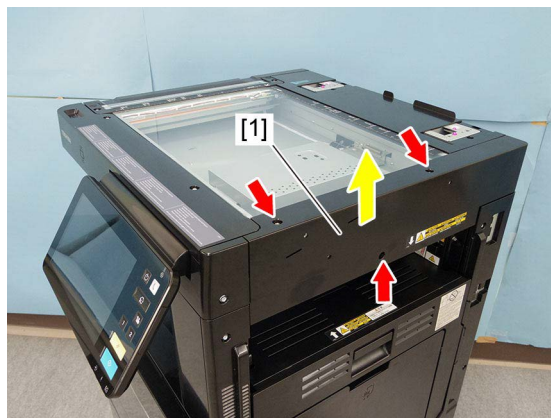


Fig. 4-9

### 4.1.9 Right front cover

- (1) Pull out the 1st and 2nd drawers.
- (2) Open the front cover.
- (3) Open the feed cover.
- (4) Open the side cover.

- (5) Remove 2 screws and take off the right front cover [1] by lifting it up.

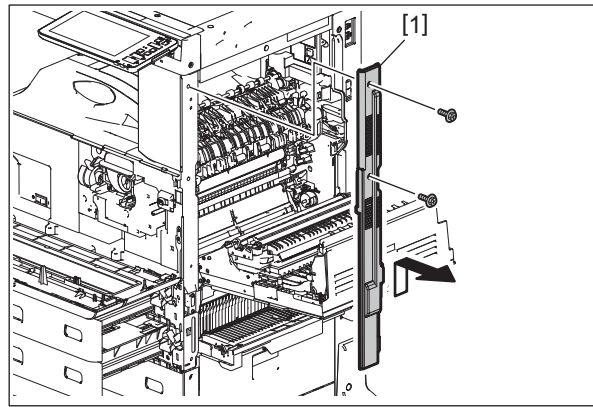


Fig. 4-10

#### 4.1.10 Right rear cover

- (1) Open the feed cover.
- (2) Remove the right top cover  
P. 4-4 "4.1.8 Right top cover"
- (3) Open the side cover.
- (4) Remove 3 screws and take off the right rear cover [1].

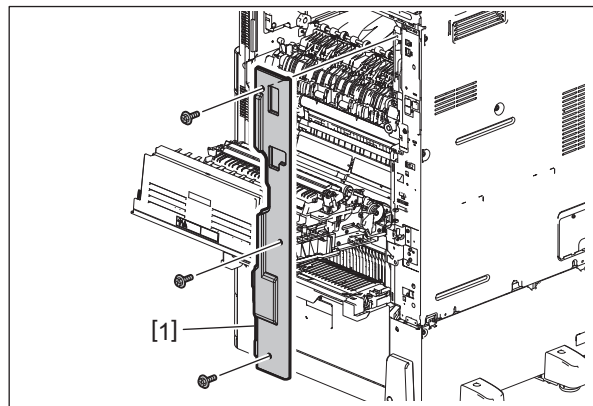


Fig. 4-11

#### 4.1.11 Front top cover

- (1) Remove the right top cover.  
P. 4-4 "4.1.8 Right top cover"
- (2) Move the control panel to the position as shown in the figure.

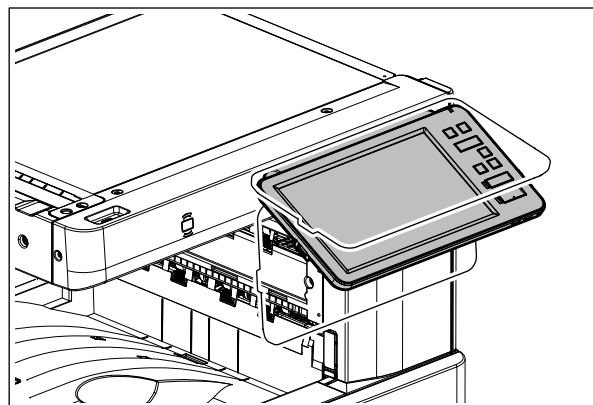


Fig. 4-12

- (3) Remove 2 caps.
- (4) Remove 3 screws and take off the front top cover [1] by sliding it toward the left side.

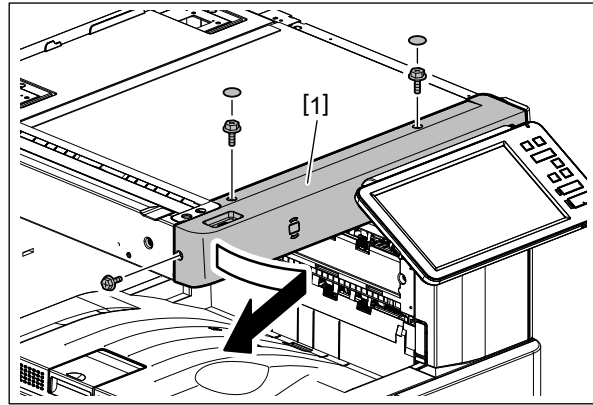


Fig. 4-13

#### 4.1.12 Control panel lower cover

- (1) Make the control panel [1] level.

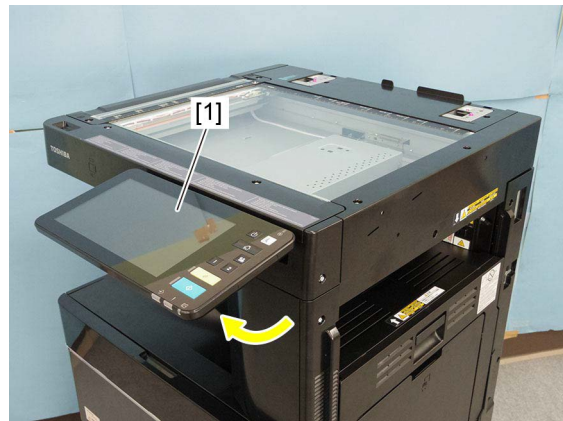


Fig. 4-14

- (2) Remove 2 screws and take off the control panel lower cover [2].

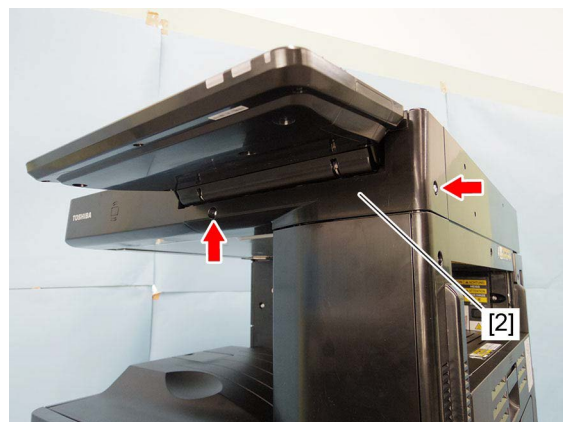


Fig. 4-15



### 4.1.13 Front right cover

- (1) Remove the control panel lower cover.  
📖 P. 4-6 "4.1.12 Control panel lower cover"
- (2) Open the front cover.
- (3) Remove 1 screw and take off the front right cover [1] by lifting it up.



Fig. 4-16

### 4.1.14 Rear top cover

- (1) Remove the RADF or the platen cover.
- (2) Remove the left top cover.  
📖 P. 4-3 "4.1.5 Left top cover"
- (3) Remove the right top cover.  
📖 P. 4-4 "4.1.8 Right top cover"
- (4) Remove 2 screws and take off the rear top cover [1].



Fig. 4-17

### 4.1.15 Rear cover

- (1) Remove 6 screws and take off the rear cover [1] by lifting it up.

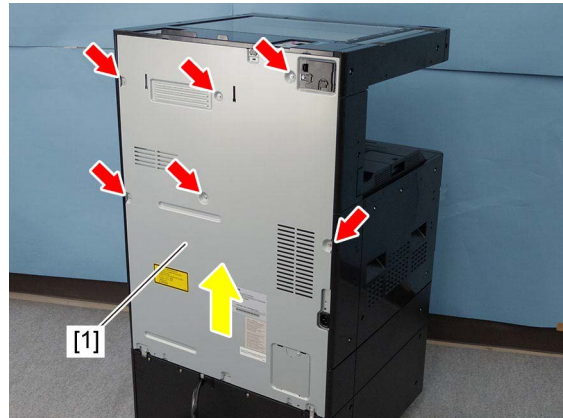


Fig. 4-18

### 4.1.16 Front cover switch (SW4)

- (1) Remove the receiving tray.  
P. 4-2 "4.1.3 Receiving tray"
- (2) Disconnect 1 connector and take off the front cover switch [1].

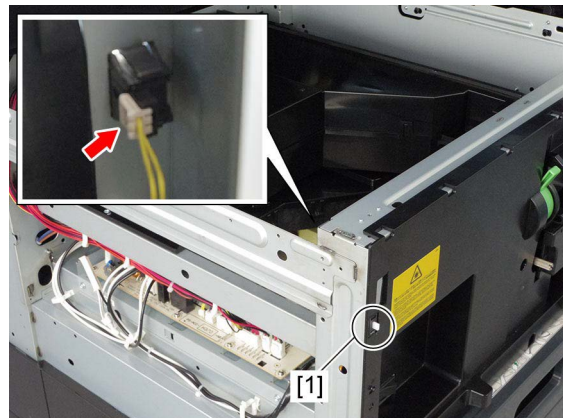


Fig. 4-19

### 4.1.17 Front cover interlock switch (SW2)

#### Notes:

If the interlock switch is not installed appropriately when it is replaced or installed, it may not work normally. If you carry out the maintenance of the equipment in such a situation, you could get an electric shock by touching live sections or be injured by touching moving sections. Therefore, to avoid this, be sure to perform correct handling and installation.

- (1) Remove the front cover.  
P. 4-1 "4.1.1 Front cover"
- (2) Remove the receiving tray.  
P. 4-2 "4.1.3 Receiving tray"
- (3) Remove the right front cover.  
P. 4-4 "4.1.9 Right front cover"
- (4) Remove the front right cover.  
P. 4-7 "4.1.13 Front right cover"
- (5) Remove the developer unit.  
P. 4-114 "4.8.1 Developer unit"

(6) Remove 5 screws and take off the inner cover [1].

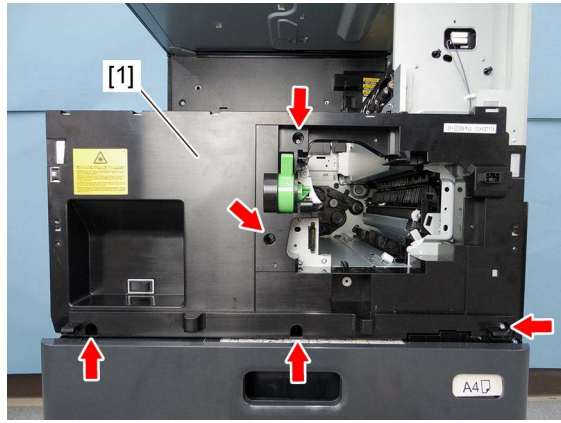


Fig. 4-20

(7) Disconnect 2 connectors and remove 2 screws [2].

(8) Remove the front cover interlock switch [3].

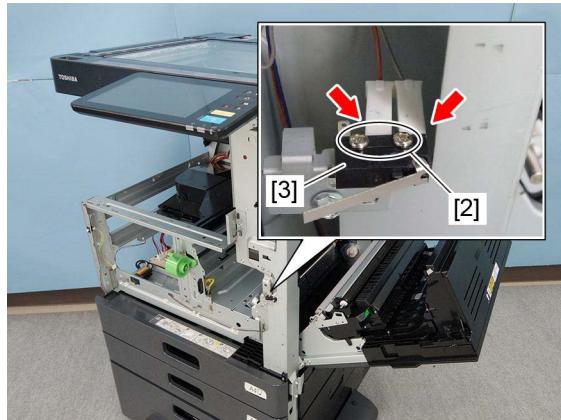



Fig. 4-21

## 4.2 Control Panel

### 4.2.1 Control panel unit

- (1) Remove the front top cover.  
 P. 4-5 "4.1.11 Front top cover"
- (2) Lower the control panel unit [1].

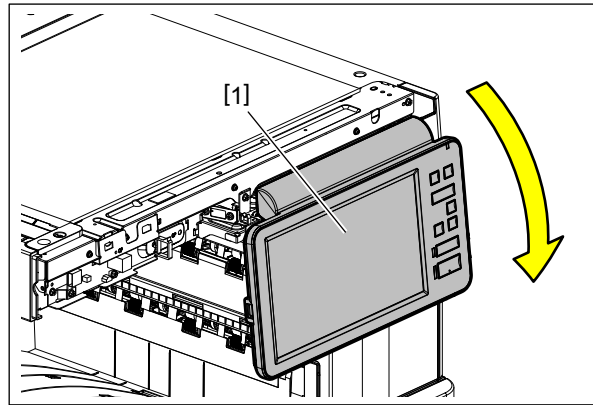


Fig. 4-22

- (3) Remove 2 screws. Remove the control panel unit [1] by sliding it.

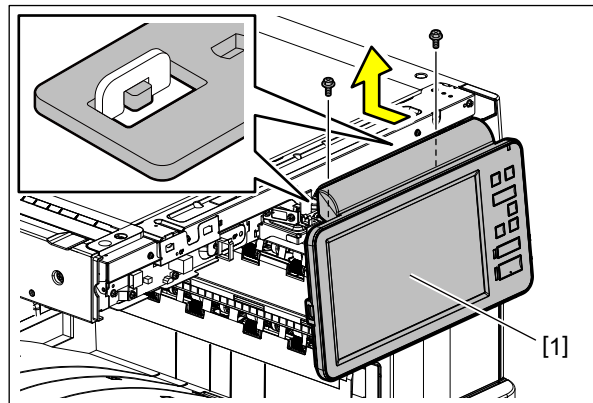


Fig. 4-23

- (4) Remove 4 screws.

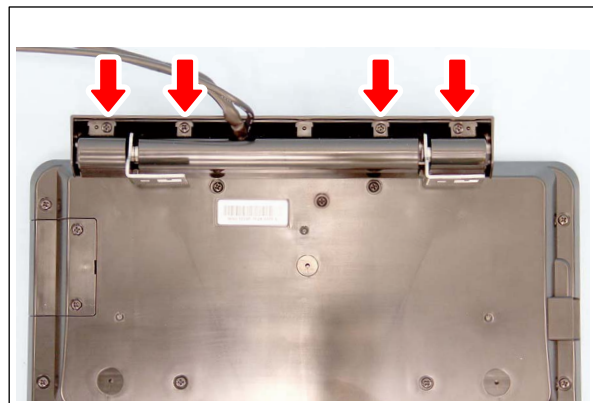


Fig. 4-24

(5) Raise 2 hinges and remove the hinge cover [3].

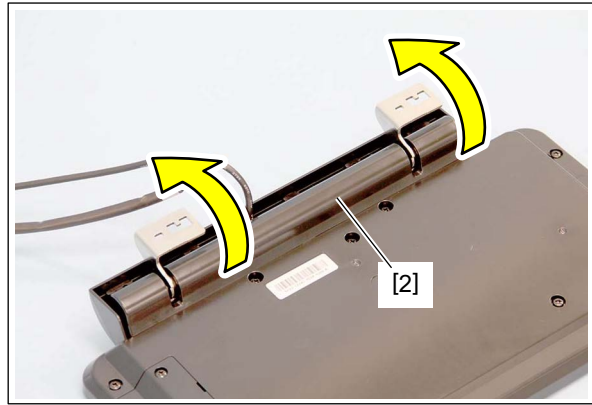


Fig. 4-25



Fig. 4-26

(6) Remove 9 screws and take off the cover [3].

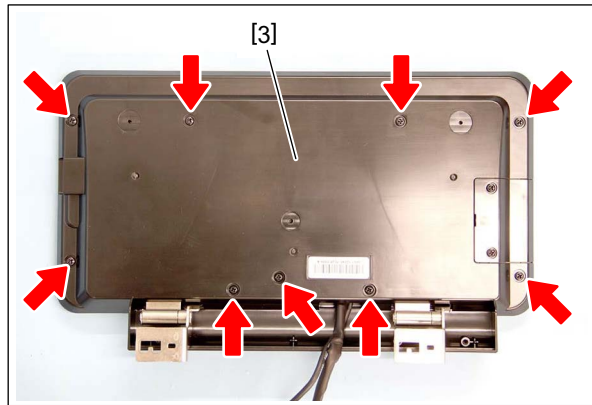


Fig. 4-27

- (7) Remove the harness from 5 hooks and disconnect connector [4] and [5], and then remove the USB harness/signal harness [6].

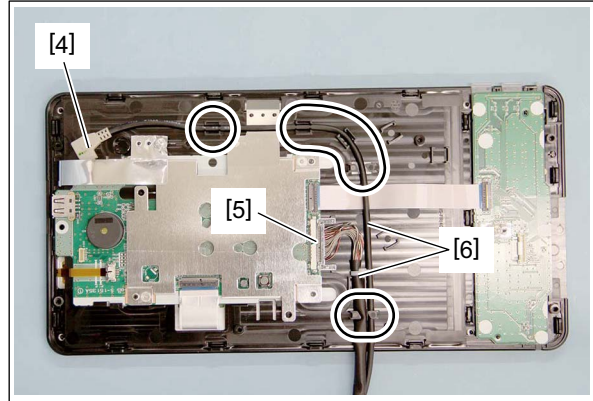


Fig. 4-28

**Notes:**

When disconnecting the connector [5], release the lock and disconnect it.

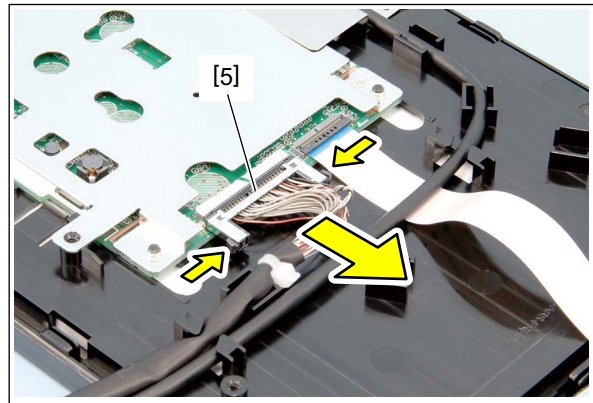


Fig. 4-29

## 4.2.2 KEY board/button

- (1) Remove the control panel unit.  
P. 4-10 "4.2.1 Control panel unit"
- (2) Disconnect the connector [1], remove 1 screw and take off the KEY board [2].

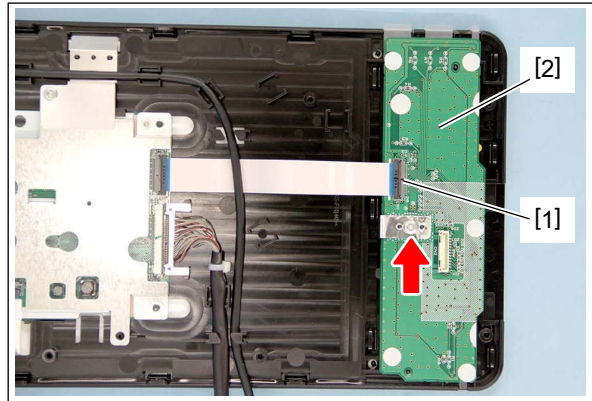


Fig. 4-30

### Notes:

When disconnecting the connector [1], release the lock by raising the latch and disconnect it.

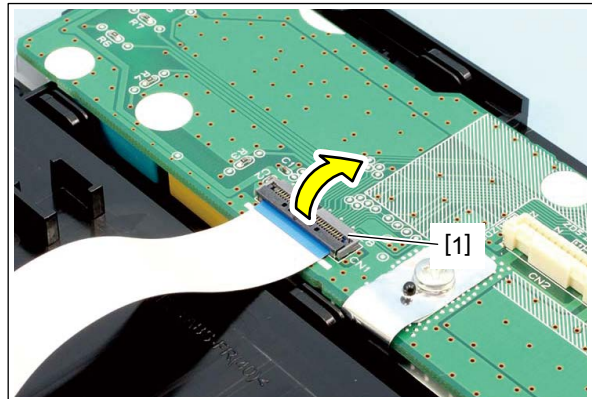


Fig. 4-31

- (3) Remove 6 buttons [3].

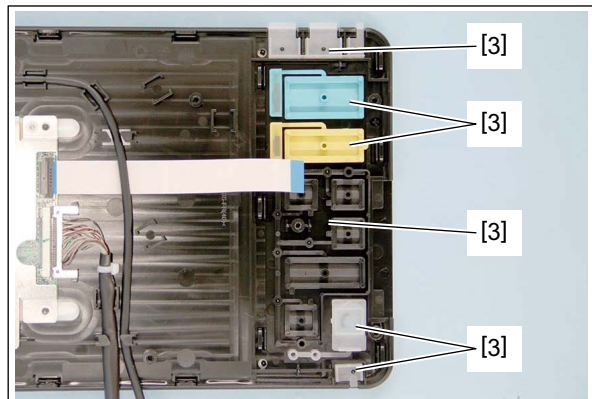


Fig. 4-32



Fig. 4-33

### 4.2.3 DSP board

- (1) Remove the control panel unit.  
 ⓘ P. 4-10 “4.2.1 Control panel unit”
- (2) Remove 2 screws and take off the grounding plate [1].
- (3) Remove flat cables [2], [3] and [4].

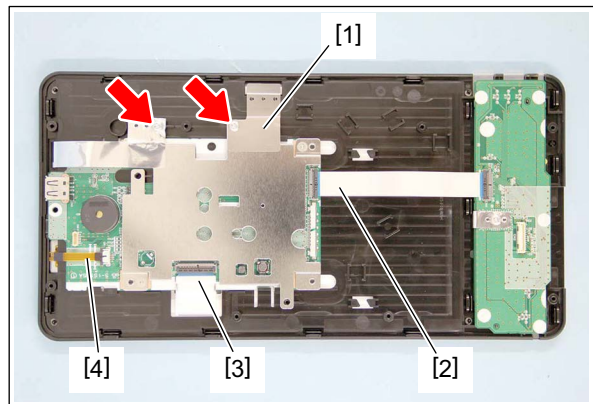


Fig. 4-34

#### Notes:

- When disconnecting the flat cable [2], release the lock by raising the latch [5] and remove the cable.

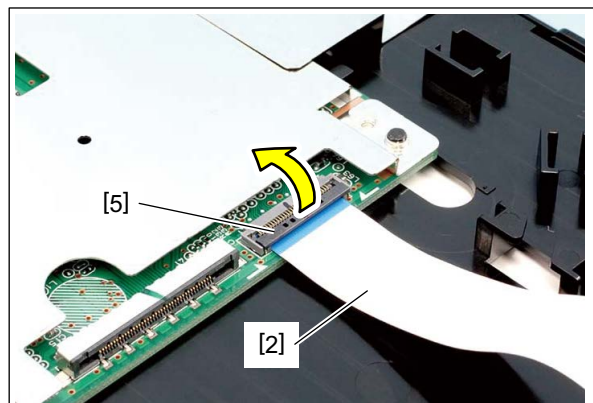


Fig. 4-35



- When disconnecting the flat cable [3], release the lock by raising the latch [6] and remove the cable.

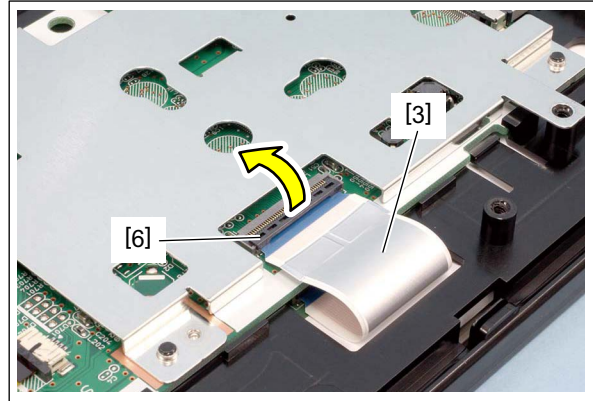


Fig. 4-36

- When disconnecting the flat cable [4], release the lock by pulling the latch [7] in the direction of the arrow shown in the figure, and then remove the cable.

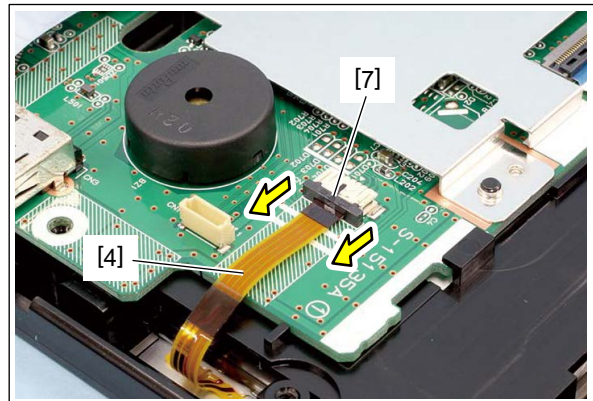


Fig. 4-37

- (4) Release 2 latches [8] and take off the DSP board [7] by sliding it in the direction of the arrow shown in the figure.

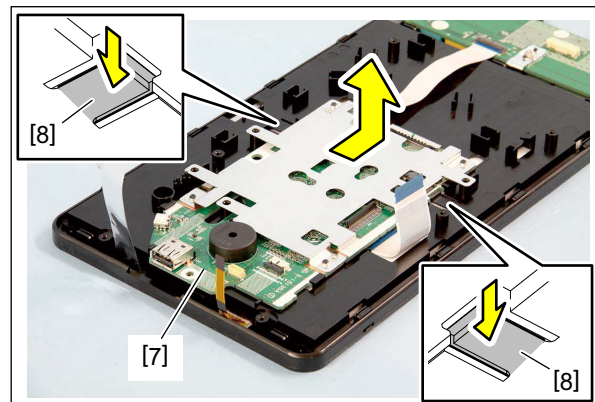


Fig. 4-38

**Notes:**

When the DSP board has been replaced, perform FS-08-9050 (Panel calibration execution) before normal start-up. P. 6-69 “6.11 Control Panel Calibration”

## 4.3 Scanner Unit

### 4.3.1 Precautions for the scanner fixing screws

- Since the scanner section is assembled with high precision, be sure not to perform any disassembling other than that instructed in the Service Manual.
- Since the scanner unit is adjusted, do not loosen the 5 scanner fixing screws shown in the figures below.

2 screws on the right-hand surface of the equipment

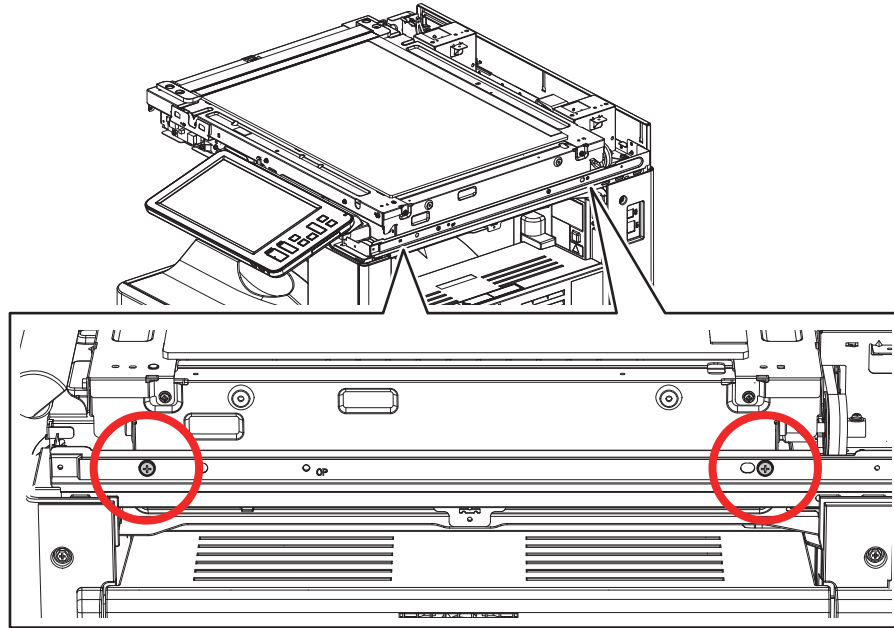


Fig. 4-39

3 screws on the left-hand surface of the equipment

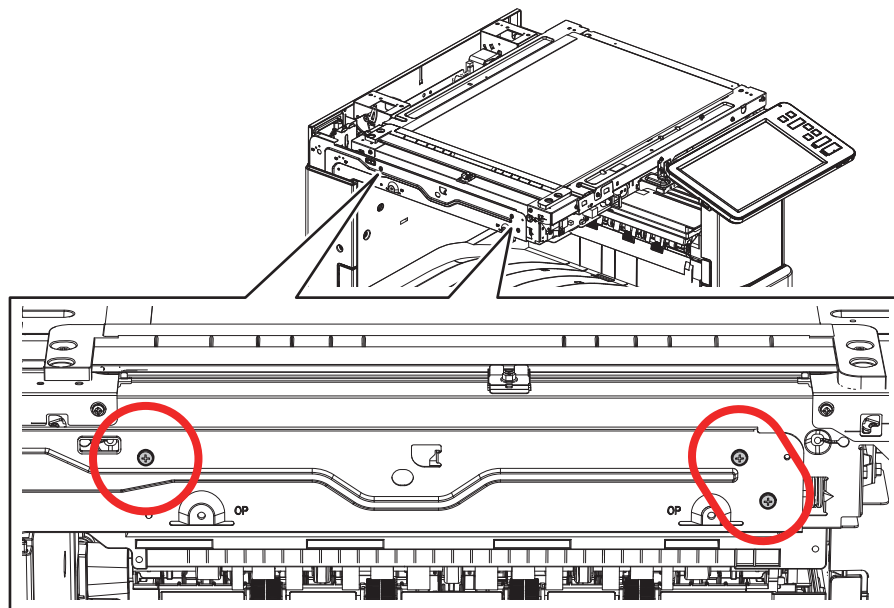


Fig. 4-40

Make sure the followings before loosening the scanner fixing screw, if it is unavoidable.

Draw the mark-off lines [1] aligning with the edge of the hole on the rear side of the right-hand surface.

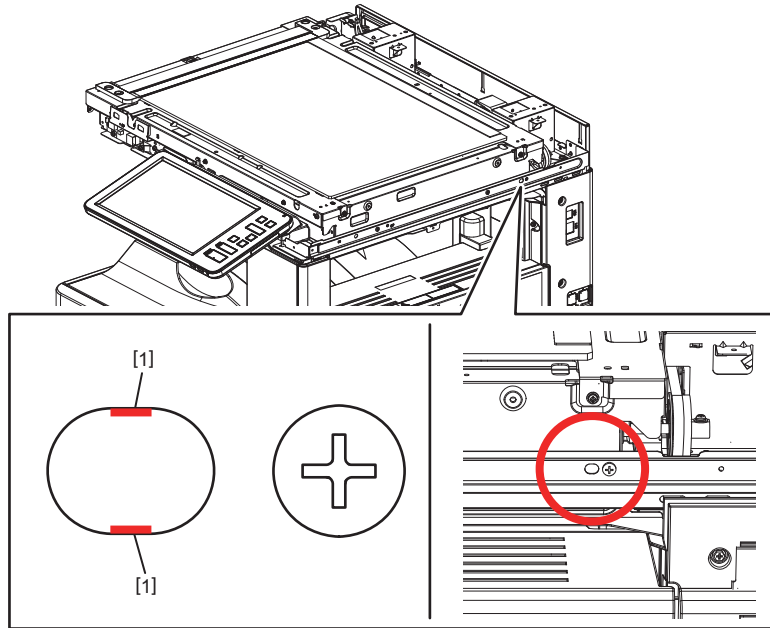


Fig. 4-41

Draw a mark-off line [2] on the edge of the front side frame on the left-hand surface.

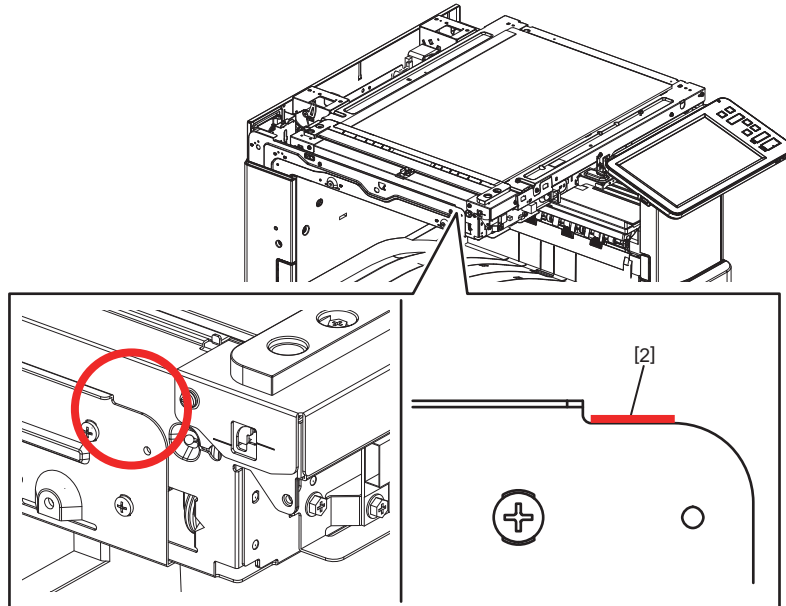


Fig. 4-42

Draw a mark-off line [3] on the edge of the rear side frame on the left-hand surface.

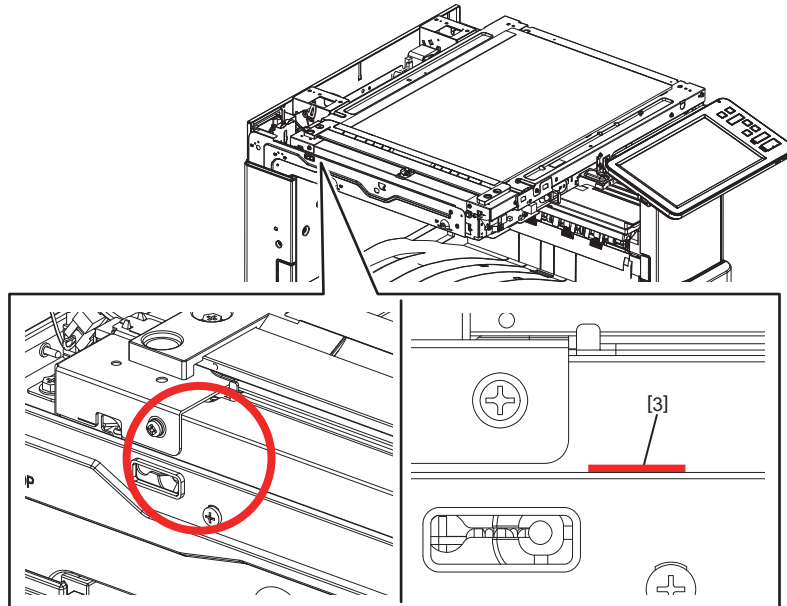


Fig. 4-43

When tightening the scanner fixing screws, align the scanner unit [4] with each mark-off line. Be sure to install the scanner unit [4] in the same position in which it was removed. In addition, the rear left/right side of the scanner unit [4] touch the DF bracket [5] and [6].

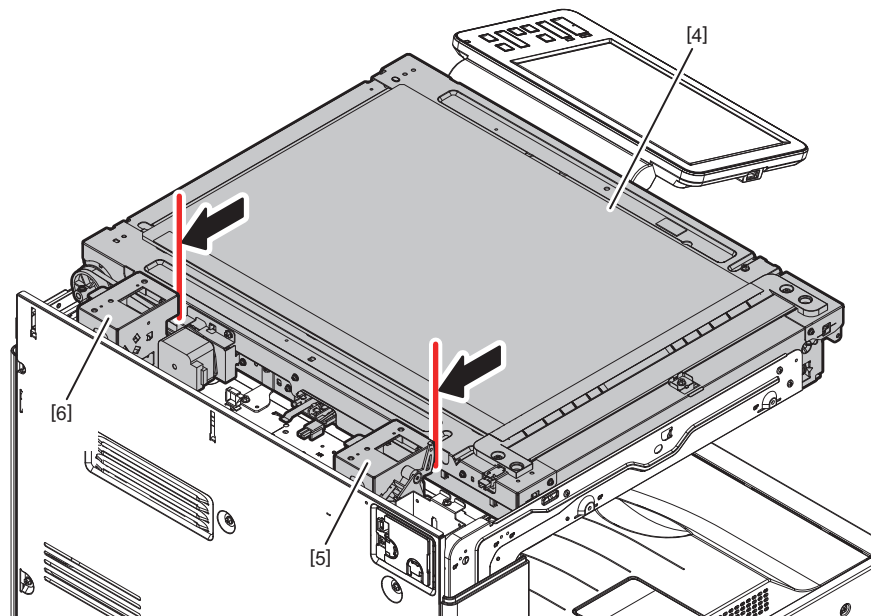


Fig. 4-44

If image distortion occurs after tightening the scanner fixing screws, adjust the image distortion according to the following procedure.

- 1. Loosen the 3 screws on the left-hand surface.
- 2. Move the front left side of the scanner unit up and down.

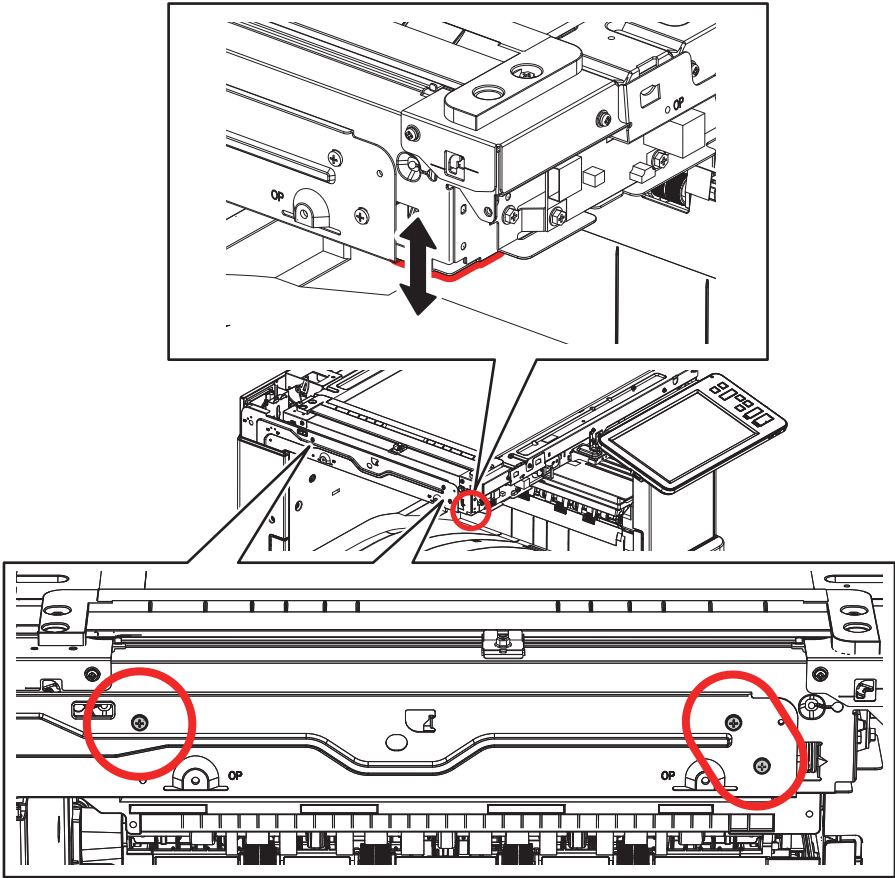



Fig. 4-45

## 4.3.2 Original glass

### [A] Removal of the original glass

- (1) Remove the right top cover.  
 P. 4-4 "4.1.8 Right top cover"
- (2) Remove 2 screws and take off the original glass [1] and ADF original glass [2].

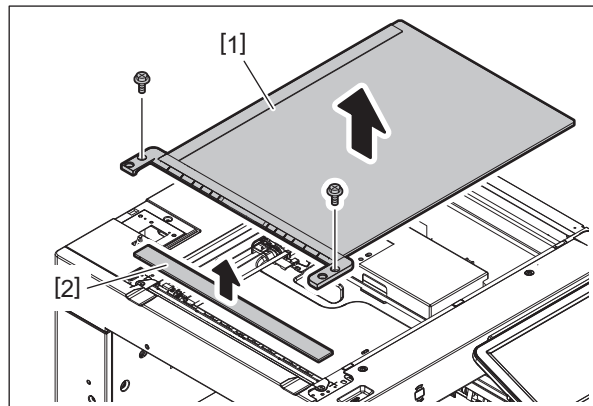


Fig. 4-46

### Notes:

- Make sure that the ADF original glass [2] is securely inserted into the groove of the fixing part of the original glass [1].
- Securely insert 2 pins of the original glass [1] into the holes in the frame.

### [B] Installation of the original glass

- (1) While taking care not to crush the cushion at the edge of the ADF original glass [2], slide it to the left side and then install the original glass [1].
- (2) Secure the original glass with 2 screws.

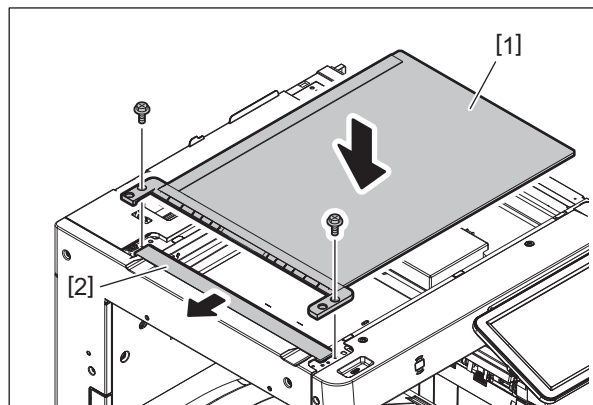


Fig. 4-47

### [C] Replacement of the ADF original glass/original glass

- (1) Remove 2 screws and take off the left top cover [3].

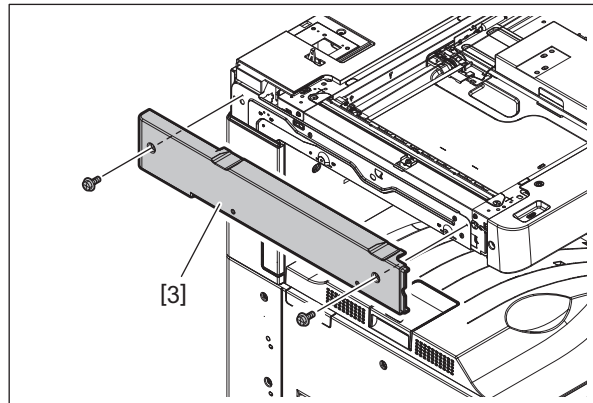


Fig. 4-48

- (2) Remove the film [5] and dispose of it.

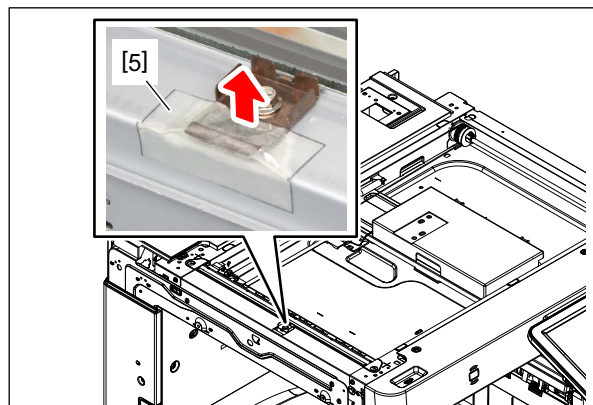


Fig. 4-49

- (3) Loosen the fixing screw of the leaf spring. Slide the leaf spring [4] by 1 mm in the direction indicated by arrow No. 2 and tighten the fixing screw temporarily.

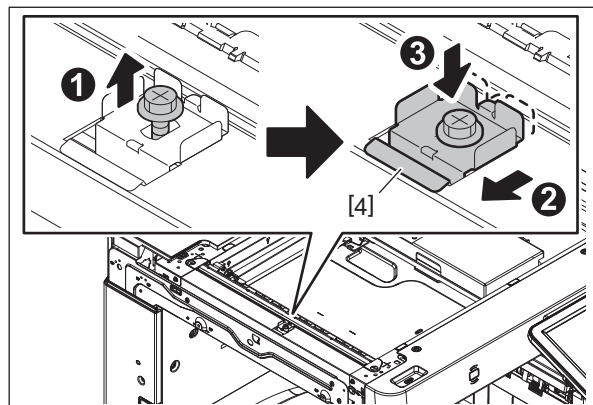


Fig. 4-50

- (4) Place the new ADF original glass [2] and set its position by aligning it to the mark-off lines.

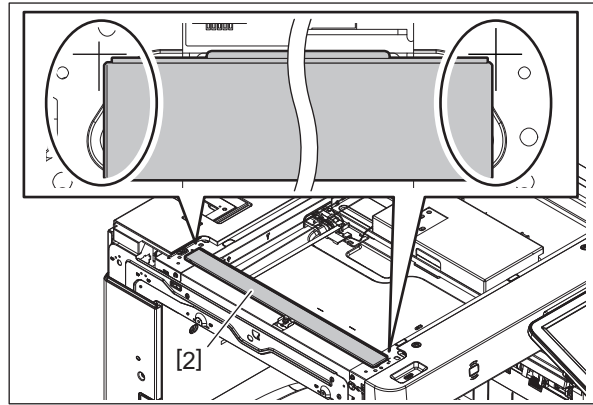


Fig. 4-51

- (5) Place the new original glass[1].

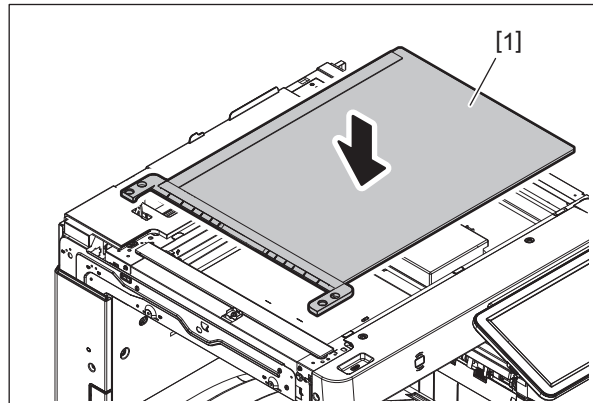


Fig. 4-52

**Notes:**

- Do not attach the fixing screws of the original glass in this step.
  - When installing the original glass, be careful not to crush the cushion added to the ADF original glass from above.
- (6) Loosen the fixing screw of the leaf spring. By means of the tension of the leaf spring, press the ADF original glass against the original glass. Tighten the fixing screw.

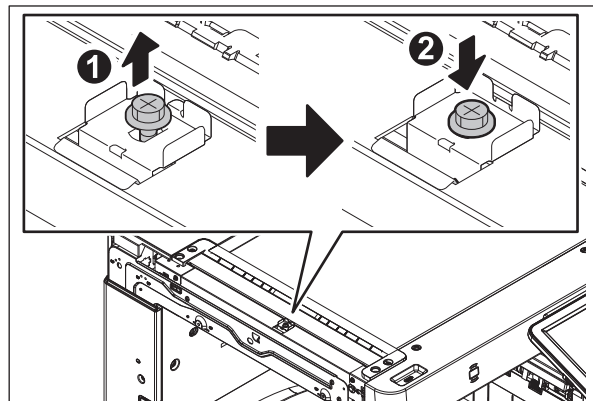


Fig. 4-53



- (7) Attach a new film [6] on the scanner frame and the edges of the leaf spring [4].

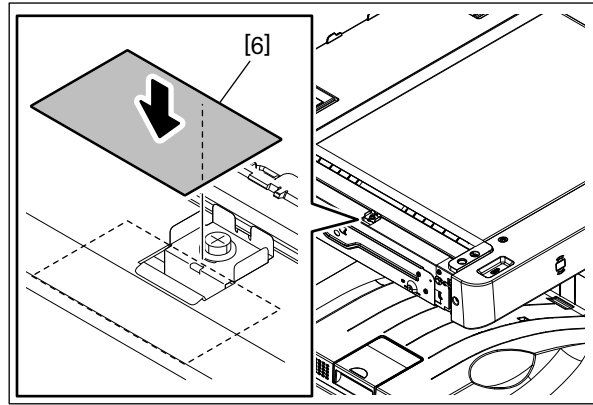


Fig. 4-54

**Notes:**

- Before attaching, clean the attachment surfaces with alcohol and wait until they have dried.
- Be sure to align the film [6] to the leaf spring [4] as shown in the figure.
- Be sure to attach the film [6] securely to the leaf spring [4].

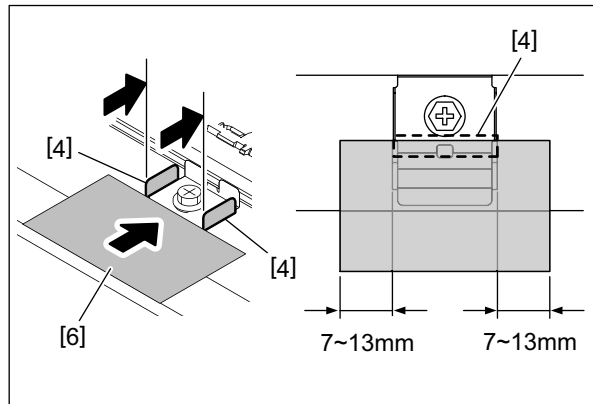


Fig. 4-55

- (8) Fold the film [6] by aligning to the corner of the scanner frame and attach it. When the film is folded, lifting will be generated at the both edges on the folded portion. Therefore, in order to remove this lifting, pinch the folded portions of the film with your fingers so that its adhesive surfaces are stuck to each other.

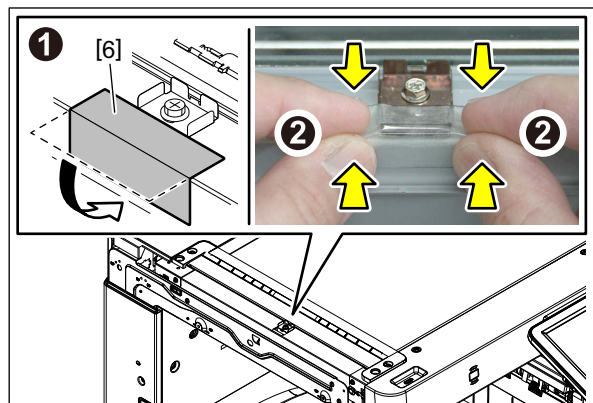


Fig. 4-56

**Notes:**

Confirm that the film is attached firmly.

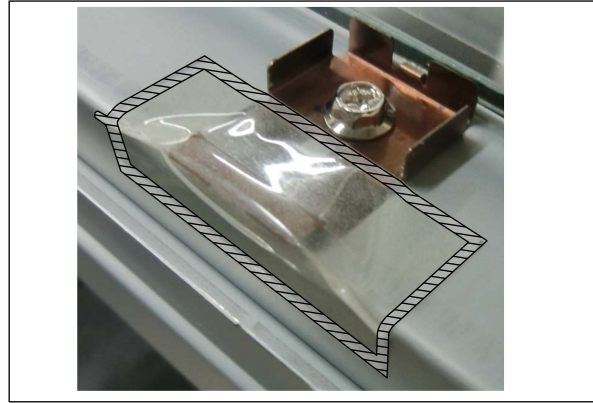


Fig. 4-57

(9) Secure the original glass [1] with 2 screws.

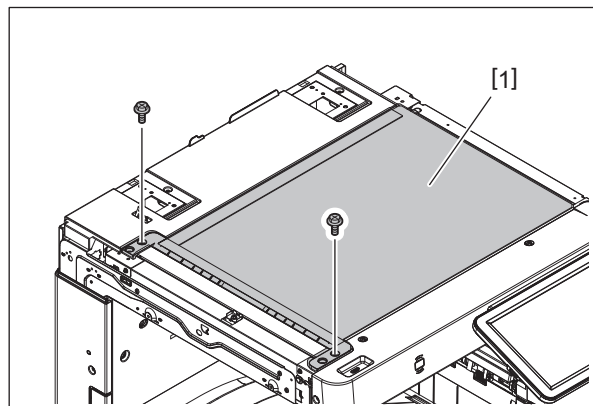


Fig. 4-58

(10) Secure the left top cover [3] with 2 screws.

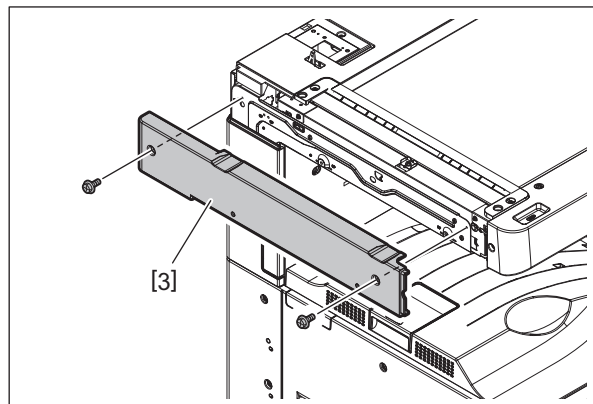


Fig. 4-59

### 4.3.3 Lens cover

- (1) Remove the original glass.  
📖 P. 4-20 "4.3.2 Original glass"
- (2) Remove 1 screw and take off the lens cover [1] as shown in the figure.

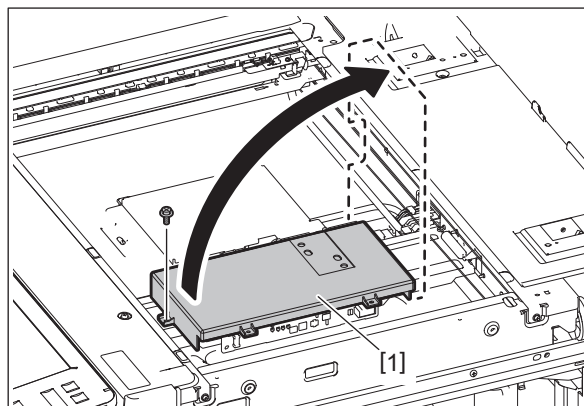


Fig. 4-60

### 4.3.4 Automatic original detection sensor-1 (S1)

- (1) Remove the lens cover.  
📖 P. 4-25 "4.3.3 Lens cover"
- (2) Remove 1 screw and disconnect 1 connector [1], and then take off the automatic original detection sensor-1 [2].

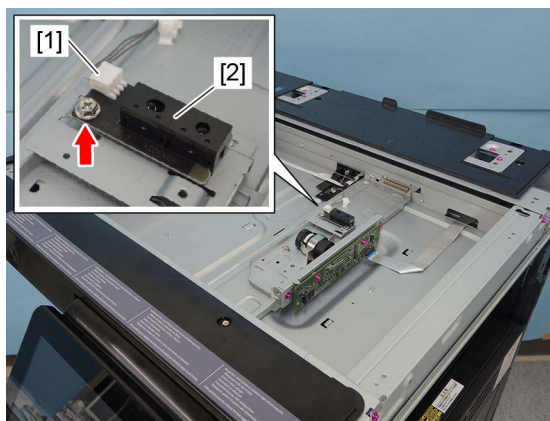



Fig. 4-61

### 4.3.5 Automatic original detection sensor-2 (S2)

- (1) Remove the lens cover.  
 P. 4-25 "4.3.3 Lens cover"
- (2) Remove 1 screw and disconnect 1 connector [1], and then take off the automatic original detection sensor-2 [2].

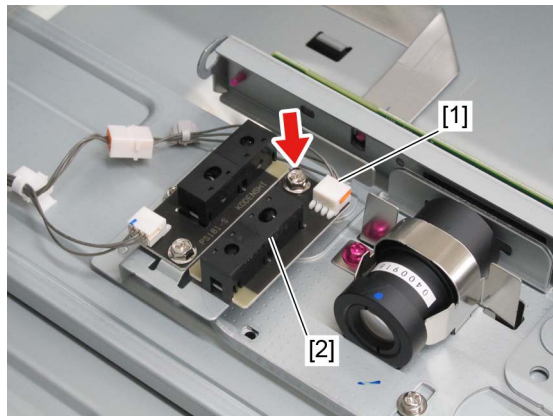



Fig. 4-62

### 4.3.6 Lens unit/CCD driving PC board

- (1) Remove the lens cover.  
 P. 4-25 "4.3.3 Lens cover"
- (2) Remove 1 screw and take off the automatic original detection sensor with the bracket [1].

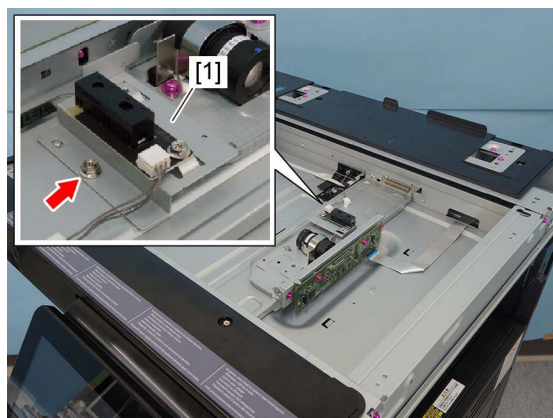


Fig. 4-63

- (3) Remove the HDMI cable [2].

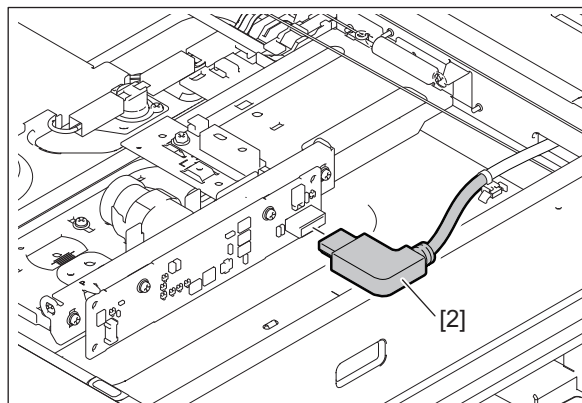


Fig. 4-64

(4) Remove 3 screws and take off the CCD lens unit [3].

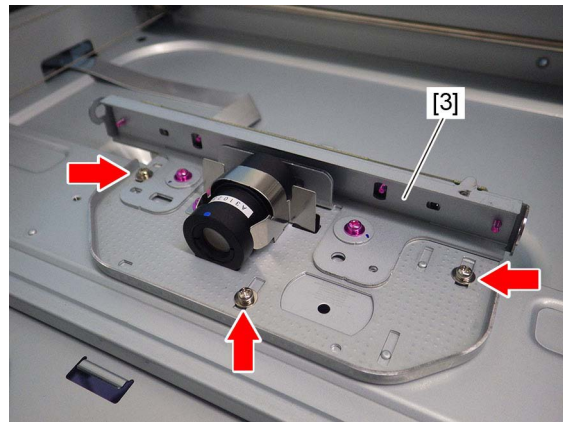


Fig. 4-65

**Notes:**

- The CCD lens unit is adjusted finely, so the re-adjustment or replacement of some parts are impossible in the field. The lens unit must be replaced on a unit basis.
- Handle the lens unit with care. Do not hold the adjustment unit or lens.
- Count the number of lines [4] and write it down for later reference before removing the CCD lens unit. When installing the CCD lens unit, the same number of lines needs to be visible.

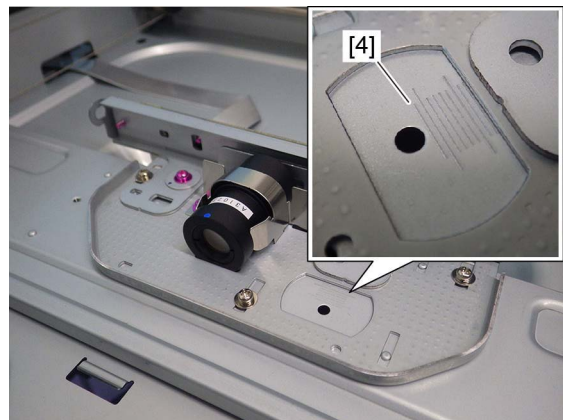


Fig. 4-66

- When replacing the lens unit, do not touch the screws (7 places).

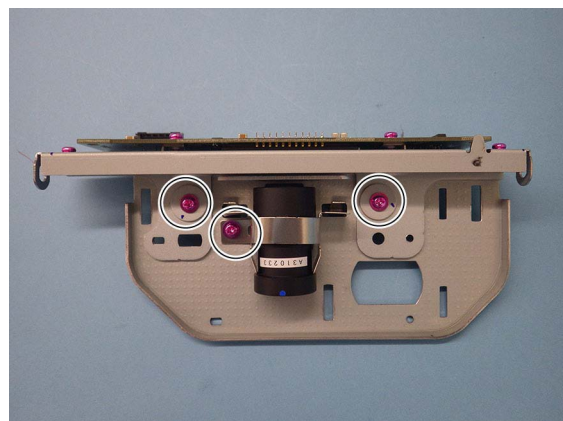


Fig. 4-67

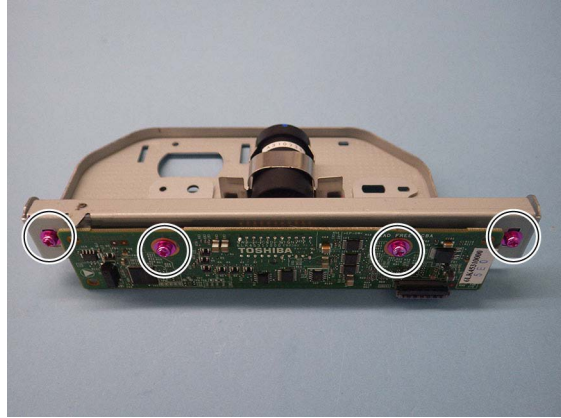


Fig. 4-68

### 4.3.7 Carriage home position sensor (S3)

- (1) Remove the original glass.  
 ☞ P. 4-20 "4.3.2 Original glass"
- (2) Remove the rear top cover.  
 ☞ P. 4-7 "4.1.14 Rear top cover"
- (3) Disconnect 1 connector [1].
- (4) Release 3 latches and remove the carriage home position sensor [2].

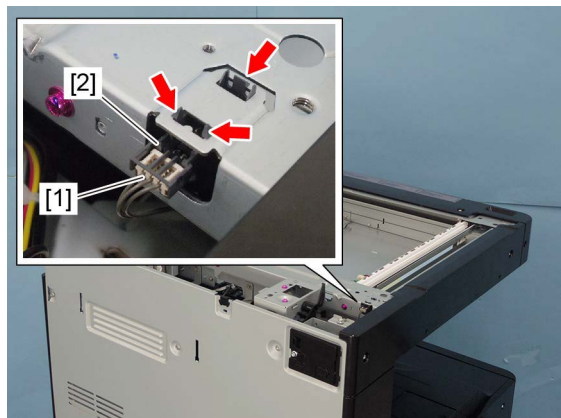


Fig. 4-69

### 4.3.8 Exposure lamp (EXP)

- (1) Remove the original glass.  
 ☞ P. 4-20 "4.3.2 Original glass"
- (2) Remove the front top cover.  
 ☞ P. 4-5 "4.1.11 Front top cover"

(3) Move carriage-1 [1] to a place where you can see the screw [2] through the frame hole.

**Notes:**

- Do not remove the black screw which can be seen through the frame hole.

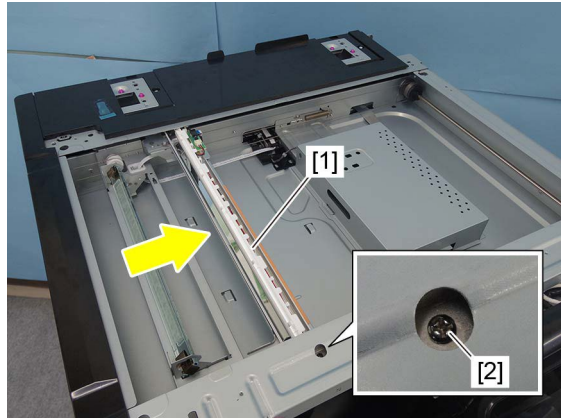


Fig. 4-70

- To move the carriage, manually rotate the drive pulley [3].

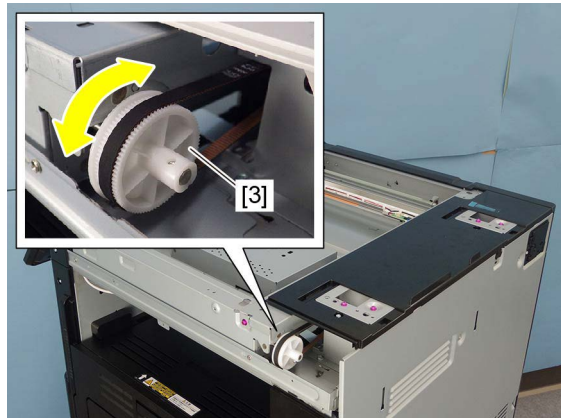


Fig. 4-71

(4) Remove 1 screw [2].

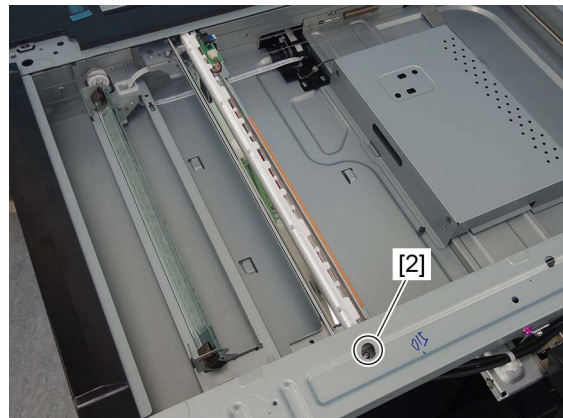


Fig. 4-72

- (5) Remove the flat cable [5] by sliding the front side of the exposure lamp [4] toward the direction of the arrow shown in the figure. Remove the exposure lamp [4] from the front side.

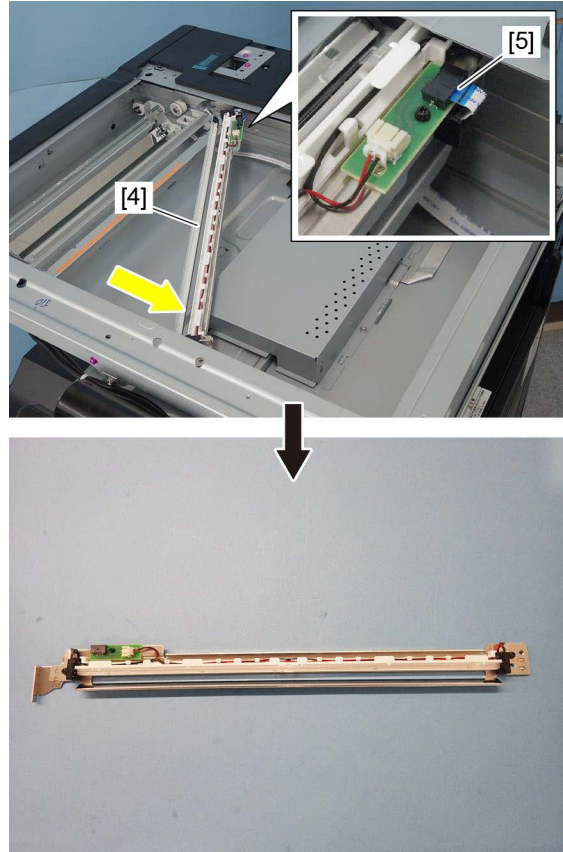


Fig. 4-73

**Notes:**

After replacing the exposure lamp, be sure to perform FS-05-3270.

### 4.3.9 Scan motor (M1)

- (1) Take off the rear top cover.  
📖 P. 4-7 "4.1.14 Rear top cover"
- (2) Remove the rear cover.  
📖 P. 4-8 "4.1.15 Rear cover"
- (3) Disconnect 1 connector.

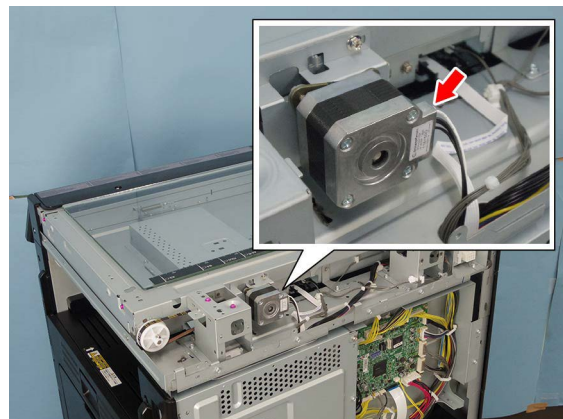


Fig. 4-74



- (4) Remove 2 screws and take off the scan motor assembly [1].

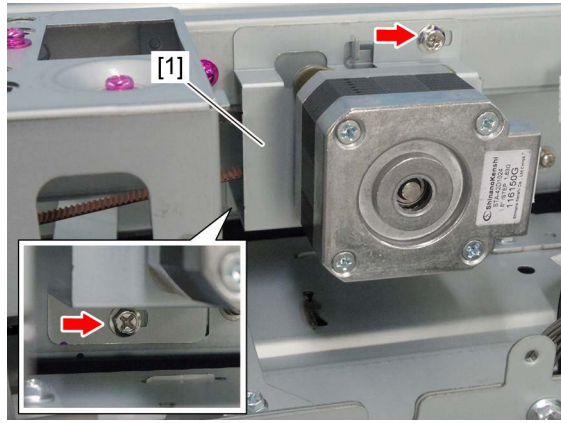


Fig. 4-75

**Notes:**

When installing the scan motor, use the belt tension jig.  
📖 P. 6-60 "6.7.3 Belt tension adjustment of the scan motor"

- (5) Remove 2 screws and take off the scan motor [2].

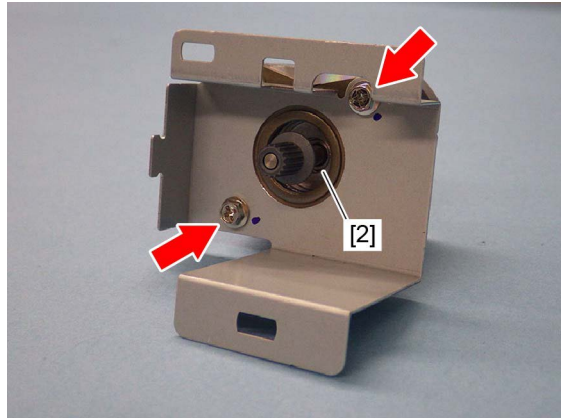



Fig. 4-76

**Notes:**

Pay attention to the size (length) of the screws. If incorrect ones are used, the motor could be damaged.

### 4.3.10 Platen sensor (S20, S21)

- (1) Remove the rear top cover.  
 P. 4-7 "4.1.14 Rear top cover"
- (2) Remove 5 screws.

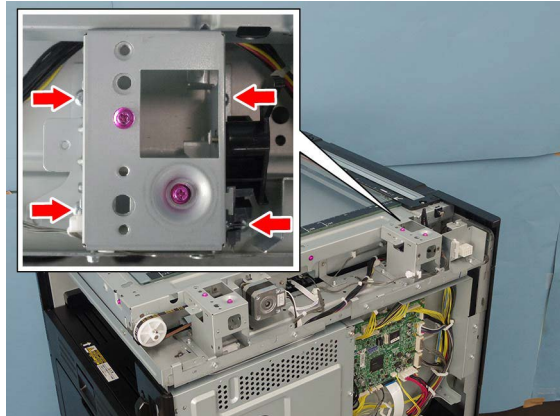


Fig. 4-77

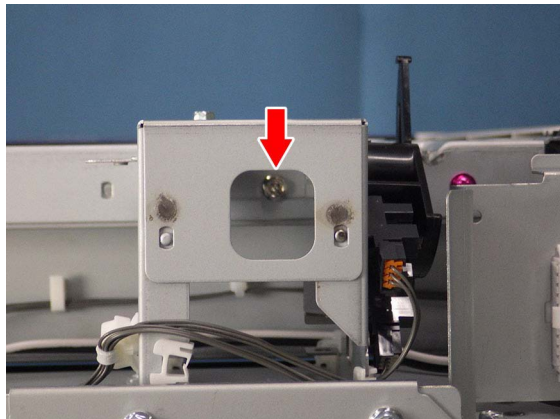


Fig. 4-78

- (3) Disconnect 2 connectors and take off the platen sensor assembly [1].

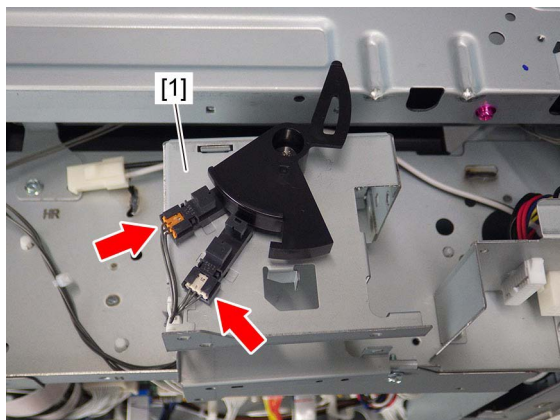


Fig. 4-79

#### Notes:

When installing, be careful not to connect each different connector.

- (4) Release each 3 latches and remove the platen sensor-1 [2] and -2 [3].

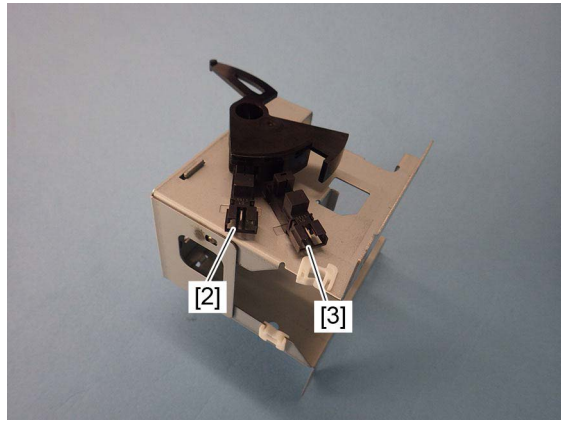


Fig. 4-80

### 4.3.11 Carriage-1

- (1) Remove the original glass.  
P. 4-20 "4.3.2 Original glass"
- (2) Remove the front top cover.  
P. 4-5 "4.1.11 Front top cover"
- (3) Move carriage-1 [1] to the leftmost side. Make sure that the screws on carriage-1 can be seen from the frame holes [2].

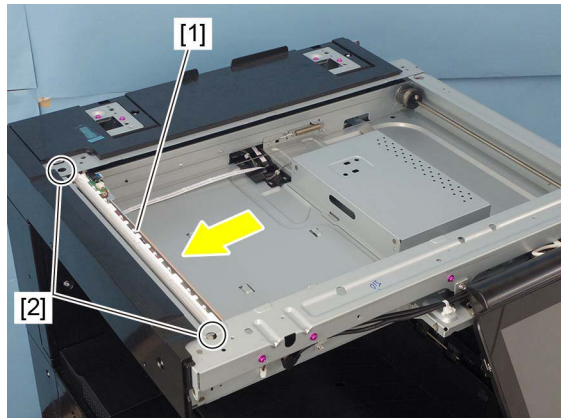


Fig. 4-81

**Notes:**

To move the carriage, manually rotate the drive pulley [3].

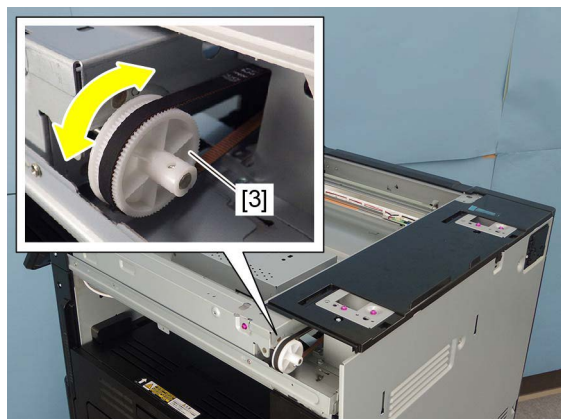


Fig. 4-82

- (4) Remove 2 screws from the frame holes [2].



Fig. 4-83

- (5) Remove the flat cable [4] from the carriage-1 [1].  
(6) Remove the flat cable [4] from the harness guide [5].

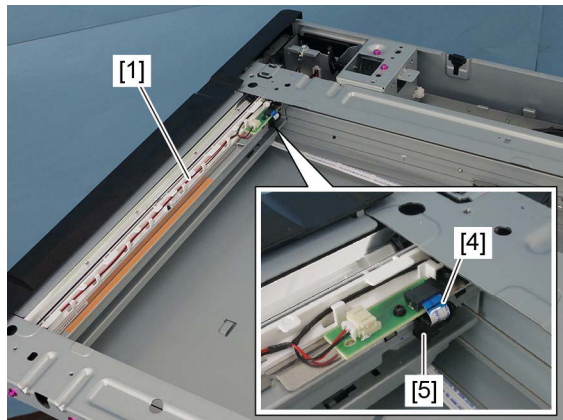


Fig. 4-84

- (7) Slide the front of the carriage-1 [1] toward the direction of the arrow shown in the figure, while trying not to touch the mirror [6]. Then remove the carriage-1 [1].

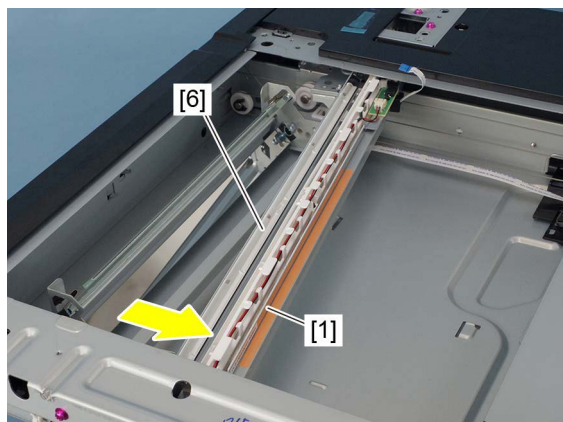


Fig. 4-85

**Notes:**

- When installing, install the flat cable [4] to the harness guide [5].

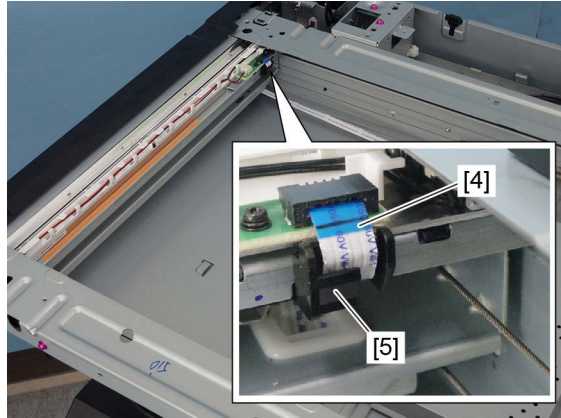


Fig. 4-86

- When installing carriage-1, make sure that the wires [7] are placed on the front and rear notches [8] of carriage-1 and fix them with screws.
- After installing, move carriage-1 to the leftmost side and check the flat cable [4] for any twists.

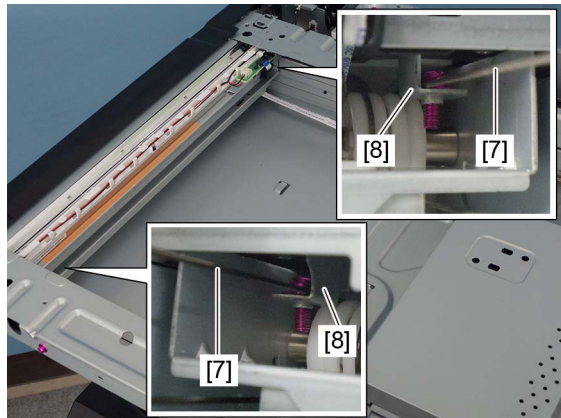


Fig. 4-87

### 4.3.12 Carriage wire, carriage-2

**Notes:**

- When replacing the carriage wire with a new one, replace the front and rear at the same time.
- When replacing the carriage wire with a new one, set the value of FS-08-6123 to "0".

**[A] Carriage wire, carriage-2**

- (1) Remove carriage-1.  
📖 P. 4-33 "4.3.11 Carriage-1"
- (2) Move carriage-2 to the center.
- (3) Attach the wire holder jig [2] to the wire pulley [1] to prevent the wire from coming loose.

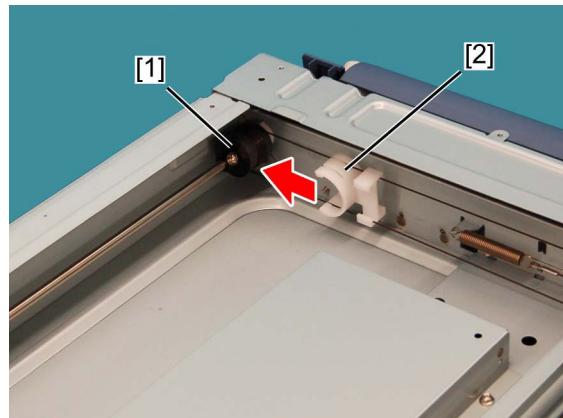


Fig. 4-88

**Notes:**

- When attaching the wire holder jig [1], make sure that the wire has not shifted or become loose.
- The wire should come out of the slot of the wire holder jig [1] and be passed under the jig arm [2].
- When installing the wire holder jig, be careful of the orientation.

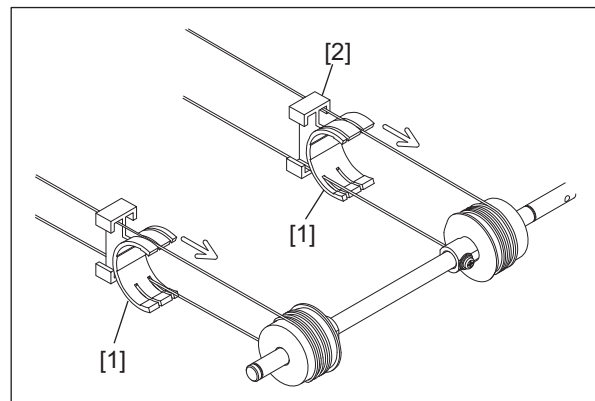


Fig. 4-89

- (4) Remove the tension springs [4] in the front and rear sides.
- (5) Remove the carriage wire [5].

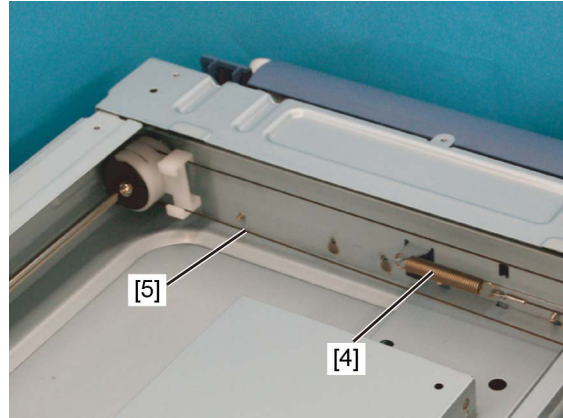


Fig. 4-90

- (6) Rotate carriage-2 [6] while trying not to touch the mirror. Then remove carriage-2 [6].

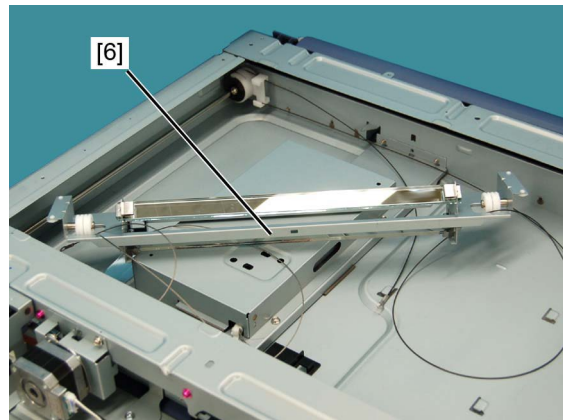


Fig. 4-91

**Notes:**

Replace mirror-2 and -3 together with carriage-2 [6]. Do not remove mirror-2 and -3.

## [B] Installing the carriage wire

- (1) Install a new wire as shown on the right when replacing the carriage wire.

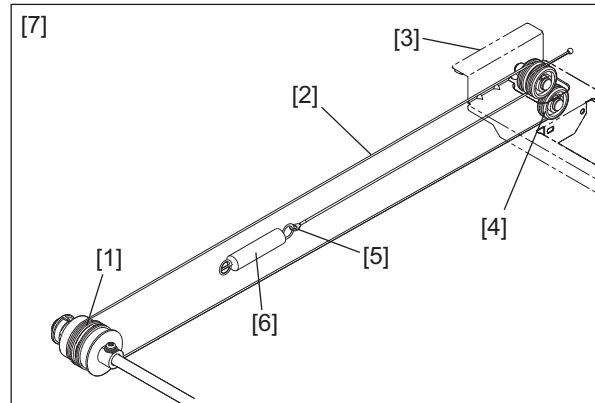


Fig. 4-92

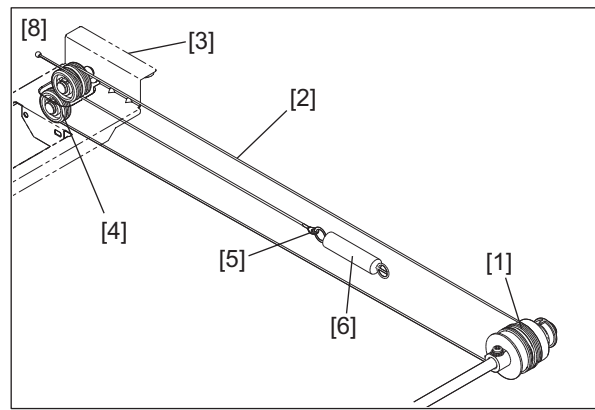


Fig. 4-93

- [1] Wire pulley
- [2] Carriage wire
- [3] Carriage-2
- [4] Idler pulley
- [5] Hook
- [6] Tension spring
- [7] Front side
- [8] Rear side

### Notes:

It is not necessary to adjust the carriage wire tension since a certain tension is applied to the carriage wires through the tension springs. Make sure the tension applied to the wire is normal.



### [C] Winding on the wire pulley

- (1) Insert the  $\varnothing 3$  ball terminal [1] located at the center of the wire into a hole on the wire pulley. One end of the wire with the hook [2] attached comes to the outside.
  - (2) Wind the wires around the wire pulleys of the front side [3] and rear side [4]. The number of turns to be wound are as follows: 3 [5] toward the opposite side (outside) of the pulley boss, and 3 [6] toward the pulley boss side (inside).
- [7] Black  
[8] Silver

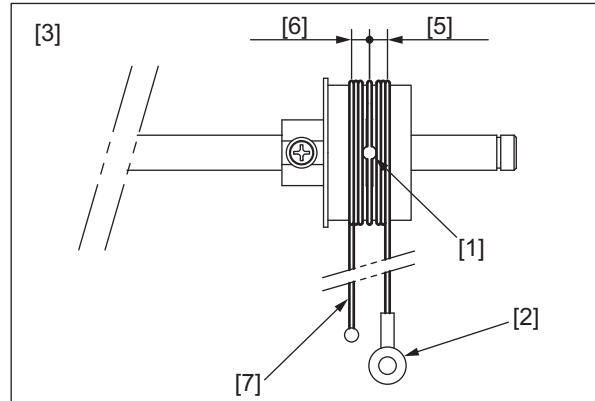


Fig. 4-94

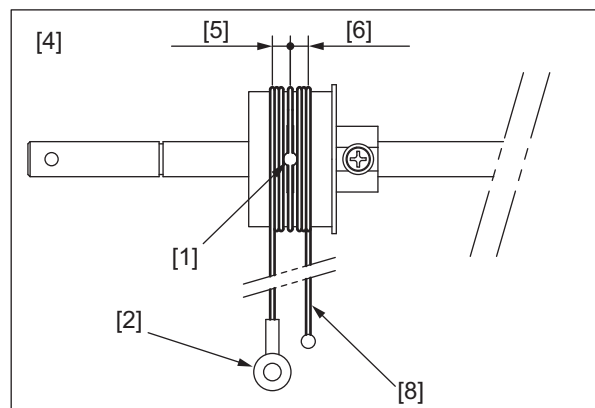


Fig. 4-95

#### Notes:

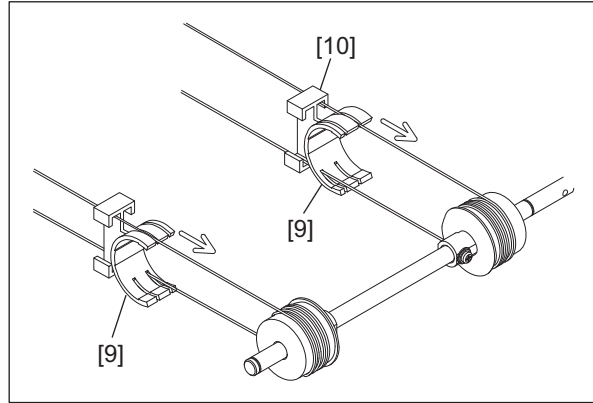
When winding the wire onto the pulley, be sure to note the following.

- Do not twist the wire.
- Wind the wires tightly so that they are in complete contact with the surface of the pulleys.
- Each turn should be pushed against the previously wound turn so that there is no space between them.

- (3) After winding the wires around the pulleys, attach the wire holder jigs to prevent the wire from coming loose.

**Notes:**

- When attaching the wire holder jig [9], make sure that the wire has not shifted or become loose.
- The wire should come out of the slot of the wire holder jig [9] and be passed under the jig arm [10].
- When installing the wire holder jig, be careful of the orientation.



**Fig. 4-96**

### 4.3.13 Scanner damp heater (DH2)

**Notes:**

Turn the power of the equipment OFF and unplug the power cable before the disassembly and installation.

- (1) Remove the original glass.  
P. 4-20 “4.3.2 Original glass”
- (2) Remove 1 connector [1].

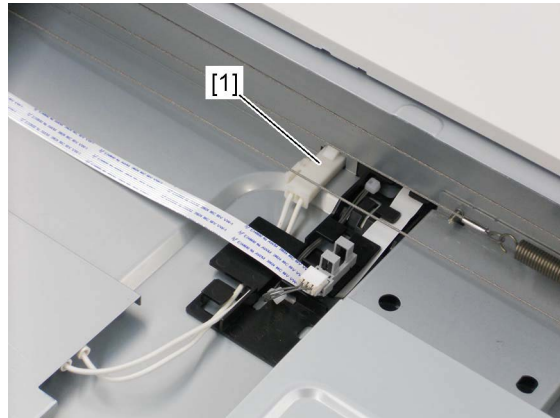


Fig. 4-97

- (3) Remove the scanner damp heater [2].

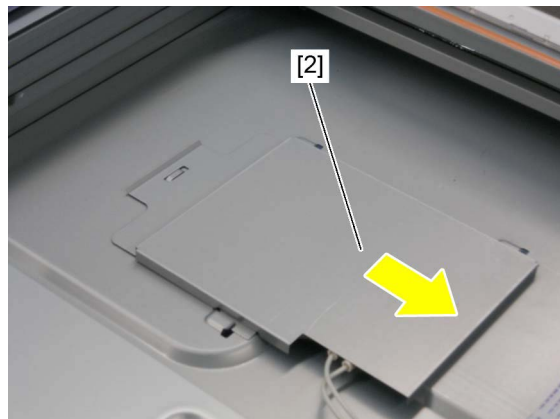


Fig. 4-98

**Notes:**

- Be sure that the fasten terminal of the thermostat is connected securely.
- Be sure that the thermostat is attached to the plate.

## 4.4 Writing Section

### 4.4.1 Laser optical unit

- (1) Remove the receiving tray.  
📖 P. 4-2 “4.1.3 Receiving tray”
- (2) Disconnect 1 connector of the duct [1].



Fig. 4-99

- (3) Remove 1 screw and take off the duct [1].



Fig. 4-100

- (4) Remove the sponge [3] from the laser optical unit [2].

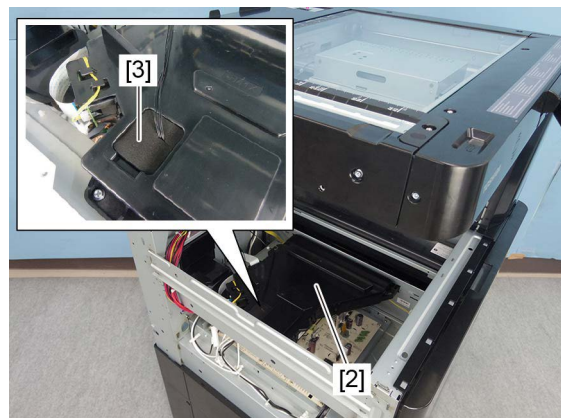


Fig. 4-101

(5) Disconnect 1 connector [4].

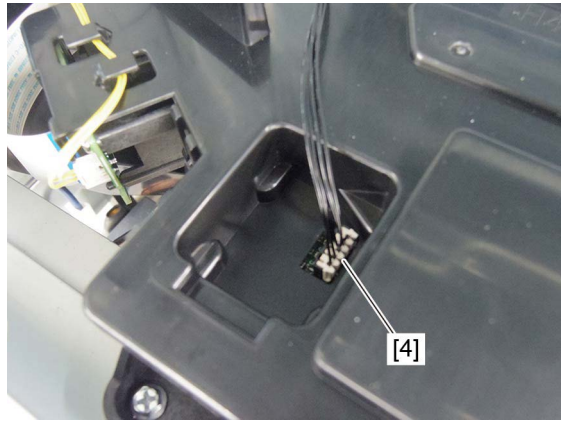


Fig. 4-102

- (6) Remove the flat cable [6] from the harness guide [5].
- (7) Remove the flat cable [6] from the laser optical unit.

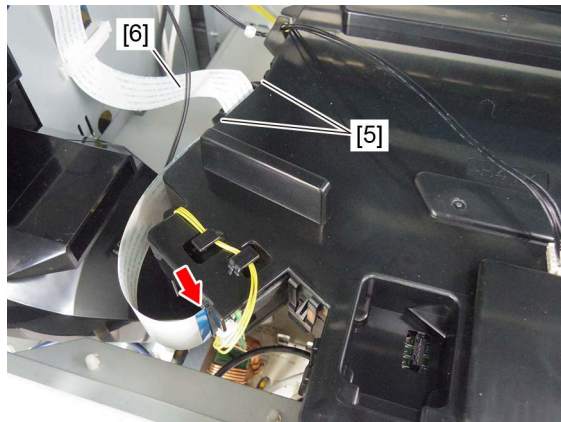


Fig. 4-103

(8) Remove 1 screw and take off the laser optical unit [2].

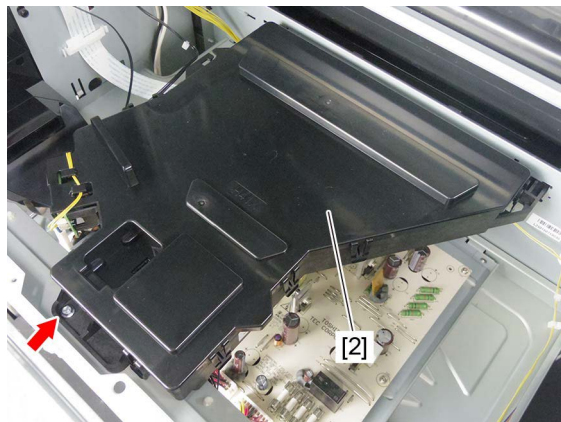
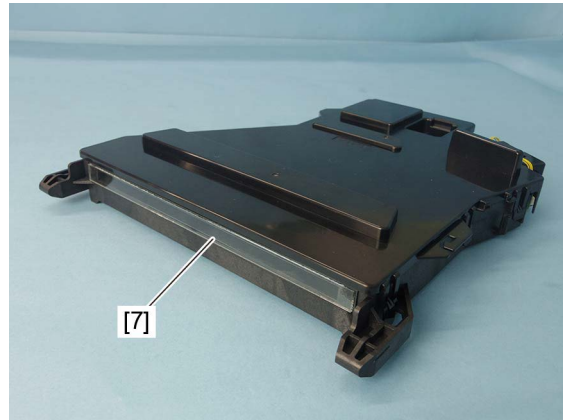


Fig. 4-104



**Notes:**

- Do not leave fingerprints or stain on the slit glass [7] of the laser optical unit.
- Pay close attention not to make an impact or vibration on the laser optical unit because it is a precise apparatus.
- Place the removed laser optical unit so as not to load on the polygonal motor.
- Do not disassemble the laser optical unit in the field because it is precisely adjusted and very sensitive to dust and stain.
- Hold the laser optical unit vertically. Do not press the top of the unit where the polygonal motor is installed with your hands or other things.

**Fig. 4-105**

## 4.5 Paper Feeding System

### 4.5.1 Bypass unit

- (1) Remove the right front cover.  
 P. 4-4 “4.1.9 Right front cover”
- (2) Remove the right rear cover.  
 P. 4-5 “4.1.10 Right rear cover”
- (3) Remove 4 screws and take off the stay [1].

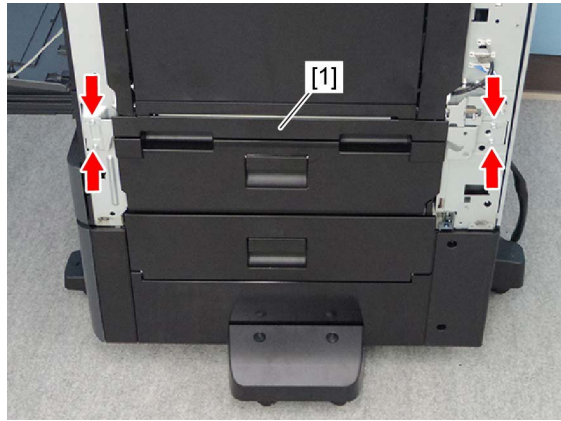


Fig. 4-106

- (4) Move the projection portion [3] on the front side and the rear side of the bypass unit [2] to the wider part of the groove of the hinge stoppers [4].

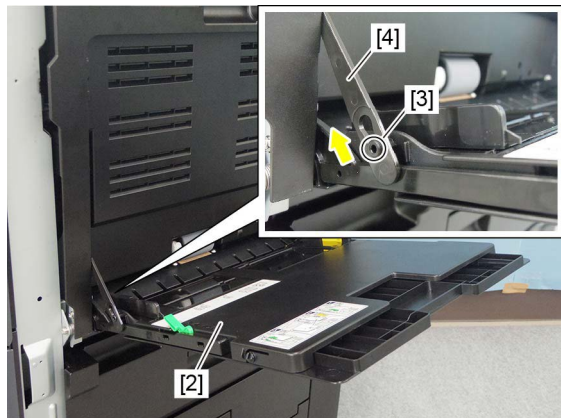


Fig. 4-107

- (5) Remove the arm [5] and paper holder release levers [6].

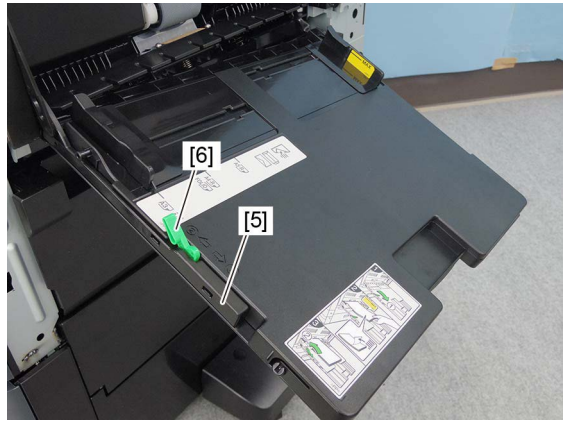


Fig. 4-108

- (6) Disconnect 1 connector and take off the bypass tray unit [2].

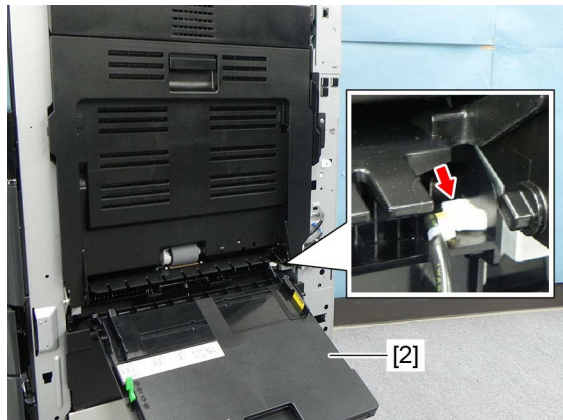


Fig. 4-109

#### 4.5.2 Bypass feed roller

- (1) Open the bypass tray [1].  
(2) Tip the paper holder release lever [2] to release the pressure.



Fig. 4-110



(3) Remove the stopper [4] from the bypass feed roller [3].

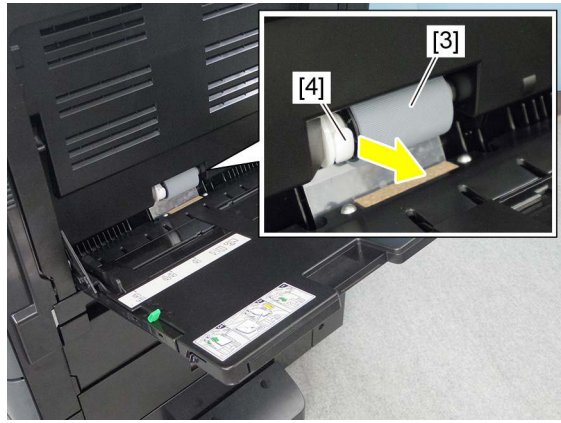


Fig. 4-111

(4) Press the collar [5] toward the rear side to release the lock.

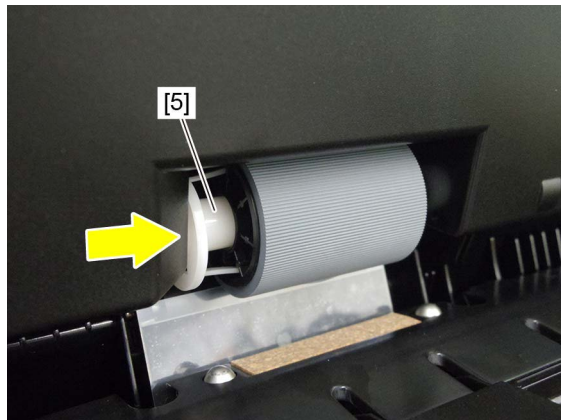


Fig. 4-112

(5) Remove the bypass feed roller [3].

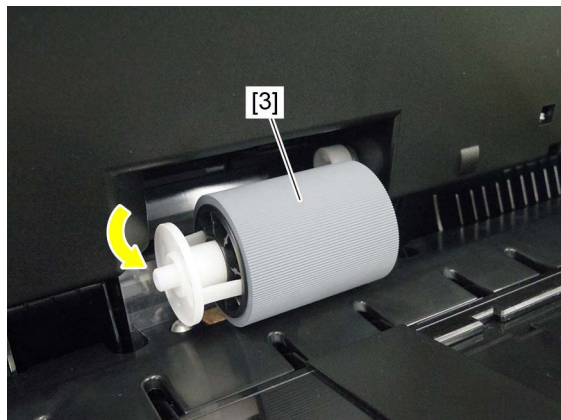


Fig. 4-113

(6) Remove the collar [5] from the bypass feed roller [3].

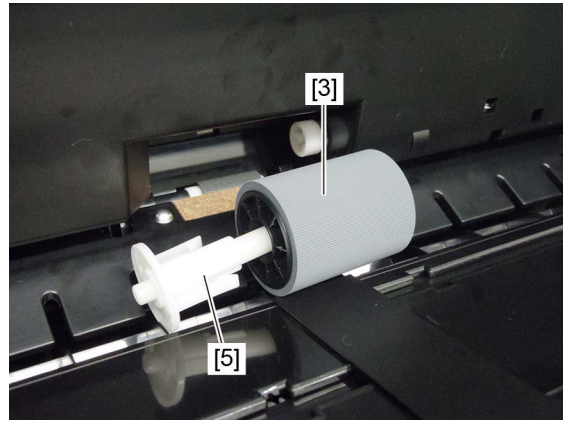


Fig. 4-114

**Notes:**

When installing the bypass feed roller [3], fit the convex portion on the roller with the concave portion on the equipment.

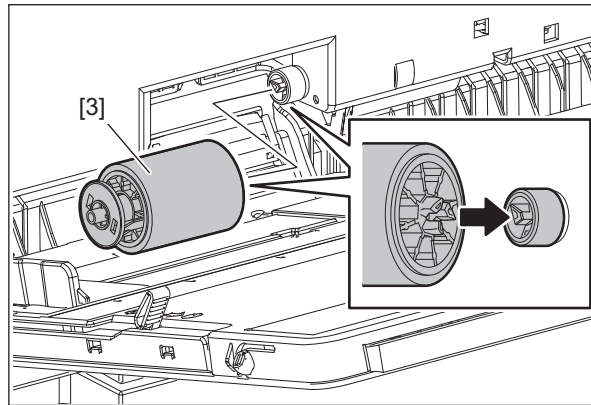


Fig. 4-115

### 4.5.3 Bypass separation roller<sup>PM</sup>

- (1) Remove the bypass feed roller.  
P. 4-46 "4.5.2 Bypass feed roller"
- (2) Lift the bypass separation roller [1] to remove it.



Fig. 4-116

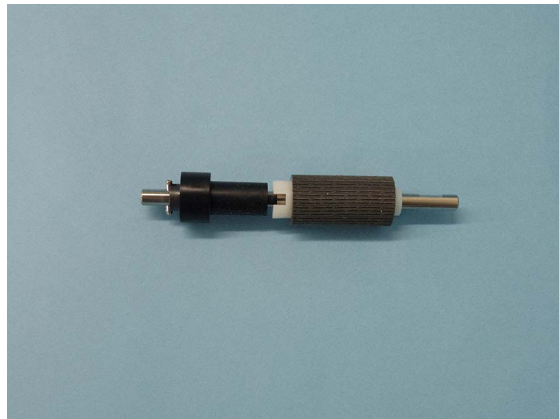


Fig. 4-117



Fig. 4-118

**Notes:**

- When installing/removing, do not twist the film.
- Handle the bypass separation roller with care so that no dirt, oils or stains adhere.
- Be careful not to drop the parts inside the equipment.
- When replacing the parts or performing machine refreshment, apply 1 rice-sized grain of white grease (Molykote HP-300) to the bushings [2] of the bypass separation roller.

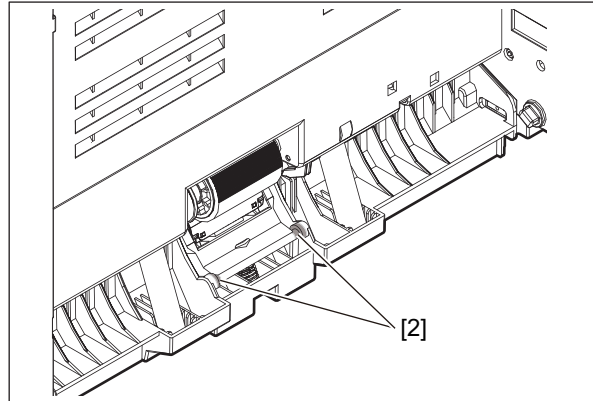


Fig. 4-119

### 4.5.4 Paper size detection board

- (1) Open the bypass tray [1] and pull out the slide tray [2].

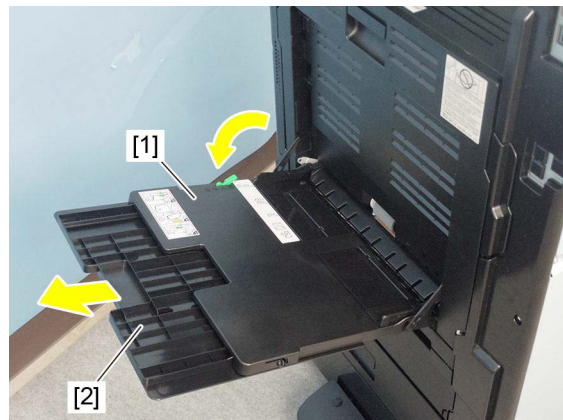


Fig. 4-120

- (2) Remove 1 screw from back side of the bypass tray. Take off the paper size detection board cover [3].

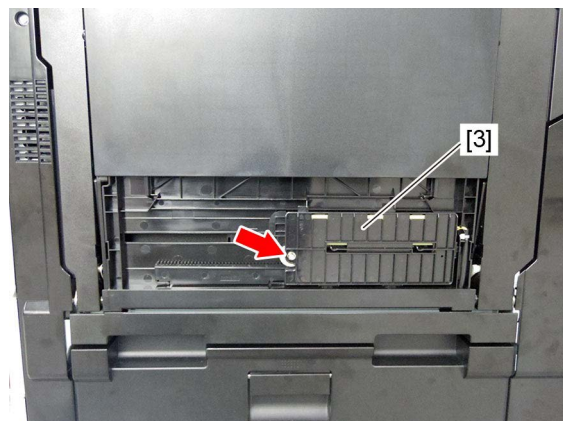


Fig. 4-121

**Notes:**

When removing the paper size detection board cover [3], be careful not to drop the gear [4].

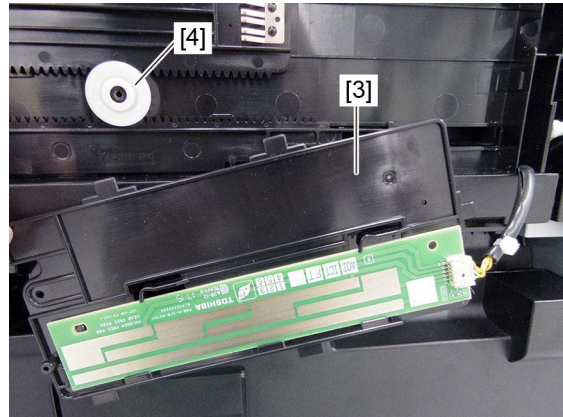


Fig. 4-122

- (3) Disconnect 1 connector and remove the paper size detection board [5].

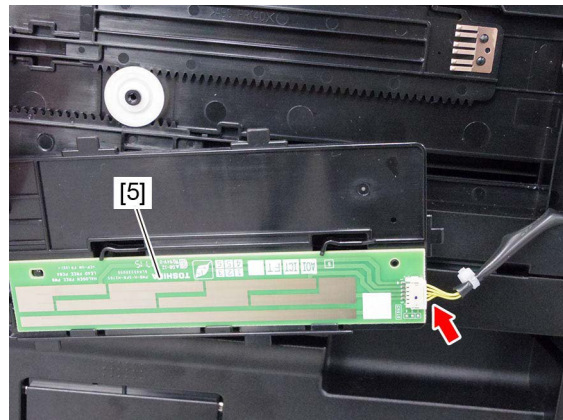


Fig. 4-123

#### 4.5.5 Bypass paper sensor (S8)

- (1) Remove the bypass feed clutch.  
📖 P. 4-168 “4.12.2 Bypass feed clutch (CLT2)”
- (2) Remove 2 screws from the automatic duplexing unit [1].

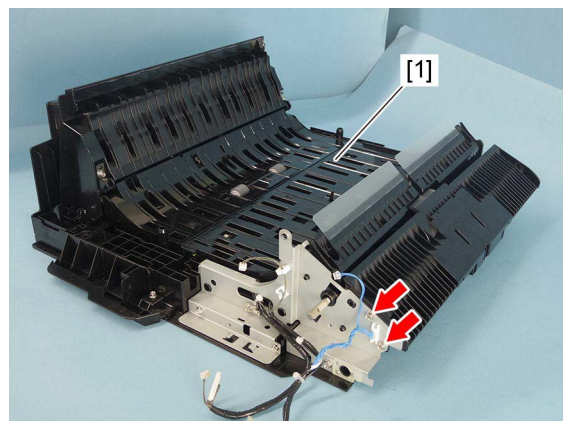


Fig. 4-124

(3) Disconnect 1 connector and remove the paper guide (lower) [2].

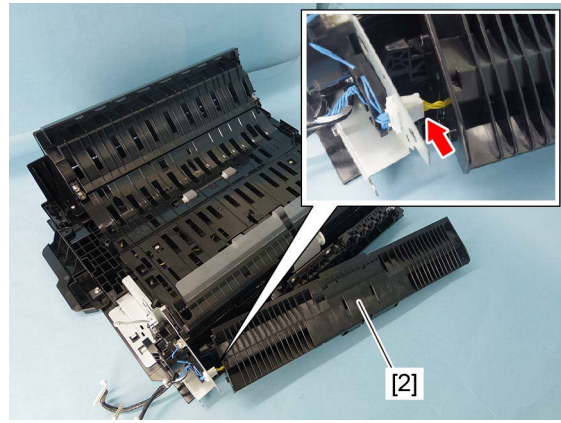


Fig. 4-125

(4) Remove 2 screws and take off the paper guide (middle) [3].

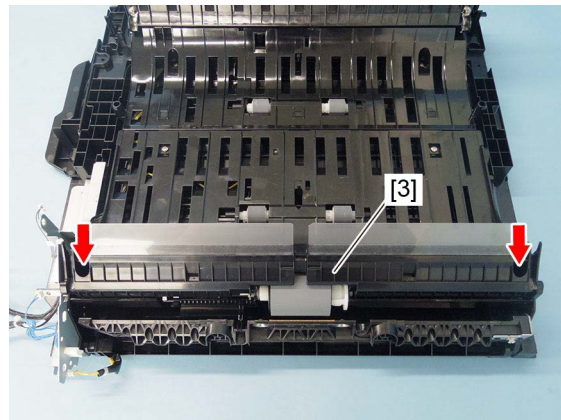


Fig. 4-126

(5) Remove the stopper [5] from the bypass feed roller [4].

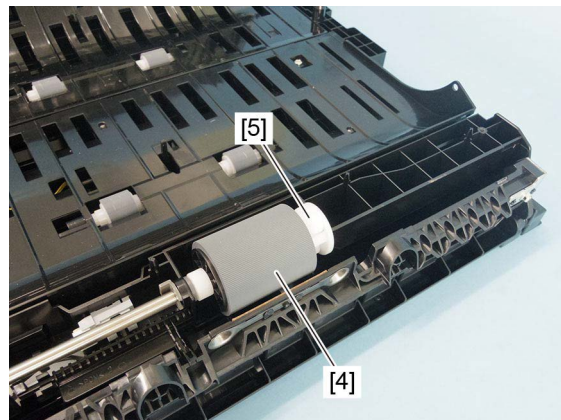


Fig. 4-127

- (6) Press the flange [6] inside and remove the bypass feed roller [4].

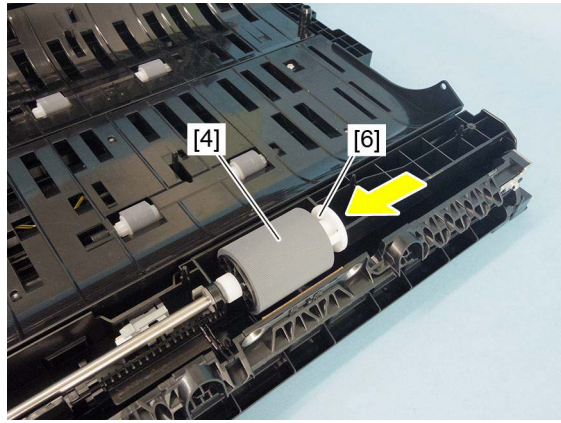


Fig. 4-128

- (7) Remove the clip [7]. Slide the shaft [8] toward the front side and remove the shaft [8]. Remove the collar [9].

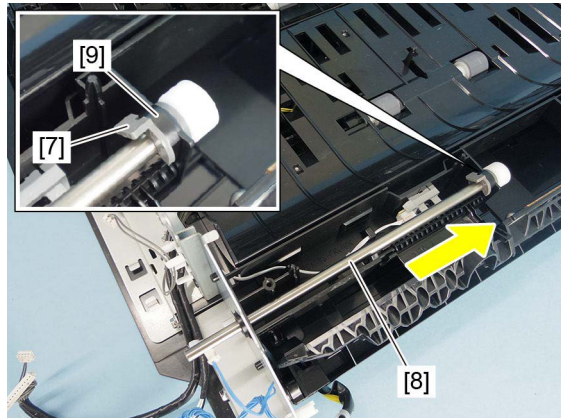


Fig. 4-129

- (8) Release the harness [10] from the harness guide.

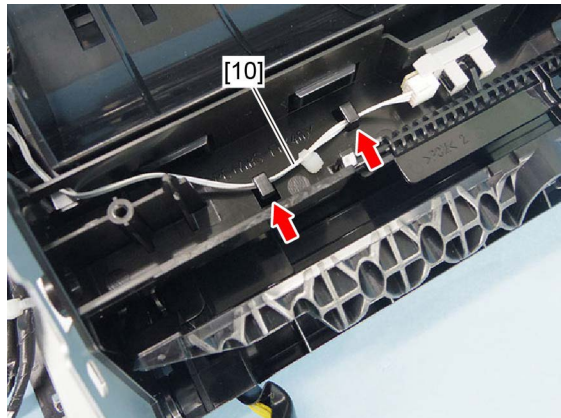


Fig. 4-130

- (9) Disconnect 1 connector [11].
- (10) Release the latch, and then remove the bypass paper sensor [12] and sensor arm [13].

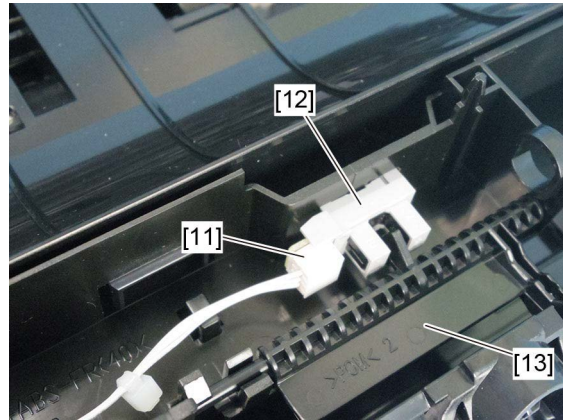


Fig. 4-131

#### 4.5.6 ADU opening/closing switch (SW5)

- (1) Open the side cover.
- (2) Release 2 hooks.



Fig. 4-132

- (3) Pull out the ADU opening/closing switch [1], and disconnect 1 connector.

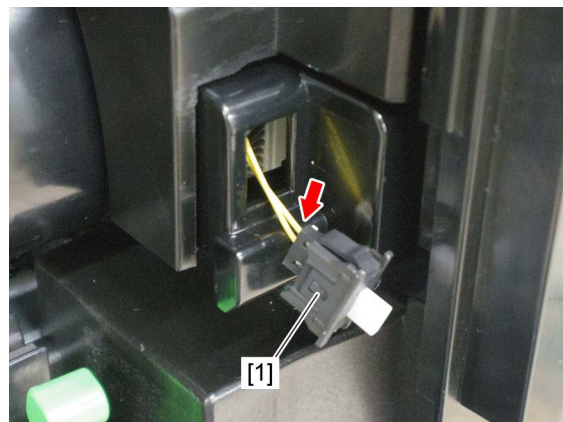


Fig. 4-133



#### 4.5.7 Registration sensor (S17), 1st transport sensor (S16)

- (1) Remove the automatic duplexing unit.  
P. 4-166 "4.12.1 Automatic duplexing unit (ADU)"
- (2) Remove the rear cover.  
P. 4-8 "4.1.15 Rear cover"
- (3) Disconnect 1 connector [1].

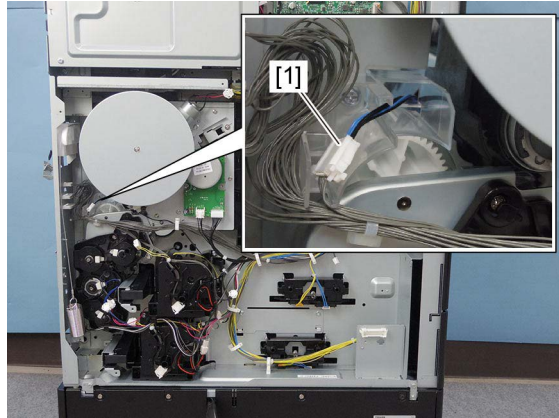


Fig. 4-134

- (4) Open the feed cover [2].

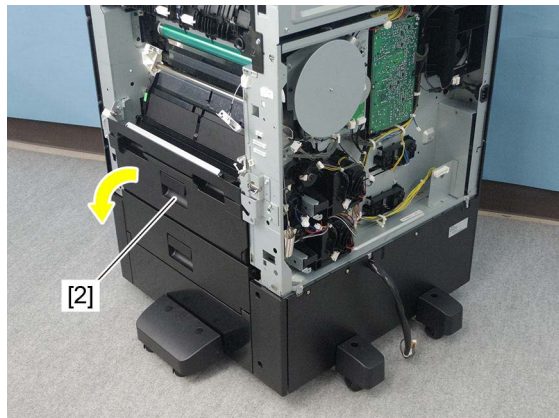


Fig. 4-135

- (5) Remove 4 screws and take off the stay [3].

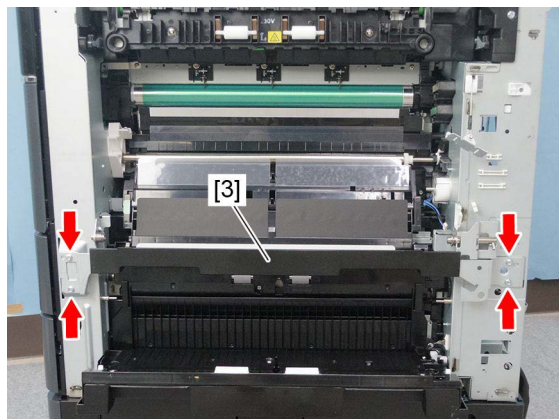


Fig. 4-136

(6) Remove 1 screw from the transport guide [4].

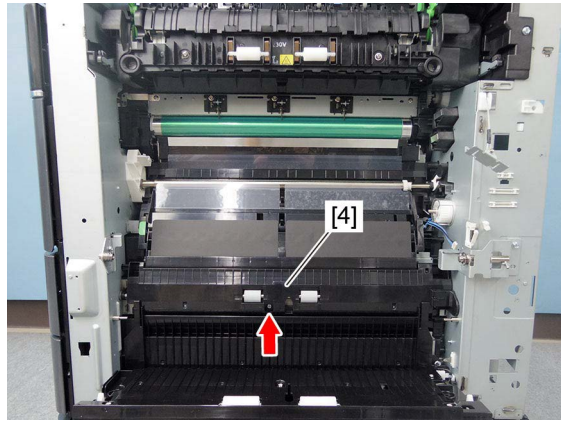


Fig. 4-137

(7) Release 2 latches [5]. Slide the transport guide [4] toward the front side, and then pull the transport guide [4] out toward you.

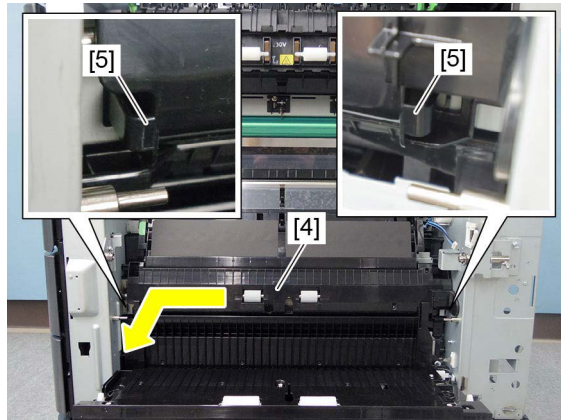


Fig. 4-138

(8) Remove 1 screw from the paper guide [6].

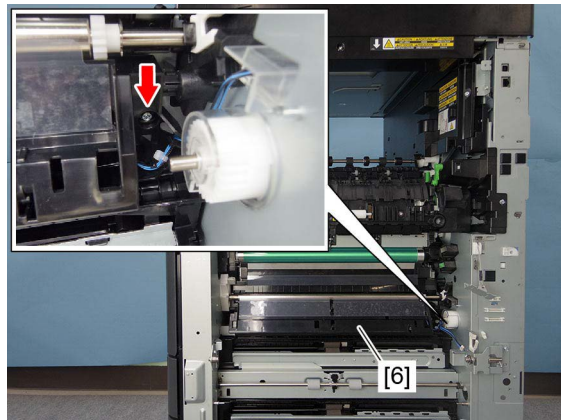


Fig. 4-139

(9) Take off the paper guide [6] by sliding it toward the front side.

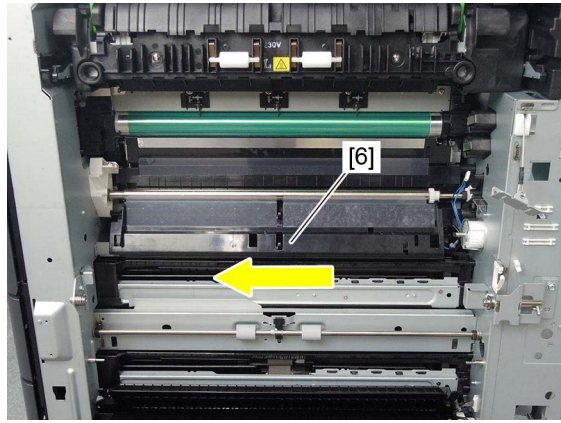


Fig. 4-140

(10) Release 2 latches and remove the sensor bracket [7].

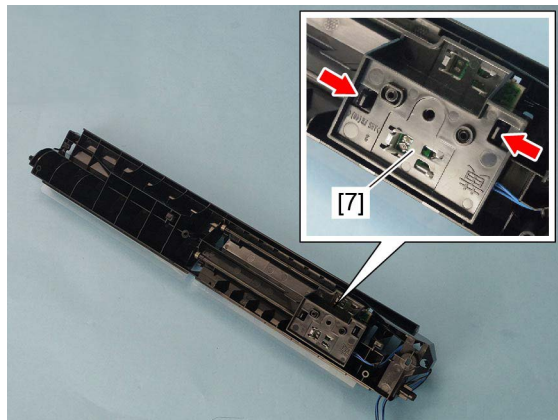


Fig. 4-141

(11) Disconnect 2 connectors. Remove the 1st transport sensor [8] and registration sensor [9].

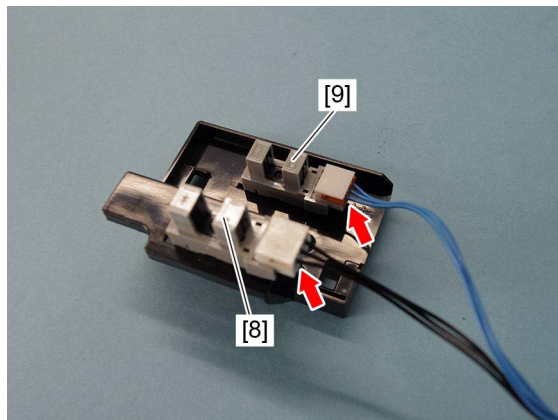



Fig. 4-142

**Notes:**

When installing connectors, connect the black wire harness to the 1st transport sensor [8], and the blue wire harness to the registration sensor [9].

## 4.5.8 Paper dust holder

- (1) Remove the process unit.  
( P. 4-99 “4.7.1 Process unit”)
- (2) Remove 1 screw and slide the paper dust holder [1] to the direction of the arrow (A) and lift it up to the direction of the arrow (B) to take it off.

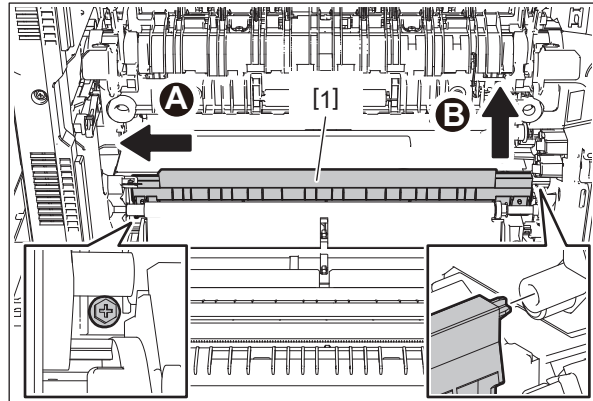


Fig. 4-143

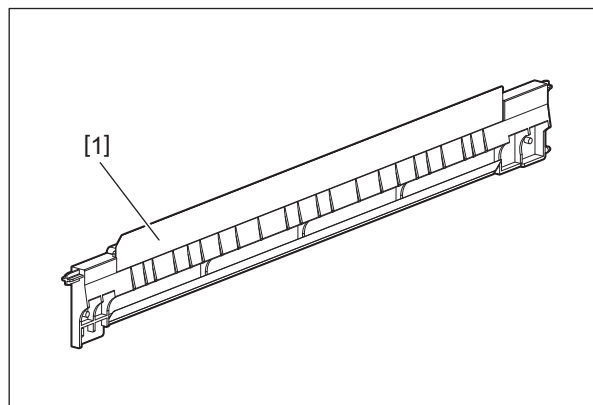



Fig. 4-144

## 4.5.9 Registration roller (on the equipment side)

- (1) Remove the registration roller clutch.  
( P. 4-91 “4.5.38 Registration roller clutch (CLT1)”)
- (2) Open the side cover.
- (3) Remove the clip [2] from the registration roller [1].

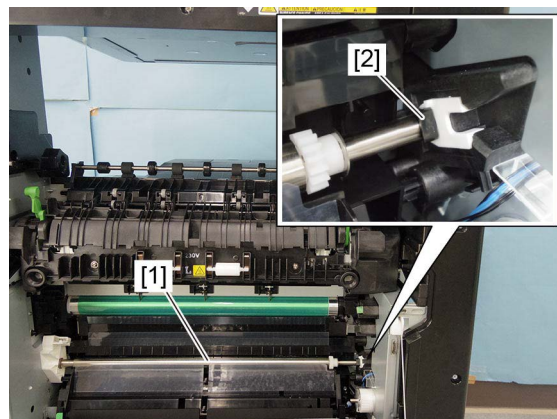


Fig. 4-145

- (4) Slide the registration roller [1] to the rear side, and then remove 1 bushing [3] on the front side. Remove the registration roller [1].

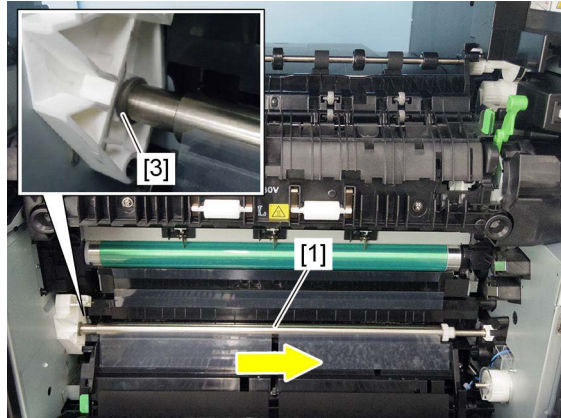


Fig. 4-146

- (5) Remove 1 stopper [4], 1 E-ring [5], 1 pin [6] and 1 gear [7] from the registration roller [1].

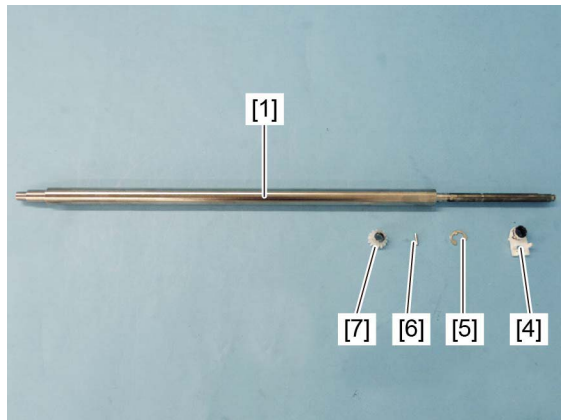


Fig. 4-147

#### 4.5.10 Registration roller (on the ADU side)

- (1) Remove the transfer unit.  
 P. 4-127 "4.9.1 Transfer unit"
- (2) Remove 1 screw while holding the shaft of the registration roller [1], and then remove the bracket [2].

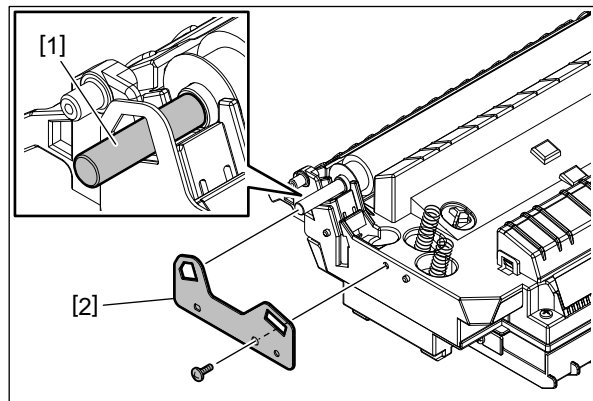


Fig. 4-148

- (3) Remove 1 screw while holding the shaft of the registration roller [3], and then remove the bracket [4].

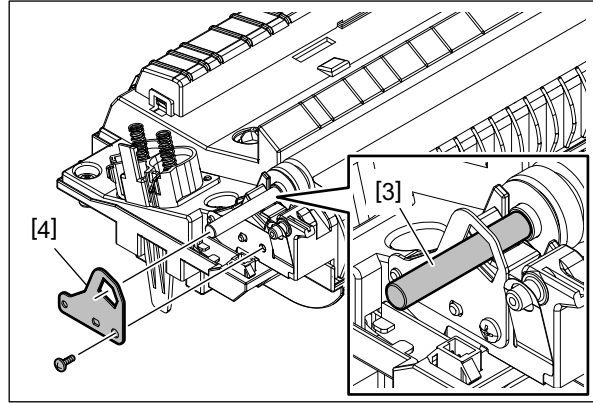


Fig. 4-149

- (4) Remove the registration roller [5].

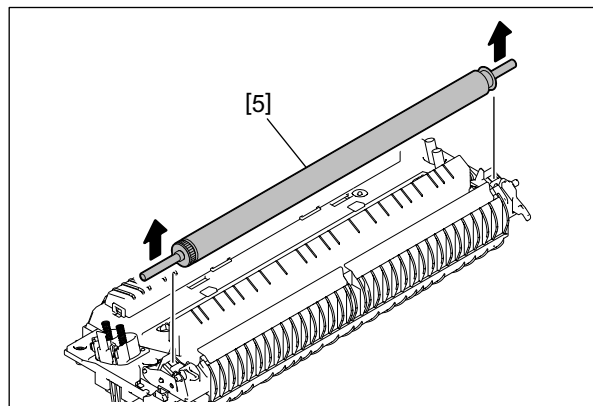


Fig. 4-150

- (5) Remove 2 washers [7], 1 E-ring [8], 1 gear [9] and 1 pin [6] from the registration roller [5].

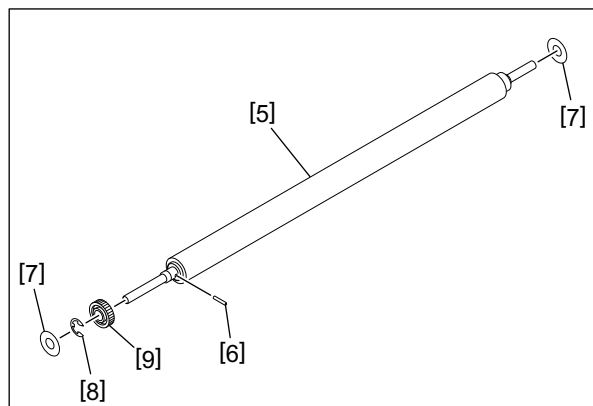


Fig. 4-151

## 4.5.11 Feed cover

- (1) Open the feed cover [1].

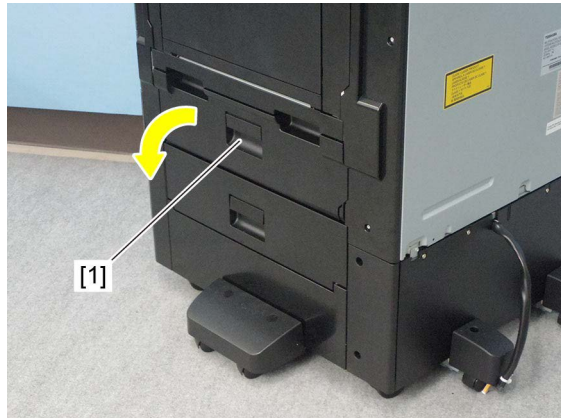


Fig. 4-152

- (2) Disconnect 1 connector [2] and remove the stopper [3].



Fig. 4-153

- (3) Press the rear hinge [4] on the rear side toward the front side. Remove the feed cover [1] while turning the feed cover [1] in the direction of the arrow.



Fig. 4-154

## 4.5.12 Transport roller

- (1) Remove the low speed transport clutch.  
📖 P. 4-88 “4.5.34 Low speed transport clutch (CLT6)”
- (2) Remove the automatic duplexing unit.  
📖 P. 4-166 “4.12.1 Automatic duplexing unit (ADU)”
- (3) Open the feed cover [1].

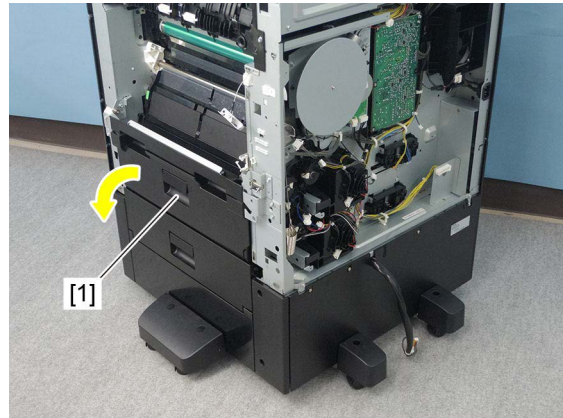


Fig. 4-155

- (4) Remove 4 screws and take off the stay [2].

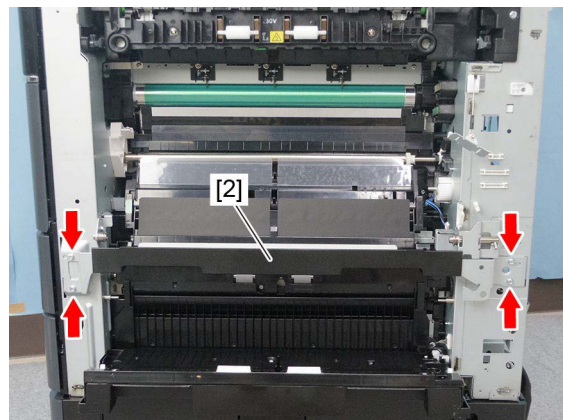


Fig. 4-156

- (5) Remove 1 screw from the transport guide [3].

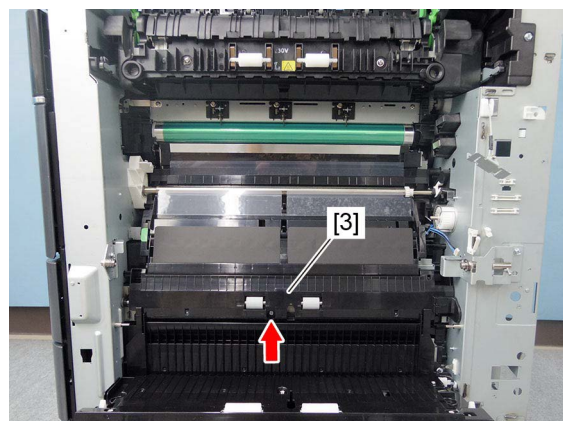


Fig. 4-157



- (6) Release 2 latches [4]. Slide the transport guide [3] to the front side, and then remove it by pulling it toward you.

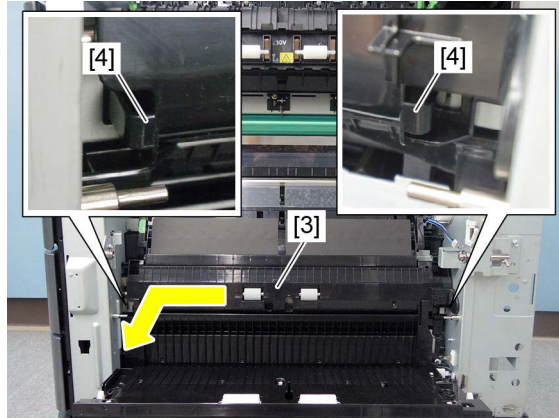


Fig. 4-158

- (7) Remove the clip from the transport roller [5].

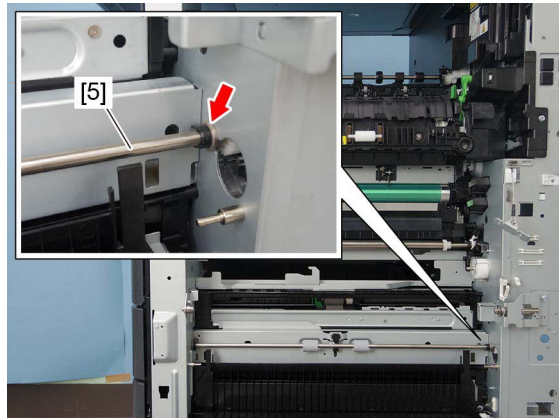


Fig. 4-159

- (8) Remove the transport roller [5] by sliding the bushing [6] toward the front side.

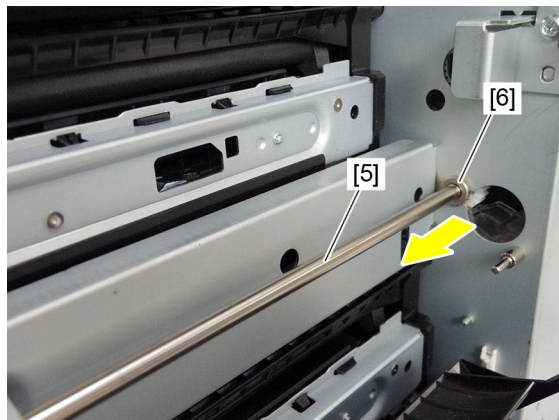


Fig. 4-160

- (9) Remove the 2 bushings [7], 1 clip [8], 1 E-ring [9] and 1 gear [10].

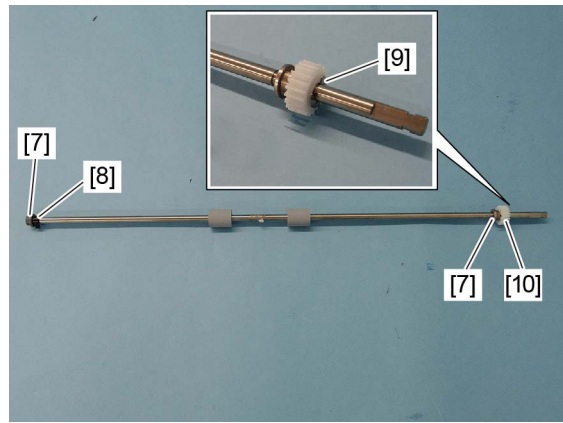


Fig. 4-161

#### 4.5.13 Feed cover opening/closing switch (SW10)

- (1) Remove the feed cover.  
P. 4-61 "4.5.11 Feed cover"
- (2) Remove 4 screws. Release 3 latches [1], and take off the cover [2].

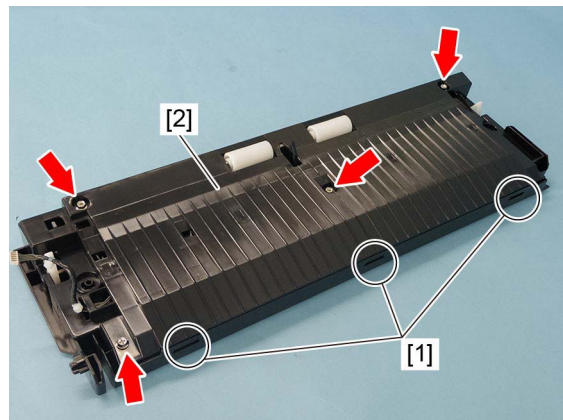


Fig. 4-162

- (3) Disconnect 1 connector [3]. Release the latch and remove the feed cover opening/closing switch [4].

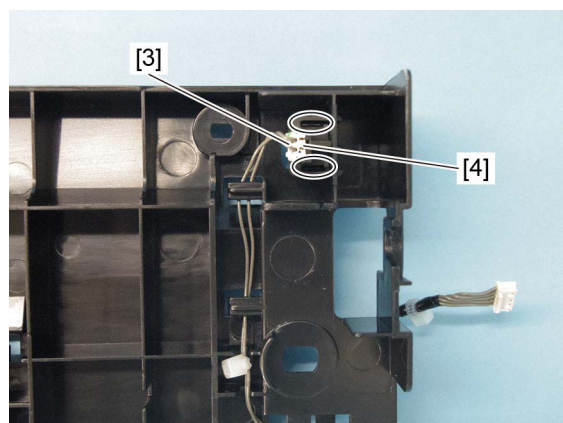


Fig. 4-163

#### 4.5.14 2nd transport sensor (S9)

- (1) Remove the feed cover.  
P. 4-61 "4.5.11 Feed cover"
- (2) Remove 4 screws. Release 3 latches [1], and take off the cover [2].

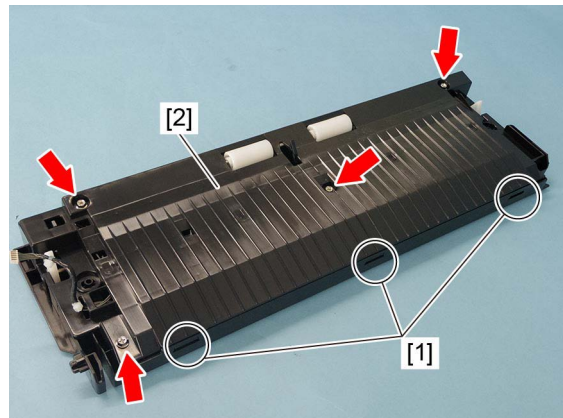


Fig. 4-164

- (3) Disconnect 1 connector [3]. Remove 2 screws and take off the cover [4].

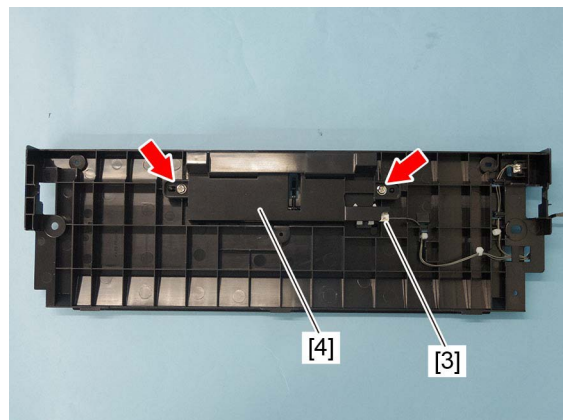


Fig. 4-165

- (4) Release the latch, and remove the 2nd transport sensor [5].

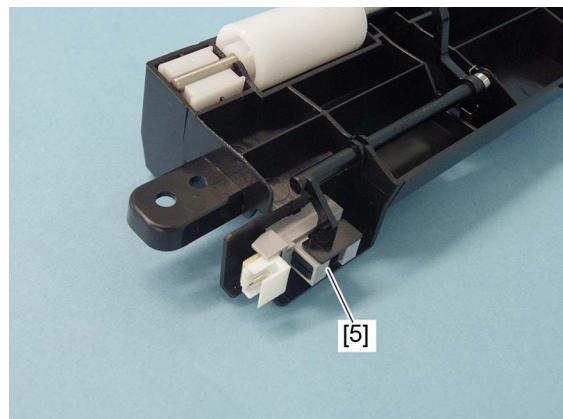



Fig. 4-166

## 4.5.15 1st drawer paper feed unit

- (1) Pull out the 1st drawer.
- (2) Remove the front cover.  
 P. 4-1 "4.1.1 Front cover"
- (3) Tilt the lock lever [1] clockwise. Pull out the 1st drawer paper feed unit [2] toward you to remove it.

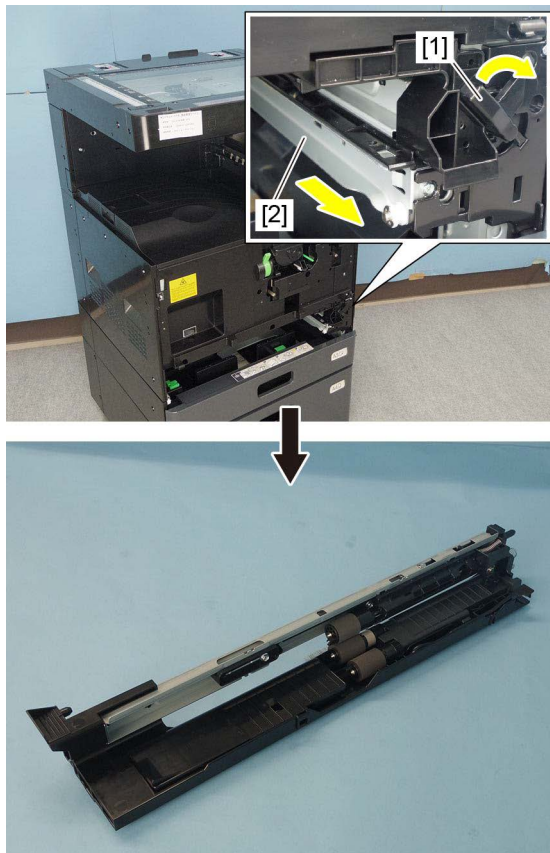


Fig. 4-167

### Notes:

When installing, align the arrow of the 1st drawer paper feed unit with the guide before inserting.

## 4.5.16 1st drawer separation roller guide

- (1) Remove the 1st drawer paper feed unit.  
P. 4-66 "4.5.15 1st drawer paper feed unit"
- (2) Remove 2 screws from the 1st drawer separation roller guide [1].

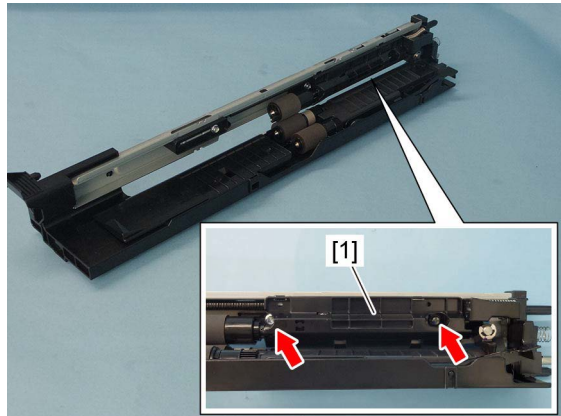


Fig. 4-168

- (3) Release two latches and remove the 1st drawer separation roller guide [1].

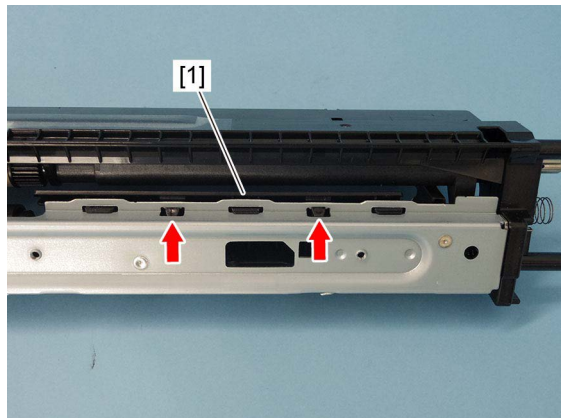


Fig. 4-169

- (4) Remove the E-ring and take off the shaft [2].

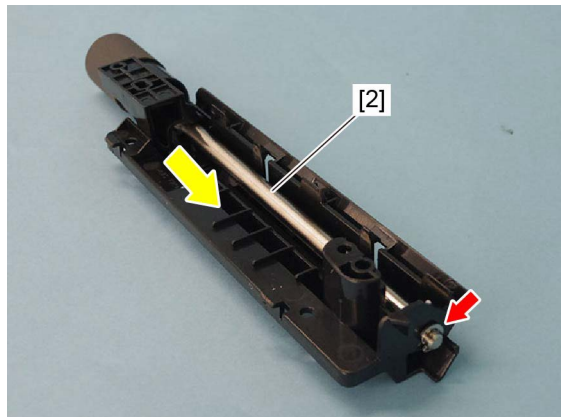


Fig. 4-170

(5) Remove the shaft cover [3].

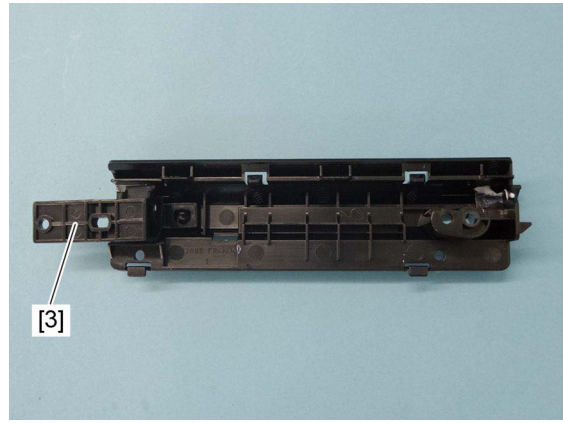


Fig. 4-171

**Notes:**

When replacing the parts or performing preventive maintenance, apply 1 rice-sized grain of white grease (Molykote HP-300) to the place [4] shown in the figure, and apply half a rice-sized grain of white grease (Molykote HP-300) to the 2 places [5] shown in the figure.

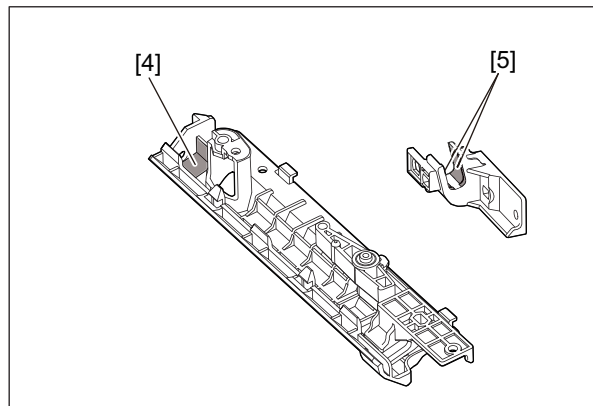


Fig. 4-172

#### 4.5.17 2nd drawer paper feed unit

- (1) Pull out the 1st drawer.
- (2) Pull out the 2nd drawer.
- (3) Tilt the lock lever [1] clockwise. Pull out the 2nd drawer paper feed unit [2] toward you to remove it.

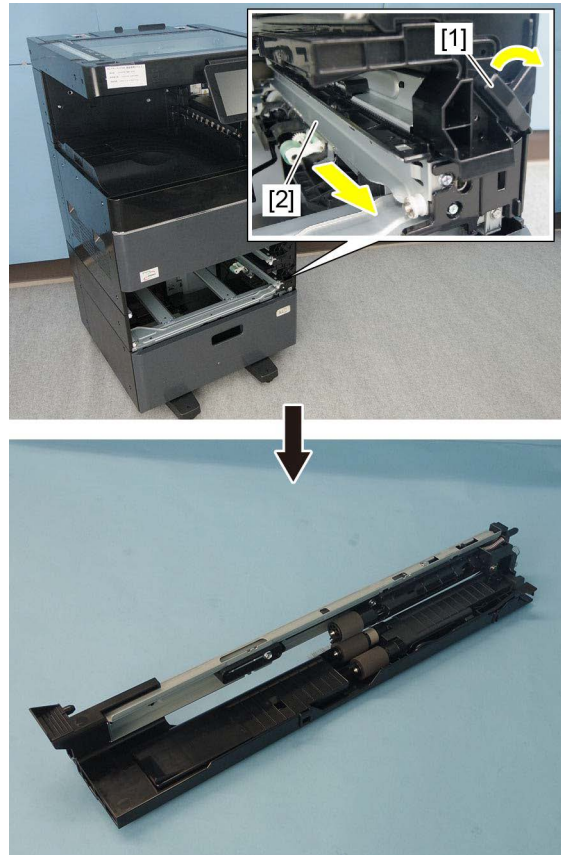


Fig. 4-173

**Notes:**

When installing, align the arrow of the 2nd drawer paper feed unit with the guide before inserting.

## 4.5.18 2nd drawer separation roller guide

- (1) Remove the 2nd drawer paper feed unit.  
📖 P. 4-69 "4.5.17 2nd drawer paper feed unit"
- (2) Remove 2 screws from the 2nd drawer separation roller guide [1].

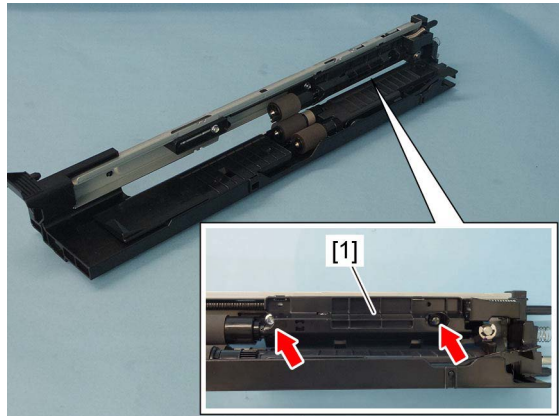


Fig. 4-174

- (3) Release 2 latches and remove the 2nd drawer separation roller guide [1].

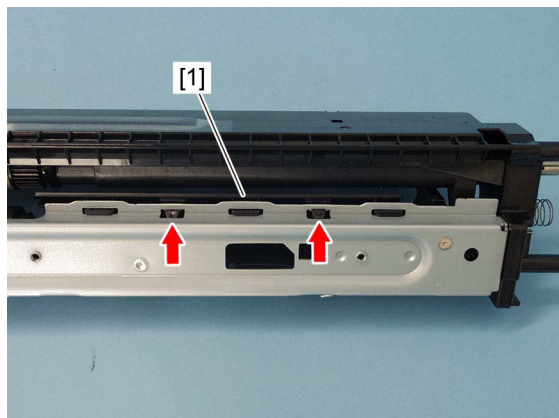


Fig. 4-175

- (4) Remove the E-ring and take off the shaft [2].

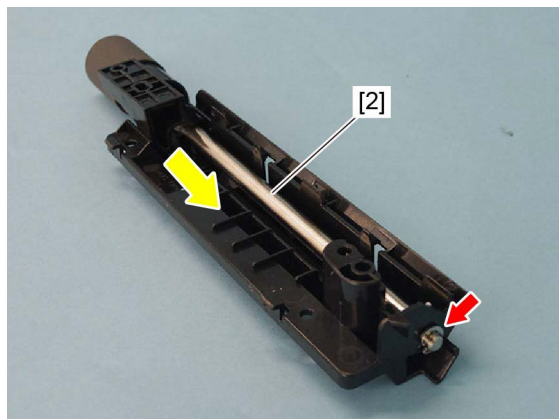


Fig. 4-176



- (5) Remove the shaft cover [3].

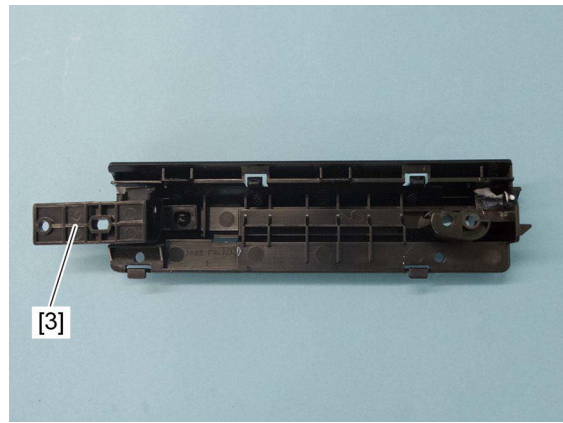


Fig. 4-177

**Notes:**

When replacing the parts or performing preventive maintenance, apply 1 rice-sized grain of white grease (Molykote HP-300) to the place [4] shown in the figure, and apply half a rice-sized grain of white grease (Molykote HP-300) to the 2 places [5] shown in the figure.

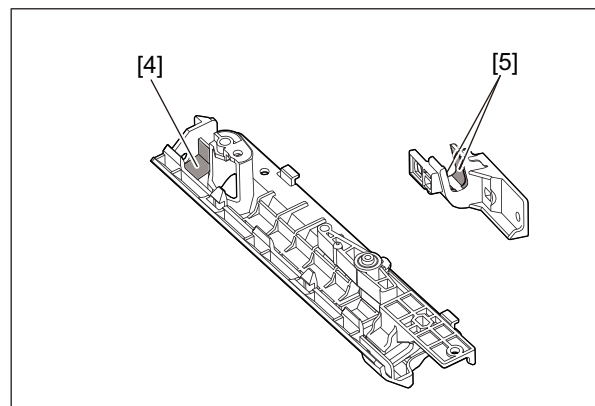


Fig. 4-178

### 4.5.19 1st drawer paper feed roller, separation roller, and pick-up roller

- (1) Remove the 1st drawer paper feed unit.  
P. 4-66 “4.5.15 1st drawer paper feed unit”
- (2) Slide the guide [1] to the front side.

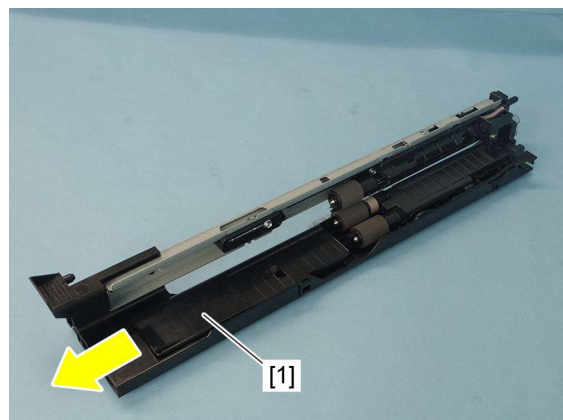


Fig. 4-179

- (3) Remove the clip [2] and take off the separation roller [3]. Remove the clip [4] and take off the feed roller [5]. Release the latch and take off the pick-up roller [6].

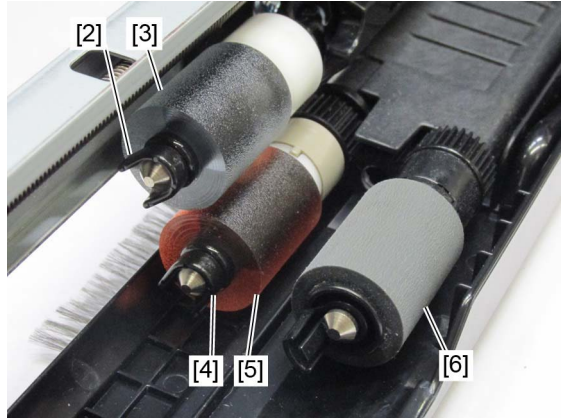


Fig. 4-180

Separation roller



Fig. 4-181

Feed roller



Fig. 4-182

## Pick-up roller



Fig. 4-183

### 4.5.20 2nd drawer paper feed roller, separation roller, and pick-up roller

- (1) Remove the 2nd drawer paper feed unit.  
P. 4-69 “4.5.17 2nd drawer paper feed unit”
- (2) Slide the guide [1] to the front side.

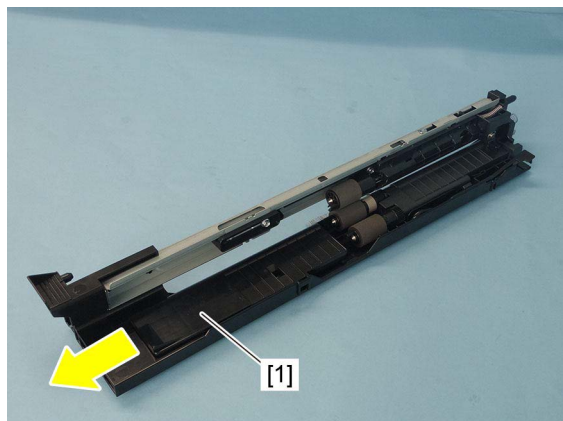


Fig. 4-184

- (3) Remove the clip [2] and take off the separation roller [3]. Remove the clip [4] and take off the feed roller [5]. Release the latch and take off the pick-up roller [6].

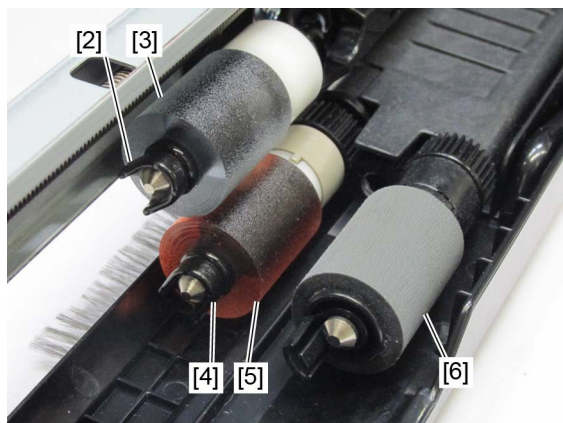


Fig. 4-185

Separation roller



**Fig. 4-186**

Feed roller



**Fig. 4-187**

Pick-up roller



**Fig. 4-188**

#### 4.5.21 1st drawer detection switch (SW11)

- (1) Remove the 1st drawer paper feed unit.  
📖 P. 4-66 "4.5.15 1st drawer paper feed unit"
- (2) Remove the 2nd drawer paper feed unit.  
📖 P. 4-69 "4.5.17 2nd drawer paper feed unit"
- (3) Remove the upper tray-up motor unit.  
📖 P. 4-77 "4.5.23 Upper tray-up motor unit"
- (4) Disconnect 1 connector [1] from the rear side, and then release 2 latches.

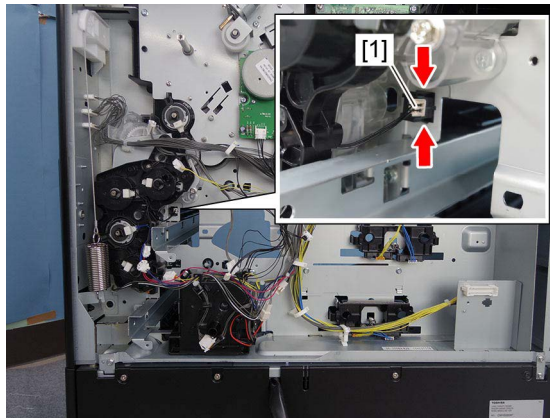


Fig. 4-189

- (5) Remove the 1st drawer detection switch [2] from the front side.

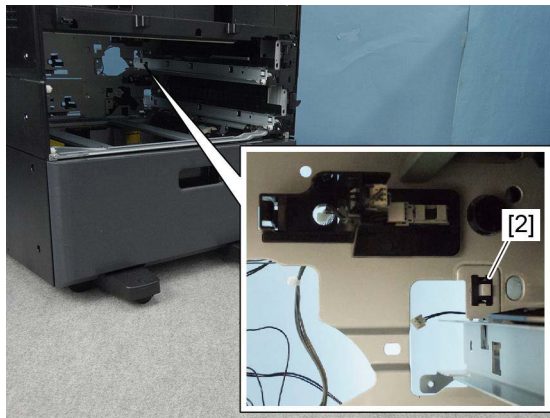


Fig. 4-190

#### 4.5.22 2nd drawer detection switch (SW12)

- (1) Remove the 1st drawer paper feed unit.  
📖 P. 4-66 "4.5.15 1st drawer paper feed unit"
- (2) Remove the 2nd drawer paper feed unit.  
📖 P. 4-69 "4.5.17 2nd drawer paper feed unit"
- (3) Remove the lower tray-up motor unit.  
📖 P. 4-77 "4.5.24 Lower tray-up motor unit"
- (4) Disconnect 1 connector [1] from the rear side, and then release 2 latches.

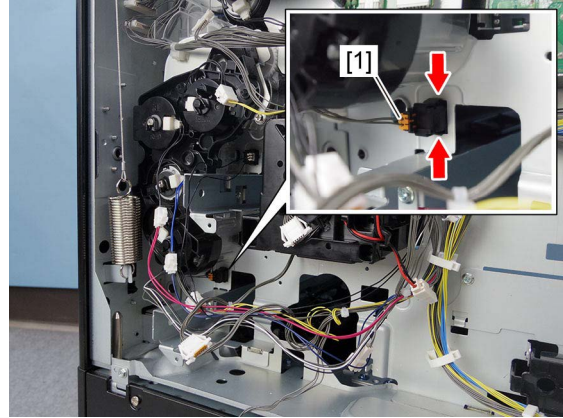


Fig. 4-191

- (5) Remove the 2nd drawer detection switch [2] from the front side.

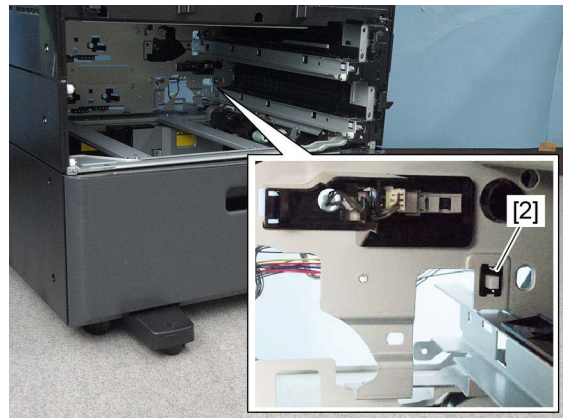


Fig. 4-192

### 4.5.23 Upper tray-up motor unit

- (1) Remove the rear cover.  
P. 4-8 "4.1.15 Rear cover"
- (2) Disconnect 1 connector [1], and then release the harness from the harness guide.

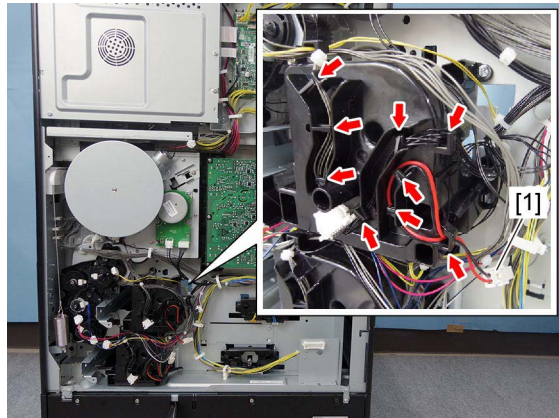


Fig. 4-193

- (3) Remove 3 screws and take off the upper tray-up motor unit [2].

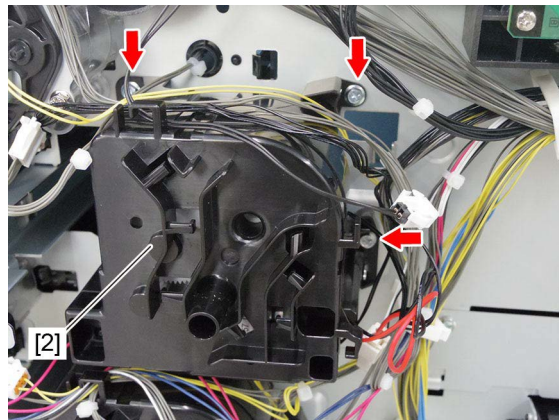


Fig. 4-194

### 4.5.24 Lower tray-up motor unit

- (1) Remove the rear cover.  
P. 4-8 "4.1.15 Rear cover"
- (2) Disconnect 1 connector [1], and then release the harness from the harness guide.

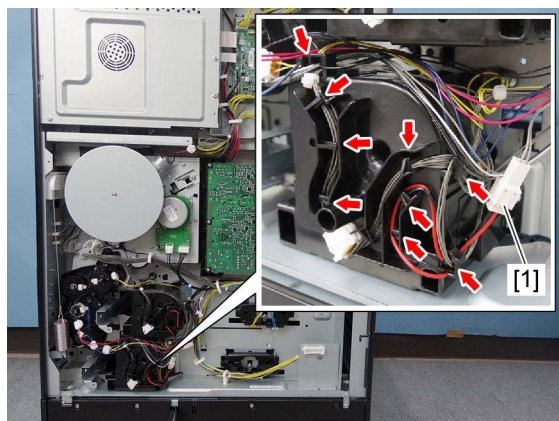


Fig. 4-195

- (3) Remove 3 screws and take off the lower tray-up motor unit [2].

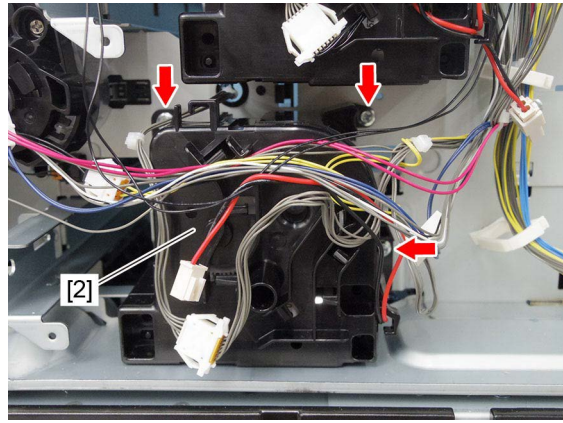


Fig. 4-196

#### 4.5.25 Upper tray-up motor (M11)

- (1) Remove the upper tray-up motor unit.  
📖 P. 4-77 "4.5.23 Upper tray-up motor unit"  
(2) Release 4 latches and remove the cover [1].

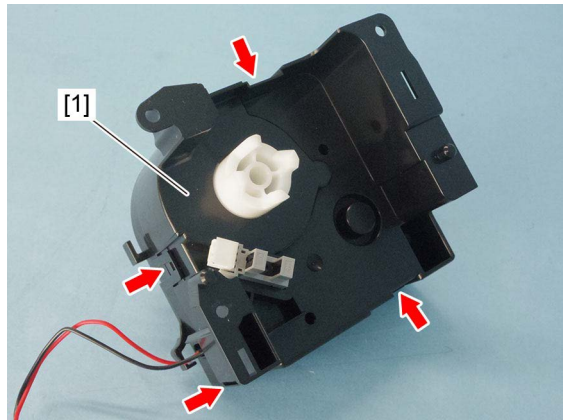


Fig. 4-197

- (3) Take off the upper tray-up motor [2].

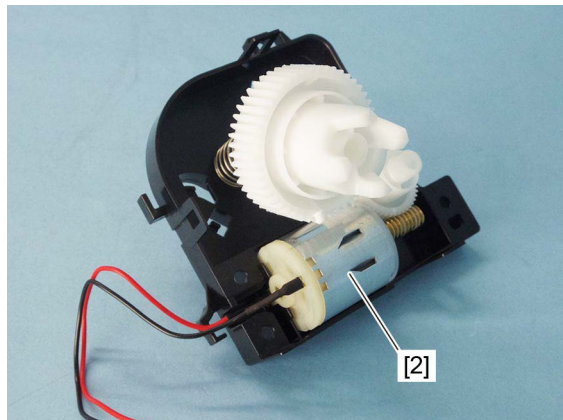


Fig. 4-198



### 4.5.26 Lower tray-up motor (M12)

- (1) Remove the lower tray-up motor unit.  
📖 P. 4-77 "4.5.24 Lower tray-up motor unit"
- (2) Release 4 latches, and then remove the cover [1].

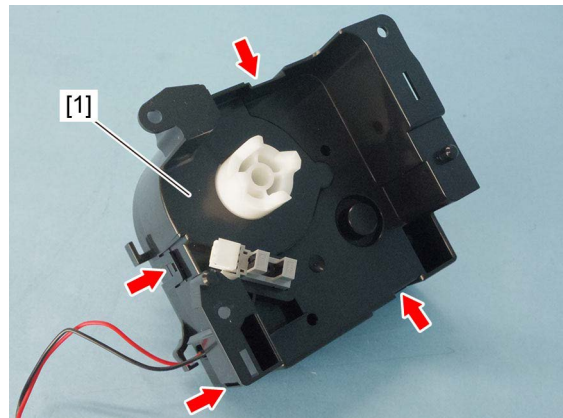


Fig. 4-199

- (3) Take off the lower tray-up motor [2].

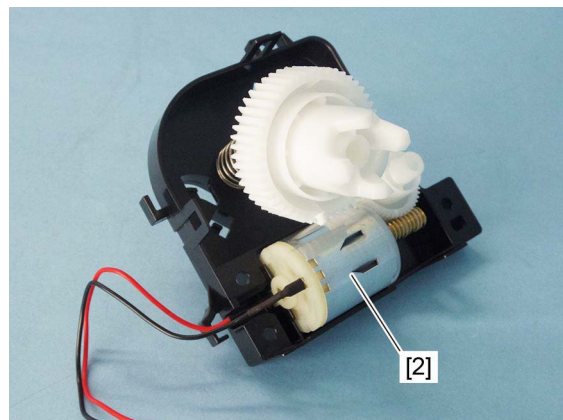


Fig. 4-200

### 4.5.27 1st drawer paper stock sensor (S10)

- (1) Remove the upper tray-up motor unit.  
📖 P. 4-77 "4.5.23 Upper tray-up motor unit"
- (2) Release 4 latches, and then remove the cover [1].

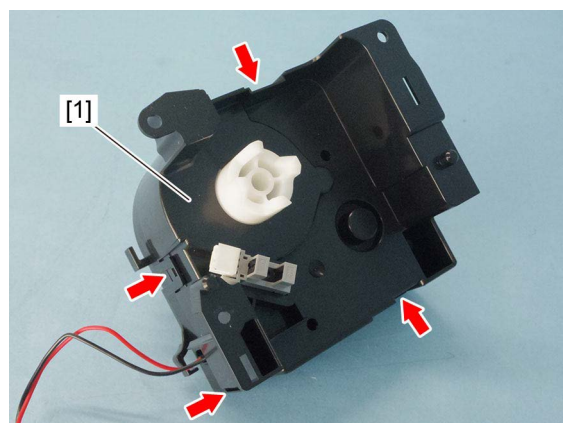


Fig. 4-201

- (3) Release 3 latches, and then remove the 1st drawer paper stock sensor [2].

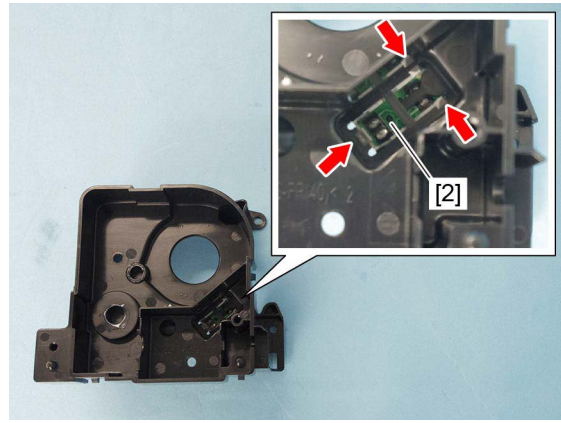


Fig. 4-202

#### 4.5.28 2nd drawer paper stock sensor (S13)

- (1) Remove the lower tray-up motor unit.  
P. 4-77 "4.5.24 Lower tray-up motor unit"
- (2) Release 4 latches, and then remove the cover [1].

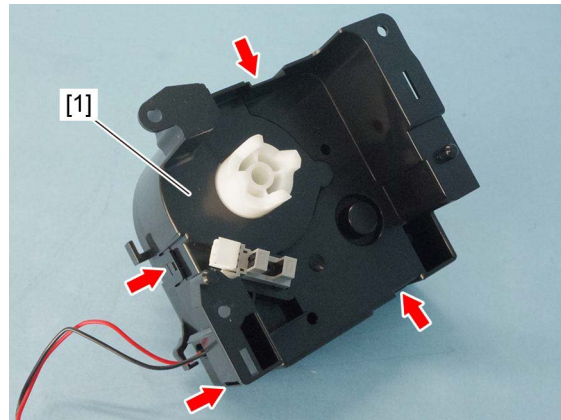


Fig. 4-203

- (3) Release 3 latches, and then remove the 2nd drawer paper stock sensor [2].

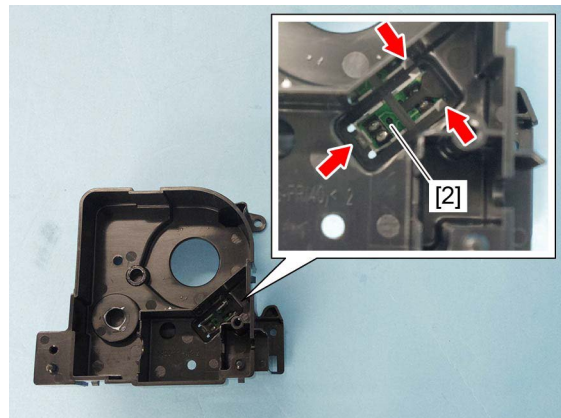


Fig. 4-204

## 4.5.29 1st drawer empty sensor (S12) and 1st drawer tray-up sensor (S11)

- (1) Remove the 1st drawer paper feed unit.  
📖 P. 4-66 “4.5.15 1st drawer paper feed unit”
- (2) Remove the 2nd drawer paper feed unit.  
📖 P. 4-69 “4.5.17 2nd drawer paper feed unit”
- (3) Remove the tray-up motor units.  
📖 P. 4-77 “4.5.23 Upper tray-up motor unit”  
📖 P. 4-77 “4.5.24 Lower tray-up motor unit”
- (4) Release 1 latch.

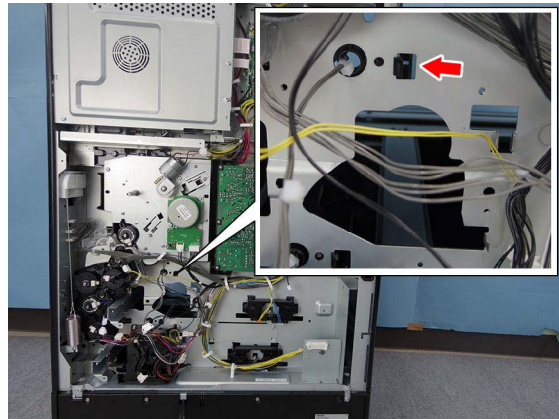


Fig. 4-205

- (5) Feed out the sensor holder [1] to the front side, and then remove it.

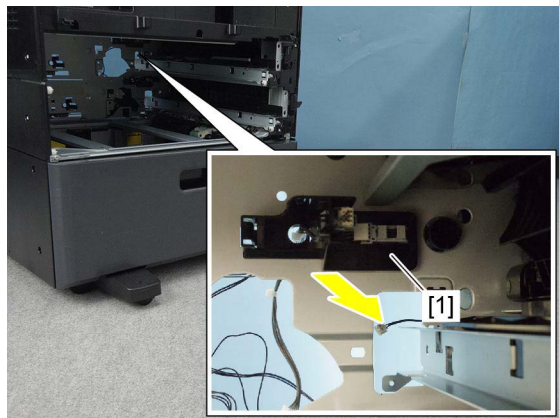


Fig. 4-206

**Notes:**

When installing, fix it using the sensor holder projection [2] and latch [3].

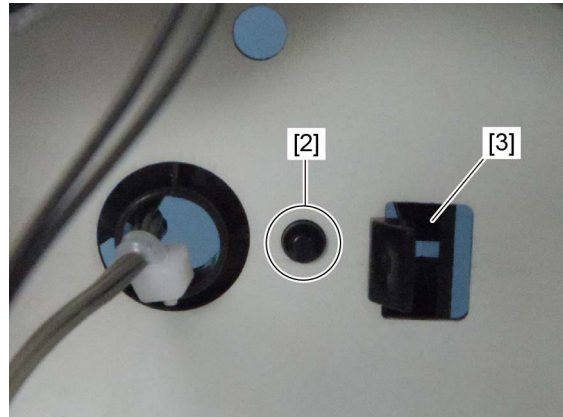


Fig. 4-207

- (6) Disconnect 2 connectors. Remove the 1st drawer empty sensor [4] and the 1st drawer tray-up sensor [5].

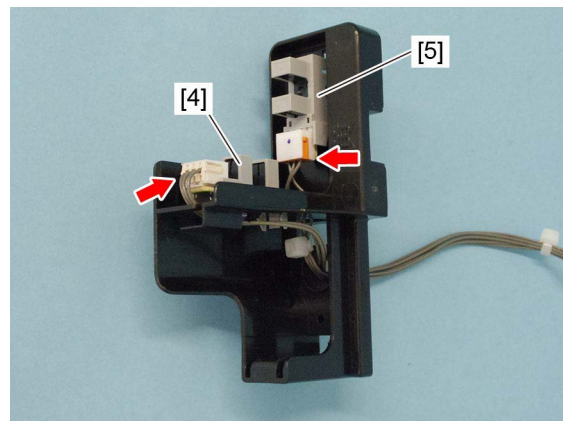


Fig. 4-208

**Notes:**

When installing connectors, connect the white connector to the 1st drawer empty sensor [4], and the yellow connector to the 1st drawer tray-up sensor [5].

### 4.5.30 2nd drawer empty sensor (S15) and 2nd drawer tray-up sensor (S14)

- (1) Remove the 1st drawer paper feed unit.  
📖 P. 4-66 "4.5.15 1st drawer paper feed unit"
- (2) Remove the 2nd drawer paper feed unit.  
📖 P. 4-69 "4.5.17 2nd drawer paper feed unit"
- (3) Remove the upper tray-up motor unit.  
📖 P. 4-77 "4.5.23 Upper tray-up motor unit"

(4) Release 1 latch.

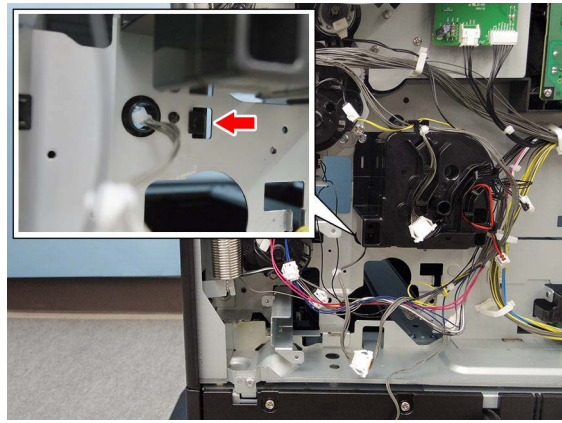


Fig. 4-209

(5) Feed out the sensor holder [1] to the rear side and then remove it.

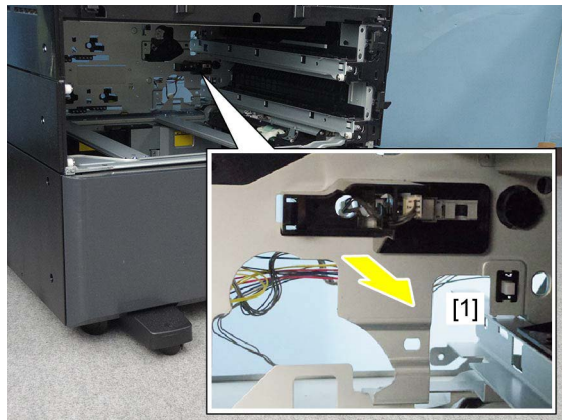


Fig. 4-210

**Notes:**

When installing, fix it using the sensor holder projection [2] and latch [3].

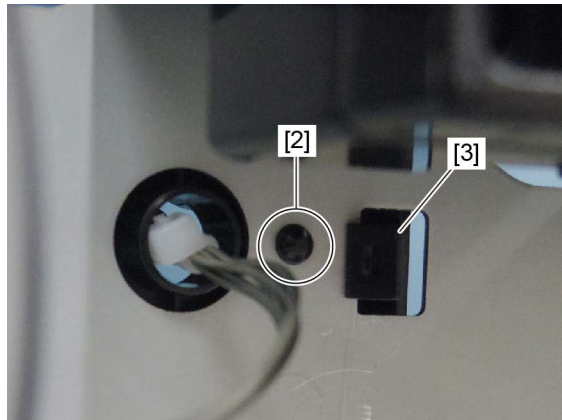


Fig. 4-211

- (6) Disconnect 2 connectors. Remove the 2nd drawer empty sensor [4] and the 2nd drawer tray-up sensor [5].

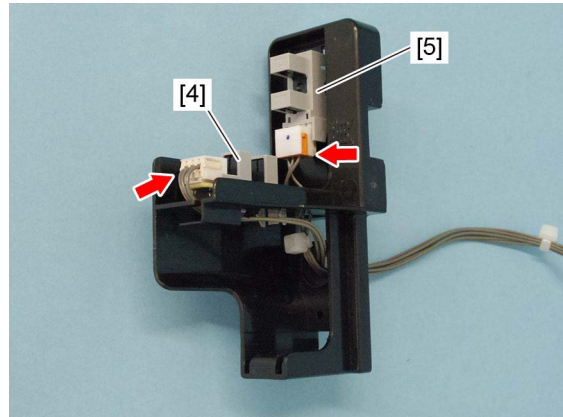


Fig. 4-212

**Notes:**

When installing connectors, connect the white connector to the 2nd drawer empty sensor [4], and the yellow connector to the 2nd drawer tray-up sensor [5].

#### 4.5.31 1st drawer paper width detection switch (SW6) and 1st drawer paper length detection switch (SW7)

- (1) Remove the rear cover.  
P. 4-8 "4.1.15 Rear cover"
- (2) Remove 1 spring [1] and disconnect the 2 connectors [2].

**Notes:**

When installing, connect the yellow harness connector to the left side.

- (3) Release the latch, and remove the switch holder [3].

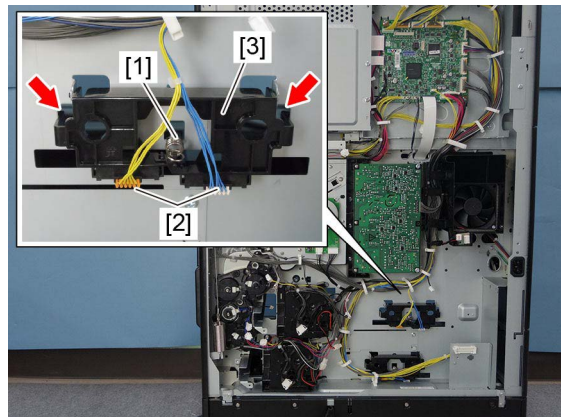


Fig. 4-213

- (4) Release the latch, and remove the 1st drawer paper width detection switch [4] and 1st drawer paper length detection switch [5].

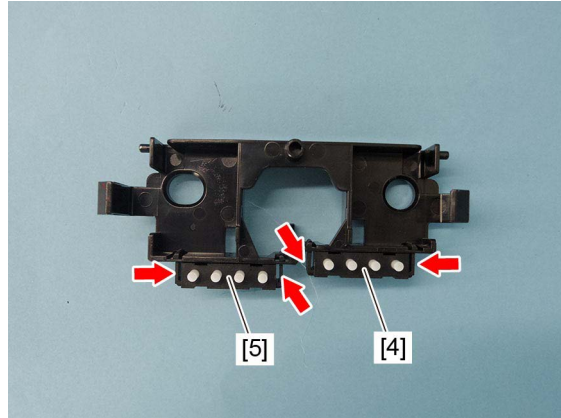


Fig. 4-214

#### 4.5.32 2nd drawer paper width detection switch (SW8) and 2nd drawer paper length detection switch (SW9)

- (1) Remove the rear cover.  
P. 4-8 “4.1.15 Rear cover”
- (2) Remove 1 spring [1] and disconnect 2 connectors [2].

**Notes:**

When installing, connect the yellow harness connector to the left side.

- (3) Release the latch, and remove the switch holder [3].

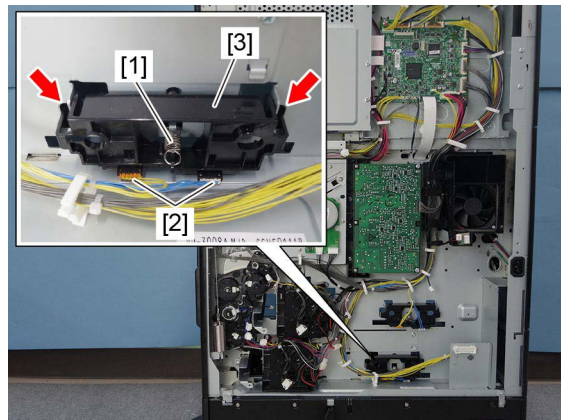


Fig. 4-215

- (4) Release the latch, and remove the 2nd drawer paper width detection switch [4] and 2nd drawer paper length detection switch [5].

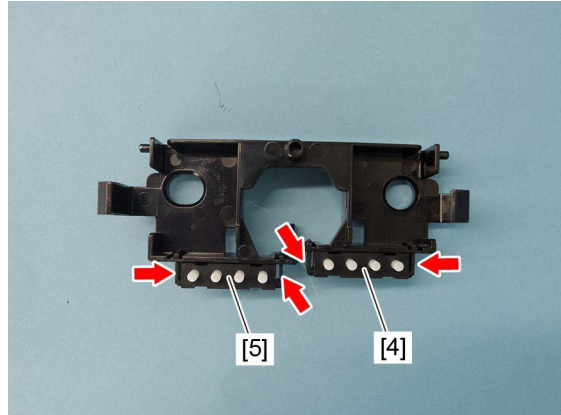


Fig. 4-216

### 4.5.33 High speed transport clutch (CLT5)

- (1) Remove the rear cover.  
P. 4-8 "4.1.15 Rear cover"
- (2) Disconnect 3 connectors [1] and release the harness from the harness guide.

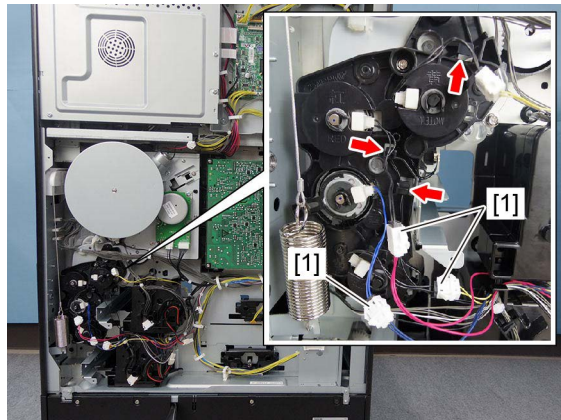


Fig. 4-217

- (3) Remove 3 clips.

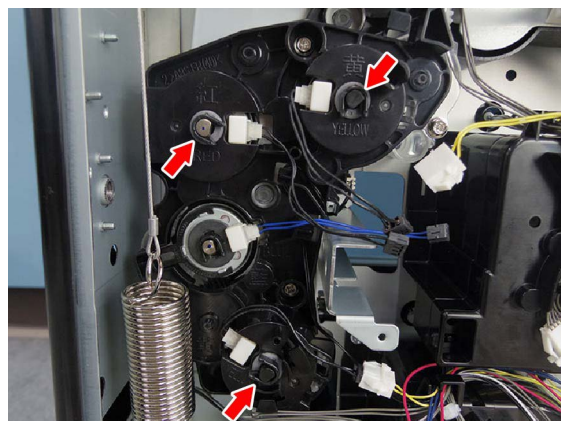


Fig. 4-218



(4) Remove 3 bushings and 2 screws [2], and then take off the clutch cover [3].

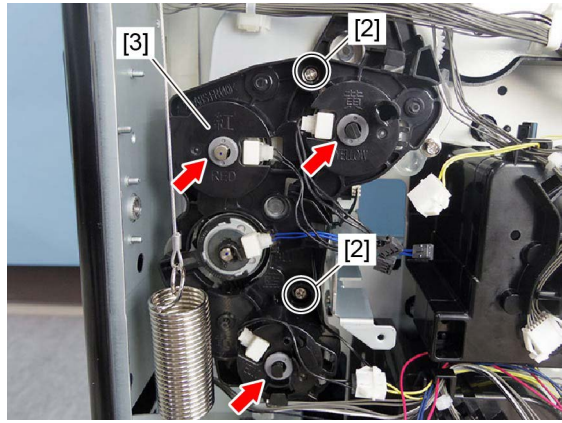


Fig. 4-219

(5) Remove the high speed transport clutch [4].

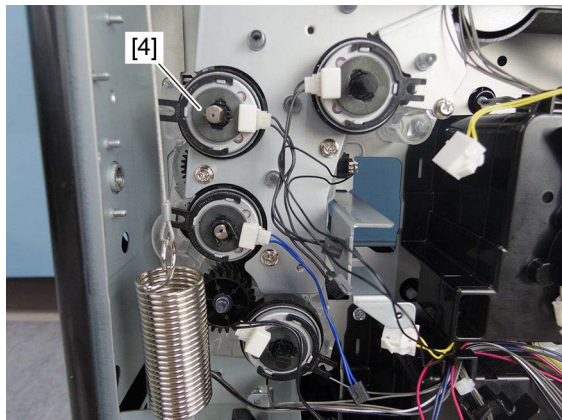


Fig. 4-220

**Notes:**

When installing the clutch, attach a rotation stopper.

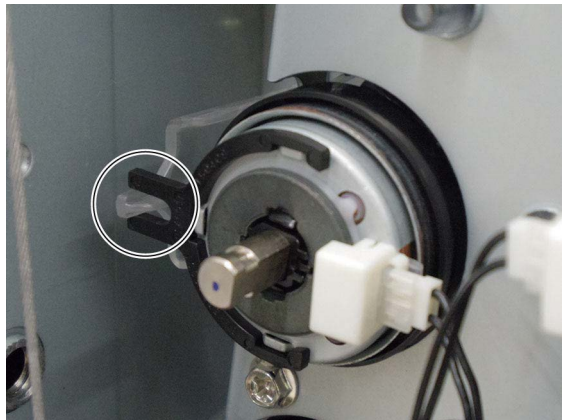


Fig. 4-221

### 4.5.34 Low speed transport clutch (CLT6)

- (1) Remove the rear cover.  
P. 4-8 "4.1.15 Rear cover"
- (2) Disconnect 1 connector [1]. Remove 1 clip and the low speed transport clutch [2].

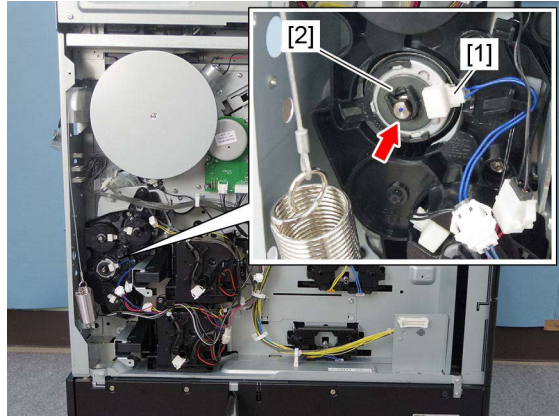


Fig. 4-222


#### Notes:

When installing the clutch, attach a rotation stopper to the clutch cover.



Fig. 4-223

### 4.5.35 1st drawer feed clutch (CLT3)

- (1) Remove the clutch cover.  
 P. 4-86 "4.5.33 High speed transport clutch (CLT5)"
- (2) Remove the 1st drawer feed clutch [1].

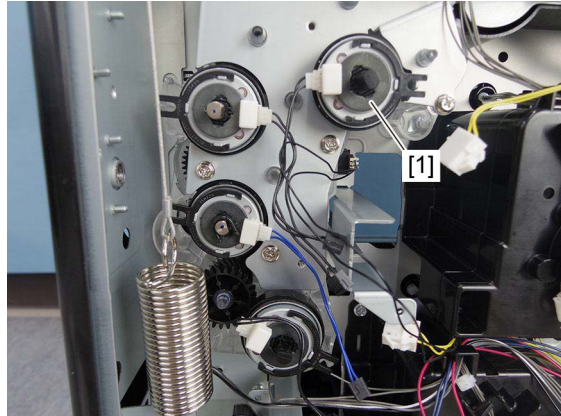


Fig. 4-224

#### Notes:

When installing the clutch, attach a rotation stopper.

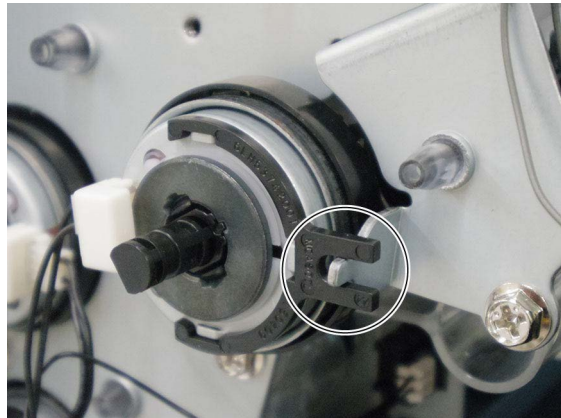



Fig. 4-225

### 4.5.36 2nd drawer feed clutch (CLT4)

- (1) Remove the clutch cover.  
 P. 4-86 "4.5.33 High speed transport clutch (CLT5)"
- (2) Remove the 2nd drawer feed clutch [1].

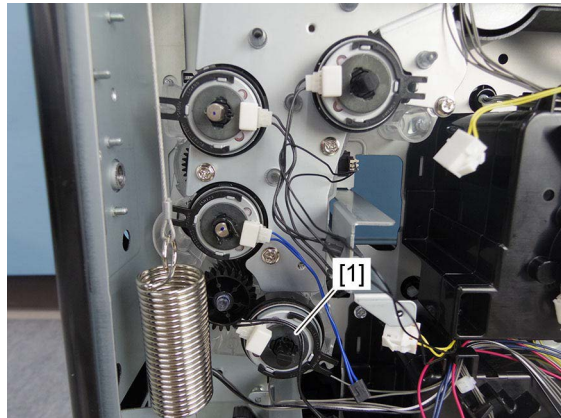


Fig. 4-226

#### Notes:

When installing the clutch, attach a rotation stopper.

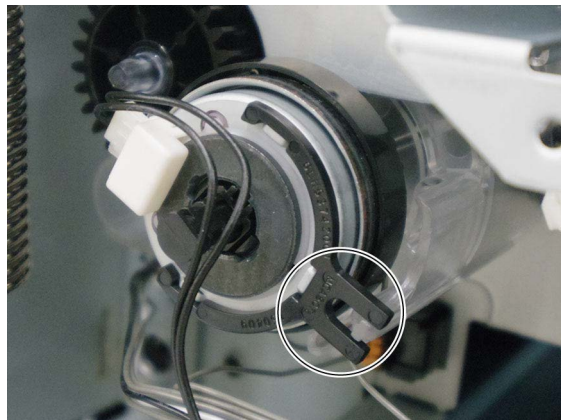


Fig. 4-227

### 4.5.37 Flywheel



- (1) Remove the rear cover.  
 P. 4-8 "4.1.15 Rear cover"
- (2) Remove 1 screw and take off the flywheel [1].



Fig. 4-228

### 4.5.38 Registration roller clutch (CLT1)

- (1) Remove the flywheel.  
 P. 4-91 "4.5.37 Flywheel"
- (2) Disconnect 1 connector [1]. Remove the clip and take off the registration roller clutch [2].

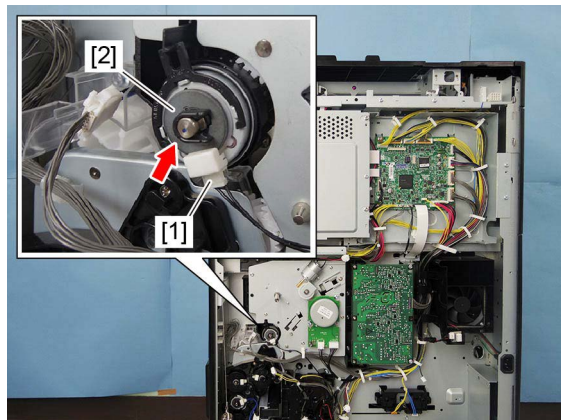


Fig. 4-229

**Notes:**

When installing the registration roller clutch, attach a rotation stopper to the clutch cover.



Fig. 4-230

### 4.5.39 Paper feed drive unit

- (1) Remove the low speed transport clutch.  
P. 4-88 "4.5.34 Low speed transport clutch (CLT6)"
- (2) Disconnect 3 connectors [3].

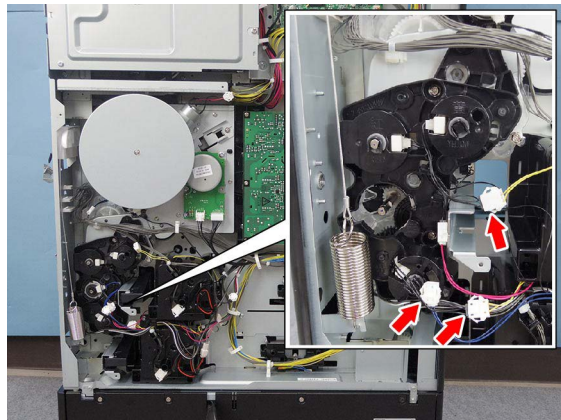


Fig. 4-231

- (3) Remove 1 harness clamp [1] and disconnect 1 connector [2].
- (4) Release the harness from the harness guide.

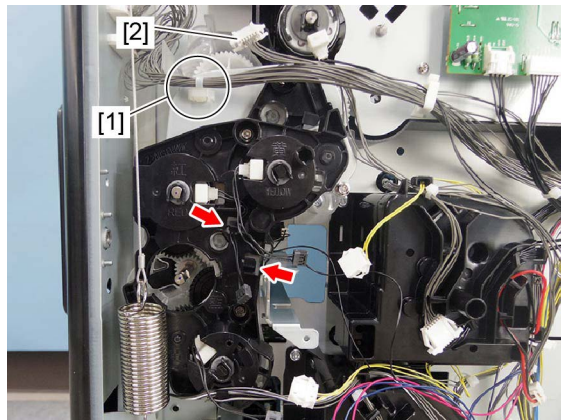


Fig. 4-232

(5) Remove the spring [3].

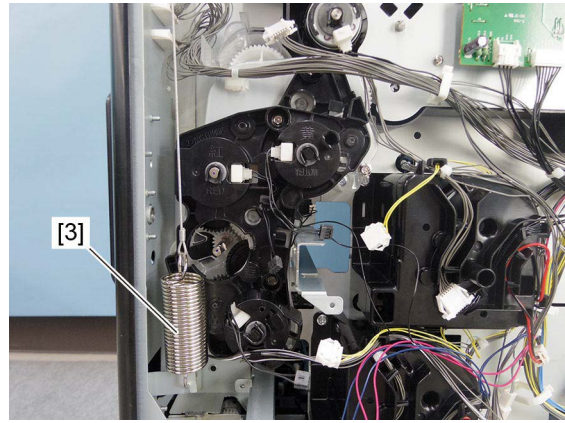


Fig. 4-233

(6) Remove 3 screws, and take off the paper feed drive unit [4].

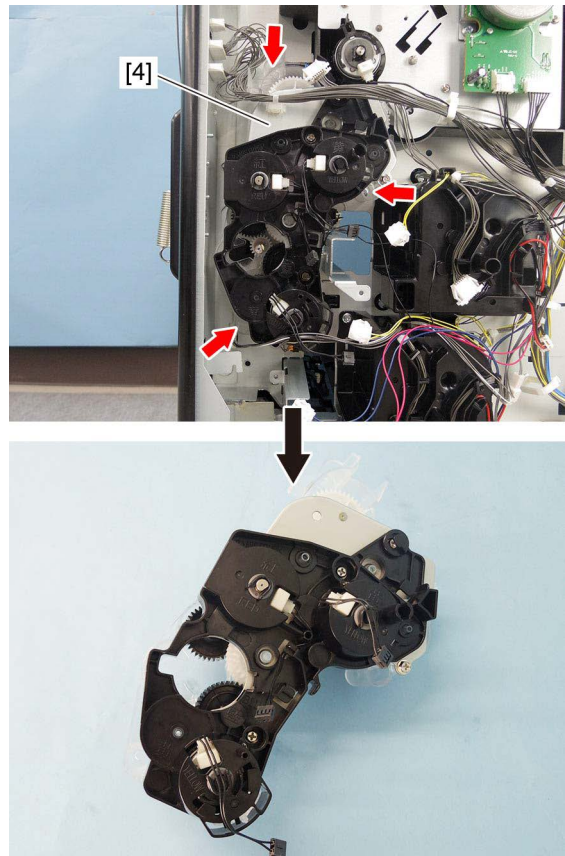


Fig. 4-234

**Notes:**

When replacing the gear, remove the clutch cover.

#### 4.5.40 Paper feed drive gear

- (1) Remove the paper feed drive unit.  
P. 4-92 "4.5.39 Paper feed drive unit"
- (2) Remove 3 clips and take off 3 bushings [1].

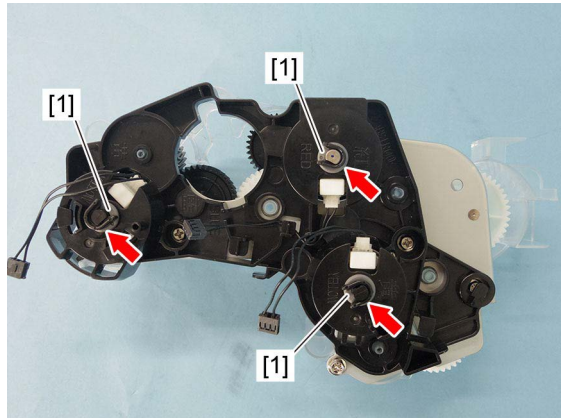


Fig. 4-235

- (3) Remove 2 screws and take off the clutch cover [2].

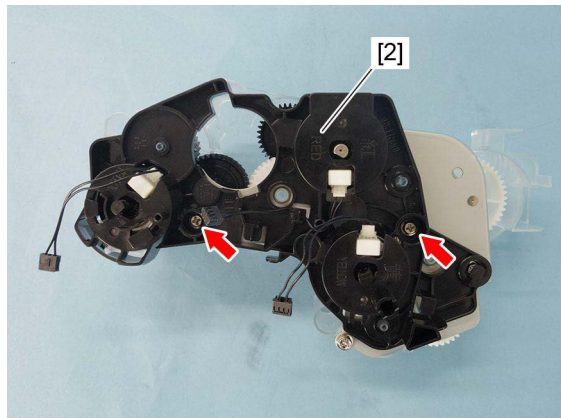


Fig. 4-236

- (4) Remove the 1st drawer paper feed clutch [3], 2nd drawer paper feed clutch [4], and high speed transport clutch [5].

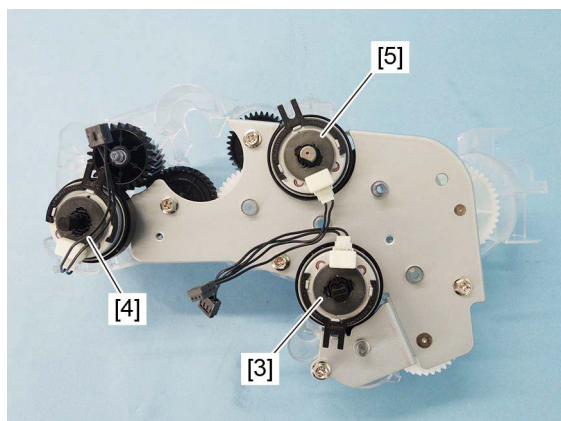


Fig. 4-237



**Notes:**

When installing the clutch, attach a rotation stopper.

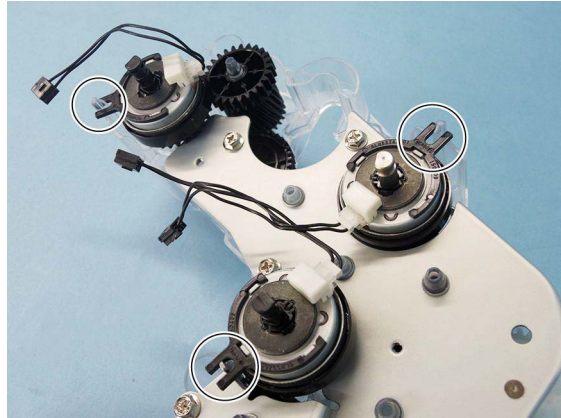


Fig. 4-238

- (5) Remove 5 screws and take off the paper feed drive gear cover [6].

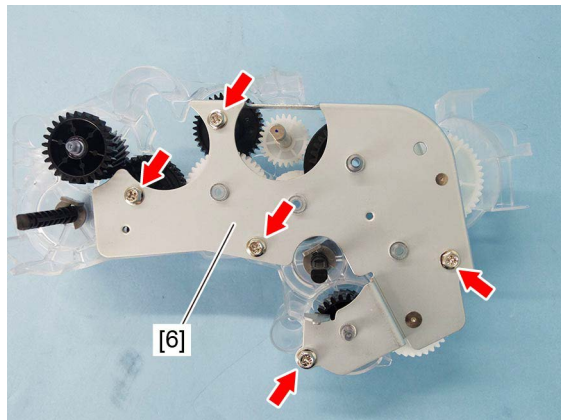


Fig. 4-239

**Notes:**

When replacing the parts or performing machine refreshment, apply 2 rice-sized grains of white grease (Molykote EM-30L) to the shaft [7].

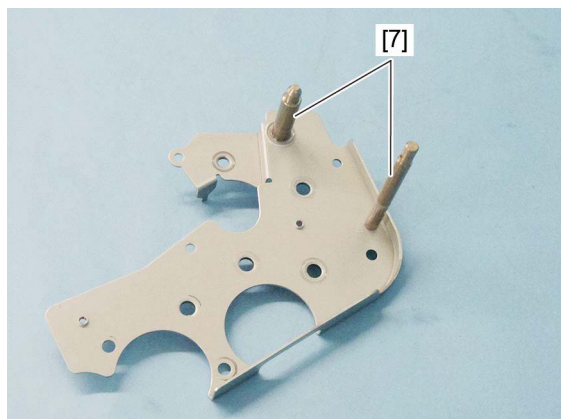


Fig. 4-240

(6) Remove the paper feed drive gear.

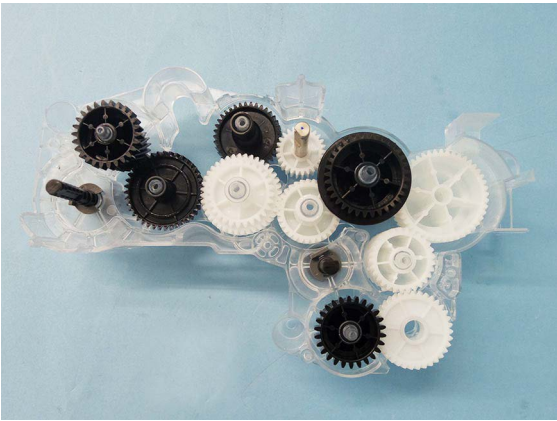



Fig. 4-241

## 4.6 Driving Section

### 4.6.1 Main motor (M8) <35ppm/45ppm/50ppm>

- (1) Remove the flywheel.  
 P. 4-91 “4.5.37 Flywheel”
- (2) Disconnect 2 connectors.

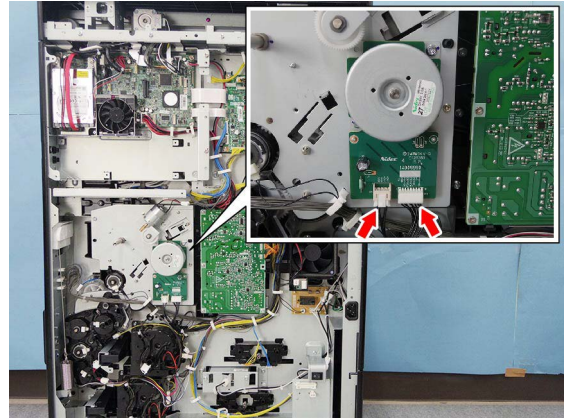


Fig. 4-242

- (3) Remove 2 screws and take off the main motor [1].

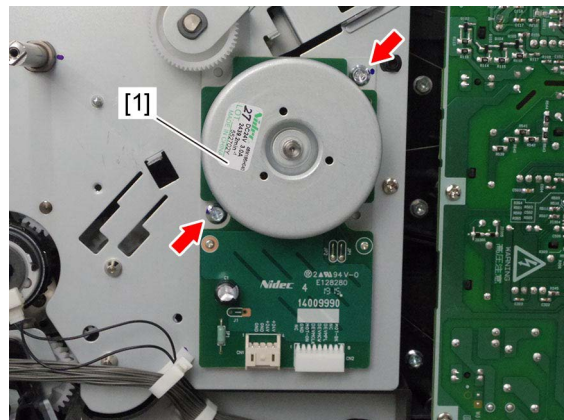



Fig. 4-243

### 4.6.2 Main motor (M8) <20ppm/25ppm/30ppm>

- (1) Remove the flywheel.  
 P. 4-91 “4.5.37 Flywheel”
- (2) Disconnect 2 connectors.

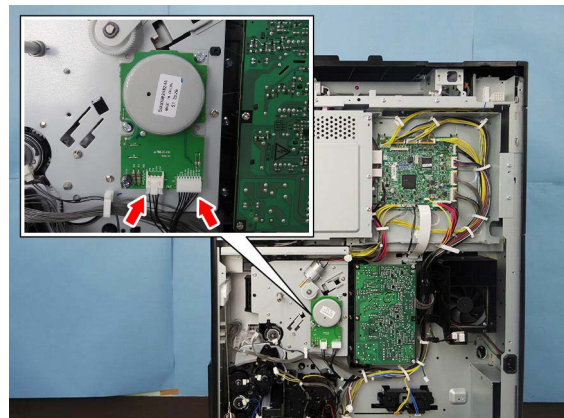


Fig. 4-244

(3) Remove 2 screws and take off the main motor [1].

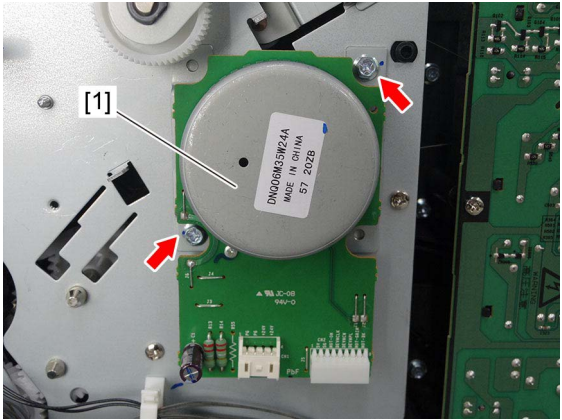


Fig. 4-245

## 4.7 Drum Related Section

### 4.7.1 Process unit

**Notes:**

Make sure to perform "FS-05-2390" and take off the process unit before the developer material is replaced.

- (1) Open the side cover.
- (2) Open the front cover.
- (3) Push down the lever [1] and remove the toner cartridge [2] by pulling it toward you.



Fig. 4-246

- (4) Loosen 2 screws and remove the process unit [3] by pulling it toward you.

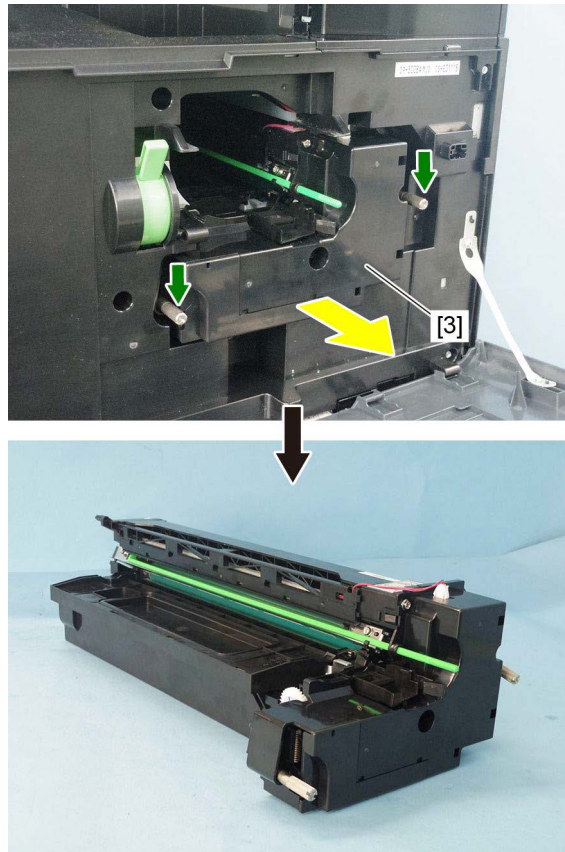



Fig. 4-247

## 4.7.2 Drum cleaner unit

- (1) Remove the process unit.  
( P. 4-99 “4.7.1 Process unit”)
- (2) Release the latch and slide the harness cover [1] downward to take it off.

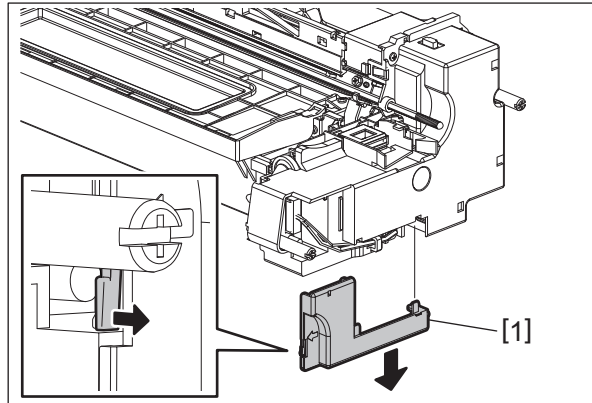


Fig. 4-248

- (3) Remove 1 screw and take off the plate [2].
- (4) Disconnect 1 connector.

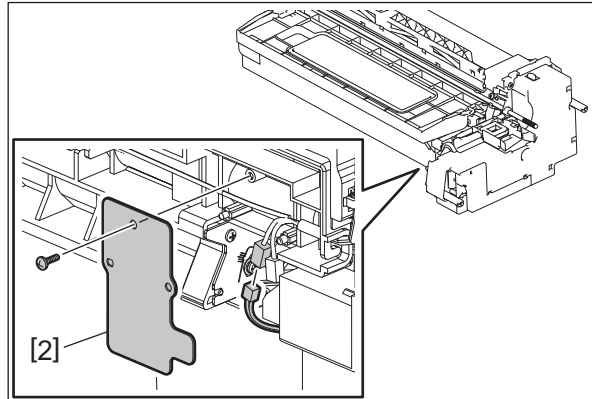


Fig. 4-249

- (5) Disconnect 2 connectors.

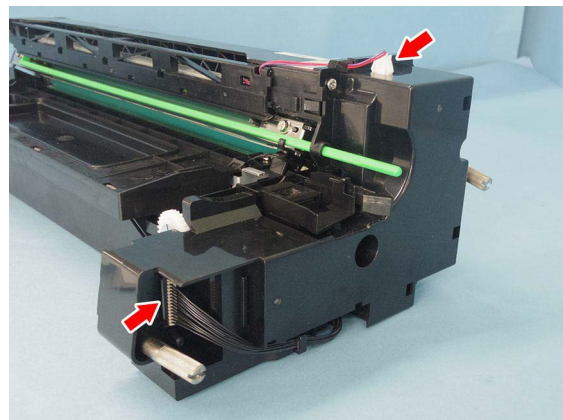


Fig. 4-250

- (6) Release the harness from the harness guide. Remove 2 screws. Release the latch and take off the process unit front cover [3].

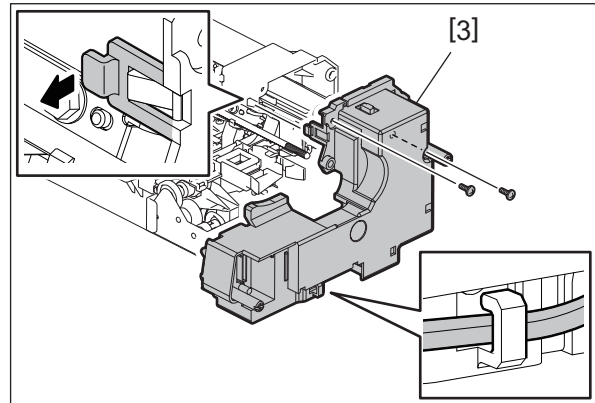


Fig. 4-251

- (7) Lift up the drum cleaner unit [4] and take it off.

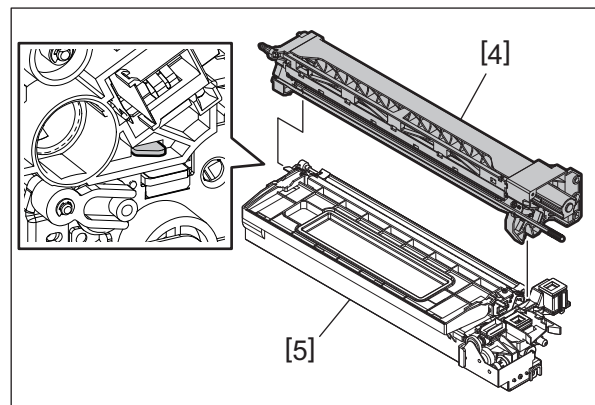


Fig. 4-252

**Notes:**

- Be careful not to touch or scratch the drum surface at this time.
- Do not deform the guide film [5] of developer unit by touching this.

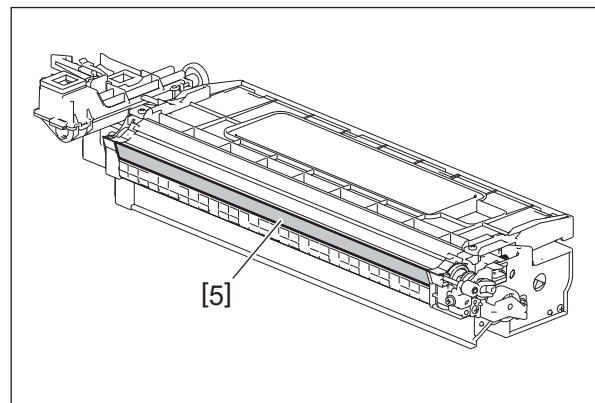



Fig. 4-253

### 4.7.3 Discharge LED

- (1) Remove the drum cleaner unit.  
( P. 4-100 “4.7.2 Drum cleaner unit”)
- (2) Release 1 latch and take off the discharge LED unit [1].

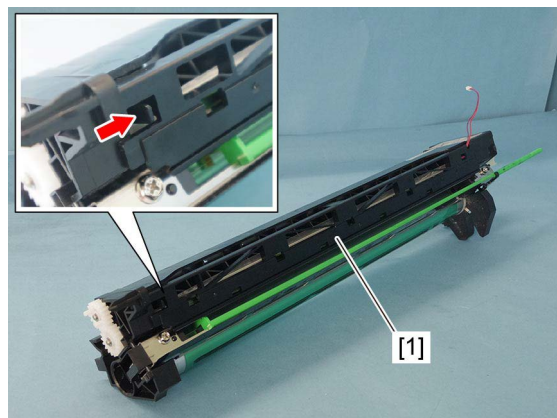


Fig. 4-254

**Notes:**

Be careful not to touch or scratch the drum surface at this time.

- (3) Release the harness [2] from the harness guide and pull out the discharge LED [3].

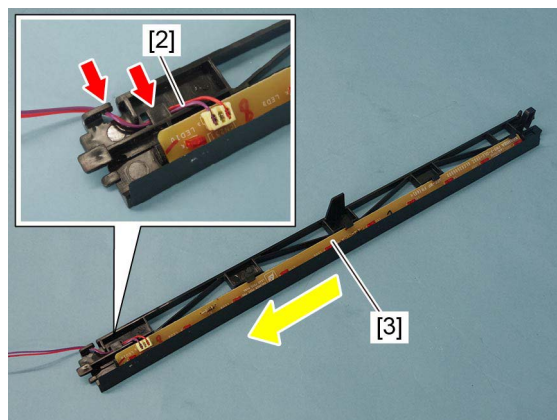


Fig. 4-255

**Notes:**

The number of the discharge LEDs for 20ppm/25ppm/30ppm differs from that for 35ppm/45ppm/50ppm, therefore do not install the LEDs in a wrong model.

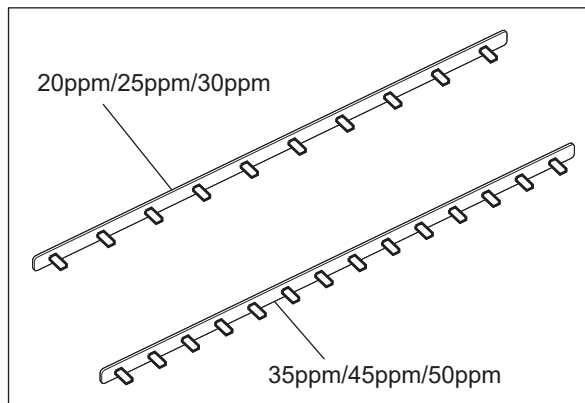



Fig. 4-256



#### 4.7.4 Main charger

- (1) Remove the discharge LED unit.  
( P. 4-102 “4.7.3 Discharge LED”)
- (2) Push the lever [1] and pull out the main charger [2].

**Notes:**

Be careful not to touch or scratch the drum surface at this time.

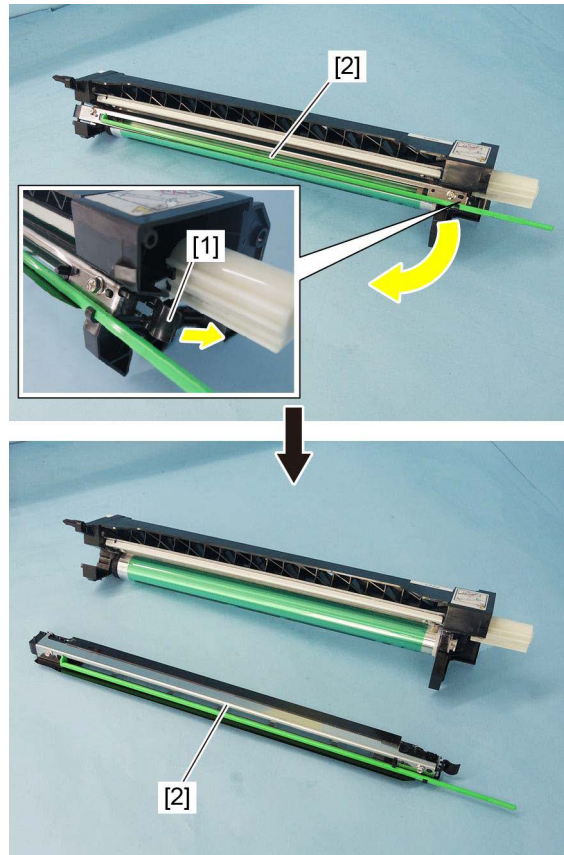



Fig. 4-257

### 4.7.5 Main charger grid

- (1) Remove the main charger.  
( P. 4-103 “4.7.4 Main charger”)
- (2) Remove the spring [1] and take off the main charger grid [2].

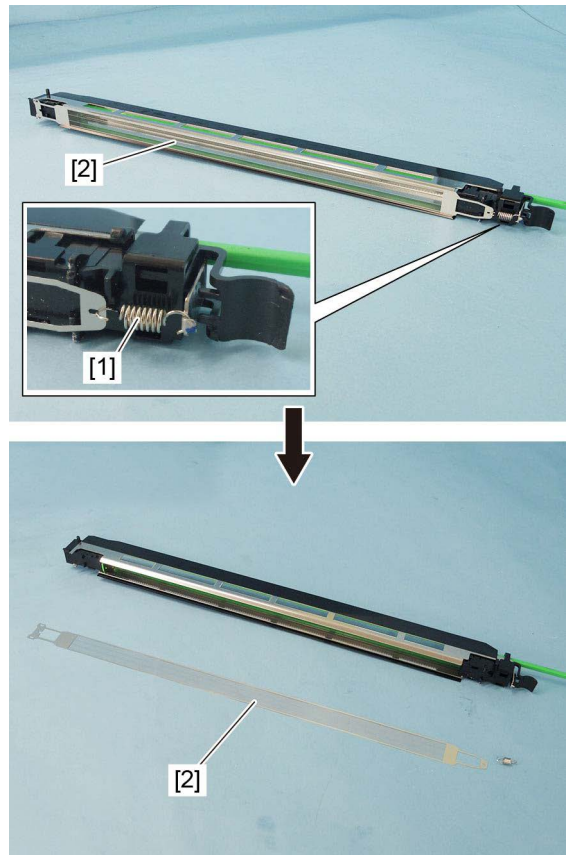



Fig. 4-258

#### Notes:

Do not touch the mesh area of the grid.

### 4.7.6 Main charger cleaner

- (1) Remove the main charger.  
( P. 4-103 “4.7.4 Main charger”)
- (2) Release the main charger cleaner [1] from the hooks [2]. Then rotate the main charger cleaner [1] at 90 degrees to take it off.

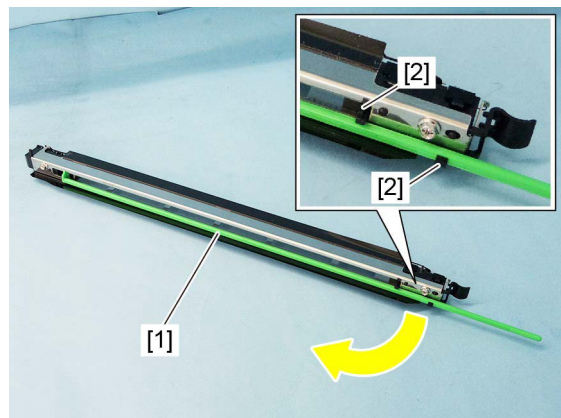




Fig. 4-259

### 4.7.7 Needle electrode

- (1) Remove the main charger grid.  
 P. 4-104 "4.7.5 Main charger grid"
- (2) Remove the main charger cleaner.  
 P. 4-104 "4.7.6 Main charger cleaner"
- (3) Release the latch and remove the terminal cover [1] at front side.
- (4) Remove the terminal cover [2] at rear side.

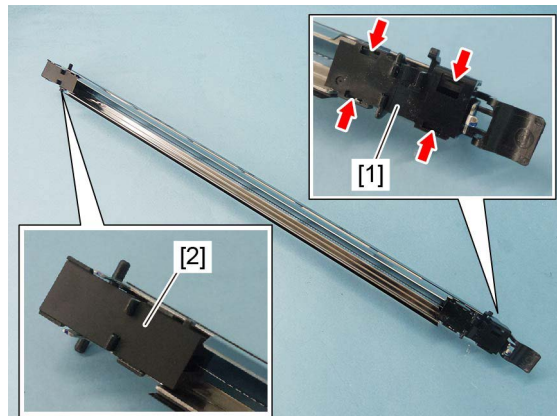


Fig. 4-260

- (5) Remove the terminal [3] and spring [4]. Then take off the needle electrode [5].

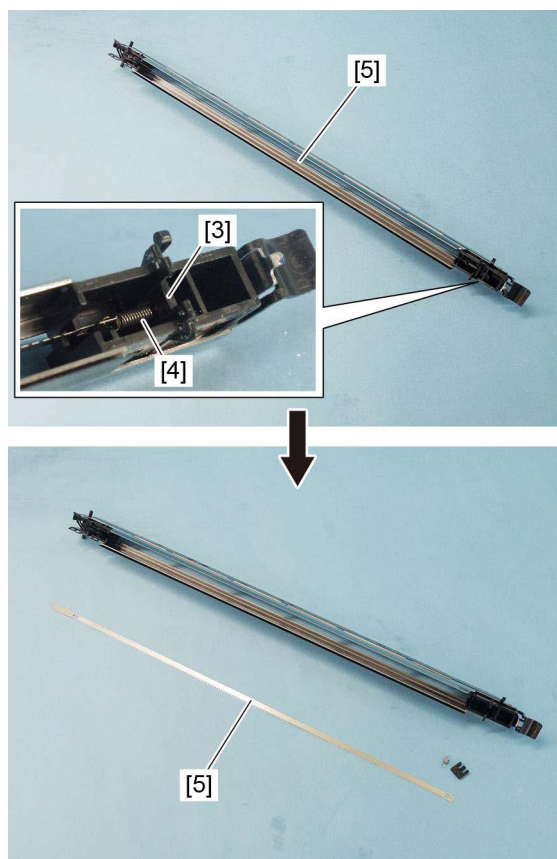
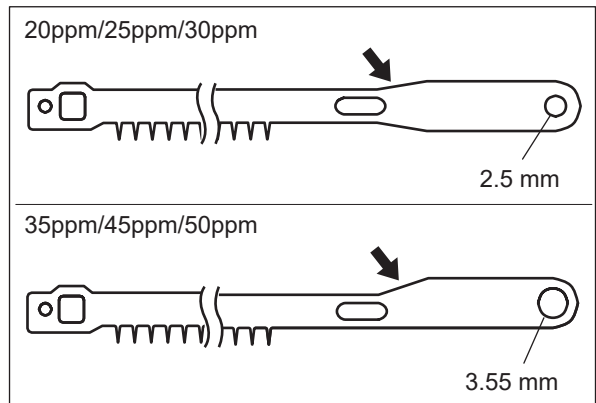


Fig. 4-261

**Notes:**

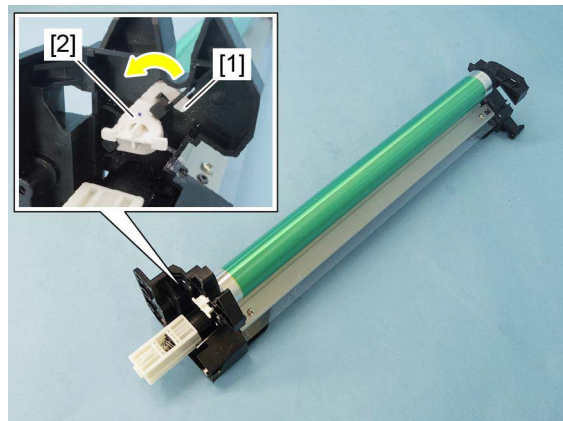
- Do not touch the needle electrode [5] directly with bare hands.
- Make sure not to hold or bend the needle electrode [5].
- The form of the needle electrode [5] differs depending on the model as shown in the figure. Do not mix them when installing.



**Fig. 4-262**

**4.7.8 Drum **

- (1) Take off the main charger.  
( P. 4-103 “4.7.4 Main charger”)
- (2) Rotate the lever [2] while pushing the latch [1]. Remove the lever [2] by pulling it toward you.



**Fig. 4-263**

(3) Remove the drum [3].

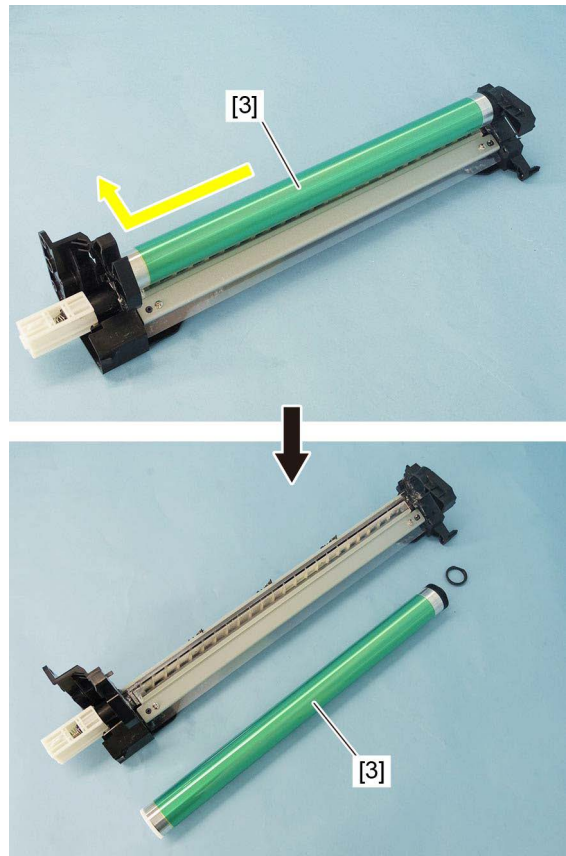



Fig. 4-264

**Notes:**

- Be careful not to touch, spit or scratch the drum surface.
- Avoid direct light. Place the drum in a dark place immediately after taking off.
- Be careful not to touch or scratch the edge of the drum cleaning blade.
- Be sure to apply patting powder (lubricant) to the entire surface of the drum when it is replaced or it is installed/removed from the cleaner.

### 4.7.9 Drum cleaning blade

- (1) Remove the drum.  
( P. 4-106 “4.7.8 Drum”)
- (2) Remove 2 screws and take off the drum cleaning blade [1].

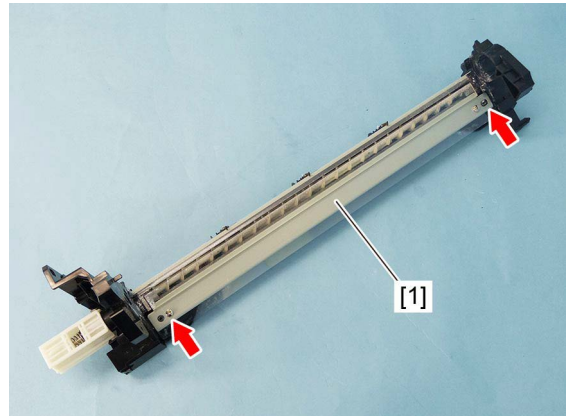



Fig. 4-265

#### Notes:

Be careful not to touch or scratch the edge of the drum cleaning blade [1].

### 4.7.10 Drum separation finger

- (1) Take off the drum.  
( P. 4-106 “4.7.8 Drum”)
- (2) Remove 1 screw of each unit to take off the drum separation finger units [1] (3 pcs.).

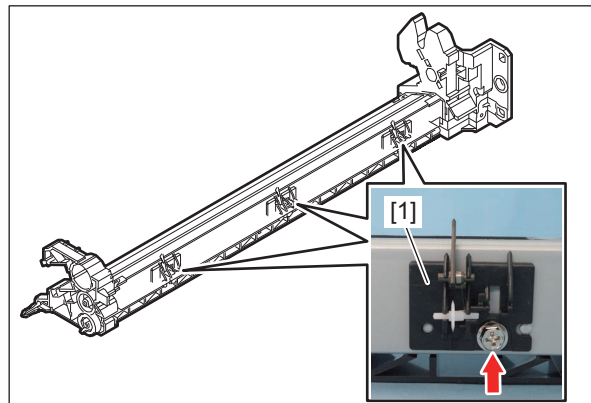


Fig. 4-266

#### Notes:

When replacing the drum separation fingers, make sure that the drum has been taken off first since the fingers may scratch the drum surface.

- (3) Remove the spring [2] and take off the drum separation fingers [3].

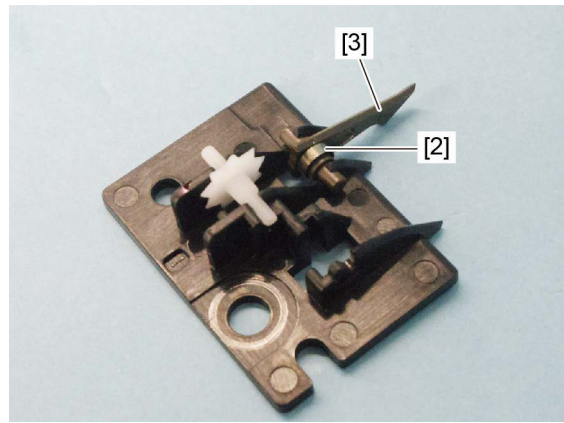



Fig. 4-267

**Notes:**

When the drum separation fingers have been replaced, check if the pressure movement is normal by moving them with your hands.

### 4.7.11 Recovery blade

- (1) Remove the drum separation finger units.  
( P. 4-108 “4.7.10 Drum separation finger”)
- (2) Remove 2 screws, and take off the whole recovery blade [1] with the bracket.

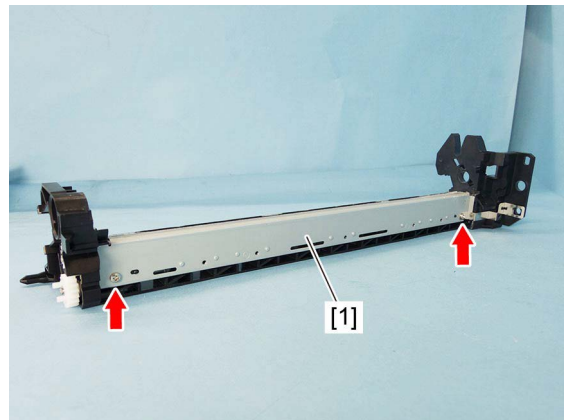


Fig. 4-268

**Notes:**

When cleaning the inside of the cleaner unit, be careful of the following in order not to damage the films [3] attached on the toner recovery auger [2]:

- Do not use an air blower for cleaning. (Use a vacuum cleaner.)
- When using a vacuum cleaner, be careful not to hit the nozzle of the vacuum cleaner to the films [3].

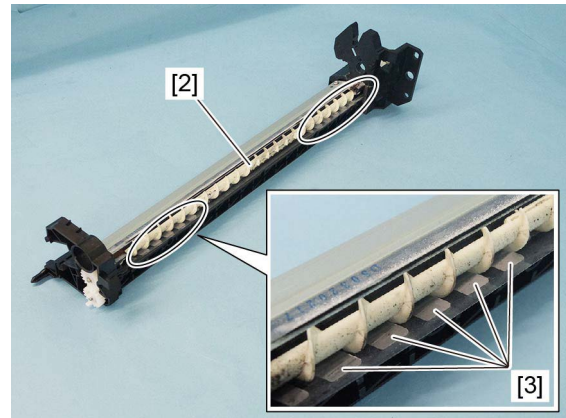


Fig. 4-269

- When rotating the toner recovery auger [2], rotate it only in the same direction as that for transporting toner.

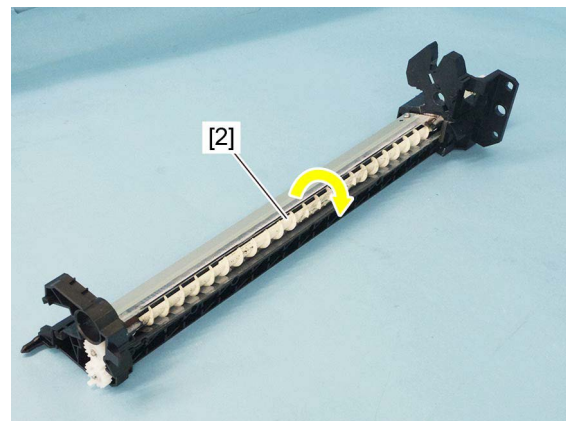


Fig. 4-270

### 4.7.12 Temperature/humidity sensor (S19)

- (1) Remove the rear cover.  
P. 4-8 “4.1.15 Rear cover”
- (2) Remove 1 screw and take off the temperature/humidity sensor [1].

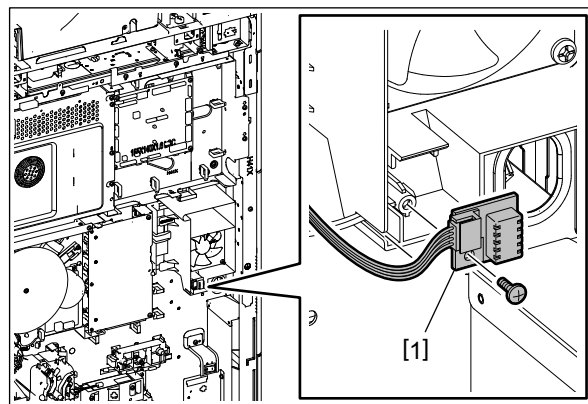


Fig. 4-271



- (3) Disconnect 1 connector from the temperature/humidity sensor [1].

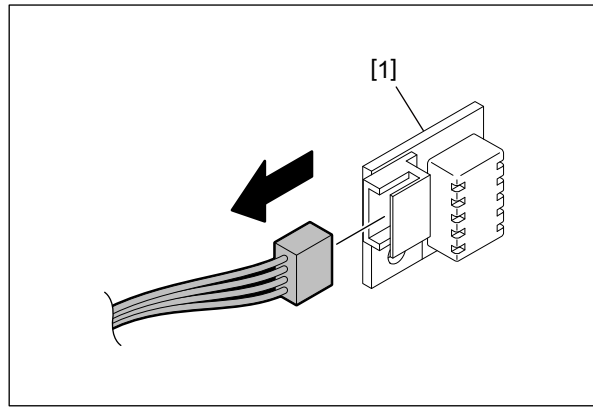


Fig. 4-272

### 4.7.13 Toner motor (M4)

- (1) Remove the flywheel.  
P. 4-91 “4.5.37 Flywheel”
- (2) Disconnect 1 connector [1] and remove 1 screw, and then take off the toner motor [2] with the bracket.

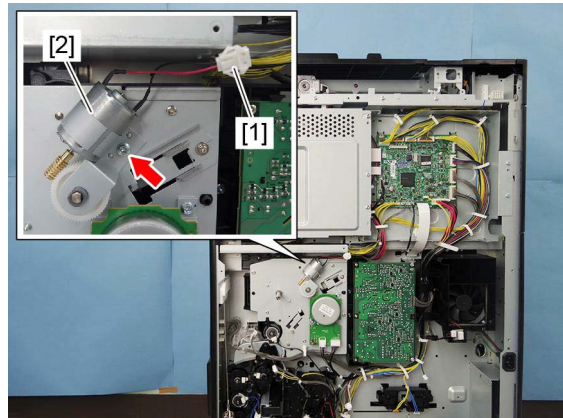


Fig. 4-273

- (3) Remove 2 screws and take off the toner motor [2].

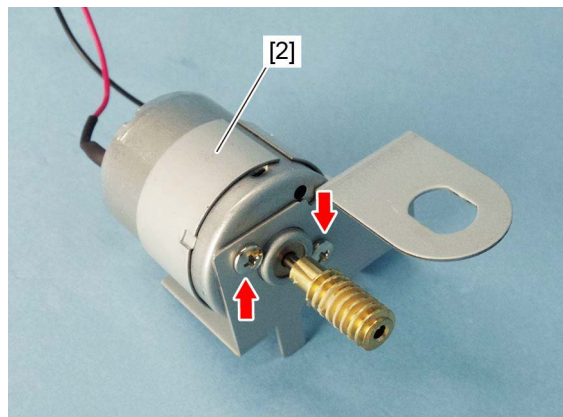


Fig. 4-274

#### Notes:

Pay attention to the size (length) of the screws. If incorrect ones are used, the motor could be damaged.

#### 4.7.14 Process unit fan (M2)

- (1) Remove the receiving tray.  
P. 4-2 "4.1.3 Receiving tray"
- (2) Disconnect 1 connector on the duct [1].



Fig. 4-275

- (3) Remove 1 screw and take off the duct [1].



Fig. 4-276

- (4) Release 8 latches and remove the duct cover [2].

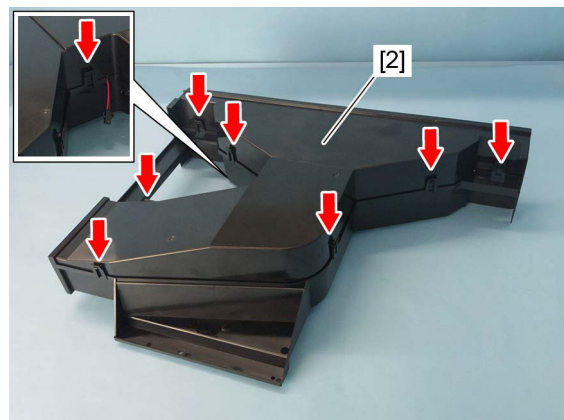


Fig. 4-277

- (5) Remove the process unit fan [3] by lifting up.

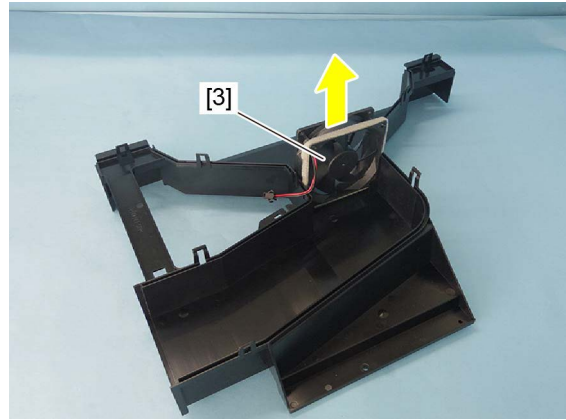


Fig. 4-278

#### 4.7.15 Main power switch (SW1)

**Notes:**

Be sure to unplug the power cable before starting this work.

- (1) Remove the left cover.  
📖 P. 4-1 “4.1.2 Left cover”
- (2) Disconnect 4 connectors and remove the main power switch [1].

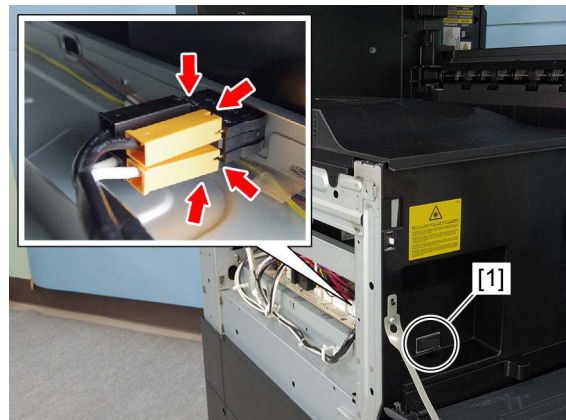



Fig. 4-279

## 4.8 Developer Unit

### 4.8.1 Developer unit

**Notes:**

Make sure to perform "FS-05-2390" and take off the process unit before the developer material is replaced.

- (1) Take out the process unit.  
( P. 4-99 "4.7.1 Process unit")
- (2) Release the latch and slide the harness cover [1] downward to take it off.

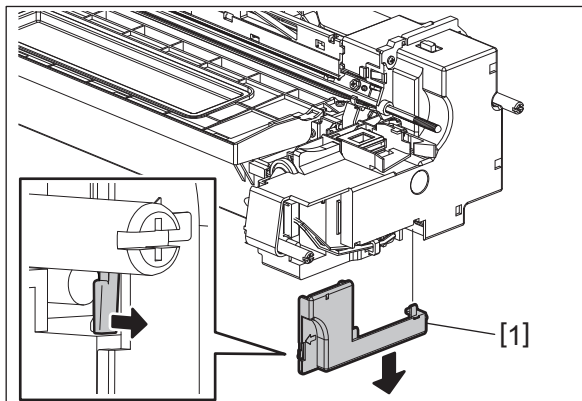


Fig. 4-280

- (3) Remove 1 screw and take off the plate [2].
- (4) Disconnect 1 connector.

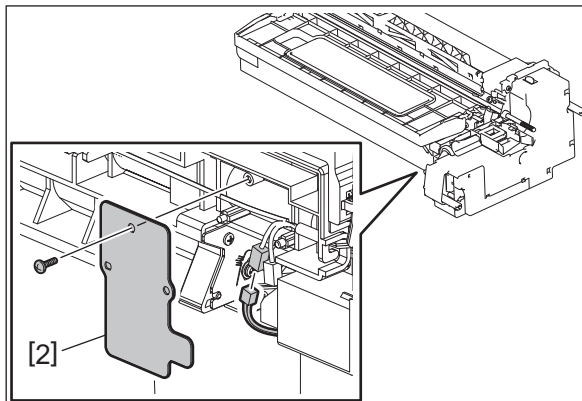


Fig. 4-281

- (5) Disconnect 2 connectors.

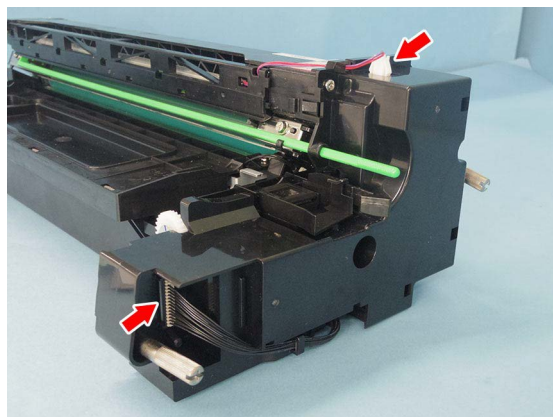


Fig. 4-282

- (6) Release the harness from the harness guide. Remove 2 screws. Release the latch and take off the process unit front cover [3].

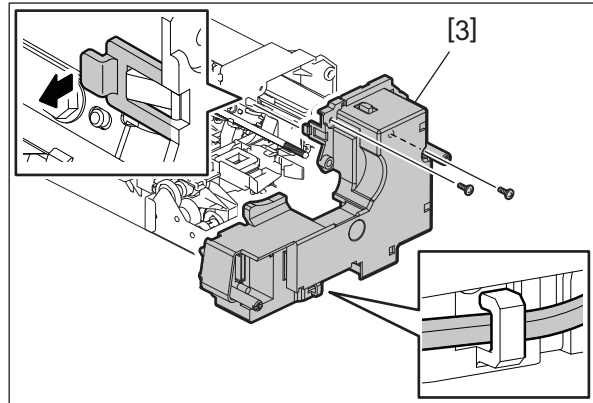


Fig. 4-283

- (7) Lift up the drum cleaner unit [4] and separate it from developer unit [5].

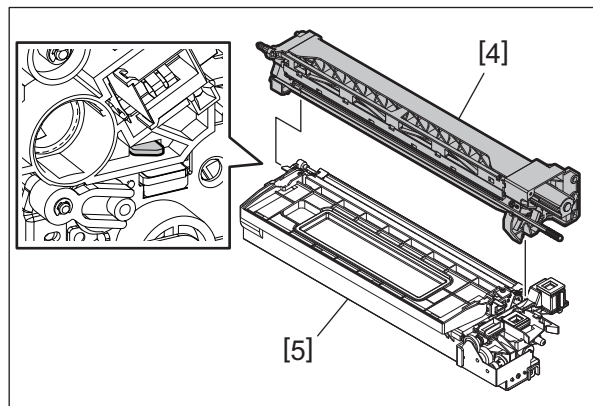


Fig. 4-284

**Notes:**

- Be careful not to touch or scratch the drum surface at this time.
- Do not deform the guide film [6] of developer unit by touching this.

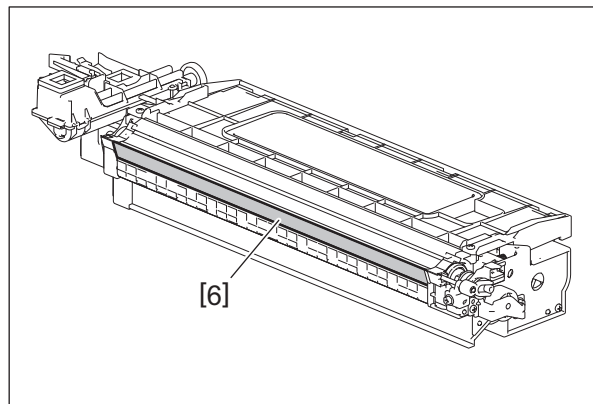



Fig. 4-285

## 4.8.2 Removing developer material

- (1) Take out the developer unit.  
( P. 4-114 “4.8.1 Developer unit”)
- (2) Remove 2 screws and slide the developer unit upper cover to the direction of the arrow and take it off.

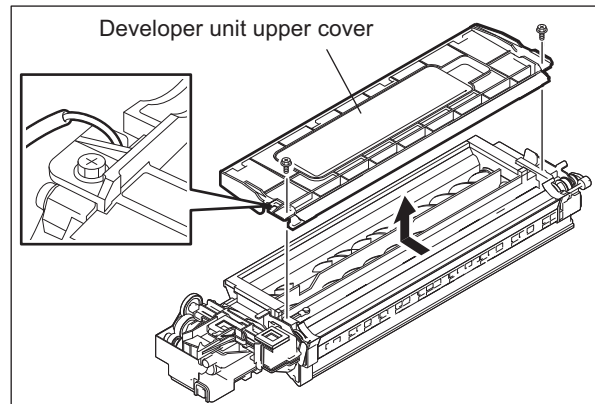


Fig. 4-286

### Notes:

When installing the developer unit upper cover, make sure that the side seal comes between the developer unit upper cover and rubber seal on the cover.

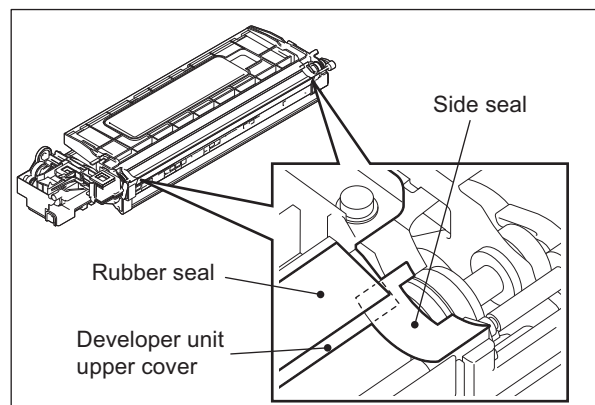


Fig. 4-287

- (3) Remove the developer material from rear side.

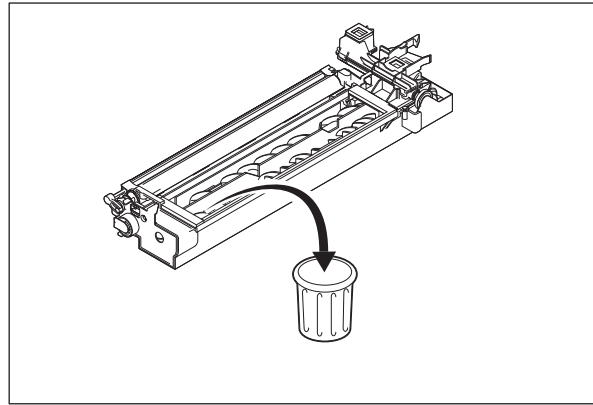


Fig. 4-288

**Notes:**

- When removing the developer material, be careful not to drop the developer material on the gears of the developer unit.
- When cleaning the developer unit, never attempt to use solvent.

### 4.8.3 Filling developer unit with developer material

- (1) Shake the developer material bag and break the seal.
- (2) Rotate the gear on the rear side of the developer unit to the direction of the arrow while filling the developer unit with the developer material. Spread out the developer material over the developer sleeve.

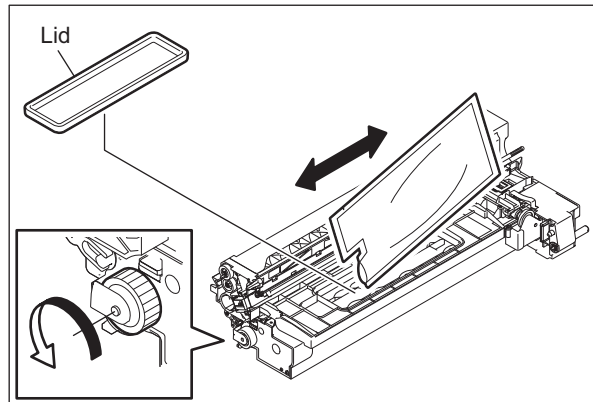



Fig. 4-289

#### 4.8.4 Auto-toner sensor (S4)

- (1) Remove the developer material.  
( P. 4-116 "4.8.2 Removing developer material")
- (2) Place the developer unit upside down. Disconnect 1 connector.

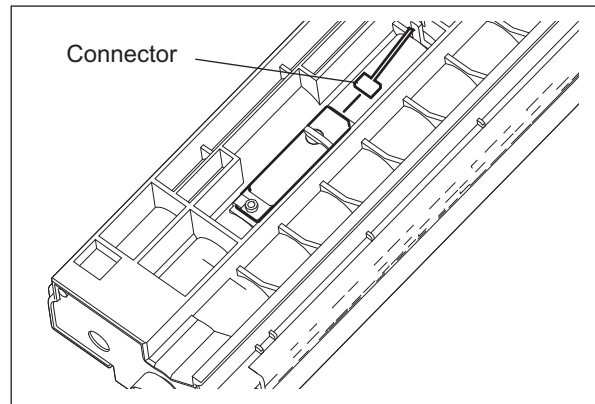


Fig. 4-290

- (3) Take off the auto-toner sensor by rotating it.

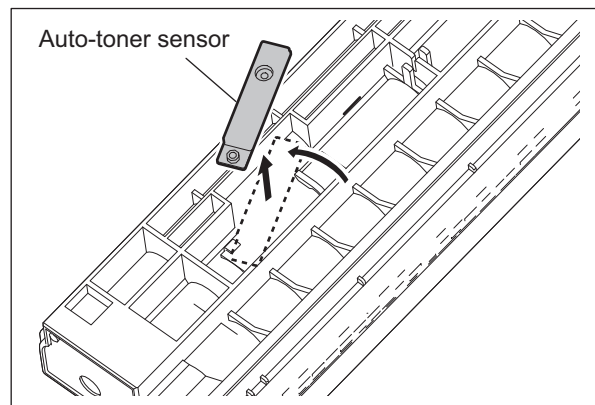



Fig. 4-291

#### 4.8.5 Drum thermistor (THMS4)

- (1) Remove the developer material.  
( P. 4-116 "4.8.2 Removing developer material")
- (2) Disconnect 1 connector, remove 1 screw and take off the drum thermistor.

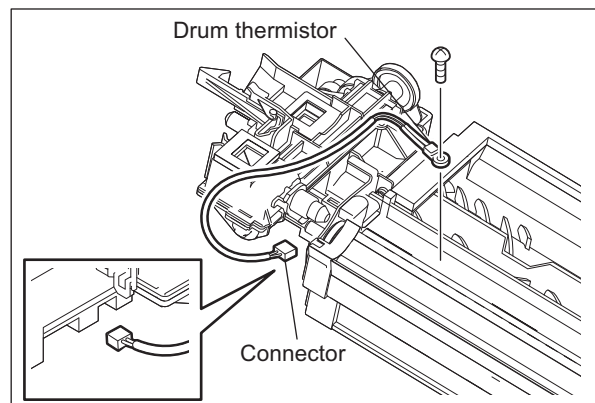



Fig. 4-292



## 4.8.6 Guide roller / Developer sleeve

- (1) Remove the developer material.  
( P. 4-116 “4.8.2 Removing developer material”)
- (2) Remove 2 screws and take off the recovered toner supply unit.

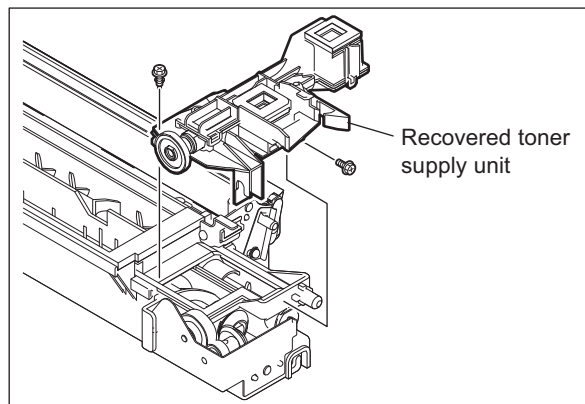


Fig. 4-293

- (3) Remove 1 screw and take off the recovered toner drive unit. Remove 1 gear.

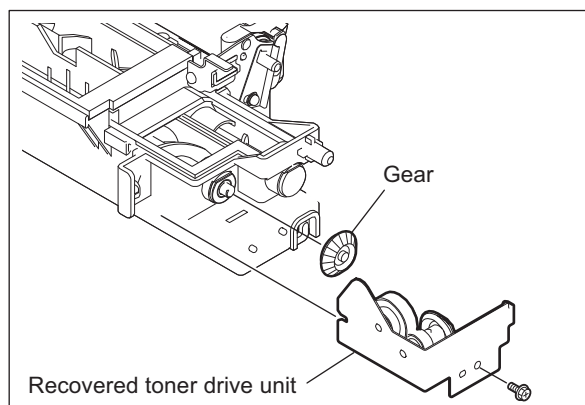


Fig. 4-294

- (4) Remove 2 plate springs fixing the doctor blade on its both ends.

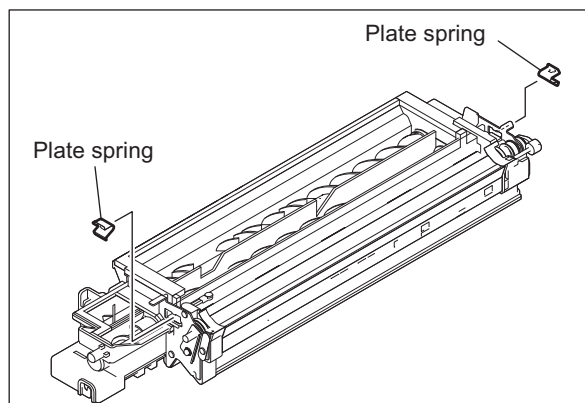


Fig. 4-295

- (5) Remove 2 screws on both ends of the doctor blade and remove 2 coil springs.

**Notes:**

When the screws on both ends of the doctor blade are removed, be sure to adjust the doctor sleeve gap ( $0.45\pm 0.05$  mm) after assembling.

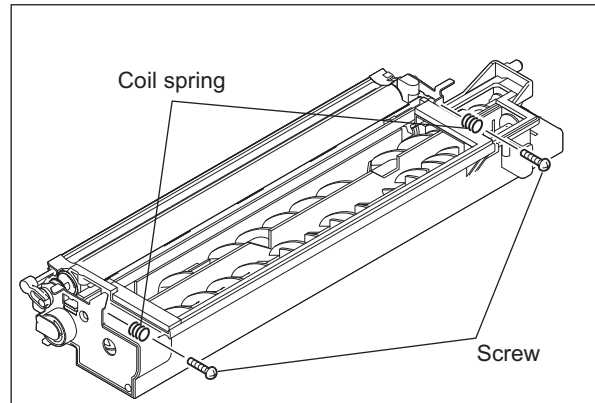


Fig. 4-296

- (6) Remove 1 screw and plate spring.  
(only the developer unit for 35ppm/45ppm/50ppm)
- (7) Remove 1 screw and take off the polarity adjustment lever.

**Notes:**

Make a note of the position where the polarity adjustment lever is pointing. (Mark the position if needed.) When reassembling, match the polarity adjustment lever with the previously marked position on the scale.

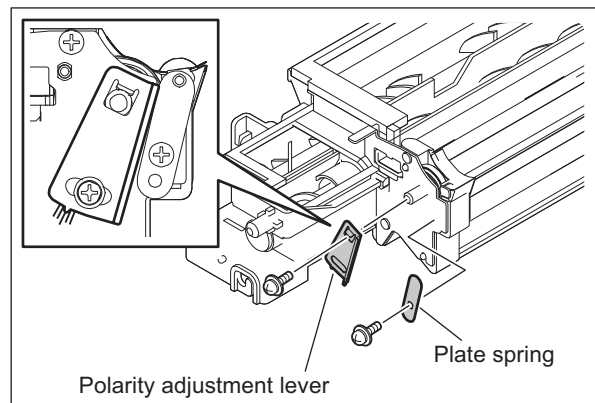


Fig. 4-297

(8) Remove 2 screws and take off the bracket.

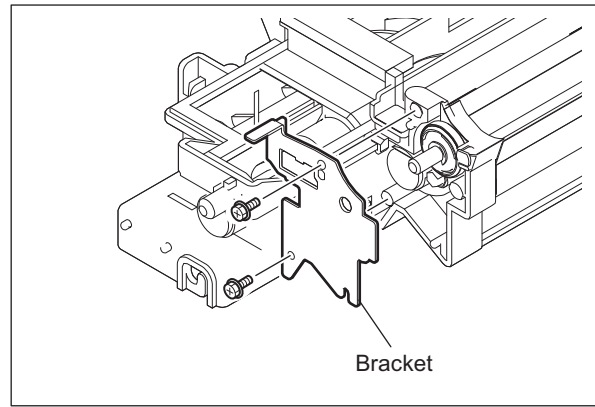


Fig. 4-298

(9) Remove 1 E-ring and take off the guide roller on the front side.

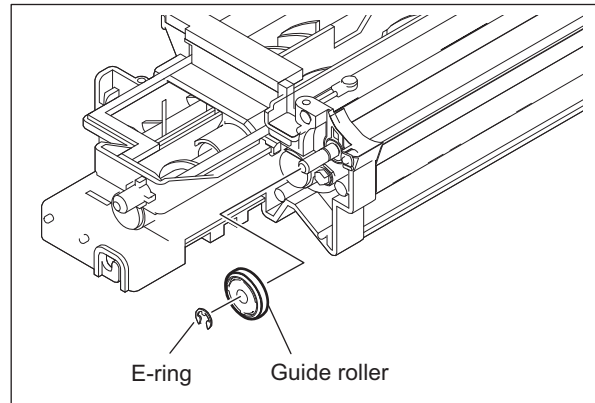


Fig. 4-299

(10) Remove 1 E-ring. Remove the arm and cam.

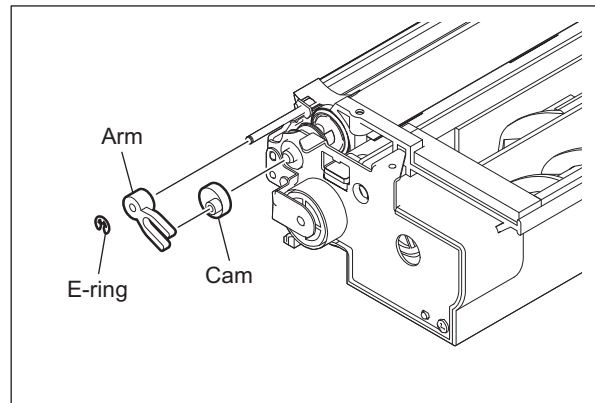


Fig. 4-300

(11) Remove 1 screw and the gear.

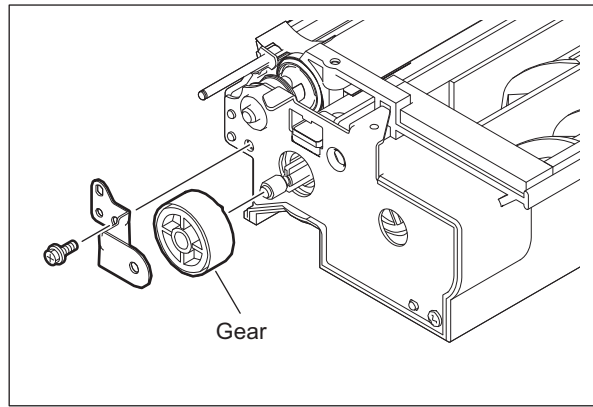


Fig. 4-301

(12) Remove 1 screw and take off the bracket.

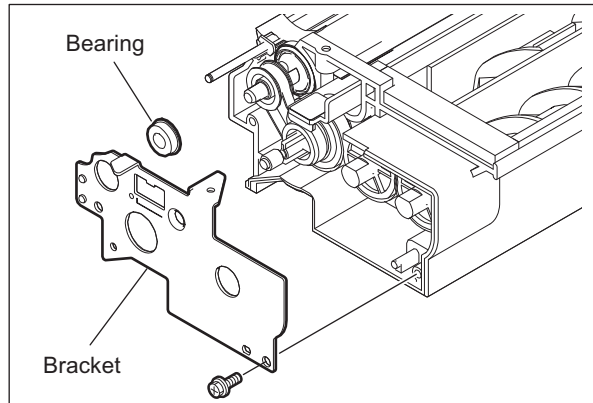


Fig. 4-302

(13) Take off 3 gears and 1 timing belt.

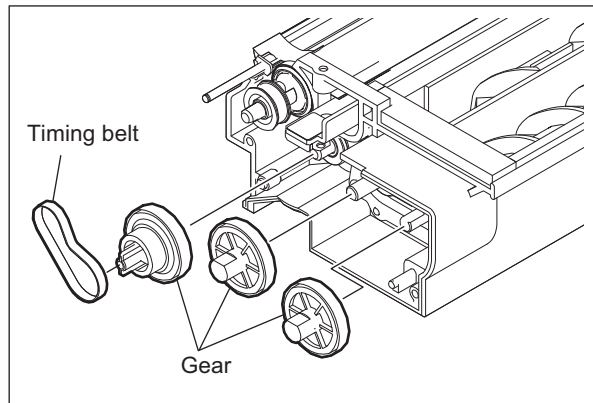


Fig. 4-303

(14) Remove 1 pin and 1 pulley.

(15) Take off the guide roller on the rear side.

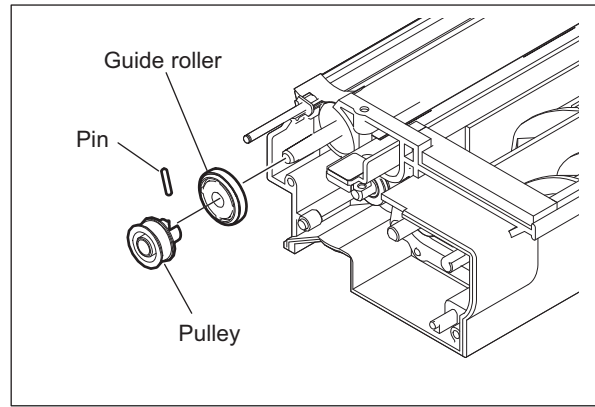


Fig. 4-304

(16) Remove the seal on the front side. Remove 1 E-ring and 1 bushing.

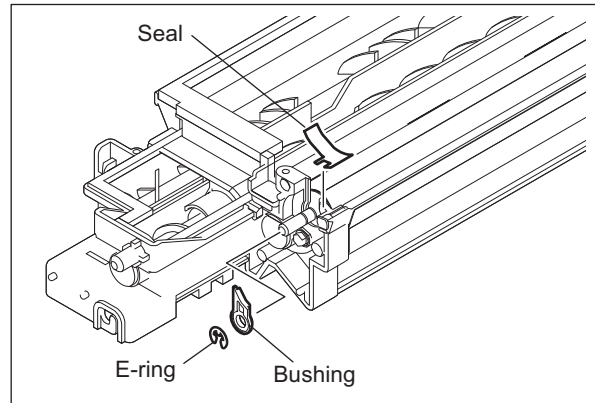


Fig. 4-305

(17) Take off the developer sleeve.

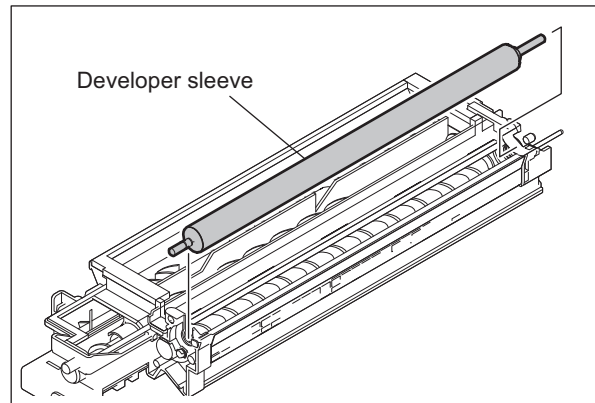



Fig. 4-306

## 4.8.7 Mixer

- (1) Take off the developer sleeve.  
( P. 4-119 “4.8.6 Guide roller / Developer sleeve”)
- (2) Take off the doctor blade.

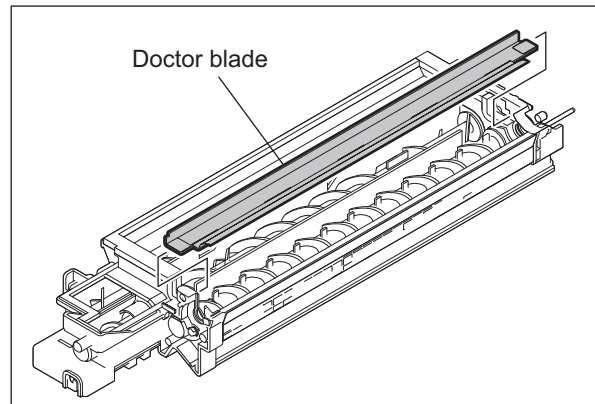


Fig. 4-307

- (3) Remove 2 screws and take off the holder.

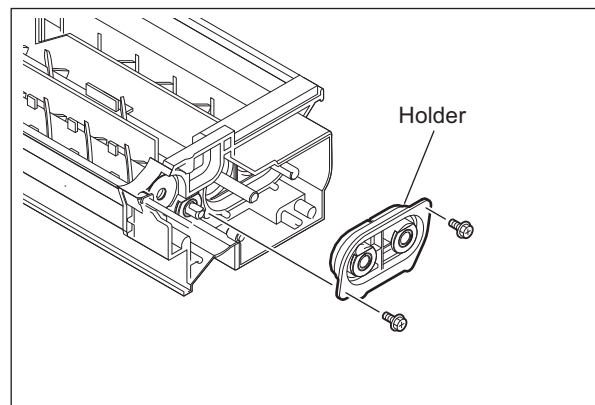



Fig. 4-308

- (4) Remove 2 bushings and 2 oil seals from the holder.  
(Replacement of Oil Seal:  P. 4-126 “4.8.8 Replacement of oil seal”)

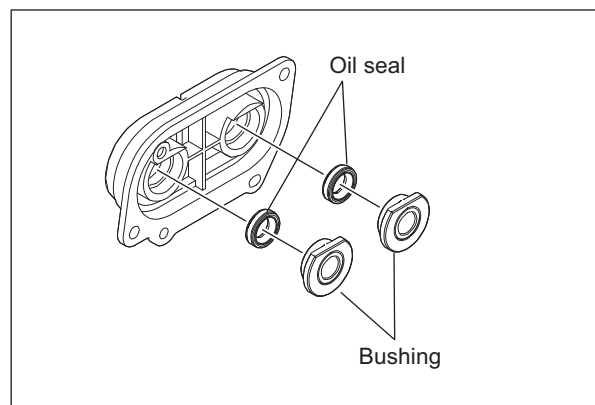


Fig. 4-309

- (5) Take off the mixers-2 and -3.

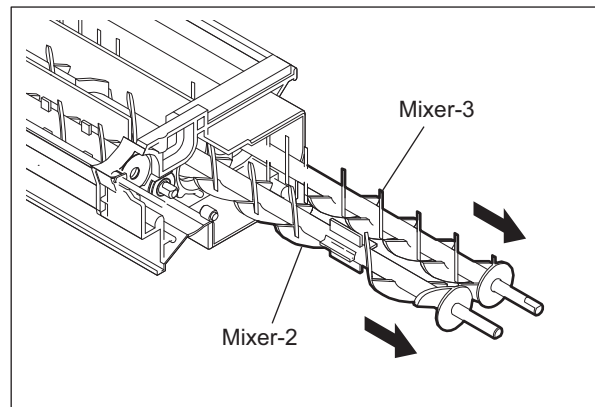



Fig. 4-310

- (6) Remove 2 bushings and 2 oil seals on the front side.  
(Replacement of Oil Seal:  P. 4-126 "4.8.8 Replacement of oil seal")

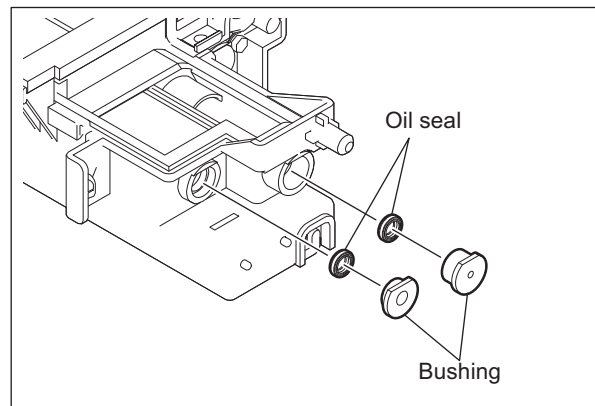



Fig. 4-311

- (7) Remove the end section of the mixer-1.  
(8) Remove the bushing and oil seal.  
(Replacement of Oil Seal:  P. 4-126 "4.8.8 Replacement of oil seal")

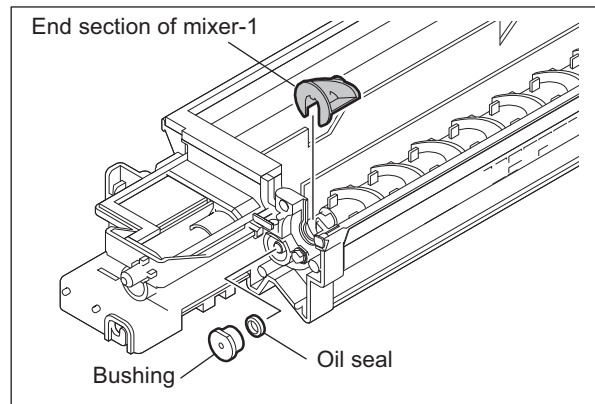


Fig. 4-312

- (9) Take off the mixer-1.

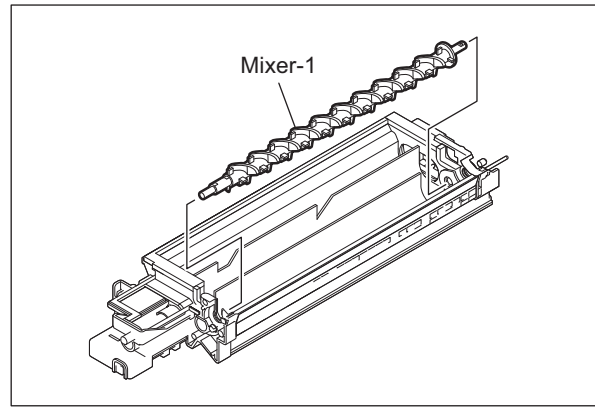



Fig. 4-313

- (10) Remove the bushing on the rear side.  
(11) Remove the oil seal.  
(Replacement of Oil Seal:  P. 4-126 “4.8.8 Replacement of oil seal”)

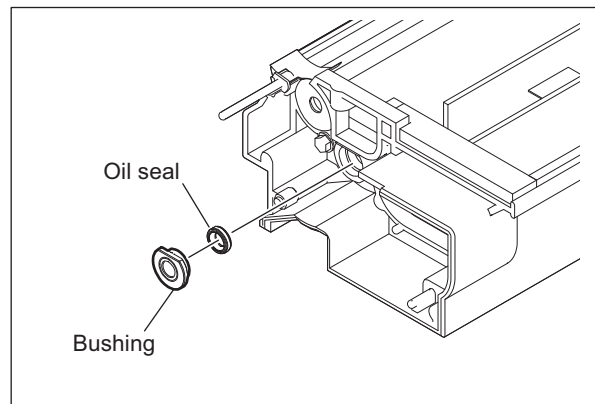


Fig. 4-314

#### 4.8.8 Replacement of oil seal

- (1) Insert a fine screwdriver into the depression of the oil seal to take it out.
- (2) Push in a new oil seal parallel to the frame or bushing (shown in the figure).
- (3) Apply the grease (Alvania No.2; amount of 2 rice grains) on entire surface of the oil seal evenly.

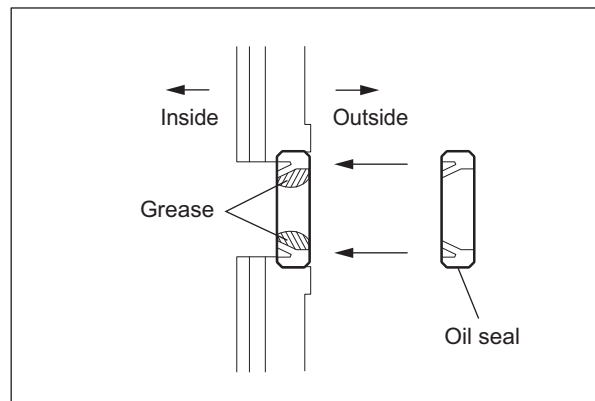


Fig. 4-315

#### Notes:

Wipe off the excessive grease.



## 4.9 Transfer Unit

### 4.9.1 Transfer unit

**Notes:**

When removing the transfer unit, remove the process unit, and avoid a direct sunlight onto the drum.

- (1) Remove the automatic duplexing unit.  
📖 P. 4-166 "4.12.1 Automatic duplexing unit (ADU)"
- (2) Remove 4 screws and take off the bracket [1].

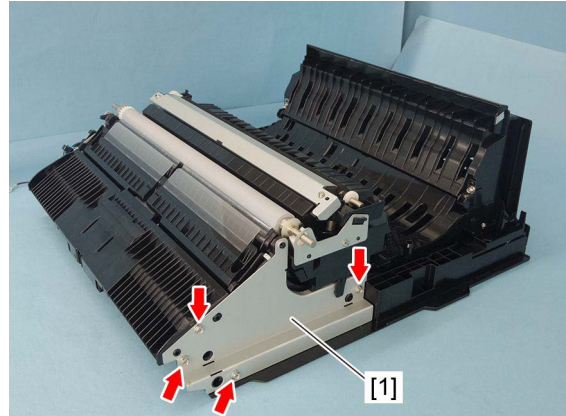


Fig. 4-316

- (3) Disconnect 1 connector and remove the transfer unit [2].

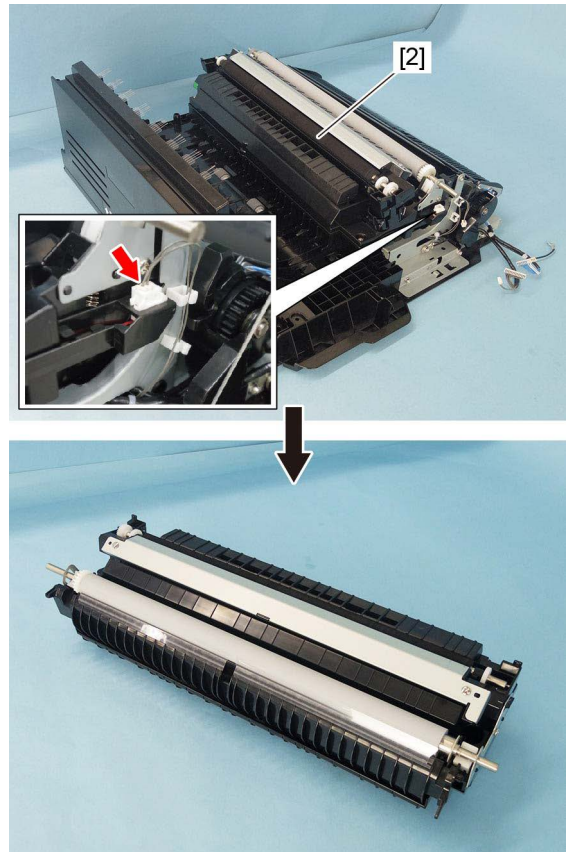


Fig. 4-317

## 4.9.2 TRU fan (M9)

- (1) Remove the transfer unit.  
P. 4-127 "4.9 Transfer Unit"
- (2) Remove 4 screws and take off the inner duct [1].

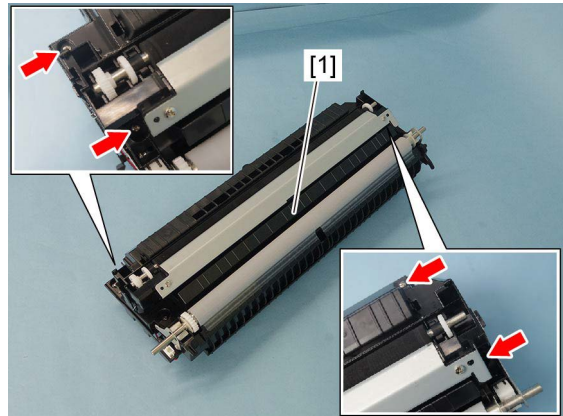


Fig. 4-318

- (3) Disconnect 1 connector [2].
- (4) Peel off the double-faced tape, and then remove the TRU fan [3].

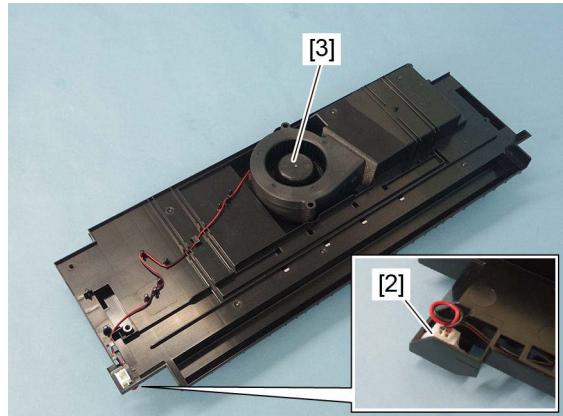


Fig. 4-319

### Notes:

When installing, pass the harness [4] through the harness guide as shown in the figure.

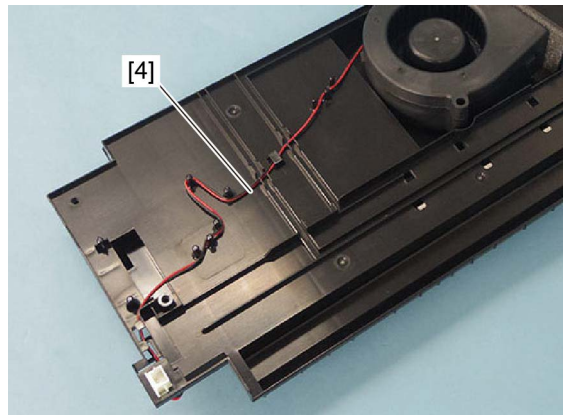


Fig. 4-320

### 4.9.3 Transfer roller unit

- (1) Open the side cover.
- (2) Release the hook on the rear side, and then remove the transfer roller unit [1].

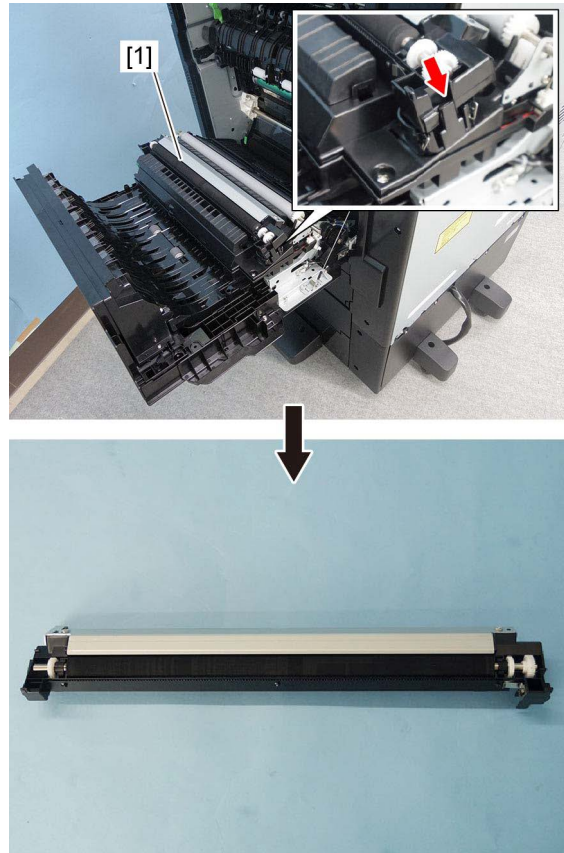


Fig. 4-321

### 4.9.4 Transfer roller **PM**

- (1) Remove the transfer roller unit.  
P. 4-129 "4.9.3 Transfer roller unit"
- (2) Release 4 latches on the transfer roller unit.

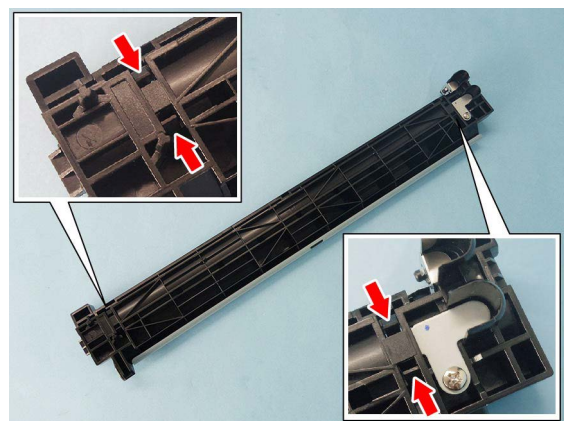


Fig. 4-322

(3) Remove the transfer roller [1].

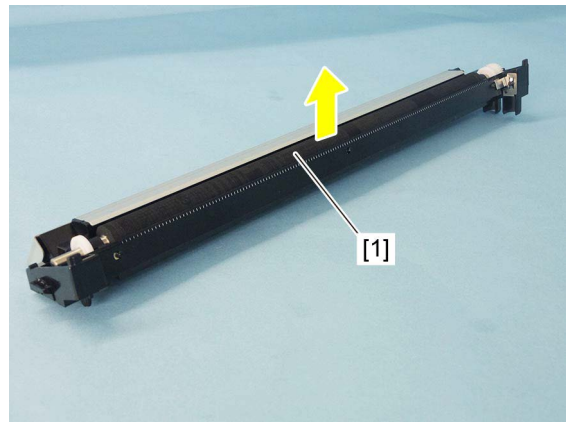


Fig. 4-323

(4) Remove 2 collars [2], 1 gear [3] and 2 stoppers [4] from the transfer roller [1].

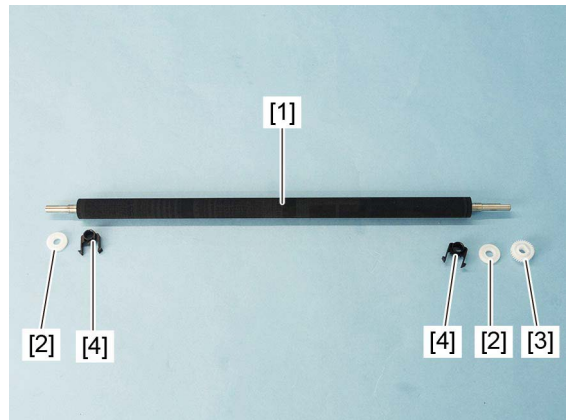


Fig. 4-324

**Notes:**

When installing the bushing and gear, be careful of the orientation.

## 4.9.5 Separation needle

- (1) Remove the transfer roller unit.  
P. 4-129 "4.9.3 Transfer roller unit"
- (2) Peel off the double-faced tape, and then remove the cover [1].

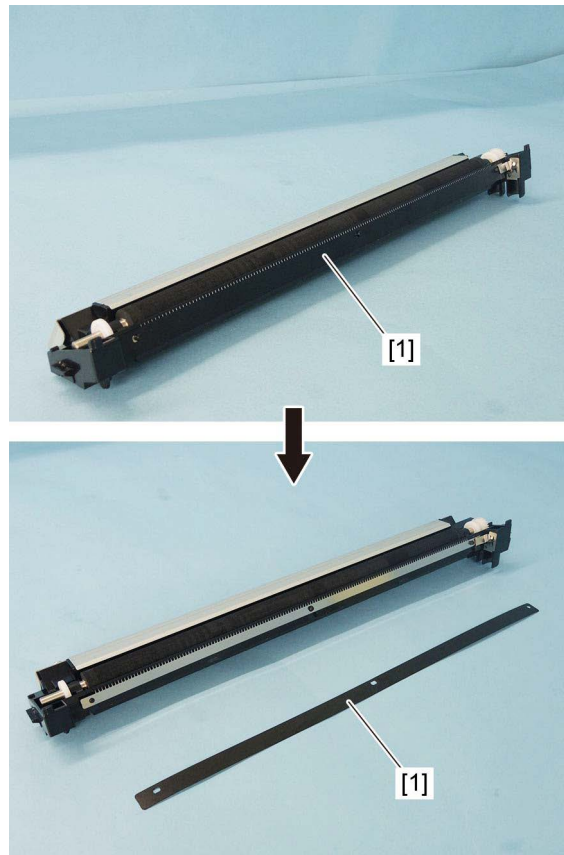


Fig. 4-325

### Notes:

When installing, insert the cover [1] into the lower side of the power supply plate [2].

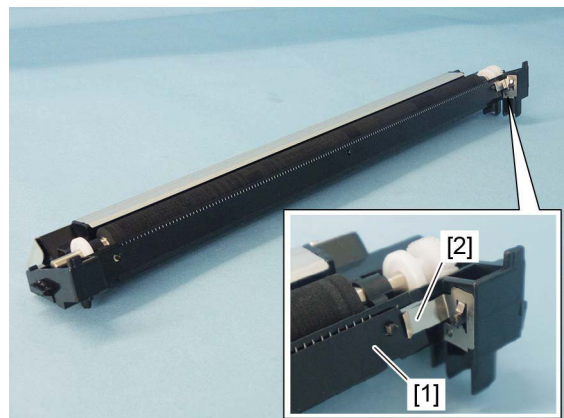


Fig. 4-326

- (3) Remove the separation needle [3] while trying not to deform it.

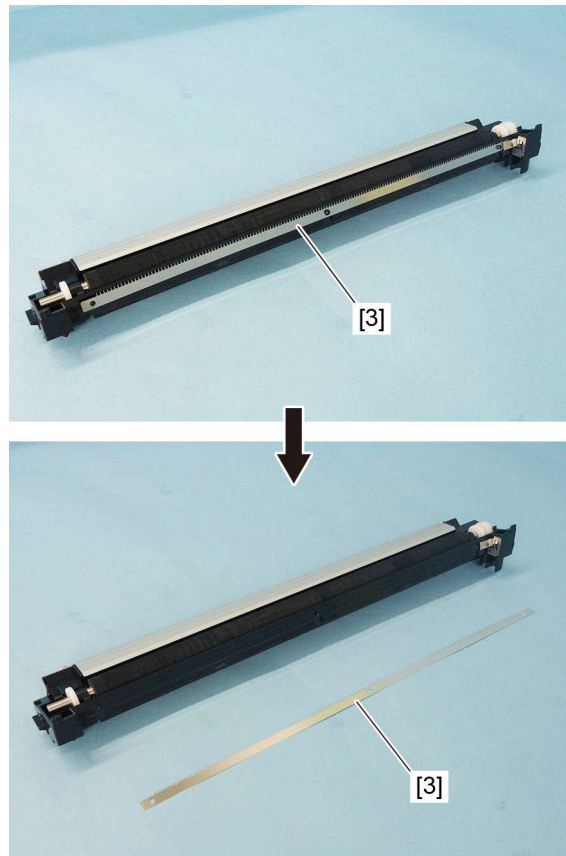


Fig. 4-327

#### 4.9.6 Ozone filter

- (1) Open the side cover.  
(2) Open the transfer unit [1].



Fig. 4-328

(3) Remove the cover [2] by sliding it toward you.

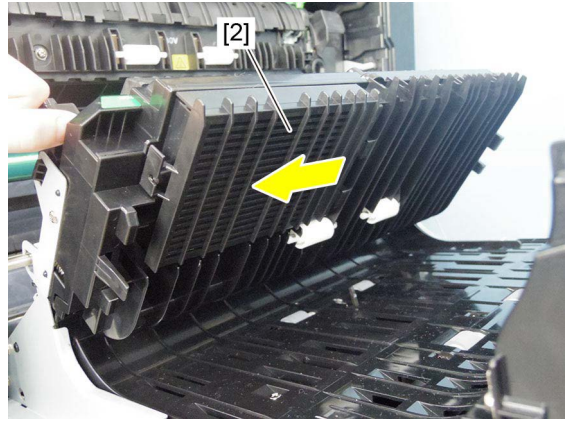


Fig. 4-329

(4) Remove the ozone filter [3].

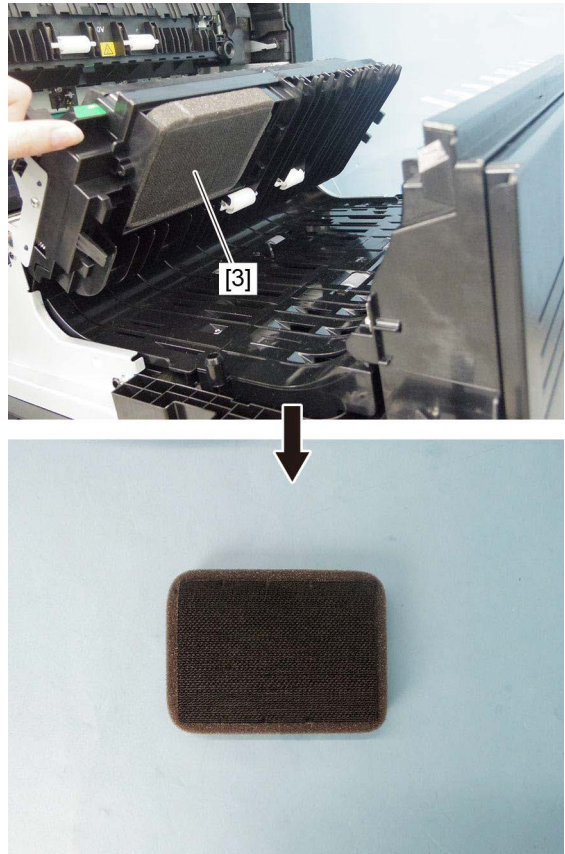


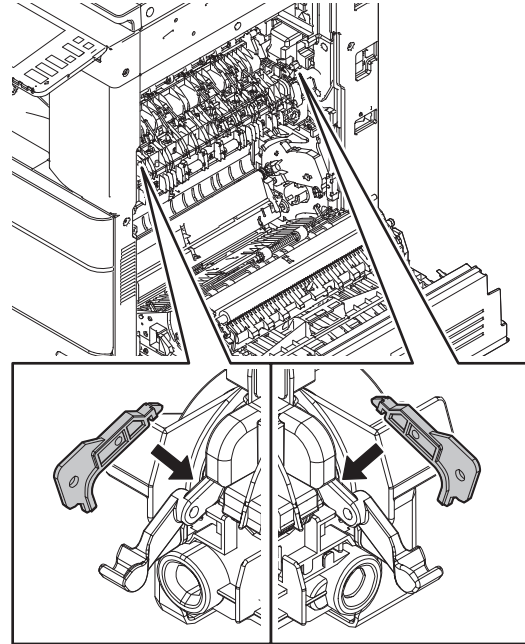
Fig. 4-330

## 4.10 Fuser Unit

### 4.10.1 Fuser unit

**Notes:**

- Be sure that the temperature of the fuser unit has lowered enough before removing it. If the unit still heated should be removed, wear a pair of gloves before working.
- When a new fuser unit is installed, be sure to check whether the fuser-related life counter values have been cleared in the list printing mode or the setting mode.
- When disassembling the fuser unit or replacing any parts in it, be sure that the wire harness is correctly set, and also be careful not to catch it between other parts.
- If the equipment and the fuser unit are left unused for a long time, install the pressure release parts (SPACER-PRS-INI) to release the pressure of the fuser unit.



**Fig. 4-331**

(1) Open the side cover.



(2) Press down the lever [1] and remove the fuser unit [2].

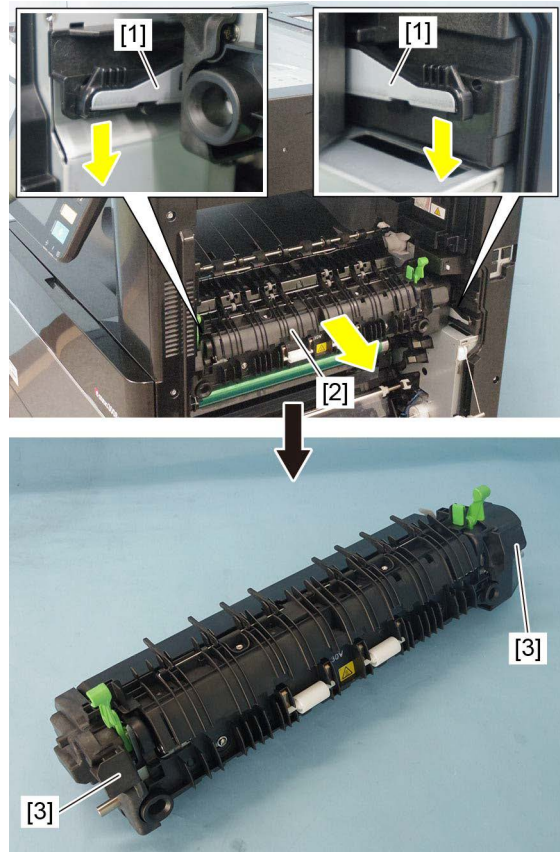


Fig. 4-332

**Notes:**

- The fuser unit is extremely hot. When removing the fuser unit, hold the handles [3] of the unit to avoid a direct touch on the unit.
- When installing the fuser unit, be sure to press it in until the lever goes up. If the lever goes down, the fuser unit has not been correctly installed.



Fig. 4-333



Fig. 4-334

- “H” is marked on the fuser unit for 35ppm/45ppm/50ppm for identification. “L” is marked on the fuser unit for 20ppm/25ppm/30ppm.

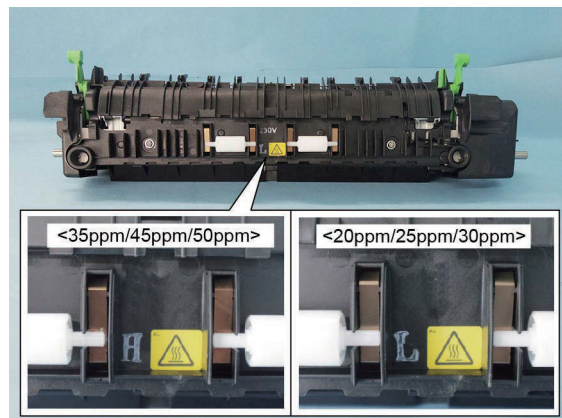


Fig. 4-335

## 4.10.2 Front side cover

- (1) Remove the fuser unit.  
P. 4-134 "4.10.1 Fuser unit"
- (2) Remove 2 screws and take off the front side cover [1].

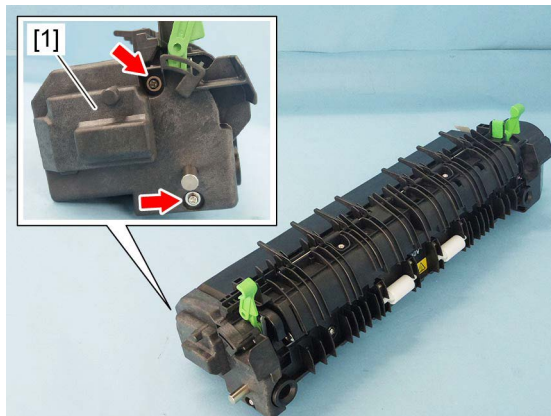


Fig. 4-336

### Notes:

When installing the cover, put the harness into the harness guide so that it will not be pinched by the cover.

## 4.10.3 Rear side cover

- (1) Remove the fuser unit.  
P. 4-134 "4.10.1 Fuser unit"
- (2) Remove 2 screws and take off the rear side cover [1].

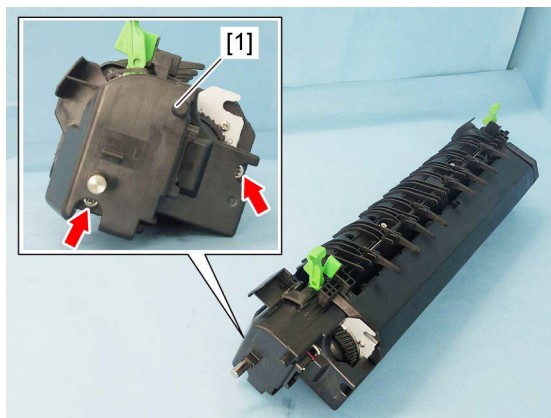


Fig. 4-337

### Notes:

When installing the cover, put the harness into the harness guide so that it will not be pinched by the cover.

#### 4.10.4 Fuser roller cover

- (1) Remove the fuser unit.  
📖 P. 4-134 "4.10.1 Fuser unit"
- (2) Remove 2 screws, and take off the fuser roller cover [1].

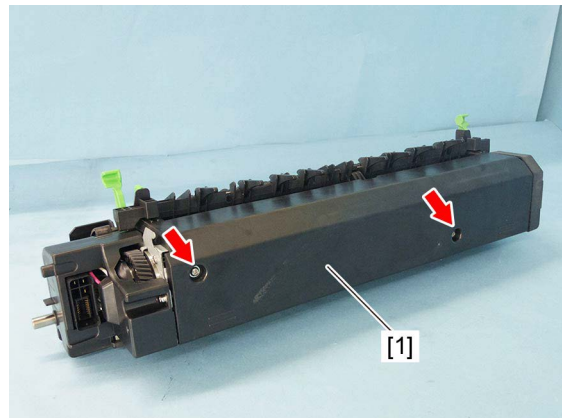


Fig. 4-338

#### 4.10.5 Paper entrance guide

- (1) Remove the front side cover.  
📖 P. 4-137 "4.10.2 Front side cover"
- (2) Remove the rear side cover.  
📖 P. 4-137 "4.10.3 Rear side cover"
- (3) Remove 2 screws, and take off the paper entrance guide [1].

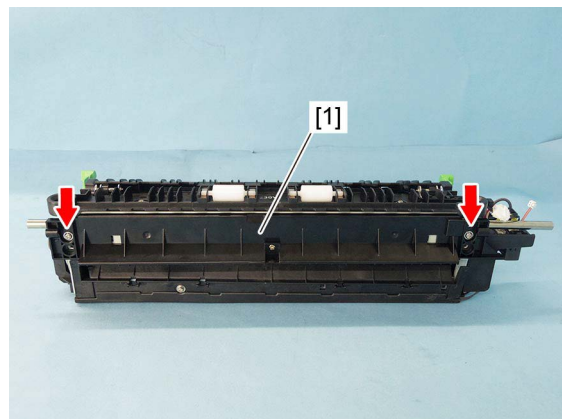


Fig. 4-339

- (4) Remove 1 screw and take off the brush [2].

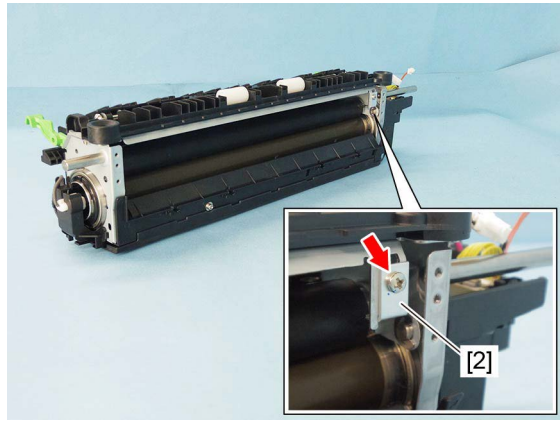




Fig. 4-340

#### 4.10.6 Separation finger

- (1) Remove the front side cover.  
 P. 4-137 "4.10.2 Front side cover"
- (2) Remove the rear side cover.  
 P. 4-137 "4.10.3 Rear side cover"
- (3) Disconnect 1 connector [1]. Remove 2 screws and take off the pressure roller cover [2].

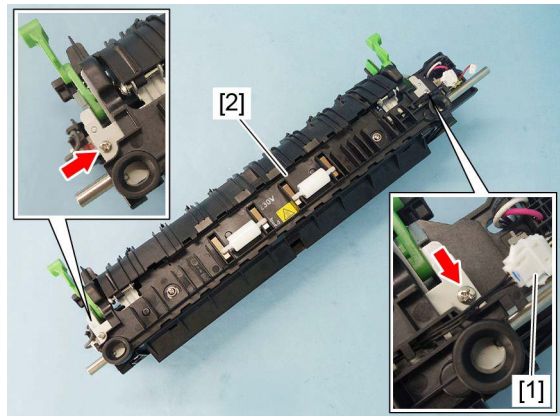


Fig. 4-341

- (4) Remove 3 screws and take off the cover [3].

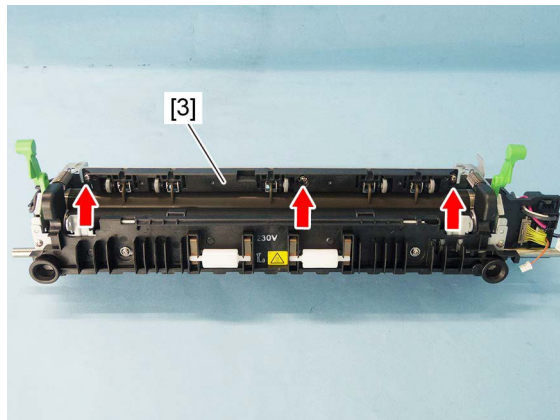


Fig. 4-342

(5) Remove 5 springs [4] and take off the 5 separation finger [5].

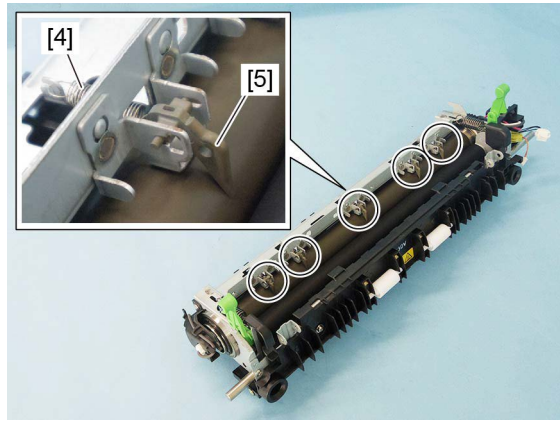


Fig. 4-343

**Notes:**

Remove the separation finger in the following procedure.

1. Lift up the separation finger and slide it toward you.
2. Slide the separation finger toward the front side and turn it as twist.
3. Remove the separation finger from the groove.

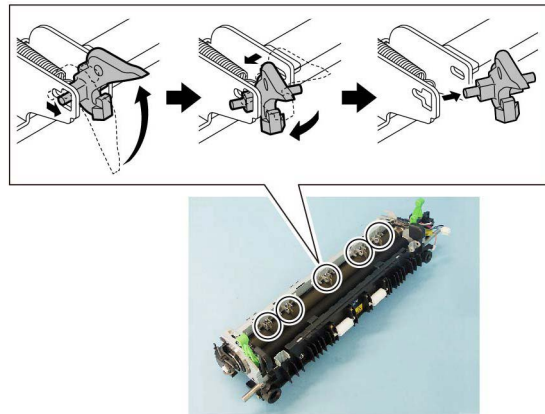


Fig. 4-344

### 4.10.7 Exit sensor (S5)

- (1) Remove the fuser unit.  
P. 4-134 "4.10.1 Fuser unit"
- (2) Tilt the pressure lever [1].
- (3) Remove 2 screws and open the pressure roller cover [2].

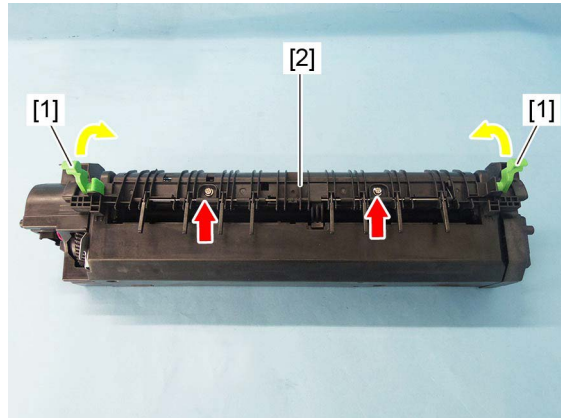


Fig. 4-345

- (4) Release 1 latch and take off the sensor cover [3].

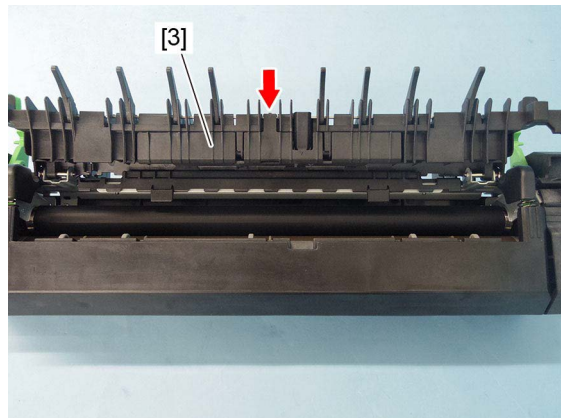


Fig. 4-346

- (5) Remove the actuator [4] and spring [5].

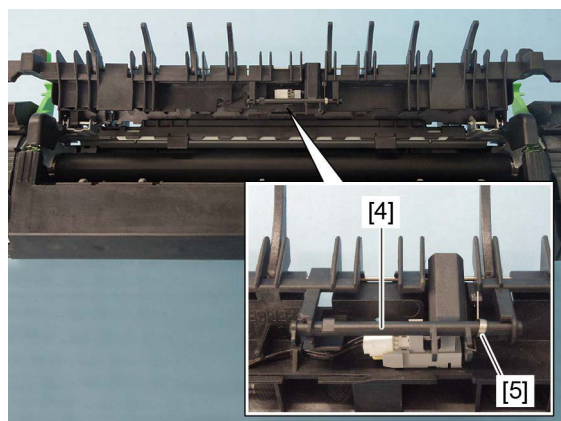


Fig. 4-347

- (6) Disconnect the connector [6].
- (7) Release the latch and take off the exit sensor [7].

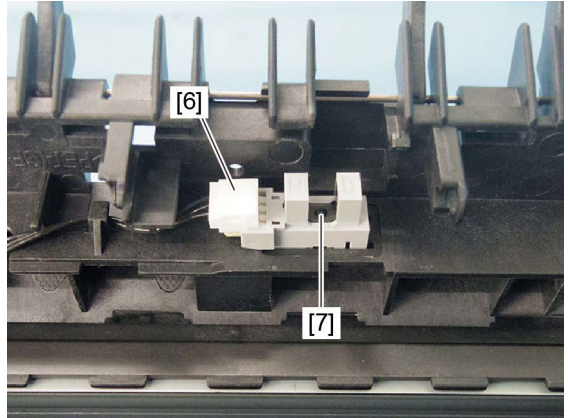



Fig. 4-348

#### 4.10.8 Fuser center thermostat (THMO1)/fuser front thermostat (THMO2)

- (1) Remove the fuser roller cover.  
 P. 4-138 "4.10.4 Fuser roller cover"
- (2) Remove 2 screws and take off the leaf spring [1].

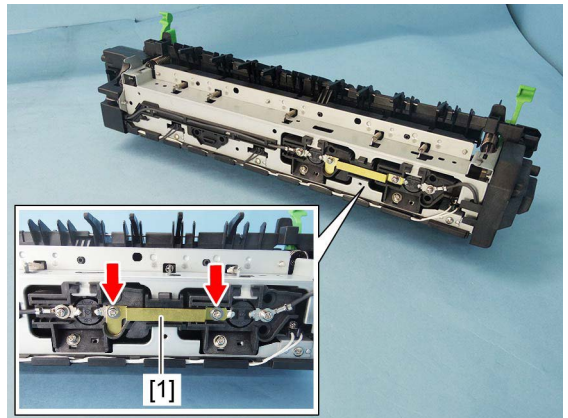


Fig. 4-349



- (3) Remove 2 screws and take off the fuser center thermostat [2] and fuser front thermostat [3].

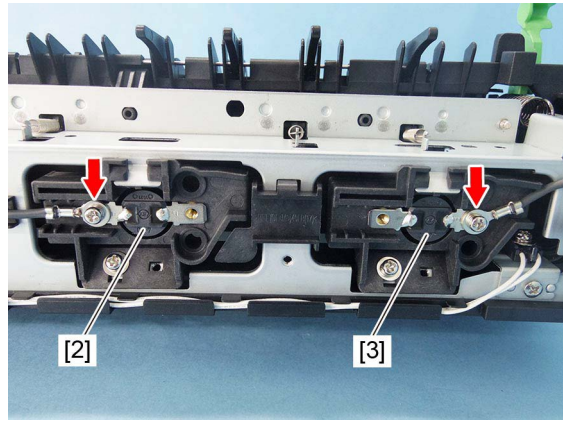


Fig. 4-350

**Notes:**

- If the thermostat is not installed appropriately when it is replaced or installed, it may not work normally. If you carry out the maintenance of the equipment in such a situation, they may result in fatal accidents as explosion or fire. Therefore, to avoid this, be sure to perform correct handling and installation.
- After installing the thermostat, check that the gap between the thermostat and fuser roller is 1.6 - 2.1 mm. If the adjustment is necessary after checking, adjust the gap between thermostat (fuser center thermostat and fuser side thermostat) and fuser roller.  
📖 P. 6-67 “6.10.1 Adjustment of the thermostat gap”
- Do not loosen the screws with the white markings that is holding the thermostat.

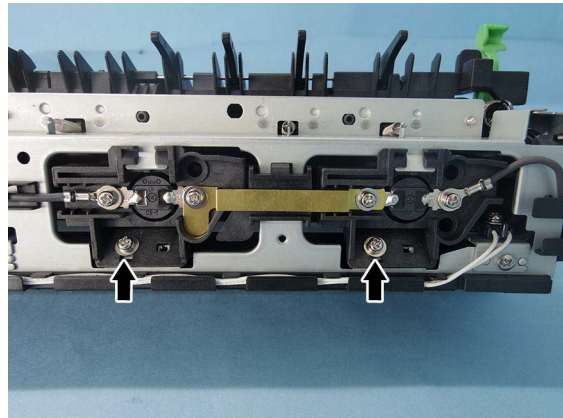


Fig. 4-351

#### 4.10.9 Center thermistor (THMS1)/side thermistor (THMS2)/edge thermistor (THMS3)

- (1) Remove the front side cover.  
📖 P. 4-137 “4.10.2 Front side cover”
- (2) Remove the rear side cover.  
📖 P. 4-137 “4.10.3 Rear side cover”
- (3) Remove the fuser roller cover.  
📖 P. 4-138 “4.10.4 Fuser roller cover”

(4) Remove 2 screws and take off the lamp holder [1] on the rear side.

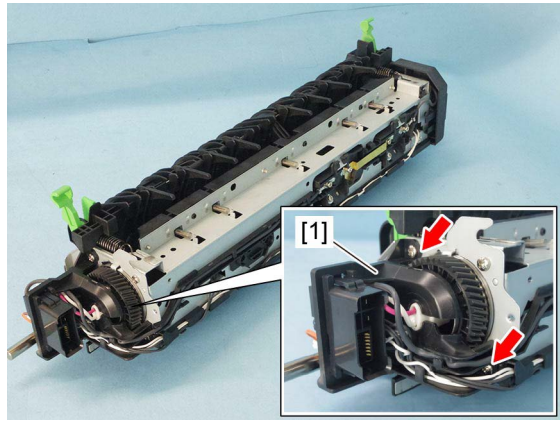


Fig. 4-352

(5) Disconnect 3 connectors.

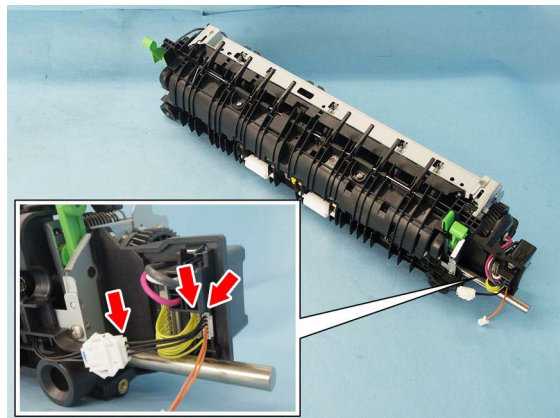


Fig. 4-353

(6) Release 2 latches and remove the connector bracket [2].

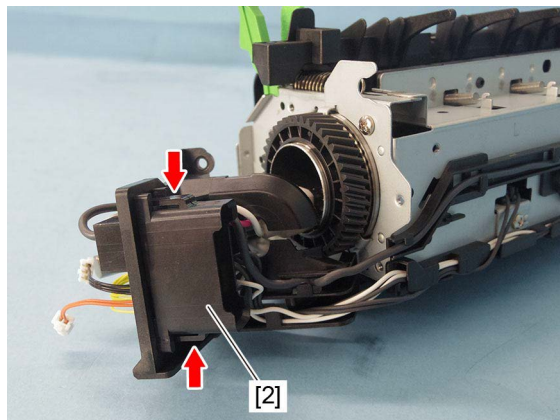


Fig. 4-354

- (7) Disconnect 1 connector [3] and release the harness from the harness guide.

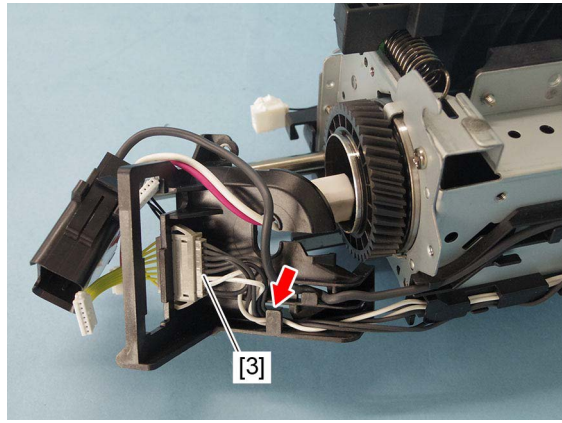


Fig. 4-355

- (8) Release the harness from the harness guide.

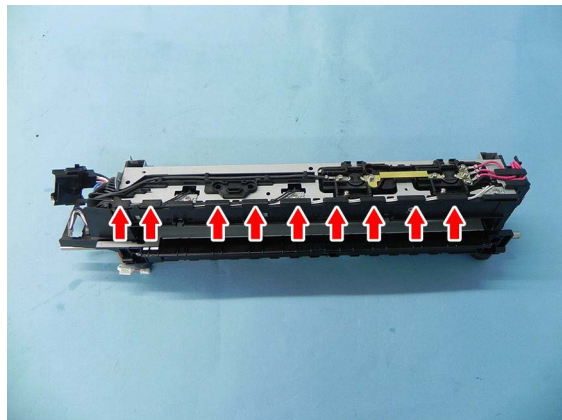


Fig. 4-356

- (9) Remove 3 screws and take off the center thermistor [4], side thermistor [5] and edge thermistor [6] with the bracket.

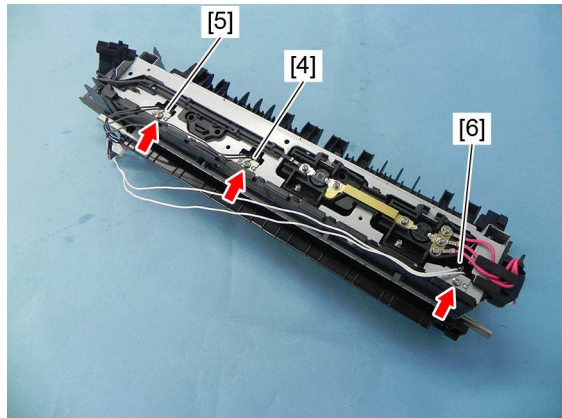


Fig. 4-357

- (10) Remove 3 screws and take off the brackets from the center thermistor [4], side thermistor [5] and edge thermistor [6].

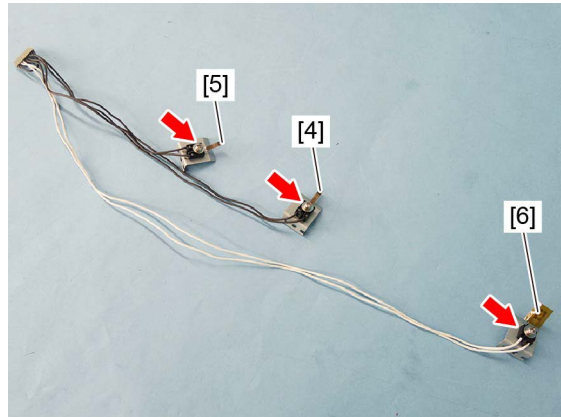


Fig. 4-358

**Notes:**

- When installing, pay attention not to deform the thermistor.
- When installing, make sure that the center thermistor [5] and side thermistor [6] are in contact with the fuser roller.
- If the thermostat is not installed appropriately when it is replaced or installed, it may not work normally. If you carry out the maintenance of the equipment in such a situation, they may result in fatal accidents as explosion or fire. Therefore, to avoid this, be sure to perform correct handling and installation.

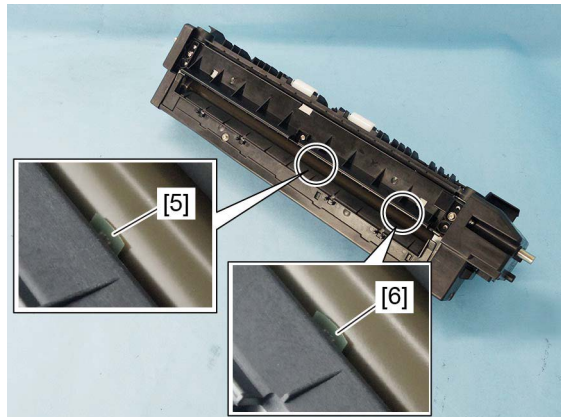


Fig. 4-359

- When installing, make sure that the edge thermistor [7] is in contact with the fuser roller.



Fig. 4-360

#### 4.10.10 Center heater lamp (LAMP1)/side heater lamp (LAMP2)

- (1) Remove the front side cover.  
📖 P. 4-137 “4.10.2 Front side cover”
- (2) Remove the rear side cover.  
📖 P. 4-137 “4.10.3 Rear side cover”
- (3) Remove the fuser roller cover.  
📖 P. 4-138 “4.10.4 Fuser roller cover”
- (4) Remove 2 screws [1] and release the harness [2] from the harness guide.

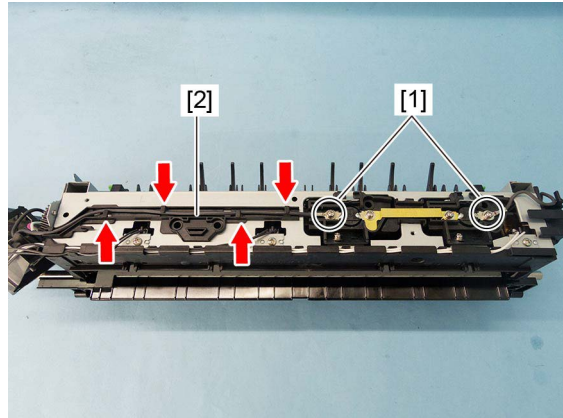


Fig. 4-361

- (5) Release the harness [3] from 3 harness guides. Remove 1 screw [4], and take off the lamp holder [5] on the front side.

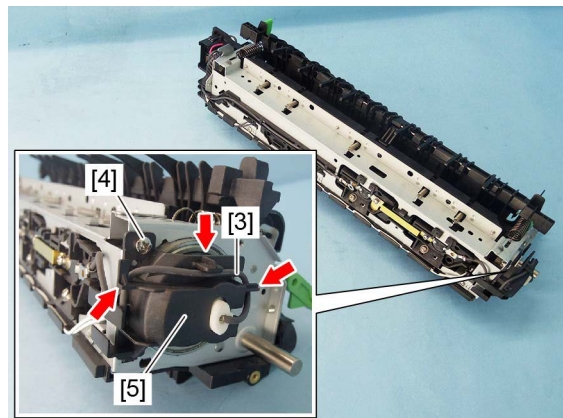


Fig. 4-362

(6) Disconnect 3 connectors.

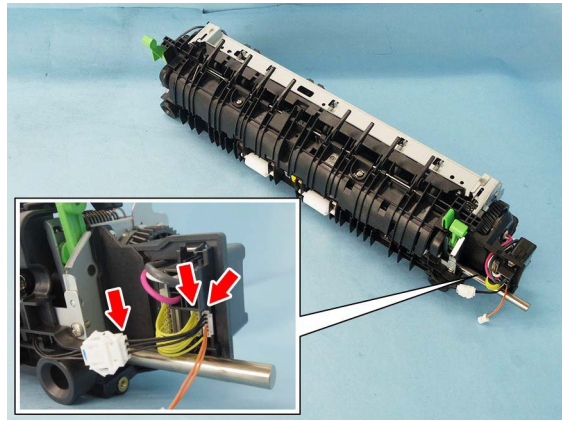


Fig. 4-363

(7) Release 2 latches and remove the connector bracket [6].

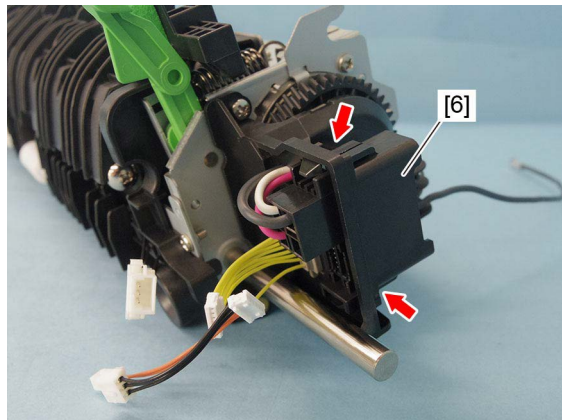


Fig. 4-364

(8) Remove 2 screws and remove the lamp holder [7] on the rear side.

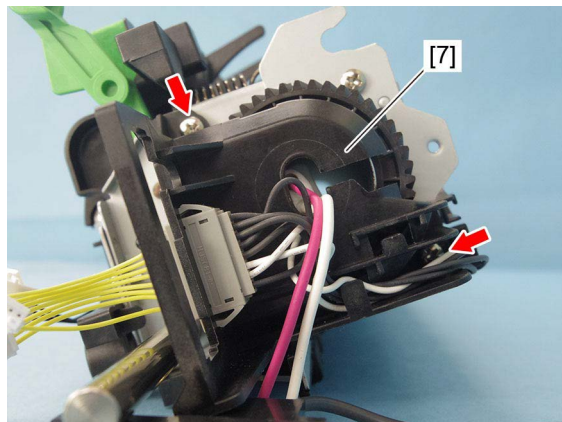


Fig. 4-365

- (9) Remove the heater lamp [8] by pulling it out toward the rear side.

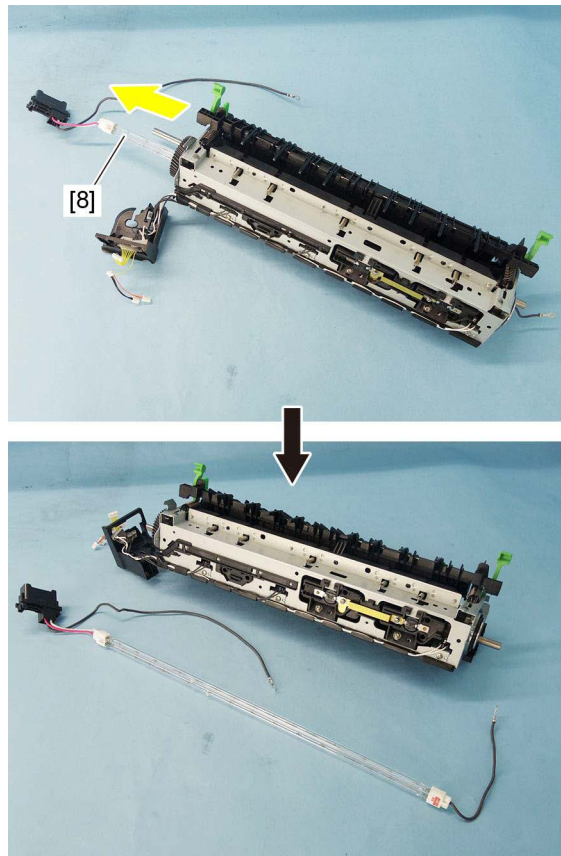


Fig. 4-366

**Notes:**

Do not touch the heater lamp with your bare hands.

#### 4.10.11 Pressure roller

- (1) Remove the front side cover.  
P. 4-137 "4.10.2 Front side cover"
- (2) Remove the rear side cover.  
P. 4-137 "4.10.3 Rear side cover"
- (3) Disconnect 1 connector [1]. Remove 2 screws and take off the pressure roller cover [2].

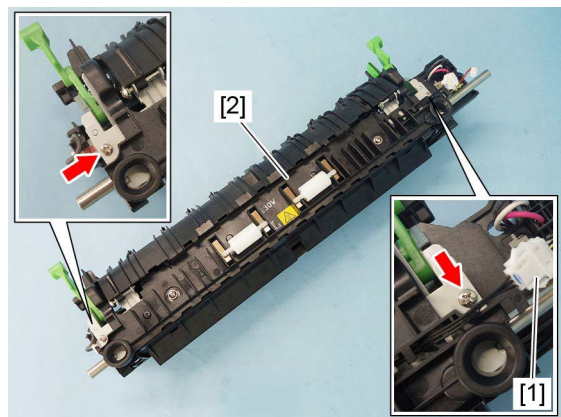


Fig. 4-367

(4) Remove 2 springs [2].

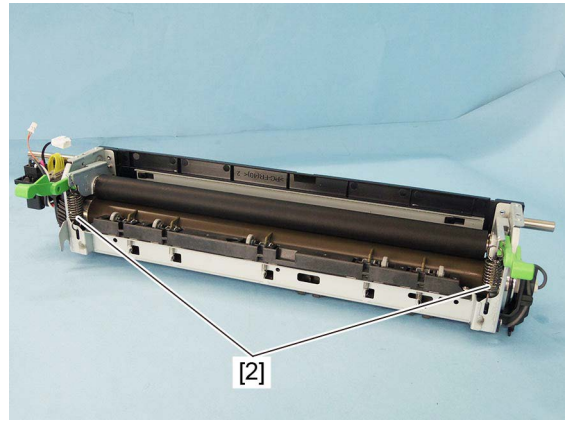


Fig. 4-368

- (5) Remove the pressure roller [4] by lifting up the pressure roller release lever [3].
- (6) Remove the 2 levers [5].

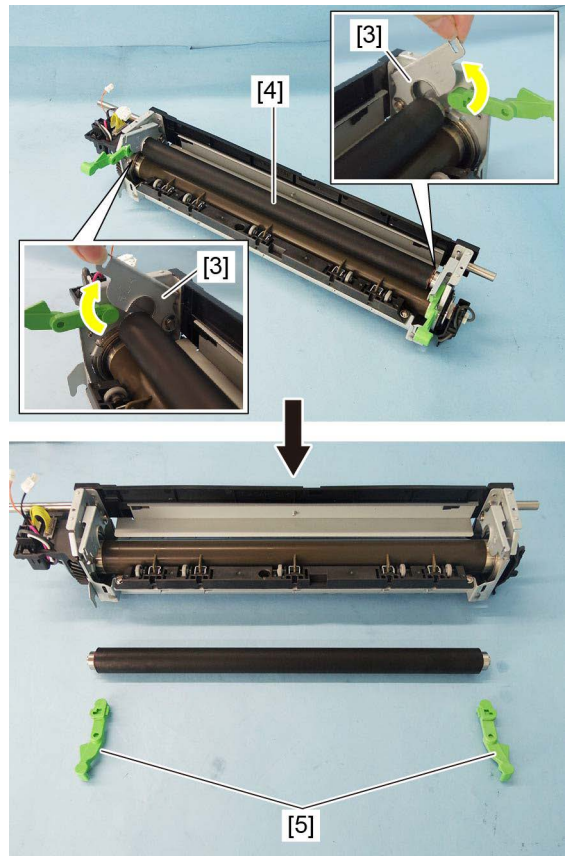






Fig. 4-369



### 4.10.12 Fuser roller

- (1) Remove the separation finger.  
 P. 4-139 “4.10.6 Separation finger”
- (2) Remove the paper entrance guide.  
 P. 4-138 “4.10.5 Paper entrance guide”
- (3) Remove the pressure roller.  
 P. 4-149 “4.10.11 Pressure roller”
- (4) Remove the heater lamp.  
 P. 4-147 “4.10.10 Center heater lamp (LAMP1)/side heater lamp (LAMP2)”
- (5) Remove the C-ring from the front side, and then remove the gear [1] and collar [2].

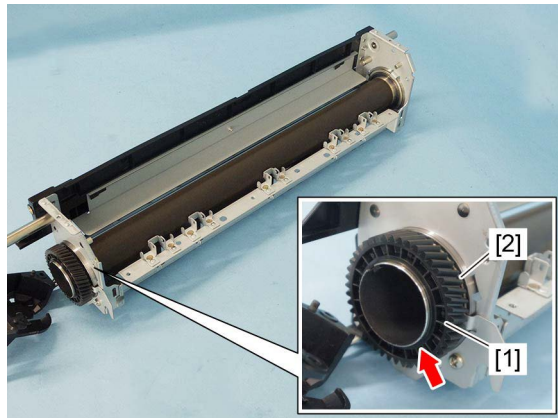


Fig. 4-370

- (6) Remove 1 C-ring and 1 washer [3] from the rear side, and then remove the collar [4].

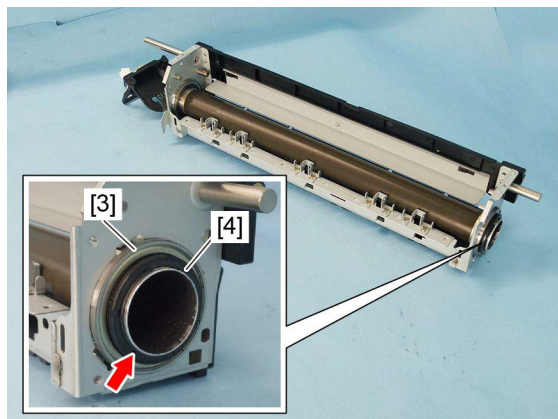


Fig. 4-371

(7) Remove the bearing [5]. Remove the fuser roller [6] by pulling it out toward the front side.

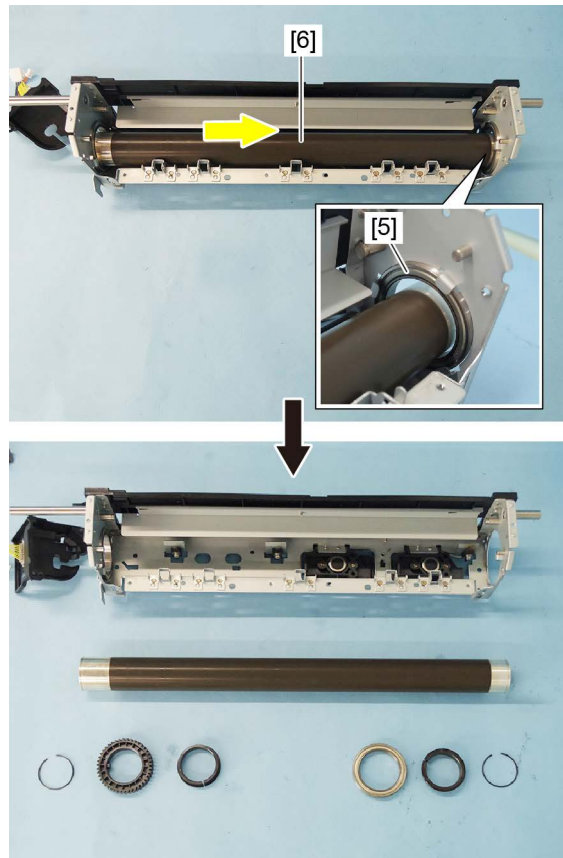


Fig. 4-372

**Notes:**

- Be sure not to damage the fuser roller.
- When installing/removing the C-ring, not to deform it by overextended.

## 4.11 Paper Exit and Reverse Sections

### 4.11.1 Reverse unit <35ppm/45ppm/50ppm>

**Notes:**

Make a note of the installation position of the reverse unit and fixing screws in advance. Mark the position if needed. When reassembling, match the reverse unit with the previously marked position.

- (1) Remove the right rear cover.  
📖 P. 4-5 "4.1.10 Right rear cover"
- (2) Remove the exit back cover.  
📖 P. 4-4 "4.1.7 Exit back cover"
- (3) Remove 2 screws.

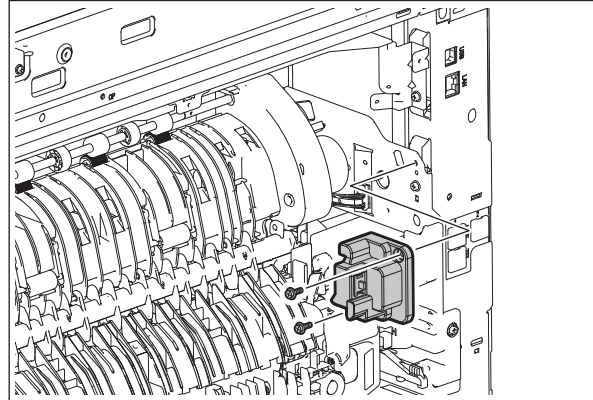


Fig. 4-373

- (4) Disconnect the 1 connector [1], and remove the switch unit [2].

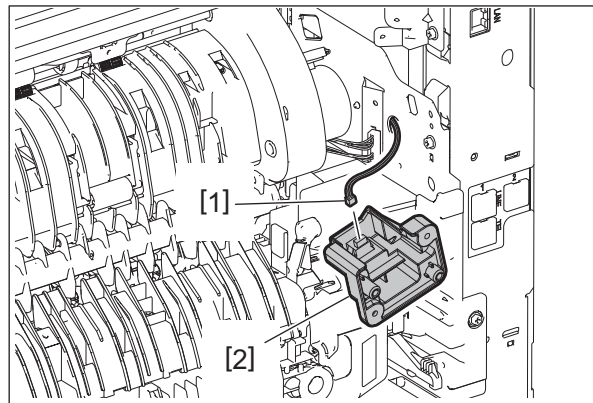


Fig. 4-374

- (5) Disconnect 1 connector [3] and remove 2 screws.

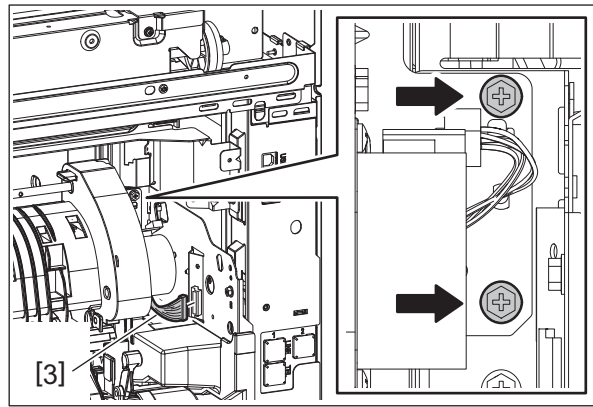


Fig. 4-375

- (6) Remove 1 screw.

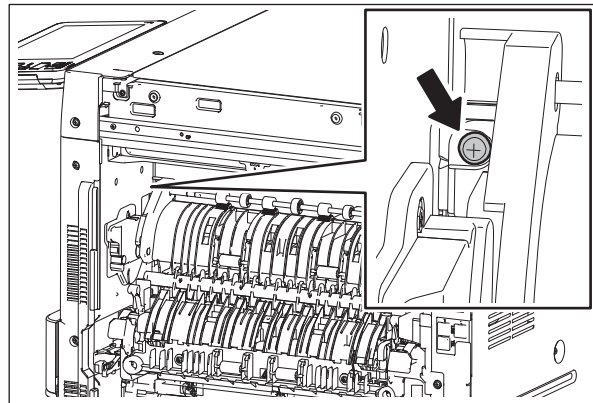


Fig. 4-376

**Notes:**

The screw on the front side is a shoulder screw. When installing, exercise care not to confuse it with other kinds of screws.

- (7) Lift the rear side [5] of the reverse unit [4] to release the rear side hook. Slide the reverse unit [4] to the rear side [6] and release the front side insertion. Pull out the reverse unit [4] by tilting it [7].

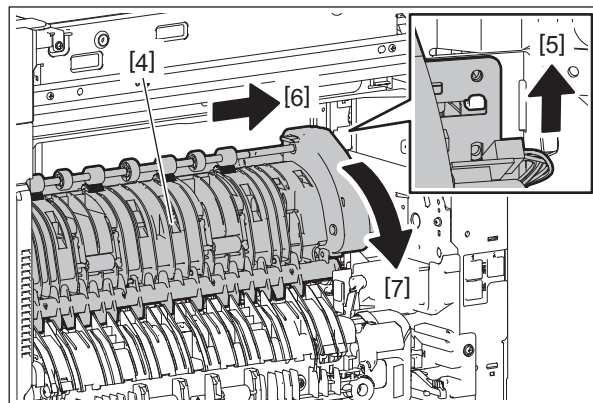


Fig. 4-377

**Notes:**

- Confirm the gaps A and B (between the roller and the guide) is 0.8mm or over when the reverse unit is installed.
- When checking the dimension of 0.8 mm, use a reverse unit gap confirmation jig with 0.8 mm.

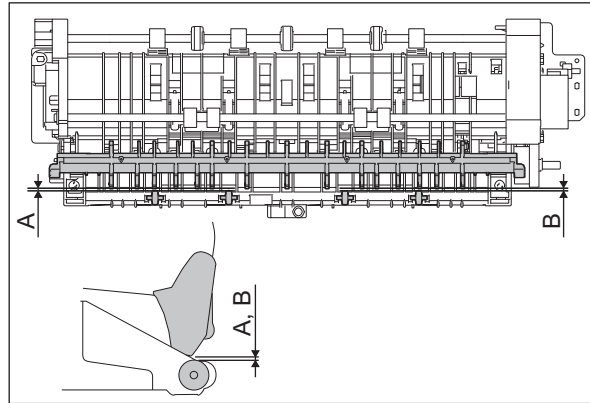


Fig. 4-378

**Remarks: Gap adjustment procedure**

1. Change the position of screw D.
2. Loosen the screws C and E.
3. Adjust the gaps A and B to 0.8 mm or over.
4. Tighten the screws C, D and E.

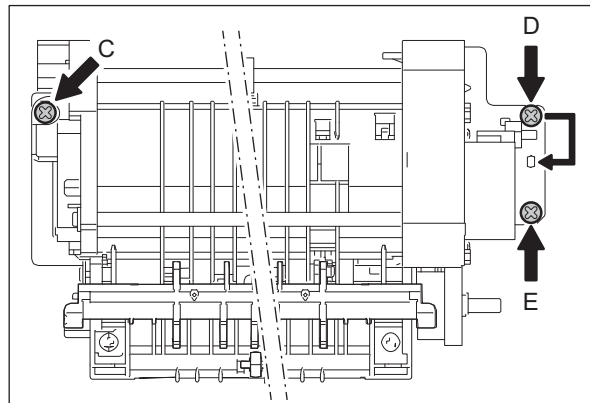


Fig. 4-379

**4.11.2 Paper exit unit <35ppm/45ppm/50ppm>**

- (1) Remove the fuser unit.  
P. 4-134 "4.10.1 Fuser unit"
- (2) Remove the reverse unit.  
P. 4-153 "4.11.1 Reverse unit <35ppm/45ppm/50ppm>"

- (3) Remove 3 screws and take off the paper exit unit [1].  
[2]: Spring screw  
[3]: Shoulder screw

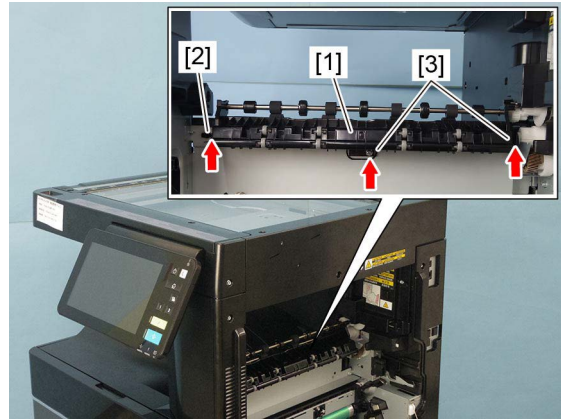


Fig. 4-380

#### 4.11.3 Paper exit unit <20ppm/25ppm/30ppm>

- (1) Remove the fuser unit.  
P. 4-134 "4.10.1 Fuser unit"
- (2) Remove 3 screws and take off the paper exit unit [1].  
[2]: Spring screw

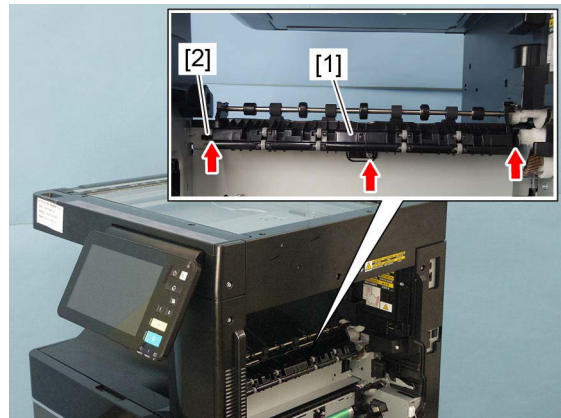


Fig. 4-381

#### 4.11.4 Exit roller / Lower exit roller

- (1) Remove the paper exit unit.  
📖 P. 4-155 "4.11.2 Paper exit unit <35ppm/45ppm/50ppm>"  
📖 P. 4-156 "4.11.3 Paper exit unit <20ppm/25ppm/30ppm>"
- (2) Remove 1 E-ring [1], 1 gear [2], and 1 bushing [3].

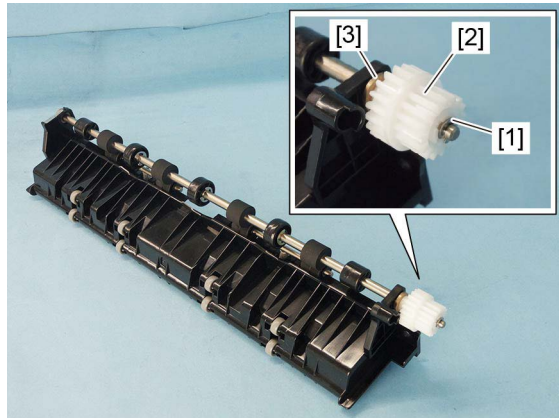


Fig. 4-382

- (3) Remove 1 E-ring [4] and 1 bushing [5].

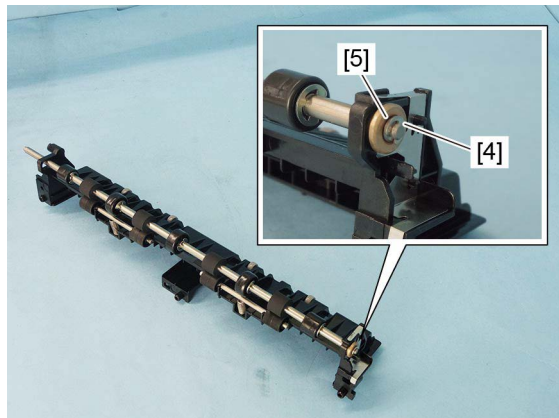


Fig. 4-383

- (4) Remove the exit roller / lower exit roller [6].

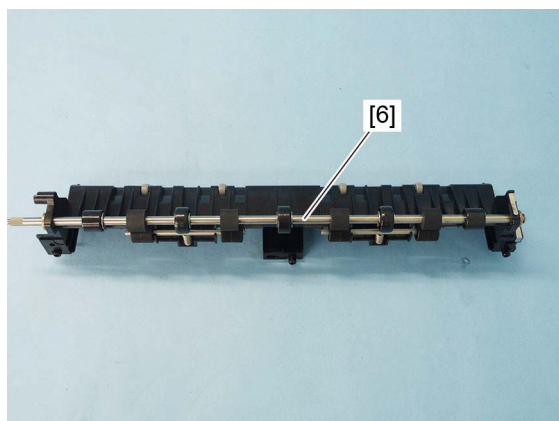


Fig. 4-384

- (5) Remove the idling roller [7] and 2 springs [8].

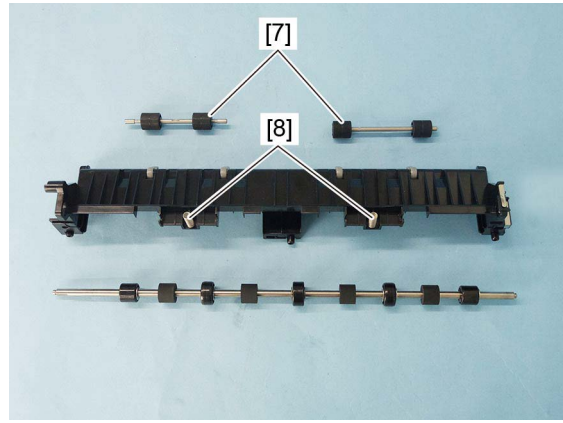


Fig. 4-385

**Notes:**

When replacing the idling roller or idling roller shaft, apply 1 rice sized grain of white grease (Molykote EM-30L) to the 2 place [9] shown in the figure 1 lap evenly.

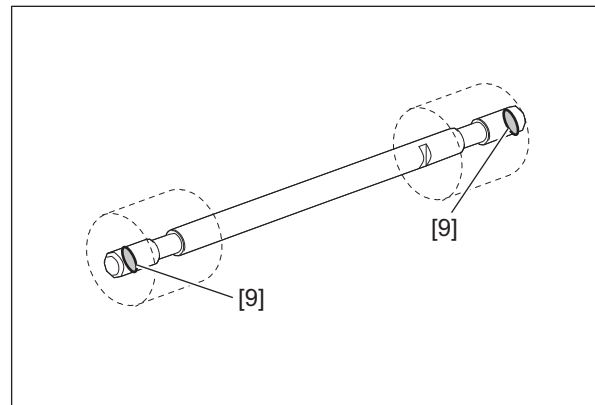


Fig. 4-386

#### 4.11.5 Exit motor (M10)

- (1) Remove the right rear cover.  
📖 P. 4-5 "4.1.10 Right rear cover"
- (2) Remove the paper exit unit.  
📖 P. 4-155 "4.11.2 Paper exit unit <35ppm/45ppm/50ppm>"
- (3) Remove the exit back cover.  
📖 P. 4-4 "4.1.7 Exit back cover"



(4) Remove 1 screw and take off the exit motor assembly [1].

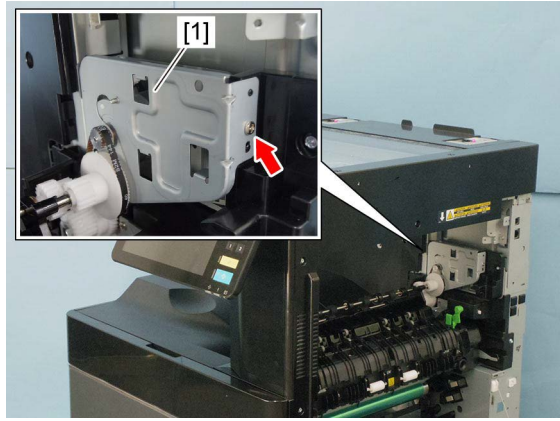


Fig. 4-387

(5) Disconnect 1 connector from the exit motor assembly [1].

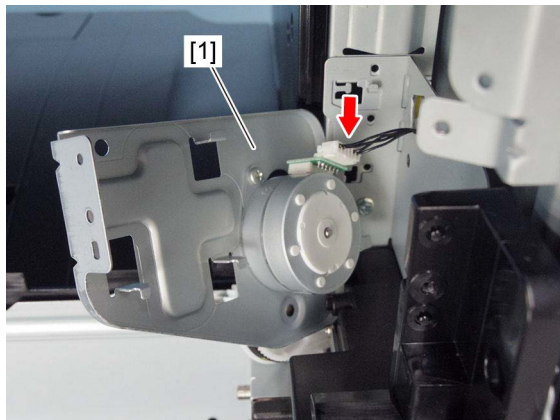


Fig. 4-388

(6) Remove the belt [2].

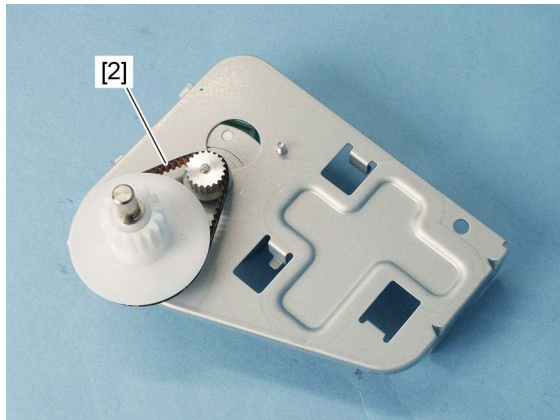


Fig. 4-389

- (7) Remove 2 screws, and then take off the exit motor [4] by letting the gear [3] out of the large hole in the bracket.

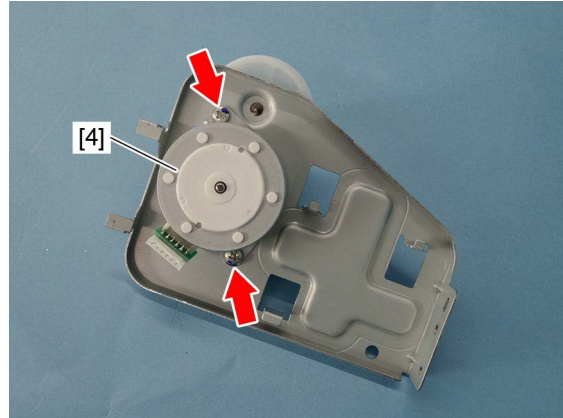


Fig. 4-390

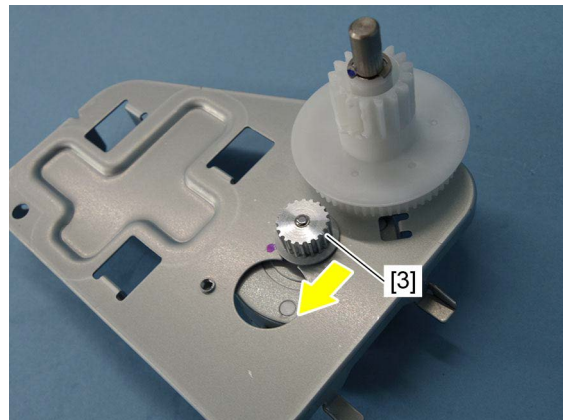


Fig. 4-391

#### 4.11.6 Reverse motor (M13) <35ppm/45ppm/50ppm>

- (1) Remove the reverse unit.  
P. 4-153 "4.11.1 Reverse unit <35ppm/45ppm/50ppm>"
- (2) Disconnect the 1 connector [1], remove 3 screws, and take off the reverse motor unit [2].

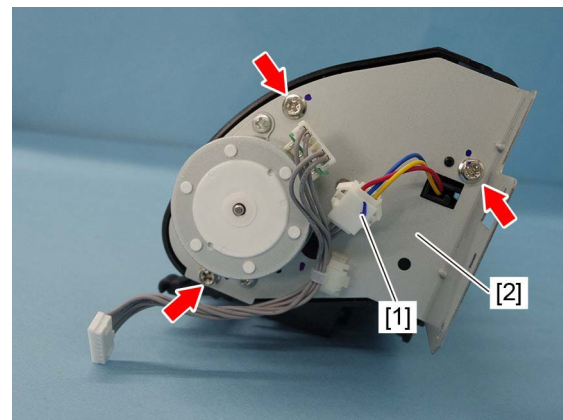


Fig. 4-392

**Notes:**

When installing, exercise care not to forget to attach the timing belt [3].

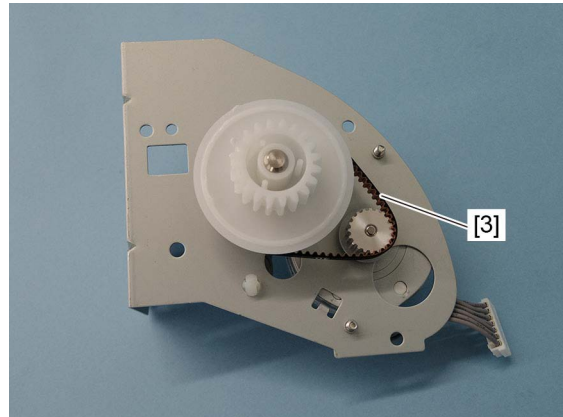


Fig. 4-393

- (3) Disconnect the 1 connector [4], remove 2 screws, and take off the reverse motor [5].

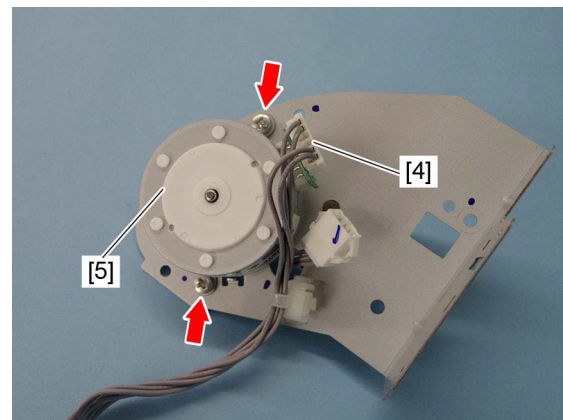


Fig. 4-394

#### 4.11.7 Reverse gate solenoid (SOL1) <35ppm/45ppm/50ppm>

- (1) Remove the reverse motor unit.  
P. 4-160 "4.11.6 Reverse motor (M13) <35ppm/45ppm/50ppm>"
- (2) Remove 2 screws and take off the cover [1].

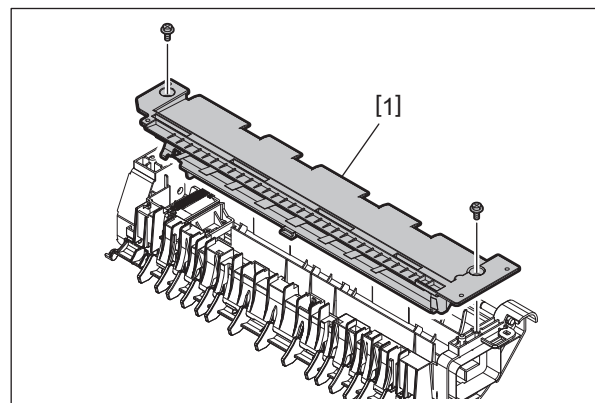


Fig. 4-395

- (3) Remove the harness from the harness guide.

(4) Remove the 1 spring [2].

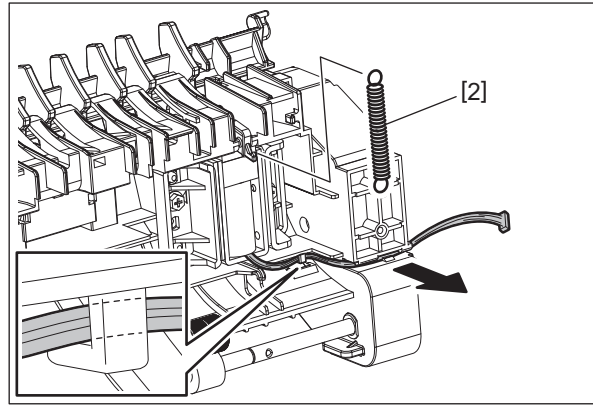


Fig. 4-396

(5) Remove 2 screws.

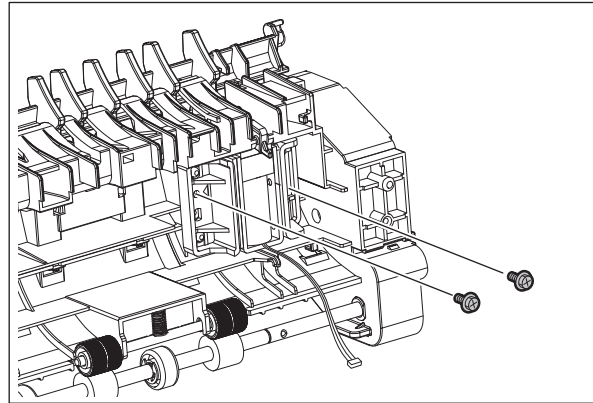


Fig. 4-397

(6) Lift up the plunger [3] and take off the reverse gate solenoid [4] and 2 brackets [5] together.

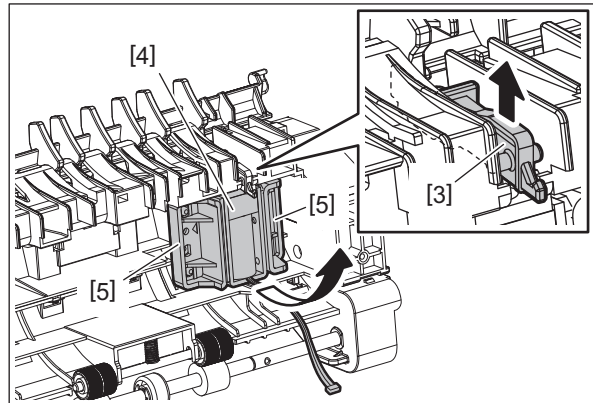


Fig. 4-398

- (7) Remove the plunger [3].

**Notes:**

When installing, insert the mold at the edge of the plunger [3] into the groove of the reverse unit.

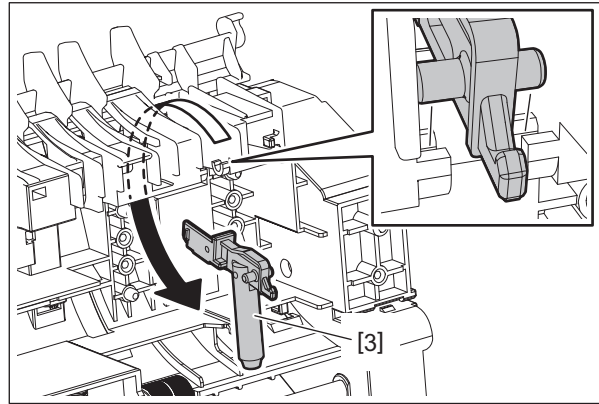


Fig. 4-399

### 4.11.8 Upper exit roller <35ppm/45ppm/50ppm>

- (1) Remove the reverse motor unit.  
P. 4-160 "4.11.6 Reverse motor (M13) <35ppm/45ppm/50ppm>"
- (2) Remove 2 screws and take off the cover [1].

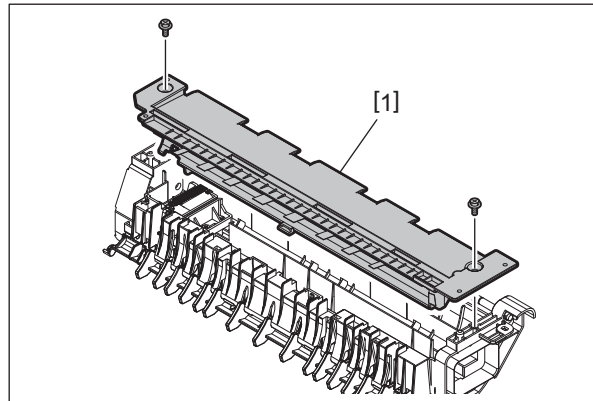


Fig. 4-400

- (3) Remove the 2 springs [2] applying pressure to the idling roller.

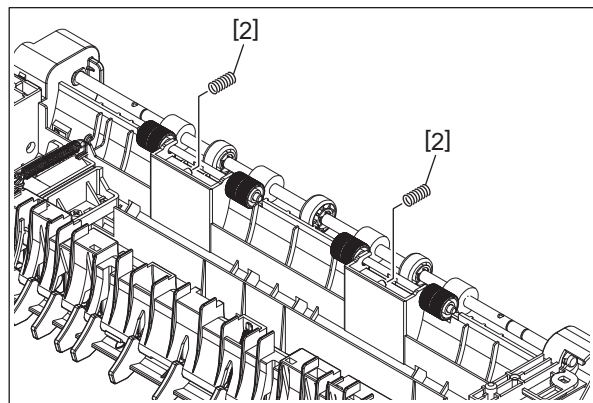


Fig. 4-401

- (4) Remove the 1 gear [3], 1 clip [4], 1 bushing (metal) [5], and 1 bushing (resin) [6], then take off the upper exit roller [7].

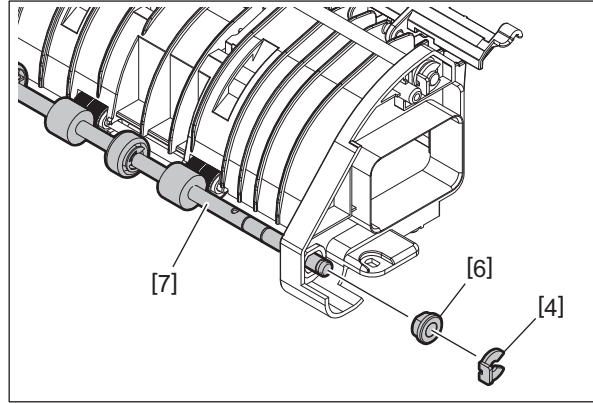


Fig. 4-402

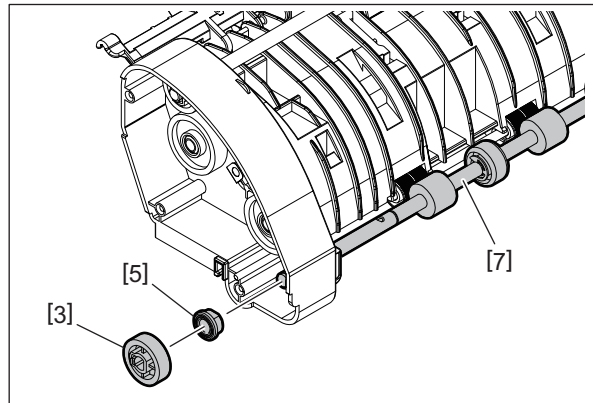


Fig. 4-403

**Notes:**

When replacing the idling roller or idling roller shaft, apply 1 rice sized grain of white grease (Molykote EM-30L) to the 2 place [8] shown in the figure 1 lap evenly.

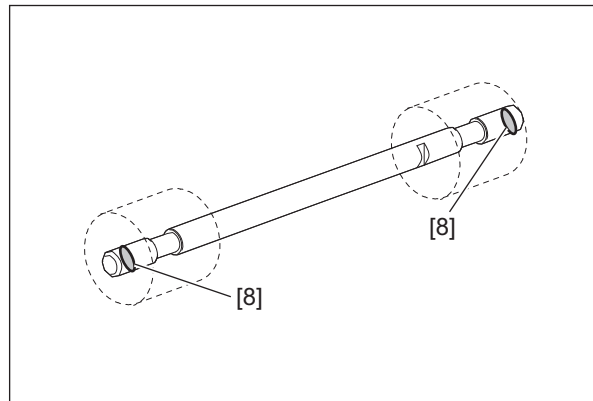


Fig. 4-404

### 4.11.9 Reverse roller <35ppm/45ppm/50ppm>

- (1) Remove the reverse motor unit.  
P. 4-160 "4.11.6 Reverse motor (M13) <35ppm/45ppm/50ppm>"
- (2) Remove the 1 gear [1], 1 clip [2], 1 bushing (metal) [3], and 1 bushing (resin) [5], then take off the reverse roller [4].

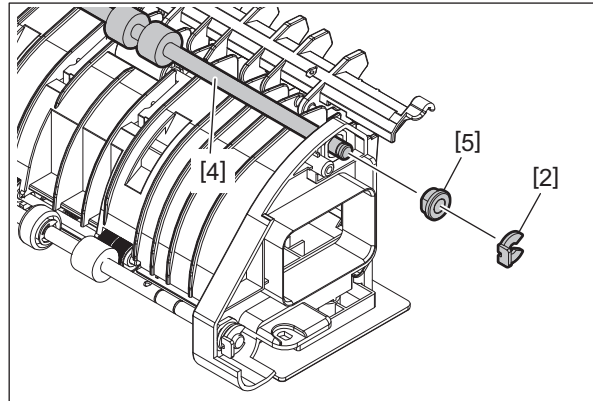


Fig. 4-405

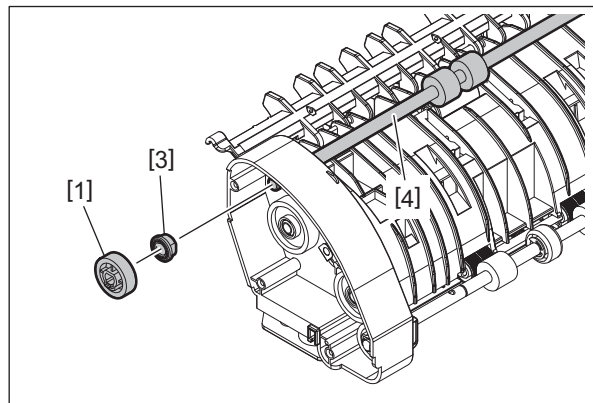


Fig. 4-406

## 4.12 Automatic Duplexing Unit (ADU)

### 4.12.1 Automatic duplexing unit (ADU)

- (1) Remove the right front cover.  
📖 P. 4-4 “4.1.9 Right front cover”
- (2) Remove the right rear cover.  
📖 P. 4-5 “4.1.10 Right rear cover”
- (3) Disconnect 3 connectors and take off 1 ground cable fixing screw [1]. Release the harnesses from the harness clamps [2].

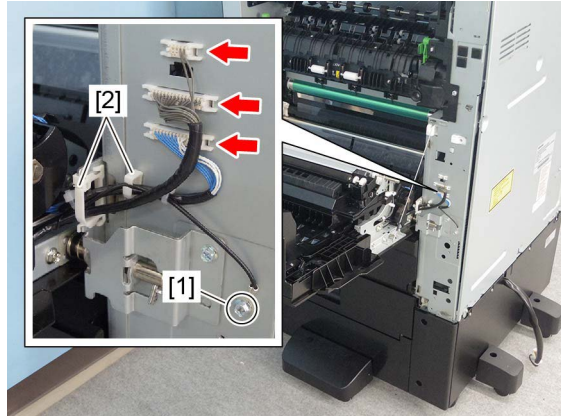


Fig. 4-407

- (4) Remove 1 screw. And then take off the wire end bracket [3] by sliding it toward the direction of the arrow shown in the figure.

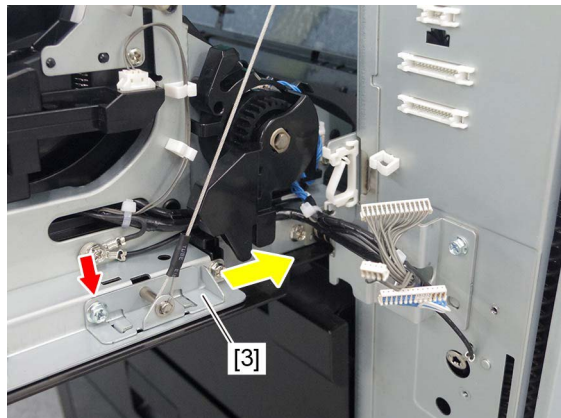


Fig. 4-408



- (5) Raise the rear hinge [4].

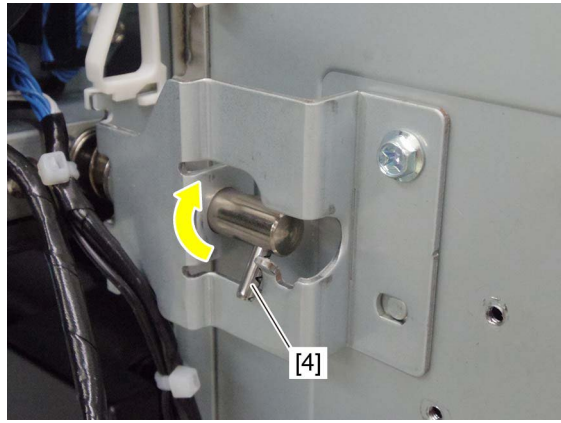


Fig. 4-409

**Notes:**

When installing, turn the rear hinge [4] downward.

- (6) Slide the rear hinge [4] toward the rear side and pull it out from the automatic duplexing unit.

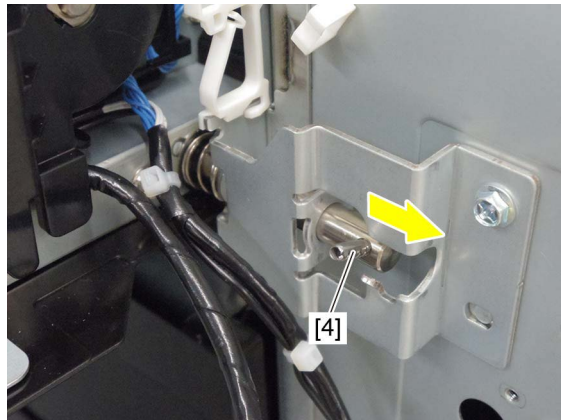


Fig. 4-410

- (7) Slightly lift up the automatic duplexing unit [5], and then remove it by sliding it toward the rear side.

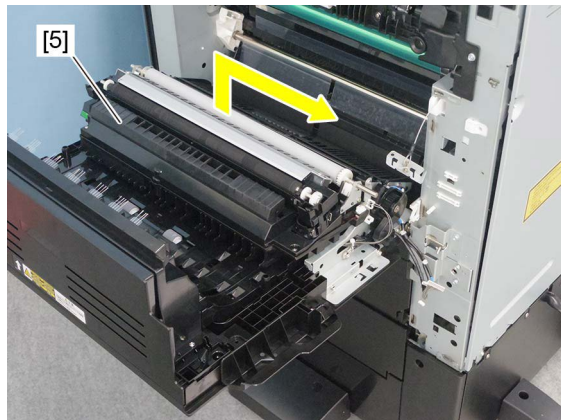


Fig. 4-411

**Notes:**

When installing, fit the boss [7] of automatic duplexing unit to the front hinge [6].

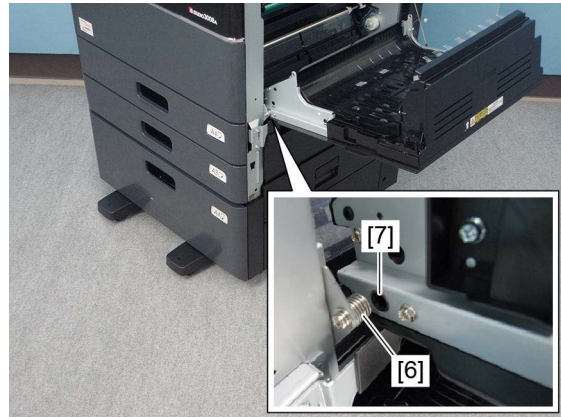


Fig. 4-412

### 4.12.2 Bypass feed clutch (CLT2)

- (1) Remove the automatic duplexing unit.  
P. 4-166 "4.12.1 Automatic duplexing unit (ADU)"
- (2) Release the harness [1] from the harness guide.

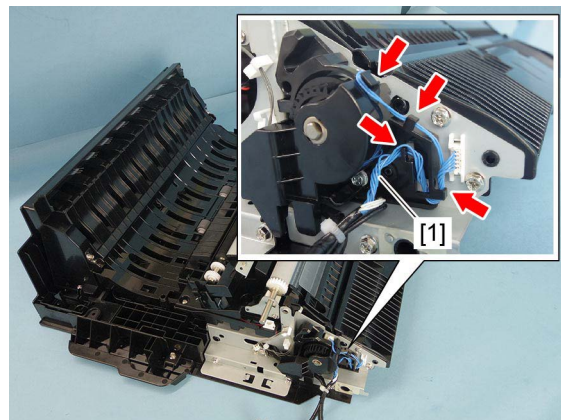


Fig. 4-413

- (3) Remove 1 screw and take off the clutch cover [2].

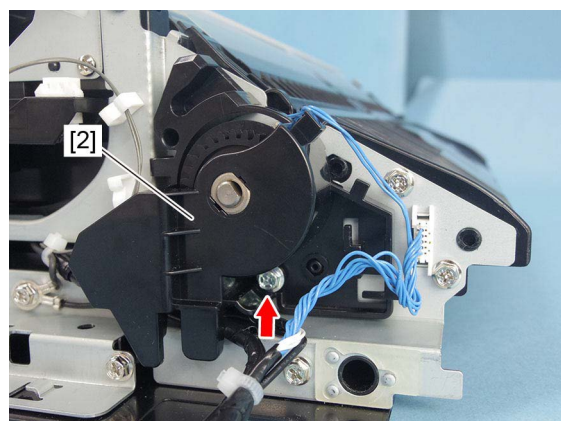


Fig. 4-414

- (4) Remove 1 bushing [3] and 1 leaf spring [4].

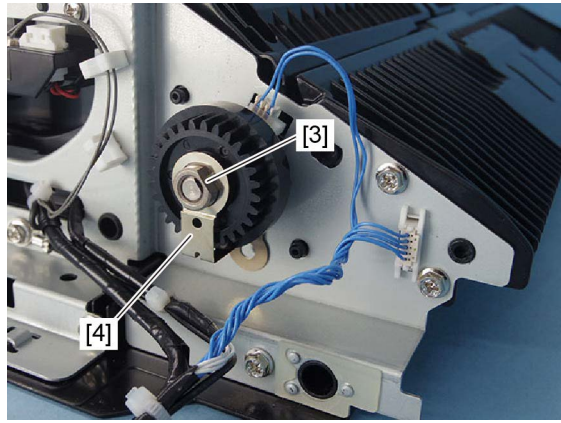


Fig. 4-415

- (5) Disconnect 1 connector and remove the bypass feed clutch [5].

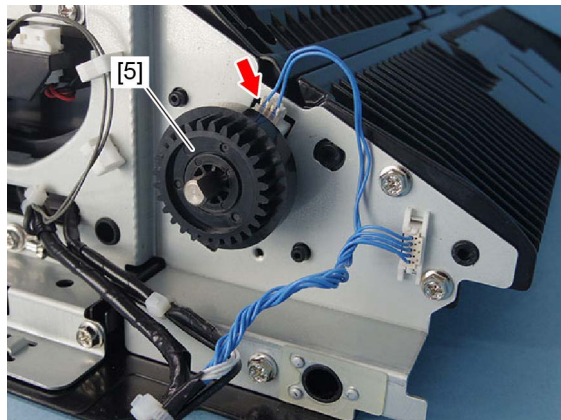


Fig. 4-416

**Notes:**

When installing the bypass feed clutch, attach the stopper [6] to the projection.

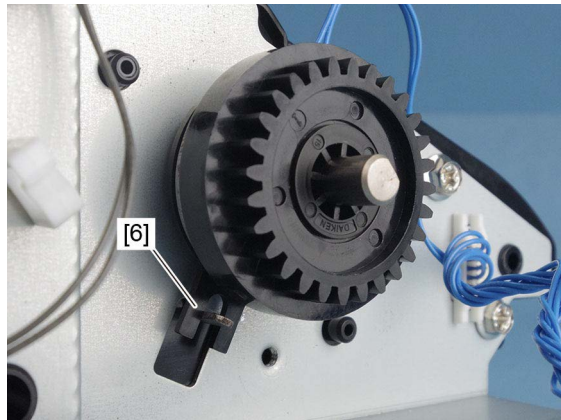


Fig. 4-417

### 4.12.3 ADU guide assembly <35ppm/45ppm/50ppm>

- (1) Remove the transfer roller unit.  
P. 4-129 "4.9.3 Transfer roller unit"
- (2) Remove the bypass feed clutch.  
P. 4-168 "4.12.2 Bypass feed clutch (CLT2)"
- (3) Remove 1 ground cable fixing screw.



Fig. 4-418

- (4) Remove 2 screws and take off the cover [1].

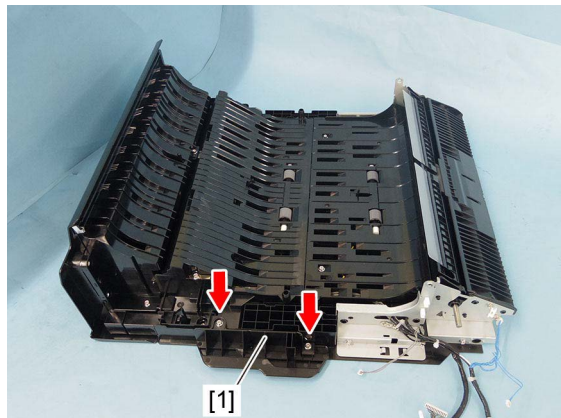


Fig. 4-419

- (5) Remove 6 screws and take off the ADU guide assembly [2].

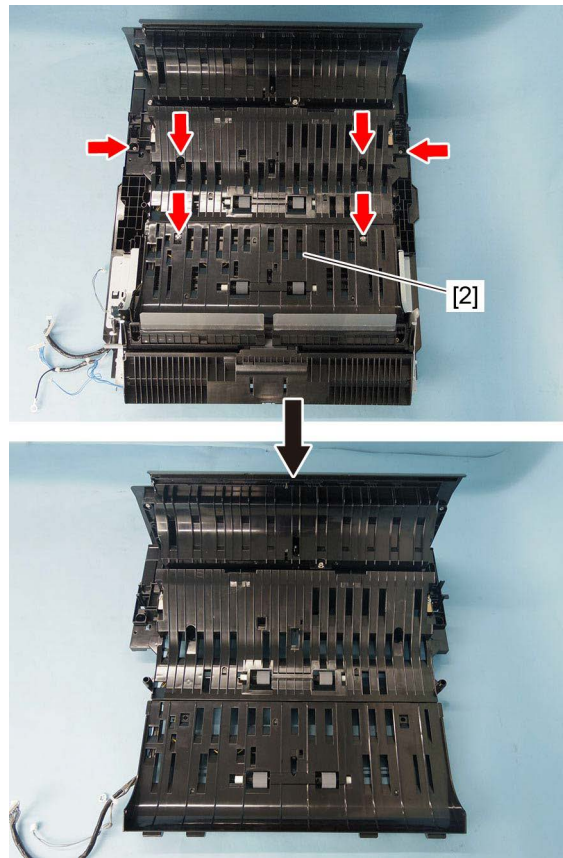


Fig. 4-420

#### 4.12.4 ADU guide assembly <20ppm/25ppm/30ppm>

- (1) Remove the transfer unit.  
📖 P. 4-127 “4.9.1 Transfer unit”
- (2) Remove the bypass feed clutch.  
📖 P. 4-168 “4.12.2 Bypass feed clutch (CLT2)”
- (3) Remove the ADU middle cover.  
📖 P. 4-175 “4.12.6 ADU middle cover <20ppm/25ppm/30ppm>”
- (4) Remove 1 ground cable fixing screw.

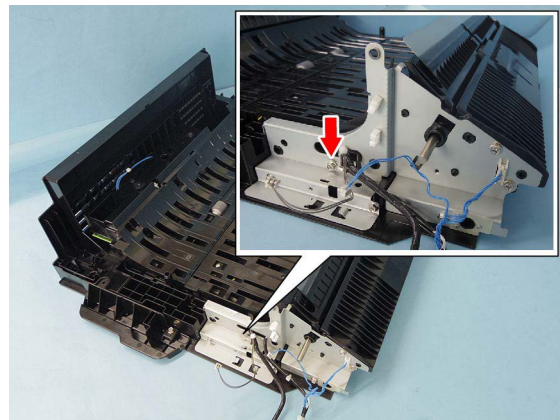


Fig. 4-421

(5) Remove 4 screws and take off the ADU guide assembly [1].

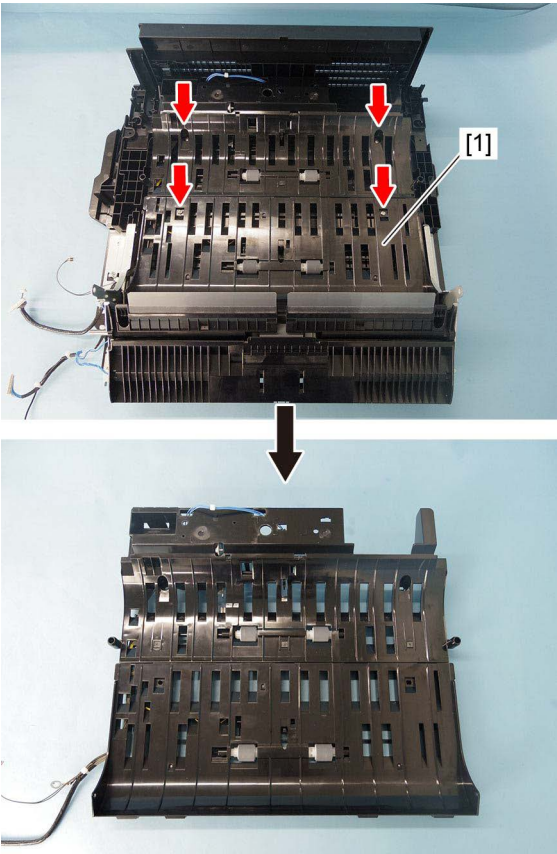


Fig. 4-422

#### 4.12.5 ADU middle cover <35ppm/45ppm/50ppm>

- (1) Remove the ADU guide assembly.  
P. 4-170 “4.12.3 ADU guide assembly <35ppm/45ppm/50ppm>”
- (2) Remove 4 screws and take off the ADU upper cover [1].

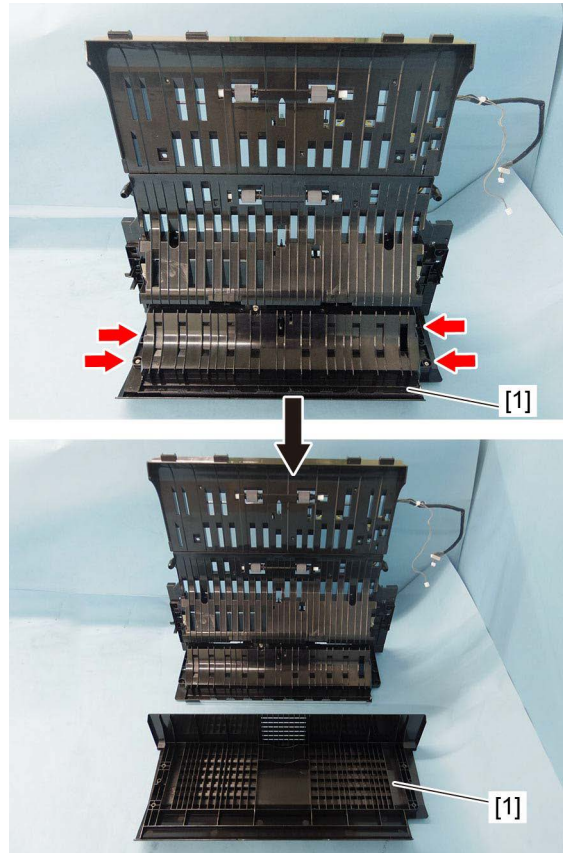


Fig. 4-423

- (3) Disconnect 2 connectors.

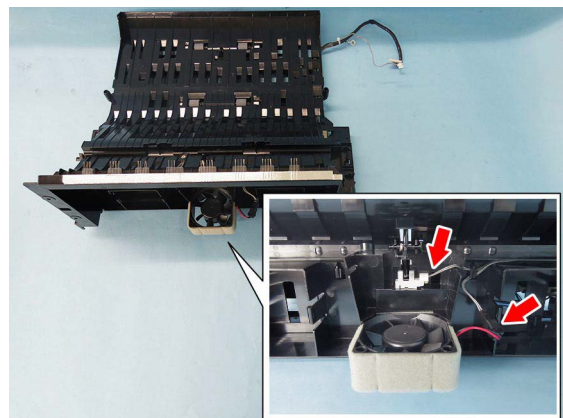


Fig. 4-424

(4) Release the harness [2] from the harness guide.

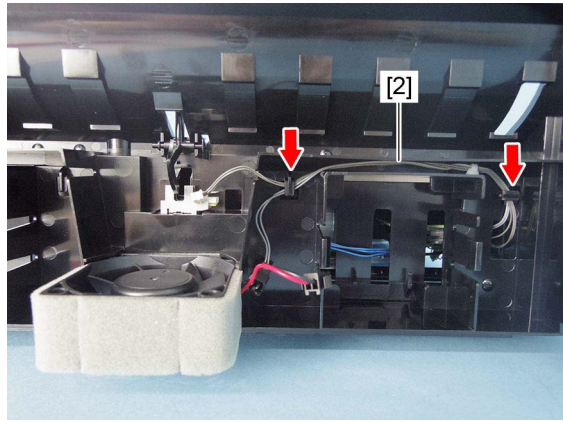


Fig. 4-425

(5) Remove 3 screws.

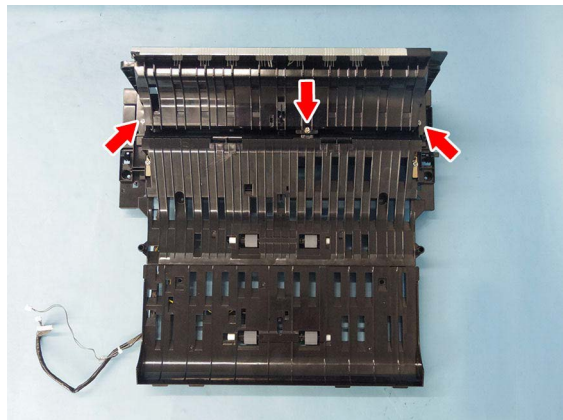


Fig. 4-426



- (6) Release 2 latches and take off the ADU middle cover [3].

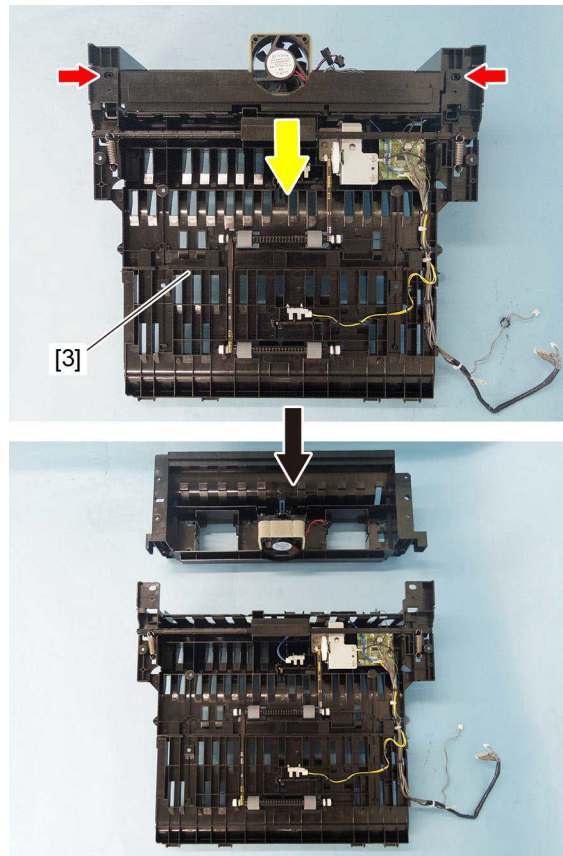


Fig. 4-427

#### 4.12.6 ADU middle cover <20ppm/25ppm/30ppm>

- (1) Remove the automatic duplexing unit (ADU).  
P. 4-166 "4.12.1 Automatic duplexing unit (ADU)"
- (2) Remove 4 screws, and take off the ADU middle cover [1].

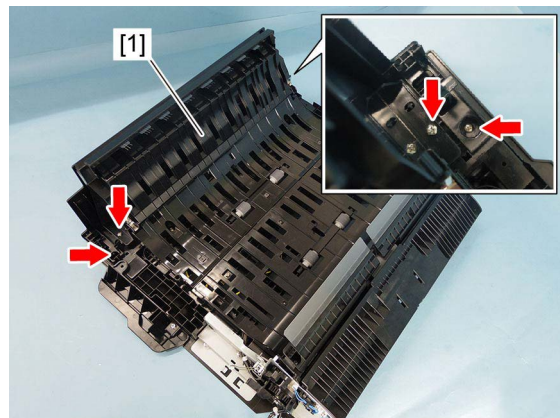



Fig. 4-428

#### 4.12.7 ADU control PC board (ADU) <35ppm/45ppm/50ppm>

- (1) Remove the ADU guide assembly.  
 P. 4-170 "4.12.3 ADU guide assembly <35ppm/45ppm/50ppm>"
- (2) Remove 2 springs and take off the side cover release lever [1].

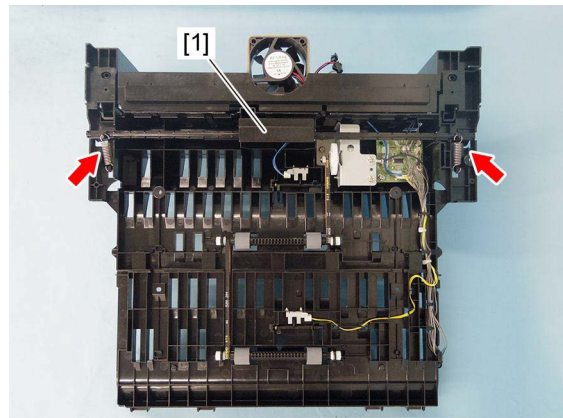


Fig. 4-429

- (3) Remove 1 ground cable fixing screw.

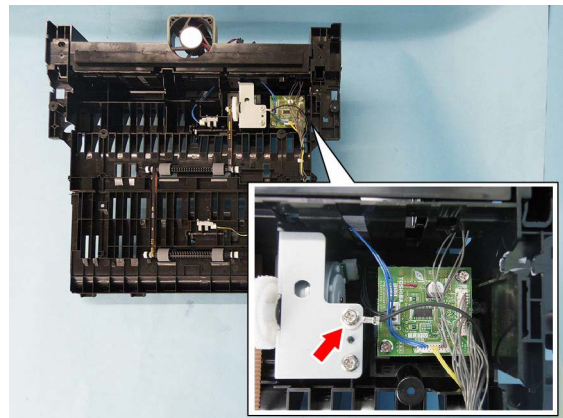


Fig. 4-430

- (4) Disconnect 3 connectors [2] and remove 2 screws, and then remove the ADU control PC board [3].

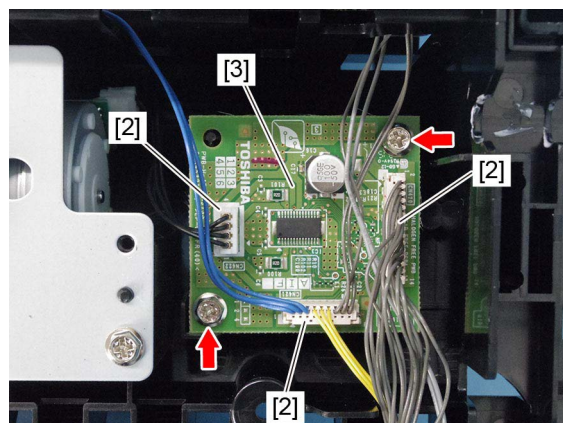


Fig. 4-431

#### 4.12.8 ADU control PC board (ADU board) (ADU) <20ppm/25ppm/30ppm>

- (1) Remove the ADU guide assembly.  
📖 P. 4-171 “4.12.4 ADU guide assembly <20ppm/25ppm/30ppm>”
- (2) Remove 1 ground cable fixing screw from the ADU guide assembly [1].

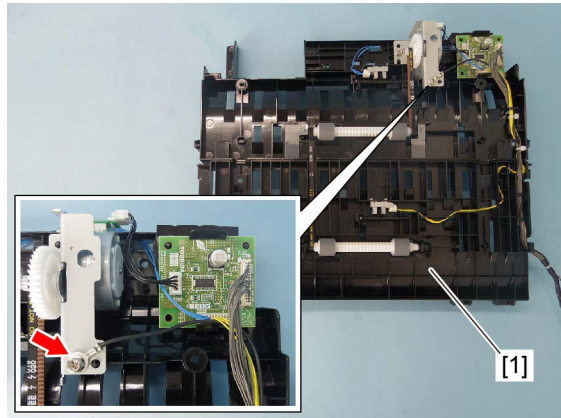


Fig. 4-432

- (3) Disconnect 3 connectors and take off the ADU control PC board [2].

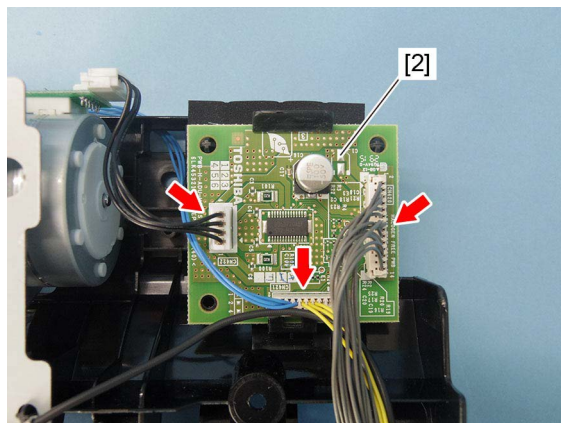


Fig. 4-433

#### 4.12.9 ADU motor (M5) <35ppm/45ppm/50ppm>

- (1) Remove the ADU guide assembly.  
P. 4-170 "4.12.3 ADU guide assembly <35ppm/45ppm/50ppm>"
- (2) Remove 2 springs and take off the side cover release lever [1].

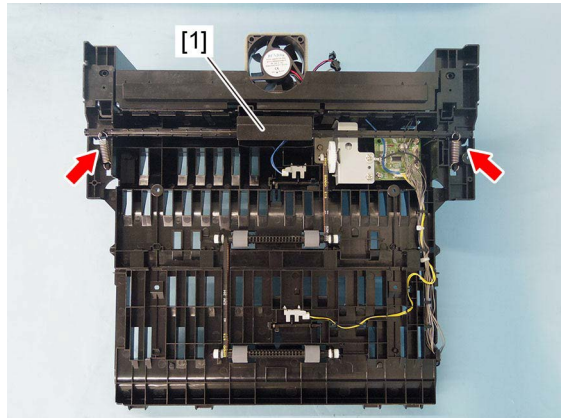


Fig. 4-434

- (3) Remove 1 ground cable fixing screw [2]. Remove 2 screws.

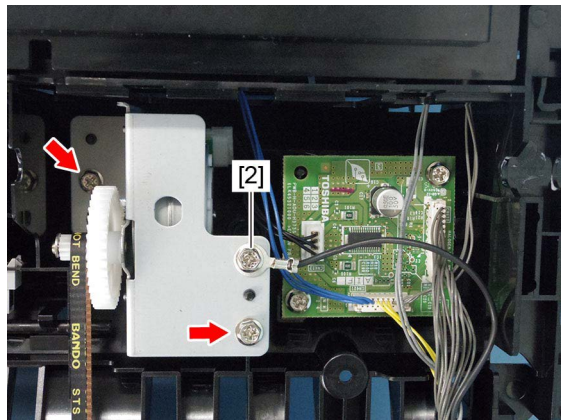


Fig. 4-435

- (4) Disconnect 1 connector and take off the ADU motor assembly [3].

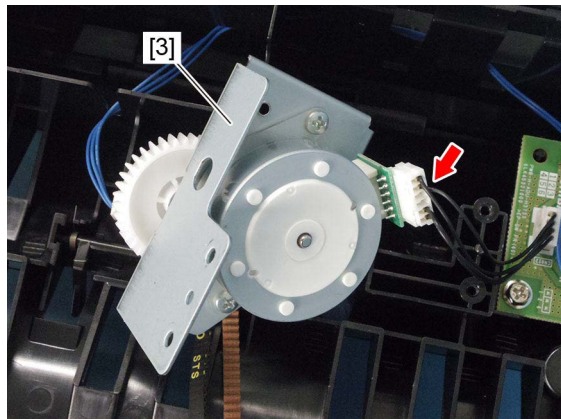


Fig. 4-436

- (5) Remove 2 screws and take off the ADU motor [4].

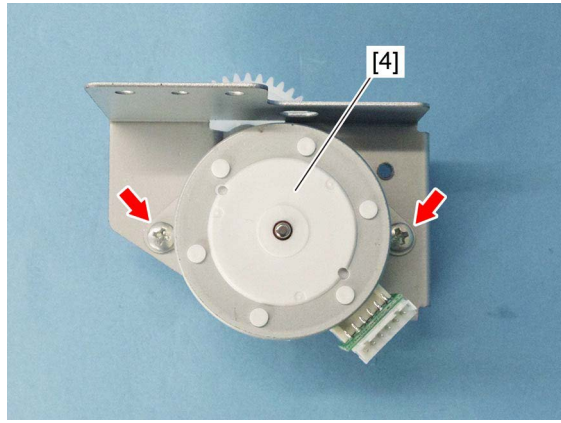


Fig. 4-437

#### 4.12.10 ADU motor (M5) <20ppm/25ppm/30ppm>

- (1) Remove the ADU guide assembly.  
P. 4-171 "4.12.4 ADU guide assembly <20ppm/25ppm/30ppm>"
- (2) Remove 2 screws from the ADU guide assembly [1].

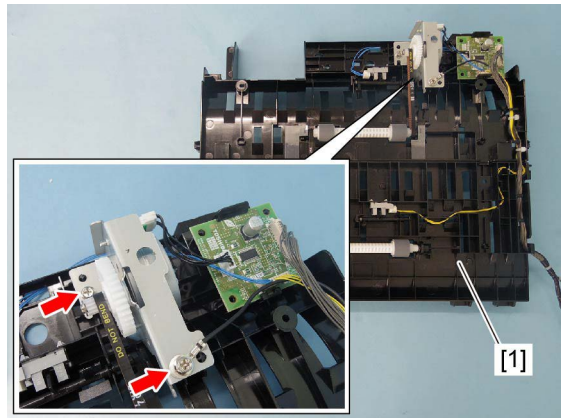


Fig. 4-438

- (3) Disconnect 1 connector and remove the ADU motor assembly [2].

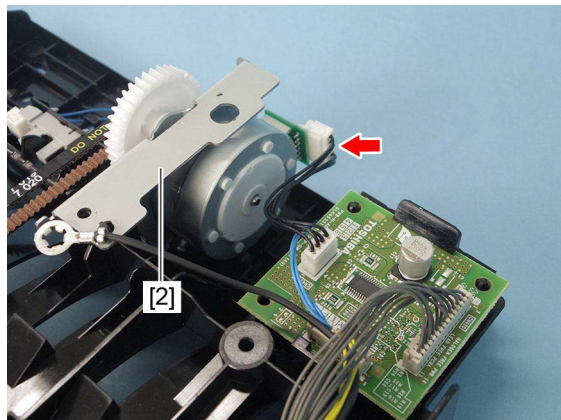


Fig. 4-439

- (4) Remove 2 screws, and take off the ADU motor [3].

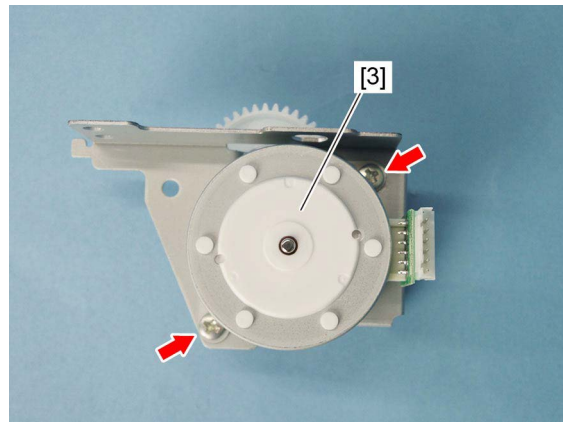


Fig. 4-440

#### 4.12.11 ADU entrance sensor (S7)

- (1) Remove the ADU guide assembly.  
<35ppm/45ppm/50ppm>  
P. 4-170 “4.12.3 ADU guide assembly <35ppm/45ppm/50ppm>”  
<20ppm/25ppm/30ppm>  
P. 4-171 “4.12.4 ADU guide assembly <20ppm/25ppm/30ppm>”
- (2) Disconnect 1 connector [2] from the ADU guide assembly [1].
- (3) Release the latch and remove the ADU entrance sensor [3].

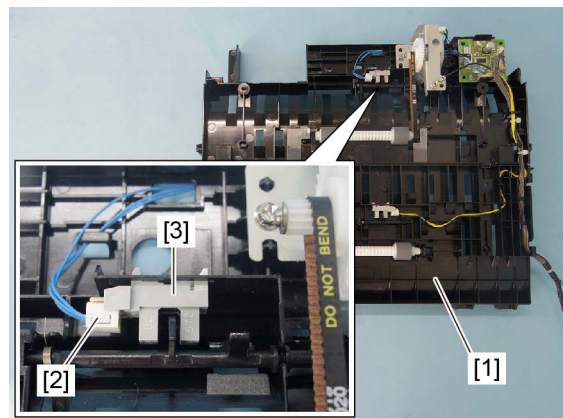


Fig. 4-441

#### 4.12.12 ADU exit sensor (S6)

- (1) Remove the ADU guide assembly.  
<35ppm/45ppm/50ppm>  
P. 4-170 “4.12.3 ADU guide assembly <35ppm/45ppm/50ppm>”  
<20ppm/25ppm/30ppm>  
P. 4-171 “4.12.4 ADU guide assembly <20ppm/25ppm/30ppm>”
- (2) Disconnect 1 connector [2] from the ADU guide assembly [1].

- (3) Release the latch and remove the ADU exit sensor [3].

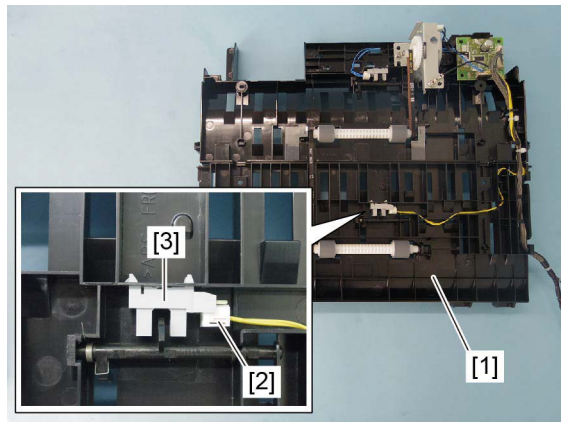


Fig. 4-442

### 4.12.13 Transport roller (Upper and lower)

- (1) Remove the ADU guide assembly.  
<35ppm/45ppm/50ppm>  
P. 4-170 "4.12.3 ADU guide assembly <35ppm/45ppm/50ppm>"  
<20ppm/25ppm/30ppm>  
P. 4-171 "4.12.4 ADU guide assembly <20ppm/25ppm/30ppm>"
- (2) Bend the rib [2] of the ADU guide assembly [1] to remove the collar [3].

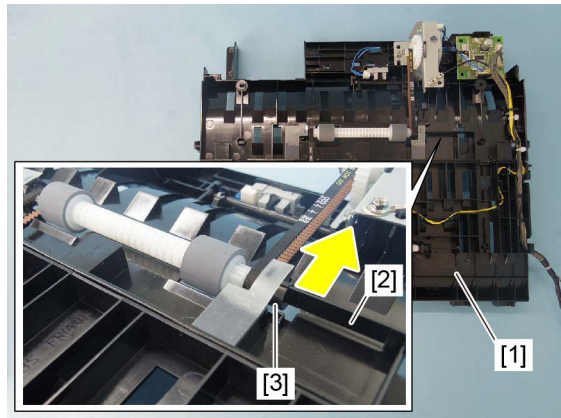


Fig. 4-443

- (3) Remove the collar [4], and then take off the transfer roller (upper) [5].

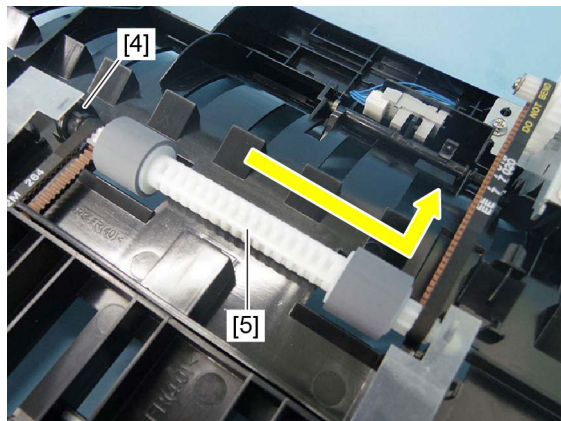


Fig. 4-444

(4) Bend the rib [6] and remove the collar [7].

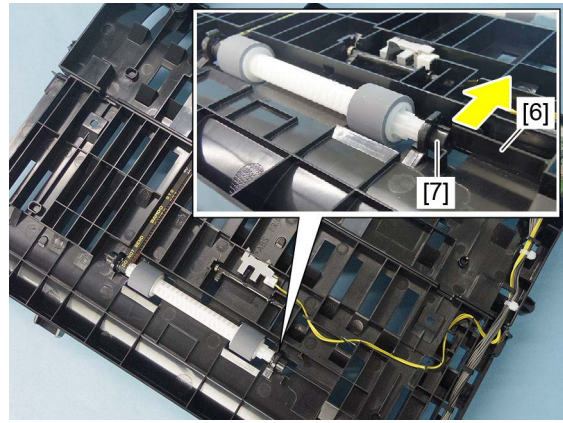


Fig. 4-445

(5) Remove the collar [8], and then take off the transfer roller (lower) [9].

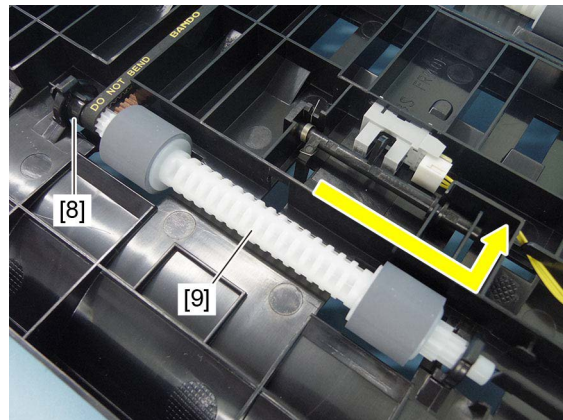


Fig. 4-446

**Notes:**

- Be sure to attach the belt [10] when carrying out installation.

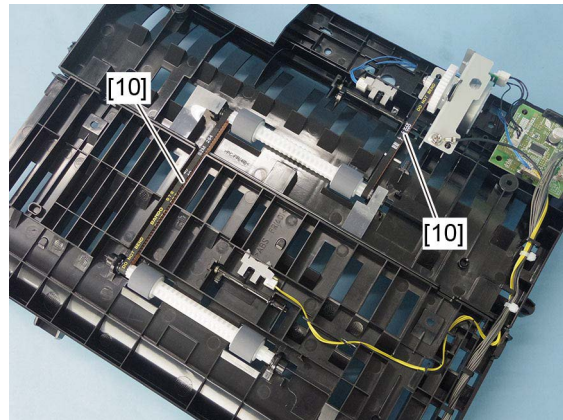


Fig. 4-447



- When replacing both the transport roller and the collar, or performing machine refreshment, apply an appropriate amount of white grease (Molykote EM-30L) inside of the collars [11]. When applying the grease, make sure that the grease is not running over.
- Grease might run out before the machine refreshment depending on frequency of use, apply an appropriate amount of grease as necessary.

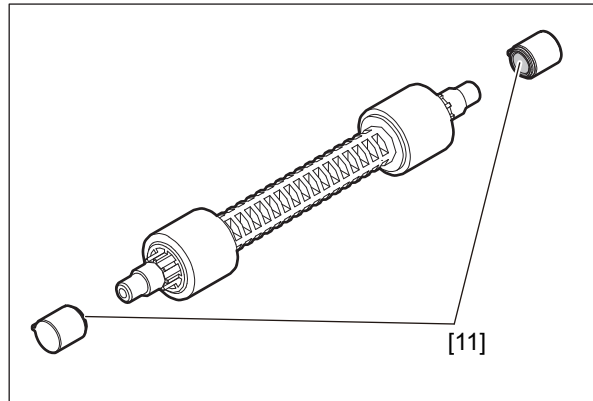


Fig. 4-448

#### 4.12.14 Reverse sensor (S18) <35ppm/45ppm/50ppm>

- (1) Remove the ADU middle cover.  
 P. 4-173 "4.12.5 ADU middle cover <35ppm/45ppm/50ppm>"
- (2) Release the latch and take off the reverse sensor [1].

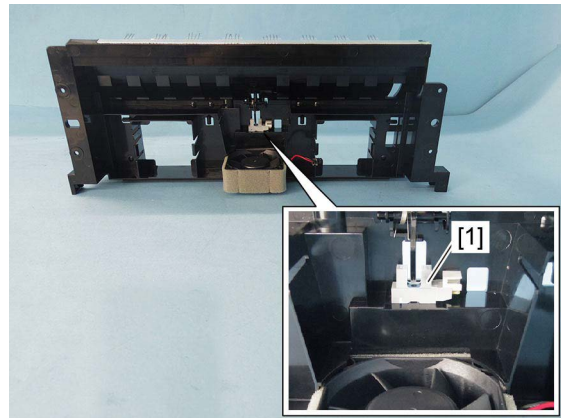


Fig. 4-449

## 4.12.15 ADU interlock switch (SW3) <35ppm/45ppm/50ppm>

### Notes:

If the interlock switch is not installed appropriately when it is replaced or installed, it may not work normally. If you carry out the maintenance of the equipment in such a situation, you could get an electric shock by touching live sections or be injured by touching moving sections. Therefore, to avoid this, be sure to perform correct handling and installation.

- (1) Remove the reverse unit.  
P. 4-153 “4.11.1 Reverse unit <35ppm/45ppm/50ppm>”
- (2) Remove 2 screws and remove the ADU interlock switch cover [1].

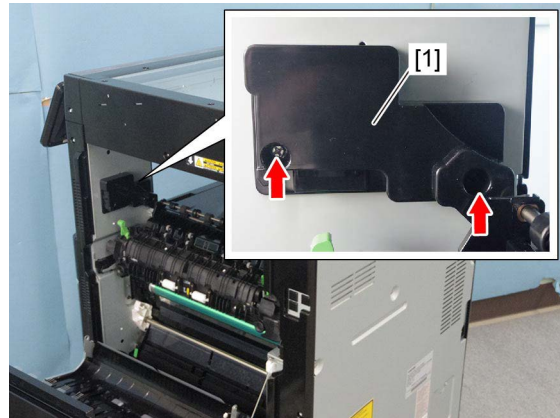


Fig. 4-450

- (3) Disconnect 2 connectors [2] from the rear side of the ADU interlock switch cover.
- (4) Release the latch [4] and remove the ADU interlock switch [3].

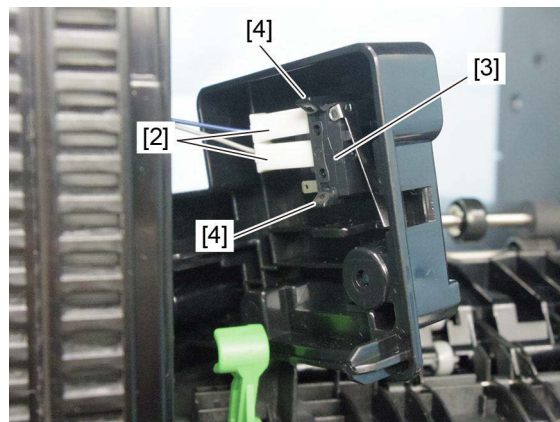


Fig. 4-451

## 4.12.16 ADU interlock switch (SW3) <20ppm/25ppm/30ppm>

### Notes:

If the interlock switch is not installed appropriately when it is replaced or installed, it may not work normally. If you carry out the maintenance of the equipment in such a situation, you could get an electric shock by touching live sections or be injured by touching moving sections. Therefore, to avoid this, be sure to perform correct handling and installation.

- (1) Open the side cover.
- (2) Remove 2 screws and take off the ADU interlock switch cover [1].

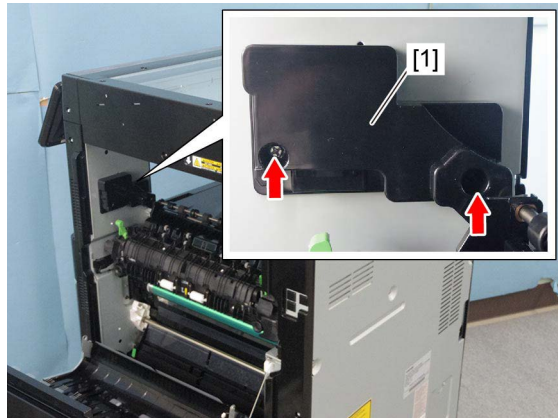


Fig. 4-452

- (3) Disconnect 2 connectors [2] from the rear side of the ADU interlock switch cover.
- (4) Release the latch [4] and remove the ADU interlock switch [3].

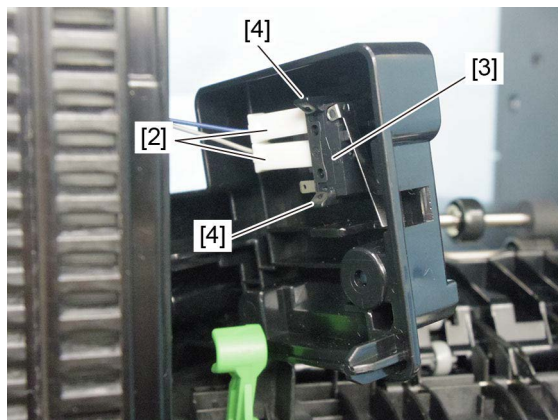



Fig. 4-453

#### 4.12.17 Exit section cooling fan (M14) <35ppm/45ppm/50ppm>

- (1) Remove the ADU guide assembly.  
 P. 4-170 “4.12.3 ADU guide assembly <35ppm/45ppm/50ppm>”
- (2) Disconnect 1 connector and remove the exit section cooling fan [1].

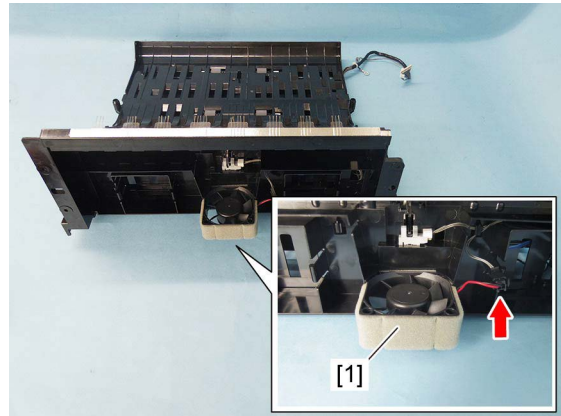


Fig. 4-454

## 4.13 Removal and Installation of Options

### Important:

Before installing or removing options, turn the main power switch off and disconnect the power cable from the outlet.

### 4.13.1 Dual Scan Document Feeder

- (1) Press the [ON/OFF] button on the control panel to shut it down.
- (2) Turn the main power switch of the equipment off.
- (3) Disconnect the power cable.
- (4) Take off the connector cover.

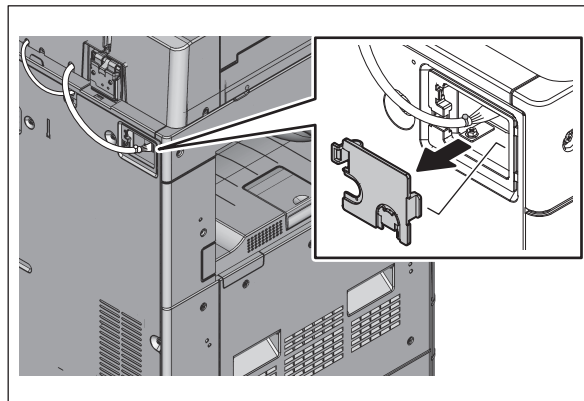


Fig. 4-455

- (5) Disconnect 1 connector.

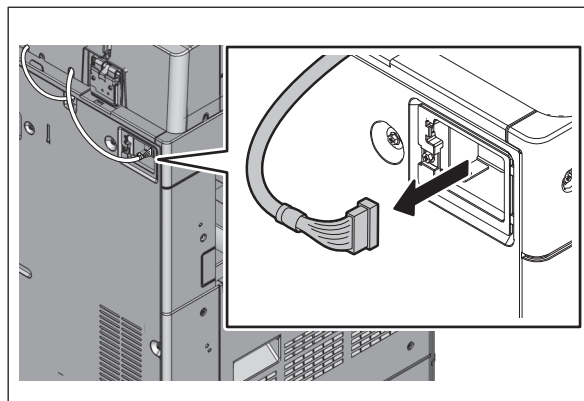


Fig. 4-456

- (6) Install the connector cover.

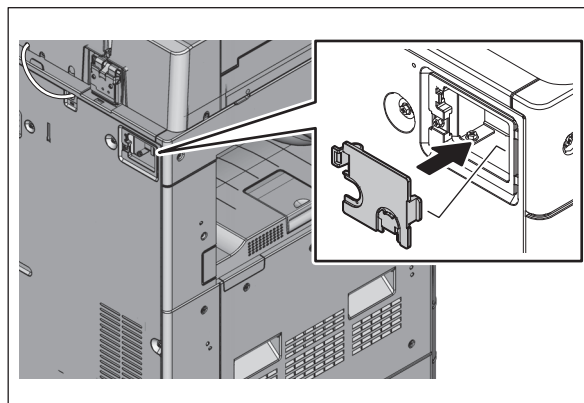


Fig. 4-457

(7) Remove 1 screw and take off the cover.

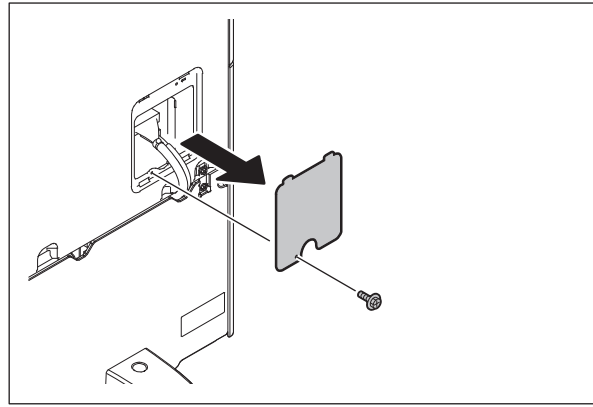


Fig. 4-458

(8) Remove 1 screw and take off the ground cable. Disconnect 2 connectors.  
[1] Damp heater harness (JPD)  
[2] Signal harness

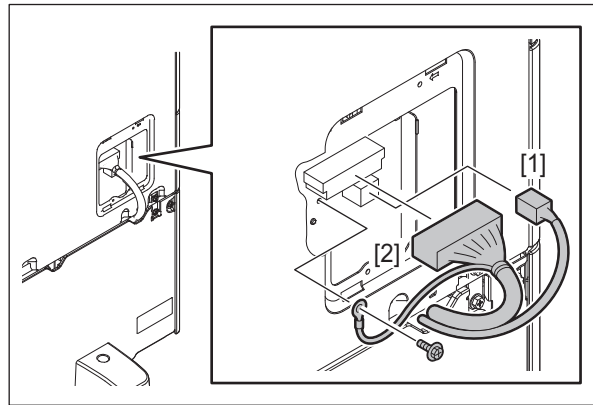


Fig. 4-459

(9) Remove 6 screws and take off the rear cover.

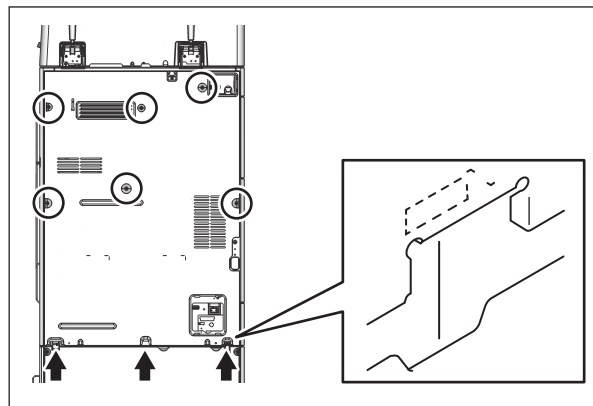


Fig. 4-460

(10) Remove 2 screws and take off the SYS board cover.

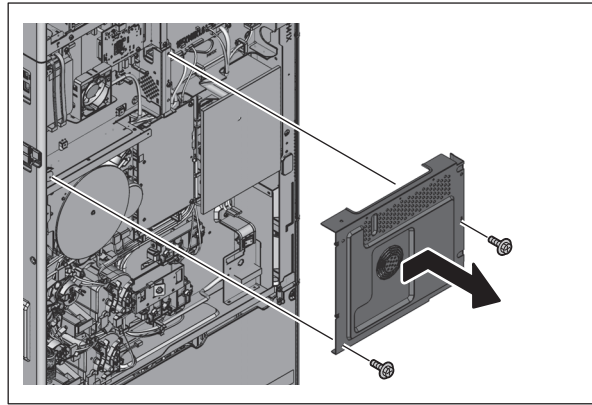


Fig. 4-461

(11) Disconnect 1 connector.

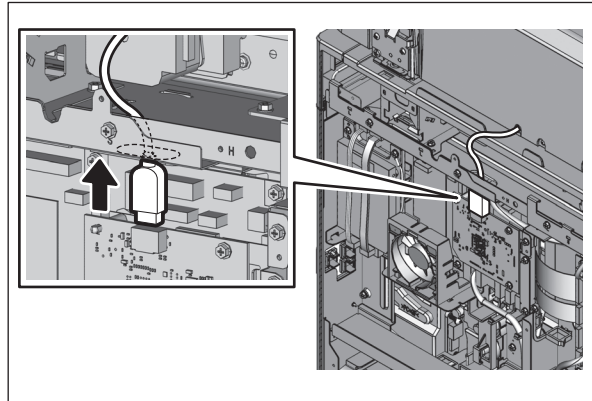


Fig. 4-462

(12) Install the SYS board cover with 2 screws.

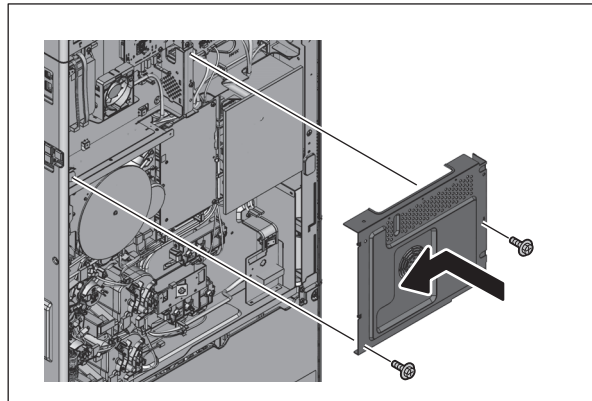


Fig. 4-463

(13) Install the rear cover with 6 screws.

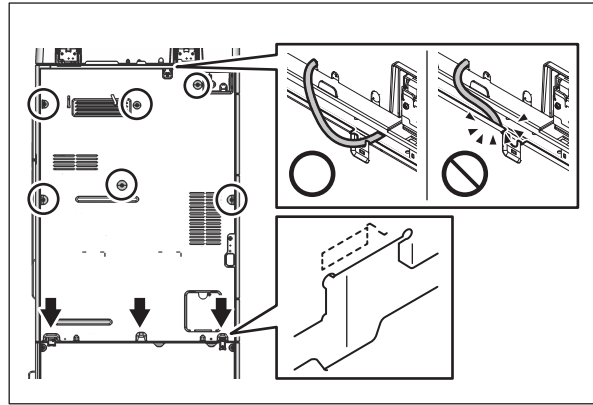


Fig. 4-464

(14) Connect 2 connectors. Install the ground cable with 1 screw.  
[1] Damp heater harness  
[2] Signal harness

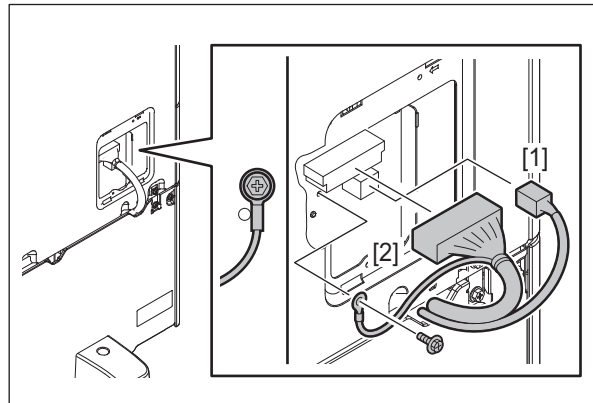


Fig. 4-465

(15) Install the cover with 1 screw.

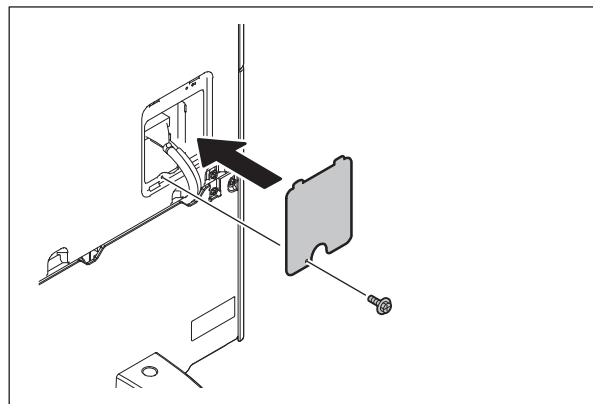


Fig. 4-466



(16) Remove 4 screws and take off 2 brackets.

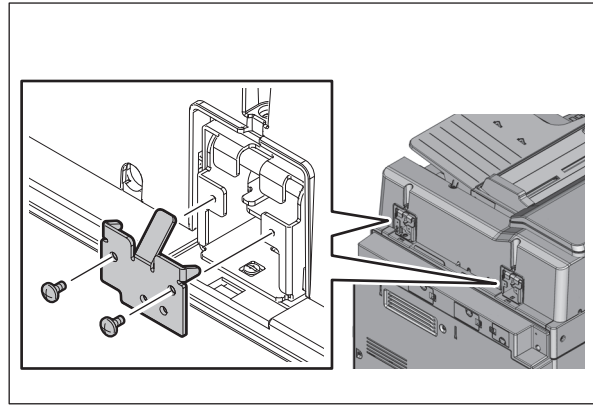


Fig. 4-467

(17) Remove 2 screws and 1 washer.

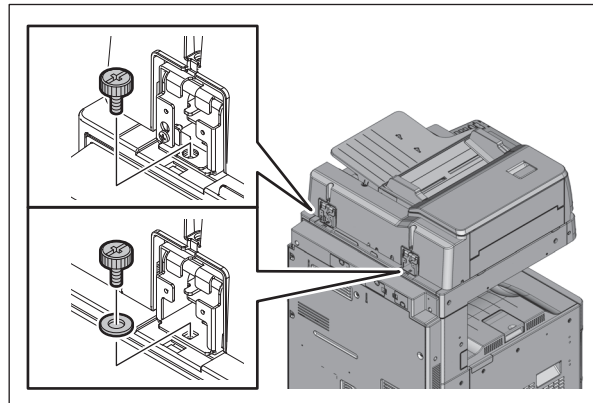


Fig. 4-468

(18) Open the dual scan document feeder. Remove 2 screws.

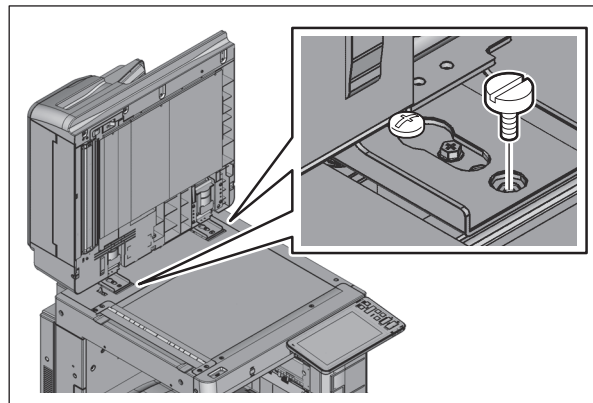


Fig. 4-469

(19) Remove the dual scan document feeder by sliding it toward the rear side.

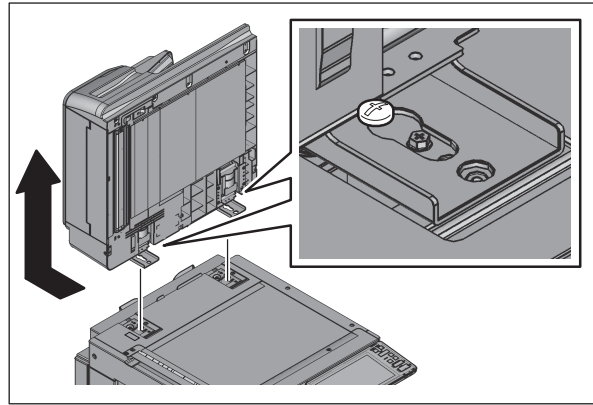


Fig. 4-470

### 4.13.2 Reversing Automatic Document Feeder

- (1) Press the [ON/OFF] button on the control panel to shut it down.
- (2) Turn the main power switch of the equipment off.
- (3) Disconnect the power cable.
- (4) Take off the connector cover.

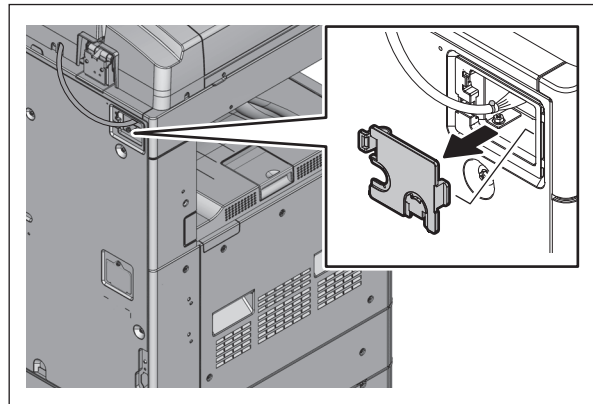


Fig. 4-471

- (5) Disconnect 1 connector.

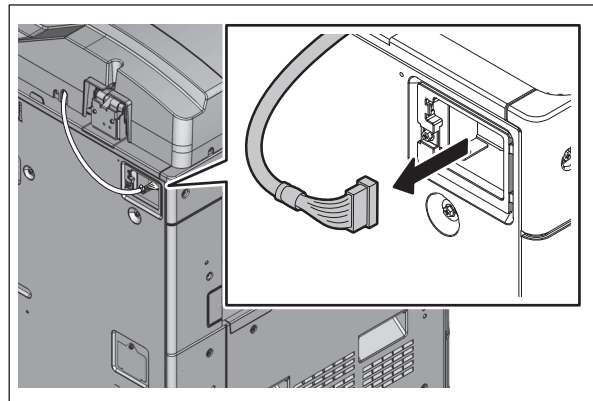


Fig. 4-472

(6) Install the connector cover.

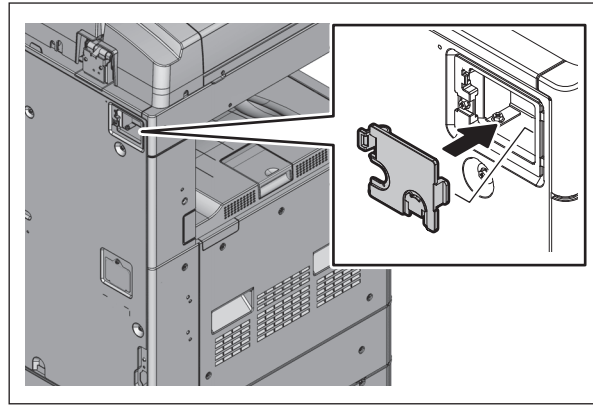


Fig. 4-473

(7) Remove 2 screws and take off 1 bracket.

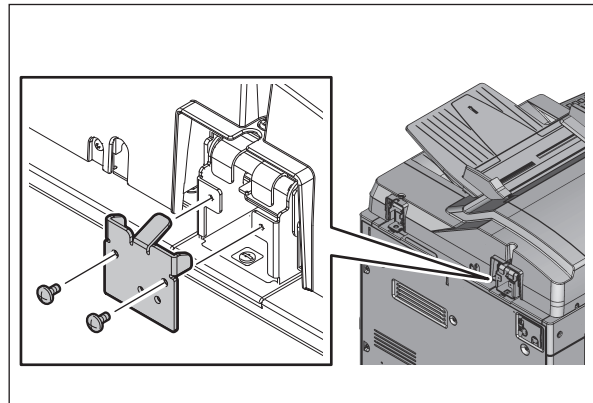


Fig. 4-474

(8) Remove the cover.

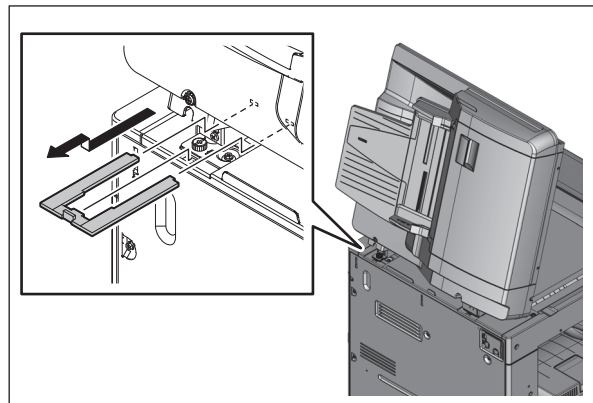


Fig. 4-475

(9) Remove 2 screws and 1 washer.

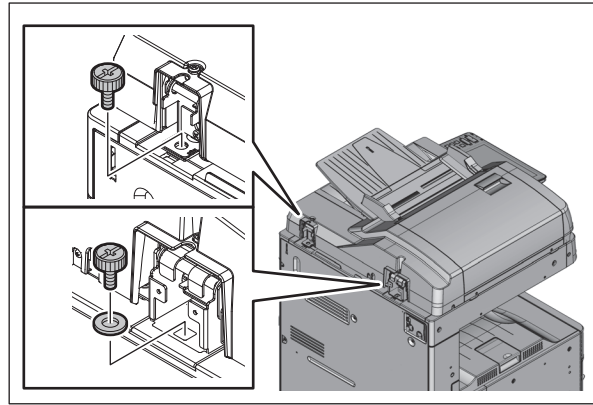


Fig. 4-476

(10) Open the reversing automatic document feeder. Remove 2 screws.

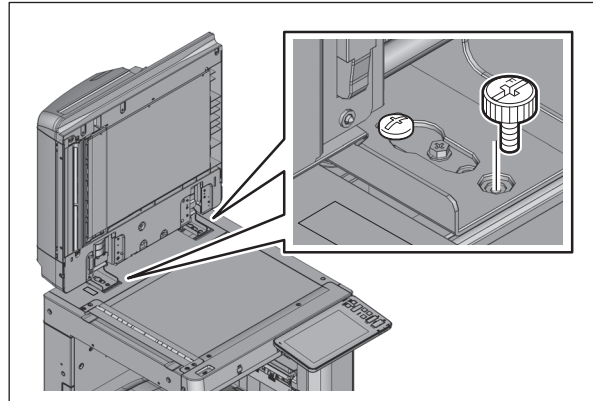


Fig. 4-477

(11) Remove the reversing automatic document feeder by sliding it toward the rear side.

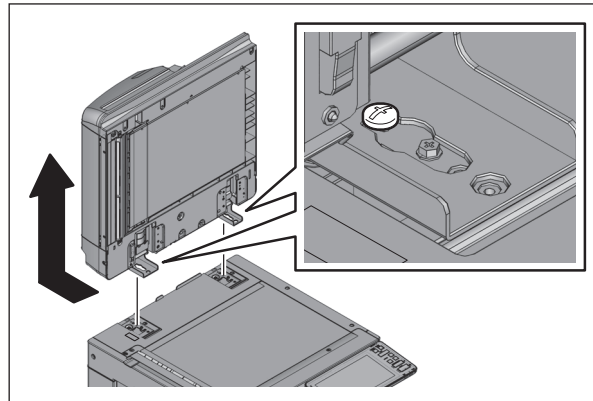


Fig. 4-478

### 4.13.3 Paper Feed Pedestal

- (1) Press the [ON/OFF] button on the control panel to shut it down.
- (2) Turn the main power switch of the equipment off.
- (3) Disconnect the power cable.
- (4) Remove 1 screw and take off the cover.

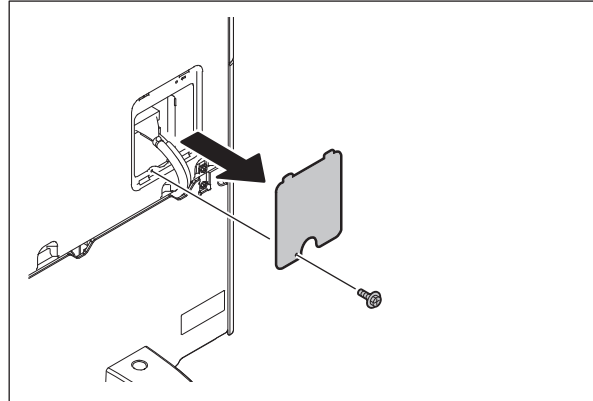


Fig. 4-479

- (5) Remove 1 screw and take off the ground cable. Disconnect 1 connector.

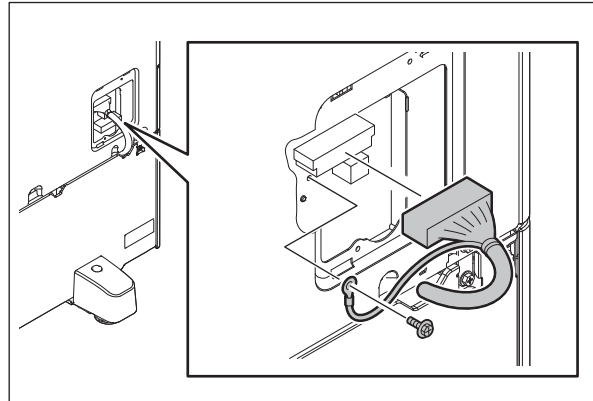


Fig. 4-480

- (6) Remove 3 screws and take off 2 fixing brackets on the rear side.

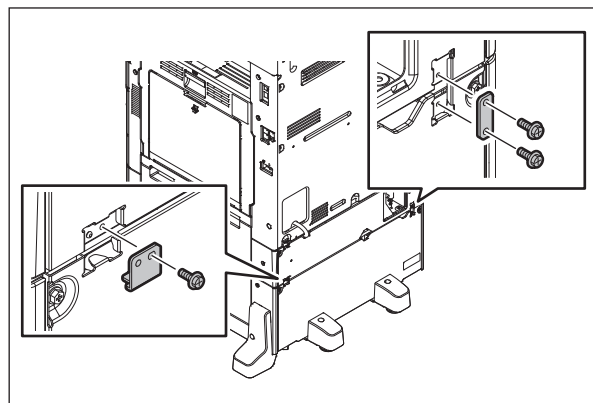


Fig. 4-481

(7) Install the cover with 1 screw.

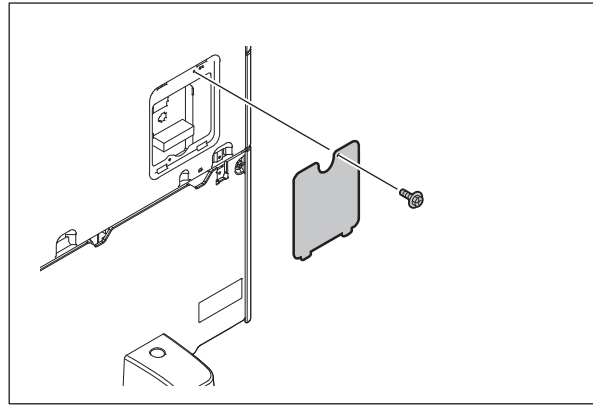


Fig. 4-482

(8) Pull out the drawer.

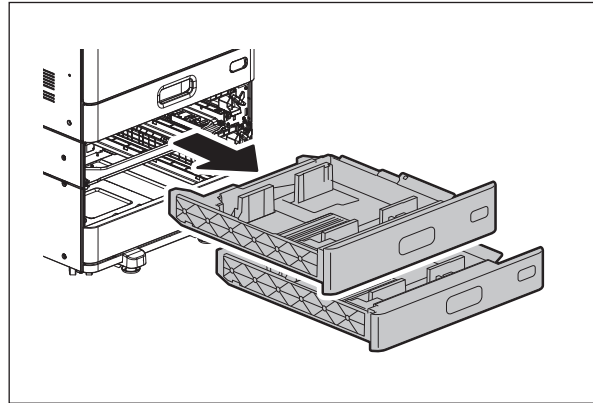


Fig. 4-483

(9) Remove 3 screws and take off 2 fixing brackets on the front side.

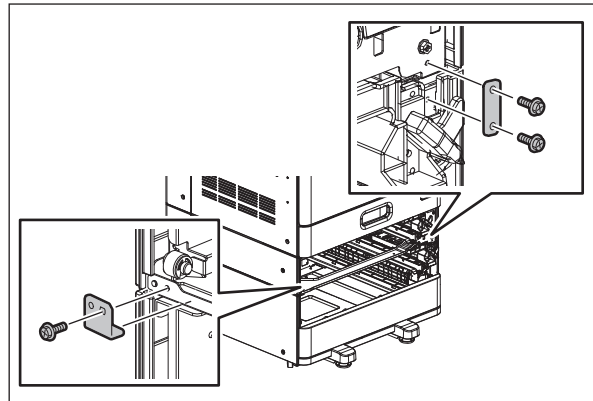


Fig. 4-484

(10) Install the drawer.

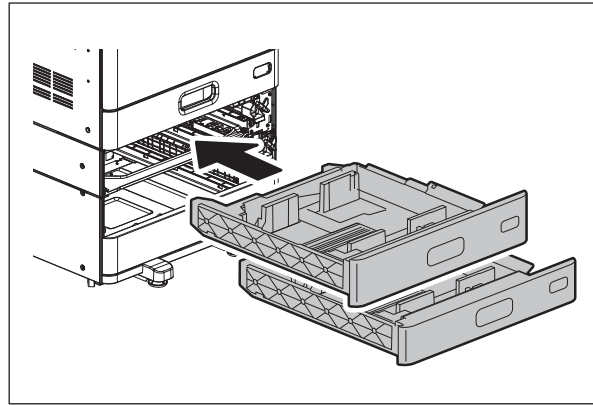


Fig. 4-485

(11) Lift the equipment up and remove the paper feed pedestal.

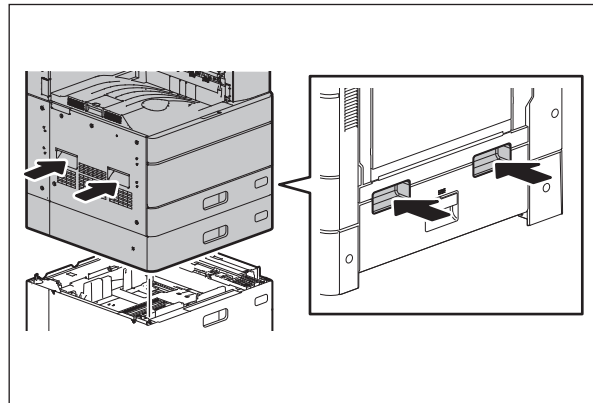


Fig. 4-486

#### 4.13.4 Large Capacity Feeder

- (1) Press the [ON/OFF] button on the control panel to shut it down.
- (2) Turn the main power switch of the equipment off.
- (3) Disconnect the power cable.
- (4) Remove 1 screw and take off the cover.

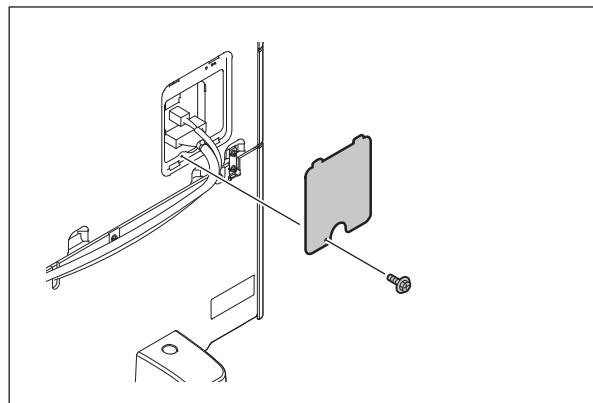


Fig. 4-487

- (5) Disconnect 2 connectors. Remove 1 screw and take off the ground cable.  
[1] Damp heater harness  
[2] Signal harness

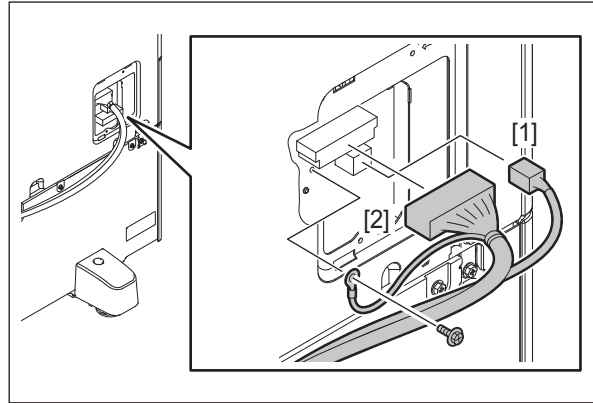


Fig. 4-488

- (6) Remove 3 screws and take off 2 fixing brackets on the rear side.

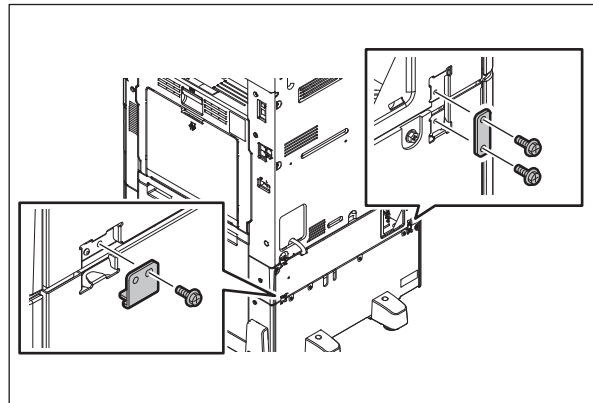


Fig. 4-489

- (7) Install the cover with 1 screw.

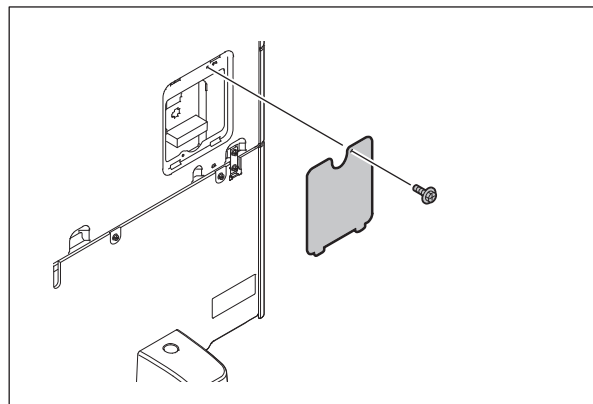


Fig. 4-490



(8) Pull out the drawer.

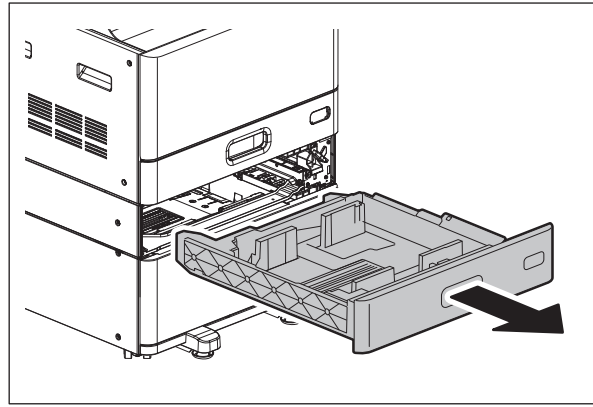


Fig. 4-491

(9) Pull out the large capacity feeder drawer.

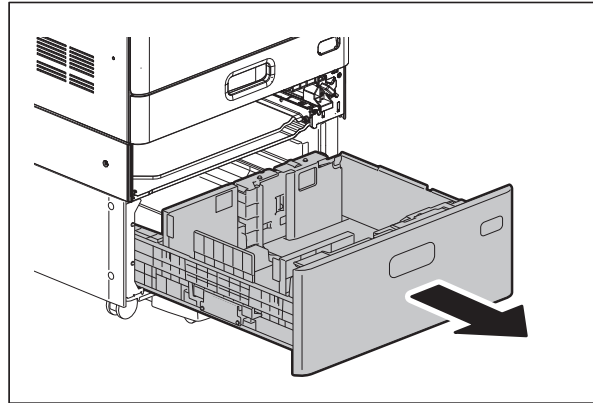


Fig. 4-492

(10) Install the right drawer.

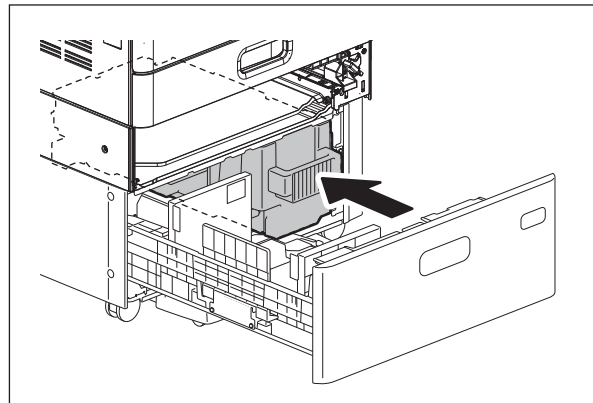


Fig. 4-493

(11) Remove 4 screws and take off 2 fixing brackets on the front side.

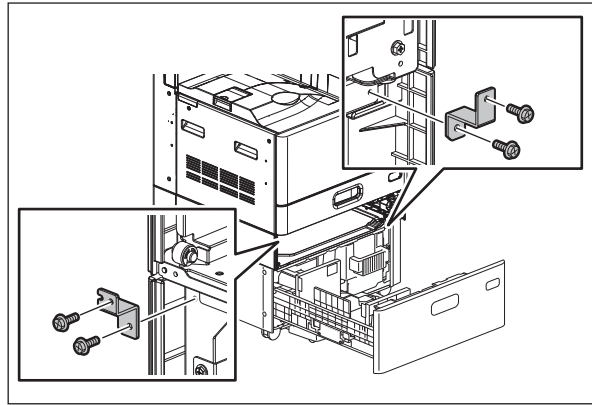


Fig. 4-494

(12) Install the large capacity feeder drawer.

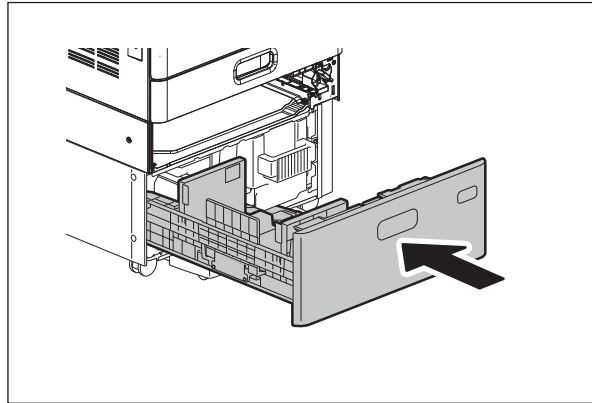


Fig. 4-495

(13) Install the drawer.

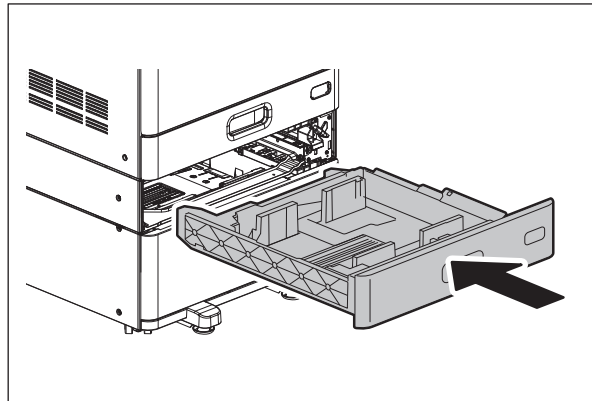


Fig. 4-496

(14) Lift the equipment up and remove the large capacity feeder.

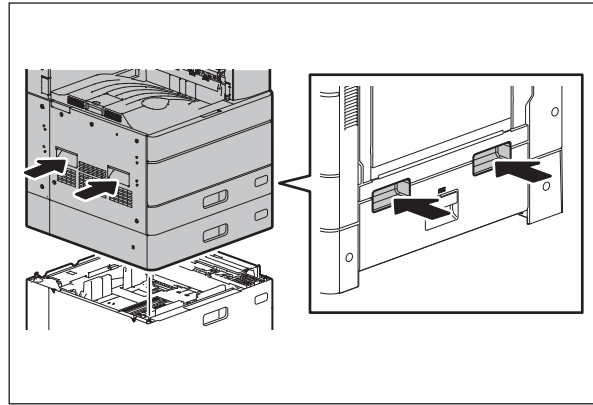


Fig. 4-497

### 4.13.5 Bridge kit

- (1) Press the [ON/OFF] button on the control panel to shut it down.
- (2) Turn the main power switch of the equipment off.
- (3) Disconnect the power cable.
- (4) Remove the exit back cover.
- (5) Disconnect 1 connector.

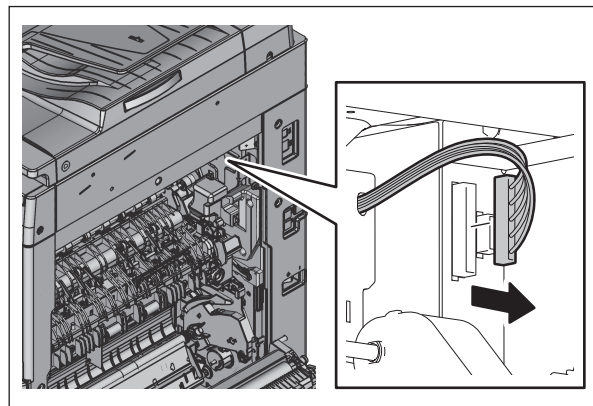


Fig. 4-498

(6) Remove 1 screw and take off the front cover of the bridge kit.

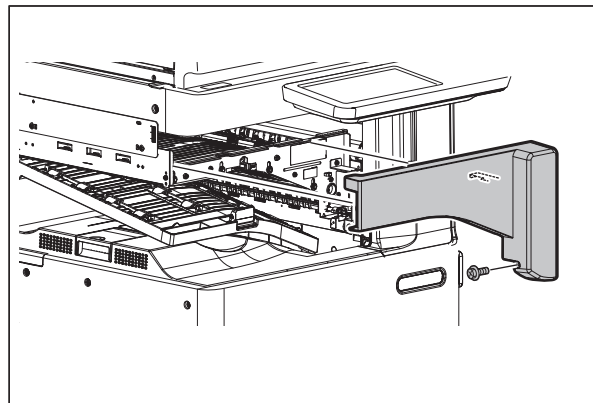


Fig. 4-499

(7) Remove 1 screw.

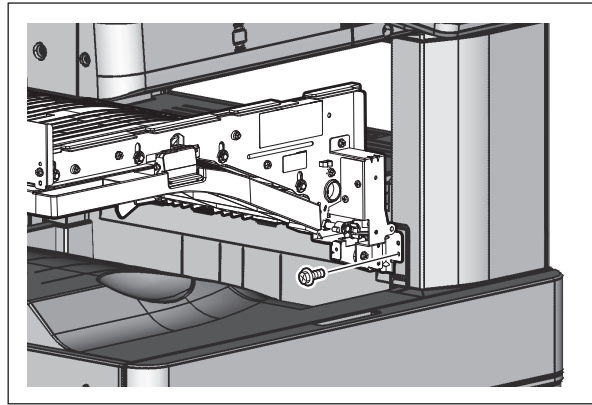


Fig. 4-500

(8) Remove 2 screws and take off the fixing bracket.

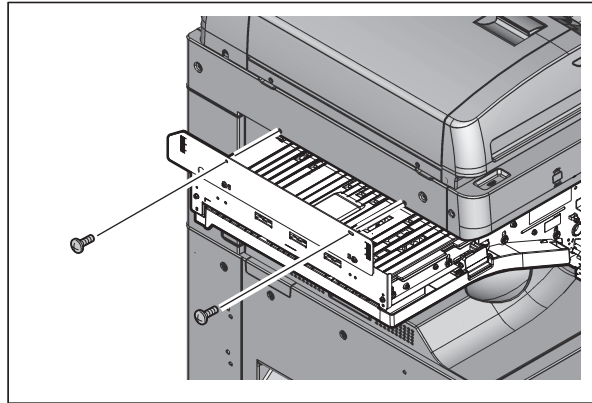


Fig. 4-501

(9) Lift the bridge kit up to pull out the hook, and pull the bridge kit toward the front side to remove it.

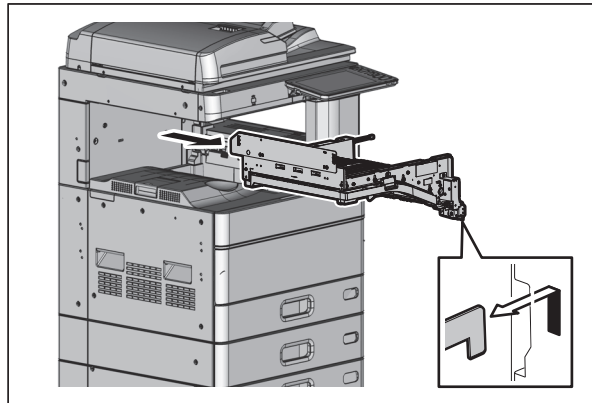


Fig. 4-502

### 4.13.6 Inner finisher

- (1) Press the [ON/OFF] button on the control panel to shut it down.
- (2) Turn the main power switch of the equipment off.
- (3) Disconnect the power cable.
- (4) Remove the connector cover.

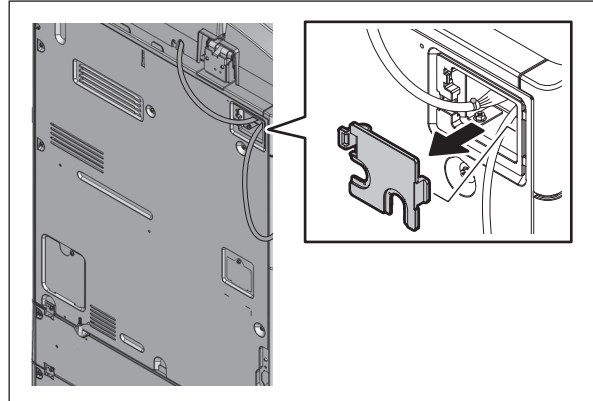


Fig. 4-503

- (5) Disconnect 1 connector.

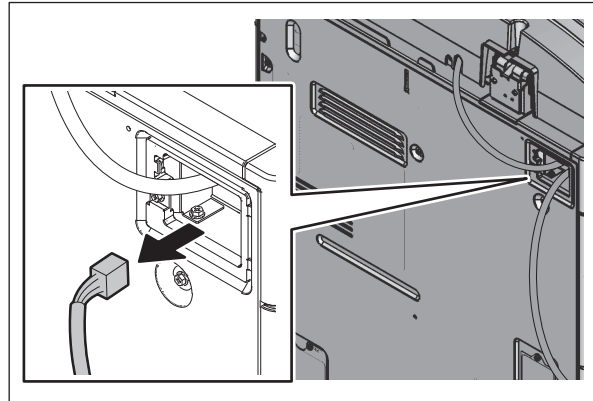


Fig. 4-504

- (6) Install the connector cover.

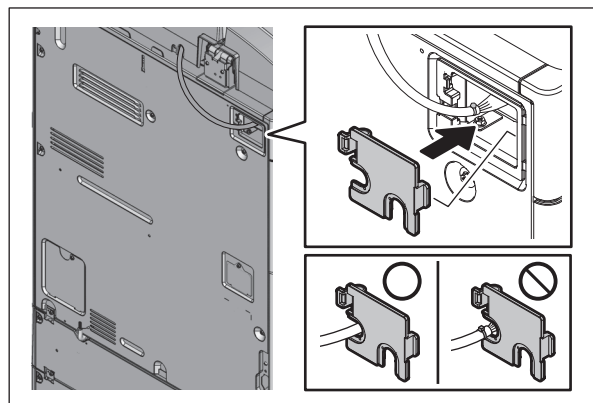


Fig. 4-505

(7) Open the finisher cover.

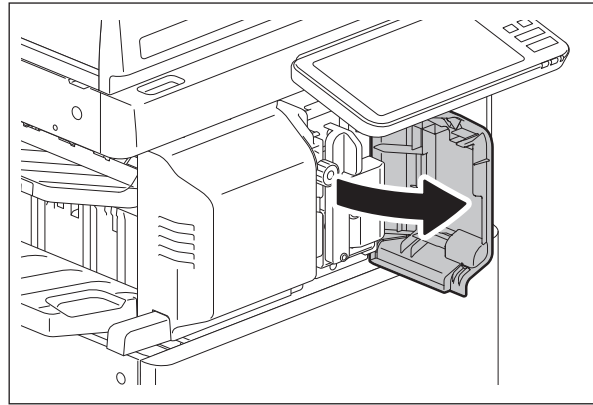


Fig. 4-506

(8) Press the button to release the lock. Pull out the finisher.

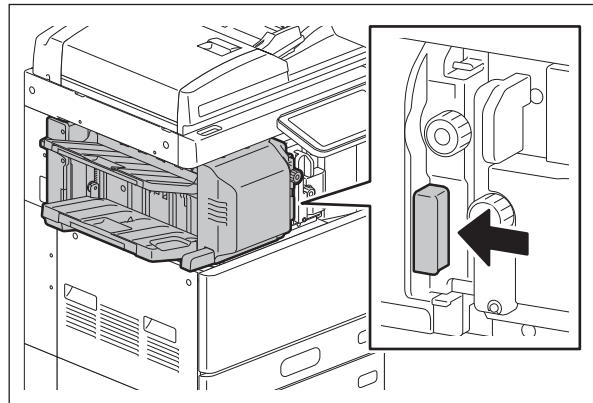


Fig. 4-507

(9) Remove 1 screw and take off 1 bracket.

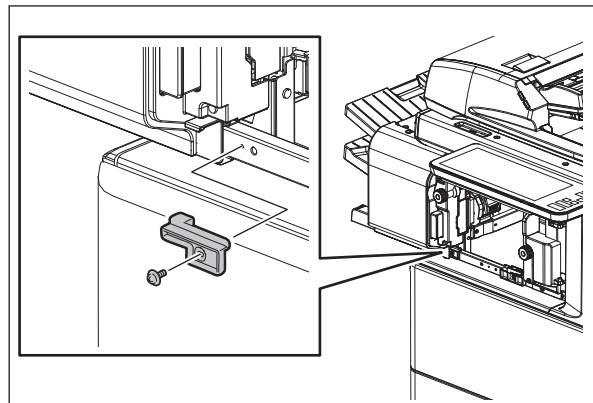


Fig. 4-508

(10) Return the finisher to the installation position temporarily by sliding it.

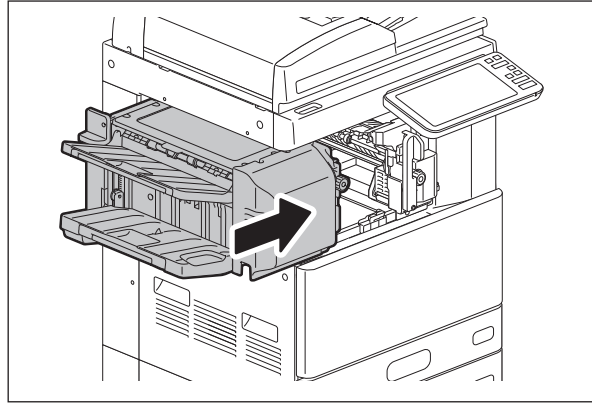


Fig. 4-509

(11) Remove 3 screws and take off the cover.

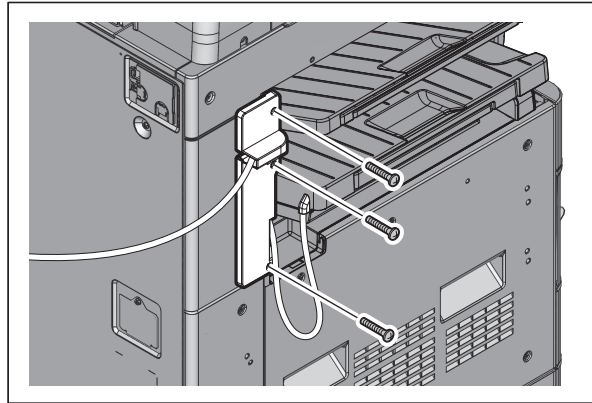


Fig. 4-510

(12) Remove 1 screw.

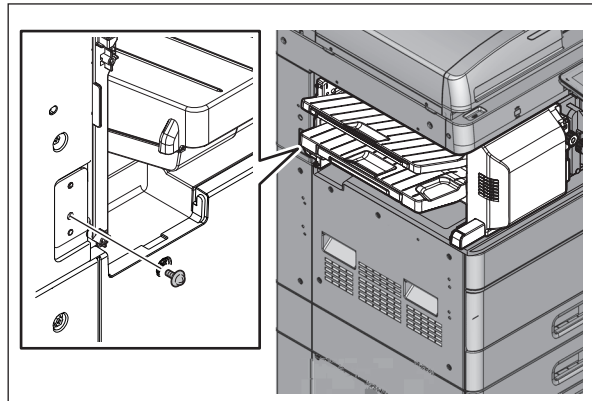


Fig. 4-511

(13) Remove the finisher.

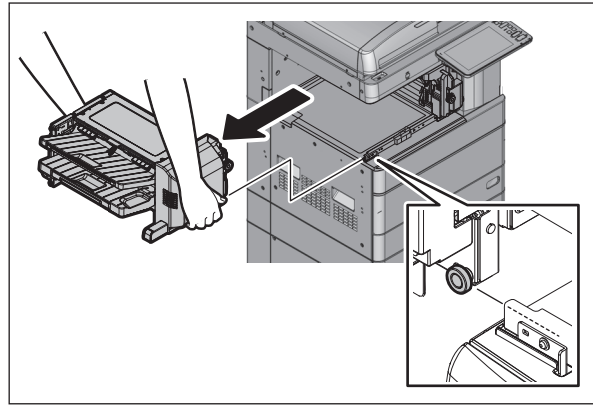


Fig. 4-512

#### 4.13.7 Saddle stitch finisher

- (1) Press the [ON/OFF] button on the control panel to shut it down.
- (2) Turn the main power switch of the equipment off.
- (3) Disconnect the power cable.
- (4) Remove the connector cover.

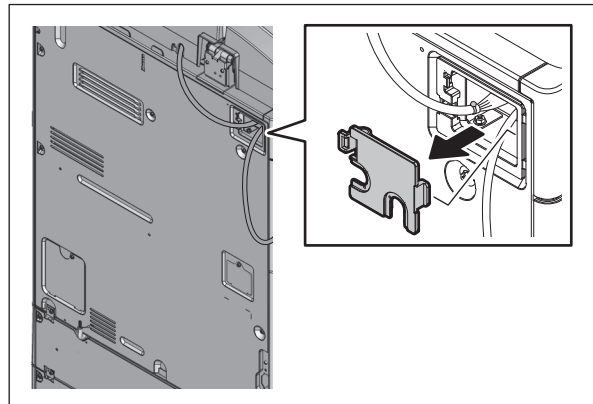


Fig. 4-513

(5) Disconnect 1 connector.

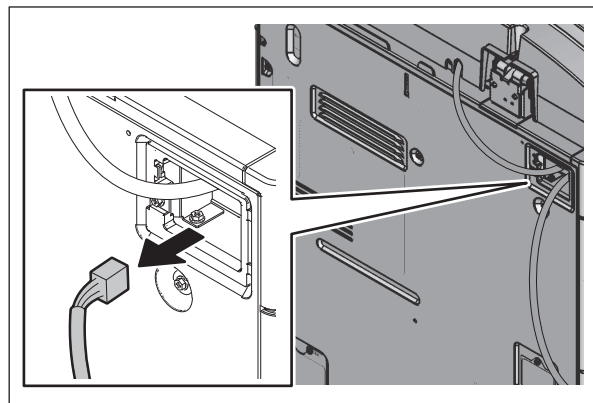


Fig. 4-514



(6) Install the connector cover.

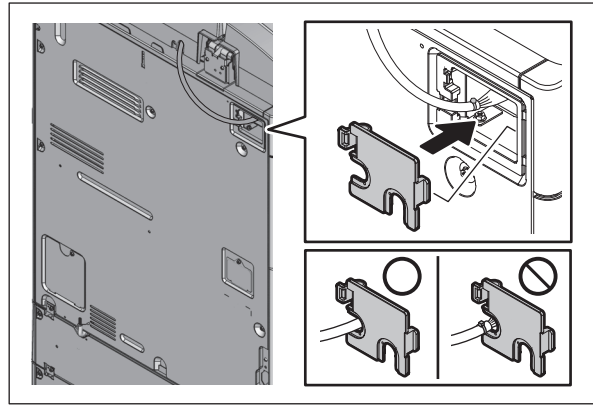


Fig. 4-515

(7) Open the finisher cover and remove 1 fixing screw. Pull out the lever.

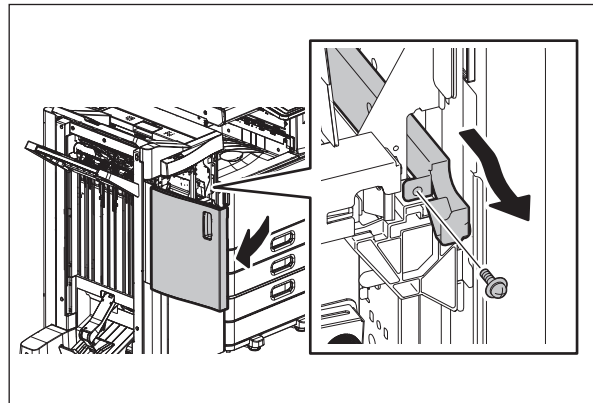


Fig. 4-516

(8) Remove the finisher.

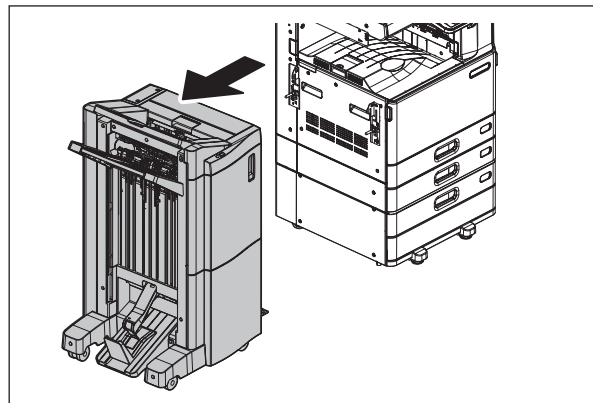


Fig. 4-517

### 4.13.8 Saddle stitch finisher (with Hole punch unit)

- (1) Press the [ON/OFF] button on the control panel to shut it down.
- (2) Turn the main power switch of the equipment off.
- (3) Disconnect the power cable.
- (4) Remove the connector cover.

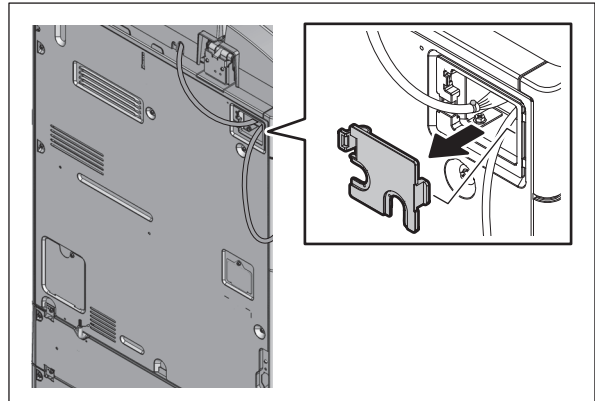


Fig. 4-518

- (5) Disconnect 1 connector.

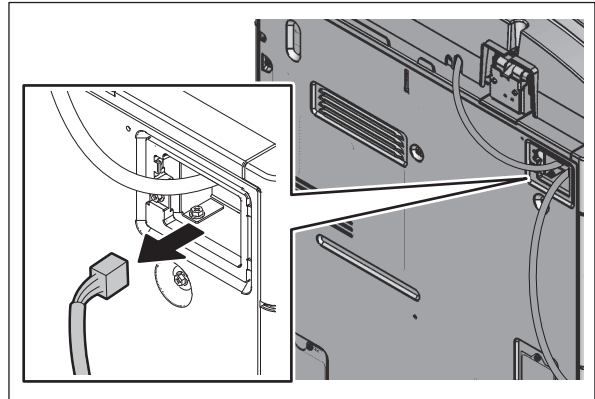


Fig. 4-519

- (6) Install the connector cover.

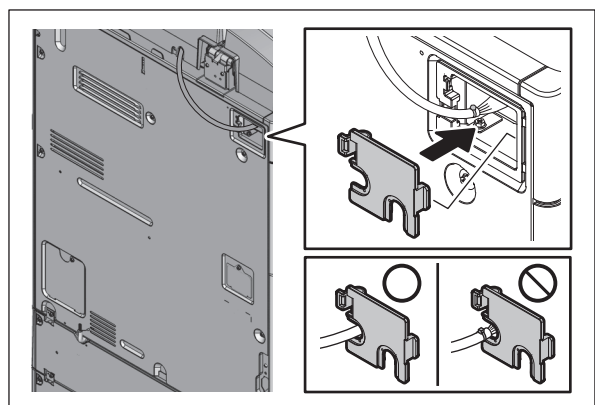


Fig. 4-520

- (7) Take off the cover of the hole punch unit lower side.

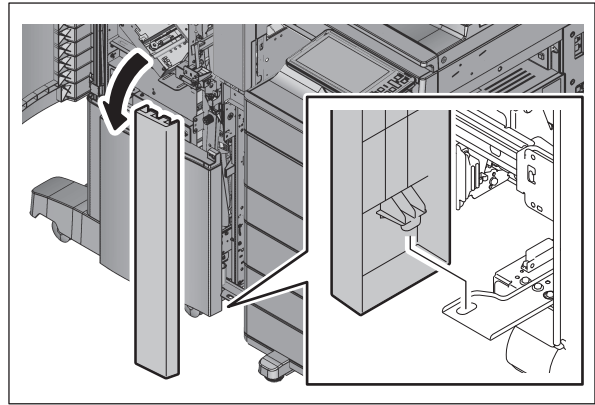


Fig. 4-521

- (8) Open the finisher cover and remove 1 fixing screw. Pull out the lever.

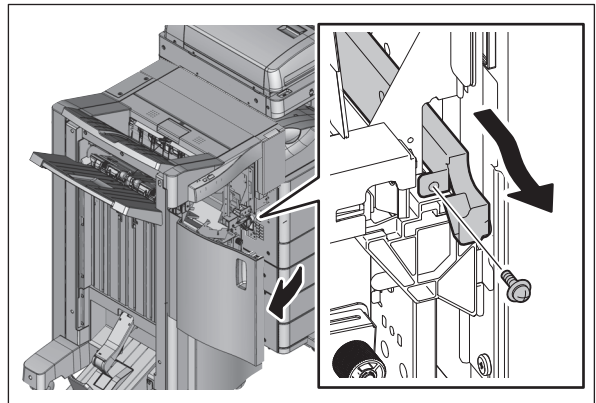


Fig. 4-522

- (9) Take off the finisher with the hole punch unit.

**Notes:**

Be careful not to fell the finisher when moving only the finisher unit.

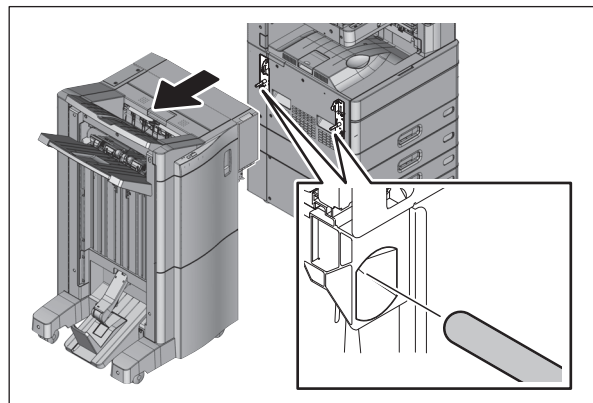


Fig. 4-523

### 4.13.9 Finisher (with Hole punch unit)

- (1) Press the [ON/OFF] button on the control panel to shut it down.
- (2) Turn the main power switch of the equipment off.
- (3) Disconnect the power cable.
- (4) Remove the connector cover.

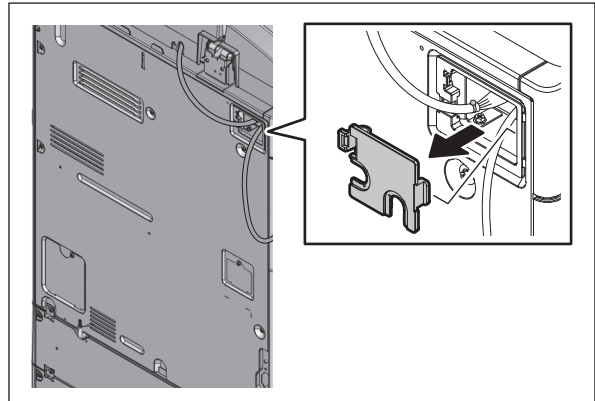


Fig. 4-524

- (5) Disconnect the connector.

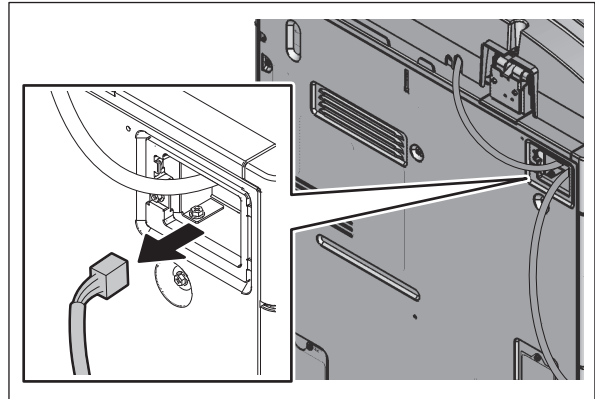


Fig. 4-525

- (6) Install the connector cover.

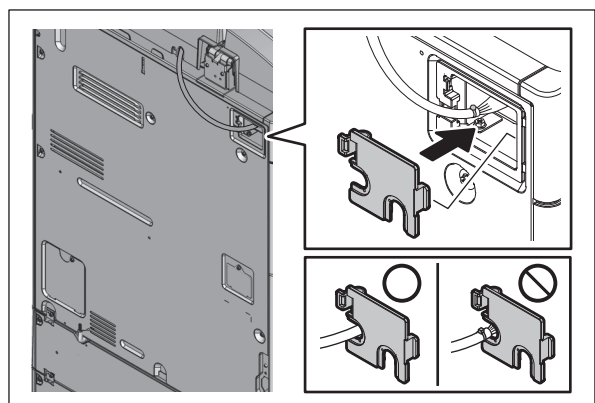


Fig. 4-526

- (7) Take off the cover of the hole punch unit lower side.

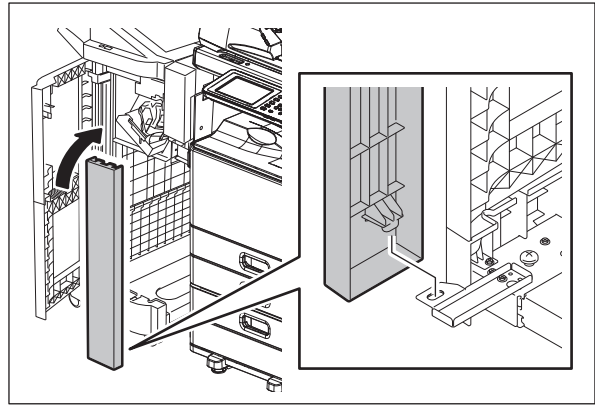


Fig. 4-527

- (8) Open the finisher cover and remove 1 fixing screw. Pull out the lever.

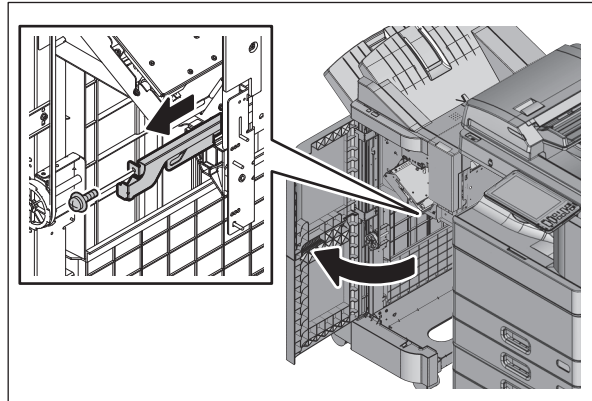


Fig. 4-528

- (9) Take off the finisher with the hole punch unit.

**Notes:**

Be careful not to fell the finisher when moving only the finisher unit.

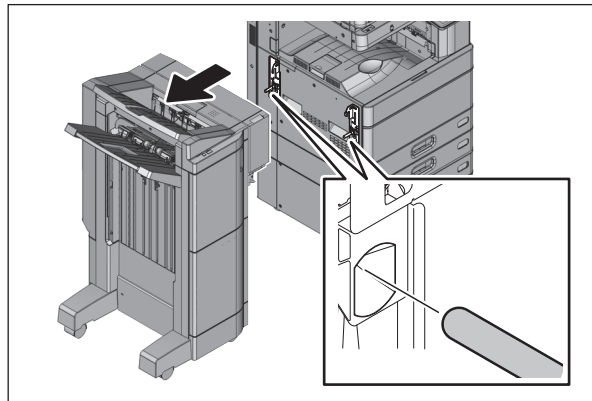


Fig. 4-529

### 4.13.10 Finisher

- (1) Press the [ON/OFF] button on the control panel to shut down the machine.
- (2) Turn the main power switch of the machine off.
- (3) Disconnect the power cable.
- (4) Remove the connector cover.

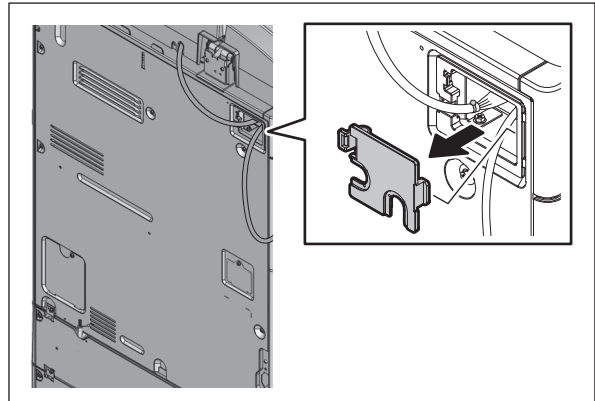


Fig. 4-530

- (5) Disconnect 1 connector.

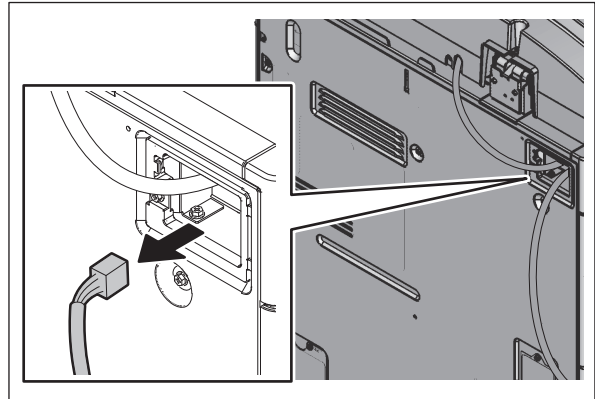


Fig. 4-531

- (6) Install the connector cover.

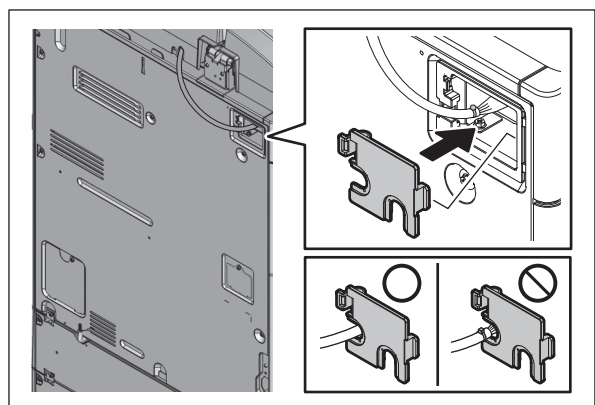


Fig. 4-532

- (7) Open the finisher cover and remove 1 fixing screw. Pull out the lever.

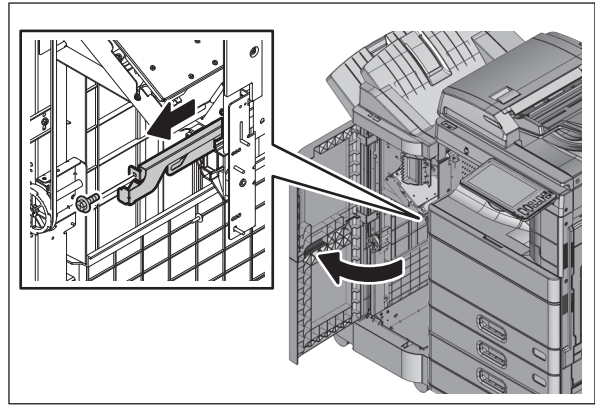


Fig. 4-533

- (8) Remove the finisher.

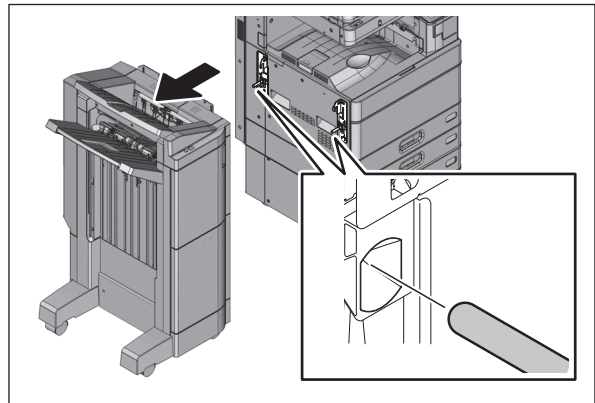


Fig. 4-534

#### 4.13.11 Job Separator <20ppm/25ppm/30ppm>

- (1) Press the [ON/OFF] button on the control panel to shut it down.
- (2) Turn the main power switch of the equipment off.
- (3) Disconnect the power cable.
- (4) Remove the tray.

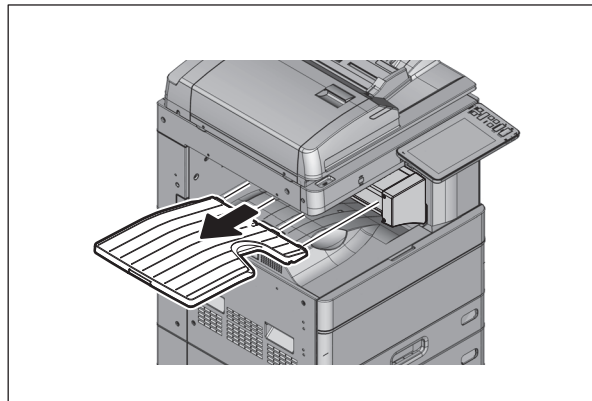


Fig. 4-535

(5) Open the side cover. Remove 1 screw and take off the exit back cover.

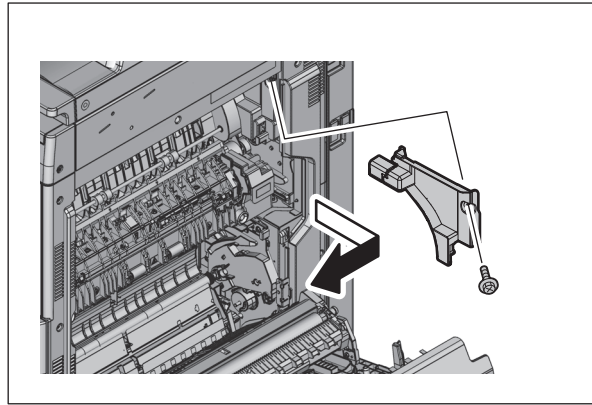


Fig. 4-536

(6) Disconnect 2 connectors.

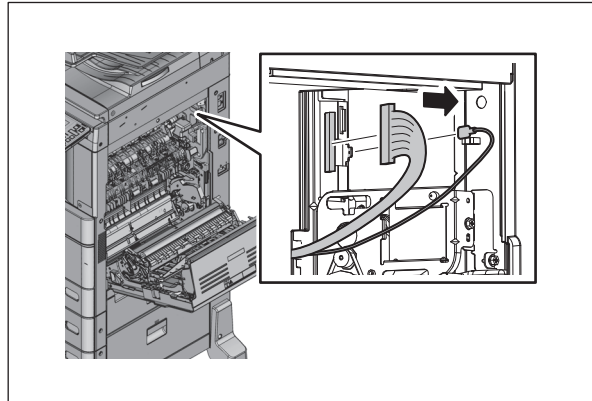


Fig. 4-537

(7) Loosen 2 screws and take off the front cover of job separator.

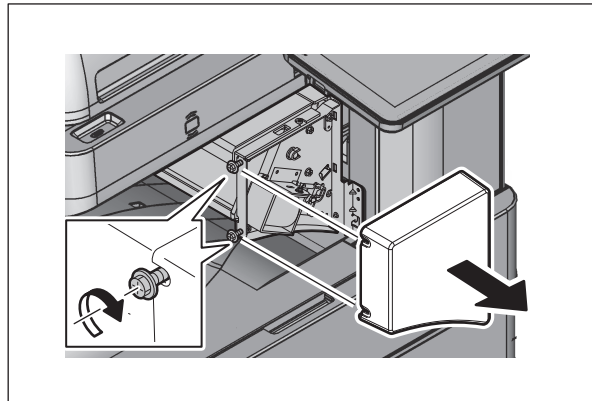


Fig. 4-538



- (8) Remove 1 screw. Lift up the job separator and release the hook. Take off the job separator toward the front.

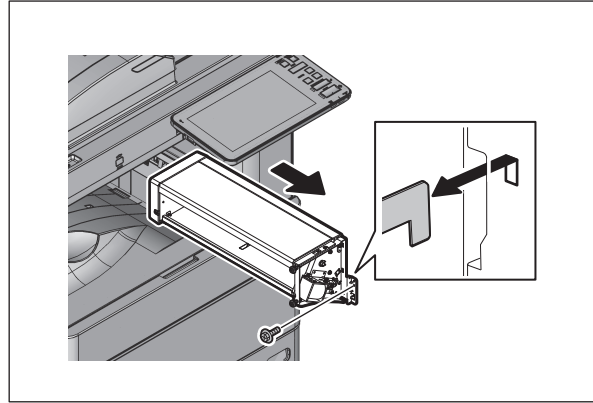


Fig. 4-539

#### 4.13.12 Job separator <35ppm/45ppm/50ppm>

- (1) Press the [ON/OFF] button on the control panel to shut it down.
- (2) Turn the main power switch of the equipment off.
- (3) Disconnect the power cable.
- (4) Remove the tray.

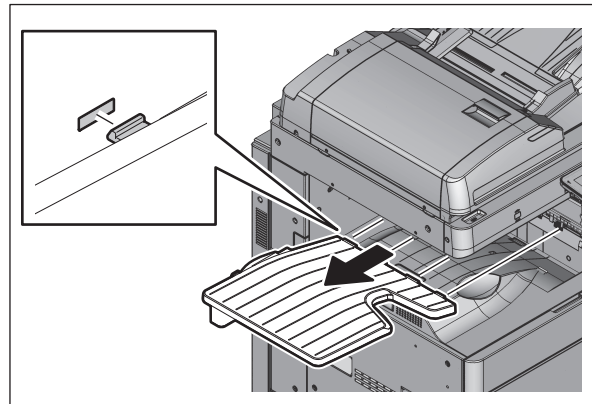


Fig. 4-540

- (5) Open the side cover. Remove 1 screw and take off the exit back cover.

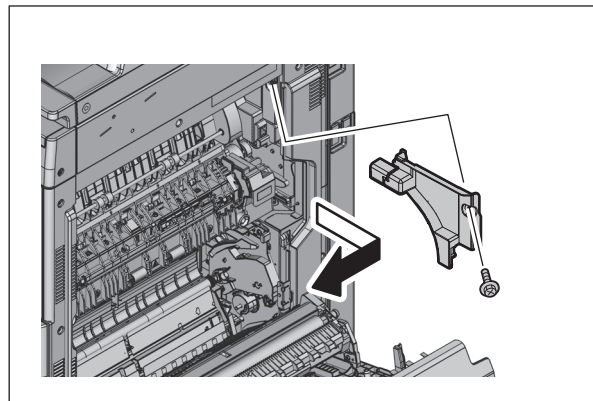


Fig. 4-541

(6) Disconnect 1 connector.

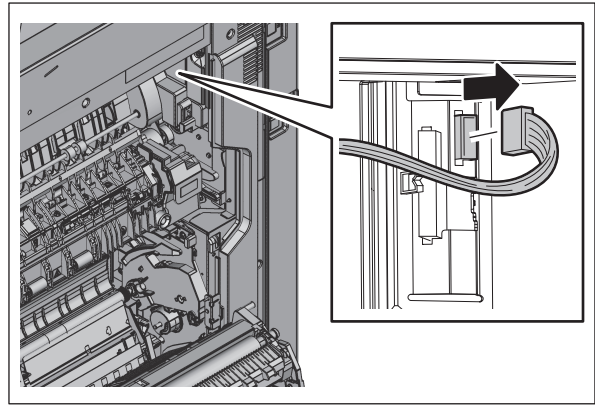


Fig. 4-542

(7) Remove 2 screws and take off the job separator.

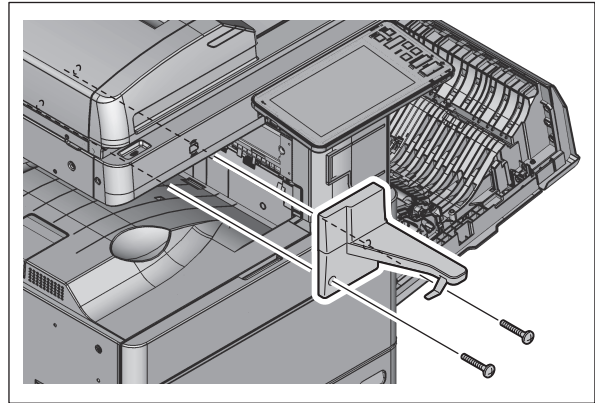


Fig. 4-543

## 5. SELF-DIAGNOSTIC MODE

### 5.1 Overview

This equipment consists of two servicing menus which have different start-up methods. Setting and adjustment can be performed by entering into a mode such as [05 ADJUSTMENT MODE] or [49 Firmware update] from each menu.

- **FS Menu**

Mode		Contents
03 TEST MODE		Checks the status of input/output signals.
04 TEST PRINT MODE		Outputs the test patterns.
05 ADJUSTMENT MODE		Adjusts various items.
08 SETTING MODE		Sets various items.
20 PM SUPPORT MODE		Clears each counter.
21 EPU REPLACE MODE		When replacing EPU, this mode is available for the installation of the EPU whose initial detection is possible.
30 LIST PRINT MODE		Prints various lists or outputs them in a CSV format.
FAX	11 FAX CLEAR MODE	Sets the fax board.
	12 FAX LIST PRINT MODE	Outputs the contents set for the fax functions.
	13 FAX FUNCTION MODE	Sets the fax functions.
	19 RAM EDIT MODE	This is the mode for the special settings. (This is not used generally.)
35 DATA BACKUP/RESTORE MODE		Backs up or restores data.
36 CLO ING		Creates and installs clone files.
37 LICENSE MANAGEMENT		Manages the license of applications.

- **HS Menu**

Mode		Contents
01 Control Panel Check		Checks various contents regarding the LCD, LED, hard keys and digital keys on the control panel.
49 Firmware Update		Performs firmware update with a USB storage device.
59 SRAM Data Cloning		Backs up the SRAM data to a USB storage device.
73 Firmware Assist		Clears error flags or SRAM, or safely deletes data in the HDD or SRAM to support the replacement of the SYS board, SRAM or HDD.
74 HDD Assist		Assists the Security HDD by checking the type of the mounted HDD or removing keys.
75 File System Recovery		Checks, recovers or initializes the file system (HDD).
76 SRAM Maintenance		Recovers the equipment from particular errors such as F800 or F900.

\* Only the modes which are available for this equipment are displayed on each menu.

## [A] Starting each Menu

Menu			Mode*1		Operation			
FS Menu [FUNCTION CLEAR] + [START] + [POWER ON]	→	Enter a service password and press [OK].	→	03 TEST MODE	→	SELF-DIAGNOSIS CODE		
				04 TEST PRINT MODE	→	SELF-DIAGNOSIS CODE		
				05 ADJUSTMENT MODE	→	CLASSIC*2	→	SELF-DIAGNOSIS CODE
				08 SETTING MODE	→	CLASSIC*2	→	SELF-DIAGNOSIS CODE
				20 PM SUPPORT MODE	→			Ch 5.8
				21 EPU REPLACE MODE	→			Ch 7.6
				30 LIST PRINT MODE	→			Ch 5.10
				FAX • 11 FAX CLEAR MODE • 12 FAX LIST PRINT MODE • 13 FAX FUNCTION MODE • 19 RAM EDIT MODE*3	→			SELF-DIAGNOSIS CODE
				35 DATA BACKUP/RESTORE MODE	→			Ch 5.12
				36 CLONING	→			Ch 5.13
				37 LICENSE MANAGEMENT	→			Ch 5.14
HS Menu [HOME] + [START] + [POWER ON]	→	Enter a service password and press [OK].	→	01 Control Panel Check	→	Ch 5.15		
				49 Firmware Update	→	Ch 11.2.4		
				59 SRAM Data Cloning	→	Ch 12.1.4		
				73 Firmware Assist	→	Ch 5.16		
				74 HDD Assist	→	Ch 5.17		
				75 File System Recovery	→	Ch 5.18		
				76 SRAM Maintenance	→	Ch 5.19		

\*1 FS menu: Select the mode and press [Next]. HS menu: Select the icon of the mode.

\*2 Press [Classic] displayed at the upper right of the menu.

\*3 This is not used generally.

## [B] Cancellation of the self-diagnostic mode

The modes, which can be entered from [FS Menu], can be canceled by the following methods.

- When [FS Menu] is displayed on the screen:  
Press [FS Menu] to return to the menu screen. Press [NORMAL].  
The self-diagnostic mode finishes and the [HOME] screen appears. Rebooting/non-rebooting of the equipment will be performed depending on the mode worked and the code operated.
- When only [Return] is displayed on the screen:  
Press [Return] for several times until [FS Menu] is displayed on the screen. When [FS Menu] appears, press it.
- When neither [Return] nor [FS Menu] are not displayed on the screen:  
Press the [ON/OFF] button and perform the shut-down operation on the screen displayed.

To cancel the modes, which can be entered from [HS Menu] press the [ON/OFF] button for a few seconds to shut down the equipment.

## [C] State transition diagram of self-diagnosis modes

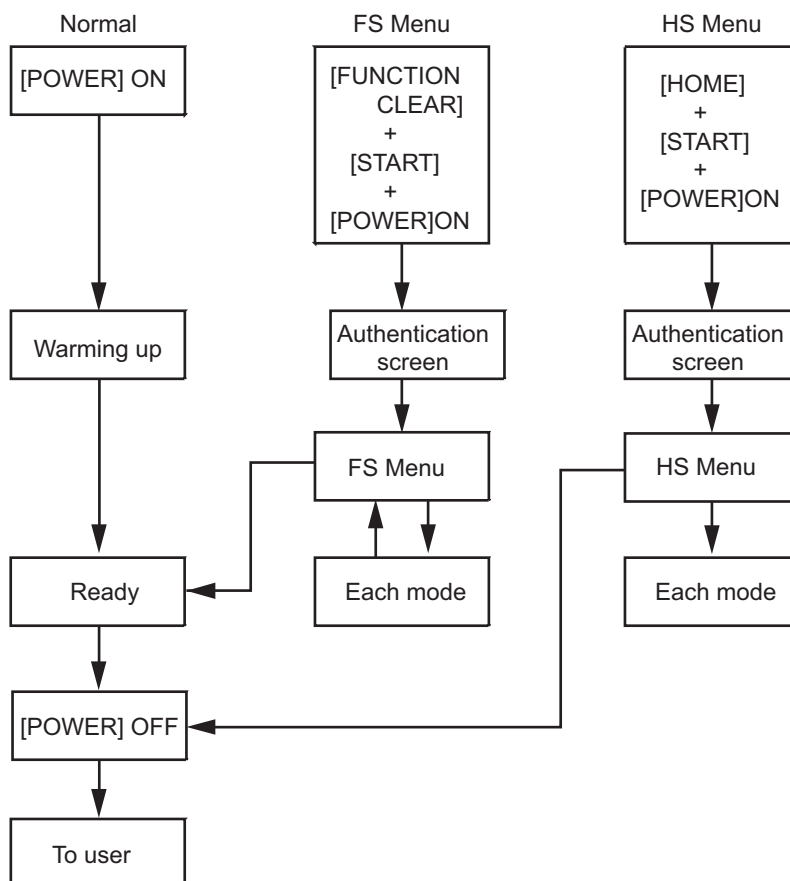


Fig.5-1

\* Be sure to cancel the self-diagnostic mode before customers start using the equipment.

## [D] Changing/setting of the service password

- (1) The [SETTINGS] screen is displayed by press [SETTINGS] on [FS Menu].
- (2) Press [Service Password] to change or reset the service password.

## 5.2 Description Rule for Each Menu and Mode

The description of the self-diagnostic code in this document complies with the rule below.

### Example

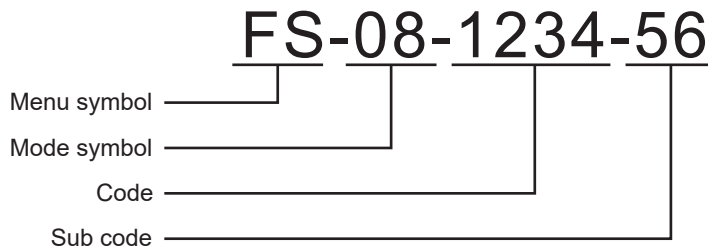


Fig.5-2

1. Symbol for the menu  
FS: FS Menu (Starting by pressing the [ON/OFF] button while pushing the [FUNCTION CLEAR] and [START] buttons simultaneously.)  
HS: HS Menu (Starting by pressing the [ON/OFF] button while pushing the [HOME] and [START] buttons simultaneously.)
2. Symbol for the mode  
The first two digits of each mode
3. Code  
The number of the code
4. Sub code  
This will only be given when a sub code exists.

### [A] FS Menu

#### [05 ADJUSTMENT MODE] or [08 SETTING MODE]:

[FS-05-1234-56] or [Perform FS-05-1234-56] is taken for explanation purposes.

- (1) Start FS Menu by pressing the [ON/OFF] button while pushing the [FUNCTION CLEAR] and [START] buttons simultaneously.

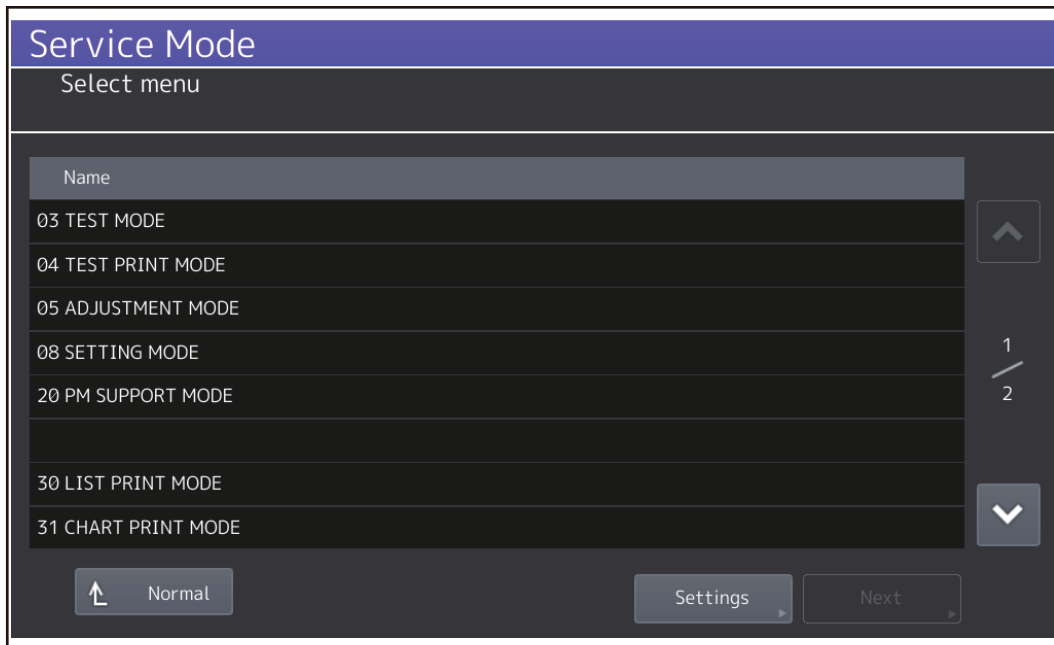


Fig.5-3

- (2) Select [05 ADJUSTMENT MODE] and press [Next].

- (3) Press [Classic] on the upper right of the menu to display the adjustment mode menu.

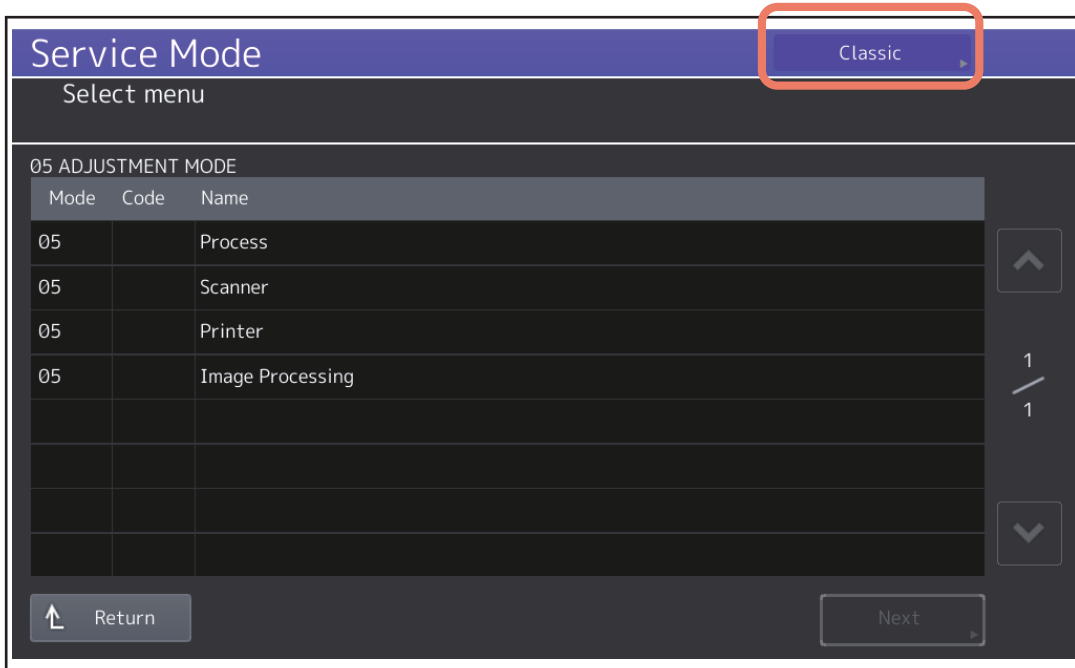


Fig.5-4

- (4) By using the digital keys displayed on the screen, enter [1], [2], [3], [4] and then press the [START] button. Enter the sub codes [5] and [6] and then press the [START] button.
- (5) Carry out the adjustment by following the instructions displayed on the screen or press the [START] button.

**[03 TEST MODE]:**

The key-pressing procedure for the modes, which are set by the combination of the [F1] and [F2] keys, are described as below.

[F1: ON]: Only F1 is turned ON.

[F1, 2: ON]: F1 and F2 are turned ON.

\* The number of the [F] key, which is turned ON, is depicted by dividing with “,” (commas) as above.

[F: OFF]: All of the [F] keys are turned OFF.

**Example:**

[FS-03-F:OFF-9-A]: Turn OFF all of the [F] keys in the FS-03 mode, select [9] and then [A].

[FS-03-F1:ON-9-A]: Turn ON the [F1] key in the FS-03 mode, select [9] and then [A].

**[FAX]:**

In case of [FS-11], [FS-12] or [FS-13] is given in the explanations, select [FAX] in the [FS Menu] and then press [Next] to choose each mode.

## [B] HS Menu

- (1) Start HS Menu by pressing the [ON/OFF] button while pushing the [HOME] and [START] buttons simultaneously.

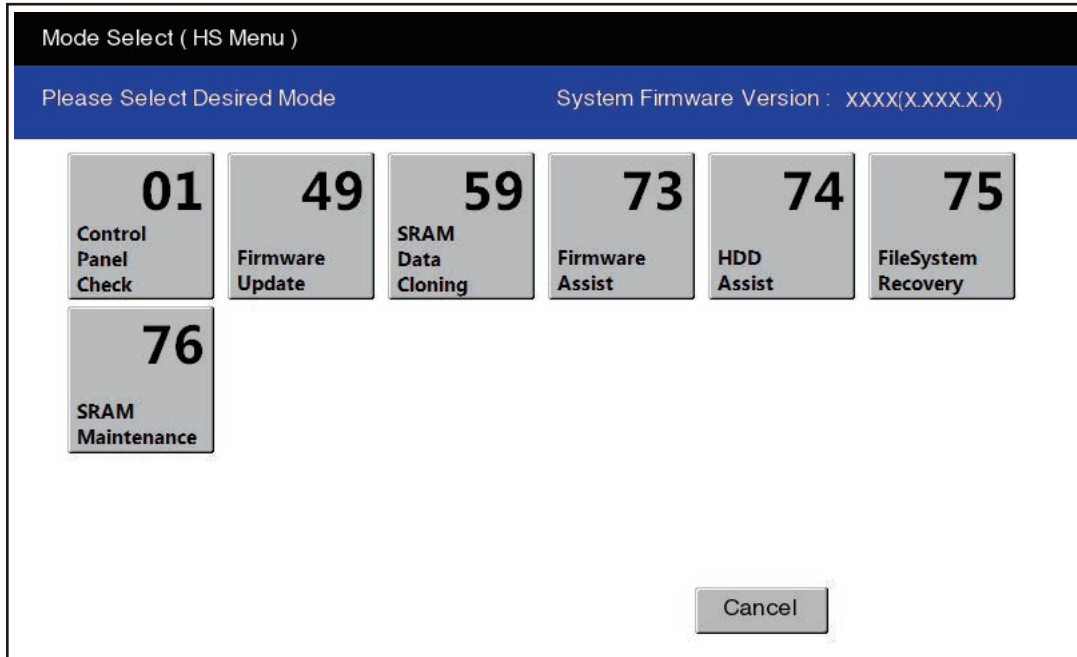


Fig.5-5

- (2) Press the icon to operate.
- (3) Follow the instructions displayed on the screen.

## [C] When a particular setting condition is applied:

The setting value is given at the end of the description by dividing with ":" (colons).

### Example:

[FS-08-8911:3]: "3" is set for FS-08-8911.



## 5.3 Service UI

### 5.3.1 Overview

Each mode of the self-diagnostic codes can be used by selecting the keyword of the screen in the Service UI.

The codes which are used frequently can be selected in the Service UI.

The Service UI can be used in the following modes in the FS Menu.

- 05 ADJUSTMENT MODE
- 08 SETTING MODE

**Notes:**

Not all codes can be used in the Service UI.

For the codes available with the Service UI, refer to the “Self-diagnostic code list” (separate document).

### 5.3.2 Operation procedure

- (1) Start the FS Menu. Select the mode of the above Service UI and press [Next].
- (2) Select the item whose setting is to be changed and press [Next] until the code number is displayed. The display shifts to the classic screen of the selected code.

### 5.3.3 Starting the FS Menu from the normal mode

If the [Gear] icon is displayed on the USER FUNCTIONS menu of the normal mode, the FS Menu can be started.

- (1) Turn the power ON.
- (2) Enter the user name and password if necessary. \*
- (3) Press [USER FUNCTIONS] on the HOME screen.
- (4) Press the [Gear] icon on the upper left of the screen for at least 3 seconds.

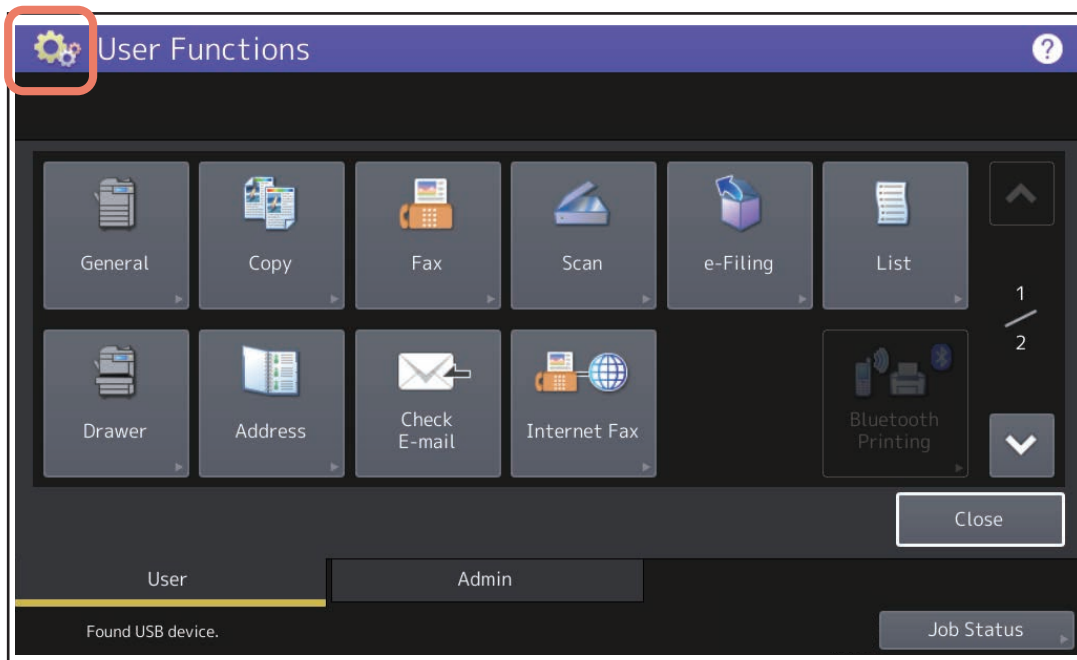


Fig.5-6

(5) Enter the service password and press [OK].  
The FS Menu appears.

\* When “3” is set for FS-08-8911 (security mode), the authentication screen is always displayed.

**Notes:**

- The service password needs to be changed to log in for the first time.
- In case the password is forgotten, ask the administrator to reset the service password.
- Note that the user data are deleted at that time.

## 5.4 03 TEST MODE

### 5.4.1 Output check

The status of the output signal can be checked.

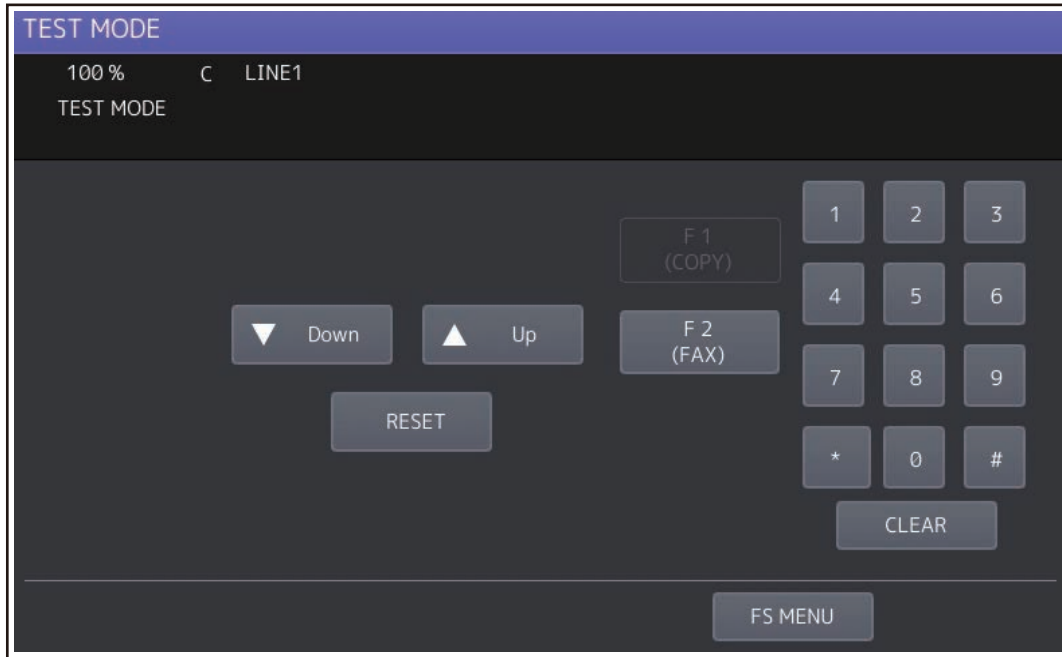


Fig.5-7

Operation procedure: Refer to SELF-DIAGNOSIS CODE.

### 5.4.2 Input check

The status of each input signal can be checked by operating the [F1], [F2] and the digital keys.



Fig.5-8

Operation procedure: Refer to SELF-DIAGNOSIS CODE.

## 5.5 04 TEST PRINT MODE

The embedded test pattern can be printed out.

Operation procedure: Refer to SELF-DIAGNOSIS CODE.

## 5.6 05 ADJUSTMENT MODE

Various adjustments and test printing can be performed.

Operation procedure: Refer to SELF-DIAGNOSIS CODE.

### 5.6.1 TEST PRINT

One sheet of the test print for various patterns can be printed out by entering 1 to 3-digit code and pressing [TEST PRINT] in the [Classic] mode standby screen in the [05 ADJUSTMENT MODE].

Operation procedure: Refer to SELF-DIAGNOSIS CODE.

## 5.7 08 SETTING MODE

Various settings can be set.

Operation procedure: Refer to SELF-DIAGNOSIS CODE.

## 5.8 20 PM SUPPORT MODE

 P. 7-5 “7.4 PM Support Mode”

**<Operation procedure>**

[FS] → [20] → (Operation started) → Exit

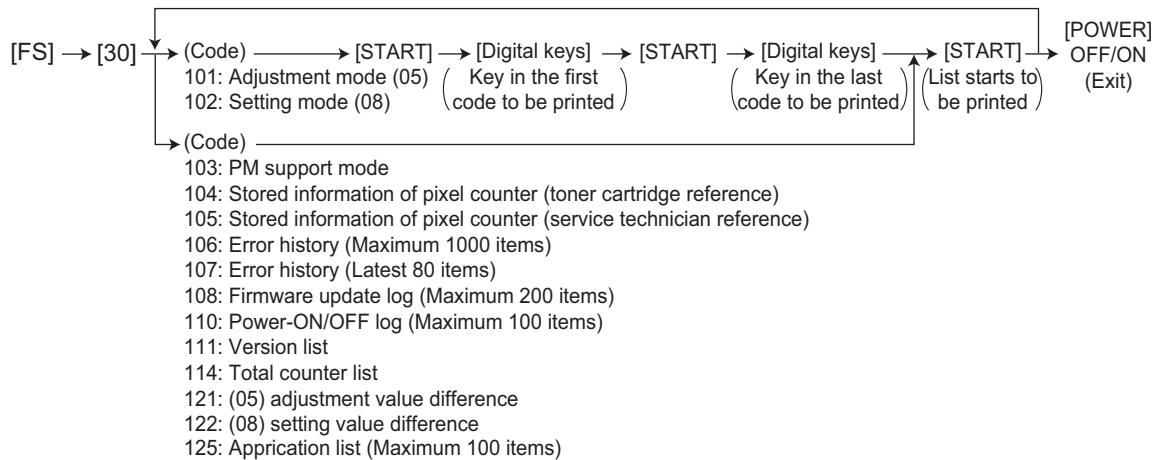
## 5.9 21 EPU REPLACE MODE

 P. 7-11 “7.6 21 EPU Replacement Mode”

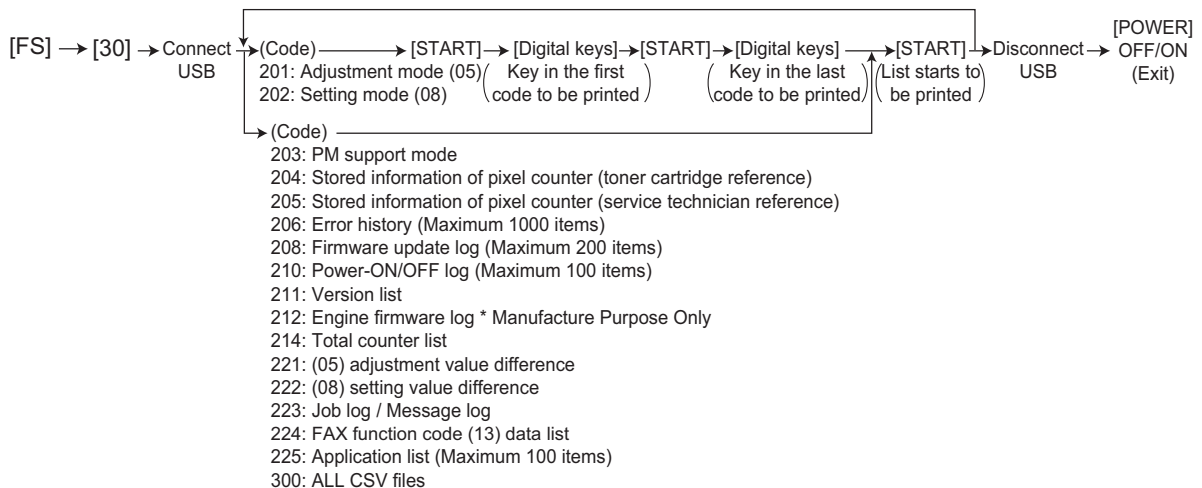
## 5.10 30 LIST PRINT MODE

### 5.10.1 Operation procedure

#### [ 1 ] Print out



#### [ 2 ] CSV output (USB)



#### Notes:

Precautions when storing information into USB device

- When storing the setting information of the equipment into a USB device, be sure to obtain permission from a user in advance.
- When storing the setting information of the equipment into a USB device, the information is printed out in a CSV format. Handle and manage the information with extra care.
- Do not lose or leak the setting information of the equipment.
- Do not use the setting information of the equipment for purposes other than maintenance or product services.
- Provide the information promptly if a user requires so.
- The buttons on the control panel keep blinking while data are being stored in the USB device. Do not disconnect the USB device while data are being stored.

**Remarks:**

In the USB storage procedure above, lists are stored in a CSV format. The names of the CSV files are shown below.

- 201: ADJUSTMENT\_LIST\_serial\_date and time(YYYYMMDDHHMMSS).csv
- 202: SETTING\_LIST\_serial\_date and time(YYYYMMDDHHMMSS).csv
- 203: PM\_LIST\_serial\_date and time(YYYYMMDDHHMMSS).csv
- 204: PIXEL\_TONER\_LIST\_serial\_date and time(YYYYMMDDHHMMSS).csv
- 205: PIXEL\_SERVICE\_LIST\_serial\_date and time(YYYYMMDDHHMMSS).csv
- 206: ERROR\_LOG\_serial\_date and time(YYYYMMDDHHMMSS).csv
- 208: FW\_UPGRADE\_LOG\_serial\_date and time(YYYYMMDDHHMMSS).csv
- 210: POWER\_ONOFF\_LOG\_serial\_date and time(YYYYMMDDHHMMSS).csv
- 211: VERSION\_LIST\_serial\_date and time(YYYYMMDDHHMMSS).csv
- 212: ENG\_FW\_LOG\_serial\_date and time(YYYYMMDDHHMMSS).csv
- 214: TOTAL\_COUNTER\_LIST\_serial\_date and time(YYYYMMDDHHMMSS).csv
- 221: 05DIFFERENCE\_CODE\_LIST\_serial\_date and time(YYYYMMDDHHMMSS).csv
- 222: 08DIFFERENCE\_CODE\_LIST\_serial\_date and time(YYYYMMDDHHMMSS).csv
- 223: JOB\_LOG\_serial\_date and time(YYYYMMDDHHMMSS) (encrypted file)/MESSAGE\_LOG\_serial\_date and time(YYYYMMDDHHMMSS) (encrypted file)
- 224: FAX\_FUNCTION\_LIST\_serial\_date and time(YYYYMMDDHHMMSS).csv
- 225: APPLICATION\_LIST\_serial\_date and time(YYYYMMDDHHMMSS).csv

**5.10.2 List printing**

Lists below are output in the list print mode.

List data are printed out or output in a CSV format by storing them in a USB device. Paper sizes available for this printing are A4 or LT or larger. This section introduces a sample of each list.

Perform [FS-30] to start the list print mode.

Lists	List code	
	Printout	CSV file output
Adjustment mode (05) data list	101	201
Setting mode (08) data list	102	202
PM support mode data list	103	203
Pixel counter code list (toner cartridge reference)	104	204
Pixel counter code list (service technician reference)	105	205
Error history list	106 (Maximum 1000 items)	206 (Maximum 1000 items)
Error history list	107 (Latest 80 items)	-
Firmware upgrade log	108 (Maximum 200 items)	208 (Maximum 200 items)
Power ON/OFF log	110 (Maximum 100 items)	210 (Maximum 100 items)
Version list	111	211
Engine firmware log	-	212
Total counter list	114	214
(05) adjustment value difference	121	221
(08) setting value difference	122	222
Application list	125 (Maximum 100 items)	225 (Maximum 100 items)
Job log/Message log	-	223
FAX function code (13) data list	-	224
Output all CSV files	-	300 *

\* (05) adjustment value difference and (08) setting value difference are not output.

- 05 ADJUSTMENT MODE

05 ADJUSTMENT MODE DATA LIST				S/N: xxxxxxxx		TOTAL: 9999999	
20xx-xx-xx xx:xx				TOSHIBA e-STUDIOxxx		DF TOTAL: 9999999	
CODE	DATA	CODE	DATA	CODE	DATA	CODE	DATA
2000	128	3860-0	88	4830	128	5920	128
.	.	.	.	.	.	.	.
.	.	.	.	.	.	.	.
.	.	.	.	.	.	.	.
.	.	.	.	.	.	.	.
.	.	.	.	.	.	.	.
.	.	.	.	.	.	.	.
.	.	.	.	.	.	.	.
.	.	.	.	.	.	.	.
.	.	.	.	.	.	.	.
.	.	.	.	.	.	.	.
.	.	.	.	.	.	.	.
.	.	.	.	.	.	.	.
.	.	.	.	.	.	.	.

Fig.5-9

The selected adjustment codes and the current adjustment value for each code are output in a list.

- 08 SETTING MODE

08 SETTING MODE DATA LIST				S/N: xxxxxxxx		TOTAL: 9999999	
20xx-xx-xx xx:xx				TOSHIBA e-STUDIOxxx		DF TOTAL: 9999999	
CODE	DATA	CODE	DATA	CODE	DATA	CODE	DATA
2010	2	2880	12	3040	0	3070-3	0
.	.	.	.	.	.	.	.
.	.	.	.	.	.	.	.
.	.	.	.	.	.	.	.
.	.	.	.	.	.	.	.
.	.	.	.	.	.	.	.
.	.	.	.	.	.	.	.
.	.	.	.	.	.	.	.
.	.	.	.	.	.	.	.
.	.	.	.	.	.	.	.
.	.	.	.	.	.	.	.
.	.	.	.	.	.	.	.
.	.	.	.	.	.	.	.
.	.	.	.	.	.	.	.

**Fig.5-10**

The selected setting codes and the current setting value for each code are output in a list.





- 20 PM SUPPORT MODE

PM SUPPORT CODE LIST				
		S/N: xxxxxxxx	TOTAL:	9999999
20xx-xx-xx xx:xx		TOSHIBA e-STUDIOxxx	DF TOTAL:	9999999
UNIT	OUTPUT PAGES/ DEVELOP COUNTS	PM OUTPUT PAGE/ DEVELOP COUNTS	DRIVE COUNTS	PM DRIVE COUNTS
DRUM	2516	70000	11735	170000
DRUM BLADE	2516	70000	11735	170000
GRID	2516	70000	11735	170000
MAIN CHARGER NEEDLE	2516	70000	11735	170000
CHARGER CLEANING PAD	2516	70000	11735	170000
:	:	:	:	:
:	:	:	:	:

**Fig.5-12**

The number of pages currently output (OUTPUT PAGES/DEVELOP COUNTS), the recommended number of output pages for PM (PM OUTPUT PAGES/DEVELOP COUNTS), the current drive count (DRIVE COUNTS) and the recommended drive count for PM (PM DRIVE COUNTS) are output together with PM units. Use this list for confirming the PM units to be replaced at each PM. See the following page for PM:


 P. 7-1 “7. PREVENTIVE MAINTENANCE (PM)”

- Pixel counter code list (toner cartridge reference)

PIXEL COUNTER CODE LIST						
		S/N: xxxxxxxx	FIN S/N: xxxxxxxx		TOTAL:	9999999
		TOSHIBA e-STUDIOxxx			DF TOTAL:	9999999
20xx-xx-xx xx:xx						
TONERCARTRIDGE						
NO.	DATE	COLOR	PPC	PRN	FAX	TOTAL
0	20xx-xx-xx	Print Count[LT/A4]	181	45	---	226
1	20xx-xx-xx	Average Pixel Count[%]	2.70	1.74	---	2.51
2	20xx-xx-xx	Latest Pixel Count[%]	6.15	0.39	---	0.39

**Fig.5-13**

Pixel counter data (toner cartridge reference) are output in a list. See the following page for the pixel counter:


 P. 5-52 “5.20 Pixel Counter”

- Pixel counter code list (service technician reference)

PIXEL COUNTER CODE LIST						
		S/N: xxxxxxxx	FIN S/N: xxxxxxxx		TOTAL:	9999999
		TOSHIBA e-STUDIOxxx			DF TOTAL:	9999999
20xx-xx-xx xx:xx						
SERVICEMAN						
NO.	DATE	COLOR	PPC	PRN	FAX	TOTAL
0	20xx-xx-xx	Print Count[LT/A4]	181	45	---	226
1	20xx-xx-xx	Average Pixel Count[%]	2.70	1.74	---	2.51
2	20xx-xx-xx	Latest Pixel Count[%]	6.15	0.39	---	0.39

**Fig.5-14**

Pixel counter data (service call reference) are output in a list. See the following page for the pixel counter:

 P. 5-52 “5.20 Pixel Counter”

- Error history

ERROR HISTORY LIST						
					S/N: xxxxxxxx	TOTAL: 9999999
					TOSHIBA e-STUDIOxxx	DF TOTAL: 9999999
20xx-xx-xx xx:xx						
CODE	COUNTER	DATE	TIME	ZOOM_XY	ABCD_EFGH_IJLOP_QR	
F110	00000000	xxxx-xx-xx	xx:xx:xx	000 000	0000_0000_0000_00_0000000000	
F110	00000000	xxxx-xx-xx	xx:xx:xx	000 000	0000_0000_0000_00_0000000000	
F110	00000000	xxxx-xx-xx	xx:xx:xx	000 000	0000_0000_0000_00_0000000000	
F110	00000000	xxxx-xx-xx	xx:xx:xx	000 000	0000_0000_0000_00_0000000000	
F110	00000000	xxxx-xx-xx	xx:xx:xx	000 000	0000_0000_0000_00_0000000000	
EAD0	00000000	xxxx-xx-xx	xx:xx:xx	000 000	0000_0000_0000_00_0000000000	
E860	00000000	xxxx-xx-xx	xx:xx:xx	000 000	0000_0000_0000_00_0000000000	
E731	00000000	xxxx-xx-xx	xx:xx:xx	000 000	0000_0000_0000_00_0000000000	
E090	00000000	xxxx-xx-xx	xx:xx:xx	000 000	0000_0000_0000_00_0000000000	
E870	00000000	xxxx-xx-xx	xx:xx:xx	000 000	0000_0000_0000_00_0000000000	
E724	00000000	xxxx-xx-xx	xx:xx:xx	000 000	0000_0000_0000_00_0000000000	

**Fig.5-15**

The error history is output. See the following page for the parameters for each error:

 P. 8-42 “8.2.4 Printer function error”



- Power-ON/OFF log

POWER ON/OFF LOG				S/N: xxxxxxxx		TOTAL: 9999999	
20xx-xx-xx xx:xx				TOSHIBA e-STUDIOxxx		DF TOTAL: 9999999	
DATE	TIME	FUNCTION	TOTAL	DATE	TIME	FUNCTION	TOTAL
xxxx-xx-xx	xx:xx:xx	ON	99999999	xxxx-xx-xx	xx:xx:xx	ON	99999999
xxxx-xx-xx	xx:xx:xx	OFF	99999999	xxxx-xx-xx	xx:xx:xx	OFF	99999999
xxxx-xx-xx	xx:xx:xx	ON	99999999	xxxx-xx-xx	xx:xx:xx	ON	99999999
xxxx-xx-xx	xx:xx:xx	OFF	99999999	xxxx-xx-xx	xx:xx:xx	OFF	99999999
xxxx-xx-xx	xx:xx:xx	ON	99999999	xxxx-xx-xx	xx:xx:xx	RMT_OFF	99999999
xxxx-xx-xx	xx:xx:xx	OFF	99999999				
xxxx-xx-xx	xx:xx:xx	ON	99999999				
xxxx-xx-xx	xx:xx:xx	OFF	99999999				
xxxx-xx-xx	xx:xx:xx	RMT_OFF	99999999				
xxxx-xx-xx	xx:xx:xx	OFF	99999999				
.	.	.	.				
.	.	.	.				
.	.	.	.				

Fig.5-17

Power ON/OFF logs are output.

- Note that cases that the power was turned OFF with the main switch (not with the [ON/OFF] button on the control panel) will not be displayed.

Item	Content
DATE	Date that the power was turned ON or OFF
TIME	Time that the power was turned ON or OFF
FUNCTION	Whether the power was turned ON or OFF, or if it was turned ON or OFF with a remote reset function
TOTAL	Total counter data when the power was turned OFF and then back ON

- Version list

```

VERSION LIST
S/N: xxxxxxxx          TOTAL:          9999999
TOSHIBA e-STUDIOxxx   DF TOTAL:       9999999

20xx-xx-xx xx:xx

SYSTEM FIRMWARE ROM VERSION      : Txxxxxxxxxxx
SYSTEM FIRMWARE INTERNAL ROM VERSION: Vx.x.x.xx.xx
PRINTER ROM VERSION              : xxxM-xxx
SCANNER ROM VERSION              : xxxS-xxx
RADF/DSDF ROM VERSION            : DF-xxx
FINISHER STACKER ROM VERSION     : FIN-
FINISHER PUNCH ROM VERSION       : PUN-
FAX BOARD FIRMWARE ROM VERSION   : Fxx-xxx
SYSTEM FIRMWARE INTERNAL OS VERSION : Vx.xxx.x.x
HDD DATA VERSION                : Txxxxxxxxxxx
SYSTEM FIRMWARE OS VERSION       : Txxxxxxxxxxx
NIC FIRMWARE ROM VERSION         : XXXXXXXXXXXX
LANGUAGE VERSION
  English(US)                    : xxx.xxx xxx xxx xx xx:xx:xx xxxxx
  .                               .
  .                               .
  .                               .
CAPACITY OF HDD                  : xx.x GB
DEVICE INFORMATION OF HDD        : xxx xxxxxxx-xxxxxx
SERIAL NUMBER OF HDD             : xx-xxxxxxxxxxxxx
MEMORY SIZE                      : xxxx MB / xxxx MB
INSTALLED ELK NAME               : Data overwrite enabler
                                IPsec enabler
                                Meta scan enabler
                                External interface enabler
                                .
                                .
                                .

```

**Fig.5-18**

The list of versions is output.

**Notes:**

Some of the characters in the fonts that are used to print the version list are not supported. As a result, the language names under LANGUAGE VERSION may not be printed correctly when printing the version list.



- Engine firmware log

```
ENGINE FW LOG
20xx/xx/xx xx:xx
TOSHIBA e-STUDIOxxxx
Cxxxxxxxx
FIN S/N-xxxxxxxx
TOTAL, 9999999, DF TOTAL, 9999999
CODE      SUB   DATA
4624      0     0
4624      1     0
4624      2     58
4624      3     3
4624      4     58
4624      5     3
4624      6     0
4624      7     56
4624      8     3
4624      9     0
4624     10    41
4624     11     1
4624     12    29
4624     13     7
4624     14     0
4624     15     0
4624     16     0
4624     17     0
4624     18     0
4624     19     0
4624     20     0
.         .     .
.         .     .
.         .     .
.         .     .
.         .     .
```

**Fig.5-19**

The file of the engine firmware log is output (but it is not printed out).

- Total counter list

TOTAL COUNTER LIST	S/N: xxxxxxxx	FIN S/N: xxxxxxxx	TOTAL	: 9999999
20xx-xx-xx xx:xx	TOSHIBA e-STUDIOxxx		DF TOTAL	: 9999999

PRINT COUNTER	COPY	FAX	PRINTER	LIST	TOTAL
SMALL	xxxxxx	xxxxxx	xxxxxx	xxxxxx	xxxxxx
LARGE	xxxxxx	xxxxxx	xxxxxx	xxxxxx	xxxxxx
TOTAL	xxxxxx	xxxxxx	xxxxxx	xxxxxx	xxxxxx

SCAN COUNTER	FULL COLOR	BLACK	TOTAL
TOTAL			
COPY	xxxxxx	xxxxxx	xxxxxx
FAX	xxxxxx	xxxxxx	xxxxxx
NETWORK	xxxxxx	xxxxxx	xxxxxx
TOTAL	xxxxxx	xxxxxx	xxxxxx

COPY	FULL COLOR	BLACK	TOTAL
SMALL	xxxxxx	xxxxxx	xxxxxx
LARGE	xxxxxx	xxxxxx	xxxxxx
TOTAL	xxxxxx	xxxxxx	xxxxxx

FAX	FULL COLOR	BLACK	TOTAL
SMALL	xxxxxx	xxxxxx	xxxxxx
LARGE	xxxxxx	xxxxxx	xxxxxx
TOTAL	xxxxxx	xxxxxx	xxxxxx

NETWORK	FULL COLOR	BLACK	TOTAL
SMALL	xxxxxx	xxxxxx	xxxxxx
LARGE	xxxxxx	xxxxxx	xxxxxx
TOTAL	xxxxxx	xxxxxx	xxxxxx

CALIBRATION COUNTER : 0

Fig.5-20

The list of total counter is output.

**Remarks:**

By performing FS-08-3667, a QR code is added to the total counter list.

- (05) adjustment value/(08) setting value difference

05 DIFFERENCE LIST			S/N: xxxxxxxx      TOTAL:      9999999		
xx-xx-xx xx:xx			TOSHIBA e-STUDIOxxxx    DF TOTAL:    9999999		
CODE	BACKUP	CURRENT	CODE	BACKUP	CURRENT
* 2400	128	160			
.	.	.			
.	.	.			
.	.	.			
.	.	.			
.	.	.			
.	.	.			
.	.	.			
.	.	.			
.	.	.			
.	.	.			
.	.	.			
.	.	.			

Fig.5-21

The value differences between the factory default and the current value of [05 Adjustment mode] and [08 Setting mode] in the FS Menu can be printed or output with a CSV file.

The mark "\*" or "+" will be added to the left side of the code in the following cases.

"\*": If there is a difference

"+": If there is no backed up value

**Notes:**

- Back-up data of the factory default are automatically created when the automatic gamma adjustment of the easy set-up mode has been completed during the unpacking and setting up of the equipment. The back-up file will be retained even if the system firmware is upgraded. However, the file will be deleted when the HDD is formatted or replaced.
- When the easy set-up mode is restarted while a specified value such as 4 through 9 is set for FS-08-9022 (Production process management status for easy setup), the back-up file stored during unpacking and setting-up is deleted after the completion of the automatic gamma adjustment and a new one is created while the value as of then is stored.
- When no back-up file exists  
 When FS-30-121 (122) is performed, the equipment returns to the ready state of the 30 LIST PRINT MODE without performing printing.  
 When FS-30-221 (222) is performed, the equipment returns to the ready state of the 30 LIST PRINT MODE and the error message "The file cannot be saved." appears on the panel.

## 5.11 FAX

Adjustment and setting of the fax functions can be performed.

Select [FAX] in the FS Menu and press [Next]. The following modes are displayed.

11 FAX CLEAR MODE

12 FAX LIST PRINT MODE

13 FAX FUNCTION MODE

19 RAM EDIT MODE

### Notes:

The data automatically received during the self-diagnostic mode are sometimes not printed.

Therefore, be sure to disconnect the modular code from the line connector (LINE1, LINE2) of the equipment before starting the self-diagnostic mode. After the equipment is released from the self-diagnostic mode, reconnect the modular code.

### 5.11.1 11 FAX CLEAR MODE

(1) Select [FAX] in the FS Menu and press [Next]. Select [11 FAX CLEAR MODE] and press [Next].

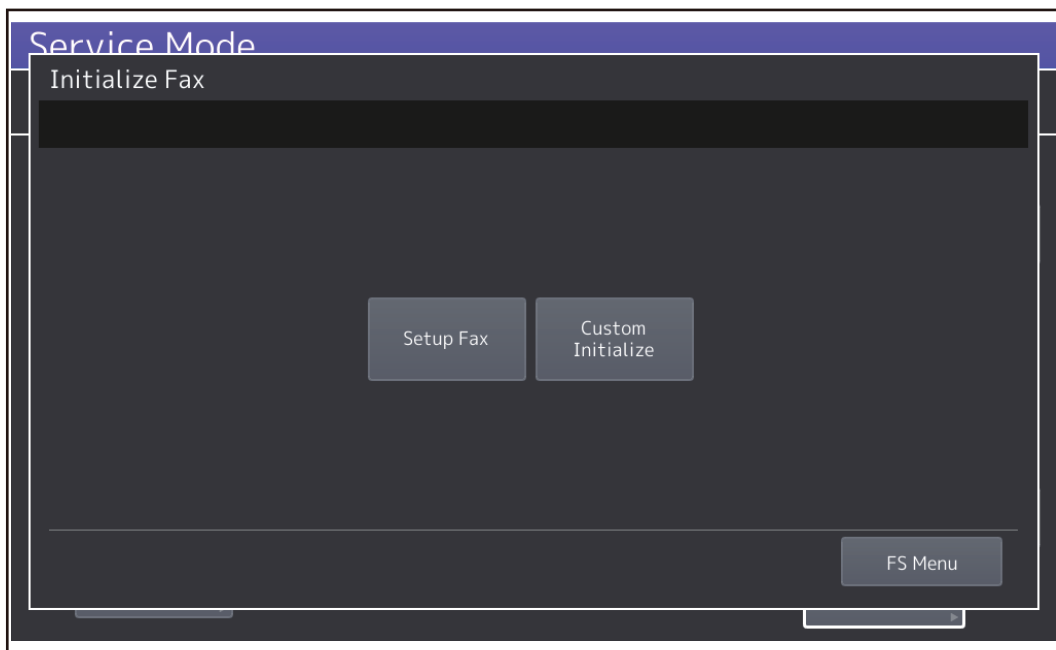


Fig.5-22

[Setup Fax] and [Custom Initialize] are displayed.

## [A] Setup Fax

The destination of the fax can be set.

- (1) Press [Setup Fax].
- (2) Select the destination and press [OK].

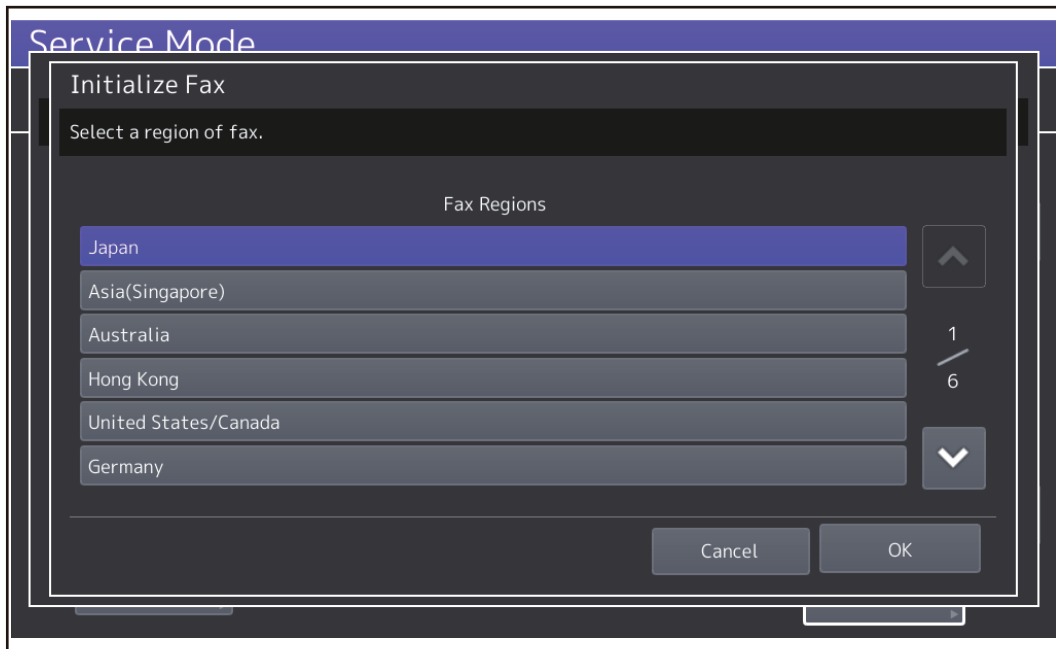


Fig.5-23

## [B] [Custom Initialize]

Various FAX memories are initialized in the FAX clearing mode

- Memory Areas
  - User registration area (SRAM)
    - ID registration area
    - Home position
  - Image data area (HDD, SRAM)
    - Transmission file
    - Reception file
    - Image data file management area
    - F-code box information
  - System setting area (NVRAM)
    - Settings in the [13 FAX FUNCTION MODE] Areas 100 - 999

### <Operation procedure>

- (1) Press [Custom Initialize].

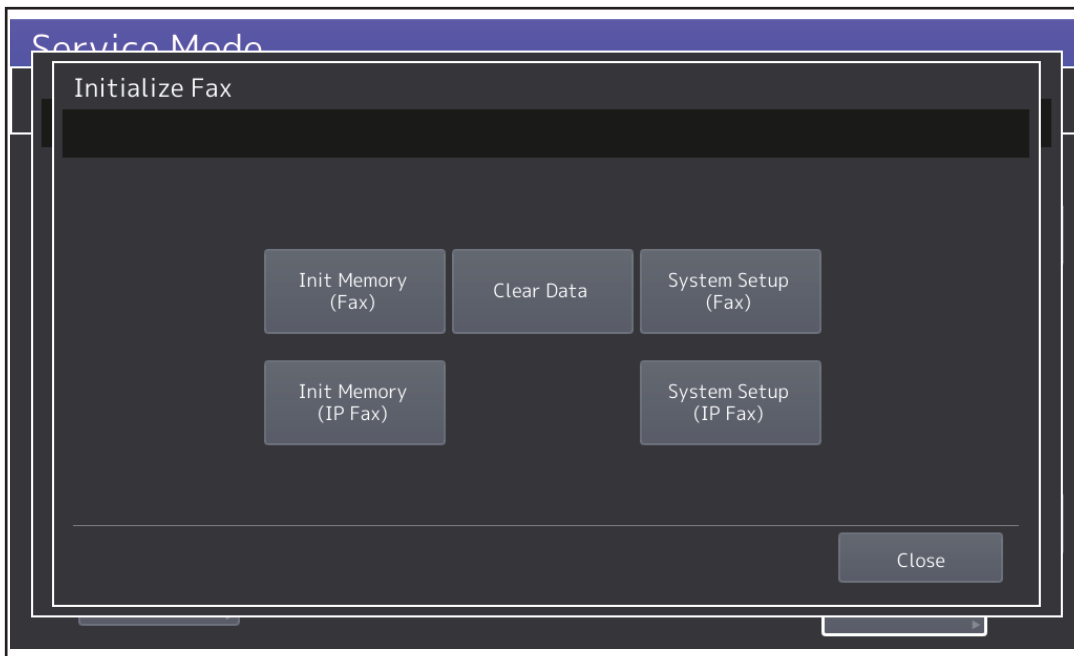


Fig.5-24

- (2) Select the mode.  
[Init Memory (Fax)], [Init Memory (IP Fax)]: Initializes the user registration area (SRAM) so that there are no data stored. Initializes the system setting area (NVRAM) so that its value is reset to the default setting.  
[Clear Data]: Initializes the image data area (HDD, SRAM) so that there are no data stored.  
[System Setup (Fax)], [System Setup (IP Fax)]: Initializes the system setting area (NVRAM) so that its value is reset to the default setting.

## 5.11.2 12 FAX LIST PRINT MODE

The setting contents of the fax function can be output.

- (1) Select [FAX] in the FS Menu and press [Next]. Select [12 FAX LIST PRINT MODE] and press [Next].

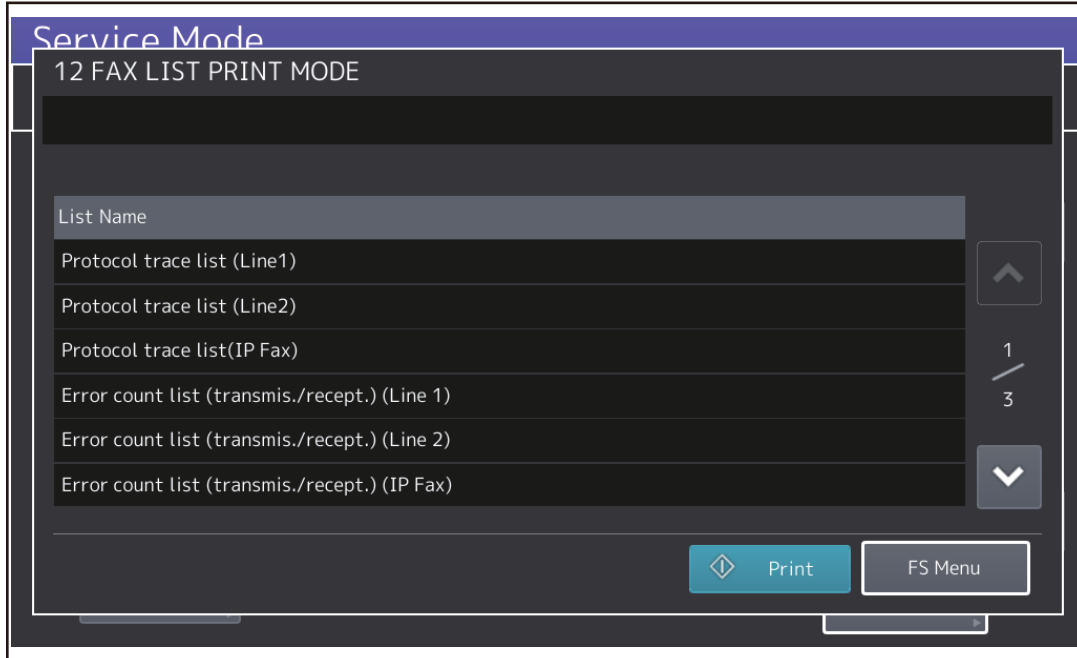


Fig.5-25

- (2) Select the list and press [Print].  
The names of the lists in [12 FAX LIST PRINT MODE] are shown below.
  - Protocol trace list (Line1)
  - Protocol trace list (Line2)
  - Protocol trace list (IP Fax)
  - Error count list (transmis./recept.) (Line 1)
  - Error count list (transmis./recept.) (Line 2)
  - Error count list (transmis./recept.) (IP Fax)
  - ERROR COUNT LIST (IFAX)
  - ERROR COUNT LIST (SCAN)
  - Function List for Maintenance
  - Memory dump list (system)
  - Memory dump list (FAX/LINE1)
  - Memory dump list (FAX/LINE2)
  - SUPPLY ORDER LIST

## 5.11.3 13 FAX FUNCTION MODE

Various fax functions can be set.

Operation procedure: Refer to SELF-DIAGNOSIS CODE.

## 5.11.4 19 RAM EDIT MODE

This is a mode for the special adjustments and settings. (This is not used generally.)

## 5.12 35 DATA BACKUP/RESTORE MODE

This function can save (back up) a back-up file of the MFP setting data in a USB media or external server, or can restore the stored (backed up) file into the equipment.

- (1) Select [35 DATA BACKUP/RESTORE MODE] in the FS Menu and press [Next].

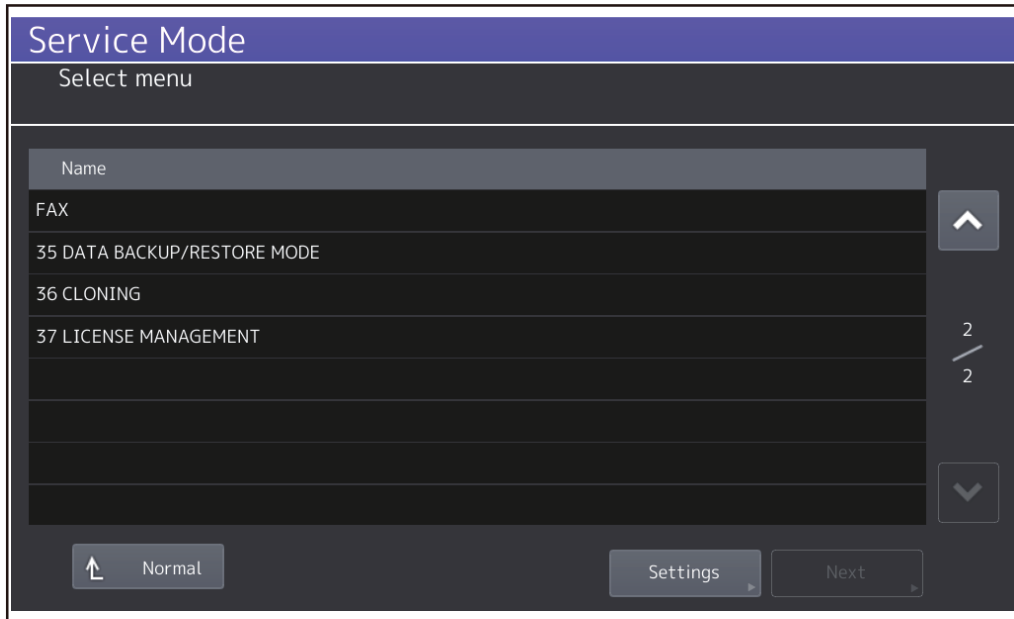


Fig.5-26

- (2) [Data Backup] and [Data Restore] are displayed.

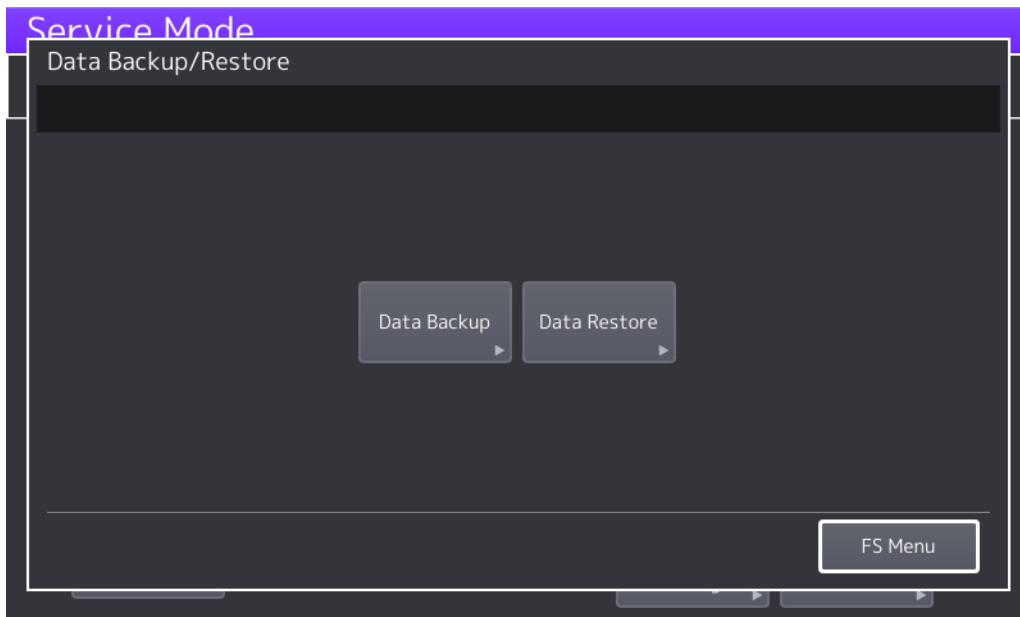


Fig.5-27

- (3) Select [Data Backup] or [Data Restore] and press [Next]. Press [USB Media].
- (4) Insert a USB storage device into the equipment and press [OK]. Backing up or restoring of the data starts.


### Remarks:

For details, refer to the "HDD Data Back-up/Restore Instruction Manual" (separate document).



## 5.13 36 CLONING

This function can create a clone file including the MFP setting data and user information or can install the clone file in this equipment.

For details, see  P. 12-5 “12.2 Cloning (FS menu)”

## 5.14 37 LICENSE MANAGEMENT

This function can register or delete the application license.

## 5.15 01 Control Panel Check Mode

The following items can be checked with this mode.

- LCD back light blinking and brightness
- LCD display
- Confirmation of hard keys (buttons on the control panel) performance
- LEDs blinking
- Performance of digital keys (ten key option)
- LCD touch sensor
- USB storage device connection

### Notes:

To check the performance of the digital keys, connect the ten key option before starting this mode.

### 5.15.1 Screen transition

#### Notes:

It is not possible to return to the HS Menu from [01 Control Panel Check]. To quit [01 Control Panel Check], display the LCD backlight check screen (Fig. A) and then press the [ON/OFF] button for a few seconds to shut down.

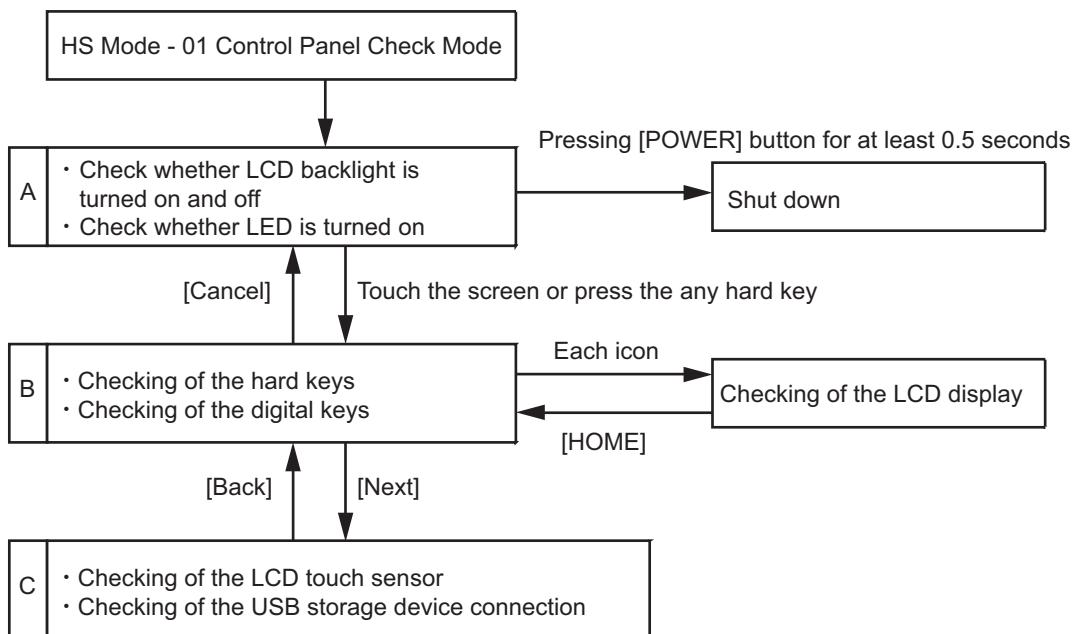


Fig.5-28

## 5.15.2 Checking of the LCD back light and LEDs

By pressing [01 Control Panel Check], the LCD back light blinks in 3-second intervals. Moreover, all LEDs are lit.

### Remarks:

By touching the screen or pressing any hard key, the screen is shifted to the hard key confirmation screen.

## 5.15.3 Checking of the LCD display, hard keys and digital keys

### [A] Checking of the LCD display

By pressing the icon on the touch panel, the LCD display (Picture 1-15) confirmation screen is displayed.

### Remarks:

The screen is returned to this one when the [HOME] button is pressed on each screen.

### [B] Checking of the hard keys

By pressing each hard key, a particular text is displayed and the blinking condition of the LED is changed.

The following table shows each text and performance when the key is pressed.

Hard key	Text	Performance
ON/OFF (Pressing for at least 0.5 seconds)	MAIN POWER	The [MEMORY RX] LED is turned OFF.
ENERGY SAVER	ENERGY SAVER	The [ENERGY SAVER] LED is turned OFF.
ACCESS	ACCESS	The [PRINT DATA] LED is turned OFF.
HOME	HOME	The [!] LED is turned OFF.
Programable key 1	P-1	The LCD back light is made darker by each pressing. (10 levels)
Programable key 2	P-2	The LCD back light is made lighter by each pressing. (10 levels)
FUNCTION CLEAR	FUNCTION CLEAR	The [FUNCTION CLEAR] LED is turned OFF.
START	START	The [START] LED is turned OFF.

The text is displayed only while the key is being pressed. Each LED is turned OFF only while the key is being pressed.

### [C] Checking of the digital keys for Ten Key option

By pressing each digital key, a particular text is displayed. The following table shows each text when the key is pressed.

digital key	Text
1	OP-1
2	OP-2
3	OP-3
4	OP-4
5	OP-5
6	OP-6
7	OP-7
8	OP-8
9	OP-9
0	OP-0
*	OP-*
#	OP-#
C	OP-CLEAR

#### Remarks:

- By pressing each icon on screen, the LCD display confirmation screen is displayed.
- The screen is shifted to the LCD touch sensor and USB storage device confirmation screen by your pressing [Next] in the LCD display confirmation screen is displayed.

### 5.15.4 Checking of the LCD touch sensor and USB storage device connection

The screen is shifted to the LCD touch sensor and USB storage device confirmation screen by pressing [Next].

#### [A] Checking of the LCD touch sensor

It can be checked whether the operations of swipe, pinch-out (enlargement) and pinch-in (reduction) are correctly detected on the screen. When the above operation is performed on the screen, an arrow which indicates the one detected by the touch sensor and a message are displayed.

Moreover, when any of [LH], [LL], [RH] or [RL] located on each corner of the screen is pressed, the calibration condition of the touched position can be checked.

#### [B] Checking of the USB storage device connection

It can be checked whether a USB storage device inserted into the USB port is connected properly. Install a USB storage device and press the [START] button.

When a USB storage device is connected properly, [USB Connection Success] is displayed. If not, [USB Connection Failed] is displayed.

#### Remarks:

It is not possible to return to the HS Menu from [01 Control Panel Check]. Return to the LCD back light blinking and brightness screen to shut down the equipment by pressing the [POWER] button for a few seconds.

## 5.16 73 Firmware Assist Mode

### 5.16.1 Overview

This mode enables you to operate the HDD partition, delete the HDD data and backup/restore the encryption key and license.

The Functions in this mode are below.

Functions	Content
Clear Software Update Error Flag	Clearing update error flag
Format Root Partition	Formatting data storage partition
Format HDD	Creating HDD partition
Key Backup/Restore	Backing up/restoring encryption key and license
Erase HDD Securely	Erasing HDD securely
Clear Service Tech Password	Clearing service password
Disable Fast boot	Disabling faster boot
Clear SRAM	Formatting SRAM data
Erase SRAM Securely	Erasing SRAM securely
Format HDD Without Key Generation	Creating HDD partition without having upgraded the key
HDD Data Restore	Performing formatting, backup data restoring and firmware upgrading in series

### 5.16.2 Operation procedure

- (1) Perform [HS-73] by pressing [73 Firmware Assist].  
The following screen is displayed.

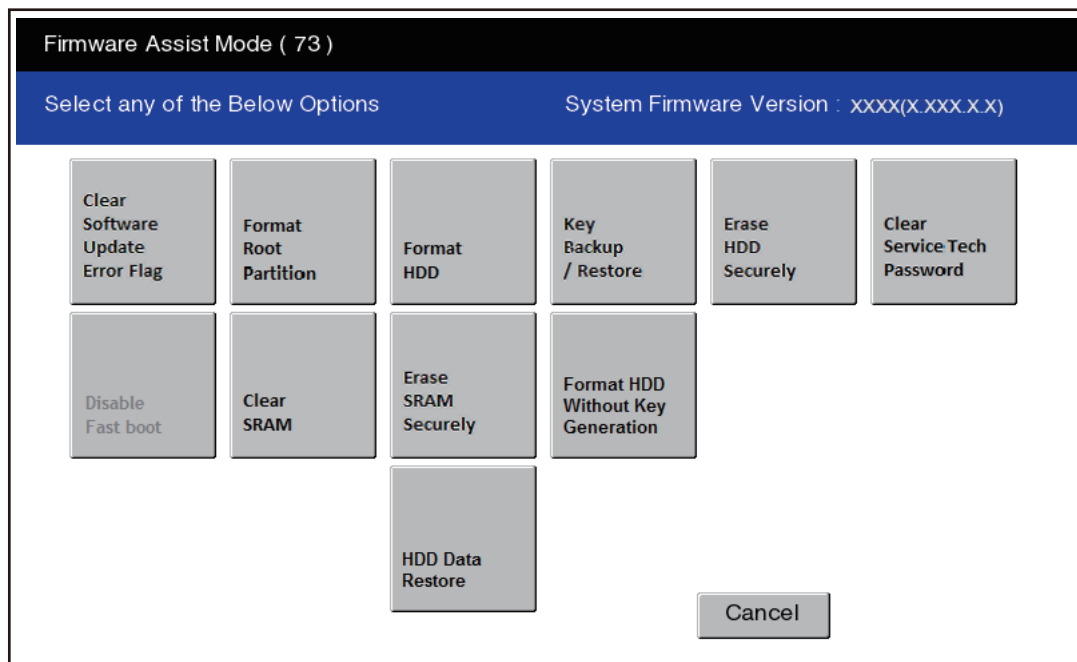


Fig.5-29

- (2) Press the icon to operate.

### 5.16.3 Functions

#### [A] Clearing update error flag (Clear Software Update Error Flag)

Even if the firmware downloading has been completed normally, the Recovery Mode may accidentally start up and an F600 error occurs when the power is turned ON again. In this case, clear the Update Error flags used in the download process with this function. (Normally, the flags are automatically cleared in the download process.)

Also in the case the Recovery Mode accidentally starts up after the replacement of SRAM, the flags are cleared with this function.

#### [B] Formatting data storage partition (Format Root Partition)

When a defect occurs on the UI data, etc. which are stored in the HDD, the partition with the stored UI data, etc. is formatted with this function.

Do not use this function since it is not normally necessary. HDD data must be installed after performing this function.

#### [C] Creating HDD partition (Format HDD)

After the HDD is replaced, when UI data are downloaded using a USB storage device, it is necessary to create a partition in the HDD of this equipment before downloading.

##### Notes:

- When this operation has been done, all data in the current HDD are erased. Therefore, perform this only when a new HDD is installed.
- When this operation has been done, do not perform SRAM data initialization (Clear SRAM) before the normal start-up.

#### [D] Backing up/restoring encryption key and license (Key Backup Restore)

When the SRAM or the SYS board is replaced or initialized, the encryption key and license are erased. Therefore, they need to be backed up or restored with this function.

Key Backup / Restore menu and functions

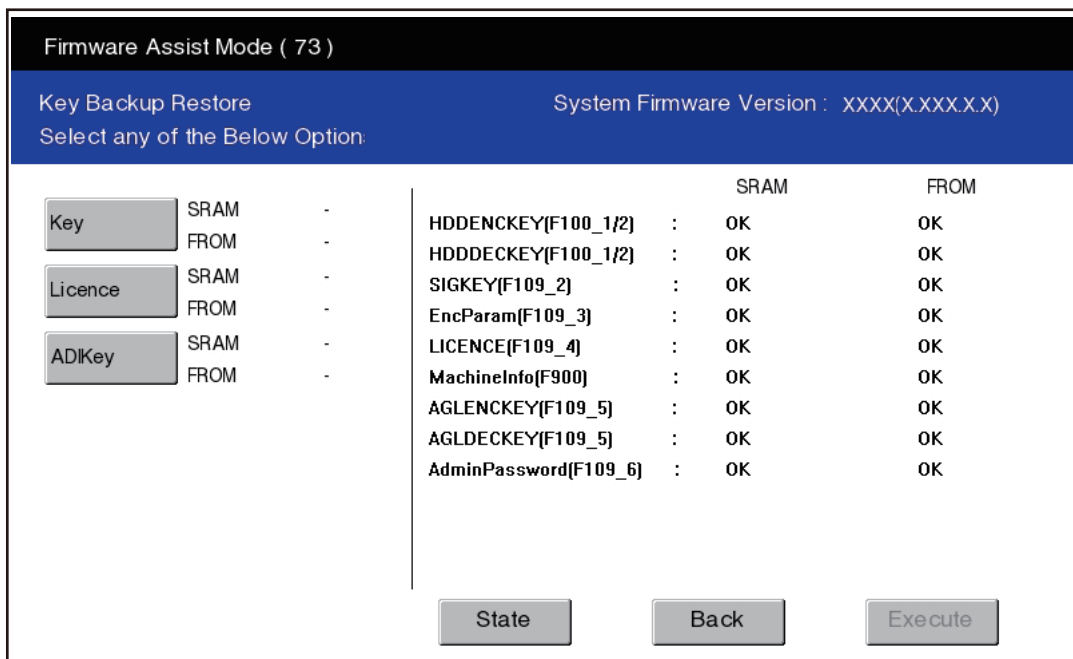


Fig.5-30

The following table shows the relationship between each Key or License and icon.

Key or License name	Icon
HDDENCKEY [F100_1/2]	Key
HDDDECKEY [F100_1/2]	Key
SIGKEY [F109_2]	Key
EncParam [F109_3]	Key
LICENSE [F109_4]	License
MachineInfo [F900]	Key
AGLENCKEY [F109_5]	ADIKey
AGLDECKEY [F109_5]	ADIKey
AdminPassword [F109_6]	ADIKey

- \* When “KeyBroken” or “KeyNull” is displayed on the SRAM row: Backs up the encryption Key or License in SRAM when the icon is pressed
- \* When “KeyBroken” or “KeyNull” is displayed on the FROM row: Recovers the encryption Key or License in SRAM when the icon is pressed

### [E] Erasing HDD securely (Erase HDD Securely)

This function is used when installing Data Overwrite Enabler (GP-1070) or before discarding the HDD. It overwrites all the used areas on the HDD with the selected data, and makes it unusable.

After selecting this function, specify the level below to be overwritten. This setting is the overwriting method complying with DoD 5220.22-M.

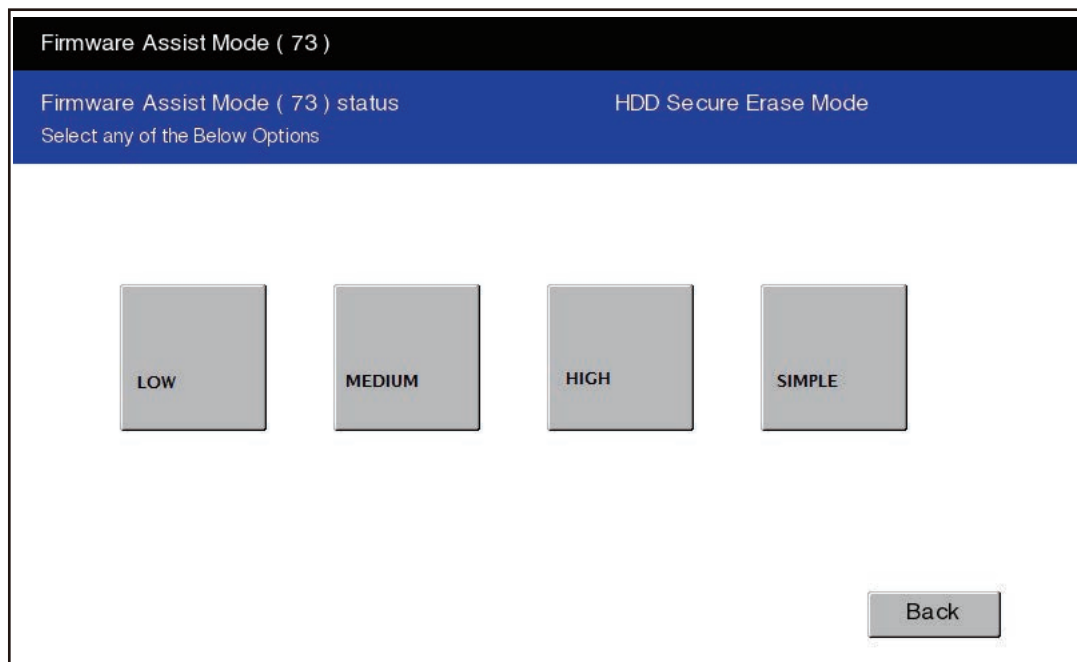


Fig.5-31

**LOW** (Normally use this setting.)

This is the standard overwriting method.

“00-FF-Random-Verify” Once

**MEDIUM**

This overwriting method is more secure than LOW. The erasing time is between LOW and HIGH.

“00-FF-Random” three times repeatedly -Verify

**HIGH**

This is the most secure overwriting method. It takes the longest time to erase data.

“00-FF-Random” five times repeatedly -Verify

## SIMPLE

This is the simple overwriting method. It takes the shortest time to erase data.  
Overwrite the Random data once

The reconfirmation screen is displayed when the icon is pressed.

Press [OK]: Processing starts.

Press [Back]: The screen returns to the previous one.

### Notes:

When this operation has been done, do not perform SRAM data formatting (Clear SRAM) before the normal start-up.

## [F] Formatting SRAM data (Clear SRAM)

When SRAM is replaced with a new one, abnormal values may be written in the new SRAM. SRAM data must be formatted with this function for such case.

### Notes:

- This function is required only when a new SRAM is installed.
- Do not perform this function in cases other than the installation of a new SRAM because all data in the SRAM will be deleted with this function.
- When this operation has been done, do not perform HDD partition creation (Format HDD) before the normal start-up.

## [G] Erasing SRAM securely (Erase SRAM Securely)

This function is used before discarding the SRAM.

It overwrites all the used areas on the SRAM with the selected data, and makes it unusable.

Immediately after selecting this function, the processing starts and is completed.

## [H] Clearing service password (Clear Service Tech Password)

This function is needed after the HDD is replaced.

When the HDD is replaced, the service password stored in the new one is set as a blank. Therefore, its password is copied to the SRAM so that both passwords become the same with this function. The setting is enabled when the equipment is started up in the normal mode after performing this function.

## [I] Disable Fast boot

This function disables faster boot (\*). Therefore, this can be operated while faster start is enabled.

- \* Faster start: The start-up method which can shorten the time for starting by approx. 5 seconds by starting up the equipment in the normal mode or while selecting the menu from the exclusive file. (There is no effect on the recovery from hibernation.)

Once the power is turned ON while the [HOME], [RESET] and [START] buttons are pressed simultaneously, a file for faster start is created and it becomes available. It will take approx. 3 minutes to create a file for faster start. When the file creation is completed, the equipment will automatically start in the normal mode.

- \* Faster start can also be disabled by the following operations.
  - Firmware update
  - HS-73 → [Format HDD]
  - Data Overwrite Enabler (GP-1070) installation or settings change
  - Security level change
  - HS-75 → [Initialize HDD]
  - HS-59 → [Restore SRAM Data from USB]

## [J] Restoring HDD Data (HDD Data Restore)

This function performs formatting, backup data restoring and firmware upgrading in series.

### Notes:

- Perform this function only after the HDD is replaced or when there will be no problem even if all the information in the HDD is erased.
- Perform this function only when a USB storage device (\*), in which the backup data and the firmware standard package are stored, is prepared.
  - \* It is available even if these 2 files are stored in different USB storage devices separately.

(1) Install the USB storage device with the backup data stored in the equipment.

(2) Perform this function.

- Format the HDD and restore the backup data.
- If the firmware standard package is stored in this USB storage device, continuously upgrade the firmware.
- If the firmware standard package is not stored in this USB storage device, an error appears. In such a case, install the USB storage device with the firmware standard package stored in the equipment and press [OK]. Firmware upgrading will start.
- After upgrading is completed, reboot the equipment.



## 5.17 74 HDD Assist Mode

### 5.17.1 Overview

This mode is available only when the security HDD (Secure HDD) is mounted in the equipment. It enables you to check the type of the mounted HDD, revert the Secure HDD to the factory default.

Functions of 74 HDD Assist mode

- Checks the type (Secure or Normal) of the mounted HDD.
- Disposes of Secure HDD data safely without any of leakage.
- Deletes image data when reusing a used Secure HDD.

### 5.17.2 Operation procedure

- (1) Perform [HS-74] by pressing [74 HDD Assist].  
Then, the type of the mounted HDD appears on the screen.

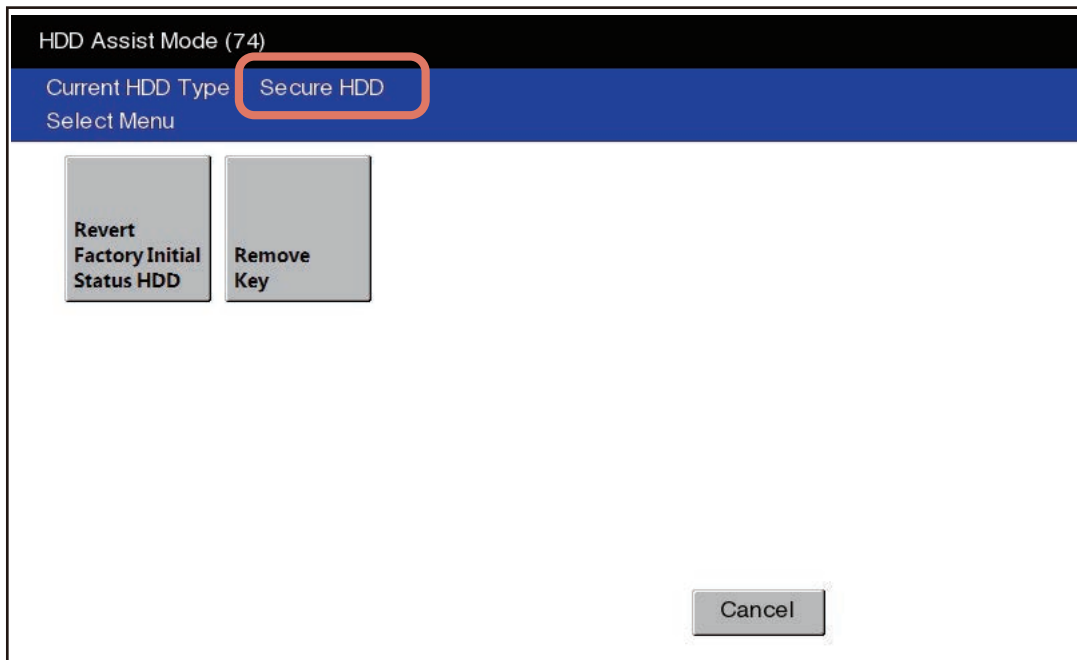


Fig.5-32


When a security HDD is mounted: Secure HDD

When a normal HDD is mounted: Normal HDD

- (2) Press the icon to operate.

#### Remarks:

If the HDD type cannot be identified, “Unknown HDD” may appear on the screen.

 P. 8-264 “ [F106\_1] HDD error (HDD type detection error)”

#### Notes:

When “Normal HDD” is displayed, the function will not be performed even if the icon is pressed. In such a case, the error message “Operation Failed. Press Soft Power Key to Switch Off.” appears.

## 5.17.3 Functions

### [A] Revert Factory Initial Status HDD

Select this to dispose of the Secure HDD as well as the equipment.

When this item is selected, all data in the HDD are deleted and the HDD is reverted to its initial status at the factory shipment. This operation requires only a few seconds; however, in order to make the HDD usable again, you need to perform [Format HDD] (creating HDD partition) in HS-73 and reinstall the HDD data with HS-49.

The following screen is displayed when [Revert Factory Initial Status HDD] is pressed.

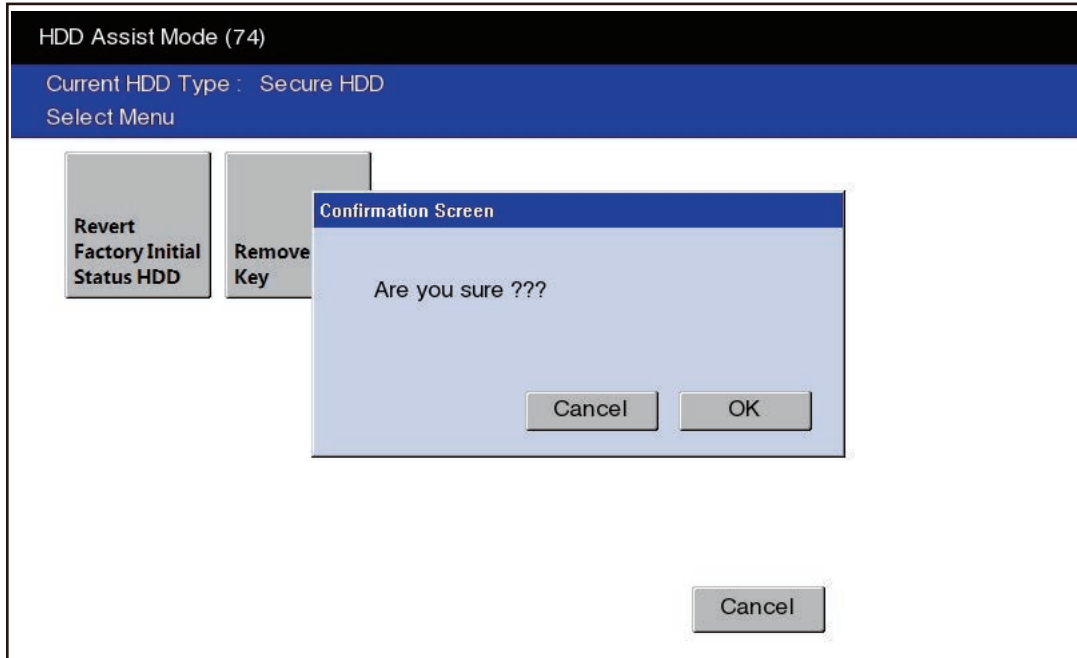


Fig.5-33

Press [OK] to carry out the operation.

When the operation is finished, the result appears on the menu.

#### Notes:

- If the equipment is started up in the normal mode under this condition, a service call (HDD mount error) will occur.
- After this has been performed, formatting of the HDD and reinstallation of applications are necessary.

## [B] Remove Key

Select this to reuse the Secure HDD as well as the equipment.

When this item is selected, image data in the HDD are deleted.

This operation requires approx. 20 minutes since the partition must be rebuilt.

The following screen is displayed when [Remove Key] is pressed.

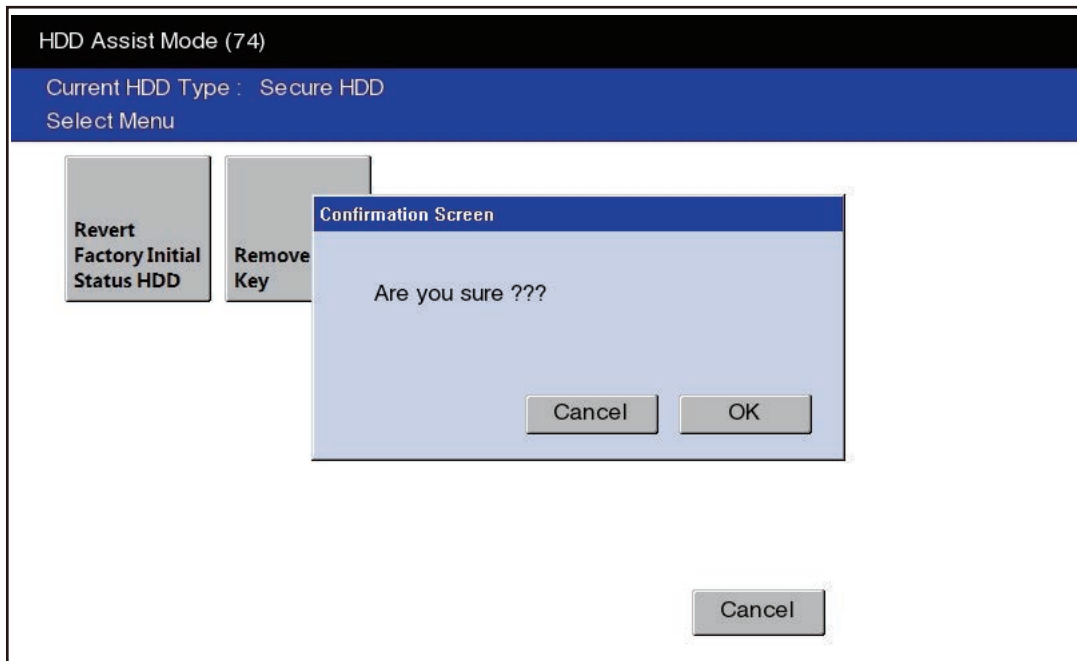


Fig.5-34

Press [OK] to carry out the operation.

When the operation is finished, the result appears on the menu.

### Remarks:

- After this operation, the equipment becomes reusable without reinstalling the firmware.
- After this has been performed, formatting of the HDD and reinstallation of applications are necessary.

## 5.18 75 File System Recovery Mode

### 5.18.1 Overview

This is a mode to check if there is any damage to the file system (HDD) and recover it if necessary. Use this mode only in the following cases.

- There is a possibility of damage to the file system (HDD).
- There is an apparent damage to the file system (HDD), requiring recovery or initialization.

This mode enables you to have the following functions.

Content	Functions
Check F/S	Checks the file system.
Recovery F/S	Recovers the file system.
Initialize HDD	Initializes partitions in the HDD.
Initialize DB	Initializes database (LDAP DB / log DB / language DB / AppMgmt DB / HomeScreen DB / JobHistory DB / AppLicense DB).
SMART Info	Displays the various information in the HDD.
DISK Info	Displays the usage rate of each partition.
HDD Utility	Initializes log files.

### 5.18.2 Operation procedure

- (1) Perform [HS-75] by pressing [75 File System Recovery].  
The following screen appears.

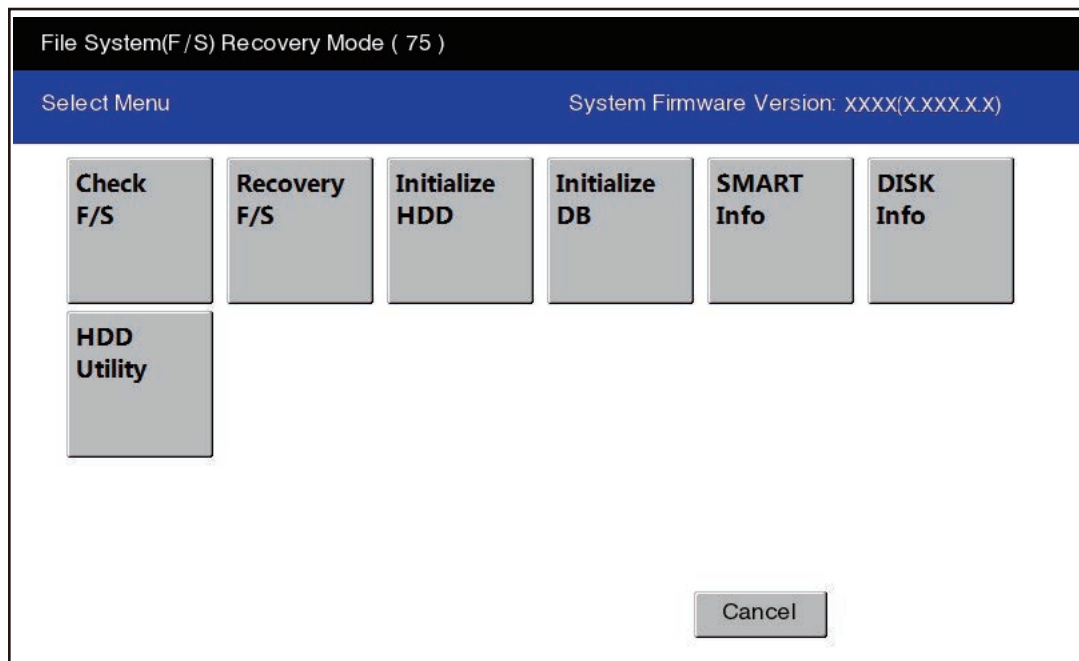


Fig.5-35

- (2) Press the icon to operate.

**Notes:**

- Do not turn the power OFF with the [MAIN POWER] button after the processing has started (while the processing is being performed).
- After the processing is completed, a beep sounds 4 times and either “Completed” or “Failed” appears on the screen.

## 5.18.3 Functions

### [A] Check of the File System (Check F/S)

In case that particular service calls occur or there is a possibility of damage to the file system, the status of each partition in the HDD can be checked.

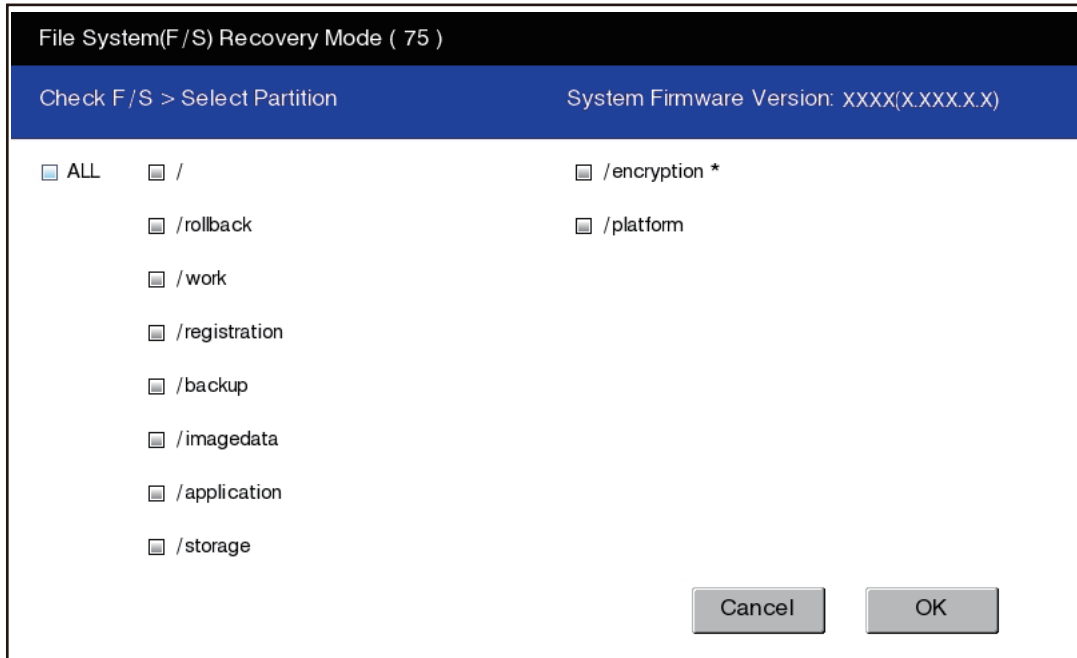


Fig.5-36

Explanation for each item

ALL: Checks all partitions.

/: Checks root partition only.

Other: Checks each partition shown above.

#### Remarks:

More than one partition can be selected. (A check mark is displayed at the selected item.)

\* If damage is discovered, recover or initialize the file system (HDD).

## [B] Recovery of the File System (Recovery F/S)

In case that an error occurs during the file system check, each partition can be recovered.

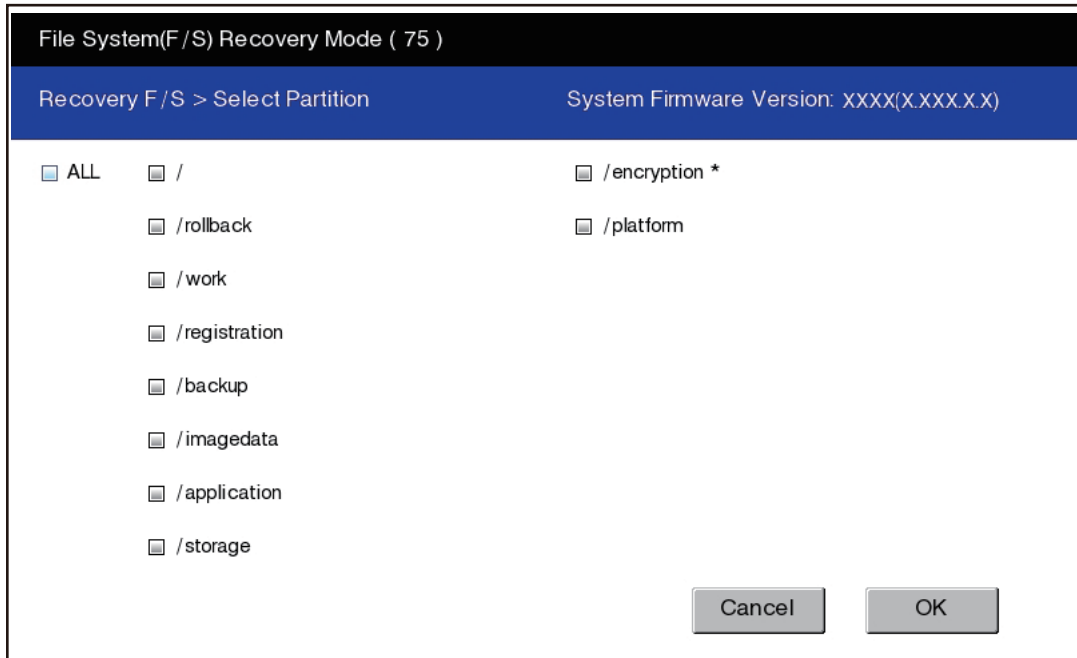


Fig.5-37

Explanation for each item

ALL: Recovers all partitions.

/: Recovers root partition only.

Other: Recovers each partition shown above.

### Remarks:

More than one partition can be selected. (A check mark is displayed at the selected item.)

\* If an error occurs during recovery, initialize the file system (HDD).

### [C] Initialize the File System (Initialize HDD)

In case that an error occurs during the file system check and the partition cannot be recovered with the recovery, each partition can be initialized.

It is recommended to export the user information such as address book before performing this function.

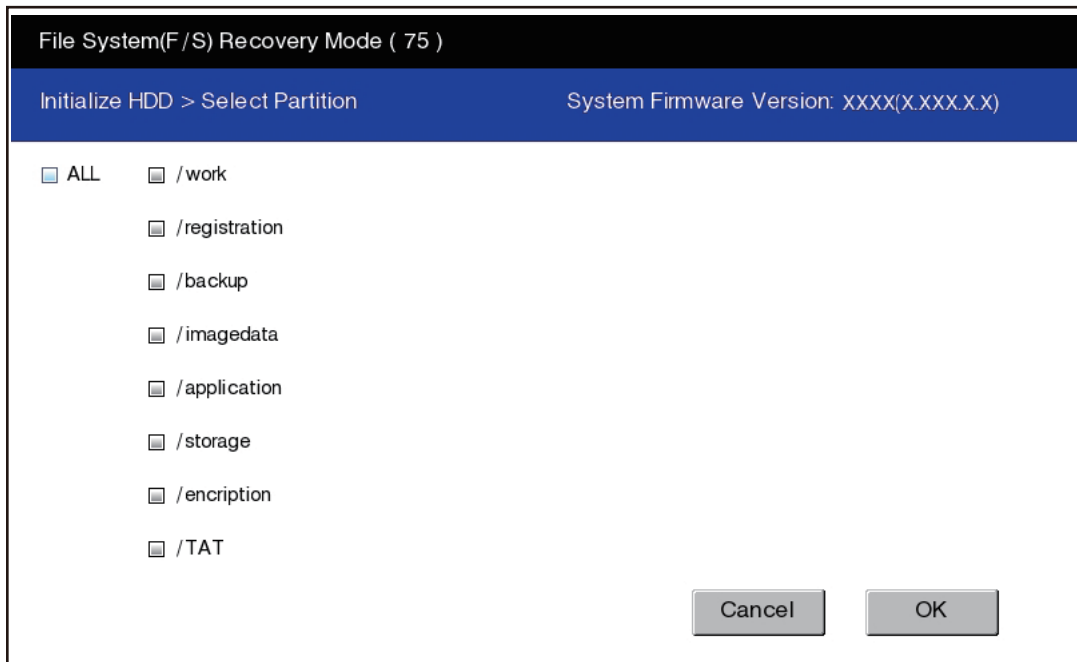


Fig.5-38

Explanation for each item

ALL: Initializes partitions other than root one and creates initial files.

Others: Initializes each partition.

#### Remarks:

More than one partition can be selected. (A check mark is displayed at the selected item.)

#### Notes:

- If initialization is carried out by selecting [ALL] or [/encription], applications and OS data in the equipment are also initialized. In this case, the applications and the file system must be reinstalled. Install the system software (HD Data) by performing [49] -> [4] after initialization.
- If [ALL] is selected, minimal data necessary for normal startup are automatically recovered.
- If initialization is carried out by selecting [ALL], the log database is also initialized. Back up the data before initializing if necessary.
- If [ALL] is selected, do not perform SRAM data formatting (Clear SRAM) before the normal start-up.

### [D] Initialize the DB (Initialize DB)

In case that particular service calls occur or there is a possibility of damage to the databases, each one can be initialized.

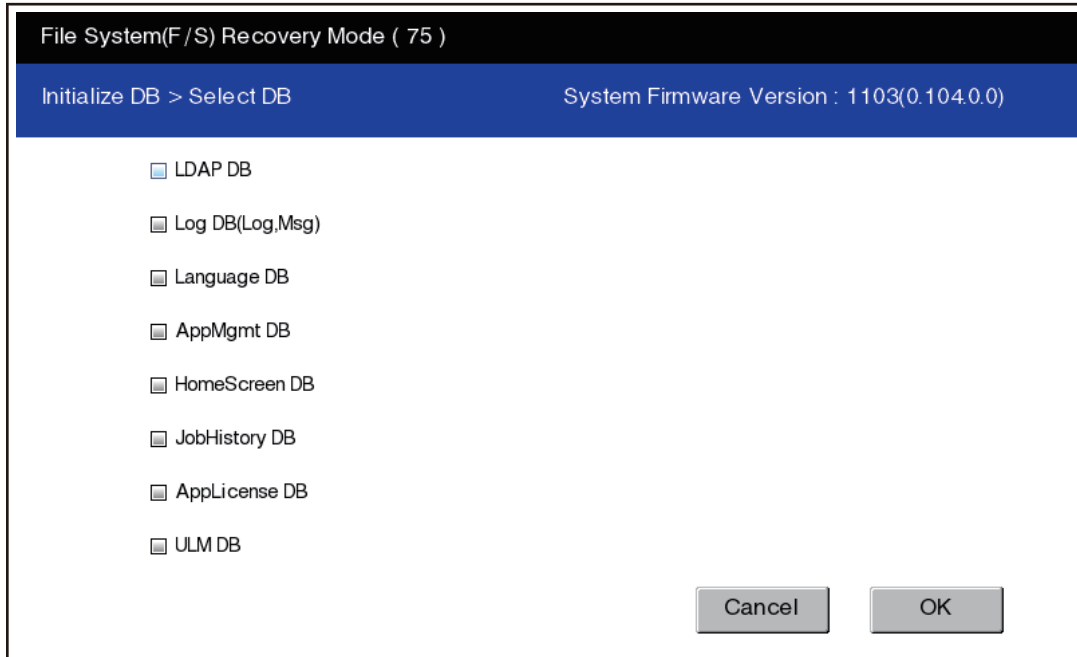


Fig.5-39

Explanation for each item

LDAP DB: Initializes address book data and the user information database.

Log DB (Log,Msg): Initializes job log data and the message database.

Language DB: Initializes the language database.

AppMgmt DB: Initializes the application database.

HomeScreen DB: Initializes the home screen database.

JobHistory DB: Initializes the job history database.

AppLicense DB: Initializes the application license database.

ULM DB: Initializes the application license management database.

#### Remarks:

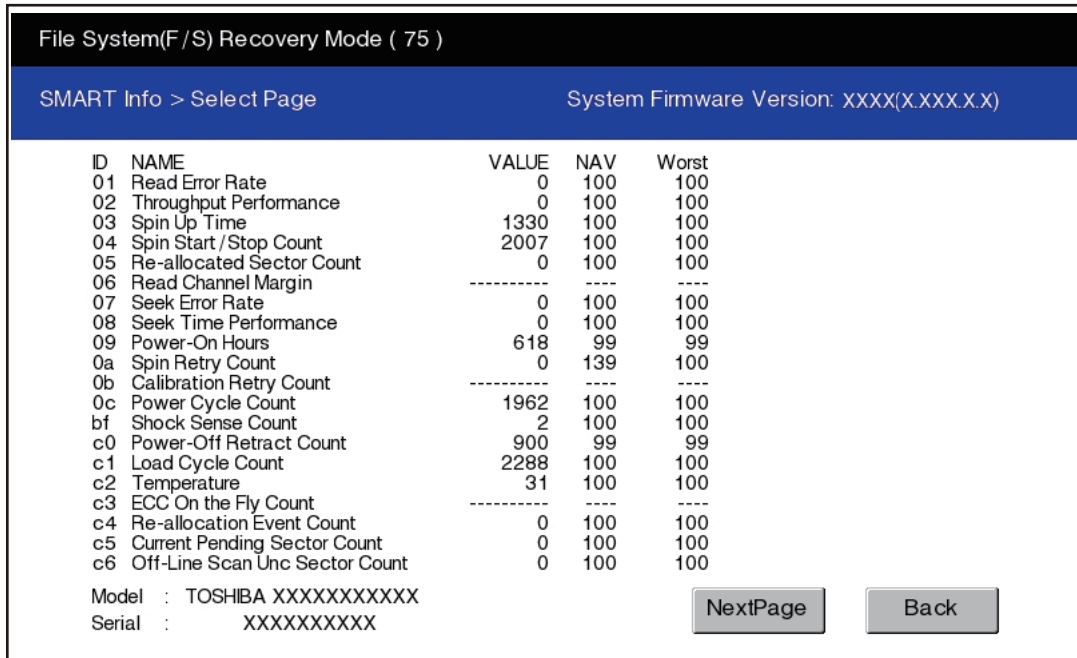
Once the databases are selected, they are initialized.



### [E] Displaying various data in the HDD (SMART Info)

Various data in the HDD can be displayed. (Data equivalent to the setting contents of FS-08-9065 are displayed.)

When this item is selected, data in the HDD embedded in the equipment are displayed. “---” is displayed for the items not supported.



File System(F/S) Recovery Mode ( 75 )

SMART Info > Select Page System Firmware Version: XXXX(X.XXX.X.X)

ID	NAME	VALUE	NAV	Worst
01	Read Error Rate	0	100	100
02	Throughput Performance	0	100	100
03	Spin Up Time	1330	100	100
04	Spin Start /Stop Count	2007	100	100
05	Re-allocated Sector Count	0	100	100
06	Read Channel Margin	-----	----	----
07	Seek Error Rate	0	100	100
08	Seek Time Performance	0	100	100
09	Power-On Hours	618	99	99
0a	Spin Retry Count	0	139	100
0b	Calibration Retry Count	-----	----	----
0c	Power Cycle Count	1962	100	100
bf	Shock Sense Count	2	100	100
c0	Power-Off Retract Count	900	99	99
c1	Load Cycle Count	2288	100	100
c2	Temperature	31	100	100
c3	ECC On the Fly Count	-----	----	----
c4	Re-allocation Event Count	0	100	100
c5	Current Pending Sector Count	0	100	100
c6	Off-Line Scan Unc Sector Count	0	100	100

Model : TOSHIBA XXXXXXXXXXXX  
Serial : XXXXXXXXXXXX

NextPage Back

Fig.5-40

#### Remarks:

NAV: Normalized Attribute Value

Indicates the value of the specified HDD condition as compared to the manufacturer's optimum value.

Worst: Worst Ever Normalized Attribute Value

Indicates the worst value of NAV permitted by the manufacturer.

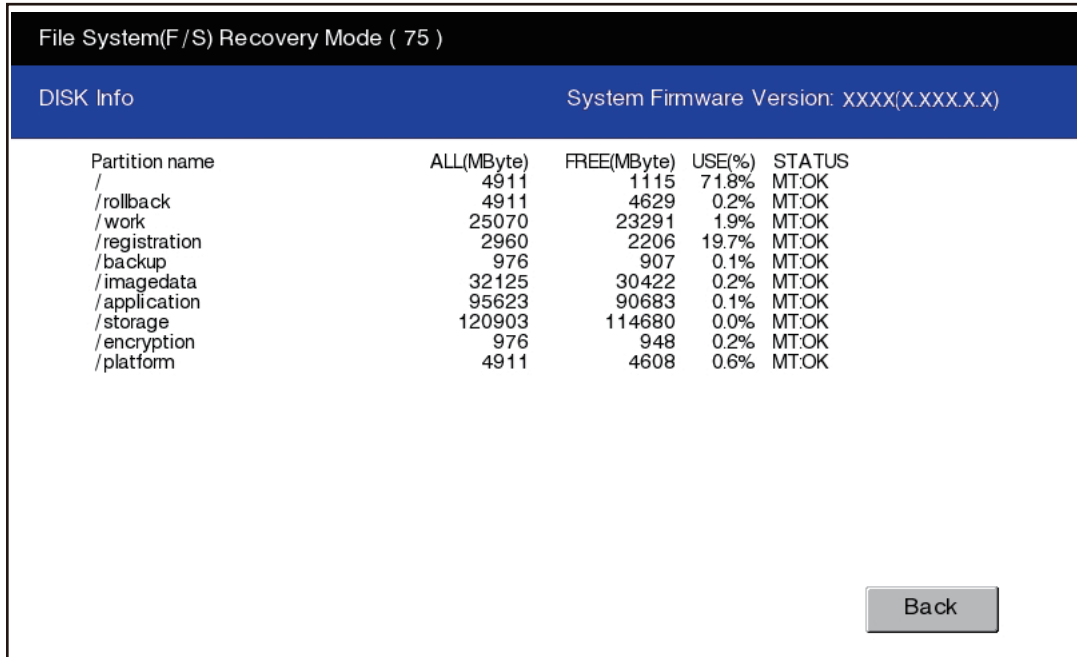
#### Notes:

The values of NAV and Worst should be treated as a rough reference since their basis may differ depending on the specification of HDD manufacturers.

### [F] Displaying usage rate of each partition (DISK Info)

The usage rate of each partition can be checked.

When this item is selected, the usage rate of each partition is displayed.



Partition name	ALL(MByte)	FREE(MByte)	USE(%)	STATUS
/	4911	1115	71.8%	MT:OK
/rollback	4911	4629	0.2%	MT:OK
/work	25070	23291	1.9%	MT:OK
/registration	2960	2206	19.7%	MT:OK
/backup	976	907	0.1%	MT:OK
/imagedata	32125	30422	0.2%	MT:OK
/application	95623	90683	0.1%	MT:OK
/storage	120903	114680	0.0%	MT:OK
/encryption	976	948	0.2%	MT:OK
/platform	4911	4608	0.6%	MT:OK

Fig.5-41

### [G] Initialization of log file (HDD Utility)

Log files for researching can be deleted. Since only a certain amount of log files for researching is usually stored in the work area of an HDD, the use of this mode is not necessary. In case the performance level of the equipment is lowered (e.g.: the response of the control panel becomes extremely slow), make use of this mode. This phenomenon may be resolved.

## 5.19 76 SRAM Maintenance Mode

### 5.19.1 Overview

This is a mode in which you can clear particular errors such as F800 or F900.  
The processing contents of this mode are the same as those for [Clear SRAM] in [HS-73].

Functions of 76 SRAM Maintenance Mode

- Sets the serial number of this equipment.
- Clears F800 error.
- Clears F900 error.

### 5.19.2 Operation procedure

- (1) Perform [HS-76] by pressing [76 SRAM Maintenance Mode].  
Then the following screen is displayed.

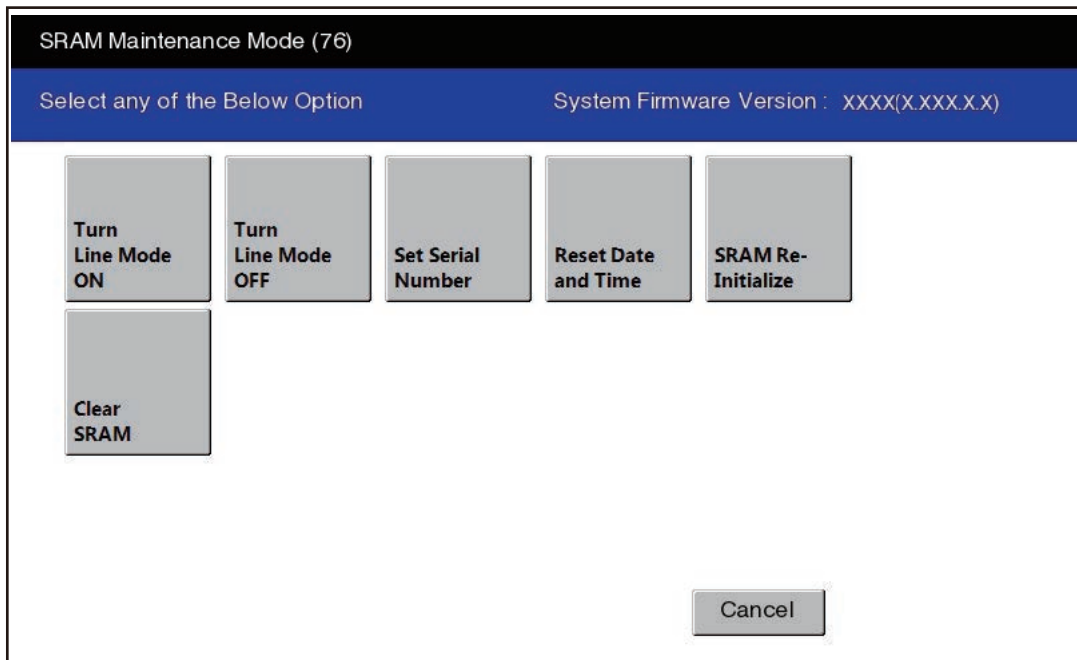


Fig.5-42

- (2) Press the icon to operate.

#### Notes:

[Turn Line Mode ON] or [Turn Line Mode OFF] starts once each icon is pressed.  
When [Set Serial Number], [Reset Date and Time], [SRAM Re-Initialize] or [Clear SRAM] is pressed, the confirmation screen appears.

## 5.19.3 Functions

### [A] Turn Line Mode ON (Manufacturing mode ON)


The equipment enters into the manufacturing mode.

### [B] Turn Line Mode OFF (Manufacturing mode OFF)

The equipment enters into the service mode.

### [C] Set Serial Number (Setting serial number)

When replacing SYS-SRAM, select this to set the serial number of the equipment since it must be done in advance of recovery from SRAM backup data.

- Clear SRAM first and then set the serial number in this mode.
- Recover from SRAM backup data after setting the serial number.  
Refer to  P. 12-2 “12.1.4 Cloning procedure”

Key in the serial number of this equipment and press [OK].

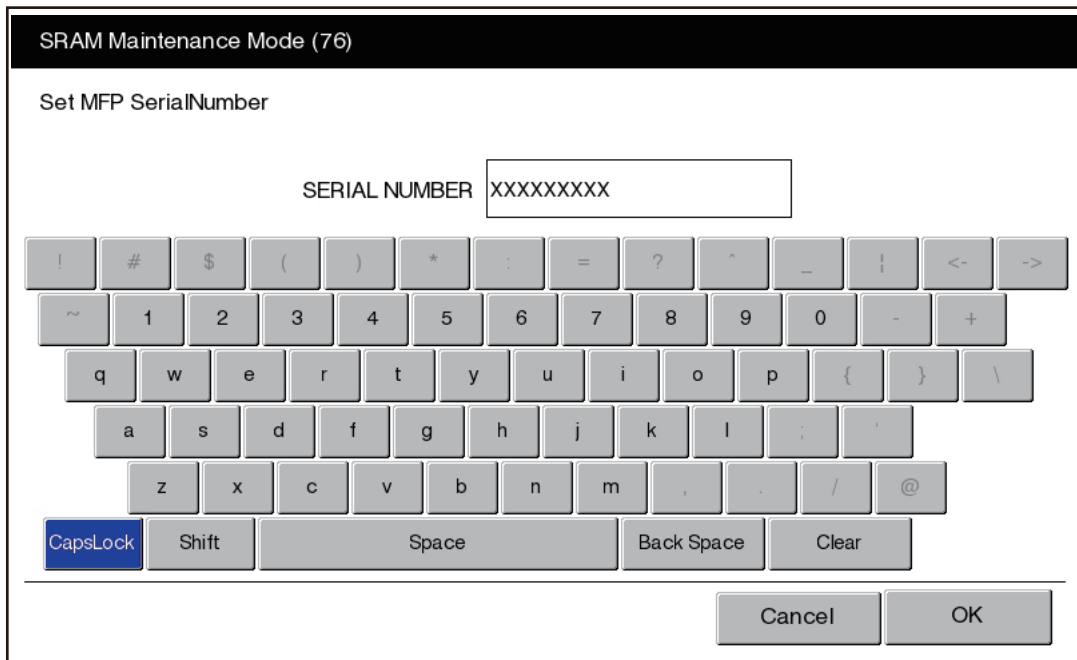


Fig.5-43

### [D] Reset Date and Time

Select this to clear an F800 error which occurred when the date and time were set as after the end of the year 2037 or when the actual end of the year 2037 has come.

- After selecting this, start the equipment in the normal mode to reset the date and time.

### [E] SRAM Re-Initialize

Since an F900 error cannot be cleared in the 73 Firmware Assist mode, use this function to clear the error in the following cases:

- When the SRAM and the SYS board are replaced at the same time
- When the SRAM is initialized with wrong destination at the replacement of the SRAM


Refer to  P. 9-26 “9.2.5 Precautions and procedure when replacing the SRAM”.

**[F] Clear SRAM**

Select this to clear all SRAM data when replacing SRAM.

Replace the SRAM and then clear the SRAM data.

After clearing the SRAM data, initialize SRAM following its replacement procedure.

Refer to  P. 9-26 “9.2.5 Precautions and procedure when replacing the SRAM”.

**Notes:**

When this operation has been done, do not perform HDD partition creation (Format HDD) before the normal start-up.

## 5.20 Pixel Counter

### 5.20.1 Outline

#### [ 1 ] Outline

Pixel counter is a function that counts the number of dots emitted by writing light source and converts it into the print ratio (%) per standard paper size. This "Print ratio (%) per standard paper size" is called Pixel count (%).

This function enables you to know how each user uses the equipment and to grasp the tendency of toner consumption (number of output pages per cartridge).

However, since some of the factors in "2" below are not taken into account by the pixel counter, its accuracy does sometimes not match the actual toner consumption.

#### [ 2 ] Factors affecting toner consumption

Standard number of output pages per cartridge shows the average number of output pages under the condition that the data of print ratio 5% is printed on the standard paper size (A4/LT) at a normal temperature and humidity.

However, users do not always print under the above condition. As for the type of original, copy/print mode and environment, each user has different tendency, and as a result, the number of output pages per cartridge becomes different depending on the user.

The major factors affecting toner consumption are as follows:

- Original/Data coverage
- Original/Data density
- Original/Print mode
- Density setting
- Print Pattern  
Character images (e.g. Text) consume more toner than solid images even though they may have the same density.
- Number of pages per job  
More toner is required when printing in the non-continuous running mode.
- Number of image quality control  
Image quality control is performed automatically when the device is switched on, when it returns from sleep mode, and also during continuous running. Toner consumption may vary depending on the number of image quality adjustments performed during operation.
- Paper  
The size, feeding direction and type of paper influence toner consumption.
- Environmental conditions  
Temperature and Humidity affect toner consumption.
- Others  
In addition to the above, there are other factors that may influence toner consumption. These include variations between individual products, life of consumable, bias voltages, Drum surface potential, etc.

The general relations between the above 4 factors and toner consumption per output page in the copy function are as follows:

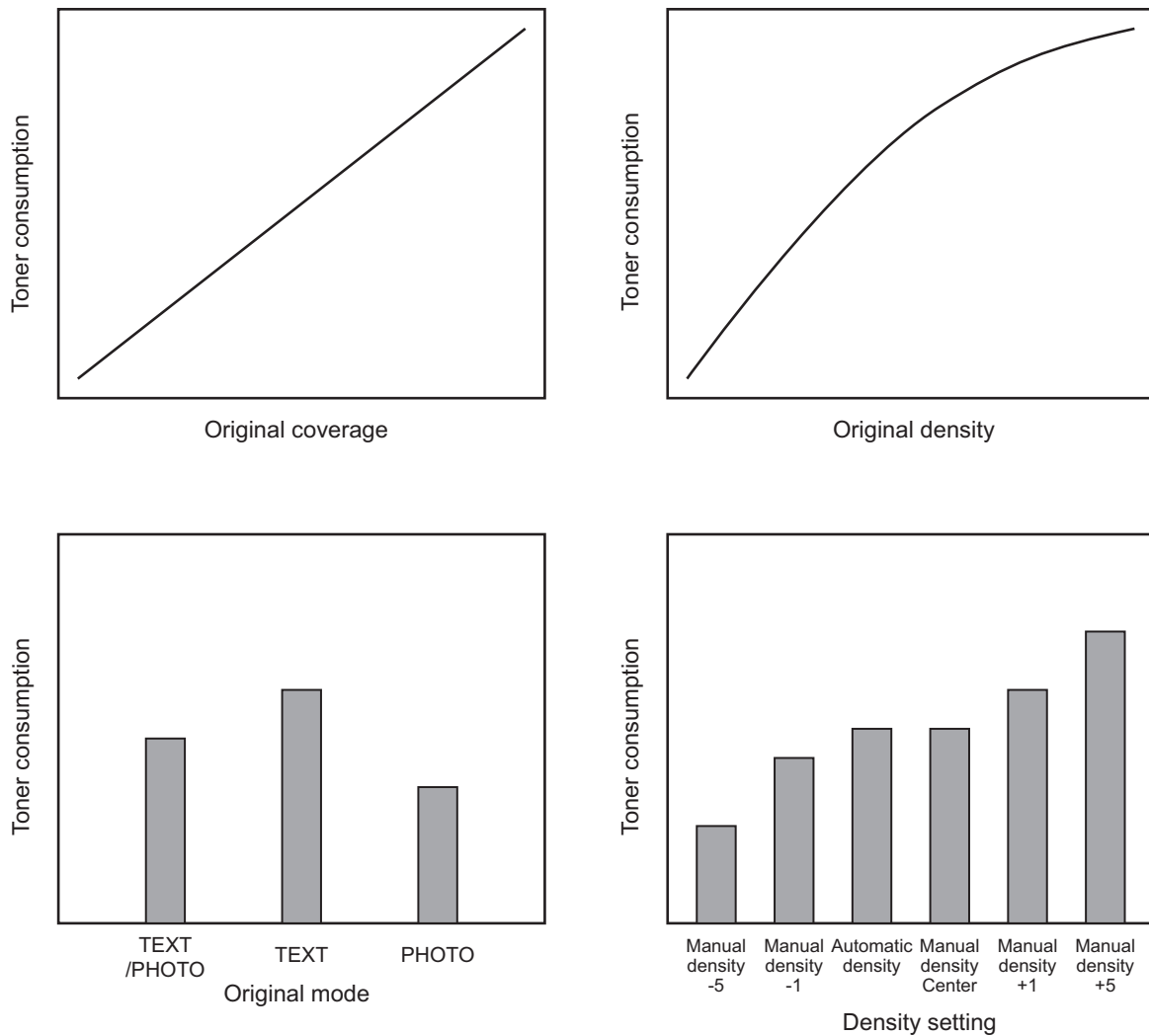


Fig.5-44 Factors affecting toner consumption and the tendency

### [ 3 ] Details of pixel counter

- Toner cartridge reference and service technician reference  
The pixel counter function in this equipment has 2 references, toner cartridge reference and service technician reference.

#### Toner cartridge reference

This is a system that accumulates data between the installation of a new toner cartridge and next installation.

The installation of new toner cartridge is judged when the total number of pixel count or output pages after the detection of toner cartridge empty has exceeded the threshold.

The threshold to be used is selectable in the FS-08-6506 between the pixel count and output pages (0: Output pages 1: Pixel counter). The threshold of pixel count is set in the FS-08-6508 and that of output pages is set in the FS-08-6507. When the new toner cartridge is judged as installed, the data related with the previous cartridge is cleared and replaced with the data after the installation of new cartridge. Clearing of the counter of the toner cartridge reference is performed in the FS-08-6503.

### Service technician reference

This is a system that accumulates data between clearing the counter of the service technician reference by service technician and subsequently clearing the same counter.

Clearing of the counter of the service technician reference is performed in the FS-08-6502.

- Print count (number of output pages)

The number of output pages shown at the pixel counter is counted after converting all paper sizes to the standard paper size (A4/LT). Printing on other than the standard size is converted by paper area ratio. The standard paper size is set in the FS-08-6500.

The examples of conversion are as follows:

#### Ex.)

When printing on A4/LT size:

Counts the number of output pages as the print count.

When printing on A3/LD size:

Counts the number of output pages multiplied by 2 as the print count. (Area ratio to A4/LT: 200%)

When printing on B4 size:

Counts the number of output pages multiplied by 1.49 as the print count. (Area ratio to A4: 149%)

When printing on LG size:

Counts the number of output pages multiplied by 1.27 as the print count. (Area ratio to LT: 127%)

- Pixel count (%)

Pixel count (%) shows the ratio of the emitting pixels of the writing light source to all pixels on standard paper.

The examples of pixel count are as follows:

#### Notes:

In the following examples, 'solid copy' is considered to be 100%. But since the image has 4 margins, it never becomes 100% actually.

#### Ex.)

Printing 5 pages on A4/LT size with solid copy (writing light source emit to all pixels.)

→ Pixel count: 100%, Print count: 5

Printing 5 pages on A4/LT size with blank copy (writing light source never emit.)

→ Pixel count: 0%, Print count: 5

Printing 2 pages on A4/LT size with solid copy (writing light source emit to all pixels.)

Printing 2 pages on A4/LT size with blank copy (writing light source never emit.)

→ Pixel count: 50%, Print count: 4

Printing 3 pages on A4/LT size with 6% of writing light source emission

Printing 1 page on A4/LT size with 2% of writing light source emission

→ Pixel count: 5%, Print count: 4

Printing 2 pages on A3/LD size with solid copy (writing light source emit to all pixels.)

→ Pixel count: 100%, Print count: 4

Printing 2 pages on A3/LD size with 6% of writing light source emission

→ Pixel count: 6%, Print count: 4



- Average pixel count (%) and latest pixel count (%)  
There are 2 types of the value calculated as the pixel count, average pixel count (%) and latest pixel count (%).

**Average pixel count (%)**

The average value of all pixel count data after each reference data is cleared is calculated and displayed.

**Latest pixel count (%)**

The value is displayed for printing just before the pixel counter is confirmed.

- Type of calculated data  
Since this is multifunctional, the data of pixel count is calculated for each function.  
The following list is the information that can be confirmed by LCD screen. But actually, more information can be confirmed by the FS-08.  
See after-mentioned “5)-Display in the FS-08 for details.

○: With data  
-: Without data

	Toner cartridge reference	Service technician reference
Copier function	○	○
Printer function	○	○
FAX function	○	○
Total	○	○

**Table 5-1 Type of calculated data**

- Setting related with the pixel counter function  
**Standard paper size setting**  
The standard paper size (A4 or LT) to convert it into the pixel count is selected (FS-08-6500).

**Pixel counter display setting**

Whether or not to display the pixel counter on the LCD screen is selected (FS-08-6504).

**Display reference setting**

The reference when displaying the pixel counter on the LCD screen (toner cartridge reference or service technician reference) is selected (FS-08-6505).

**Determination counter of toner empty**

This is the counter to determine the replacement of new toner cartridge after the toner empty is detected.

After the toner empty is detected by the auto-toner sensor, this counter checks if toner empty is not detected one more time while the specified number of pixel count or output pages is counted.  
When the toner empty is not detected, the installation of a new toner cartridge is judged.

**Pixel counter clearing**

There are 3 types for the pixel count clear as follows:

FS-08-6501: All information related to the pixel count is cleared.

FS-08-6502: All information related to the service technician reference pixel count is cleared.

FS-08-6503: All information related to the toner cartridge reference pixel count is cleared.

#### [ 4 ] Relation between pixel count and toner consumption

The user's printing out the image with large coverage or high density may cause the large value of pixel count. And the setting that toner consumption becomes high in the original mode or density setting may cause it as well.

In this case, the replacement cycle of toner cartridge is faster than the standard number of output pages. Therefore, this trend needs to be grasped for the service.

The relation between pixel count and number of output pages per cartridge is as follows:

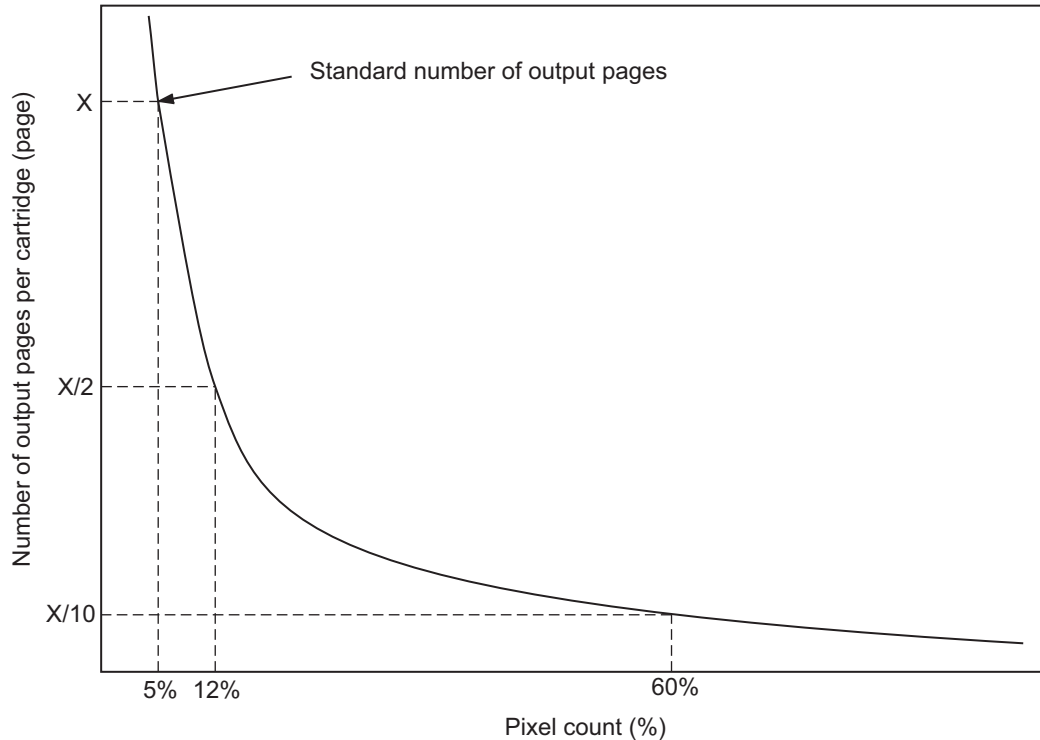


Fig.5-45 Pixel count and number of output pages per cartridge

#### [ 5 ] Pixel counter confirmation

- Display on LCD screen  
Whether or not to display the pixel counter on the LCD screen is selected (0: Displayed, 1: Not displayed) in the setting mode (FS-08-6504), and whether or not to display it at the service technician reference or toner cartridge reference is selected (0: Service technician reference, 1: Toner cartridge reference) in the FS-08-6505.

The following screen is displayed when the buttons, [COUNTER] and [PIXEL COUNTER] are pressed in this order after "Displayed" is selected with the code above and the power is, as usual, turned ON. (The displayed buttons are depending on the FS-08-6505.)

When [TONER CARTRIDGE] is pressed, the following screen appears.

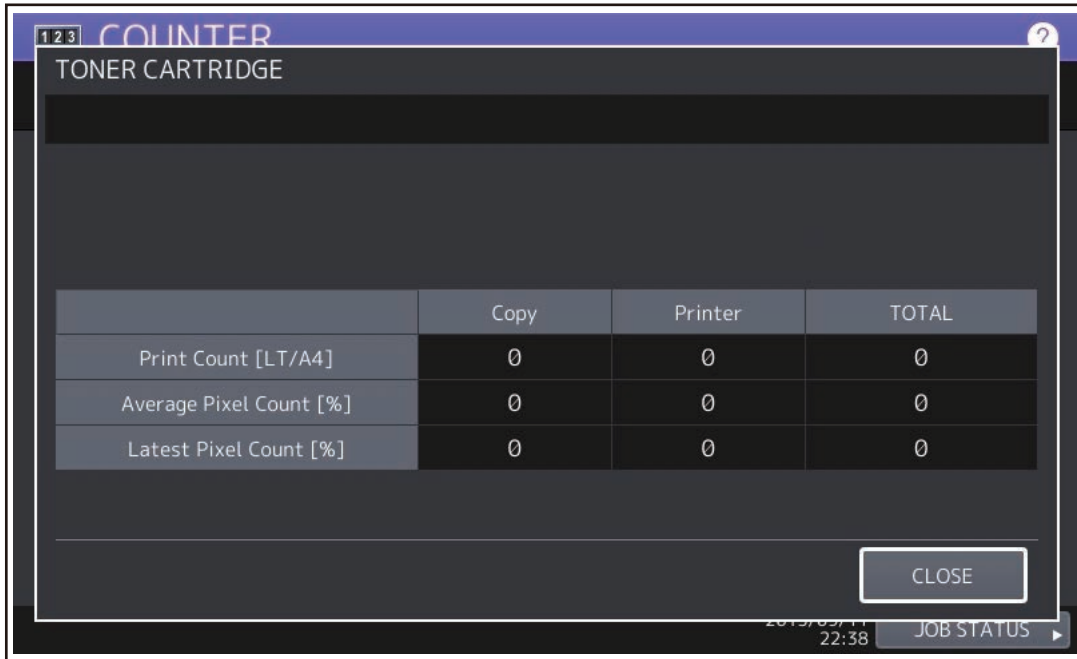


Fig.5-46 Information screen of toner cartridge reference

When [SERVICE] is pressed, the following screen appears.

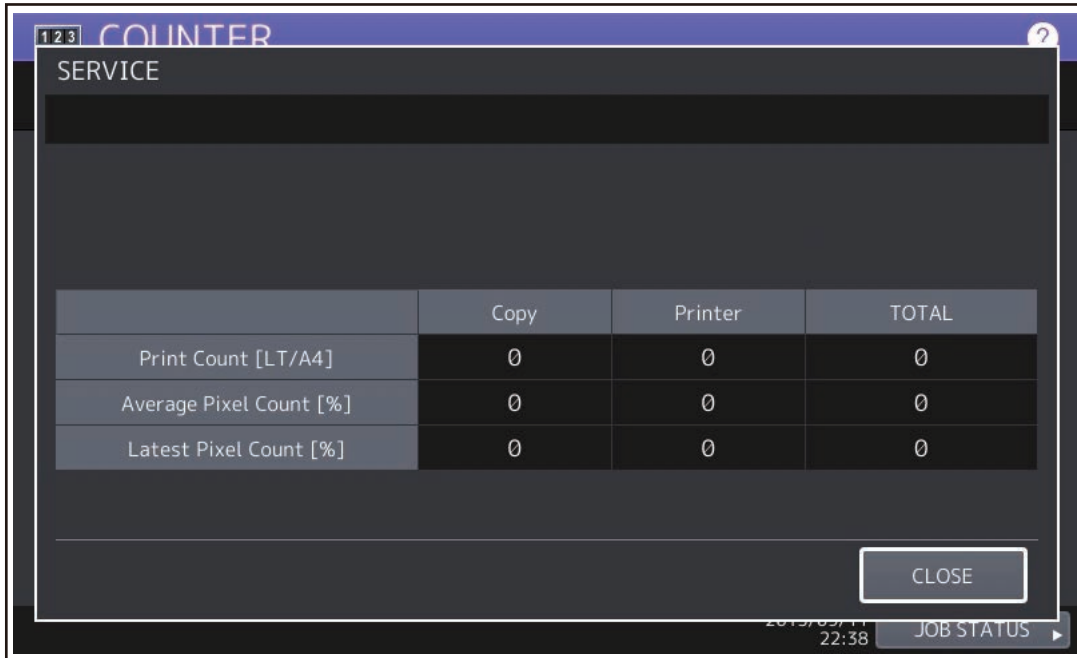


Fig.5-47 Information screen of service technician reference (full color)

- Data list printing  
 The data for pixel counter can be printed in FS-30 LIST PRINT MODE.  
 FS-9S-104: The data of the toner cartridge reference is printed.  
 FS-9S-105: The data of service technician reference is printed.

PIXEL COUNTER CODE LIST		S/N: xxxxxxxx	FIN S/N: xxxxxxxx	TOTAL:	9999999	
20xx-xx-xx xx:xx		TOSHIBA e-STUDIOxxx		DF TOTAL:	9999999	
TONERCARTRIDGE						
NO.	DATE	COLOR	PPC	PRN	FAX	TOTAL
0	20xx-xx-xx	Print Count[LT/A4]	181	45	---	226
1	20xx-xx-xx	Average Pixel Count[%]	2.70	1.74	---	2.51
2	20xx-xx-xx	Latest Pixel Count[%]	6.15	0.39	---	0.39

**Fig.5-48 Data list of toner cartridge reference**

PIXEL COUNTER CODE LIST		S/N: xxxxxxxx	FIN S/N: xxxxxxxx	TOTAL:	9999999	
20xx-xx-xx xx:xx		TOSHIBA e-STUDIOxxx		DF TOTAL:	9999999	
SERVICEMAN						
NO.	DATE	COLOR	PPC	PRN	FAX	TOTAL
0	20xx-xx-xx	Print Count[LT/A4]	181	45	---	226
1	20xx-xx-xx	Average Pixel Count[%]	2.70	1.74	---	2.51
2	20xx-xx-xx	Latest Pixel Count[%]	6.15	0.39	---	0.39

**Fig.5-49 Data list of service technician reference**

- Display in the FS-08 SETTING MODE  
Information of pixel count can be also checked in the 08 SETTING MODE.

**Print count, pixel count**

		Toner cartridge reference	Service technician reference
Copier function	Print count (page)	6563	6558
	Average pixel count (%)	6623	6602
	Latest pixel count (%)	6724	6616
Printer function	Print count (page)	6565	6560
	Average pixel count (%)	6629	6603
	Latest pixel count (%)	6725	6617
FAX function	Print count (page)	6566	6561
	Average pixel count (%)	6635	6604
	Latest pixel count (%)	6644	6618
Total	Average pixel count (%)	6634	6605

**Table 5-2 Pixel count code table**

**Notes:**

By entering the sub code at the above code, the pixel count distribution can be displayed dividing into 10 ranges. The sub codes are as follows.

0: 0 - 5%, 1: 5.1 - 10%, 2: 10.1 - 15%, 3: 15.1 - 20%, 4: 20.1 - 25%  
5: 25.1 - 30%, 6: 30.1 - 40%, 7: 40.1 - 60%, 8: 60.1- 80%, 9: 80.1 - 100%

**Other information**

Toner cartridge replacement counter

The toner cartridge replacement count is displayed. (08-6576)

Toner cartridge reference count started date

The toner cartridge reference count started date is displayed. (08-6522)

Service technician reference cleared date

The service technician reference cleared date is displayed.(08-6510)

The date (08-6502 was performed) is stored.

Toner cartridge reference cleared date

The toner cartridge reference cleared date is displayed.

The date (08-6503 was performed) is stored.

## 5.21 Batch Setting for Self-Diagnostic Codes

### 5.21.1 General description

The setting files encrypted in which each setting value has been written can be stored in a USB storage device. Installing this USB storage device in the equipment and reading a setting file enables the batch setting for the self-diagnostic codes.

- After the batch setting is performed, a result file is stored in the USB storage device.
- A maximum of 100 codes can be set in one file. If a code has sub codes, each of them is counted as one code.

**Notes:**

This function is not available if an automatic execution script such as a log collection is stored in a USB storage device.

### 5.21.2 Applicable codes

This function is available for the codes, whose values can be set by the service technicians, FS-05/08/13.

**Notes:**

- The codes only displaying the values and the ones acquiring or clearing the values by automatic execution are not included.
- When a value of the code which exchanges another one sequentially is changed, another one is altered in conjunction with it.
- Setting of the codes FS-08-8911 and FS-08-9000 is not possible.

### 5.21.3 Setting files

#### [ 1 ] Setting files

An encrypted file in which the setting values for each code to be changed is written in an XML format. A maximum of 100 codes can be set in one file. If a code has sub codes, each of them is counted as one code.

File name: Apply a name by employing the usable characters for an FAT32 format (extension: .diag).

File format: xml format

**Notes:**

- A setting file has to be encrypted by a dedicated encryption tool to be stored in a USB storage device.
- A setting file has to be located in the 1st or 2nd layer of the root folder of a USB storage device.
- No other automatic execution script has to be located in the same layer in which a setting file is stored.

#### [ 2 ] Example

```
<Policy>
  <Data>
    <Category-05/>
    <Category-08>
      <Code>
        <MainCode>8724</MainCode>
        <Value>1</Value>
      </Code>
      <Code>
        <MainCode>9240</MainCode>
```

```

        <Value>2</Value>
    </Code>
    <Code>
        <MainCode>9264</MainCode>
        <SubCode>1</SubCode>
        <Value>1</Value>
    </Code>
</Category-08>
<Category-13/>
</Data>
</Policy>

```

#### Notes:

- The setting value of the code in procedure 10 is written by inserting a comma to divide the values.  
E.g.: 08-4106 <Value>128,128</Value>
- Setting is carried out in order of written.
- The read-only codes and the execution codes are skipped to continue the processing if they are included.
- Even if writing of the setting value has failed, the processing will not stop and writing into the setting file will continue to its end.  
After the processing has been completed, the result of writing of all codes is stored in a result file and then a message indicating partial success will be displayed.
- Storing of a result file is not desired, add “<ResultFile>>false</ResultFile>” under “<Policy>”.  
Example

```

<Policy>
    <ResultFile>>false</ResultFile>
    <Data>
        <Category-05/>
        <Category-08>
            <Code>
                <MainCode>8724</MainCode>
                <Value>1</Value>
            </Code>

```

## 5.21.4 Result files

### [ 1 ] Result files

A file in which success or failure of the replacement of the setting values for each code included in the setting files is written. A result file is stored in a USB storage device after this code is performed.

File name: DIG\_RESULT\_XXXX\_yymmddhhmmss.xml (XXXX: Serial No.)

File format: xml format

### [ 2 ] Example

```

<Policy>
    <Data>
        <Category-05/>
        <Category-08>
            <Code>

```

```

        <MainCode>8724</MainCode>
        <RESULT>SUCCESS</RESULT>
    </Code>
    <Code>
        <MainCode>9240</MainCode>
        <RESULT>FAILED</RESULT>
    </Code>
    <Code>
        <MainCode>9264</MainCode>
        <SubCode>1</SubCode>
        <RESULT>UNSPECIFIED</RESULT>
    </Code>
</Category-08>
<Category-13/>
</Data>
</Policy>

```

- \* SUCCESS: Values are updated successfully.
  - \* FAILED: Update of values fails.
  - \* UNSPECIFIED: No codes written exist.
- A value to be set is outside the assignable range.

**Notes:**

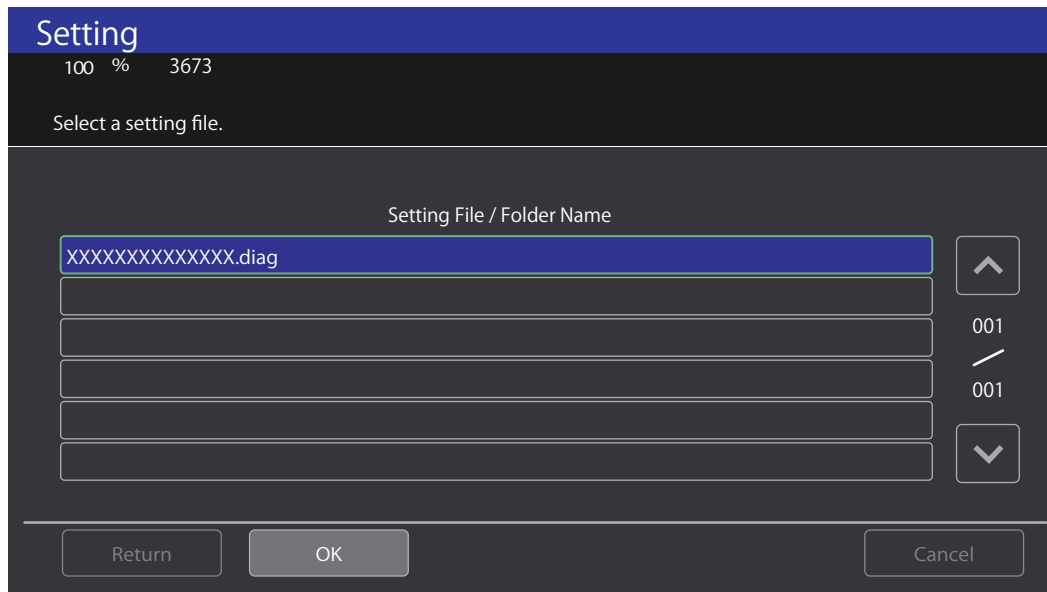
- As for the codes whose values have been altered caused by batch setting of another one, their items, such as the code number, value changed and success/failure of the change, are not described in a result file.
- In case an unavailable code for writing is included in the setting file, the processing will continue and then a message indicating partial success will be displayed after the setting of all codes has been completed. Unavailable codes for writing are displayed in the list by pressing [View]. When [OK] is pressed on the screen of the message indicating partial success or the list screen, the display is returned to the BASIC screen.

### 5.21.5 Operation procedure

1. Enter into the Classic mode with [FS-08].
2. Install a USB storage device, in which setting files are stored, in the MFP.
3. Key in [3673] and then press the [START] button.



4. Select a setting file.



**Fig.5-50**

5. Press [OK].
6. Setting for all codes included in the setting file are completed, the BASIC screen of the 08 mode appears.
7. Remove the USB storage device.



## 6. SETTING / ADJUSTMENT

### 6.1 Image Related Adjustment

#### 6.1.1 Adjustment order

This chapter mainly explains the procedures for image related adjustment. When replacing components which have other specified instructions for adjustment, those specified instructions are to be obeyed in priority. In the following diagram, the solid lines with arrow lead to essential adjustments, while the dotted lines lead to adjustments to be performed if necessary.

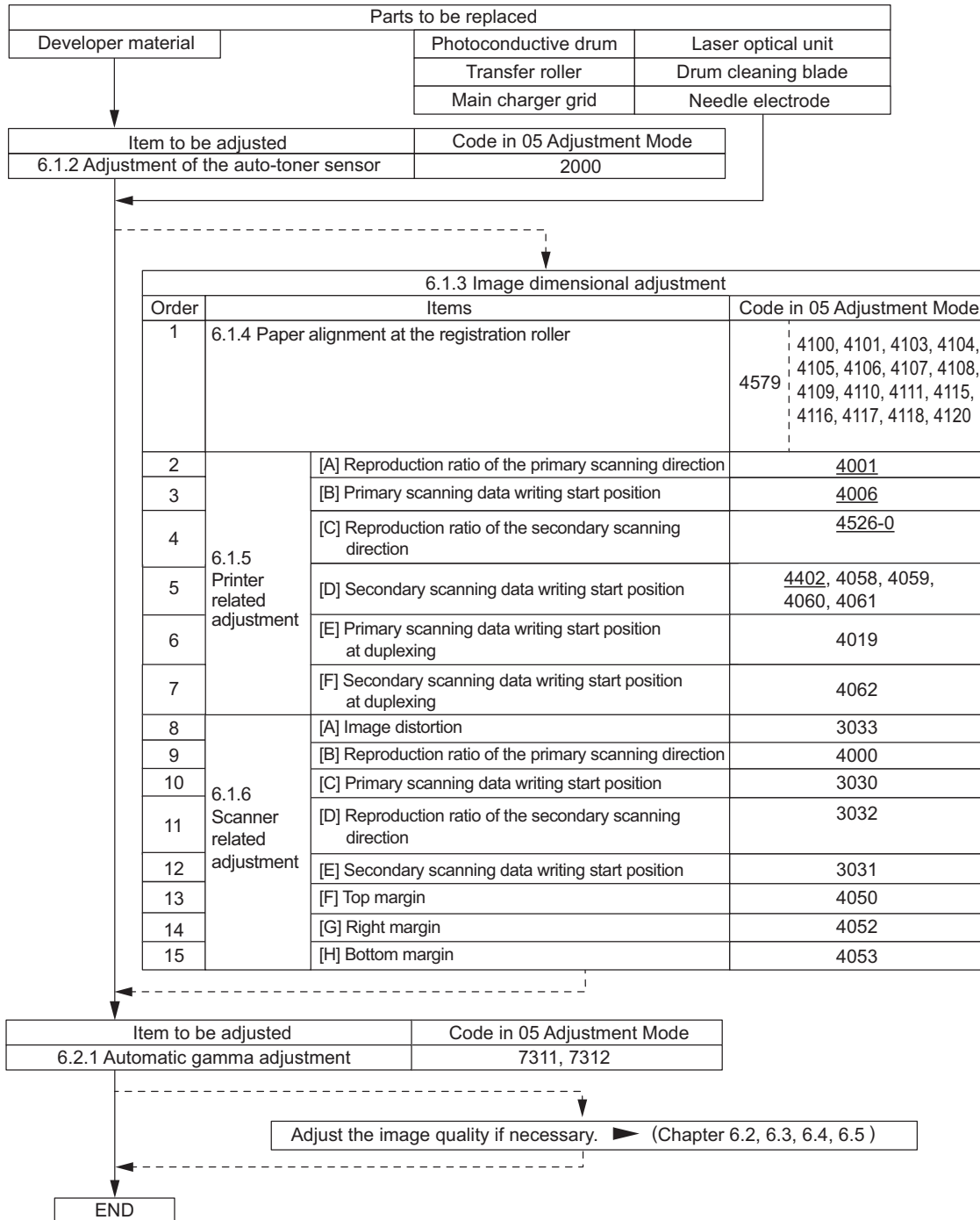


Fig.6-1

## 6.1.2 Adjustment of auto-toner sensor

When the developer material is replaced, adjust the auto-toner sensor in the following procedure.

- (1) Install the process unit into the equipment.
- (2) Perform FS-05-2000.  
The display changes as follows.

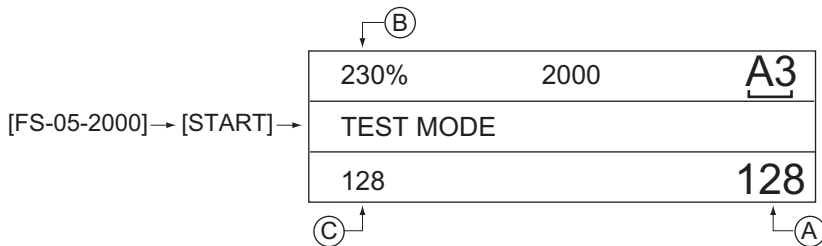


Fig.6-2

### Notes:

- A indicates the controlled value of the auto-toner sensor output. Press the Up or Down button to change the value.
- B indicates the output voltage of the auto-toner sensor (2.30 V in the above case).  
The drum, developer unit, etc. are in operation.
- C indicates the latest adjustment value.

- (3) After about two minutes, the value B automatically starts changing.

230%	2000	<u>A3</u>
TEST MODE		WAIT
128		128

Fig.6-3

- (4) After a short time, the value B becomes stable and the display changes as follows.

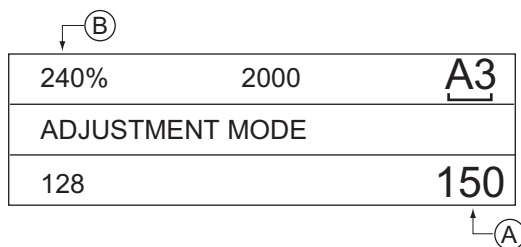


Fig.6-4

- (5) Check if the value B is within the range of 234 to 246 (the output voltage range of the auto-toner sensor is 2.34 V to 2.46 V).

- (6) If the value B is not within the range of 234 to 246, press the Up or Down button to adjust the value manually.

**Notes:**

The relation between the button and the values A and B is as follows.

Button to be pressed	Value A	Value B
Up	Increased	Increased
Down	Decreased	Decreased

- (7) Press [OK].  
The drum, developer unit, etc. are stopped and the following is displayed.

	100%	A	<u>A3</u>
[OK] →	TEST MODE		

**Fig.6-5**

- (8) Turn the power OFF.  
(9) Install the toner cartridge.

### 6.1.3 Image dimensional adjustment

There are several adjustment items in the image dimensional adjustment, as listed below. When adjusting these items, the following adjustment order should strictly be observed.

Item to be adjusted		Code in 05 Adjustment Mode
1. Paper alignment at the registration roller		4579 4100, 4101, 4103, 4104, 4105, 4106, 4107, 4108, 4109, 4110, 4111, 4115, 4116, 4117, 4118, 4120
2. Printer related image dimensional adjustment	Reproduction ratio of the primary scanning direction	4001
	Primary scanning data writing start position	4006
	Reproduction ratio of the secondary scanning direction (Fine adjustment of main motor rotation speed)	4526-0
	Secondary scanning data writing start position	4402, 4058, 4059, 4060, 4061, 4560
	Primary scanning data writing start position at duplexing	4019
	Secondary scanning data writing start position at duplexing	4062
3. Scanner related image dimensional adjustment	Image distortion	3033
	Reproduction ratio of the primary scanning direction	4000
	Primary scanning data writing start position	3030
	Reproduction ratio of the secondary scanning direction	3032
	Secondary scanning data writing start position	3031
	Top margin	4050
	Right margin	4052
	Bottom margin	4053

**Notes:**

Once the adjustment of the following codes has been performed, when image adjustment has been done by other codes and then adjustment of any of the following codes has been made again, recheck the images by outputting them from all drawers. In addition, retry the image dimensional adjustment from the beginning, if necessary.  
05-4001, 4006, 4526-0, 4402

**Remarks:**

By entering the paper size used in the field in FS-05-4922 and then performing FS-05-4920, the differential in the paper size between the one used at the adjustment before factory shipment and the one used in the field is reflected to the equipment. Due to this, the margin around the image can be corrected easily.

[Procedure to key in adjustment values]

In accordance with the procedure described below, adjust the value of each item so that the measured values obtained from test copies satisfy the specification. By pressing [TEST COPY] in the ready state of 05 Adjustment Mode, single sided test copying in the normal copy mode can be performed.

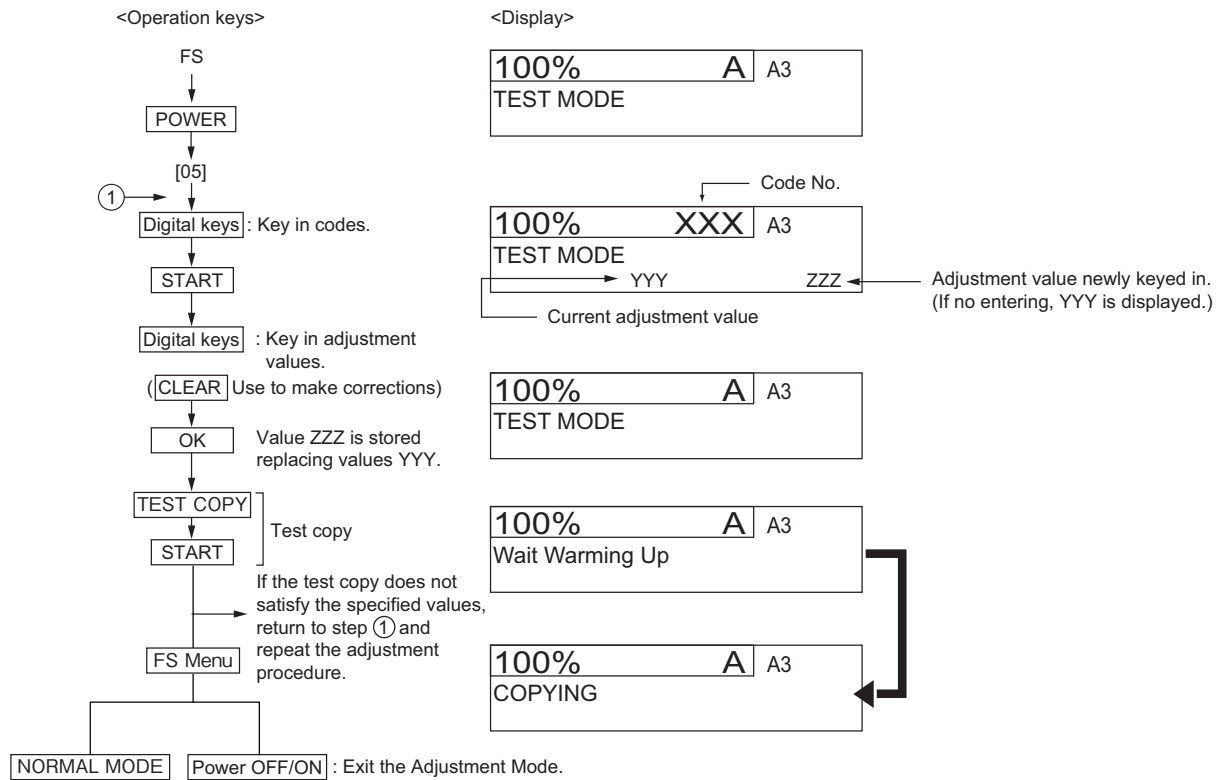


Fig.6-6

## 6.1.4 Paper alignment at the registration roller

### [A] Adjustment with control panel

Paper alignment at the registration roller can be adjusted in the following procedure by performing the code FS-05-4579.

1. Select the drawer.

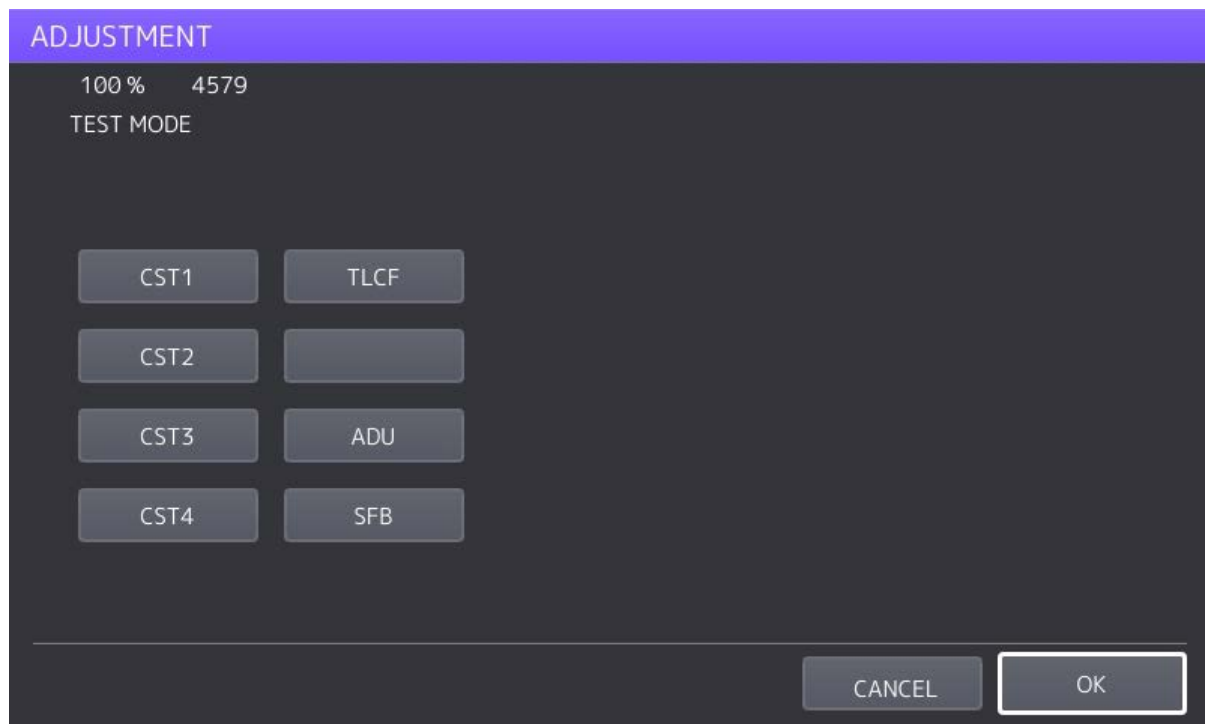


Fig.6-7

2. Select the paper size.

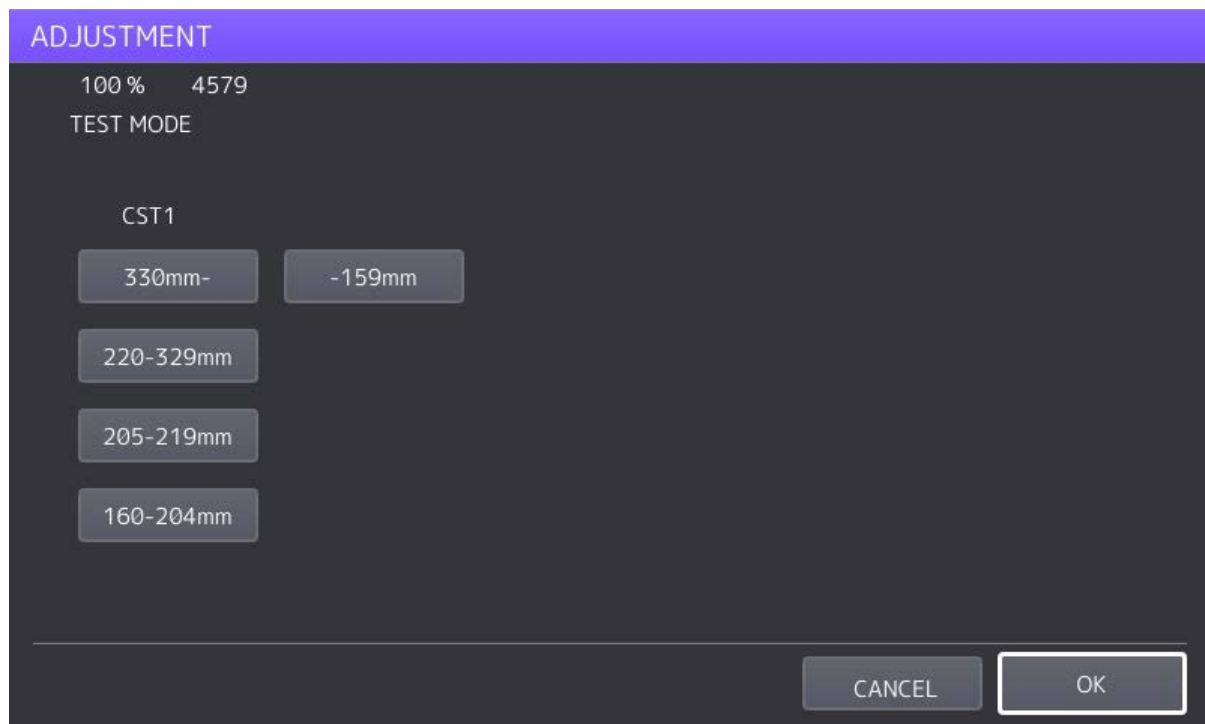


Fig.6-8



3. Select the media type.

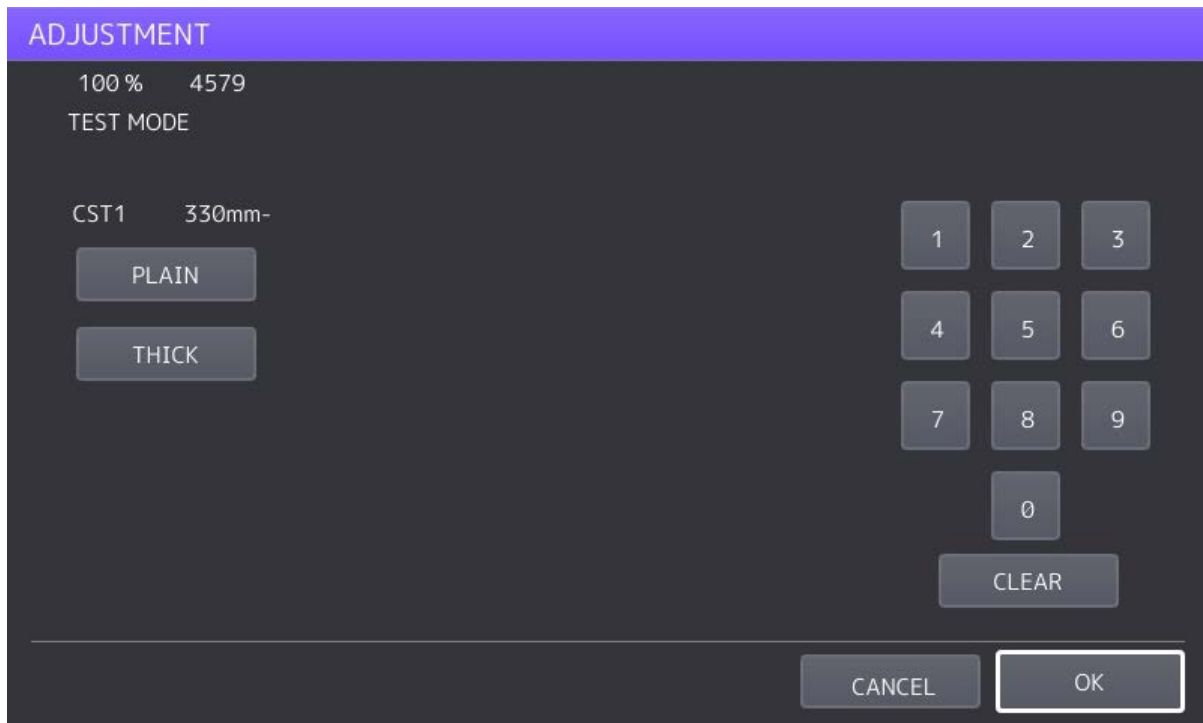


Fig.6-9

4. Key in the adjustment value.

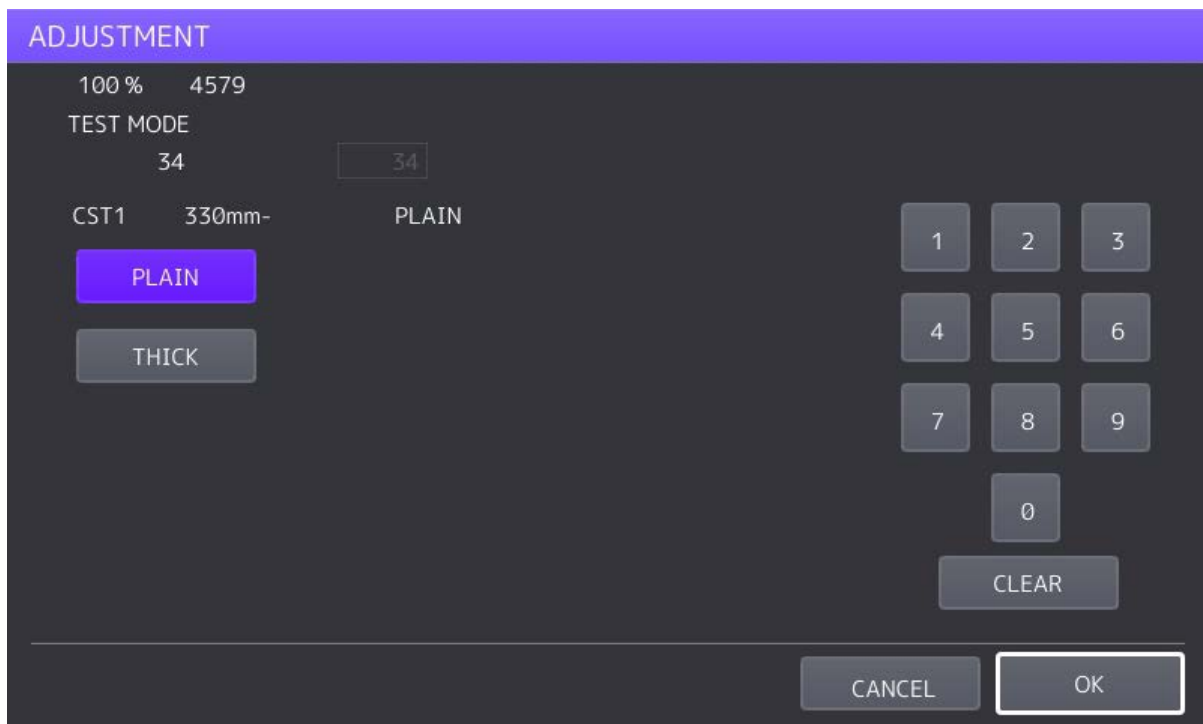


Fig.6-10

5. Press [OK] to finish the adjustment.

\* Press the [FUNCTION CLEAR] button to return to the previous menu.

**[B] The aligning amount is adjusted by using the following codes in 05 Adjustment Mode.**

Drawer	Code	Sub code	Paper size (Select the paper size with the sub code.)	Paper type*
1st drawer (CST1)	4100	0,1,2,3,4	0: 330 mm or longer (13.0 inches or longer) 1: 220-329 mm (8.7-12.9 inches) 2: 205-219 mm (8.1-8.6 inches) 3: 160-204 mm (6.3-8.0 inches) 4: 159 mm or shorter (6.26 inches or shorter)	Plain/Recycled/Thick
	4115	0,1,2,3,4		Thick1/Thick2/Thick3
2nd drawer (CST2)	4101	0,1,2,3,4		Plain/Recycled/Thick
	4116	0,1,2,3,4		Thick1/Thick2/Thick3/Envelope
3rd drawer (CST3)	4108	0,1,2,3,4		Plain/Recycled/Thick
	4117	0,1,2,3,4		Thick1/Thick2/Thick3/Envelope
4th drawer (CST4)	4109	0,1,2,3,4		Plain/Recycled/Thick
	4118	0,1,2,3,4		Thick1/Thick2/Thick3/Envelope
Bypass feed	4103	0,1,2,3,4		Plain/Recycled/Thick/Thin
	4104	0,1,2,3,4		Thick1
	4105	0,1,2,3,4	Thick2/Envelope	
	4106	0,1,2,3,4	Thick3	
	4107	0,1,2,3,4	OHP	
ADU	4110	0,1,2,3,4	Plain/Recycled/Thick	
	4120	0,1,2,3,4	Thick1/Thick2/Thick3	
LCF	4111	-	-	Plain

\* Weight:

Thin: 52 to 59 g/m<sup>2</sup> (14 lb. Bond to 16 lb. Bond)

Plain: 60 to 80 g/m<sup>2</sup> (16 lb. Bond to 22 lb. Bond)

Thick: 81 to 105 g/m<sup>2</sup> (22 lb. Bond to 28 lb. Bond)

Thick 1: 106 to 163 g/m<sup>2</sup> (28 lb. Bond to 60 lb. Cover (90 lb. Index))

Thick 2: 164 to 209 g/m<sup>2</sup> (61 lb. Cover to 77.3 lb. Cover (115.7 lb. Index))

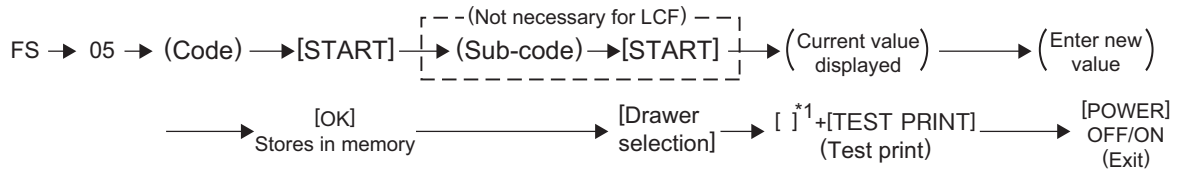
Thick 3: 210 to 256 g/m<sup>2</sup> (140 lb. Index)

**Notes:**

- Long size: 330 mm or longer (13.0 inches or longer)  
Middle size: 220-239 mm (8.7-12.9 inches)  
Short size: 219 mm or shorter (8.6 inches or shorter)
- The adjustment of "Post card" is for Japan only.

(1) Perform the test print according to the following procedure.

<Procedure>



\*1 1: Single-sided grid pattern, 3: Double-sided grid pattern

- (2) Check if any transfer void is occurring. If there is a transfer problem, try the values in descending order as “31” → “30” → “29”... until the transfer void disappears. At the same time, confirm if any paper jam occurs. Also, when the aligning amount has been increased, this may increase the scraping noise caused by the paper and the film sheet as it is transported by the registration roller. If this scraping noise is annoying, try to decrease the value.

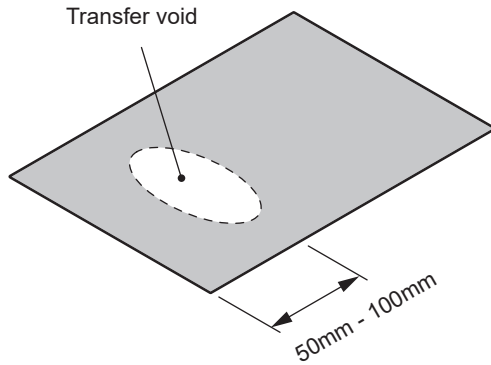


Fig.6-11

- (3) Perform the same procedure for all paper sources.

**Notes:**

When paper thinner than specified is used, paper jams may occur frequently at the registration section. In this case, it is advisable to change (or reduce) the aligning amount. However, if the aligning amount is reduced too much, this may cause the shift of leading edge position. So, when adjusting the aligning amount, try to choose the appropriate amount while confirming the leading edge position is not shifted.

## 6.1.5 Image dimensional adjustment at the printing section

This adjustment is performed by using the chart output from the equipment. There are two ways of the image dimensional adjustment; Type 1 and Type 2.

- Type 1: Adjusts the image position and the ratio by using the front side of the leading edge as a reference.

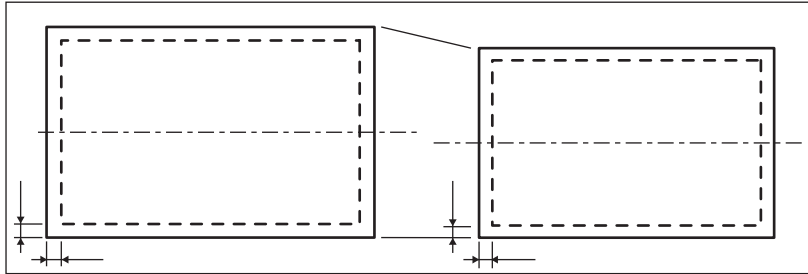


Fig.6-12

- Adjustment can be made with a high degree of accuracy.
  - The reference is given to the front side of the leading edge. Therefore, when the paper size is changed, the margin around the paper tends to be altered accordingly.
- Type 2: Adjusts the image position and the ratio by using the center of the paper path and that for the image.

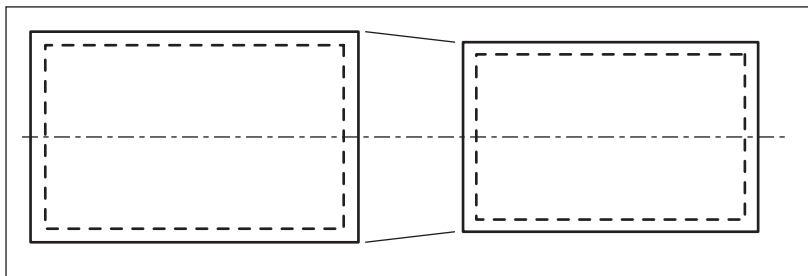




Fig.6-13

- The image position at the front and the back sides can make to be aligned easily.
- The margin around the paper can make to be evenly aligned easily.

Use the appropriate chart corresponding to the adjustment instruction.

In addition, check that no gap has occurred in the following adjustments.

Scanner:  P. 6-13 “[C] Reproduction ratio of the secondary scanning direction”

RADF:  P. 6-106 “6.13.6 Adjustment of copy ratio”

Type 1: Adjustment to make the size of an image match

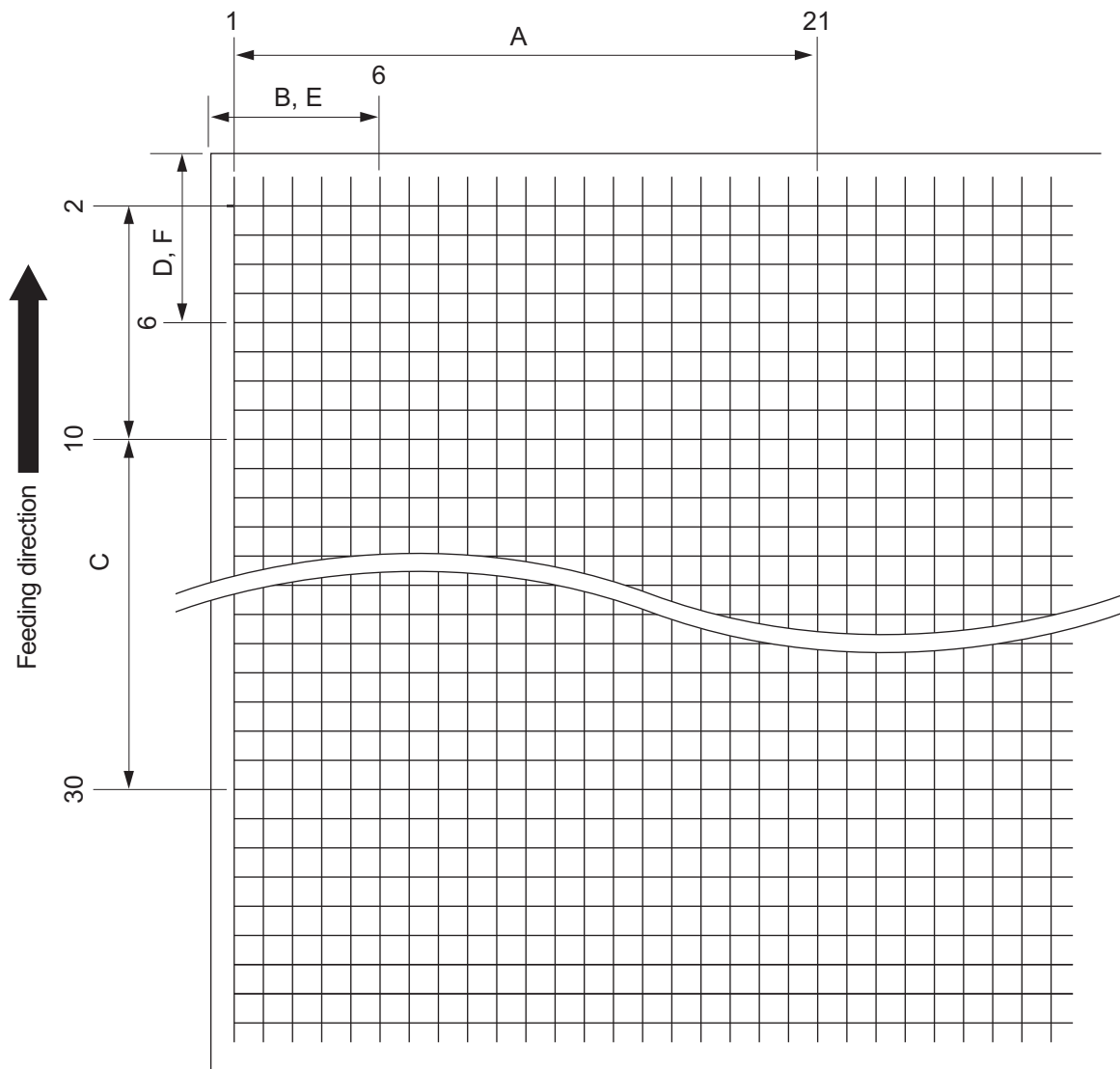


Fig.6-14 Grid pattern

	Adjustment Tolerance	Detail of adjustment	Chart
A	200 ± 0.5mm	📖 P. 6-13 "[A] Reproduction ratio of the primary scanning direction"	05-1
B	52 ± 0.5mm	📖 P. 6-13 "[B] Primary scanning data writing start position"	
C	200 ± 0.5mm	📖 P. 6-13 "[C] Reproduction ratio of the secondary scanning direction"	
D	52 ± 0.5mm	📖 P. 6-14 "[D] Secondary scanning data writing start position"	05-3
E	52 ± 0.5mm	📖 P. 6-15 "[E] Primary scanning data writing start position at duplexing"	
E	52 ± 0.5mm	📖 P. 6-16 "[F] Secondary scanning data writing start position at duplexing"	

## Type 2: Adjustment to make the void width match

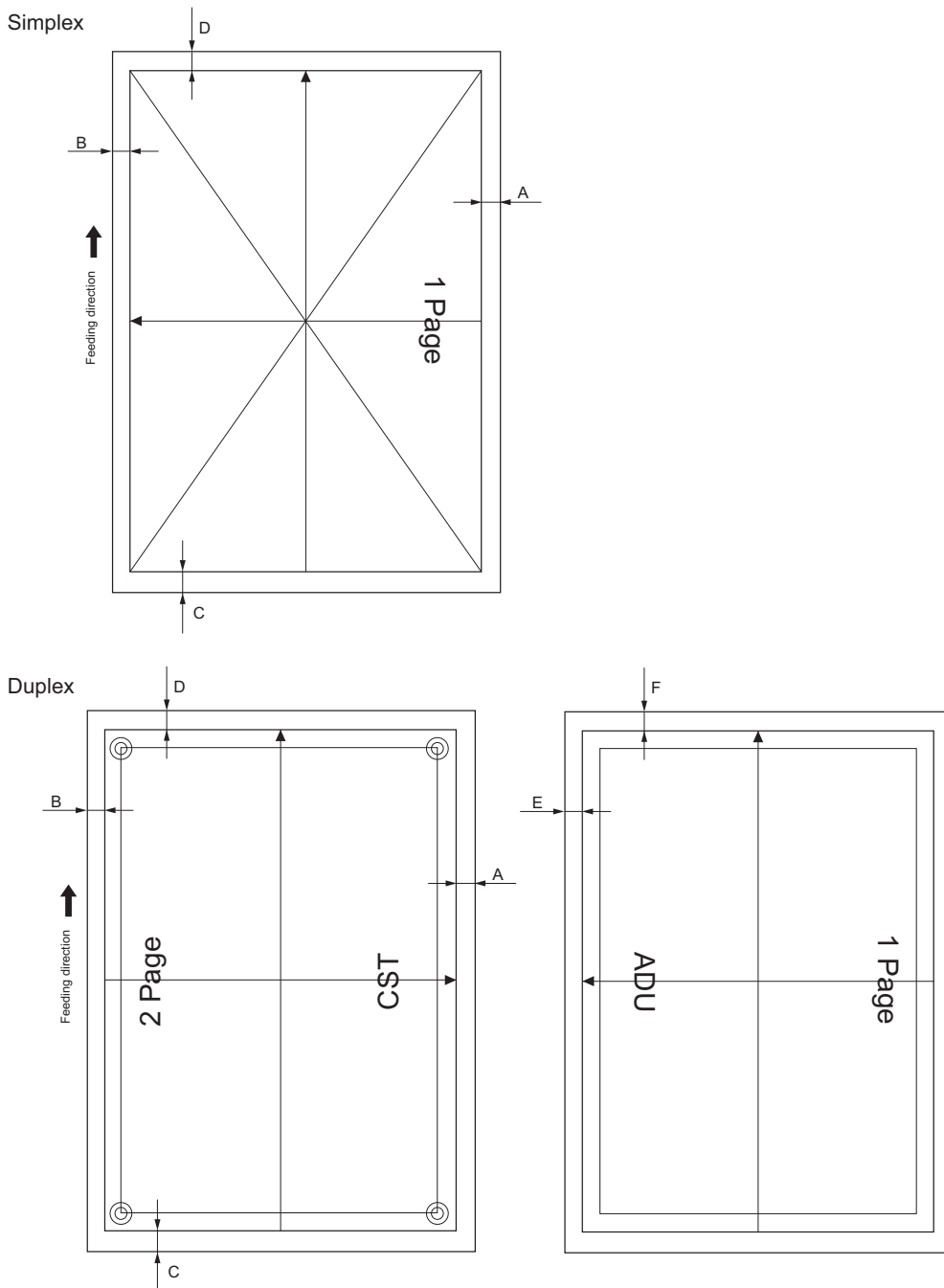


Fig.6-15 Grid pattern

	Adjustment Tolerance	Detail of adjustment	Chart
A	$4.2 \pm 0.5\text{mm}$	📖 P. 6-13 “[A] Reproduction ratio of the primary scanning direction”	05-315
B	$4.2 \pm 0.5\text{mm}$	📖 P. 6-13 “[B] Primary scanning data writing start position”	
C	$4.2 \pm 0.5\text{mm}$	📖 P. 6-13 “[C] Reproduction ratio of the secondary scanning direction”	
D	$4.2 \pm 0.5\text{mm}$	📖 P. 6-14 “[D] Secondary scanning data writing start position”	
E	$4.2 \pm 0.5\text{mm}$	📖 P. 6-15 “[E] Primary scanning data writing start position at duplexing”	05-316
F	$4.2 \pm 0.5\text{mm}$	📖 P. 6-16 “[F] Secondary scanning data writing start position at duplexing”	

**[A] Reproduction ratio of the primary scanning direction**

1. Print out the chart in the ready state of FS-05 (Classic mode).  
Press FS-05-1 or FS-05-315 → [TEST PRINT].  
\* Use A3/LD from the 2nd drawer.
2. Check that the distance A of each chart is within the acceptable range.  
FS-05-1:  $200 \pm 0.5$  mm  
FS-05-315:  $4.2 \pm 0.5$  mm  
\* When A3/LD is used, the margin at the trailing edge of the paper will be deleted. Due to this, it is recommended to adjust between 199.5 to 200 mm.
3. If not, use the following procedure to change the values and measure the distance A again.  
<Procedure>  
FS-05-4001 → [START]  
→ (Key in a value (acceptable values: 0 to 255))  
→ [OK] (Stored in the memory)  
→ "100% A" is displayed → Key in the chart number → [TEST PRINT] → (A chart is printed out.)  
\* The larger the adjustment value is, the longer the distance A becomes (approx. 0.1 mm/step).

**[B] Primary scanning data writing start position**

1. Print out the chart in the ready state of FS-05 (Classic mode).  
Press FS-05-1 or FS-05-315 → [TEST PRINT].  
\* Use A3/LD from the 2nd drawer.
2. Check that the distance B of each chart is within the acceptable range.  
FS-05-1:  $52 \pm 0.5$  mm  
FS-05-315:  $4.2 \pm 0.5$  mm
3. If not, use the following procedure to change the values and measure the distance B again.  
<Procedure>  
FS-05-4006 → [START]  
→ (Key in a value (acceptable values: 0 to 255))  
→ [OK] (Stored in the memory)  
→ "100% A" is displayed → Key in the chart number → [TEST PRINT] → (A chart is printed out.)  
\* The larger the adjustment value is, the longer the distance B becomes (approx. 0.0423 mm/step).

**Notes:**

Make sure the first line of the grid pattern (05-1) is printed out since the line is occasionally vanished.

**[C] Reproduction ratio of the secondary scanning direction**

1. Print out the chart in the ready state of FS-05 (Classic mode).  
Press FS-05-1 or FS-05-315 → [TEST PRINT].  
\* Use A3/LD from the 2nd drawer.
2. Check that the distance C of each chart is within the acceptable range.  
FS-05-1:  $200 \pm 0.5$  mm \*  
FS-05-315:  $4.2 \pm 0.5$  mm  
\* For A3/LD, it is recommended to adjust the distance C above within the range of 199.5 mm and 200 mm otherwise the margin of the trailing edge may be deleted.
3. If not, use the following procedure to change the values and measure the distance C again.  
<Procedure>  
FS-05-4526-0 → [START]  
→ (Key in a value (acceptable values: 0 to 255))  
→ [OK] (Stored in the memory)  
→ "100% A" is displayed → Key in the chart number → [TEST PRINT] → (A chart is printed out.)  
\* The larger the adjustment value is, the longer the distance C becomes (approx. 0.25 mm/step).

## [D] Secondary scanning data writing start position

Performing the code FS-05-4402 covers this adjustment for all paper sources.  
The adjustment for each paper source is also available.

### For all paper sources

Code	Paper size	Acceptable value	Remarks
4402	A3/LD	0 to 200	Perform the adjustment for all paper sources.

### For each paper source

Order for adjustment	Paper source	Code	Paper size	Acceptable value	Remarks
1	2nd drawer	4059	A3/LD	0 to 100	
2	1st drawer	4058	A4/LT	0 to 100	
3	LCF*	4561	A4/LT	0 to 100	
4	3rd drawer	4060	A4/LT	0 to 100	
5	4th drawer	4560	A4/LT	0 to 100	
6	Bypass feed	4061	A4/LT	0 to 100	

\* When the LCF is installed, adjustment of the PFP (the 3rd and 4th drawers) is unnecessary.  
When the PFP is installed, adjustment of the LCF is unnecessary.

1. Print out the chart in the ready state of FS-05 (Classic mode).  
Press FS-05-1 or FS-05-315 → [TEST PRINT].  
\* Use A3/LD from the 2nd drawer.
2. Check that the distance D of each chart is within the acceptable range.  
FS-05-1:  $52 \pm 0.5$  mm  
FS-05-315:  $4.2 \pm 0.5$  mm
3. If not, use the following procedure to change the values and measure the distance D again.  
<Procedure>  
FS-05 → (Key in the code shown above) → [START]  
→ (Key in an acceptable value shown above)  
→ [OK] (Stored in the memory)  
→ "100% A" is displayed → Key in the chart number → [TEST PRINT] → (A chart is printed out.)  
\* The larger the adjustment value is, the shorter the distance D becomes (approx. 0.1 mm/step).



## [E] Primary scanning data writing start position at duplexing

### Notes:

Make sure the first line of the grid pattern (05-3) is printed out since the line is occasionally vanished.

### [E-1] Adjustment for long-sized paper

1. Print out the chart in the ready state of FS-05 (Classic mode).  
Press FS-05-3 or FS-05-316 → [TEST PRINT].  
\* Use A3/LD from the 2nd drawer.
2. Check that the distance E of each chart is within the acceptable range.  
FS-05-3:  $52 \pm 0.5$  mm  
FS-05-316:  $4.2 \pm 0.5$  mm
3. If not, use the following procedure to change the values and measure the distance E again.  
<Procedure>  
FS-05-4019 → [START] → [0] → [START]  
→ (Key in a value (acceptable values: 0 to 255))  
→ [OK] (Stored in the memory)  
→ "100% A" is displayed → Key in the chart number → [TEST PRINT] → (A chart is printed out.)  
\* The larger the adjustment value is, the longer the distance E becomes (approx. 0.04 mm/step).

### [E-2] Adjustment for short-sized paper

1. Print out the chart in the ready state of FS-05 (Classic mode).  
Press FS-05-3 or FS-05-316 → [TEST PRINT].  
\* Use A4/LT from the 1st drawer.
2. Check that the distance E of each chart is within the acceptable range.  
FS-05-3:  $52 \pm 0.5$  mm  
FS-05-316:  $4.2 \pm 0.5$  mm
3. If not, use the following procedure to change the values and measure the distance E again.  
<Procedure>  
FS-05-4019 → [START] → [1] → [START]  
→ (Key in a value (acceptable values: 0 to 255))  
→ [OK] (Stored in the memory)  
→ "100% A" is displayed → Key in the chart number → [TEST PRINT] → (A chart is printed out.)  
\* The larger the adjustment value is, the longer the distance E becomes (approx. 0.04 mm/step).

### [E-3] Adjustment for medium-sized paper (Length: 220 mm to 329 mm)

1. Print out the chart in the ready state of FS-05 (Classic mode).  
Press FS-05-3 or FS-05-316 → [TEST PRINT].  
\* Use A4-R/LT-R.
2. Check that the distance E of each chart is within the acceptable range.  
FS-05-3:  $52 \pm 0.5$  mm  
FS-05-316:  $4.2 \pm 0.5$  mm
3. If not, use the following procedure to change the values and measure the distance E again.  
<Procedure>  
FS-05-4019 → [START] → [2] → [START]  
→ (Key in a value (acceptable values: 0 to 255))  
→ [OK] (Stored in the memory)  
→ "100% A" is displayed → Key in the chart number → [TEST PRINT] → (A chart is printed out.)  
\* The larger the adjustment value is, the longer the distance E becomes (approx. 0.04 mm/step).

## [F] Secondary scanning data writing start position at duplexing

1. Print out the chart in the ready state of FS-05 (Classic mode).  
Press FS-05-3 or 05-316 → [TEST PRINT].  
\* Use A3/LD from the 2nd drawer.
2. Check that the distance F of each chart is within the acceptable range.  
FS-05-3:  $52 \pm 0.5$  mm  
FS-05-316:  $4.2 \pm 0.5$  mm
3. If not, use the following procedure to change the values and measure the distance F again.  
<Procedure>  
Press FS-05-4062 → [START] button  
→ Key in a value (acceptable values: 0 to 255) → [OK] (Stored in the memory)  
→ "100% A" is displayed → Key in the chart number → [TEST PRINT] → (A chart is printed out.)  
\* The larger the adjustment value is, the longer the distance F becomes (approx. 0.10 mm/step).

### Notes:

Make sure the first line of the grid pattern (05-3) is printed out since the line is occasionally vanished.

<Adjustment procedure summarization for A to F>

Type 1: Adjustment to make the size of an image match

FS-05 → [1] ([3] for duplexing) → [TEST PRINT]

- A: FS-05-4001 (2nd drawer, A3/LD) →  $200 \pm 0.5$  mm (0.15 mm/step)
- B: FS-05-4006 (2nd drawer, A3/LD) →  $52 \pm 0.5$  mm (0.04 mm/step)
- C: FS-05-4526-0 (2nd drawer, A3/LD) →  $200 \pm 0.5$  mm (0.25 mm/step)
- D: FS-05-4402 (2nd drawer, A3/LD) →  $52 \pm 0.5$  mm (0.1 mm/step)  
FS-05-4058 (1st drawer, A4/LT)  
FS-05-4059 (2nd drawer, A3/LD)  
FS-05-4060 (3rd drawer, A4/LT)  
FS-05-4560 (4th drawer, A4/LT)  
FS-05-4061 (Bypass feed, A4/LT)
- E: FS-05-4019-0 (2nd drawer, A3/LD) →  $52 \pm 0.5$  mm (0.04 mm/step)  
FS-05-4019-1 (1st drawer, A4/LT)  
FS-05-4019-2 (A4-R/LT-R)
- F: FS-05-4062 (2nd drawer, A3/LD) →  $52 \pm 0.5$  mm (0.1 mm/step)

Type 2: Adjustment to make the void width match

FS-05 → 315(316 for duplexing) → [TEST PRINT]

- A: FS-05-4001 (2nd drawer, A3/LD) →  $4.2 \pm 0.5$  mm (0.1 mm/step)
- B: FS-05-4006 (2nd drawer, A3/LD) →  $4.2 \pm 0.5$  mm (0.04 mm/step)
- C: FS-05-4526-0 (2nd drawer, A3/LD) →  $4.2 \pm 0.5$  mm (0.1 mm/step)
- D: FS-05-4402 (2nd drawer, A3/LD) →  $4.2 \pm 0.5$  mm (0.1 mm/step)  
FS-05-4058 (1st drawer, A4/LT)  
FS-05-4059 (2nd drawer, A3/LD)  
FS-05-4060 (3rd drawer, A4/LT)  
FS-05-4560 (4th drawer, A4/LT)  
FS-05-4061 (Bypass feed, A4/LT)
- E: FS-05-4019-0 (2nd drawer, A3/LD) →  $4.2 \pm 0.5$  mm (0.04 mm/step)  
FS-05-4019-1 (1st drawer, A4/LT)  
FS-05-4019-2 (A4-R/LT-R)
- F: FS-05-4062 (2nd drawer, A3/LD) →  $4.2 \pm 0.5$  mm (0.1 mm/step)

## 6.1.6 Scanner related adjustment

### [A] Image distortion

#### Notes:

- The specification of the distortion is 1 mm to 200 mm when a drawer equipped as standard is used, and is 3 mm to 200 mm when an optional drawer (PFP and LCF) is used.
- Do not perform this adjustment when the distortion is within the above value. If the adjustment has failed, fogging or a C260 error will occur.
- This adjustment is for the distortion in the scanning section. Therefore, do not use this to correct paper skew at paper feeding.
- When performing the adjustment, marginally rotate the screw by approximately one quarter while checking the image.

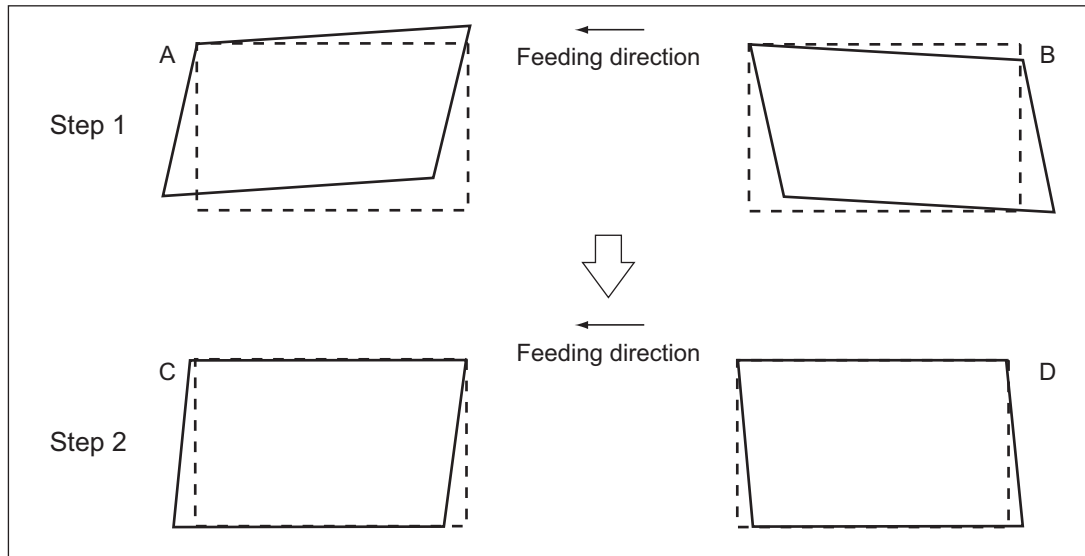


Fig.6-16

- (1) While pressing [0] and [5] simultaneously, turn the power ON.
- (2) Press [TEST COPY] → [START] to make a copy of any image on a sheet of A3/LD paper.
- (3) Key in [3033] and press the [START] button to move the carriage to the adjustment position.
- (4) Make an adjustment in the order of step 1 and 2.

#### Step 1

In case of A:

Tighten the mirror-3 adjustment screw (Rear) [1] (CW).

In case of B:

Loosen the mirror-3 adjustment screw (Rear) [1] (CCW).

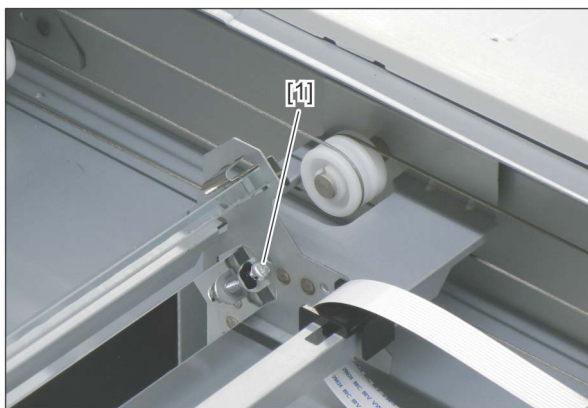


Fig.6-17

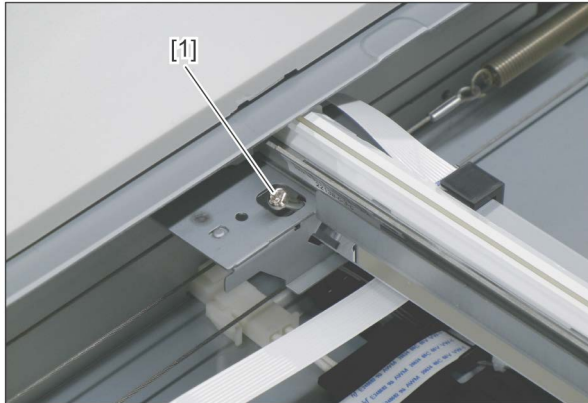
## Step 2

In case of C:

Tighten the mirror-1 adjustment screw (Rear) [1] (CW).

In case of D:

Loosen the mirror-1 adjustment screw (Rear) [1] (CCW).



**Fig.6-18**

- (5) Apply the screw locking agents to the adjustment screws. (2 areas)
- Recommended screw lock agent  
Manufacturer: Three Bond  
Product name: 1401E

**[B] Reproduction ratio of the primary scanning direction**

- (1) Perform FS-05.
- (2) Place a ruler on the original glass (along the direction from the rear to the front of the equipment).
- (3) Press [TEST COPY] → [START] to make a copy at the mode of A3/LD, 100% and the 2nd drawer (refer to \*).
- (4) Measure the distance A from 10 mm to 270 mm of the copied image of the ruler.
- (5) Check if the distance A is within the range of  $260 \pm 0.5$  mm.
- (6) If not, use the following procedure to change values and repeat the steps (3) to (5) above.  
<Procedure>  
FS-05-4000 → [START]  
→ (Key in a value (acceptable values: 0 to 255))  
→ Press [OK] (stored in the memory).  
→ ("100% A" is displayed.)

\* The larger the adjustment value is, the higher the reproduction ratio and the longer the distance A become.(approx. 0.1 mm/step)

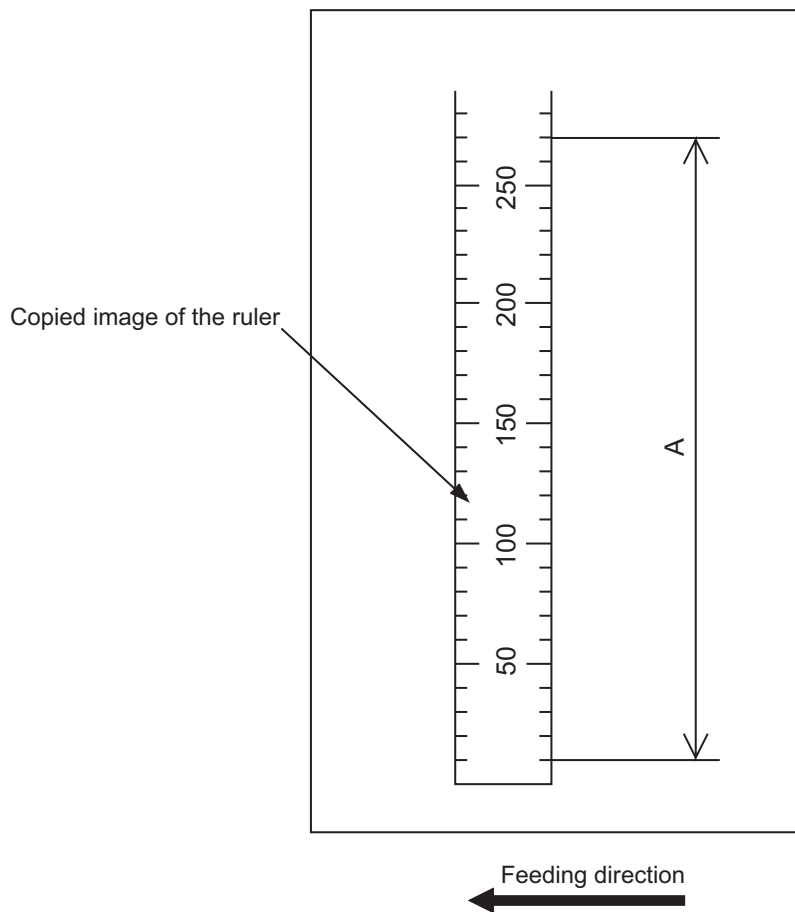


Fig.6-19

### [C] Primary scanning position

- (1) Perform FS-05.
- (2) Place a ruler on the original glass with its leading edge pushed against the rear side and its side along the original scale on the left.
- (3) Press [TEST COPY] → [START] to make a copy at the mode of A3 (LD), 100% and the 2nd drawer (Refer to \*).
- (4) Measure the distance B from the left edge of the paper to 10 mm of the copied image of the ruler.
- (5) Check if the distance B is within the range of  $10 \pm 0.5$  mm.
- (6) If not, use the following procedure to change values and repeat the steps (3) to (5) above.  
<Procedure>  
FS-05-3030 → [START]  
→ (Key in a value (acceptable values: 0 to 255))  
→ Press [OK] (stored in the memory).  
→ ("100% A" is displayed.)

\* The smaller the adjustment value is, the more the image is shifted to the left and the distance B becomes narrower. (approx. 0.04 mm/step)

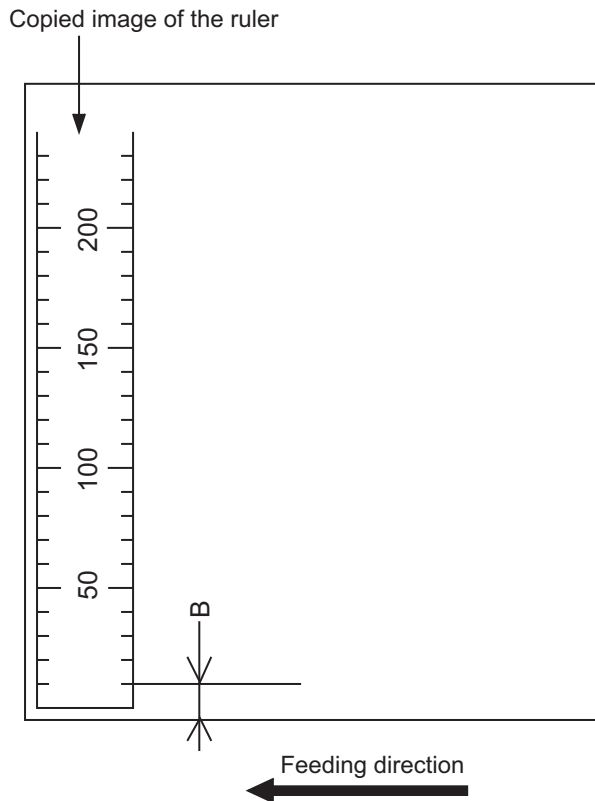
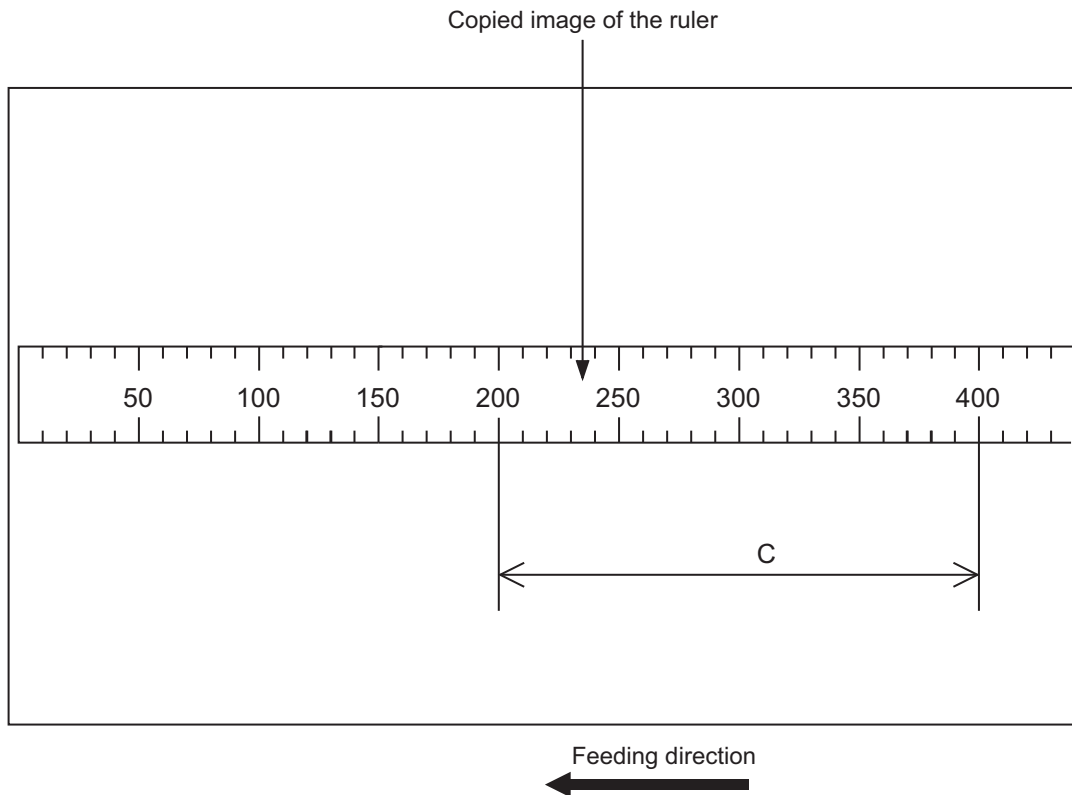


Fig.6-20

**[D] Reproduction ratio of the secondary scanning direction**

- (1) Perform FS-05.
- (2) Place a ruler on the original glass with its leading edge pushed against the original scale on the left.
- (3) Press [TEST COPY] → [START] to make a copy at the mode of A3 (LD), 100% and the 2nd drawer (Refer to \*).
- (4) Measure the distance C from 200 mm to 400 mm of the copied image of the ruler.
- (5) Check if the distance C is within the range of  $200 \pm 0.5$  mm.
- (6) If not, use the following procedure to change values and repeat steps (3) to (5) above.  
<Procedure>  
FS-05-3032 → [START]  
→ (Key in a value (acceptable values: 63 to 193))  
→ Press [OK] (stored in the memory).  
→ ("100% A" is displayed.)

\* The smaller the adjustment value is, the lower the reproduction ratio becomes. (approx. 0.018%/step)



**Fig.6-21**

### [E] Secondary scanning position

- (1) Perform FS-05.
- (2) Place a ruler on the original glass with its leading edge pushed against the original scale on the left.
- (3) Press [TEST COPY] → [START] to make a copy at the mode of A3 (LD), 100% and the 2nd drawer (Refer to \*).
- (4) Measure the distance D from the leading edge of the paper to 10 mm of the copied image of the ruler.
- (5) Check if the distance D is within the range of  $10 \pm 0.5$  mm.
- (6) If not, use the following procedure to change values and repeat the steps (3) to (5) above.  
<Procedure>  
FS-05-3031 → [START]  
→ (Key in a value (acceptable values: 90 to 166))  
→ Press [OK] (stored in the memory).  
→ ("100% A" is displayed.)

\* The larger the adjustment value is, the longer the distance D becomes (approx. 0.08 mm/step).

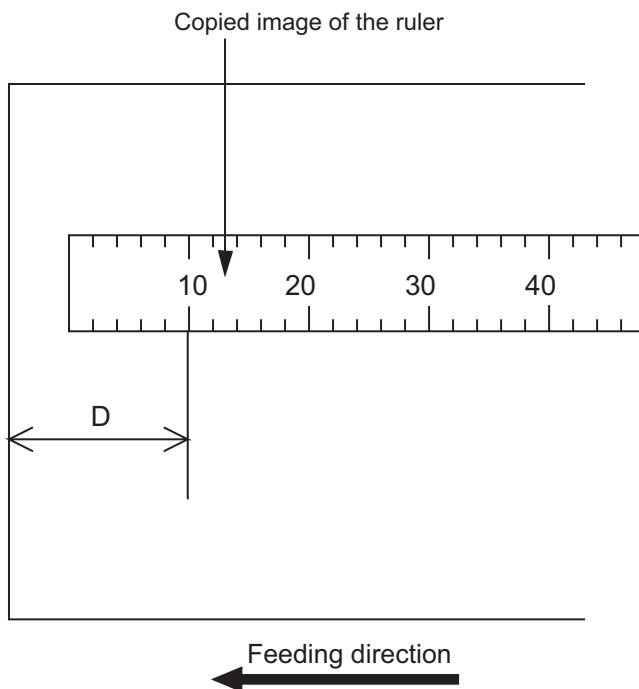


Fig.6-22



## [F] Top margin

- (1) Perform FS-05.
- (2) Open the original cover or DF.
- (3) Press [TEST COPY] → [START] to make a copy at the mode of A3/LD, 100%, Text/Photo and the 2nd drawer (Refer to \*).
- (4) Measure the blank area E at the leading edge of the copied image.
- (5) Check if the blank area E is within the range of  $4.2 \pm 0.5$  mm.
- (6) If not, use the following procedure to change values and repeat the steps (3) to (5) above.  
<Procedure>  
FS-05-4050 → [START]  
→ (Key in a value (acceptable values: 0 to 255))  
→ Press [OK] (stored in the memory).  
→ ("100% A" is displayed.)

\* The larger the adjustment value is, the wider the blank area at the leading edge becomes (approx. 0.04 mm/step).

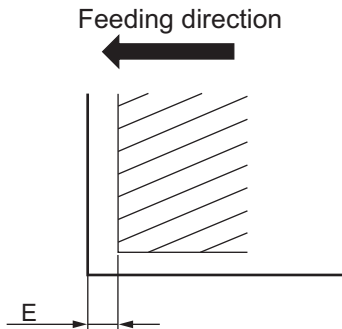


Fig.6-23

## [G] Right margin

- (1) Perform FS-05.
- (2) Open the original cover or DF.
- (3) Press [TEST COPY] → [START] to make a copy at the mode of A3/LD, 100%, Text/Photo and the 2nd drawer (Refer to \*).
- (4) Measure the blank area F at the right side of the copied image.
- (5) Check if the blank area F is within the range of  $4.2 \pm 1.0$  mm.
- (6) If not, use the following procedure to change values and repeat the steps (3) to (5) above.  
<Procedure>  
FS-05-4052 → [START]  
→ (Key in a value (acceptable values: 0 to 255))  
→ Press [OK] (stored in the memory).  
→ ("100% A" is displayed.)

\* The larger the adjustment value is, the wider the blank area at the right side becomes (approx. 0.04 mm/step).

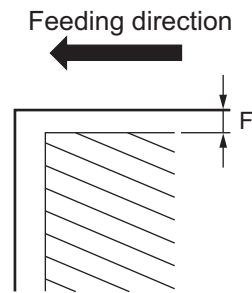


Fig.6-24

## [H] Bottom margin

- (1) Perform FS-05.
- (2) Open the original cover or DF.
- (3) Press [TEST COPY] → [START] to make a copy at the mode of A3/LD, 100%, Text/Photo and the 2nd drawer (Refer to \*).
- (4) Measure the blank area G at the trailing edge of the copied image.
- (5) Check if the blank area G is within the range of  $4.2 \pm 1.0$  mm.
- (6) If not, use the following procedure to change values and repeat the steps (3) to (5) above.  
<Procedure>  
FS-05-4053 → [START]  
→ (Key in value (acceptable values: 0 to 255))  
→ Press [OK] (stored in the memory).  
→ ("100% A" is displayed.)

\* The larger the adjustment value is, the wider the blank area at the trailing edge becomes (approx. 0.04 mm/step).

Feeding direction

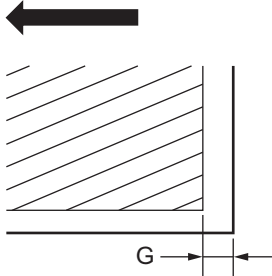


Fig.6-25

## 6.2 Image Quality Adjustment (Copying Function)

### 6.2.1 Automatic gamma adjustment (600dpi)

When the reproduction of gradation is not appropriate, it can be corrected by performing this automatic gamma adjustment. At the parts replacement and in case the gradation reproduction of the image is not satisfactory, make this adjustment as described below.

- (1) When unpacking or any of the following parts has been replaced, be sure to make this adjustment:
  - Photoconductive drum
  - Developer material
  - Laser optical unit
  - Transfer roller
  - Drum cleaning blade
  - Main charger grid
  - SRAM
- (2) Be sure to perform this adjustment whenever HDD data are cleared.

< 05 Adjustment Mode >

Code	Item to be adjusted	Chart Number	Contents
7311	Copy, Print (600dpi)	93	When the reproduction of gradation is not appropriate, it can be corrected by performing this automatic gamma adjustment.

<Procedure>

- (1) Perform FS-05. → 05 Adjustment Mode
- (2) Select the A4/LT drawer. Key in "93" and press [TEST PRINT] to print a "Patch chart for gamma adjustment".
- (3) Place the patch chart for the adjustment printed in step (2) on the original glass by putting its printed side face down and aligning its side with 2 black squares to the original scale.
- (4) Key in a code and press the [START] button.
- (5) If the adjustment is finished properly, press [OK] to have its results reflected.  
(To cancel the reflection of adjustment results, press [CANCEL].)  
In the case of an abnormal ending, "ADJUSTMENT ERROR" is shown.  
Press [CANCEL] to clear the error display. When it is cleared, the control panel display will return to the ready state. Then, check if the patch chart on the original glass is placed in the wrong direction or if it is placed inclined on the original glass, and then repeat step (3) and afterward.

#### Notes:

Adjustment for both copy and print (600dpi) is performed at the same time.

## 6.2.2 Density adjustment

Adjusts the center density.

< 05 Adjustment Mode >

Original mode				Drop out color	Item to be adjusted	Remarks
Text/Photo	Photo	Text	User Custom			
7114	7116	7115	7134	7160	Manual density mode center value	The larger the value is, the darker the image becomes. Acceptable values: 0 to 255 (Default: 128)
7123	7125	7124	7137	-	Automatic density mode	The larger the value is, the darker the image becomes. Acceptable values: 0 to 255 (Default: 128)

Make a test copy and compare the image obtained with the current settings; if necessary, make adjustment using the following procedure.

<Procedure>

- (1) Perform FS-05.
- (2) Key in a code and press the [START] button.
- (3) Key in an adjustment value.  
(To correct the keyed-in value, press [CLEAR].)
- (4) Press [OK] to store the value. → The equipment goes back to the ready state.
- (5) Press [TEST COPY] and then the [START] button. Then perform test copying.
- (6) If the desired image density has not been attained, repeat step (2) to (5).

### Notes:

To check an image of [User Custom], use the one copied in the normal startup.

## 6.2.3 Gamma balance adjustment

The density can be adjusted by regulating the gamma balance. The adjustment can be performed by selecting its density area from the following: low density, medium density and high density.

< 05 Adjustment Mode >

Language and screen				Drop out color	Item to be adjusted	Remarks
Text/ Photo	Photo	Text	User custom			
7190-0	7192-0	7191-0	7189-0	7187-0	Low density	The larger the value is, the density of the item to be adjusted becomes darker. Acceptable values: 0 to 255. (Default: 128)
7190-1	7192-1	7191-1	7189-1	7187-1	Medium density	
7190-2	7192-2	7191-2	7189-2	7187-2	High density	

### Notes:

Changing the adjustment setting influences the adjacent density area slightly.

E.g.: When the value of the medium density is larger, the adjacent areas in the low density and high density range will become slightly darker.

<Procedure>

- (1) Perform FS-05.
- (2) Key in the code for an item to be adjusted and then press the [START] button.
- (3) Key in a number for the density area to be adjusted (0, 1 or 2), and then press the [START] button.  
0: Low density, 1: Medium density, 2: High density
- (4) Key in an adjustment value.  
(To correct the keyed-in value, press [CLEAR].)
- (5) Press [OK] to store the value in memory. The equipment goes back to the ready state.
- (6) For resetting the value, repeat step (2) to (5).
- (7) Press [TEST COPY] and then the [START] button. Then perform test copying.
- (8) If the desired image density has not been attained, repeat step (2) to (7).

### Notes:

To check an image of [User Custom] and [Drop out color], use the one copied in the normal startup.

## 6.2.4 Background adjustment

The density of the background can be adjusted as follows.

< 05 Adjustment Mode >

Original mode				Drop out color	Item to be adjusted	Remarks
Text/ Photo	Photo	Text	User Custom			
7100	7102	7101	7106	7107	Background adjustment (Auto/Manual)	The larger the value is, the darker the background becomes. Acceptable values:0 to 255 (Default: 128)
7086	-	-	-	-	Background adjustment (Only Manual)	

Make a test copy and compare the image obtained with the current settings; if necessary, make adjustment using the following procedure.

<Procedure>

Procedure is same as that of  P. 6-27 "6.2.2 Density adjustment".

### Notes:

To check an image of [User Custom] and [Drop out color], use the one copied in the normal startup.

## 6.2.5 Sharpness adjustment

If you want to make copy images look softer or sharper, perform the following adjustment.

< 05 Adjustment Mode >

Original mode				Drop out color	Item to be adjusted	Remarks
Text/ Photo	Photo	Text	User Custom			
7056	7058	7057	7249	7062	Sharpness adjustment	The larger the value is, the sharper the image becomes; while the smaller the value is, the softer the image becomes. The smaller the value is, the less moire tends to appear. Acceptable values: 0 to 255 (Default: 128)

Make a test copy and compare the image obtained with the current settings; if necessary, make adjustment using the following procedure.

<Procedure>

Procedure is same as that of  P. 6-27 "6.2.2 Density adjustment".

### Notes:

To check an image of [User Custom] and [Drop out color], use the one copied in the normal startup.

## 6.2.6 Setting range correction

The values of the background peak in the range correction can be switched to “varied” or “fixed” in the following codes. If they are fixed, the range correction is performed with standard values. The values of the background peak affect the reproduction of the background density.

< 05 Adjustment Mode >

Original mode			Item to be adjusted	Remarks
Text/Photo	Text	User Custom		
7286	7287	7237	Manual density mode	0: Background peak / fixed 1: Background peak / varied

Make a test copy and compare the image obtained with the current settings; if necessary, make adjustment using the following procedure.

<Procedure>

Procedure is same as that of  P. 6-27 “6.2.2 Density adjustment”.

### Notes:

To check an image of [User Custom], use the one copied in the normal startup.

## 6.2.7 Adjustment of smudged text in black

The smudged/faint text can be set at the following codes.

< 05 Adjustment Mode >

Original mode			Item to be adjusted	Remarks
Text/Photo	Text	User custom		
7097	7098	7252	Adjustment of smudged text in black	When a larger value is set, black text becomes thinner. When a smaller value is set, it becomes thicker. Acceptable values: 0 to 4 (Default: 2) <b>Notes:</b> Remember the image specifications and life span of the replacing parts may not meet the standard when the setting value is changed from the default value.

<Procedure>

Procedure is same as that of  P. 6-27 “6.2.2 Density adjustment”.

### Notes:

To check an image of [User Custom], use the one copied in the normal startup.



## 6.2.8 Emission level adjustment

The emission level can be adjusted as follows. This adjustment adjusts the dot size.

<05 Adjustment Mode>

Text/Photo	Text	Photo	Item to be adjusted	Remarks
7218-0	7219-0	7220-0	Emission level 0/4	The smaller the value is, the smaller the emission level becomes. Therefore, the smaller dot is reproduced accordingly. Acceptable values: 0 to 255 (Default: Level 0/4: 0, Level 1/4: 63, Level 2/4: 127, Level 3/4: 191, Level 4/4: 255)
7218-1	7219-1	7220-1	Emission level 1/4	
7218-2	7219-2	7220-2	Emission level 2/4	
7218-3	7219-3	7220-3	Emission level 3/4	
7218-4	7219-4	7220-4	Emission level 4/4	

Make a test copy and compare the image obtained with the current settings; if necessary, make adjustments according to the following procedure.

<Procedure>

- (1) Perform FS-05.
- (2) Key in a code and press the [START] button.
- (3) Key in a sub-code and press the [START] button.
- (4) Key in an adjustment value.  
(To correct a value once keyed in, press [CLEAR].)
- (5) Press [OK] to store the value. → The equipment goes back to the ready state.
- (6) Press [TEST COPY] and then press the [START] button to make a test copy.
- (7) If the desired image quality has not been attained, repeat step (2) to (6).

### Notes:

- Change the setting value increment of 8 as a guide.
- Be sure to confirm the image when the setting value is changed.
- The setting value must increase as the emission level number (0 to 4) becomes higher. Do not increase this order when setting the values.

## 6.2.9 Judgment threshold adjustment for blank originals (common for copy and scan)

The judgment level is adjusted for automatic identification of whether the original set is blank or not. This adjustment is made when "OMIT BLANK PAGE" is selected on the control panel. The adjustment value is simultaneously applied to all modes at PPC and scanning.

< 05 Adjustment Mode >

Code	Item to be adjusted	Remarks
7618	Judgment threshold adjustment for blank originals	The larger the value is, the more an original tends to be judged as a blank sheet. Acceptable values: 0 to 255 (Default: 128)

<Procedure>

The procedure is the same as that of  P. 6-27 "6.2.2 Density adjustment".

## 6.2.10 Image area adjustment for blank original judgment (common for copying and scanning)

The surrounding void amount of an image is adjusted when blank original judgment is performed.  
<05 Adjustment Mode>

Code	Item to be adjusted	Contents
7616-0	Void amount adjustment for blank page judgment	When a larger value is set, the image area to be used for the judgment is decreased. When a smaller value is set, the image area to be used for the judgment is increased. Acceptable value: 0 to 255 (Default: 200)

### Notes:

If a value, which is too smaller, is set, the shadow of the original may be used for the judgment and this may become the cause of a misjudgment.

<Procedure>

- (1) Perform FS-05.
- (2) Key in a code and press the [START] button.
- (3) Key in the adjustment value.  
(To correct the value once keyed in, press [CLEAR].)
- (4) Press [OK] to store the value. -> The equipment returns to the ready state.
- (5) Start up the equipment in the normal mode and make a copy.
- (6) If the desired image density has not been attained, repeat steps (1) to (5).

## 6.2.11 Drop out color adjustment


The density level to be dropped out can be adjusted when copying is performed while selecting [Drop out color].

<05 Adjustment Mode>

Color mode	Code	Item to be adjusted	Remarks
Black	7066	Drop out color adjustment	When a larger value is set, a gray-like color in an original tends to be dropped out. When a smaller value is set, a gray-like color in an original tends to be remaining. Acceptable value: 20 to 80 (Default: 50)

### Notes:

Perform the adjustment in accordance with the procedure below.

 P. 6-26 "6.2.1 Automatic gamma adjustment (600dpi)"

<Procedure>

The procedure is the same as that of  P. 6-27 "6.2.2 Density adjustment".

### Notes:

To check an image, use the one copied in the normal startup.

## 6.2.12 Background offsetting adjustment for DF (common for copy, scan and fax)

The background level for scanning originals with the DF is adjusted when the background fogging at the scanning of a manually-set original and an original used with the DF is different. This is to adjust the level of the background image removed when the scanning of the originals with the DF is performed. The adjustment value is applied to both the front and back sides.

< 05 Adjustment Mode >

Color mode	Code	Remarks
Black	7025	The larger the value is, the darker the background density becomes. Acceptable values: 0 to 255 (Default: 128)

<Procedure>

Procedure is same as that of  P. 6-27 "6.2.2 Density adjustment".

## 6.2.13 Background offsetting adjustment in back side for DSDF (common for copy, scan and fax)

The background level for scanning the back side of originals with the DSDF can be adjusted when there is a different background fogging level at the scanning of the back and front sides with the DSDF. This is to adjust the level of the background image removed when the scanning of the back side of the original with the DSDF is performed.

< 05 Adjustment Mode >

Color mode	Code	Remarks
Black	7023	The larger the adjustment value, the darker the background becomes. Acceptable values: 0 to 255 (Default: 128)

<Procedure>

The procedure is the same as that of  P. 6-27 "6.2.2 Density adjustment".

## 6.2.14 RADF scan noise reduction

The noise reduction level for streaks can be adjusted with the following codes when a scan job is performed using the ADF

< 05 Adjustment Mode >

Code				Item to be adjusted	Remarks
Text/photo	Text	Photo	User custom		
7151	7152	7153	7150	Scan noise reduction	When the value decreases, the effect of reducing streaks becomes larger. When the value increases, the effect of reducing streaks becomes smaller. When "0" is set, this function is disabled. Acceptable values: 0 to 200 (Default: 100) <b>Notes:</b> If too small a value is set, the text may not be printed clearly.

<Procedure>

Procedure is same as that of  P. 6-27 "6.2.2 Density adjustment".

### Notes:

To check an image of [User Custom], use the one copied in the normal startup.

## 6.3 Image Quality Adjustment (Printing Function)

### 6.3.1 Automatic gamma adjustment

When the reproduction of gradation is not appropriate, it can be corrected by performing this automatic gamma adjustment. At the parts replacement and in case the gradation reproduction of the image is not satisfactory, make this adjustment as described below.

- (1) When unpacking or any of the following parts has been replaced, be sure to make this adjustment:
  - Photoconductive drum
  - Developer material
  - Laser optical unit
  - Transfer roller
  - Drum cleaning blade
  - Main charger grid
  - SRAM
- (2) Be sure to perform this adjustment whenever HDD data are cleared.

< 05 Adjustment Mode >

Code	Item to be adjusted	Chart Number	Contents
7311	Copy/Print (600dpi)	93	When the reproduction of gradation is not appropriate, it can be corrected by performing this automatic gamma adjustment.
7312	Print (1200dpi)	253	

<Procedure>

- (1) Perform FS-05. → 05 Adjustment Mode
- (2) Select the A4/LT drawer. Key in "93" and press [TEST PRINT] to print a "Patch chart for gamma adjustment".
- (3) Place the patch chart for the adjustment printed in step (2) on the original glass by putting its printed side face down and aligning its side with 2 black squares to the original scale.
- (4) Key in a code and press the [START] button.
- (5) If the adjustment is finished properly, press [OK] to have its results reflected.  
(To cancel the reflection of adjustment results, press [CANCEL].)  
In the case of an abnormal ending, "ADJUSTMENT ERROR" is shown.  
Press [CANCEL] to clear the error display. When it is cleared, the control panel display will return to the ready state. Then, check if the patch chart on the original glass is placed in the wrong direction or if it is placed inclined on the original glass, and then repeat step (3) and afterward.

#### Notes:

600dpi adjustment for both copy and print is performed at the same time.

## 6.3.2 Gamma balance adjustment

The density is adjusted by adjusting the gamma balance. The adjustment is performed by selecting its density area from the following: low density, medium density and high density.

<05 Adjustment Mode>

Mode	PS		PCL		XPS		Item to be adjusted Item to be adjusted	Remarks
	Smooth	Detail	Smooth	Detail	Smooth	Detail		
600dpi	7315-0	7316-0	7317-0	7318-0	7319-0	7320-0	Low density	The larger the value is, the density of the item to be adjusted becomes darker. Acceptable values: 0 to 255 (Default: 128)
	7315-1	7316-1	7317-1	7318-1	7319-1	7320-1	Medium density	
	7315-2	7316-2	7317-2	7318-2	7319-2	7320-2	High density	
1200dpi	7309-0	7310-0	-	-	-	-	Low density	Acceptable values: 0 to 255 (Default: 128)
	7309-1	7310-1	-	-	-	-	Medium density	
	7309-2	7310-2	-	-	-	-	High density	

Mode	Auto (PS)			Item to be adjusted	Remarks
	Text	Graphics	Image		
600dpi	7360-0	7361-0	7362-0	Low density	The larger the value is, the density of the item to be adjusted becomes darker. Acceptable values: 0 to 255 (Default: 128)
	7360-1	7361-1	7362-1	Medium density	
	7360-2	7361-2	7362-2	High density	

Mode	Auto (PS)			Item to be adjusted	Remarks
	Text	Graphics	Image		
1200dpi	7357-0	7358-0	7359-0	Low density	The larger the value is, the density of the item to be adjusted becomes darker. Acceptable values: 0 to 255 (Default: 128)
	7357-1	7358-1	7359-1	Medium density	
	7357-2	7358-2	7359-2	High density	

Mode	Auto (XPS)			Item to be adjusted	Remarks
	Text	Graphics	Image		
600dpi	7366-0	7367-0	7368-0	Low density	The larger the value is, the density of the item to be adjusted becomes darker. Acceptable values: 0 to 255 (Default: 128)
	7366-1	7367-1	7368-1	Medium density	
	7366-2	7367-2	7368-2	High density	

### Notes:

Changing the adjustment setting influences the adjacent density area slightly.

E.g.: When the value of the medium density is larger, the adjacent areas in the low density and high density range will become slightly darker.

<Procedure>

- (1) Perform FS-05.
- (2) Key in the codes to be adjusted (language and screen) and press the [START] button.
- (3) Key in the value corresponding to the density area to be adjusted (0, 1 or 2) and press the [START] button.  
0: Low density 1: Medium density 2: High density
- (4) Key in the adjustment value. (To correct the value once keyed in, press [CLEAR].)
- (5) Press [OK] to store the value in memory. → The equipment goes back to the ready state.
- (6) For resetting the value, repeat step (2) to (5).
- (7) Turn the power OFF and then back ON. Then perform printing.
- (8) If the image density has not been attained, repeat step (2) to (7).


### 6.3.3 Upper limit value in the toner saving mode (1200dpi)

The upper limit value of the density when “Toner save” is selected in the Custom tab of the printer driver can be adjusted.

< 05 Adjustment Mode >

Mode	Code	Remarks
1200dpi	7302	The smaller the value is, the lighter the density of image becomes. Acceptable values: 0 to 255 (Default: 176)

<Procedure>


The procedure is the same as that of  P. 6-35 “6.3.2 Gamma balance adjustment”.

### 6.3.4 Thin line width lower limit adjustment

< 05 Adjustment Mode >

Mode	Code	Remarks
600dpi	8240	Sets the lower limit value of the thin line width when “Distinguish Thin Lines” is selected in the screen selecting menu of the printer driver. The larger the value is, the thicker (darker) the thin line becomes. Acceptable values: 1 to 9 (Default: 2)
1200dpi	8241	

<Procedure>

The procedure is the same as that of  P. 6-38 “6.3.8 Adjustment of smudged text in black”.

### 6.3.5 Emission level adjustment

The emission level in the e-Filing printing (Monochrome/binary), the Network FAX and the Internet FAX can be adjusted as follows. This adjustment adjusts the dot size.

<05 Adjustment Mode>

Code	Item to be adjusted	Function	Remarks
7350-0	Emission level 0/4	Network FAX, Internet FAX	The smaller the value is, the smaller the emission level becomes. Therefore, the smaller dot is reproduced accordingly. Acceptable values: 0 to 255 (Default Level 0/4: 0, Level 1/4: 63, Level 2/4: 127, Level 3/4: 191, Level 4/4: 255)
7350-1	Emission level 1/4		
7350-2	Emission level 2/4		
7350-3	Emission level 3/4		
7350-4	Emission level 4/4		
7356-0	Emission level 0/4	e-Filing printing (Monochrome/binary)	
7356-1	Emission level 1/4		
7356-2	Emission level 2/4		
7356-3	Emission level 3/4		
7356-4	Emission level 4/4		

<Procedure>

The procedure is the same as that of  P. 6-31 “6.2.8 Emission level adjustment”.

#### Notes:

- Change the setting value increment of 8 as a guide.
- Be sure to confirm the image when the setting value is changed.
- The setting value must increase as the emission level number (0 to 4) becomes higher. Do not increase this order when setting the values.

### 6.3.6 Density adjustment of graphic lines (1200dpi)

This adjustment is available regardless of whether “Distinguish Thin Lines” of the printer driver is selected or not.

< 05 Adjustment Mode >

Density adjustment

Code	Remarks
8242-0	The density of the line in Black in the line density range specified by 8243-0 or 8243-1 can be adjusted. The larger the value is, the darker the line density becomes. Acceptable value: 0 to 5 (Default: 3)


Effective range

Code	Remarks
8243-0	The effective range (lower limit) of the density adjustment for the line in Black can be set. Acceptable value: 0 to 255 (Default: 1)
8243-1	The effective range (upper limit) of the density adjustment for the line in Black can be set. Acceptable value: 0 to 255 (Default: 200)

**Notes:**

Be sure to set the values of the upper and lower limit properly so that they are not set in reverse.

<Procedure>

The procedure is the same as that of  P. 6-35 “6.3.2 Gamma balance adjustment”.


### 6.3.7 Gradation switching for black mode printing text

The gradation level of the TEXT object in black mode printing can be switched.

< 05 Adjustment Mode >

Mode	PS	PCL	XPS	Remarks
Black (600dpi)	7386-0	7386-1	7386-2	0: Text reproduction priority (Text with medium density will be reproduced darker.) 1: Gradation reproduction priority (Text with medium density will be reproduced lighter.) Acceptable values: 0 to 1 (Default: 0)
Black (1200dpi)	7387	-	-	

<Procedure>

The procedure is the same as that of  P. 6-38 “6.3.8 Adjustment of smudged text in black”.

### 6.3.8 Adjustment of smudged text in black

The smudged/faint text can be set at the following codes.

< 05 Adjustment Mode >

Mode	Language			Remarks
	PS	PCL	XPS	
600dpi	7325	7326	7327	When a larger value is set, black text becomes thinner. When a smaller value is set, it becomes thicker. Acceptable values: 0 to 9 (Default: 5)
1200dpi	7305	-	-	

<Procedure>

- (1) Perform FS-05.
- (2) Key in a code and press the [START] button.
- (3) Key in an adjustment value.  
(To correct the keyed-in value, press [CLEAR].)
- (4) Press [OK] to store the value. The equipment goes back to the ready state.
- (5) Turn the power OFF and then back ON to perform printing job.
- (6) If the desired text density has not been attained, repeat step (2) to (5).



## 6.4 Image Quality Adjustment (Scanning Function)

### 6.4.1 Gamma balance adjustment

The density is adjusted by adjusting the gamma balance. The adjustment is performed by selecting its density area from the following: low density, medium density and high density.

<05 Adjustment Mode>

Black			Gray Scale	Item to be adjusted	Remarks
Original mode					
Text/Photo	Photo	User custom			
7485-0	7487-0	7480-0	7488-0	Low density	The larger the value is, the density of the item to be adjusted becomes darker. Acceptable values: 0 to 255 (Default: 128)
7485-1	7487-1	7480-1	7488-1	Medium density	
7485-2	7487-2	7480-2	7488-2	High density	

#### Notes:

Changing the adjustment setting influences the adjacent density area slightly.

E.g.: When the value of the medium density is larger, the adjacent areas in the low density and high density range will become slightly darker.

<Procedure>

- (1) Perform FS-05.
- (2) Key in the code corresponding to the desired original mode and press the [START] button.
- (3) Key in the value corresponding to the density area to be adjusted (0, 1 or 2) and press the [START] button.  
0: Low density (L), 1: Medium density (M), 2: High density (H)
- (4) Key in the adjustment value. (To correct the value once keyed in, press [CLEAR].)
- (5) Press [OK] to store the value in memory. → The equipment goes back to the ready state.
- (6) For resetting the value, repeat step (2) to (5).
- (7) Turn the power OFF and then back ON. Then perform scanning.
- (8) If the desired image has not been attained, repeat step (2) to (7).

### 6.4.2 RGB Color balance adjustment

The color balance of the images scanned in the color mode can be adjusted.

<05 Adjustment Mode>

Original mode	Item to be adjusted			Remarks
	Red	Green	Blue	
Text/Photo	8425-0	8425-1	8425-2	When a larger value is set, red becomes darker. When a smaller value is set, it becomes lighter. Acceptable values: 0 to 255 (Default: 128)
Text	8426-0	8426-1	8426-2	
Photo	8427-0	8427-1	8427-2	
Custom	8428-0	8428-1	8428-2	

<Procedure>

- (1) Perform FS-05.
- (2) Key in the code corresponding to the desired original mode and press the [START] button.
- (3) Key in the value corresponding to the sub code to be adjusted (0, 1 or 2) and press the [START] button.  
0: Red, 1: Green, 2: Blue
- (4) Key in the adjustment value. (Acceptable values: 0 to 255)  
(To correct the value once keyed in, press [CLEAR].)

- (5) Press [OK] to store the value in memory.  
→The equipment goes back to the ready state.
- (6) Turn the power ON again. Scan an original and check the images.
- (7) If the desired image has not been attained, repeat step (1) to (6).

### 6.4.3 Density adjustment

Adjusts the center density.

<05 Adjustment Mode>

Color				Item to be adjusted	Remarks
Original mode					
Text /Photo	Text	Photo	User custom		
8339	8340	8341	8380	Manual density center value	The larger the value is, the darker the image becomes. Acceptable values: 0 to 255 (Default: 128)

<05 Adjustment Mode>

Black				Gray Scale	Item to be adjusted	Remarks
Original mode						
Text /Photo	Text	Photo	User custom			
7444	7445	7446	7475	7447	Manual density center value	The larger the value is, the darker the image becomes. Acceptable values: 0 to 255 (Default: 128)
7456	7457	7458	7478	7459	Automatic density	

<Procedure>

- (1) Perform FS-05.
- (2) Key in a code and press the [START] button.
- (3) Key in an adjustment value (acceptable values: 0 to 255).  
(To correct a value once keyed in, press [CLEAR].)
- (4) Press [OK] to store the value in memory. → The equipment goes back to the ready state.
- (5) Turn the power OFF and then back ON. Then perform scanning.
- (6) If the desired image quality has not been attained, repeat step (1) to (5).

## 6.4.4 Background adjustment (Color)

The adjustment level of background center value is adjusted.

<05 Adjustment Mode>

Code	Original mode	Remarks
8309	Text/Photo	The larger the value is, the background becomes darker. Acceptable values: 0 to 255 (Default: 128)
8310	Text	
8311	Photo	
8370	User custom	

If the setting value is changed, each step for the background adjustment performed by using the buttons will be affected.

<Procedure>

The procedure is the same as that of  P. 6-40 “6.4.3 Density adjustment”.

## 6.4.5 Background adjustment (Black/Grayscale)

<05 Adjustment Mode>

Code	Color mode	Original mode	Remarks
7436	Black	Text/Photo	The larger the value is, the background becomes darker. Acceptable values: 0 to 255 (Default: 128)
7437		Text	
7438		Photo	
7441		Custom mode	
7439	Grayscale	-	

<Procedure>

The procedure is the same as that of  P. 6-40 “6.4.3 Density adjustment”.

## 6.4.6 Judgment for ACS adjustment

The judgment level is adjusted for the automatic identification of whether the original set on the glass is black or color. Namely, this is to adjust the judgment level used when “Auto Color” is selected at color modes.

<05 Adjustment Mode>

Code	Item to be adjusted	Contents
7630	Judgment for ACS adjustment	The larger the value is, the more an original tends to be judged as black even at the Auto Color Mode. The smaller the value is, the more it tends to be judged as color. Acceptable values: 0 to 255 (Default: 70)

<Procedure>

The procedure is the same as that of  P. 6-40 “6.4.3 Density adjustment”.

## 6.4.7 Sharpness adjustment

If you want to make scan images look softer or sharper, perform the following adjustment. The adjustment can be made for each of the color modes and original modes independently.

<05 Adjustment Mode>

Code	Color mode	Original mode	Contents
8335	Full Color	Text	The larger the value is, the sharper the image becomes; while the smaller the value is, the softer the image becomes. The smaller the value is, the less moire tends to appear. The acceptable values are 0 to 255 (Default: 128)
8336		Photo	
8354		Text/Photo	
8375		User custom	
7430	Black	Text/Photo	
7431		Text	
7432		Photo	
7470		User custom	
7433	Gray Scale	-	

### Notes:

You have to make adjustment by balancing between moire and sharpness.

<Procedure>

The procedure is the same as that of  P. 6-40 "6.4.3 Density adjustment".

## 6.4.8 Contrast adjustment

The contrast of the images scanned in the color mode can be adjusted.

<05 Adjustment Mode>

Original mode	Code	Remarks
Text/Photo	8419	When a larger value is set, the contrast becomes higher. When a smaller value is set, it becomes lower. Acceptable values: 0 to 255 (Default: 128)
Text	8420	
Photo	8421	
Custom	8422	

<Procedure>

- (1) Perform FS-05.
- (2) Key in the code corresponding to the desired original mode and press the [START] button.
- (3) Key in the adjustment value. (Acceptable values: 0 to 255)  
(To correct the value once keyed in, press [CLEAR].)
- (4) Press [OK] to store the value in memory.  
→ The equipment goes back to the ready state.
- (5) Turn the power ON again. Scan an original and check the images.
- (6) If the desired image has not been attained, repeat step (1) to (5).

## 6.4.9 Fine adjustment of black density

The density of black side on scanned image is adjusted at color-scanning.

<05 Adjustment Mode>

Code	Original mode	Remarks
8314	Text / Photo	The larger the value is, the black side of the image becomes darker. Acceptable values: 0 to 4 (Default: Text/Photo: 1, Others: 0)
8315	Text	
8316	Photo	
8371	User custom	

### Notes:

Be careful for the value not to be too large since the gradation is reproduced worse in darker side.

<Procedure>

The procedure is the same as that of  P. 6-40 "6.4.3 Density adjustment".

## 6.4.10 RGB conversion method selection

The color space conversion method of image is decided at color-scanning.

<05 Adjustment Mode>

Code	Original mode	Remarks
8319	Text /Photo	0: sRGB, 1: AppleRGB, 2: ROMMRGB, 3: AdobeRGB (Default: 0)
8320	Text	
8321	Photo	
8372	User custom	

<Procedure>

The procedure is the same as that of  P. 6-40 "6.4.3 Density adjustment".

## 6.4.11 Adjustment of saturation

The saturation of the scanned image is adjusted for color-scanning.

<05 Adjustment Mode>

Code	Original mode	Remarks
8324	Text / Photo	The larger the value is, the brighter the image becomes. The smaller the value is, the duller the image becomes. Acceptable values: 0 to 255 (Default: 128)
8325	Text	
8326	Photo	
8373	User custom	

<Procedure>

The procedure is the same as that of  P. 6-40 “6.4.3 Density adjustment”.

## 6.4.12 Background offsetting adjustment for DF (common for copy, scan and fax)

The background level for scanning originals with the DF is adjusted when the background fogging at the scanning of a manually-set original and an original used with the DF is different. This is to adjust the level of the background image removed when the scanning of the originals with the DF is performed. The adjustment value is applied to both the front and back sides.

<05 Adjustment Mode>

Color mode	Code	Remarks
Color	7026	The larger the adjustment value is, the darker the background becomes. Acceptable values: 0 to 255 (Default: 128)
Black	7025	

<Procedure>

The procedure is the same as that of  P. 6-40 “6.4.3 Density adjustment”.

## 6.4.13 Background offsetting adjustment in back side for DSDF (common for copy, scan and fax)

The background level for scanning the back side of originals with the DSDF can be adjusted when there is a different background fogging level at the scanning of the back and front sides with the DSDF. This is to adjust the level of the background image removed when the scanning of the back side of the original with the DSDF is performed.

< 05 Adjustment Mode >

Color mode	Code	Remarks
Color	7024	The larger the adjustment value, the darker the background becomes. Acceptable values: 0 to 255 (Default: 128)
Black	7023	

<Procedure>

The procedure is the same as that of  P. 6-27 “6.2.2 Density adjustment”.

## 6.4.14 Adjustment of the capacity and image quality of SlimPDF

A SlimPDF is saved using different compression ratios and resolutions by being divided into the text and other portions.

The file size and the image quality can be adjusted by changing the compression ratio and resolution for areas other than text (e.g.: background).

<05 Adjustment Mode>

Code	Item to be adjusted	Remarks
9104	Compression quality of SlimPDF background processing	The compression ratio can be adjusted. This code is used to improve the image quality of the background. When a larger value is set, mosquito noise in the outline or boundary will be decreased and better image quality can be obtained; however, the file size will become larger. When a smaller value is set, the file size will be reduced; however, the noise in the outline or boundary will be increased and thus the image quality will become worse. Especially, the noise in the boundary between the white and color portions will become conspicuous. Change the setting value by 2 steps from the default as a target. Acceptable value: 0 to 10 (Default: 5)
9105	Sharpening of SlimPDF background processing	The sharpness can be adjusted. This code is used to improve the image quality of the background. The larger the value is, the better the sharpness of the outline and boundary becomes. However, if the value is too large, the noise will be enhanced or the moire will occur. The smaller the value is, the lower the noise or moire will occur. However, if the value is too small, blurred images will occur. Change the setting value by 2 steps from the default as a target. Acceptable value: 0 to 10 (Default: 5) Recommended value: 3 to 7
9107	Resolution of SlimPDF background processing	The resolution can be adjusted. This code is used to improve the image quality of the background. When a larger value is set, the image quality becomes sharper; however, the file size becomes larger. When a smaller value is set, the file size will be reduced; however, blurred images will occur. 0: 75dpi 1: 100dpi 2: 150dpi 3: 200dpi Acceptable value: 0 to 3 (Default: 1)

<Procedure>

- (1) Perform FS-05.
- (2) Key in the codes to be adjusted and press the [START] button.
- (3) Key in the adjustment value. (To correct a value once keyed in, press [CLEAR].)
- (4) Press [OK] to store the value in memory. → The equipment goes back to the ready state.
- (5) Turn the power OFF and then back ON. Then obtain a SlimPDF and check the images.
- (6) If the desired image quality has not been attained, repeat step (1) to (5).

### Notes:

The image quality of the portions which are not recognized as text will be improved by setting the value "2" or larger in 05-9107.

In such a case; however, the file size will become larger. Therefore, to make the file size smaller, set the value "4" or smaller in 05-9104.

## 6.4.15 Surrounding void amount adjustment

The void amount around the network scanned image is adjusted.

In network scanning, since the void amount is very small in stored images, a shadow may appear around the scanned image due to the subtle difference in the original sizes. This shadow can be eliminated by adjusting the setting value.

The setting value is applied to all resolutions and color modes.

< 05 Adjustment Mode >

Code	Item to be adjusted	Remark
7489	Surrounding void amount adjustment	When the value increases, the blank area around the scanned image becomes wider and is replaced with white data. Acceptable value: 0 to 255 (Default: 0) Equivalent to 24 by 1 mm

<Procedure>

The procedure is the same as that of  P. 6-27 “6.2.2 Density adjustment”.

## 6.4.16 Surrounding void amount adjustment (custom size scan)

When the custom size is specified during original size setting for network scanning, the void amount around the network scanned image is adjusted. A shadow may appear around the scanned image and this can be eliminated by means of the setting.

The adjustable types of the custom size are [Registered Size] and [Auto Detected] only.

The setting value is applied to all resolutions and color modes.

<05 Adjustment Mode>

Code	Item to be adjusted	Remarks
7090	Surrounding void amount adjustment of [Registered Size]	When the value increases, the blank area around the image scanned while [Registered Size] is set becomes wider and is replaced with white data. Acceptable value: 0 to 255 (Default: 0) Approx. 1 mm void is attached by the setting value “24”.
7091	Surrounding void amount adjustment of [Auto Detected]	When the value increases, the blank area around the image scanned while [Auto Detected] is set becomes wider and is replaced with white data. Acceptable value: 0 to 255 (Default: 0) Approx. 1 mm void is attached by the setting value “24”.

<Procedure>

The procedure is the same as that of  P. 6-40 “6.4.3 Density adjustment”.

## 6.4.17 Judgment threshold adjustment for blank originals (common for copy and fax)

The judgment level is adjusted for automatic identification of whether the original set is blank or not.

This adjustment is made when “OMIT BLANK PAGE” is selected on the control panel.

The adjustment value is simultaneously applied to all modes at PPC and scanning.

< 05 Adjustment Mode >

Code	Item to be adjusted	Remarks
7618	Judgment threshold adjustment for blank originals	The larger the value is, the more an original tends to be judged as a blank sheet. Acceptable values: 0 to 255 (Default: 128)

<Procedure>

The procedure is the same as that of  P. 6-27 “6.2.2 Density adjustment”.



## 6.4.18 Image area adjustment for blank original judgment and ACS judgment (for scanning)

The surrounding void amount of an image is adjusted when ACS judgment are performed.

<05 Adjustment Mode>

Code	Item to be adjusted	Contents
7616-1	Void amount adjustment for ACS judgment	When a larger value is set, the image area to be used for the judgment is decreased. When a smaller value is set, the image area to be used for the judgment is increased. Acceptable value: 0 to 255 (Default: 200)

### Notes:

If a value, which is too smaller, is set, the shadow of the original may be used for the judgment and this may become the cause of a misjudgment.

<Procedure>

- (1) Perform FS-05.
- (2) Key in a code and press the [START] button.
- (3) Key in the adjustment value.  
(To correct the value once keyed in, press [CLEAR].)
- (4) Press [OK] to store the value. -> The equipment returns to the ready state.
- (5) Start up the equipment in the normal mode and make a copy.
- (6) If the desired image density has not been attained, repeat steps (1) to (5).

## 6.4.19 JPEG compression level adjustment

The compression level for saving the scanned data in the JPEG format can be adjusted as follows.

< 05 Adjustment Mode >

Code	Item to be adjusted	Remark
8304-0	High quality	The larger the value is, the better the quality becomes, and the larger the size of file becomes. Acceptable values: 0 to 255 (Default: 128)
8304-1	Standard	
8304-2	Low quality	

<Procedure>

Procedure is same as that of  P. 6-40 "6.4.3 Density adjustment".

## 6.4.20 DF scan noise reduction

The noise reduction level for streaks can be adjusted with the following codes when a scan job is performed using the DF.

< 05 Adjustment Mode >

Color				Item to be adjusted	Remarks
Original mode					
Text/ photo	Text	Photo	User custom		
8413	8414	8415	8412	DF scan noise reduction	<p>When the value decreases, the effect of reducing streaks becomes larger. When the value increases, the effect of reducing streaks becomes smaller. When "0" is set, this function is disabled. Acceptable values: 0 to 200 (Default: 100)</p> <p><b>Notes:</b> If too small a value is set, the text may not be printed clearly.</p>

Black					Item to be adjusted	Remarks
Original mode						
Text/ photo	Text	Photo	Gray scale	User custom		
7401	7402	7403	7404	7400	DF scan noise reduction	<p>When the value decreases, the effect of reducing streaks becomes larger. When the value increases, the effect of reducing streaks becomes smaller. When "0" is set, this function is disabled. Acceptable values: 0 to 200 (Default: 100)</p> <p><b>Notes:</b> If too small a value is set, the text may not be printed clearly.</p>

<Procedure>

Procedure is same as that of  P. 6-27 "6.2.2 Density adjustment".

## 6.5 Image Quality Adjustment (FAX Function)

### 6.5.1 Density adjustment

Adjusts the center density.

<05 Adjustment Mode>

Color mode	Original mode			Item to be adjusted	Remarks
	Text/Photo	Text *	Photo		
Black	7533	7534	7535	Manual density center value	The larger the value is, the darker the image becomes. Acceptable values: 0 to 255 (Default: 128)
	7542	-	7543	Automatic density mode	

\* Since the gradation in this mode is reproduced in a binary image (black and white), this adjustment should be a simple binary threshold adjustment.

<Procedure>

- (1) Perform FS-05.
- (2) Key in a code and press the [START] button.
- (3) Key in an adjustment value.  
(To correct the value once keyed in, press [CLEAR].)
- (4) Press [OK] to store the value. → The equipment goes back to the ready state.
- (5) To set it again, repeat step (2) to (4).
- (6) Turn the power OFF.

<Confirmation>

If possible, perform a Fax transmission and check the adjusted density with the image on the recipient's side.

### 6.5.2 Emission level adjustment

The emission level in the fax function can be set. In this setting the size of dots is adjusted.

<05 Adjustment Mode>

Code	Item to be adjusted	Remarks
7595-0	Emission level 0/4	The smaller the value is, the smaller the emission level becomes. Therefore, the smaller dot is reproduced accordingly. Acceptable values: 0 to 255 (Default: Level 0/4: 0, Level 1/4: 63, Level 2/4: 127, Level 3/4: 191, Level 4/4: 255)
7595-1	Emission level 1/4	
7595-2	Emission level 2/4	
7595-3	Emission level 3/4	
7595-4	Emission level 4/4	

<Procedure>

The procedure is the same as that of  P. 6-31 "6.2.8 Emission level adjustment".

<Confirmation>

Check the emission level setting with the actual fax data received, if possible.

#### Notes:

- Change the setting value increment of 8 as a guide.
- Be sure to confirm the image when the setting value is changed.
- The setting value must increase as the emission level number (0 to 4) becomes higher. Do not increase this order when setting the values.

### 6.5.3 Background offsetting adjustment for DF (common for copy, scan and fax)

The background level for scanning originals with the DF is adjusted when the background fogging at the scanning of a manually-set original and an original used with the DF is different. This is to adjust the level of the background image removed when the scanning of the originals with the DF is performed. The adjustment value is applied to both the front and back sides.

<05 Adjustment Mode>

Color mode	Code	Remarks
Black	7025	The larger the adjustment value is, the darker the background becomes. Acceptable values: 0 to 255 (Default: 128)

<Procedure>

The procedure is the same as that of  P. 6-40 "6.4.3 Density adjustment".

### 6.5.4 Background offsetting adjustment in back side for DSDF (common for copy, scan and fax)

The background level for scanning the back side of originals with the DSDF can be adjusted when there is a different background fogging level at the scanning of the back and front sides with the DSDF. This is to adjust the level of the background image removed when the scanning of the back side of the original with the DSDF is performed.

< 05 Adjustment Mode >

Color mode	Code	Remarks
Black	7023	The larger the adjustment value, the darker the background becomes. Acceptable values: 0 to 255 (Default: 128)

<Procedure>






The procedure is the same as that of  P. 6-27 "6.2.2 Density adjustment".

## 6.6 Adjustment of High-Voltage Transformer

When replacing the high-voltage transformer, you must check each output adjustment of the main charger bias, developer bias, transfer bias, transfer cleaning bias (positive), transfer cleaning bias (negative) and separation bias.

### 6.6.1 Adjustment

#### [ 1 ] Preparation

Items to check		Developer Bias	Main Charger	Transfer Bias, Transfer Cleaning Bias (positive), Transfer Cleaning Bias (negative)	Separation Charger
Process Unit		Take the process unit out of the equipment, and then install the high-voltage transformer jig to the unit.			
High-Voltage Transformer Jig		Install the high-voltage transformer jig in the equipment. <b>Notes:</b> Connect the green cable of the high-voltage transformer jig to ground on the equipment frame.  P. 6-52 "[A] Installation of the high-voltage transformer jig".			
Digital Tester	(+) terminal	Connect with the black cable (thick line) of the high-voltage transformer jig.	Connect with the red cable (thick line) of the high-voltage transformer jig.	Connect with the red cable (thin line) of the high-voltage transformer jig.	Connect with the gray cable of the high-voltage transformer jig.
	(-) terminal	Connect with the black cable (thin line) of the high-voltage transformer jig.			
	Function switch	DC			
	Full-scale (range)	1000 V		200 $\mu$ A	
	Remarks	Use a digital tester with an input resistance of 10 M $\Omega$ (RMS value) or higher.			
How to turn ON the power		Attach the door switch jig and start with the adjustment mode [05] while the front cover opened.			
Note		 P. 6-54 "[B] Connection for developer bias adjustment"	 P. 6-54 "[C] Connection for main charger adjustment"	 P. 6-55 "[D] Connection the transfer bias, transfer cleaning bias (positive) and transfer cleaning bias (negative) adjustment"	 P. 6-55 "[E] Connection for separation charger adjustment"

### [A] Installation of the high-voltage transformer jig

The high-voltage transformer jig is composed of 2 cables and 1 adapter with a harness. Attach them to the process unit as shown in the figure.

- \* Black cable (thick line): Use the screw for the jig. (M3 x 8)
- \* Red cable (thick line): Use the screw for the process unit.
- \* Adapter: Use the screw for the process unit.

#### Notes:

The adjustment may damage the drum. Therefore be sure to replace the drum with the one that you brought (or the one for measurement) before starting the adjustment.

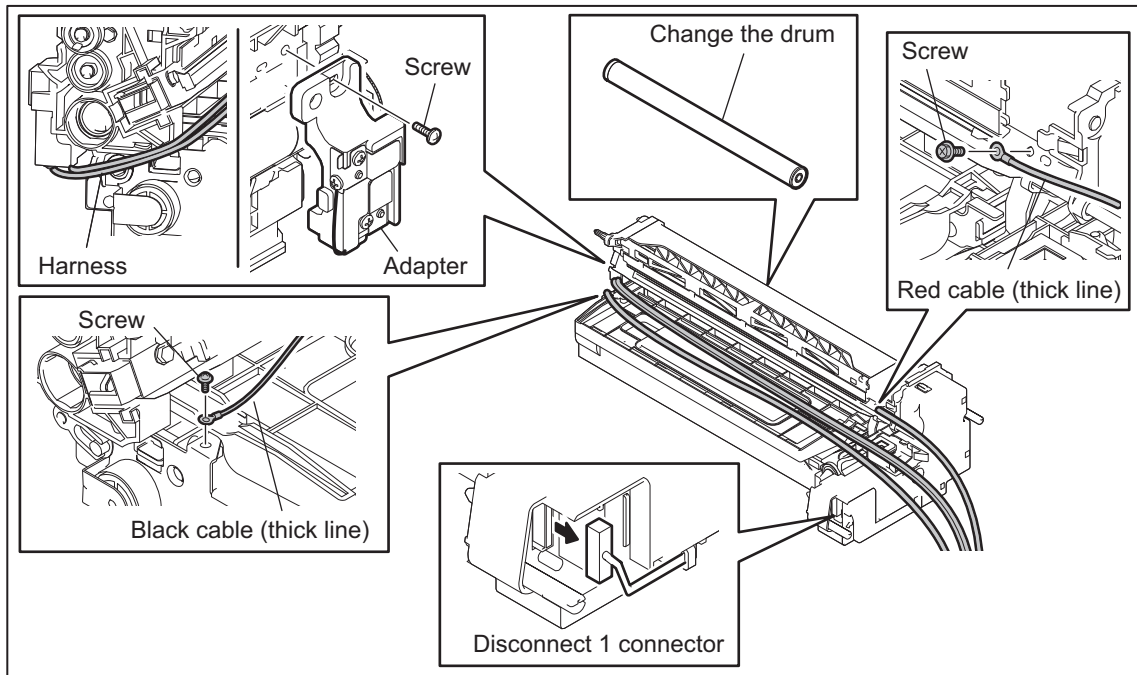


Fig.6-26

- (1) Open the automatic duplexing unit.
- (2) Open the front cover and take off the toner cartridge.
- (3) Loosen 2 screws and pull out the process unit [1].

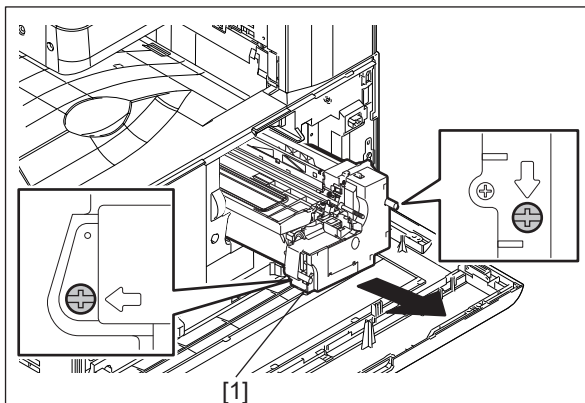


Fig.6-27

- (4) Install the high-voltage transformer jig [1] and fix it with 2 screws.

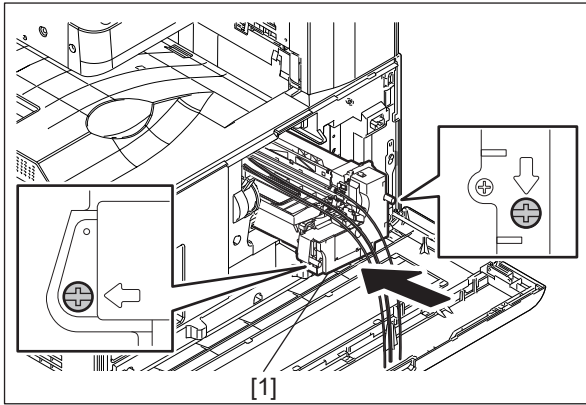


Fig.6-28

**Notes:**

Be careful not to let the connector and the harness be caught.

- (5) Fix the green cable [2] of the high-voltage transformer jig to the frame of the equipment.

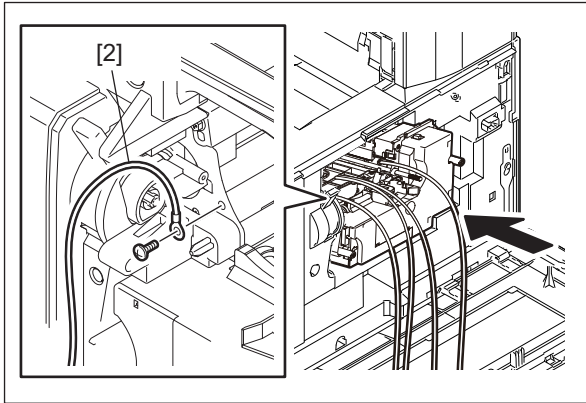


Fig.6-29

- (6) Install the door switch jig [3].

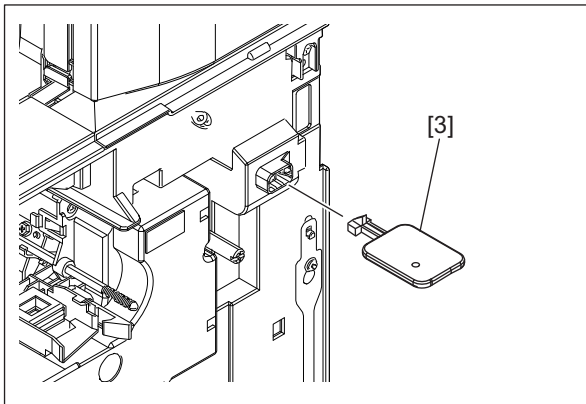
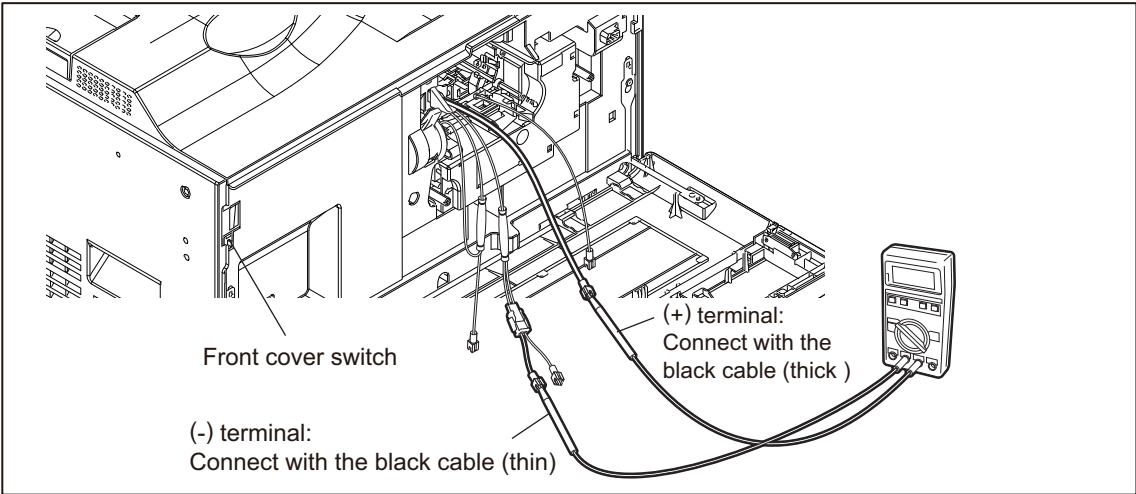


Fig.6-30

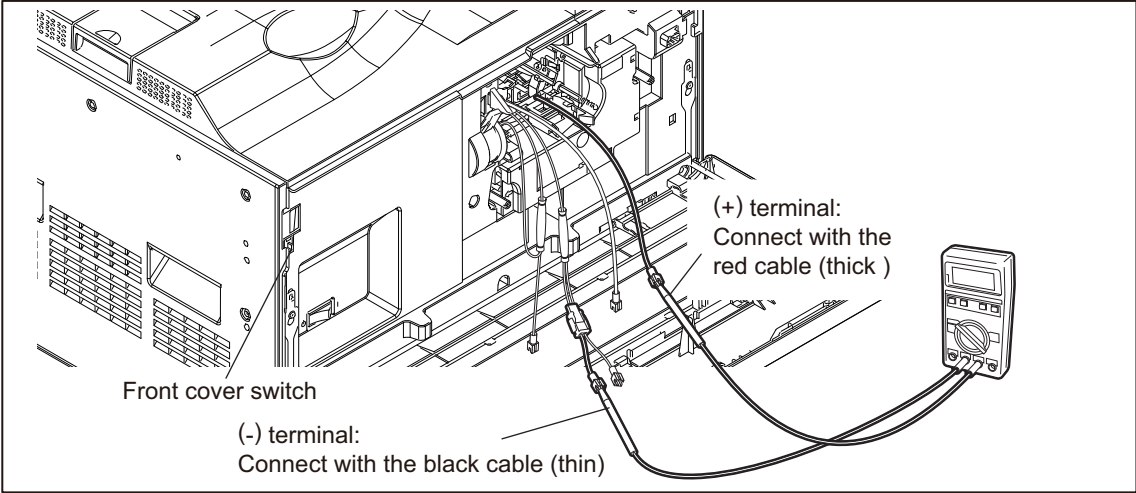
- (7) Take off the transfer roller unit.  
(8) Close the automatic duplexing unit.

**[B] Connection for developer bias adjustment**



**Fig.6-31**

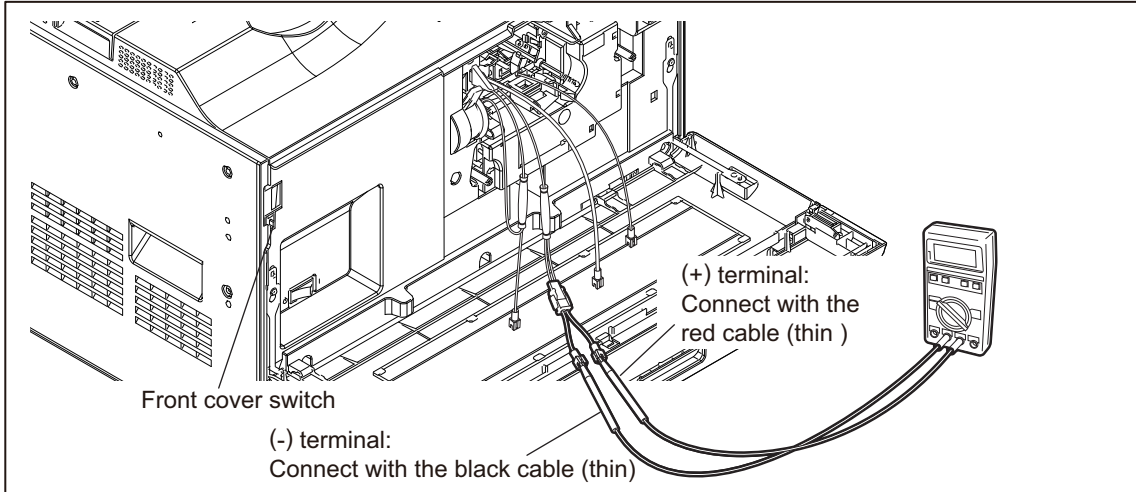
**[C] Connection for main charger adjustment**



**Fig.6-32**

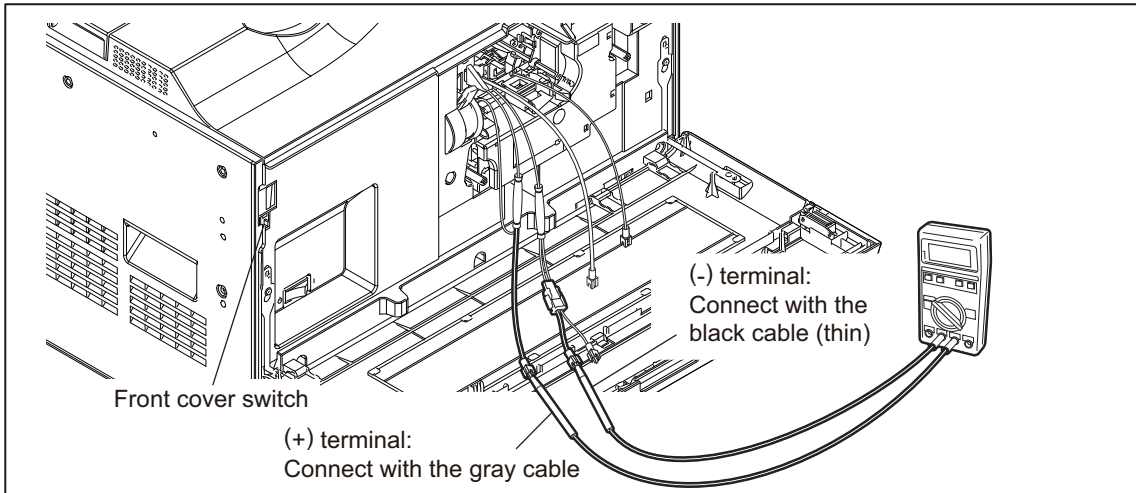


**[D] Connection the transfer bias, transfer cleaning bias (positive) and transfer cleaning bias (negative) adjustment**



**Fig.6-33**

**[E] Connection for separation charger adjustment**



**Fig.6-34**

## [ 2 ] Operation

### Notes:

When adjusting output of high-voltage transformer, make sure to use the high-voltage transformer jig.

Connect the digital testers as described in "[1] Preparation", and follow the procedure on the next page to adjust the output from the main charger, developer bias charger, transfer charger and separation charger.

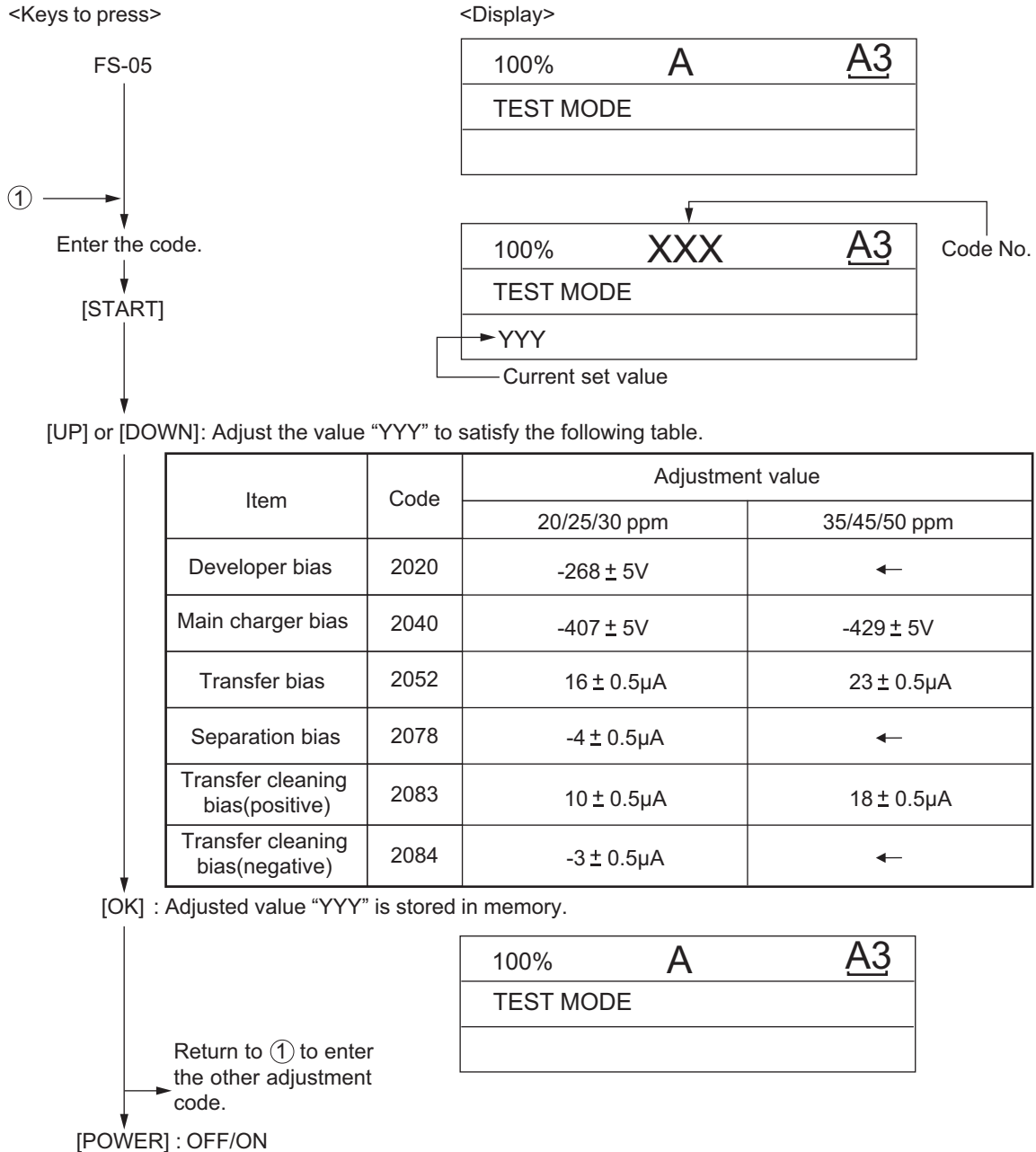


Fig.6-35

## 6.6.2 Precautions

### [ 1 ] Developer bias

#### Note for adjustment

Adjust the developer bias if fogging occurs over the entire image even though the main charger grid voltage and toner density are appropriate. However, the following may occur if the developer bias is lowered too much:

- Image contrast becomes low.
- Image is patchy or blurred.
- The carrier in the developer material adheres to the photoconductive drum, causing scratches around the cleaner.

### [ 2 ] Transfer

#### Items to check before adjustment

Blotched image or poor transfer can be also caused by matters other than defective adjustment of transfer output. Check the following items before adjusting the transfer charger. If there is no problem, adjust the output of the transfer.

- Are the transfer roller unit, transfer roller and power supply spring properly installed? Is there any foreign matter or damage on the transfer roller surface? Is the transfer guide deformed?
- Is the process unit properly installed? Is the developer magnetic brush in contact with the drum? Is the process unit worked correctly? Is the toner density low?
- Is the copy paper fed straight? Is the copy paper abnormally moist?
- Is the rotation of the registration roller normal?
- Is the separation output different from the set value?
- Is the developer bias value an appropriate one?

#### Note for adjustment

##### When blotched image appear:

- If blotched image appear in halftone areas, lower the transfer output value. Remember that transfer performance becomes low if the transfer output value is lowered too much.

##### When poor transfer occurs:

Increase the transfer output value under the following conditions. Remember that blotched image appear if the transfer output value is increased too much.

- Poor transfer occurs although the transfer roller unit, transfer roller and power supply spring are properly installed and no abnormality exists on the appearance of the transfer roller.
- Thick paper has been frequently used.

### [ 3 ] Separation

#### Items to check before adjustment

Poor paper separation from the drum can be also caused by matters other than defective adjustment of the separation output. Check the following items before making an adjustment. If there is no problem, adjust the output of the separation charger.

- Are the erasing needle and the power supply bracket dirty or dislocated?
- Is the mode selected properly according to the paper weight?
- Is the process unit installed properly? Is the developer magnetic brush in contact with the drum?
- Is the process unit worked correctly? Is the toner density low?
- Is the copy paper fed straight? Is the copy paper abnormally moist?
- Is the rotation of the registration roller normal?
- Is the output of the main charger normal?
- Is the developer bias an appropriate value?
- Is the transfer output different from the set value?
- Is the separation finger in contact with the drum surface?

#### Note for adjustment

##### When poor paper separation occurs:

Increase the separation output value under the following conditions. Note that poor transfer occurs if the separation output value is too high.

- Poor separation occurs even though the separation needle is not dirty.
- Thin paper has been frequently used.

##### When poor transfer occurs:

Decrease the separation output value when poor transfer occurs. Remember that the separation performance becomes low if the separation output value is decreased too much.

## 6.7 Scanner

### 6.7.1 Adjustment carriages-1 positions

- (1) Take off the RADF/DSDF.  
📖 P. 4-192 “4.13.2 Reversing Automatic Document Feeder”
- (2) Take off the right top cover.  
📖 P. 4-4 “4.1.8 Right top cover”
- (3) Take off the original glass.  
📖 P. 4-20 “4.3.2 Original glass”
- (4) Take off the left top cover.  
📖 P. 4-3 “4.1.5 Left top cover”
- (5) Move the carriage-1[1] toward the exit side.

**Notes:**

Rotate the drive pulley to move the carriage.

- (6) Loosen the 2 fixing screws of the wire. Tighten the screws by aligning the sections [5] and [6] of the carriage-1 with the inside of the exit side frame [2].

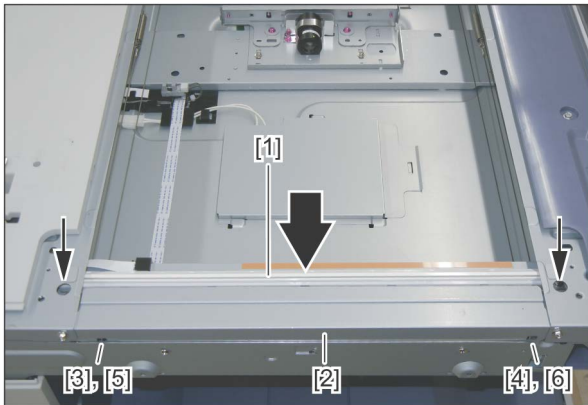


Fig.6-36

**Notes:**

Confirm that they are aligned properly through the windows [3] and [4] of the exit side frame [2].

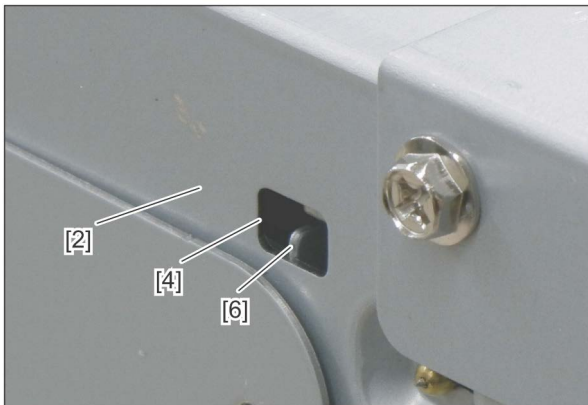


Fig.6-37

## 6.7.2 Position adjustment of CCD lens unit

Count the number of lines and write it down for later reference before removing the CCD lens unit. When installing the CCD lens unit, the same number of lines needs to be visible.

📖 P. 4-26 “4.3.6 Lens unit/CCD driving PC board”

## 6.7.3 Belt tension adjustment of the scan motor

- (1) Take off the rear cover.

📖 P. 4-8 “4.1.15 Rear cover”

- (2) Hook the belt tension jig[1] to the motor bracket[2] and hook section of the flame[3].
- (3) Loosen the screws [4] and [5].
- (4) The scan motor [6] is pulled by the belt tension jig [1]. When it is stopped, tighten the screws in order of [4] and [5].
- (5) Remove the belt tension jig[1].

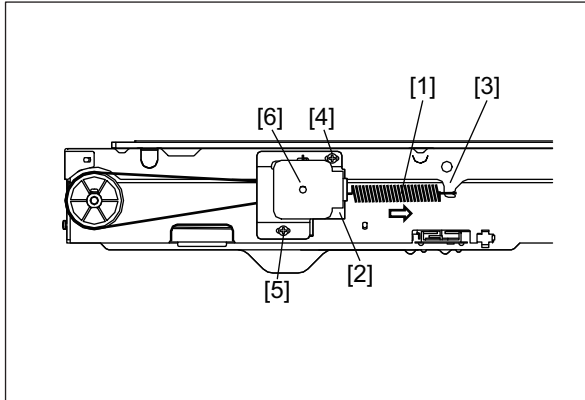


Fig.6-38

# 6.8 Paper Feeding System

## 6.8.1 Adjusting the clearance of the paper and side guides

If the clearance between the paper and the side guides is too wide, it can be adjusted to between 0 and 1 mm using the following procedure (the clearance between the paper and the guides is 1 to 2 mm including both front and rear sides).

<Procedure>

- (1) Take out the drawer.
- (2) Move the side guide[1]. Loosen 2 screws.

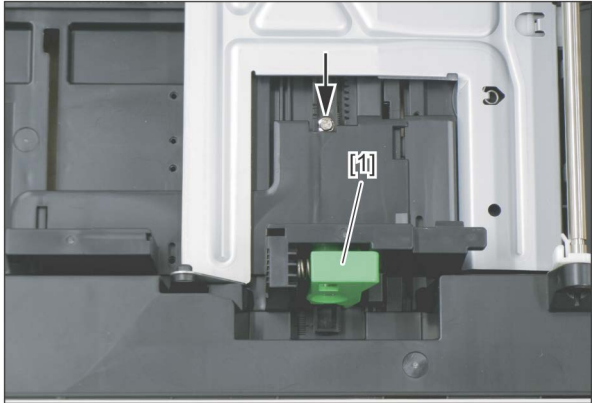


Fig.6-39

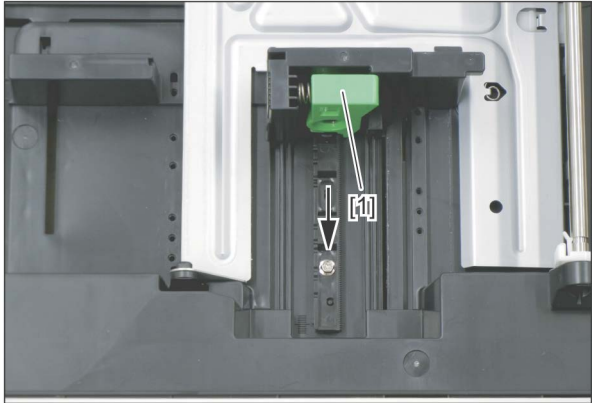


Fig.6-40

- (3) Move the side guide adjustment piece[1] to the front and tighten the screws (by 0.5 mm).

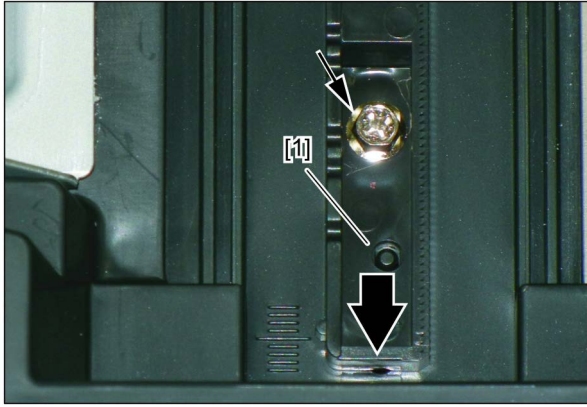


Fig.6-41

## 6.8.2 Separation roller pressure force adjustment

Generally paper jams and multiple feeding often occur as the life end of the roller approaches. However, if they often occur even though its life has not yet reached its replacement timing, or if the life end comes much earlier than the scheduled replacement timing, the jams and multiple feeding can be suppressed by adjusting the pressure force of the separation roller.

In this method, however, when the roller life becomes longer, jams and multiple feeding may occur frequently, and when the jams and multiple feeding are suppressed, the roller life may become shorter. Therefore, perform this adjustment while checking the status carefully, and if necessary, give a sufficient explanation to users.

<Adjustment procedure>

- (1) Take off the drawer feeding unit.
  - 📖 P. 4-66 "4.5.15 1st drawer paper feed unit"
  - 📖 P. 4-69 "4.5.17 2nd drawer paper feed unit"
- (2) Remove 1 screw, and then screw it temporarily into the oblong hole which is located next to it.

### Notes:

Make a mark for the installation position of the holder [1] in advance.

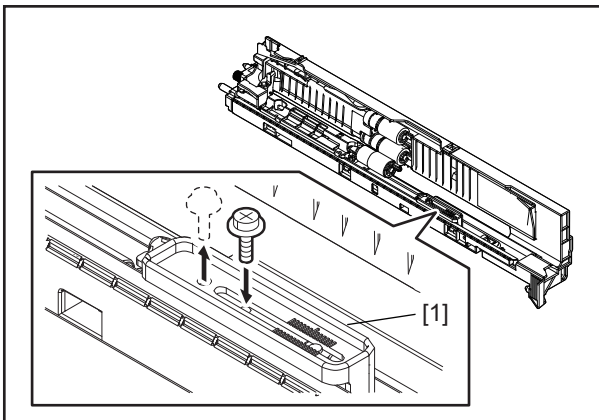


Fig.6-42



(3) Move the holder [1].

**Remarks:**

- Moving in the direction of A: The roller life will become longer (but multiple feeding may occur frequently).
- Moving in the direction of B: Multiple feeding will be suppressed (but the roller life may become shorter).

**Notes:**

The recommended moving distance of the holder [1] is within 1 or 2 scale marks.

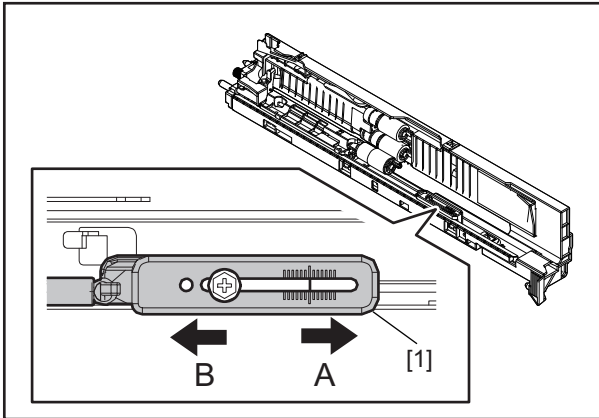


Fig.6-43

## 6.9 Adjustment of Developer Unit

### 6.9.1 Doctor-to-sleeve gap

Adjustment tool to use: Doctor-sleeve jig

<Procedure>

- (1) Perform FS-05-2390.
- (2) Take out the process unit from the equipment.
- (3) Take out the developer unit from the process unit.
- (4) Remove 2 screws and take off the developer material cover and discharge the developer material.

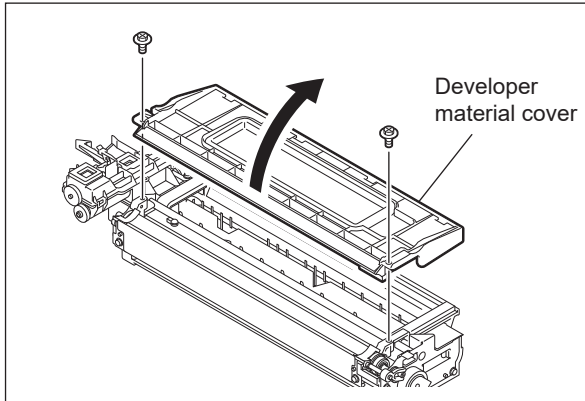


Fig.6-44

#### Notes:

Discharge the developer material from the rear side, being careful not to let it be scattered on the gear.

- (5) Turn the adjustment screw to widen the gap so that the jig can be inserted in it.  
(Turning the screw clockwise widens the gap)

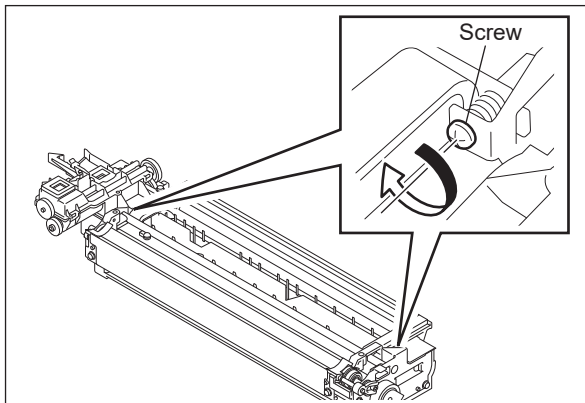


Fig.6-45

- (6) Insert the gauge with the thickness “0.45” of the doctor sleeve jig into the gap between the developer sleeve and doctor blade after lifting up the toner scattering prevention sheet. Adjust the screws with the doctor blade to push the doctor sleeve jig lightly.

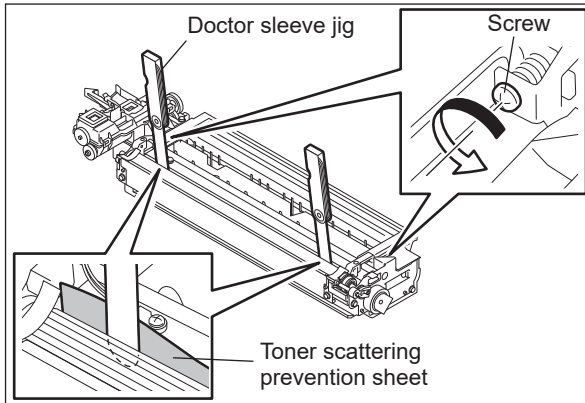


Fig.6-46

- (7) Insert the gauge “0.40” of the doctor sleeve jig into the gap between the developer sleeve and doctor blade. Confirm that the jig moves smoothly to the front and rear side, and the gauge “0.50” cannot be inserted into the gap.

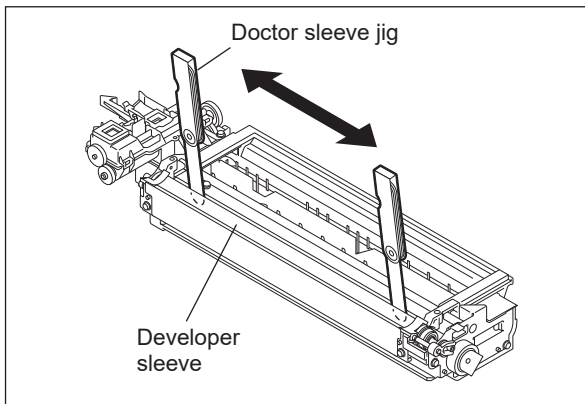


Fig.6-47

- (8) Confirm that the side seals are attached on the toner scattering prevention sheet.

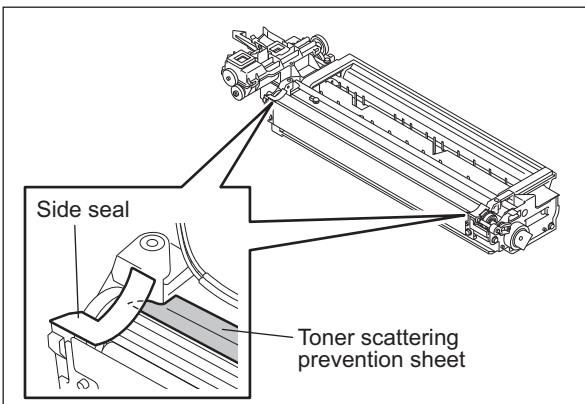


Fig.6-48

(9) Attach the developer material cover and tighten 2 screws.

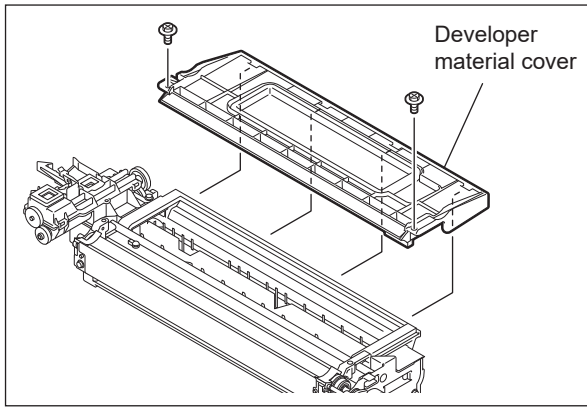



Fig.6-49

**Notes:**

- After the developer material has been replaced, adjust the auto-toner sensor. (See  P. 6-2 “6.1.2 Adjustment of auto-toner sensor”.)
- When installing the developer unit upper cover, make sure that the side seal comes between the developer unit upper cover and rubber seal on the cover.

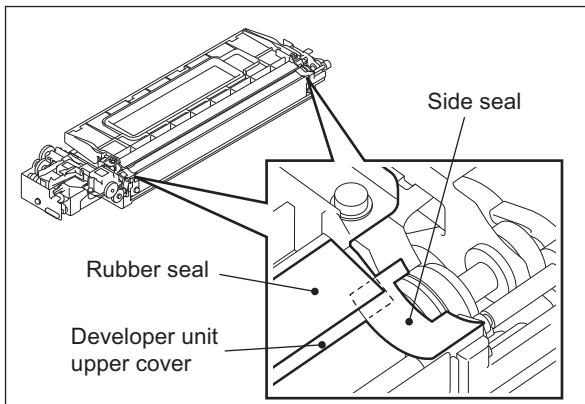


Fig.6-50

## 6.10 Fuser Unit

### 6.10.1 Adjustment of the thermostat gap

Perform this adjustment when the following parts are replaced or disassembled.






- Fuser roller
- Center thermostat
- Side thermostat

Adjustment tool to use: Non-contact thermistor/thermostat gap jig (Thick side)

#### Notes:

- Wait until the fuser unit is completely cooled down, and then start the adjustment.
- Place the fuser unit on a flat surface.
- Make sure that the pressure roller is pressed.
- Be careful not to damage the fuser roller and jig.

<Adjustment procedure>

- (1) Take off the fuser unit.  
 P. 4-134 "4.10.1 Fuser unit"
- (2) Take off the front side cover, rear side cover, and fuser roller cover.  
 P. 4-137 "4.10.2 Front side cover"  
 P. 4-137 "4.10.3 Rear side cover"  
 P. 4-138 "4.10.4 Fuser roller cover"
- (3) Take off the fuser roller separation finger installed in the window in which the side thermostat[1] can be seen.  
 P. 4-139 "4.10.6 Separation finger"
- (4) Remove 1 screw and take off the bracket [2].

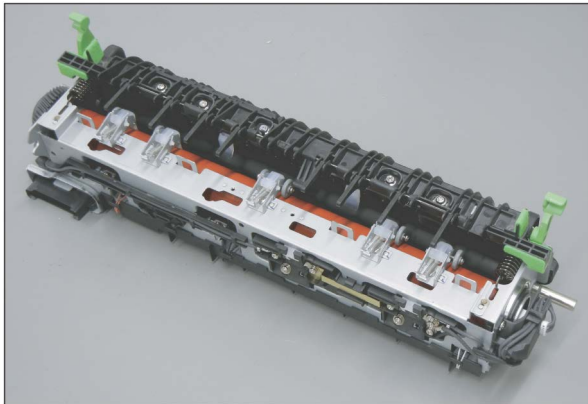


Fig.6-51

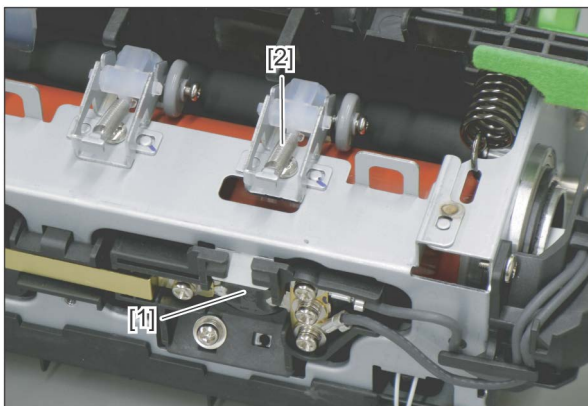
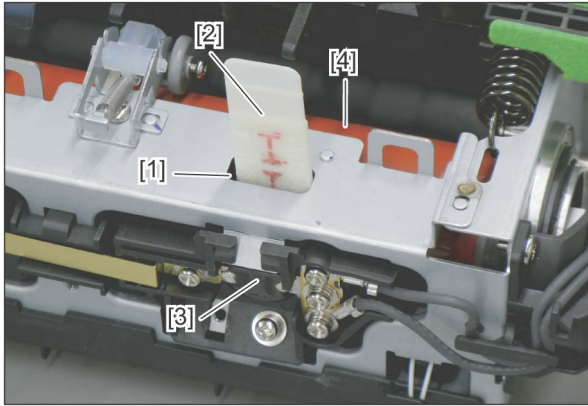


Fig.6-52

- (5) Insert the jig [2] between the side thermostat [3] and the fuser roller [4] through the window [1] in which the side thermostat [3] can be seen. Then confirm that the portion of the jig coming out of the window falls within the specified range of the scales.

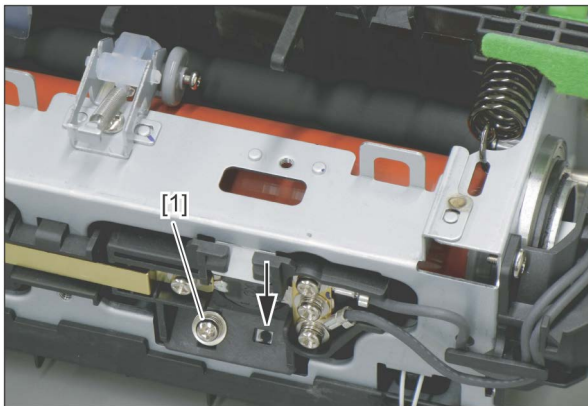
**Notes:**

The jig should be inserted under its own weight.



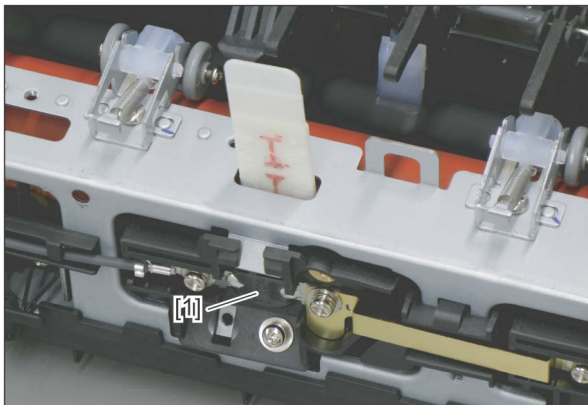
**Fig.6-53**

- (6) If the gap is not at the specified value, remove 1 screw of the side thermostat and screw it in the adjustment hole [1]. Then adjust the gap and tighten the screw. Repeat the confirmation of step 5 until the portion falls within the specified range.



**Fig.6-54**

- (7) Check the gap between the center thermostat [1] and the fuser roller as in the same manner. Adjust it if needed.



**Fig.6-55**

## 6.11 Control Panel Calibration

### 6.11.1 General description

Due to disassembling and replacing of the control panel or its temporary change, the touched position on the control panel sometimes cannot be detected properly, such as touch-and-response position mismatch or slow response. This function corrects this phenomenon.

**Remarks:**

If the control panel is replaced in a unit base, performing this function is not necessary.

### 6.11.2 Operation procedure

- (1) Perform FS-08-9050.  
The calibration screen appears and a plus mark is displayed on the upper left of the screen.
- (2) Touch the center of the plus mark in the following order.  
The plus mark is displayed in the order of 2 -> 3 -> 4, when it is touched and recognized.

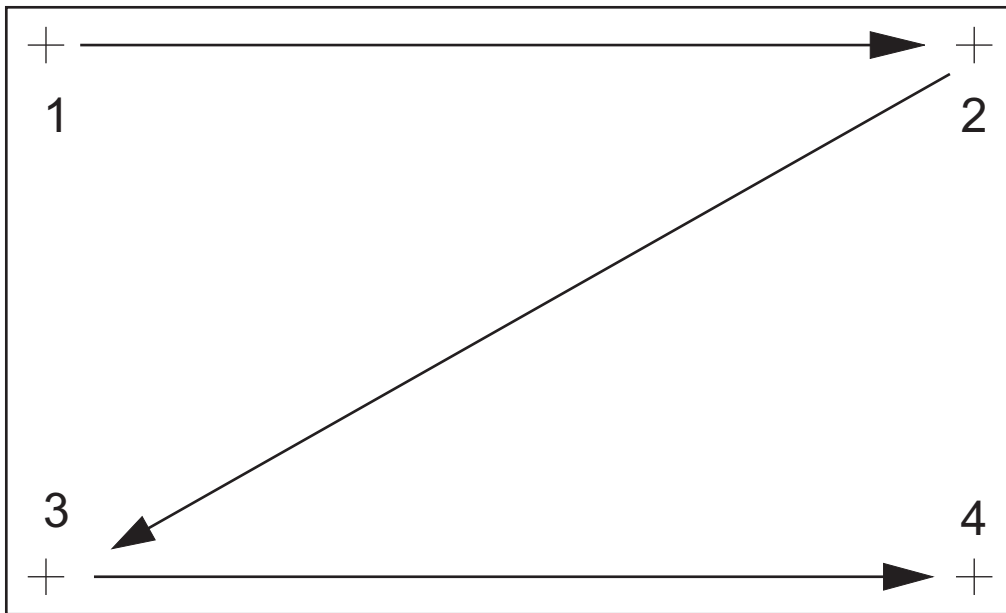


Fig.6-56

**Notes:**

- It is recommended to touch the plus mark using a touch pen with a fine tip.
- Calibration is performed at the touched position. Therefore, touch the center of the plus mark properly.

- (3) When circle marks are displayed, keep touching the center of the marks with your fingers in the following order.  
After a few seconds have passed, the next circle marks are displayed.

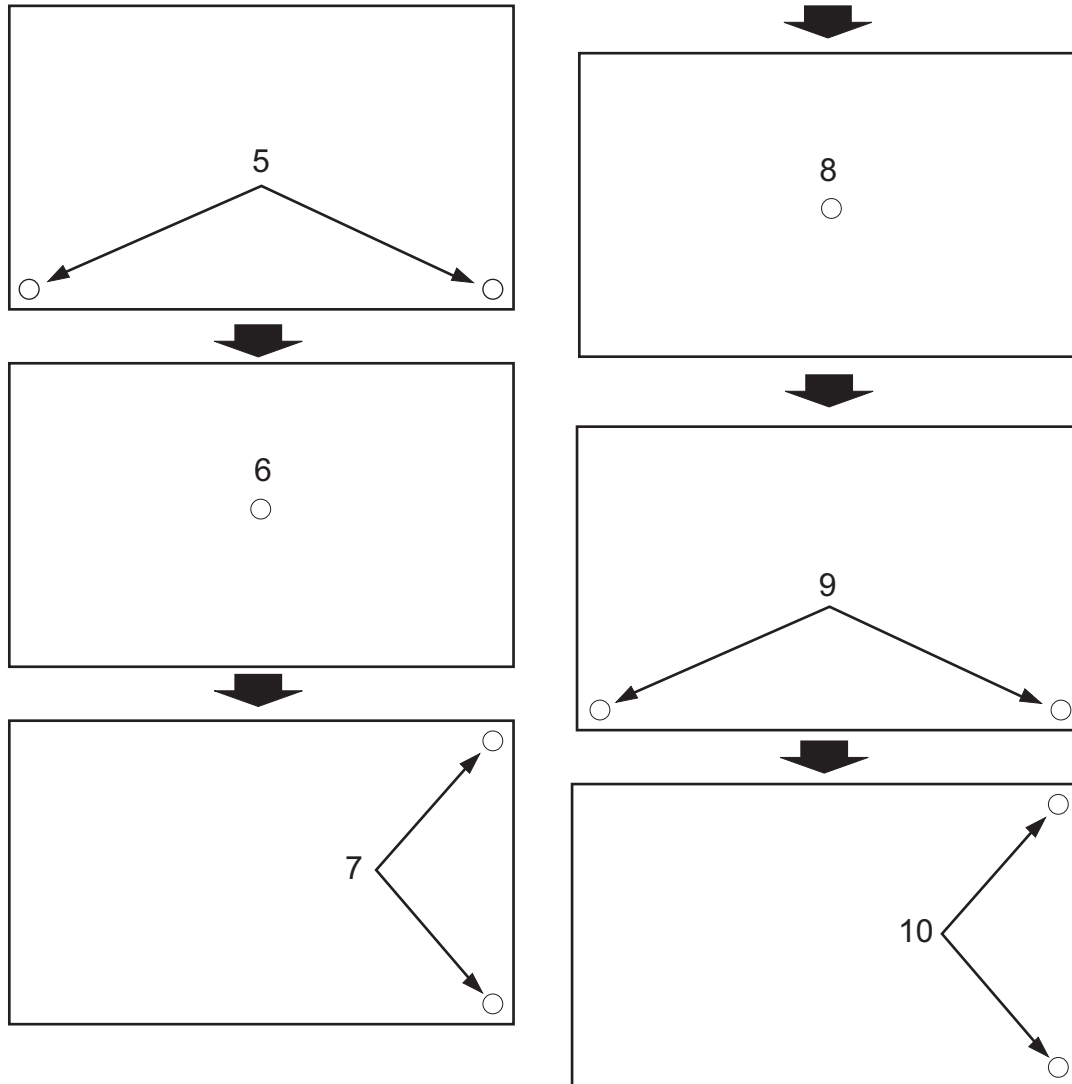


Fig.6-57

**Notes:**

- When two circle marks are displayed, touch them simultaneously.
- Calibration is performed at the touched position. Therefore, touch the circle marks properly.



(4) After all the marks are touched, the following screen appears and then calibration is completed.

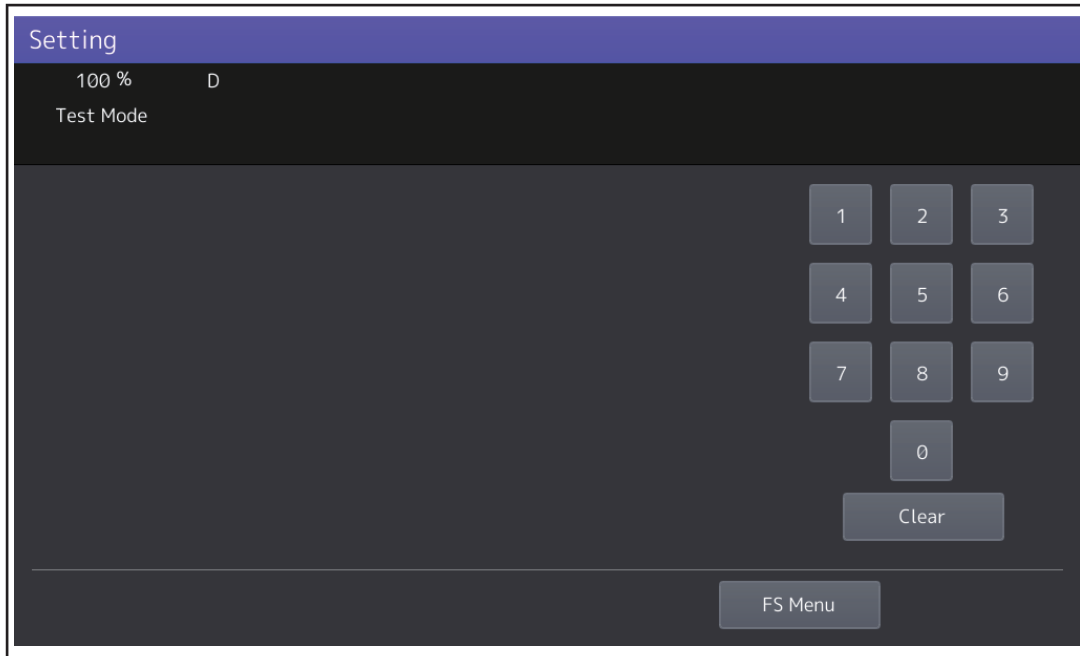


Fig.6-58

## 6.12 Adjustment of the DSDF

### 6.12.1 Adjustment of position

Perform this adjustment when the DSDF is not installed in the correct position.

**Notes:**

Check if the image adjustment for the equipment is performed properly before this adjustment of the DSDF. (See the Service Manual of the applicable equipment.)

**[A] Checking**

- (1) Open the DSDF and install 2 positioning pins.

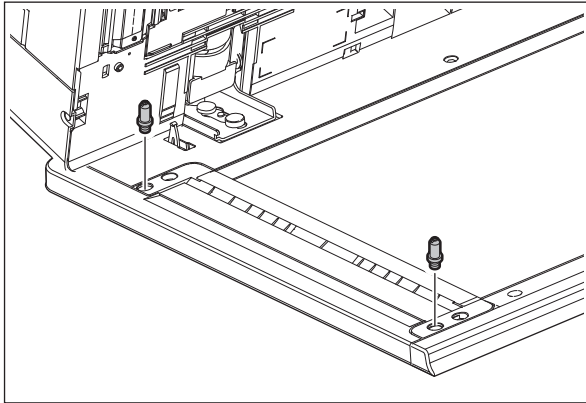


Fig.6-59

- (2) Remove the platen sheet.

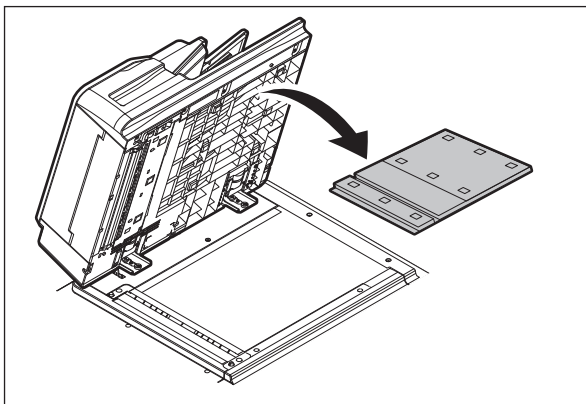



Fig.6-60

- (3) Close the DSDF and check if the positioning pins fit the holes on the DSDF.

**Notes:**

If the positioning pins cannot be fitted into the holes on the DSDF properly, go to  P. 6-74 “[B] Adjustment” to adjust the position of the DSDF and then install it.

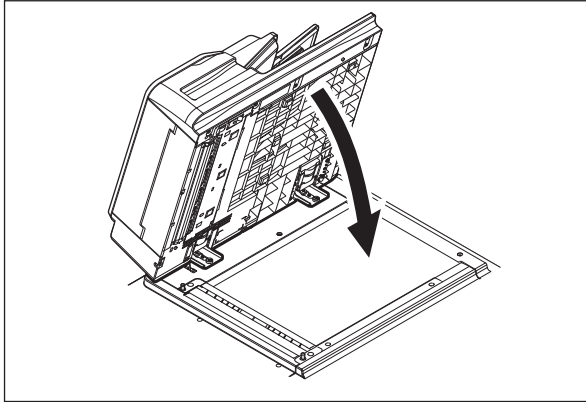


Fig.6-61

- (4) Place the platen sheet on the original glass and align it to the top left corner. Close the DSDF gently and open it to check if the platen sheet is attached properly.

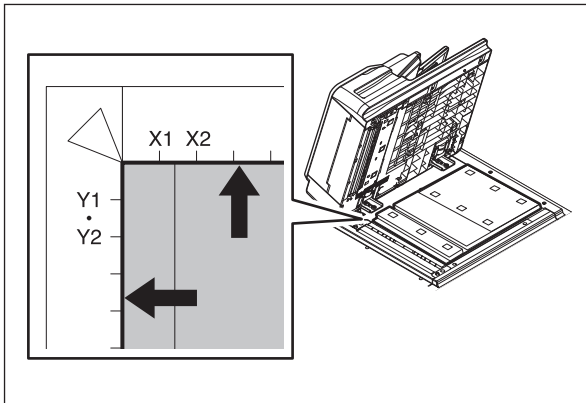


Fig.6-62

## [B] Adjustment

If the pins cannot be fitted into the holes, perform the adjustment according to the following procedure.

- (1) Remove the brackets on the hinges.

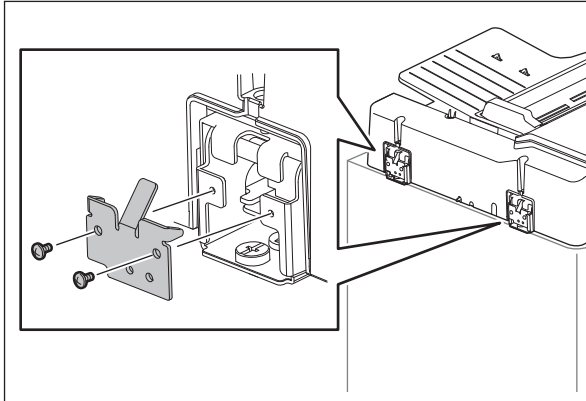


Fig.6-63

- (2) Loosen fixing screws.

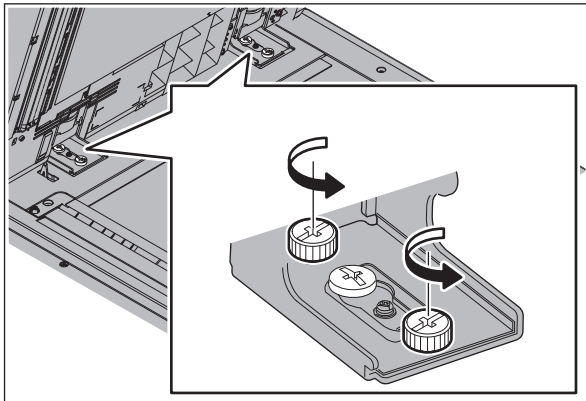


Fig.6-64

- (3) Position the pins with the holes on the DSDF by moving it so that the pins fit into the holes when the DSDF is closed.

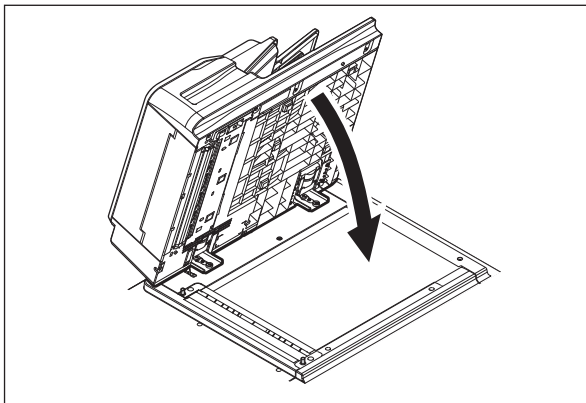


Fig.6-65

(4) Tighten the fixing screws of the rear side.

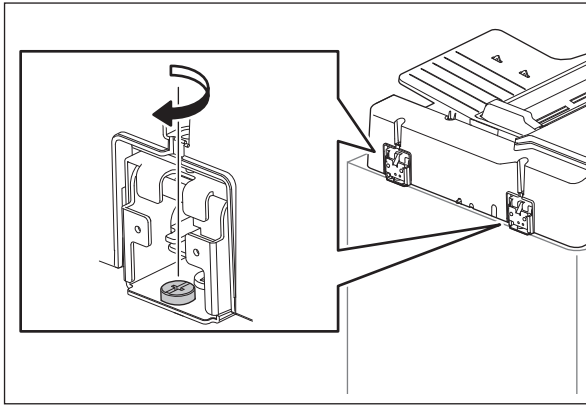


Fig.6-66

(5) Tighten the fixing screws of the front side.

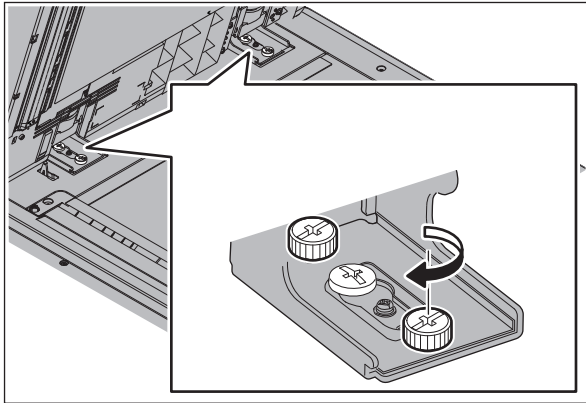


Fig.6-67

(6) Install the brackets on the hinges.

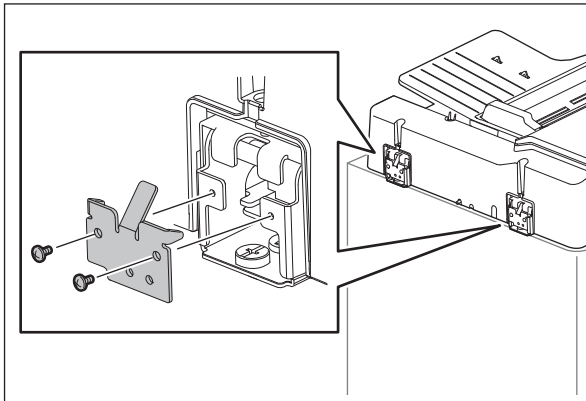
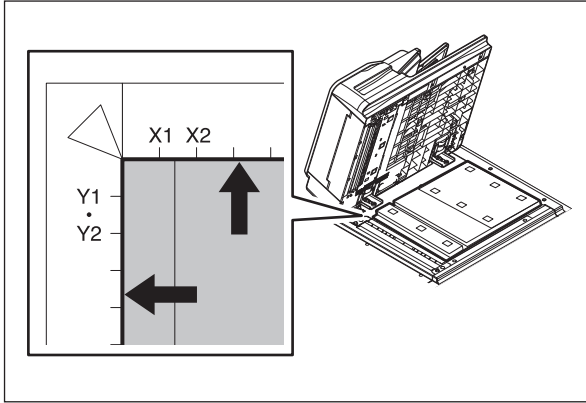


Fig.6-68

- (7) Place the platen sheet on the original glass and align it to the top left corner.  
Close the DSDF gently and open it to check if the platen sheet is attached properly.



**Fig.6-69**

## 6.12.2 Adjustment of height

### Notes:

Check if the image adjustment for the equipment is performed properly before this adjustment of the DSD. (See the Service Manual of the applicable equipment.)

### [A] Checking

- (1) Close the DSD.
- (2) Light the exposure lamp.  
Perform FS-03-267.
- (3) Visually check the gap between platen guide holder "A" and upper surface of the cover "B" from the left hand side of the equipment. If the value is not within the tolerance, perform the adjustment according to the following procedure.

[Tolerance of the gap]

Rear side: 0 - 0.5 mm

Front side: 0 mm

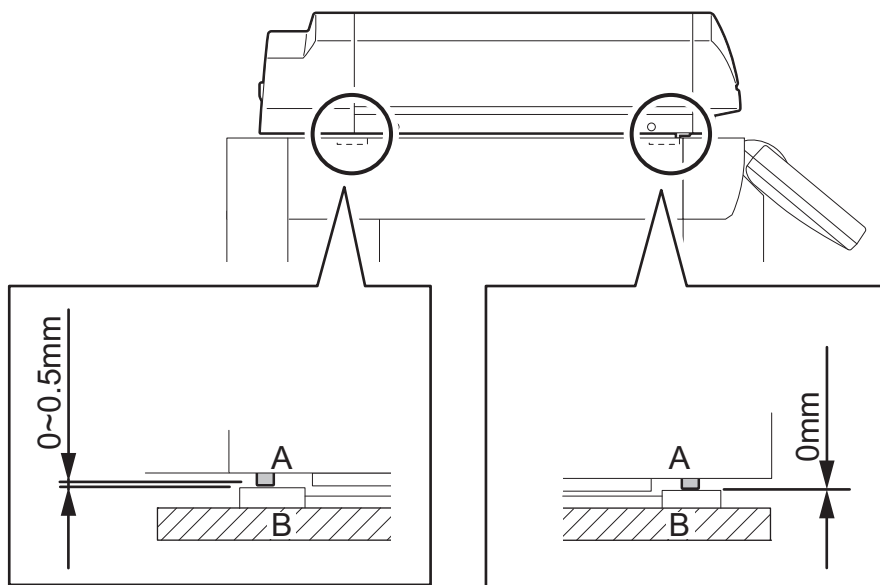


Fig.6-70

## [B] Adjustment

- (1) Close the DSDF.
- (2) Adjust it by turning the adjustment screws on the hinges.
  - Adjust the height on the rear side by means of the screw on the hinge on the feed side of the DSDF.

Turn it clockwise: Heightened

Turn it counterclockwise: Lowered

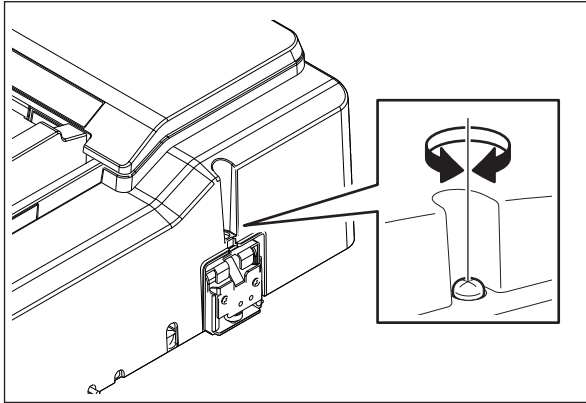


Fig.6-71

- Adjust the gap on the front side by means of the screw on the hinge on the exit side of the DSDF.

Turn it clockwise: Lowered

Turn it counterclockwise: Heightened

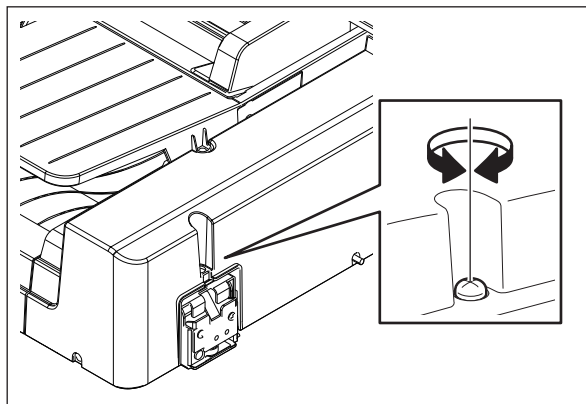


Fig.6-72



### 6.12.3 Adjustment of skew

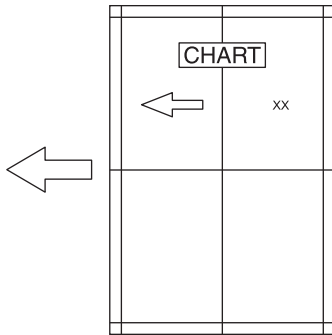
**Notes:**

- Check if the image adjustment for the equipment is performed properly before this adjustment of the DSDF. (See the Service Manual of the applicable equipment.)
- The DSDF position adjustment shall be adjusted properly.

**[A] Checking**

Check the image using the chart (original) with vertical and horizontal lines in the following procedure.

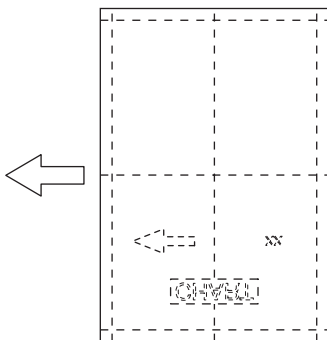
Simplex (front side) copying



**Fig.6-73**

- (1) Place the chart provided as an original with its face up on the original tray of the DSDF, select [Sort mode] and [1 -> 1 Simplex] and then press the [START] button.
- (2) Superimpose the chart on the copy and check the inclination of the copy image.

Duplex (back side) copying



**Fig.6-74**

- (1) Place the chart provided as an original with its face down on the original tray of the DSDF, select [Sort mode] and [2 -> 2 Duplex] and then press the [START] button.
- (2) Superimpose the chart on the copy and check the inclination of the copy image.

## [B] Adjustment

### Simplex (front side) copying

- (1) Change the fixing screws of the front side to the shoulder head screw (service parts).

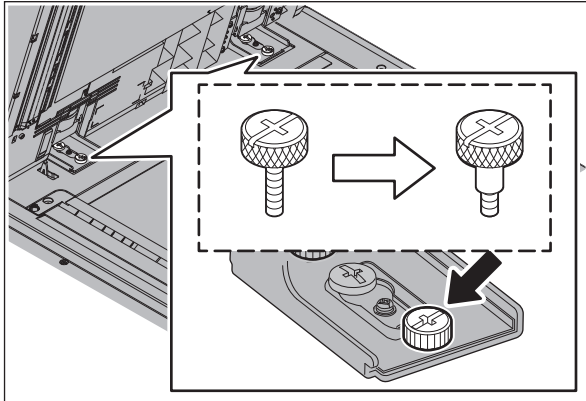


Fig.6-75

- (2) Turn the adjustment screw while checking the scale of the hinge.

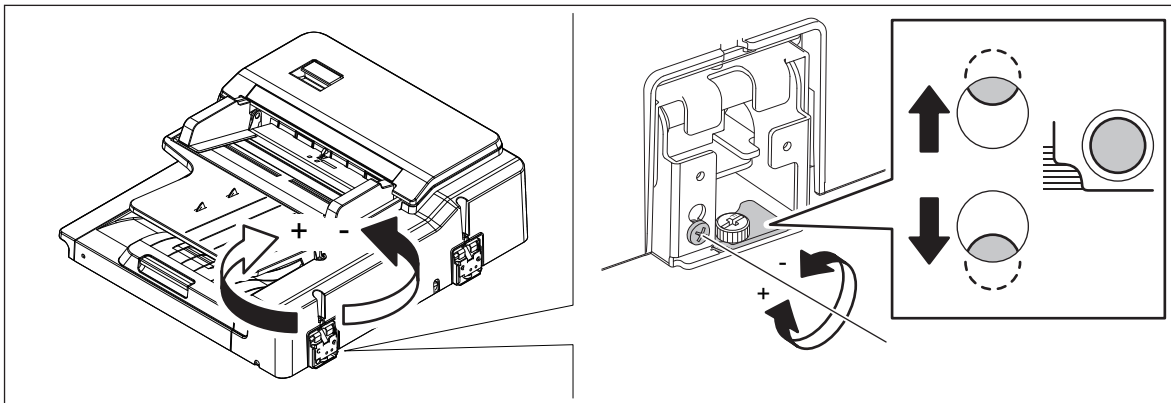


Fig.6-76

- (3) If the image skew is "C" as shown in the figure below, shift the aligning plate in the direction of "-", and if "D", shift it to "+".

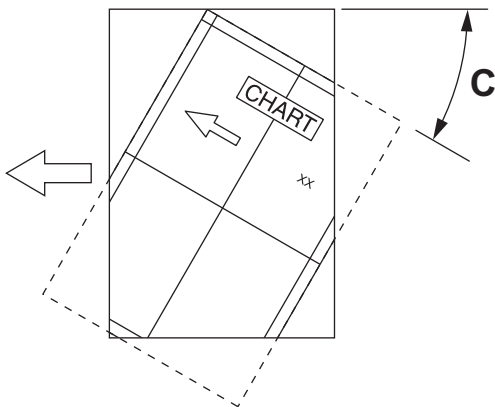


Fig.6-77

Shift the aligning plate in the direction of "-".

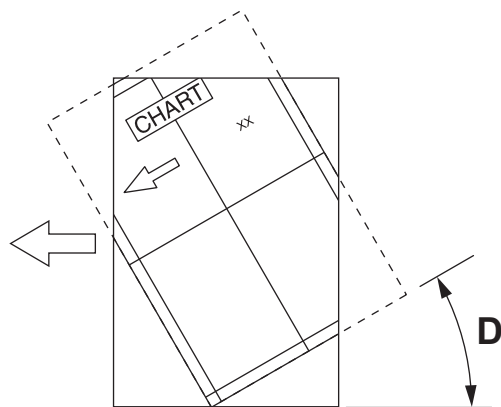


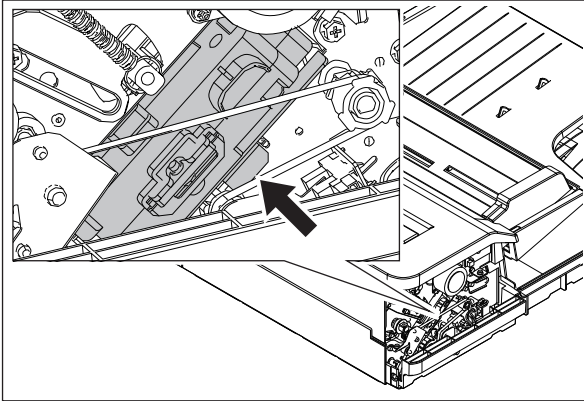
Fig.6-78

Shift the aligning plate in the direction of "+".

- (4) Check the skew of the copy image by using a chart.

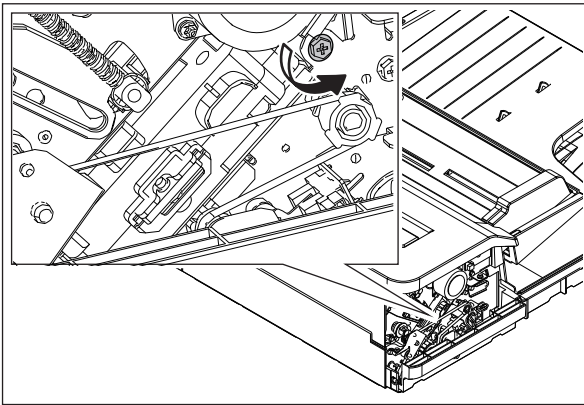
**Duplex (back side) copying**

- (1) Remove the DSDF front side cover. (Refer to the service manual of applicable model.)
- (2) Clarify the attachment position of the plate by drawing a marking-off line.



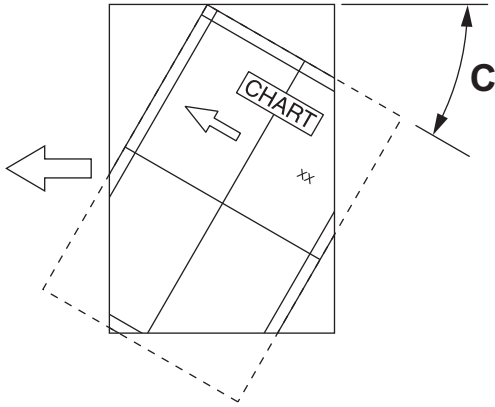
**Fig.6-79**

- (3) Loosen 1 screw.

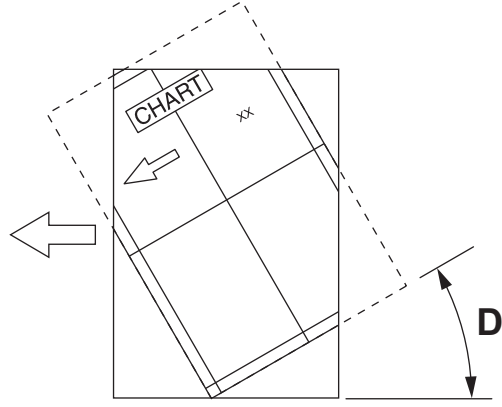


**Fig.6-80**

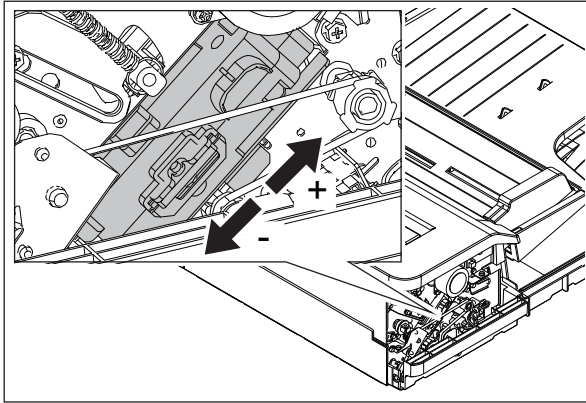
- (4) If the image skew is "C" as shown in the figure below, shift the aligning plate in the direction of "-", and if "D", shift it to "+".



**Fig.6-81**  
Shift the aligning plate in the direction of "-".



**Fig.6-82**  
Shift the aligning plate in the direction of "+".



**Fig.6-83**

- (5) Tighten the screw loosened in step (3). Check the skew of the copy image by using a chart.  
 (6) Install the DSDF front side cover.

## 6.12.4 Adjustment of the leading edge position

### Notes:

Check if the image adjustment for the equipment is performed properly before this adjustment of the DSDF. (See the Service Manual of the applicable equipment.)  
Also, the DSDF position and height shall be adjusted properly.

### [A] Checking

Check the image using the chart (original) with vertical and horizontal lines in the following procedure.

#### Simplex (front side) copying

- (1) Place the chart provided as an original with its face up on the original tray of the DSDF, select [Sort mode] and [1 -> 1 Simplex] and then press the [START] button.
- (2) Superimpose the chart on the copy and check the leading edge E of the chart and F of the copy.

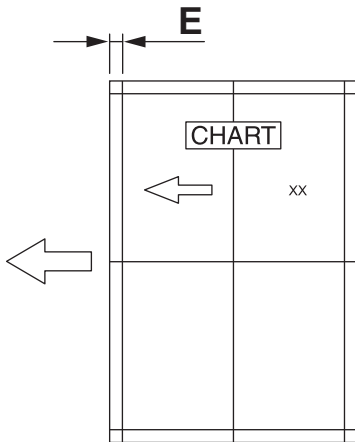


Fig.6-84 Chart (Original)

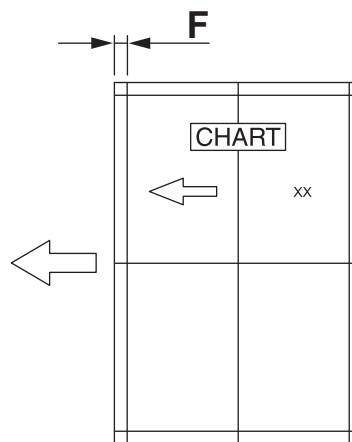


Fig.6-85 Copy

#### Duplex (back side) copying

- (1) Place the chart provided as an original with its face down on the original tray of the DSDF, select [Sort mode] and [2 -> 2 Duplex] and then press the [START] button.
- (2) Superimpose the chart on the copy and check the leading edge E of the chart and F of the copy.

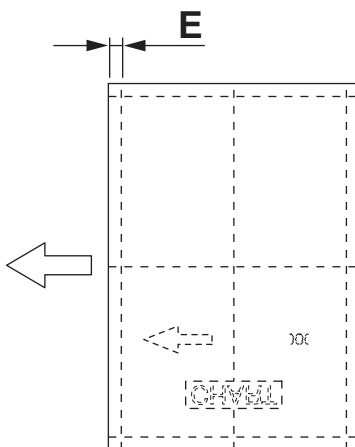


Fig.6-86 Chart (Original)

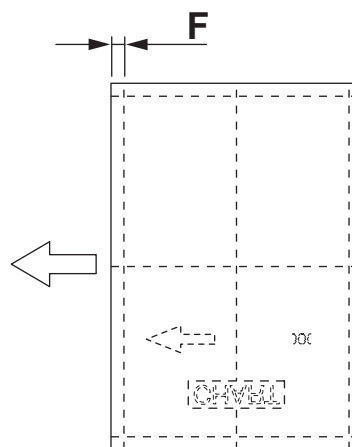


Fig.6-87 Copy

## **[B] Adjustment**

### Simplex (front side) copying

- (1) Perform FS-05-3044.
- (2) Enter the value.

#### **Notes:**

Changing one value shifts the copy image by 0.1 mm.

- If the leading edge (F) margin of the copy image is larger than the (E) margin of the chart, enter a value smaller than the current one.
- If the leading edge (F) margin of the copy image is smaller than the (E) margin of the chart, enter a value larger than the current one.

- (3) Press [OK].

### Duplex (back side) copying

- (1) Perform FS-05-3045.

- (2) Enter the value.

- If the leading edge (F) margin of the copy image is larger than the (E) margin of the chart, enter a value smaller than the current one.
- If the leading edge (F) margin of the copy image is smaller than the (E) margin of the chart, enter a value larger than the current one.

#### **Notes:**

Changing one value shifts the copy image by 0.1 mm.

- (3) Press [OK].

## 6.12.5 Adjustment of horizontal position

### Notes:

Check if the image adjustment for the equipment is performed properly before this adjustment of the DSDF.

(See the Service Manual of the applicable equipment.)

Also, the DSDF position and height shall be adjusted properly.

### [ 1 ] Front side

#### [A] Checking (Front side)

Check the image using the chart (original) with a center line in the following procedure.

- (1) Place the chart provided as an original with its face up on the original tray of the DSDF.
- (2) Select the [Sort mode] and press the [START] button.
- (3) Fold the copy in half and check if the center line is misaligned.

#### [B] Adjustment (Front side)

- (1) Perform FS-05-3043.
  - If the center line of the copy image is shifted to the front side of the equipment, enter a value larger than the current one.

### Notes:

Changing one value shifts the copy image by 0.0423 mm.

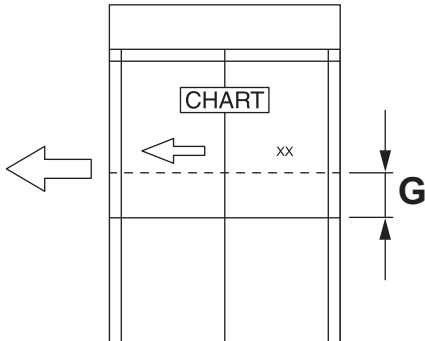


Fig.6-88

- If the center line of the copy image is shifted to the rear side of the equipment, enter a value smaller than the current one.

### Notes:

Changing one value shifts the copy image by 0.0423 mm.

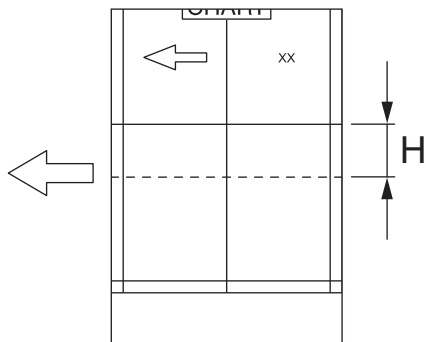


Fig.6-89

- (2) Press [OK].

## [ 2 ] Back side

### [A] Checking (back side)

Check the image using the chart (original) with a center line in the following procedure.

- (1) Place the chart provided as an original with its face down on the original tray of the DSDF.

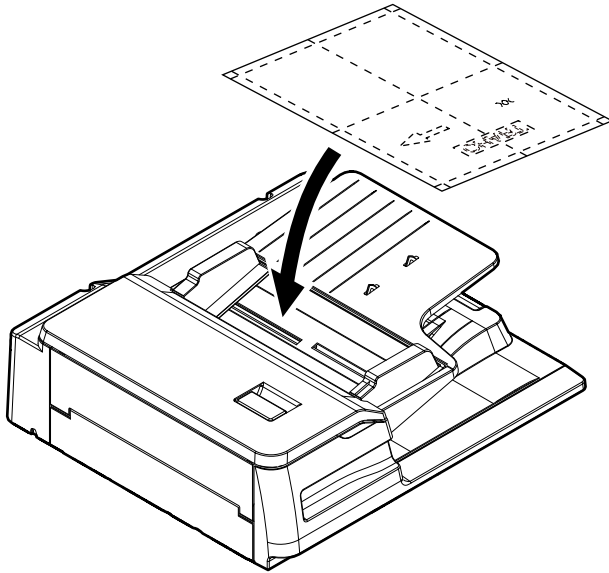


Fig.6-90

- (2) Select [2 Sided -> 1 Sided] and press the [START] button.
- (3) Fold the copy in half and check if the center line is misaligned.

### [B] Adjustment (Back side)

- (1) Perform FS-05-3049.

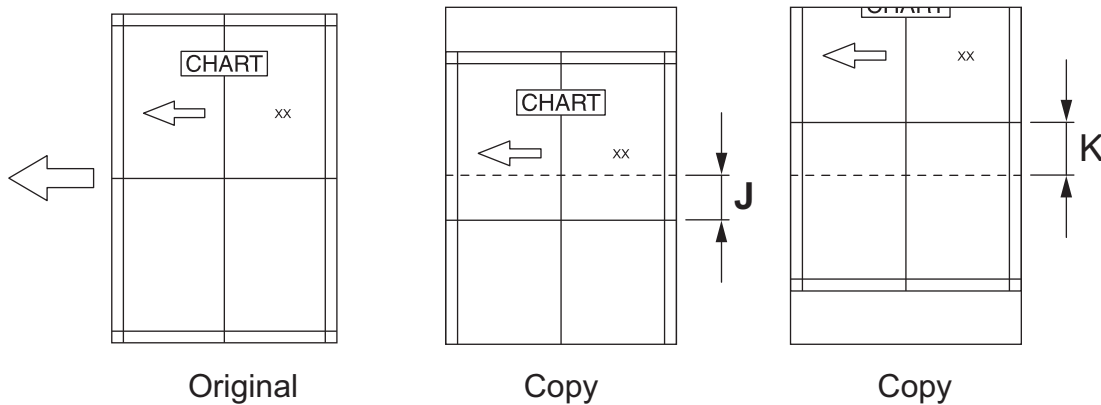


Fig.6-91

- If the center line of the copy image is shifted to the right side to the feeding direction (J), enter a value larger than the current one.
- If the center line of the copy image is shifted to the left side to the feeding direction (K), enter a value smaller than the current one.

#### Notes:

Changing one value shifts the copy image by 0.0423mm.

- (2) Press [OK].



## 6.12.6 Adjustment of copy ratio

### Notes:

Check if the image adjustment for the equipment is performed properly before this adjustment of the DSDF.

(See the Service Manual of the applicable equipment.)

Also, the DSDF position and height shall be adjusted properly.

### [A] Checking

Check the image using the chart (original) with vertical and horizontal lines in the following procedure.

- (1) Place the chart provided as an original with its face up on the original tray of the DSDF.
- (2) Select the [Sort mode] and press the [START] button.
- (3) Superimpose the chart on the copy and check the image dimension "l".

### [B] Adjustment

- (1) Perform FS-05-3042.
  - If the copy image dimension "l" is larger than the chart dimension, enter a value smaller than the current one.
  - If the copy image dimension "l" is smaller than the chart dimension, enter a value larger than the current one.

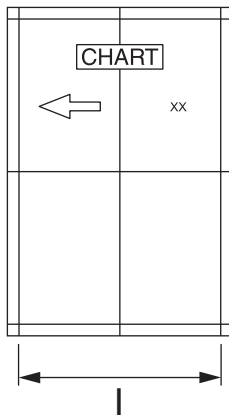


Fig.6-92

- (2) Press [OK].

## 6.12.7 DSDF read-in sensor-1 adjustment

### [A] DSDF read-in sensor-1 automatic adjustment

**Notes:**

When the DSDF control PC board or the DSDF read-in sensor-1 is replaced, be sure to perform this adjustment.

If not, paper jams (E721, E725, E774) or operational problems may occur.

- (1) Perform FS-05-3210.

**Notes:**

- Be sure to close all of the DSDF cover before the adjustment is performed.
- Check that there is no paper on the DSDF read-in sensor-1 so that the light is not shielded.

### [B] DSDF read-in sensor-1 manual adjustment

**Notes:**

When the DSDF read-in sensor-1 is replaced or re-installed, perform this manual adjustment.

- (1) Take off the DSDF left cover. (Refer to the service manual of applicable model.)
- (2) Close the original jam access cover and the DSDF.
- (3) Perform FS-05-3221.

**Notes:**

Be sure not to close or open the original jam access cover and the DSDF until step (5) is finished. If you do so, the adjustment value will be reset. In this case, repeat the adjustment from step (2).

- (4) Loosen 1 prism adjustment screw.

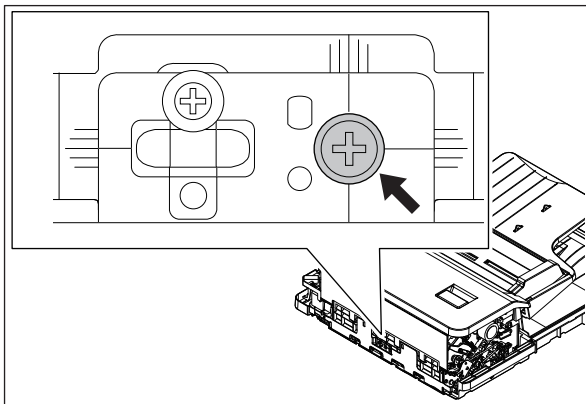


Fig.6-93

- (5) Slide the prism vertically. When the prism comes to the proper adjustment position, LED1 on the DSDF control PC board lights. At this position, tighten 1 prism adjustment screw.

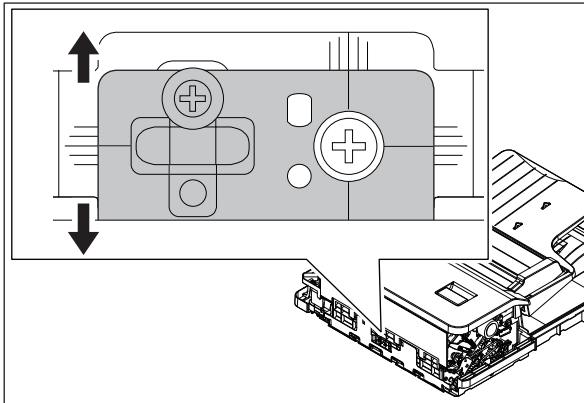


Fig.6-94

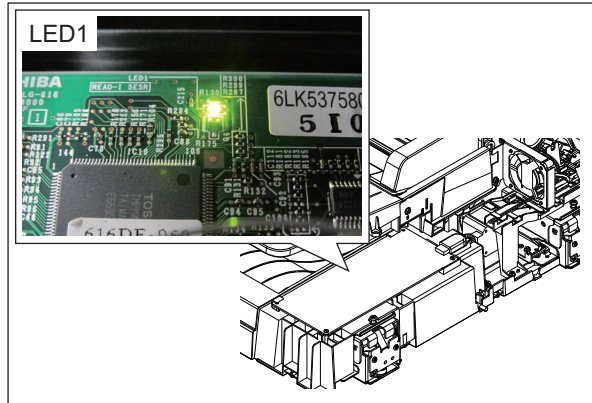


Fig.6-95

- (6) Perform automatic adjustment (FS-05-3210).

**Notes:**

After the manual adjustment is performed, be sure to do the automatic one.

- (7) Turn the power OFF and install the cover.

## 6.12.8 Platen sheet

If a shadow-like dark area appears on the edge of the image, reset the platen sheet.

- (1) Open the RADF and remove the platen sheet.

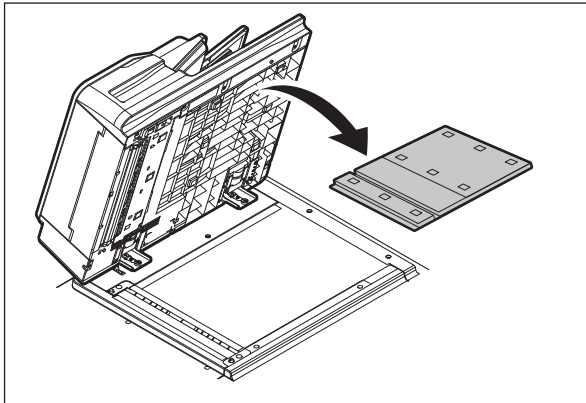


Fig.6-96

- (2) Place the platen sheet on the original glass and align it to the top left corner. Close the DSDF gently and open it to check if the platen sheet is attached properly.

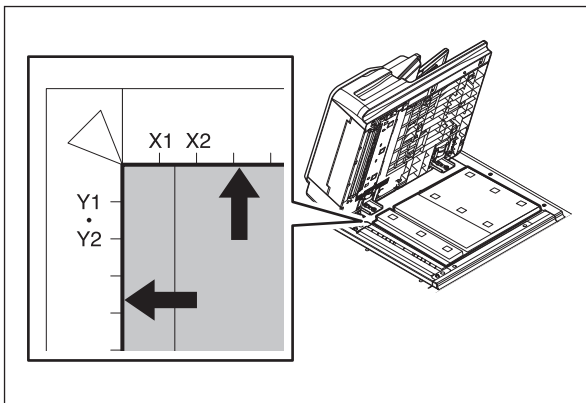


Fig.6-97

## 6.12.9 DSDF separation roller pressure force adjustment

In some cases the life of the separation roller may be shortened or paper jams (E712, E721) and multiple feeding (E724) may occur regardless of the operation frequency of the DSDF. This comes from the weight or edge status of paper used and the amount of paper dust.

Generally paper jams and multiple feeding often occur as the life end of the roller approaches.

However, if they often occur even though its life has not yet reached its replacement timing, or if the life end comes much earlier than the scheduled replacement timing, the jams and multiple feeding can be suppressed by adjusting the pressure force of the separation roller.

In this method; however, when the roller life becomes longer, jams and multiple feeding may occur frequently, and when the jams and multiple feeding are suppressed, the roller life may become shorter. Therefore, perform this adjustment while checking the status carefully, and if necessary, give a sufficient explanation to users.

- (1) Remove the DSDF pickup unit [1].
- (2) Open the DSDF separation roller cover [1].

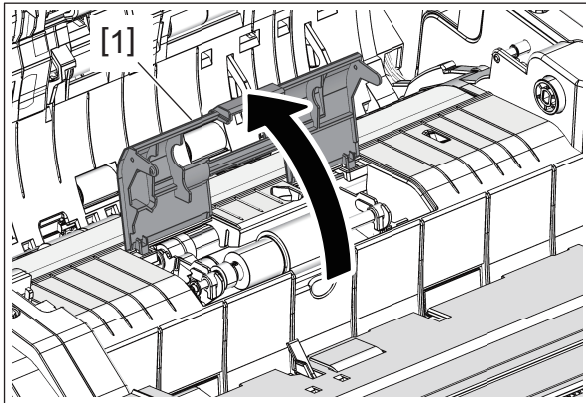


Fig.6-98

- (3) Turn the arm [2] to release the lock.

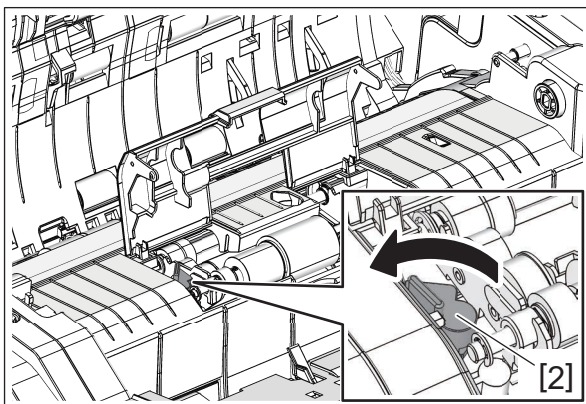


Fig.6-99

(4) Lift up the DSDF separation roller unit [3].

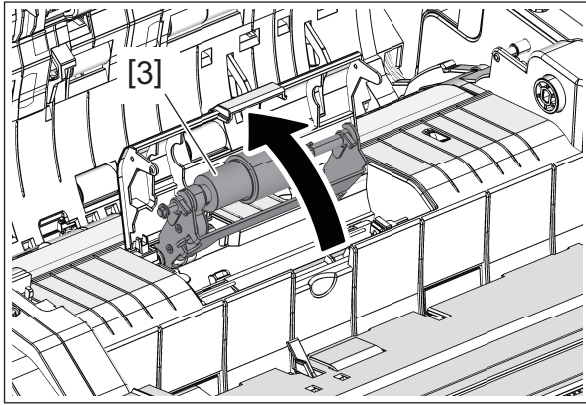


Fig.6-100

(5) Move the adjustment plate [4] in the direction of F or R by 1 scale.

- Move to the direction F: Paper jams (E712, E721) will be suppressed. The roller life will become longer (but multiple feeding may occur frequently).
- Move to the direction R: Multiple feeding will be suppressed (but the roller life may become shorter).

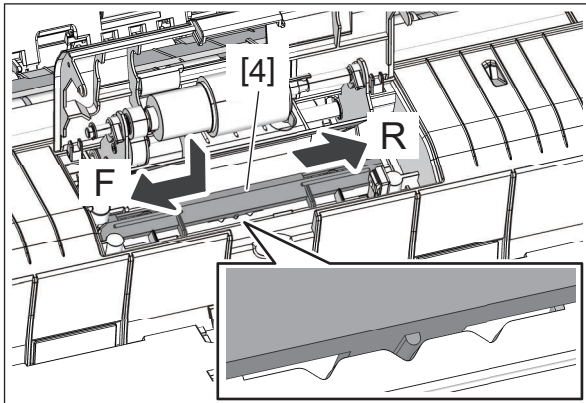


Fig.6-101

## 6.13 Adjustment of the RADF

### 6.13.1 Adjustment of RADF position

Perform this adjustment when the RADF is not installed in the correct position.

**Notes:**

Check if the image adjustment for the equipment is performed properly before this adjustment of the RADF.

**[A] Checking**

- (1) Open the RADF and install 2 positioning pins (the positioning pins are installed to the back side of the hinge which is on the left side of the RADF).

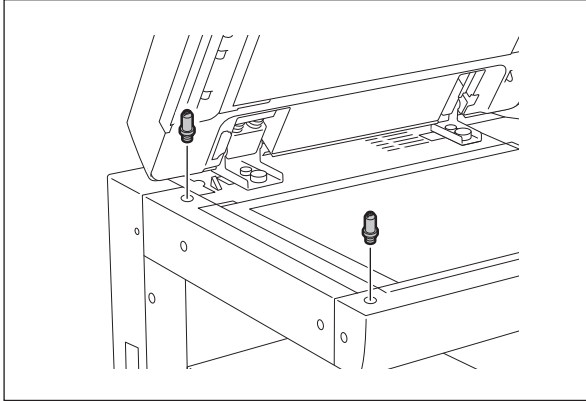


Fig.6-102

- (2) Remove the platen sheet.

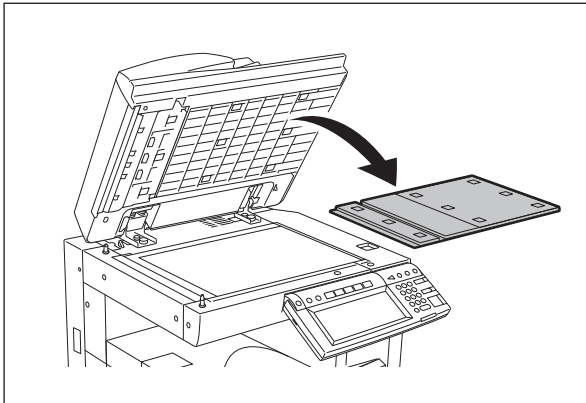


Fig.6-103

(3) Close the RADF and check if the positioning pins fit the holes on the RADF.

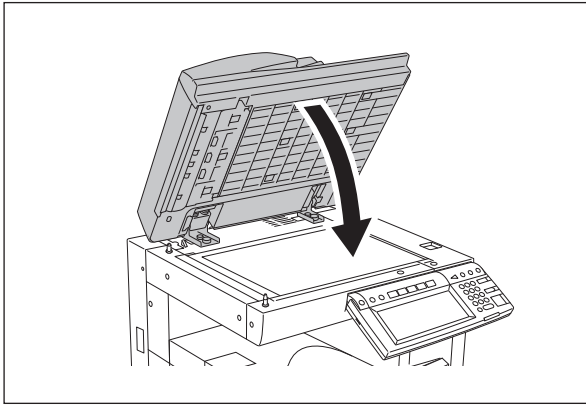


Fig.6-104

### [B] Adjustment

If the pins cannot be fitted into the holes, perform the adjustment according to the following procedure.

(1) Remove the right-hand hinge screw at the rear side.

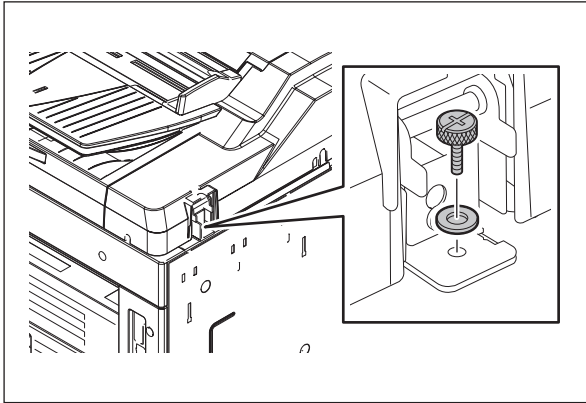


Fig.6-105

(2) Remove the bracket on the left-hand hinge.

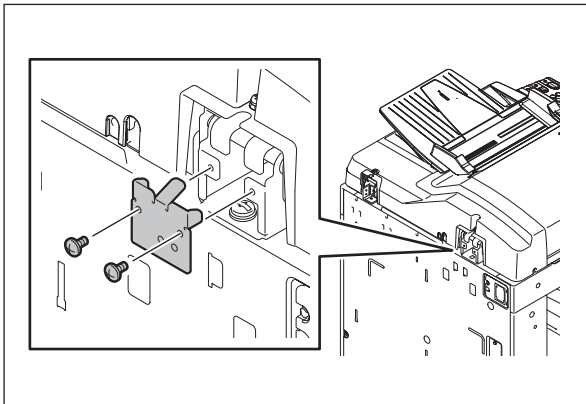


Fig.6-106



- (3) Loosen the left-hand hinge screw at the rear side.

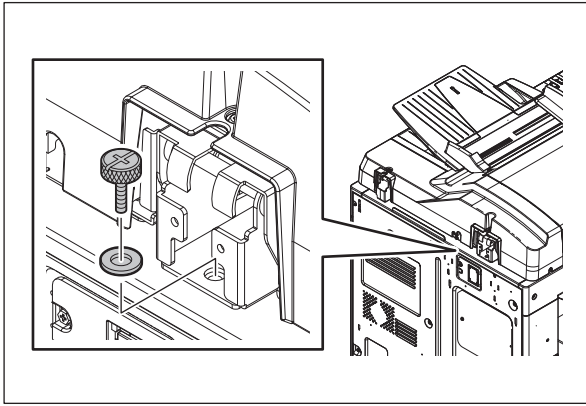


Fig.6-107

- (4) Tighten the hinge screws at the front side.

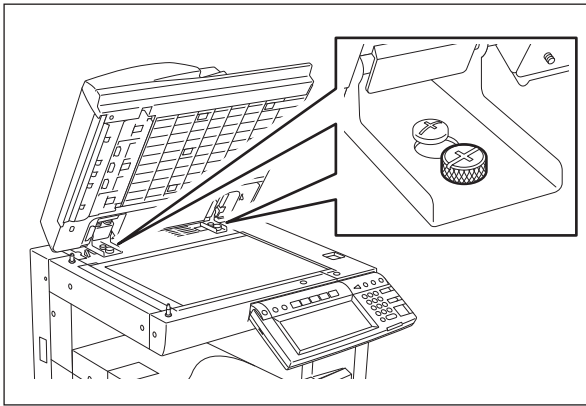


Fig.6-108

- (5) Position the pins with the holes on the RADF by moving it so that the pins fit into the holes when the RADF is closed.

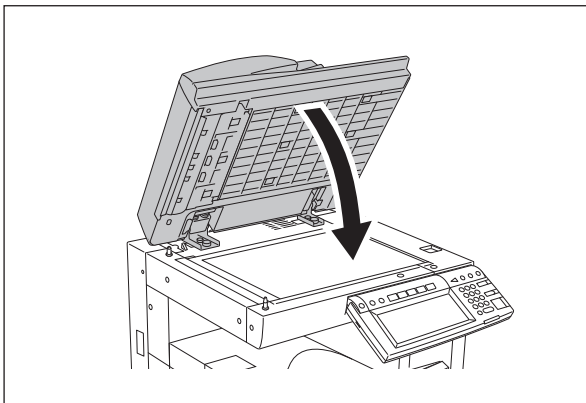


Fig.6-109

(6) Tighten the left-hand hinge screw at the rear side.

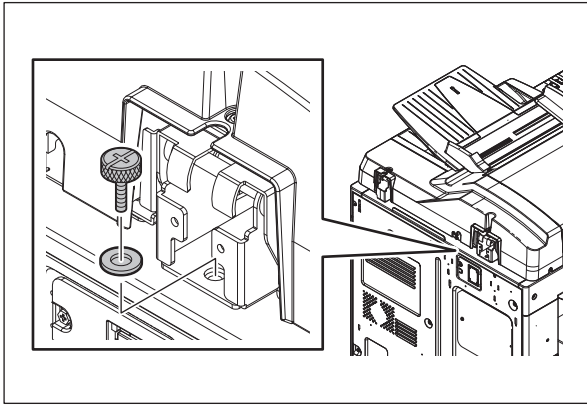


Fig.6-110

(7) Match the screw hole positions.

**Notes:**

Turn it clockwise: It moves toward the rear side.

Turn it counterclockwise: It moves toward the front side.

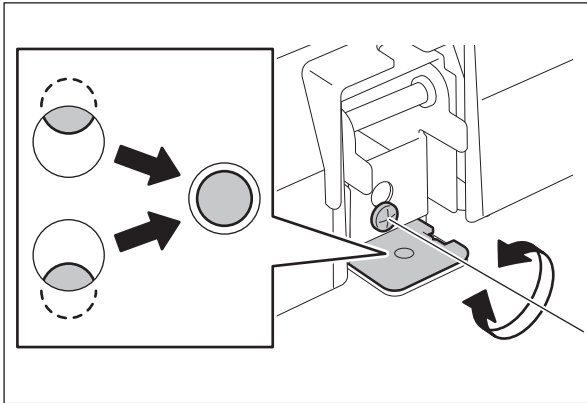


Fig.6-111

(8) Install the right-hand hinge screw at the rear side.

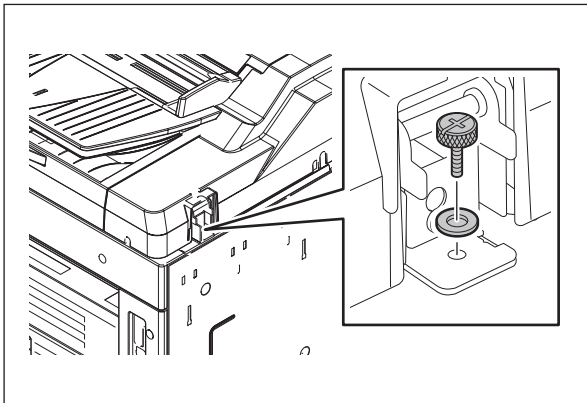


Fig.6-112

(9) Install the bracket on the left-hand hinge.

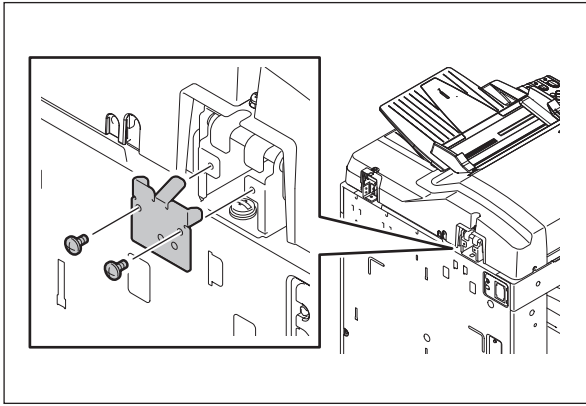


Fig.6-113

(10) Loosen the hinge screws at the front side.

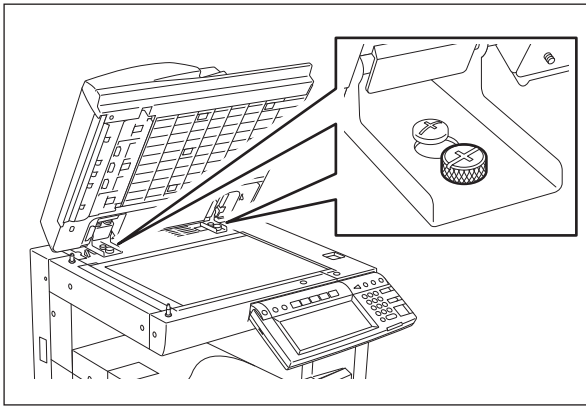


Fig.6-114

(11) Place the platen sheet on the original glass and align it to the top left corner. Close the RADF gently and open it to check if the platen sheet is attached properly.

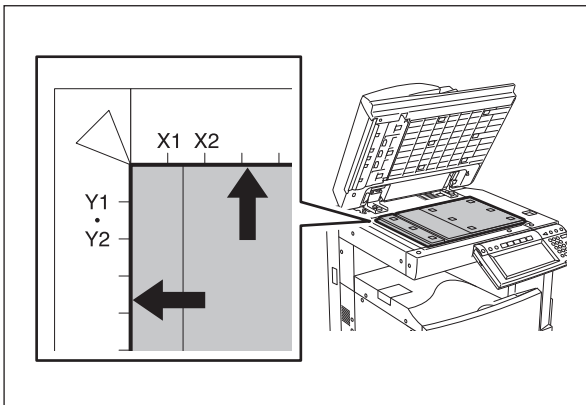


Fig.6-115

## 6.13.2 Adjustment of RADF height

### Notes:

Check if the image adjustment for the equipment is performed properly before this adjustment of the RADF.

### [A] Checking

- (1) Close the RADF.
- (2) Light the exposure lamp.
  - Perform FS-03.
  - Key in [267] and then press the [START] button. The exposure lamp is turned ON for a given length of time.
- (3) Visually check the gap between platen guide holder "A" and upper surface of the original glass "B" from the left hand side of the equipment. If the value is not within the tolerance, perform the adjustment according to the following procedure.

[Tolerance of the gap]

Rear side: 0 - 0.5 mm

Front side: 0 mm

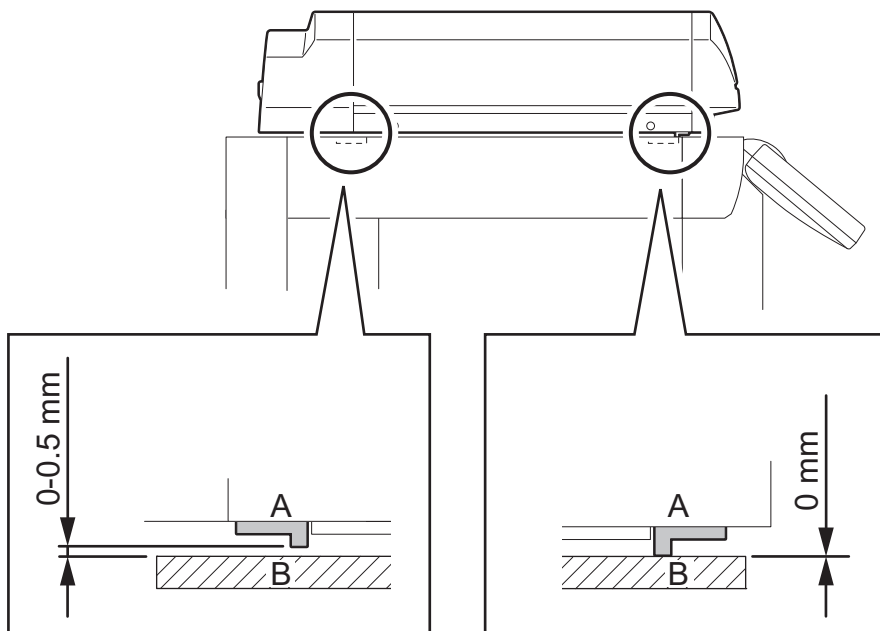


Fig.6-116

## [B] Adjustment

- (1) Close the RADF.
- (2) Adjust it by turning the adjustment screws on the hinges.
  - Adjust the height on the rear side by means of the screw on the hinge on the exit side of the RADF.

Turn it clockwise: Heightened

Turn it counterclockwise: Lowered

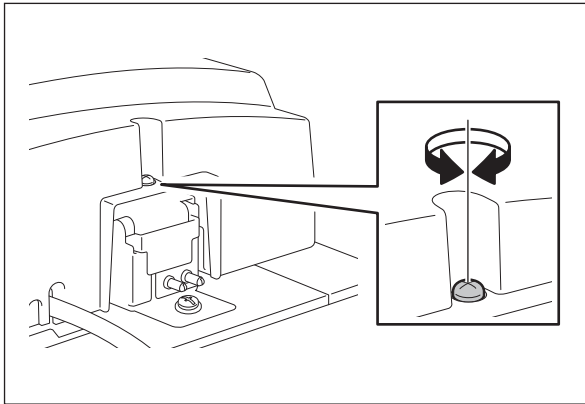


Fig.6-117

- Adjust the gap on the rear side by means of the screw on the hinge on the feed side of the RADF.

Turn it clockwise: Lowered

Turn it counterclockwise: Heightened

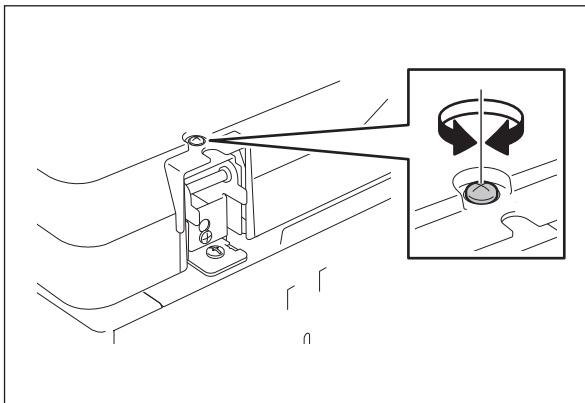


Fig.6-118

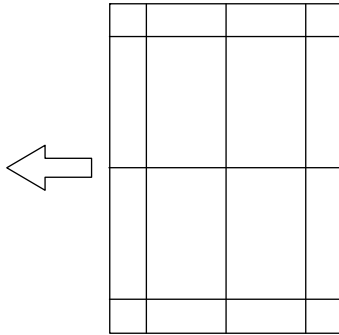
### 6.13.3 Adjustment of skew

**Notes:**

Check if the image adjustment for the equipment is performed properly before this adjustment of the RADF. Also, the RADF position and height shall be adjusted properly.

**[A] Checking**

Check the image using the chart (original) with vertical and horizontal lines in the following procedure.



**Fig.6-119 Chart (Original)**

Simplex copying:

- (1) Place the chart provided as an original with its face up on the original tray of the RADF, select [Sort] and [1 → 1 Simplex] and then press the [START] button.
- (2) Superimpose the chart on the copy and check the inclination of the copy image.

Duplex copying:

- (1) Place the chart provided as an original with its face down on the original tray of the RADF, select [Sort] and [2 → 2 Duplex] and then press the [START] button.
- (2) Superimpose the chart on the copy and check the inclination of the copy image.

## [B] Adjustment

### Simplex copying:

- (1) Shift the aligning plate with the scale as the guide shown in the figure below to adjust the skew.

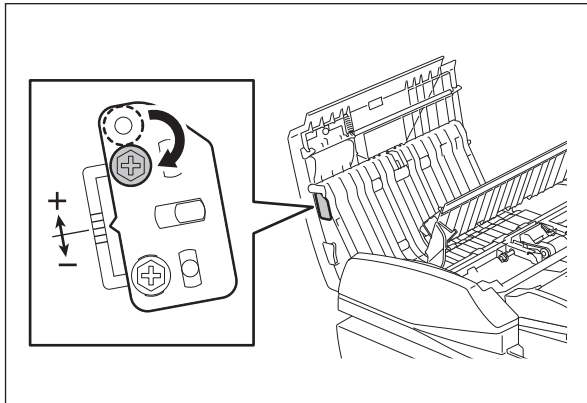


Fig.6-120

- (2) If the image skew is "C" as shown in the figure below, shift the aligning plate in the direction of "+", and if "D", shift it to "-".

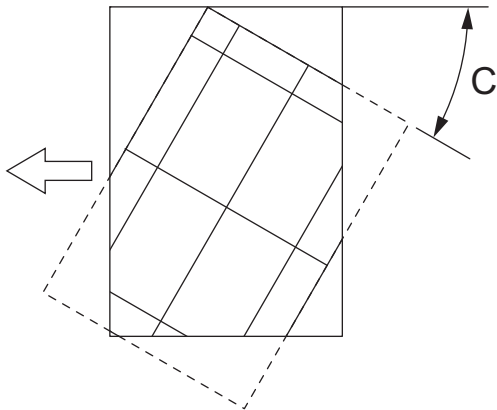


Fig.6-121

Shift the aligning plate in the direction of "+".

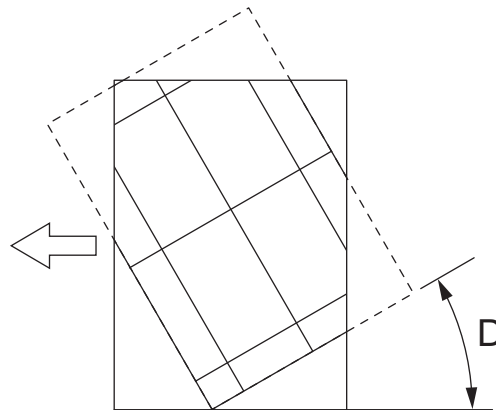


Fig.6-122

Shift the aligning plate in the direction of "-".

Duplex copying:

(1) Shift the aligning plate with the scale as the guide shown in the figure below to adjust the skew.

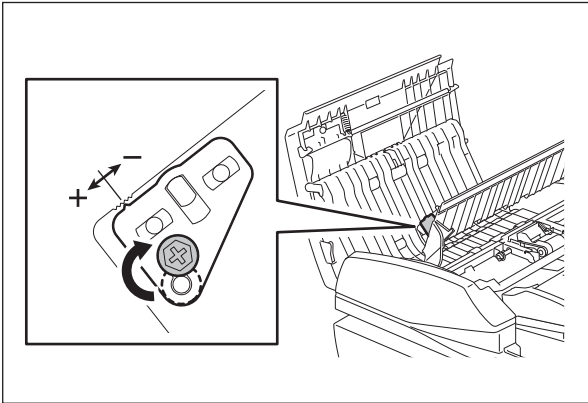


Fig.6-123

(2) If the image skew is "C" as shown in the figure below, shift the aligning plate in the direction of "-", and if "D", shift it to "+".

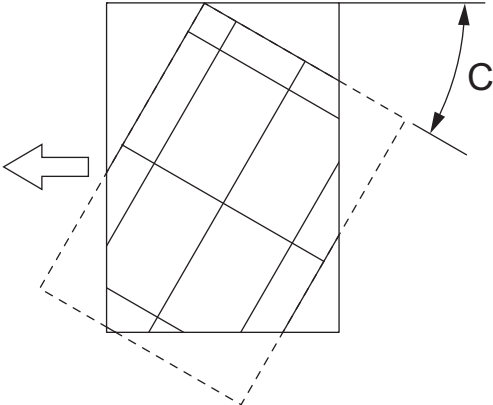


Fig.6-124  
Shift the aligning plate in the direction of "-".

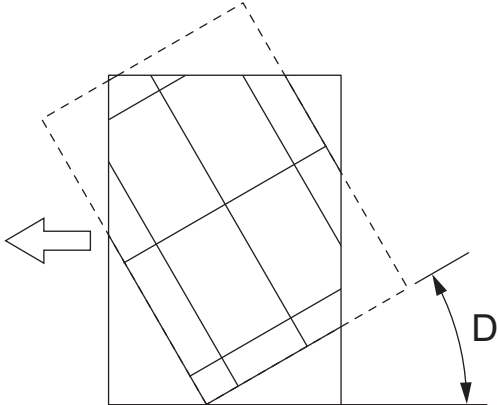


Fig.6-125  
Shift the aligning plate in the direction of "+".



## 6.13.4 Adjustment of the leading edge position

### Notes:

Check if the image adjustment for the equipment is performed properly before this adjustment of the RADF. Also, the RADF position and height shall be adjusted properly.

### [A] Checking

Check the image using the chart (original) with vertical and horizontal lines in the following procedure.

#### Simplex copying:

- (1) Place the chart provided as an original with its face up on the original tray of the RADF, select [Sort] and [1 → 1 Simplex] and then press the [START] button.
- (2) Superimpose the chart on the copy and check the leading edge E of the chart and F of the copy.

#### Duplex copying:

- (1) Place the chart provided as an original with its face down on the original tray of the RADF, select [Sort] and [2 → 2 Duplex] and then press the [START] button.
- (2) Superimpose the chart on the copy and check the leading edge E of the chart and F of the copy.

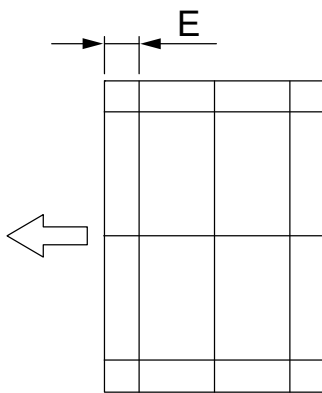


Fig.6-126 Chart (Original)

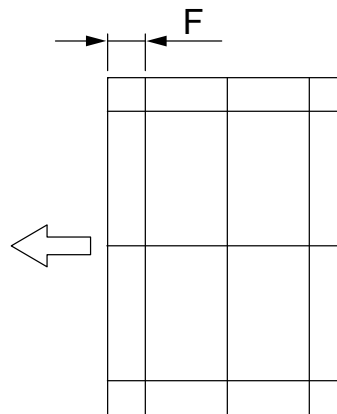


Fig.6-127 Copy

## [B] Adjustment

### Simplex copying:

- (1) Perform FS-05-3044.
- (2) Enter the value.
  - If the leading edge (F) margin of the copy image is larger than the (E) margin of the chart, enter a value smaller than the current one.

**Notes:**

Changing one value shifts the copy image by 0.1 mm.

- If the leading edge (F) margin of the copy image is smaller than the (E) margin of the chart, enter a value larger than the current one.

**Notes:**

Changing one value shifts the copy image by 0.1 mm.

- (3) Press [OK].

### Duplex copying:

- (1) Perform FS-05-3045.
- (2) Enter the value.
  - If the leading edge (F) margin of the copy image is larger than the (E) margin of the chart, enter a value smaller than the current one.

**Notes:**

Changing one value shifts the copy image by 0.1 mm.

- If the leading edge (F) margin of the copy image is smaller than the (E) margin of the chart, enter a value larger than the current one.

**Notes:**

Changing one value shifts the copy image by 0.1 mm.

- (3) Press [OK].

## 6.13.5 Adjustment of horizontal position

### Notes:

Check if the image adjustment for the equipment is performed properly before this adjustment of the RADF. Also, the RADF position and height shall be adjusted properly.

### [A] Checking

Check the image using the chart (original) with a center line in the following procedure.

- (1) Place the chart provided as an original with its face up on the original tray of the RADF.
- (2) Select the [Sort] and then press the [START] button.
- (3) Fold the copy in half and check if the center line is misaligned.

### [B] Adjustment

- (1) Perform FS-05-3043.
  - If the center line of the copy image is shifted to the front side of the equipment, enter a value larger than the current one.

### Notes:

Changing one value shifts the copy image by 0.042 mm.

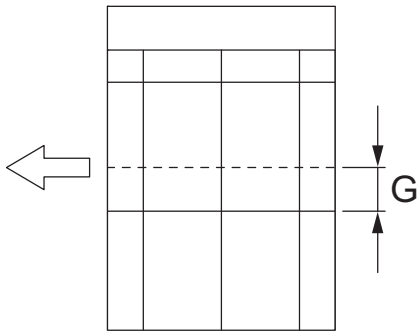


Fig.6-128

- If the center line of the copy image is shifted to the rear side of the equipment, enter a value smaller than the current one.

### Notes:

Changing one value shifts the copy image by 0.042 mm.

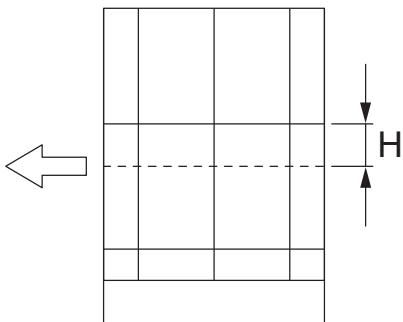


Fig.6-129

- (2) Press [OK].

## 6.13.6 Adjustment of copy ratio

### Notes:

Check if the image adjustment for the equipment is performed properly before this adjustment of the RADF. Also, the RADF position and height shall be adjusted properly.

### [A] Checking

Check the image using the chart (original) with vertical and horizontal lines in the following procedure.

- (1) Place the chart provided as an original with its face up on the original tray of the RADF.
- (2) Select the [Sort] and then press the [START] button.
- (3) Superimpose the chart on the copy and check the image dimension "l".

### [B] Adjustment

- (1) Perform FS-05-3042.
  - If the copy image dimension "l" is larger than the chart dimension, enter a value smaller than the current one.
  - If the copy image dimension "l" is smaller than the chart dimension, enter a value larger than the current one.

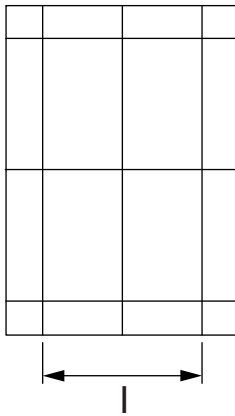


Fig.6-130

### Notes:

When the value increases by "1", the reproduction ratio of the secondary scanning direction when using the RADF increases by approx. 0.1%.

- (2) Press [OK].

## 6.13.7 RADF Separation roller pressure force adjustment

In some cases the life of the separation roller may be shortened or paper jams (E712, E721) and multiple feeding (E724) may occur regardless of the operation frequency of the equipment. This comes from the weight or edge status of paper used and the amount of paper dust.

Generally paper jams and multiple feeding often occur as the life end of the roller approaches. However, if they often occur even though its life has not yet reached its replacement timing, or if the life end comes much earlier than the scheduled replacement timing, the jams and multiple feeding can be suppressed by adjusting the pressure force of the separation roller.

In this method, however, when the roller life becomes longer, jams and multiple feeding may occur frequently, and when the jams and multiple feeding are suppressed, the roller life may become shorter. Therefore, perform this adjustment while checking the status carefully, and if necessary, give a sufficient explanation to users.

### [A] Adjustment procedure

- (1) Open the jam access cover.
- (2) Take off the paper feeder unit [1].

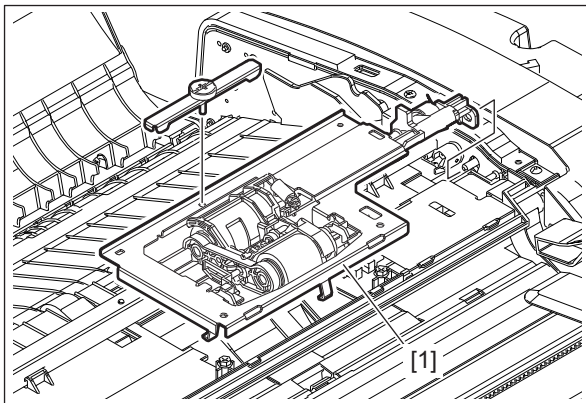


Fig.6-131

- (3) Remove 2 screws. Lift up the feeder upper guide [2] by sliding it to the right.

#### Notes:

Do not pull the harness too strong.

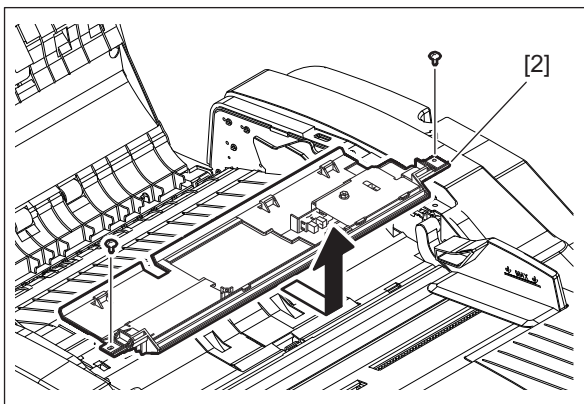


Fig.6-132

- (4) Take off the separation roller holder [3].

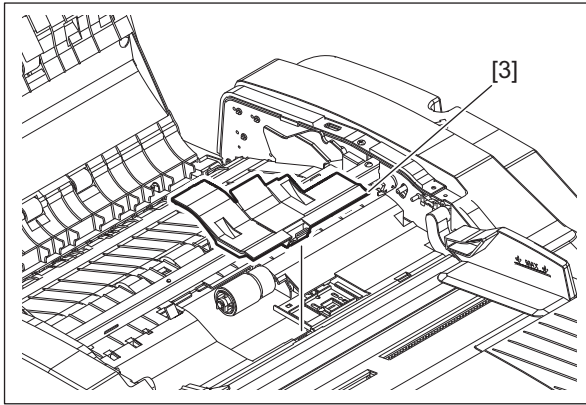


Fig.6-133

- (5) While holding the bracket [5] with your hand, remove the screw [4].

**Notes:**

When installing or taking off the bracket [5], keep it setting up because it is tensed with a spring to L direction.

- (6) Move the bracket [5].
- Move to the direction R: Paper jams (E712, E721) will be suppressed. The roller life will become longer (but multiple feeding may occur frequently).
  - Move to the direction L: Multiple feeding will be suppressed (but the roller life may become shorter).
  - The upper limit of the movement of the bracket for the adjustment is 1 scale. If the bracket is moved by 2 scales, deterioration of the pressure spring may occur.
- (7) Tighten the screw [4].

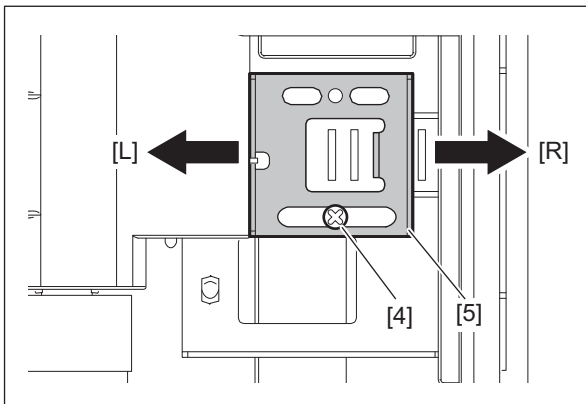


Fig.6-134

## 6.14 Adjustment of the Inner Finisher

### Notes:

- Before performing each adjustment, make sure that all covers (incl. those of the finisher and equipment) are closed. Otherwise, no power is supplied to the Finisher and the adjustment may not be performed properly.
- Do not enter a value which exceeds the range of the adjustment value. Although such value can be entered depending on the models, adjustment will be performed with the default value.

### 6.14.1 Alignment position adjustment

#### [A] Alignment position adjustment (front)

This adjustment is performed in the Adjustment Mode (FS-05-4822-0) of the equipment.

Adjustment scale	0.2mm	
Adjustable range	-3.4 mm to 3.4 mm	
Adjustment value	-17 to 17 (Default value: 0)	
Adjustment direction	Increasing the value	The alignment plate moves to the center.
	Decreasing the value	The alignment plate moves to the edge of paper.

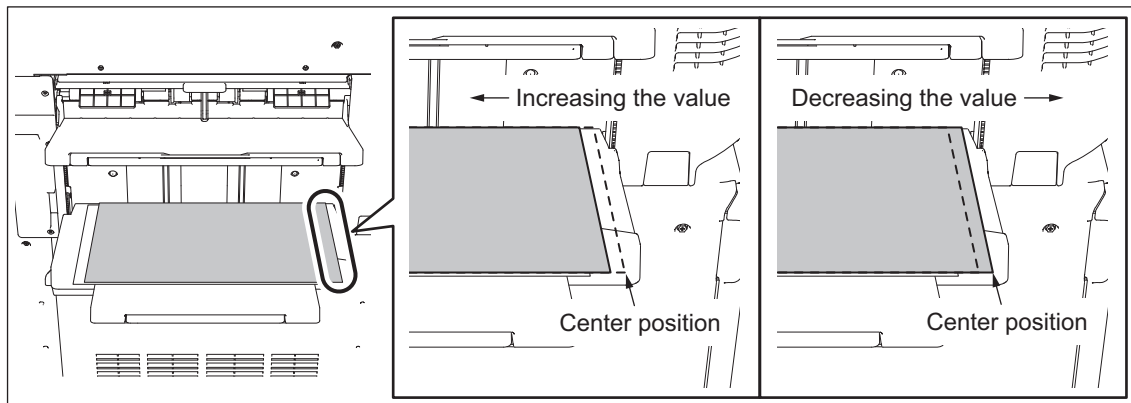


Fig.6-135

## [B] Alignment position adjustment (rear)

This adjustment is performed in the Adjustment Mode (FS-05-4822-1) of the equipment.

Adjustment scale	0.2mm	
Adjustable range	-3.4 mm to 3.4 mm	
Adjustment value	-17 to 17 (Default value: 0)	
Adjustment direction	Increasing the value	The alignment plate moves to the center.
	Decreasing the value	The alignment plate moves to the edge of paper.

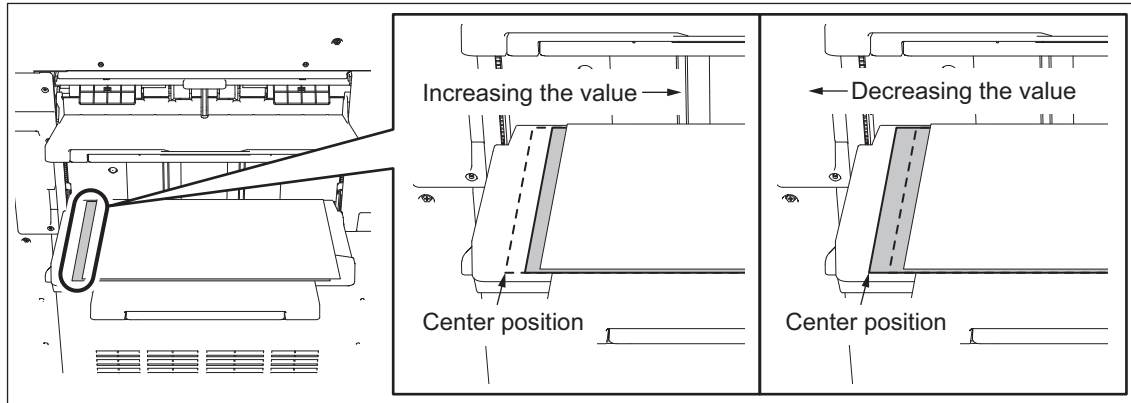


Fig.6-136

## 6.14.2 Stapling position adjustment

### [A] Stapling position adjustment (rear 1-point / paper output direction: portrait)

This adjustment is performed in the Adjustment Mode (FS-05-4823-0) of the equipment.

Adjustment scale	0.2mm	
Adjustable range	-3.4 mm to 3.4 mm	
Adjustment value	-17 to 17 (Default value: 0)	
Adjustment direction	Increasing the value	The distance between the stapling position and the edge of the paper becomes longer
	Decreasing the value	The distance between the stapling position and the edge of the paper becomes shorter.

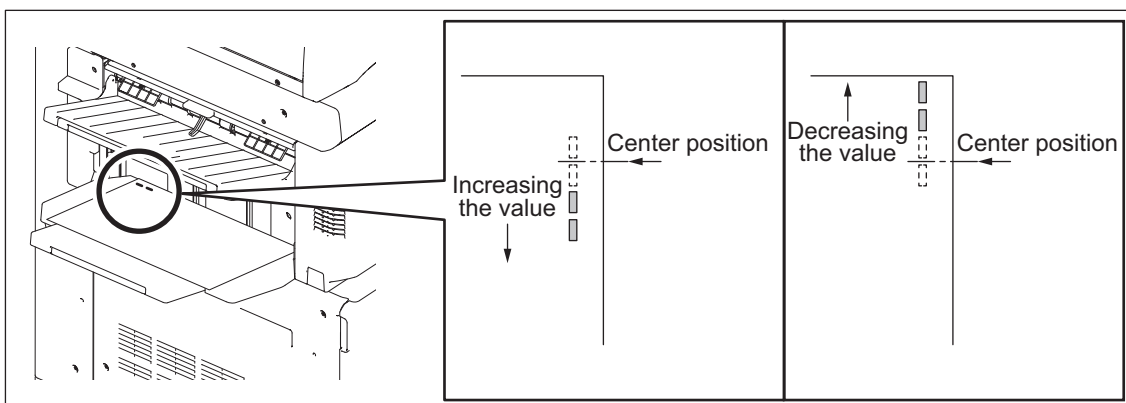


Fig.6-137



**[B] Stapling position adjustment (rear 1-point / paper output direction: landscape)**

This adjustment is performed in the Adjustment Mode (FS-05-4823-1) of the equipment.

Adjustment scale	0.2mm	
Adjustable range	-3.4mm to 3.4 mm	
Adjustment value	-17 to 17 (Default value: 0)	
Adjustment direction	Increasing the value	The distance between the stapling position and the edge of the paper becomes longer
	Decreasing the value	The distance between the stapling position and the edge of the paper becomes shorter.

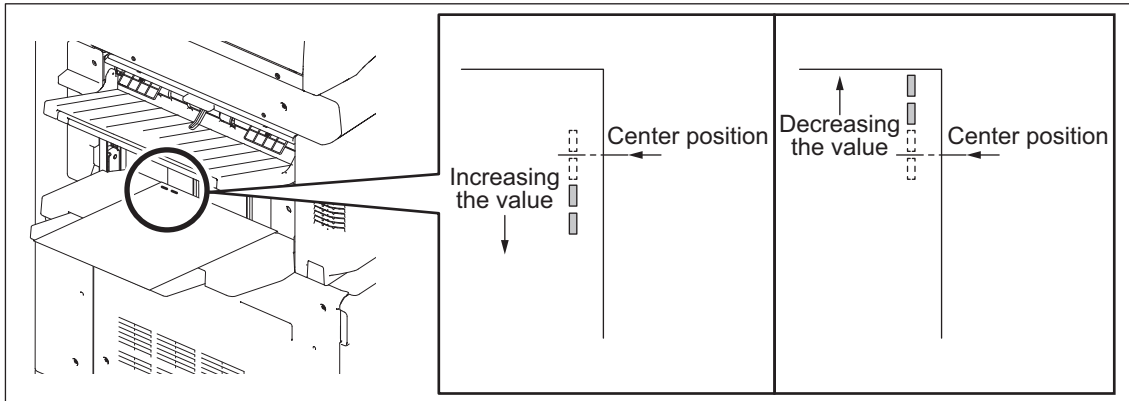


Fig.6-138

**[C] Stapling position adjustment (front 1-point / paper output direction: portrait)**

This adjustment is performed in the Adjustment Mode (FS-05-4823-2) of the equipment.

Adjustment scale	0.2mm	
Adjustable range	-3.4 mm to 3.4 mm	
Adjustment value	-17 to 17 (Default value: 0)	
Adjustment direction	Increasing the value	The distance between the stapling position and the edge of the paper becomes shorter.
	Decreasing the value	The distance between the stapling position and the edge of the paper becomes longer.

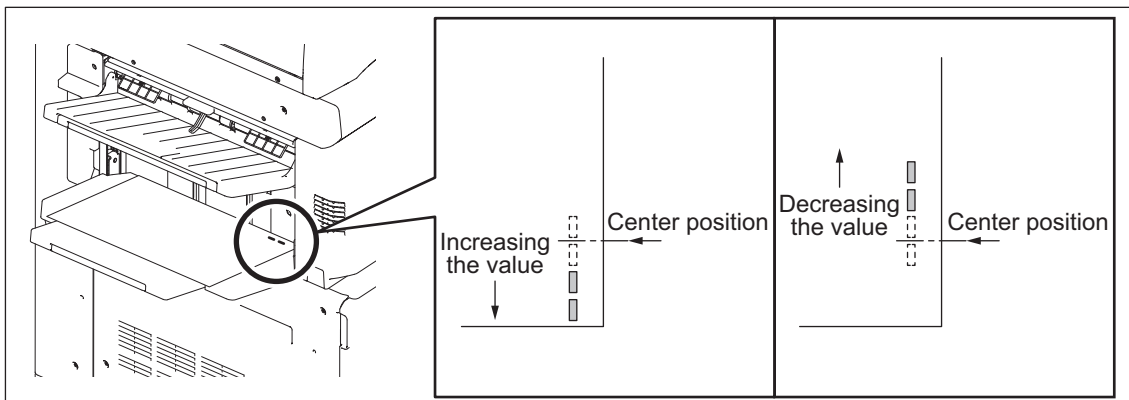


Fig.6-139

**[D] Stapling position adjustment (front 1-point / paper output direction: landscape)**

This adjustment is performed in the Adjustment Mode (FS-05-4823-3) of the equipment.

Adjustment scale	0.2mm	
Adjustable range	-3.4 mm to 3.4 mm	
Adjustment value	-17 to 17 (Default value: 0)	
Adjustment direction	Increasing the value	The distance between the stapling position and the edge of the paper becomes shorter.
	Decreasing the value	The distance between the stapling position and the edge of the paper becomes longer.

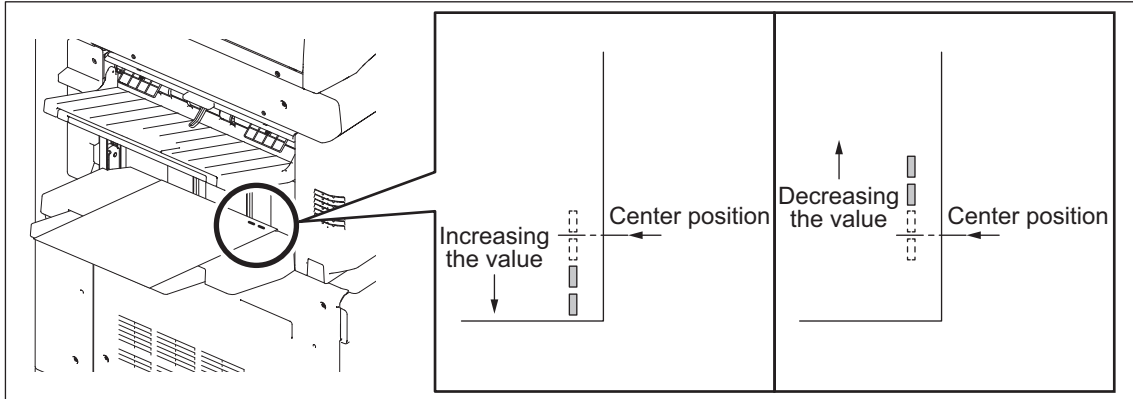


Fig.6-140

**[E] Stapling position adjustment (center 2-point)**

This adjustment is performed in the Adjustment Mode (FS-05-4823-4) of the equipment.

Adjustment scale	0.2mm	
Adjustable range	-3.4 mm to 3.4 mm	
Adjustment value	-17 to 17 (Default value: 0)	
Adjustment direction	Increasing the value	The stapling position moves farther to the front side from the center position.
	Decreasing the value	The stapling position moves farther to the rear side from the center position.

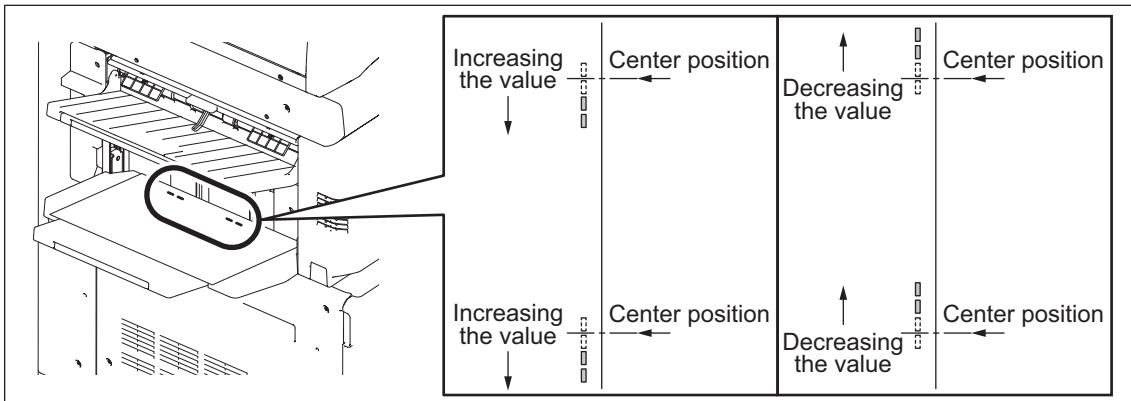


Fig.6-141

### 6.14.3 Punch hole position adjustment

This adjustment is performed in the Adjustment Mode (FS-05-4825) of the equipment.

Adjustment scale	0.2mm	
Adjustable range	-3.4 mm to 2.4 mm	
Adjustment value	-17 to 12 (Default value: 0)	
Adjustment direction	Increasing the value	The distance between the punch hole and the trailing edge of the paper becomes shorter.
	Decreasing the value	The distance between the punch hole and the trailing edge of the paper becomes longer.

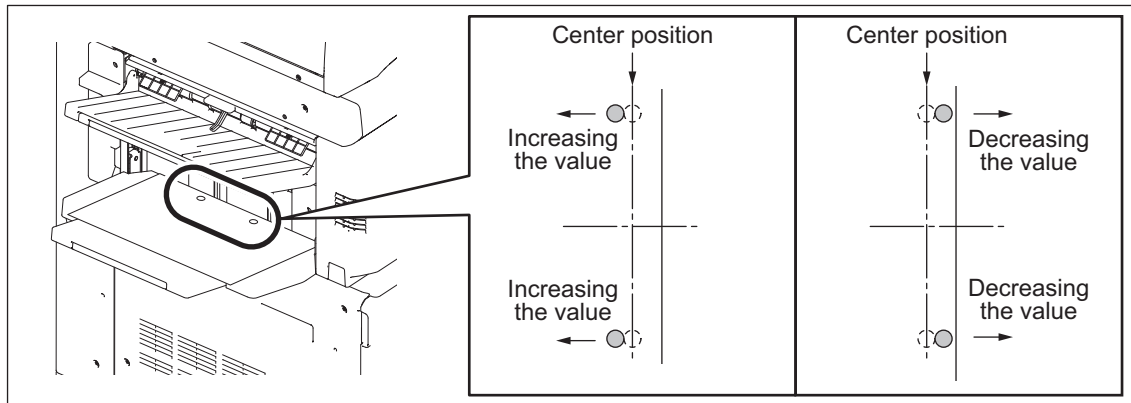


Fig.6-142

## 6.15 Adjustment of the Console Finisher

### Notes:

Before performing each adjustment, make sure that all covers (incl. those of the finisher and host machine) are closed. Otherwise, the power is not supplied to the finisher and the adjustment may not be performed properly.

### 6.15.1 Adjusting the alignment position

Perform this adjustment after replacing the Finisher control board or when the alignment position must be changed for some reason.

#### [A] Reading/writing of the adjustment value with the self-diagnostic mode

If the adjustment values can be confirmed from the pre-change board, check them from the connected equipment and then set them into the post-change board.

A4-size adjustment value check: Perform FS-05-4838-1.

LT-size adjustment value check: Perform FS-05-4838-2.

Item to be adjusted		Code	Remarks
Horizontal position of the paper	A-series paper	FS-05-4838-1	Adjusts the horizontal position of the paper. When a positive value is set, the pitch of the alignment plate becomes smaller. When a negative value is set, the pitch of the alignment plate becomes larger. 0: Finisher not installed 1: -2.10mm, 2: -1.68mm, 3: -1.26mm, 4: -0.84mm, 5: -0.42mm, 6: 0.00mm, 7: +0.42mm, 8: +0.84mm, 9: +1.26mm, 10: +1.68mm, 11: +2.10mm
	LT-series paper	FS-05-4838-2	

If the adjustment values cannot be confirmed, perform the adjustment in the following procedure.

#### [B] Adjustment with DIP-SW

Adjustment must be performed with 2 types of adjustment sheets for the A4 and LT series.

The adjustment value of A4 will be applied to the operation with A3, A4, A4-R, B4, B5, FOLIO, 8K, 16K. The adjustment value of LT will be applied to the operation with LD, LG, LT, LT-R, COMP, 13 LG, 8.5" SQ.

- (1) Turn OFF the power of the equipment.
- (2) Remove 1 screw and take off the board access cover [1].
- (3) Set the SW1 [2] on the Finisher control board as shown in the figures below.

Adjusting for A4 size paper: Turn ON pin 2 and 4.

Adjusting for LT size paper: Turn ON pin 1, 2, and 4.

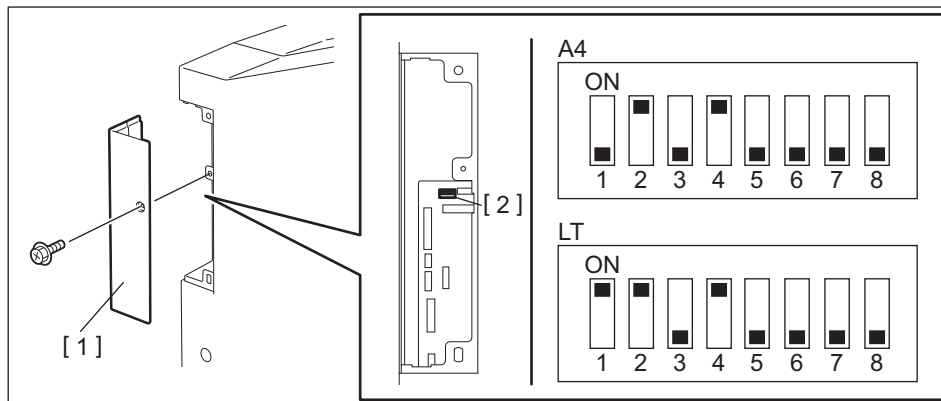


Fig.6-143

- (4) Start the equipment in the HS mode.  
The alignment plate moves to the SW1 set position and then stops.
- (5) Press the [Button1] to adjust the alignment position.  
Every time [Button1] is pressed, the alignment plate shifts by 0.42 mm. (The gap between the alignment plates becomes narrower.)

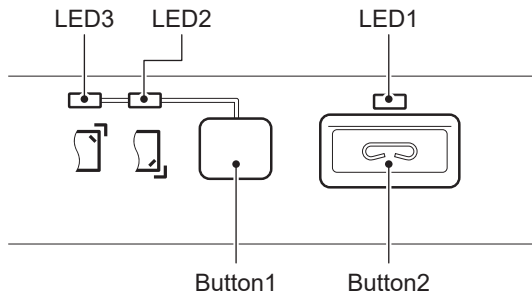


Fig.6-144

- (6) Place the adjustment sheet [1] on the process tray and adjust the position to make the gap between paper and the alignment plate [2] "0".  
Then setting is performed at a value that is one smaller than the adjustment value.

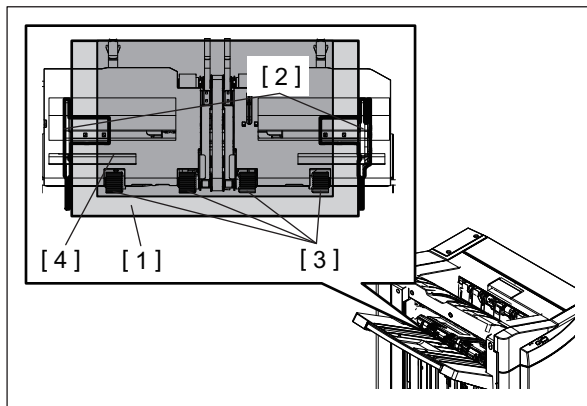


Fig.6-145

**Remarks:**

- Use an adjustment sheet [1] made of plastic resin which is light and accurate in measurement (e.g. OHP film).
- To reduce frictional resistance with the vertical alignment roller [3] on the process tray, place a sheet of B5 paper [4] beneath the adjustment sheet [1] on the vertical alignment roller [3].
- Confirm the gap between paper and the alignment plate [2] by moving the adjustment sheet [1] forward and backward.

- (7) When the adjustment is completed, press the [Button2] on the finisher control panel to store the adjustment value in memory.  
 When the value is stored normally, the [LED1] on the control panel will blink for a number of times that corresponds to the adjustment value set for the equipment.  
 See the following table for the number of times the [LED1] blinks and its corresponding moved amount (mm).

Number of Blinking	Distance from the center value (mm)
1	-2.10
2	-1.68
3	-1.26
4	-0.84
5	-0.42
6	Center value (0.00)
7	+0.42
8	+0.84
9	+1.26
10	+1.68
11	+2.10

- (8) Turn OFF the power of the equipment.
- (9) Turn OFF all bits of the SW1 on the Finisher control board.
- (10) Install the board access cover.

## 6.15.2 Adjusting the stapling position

Perform this adjustment after replacing the Finisher control board or when the stapling position must be changed for some reason.

### [A] Reading/writing of the adjustment value with the self-diagnostic mode

If the adjustment values can be confirmed from the pre-change board, check them from the connected equipment and then set them into the post-change board.

Adjustment value check (common for A4-size and LT-size): Perform FS-05-4838-3.

Item to be adjusted	Code	Remarks
Stapling position	FS-05-4838-3	Adjusts the stapling position. When a positive value is set, it shifts toward the rear side. When a negative value is set, it shifts toward the front side. 0: Finisher not installed 1: -2.16mm, 2: -1.89mm, 3: -1.62mm, 4: -1.35mm, 5: -1.08mm, 6: -0.81mm, 7: -0.54mm, 8: -0.27mm, 9: ±0.00mm, 10: +0.27mm, 11: +0.54mm, 12: +0.81mm, 13: +1.08mm, 14: +1.35mm, 15: +1.62mm, 16: +1.89mm, 17: +2.16mm

If the adjustment values cannot be confirmed, perform the adjustment in the following procedure.

### [B] Adjustment with DIP-SW

- (1) Turn OFF the power of the equipment.
- (2) Remove 1 screw and take off the board access cover [1].
- (3) Set the SW1 [2] on the Finisher control board as shown in the figures below.

When adjusting the rear side for A4 size paper: Turn ON pin 1, 3, and 4.	When adjusting the rear side for LT size paper: Turn ON pin 1, 2, 3, and 4.
When adjusting the front side for A4 size paper: Turn ON pin 3 and 4.	When adjusting the front side for LT size paper: Turn ON pin 2, 3, and 4.

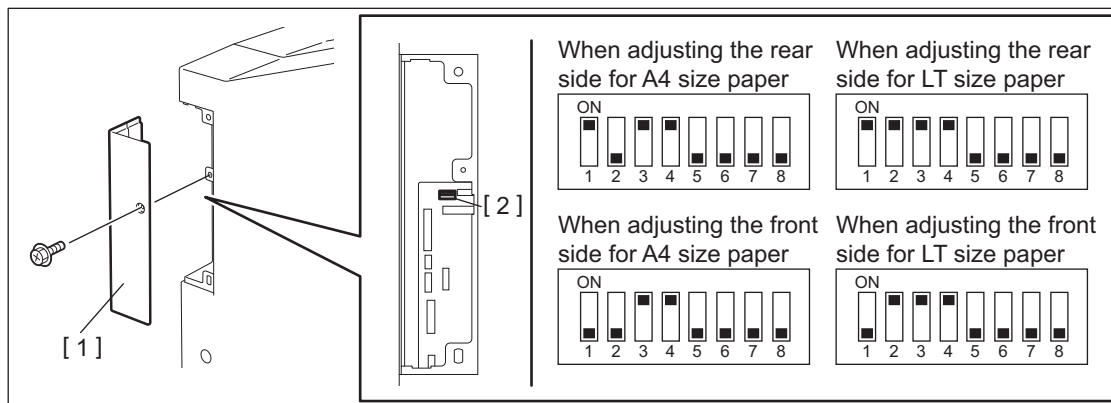


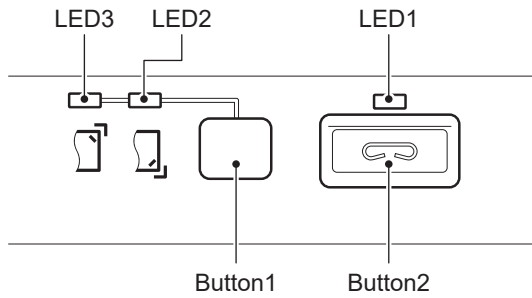
Fig.6-146

#### Remarks:

Although there are four setting types for the SW1 as shown above, perform only one of them since the adjustment values are used in common.

- (4) Start the equipment in the HS mode.  
The staple unit moves to the rear or front side stapling position and stops. (It stops at the position of -2.16 mm (at the front side) from the center value of the adjustment range.)

- (5) Press [Button 1] to adjust the stapling position.  
 Every time [Button 1] is pressed, the staple unit shifts by +0.27 mm (toward the rear side).  
 Adjustment range is from -2.16 to +2.16 mm. If [Button 1] is pressed when the alignment position is at +2.16 mm, the unit will return to -2.16 mm.



**Fig.6-147**

- (6) When the adjustment is completed, press [Button 2] on the finisher control panel to store the adjustment value in memory without sheets on the finishing tray.  
 When the value is stored normally, [LED 1] on the control panel will blink for a number of times that corresponds to the adjustment value set for the equipment.  
 See the following table for the number of times [LED 1] blinks and its corresponding adjustment value.

Number of blinking	Distance from the center value (mm)
1	-2.16
2	-1.89
3	-1.62
4	-1.35
5	-1.08
6	-0.81
7	-0.54
8	-0.27
9	Center value (0.00)
10	+0.27
11	+0.54
12	+0.81
13	+1.08
14	+1.35
15	+1.62
16	+1.89
17	+2.16

- (7) Turn OFF the power of the equipment.  
 (8) Turn OFF all bits of the SW1 on the Finisher control board.  
 (9) Install the board access cover.



## 6.16 Adjustment of the Saddle Stitch Finisher

### Notes:

Before performing each adjustment, make sure that all covers (incl. those of the finisher and host machine) are closed. Otherwise, the power is not supplied to the finisher and the adjustment may not be performed properly.

### 6.16.1 Adjusting the alignment position

Perform this adjustment after replacing the Finisher control board or when the alignment position must be changed for some reason.

#### [A] Reading/writing of the adjustment value with the self-diagnostic mode

If the adjustment values can be confirmed from the pre-change board, check them from the connected equipment and then set them into the post-change board.

A4-size adjustment value check: Perform FS-05-4838-1.

LT-size adjustment value check: Perform FS-05-4838-2.

Item to be adjusted		Code	Remarks
Horizontal position of the paper	A-series paper	FS-05-4838-1	Adjusts the horizontal position of the paper. When a positive value is set, the pitch of the alignment plate becomes smaller. When a negative value is set, the pitch of the alignment plate becomes larger. 0: Finisher not installed 1: -2.10mm, 2: -1.68mm, 3: -1.26mm, 4: -0.84mm, 5: -0.42mm, 6: 0.00mm, 7: +0.42mm, 8: +0.84mm, 9: +1.26mm, 10: +1.68mm, 11: +2.10mm
	LT-series paper	FS-05-4838-2	

If the adjustment values cannot be confirmed, perform the adjustment in the following procedure.

#### [B] Adjustment with DIP-SW

Adjustment must be performed with 2 types of adjustment sheets for the A4 and LT series.

The adjustment value of A4 will be applied to the operation with A3, A4, A4-R, B4, B5, FOLIO, 8K, 16K. The adjustment value of LT will be applied to the operation with LD, LG, LT, LT-R, COMP, 13 LG, 8.5" SQ.

- (1) Turn OFF the power of the equipment.
- (2) Remove 2 screws and take off the board access cover [1].
- (3) Set the SW1 on the Finisher control board as shown in the figures below.

Adjusting for A4 size paper:  
Turn ON pin 2 and 4.

Adjusting for LT size paper:  
Turn ON pin 1, 2, and 4.

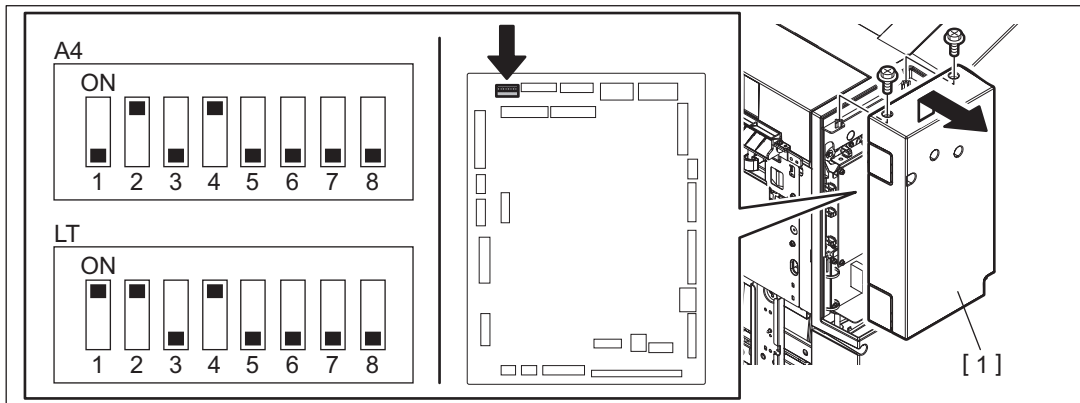


Fig.6-148

- (4) Start the equipment in the HS mode.  
The alignment plate moves to the SW1 set position and then stops.
- (5) Press [Button1] to adjust the alignment position.  
Every time [Button1] is pressed, the alignment plate shifts by 0.42 mm. (The gap between the alignment plates becomes narrower.)

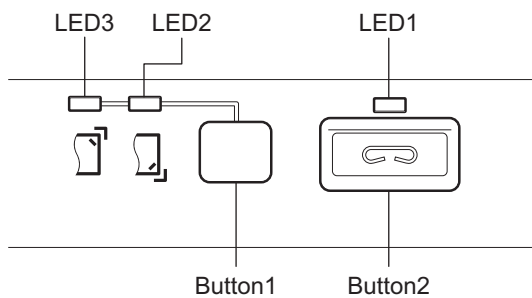


Fig.6-149

- (6) Place the adjustment sheet [1] on the process tray and adjust the position to make the gap between paper and the alignment plate [2] "0".  
Then setting is performed at a value that is one smaller than the adjustment value.

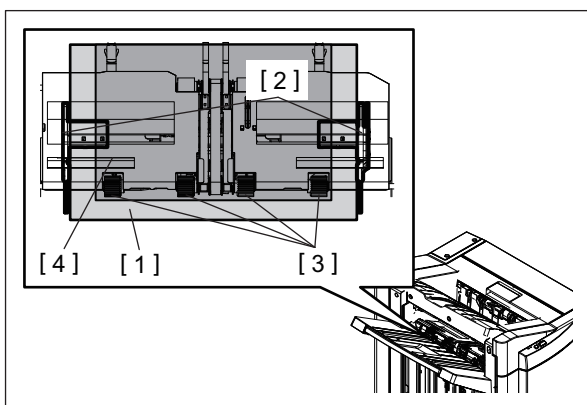


Fig.6-150

**Remarks:**

- Use an adjustment sheet [1] made of plastic resin which is light and accurate in measurement (e.g. OHP film).
- To reduce frictional resistance with the vertical alignment roller [3] on the process tray, place a sheet of B5 paper [4] beneath the adjustment sheet [1] on the vertical alignment roller [3].
- Confirm the gap between paper and the alignment plate [2] by moving the adjustment sheet [1] forward and backward.

(7) When the adjustment is completed, press the [Button2] on the finisher control panel to store the adjustment value in memory.

When the value is stored normally, the [LED1] on the control panel will blink for a number of times that corresponds to the adjustment value set for the equipment.

See the following table for the number of times [LED1] blinks and its corresponding moved amount (mm).

Number of Blinking	Distance from the center value (mm)
1	-2.10
2	-1.68
3	-1.26
4	-0.84
5	-0.42
6	Center value (0.00)
7	+0.42
8	+0.84
9	+1.26
10	+1.68
11	+2.10

(8) Turn OFF the power of the equipment.

(9) Turn OFF all bits of the SW1 on the Finisher control board.

(10) Install the board access cover.

## 6.16.2 Adjusting the stapling position

Perform this adjustment after replacing the Finisher control board or when the stapling position must be changed for some reason.

### [A] Reading/writing of the adjustment value with the self-diagnostic mode

If the adjustment values can be confirmed from the pre-change board, check them from the connected equipment and then set them into the post-change board.

Adjustment value check (common for A4-size and LT-size): Perform FS-05-4838-3.

Item to be adjusted	Code	Remarks
Stapling position	FS-05-4838-3	Adjusts the stapling position. When a positive value is set, it shifts toward the rear side. When a negative value is set, it shifts toward the front side. 0: Finisher not installed 1: -2.16mm, 2: -1.89mm, 3: -1.62mm, 4: -1.35mm, 5: -1.08mm, 6: -0.81mm, 7: -0.54mm, 8: -0.27mm, 9: ±0.00mm, 10: +0.27mm, 11: +0.54mm, 12: +0.81mm, 13: +1.08mm, 14: +1.35mm, 15: +1.62mm, 16: +1.89mm, 17: +2.16mm

If the adjustment values cannot be confirmed, perform the adjustment in the following procedure.

### [B] Adjustment with DIP-SW

- (1) Turn OFF the power of the equipment.
- (2) Remove 2 screws and take off the board access cover [1].
- (3) Set the SW1 on the Finisher control board as shown in the figures below.

When adjusting the rear side for A4 size paper: Turn ON pin 1, 3, and 4.	When adjusting the rear side for LT size paper: Turn ON pin 1, 2, 3, and 4.
When adjusting the front side for A4 size paper: Turn ON pin 3 and 4.	When adjusting the front side for LT size paper: Turn ON pin 2, 3, and 4.

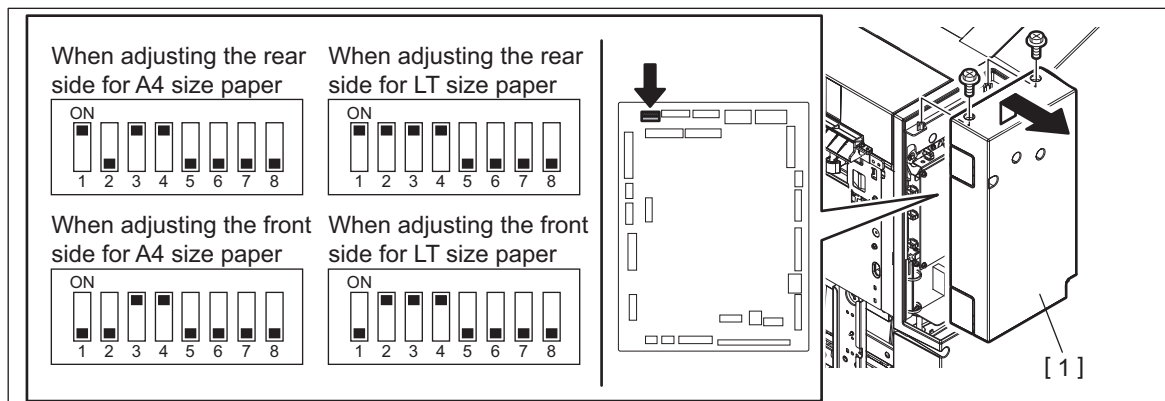


Fig.6-151

#### Remarks:

Although there are four setting types for the SW1 as shown above, perform only one of them since the adjustment values are used in common.

- (4) Start the equipment in the HS mode.  
The staple unit moves to the rear or front side stapling position and stops. (It stops at the position of -2.16 mm (at the front side) from the center value of the adjustment range.)

- (5) Press [Button 1] to adjust the stapling position.  
 Every time [Button 1] is pressed, the staple unit shifts by +0.27 mm (toward the rear side).  
 Adjustment range is from -2.16 to +2.16 mm. If [Button 1] is pressed when the alignment position is at +2.16 mm, the unit will return to -2.16 mm.

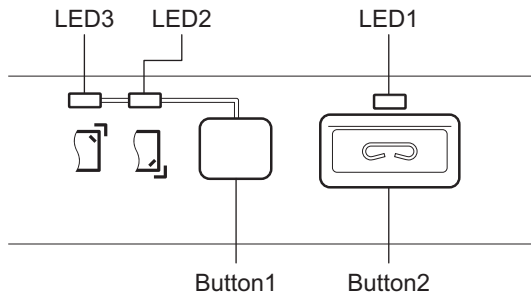


Fig.6-152

- (6) When the adjustment is completed, press [Button 2] on the finisher control panel to store the adjustment value in memory without sheets on the finishing tray.  
 When the value is stored normally, [LED 1] on the control panel will blink for a number of times that corresponds to the adjustment value set for the equipment.  
 See the following table for the number of times [LED 1] blinks and its corresponding adjustment value.

Number of blinking	Distance from the center value (mm)
1	-2.16
2	-1.89
3	-1.62
4	-1.35
5	-1.08
6	-0.81
7	-0.54
8	-0.27
9	Center value (0.00)
10	+0.27
11	+0.54
12	+0.81
13	+1.08
14	+1.35
15	+1.62
16	+1.89
17	+2.16

- (7) Turn OFF the power of the equipment.  
 (8) Turn OFF all bits of the SW1 on the Finisher control board.  
 (9) Install the board access cover.

### 6.16.3 Stapling/folding position adjustment in saddle stitch unit

Perform this adjustment when the saddle control PC board was replaced or the stapling/folding position must be changed for some reason.

Prepare 2 types of booklet samples using the main unit and use them for adjustment accordingly.

- (1) Create 2 types of booklet samples (1 set each) using the main unit.

	Sample 1	Sample 2
Media type	Recommended paper	Recommended paper
Paper size	A4	A3
Number of sheet	5 sheets	5 sheets

- (2) Measure the stapling and folding positions of the samples, and then perform adjustment accordingly.  
For stapling and folding, paper on the stacker of the stacker unit is moved to an exclusive mechanism for stapling or folding. Therefore adjustment must be performed individually for the folding stopping position of the stacker and the stapling stopping position.

- \* Check the folding position at the centerfold page of the sample.

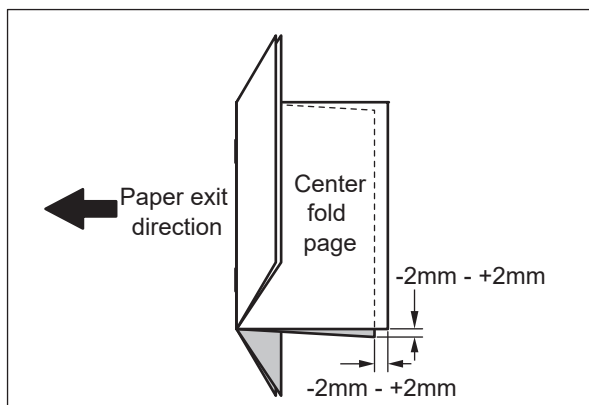


Fig.6-153

- \* Check the stapling position at the centerfold page of the sample.

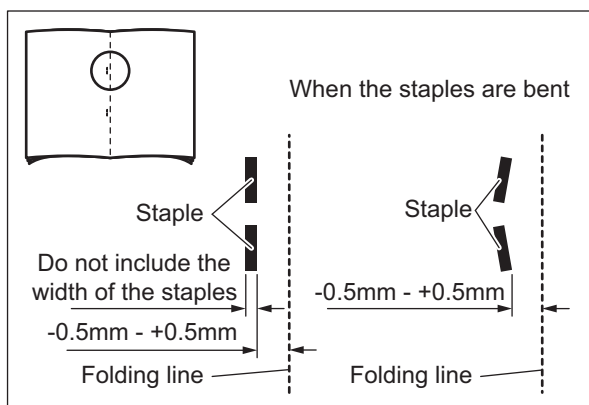
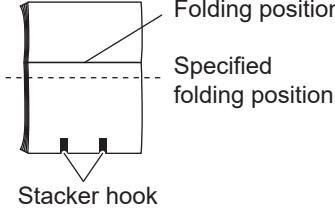
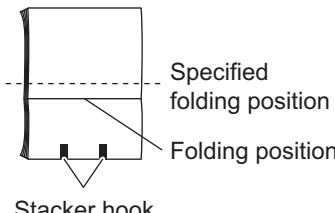
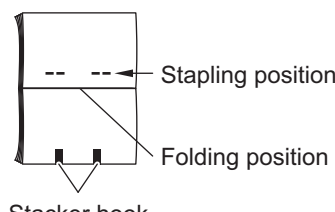
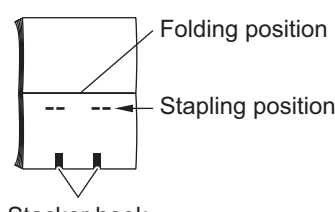


Fig.6-154

**Notes:**

Perform adjustment for the folding position first because the stapling position must be adjusted referring to the folding line.

Phenomenon	Contents	Adjustment
 <p>Fig.6-155</p>	<p>When the folding position is deviated from the specified one by more than -2.0 mm</p>	<p>Increase the value of the folding position adjustment in order to move the folding stopping position (the position of the stacker hooks) of the stacker upward.  <small>📖 P. 6-126 "[A] Adjustment with self-diagnostic mode"</small></p>
 <p>Fig.6-156</p>	<p>When the folding position is deviated from the specified one by more than 2.0 mm</p>	<p>Decrease the value of the folding position adjustment in order to move the folding stopping position (the position of the stacker hooks) of the stacker downward.  <small>📖 P. 6-126 "[A] Adjustment with self-diagnostic mode"</small></p>
 <p>Fig.6-157</p>	<p>When the stapling position is deviated from the specified one more than -0.50 mm</p>	<p>Decrease the value of the stapling position adjustment in order to move the stapling stopping position (the position of the stacker hooks) of the stacker downward.  <small>📖 P. 6-126 "[A] Adjustment with self-diagnostic mode"</small></p>
 <p>Fig.6-158</p>	<p>When the stapling position is deviated from the specified one more than 0.50 mm</p>	<p>Increase the value of the stapling position adjustment in order to move the stapling stopping position (the position of the stacker hooks) of the stacker upward.  <small>📖 P. 6-126 "[A] Adjustment with self-diagnostic mode"</small></p>

## 6.16.4 Folding position adjustment

### [A] Adjustment with self-diagnostic mode

Perform the adjustment from the connected equipment.

If the adjustment values can be confirmed from the pre-change board, check them from the connected equipment and then set them into the post-change board.

LD-size and A3-size adjustment value check: Perform FS-05-4838-6.

LG-size, B4-size, A4R-size, and 8K-size adjustment value check: Perform FS-05-4838-7.

Item to be adjusted		Code	Remarks
Saddle stitch folding position	A3,LD	FS-05-4838-6	Adjusts the saddle stitch folding position in the paper feeding direction. When a positive value is set, it shifts toward the trailing edge of the paper (stacker hook side). When a negative value is set, it shifts toward the leading edge of the paper. 0: Finisher not installed 1: -1.4mm, 2: -1.2mm, 3: -1.0mm, 4: -0.8mm, 5: -0.6mm, 6: -0.4mm, 7: -0.2mm, 8: 0.0mm, 9: +0.2mm, 10: +0.4mm, 11: +0.6mm, 12: +0.8mm, 13: +1.0mm, 14: +1.2mm, 15: +1.4mm
	Other than A3 and LD	FS-05-4838-7	

## 6.16.5 Stapling position adjustment

### [A] Adjustment with self-diagnostic mode

Perform the adjustment from the connected equipment.

If the adjustment values can be confirmed from the pre-change board, check them from the connected equipment and then set them into the post-change board.

LD-size and A3-size adjustment value check: Perform FS-05-4838-4.

LG-size, B4-size, A4R-size, and 8K-size adjustment value check: Perform FS-05-4838-5.

Item to be adjusted		Code	Remarks
Saddle stitch stapling position	A3,LD	FS-05-4838-4	Adjusts the saddle stitch stapling position in the paper feeding direction. When a positive value is set, it shifts toward the trailing edge of the paper (stacker hook side). When a negative value is set, it shifts toward the leading edge of the paper. 0: Finisher not installed 1: -2.8mm, 2: -2.4mm, 3: -2.0mm, 4: -1.8mm, 5: -1.2mm, 6: -0.8mm, 7: -0.4mm, 8: 0.0mm, 9: +0.4mm, 10: +0.8mm, 11: +1.2mm, 12: +1.6mm, 13: +2.0mm, 14: +2.4mm, 15: +2.8mm
	Other than A3 and LD	FS-05-4838-5	



## 6.16.6 Saddle stitch skew adjustment

Perform this adjustment when the folding position for saddle stitching is tilted.

- (1) Turn OFF the power of the equipment.
- (2) Open the cover, pull out the saddle stitch section, and then loosen the 2 screws.

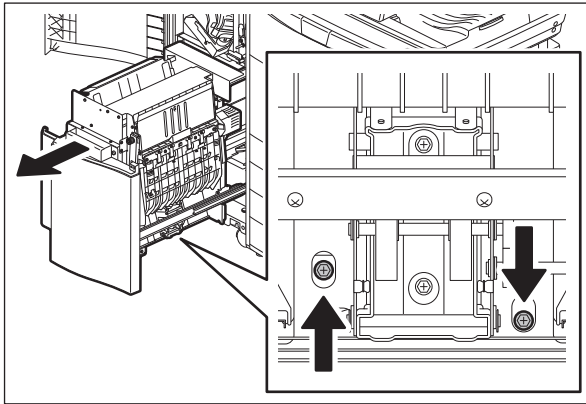


Fig.6-159

- (3) Rotate the adjustment screw slightly.

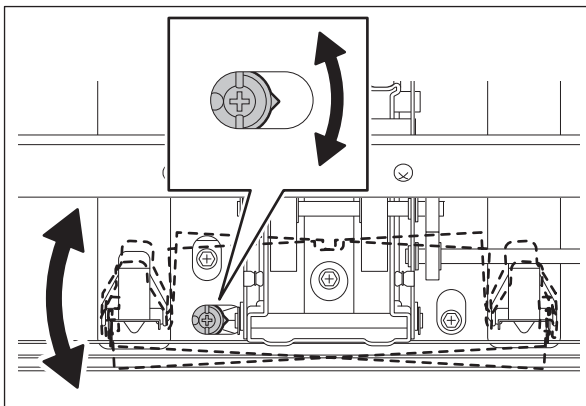


Fig.6-160

- (4) Tighten the 2 screws, return the saddle stitch section, and then close the cover.

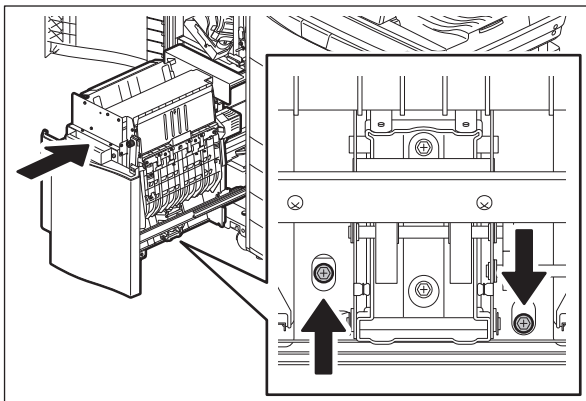


Fig.6-161

## 6.17 Adjustment of Hole Punch Unit

### 6.17.1 Destination setting of hole punch control PC board

This setting is performed when the hole punch control PC board (HP) [1] is replaced with a DIP switch [2] on it.

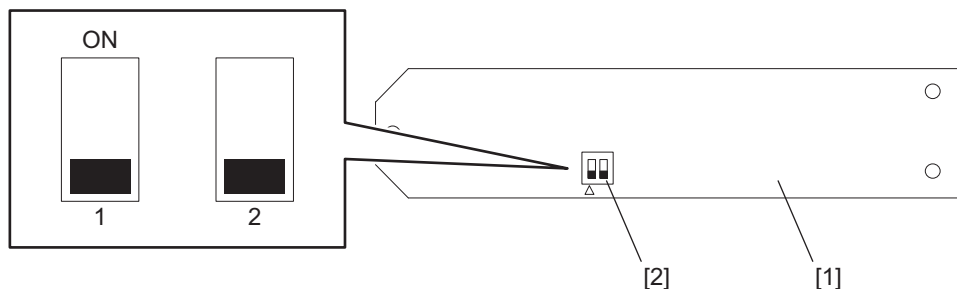


Fig.6-162

Refer to the table below for the destination settings.

Destination	Number of punch holes	DIP switch	
		1	2
MJ-6011E (Europe/Japan/China)	2 holes	OFF	OFF
MJ-6011N (North America)	2/3 holes	ON	OFF
MJ-6011F (France)	4 holes	OFF	ON
MJ-6011S (Sweden)	4 holes	ON	ON

## 6.17.2 Stopping position adjustment (MJ-6105)

This adjustment can change the position where paper transport stops during the punching operation. Perform this adjustment when you adjust the punching position on the paper in the transporting direction.

### [A] Adjustment with self-diagnostic mode

Item to be adjusted	Code	Remarks
Hole punch position	FS-05-4838-0	Adjusts the hole punch position in the paper feeding direction. When a positive value is set, it shifts toward the feeding side. When a negative value is set, it shifts toward the exit side. 0: Finisher not installed 1: -1.10mm, 2: -0.88mm, 3: -0.66mm, 4: -0.44mm, 5: -0.22mm, 6: 0.00mm, 7: +0.22mm, 8: +0.44mm, 9: +0.66mm, 10: +0.88mm, 11: +1.10mm

### [B] Adjustment with DIP-SW

If the adjustment values can be confirmed from the pre-change board, check them from the connected equipment and then set them into the post-change board.

Adjustment value check: Perform FS-05-4838-0.

If the adjustment values cannot be confirmed, perform the adjustment in the following procedure.

- (1) Turn the power of the equipment OFF.
- (2) Take off the board access cover [1] of the Finisher. Then set SW1 (DIP-SW) [2] on the finisher control PC board as shown below.

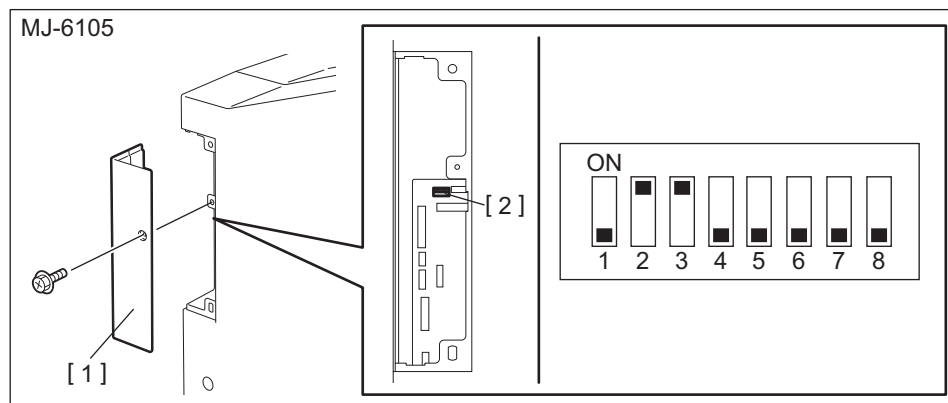


Fig.6-163

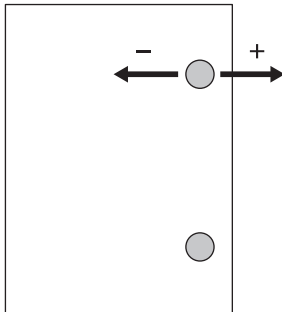
- (3) Turn the power of the equipment ON. The finisher enters into the stopping position adjustment mode.
- (4) LED1 on the finisher control panel blinks. The number of times it blinks indicates the current adjustment value.

- (5) Press Button1 on the finisher control panel to change the adjustment value. The number of times LED1 blinks changes in ascending order (e.g. 1, 2, 3... 11) each time you press Button1.

Number of LED1's blinking	Adjustment Value (Steps from the center value)	Distance from the center value
1	-5	1.10 mm
2	-4	0.88 mm
3	-3	0.66 mm
4	-2	0.44 mm
5	-1	0.22 mm
6	0	0 mm (Center value)
7	+1	0.22 mm
8	+2	0.44 mm
9	+3	0.66 mm
10	+4	0.88 mm
11	+5	1.10 mm

**Notes:**

When the adjustment value goes further in minus numbers in the table above, the distance between the paper edge and the holes becomes wider. When it goes further in plus numbers, this distance becomes narrower.



- (6) When the value change is completed, press Button2 on the finisher control panel to determine the adjustment value. (The adjustment value is written into the flash ROM.)
- (7) Turn the power of the equipment OFF.
- (8) Turn all the bits of SW1 (DIP-SW) on the finisher control PC board OFF.
- (9) Install the board access cover of the Finisher.

## 7. PREVENTIVE MAINTENANCE (PM)

### 7.1 General Description

The purpose of preventive maintenance (PM) is to maintain the quality level of this equipment by periodically inspecting and cleaning this equipment and also replacing the parts whose replacement timing has come according to the maintenance contract. There are PM kits packaged for each unit or a group of parts with the same replacement number of output pages, allowing you to carry out efficient parts replacement.

Also to maintain the quality level of the equipment, overhauling is required when a specified number of pages has been printed or when a specified period of time has passed, regardless of the number of output pages.

### 7.2 PM Display

#### 7.2.1 General description

The maintenance times of the PM parts vary depending on the state of the parts, for example, if one part is replaced due to a problem during the operation, the maintenance time of another part will change accordingly. In this equipment, the optimal maintenance time corresponding to each part is displayed on the control panel LCD.

The [process unit (K)] explained below is a photoconductive drum or a cleaner unit which includes a photoconductive drum. The [developer material (K)] explained below is a developer material or a developer unit which includes a developer material. The [PM part other than the process unit] explained below is a fuser roller or a fuser unit which includes a fuser roller.

#### 7.2.2 PM display conditions

The conditions of the PM display consist of the codes of the 08 Setting Mode for “the setting value treated as a threshold of the PM display”, “the counter indicating the current number of prints and driving time” and “the setting value which determines the display conditions”.

The PM timing is displayed when the counter exceeds the setting value according to the display condition based on “the setting value which determines the display conditions”.

- Setting value treated as a threshold of the PM display

**Notes:**

When “0” is entered as the setting value, PM timing is not displayed.

FS-08-6190: Setting value of PM counter [process unit (K)]

FS-08-6191: Setting value of PM time counter [process unit (K)]

FS-08-5554: Setting value of PM counter [developer material (K)]

FS-08-5555: Setting value of PM time counter [developer material (K)]

FS-08-5562: Setting value of PM counter [parts other than the PM parts of the process unit]

FS-08-5563: Setting value of PM time counter [parts other than the PM parts of the process unit]

- Counter indicating the current number of prints and driving time
  - FS-08-6194: Current value of PM counter [process unit (K)]
  - FS-08-6195: Current value of PM time counter [process unit (K)]
  - FS-08-5568: Current value of PM counter [developer material (K)]
  - FS-08-5569: Current value of PM time counter [developer material (K)]
  - FS-08-5576: Current value of PM counter [parts other than the PM parts of the process unit]
  - FS-08-5577: Current value of PM time counter [parts other than the PM parts of the process unit]
- Setting value which determines the display conditions
  - FS-08-6198: Switching of output pages/driving counts at PM [process unit (K)]
  - FS-08-5581: Switching of output pages/driving counts at PM [developer material (K)]
  - FS-08-5585: Switching of output pages/driving counts at PM [parts other than the PM parts of the process unit]

For example, you can set the conditions of the PM display of the [process unit (K)] as follows.

PM display by specifying the number of prints	<ol style="list-style-type: none"> <li>1. Key in "0" for FS-08-6198 (Switching of output pages/driving counts at PM [process unit (K)]).</li> <li>2. Key in the value of the number of prints for the PM display other than "0" for FS-08-6190 (Setting value of PM counter [process unit (K)]).</li> </ol>
PM display by specifying the driving time	<ol style="list-style-type: none"> <li>1. Key in "1" for FS-08-6198 (Switching of output pages/driving counts at PM [process unit (K)]).</li> <li>2. Key in the value of the driving time for the PM display other than "0" for FS-08-6191 (Setting value of PM time counter [process unit (K)]).</li> </ol>
PM display by the earlier one: when the number of prints or the driving time reaches the set value	<ol style="list-style-type: none"> <li>1. Key in "2" for FS-08-6198 (Switching of output pages/driving counts at PM [process unit (K)]).</li> <li>2. Key in the value of the number of sheets for the PM display other than "0" for FS-08-6190 (Setting value of PM counter [process unit (K)]).</li> <li>3. Key in the value of the driving time other than "0" for FS-08-6191 (Setting value of PM time counter [process unit (K)]).</li> </ol>

If the value of FS-08-9891 (Warning message on the touch panel when PM time has come) is set to "0: No warning notification", the PM display is not performed regardless of the settings above. (Default value is "1: Display warning notification")

### 7.2.3 PM display contents

When the counter value exceeds the setting value, the equipment notifies you of when the maintenance time has come by displaying the message “Time for periodic maintenance \*\*\*\*” on the control panel LCD. “\*\*\*\*” in the message is a 4-digit hexadecimal number code. This number is allocated in the following manner, therefore the parts needing maintenance can be identified.

PM parts of the process unit (K): 0008  
PM parts of the developer material (K): 0080  
Parts other than the PM parts of the process unit: 0100

If multiple parts have reached the maintenance time, the sum of the corresponding code values listed above is displayed in hexadecimal numbers.

For example, if the peripheral parts of the process units (K) and developer material (K) reach the maintenance time, the 4-digit hexadecimal number code will be “0188” in hexadecimal numbers:  $0008+0080+0100=0188$ .

### 7.2.4 Clearing counter

The counter indicating “current number of prints and driving time” used for the PM display function is reset by entering “0” in it or clearing it in the 20 PM support mode.

**Notes:**

Even if “0” is entered in the PM management setting value of the 08 Setting Mode, the corresponding counter for the PM display is not reset. Be sure to clear the counter in the 20 PM Support Mode when the maintenance is finished.

The reset condition of each counter is as follows:

- FS-08-6194: Current value of PM counter [process unit (K)]
- FS-08-6195: Current value of PM time counter [process unit (K)]  
When the current value of “CLEANER/DRUM” on the main screen or “DRUM” on the sub-screen in the PM support mode is cleared, the counter is reset.
- FS-08-5568: Current value of PM time counter [developer material (K)]
- FS-08-5569: Current value of PM time counter [developer material (K)]  
When the current value of “DEVELOPER” on the main screen or “DEVELOPER” on the sub-screen in the PM support mode is cleared, the counter is reset.
- FS-08-5576: Current value of PM counter [parts other than the PM parts of the process unit]
- FS-08-5577: Current value of PM time counter [parts other than the PM parts of the process unit]
- FS-08-6225: Number of output pages (Thick paper 1)
- FS-08-6226: Number of output pages (Thick paper 2)
- FS-08-6227: Number of output pages (Thick paper 3)
- FS-08-6228: Number of output pages (OHP film)
- FS-08-6244: Counter for tab paper
- FS-08-6247: Counter for envelope  
When the current value of “FUSER” on the main screen or “FUSER ROLLER” on the sub screen in the PM support mode is cleared, the counter is reset.

**Notes:**

The following counters are cleared by executing the EPU replacement mode.

FS-08-6194: Current value of PM counter [process unit (K)]  
FS-08-6195: Current value of PM time counter [process unit (K)]  
FS-08-5568: Current value of PM counter [developer material (K)]  
FS-08-5569: Current value of PM time counter [developer material (K)]

## 7.3 General Descriptions for PM Procedure

Perform the preventive maintenance in the following timing.

- 20ppm: every 80,000 sheets
- 25ppm: every 100,000 sheets
- 30ppm: every 120,000 sheets
- 35ppm: every 125,000 sheets
- 45ppm: every 150,000 sheets
- 50ppm: every 150,000 sheets

### (1) Preparation

- Ask the user about the current conditions of the equipment and note them down.
- Before starting maintenance, make some sample copies and store them.
- See the replacement record and check the parts to be replaced in the 20 PM Support Mode or 30 List Printing Mode.
  - 20 PM Support Mode: Perform FS-20
  - 30 List Printing Mode: Perform FS-30-103

UNIT	OUTPUT PAGES DEVELOP COUNTS	PM OUTPUT PAGES DEVELOP COUNTS	DRIVE COUNTS	PM DRIVE COUNTS
DRUM	1957	1957	10870	170000
DRUM BLADE	1957	1957	10870	170000
GRID	1957	1957	10870	170000
NEEDLE ELECTRODE	1957	1957	10870	170000
SEPARATION FINGER (DRUM)	1077	1077	3766	170000
RECOVERY BLADE	1077	1077	3766	170000
DEVELOPER	1077	1077	3766	170000
TRANSFER ROLLER	1077	1077	3766	170000
OZONE FILTER	1077	1077	3766	170000
FUSER ROLLER	1077	1077	9547	170000
PRESS ROLLER	1077	1077	9547	170000
SEPARATION FINGER (FUSER)	1077	1077	9547	170000
PICK UP ROLLER (1st CST.)	1077	1077	9547	170000
FEED ROLLER (1st CST.)	1077	1077	9547	170000
SEP ROLLER (1st CST.)	1077	1077	9547	170000
PICK UP ROLLER (2nd CST.)	1077	1077	9547	170000

Fig. 7-1

- Turn OFF the power and make sure to unplug the equipment.
- (2) Perform a preventive maintenance using the checklist.
  - (3) Plug in the equipment after the maintenance has been finished. Then turn ON the power and make some copies to confirm that the equipment is working properly.



## 7.4 PM Support Mode

### 7.4.1 General description

The timing for the parts replacement usually depends on the number of output pages ever printed after they were replaced before. However, the life span of them changes depending on the general use of users and the environment in which the equipment is placed. Therefore, it is necessary to consider not only the number of output pages but also the drive counts when deciding the timing for the parts replacement in order to utilize the parts and materials effectively.

This equipment has the PM support mode, which makes it possible to see the general use of each part (the number of output pages, drive counts) and replacement record and to do a counter clearing operation more efficiently when replacing.

The replacement record can be printed out in the 30 List Printing Mode.

### 7.4.2 Operational flow and operational screen

#### [ 1 ] Operational flow

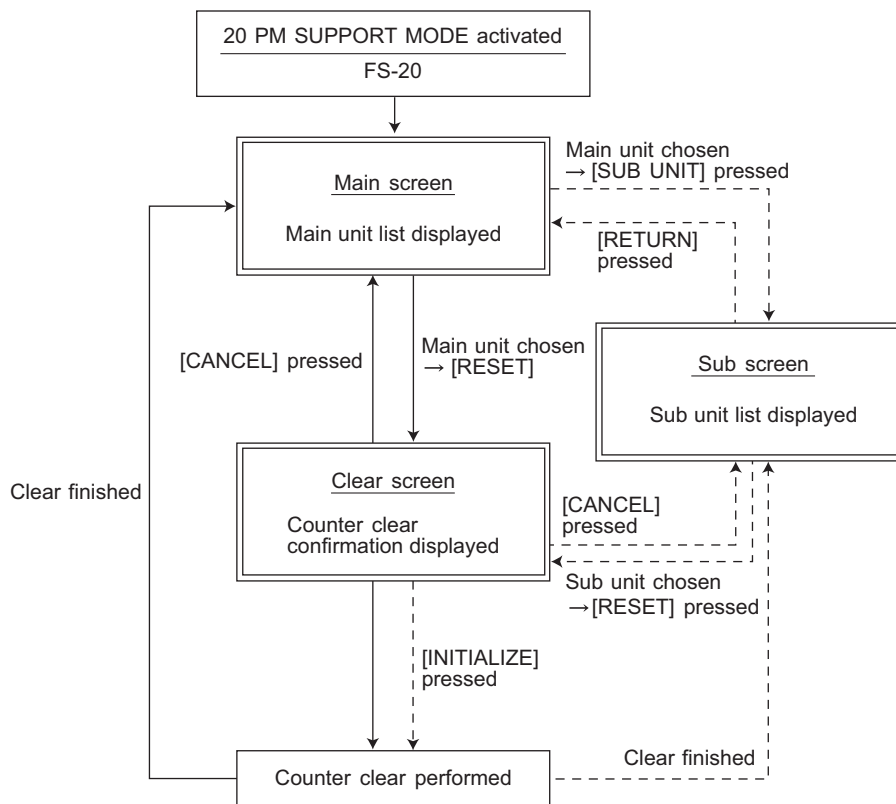


Fig. 7-2

- \* When the authentication screen appears, press [OK]. (Enter the password, if one has been set.)
- \* The screen goes back to the main screen when the counter clear is executed or the [CANCEL] button is pressed after moving from the main screen, while it goes back to the sub screen after moving from the sub screen.

## [ 2 ] Operational screen

### [ 2-1 ] Main screen

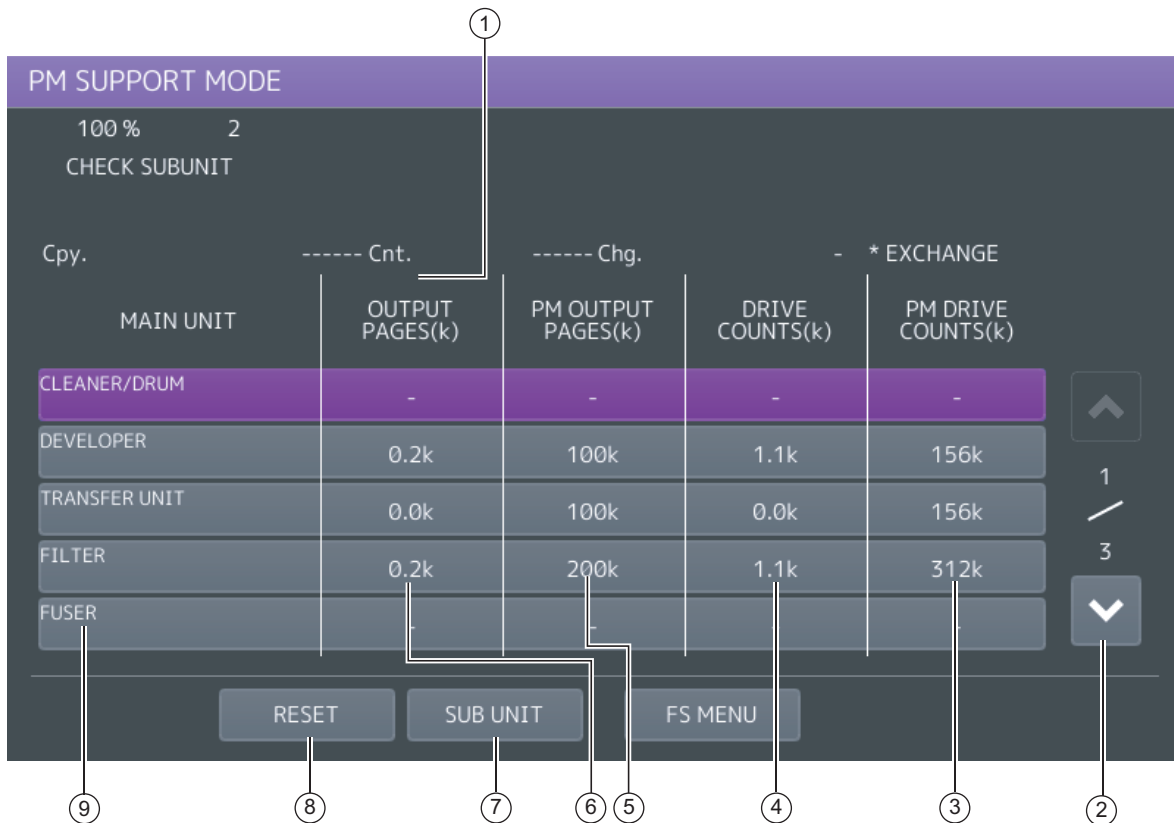


Fig. 7-3

1. Displaying of the number of print / develop pages (Page/D. cnt), drive counts (Cnt.) and previous replacement date (Chg.) for a chosen unit  
When the replacement date for the sub unit is different, press the [SUB UNIT] button to move to the sub screen and see each information, otherwise information is not displayed
2. Moving to the next/previous page
3. Displaying of the standard number of drive counts to replace the unit parts
4. Displaying of the present drive counts  
“\*” is displayed next to the present number when the number of drive counts has exceeded its PM standard number.
5. Displaying of the present number of print / develop pages
6. Displaying of the standard number of print / develop pages to replace the unit parts  
When there are differences among the sub units (parts), “\_” is displayed and “CHECK SUBUNIT” is displayed at the top  
“\*” is displayed next to the present number when the number of print / develop pages has exceeded its PM standard number.
7. Moving to the sub screen of the selected unit
8. Moving to the clear screen to clear the selected unit counters 4 and 6, including all sub unit (parts) counters belonging to that unit When the unit is not selected, all counters are cleared.
9. Displaying of the main unit name

#### Notes:

- “—” is always displayed at the drive counts section for the reversing automatic document feeder (RADF) and feed unit.
- The paper source differs depending on the structure of options, however, “0.0k” is displayed in “OUTPUT PAGES (k)” and its standard number of output pages is displayed in “PM OUTPUT PAGES (k)” even for the installed paper source.

[ 2-2 ] Sub screen

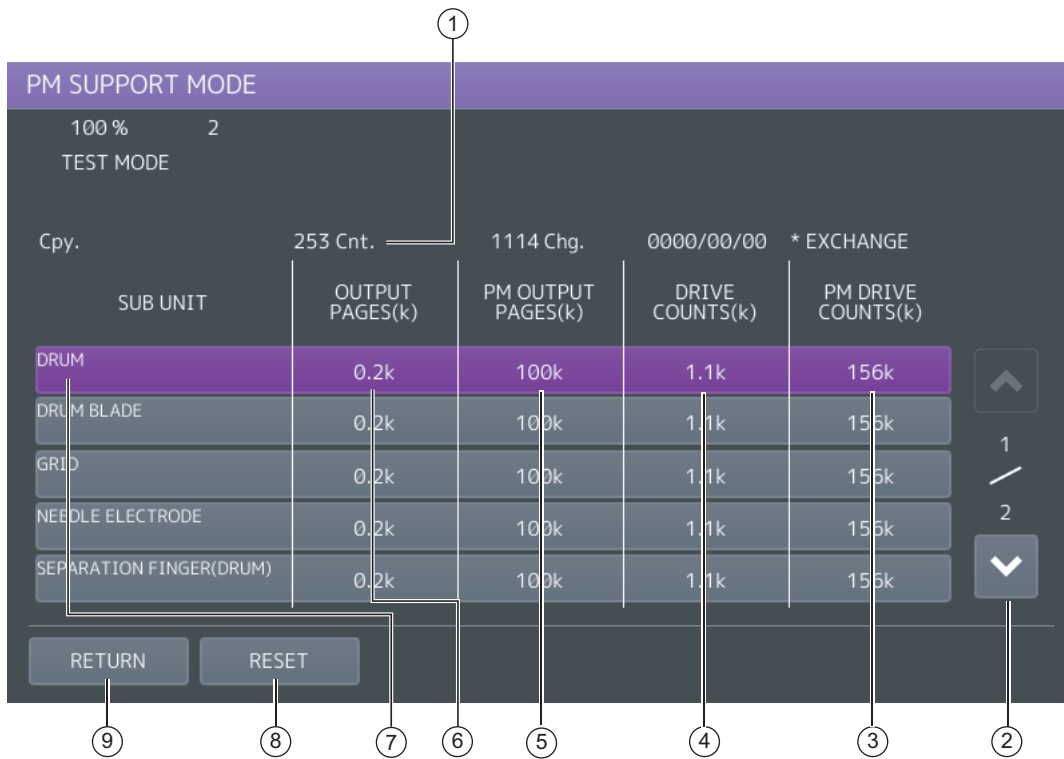


Fig. 7-4

1. Displaying of the number of print / develop pages and drive counts and previous replacement date for a chosen sub unit
2. Moving to the next/previous page
3. Displaying of the standard number of drive counts to replace the sub unit (parts)
4. Displaying of the present drive counts  
 “\*” is displayed next to the present number when the number of drive counts has exceeded its PM standard number.
5. Displaying of the standard number of print / develop pages to replace the sub unit (parts)
6. Displaying of the present number of print / develop pages  
 “\*” is displayed next to the present number when the number of print / develop pages has exceeded its PM standard number.
7. Displaying of the sub unit (parts) name
8. Moving to the clear screen to clear the selected unit (parts) counters
9. Back to the main screen

## [ 2-3 ] Clear screen

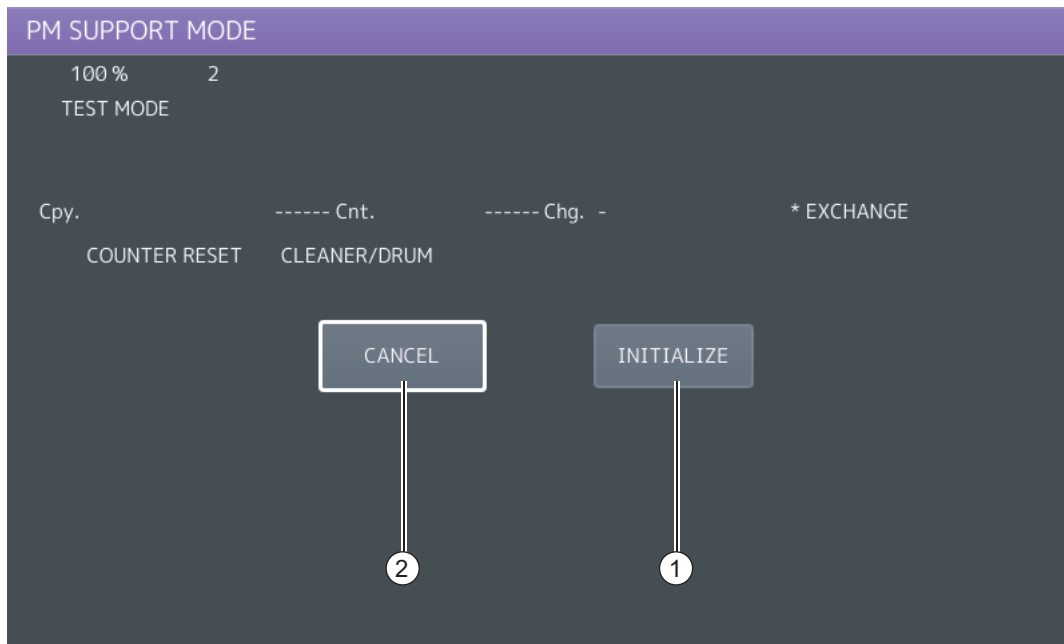


Fig. 7-5

1. When the [INITIALIZE] button is pressed, "Present number of print / develop pages" and "Present driving counts" are cleared and "Previous replacement date" is updated.
2. When the [CANCEL] button is pressed, the counter is not cleared and the display returns to the main or sub screen.

### [ 3 ] LCD screen display list

The relation between the main unit and the sub unit is shown below.

**Notes:**

Some parts in this manual are described with different names on the LCD screen. In this case, the name in this manual is indicated in square brackets [ ].

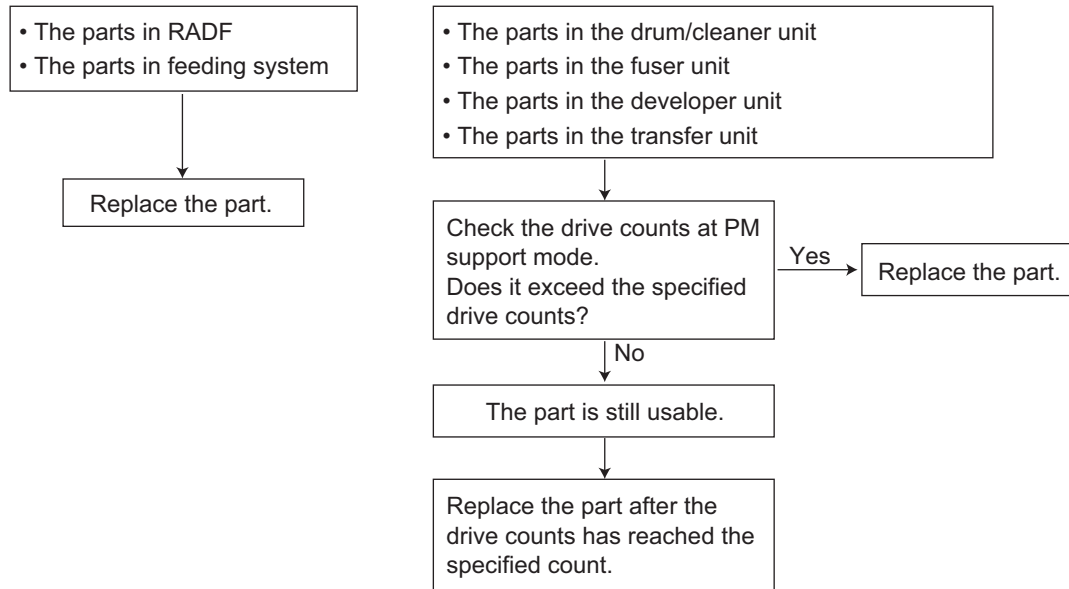
Main screen	Sub-screen
CLEANER/DRUM [Drum/cleaner unit]	DRUM [Drum] DRUM BLADE [Drum cleaning blade] GRID [Main charger grid] NEEDLE ELECTRODE [Needle electrode] SEPARATION FINGER (DRUM) [Separation finger for drum] RECOVERY BLADE [Recovery blade]
DEVELOPER [Developer unit]	DEVELOPER [Developer]
TRANSFER UNIT [Transfer unit]	TRANSFER ROLLER [Transfer roller]
FILTER [Filter]	OZONE FILTER [Ozone filter]
FUSER [Fuser unit]	FUSER ROLLER [Fuser roller] PRESS ROLLER [Pressure roller] SEPARATION FINGER (FUSER) [Separation finger for fuser roller]
1st CST. [Upper drawer]	PICK UP ROLLER (1st CST.) [Pick-up roller] FEED ROLLER (1st CST.) [Feed roller] SEP ROLLER (1st CST.) [Separation roller]
2nd CST. [Lower drawer]	PICK UP ROLLER (2nd CST.) [Pick-up roller] FEED ROLLER (2nd CST.) [Feed roller] SEP ROLLER (2nd CST.) [Separation roller]
SFB [Bypass unit]	FEED ROLLER (SFB) [Feed roller] SEP PAD (SFB) [Separation pad]
DF [Document feeder]	PICK UP ROLLER (DF) [Pick-up roller] FEED ROLLER (DF) [Feed roller] SEP ROLLER (DF) [Separation roller]
LCF [LCF]	PICK UP ROLLER (LCF) [Pick-up roller] FEED ROLLER (LCF) [Feed roller] SEP ROLLER (LCF) [Separation roller]
3rd CST. [PFP upper drawer]	PICK UP ROLLER (3rd CST.) [Pick-up roller] FEED ROLLER (3rd CST.) [Feed roller] SEP ROLLER (3rd CST.) [Separation roller]
4th CST. [PFP lower drawer]	PICK UP ROLLER (4th CST.) [Pick-up roller] FEED ROLLER (4th CST.) [Feed roller] SEP ROLLER (4th CST.) [Separation roller]

## 7.5 Work flow of parts replacement

The timing for the parts replacement usually depends on the number of output pages ever made after they were replaced before. However, its drive counts time is also to be considered when replacing the parts. Even if the number of output pages has reached the level of replacement, for instance, the part may still be usable with its drive counts not reaching the specified drive counts. On the other hand, the part may need replacement even if the number of output pages has not reached the level of replacement with its driving time exceeding the specified drive counts. The life span of some parts such as feed roller is heavily dependent on the number of output pages rather than the drive counts. The following work flow diagram shows how to judge the timing of replacement with the number of output pages and the drive counts.

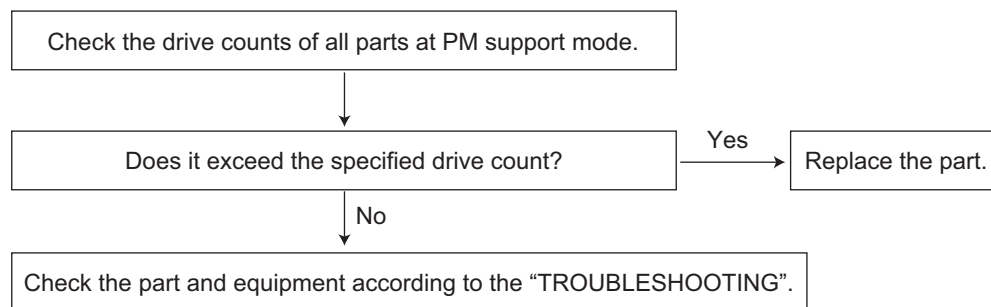
### **Example 1:**

#### **When the number of output pages has reached the specified level**



### **Example 2:**

#### **When the image failure occurred before the number of output pages has reached the specified level**



## 7.6 21 EPU Replacement Mode

### 7.6.1 General description

As this equipment complies with the ERU (Easy Replacement Unit) rule, the EPUs (drum/cleaner unit, developer unit) of this equipment can be removed or reinstalled easily.

When each EPU is replaced with a new unit at PM, the IC chip in the EPU board installed at the bottom of the developer unit detects whether a new or an old unit is installed. When the IC chip memory judges that the installed unit is a new one, the series of operations required at the replacement (counter reset for supply items in the EPU, auto-toner sensor initial adjustment and automatic gamma adjustment) is smoothly performed.

#### Notes:

If only the supply items in the EPU at PM are to be replaced, perform the life counter reset for each supply item; if developer material is to be replaced, perform the auto-toner sensor adjustment and the automatic gamma adjustment in the 20 PM Support Mode as described in Chapter 5.

### 7.6.2 Operation flow

The following is the operation flow.

#### Advance preparation

A4/LT size papers need to be loaded in the cassette for automatic gamma adjustment. Before performing the EPU replacement mode, load the A4/LT size papers into the cassette, then set the cassette paper size.

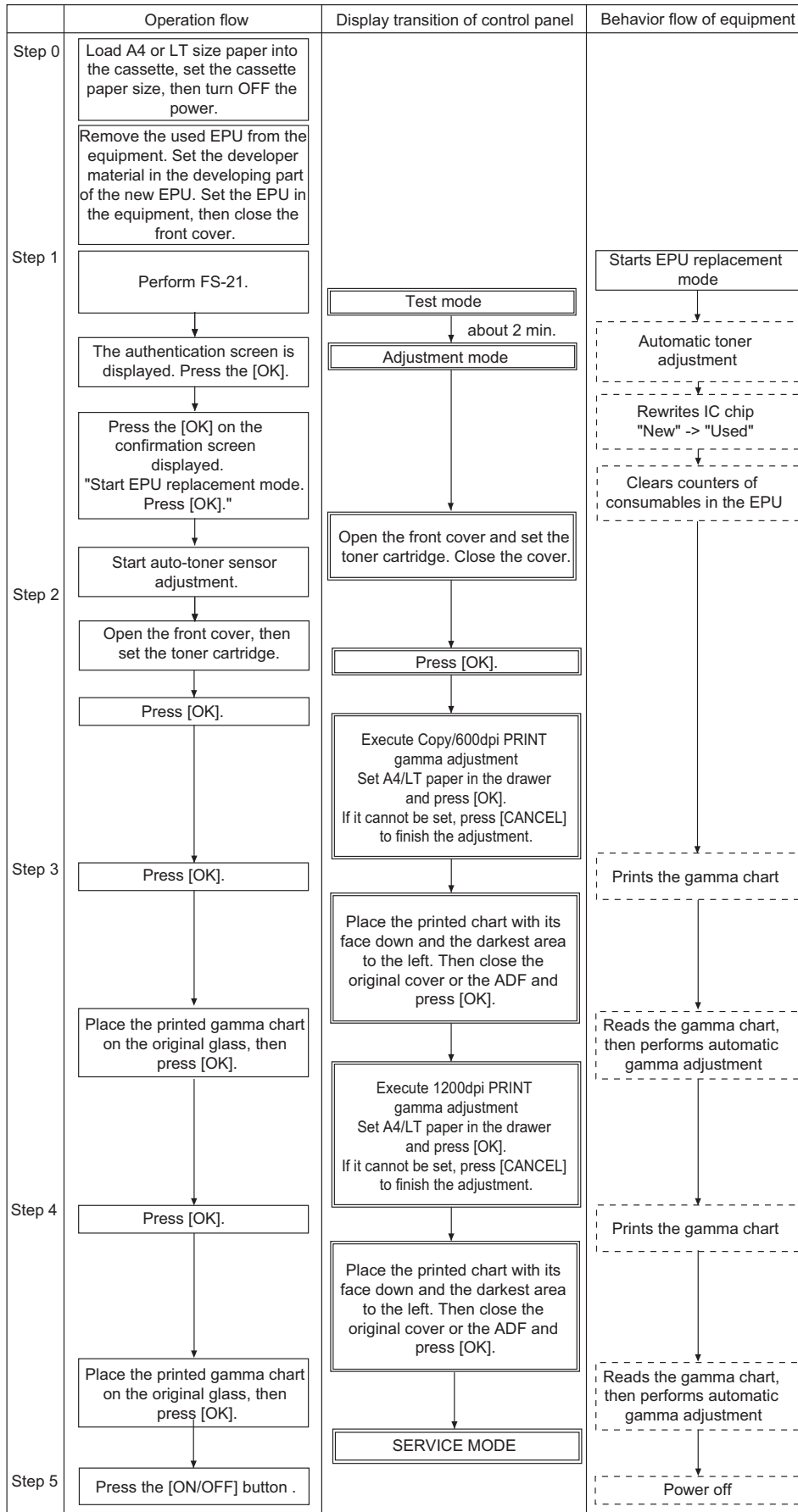


Fig. 7-6



### 7.6.3 Counters to be cleared

- FS-08-6250: Drum counter
- FS-08-6258: Drum cleaning blade counter
- FS-08-6274: Main charger grid counter
- FS-08-6282: Needle electrode counter
- FS-08-6272: Drum separation finger counter
- FS-08-6436: Recovery blade counter
- FS-08-6300: Developer material counter
- FS-08-6194: K-PM counter current value
- FS-08-6195: K-PM time counter current value
- FS-08-5568: Developer material-K PM counter current value
- FS-08-5569: Developer material-K PM time counter current value

### 7.6.4 Precautions

- When the power is turned ON in the normal mode or during warming-up in the normal mode, the error code C3D1 appears after a new EPU unit (with new IC chip data) is installed. This indicates that the installed EPU unit has not been set up. Turn the power OFF and then perform FS-21. Then the equipment enters the EPU replacing mode.
- After Performing FS-21, the error code C3D2 appears after an old EPU unit (with old IC chip data) is installed. This is for preventing the equipment from detecting that the installed unit is a new one and performing wrong operations such as supply item counter reset. In this case, turn the power OFF and then back ON in the normal mode. The equipment returns to its normal operations.
- If IC chip information is not written as “used IC chip” in step 1, an error (C3D0) is displayed. If it occurs, perform the maintenance of each part according to the Troubleshooting.
- If you press [CANCEL] in step 3, the 21 EPU Replacement Mode ends without automatic gamma adjustment being performed.
- If [Adjustment error Press [OK] to perform the adjustment again or [CANCEL] to finish it.] is displayed in step 4, this means that the automatic gamma adjustment has failed. Check that the original is placed on the original glass in the correct direction, and press [OK] to start the adjustment again. If you press [CANCEL], the adjustment is canceled and the 21 EPU Replacement Mode ends.
- If automatic gamma adjustment is not performed in the 21 EPU Replacement Mode, the default gamma slope angle is used. To obtain optimal image quality, perform the adjustment according to the procedure in the “Automatic gamma adjustment” in the chapter of “Image Quality Adjustment”.
- If the 21 EPU Replacement Mode does not function, check that the value of FS-08-4556 (Detection setting of new or old EPU) is set to “1: Enabled”. If this value is set to “0: Disabled”, the EPU replacement mode does not function.

### **7.6.5 To allow the equipment to detect a recycled unit as a new one after replacement**

To recycle an old EPU after replacement and also let the equipment detect that it is a new one, the supply items in the EPU and the IC chip data in the EPU board must be replaced. In this case, the EPU board itself must be replaced with a new one (service part).

However, the EPU board is not installed in the EPU co-packed with the equipment. Therefore, in order to recycle it, it is necessary to install the EPU board which is supplied as a service part. Install the EPU board by the following order.

Remove the sheet (PLATE-HLDR-HRNS-DEV)). -> Attach the harnesses (HRNS-ATS-471, HRNS-EPU-471) supplied as a service part. -> Install the EPU board.

If the EPUs are replaced in the 20 PM Support Mode instead of the 21 EPU Replacement Mode noted in this chapter, the replacement or installation of the EPU board is not necessary.

Information in the IC chip can be confirmed with FS-08-4555-0 (Information check of new or old EPU memory). The display of [0xff00(NEW)] indicates a new IC chip while [0x00ff(OLD)] indicates a used one. A hexadecimal value ending with “-” indicates that invalid data have been entered.

## 7.7 Fuser Unit Status Detection Mode

### 7.7.1 General description

As this equipment complies with the ERU provisions (Easy Replacement Unit), the fuser unit can be removed or reinstalled without any problem.

The fuse (service part) for detection of a new fuser unit can be installed in the unit. The circuit determining the fuser unit status judges whether the fuser unit is new or used by detecting the status of the fuse. In addition, when the circuit detects that a new fuser unit is connected, it supplies current to blow out the fuse to clear the fuser-related life counters.

**Notes:**

If only the supply parts in the fuser unit are to be replaced at PM, perform life counter clearing for each one in the PM support mode as described in this chapter.

### 7.7.2 Operational flow

- (1) When replacing supply parts or the fuser unit at PM, install a new fuse in it.

**Notes:**

If a fuser unit with an installed fuse is selected, replace that the fuse with a new one because it will have been blown out.

- (2) Install the fuser unit in the equipment.
- (3) Turn the power ON. If the fuser unit is then judged determined to be new, the fuser-related life counters are automatically cleared.

### 7.7.3 Counters to be cleared

- FS-08-6346: Fuser roller counter
- FS-08-6350: Pressure roller counter
- FS-08-6368: Fuser roller separation finger counter
- FS-08-6225: Number of output pages (Thick paper 1)
- FS-08-6226: Number of output pages (Thick paper 2)
- FS-08-6227: Number of output pages (Thick paper 3)
- FS-08-6228: Number of output pages (OHP film)
- FS-08-6247: Counter for envelopes
- FS-08-6244: Counter for tab paper

### 7.7.4 Precautions

- When the counters are not cleared, though the fuser unit is new, check that the value of the code FS-08-4549 is set at "0". If the value is "1", change it to "0", turn the power OFF and then back ON. Then check the counter values again.  
FS-08-4549 (Detection setting of new or old fuser unit) 0: Enabled, 1: Disabled
- When the fuse is not blown out, though the fuser unit is new, a C4C0 error occurs. In this case, replace the fuse and turn the power OFF and then back ON, or remove the fuse and clear the counters in the PM support mode.

## 7.8 Preventive Maintenance Checklist

The check items for each unit at the preventive maintenance are shown below.

Symbols/Values used in the checklist

Cleaning	Lubrication/Coating	Replacement	Operation check
A: Clean with alcohol B: Clean with soft pad, cloth or vacuum cleaner	L: Launa 40 Sl: Silicon oil W1: White grease (Molykote EM-30L) W2: White grease (Molykote HP-300) AV: Alvania No.2 FL: FLOIL (GE-334C) CG: Conductive grease (KS-660) C: Coating material (SANKOL CFD-409M)	Value: Replacement cycle R1: Replacement R3: Replace if deformed or damaged.	○ After cleaning or replacement, confirm there is no problem.

### Notes:

- Perform cleaning and lubricating in the following timing. Lubricate the replacement parts according to the replacement cycle.

Model	Replacement cycle
20ppm	every 80,000 sheets
25ppm	every 100,000 sheets
30ppm	every 120,000 sheets
35ppm	every 125,000 sheets
45ppm	every 150,000 sheets
50ppm	every 150,000 sheets

- Values under “Replacement” indicate the replacement cycle for the e-STUDIO2018A/2518A/3018A/3518A/4518A/5018A.
- The replacement cycle of the parts in the feeding section equals to the number of sheets fed from each paper source.
- Be careful not to put oil on the rollers, belts and belt pulleys when lubricating.

## 7.8.1 Scanner

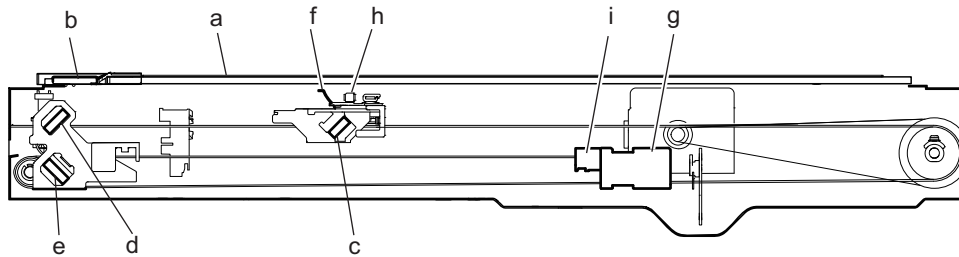


Fig. 7-7

Items to check		Cleaning	Lubrication	Replacement (x 1,000 sheets)	Operation check	Parts list <P-I>
a	Original glass	A or B				21-2
b	ADF original glass	B				21-3
c	Mirror 1	B				22-1
d	Mirror 2	B				23-1
e	Mirror 3	B				23-1
f	Reflector	B				22-1
g	Lens	B				11-9
h	Exposure lamp			R3	○	22-3 22-1
i	Automatic original detection sensor	B			○	11-12

- \* a, b. Original glass/ADF original glass  
 Clean both sides of the original glass and ADF original glass. Also clean the film attached to the DF original glass in order to wipe off any dirt or paper dust.  
 Make sure that there is no dust on the mirrors-1, -2, -3 and lens after cleaning. Then install the original glass and ADF original glass.

### Notes:

- Make sure that there is no fingerprints or oil staining on part of the original glass on where the original scale is mounted since the shading correction plate is located below the scale to be scanned.
- Do not use such solvents as alcohol when cleaning the surface of the ADF original glass, because it is coated so as not to be scratched by originals.
- When cleaning the original glass with alcohol, do so only for the stained areas because fog may appear.

## 7.8.2 Laser optical unit

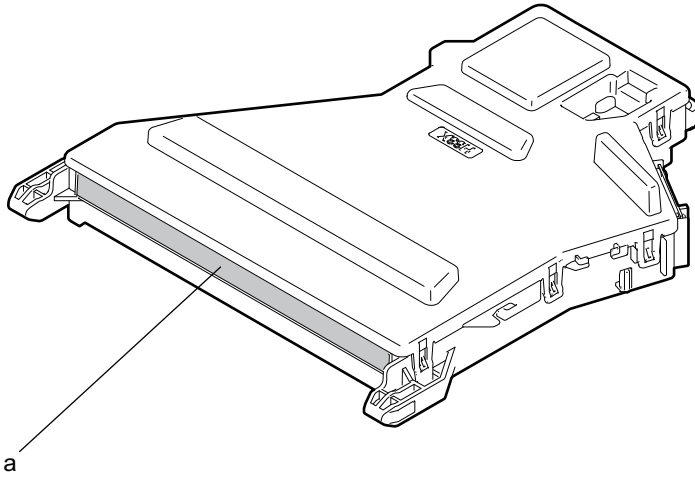


Fig. 7-8

Items to check		Cleaning	Lubrication	Replacement (x 1,000 sheets)	Operation check	Parts list <P- I>
a	Slit glass	B				10-1

### 7.8.3 Paper feeding section

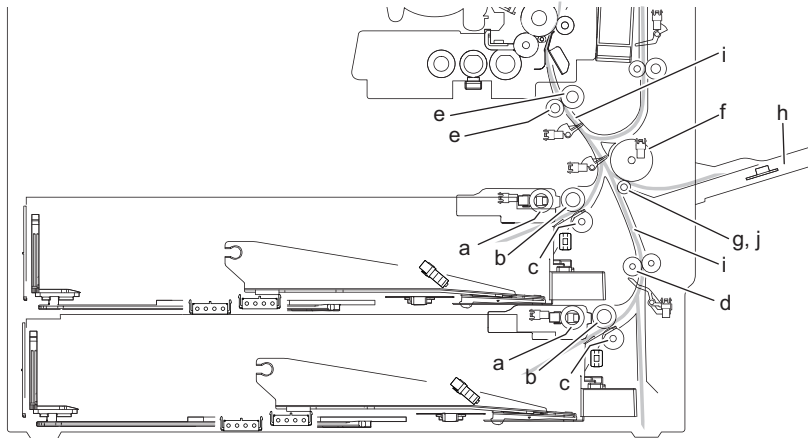


Fig. 7-9

Items to check		Cleaning	Lubrication	Replacement (x 1,000 sheets)	Operation check	Parts list <P- I>
a	Pick-up roller			R1 80/80/80/80/80/80		16-29
b	Feed roller			R1 80/80/80/80/80/80		16-43
c	Separation roller		AV, W2	R1 80/80/80/80/80/80		16-30
d	Transport roller	A		R3		16-35
e	Registration roller	A		R3		12-17 20-3
f	Bypass Feed roller			R1 80/80/80/80/80/80		19-19
g	Bypass Separation roller		AV, W2	R1 80/80/80/80/80/80		19-37
h	Bypass tray	B				18-2 18-13
i	Paper guide	B				
j	Bypass separation roller holder		W2			19-24

\* e. Registration roller (Pusher)

Apply grease to the 2 contact points (at the front and rear) of the registration roller (rubber) and the pusher in the following manner.

Pusher at the front side (white): 2-rice sized grains of Molykote (EM-30L)

Pusher at the rear side (black): 2-rice sized grains of FLOIL (GE-344C)

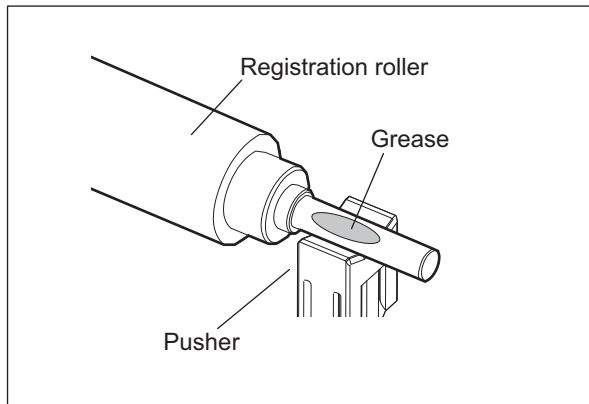


Fig. 7-10



## 7.8.4 Drum related section

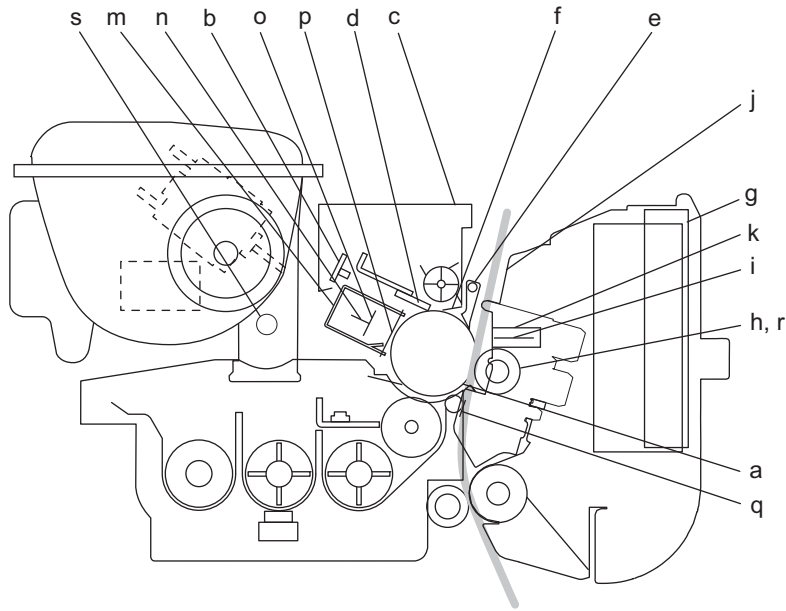


Fig. 7-11

Items to check		Cleaning	Lubrication	Replacement (x 1,000 sheets)	Operation check	Parts list <P- I>
a	Photoconductive drum			R1 80/100/120/125/ 150/150		
b	Discharge LED	B				26-32
c	Whole cleaner unit	B				
d	Drum cleaning blade			R1 80/100/120/125/ 150/150		26-8
e	Separation finger for drum			R1 80/100/120/125/ 150/150		26-12
f	Recovery blade	B		R1 80/100/120/125/ 150/150		26-10
g	Ozone filter			R1 240/200/240/250/ 300/300		12-14
h	Transfer roller			R1 80/100/120/125/ 150/150		25-1 25-5
i	Separation needle	B		R3		25-1 25-11
j	Transfer guide	B				25-1 25-2
k	Separation cover	B				26-12
m	Main charger case	B				24-1
n	Needle electrode			R1 80/100/120/125/ 150/150		24-1 24-6

Items to check		Cleaning	Lubrication	Replacement (x 1,000 sheets)	Operation check	Parts list <P- I>
o	Main charger wire cleaner			R3	○	24-1 24-14
p	Main charger grid			R1 80/100/120/125/ 150/150		24-1 24-11
q	Front-transfer guide	B				25-1 25-14
r	Transfer roller gear	B				25-9
s	Toner cartridge drive gear shaft		W1			
t	Contact point of terminals	B				

\* d. Drum cleaning blade

Since the edge of the blade is vulnerable and can be easily damaged by factors such as the adherence of paper dust. Replace the cleaning blade with new ones if poor images are printed due to the damaged blade regardless of the number of output pages if which have been made.

\* e. Separation fingers for drum

The paper jam may be caused if the tip of the separation finger is damaged or deformed. If there is any problem with it, replace the finger with a new one regardless of the number of output pages which have been made.

If any mark which was made by the finger appears on the printed image, clean the tip of the finger.

**Notes:**

- Wipe the tip of the finger lightly with a dry cloth trying not to deform it.
- Do not leave the lint on the tip.
- Apply patting powder to the tip of the fingers and drum surface after replacing or cleaning them to reduce the load on the drum surface by the finger.

\* f. Recovery blade

Replace the recovery blade regardless the number of output pages if the edge of the blade get damaged.

When cleaning the inside of the cleaner unit, be careful of the following in order not to damage the film attached on the toner recovery auger:

- Do not use an air blower for cleaning (Use a vacuum cleaner).
- When using a vacuum cleaner, be careful not to hit the nozzle of the vacuum cleaner to the film.
- When rotating the toner recovery auger, rotate it only in the same direction as that for transporting toner.

\* h. Transfer roller

If there is damage on the roller, replace it even if the replacement time has not come.

\* i. Separation needle

When cleaning the separation needle, be careful not to bend the needlepoint or leave lint on the needlepoint. If removing the dust is difficult, use brush to remove it.

\* j. Transfer guide

If there is paper dust in the whole transfer unit including the transfer guide, wipe them with a dry cloth. If the transfer guide is removed, clean the wall inside the unit.

\* m, n. Main charger case/Needle electrode

Clean the main charger case with a cloth soaked in water and squeezed tightly, and then wipe them with a dry cloth.

Clean the needle electrode only with the main charger cleaner.

Replace the needle electrode with a new one if it is damaged regardless of the number of output pages which have been made.

**Notes:**

Do not touch the needle electrode with your bare hand when attaching the needle electrode.

## 7.8.5 Developer section

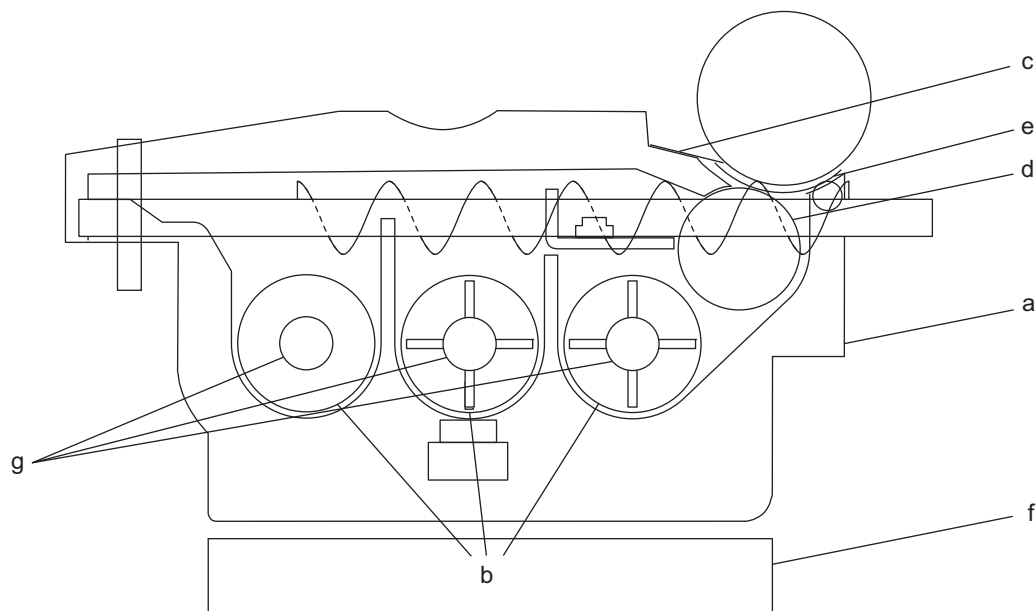


Fig. 7-12

Items to check		Cleaning	Lubrication	Replacement (x 1,000 sheets)	Operation check	Parts list <P- I>
a	Whole developer unit	B				
b	Developer material			R1 80/100/120/125/ 150/150		
c	Front shield	B		R3		27-32
d	Guide roller	B				27-26 27-37
e	Side shield	B		R3		27-30 27-31
f	Developer unit lower stay	B				
g	Oil seal (6 pcs.)		AV	R3		27-1 28-8 28-12

\* a. Do not use alcohol for cleaning the developer unit.

\* b. Developer material  
After replacing the developer material, be sure to perform the auto-toner adjustment.  
📖 P. 6-2 “6.1.2 Adjustment of auto-toner sensor”

\* g. Oil seal  
Mixer unit (Shafts of mixers 1, 2 and 3) 6 pcs.

During replacement, coat the oil seal with grease (Alvanian No.2).

- (1) Push in a new oil seal parallel to the mounting hole section of the developer frame or outside of the holder.  
\* Pay attention to the direction in which the oil seal is attached. (See the following figure.)
- (2) Apply an even coat of grease to the inside of the oil seal.  
Amount: About two small drops
- (3) Wipe off any grease the exudes from the inside.

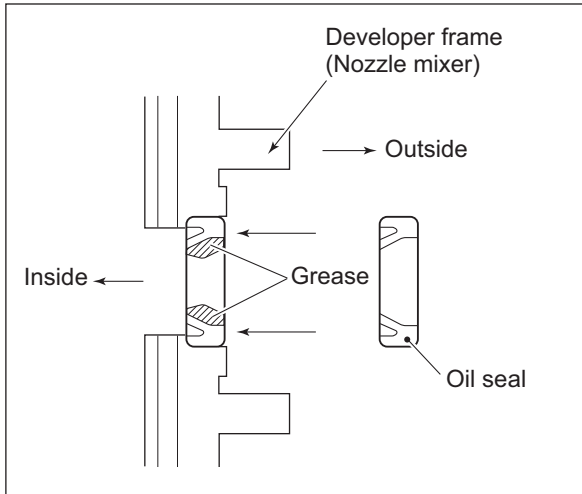


Fig. 7-13

## 7.8.6 Fuser unit

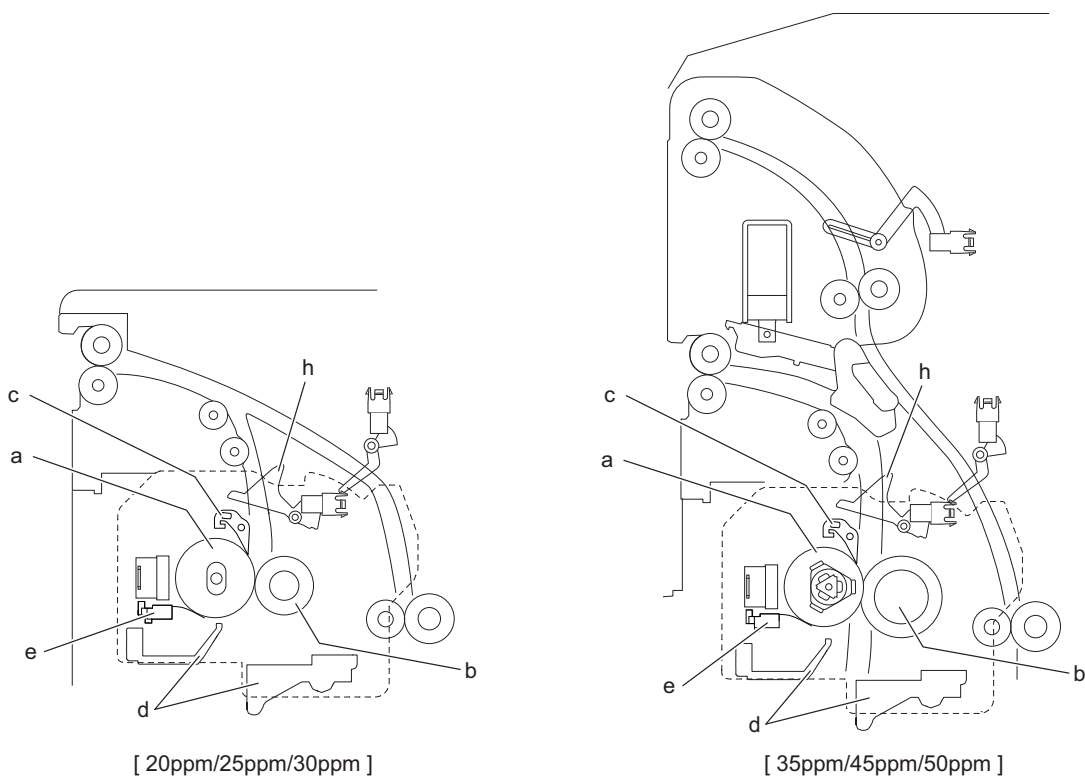


Fig. 7-14

Items to check		Cleaning	Lubrication	Replacement (x 1,000 sheets)	Operation check	Parts list <P- I>
a	Fuser roller	A		R1 240/200/240/250/ 300/300		31-15
b	Pressure roller	A		R1 240/200/240/250/ 300/300		31-20
c	Separation finger for fuser roller	A		R1 240/200/240/250/ 300/300		31-26
d	Fuser unit entrance guide	A				30-11 31-12
e	Thermistor (3 pcs.)	A		R3		31-4
f	Drive gear (tooth face and shaft)		W2	R3		31-17
g	Fuser roller gear			R3		31-17
h	Exit sensor actuator	A				32-24

- \* a. Fuser roller  
Do not deform or damage the fuser roller during the cleaning.
- \* b. Pressure roller  
Do not deform or damage the pressure roller during the replacing.  
Do not deform or damage the pressure roller during the cleaning.
- \* c. Separation fingers for fuser roller  
The paper jam may be caused if the tip of the finger is damaged or deformed. If there is any problem with it, replace the finger with a new one regardless of the number of output pages which have been made. Do not damage the tip of the finger during the cleaning. The finger may be damaged if the toner adhering to the tip of it is scraped off forcibly. Replace the finger if the toner is sticking to it heavily.
- \* e. Thermistor  
Clean the thermistor with alcohol if the toner or dirt is sticking to it when the fuser roller is replaced.  
Do not deform or damage the thermistor during the cleaning. Replace the thermistor with a new one if it is damaged or deformed regardless of degree.
- \* h. Exit sensor actuator  
If toner has adhered, wipe it off with alcohol.

## 7.8.7 Paper exit section / Reverse section

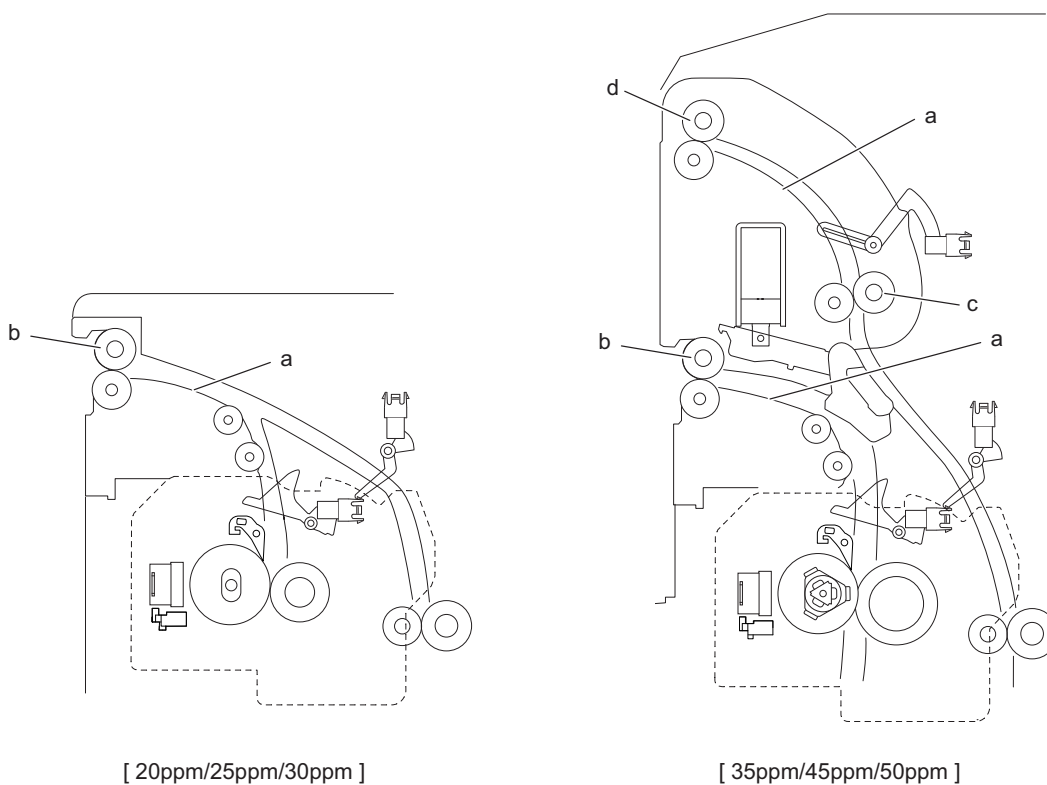


Fig. 7-15

Items to check		Cleaning	Lubrication	Replacement (x 1,000 sheets)	Operation check	Parts list <P-I>
a	Exit/reverse guide	A				39-8
	Exit/reverse guide (Upper)	A				39-20
b	Exit roller (20ppm/25ppm/ 30ppm)	A		R3		39-11
	Lower exit roller (35ppm/ 45ppm/50ppm)	A		R3		39-11
c	Reverse roller	A		R3		31-32
d	Upper exit roller	A		R3		39-31
e	Drive gear		W1			39-24 39-47
f	Conductive bushing		CG			39-40

\* b. Exit roller / Lower exit roller

\* c. Reverse roller

\* d. Upper exit roller

Clean the pinch rollers facing the above rollers with alcohol at the same time as them.



## 7.8.8 Automatic duplexing unit

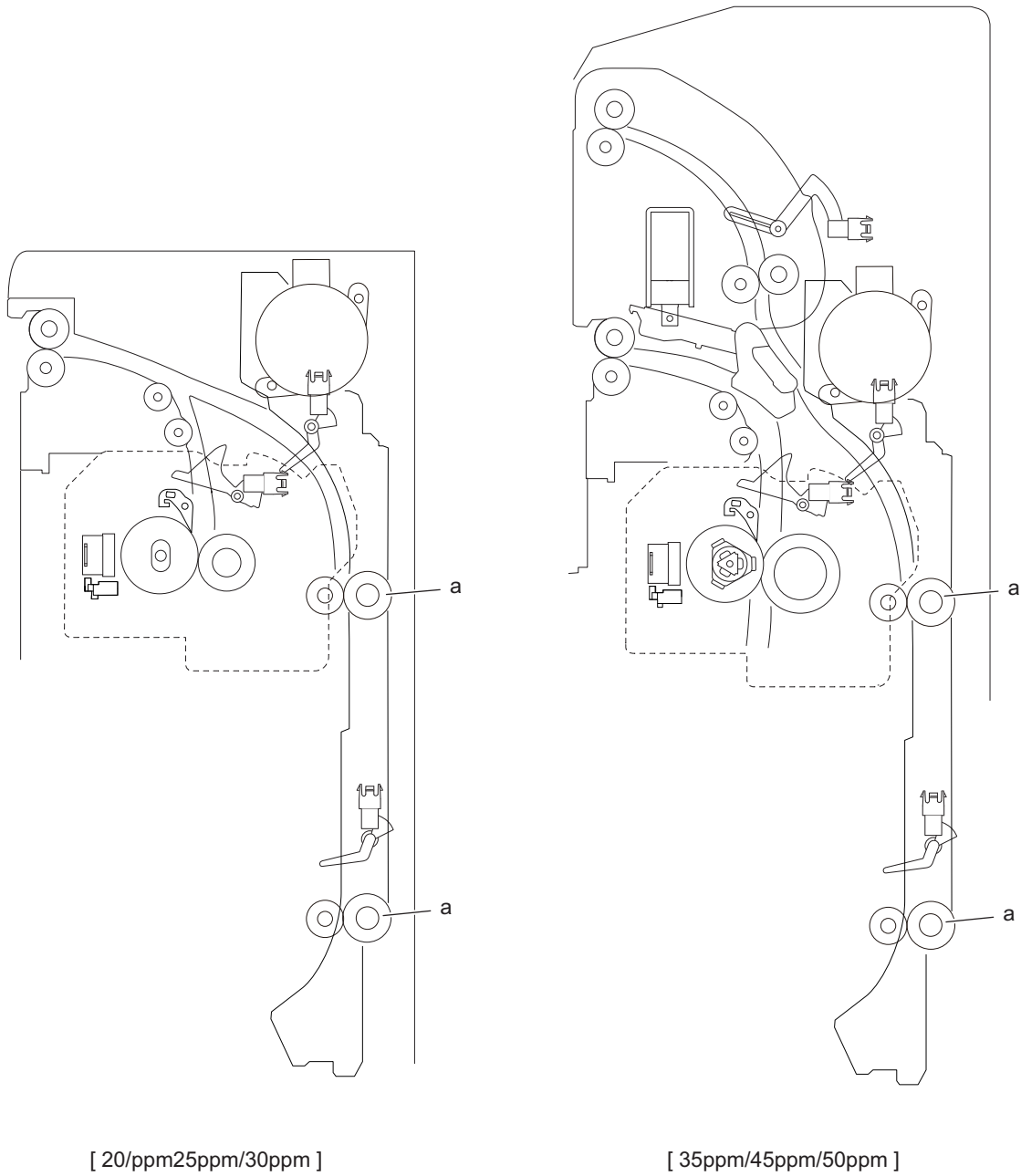


Fig. 7-16

Items to check		Cleaning	Lubrication	Replacement (x 1,000 sheets)	Operation check	Parts list <P-I>
a	Transport roller (upper and lower)	A		R3		33-10
b	Drive gear		W1			33-14

- \* a. Transport roller (upper and lower)  
Clean the pinch rollers facing the above rollers with alcohol at the same time as them.

## 7.8.9 DSDF

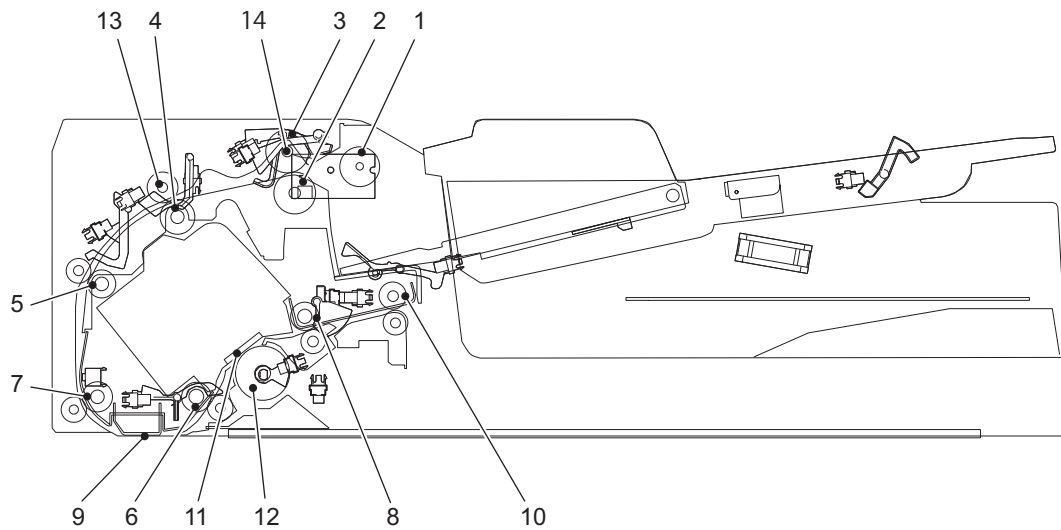


Fig. 7-17

	Items to check	Cleaning *1	Lubrication/ Coating *1	Replacement (x 1,000)	Operation check	Parts list <P-I>	Remarks
1	DSDF pickup roller	A		R1 120		1-18	*2
2	DSDF separation roller	A		R1 120		5-21	
3	DSDF feed roller	A		R1 120		1-14	
4	DSDF registration roller	A				7-14	
5	Pre-read roller-1	A				7-13	
6	Pre-read roller-2	A				7-21	
7	Post-read roller-1	A				14-12	
8	Post-read roller-2	A				11-15	
9	Reading guide	A				15-3	
10	DSDF exit roller	A				11-12	
11	DSDF-CCD original glass	B				5-22	
12	Shading plate	A				12-14	
13	Registration pinch roller shaft		W			4-2	
14	DSDF feed roller shaft		W			1-21	*3

\* Page-Item (P-I) is described in the column of the Parts list.

\*1: Perform cleaning / lubrication for the DSDF at the same interval as for the main equipment to which the DSDF is connected.

\*2: When the DSDF pickup roller is replaced, clean its shaft holes in the DSDF pickup unit.

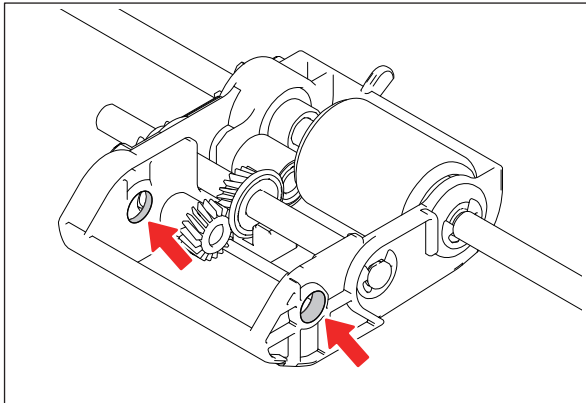


Fig. 7-18

\*3: Remove the DSDF pickup unit. Release the hook. Remove the lever from the DSDF pickup unit. Apply grease (Molykote EM-30L) by 0.01 cc to the edge of the shaft. (See the figure below.)

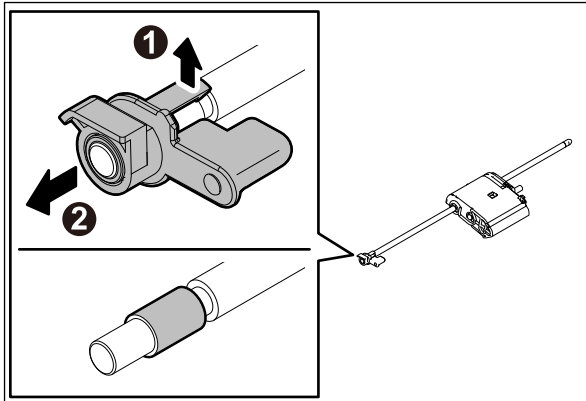


Fig. 7-19

## 7.8.10 RADF

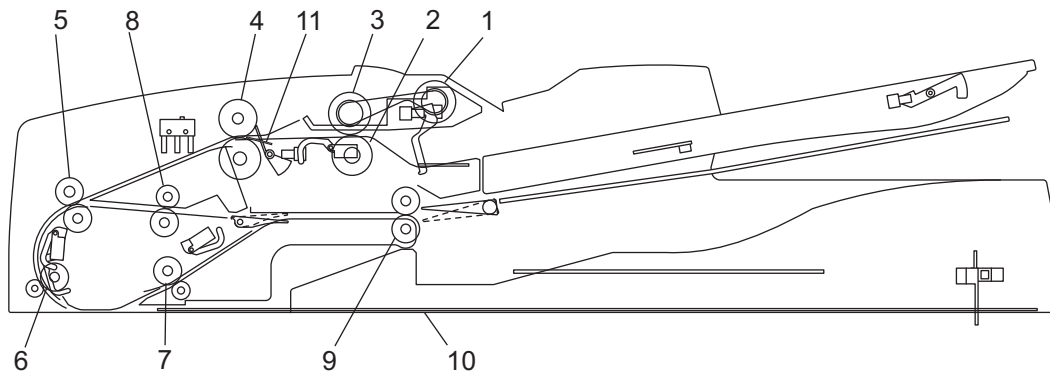


Fig. 7-20

	Items to check	Cleaning	Lubrication/ Coating	Replacement		Operation check	Parts list <P-I>
				(x 1,000 sheets)	(x 1,000 drive counts)		
1	Pick-up roller	A		R1 120	-		5-27
2	Separation roller	A		R1 120	-		4-10
3	Feed roller	A		R1 120	-		5-27
4	Registration roller	A					4-30
5	Intermediate transfer roller	A					3-13
6	Front read roller	A					3-14
7	Rear read roller	A					3-1
8	Reverse registration roller	A					3-10
9	Exit/reverse roller	A					4-25
10	Platen sheet	A or B					1-25
11	Registration roller front sheet*			R1 120			

\* Registration roller front sheet: Attached on the feeder lower guide.

## 7.8.11 PFP

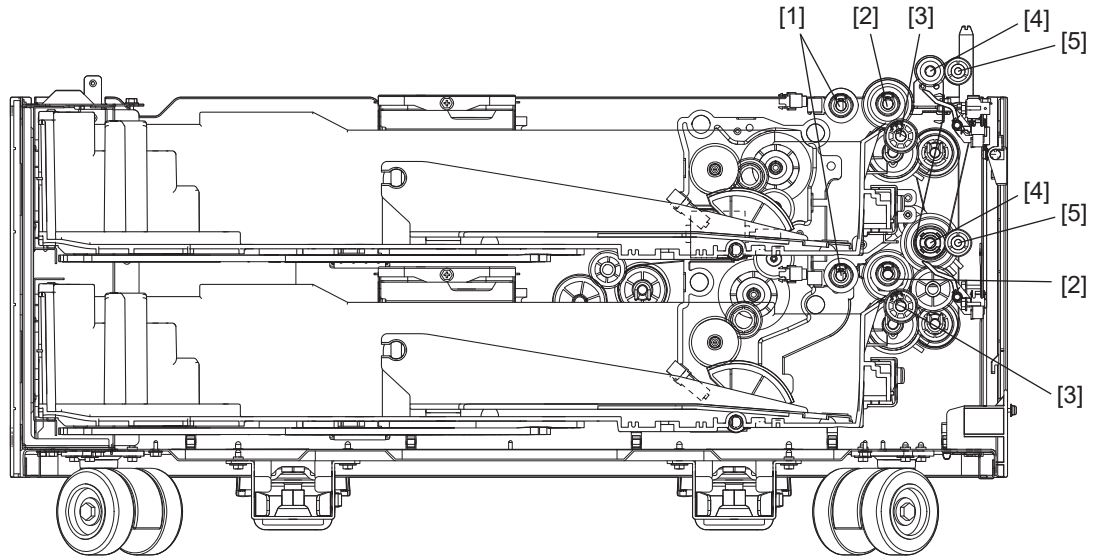


Fig. 7-21

	Items to check	Cleaning	Lubrication/ Coating	Replacement		Operation check	Parts list <P->
				(x 1,000 sheets)	(x 1,000 drive counts)		
1	Pick-up roller (upper/lower)	A		80 or every 2.5 years, whichever comes first			5-26
2	Feed roller (upper/lower)	A		80 or every 2.5 years, whichever comes first			5-26
3	Separation roller (upper/lower)	A		80 or every 2.5 years, whichever comes first			5-30
4	Transport roller (tooth face)	A		R			2-35 2-40
5	Idling roller (upper/lower) Clean the inner diameter of the idling roller and the shaft.	A	W1				4-2
6	Paper guide	B					4-1 4-11

## 7.8.12 LCF

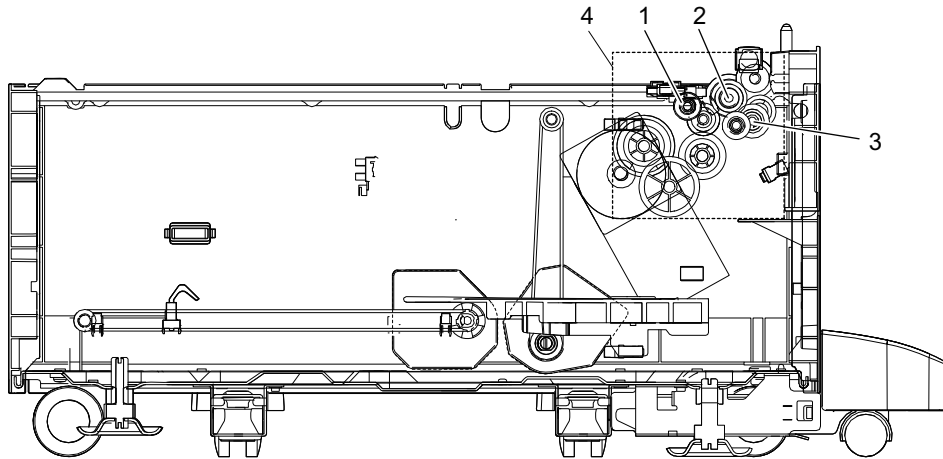


Fig. 7-22

Items to check		Cleaning	Lubrication/ Coating	Replacement		Operation check	Parts list <P-I>
				(x 1,000 sheets)	(x 1,000 drive counts)		
1	Pick-up roller	A		160			4-4
2	Feed roller	A		160			4-3
3	Separation roller	A		160			5-8
4	Drive gear (tooth face)		W1				-

## 7.8.13 Job separator (MJ-5014)

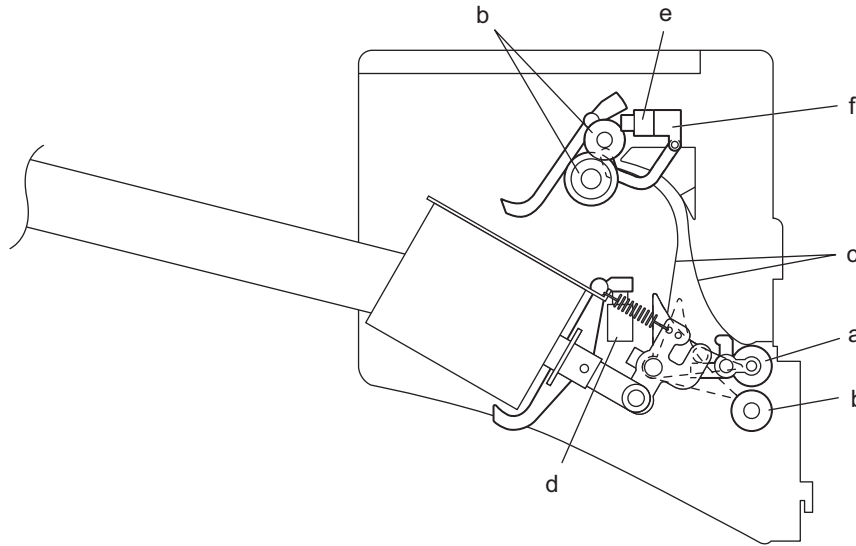


Fig. 7-23

Items to check		Cleaning	Lubrication	Replacement (x 1,000 sheets)	Operation check	Parts list <P->
a	Idling roller	A or B	W1			
b	Other rollers	A or B				
c	Paper guide	A or B				
d	JSP upper stuck sensor	B			○	1-51
e	JSP lower stuck sensor	B			○	1-12
f	JSP paper jam sensor	B			○	

\* a. Idling roller

Apply one-rice-grain-amount of white grease (Molykote EM-30L) to each part A in the figure below.

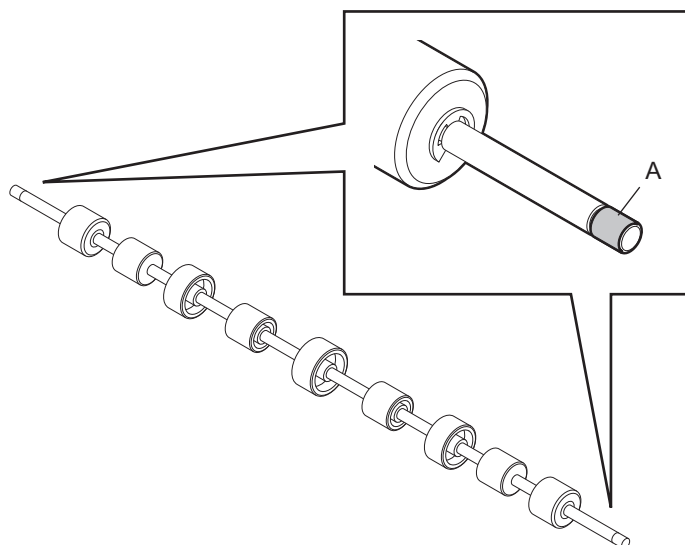


Fig. 7-24

## 7.8.14 Inner Finisher

Item	Interval	Description	Remarks
Transport roller	Every 30,000 of paper feeding times	Cleaning	Wipe with a cloth soaked in water and then tightly squeezed.
Small roller in the paper transport section			
Transport path and guides			
Transport path sensor			Wipe with a dry cloth.
Grease application to drive unit	As needed	Applying grease	EM-50L
Paper detection sensor	Minimum maintenance interval set for the equipment	Cleaning	Wipe with a dry cloth or alcohol



## 7.8.15 Saddle stitch finisher / Finisher

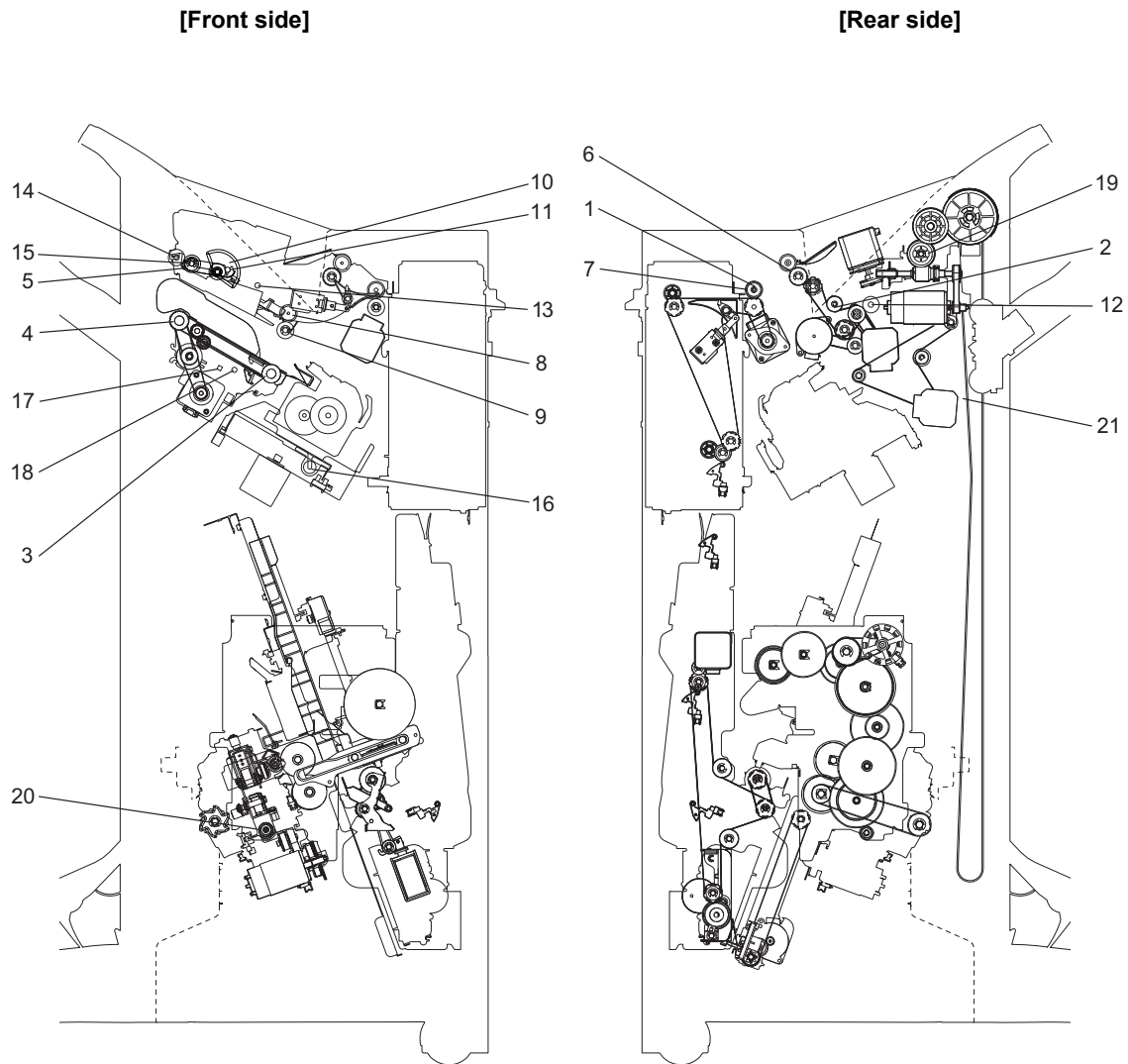


Fig. 7-25

Items to check		Cleaning	Lubrication	Replacement (x1,000)	Operation check	Parts list (P-I)	Remarks
1	Entrance sensor (S1)	A					
2	Transport sensor (S2)	A					
3	Stack transport roller-1	A					
4	Stack transport roller-2	A					
5	Buffer roller	A					
6	Exit roller	A					
7	Entrance roller	A					
8	Transport roller	A					
9	Paddle			1,000			
10	Front assist guide cam/ Rear assist guide cam		C				*a
11	Buffer roller link		W3				*b
12	Shaft		W3				*c

Items to check		Cleaning	Lubrication	Replacement (x1,000)	Operation check	Parts list (P-I)	Remarks
13	Buffer tray shaft		W3				*d
14	Pinch roller shaft		W3				*e
15	Buffer roller shaft		W3				*f
16	Stapler carrier shaft		W3				*g
17	Rack gear (Aligning plate)		W3				*h
18	Finishing tray shaft		W3				*i
19	Movable tray drive gear		W2				*j
20	Additional folding unit carrier shaft		W3				*k
21	Grate-shaped guide	A	C				*l

**\*a Front assist guide cam/Rear assist guide cam**

Apply coating material (SANKOL CFD-409M) by using a cleaning brush to the portion on the guide with which the all around the assist guide cam [1].

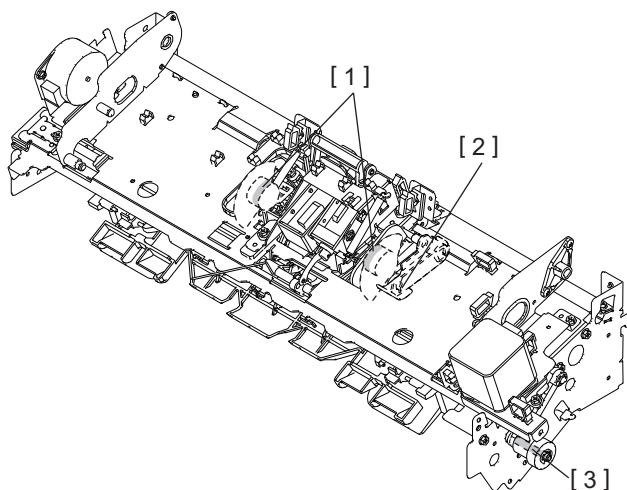
- \* Use a cleaning brush (4407915710 BRUSH-33) because cloth contaminated with the coating material shall be treated as industrial waste.
- \* Do not apply coating material to the rubber section.
- \* When coating material adheres to the skin, rinse it well with water.
- \* The brush with which the coating agent (SANKOL CFD-409M) was applied must be exclusive for coating. Do not use it to clean other areas.

**\*b. Buffer roller link**

Apply an adequate amount of white grease (Molykote EM-30L) to the entire buffer roller link [2].

**\*c. Shaft**

Apply an adequate amount of white grease (Molykote EM-30L) to the entire shaft [3].



**Fig. 7-26**

**\*d. Buffer tray shaft**

Apply an adequate amount of white grease (Molykote EM-30L) to the entire buffer tray shaft [1].

**\*e. Pinch roller shaft**

Apply an adequate amount of white grease (Molykote EM-30L) to the entire pinch roller shaft [2].

\*f. Buffer roller shaft

Apply an adequate amount of white grease (Molykote EM-30L) to the entire buffer roller shaft [3].

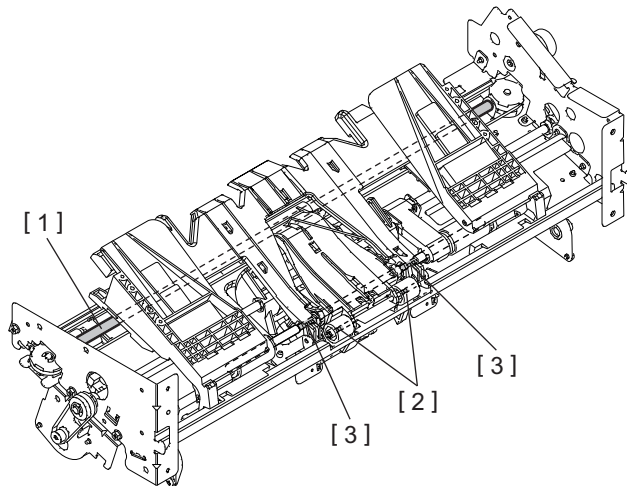


Fig. 7-27

\*g. Stapler carrier shaft

Apply an adequate amount of white grease (Molykote EM-30L) to the entire stapler carrier shaft [1].

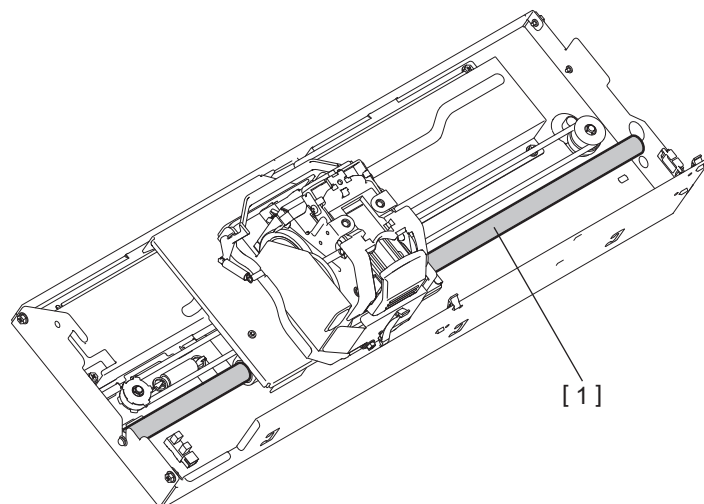


Fig. 7-28

\*h. Rack gear (Aligning plate)

\*i. Finishing tray shaft

1. Take off the junction box unit.

\* If the hole punch unit is installed, take it off beforehand.

2. Apply oil as follows through the opening which shows up when the junction box unit has been removed.

Apply an adequate amount of white grease (Molykote EM-30L) to the gear teeth of the rack gear [1] which drive the aligning plate, and the entire finishing tray shaft [2].

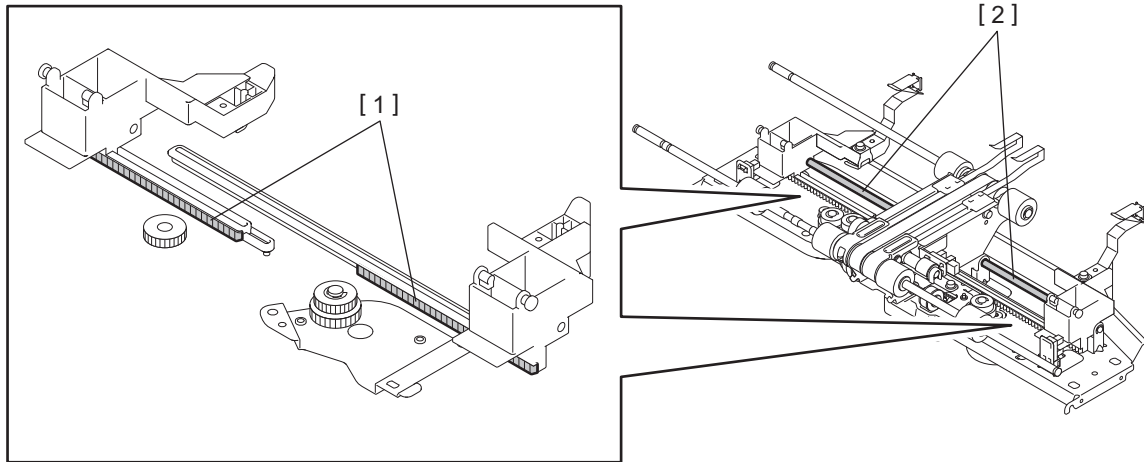


Fig. 7-29

\*j. Movable tray drive gear

Apply an adequate amount of white grease (Molykote HP-300) to the gear teeth of the movable tray drive gear [1].

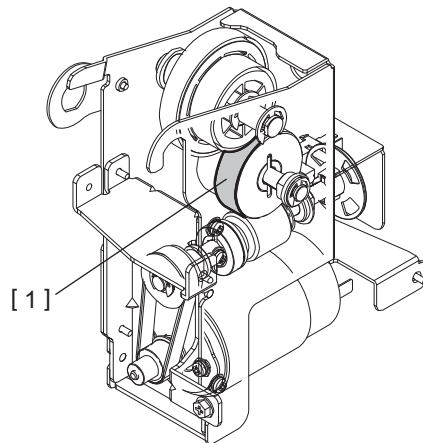


Fig. 7-30

\*k Additional folding unit carrier shaft

Apply an adequate amount of white grease (Molykote EM-30L) to the entire Additional folding unit carrier shaft [1].

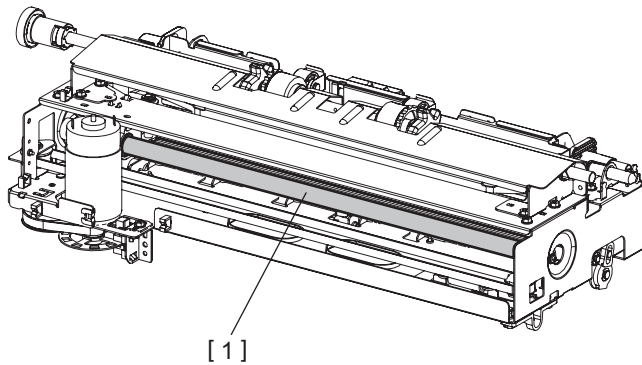


Fig. 7-31

\*l Grate-shaped guide

When an abnormal noise occurs in the grate-shaped guide or the trailing edge of the paper stacked on the tray is dirty, apply coating material (SANKOL CFD-409M) by using a cleaning brush to the portion on the guide with which the paper edge is in contact.

- \* Use a cleaning brush (4407915710 BRUSH-33) because cloth contaminated with the coating material shall be treated as industrial waste.
- \* Do not apply coating material (Molykote PD-910) to the rubber section of the grate-shaped tray.
- \* When coating material adheres to the skin, rinse it well with water.
- \* The brush with which the coating agent (SANKOL CFD-409M) was applied must be exclusive for coating. Do not use it to clean other areas.

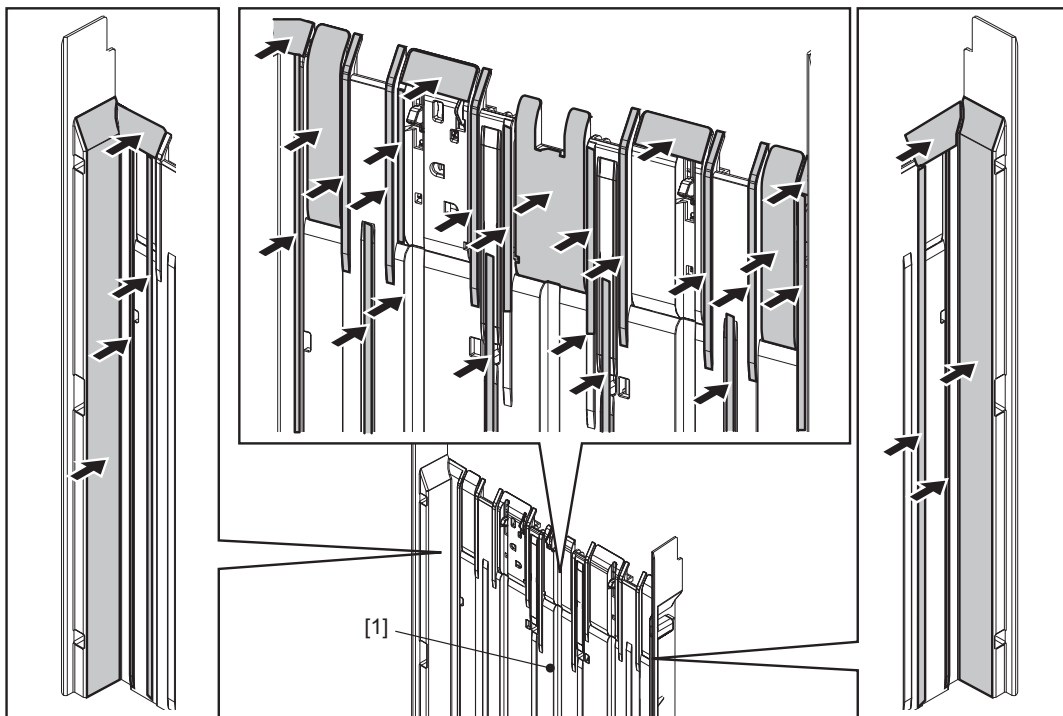


Fig. 7-32

## 7.8.16 Hole punch unit (MJ-6105)

Items to check*1		Cleaning	Lubrication *2	Replacement (x1,000)	Operation check	Parts list (P-I) *3
1	Transport roller	A			O	
2	Sensors	B				
3	Drive gears		W1		O	
4	Punched scrap container	Dispose of the punched paper bits.				
5	Punching unit *4			R1 1000		

\*1 : Perform maintenance in the timing of preventive maintenance of the equipment.

\*2 : Be careful not to put oil on the rollers, belts and belt pulleys when lubricating.

\*3 : Page-Item (P-I) is described in the column of the Parts list.

\*4 : This unit may require replacement once or more over the period of machine warranty because of deterioration or damage. Replace them as needed.

## 7.9 Machine Refreshing Checklist

The check items for each unit at the machine refreshment are shown below.  
Symbols/value used in the checklist

Item	Description
Cleaning	A: Clean with alcohol B: Clean with soft pad, cloth or vacuum cleaner
Lubrication / Coating	W1: White grease (Molykote EM-30L) W2: White grease (Molykote HP-300)
Replacement	Value: Replacement cycle R1: Replacement R2: For preventive maintenance, check if the parts are damaged and replace them as required. If the parts are not replaced at the machine refreshing interval, inspect them at the subsequent PM. R3: Replace if deformed or damaged. If the parts are not replaced at the machine refreshing interval, inspect them at the subsequent PM. R4: Lubrication recommended: If the parts are not lubricated at the machine refreshing interval, inspect their lubrication status at the subsequent PM.
Operation check	O: After cleaning or replacement, confirm there is no problem.

### Notes:

- When performing machine refreshment, check the items in the preventive maintenance checklist in addition to the items in the machine refreshing checklist.
- Perform cleaning and lubricating in the following timing. Lubricate the replacement parts according to the replacement cycle.

Model	Replacement cycle
20ppm	400,000 sheets
25ppm	500,000 sheets
30ppm	600,000 sheets
35ppm	625,000 sheets
45ppm	750,000 sheets
50ppm	750,000 sheets

- The value in the “Replacement” field of the table below indicates the replacement number of output pages in either the black mode.
- The replacement cycle of the parts in the feeding section equals to the number of sheets fed from each paper source.
- Be careful not to put oil on the rollers, belts and belt pulleys when lubricating.
- Parts list <P-I> represents the page item in “e-STUDIO2018A/2518A/3018A/3518A/4518A/5018A Service Parts List”.

Items to check		Cleaning	Lubrication	Replacement (x 1,000 sheets)	Operation check	Parts list <P-I>
1	Drum drive unit		W1	R4		-
2	Development drive unit		W1	R4		-
3	Paper feeding drive unit		W1	R4		-
4	Fuser unit drive gear		W1	R4		-

## 7.10 Precautions for Storing and Handling Supplies

### 7.10.1 Precautions for storing TOSHIBA supplies

- Toner/Developer  
Toner and developer should be stored in a place where the ambient temperature is between 10°C to 35°C (no condensation), and should also be protected against direct sunlight during transportation.
- Photoconductive drum  
Like the toner and developer, photoconductive drum should be stored in a dark place where the ambient temperature is between 10°C to 35°C (no condensation). Be sure to avoid places where drums may be subjected to high humidity, chemicals and/or their fumes.  
If drums are left near a window exposed to direct sunlight or intense light, they will be worn out. Due to this, fogging may occur immediately after installing in the equipment.
- Drum cleaning blade  
This item should be stored in a flat place where the ambient temperature is between 10°C to 35°C, and should also be protected against high humidity, chemicals and/or their fumes.
- Fuser roller / Pressure roller  
Avoid places where the rollers may be subjected to high humidity, chemicals and/or their fumes.
- Paper
  - Avoid storing paper in places where it may be subjected to high humidity. After a package is opened, be sure to place and store it in a storage bag.
  - When using thick paper whose weight is 157 g/m<sup>2</sup> or more, select that which is being stored in a place where the temperature is 19 to 25°C and the RH is 45 to 70%.
- Transfer roller  
Transfer roller should be stored in a place where the ambient temperature is between 10°C to 35°C (no condensation). Be sure to avoid places where transfer roller may be subjected to high humidity, chemicals and/or their fumes.



## 7.10.2 Checking and cleaning of photoconductive drum

### 1. Use of gloves

If fingerprints or oil adhere to the drum surface, the property of the photoconductive drum may degrade, affecting the quality of the print image. So, do not touch the drum surface with your bare hands.

### 2. Handling precautions

As the photoconductive drum surface is very sensitive, be sure to handle the drum carefully when installing and removing it so as not damage its surface.

Be sure to apply "patting powder" (lubricant) to the entire surface of the drum (including both ends of the drum where OPC is not coated) when replacing the drum. When the drum has been replaced with a new one, the drum counter (the Setting Mode FS-08-6250-0, 3, 6 and 7) must be cleared to 0 (zero).

This clearing can be performed in the 20 PM Support Mode.

#### Notes:

- Application of patting powder is for reducing the friction between the drum and cleaning blade. If the application of patting powder is neglected, the drum and cleaning blade may be damaged.
- When paper fibers or thread adhere to the cleaning blade edge, they may reduce the cleaning efficiency and, in addition, may damage the blade and the drum. Be sure to remove any fibers found adhering to the blade.

### 3. Installation of the equipment and storage of drum

Avoid installing the equipment where it may be subjected to high temperature, high humidity, chemicals and/or their fumes.

Do not place the light drum in a location where it is exposed to direct sunlight or high intensity light such as near a window. Otherwise the drum will fatigue, and will not produce sufficient image density immediately after being installed in the equipment.

### 4. Cleaning the drum

At preventive maintenance calls, wipe the entire surface of the drum clean using the designated cleaning cotton. Use sufficiently thick cleaning cotton (dry soft pad) so as not to scratch the drum surface inadvertently with your fingertips or nails. Also, remove your rings and wristwatch before starting cleaning work to prevent accidental damage to the drum.

Do not use alcohol, selenium refresher and other organic solvents or silicon oil as they will have an adverse effect on the drum.

### 5. Scratches on photoconductive drum surface

If the surface is scratched in such a way that the aluminum substrate is exposed, no print image will be produced on this area. In addition, the cleaning blade will be damaged so replacement with a new drum will be necessary.

### 6. Collecting used photoconductive drums

Regarding the recovery and disposal of used photoconductive drums, we recommend following the relevant local regulations or rules.

### 7.10.3 Checking and cleaning of drum cleaning blade

- Handling precautions  
Pay attention to the following points as the cleaning blade life is determined by the condition of its edge:
  - Do not allow hard objects to hit or rub against blade edge.
  - Do not rub the edge with a cloth or soft pad.
  - Do not leave oil (or fingerprints, etc.) on the edge.
  - Do not apply solvents such as paint thinner to the blade.
  - Do not allow paper fibers or dirt to contact the blade edge.
  - Do not place the blade near a heat source.
- Cleaning procedure  
Clean the blade edge with a cloth moistened with water and squeezed lightly.

#### Notes:

- Remove the cleaning and recovery blades before sucking the dirt from the cleaner.
- It should be cleaned by suction since the PET sheet attached to the toner recovery auger may be damaged if air blowing is used. Be careful not to allow the suction nozzle to contact with the PET sheet. This may damage the PET sheet.

### 7.10.4 Checking and cleaning of fuser roller and pressure roller

- Handling precautions
  - Fuser roller  
Do not leave any oil (fingerprints, etc.) on the fuser roller.  
Be careful not to allow any hard object to hit or rub against the fuser roller, or it may be damaged, possibly resulting in poor cleaning.
  - Pressure roller  
Do not leave any oil (fingerprints, etc.) on the pressure roller.
- Checking
  - Check for stain and damage on the fuser and pressure rollers, and clean if necessary.
  - Check the separation guide and fingers and check for chipped tips.
  - Check the thermistors for proper contact with the pressure roller.
  - Check the fused and fixed condition of the toner.
  - Check the gap between the entrance guide and pressure roller.
  - Check the fuser roller for proper rotation.
- Cleaning procedure  
When fuser roller and pressure roller become dirty, they will cause jamming. If this happens, wipe the surface clean with a piece of soft cloth. For easier cleaning, clean the roller while they are still warm.

#### Notes:

- Be careful not to rub the fuser roller and pressure roller surface with your nails or hard objects because it can be easily damaged. Do not use silicone oil on the fuser roller and pressure roller.

## 7.10.5 Checking and replacing the transfer roller

- Handling precautions
  - Wear gloves to avoid touching the drum surface with your bare hands.
  - Do not allow oil or fingerprints to come in contact with the surface.
  - Do not hit or scratch the surface.
  - Make sure you do not get any bits of thread, etc. on the surface.
  - Do not allow solvent, such as thinner, to come in contact with the surface.
  - Keep away from a source of heat.
- Cleaning procedure

If bits of thread or similar adhere to the surface, remove them with gloves or a pair of tweezers. Be careful that the roller surface is not damaged by the points of the tweezers.

## 7.11 PM KIT

A PM kit is a package that includes replacement parts for each unit.

KIT name	Component	Qty.	P-I
DEV-KIT-5008A	Drum cleaning blade	1	26-8
	Recovery blade	1	26-10
	Separation finger for drum	3	26-12
	Main charger grid	1	24-11
	Needle electrode	2	24-6
	Transfer roller	1	25-5
	Developer material	1	-
FR-KIT-5008A	Fuser roller	1	31-15
	Pressure roller	1	31-20B
	Separation finger for fuser roller	5	31-26
	Ozone filter	1	13-14
FR-KIT-3008A	Fuser roller	1	31-20
	Pressure roller	1	31-20A
	Separation finger for fuser roller	5	31-26
	Ozone filter	1	12-14
ROL-KIT-FC30-U *1	Feed roller	1	16-29
	Transport roller	1	16-43
	Separation roller	1	16-30
DF-KIT-3031 *2	Pick-up roller	1	5-13
	Feed roller	1	5-13
	Separation roller	1	4-10
	Registration roller front sheet	3	4-38 4-39
ROL-KIT-1026 *3	Pick up roller	1	4-4
	Feed roller	1	4-3
	Separation roller	1	5-8
KIT-ROL-DSDF (DSDF)	DSDF pick-up roller	1	1-18
	DSDF feed roller	1	1-14
	DSDF separation roller	1	5-21

\*1 For Equipment drawer / PFP drawer / Drawer Module

\*2 For RADF

\*3 For LCF

## 7.12 Maintenance Part List

The parts used for the maintenance of this equipment are as follows.

No.	Item	Purpose	Parts list <P-I>
1	Door switch jig	Used to adjust high-voltage transformer.	101-1
2	Brush	Cleaning inside of the equipment	101-2
3	Doctor sleeve jig	Measuring the gap between the developer sleeve and the doctor blade	101-3
4	Wire holder jig	Fixing the wire at the assembly of the carriage wire	101-5
5	Belt tension jig	Adjusting the belt tension at the installation of the scan motor	101-6
6	High-voltage transformer jig	Used to adjust high-voltage transformer.	101-7
7	Drum bag	Storing the drum	102-21
8	Patting powder	For photoconductive drum	101-17
9	Color test chart (TCC-2)	For test print (A4/LT)	101-22
10	Color test chart (TCC-3)	For test print (A3/LD)	101-23
11	Fuser unit fuse	For fuser unit	101-18
12	Thermostat gap adjustment jig	Used to adjust the gap between the thermostat and the fuser roller	101-9
13	Reverse unit gap confirmation jig	Used to check the gap when the reverse unit is installed	101-24

\* "P-I" represents the page item in the parts list.

Refer to "e-STUDIO2018A/2518A/3018A/3518A/4518A/5018A Service Parts List".

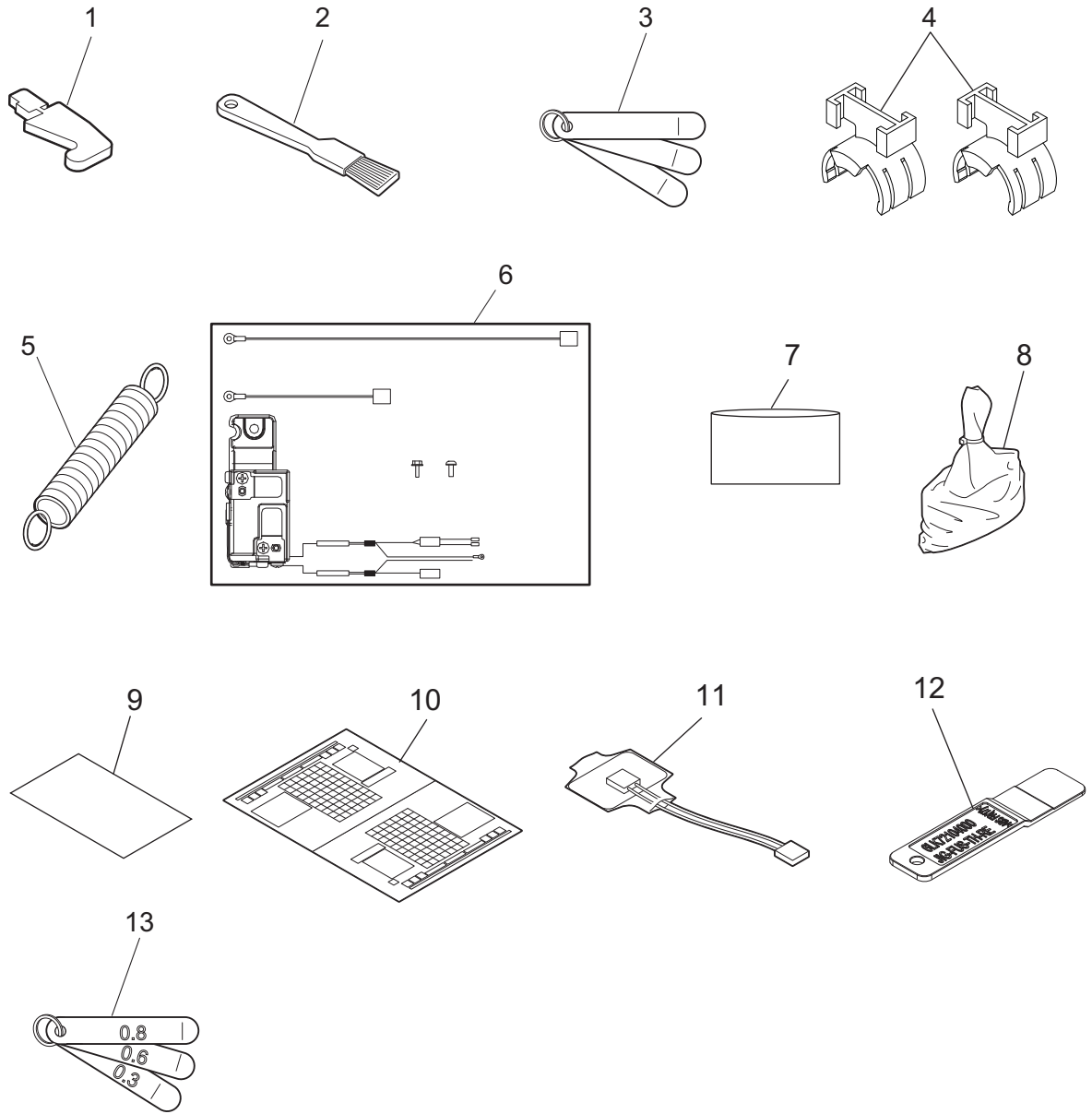


Fig. 7-33

## 7.13 Grease List

The greases used for the maintenance of this equipment are as follows.

Symbol	Grease name	Type	Color	Volume	Container	Parts list <P-I>*
L	Launa 40	Lubricating oil	Yellow or transparent	100 cc	Oiler	101-11
W1	White grease (Molykote EM-30L)	Grease	White	100 g	Bottle	101-14
W2	White grease (Molykote HP-300)	Heat-resisting grease	White	10 g	Bottle	101-12B
AV	Alvania No.2	Grease	Amber	100 g	Tube	101-13
FL	FLOIL (GE-334C)	Conductive grease	Black	20 g	Bottle	101-15
SI	Silicon oil	Lubricating oil	Transparent	100 cc	Bottle	101-16





## 8. ERROR CODE AND TROUBLESHOOTING

### 8.1 General Descriptions

This chapter explains the procedures for solving troubles occurring in the equipment. When a trouble occurs, check if an error code is displayed on the LCD screen of the control panel first. If displayed, refer to “8.2 Error Code List” to figure out the classification and contents of the error, and then refer to “8.3 Diagnosis and Prescription for Each Error Code” to remove its cause. When no error is displayed but the equipment does not operate properly or images are not printed properly, refer to “8.5 Troubleshooting for the Image” to remove its cause.

When troubles have occurred in the equipment, various causes can be considered. Check the items below first.

- Is there any problem with the power cable or an outlet?  
Check if the power cable is inserted securely. When it is almost removed or not inserted securely, power voltage may become unstable, causing a trouble in the equipment.
- Are the connectors connected securely?  
Reconnect them securely. Even if they are apparently inserted, there may be a contact failure. Carefully check if the connection is secured especially after the disassembly or replacement of parts.
- Are there any abnormalities in the setting value of the self-diagnostic code?  
If an abnormal value has been entered in the self-diagnostic code related to the problem, an operation failure may occur. If an abnormal value has been entered in the self-diagnostic code related to the image quality adjustment, defective images may occur. Therefore, check that the proper value has been entered in the self-diagnostic code.
- Are there any similar cases?  
Check if there have been any similar problems in the troubleshooting in the Service Manual. If there are similar cases, refer to their troubleshooting.

#### Notes:

If unusual odor is detected or if smoke or fire comes out of the equipment, immediately turn the power OFF.

Even in the cases other than the above, fully observe safety precautions.

If any PC board or HDD shall be replaced, refer to 9.REPLACEMENT OF PC BOARDS/HDD.


### 8.1.1 If a problem continues even after performing all troubleshooting.

If a problem continues even after performing all troubleshooting and technical tips, report the problem to the appropriate Toshiba service center along with the following information. This information will help the service center understand your problem and take quick action to find the solution.

1. Serial Number
2. List Print

Refer to the appropriate Service Manual for the detailed procedure to obtain a List Print.

- A. Enter the value given below to obtain a List Print by CSV file.  
FS-30-300: All CSV files
- B. Enter the value given below to obtain a List Print by printing it out.  
FS-30-101: 05 ADJUSTMENT MODE  
FS-30-102: 08 SETTING MODE  
FS-30-104: Pixel counter data (Toner cartridge standard)  
FS-30-106: Error history (1000 cases max)  
FS-30-108: Firmware update log (200 cases max)  
FS-30-110: Power on/off log (100 cases max)

3. For an image-related problem, refer to  P. 8-451 “8.5.30 If an image-related problem continues after performing all troubleshooting”.

If a problem nevertheless continues to persist, collect image samples with the problem areas and the feeding direction marked first. Then provide information about the type, size, and weight of the paper along with a copy of the print data / spool file causing the problem.

4. For abnormal acoustic noise, describe the situation in as much detail as possible.
5. For hardware-related problems, provide photos of any broken parts, paper jams, etc.  
In case of paper jams, include the type of paper and its manufacturer.
6. For software-related problems, provide list prints, TopAccess Logs and the detailed procedure needed to duplicate the problem.

\* This is the minimum information required to report a complaint. It would be appreciated if you could obtain additional information.

\* Follow the directions of the service center if they request additional information as each issue is unique to some degree.

## 8.1.2 Collection of debug logs with a USB device

### [ 1 ] General description

The purpose of collecting the debug logs is to acquire the information for analyzing problems which occurred during the MFP's operation. In such a case, you can collect the debug logs by inserting a USB device containing the dedicated script file into the MFP. Even if the power has to be turned OFF with the main power switch after a problem occurs, the debug logs will be saved in the MFP (up to 3 logs). If the debug logs have already been saved in the MFP, they also can be collected.

The following information is included in the USB debug logs.

Internal operation, Job history, HDD/memory usage status, etc. (Personal/Corporate information (address book) not included)

When the debug logs are collected, also do so for the following information. since it may be difficult to investigate only using the debug log.

- List print mode [FS-30-300: All CSV files]
- Job logs below in TopAccess > [Logs] > [Export Logs]
  - Print Job Log Export
  - Fax Transmission Journal Export
  - Fax Reception Journal Export
  - Scan Log Export
  - Messages Log Export
- Problem occurrence time  
Or the time when the customer called if it is difficult to work out when it occurred
- Status of when you collected the debug log  
As in the example below, check the status to know if the problem occurred at the debug log collection or how the customer recovered it.  
E.g.
  - You checked the problem and connected a USB device to the equipment.
  - No problem occurred when an attempt to collect the debug log was made; however the customer did turn the main power switch OFF when the problem occurred, so the log can be collected.

### [ 2 ] Collection procedure

1. Note  
When collecting a log, be sure to obtain consent from the user in advance and get the dedicated script file from the service center.
2. About USB devices  
Be sure to format the USB device with FAT16/32 beforehand. (Recommend size: 2GB or more)
3. Advance preparation of collection  
Store the dedicated script file to the root directory of the USB device.
4. Procedure for collecting debug logs
  - (1) Insert the USB device, in which the dedicated script file is stored, into the MFP while the power is ON.
    - After the USB device is inserted into the MFP, the screen will change.
  - (2) Select [Basic Debug Logs], [All Debug Logs] or [9S-300CSV Print Job List] and then press the [START] button.
    - [9S-300CSV Print Job List] can be selected together with [Basic Debug Logs] or [All Debug Logs].
    - The log collection of [All Debug Logs] will start automatically if no operation is made for 30 seconds after the screen has been changed.
    - The LED of the MFP starts blinking when the log collection has begun.
    - The panel display will be changed during the log collection depending on the conditions of the MFP. However, the log collection will continue as long as the LED is blinking.
  - (3) When the log collection is finished, the beeping is heard. After the beeping has stopped, remove the USB device.
    - The MFP will reboot automatically in 10 seconds after a beeping sound.

- If this has not been done automatically after 30 seconds have passed, reboot the MFP manually.

**Notes:**

- Do not remove the USB device while the LED in the MFP is blinking.
- If the LED does not start blinking after the USB device is inserted and a few minutes have passed, try the procedure from step (1) again.
- If there is no beeping after the LED starts blinking (about 20 minutes), try procedure from step (1) again.
- If the USB device is inserted when the MFP is not ready, the debug logs cannot be collected.

5. Collected debug logs

- When the collection of the debug logs is completed, the compressed file of the collected logs is stored in the root directory of the USB device.  
File name:

XXXX.YYYYMMDDHHmmSS	(for basic version and all version)
XXXX.YYYYMMDDHHmmSS.Defunct	(for all version)
XXXX.YYYYMMDDHHmmSS.PowerOff	(for all version)
XXXX.YYYYMMDDHHmmSS_9S300	(for "9S300 csv files, Print job list")
XXXX.YYYYMMDDHHmmSS_JobList	(for "9S300 csv files, Print job list")
XXXX.YYYYMMDDHHmmSS.USBLog	(for basic version, all version and "9S300 csv files, Print job list")
md5sum.txt	(for basic version, all version and "9S300 csv files, Print job list")

(XXXX= Serial number of the equipment, YYYY= year, MM= month, DD= day, HH= hour, mm= minute, SS= second)

- After the debug logs have been collected, be sure to send them to the service center together with a report.

### 8.1.3 Traceability label

A traceability label on which a management No. at the manufacturing has been printed is attached to some units. If a problem occurs in a unit, report it to the appropriate Toshiba service center along with the traceability label information to help them to understand it.

#### [ 1 ] Management No.

A management No. consists of 13 digits with letters of the alphabet and numbers. The following shows the meaning of each block.

- From the 1st to 4th digits: Classification
- From the 5th to 10th digits: Production date
- From the 11th to 13th digits: Sequential numbers

Classification				Production date						Sequential numbers			
1	2	3	4	5	6	7	8	9	10	11	12	13	(digits)
1	2	3	4	1	2	3	4	5	6	1	2	3	

#### [ 2 ] Applicable units

A traceability label is attached to the following units.

No.	Unit	Remarks
1	USB-Hub (HUB board)	
2	High-voltage transformer	
3	Automatic duplexing unit (ADU)	
4	Laser optical unit (LSU)	
5	Process unit	
6	Scanner frame	
7	CCD driving PC board (CCD board)	
8	Control panel	
9	Switching regulator	
10	System control PC board (SYS board)	
11	Logic PC board (LGC board)	
12	Hard disk (HDD)	

## 8.2 Error Code List

The following error codes is displayed at the upper right of the screen when the “CLEAR PAPER” or “CALL SERVICE” symbol is blinking.

### Remarks:

Elision character of the “Error code display media”

Panl: Control panel

JLog: JobLog (TopAccess Print Log - Scan Log)

ML: Message Log (TopAccess Message Log)

Noti: Notification

CSV: CSV output (List print)

Y: Yes

2nd: An error status has been detected twice (= error code has been determined)

5th: An error status has been detected five times (= error code has been determined)

### 8.2.1 Jam

Error code	Classification	Message	Contents	Error code display media					Troubleshooting
				Panl	JL	ML	Noti	CSV	
E010	Paper exit jam	Paper Ejection Jam - Please Clear Paper Path.	Jam not reaching the exit sensor	-	-	Y	Y	Y	P. 8-110
E020	Paper exit jam	Paper Ejection Jam - Please Clear Paper Path.	Stop jam at the exit sensor	-	-	Y	Y	Y	P. 8-110
E030	Other paper jam	Paper Jam in Printer - Please Clear Paper Path.	Power-ON jam	-	-	Y	Y	Y	P. 8-133
E061	Other paper jam	Paper Jam in Printer - Please Clear Paper Path.	Incorrect paper size setting for 1st drawer	-	-	Y	Y	Y	P. 8-134
E062	Other paper jam	Paper Jam in Printer - Please Clear Paper Path.	Incorrect paper size setting for 2nd drawer	-	-	Y	Y	Y	P. 8-134
E063	Other paper jam	Paper Jam in Printer - Please Clear Paper Path.	Incorrect paper size setting for PFP upper drawer	-	-	Y	Y	Y	P. 8-134
E064	Other paper jam	Paper Jam in Printer - Please Clear Paper Path.	Incorrect paper size setting for PFP lower drawer	-	-	Y	Y	Y	P. 8-134
E065	Other paper jam	Paper Jam in Printer - Please Clear Paper Path.	Incorrect paper size setting for bypass tray	-	-	Y	Y	Y	P. 8-134
E090	Other paper jam	Paper Jam in Printer - Please Clear Paper Path.	Image data delay jam	-	-	Y	Y	Y	P. 8-136
E0A0	Other paper jam	Paper Jam in Printer - Please Clear Paper Path.	Image transport ready time-out jam	-	-	Y	Y	Y	P. 8-136
E110	Paper misfeeding	Paper Insertion Jam - Please Clear Paper Path.	ADU misfeeding (paper not reaching the registration sensor)	-	-	Y	Y	Y	P. 8-122
E120	Paper misfeeding	Paper Insertion Jam - Please Clear Paper Path.	Bypass misfeeding (paper not reaching the 1st transport sensor)	-	-	Y	Y	Y	P. 8-122

Error code	Classification	Message	Contents	Error code display media					Troubleshooting
				Panl	JL	ML	Noti	CSV	
E130	Paper misfeeding	Paper Insertion Jam - Please Clear Paper Path.	1st drawer misfeeding (paper not reaching the 1st drawer feed sensor)	-	-	Y	Y	Y	P. 8-123
E140	Paper misfeeding	Paper Insertion Jam - Please Clear Paper Path.	2nd drawer misfeeding (paper not reaching the 2nd drawer feed sensor)	-	-	Y	Y	Y	P. 8-124
E150	Paper misfeeding	Paper Insertion Jam - Please Clear Paper Path.	PFP upper drawer misfeeding (paper not reaching the PFP upper drawer feed sensor)	-	-	Y	Y	Y	P. 8-125
E160	Paper misfeeding	Paper Insertion Jam - Please Clear Paper Path.	PFP lower drawer misfeeding (paper not reaching the PFP lower drawer feed sensor)	-	-	Y	Y	Y	P. 8-126
E190	Paper misfeeding	Paper Insertion Jam - Please Clear Paper Path.	T-LCF misfeeding (paper not reaching the T-LCF transport sensor)	-	-	Y	Y	Y	P. 8-127
E200	Paper transport jam	Paper Jam in Printer - Please Clear Paper Path.	1st drawer transport jam (paper not reaching the registration sensor)	-	-	Y	Y	Y	P. 8-111
E210	Paper transport jam	Paper Jam in Printer - Please Clear Paper Path.	2nd drawer transport jam (paper not reaching the registration sensor)	-	-	Y	Y	Y	P. 8-111
E220	Paper transport jam	Paper Jam in Printer - Please Clear Paper Path.	2nd drawer transport jam (paper not reaching the 1st transport sensor)	-	-	Y	Y	Y	P. 8-112
E270	Paper transport jam	Paper Insertion Jam - Please Clear Paper Path.	Bypass transport jam (paper not reaching the registration sensor)	-	-	Y	Y	Y	P. 8-112
E300	Paper transport jam	Paper Jam in Printer - Please Clear Paper Path.	PFP upper drawer transport jam (paper not reaching the registration sensor)	-	-	Y	Y	Y	P. 8-111
E310	Paper transport jam	Paper Jam in Printer - Please Clear Paper Path.	PFP upper drawer transport jam (paper not reaching the 1st transport sensor)	-	-	Y	Y	Y	P. 8-112
E320	Paper transport jam	Paper Jam in Printer - Please Clear Paper Path.	PFP upper drawer transport jam (paper not reaching the 2nd transport sensor)	-	-	Y	Y	Y	P. 8-113

Error code	Classification	Message	Contents	Error code display media					Troubleshooting
				Panl	JL	ML	Noti	CSV	
E330	Paper transport jam	Paper Jam in Printer - Please Clear Paper Path.	PFP lower drawer transport jam (paper not reaching the registration sensor)	-	-	Y	Y	Y	P. 8-111
E340	Paper transport jam	Paper Jam in Printer - Please Clear Paper Path.	PFP lower drawer transport jam (paper not reaching the 1st transport sensor)	-	-	Y	Y	Y	P. 8-112
E350	Paper transport jam	Paper Jam in Printer - Please Clear Paper Path.	PFP lower drawer transport jam (paper not reaching the 2nd transport sensor)	-	-	Y	Y	Y	P. 8-113
E360	Paper transport jam	Paper Jam in Printer - Please Clear Paper Path.	PFP lower drawer transport jam (paper not reaching the PFP upper drawer feed sensor)	-	-	Y	Y	Y	P. 8-120
E3C0	Paper transport jam	Paper Jam in Printer - Please Clear Paper Path.	LCF transport jam (paper not reaching the registration sensor)	-	-	Y	Y	Y	P. 8-111
E3D0	Paper transport jam	Paper Jam in Printer - Please Clear Paper Path.	LCF transport jam (paper not reaching the 1st transport sensor)	-	-	Y	Y	Y	P. 8-112
E3E0	Paper transport jam	Paper Jam in Printer - Please Clear Paper Path.	LCF transport jam (paper not reaching the 2nd transport sensor)	-	-	Y	Y	Y	P. 8-113
E410	Cover open jam	Paper Jam in Printer - Please Clear Paper Path.	Front cover open jam	-	-	Y	Y	Y	P. 8-128
E420	Cover open jam	Paper Jam in Printer - Please Clear Paper Path.	PFP side cover open jam	-	-	Y	Y	Y	P. 8-128
E430	Cover open jam	Paper Jam in Printer - Please Clear Paper Path.	Duplexing unit cover open jam	-	-	Y	Y	Y	P. 8-129
E440	Cover open jam	Paper Jam in Printer - Please Clear Paper Path.	Paper feed cover open jam	-	-	Y	Y	Y	P. 8-130
E450	Cover open jam	Paper Jam in Printer - Please Clear Paper Path.	LCF side cover open jam	-	-	Y	Y	Y	P. 8-130
E480	Cover open jam	Paper Jam in Printer - Please Clear Paper Path.	Bridge unit open jam	-	-	Y	Y	Y	P. 8-131
E490	Cover open jam	Paper Jam in Printer - Please Clear Paper Path.	Job separator cover open jam	Y	-	Y	Y	Y	P. 8-131
E510	Paper transport jam	Paper Jam in Automatic Duplexing Unit - Please Clear Paper Path.	Paper not reaching the ADU entrance sensor jam	-	-	Y	Y	Y	P. 8-114



Error code	Classification	Message	Contents	Error code display media					Troubleshooting
				Panl	JL	ML	Noti	CSV	
E520	Paper transport jam	Paper Jam in Automatic Duplexing Unit - Please Clear Paper Path.	Stop jam in the ADU	-	-	Y	Y	Y	P. 8-115
E550	Other paper jam	Paper Jam in the engine. Please clear paper path	Paper remaining jam on the transport path	-	-	Y	Y	Y	P. 8-134
E551	Other paper jam	Paper Jam in the engine. Please clear paper path	Paper remaining jam on the transport path (when a service call occurs)	-	-	Y	Y	Y	P. 8-135
E552	Other paper jam	Paper Jam in the engine. Please clear paper path	Paper remaining jam on the transport path (when the cover is closed)	-	-	Y	Y	Y	P. 8-135
E570	Paper transport jam	Paper Jam in Printer - Please Clear Paper Path.	Jam not reaching the reverse sensor	-	-	Y	Y	Y	P. 8-116
E580	Paper transport jam	Paper Jam in Printer - Please Clear Paper Path.	Stop jam at the reverse sensor	-	-	Y	Y	Y	P. 8-116
E712	DSDF jam	Paper Jam in Automatic Document Feeder - Please Clear Paper Path.	Jam not reaching the DSDF registration sensor	-	-	Y	-	Y	P. 8-138
	RADF jam		Jam not reaching the original registration sensor	-	-	Y	-	Y	P. 8-138
E714	DSDF jam	Paper Jam in Automatic Document Feeder - Please Clear Paper Path.	DSDF feed signal reception jam	-	-	Y	-	Y	P. 8-138
	RADF jam		Feed signal reception jam	-	-	Y	-	Y	P. 8-139
E717	DSDF jam	Paper Jam in Automatic Document Feeder - Please Clear Paper Path.	Original not reaching the DSDF original feed sensor jam	-	-	Y	-	Y	P. 8-139
E718	DSDF jam	Paper Jam in Automatic Document Feeder - Please Clear Paper Path.	Original setting jam / Original tray lift abnormality	-	-	Y	-	Y	P. 8-140
E721	DSDF jam	Paper Jam in Automatic Document Feeder - Please Clear Paper Path.	Original not reaching the DSDF read-in sensor-1 jam	-	-	Y	-	Y	P. 8-141
	RADF jam		Jam not reaching the read sensor	-	-	Y	-	Y	P. 8-141
E722	DSDF jam	Paper Jam in Automatic Document Feeder - Please Clear Paper Path.	Original not reaching the DSDF exit sensor jam	-	-	Y	-	Y	P. 8-142
	RADF jam		Jam not reaching the original exit / reverse sensor (during scanning)	-	-	Y	-	Y	P. 8-142

Error code	Classification	Message	Contents	Error code display media					Troubleshooting
				Panl	JL	ML	Noti	CSV	
E724	DSDF jam	Paper Jam in Automatic Document Feeder - Please Clear Paper Path.	Original stopping at the DSDF registration sensor jam	-	-	Y	-	Y	P. 8-142
	RADF jam		Stop jam at the registration sensor	-	-	Y	-	Y	P. 8-143
E725	DSDF jam	Paper Jam in Automatic Document Feeder - Please Clear Paper Path.	Original stopping at the DSDF read-in sensor-1 jam	-	-	Y	-	Y	P. 8-144
	RADF jam		Stop jam at the read sensor	-	-	Y	-	Y	P. 8-144
E726	DSDF jam	Paper Jam in Automatic Document Feeder - Please Clear Paper Path.	Transport / exit signal reception jam	-	-	Y	-	Y	P. 8-145
	RADF jam		Transport / exit signal reception jam	-	-	Y	-	Y	P. 8-145
E727	DSDF jam	Automatic Document Feeder - Please Clear Paper Path.	Original not reaching the DSDF read-in sensor-2 jam	-	-	Y	-	Y	P. 8-146
E729	DSDF jam	Paper Jam in Automatic Document Feeder - Please Clear Paper Path.	Original stopping at the DSDF read-in sensor-2 jam	-	-	Y	-	Y	P. 8-147
E731	DSDF jam	Paper Jam in Automatic Document Feeder - Please Clear Paper Path.	Original stopping at the DSDF exit sensor jam	-	-	Y	-	Y	P. 8-147
	RADF jam		Stop jam at the original exit / reverse sensor	-	-	Y	-	Y	P. 8-148
E762	DSDF jam	Paper Jam in Automatic Document Feeder - Please Clear Paper Path.	Original remaining at the DSDF registration sensor jam	-	-	Y	-	Y	P. 8-148
E769	DSDF jam	Paper Jam in Automatic Document Feeder - Please Clear Paper Path.	Original remaining at the DSDF feed sensor jam	-	-	Y	-	Y	P. 8-149
E770	DSDF jam	Paper Jam in Automatic Document Feeder - Please Clear Paper Path.	Original remaining at the DSDF original width detection sensor-1 jam	-	-	Y	-	Y	P. 8-149
E771	DSDF jam	Paper Jam in Automatic Document Feeder - Please Clear Paper Path.	Original remaining at the DSDF original width detection sensor-2 jam	-	-	Y	-	Y	P. 8-150
E774	DSDF jam	Paper Jam in Automatic Document Feeder - Please Clear Paper Path.	Original remaining at the DSDF read-in sensor-1 jam	-	-	Y	-	Y	P. 8-150

Error code	Classification	Message	Contents	Error code display media					Troubleshooting
				Panl	JL	ML	Noti	CSV	
E775	DSDF jam	Paper Jam in Automatic Document Feeder - Please Clear Paper Path.	Original remaining at the DSDF read-in sensor-2 jam	-	-	Y	-	Y	P. 8-150
E777	DSDF jam	Paper Jam in Automatic Document Feeder - Please Clear Paper Path.	Original remaining at the DSDF exit sensor jam	-	-	Y	-	Y	P. 8-152
E860	RADF jam	Paper Jam in Automatic Document Feeder - Please Clear Paper Path.	RADF jam access cover open jam	-	-	Y	-	Y	P. 8-152
E860	DSDF jam	Paper Jam in Automatic Document Feeder - Please Clear Paper Path.	DSDF original jam access cover open jam / DSDF shading sheet HP sensor abnormal	-	-	Y	-	Y	P. 8-153
E870	RADF jam	Paper Jam in Automatic Document Feeder - Please Clear Paper Path.	RADF open jam	-	-	Y	-	Y	P. 8-154
E910	Finisher jam (Bridge unit)	Paper Jam in Printer - Please Clear Paper Path.	Paper not reaching the bridge unit transport sensor-1	Y	-	Y	Y	Y	P. 8-155
E920	Finisher jam (Bridge unit)	Paper Jam in Printer - Please Clear Paper Path.	Paper stopping at the bridge unit transport sensor-1	Y	-	Y	Y	Y	P. 8-155
E930	Finisher jam (Bridge unit)	Paper Jam in Printer - Please Clear Paper Path.	Paper not reaching the bridge unit transport sensor-2	Y	-	Y	Y	Y	P. 8-156
E940	Finisher jam (Bridge unit)	Paper Jam in Printer - Please Clear Paper Path.	Paper stopping at the bridge unit transport sensor-2	Y	-	Y	Y	Y	P. 8-156
E950	Job separator jam	Paper Jam in Printer - Please Clear Paper Path.	Jam not reaching the JSP feed sensor	Y	-	Y	Y	Y	P. 8-158
E951	Job separator jam	Paper Jam in Printer - Please Clear Paper Path.	Stop jam at the JSP feed sensor	Y	-	Y	Y	Y	P. 8-158
E9F0	Finisher jam Hole punch unit	Hole Punch Unit Jam in Finisher - Please Clear Hole Punch.	Punching jam	Y	-	Y	Y	Y	P. 8-159
EA10	Finisher jam (Finisher section)	Paper Jam in Finisher - Please Clear Paper Path.	Paper transport delay jam	Y	-	Y	Y	Y	P. 8-160 P. 8-160
EA20	Finisher jam (Finisher section)	Paper Jam in Finisher - Please Clear Paper Path.	Paper transport stop jam	Y	-	Y	Y	Y	P. 8-161 P. 8-161
EA21	Finisher jam (Finisher section)	Paper Jam in Finisher - Please Clear Paper Path.	Paper size error jam (transport sensor)	Y	-	Y	Y	Y	P. 8-161
EA22	Finisher jam Hole punch unit	Paper Jam in Finisher - Please Clear Paper Path.	Paper size error jam (Paper position sensor)	-	-	Y	Y	Y	P. 8-162

Error code	Classification	Message	Contents	Error code display media					Troubleshooting
				Panl	JL	ML	Noti	CSV	
EA23	Finisher jam (Finisher section)	Paper Jam in Finisher - Please Clear Paper Path.	Paper stopping jam (transport sensor)	-	-	Y	Y	Y	P. 8-162
EA24	Finisher jam (Finisher section)	Paper Jam in Finisher - Please Clear Paper Path.	Paper transport delay jam (between entrance and transport sensor)	-	-	Y	Y	Y	P. 8-163
EA25	Finisher jam (Finisher section)	Paper Jam in Finisher - Please Clear Paper Path.	Paper transport jam in Finisher (after paper stack was exited)	-	-	Y	Y	Y	P. 8-164 P. 8-164
EA26	Finisher jam (Finisher section)	Paper Jam in Finisher - Please Clear Paper Path.	Paper transport stop jam (stop command request)	-	-	Y	Y	Y	P. 8-164 P. 8-165
EA27	Finisher jam (Finisher section)	Paper Jam in Finisher - Please Clear Paper Path.	Paper transport jam in Finisher	-	-	Y	Y	Y	P. 8-165
EA28	Finisher jam (Finisher section)	Paper Jam in Finisher - Please Clear Paper Path.	Paper transport jam (paper holder plate operation delay)	-	-	Y	Y	Y	P. 8-165
EA29	Finisher jam (Finisher section)	Paper Jam in Finisher - Please Clear Paper Path.	Paper transport jam (stack transport delay)	-	-	Y	Y	Y	P. 8-166
EA2A	Finisher jam (Finisher section)	Paper Jam in Finisher - Please Clear Paper Path.	Paper transport jam in the Finisher (between the entrance path and middle path sensor)	-	-	Y	Y	Y	P. 8-166
EA2B	Finisher jam (Finisher section)	Paper Jam in Finisher - Please Clear Paper Path.	Paper transport jam in the Finisher (middle path sensor)	-	-	Y	Y	Y	P. 8-167
EA2C	Finisher jam (Finisher section)	Paper Jam in Finisher - Please Clear Paper Path.	Paper transport jam in the Finisher (between the entrance path and sub-path sensor)	-	-	Y	Y	Y	P. 8-167
EA2D	Finisher jam (Finisher section)	Paper Jam in Finisher - Please Clear Paper Path.	Paper transport jam in the Finisher (sub-path sensor)	-	-	Y	Y	Y	P. 8-168
EA2E	Finisher jam (Finisher section)	Paper Jam in Finisher - Please Clear Paper Path.	Paper transport remaining jam in the Finisher (sub-path sensor)	-	-	Y	Y	Y	P. 8-168
EA31	Finisher jam (Finisher section)	Paper Jam in Finisher - Please Clear Paper Path.	Transport path paper remaining jam	Y	-	Y	Y	Y	P. 8-169 P. 8-169
EA32	Finisher jam (Finisher section)	Paper Jam in Finisher - Please Clear Paper Path.	Exit paper remaining jam	Y	-	Y	Y	Y	P. 8-170 P. 8-170
EA40	Finisher jam (Finisher section)	Paper Jam in Finisher - Please Clear Paper Path.	Cover open jam	Y	-	Y	Y	Y	P. 8-170 P. 8-171
EA50	Finisher jam (Finisher section)	Staple Jam in Finisher - Please Clear Staple.	Stapling jam	Y	-	Y	Y	Y	P. 8-171 P. 8-172

Error code	Classification	Message	Contents	Error code display media					Troubleshooting
				Panl	JL	ML	Noti	CSV	
EA60	Finisher jam (Finisher section)	Paper Jam in Finisher - Please Clear Paper Path.	Early arrival jam	Y	-	Y	Y	Y	P. 8-172
EA70	Finisher jam (Finisher section)	Paper Jam in Finisher - Please Clear Paper Path.	Stack exit belt home position error	Y	-	Y	Y	Y	P. 8-173
EA90	Finisher jam (Saddle stitch section)	Paper Jam in Finisher - Please Clear Paper Path.	Cover open jam	Y	-	Y	Y	Y	P. 8-175
EAA0	Finisher jam (Saddle stitch section)	Paper Jam in Finisher - Please Clear Paper Path.	Paper remaining jam in Saddle Stitch Unit	Y	-	Y	Y	Y	P. 8-175
EAB0	Finisher jam (Saddle stitch section)	Paper Jam in Finisher - Please Clear Paper Path.	Paper transport jam in Saddle Stitch Unit	Y	-	Y	Y	Y	P. 8-176
EAB1	Finisher jam (Saddle stitch section)	Paper Jam in Finisher - Please Clear Paper Path.	Paper size error jam	Y	-	Y	Y	Y	P. 8-177
EAD0	Other paper jam	Paper Jam in Printer - Please Clear Paper Path.	Print end command time-out jam	-	-	Y	Y	Y	P. 8-137
EAE0	Finisher jam	Paper Jam in Printer - Please Clear Paper Path.	Receiving time-out jam	-	-	Y	Y	Y	P. 8-178
EAFA	Finisher jam (Finisher section)	Paper Jam in Finisher - Please Clear Paper Path.	Stack exit roller home position sensor detection error	Y	-	Y	Y	Y	P. 8-173
EAF2	Finisher jam (Finisher section)	Paper Jam in Finisher - Please Clear Paper Path.	Stapler unit sliding motor home position detection error	Y	-	Y	Y	Y	P. 8-173
EAFB	Finisher jam (Finisher section)	Paper Jam in Finisher - Please Clear Paper Path.	Catching motor home position detection error	Y	-	Y	Y	Y	P. 8-174
EAFD	Finisher jam (Finisher section)	Paper Jam in Finisher - Please Clear Paper Path.	Stapler movement error	Y	-	Y	Y	Y	P. 8-234
EAFE	Finisher jam (Finisher section)	Paper Jam in Finisher - Please Clear Paper Path.	Movable tray height error	Y	-	Y	Y	Y	P. 8-230
EAFC	Finisher jam (Finisher section)	Paper Jam in Finisher - Please Clear Paper Path.	Movable tray movement error	Y	-	Y	Y	Y	P. 8-231
EAFD	Finisher jam (Finisher section)	Paper Jam in Finisher - Please Clear Paper Path.	Assist guide cam position error	Y	-	Y	Y	Y	P. 8-228
EAFE	Finisher jam (Finisher section)	Paper Jam in Finisher - Please Clear Paper Path.	Ready time-out jam	-	-	Y	Y	Y	P. 8-178
EB30	Other paper jams	Paper Jam in Printer - Please Clear Paper Path.	Paper remaining on the transport path due to multiple feeding	-	-	Y	Y	Y	P. 8-117
EB50	Paper transport jam	Paper Jam in Printer - Please Clear Paper Path.	Paper remaining on the transport path due to multiple feeding	-	-	Y	Y	Y	P. 8-117
EB60	Paper transport jam	Paper Jam in Printer - Please Clear Paper Path.	Paper remaining on the transport path due to multiple feeding	-	-	Y	Y	Y	P. 8-120

Error code	Classification	Message	Contents	Error code display media					Troubleshooting
				Panl	JL	ML	Noti	CSV	
ED10	Finisher jam (Hole Punch section)	Paper Jam in Finisher - Please Clear Paper Path.	Skew adjustment motor home position detection error	Y	-	Y	Y	Y	P. 8-179
ED11	Finisher jam (Hole Punch section)	Paper Jam in Finisher - Please Clear Paper Path.	Sideways adjustment motor home position detection error	Y	-	Y	Y	Y	P. 8-179
ED13	Finisher jam (Finisher section)	Paper Jam in Finisher - Please Clear Paper Path.	Front alignment plate home position error	Y	-	Y	Y	Y	P. 8-180
ED14	Finisher jam (Finisher section)	Paper Jam in Finisher - Please Clear Paper Path.	Rear alignment plate home position error	Y	-	Y	Y	Y	P. 8-180
ED15	Finisher jam (Finisher section)	Paper Jam in Finisher - Please Clear Paper Path.	Paddle home position error	Y	-	Y	Y	Y	P. 8-181
ED16	Finisher jam	Paper Jam in Finisher - Please Clear Paper Path.	Buffer tray home position error	Y	-	Y	Y	Y	P. 8-181
EF10	Finisher jam (Saddle stitch section)	Paper Jam in Finisher - Please Clear Paper Path.	Paper not supported for saddle stitch finisher	Y	-	Y	Y	Y	P. 8-182
EF11	Finisher jam (Saddle stitch section)	Paper Jam in Finisher - Please Clear Paper Path.	Saddle stitch finisher stapling error (front)	Y	-	Y	Y	Y	P. 8-182
EF12	Finisher jam (Saddle stitch section)	Paper Jam in Finisher - Please Clear Paper Path.	Saddle stitch finisher stapling error (rear)	Y	-	Y	Y	Y	P. 8-182
EF13	Finisher jam (Saddle stitch section)	Paper Jam in Finisher - Please Clear Paper Path.	Saddle stitch unit paper holding home position detection error	Y	-	Y	Y	Y	P. 8-183
EF14	Finisher jam (Saddle stitch section)	Paper Jam in Finisher - Please Clear Paper Path.	Saddle stitch unit paper exit jam	Y	-	Y	Y	Y	P. 8-183
EF15	Finisher jam (Saddle stitch section)	Paper Jam in Finisher - Please Clear Paper Path.	Saddle stitch finisher side alignment motor home position detection abnormality	Y	-	Y	Y	Y	P. 8-190
EF16	Finisher jam (Saddle stitch section)	Paper Jam in Finisher - Please Clear Paper Path.	Saddle stitch finisher stacker motor home position detection abnormality	Y	-	Y	Y	Y	P. 8-191
EF17	Finisher jam (Saddle stitch section)	Paper Jam in Finisher - Please Clear Paper Path.	Saddle stitch finisher folding blade home position detection abnormality	Y	-	Y	Y	Y	P. 8-191
EF18	Finisher jam (Saddle stitch section)	Paper Jam in Finisher - Please Clear Paper Path.	Saddle stitch finisher additional folding roller home position detection abnormality	Y	-	Y	Y	Y	P. 8-192
EF19	Finisher jam (Saddle stitch section)	Paper Jam in Finisher - Please Clear Paper Path.	Saddle stitch unit paper folding jam	Y	-	Y	Y	Y	P. 8-192

Error code	Classification	Message	Contents	Error code display media					Troubleshooting
				Panl	JL	ML	Noti	CSV	
EF20	Finisher jam (Saddle stitch section)	Paper Jam in Finisher - Please Clear Paper Path.	Saddle stitch unit stacker jam	-	-	Y	Y	Y	P. 8-194

## 8.2.2 Service call

Error code	Classification	Message	Contents	Error code display media					Troubleshooting
				Panl	JL	ML	Noti	CSV	
C010	Drive system related service call		Main motor abnormality	-	-	-	-	Y	P. 8-195
C040	Paper feeding system related service call	Printer Input Error.	PFP motor abnormality	Y	-	Y	Y	Y	P. 8-197
C130	Paper feeding system related service call	Printer Input Error.	1st drawer tray abnormality	Y	-	Y	Y	Y	P. 8-198
C140	Paper feeding system related service call	Printer Input Error.	2nd drawer tray abnormality	Y	-	Y	Y	Y	P. 8-198
C150	Paper feeding system related service call	Printer Input Error.	PFP upper drawer tray abnormality	Y	-	Y	Y	Y	P. 8-199
C160	Paper feeding system related service call	Printer Input Error.	PFP lower drawer tray abnormality	Y	-	Y	Y	Y	P. 8-199
C180	Paper feeding system related service call	Printer Input Error.	LCF tray-up motor abnormality	Y	-	Y	Y	Y	P. 8-200
C1A0	Paper feeding system related service call	Printer Input Error.	LCF end fence motor abnormality	Y	-	Y	Y	Y	P. 8-201
C1B0	Paper feeding system related service call	Printer Input Error.	LCF transport motor abnormality	Y	-	Y	Y	Y	P. 8-202
C260	Scanning system related service call	Fatal Error - Please Contact Service Technician.	Peak detection error	2nd	-	Y	Y	Y	P. 8-203
C262	Scanning system related service call	Fatal Error - Please Contact Service Technician.	Communication error	2nd	-	Y	Y	Y	P. 8-204
C270	Scanning system related service call	Fatal Error - Please Contact Service Technician.	Carriage home position sensor not turning OFF within a specified period of time / Downloading firmware with an incorrect model	Y	-	Y	Y	Y	P. 8-204
C280	Scanning system related service call	Fatal Error - Please Contact Service Technician.	Carriage home position sensor not turning ON within a specified period of time	Y	-	Y	Y	Y	P. 8-205
C290	Scanning system related service call	Fatal Error - Please Contact Service Technician.	Scanner fuse blowout	2nd	-	Y	Y	Y	P. 8-206
C3D0	Process related service call		EPU board memory overwriting error	-	-	-	-	Y	P. 8-207
C3D1	Process related service call		EPU board memory new parts detection error	-	-	-	-	Y	P. 8-207



Error code	Classification	Message	Contents	Error code display media					Troubleshooting
				Panl	JL	ML	Noti	CSV	
C3D2	Process related service call		EPU board memory old parts detection error	-	-	-	-	Y	P. 8-207
C411	Fuser unit related service call		Thermistor or heater abnormality at power-ON	-	-	-	-	Y	P. 8-210
C412	Fuser unit related service call		Thermistor or heater abnormality at power-ON	-	-	-	-	Y	P. 8-210
C443	Fuser unit related service call		Thermistor or heater abnormality after abnormality judgment	-	-	-	-	Y	P. 8-211
C445	Fuser unit related service call	Fatal Error - Please Contact Service Technician.	Fusing temperature abnormality after abnormality judgment (pre-running end temperature abnormality)	Y	-	Y	Y	Y	P. 8-211
C447	Fuser unit related service call	Fatal Error - Please Contact Service Technician.	Fusing temperature abnormality after abnormality judgment (temperature abnormality at ready status / during printing)	Y	-	Y	Y	Y	P. 8-211
C449	Fuser unit related service call	Fatal Error - Please Contact Service Technician.	Fusing temperature abnormality after abnormality judgment (high temperature abnormality)	Y	-	Y	Y	Y	P. 8-211
C450	Fuser unit related service call		Heater abnormality after abnormality judgment	-	-	-	-	Y	P. 8-211
C452	Fuser unit related service call		Heater lamp abnormality after abnormality judgment	-	-	-	-	Y	P. 8-211
C4B0	Fuser unit related service call	Fatal Error - Please Contact Service Technician.	Status counter abnormality	Y	-	Y	Y	Y	P. 8-211
C4C0	Fuser unit related service call	Fatal Error - Please Contact Service Technician.	Fuser unit old / new detection fuse abnormality	2nd	-	Y	Y	Y	P. 8-212
C550	DSDF service call	Fatal Error - Please Contact Service Technician.	Communication error between the scanner and DF	5th	-	Y	Y	Y	P. 8-213
	RADF service call			5th	-	Y	Y	Y	P. 8-213
C551	DSDF / RADF service call	Fatal Error - Please Contact Service Technician.	DF model detection error	2nd	-	Y	Y	Y	P. 8-214

Error code	Classification	Message	Contents	Error code display media					Troubleshooting
				Panl	JL	ML	Noti	CSV	
C552	DSDF / RADF service call	Fatal Error - Please Contact Service Technician.	DF abnormality	2nd	-	Y	Y	Y	P. 8-214
C553	DSDF service call	Fatal Error - Please Contact Service Technician.	DSDF CCD-module Peak detection error	5th	-	Y	Y	Y	P. 8-214
C554	DSDF service call	Fatal Error - Please Contact Service Technician.	AFE communication error	5th	-	Y	Y	Y	P. 8-215
C580	Option related service call	Fatal Error - Please Contact Service Technician.	Communication error between the LGC board and the finisher	2nd	-	Y	Y	Y	P. 8-216
C5A0	Circuit related service call	Fatal Error - Please Contact Service Technician.	EEPROM abnormality (LGC board)	Y	-	Y	Y	Y	P. 8-220
C5A1	Circuit related service call	Fatal Error - Please Contact Service Technician.	EEPROM data abnormality (LGC board)	Y	-	Y	Y	Y	P. 8-220
C730	DSDF service call	Automatic Document Feeder Error - Please Contact Service Technician.	DSDF EEPROM writing error	2nd	-	Y	Y	Y	P. 8-216
C7B0	DSDF service call	Automatic Document Feeder Error - Please Contact Service Technician.	Initial time-out error	5th	-	Y	Y	Y	P. 8-216
C8C0	DSDF service call	Automatic Document Feeder Error - Please Contact Service Technician.	DSDF read-in sensor-1 automatic adjustment error	2nd	-	Y	Y	Y	P. 8-216
C8E0	DSDF / RADF service call	Automatic Document Feeder Error - Please Contact Service Technician.	DF control abnormality (communication protocol abnormality)	5th	-	Y	Y	Y	P. 8-217
F115	Scanning system related service call	Fatal Error - Please Contact Service Technician.	S-VDEN ON signal time-out error	2nd	-	Y	Y	Y	P. 8-217
F116	Scanning system related service call	Fatal Error - Please Contact Service Technician.	S-VDEN OFF signal time-out error	2nd	-	Y	Y	Y	P. 8-217
F117	Scanning system related service call (DSDF)	Fatal Error - Please Contact Service Technician.	S-VDEN ON (back side) signal time-out error	2nd	-	Y	Y	Y	P. 8-217
F118	Scanning system related service call (DSDF)	Fatal Error - Please Contact Service Technician.	S-VDEN OFF (back side) signal time-out error	2nd	-	Y	Y	Y	P. 8-217

Error code	Classification	Message	Contents	Error code display media					Troubleshooting
				Panl	JL	ML	Noti	CSV	
F119	Scanning system related service call	Fatal Error - Please Contact Service Technician.	Scanner abnormality detection	2nd	-	Y	Y	Y	P. 8-225
F11A	Scanning system related service call	Fatal Error - Please Contact Service Technician.	Communication error between the SYS board and the CCD board	2nd	Y	Y	Y	Y	P. 8-218
F11B	Scanning system related service call	Fatal Error - Please Contact Service Technician.	Communication error between the SYS board and the DSDF-CCD module	2nd	Y	Y	Y	Y	P. 8-218
C911	Toner cartridge related service call	Failed to access to the toner IC chip	Toner cartridge PC board access abnormality (K)	-	-	Y	Y	Y	P. 8-208
C916	Circuit related service call	Fatal Error - Please Contact Service Technician.	Sub-CPU access abnormality	-	-	Y	Y	Y	P. 8-220
C940	Circuit related service call	Fatal Error - Please Contact Service Technician.	Engine-CPU abnormality	2nd	-	Y	Y	Y	P. 8-220
C970	Process related service call	Fatal Error - Please Contact Service Technician.	High-voltage transformer abnormality	2nd	-	Y	Y	Y	P. 8-209
CA10	Laser optical unit related service call	Fatal Error - Please Contact Service Technician.	Polygonal motor abnormality	Y	-	Y	Y	Y	P. 8-226
CA20	Laser optical unit related service call	Fatal Error - Please Contact Service Technician.	H-Sync detection error	Y	-	Y	Y	Y	P. 8-226
CB00	Finisher related service call	Fatal Error - Please Contact Service Technician.	Finisher communication error	5th	-	Y	Y	Y	P. 8-227
CB10	Finisher related service call	Fatal Error - Please Contact Service Technician.	Entrance motor abnormality	2nd	-	Y	Y	Y	P. 8-227
CB11	Finisher related service call	Fatal Error - Please Contact Service Technician.	Buffer tray guide motor abnormality	5th	-	Y	Y	Y	P. 8-227
CB13	Finisher related service call	Fatal Error - Please Contact Service Technician.	Finisher exit motor abnormality	2nd	-	Y	Y	Y	P. 8-228
CB14	Finisher related service call	Fatal Error - Please Contact Service Technician.	Finisher assist guide motor abnormality	5th	-	Y	Y	Y	P. 8-228
CB15	Finisher related service call	Fatal Error - Please Contact Service Technician.	Catching motor abnormality	5th	-	Y	Y	Y	P. 8-229

Error code	Classification	Message	Contents	Error code display media					Troubleshooting
				Panl	JL	ML	Noti	CSV	
CB30	Finisher related service call	Printer Output Error.	[MJ-1042] Movable tray shift motor abnormality [MJ-1109/1110] Movable tray shift motor abnormality	2nd	-	Y	Y	Y	P. 8-229  P. 8-230
CB31	Finisher related service call	Fatal Error - Please Contact Service Technician.	Movable tray paper-full detection error	5th	-	Y	Y	Y	P. 8-231
CB40	Finisher related service call	Printer Output Error.	[MJ-1042] Front alignment plate home position detection error [MJ-1109/1110] Front alignment motor abnormality	5th	-	Y	Y	Y	P. 8-231  P. 8-232
CB50	Finisher related service call	Printer Output Error.	[MJ-1042] Stapler home position detection error [MJ-1109/1110] Stapler home position error	5th	-	Y	Y	Y	P. 8-233  P. 8-233
CB51	Finisher related service call	Fatal Error - Please Contact Service Technician.	[MJ-1042] Stapler unit sliding home position detection error [MJ-1109/1110] Stapler shift home position error	5th	-	Y	Y	Y	P. 8-234  P. 8-234
CB60	Finisher related service call	Printer Output Error.	Stapler unit shift motor abnormality	5th	-	Y	Y	Y	P. 8-235
CB80	Finisher related service call	Printer Output Error.	[MJ-1042] Finisher control PC board backup RAM error [MJ-1109/1110] Backup RAM data abnormality	2nd	-	Y	Y	Y	P. 8-235  P. 8-235
CB81	Finisher related service call	Fatal Error - Please Contact Service Technician.	Flash ROM abnormality	2nd	-	Y	Y	Y	P. 8-236
CB82	Finisher related service call (Finisher section)	Fatal Error - Please Contact Service Technician.	Finisher - Main program error	2nd	-	Y	Y	Y	P. 8-236
CB83	Finisher related service call (Saddle stitch unit)	Fatal Error - Please Contact Service Technician.	Saddle stitch finisher - Main program error	2nd	-	Y	Y	Y	P. 8-236
CB84	Finisher related service call (Hole punch unit)	Fatal Error - Please Contact Service Technician.	Hole punch unit - Main program error	2nd	-	Y	Y	Y	P. 8-237
CB92	Finisher related service call (Saddle stitch unit)	Fatal Error - Please Contact Service Technician.	Saddle stitch finisher RAM abnormality	2nd	-	Y	Y	Y	P. 8-237
CB93	Finisher related service call (Saddle stitch unit)	Fatal Error - Please Contact Service Technician.	Saddle stitch finisher additional folding motor abnormality	5th	-	Y	Y	Y	P. 8-237

Error code	Classification	Message	Contents	Error code display media					Troubleshooting
				Panl	JL	ML	Noti	CSV	
CB94	Finisher related service call (Saddle stitch unit)	Fatal Error - Please Contact Service Technician.	Saddle transport motor abnormality	5th	-	Y	Y	Y	P. 8-238
CB95	Finisher related service call (Saddle stitch unit)	Fatal Error - Please Contact Service Technician.	Saddle stitch finisher stacker motor abnormality	5th	-	Y	Y	Y	P. 8-238
CBA0	Finisher related service call (Saddle stitch unit)	Fatal Error - Please Contact Service Technician.	Front saddle stapler home position error	5th	-	Y	Y	Y	P. 8-238
CBB0	Finisher related service call (Saddle stitch unit)	Fatal Error - Please Contact Service Technician.	Rear saddle stapler home position error	5th	-	Y	Y	Y	P. 8-239
CBC0	Finisher related service call (Saddle stitch unit)	Fatal Error - Please Contact Service Technician.	Saddle stitch finisher side alignment motor abnormality	5th	-	Y	Y	Y	P. 8-239
CBE0	Finisher related service call (Saddle stitch unit)	Fatal Error - Please Contact Service Technician.	Saddle stitch finisher folding motor abnormality	5th	-	Y	Y	Y	P. 8-240
CC02	Finisher related service call (Finisher section)	Fatal Error - Please Contact Service Technician.	Stack exit roller nip home position detection error	2nd	-	Y	Y	Y	P. 8-240
CC20	Finisher related service call	Fatal Error - Please Contact Service Technician.	Saddle stitch communication error	2nd	-	Y	Y	Y	P. 8-240
CC30	Finisher related service call (Finisher section)	Fatal Error - Please Contact Service Technician.	Stack transport motor abnormality	5th	-	Y	Y	Y	P. 8-241
CC31	Finisher related service call (Finisher section)	Fatal Error - Please Contact Service Technician.	Transport motor abnormality	2nd	-	Y	Y	Y	P. 8-241
CC41	Finisher related service call (Finisher section)	Fatal Error - Please Contact Service Technician.	Assist guide cam home position abnormality	2nd	-	Y	Y	Y	P. 8-241
CC51	Finisher related service call (Hole punch unit)	Fatal Error - Please Contact Service Technician.	[MJ-1042] (When MJ-6011 is installed) Punch unit sliding motor abnormality [MJ-1109/1110] (When MJ-6105 is installed) Sideways adjustment motor abnormality	2nd	-	Y	Y	Y	P. 8-242 P. 8-242
CC52	Finisher related service call (Hole punch unit)	Fatal Error - Please Contact Service Technician.	Skew adjustment motor abnormality	5th	-	Y	Y	Y	P. 8-243
CC54	Finisher related service call (Hole punch unit)	Fatal Error - Please Contact Service Technician.	Paper detection sensors abnormality	2nd	-	Y	Y	Y	P. 8-243

Error code	Classification	Message	Contents	Error code display media					Troubleshooting
				Panl	JL	ML	Noti	CSV	
CC60	Finisher related service call (Hole punch unit)	Fatal Error - Please Contact Service Technician.	Punch motor abnormality	2nd	-	Y	Y	Y	P. 8-244
CC61	Finisher related service call (Hole punch unit)		[MJ-1042] (When MJ-6011 is installed) Punch motor abnormality [MJ-1109/1110] (When MJ-6105 is installed) Punch motor home position detection error	5th	-	Y	Y	Y	P. 8-244 P. 8-245
CC71	Finisher related service call (Hole punch unit)	Fatal Error - Please Contact Service Technician.	Punch ROM checksum error	Y	-	Y	Y	Y	P. 8-245
CC72	Finisher related service call (Hole punch unit)	Fatal Error - Please Contact Service Technician.	Punch RAM read / write error	Y	-	Y	Y	Y	P. 8-245
CC80	Finisher related service call (Finisher section)	Fatal Error - Please Contact Service Technician.	[MJ-1042] Front alignment motor abnormality [MJ-1109/1110] Rear alignment motor abnormality	2nd	-	Y	Y	Y	P. 8-246 P. 8-246
CC93	Finisher related service call (Finisher section)	Fatal Error - Please Contact Service Technician.	Knurled roller shift solenoid abnormality	2nd	-	Y	Y	Y	P. 8-247
CC94	Finisher related service call (Finisher section)	Fatal Error - Please Contact Service Technician.	Fan motor abnormality	2nd	-	Y	Y	Y	P. 8-247
CCF1	Finisher related service call (Finisher section)	Fatal Error - Please Contact Service Technician.	Tray safety switch abnormality	2nd	-	Y	Y	Y	P. 8-248
CDE0	Finisher related service call (Finisher section)	Printer Output Error.	Paddle motor abnormality	5th	-	Y	Y	Y	P. 8-248
CE00	Finisher related service call	Fatal Error - Please Contact Service Technician.	Communication error between the finisher and the punch unit	2nd	-	Y	Y	Y	P. 8-219
CE50	Image control related service call	Fatal Error - Please Contact Service Technician.	Temperature / humidity sensor abnormality	2nd	-	Y	Y	Y	P. 8-208
CE90	Image control related service call	Fatal Error - Please Contact Service Technician.	Drum thermistor abnormality	2nd	-	Y	Y	Y	P. 8-208
CF10	Finisher related service call	Printer Output Error.	Communication module writing failure	2nd	-	Y	Y	Y	P. 8-249

Error code	Classification	Message	Contents	Error code display media					Troubleshooting
				Panl	JL	ML	Noti	CSV	
F040	Option related service call	Fatal Error - Please Contact Service Technician.	Option installation error	Y	-	Y	Y	-	P. 8-223
F070	Communication related service call	Fatal Error - Please Contact Service Technician.	Communication error between the system-CPU and the engine-CPU	5th	-	Y	Y	Y	P. 8-223
F071	Communication related service call	Fatal Error - Please Contact Service Technician.	Communication initialization error between the system-CPU and the engine-CPU	2nd	-	Y	Y	-	P. 8-224
F074	Communication related service call	Fatal Error - Please Contact Service Technician.	Communication error between the system-CPU and the engine-CPU (engine-CPU response abnormality)	2nd	-	Y	Y	Y	P. 8-224
F090	Circuit related service call	Fatal Error - Please Contact Service Technician.	SRAM abnormality on the SYS board	Y	-	Y	Y	-	P. 8-221
F100_0	Other service call	Fatal Error - Please Contact Service Technician.	HDD format error (Operation failure of key data)	Y	-	Y	Y	-	P. 8-250
F100_1	Other service call	Fatal Error - Please Contact Service Technician.	HDD format error (HDD encryption key data damaged - one board)	Y	-	Y	Y	-	P. 8-250
F100_2	Other service call	Fatal Error - Please Contact Service Technician.	HDD format error (HDD encryption key data damaged - both boards)	Y	-	Y	Y	-	P. 8-251
F100_3	Other service call	Fatal Error - Please Contact Service Technician.	Serial number value error	Y	-	Y	Y	-	P. 8-252
F100_4	Other service call	Fatal Error - Please Contact Service Technician.	Hash check error of encryption partition key	Y	-	Y	Y	-	P. 8-252
F101_0	Other service call	Fatal Error - Please Contact Service Technician.	HDD connection error (HDD connection cannot be detected)	Y	-	Y	Y	-	P. 8-253
F101_1	Other service call	Fatal Error - Please Contact Service Technician.	Root partition mount error (HDD formatting fails)	Y	-	Y	Y	-	P. 8-253
F101_2	Other service call	Fatal Error - Please Contact Service Technician.	Partition mount error	Y	-	Y	Y	-	P. 8-253
F101_3	Other service call	Fatal Error - Please Contact Service Technician.	Partition mount error	Y	-	Y	Y	-	P. 8-253

Error code	Classification	Message	Contents	Error code display media					Troubleshooting
				Panl	JL	ML	Noti	CSV	
F101_4	Other service call	Fatal Error - Please Contact Service Technician.	Partition mount error	-	-	-	-	-	P. 8-254
F101_5	Other service call	Fatal Error - Please Contact Service Technician.	Partition mount error	-	-	-	-	-	P. 8-255
F101_6	Other service call	Fatal Error - Please Contact Service Technician.	Partition mount error	-	-	-	-	-	P. 8-256
F101_7	Other service call	Fatal Error - Please Contact Service Technician.	Partition mount error	-	-	-	-	-	P. 8-257
F101_8	Other service call	Fatal Error - Please Contact Service Technician.	Partition mount error	-	-	-	-	-	P. 8-258
F101_9	Other service call	Fatal Error - Please Contact Service Technician.	Partition mount error	-	-	-	-	-	P. 8-259
F101_10	Other service call	Fatal Error - Please Contact Service Technician.	Partition mount error	-	-	-	-	-	P. 8-260
F101_11	Other service call	Fatal Error - Please Contact Service Technician.	Partition mount error	-	-	-	-	-	P. 8-261
F101_12	Other service call	Fatal Error - Please Contact Service Technician.	Partition mount error	-	-	-	-	-	P. 8-254
F101_13	Other service call	Fatal Error - Please Contact Service Technician.	Error due to damage to file	-	-	-	-	-	P. 8-262
F101_14	Other service call	Fatal Error - Please Contact Service Technician.	Partition mount error	-	-	-	-	-	P. 8-263
F102	Other service call	Fatal Error - Please Contact Service Technician.	HDD start error	2nd	-	Y	Y	-	P. 8-263
F103	Other service call	Fatal Error - Please Contact Service Technician.	HDD transfer time-out	5th	-	Y	Y	-	P. 8-263
F104	Other service call	Fatal Error - Please Contact Service Technician.	HDD data error	5th	-	Y	Y	-	P. 8-263
F105	Other service call	Fatal Error - Please Contact Service Technician.	HDD other error	5th	-	Y	Y	-	P. 8-263



Error code	Classification	Message	Contents	Error code display media					Troubleshooting
				Panl	JL	ML	Noti	CSV	
F106_0	Other service call		HDD error (Illegal disk replacement detected)	2nd	-	-	-	-	P. 8-264
F106_1	Other service call		HDD error (HDD type detection error)	2nd	-	-	-	-	P. 8-264
F106_2	Other service call		HDD error (Secure HDD encryption key download operation error)	2nd	-	-	-	-	P. 8-265
F106_3	Other service call		HDD error (Secure HDD authentication Admin Password generation error)	2nd	-	-	-	-	P. 8-266
F106_4	Other service call		HDD error (Authentication random number generation error)	2nd	-	-	-	-	P. 8-266
F106_5	Other service call		HDD error (Authentication data transmission error)	2nd	-	-	-	-	P. 8-267
F106_6	Other service call		HDD error (Error caused by reason other than F106_0 to 5 errors)	2nd	-	-	-	-	P. 8-268
F106_7	Other service call		HDD error (Error caused by reason other than F106_0 to 5 errors)	2nd	-	-	-	-	P. 8-268
F106_8	Other service call		HDD error (Error caused by reason other than F106_0 to 5 errors)	2nd	-	-	-	-	P. 8-268
F106_10	Other service call		HDD error (Error caused by reason other than F106_0 to 5 errors)	2nd	-	-	-	-	P. 8-268
F106_11	License Management		License damaged (HDD and SRAM)	2nd	-	-	-	-	P. 8-268
F106_12	License Management		License damaged (SRAM)	2nd	-	-	-	-	P. 8-269
F106_UNDEF	Other service call		HDD error (Error caused by reason other than F106_0 to 5 errors)	2nd	-	-	-	-	P. 8-268
F109_0	Other service call		Key consistency error (Consistency check operation error)	Y	-	-	-	-	P. 8-269
F109_1	Other service call		Key consistency error (SRAM encryption AES key data damage)	Y	-	-	-	-	P. 8-269
F109_2	Other service call		Key consistency error (Signature Check public key damage)	Y	-	-	-	-	P. 8-270

Error code	Classification	Message	Contents	Error code display media					Troubleshooting
				Panl	JL	ML	Noti	CSV	
F109_3	Other service call		Key consistency error (HDD encryption parameter damage)	Y	-	-	-	-	P. 8-270
F109_4	Other service call		Key consistency error (license data damage)	Y	-	-	-	-	P. 8-272
F109_5	Other service call		Key consistency error (encryption key for HDD is damaged)	Y	-	-	-	-	P. 8-272
F109_6	Other service call		Key consistency error (administrator password error for HDD authentication)	Y	-	-	-	-	P. 8-274
F109_7	Other service call		Hash check error of ADI-HDD authentication key	Y	-	-	-	-	P. 8-275
F110	Communication related service call	Fatal Error - Please Contact Service Technician.	Communication error between the system-CPU and the scanner-CPU	5th	-	-	-	Y	P. 8-224
F111	Communication related service call	Fatal Error - Please Contact Service Technician.	Communication error between the system-CPU and the scanner-CPU	5th	-	-	-	Y	P. 8-224
F120	Other service call	Fatal Error - Please Contact Service Technician.	Database abnormality	Y	-	Y	Y	-	P. 8-276
F121	Other service call	User Management DB corrupted.	Database abnormality (user information management database error)	2nd	-	Y	Y	-	P. 8-276
F122	Other service call	User Management DB corrupted.	Database abnormality (message / job log management database error)	Y	-	Y	Y	-	P. 8-277
F124	Other service call	AppManagement DB corrupted.	Database abnormality (application management database damage error)	Y	-	Y	Y	-	P. 8-277
F125	Other service call	HomeScreen DB corrupted.	Database abnormality (Home screen database damage error)	Y	-	Y	Y	-	P. 8-277
F126	Other service call	JobHistory DB corrupted.	Database abnormality (Job history database damage error)	Y	-	Y	Y	-	P. 8-278
F127	Other service call	AppLicense DB corrupted.	Database abnormality (application license management database damage error)	Y	-	Y	Y	-	P. 8-278

Error code	Classification	Message	Contents	Error code display media					Troubleshooting
				Panl	JL	ML	Noti	CSV	
F128	License Management	LMDB ERROR	License management database damage	-	-	Y	Y	-	P. 8-278
F130	Other service call		Invalid MAC address	2nd	-	-	-	-	P. 8-279
F131	Other service call	Fatal Error - Please Contact Service Technician.	Filtering setting file damage error	Y	-	Y	Y	-	P. 8-279
F140	Other service call	Fatal Error - Please Contact Service Technician.	ASIC format abnormality	Y	-	Y	Y	Y	P. 8-279
F150	Other service call		Power failure during the manufacturing mode	Y	-	Y	Y	-	P. 8-280
F200	Other service call	Fatal Error - Please Contact Service Technician.	Data Overwrite option (GP-1070) disabled	Y	-	Y	Y	-	P. 8-280
F350	Circuit related service call	Fatal Error - Please Contact Service Technician.	SYS board abnormality	Y	-	Y	Y	Y	P. 8-221
F400	Circuit related service call	Fatal Error - Please Contact Service Technician.	SYS board cooling fan abnormality	Y	-	Y	Y	-	P. 8-222
F410	Circuit related service call	Fatal Error - Please Contact Service Technician.	Power abnormality	Y	-	Y	Y	-	P. 8-222
F510	Other service call		Application start error	Y	-	-	-	-	P. 8-281
F520	Other service call		Operating system start error	Y	-	-	-	-	P. 8-281
F521	Other service call		Integrity check error	Y	-	-	-	-	P. 8-281
F523	Other service call		Security check error at the startup	Y	-	-	-	-	P. 8-282
F550	Other service call	Fatal Error - Please Contact Service Technician.	Encryption partition error	-	-	Y	Y	-	P. 8-282
F600	Other service call	Fatal Error - Please Contact Service Technician.	Firmware update error	Y	-	-	-	-	P. 8-282
F700	Other service call	Fatal Error - Please Contact Service Technician.	Overwrite error	-	-	Y	Y	-	P. 8-282
F800	Other service call	Fatal Error - Please Contact Service Technician.	Date error	2nd	-	-	-	-	P. 8-282
F900	Other service call		Model information alignment error	Y	-	-	-	-	P. 8-283

Error code	Classification	Message	Contents	Error code display media					Troubleshooting
				Panl	JL	ML	Noti	CSV	
F901_0	Other service call		Communication error	Y	-	-	-	-	P. 8-283
F901_1	Other service call		Communication error	Y	-	-	-	-	P. 8-283
F901_2	Other service call		Communication error	Y	-	-	-	-	P. 8-283
F901_3	Other service call		Communication error	Y	-	-	-	-	P. 8-283

## 8.2.3 Error in Internet FAX / Scanning function

### 1. Internet FAX related error

Error code	Classification	Message	Contents	Error code display media					Troubleshooting
				Panl	JL	ML	Noti	CSV	
1C10	Internet FAX related error		System access abnormality	-	Y	-	Y	-	P. 8-285
1C11	Internet FAX related error		Insufficient memory	-	Y	-	Y	-	P. 8-285
1C12	Internet FAX related error		Message reception error	-	Y	-	Y	-	P. 8-286
1C13	Internet FAX related error		Message transmission error	-	Y	-	Y	-	P. 8-286
1C14	Internet FAX related error		Invalid parameter	-	Y	-	Y	-	P. 8-286
1C15	Internet FAX related error		Exceeding file capacity	-	Y	-	Y	-	P. 8-286
1C30	Internet FAX related error		Directory creation failure	-	Y	-	Y	-	P. 8-286
1C31	Internet FAX related error		File creation failure	-	Y	-	Y	-	P. 8-286
1C32	Internet FAX related error		File deletion failure	-	Y	-	Y	-	P. 8-285
1C33	Internet FAX related error		File access failure	-	Y	-	Y	-	P. 8-286
1C40	Internet FAX related error		Image conversion abnormality	-	Y	-	Y	-	P. 8-286
1C60	Internet FAX related error	Syntax error, command unrecognized	HDD full failure during processing	-	Y	-	Y	-	P. 8-287
1C61	Internet FAX related error		AddressBook reading failure	-	Y	-	Y	-	P. 8-287
1C63	Internet FAX related error		Terminal IP address unset	-	Y	-	Y	-	P. 8-287
1C64	Internet FAX related error		Terminal mail address unset	-	Y	-	Y	-	P. 8-287
1C65	Internet FAX related error		SMTP mail address unset	-	Y	-	Y	-	P. 8-288
1C66	Internet FAX related error		Server time-out error	-	Y	-	Y	-	P. 8-288
1C69	Internet FAX related error		SMTP server connection error	-	Y	-	Y	-	P. 8-288
1C6B	Internet FAX related error		Terminal mail address error	-	Y	-	Y	-	P. 8-288
1C6C	Internet FAX related error		Destination mail address error	-	Y	-	Y	-	P. 8-288
1C6D	Internet FAX related error		System error	-	Y	-	Y	-	P. 8-289
1C70	Internet FAX related error		SMTP client OFF	-	Y	-	Y	-	P. 8-289
1C71	Internet FAX related error		SMTP authentication error	-	Y	-	Y	-	P. 8-289
1C72	Internet FAX related error		POP before SMTP error	-	Y	-	Y	-	P. 8-289
1CC0	Internet FAX related error		Job canceling	-	Y	-	Y	-	-
1CC1	Internet FAX related error		Power failure	-	Y	-	Y	-	P. 8-289

## 2. RFC related error

Error code	Classification	Message	Contents	Error code display media					Troubleshooting
				Panl	JL	ML	Noti	CSV	
2500	RFC related error	Syntax error, command unrecognized	HOST NAME error (RFC: 500) / Destination mail address error (RFC: 500) / Terminal mail address error (RFC: 500)	-	Y	-	Y	-	P. 8-290
2501	RFC related error	Syntax error in parameters or arguments	HOST NAME error (RFC: 501) / Destination mail address error (RFC: 501) / Terminal mail address error (RFC: 501)	-	Y	-	Y	-	P. 8-290
2503	RFC related error	Bad sequence of commands	Destination mail address error (RFC: 503)	-	Y	-	Y	-	P. 8-290
2504	RFC related error	Command parameter not implemented	HOST NAME error (RFC: 504)	-	Y	-	Y	-	P. 8-290
2550	RFC related error	Mailbox unavailable	Destination mail address error (RFC: 550)	-	Y	-	Y	-	P. 8-290
2551	RFC related error	User not local	Destination mail address error (RFC: 551)	-	Y	-	Y	-	P. 8-290
2552	RFC related error	Insufficient system storage	Terminal / Destination address error (RFC: 552)	-	Y	-	Y	-	P. 8-290
2553	RFC related error	Mailbox name not allowed	Destination mail address error (RFC: 553)	-	Y	-	Y	-	P. 8-291

### 3. Remote scanning related error

Error code	Classification	Message	Contents	Error code display media					Troubleshooting
				Panl	JL	ML	Noti	CSV	
2A00	Remote scanning related error		Successful completion (BoxInTA)	-	Y	-	-	-	-
2A20	Remote scanning related error	Failed to acquire resource	System management module resource acquiring failure	-	Y	-	-	-	P. 8-291
2A31	Remote scanning related error	WS Scan function is not available	WS Scan disabled	-	Y	-	-	-	P. 8-291
2A40	Remote scanning related error	System fatal error	System error	-	Y	-	-	-	P. 8-291
2A50	Remote scanning related error	Job canceling	Job canceled	-	Y	-	-	-	-
2A51	Remote scanning related error	Power failure	Power failure	-	Y	-	-	-	P. 8-291
2A60	Remote scanning related error	Authentication for WS Scan failed	WS Scan user authentication failure	-	Y	-	-	-	P. 8-292
2A70	Remote scanning related error	Insufficient permission to execute RemoteScan	Remote Scan privilege check error	-	-	Y	-	-	P. 8-292
2A71	Remote scanning related error	Insufficient permission to execute WS Scan	WS Scan privilege check error	-	Y	-	-	-	P. 8-292
2A72	Remote scanning related error	Insufficient permission to access e-Filing box using scan utility	e-Filing box data access privilege check error (Scan Utility)	-	-	Y	-	-	P. 8-292
2A73	Remote scanning related error	Insufficient permission to execute Addressbook Export/Import operation	Error in the AddressBook operation privilege check	-	-	-	-	-	-
2AD0	Remote scanning related error	Backup operation of e-Filing data from Backup/Restore Utility is done	e-Filing box data backing up	-	-	-	-	-	-
2AD1	Remote scanning related error	Restore operation of e-Filing data from Backup/Restore Utility is done	e-Filing box data restoring	-	-	-	-	-	-
2AD2	Remote scanning related error	Archive operation of e-Filing data is done	e-Filing box data archiving	-	-	-	-	-	-
2AD3	Remote scanning related error	Restore operation of e-Filing data is done	Archived e-Filing box data restoring	-	-	-	-	-	-
2AD4	Remote scanning related error	e-Filing data was downloaded by scan utility	e-Filing box data downloading (Scan Utility)	-	-	-	-	-	-

#### 4. Electronic Filing related error

Error code	Classification	Message	Contents	Error code display media					Troubleshooting
				Panl	JL	ML	Noti	CSV	
2B00	e-Filing box related error	Successfully stored document.	Doc saving successful	-	Y	-	Y	-	-
2B01	e-Filing box related error	Successfully sent document to print queue	Successful completion (BoxPrnTA)	-	-	-	-	-	-
2B11	e-Filing box related error	Job status failed	Job status abnormality	-	Y	-	Y	-	P. 8-292
2B20	e-Filing box related error	Failed to access file	File library function error	-	Y	-	Y	-	P. 8-292
2B30	e-Filing box related error	Insufficient disk space	Insufficient disk space in BOX partition	-	Y	-	Y	-	P. 8-292
2B31	e-Filing box related error	Failed to access Electronic Filing	Status of the specified e-Filing box or folder is undefined or being created / deleted	-	Y	-	Y	-	P. 8-293
2B50	e-Filing box related error	Failed to process image	Image library error	-	Y	-	Y	-	P. 8-293
2B51	e-Filing box related error	Failed to print images from the document box	List library error	-	Y	-	Y	-	P. 8-293
2B71	e-Filing box related error	Document(s) expire(s) in a few days	There are documents which will expire in a few days	-	-	Y	Y	-	-
2B80	e-Filing box related error	Hard Disk space for Electronic Filing nearly full	Hard disk space in BOX partition is nearly full (90%)	-	-	Y	Y	-	-
2B90	e-Filing box related error	Insufficient Memory	Insufficient memory capacity	-	Y	-	Y	-	P. 8-293
2BA0	e-Filing box related error	Invalid Box password specified	Invalid Box password	-	Y	-	Y	-	P. 8-294
2BA1	e-Filing box related error	Incorrect paper size / invalid color mode / invalid resolution	The specified paper size, color mode or resolution is not available	-	-	-	Y	-	P. 8-294
2BB0	e-Filing box related error	Job canceled	Job canceling	-	Y	-	Y	-	-
2BB1	e-Filing box related error	Power failure occurred	Power failure	-	Y	-	Y	-	P. 8-294
2BC0	e-Filing box related error	System fatal error	Fatal failure occurred	-	Y	-	Y	-	P. 8-292
2BD0	e-Filing box related error	Power failure occurred during e-Filing restoring	Power failure during restoring of e-Filing box	-	-	Y	Y	-	P. 8-294
2BD1	e-Filing box related error	e-Filing Box Storage is initialized.	e-Filing box is initialized.	-	-	Y	Y	-	-
2BE0	e-Filing box related error	Failed to get machine parameter	Machine parameter reading error	-	Y	-	Y	-	P. 8-294
2BF0	e-Filing box related error	Maximum number of page range is reached	Exceeding the maximum number of pages	-	Y	-	Y	-	P. 8-294



Error code	Classification	Message	Contents	Error code display media					Troubleshooting
				PanI	JL	ML	Noti	CSV	
2BF1	e-Filing box related error	Maximum number of document range is reached	Exceeding the maximum number of documents	-	Y	-	Y	-	P. 8-295
2BF2	e-Filing box related error	Maximum number of folder range is reached	Exceeding the maximum number of folders	-	Y	-	Y	-	P. 8-295

## 5. E-mail related error

Error code	Classification	Message	Contents	Error code display media					Troubleshooting
				Panl	JL	ML	Noti	CSV	
2C00	E-mail related error		Communication successful completion	-	Y	-	Y	-	-
2C01	E-mail related error		Transferring completion (Fax reception)	-	Y	-	Y	-	-
2C02	E-mail related error		Transferring completion (E-mail reception)	-	Y	-	Y	-	-
2C04	E-mail related error		Notification transmission successful completion	-	Y	-	Y	-	-
2C10	E-mail related error	Illegal Job status	System access abnormality	-	Y	-	Y	-	P. 8-295
2C11	E-mail related error	Not enough memory	Insufficient memory	-	Y	-	Y	-	P. 8-295
2C12	E-mail related error	Illegal Job status	Message reception error	-	Y	-	Y	-	P. 8-296
2C13	E-mail related error	Illegal Job status	Message transmission error	-	Y	-	Y	-	P. 8-296
2C14	E-mail related error	Invalid parameter specified	Invalid parameter	-	Y	-	Y	-	P. 8-296
2C15	E-mail related error	Email size exceeded limit or maximum size	Exceeding file capacity	-	Y	-	Y	-	P. 8-296
2C20	E-mail related error	Illegal Job status	System management module access abnormality	-	Y	-	Y	-	P. 8-296
2C21	E-mail related error	Illegal Job status	Job control module access abnormality	-	Y	-	Y	-	P. 8-296
2C22	E-mail related error	Illegal Job status	Job control module access abnormality	-	Y	-	Y	-	P. 8-296
2C30	E-mail related error	Failed to create directory	Directory creation failure	-	Y	-	Y	-	P. 8-297
2C31	E-mail related error	Failed to create file	File creation failure	-	Y	-	Y	-	P. 8-297
2C32	E-mail related error	Failed to delete file	File deletion failure	-	Y	-	Y	-	P. 8-295
2C33	E-mail related error	Failed to create file	File access failure	-	Y	-	Y	-	P. 8-297
2C40	E-mail related error	Failed to convert image file format	Image conversion abnormality	-	Y	-	Y	-	P. 8-297
2C43	E-mail related error	Encryption error. Failed to create file	Encryption error	-	Y	-	Y	-	P. 8-297
2C44	E-mail related error	Creating the image file was not permitted	Encryption PDF enforced mode error	-	Y	-	Y	-	P. 8-297
2C45	E-mail related error	Failed in making meta data	Meta data creation error (Scan to Email)	-	Y	-	Y	-	P. 8-298
2C50	E-mail related error	Insufficient permission to execute Scan job	Authentication failure at job execution	-	Y	-	Y	-	-

Error code	Classification	Message	Contents	Error code display media					Troubleshooting
				Panl	JL	ML	Noti	CSV	
2C60	E-mail related error	Failed to process your Job. Insufficient disk space.	HDD full failure during processing	-	Y	-	Y	-	P. 8-298
2C61	E-mail related error	Failed to read AddressBook	AddressBook reading failure	-	Y	-	Y	-	P. 8-298
2C62	E-mail related error	Not enough memory	Memory acquiring failure	-	Y	-	Y	-	P. 8-297
2C63	E-mail related error	Invalid Domain Address	Terminal IP address unset	-	Y	-	Y	-	P. 8-298
2C64	E-mail related error	Invalid Domain Address	Terminal mail address unset	-	Y	-	Y	-	P. 8-299
2C65	E-mail related error	Failed to connect to SMTP server	SMTP address unset	-	Y	-	Y	-	P. 8-299
2C66	E-mail related error	Failed to connect to SMTP server	Server time-out error	-	Y	-	Y	-	P. 8-299
2C69	E-mail related error	Failed to connect to SMTP server	SMTP server connection error	-	Y	-	Y	-	P. 8-299
2C6A	E-mail related error	Failed to send E-Mail message	HOST NAME error (No RFC error)	-	Y	-	Y	-	P. 8-299
2C6B	E-mail related error	Invalid address specified in From: field	Terminal mail address error	-	Y	-	Y	-	P. 8-300
2C6C	E-mail related error	Invalid address specified in To: field	Destination mail address error (No RFC error)	-	Y	-	Y	-	P. 8-300
2C70	E-mail related error	SMTP service is not available	SMTP client OFF	-	Y	-	Y	-	P. 8-300
2C71	E-mail related error	Failed SMTP Authentication	SMTP authentication error	-	Y	-	Y	-	P. 8-300
2C72	E-mail related error	POP Before SMTP Authentication Failed	POP before SMTP error	-	Y	-	Y	-	P. 8-300
2CC0	E-mail related error	Job canceled	Job canceling	-	Y	-	Y	-	-
2CC1	E-mail related error	Power failure occurred	Power failure	-	Y	-	Y	-	P. 8-301

## 6. File sharing related error

Error code	Classification	Message	Contents	Error code display media					Troubleshooting
				PanI	JL	ML	Noti	CSV	
2D00	File sharing related error		Successful completion (saving in a local directory)	-	Y	-	Y	-	-
2D01	File sharing related error		Successful completion (saving in remote)	-	Y	-	Y	-	-
2D02	File sharing related error		Successful completion (saving of a received FaxtoFile / &File in a local directory)	-	Y	-	Y	-	-
2D03	File sharing related error		Successful completion (saving of a received FaxtoFile / &File in remote)	-	Y	-	Y	-	-
2D04	File sharing related error		Successful completion (saving of a received EmailtoFile / &File in a local directory)	-	Y	-	Y	-	-
2D05	File sharing related error		Successful completion (saving of a received EmailtoFile / &File in remote)	-	Y	-	Y	-	-
2D10	File sharing related error	Illegal Job status	System access abnormality	-	Y	-	Y	-	P. 8-301
2D11	File sharing related error	Not enough memory	Insufficient memory	-	Y	-	Y	-	P. 8-301
2D12	File sharing related error	Illegal Job status	Message reception error	-	Y	-	Y	-	P. 8-301
2D13	File sharing related error	Illegal Job status	Message transmission error	-	Y	-	Y	-	P. 8-301
2D14	File sharing related error	Invalid parameter specified	Invalid parameter	-	Y	-	Y	-	P. 8-302
2D15	File sharing related error	Document size exceeded limit or maximum size	Exceeding the maximum size for file sharing	-	Y	-	Y	-	P. 8-302
2D30	File sharing related error	Failed to create directory	Directory creation failure	-	Y	-	Y	-	P. 8-302
2D31	File sharing related error	Failed to create file	File creation failure	-	Y	-	Y	-	P. 8-302
2D32	File sharing related error	Failed to delete file	File deletion failure	-	Y	-	Y	-	P. 8-301
2D33	File sharing related error	Failed to create file	File access failure	-	Y	-	Y	-	P. 8-302
2D40	File sharing related error	Failed to convert image file format	Image conversion abnormality	-	Y	-	Y	-	P. 8-302
2D43	File sharing related error	Encryption error. Failed to create file	Encryption error	-	Y	-	Y	-	P. 8-302
2D44	File sharing related error	Creating the image file was not permitted	Encryption PDF enforced mode error	-	Y	-	Y	-	P. 8-303
2D45	File sharing related error	Failed in making meta data	Meta data creation error (Scan to File)	-	Y	-	Y	-	P. 8-303

Error code	Classification	Message	Contents	Error code display media					Troubleshooting
				Panl	JL	ML	Noti	CSV	
2D50	File sharing related error	Insufficient permission to execute Scan job	Authentication failure at job execution	-	Y	-	Y	-	P. 8-303
2D62	File sharing related error	Failed to connect to network destination. Check destination path	File server connection failure	-	Y	-	Y	-	P. 8-303
2D63	File sharing related error	Specified network path is invalid. Check destination path	Invalid network path	-	Y	-	Y	-	P. 8-303
2D64	File sharing related error	Logon to file server failed. Check username and password	Login failure	-	Y	-	Y	-	P. 8-304
2D65	File sharing related error	There are too many documents in the folder. Failed in creating new document.	New document creation failure caused by an excess of documents in a folder	-	Y	-	Y	-	P. 8-304
2D66	File sharing related error	Failed To Process your Job. Insufficient Storage space.	Storage capacity full failure during processing	-	Y	-	Y	-	P. 8-304
2D67	File sharing related error	FTP service is not available	FTP service not available	-	Y	-	Y	-	P. 8-304
2D68	File sharing related error	File Sharing service is not available	File sharing service not available	-	Y	-	Y	-	P. 8-304
2D69	File sharing related error	NetWare service is not available	NetWare service not available	-	Y	-	Y	-	P. 8-305
2DA0	File sharing related error	Expired scan documents deleted from share folder	Periodical deletion of scanned documents has been completed properly	-	-	Y	Y	-	-
2DA1	File sharing related error	Expired Sent Fax documents deleted from shared folder	Periodical deletion of transmitted Fax documents has been completed properly	-	-	Y	Y	-	-
2DA2	File sharing related error	Expired Received Fax documents deleted from shared folder	Periodical deletion of received Fax documents has been completed properly	-	-	Y	Y	-	-
2DA3	File sharing related error	Scanned documents in shared folder deleted upon user's request	Manual deletion of scanned documents has been completed properly	-	-	Y	Y	-	-
2DA4	File sharing related error	Sent Fax Documents in shared folder deleted upon user's request.	Manual deletion of transmitted Fax documents has been completed properly	-	-	Y	Y	-	-
2DA5	File sharing related error	Received Fax Documents in shared folder deleted upon user's request.	Manual deletion of received Fax documents has been completed properly	-	-	Y	Y	-	-

Error code	Classification	Message	Contents	Error code display media					Troubleshooting
				Panl	JL	ML	Noti	CSV	
2DA6	File sharing related error	Failed to delete file	File deletion failure	-	-	Y	Y	-	P. 8-301
2DA7	File sharing related error	Failed to acquire resource.	Resource acquiring failure	-	-	Y	Y	-	P. 8-301
2DC0	File sharing related error	Job canceled	Job canceling	-	Y	-	Y	-	-
2DC1	File sharing related error	Power failure occurred	Power failure	-	Y	-	Y	-	P. 8-305
2E00	File sharing related error		Successful completion (saving in a USB storage)	-	Y	-	Y	-	-
2E01	File sharing related error		Successful completion (saving of a received FaxtoFile / &File in a USB storage)	-	Y	-	Y	-	-
2E02	File sharing related error		Successful completion (saving of a received EmailtoFile / &File in a USB storage)	-	Y	-	Y	-	-
2E10	File sharing related error	Failed to store document(s) in USB folder.	System access abnormality in USB storage	-	Y	-	Y	-	P. 8-305
2E11	File sharing related error	Failed to store document(s) in USB folder.	Insufficient memory capacity for USB storage	-	Y	-	Y	-	P. 8-305
2E12	File sharing related error	Failed to store document(s) in USB folder.	Message reception error in USB storage	-	Y	-	Y	-	P. 8-305
2E13	File sharing related error	Failed to store document(s) in USB folder.	Message transmission error in USB storage	-	Y	-	Y	-	P. 8-305
2E14	File sharing related error	Failed to store document(s) in USB folder.	Invalid parameter for USB storage	-	Y	-	Y	-	P. 8-306
2E15	File sharing related error	Document size exceeded limit or maximum size	Exceeding the maximum size for file sharing	-	Y	-	Y	-	P. 8-306
2E30	File sharing related error	Failed to store document(s) in USB folder	Directory creation failure in USB storage	-	Y	-	Y	-	P. 8-306
2E31	File sharing related error	Failed to store document(s) in USB folder	File creation failure in USB storage	-	Y	-	Y	-	P. 8-306
2E32	File sharing related error	Failed to store document(s) in USB folder	File deletion failure in USB storage	-	Y	-	Y	-	P. 8-306
2E33	File sharing related error	Failed to store document(s) in USB folder	File access failure in USB storage	-	Y	-	Y	-	P. 8-306
2E40	File sharing related error	Failed to convert image file format	Image conversion abnormality in USB storage	-	Y	-	Y	-	P. 8-307
2E43	File sharing related error	Encryption error. Failed to create file.	Encryption failure in USB storage	-	Y	-	Y	-	P. 8-307

Error code	Classification	Message	Contents	Error code display media					Troubleshooting
				Panl	JL	ML	Noti	CSV	
2E44	File sharing related error	Creating the image file was not permitted	Encryption PDF enforced mode error in USB storage	-	-	-	Y	-	P. 8-307
2E45	File sharing related error	Failed in making meta data	Meta data creation error in USB storage (Scan to File)	-	Y	-	Y	-	P. 8-307
2E50	File sharing related error	Insufficient permission to execute Scan job	Authentication failure at job execution	-	Y	-	Y	-	P. 8-298
2E65	File sharing related error	There are too many documents in folders. Failed in creating new document.	File creation error due to insufficient USB folder capacity	-	Y	-	Y	-	P. 8-308
2E66	File sharing related error	Failed To Process your Job. Insufficient Storage space.	HDD full failure during USB storage process	-	Y	-	Y	-	P. 8-308
2EC0	File sharing related error	Job canceled	Job canceling	-	Y	-	Y	-	-
2EC1	File sharing related error	Power Failure Job Aborted	Power failure in USB storage	-	Y	-	Y	-	P. 8-308

## 7. E-mail reception related error

Error code	Classification	Message	Contents	Error code display media					Troubleshooting
				Panl	JL	ML	Noti	CSV	
3000	E-mail reception related error		E-mail reception is completed properly	-	Y	-	Y	-	-
3A10	E-mail reception related error	MIME Error has been detected in the received mail.	E-mail MIME error	-	Y	-	Y	-	P. 8-308
3A20	E-mail reception related error	Analyze Error has been detected in the received mail.	E-mail analysis error	-	Y	-	Y	-	P. 8-308
3A30	E-mail reception related error	Whole partial mails were not reached by timeout.	Partial mail time-out error	-	Y	-	Y	-	P. 8-309
3A40	E-mail reception related error	Partial Mail Error has been detected in the received mail.	Partial mail related error	-	Y	-	Y	-	P. 8-309
3A50	E-mail reception related error	HDD Full Error has been occurred in this mail.	Insufficient HDD capacity error	-	Y	-	Y	-	P. 8-309
3A70	E-mail reception related error	Receiving partial mail was aborted since the partial mail setting has been changed to Disable.	Error of partial mail interruption	-	Y	-	Y	-	P. 8-309
3A80	E-mail reception related error	Partial mail was received during the partial mail setting is disabled.	Partial mail reception setting OFF	-	Y	-	Y	-	P. 8-310
3B10	E-mail reception related error	Format Error has been detected in the received mail.	E-mail format error	-	Y	-	Y	-	P. 8-308
3B20	E-mail reception related error	Content-Type Error has been detected in the received mail.	Content-Type error	-	Y	-	Y	-	P. 8-310
3B40	E-mail reception related error	Decode Error has been detected in the received mail.	E-mail decode error	-	Y	-	Y	-	P. 8-308
3B50	E-mail reception related error	Received Email data was broken. It was deleted from mail server.	Received mail data deletion	-	Y	-	Y	-	-
3C10	E-mail reception related error	Tiff Analyze Error has been detected in the received mail.	TIFF analysis error	-	Y	-	Y	-	P. 8-310
3C13	E-mail reception related error	Tiff Analyze Error has been detected in the received mail.	TIFF analysis error	-	Y	-	Y	-	P. 8-310
3C20	E-mail reception related error	Tiff Compression Error has been detected in the received mail.	TIFF compression error	-	Y	-	Y	-	P. 8-310
3C30	E-mail reception related error	Tiff Resolution Error has been detected in the received mail.	TIFF resolution error	-	Y	-	Y	-	P. 8-310



Error code	Classification	Message	Contents	Error code display media					Troubleshooting
				Panl	JL	ML	Noti	CSV	
3C40	E-mail reception related error	Tiff Paper Size Error has been detected in the received mail.	TIFF paper size error	-	Y	-	Y	-	P. 8-311
3C50	E-mail reception related error	Offramp Destination Error has been detected in the received mail.	Offramp destination error	-	Y	-	Y	-	P. 8-311
3C60	E-mail reception related error	Offramp Security Error has been detected in the received mail.	Offramp security error	-	Y	-	Y	-	P. 8-311
3C70	E-mail reception related error	Power Failure has been occurred in Email receiving.	Power failure error	-	Y	-	Y	-	P. 8-311
3C90	E-mail reception related error	OffRamp Fax transmission disable error has been detected in the received mail.	Offramp Fax transmission disable error	-	Y	-	Y	-	P. 8-311
3D10	E-mail reception related error	SMTP Destination Error has been detected in the received mail. This mail was deleted.	Destination address error	-	-	Y	Y	-	P. 8-312
3D20	E-mail reception related error	Offramp Destination limitation Error has been detected in the received mail.	Offramp destination limitation error	-	-	Y	Y	-	P. 8-312
3D30	E-mail reception related error	Fax Board Error has been occurred in the received mail.	FAX Unit error	-	-	Y	Y	-	P. 8-312
3E10	E-mail reception related error	POP3 Connection Error has been occurred in the received mail.	POP3 server connection error	-	-	Y	Y	-	P. 8-312
3E20	E-mail reception related error	POP3 Connection Timeout Error has been occurred in the received mail.	POP3 server connection time-out error	-	-	Y	Y	-	P. 8-312
3E30	E-mail reception related error	POP3 Login Error has been occurred in the received mail.	POP3 login error	-	-	Y	Y	-	P. 8-313
3E40	E-mail reception related error	POP3 Login Error occurred in the received mail.	POP3 login type error	-	-	Y	Y	-	P. 8-313
3F10	E-mail reception related error	File I/O Error has been occurred in this mail. The mail could not be received until File I/O is recovered.	File I/O error	-	-	Y	Y	-	P. 8-313
3F20	E-mail reception related error	File I/O Error has been occurred in this mail. The mail could not be received until File I/O is recovered.	File I/O error	-	Y	-	Y	-	P. 8-313

## 8.2.4 Printer function error

Following codes are displayed at the end of the user name on the print job log screen.

Error code	Classification	Message	Contents	Error code display media					Troubleshooting
				Panl	JL	ML	Noti	CSV	
4000	Printer error	-	Successful completion	-	-	-	-	-	-
4011	Printer error	-	Print job cancellation	-	-	-	-	-	P. 8-314
4021	Printer error	-	Print job power failure	-	-	-	-	-	P. 8-314
4031	Printer error	-	HDD full during print	-	-	-	-	-	P. 8-314
4032	Printer error	-	Exceeding the upper limit of the registration number for the sharing jobs	-	-	-	-	-	P. 8-314
4033	Printer error	-	Network setting error	-	-	-	-	-	P. 8-314
4041	Printer error	-	User authentication error	-	-	-	-	-	P. 8-315
4042	Printer error	-	Department authentication error	-	-	-	-	-	P. 8-315
4043	Printer error	-	Project authentication error	-	Y	-	-	-	P. 8-315
4045	Printer error	-	Problem in LDAP server connection or LDAP server authorization settings	-	-	-	-	-	P. 8-315
4111	Printer error	-	Quota over error (no quota in a department and user)	-	-	-	-	-	P. 8-315
4112	Printer error	-	Quota over error (no quota in a user)	-	-	-	-	-	P. 8-316
4113	Printer error	-	Quota over error (no quota in a department)	-	-	-	-	-	P. 8-316
4121	Printer error	-	Job canceling due to external counter error	-	-	-	-	-	P. 8-316
4211	Printer error	-	Printing data storing limitation error	-	-	-	-	-	-
4212	Printer error	-	e-Filing box storing limitation error	-	-	-	-	-	P. 8-316
4213	Printer error	-	File storing limitation error	-	-	-	-	-	P. 8-316
4214	Printer error	-	Fax / Internet Fax transmission limitation error	-	-	-	-	-	P. 8-317
4221	Printer error	-	Private-print-only error	-	-	-	-	-	P. 8-317
4222	Printer error	-	Hold-print-only error	-	Y	-	-	-	P. 8-317

Error code	Classification	Message	Contents	Error code display media					Troubleshooting
				Panl	JL	ML	Noti	CSV	
4223	Printer error	-	Private-print-only / Hold-print-only error	-	Y	-	-	-	P. 8-317
4231	Printer error	-	Hardcopy security printing error	-	-	-	-	-	P. 8-317
4241	Printer error	-	No Printer kit / Printer function disabled	-	-	-	-	-	P. 8-317
4242	Printer error	-	No Scanner kit / Scanner function disabled	-	-	-	-	-	P. 8-318
4243	Printer error	-	Sharing job - An error caused by not having a license	-	-	-	-	-	-
4244	Printer error	-	Sharing job - An error caused by function disabled	-	-	-	-	-	-
4245	Printer error	-	OCR functions not available	-	-	-	-	-	P. 8-318
4311	Printer error	-	No privilege to perform a job	-	-	-	-	-	P. 8-318
4312	Printer error	-	Not authorized to store a file	-	-	-	-	-	P. 8-318
4313	Printer error	-	No privilege for e-Filing box storage	-	-	-	-	-	P. 8-318
4314	Printer error	-	No privilege for Fax / Internet Fax transmission	-	-	-	-	-	P. 8-318
4411	Printer error	-	Image data creation failure	-	-	-	-	-	P. 8-319
4412	Printer error	-	Double-sign encoding error	-	-	-	-	-	P. 8-319
4511	Printer error	Print failure due to connection timeout	Connection timeout	-	-	Y	-	-	P. 8-319
4521	Printer error	Cannot print due to connection limit	Reaching the maximum number of connections	-	-	Y	-	-	P. 8-319
4522	Printer error	Registered print job number reached to limit during printing	Exceeding the upper limit of the registration number of jobs during data reception	-	-	Y	-	-	P. 8-319
4523	Printer error	Storage full occurred during printing	HDD full during data reception	-	-	Y	-	-	P. 8-320
4611	Printer error	-	Font download failure (exceeding the maximum number of registrations)	-	-	-	-	-	P. 8-320
4612	Printer error	-	Font download failure (HDD full)	-	-	-	-	-	P. 8-320
4613	Printer error	-	Font download failure (others)	-	-	-	-	-	P. 8-320
4621	Printer error	-	Downloaded font deletion failure	-	-	-	-	-	P. 8-320

Error code	Classification	Message	Contents	Error code display media					Troubleshooting
				Panl	JL	ML	Noti	CSV	
4721	Printer error	-	Connection failure of Multi Station Print because of an unexpected ROM version combination	-	-	Y	-	-	P. 8-320
4F10	Printer error	-	System abnormality	-	-	-	-	-	P. 8-321

## 8.2.5 TopAccess related error/Communication error with external application

Error code	Classification	Message	Contents	Error code display media					Troubleshooting
				Panl	JL	ML	Noti	CSV	
5012	Communication error	Remote monitoring system error	Authentication error	-	-	Y	Y	-	P. 8-322
5013	Communication error	Remote monitoring system error	Communication error between eBR	-	-	Y	-	-	P. 8-322
5014	Communication error	Remote monitoring system error	No SSL certificate	-	-	Y	-	-	P. 8-322
5015	Communication error	Remote monitoring system error	Invalid SSL certificate error	-	-	Y	-	-	P. 8-322
5016	Communication error	Remote monitoring system error	Expired SSL certificate error	-	-	Y	-	-	P. 8-322
5017	Communication error	Remote monitoring system error	Other SSL certificate related error	-	-	Y	-	-	P. 8-322
5018	Communication error	Remote monitoring system error	Invalid DNS error	-	-	Y	-	-	P. 8-323
5019	Communication error	Remote monitoring system error	Connection error	-	-	Y	-	-	P. 8-323
501A	Communication error	Remote monitoring system error	Proxy error	-	-	Y	-	-	P. 8-323
501B	Communication error	Remote monitoring system error	No URL (host / port) or invalid path	-	-	Y	-	-	P. 8-323
5020	Communication error	The first registration was completed.	Initial registration completion	-	-	Y	-	-	-
5021	Communication error	Remote monitoring system error	Successful communication with an eBR2 server	-	-	Y	-	-	-
5030	Communication error	Remote monitoring system error	An error has occurred in the HTTP communication	-	-	Y	-	-	P. 8-323
50FF	Communication error	Remote monitoring system error	eBR2 internal error	-	-	Y	-	-	P. 8-324
5110	Communication error		Toner cartridge detection error	-	-	-	-	-	P. 8-324
5211	Communication error		PM counter excess	-	-	Y	Y	-	-
5212	Communication error		Time for cleaning of the main charger	-	-	Y	Y	-	P. 8-324
5310	Communication error		Toner-K empty	-	-	-	-	-	-
5400	Communication error	Succeeded in MFP registration	MFP registration success	-	-	Y	Y	-	-
5401	Information	Immediate connection to the remote maintenance service has been executed.	Immediate connection execution to an eCC server	-	-	Y	Y	-	-
5410	Communication error	Remote maintenance service error	MFP registration error	-	-	Y	Y	-	P. 8-324

Error code	Classification	Message	Contents	Error code display media					Troubleshooting
				Panl	JL	ML	Noti	CSV	
5411	Communication error	Remote maintenance service error	MFP registration lock error	-	-	Y	Y	-	P. 8-324
5412	Communication error	Remote maintenance service error	Server busy error	-	-	Y	Y	-	P. 8-325
5413	Communication error	Remote maintenance service error	Server error	-	-	Y	Y	-	P. 8-325
5414	Communication error	Remote maintenance service error	Invalid device file error	-	-	Y	Y	-	P. 8-325
5415	Communication error	Remote maintenance service error	Communication error	-	-	Y	Y	-	P. 8-325
5416	Communication error	Remote maintenance service error	Update failure of system software / setting files of the equipment	-	-	Y	Y	-	P. 8-326
5417	Communication error	Remote maintenance service error	Invalid setting files of the equipment or system software	-	-	Y	Y	-	P. 8-326
5A10	Communication error	Trial Day will expire in a few days	End of trial day	-	-	Y	Y	-	-
5BD0	Communication error	Power failure occurred during restore	Power failure during restoration	-	-	Y	Y	-	P. 8-326
5C10	Communication error	FAX Unit is not attached.	FAX Unit attachment error	-	-	Y	Y	-	P. 8-326
5C11	Communication error	Security error on Address Book.	Network Fax transmission error	-	-	Y	Y	-	P. 8-327

## 8.2.6 MFP access error

Error code	Classification	Message	Contents	Error code display media					Troubleshooting
				Panl	JL	ML	Noti	CSV	
6000	MFP access error	Successful user login	User login success to an MFP	-	-	Y	Y	-	-
6001	MFP access error	Failed user login	User login failure to an MFP	-	-	Y	Y	-	-
6002	MFP access error	Successful user logout	User logout success from an MFP: Manual logout	-	-	Y	Y	-	-
6003	MFP access error	Successful user logout (Session Time Out)	User logout success from an MFP: Automatic logout	-	-	Y	Y	-	-
6004	MFP access error	Successful User Box Authentication	Authentication success of a user box password	-	-	Y	Y	-	-
6005	MFP access error	Failed User Box Authentication	Authentication failure of a user box password	-	-	Y	Y	-	-
6006	MFP access error	User login information was broken	UserToken binding failure	-	-	Y	Y	-	-
6007	MFP access error	Failed user login	Unsuccessful User Login to MFP	-	-	Y	Y	-	P. 8-328
6008	MFP access error	Failed to connect on External LDAP server for Role Base Access Control	Connection failure to an external Role Base Access Control (LDAP) server	-	-	Y	Y	-	P. 8-328
6009	MFP access error	Failed user login (Authentication server connection error)	User login failure to an MFP (during NIC initialization)	-	-	Y	Y	-	-
600A	MFP access error	Department code has not been assigned to the user	Department code not assigned to a user	-	-	Y	Y	-	-
6010	MFP access error	Cannot find the Home Directory.	Home directory not found	-	-	Y	Y	-	-
6011	MFP access error	Failed to register the user by automatically (Maximum number of registered users)	User automatic registration failure (due to an upper limit of the user registration number)	-	-	Y	Y	-	-
6013	MFP access error	Failed to connect on the authentication server	Connection failure to the authentication server	-	-	Y	Y	-	P. 8-328
6014	MFP access error	Detected the authentication server that can not be connected	Inaccessible authentication server detection	-	-	Y	Y	-	P. 8-328
6031	MFP access error	Illegal CL code	Invalid setting: Invalid CL code	-	-	Y	Y	-	-
6032	MFP access error	Illegal period	Card related error: Expired card	-	-	Y	Y	-	P. 8-328

Error code	Classification	Message	Contents	Error code display media					Troubleshooting
				Panl	JL	ML	Noti	CSV	
6033	MFP access error	No entering record	Card related error: Invalid flag data (no room-entry data)	-	-	Y	Y	-	P. 8-329
6034	MFP access error	Illegal entering record	Card related error: Invalid flag data (invalid card data)	-	-	Y	Y	-	P. 8-329
6035	MFP access error	Illegal SSFC settings of MFP.	Invalid setting: Invalid flag information (not set in an MFP)	-	-	Y	Y	-	P. 8-329
6036	MFP access error	Unmatch settings and card info.	Invalid setting: Invalid flag information (Information between an MFP and card does not match)	-	-	Y	Y	-	-
6037	MFP access error	You cannot be used.	Permission flag for use not available	-	-	Y	Y	-	P. 8-329
6040	MFP access error	Failed to read the card	Card authentication: Read error	-	-	Y	Y	-	
6041	MFP access error	Card Authentication Failed because of Card Reading Error	Card authentication: Card related error	-	-	Y	Y	-	P. 8-329
6042	MFP access error	Card Authentication Failed because of setting Error	Card authentication: Card setting error	-	-	Y	Y	-	P. 8-330
6043	MFP access error	Card Authentication Failed because the card information was duplicated on the card server.	Card authentication failure (duplication of card information)	-	-	Y	Y	-	-
6044	MFP access error	Communication Error of CardNotificcation	Card notification failure (Stage2)	-	-	Y	Y	-	-
6066	MFP access error	PIN Authentication Failed because the PIN code was duplicated on the PIN server.	PIN authentication failure (duplication of a PIN code)	-	-	Y	Y	-	-
6100	MFP access error	User account is locked	User account locking out	-	-	Y	Y	-	P. 8-330
6101	MFP access error	Box is locked	e-Filing box locking out	-	-	Y	Y	-	P. 8-330
6102	MFP access error	Failed to login because the user account had been locked out.	User account being locking out	-	-	Y	Y	-	P. 8-330
6103	MFP access error	Failed to access Box because the Box had been locked out.	e-Filing box being locking out	-	-	Y	Y	-	P. 8-330
6121	MFP access error	SecureErase fails	Automatic secure erase failure	-	-	Y	Y	-	P. 8-330



Error code	Classification	Message	Contents	Error code display media					Troubleshooting
				Panl	JL	ML	Noti	CSV	
6130	MFP access error	Successfully verified clock with Time Server	Synchronization success to a time server	-	-	Y	Y	-	-
6131	MFP access error	SNTP server synchronization failure	Synchronization with a time server has failed	-	-	Y	Y	-	P. 8-331
6150	MFP access error	Print Log full (100% Used) Log OverWrite will be start	Print log database full	-	-	Y	Y	-	P. 8-331
6151	MFP access error	Print Log near full (95% Used)	Print log database nearly full (95%)	-	-	Y	Y	-	P. 8-331
6152	MFP access error	Print Log near full (90% Used)	Print log database nearly full (90%)	-	-	Y	Y	-	P. 8-331
6153	MFP access error	Print Log near full (80% Used)	Print log database nearly full (80%)	-	-	Y	Y	-	P. 8-331
6154	MFP access error	Print Log near full (70% Used)	Print log database nearly full (70%)	-	-	Y	Y	-	P. 8-332
6160	MFP access error	Scan Log full (100% Used) Log OverWrite will be start	Scan log database full	-	-	Y	Y	-	P. 8-332
6161	MFP access error	Scan Log near full (95% Used)	Scan log database nearly full (95%)	-	-	Y	Y	-	P. 8-332
6162	MFP access error	Scan Log near full (90% Used)	Scan log database nearly full (90%)	-	-	Y	Y	-	P. 8-332
6163	MFP access error	Scan Log near full (80% Used)	Scan log database nearly full (80%)	-	-	Y	Y	-	P. 8-332
6164	MFP access error	Scan Log near full (70% Used)	Scan log database nearly full (70%)	-	-	Y	Y	-	P. 8-332
6170	MFP access error	FAX_Transmission Log full (100% Used) Log OverWrite will be started	Fax transmission database full	-	-	Y	Y	-	P. 8-333
6171	MFP access error	FAX_Transmission Log near full (95% Used)	Fax transmission database nearly full (95%)	-	-	Y	Y	-	P. 8-333
6172	MFP access error	FAX_Transmission Log near full (90% Used)	Fax transmission database nearly full (90%)	-	-	Y	Y	-	P. 8-333
6173	MFP access error	FAX_Transmission Log near full (80% Used)	Fax transmission database nearly full (80%)	-	-	Y	Y	-	P. 8-333
6174	MFP access error	FAX_Transmission Log near full (70% Used)	Fax transmission database nearly full (70%)	-	-	Y	Y	-	P. 8-333
6180	MFP access error	FAX_Receive Log full (100% Used) Log OverWrite will be start	Fax reception database full	-	-	Y	Y	-	P. 8-334
6181	MFP access error	FAX_Receive Log near full (95% Used)	Fax reception database nearly full (95%)	-	-	Y	Y	-	P. 8-334
6182	MFP access error	FAX_Receive Log near full (90% Used)	Fax reception database nearly full (90%)	-	-	Y	Y	-	P. 8-334
6183	MFP access error	FAX_Receive Log near full (80% Used)	Fax reception database nearly full (80%)	-	-	Y	Y	-	P. 8-334

Error code	Classification	Message	Contents	Error code display media					Troubleshooting
				Panl	JL	ML	Noti	CSV	
6184	MFP access error	FAX_Receive Log near full (70% Used)	Fax reception database nearly full (70%)	-	-	Y	Y	-	P. 8-334
6190	MFP access error	Message Log full (100% Used) Log OverWrite will be start	Message log database full	-	-	Y	Y	-	P. 8-335
6191	MFP access error	Message Log near full (95% Used)	Message log database nearly full (95%)	-	-	Y	Y	-	P. 8-335
6192	MFP access error	Message Log near full (90% Used)	Message log database nearly full (90%)	-	-	Y	Y	-	P. 8-335
6193	MFP access error	Message Log near full (80% Used)	Message log database nearly full (80%)	-	-	Y	Y	-	P. 8-335
6194	MFP access error	Message Log near full (70% Used)	Message log database nearly full (70%)	-	-	Y	Y	-	P. 8-335
61A0	Information	Secure Receive was enabled	Shifting to the Secure RX ON mode is recorded	-	-	Y	Y	-	-
61A1	Information	Secure Receive was disabled	Shifting to the Secure RX OFF mode is recorded	-	-	Y	Y	-	-
61C0	MFP access error	Application Log full (100% Used) Log OverWrite will be start	Application log database full	-	-	Y	Y	-	-
61C1	MFP access error	Application Log near full (95% Used)	Application log database nearly full (95%)	-	-	Y	Y	-	-
61C2	MFP access error	Application Log near full (90% Used)	Application log database nearly full (90%)	-	-	Y	Y	-	-
61C3	MFP access error	Application Log near full (80% Used)	Application log database nearly full (80%)	-	-	Y	Y	-	-
61C4	MFP access error	Application Log near full (70% Used)	Application log database nearly full (70%)	-	-	Y	Y	-	-
61D0	Data Backup / Data Restore	Please make a backup of HDD data.	Backup is required since an HDD may be damaged	-	-	Y	Y	-	-
61D1	Data Backup / Data Restore	Exchange of the HDD is required. Please contact service.	Replacement is required since an HDD is likely to fail in the near future	-	-	Y	Y	-	-
6200	MFP access error	Service Technician changed Security Level	Security level change of an MFP by a service technician	-	-	Y	Y	-	-
6220	MFP access error	Administrator's setting wizard is finished	Execution of the administrator setting wizard	-	-	-	-	-	-
6221	MFP access error	Security settings are changed by Administrator	Security setting items change by an administrator	-	-	-	-	-	-

Error code	Classification	Message	Contents	Error code display media					Troubleshooting
				Panl	JL	ML	Noti	CSV	
6240	MFP access error	User account password is not pursuant to Security Policy	A user password is outside the security policy.	-	-	-	-	-	-
6241	MFP access error	e-Filing Box password is not pursuant to Security Policy	An e-Filing box password is outside the security policy.	-	-	-	-	-	-
6260	MFP access error	User Information updated	User information change	-	-	-	-	-	-
6261	MFP access error	Role Information updated	Role information change	-	-	-	-	-	-
6262	MFP access error	Role in Group is edited	Group role information change	-	-	-	-	-	-
6280	MFP access error	Selfsigned Certificate generated	Self-signed certification generation	-	-	-	-	-	-
6281	MFP access error	Server Certificate generated	Server certification generation	-	-	-	-	-	-
6282	MFP access error	Failed to add certificate	Certification addition failure	-	-	-	-	-	-
6283	MFP access error	Cryptographic key generated	Encryption key generation	-	-	-	-	-	-

## 8.2.7 Maintenance error

Error code	Classification	Message	Contents	Error code display media					Troubleshooting
				Panl	JL	ML	Noti	CSV	
7100	Maintenance error	Successfully updated Copier Firmware	System firmware installation success	-	-	Y	Y	-	-
7101	Maintenance error	Failed to update Copier Firmware	System firmware installation failure	-	-	Y	Y	-	P. 8-336
7102	Information	Successfully updated Copier Main ROM	Succeeded in installation of engine firmware	-	-	Y	Y	-	-
7103	Maintenance error	Failed to update Copier Main ROM	Engine firmware installation failure	-	-	Y	Y	-	P. 8-336
7104	Information	Successfully updated Copier Scanner ROM	Succeeded in installation of scanner firmware	-	-	Y	Y	-	-
7105	Maintenance error	Failed to update Copier Scanner ROM	Scanner firmware installation failure	-	-	Y	Y	-	P. 8-336
7108	Information	Successfully updated Printer Driver	Succeeded in installation of printer driver	-	-	Y	Y	-	-
7109	Maintenance error	Failed to update Printer Driver	Printer driver update failure	-	-	Y	Y	-	P. 8-336
710A	Information	Successfully updated Point And Print	Succeeded in installation of point and print data	-	-	Y	Y	-	-
710B	Maintenance error	Failed to update Point And Print	Point and Print data installation failure	-	-	Y	Y	-	P. 8-336
710E	Information	Successfully installed Language Pack	Succeeded in installation of language pack	-	-	Y	Y	-	-
710F	Maintenance error	Failed to install Language Pack	Language pack installation failure	-	-	Y	Y	-	P. 8-336
7110	Information	Successfully installed Patch	Succeeded in installation of patch	-	-	Y	Y	-	-
7111	Maintenance error	Failed to install Patch	Patch installation failure	-	-	Y	Y	-	P. 8-336
7112	Information	Successfully installed Plugin	Succeeded in installation of plug-in	-	-	Y	Y	-	-
7113	Maintenance error	Failed to install Plugin	Plug-in installation failure	-	-	Y	Y	-	P. 8-336
7114	Information	Successfully updated HDD Data	Successful Installation of HDD Data	-	-	Y	Y	-	-
7115	Maintenance error	Failed to update HDD Data	HDD data installation failure	-	-	Y	Y	-	P. 8-336
7116	Information	Successfully updated Reversing Automatic Document Feeder ROM	Succeeded in installation of DF firmware	-	-	Y	Y	-	-
7117	Maintenance error	Failed to update Reversing Automatic Document Feeder ROM	DF firmware installation failure	-	-	Y	Y	-	P. 8-336

Error code	Classification	Message	Contents	Error code display media					Troubleshooting
				Panl	JL	ML	Noti	CSV	
711A	Maintenance error	Cleared License Key	Electronic key clear	-	-	Y	Y	-	-
711C	Maintenance error	Successfully removed License Key	Electronic key returning success	-	-	Y	Y	-	-
711D	Maintenance error	Failed to remove License Key	License key returning failure	-	-	Y	Y	-	P. 8-337
711E	Maintenance error	Successfully installed License Key	Electronic key installation success	-	-	Y	Y	-	-
711F	Maintenance error	Failed to install License Key	License key installation failure	-	-	Y	Y	-	P. 8-337
7120	Information	Successfully imported Address Book	Succeeded in import of AddressBook data	-	-	Y	Y	-	-
7121	Maintenance error	Failed to import Address Book	Unsuccessful import of AddressBook data	-	-	Y	Y	-	P. 8-337
7122	Information	Successfully imported Template	Successful import of template data	-	-	Y	Y	-	-
7123	Maintenance error	Failed to import Template	Unsuccessful import of template data	-	-	Y	Y	-	P. 8-337
7124	Information	Successfully imported Mail Boxes	Successful import of mailbox data	-	-	Y	Y	-	-
7125	Maintenance error	Failed to import Mail Boxes	Unsuccessful import of mailbox data	-	-	Y	Y	-	P. 8-337
7126	Information	Successfully imported XML Format File	Successful import of format file for metascan	-	-	Y	Y	-	-
7127	Maintenance error	Failed to import XML Format File	Unsuccessful import of format file for metascan	-	-	Y	Y	-	P. 8-337
7128	Information	Successfully imported User Information	Successful import of user information	-	-	Y	Y	-	-
7129	Maintenance error	Failed to import User Information	Unsuccessful import of user information	-	-	Y	Y	-	P. 8-338
712A	Information	Successfully imported Role Information	Successful import of role information	-	-	Y	Y	-	-
712B	Maintenance error	Failed to import Role Information	Unsuccessful import of role information	-	-	Y	Y	-	P. 8-338
712C	Information	Successfully imported Department Code	Successful import of department data	-	-	Y	Y	-	-
712D	Maintenance error	Failed to import Department Code	Unsuccessful import of department data	-	-	Y	Y	-	P. 8-338
7130	Information	Successfully imported Print Data Converter	Successfully imported print data converter	-	-	Y	Y	-	-
7131	Maintenance error	Failed to import Print Data Converter	Failed to import print data converter	-	-	Y	Y	-	P. 8-338

Error code	Classification	Message	Contents	Error code display media					Troubleshooting
				Panl	JL	ML	Noti	CSV	
7132	Maintenance error	Failed to import some User Information	Failed to import any user informations	-	-	Y	Y	-	P. 8-338
7133	Maintenance error	Failed to import some User, Role and Group information	Failed to import any user, role and group information	-	-	Y	Y	-	P. 8-338
7134	Maintenance error	Failed to import some Department Code	Failed to import any department code	-	-	Y	Y	-	P. 8-339
7136	Maintenance error	Successfully imported EWB error screen file	EWB error screen file importing success	-	-	Y	Y	-	-
7137	Maintenance error	Failed to imported EWB error screen file	EWB error screen file importing failure	-	-	Y	Y	-	-
7138	Information	Successfully imported the certificate by SCEP	Succeeded in acquisition of certificate from SCEP server	-	-	Y	Y	-	-
7139	Maintenance error	Failed to import the certificate by SCEP	Failed in acquisition of certificate from SCEP server	-	-	Y	Y	-	P. 8-339
713A	Information	Successfully imported the certificate	Succeeded in import of certificate from TopAccess	-	-	Y	Y	-	-
713B	Maintenance error	Failed to import the certificate	Failed in import of certificate from TopAccess	-	-	Y	Y	-	P. 8-339
713C	Information	Successfully imported Combined data(User Information, Role, Group)	Successful import of user combined data	-	-	Y	Y	-	-
713D	Maintenance error	Failed to import Combined data (User Information, Role, Group)	Unsuccessful import of user combined data	-	-	Y	Y	-	P. 8-339
713E	Information	Successfully imported Combined data (Template, Address Book, Mail Boxes)	Successful import of all data (Template / AddressBook / Mailbox)	-	-	Y	Y	-	-
713F	Maintenance error	Failed to import Combined data (Template, Address Book, Mail Boxes)	Unsuccessful import of all data (Template / AddressBook / Mailbox)	-	-	Y	Y	-	P. 8-339
7140	Information	Successfully exported Address Book	Succeeded in export of AddressBook data	-	-	Y	Y	-	-
7141	Maintenance error	Failed to export Address Book	Failed in export of AddressBook data	-	-	Y	Y	-	P. 8-340
7142	Information	Successfully exported Template	Succeeded in export of template data	-	-	Y	Y	-	-
7143	Maintenance error	Failed to export Template	Failed in export of template data	-	-	Y	Y	-	P. 8-340

Error code	Classification	Message	Contents	Error code display media					Troubleshooting
				Panl	JL	ML	Noti	CSV	
7144	Information	Successfully exported Mail Boxes	Succeeded in export of mailbox data	-	-	Y	Y	-	-
7145	Maintenance error	Failed to export Mail Boxes	Failed in export of mailbox data	-	-	Y	Y	-	P. 8-340
7148	Information	Successfully exported User Information	Succeeded in export of user information	-	-	Y	Y	-	-
7149	Maintenance error	Failed to export User Information	Failed in export of user information	-	-	Y	Y	-	P. 8-340
714A	Information	Successfully exported Role Information	Succeeded in export of role information	-	-	Y	Y	-	-
714B	Maintenance error	Failed to export Role Information	Failed in export of role information	-	-	Y	Y	-	P. 8-340
714C	Information	Successfully exported Department Code	Succeeded in export of department information	-	-	Y	Y	-	-
714D	Maintenance error	Failed to export Department Code	Failed in export of department information	-	-	Y	Y	-	P. 8-340
714E	Information	Successfully exported ICC Profile	Succeeded in export of ICC profile	-	-	Y	Y	-	-
714F	Maintenance error	Failed to export ICC Profile	Failed in export of ICC profile	-	-	Y	Y	-	P. 8-341
7150	Information	Successfully exported Log data	Succeeded in export of log data	-	-	Y	Y	-	-
7151	Maintenance error	Failed to export Log data	Failed in export of log data	-	-	Y	Y	-	P. 8-341
7152	Information	Cleared Log data	Clear log	-	-	Y	Y	-	-
7154	Maintenance error	Rebuilt the Log DB by Log DB corruption	Log database rebuilding caused by damage on it	-	-	Y	Y	-	-
7156	Maintenance error	Rebuilt the AppManagement DB by AppManagement DB corruption	App Management database rebuilding has been performed automatically since it was damaged	-	-	Y	Y	-	-
7157	Maintenance error	Rebuilt the HomeScreen DB by HomeScreen DB corruption	HomeScreen database rebuilding has been performed automatically since it was damaged	-	-	Y	Y	-	-
7158	Maintenance error	Rebuilt the JobHistory DB by JobHistory DB corruption	JobHistory database rebuilding has been performed automatically since it was damage	-	-	Y	Y	-	-
7159	Maintenance error	Rebuilt the AppLicense DB by AppLicense DB corruption	AppLicense database rebuilding has been performed automatically since it was damaged	-	-	Y	Y	-	-

Error code	Classification	Message	Contents	Error code display media					Troubleshooting
				Panl	JL	ML	Noti	CSV	
715A	Information	Successfully exported Print Data Converter	Successful print data converter	-	-	Y	Y	-	-
715B	Maintenance error	Failed to export Print Data Converter	Unsuccessful print data converter	-	-	Y	Y	-	P. 8-341
715C	Information	Successfully exported Combined data (User Information, Role, Group)	Successful export of user combined data	-	-	Y	Y	-	-
715D	Maintenance error	Failed to export Combined data (User Information, Role, Group)	Unsuccessful export of user combined data	-	-	Y	Y	-	P. 8-341
715E	Information	Successfully exported Combined data (Template, Address Book, Mail Boxes)	Successful export of all data (Template / AddressBook / Mailbox)	-	-	Y	Y	-	-
715F	Maintenance error	Failed to export Combined data (Template, Address Book, Mail Boxes)	Unsuccessful export of all data (Template / AddressBook / Mailbox)	-	-	Y	Y	-	P. 8-341
7160	Information	Added new contact	Addition of AddressBook	-	-	Y	Y	-	-
7161	Information	Added new Template Group	Addition of template group	-	-	Y	Y	-	-
7162	Information	Added new User Box	Addition of e-Filing box	-	-	Y	Y	-	-
7163	Information	Added new Department Code	Addition of department information	-	-	Y	Y	-	-
7165	Information	Cleared Department Counter	Clear department counter	-	-	Y	Y	-	-
7166	Information	Edited Address Book	Modification of AddressBook	-	-	Y	Y	-	-
7167	Information	Edited Template	Edit of template group and Add / Delete / Edit a template in this group	-	-	Y	Y	-	-
7168	Information	Edited e-Filing	Modification of e-Filing box	-	-	Y	Y	-	-
7169	Information	Edited Department Code	Modification of department information	-	-	Y	Y	-	-
7170	Information	Removed a contact	Deletion of AddressBook	-	-	Y	Y	-	-
7171	Information	Removed a Template Group	Deletion of template	-	-	Y	Y	-	-
7172	Information	Removed a User Box	Deletion of e-Filing box	-	-	Y	Y	-	-
7173	Information	Removed a Department Code	Deletion of department information	-	-	Y	Y	-	-



Error code	Classification	Message	Contents	Error code display media					Troubleshooting
				Panl	JL	ML	Noti	CSV	
7174	Information	Updated user information: New User created	Addition of user information	-	-	Y	Y	-	-
7175	Information	Updated user information: User Information modified	Change of user information	-	-	Y	Y	-	-
7176	Information	Updated user information: User removed	Deletion of user information	-	-	Y	Y	-	-
7177	Information	Updated role Information: New Role created	Addition of role Information	-	-	Y	Y	-	-
7178	Information	Updated role Information: Role information modified	Modification of role Information	-	-	Y	Y	-	-
7179	Information	Updated role Information: Role removed	Deletion of role Information	-	-	Y	Y	-	-
717A	Information	Updated group information: New Group created	Addition of group role Information	-	-	Y	Y	-	-
717B	Information	Updated group information: Group information modified	Modification of group information	-	-	Y	Y	-	-
717C	Information	Updated group information: Group removed	Deletion of group information	-	-	Y	Y	-	-
7182	Information	Edited Device Setting	Modification of device setting	-	-	Y	Y	-	-
7183	Information	Edited Network Setting	Modification of network setting	-	-	Y	Y	-	-
7184	Information	Edited Security Setting	Modification of security setting	-	-	Y	Y	-	-
7185	Information	Edited Authentication Setting	Modification of authentication setting	-	-	Y	Y	-	-
7188	Maintenance error	Failed to change user password because of password policy mismatch	Failed in modification because of password policy violation at modification of user password	-	-	Y	Y	-	-
7189	Maintenance error	eFiling Box password is not pursuant to Security Policy	Failed in modification because of password policy violation at modification of e-Filing box password	-	-	Y	Y	-	-
718A	Maintenance error	Edited Date & Time Setting	The time set in the MFP has been changed	-	-	Y	Y	-	-
718B	Maintenance error	Started the Daylight Savings Time	Summer time has started	-	-	Y	Y	-	-

Error code	Classification	Message	Contents	Error code display media					Troubleshooting
				Panl	JL	ML	Noti	CSV	
718C	Maintenance error	Ended the Daylight Savings Time	Summer time has ended	-	-	Y	Y	-	-
7190	Information	Successfully uploaded DDNS public key file	DDNS public key file upload succeed	-	-	Y	Y	-	-
7192	Information	Successfully uploaded DDNS private key file	DDNS private key file upload succeed	-	-	Y	Y	-	-
7193	Maintenance error	Failed to upload DDNS private key file	DDNS private key file upload failure	-	-	Y	Y	-	P. 8-342
71A0	Information	Generated Self signed Certificate	Self-signed certificate was issued	-	-	Y	Y	-	-
71A1	Information	Success to add CA certificate	Success in addition of CA certificate	-	-	Y	Y	-	-
71A2	Maintenance error	Failed to add CA certificate	Unsuccessful addition of CA certificate	-	-	Y	Y	-	P. 8-342
71A3	Information	Generated Cryptographic key	Encryption key was generated	-	-	Y	Y	-	-
71A4	Maintenance error	Failed in consistency confirmation of cryptographic key	Failed in consistency confirmation in cryptographic key	-	-	Y	Y	-	P. 8-342
71A5	Information	Successfully deleted Device Certificate.	Successfully deleted device certificate	-	-	Y	Y	-	-
71A6	Maintenance error	Failed to delete Device Certificate.	Failed to delete device certificate	-	-	Y	Y	-	P. 8-342
71A7	Information	Successfully deleted CA Certificate.	Successfully deleted CA certificate	-	-	Y	Y	-	-
71A8	Maintenance error	Failed to delete CA Certificate.	Failed to delete CA certificate	-	-	Y	Y	-	P. 8-342
71AA	Maintenance error	Invalid Error Occurd while getting Certificate from SCEP server	Invalid error occurred while getting certificate from SCEP server	-	-	Y	Y	-	P. 8-343
71AB	Maintenance error	Timeout Error Occurd while getting Certificate from SCEP server	Timeout error occurred while getting certificate from SCEP server	-	-	Y	Y	-	P. 8-343
71AC	Maintenance error	File Save Error Occurd while getting Certificate from SCEP server	File Save error occurred while getting certificate from SCEP server	-	-	Y	Y	-	P. 8-343
71AD	Maintenance error	SCEP operation failure.	Failed SCEP operation	-	-	Y	Y	-	P. 8-343
71B0	Maintenance error	Failed to decrypt Software Package	Software package file decryption failure	-	-	Y	Y	-	P. 8-343
71B2	Maintenance error	Successfully updated Laser ROM	Laser firmware installation success	-	-	Y	Y	-	-
71B3	Maintenance error	Failed to update Laser ROM	Laser firmware installation failure	-	-	Y	Y	-	-
71B4	Maintenance error	Successfully updated Finisher ROM	Finisher firmware installation success	-	-	Y	Y	-	-

Error code	Classification	Message	Contents	Error code display media					Troubleshooting
				Panl	JL	ML	Noti	CSV	
71B5	Maintenance error	Failed to update Finisher ROM	Finisher firmware installation failure	-	-	Y	Y	-	-
71B6	Maintenance error	Successfully updated Saddle ROM	Saddle firmware installation success	-	-	Y	Y	-	-
71B7	Maintenance error	Failed to update Saddle ROM	Saddle firmware installation failure	-	-	Y	Y	-	-
71B8	Maintenance error	Successfully updated Punch ROM	Punch firmware installation success	-	-	Y	Y	-	-
71B9	Maintenance error	Failed to update Punch ROM	Punch firmware installation failure	-	-	Y	Y	-	-
71BA	Maintenance error	Successfully updated UI Data	UI data installation success	-	-	Y	-	-	-
71BB	Maintenance error	Failed to update UI Data	UI data installation failure	-	-	Y	-	-	-
71BC	Maintenance error	Successfully rollback UI Data	UI data recovery success	-	-	Y	-	-	-
71BD	Maintenance error	Failed to rollback UI Data	UI data recovery failure	-	-	Y	-	-	-
71BE	Maintenance error	Failed to update UI Data (non-permitted machine)	UI data installation failure	-	-	Y	-	-	-
71BF	Maintenance error	Failed to update UI Data (non-permitted model)	UI data installation failure	-	-	Y	-	-	-
71C0	Information	Integrity Check requested by User is started.	Integrity check requested by user is started	-	-	Y	Y	-	-
71C1	Information	No problems found by Integrity Check requested by User.	Integrity check requested by user is finished [NO ISSUE FOUND]	-	-	Y	Y	-	-
71C2	Information	Integrity Check is canceled by User.	Integrity check requested by user is canceled	-	-	Y	Y	-	-
71C3	Information	No problems found by start up Integrity Check.	Startup Integrity check is finished [NO ISSUE FOUND]	-	-	Y	Y	-	-
71E0	License Management	LMDB Recovery	License abnormality due to damage on the license manager database	-	-	Y	Y	-	P. 8-344
71F0	Information	Successfully created Clone File	Successfully created clone file	-	-	Y	Y	-	-
71F2	Information	Successfully imported Clone File	Successfully imported clone file	-	-	Y	Y	-	-
7210	Maintenance error	Successful synchronization of User Management information	User management information synchronization success	-	-	Y	Y	-	-
7211	Maintenance error	Failed to synchronize User Management information	User management information synchronization failure	-	-	Y	Y	-	-

Error code	Classification	Message	Contents	Error code display media					Troubleshooting
				Panl	JL	ML	Noti	CSV	
7212	Maintenance error	Failed to synchronize User Management information (setting mistake)	User management information synchronization failure (incorrect setting)	-	-	Y	Y	-	-
7213	Maintenance error	Failed to synchronize User Management information for some Secondary MFP	Some user management information synchronization failure	-	-	Y	Y	-	-
7220	Maintenance error	Successful synchronization of AddressBook	AddressBook delivery success	-	-	Y	Y	-	-
7221	Maintenance error	Failed to synchronize AddressBook	AddressBook delivery failure	-	-	Y	Y	-	-
7222	Maintenance error	Failed to synchronize AddressBook for some Secondary MFP	Some AddressBook delivery failure	-	-	Y	Y	-	-
7230	Maintenance error	Added new Project Code	Project creation	-	-	Y	Y	-	-
7231	Maintenance error	Edited Project Code	Project edition	-	-	Y	Y	-	-
7232	Maintenance error	Removed a Project Code	Project deletion	-	-	Y	Y	-	-
7233	Maintenance error	Successfully exported Project Code	Project export success	-	-	Y	Y	-	-
7234	Maintenance error	Failed to export Project Code	Project export failure	-	-	Y	Y	-	-
7235	Maintenance error	Download Project Code.	Exported project downloading	-	-	Y	Y	-	-
7236	Maintenance error	Successfully imported Project Code	Project import success	-	-	Y	Y	-	-
7237	Maintenance error	Failed to import Project Code	Project import failure	-	-	Y	Y	-	-
7238	Maintenance error	Failed to import some Project Code	Some project import failure	-	-	Y	Y	-	-
7240	Information	Download Address Book.	Download AddressBook	-	-	Y	Y	-	-
7241	Information	Download Template.	Download template	-	-	Y	Y	-	-
7242	Information	Download Mail Boxes.	Download mailboxes	-	-	Y	Y	-	-
7244	Information	Download User Information.	Download user information	-	-	Y	Y	-	-
7245	Information	Download Role Information.	Download role information	-	-	Y	Y	-	-
7246	Information	Download Department Code.	Download department code	-	-	Y	Y	-	-
7247	Information	Download ICC Profile.	Download ICC profile	-	-	Y	Y	-	-
7248	Information	Download Log data.	Download log data	-	-	Y	Y	-	-

Error code	Classification	Message	Contents	Error code display media					Troubleshooting
				Panl	JL	ML	Noti	CSV	
7249	Information	Download Combined data (User Information, Role, Group).	Download combined data (user information, role, group)	-	-	Y	Y	-	-
724A	Information	Download Combined data (Template, Address Book, Mail Boxes).	Operation to download template, AddressBook, mailboxes	-	-	Y	Y	-	-
724B	Information	Download Clone File.	Operation to download clone file	-	-	Y	Y	-	-
724C	Information	Download Print Data Converter.	Operation to download print data converter	-	-	Y	Y	-	-
7272	Maintenance error	Successfully updated FAX FIRMWARE1	Fax firmware1 installation success	-	-	Y	Y	-	-
7273	Maintenance error	Failed to update FAX FIRMWARE1	Fax firmware1 installation failure	-	-	Y	Y	-	-
7274	Maintenance error	Successfully updated FAX FIRMWARE2	Fax firmware2 installation success	-	-	Y	Y	-	-
7275	Maintenance error	Failed to update FAX FIRMWARE2	Fax firmware2 installation failure	-	-	Y	Y	-	-
7276	Maintenance error	Successfully updated NIC FIRMWARE	NIC firmware installation success	-	-	Y	Y	-	-
7277	Maintenance error	Failed to update NIC FIRMWARE	NIC firmware installation failure	-	-	Y	Y	-	-
7278	Maintenance error	Successfully installed Monotype RIP Font	Monotype RIP font installation success	-	-	Y	Y	-	-
7279	Maintenance error	Failed to install Monotype RIP Font	Monotype RIP font installation failure	-	-	Y	Y	-	-
7280	Data Backup / Data Restore	Data Backup file storage was completed successfully	Storing of the data backup file has succeeded	-	-	Y	Y	-	-
7281	Data Backup / Data Restore	Data Backup file storage was cancelled	Storing of the data backup file has been canceled	-	-	Y	Y	-	-
7282	Data Backup / Data Restore	Regular Data Backup was not performed	Periodical data backing up has not been executed	-	-	Y	Y	-	-
7283	Data Backup / Data Restore	Data Backup file storage failed (USB media was not inserted)	Storing of the data backup file has failed (A USB storage has not been inserted)	-	-	Y	Y	-	-
7284	Data Backup / Data Restore	Data Backup file storage failed (Failed to save the file to USB media)	Storing of the data backup file has failed (Storing of a file into a USB storage has failed)	-	-	Y	Y	-	-
7285	Data Backup / Data Restore	Data Backup file storage failed (Failed to connect to the external server)	Storing of the data backup file has failed (Connection to an external server is not possible)	-	-	Y	Y	-	-

Error code	Classification	Message	Contents	Error code display media					Troubleshooting
				Panl	JL	ML	Noti	CSV	
7286	Data Backup / Data Restore	Data Backup file storage failed (Failed to save the file to the external server)	Storing of the data backup file has failed (Storing of a file into an external server has failed)	-	-	Y	Y	-	-
7287	Data Backup / Data Restore	Data Backup file storage failed	Storing of the data backup file has failed	-	-	Y	Y	-	-
7290	Data Backup / Data Restore	Data Restore process was completed successfully	Restoring of the data has succeeded	-	-	Y	Y	-	-
7291	Data Backup / Data Restore	Data Restore from USB media or the external server was cancelled	Job cancel of data restore processing	-	-	Y	Y	-	-
7292	Data Backup / Data Restore	Data Restore process failed (USB media was not inserted)	Data restore processing failure (A USB storage is not inserted)	-	-	Y	Y	-	-
7293	Data Backup / Data Restore	Data Restore process failed (Failed to connect to the external server)	Data restore processing failure (Connection to an external server is not possible)	-	-	Y	Y	-	-
7294	Data Backup / Data Restore	Data Restore process failed (Failed to get the Data Backup file from USB media)	Data restore processing failure (Obtaining a file from a USB storage has failed)	-	-	Y	Y	-	-
7295	Data Backup / Data Restore	Data Restore process failed (Failed to get the Data Backup file from external server)	Data restore processing failure (Obtaining a file from an external server has failed)	-	-	Y	Y	-	-
7296	Data Backup / Data Restore	Data Restore process failed (Data Backup file is corrupted)	Data restore processing failure (Data backup file invalid)	-	-	Y	Y	-	-
7297	Data Backup / Data Restore	Data Restore process failed	Data restore processing failure	-	-	Y	Y	-	-
72A0	Maintenance error	Notification events that were registered from an application were deleted	Deletion of event notification destination information registered from an application	-	-	Y	Y	-	-
72D0	Maintenance error	Failed to update UI Data (compatibility check error)	UI data installation failure	-	-	Y	-	-	-
72D1	Maintenance error	Failed to update Copier Firmware (compatibility check error)	System firmware installation failure	-	-	Y	-	-	-
72D2	Maintenance error	Successfully updated plugin of printer driver.	Upgrading of the plug-in for printer drivers has succeeded	-	-	Y	Y	-	-
72D3	Maintenance error	Failed to update plugin of printer driver.	Upgrading of the plug-in for printer drivers has failed	-	-	Y	Y	-	-

Error code	Classification	Message	Contents	Error code display media					Troubleshooting
				Panl	JL	ML	Noti	CSV	
72D4	Maintenance error	Successfully deleted plugin of printer driver.	Deletion of the plug-in for printer drivers has succeeded	-	-	Y	Y	-	-
72D5	Maintenance error	Failed to delete plugin of printer driver.	Deletion of the plug-in for printer drivers has failed	-	-	Y	Y	-	-
72D6	Maintenance error	Failed to update UI Data (License check error)	UI data installation failure	-	-	Y	-	-	-
7300	Maintenance error	Successfully installed Application	An application is installed	-	-	Y	Y	-	-
7301	Maintenance error	Failed to install Application	Installation of an application fails	-	-	Y	Y	-	P. 8-345
7302	Maintenance error	Successfully uninstalled Application	An application is uninstalled	-	-	Y	Y	-	-
7303	Maintenance error	Failed to uninstall Application	Uninstallation of an application fails	-	-	Y	Y	-	-
7304	Maintenance error	Successfully updated Application	An application is updated	-	-	Y	Y	-	-
7305	Maintenance error	Failed to update Application	Updating of an application fails	-	-	Y	Y	-	-
7306	Maintenance error	Application was all removed.	Deletion of all the applications has succeeded	-	-	Y	Y	-	-
7307	Maintenance error	Failed to Delete all of the applications.	Deletion of all the applications has failed	-	-	Y	Y	-	-
7308	Maintenance error	Automatically stopped the application.	Applications have automatically stopped	-	-	Y	Y	-	-
7309	Maintenance error	Automatically started the application.	Applications have automatically started	-	-	Y	Y	-	-
7311	Maintenance error	Failed to start Application	Start of an application fails	-	-	Y	Y	-	-
7313	Maintenance error	Application was terminated abnormally	An application ends abnormally	-	-	Y	Y	-	-
7315	Maintenance error	App start duplicated error. Please retry later.	App start duplicated error	-	-	Y	Y	-	-
7316	Maintenance error	License is Fraud error.	Application license is invalid	-	-	Y	Y	-	-
7320	Maintenance error	Application license was activated.	The license of an application is enabled	-	-	Y	Y	-	-
7321	Maintenance error	Failed to activation of application license	Enabling of the license for an application fails	-	-	Y	Y	-	-
7322	Maintenance error	Application license was inactivated.	The license of an application is disabled	-	-	Y	Y	-	-
7323	Maintenance error	Failed to inactivation of application license	Disabling of the license for an application fails	-	-	Y	Y	-	-

Error code	Classification	Message	Contents	Error code display media					Troubleshooting
				Panl	JL	ML	Noti	CSV	
7324	Maintenance error	Installed the application license.	Installation of the application license has succeeded	-	-	Y	Y	-	-
7325	Maintenance error	Failed to install the application license.	Installation of the application license has failed	-	-	Y	Y	-	-
7326	Maintenance error	Application license uninstalled.	Application license has been uninstalled	-	-	Y	Y	-	-
7327	Maintenance error	Failed to uninstall the application license.	Uninstallation of the application license has failed	-	-	Y	Y	-	-
7328	Maintenance error	Application license was all removed.	Deletion of all the application licenses has succeeded	-	-	Y	Y	-	-
7329	Maintenance error	Failed to Delete all of the application license.	Deletion of all the application licenses has failed	-	-	Y	Y	-	-
7330	Maintenance error	The expiration date of the license of the application approaches.	The validated date of the license for an application will nearly have expired	-	-	Y	Y	-	-
7331	Maintenance error	The time limit of the application license expired.	The validity date of the license for an application has expired	-	-	Y	Y	-	-
7332	Maintenance error	Application install error. Please update the application.	Application installation error	-	-	Y	Y	-	-
7333	Maintenance error	Application start error. Please update the application.	Application start error	-	-	Y	Y	-	-
7334	Maintenance error	Successfully installed Application Localization.	Installation of the application localization data has succeeded	-	-	Y	Y	-	-
7335	Maintenance error	Failed to install Application Localization.	Installation of the application localization data has failed	-	-	Y	Y	-	-
7336	Maintenance error	Application install error. The application is not supported for this MFP.	Application install error	-	-	Y	Y	-	-
7337	Maintenance error	Failed to add application button automatically.	Automatic addition of application icons has failed since the Home screen to which they are automatically added had already become full	-	-	Y	Y	-	-
7400	License Management	License Activation Success(Online)	License activation success (Online)	-	-	Y	Y	-	-
7401	License Management	License Activation Success(Offline)	License activation success (Offline)	-	-	Y	Y	-	-



Error code	Classification	Message	Contents	Error code display media					Troubleshooting
				Panl	JL	ML	Noti	CSV	
7402	License Management	License Activation failed	License activation failure (Online)	-	-	Y	Y	-	P. 8-345
7403	License Management	License Activation failed, NW timeout	License activation failure (network timeout)	-	-	Y	Y	-	P. 8-345
7404	License Management	License Activation failed, NW error	License activation failure (network error)	-	-	Y	Y	-	P. 8-345
7410	License Management	License Deactivate Success(Online)	License deactivation success (Online)	-	-	Y	Y	-	-
7411	License Management	License Deactivate Success(Offline)	License deletion success (Offline)	-	-	Y	Y	-	-
7412	License Management	License Deactivation failed	License deactivation failure (Online)	-	-	Y	Y	-	P. 8-346
7423	License Management	License Deactivation failed, NW timeout	License deactivation failure (network timeout)	-	-	Y	Y	-	P. 8-346
7424	License Management	License Deactivation failed, NW error	License deactivation failure (network error)	-	-	Y	Y	-	P. 8-346
7430	License Management	License Activation failed, Invalid serial number	Serial number mismatching	-	-	Y	Y	-	P. 8-346
7431	License Management	License Activation failed, Invalid subnet	Subnet mismatching	-	-	Y	Y	-	P. 8-346
7432	License Management	License Activation failed, Invalid Domain	Domain mismatching	-	-	Y	Y	-	P. 8-347
7433	License management	License Activation failed (Invalid input)	License certificate ID invalid	-	-	Y	Y	Y	P. 8-347
7434	License management	License Activation failed (Same license)	License duplicating installation	-	-	Y	Y	Y	P. 8-347
7435	License management	License Activation failed (unsupported license)	Unsupported license activation	-	-	Y	Y	Y	P. 8-347
7440	License Management	License file Signature mismatch error	Signature mismatching	-	-	Y	Y	-	P. 8-348
7441	License Management	Trial License expired	End of the trial period	-	-	Y	Y	-	-
7442	License Management	License period expired	End of the valid period	-	-	Y	Y	-	-
7443	License Management	License Expired	License use period expired	-	-	Y	Y	-	P. 8-348
7444	License Management	License Not Found	No license exists	-	-	Y	Y	-	P. 8-348
7445	License Management	License Full	Full of the license	-	-	Y	Y	-	P. 8-348

## 8.2.8 Network error

Error code	Classification	Message	Contents	Error code display media					Troubleshooting
				Panl	JL	ML	Noti	CSV	
8000	Network error	Static IPv4 duplicated address detected	IPv4 address conflict	-	-	Y	Y	-	P. 8-349
8011	Network error	Link Local address of IPv6 was duplicated.	IPv6 link local address conflict	-	-	Y	Y	-	P. 8-349
8012	Network error	Manual address of IPv6 was duplicated.	IPv6 manual address conflict	-	-	Y	Y	-	P. 8-349
8013	Network error	Stateless address of IPv6 was duplicated.	IPv6 stateless address conflict	-	-	Y	Y	-	P. 8-349
8014	Network error	Stateful address of IPv6 was duplicated.	IPv6 stateful address conflict	-	-	Y	Y	-	P. 8-349
8021	Network error	N/A	Authentication success	-	-	Y	Y	-	-
8022	Network error	Authentication Failure	802.1X authentication failure	-	-	Y	Y	-	P. 8-349
8023	Network error	Can not contact Authentication Server/Switch	Connection failure to an authentication server and a switch	-	-	Y	Y	-	P. 8-350
8024	Network error	Certificate verification Failure	Failure in verification of certification	-	-	Y	Y	-	P. 8-350
8031	Network error	No IKE proposal chosen	IPsec error for IKEv1 certification failure	-	-	Y	Y	-	P. 8-350
8032	Network error	IKE Certificate Authentication failed	IPsec error for wrong proposal selection	-	-	Y	Y	-	P. 8-350
8033	Network error	IKE Pre-shared key Authentication failed	IPsec error for shared key authentication failure	-	-	Y	Y	-	P. 8-350
8034	Network error	Invalid Certificate	IPsec error for invalid certificate upload	-	-	Y	Y	-	P. 8-351
8035	Network error	Certificate Type unsupported	IPsec error for non-supported certification	-	-	Y	Y	-	P. 8-351
8036	Network error	Invalid certificate authority	IPsec error for invalid certification of authentication	-	-	Y	Y	-	P. 8-351
8037	Network error	Certificate unavailable	IPsec error for certification disable	-	-	Y	Y	-	P. 8-351
8038	Network error	No ISAKMP SA established	IPsec error for SA is not present	-	-	Y	Y	-	P. 8-351
8039	Network error	Invalid Signature	IPsec error for invalid signature for certification	-	-	Y	Y	-	P. 8-351
803A	Network error	No IKEv2 proposal chosen	IPsec error for wrong selection of proposal	-	-	Y	Y	-	P. 8-352

Error code	Classification	Message	Contents	Error code display media					Troubleshooting
				Panl	JL	ML	Noti	CSV	
803B	Network error	IKEv2 Certificate Authentication failed	IPsec error for IKEv2 certification failure	-	-	Y	Y	-	P. 8-352
803C	Network error	IKEv2 Secret key Authentication failed	IKEv2 error for IKEv2 if secret key authentication failed	-	-	Y	Y	-	P. 8-352
803D	Network error	Falling Back to IKEv1	IPsec error if peer does not support IKEv2 and falling back to IKEv1	-	-	Y	Y	-	P. 8-352
803E	Network error	ISAKMP SA unusable (deleted)	IPsec error if ISAKMP SA is uncreated or destroyed due to some uncertain conditions	-	-	Y	Y	-	P. 8-352
803F	Network error	Crypto operation failed	IPsec error for IKEv2 if crypto operation failed	-	-	Y	Y	-	P. 8-353
8040	Network error	Invalid key information	IPsec error for IKEv2 if key info is invalid	-	-	Y	Y	-	P. 8-353
8041	Network error	CA not trusted	IPsec error for IKEv2 if CA is not trusted	-	-	Y	Y	-	P. 8-353
8042	Network error	Authentication Method mismatch	IPsec error for authentication method inconsistency	-	-	Y	Y	-	P. 8-353
8043	Network error	IKE Version mismatch	IPsec error for version inconsistency	-	-	Y	Y	-	P. 8-353
8044	Network error	Encapsulation mode mismatch	IPsec error for encapsulation inconsistency	-	-	Y	Y	-	P. 8-353
8045	Network error	Peer IP Address mismatch	IPsec error for peer IP inconsistency	-	-	Y	Y	-	P. 8-354
8046	Network error	Local IP Address mismatch	IPsec error for local IP inconsistency	-	-	Y	Y	-	P. 8-354
8047	Network error	Local ID mismatch	IPsec error for local ID inconsistency	-	-	Y	Y	-	P. 8-354
8048	Network error	Remote ID mismatch	IPsec error for remote ID inconsistency	-	-	Y	Y	-	P. 8-354
8049	Network error	IPsec Remote IP mismatch	IPsec error for remote IP inconsistency	-	-	Y	Y	-	P. 8-354
804A	Network error	IKEv1/IKEv2 Timed out	IPsec error for IKEv2 timeout	-	-	Y	Y	-	P. 8-354
804B	Network error	Invalid manual key data	IPsec error for invalid of ID manual key	-	-	Y	Y	-	P. 8-355
8061	Network error	Secure Update to Primary IPv4 DDNS failed.	Update error for secure primary DDNS	-	-	Y	Y	-	P. 8-355

Error code	Classification	Message	Contents	Error code display media					Troubleshooting
				Panl	JL	ML	Noti	CSV	
8062	Network error	Secure Update to Secondary IPv4 DDNS failed	Update error for secure secondary DDNS	-	-	Y	Y	-	P. 8-355
8063	Network error	Secure Update to Primary IPv6 DDNS failed.	Update error for IPv6 secure primary DDNS	-	-	Y	Y	-	P. 8-355
8064	Network error	Secure Update to Secondary IPv6 DDNS failed	Update error for IPv6 secure secondary DDNS	-	-	Y	Y	-	P. 8-355
8065	Network error	IPv6 Update to Primary DDNS failed.	Update error for IPv6 primary DDNS	-	-	Y	Y	-	P. 8-355
8066	Network error	IPv6 Update to Secondary DDNS failed.	Update error for IPv6 secondary DDNS	-	-	Y	Y	-	P. 8-355
8067	Network error	IPv4 Update to Primary DDNS failed.	Update error for IPv4 primary DDNS	-	-	Y	Y	-	P. 8-355
8068	Network error	IPv4 Update to Secondary DDNS failed.	Update error for IPv4 secondary DDNS	-	-	Y	Y	-	P. 8-355
8069	Network error	Invalid TSIG/ SIG(0) Key file uploaded	This message is displayed when the key file for SIG(0) or TSIG is invalid	-	-	Y	Y	-	P. 8-355
80B1	Network error		Bluetooth connection failure	-	-	Y	Y	-	P. 8-355
80B2	Network error		Bluetooth print error	-	-	Y	Y	-	-
80B3	Network error		Bluetooth fatal error	-	-	Y	Y	-	-
80B4	Network error		Bluetooth storage near full	-	-	Y	Y	-	-
80B5	Network error		Bluetooth storage full	-	-	Y	Y	-	-
80C0	Network error	Failed to establish the TLS session (unexpected message)	TLS session establishment failure (invalid message)	-	-	Y	Y	-	P. 8-356
80C1	Network error	Failed to establish the TLS session (bad record mac)	TLS session establishment failure (invalid MAC data)	-	-	Y	Y	-	P. 8-356
80C2	Network error	Failed to establish the TLS session (decryption failed)	TLS session establishment failure (decoding failure)	-	-	Y	Y	-	P. 8-356
80C3	Network error	Failed to establish the TLS session (record overflow)	TLS session establishment failure (recording length abnormality)	-	-	Y	Y	-	P. 8-356
80C4	Network error	Failed to establish the TLS session (decompression failure)	TLS session establishment failure (data decompression failure)	-	-	Y	Y	-	P. 8-356
80C5	Network error	Failed to establish the TLS session (handshake failure)	TLS session establishment failure (handshake failure)	-	-	Y	Y	-	P. 8-356

Error code	Classification	Message	Contents	Error code display media					Troubleshooting
				Panl	JL	ML	Noti	CSV	
80C6	Network error	Failed to establish the TLS session (bad certificate)	TLS session establishment failure (certificate abnormality)	-	-	Y	Y	-	P. 8-357
80C7	Network error	Failed to establish the TLS session (unsupported certificate)	TLS session establishment failure (non-support certificate)	-	-	Y	Y	-	P. 8-357
80C8	Network error	Failed to establish the TLS session (certificate revoked)	TLS session establishment failure (invalid certificate)	-	-	Y	Y	-	P. 8-357
80C9	Network error	Failed to establish the TLS session (certificate expired)	TLS session establishment failure (certificate with validity date expired)	-	-	Y	Y	-	P. 8-357
80CA	Network error	Failed to establish the TLS session (certificate unknown)	TLS session establishment failure (certificate process error)	-	-	Y	Y	-	P. 8-357
80CB	Network error	Failed to establish the TLS session (illegal parameter)	TLS session establishment failure (invalid parameter)	-	-	Y	Y	-	P. 8-358
80CC	Network error	Failed to establish the TLS session (unknown ca)	TLS session establishment failure (unknown CA certificate)	-	-	Y	Y	-	P. 8-358
80CD	Network error	Failed to establish the TLS session (access denied)	TLS session establishment failure (access rejection)	-	-	Y	Y	-	P. 8-358
80CE	Network error	Failed to establish the TLS session (decode error)	TLS session establishment failure (decoding error)	-	-	Y	Y	-	P. 8-358
80CF	Network error	Failed to establish the TLS session (decrypt error)	TLS session establishment failure (decoding error)	-	-	Y	Y	-	P. 8-358
80D0	Network error	Failed to establish the TLS session (export restriction)	TLS session establishment failure (export restrictions)	-	-	Y	Y	-	P. 8-359
80D1	Network error	Failed to establish the TLS session (protocol version)	TLS session establishment failure (non-support protocol version)	-	-	Y	Y	-	P. 8-359
80D2	Network error	Failed to establish the TLS session (internal error)	TLS session establishment failure (internal error)	-	-	Y	Y	-	P. 8-359
80D3	Network error	Failed to establish the TLS session (user canceled)	TLS session establishment failure (cancellation by a user)	-	-	Y	Y	-	P. 8-359

Error code	Classification	Message	Contents	Error code display media					Troubleshooting
				Panl	JL	ML	Noti	CSV	
80D4	Network error	Failed to establish the TLS session (no renegotiation)	TLS session establishment failure (invalid renegotiation)	-	-	Y	Y	-	P. 8-359
8101	Network error	Wireless association with Access point failure	Wireless connection in the Access point failure	-	-	Y	Y	-	P. 8-360
8102	Network error	Unable to contact Access point	Connection of MFP to the Access point with a specified SSID failure	-	-	Y	Y	-	P. 8-360
8103	Network error	Wireless Certificate verification failure	Wireless certificate verification failure	-	-	Y	Y	-	P. 8-360
8104	Network error	Wireless module Error	Wireless LAN / Bluetooth module hardware error	-	-	Y	Y	-	P. 8-360
8106	Network error	Wi-Fi Direct Session MAX	The number of connection sessions of Wi-Fi Direct has reached the maximum.	-	-	Y	Y	-	-
8121	Network error	Domain - General Failure during Authentication	Domain: Authentication failure	-	-	Y	Y	-	P. 8-360
8122	Network error	Domain - Invalid Username or Password	Domain: Invalid user name or password	-	-	Y	Y	-	P. 8-360
8123	Network error	Domain - Server not present in Network	Domain: Invalid server	-	-	Y	Y	-	P. 8-361
8124	Network error	Domain - User account is disabled on Server	Domain: Invalid user account	-	-	Y	Y	-	P. 8-361
8125	Network error	Domain - User account has expired and cannot be used for logon	Domain: Expired user account (cannot be used for logon)	-	-	Y	Y	-	P. 8-361
8126	Network error	Domain - User account is locked and cannot be used for logon	Domain: Locked user account (cannot be used for logon)	-	-	Y	Y	-	P. 8-361
8127	Network error	Domain - Invalid logon hours for the User	Domain: Invalid logon time	-	-	Y	Y	-	P. 8-361
8128	Network error	Active Directory Domain - Clock Skew error due to difference in Time between Server and MFP	Active directory domain: Clock skew error (due to difference in time between the server and the MFP)	-	-	Y	Y	-	P. 8-362
8129	Network error	Active Directory Domain - Kerberos Ticket has expired and cannot be used for Authentication	Active directory domain: Expired Kerberos ticket (cannot be used for authentication)	-	-	Y	Y	-	P. 8-362

Error code	Classification	Message	Contents	Error code display media					Troubleshooting
				Panl	JL	ML	Noti	CSV	
812A	Network error	Active Directory Domain - Verification of the Ticket has failed	Active directory domain: Kerberos ticket authentication failure	-	-	Y	Y	-	P. 8-362
812B	Network error	Active Directory Domain - The Domain specified could not be found	Active directory domain: Invalid realm name	-	-	Y	Y	-	P. 8-362

## 8.2.9 Notification

Error code	Classification	Message	Contents	Error code display media					Troubleshooting
				Panl	JL	ML	Noti	CSV	
A08B	Information	-	Insufficient disk space for the 1st saving of the image data	-	-	-	-	-	-
A15D	Information	-	Memory Full	-	-	-	-	-	-
A240	Information	-	Paper empty during scanning	-	-	-	-	-	-
A248	Information	-	Scanner cover open	-	-	-	-	-	-
A249	Information	-	DSDF jam	-	-	-	-	-	-
A24C	Information	-	Detach Key Counter	-	-	-	-	-	-
A24D	Information	-	Service call occurs in scanner device	-	-	-	-	-	-
A24E	Information	-	Service call occurs in DSDF	-	-	-	-	-	-
A24F	Information	-	Unknown error	-	-	-	-	-	-
A250	Information	-	Error due to the use of an invalid original	-	-	-	-	-	-
A251	Information	-	There is no drawer for the size detected by APS	-	-	-	-	-	-
A252	Information	-	Different orientation of an original	-	-	-	-	-	-
A253	Information	-	No upcoming originals	-	-	-	-	-	-
A254	Information	-	An original is not set on the DSDF	-	-	-	-	-	-
A256	Information	-	Exceeding the maximum number of sheets for an original of 1 job	-	-	-	-	-	-
A257	Information	-	Software inside error	-	-	-	-	-	-
A258	Information	-	There is no drawer for the size with the different orientation set from that for an original	-	-	-	-	-	-
A259	Information	-	Fatal error of the software	-	-	-	-	-	-
A260	Information	-	Detection of the finisher non-supported original size	-	-	-	-	-	-
A266	Information	-	Non-standard original size This will occur only when APS or AMS is set	-	-	-	-	-	-
A275	Information	-	Paper is fed from the drawer set for Cover or Insert	-	-	-	-	-	-



Error code	Classification	Message	Contents	Error code display media					Troubleshooting
				Panl	JL	ML	Noti	CSV	
A277	Information	-	Detection of the punching non-supported original size	-	-	-	-	-	-
A280	Information	-	Non-standard paper size	-	-	-	-	-	-
A28E	Information	-	All pages are detected as blank	-	-	-	-	-	-
A2B0	Information	-	Job cancelation by means of an external counter	-	-	-	-	-	-
D101	Information		Paper presence / absence in the LCF	-	-	Y	Y	-	-
D102	Information		Paper presence / absence in the SFB	-	-	-	-	-	-
D103	Information	Paper Empty in Drawer 1 - Please Add Paper.	Paper presence / absence in the 1st drawer	-	-	Y	Y	-	-
D104	Information		Paper presence / absence in the 2nd drawer	-	-	Y	Y	-	-
D105	Information		Paper presence / absence in the PFP1	-	-	Y	Y	-	-
D106	Information		Paper presence / absence in the PFP2	-	-	Y	Y	-	-
D201	Information	Front Cover Open - Please Close Cover.	Front cover	-	-	Y	Y	-	-
D202	Information	Paper Feeding Cover Open - Please Close Cover.	Paper feed cover of the equipment	-	-	Y	Y	-	-
D204	Information	Lower Side Cover Open - Please Close Cover.	T-LCF cover (taking off of the LCF (large capacitor feeder))	-	-	Y	Y	-	-
D205	Information	Lower Side Cover Open - Please Close Cover.	Paper feed cover of the PFP (side cover)	-	-	Y	Y	-	-
D206	Information	Automatic Duplexing Unit Cover Open - Please Close Cover.	ADU cover / unit	-	-	Y	Y	-	-
D207	Information	Relay Unit Cover Open - Please Close Cover.	Bridge unit transport cover	-	-	Y	Y	-	-
D209	Information	Finisher Joint Cover Open - Please Close Cover.	Finisher joint (when a hanging finisher is taken off)	-	-	Y	Y	-	-
D20A	Information	Finisher Door Open - Please Close Door.	Finisher door	-	-	Y	Y	-	-

Error code	Classification	Message	Contents	Error code display media					Troubleshooting
				Panl	JL	ML	Noti	CSV	
D20E	Information	Lower Tray Delivery Cover Open - Please Close Cover	Saddle stitch stapler connection	-	-	Y	Y	-	-
D20F	Information	Punch Unit Front Cover Open - Please Close Cover.	Front cover of the punch unit	-	-	Y	Y	-	-
D211	Information	Job Separator Cover Open - Please Close Cover.	Job separator cover	-	-	Y	Y	-	-
D217	Information	Finisher Door Open - Please Close Door.	Upper cover of the finisher	-	-	Y	Y	-	-
D301	Information	Black Toner Empty - Please Refill.	Toner-K empty	-	-	Y	Y	-	-
D311	Information		Non-genuine toner-K	-	-	-	-	-	-
D321	Information		Toner-K nearly empty	Y	-	-	-	-	-
D401	Information	Close Drawer 1	1st drawer	-	-	Y	Y	-	-
D402	Information	Close Drawer 2	2nd drawer	-	-	Y	Y	-	-
D403	Information	Close Drawer 3	3rd drawer	-	-	Y	Y	-	-
D404	Information	Close Drawer 4	4th drawer	-	-	Y	Y	-	-
D405	Information	Close large capacity feeder (LCF)	Paper supply door of the T-LCF	-	-	Y	Y	-	-
D407	Information	Close large capacity feeder (LCF)	Paper supply door of the T-LCF (left side)	-	-	Y	Y	-	-
D712	Information	Add/Remove Drawer 3	3rd drawer installation / removal	-	-	Y	Y	-	-
D713	Information	Add/Remove Drawer 4	4th drawer installation / removal	-	-	Y	Y	-	-
D718	Information	Add/Remove Large Capacity Feeder	LCF installation / removal	-	-	Y	Y	-	-
D730	Information	Add/Remove Finisher	Finisher installation / removal	-	-	Y	Y	-	-
D731	Information	Add/Remove Saddle Finisher	Saddle stitch unit installation / removal	-	-	Y	Y	-	-
D732	Information	Add/Remove Hole Punch Unit	Hole punch unit installation / removal	-	-	Y	Y	-	-
D751	Information	Add/Remove Relay Unit	Bridge unit installation / removal	-	-	Y	Y	-	-
D7B0	Information	Add/Remove Fax Unit(Line1)	FAX Unit line 1 installation / removal	-	-	Y	Y	-	-
D7B1	Information	Add/Remove Fax Unit(Line2)	FAX Unit line 2 installation / removal	-	-	Y	Y	-	-

Error code	Classification	Message	Contents	Error code display media					Troubleshooting
				Panl	JL	ML	Noti	CSV	
D7E0	Information	Add/Remove Coin Controller	Coin controller installation / removal	-	-	Y	Y	-	-
D7E1	Information	Add/Remove Key Copy Counter	Key counter installation / removal	-	-	Y	Y	-	-
D800	Information	The machine was shut down	Shutdown	-	-	Y	Y	-	-
D801	Information	Turned on the power	Power ON	-	-	Y	Y	-	-
D802	Information	Gone into the energy save mode	Move low power	-	-	Y	Y	-	-
D803	Information	Gone into the sleep mode	Move sleep	-	-	Y	-	-	-
D804	Information	The machine was rebooted	Execute reboot	-	-	Y	Y	-	-
D806	Information	Reboot By Service Call	Rebooting for recovering from an internal error (service call)	Y	-	Y	-	-	-

## 8.2.10 FAX error

Error code	Classification	Message	Contents	Error code display media					Troubleshooting
				PanI	JL	ML	Noti	CSV	
0000	Fax	-	Information: The Fax transmission has succeeded.	-	Y	-	Y	-	-
	Fax	-	Information: The Fax reception has succeeded.	-	Y	-	Y	-	
	IP Fax	-	Information: The IP Fax transmission has succeeded.	-	Y	-	Y	-	
	IP Fax	-	Information: The IP Fax reception has succeeded.	-	Y	-	Y	-	
0012	Fax	-	Original jam: The Fax transmission has failed since an original was misfed in the DF while a Fax job was being sent.	-	Y	-	Y	-	P. 8-363
0013	Fax	-	Cover is open: The Fax transmission has failed since the cover of the equipment or options that process paper was opened.	-	Y	-	Y	-	P. 8-363
0020	Fax	-	Power failure: The Fax transmission has failed due to a power failure.	-	Y	-	Y	-	P. 8-363
	Fax	-	Power failure: The Fax reception has failed due to a power failure.	-	Y	-	Y	-	
	IP Fax	-	Power failure: The IP Fax transmission has failed due to a power failure.	-	Y	-	Y	-	
	IP Fax	-	Power failure: The IP Fax reception has failed due to a power failure.	-	Y	-	Y	-	

Error code	Classification	Message	Contents	Error code display media					Troubleshooting
				Panl	JL	ML	Noti	CSV	
0030	Fax	-	Recording paper jam: The Fax transmission has been stopped due to the following reason. <ul style="list-style-type: none"> <li>Paper misfeeding occurred with another job.</li> <li>A Fax job was canceled.</li> </ul>	-	Y	-	Y	-	P. 8-364
0033	Fax	-	Polling error: The polling reception has failed due to the following reason. <ul style="list-style-type: none"> <li>A polling original was not set on the other side's device.</li> <li>The security setting between this equipment and the other side's device did not match.</li> </ul>	-	Y	-	Y	-	P. 8-364
0040	Fax	-	Modem communication error: The Fax transmission has failed since the modem could not send the signal properly.	-	Y	-	Y	-	P. 8-364
	Fax	-	Modem communication error: The Fax reception has failed since the modem could not receive the signal properly.	-	Y	-	Y	-	

Error code	Classification	Message	Contents	Error code display media					Troubleshooting
				Panl	JL	ML	Noti	CSV	
0042	Fax	-	Memory full: The Fax reception has been canceled since the capacity shortage or an abnormality occurred in the storage while a Fax job was being received. (Pages which are received successfully will be printed out.)	-	Y	-	Y	-	P. 8-365
	IP Fax	-	Memory full: The IP Fax reception has been canceled since the capacity shortage or an abnormality occurred in the storage while an IP Fax job was being received. (Pages which are received successfully will be printed out.)	-	Y	-	Y	-	
0050	Fax	-	Line is busy: Since the line of the other side's device was busy, the Fax transmission has failed even though the redialing was carried out by the maximum number of specified times.	-	Y	-	Y	-	P. 8-365
0051	Fax	Please confirm the cable or connection equipment for Line1.	No cable connected for Fax line: The Fax transmission has failed since no cable for the Fax line was connected.	Y	Y	-	Y	-	P. 8-365
		Please confirm the cable or connection equipment for Line2.							
0052	Fax	-	T1 time-out: The Fax transmission has failed since NSF / DIS could not be detected. (Memory transmission)	-	Y	-	Y	-	P. 8-366
	IP Fax	-	T1 time-out: The IP Fax transmission has failed since NSF / DIS could not be detected. (Memory transmission)	-	Y	-	Y	-	

Error code	Classification	Message	Contents	Error code display media					Troubleshooting
				Panl	JL	ML	Noti	CSV	
00B0	Fax	-	Initial signal not detected: The Fax transmission has failed since NSF / DIS could not be detected. (Direct transmission)	-	Y	-	Y	-	P. 8-366
00B1	Fax	-	Terminal constants not compatible: The Fax transmission has failed since the other side's device did not have the capability which was transferred by NSF / DIS on this equipment.	-	Y	-	Y	-	P. 8-366
	Fax	-	Terminal constants not compatible: The Fax reception has failed since NSS / DCS, which was a capability other than the ones transferred by NSF / DIS on this equipment, was received.	-	Y	-	Y	-	
	IP Fax	-	Terminal constants not compatible: The IP Fax transmission has failed since the other side's device did not have the capability which was transferred by NSF / DIS on this equipment.	-	Y	-	Y	-	
	IP Fax	-	Terminal constants not compatible: The IP Fax job reception has failed since NSS / DCS, which was a capability other than the ones transferred by NSF / DIS on this equipment, was received.	-	Y	-	Y	-	

Error code	Classification	Message	Contents	Error code display media					Troubleshooting
				Panl	JL	ML	Noti	CSV	
00B2	Fax	-	Reception of DCN (Phase B): The Fax transmission has failed since DCN was sent in Phase B.	-	Y	-	Y	-	P. 8-367
	Fax	-	Reception of DCN (Phase B): The Fax reception has failed since DCN was received in Phase B.	-	Y	-	Y	-	
	IP Fax	-	Reception of DCN (Phase B): The IP Fax transmission has failed since DCN was sent in Phase B.	-	Y	-	Y	-	
	IP Fax	-	Reception of DCN (Phase B): The IP Fax reception has failed since DCN was received in Phase B.	-	Y	-	Y	-	
00B3	Fax	-	DCS / DTC not detected: The Fax reception has failed since DCS / DTC could not be detected.	-	Y	-	Y	-	P. 8-368
	IP Fax	-	DCS / DTC not detected: The IP Fax transmission has failed since DCS / DTC could not be detected.	-	Y	-	Y	-	
	IP Fax	-	DCS / DTC not detected: The IP Fax reception has failed since DCS / DTC could not be detected.	-	Y	-	Y	-	



Error code	Classification	Message	Contents	Error code display media					Troubleshooting
				Panl	JL	ML	Noti	CSV	
00B4	Fax	-	Training error: This equipment has performed fall-back but the Fax transmission has failed.	-	Y	-	Y	-	P. 8-368
	Fax	-	Training error: The Fax reception has failed since after receiving FTT, the receiver has received a timeout or DCN.	-	Y	-	Y	-	
	IP Fax	-	Training error: This equipment has performed fall-back but the IP Fax transmission has failed.	-	Y	-	Y	-	
	IP Fax	-	Training error: The IP Fax reception has failed since after receiving FTT, the receiver has received a timeout or DCN.	-	Y	-	Y	-	
00B5	Fax	-	CFR not detected: The Fax transmission has failed since a training signal has been sent out but CFR could not be detected.	-	Y	-	Y	-	P. 8-369
	IP Fax	-	CFR not detected: The IP Fax transmission has failed since a training signal has been sent out but CFR could not be detected.	-	Y	-	Y	-	

Error code	Classification	Message	Contents	Error code display media					Troubleshooting
				Panl	JL	ML	Noti	CSV	
00B6	Fax	-	No response made to CTC: The Fax transmission has failed since no response was made to CTC.	-	Y	-	Y	-	P. 8-369
	IP Fax	-	No response made to CTC: The IP Fax transmission has failed since no response was made to CTC.	-	Y	-	Y	-	
	IP Fax	-	No response made to CTC: The IP Fax reception has failed since DCN was received during ECM transmission.	-	Y	-	Y	-	
00B7	Fax	-	Phase B cannot be completed: The Fax transmission has failed since a modem error or a sequence error in the FAX Unit occurred.	-	Y	-	Y	-	P. 8-370
	Fax	-	Phase B cannot be completed: The Fax reception has failed since a modem error or a sequence error in the FAX Unit occurred.	-	Y	-	Y	-	
	IP Fax	-	Phase B cannot be completed: The IP Fax transmission has failed since an error occurred in the system.	-	Y	-	Y	-	
	IP Fax	-	Phase B cannot be completed: The IP Fax reception has failed since an error occurred in the system.	-	Y	-	Y	-	
00C0	Fax	-	Image signal carrier not detected: The Fax reception has failed since this equipment has failed to detect a carrier.	-	Y	-	Y	-	P. 8-371

Error code	Classification	Message	Contents	Error code display media					Troubleshooting
				Panl	JL	ML	Noti	CSV	
00C1	Fax	-	High-speed signal not detected: The Fax reception has failed since this equipment has failed to detect a high-speed signal.	-	Y	-	Y	-	P. 8-371
	IP Fax	-	High-speed signal not detected: The IP Fax reception has failed since this equipment has failed to detect a high-speed signal.	-	Y	-	Y	-	
00C2	Fax	-	Image signal carrier disconnected: The Fax transmission has failed since a carrier disconnection was detected after the image signal was picked up by the other side's device.	-	Y	-	Y	-	P. 8-371
	Fax	-	Image signal carrier disconnected: The Fax reception has failed since a carrier disconnection was detected after the image signal was picked up by this equipment.	-	Y	-	Y	-	
	IP Fax	-	Image signal carrier disconnected: The IP Fax reception has failed since a carrier disconnection was detected after the image signal was picked up by this equipment.	-	Y	-	Y	-	
00C4	Fax	-	EOL time-out: The Fax reception has failed since this equipment could not detect EOL or not decode with MMR.	-	Y	-	Y	-	P. 8-372

Error code	Classification	Message	Contents	Error code display media					Troubleshooting
				Panl	JL	ML	Noti	CSV	
00C5	Fax	-	Excess length of data received: The Fax reception has failed due to the disconnection of the communication since the length of the received original exceeded 2 m.	-	Y	-	Y	-	P. 8-372
	IP Fax	-	Excess length of data received: The IP Fax reception has failed due to the disconnection of the communication since the length of the received original exceeded 2 m.	-	Y	-	Y	-	
00C6	Fax	-	Image code conversion error: The Fax reception has failed since the conversion of the received image went wrong.	-	Y	-	Y	-	P. 8-372
	IP Fax	-	Image code conversion error: The IP Fax reception has failed since the conversion of the received image went wrong.	-	Y	-	Y	-	

Error code	Classification	Message	Contents	Error code display media					Troubleshooting
				Panl	JL	ML	Noti	CSV	
00C7	Fax	-	Phase C cannot be completed: The Fax transmission has failed since a modem error or a sequence error in the FAX Unit occurred.	-	Y	-	Y	-	P. 8-373
	Fax	-	Phase C cannot be completed: The Fax reception has failed since a modem error or a sequence error in the FAX Unit occurred.	-	Y	-	Y	-	
	IP Fax	-	Phase C cannot be completed: The IP Fax transmission has failed since a system error or a sequence error occurred.	-	Y	-	Y	-	
	IP Fax	-	Phase C cannot be completed: The IP Fax reception has failed since a system error or a sequence error occurred.	-	Y	-	Y	-	
00C8	IP Fax	-	Transmitted image was not made in time: The IP Fax transmission has failed due to the disconnection of the communication from the other side's device since the notification of the transmitted image was not made in time.	-	Y	-	Y	-	P. 8-373

Error code	Classification	Message	Contents	Error code display media					Troubleshooting
				Pani	JL	ML	Noti	CSV	
00D0	Fax	-	Post message not detected: The Fax transmission has failed since this equipment could not detect an MCF, RTP, RTN, PIN or PIP or the other side's device could not detect MPS, EOM or EOP.	-	Y	-	Y	-	P. 8-374
	Fax	-	Post message not detected: The Fax reception has failed since the other side's device could not detect an MCF, RTP, RTN, PIN or PIP or this equipment could not detect MPS, EOM or EOP.	-	Y	-	Y	-	
	IP Fax	-	Post message not detected: The IP Fax transmission has failed since this equipment could not detect an MCF, RTP, RTN, PIN or PIP or the other side's device could not detect MPS, EOM or EOP.	-	Y	-	Y	-	
	IP Fax	-	Post message not detected: The IP Fax reception has failed since the other side's device could not detect an MCF, RTP, RTN, PIN or PIP or this equipment could not detect MPS, EOM or EOP.	-	Y	-	Y	-	
00D1	Fax	-	Reception of DCN: The Fax reception has failed since DCN was received.	-	Y	-	Y	-	P. 8-374
	IP Fax	-	Reception of DCN: The IP Fax transmission has failed since DCN was received.	-	Y	-	Y	-	
	IP Fax	-	Reception of DCN: The IP Fax reception has failed since DCN was received.	-	Y	-	Y	-	

Error code	Classification	Message	Contents	Error code display media					Troubleshooting
				Panl	JL	ML	Noti	CSV	
00D2	Fax	-	Poor image quality: The Fax transmission has failed since the quality of the received image was poor in the other side's device.	-	Y	-	Y	-	P. 8-375
	Fax	-	Poor image quality: The Fax reception has failed since the quality of the received image was poor.	-	Y	-	Y	-	
	IP Fax	-	Poor image quality: The IP Fax transmission has failed since the quality of the received image was poor in the other side's device.	-	Y	-	Y	-	
	IP Fax	-	Poor image quality: The IP Fax reception has failed since the quality of the received image was poor.	-	Y	-	Y	-	
00D3	Fax	-	No response made to EOR: The Fax transmission has failed since no response was made to EOR or DCN was received during ECM transmission.	-	Y	-	Y	-	P. 8-376
	IP Fax	-	No response made to EOR: The IP Fax transmission has failed since no response was made to EOR or DCN was received during ECM transmission.	-	Y	-	Y	-	

Error code	Classification	Message	Contents	Error code display media					Troubleshooting
				Panl	JL	ML	Noti	CSV	
00D4	Fax	-	No response made to RR: The Fax transmission has failed since no response was made to RR or DCN was received during ECM transmission.	-	Y	-	Y	-	P. 8-376
	IP Fax	-	No response made to RR: The IP Fax transmission has failed since no response was made to RR or DCN was received during ECM transmission.	-	Y	-	Y	-	
00D5	Fax	-	T5 time-out: The Fax transmission has failed since RNR-RR was repeated and the line was disconnected due to timeout during ECM transmission.	-	Y	-	Y	-	P. 8-376
00D6	Fax	-	ERR returned to EOR: The Fax reception has failed due to the bad condition of the communication.	-	Y	-	Y	-	P. 8-377
	IP Fax	-	ERR returned to EOR: The IP Fax reception has failed due to the bad condition of the communication.	-	Y	-	Y	-	



Error code	Classification	Message	Contents	Error code display media					Troubleshooting
				Panl	JL	ML	Noti	CSV	
00D7	Fax	-	Line disconnected by transmission of EOR: The Fax transmission has failed since the line was disconnected after EOR was sent by this equipment during ECM transmission.	-	Y	-	Y	-	P. 8-377
	IP Fax	-	Line disconnected by transmission of EOR: The IP Fax transmission has failed since the line was disconnected after EOR was sent by this equipment during ECM transmission.	-	Y	-	Y	-	
00D8	Fax	-	Time-out between FCD frames: The Fax reception has failed since a time-out occurred between the FCD frames.	-	Y	-	Y	-	P. 8-377
00DA	Fax	-	MCF not returned: The Fax reception has failed since MCF could not be returned from this equipment.	-	Y	-	Y	-	P. 8-378
	IP Fax	-	MCF not returned: The IP Fax reception has failed since MCF could not be returned from this equipment.	-	Y	-	Y	-	
00E8	Fax	-	HDD error: The Fax transmission has failed due to a defective HDD.	-	Y	-	Y	-	P. 8-378
	Fax	-	HDD error: The Fax reception has failed due to a defective HDD.	-	Y	-	Y	-	
	IP Fax	-	HDD error: The IP Fax transmission has failed due to a defective HDD.	-	Y	-	Y	-	
	IP Fax	-	HDD error: The IP Fax reception has failed due to a defective HDD.	-	Y	-	Y	-	

Error code	Classification	Message	Contents	Error code display media					Troubleshooting
				Panl	JL	ML	Noti	CSV	
00F0	Fax	-	Software trouble: The Fax transmission has failed due to defective software.	-	Y	-	Y	-	P. 8-379
	Fax	-	Software trouble: The Fax reception has failed due to defective software.	-	Y	-	Y	-	
	IP Fax	-	Software trouble: The IP Fax transmission has failed due to defective software.	-	Y	-	Y	-	
	IP Fax	-	Software trouble: The IP Fax reception has failed due to defective software.	-	Y	-	Y	-	
00F1	Fax	-	Hardware noise: The Fax transmission has failed due to defective hardware.	-	Y	-	Y	-	P. 8-379
	Fax	-	Hardware noise: The Fax reception has failed due to defective hardware.	-	Y	-	Y	-	
00F4	Fax	-	Software trouble (FAX Unit): The Fax transmission has failed due to defective software.	-	Y	-	Y	-	P. 8-380
	Fax	-	Software trouble (FAX Unit): The Fax reception has failed due to defective software.	-	Y	-	Y	-	
0100	IP Fax	Registration to SIP server Success.	Registration Success: The registration to an SIP server has succeeded.	-	-	Y	-	-	-
0101	IP Fax	Registration to SIP server failed.	Response TimeOut (Registration): A time-out has occurred since there was no response from an SIP server. (Register)	Y	-	Y	Y	-	P. 8-380
0102	IP Fax	-	Response TimeOut (Invite): The IP Fax transmission has failed due to a time-out since there was no response from an SIP server. (Invite)	-	Y	-	Y	-	P. 8-380

Error code	Classification	Message	Contents	Error code display media					Troubleshooting
				Panl	JL	ML	Noti	CSV	
0103	IP Fax	Registration to SIP server failed.	"Multiple Choices" Received: The registration to an SIP server has failed due to an error. (Multiple Choices)	Y	-	Y	Y	-	P. 8-380
0104	IP Fax	Registration to SIP server failed.	"Moved Permanently" Received: The registration to an SIP server has failed due to an error. (Moved Permanently)	Y	-	Y	Y	-	P. 8-381
0105	IP Fax	Registration to SIP server failed.	"Moved Temporarily" Received: The registration to an SIP server has failed due to an error. (Moved Temporarily)	Y	-	Y	Y	-	P. 8-381
0106	IP Fax	Registration to SIP server failed.	"Use Proxy" Received: The registration to an SIP server has failed due to an error. (Use Proxy)	Y	-	Y	Y	-	P. 8-381
0107	IP Fax	Registration to SIP server failed.	"Alternative Service" Received: The registration to an SIP server has failed due to an error. (Alternative Service)	Y	-	Y	Y	-	P. 8-381
0109	IP Fax	Registration to SIP server failed.	"Bad Request" Received: The registration to an SIP server has failed due to an error. (Bad Request)	Y	-	Y	Y	-	P. 8-381
010A	IP Fax	Registration to SIP server failed.	"Unauthorized" Received: The registration to an SIP server has failed due to an error. (Unauthorized)	Y	-	Y	Y	-	P. 8-382
010B	IP Fax	Registration to SIP server failed.	"Payment Required" Received: The registration to an SIP server has failed due to an error. (Payment Required)	Y	-	Y	Y	-	P. 8-382
010C	IP Fax	Registration to SIP server failed.	"Forbidden" Received: The registration to an SIP server has failed due to an error. (Forbidden)	Y	-	Y	Y	-	P. 8-382

Error code	Classification	Message	Contents	Error code display media					Troubleshooting
				Panl	JL	ML	Noti	CSV	
010D	IP Fax	Registration to SIP server failed.	"Not Found" Received: The registration to an SIP server has failed due to an error. (Not Found)	Y	-	Y	Y	-	P. 8-382
010E	IP Fax	Registration to SIP server failed.	"Method Not Allowed" Received: The registration to an SIP server has failed due to an error. (Method Not Allowed)	Y	-	Y	Y	-	P. 8-382
010F	IP Fax	Registration to SIP server failed.	"Not Acceptable" Received: The registration to an SIP server has failed due to an error. (Not Acceptable)	Y	-	Y	Y	-	P. 8-383
0110	IP Fax	Registration to SIP server failed.	"Proxy Authentication Required" Received: The registration to an SIP server has failed due to an error. (Proxy Authentication Required)	Y	-	Y	Y	-	P. 8-383
0111	IP Fax	Registration to SIP server failed.	"Request Timeout" Received: The registration to an SIP server has failed due to an error. (Request Timeout)	Y	-	Y	Y	-	P. 8-383
0113	IP Fax	Registration to SIP server failed.	"Gone" Received: The registration to an SIP server has failed due to an error. (Gone)	Y	-	Y	Y	-	P. 8-383
0115	IP Fax	Registration to SIP server failed.	"Precondition Failed" Received: The registration to an SIP server has failed due to an error. (Precondition Failed)	Y	-	Y	Y	-	P. 8-383
0116	IP Fax	Registration to SIP server failed.	"Request Entity Too Large" Received: The registration to an SIP server has failed due to an error. (Request Entity Too Large)	Y	-	Y	Y	-	P. 8-384
0117	IP Fax	Registration to SIP server failed.	"Request-URI Too Long" Received: The registration to an SIP server has failed due to an error. (Request-URI Too Long)	Y	-	Y	Y	-	P. 8-384

Error code	Classification	Message	Contents	Error code display media					Troubleshooting
				Panl	JL	ML	Noti	CSV	
0118	IP Fax	Registration to SIP server failed.	“Unsupported Media Type” Received: The registration to an SIP server has failed due to an error. (Unsupported Media Type)	Y	-	Y	Y	-	P. 8-384
0119	IP Fax	Registration to SIP server failed.	“Unsupported URI Scheme” Received: The registration to an SIP server has failed due to an error. (Unsupported URI Scheme)	Y	-	Y	Y	-	P. 8-384
011A	IP Fax	Registration to SIP server failed.	“Unknown Resource-Priority” Received: The registration to an SIP server has failed due to an error. (Unknown Resource-Priority)	Y	-	Y	Y	-	P. 8-384
011B	IP Fax	Registration to SIP server failed.	“Bad Extension” Received: The registration to an SIP server has failed due to an error. (Bad Extension)	Y	-	Y	Y	-	P. 8-385
011C	IP Fax	Registration to SIP server failed.	“Extension Required” Received: The registration to an SIP server has failed due to an error. (Extension Required)	Y	-	Y	Y	-	P. 8-385
011D	IP Fax	Registration to SIP server failed.	“Session Timer Too Small” Received: The registration to an SIP server has failed due to an error. (Session Timer Too Small)	Y	-	Y	Y	-	P. 8-385
011E	IP Fax	Registration to SIP server failed.	“Interval Too Brief” Received: The registration to an SIP server has failed due to an error. (Interval Too Brief)	Y	-	Y	Y	-	P. 8-385
011F	IP Fax	Registration to SIP server failed.	“Anonymity disallowed” Received: The registration to an SIP server has failed due to an error. (Anonymity disallowed)	Y	-	Y	Y	-	P. 8-385

Error code	Classification	Message	Contents	Error code display media					Troubleshooting
				Panl	JL	ML	Noti	CSV	
0120	IP Fax	Registration to SIP server failed.	“Temporarily Unavailable” Received: The registration to an SIP server has failed due to an error. (Temporarily Unavailable)	Y	-	Y	Y	-	P. 8-386
0121	IP Fax	Registration to SIP server failed.	“Call/Transaction Does Not Exist” Received: The registration to an SIP server has failed due to an error. (Call/Transaction Does Not Exist)	Y	-	Y	Y	-	P. 8-386
0122	IP Fax	Registration to SIP server failed.	“Loop Detected” Received: The registration to an SIP server has failed due to an error. (Loop Detected)	Y	-	Y	Y	-	P. 8-386
0123	IP Fax	Registration to SIP server failed.	“Too Many Hops” Received: The registration to an SIP server has failed due to an error. (Too Many Hops)	Y	-	Y	Y	-	P. 8-386
0124	IP Fax	Registration to SIP server failed.	“Address Incomplete” Received: The registration to an SIP server has failed due to an error. (Address Incomplete)	Y	-	Y	Y	-	P. 8-386
0125	IP Fax	Registration to SIP server failed.	“Ambiguous” Received: The registration to an SIP server has failed due to an error. (Ambiguous)	Y	-	Y	Y	-	P. 8-387
0126	IP Fax	Registration to SIP server failed.	“Busy Here” Received: The registration to an SIP server has failed due to an error. (Busy Here)	Y	-	Y	Y	-	P. 8-387
0127	IP Fax	Registration to SIP server failed.	“Request Terminated” Received: The registration to an SIP server has failed due to an error. (Request Terminated)	Y	-	Y	Y	-	P. 8-387

Error code	Classification	Message	Contents	Error code display media					Troubleshooting
				Panl	JL	ML	Noti	CSV	
0128	IP Fax	Registration to SIP server failed.	“Not acceptable here” Received: The registration to an SIP server has failed due to an error. (Not acceptable here)	Y	-	Y	Y	-	P. 8-387
0129	IP Fax	Registration to SIP server failed.	“Bad Event” Received: The registration to an SIP server has failed due to an error. (Bad Event)	Y	-	Y	Y	-	P. 8-387
012A	IP Fax	Registration to SIP server failed.	“Request Updated” Received: The registration to an SIP server has failed due to an error. (Request Updated)	Y	-	Y	Y	-	P. 8-388
012B	IP Fax	Registration to SIP server failed.	“Request Pending” Received: The registration to an SIP server has failed due to an error. (Request Pending)	Y	-	Y	Y	-	P. 8-388
012C	IP Fax	Registration to SIP server failed.	“Undecipherable” Received: The registration to an SIP server has failed due to an error. (Undecipherable)	Y	-	Y	Y	-	P. 8-388
012D	IP Fax	Registration to SIP server failed.	“Security Agreement Required” Received: The registration to an SIP server has failed due to an error. (Security Agreement Required)	Y	-	Y	Y	-	P. 8-388
012E	IP Fax	Registration to SIP server failed.	“Internal Server Error” Received: The registration to an SIP server has failed due to an error. (Internal Server Error)	Y	-	Y	Y	-	P. 8-388
012F	IP Fax	Registration to SIP server failed.	“Not Implemented” Received: The registration to an SIP server has failed due to an error. (Not Implemented)	Y	-	Y	Y	-	P. 8-389

Error code	Classification	Message	Contents	Error code display media					Troubleshooting
				Panl	JL	ML	Noti	CSV	
0130	IP Fax	Registration to SIP server failed.	"Bad Gateway" Received: The registration to an SIP server has failed due to an error. (Bad Gateway)	Y	-	Y	Y	-	P. 8-389
0131	IP Fax	(Panl) Due to IP line traffic,It may take time to send. (ML) ITransmission takes time because IP line is crowded.	"Service Unavailable" Received: The IP Fax transmission took time since the IP line was busy.	Y	-	Y	Y	-	P. 8-389
0132	IP Fax	Registration to SIP server failed.	"Gateway Time-out" Received: The registration to an SIP server has failed due to an error. (Gateway Time-out)	Y	-	Y	Y	-	P. 8-389
0133	IP Fax	Registration to SIP server failed.	"Version Not Supported" Received: The registration to an SIP server has failed due to an error. (Version Not Supported)	Y	-	Y	Y	-	P. 8-389
0134	IP Fax	Registration to SIP server failed.	"Message Too Large" Received: The registration to an SIP server has failed due to an error. (Message Too Large)	Y	-	Y	Y	-	P. 8-390
0135	IP Fax	Registration to SIP server failed.	"Precondition Failure" Received: The registration to an SIP server has failed due to an error. (Precondition Failure)	Y	-	Y	Y	-	P. 8-390
0136	IP Fax	Registration to SIP server failed.	"Busy Everywhere" Received: The registration to an SIP server has failed due to an error. (Busy Everywhere)	Y	-	Y	Y	-	P. 8-390
0137	IP Fax	Registration to SIP server failed.	"Decline" Received: The registration to an SIP server has failed due to an error. (Decline)	Y	-	Y	Y	-	P. 8-390
0138	IP Fax	Registration to SIP server failed.	"Does Not Exist Anywhere" Received: The registration to an SIP server has failed due to an error. (Does Not Exist Anywhere)	Y	-	Y	Y	-	P. 8-390



Error code	Classification	Message	Contents	Error code display media					Troubleshooting
				Panl	JL	ML	Noti	CSV	
0139	IP Fax	Registration to SIP server failed.	“Not Acceptable” Received: The registration to an SIP server has failed due to an error. (Not Acceptable)	Y	-	Y	Y	-	P. 8-391
013D	IP Fax	Registration to SIP server failed.	Registration failed: The registration to an SIP server has failed due to an error. (Other errors)	Y	-	Y	Y	-	P. 8-391
013E	IP Fax	-	Invite failed: The IP Fax transmission / reception has failed due to a communication error. (Other errors)	-	-	-	Y	-	P. 8-391
0140	IP Fax	(Panl) Reboot machine due to IP Fax initializing error. (ML) Failed to start IP Fax.	Failed to start: The starting of the IP Fax function has failed.	Y	-	Y	Y	-	P. 8-391
0141	IP Fax	-	Job interruption due to setting change occurred: The implementation of an IP Fax job has been stopped since the settings were changed.	-	Y	-	Y	-	P. 8-391
0142	IP Fax	-	Irregal address: The IP Fax transmission has failed due to a communication error. (Recipient entry error)	-	-	-	Y	-	P. 8-392
0143	IP Fax	-	SIP server is unavailable: The IP Fax transmission / reception has failed due to a communication error. (SIP server unusable)	-	Y	-	Y	-	P. 8-392
0144	IP Fax	-	Under congestion: The IP Fax transmission has failed due to a communication error. (Under congestion)	-	-	-	Y	-	P. 8-392

Error code	Classification	Message	Contents	Error code display media					Troubleshooting
				PanI	JL	ML	Noti	CSV	
0150	IP Fax	-	Disconnected by communication partner: The IP Fax transmission has failed due to a communication error. (Communication disconnection from the other side's device)	-	Y	-	Y	-	P. 8-392
	IP Fax	-	Disconnected by communication partner: The IP Fax reception has failed due to a communication error. (Communication disconnection from the other side's device)	-	Y	-	Y	-	
0200	IP Fax	-	Success: The IP Fax transmission has been completed.	-	Y	-	Y	-	-
0300	IP Fax	-	"Multiple Choices" Received: The IP Fax transmission / reception has failed due to a communication error. (Multiple Choices)	-	Y	-	Y	-	P. 8-393
0301	IP Fax	-	"Moved Permanently" Received: The IP Fax transmission / reception has failed due to a communication error. (Moved Permanently)	-	Y	-	Y	-	P. 8-393
0302	IP Fax	-	"Moved Temporarily" Received: The IP Fax transmission / reception has failed due to a communication error. (Moved Temporarily)	-	Y	-	Y	-	P. 8-393
0305	IP Fax	-	"Use Proxy" Received: The IP Fax transmission / reception has failed due to a communication error. (Use Proxy)	-	Y	-	Y	-	P. 8-393

Error code	Classification	Message	Contents	Error code display media					Troubleshooting
				Panl	JL	ML	Noti	CSV	
0380	IP Fax	-	"Alternative Service" Received: The IP Fax transmission / reception has failed due to a communication error. (Alternative Service)	-	Y	-	Y	-	P. 8-393
0400	IP Fax	-	"Bad Request" Received: The IP Fax transmission / reception has failed due to a communication error. (Bad Request)	-	Y	-	Y	-	P. 8-394
0401	IP Fax	-	"Unauthorized" Received: The IP Fax transmission / reception has failed due to a communication error. (Unauthorized)	-	Y	-	Y	-	P. 8-394
0402	IP Fax	-	"Payment Required" Received: The IP Fax transmission / reception has failed due to a communication error. (Payment Required)	-	Y	-	Y	-	P. 8-394
0403	IP Fax	-	"Forbidden" Received: The IP Fax transmission / reception has failed due to a communication error. (Forbidden)	-	Y	-	Y	-	P. 8-394
0404	IP Fax	-	"Not Found" Received: The IP Fax transmission / reception has failed due to a communication error. (Not Found)	-	Y	-	Y	-	P. 8-394
0405	IP Fax	-	"Method Not Allowed" Received: The IP Fax transmission / reception has failed due to a communication error. (Method Not Allowed)	-	Y	-	Y	-	P. 8-395

Error code	Classification	Message	Contents	Error code display media					Troubleshooting
				Panl	JL	ML	Noti	CSV	
0406	IP Fax	-	"Not Acceptable" Received: The IP Fax transmission / reception has failed due to a communication error. (Not Acceptable)	-	Y	-	Y	-	P. 8-395
0407	IP Fax	-	"Proxy Authentication Required" Received: The IP Fax transmission / reception has failed due to a communication error. (Proxy Authentication Required)	-	Y	-	Y	-	P. 8-395
0408	IP Fax	-	"Request Timeout" Received: The IP Fax transmission / reception has failed due to a communication error. (Request Timeout)	-	Y	-	Y	-	P. 8-395
0410	IP Fax	-	"Gone" Received: The IP Fax transmission / reception has failed due to a communication error. (Gone)	-	Y	-	Y	-	P. 8-395
0412	IP Fax	-	"Precondition Failed" Received: The IP Fax transmission / reception has failed due to a communication error. (Precondition Failed)	-	Y	-	Y	-	P. 8-396
0413	IP Fax	-	"Request Entity Too Large" Received: The IP Fax transmission / reception has failed due to a communication error. (Request Entity Too Large)	-	Y	-	Y	-	P. 8-396
0414	IP Fax	-	"Request-URI Too Long" Received: The IP Fax transmission / reception has failed due to a communication error. (Request-URI Too Long)	-	Y	-	Y	-	P. 8-396

Error code	Classification	Message	Contents	Error code display media					Troubleshooting
				Panl	JL	ML	Noti	CSV	
0415	IP Fax	-	“Unsupported Media Type” Received: The IP Fax transmission / reception has failed due to a communication error. (Unsupported Media Type)	-	Y	-	Y	-	P. 8-396
0416	IP Fax	-	“Unsupported URI Scheme” Received: The IP Fax transmission / reception has failed due to a communication error. (Unsupported URI Scheme)	-	Y	-	Y	-	P. 8-396
0417	IP Fax	-	“Unknown Resource-Priority” Received: The IP Fax transmission / reception has failed due to a communication error. (Unknown Resource-Priority)	-	Y	-	Y	-	P. 8-397
0420	IP Fax	-	“Bad Extension” Received: The IP Fax transmission / reception has failed due to a communication error. (Bad Extension)	-	Y	-	Y	-	P. 8-397
0421	IP Fax	-	“Extension Required” Received: The IP Fax transmission / reception has failed due to a communication error. (Extension Required)	-	Y	-	Y	-	P. 8-397
0422	IP Fax	-	“Session Timer Too Small” Received: The IP Fax transmission / reception has failed due to a communication error. (Session Timer Too Small)	-	Y	-	Y	-	P. 8-397

Error code	Classification	Message	Contents	Error code display media					Troubleshooting
				Panl	JL	ML	Noti	CSV	
0423	IP Fax	-	"Interval Too Brief" Received: The IP Fax transmission / reception has failed due to a communication error. (Interval Too Brief)	-	Y	-	Y	-	P. 8-397
0433	IP Fax	-	"Anonymity disallowed" Received: The IP Fax transmission / reception has failed due to a communication error. (Anonymity disallowed)	-	Y	-	Y	-	P. 8-398
0480	IP Fax	-	"Temporarily Unavailable" Received: The IP Fax transmission / reception has failed due to a communication error. (Temporarily Unavailable)	-	Y	-	Y	-	P. 8-398
0481	IP Fax	-	"Call/Transaction Does Not Exist" Received: The IP Fax transmission / reception has failed due to a communication error. (Call/Transaction Does Not Exist)	-	Y	-	Y	-	P. 8-398
0482	IP Fax	-	"Loop Detected" Received: The IP Fax transmission / reception has failed due to a communication error. (Loop Detected)	-	Y	-	Y	-	P. 8-398
0483	IP Fax	-	"Too Many Hops" Received: The IP Fax transmission / reception has failed due to a communication error. (Too Many Hops)	-	Y	-	Y	-	P. 8-398

Error code	Classification	Message	Contents	Error code display media					Troubleshooting
				Panl	JL	ML	Noti	CSV	
0484	IP Fax	-	"Address Incomplete" Received: The IP Fax transmission / reception has failed due to a communication error. (Address Incomplete)	-	Y	-	Y	-	P. 8-399
0485	IP Fax	-	"Ambiguous" Received: The IP Fax transmission / reception has failed due to a communication error. (Ambiguous)	-	Y	-	Y	-	P. 8-399
0486	IP Fax	-	"Busy Here" Received: The IP Fax transmission / reception has failed due to a communication error. (Busy Here)	-	Y	-	Y	-	P. 8-399
0487	IP Fax	-	"Request Terminated" Received: The IP Fax transmission / reception has failed due to a communication error. (Request Terminated)	-	Y	-	Y	-	P. 8-399
0488	IP Fax	-	"Not acceptable here" Received: The IP Fax transmission / reception has failed due to a communication error. (Not acceptable here)	-	Y	-	Y	-	P. 8-399
0489	IP Fax	-	"Bad Event" Received: The IP Fax transmission / reception has failed due to a communication error. (Bad Event)	-	Y	-	Y	-	P. 8-400
0490	IP Fax	-	"Request Updated" Received: The IP Fax transmission / reception has failed due to a communication error. (Request Updated)	-	Y	-	Y	-	P. 8-400

Error code	Classification	Message	Contents	Error code display media					Troubleshooting
				Panl	JL	ML	Noti	CSV	
0491	IP Fax	-	"Request Pending" Received: The IP Fax transmission / reception has failed due to a communication error. (Request Pending)	-	Y	-	Y	-	P. 8-400
0493	IP Fax	-	"Undecipherable" Received: The IP Fax transmission / reception has failed due to a communication error. (Undecipherable)	-	Y	-	Y	-	P. 8-400
0494	IP Fax	-	"Security Agreement Required" Received: The IP Fax transmission / reception has failed due to a communication error. (Security Agreement Required)	-	Y	-	Y	-	P. 8-400
0500	IP Fax	-	"Internal Server Error" Received: The IP Fax transmission / reception has failed due to a communication error. (Internal Server Error)	-	Y	-	Y	-	P. 8-401
0501	IP Fax	-	"Not Implemented" Received: The IP Fax transmission / reception has failed due to a communication error. (Not Implemented)	-	Y	-	Y	-	P. 8-401
0502	IP Fax	-	"Bad Gateway" Received: The IP Fax transmission / reception has failed due to a communication error. (Bad Gateway)	-	Y	-	Y	-	P. 8-401



Error code	Classification	Message	Contents	Error code display media					Troubleshooting
				Panl	JL	ML	Noti	CSV	
0503	IP Fax	(Panl) Due to IP line traffic,It may take time to send. (ML) ITransmission takes time because IP line is crowded.	“Service Unavailable” Received: The IP Fax transmission / reception has failed due to a communication error. (Service Unavailable)	Y	Y	-	Y	-	P. 8-401
0504	IP Fax	-	“Gateway Time-out” Received: The IP Fax transmission / reception has failed due to a communication error. (Gateway Time-out)	-	Y	-	Y	-	P. 8-401
0505	IP Fax	-	“Version Not Supported” Received: The IP Fax transmission / reception has failed due to a communication error. (Version Not Supported)	-	Y	-	Y	-	P. 8-402
0513	IP Fax	-	“Message Too Large” Received: The IP Fax transmission / reception has failed due to a communication error. (Message Too Large)	-	Y	-	Y	-	P. 8-402
0580	IP Fax	-	“Precondition Failure” Received: The IP Fax transmission / reception has failed due to a communication error. (Precondition Failure)	-	Y	-	Y	-	P. 8-402
0600	IP Fax	-	“Busy Everywhere” Received: The IP Fax transmission / reception has failed due to a communication error. (Busy Everywhere)	-	Y	-	Y	-	P. 8-402
0603	IP Fax	-	“Decline” Received: The IP Fax transmission / reception has failed due to a communication error. (Decline)	-	Y	-	Y	-	P. 8-402

Error code	Classification	Message	Contents	Error code display media					Troubleshooting
				Panl	JL	ML	Noti	CSV	
0604	IP Fax	-	"Does Not Exist Anywhere" Received: The IP Fax transmission / reception has failed due to a communication error. (Does Not Exist Anywhere)	-	Y	-	Y	-	P. 8-403
0606	IP Fax	-	"Not Acceptable" Received: The IP Fax transmission / reception has failed due to a communication error. (Not Acceptable)	-	Y	-	Y	-	P. 8-403
4246	IP Fax	IP Fax license is not installed	IP Fax license is not installed: The license of the IP Fax has not been installed.	-	-	Y	-	-	P. 8-403
DA01	Fax	(Panl) Fax line1 is out of order. Reboot the machine. (ML) FAX Unit Line1 is broken. Please Contact Service Technician.	The FAX Unit of line 1 has been damaged: The FAX Unit of line 1 has been damaged or an abnormality has occurred in the interface between the systems.	Y	-	Y	-	-	P. 8-403
DA02	Fax	(Panl) Fax line2 is out of order. Reboot the machine. (ML) FAX Unit Line2 is broken. Please Contact Service Technician.	The FAX Unit of line 2 has been damaged: The FAX Unit of line 2 has been damaged or an abnormality has occurred in the interface between the systems.	Y	-	Y	-	-	P. 8-403

## 8.2.11 Error history

In the setting mode (08-9703), the latest twenty groups of error data will be displayed.

Display example

EA10	99999999	2013-07-11 17:05:32	064	064	2362_1000_0000_0_XXXXXXX
Error code	Total counter	YYYY-MM-DD HH:MM:SS	MMM	NNN	ABCD_EFHI_JLOP_Q_R
4 digits	8 digits	14 digits	3 digits	3 digits	23 digits

A	Paper source
	0: Not selected, 1: Bypass feed, 2: LCF, 3: Upper drawer, 4: Lower drawer, 5: PFP upper drawer, 6: PFP lower drawer, 7: Unused, 8: Unused
B	Paper size code
	0: A5/ST, 1: A5-R, 2: ST-R, 3: LT, 4: A4, 5: B5-R, 6: LT-R, 7: A4-R, 8: OTHER/UNIV, 9: B5, A: FOLIO/COMP, B: LG, C: B4, D: LD, E: A3, F: 13" LG, G: Unused, H: A6-R, I: Postcard, J: 8.5SQ, K: Unused, L: Unused, M: 8K, N: 16K-R, O: 16K, P: Envelope COM10, Q: Envelope DL, R: Envelope Monarch, S: Envelope (lengthwise, No. 3), T: Envelope (lengthwise, No. 4), U: Unused, V: Unused, Z: Not selected, a: Envelope Kaku-2
C	Sort mode/staple mode
	0: Non-sort/Non-staple, 1: Group, 2: Sort, 7: Front staple, 8: Double staple, 9: Rear staple, A: Saddle stitch, B: Center fold, C: Top Left, D: Top Right, E: Top Center, F: Left Center
D	ADF mode
	0: Unused, 1: AUTO FEED (SADF), 2: STACK FEED
E	APS/AMS mode
	0: Not selected, 1: APS, 2: AMS
F	Duplex mode
	Copy: 0: Single-sided/Single-sided, 1: Book, 2: Double-sided/Single-sided, 4: Double-sided/Duplex copying, 8: Single-sided/Duplex copying
	Printer 0: Single-sided, 8: Double-sided
	FAX 0: Single-sided, 8: Double-sided
	e-Filing 0: Single-sided, 8: Double-sided
H	List printing 0: Single-sided
	Image shift
I	0: Unused, 1: Book, 2: Left, 3: Right, 4: Top, 5: Bottom, 6: Book+Top, 7: Book+Bottom, 8: Left+Top, 9: Left+Bottom, A: Right+Top, B: Right+Bottom
	Editing
J	0: Unused, 1: Masking, 2: Trimming, 3: Mirror image, 4: Unused, 5: Positive/negative reverse
	Edge erase/Dual-page
K	0: Unused, 1: Edge erase, 2: Dual-page, 3: Edge erase & Dual-page
	Unused
L	Function
	0: Unused, 1: Copying, 2: FAX/Internet FAX transmission, 3: FAX/Internet FAX/E-mail reception printing, 4: Unused, 5: Printing/List print, 6: Scan/E-mail transmission
MMM	Primary scanning reproduction ratio (Display in hexadecimal)
	Mx256)+(Mx16)+M

NNN	Secondary scanning reproduction ratio (Display in hexadecimal)
	(Nx256)+(Nx16)+N
O	Mode
	0: Auto color, 1: Full color, 2: Black, 3: Unused, 4: Unused, 5: Gray scale (scan), 6: Unused, 7: Unused
P	Media type
	0: Plain paper, 1: Thick 1, 2: Thick 2, 3: Thick 3, 4: Unused, 5: Unused, 6: Unused, 7: Recycled paper, 8: Unused, 9: Unused, A: Thin paper, B: OHP film, C: Thick 1/ reverse, D: Thick 2/ reverse, E: Thick 3/ reverse, F: Unused, G: Unused, H: Unused, I: Envelope, J: Tab paper, K: Plain paper / reverse, L: Recycled paper / reverse, M: Thin paper / reverse, N: Unused, O: Unused, P: Envelope /reverse, Q: Thick, R: Thick / reverse, S to Z: Unused, a: User type 1, b: User type 2, c: User type 3, d: User type 4, e: User type 5, f: User type 6, g: User type 7, h: User type 8, i: User type 9, j: User type 10
Q	RADF size mixed
	0: Unused, 1: Size mixed, 2: Single-size document
R	Workflow ID: 10-digit ID

## 8.3 Diagnosis and Prescription for Each Error Code

### 8.3.1 Check item

Check item	Contents
Sensor check	<ul style="list-style-type: none"><li>• Check the sensor in the test mode.</li><li>• Check that there is no dust on the sensor.</li><li>• Check that the actuator is correctly operated.</li></ul>
Connector check	<ul style="list-style-type: none"><li>• Check that the connector is not disconnected.</li><li>• Check that the pins are not deformed and do not come off.</li><li>• Disconnect and reconnect the connector.</li></ul>
Harness check	<ul style="list-style-type: none"><li>• Check if the harnesses are open circuited.</li></ul>
Motor check	<ul style="list-style-type: none"><li>• Check the motor in the test mode.</li><li>• Check that there is no abnormality in the driving section.</li><li>• Check that there is no abnormality in the roller.</li></ul>
Board check	<ul style="list-style-type: none"><li>• Check if the board is short circuited or open circuited.</li></ul>

## 8.3.2 Paper exit jam

[E010] Jam not reaching the exit sensor

[E020] Stop jam at the exit sensor

Classification	Error content
Paper exit jam	[E010] The paper which has passed through the fuser unit does not reach the exit sensor. [E020] The trailing edge of the paper does not pass the exit sensor after its leading edge has reached this sensor.

Procedure	Check item	Result	Measures	Next Step
1	Open the Automatic duplexing unit. Is there any paper on the transport path?	Yes	Remove the paper.	
		No		2
2	Check if the reverse unit is installed properly.	Yes		3
		No	Be sure to perform correct installation ☞ P. 4-153 "4.11.1 Reverse unit <35ppm/45ppm/50ppm>"	
3	Is the exit sensor working? (Perform the input check in the test mode: FS-03-[ALL]OFF/[9]/[C])	Yes		4
		No	<ul style="list-style-type: none"> <li>• Check if the connector of the exit sensor is disconnected.</li> <li>• Check if the connector CN308 on the LGC board is disconnected.</li> <li>• Check if the connector pins are disconnected and the harnesses are open circuited.</li> <li>• Check if the conductor pattern on the LGC board is short circuited or open circuited.</li> <li>• Replace the exit sensor</li> <li>• Replace the LGC board</li> </ul>	
4	Is the registration roller clutch working?(Perform the output check in the test mode: FS-03-108/158)	Yes		5
		No	<ul style="list-style-type: none"> <li>• Check if the connector of the registration roller clutch is disconnected.</li> <li>• Check if the connector CN318 on the LGC board is disconnected.</li> <li>• Check if the connector pins are disconnected and the harnesses are open circuited.</li> <li>• Check if the conductor pattern on the LGC board is short circuited or open circuited.</li> <li>• Replace the registration roller clutch.</li> <li>• Replace the LGC board.</li> </ul>	
5	Registration roller		<ul style="list-style-type: none"> <li>• Check the registration roller. Replace it if it is worn out.</li> </ul>	

Parts to be replaced	Remark
Exit sensor	
LGC board	
Registration roller clutch	
Registration roller	

### 8.3.3 Paper transport jam

[E200] 1st drawer transport jam (paper not reaching the registration sensor)

[E210] 2nd drawer transport jam (paper not reaching the registration sensor)

[E300] PFP upper drawer transport jam (paper not reaching the registration sensor)

[E330] PFP lower drawer transport jam (paper not reaching the registration sensor)

[E3C0] LCF transport jam (paper not reaching the registration sensor)

Classification	Error content
Paper transport jam	[E200] [E210] The paper does not reach the registration sensor after it has passed the 1st transport sensor. [E300] Paper fed from the PFP upper drawer does not reach the registration sensor after it has passed through the 1st transport sensor. [E330] Paper fed from the PFP lower drawer does not reach the registration sensor after it has passed through the 1st transport sensor. [E3C0] Paper fed from the LCF does not reach the registration sensor after it has passed through the 1st transport sensor.

Procedure	Check item	Result	Measures	Next Step
1	Open the Automatic duplexing unit. Is there paper in front of the registration sensor?	Yes	Remove the paper.	
		No		2
2	Is the registration sensor working?(Perform the input check in the test mode: FS-03-[ALL]OFF/[9]/[A])	Yes		3
		No	<ul style="list-style-type: none"> <li>Check if the connector of the registration sensor is disconnected.</li> <li>Check if the connector CN318 on the LGC board is disconnected.</li> <li>Check if the connector pins are disconnected and the harnesses are open circuited</li> <li>Check if the conductor pattern on the LGC board is short circuited or open circuited.</li> <li>Replace the registration sensor.</li> <li>Replace the LGC board.</li> </ul>	
3	Are the (high-speed/low-speed) clutches working?(Perform the output check in the test mode: 03-203, 205)	Yes		4
		No	<ul style="list-style-type: none"> <li>Check if the connectors of the (high-speed/low-speed) transport clutches are disconnected.</li> <li>Check if the connector CN318 on the LGC board is disconnected.</li> <li>Check if the connector pins are disconnected and the harnesses are open circuited.</li> <li>Check if the conductor pattern on the LGC board is short circuited or open circuited.</li> <li>Replace the (high-speed/low-speed) transport clutches.</li> <li>Replace the LGC board.</li> </ul>	
4	Feed roller Separation roller Pick-up roller Transfer roller		<ul style="list-style-type: none"> <li>Check the condition of the feed roller, separation roller and pick-up roller of each paper source, and replace them if they are worn out.</li> <li>Check the transport roller. Replace it if it is worn out.</li> </ul>	

Parts to be replaced	Remark
Registration roller	
LGC board	
High-speed/low-speed transport clutches	
Feed roller	Replace it if it is worn out.
Separation roller	Replace it if it is worn out.
Pick-up roller	Replace it if it is worn out.
Transfer roller	Replace it if it is worn out.

**[E270] Bypass transport jam (paper not reaching the registration sensor)**

Classification	Error content
Paper transport jam	The paper does not reach the registration sensor after it has passed the 1st transport sensor.

Procedure	Check item	Result	Measures	Next Step
1	Open the Automatic duplexing unit. Is there paper in front of the registration sensor?	Yes	Remove the paper.	2
		No		
2	Is the registration sensor working?(Perform the input check in the test mode: FS-03-[ALL]OFF/[9]/[A])	Yes		3
		No	<ul style="list-style-type: none"> <li>• Check if the connector of the registration sensor is disconnected.</li> <li>• Check if the connector CN318 on the LGC board is disconnected.</li> <li>• Check if the connector pins are disconnected and the harnesses are open circuited.</li> <li>• Check if the conductor pattern on the LGC board is short circuited or open circuited.</li> <li>• Replace the registration sensor.</li> <li>• Replace the LGC board.</li> </ul>	
3	Is the bypass feed clutch working?(Perform the output check in the test mode: FS-03-204)	Yes		4
		No	<ul style="list-style-type: none"> <li>• Check if the connector of the bypass feed clutch is disconnected.</li> <li>• Check if the connector CN321 on the LGC board is disconnected.</li> <li>• Check if the connector pins are disconnected and the harnesses are open circuited.</li> <li>• Check if the conductor pattern on the LGC board is short circuited or open circuited.</li> <li>• Replace the bypass feed clutch.</li> <li>• Replace the LGC board.</li> </ul>	
4	Registration roller		<ul style="list-style-type: none"> <li>• Check the registration roller. Replace it if it is worn out.</li> </ul>	

Parts to be replaced	Remark
Registration sensor.	
LGC board	
Bypass feed clutch	
Registration roller	

**[E220] 2nd drawer transport jam (paper not reaching the 1st transport sensor)**

**[E310] PFP upper drawer transport jam (paper not reaching the 1st transport sensor)**

**[E340] PFP lower drawer transport jam (paper not reaching the 1st transport sensor)**

**[E3D0] LCF transport jam (paper not reaching the 1st transport sensor)**

Classification	Error content
Paper transport jam	<p>[E220] The paper does not reach the 1st transport sensor after it has passed the lower drawer feed sensor.</p> <p>[E310] Paper fed from the PFP upper drawer does not reach the 1st transport sensor after it has passed through the 2nd transport sensor.</p> <p>[E340] Paper fed from the PFP lower drawer does not reach the 1st transport sensor after it has passed through the PFP lower drawer paper feed sensor.</p> <p>[E3D0] Paper fed from the LCF does not reach the 1st transport sensor after it has passed through the 2nd transport sensor.</p>



Procedure	Check item	Result	Measures	Next Step
1	Open the Automatic duplexing unit. Is there paper in front of the 1st transport sensor?	Yes	Remove the paper.	2
		No		
2	Is the 1st transport sensor working?(Perform the input check in the test mode: FS-03-[ALL]OFF/[9]/[B])	Yes		3
		No	<ul style="list-style-type: none"> <li>• Check if the connector of the 1st transport sensor is disconnected. (J661, J659)</li> <li>• Check if the connector CN318 on the LGC board is disconnected.</li> <li>• Check if the connector pins are disconnected and the harnesses are open circuited.</li> <li>• Check if the conductor pattern on the LGC board is short circuited or open circuited.</li> <li>• Replace the 1st transport sensor.</li> <li>• Replace the LGC board.</li> </ul>	
3	Are the (high-speed/low-speed) transport clutches working?(Perform the output check in the test mode: 03-203, 205)	Yes		4
		No	<ul style="list-style-type: none"> <li>• Check if the connectors of the (high-speed/low-speed) transport clutches are disconnected.</li> <li>• Check if the connector CN318 on the LGC board is disconnected.</li> <li>• Check if the connector pins are disconnected and the harnesses are open circuited.</li> <li>• Check if the conductor pattern on the LGC board is short circuited or open circuited.</li> <li>• Replace the (high-speed/low-speed) transport clutches.</li> <li>• Replace the LGC board.</li> </ul>	
4	Feed roller Separation roller Pick-up roller Transfer roller		<ul style="list-style-type: none"> <li>• Check the condition of the feed roller, separation roller and pick-up roller of each paper source, and replace them if they are worn out.</li> <li>• Check the transport roller. Replace it if it is worn out.</li> </ul>	

Parts to be replaced	Remark
1st transport sensor	
LGC board	
Feed roller	Replace it if it is worn out.
Separation roller	Replace it if it is worn out.
Pick-up roller	Replace it if it is worn out.
Transfer roller	Replace it if it is worn out.

**[E320] PFP upper drawer transport jam (paper not reaching the 2nd transport sensor)**  
**[E350] PFP lower drawer transport jam (paper not reaching the 2nd transport sensor)**  
**[E3E0] LCF transport jam (paper not reaching the 2nd transport sensor)**

Classification	Error content
Paper transport jam	<p>[E320] Paper fed from the PFP upper drawer does not reach the 2nd transport sensor after it has passed through the PFP upper drawer paper feed sensor.</p> <p>[E350] Paper fed from the PFP lower drawer does not reach the 2nd transport sensor after it has passed through the PFP upper drawer paper feed sensor.</p> <p>[E3E0] Paper fed from the LCF does not reach the 2nd transport sensor after it has passed through the LCF paper feed sensor.</p>

Procedure	Check item	Result	Measures	Next Step
1	Open the side cover. Is there paper in front of the 2nd transport sensor?	Yes	Remove the paper.	
		No		2
2	Is the 2nd transport sensor working?(Perform the input check in the test mode: FS-03-[F2]ON/[4]/[D])	Yes		3
		No	<ul style="list-style-type: none"> <li>Check if the connector of the 2nd transport sensor is disconnected.</li> <li>Check if the connector CN318 on the LGC board is disconnected.</li> <li>Check if the connector pins are disconnected and the harnesses are open circuited.</li> <li>Check if the conductor pattern on the LGC board is short circuited or open circuited.</li> <li>Replace the 2nd transport sensor.</li> <li>Replace the LGC board.</li> </ul>	
3	Is the PFP transport clutch working? (Perform the output check in the test mode: 03-225)	Yes		4
		No	<ul style="list-style-type: none"> <li>Check if the connector of the PFP transport clutch is disconnected.</li> <li>Check if any of the connectors CN241 and CN247 on the PFP board is disconnected.</li> <li>Check if the connector CN315 on the LGC board is disconnected.</li> <li>Check if the connector pins are disconnected and the harnesses are open circuited.</li> <li>Check if the conductor patterns on the PFP board and LGC board are short circuited or open circuited.</li> <li>Replace the PFP transport clutch.</li> <li>Replace the PFP board.</li> <li>Replace the LGC board.</li> </ul>	
4	Feed roller Separation roller] Pick-up roller Transfer roller		<ul style="list-style-type: none"> <li>Check the condition of the feed roller, separation roller and pick-up roller of each paper source, and replace them if they are worn out.</li> <li>Check the transport roller. Replace it if it is worn out.</li> </ul>	

Parts to be replaced	Remark
2nd transport sensor.	
LGC board	
PFP transport clutch	
PFP board	
Feed roller	Replace it if it is worn out.
Separation roller	Replace it if it is worn out.
Pick-up roller	Replace it if it is worn out.
Transfer roller	Replace it if it is worn out.

### [E510] Paper not reaching the ADU entrance sensor jam

Classification	Error content
Paper transport jam	The paper does not reach the ADU entrance sensor after it is switchbacked in the exit section.

Procedure	Check item	Result	Measures	Next Step
1	Open the ADU. Is there any paper in front of the ADU entrance sensor?	Yes	Remove the paper.	
		No		2

Procedure	Check item	Result	Measures	Next Step
2	Is the ADU entrance sensor working? (Perform the input check in the test mode: FS-03-[ALL]OFF/[9]/[G])	Yes		3
		No	<ul style="list-style-type: none"> <li>Check if the connector of the ADU entrance sensor is disconnected.</li> <li>Check if the connector CN321 on the LGC board is disconnected.</li> <li>Check if the connector pins are disconnected and the harnesses are open circuited.</li> <li>Check if the conductor patterns on the ADU board and LGC board are short circuited or open circuited.</li> <li>Replace the ADU entrance sensor.</li> <li>Replace the ADU board.</li> <li>Replace the LGC board.</li> </ul>	
3	Is the exit motor / reverse motor (rotating in reverse) working? (Perform the output check in the test mode: FS-03-121/171)	Yes		4
		No	<p>[20ppm/25ppm/30ppm]</p> <ul style="list-style-type: none"> <li>Check if the connector of the exit motor is disconnected. (J609, J611)</li> <li>Check if the connector CN324 on the LGC board is disconnected.</li> <li>Check if the connector pins are disconnected and the harnesses are open circuited.</li> <li>Replace the exit motor.</li> <li>Replace the LGC board.</li> </ul> <p>[35ppm/45ppm/50ppm]</p> <ul style="list-style-type: none"> <li>Check if the connector of the reverse motor is disconnected. (J609, J611)</li> <li>Check if the connector CN307 on the LGC board is disconnected.</li> <li>Check if the connector pins are disconnected and the harnesses are open circuited.</li> <li>Replace the reverse motor.</li> <li>Replace the LGC board.</li> </ul>	
4	ADU		<ul style="list-style-type: none"> <li>Check the rollers in the ADU and the exit roller / upper exit roller / reverse roller of the equipment. Replace them if they are worn out.</li> </ul>	

Parts to be replaced	Remark
ADU entrance sensor	
LGC board	
Exit motor / Reverse motor	
Rollers in the ADU	
Exit roller / Upper exit roller / Reverse roller	Clean or replace it if it is worn out.

### [E520] Stop jam in the ADU

Classification	Error content
Paper transport jam	The paper does not reach the ADU exit sensor after it has passed the ADU entrance sensor.

Procedure	Check item	Result	Measures	Next Step
1	Open the ADU. Is there any paper in front of the ADU exit sensor?	Yes	Remove the paper.	
		No		2


Procedure	Check item	Result	Measures	Next Step
2	Is the ADU exit sensor working?(Perform the input check in the test mode: FS-03-[ALL]OFF/[9]/[H])	Yes		3
		No	<ul style="list-style-type: none"> <li>• Check if the connector of the ADU exit sensor is disconnected.</li> <li>• Check if the connector CN321 on the LGC board is disconnected.</li> <li>• Check if the connector pins are disconnected and the harnesses are open circuited.</li> <li>• Check if the conductor patterns on the LGC board or ADU board are short circuited or open circuited.</li> <li>• Replace the ADU exit sensor.</li> <li>• Replace the ADU board.</li> <li>• Replace the LGC board.</li> </ul>	
3	Is the ADU motor working? (Perform the output check in the test mode: FS-03-110/160)	Yes		4
		No	<ul style="list-style-type: none"> <li>• Check if the connector of the ADU motor is disconnected.</li> <li>• Check if the connector CN420 and CN422 on the ADU board is disconnected.</li> <li>• Check if the connector CN321 on the LGC board is disconnected.</li> <li>• Check if the connector pins are disconnected and the harnesses are open circuited.</li> <li>• Check if the conductor patterns on the LGC board and ADU board are short circuited or open circuited.</li> <li>• Replace the ADU motor.</li> <li>• Replace the ADU board.</li> <li>• Replace the LGC board.</li> </ul>	
4	ADU		<ul style="list-style-type: none"> <li>• Check the rollers in the ADU. Replace them if they are worn out.</li> </ul>	


Parts to be replaced	Remark
ADU exit sensor	
ADU motor	
LGC board	
ADU exit sensor	
ADU board	
Rollers in the ADU	Replace it if it is worn out.
Pressure spring	Replace if pressurization is insufficient.

### [E570] Jam not reaching the reverse sensor

### [E580] Stop jam at the reverse sensor

Classification	Error content
Paper transport jam	<p>[E570] The paper which has passed the exit sensor does not reach the reverse sensor.</p> <p>[E580] The trailing edge of the paper does not pass the reverse sensor after its leading edge has reached this sensor.</p>

Procedure	Check item	Result	Measures	Next Step
1	Checking of paper		<ul style="list-style-type: none"> <li>• Open the ADU and remove paper if there is any on the transport path.</li> <li>* If the error still occurs, check the following:</li> </ul>	2
2	Check if the reverse unit is installed properly.	Yes		3
		No	Be sure to perform correct installation  P. 4-153 "4.11.1 Reverse unit <35ppm/45ppm/50ppm>"	

Procedure	Check item	Result	Measures	Next Step
3	Check if the fuser unit is installed properly.	Yes		4
		No	Be sure to perform correct installation  P. 8-442 "8.5.26 Image skewing on paper trailing edge"	
4	Is the reverse sensor working? (Perform the input check in the test mode: FS-03-[ALL]OFF/[9]/[D])	Yes		5
		No	<ul style="list-style-type: none"> <li>• Check if the connector pins are disconnected or the harnesses are open circuited between the reverse sensor and the connector on the LGC board. Correct if there is any (CN321, CN420, CN421) abnormality.</li> <li>• Check if the connector pins are disconnected or the harnesses are open circuited between the reverse sensor and the connector on the LGC board. Correct if there is any (CN321, CN420, CN421) abnormality.</li> <li>• Check if the conductor patterns on the LGC board or ADU board are short circuited or open circuited.</li> <li>• Replace the reverse sensor.</li> <li>• Replace the ADU board.</li> <li>• Replace the LGC board.</li> </ul>	
5	Is the reverse gate working? (Perform the output check in the test mode: FS-03-222/223)	Yes		6
		No	<ul style="list-style-type: none"> <li>• Check if the connector pins are disconnected or the harnesses are open circuited between the reverse solenoid and the connector on the LGC board. Correct if there is any (CN307, J609, J610) abnormality.</li> <li>• Check if the conductor patterns on the LGC board is short circuited or open circuited.</li> <li>• Check if the gate guide is deformed.</li> <li>• Replace the reverse gate</li> <li>• Replace the reverse solenoid.</li> <li>• Replace the LGC board.</li> </ul>	
6	Is the reverse motor working? (Perform the output check in the test mode: FS-03-120/121)	Yes	Check the reverse roller and upper exit roller. Replace it if it is worn out.	
		No	<ul style="list-style-type: none"> <li>• Check if the connector pins are disconnected or the harnesses are open circuited between the reverse motor and the connector on the LGC board. Correct if there is any abnormality. (CN321, CN420, CN422)</li> <li>• Replace the reverse motor.</li> <li>• Replace the ADU board.</li> <li>• Replace the LGC board.</li> </ul>	

Parts to be replaced	Remark
Reverse sensor	
LGC board	
Reverse gate solenoid	
Reverse gate	
Reverse roller	
Upper exit roller	
Reverse motor	
ADU board	

**[EB50] Paper remaining on the transport path due to multiple feeding**

Classification	Error content
Paper transport jam	The multiple feeding of preceding paper caused the misfeeding of upcoming paper.

When the paper is fed from the upper drawer:

Procedure	Check item	Result	Measures	Next Step
1	ADU		Open the ADU and remove paper if there is any on the transport path.	2
2	Is the registration sensor working? (Perform the input check: FS-03-[ALL]OFF/[9]/[A])	Yes	Check the rollers. Replace them if they are worn out	3
		No	Replace the registration sensor.	3
3	LGC board		<ul style="list-style-type: none"> <li>Check if the connector CN318 on the LGC board is disconnected.</li> <li>Check if the connector pins are disconnected or the harnesses are open circuited. (J659, J660)</li> <li>Check if the conductor patterns on the LGC board are short circuited or open circuited.</li> </ul>	4
4	1st drawer feed clutch		Harness check (CN316, J666) Connector check	

Parts to be replaced	Remark
Registration sensor	
LGC board	
Rollers on the transport path	Replace it if it is worn out.
1st drawer feed clutch	

When the paper is fed from the bypass tray:

Procedure	Check item	Result	Measures	Next Step
1	ADU		Open the ADU and remove paper if there is any on the transport path.	2
2	Is the 1st transport sensor working? (Perform the input check: FS-03-[ALL]OFF/[9]/[B])	Yes		3
		No	Replace the 1st transport sensor.	3
3	Is the registration sensor working? (Perform the input check in the test mode: FS-03-[ALL]OFF/[9]/[A])	Yes	Check the rollers. Replace them if they are worn out	4
		No	Replace the registration sensor.	4
4	LGC board		<ul style="list-style-type: none"> <li>Check if the connector CN318 on the LGC board is disconnected.</li> <li>Check if the connector pins are disconnected or the harnesses are open circuited. (J659, J660, J661)</li> <li>Check if the conductor patterns on the LGC board are short circuited or open circuited.</li> <li>Replace the LGC board.</li> </ul>	5
5	Bypass feed clutch		Harness check (CN321, J699, J696) Connector check	

Parts to be replaced	Remark
1st transport sensor	
LGC board	
Registration sensor	
Rollers on the transport path	Replace it if it is worn out.
Bypass feed clutch	

When the paper is fed from the lower drawer:

Procedure	Check item	Result	Measures	Next Step
1	ADU		Open the ADU and remove paper if there is any on the transport path.	2
2	Is the registration sensor working? (Perform the input check: FS-03-[ALL]OFF/[9]/[A])	Yes	Check the rollers. Replace them if they are worn out	3
		No	Replace the registration sensor.	3
3	LGC board		<ul style="list-style-type: none"> <li>Check if the connector CN318 on the LGC board is disconnected.</li> <li>Check if the connector pins are disconnected or the harnesses are open circuited. (J659, J660)</li> <li>Check if the conductor patterns on the LGC board are short circuited or open circuited.</li> <li>Replace the LGC board.</li> </ul>	4
4	Transport clutch (H)		Harness check (CN318, J665) Connector check	5
5	Transport clutch (L)		Harness check (CN318, J664) Connector check	

Parts to be replaced	Remark
Registration sensor	
LGC board	
Rollers on the transport path	Replace it if it is worn out.
Transport clutch (H)	
Transport clutch (L)	

When the paper is fed from the PFP or LCF

Procedure	Check item	Result	Measures	Next Step
1	Feed cover		Open the feed cover and remove paper if there is any on the transport path.	2
2	Is the 2nd transport sensor working? (Perform the input check: FS-03-[F2]ON/[4]/[D])	Yes	Check the rollers. Replace them if they are worn out	3
		No	Replace the 2nd transport sensor.	3
3	LGC board		<ul style="list-style-type: none"> <li>Check if the connector CN318 on the LGC board is disconnected.</li> <li>Check if the connector pins are disconnected or the harnesses are open circuited. (J686, J688)</li> <li>Check if the conductor patterns on the LGC board are short circuited or open circuited.</li> <li>Replace the LGC board.</li> </ul>	4
4	Transport clutch (H)		Harness check (CN318, J665) Connector check	5
5	Transport clutch (L)		Harness check (CN318, J664) Connector check	

Parts to be replaced	Remark
LGC board	
2nd transport sensor	
Rollers on the transport path	Replace it if it is worn out.
Transport clutch (H)	
Transport clutch (L)	

**[EB60] Paper remaining on the transport path due to multiple feeding**

Classification	Error content
Paper transport jam	The multiple feeding of preceding paper caused the misfeeding of upcoming paper.

Procedure	Check item	Result	Measures	Next Step
1	Open the Automatic duplexing unit. Is there any paper in front of the registration sensor?	Yes	Remove the paper.	2
		No		
2	Is the registration sensor working?(Perform the input check in the test mode: FS-03-[ALL]OFF/[9]/[A])	Yes		3
		No	<ul style="list-style-type: none"> <li>• Clean the registration sensor.</li> <li>• Check if the connector CN318 on the LGC board is disconnected.</li> <li>• Check if the connector of the registration sensor is disconnected. (J659, J660)</li> <li>• Check if the connector pins are disconnected and the harnesses are open circuited.</li> <li>• Check if the conductor pattern on the LGC board is short circuited or open circuited.</li> <li>• Replace the registration sensor.</li> <li>• Replace the LGC board.</li> </ul>	
3	Roller		<ul style="list-style-type: none"> <li>• Check the rollers. Replace them if they are worn out.</li> </ul>	

Parts to be replaced	Remark
Registration sensor	
LGC board	
Rollers on the transport path	Replace it if it is worn out.

**[E360] PFP lower drawer transport jam (paper not reaching the PFP upper drawer feed sensor)**

Classification	Error content
Paper transport jam	Paper fed from the PFP lower drawer does not reach the PFP upper drawer paper feed sensor after it has passed through the PFP lower drawer paper feed sensor.

Procedure	Check item	Result	Measures	Next Step
1	Open the PFP side cover. Is there any paper in front of the PFP upper drawer feed sensor?	Yes	Remove the paper.	2
		No		
2	Is the PFP upper drawer feed sensor working?(Perform the input check in the test mode: FS-03-[F2]ON/[0]/[C])	Yes		3
		No	<ul style="list-style-type: none"> <li>• Check if the connector of the PFP upper drawer feed sensor is disconnected.</li> <li>• Check if either of the connectors CN247, J959 or J975 on the PFP board is disconnected.</li> <li>• Check if the connector CN318 on the LGC board is disconnected.</li> <li>• Check if the connector pins are disconnected and the harnesses are open circuited.</li> <li>• Check if the conductor patterns on the PFP board and LGC board are short circuited or open circuited.</li> <li>• Replace the PFP upper drawer feed sensor.</li> <li>• Replace the PFP board.</li> <li>• Replace the LGC board.</li> </ul>	



Procedure	Check item	Result	Measures	Next Step
3	Is the PFP feed clutch working? (Perform the output check in the test mode: FS-03-226, FS-03-228)	Yes		4
		No	<ul style="list-style-type: none"> <li>• Check if the connector of the PFP transport clutch is disconnected.</li> <li>• Check if any of the connectors CN241, CN247 or J957 on the PFP board is disconnected.</li> <li>• Check if the connector CN315 on the LGC board is disconnected.</li> <li>• Check if the connector pins are disconnected and the harnesses are open circuited.</li> <li>• Check if the conductor patterns on the PFP board and LGC board are short circuited or open circuited.</li> <li>• Replace the PFP transport clutch.</li> <li>• Replace the PFP board.</li> <li>• Replace the LGC board.</li> </ul>	
4	Feed roller Separation roller Pick-up roller PFP transfer roller		<ul style="list-style-type: none"> <li>• Check the condition of the feed roller, separation roller and pick-up roller of each paper source, and replace them if they are worn out.</li> <li>• Check the PFP transport roller. Replace it if it is worn out.</li> </ul>	

Parts to be replaced	Remark
PFP upper drawer feed sensor	
PFP board	
LGC board	
PFP transport clutch	
Feed roller	Replace it if it is worn out.
Separation roller	Replace it if it is worn out.
Pick-up roller	Replace it if it is worn out.
PFP transport roller	Replace it if it is worn out.

### 8.3.4 Paper misfeeding

#### [E110] ADU misfeeding (paper not reaching the registration sensor)

Classification	Error content
Paper misfeeding	The paper which has passed through ADU does not reach the registration sensor during duplex printing.

Procedure	Check item	Result	Measures	Next Step
1	Open the ADU. Is there any paper in front of the registration sensor?	Yes	Remove the paper.	
		No		2
2	Is the registration sensor working?(Perform the input check in the test mode: FS-03-[ALL]OFF/[9]/[A])	Yes		3
		No	<ul style="list-style-type: none"> <li>• Check if the connector of the 1st transport sensor is disconnected.</li> <li>• Check if the connector CN318 on the LGC board is disconnected.</li> <li>• Check if the connector pins are disconnected and the harnesses are open circuited.</li> <li>• Check if the conductor pattern on the LGC board is short circuited or open circuited.</li> <li>• Replace the 1st registration sensor.</li> <li>• Replace the LGC board.</li> </ul>	
3	Is the ADU clutch working? (Perform the output check in the test mode: FS-03-110/160)	Yes		4
		No	<ul style="list-style-type: none"> <li>• Check if the connector of the ADU motor is disconnected. (J691)</li> <li>• Check if the connector CN321 on the LGC board is disconnected.</li> <li>• Check if the connector CN422 and CN420 on the ADU board is disconnected.</li> <li>• Check if the connector pins are disconnected and the harnesses are open circuited.</li> <li>• Check if the conductor pattern on the LGC board is short circuited or open circuited.</li> <li>• Replace the ADU motor.</li> <li>• Replace the LGC board.</li> <li>• Replace the ADU board.</li> </ul>	
4	Rollers in the ADU		Check the rollers in the ADU. Replace them if they are worn out.	

Parts to be replaced	Remark
ADU motor	
LGC board	
ADU board	
Rollers in the ADU	

#### [E120] Bypass misfeeding (paper not reaching the 1st transport sensor)

Classification	Error content
Paper misfeeding	The paper fed from the bypass tray does not reach the 1st transport sensor.

Procedure	Check item	Result	Measures	Next Step
1	Open the Automatic duplexing unit. Is there any paper in front of the 1st transport sensor?	Yes	Remove the paper.	
		No		2

Procedure	Check item	Result	Measures	Next Step
2	Is the 1st transport sensor working?(Perform the input check in the test mode: FS-03-[ALL]OFF/[9]/[B])	Yes		3
		No	<ul style="list-style-type: none"> <li>Check if the connector of the 1st transport sensor is disconnected. (J661, J659)</li> <li>Check if the connector CN316 on the LGC board is disconnected.</li> <li>Check if the connector pins are disconnected and the harnesses are open circuited.</li> <li>Check if the conductor pattern on the LGC board is short circuited or open circuited.</li> <li>Replace the 1st transport sensor.</li> <li>Replace the LGC board.</li> </ul>	
3	Is the bypass feed clutch working? (Perform the output check in the test mode: 03-204)Is the bypass paper sensor working? (Perform the input check in the test mode: FS-03-[ALL]OFF/[2]/[E])	Yes		4
		No	<ul style="list-style-type: none"> <li>Check if the connector of the bypass feed clutch and bypass paper sensor are disconnected. (J695, J696, J699)</li> <li>Check if the connector CN321 on the LGC board is disconnected.</li> <li>Check if the connector pins are disconnected and the harnesses are open circuited.</li> <li>Check if the conductor pattern on the LGC board is short circuited or open circuited.</li> <li>Replace the bypass feed clutch and bypass paper sensor.</li> <li>Replace the LGC board.</li> </ul>	
4	Bypass feed roller Separation pad		Check the bypass feed roller and separation roller. Replace them if they are worn out.	

Parts to be replaced	Remark
1st transport sensor	
LGC board	
Bypass feed clutch	
Bypass paper sensor	
Bypass feed roller	Replace it if it is worn out.
Bypass separation roller	Replace it if it is worn out.

### [E130] 1st drawer misfeeding (paper not reaching the 1st drawer feed sensor)

Classification	Error content
Paper misfeeding	The paper fed from the 1st drawer does not reach the 1st drawer feed sensor.

Procedure	Check item	Result	Measures	Next Step
1	Open the Automatic duplexing unit. Is there any paper in front of the 1st transport sensor?	Yes	Remove the paper.	
		No		2
2	Is the 1st transport sensor working?(Perform the input check in the test mode: FS-03-[ALL]OFF/[9]/[B])	Yes		3
		No	<ul style="list-style-type: none"> <li>Check if the connector of the 1st transport sensor is disconnected. (J661, J659)</li> <li>Check if the connector CN318 on the LGC board is disconnected.</li> <li>Check if the connector pins are disconnected and the harnesses are open circuited.</li> <li>Check if the conductor pattern on the LGC board is short circuited or open circuited.</li> <li>Replace the 1st transport sensor.</li> <li>Replace the LGC board.</li> </ul>	

Procedure	Check item	Result	Measures	Next Step
3	Is the 1st drawer feed clutch working?(Perform the output check in the test mode: FS-03-201)	Yes		4
		No	<ul style="list-style-type: none"> <li>Check if the connector of the 1st drawer feed clutch is disconnected. (J666)</li> <li>Check if the connector CN316 on the LGC board is disconnected.</li> <li>Check if the connector pins are disconnected and the harnesses are open circuited.</li> <li>Check if the conductor pattern on the LGC board is short circuited or open circuited.</li> <li>Replace the 1st drawer feed clutch.</li> <li>Replace the LGC board.</li> </ul>	
4	1st drawer feed roller Separation roller Pick-up roller		Check the 1st drawer feed roller, separation roller and pick-up roller. Replace them if they are worn out.	

Parts to be replaced	Remark
1st transport sensor.	
LGC board	
1st drawer feed clutch	
1st drawer feed roller	Replace it if it is worn out.
1st drawer separation roller	Replace it if it is worn out.
1st drawer pick-up roller	Replace it if it is worn out.

#### [E140] 2nd drawer misfeeding (paper not reaching the 2nd drawer feed sensor)

Classification	Error content
Paper misfeeding	The paper fed from the 2nd drawer does not reach the 2nd drawer feed sensor.

Procedure	Check item	Result	Measures	Next Step
1	Open the feed cover. Is there any paper in front of the 2nd transport sensor?	Yes	Remove the paper.	
		No		2
2	Is the 2nd transport sensor working?(Perform the input check in the test mode: FS-03-[F2]ON/[4]/[D])	Yes		3
		No	<ul style="list-style-type: none"> <li>Check if the connector of the 2nd transport sensor is disconnected. (J676)</li> <li>Check if the connector CN318 on the LGC board is disconnected.</li> <li>Check if the connector pins are disconnected and the harnesses are open circuited.</li> <li>Check if the conductor pattern on the LGC board is short circuited or open circuited.</li> <li>Replace the 2nd transport sensor.</li> <li>Replace the LGC board.</li> </ul>	
3	Is the 2nd drawer feed clutch working?(Perform the output check in the test mode: FS-03-202)	Yes		4
		No	<ul style="list-style-type: none"> <li>Check if the connector of the 2nd drawer feed clutch is disconnected.</li> <li>Check if the connector CN316 on the LGC board is disconnected.</li> <li>Check if the connector pins are disconnected and the harnesses are open circuited.</li> <li>Check if the conductor pattern on the LGC board is short circuited or open circuited.</li> <li>Replace the 2nd drawer feed clutch.</li> <li>Replace the LGC board.</li> </ul>	
4	2nd drawer feed roller Separation roller Pick-up roller		Check the 2nd drawer feed roller, separation roller and pick-up roller. Replace them if they are worn out.	

Parts to be replaced	Remark
2nd transport sensor	
LGC board	
2nd drawer feed clutch	
2nd drawer feed roller	Replace it if it is worn out.
2nd drawer separation roller	Replace it if it is worn out.
2nd drawer pick-up roller	Replace it if it is worn out.

### [E150] PFP upper drawer misfeeding (paper not reaching the PFP upper drawer feed sensor)

Classification	Error content
Paper misfeeding	The paper fed from the PFP upper drawer does not reach the PFP upper drawer feed sensor.

Procedure	Check item	Result	Measures	Next Step
1	Open the PFP side cover. Is there any paper in front of the PFP upper drawer feed sensor?	Yes	Remove the paper.	2
		No		
2	Is the PFP upper drawer feed sensor working?(Perform the input check in the test mode: FS-03-[F2]ON/[0]/[C])	Yes		3
		No	<ul style="list-style-type: none"> <li>• Check if the connector of the PFP upper drawer feed sensor is disconnected.</li> <li>• Check if either of the connectors CN241 or CN247 on the PFP board is disconnected.</li> <li>• Check if the connector CN315 on the LGC board is disconnected.</li> <li>• Check if the connector pins are disconnected and the harnesses are open circuited.</li> <li>• Check if the conductor patterns on the PFP board and LGC board are short circuited or open circuited.</li> <li>• Replace the PFP upper drawer feed sensor.</li> <li>• Replace the PFP board.</li> <li>• Replace the LGC board.</li> </ul>	
3	Is the PFP upper drawer feed clutch working?(Perform the output check in the test mode: FS-03-226)	Yes		4
		No	<ul style="list-style-type: none"> <li>• Check if the connector of the PFP upper drawer feed clutch is disconnected.</li> <li>• Check if any of the connectors CN241 and CN246 on the PFP board is disconnected.</li> <li>• Check if the connector CN315 on the LGC board is disconnected.</li> <li>• Check if the connector pins are disconnected and the harnesses are open circuited.</li> <li>• Check if the conductor patterns on the PFP board and LGC board are short circuited or open circuited.</li> <li>• Replace the PFP upper drawer feed clutch.</li> <li>• Replace the PFP board.</li> <li>• Replace the LGC board.</li> </ul>	
4	PFP upper drawer feed roller Separation roller Pick-up roller		Check the PFP upper drawer feed roller, separation roller and pick-up roller. Replace them if they are worn out.	

Parts to be replaced	Remark
PFP upper drawer feed sensor	
PFP board	
LGC board	
PFP upper drawer feed clutch	

Parts to be replaced	Remark
PFP upper drawer feed roller	Replace it if it is worn out.
PFP upper drawer separation roller	Replace it if it is worn out.
PFP upper drawer pick-up roller	Replace it if it is worn out.

### [E160] PFP lower drawer misfeeding (paper not reaching the PFP lower drawer feed sensor)

Classification	Error content
Paper misfeeding	The paper fed from the PFP lower drawer does not reach the PFP lower drawer feed sensor.

Procedure	Check item	Result	Measures	Next Step
1	Open the PFP side cover. Is there any paper in front of the PFP lower drawer feed sensor?	Yes	Remove the paper.	2
		No		
2	Is the PFP lower drawer feed sensor working?(Perform the input check in the test mode: FS-03-[F2]ON/[0]/[D])	Yes		3
		No	<ul style="list-style-type: none"> <li>• Check if the connector of the PFP lower drawer feed sensor is disconnected.</li> <li>• Check if either of the connectors CN241 or CN247 on the PFP board is disconnected.</li> <li>• Check if the connector CN315 on the LGC board is disconnected.</li> <li>• Check if the connector pins are disconnected and the harnesses are open circuited.</li> <li>• Check if the conductor patterns on the PFP board and LGC board are short circuited or open circuited.</li> <li>• Replace the PFP lower drawer feed sensor.</li> <li>• Replace the PFP board.</li> <li>• Replace the LGC board.</li> </ul>	
3	Is the PFP lower drawer feed clutch working?(Perform the output check in the test mode: FS-03-228)	Yes		4
		No	<ul style="list-style-type: none"> <li>• Check if the connector of the PFP lower drawer feed clutch is disconnected.</li> <li>• Check if any of the connectors CN241 and CN246 on the PFP board is disconnected.</li> <li>• Check if the connector CN315 on the LGC board is disconnected.</li> <li>• Check if the connector pins are disconnected and the harnesses are open circuited.</li> <li>• Check if the conductor patterns on the PFP board and LGC board are short circuited or open circuited.</li> <li>• Replace the PFP lower drawer feed clutch.</li> <li>• Replace the PFP board.</li> <li>• Replace the LGC board.</li> </ul>	
4	PFP lower drawer feed roller Separation roller Pick-up roller		Check the PFP lower drawer feed roller, separation roller and pick-up roller. Replace them if they are worn out.	

Parts to be replaced	Remark
PFP lower drawer feed sensor.	
PFP board	
LGC board	
PFP lower drawer feed clutch	
PFP lower drawer feed roller,	Replace it if it is worn out.
PFP lower drawer separation roller	Replace it if it is worn out.
PFP lower drawer pick-up roller	Replace it if it is worn out.

**[E190] T-LCF misfeeding (paper not reaching the T-LCF transport sensor)**

Classification	Error content
Paper misfeeding	The paper fed from the T-LCF does not reach the T-LCF feed sensor.

Procedure	Check item	Result	Measures	Next Step
1	Open the LCF side cover. Is there any paper in front of the LCF transport sensor?	Yes	Remove the paper.	2
		No		
2	Is the LCF transport sensor working?(Perform the input check in the test mode: FS-03-[F1]ON/[9]/[F])	Yes		3
		No	<ul style="list-style-type: none"> <li>• Check if the connector of the LCF transport sensor is disconnected.</li> <li>• Check if either of the connectors CN1 or CN2 on the LCF board is disconnected.</li> <li>• Check if the connector CN315 on the LGC board is disconnected.</li> <li>• Check if the connector pins are disconnected and the harnesses are open circuited.</li> <li>• Check if the conductor patterns on the LCF board and LGC board are short circuited or open circuited.</li> <li>• Replace the LCF transport sensor.</li> <li>• Replace the LCF board.</li> <li>• Replace the LGC board.</li> </ul>	
3	Is the LCF feed clutch working? (Perform the output check in the test mode: FS-03-209)	Yes		4
		No	<ul style="list-style-type: none"> <li>• Check if the connector of the LCF feed clutch is disconnected.</li> <li>• Check if any of the connectors CN1 and CN6 on the LCF board is disconnected.</li> <li>• Check if the connector CN315 on the LGC board is disconnected.</li> <li>• Check if the connector pins are disconnected and the harnesses are open circuited.</li> <li>• Check if the conductor patterns on the LCF board and LGC board are short circuited or open circuited.</li> <li>• Replace the LCF feed clutch.</li> <li>• Replace the LCF board.</li> <li>• Replace the LGC board.</li> </ul>	
4	LCF feed roller Separation roller Pick-up roller		Check the LCF feed roller, separation roller and pick-up roller. Replace them if they are worn out.	

Parts to be replaced	Remark
LCF transport sensor	
LCF board	
LGC board	
LCF feed clutch	
LCF feed roller	Replace it if it is worn out.
LCF separation roller	Replace it if it is worn out.
LCF pick-up roller	Replace it if it is worn out.

### 8.3.5 Cover open jam

#### [E410] Front cover open jam

Classification	Error content
Cover open jam	The front cover has opened during printing.

Procedure	Check item	Result	Measures	Next Step
1	Is the front cover open?	Yes	Close the cover.	
		No		2
2	Is the front cover switch working?(Perform the input check in the test mode: FS-03-[ALL]OFF/[7]/[C])	Yes		3
		No	<ul style="list-style-type: none"> <li>• Check if the connector of the front cover switch is disconnected.</li> <li>• Check if the connector CN319 on the LGC board is disconnected.</li> <li>• Check if the connector pins are disconnected and the harnesses are open circuited.</li> <li>• Check if the conductor pattern on the LGC board is short circuited or open circuited.</li> <li>• Replace the front cover switch.</li> <li>• Replace the LGC board.</li> </ul>	
3	Is the voltage of 24V being supplied from the power supply unit?(Perform the input check in the test mode: FS-03-[ALL]OFF/[7]/[D])	Yes		4
		No	<ul style="list-style-type: none"> <li>• Check if the connector for 24 V power supply is disconnected.</li> <li>• Check if the connector CN301 on the LGC board is disconnected.</li> <li>• Check if the connector pins are disconnected and the harnesses are open circuited.</li> <li>• Check if the conductor pattern on the LGC board is short circuited or open circuited.</li> <li>• Replace the LGC board.</li> </ul>	
4	LGC board		Replace the LGC board.	

Parts to be replaced	Remark
Front cover switch	
LGC board	

#### [E420] PFP side cover open jam

Classification	Error content
Cover open jam	The PFP side cover has opened during printing.

Procedure	Check item	Result	Measures	Next Step
1	Is the PFP side cover open?	Yes	Remove the paper if there is any, then close the cover.	
		No		2



Procedure	Check item	Result	Measures	Next Step
2	Is the PFP side cover opening/closing switch working?(Perform the input check in the test mode: FS-03-[F2]ON/[0]/[A])	Yes		3
		No	<ul style="list-style-type: none"> <li>Check if the connector of the PFP side cover opening/closing switch is disconnected.</li> <li>Check if either of the connectors CN241 or CN247 on the PFP board is disconnected.</li> <li>Check if the connector CN315 on the LGC board is disconnected.</li> <li>Check if the connector pins are disconnected and the harnesses are open circuited.</li> <li>Check if the conductor patterns on the PFP board and LGC board are short circuited or open circuited.</li> <li>Replace the PFP side cover opening/closing switch.</li> <li>Replace the PFP board.</li> <li>Replace the LGC board.</li> </ul>	
3	Replacing board		<ul style="list-style-type: none"> <li>Replace the PFP board.</li> <li>Replace the LGC board.</li> </ul>	

Parts to be replaced	Remark
PFP side cover opening/closing switch	
PFP board	
LGC board	

### [E430] Duplexing unit cover open jam

Classification	Error content
Cover open jam	The duplexing unit cover has opened during printing.

Procedure	Check item	Result	Measures	Next Step
1	Is the ADU open?	Yes	Remove the paper if there is any, then close the ADU.	
		No		2
2	Is the ADU opening/closing switch working?(Perform the input check in the test mode: FS-03-[ALL]OFF/[7]/[A])	Yes		3
		No	<ul style="list-style-type: none"> <li>Check if the connector of the ADU opening/closing switch is disconnected.</li> <li>Check if the connector CN311 on the LGC board is disconnected.</li> <li>Check if the connector pins are disconnected and the harnesses are open circuited.</li> <li>Check if the conductor patterns on the LGC board are short circuited or open circuited.</li> <li>Replace the ADU opening/closing switch.</li> <li>Replace the LGC board.</li> </ul>	4
3	Replacing board		Replace the LGC board.	4
4	Switching regulator		Replace the switching regulator.	

Parts to be replaced	Remark
ADU opening/closing switch	
LGC board	
Switching regulator	

### [E440] Paper feed cover open jam

Classification	Error content
Cover open jam	The paper feed cover has opened during printing.

Procedure	Check item	Result	Measures	Next Step
1	Is the feed cover open?	Yes	Remove the paper if there is any, then close the cover.	
		No		
2	Is the feed cover opening/closing switch working?(Perform the input check in the test mode: FS-03-[F2]ON/[4]/[A])	Yes		3
		No	<ul style="list-style-type: none"> <li>• Check if the connector of the feed cover opening/closing switch is disconnected.</li> <li>• Check if the connector CN318 on the LGC board is disconnected.</li> <li>• Check if the connector pins are disconnected and the harnesses are open circuited.</li> <li>• Check if the conductor pattern on the LGC board is short circuited or open circuited.</li> <li>• Replace the feed cover opening/closing switch.</li> <li>• Replace the LGC board.</li> </ul>	
3	Replacing board		Replace the LGC board.	

Parts to be replaced	Remark
Feed cover opening/closing switch	
LGC board	

### [E450] LCF side cover open jam

Classification	Error content
Cover open jam	The LCF side cover has opened during printing.

Procedure	Check item	Result	Measures	Next Step
1	Is the LCF jam access cover open?	Yes	Remove the paper if there is any, then close the cover.	
		No		
2	Is the LCF jam access cover opening/closing switch working?(Perform the input check in the test mode: FS-03-[F1]ON/[9]/[A])	Yes		3
		No	<ul style="list-style-type: none"> <li>• Check if the connector of the LCF jam access cover opening/closing switch is disconnected.</li> <li>• Check if either of the connectors CN1 or CN7 on the LCF board is disconnected.</li> <li>• Check if the connector CN315 on the LGC board is disconnected.</li> <li>• Check if the connector pins are disconnected and the harnesses are open circuited.</li> <li>• Check if the conductor patterns on the LCF board and LGC board are short circuited or open circuited.</li> <li>• Replace the LCF jam access cover opening/closing switch.</li> <li>• Replace the LCF board.</li> <li>• Replace the LGC board.</li> </ul>	
3	Replacing board		<ul style="list-style-type: none"> <li>• Replace the LCF board.</li> <li>• Replace the LGC board.</li> </ul>	

Parts to be replaced	Remark
LCF jam access cover opening/closing switch	
LCF board	
LGC board	

### [E480] Bridge unit open jam

Classification	Error content
Cover open jam	The bridge unit has opened during printing.

Procedure	Check item	Result	Measures	Next Step
1	Is the bridge unit open?	Yes	Remove the paper if there is any, then close the unit.	
		No		2
2	Is the bridge unit opening/closing switch working?(Perform the input check in the test mode: FS-03-[ALL]OFF/[7]/[B])	Yes		3
		No	<ul style="list-style-type: none"> <li>Check if the connector of the bridge unit opening/closing switch is disconnected.</li> <li>Check if the connector CN311 on the LGC board is disconnected.</li> <li>Check if the connector pins are disconnected and the harnesses are open circuited.</li> <li>Check if the conductor pattern on the LGC board is short circuited or open circuited.</li> <li>Replace the bridge unit opening/closing switch.</li> <li>Replace the LGC board.</li> </ul>	
3	Replacing board		Replace the LGC board.	

Parts to be replaced	Remark
The bridge unit opening/closing switch	
LGC board	

### [E490] Job separator cover open jam

Classification	Error content
Cover open jam	The job separator cover has opened during printing.

Procedure	Check item	Result	Measures	Next Step
1	Is the JSP cover open?	Yes	Remove the paper if there is any, then close the cover.	
		No		2
2	Is the JSP cover switch working?(Perform the input check in the test mode: FS-03-[ALL]OFF/[7]/[B])	Yes		3
		No	<ul style="list-style-type: none"> <li>Check if the connector of the JSP cover switch is disconnected.</li> <li>Check if either of the connectors CN260 or CN261 on the JSP board is disconnected.</li> <li>Check if the connector CN311 on the LGC board is disconnected.</li> <li>Check if the connector pins are disconnected and the harnesses are open circuited.</li> <li>Check if the conductor patterns on the JSP board and LGC board are short circuited or open circuited.</li> <li>Replace the JSP cover switch.</li> <li>Replace the JSP board.</li> <li>Replace the LGC board.</li> </ul>	

Procedure	Check item	Result	Measures	Next Step
3	Replacing board		<ul style="list-style-type: none"> <li>• Replace the JSP board.</li> <li>• Replace the LGC board.</li> </ul>	

Parts to be replaced	Remark
JSP cover switch	
JSP board	
LGC board	

## 8.3.6 Other jam

### [E030] Power-ON jam

Classification	Error content
Other paper jam	The paper is remaining on the paper transport path when power is turned ON.

Procedure	Check item	Result	Measures	Next Step
1	Open the cover of the unit/ area whose picture is blinking on the control panel. Is there any paper on the transport path? (Refer to the following table.)	Yes	Remove the paper.	2
		No		
2	Is the sensor in the jamming area working? (Perform the input check in the test mode: refer to the following table.)	Yes		3
		No	<ul style="list-style-type: none"> <li>• Check if the connector of the sensor is disconnected.</li> <li>• Check if any of the connectors on the LGC board is disconnected.</li> <li>• Check if the connector pins are disconnected and the harnesses are open circuited.</li> <li>• Check if the conductor pattern on the LGC board is short circuited or open circuited.</li> <li>• Replace the sensor</li> <li>• Replace the LGC board.</li> </ul>	
3	LGC board		Replace the LGC board.	

Parts to be replaced	Remark
Sensor	Refer to the following table
LGC board	

Relation between the jamming area and the corresponding sensors and covers  
(If a jam is occurring in the ADU, LCF, PFP or JSP check the board in each unit.)

Jamming area	Cover	Sensor	Test mode / Input check
Registration area	Automatic duplexing unit	Registration sensor	FS-03-[ALL]OFF/[9]/[A]
		1st transport sensor	FS-03-[ALL]OFF/[9]/[B]
Exit area	Automatic duplexing unit	Exit sensor	FS-03-[ALL]OFF/[9]/[C]
ADU	ADU	ADU entrance sensor	FS-03-[ALL]OFF/[9]/[G]
		ADU exit sensor	FS-03-[ALL]OFF/[9]/[H]
Feeding area (Main unit)	Feed cover	2nd transport sensor	FS-03-[F2]ON/[4]/[D]
LCF	LCF side cover	LCF feed sensor	FS-03-[F1]ON/[9]/[F]
PFP	PFP side cover	PFP upper drawer feed sensor	FS-03-[F2]ON/[0]/[C]
		PFP lower drawer feed sensor	FS-03-[F2]ON/[0]/[D]
Bridge unit	Bridge unit	Bridge unit transport sensor-1	FS-03-[ALL]OFF/[0]/[A]
		Bridge unit transport sensor-2	FS-03-[ALL]OFF/[0]/[B]
JSP	JSP cover	JSP feed sensor	FS-03-[ALL]OFF/[0]/[A]


- [E061] Incorrect paper size setting for 1st drawer**
- [E062] Incorrect paper size setting for 2nd drawer**
- [E063] Incorrect paper size setting for PFP upper drawer**
- [E064] Incorrect paper size setting for PFP lower drawer**
- [E065] Incorrect paper size setting for bypass tray**

Classification	Error content
Other paper jam	<ul style="list-style-type: none"> <li>The size of paper in the drawer differs from size setting of the equipment.</li> <li>The size of paper in the bypass tray differs from size setting of the equipment.</li> </ul>

Check item	Measures
Paper size	<p>If any paper remains in the equipment or drawer, remove it. Match the paper size of the drawer setting and the one in the drawer.</p> <p>* Paper size detection is performed at the first sheet of paper when the drawer is opened or closed, or when the power of the equipment is turned ON.</p>

**[E550] Paper remaining jam on the transport path**

Classification	Error content
Other paper jam	Paper is remaining on the transport path when printing is finished (caused by a multiple paper feeding).

Procedure	Check item	Result	Measures	Next Step
1	Open the cover of the unit/ area whose picture is blinking on the control panel. Is there any paper on the transport path?	Yes	Remove the paper.	2
		No		
2	Check if the reverse unit is installed properly.	Yes		3
		No	Be sure to perform correct installation  P. 4-153 "4.11.1 Reverse unit <35ppm/45ppm/50ppm>"	
3	Is the sensor in the jamming area working? (Perform the input check in the test mode: refer to the following table)	Yes		4
		No	<ul style="list-style-type: none"> <li>Check if the connector of the sensor is disconnected.</li> <li>Check if any of the connectors on the LGC board is disconnected.</li> <li>Check if the connector pins are disconnected and the harnesses are open circuited.</li> <li>Check if the conductor pattern on the LGC board is short circuited or open circuited.</li> <li>Replace the sensor.</li> <li>Replace the LGC board.</li> </ul>	
4	LGC board		Replace the LGC board.	

Parts to be replaced	Remark
Sensor	Refer to the following table
LGC board	

Relation between the jamming area and the corresponding sensors/covers  
(If a jam is occurring in the ADU, LCF, PFP or JSP check the board in each unit.)

Jamming area	Cover	Sensor	Test mode/Input check
Registration area	Automatic duplexing unit	Registration sensor	FS-03-[ALL]OFF/[9]/[A]
		1st transport sensor	FS-03-[ALL]OFF/[9]/[B]
Exit area	Automatic duplexing unit	Exit sensor	FS-03-[ALL]OFF/[9]/[C]
ADU	ADU	ADU entrance sensor	FS-03-[ALL]OFF/[9]/[G]
		ADU exit sensor	FS-03-[ALL]OFF/[9]/[H]
Feeding area (Main unit)	Feed cover	2nd transport sensor	FS-03-[F2]ON/[4]/[D]
LCF	LCF side cover	LCF feed sensor	FS-03-[F1]ON/[9]/[F]
PFP	PFP side cover	PFP upper drawer feed sensor	FS-03-[F2]ON/[0]/[C]
		PFP lower drawer feed sensor	FS-03-[F2]ON/[0]/[D]
Bridge unit	Bridge unit	Bridge unit transport sensor-1	FS-03-[ALL]OFF/[0]/[A]
		Bridge unit transport sensor-2	FS-03-[ALL]OFF/[0]/[B]
JSP	JSP cover	JSP feed sensor	FS-03-[ALL]OFF/[0]/[A]
Finisher	Finisher door	Sensors in the finisher	-

**[E551] Paper remaining jam on the transport path (when a service call occurs)**

**[E552] Paper remaining jam on the transport path (when the cover is closed)**

Classification	Error content
Other paper jam	[E551] The paper is detected on the transport path when a service call occurs. [E552] The paper is detected on the transport path after the cover is opened and closed.

Step	Check Item	Result	Measures	Next Step
1	Jamming transport path		Open the cover of the unit/area whose picture is flashing on the control panel and remove any paper on the transport path.	
2	Sensor in the jamming area		<ul style="list-style-type: none"> <li>• Sensor check (Refer to the table below)</li> <li>• Harness check</li> <li>• Connector check</li> </ul>	
3	LGC board		<ul style="list-style-type: none"> <li>• Harness check</li> <li>• Connector check</li> <li>• Board check</li> </ul>	
	<b>Notes:</b> If the jam is occurring in the ADU, LCF or PFP, check the board in each unit.			

Parts to be replaced	Remark
Sensor in the jamming area	Refer to the table below.
LGC board	

Jamming area	Cover	Sensor	Test Mode/Input check
Paper path section	Side cover	Registration sensor	FS-03-[ALL]OFF/[9]/[A]
		1st transport sensor	FS-03-[ALL]OFF/[9]/[B]
Fuser	Fuser / paper exit unit	Exit sensor	FS-03-[ALL]OFF/[9]/[C]
		Reverse sensor	FS-03-[ALL]OFF/[9]/[D]
ADU	Duplexing unit Cover	ADU exit sensor	FS-03-[ALL]OFF/[9]/[H]
		ADU entrance sensor	FS-03-[ALL]OFF/[9]/[G]
Bypass unit	Duplexing unit	Bypass paper sensor	FS-03-[ALL]OFF/[2]/[E]

Jamming area	Cover	Sensor	Test Mode/Input check
Feeding area	Paper feed cover	LCF Transport sensor	FS-03-[F1]ON/[9]/[F]
		PFP lower drawer feed sensor	FS-03-[F2]ON/[0]/[D]
		PFP upper drawer feed sensor	FS-03-[F2]ON/[0]/[C]
		2nd drawer transport sensor	FS-03-[F2]ON/[4]/[D]
Bridge kit	Bridge unit cover	Bridge kit transport sensor-1	FS-03-[ALL]OFF/[0]/[A]
		Bridge kit transport sensor-2	FS-03-[ALL]OFF/[0]/[B]
Finisher	Finisher door	Sensors in the finisher	-

### [E090] Image data delay jam

Classification	Error item
Other paper jam	Image data to be printed cannot be prepared.

Check item	Measures
Paper path	<ul style="list-style-type: none"> <li>Remove the paper remained in front of the registration sensor.</li> <li>Check if the error is cleared by turning the power OFF and then back ON.</li> </ul>
Power	<ul style="list-style-type: none"> <li>Check if the error is cleared by turning the power OFF and then back ON.</li> </ul>
SYS board	<ul style="list-style-type: none"> <li>Connector check</li> <li>Main memory check</li> <li>Board check</li> </ul>
LGC board	<ul style="list-style-type: none"> <li>Connector check</li> <li>Board check</li> </ul>
HDD	<ul style="list-style-type: none"> <li>Connector check</li> <li>HDD check</li> </ul>
Main memory	<ul style="list-style-type: none"> <li>Check if the main memory is correctly connected to the connector on the SYS board.</li> </ul>

Parts to be replaced	Remarks
SYS board	
LGC board	
HDD	
Main memory	

### [E0A0] Image transport ready time-out jam

Classification	Error content
Other paper jam	Image data to be printed cannot be sent.

Check item	Measures
LGC board	<ul style="list-style-type: none"> <li>Flat cable check (SYS board - LGC board)</li> <li>Connector check (CN309)</li> <li>Board check</li> </ul>
SYS board	<ul style="list-style-type: none"> <li>Flat cable check (SYS board - LGC board)</li> <li>Connector check (CN133)</li> <li>Board check</li> </ul>

Parts to be replaced	Remark
LGC board	
SYS board	
Flat cable	



**[EAD0] Print end command time-out jam**

Classification	Error content
Other paper jam	The printing has not finished normally because of the communication error between the SYS board and LGC board at the end of printing.

Check item	Measures
Power	<ul style="list-style-type: none"><li>• Check if the error is cleared by turning the power OFF and then back ON.</li></ul>
SYS board	<ul style="list-style-type: none"><li>• Connector check</li><li>• Board check</li></ul>
LGC board	<ul style="list-style-type: none"><li>• Connector check</li><li>• Board check</li></ul>

Parts to be replaced	Remark
SYS board	
LGC board	

### 8.3.7 RADF jam

#### [E712] Jam not reaching the DSDF registration sensor

Classification	Error content
DSDF jam	The original fed from the original tray does not reach the DSDF registration sensor.

Check item	Measures
Original	Flatten the original if it is folded or excessively curled and place it again.
Roller	Clean the DSF pickup roller, DSDF feed roller and DSDF separation roller if they are stained.
DSDF registration sensor	<ul style="list-style-type: none"> <li>Check if the DSDF registration sensor is working properly. (Perform the input check: FS-03-[F2]ON/[7]/[H])</li> <li>Replace the DSDF registration sensor.</li> </ul>
Connector	Check if the connectors (J975, J950 and CN74) on the DSDF control PC board are disconnected from the DSDF registration sensor or the harnesses are open circuited. Correct if any.
DSDF control PC board	Replace the DSDF control PC board.

Parts to be replaced	Remark
Roller	DSF pickup roller, DSDF feed roller, DSDF separation roller
DSDF registration sensor	
DSDF control PC board	

#### [E712] Jam not reaching the original registration sensor

Classification	Error content
RADF jam	The original fed from the original feeding tray does not reach the registration sensor.

Check item	Measures
Pick-up roller Feed roller Separation roller	Clean them if there are stained.
Original registration sensor	<ul style="list-style-type: none"> <li>Sensor check (Perform the input check: FS-03-[F2]ON/[7]/[H])</li> <li>Connector check (CN74, J88, J86)</li> <li>Harness check</li> </ul>
RADF board	<ul style="list-style-type: none"> <li>Board check</li> <li>Connector check (CN74)</li> <li>Harness check</li> </ul>

Parts to be replaced	Remark
Original registration sensor	
RADF board	
Pick-up roller	Replace it if it is worn out
Feed roller	Replace it if it is worn out.
Separation roller	Replace it if it is worn out.

#### [E714] DSDF feed signal reception jam

Classification	Error content
DSDF jam	The feed signal from the equipment is received even though there is no original on the original tray.

Check item	Measures
Reproducing ability	Release the paper jam and reattempt copying or scanning.
DSDF empty sensor	<ul style="list-style-type: none"> <li>Check if the DSDF empty sensor is working properly. (Perform the input check: FS-03-[F2]ON/[7]/[B])</li> <li>Check if the connector (CN75) on the DSDF control PC board is disconnected from the DSDF empty sensor or the harnesses are open circuited. Correct if any.</li> <li>Replace the DSDF empty sensor.</li> </ul>
DSDF control PC board	Replace the DSDF control PC board.

Parts to be replaced	Remark
DSDF empty sensor	
DSDF control PC board	

### [E714] Feed signal reception jam

Classification	Error content
RADF jam	The feed signal from the equipment is received even though there is no original on the original tray.

Check item	Measures
Original Empty sensor	<ul style="list-style-type: none"> <li>Sensor check (Perform the input check: FS-03-[F2]ON/[7]/[B])</li> <li>Lever check</li> <li>Connector check (CN75, J92, J96)</li> <li>Harness check</li> </ul>
RADF board	<ul style="list-style-type: none"> <li>Board check</li> <li>Connector check (CN75)</li> <li>Harness check</li> </ul>

Parts to be replaced	Remark
Original Empty sensor	
RADF board	

### [E717] Original not reaching the DSDF original feed sensor jam

Classification	Error content
DSDF jam	The original does not reach the DSDF feed sensor even though original feeding has started.

Check item	Measures
DSDF feed sensor	<ul style="list-style-type: none"> <li>Check if the DSDF feed sensor is working properly. (Perform the input check: FS-03-[F2]ON/[8]/[E])</li> <li>Replace the DSDF feed sensor.</li> </ul>
Connector	Check if the connectors (J974, J950 and CN74) on the DSDF control PC board are disconnected from the DSDF feed sensor or the harnesses are open circuited. Correct if any.
DSDF feed motor	Check if the DSDF feed motor is working properly.
Connector	Check if the connectors (J990 and CN77) on the DSDF control PC board are disconnected from the DSDF feed motor or the harnesses are open circuited. Correct if any.
DSDF control PC board	Replace the DSDF control PC board.

Parts to be replaced	Remark
DSDF feed sensor	
DSDF feed motor	

Parts to be replaced	Remark
DSDF control PC board	

### [E718] Original setting jam / Original tray lift abnormality

**A paper jam which may occur when the original tray lift is working (before the original feeding operation)**

Classification	Error content
DSDF jam	The original tray lift has been driven to raise or lower and the DSDF tray lift upper limit sensor / DSDF tray lift lower limit sensor have not been turned ON within a specified time.

Check item	Measures
<ul style="list-style-type: none"> <li>When a paper jam has occurred after an original is set, during original feeding, during the initial operation or when an original is pulled out</li> </ul>	
Malfunction	<ul style="list-style-type: none"> <li>Check whether an operation to apply a load to the original tray has been performed while it is being raised or lowered.</li> <li>Check if there is a foreign matter in the tray lifting section. If there is any, remove it, open and then close the cover to release the paper jam status. If there is none, take the following measure.</li> </ul>
<ul style="list-style-type: none"> <li>When the original tray lift is being rising (When a paper jam has occurred after the original placed or during original feeding)</li> </ul>	
DSDF tray lift upper limit sensor	<p>There will be an abnormality in the DSDF tray lift upper limit sensor when an error occurs while the tray is rising. (Perform the input check: FS-03-[F2]ON/[6]/[E])</p> <ul style="list-style-type: none"> <li>Check if the sensor is damaged, the connector is disconnected or the harness is open circuited. If yes, replace any of them.</li> </ul>
<ul style="list-style-type: none"> <li>When the original tray lift is being lowering (When a paper jam has occurred if an original is pulled out during the initial operation or the operation itself)</li> </ul>	
DSDF tray lift lower limit sensor	<p>There will be an abnormality in the DSDF tray lift lower limit sensor when an error occurs while the tray is lowering. (Perform the input check: FS-03-[F2]ON/[6]/[F])</p> <ul style="list-style-type: none"> <li>Check if the sensor is damaged, the connector is disconnected or the harness is open circuited. If yes, replace any of them.</li> </ul>
<ul style="list-style-type: none"> <li>When the rising or lowering of the original tray lift does not work</li> </ul>	
DSDF tray-up clutch	<p>There will be an abnormality in the DSDF tray-up clutch if it does not work.</p> <ul style="list-style-type: none"> <li>Check if the clutch is damaged, the connector is disconnected or the harness is open circuited. If yes, replace any of them.</li> </ul>
DSDF separation motor	<p>There will be an abnormality in the DSDF separation motor if it does not work. (Perform the output check: FS-03-291/292)</p> <ul style="list-style-type: none"> <li>Check if the motor is damaged, the connector is disconnected or the harness is open circuited. If yes, replace any of them.</li> </ul>
<ul style="list-style-type: none"> <li>All</li> </ul>	
DSDF control PC board	Check that there is no abnormality on the DSDF control PC board when operation failure has occurred in the DSDF tray lift upper limit sensor, DSDF tray lift lower limit sensor, DSDF tray-up clutch or DSDF separation motor. If yes, replace any of them.

Parts to be replaced	Remark
DSDF tray lift upper limit sensor	
DSDF tray lift lower limit sensor	
DSDF tray-up clutch	
DSDF separation motor	
DSDF control PC board	

## [E721] Original not reaching the DSDF read-in sensor-1 jam

Classification	Error content
DSDF jam	The original does not reach the DSDF read-in sensor-1 after it has passed through the DSDF registration sensor.

Check item	Measures
Roller	Clean the DSDF registration roller and pre-read rollers if they are stained.
DSDF read-in sensor-1	<ul style="list-style-type: none"> <li>Check if the DSDF read-in sensor-1 is working properly. (Perform the input check: FS-03-[F2]ON/[7]/[G])</li> <li>Perform the DSDF read-in sensor-1 automatic adjustment.</li> </ul>
Aligning amount	Perform the aligning amount adjustment (FS-05-3040).
Connector	Check if the connectors (J983, J956 and CN75) on the DSDF control PC board are disconnected from the DSDF read-in sensor-1 or the harnesses are open circuited. Correct if any.
DSDF read motor	<ul style="list-style-type: none"> <li>Check if the DSDF read motor is working properly.</li> <li>Check if the connectors (J992 and CN79) on the DSDF control PC board are disconnected from the DSDF read motor or the harnesses are open circuited. Correct if any.</li> </ul>
DSDF registration motor	<ul style="list-style-type: none"> <li>Check if the DSDF registration motor is working properly.</li> <li>Check if the connectors (J982 and CN79) on the DSDF control PC board are disconnected from the DSDF read motor or the harnesses are open circuited. Correct if any.</li> </ul>
DSDF control PC board	Replace the DSDF control PC board.

Parts to be replaced	Remark
Roller	DSDF registration roller, Pre-read roller
DSDF read-in sensor-1	
DSDF read motor	
DSDF registration motor	
DSDF control PC board	

## [E721] Jam not reaching the read sensor

Classification	Error content
RADF jam	The original does not reach the read sensor after it has passed the registration sensor (when scanning the front side) or the reverse sensor (when scanning the back side).

Phenomenon of paper jamming	Check item	Measures
All	Registration sensor Read roller	Clean the registration roller and the read roller if they are stained.
	Read sensor	<ul style="list-style-type: none"> <li>Sensor check (Perform the input check: FS-03-[F2]ON/[7]/[G])</li> <li>Connector check (CN75, J94)</li> <li>Harness check</li> </ul>
	RADF board	<ul style="list-style-type: none"> <li>Board check</li> <li>Connector check (CN75)</li> <li>Harness check</li> </ul>

Parts to be replaced	Remark
Reading start guide of the RADF	
Paper guide of the RADF	
Read sensor	

Parts to be replaced	Remark
RADF board	
Registration roller	Clean or replace it.
Read roller	Clean or replace it.

### [E722] Original not reaching the DSDF exit sensor jam

Classification	Error content
DSDF jam	The original does not reach the DSDF exit sensor after it has passed through the DSDF read-in sensor-2.

Check item	Measures
Roller	Clean the post-read roller-2 if it is stained.
DSDF exit sensor	<ul style="list-style-type: none"> <li>Check if the DSDF exit sensor is working properly. (Perform the input check: FS-03-[F2]ON/[7]/[E])</li> <li>Replace the DSDF exit sensor.</li> </ul>
Connector	Check if the connectors (J985, J957 and CN75) on the DSDF control PC board are disconnected from the DSDF exit sensor or the harnesses are open circuited. Correct if any.
DSDF control PC board	Replace the DSDF control PC board.

Parts to be replaced	Remark
Roller	Post-read roller-2
DSDF exit sensor	
DSDF control PC board	

### [E722] Jam not reaching the original exit / reverse sensor (during scanning)

Classification	Error content
RADF jam	The original which passed the read sensor does not reach the exit sensor when it is transported from the scanning section to exit section.

Check item	Measures
Read roller	Clean the read roller if it is stained.
Original exit/reverse sensor	<ul style="list-style-type: none"> <li>Sensor check (Perform the input check: FS-03-[F2]ON/[7]/[E])</li> <li>Connector check (CN75, J93)</li> <li>Harness check</li> </ul>
RADF board	<ul style="list-style-type: none"> <li>Board check</li> <li>Connector check (CN75)</li> <li>Harness check</li> </ul>

Parts to be replaced	Remark
Original exit/reverse sensor	
RADF board	
Read roller	Replace it if it is worn out.

### [E724] Original stopping at the DSDF registration sensor jam

Classification	Error content
DSDF jam	The trailing edge of the original does not pass through the DSDF registration sensor after its leading edge has passed through this sensor.

Check item	Measures
Roller	Clean the DSDF registration roller if it is stained.

Check item	Measures
DSDF registration sensor	<ul style="list-style-type: none"> <li>Check if the DSDF registration sensor is working properly. (Perform the input check: FS-03-[F2]ON/[7]/[H])</li> <li>Replace the DSDF registration sensor.</li> </ul>
DSDF tray original length sensor-1, DSDF tray original length sensor-2 DSDF tray original width sensor-1, DSDF tray original width sensor-2	<ul style="list-style-type: none"> <li>Check if these sensors can detect an original properly.</li> <li>Check if the DSDF tray original width sensor-1 and DSDF tray original width sensor-2 are working properly. (Perform the input check: FS-03-[F2]ON/[8]/[F], FS-03-[F2]ON/[8]/[G])</li> <li>Check if the DSDF tray original length sensor-1 and DSDF tray original length sensor-2 are working properly. (Perform the input check: FS-03-[F2]ON/[8]/[D], FS-03-[F2]ON/[7]/[A])</li> <li>Replace the DSDF tray original width sensor-1 and -2, DSDF tray original length sensor-1 and -2.</li> </ul>
Connector	<ul style="list-style-type: none"> <li>Check if the connectors (J975, J950 and CN74) on the DSDF control PC board are disconnected from the DSDF registration sensor or the harnesses are open circuited. Correct if any.</li> <li>Check if the connectors (J970, J971 and CN76) on the DSDF control PC board are disconnected from the DSDF tray original length sensor-1 and DSDF tray original length sensor-2 or the harnesses are open circuited. Correct if any.</li> </ul>
DSDF control PC board	Replace the DSDF control PC board.

Parts to be replaced	Remark
DSDF registration sensor	
DSDF tray original length sensor-1, DSDF tray original length sensor-2	
DSDF tray original width sensor-1, DSDF tray original width sensor-2	
DSDF control PC board	

### [E724] Stop jam at the registration sensor

Classification	Error content
RADF jam	The trailing edge of the original does not pass the registration sensor after its leading edge has reached this sensor.

Check item	Measures
Registration roller	Clean the registration roller if it is stained.
Registration sensor	<ul style="list-style-type: none"> <li>Sensor check (Perform the input check: FS-03-[F2]ON/[7]/[H])</li> <li>Connector check (CN74, J88, J86)</li> <li>Harness check</li> </ul>
RADF board	<ul style="list-style-type: none"> <li>Board check</li> <li>Connector check (CN74)</li> <li>Harness check</li> </ul>
Original width detection sensor-1	<ul style="list-style-type: none"> <li>Sensor check (Perform the input check: FS-03-[F2]ON/[8]/[F])</li> <li>Connector check (CN74, J86, J89)</li> <li>Harness check</li> </ul>
Original width detection sensor-2	<ul style="list-style-type: none"> <li>Sensor check (Perform the input check: FS-03-[F2]ON/[8]/[G])</li> <li>Connector check (CN74, J86, J90)</li> <li>Harness check</li> </ul>

Parts to be replaced	Remark
Registration sensor	
RADF board	
Registration roller	Replace it if it is worn out.
Original width detection sensor-1	
Original width detection sensor-2	

### [E725] Original stopping at the DSDF read-in sensor-1 jam

Classification	Error content
DSDF jam	The trailing edge of the original does not pass through the DSDF read-in sensor-1 after its leading edge has passed through this sensor.

Check item	Measures
Roller	Clean the post-read roller-1 if it is stained.
DSDF read-in sensor-1	<ul style="list-style-type: none"> <li>Check if the DSDF read-in sensor-1 is working properly. (Perform the input check: FS-03-[F2]ON/[7]/[G])</li> <li>Perform the DSDF read-in sensor-1 automatic adjustment.</li> </ul>
Connector	Check if the connectors (J983, J956 and CN75) on the DSDF control PC board are disconnected from the DSDF read-in sensor-1 or the harnesses are open circuited. Correct if any.
DSDF control PC board	Replace the DSDF control PC board.

Parts to be replaced	Remark
DSDF read-in sensor-1	
DSDF control PC board	

### [E725] Stop jam at the read sensor

Classification	Error content
RADF jam	The trailing edge of the original does not pass the read sensor after its leading edge has reached this sensor.

Check item	Measures
Read roller	Clean the read roller if it is stained.
Read sensor	<ul style="list-style-type: none"> <li>Sensor check (Perform the input check: FS-03-[F2]ON/[7]/[G])</li> <li>Connector check (CN75, J94)</li> <li>Harness check</li> </ul>
Original intermediate transport sensor	<ul style="list-style-type: none"> <li>Sensor check (Perform the input check: FS-03-[F2]ON/[7]/[F])</li> <li>Connector check (CN75, J94)</li> <li>Harness check</li> </ul>
RADF board	<ul style="list-style-type: none"> <li>Board check</li> <li>Connector check (CN75)</li> <li>Harness check</li> </ul>

Parts to be replaced	Remark
Read sensor	
RADF board	
Read roller	Replace it if it is worn out.
Original intermediate transport sensor	



**[E726] Transport / exit signal reception jam**

Classification	Error content
DSDF jam	The transport or exit signal has been received while no original is placed in the DSDF.

Check item	Measures
Reproducing ability	Turn the power OFF and then back ON to check the occurrence.

Parts to be replaced	Remark
-	

**[E726] Transport / exit signal reception jam**

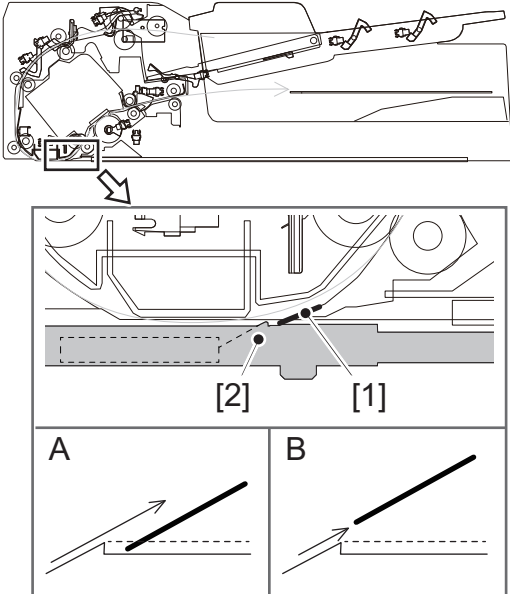
Classification	Error content
RADF jam	RADF receives the transport / exit reception signal from the equipment when no original is at the exposure waiting position.

Check item	Measures
RADF board	<ul style="list-style-type: none"> <li>• Board check</li> <li>• Connector check</li> <li>• Harness check</li> </ul>
SYS board	<ul style="list-style-type: none"> <li>• Board check</li> <li>• Connector check</li> <li>• Harness check</li> </ul>
Switching power supply	<ul style="list-style-type: none"> <li>• Check if the 24V and 5V outputs of the switching power supply are normal.</li> <li>• Board check</li> <li>• Connector check</li> <li>• Harness check</li> </ul>

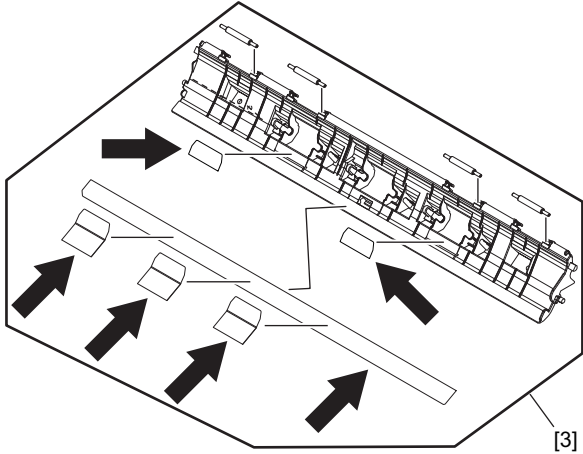
Parts to be replaced	Remark
RADF board	
SYS board	
Switching power supply	

**[E727] Original not reaching the DSDF read-in sensor-2 jam**

Classification	Error content
DSDF jam	The original does not reach the DSDF read-in sensor-2 after it has passed through the DSDF read-in sensor-1.

Check item	Measures
An original has stopped at the transparent film [1].	<p>Turn on the exposure lamp (output check: FS-03-267) and confirm the position between the transparent film [1] and the upper edge of the slope [2].</p>  <p><b>Fig.8-1</b></p> <ul style="list-style-type: none"> <li>• State A (throughout the whole of the transparent film): OK (Go to the next step.)</li> <li>• State B: Perform the height adjustment. (P. 6-77 “6.12.2 Adjustment of height”) Replace the transparent film if the position between it and the upper edge of the slope cannot be adjusted as shown above [A].</li> </ul>
Roller	Clean the post-read roller-1 if it is stained.
Installation	Check if the DSDF is installed properly.
DSDF read-in sensor-2	<ul style="list-style-type: none"> <li>• Check if the DSDF read-in sensor-2 is working properly. (Perform the input check: FS-03-[F2]ON/[6]/[D])</li> <li>• Replace the DSDF read-in sensor-2.</li> </ul>
Connector	Check if the connectors (J984, J956 and CN75) on the DSDF control PC board are disconnected from the DSDF read-in sensor-2 or the harnesses are open circuited. Correct if any.
DSDF control PC board	Replace the DSDF control PC board.

Parts to be replaced	Remark
DSDF read-in sensor-2	
DSDF control PC board	

Parts to be replaced	Remark
Transparent film set	 <p><b>Fig.8-2</b></p> <p>Perform the replacement with the transparent film set or with the guide [3].</p>

### [E729] Original stopping at the DSDF read-in sensor-2 jam

Classification	Error content
DSDF jam	The trailing edge of the original does not pass through the DSDF read-in sensor-2 after its leading edge has passed through this sensor.

Check item	Measures
Roller	Clean the pre-read roller-2 if it is stained.
DSDF read-in sensor-2	<ul style="list-style-type: none"> <li>Check if the DSDF read-in sensor-2 is working properly. (Perform the input check: FS-03-[F2]ON/[6]/[D])</li> <li>Replace the DSDF read-in sensor-2.</li> </ul>
Connector	Check if the connectors (J984, J956 and CN75) on the DSDF control PC board are disconnected from the DSDF read-in sensor-2 or the harnesses are open circuited. Correct if any.
DSDF exit motor	<ul style="list-style-type: none"> <li>Check if the DSDF exit motor is working properly.</li> <li>Check if the connectors (J991 and CN77) on the DSDF control PC board are disconnected from the DSDF exit motor or the harnesses are open circuited. Correct if any.</li> </ul>
DSDF control PC board	Replace the DSDF control PC board.

Parts to be replaced	Remark
DSDF read-in sensor-2	
DSDF exit motor	
DSDF control PC board	

### [E731] Original stopping at the DSDF exit sensor jam

Classification	Error content
DSDF jam	The trailing edge of the original does not pass through the DSDF exit sensor after its leading edge has passed through this sensor.

Check item	Measures
Roller	Clean the DSDF exit roller if it is stained.
Transport path	Check if there is a paper or foreign matter in the exit section of the DSDF.

Check item	Measures
DSDF exit sensor	<ul style="list-style-type: none"> <li>Check if the DSDF exit sensor is working properly. (Perform the input check: FS-03-[F2]ON/[7]/[E])</li> <li>Replace the DSDF sensor.</li> </ul>
Connector	Check if the connectors (J985, J957 and CN75) on the DSDF control PC board are disconnected from the DSDF exit sensor or the harnesses are open circuited. Correct if any.
DSDF control PC board	Replace the DSDF control PC board.

Parts to be replaced	Remark
DSDF exit sensor	
DSDF control PC board	

### [E731] Stop jam at the original exit / reverse sensor

Classification	Error content
RADF jam	The trailing edge of the original does not pass the original exit / reverse sensor after its leading edge has reached this sensor.

Check item	Measures
Exit roller	Clean the exit roller if it is stained.
Stop jam at the original exit/ reverse sensor	<ul style="list-style-type: none"> <li>Sensor check (Perform the input check: FS-03-[F2]ON/[7]/[E])</li> <li>Connector check (J93, CN75)</li> <li>Harness check</li> </ul>
RADF board	<ul style="list-style-type: none"> <li>Board check</li> <li>Connector check (CN75)</li> <li>Harness check</li> </ul>

Parts to be replaced	Remark
Exit sensor	
RADF board	
Exit roller	Replace it if it is worn out.

### [E762] Original remaining at the DSDF registration sensor jam

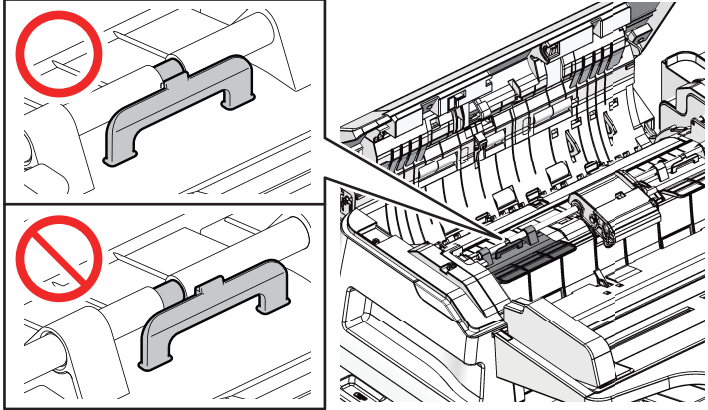
Classification	Error content
DSDF jam	The DSDF registration sensor remains turned ON.

Check item	Measures
Transport path	Check if there is a paper or foreign matter in the transport path of the DSDF.
DSDF registration sensor	<ul style="list-style-type: none"> <li>Check if the DSDF registration sensor is working properly. (Perform the input check: FS-03-[F2]ON/[7]/[H])</li> <li>Replace the DSDF registration sensor.</li> </ul>
Connector	Check if the connectors (J975, J950 and CN74) on the DSDF control PC board are disconnected from the DSDF registration sensor or the harnesses are open circuited. Correct if any.
DSDF control PC board	Replace the DSDF control PC board.

Parts to be replaced	Remark
DSDF registration sensor	
DSDF control PC board	

### [E769] Original remaining at the DSDF feed sensor jam

Classification	Error content
DSDF jam	The DSDF feed sensor remains turned ON.

Check item	Measures
Corner folding prevention guide	<p>Check if the corner folding prevention guide is installed properly. If the latch of the corner folding prevention guide has come off from the shaft groove, slide the guide to reinstall it. Replace the corner folding prevention guide if it is damaged.</p>  <p><b>Fig.8-3</b></p>
Connector	Check if the connectors (J974, J950 and CN74) on the DSDF control PC board are disconnected from the DSDF feed sensor or the harnesses are open circuited. Correct if any.
DSDF feed sensor	<ul style="list-style-type: none"> <li>Check if the DSDF feed sensor is working properly. (Perform the input check: FS-03-[F2]ON/[8]/[E])</li> <li>Replace the DSDF feed sensor.</li> </ul>
DSDF control PC board	Replace the DSDF control PC board.

Parts to be replaced	Remark
Corner folding prevention guide	
DSDF feed sensor	
DSDF control PC board	

### [E770] Original remaining at the DSDF original width detection sensor-1 jam

Classification	Error content
DSDF jam	The DSDF original width detection sensor-1 remains turned ON.

Check item	Measures
Connector	Check if the connectors (J972, J950 and CN75) on the DSDF control PC board are disconnected from the DSDF original width detection sensor-1 or the harnesses are open circuited. Correct if any.
DSDF original width detection sensor-1	<ul style="list-style-type: none"> <li>Check if the DSDF original width detection sensor-1 is working properly. (Perform the input check: FS-03-[F2]ON/[8]/[F])</li> <li>Replace the DSDF original width detection sensor-1.</li> </ul>
DSDF control PC board	Replace the DSDF control PC board.

Parts to be replaced	Remark
DSDF original width detection sensor-1	

Parts to be replaced	Remark
DSDF control PC board	

#### [E771] Original remaining at the DSDF original width detection sensor-2 jam

Classification	Error content
DSDF jam	The DSDF original width detection sensor-2 remains turned ON.

Check item	Measures
Connector	Check if the connectors (J973, J950 and CN75) on the DSDF control PC board are disconnected from the DSDF original width detection sensor-2 or the harnesses are open circuited. Correct if any.
DSDF original width detection sensor-2	<ul style="list-style-type: none"> <li>Check if the DSDF original width detection sensor-2 is working properly. (Perform the input check: FS-03-[F2]ON/[8]/[G])</li> <li>Replace the DSDF original width detection sensor-2.</li> </ul>
DSDF control PC board	Replace the DSDF control PC board.

Parts to be replaced	Remark
DSDF original width detection sensor-2	
DSDF control PC board	

#### [E774] Original remaining at the DSDF read-in sensor-1 jam

Classification	Error content
DSDF jam	The DSDF read-in sensor-1 remains turned ON.

Check item	Measures
Roller	Clean the post-read roller-1 if it is stained.
Connector	Check if the connectors (J983, J956 and CN75) on the DSDF control PC board are disconnected from the DSDF read-in sensor-1 or the harnesses are open circuited. Correct if any.
DSDF read-in sensor-1	<ul style="list-style-type: none"> <li>Check if the DSDF read-in sensor-1 is working properly. (Perform the input check: FS-03-[F2]ON/[7]/[G])</li> <li>Perform the DSDF read-in sensor-1 automatic adjustment.</li> </ul>
DSDF control PC board	Replace the DSDF control PC board.

Parts to be replaced	Remark
DSDF read-in sensor-1	
DSDF control PC board	

#### [E775] Original remaining at the DSDF read-in sensor-2 jam

Classification	Error content
DSDF jam	The DSDF read-in sensor-2 remains turned ON.

Check item	Measures
Roller	Clean the pre-read roller-2 if it is stained.
Connector	Check if the connectors (J984, J956 and CN75) on the DSDF control PC board are disconnected from the DSDF read-in sensor-2 or the harnesses are open circuited. Correct if any.
DSDF read-in sensor-2	<ul style="list-style-type: none"> <li>Check if the DSDF read-in sensor-2 is working properly. (Perform the input check: FS-03-[F2]ON/[6]/[D])</li> <li>Replace the DSDF read-in sensor-2.</li> </ul>

Check item	Measures
DSDf control PC board	Replace the DSDf control PC board.

Parts to be replaced	Remark
DSDf read-in sensor-2	
DSDf control PC board	

**[E777] Original remaining at the DSDF exit sensor jam**

Classification	Error content
DSDF jam	The DSDF exit sensor remains turned ON.

Check item	Measures
Roller	Clean the DSDF exit roller if it is stained.
Connector	Check if the connectors (J985, J957 and CN75) on the DSDF control PC board are disconnected from the DSDF exit sensor or the harnesses are open circuited. Correct if any.
DSDF exit sensor	<ul style="list-style-type: none"> <li>Check if the DSDF exit sensor is working properly. (Perform the input check: FS-03-[F2]ON/[7]/[E])</li> <li>Replace the DSDF sensor.</li> </ul>
DSDF control PC board	Replace the DSDF control PC board.

Parts to be replaced	Remark
DSDF exit sensor	
DSDF control PC board	

**[E860] RADF jam access cover open jam**

Classification	Error content
RADF jam	The RADF jam access cover has opened during RADF operation.

Check item	Measures
RADF jam access cover sensor	<ul style="list-style-type: none"> <li>Switch check (Perform the input check: FS-03-[F2]ON/[7]/[C])</li> <li>Connector check (CN75, J92, J97)</li> <li>Harness check</li> </ul>
RADF board	<ul style="list-style-type: none"> <li>Board check</li> <li>Connector check (CN75)</li> <li>Harness check</li> </ul>

Parts to be replaced	Remark
RADF jam access cover sensor	
RADF board	



**[E860] DSDF original jam access cover open jam / DSDF shading sheet HP sensor abnormal**

Classification	Error content
DSDF jam	<ul style="list-style-type: none"> <li>The jam access cover of the DSDF has become opened during its operation.</li> <li>The DSDF exit motor has been driven and the DSDF shading sheet HP sensor has not been turned ON within a specified time.</li> </ul> <p>Details: If a paper jam has occurred at the start of a duplex copying or scanning job or at the end of a copying or scanning job, the cover may have opened as a result.</p> <p>The home position detection is carried out by the DSDF shading sheet HP sensor when the cover or DSDF is closed, the power is turned ON, during the initial operation or at the end of a job. This home position detection checks that the DSDF shading sheet HP sensor is turned ON within a specified time after the DSDF exit motor has started driving. If the home position cannot be detected when the cover or DSDF is closed or the power is turned ON, a cover open error will be displayed. If the home position cannot be detected during the initial operation or at the end of a job, a DSDF shading sheet HP sensor abnormality will occur and this error code will be displayed.</p>

Check item	Measures
<ul style="list-style-type: none"> <li>When a paper jam has occurred at the start or end of the original transportation</li> </ul>	
DSDF lower cover	Check if the DSDF lower cover is closed appropriately.
DSDF lower cover opening/closing detection sensor	<ul style="list-style-type: none"> <li>Check if the connectors (J980, J953 and CN75) on the DSDF control PC board are disconnected from the DSDF lower cover opening/closing detection sensor or the harnesses are open circuited. Correct if any.</li> <li>Check if the DSDF lower cover opening/closing detection sensor is working properly. (Perform the input check: FS-03-[F2]ON/[6]/[C])</li> <li>Replace the DSDF lower cover opening/closing detection sensor.</li> </ul>
DSDF lower cover interlock switch	<ul style="list-style-type: none"> <li>Check if the DSDF lower cover interlock switch is working properly.</li> <li>Replace the DSDF lower cover interlock switch.</li> </ul>
DSDF exit motor	<ul style="list-style-type: none"> <li>Check if the DSDF exit motor rotates properly. (Perform the input check: FS-03-284) If yes, check the DSDF shading sheet HP sensor.</li> <li>Check if the connector of the DSDF exit motor is disconnected or the harnesses are open circuited.</li> <li>Replace the DSDF exit motor.</li> </ul>
DSDF shading sheet HP sensor	<ul style="list-style-type: none"> <li>Check if the DSDF shading sheet HP sensor is working properly. (Perform the input check: FS-03-[F2]ON/[6]/[A])</li> <li>Check if the connector of the DSDF shading sheet HP sensor is disconnected or the harnesses are open circuited.</li> <li>Replace the DSDF shading sheet HP sensor.</li> </ul>
DSDF control PC board	<ul style="list-style-type: none"> <li>Check if the connector of the DSDF control PC board is disconnected or the harnesses are open circuited.</li> <li>Replace the DSDF control PC board.</li> </ul>
<ul style="list-style-type: none"> <li>When a paper jam has occurred during original transportation</li> </ul>	
Cover	<ul style="list-style-type: none"> <li>Check if the DSDF upper cover is closed appropriately.</li> <li>Check if the DSDF lower cover is closed appropriately.</li> <li>Check if the front cover of the equipment is closed appropriately.</li> </ul>
DSDF upper cover opening/closing detection sensor	<ul style="list-style-type: none"> <li>Check if the connectors (J981, J954 and CN75) on the DSDF control PC board are disconnected from the DSDF upper cover opening/closing detection sensor or the harnesses are open circuited. Correct if any.</li> <li>Check if the DSDF upper cover opening/closing detection sensor is working properly. (Perform the input check: FS-03-[F2]ON/[7]/[C])</li> <li>Replace the DSDF upper cover opening/closing detection sensor.</li> </ul>
DSDF upper cover interlock switch	<ul style="list-style-type: none"> <li>Check if the DSDF upper cover interlock switch is working properly.</li> <li>Replace the DSDF upper cover interlock switch.</li> </ul>

Check item	Measures
DSDF lower cover opening/closing detection sensor	<ul style="list-style-type: none"> <li>Check if the connectors (J980, J953 and CN75) on the DSDF control PC board are disconnected from the DSDF lower cover opening/closing detection sensor or the harnesses are open circuited. Correct if any.</li> <li>Check if the DSDF lower cover opening/closing detection sensor is working properly. (Perform the input check: FS-03-[F2]ON/[6]/[C])</li> <li>Replace the DSDF lower cover opening/closing detection sensor.</li> </ul>
DSDF lower cover interlock switch	<ul style="list-style-type: none"> <li>Check if the DSDF lower cover interlock switch is working properly.</li> <li>Replace the DSDF lower cover interlock switch.</li> </ul>
DSDF exit motor	<ul style="list-style-type: none"> <li>Check if the DSDF exit motor rotates properly. (Perform the input check: FS-03-284) If yes, check the DSDF shading sheet HP sensor.</li> <li>Check if the connector of the DSDF exit motor is disconnected or the harnesses are open circuited.</li> <li>Replace the DSDF exit motor.</li> </ul>
DSDF shading sheet HP sensor	<ul style="list-style-type: none"> <li>Check if the DSDF shading sheet HP sensor is working properly. (Perform the input check: FS-03-[F2]ON/[6]/[A])</li> <li>Check if the connector of the DSDF shading sheet HP sensor is disconnected or the harnesses are open circuited.</li> <li>Replace the DSDF shading sheet HP sensor.</li> </ul>
DSDF control PC board	<ul style="list-style-type: none"> <li>Check if the connector of the DSDF control PC board is disconnected or the harnesses are open circuited.</li> <li>Replace the DSDF control PC board.</li> </ul>

Parts to be replaced	Remark
DSDF upper cover opening/closing detection sensor	
DSDF upper cover interlock switch	
DSDF lower cover opening/closing detection sensor	
DSDF lower cover interlock switch	
DSDF exit motor	
DSDF shading sheet HP sensor	
DSDF control PC board	

### [E870] RADF open jam

Classification	Error content
RADF jam	The RADF has become opened during its operation.

Check item	Measures
Platen sensor	<ul style="list-style-type: none"> <li>Sensor check (Perform the input check: Platen sensor-1: FS-03-[F2]ON[5]/[C], Platen sensor-2: FS-03-[F2]ON[5]/[G])</li> <li>Connector check (CN121, J1003, J1004)</li> <li>Harness check</li> </ul>
LGC board	<ul style="list-style-type: none"> <li>Board check</li> <li>Connector check (CN121)</li> <li>Harness check</li> </ul>

Parts to be replaced	Remark
Platen sensor	
LGC board	

## 8.3.8 Finisher jam

### [ 1 ] Jam in bridge unit

[E910] Paper not reaching the bridge unit transport sensor-1

[E920] Paper stopping at the bridge unit transport sensor-1

Classification	Error content
Finisher jam (Bridge unit)	[E910] The paper does not reach the bridge unit transport sensor-1 after it has passed the exit sensor. [E920] The trailing edge of the paper does not pass the bridge unit transport sensor-1 after its leading edge has reached the sensor.

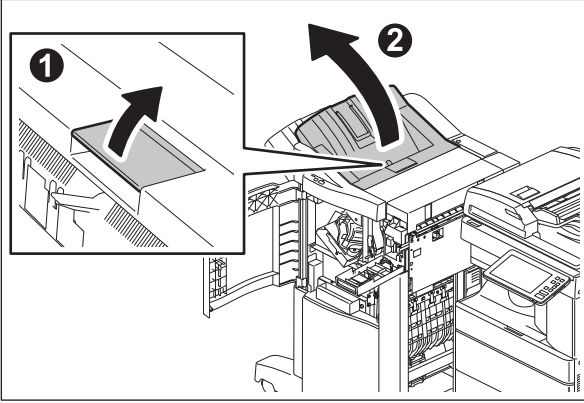
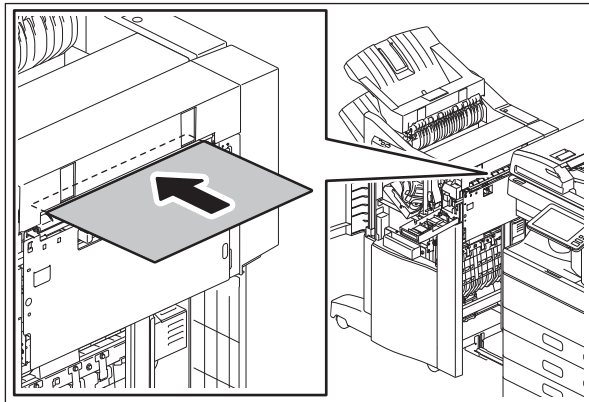
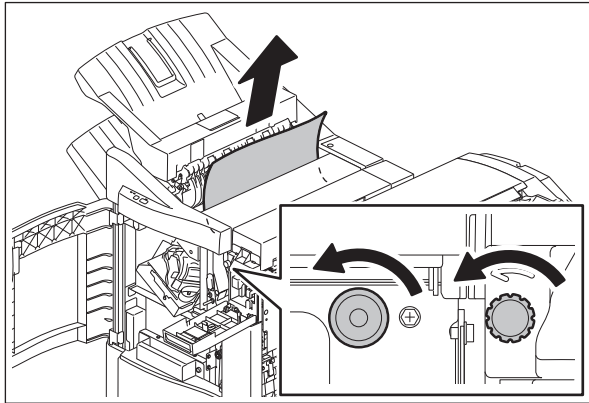
Phenomenon of paper jamming	Check item	Measures
There are scratches on the leading paper edge		Replace it if needed. Check if the guide is not deformed. Replace it if needed.
All	Drawer	Check that paper is not skewed in the side guides of the drawer.
	Bridge unit exit	Check that Mylar on the bridge unit exit is not deformed. Replace it if needed. (E920)
	Finisher	Check if paper jamming occurs in the finisher.
	Bridge unit transport sensor-1 (entrance sensor)	<ul style="list-style-type: none"> <li>• Sensor check (Perform the input check: FS-03-[ALL]OFF[0]/[A])</li> <li>• Connector check (CN311, J607, J801)</li> <li>• Harness check</li> </ul>
	Bridge unit gate solenoid	<ul style="list-style-type: none"> <li>• Solenoid check (Perform the output check: FS-03-232)</li> <li>• Connector check (CN311, J607, J801)</li> <li>• Harness check</li> </ul>
	LGC board	<ul style="list-style-type: none"> <li>• Board check</li> <li>• Connector check (CN311)</li> <li>• Harness check</li> </ul>
	Bridge unit	<ul style="list-style-type: none"> <li>• Does the transport roller of the bridge unit work when the main motor is rotated? (Perform the output check: FS-03-101/151)</li> <li>• Check the drive system of the equipment and bridge unit.</li> <li>• Check if the rollers in exit section, bridge unit and pressure spring are worn out.</li> </ul>

Parts to be replaced	Remark
Bridge unit transport sensor-1 (entrance sensor)	
LGC board	
Bridge unit gate solenoid	

**[E930] Paper not reaching the bridge unit transport sensor-2**  
**[E940] Paper stopping at the bridge unit transport sensor-2**

Classification	Error content
Finisher jam (Bridge unit)	[E930] The trailing edge of the paper does not reach the bridge unit transport sensor-2 after its leading edge has reached the bridge unit transport sensor-1. [E940] The trailing edge of the paper does not reach the bridge unit transport sensor-2 after its leading edge has reached the bridge unit transport sensor-2.

Check item	Measures
Bridge unit transport sensor-2 (exit sensor)	<ul style="list-style-type: none"> <li>• Sensor check (Perform the input check: FS-03-[ALL]OFF[0]/[B])</li> <li>• Connector check (CN311, J607, J802)</li> <li>• Harness check</li> </ul>
LGC board	<ul style="list-style-type: none"> <li>• Board check</li> <li>• Connector check (CN311)</li> <li>• Harness check</li> </ul>
Bridge unit	<ul style="list-style-type: none"> <li>• Does the transport roller of the bridge unit work when the main motor is rotated? (Perform the output check: FS-03-101/151)</li> <li>• Check the drive system of the equipment and bridge unit.</li> <li>• Check if the rollers in exit section, bridge unit and pressure spring are worn out.</li> </ul>

Check item	Measures
<p>Hole punch unit(When an error has occurred immediately after the time of unpacking and installation)</p>	<p>A sheet in the finisher (hole punch unit) may be deformed. Correct this.</p> <ol style="list-style-type: none"> <li>1. Separate the finisher (hole punch unit) from the equipment.</li> <li>2. Open the stationary tray of the finisher (hole punch unit).</li> </ol>  <ol style="list-style-type: none"> <li>3. Insert one sheet of A4/LT-size thick paper into the paper transport inlet of the finisher (hole punch unit).</li> </ol>  <p><b>Remarks:</b> Use the thick paper of A4-LT size and 216g/m2 (80 lb. Bond) or equivalent.</p> <ol style="list-style-type: none"> <li>4. Open the front cover of the finisher (hole punch unit). Turn the 2 knobs simultaneously. Transport the thick paper by turning the knobs in the direction of the arrow to remove it.</li> </ol> 

Parts to be replaced	Remark
Bridge unit transport sensor-2 (exit sensor)	
LGC board	

## [ 2 ] Job separator jam

[E950] Jam not reaching the JSP feed sensor

[E951] Stop jam at the JSP feed sensor

Classification	Error content
Job separator jam	[E950] The paper has passed through the exit sensor does not reach the JSP feed sensor. [E951] The trailing edge of the paper does not pass the JSP feed sensor after its leading edge has reached this sensor.

Procedure	Check item	Result	Measures	Next Step
1	Open the JSP cover. Is there any paper on the transport path?	Yes	Remove the paper.	
		No		2
2	Is the JSP feed sensor working?(Perform the input check in the test mode: 03-[ALL]OFF/[0]/[A])	Yes		3
		No	<ul style="list-style-type: none"> <li>• Check if the connector of the JSP feed sensor is disconnected.</li> <li>• Check if either of the connectors CN260 or CN262 on the JSP board is disconnected.</li> <li>• Check if the connector CN311 on the LGC board is disconnected.</li> <li>• Check if the connector pins are disconnected and the harnesses are open circuited.</li> <li>• Check if the conductor patterns on the JSP board and LGC board are short circuited or open circuited.</li> <li>• Replace the JSP feed sensor.</li> <li>• Replace the JSP board.</li> <li>• Replace the LGC board.</li> </ul>	
3	Replacing board		<ul style="list-style-type: none"> <li>• Replace the JSP board.</li> <li>• Replace the LGC board.</li> </ul>	

Parts to be replaced	Remark
JSP feed sensor	
JSP board	
LGC board	

**[ 3 ] Paper jam in puncher unit**  
**[E9F0] Punching jam**

Classification	Error content
Finisher jam Hole punch unit	Punching is not performed properly.

MJ-1042 (When MJ-6011 is installed)

Probable cause	Checking and measures
Punch unit sliding motor abnormality	Check if the electrical continuity of the coil is normal. If electricity is not conducted, replace the motor.
Punch sliding unit home position sensor abnormality	Measure the voltage on TP26 on the hole punch control PC board. Then check that the measured voltage is 1V or lower when not shielded and within the range of $5V \pm 5\%$ when shielded. If the voltage does not fall within the range mentioned, replace the sensor.
Paper detection sensor (light-receiving/light-emitting) (S24/S25)	Measure the voltage on 8-pin of CN6 on the hole punch control PC board. Then check that the measured voltage is 3.0V or higher when not shielded and 1.2 or lower when shielded. If the voltage does not fall within the range mentioned, replace the sensor.
Faulty cables and connectors	Check if the electrical continuity between the connector terminals is normal. If electricity is not conducted, replace the connector. (Hole punch control PC board: CN3, CN4, CN5, CN6, CN7)
Hole punch control PC board abnormality	If the error still occurs after replacing the sensor and the connector, replace the hole punch control PC board.
Finisher control PC board (FIN) abnormality	Replace the finisher control PC board (FIN).

MJ-1109/1110 (When MJ-6105 is installed)

Check item	Measures
Paper	Check if there is any paper on the transport path of the equipment and remove it if there is.
Punch motor (M3)	<ul style="list-style-type: none"> <li>• Motor check</li> <li>• Connector check</li> <li>• Harness check</li> </ul>
Punch HP sensor (S4)	<ul style="list-style-type: none"> <li>• Sensor check</li> <li>• Connector check</li> <li>• Harness check</li> </ul>
Punch sensor (S5)	<ul style="list-style-type: none"> <li>• Sensor check</li> <li>• Connector check</li> <li>• Harness check</li> </ul>
Hole punch control PC board (HP)	<ul style="list-style-type: none"> <li>• Board check</li> <li>• Connector check</li> <li>• Harness check</li> </ul>

Parts to be replaced	Remark
Punch HP sensor (S4)	
Punch sensor (S5)	
Punch motor (M3)	
Hole punch control PC board (HP)	

## [ 4 ] Paper jam in finisher section

### [EA10] Paper transport delay jam

MJ-1042

Classification	Error content
Finisher jam (Finisher section)	1st transport motor (M8) fault / 2nd transport motor (M4) fault.

Probable cause	Checking and measures
1st transport motor (M8) abnormality	Check if the electrical continuity of the coil is normal. If electricity is not conducted, replace the motor.
Faulty cables and connectors	Check if the electrical continuity between the connector terminals is normal. If electricity is not conducted, replace the connector. (Finisher control PC board (FIN): CN22)
2nd transport motor (M4) abnormality	Check if the electrical continuity of the coil is normal. If electricity is not conducted, replace the motor.
Faulty cables and connectors	Check if the electrical continuity between the connector terminals is normal. If electricity is not conducted, replace the connector. (Finisher control PC board (FIN): CN14)
Finisher control PC board (FIN) abnormality	If the error still occurs after replacing the motor and the connector, exchange the finisher control PC board (FIN).

### [EA10] Paper transport delay jam

MJ-1109/MJ-1110

Classification	Error content
Finisher jam (Finisher section)	[MJ-1109] Paper transport delay jam. [MJ-1110] Paper transport delay non-inserting jam.

Check item	Measures
Paper	Check if there is any paper in the finisher or on the transport path of the equipment and remove it if there is.
Feeding sensor (S22)	Check if there is a disconnection of the connector, incorrect installation or breakage of the feeding sensor (S22). If there is, reinstall the sensor correctly or replace it.
Transport path switching solenoid (SOL5)	Check that the gap between the transfer guide surface and the upper surface of the flapper tip is in the acceptable range according to the status of the transport path switching solenoid (SOL5) (solenoid OFF: 1.5 to 2.1 mm, solenoid ON: 2.3 to 2.9 mm). If it is not, adjust it. Check the harness between the transport path switching solenoid (SOL5) and the finisher control PC board (CN1). If there is any abnormality, correct it.
Entrance motor (M1)	Check the harness between the entrance motor (M1) and the finisher control PC board (CN17). If there is any abnormality, correct it.
Finisher control PC board (FIN)	<ul style="list-style-type: none"> <li>• Board check</li> <li>• Connector check (CN1, CN17)</li> <li>• Harness check</li> </ul>

Parts to be replaced	Remark
Feeding sensor (S22)	
Transport path switching solenoid (SOL5)	
Entrance motor (M1)	
Finisher control PC board (FIN)	



**[EA20] Paper transport stop jam**

MJ-1042

Classification	Error content
Finisher jam (Finisher section)	1st transport motor (M8) fault / 2nd transport motor (M4) fault.

Probable cause	Checking and measures
1st transport motor (M8) abnormality	Check if the electrical continuity of the coil is normal. If electricity is not conducted, replace the motor.
Faulty cables and connectors	Check if the electrical continuity between the connector terminals is normal. If electricity is not conducted, replace the connector. (Finisher control PC board (FIN): CN22)
2nd transport motor (M4) abnormality	Check if the electrical continuity of the coil is normal. If electricity is not conducted, replace the motor.
Faulty cables and connectors	Check if the electrical continuity between the connector terminals is normal. If electricity is not conducted, replace the connector. (Finisher control PC board (FIN): CN14)
Finisher control PC board (FIN) abnormality	If the error still occurs after replacing the motor and the connector, exchange the finisher control PC board (FIN).

**[EA20] Paper transport stop jam**

MJ-1109/1110

Classification	Error content
Finisher jam (Finisher section)	Paper stopping jam.

Check item	Measures
Paper	Check if there is any paper in the finisher or on the transport path of the equipment and remove it if there is.
Entrance sensor (S1)	<ul style="list-style-type: none"> <li>• Sensor check</li> <li>• Connector check</li> <li>• Harness check</li> </ul>
Finisher control PC board (FIN)	<ul style="list-style-type: none"> <li>• Board check</li> <li>• Connector check (CN8)</li> <li>• Harness check</li> </ul>
Assist guide	Check that there is no abnormality in the adjustment for its height.

Parts to be replaced	Remark
Entrance sensor (S1)	
Finisher control PC board (FIN)	
Assist guide	

**[EA21] Paper size error jam (transport sensor)**

MJ-1109/1110

Classification	Error content
Finisher jam (Finisher section)	The transport sensor on the finisher transport path detects that the paper is shorter than the acceptable size.

Check item	Measures
Paper	<ul style="list-style-type: none"> <li>• Check if there is any paper in the finisher or on the transport path of the equipment and remove it if there is.</li> <li>• Use paper accepted in the specifications.</li> </ul>

Check item	Measures
Entrance sensor (S1)	<ul style="list-style-type: none"> <li>• Sensor check</li> <li>• Connector check</li> <li>• Harness check</li> </ul>
Transport sensor (S2)	<ul style="list-style-type: none"> <li>• Sensor check</li> <li>• Connector check</li> <li>• Harness check</li> </ul>
Finisher control PC board (FIN)	<ul style="list-style-type: none"> <li>• Board check</li> <li>• Connector check (CN8)</li> <li>• Harness check</li> </ul>

Parts to be replaced	Remark
Entrance sensor (S1)	
Transport sensor (S2)	
Finisher control PC board (FIN)	

### [EA22] Paper size error jam (Paper position sensor)

MJ-1109/1110 (MJ-6105)

Classification	Error content
Finisher jam Hole punch unit	The paper position sensor on the hole punch unit detects that the paper is shorter than the acceptable size.

Check item	Measures
Paper	Check if there is any paper in the finisher or on the transport path of the equipment and remove it if there is.
Entrance sensor (S1)	<ul style="list-style-type: none"> <li>• Sensor check</li> <li>• Connector check</li> <li>• Harness check</li> </ul>
Transport sensor (S2)	<ul style="list-style-type: none"> <li>• Sensor check</li> <li>• Connector check</li> <li>• Harness check</li> </ul>
Paper position sensor (Hole punch unit)	<ul style="list-style-type: none"> <li>• Sensor check (S6-1, S6-2)</li> <li>• Connector check (CN1, CN4, CN5)</li> <li>• Harness check</li> </ul>
Finisher control PC board (FIN)	<ul style="list-style-type: none"> <li>• Board check</li> <li>• Connector check (CN8)</li> <li>• Harness check</li> </ul>

Parts to be replaced	Remark
Entrance sensor (S1)	
Transport sensor (S2)	
Paper position sensor (S6-1, S6-2)	Hole punch unit
Finisher control PC board (FIN)	

### [EA23] Paper stopping jam (transport sensor)

MJ-1109/MJ-1110

Classification	Error content
Finisher jam (Finisher section)	The trailing edge of the paper does not pass through the transport sensor after its leading edge has passed through this sensor on the finisher transport path.

Check item	Measures
Paper	Check if there is any paper in the finisher or on the transport path of the equipment and remove it if there is.
Transport sensor (S2)	<ul style="list-style-type: none"> <li>• Sensor check</li> <li>• Connector check</li> <li>• Harness check</li> </ul>
Finisher control PC board (FIN)	<ul style="list-style-type: none"> <li>• Board check</li> <li>• Connector check (CN8)</li> <li>• Harness check</li> </ul>

Parts to be replaced	Remark
Transport sensor (S2)	
Finisher control PC board (FIN)	

### [EA24] Paper transport delay jam (between entrance and transport sensor)

MJ-1109/MJ-1110

Classification	Error content
Finisher jam (Finisher section)	The leading edge of paper which has passed the entrance sensor on the Finisher transport path does not reach the transport sensor.

Check item	Measures
Paper	Check if there is any paper in the finisher or on the transport path of the equipment and remove it if there is.
Pinch roller arm	Check the position of pinch roller arm. If it is down, fix its mechanism.
Transport path switching solenoid (SOL5)	<ul style="list-style-type: none"> <li>• Check that the gap between the transfer guide surface and the upper surface of the flapper tip is in the acceptable range according to the status of the transport path switching solenoid (SOL5) (solenoid OFF: 1.5 to 2.1 mm, solenoid ON: 2.3 to 2.9 mm). If it is not, adjust it.</li> <li>• Check the harness between the transport path switching solenoid (SOL5) and the finisher control PC board (CN1). If there is any abnormality, correct it.</li> </ul>
Entrance sensor (S1)	<ul style="list-style-type: none"> <li>• Sensor check</li> <li>• Connector check (CN8)</li> <li>• Harness check</li> </ul>
Transport sensor (S2)	<ul style="list-style-type: none"> <li>• Sensor check</li> <li>• Connector check (CN8)</li> <li>• Harness check</li> </ul>
Entrance motor (M1)	<ul style="list-style-type: none"> <li>• Motor check</li> <li>• Connector check (CN17)</li> <li>• Harness check</li> </ul>
Finisher control PC board (FIN)	<ul style="list-style-type: none"> <li>• Board check</li> <li>• Connector check (CN8, CN17)</li> <li>• Harness check</li> </ul>

Parts to be replaced	Remark
Transport path switching solenoid (SOL5)	
Entrance sensor (S1)	
Transport sensor (S2)	
Entrance motor (M1)	
Finisher control PC board (FIN)	

**[EA25] Paper transport jam in Finisher (after paper stack was exited)**

MJ-1042

Classification	Error content
Finisher jam (Finisher section)	Stack exit motor (M5) abnormality.

Probable cause	Checking and measures
Stack exit motor (M5) abnormality	Check if the electrical continuity of the coil is normal. If electricity is not conducted, replace the motor.
Faulty cables and connectors	Check if the electrical continuity between the connector terminals is normal. If electricity is not conducted, replace the connectors. (Finisher control PC board (FIN): CN14)
Finisher control PC board (FIN) abnormality	If the error still occurs after replacing the motor, sensor and connectors, exchange the finisher control PC board (FIN).

**[EA25] Paper transport jam in Finisher (after paper stack was exited)**

MJ-1109/MJ-1110

Classification	Error content
Finisher jam (Finisher section)	The finishing tray paper detection sensor detects paper after a stack of paper exits from the finishing tray.

Check item	Measures
Paper	Check if there is any paper in the finisher or on the transport path of the equipment and remove it if there is.
Finishing tray paper detection sensor (S12)	<ul style="list-style-type: none"> <li>• Sensor check</li> <li>• Connector check (CN25)</li> <li>• Harness check</li> </ul>
Finisher control PC board (FIN)	<ul style="list-style-type: none"> <li>• Board check</li> <li>• Connector check (CN25)</li> <li>• Harness check</li> </ul>

Parts to be replaced	Remark
Finishing tray paper detection sensor (S12)	
Finisher control PC board (FIN)	

**[EA26] Paper transport stop jam (stop command request)**

MJ-1042

Classification	Error content
Finisher jam (Finisher section)	The equipment sends a stop signal during feeding.

Check item	Measures
Finisher	<ul style="list-style-type: none"> <li>• Check if the harness connecting the equipment and the finisher control PC board is disconnected or open circuited.</li> <li>• Check if the conductor pattern on the finisher control PC board is open circuited or short circuited.</li> <li>• Update the finisher firmware.</li> <li>• Replace the finisher control PC board.</li> </ul>
LGC board	<ul style="list-style-type: none"> <li>• Check if the harness connecting the finisher and the LGC board on the equipment is disconnected or open circuited.</li> <li>• Connector check</li> <li>• Check if the conductor pattern on the LGC board is open circuited or short circuited.</li> <li>• Replace the LGC board.</li> </ul>

Parts to be replaced	Remark
Finisher control PC board (FIN)	
LGC board (LGC)	

**[EA26] Paper transport stop jam (stop command request)**

**[EA27] Paper transport jam in Finisher**

MJ-1109/MJ-1110

Classification	Error content
Finisher jam (Finisher section)	[EA26] The equipment sends a stop signal during feeding. [EA27] The entrance sensor is turned ON later than the specified timing.

Check item	Measures
Paper	Check if there is any paper in the finisher or on the transport path of the equipment and remove it if there is.
Entrance sensor (S1)	<ul style="list-style-type: none"> <li>• Sensor check</li> <li>• Connector check (CN8)</li> <li>• Harness check</li> </ul>
Finisher control PC board (FIN)	<ul style="list-style-type: none"> <li>• Board check</li> <li>• Connector check (CN8)</li> <li>• Harness check</li> </ul>

Parts to be replaced	Remark
Entrance sensor (S1)	
Finisher control PC board (FIN)	

**[EA28] Paper transport jam (paper holder plate operation delay)**

MJ-1109/MJ-1110

Classification	Error content
Finisher jam (Finisher section)	An attempt to start the paper holder plate operation for dropping paper on the finishing tray is made, but the previous paper holder plate operation has not yet been finished.

Check item	Measures
Paper	Check if there is any paper in the finisher or on the transport path of the equipment and remove it if there is.
Assist guide	Is there any mechanical problem when the assist guide is rotated? If there is any mechanical problem, fix its mechanism.
Assist guide motor (M10)	<ul style="list-style-type: none"> <li>• Motor check</li> <li>• Connector check (CN10)</li> <li>• Harness check</li> </ul>
Finisher control PC board (FIN)	<ul style="list-style-type: none"> <li>• Board check</li> <li>• Connector check (CN10)</li> <li>• Harness check</li> </ul>

Parts to be replaced	Remark
Assist guide motor (M10)	
Finisher control PC board (FIN)	

**[EA29] Paper transport jam (stack transport delay)**

MJ-1109/MJ-1110

Classification	Error content
Finisher jam (Finisher section)	The buffer tray is extended to drop a stack of paper on the finishing tray but the previous stack has not yet exited.

Check item	Measures
Paper	Check if there is any paper in the finisher or on the transport path of the equipment and remove it if there is.
Buffer tray guide	Is there any mechanical problem when the buffer tray guide is opened and closed while the buffer roller is kept raised? If there is any mechanical problem, fix its mechanism.
Buffer tray guide motor (M2)	<ul style="list-style-type: none"> <li>• Motor check</li> <li>• Connector check (CN10)</li> <li>• Harness check</li> </ul>
Finisher control PC board (FIN)	<ul style="list-style-type: none"> <li>• Board check</li> <li>• Connector check (CN8)</li> <li>• Harness check</li> </ul>

Parts to be replaced	Remark
Buffer tray guide motor (M2)	
Finisher control PC board (FIN)	

**[EA2A] Paper transport jam in the Finisher (between the entrance path and middle path sensor)**

MJ-1042

Classification	Error content
Finisher jam (Finisher section)	The leading edge of the paper has passed the entrance path sensor, but does not reach the middle path sensor in the Finisher Unit transport path.

Probable cause	Checking and measures
1st transport motor (M8) abnormality	Check if the electrical continuity of the coil is normal. If electricity is not conducted, replace the motor.
2nd transport motor (M4) abnormality	Check if the electrical continuity of the coil is normal. If electricity is not conducted, replace the motor.
Entrance path sensor (S19) abnormality	Measure the voltage on TP86 on the finisher control PC board (FIN). Then check that the measured voltage is 1V or lower when not shielded and within the range of 3.3V±5% when shielded. If the voltage does not fall within the range mentioned, replace the sensor.
Middle path sensor (S7) abnormality	Measure the voltage on TP84 on the finisher control PC board (FIN). Then check that the measured voltage is 1V or lower when not shielded and within the range of 3.3V±5% when shielded. If the voltage does not fall within the range mentioned, replace the sensor.
Faulty cables and connectors	Check if the electrical continuity between the connector terminals is normal. If electricity is not conducted, replace the connector. (Finisher control PC board (FIN): CN6, CN14, CN22)
Finisher control PC board (FIN) abnormality	If the error still occurs after replacing the sensor and the connector, replace the finisher control PC board (FIN).

**[EA2B] Paper transport jam in the Finisher (middle path sensor)**

MJ-1042

Classification	Error content
Finisher jam (Finisher section)	The paper remains at the middle path sensor for a longer period than specified while being transported on the Finisher Unit transport path.

Probable cause	Checking and measures
2nd transport motor (M4) abnormality	Check if the electrical continuity of the coil is normal. If electricity is not conducted, replace the motor.
Entrance path sensor (S19) abnormality	Measure the voltage on TP86 on the finisher control PC board (FIN). Then check that the measured voltage is 1V or lower when not shielded and within the range of $3.3V \pm 5\%$ when shielded. If the voltage does not fall within the range mentioned, replace the sensor.
Middle path sensor (S7) abnormality	Measure the voltage on TP84 on the finisher control PC board (FIN). Then check that the measured voltage is 1V or lower when not shielded and within the range of $3.3V \pm 5\%$ when shielded. If the voltage does not fall within the range mentioned, replace the sensor.
Faulty cables and connectors	Check if the electrical continuity between the connector terminals is normal. If electricity is not conducted, replace the connector. (Finisher control PC board (FIN): CN6, CN14, CN22)
Finisher control PC board (FIN) abnormality	If the error still occurs after replacing the sensor and the connector, replace the finisher control PC board (FIN).

**[EA2C] Paper transport jam in the Finisher (between the entrance path and sub-path sensor)**

MJ-1042

Classification	Error content
Finisher jam (Finisher section)	The leading edge of the paper has passed the entrance sensor, but does not reach the sub-path sensor in the Finisher Unit transport path.

Probable cause	Checking and measures
1st transport motor (M8) abnormality	Check if the electrical continuity of the coil is normal. If electricity is not conducted, replace the motor.
2nd transport motor (M4) abnormality	Check if the electrical continuity of the coil is normal. If electricity is not conducted, replace the motor.
Entrance path sensor (S19) abnormality	Measure the voltage on TP86 on the finisher control PC board (FIN). Then check that the measured voltage is 1V or lower when not shielded and within the range of $3.3V \pm 5\%$ when shielded. If the voltage does not fall within the range mentioned, replace the sensor.
Sub-path sensor (S8) abnormality	Measure the voltage on TP85 on the finisher control PC board (FIN). Then check that the measured voltage is 1V or lower when not shielded and within the range of $3.3V \pm 5\%$ when shielded. If the voltage does not fall within the range mentioned, replace the sensor.
Stationary tray full detection sensor (S11) abnormality	Measure the voltage on TP26 on the finisher control PC board (FIN). Then check that the measured voltage is 1V or lower when not shielded and within the range of $3.3V \pm 5\%$ when shielded. If the voltage does not fall within the range mentioned, replace the sensor.
Faulty cables and connectors	Check if the electrical continuity between the connector terminals is normal. If electricity is not conducted, replace the connector. (Finisher control PC board (FIN): CN6, CN10, CN14, CN22)
Finisher control PC board (FIN) abnormality	If the error still occurs after replacing the sensor and the connector, replace the finisher control PC board (FIN).

**[EA2D] Paper transport jam in the Finisher (sub-path sensor)**

MJ-1042

Classification	Error content
Finisher jam (Finisher section)	The paper remains at the sub-path sensor for a longer period than specified while being transported on the Finisher Unit transport path.

Probable cause	Checking and measures
2nd transport motor (M4) abnormality	Check if the electrical continuity of the coil is normal. If electricity is not conducted, replace the motor.
Entrance path sensor (S19) abnormality	Measure the voltage on TP86 on the finisher control PC board (FIN). Then check that the measured voltage is 1V or lower when not shielded and within the range of $3.3V \pm 5\%$ when shielded. If the voltage does not fall within the range mentioned, replace the sensor.
Sub-path sensor (S8) abnormality	Measure the voltage on TP85 on the finisher control PC board (FIN). Then check that the measured voltage is 1V or lower when not shielded and within the range of $3.3V \pm 5\%$ when shielded. If the voltage does not fall within the range mentioned, replace the sensor.
Stationary tray full detection sensor (S11) abnormality	Measure the voltage on TP26 on the finisher control PC board (FIN). Then check that the measured voltage is 1V or lower when not shielded and within the range of $3.3V \pm 5\%$ when shielded. If the voltage does not fall within the range mentioned, replace the sensor.
Faulty cables and connectors	Check if the electrical continuity between the connector terminals is normal. If electricity is not conducted, replace the connector. (Finisher control PC board (FIN): CN6, CN10, CN14, CN22)
Finisher control PC board (FIN) abnormality	If the error still occurs after replacing the sensor and the connector, replace the finisher control PC board (FIN).

**[EA2E] Paper transport remaining jam in the Finisher (sub-path sensor)**

MJ-1042

Classification	Error content
Finisher jam (Finisher section)	Paper is detected in the sub-path sensor when the power is turned ON or the cover is closed.

Probable cause	Checking and measures
Entrance path sensor (S19) abnormality	Measure the voltage on TP86 on the finisher control PC board (FIN). Then check that the measured voltage is 1V or lower when not shielded and within the range of $3.3V \pm 5\%$ when shielded. If the voltage does not fall within the range mentioned, replace the sensor.
Sub-path sensor (S8) abnormality	Measure the voltage on TP85 on the finisher control PC board (FIN). Then check that the measured voltage is 1V or lower when not shielded and within the range of $3.3V \pm 5\%$ when shielded. If the voltage does not fall within the range mentioned, replace the sensor.
Stationary tray full detection sensor (S11) abnormality	Measure the voltage on TP26 on the finisher control PC board (FIN). Then check that the measured voltage is 1V or lower when not shielded and within the range of $3.3V \pm 5\%$ when shielded. If the voltage does not fall within the range mentioned, replace the sensor.
Faulty cables and connectors	Check if the electrical continuity between the connector terminals is normal. If electricity is not conducted, replace the connector. (Finisher control PC board (FIN): CN6, CN10, CN22)
Finisher control PC board (FIN) abnormality	If the error still occurs after replacing the sensor and the connector, replace the finisher control PC board (FIN).



### [EA31] Transport path paper remaining jam

MJ-1042

Classification	Error content
Finisher jam (Finisher section)	Paper is detected in the entrance path sensor or middle path sensor when the power is turned ON or the cover is closed.

Probable cause	Checking and measures
Entrance path sensor (S19) abnormality	Measure the voltage on TP86 on the finisher control PC board (FIN). Then check that the measured voltage is 1V or lower when not shielded and within the range of $3.3V \pm 5\%$ when shielded. If the voltage does not fall within the range mentioned, replace the sensor.
Middle path sensor (S7) abnormality	Measure the voltage on TP84 on the finisher control PC board (FIN). Then check that the measured voltage is 1V or lower when not shielded and within the range of $3.3V \pm 5\%$ when shielded. If the voltage does not fall within the range mentioned, replace the sensor.
Sub-path sensor (S8) abnormality	Measure the voltage on TP85 on the finisher control PC board (FIN). Then check that the measured voltage is 1V or lower when not shielded and within the range of $3.3V \pm 5\%$ when shielded. If the voltage does not fall within the range mentioned, replace the sensor.
Faulty cables and connectors	Check if the electrical continuity between the connector terminals is normal. If electricity is not conducted, replace the connector. (Finisher control PC board (FIN): CN6, CN22)
Finisher control PC board (FIN) abnormality	If the error still occurs after replacing the sensor and the connector, exchange the finisher control PC board (FIN).

### [EA31] Transport path paper remaining jam

MJ-1109/1110

Classification	Error content
Finisher jam (Finisher section)	Paper which has passed through the entrance sensor does not reach the transport sensor.

Check item	Measures
Paper	Check if there is any paper in the finisher or on the transport path of the equipment and remove it if there is.
Entrance sensor (S1)	<ul style="list-style-type: none"> <li>• Sensor check</li> <li>• Connector check (CN8)</li> <li>• Harness check</li> </ul>
Feeding sensor (S22)	<ul style="list-style-type: none"> <li>• Sensor check (S22)</li> <li>• Connector check (CN1)</li> <li>• Harness check</li> </ul>
Paper position sensor (Hole punch unit: S6-1, S6-2)	<ul style="list-style-type: none"> <li>• Remove any paper dust in and around the sensors (S6-1 and S6-2) and clean them.</li> </ul>
	<ul style="list-style-type: none"> <li>• Sensor check (S6-1, S6-2)</li> <li>• Connector check (CN1, CN4, CN5)</li> <li>• Harness check</li> </ul>
Transport sensor (S2)	<ul style="list-style-type: none"> <li>• Sensor check</li> <li>• Connector check (CN8)</li> <li>• Harness check</li> </ul>
Finisher control PC board (FIN)	<ul style="list-style-type: none"> <li>• Board check</li> <li>• Connector check (CN1, CN8)</li> <li>• Harness check</li> </ul>

Parts to be replaced	Remark
Entrance sensor (S1)	
Feeding sensor (S22)	

Parts to be replaced	Remark
Paper position sensor (S6-1, S6-2)	Hole punch unit
Transport sensor (S2)	
Finisher control PC board (FIN)	

### [EA32] Exit paper remaining jam

MJ-1042

Classification	Error content
Finisher jam (Finisher section)	Paper is detected in the finishing tray sensors when the power is turned ON.

Probable cause	Checking and measures
Finishing tray sensor (S4) abnormality	Measure the voltage on TP14 on the finisher control PC board (FIN). Then check that the measured voltage is 1V or lower when not shielded and within the range of $3.3V \pm 5\%$ when shielded. If the voltage does not fall within the range mentioned, replace the sensor.
Faulty cables and connectors	Check if the electrical continuity between the connector terminals is normal. If electricity is not conducted, replace the connector. (Finisher control PC board (FIN): CN5)
Finisher control PC board (FIN) abnormality	If the error still occurs after replacing the sensor and the connector, exchange the finisher control PC board (FIN).

### [EA32] Exit paper remaining jam

MJ-1109/1110

Classification	Error content
Finisher jam (Finisher section)	Paper is detected in the finishing tray paper detection sensor when the power is turned ON.

Check item	Measures
Paper	Check if there is any paper in the finisher or on the transport path of the equipment and remove it if there is.
Processing tray sensor (S12)	<ul style="list-style-type: none"> <li>• Sensor check</li> <li>• Connector check</li> <li>• Harness check</li> </ul>
Finisher control PC board (FIN)	<ul style="list-style-type: none"> <li>• Board check</li> <li>• Connector check (CN25)</li> <li>• Harness check</li> </ul>

Parts to be replaced	Remark
Processing tray sensor (S12)	
Finisher control PC board (FIN)	

### [EA40] Cover open jam

MJ-1042

Classification	Error content
Finisher jam (Finisher section)	The finisher cover has opened during paper transport.

Probable cause	Checking and measures
Sub-path opening/closing sensor (S12) abnormality	Measure the voltage on TP12 on the finisher control PC board (FIN). Then check that the measured voltage is 1V or lower when not shielded and within the range of $3.3V \pm 5\%$ when shielded. If the voltage does not fall within the range mentioned, replace the sensor.

Probable cause	Checking and measures
Front cover switch (SW1) abnormality	Measure the voltage on TP77 on the finisher control PC board (FIN). Then check that the measured voltage is 1V or lower when the switch is ON and within the range of $3.3V \pm 5\%$ when OFF. If the voltage does not fall within the range mentioned, replace the switch.
Faulty cables and connectors	Check if the electrical continuity between the connector terminals is normal. If electricity is not conducted, replace the connector. (Finisher control PC board (FIN): CN10, CN13)
Finisher control PC board (FIN) abnormality	If the error still occurs after replacing the switches, sensor and connector, exchange the finisher control PC board (FIN).

### [EA40] Cover open jam

MJ-1109/1110

Classification	Error content
Finisher jam (Finisher section)	The finisher cover has opened during paper transport.

Check item	Measures
Cover / stationary tray	<ul style="list-style-type: none"> <li>Close the front cover or the stationary tray if they are opened.</li> </ul>
Front cover switch (SW1)	<ul style="list-style-type: none"> <li>Switch check</li> <li>Connector check</li> <li>Harness check</li> </ul>
Stationary tray opening/closing switch (SW2)	<ul style="list-style-type: none"> <li>Switch check</li> <li>Connector check</li> <li>Harness check</li> </ul>
Finisher control PC board	<ul style="list-style-type: none"> <li>Connector check (CN14)</li> <li>Board check</li> <li>Harness check</li> </ul>

Parts to be replaced	Remark
Cover locking bracket	If it is broken.
Front cover switch (SW1)	
Stationary tray opening/closing switch (SW2)	
Finisher control PC board (FIN)	

### [EA50] Stapling jam

MJ-1042

Classification	Error content
Finisher jam (Finisher section)	Stapling is not performed properly.

Probable cause	Checking and measures
Staple unit stapling start position sensor (S17) abnormality	Measure the voltage on TP23 on the finisher control PC board (FIN). Then check that the measured voltage is 1V or lower when the sensor is ON and within the range of $3.3V \pm 5\%$ when OFF. If the voltage does not fall within the range mentioned, replace the staple unit.
Staple unit staple empty sensor (S18) abnormality	Measure the voltage on TP24 on the finisher control PC board (FIN). Then check that the measured voltage is 1V or lower when the sensor is ON and within the range of $3.3V \pm 5\%$ when OFF. If the voltage does not fall within the range mentioned, replace the staple unit.
Faulty cables and connectors	Check if the electrical continuity between the connector terminals is normal. If electricity is not conducted, replace the connectors. (Finisher control PC board (FIN): CN17)
Finisher control PC board (FIN) abnormality	If the error still occurs after replacing the staple unit and the connectors, exchange the finisher control PC board (FIN).

**[EA50] Stapling jam**

MJ-1109/1110

Classification	Error content
Finisher jam (Finisher section)	Stapling is not performed properly.

Check item	Measures
Stapler	<ul style="list-style-type: none"> <li>• Check if there is any paper in the finisher or on the transport path of the equipment or on the finishing tray. Remove it if there is</li> <li>• Is the jam cleared by taking off the staple cartridge from the finisher and removing the staple sheet slid from the staple case?</li> <li>• If the actuator of the stapler safety sensor (S11) does not move smoothly, remove its clip from the side and then reattach it.</li> <li>• Connector check</li> <li>• Harness check</li> </ul>
Finisher control PC board (FIN)	<ul style="list-style-type: none"> <li>• Board check</li> <li>• Connector check (CN2)</li> <li>• Harness check</li> </ul>

Parts to be replaced	Remark
Stapler	
Finisher control PC board (FIN)	

**[EA60] Early arrival jam**

Classification	Error content
Finisher jam (Finisher section)	A paper jam occurs because paper from the equipment arrives at the Finisher too early.

MJ-1042

Probable cause	Checking and measures
Entrance path sensor (S19) abnormality	Measure the voltage on TP86 on the finisher control PC board (FIN). Then check that the measured voltage is 1V or lower when not shielded and within the range of 3.3V±5% when shielded. If the voltage does not fall within the range mentioned, replace the sensor.
Faulty cables and connectors	Check if the electrical continuity between the connector terminals is normal. If electricity is not conducted, replace the connector. (Finisher control PC board (FIN): CN22)
Finisher control PC board (FIN) abnormality	If the error still occurs after replacing the sensor and the connector, exchange the finisher control PC board (FIN).

MJ-1109/1110

Check item	Measures
Paper	Check if there is any paper in the finisher or on the transport path of the equipment and remove it if there is.
Feeding sensor (S22)	<ul style="list-style-type: none"> <li>• Sensor check(S22)</li> <li>• Connector check (CN1)</li> <li>• Harness check</li> </ul>
Finisher control PC board (FIN)	<ul style="list-style-type: none"> <li>• Board check</li> <li>• Connector check (CN1)</li> <li>• Harness check</li> </ul>

Parts to be replaced	Remark
Feeding sensor (S22)	
Finisher control PC board (FIN)	

**[EA70] Stack exit belt home position error**

Classification	Error content
Finisher jam (Finisher section)	The stack exit belt is not at the home position.

MJ-1109/1110

Check item	Measures
Stack belt exit home position sensor (S9)	Check if there is a disconnection of the connector, incorrect installation or breakage of the stack belt exit home position sensor (S9). If there is, reinstall the sensor correctly or replace it.
	Check if the connector (CN25) on the finisher control PC board is disconnected from the stack belt exit home position sensor (S9) and the harnesses are open circuited. Correct if any.
Stack transport motor (M8)	Check if the connector (CN18) on the finisher control PC board is disconnected from the stack transport motor (M8) and the harnesses are open circuited. Correct if any.

Parts to be replaced	Remark
Stack belt exit home position sensor (S9)	
Stack transport motor (M8)	
Finisher control PC board (FIN)	

**[EAF1] Stack exit roller home position sensor detection error**

MJ-1042

Classification	Error content
Finisher jam (Finisher section)	The detection of the home position of the stack exit roller shift motor ends abnormally. This error may occur if paper is jammed while being transported, so it is treated as a paper jam.

Parts to be replaced	Measures
Stack exit roller shift motor (M6) Stack exit roller home position sensor (S13)	The stack exit roller home position sensor (S13) does not detect that the exit roller is not at the upper position after the stack exit roller motor (M6) has been driven in the specified time when the exit roller is moved down.
	The stack exit roller home position sensor (S13) does not detect that the exit roller is at the upper position after the stack exit roller shift motor (M6) has been driven in the specified time when the exit roller is moved up.

**[EAF2] Stapler unit sliding motor home position detection error**

MJ-1042

Classification	Error content
Finisher jam (Finisher section)	The detection of the home position of the stapler unit sliding motor ends abnormally. This error may occur if paper is jammed while being transported, so it is treated as a paper jam.

Error	Timing of detection
Staple unit sliding motor (M7) Staple unit sliding home position sensor (S3)	The turning OFF of the staple unit sliding home position sensor (S3) is not detected when the staple unit is moved from a point where this sensor is turned ON to one point where this sensor is turned OFF after the staple unit sliding motor (M7) has been driven at the specified number of pulse.
	The turning ON of the staple unit sliding home position sensor (S3) is not detected when the staple unit is moved from a point where this sensor is turned OFF to one point where this sensor is turned ON after the staple unit sliding motor (M7) has been driven at the specified number of pulse.

Probable cause	Checking and measures
Staple unit sliding motor (M7) abnormality	Check if the electrical continuity of the coil is normal. If electricity is not conducted, replace the staple unit.
Staple unit sliding home position sensor (S3) abnormality	Measure the voltage on TP18 on the finisher control PC board (FIN). Then check that the measured voltage is 1V or lower when not shielded and within the range of $3.3V \pm 5\%$ when shielded. If the voltage does not fall within the range mentioned, replace the sensor.
Faulty cables and connectors	Check if the electrical continuity between the connector terminals is normal. If electricity is not conducted, replace the connectors. (Finisher control PC board (FIN): CN3, CN18)
Finisher control PC board (FIN) abnormality	If the error still occurs after replacing the staple unit, sensors and connectors, exchange the finisher control PC board (FIN).

### [EAFA] Catching motor home position detection error

Classification	Error content
Finisher jam (Finisher section)	Catching motor home position detection error.

MJ-1109/1110

Check item	Measures
Catching motor (M21)	Is there any mechanical problem when the catching motor is rotated? If there is any mechanical problem, fix its mechanism.
Catching home position sensor (S52)	<ul style="list-style-type: none"> <li>• Sensor check</li> <li>• Connector check</li> <li>• Harness check</li> </ul>
Harness	Check if the connector on the finisher control PC board is disconnected from the catching home position sensor and the harnesses are open circuited. Correct if any.
Finisher control PC board (FIN)	<ul style="list-style-type: none"> <li>• Board check</li> <li>• Connector check</li> <li>• Harness check</li> </ul>

Parts to be replaced	Remark
Catching home position sensor (S52)	
Harness	
Finisher control PC board (FIN)	

## [ 5 ] Paper jam in saddle stitch section

### [EA90] Cover open jam

MJ-1110

Classification	Error item
Finisher jam (Saddle stitch section)	The saddle stitch unit has opened during printing.

Check item	Measures
Saddle stitch unit	Close the saddle stitch unit if it is open.
Paper	Remove any paper on the stacker.
Saddle stitch unit opening/closing switch (SW5)	<p>Check if there is a disconnection of the connector, incorrect installation or breakage of the saddle stitch unit opening/closing switch (SW5). If there is, reinstall the sensor correctly or replace it.</p> <p>Check if the harness between the saddle stitch unit opening/closing switch (SW5) and the CN26 of the finisher control PC board (FIN) is disconnected or open circuited. Correct if so.</p>

Parts to be replaced	Remarks
Saddle stitch unit opening/closing switch (SW5)	
Finisher control PC board (FIN)	

### [EAA0] Paper remaining jam in Saddle Stitch Unit

MJ-1110

Classification	Error item
Finisher jam (Saddle stitch section)	Paper remaining in Saddle Stitch Unit when the power is turned ON.

Check item	Measures
Paper	<ul style="list-style-type: none"> <li>Check if there is any paper in the finisher, saddle stitch unit or the on the transport path of the equipment. Remove it if there is.</li> <li>Use paper accepted in the specifications.</li> </ul> <p>Do not use the paper shorter than the specification.</p>
Junction box paper detection sensor (S26)	<ul style="list-style-type: none"> <li>Sensor check(S26)</li> <li>Connector check(CN1)</li> <li>Harness check</li> </ul>
Transport path-2 sensor (S27)	<ul style="list-style-type: none"> <li>Sensor check(S27)</li> <li>Connector check(CN3)</li> <li>Harness check</li> </ul>
Transport path-3 sensor (S28)	<ul style="list-style-type: none"> <li>Sensor check(S28)</li> <li>Connector check(CN3)</li> <li>Harness check</li> </ul>
Ejecting roller sensor(S29)	<ul style="list-style-type: none"> <li>Sensor check(S29)</li> <li>Connector check(CN3)</li> <li>Harness check</li> </ul>
Harness	Check if the flat cable between the finisher control PC board (FIN) and the saddle control PC board (SDL) is disconnected or open circuited. Correct if so. (Replace the harness if open circuited. Reconnect the connector securely if there is any disconnection.)
Finisher control PC board (FIN)	<ul style="list-style-type: none"> <li>Board check</li> <li>Connector check(CN21)</li> <li>Harness check</li> </ul>
Saddle control PC board (SDL)	<ul style="list-style-type: none"> <li>Board check</li> <li>Connector check(CN3, CN6)</li> <li>Harness check</li> </ul>

Parts to be replaced	Remarks
Junction box paper detection sensor (S26)	
Transport path-2 sensor (S27)	
Transport path-3 sensor (S28)	
Ejecting roller sensor (S29)	
Finisher control PC board (FIN)	
Saddle control PC board (SDL)	

### [EAB0] Paper transport jam in Saddle Stitch Unit

MJ-1110

Classification	Error item
Finisher jam (Saddle stitch section)	Paper has remained in the transport path.

Check item	Measures
Paper	<ul style="list-style-type: none"> <li>Check if there is any paper in the finisher, saddle stitch unit or the on the transport path of the equipment. Remove it if there is.</li> <li>Use paper accepted in the specifications.</li> </ul> <p>Do not use the paper longer than the specification.</p>
Transport roller	Fix any mechanical problem occurring when the transfer roller is rotated.
Feeding sensor (S22)	<ul style="list-style-type: none"> <li>Sensor check(S22)</li> <li>Connector check (CN1)</li> <li>Harness check</li> </ul>
Junction box paper detection sensor (S26)	<ul style="list-style-type: none"> <li>Sensor check(S26)</li> <li>Connector check(CN1)</li> <li>Harness check</li> </ul>
Transport path-2 (S27)	<ul style="list-style-type: none"> <li>Sensor check(S27)</li> <li>Connector check(CN3)</li> <li>Harness check</li> </ul>
Transport path-3 (S28)	<ul style="list-style-type: none"> <li>Sensor check(S28)</li> <li>Connector check(CN3)</li> <li>Harness check</li> </ul>
Ejecting roller sensor(S29)	<ul style="list-style-type: none"> <li>Sensor check(S29)</li> <li>Connector check(CN3)</li> <li>Harness check</li> </ul>
Saddle transport motor (M16)	<ul style="list-style-type: none"> <li>Motor check(M16)</li> <li>Connector check(CN5)</li> <li>Harness check</li> </ul>
Transport path switching solenoid (SOL5)	<p>Check that the gap between the transfer guide surface and the upper surface of the flapper tip is in the acceptable range according to the status of the transport path switching solenoid (SOL5) (solenoid OFF: 1.5 to 2.1 mm, solenoid ON: 2.3 to 2.9 mm). If it is not, adjust it.</p> <p>Check if the harness between the transport path switching solenoid (SOL5) and the CN1 of the finisher control PC board (FIN) is disconnected or open circuited. Correct if so.</p>
Entrance motor (M1)	<ul style="list-style-type: none"> <li>Motor check(M1)</li> <li>Connector check(CN17)</li> <li>Harness check</li> </ul>
Harness	Check if the flat cable between the finisher control PC board (FIN) and the saddle control PC board (SDL) is disconnected or open circuited. Correct if so. (Replace the harness if open circuited. Reconnect the connector securely if there is any disconnection.)
Finisher control PC board (FIN)	<ul style="list-style-type: none"> <li>Board check</li> <li>Connector check(CN21)</li> <li>Harness check</li> </ul>



Check item	Measures
Saddle control PC board (SDL)	<ul style="list-style-type: none"> <li>Board check</li> <li>Connector check(CN3, CN6)</li> <li>Harness check</li> </ul>

Parts to be replaced	Remarks
Junction box paper detection sensor (S26)	
Feeding sensor (S22)	
Transport path-2 (S27)	
Transport path-3 (S28)	
Ejecting roller sensor (S29)	
Saddle transport motor (M16)	
Entrance motor (M1)	
Transport path switching solenoid (SOL5)	
Saddle control PC board (SDL)	
Finisher control PC board (FIN)	

### [EAB1] Paper size error jam MJ-1110

Classification	Error item
Finisher jam (Saddle stitch section)	Paper does not reach the sensor because the paper is shorter than spec.

Check item	Measures
Paper	<ul style="list-style-type: none"> <li>Check if there is any paper in the finisher, saddle stitch unit or the on the transport path of the equipment. Remove it if there is.</li> <li>Use paper accepted in the specifications.</li> </ul>
Feeding sensor (S22)	<ul style="list-style-type: none"> <li>Sensor check (S22)</li> <li>Connector check (CN1)</li> <li>Harness check</li> </ul>
Junction box paper detection sensor (S26)	<ul style="list-style-type: none"> <li>Sensor check (S26)</li> <li>Connector check (CN1)</li> <li>Harness check</li> </ul>
Transport path-2 sensor (S27)	<ul style="list-style-type: none"> <li>Sensor check (S27)</li> <li>Connector check (CN3)</li> <li>Harness check</li> </ul>
Transport path-3 sensor (S28)	<ul style="list-style-type: none"> <li>Sensor check (S28)</li> <li>Connector check (CN3)</li> <li>Harness check</li> </ul>
Ejecting roller sensor (S29)	<ul style="list-style-type: none"> <li>Sensor check (S29)</li> <li>Connector check (CN3)</li> <li>Harness check</li> </ul>
Harness	Check if the flat cable between the finisher control PC board (FIN) and the saddle control PC board (SDL) is disconnected or open circuited. Correct if so. (Replace the harness if open circuited. Reconnect the connector securely if there is any disconnection.)
Finisher control PC board (FIN)	<ul style="list-style-type: none"> <li>Board check</li> <li>Connector check (CN1, CN21)</li> <li>Harness check</li> </ul>
Saddle control PC board (SDL)	<ul style="list-style-type: none"> <li>Connector check (CN3, CN6)</li> <li>Board check</li> </ul>

Parts to be replaced	Remarks
Feeding sensor (S22)	

Parts to be replaced	Remarks
Junction box paper detection sensor (S26)	
Transport path-2 sensor (S27)	
Transport path-3 sensor (S28)	
Ejecting roller sensor (S29)	
Finisher control PC board (FIN)	
Saddle control PC board (SDL)	

### [EAE0] Receiving time-out jam

Classification	Error content
Finisher jam	The printing has been interrupted because of the communication error between the equipment and finisher when the paper is transported from the equipment to the finisher.

Check item	Measures
Finisher	<ul style="list-style-type: none"> <li>Is the finisher working?</li> <li>Check if the voltage (24V) is being supplied to the finisher.</li> <li>Check if the harness connecting the I/F connector of the finisher side and LGC board is open circuited.</li> <li>Connector check</li> </ul>
LGC board	<ul style="list-style-type: none"> <li>Connector check(CN314, J612)</li> <li>Check if the harness connecting the finisher and LGC board is open circuited.</li> <li>Check if the conductor pattern on the LGC board is short circuited or open circuited.</li> </ul>

Parts to be replaced	Remark
LGC board	
Harness	

### [EB30] Ready time-out jam

Classification	Error content
Other paper jams	The equipment judges that the paper transport to the finisher is disabled because of the communication error between the equipment and finisher at the start of printing.

Check item	Measures
Finisher	<ul style="list-style-type: none"> <li>Check if the connector on the equipment is disconnected from the finisher or the harnesses are open circuited. Correct if any.</li> <li>Check the finisher firmware version.</li> <li>Update the finisher firmware to the latest one.</li> </ul>

Parts to be replaced	Remark
LGC board	

**[ED10] Skew adjustment motor home position detection error**

MJ-1109/1110 (when MJ-6105 is installed)

Classification	Error content
Finisher jam (Hole Punch section)	The skew adjustment motor is not at the home position.

Check item	Measures
Paper	<ul style="list-style-type: none"> <li>Check if there is any paper in the hole punch unit, finisher or the on the transport path of the equipment. Remove it if there is.</li> <li>Use paper accepted in the specifications.</li> </ul>
Skew adjustment motor (M1)	Rotate skew adjustment motor and fix its mechanism if it does not rotate smoothly.
Skew HP sensor (S2) Skew adjustment motor (M1) Hole punch control PC board	Check if the connectors on the hole punch control PC board (HP board) are disconnected from the skew HP sensor (S2) and the skew adjustment motor, or the harnesses are open circuited. Correct if any.

Parts to be replaced	Remark
Skew adjustment motor (M1)	
Skew HP sensor (S2)	
Hole punch control PC board (HP)	

**[ED11] Sideways adjustment motor home position detection error**

MJ-1109/1110 (when MJ-6105 is installed)

Classification	Error content
Finisher jam (Hole Punch section)	The sideways adjustment motor is not at the home position.

Check item	Measures
Paper	<ul style="list-style-type: none"> <li>Check if there is any paper in the hole punch unit, finisher or the on the transport path of the equipment. Remove it if there is.</li> <li>Use paper accepted in the specifications.</li> </ul>
Sideways adjustment motor (M2)	Rotate sideways adjustment motor and fix its mechanism if it does not rotate smoothly.
Sideways deviation HP sensor (S3) Sideways adjustment motor (M2) Hole punch control PC board (HP)	Check if the connectors on the hole punch control PC board (HP board) are disconnected from the sideways deviation HP sensor (S3) and the sideways adjustment motor, or the harnesses are open circuited. Correct if any.

Parts to be replaced	Remark
Sideways adjustment motor (M2)	
Sideways deviation HP sensor (S3)	
Hole punch control PC board (HP)	

**[ED13] Front alignment plate home position error**

MJ-1109/1110

Classification	Error content
Finisher jam (Finisher section)	The front alignment plate is not at the home position.

Check item	Measures
Front alignment plate	Move the front alignment plate. Fix any mechanical problem.
Front alignment plate home position sensor (S7)	Check if there is a disconnection of the connector, incorrect installation or breakage of the front alignment plate home position sensor (S7). If there is, reinstall the sensor correctly or replace it.
	Check if the connector (CN25) on the finisher control PC board is disconnected from the front alignment plate home position sensor (S7) and the harnesses are open circuited. Correct if so.
Front alignment motor (M5)	Check if the connector (CN18) on the finisher control PC board is disconnected from the front alignment motor (M5) and the harnesses are open circuited. Correct if so.

Parts to be replaced	Remark
Front alignment plate home position sensor (S7)	
Front alignment motor (M5)	
Finisher control PC board (FIN)	

**[ED14] Rear alignment plate home position error**

Classification	Error content
Finisher jam (Finisher section)	The rear alignment plate is not at the home position.

MJ-1109/1110

Check item	Measures
Rear alignment plate	Move the rear alignment plate. Fix any mechanical problem.
Rear alignment plate home position sensor (S8)	Check if there is a disconnection of the connector, incorrect installation or breakage of the rear alignment plate home position sensor (S8). If there is, reinstall the sensor correctly or replace it.
	Check if the connector (CN25) on the finisher control PC board is disconnected from the rear alignment plate home position sensor (S8) and the harnesses are open circuited. Correct if so.
Rear alignment motor (M6)	Check if the connector (CN18) on the finisher control PC board is disconnected from the rear alignment motor (M6) and the harnesses are open circuited. Correct if so.

Parts to be replaced	Remark
Rear alignment plate home position sensor (S8)	
Rear alignment motor (M6)	
Finisher control PC board (FIN)	

**[ED15] Paddle home position error**

MJ-1109/1110

Classification	Error content
Finisher jam (Finisher section)	The paddle is not at the home position.

Check item	Measures
Paddle	Rotate the paddle. If there is any mechanical problem, fix its mechanism.
Paddle home position sensor Paddle motor Finisher control PC board	Check if the connectors (CN15, CN16) on the finisher control PC board (FIN) are disconnected from the paddle home position sensor (S3) and the paddle motor (M3), or the harnesses are open circuited. Correct if any.

Parts to be replaced	Remark
Paddle motor (M3)	
Paddle home position sensor (S3)	
Finisher control PC board (FIN)	

**[ED16] Buffer tray home position error**

MJ-1109/1110

Classification	Error content
Finisher jam	The buffer tray is not at the home position.

Check item	Measures
Buffer tray guide	Open and close the buffer tray guide. Fix any mechanical problem.
Buffer tray home position sensor (S5)	Check if there is a disconnection of the connector, incorrect installation or breakage of the buffer tray home position sensor (S5). If there is, reinstall the sensor correctly or replace it. Check if the connector (CN11) on the finisher control PC board is disconnected from the buffer tray home position sensor (S5) and the harnesses are open circuited. Correct if so.
Assist arm motor (M10)	Check if the connector (CN10) on the finisher control PC board is disconnected from the assist arm motor (M10) and the harnesses are open circuited. Correct if so.
Buffer tray guide motor (M2)	Check if the connector (CN10) on the finisher control PC board is disconnected from the buffer tray guide motor (M2) and the harnesses are open circuited. Correct if so.

Parts to be replaced	Remark
Buffer tray home position sensor (S5)	
Assist arm motor (M10)	
Buffer tray guide motor (M2)	
Finisher control PC board (FIN)	

**[EF10] Paper not supported for saddle stitch finisher**

MJ-1110

Classification	Error item
Finisher jam (Saddle stitch section)	Unsupported paper size, type and an excess number of pages for stapling are selected.

Check item	Measures
Paper	<ul style="list-style-type: none"> <li>Check the paper size, paper type, or number of pages for stapling. Change them if they are unsupported.</li> </ul>

**[EF11] Saddle stitch finisher stapling error (front)**

MJ-1110

Classification	Error item
Finisher jam (Saddle stitch section)	Front stapling is not correctly done.

Check item	Measures
Paper	<ul style="list-style-type: none"> <li>Check if there is any paper in the hole punch unit, finisher or the on the transport path of the equipment. Remove it if there is.</li> <li>Use paper accepted in the specifications.</li> </ul>
Staple cartridge (front side)	<ul style="list-style-type: none"> <li>Is the jam released by taking off the front staple cartridge from the Finisher and removing the staple sheet slid from the staple case?</li> </ul>
Front saddle stapler drive unit	<ul style="list-style-type: none"> <li>Unit check</li> <li>Connector check</li> <li>Harness check</li> </ul>
Saddle control PC board (SDL)	<ul style="list-style-type: none"> <li>Connector check (CN2)</li> <li>Board check</li> </ul>

Parts to be replaced	Remarks
Front saddle stapler drive unit	
Saddle control PC board (SDL)	

**[EF12] Saddle stitch finisher stapling error (rear)**

MJ-1110

Classification	Error item
Finisher jam (Saddle stitch section)	Rear stapling is not correctly done.

Check item	Measures
Paper	<ul style="list-style-type: none"> <li>Check if there is any paper in the hole punch unit, finisher or the on the transport path of the equipment. Remove it if there is.</li> <li>Use paper accepted in the specifications.</li> </ul>
Staple cartridge (rear side)	<ul style="list-style-type: none"> <li>Is the jam released by taking off the rear staple cartridge from the Finisher and removing the staple sheet slid from the staple case?</li> </ul>
Rear saddle stapler drive unit	<ul style="list-style-type: none"> <li>Unit check</li> <li>Connector check</li> <li>Harness check</li> </ul>
Saddle control PC board (SDL)	<ul style="list-style-type: none"> <li>Connector check (CN1)</li> <li>Board check</li> </ul>

Parts to be replaced	Remarks
Rear saddle stapler drive unit	

Parts to be replaced	Remarks
Saddle control PC board (SDL)	

### [EF13] Saddle stitch unit paper holding home position detection error

MJ-1110

Classification	Error item
Finisher jam (Saddle stitch section)	The paper holder home position cannot be detected.

Check item	Measures
Paper holding cam	<ul style="list-style-type: none"> <li>Is there any mechanical problem when the paper holding cam is rotated? Correct if so.</li> </ul>
Paper holding home position sensor (S38)	<ul style="list-style-type: none"> <li>Sensor check</li> <li>Connector check</li> <li>Harness check</li> </ul>
Paper holding clutch (CLT4)	Check if the harness between the saddle control PC board (SDL) and the paper holding clutch (CLT4) is disconnected or open circuited. Correct if so. (Replace the harness if open circuited. Reconnect the connector securely if there is any disconnection.)
Saddle transport motor (M16)	Check if the harness between the saddle control PC board (SDL) and the saddle transport motor (M16) is disconnected or open circuited. Correct if so. (Replace the harness if open circuited. Reconnect the connector securely if there is any disconnection.)
Saddle control PC board (SDL)	<ul style="list-style-type: none"> <li>Connector check (CN5)</li> <li>Board check</li> </ul>

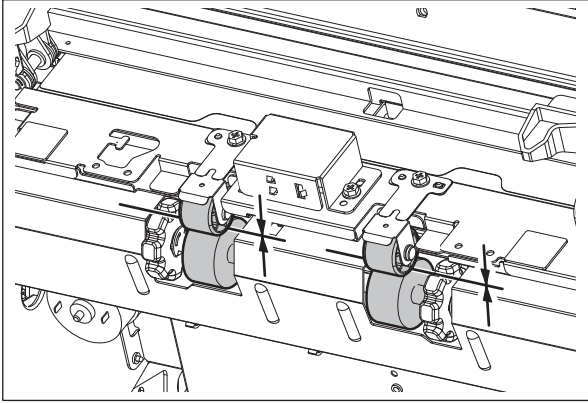
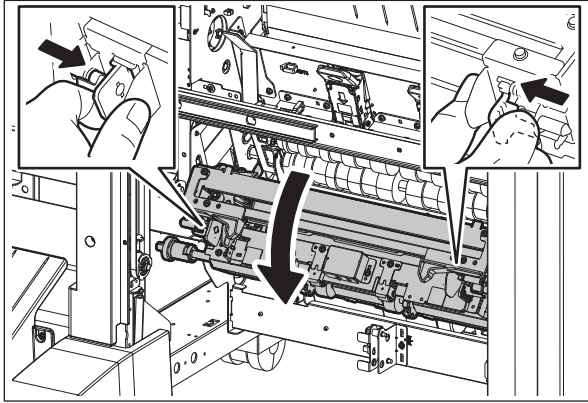
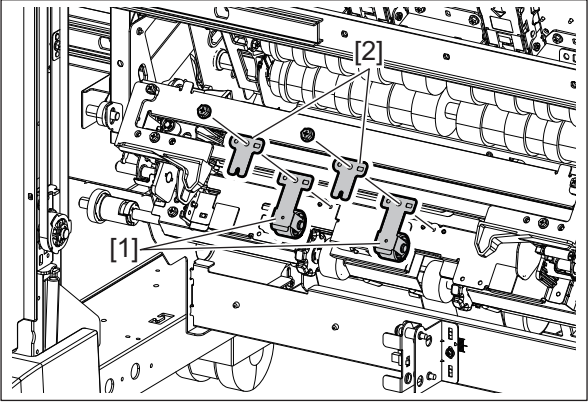
Parts to be replaced	Remarks
Paper holding home position sensor (S38)	
Paper holding clutch (CLT4)	
Saddle transport motor (M16)	
Saddle control PC board (SDL)	

### [EF14] Saddle stitch unit paper exit jam

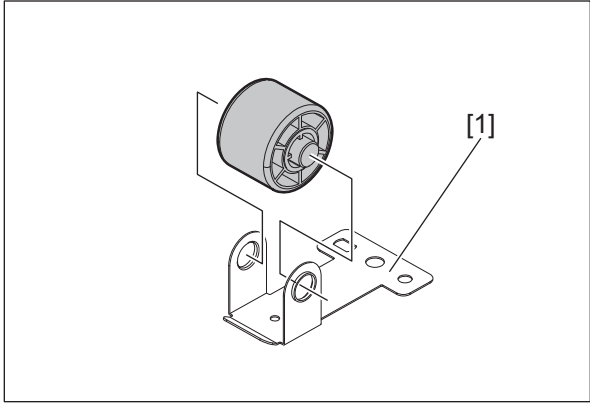
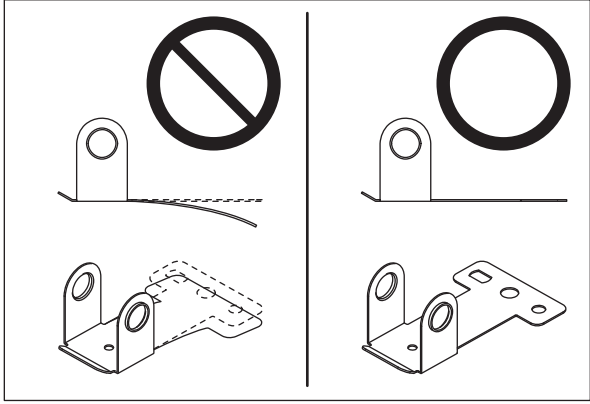
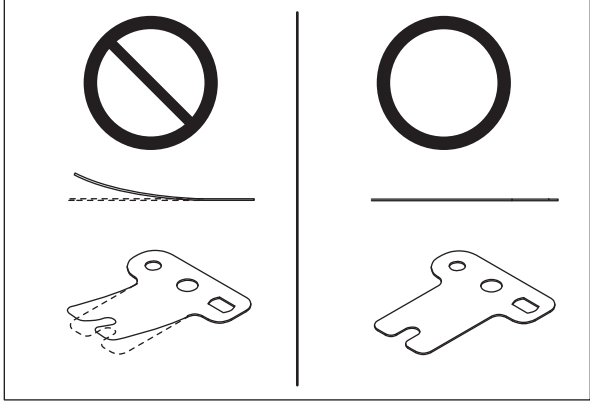
MJ-1110

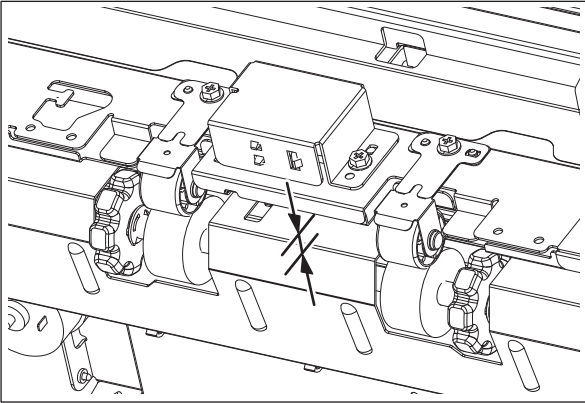
Classification	Error item
Finisher jam (Saddle stitch section)	Outputting paper is not completed within a fixed time.

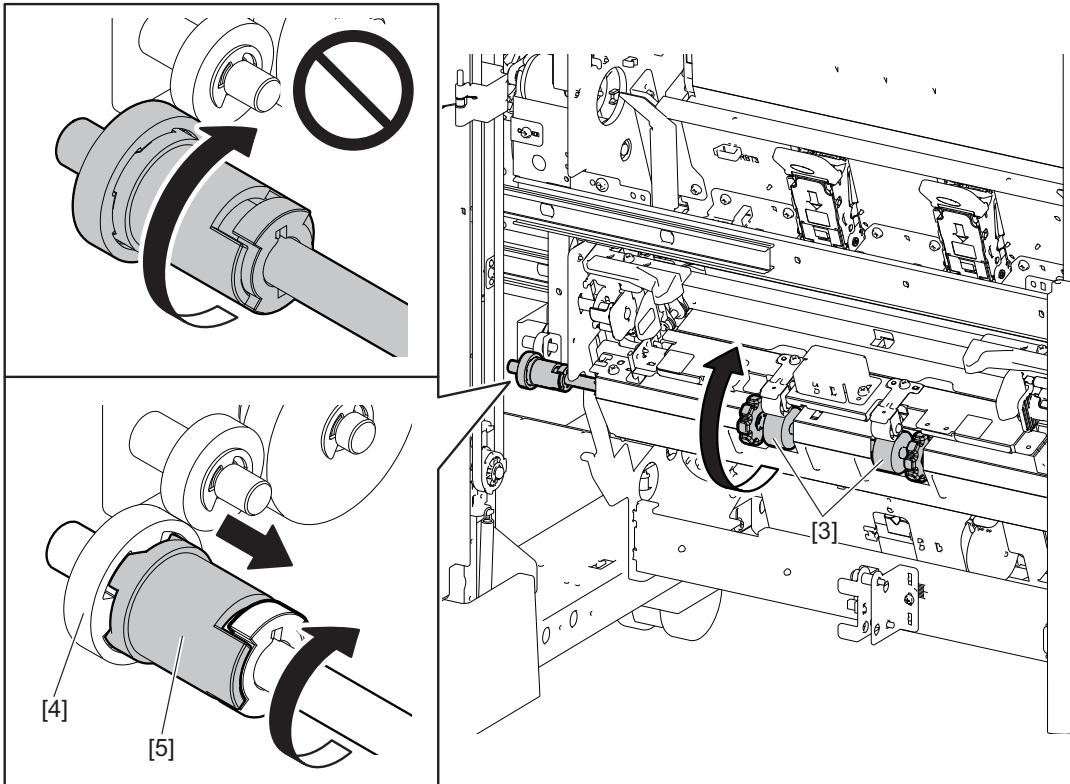
Check item	Measures
Paper	<ul style="list-style-type: none"> <li>Is there any paper remaining in the paper transport path of the equipment or the saddle stitch section of the Finisher?</li> </ul>
Exit sensor (S31)	<ul style="list-style-type: none"> <li>Sensor check</li> <li>Connector check (CN7)</li> <li>Harness check</li> </ul>
Harness	Check if the harness between the finisher control PC board (FIN) and the saddle control PC board (SDL) is disconnected or open circuited. Correct if so. (Replace the harness if open circuited. Reconnect the connector securely if there is any disconnection.)
Finisher control PC board (FIN)	<ul style="list-style-type: none"> <li>Board check</li> <li>Connector check (CN21)</li> <li>Harness check</li> </ul>
Saddle control PC board (SDL)	<ul style="list-style-type: none"> <li>Connector check (CN6, CN7)</li> <li>Board check</li> </ul>

Check item	Measures
<p>Leaf springs and assist leaf springs of the transport pinch roller (for the saddle)</p>	<ul style="list-style-type: none"> <li>Check if there is any gap between the exit roller (for the saddle) and the transport pinch roller (for the saddle). If there is, replace the leaf springs [1] and the assist leaf springs [2] of the transport pinch roller (for the saddle).</li> </ul> 
	<p><b>Fig.8-4</b></p> <ul style="list-style-type: none"> <li>Check if the leaf springs [1] and the assist leaf springs [2] of the transport pinch roller (for the saddle) are missshapen. If they are warped or deformed, replace them. For the removal procedure of the leaf springs [1] and the assist leaf springs [2], refer to the following figures.</li> </ul> 
	 <p><b>Fig.8-6</b></p>

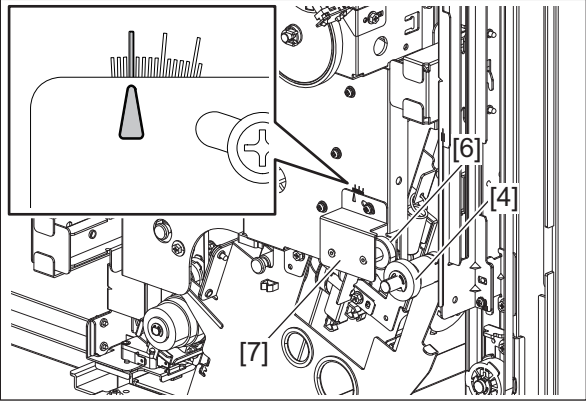
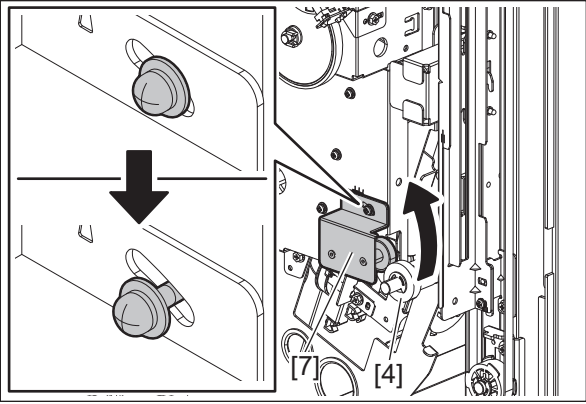
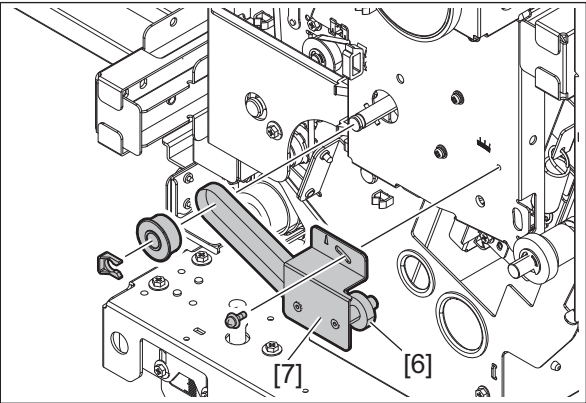


Check item	Measures
<p>Leaf springs and assist leaf springs of the transport pinch roller (for the saddle)</p>	<ul style="list-style-type: none"> <li>Take off the leaf springs [1].</li> </ul> <div data-bbox="683 193 1275 597" style="border: 1px solid black; padding: 10px; margin: 10px 0;">  </div> <p><b>Fig.8-7</b></p> <p><b>Notes:</b>  In order to confirm that there is no warpage or deformation on the leaf springs [1] and the assist leaf springs [2] of the transport pinch roller (for the saddle), remove them and put them on a flat place.</p> <div data-bbox="683 842 1275 1247" style="border: 1px solid black; padding: 10px; margin: 10px 0;">  </div> <p><b>Fig.8-8</b></p> <div data-bbox="683 1357 1275 1761" style="border: 1px solid black; padding: 10px; margin: 10px 0;">  </div> <p><b>Fig.8-9</b></p>

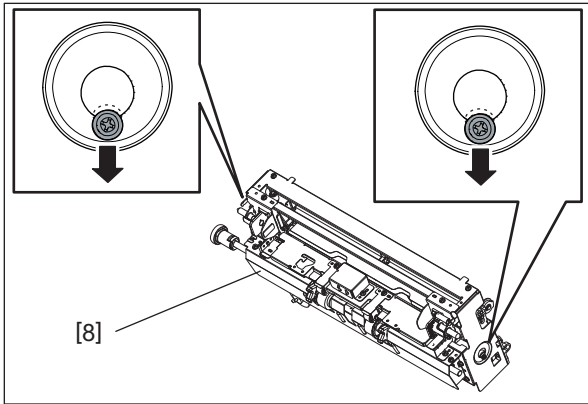
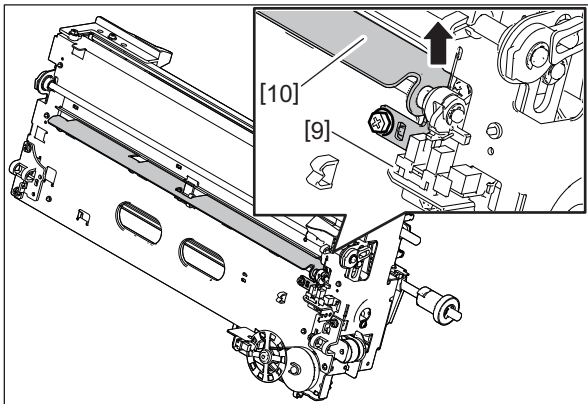
Check item	Measures
Lower transport guide	<p>Check that the gap of the lower transport guide is 15 mm or below.            15 mm or below: OK            Larger than 15 mm: Not good</p>  <p><b>Fig.8-10</b></p> <p>If the gap is larger than 15 mm, check the attachment condition or replace the lower transport guide.</p>
Exit roller (for the saddle)	<ul style="list-style-type: none"> <li>• Check the engagement status of the gear [4] by rotating the exit roller [3] (for the saddle) in the direction of the arrow (opposite direction of the exiting).           <ul style="list-style-type: none"> <li>- When not good: The gear [4] rotates without having been engaged. (The ratchet [5] does not rotate.)</li> <li>- When OK: The ratchet [5] rotates while sliding, but the gear [4] is stopped. (The gear [4] is engaged.)</li> </ul> </li> </ul>



**Fig.8-11**

Check item	Measures
Exit roller (for the saddle)	<ul style="list-style-type: none"> <li>In the case of “not good”, replace the bracket [7] at the idle gear [6] side.</li> </ul> <p><b>Notes:</b> When replacing, check the position where the pre-change bracket [7] is attached and add its marking in order to install the post-change one in the same place.</p>  <p><b>Fig.8-12</b></p> <ul style="list-style-type: none"> <li>For the removal procedure of the bracket [7], refer to the following figures.</li> </ul>  <p><b>Fig.8-13</b></p>  <p><b>Fig.8-14</b></p>

Check item	Measures
Exit roller (for the saddle)	<p data-bbox="657 583 746 610">Fig.8-15</p>

Check item	Measures
EFS unit	<ul style="list-style-type: none"> <li>• Correct the misalignment of the shaft of the EFS unit [8]. Move the screws in the direction of the arrow and secure them. (both the front and rear)</li> </ul>  <p><b>Fig.8-16</b></p> <ul style="list-style-type: none"> <li>• Replace the following parts. <ul style="list-style-type: none"> <li>- BRIR-ROD-EX-F-SDL-F5330</li> <li>- PLT-BURR-ROD-EX-F-SDL</li> <li>- ASYS-PLT3-FILM3-EFS</li> <li>- FILM4-EFS</li> <li>- ACTR-EX-F-SDL</li> <li>- SPG-ACTR-EX-F-SDL</li> <li>- SHAFT-ACTR-EX-F-SDL</li> <li>- ACTR2-EFS</li> <li>- SPG-T-11R5XR55X5R5L-SDL3</li> </ul> </li> <li>• Check if there is a disconnection of the connector, incorrect installation or breakage of the exit transport sensor (S41) [9]. If there is, reinstall the sensor correctly or replace it. Move the bracket [10] in the direction of the arrow and secure it with the screw.</li> </ul>  <p><b>Fig.8-17</b></p>

Parts to be replaced	Remarks
Exit sensor (S31)	
Saddle control PC board (SDL)	
Finisher control PC board (FIN)	
Leaf springs for the transport pinch roller (for the saddle)	Even if no abnormalities have been confirmed by the check items for the lower transport guide (for the saddle) and the transport pinch roller (for the saddle), replace the leaf springs and the assist leaf springs of the transport pinch roller (for the saddle) if an EF14 error has occurred.
Assist leaf springs for the transport pinch roller (for the saddle)	

Parts to be replaced	Remarks
Bracket at the idle gear side	
Lower transport guide (for the saddle)	
Exit roller (for the saddle)	
EFS unit	<ul style="list-style-type: none"> <li>• BRIR-ROD-EX-F-SDL-F5330</li> <li>• PLT-BURR-ROD-EX-F-SDL</li> <li>• ASYS-PLT3-FILM3-EFS</li> <li>• FILM4-EFS</li> <li>• ACTR-EX-F-SDL</li> <li>• SPG-ACTR-EX-F-SDL</li> <li>• SHAFT-ACTR-EX-F-SDL</li> <li>• ACTR2-EFS</li> <li>• SPG-T-11R5XR55X5R5L-SDL3</li> <li>• Exit transport sensor (S41)</li> </ul>

**[EF15] Saddle stitch finisher side alignment motor home position detection abnormality**  
MJ-1110

Classification	Error item
Finisher jam (Saddle stitch section)	The side alignment motor home position cannot be detected.

Check item	Measures
Jog	<ul style="list-style-type: none"> <li>• Is there any mechanical problem when the jog is moved? Correct if so.</li> </ul>
Side alignment home position sensor (S36)	<ul style="list-style-type: none"> <li>• Sensor check</li> <li>• Connector check</li> <li>• Harness check</li> </ul>
Side alignment motor (M15)	<ul style="list-style-type: none"> <li>• Motor check</li> <li>• Connector check</li> <li>• Harness check</li> </ul>
Saddle control PC board (SDL)	<ul style="list-style-type: none"> <li>• Connector check (CN4)</li> <li>• Board check</li> </ul>

Parts to be replaced	Remarks
Side alignment home position sensor (S36)	
Side alignment motor (M15)	
Saddle control PC board (SDL)	

**[EF16] Saddle stitch finisher stacker motor home position detection abnormality**  
MJ-1110

Classification	Error item
Finisher jam (Saddle stitch section)	The stacker motor home position cannot be detected.

Check item	Measures
Stacker carrier	<ul style="list-style-type: none"> <li>Is there any mechanical problem when the stacker carrier is moved? Correct if so.</li> </ul>
Stacker home position sensor (S33)	<ul style="list-style-type: none"> <li>Sensor check</li> <li>Connector check</li> <li>Harness check</li> </ul>
Stacker motor (M14)	<ul style="list-style-type: none"> <li>Motor check</li> <li>Connector check</li> <li>Harness check</li> </ul>
Saddle control PC board (SDL)	<ul style="list-style-type: none"> <li>Connector check (CN8)</li> <li>Board check</li> </ul>

Parts to be replaced	Remarks
Stacker home position sensor (S33)	
Stacker motor (M14)	
Saddle control PC board (SDL)	

**[EF17] Saddle stitch finisher folding blade home position detection abnormality**  
MJ-1110

Classification	Error item
Finisher jam (Saddle stitch section)	The folding blade home position cannot be detected.

Check item	Measures
Folding blade cam	<ul style="list-style-type: none"> <li>Is there any mechanical problem when the folding blade cam is rotated? Correct if so.</li> </ul>
Folding blade home position sensor (S35)	<ul style="list-style-type: none"> <li>Sensor check</li> <li>Connector check (CN12)</li> <li>Harness check</li> </ul>
Folding blade clutch (CLT3)	<ul style="list-style-type: none"> <li>Clutch check</li> <li>Connector check (CN13)</li> <li>Harness check</li> </ul>
Saddle control PC board (SDL)	<ul style="list-style-type: none"> <li>Connector check (CN12, CN13)</li> <li>Board check</li> </ul>

Parts to be replaced	Remarks
Folding blade home position sensor (S35)	
Folding blade clutch (CLT3)	
Saddle control PC board (SDL)	

**[EF18] Saddle stitch finisher additional folding roller home position detection abnormality**  
MJ-1110

Classification	Error item
Finisher jam (Saddle stitch section)	The additional folding roller home position cannot be detected.

Check item	Measures
Additional folding carrier	<ul style="list-style-type: none"> <li>Is there any mechanical problem when the additional folding carrier is moved? Correct if so.</li> </ul>
Additional folding home position sensor (S39) Additional folding motor encoder sensor (S42)	<ul style="list-style-type: none"> <li>Sensor check</li> <li>Connector check (CN7)</li> <li>Harness check</li> </ul>
Additional folding motor (M20)	<ul style="list-style-type: none"> <li>Motor check. Check if the motor and timing belt is installed properly.</li> <li>Connector check (CN10)</li> <li>Harness check</li> </ul>
Saddle control PC board (SDL)	<ul style="list-style-type: none"> <li>Connector check (CN7, CN10)</li> <li>Board check</li> </ul>

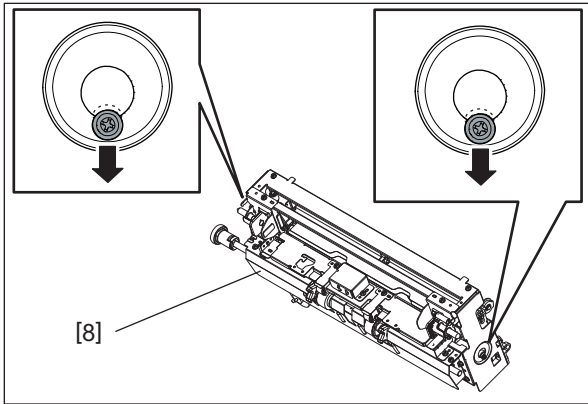
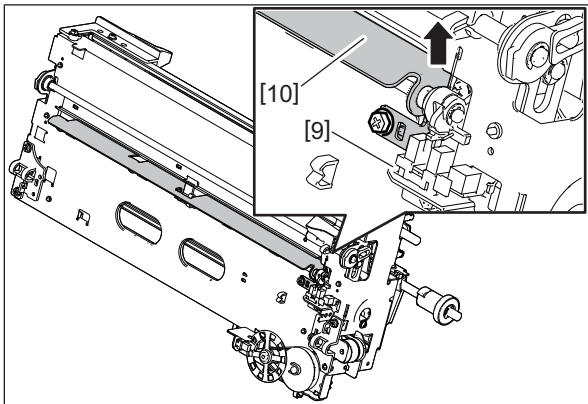
Parts to be replaced	Remarks
Additional folding home position sensor (S39)	
Additional folding motor encoder sensor (S42)	
Additional folding motor (M20)	
Saddle control PC board (SDL)	

**[EF19] Saddle stitch unit paper folding jam**  
MJ-1110

Classification	Error item
Finisher jam (Saddle stitch section)	Fold processed paper cannot be transported to the additional folding roller.

Check item	Measures
Paper	<ul style="list-style-type: none"> <li>Is there any paper remaining in the paper transport path in the equipment or the saddle stitch section of the Finisher?</li> <li>Use paper accepted in the specifications.</li> </ul>
Exit transport sensor (S41)	<ul style="list-style-type: none"> <li>Sensor check</li> <li>Connector check (CN7)</li> <li>Harness check</li> </ul>
Stacker paper detection sensor (S30)	<ul style="list-style-type: none"> <li>Sensor check</li> <li>Connector check (CN3)</li> <li>Harness check</li> </ul>
Harness	<ul style="list-style-type: none"> <li>Connector check</li> <li>Flat harness check</li> </ul>
Finisher control PC board (FIN)	<ul style="list-style-type: none"> <li>Board check</li> <li>Connector check (CN21)</li> <li>Harness check</li> </ul>
Saddle control PC board (SDL)	<ul style="list-style-type: none"> <li>Connector check (CN7)</li> <li>Board check</li> </ul>



Check item	Measures
EFS unit	<ul style="list-style-type: none"> <li>• Correct the misalignment of the shaft of the EFS unit [8]. Move the screws in the direction of the arrow and secure them. (both the front and rear)</li> </ul>  <p><b>Fig.8-18</b></p> <ul style="list-style-type: none"> <li>• Replace the following parts. <ul style="list-style-type: none"> <li>- BRIR-ROD-EX-F-SDL-F5330</li> <li>- PLT-BURR-ROD-EX-F-SDL</li> <li>- ASYS-PLT3-FILM3-EFS</li> <li>- FILM4-EFS</li> <li>- HLDR-P-SNSR-SDL</li> <li>- ACTR-P-SNSR-SDL</li> <li>- SPG-P-SNSR-SDL</li> <li>- ACTR2-EFS</li> <li>- SPG-T-11R5XR55X5R5L-SDL3</li> </ul> </li> <li>• Check if there is a disconnection of the connector, incorrect installation or breakage of the exit transport sensor (S41) [9]. If there is, reinstall the sensor correctly or replace it. Move the bracket [10] in the direction of the arrow and secure it with the screw.</li> </ul>  <p><b>Fig.8-19</b></p>

Parts to be replaced	Remarks
Exit transport sensor (S41)	
Stacker paper detection sensor (S30)	
Saddle control PC board (SDL)	
Finisher control PC board (FIN)	
EFS unit	<ul style="list-style-type: none"> <li>• BRIR-ROD-EX-F-SDL-F5330</li> <li>• PLT-BURR-ROD-EX-F-SDL</li> <li>• ASYS-PLT3-FILM3-EFS</li> <li>• FILM4-EFS</li> <li>• HLDR-P-SNSR-SDL</li> <li>• ACTR-P-SNSR-SDL</li> <li>• SPG-P-SNSR-SDL</li> <li>• ACTR2-EFS</li> <li>• SPG-T-11R5XR55X5R5L-SDL3</li> </ul>

### [EF20] Saddle stitch unit stacker jam

MJ-1110

Classification	Error item
Finisher jam (Saddle stitch section)	Transported paper cannot be detected in the stacker paper detection sensor.

Check item	Measures
Paper	<ul style="list-style-type: none"> <li>• Is there any paper remaining in the paper transport path in the equipment or the saddle stitch section of the Finisher?</li> <li>• Use paper accepted in the specifications.</li> </ul>
Stacker paper detection sensor (S30)	<ul style="list-style-type: none"> <li>• Sensor check</li> <li>• Connector check (CN3)</li> <li>• Harness check</li> </ul>
Harness	<ul style="list-style-type: none"> <li>• Connector check</li> <li>• Flat harness check</li> </ul>
Finisher control PC board (FIN)	<ul style="list-style-type: none"> <li>• Board check</li> <li>• Connector check (CN21)</li> <li>• Harness check</li> </ul>
Saddle control PC board (SDL)	<ul style="list-style-type: none"> <li>• Connector check (CN3)</li> <li>• Board check</li> </ul>

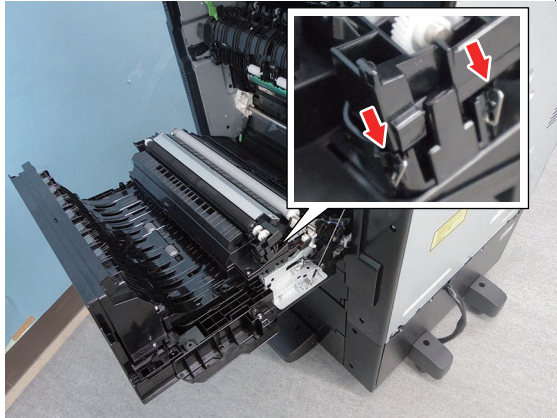
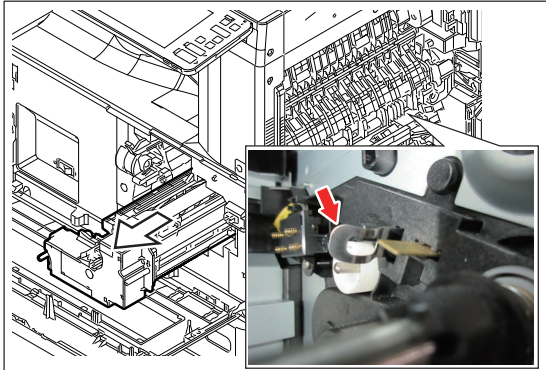
Parts to be replaced	Remarks
Stacker paper detection sensor (S30)	
Saddle control PC board (SDL)	

### 8.3.9 Drive system related service call

#### [C010] Main motor abnormality

Classification	Error content
Drive system related service call	The main motor is not rotating normally.

Procedure	Check item	Result	Measures	Next Step
1	Is the main motor working? (Perform the output check in the test mode: 03-101/151)	Yes		2
		No	<ul style="list-style-type: none"> <li>• Check if the connector (CN650, CN651) of the main motor is disconnected.</li> <li>• Check if the connector CN303 on the LGC board is disconnected.</li> <li>• Check if the connector pins are disconnected and the harnesses are open circuited.</li> <li>• Check if the conductor patterns on the main motor board and LGC board are short circuited or open circuited.</li> <li>• Replace the main motor.</li> <li>• Replace the LGC board.</li> </ul>	
2	Are there any damage or scratches on the main motor board?	Yes		3
		No	<ul style="list-style-type: none"> <li>• Check if the connector pins are disconnected and the harnesses are open circuited.</li> <li>• Check if the conductor patterns on the main motor board and LGC board are short circuited or open circuited.</li> <li>• Replace the main motor.</li> </ul>	
3	LGC board		<ul style="list-style-type: none"> <li>• Replace the LGC board.</li> </ul>	

Procedure	Check item	Result	Measures	Next Step
4	Is there any damage to the high-voltage power supplying springs?	Yes	<ul style="list-style-type: none"> <li>If the power supplying spring for transfer/separation is unhooked, attach it properly.</li> </ul>  <p><b>Fig.8-20</b></p> <ul style="list-style-type: none"> <li>If the power supplying spring for the main charger is deformed, replace it.</li> </ul>  <p><b>Fig.8-21</b></p>	
		No		5
5	Can the gear of the process unit be rotated when it is turned manually?	Yes		6
		No	Replace the process unit.	
6	Fuser unit		Release the pressure lever and turn the gear of the fuser unit manually. If not, replace the fuser unit.	

Parts to be replaced	Remark
Main motor	
LGC board	
High-voltage power supplying springs	
Process unit	
Fuser unit	

### 8.3.10 Paper feeding system related service call

#### [C040] PFP motor abnormality

Classification	Error content
Paper feeding system related service call	The PFP motor is not rotating normally.

Procedure	Check item	Result	Measures	Next Step
1	Is the PFP motor working? (Perform the output check in the test mode: 03-109/159)	Yes		2
		No	<ul style="list-style-type: none"> <li>• Check if the signal line connector J952 of the PFP motor is disconnected.</li> <li>• Check if the connector CN245 on the PFP board is disconnected.</li> <li>• Check if the connector CN241 on the PFP board is disconnected.</li> <li>• Check if the connector CN315 on the LGC board is disconnected.</li> <li>• Check if the connector pins are disconnected and the harnesses are open circuited.</li> <li>• Check if the conductor patterns on the PFP motor board, PFP board and LGC board are short circuited or open circuited.</li> <li>• Replace the PFP motor.</li> </ul>	
2	Is the LED on the PFP motor board lit without flickering?	Yes		3
		No	<ul style="list-style-type: none"> <li>• Check if the connector pins are disconnected and the harnesses are open circuited.</li> <li>• Check if the conductor patterns on the PFP motor board, PFP board and LGC board are short circuited or open circuited.</li> <li>• Replace the PFP motor.</li> </ul>	
3	PFP board LGC board		<ul style="list-style-type: none"> <li>• Replace the PFP board.</li> <li>• Replace the LGC board.</li> </ul>	

Parts to be replaced	Remark
PFP motor	
PFP board	
LGC board	

8

**[C130] 1st drawer tray abnormality**

**[C140] 2nd drawer tray abnormality**

Classification	Error content
Paper feeding system related service call	<ul style="list-style-type: none"> <li>The upper tray-up motor is not rotating or the 1st drawer tray is not moving normally.</li> <li>The lower tray-up motor is not rotating or the 2nd drawer tray is not moving normally.</li> </ul>

Procedure	Check item	Result	Measures	Next Step
1	Does the tray go up? (Perform the output check in the test mode: FS-03-242, FS-03-243)	Yes		2
		No	<ul style="list-style-type: none"> <li>Check if the connector of the upper tray-up motor is disconnected.</li> <li>Check if the connector of the lower tray-up motor is disconnected (J677).</li> <li>Check if the connector CN318 on the LGC board is disconnected.</li> <li>Check if the connector pins are disconnected and the harnesses are open circuited.</li> <li>Check if the conductor pattern on the LGC board is short circuited or open circuited.</li> </ul>	
2	Is the tray-up sensor working?(Perform the input check in the test mode: FS-03-[ALL]OFF/[0]/[E], FS-03-[F2]ON/[4]/[E])	Yes		3
		No	<ul style="list-style-type: none"> <li>Check if the connector of the sensor is disconnected.</li> <li>Check if the connector CN316 on the LGC board is disconnected.</li> <li>Check if the slit reaches the sensor.</li> <li>Check if the connector pins are disconnected and the harnesses are open circuited.</li> <li>Check if the conductor pattern on the LGC board is short circuited or open circuited.</li> </ul>	
3	LGC board		<ul style="list-style-type: none"> <li>Check if the conductor pattern on the LGC board is short circuited or open circuited.</li> <li>Replace the LGC board.</li> </ul>	

Parts to be replaced	Remark
LGC board	
Upper tray-up motor Lower tray-up motor	
1st drawer tray-up sensor 2nd drawer tray-up sensor	

**[C150] PFP upper drawer tray abnormality**

**[C160] PFP lower drawer tray abnormality**

Classification	Error content
Paper feeding system related service call	<ul style="list-style-type: none"> <li>The PFP tray-up motor is not rotating or the PFP upper drawer tray is not moving normally.</li> <li>The PFP tray-up motor is not rotating or the PFP lower drawer tray is not moving normally.</li> </ul>

Procedure	Check item	Result	Measures	Next Step
1	Does the tray go up? (Perform the output check in the test mode: FS-03-278, FS-03-280)	Yes		2
		No	<ul style="list-style-type: none"> <li>Check if the connector of the tray-up motor is disconnected. (J967, J961, CN244)</li> <li>Check if any of the connectors CN241 and CN244 on the PFP board is disconnected.</li> <li>Check if the connector CN315 on the LGC board is disconnected.</li> <li>Check if the connector pins are disconnected and the harnesses are open circuited.</li> <li>Check if the conductor patterns on the PFP board and LGC board are short circuited or open circuited.</li> </ul>	
2	Is the tray-up sensor working?(Perform the input check in the test mode: FS-03-[F1]ON/[5]/[A], FS-03-[F1]ON/[5]/[E])	Yes		3
		No	<ul style="list-style-type: none"> <li>Check if the connector of the sensor is disconnected. (J972, J966, J970, J965)</li> <li>Check if any of the connectors CN241 and CN246 on the PFP board is disconnected.</li> <li>Check if the connector CN315 on the LGC board is disconnected.</li> <li>Check if the slit reaches the sensor.</li> <li>Check if the connector pins are disconnected and the harnesses are open circuited.</li> <li>Check if the conductor patterns on the PFP board and LGC board are short circuited or open circuited.</li> </ul>	
3	LGC board		<ul style="list-style-type: none"> <li>Check if the conductor pattern on the LGC board is short circuited or open circuited.</li> <li>Replace the LGC board.</li> </ul>	
4	PFP board		<ul style="list-style-type: none"> <li>Check if the conductor pattern on the PFP board is short circuited or open circuited.</li> <li>Replace the PFP board.</li> </ul>	

Parts to be replaced	Remark
PFP board	
LGC board	
Tray-up motor	
Tray-up sensor	

## [C180] LCF tray-up motor abnormality

Classification	Error content
Paper feeding system related service call	The LCF tray-up motor is not rotating or the LCF tray is not moving normally.

Procedure	Check item	Result	Measures	Next Step
1	Does the tray move? (Perform the output check in the test mode: FS-03-271)	Yes		2
		No	<ul style="list-style-type: none"> <li>Does the tray move? (Perform the output check in the test mode: FS-03-271)</li> <li>Check if the connector of the LCF tray-up motor is disconnected. (CN5, CN50)</li> <li>Check if any of the connectors CN1 and CN5 on the LCF board is disconnected.</li> <li>Check if the connector CN315 on the LGC board is disconnected.</li> <li>Check if the connector pins are disconnected and the harnesses are open circuited.</li> <li>Check if the conductor patterns on the LCF board and LGC board are short circuited or open circuited.</li> </ul>	
2	Are the LCF tray bottom sensor and LCF feeding side bottom sensor working?(Perform the input check in the test mode: FS-03-[F1]ON/[8]/[A], FS-03-[F1]ON/[8]/[E])	Yes		3
		No	<ul style="list-style-type: none"> <li>Check if the connectors of the sensors are disconnected. (CN205, CN200, CN64)</li> <li>Check if any of the connectors CN1, CN2 and CN6 on the LCF board is disconnected.</li> <li>Check if the connector CN315 on the LGC board is disconnected.</li> <li>Check if the slit reaches the sensors.</li> <li>Check if the connector pins are disconnected and the harnesses are open circuited.</li> <li>Check if the conductor patterns on the LCF board and LGC board are short circuited or open circuited.</li> </ul>	
3	LGC board		<ul style="list-style-type: none"> <li>Check if the conductor pattern on the LGC board is short circuited or open circuited.</li> <li>Replace the LGC board.</li> </ul>	
4	LCF board		<ul style="list-style-type: none"> <li>Check if the conductor pattern on the LCF board is short circuited or open circuited.</li> <li>Replace the LCF board.</li> </ul>	

Parts to be replaced	Remark
LCF board	
LGC board	
LCF tray-up motor	
LCF tray-up sensor	
LCF feeding side bottom sensor	



## [C1A0] LCF end fence motor abnormality

Classification	Error content
Paper feeding system related service call	The LCF end fence motor is not rotating or the LCF end fence is not moving normally.

Procedure	Check item	Result	Measures	Next Step
1	Is the LCF end fence motor working? (Perform the output check in the test mode: FS-03-207)	Yes		2
		No	<ul style="list-style-type: none"> <li>Check if the connector of the LCF end fence motor is disconnected. (CN5, CN51)</li> <li>Check if any of the connectors CN100 and CN101 on the LCF board is disconnected.</li> <li>Check if the connector CN315 on the LGC board is disconnected.</li> <li>Check if the connector pins are disconnected and the harnesses are open circuited.</li> <li>Check if the conductor patterns on the LCF board and LGC board are short circuited or open circuited.</li> </ul>	
2	Are the LCF end fence home/stop position sensors working?(Perform the input check: FS-03-[F1]ON/[8]/[H], FS-03-[F1]ON/[8]/[G])	Yes		3
		No	<ul style="list-style-type: none"> <li>Check if the connectors of the sensors are disconnected. (CN4, CN40, CN400, N402, CN403)</li> <li>Check if either of the connectors CN1 or CN4 on the LCF board is disconnected.</li> <li>Check if the connector CN315 on the LGC board is disconnected.</li> <li>Check if the slit reaches the sensors.</li> <li>Check if the connector pins are disconnected and the harnesses are open circuited.</li> <li>Check if the conductor patterns on the LCF board and LGC board are short circuited or open circuited.</li> </ul>	
3	LGC board		<ul style="list-style-type: none"> <li>Check if the conductor pattern on the LGC board is short circuited or open circuited.</li> <li>Replace the LGC board.</li> </ul>	
4	LCF board		<ul style="list-style-type: none"> <li>Check if the conductor pattern on the LCF board is short circuited or open circuited.</li> <li>Replace the LCF board.</li> </ul>	

Parts to be replaced	Remark
LCF board	
LGC board	
LCF end fence motor	
LCF end fence home position sensor LCF end fence stop position sensor	

## [C1B0] LCF transport motor abnormality

Classification	Error content
Paper feeding system related service call	The LCF transport motor is not rotating normally (when paper can be fed from any drawer except the LCF).

Procedure	Check item	Result	Measures	Next Step
1	Is the LCF transport motor working? (Perform the output check: FS-03-122/172)	Yes		2
		No	<ul style="list-style-type: none"> <li>• Check if the connector CN3, CN30 of the LCF transport motor is disconnected.</li> <li>• Check if the signal line connector CN100 on the LCF board is disconnected.</li> <li>• Check if the power line connector CN101 on the LCF board is disconnected.</li> <li>• Check if the connector CN315 on the LGC board is disconnected.</li> <li>• Check if the connector pins are disconnected or the harnesses are open circuited.</li> <li>• Check if the conductor patterns on the LCF transport motor board, LCF board and LGC board are short circuited or open circuited.</li> </ul>	
2	LCF transport motor		<ul style="list-style-type: none"> <li>• Check if the connector pins are disconnected or the harnesses are open circuited.</li> <li>• Check if the conductor patterns on the LCF transport motor board, LCF board and LGC board are short circuited or open circuited.</li> <li>• Replace the LCF transport motor.</li> </ul>	

Parts to be replaced	Remark
LCF transport motor	
LCF board	
LGC board	

## 8.3.11 Scanning system related service call

### [C260] Peak detection error

Classification	Error content
Scanning system related service call	Lighting of the exposure lamp (white reference) is not detected when power is turned ON.

Procedure	Check item	Result	Measures	Next Step
1	Is the exposure lamp lit?(Output check: FS-03-267)	Yes	It is lit.	2
		No	It is not lit.	3
2	Shading correction plate	<ul style="list-style-type: none"> <li>Check if there is any scratch or stain on the shading correction plate.</li> <li>Check if the shading correction plate is any scratch or dirty.</li> </ul>		
	Mirror	Check if the mirror is tilted. <ul style="list-style-type: none"> <li>Check that the lens is reflected in the mirror looking at carriage-1 from an upper position.</li> <li>Check that the mirror is secured at the leaf spring.</li> </ul> <b>Notes:</b> Do not turn the mirror adjustment screw more than necessary.		
	Carriage	<ul style="list-style-type: none"> <li>Check if the carriage is tilted by moving it to the left stopping point.</li> <li>Check if the wire fixing screw is loosened.</li> <li>Check if the movement of the carriage is unstable due to disengagement of the carriage roller.</li> </ul>		
	Exposure lamp	<ul style="list-style-type: none"> <li>Check if the exposure lamp is flickering when it is turned on.</li> <li>Check if the connector is properly connected all the way in the board of LED lamp unit.</li> <li>While the carriage is being driven, check if the harness catches it or interferes with it.</li> </ul>		
	CCD board	<ul style="list-style-type: none"> <li>Check if the connector is properly connected all the way in the CCD board.</li> <li>Check if the CCD board or the lens unit is tilted. Check if the screw is securely tightened.</li> <li>Replace the lens unit.</li> </ul>		
	SYS board	<ul style="list-style-type: none"> <li>Check if the connector is properly connected all the way in the SYS board. (CN120, CN123)</li> <li>Check if there is any abnormality in the parts mounted on the SYS board or in the appearance of the SYS board.</li> <li>Check if the voltage is output from the power supply for the CCD.</li> <li>Replace the SYS board.</li> </ul>		
3	Exposure lamp	<ul style="list-style-type: none"> <li>Check if the connector is properly connected to the board of LED lamp unit.</li> <li>Check if there are any scratches or damage on the board of LED lamp unit.</li> <li>Replace the exposure lamp unit.</li> </ul>		
	Harness	<ul style="list-style-type: none"> <li>Check if wiring of the harness (CN125 on the SYS board) is abnormal.</li> <li>Check if the harness (CN125 on the SYS board) has any scratch on it or is open circuited or caught anywhere.</li> <li>Replace the harness (CN125 on the SYS board).</li> </ul>		

Parts to be replaced	Remark
LED lamp unit	
Lens unit	
SYS board	
Harness	
Carriage-1	
Carriage-2	

## [C262] Communication error

Classification	Error content
Scanning system related service call	Communication error between the CCD board and the SYS board. CPU abnormality.

Procedure	Check item	Measure
1	RADF/DSDF	Turn the power OFF and disconnect the harness between the RADF/DSDF and the equipment from the SYS board. Then check if the error is reproduced under this situation. If the error is not reproduced, perform the following measures. 1. Check if the connectors between the RADF/DSDF and the equipment are connected properly. (CN122, CN71, CN70, J12) 2. If there is any abnormality in the harness and connectors, replace them. 3. Check if there is any abnormality in the appearance of the parts mounted on the RADF control PC board / DSDF control PC board. 4. Replace the RADF control PC board / DSDF control PC board. If the error is reproduced, perform the following measures after step 2.
2	Harness	Check if the connectors between the SYS board and the CCD board are connected properly. (CN120, CN001) If there is any abnormality in the harness and connectors between the SYS board and the CCD board, replace the harness and connectors.
3	Lens unit	1. Check if there is any abnormality in the appearance of the parts mounted on the CCD board. 2. Replace the lens unit.
4	SYS board	1. Check if the connectors of the SYS board are connected properly. (CN120, CN105) 2. Check if there is any abnormality in the appearance of the parts mounted on the SYS board. 3. Replace the SYS board.

Parts to be replaced	Remark
RADF control PC board / DSDF control PC board	
Harnesses	
Lens unit	
SYS board	

## [C270] Carriage home position sensor not turning OFF within a specified period of time / Downloading firmware with an incorrect model

Classification	Error content
Scanning system related service call	The carriage does not shift from its home position in a specified time / Downloading firmware with an incorrect model.

Procedure	Check item	Result	Measures	Next Step
1	Carriage locking		Check if the carriage locking screw for packaging is attached.	
2	Are the carriages slightly moved to the feeding direction?/Are the carriages staying at a position other than home position?	Yes	Check if the circuits of the CCD board are abnormal.	3
		No		

Procedure	Check item	Result	Measures	Next Step
3	CCD board		<ul style="list-style-type: none"> <li>Check if the connector pin is disconnected or the harness is short circuited or open circuited. (CN001)</li> <li>Check if the conductor pattern on the CCD board is short circuited or open circuited.</li> <li>If the model of the firmware downloaded is incorrect, a C270 error (exposure lamp blinks twice) occurs. If the exposure lamp blinks twice, download the correct firmware.</li> </ul>	
4	Carriage home position sensor		<ul style="list-style-type: none"> <li>Check if the harness of the carriage home position sensor is connected properly. (CN121, J002)</li> <li>Check if the harness is caught or open circuited.</li> </ul>	
5	SYS board		<ul style="list-style-type: none"> <li>Check if the connector of the SYS board (CN120, CN121, CN124, CN125) is connected properly.</li> <li>Check if the mounted parts on the SYS board are damaged or abnormal.</li> <li>Check if 24 V (CN125) on the SYS board is short circuited.</li> <li>Check if 24 V is supplied to the SYS board (CN125).</li> </ul>	
6	Scan motor		<ul style="list-style-type: none"> <li>Check if the belt tension is loosened.</li> <li>Check if the motor fixing screw is loosened.</li> <li>Check if the carriage wire and the timing belt come off.</li> <li>Check if the connector (CN124) is connected to the motor properly.</li> <li>Check if the harness of the motor is caught or open circuited.</li> </ul>	
7	Setting		Clear the SRAM.	

Parts to be replaced	Remark
CCD board	
Carriage home position sensor	
Carriage home position sensor harness	
SYS board	
Scan motor	
Scan motor harness	

### [C280] Carriage home position sensor not turning ON within a specified period of time

Classification	Error content
Scanning system related service call	Carriage home position sensor not turning ON within a specified time.

Procedure	Check item	Measures
1	Carriage locking	Check if the carriage locking screw for packaging is attached.
2	Carriage hole position sensor	<ul style="list-style-type: none"> <li>Check if the harness is properly connected to the sensor.</li> <li>Check if the harness is caught or open circuited.</li> </ul>
3	SYS board	<ul style="list-style-type: none"> <li>Check if the harness (CN121, J002) of the carriage home position sensor is connected properly.</li> <li>Check if the mounted parts on the SYS board are damaged or abnormal.</li> <li>Check if 24 V (CN125) on the SYS board is short circuited.</li> <li>Check if 24 V is supplied to the SYS board (CN125).</li> </ul>

Procedure	Check item	Measures
4	Scan motor	<ul style="list-style-type: none"> <li>• Check if the belt tension is loosened (if the motor screw is loosened).</li> <li>• Check if the carriage wire and the timing belt come off.</li> <li>• Check if the connector (CN124) is connected to the motor properly.</li> <li>• Check if the harness of the motor is caught or open circuited.</li> </ul>

Parts to be replaced	Remark
Carriage home position sensor	
Carriage home position sensor harness	
SYS board	
Scan motor	
Scan motor harness	

### [C290] Scanner fuse blowout

Classification	Error content
Scanning system related service call	The scanning system does not operate due to a blowout of the fuse in the scanning system.

Check item	Result	Measures
Is 24V supplied to the SYS board?	Yes	Check the following because the signal for checking 24V on the SYS board is abnormal. <ul style="list-style-type: none"> <li>• Check if the scanner CPU (IC26) is damaged or abnormal.</li> <li>• Check if the mounted parts on the SYS board are damaged or abnormal.</li> <li>• Check if 24V on the SYS board is short circuited.</li> <li>• Check if 24V is supplied to the SYS board (CN125).</li> </ul>
	No	<ul style="list-style-type: none"> <li>• Check if the 24V supply harness is properly connected to the connector (CN125).</li> <li>• Check if 24V and SG on the SYS board are short circuited.</li> <li>• Check if the power supply is short circuited by pulling out the supply harness on the SYS board (CN125).</li> <li>• Check if the fuse on the LVPS (F203) is open circuited.</li> <li>• Check if there is no abnormality on the LVPS.</li> </ul>

Parts to be replaced	Remark
SYS board	
Fuse (F203)	
Power supply harness	
LVPS	

## 8.3.12 Process related service call

### [C3D0] EPU board memory overwriting error

Classification	Error content
Process related service call	The overwriting of the EPU board memory fails.

Check item	Measures
Process unit	Check if the process unit is properly installed, and check if the connector pins that are connected to the equipment are disconnected or have any abnormality such as deformation.
EPU memory board	Check if the harness connected to the connector J451 on the EPU board has any abnormality.

Parts to be replaced	Remark
EPU memory board	
LGC board	

### [C3D1] EPU board memory new parts detection error

Classification	Error content
Process related service call	The EPU board detects the process unit as a new unit when the equipment is started in the normal mode.

Check item	Measures
Process unit	<ul style="list-style-type: none"> <li>• If the process unit has been replaced with a new one before the equipment is started, turn the power OFF and then back ON in the EPU replacement mode.</li> <li>• If the process unit has not been replaced, check the following.</li> <li>• Check if the process unit is properly installed, and check if the connector pins that are connected to the equipment are disconnected or have any abnormality such as deformation.</li> <li>• Check if the harness connected to the connector J451 on the EPU board has any abnormality.</li> </ul>

Parts to be replaced	Remark
EPU memory board	
LGC board	

### [C3D2] EPU board memory old parts detection error

Classification	Error content
Process related service call	The EPU board cannot detect the new process unit when the equipment is started in the 21 EPU REPLACE MODE.

Check item	Measures
Process unit EPU memory board	<ul style="list-style-type: none"> <li>• Check if the process unit is a new one. If it is a new one, check the following:</li> <li>• Check if the process unit is properly installed, and check if the connector pins that are connected to the equipment are disconnected or have any abnormality such as deformation.</li> <li>• Check if the harness connected to the connector J451 on the EPU board has any abnormality.</li> </ul>

Parts to be replaced	Remark
EPU memory board	

Parts to be replaced	Remark
LGC board	

### [CE50] Temperature / humidity sensor abnormality

Classification	Contents
Image control related service call	The output value of temperature / humidity sensor is out of a specified range.

Check Item	Result	Measures
Is the connector CN320 on the LGC board or the connector of the temperature/humidity sensor disconnected? Is the harness between the LGC board and the temperature/humidity sensor disconnected?	Yes	Connect the connector securely. Replace the harness.
	No	<ul style="list-style-type: none"> <li>Replace the temperature/humidity sensor.</li> <li>Replace the LGC board.</li> </ul>

Parts to be replaced	Remark
Temperature/humidity sensor	
LGC board	

### [CE90] Drum thermistor abnormality

Classification	Contents
Image control related service call	The output value of the drum thermistor is out of a specified range.

Check Item	Measures
LGC board Process unit	<ul style="list-style-type: none"> <li>Thermistor check (Perform the input check: FS-03-[F1]ON/[3])</li> <li>Check if there is any abnormality on the connector between the equipment and the process unit.</li> <li>Is the harness between the LGC board and the drawer connector for process unit disconnected? (J451, J454, J626)</li> <li>Is the harness inside of the process unit and the harness of the drum thermistor disconnected?</li> <li>Is the connector CN319 on the LGC board, or the connector of the drum thermistor disconnected?</li> </ul>

Parts to be replaced	Remark
Drum thermistor	
EPU memory board	
LGC board	

### [C911] Toner cartridge PC board access abnormality (K)

Classification	Contents
Toner cartridge related service call	Abnormal access to the toner cartridge IC chip.

Check Item	Measures
1. Toner cartridge	<ul style="list-style-type: none"> <li>Check if the recommended toner cartridge is used.</li> <li>Check if the CTRG board is installed properly.</li> <li>Wipe the contact point with a soft cloth if it's stained.</li> <li>Avoid touching the contact point.</li> </ul>
2. CTIF board	<ul style="list-style-type: none"> <li>Check if the contact-point spring is deformed.</li> <li>Check if the contact-point spring is returned to its original position when it is pushed.</li> <li>Check if the CTIF board is installed properly.</li> </ul>



Check Item	Measures
3. LGC board	<ul style="list-style-type: none"> <li>• Check if there is no abnormality on the LGC board.</li> <li>• Check if the conductor pattern on the LGC board is open or short circuited.</li> <li>• Check if the connector CN325 is disconnected.</li> </ul>
4. Harness	<ul style="list-style-type: none"> <li>• Check the harness connecting the LGC board and the CTIF board.</li> <li>• Check the connectors (CN325 at the LGC board and CN231 at the CTIF board).</li> </ul>
5. Setting	Perform the above troubleshooting and if the C911 error is cleared, set the following self diagnostic codes to "0" (normal). <ul style="list-style-type: none"> <li>• FS-08-4689-3: Board information of toner cartridge (K)</li> </ul>

Parts to be replaced	Remark
Toner cartridge	
CTIF board	
LGC board	
Harness	

### [C970] High-voltage transformer abnormality

Classification	Contents
Copy Process related service call	Leakage of the main charger is detected.

Check Item	Measures
High-voltage section	<ul style="list-style-type: none"> <li>• Is the main charger installed securely?</li> <li>• Check if the spring of high-voltage supply contact point is deformed.</li> <li>• Check if the needle electrode is broken or the main charger grid is deformed.</li> <li>• Check if any foreign matters is on the needle electrode or the main charger grid.</li> <li>• Check if the transfer roller and the separation needle are installed securely.</li> <li>• Check if the transfer roller or the separation needle is removed.</li> <li>• Check if there is any foreign matter attached on the transfer roller or the separation needle.</li> </ul>

## 8.3.13 Fuser unit related service call

**Important:**

Be sure to turn OFF the power and unplug the power cable beforehand when checking the heater. The fuser unit itself or the part of the unit remains heated and the capacitors are still charged after a while the power cable is unplugged. So make sure the unit is cooled down enough before checking.

### [C411/C412] Thermistor or heater abnormality at power-ON

Classification	Error content
Fuser unit related service call	Abnormality of the thermistor is detected when the power is turned ON or the temperature of the fuser roller does not rise in a specified period of time after the power is turned ON.

Procedure	Check item	Measures
1	Fuser unit	<ul style="list-style-type: none"> <li>Check that the fuser unit is installed properly.</li> <li>Check if the drawer connector of the fuser unit is damaged or its connection is detected.</li> </ul>
2	Power voltage	Check if the power voltage is normal. (Is the voltage during the operation $\pm 10\%$ of the rated voltage?)
3	Thermistor	<ul style="list-style-type: none"> <li>Check if the center, side and front thermistor are installed properly.</li> <li>Check if the harnesses of the center, side and front thermistor are open circuited.</li> <li>Check if the connectors of the center, side and front thermistor are disconnected (J623, J621, CN308).</li> </ul>
4	Power supply unit and fuser unit	<ul style="list-style-type: none"> <li>Is the fuser unit installed correctly?</li> <li>Check if the heater lamp is broken.</li> <li>Check if the terminal of the heater lamp is attached securely.</li> <li>Check if the center and side thermostat are blown</li> <li>Check if the drawer connector is damaged or its connection is detected.</li> <li>Check if the connectors of the power supply unit are disconnected (CN504, CN508).</li> <li>Check if the power supply unit is abnormal.</li> </ul>
5	LGC board	<ul style="list-style-type: none"> <li>Check if the connectors CN301, CN308 and CN302 are disconnected.</li> <li>Check if the conductor pattern on the LGC board is short circuited or open circuited.</li> </ul>
6	Status counter	After repairing the matter which caused the error [C411/C412], perform the following: <ul style="list-style-type: none"> <li>Perform FS-08-2002.</li> <li>Change the current status counter value "1", "2" or "4" to "0".</li> <li>Turn the power OFF and then back ON. Make sure that the equipment enters the normal ready state.</li> </ul>

Parts to be replaced	Remark
Power supply unit.	
Thermistor	
LGC board	

[C443] Thermistor or heater abnormality after abnormality judgment

[C445] Fusing temperature abnormality after abnormality judgment (pre-running end temperature abnormality)

[C447] Fusing temperature abnormality after abnormality judgment (temperature abnormality at ready status / during printing)

[C449] Fusing temperature abnormality after abnormality judgment (high temperature abnormality)

[C450] Heater abnormality after abnormality judgment

[C452] Heater lamp abnormality after abnormality judgment

Classification	Error content
Fuser unit related service call	<p>[C443] Abnormality of the thermistor is detected when the power is turned ON or the temperature of the fuser roller does not rise in a specified period of time after the power is turned ON.</p> <p>[C445] [C447] Abnormality of the thermistor is detected or the temperature of the fuser roller does not rise in a specified period of time.</p> <p>[C449] The temperature of the fuser roller has exceeded the range.</p> <p>[C450] Abnormality of the thermistor is detected during printing.</p> <p>[C452] An abnormal temperature difference of the thermistor is detected.</p>

Check the procedures 1 to 6 for [C411/C412].

Procedure	Check item	Measures
7	Clear the status counter	<p>Change the current status counter value "3", "5", "6", "7", "8", "9", "19", "21", "22", "23", "25", "27", "29", "45" or "62" to "0" for [C44X], taking the same procedure as that for [C41X].</p> <ul style="list-style-type: none"> <li>The status counter value is as follows in the following cases. <ul style="list-style-type: none"> <li>C443: "3" is written in the status counter.</li> <li>C445: "5" is written in the status counter.</li> <li>C447: "7" or "8" is written in the status counter.</li> <li>C449: "9", "19", "21", "22", "23", "25", "27", "29" or "45" is written in the status counter.</li> <li>C450: "6" is written in the status counter.</li> <li>C452: "62" is written in the status counter.</li> </ul> </li> <li>[C443][C445] The temperature of the fuser roller does not rise within a specified period after the power is turned ON.</li> <li>[C447] The fusing temperature is 40°C or lower.</li> <li>[C449] The fusing temperature is above 240°C.</li> <li>[C450] Thermistor abnormality during printing.</li> <li>[C452] The temperature between the center and edge thermistors differs by more than 100°C when reaching the Ready temperature.</li> </ul>

### [C4B0] Status counter abnormality

Classification	Error content
Fuser unit related service call	An abnormal value is entered in the status counter.

Check item	Measures
1. Check the LGC board	<ul style="list-style-type: none"> <li>Check if the conductor pattern on the LGC board is open or short circuited.</li> <li>Check if the EEPROM is installed properly.</li> <li>Replace the LGC board.</li> </ul>
2. Clear the status counter	<ul style="list-style-type: none"> <li>Change the value of the status counter (FS-08-2002) to "0".</li> <li>Turn the power OFF and then back ON. Make sure that the equipment enters the normal status.</li> </ul>

Parts to be replaced	Remark
LGC board	

**[C4C0] Fuser unit old / new detection fuse abnormality**

Classification	Error content
Fuser unit related service call	Fuser unit old / new detection fuse abnormality.

Check item	Measures
1. Check the fuser unit.	<ul style="list-style-type: none"> <li>• Are the connectors disconnected?</li> <li>• Are the harnesses open circuited?</li> <li>• Replace the fuser unit.</li> </ul>
2. Check the PC board	<ul style="list-style-type: none"> <li>• Are the connectors disconnected?</li> <li>• Are the harnesses short circuited or open circuited?</li> <li>• Replace the LGC board.</li> </ul>

Parts to be replaced	Remark
Fuser unit.	
PC board	

### 8.3.14 Optional communication related service call

#### [C550] Communication error between the scanner and DF

Classification	Error content
DSDF service call	Communication error between the scanner and DF.

Check item	Measures
Connector	<ul style="list-style-type: none"> <li>Check if the connectors (CN70, CN71 and J97) connected the DSDF and the equipment are connected properly.</li> </ul>
HDMI cable	<ul style="list-style-type: none"> <li>Check if the HDMI cables (CN78 and CN90) are connected properly.</li> </ul>
DSDF I/F board	<ul style="list-style-type: none"> <li>Check if the DSDF I/F board is installed in the SYS board properly.</li> </ul>
Connector	<ul style="list-style-type: none"> <li>Check if the connectors of the SYS board and the DSDF board are connected properly.</li> <li>Replace the harness.</li> </ul>
DSDF board	<ul style="list-style-type: none"> <li>Replace the DSDF control PC board.</li> </ul>
SYS board	<ul style="list-style-type: none"> <li>Check the connector (CN122) of the SYS board.</li> <li>Check if the connectors on the SYS board are disconnected from the DSDF board or the harnesses are open circuited. Correct if any.</li> <li>Check the SYS board (IC25, IC28).</li> <li>Replace the SYS board.</li> </ul>

Parts to be replaced	Remark
HDMI cable / Harness	
DSDF I/F board	
DSDF board	
SYS board	

#### [C550] Communication error between the scanner and DF

Classification	Error content
RADF service call	Communication error between the scanner and DF.

Check item	Measures
RADF board	<ul style="list-style-type: none"> <li>Check if the harness connecting the RADF board and SYS board is disconnected or open circuited. (CN122, J12, CN71)</li> <li>Check if the conductor pattern on the RADF board is short circuited or open circuited.</li> <li>Connector check</li> </ul>
SYS board	<ul style="list-style-type: none"> <li>Check if the conductor pattern on the SYS board is short circuited or open circuited.</li> <li>Check the connector (CN122) of the SYS board.</li> <li>Check if the connectors on the SYS board are disconnected from the RADF board or the harnesses are open circuited. Correct if any.</li> <li>Check the SYS board (IC25, IC28).</li> <li>Replace the SYS board.</li> </ul>

Parts to be replaced	Remark
RADF board	
SYS board	

### [C551] DF model detection error

Classification	Error content
DSDF / RADF service call	Incorrect DF installed in the equipment.

Check item	Measures
RADF / DSDF	<ul style="list-style-type: none"> <li>Check if the installed RADF / DSDF is an option exclusively set for the model.</li> <li>Replace the RADF / DSDF with the one exclusively set for the model.</li> </ul>
DSDF I/F board	<ul style="list-style-type: none"> <li>Check the DSDF I/F board installation.</li> <li>Check the connector (CN89) of the DSDF I/F board.</li> <li>Check if the connectors on the DSDF I/F board are disconnected from the DSDF control PC board or the harnesses are open circuited. Correct if any.</li> <li>Replace the DSDF I/F board.</li> </ul>
SYS board	<ul style="list-style-type: none"> <li>Check the connector (CN129) of the SYS board.</li> <li>Replace the SYS board.</li> </ul>

Parts to be replaced	Remark
RADF / DSDF	
RADF board, DSDF I/F board	
SYS board	

### [C552] DF abnormality

Classification	Error content
DSDF / RADF service call	DF abnormality.

Check item	Measures
Connector	Check if the connectors (CN70, CN71 and J97) connected the DSDF and the equipment are connected properly. Check if the connectors (CN70 and CN71) connected the RADF and the equipment are connected properly.
Firmware	Update the firmware of the DSDF/RADF.
Connector	<ul style="list-style-type: none"> <li>Check if the connectors of the DSDF control PC board are connected properly.</li> <li>Replace the harness.</li> </ul>
DSDF control PC board / RADF control PC board	Replace the DSDF control PC board / RADF control PC board.

Parts to be replaced	Remark
DSDF control PC board / RADF control PC board	

### [C553] DSDF CCD-module Peak detection error

Classification	Error content
DSDF service call	The light source of the DSDF-CCD module does not light, or there is a detection error of the light source.

Check item	Measures
HDMI cable	Check if the HDMI cables (CN78 and CN90) are connected properly.

Check item	Measures
DSDF I/F board	<ul style="list-style-type: none"> <li>Check if the DSDF I/F board is installed in the SYS board properly.</li> <li>Check the connector (CN89) of the DSDF I/F board.</li> <li>Check if the connectors on the DSDF I/F board are disconnected from the DSDF control PC board or the harnesses are open circuited. Correct if any.</li> <li>Replace the DSDF control board.</li> </ul>
Connector	<ul style="list-style-type: none"> <li>Check if the connectors of the SYS board and the DSDF control PC board are connected properly.</li> <li>Replace the harness.</li> </ul>
Power supply	Check if 24V is supplied to the DSDF control PC board properly. <ul style="list-style-type: none"> <li>Check the connector of the power supply of the DSDF control PC board: CN70 Pins 1 and 2.</li> <li>Check the connector of the power supply of the SYS board: CN122 Pins 19 and 20.</li> </ul>
DSDF exit motor	<ul style="list-style-type: none"> <li>Check if the DSDF exit motor is working properly.</li> <li>Check if the connectors (J991 and CN77) on the DSDF control PC board are disconnected from the DSDF exit motor or the harnesses are open circuited. Correct if any.</li> </ul>
DSDF-CCD module	<ul style="list-style-type: none"> <li>Check if the connectors of the DSDF-CCD module and the DSDF control PC board are connected properly.</li> <li>Check that there is no abnormality in the DSDF-CCD module.</li> </ul>
SYS board	<ul style="list-style-type: none"> <li>Check the connector (CN122) of the SYS board.</li> <li>Check the SYS board (IC31, IC32).</li> <li>Replace the SYS board.</li> </ul>

Parts to be replaced	Remark
DSDF I/F board	
DSDF exit motor	
DSDF-CCD module	
SYS board	

#### [C554] AFE communication error

Classification	Error content
DSDF service call	Communication error between the DSDF-CCD module and SYS board.

Check item	Measures
HDMI cable	Check if the HDMI cables (CN78 and CN90) are connected properly.
DSDF I/F board	<ul style="list-style-type: none"> <li>Check if the DSDF I/F board is installed in the SYS board properly.</li> <li>Check the connector (CN89) of the DSDF I/F board.</li> <li>Check if the connectors on the DSDF I/F board are disconnected from the DSDF control PC board or the harnesses are open circuited. Correct if any.</li> <li>Check the DSDF I/F board (IC6, IC9, IC204).</li> <li>Replace the DSDF I/F board.</li> </ul>
Connector	<ul style="list-style-type: none"> <li>Check if the connectors of the SYS board and the DSDF control PC board are connected properly.</li> <li>Replace the harness.</li> </ul>
DSDF-CCD module	<ul style="list-style-type: none"> <li>Check if the connectors of the DSDF-CCD module and the DSDF control PC board are connected properly.</li> <li>Check that there is no abnormality in the DSDF-CCD module.</li> </ul>
SYS board	<ul style="list-style-type: none"> <li>Check the connector (CN129) of the SYS board.</li> <li>Check the SYS board (IC26).</li> <li>Replace the SYS board.</li> </ul>

Parts to be replaced	Remark
DSDF I/F board	
DSDF-CCD module	

Parts to be replaced	Remark
SYS board	

### [C580] Communication error between the LGC board and the finisher

Classification	Error content
Option related service call	Communication error between the LGC board and the finisher.

Check item	Measures
Finisher	Check if the specified finisher is attached.
LGC board	<ul style="list-style-type: none"> <li>Check if the harness connecting the LGC board and the Finisher control PC board (FIN) is disconnected or open circuited.</li> <li>Check if the conductor pattern on the LGC board is open circuited or short circuited.</li> </ul>
Finisher control PC board (FIN)	Check if the conductor pattern on the Finisher control PC board (FIN) is open circuited or short circuited.

Parts to be replaced	Remarks
LGC board	
Finisher control PC board (FIN)	

### [C730] DSDF EEPROM writing error

Classification	Error content
DSDF service call	An abnormality occurs while the data are being written in the EEPROM of the DSDF.

Check item	Measures
Adjustment	Perform the DSDF read-in sensor-1 automatic adjustment.
DSDF control PC board	If this error still persists after the DSDF read-in sensor-1 automatic adjustment has been performed, replace the DSDF control PC board.

Parts to be replaced	Remark
DSDF control PC board	

### [C7B0] Initial time-out error

Classification	Error content
DSDF service call	The initialization is not completed within the specified time.

Check item	Measures
Reproducing ability	Turn the power OFF and then back ON to check the occurrence.
DSDF shading sheet	Clean the DSDF shading sheet.

Parts to be replaced	Remark
DSDF shading sheet	

### [C8C0] DSDF read-in sensor-1 automatic adjustment error

Classification	Error content
DSDF service call	An adjustment value becomes outside the specified one during DSDF read-in sensor-1 automatic adjustment.



Check item	Measures
DSDF read-in sensor-1	<ul style="list-style-type: none"> <li>Perform the DSDF read-in sensor-1 adjustment manually.</li> <li>If the LED does not light even if the adjustment has been performed, check the DSDF read-1 sensor-1 and the DSDF control PC board.</li> <li>Check if the connector on the DSDF control PC board is disconnected from the DSDF read-in sensor-1 or the harnesses are open circuited. Correct if any.</li> <li>Replace the DSDF read-in sensor-1.</li> </ul>
DSDF control PC board	Replace the DSDF control PC board.

Parts to be replaced	Remark
DSDF read-in sensor-1	
DSDF control PC board	

### [C8E0] DF control abnormality (communication protocol abnormality)

Classification	Error content
DSDF / RADF service call	System stop is required due to the control abnormality.

Check item	Measures
Power	<ul style="list-style-type: none"> <li>Turn the power OFF and then back ON to check if the equipment operates normally.</li> </ul>
DSDF / RADF board	<ul style="list-style-type: none"> <li>Connector check</li> <li>Board check</li> </ul>

Parts to be replaced	Remark
DSDF/RADF board	

### [F115] S-VDEN ON signal time-out error

### [F116] S-VDEN OFF signal time-out error

### [F117] S-VDEN ON (back side) signal time-out error

### [F118] S-VDEN OFF (back side) signal time-out error

Classification	Error content
[F115] [F116] Scanning system related service call	The scanning job has not finished normally.
[F117] [F118] Scanning system related service call (DSDF)	

Check item	Measures
Reproducing ability	Turn the power OFF and then back ON to check the occurrence.
Connector / Harness	<ul style="list-style-type: none"> <li>Check if the joint connector (J12) between the DF and the equipment is disconnected or its pin is deformed.</li> <li>Check if the SYS board connector (CN122) and the DSDF control PC board / RADF control PC board connector (CN71) are disconnected.</li> <li>Check if the harnesses between the SYS board and the joint connector and between the joint connector and the DSDF control PC board / RADF control PC board are normal. If the harnesses have any scratches on them, are open circuited, caught anywhere or their pin is deformed, replace them.</li> </ul>
RADF control PC board / DSDF control PC board	Replace the board.
SYS board	Replace the board.

Parts to be replaced	Remark
Harness	Be sure to exchange the parts in the order of the harness, DSDf control PC board or RADf control PC board and SYS board.
DSDf control PC board	Be sure to exchange the parts in the order of the harness, DSDf control PC board or RADf control PC board and SYS board. After the DSDf control PC board has been replaced, perform FS-05-3210.
RADf control PC board	Be sure to exchange the parts in the order of the harness, DSDf control PC board or RADf control PC board and SYS board.
SYS board	Be sure to exchange the parts in the order of the harness, DSDf control PC board or RADf control PC board and SYS board.

### [F11A] Communication error between the SYS board and the CCD board

Classification	Error content
Scanning system related service call	Communication error between the SYS board and the CCD board.

Check item	Measures
Reproducing ability	Turn the power OFF and then back ON to check the occurrence.
SYS board	<ul style="list-style-type: none"> <li>Check if the connectors of the CCD board and SYS board are disconnected or the harnesses are open circuited. (CN120, CN001)</li> <li>Check if there is no abnormality in the SYS board.</li> </ul>

Parts to be replaced	Remark
Harness	Be sure to exchange the parts in the order of the harness, CCD board and SYS board.
CCD board	Be sure to exchange the parts in the order of the harness, CCD board and SYS board.
SYS board	Be sure to exchange the parts in the order of the harness, CCD board and SYS board.

### [F11B] Communication error between the SYS board and the DSDf-CCD module

Classification	Error content
Scanning system related service call (DSDf)	Communication error between the SYS board and the DSDf-CCD module.

Check item	Measures
Reproducing ability	Turn the power OFF and then back ON to check the occurrence.
SYS board	<ul style="list-style-type: none"> <li>Check the connector (CN129) of the SYS board.</li> <li>Check the SYS board (IC26).</li> <li>Replace the SYS board.</li> </ul>
HDMI cable	Check if the HDMI cables (CN78 and CN90) are connected properly.
DSDf I/F board	<ul style="list-style-type: none"> <li>Check if the DSDf I/F board is installed in the SYS board properly.</li> <li>Check the connector (CN89) of the DSDf I/F board.</li> <li>Check if the connectors on the DSDf I/F board are disconnected from the DSDf control PC board or the harnesses are open circuited. Correct if any.</li> <li>Check the DSDf I/F board (IC6, IC9, IC204).</li> <li>Replace the DSDf I/F board.</li> </ul>
Connector	<ul style="list-style-type: none"> <li>Check if the connectors of the SYS board and the DSDf control PC board are connected properly.</li> <li>Replace the harness.</li> </ul>
DSDf-CCD module	<ul style="list-style-type: none"> <li>Check if the connectors of the DSDf-CCD module and the DSDf control PC board are connected properly.</li> <li>Check that there is no abnormality in the DSDf-CCD module.</li> </ul>

Parts to be replaced	Remark
Harness	Be sure to exchange the parts in the order of the harness, DSDF I/F board, DSDF-CCD module and SYS board.
DSDF I/F board	Be sure to exchange the parts in the order of the harness, DSDF I/F board, DSDF-CCD module and SYS board.
DSDF-CCD module	Be sure to exchange the parts in the order of the harness, DSDF I/F board, DSDF-CCD module and SYS board.
SYS board	Be sure to exchange the parts in the order of the harness, DSDF I/F board, DSDF-CCD module and SYS board.

**[CE00] Communication error between the finisher and the punch unit**  
 MJ-1109/1110 (MJ-6105)

Classification	Contents
Finisher related service call	Communication error between finisher control PC board and hole punch control PC board.

Check Item	Measures
Hole punch control PC board (HP)	<ul style="list-style-type: none"> <li>Check the connectors and harnesses between the hole punch control PC board (HP) and the finisher control PC board (FIN).</li> <li>Board check</li> </ul>

Parts to be replaced	Measures
Hole punch control PC board (HP)	
Finisher control PC board (FIN)	

### 8.3.15 Circuit related service call

#### [C5A0] EEPROM abnormality (LGC board)

Classification	Error content
Circuit related service call	EEPROM abnormality (LGC board).

Check item	Measures
EEPROM	Check if the EEPROM is installed properly.

Parts to be replaced	Remark
EEPROM	
LGC board	

#### [C5A1] EEPROM data abnormality (LGC board)

Classification	Contents
Circuit related service call	EEPROM data abnormality (LGC board).

Check item	Measures
EEPROM	EEPROM check
LGC board	<ul style="list-style-type: none"><li>• IC socket check</li><li>• Board check</li></ul>

Parts to be replaced	Remark
EEPROM	
LGC board	

#### [C916] Sub-CPU access abnormality

Classification	Contents
Circuit related service call	Sub-CPU access abnormality.

Check item	Measures
LGC board	<ol style="list-style-type: none"><li>1. Check if there is no abnormality in the LGC board.</li><li>2. Check if the conductor pattern of the LGC board is short circuited or open circuited.</li></ol>

Parts to be replaced	Remark
LGC board	

#### [C940] Engine-CPU abnormality

Classification	Contents
Circuit related service call	Engine-CPU abnormality.

Check Item	Measures
Main power switch	Turn OFF the main power switch, then back ON.
Engine-CPU and FROM	Check if the conductor pattern between the Engine-CPU and FROM is short circuited or open circuited.
LGC board	Board check

Parts to be replaced	Measures
LGC board	

### [F090] SRAM abnormality on the SYS board

Classification	Contents
Circuit related service call	SRAM abnormality on the SYS board.

Check Item	Measures
SRAM	<ol style="list-style-type: none"> <li>1. Check that the SRAM is installed properly.</li> <li>2. Shut down the equipment.</li> <li>3. Perform [FS-08].</li> <li>4. Press [CLASSIC].</li> <li>5. When "SRAM REQUIRES INITIALIZATION" appears on the LCD screen, confirm the destination and press the [START] button. If the destination is incorrect, enter the number for the correct one and press the [START] button.</li> <li>6. When the confirmation message appears on the LCD screen, press [INITIALIZE]. (SRAM initialization starts.)</li> <li>7. Enter the serial number of the equipment correctly. (FS-08-9601)</li> <li>8. Initialize the NIC information. (FS-08-9083)</li> <li>9. Shut down the equipment.</li> <li>10. Perform [FS-05].</li> <li>11. Press [CLASSIC].</li> <li>12. Perform "Data transfer of characteristic value of scanner". (FS-05-3203, FS-05-3240)</li> <li>13. By using the [93] [TEST PRINT] test pattern, perform "Automatic gamma adjustment" &lt;PPC&gt;. (FS-05-7311)</li> <li>14. Reboot the equipment.</li> <li>15. If the error still occurs, replace the SRAM.</li> </ol>
SYS board	Board check

Parts to be replaced	Remark
SRAM	Be sure to exchange the parts in the order of the SRAM and SYS board.
SYS board	Be sure to exchange the parts in the order of the SRAM and SYS board.

### [F350] SYS board abnormality

Classification	Contents
Circuit related service call	SYS board abnormality.

Check item	Measures
SYS board	Board check
Combination of the firmware version	<ul style="list-style-type: none"> <li>• Check the combination of the firmware version of the system firmware, system software, engine firmware, and scanner firmware.</li> <li>• Reinstall the firmware of correct combination.</li> </ul>

Parts to be replaced	Remark
SYS board	

## [F400] SYS board cooling fan abnormality

SYS board cooling fan abnormality	Contents
Circuit related service call	SYS board cooling fan abnormality.

Check Item	Measures
SYS board cooling fan	Check if the fan is rotating properly. If not, check if any foreign object is adhered.
SYS board	Check the connector (CN117) and relay connector.

Parts to be replaced	Remark
SYS board cooling fan	Be sure to exchange the parts in the order of the SYS cooling fan and SYS board.
SYS board	Be sure to exchange the parts in the order of the SYS cooling fan and SYS board.

## [F410] Power abnormality

Classification	Contents
Circuit related service call	This error occurs when the status of the LSI mounted on the SYS board has become an error due to a power abnormality. The equipment will be automatically rebooted at the first-time occurrence; however, the error history will not remain when rebooting is done automatically. This error code appears if an error has occurred continuously.

Check item	Measures
Power cable	Check that the power cable is inserted securely or it is not damaged.
User's site	<ul style="list-style-type: none"><li>Do not plug any cables for other devices in the outlet to which that for the equipment is connected.</li><li>The power cable co-packed with the equipment must be used without employing any extension cables.</li><li>Be sure to use an outlet which is far from the one to which a device, such as an air conditioner or a printer, which uses a large amount of power is connected.</li></ul>
Board	<ul style="list-style-type: none"><li>Power supply unit</li><li>SYS board</li></ul>

Parts to be replaced	Remark
1. Power supply unit	Be sure to exchange the power supply unit and the SYS board in the order described on the left-hand side.
2. SYS board	

## 8.3.16 Communication related service call

### [F040] Option installation error

Classification	Error content
Option related service call	The size of the attached main memory is 2 GB when the DSDF is installed.

Check item	Measures
Main memory	Replace the main memory with a 4 GB one.
DSDF	<ul style="list-style-type: none"> <li>Remove the DSDF.</li> <li>Replace the DSDF with an RADF.</li> </ul>

Parts to be replaced	Remark
Main memory	
DSDF	

### [F070] Communication error between the system-CPU and the engine-CPU

Classification	Error content
Communication related service call	Communication error between the system-CPU and the engine-CPU.

Check item	Measures
Error code	<ul style="list-style-type: none"> <li>Turn the power OFF and then back ON using the main power switch, and then check if the error code changes to another one.</li> <li>If it changes to another one, follow the procedure for the changed error code.</li> </ul>
Check firmware version	<ul style="list-style-type: none"> <li>Check the version of the system firmware on the SYS board.</li> <li>Check the version of the engine firmware on the LGC board.</li> </ul>
Board check	<ul style="list-style-type: none"> <li>Check if the connector (CN133, CN132) on the SYS board and the connector (CN309, CN310) on the LGC board are completely inserted.</li> <li>Check if the connector pin between the SYS board connectors (CN133, CN132) and the LGC board connectors (CN309, CN310) is disconnected.</li> <li>Check if the connector CN301 on the LGC board and the connector CN512 on the PS-ACC are completely inserted.</li> <li>Check if the conductor patterns on the LGC board and SYS board are short circuited or open circuited</li> </ul>
Harness	<ul style="list-style-type: none"> <li>Connector check</li> <li>Harness check</li> </ul>

Parts to be replaced	Remark
Harness	Be sure to exchange the parts in the order of the harness, LGC board and SYS board.
LGC board	Be sure to exchange the parts in the order of the harness, LGC board and SYS board.
SYS board	Be sure to exchange the parts in the order of the harness, LGC board and SYS board.

**[F071] Communication initialization error between the system-CPU and the engine-CPU****[F074] Communication error between the system-CPU and the engine-CPU (engine-CPU response abnormality)**

Classification	Error content
Communication related service call	[F071] Communication initialization error between the system-CPU and the engine-CPU. [F074] Communication error between the system-CPU and the engine-CPU (engine-CPU response abnormality).

Check item	Measures
Error code	<ul style="list-style-type: none"> <li>Turn the power OFF and then back ON using the main power switch, and then check if the error code changes to another one.</li> <li>If it changes to another one, follow the procedure for the changed error code.</li> </ul>
Check firmware version	<ul style="list-style-type: none"> <li>Check the version of the system firmware on the SYS board.</li> <li>Check the version of the engine firmware on the LGC board.</li> </ul>
Board check	<ul style="list-style-type: none"> <li>Check if the connector (CN133, CN132) on the SYS board and the connector (CN309, CN310) on the LGC board are completely inserted.</li> <li>Check if the connector pin between the SYS board connectors (CN133, CN132) and the LGC board connectors (CN309, CN310) is disconnected.</li> <li>Check if the connector CN301 on the LGC board and the connector CN512 on the PS-ACC are completely inserted.</li> <li>Check if the conductor patterns on the LGC board and SYS board are short circuited or open circuited</li> </ul>
Harness	<ul style="list-style-type: none"> <li>Connector check</li> <li>Harness check</li> </ul>
LGC board	<ul style="list-style-type: none"> <li>Measure the voltage on TP7 on the LGC board. Then check that the measured voltage is 3.3V. If the voltage does not output, replace the LGC board.</li> </ul>

Parts to be replaced	Remark
Harness	Be sure to exchange the parts in the order of the harness, LGC board and SYS board.
LGC board	Be sure to exchange the parts in the order of the harness, LGC board and SYS board.
SYS board	Be sure to exchange the parts in the order of the harness, LGC board and SYS board.



**[F110] Communication error between the system-CPU and the scanner-CPU****[F111] Communication error between the system-CPU and the scanner-CPU**

Classification	Error content
Communication related service call	Communication error between the system-CPU and the scanner-CPU.

Check item	Measures
Reproducibility	Turn the power OFF and then back ON using the main power switch.
Setting	<p>Check if the value of 08-9000 (Destination setting of the equipment) is set correctly.</p> <ul style="list-style-type: none"> <li>Perform "Data transfer of characteristic value of scanner". (FS-05-3203)</li> <li>Update the scanner firmware.</li> </ul>
Board check	<ul style="list-style-type: none"> <li>Check if the conductor pattern on the SYS board is short circuited or open circuited.</li> <li>Connector check</li> <li>Harness check</li> </ul>
SYS board	<ul style="list-style-type: none"> <li>Perform "Data transfer of characteristic value of scanner". (FS-05-3203)</li> <li>Reinstall the scanner firmware.</li> </ul>



Check item	Measures
HDD	Connector check

Parts to be replaced	Remark
SYS board	Refer to the following sections: <ul style="list-style-type: none"> <li>•  P. 9-3 "9.1.4 SYS board"</li> <li>•  P. 9-22 "9.2.4 Precautions and procedures when replacing the SYS board"</li> </ul>

### [F119] Scanner abnormality detection

Classification	Error item
Scanning system related service call	Connection error between scanner CPU and system CPU.

Check item	Measures
SYS board	<ul style="list-style-type: none"> <li>• Check if there is any abnormality in the appearance of parts mounted on the SYS board.</li> <li>• Replace the SYS board.</li> </ul>

Parts to be replaced	Remarks
SYS board	

## 8.3.17 Laser optical unit related service call

### [CA10] Polygonal motor abnormality

Classification	Error content
Laser optical unit related service call	The polygonal motor is not rotating normally.

Check item	Measures
Harness	<ul style="list-style-type: none"> <li>Check if the connector (CN306) of the LGC board and the one (CN204) of the laser optical unit are disconnected. Even if the connectors are not apparently disconnected, they may be connected too loosely. Therefore, check carefully and connect them securely.</li> <li>Check if the harness between the LGC board and the laser optical unit is open circuited or damaged. Replace it if it is open circuited or damaged.</li> </ul>
Laser optical unit	Polygonal motor check (Input check: FS-03-[ALL]OFF/[5]/[B]) If there is any abnormality, replace the laser optical unit.
LGC board	Check if there is any abnormality such as an open circuit or a short circuit on the LGC board. If yes, replace the LGC board.

Parts to be replaced	Remark
Harness	
Laser optical unit	
LGC board	

### [CA20] H-sync detection error

Classification	Error content
Laser optical unit related service call	The laser beams cannot be detected by the H-sync detection PC board.

Check item	Measures
Flat cable	<ul style="list-style-type: none"> <li>Check if the flat cable connected to the connector (CN304) of the LGC board and the one (CN201) of the laser optical unit are disconnected. Even if the flat cable is not apparently disconnected, it may be connected too loosely. Therefore, check carefully and connect it securely.</li> <li>Check if the flat cable between the LGC board and the laser optical unit is open circuited or damaged. Replace it if it is open circuited or damaged.</li> </ul>
Laser optical unit	Check if there is any abnormality in the laser optical unit. If yes, replace the laser optical unit.
LGC board	Check if there is any abnormality such as an open circuit or a short circuit on the LGC board. If yes, replace the LGC board.

Parts to be replaced	Remark
Flat cable	
Laser optical unit	
LGC board	

## 8.3.18 Finisher related service call

### [CB00] Finisher communication error

Classification	Error content
Finisher related service call	Communication error has occurred between the equipment and finisher.

Check item	Measures
Finisher	<ul style="list-style-type: none"> <li>Check if the harness connecting the equipment and the finisher control PC board (FIN) is disconnected or open circuited.</li> <li>Check if the conductor pattern on the finisher control PC board (FIN) is open circuited or short circuited.</li> <li>Update the finisher firmware.</li> <li>Replace the finisher control PC board (FIN).</li> </ul>
LGC board	<ul style="list-style-type: none"> <li>Check if the harness connecting the finisher and the LGC board on the equipment is disconnected or open circuited.</li> <li>Connector check (CN314)</li> <li>Check if the conductor pattern on the LGC board is open circuited or short circuited.</li> <li>Replace the LGC board.</li> </ul>

Parts to be replaced	Remark
Finisher control PC board (FIN)	
LGC board (LGC)	

### [CB10] Entrance motor abnormality

MJ-1109/1110

Classification	Contents
Finisher related service call	The entrance motor is not rotating normally.

Check Item	Measures
Feeding roller	Rotate the feeding roller. Fix any mechanical problem.
Entrance motor (M1)	Check if the connector (CN17) on the finisher control PC board is disconnected from the entrance motor (M1) and the harnesses are open circuited. Correct if so.

Parts to be replaced	Remark
Entrance motor (M1)	
Finisher control PC board (FIN)	

### [CB11] Buffer tray guide motor abnormality

MJ-1109/1110

Classification	Contents
Finisher related service call	<p>The buffer tray guide motor is not rotating or the buffer tray guide is not moving normally.</p> <ul style="list-style-type: none"> <li>A [CB11] error occurs if the [ED16] error occurs three times in succession or the [ED16] error occurs during the initialization.</li> </ul>

Check Item	Measures
Buffer tray guide	Raise the buffer roller and open/close the buffer tray guide. Fix any mechanical problem.

Check Item	Measures
Buffer tray guide motor (M2)	Check if the connector (CN10) on the finisher control PC board (FIN) is disconnected from the buffer tray guide motor (M2) and the harnesses are open circuited. Correct if so.

Parts to be replaced	Remark
Buffer tray guide motor (M2)	
Finisher control PC board (FIN)	

### [CB13] Finisher exit motor abnormality

MJ-1109/1110

Classification	Error item
Finisher related service call	The finisher exit motor is not rotating or the finisher exit roller is not moving normally.

Check item	Measures
Exit roller	<ul style="list-style-type: none"> <li>• Check if properly installed.</li> <li>• Is there any mechanical problem when the exit roller is rotated? Correct if so.</li> </ul>
Exit motor (M11).	<ul style="list-style-type: none"> <li>• Motor check</li> <li>• Connector check (CN15)</li> <li>• Harness check</li> </ul>
Finisher control PC board (FIN)	<ul style="list-style-type: none"> <li>• Connector check (CN15)</li> <li>• Board check</li> </ul>

Parts to be replaced	Remarks
Exit motor (M11)	
Finisher control PC board (FIN)	

### [CB14] Finisher assist guide motor abnormality

#### [EAFE] Assist guide cam position error

MJ-1109/1110

Classification	Error item
[CB14] Finisher related service call	The finisher assist guide motor is not rotating or the assist guide cam is not moving normally.
[EAFE] Finisher jam (Finisher section)	The assist guide motor is not rotating or the paper pusher cam is not moving normally.

Check item	Measures
Paper pusher cam	<ul style="list-style-type: none"> <li>• Check if properly installed.</li> <li>• Is there any mechanical problem when the paper pusher cam is rotated?</li> </ul>
Assist arm motor (M10)	<ul style="list-style-type: none"> <li>• Motor check</li> <li>• Connector check (CN10)</li> <li>• Harness check</li> </ul>
Finisher control PC board (FIN)	<ul style="list-style-type: none"> <li>• Connector check (CN10)</li> <li>• Board check</li> </ul>

Parts to be replaced	Remarks
Assist arm motor (M10)	
Finisher control PC board (FIN)	

**[CB15] Catching motor abnormality**  
MJ-1109/1110

Classification	Error item
Finisher related service call	Catching motor abnormality.

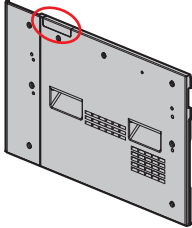
Check item	Measures
Catching motor (M21)	Is there any mechanical problem when the catching motor is rotated? If there is any mechanical problem, fix its mechanism.
Harness	Check if the connector on the finisher control PC board is disconnected from the catching motor (M21) and the harnesses are open circuited. Correct if any.
Finisher control PC board (FIN)	<ul style="list-style-type: none"> <li>• Harness check</li> <li>• Connector check</li> <li>• Board check</li> </ul>

Parts to be replaced	Remarks
Catching motor (M21)	
Harness	
Finisher control PC board (FIN)	

**[CB30] Movable tray shift motor abnormality**  
MJ-1042

Classification	Contents
Finisher related service call	The movable tray shift motor is not rotating or the movable tray is not moving normally.

Error	Timing of detection
Movable tray shift motor (M1) Stack top detection solenoid (SOL1) Stack top detection sensor-1 (S1) Stack top detection sensor-2 (S2) Movable tray lower limit sensor (S14)	A locking signal is detected after the specified time *while the movable tray is moving. * A locking signal is not monitored from the start driving the motor until the specified time has passed.
	The stack top position of paper is not detected after the movable tray shift motor (M1) is driven in the specified time when the movable tray is moved up.
	The lower limit position of the stack top of paper is not detected after the movable tray shift motor (M1) has been driven in the specified time during the initial movement of the movable tray.
	The turning OFF of the movable tray lower limit sensor (S14) is not detected when the movable tray is moved from a point where this sensor is turned ON to one point where this sensor is turned OFF after the movable tray shift motor (M1) has been driven in the specified time.

Probable cause	Checking and measures
Movable tray	<p>If there is mechanical problem when the movable tray is moved, fix the mechanism.</p> <ul style="list-style-type: none"> <li>When installing the finisher, exercise care not to forget to remove the small left cover.</li> </ul>  <p><b>Fig.8-22</b></p> <ul style="list-style-type: none"> <li>Check there is any obstacle which obstructs of operation under a movable tray. Remove any obstacles from the area of the movable tray operation.</li> </ul>
Movable tray shift motor (M1) abnormality	Check if the electrical continuity of the coil is normal. If electricity is not conducted, replace the motor.
Movable tray lower limit sensor (S14) abnormality	Measure the voltage on TP17 on the finisher control PC board (FIN). Then check that the measured voltage is 1V or lower when not shielded and within the range of 3.3V±5% when shielded. If the voltage does not fall within the range mentioned, replace the sensor.
Faulty cables and connectors	Check if the electrical continuity among the connector terminals is normal. If electricity is not conducted, replace the connectors. (Finisher control PC board (FIN): CN4, CN10)
Finisher control PC board (FIN) abnormality	If the error still occurs after replacing the motor, sensors and connectors, exchange the finisher control PC board (FIN).
Stack top detection solenoid (SOL1) abnormality	Check if the electrical continuity of the coil is normal. If electricity is not conducted, replace the solenoid.
Stack top detection sensor-1 (S1) abnormality	Measure the voltage on TP11 on the finisher control PC board (FIN). Then check that the measured voltage is 1V or lower when not shielded and within the range of 3.3V±5% when shielded. If the voltage does not fall within the range mentioned, replace the sensor.
Stack top detection sensor-2 (S2) abnormality	Measure the voltage on TP20 on the finisher control PC board (FIN). Then check that the measured voltage is 1V or lower when not shielded and within the range of 3.3V±5% when shielded. If the voltage does not fall within the range mentioned, replace the sensor.
Faulty cables and connectors	Check if the electrical continuity between the connector terminals is normal. If electricity is not conducted, replace the connector. (Finisher control PC board (FIN): CN3)
Finisher control PC board (FIN) abnormality	If the error still occurs after replacing the solenoid, sensors and connector, exchange the finisher control PC board (FIN).

### [CB30] Movable tray shift motor abnormality

### [EAFC] Movable tray height error

MJ-1109/1110

Classification	Contents
[CB30] Finisher related service call	The movable tray shift motor is not rotating or the movable tray is not moving normally.
[EAFC] Finisher jam (Finisher section)	Movable tray shift motor abnormality: The movable tray shift motor is not rotating or the movable tray is not moving normally.

Check item	Measures
Movable tray	If there is mechanical problem when the movable tray is moved, fix the mechanism.

Check item	Measures
Movable tray shift motor (M12)	Check the connectors and harnesses between the movable tray shift motor (M12) and the finisher control PC board (CN19).
Movable tray position A, B, and C sensors (S13, S14 and S15)	<ul style="list-style-type: none"> <li>• Connector check (CN20)</li> <li>• Sensor check</li> <li>• Harness check</li> </ul>

Parts to be replaced	Remark
Movable tray shift motor (M12)	
Movable tray position A, B, and C sensors (S13, S14 and S15)	
Finisher control PC board (FIN)	

### [CB31] Movable tray paper-full detection error

### [EAFD] Movable tray movement error

MJ-1109/1110

Classification	Contents
[CB31] Finisher related service call	The actuator of the movable tray paper-full detection sensor does not move smoothly.
[EAFD] Finisher jam (Finisher section)	Movable tray paper-full detection error: The actuator of the movable tray paper-full detection sensor does not move smoothly.

Check item	Measures
Movable tray paper-full sensor (S16)	Fix any mechanical problem occurring when the actuator is moved.
	Check if there is a disconnection of the connector, incorrect installation or breakage of the movable tray paper-full sensor (S16). If there is, reinstall the sensor correctly or replace it.
	Check if the connector (CN22) on the finisher control PC board is disconnected from the movable tray paper-full sensor (S16) and the harnesses are open circuited. Correct if so.
Movable tray position A, B, and C sensors (S13, S14 and S15)	<ul style="list-style-type: none"> <li>• Connector check (CN20)</li> <li>• Sensor check</li> <li>• Harness check</li> </ul>

Parts to be replaced	Remark
Movable tray paper-full sensor (S16)	
Movable tray position A, B, and C sensors (S13, S14 and S15)	
Finisher control PC board (FIN)	

### [CB40] Front alignment plate home position detection error

MJ-1042

Classification	Contents
Finisher related service call	<p>The front alignment motor is not rotating or the front alignment plate is not moving normally.</p> <ul style="list-style-type: none"> <li>• You receive a [CB40] error when the [ED13] error occurs three times in succession.</li> </ul>

Error	Timing of detection
Rear alignment motor (M3) Rear alignment plate home position sensor (S6)	The turning OFF of the rear alignment plate home position sensor (S6) is not detected when the rear alignment plate is moved from a point where this sensor is turned ON to one point where this sensor is turned OFF after the rear alignment motor (M3) has been driven at the specified number of pulse.  The turning ON of the rear alignment plate home position sensor (S6) is not detected when the rear alignment plate is moved from a point where this sensor is turned OFF to one point where this sensor is turned ON after the rear alignment motor (M3) has been driven at the specified number of pulse.

Probable cause	Checking and measures
Rear alignment motor (M3) abnormality	Check if the electrical continuity of the coil is normal. If electricity is not conducted, replace the motor.
Rear alignment plate home position sensor (S6) abnormality	Measure the voltage on TP16 on the finisher control PC board (FIN). Then check that the measured voltage is 1V or lower when not shielded and within the range of $3.3V \pm 5\%$ when shielded. If the voltage does not fall within the range mentioned, replace the sensor.
Faulty cables and connectors	Check if the electrical continuity between the connector terminals is normal. If electricity is not conducted, replace the connectors. (Finisher control PC board (FIN): CN5, CN12)
Finisher control PC board (FIN) abnormality	If the error still occurs after replacing the motor, sensor and connectors, exchange the finisher control PC board (FIN).

#### [CB40] Front alignment motor abnormality

MJ-1109/1110

Classification	Contents
Finisher related service call	The front alignment motor is not rotating or the front alignment plate is not moving normally. <ul style="list-style-type: none"> <li>You receive a [CB40] error when the [ED13] error occurs three times in succession.</li> </ul>

Check Item	Measures
Rear alignment plate	If there is mechanical problem when the rear alignment plate is moved, fix the mechanism.
Rear alignment motor (M6)	Check the connectors and harnesses between the rear alignment motor (M6) and the finisher control PC board (CN18).

Parts to be replaced	Remark
Rear alignment motor (M6)	
Finisher control PC board (FIN)	



## [CB50] Stapler home position detection error

MJ-1042

Classification	Contents
Finisher related service call	<p>Staple unit clinching home position sensor does not work.</p> <ul style="list-style-type: none"> <li>You receive a [CB50] error when the [EA50] error occurs three times in succession.</li> </ul>

Error	Timing of detection
Stapler motor (M10) Staple unit clinching home position sensor (S16)	The staple unit clinching home position sensor (S16) does not detect the opening of the staple unit after the stapler motor (M10) has been driven reversely in the specified time from the closing during the initial movement of the staple unit.
	The staple unit clinching home position sensor (S16) does not detect the opening of the staple unit in the specified time from the closing during the clinching movement of the staple unit, and also this sensor does not detect the opening by the reverse rotation of the motor after the stapler is stopped.
	The staple unit clinching home position sensor (S16) does not detect the closing of the staple unit after the specified time during the clinching movement of the staple unit.
	The staple unit clinching home position sensor (S16) does not detect the opening of the staple unit at the start of the clinching.

Probable cause	Checking and measures
Staple motor (M10) abnormality	Check if the electrical continuity of the coil is normal. If electricity is not conducted, replace the staple unit.
Staple unit clinching home position sensor (S16) abnormality	Measure the voltage on CN16 on the finisher control PC board (FIN). Then check that the measured voltage is 1V or lower when the sensor is ON and within the range of $3.3V \pm 5\%$ when OFF. If the voltage does not fall within the range mentioned, replace the staple unit.
Staple unit improper clinching prevention sensor (S15) abnormality	Measure the voltage on TP25 on the finisher control PC board (FIN). Then check that the measured voltage is 1V or lower when not shielded and within the range of $3.3V \pm 5\%$ when shielded. If the voltage does not fall within the range mentioned, replace the sensor.
Faulty cables and connectors	Check if the electrical continuity between the connector terminals is normal. If electricity is not conducted, replace the connectors. (Finisher control PC board (FIN): CN16, CN17)
Finisher control PC board (FIN) abnormality	If the error still occurs after replacing the motor, sensors, switch and connectors, exchange the finisher control PC board (FIN).

## [CB50] Stapler home position error

MJ-1109/1110

Classification	Contents
Finisher related service call	<p>Stapler home position sensor does not work.</p> <ul style="list-style-type: none"> <li>You receive a [CB50] error when the [EA50] error occurs three times in succession.</li> </ul>

Check item	Measures
Stapler	<ul style="list-style-type: none"> <li>Check the connectors and harnesses between the stapler and finisher control PC board (CN2).</li> <li>Check the harnesses in the stapler.</li> </ul>

Parts to be replaced	Remark
Stapler	
Finisher control PC board (FIN)	

## [CB51] Stapler unit sliding home position detection error

MJ-1042

Classification	Contents
Finisher related service call	The stapler is not at the home position.

Error	Timing of detection
Staple unit sliding motor (M7) Staple unit sliding home position sensor (S3)	The turning OFF of the staple unit sliding home position sensor (S3) is not detected when the staple unit is moved from a point where this sensor is turned ON to one point where this sensor is turned OFF after the staple unit sliding motor (M7) has been driven at the specified number of pulse.
	The turning ON of the staple unit sliding home position sensor (S3) is not detected when the staple unit is moved from a point where this sensor is turned OFF to one point where this sensor is turned ON after the staple unit sliding motor (M7) has been driven at the specified number of pulse.

Probable cause	Checking and measures
Staple unit sliding motor (M7) abnormality	Check if the electrical continuity of the coil is normal. If electricity is not conducted, replace the staple unit.
Staple unit sliding home position sensor (S3) abnormality	Measure the voltage on TP18 on the finisher control PC board (FIN). Then check that the measured voltage is 1V or lower when not shielded and within the range of $3.3\pm 5\%$ when shielded. If the voltage does not fall within the range mentioned, replace the sensor.
Faulty cables and connectors	Check if the electrical continuity between the connector terminals is normal. If electricity is not conducted, replace the connectors. (Finisher control PC board (FIN): CN3, CN18)
Finisher control PC board (FIN) abnormality	If the error still occurs after replacing the staple unit, sensors and connectors, exchange the finisher control PC board (FIN).

## [CB51] Stapler shift home position error

### [EAFB] Stapler movement error

MJ-1109/1110

Classification	Contents
[CB51] Finisher related service call	The stapler is not at the home position.
[EAFB] Finisher jam (Finisher section)	Stapler shift home position error: The stapler is not at the home position.

Check item	Measures
Stapler	Move the stapler. Fix any mechanical problem.
Stapler unit home position sensor (S10)	Check if there is a disconnection of the connector, incorrect installation or breakage of the stapler unit home position sensor (S10). If there is, reinstall the sensor correctly or replace it.
	Check if the connector (CN27) on the finisher control PC board is disconnected from the stapler unit home position sensor (S10) and the harnesses are open circuited. Correct if so.
Stapler unit shift motor (M9)	Check if the connector (CN15) on the finisher control PC board (FIN) is disconnected from the stapler unit shift motor (M9) and the harnesses are open circuited. Correct if so.

Parts to be replaced	Remark
Stapler unit home position sensor (S10)	

Parts to be replaced	Remark
Stapler unit shift motor (M9)	
Finisher control PC board (FIN)	

### [CB60] Stapler unit shift motor abnormality

MJ-1109/1110

Classification	Contents
Finisher related service call	Stapler unit shift motor is not rotating or stapler unit is not moving normally.

Check Item	Measures
Stapler	If there is mechanical problem when the stapler is moved, fix the mechanism.
Stapler unit shift motor (M9)	Check the connectors and harnesses between the stapler unit shift motor (M9) and the finisher control PC board (CN15).

Parts to be replaced	Remark
Stapler unit shift motor (M9)	
Finisher control PC board (FIN)	

### [CB80] Finisher control PC board backup RAM error

MJ-1042

Classification	Contents
Finisher related service call	Abnormality of checksum value on finisher control PC board is detected when the power is turned ON.

Error	Timing of detection
EEPROM	Data readout check is performed after data writing and the result of the data readout check does not conform to the written data. The equipment does not enter the ready status after the specified time has passed from data writing.

Probable cause	Checking and measures
Finisher control PC board (FIN) abnormality	Replace the finisher control PC board (FIN) as the cause is a fault in the IC of the backup RAM.

Parts to be replaced	Remark
Finisher control PC board (FIN)	

### [CB80] Backup RAM data abnormality

MJ-1109/1110

Classification	Contents
Finisher related service call	Abnormality of checksum value on finisher control PC board is detected when the power is turned ON.

Check Item	Measures
Main power switch	Turn OFF the main power switch, then back ON.

Parts to be replaced	Remark
Finisher control PC board (FIN)	

### [CB81] Flash ROM abnormality

MJ-1109/1110

Classification	Contents
Finisher related service call	Abnormality of checksum value on finisher control PC board is detected when the power is turned ON.

Check Item	Measures
Main power switch	Turn OFF the main power switch, then back ON.
Finisher control PC board (FIN)	Board check

Parts to be replaced	Remark
Finisher control PC board (FIN)	

### [CB82] Finisher - Main program error

MJ-1109/1110

Classification	Error item
Finisher related service call (Finisher section)	Finisher - Main program error.

Check item	Measures
Finisher control PC board (FIN)	<ul style="list-style-type: none"> <li>Update the firmware version of the finisher control PC board (FIN).</li> <li>Board check</li> </ul>

Parts to be replaced	Remarks
Finisher control PC board (FIN)	

### [CB83] Saddle stitch finisher - Main program error

MJ-1110

Classification	Error item
Finisher related service call (Saddle stitch unit)	Saddle stitch finisher - Main program error.

Check item	Measures
Saddle control PC board (SDL)	<ul style="list-style-type: none"> <li>Update the firmware version of the saddle control PC board (SDL).</li> <li>Board check</li> </ul>

Parts to be replaced	Remarks
Saddle control PC board (SDL)	

**[CB84] Hole punch unit - Main program error**

MJ-1109/1110 (When MJ-6105 is installed)

Classification	Error item
Finisher related service call (Hole punch unit)	Hole punch unit - Main program error.

Check item	Measures
Hole punch control PC board (HP)	<ul style="list-style-type: none"> <li>Update the firmware version of the hole punch control PC board (HP).</li> <li>Board check</li> </ul>

Parts to be replaced	Remarks
Hole punch control PC board (HP)	

**[CB92] Saddle stitch finisher RAM abnormality**

MJ-1110

Classification	Error item
Finisher related service call (Saddle stitch unit)	Saddle stitch finisher RAM abnormality.

Check item	Measures
Reproducibility	Turn the power OFF and then back ON.
Saddle control PC board (SDL)	<ul style="list-style-type: none"> <li>Check if the conductor pattern on the saddle control PC board (SDL) is open circuited or short circuited.</li> <li>Board check</li> </ul>

Parts to be replaced	Remarks
Saddle control PC board (SDL)	

**[CB93] Saddle stitch finisher additional folding motor abnormality**

MJ-1110

Classification	Error item
Finisher related service call (Saddle stitch unit)	<p>An abnormal interruption of the encoder pulse of the additional folding motor occurs.</p> <ul style="list-style-type: none"> <li>The [CB93] error also occurs when the error [EF18] has occurred consecutively for 3 times.</li> </ul>

Check item	Measures
Additional folding carrier	<ul style="list-style-type: none"> <li>Check if properly installed.</li> <li>Is there any mechanical problem when the additional folding carrier is moved? Correct if so.</li> </ul>
Additional folding motor (M20)	<ul style="list-style-type: none"> <li>Motor check</li> <li>Connector check (CN10)</li> <li>Harness check</li> </ul>
Saddle control PC board (SDL)	<ul style="list-style-type: none"> <li>Connector check (CN10)</li> <li>Board check</li> </ul>

Parts to be replaced	Remarks
Additional folding motor (M20)	
Saddle control PC board (SDL)	

**[CB94] Saddle transport motor abnormality**

MJ-1110

Classification	Error item
Finisher related service call (Saddle stitch unit)	Saddle transport motor abnormality or the motor is not moving normally. Paper holding mechanism or transport path switching solenoid abnormality. <ul style="list-style-type: none"> <li>The [CB94] error also occurs when the error [EAB0] or [EF13] has occurred consecutively for 3 times.</li> </ul>

Check item	Measures
Transport roller	<ul style="list-style-type: none"> <li>Check if properly installed.</li> <li>Is there any mechanical problem when the transport rollers are rotated?</li> </ul>
Saddle transport motor (M16)	<ul style="list-style-type: none"> <li>Motor check</li> <li>Connector check (CN5)</li> <li>Harness check</li> </ul>
Saddle control PC board (SDL)	<ul style="list-style-type: none"> <li>Connector check (CN5)</li> <li>Board check</li> </ul>

Parts to be replaced	Remarks
Saddle transport motor (M16)	
Saddle control PC board (SDL)	

**[CB95] Saddle stitch finisher stacker motor abnormality**

MJ-1110

Classification	Error item
Finisher related service call (Saddle stitch unit)	An interruption error or rotation abnormality occurs in the saddle stitch finisher stacker motor. <ul style="list-style-type: none"> <li>The [CB95] error also occurs when the error [EF16] has occurred consecutively for 3 times.</li> </ul>

Check item	Measures
Stacker carrier	<ul style="list-style-type: none"> <li>Check if properly installed.</li> <li>Is there any mechanical problem when the stacker carrier is moved?</li> </ul>
Stacker motor (M14)	<ul style="list-style-type: none"> <li>Motor check</li> <li>Connector check (CN8)</li> <li>Harness check</li> </ul>
Saddle control PC board (SDL)	<ul style="list-style-type: none"> <li>Connector check (CN8)</li> <li>Board check</li> </ul>

Parts to be replaced	Remarks
Stacker motor	
Saddle control PC board	

**[CBA0] Front saddle stapler home position error**

MJ-1110

Classification	Error item
Finisher related service call (Saddle stitch unit)	The detection of the home position of the stapler unit ends abnormally.

Check item	Measures
Front saddle stapler clinch unit	<ul style="list-style-type: none"> <li>• Harness check</li> <li>• Connector check</li> </ul>
Saddle control PC board (SDL)	<ul style="list-style-type: none"> <li>• Connector check (CN2)</li> <li>• Board check</li> </ul>

Parts to be replaced	Remarks
Front saddle stapler clinch unit	
Saddle control PC board (SDL)	

### [CBB0] Rear saddle stapler home position error

MJ-1110

Classification	Error item
Finisher related service call (Saddle stitch unit)	The detection of the home position of the stapler unit ends abnormally.

Check item	Measures
Rear saddle stapler clinch unit	Harness check
Saddle control PC board (SDL)	<ul style="list-style-type: none"> <li>• Connector check (CN1)</li> <li>• Board check</li> </ul>

Parts to be replaced	Remarks
Rear saddle stapler clinch unit	
Saddle control PC board (SDL)	

### [CBC0] Saddle stitch finisher side alignment motor abnormality

MJ-1110

Classification	Error item
Finisher related service call (Saddle stitch unit)	<p>The side alignment motor is not rotating or the jog is not moving normally.</p> <ul style="list-style-type: none"> <li>• A [CBC0] error will occur when an [EF15] error has arisen consecutively for 3 times.</li> </ul>

Check item	Measures
Saddle stitch unit	Is there any mechanical problem when the jog is moved? Correct if so.
Side alignment motor (M15)	<ul style="list-style-type: none"> <li>• Harness check</li> <li>• Connector check (CN4)</li> </ul>
Saddle control PC board (SDL)	<ul style="list-style-type: none"> <li>• Connector check (CN4)</li> <li>• Board check</li> </ul>

Parts to be replaced	Remarks
Side alignment motor (M15)	
Saddle control PC board (SDL)	

**[CBE0] Saddle stitch finisher folding motor abnormality**

MJ-1110

Classification	Contents
Finisher related service call (Saddle stitch unit)	An encoder pulse interruption error or rotation abnormality occurs in the saddle stitch finisher folding motor. <ul style="list-style-type: none"> <li>You receive a [CBE0] error when the [EF17] error occurs three times in succession.</li> </ul>

Check Item	Measures
Folding motor encoder sensor (S34)	<ul style="list-style-type: none"> <li>Sensor check (S34)</li> <li>Connector check (CN13)</li> <li>Harness check</li> </ul>
Folding motor (M17)	<ul style="list-style-type: none"> <li>Harness check</li> <li>Connector check (CN19)</li> </ul>
Saddle control PC board (SDL)	<ul style="list-style-type: none"> <li>Connector check (CN13, CN19)</li> <li>Board check</li> </ul>

Parts to be replaced	Measures
Folding motor encoder sensor (S34)	
Folding motor (M17)	
Saddle control PC board (SDL)	

**[CC02] Stack exit roller nip home position detection error**

MJ-1042

Classification	Contents
Finisher related service call (Finisher section)	The detection of the home position of the stack exit roller nip ends abnormally.

Check Item	Measures
Stack exit roller shift motor (M6) Stack exit roller home position sensor (S13)	<p>The stack exit roller home position sensor (S13) does not detect that the exit roller is not at the upper position after the stack exit roller motor (M6) has been driven in the specified time when the exit roller is moved down.</p> <p>The stack exit roller home position sensor (S13) does not detect that the exit roller is at the upper position after the stack exit roller shift motor (M6) has been driven in the specified time when the exit roller is moved up.</p>

**[CC20] Saddle stitch communication error**

MJ-1110

Classification	Contents
Finisher related service call	Communication error between finisher controller PC board and saddle stitcher controller board.

Check Item	Measures
Finisher control PC board (FIN)	<ul style="list-style-type: none"> <li>Connector check</li> <li>Harness check</li> <li>Board check</li> </ul>
Saddle control PC board (SDL)	<ul style="list-style-type: none"> <li>Connector check</li> <li>Harness check</li> <li>Board check</li> </ul>
Finisher control PC board (FIN)	Update the firmware version of the finisher control PC board (FIN).



Check Item	Measures
Saddle control PC board (SDL)	Update the firmware version of the saddle control PC board (SDL).

Parts to be replaced	Remark
Finisher control PC board (FIN)	
Saddle control PC board (SDL)	

### [CC30] Stack transport motor abnormality

MJ-1109/1110

Classification	Contents
Finisher related service call (Finisher section)	The stack transport motor is not rotating or the paper exit belt is not moving normally. <ul style="list-style-type: none"> <li>You receive a [CC30] error when the [EA70] error occurs three times in succession.</li> </ul>

Check item	Measures
Stack transport belt	Move the stack transport belt. Fix any mechanical problem.
Stack transport motor (M8)	Check if the connector (CN18) on the finisher control PC board (FIN) is disconnected from the stack transport motor (M8) and the harnesses are open circuited. Correct if so.

Parts to be replaced	Remark
Stack transport motor (M8)	
Finisher control PC board (FIN)	

### [CC31] Transport motor abnormality

MJ-1109/1110

Classification	Contents
Finisher related service call (Finisher section)	The transport motor is not rotating or the stack transport roller -1 and -2 is not rotating normally.

Check item	Measures
Stack transport roller -1 Stack transport roller -2	Rotate the stack transport roller -1 and -2. Fix any mechanical problem.
Transport motor	Check if the connector (CN15) on the finisher control PC board (FIN) is disconnected from the transport motor (M7) and the harnesses are open circuited. Correct if so.

Parts to be replaced	Remark
Transport motor (M7)	
Finisher control PC board (FIN)	

### [CC41] Assist guide cam home position abnormality

MJ-1109/1110

Classification	Contents
Finisher related service call (Finisher section)	Assist guide cam home position abnormality.

Check item	Measures
Paper pusher cam	Rotate the paper pusher cam. Fix any mechanical problem.

Check item	Measures
Paper holder home position sensor (S6)	Check if the connector (CN11) on the finisher control PC board (FIN) is disconnected from the paper holder home position sensor (S6) and the harnesses are open circuited. Correct if so.

Parts to be replaced	Remark
Paper holder home position sensor (S6)	
Finisher control PC board (FIN)	

### [CC51] Punch unit sliding motor abnormality

MJ-1042 (When MJ-6011 is installed)

Classification	Contents
Finisher related service call (Hole punch unit)	Punch unit sliding motor abnormality.

Error	Timing of detection
Punch unit sliding motor (M12) Punch sliding unit home position sensor (S23)	The punch sliding unit is not slid after sliding request is sent.
	The punch sliding unit home position sensor (S23) does not detect that the unit is at its home position after the specified time when the unit is returned to the home position, or this sensor does not detect that the unit is out of its home position after the specified time when the unit is released.
	The punch sliding unit home position sensor (S23) does not detect that the unit is at its home position after the specified time when the unit is moved, or this sensor does not detect that the unit is at its home position when the unit is released.

Probable cause	Checking and measures
Punch unit sliding motor (M12) abnormality	Check if the electrical continuity of the coil is normal. If electricity is not conducted, replace the motor.
Punch sliding unit home position sensor (S23) abnormality	Measure the voltage on TP26 on the hole punch control PC board (HP). Then check that the measured voltage is 1V or lower when not shielded and within the range of 5V±5% when shielded. If the voltage does not fall within the range mentioned, replace the sensor.
Faulty cables and connectors	Check if the electrical continuity between the connector terminals is normal. If electricity is not conducted, replace the connector. (Hole punch control PC board (HP): CN3, CN4, CN5, CN6, CN7)
Hole punch control PC board (HP) abnormality	If the error still occurs after replacing the motor, sensor and connectors, exchange the hole punch control PC board (HP).

### [CC51] Sideways adjustment motor abnormality

MJ-1109/1110 (When MJ-6105 is installed)

Classification	Contents
Finisher related service call (Hole punch unit)	Sideways adjustment motor is not rotating or punching unit is not shifting normally. <ul style="list-style-type: none"> <li>The [CC51] error will be displays when the [ED11] error occurs three times in succession or during the initial operation.</li> </ul>

Check Item	Measures
Paper	If there is any paper remaining on the transport path, remove the paper.

Check Item	Measures
Sideways adjustment motor (M2)	<ul style="list-style-type: none"> <li>If there is mechanical problem when the sideways adjustment motor (M2) is rotated, fix the mechanism.</li> <li>Check the connector (CN10) and harnesses between the hole punch control PC board (HP) and sideways adjustment motor (M2).</li> </ul>
Sideways deviation home position sensor (S3)	<ul style="list-style-type: none"> <li>Sensor check</li> <li>Harness check</li> <li>Connector check (CN8)</li> </ul>

Parts to be replaced	Remark
Sideways adjustment motor (M2)	
Sideways deviation home position sensor (S3)	
Hole punch control PC board (HP)	

### [CC52] Skew adjustment motor abnormality

MJ-1109/1110 (When MJ-6105 is installed)

Classification	Contents
Finisher related service call (Hole punch unit)	Skew adjustment motor is not rotating or punching unit is not shifting normally. <ul style="list-style-type: none"> <li>The [CC52] error will be displays when the [ED10] error occurs three times in succession or during the initial operation.</li> </ul>

Check Item	Measures
Paper	If there is any paper remaining on the transport path, remove the paper.
Skew adjustment motor (M1)	<ul style="list-style-type: none"> <li>If there is mechanical problem when the skew adjustment motor (M1) is rotated, fix the mechanism.</li> <li>Check the connector (CN10) and harnesses between the hole punch control PC board (HP) and skew adjustment motor (M1).</li> </ul>
Skew home position sensor (S2)	<ul style="list-style-type: none"> <li>Sensor check</li> <li>Harness check</li> <li>Connector check (CN10)</li> </ul>

Parts to be replaced	Remark
Skew home position sensor (S2)	
Skew adjustment motor (M1)	
Hole punch control PC board (HP)	

### [CC54] Paper detection sensors abnormality

MJ-1042

Classification	Contents
Finisher related service call (Hole punch unit)	The adjustment of the paper detection sensors has failed.

Probable cause	Checking and measures
Paper detection sensors (S24 and S25) abnormality	Measure the voltage on pin CN6.8 on the hole punch control PC board (HP). Then check that the measured voltage is 3.0V or higher when not shielded and 1.2V or lower when shielded. If the voltage does not fall within the range mentioned, replace a couple of PC boards on either the light-receiving side or the light-emitting side.
Faulty cables and connectors	Check if the electrical continuity between the connector terminals is normal. If electricity is not conducted, replace the connector. (Hole punch control PC board (HP): CN4, CN5, CN6)

Probable cause	Checking and measures
Hole punch control PC board (HP) abnormality	If the error still occurs after replacing the sensors and the connectors, exchange the hole punch control PC board (HP).

## [CC60, CC61] Punch motor abnormality

MJ-1042

Error	Timing of detection
Finisher related service call (Hole punch unit)	<p>[CC60] Punch motor is not rotating or punch unit is not shifting normally.</p> <p>[CC61] Punch motor abnormality.</p> <ul style="list-style-type: none"> <li>The [CC61] error occurs when the [E9F0] error occurs three times in succession or during the initial operation.</li> </ul>

Error	Timing of detection
Punch motor (M11) Paper detection sensor (S24/S25) Punch shaft home position sensor (S26) Rear punch shaft home position sensor (S22)	The paper detection sensors (S24 and S25) do not emit light after specified time when they are selected
	The level of the light-receiving amount is not lowered after the light-emitting amount of the paper detection sensors (S24 and S25) is adjusted to the lower limit.
	Punching is not performed after punching request is sent, or the punching request is sent during the punching.
	The status of the punch shaft home position sensor (S26) or the rear punch shaft home position sensor (S22) is not changed after punching request is sent.
	A punching locking signal is detected consistently over the specified time.
	The punch shaft home position sensor (S26) or the rear punch shaft home position sensor (S22) does not detect that the shaft is not at its home position at the start of punching or punch waste full detection.

Probable cause	Checking and measures
Punch motor (M11) abnormality	Check if the electrical continuity of the coil is normal. If electricity is not conducted, replace the motor.
Rear punch shaft home position sensor (S22) abnormality	Measure the voltage on TP25 on the hole punch control PC board (HP). Then check that the measured voltage is 1V or lower when not shielded and within the range of $5V \pm 5\%$ when shielded. If the voltage does not fall within the range mentioned, replace the sensor.
Punch shaft home position sensor (S26) abnormality	Measure the voltage on TP24 on the hole punch control PC board (HP). Then check that the measured voltage is 1V or lower when not shielded and within the range of $5V \pm 5\%$ when shielded. If the voltage does not fall within the range mentioned, replace the sensor.
Punch motor clock sensor (S20) abnormality	Measure the voltage on TP27 on the hole punch control PC board (HP). Then check that the measured voltage is 1V or lower when not shielded and within the range of $5V \pm 5\%$ when shielded. If the voltage does not fall within the range mentioned, replace the sensor.
Faulty cables and connectors	Check if the electrical continuity between the connector terminals is normal. If electricity is not conducted, replace the connector. (Hole punch control PC board (HP): CN2, CN5, CN6, CN7, CN8)
Hole punch control PC board (HP) abnormality	If the error still occurs after replacing the motor, sensors and connectors, exchange the hole punch control PC board (HP).

**[CC61] Punch motor home position detection error**

MJ-1109/1110 (When MJ-6105 is installed)

Classification	Contents
Finisher related service call (Hole punch unit)	Punch motor is not rotating or punch unit is not shifting normally. <ul style="list-style-type: none"> <li>The [CC61] error occurs when the [E9F0] error occurs three times in succession or during the initial operation.</li> </ul>

Check Item	Measures
Paper	If there is any paper remaining on the transport path, remove the paper.
Punch motor (M3)	<ul style="list-style-type: none"> <li>If there is mechanical problem when the punch motor (M3) is rotated, fix the mechanism.</li> <li>Check the connector (CN2) and harnesses between the hole punch control PC board (HP) and punch motor (M3).</li> </ul>
Punch home position sensor (S4)	<ul style="list-style-type: none"> <li>Sensor check</li> <li>Harness check</li> <li>Connector check (CN3)</li> </ul>

Parts to be replaced	Remark
Punch home position sensor (S4)	
Punch motor (M3)	
Hole punch control PC board (HP)	

**[CC71] Punch ROM checksum error**

MJ-1109/1110 (When MJ-6105 is installed)

Classification	Contents
Finisher related service call (Hole punch unit)	Abnormality of checksum value on Hole punch control PC board is detected when the power is turned on.

Check Item	Measures
Hole punch control PC board (HP)	Board check

Parts to be replaced	Measures
Hole punch control PC board (HP)	

**[CC72] Punch RAM read / write error**

MJ-1109/1110 (When MJ-6105 is installed)

Classification	Contents
Finisher related service call (Hole punch unit)	Abnormality of checksum value on Hole punch control PC board is detected when the power is turned on.

Check Item	Measures
Hole punch control PC board (HP)	Board check

Parts to be replaced	Measures
Hole punch control PC board (HP)	

## [CC80] Front alignment motor abnormality

MJ-1042

Classification	Contents
Finisher related service call (Finisher section)	Front alignment motor abnormality.

Error	Timing of detection
Front alignment motor (M2) Front alignment plate home position sensor (S5)	The turning OFF of the front alignment plate home position sensor (S5) is not detected when the front alignment plate is moved from a point where this sensor is turned ON to one point where this sensor is turned OFF after the front alignment motor (M2) has been driven at the specified number of pulse.
	The turning ON of the front alignment plate home position sensor (S5) is not detected when the front alignment plate is moved from a point where this sensor is turned OFF to one point where this sensor is turned ON after the front alignment motor (M2) has been driven at the specified number of pulse.

Probable cause	Checking and measures
Front alignment motor (M2) abnormality	Check if the electrical continuity of the coil is normal. If electricity is not conducted, replace the motor.
Front alignment plate home position sensor (S5) abnormality	Measure the voltage on TP15 on the finisher control PC board (FIN). Then check that the measured voltage is 1V or lower when not shielded and within the range of $3.3V \pm 5\%$ when shielded. If the voltage does not fall within the range mentioned, replace the sensor.
Faulty cables and connectors	Check if the electrical continuity between the connector terminals is normal. If electricity is not conducted, replace the connectors. (Finisher control PC board (FIN): CN5, CN12)
Finisher control PC board (FIN) abnormality	If the error still occurs after replacing the motor, sensor and connectors, exchange the finisher control PC board (FIN).

## [CC80] Rear alignment motor abnormality

\* You receive a [CC80] error when the [ED14] error occurs three times in succession.

Classification	Contents
Finisher related service call (Finisher section)	The rear alignment motor is not rotating or the rear alignment plate is not moving normally. <ul style="list-style-type: none"><li>You receive a [CC80] error when the [ED14] error occurs three times in succession.</li></ul>

MJ-1109/1110

Check item	Measures
Front alignment plate	If there is mechanical problem when the front alignment plate is moved, fix the mechanism.
Front alignment motor (M5)	Check the connectors and harnesses between the front alignment motor (M5) and the finisher control PC board (CN18).

Parts to be replaced	Remark
Front alignment motor (M5)	
Finisher control PC board (FIN)	

**[CC93] Knurled roller shift solenoid abnormality**  
MJ-1042

Classification	Contents
Finisher related service call (Finisher section)	An abnormality occurs in the knurled roller shift solenoid.

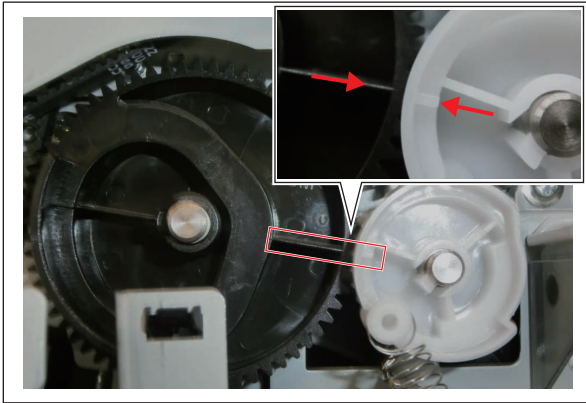
Error	Timing of detection
Knurled roller shift solenoid (SOL3) 2nd transport motor (M4) Knurled roller home position sensor (S10)	The knurled roller home position sensor (S10) does not detect that the knurled roller is at the upper position after the 2nd transport motor (M4) has been driven at the specified number of pulses during the initial rising movement of the knurled roller.
	The knurled roller home position sensor (S10) does not detect that the knurled roller is not at the upper position after the 2nd transport motor (M4) has been driven at the specified number of pulses during the initial lowering movement of the knurled roller.
	The knurled roller home position sensor (S10) does not detect that the knurled roller is at the upper position when the pressurization of stack exit movement is finished.
Gear	Check the gear of transport unit in finishing section. When assembling the gear, align its rib to the protrusion as shown in the figure.  

Fig.8-23

**[CC94] Fan motor abnormality**  
MJ-1042

Classification	Contents
Finisher related service call (Finisher section)	Fan motor abnormality.

Error	Timing of detection
Fan motor (M9)	The turning ON of the fan locking signal is detected consistently after the specified time*. * A locking signal is not monitored from the start driving the motor until the specified time has passed.

**[CCF1] Tray safety switch abnormality**  
MJ-1110

Classification	Error item
Finisher related service call (Finisher section)	<ul style="list-style-type: none"> <li>The tray safety switch turned on during tray operation (moving up or down).</li> <li>The tray operated with the tray safety switch turned on.</li> </ul>

Check item	Measures
Tray safety switch (SW2)	Check the connectors and harnesses between the tray safety switch (SW2) and the connector J110 on the finisher control PC board.
Stack tray shift motor (M2)	Check the connectors and harnesses between the stack tray shift motor (M2) and the connector J114 on the finisher control PC board.
Finisher control PC board (FIN)	<ul style="list-style-type: none"> <li>Board check</li> <li>Connector check</li> <li>Harness check</li> </ul>

Parts to be replaced	Remarks
Tray safety switch (SW2)	
Stack tray shift motor (M2)	
Finisher control PC board (FIN)	

**[CDE0] Paddle motor abnormality**  
MJ-1109/1110

Classification	Contents
Finisher related service call (Finisher section)	<p>The paddle motor is not rotating or the paddle is not rotating normally.</p> <ul style="list-style-type: none"> <li>You receive a [CDE0] error when the [ED15] error occurs three times in succession.</li> </ul>

Check Item	Measures
Paddle	Rotate the paddle. Fix any mechanical problem.
Paddle motor (M3)	Check the connectors and harnesses between the paddle motor (M3) and the finisher control PC board (CN16).

Parts to be replaced	Remark
Paddle motor (M3)	
Finisher control PC board (FIN)	



**[CF10] Communication module writing failure**

MJ-1109/1110

Classification	Contents
Finisher related service call	Communication module writing failure.

Check item	Measures
Finisher	<ul style="list-style-type: none"><li>• Check if the harness connecting the equipment and the finisher control PC board (FIN) is disconnected or open circuited.</li><li>• Check if the conductor pattern on the finisher control PC board (FIN) is open circuited or short circuited.</li><li>• Update the finisher firmware.</li></ul>
LGC board	<ul style="list-style-type: none"><li>• Check if the harness connecting the finisher and the LGC board on the equipment is disconnected or open circuited.</li><li>• Connector check</li><li>• Check if the conductor pattern on the LGC board is open circuited or short circuited.</li></ul>

Parts to be replaced	Remark
Finisher control PC board (FIN)	
LGC board	

### 8.3.19 Service call for others

#### [F100\_0] HDD format error (Operation failure of key data)

Classification	Contents
Other service call	Operation of HDD key data fails.

Check item	Measures
Setting	Reboot the equipment. If it cannot be recovered, reinstall the software in the following procedure. 1. Install the system firmware. 📖 P. 11-2 "11.2 Firmware Updating with USB Device"
SRAM	Replace the SRAM.
SYS board	Replace the SYS board.

Parts to be replaced	Remarks
SRAM	Be sure to exchange the parts in the order of the SRAM and SYS board.
SYS board	Be sure to exchange the parts in the order of the SRAM and SYS board.

#### [F100\_1] HDD format error (HDD encryption key data damaged - one board)

Classification	Contents
Other service call	Encryption key data of either the SYS board or the SRAM are damaged.

Check item	Measures
Encryption key status	Check the displayed message. (HS-73 Firmware Assist mode > Key Backup/Restore)

Take appropriate countermeasures shown in the table below according to the messages displayed in "SRAM" and "FROM".

#### Remarks:

If the error is not cleared, reinstallation of the system firmware and system software is needed. (HS-49 Firmware Update mode)

📖 P. 11-2 "11.2 Firmware Updating with USB Device"

SRAM	FROM	Measures
OK	AccessFailed	Replace the SYS board. 📖 P. 9-22 "9.2.4 Precautions and procedures when replacing the SYS board" (all steps)
OK	KeyNull KeyBroken	Recover the encryption key on the SYS board. 📖 P. 9-22 "9.2.4 Precautions and procedures when replacing the SYS board" ([D]Restore encryption key)
AccessFailed	OK	Replace the SRAM. (USB backup data are not used) 📖 P. 9-22 "9.2.4 Precautions and procedures when replacing the SYS board" (all steps)
KeyNull KeyBroken	OK	Recover the encryption key on the SRAM. 📖 P. 9-26 "9.2.5 Precautions and procedure when replacing the SRAM" ([H]Backup encryption key (FROM > SRAM))

SRAM	FROM	Measures
Keymismatch	Keymismatch	<p>&lt;The error occurs when the SYS board is replaced&gt;  Recover the encryption key on the SYS board.  📖 P. 9-22 “9.2.4 Precautions and procedures when replacing the SYS board” ([D]Restore encryption key)</p> <p>&lt;The error occurs except when the SYS board is replaced&gt;  Replace the SRAM.  📖 P. 9-26 “9.2.5 Precautions and procedure when replacing the SRAM” (all steps)</p>

Parts to be replaced	Remarks
SRAM	Be sure to exchange the parts in the order of the SRAM and SYS board.
SYS board	Be sure to exchange the parts in the order of the SRAM and SYS board.

### [F100\_2] HDD format error (HDD encryption key data damaged - both boards)

Classification	Contents
Other service call	Encryption key data of both the SYS board and the SRAM are damaged.



Check item	Measures
Encryption key status	Check the displayed message. (HS-73 Firmware Assist mode > Key Backup/Restore)

Take appropriate countermeasures shown in the table below according to the messages displayed in “SRAM” and “FROM”.

#### Remarks:

If the error is not cleared, reinstallation of the system firmware and system software is needed. (HS-49 Firmware Update mode)

SRAM	FROM	Measures
*	AccessFailed	<p>Replace the SYS board.  📖 P. 9-22 “9.2.4 Precautions and procedures when replacing the SYS board” (all steps)</p> <p>&lt;With USB backup data: All key data recovery&gt;</p> <ol style="list-style-type: none"> <li>1. Recover all the data on the SRAM.  HS-59 SRAM Data Cloning mode &gt; Restore SRAM Data from USB (For details, see “12.1.4Cloning procedure [B]Restore procedure”)</li> <li>2. Recover the encryption key/license on the SYS board.  Follow the procedures below noted in 📖 P. 9-22 “9.2.4 Precautions and procedures when replacing the SYS board”.  [C] Restore ADI key (only when Secure HDD is installed)  [D] Restore encryption key  [E] Restore license</li> </ol>
AccessFailed	*	<p>Replace the SRAM.  📖 P. 9-26 “9.2.5 Precautions and procedure when replacing the SRAM” (for the SYS board, all steps)</p>

SRAM	FROM	Measures
KeyNull/ KeyBroken	KeyNull/ KeyBroken	<p>&lt;No USB backup data&gt;</p> <p>1. Reinstall the system software.   P. 11-2 "11.2 Firmware Updating with USB Device"</p> <p>&lt;With USB backup data: All key data recovery&gt;</p> <p>1. Recover all the data on the SRAM.  HS-59 SRAM Data Cloning mode &gt; Restore SRAM Data from USB  (For details, see "12.1.4Cloning procedure [B]Restore procedure")</p> <p>2. Recover the encryption key/license on the SYS board.  Follow the procedures below noted in  P. 9-22 "9.2.4 Precautions and procedures when replacing the SYS board".  [C] Restore ADI key (only when Secure HDD is installed)  [D] Restore encryption key  [E] Restore license</p>

\* AccessFailed, KeyNull or KeyBroken

Parts to be replaced	Remarks
SRAM	Be sure to exchange the parts in the order of the SRAM and SYS board.
SYS board	Be sure to exchange the parts in the order of the SRAM and SYS board.


### [F100\_3] Serial number value error

Classification	Contents
Other service call	Only the first two characters of the serial number are entered. (The serial number is not completely entered.)

Check item	Measures
Serial number	Enter the serial number with [FS-08-9601]. If an F100_3 error occurs at the FS Menu startup, select HS-76 SRAM clear mode > Set Serial Number and enter the serial number.

### [F100\_4] Hash check error of encryption partition key

Classification	Contents
Other service call	Hash check error of encryption partition key.

Check item	Measures
SYS board	Replace the SYS board.  P. 9-22 "9.2.4 Precautions and procedures when replacing the SYS board"

Parts to be replaced	Remark
SYS board	

**[F101\_0] HDD connection error (HDD connection cannot be detected)**

**[F101\_1] Root partition mount error (HDD formatting fails)**

**[F101\_2][F101\_3] Partition mount error**

Classification	Contents
Other service call	Sub-code 0: HDD connection error (HDD connection cannot be detected). Sub-code 1: The HDD cannot be connected (mounted) caused by damage to the areas in which the program is mainly stored. Sub-code 2, 3: The areas other than those described in the F101_1 and F101_4 to F101_10 errors are damaged.

Check item	Measures
HDD, SYS board, Setting	<ol style="list-style-type: none"> <li>1. Turn the power of the equipment OFF and check the connection of the HDD. <ul style="list-style-type: none"> <li>- Connector and harness check</li> <li>- Check if the connector pins of the HDD are bent.</li> <li>- Check if HDD for other equipment is not installed.</li> <li>- Check if SRAM for other equipment is not installed.</li> </ul> </li> <li>2. If the error still occurs after step 1, perform the following. <ul style="list-style-type: none"> <li>- Perform HS-73 Firmware Assist mode &gt; Key Backup/Restore and check that each Key Status is "OK".</li> <li>- If not, recover the key (press [Key] and select the menu, and then press [Execute]).</li> </ul> </li> <li>3. If the error still persists after step 2, perform the following. <ul style="list-style-type: none"> <li>- Perform HS-73 Firmware Assist mode &gt; Format HDD, and then install "System Software (HD data)" with HS-49 Firmware Update mode.</li> </ul> <p><b>Notes:</b> The following items will be deleted by HS-73 Firmware Assist mode &gt; Format HDD.</p> <ul style="list-style-type: none"> <li>• Message Log</li> <li>• Job Log</li> <li>• Spool Data (Print, Email reception)</li> <li>• Template</li> </ul> <p>If F101_1 occurs with secure HDD or the error persists after performing step 3, perform step 3 after performing the following.</p> <ul style="list-style-type: none"> <li>- HS-74 HDD Assist mode &gt; Revert Factory Initial Status HDD.</li> </ul> </li> <li>4. If the error persists even after step 3, replace the HDD harness.</li> <li>5. If the error persists even after step 4, replace the HDD.</li> <li>6. If the error persists even after step 5, replace the SYS board.</li> </ol>

Parts to be replaced	Remark
HDD harness	Be sure to exchange the parts in the order of the HDD harness, HDD and SYS board.
HDD	Be sure to exchange the parts in the order of the HDD harness, HDD and SYS board.
SYS board	Be sure to exchange the parts in the order of the HDD harness, HDD and SYS board.

**[F101\_4] Partition mount error**  
**[F101\_12] Partition mount error**

Classification	Contents
Other service call	Sub-code 4: The "/work" partition is damaged. Sub-code 12: File link error in the "/work" partition.

Check item	Measures
HDD, SYS board, Setting	<ol style="list-style-type: none"> <li>1. Turn the power of the equipment OFF and check the connection of the HDD. <ul style="list-style-type: none"> <li>- Connector and harness check</li> <li>- Check if the connector pins of the HDD are bent.</li> <li>- Check if HDD for other equipment is not installed.</li> <li>- Check if SRAM for other equipment is not installed.</li> </ul> </li> <li>2. If the error still occurs after step 1, perform the following. <ul style="list-style-type: none"> <li>- Perform HS-73 Firmware Assist mode &gt; Key Backup/Restore and check that each Key Status is "OK".</li> <li>- If not, recover the key (press [Key] and select the menu, and then press [Execute]).</li> </ul> </li> <li>3. If the error persists after step 2, perform HS-75 File System Recovery mode &gt; Recovery F/S &gt; /work, and then restart the equipment.</li> <li>4. If the error persists after step 3, perform HS-75 File System Recovery mode &gt; Initialize HDD &gt; /work, and then restart the equipment.</li> <li>5. If the error still persists after step 4, perform the following. <ul style="list-style-type: none"> <li>- Perform HS-73 Firmware Assist mode &gt; Format HDD, and then install "System Software (HD data)" with HS-49 Firmware Update mode.</li> </ul> <p><b>Notes:</b> The following items will be deleted by performing HS-73 Firmware Assist mode &gt; Format HDD.</p> <ul style="list-style-type: none"> <li>• Message Log</li> <li>• Job Log</li> <li>• Spool Data (Print, Email reception)</li> <li>• Template</li> </ul> <p>If the error still persists even after step 5, perform the following and then reattempt step 5.</p> <ul style="list-style-type: none"> <li>- HS-74 HDD Assist mode &gt; Revert Factory Initial Status HDD.</li> </ul> </li> <li>6. If the error persists even after step 5, replace the HDD harness.</li> <li>7. If the error persists even after step 6, replace the HDD.</li> <li>8. If the error persists even after step 7, replace the SYS board.</li> </ol>

Parts to be replaced	Remark
HDD harness	Be sure to exchange the parts in the order of the HDD harness, HDD and SYS board.
HDD	Be sure to exchange the parts in the order of the HDD harness, HDD and SYS board.
SYS board	Be sure to exchange the parts in the order of the HDD harness, HDD and SYS board.

## [F101\_5] Partition mount error

Classification	Contents
Other service call	Sub-code 5: The "/registration" partition is damaged.

Check item	Measures
HDD, SYS board, Setting	<ol style="list-style-type: none"> <li>1. Turn the power of the equipment OFF and check the connection of the HDD. <ul style="list-style-type: none"> <li>- Connector and harness check</li> <li>- Check if the connector pins of the HDD are bent.</li> <li>- Check if HDD for other equipment is not installed.</li> <li>- Check if SRAM for other equipment is not installed.</li> </ul> </li> <li>2. If the error still occurs after step 1, perform the following. <ul style="list-style-type: none"> <li>- Perform HS-73 Firmware Assist mode &gt; Key Backup/Restore and check that each Key Status is "OK".</li> <li>- If not, recover the key (press [Key] and select the menu, and then press [Execute]).</li> </ul> </li> <li>3. If the error persists after step 2, perform HS-75 File System Recovery mode &gt; Recovery F/S &gt; /registration, and then restart the equipment.</li> <li>4. If the error persists after step 3, perform HS-75 File System Recovery mode &gt; Initialize HDD &gt; /registration, and then restart the equipment.</li> <li>5. If the error still persists after step 4, perform the following. <ul style="list-style-type: none"> <li>- Perform HS-73 Firmware Assist mode &gt; Format HDD, and then install "System Software (HD data)" with HS-49 Firmware Update mode.</li> </ul> <p><b>Notes:</b> The following items will be deleted by performing HS-73 Firmware Assist mode &gt; Format HDD.</p> <ul style="list-style-type: none"> <li>• Message Log</li> <li>• Job Log</li> <li>• Spool Data (Print, Email reception)</li> <li>• Template</li> </ul> <p>If the error still persists even after step 5, perform the following and then reattempt step 5.</p> <ul style="list-style-type: none"> <li>- HS-74 HDD Assist mode &gt; Revert Factory Initial Status HDD.</li> </ul> </li> <li>6. If the error persists even after step 5, replace the HDD harness.</li> <li>7. If the error persists even after step 6, replace the HDD.</li> <li>8. If the error persists even after step 7, replace the SYS board.</li> </ol>

Parts to be replaced	Remark
HDD harness	Be sure to exchange the parts in the order of the HDD harness, HDD and SYS board.
HDD	Be sure to exchange the parts in the order of the HDD harness, HDD and SYS board.
SYS board	Be sure to exchange the parts in the order of the HDD harness, HDD and SYS board.

## [F101\_6] Partition mount error

Classification	Contents
Other service call	Sub-code 6: The “/backup” partition is damaged.

Check item	Measures
HDD, SYS board, Setting	<ol style="list-style-type: none"> <li>1. Turn the power of the equipment OFF and check the connection of the HDD. <ul style="list-style-type: none"> <li>- Connector and harness check</li> <li>- Check if the connector pins of the HDD are bent.</li> <li>- Check if HDD for other equipment is not installed.</li> <li>- Check if SRAM for other equipment is not installed.</li> </ul> </li> <li>2. If the error still occurs after step 1, perform the following. <ul style="list-style-type: none"> <li>- Perform HS-73 Firmware Assist mode &gt; Key Backup / Restore and check that each Key Status is “OK”.</li> <li>- If not, recover the key (press [Key] and select the menu, and then press [Execute]).</li> </ul> </li> <li>3. If the error persists after step 2, perform HS-75 File System Recovery mode &gt; Recovery F/S &gt; /backup, and then restart the equipment.</li> <li>4. If the error persists after step 3, perform HS-75 File System Recovery mode &gt; Initialize HDD &gt; /backup, and then restart the equipment.</li> <li>5. If the error still persists after step 4, perform the following. <ul style="list-style-type: none"> <li>- Perform HS-73 Firmware Assist mode &gt; Format HDD, and then install “System Software (HD data)” with HS-49 Firmware Update mode.</li> </ul> <p><b>Notes:</b> The following items will be deleted by performing HS-73 Firmware Assist mode &gt; Format HDD.</p> <ul style="list-style-type: none"> <li>• Message Log</li> <li>• Job Log</li> <li>• Spool Data (Print, Email reception)</li> <li>• Template</li> </ul> <p>If the error still persists even after step 5, perform the following and then reattempt step 5.</p> <ul style="list-style-type: none"> <li>- HS-74 HDD Assist mode &gt; Revert Factory Initial Status HDD.</li> </ul> </li> <li>6. If the error persists even after step 5, replace the HDD harness.</li> <li>7. If the error persists even after step 6, replace the HDD.</li> <li>8. If the error persists even after step 7, replace the SYS board.</li> </ol>

Parts to be replaced	Remark
HDD harness	Be sure to exchange the parts in the order of the HDD harness, HDD and SYS board.
HDD	Be sure to exchange the parts in the order of the HDD harness, HDD and SYS board.
SYS board	Be sure to exchange the parts in the order of the HDD harness, HDD and SYS board.



## [F101\_7] Partition mount error

Classification	Contents
Other service call	Sub-code 7: The "/imagedata" partition is damaged.

Check item	Measures
HDD, SYS board, Setting	<ol style="list-style-type: none"> <li>1. Turn the power of the equipment OFF and check the connection of the HDD. <ul style="list-style-type: none"> <li>- Connector and harness check</li> <li>- Check if the connector pins of the HDD are bent.</li> <li>- Check if HDD for other equipment is not installed.</li> <li>- Check if SRAM for other equipment is not installed.</li> </ul> </li> <li>2. If the error still occurs after step 1, perform the following. <ul style="list-style-type: none"> <li>- Perform HS-73 Firmware Assist mode &gt; Key Backup/Restore and check that each Key Status is "OK".</li> <li>- If not, recover the key (press [Key] and select the menu, and then press [Execute]).</li> </ul> </li> <li>3. If the error persists after step 2, perform HS-75 File System Recovery mode &gt; Recovery F/S &gt; /imagedata, and then restart the equipment.</li> <li>4. If the error persists after step 3, perform HS-75 File System Recovery mode &gt; Initialize HDD &gt; /imagedata, and then restart the equipment.</li> <li>5. If the error still persists after step 4, perform the following. <ul style="list-style-type: none"> <li>- Perform HS-73 Firmware Assist mode &gt; Format HDD, and then install "System Software (HD data)" with HS-49 Firmware Update mode.</li> </ul> <p><b>Notes:</b> The following items will be deleted by performing HS-73 Firmware Assist mode &gt; Format HDD.</p> <ul style="list-style-type: none"> <li>• Message Log</li> <li>• Job Log</li> <li>• Spool Data (Print, Email reception)</li> <li>• Template</li> </ul> <p>If the error still persists even after step 5, perform the following and then reattempt step 5.</p> <ul style="list-style-type: none"> <li>- HS-74 HDD Assist mode &gt; Revert Factory Initial Status HDD.</li> </ul> </li> <li>6. If the error persists even after step 5, replace the HDD harness.</li> <li>7. If the error persists even after step 6, replace the HDD.</li> <li>8. If the error persists even after step 7, replace the SYS board.</li> </ol>

Parts to be replaced	Remark
HDD harness	Be sure to exchange the parts in the order of the HDD harness, HDD and SYS board.
HDD	Be sure to exchange the parts in the order of the HDD harness, HDD and SYS board.
SYS board	Be sure to exchange the parts in the order of the HDD harness, HDD and SYS board.

## [F101\_8] Partition mount error

Classification	Contents
Other service call	Sub-code 8: The "/storage" partition is damaged.

Check item	Measures
HDD, SYS board, Setting	<ol style="list-style-type: none"> <li>1. Turn the power of the equipment OFF and check the connection of the HDD. <ul style="list-style-type: none"> <li>- Connector and harness check</li> <li>- Check if the connector pins of the HDD are bent.</li> <li>- Check if HDD for other equipment is not installed.</li> <li>- Check if SRAM for other equipment is not installed.</li> </ul> </li> <li>2. If the error still occurs after step 1, perform the following. <ul style="list-style-type: none"> <li>- Perform HS-73 Firmware Assist mode &gt; Key Backup/Restore and check that each Key Status is "OK".</li> <li>- If not, recover the key (press [Key] and select the menu, and then press [Execute]).</li> </ul> </li> <li>3. If the error persists after step 2, perform HS-75 File System Recovery mode &gt; Recovery F/S &gt; /storage, and then restart the equipment.</li> <li>4. If the error persists after step 3, perform HS-75 File System Recovery mode &gt; Initialize HDD &gt; /storage, and then restart the equipment.</li> <li>5. If the error still persists after step 4, perform the following. <ul style="list-style-type: none"> <li>- Perform HS-73 Firmware Assist mode &gt; Format HDD, and then install "System Software (HD data)" with HS-49 Firmware Update mode.</li> </ul> <p><b>Notes:</b> The following items will be deleted by performing HS-73 Firmware Assist mode &gt; Format HDD.</p> <ul style="list-style-type: none"> <li>• Message Log</li> <li>• Job Log</li> <li>• Spool Data (Print, Email reception)</li> <li>• Template</li> </ul> <p>If the error still persists even after step 5, perform the following and then reattempt step 5.</p> <ul style="list-style-type: none"> <li>- HS-74 HDD Assist mode &gt; Revert Factory Initial Status HDD.</li> </ul> </li> <li>6. If the error persists even after step 5, replace the HDD harness.</li> <li>7. If the error persists even after step 6, replace the HDD.</li> <li>8. If the error persists even after step 7, replace the SYS board.</li> </ol>

Parts to be replaced	Remark
HDD harness	Be sure to exchange the parts in the order of the HDD harness, HDD and SYS board.
HDD	Be sure to exchange the parts in the order of the HDD harness, HDD and SYS board.
SYS board	Be sure to exchange the parts in the order of the HDD harness, HDD and SYS board.

## [F101\_9] Partition mount error

Classification	Contents
Other service call	Sub-code 9: The "/encryption" partition is damaged.

Check item	Measures
HDD, SYS board, Setting	<ol style="list-style-type: none"> <li>1. Turn the power of the equipment OFF and check the connection of the HDD. <ul style="list-style-type: none"> <li>- Connector and harness check</li> <li>- Check if the connector pins of the HDD are bent.</li> <li>- Check if HDD for other equipment is not installed.</li> <li>- Check if SRAM for other equipment is not installed.</li> </ul> </li> <li>2. If the error still occurs after step 1, perform the following. <ul style="list-style-type: none"> <li>- Perform HS-73 Firmware Assist mode &gt; Key Backup/Restore and check that each Key Status is "OK".</li> <li>- If not, recover the key (press [Key] and select the menu, and then press [Execute]).</li> </ul> </li> <li>3. If the error persists after step 2, perform HS-75 File System Recovery mode &gt; Recovery F/S &gt; /encryption, and then restart the equipment.</li> <li>4. If the error persists after step 3, perform HS-75 File System Recovery mode &gt; Initialize HDD &gt; /encryption, and then restart the equipment.</li> <li>5. If the error still persists after step 4, perform the following. <ul style="list-style-type: none"> <li>- Perform HS-73 Firmware Assist mode &gt; Format HDD, and then install "System Software (HD data)" with HS-49 Firmware Update mode.</li> </ul> <p><b>Notes:</b> The following items will be deleted by performing HS-73 Firmware Assist mode &gt; Format HDD.</p> <ul style="list-style-type: none"> <li>• Message Log</li> <li>• Job Log</li> <li>• Spool Data (Print, Email reception)</li> <li>• Template</li> </ul> <p>If the error still persists even after step 5, perform the following and then reattempt step 5.</p> <ul style="list-style-type: none"> <li>- HS-74 HDD Assist mode &gt; Revert Factory Initial Status HDD.</li> </ul> </li> <li>6. If the error persists even after step 5, replace the HDD harness.</li> <li>7. If the error persists even after step 6, replace the HDD.</li> <li>8. If the error persists even after step 7, replace the SYS board.</li> </ol>

Parts to be replaced	Remark
HDD harness	Be sure to exchange the parts in the order of the HDD harness, HDD and SYS board.
HDD	Be sure to exchange the parts in the order of the HDD harness, HDD and SYS board.
SYS board	Be sure to exchange the parts in the order of the HDD harness, HDD and SYS board.

## [F101\_10] Partition mount error

Classification	Contents
Other service call	Sub-code 10: The "/application" partition is damaged.

Check item	Measures
HDD, SYS board, Setting	<ol style="list-style-type: none"> <li>1. Turn the power of the equipment OFF and check the connection of the HDD. <ul style="list-style-type: none"> <li>- Connector and harness check</li> <li>- Check if the connector pins of the HDD are bent.</li> <li>- Check if HDD for other equipment is not installed.</li> <li>- Check if SRAM for other equipment is not installed.</li> </ul> </li> <li>2. If the error still occurs after step 1, perform the following. <ul style="list-style-type: none"> <li>- Perform HS-73 Firmware Assist mode &gt; Key Backup/Restore and check that each Key Status is "OK".</li> <li>- If not, recover the key (press [Key] and select the menu, and then press [Execute]).</li> </ul> </li> <li>3. If the error persists after step 2, perform HS-75 File System Recovery mode &gt; Recovery F/S &gt; /application, and then restart the equipment.</li> <li>4. If the error persists after step 3, perform HS-75 File System Recovery mode &gt; Initialize HDD &gt; /application, and then restart the equipment.</li> <li>5. If the error still persists after step 4, perform the following. <ul style="list-style-type: none"> <li>- Perform HS-73 Firmware Assist mode &gt; Format HDD, and then install "System Software (HD data)" with HS-49 Firmware Update mode.</li> </ul> <p><b>Notes:</b> The following items will be deleted by performing HS-73 Firmware Assist mode &gt; Format HDD.</p> <ul style="list-style-type: none"> <li>• Message Log</li> <li>• Job Log</li> <li>• Spool Data (Print, Email reception)</li> <li>• Template</li> </ul> <p>If the error still persists even after step 5, perform the following and then reattempt step 5.</p> <ul style="list-style-type: none"> <li>- HS-74 HDD Assist mode &gt; Revert Factory Initial Status HDD.</li> </ul> </li> <li>6. If the error persists even after step 5, replace the HDD harness.</li> <li>7. If the error persists even after step 6, replace the HDD.</li> <li>8. If the error persists even after step 7, replace the SYS board.</li> </ol>

Parts to be replaced	Remark
HDD harness	Be sure to exchange the parts in the order of the HDD harness, HDD and SYS board.
HDD	Be sure to exchange the parts in the order of the HDD harness, HDD and SYS board.
SYS board	Be sure to exchange the parts in the order of the HDD harness, HDD and SYS board.

## [F101\_11] Partition mount error

Classification	Contents
Other service call	Sub-code 11: The "/platform" partition is damaged.

Check item	Measures
HDD, SYS board, Setting	<ol style="list-style-type: none"> <li>1. Turn the power of the equipment OFF and check the connection of the HDD. <ul style="list-style-type: none"> <li>- Connector and harness check</li> <li>- Check if the connector pins of the HDD are bent.</li> <li>- Check if an HDD for other equipment is not installed.</li> <li>- Check if a SRAM for other equipment is not installed.</li> </ul> </li> <li>2. If the error still occurs after step 1, perform the following. <ul style="list-style-type: none"> <li>- Perform HS-73 Firmware Assist mode &gt; Format HDD, and then install "System Software (HD data)" with HS-49 Firmware Update mode.</li> </ul> <p><b>Notes:</b> The following items will be deleted by performing HS-73 Firmware Assist mode &gt; Format HDD.</p> <ul style="list-style-type: none"> <li>• Message Log</li> <li>• Job Log</li> <li>• Spool Data (Print, Email reception)</li> <li>• Template</li> </ul> </li> <li>3. If the error still persists even after step 2, perform the following and then reattempt step 2. <ul style="list-style-type: none"> <li>- Perform HS-74 HDD Assist mode &gt; Initialize HDD &gt; / application and then reboot the equipment.</li> </ul> </li> <li>4. If the error still persists even after step 3, replace the HDD harness.</li> <li>5. If the error still persists even after step 4, replace the HDD.</li> <li>6. If the error still persists even after step 5, replace the SYS board.</li> </ol>

Parts to be replaced	Remark
HDD harness	Be sure to exchange the parts in the order of the HDD harness, HDD and SYS board.
HDD	Be sure to exchange the parts in the order of the HDD harness, HDD and SYS board.
SYS board	Be sure to exchange the parts in the order of the HDD harness, HDD and SYS board.

## [F101\_13] Error due to damage to file

Classification	Contents
Other service call	HDD not mounted - The detection of the HDD has failed. Sub-code 13: The files under the "/imagedata" are corrupted.

Check item	Measures
HDD, SYS board, Setting	<ol style="list-style-type: none"> <li>1. Turn the power of the equipment OFF and check the connection of the HDD. <ul style="list-style-type: none"> <li>- Check the connectors and harnesses.</li> <li>- Check if the connector pins of the HDD are bent.</li> <li>- Check if an HDD for other equipment is installed.</li> <li>- Check if a SRAM for other equipment is installed.</li> </ul> </li> <li>2. If the error still persists after step 1, perform the following items. <ul style="list-style-type: none"> <li>- Perform HS-75 File System Recovery mode &gt; Recovery F/S &gt; /imagedata and reboot the equipment.</li> </ul> </li> <li>3. If the error still persists after step 2, perform the following items. <ul style="list-style-type: none"> <li>- Perform HS-73 Firmware Assist mode &gt; [Format HDD], and then reinstall "System Software (HD data)" with HS-49 Firmware Update mode.</li> </ul> <p><b>Notes:</b> The following items will be deleted by performing HS-73 Firmware Assist mode &gt; [Format HDD].</p> <ul style="list-style-type: none"> <li>• Message Log</li> <li>• Job Log</li> <li>• Spool Data (Print, Email reception)</li> <li>• Template</li> </ul> </li> <li>4. If the error still persists even after step 3, perform the following and then reattempt step 3. <ul style="list-style-type: none"> <li>- HS-74 &gt; [Revert Factory Initial Status HDD]</li> </ul> </li> <li>5. If the error still persists even after step 4, replace the HDD harness.</li> <li>6. If the error still persists even after step 5, replace the HDD.</li> <li>7. If the error still persists even after step 6, replace the SYS board.</li> </ol>

Parts to be replaced	Remark
HDD harness	Be sure to exchange the parts in the order of the HDD harness, HDD and SYS board.
HDD	Be sure to exchange the parts in the order of the HDD harness, HDD and SYS board.
SYS board	Be sure to exchange the parts in the order of the HDD harness, HDD and SYS board.

## [F101\_14] Partition mount error

Classification	Contents
Other service call	Sub-code 14: HDD cannot be connected (mounted) due to damage to the "/rollback" partition.

Check item	Measures
HDD, SYS board, Setting	<ol style="list-style-type: none"> <li>1. Reboot the equipment. If the error still persists, perform the following steps.</li> <li>2. Turn the power of the equipment OFF and check the connection of the HDD. <ul style="list-style-type: none"> <li>- Connector and harness check.</li> <li>- Check if the connector pins of the HDD are bent.</li> <li>- Check if an HDD for other equipment is installed.</li> <li>- Check if a SRAM for other equipment is installed.</li> </ul> </li> <li>3. If the error still persists after step 2, perform the following items. <ul style="list-style-type: none"> <li>- Perform HS-73 Firmware Assist mode &gt; [Format HDD], and then install "System Software (HD data)" with HS-49 Firmware Update mode.</li> </ul> <p><b>Notes:</b> The following items will be deleted by performing HS-73 Firmware Assist mode &gt; [Format HDD].</p> <ul style="list-style-type: none"> <li>• Message Log</li> <li>• Job Log</li> <li>• Spool Data (Print, Email reception)</li> <li>• Template</li> </ul> </li> <li>4. If the error still persists even after step 3, perform the following and then reattempt step 3. <ul style="list-style-type: none"> <li>- HS-74 &gt; [Revert Factory Initial Status HDD]</li> </ul> </li> <li>5. If the error still persists even after step 4, replace the HDD harness.</li> <li>6. If the error still persists even after step 5, replace the HDD.</li> <li>7. If the error still persists even after step 6, replace the SYS board.</li> </ol>

Parts to be replaced	Remark
HDD harness	Be sure to exchange the parts in the order of the HDD harness, HDD and SYS board.
HDD	Be sure to exchange the parts in the order of the HDD harness, HDD and SYS board.
SYS board	Be sure to exchange the parts in the order of the HDD harness, HDD and SYS board.

### [F102] HDD start error

### [F103] HDD transfer time-out

### [F104] HDD data error

### [F105] HDD other error

Classification	Contents
Other service call	<p>[F102] HDD cannot become "Ready" state.</p> <p>[F103] Reading / writing cannot be performed in the specified period of time.</p> <p>[F104] Abnormality is detected in the data of HDD.</p> <p>[F105] HDD other error.</p>

Check item	Measures
HDD	<ul style="list-style-type: none"> <li>Connector and harness check</li> <li>Check if the connector pins of the HDD are bent.</li> <li>Perform the bad sector check (FS-08-9072). If the check result is OK, recover the data in the HDD. If the check result is failed, replace the HDD.</li> </ul>

Parts to be replaced	Remark
HDD harness	Be sure to exchange the parts in the order of the HDD harness, HDD and SYS board.
HDD	Be sure to exchange the parts in the order of the HDD harness, HDD and SYS board.
SYS board	Be sure to exchange the parts in the order of the HDD harness, HDD and SYS board.

### [F106\_0] HDD error (Illegal disk replacement detected)

Classification	Error item
Other service call	The Secure HDD has been replaced illegally to Normal HDD.

Check item	Measures
Setting	<p>Check if the HDD has been replaced with a Normal HDD.</p> <ol style="list-style-type: none"> <li>Start the equipment in the 4C mode: Perform HS-74 HDD assist mode.</li> <li>Check the type of the HDD shown on the top left of the control panel display "Current HDD type". <ul style="list-style-type: none"> <li>In case of Normal HDD, replace it with the original Secure HDD or a new Secure HDD.</li> </ul> </li> </ol> <p><b>Notes:</b></p> <ul style="list-style-type: none"> <li>To replace with the original Secure HDD, start the equipment in the normal mode and then reinstall system software only if any abnormality occurs.</li> <li>In case of "Secure HDD" <ul style="list-style-type: none"> <li>Check each item in the Measures field for the HDD below. If the error still occurs, reinstall the system software.</li> </ul> </li> </ul>
HDD	<ul style="list-style-type: none"> <li>Connector check</li> <li>Harness check</li> </ul> <p>Follow the procedure below if no abnormality is found in the check items above.</p> <ol style="list-style-type: none"> <li>Perform HS-74 HDD assist mode. &gt; Revert Factory Initial Status HDD</li> <li>Reinstall the system software.</li> </ol> <p>If the error persists even after above step, replace the HDD. If the equipment operation disabled after above step, replace the HDD.</p>

Parts to be replaced	Remarks
HDD harness	Be sure to exchange the parts in the order of the HDD harness, HDD and SYS board.
HDD	Be sure to exchange the parts in the order of the HDD harness, HDD and SYS board.
SYS board	Be sure to exchange the parts in the order of the HDD harness, HDD and SYS board.

### [F106\_1] HDD error (HDD type detection error)

Classification	Error item
Other service call	HDD type detection fails.



Check item	Measures
Setting	If the error is not recovered after rebooting the equipment or no abnormality is found on any check items for the HDD, reinstall the system software.
HDD	<ul style="list-style-type: none"> <li>• Connector check</li> <li>• Harness check</li> <li>• Perform HS-75 File system recovery mode. Check the file system and recover it if necessary. If the recovery fails, replace the HDD. If the equipment does not start in the HS-75 File system recovery mode, also replace the HDD.</li> <li>• Check that either the Secure HDD or Normal HDD is mounted.               <ol style="list-style-type: none"> <li>1. Perform HS-74 HDD assist mode.</li> <li>2. Check the type of the HDD shown on the control panel display "Current HDD type". Normal status: Secure HDD or Normal HDD Abnormal status: Unknown HDD</li> </ol>               If "Unknown HDD" is displayed, reinstall the system software. If the error persists even after above step, replace the HDD. If the above step cannot be performed, replace the HDD.             </li> </ul>

Parts to be replaced	Remarks
HDD harness	Be sure to exchange the parts in the order of the HDD harness, HDD and SYS board.
HDD	Be sure to exchange the parts in the order of the HDD harness, HDD and SYS board.
SYS board	Be sure to exchange the parts in the order of the HDD harness, HDD and SYS board.

#### [F106\_2] HDD error (Secure HDD encryption key download operation error)

Classification	Error item
Other service call	Downloading of or consistency check for Secure HDD encryption key fails.

Check item	Measures
Setting	<p>Checking of Secure HDD encryption key status</p> <ol style="list-style-type: none"> <li>1. Perform HS-73 Assist mode.</li> <li>2. Perform "Key Backup / Restore".</li> <li>3. Check the status of the Secure HDD encryption key on the Key Backup / Restore menu.</li> <li>4. After the operation is completed, shut down the equipment.</li> </ol> <ul style="list-style-type: none"> <li>• In case both the ADIKey SRAM/FROM status are OK Reinstall the system firmware.</li> <li>• In case either the ADIKey SRAM/FROM status is other than OK Restore the Secure HDD encryption key.</li> <li>• In case both of the ADIKey SRAM/FROM status are other than OK Reinstall the system software.</li> </ul>
HDD	If the error persists even after above step, replace the HDD. If the equipment operation disabled after above step, replace the HDD.

Parts to be replaced	Remarks
HDD harness	Be sure to exchange the parts in the order of the HDD harness, HDD and SYS board.
HDD	Be sure to exchange the parts in the order of the HDD harness, HDD and SYS board.

Parts to be replaced	Remarks
SYS board	Be sure to exchange the parts in the order of the HDD harness, HDD and SYS board.

### [F106\_3] HDD error (Secure HDD authentication Admin Password generation error)

Classification	Error item
Other service call	The generation of Secure HDD authentication Admin Password fails.

Check item	Measures
Setting	<p>Perform HS-73 Assist mode &gt; Format HDD, and then install the system software by performing HS-49 Firmware update mode &gt; SYSTEM SOFTWARE (HD Data).</p> <p><b>Notes:</b> The following items will be deleted by performing HS-73 Assist mode &gt; Format HDD.</p> <ul style="list-style-type: none"> <li>• Message Log</li> <li>• Job Log</li> <li>• Spool Data (Print, Email reception)</li> <li>• Template</li> </ul>
HDD	<p>If the error persists even after above step, replace the HDD. If the equipment operation disabled after above step, replace the HDD.</p>

Parts to be replaced	Remarks
HDD harness	Be sure to exchange the parts in the order of the HDD harness, HDD and SYS board.
HDD	Be sure to exchange the parts in the order of the HDD harness, HDD and SYS board.
SYS board	Be sure to exchange the parts in the order of the HDD harness, HDD and SYS board.

### [F106\_4] HDD error (Authentication random number generation error)

Classification	Error item
Other service call	The generation of a random number for authentication data fails.

Check item	Measures
Setting	<p>Perform HS-73 Assist mode &gt; Format HDD, and then install the system software by performing HS-49 Firmware update mode &gt; SYSTEM SOFTWARE (HD Data).</p> <p><b>Notes:</b> The following items will be deleted by performing HS-73 Assist mode &gt; Format HDD.</p> <ul style="list-style-type: none"> <li>• Message Log</li> <li>• Job Log</li> <li>• Spool Data (Print, Email reception)</li> <li>• Template</li> </ul>
HDD	<p>If the error persists even after above step, replace the HDD. If the equipment operation disabled after above step, replace the HDD.</p>

Parts to be replaced	Remarks
HDD harness	Be sure to exchange the parts in the order of the HDD harness, HDD and SYS board.

Parts to be replaced	Remarks
HDD	Be sure to exchange the parts in the order of the HDD harness, HDD and SYS board.
SYS board	Be sure to exchange the parts in the order of the HDD harness, HDD and SYS board.

### [F106\_5] HDD error (Authentication data transmission error)

Classification	Error item
Other service call	The transmission of authentication data fails.

Check item	Measures
Setting	<p>Perform HS-73 Assist mode &gt; Format HDD, and then install the system software by performing HS-49 Firmware update mode &gt; SYSTEM SOFTWARE (HD Data).</p> <p><b>Notes:</b> The following items will be deleted by performing HS-73 Assist mode &gt; Format HDD.</p> <ul style="list-style-type: none"> <li>• Message Log</li> <li>• Job Log</li> <li>• Spool Data (Print, Email reception)</li> <li>• Template</li> </ul> <ul style="list-style-type: none"> <li>• In case this error occurred after returning SRAM data for SRAM cloning: Copy the Secure HDD key from FROM to SRAM. <ol style="list-style-type: none"> <li>1. Perform HS-73 Assist mode.</li> <li>2. Select "Key Backup / Restore".</li> <li>3. Check the status of the Secure HDD key on the Key/Backup Restore menu.</li> <li>4. Select [ADikey] twice.</li> <li>5. Check that copying of the Secure HDD key from the FROM to SRAM is selected.</li> <li>6. Press [Execute].</li> <li>7. When the restoring of the encryption key is completed, "Success" appears to the right-hand side of [ADiKey] FROM.</li> <li>8. After the operation has been completed, shut down the equipment.</li> </ol> </li> </ul>
HDD	If the error persists even after above step, replace the HDD. If the equipment operation disabled after above step, replace the HDD.

Parts to be replaced	Remarks
HDD harness	Be sure to exchange the parts in the order of the HDD harness, HDD and SYS board.
HDD	Be sure to exchange the parts in the order of the HDD harness, HDD and SYS board.
SYS board	Be sure to exchange the parts in the order of the HDD harness, HDD and SYS board.

**[F106\_6] [F106\_7] [F106\_8] [F106\_10] [F106\_UNDEF] HDD error (Error caused by reason other than F106\_0 to 5 errors)**

Classification	Error item
Other service call	Error caused by reason other than F106_0 to 5 errors.

Check item	Measures
Setting	<p>Perform HS-73 Assist mode &gt; Format HDD, and then install the system software by performing HS-49 Firmware update mode &gt; SYSTEM SOFTWARE (HD Data).</p> <p><b>Notes:</b>                      The following items will be deleted by performing HS-73 Assist mode &gt; Format HDD.</p> <ul style="list-style-type: none"> <li>• Message Log</li> <li>• Job Log</li> <li>• Spool Data (Print, Email reception)</li> <li>• Template</li> </ul>
HDD	<p>If the error persists even after above step, replace the HDD.                      If the equipment operation disabled after above step, replace the HDD.</p>

Parts to be replaced	Remarks
HDD harness	Be sure to exchange the parts in the order of the HDD harness, HDD and SYS board.
HDD	Be sure to exchange the parts in the order of the HDD harness, HDD and SYS board.
SYS board	Be sure to exchange the parts in the order of the HDD harness, HDD and SYS board.

**[F106\_11] License damaged (HDD and SRAM)**

Classification	Error content
License management	Both licenses registered in the HDD and SRAM are damaged.

Check item	Measures
Backup data	<p>Restore the backup data in which all the activated licenses with the latest status are stored.</p> <p><b>Remarks:</b>                      Applications with the trial license cannot be recovered from the backup data. If necessary, reinstall the applications.</p>
License	<ul style="list-style-type: none"> <li>• If there are no backup data as above, reactivate all the licenses which have been activated in this equipment.</li> <li>• If the functions have been activated by the export license file, import the license exported from the host unit of the equipment.</li> </ul>

Parts to be replaced	Remarks
HDD harness	Be sure to exchange the parts in the order of the HDD harness, HDD, SRAM and SYS board.
HDD	Be sure to exchange the parts in the order of the HDD harness, HDD, SRAM and SYS board.
SRAM	Be sure to exchange the parts in the order of the HDD harness, HDD, SRAM and SYS board.
SYS board	Be sure to exchange the parts in the order of the HDD harness, HDD, SRAM and SYS board.

### [F106\_12] License damaged (SRAM)

Classification	Error content
License management	The license registered in the SRAM is damaged.

Check item	Measures
-	<ol style="list-style-type: none"> <li>1. Reboot the equipment.</li> <li>2. If the problem still persists, perform FS-08-9053 and reboot the equipment again.</li> <li>3. If the problem still occurs after performing step 2, replace the SRAM.</li> </ol>

Parts to be replaced	Remarks
SRAM	Be sure to exchange the parts in the order of the SRAM and SYS board.
SYS board	Be sure to exchange the parts in the order of the SRAM and SYS board.

### [F109\_0] Key consistency error (Consistency check operation error)

Classification	Contents
Other service call	Key consistency check on each key data fails.

Check item	Measures
Setting	<p>Reboot the equipment. If it cannot be recovered, reinstall the software in the following procedure.</p> <ol style="list-style-type: none"> <li>1. Install the system firmware.</li> <li>2. If the error cannot be solved after installing the system firmware, reinstall the system software and application program.</li> </ol> <p>📖 P. 11-6 “11.2.4 Update procedure”(📖 P. 11-6 “[A] Updating firmware”)</p>
SRAM	<p>If the error is not cleared after the software reinstallation, replace the SRAM.</p> <p>📖 P. 9-26 “9.2.5 Precautions and procedure when replacing the SRAM”</p>
SYS board	<p>If the error is not cleared after this (see above), replace the SYS board.</p> <p>📖 P. 9-22 “9.2.4 Precautions and procedures when replacing the SYS board”</p>

Parts to be replaced	Remark
SRAM	Be sure to exchange the parts in the order of the SRAM and SYS board.
SYS board	Be sure to exchange the parts in the order of the SRAM and SYS board.

### [F109\_1] Key consistency error (SRAM encryption AES key data damage)

Classification	Contents
Other service call	AES key data used for SRAM encryption are damaged.

Check item	Measures
Setting	Reboot the equipment. If it cannot be recovered, reinstall the software in the following procedure. 1. Install the system firmware. 2. If the error cannot be solved after installing the system firmware, reinstall the system software and application program. ☞ P. 11-6 “11.2.4 Update procedure”(☞ P. 11-6 “[A] Updating firmware”)
SRAM	If the error is not cleared after the software reinstallation, replace the SRAM.
SYS board	If the error is not cleared after this (see above), replace the SYS board.

Parts to be replaced	Remarks
SRAM	Be sure to exchange the parts in the order of the SRAM and SYS board.
SYS board	Be sure to exchange the parts in the order of the SRAM and SYS board.

### [F109\_2] Key consistency error (Signature Check public key damage)

Classification	Contents
Other service call	Public key data used for Integrity Check are damaged.

Check item	Measures
Setting	Reboot the equipment. If it cannot be recovered, reinstall the software in the following procedure. 1. Install the system firmware. 2. If the error cannot be solved after installing the system firmware, reinstall the system software and application program. ☞ P. 11-6 “11.2.4 Update procedure”(☞ P. 11-6 “[A] Updating firmware”)
SRAM	If the error is not cleared after the software reinstallation, replace the SRAM.
SYS board	If the error is not cleared after this (see above), replace the SYS board.

Parts to be replaced	Remarks
SRAM	Be sure to exchange the parts in the order of the SRAM and SYS board.
SYS board	Be sure to exchange the parts in the order of the SRAM and SYS board.

### [F109\_3] Key consistency error (HDD encryption parameter damage)

Classification	Contents
Other service call	Parameter used for HDD partition encryption are damaged.

Check item	Measures
Encryption key status confirmation	Check the message displayed by HS-73 Assist mode > Key Backup / Restore.

Take measures given in the following table according to the messages displayed in the SRAM and FROM fields.

**Remarks:**

If the error is not cleared, reinstallation of the system firmware and system software is needed. (HS-49 Firmware update mode)

SRAM	FROM	Measures
*	AccessFailed	Replace the SYS board. P. 9-22 "9.2.4 Precautions and procedures when replacing the SYS board" (all steps) <With USB backup data: All key data recovery> 1. Recover all the data on the SRAM. HS-59 SRAM data cloning mode > Restore SRAM Data from USB (For details, see "12.1.4Cloning procedure [B]Restore procedure") 2. Recover the encryption key/license on the SYS board. Follow the procedures below noted in  P. 9-22 "9.2.4 Precautions and procedures when replacing the SYS board". [C] Restore ADI key (only when Secure HDD is installed) [D] Restore encryption key [E] Restore license
AccessFailed	*	Replace the SYS board. P. 9-26 "9.2.5 Precautions and procedure when replacing the SRAM" (for the SYS board, all steps)
OK	KeyNull/ KeyBroken	Recover the encryption key on the SYS board. P. 9-22 "9.2.4 Precautions and procedures when replacing the SYS board" ([D]Restore encryption key)
AccessFailed	OK	Replace the SRAM. P. 9-26 "9.2.5 Precautions and procedure when replacing the SRAM" (all steps)
KeyNull/ KeyBroken	OK	Recover the encryption key on the SRAM. P. 9-26 "9.2.5 Precautions and procedure when replacing the SRAM" (for the SYS board, [H]Backup encryption key (FROM > SRAM))
KeyNull/ KeyBroken	KeyNull/ KeyBroken	<No USB backup data> 1. Reinstall the system software. P. 11-2 "11.2 Firmware Updating with USB Device" <With USB backup data: All key data recovery> 1. Recover all the data on the SRAM. HS-59 SRAM data cloning mode > Restore SRAM Data from USB (For details, see "12.1.4Cloning procedure [B]Restore procedure") 2. Recover the encryption key/license on the SYS board. Follow the procedures below noted in  P. 9-22 "9.2.4 Precautions and procedures when replacing the SYS board". [C] Restore ADI key (only when Secure HDD is installed) [D] Restore encryption key [E] Restore license

\* AccessFailed, KeyNull or KeyBroken

Parts to be replaced	Remarks
SRAM	Be sure to exchange the parts in the order of the SRAM and SYS board.
SYS board	Be sure to exchange the parts in the order of the SRAM and SYS board.

### [F109\_4] Key consistency error (license data damage)

Classification	Contents
Other service call	The license data are damaged.

Check item	Measures
Encryption key status confirmation	Check the message displayed by HS-73 Assist mode > Key Backup / Restore.

Take appropriate countermeasures shown in the table below according to the messages displayed in the SRAM and FROM fields of LICENCE [F109\_4].

#### Remarks:

If the error is not cleared, it is required to reinstall the system firmware, system software and application. (HS-49 Firmware update mode)

SRAM License Status	FROM License Status	Measures
*	AccessFailed	Replace the SYS board. ☞ P. 9-22 "9.2.4 Precautions and procedures when replacing the SYS board" (all steps) <With USB backup data: All key data recovery> 1. Recover all the data on the board. HS-59 SRAM data cloning mode > Restore SRAM Data from USB (For details, see "12.1.4 Cloning procedure [B] Restore procedure") 2. Recover the encryption key/license on the SYS board. Follow the procedures below noted in ☞ P. 9-22 "9.2.4 Precautions and procedures when replacing the SYS board". [C] Restore ADI key (only when Secure HDD is installed) [D] Restore encryption key [E] Restore license
AccessFailed	*	Replace the SRAM. ☞ P. 9-26 "9.2.5 Precautions and procedure when replacing the SRAM" (all steps)
KeyMismatch	KeyMismatch	<The error occurs when the SYS board is replaced> Recover the license on the SYS board. (Transfer the license from SRAM to FROM.) ☞ P. 9-22 "9.2.4 Precautions and procedures when replacing the SYS board"([E]Restore license) <The error occurs except when the SYS board is replaced> Recover the license on the SRAM. (Transfer the license from FROM to SRAM.) ☞ P. 9-26 "9.2.5 Precautions and procedure when replacing the SRAM"([I]Backup license (FROM > SRAM))

\* AccessFailed or KeyMismatch

Parts to be replaced	Remarks
SRAM	Be sure to exchange the parts in the order of the SRAM and SYS board.
SYS board	Be sure to exchange the parts in the order of the SRAM and SYS board.

### [F109\_5] Key consistency error (encryption key for HDD is damaged)

Classification	Contents
Other service call	Encryption key for HDD is damaged.



Check item	Measures
Encryption key status confirmation	Check the message displayed by HS-73 Assist mode > Key Backup Restore.

Take appropriate countermeasures shown in the table below according to the messages displayed in the SRAM and FROM fields of AGLNCKEY [F109\_5] / AGLDECKEY [F109\_5].

**Remarks:**

If the error is not cleared, reinstallation of the system firmware and system software is needed. (HS-49 Firmware update mode)

SRAM	FROM	Measures
*	AccessFailed	Replace the SYS board. P. 9-22 “9.2.4 Precautions and procedures when replacing the SYS board” (all steps) <With USB backup data: All key data recovery> 1. Recover all the data on the SRAM. HS-59 SRAM data cloning mode > Restore SRAM Data from USB (For details, see “12.1.4Cloning procedure [B]Restore procedure”) 2. Recover the encryption key/license on the SYS board. Follow the procedures below noted in  P. 9-22 “9.2.4 Precautions and procedures when replacing the SYS board”. [C] Restore ADI key (only when Secure HDD is installed) [D] Restore encryption key [E] Restore license
AccessFailed	*	Replace the SRAM. P. 9-26 “9.2.5 Precautions and procedure when replacing the SRAM” (all steps)
OK	KeyNull/ KeyBroken	Recover the ADI key on the SYS board. P. 9-22 “9.2.4 Precautions and procedures when replacing the SYS board” ([C]Restore ADI key)
KeyNull/ KeyBroken	OK	Recover the ADI key on the SRAM. P. 9-26 “9.2.5 Precautions and procedure when replacing the SRAM” ([G]Backup ADI key (FROM > SRAM))
KeyNull/ KeyBroken	KeyNull/ KeyBroken	<No USB backup data> 1. Create the partition in the HDD, and reinstall the system software. P. 9-18 “9.2.3 Precautions and procedures when replacing the HDD/SSD” (Perform step 3 or later in “[E]Replace / Format HDD”) <With USB backup data: All key data recovery> 1. Recover all the data on the SRAM. HS-59 SRAM data cloning mode > Restore SRAM Data from USB (For details, see “12.1.4Cloning procedure [B]Restore procedure”) 2. Recover the encryption key/license on the SYS board. Follow the procedures below noted in  P. 9-22 “9.2.4 Precautions and procedures when replacing the SYS board”. [C] Restore ADI key (only when Secure HDD is installed) [D] Restore encryption key [E] Restore license
KeyMismatch	KeyMismatch	<The error occurs when the SYS board is replaced> Recover the ADI key on the SYS board. (Transfer the ADI key from SRAM to FROM.) P. 9-22 “9.2.4 Precautions and procedures when replacing the SYS board”([C]Restore ADI key) <The error occurs except when the SYS board is replaced> Recover the ADI key on the SRAM. (Transfer the ADI key from FROM to SRAM.) P. 9-26 “9.2.5 Precautions and procedure when replacing the SRAM”([G]Backup ADI key (FROM > SRAM))

\* AccessFailed or KeyMismatch

Parts to be replaced	Remarks
SRAM	Be sure to exchange the parts in the order of the SRAM and SYS board.
SYS board	Be sure to exchange the parts in the order of the SRAM and SYS board.

### [F109\_6] Key consistency error (administrator password error for HDD authentication)

Classification	Contents
Other service call	Administrator password error for HDD authentication.

Check item	Measures
Encryption key status confirmation	Check the message displayed by HS-73 Assist mode > Key Backup Restore.

Take appropriate countermeasures shown in the table below according to the messages displayed in the SRAM and FROM fields of AdminPassword [F109\_6].

#### Remarks:

If the error is not cleared, reinstallation of the system firmware and system software is needed. (HS-49 Firmware update mode)

SRAM	FROM	Measures
*	AccessFailed	Replace the SYS board. ☞ P. 9-22 “9.2.4 Precautions and procedures when replacing the SYS board” (all steps) <With USB backup data: All key data recovery> 1. Recover all the data on the SRAM. HS-59 SRAM data cloning mode > Restore SRAM Data from USB (For details, see “12.1.4Cloning procedure [B]Restore procedure”) 2. Recover the encryption key/license on the SYS board. Follow the procedures below noted in ☞ P. 9-22 “9.2.4 Precautions and procedures when replacing the SYS board”. [C] Restore ADI key (only when Secure HDD is installed) [D] Restore encryption key [E] Restore license
AccessFailed	*	Replace the SRAM. ☞ P. 9-26 “9.2.5 Precautions and procedure when replacing the SRAM” (all steps)
OK	KeyNull/ KeyBroken	Recover the ADI key on the SYS board. ☞ P. 9-22 “9.2.4 Precautions and procedures when replacing the SYS board” ([C]Restore ADI key)
KeyNull/ KeyBroken	OK	Recover the ADI key on the SRAM. ☞ P. 9-26 “9.2.5 Precautions and procedure when replacing the SRAM” ([G]Backup ADI key (FROM > SRAM))
KeyNull/ KeyBroken	KeyNull/ KeyBroken	<No USB backup data> 1. Create the partition in the HDD, and reinstall the system software. ☞ P. 9-18 “9.2.3 Precautions and procedures when replacing the HDD/SSD” (Perform step 3 or later in “[E]Replace / Format HDD”) <With USB backup data: All key data recovery> 1. Recover all the data on the SRAM. HS-59 SRAM data cloning mode > Restore SRAM Data from USB (For details, see “12.1.4Cloning procedure [B]Restore procedure”) 2. Recover the encryption key/license on the SYS board. Follow the procedures below noted in ☞ P. 9-22 “9.2.4 Precautions and procedures when replacing the SYS board”. [C] Restore ADI key (only when Secure HDD is installed) [D] Restore encryption key [E] Restore license

SRAM	FROM	Measures
KeyMismatch	KeyMismatch	<p>&lt;The error occurs when the SYS board is replaced&gt;  Recover the ADI key on the SYS board. (Transfer the ADI key from SRAM to FROM.)  📖 P. 9-22 "9.2.4 Precautions and procedures when replacing the SYS board"([C]Restore ADI key)</p> <p>&lt;The error occurs except when the SYS board is replaced&gt;  Recover the ADI key on the SRAM. (Transfer the ADI key from FROM to SRAM.)  📖 P. 9-26 "9.2.5 Precautions and procedure when replacing the SRAM"([G]Backup ADI key (FROM &gt; SRAM))</p>

\* AccessFailed or KeyMismatch

Parts to be replaced	Remarks
SRAM	Be sure to exchange the parts in the order of the SRAM and SYS board.
SYS board	Be sure to exchange the parts in the order of the SRAM and SYS board.

### [F109\_7] Hash check error of ADI-HDD authentication key

Classification	Contents
Other service call	Hash check error of ADI-HDD authentication key.

Check item	Measures
Setting	<p>Install the system software in the following procedure: HS-73 Assist mode &gt; Format HDD &gt; HS-49 Firmware update mode &gt; SYSTEM SOFTWARE (HD Data)</p> <p><b>Notes:</b>  Once HS-73 Assist mode &gt; Format HDD has been carried out, the user data are deleted.</p>
SRAM	If the error is not cleared after the software reinstallation, replace the SRAM.
SYS board	If the error is not cleared after this (see above), replace the SYS board.

Parts to be replaced	Remarks
SRAM	Be sure to exchange the parts in the order of the SRAM and SYS board.
SYS board	Be sure to exchange the parts in the order of the SRAM and SYS board.

## [F120] Database abnormality

Classification	Error item
Other service call	Database is not operating normally.

Check item	Measures
Setting	<ol style="list-style-type: none"><li>1. Check that no jobs remain and rebuild the databases.<ul style="list-style-type: none"><li>- HS-75 File system recovery mode &gt; Initialize database &gt; LDAP DB and Log DB (Job,Msg).</li></ul></li><li>2. If the error is not recovered, reinstall the system software.<ul style="list-style-type: none"><li>- HS-49 Firmware update mode &gt; System Software (HD data)</li></ul></li></ol> <p><b>Notes:</b></p> <ul style="list-style-type: none"><li>• If you rebuild the databases with a job remaining, delete it after finishing.</li><li>• When "Rebuilding all databases" is performed, all data including log/user/role/group/department information and address book data are deleted. If you back up the data in advance, they will be recovered by restoring them after rebuilding the database.</li></ul>

Parts to be replaced	Remarks
HDD	

## [F121] Database abnormality (user information management database error)

Classification	Error item
Other service call	Login after the startup fails in any starting mode because user management database is corrupted.

Check item	Measures
Setting	<ol style="list-style-type: none"><li>1. Check that no jobs remain and rebuild the databases.</li><li>2. Delete the data in the following procedure.<ul style="list-style-type: none"><li>- HS-75 File system recovery mode &gt; Initialize database &gt; LDAP database (Note that all user, role, group and accounting data will be deleted.)</li></ul></li><li>3. If the error is not recovered, reinstall the system software.<ul style="list-style-type: none"><li>- HS-49 Firmware update mode &gt; System Software (HD data)</li></ul></li></ol> <p><b>Notes:</b></p> <ul style="list-style-type: none"><li>• If you rebuild the databases with a job remaining, delete it after finishing.</li><li>• When "Rebuilding all databases" is performed, all data including log/user/role/group/department information and address book data are deleted. If you back up the data in advance, they will be recovered by restoring them after rebuilding the database.</li></ul>

Parts to be replaced	Remarks
HDD	

**[F122] Database abnormality (message / job log management database error)**

Classification	Error item
Other service call	Login after the startup fails in any starting mode because log management database is corrupted.

Check item	Measures
Setting	<ol style="list-style-type: none"> <li>Check that no jobs remain and rebuild the databases.</li> <li>Delete the data in the following procedure. <ul style="list-style-type: none"> <li>HS-75 File system recovery mode &gt; Initialize database &gt; Log database (jobs and messages) (Note that all job and message logs will be deleted.)</li> </ul> </li> <li>If the error is not recovered, reinstall the system software. <ul style="list-style-type: none"> <li>HS-49 Firmware update mode &gt; System Software (HD data)</li> </ul> </li> </ol> <p><b>Notes:</b></p> <ul style="list-style-type: none"> <li>If you rebuild the databases with a job remaining, delete it after finishing.</li> <li>When "Rebuilding all databases" is performed, all data including log/user/role/group/department information and address book data are deleted. If you back up the data in advance, they will be recovered by restoring them after rebuilding the database.</li> </ul>

Parts to be replaced	Remarks
HDD	

**[F124] Database abnormality (application management database damage error)**

Classification	Error item
Other service call	Application management database is damaged.

Check item	Measures
Setting	<ol style="list-style-type: none"> <li>Delete the journal file by the following procedure. <ul style="list-style-type: none"> <li>HS-75 File System recovery mode &gt; Initialize DB &gt; AppMgmt DB</li> </ul> </li> </ol> <p><b>Notes:</b></p> <p>All of the application information will be deleted.</p> <ol style="list-style-type: none"> <li>If the error is not recovered, reinstall the system software. <ul style="list-style-type: none"> <li>HS-49 Firmware update mode &gt; System Software (HD data)</li> </ul> </li> </ol>

Parts to be replaced	Remarks
HDD	

**[F125] Database abnormality (Home screen database damage error)**

Classification	Error item
Other service call	Home screen database is damaged.

Check item	Measures
Setting	<ol style="list-style-type: none"> <li>Delete the journal file by the following procedure. <ul style="list-style-type: none"> <li>HS-75 File System recovery mode &gt; Initialize DB &gt; HomeScreen DB</li> </ul> </li> <li>If the error is not recovered, reinstall the system software. <ul style="list-style-type: none"> <li>HS-49 Firmware update mode &gt; System Software (HD data)</li> </ul> </li> </ol>

Parts to be replaced	Remarks
HDD	

### [F126] Database abnormality (Job history database damage error)

Classification	Error item
Other service call	Job history database is damaged.

Check item	Measures
Setting	<ol style="list-style-type: none"> <li>1. Delete the journal file by the following procedure. <ul style="list-style-type: none"> <li>- HS-75 File System recovery mode &gt; Initialize DB &gt; JobHistory DB</li> </ul> </li> <li>2. If the error is not recovered, reinstall the system software. <ul style="list-style-type: none"> <li>- HS-49 Firmware update mode &gt; System Software (HD data)</li> </ul> </li> </ol>

Parts to be replaced	Remarks
HDD	

### [F127] Database abnormality (application license management database damage error)

Classification	Error item
Other service call	Application license management database is damaged.

Check item	Measures
Setting	<ol style="list-style-type: none"> <li>1. Delete the journal file by the following procedure. <ul style="list-style-type: none"> <li>- HS-75 File System recovery mode &gt; Initialize DB &gt; AppLicense DB</li> </ul> </li> <li>2. If the error is not recovered, reinstall the system software. <ul style="list-style-type: none"> <li>- HS-49 Firmware update mode &gt; System Software (HD data)</li> </ul> </li> </ol>

Parts to be replaced	Remarks
HDD	

### [F128] License management database damage

Classification	Error content
License management	The license management database stored in the HDD has been damaged.

Check item	Measures
-	<p>Reboot the equipment.</p> <p>When a 71E0 error has appeared, perform its troubleshooting.</p> <p>If an F128 error has appeared again, perform the following procedure.</p> <ol style="list-style-type: none"> <li>(1) Open HS-[75 File System Recovery]-[Initialize DB].</li> <li>(2) Select [ULM DB] only and press [OK].</li> <li>(3) Reboot the equipment. When a 71E0 error has appeared, perform its troubleshooting.</li> </ol>

Parts to be replaced	Remarks
HDD	Be sure to exchange the parts in the order of the HDD and SRAM.
SRAM	Be sure to exchange the parts in the order of the HDD and SRAM.

### [F130] Invalid MAC address

Classification	Contents
Other service call	This error occurs when the top 3 bytes of the MAC address is not "00", "80", "91".

Check item	Measures
Setting	This error occurs when the top 3 bytes of the MAC address is not "00" "80" "91".
SYS board	Replace the SYS board

Parts to be replaced	Remarks
SYS board	

### [F131] Filtering setting file damage error

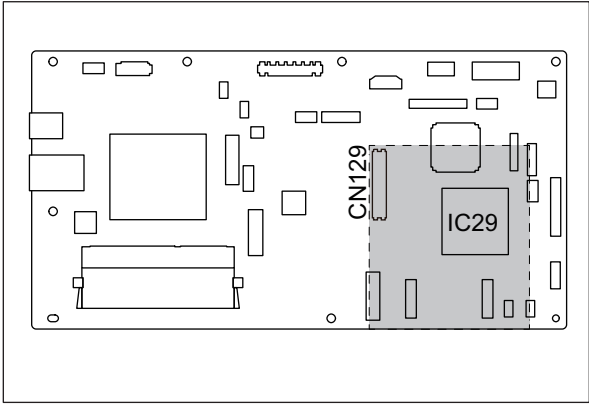
Classification	Contents
Other service call	The filtering function is not working properly due to the damage to the file for the filtering setting.

Check item	Measures
Setting	<ol style="list-style-type: none"><li>1. Check the bad sector of the HDD (FS-08-9072). If the result is "NG", replace the HDD. <b>Notes:</b> It may take more than 30 minutes to finish the checking.</li><li>2. Perform HS-73 Assist mode &gt; Format HDD, and then reinstall the HDD software. <b>Notes:</b> User data will be deleted when HS-73 Assist mode &gt; Format HDD is performed.</li></ol>

Parts to be replaced	Remarks
HDD	

### [F140] ASIC format abnormality

Classification	Contents
Other service call	ASIC format abnormality.

Check item	Measures
SYS board	<ul style="list-style-type: none"> <li>Connector check (CN129) Check if the connector is disconnected, the terminals are folded or there is any foreign matter. (When the DSDF I/F board installed, take it off to perform the check.)</li> <li>Board check Check both front and back side of the board if there is an abnormality such as staining, foreign matter or scratches around IC29 (indicated in the figure below).</li> </ul>  <p><b>Fig.8-24</b></p>

Parts to be replaced	Remarks
SYS board	

### [F150] Power failure during the manufacturing mode

Classification	Contents
Other service call	When a power failure occurred during the manufacturing mode, this error code appears at the next startup.

Check item	Measures
Power supply	<ul style="list-style-type: none"> <li>Turn the power OFF and then back ON.</li> <li>Set the value of FS-08-9010 to "0".</li> <li>If it changes to another error code, follow the procedure for the changed error code.</li> </ul>

### [F200] Data Overwrite option (GP-1070) disabled

Classification	Contents
Other service call	Data Overwrite option (GP-1070) disabled.

Check item	Measures
Setting	Perform FS-08-3840 to install the Data Overwrite Enabler (GP-1070).



### [F510] Application start error

Classification	Error item
Other service call	The application fails to start.

Check item	Measures
Setting	<ol style="list-style-type: none"><li>1. Reboot.</li><li>2. If it has still not recovered, reinstall the system software.</li><li>3. If it still persists after step 2, perform HS-73 Assist mode &gt; Format HDD, and then reinstall the system software.</li></ol> <p><b>Notes:</b> User data will be deleted when HS-73 Assist mode &gt; Format HDD is performed.</p>

### [F520] Operating system start error

Classification	Error item
Other service call	The operating system fails to start.

Check item	Measures
Setting	<ol style="list-style-type: none"><li>1. Reboot.</li><li>2. If it has still not recovered, reinstall the system software.</li><li>3. If it still persists after step 2, perform HS-75 File System Recovery &gt; Check F/S. If there is a partition in error, recover it in Recovery F/S. If the partition is not recovered, format it by Initialize HDD.</li><li>4. Reboot the equipment. Confirm that the equipment has started normally. If not, perform HS-73 Assist mode &gt; Format HDD, and then reinstall the system software.</li></ol> <p><b>Notes:</b></p> <ul style="list-style-type: none"><li>• User data will be deleted when HS-73 Assist mode &gt; Format HDD is performed.</li><li>• User data will be deleted when HS-73 Assist mode &gt; Format HDD is performed.</li></ul>

### [F521] Integrity check error

Classification	Error item
Other service call	The program data fails to be authenticated.

Check item	Measures
Setting	<p>Restart the equipment.</p> <p>If the error is not recovered after restarting the equipment, reinstall software.</p> <ul style="list-style-type: none"><li>• System software, application program, Engine firmware, Scanner firmware, FAX firmware (GD-1370)</li></ul>

**[F523] Security check error at the startup**

Classification	Error item
Other service call	An abnormality has been detected during the security condition check at the startup.

Check item	Measures
Setting	Restart the equipment. If the error is not recovered after restarting the equipment, reinstall software. <ul style="list-style-type: none"> <li>System software, application program, Engine firmware, Scanner firmware, FAX firmware (GD-1370)</li> </ul>

**[F550] Encryption partition error**

Classification	Error item
Other service call	The encryption partition fails to be read and written.

Check item	Measures
Setting	Recover the encryption key with HS-73 Assist mode > Key Backup/Restore.

**[F600] Firmware update error**

Classification	Error item
Other service call	The firmware fails to be updated.

Check item	Measures
Setting	<ul style="list-style-type: none"> <li>Perform HS-73 Assist mode &gt; Clear Software Update Error Flag.</li> <li>Reinstall the firmware in error displayed on the F600 error screen.</li> </ul>

**[F700] Overwrite error**

Classification	Error item
Other service call	Overwriting fails.

Check item	Measures
Setting	If a service call occurs again after the reboot, replace the HDD.

Parts to be replaced	Remarks
HDD	

**[F800] Date error**

Classification	Error item
Other service call	The year 2038 problem.

Check item	Measures
Setting	Reset the date, and request the administrator to set the date and time. <ul style="list-style-type: none"> <li>Perform HS-76 SRAM clear mode &gt; Reset Date and Time.</li> <li>Request the administrator to set the date and time.</li> </ul>

Parts to be replaced	Remarks
SYS board	

### [F900] Model information alignment error

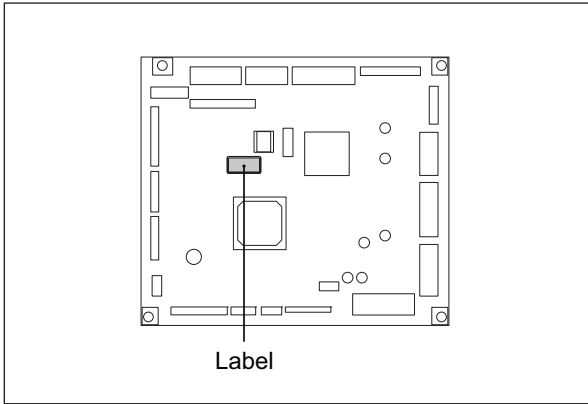

Classification	Error item
Other service call	The model information is damaged.

Check item	Measures
Setting	<p>Recover the machine information by means of the following procedure.</p> <p>&lt;Machine information recovery&gt;</p> <ol style="list-style-type: none"> <li>1. Perform HS-76 SRAM clear mode &gt; SRAM Re-Initialize.</li> <li>2. After the operation is completed, shut down the equipment. * If it is not recovered, perform the following procedure.</li> <li>3. Perform HS-73 Assist mode &gt; Key Backup/Restore.</li> <li>4. Press [Key] twice.</li> <li>5. Check that copying of the key from the FROM to SRAM is selected.</li> <li>6. Press [Execute].</li> <li>7. When the restoring of the key is completed, "Success" appears to the right-hand side of [Key] FROM.</li> <li>8. After the operation is completed, shut down the equipment.</li> </ol>

### [F901\_0] [F901\_1] [F901\_2] [F901\_3] Communication error

Classification	Error item
Other service call	<ul style="list-style-type: none"> <li>• The information of the LGC board is damaged.</li> <li>• The LGC board in which is not corresponding to the equipment model is installed.</li> </ul>


Check item	Measures
Harness	Check all of the connector and harnesses connected to the LGC board.

Check item	Measures
LGC board	<p>Check if the LGC board in which is corresponded to the equipment model is installed.</p> <p>Check if the label color of the LGC board (indicated in the figure with the arrow) is corresponded to the equipment model (indicated on the rating label).</p> <p>20ppm: White  25ppm: Pink  30ppm: Blue  35ppm: Yellow  45ppm: Green  50ppm: Red</p> <ul style="list-style-type: none"> <li>Position of the label to be checked</li> </ul> <div data-bbox="683 512 1273 917" style="text-align: center;">  <p>The diagram shows a rectangular LGC board with various components. A small rectangular label is located in the lower-left quadrant of the board. A black box highlights this label, and a vertical arrow points from the word 'Label' centered below the board to the highlighted label.</p> </div> <p>If they are not corresponding correctly, replace the LGC board with the correct one by referring to the procedures described below.  Reference:  P. 9-31 "9.2.6 Procedures when replacing the LGC board"</p>

Parts to be replaced	Remark
Harness	Be sure to exchange the parts in the order of the harness and LGC board.
LGC board	Be sure to exchange the parts in the order of the harness and LGC board.

## 8.3.20 Error in Internet FAX / Scanning function

### Notes:

When formatting the HDD (HS-75 > Initialize HDD > Except /), all data in the shared folder, Electronic Filing, Address Book, template, etc. are erased. Back up these data before the initialization. Note that some of data cannot be backed up.  P. 9-18 “9.2.3 Precautions and procedures when replacing the HDD/SSD”

### [ 1 ] Internet FAX related error

#### [1C10] System access abnormality

Classification	Error item
Internet FAX related error	System access abnormality.

Check item	Measures
Setting	<ul style="list-style-type: none"> <li>• Turn the power OFF and then back ON. Perform the job in error again.</li> <li>• If the error still persists, check if the settings of SSL/TLS and the authentication are specified properly in the SMTP client setting.</li> <li>• If the error nevertheless continues to persist, check if there are no jobs existing and then perform HDD formatting.</li> </ul>

Parts to be replaced	Remarks

#### [1C32] File deletion failure

Classification	Error item
Internet FAX related error	File deletion failure.

Check item	Measures
Setting	<ul style="list-style-type: none"> <li>• Turn the power OFF and then back ON. Perform the job in error again.</li> <li>• If the error still occurs, first, check if there are no jobs existing and then perform the HDD formatting (HS-75 &gt; Initialize HDD &gt; Except /).</li> </ul>

#### [1C11] Insufficient memory

Classification	Error item
Internet FAX related error	Insufficient memory.

Check item	Measures
Setting	<ul style="list-style-type: none"> <li>• When there are running jobs, perform the job in error again after the completion of the running jobs.</li> <li>• If the error still occurs, turn the power OFF and then back ON, and perform the job again.</li> </ul>

**[1C12] Message reception error****[1C13] Message transmission error**

Classification	Error item
Internet FAX related error	[1C12] Message reception error. [1C13] Message transmission error.

Check item	Measures
Setting	Turn the power OFF and then back ON. Perform the job in error again.

**[1C14] Invalid parameter**

Classification	Error item
Internet FAX related error	Invalid parameter.

Check item	Measures
Setting	<ul style="list-style-type: none"> <li>When a template is used, form the template again.</li> <li>If the error still occurs, turn the power OFF and then back ON, and perform the job again.</li> </ul>

**[1C15] Exceeding file capacity**

Classification	Error item
Internet FAX related error	Exceeding file capacity.

Check item	Measures
Setting	Reset and extend the "Maximum send to E-mail/iFAX size" or reduce the number of pages and perform the job again.

**[1C30] Directory creation failure****[1C31] File creation failure****[1C33] File access failure**

Classification	Error item
Internet FAX related error	[1C30] Directory creation failure. [1C31] File creation failure. [1C33] File access failure.

Check item	Measures
Setting	Check if the access privilege to the storage directory is writable. Check if the server or local disk has a sufficient space in disk capacity.

**[1C40] Image conversion abnormality**

Classification	Error item
Internet FAX related error	Image conversion abnormality.

Check item	Measures
Setting	<ul style="list-style-type: none"> <li>Turn the power OFF and then back ON. Perform the job in error again.</li> <li>Replace the main memory and perform the job again.</li> </ul>

Parts to be replaced	Remarks
Main memory	

### [1C60] HDD full failure during processing

Classification	Error item
Internet FAX related error	HDD full failure during processing.

Check item	Measures
Setting	<ul style="list-style-type: none"> <li>Delete the job in progress or being set or in the HOLD/PRIVATE/PROOF/INVALID, and perform it again.</li> <li>Check if the server or local disk has a sufficient space in disk capacity.</li> </ul>

Parts to be replaced	Remarks
Main memory	

### [1C61] AddressBook reading failure

Classification	Error item
Internet FAX related error	AddressBook reading failure.

Check item	Measures
Setting	<ul style="list-style-type: none"> <li>Turn the power OFF and then back ON. Perform the job in error again.</li> <li>Reset the data in the Address Book and perform the job again.</li> </ul>

### [1C63] Terminal IP address unset

Classification	Error item
Internet FAX related error	Terminal IP address unset.

Check item	Measures
Setting	<ul style="list-style-type: none"> <li>Reset the Terminal IP address.</li> <li>Turn the power OFF and then back ON. Perform the job in error again.</li> </ul>

### [1C64] Terminal mail address unset

Classification	Error item
Internet FAX related error	Terminal mail address unset.

Check item	Measures
Setting	<ul style="list-style-type: none"> <li>Reset the Terminal mail address.</li> <li>Turn the power OFF and then back ON. Perform the job in error again.</li> </ul>

### [1C65] SMTP mail address unset

Classification	Error item
Internet FAX related error	SMTP mail address unset.

Check item	Measures
Setting	<ul style="list-style-type: none"><li>Reset the SMTP address and perform the job.</li><li>Turn the power OFF and then back ON. Perform the job in error again.</li></ul>

### [1C66] Server time-out error

Classification	Error item
Internet FAX related error	Server time-out error.

Check item	Measures
Setting	Check if the SMTP server is operating properly.

### [1C69] SMTP server connection error

Classification	Error item
Internet FAX related error	SMTP server connection error.

Check item	Measures
Setting	<ul style="list-style-type: none"><li>Reset the login name or password of SMTP server and perform the job again.</li><li>Check if the SMTP server is operating properly.</li></ul>

### [1C6B] Terminal mail address error

Classification	Error item
Internet FAX related error	Terminal mail address error.

Check item	Measures
Setting	<ul style="list-style-type: none"><li>Check the SMTP Authentication method.</li><li>Check if there is an illegal character in the Terminal mail address.</li><li>Set the correct SMTP Authentication method or delete the illegal character and reset the appropriate Terminal mail address, then perform the job again.</li></ul>

### [1C6C] Destination mail address error

Classification	Error item
Internet FAX related error	Destination mail address error.

Check item	Measures
Setting	<ul style="list-style-type: none"><li>Check if there is an illegal character in the Destination mail address.</li><li>Delete the illegal character and reset the appropriate Destination mail address, then perform the job again.</li></ul>



### [1C6D] System error

Classification	Error item
Internet FAX related error	System error.

Check item	Measures
Setting	<ul style="list-style-type: none"><li>• Turn the power OFF and then back ON. Perform the job in error again.</li><li>• If the error still occurs, replace the SYS board.</li></ul>

Parts to be replaced	Remarks
SYS board	

### [1C70] SMTP client OFF

Classification	Error item
Internet FAX related error	SMTP client OFF.

Check item	Measures
Setting	Set the SMTP valid and perform the job again.

### [1C71] SMTP authentication error

Classification	Error item
Internet FAX related error	SMTP authentication error.

Check item	Measures
Setting	Check that SMTP authentication method, login name and password are correct, then perform authentication again.

### [1C72] POP before SMTP error

Classification	Error item
Internet FAX related error	POP before SMTP error.

Check item	Measures
Setting	Check that both the POP Before SMTP setting and POP3 setting are correct, then perform authentication again.

### [1CC1] Power failure

Classification	Error item
Internet FAX related error	Power failure.

Check item	Measures
Setting	<ul style="list-style-type: none"><li>• Check if the power cable is connected properly and it is inserted securely.</li><li>• Check if the power voltage is unstable.</li></ul>

## [ 2 ] RFC related error

[2500] HOST NAME error (RFC: 500) / Destination mail address error (RFC: 500) / Terminal mail address error (RFC: 500)

[2501] HOST NAME error (RFC: 501) / Destination mail address error (RFC: 501) / Terminal mail address error (RFC: 501)

Classification	Error item
RFC related error	[2500] HOST NAME error (RFC: 500) / Destination mail address error (RFC: 500) / Terminal mail address error (RFC: 500) [2501] HOST NAME error (RFC: 501) / Destination mail address error (RFC: 501) / Terminal mail address error (RFC: 501)

Check item	Measures
Setting	<ul style="list-style-type: none"><li>• Check if the Terminal mail address and Destination mail address are correct.</li><li>• Check if the mail server is operating properly.</li><li>• Turn the power OFF and then back ON. Perform the job in error again.</li></ul>

[2503] Destination mail address error (RFC: 503)

[2504] HOST NAME error (RFC: 504)

[2551] Destination mail address error (RFC: 551)

Classification	Error item
RFC related error	[2503] Destination mail address error (RFC: 503) [2504] HOST NAME error (RFC: 504) [2551] Destination mail address error (RFC: 551)

Check item	Measures
Setting	<ul style="list-style-type: none"><li>• Check if the mail server is operating properly.</li><li>• Turn the power OFF and then back ON. Perform the job in error again.</li><li>• If the error still occurs, replace the SYS board.</li></ul>

Parts to be replaced	Remarks
SYS board	

[2550] Destination mail address error (RFC: 550)

Classification	Error item
RFC related error	Destination mail address error (RFC: 550)

Check item	Measures
Setting	Check the state of the mail box in the mail server.

[2552] Terminal / Destination mail address error (RFC: 552)

Classification	Error item
RFC related error	Terminal / Destination mail address error (RFC: 552)

Check item	Measures
Setting	<ul style="list-style-type: none"> <li>• Confirm the size on the mail server.</li> <li>• Transmit again in text mode or with lower resolution or divide the document and transmit again.</li> <li>• If the error still occurs, turn the power OFF and then back ON. Perform the job in error again.</li> </ul>

### [2553] Destination mail address error (RFC: 553)

Classification	Error item
RFC related error	Destination mail address error (RFC: 553)

Check item	Measures
Setting	Check if there is an illegal character in the mail box in the mail server.

### [ 3 ] Remote scanning related error

#### [2A20] System management module resource acquiring failure

Classification	Error item
Remote scanning related error	System management module resource acquiring failure.

Check item	Measures
Setting	<ul style="list-style-type: none"> <li>• Retry the job in error.</li> <li>• If the error still occurs, turn the power OFF and then back ON, then retry the job in error.</li> </ul>

#### [2A31] WS Scan disabled

Classification	Error item
Remote scanning related error	A job is performed while WS Scan function is disabled.

Check item	Measures
Setting	Check if WS Scan (Web Scanning Services) function is disabled on the TopAccess screen. If it is disabled, enable it. Or, check if the forcible encryption setting of the secure PDF is enabled.

#### [2A40] System error

Classification	Error item
Remote scanning related error	System error.

Check item	Measures
Setting	Turn the power OFF and then back ON, then retry the job in error.

#### [2A51] Power failure

Classification	Error item
Remote scanning related error	Power failure.

Check item	Measures
Setting	Check if the power supply voltage is inconstant.

#### [2A60] WS Scan user authentication failure

Classification	Error item
Remote scanning related error	WS Scan for job authentication failed.

Check item	Measures
Setting	<ul style="list-style-type: none"> <li>When "1" (TTEC's WIA driver) is set for 08-9749 and also Windows Fax&amp;Scan is used Check if the user name that you used to log in Windows is a name registered as a user.</li> <li>When MFP panel or EWB Scan is used Check if the login user name is a name registered as a user.</li> </ul>

#### [2A70] Remote Scan privilege check error

Classification	Error item
Remote scanning related error	A job is performed by a user without Remote Scan privilege.

Check item	Measures
Setting	Check if correct privilege is given to the user.

#### [2A71] WS Scan privilege check error

Classification	Error item
Remote scanning related error	A job is performed by a user without WS Scan privilege.

Check item	Measures
Setting	Check if correct privilege is given to the user.

#### [2A72] e-Filing box data access privilege check error (Scan Utility)

Classification	Error item
Remote scanning related error	A user without e-Filing box data access privilege tried to use Scan utility.

Check item	Measures
Setting	Check if correct privilege is given to the user.

#### [ 4 ] Electronic Filing related error

[2B11] Job status abnormality

[2B20] File library function error

[2B30] Insufficient disk space in BOX partition

[2BC0] Fatal failure occurred

Classification	Error item
e-Filing box related error	[2B11] Job status abnormality. [2B20] File library function error. [2B30] Insufficient disk space in BOX partition. [2BC0] Fatal failure occurred.

Check item	Measures
Setting	<ul style="list-style-type: none"> <li>• Erase some data in the Electronic Filing or the shared folder and perform the job in error again (in case of [2B30]).</li> <li>• Turn the power OFF and then back ON. Perform the job in error again.</li> <li>• Check if there are no other running jobs and perform the HDD formatting (HS-75 &gt; Initialize HDD &gt; Clear Error Flag in Software Installation).</li> <li>• If the recovery is still not completed, replace the SYS board.</li> </ul>

Parts to be replaced	Remarks
SYS board	

### [2B31] Status of the specified e-Filing box or folder is undefined or being created / deleted

Classification	Error item
e-Filing box related error	Status of the specified e-Filing box or folder is undefined or being created / deleted.

Check item	Measures
Setting	<ul style="list-style-type: none"> <li>• Check if the specified Electronic Filing or folder exists. (If no, this error would not occur.)</li> <li>• Delete the specified Electronic Filing or folder.</li> <li>• Change the name of folder to be created.</li> <li>• Perform the job in error again.</li> </ul>

### [2B50] Image library error [2B90] Insufficient memory capacity

Classification	Error item
e-Filing box related error	[2B50] Image library error. [2B90] Insufficient memory capacity.

Check item	Measures
Setting	<ul style="list-style-type: none"> <li>• Turn the power OFF and then back ON. Perform the job in error again.</li> <li>• If the error still occurs, replace the main memory.</li> <li>• Delete the job in progress or being set or in the HOLD/PRIVATE/PROOF/INVALID, and retry the job in error.</li> </ul>

Parts to be replaced	Remarks
Main memory	

### [2B51] List library error

Classification	Error item
e-Filing box related error	List library error.

Check item	Measures
Setting	<ul style="list-style-type: none"> <li>• Check if the Function list can be printed.</li> <li>• If it can be printed, retry the job which was in error.</li> <li>• If it cannot be printed, replace the main memory.</li> <li>• If it still cannot be printed, initialize the HDD (HS-75 &gt; Initialize HDD &gt; Clear Error Flag in Software Installation).</li> </ul>

## [2BA0] Invalid Box password

Classification	Error item
e-Filing box related error	Invalid Box password.

Check item	Measures
Setting	<ul style="list-style-type: none"><li>• Check if the password is correct.</li><li>• Reset the password.</li><li>• When this error occurs when printing the data in the Electronic Filing, perform the printing with the administrator's password.</li></ul>

## [2BA1] The specified paper size, color mode or resolution is not available

Classification	Error item
e-Filing box related error	Invalid paper size / color mode / resolution.

Check item	Measures
Setting	The specified paper size, color mode or resolution cannot be used. Check the setting.

## [2BB1] Power failure

### [2BD0] Power failure during restoring of e-Filing box

Classification	Error item
e-Filing box related error	[2BB1] Power failure. [2BD0] Power failure during restoring of e-Filing box.

Check item	Measures
Setting	<ul style="list-style-type: none"><li>• Check if the power cable is connected properly and it is inserted securely.</li><li>• Check if the power voltage is unstable.</li></ul>

## [2BE0] Machine parameter reading error

Classification	Error item
e-Filing box related error	Machine parameter reading error.

Check item	Measures
Setting	Turn the power OFF and then back ON. Perform the job in error again.

## [2BF0] Exceeding the maximum number of pages

Classification	Error item
e-Filing box related error	Exceeding the maximum number of pages.

Check item	Measures
Setting	Reduce the number of inserting pages and perform the job again.

**[2BF1] Exceeding the maximum number of documents**

Classification	Error item
e-Filing box related error	Exceeding the maximum number of documents.

Check item	Measures
Setting	Backup the documents in the box or folder to PC or delete them.

**[2BF2] Exceeding the maximum number of folders**

Classification	Error item
e-Filing box related error	Exceeding the maximum number of folders.

Check item	Measures
Setting	Backup the folders in the box or folder to PC or delete them.

**[ 5 ] E-mail related error**

**[2C10] System access abnormality**

Classification	Error item
E-mail related error	System access abnormality.

Check item	Measures
Setting	<ul style="list-style-type: none"> <li>• Turn the power OFF and then back ON. Perform the job in error again.</li> <li>• If the error still persists, check if the settings of SSL/TLS and the authentication are specified properly in the SMTP client setting.</li> <li>• If the error nevertheless continues to persist, check if there are no jobs existing and then perform HDD formatting.</li> </ul>

Parts to be replaced	Remarks

**[2C32] File deletion failure**

Classification	Error item
E-mail related error	File deletion failure.

Check item	Measures
Setting	<ul style="list-style-type: none"> <li>• Turn the power OFF and then back ON. Perform the job in error again.</li> <li>• If the error still occurs, first, check if there are no jobs existing and then perform the HDD formatting (HS-75 &gt; Initialize HDD &gt; Clear Error Flag in Software Installation).</li> </ul>

**[2C11] Insufficient memory**

Classification	Error item
E-mail related error	Insufficient memory.

Check item	Measures
Setting	<ul style="list-style-type: none"> <li>When there are running jobs, perform the job in error again after the completion of the running jobs.</li> <li>If the error still occurs, turn the power OFF and then back ON, and perform the job again.</li> </ul>

**[2C12] Message reception error**

**[2C13] Message transmission error**

Classification	Error item
E-mail related error	[2C12] Message reception error. [2C13] Message transmission error.

Check item	Measures
Setting	Turn the power OFF and then back ON. Perform the job in error again.

**[2C14] Invalid parameter**

Classification	Error item
E-mail related error	Invalid parameter.

Check item	Measures
Setting	<ul style="list-style-type: none"> <li>When a template is used, form the template again.</li> <li>If the error still occurs, turn the power OFF and then back ON, and perform the job again.</li> </ul>

**[2C15] Exceeding file capacity**

Classification	Error item
E-mail related error	Exceeding file capacity.

Check item	Measures
Setting	Reset and extend the "Maximum send to E-mail/iFAX size" or reduce the number of pages and perform the job again.

**[2C20] System management module access abnormality**

**[2C21] Job control module access abnormality**

**[2C22] Job control module access abnormality**

Classification	Error item
E-mail related error	[2C20] System management module access abnormality. [2C21], [2C22] Job control module access abnormality.

Check item	Measures
Setting	<ul style="list-style-type: none"> <li>Turn the power OFF and then back ON. Perform the job in error again.</li> <li>Check if there are no other running jobs and perform the HDD formatting (HS-75 &gt; Initialize HDD &gt; Clear Error Flag in Software Installation).</li> <li>If the recovery is still not completed, replace the SYS board.</li> </ul>



Parts to be replaced	Remarks
SYS board	

**[2C30] Directory creation failure**

**[2C31] File creation failure**

**[2C33] File access failure**

Classification	Error item
E-mail related error	[2C30] Directory creation failure. [2C31] File creation failure. [2C33] File access failure.

Check item	Measures
Setting	<ul style="list-style-type: none"> <li>• Check if the access privilege to the storage directory is writable.</li> <li>• Check if the server or local disk has a sufficient space in disk capacity.</li> </ul>

**[2C40] Image conversion abnormality**

**[2C62] Memory acquiring failure**

Classification	Error item
E-mail related error	[2C40] Image conversion abnormality. [2C62] Memory acquiring failure.

Check item	Measures
Setting	<ul style="list-style-type: none"> <li>• Turn the power OFF and then back ON. Perform the job in error again.</li> <li>• Replace the main memory and perform the job again.</li> </ul>

Parts to be replaced	Remarks
Main memory	

**[2C43] Encryption error**

Classification	Error item
E-mail related error	Encryption error.

Check item	Measures
Setting	Turn the power OFF and then back ON. Perform the job in error again.

**[2C44] Encryption PDF enforced mode error**

Classification	Error item
E-mail related error	Encryption PDF enforced mode error.

Check item	Measures
Setting	<ul style="list-style-type: none"> <li>• Reset the encryption and perform the job in error again.</li> <li>• If an image file not encrypted is created, consult your administrators.</li> </ul>

### [2C45] Meta data creation error (Scan to Email)

Classification	Error item
E-mail related error	Creation of meta data failed when a user tried to perform meta scan for Scan to Email.

Check item	Measures
Setting	Check the template settings. Perform the job in error again. If the error still occurs, turn the power OFF and then back ON, and then perform the job in error again.

### [2C50] Authentication failure at job execution

Classification	Error item
E-mail related error	A Scan To File job is carried out while user authentication or department authentication has not been done.

Check item	Measures
Setting	Retry the job after user authentication or department authentication has been done.

### [2C60] HDD full failure during processing

Classification	Error item
E-mail related error	HDD full failure during processing.

Check item	Measures
Setting	<ul style="list-style-type: none"><li>• Delete the job in progress or being set or in the HOLD/PRIVATE/PROOF/INVALID, and perform it again.</li><li>• Check if the server or local disk has a sufficient space in disk capacity.</li><li>• Check that there is enough space in the server or local disk.</li></ul>

### [2C61] AddressBook reading failure

Classification	Error item
E-mail related error	AddressBook reading failure.

Check item	Measures
Setting	<ul style="list-style-type: none"><li>• Turn the power OFF and then back ON. Perform the job in error again.</li><li>• Reset the data in the Address Book and perform the job again.</li></ul>

### [2C63] Terminal IP address unset

Classification	Error item
E-mail related error	Terminal IP address unset.

Check item	Measures
Setting	<ul style="list-style-type: none"><li>• Reset the Terminal IP address.</li><li>• Turn the power OFF and then back ON. Perform the job in error again.</li></ul>

### [2C64] Terminal mail address unset

Classification	Error item
E-mail related error	Terminal mail address unset.

Check item	Measures
Setting	<ul style="list-style-type: none"><li>Reset the Terminal mail address.</li><li>Turn the power OFF and then back ON. Perform the job in error again.</li></ul>

### [2C65] SMTP address unset

Classification	Error item
E-mail related error	SMTP address unset.

Check item	Measures
Setting	<ul style="list-style-type: none"><li>Reset the SMTP address and perform the job.</li><li>Turn the power OFF and then back ON. Perform the job in error again.</li></ul>

### [2C66] Server time-out error

Classification	Error item
E-mail related error	Server time-out error.

Check item	Measures
Setting	Check if the SMTP server is operating properly.

### [2C69] SMTP server connection error

Classification	Error item
E-mail related error	SMTP server connection error.

Check item	Measures
Setting	<ul style="list-style-type: none"><li>Reset the login name and password of SMTP server and perform the job again.</li><li>Check if the SMTP server is operating properly.</li></ul>

### [2C6A] HOST NAME error (No RFC error)

Classification	Error item
E-mail related error	HOST NAME error (No RFC error).

Check item	Measures
Setting	<ul style="list-style-type: none"><li>Check if there is an illegal character in the device name.</li><li>Delete the illegal character and reset the appropriate device name.</li></ul>

## [2C6B] Terminal mail address error

Classification	Error item
E-mail related error	

Terminal mail address error.	Measures
Setting	<ul style="list-style-type: none"><li>• Check the SMTP Authentication method.</li><li>• Check if there is an illegal character in the Terminal mail address.</li><li>• Set the correct SMTP Authentication method or delete the illegal character and reset the appropriate Terminal mail address, then perform the job again.</li></ul>

## [2C6C] Destination mail address error (No RFC error)

Classification	Error item
E-mail related error	Destination mail address error (No RFC error).

Check item	Measures
Setting	<ul style="list-style-type: none"><li>• Check if there is an illegal character in the Destination mail address.</li><li>• Delete the illegal character and reset the appropriate Destination mail address, then perform the job again.</li></ul>

## [2C70] SMTP client OFF

Classification	Error item
E-mail related error	SMTP client OFF.

Check item	Measures
Setting	Set the SMTP valid and perform the job again.

## [2C71] SMTP authentication error

Classification	Error item
E-mail related error	SMTP authentication error.

Check item	Measures
Setting	Check that SMTP authentication method, login name and password are correct, then perform authentication again.

## [2C72] POP before SMTP error

Classification	Error item
E-mail related error	POP before SMTP error.

Check item	Measures
Setting	Check that both the POP Before SMTP setting and POP3 setting are correct, then perform authentication again.

## [2CC1] Power failure

Classification	Error item
E-mail related error	Power failure.

Check item	Measures
Setting	<ul style="list-style-type: none"><li>• Check if the power cable is connected properly and it is inserted securely.</li><li>• Check if the power voltage is unstable.</li></ul>

## [ 6 ] File sharing related error

### [2D10] System access abnormality

### [2D32] File deletion failure

### [2DA6] File deletion failure

### [2DA7] Resource acquiring failure

Classification	Error item
File sharing related error	[2D10] System access abnormality. [2D32] [2DA6] File deletion failure. [2DA7] Resource acquiring failure.

Check item	Measures
Setting	<ul style="list-style-type: none"><li>• Delete some files in the shared folder by using Explorer because of automatic/manual file deletion failure (in case of [2DA6])</li><li>• Turn the power OFF and then back ON. Perform the job in error again.</li><li>• If the error still occurs, first, check if there are no jobs existing and then perform the HDD formatting (HS-75 &gt; Initialize HDD &gt; Clear Error Flag in Software Installation).</li></ul>

## [2D11] Insufficient memory

Classification	Error item
File sharing related error	Insufficient memory.

Check item	Measures
Setting	<ul style="list-style-type: none"><li>• When there are running jobs, perform the job in error again after the completion of the running jobs.</li><li>• If the error still occurs, turn the power OFF and then back ON, and perform the job again.</li></ul>

## [2D12] Message reception error

## [2D13] Message transmission error

Classification	Error item
File sharing related error	[2D12] Message reception error. [2D13] Message transmission error.

Check item	Measures
Setting	Turn the power OFF and then back ON. Perform the job in error again.

#### [2D14] Invalid parameter

Classification	Error item
File sharing related error	Invalid parameter.

Check item	Measures
Setting	<ul style="list-style-type: none"><li>• When a template is used, form the template again.</li><li>• If the error still occurs, turn the power OFF and then back ON, and perform the job again.</li></ul>

#### [2D15] Exceeding the maximum size for file sharing

Classification	Error item
File sharing related error	Exceeding the maximum size for file sharing.

Check item	Measures
Setting	Divide the file in error into several files and retry. Or retry the job in a single-page format.

#### [2D30] Directory creation failure

#### [2D31] File creation failure

#### [2D33] File access failure

Classification	Error item
File sharing related error	[2D30] Directory creation failure. [2D31] File creation failure. [2D33] File access failure.

Check item	Measures
Setting	<ul style="list-style-type: none"><li>• Check if the access privilege to the storage directory is writable.</li><li>• Check if the server or local disk has a sufficient space in disk capacity.</li></ul>

#### [2D40] Image conversion abnormality

Classification	Error item
File sharing related error	Image conversion abnormality.

Check item	Measures
Setting	<ul style="list-style-type: none"><li>• Turn the power OFF and then back ON. Perform the job in error again.</li><li>• Replace the main memory and perform the job again.</li></ul>

#### [2D43] Encryption error

Classification	Error item
File sharing related error	Encryption error.

Check item	Measures
Setting	Turn the power OFF and then back ON. Perform the job in error again.

## [2D44] Encryption PDF enforced mode error

Classification	Error item
File sharing related error	Encryption PDF enforced mode error.

Check item	Measures
Setting	<ul style="list-style-type: none"><li>Reset the encryption and perform the job in error again.</li><li>If an image file not encrypted is created, consult your administrators.</li></ul>

## [2D45] Meta data creation error (Scan to File)

Classification	Error item
File sharing related error	Creation of meta data failed when a user tried to perform meta scan for Scan to File.

Check item	Measures
Setting	Check the template settings. Perform the job in error again. If the error still occurs, turn the power OFF and then back ON, and then perform the job in error again.

## [2D50] Authentication failure at job execution

Classification	Error item
File sharing related error	A Scan To File job is carried out while user authentication or department authentication has not been done.

Check item	Measures
Setting	Retry the job after user authentication or department authentication has been done.

## [2D62] File server connection failure

Classification	Error item
File sharing related error	File server connection failure.

Check item	Measures
Setting	<ul style="list-style-type: none"><li>Check the IP address or path of the server.</li><li>Check if the server is operating properly.</li></ul>

## [2D63] Invalid network path

Classification	Error item
File sharing related error	Invalid network path.

Check item	Measures
Setting	<ul style="list-style-type: none"><li>Check the network path.</li><li>If the path is correct, turn the power OFF and then back ON, and perform the job again.</li></ul>

### [2D64] Login failure

Classification	Error item
File sharing related error	Login failure.

Check item	Measures
Setting	<ul style="list-style-type: none"><li>Reset the login name and password. Perform the job.</li><li>Check if the account of the server is properly set up.</li></ul>

### [2D65] New document creation failure caused by an excess of documents in a folder

Classification	Error item
File sharing related error	New document creation failure caused by an excess of documents in a folder.

Check item	Measures
Setting	Delete some documents in the folder.

### [2D66] Storage capacity full failure during processing

Classification	Error item
File sharing related error	Storage capacity full failure during processing.

Check item	Measures
Setting	<ul style="list-style-type: none"><li>Delete the job in progress or being set or in the HOLD/PRIVATE/PROOF/INVALID, and perform it again.</li><li>Check if the server or local disk has a sufficient space in disk capacity.</li><li>Check that there is enough space in the server or local disk.</li></ul>

### [2D67] FTP service not available

Classification	Error item
File sharing related error	FTP service not available.

Check item	Measures
Setting	Check if the setting of FTP service is valid.

### [2D68] File sharing service not available

Classification	Error item
File sharing related error	File sharing service not available.

Check item	Measures
Setting	Check if the setting of SMB is valid.



## [2D69] NetWare service not available

Classification	Error item
File sharing related error	When a user tried to perform Scan to File with NetWare protocol even though the NetWare setting is disabled, a message notifies the user that NetWare service is disabled.

Check item	Measures
Setting	Check if the Netware setting is enabled.

## [2DC1] Power failure

Classification	Error item
File sharing related error	Power failure.

Check item	Measures
Setting	<ul style="list-style-type: none"><li>• Check if the power cable is connected properly and it is inserted securely.</li><li>• Check if the power voltage is unstable.</li></ul>

## [2E10] System access abnormality in USB storage

Classification	Error item
File sharing related error	Job status is invalid.

Check item	Measures
Setting	Turn the power OFF and then back ON. Perform the job in error again. If the error still occurs, first, check if there are no jobs existing and then perform HDD formatting (HS-75 > Initialize HDD > Clear Error Flag in Software Installation).

## [2E11] Insufficient memory capacity for USB storage

Classification	Error item
File sharing related error	Insufficient memory capacity for USB storage.

Check item	Measures
Setting	If there is a job in progress, perform the job in error again after the job in progress is finished. If the error still occurs, turn the power OFF and then back ON, and then perform the job in error again.

## [2E12] Message reception error in USB storage

## [2E13] Message transmission error in USB storage

Classification	Error item
File sharing related error	Job status is invalid.

Check item	Measures
Setting	Turn the power OFF and then back ON. Perform the job in error again.

**[2E14] Invalid parameter for USB storage**

Classification	Error item
File sharing related error	The specified parameter is invalid.

Check item	Measures
Setting	If a template is being used, recreate the template. If the error still occurs, turn the power OFF and then back ON. Perform the job in error again.

**[2E15] Exceeding the maximum size for file sharing**

Classification	Error item
File sharing related error	There are too many files in the folder. Creation of a document failed.

Check item	Measures
Setting	Delete some files in the folder. Perform the job in error again.

**[2E30] Directory creation failure in USB storage**

Classification	Error item
File sharing related error	Creation of a directory failed.

Check item	Measures
Setting	Check if access privilege to the storage directory is writable. Check if the server or local disk has sufficient space in its disk capacity.

**[2E31] File creation failure in USB storage**

Classification	Error item
File sharing related error	Creation of a file failed.

Check item	Measures
Setting	Check if access privilege to the storage directory is writable. Check if the server or local disk has sufficient space in its disk capacity.

**[2E32] File deletion failure in USB storage**

Classification	Error item
File sharing related error	Deletion of a file failed.

Check item	Measures
Setting	Turn the power OFF and then back ON. Perform the job in error again. If the error still occurs, first, check if there are no jobs existing and then perform HDD formatting (HS-75 > Initialize HDD > Clear Error Flag in Software Installation).

**[2E33] File access failure in USB storage**

Classification	Error item
File sharing related error	Access to a file failed.

Check item	Measures
Setting	Check if access privilege to the storage directory is writable. Check if the server or local disk has sufficient space in its disk capacity.

#### [2E40] Image conversion abnormality in USB storage

Classification	Error item
File sharing related error	Conversion of image file format failed.

Check item	Measures
Setting	Turn the power OFF and then back ON. Perform the job in error again. Replace the main memory and then perform the job in error again.

#### [2E43] Encryption failure in USB storage

Classification	Error item
File sharing related error	Creation of a file failed due to PDF encryption error.

Check item	Measures
Setting	Turn the power OFF and then back ON. Perform the job in error again.

#### [2E44] Encryption PDF enforced mode error in USB storage

Classification	Error item
File sharing related error	Creation of an image file is not permitted.

Check item	Measures
Setting	Reset the encryption and perform the job in error again. To create an image file not encrypted, consult your administrator.

#### [2E45] Meta data creation error in USB storage (Scan to File)

Classification	Error item
File sharing related error	Creation of meta data failed.

Check item	Measures
Setting	Check the template settings. Perform the job in error again. If the error still occurs, turn the power OFF and then back ON, and then perform the job in error again.

#### [2E50] Authentication failure at job execution

Classification	Error item
File sharing related error	A Scan To USB job is carried out while user authentication or department authentication has not been done.

Check item	Measures
Setting	Retry the job after user authentication or department authentication has been done.

### [2E65] File creation error due to insufficient USB folder capacity

Classification	Error item
File sharing related error	Creation of a new file failed because there were too many files in the USB folder.

Check item	Measures
Setting	Delete unnecessary files in the folder.

### [2E66] HDD full failure during USB storage process

Classification	Error item
File sharing related error	HDD became full while storing data in HDD.

Check item	Measures
Setting	Delete the job in progress or being set or in the HOLD/PRIVATE/PROOF/INVALID, and perform it again. Check if the server or local disk has a sufficient space in disk capacity. Check that there is enough space in the USB memory.

### [2EC1] Power failure in USB storage

Classification	Error item
File sharing related error	A job was interrupted due to a power failure.

Check item	Measures
Setting	Check if the power cable is connected properly and inserted securely. Check if the power voltage is unstable.

### [ 7 ] E-mail reception related error

#### [3A10] E-mail MIME error

Classification	Error item
E-mail reception related error	E-mail MIME error.

Check item	Measures
Setting	<ul style="list-style-type: none"><li>The format of the mail is not corresponding to MIME 1.0.</li><li>Request the sender to retransmit the mail in the format corresponding to MIME 1.0.</li></ul>

#### [3A20] E-mail analysis error

#### [3B10] E-mail format error

#### [3B40] E-mail decode error

Classification	Error item
E-mail reception related error	[3A20] E-mail analysis error. [3B10] E-mail format error. [3B40] E-mail decode error.

Check item	Measures
Setting	<ul style="list-style-type: none"> <li>• These errors occur when the mail data is damaged from the transmission to the reception of the mail.</li> <li>• Request the sender to retransmit the mail.</li> </ul>

### [3A30] Partial mail time-out error

Classification	Error item
E-mail reception related error	Partial mail time-out error.

Check item	Measures
Setting	<ul style="list-style-type: none"> <li>• The partial mail is not received in a specified period of time.</li> <li>• Request the sender to retransmit the partial mail, or set the time-out period of the partial mail longer.</li> </ul>

### [3A40] Partial mail related error

Classification	Error item
E-mail reception related error	Partial mail related error.

Check item	Measures
Setting	<ul style="list-style-type: none"> <li>• The format of the partial mail is not compatible to this equipment.</li> <li>• Request the sender to remake and retransmit the partial mail in RFC2046 format.</li> </ul>

### [3A50] Insufficient HDD capacity error

Classification	Error item
E-mail reception related error	Insufficient HDD capacity error.

Check item	Measures
Setting	<ul style="list-style-type: none"> <li>• This error occurs when the HDD capacity is not sufficient for a temporary concentration of the jobs, etc.</li> <li>• Request the sender to retransmit after a certain period of time, or divide the mail into more than one.</li> <li>• Insufficient HDD capacity error also occurs when printing cannot be performed for reasons such as lack of printing paper.</li> <li>• In this case, supply the printing paper.</li> </ul>

### [3A70] Error of partial mail interruption

Classification	Error item
E-mail reception related error	Error of partial mail interruption.

Check item	Measures
Setting	<ul style="list-style-type: none"> <li>• This error occurs when the partial mail reception setting becomes OFF during the partial mail reception.</li> <li>• Reset the partial mail reception setting ON and then request the sender to retransmit the mail.</li> </ul>

### [3A80] Partial mail reception setting OFF

Classification	Error item
E-mail reception related error	Partial mail reception setting OFF.

Check item	Measures
Setting	Reset the partial mail reception setting ON and then request the sender to retransmit the mail.

### [3B20] Content-Type error

Classification	Error item
E-mail reception related error	Content-Type error.

Check item	Measures
Setting	<p>The file format attached to the e-mail is not supported by this equipment (TIFF-FX/PDF/JPEG/XPS).</p> <p>Or the combination of the file formats attached to the e-mail is not available to be received together by this equipment. (The file format TIFF-FX cannot be received together PDF, JPEG and XPS ones.)</p> <p>Request the sender to retransmit the file by modifying the file format which is supported by this equipment.</p> <p>Or request the sender to retransmit the e-mail by attaching only TIFF-FX format files or by attaching PDF, JPEG and XPS format files (a mixture of the formats is available).</p>

### [3C10] TIFF analysis error

### [3C13] TIFF analysis error

Classification	Error item
E-mail reception related error	TIFF analysis error.

Check item	Measures
Setting	<ul style="list-style-type: none"><li>• These errors occur when the mail data is damaged from the transmission to the reception of the mail, or when the format of the attached file is not supported by this equipment (TIFF-FX).</li><li>• Request the sender to retransmit the mail.</li></ul>

### [3C20] TIFF compression error

Classification	Error item
E-mail reception related error	TIFF compression error.

Check item	Measures
Setting	<ul style="list-style-type: none"><li>• The compression method of the TIFF file is not acceptable for this equipment. (Acceptable: MH/MR/MMR/JBIG)</li><li>• Request the sender to retransmit the file in the acceptable compression method.</li></ul>

### [3C30] TIFF resolution error

Classification	Error item
E-mail reception related error	TIFF resolution error.

Check item	Measures
Setting	<ul style="list-style-type: none"> <li>The resolution of the TIFF file is not acceptable for this equipment. (Acceptable: 200 x 100, 200 x 200, 200 x 400, 400 x 400, 300 x 300 or equivalent)</li> <li>Request the sender to retransmit the file in the acceptable resolution.</li> </ul>

### [3C40] TIFF paper size error

Classification	Error item
E-mail reception related error	TIFF paper size error.

Check item	Measures
Setting	<ul style="list-style-type: none"> <li>The paper size of the TIFF file is not acceptable for this equipment. (Acceptable: A4, B4, A3, B5, LT, LG, LD or ST)</li> <li>Request the sender to retransmit the file in the acceptable paper size.</li> </ul>

### [3C50] Offramp destination error

Classification	Error item
E-mail reception related error	Offramp destination error.

Check item	Measures
Setting	<ul style="list-style-type: none"> <li>These errors occur when the FAX number of the offramp destination is incorrect.</li> <li>Request the sender to correct the FAX number of offramp destination and then retransmit the mail.</li> </ul>

### [3C60] Offramp security error

Classification	Error item
E-mail reception related error	Offramp security error.

Check item	Measures
Setting	<ul style="list-style-type: none"> <li>These errors occur when the FAX number of the offramp destination is not on the Address Book.</li> <li>Check if the FAX number of the offramp destination is correctly entered or the number has not been changed.</li> </ul>

### [3C70] Power failure error

Classification	Error item
E-mail reception related error	Power failure error.

Check item	Measures
Setting	<ul style="list-style-type: none"> <li>Check if the mail is recovered after turning ON the power again.</li> <li>Request the sender to retransmit the mail if it is not recovered.</li> </ul>

### [3C90] Offramp Fax transmission disable error

Classification	Error item
E-mail reception related error	Offramp Fax transmission disable error.

Check item	Measures
Setting	<ul style="list-style-type: none"> <li>This error is displayed when a Fax/Internet Fax transmission limitation error has occurred during OffRamp gateway function.</li> <li>Confirm if the Fax Send Function of MFP setting is disable or not.</li> </ul>

### [3D10] Destination address error

Classification	Error item
E-mail reception related error	Destination address error.

Check item	Measures
Setting	<ul style="list-style-type: none"> <li>Check if the setting of the server or DNS is correct. Correct if any of the setting is incorrect.</li> <li>When the content of the setting is correct, confirm the sender if the destination is correct.</li> </ul>

### [3D20] Offramp destination limitation error

Classification	Error item
E-mail reception related error	Offramp destination limitation error.

Check item	Measures
Setting	Inform the sender that the transfer of the FAX data over 40 is not supported.

### [3D30] FAX Unit error

Classification	Error item
E-mail reception related error	FAX Unit error.

Check item	Measures
Setting	<ul style="list-style-type: none"> <li>This error occurs when the FAX board is not installed or the FAX board has an abnormality.</li> <li>Check if the FAX board is correctly connected.</li> </ul>

### [3E10] POP3 server connection error

Classification	Error item
E-mail reception related error	POP3 server connection error.

Check item	Measures
Setting	Check if the IP address or domain name of the POP3 server set for this equipment is correct, or check if POP3 server to be connected is operating properly.

### [3E20] POP3 server connection time-out error

Classification	Error item
E-mail reception related error	POP3 server connection time-out error.



Check item	Measures
Setting	<ul style="list-style-type: none"> <li>• Check if POP3 server to be connected is operating properly.</li> <li>• Check if the LAN cable is correctly connected.</li> </ul>

### [3E30] POP3 login error

Classification	Error item
E-mail reception related error	POP3 login error.

Check item	Measures
Setting	Check if the POP3 server login name and password set for this equipment are correct.

### [3E40] POP3 login type error

Classification	Error item
E-mail reception related error	POP3 login type error.

Check item	Measures
Setting	Check that the login type (Auto, POP3 or APOP) to the POP3 server is correct.

### [3F10] File I/O error

### [3F20] File I/O error

Classification	Error item
E-mail reception related error	File I/O error.

Check item	Measures
Setting	<ul style="list-style-type: none"> <li>• These errors occur when the mail data is not transferred properly to the HDD.</li> <li>• Request the sender to retransmit the mail.</li> <li>• Replace the HDD if the error still occurs after retransmission.</li> </ul>

## 8.3.21 Printer function error

### [4011] Print job cancellation

Classification	Error item
Printer function error	A print job (copy, list print, network print) is deleted from the print job screen.

Check item	Measures
Setting	This message appears when deleting the job on the screen.

### [4021] Print job power failure

Classification	Error item
Printer function error	The power of the equipment is turned OFF during a print job (copy, list print, network print) process.

Check item	Measures
Setting	When there are running jobs, perform the job in error again after the completion of the running jobs. If the error still occurs, turn the power OFF and then back ON, and perform the job again.

### [4031] HDD full during print

Classification	Error item
Printer function error	A large amount of image data is saved in an HDD at private print or invalid network print.

Check item	Measures
Setting	Delete unnecessary private print jobs and invalid department print jobs. <ul style="list-style-type: none"><li>• Check if the server or local disk has sufficient space in its disk capacity.</li></ul>

### [4032] Exceeding the upper limit of the registration number for the sharing jobs

Classification	Error item
Printer function error	No more sharing jobs can be registered because its registration number as a personal or functional has reached the upper limit. (A specific error for the Serverless Location Free Print function)

Check item	Measures
Setting	Select "Private", and then perform the printing again.

### [4033] Network setting error

Classification	Error item
Printer function error	A sharing job cannot be registered since the applicable address has not been found from the list used for the Serverless Location Free Print function. (A specific error for the Serverless Location Free Print function)

Check item	Measures
Setting	Select "Normal Print", and then perform the printing again.

**[4041] User authentication error**

Classification	Error item
Printer function error	The user who intended to print a document is not registered as a user.

Check item	Measures
Setting	Perform the authentication or register as a user, and then perform the printing again.

**[4042] Department authentication error**

Classification	Error item
Printer function error	The department whose code is specified for a print job is not registered.

Check item	Measures
Setting	Check department information registered in this equipment.

**[4043] Project authentication error**

Classification	Error item
Printer function error	The project whose code is specified for a print job is not registered.

Check item	Measures
Setting	Check project information registered in this equipment.

**[4045] Problem in LDAP server connection or LDAP server authorization settings**

Classification	Error item
Printer function error	Problem in LDAP server connection or LDAP server authorization settings.

Check item	Measures
Setting	Confirm the administrator for the LDAP server connection or LDAP server authorization settings.

**[4111] Quota over error (no quota in a department and user)**

Classification	Error item
Printer function error	The number of the assigned pages set by the department and user management has reached 0.

Check item	Measures
Setting	The number of the assigned pages set by the department and the number of those assigned by user management have both reached 0. Assign the number of the pages again or perform initialization.

**[4112] Quota over error (no quota in a user)**

Classification	Error item
Printer function error	The number of the assigned pages set by the user management has reached 0.

Check item	Measures
Setting	The number of the assigned pages set by the user management has reached 0. Assign the number of the pages again or perform initialization.

**[4113] Quota over error (no quota in a department)**

Classification	Error item
Printer function error	The number of the assigned pages set by the department management has reached 0.

Check item	Measures
Setting	The number of the assigned pages set by the department management has reached 0. Assign the number of the pages again or perform initialization.

**[4121] Job canceling due to external counter error**

Classification	Error item
Printer function error	Job canceling due to external counter error.

Check item	Measures
Setting	<ol style="list-style-type: none"> <li>1. Drop a coin in. Perform the print job in error again.</li> <li>2. Insert a key card and then perform the print job in error again, or consult your administrator.</li> <li>3. Insert a key copy counter and then perform the print job in error again.</li> <li>4. Reset the scheduled print job and then perform the print job in error again.</li> </ol>

**[4212] e-Filing box storing limitation error**

Classification	Error item
Printer function error	Printing with its data being stored to the HDD (print and e-Filing, print to e-Filing, etc.) has been performed.

Check item	Measures
Setting	Select "Normal Print", and then perform the printing again.

**[4213] File storing limitation error**

Classification	Error item
Printer function error	The file storing function is set to "disabled".

Check item	Measures
Setting	Select "Remote" (SMB/FTP) for the destination of the file to save.

**[4214] Fax / Internet Fax transmission limitation error**

Classification	Error item
Printer function error	The Fax / Internet Fax transmission function or the Network Fax / Internet Fax function is set to "disabled".

Check item	Measures
Setting	Check the settings of this equipment.

**[4221] Private-print-only error**

Classification	Error item
Printer function error	Jobs other than Private print ones have been performed.

Check item	Measures
Setting	E-mail direct printing cannot be performed since Private printing is not selectable for it. Select "Private print", and then perform the printing again.

**[4222] Hold-print-only error**

Classification	Error item
Printer function error	Hold-print-only error.

Check item	Measures
Setting	E-mail direct printing cannot be performed since Hold printing is not selectable for it.

**[4223] Private-print-only / Hold-print-only error**

Classification	Error item
Printer function error	Private-print-only / Hold-print-only error.

Check item	Measures
Setting	Email direct printing cannot be performed since Private printing and Hold printing are not selectable for it.

**[4231] Hardcopy security printing error**

Classification	Error item
Printer function error	A hardcopy security printing job has been performed when the function is restricted.

Check item	Measures
Setting	Hardcopy security printing cannot be performed because the function is restricted in the self-diagnosis mode. Check the settings of the equipment.

**[4241] No Printer kit / Printer function disabled**

Classification	Error item
Printer function error	Printing functions are disabled since the Printer kit or Printer / Scanner kit is not installed firmly.

Check item	Measures
Setting	Check that the Printer kit or Printer/Scanner kit is installed firmly.

#### [4242] No Scanner kit / Scanner function disabled

Classification	Error item
Scanner function error	Internet Fax or storing to a share folder function using a Network Fax driver is disabled since the Scanner kit is not installed firmly, but the Printer kit is installed.

Check item	Measures
Setting	Check that the Scanner kit is installed firmly.

#### [4245] OCR functions not available

Classification	Error item
Printer function error	OCR functions not available.

Check item	Measures
Setting	Check whether the OCR license or an extended memory is installed.

#### [4311] No privilege to perform a job

Classification	Error item
Printer function error	No privilege to perform a job.

Check item	Measures
Setting	Confirm the administrator for the JOB authorization.

#### [4312] Not authorized to store a file

Classification	Error item
Printer function error	Not authorized to store a file.

Check item	Measures
Setting	The user has not been authorized to perform this operation. Ask your administrator.

#### [4313] No privilege for e-Filing box storage

#### [4314] No privilege for Fax / Internet Fax transmission

Classification	Error item
Printer function error	[4313] No privilege to store e-Filing box data is given. (e-Filing box storage permission) [4314] No privilege to send a Fax or Internet Fax jobs is given. (Fax / Internet Fax transmission permission)

Check item	Measures
Setting	Check the privilege given, or request the administrator to add the necessary privilege.

#### [4411] Image data creation failure

Classification	Error item
Printer function error	Image data creation failure.

Check item	Measures
Setting	Check if the file to be printed is broken. Perform printing again or use another printer driver. <ul style="list-style-type: none"><li>• Network print: Perform the print job in error again, or use another printer driver (e.g.; PS3, Universal).</li><li>• Direct print: Check if the file is corrupted (e.g. checking if the file is displayed on your PC monitor), or check if the file format is supported by this equipment.</li></ul>

#### [4412] Double-sign encoding error

Classification	Error item
Printer function error	A double-sign encoding error has occurred because the PDF file is encrypted in a forbidden language or in a language not supported.

Check item	Measures
Setting	Printing using this function cannot be performed due to a decoding process error which occurs because the PDF file is encrypted incorrectly or encrypted in a language not supported.

#### [4511] Connection timeout

Classification	Error item
Printer function error	In the case the print data is not sent from the client PC during printing and print ends in error, or connection is not disconnected from the PC, timeout error is detected.

Check item	Measures
Setting	<ul style="list-style-type: none"><li>• Check that the Ethernet setting of the MFP is the same as that for the hub to which the MFP is being connected.</li><li>• Check that the Ethernet cable is connected properly.</li></ul>

#### [4521] Reaching the maximum number of connections

Classification	Error item
Printer function error	In the case the MFP reaches the max. number of connections and cannot receive a job.

Check item	Measures
Setting	<ul style="list-style-type: none"><li>• Perform printing again after a certain period of time.</li><li>• If this frequently occurs due to the network environment or the number of the client PCs, change the setting of the following self-diagnostic codes. FS-08-3727, FS-08-3731, FS-08-3732, FS-08-3765, FS-08-9561</li></ul>

#### [4522] Exceeding the upper limit of the registration number of jobs during data reception

Classification	Error item
Printer function error	Since the MFP nears the Workflow Full, reception of the jobs is limited.

Check item	Measures
Setting	<ul style="list-style-type: none"> <li>• Wait until the printing of the jobs which are being processed or are waiting is completed and then perform printing again.</li> <li>• Delete unnecessary private print jobs and invalid department print jobs and then perform printing again.</li> </ul>

#### [4523] HDD full during data reception

Classification	Error item
Printer function error	Since the MFP nears the HDD Full, reception of the jobs is limited.

Check item	Measures
Setting	<ul style="list-style-type: none"> <li>• Delete unnecessary private print jobs and invalid department print jobs and then perform printing again.</li> <li>• Check if the server or local disk has sufficient space in its disk capacity.</li> </ul>

#### [4611] Font download failure (exceeding the maximum number of registrations)

#### [4612] Font download failure (HDD full)

Classification	Error item
Printer function error	<p>[4611] A new font cannot be registered because the number of fonts registered in this equipment has already reached the limit.</p> <p>[4612] A new font cannot be registered because there is insufficient space in the font storage area of this equipment.</p>

Check item	Measures
Setting	Delete one or more fonts already registered.

#### [4613] Font download failure (others)

Classification	Error item
Printer function error	A new font cannot be registered due to other abnormalities.

Check item	Measures
Setting	Reattempt the downloading. Recreate font data and reattempt the downloading.

#### [4621] Downloaded font deletion failure

Classification	Error item
Printer function error	The specified font cannot be deleted because it does not exist, it is undeletable or any another abnormality has occurred.

Check item	Measures
Setting	Check if the font to be deleted is registered (or pre-registered) in this equipment.

#### [4721] Connection Error of Multi Station Print (Unexpected combination of ROM version)



Classification	Error item
Printer function error	Connection failure of Multi Station Print because of an unexpected ROM version combination.



Check item	Measures
Setting	<ul style="list-style-type: none"> <li>• Connection failure of Multi Station Print because of an unexpected ROM version combination.</li> <li>• Check the version of the equipment to connect and then update the version of the unconnectable equipment to become the same as that for the connected one.</li> </ul>

#### [4F10] System abnormality

Classification	Error item
Printer function error	Printing was not performed successfully due to other abnormalities.

Check item	Measures
Setting	<ul style="list-style-type: none"> <li>• Perform the job in error again. If the error still occurs, turn the power OFF and then back ON, and perform the job again.</li> <li>• Collect the debug log with USB media.   P. 8-3 "8.1.2 Collection of debug logs with a USB device"</li> <li>• Initialize HDD.  Refer to step 3 and later in [E]Replace / Format HDD in   P. 9-18 "9.2.3 Precautions and procedures when replacing the HDD/SSD".</li> </ul>

## 8.3.22 TopAccess related error

### [5012] Authentication error

Classification	Error item
Communication error with external application	A temporary password entered in this equipment by downloading from e-Bridge is invalid, or the permanent password set in e-Bridge is invalid.

Check item	Measures
Setting	Confirm the user name and temporary password.

### [5013] Communication error between eBR

Classification	Error item
Communication error with external application	Communication is attempted while the eBR is enabled for some reason such as version upgrade.

Check item	Measures
Setting	Check if the MFP is connected to the eBR2 server.

### [5014] No SSL certificate

Classification	Error item
Communication error with external application	There is no SSL certificate or the certificate is not in a correct file format.

Check item	Measures
Setting	Install the correct SSL certificate.

### [5015] Invalid SSL certificate error

Classification	Error item
Communication error with external application	The SSL certificate is incorrect.

Check item	Measures
Setting	Install the correct SSL certificate.

### [5016] Expired SSL certificate error

Classification	Error item
Communication error with external application	The SSL certificate is expired.

Check item	Measures
Setting	Set the correct time.

### [5017] Other SSL certificate related error

Classification	Error item
Communication error with external application	The SSL certificate is invalid.

Check item	Measures
Setting	Install the correct SSL certificate.

#### [5018] Invalid DNS error

Classification	Error item
Communication error with external application	The DNS address is incorrect.

Check item	Measures
Setting	Set the correct DNS address. If any setting is needed in DNS, consult your administrators.

#### [5019] Connection error

Classification	Error item
Communication error with external application	Settings for the initial URL and proxy are incorrect.

Check item	Measures
Setting	Perform the correct settings for initial URL and proxy.

#### [501A] Proxy error

Classification	Error item
Communication error with external application	Settings for the IP address or port are incorrect.

Check item	Measures
Setting	Set the correct IP address or port for the proxy setting. If any setting is needed in proxy, consult your administrators.

#### [501B] No URL (host / port) or invalid path

Classification	Error item
Communication error with external application	The initial URL is incorrect.

Check item	Measures
Setting	Set the correct initial URL.

#### [5030] An error has occurred in the HTTP communication

Classification	Error item
Communication error with external application	An error in the HTTP communication.

Check item	Measures
Setting	Check the URL for communication. Check that the valid IP address is assigned to connect to the server.

### [50FF] eBR2 internal error

Classification	Error item
Communication error with external application	A fatal error occurred in the MFP.

Check item	Measures
Setting	Restart the MFP, and then try again.

### [5110] Toner cartridge detection error

Classification	Error item
TopAccess related error	Toner cartridge detection error.

Check item	Measures
Toner cartridge	Refer to the troubleshooting for C911 error. P. 8-208 " [C911] Toner cartridge PC board access abnormality (K)"

### [5212] Time for cleaning of the main charger

Classification	Error item
TopAccess related error	Appears when the time for main charger cleaning comes (at the output of approx. every 10,000 sheets).

Check item	Measures
Main charger	<ul style="list-style-type: none"><li>• Clean the main charger.</li><li>• If the message is not cleared after the cleaning, check if there is any detection error, breakage or poor connection of the needle electrode cleaner detection sensor.</li></ul>

### [5410] MFP registration error

Classification	Error item
Communication error with external application	The serial number of the equipment is not registered in the Remote maintenance service. The registration processing from the equipment to the Remote maintenance service has failed.

Check item	Measures
Remote maintenance service setting	Contact the administrator of the Remote maintenance service to confirm that the serial number and model name of the equipment have been correctly imported to the Remote maintenance server. (Be sure the serial number of the equipment is CAPITALIZED.)

### [5411] MFP registration lock error

Classification	Error item
Communication error with external application	Data to send to the Remote maintenance server from the equipment have been damaged or incorrect authentication data have been sent.

Check item	Measures
Setting of a remote maintenance service	Check that the local date and time are correctly set in the equipment. If not, enter the correct ones. If an error continues to be recorded for several days even though the date and time have been correctly set, contact the administrator of the Remote Maintenance service.

#### [5412] Server busy error

Classification	Error item
Communication error with external application	The Remote maintenance service cannot handle the periodic communication from the equipment due to overloading in the Remote maintenance service.

Check item	Measures
None	The equipment performs the periodic communication automatically. Therefore, check that no error will occur at the next periodic communication. If an error continues to be recorded for several days, contact the administrator of the Remote Maintenance service.

#### [5413] Server error

Classification	Error item
Communication error with external application	The server of the Remote maintenance service cannot make response to the equipment. A temporary power failure has occurred.

Check item	Measures
Remote maintenance service setting	Contact the administrator of the Remote maintenance service to confirm that the serial number and model name of the equipment have been correctly imported to the Remote maintenance server. (Be sure the serial number of the equipment is CAPITALIZED.) If an error continues to be recorded for several days, contact the administrator of the Remote Maintenance service.

#### [5414] Invalid device file error

Classification	Error item
Communication error with external application	A device file to sent to the Remote maintenance service from the equipment has been damaged.

Check item	Measures
Communication environment	The equipment performs the periodic communication automatically. Therefore, check that no error will occur at the next periodic communication. If an error continues to be recorded for several days, contact the administrator of the Remote Maintenance service.

#### [5415] Communication error

Classification	Error item
Communication error with external application	The equipment cannot communicate the Remote maintenance service.

Check item	Measures
Setting	Check that there is no problem in the wiring connection between the equipment and the Remote maintenance service as well as in the connection and setting of network devices.

#### [5416] Update failure of system software / setting files of the equipment

Classification	Error item
Communication error with external application	The setting files and the system software of the equipment cannot be updated because there is an ongoing job. There are too many printing and fax jobs which are ongoing.

Check item	Measures
Communication environment	Have the customer clear pending jobs in the equipment job queues and retry the update by the Remote maintenance service.

#### [5417] Invalid setting files of the equipment or system software

Classification	Error item
Communication error with external application	Upgrading has failed since the setting files of the equipment or the system software that has been downloaded from the Remote maintenance server has been incorrect or has been damaged.

Check item	Measures
Communication environment	Contact the administrator of the Remote maintenance service to check that the setting files of the equipment or the system software that has been downloaded is applicable to the model.

#### [5BD0] Power failure during restoration

Classification	Error item
TopAccess related error	Power supply has been cut off during the restoration of the database sent from TopAccess.

Check item	Measures
Power	<ul style="list-style-type: none"> <li>• Check if the power cable is connected properly and is inserted securely.</li> <li>• Check if the power voltage is unstable.</li> <li>• Reattempt the restoration of the database (Address Book, templates, F-code (Mailbox) or user information).</li> </ul>

#### [5C10] FAX Unit attachment error

Classification	Error item
TopAccess related error	Network Fax is disabled because no FAX Unit is installed.

Check item	Measures
FAX unit	<ul style="list-style-type: none"> <li>• Check if the FAX Unit is attached.</li> <li>• Check if there is any damage or abnormality on the FAX Unit.</li> <li>• Check if the connector on the FAX Unit is connected properly.</li> </ul>

## [5C11] Network Fax transmission error

Classification	Error item
TopAccess related error	A Network Fax job has failed because the specified address is not registered in the AddressBook.

Check item	Measures
Setting	The address specified for the Network Fax is not registered on the AddressBook. Register it.

### 8.3.23 MFP access error

#### [6007] Unsuccessful User Login to MFP

Classification	Error item
MFP access error	User authentication cannot be done because connection to the authentication server has failed.

Check item	Measures
Setting	Check if the operating status of the server and connection from an MFP have been confirmed.

#### [6008] Connection failure to an external Role Base Access Control (LDAP) server

Classification	Error item
MFP access error	User authentication cannot be done because connection to an external RBAC server has failed.

Check item	Measures
Setting	Check if the operating status of the server and connection from the MFP have been confirmed.

#### [6013] Connection failure to the authentication server

Classification	Error item
MFP access error	Failed to connect to the authentication server.

Check item	Measures
Setting	Check that the server setting is proper by accessing [TopAccess] > [Administration] > [Maintenance] > [Directory Service]. When "Auto" is selected as the authentication method, this error may output to the log depending on the environment.

#### [6014] Inaccessible authentication server detection

Classification	Error item
MFP access error	The authentication server that cannot be accessed is detected.

Check item	Measures
Setting	There is an inaccessible authentication server. Make sure no authentication server is down. Access to the inaccessible server will be attempted again when the time set in FS-08-8788 has passed since the inaccessibility detection or when the equipment is turned off and on.

#### [6032] Card related error: Expired card

Classification	Error item
MFP access error	The card cannot be used because it has expired.

Check item	Measures
Setting	Use a card with a valid expiration.



**[6033] Card related error: Invalid flag data (no room-entry data)**

Classification	Error item
MFP access error	The card cannot be used because no room-entry data are recorded in it.

Check item	Measures
Setting	Use a correct card that has been used for entering the room.

**[6034] Card related error: Invalid flag data (invalid card data)**

Classification	Error item
MFP access error	The card cannot be used because the data required for the use of the card are not correctly set.

Check item	Measures
Setting	Use a valid card.

**[6035] Invalid setting: Invalid flag information (not set in an MFP)**

Classification	Error item
MFP access error	The necessary information in order to use a card is not set in the equipment.

Check item	Measures
Setting	Use an available card or ask the administrator to register the information.

**[6037] Permission flag for use not available**

Classification	Error item
MFP access error	A card is not usable since the privilege to use the device or equipment is not applied.

Check item	Measures
Setting	Use an available card or request the administrator to give the privilege.

**[6041] Card authentication: Card related error**

Classification	Error item
MFP access error	Card data cannot be obtained correctly.

Check item	Measures
Setting	Reattempt scanning. If the error still occurs after reattemptingscanning several times, card data may be corrupted or the card reader may be out of order.

**[6042] Card authentication: Card setting error**

Classification	Error item
MFP access error	The self-diagnostic code required for card authentication is not set in this equipment correctly.

Check item	Measures
MFP access error	Set the correct self-diagnostic code.

**[6100] User account locking out**

Classification	Error item
MFP access error	User account is locked out.

Check item	Measures
Setting	Log into TopAccess as an administrator, and release the locked user account.

**[6101] e-Filing box locking out**

Classification	Error item
MFP access error	An e-Filing box becomes unusable since the entry of a password has failed for a specified number of times.

Check item	Measures
Setting	Reattempt to access the e-Filing box after a while. Contact the administrator to check this.

**[6102] User account being locking out**

Classification	Error item
MFP access error	Failed to login because the user account had been locked out.

Check item	Measures
Setting	Log into TopAccess as an administrator, and release the locked user account.

**[6103] e-Filing box being locking out**

Classification	Error item
MFP access error	The e-Filing box became inaccessible because an incorrect password has been entered for the specified number of times.

Check item	Measures
Setting	Retry access after a few minutes. For the locking period, ask your administrator.

**[6121] Automatic secure erase failure**

Classification	Error item
MFP access error	The automatic secure erase fails.

Check item	Measures
Setting	Data overwriting failed for some reason. If the error still occurs after rebooting the equipment, start up using the following procedure: HS-73 Assist mode > Format HDD > Reinstallation of software or HDD replacement

### [6131] MFP fail to verify clock with time server

Classification	Error item
MFP access error	The MFP is not synchronized with the SNTP server.

Check item	Measures
Setting	Check that the SNTP server is operating correctly. Check that the path to the SNTP server is operating correctly. Check that the settings are correct in TopAccess > [Administrator] > [Setup] > [General] > [SNTP Service].

### [6150] Print log database full

Classification	Error item
MFP access error	Print log database full.

Check item	Measures
Setting	Perform Clear Log with TopAccess Logs > Export Logs > Print Job Log Export.

### [6151] Print log database near-full (95%)

Classification	Error item
MFP access error	Print log database near-full (95%).

Check item	Measures
Setting	Perform Clear Log with TopAccess Logs > Export Logs > Print Job Log Export.

### [6152] Print log database near-full (90%)

Classification	Error item
MFP access error	Print log database near-full (90%).

Check item	Measures
Setting	Perform Clear Log with TopAccess Logs > Export Logs > Print Job Log Export.

### [6153] Print log database near-full (80%)

Classification	Error item
MFP access error	Print log database near-full (80%).

Check item	Measures
Setting	Perform Clear Log with TopAccess Logs > Export Logs > Print Job Log Export.

**[6154] Print log database near-full (70%)**

Classification	Error item
MFP access error	Print log database near-full (70%).

Check item	Measures
Setting	Perform Clear Log with TopAccess Logs > Export Logs > Print Job Log Export.

**[6160] Scan log database full**

Classification	Error item
MFP access error	Scan log database full.

Check item	Measures
Setting	Perform Clear Log with TopAccess Logs > Export Logs > Scan Job Log Export.

**[6161] Scan log database near-full (95%)**

Classification	Error item
MFP access error	Scan log database near-full (95%).

Check item	Measures
Setting	Perform Clear Log with TopAccess Logs > Export Logs > Scan Job Log Export.

**[6162] Scan log database near-full (90%)**

Classification	Error item
MFP access error	Scan log database near-full (90%).

Check item	Measures
Setting	Perform Clear Log with TopAccess Logs > Export Logs > Scan Job Log Export.

**[6163] Scan log database near-full (80%)**

Classification	Error item
MFP access error	Scan log database near-full (80%).

Check item	Measures
Setting	Perform Clear Log with TopAccess Logs > Export Logs > Scan Job Log Export.

**[6164] Scan log database near-full (70%)**

Classification	Error item
MFP access error	Scan log database near-full (70%).

Check item	Measures
Setting	Perform Clear Log with TopAccess Logs > Export Logs > Scan Job Log Export.

#### [6170] Fax transmission log database full

Classification	Error item
MFP access error	Fax transmission log database full.

Check item	Measures
Setting	Perform Clear Log with TopAccess Logs > Export Logs > Fax Transmission Journal Export.

#### [6171] Fax transmission log database near-full (95%)

Classification	Error item
MFP access error	Fax transmission log database near-full (95%).

Check item	Measures
Setting	Perform Clear Log with TopAccess Logs > Export Logs > Fax Transmission Journal Export.

#### [6172] Fax transmission log database near-full (90%)

Classification	Error item
MFP access error	Fax transmission log database near-full (90%).

Check item	Measures
Setting	Perform Clear Log with TopAccess Logs > Export Logs > Fax Transmission Journal Export.

#### [6173] Fax transmission log database near-full (80%)

Classification	Error item
MFP access error	Fax transmission log database near-full (80%).

Check item	Measures
Setting	Perform Clear Log with TopAccess Logs > Export Logs > Fax Transmission Journal Export.

#### [6174] Fax transmission log database near-full (70%)

Classification	Error item
MFP access error	Fax transmission log database near-full (70%).

Check item	Measures
Setting	Perform Clear Log with TopAccess Logs > Export Logs > Fax Transmission Journal Export.

**[6180] Fax reception log database full**

Classification	Error item
MFP access error	Fax reception log database full.

Check item	Measures
Setting	Perform Clear Log with TopAccess Logs > Export Logs > Fax Reception Journal Export.

**[6181] Fax reception log database near-full (95%)**

Classification	Error item
MFP access error	Fax reception log database near-full (95%).

Check item	Measures
Setting	Perform Clear Log with TopAccess Logs > Export Logs > Fax Reception Journal Export.

**[6182] Fax reception log database near-full (90%)**

Classification	Error item
MFP access error	Fax reception log database near-full (90%).

Check item	Measures
Setting	Perform Clear Log with TopAccess Logs > Export Logs > Fax Reception Journal Export.

**[6183] Fax reception log database near-full (80%)**

Classification	Error item
MFP access error	Fax reception log database near-full (80%).

Check item	Measures
Setting	Perform Clear Log with TopAccess Logs > Export Logs > Fax Reception Journal Export.

**[6184] Fax reception log database near-full (70%)**

Classification	Error item
MFP access error	Fax reception log database near-full (70%).

Check item	Measures
Setting	Perform Clear Log with TopAccess Logs > Export Logs > Fax Reception Journal Export.

**[6190] Message log database full**

Classification	Error item
MFP access error	Message log database full.

Check item	Measures
Setting	Perform Clear Log with TopAccess Logs > Export Logs > Message Log Export.

**[6191] Message log database near-full (95%)**

Classification	Error item
MFP access error	Message log database near-full (95%).

Check item	Measures
Setting	Perform Clear Log with TopAccess Logs > Export Logs > Message Log Export.

**[6192] Message log database near-full (90%)**

Classification	Error item
MFP access error	Message log database near-full (90%).

Check item	Measures
Setting	Perform Clear Log with TopAccess Logs > Export Logs > Message Log Export.

**[6193] Message log database near-full (80%)**

Classification	Error item
MFP access error	Message log database near-full (80%).

Check item	Measures
Setting	Perform Clear Log with TopAccess Logs > Export Logs > Message Log Export.

**[6194] Message log database near-full (70%)**

Classification	Error item
MFP access error	Message log database near-full (70%).

Check item	Measures
Setting	Perform Clear Log with TopAccess Logs > Export Logs > Message Log Export.

## 8.3.24 Maintenance error

[7101] System firmware installation failure

[7103] Engine firmware installation failure

[7105] Scanner firmware installation failure

[7111] Patch installation failure

[7113] Plug-in installation failure

[7115] HDD data installation failure

[7117] DF firmware installation failure

Classification	Error item
Maintenance error	[7101] System firmware installation failed.[7103] Engine firmware installation failed.[7105] Scanner firmware installation failed. [7111] Patch installation failed.[7113] Plug-in installation failed.[7115] HDD data installation failed.[7117] DF firmware installation failed.

Check item	Measures
Setting	Software package file may have a problem or may be corrupted. Check the software package file and then reattempt the installation.

### [7109] Printer driver update failure

Classification	Error item
Maintenance error	Printer driver update failed.

Check item	Measures
Setting	Printer driver file may have a problem or may be corrupted. Check the package file and then reattempt the upload.

### [710B] Point and Print data installation failure

Classification	Error item
Maintenance error	Point and Print data installation failure.

Check item	Measures
Setting	Point and Print data may have a problem or may be corrupted. Check the package file and then reattempt the upload.

### [710F] Language pack installation failure

Classification	Error item
Maintenance error	Language pack installation failed.

Check item	Measures
Setting	Language Pack file may have a problem or may be corrupted. Check the package file and then reattempt the installation.



### [711D] License key returning failure

Classification	Error item
Maintenance error	The one-time dongle license fails to be returned to USB storage.

Check item	Measures
Setting	Return the license to the USB media used for installing the license. Check that the USB media is correctly installed. <b>Notes:</b> The GP-1080 IPsec Enabler cannot return to the USB media due to license problem. The GP-1070 Overwrite Enabler cannot return to the USB media in the high security (08-8911: 3).

### [711F] License key installation failure

Classification	Error item
Maintenance error	The one-time dongle license fails to be installed.

Check item	Measures
Setting	Check that the USB media is correctly installed.

### [7121] Unsuccessful import of AddressBook data

Classification	Error item
Maintenance error	The import of AddressBook data failed.

Check item	Measures
Setting	Check if you are importing a valid file.

### [7123] Unsuccessful import of template data

Classification	Error item
Maintenance error	The import of template data failed.

Check item	Measures
Setting	Check if you are importing a valid file.

### [7125] Unsuccessful import of mailbox data

Classification	Error item
Maintenance error	The import of mailbox data failed.

Check item	Measures
Setting	Check if you are importing a valid file.

### [7127] Unsuccessful import of format file for metascan

Classification	Error item
Maintenance error	The import of metascan format file failed.

Check item	Measures
Setting	Check if you are importing a valid file.

#### [7129] Unsuccessful import of user information

Classification	Error item
Maintenance error	The import of user information failed.

Check item	Measures
Setting	Check if you are importing a valid file.

#### [712B] Unsuccessful import of role information

Classification	Error item
Maintenance error	The import of role information failed.

Check item	Measures
Setting	Check if you are importing a valid file.

#### [712D] Unsuccessful import of department data

Classification	Error item
Maintenance error	The import of department data failed.

Check item	Measures
Setting	Check if you are importing a valid file.

#### [7131] Failed to import print data converter

Classification	Error item
Maintenance error	The import of print data converter failed.

Check item	Measures
Setting	Check if you are importing a valid file.

#### [7132] Failed to import any user informations

Classification	Error item
Maintenance error	A part of the user information was not imported.

Check item	Measures
Setting	There is a possibility that the amount of user information has exceeded the maximum for registration during the import or the file contains invalid data. Check if you are importing a valid file and also that the amount of user information does not exceed the maximum.

#### [7133] Failed to import any user, role and group information

Classification	Error item
Maintenance error	A part of the user, role or group information was not imported.

Check item	Measures
Setting	There is a possibility that the amount of the combined user information has exceeded the maximum for registration during the import or the file contains invalid data. Check if you are importing a valid file and also that the amount of the combined user information does not exceed the maximum.

#### [7134] Failed to import any department code

Classification	Error item
Maintenance error	A part of the department data was not imported.

Check item	Measures
Setting	There is a possibility that the amount of department data has exceeded the maximum for registration during the import or the file contains invalid data. Check if you are importing a valid file and also that the amount of department data does not exceed the maximum.

#### [7139] Failed in acquisition of certificate from SCEP server

Classification	Error item
Maintenance error	Failed to import the certificate by SCEP server.

Check item	Measures
Setting	Check the SCEP server and the SCEP setting (automatic) in TopAccess Administration > Security > Certificate Management.

#### [713B] Failed in import of certificate from TopAccess

Classification	Error item
Maintenance error	Failed to import the certificate.

Check item	Measures
Setting	Certificate may have a problem or be corrupted. Check the certificate and perform the job again.

#### [713D] Unsuccessful import of user combined data

Classification	Error item
Maintenance error	The import of combined user information failed.

Check item	Measures
Setting	Check if you are importing a valid file.

#### [713F] Unsuccessful import of all data (Template / AddressBook / Mailbox)

Classification	Error item
Maintenance error	The import of all data (Template / AddressBook / Mailbox) failed.

Check item	Measures
Setting	Check if you are importing a valid file.

**[7141] Failed in export of AddressBook data**

Classification	Error item
Maintenance error	The export of AddressBook data failed.

Check item	Measures
Setting	Check if there is enough capacity in the HDD and then retry the export.

**[7143] Failed in export of template data**

Classification	Error item
Maintenance error	The export of template data failed.

Check item	Measures
Setting	Check if there is enough capacity in the HDD and then retry the export.

**[7145] Failed in export of mailbox data**

Classification	Error item
Maintenance error	The export of mailbox data failed.

Check item	Measures
Setting	Check if there is enough capacity in the HDD and then retry the export.

**[7149] Failed in export of user information**

Classification	Error item
Maintenance error	The export of user information failed.

Check item	Measures
Setting	Check if there is enough capacity in the HDD and then retry the export.

**[714B] Failed in export of role information**

Classification	Error item
Maintenance error	The export of role information failed.

Check item	Measures
Setting	Check if there is enough capacity in the HDD and then retry the export.

**[714D] Failed in export of department information**

Classification	Error item
Maintenance error	The export of department data failed.

Check item	Measures
Setting	Check if there is enough capacity in the HDD and then retry the export.

#### [714F] Failed in export of ICC profile

Classification	Error item
Maintenance error	The export of ICC profile failed.

Check item	Measures
Setting	Check if there is enough capacity in the HDD and then retry the export.

#### [7151] Failed in export of log data

Classification	Error item
Maintenance error	The export of log data failed.

Check item	Measures
Setting	Check if there is enough capacity in the HDD and the USB media and then retry the export.

#### [715B] Unsuccessful print data converter

Classification	Error item
Maintenance error	The export of print data converter failed.

Check item	Measures
Setting	Check if there is enough capacity in the HDD and then retry the export.

#### [715D] Unsuccessful export of user combined data

Classification	Error item
Maintenance error	The export of combined user information failed.

Check item	Measures
Setting	Check if there is enough capacity in the HDD and then retry the export.

#### [715F] Unsuccessful export of all data (Template / AddressBook / Mailbox)

Classification	Error item
Maintenance error	The export of all data (Template / AddressBook / Mailbox) failed.

Check item	Measures
Setting	Check if there is enough capacity in the HDD and then retry the export.

### [7191] DDNS public key file upload failure

Classification	Error item
Maintenance error	Failed to upload DDNS public key file.

Check item	Measures
Setting	DDNS public key file may have a problem or be corrupted. Check the file and perform the job again.

### [7193] DDNS private key file upload failure

Classification	Error item
Maintenance error	Failed to upload DDNS private key file.

Check item	Measures
Setting	DDNS private key file may have a problem or be corrupted. Check the file and perform the job again.

### [71A2] Unsuccessful addition of CA certificate

Classification	Error item
Maintenance error	Failed to add CA certificate.

Check item	Measures
Setting	CA certificate may have a problem or be corrupted. Check the CA certificate and perform the job again.

### [71A4] Failed in consistency confirmation in cryptographic key

Classification	Error item
Maintenance error	Cryptographic key consistency confirmation failed.

Check item	Measures
Setting	Start up the equipment in the following procedure: HS-73 Firmware Assist > Key Backup / Restore Then overwrite the corrupted license key with a normal one.

### [71A6] Failed to delete device certificate

Classification	Error item
Maintenance error	The deletion of device certificate failed.

Check item	Measures
Setting	Restart the equipment and then retry.

### [71A8] Failed to delete CA certificate

Classification	Error item
Maintenance error	The deletion of the CA certificate failed.

Check item	Measures
Setting	Restart the equipment and then retry.

#### [71AA] Invalid error occurred while getting certificate from SCEP server

Classification	Error item
Maintenance error	Unidentified error occurred during certificate acquisition from SCEP server.

Check item	Measures
Setting	Check SCEP server and the SCEP setting (automatic) on the TopAccess screen as follows: TopAccess Administration > Security > Certificate Management

#### [71AB] Timeout error occurred while getting certificate from SCEP server

Classification	Error item
Maintenance error	Timeout error occurred during certificate acquisition from SCEP server.

Check item	Measures
Setting	Check SCEP server and the SCEP setting (automatic) on the TopAccess screen in the following procedure: TopAccess Administration > Security > Certificate Management

#### [71AC] File save error occurred while getting certificate from SCEP server

Classification	Error item
Maintenance error	File save error occurred during certificate acquisition from SCEP server.

Check item	Measures
Setting	File saving failed for some reason. If the error still occurs after rebooting the equipment, start up using the following procedure: HS-73 Assist mode > Format HDD > Reinstallation of software or HDD replacement

#### [71AD] Failed SCEP operation

Classification	Error item
Maintenance error	SCEP operation is failed.

Check item	Measures
Setting	Check SCEP server and the SCEP setting on the TopAccess menu as follows:[Administration] > [Security] > [Certificate Management] > SCEP (Automatic)

#### [71B0] Software package file decryption failure

Classification	Error item
Maintenance error	Software package file decryption failed.

Check item	Measures
Setting	Software package file may have a problem or may be corrupted. Check the software package file and then reattempt the installation.

#### [71D0] Factory default setting failed

Classification	Error item
Maintenance error	Factory default setting failed.

Check item	Measures
Setting	Restart the equipment and then retry.

#### [71E0] License abnormality due to damage on the license manager database

Classification	Error content
License management	A message which notifies that the license manager database has been restored and the recovery of the license has become possible.

Check item	Measures
Backup data	Restore the backup data with the latest status, including all the activated licenses, are stored. <b>Remarks:</b> Applications with the trial license cannot be recovered from the backup data. If necessary, reinstall the applications.
License	<ul style="list-style-type: none"> <li>If there are no backup data as above, reactivate all the licenses which have been activated in this equipment.</li> <li>If the functions have been activated by the export license file, import the license exported from the host unit of the equipment.</li> </ul>

#### [71F1] Unsuccessful creation of clone file

Classification	Error item
Maintenance error	The creation of a clone file failed.

Check item	Measures
Setting	Check if there is enough capacity in the HDD and the USB media and then retry the creation.

#### [71F3] Failed to import clone file

Classification	Error item
Maintenance error	The import of clone file failed.

Check item	Measures
Setting	The clone file may be invalid. Check the file and then retry the import.

#### [71F4] Failed to decrypt clone file

Classification	Error item
Maintenance error	The decryption of a clone file failed.



Check item	Measures
Setting	The clone file may be invalid or the password may be incorrect. Check the file and the password, and then retry the import.

#### [71F5] Failed to encrypt clone file

Classification	Error item
Maintenance error	The encryption of a clone file failed.

Check item	Measures
Setting	Restart the equipment and then retry the encryption.

#### [7301] Failed to install application

Classification	Error content
Maintenance error	Failed to install application

Check item	Measures
When you install the application, you will see the "The version of framework is old." Did you see the message?	<ul style="list-style-type: none"> <li>Updating System firmware.</li> <li>After updating the system firmware, reinstall the application.</li> </ul>

#### [7402] License activation failure (Online)

Classification	Error content
License management	License activation by means of "Online" has failed.

Check item	Measures
License	Ask the license provider whether the license is correct or not. If the license is not correct, ask the license provider to issue the correct license authentication ID.

#### [7403] License activation failure (network timeout)

#### [7404] License activation failure (network error)

Classification	Error content
License management	License activation by means of "Online" has failed due to a network problem.

Check item	Measures
Network setting	<ul style="list-style-type: none"> <li>Check that the URL for the license server has not been changed. If the URL for the license server has been changed, enter the post-change URL into FS-08-3634 and then reattempt the activation.</li> <li>Ask a user (a network administrator) to check that the value entered in the following code is correct. FS-08-8693~8696</li> </ul>
Network environment	Ask a user (a network administrator) to check whether the following settings are correct. <ul style="list-style-type: none"> <li>The proxy is not filtered.</li> <li>The firewall is set properly.</li> </ul>
License server	Ask the license provider that both servers are working. If they are not working, reattempt the activation after recovering.

### [7412] License deactivation failure (Online)

Classification	Error content
License management	License deactivation by means of "Online" has failed.

Check item	Measures
License server	Ask the license provider whether the license information exists in the server.

### [7423] License deactivation failure (network timeout)

### [7424] License deactivation failure (network error)

Classification	Error content
License management	License deactivation by means of "Online" has failed due to a network problem.

Check item	Measures
Network setting	<ul style="list-style-type: none"><li>• Check that the URL for the license server has not been changed. If the URL for the license server has been changed, enter the post-change URL into FS-08-3634 and then reattempt the activation.</li><li>• Ask a user (a network administrator) to check that the value entered in the following code is correct. FS-08-8693~8696</li></ul>
Network environment	Ask a user (a network administrator) to check whether the following settings are correct. <ul style="list-style-type: none"><li>• The proxy is not filtered.</li><li>• The firewall is set properly.</li></ul>
License server	Ask the license provider that both servers are working. If they are not working, reattempt the deactivation after recovering.

### [7430] Serial number mismatching

Classification	Error content
License management	The serial number registered in the license does not match that for the activated equipment while the license has been activated by means of "Offline".

Check item	Measures
Serial number	Check whether the serial number for the equipment matches the one included in the file name of the license file. If the serial number does not match, perform the activation in the equipment which has a serial number which is included in the file name of the license file.

### [7431] Subnet mismatching

Classification	Error content
License management	The values of the 1st to 3rd octet registered in the license do not match those for the IP address of the equipment in which activation is being performed while the license has been activated by means of "Offline".

Check item	Measures
IP address	If this error has occurred during the activation in the host unit of the equipment, ask the license provider to rerelease the license with the correct information. If this error has occurred during the activation by means of the export license file, check that the values of the 1st to 3rd octet for the IP address of the equipment in which activation is being performed match those for the host unit.

### [7432] Domain mismatching

Classification	Error content
License management	The domain registered in the license does not match that for the equipment while the license has been activated by means of "Offline".

Check item	Measures
IP address	If this error has occurred during the activation in the host unit of the equipment, ask the license provider to rerelease the license with the correct domain. If this error has occurred during the activation by means of the export license file, check that the domain of the equipment in which activation is being performed matches that for the host unit.

### [7433] License certificate ID invalid

Classification	Error content
License management	The license certificate ID format does not match.

Check item	Measures
License	<ul style="list-style-type: none"> <li>If the certificate ID was manually entered, check it. If it is incorrect, enter the correct one.</li> <li>If the certificate ID was selected from the file, check which is correct, the file or the certificate ID. If the file or the certificate file is incorrect, enter the correct one.</li> </ul>

### [7434] License duplicating installation

Classification	Error content
License management	The license to be installed has already been installed.

Check item	Measures
License	<ul style="list-style-type: none"> <li>Check that the license to be installed is correct. If not, install the correct one.</li> <li>Check that the equipment in which the license is installed is correct. Check if the equipment is the one in which the license has already been installed.</li> </ul>

### [7435] Unsupported license activation

Classification	Error content
License management	The license cannot be installed since it is not supported for the equipment.

Check item	Measures
License	Check that the equipment in which the license is installed is correct. Check if the equipment is supported.

#### [7440] Signature mismatching

Classification	Error content
License management	The license file is broken.

Check item	Measures
License server	Ask the license provider to rerelease the license.

#### [7443] License use period expired

Classification	Error content
License management	More than 30 days have passed after the license file or the export license file was created.

Check item	Measures
License created date	If this error has occurred in the host unit of the equipment of the node license or the subnet/domain license, ask the license provider to release the reusable license. If this error has occurred in the export license file, export the license from the host unit again. * The license created date can be checked by the time stamp on the license file.

#### [7444] No license exists

Classification	Error content
License management	License not found.

Check item	Measures
License status	Wait for a while and then reattempt the same operation. If this error has occurred repeatedly and the license is used continuously, deactivate or delete the license and then perform reactivation with the reusable license.

#### [7445] Full of the license

Classification	Error content
License management	Since the number of the licenses registered in this equipment has reached the maximum, new ones cannot be activated.

Check item	Measures
License	Deactivate or delete the licenses which are not being used.

## 8.3.25 Network error

### [8000] IPv4 address conflict

Classification	Error item
Network error	IPv4 address conflict.

Check item	Measures
Setting	Check if the same IP address is not used by another machine.

### [8011] IPv6 link local address conflict

Classification	Error item
Network error	IPv6 link local address conflict.

Check item	Measures
Setting	Check if the same IP address is not used by other machine.

### [8012] IPv6 manual address conflict

Classification	Error item
Network error	IPv6 manual address conflict.

Check item	Measures
Setting	Check if the same IP address is not used by other machine.

### [8013] IPv6 stateless address conflict

Classification	Error item
Network error	IPv6 stateless address conflict.

Check item	Measures
Setting	Check if the same IP address is not used by other machine.

### [8014] IPv6 stateful address conflict

Classification	Error item
Network error	IPv6 stateful address conflict.

Check item	Measures
Setting	Check if the same IP address is not used by other machine.

### [8022] 802.1X authentication failure

Classification	Error item
Network error	Failed in 802.1X authentication.

Check item	Measures
Setting	Check the user credential.

### [8023] Connection failure to an authentication server and a switch

Classification	Error item
Network error	Failed in connection to authentication server and switch.

Check item	Measures
Setting	Check connectivity to switch or server.

### [8024] Failure in verification of certification

Classification	Error item
Network error	Failed in verification of certificate.

Check item	Measures
Setting	Check if a valid certificate is installed.

### [8031] IPsec error for IKEv1 certification failure

Classification	Error item
Network error	IKEv1 certification failed.

Check item	Measures
Setting	Check <ul style="list-style-type: none"><li>• CA and user certificate in both MFP and remote peer - certificate timestamp and IPsec Certificate template should be valid.</li><li>• CRL DP server name is mapped in MFP's host table or DNS entry.</li><li>• Certificate against CRL.</li></ul>

### [8032] IPsec error for wrong proposal selection

Classification	Error item
Network error	IKEv1 wrong proposal chosen.

Check item	Measures
Setting	Check the IKEv1 IPsec proposal parameters (like encryption/ authentication algorithms, DH group, authentication methods) in the MFP and peer machine.

### [8033] IPsec error for shared key authentication failure

Classification	Error item
Network error	IKEv1 shared key authentication failed.

Check item	Measures
Setting	Mismatch in IKEv1 Pre Shared Key. Check the PSK in MFP and remote machine.

**[8034] IPsec error for invalid certificate upload**

Classification	Error item
Network error	IKEv1 invalid certificate.

Check item	Measures
Setting	Check the CA and User certificate in MFP and peer machine.

**[8035] IPsec error for non-supported certification**

Classification	Error item
Network error	IKEv1 certificate not supported.

Check item	Measures
Setting	Check the User certificate type.

**[8036] IPsec error for invalid certification of authentication**

Classification	Error item
Network error	IKEv1 invalid certificate authentication.

Check item	Measures
Setting	Check the CA certificate in MFP and Peer machine.

**[8037] IPsec error for certification disable**

Classification	Error item
Network error	IKEv1 certificate unavailable.

Check item	Measures
Setting	Certificate has been deleted from Certificate store. Re-upload the corresponding certificates.

**[8038] IPsec error for SA is not present**

Classification	Error item
Network error	IKEv1 no SA established.

Check item	Measures
Setting	Check the IKEv1/IPsec proposal parameters (like encryption/ authentication algorithms, DH group, authentication methods) in MFP and peer machine. Check <ul style="list-style-type: none"> <li>• CA and user certificate in both MFP and remote peer - certificate timestamp and IPsec Certificate template.</li> </ul>

**[8039] IPsec error for invalid signature for certification**

Classification	Error item
Network error	IKEv1 invalid signature.

Check item	Measures
Setting	Mismatch in Signature payload (MAC or IV). Check the CA and user certificate in MFP and peer machine.

### [803A] IPsec error for wrong selection of proposal

Classification	Error item
Network error	IKEv2 wrong proposal chosen.

Check item	Measures
Setting	Check the IKEv2/IPsec proposal parameters (encryption/ authentication algorithms, DH group, authentication methods) in MFP and peer machine.

### [803B] IPsec error for IKEv2 certification failure

Classification	Error item
Network error	IKEv2 Certificate failed.

Check item	Measures
Setting	Check <ul style="list-style-type: none"> <li>• CA and user certificate in both MFP and remote peer - certificate timestamp and IPsec Certificate template should be valid.</li> <li>• CRL DP server name is mapped in MFP's host table or DNS entry.</li> <li>• Certificate against CRL.</li> </ul>

### [803C] IKEv2 error for IKEv2 if secret key authentication failed

Classification	Error item
Network error	IKEv2 secret key authentication failed.

Check item	Measures
Setting	Mismatch in IKEv2 Pre Shared Key. Check the PSK in MFP and peer machine.

### [803D] IPsec error if peer does not support IKEv2 and falling back to IKEv1

Classification	Error item
Network error	IKEv2 falling back to IKEv1.

Check item	Measures
Setting	Remote machine does not support IKEv2. Downgrade and use IKEv1.

### [803E] IPsec error if ISAKMP SA is uncreated or destroyed due to some uncertain conditions

Classification	Error item
Network error	IKEv2 ISAKMP SA unavailable.

Check item	Measures
Setting	Restart IPsec service on Peer and retry.



### [803F] IPsec error for IKEv2 if crypto operation failed

Classification	Error item
Network error	IKEv2 cryptographic operation failed.

Check item	Measures
Setting	If Certificates are being used, re-upload the corresponding certificates using Security Services. Restart IPsec Service on MFP.

### [8040] IPsec error for IKEv2 if key info is invalid

Classification	Error item
Network error	IKEv2 invalid key information.

Check item	Measures
Setting	Check IKE settings in MFP and peer.

### [8041] IPsec error for IKEv2 if CA is not trusted

Classification	Error item
Network error	IKEv2 CA not trusted.

Check item	Measures
Setting	Check the CA certificate in MFP and peer machine. Check the CA certificate timestamp.

### [8042] IPsec error for authentication method inconsistency

Classification	Error item
Network error	IKEv2 Authentication method mismatch.

Check item	Measures
Setting	Mismatch in IKE authentication type. Check the Authentication type in MFP and peer.

### [8043] IPsec error for version inconsistency

Classification	Error item
Network error	IPsec IKE version mismatch.

Check item	Measures
Setting	Mismatch in IKE version. Check the IKE version in MFP and peer.

### [8044] IPsec error for encapsulation inconsistency

Classification	Error item
Network error	IPsec encapsulation mismatch.

Check item	Measures
Setting	Check the IPsec mode (Transport/Tunnel) in MFP and peer.

#### [8045] IPsec error for peer IP inconsistency

Classification	Error item
Network error	IPsec peer IP mismatch.

Check item	Measures
Setting	Remote Traffic selector mismatch. Check the destination address/port in IPsec filter.

#### [8046] IPsec error for local IP inconsistency

Classification	Error item
Network error	IPsec local IP mismatch.

Check item	Measures
Setting	Local traffic selector mismatch. Check the source address/port in IPsec filter.

#### [8047] IPsec error for local ID inconsistency

Classification	Error item
Network error	IPsec local ID mismatch.

Check item	Measures
Setting	Check the user certificate in MFP

#### [8048] IPsec error for remote ID inconsistency

Classification	Error item
Network error	IPsec remote ID mismatch.

Check item	Measures
Setting	Check the user certificate in peer machine.

#### [8049] IPsec error for remote IP inconsistency

Classification	Error item
Network error	IPsec remote IP mismatch.

Check item	Measures
Setting	Remote traffic selector mismatch. Check the source address/port in IPsec filter.

#### [804A] IPsec error for IKEv2 timeout

Classification	Error item
Network error	IPsec IKEv1 / IKEv2 timeout.

Check item	Measures
Setting	Check the network connectivity between MFP and peer machine. Select the Flush Connections Option and retry.

#### [804B] IPsec error for invalid of ID manual key

Classification	Error item
Network error	IPsec invalid manual key.

Check item	Measures
Setting	Check the Inbound and Outbound (ESP Encryption/Authentication and AH Authentication) keys in MFP and Remote PC.

- [8061] Update error for secure primary DDNS
- [8062] Update error for secure secondary DDNS
- [8063] Update error for IPv6 secure primary DDNS
- [8064] Update error for IPv6 secure secondary DDNS
- [8065] Update error for IPv6 primary DDNS
- [8066] Update error for IPv6 secondary DDNS
- [8067] Update error for IPv4 primary DDNS
- [8068] Update error for IPv4 secondary DDNS

Classification	Error item
Network error	[8061] Secure update to primary IPv4 server failed. [8062] Secure update to secondary IPv4 server failed. [8063] Secure update to primary IPv6 server failed. [8064] Secure update to secondary IPv6 server failed. [8065] IPv6 primary DDNS update error. [8066] IPv6 secondary DDNS update error. [8067] IPv4 primary DDNS update error. [8068] IPv4 secondary DDNS update error.

Check item	Measures
Setting	Check if there is any problem with DNS or DDNS settings.

#### [8069] This message is displayed when the key file for SIG(0) or TSIG is invalid

Classification	Error item
Network error	This message is displayed when the key file for SIG(0) or TSIG is invalid.

Check item	Measures
Setting	Verify the TSIG/SIG(0) key files used.

#### [80B1] Bluetooth connection failure

Classification	Error item
Network error	Bluetooth connection failure.

Check item	Measures
Wireless LAN/Bluetooth module connection status	Check the connection of the wireless LAN/Bluetooth module.

**[80C0] TLS session establishment failure (invalid message)**

Classification	Error item
Network error	An inappropriate message has been received.

Check item	Measures
Setting	Check the SSL/TLS settings of a connect-to server. Check the SSL certificate installed in the equipment.

**[80C1] TLS session establishment failure (invalid MAC data)**

Classification	Error item
Network error	Invalid MAC data have been received.

Check item	Measures
Setting	Check the SSL/TLS settings of a connect-to server. Check the SSL certificate installed in the equipment.

**[80C2] TLS session establishment failure (decoding failure)**

Classification	Error item
Network error	TLSCiphertext data structure has been encoded by an invalid method.

Check item	Measures
Setting	Check the SSL/TLS settings of a connect-to server. Check the SSL certificate installed in the equipment.

**[80C3] TLS session establishment failure (recording length abnormality)**

Classification	Error item
Network error	A TLSCiphertext record whose size is $2^{14}+2048$ bytes or more has been received. Or, decoding to a TLSCompressed record whose size is $2^{14}+2048$ bytes or more has been carried out.

Check item	Measures
Setting	Check the SSL/TLS settings of a connect-to server. Check the SSL certificate installed in the equipment.

**[80C4] TLS session establishment failure (data decompression failure)**

Classification	Error item
Network error	Data (output) with an invalid expansion function have been received. (E.g.: Data with length exceeded)

Check item	Measures
Setting	Check the SSL/TLS settings of a connect-to server. Check the SSL certificate installed in the equipment.

**[80C5] TLS session establishment failure (handshake failure)**

Classification	Error item
Network error	A handshake_failure alert message has been received.

Check item	Measures
Setting	Check the SSL/TLS settings of a connect-to server. Check the SSL certificate installed in the equipment.

#### [80C6] TLS session establishment failure (certificate abnormality)

Classification	Error item
Network error	A certificate has been broken. Or, a signature which cannot be verified properly has been included.

Check item	Measures
Setting	Check the SSL certificate installed in the equipment.

#### [80C7] TLS session establishment failure (non-support certificate)

Classification	Error item
Network error	The type of the certificate has not been supported.

Check item	Measures
Setting	Check the SSL certificate installed in the equipment.

#### [80C8] TLS session establishment failure (invalid certificate)

Classification	Error item
Network error	The certificate has been disabled by its signer.

Check item	Measures
Setting	Check the SSL certificate installed in the equipment.

#### [80C9] TLS session establishment failure (certificate with validity date expired)

Classification	Error item
Network error	The validity date of the certificate has expired.

Check item	Measures
Setting	Check the SSL certificate installed in the equipment.

#### [80CA] TLS session establishment failure (certificate process error)

Classification	Error item
Network error	Since a non-specified problem has occurred, the certification process has failed.

Check item	Measures
Setting	Check the SSL certificate installed in the equipment.

**[80CB] TLS session establishment failure (invalid parameter)**

Classification	Error item
Network error	The acceptable range of the field for handshake has been exceeded. Or, an inconsistency between another field has occurred.

Check item	Measures
Setting	Check the SSL/TLS settings of a connect-to server. Check the SSL certificate installed in the equipment.

**[80CC] TLS session establishment failure (unknown CA certificate)**

Classification	Error item
Network error	A valid certificate chain or a part of the chain has been received; however, there is no CA certificate. Or, a certificate could not be received since it does not match the already-known relied CA.

Check item	Measures
Setting	Check the SSL certificate installed in the equipment.

**[80CD] TLS session establishment failure (access rejection)**

Classification	Error item
Network error	Although a valid certificate has been received, a connect-to server has rejected the access when access control was applied.

Check item	Measures
Setting	Check the SSL/TLS settings of a connect-to server.

**[80CE] TLS session establishment failure (decoding error)**

Classification	Error item
Network error	A value in the field is outside of the range. Or, a message could be decoded since its length was inappropriate.

Check item	Measures
Setting	Check the SSL/TLS settings of a connect-to server. Check the SSL certificate installed in the equipment.

**[80CF] TLS session establishment failure (decoding error)**

Classification	Error item
Network error	A handshake encryption process has failed.

Check item	Measures
Setting	Check the SSL/TLS settings of a connect-to server. Check the SSL certificate installed in the equipment.

**[80D0] TLS session establishment failure (export restrictions)**

Classification	Error item
Network error	A negotiation which does not comply with the export restrictions of the regulation has been detected.

Check item	Measures
Setting	Check the SSL/TLS settings of a connect-to server. Check the SSL certificate installed in the equipment.

**[80D1] TLS session establishment failure (non-support protocol version)**

Classification	Error item
Network error	Unsupported versions of the TLS protocol have been recognized.

Check item	Measures
Setting	Check that the communication with a client, server or external applications is made using the supported TLS protocol (only TLS1.2 available as of 2020) in the SSL/TLS settings. Check the SSL/TLS certificate installed in the equipment.

**[80D2] TLS session establishment failure (internal error)**

Classification	Error item
Network error	A process cannot be continued due to an internal error.

Check item	Measures
Setting	Check the SSL/TLS settings of a connect-to server. Check the SSL certificate installed in the equipment.

**[80D3] TLS session establishment failure (cancellation by a user)**

Classification	Error item
Network error	A handshake has been canceled for a reason other than a protocol error.

Check item	Measures
Setting	Check the SSL/TLS settings of a connect-to server. Check the SSL certificate installed in the equipment.

**[80D4] TLS session establishment failure (invalid renegotiation)**

Classification	Error item
Network error	The following items are improper. - A client response to a HelloRequest message. - A server response to a ClientHello message received after the first handshake. - Renegotiation performed later.

Check item	Measures
Setting	Check the SSL/TLS settings of a connect-to server. Check the SSL certificate installed in the equipment.

**[8101] Wireless connection in the Access point failure**

Classification	Error item
Network error	Wireless connection in the Access point failure.

Check item	Measures
Setting	Verify the credentials used for association with Access point.

**[8102] Connection of MFP to the Access point with a specified SSID failure**

Classification	Error item
Network error	Connection of MFP to the Access point with a specified SSID failure.

Check item	Measures
Setting	Verify the access point name setting and mechanism used for association same as Access Point setting.

**[8103] Wireless certificate verification failure**

Classification	Error item
Network error	Wireless certificate verification failure.

Check item	Measures
Setting	Verify the certificate settings used for association.

**[8104] Wireless LAN / Bluetooth module hardware error**

Classification	Error item
Network error	Wireless LAN / Bluetooth module hardware error.

Check item	Measures
Wireless LAN/Bluetooth module	Check the connection of the wireless LAN/Bluetooth module. Replace the wireless LAN/Bluetooth module.

**[8121] Domain: Authentication failure**

Classification	Error item
Network error	An unknown domain authentication error occurs when connecting to the domain controller.

Check item	Measures
Setting	Check the network configuration of this equipment and then reconnect to the domain controller.

**[8122] Domain: Invalid user name or password**

Classification	Error item
Network error	The user name or password of the domain authentication is not valid and the user cannot log on.



Check item	Measures
Setting	Check if the user name and the password for this equipment are correct. Specify upper- and lower-case characters correctly when you enter them.

### [8123] Domain: Invalid server

Classification	Error item
Network error	The server cannot be detected at domain authentication.

Check item	Measures
Setting	Check if the server is down or the network configuration of this equipment is correct. If domain name resolution is used, check the DNS and DDNS settings.

### [8124] Domain: Invalid user account

Classification	Error item
Network error	The user account is invalid at domain authentication and it cannot be used to log on.

Check item	Measures
Setting	Check the setting to see if the user account noted in the Active Directory Users and Computers window is valid.

### [8125] Domain: Expired user account (cannot be used for logon)

Classification	Error item
Network error	The user account has expired at domain authentication and it cannot be used to log on.

Check item	Measures
Setting	Check the setting to see if the user account noted in the Active Directory Users and Computers window is not expired.

### [8126] Domain: Locked user account (cannot be used for logon)

Classification	Error item
Network error	The user account is locked at domain authentication and it cannot be used to log on.

Check item	Measures
Setting	Check the account lockout setting of the server.

### [8127] Domain: Invalid logon time

Classification	Error item
Network error	The user logon time is invalid at domain authentication and the user cannot logon.

Check item	Measures
Setting	Check the logon hour setting for the user account noted in the Active Directory Users and Computers window.

**[8128] Active directory domain: Clock skew error (due to difference in time between the server and the MFP)**

Classification	Error item
Network error	The difference between the time set in the equipment and that set in the server is more than five minutes at domain authentication of the Active Directory and the user cannot log on.

Check item	Measures
Setting	Set the time of this equipment and that of the domain controller the same. SNTP is recommended if there is an SNTP server in the network.

**[8129] Active directory domain: Expired Kerberos ticket (cannot be used for authentication)**

Classification	Error item
Network error	A Kerberos ticket has expired at the domain authentication of the Active Directory and the user cannot log on.

Check item	Measures
Setting	Check if the Kerberos ticket on the Kerberos server is expired.

**[812A] Active directory domain: Kerberos ticket authentication failure**

Classification	Error item
Network error	A Kerberos ticket authentication error of the Active Directory domain authentication occurs and the user cannot log on.

Check item	Measures
Setting	Check if the user name and the password for this equipment are correct. If the error still occurs, ask your Windows Server administrator.

**[812B] Active directory domain: Invalid realm name**

Classification	Error item
Network error	The realm name for the domain authentication of the Active Directory is invalid and the user cannot log on.

Check item	Measures
Setting	Check if the realm name of this equipment for the Active Directory server is correct. If the error still occurs, ask your Windows Server administrator.

## 8.3.26 FAX error

### [0012] Original jam

Classification	Error item
Fax	The Fax transmission has failed since an original was misfed in the DF while a Fax job was being sent.

Check item	Measures
Setting	Remove the misfed original and reattempt the Fax transmission.

### [0013] Cover is open

Classification	Error item
Fax	The Fax transmission has failed since the cover of the equipment or options that process paper was opened.

Check item	Measures
Setting	Close the cover and reattempt the Fax transmission.

### [0020] Power failure Transmission

Classification	Error item
Fax	The Fax transmission has failed due to a power failure.

Check item	Measures
Setting	Reattempt the Fax transmission.

### Reception

Classification	Error item
Fax	The Fax reception has failed due to a power failure.

Check item	Measures
Setting	Reattempt the Fax reception.

### Transmission

Classification	Error item
IP Fax	The IP Fax transmission has failed due to a power failure.

Check item	Measures
Setting	Reattempt the IP Fax transmission.

### Reception

Classification	Error item
IP Fax	The IP Fax reception has failed due to a power failure.

Check item	Measures
Setting	Reattempt the IP Fax reception.

### [0030] Recording paper jam

Classification	Error item
Fax	The Fax transmission has been stopped due to the following reason. <ul style="list-style-type: none"><li>• Paper misfeeding occurred with another job.</li><li>• A Fax job was canceled.</li></ul>

Check item	Measures
Setting	In the case of paper misfeeding, remove it and reattempt the Fax transmission.

### [0033] Polling error

Classification	Error item
Fax	The polling reception has failed due to the following reason. <ul style="list-style-type: none"><li>• A polling original was not set on the other side's device.</li><li>• The security setting between this equipment and the other side's device did not match.</li></ul>

Check item	Measures
Setting	Take the following action and reattempt the polling reception. <ul style="list-style-type: none"><li>• Ask to set the polling original on the other side's device.</li><li>• Make the security setting matched between this equipment and the other side's device.</li></ul>

### [0040] Modem communication error Transmission

Classification	Error item
Fax	The Fax transmission has failed since the modem could not send the signal properly.

Check item	Measures
Setting	Reattempt the Fax transmission.

### Reception

Classification	Error item
Fax	The Fax reception has failed since the modem could not receive the signal properly.

Check item	Measures
Setting	Reattempt the Fax reception.

## [0042] Memory full

Classification	Error item
Fax	The Fax reception has been canceled since the capacity shortage or an abnormality occurred in the storage while a Fax job was being received. (Pages which are received successfully will be printed out.)

Check item	Measures
Setting	Take the following action and reattempt the Fax reception. <ul style="list-style-type: none"><li>• In the case of a capacity shortage, free up the memory space.</li><li>• In the case of an abnormality, replace the storage.</li></ul>

Classification	Error item
IP Fax	The IP Fax reception has been canceled since the capacity shortage or an abnormality occurred in the storage while an IP Fax job was being received. (Pages which are received successfully will be printed out.)

Check item	Measures
Setting	Take the following action and reattempt the IP Fax reception. <ul style="list-style-type: none"><li>• In the case of a capacity shortage, free up the memory space.</li><li>• In the case of an abnormality, replace the storage.</li></ul>

## [0050] Line is busy

Classification	Error item
Fax	Since the line of the other side's device was busy, the Fax transmission has failed even though the redialing was carried out by the maximum number of specified times.

Check item	Measures
Setting	Reattempt the Fax transmission. Increase the number of redialing times if required.

## [0051] No cable connected for Fax line

Classification	Error item
Fax	The Fax transmission has failed since no cable for the Fax line was connected.

Check item	Measures
Setting	Connect a cable for the Fax line and reattempt the Fax transmission.

## [0052] T1 time-out

Classification	Error item
Fax	The Fax transmission has failed since NSF / DIS could not be detected. (Memory transmission)

Check item	Measures
Setting	Check that the other side's device is answering in the Fax mode and reattempt the Fax transmission.

Classification	Error item
IP Fax	The IP Fax transmission has failed since NSF / DIS could not be detected. (Memory transmission)

Check item	Measures
Setting	Check that the other side's device is answering in the Fax mode and reattempt the IP Fax transmission.

## [00B0] Initial signal not detected

Classification	Error item
Fax	The Fax transmission has failed since NSF / DIS could not be detected. (Direct transmission)

Check item	Measures
Setting	Check that the other side's device is answering in the Fax mode and reattempt the Fax transmission.

## [00B1] Terminal constants not compatible

### Transmission

Classification	Error item
Fax	The Fax transmission has failed since the other side's device did not have the capability which was transferred by NSF / DIS on this equipment.

Check item	Measures
Setting	Check the capability of the other side's device and reattempt the Fax transmission by using a receivable mode for it.

### Reception

Classification	Error item
Fax	The Fax reception has failed since NSS / DCS, which was a capability other than the ones transferred by NSF / DIS on this equipment, was received.

Check item	Measures
Setting	Check the capability of this equipment and reattempt the Fax reception by using a receivable mode for it.

### Transmission

Classification	Error item
IP Fax	The IP Fax transmission has failed since the other side's device did not have the capability which was transferred by NSF / DIS on this equipment.

Check item	Measures
Setting	Check the capability of the other side's device and reattempt the IP Fax transmission by using a receivable mode for it.

### Reception

Classification	Error item
IP Fax	The IP Fax job reception has failed since NSS / DCS, which was a capability other than the ones transferred by NSF / DIS on this equipment, was received.

Check item	Measures
Setting	Check the capability of this equipment and reattempt the IP Fax reception by using a receivable mode for it.

### [00B2] Reception of DCN (Phase B) Transmission

Classification	Error item
Fax	The Fax transmission has failed since DCN was sent in Phase B.

Check item	Measures
Setting	Reattempt the Fax transmission.

### Reception

Classification	Error item
Fax	The Fax reception has failed since DCN was received in Phase B.

Check item	Measures
Setting	Reattempt the Fax reception.

### Transmission

Classification	Error item
IP Fax	The IP Fax transmission has failed since DCN was sent in Phase B.

Check item	Measures
Setting	Reattempt the IP Fax transmission.

### Reception

Classification	Error item
IP Fax	The IP Fax reception has failed since DCN was received in Phase B.

Check item	Measures
Setting	Reattempt the IP Fax reception.

**[00B3] DCS / DTC not detected**

Classification	Error item
Fax	The Fax reception has failed since DCS / DTC could not be detected.

Check item	Measures
Setting	Reattempt the Fax reception.

**Transmission**

Classification	Error item
IP Fax	The IP Fax transmission has failed since DCS / DTC could not be detected.

Check item	Measures
Setting	Reattempt the IP Fax transmission.

**Reception**

Classification	Error item
IP Fax	The IP Fax reception has failed since DCS / DTC could not be detected.

Check item	Measures
Setting	Reattempt the IP Fax reception.

**[00B4] Training error****Transmission**

Classification	Error item
Fax	This equipment has performed fall-back but the Fax transmission has failed.

Check item	Measures
Setting	Adjust the attenuator and link equalizer of this equipment and the other side's device and reattempt the Fax transmission.

**Reception**

Classification	Error item
Fax	The Fax reception has failed since after receiving FTT, the receiver has received a timeout or DCN.

Check item	Measures
Setting	Adjust the attenuator and link equalizer of this equipment and the other side's device and reattempt the Fax reception.

**Transmission**

Classification	Error item
IP Fax	This equipment has performed fall-back but the IP Fax transmission has failed.



Check item	Measures
Setting	Check the following items and reattempt the IP Fax transmission. <ul style="list-style-type: none"> <li>This equipment and the other side's device are connected to a network properly.</li> <li>If the other side's device is in the Fax mode, its attenuator and link equalizer are adjusted properly.</li> </ul>

## Reception

Classification	Error item
IP Fax	The IP Fax reception has failed since after receiving FTT, the receiver has received a timeout or DCN.

Check item	Measures
Setting	Check the following items and reattempt the IP Fax reception. <ul style="list-style-type: none"> <li>This equipment and the other side's device are connected to a network properly.</li> <li>If the other side's device is in the Fax mode, its attenuator and link equalizer are adjusted properly.</li> </ul>

## [00B5] CFR not detected

Classification	Error item
Fax	The Fax transmission has failed since a training signal has been sent out but CFR could not be detected.

Check item	Measures
Setting	Adjust the attenuator and link equalizer of this equipment and the other side's device and reattempt the Fax transmission.

Classification	Error item
IP Fax	The IP Fax transmission has failed since a training signal has been sent out but CFR could not be detected.

Check item	Measures
Setting	Check the following items and reattempt the IP Fax transmission. <ul style="list-style-type: none"> <li>The network of this equipment is functioning properly.</li> <li>The IP Fax function of this equipment is set properly.</li> <li>If the other side's device is in the Fax mode, its attenuator and link equalizer are adjusted properly.</li> </ul>

## [00B6] No response made to CTC

Classification	Error item
Fax	The Fax transmission has failed since no response was made to CTC.

Check item	Measures
Setting	Adjust the attenuator and link equalizer of this equipment and the other side's device and reattempt the Fax transmission.

## Transmission

Classification	Error item
IP Fax	The IP Fax transmission has failed since no response was made to CTC.

Check item	Measures
Setting	Check the following items and reattempt the IP Fax transmission. <ul style="list-style-type: none"> <li>• The network of this equipment is functioning properly.</li> <li>• The IP Fax function of this equipment is set properly.</li> <li>• If the other side's device is in the Fax mode, its attenuator and link equalizer are adjusted properly.</li> </ul>

### Reception

Classification	Error item
IP Fax	The IP Fax reception has failed since DCN was received during ECM transmission.

Check item	Measures
Setting	Check the following items and reattempt the IP Fax reception. <ul style="list-style-type: none"> <li>• The network of this equipment is functioning properly.</li> <li>• The IP Fax function of this equipment is set properly.</li> <li>• If the other side's device is in the Fax mode, its attenuator and link equalizer are adjusted properly.</li> </ul>

### [00B7] Phase B cannot be completed Transmission

Classification	Error item
Fax	The Fax transmission has failed since a modem error or a sequence error in the FAX Unit occurred.

Check item	Measures
Setting	Reattempt the Fax transmission. If the error persists, replace the FAX Unit.

### Reception

Classification	Error item
Fax	The Fax reception has failed since a modem error or a sequence error in the FAX Unit occurred.

Check item	Measures
Setting	Reattempt the Fax reception. If the error persists, replace the FAX Unit.

### Transmission

Classification	Error item
IP Fax	The IP Fax transmission has failed since an error occurred in the system.

Check item	Measures
Setting	Reboot this equipment and reattempt the IP Fax transmission.

### Reception

Classification	Error item
IP Fax	The IP Fax reception has failed since an error occurred in the system.

Check item	Measures
Setting	Reboot this equipment and reattempt the IP Fax reception.

### [00C0] Image signal carrier not detected

Classification	Error item
Fax	The Fax reception has failed since this equipment has failed to detect a carrier.

Check item	Measures
Setting	Adjust the attenuator and link equalizer of this equipment and the other side's device and reattempt the Fax reception.

### [00C1] High-speed signal not detected

Classification	Error item
Fax	The Fax reception has failed since this equipment has failed to detect a high-speed signal.

Check item	Measures
Setting	Adjust the attenuator and link equalizer of this equipment and the other side's device and reattempt the Fax reception.

Classification	Error item
IP Fax	The IP Fax reception has failed since this equipment has failed to detect a high-speed signal.

Check item	Measures
Setting	Check the following items and reattempt the IP Fax reception. <ul style="list-style-type: none"><li>• The network of this equipment and the other side's device is functioning properly.</li><li>• The IP Fax function of this equipment is set properly.</li><li>• If the other side's device is in the Fax mode, its attenuator and link equalizer are adjusted properly.</li></ul>

### [00C2] Image signal carrier disconnected Transmission

Classification	Error item
Fax	The Fax transmission has failed since a carrier disconnection was detected after the image signal was picked up by the other side's device.

Check item	Measures
Setting	Reattempt the Fax transmission.

### Reception

Classification	Error item
Fax	The Fax reception has failed since a carrier disconnection was detected after the image signal was picked up by this equipment.

Check item	Measures
Setting	Reattempt the Fax reception.

Classification	Error item
IP Fax	The IP Fax reception has failed since a carrier disconnection was detected after the image signal was picked up by this equipment.

Check item	Measures
Setting	Reattempt the IP Fax reception.

#### [00C4] EOL time-out

Classification	Error item
Fax	The Fax reception has failed since this equipment could not detect EOL or not decode with MMR.

Check item	Measures
Setting	Reattempt the Fax reception.

#### [00C5] Excess length of data received

Classification	Error item
Fax	The Fax reception has failed due to the disconnection of the communication since the length of the received original exceeded 2 m.

Check item	Measures
Setting	Ask to make the length of the original 2 m or less and reattempt the Fax reception.

Classification	Error item
IP Fax	The IP Fax reception has failed due to the disconnection of the communication since the length of the received original exceeded 2 m.

Check item	Measures
Setting	Ask to make the length of the original 2 m or less and reattempt the IP Fax reception.

#### [00C6] Image code conversion error

Classification	Error item
Fax	The Fax reception has failed since the conversion of the received image went wrong.

Check item	Measures
Setting	Reattempt the Fax reception.

Classification	Error item
IP Fax	The IP Fax reception has failed since the conversion of the received image went wrong.

Check item	Measures
Setting	Reattempt the IP Fax reception.

**[00C7] Phase C cannot be completed****Transmission**

Classification	Error item
Fax	The Fax transmission has failed since a modem error or a sequence error in the FAX Unit occurred.

Check item	Measures
Setting	Reattempt the Fax transmission. If the error persists, replace the FAX Unit.

**Reception**

Classification	Error item
Fax	The Fax reception has failed since a modem error or a sequence error in the FAX Unit occurred.

Check item	Measures
Setting	Reattempt the Fax reception. If the error persists, replace the FAX Unit.

**Transmission**

Classification	Error item
IP Fax	The IP Fax transmission has failed since a system error or a sequence error occurred.

Check item	Measures
Setting	Reboot this equipment and reattempt the IP Fax transmission.

**Reception**

Classification	Error item
IP Fax	The IP Fax reception has failed since a system error or a sequence error occurred.

Check item	Measures
Setting	Reboot this equipment and reattempt the IP Fax reception.

**[00C8] Transmitted image was not made in time**

Classification	Error item
IP Fax	The IP Fax transmission has failed due to the disconnection of the communication from the other side's device since the notification of the transmitted image was not made in time.

Check item	Measures
Setting	Reattempt the IP Fax transmission.

**[00D0] Post message not detected****Transmission**

Classification	Error item
Fax	The Fax transmission has failed since this equipment could not detect an MCF, RTP, RTN, PIN or PIP or the other side's device could not detect MPS, EOM or EOP.

Check item	Measures
Setting	Reattempt the Fax transmission.

**Reception**

Classification	Error item
Fax	The Fax reception has failed since the other side's device could not detect an MCF, RTP, RTN, PIN or PIP or this equipment could not detect MPS, EOM or EOP.

Check item	Measures
Setting	Reattempt the Fax reception.

**Transmission**

Classification	Error item
IP Fax	The IP Fax transmission has failed since this equipment could not detect an MCF, RTP, RTN, PIN or PIP or the other side's device could not detect MPS, EOM or EOP.

Check item	Measures
Setting	Reattempt the IP Fax transmission.

**Reception**

Classification	Error item
IP Fax	The IP Fax reception has failed since the other side's device could not detect an MCF, RTP, RTN, PIN or PIP or this equipment could not detect MPS, EOM or EOP.

Check item	Measures
Setting	Reattempt the IP Fax reception.

**[00D1] Reception of DCN**

Classification	Error item
Fax	The Fax reception has failed since DCN was received.

Check item	Measures
Setting	Reattempt the Fax reception.

**Transmission**

Classification	Error item
IP Fax	The IP Fax transmission has failed since DCN was received.

Check item	Measures
Setting	Reattempt the IP Fax transmission.

## Reception

Classification	Error item
IP Fax	The IP Fax reception has failed since DCN was received.

Check item	Measures
Setting	Reattempt the IP Fax reception.

## [00D2] Poor image quality

### Transmission

Classification	Error item
Fax	The Fax transmission has failed since the quality of the received image was poor in the other side's device.

Check item	Measures
Setting	Reattempt the Fax transmission.

## Reception

Classification	Error item
Fax	The Fax reception has failed since the quality of the received image was poor.

Check item	Measures
Setting	Reattempt the Fax reception.

### Transmission

Classification	Error item
IP Fax	The IP Fax transmission has failed since the quality of the received image was poor in the other side's device.

Check item	Measures
Setting	Check the following items and reattempt the IP Fax transmission. <ul style="list-style-type: none"><li>• The network of this equipment and the other side's device is functioning properly.</li><li>• The IP Fax function of this equipment is set properly.</li></ul>

## Reception

Classification	Error item
IP Fax	The IP Fax reception has failed since the quality of the received image was poor.

Check item	Measures
Setting	Check the following items and reattempt the IP Fax reception. <ul style="list-style-type: none"><li>• The network of this equipment and the other side's device is functioning properly.</li><li>• The IP Fax function of this equipment is set properly.</li></ul>

**[00D3] No response made to EOR**

Classification	Error item
Fax	The Fax transmission has failed since no response was made to EOR or DCN was received during ECM transmission.

Check item	Measures
Setting	Ask to adjust the attenuator and link equalizer of the other side's device and reattempt the Fax transmission.

Classification	Error item
IP Fax	The IP Fax transmission has failed since no response was made to EOR or DCN was received during ECM transmission.

Check item	Measures
Setting	Check the following items and reattempt the IP Fax transmission. <ul style="list-style-type: none"> <li>• The network of this equipment device is functioning properly.</li> <li>• The IP Fax function of this equipment is set properly.</li> <li>• If the other side's device is in the Fax mode, its attenuator and link equalizer are adjusted properly.</li> </ul>

**[00D4] No response made to RR**

Classification	Error item
Fax	The Fax transmission has failed since no response was made to RR or DCN was received during ECM transmission.

Check item	Measures
Setting	Ask to adjust the attenuator and link equalizer of the other side's device and reattempt the Fax transmission.

Classification	Error item
IP Fax	The IP Fax transmission has failed since no response was made to RR or DCN was received during ECM transmission.

Check item	Measures
Setting	Check the following items and reattempt the IP Fax transmission. <ul style="list-style-type: none"> <li>• The network of this equipment device is functioning properly.</li> <li>• The IP Fax function of this equipment is set properly.</li> <li>• If the other side's device is in the Fax mode, its attenuator and link equalizer are adjusted properly.</li> </ul>

**[00D5] T5 time-out**

Classification	Error item
Fax	The Fax transmission has failed since RNR-RR was repeated and the line was disconnected due to timeout during ECM transmission.

Check item	Measures
Setting	Reattempt the Fax transmission. If the error persists, check whether the other side's device can output MCF or not.



### [00D6] ERR returned to EOR

Classification	Error item
Fax	The Fax reception has failed due to the bad condition of the communication.

Check item	Measures
Setting	Reattempt the Fax reception.

Classification	Error item
IP Fax	The IP Fax reception has failed due to the bad condition of the communication.

Check item	Measures
Setting	Check the following items and reattempt the IP Fax reception. <ul style="list-style-type: none"><li>• The network of this equipment and the other side's device is functioning properly.</li><li>• The IP Fax function of this equipment is set properly.</li></ul>

### [00D7] Line disconnected by transmission of EOR

Classification	Error item
Fax	The Fax transmission has failed since the line was disconnected after EOR was sent by this equipment during ECM transmission.

Check item	Measures
Setting	Adjust the attenuator and link equalizer of this equipment and reattempt the Fax transmission.

Classification	Error item
IP Fax	The IP Fax transmission has failed since the line was disconnected after EOR was sent by this equipment during ECM transmission.

Check item	Measures
Setting	Check the following items and reattempt the IP Fax transmission. <ul style="list-style-type: none"><li>• The network of this equipment and the other side's device is functioning properly.</li><li>• The IP Fax function of this equipment is set properly.</li></ul>

### [00D8] Time-out between FCD frame

Classification	Error item
Fax	The Fax reception has failed since a time-out occurred between the FCD frames.

Check item	Measures
Setting	Reattempt the Fax reception.

**[00DA] MCF not returned**

Classification	Error item
Fax	The Fax reception has failed since MCF could not be returned from this equipment.

Check item	Measures
Setting	Reattempt the Fax reception.

Classification	Error item
IP Fax	The IP Fax reception has failed since MCF could not be returned from this equipment.

Check item	Measures
Setting	Reattempt the IP Fax reception.

**[00E8] HDD error  
Transmission**

Classification	Error item
Fax	The Fax transmission has failed due to a defective HDD.

Check item	Measures
Setting	Reattempt the Fax transmission. If the error persists, replace the HDD.

**Reception**

Classification	Error item
Fax	The Fax reception has failed due to a defective HDD.

Check item	Measures
Setting	Reattempt the Fax reception. If the error persists, replace the HDD.

**Transmission**

Classification	Error item
IP Fax	The IP Fax transmission has failed due to a defective HDD.

Check item	Measures
Setting	Reattempt the IP Fax transmission. If the error persists, replace the HDD.

**Reception**

Classification	Error item
IP Fax	The IP Fax reception has failed due to a defective HDD.

Check item	Measures
Setting	Reattempt the IP Fax reception. If the error persists, replace the HDD.

**[00F0] Software trouble****Transmission**

Classification	Error item
Fax	The Fax transmission has failed due to defective software.

Check item	Measures
Setting	Reinstall the Fax firmware. If the error persists, replace the Fax unit.

**Reception**

Classification	Error item
Fax	The Fax reception has failed due to defective software.

Check item	Measures
Setting	Reinstall the Fax firmware. If the error persists, replace the Fax unit.

**Transmission**

Classification	Error item
IP Fax	The IP Fax transmission has failed due to defective software.

Check item	Measures
Setting	Check that the IP Fax function of this equipment is set properly. Reboot this equipment and reattempt the IP Fax transmission.

**Reception**

Classification	Error item
IP Fax	The IP Fax reception has failed due to defective software.

Check item	Measures
Setting	Check that the IP Fax function of this equipment is set properly. Reboot this equipment and reattempt the IP Fax reception.

**[00F1] Hardware noise****Transmission**

Classification	Error item
Fax	The Fax transmission has failed due to defective hardware.

Check item	Measures
Setting	<ul style="list-style-type: none"> <li>• Reboot this equipment and reattempt the Fax transmission.</li> <li>• Reinstall the Fax firmware.</li> <li>• If the error persists, replace the Fax unit.</li> </ul>

**Reception**

Classification	Error item
Fax	The Fax reception has failed due to defective hardware.

Check item	Measures
Setting	<ul style="list-style-type: none"> <li>• Reboot this equipment and reattempt the Fax reception.</li> <li>• Reinstall the Fax firmware.</li> <li>• If the error persists, replace the Fax unit.</li> </ul>

#### [00F4] Software trouble (FAX Unit)

##### Transmission

Classification	Error item
Fax	The Fax transmission has failed due to defective software.

Check item	Measures
Setting	<ul style="list-style-type: none"><li>• Reboot this equipment and reattempt the Fax transmission.</li><li>• Reinstall the Fax firmware.</li><li>• If the error persists, replace the FAX Unit.</li></ul>

##### Reception

Classification	Error item
Fax	The Fax reception has failed due to defective software.

Check item	Measures
Setting	<ul style="list-style-type: none"><li>• Reboot this equipment and reattempt the Fax reception.</li><li>• Reinstall the Fax firmware.</li><li>• If the error persists, replace the Fax unit.</li></ul>

#### [0101] Response TimeOut (Registration)

Classification	Error item
IP Fax	A time-out has occurred since there was no response from an SIP server. (Register)

Check item	Measures
Setting	Check the setting of the network or the SIP server.

#### [0102] Response TimeOut (Invite)

Classification	Error item
IP Fax	The IP Fax transmission has failed due to a time-out since there was no response from an SIP server. (Invite)

Check item	Measures
Setting	Reattempt the IP Fax transmission. If the error persists, check the network or the server setting and recipient information.

#### [0103] "Multiple Choices" Received

Classification	Error item
IP Fax	The registration to an SIP server has failed due to an error. (Multiple Choices)

Check item	Measures
Setting	Check the setting of the network or the SIP server.

**[0104] “Moved Permanently” Received**

Classification	Error item
IP Fax	The registration to an SIP server has failed due to an error. (Moved Permanently)

Check item	Measures
Setting	Check the setting of the network or the SIP server.

**[0105] “Moved Temporarily” Received**

Classification	Error item
IP Fax	The registration to an SIP server has failed due to an error. (Moved Temporarily)

Check item	Measures
Setting	Check the setting of the network or the SIP server.

**[0106] “Use Proxy” Received**

Classification	Error item
IP Fax	The registration to an SIP server has failed due to an error. (Use Proxy)

Check item	Measures
Setting	Check the setting of the network or the SIP server.

**[0107] “Alternative Service” Received**

Classification	Error item
IP Fax	The registration to an SIP server has failed due to an error. (Alternative Service)

Check item	Measures
Setting	Check the setting of the network or the SIP server.

**[0109] “Bad Request” Received**

Classification	Error item
IP Fax	The registration to an SIP server has failed due to an error. (Bad Request)

Check item	Measures
Setting	Check the setting of the network or the SIP server.

**[010A] “Unauthorized” Received**

Classification	Error item
IP Fax	The registration to an SIP server has failed due to an error. (Unauthorized)

Check item	Measures
Setting	Check the setting of the network or the SIP server.

**[010B] “Payment Required” Received**

Classification	Error item
IP Fax	The registration to an SIP server has failed due to an error. (Payment Required)

Check item	Measures
Setting	Check the setting of the network or the SIP server.

**[010C] “Forbidden” Received**

Classification	Error item
IP Fax	The registration to an SIP server has failed due to an error. (Forbidden)

Check item	Measures
Setting	Check the setting of the network or the SIP server.

**[010D] “Not Found” Received**

Classification	Error item
IP Fax	The registration to an SIP server has failed due to an error. (Not Found)

Check item	Measures
Setting	Check the setting of the network or the SIP server.

**[010E] “Method Not Allowed” Received**

Classification	Error item
IP Fax	The registration to an SIP server has failed due to an error. (Method Not Allowed)

Check item	Measures
Setting	Check the setting of the network or the SIP server.

### [010F] “Not Acceptable” Received

Classification	Error item
IP Fax	The registration to an SIP server has failed due to an error. (Not Acceptable)

Check item	Measures
Setting	Check the setting of the network or the SIP server.

### [0110] “Proxy Authentication Required” Received

Classification	Error item
IP Fax	The registration to an SIP server has failed due to an error. (Proxy Authentication Required)

Check item	Measures
Setting	Check the setting of the network or the SIP server.

### [0111] “Request Timeout” Received

Classification	Error item
IP Fax	The registration to an SIP server has failed due to an error. (Request Timeout)

Check item	Measures
Setting	Check the setting of the network or the SIP server.

### [0113] “Gone” Received

Classification	Error item
IP Fax	The registration to an SIP server has failed due to an error. (Gone)

Check item	Measures
Setting	Check the setting of the network or the SIP server.

### [0115] “Precondition Failed” Received

Classification	Error item
IP Fax	The registration to an SIP server has failed due to an error. (Precondition Failed)

Check item	Measures
Setting	Check the setting of the network or the SIP server.

### [0116] “Request Entity Too Large” Received

Classification	Error item
IP Fax	The registration to an SIP server has failed due to an error. (Request Entity Too Large)

Check item	Measures
Setting	Check the setting of the network or the SIP server.

### [0117] “Request-URI Too Long” Received

Classification	Error item
IP Fax	The registration to an SIP server has failed due to an error. (Request-URI Too Long)

Check item	Measures
Setting	Check the setting of the network or the SIP server.

### [0118] “Unsupported Media Type” Received

Classification	Error item
IP Fax	The registration to an SIP server has failed due to an error. (Unsupported Media Type)

Check item	Measures
Setting	Check the setting of the network or the SIP server.

### [0119] “Unsupported URI Scheme” Received

Classification	Error item
IP Fax	The registration to an SIP server has failed due to an error. (Unsupported URI Scheme)

Check item	Measures
Setting	Check the setting of the network or the SIP server.

### [011A] “Unknown Resource-Priority” Received

Classification	Error item
IP Fax	The registration to an SIP server has failed due to an error. (Unknown Resource-Priority)

Check item	Measures
Setting	Check the setting of the network or the SIP server.



**[011B] “Bad Extension” Received**

Classification	Error item
IP Fax	The registration to an SIP server has failed due to an error. (Bad Extension)

Check item	Measures
Setting	Check the setting of the network or the SIP server.

**[011C] “Extension Required” Received**

Classification	Error item
IP Fax	The registration to an SIP server has failed due to an error. (Extension Required)

Check item	Measures
Setting	Check the setting of the network or the SIP server.

**[011D] “Session Timer Too Small” Received**

Classification	Error item
IP Fax	The registration to an SIP server has failed due to an error. (Session Timer Too Small)

Check item	Measures
Setting	Check the setting of the network or the SIP server.

**[011E] “Interval Too Brief” Received**

Classification	Error item
IP Fax	The registration to an SIP server has failed due to an error. (Interval Too Brief)

Check item	Measures
Setting	Check the setting of the network or the SIP server.

**[011F] “Anonymity disallowed” Received**

Classification	Error item
IP Fax	The registration to an SIP server has failed due to an error. (Anonymity disallowed)

Check item	Measures
Setting	Check the setting of the network or the SIP server.

**[0120] “Temporarily Unavailable” Received**

Classification	Error item
IP Fax	The registration to an SIP server has failed due to an error. (Temporarily Unavailable)

Check item	Measures
Setting	Check the setting of the network or the SIP server.

**[0121] “Call/Transaction Does Not Exist” Received**

Classification	Error item
IP Fax	The registration to an SIP server has failed due to an error. (Call/Transaction Does Not Exist)

Check item	Measures
Setting	Check the setting of the network or the SIP server.

**[0122] “Loop Detected” Received**

Classification	Error item
IP Fax	The registration to an SIP server has failed due to an error. (Loop Detected)

Check item	Measures
Setting	Check the setting of the network or the SIP server.

**[0123] “Too Many Hops” Received**

Classification	Error item
IP Fax	The registration to an SIP server has failed due to an error. (Too Many Hops)

Check item	Measures
Setting	Check the setting of the network or the SIP server.

**[0124] “Address Incomplete” Received**

Classification	Error item
IP Fax	The registration to an SIP server has failed due to an error. (Address Incomplete)

Check item	Measures
Setting	Check the setting of the network or the SIP server.

**[0125] “Ambiguous” Received**

Classification	Error item
IP Fax	The registration to an SIP server has failed due to an error. (Ambiguous)

Check item	Measures
Setting	Check the setting of the network or the SIP server.

**[0126] “Busy Here” Received**

Classification	Error item
IP Fax	The registration to an SIP server has failed due to an error. (Busy Here)

Check item	Measures
Setting	Check the setting of the network or the SIP server.

**[0127] “Request Terminated” Received**

Classification	Error item
IP Fax	The registration to an SIP server has failed due to an error. (Request Terminated)

Check item	Measures
Setting	Check the setting of the network or the SIP server.

**[0128] “Not acceptable here” Received**

Classification	Error item
IP Fax	The registration to an SIP server has failed due to an error. (Not acceptable here)

Check item	Measures
Setting	Check the setting of the network or the SIP server.

**[0129] “Bad Event” Received**

Classification	Error item
IP Fax	The registration to an SIP server has failed due to an error. (Bad Event)

Check item	Measures
Setting	Check the setting of the network or the SIP server.

**[012A] “Request Updated” Received**

Classification	Error item
IP Fax	The registration to an SIP server has failed due to an error. (Request Updated)

Check item	Measures
Setting	Check the setting of the network or the SIP server.

**[012B] “Request Pending” Received**

Classification	Error item
IP Fax	The registration to an SIP server has failed due to an error. (Request Pending)

Check item	Measures
Setting	Check the setting of the network or the SIP server.

**[012C] “Undecipherable” Received**

Classification	Error item
IP Fax	The registration to an SIP server has failed due to an error. (Undecipherable)

Check item	Measures
Setting	Check the setting of the network or the SIP server.

**[012D] “Security Agreement Required” Received**

Classification	Error item
IP Fax	The registration to an SIP server has failed due to an error. (Security Agreement Required)

Check item	Measures
Setting	Check the setting of the network or the SIP server.

**[012E] “Internal Server Error” Received**

Classification	Error item
IP Fax	The registration to an SIP server has failed due to an error. (Internal Server Error)

Check item	Measures
Setting	Check the setting of the network or the SIP server.

**[012F] “Not Implemented” Received**

Classification	Error item
IP Fax	The registration to an SIP server has failed due to an error. (Not Implemented)

Check item	Measures
Setting	Check the setting of the network or the SIP server.

**[0130] “Bad Gateway” Received**

Classification	Error item
IP Fax	The registration to an SIP server has failed due to an error. (Bad Gateway)

Check item	Measures
Setting	Check the setting of the network or the SIP server.

**[0131] “Service Unavailable” Received**

Classification	Error item
IP Fax	The IP Fax transmission took time since the IP line was busy.

Check item	Measures
Setting	Wait for a while and then reattempt the IP Fax transmission. If this still persists, check the setting of the SIP server.

**[0132] “Gateway Time-out” Received**

Classification	Error item
IP Fax	The registration to an SIP server has failed due to an error. (Gateway Time-out)

Check item	Measures
Setting	Check the setting of the network or the SIP server.

**[0133] “Version Not Supported” Received**

Classification	Error item
IP Fax	The registration to an SIP server has failed due to an error. (Version Not Supported)

Check item	Measures
Setting	Check the setting of the network or the SIP server.

**[0134] “Message Too Large” Received**

Classification	Error item
IP Fax	The registration to an SIP server has failed due to an error. (Message Too Large)

Check item	Measures
Setting	Check the setting of the network or the SIP server.

**[0135] “Precondition Failure” Received**

Classification	Error item
IP Fax	The registration to an SIP server has failed due to an error. (Precondition Failure)

Check item	Measures
Setting	Check the setting of the network or the SIP server.

**[0136] “Busy Everywhere” Received**

Classification	Error item
IP Fax	The registration to an SIP server has failed due to an error. (Busy Everywhere)

Check item	Measures
Setting	Check the setting of the network or the SIP server.

**[0137] “Decline” Received**

Classification	Error item
IP Fax	The registration to an SIP server has failed due to an error. (Decline)

Check item	Measures
Setting	Check the setting of the network or the SIP server.

**[0138] “Does Not Exist Anywhere” Received**

Classification	Error item
IP Fax	The registration to an SIP server has failed due to an error. (Does Not Exist Anywhere)

Check item	Measures
Setting	Check the setting of the network or the SIP server.

**[0139] “Not Acceptable” Received**

Classification	Error item
IP Fax	The registration to an SIP server has failed due to an error. (Not Acceptable)

Check item	Measures
Setting	Check the setting of the network or the SIP server.

**[013D] Registration failed**

Classification	Error item
IP Fax	The registration to an SIP server has failed due to an error. (Other errors)

Check item	Measures
Setting	Check the setting of the network or the SIP server.

**[013E] Invite failed**

Classification	Error item
IP Fax	The IP Fax transmission / reception has failed due to a communication error. (Other errors)

Check item	Measures
Setting	Check the setting of the network or the SIP server.

**[0140] Failed to start**

Classification	Error item
IP Fax	The starting of the IP Fax function has failed.

Check item	Measures
Setting	Reboot the equipment.

**[0141] Job interruption due to setting change occurred**

Classification	Error item
IP Fax	The implementation of an IP Fax job has been stopped since the settings were changed.

Check item	Measures
Setting	Reattempt the IP Fax transmission / reception.

### [0142] Irregal address

Classification	Error item
IP Fax	The IP Fax transmission has failed due to a communication error. (Recipient entry error)

Check item	Measures
Setting	Correct the recipient and reattempt the IP Fax transmission.

### [0143] SIP server is unavailable

Classification	Error item
IP Fax	The IP Fax transmission / reception has failed due to a communication error. (SIP server unusable)

Check item	Measures
Setting	Check the setting of the network or the SIP server.

### [0144] Under congestion

Classification	Error item
IP Fax	The IP Fax transmission has failed due to a communication error. (Under congestion)

Check item	Measures
Setting	Wait for a while and then reattempt the IP Fax transmission.

### [0150] Disconnected by communication partner Transmission

Classification	Error item
IP Fax	The IP Fax transmission has failed due to a communication error. (Communication disconnection from the other side's device)

Check item	Measures
Setting	Wait for a while and then reattempt the IP Fax transmission.

### Reception

Classification	Error item
IP Fax	The IP Fax reception has failed due to a communication error. (Communication disconnection from the other side's device)

Check item	Measures
Setting	Reattempt the IP Fax reception.



**[0300] “Multiple Choices” Received**

Classification	Error item
IP Fax	The IP Fax transmission / reception has failed due to a communication error. (Multiple Choices)

Check item	Measures
Setting	Check the setting of the network or the SIP server.

**[0301] “Moved Permanently” Received**

Classification	Error item
IP Fax	The IP Fax transmission / reception has failed due to a communication error. (Moved Permanently)

Check item	Measures
Setting	Check the setting of the network or the SIP server.

**[0302] “Moved Temporarily” Received**

Classification	Error item
IP Fax	The IP Fax transmission / reception has failed due to a communication error. (Moved Temporarily)

Check item	Measures
Setting	Check the setting of the network or the SIP server.

**[0305] “Use Proxy” Received**

Classification	Error item
IP Fax	The IP Fax transmission / reception has failed due to a communication error. (Use Proxy)

Check item	Measures
Setting	Check the setting of the network or the SIP server.

**[0380] “Alternative Service” Received**

Classification	Error item
IP Fax	The IP Fax transmission / reception has failed due to a communication error. (Alternative Service)

Check item	Measures
Setting	Check the setting of the network or the SIP server.

**[0400] “Bad Request” Received**

Classification	Error item
IP Fax	The IP Fax transmission / reception has failed due to a communication error. (Bad Request)

Check item	Measures
Setting	Wait for a while and then reattempt the IP Fax transmission.

**[0401] “Unauthorized” Received**

Classification	Error item
IP Fax	The IP Fax transmission / reception has failed due to a communication error. (Unauthorized)

Check item	Measures
Setting	Wait for a while and then reattempt the IP Fax transmission.

**[0402] “Payment Required” Received**

Classification	Error item
IP Fax	The IP Fax transmission / reception has failed due to a communication error. (Payment Required)

Check item	Measures
Setting	Wait for a while and then reattempt the IP Fax transmission.

**[0403] “Forbidden” Received**

Classification	Error item
IP Fax	The IP Fax transmission / reception has failed due to a communication error. (Forbidden)

Check item	Measures
Setting	Wait for a while and then reattempt the IP Fax transmission.

**[0404] “Not Found” Received**

Classification	Error item
IP Fax	The IP Fax transmission / reception has failed due to a communication error. (Not Found)

Check item	Measures
Setting	Wait for a while and then reattempt the IP Fax transmission.

**[0405] “Method Not Allowed” Received**

Classification	Error item
IP Fax	The IP Fax transmission / reception has failed due to a communication error. (Method Not Allowed)

Check item	Measures
Setting	Wait for a while and then reattempt the IP Fax transmission.

**[0406] “Not Acceptable” Received**

Classification	Error item
IP Fax	The IP Fax transmission / reception has failed due to a communication error. (Not Acceptable)

Check item	Measures
Setting	Wait for a while and then reattempt the IP Fax transmission.

**[0407] “Proxy Authentication Required” Received**

Classification	Error item
IP Fax	The IP Fax transmission / reception has failed due to a communication error. (Proxy Authentication Required)

Check item	Measures
Setting	Wait for a while and then reattempt the IP Fax transmission.

**[0408] “Request Timeout” Received**

Classification	Error item
IP Fax	The IP Fax transmission / reception has failed due to a communication error. (Request Timeout)

Check item	Measures
Setting	Wait for a while and then reattempt the IP Fax transmission.

**[0410] “Gone” Received**

Classification	Error item
IP Fax	The IP Fax transmission / reception has failed due to a communication error. (Gone)

Check item	Measures
Setting	Wait for a while and then reattempt the IP Fax transmission.

**[0412] “Precondition Failed” Received**

Classification	Error item
IP Fax	The IP Fax transmission / reception has failed due to a communication error. (Precondition Failed)

Check item	Measures
Setting	Wait for a while and then reattempt the IP Fax transmission.

**[0413] “Request Entity Too Large” Received**

Classification	Error item
IP Fax	The IP Fax transmission / reception has failed due to a communication error. (Request Entity Too Large)

Check item	Measures
Setting	Wait for a while and then reattempt the IP Fax transmission.

**[0414] “Request-URI Too Long” Received**

Classification	Error item
IP Fax	The IP Fax transmission / reception has failed due to a communication error. (Request-URI Too Long)

Check item	Measures
Setting	Wait for a while and then reattempt the IP Fax transmission.

**[0415] “Unsupported Media Type” Received**

Classification	Error item
IP Fax	The IP Fax transmission / reception has failed due to a communication error. (Unsupported Media Type)

Check item	Measures
Setting	Wait for a while and then reattempt the IP Fax transmission.

**[0416] “Unsupported URI Scheme” Received**

Classification	Error item
IP Fax	The IP Fax transmission / reception has failed due to a communication error. (Unsupported URI Scheme)

Check item	Measures
Setting	Wait for a while and then reattempt the IP Fax transmission.

**[0417] “Unknown Resource-Priority” Received**

Classification	Error item
IP Fax	The IP Fax transmission / reception has failed due to a communication error. (Unknown Resource-Priority)

Check item	Measures
Setting	Wait for a while and then reattempt the IP Fax transmission.

**[0420] “Bad Extension” Received**

Classification	Error item
IP Fax	The IP Fax transmission / reception has failed due to a communication error. (Bad Extension)

Check item	Measures
Setting	Wait for a while and then reattempt the IP Fax transmission.

**[0421] “Extension Required” Received**

Classification	Error item
IP Fax	The IP Fax transmission / reception has failed due to a communication error. (Extension Required)

Check item	Measures
Setting	Wait for a while and then reattempt the IP Fax transmission.

**[0422] “Session Timer Too Small” Received**

Classification	Error item
IP Fax	The IP Fax transmission / reception has failed due to a communication error. (Session Timer Too Small)

Check item	Measures
Setting	Wait for a while and then reattempt the IP Fax transmission.

**[0423] “Interval Too Brief” Received**

Classification	Error item
IP Fax	The IP Fax transmission / reception has failed due to a communication error. (Interval Too Brief)

Check item	Measures
Setting	Wait for a while and then reattempt the IP Fax transmission.

**[0433] “Anonymity disallowed” Received**

Classification	Error item
IP Fax	The IP Fax transmission / reception has failed due to a communication error. (Anonymity disallowed)

Check item	Measures
Setting	Wait for a while and then reattempt the IP Fax transmission.

**[0480] “Temporarily Unavailable” Received**

Classification	Error item
IP Fax	The IP Fax transmission / reception has failed due to a communication error. (Temporarily Unavailable)

Check item	Measures
Setting	Wait for a while and then reattempt the IP Fax transmission.

**[0481] “Call/Transaction Does Not Exist” Received**

Classification	Error item
IP Fax	The IP Fax transmission / reception has failed due to a communication error. (Call/Transaction Does Not Exist)

Check item	Measures
Setting	Wait for a while and then reattempt the IP Fax transmission.

**[0482] “Loop Detected” Received**

Classification	Error item
IP Fax	The IP Fax transmission / reception has failed due to a communication error. (Loop Detected)

Check item	Measures
Setting	Wait for a while and then reattempt the IP Fax transmission.

**[0483] “Too Many Hops” Received**

Classification	Error item
IP Fax	The IP Fax transmission / reception has failed due to a communication error. (Too Many Hops)

Check item	Measures
Setting	Wait for a while and then reattempt the IP Fax transmission.

**[0484] “Address Incomplete” Received**

Classification	Error item
IP Fax	The IP Fax transmission / reception has failed due to a communication error. (Address Incomplete)

Check item	Measures
Setting	Wait for a while and then reattempt the IP Fax transmission.

**[0485] “Ambiguous” Received**

Classification	Error item
IP Fax	The IP Fax transmission / reception has failed due to a communication error. (Ambiguous)

Check item	Measures
Setting	Wait for a while and then reattempt the IP Fax transmission.

**[0486] “Busy Here” Received**

Classification	Error item
IP Fax	The IP Fax transmission / reception has failed due to a communication error. (Busy Here)

Check item	Measures
Setting	Wait for a while and then reattempt the IP Fax transmission.

**[0487] “Request Terminated” Received**

Classification	Error item
IP Fax	The IP Fax transmission / reception has failed due to a communication error. (Request Terminated)

Check item	Measures
Setting	Wait for a while and then reattempt the IP Fax transmission.

**[0488] “Not acceptable here” Received**

Classification	Error item
IP Fax	The IP Fax transmission / reception has failed due to a communication error. (Not acceptable here)

Check item	Measures
Setting	Wait for a while and then reattempt the IP Fax transmission.

**[0489] “Bad Event” Received**

Classification	Error item
IP Fax	The IP Fax transmission / reception has failed due to a communication error. (Bad Event)

Check item	Measures
Setting	Wait for a while and then reattempt the IP Fax transmission.

**[0490] “Request Updated” Received**

Classification	Error item
IP Fax	The IP Fax transmission / reception has failed due to a communication error. (Request Updated)

Check item	Measures
Setting	Wait for a while and then reattempt the IP Fax transmission.

**[0491] “Request Pending” Received**

Classification	Error item
IP Fax	The IP Fax transmission / reception has failed due to a communication error. (Request Pending)

Check item	Measures
Setting	Wait for a while and then reattempt the IP Fax transmission.

**[0493] “Undecipherable” Received**

Classification	Error item
IP Fax	The IP Fax transmission / reception has failed due to a communication error. (Undecipherable)

Check item	Measures
Setting	Wait for a while and then reattempt the IP Fax transmission.

**[0494] “Security Agreement Required” Received**

Classification	Error item
IP Fax	The IP Fax transmission / reception has failed due to a communication error. (Security Agreement Required)

Check item	Measures
Setting	Wait for a while and then reattempt the IP Fax transmission.



**[0500] “Internal Server Error” Received**

Classification	Error item
IP Fax	The IP Fax transmission / reception has failed due to a communication error. (Internal Server Error)

Check item	Measures
Setting	Check the setting of the SIP server.

**[0501] “Not Implemented” Received**

Classification	Error item
IP Fax	The IP Fax transmission / reception has failed due to a communication error. (Not Implemented)

Check item	Measures
Setting	Check the setting of the SIP server.

**[0502] “Bad Gateway” Received**

Classification	Error item
IP Fax	The IP Fax transmission / reception has failed due to a communication error. (Bad Gateway)

Check item	Measures
Setting	Check the setting of the SIP server.

**[0503] “Service Unavailable” Received**

Classification	Error item
IP Fax	The IP Fax transmission / reception has failed due to a communication error. (Service Unavailable)

Check item	Measures
Setting	Wait for a while and then reattempt the IP Fax transmission.

**[0504] “Gateway Time-out” Received**

Classification	Error item
IP Fax	The IP Fax transmission / reception has failed due to a communication error. (Gateway Time-out)

Check item	Measures
Setting	Check the setting of the SIP server.

**[0505] “Version Not Supported” Received**

Classification	Error item
IP Fax	The IP Fax transmission / reception has failed due to a communication error. (Version Not Supported)

Check item	Measures
Setting	Check the setting of the SIP server.

**[0513] “Message Too Large” Received**

Classification	Error item
IP Fax	The IP Fax transmission / reception has failed due to a communication error. (Message Too Large)

Check item	Measures
Setting	Check the setting of the SIP server.

**[0580] “Precondition Failure” Received**

Classification	Error item
IP Fax	The IP Fax transmission / reception has failed due to a communication error. (Precondition Failure)

Check item	Measures
Setting	Check the setting of the SIP server.

**[0600] “Busy Everywhere” Received**

Classification	Error item
IP Fax	The IP Fax transmission / reception has failed due to a communication error. (Busy Everywhere)

Check item	Measures
Setting	Check the setting of the network or the SIP server.

**[0603] “Decline” Received**

Classification	Error item
IP Fax	The IP Fax transmission / reception has failed due to a communication error. (Decline)

Check item	Measures
Setting	Check the setting of the network or the SIP server.

**[0604] “Does Not Exist Anywhere” Received**

Classification	Error item
IP Fax	The IP Fax transmission / reception has failed due to a communication error. (Does Not Exist Anywhere)

Check item	Measures
Setting	Check the setting of the network or the SIP server.

**[0606] “Not Acceptable” Received**

Classification	Error item
IP Fax	The IP Fax transmission / reception has failed due to a communication error. (Not Acceptable)

Check item	Measures
Setting	Check the setting of the network or the SIP server.

**[4246] IP Fax license is not installed**

Classification	Error item
IP Fax	The license of the IP Fax has not been installed.

Check item	Measures
Setting	Check that the license of the IP Fax has been installed.

**[DA01] The FAX Unit of line 1 has been damaged**

Classification	Error item
Fax	The FAX Unit of line 1 has been damaged or an abnormality has occurred in the interface between the systems.

Check item	Measures
Setting	Reboot the equipment. If the error still persists, replace the FAX Unit of line 1.

**[DA02] The FAX Unit of line 2 has been damaged**

Classification	Error item
Fax	The FAX Unit of line 2 has been damaged or an abnormality has occurred in the interface between the systems.

Check item	Measures
Setting	Reboot the equipment. If the error still persists, replace the FAX Unit of line 2.

## 8.4 Other Errors

### 8.4.1 Wireless LAN connection disabled

The connection state and settings of the Wireless LAN can be checked with [USER FUNCTIONS]> [ADMIN]> [WIRELESS LAN] >[SETTING CHECK].

Confirm the settings with the administrator.

- “NIC INITIALIZING” does not disappear at the time of the power being turned ON and it disappears after 6 minutes with the NIC initializing time-out. In this case, the connection to the Wireless LAN does not succeed even though “NIC INITIALIZING” disappears.
- The connection to the Wireless LAN cannot be made if the Access Point to be connected is not found or security settings are not correct.

### 8.4.2 “Invalid Department Code” is displayed

Log in to TopAccess as an administrator, select [Authentication] on the [User Management] tab, and then check whether Department Setting is enabled or disabled.

Department Setting is enabled:

- Log in to TopAccess as an administrator, select [Authentication] on the [User Management] tab, and then check User Management Setting.
- Confirm the settings of FS-08-3805 in the setting mode.

Department Setting is disabled:

- Log in to TopAccess as an administrator, select [Authentication] on the [User Management] tab, and then check User Management Setting.

### 8.4.3 When “SET FUSER UNIT” is displayed.

When the signal for installing the fuser unit cannot be detected with the LGC board, “SET FUSER UNIT” appears.


In this case, check the following.

1. Check that the fuser unit is installed properly.
2. Check if the drawer connector of the fuser unit is damaged or its connection is detected.
3. Remove CN308 and check if the circuit between 1-pin and 7-pin is electrically conducted.
4. Replace the LGC board.

### 8.4.4 Toner cartridge unrecognized

If the toner cartridge is not recognized, check the following.


- Check that there is no access abnormality to the toner cartridge IC chip.
- Check the setting of FS-08-4689 in the setting mode. If the value is “1” to “5”, perform the C911 troubleshooting.

 P. 8-208 “ [C911] Toner cartridge PC board access abnormality (K)”

### 8.4.5 “Authentication Failed” is displayed

- Reset the service password  
Reset the service password by accessing [USER FUNCTIONS] > [ADMIN] > [GENERAL] > [PASSWORD SETUP] > [RESET SERVICE PASSWORD].

- Replace the SRAM.

 P. 9-26 “9.2.5 Precautions and procedure when replacing the SRAM”.

## 8.4.6 Error code “M00” is displayed while updating firmware

Check Item	Measures
Switching regulator	<ul style="list-style-type: none"> <li>Connector check (CN415)</li> <li>Harness check</li> </ul>
LGC board	<ul style="list-style-type: none"> <li>Connector check (CN301, CN312)</li> <li>Harness check</li> </ul>

Parts to be replaced	Remark
Switching regulator	
LGC board	

## 8.4.7 “COVER OPEN” continues to be displayed

Check Item	Measures
Front cover	<ul style="list-style-type: none"> <li>Confirm that both the front cover is closed.</li> <li>Confirm that the front cover interlock switch (SW2) is turned ON properly when the front cover is closed.</li> </ul>
Automatic Duplexing Unit (ADU)	<ul style="list-style-type: none"> <li>Confirm that both the automatic duplexing unit (ADU) is closed.</li> <li>Confirm that the ADU interlock switch (SW3) is turned ON properly when the front cover is closed.</li> </ul>
LGC board	Replace the LGC board.
Switching regulator	Replace the switching regulator.

Parts to be replaced	Remark
LGC board	
Switching regulator	

## 8.4.8 The equipment does not start after the power has been turned ON.

### [ 1 ] The LCD screen does not display after the power has been turned ON.

#### 1. General description

When the lamps on the control panel do not light or error codes are not displayed on the LCD screen after the power has been turned ON, perform this troubleshooting.

#### 2. Status LED / Power LED

After the power is turned ON, the status of the equipment from the startup until the end of system device initialization (the LCD screen works) is displayed by the status LED (8-bit) on the SYS board. When the equipment does not start or the LCD screen does not display after the power is turned ON, check this status LED on the SYS board in order to judge the corresponding troubleshooting. In addition to this, the power LED is lit when 12 VA power is being supplied to the SYS board.

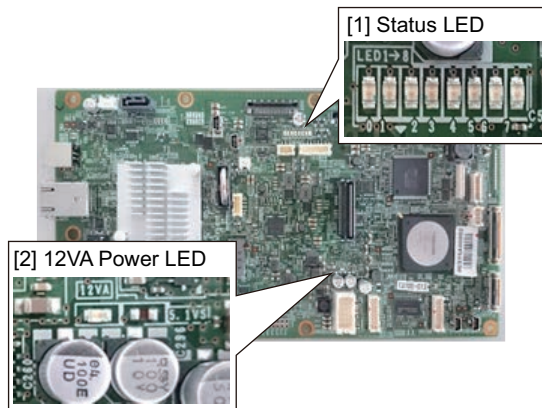


Fig.8-25

#### 3. Measures

When an error code is displayed, perform its troubleshooting.

If the LCD screen is turned OFF and an error code cannot be confirmed as a result, check the lighting condition of each LED and perform the troubleshooting according to the status below.

## Main Power LED / Energy Saver LED (on Control panel)

LED	Lighting condition	SYS power LED	Troubleshooting
Main Power LED	ON	ON	<p>The control panel does not operate normally.</p> <ul style="list-style-type: none"> <li>• Check the connection of the harness (41-pin) of the control panel. Check if there is no abnormality in the harness.</li> <li>• Check if there is no abnormality in the parts of the control panel.</li> <li>• Download the system software again.</li> <li>• Check if there is no abnormality in the SYS board.</li> <li>• Replace the main memory (DIMM).</li> <li>• Replace the control panel.</li> <li>• Replace the SYS board.</li> </ul>
		OFF	<p>The 12 VA power is not supplied to the SYS board.</p> <ul style="list-style-type: none"> <li>• Check the connection of the power harness of the SYS board. Check if there is no abnormality in the harness.</li> <li>• Check if there is no abnormality in the switching regulator.</li> <li>• Check if there is no abnormality in the SYS board.</li> <li>• Replace the power harness of the SYS board.</li> <li>• Replace the switching regulator.</li> <li>• Replace the SYS board.</li> </ul> <p>The 12 VA power supply is stopped due to an overcurrent.</p> <ul style="list-style-type: none"> <li>• Turn OFF the main power switch and open the front cover. While keeping this status, press the main power switch to check that the SYS power LED is turned ON.</li> </ul> <p>[If the SYS power LED is turned ON]</p> <ul style="list-style-type: none"> <li>• Check if there is no abnormality in all harnesses with the 24 V power supplied.</li> <li>• Check if there is no abnormality in all boards with the 24 V power supplied.</li> <li>• Replace all boards with the 24 V power supplied.</li> </ul> <p>[If the SYS power LED is not turned ON]</p> <ul style="list-style-type: none"> <li>• Check if there is no abnormality in all harnesses with the 12 VA power supplied.</li> <li>• Check if there is no abnormality in all boards with the 12 VA power supplied.</li> <li>• Replace all boards with the 12 VA power supplied.</li> </ul>
	OFF	ON	<p>The 5 VS power is not supplied to the control panel.</p> <ul style="list-style-type: none"> <li>• Check the connection of the harness of the control panel.</li> <li>• Check if there is no abnormality in the parts of the control panel.</li> </ul>
		OFF	<p>The power is not supplied to the SYS board.</p> <ul style="list-style-type: none"> <li>• Check the connection of the power harness of the SYS board.</li> <li>• Check if there is no abnormality in the switching regulator.</li> <li>• Check if there is no abnormality in the SYS board.</li> </ul>

LED	Lighting condition	SYS power LED	Troubleshooting
Energy Saver LED	ON	-	-
	Blinking	-	When the Energy Saver LED is turned OFF after a certain time has passed: Initialization between the control panel and the SYS board is not completed. <ul style="list-style-type: none"> <li>• Check the connection of the harness of the control panel.</li> <li>• SYS board abnormality (Check the lighting condition of the SYS power LED and the SYS status LED, and perform the measures described in the next table.)</li> </ul>
		-	When the Energy Saver LED blinks even if some times have passed: The LCD is not turned ON after initialization between the control panel and the SYS board is completed. <ul style="list-style-type: none"> <li>• Check the connection of the harness of the control panel.</li> <li>• Check if there is no abnormality in the parts of the control panel.</li> <li>• SYS board abnormality (Check the lighting condition of the SYS power LED and the SYS status LED, and perform the measures described in the next table.)</li> </ul>
	OFF	ON	The 12 VA power is not supplied to the control panel. <ul style="list-style-type: none"> <li>• Check the connection of the harness of the control panel.</li> <li>• Check if there is no abnormality in the parts of the control panel.</li> </ul>
		OFF	The power is not supplied to the SYS board <ul style="list-style-type: none"> <li>• Check the connection of the power harness of the SYS board</li> <li>• Check if there is no abnormality in the switching regulator.</li> <li>• Check if there is no abnormality in the SYS board.</li> </ul>



Power LED / Status LED (on SYS board)

LED		Lighting condition	SYS board status	Troubleshooting
Power LED		OFF	Waiting for the power supply	Check the connection of the switching regulator harness and the power supply harness.
Status LED	Bit7	ON	Main memory abnormality	<ul style="list-style-type: none"> <li>• Check the installation status of the main memory, and reinstall it if necessary.</li> <li>• Perform calibration of the main memory at the startup.</li> <li>• Replace the main memory or the SYS board.</li> </ul>
	Bit4	ON	Network IC communication error	Replace the SYS board.
	Bit3	ON	ASIC detection error	Replace the SYS board.
	Bit2	ON	HDD/SSD detection error	<ul style="list-style-type: none"> <li>• When the error code is from F100 to F109, perform the HDD/SSD fault diagnosis by following each troubleshooting.</li> <li>• If the LCD screen does not display, check the connection of the HDD harness.</li> </ul>
	Bit1	ON	Control panel communication error	<ul style="list-style-type: none"> <li>• Check the connection of the harness of the control panel.</li> <li>• Check if there is no abnormality in the parts of the control panel.</li> </ul>
	Bit0	ON	Errors other than the above	Replace the SYS board.

**Remarks:**

- When Bit1 or Bit7 of the status LED is ON and an error code is displayed on the LCD screen, perform the troubleshooting for each error code.
- The lighting condition of the status LED is determined while Bit0 is turned OFF. Due to this, be sure to check the condition from Bit1 to Bit7 while Bit0 is turned OFF.

## 8.4.9 Countermeasure to sudden power failure

	Phenomenon	Check item	Measures
1	The [ENERGY SAVER] button is lit. The power supply is recovered by pressing the [ENERGY SAVER] button.	The mode is at the Sleep mode.	Turn off the Sleep mode setting. Or change the setting.
2	The power supply is recovered by pressing the [POWER] button.	The weekly timer has run.	<ul style="list-style-type: none"> <li>Turn off the setting of the weekly timer. Or change the setting.</li> <li>Check if the time is set correctly.</li> </ul>
3	The power supply is not recovered even if the [POWER] button is pressed.	The harnesses of 12V or 24V are short circuited. <ul style="list-style-type: none"> <li>Check if there is any abnormality, such as scratches or being caught on the harnesses of each board, and damage on the connector pins.</li> </ul>	<ul style="list-style-type: none"> <li>Replace the harness.</li> <li>Replace the switching regulator.</li> </ul>
4	The LED of the main power is not lit.	<ul style="list-style-type: none"> <li>Check if there is any abnormality in the power cable.</li> <li>Check if there is any abnormality such as scratches or being caught on the harnesses for the inlet or the main power switch.</li> <li>Check if the fuses (F101/102) for the main power switch are cut.</li> <li>Check if the harness for the switching regulator is properly connected.</li> </ul>	<ul style="list-style-type: none"> <li>Replace the power cable.</li> <li>Replace the harnesses for the inlet, the main power switch and the switching regulator.</li> <li>Replace the switching regulator.</li> </ul>
5	The LED of the main power is lit.	Check the voltage of the power connector (CN105) on the SYS board. <ul style="list-style-type: none"> <li>The voltage of 5-pin is lower than 4.8V.</li> <li>The voltage of 9-pin is lower than 10.8V.</li> <li>The voltage of 5-pin is 4.8V or more, that for 9-pin is 0V and that for 1-pin is 0V.</li> </ul>	Replace the switching regulator.
		Check the voltage of the power connector (CN105) on the SYS board. <ul style="list-style-type: none"> <li>The voltage of 5-pin is 4.8V or more, that for 9-pin is 0V and that for 1-pin is 4.8V or more.</li> </ul>	Replace the SYS board.
6	Power supply failed at warming up. (The LED of the main power is lit.)	Check if there is any abnormality in the fuser unit. <ul style="list-style-type: none"> <li>Check if there is any abnormality in the terminal of the connector.</li> <li>Check if there is any abnormality in the installation of the thermistor and no dust on it.</li> </ul>	<ul style="list-style-type: none"> <li>Repair the defective portions of the fuser unit.</li> <li>Replace the fuser unit.</li> </ul>
		Check if there is any abnormality in the LGC board. <ul style="list-style-type: none"> <li>Check if the connectors of LGC board are disconnected, installed properly or their pins are damaged.</li> </ul>	<ul style="list-style-type: none"> <li>Replace the harness.</li> <li>Replace the LGC board.</li> </ul>
		Check if there is any abnormality in the switching regulator.	Replace the switching regulator.

	Phenomenon	Check item	Measures
7	Power supply failed when the motor rotates. Power supply failed when the cover is closed.	Check if there is any abnormality in the motor. <ul style="list-style-type: none"> <li>• Check if there is any abnormality which makes the motor disable to rotate.</li> <li>• Check if there is any abnormality such as scratches or being caught on the harness of the motor.</li> </ul>	Release the problems or replace the motor and harness.
		Check if there is any abnormality in the options. <ul style="list-style-type: none"> <li>• Check if the problem is released when disconnecting the option.</li> </ul>	Check if there is any abnormality in the disconnected option and release the problems.
8	Power supply failed when the ADU is opened and closed.	Check if there is any abnormality such as scratches or being caught on the harness for the ADU hinge.	Replace the harness.
9	Power supply failed when the DF is opened and closed.	<ul style="list-style-type: none"> <li>• Check if there is any abnormality such as scratches or being caught on the harness for the DF and the scanner.</li> <li>• Check if there is any abnormality such as scratches or being caught on the harness between the SYS board and the scanner. Check if there is any abnormality on the connector pins.</li> </ul>	Replace the harness.
10	The equipment is rebooted.	An error occurred. (Depending on the error, the equipment will reboot at its first time and then a service call will happen at its second time.)	<ul style="list-style-type: none"> <li>• Check the error code and solve the problem.</li> <li>• Check the installation status of the main memory, and reinstall it if necessary.</li> <li>• Replace the main memory.</li> </ul>

Parts to be replaced	Remarks
Power cable	
Switching regulator	
Fuser unit	
SYS board	
LGC board	
Harnesses in question	
Main memory	

## 8.4.10 “Latch the developer unit” remains displayed

After the power is turned ON, “Latch the developer unit” is displayed on the panel. This display is not changed even if the developer unit is removed and then installed.

Step	Check item	Measures
1	Installation state of the developer unit	<ul style="list-style-type: none"> <li>Remove and install the developer unit. Close the front cover.</li> <li>Make sure the drawer connector is connected securely and there is no deformed connector pins.</li> </ul>
2	Change in the display	Check if the display is changed when the power is turned OFF and then back ON. If an error indication is displayed, perform its troubleshooting in accordance with its procedure.
3	SYS board	<ul style="list-style-type: none"> <li>Connector check (CN132)</li> <li>Harness check</li> <li>Short circuited or open circuited check</li> </ul>
4	LGC board	<ul style="list-style-type: none"> <li>Connector check (CN310)</li> <li>Harness check</li> <li>Short circuited or open circuited check</li> </ul>
		<ul style="list-style-type: none"> <li>Connector check (CN319)</li> <li>Harness check</li> <li>Short circuited or open circuited check</li> </ul>
		<ul style="list-style-type: none"> <li>Connector check (CN313)</li> <li>Harness check</li> <li>Short circuited or open circuited check</li> </ul>
5	EPU board	<ul style="list-style-type: none"> <li>Connector check (CN451, CN453)</li> <li>Harness check</li> <li>Short circuited or open circuited check</li> </ul>
6	Flat cable	Check if there is any abnormality in the terminal of the flat cable between the SYS and LGC boards. Check if the flat cable is open circuited.
7	Harness	Check if there is a short circuit or open circuit in the harness (CN313) for connecting the LGC board and the developer unit whose display is not changed.

Parts to be replaced	Remark
Flat cable	
SYS board	
LGC board	
EPU board	
Developer unit	

## 8.5 Troubleshooting for the Image

### 8.5.1 Abnormality of image density / Gray balance

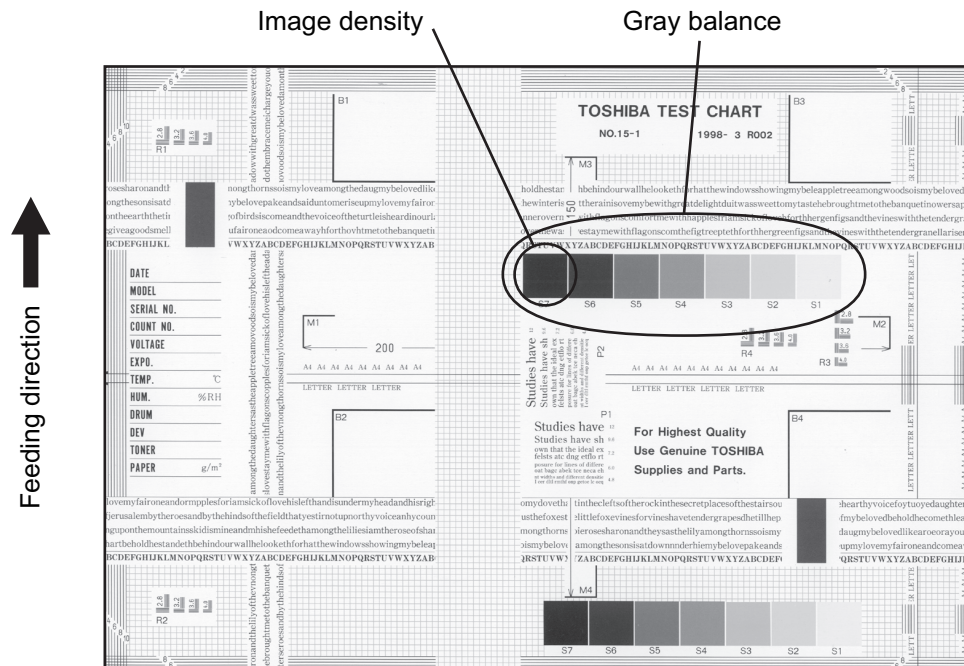


Fig.8-26

Defective area	Step	Check items	Prescription
Density/Gray balance	1	Check the density/gray balance.	Adjust the density.
Printer section	2	Check test print image (04-114).	Go to step 4 if there is any problem on image.
Scanner	3	Are the original glass, mirrors and lens dirty?	Clean them.
Printed image	4	Is the image faded?	Perform troubleshooting for faded image.
	5	Is background fogging occurring?	Perform troubleshooting for background fogging.
	6	Is there a blotch on the image?	Perform troubleshooting for blotched image.
	7	Is the image transferred normally?	Perform troubleshooting for abnormal transfer.

## 8.5.2 Background fogging

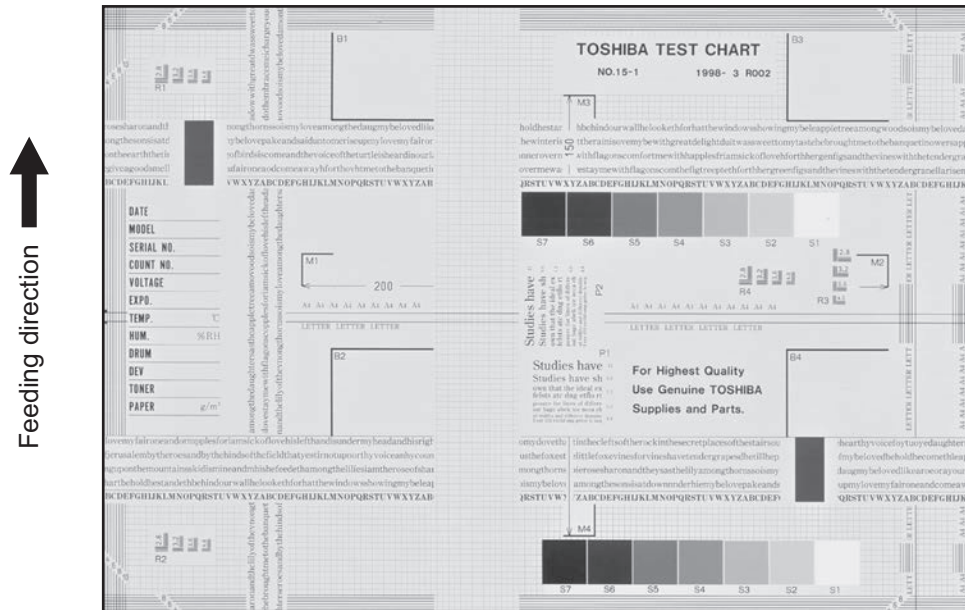


Fig.8-27

Defective area	Step	Check items	Prescription
Adjustment	1	Perform the shading correction.	Perform 05-3218. If an error occurs, retry it. If the error still persists, clean the original glass covering the shading correction plate and perform FS-05-3218 again.
Density reproduction	2	Check the reproduction of the image density.	Adjust the density.
Background reproduction	3	Check the background reproduction.	Adjust the background.
Printer section	4	Check test print image (04-114).	Go to step 5 if there is any problem on image.
Scanner	5	Check if the original glass, DF original glass, mirrors or lens is dirty.	Clean them.
Auto-toner	6	Is the auto-toner sensor normal?	Check the performance of the auto-toner sensor and readjust.
	7	Is the toner supplied normally?	Check the motor and circuits.
High-voltage transformer (Main charger / Developer bias)	8	Is the high-voltage transformer output defective?	Adjust the output, or replace the transformer.
Developer unit	9	Is the contact between the drum and developer material normal?	Adjust the doctor-sleeve gap and polarity.
Developer material/Toner/Drum	10	Using the specified developer material, toner and drum?	Use the specified developer material, toner and drum.
	11	Have the developer material and drum reached their PM life?	Replace the developer material and drum.
	12	Is the storage environment of the toner cartridge 35°C less without dew?	Use the toner cartridge stored in the environment within specification.
Drum cleaning blade	13	Is the drum cleaned properly?	Check the pressure of the drum cleaning blade.
Toner dusting	14	Is toner heaped on the seal of the developer unit?	Remove the toner and clean the developer unit.

### 8.5.3 Moire/lack of sharpness

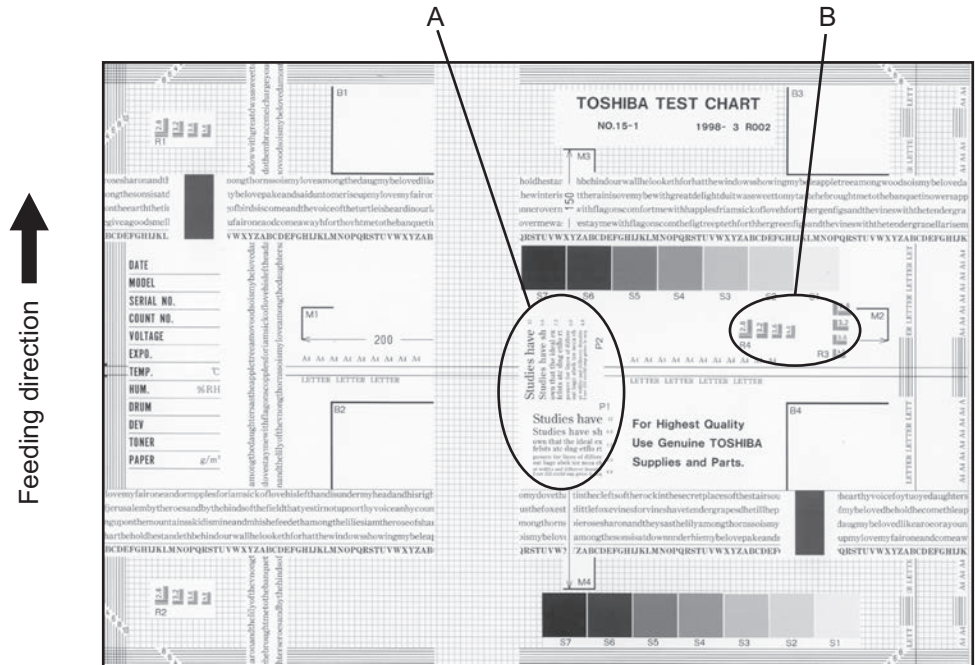


Fig.8-28

#### Moire

Defective area	Step	Check items	Prescription
Density reproduction	1	Check the reproduction of the image density.	Adjust the density.
Parameter adjustment value	2	Check the image processing parameters.	Check the adjustment value for sharpness.
Printer section	3	Check test print image (04-114).	When defects occur, perform the corresponding troubleshooting procedure.

#### Lack of sharpness

Defective area	Step	Check items	Prescription
Density reproduction	1	Check the reproduction of the image density.	Adjust the density.
Parameter adjustment value	2	Check the image processing parameters.	Check the adjustment value for sharpness.
Printer section	3	Check test print image (04-114).	When defects occur, perform the corresponding troubleshooting procedure.
	4	Check the image processing parameters.	Check the encircled areas A and B in the image, and change the sharpness intensity in the sharpness adjustment mode.

## 8.5.4 Toner offset

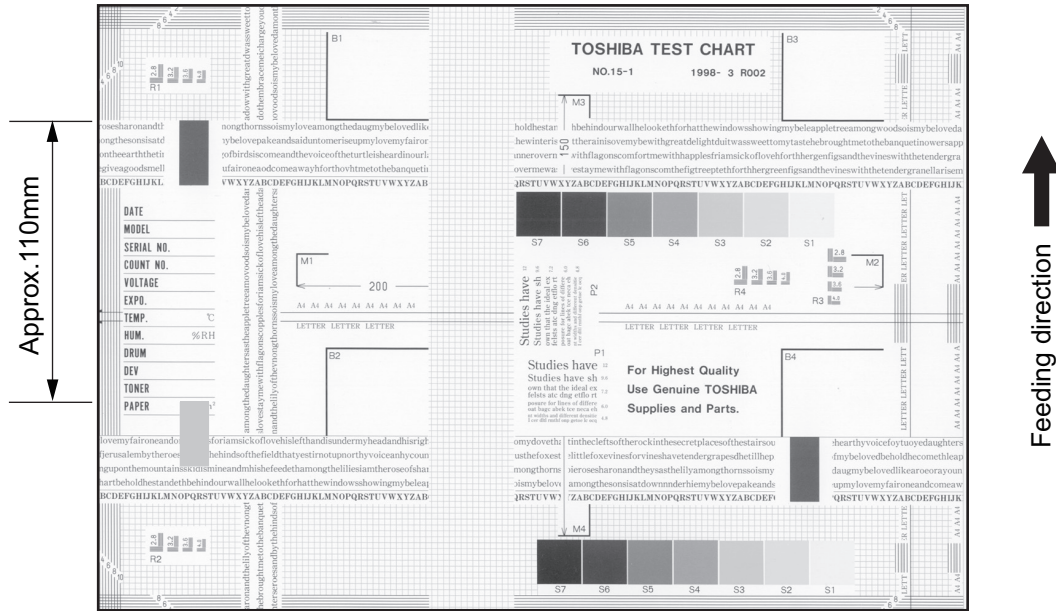


Fig.8-29

Toner offset (Shadow image appears approx. 110mm toward the dark image.)

Defective area	Step	Check items	Prescription
Density	1	Is the density too high?	Adjust the density.
Fuser unit	2	Is the pressure of the fuser roller normal?	Check the pressure releasing parts and pressurization mechanism.
	3	Is the thermistor in contact with the fuser roller?	Contact the thermistor with the fuser roller.
	4	Is there a scratch on the fuser roller surface?	Replace the fuser roller.
	5	Has the fuser roller reached its PM life?	Replace the fuser roller.
	6	Is the setting temperature of the fuser roller normal?	Check the adjustment values of fuser roller temperature? FS-08-2120, 2010, 2009, 2140, 2100, 2101, 5285 (Only 35/45/50 ppm)
	7	Is the power supplied between the fuser unit entrance guide and the registration roller on the equipment side?	Check if the power supply bracket of the fuser unit is installed properly.
Paper	8	Has the appropriate paper type been selected?	Select a proper mode.
	9	Is the setting temperature of the fuser roller in each paper type normal?	Check the setting and correct it. FS-08-2028, 2049, 2050, 2051, 2141, 2142, 2143, 2192, 2194, 2195 (08-5328, 5329, 5330, 5331, 5332: Only 35/45/50 ppm)
	10	Using the recommended paper?	Use the recommended paper.
Developer material	11	Using the specified developer material?	Use the specified developer material and toner.
Scanner	12	Are the original glass (especially the position of shading correction plate), mirror and lens dirty?	Clean them.



<b>Defective area</b>	<b>Step</b>	<b>Check items</b>	<b>Prescription</b>
Power supply	13	Check if the power is being supplied to the heater lamp. Check that there is no abnormality in the switching regulator.	Replace the switching regulator.

## 8.5.5 Toner offset (shadow image) at the edges

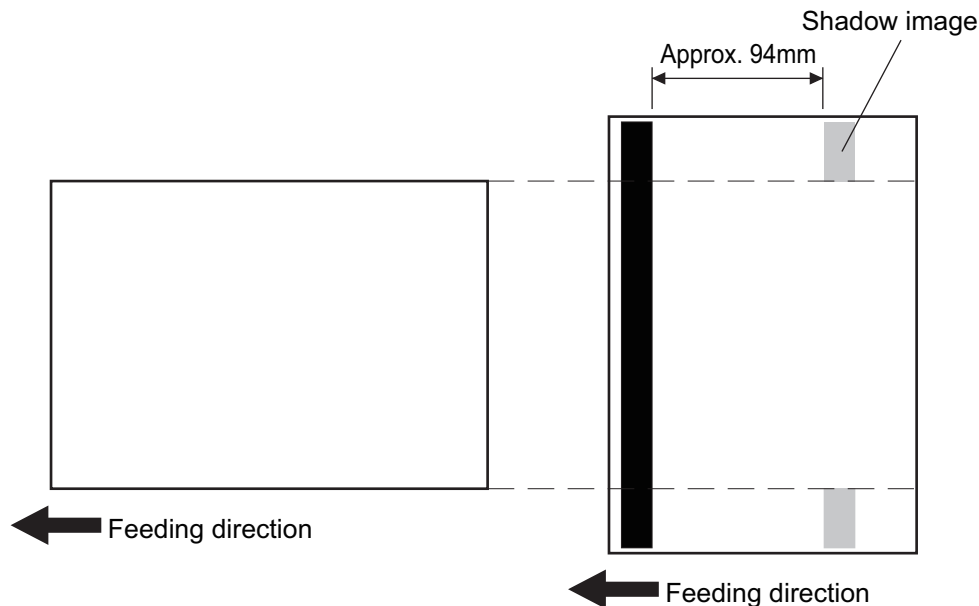


Fig.8-30

Toner offset (shadow image) sometimes appears at both edges of the paper when a wide-size sheet is printed following the continuous printing of narrow-size ones or rotate sort-printing. In such a case, change the setting of Wait between the printings of narrow-size and wide-size paper.

**Notes:**

- When the setting is changed, toner offset can be reduced; however, the performance (printing speed) will also be lowered accordingly. Therefore, the setting should only be changed depending on the occurrence frequency or corresponding to users' requests.
- The values below are the recommended ones. Therefore, adjust the values according to the situation.

1. Combined job

Code	Recommended setting value	Remarks
FS-08-5455	5	Wait is carried out with a small number of sheets.
FS-08-5456-0	45	The Wait period is extended.
FS-08-5456-1	45	
FS-08-5456-2	45	

2. When Ready is inserted between jobs

Code	Recommended setting value	Remarks
FS-08-2074	3	The Wait period is extended.

## 8.5.6 Blurred image

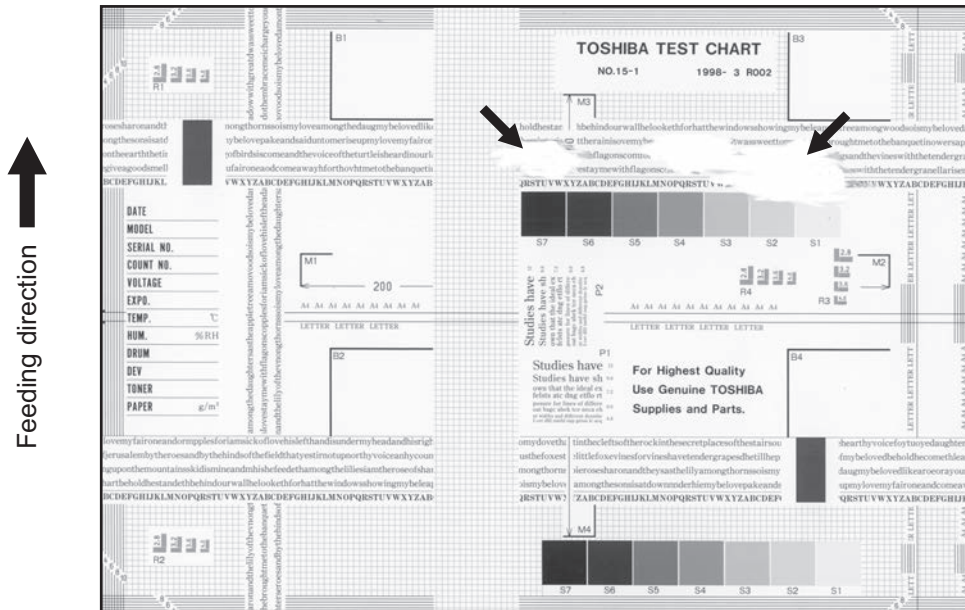


Fig.8-31

Defective area	Step	Check items	Prescription
Paper	1	Is the paper in the drawer or LCF damp?	Change paper. Avoid storing paper in damp place.
Bedewed scanner	2	Is the scanner bedewed?	Clean the scanner.
Drum	3	Is the drum surface wet or dirty?	Wipe the drum with a piece of dry cloth. * Do not use alcohol or other organic solvents.
Ozone exhaust	4	Is the exhaust fan operating properly?	Check the connection of connector. Replace the ozone exhaust fan.
	5	Is the ozone filter stained or damaged?	Replace the ozone filter.

## 8.5.7 Poor fusing

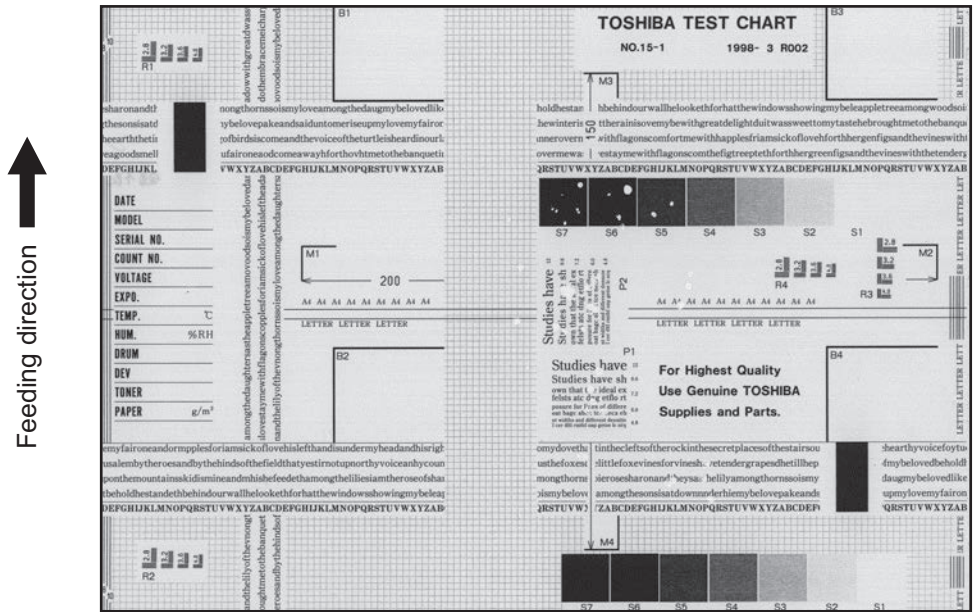


Fig.8-32

Defective area	Step	Check items	Prescription
Heater electric power	1	Check if the connector contacts properly.	Correct it.
	2	Is the heater shorted or broken?	Replace the heater.
Insufficient pressure between fuser roller and pressure roller	3	Are the pressure springs working properly?	Check and adjust the pressure springs.
Fuser roller temperature	4	Is the temperature of the fuser roller normal?	Check the setting and correct it. FS-08-2120, 2010, 2009, 2140, 515, 516, 5285 (Only 35/45/50 ppm)
Developer material/Toner	5	Using the specified developer material and toner?	Use the specified developer material and toner.
Paper	6	Is the paper in the drawer or LCF damp?	Avoid storing paper in damp place.
	7	Is the paper type corresponding to its mode?	Use the proper type of paper or select the proper mode.
	8	Is the setting temperature of the fuser roller in each paper type normal?	Check the setting and correct it. FS-08-2028, 2049, 2050, 2051, 2141, 2142, 2143, 2192, 2194, 2195 (FS-08-5328, 5329, 5330, 5331, 5332: Only 35/45/50 ppm)
	9	Using the recommended paper?	Use the recommended paper.
Power supply	10	Check if the power is being supplied to the heater lamp. Check that there is no abnormality in the switching regulator.	Replace the switching regulator.

## 8.5.8 Blank copy



Fig.8-33

Defective area	Step	Check items	Prescription
Transfer roller unit	1	Is the power supplying spring of the transfer roller installed securely? (Is it almost detached?)	Check the power supplying spring and reinstall it.
High-voltage transformer (Transfer roller unit, Developer bias)	2	Is the high-voltage transformer output defective?	Adjust the output, or replace the transformer.
	3	Are the connectors of the high-voltage harness securely connected? Is the harness open circuited?	Reconnect the harness securely. Replace the high-voltage harness.
Developer unit	4	Is the developer unit installed properly?	Check and correct the engaging condition of the developer unit gears.
	5	Do the developer sleeve and mixers rotate?	Check and fix the drive system of the developer unit.
	6	Is the developer material smoothly transported?	Remove the foreign matter from the developer material.
	7	Has the magnetic brush phase been shifted?	Adjust the developer polarity.
	8	Is the doctor blade positioned properly?	Adjust it using the doctor-sleeve jig.
Drum	9	Is the drum rotating?	Check the drive system of the drum.
CCD, SYS, LGC boards and harnesses	10	Are the connectors securely connected? Check if the harnesses connecting the boards are open circuited.	Connect the connectors securely. Replace the harness.

## 8.5.9 Solid copy



Fig.8-34

Defective area	Step	Check items	Prescription
Exposure lamp	1	Does the exposure lamp light?	Check if the connector contacts with the exposure lamp terminal. Replace the defective lamp.
Scanner	2	Is there any foreign matter on the light path?	Remove it.
Bedewed scanner and drum	3	Is the scanner or drum bedewed?	Clean the mirrors, lens and drum. Keep the power cord plugged in all through the day and night. (For the model with damp heater)
Main charger	4	Is the main charger securely installed?	Install it securely.
	5	Is the needle electrode broken?	Replace the needle electrode.
High-voltage transformer (Main charger)	6	Is the high-voltage transformer output defective?	Adjust the output, or replace the transformer.
	7	Are the connectors of the high-voltage harness securely connected? Is the harness open circuited?	Reconnect the harness securely. Replace the high-voltage harness.
CCD, SYS, LGC boards and harnesses	8	Are the connectors securely connected? Check if the harnesses connecting the boards are open circuited.	Connect the connectors securely. Replace the harness.

## 8.5.10 White banding or white void (in the feeding direction)

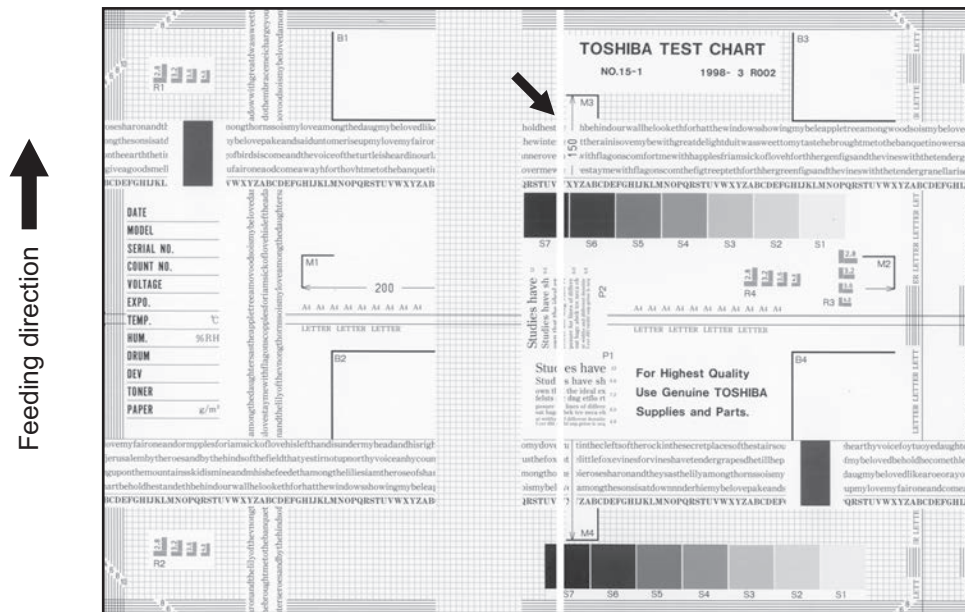


Fig.8-35

Defective area	Step	Check items	Prescription
Laser optical unit	1	Is there a foreign matter or stain on the slit glass?	Remove the foreign matter or stain.
Main charger grid	2	Is there a foreign matter or dew on the charger grid?	Remove the foreign matter.
Toner cartridge	3	Is the adhered foreign matter blocking the laser light path?	Remove the foreign matter.
Developer unit	4	Is the floated lid of the developer bottle blocking the laser light path?	Check the lid and place it properly.
	5	Is the developer material transported properly?	Remove the foreign matter if there is any. *1)
	6	Is there a foreign matter or dew on the drum seal?	Remove the foreign matter or dew.
	7	Is the upper drum seal of the developer unit in contact with the drum?	Correct the position of the drum seal or replace it.
Drum	8	Is there a foreign matter on the drum surface?	Replace the drum. If there is a convex foreign matter adhering to the drum surface, it indicates that the blade edge at this area is worn out. In this case, replace both the drum and the drum cleaning blade.
Transport path	9	Does the toner image contact with any foreign matter before the paper enters the fusing section after the separation?	Remove the foreign matter.
Discharge LED	10	Is any of the discharge LEDs off?	Replace the discharge LED.
	Scanner	11	Is there a foreign matter on the light path?
	12	Are the original glass (especially the position of shading correction plate) mirror and lens dirty?	Clean them.

Defective area	Step	Check items	Prescription
Cleaner	13	Is there any foreign matter, which contacts the drum on the cleaner stay?	Remove the foreign matter.

\*1) Prescription for foreign matter in the doctor sleeve gap

- Pull the doctor blade in the direction of the arrow.
- Rotate the gear.
- Remove the foreign matter that has come out on the developer sleeve.

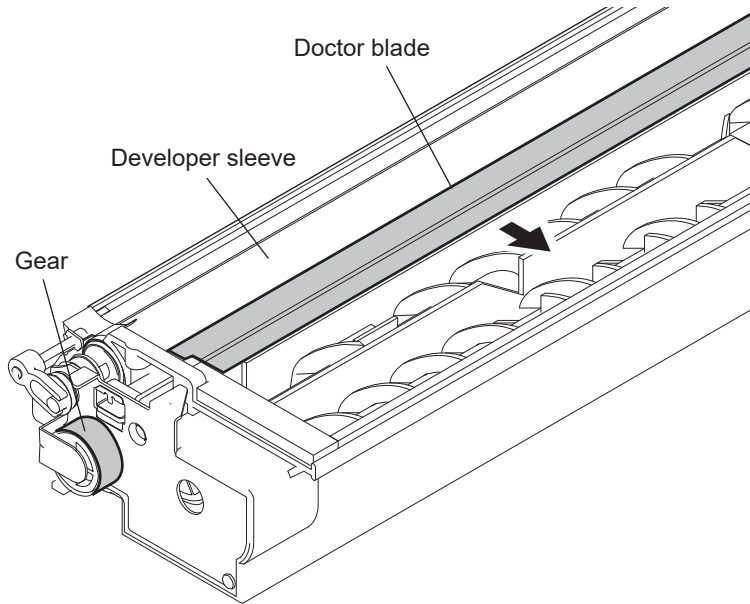


Fig.8-36



## 8.5.11 White banding (at right angle with the feeding direction)

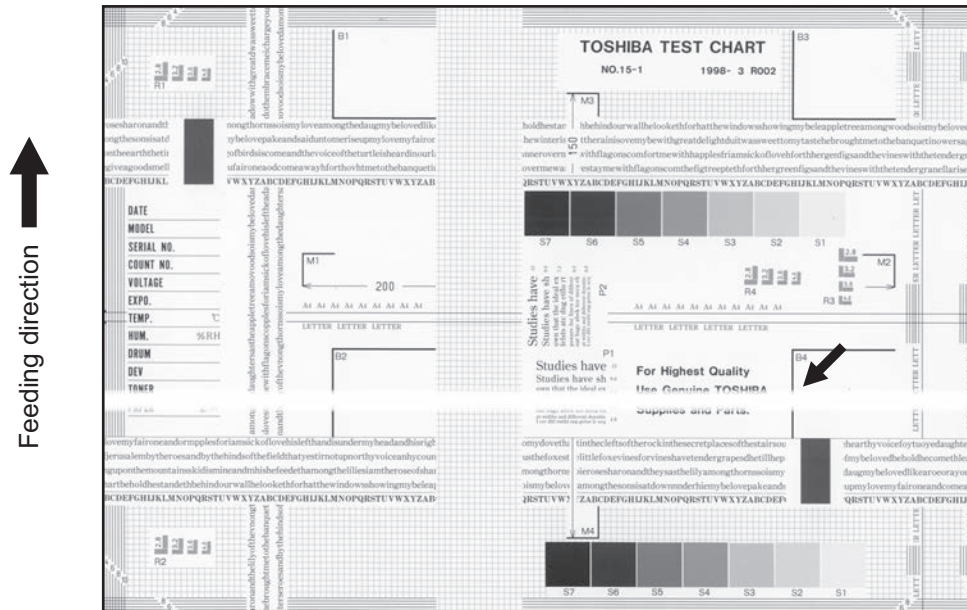


Fig.8-37

Defective area	Step	Check items	Prescription
Main charger	1	Is there a foreign matter on the charger?	Remove the foreign matter.
	2	Is the connector in proper contact with the terminal?	Clean or adjust the terminal.
Drum	3	Is there any abnormality on the drum surface?	Replace the drum.
Discharge LED	4	Does the discharge LED light normally?	Replace the discharge LED or check the harness and the circuit.
Developer unit	5	Is the developer sleeve rotating normally? Is there any abnormality on the sleeve surface?	Check the drive system of the developer unit, or clean the sleeve surface.
Drive system	6	Are the drum and scanner jittering?	Check each drive system.
High-voltage transformer (Main charger / Developer bias / Transfer roller unit)	7	Is the high-voltage transformer output defective?	Adjust the output, or replace the transformer.
Transfer roller unit	8	Is there any foreign matter adhering to the transfer roller? Is there any abnormality in the appearance of the roller? Has the number of output pages exceeded the threshold for the life of the transfer roller?	Remove the foreign matter from the roller surface. Replace the roller if there is any abnormality in its appearance. Also replace the roller if the number of output pages has exceeded the threshold of its life.
Feed system	9	Is the aligning amount proper?	Adjust the aligning amount.

## 8.5.12 Skew (inclined image)

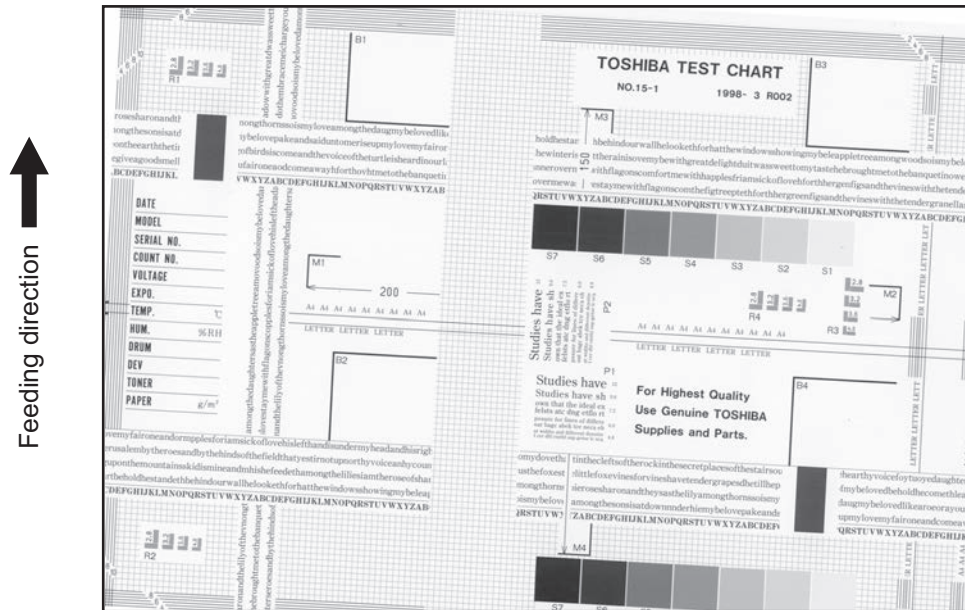


Fig.8-38

Defective area	Step	Check items	Prescription
Drawers LCF	1	Is the drawer or LCF properly installed?	Install the drawer or LCF properly.
	2	Is there too much paper in the drawer or LCF?	Reduce paper to 550 or fewer sheets in the drawer. Reduce paper to 1000 or fewer sheets in the feeding side tray and the standby side tray of LCF, respectively.
	3	Is the corner of the paper folded?	Change the direction of the paper and set it again.
	4	Are the side guides of the drawer or LCF properly installed?	Adjust the position of the side guides.
Feed roller	5	Is the surface of the feed roller dirty?	Clean the feed roller surface with alcohol, or replace the roller.
Rollers	6	Are the roller and shaft secured?	Check and tighten the E-rings, pins, clips and setscrews.
Registration roller	7	Is the spring detached from the registration roller?	Attach the spring correctly. Clean the roller if it is dirty.
Pre-registration guide	8	Is the pre-registration guide properly installed?	Correct it.
Scanner	9	Is the carriage-1 slanted?	Adjust the carriage-1.

## 8.5.13 Black banding (in the feeding direction)

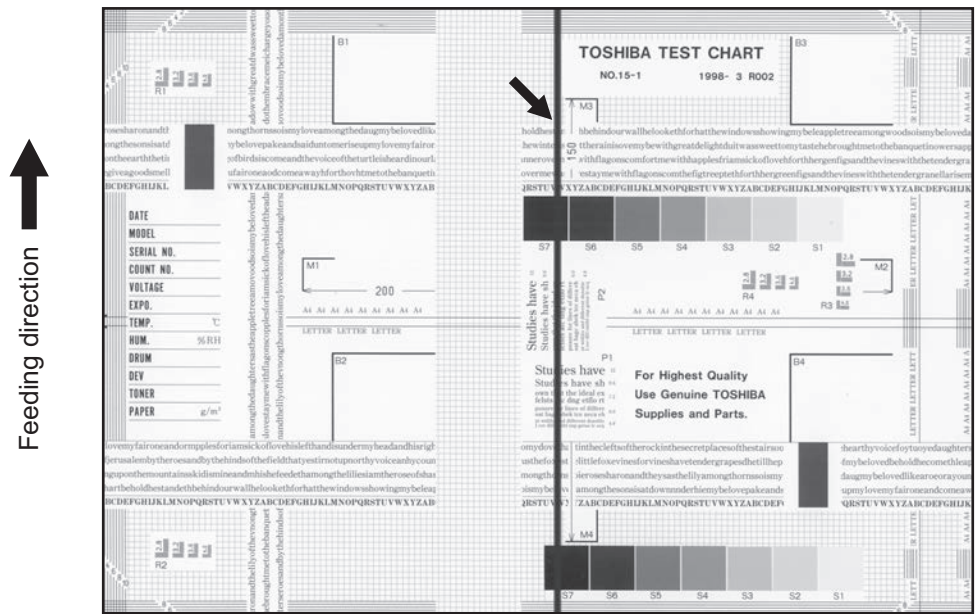


Fig.8-39

Defective area	Step	Check items	Prescription
Scanner	1	Is there a foreign matter on the light path?	Clean the slit, lens and mirrors.
	2	Is there dust or stain on the shading correction plate or ADF original glass?	Clean the plate.
	3	Disconnect the harness from the connector at the CCD board to confirm that no foreign matter is adhering to the connector and the terminal of the harness.	Clean the terminals of the connector and the harness with an air blower or brush.
Main charger	4	Is there a foreign matter on the main charger grid?	Remove the foreign matter.
	5	Is the main charger grid dirty or deformed?	Clean or replace the main charger grid.
	6	Is there a foreign matter on the main charger?	Remove the foreign matter.
	7	Is the needle electrode dirty or deformed?	Clean or replace the needle electrode.
	8	Is there a foreign matter inside the main charger case?	Remove the foreign matter.
	9	Is the inside of the main charger case dirty?	Clean the inside of the main charger case.
Cleaner	10	Is there paper dust sticking to the drum cleaning blade edge?	Clean or replace the cleaning blade.
	11	Is the drum cleaning blade working properly?	Check the pressurization of the drum cleaning blade.
	12	Has the used toner been recovered properly?	Clean the toner recovery auger.
Paper dust holder	13	Is paper dust accumulated in the paper dust holder?	Take off the paper dust holder and clean it. (Remove the paper dust.)

Defective area	Step	Check items	Prescription
Fuser unit	14	Is the fuser roller surface dirty or damaged?	Clean or replace the fuser roller.
	15	Is the thermistor dirty?	Clean the thermistor.
Drum	16	Are there scratches on the drum surface?	Replace the drum.
Laser optical unit	17	Is there a foreign matter or stain on the slit glass?	Remove the foreign matter or the stain.
SYS board	18	Disconnect the harness (between the CCD and the SYS board) from the connector at the SYS board to confirm that no foreign matter is adhering to the connector and the terminal of the harness.	Clean the terminals of the connector and the harness with an air blower or brush.

## 8.5.14 Black banding (at right angle with the feeding direction)

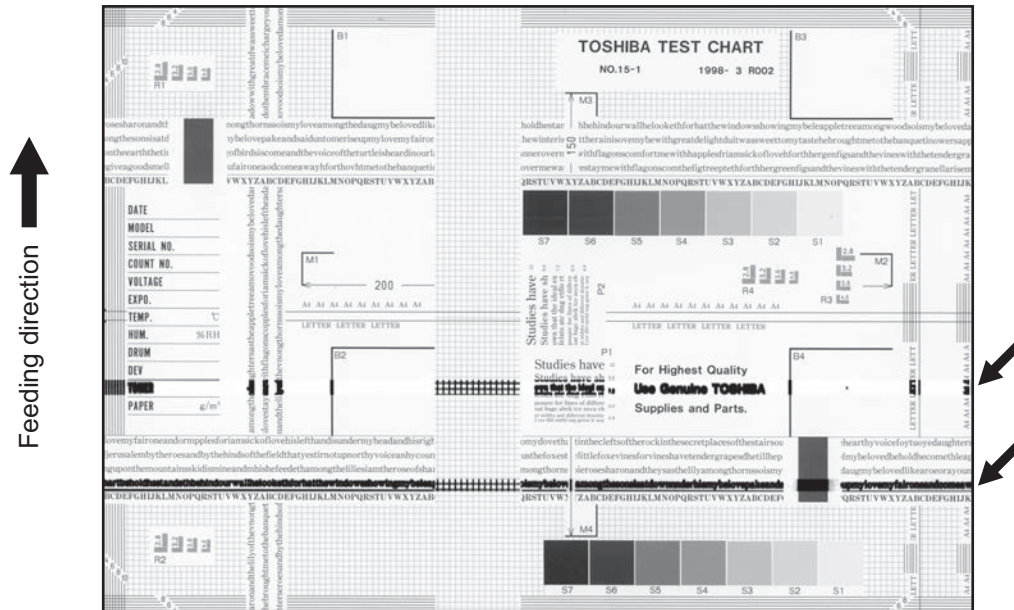


Fig.8-40

Defective area	Step	Check items	Prescription
Main charger	1	Is the needle electrode dirty or deformed?	Clean or replace the needle electrode.
Fuser unit	2	Are the fuser roller, separation finger for fuser roller and thermistor dirty?	Clean them.
	3	Has the fuser roller and separation finger for fuser roller reached their PM life?	Replace them.
High-voltage transformer (Main charger / Developer bias / Transfer roller unit)	4	Is the high-voltage transformer output defective?	Adjust the output, or replace the transformer.
Drum	5	Is there a deep scratch on the drum surface?	Replace the drum if the scratch has reached the aluminum base.
	6	Is there thin scratch (drum pitting) on the drum surface?	Check and adjust the contact condition of the cleaning blade and recovery blade.
Scanner	7	Is there a foreign matter on the carriage rail?	Remove the foreign matter.

## 8.5.15 White spots



Fig.8-41

Defective area	Step	Check items	Prescription
Developer unit, Toner cartridge	1	Is the toner density in the developer material appropriate?	Check and correct the auto-toner sensor and toner supply operation. Check if the amount of the toner is sufficient in the toner cartridge.
	2	Is the doctor-sleeve gap proper?	Adjust the doctor-sleeve gap.
Developer material, Toner, Drum	3	Using the specified developer material, toner and drum?	Use the specified developer material, toner and drum.
	4	Have the developer material and drum reached their PM life?	Replace the developer material and drum.
	5	Is the storage environment of the toner cartridge 35°C or less without dew?	Use the toner cartridge stored in the environment with specification.
	6	Is there any dent on the drum surface?	Replace the drum.
	7	Is there any film forming on the drum?	Clean or replace the drum.
Main charger	8	Is there any foreign matter on the charger?	Remove it.
	9	Is the needle electrode dirty or deformed?	Clean or replace the needle electrode.
High-voltage transformer (Main charger / Developer bias / Transfer roller unit)	10	Is the high-voltage transformer output defective?	Adjust the output, or replace the transformer.
Transfer roller unit	11	Is there any foreign matter such as fiber in the paper transport area of the transfer roller unit?	Clean the transfer roller unit.
	12	Is there any foreign matter on the transfer roller? Is there any abnormality on its appearance?	Remove the foreign matter or replace the transfer roller.

## 8.5.16 Poor image transfer

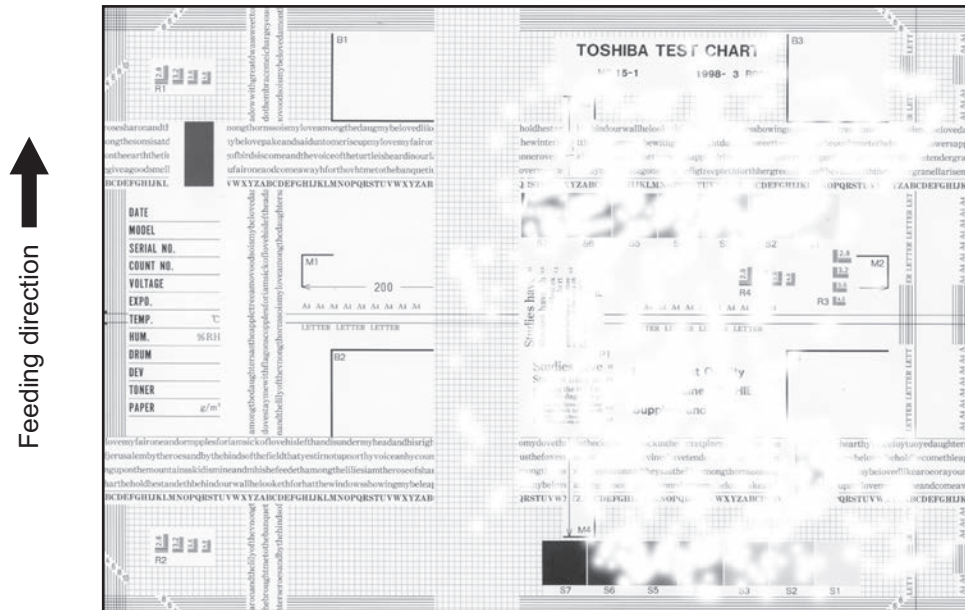


Fig.8-42

Defective area	Step	Check items	Prescription
Paper	1	Is the paper in the drawer or LCF/ PFP curled?	Reinsert the paper with the reverse side up or change the paper.
	2	Is the paper in the drawer or LCF damp?	Avoid storing paper in damp place.
	3	Is the paper type corresponding to its mode?	Select the proper mode.
	4	Using the recommended paper?	Use the recommended paper.
Transfer roller unit	5	Is the transfer roller contacting with the drum? Are the charger pushing-spring and the transfer roller pressure spring installed properly?	Check them and reinstall if required.
Registration roller	6	Is there any abnormality related to the registration roller or with the roller itself?	Clean the roller if it is dirty. Securely attach the springs if they are detached. Replace the clutch if it is defective. Adjust the rotation speed of the roller.
High-voltage transformer (Transfer roller unit)	7	Is the high-voltage transformer output defective?	Adjust the output, or replace the transformer.

## 8.5.17 Uneven image density

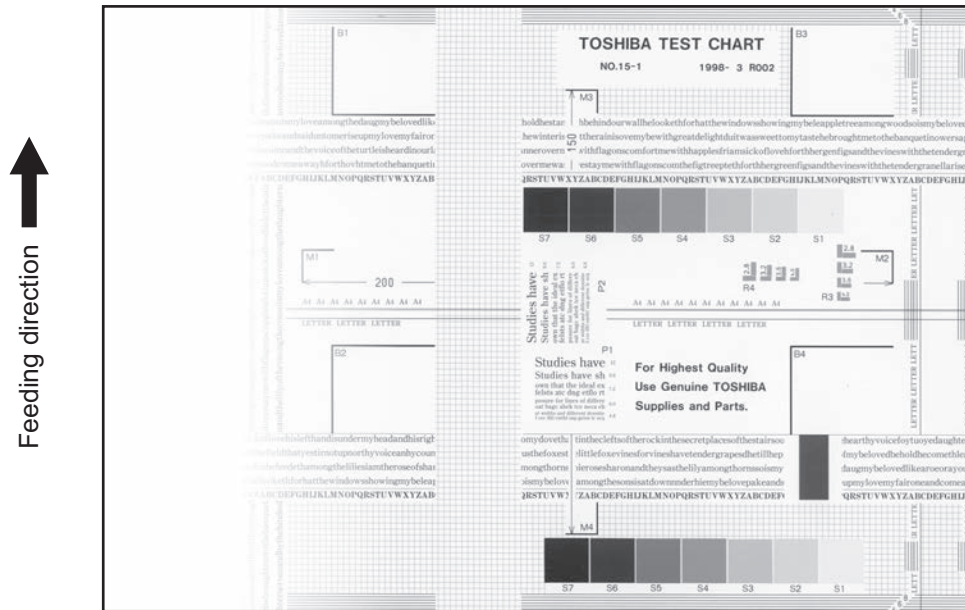


Fig.8-43

Defective area	Step	Check items	Prescription
Main charger	1	Is the main charger dirty?	Clean or replace the needle electrode and main charger grid.
Transfer roller unit	2	Is the transfer roller contacting with the drum? Are the charger pushing-spring and the transfer roller pressure spring installed properly?	Check them and reinstall if required.
Laser optical unit	3	Is there any foreign matter or stain on the slit glass?	Remove the foreign matter or stain.
Discharge LED	4	Are the connectors of discharge LED harness securely connected?	Reconnect the harness securely.
	5	Is the discharge LED dirty?	Clean the discharge LED.
	6	Is any of the discharge LEDs off?	Replace the discharge LED.
Developer unit	7	Is the magnetic brush in proper contact with the drum?	Adjust the doctor-sleeve gap.
	8	Is the developer sleeve pressurization mechanism working?	Check the mechanism.
	9	Is the developer material transported normally?	Remove foreign matters if there is any.
Scanner	10	Is the original cover or RADF opened?	Close the original cover or RADF.
	11	Are the original glass (especially the position of shading correction plate), mirror and lens dirty?	Clean them.



## 8.5.18 Faded image (low density, abnormal gray balance)

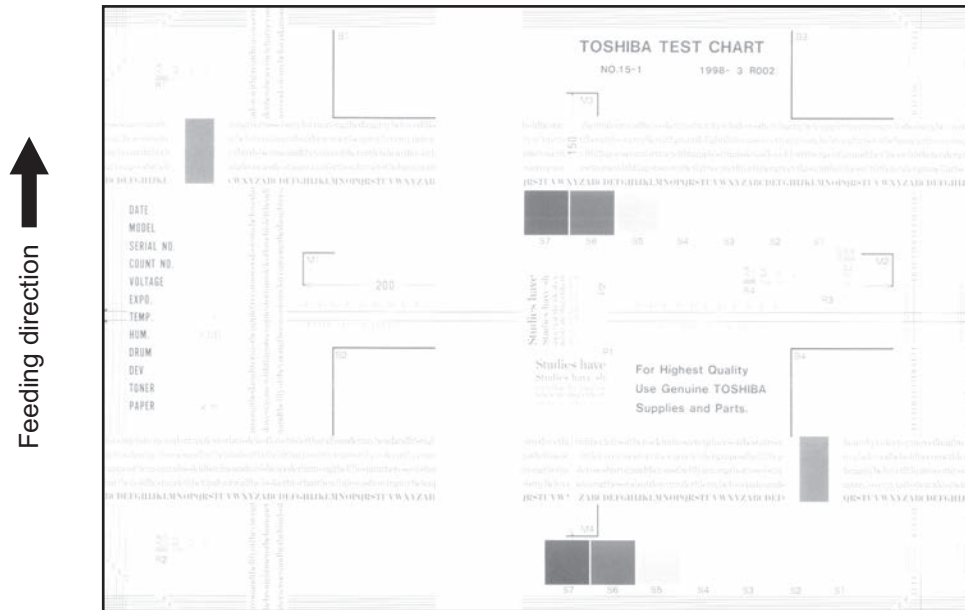


Fig.8-44

Defective area	Step	Check items	Prescription
Toner empty	1	Is "ADD TONER" symbol lit?	Replace the toner cartridge.
Auto-toner circuit	2	Is there enough toner in the cartridge?	Check the performance of the auto-toner circuit.
	3	Is the toner density in the developer material too low?	
Toner motor	4	Is the toner motor working normally?	Check the toner motor and the motor drive.
Toner cartridge	5	Is there any problem with the toner cartridge?	Replace the toner cartridge.
Developer material	6	Has the developer material reached its PM life?	Replace the developer material.
Developer unit	7	Is the magnetic brush in proper contact with the drum?	Check the installation of the developer unit. Adjust the doctor-sleeve gap and polarity.
	8	Is the developer sleeve pressurization mechanism working?	Check the mechanism.
Main charger	9	Is the main charger dirty?	Clean it or replace the needle electrode and main charger grid.
Drum	10	Is "film-forming" occurring on the drum surface?	Clean or replace the drum.
	11	Has the drum reached its PM life?	Replace the drum.
Transfer roller unit	12	Is the transfer roller contacting with the drum? Is the transfer roller pressure spring installed properly?	Check them and reinstall if required.
High-voltage transformer	13	Is the setting for the high-voltage transformer proper?	Adjust the output from the high-voltage transformer.
	14	Are the connectors of the high-voltage harness securely connected? Is the harness open circuited?	Reconnect the harness securely. Replace the high-voltage harness.
Discharge LED	15	Are the connectors of discharge LED harness securely connected?	Reconnect the harness securely.

## 8.5.19 Image dislocation in feeding direction

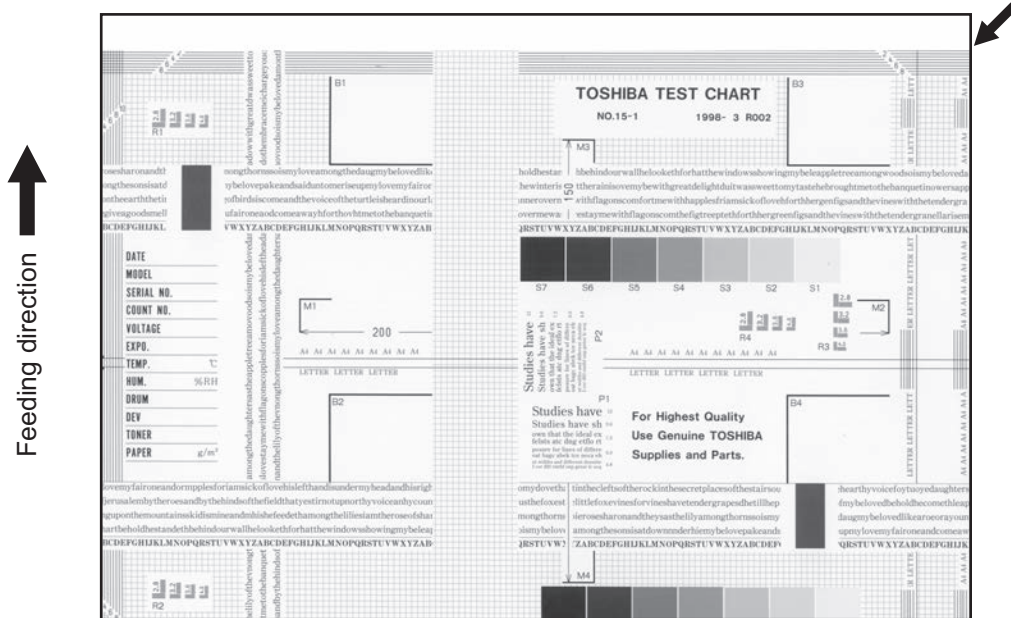


Fig.8-45

Defective area	Step	Check items	Prescription
Scanner/Printer adjustment	1	Have the printed images been dislocated in the same manner?	Adjust the position of the leading edge of paper in the Adjustment Mode.
Registration roller	2	Is the registration roller dirty, or the spring detached?	Clean the registration roller with alcohol. Securely attach the springs.
	3	Is the registration roller working properly?	Adjust or replace the gears if they are not engaged properly.
Feed clutch	4	Is the feed clutch working properly?	Check the circuit or feed clutch, and replace them if necessary.
Pre-registration guide	5	Is the pre-registration guide installed properly?	Install the guide properly.

## 8.5.20 Jittering image

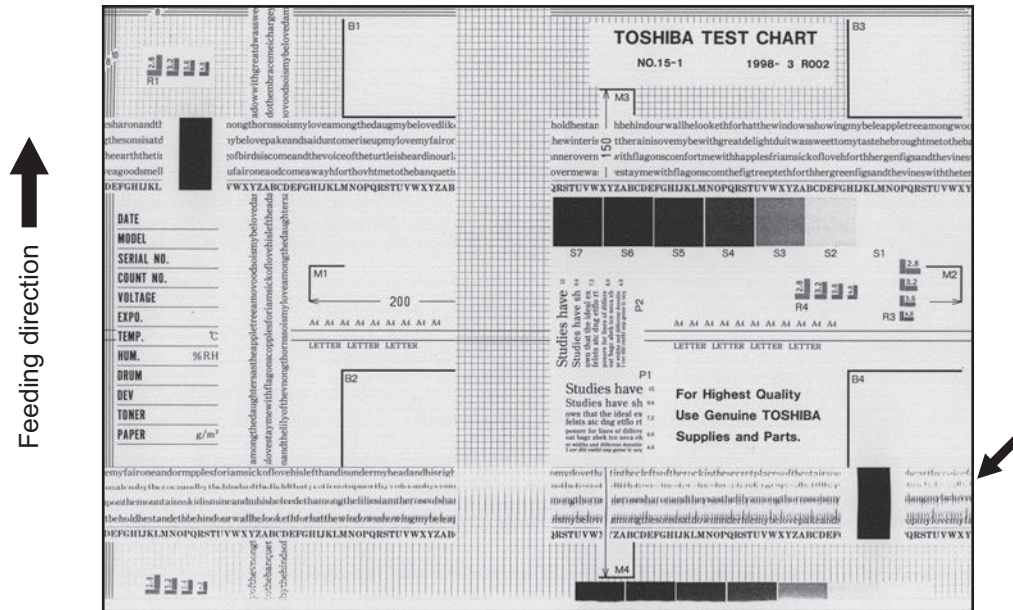


Fig.8-46

Defective area	Step	Check items	Prescription
—	1	Is the toner image on the drum normal?	If normal, perform steps 2 to 4. Perform step 5 and followings in case the image is abnormal.
Registration roller	2	Is the registration roller rotating normally?	Check the registration roller area and springs for installation condition.
Fuser roller and pressure roller	3	Are the fuser roller and pressure roller rotating normally?	Check the fuser roller area. Replace the rollers if necessary.
Drum	4	Is there a big scratch on the drum?	Replace the drum.
Operation of carriage	5	Is there any problem with the carriage foot?	Replace the carriage foot.
	6	Is the tension of the timing belt normal?	Adjust the tension.
	7	Is there any problem with the drive system of the carriage?	Check the drive system of the carriage.
Scanner	8	Is the mirror secured?	Secure it.
Drum drive system	9	Is there any problem with the drive system of the drum?	Check the drive system of the drum. Clean or replace the gears if they have stains or scratches.

## 8.5.21 Poor cleaning

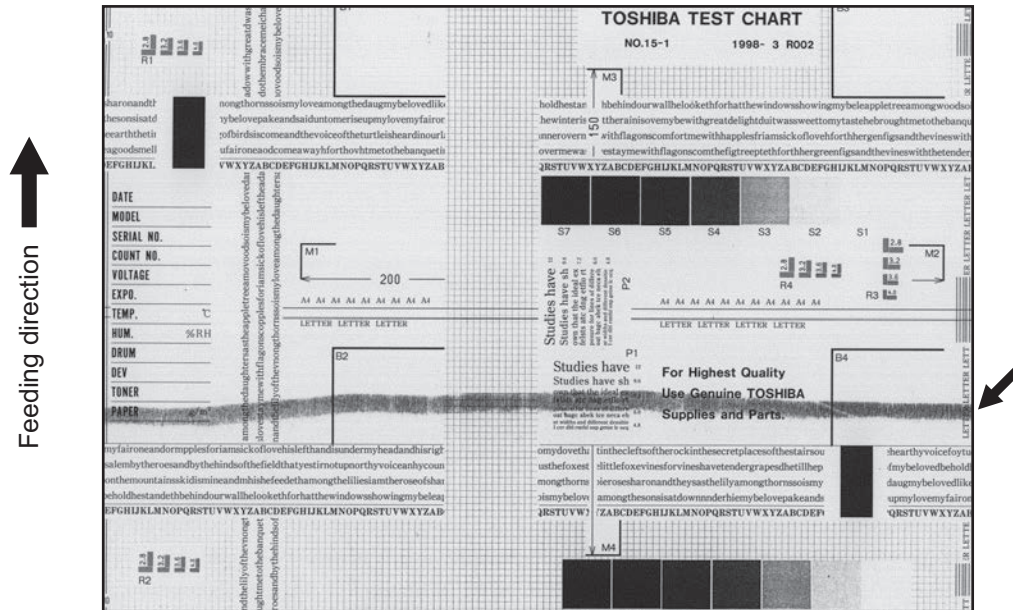


Fig.8-47

Defective area	Step	Check items	Prescription
Developer material	1	Using the specified developer material?	Use the specified developer material and toner.
Cleaner	2	Is the cleaning blade in proper contact with the drum?	Check the cleaning blade.
	3	Has the cleaning blade been turned up?	Replace the cleaning blade. Check and replace drum if necessary.
Paper dust holder	4	Is paper dust accumulated in the paper dust holder?	Take off the paper dust holder and clean it. (Remove the paper dust.)
Toner recovery auger	5	Is the toner recovered normally?	Clean the toner recovery auger. Check the pressure of the cleaning blade. Check if the toner recovery auger is rotated properly.
Fuser unit	6	Are there bubble-like scratches on the fuser roller (94 mm pitch on the image)?	Replace the fuser roller. Check and adjust the temperature control circuit.
	7	Has the fuser roller reached its PM life?	Replace the fuser roller.
	8	Is the pressure of the fuser roller normal?	Check and adjust the mechanism.
	9	Is the setting temperature of the fuser roller normal?	Check the setting and correct it. FS-08-2009, 2010, 2101, 2120, 2140, (5285: 35/45/50 ppm)

## 8.5.22 Uneven light distribution



Fig.8-48

Defective area	Step	Check items	Prescription
Original glass	1	Is the original glass dirty?	Clean the original glass.
Main charger	2	Are the needle electrode, main charger grid and main charger case dirty?	Clean or replace them.
Discharge LED	3	Is the discharge LED dirty?	Clean the discharge LED.
	4	Is any of the discharge LEDs off?	Replace the discharge LED.
Scanner	5	Are the reflector, exposure lamp, mirrors, lens, and original glass (especially the position of shading correction plate) dirty?	Clean them.
Exposure lamp	6	Is the exposure lamp tilted?	Adjust the position of the exposure lamp.
	7	Is the exposure lamp discolored or degraded?	Replace the exposure lamp.

### 8.5.23 Blotched image

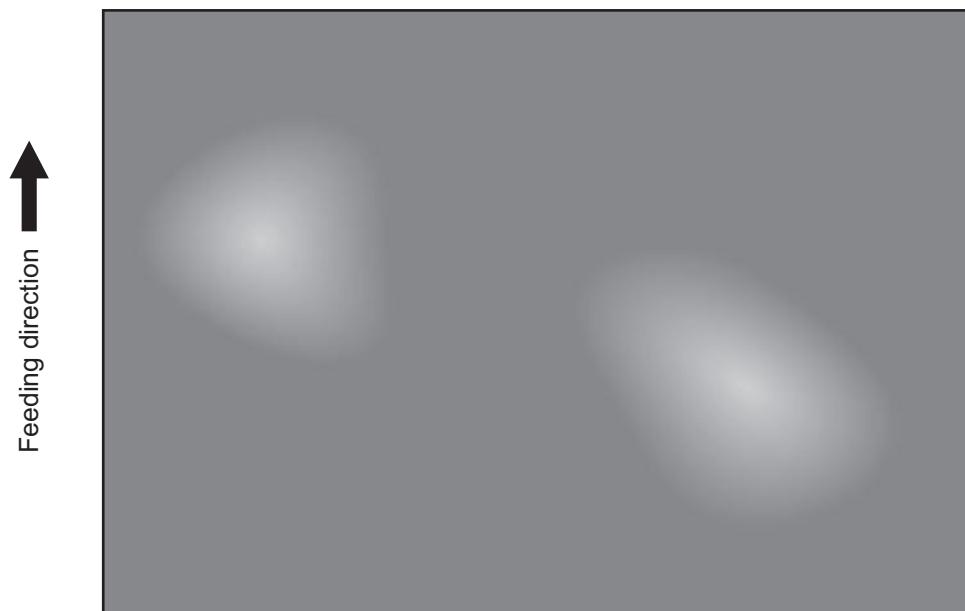


Fig.8-49

Defective area	Step	Check items	Prescription
Paper	1	Is the paper type corresponding to its mode?	Check the paper type and mode.
	2	Is the paper too dry?	Change the paper.
Transfer roller unit	3	Is the power supplying spring of the transfer roller installed securely? (Is it almost detached?)	Check the power supplying spring and reinstall it.
High-voltage transformer (Transfer roller unit)	4	Is the output from the high-voltage transformer normal?	Adjust the output. Replace the transformer if necessary.
Separation	5	Is the output from the separation charger too high?	Adjust the output, from the separation charger.

## 8.5.24 Black streaks on image leading edge during scanning

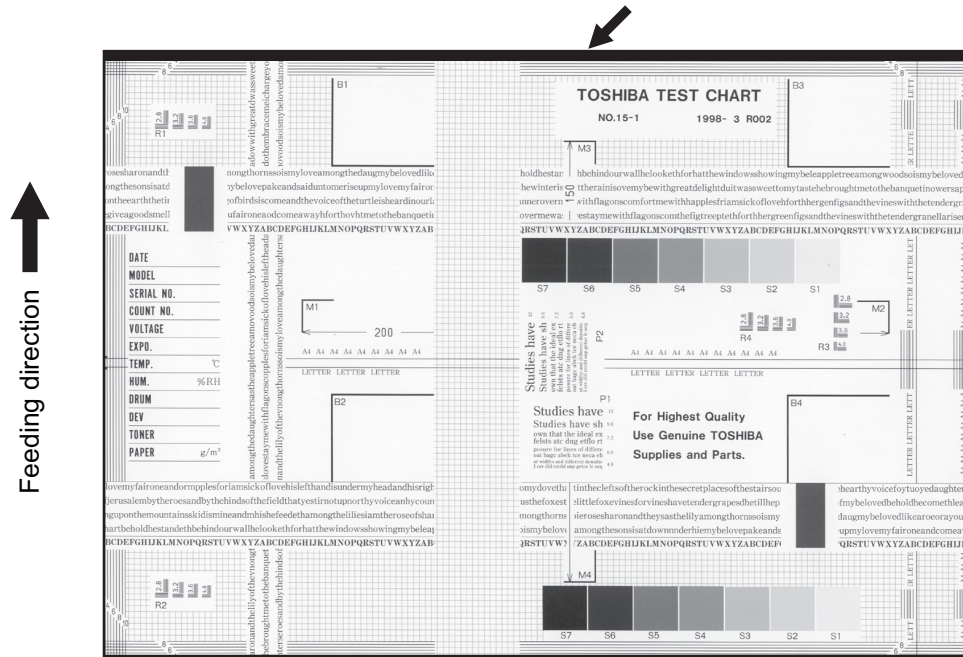


Fig.8-50

Defective area	Step	Check items	Prescription
Scanner	1	Amount of surrounding void (network scanning)	Perform 05-7489 to adjust the amount of the surrounding void during network scanning.

8.5.25 Image distortion (dogleg image)

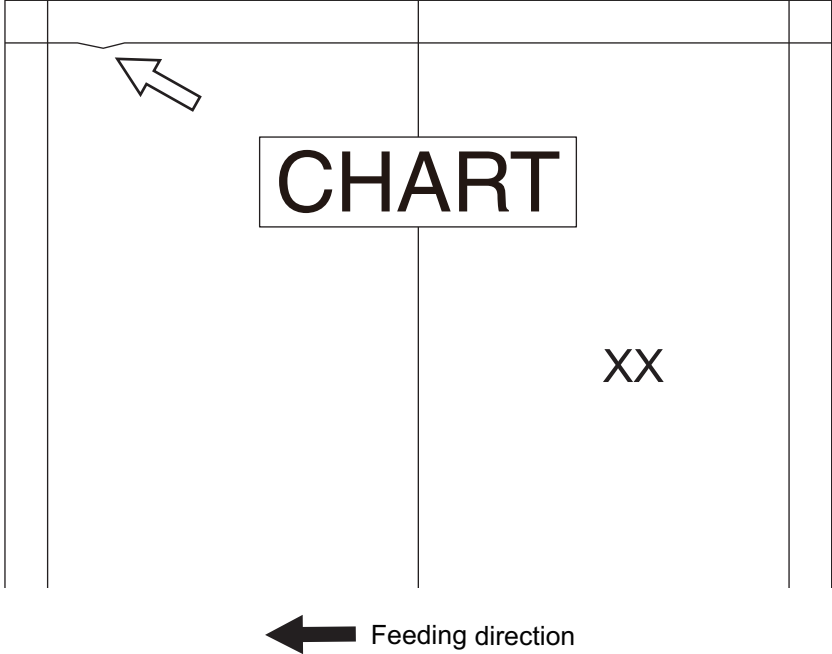


Fig.8-51

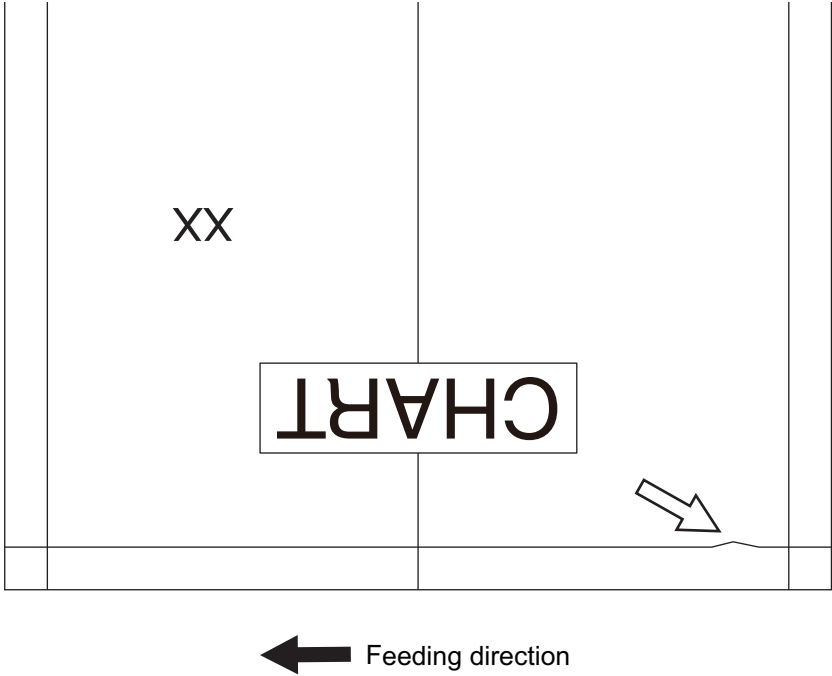


Fig.8-52

The image distortion (dogleg image) shown upper occur on the leading or trailing edge at the back side of the copied or scanned paper while the DSDF was used.



Cause/Section	Step	Check item	Measures
DSDF	1	Adjustment of position / Adjustment of height	<p>Check the installation condition of the DSDF and confirm that there are no abnormalities in the adjustment for its position and height.</p> <p>📖 P. 6-72 "6.12.1 Adjustment of position"</p> <p>📖 P. 6-77 "6.12.2 Adjustment of height"</p>
	2	Adjustment of skew	<p>Perform the adjustment of image tilting at the back side.</p> <p>📖 P. 6-79 "6.12.3 Adjustment of skew"</p> <p><b>Remarks:</b></p> <p>The phenomenon tends to be reduced if the CCD module is moved in the "+" direction.</p> <p>Perform the adjustment of image tilting at the front side corresponding to the tilted amount of the back side.</p> <p><b>Notes:</b></p> <ul style="list-style-type: none"> <li>• When this adjustment is performed, the entire image may be tilted.</li> <li>• Even if this adjustment is performed, a dogleg image will not be resolved completely.</li> </ul>

## 8.5.26 Image skewing on paper trailing edge

When a grid pattern is output, follow the procedure below if the image on the paper trailing edge is skewed by 1.0 mm or more.

[A] The rear side in the secondary scanning direction is longer than the front side. (Front < Rear)

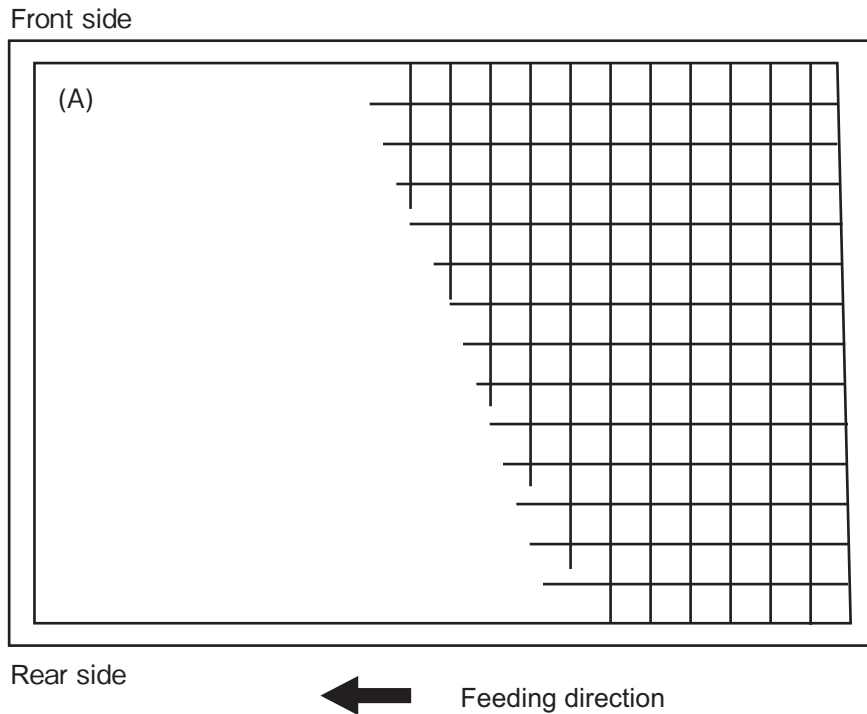


Fig.8-53

Cause/Section	Step	Check Item	Measures
Fuser unit	1	Fuser unit guide rail	Adjust the fuser unit guide rail (Fig.8-54) <ol style="list-style-type: none"> <li>1. Take off the fuser unit.</li> <li>2. Loosen the 1 screw [1] of the front guide rail in the fuser unit.</li> <li>3. Remove 1 screw [2] and attach it to the screw hole for adjustment [3].</li> <li>4. Move the guide rail upward by 1 mm.               <ul style="list-style-type: none"> <li>- Moving it by 1 mm changes the screw in the trailing edge by 0.65 mm.</li> <li>- There is a 1-mm scale on the part marked with [4].</li> </ul> </li> <li>5. Tighten the 1 screw [1] of the front guide rail in the fuser unit.</li> <li>6. Install the fuser unit.               <ul style="list-style-type: none"> <li>- Check that the image on the paper trailing edge is skewed by 1 mm or less after the adjustment.</li> </ul> </li> </ol>

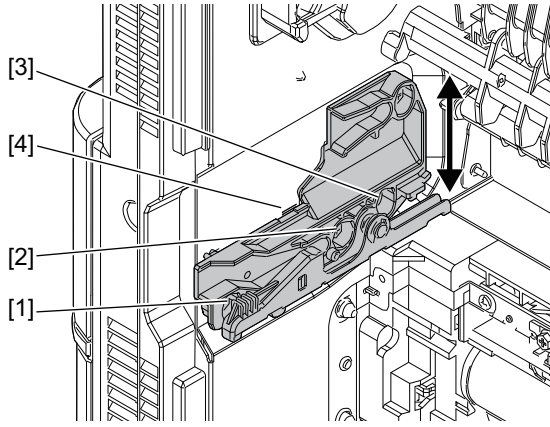


Fig.8-54

**Notes:**

Adjust the fuser unit installation position within the range “A” as shown in the figure below.

- Upper limit: The first line from the center
- Lower limit: The first line from the center

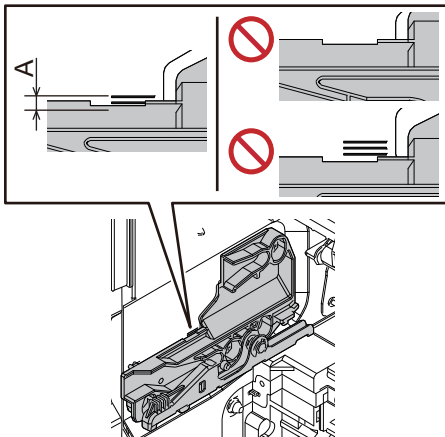


Fig.8-55

[B] The front side in the secondary scanning direction is longer than the rear side. (Front > Rear)

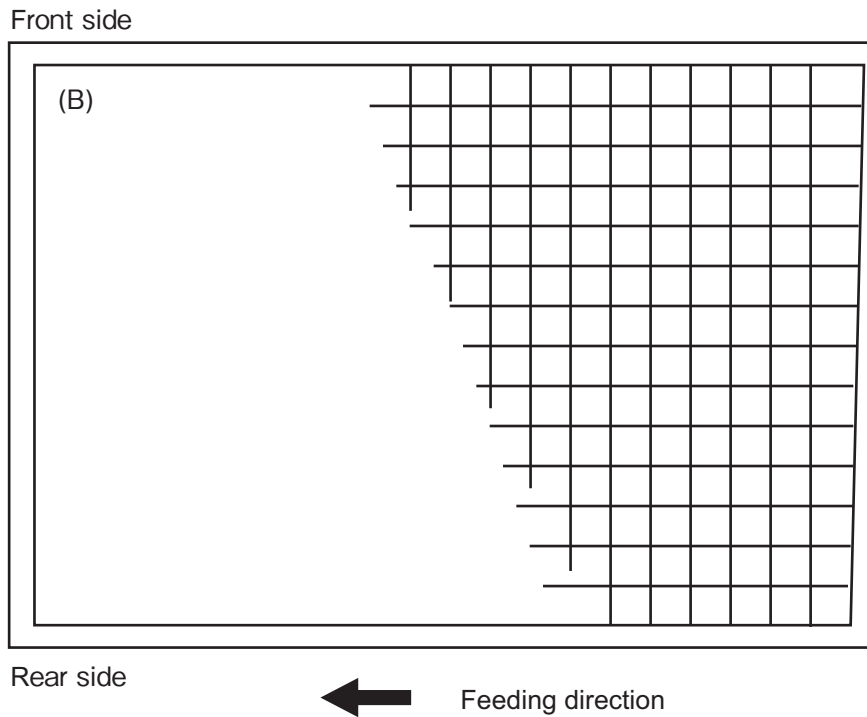


Fig.8-56

Cause/Section	Step	Check Item	Measures
Fuser unit	1	Fuser unit guide rail	<p>Adjust the fuser unit guide rail ( P. 8-445 "Fig.8-57 ")</p> <ol style="list-style-type: none"> <li>1. Take off the fuser unit.</li> <li>2. Loosen the 1 screw [1] of the front guide rail in the fuser unit.</li> <li>3. Remove 1 screw [2] and attach it to the screw hole for adjustment [3].</li> <li>4. Move the guide rail downward by 1 mm. <ul style="list-style-type: none"> <li>- Moving it by 1 mm changes the screw in the trailing edge by 0.65 mm.</li> <li>- There is 1mm scale [4].</li> </ul> </li> <li>5. Tighten the 1 screw [1] of the front guide rail in the fuser unit.</li> <li>6. Install the fuser unit. <ul style="list-style-type: none"> <li>- Check that the image on the paper trailing edge is skewed by 1 mm or less after the adjustment.</li> </ul> </li> </ol>

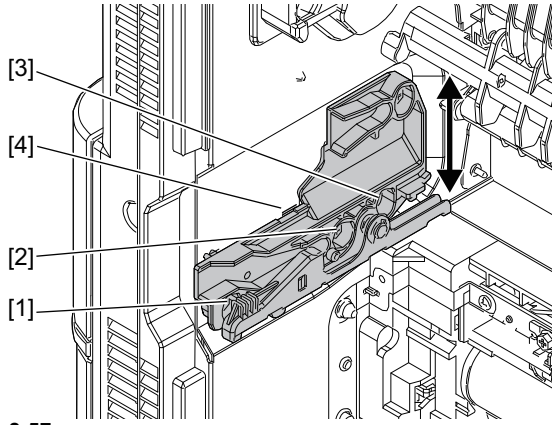


Fig.8-57

## 8.5.27 Shadow in copied/scanned images when using the DSDF



← Feeding direction

Fig.8-58

Cause/Section	Step	Check item	Measures	
Prior confirmation (MFP/DSDF adjustment condition check)	1	Check that the image dimensional adjustment of the MFP is performed properly.	If the adjustment is insufficient, perform the following items. 1. Image dimensional adjustment at the printing section 2. Image dimensional adjustment at the scanning section	If there is no problem in the adjustment condition, start the adjustment from step 3.
	2	Check that the image related adjustment of the DSDF is performed properly.	If the adjustment is insufficient, perform the following items. 1. Adjustment of the leading edge position 2. Adjustment of the horizontal position 3. Adjustment of the copy ratio	

Cause/Section	Step	Check item	Measures	
Image related adjustment of the MFP/DSDF	3	Perform scanning from the DSDF and check whether a shadow or an image void has appeared at the leading or trailing edge in the feeding direction.	If any defects occur, perform the following items. <ol style="list-style-type: none"> <li>Image dimensional adjustment at the printing section (Secondary scanning data writing start position adjustment, Reproduction ratio of the secondary scanning direction adjustment)</li> <li>Image dimensional adjustment at the scanning section (Secondary scanning data writing start position adjustment)</li> <li>Image related adjustment of the DSDF (Adjustment of the leading edge position, Adjustment of the copy ratio)</li> </ol>	
	4	Perform scanning from the DSDF and check whether a shadow or an image void has appeared at the left or right edge in the feeding and vertical direction.	If any defects occur, perform the following items. <ol style="list-style-type: none"> <li>Image dimensional adjustment at the printing section (Primary scanning data writing start position adjustment)</li> <li>Image dimensional adjustment at the scanning section (Primary scanning data writing start position adjustment)</li> <li>Image related adjustment of the DSDF (Adjustment of the horizontal position)</li> </ol>	
Copying	5	<ul style="list-style-type: none"> <li>Check whether a trailing edge shadow of an original has appeared at copying only.</li> <li>Check whether a trailing edge shadow of an original has appeared when copying is made by selecting a larger size of paper than that for an original or by reducing the size.</li> </ul>	If any defects occur, perform the following items. <ol style="list-style-type: none"> <li>Change the value of FS-08-3075 (Allowing of trailing edge adjustment of scanning) to "1" (Allowed).</li> <li>Decrease the value of FS-05-3350 (Scan trailing edge adjustment for the front side) and FS-05-3351 (Scan trailing edge adjustment for the back side) from 50 until the trailing edge shadow of an original has disappeared.</li> </ol> <p><b>Remarks:</b> When the value is decreased by "1", the image will be cut (become shorter) by 0.3 mm.</p>	This adjustment is available only for the copying function. (This adjustment cannot be performed in the scanning function.)

## 8.5.28 Scanned image abnormality

When the following abnormality has appeared on images in the scanning and copying functions even if there is no abnormality in the output images in the printing function, there will be an abnormality in the scanner. In such a case, perform this countermeasure.

Example of abnormal images

- (1) The entire image has become lighter or darker.
- (2) The entire image has been colored.
- (3) The color of the image does not match that of the original.



Fig.8-59

- Abnormality in the scanner of the equipment
  - When an abnormality in the images has occurred in scanning using the original glass
  - When an abnormality in the images has occurred in scanning using the RADF
  - When an abnormality in the images only on the front side has occurred in scanning using the DADF

Cause/Section	Step	Check item	Measures
Connector	1	Are the connectors securely connected?	<ul style="list-style-type: none"> <li>• Reconnect the connector (CN120) of the SYS board and then check the image.</li> <li>• Reconnect the connector (CN001) of the CCD board and then check the image.</li> </ul>
SYS board	2	Is there any abnormality in the SYS board?	<ul style="list-style-type: none"> <li>• If this problem still persists even after step 1 was performed, replace the SYS board and then check the image. Do not perform 05-3203 (Data transfer of characteristic value) at this time.</li> <li>• If the image condition has become better, finish this troubleshooting without carrying out 05-3203. (It is not necessary to continue to perform the subsequent steps.)</li> </ul>
CCD board	3	Is there any abnormality in the CCD board?	<ul style="list-style-type: none"> <li>• If this problem still persists even after step 2 was performed, replace the CCD board. Do not perform 05-3209 (Data transfer of characteristic value of scanner: SYS board &gt; CCD board) at this time. After replacing, check the image.</li> <li>• If the image condition has become better, finish this troubleshooting without carrying out 05-3209. (It is not necessary to continue to perform the subsequent steps.)</li> </ul>



Cause/Section	Step	Check item	Measures
SRAM	4	Is there any abnormality in the SRAM data?	<ul style="list-style-type: none"> <li>If this problem still persists even after step 3 was performed, return the CCD board to an removed one. Perform 05-3203 (Data transfer of characteristic value) and check the image.</li> <li>If the image condition has become better, finish this troubleshooting.</li> </ul>
CCD board / SRAM	5	Is there any abnormality in both the CCD board and the SRAM?	<ul style="list-style-type: none"> <li>If this problem still persists even after step 4 was performed, replace the CCD board with the one used in step 3. Perform 05-3203 (Data transfer of characteristic value) and check the image.</li> <li>If the image condition has become better, finish this troubleshooting.</li> </ul>

- Abnormality in the scanner (DSDF-CCD module) of the DSDF
  - When an abnormality in the images only on the back side has occurred in scanning using the DSDF

Cause/Section	Step	Check item	Measures
Connector	1	Are the connectors securely connected?	<ul style="list-style-type: none"> <li>Reinstall the DSDF-I/F board and check the image.</li> <li>If this problem still persists even after step 1 was performed, replace the DSDF-I/F board and then check the image.</li> <li>If the image condition has become better, finish this troubleshooting.</li> </ul>
DSDF-I/F board	2	Is there any abnormality in the DSDF-I/F board?	<ul style="list-style-type: none"> <li>If this problem still persists even after step 1 was performed, replace the DSDF-I/F board and then check the image.</li> <li>If the image condition has become better, finish this troubleshooting.</li> </ul>
SYS board	3	Is there any abnormality in the SYS board?	<ul style="list-style-type: none"> <li>If this problem still persists even after step 2 was performed, replace the SYS board and then check the image. Do not perform 05-3203 (Data transfer of characteristic value) at this time.</li> <li>If the image condition has become better, finish this troubleshooting without carrying out 05-3203. (It is not necessary to continue to perform the subsequent steps.)</li> </ul>
CCD module	4	Is there any abnormality in the DSDF-CCD module?	<ul style="list-style-type: none"> <li>If this problem still persists even after step 3 was performed, replace the DSDF-CCD module. Perform 05-3240 (Data transfer of characteristic value of the scanner) and check the image.</li> <li>If the image condition has become better, finish this troubleshooting.</li> </ul>

## 8.5.29 Drum pitch fogging

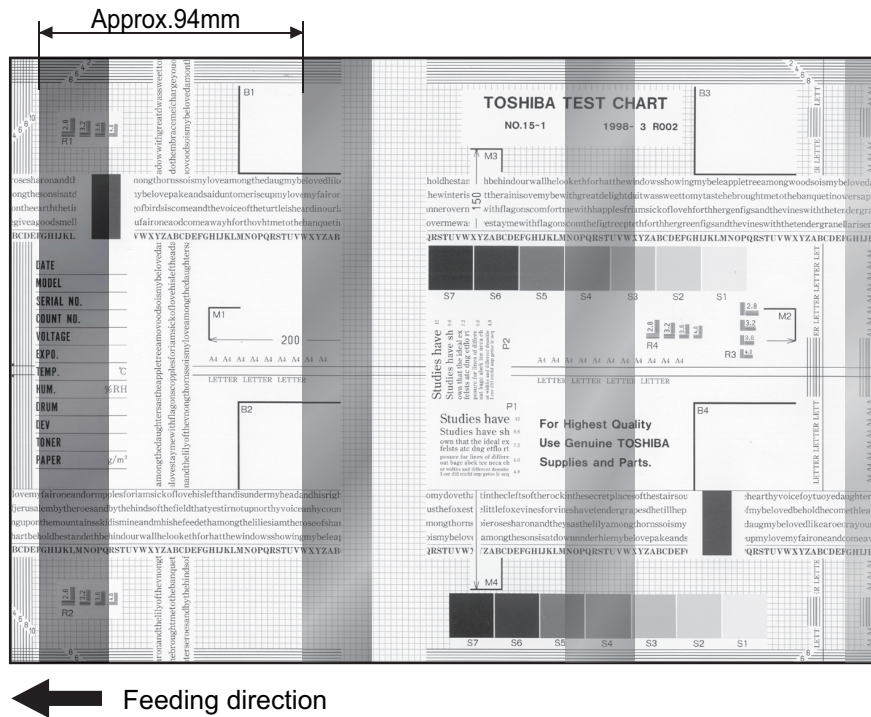


Fig.8-60

Cause/Section	Step	Check item	Measures
Image	1	Does fogging appear in at right angles to the paper feeding direction cyclically (approx. 94 mm pitch)?	<p>Set "14" (30 sec.) in FS-08-2111-0 and FS-08-2111-1 as a guide.</p> <p><b>Notes:</b> Once this adjustment has been performed, the warming-up time after power-ON and recovering from the sleep mode will become longer.</p>

### 8.5.30 If an image-related problem continues after performing all troubleshooting

If an image-related problem continues even after performing all the troubleshooting, an abnormal value may have been entered in the self-diagnostic code. In such a case, attempt the initialization of the self-diagnostic code in accordance with the table below.

**Notes:**

- Perform the list print before the initialization.
- Initialization should be performed only for the function in which the image-related problem has occurred.
- The self-diagnostic code which will be initialized is related to the image adjustment. Therefore, only problems which have occurred during the image processing can be solved. If a cause of the problem is related to the hardware or other system issues, it will not be able to be solved even if the initialization of the self-diagnostic code is performed.


Function	Self-diagnostic code to be initialized	Precautions
Copying	FS-08-7000	After the initialization has been carried out, perform automatic gamma adjustment.
Printing	FS-08-7300	After the initialization has been carried out, perform automatic gamma adjustment (600 dpi and 1200 dpi).
Scanning	FS-08-7400	None
Fax	FS-08-7500	None




## 9. REPLACEMENT OF PC BOARDS/HDD

### 9.1 Removal and Installation of PC Boards/HDD

#### Notes:

When the PC board/HDD is replaced, refer to the respective Notes and Cautions of “Replacement of PC boards and HDD” in  P. 9-14 “9.2 Precautions and Procedures for Replacing PC Boards and HDD/SSD”.

#### 9.1.1 SYS board cover

- (1) Remove the rear cover.  
 P. 4-8 “4.1.15 Rear cover”
- (2) Remove 1 screw and take off the SYS board cover [1] by sliding it toward the right side.

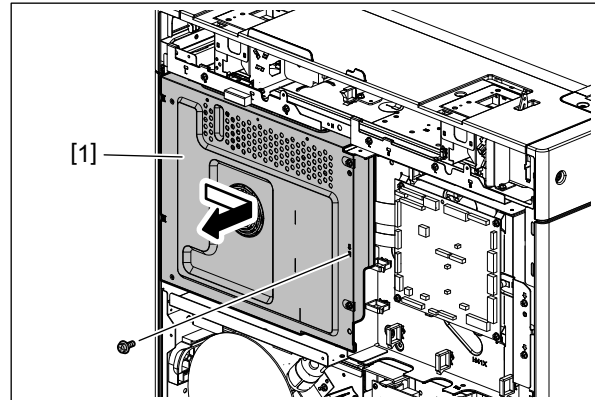



Fig. 9-1

#### 9.1.2 SYS board cooling fan (M6)

- (1) Remove the SYS board cover.  
 P. 9-1 “9.1.1 SYS board cover”
- (2) Disconnect 1 connector [1] from the SYS board.
- (3) Lift 2 latches and remove the SYS board cooling fan [2] by sliding it toward you.

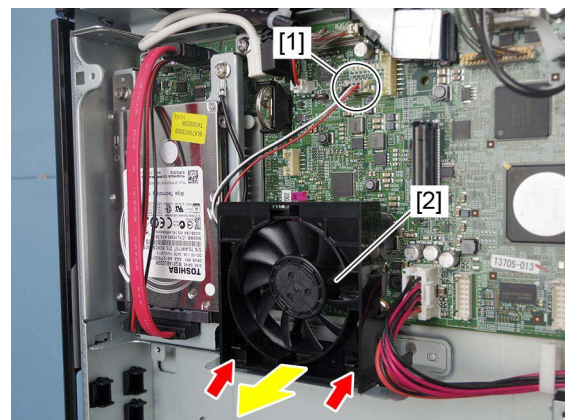


Fig. 9-2

### 9.1.3 Hard disk (HDD)

- (1) Remove the SYS board cover.  
P. 9-1 "9.1.1 SYS board cover"
- (2) Remove 4 screws and disconnect 2 connectors [1], and then take off the HDD unit [2].

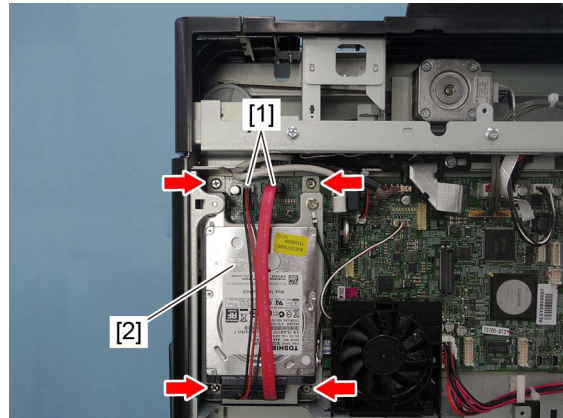


Fig. 9-3

- (3) Loosen 4 screws.

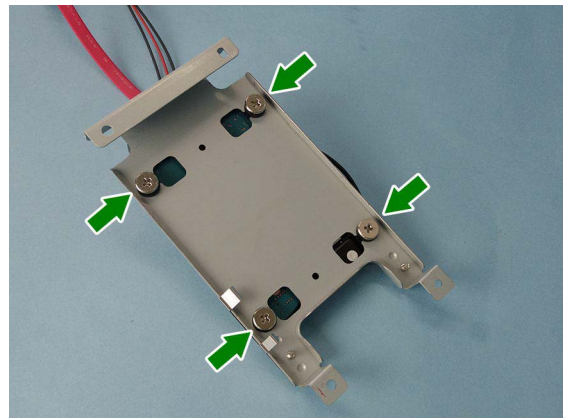


Fig. 9-4

- (4) Remove 2 screws and take off the ground cable [3]. Remove the hard disk [4] from the bracket.

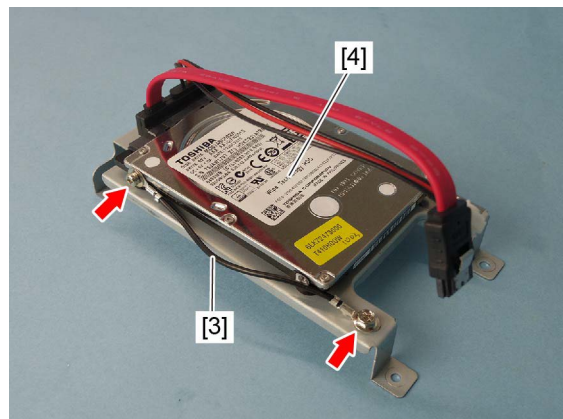


Fig. 9-5

## 9.1.4 SYS board

### Notes:

- When the SYS board or main memory has been replaced, be sure to perform the calibration of memory.
  - When performing the calibration of memory, press the [ENERGY SAVER] button and turn the power ON.
  - When the equipment is started up normally, the calibration has been completed.
  - If the calibration is not performed, the equipment may be not started up normally.
- (1) Remove the SYS Board cover.  
📖 P. 9-1 “9.1.1 SYS board cover”
  - (2) If the DSDF is installed, remove the DSDF I/F board.  
📖 P. 9-13 “9.1.13 DSDF I/F board”
  - (3) Remove the HDD unit.  
📖 P. 9-2 “9.1.3 Hard disk (HDD)”
  - (4) Remove the SYS board cooling fan.  
📖 P. 9-1 “9.1.2 SYS board cooling fan (M6)”
  - (5) Disconnect 11 connectors from the SYS board. Remove 2 flat cables [1].

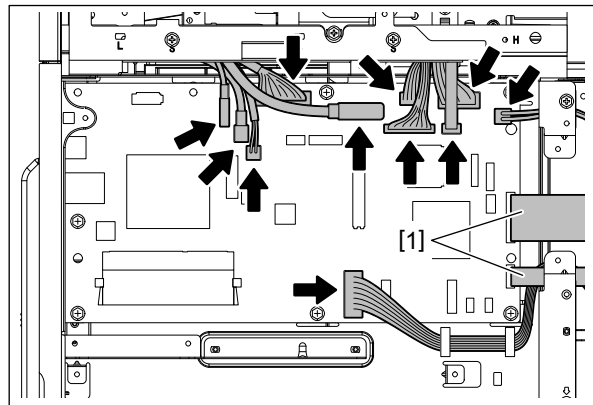


Fig. 9-6

### Notes:

- When installing the harnesses, be careful not to connect each different USB harness.  
CN112: Gray USB connector (The harness of the control panel)  
CN113: Black USB connector (The harness of the USB Hub board)
- When disconnecting the flat cable [1], release the lock by raising the flap [2] and remove the cable.
- When connecting the flat cable [1], insert it and lock it by tilting the flap [4].
- When installing the flat cables [1], do not push them in strongly.
- When installing the flat cables [1], be careful not to insert them at an angle.
- Do not apply pressure to or damage the edge of the flat cable [1].

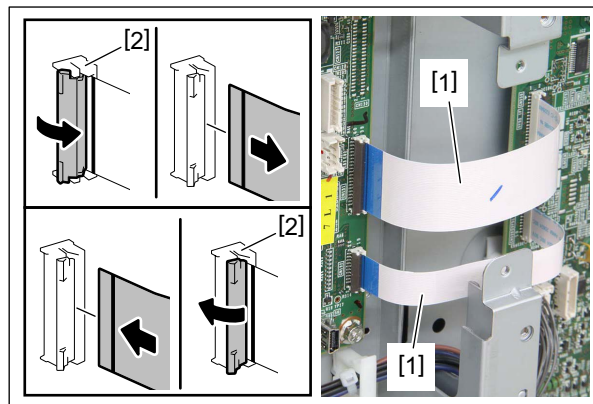


Fig. 9-7

(6) Remove 6 screws and take off the SYS board [3].

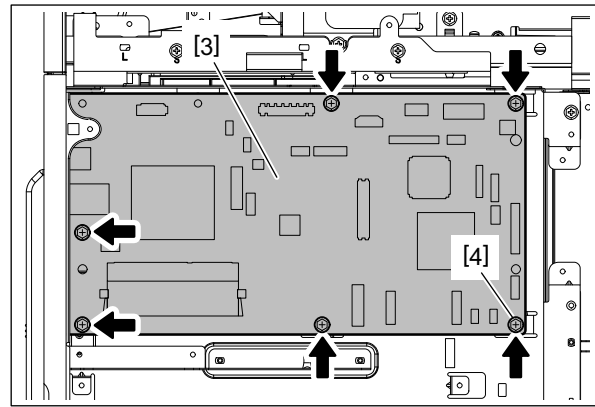


Fig. 9-8

**Notes:**

- When attaching the SYS board, tighten the screw [4] first.
- The SYS board to be installed differs depending on the models. Due to this, before replacing, be sure to check the color of the identification label on the SYS board to install the corresponding one in the equipment.
  - 4GB model: Pink
  - 2GB model: Brown
  - SSD model: Grey

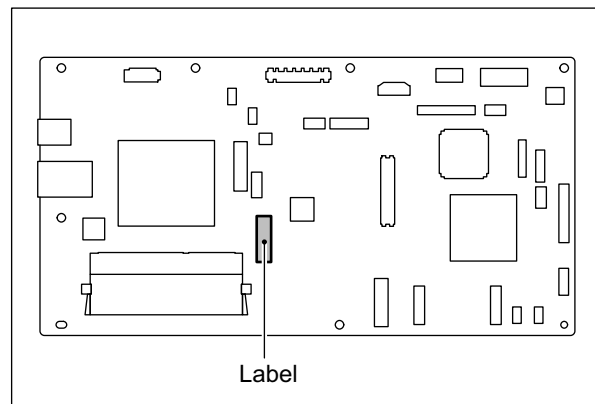


Fig. 9-9



## 9.1.5 SYS board case

- (1) Remove the SYS board cover.  
P. 9-1 "9.1.1 SYS board cover"
- (2) Disconnect 11 connectors from the SYS board. Release the lock by raising the flap and remove 2 flat cables [1].

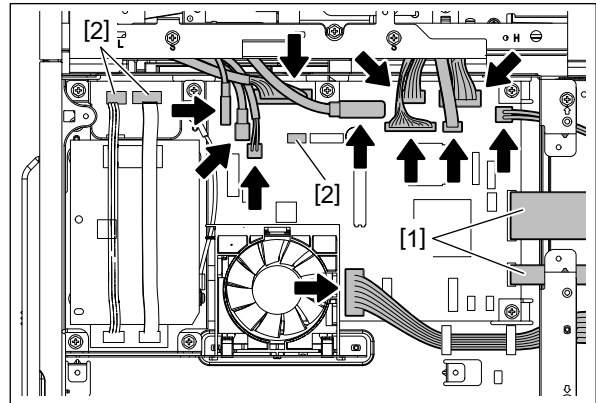


Fig. 9-10

### Notes:

- Do not disconnect 3 connectors [2] connected to the HDD and SYS board cooling fan. When installing the harnesses, be careful not to connect each different USB harness.  
CN112: Gray USB connector (The harness of the control panel)  
CN113: Black USB connector (The harness of the USB Hub board)
- When removing the flat cable [1], release the lock by raising the flap [2] and pull out the cable. When installing the flat cable [1], attach the cable to the connector and lock the cable by tilting the flap [2].  
When installing the flat cable [1], do not push it in strongly.  
When installing the flat cable [1], be careful not to insert it at an angle.  
Do not apply pressure to or damage the edge of the flat cable [1].

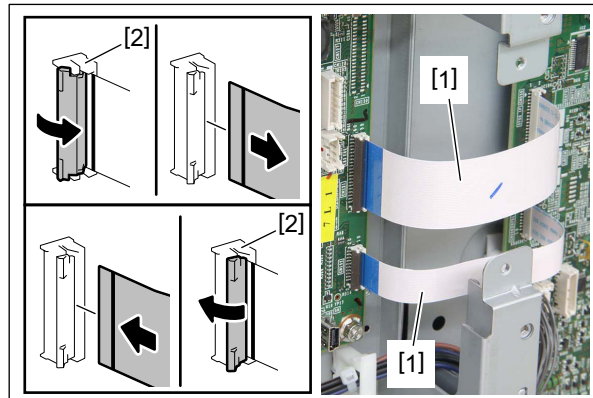


Fig. 9-11

- (3) Remove 6 screws and release the harness from the harness clamps [4]. Remove 6 screws and take off the SYS board case [5].

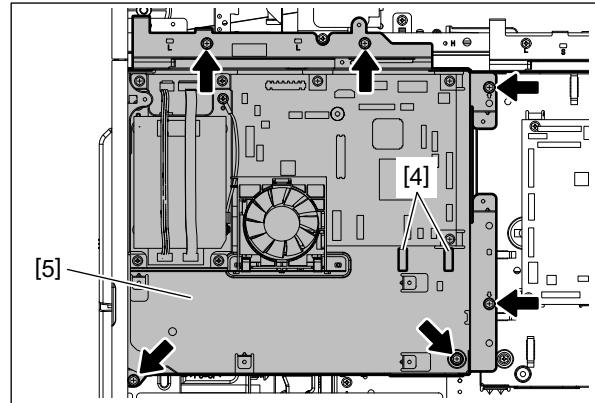



Fig. 9-12

**Notes:**

Hold the SYS board case to remove it.

## 9.1.6 LGC board

- (1) Remove the rear cover.  
 P. 4-8 "4.1.15 Rear cover"
- (2) Disconnect 16 connectors and remove the flat cable [2] connected to the LGC board [1].

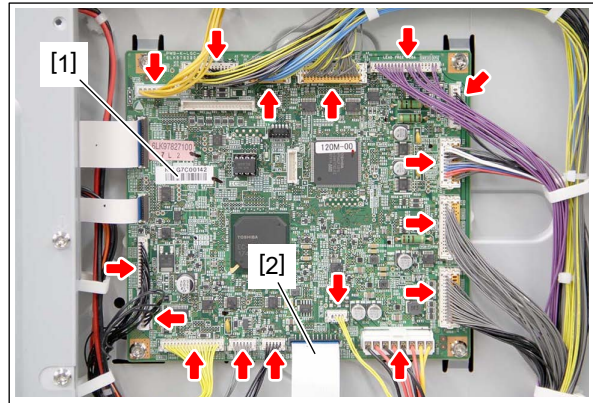


Fig. 9-13

- (3) Release the lock of the flap [3] and then remove 2 flat cables [4].

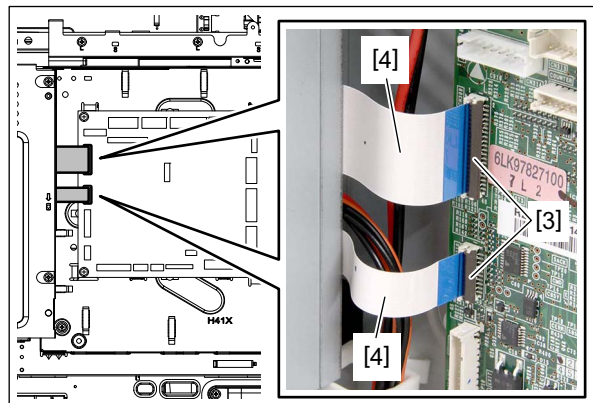


Fig. 9-14

### Notes:

- When disconnecting the flat cable [4], release the lock by raising the flap [3] and remove the cable.
- When connecting the flat cable [4], insert it and lock it by tilting the flap [3].
- When installing the flat cables [4], do not push them in strongly.
- When installing the flat cables [4], be careful not to insert them at an angle.
- Do not apply pressure to or damage the edge of the flat cable [4].

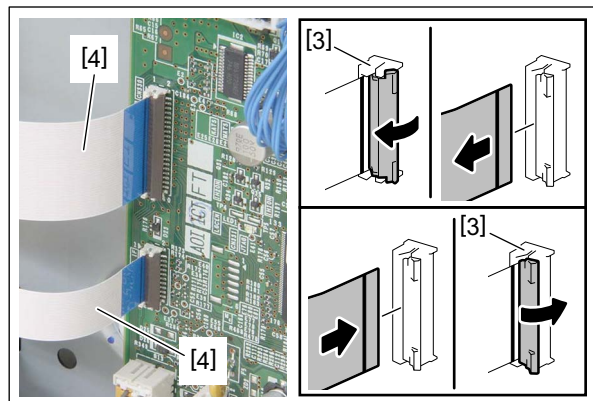


Fig. 9-15

(4) Remove 4 screws and take off the LGC board [1].

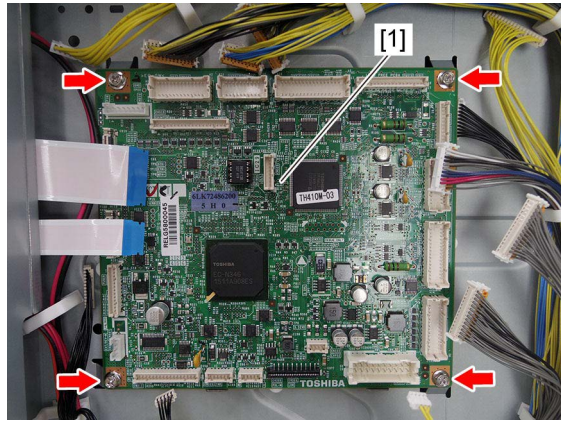


Fig. 9-16

**Notes:**

The LGC board to be installed differs depending on the models. Due to this, before replacing, be sure to check the color of the identification label on the LGC board to install the corresponding one in the equipment.

- 20ppm: White
- 25ppm: Pink
- 30ppm: Blue
- 35ppm: Yellow
- 45ppm: Green
- 50ppm: Red

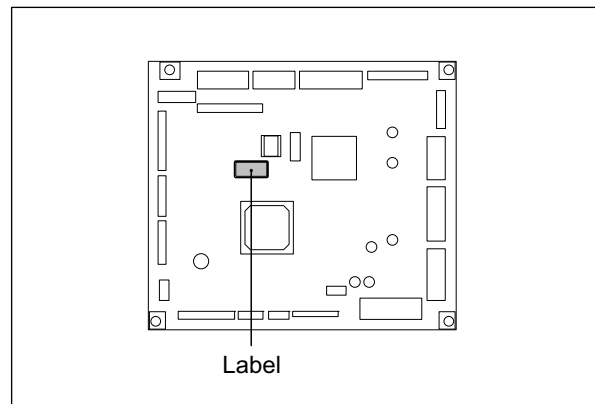


Fig. 9-17

## 9.1.7 Switching regulator

### Notes:

- Be sure to unplug the power cable before starting this work.
- Electric charge may remain in the capacitors on the switching regulator even if the main power is turned off and the plug is disconnected.
- Since there is a risk of an electric shock, pay full attention not to touch the board and mounted parts while handling the switching regulator.

- (1) Remove the left cover.  
📖 P. 4-1 “4.1.2 Left cover”
- (2) Release the harnesses from the harness clamps [1].
- (3) Remove 2 screws and slide the switching regulator unit [2] slightly toward you.

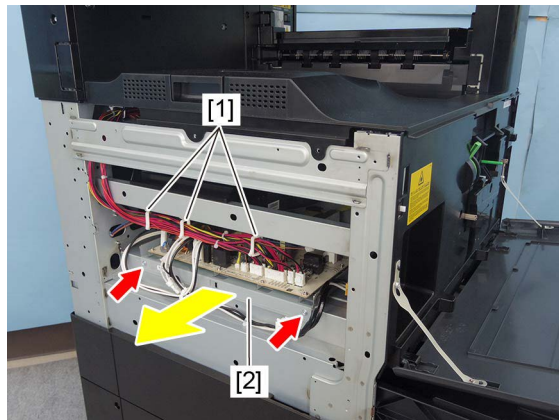


Fig. 9-18

- (4) Disconnect 11 connectors. Slide the switching regulator unit [2] toward you and take it off.

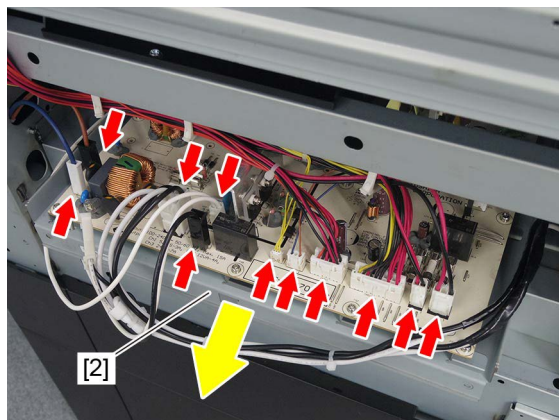


Fig. 9-19

### 9.1.8 High-voltage transformer (HVT)

**Notes:**

Be sure to unplug the power cable before starting this work.

- (1) Remove the rear cover.  
P. 4-8 "4.1.15 Rear cover"
- (2) Remove 5 screws.

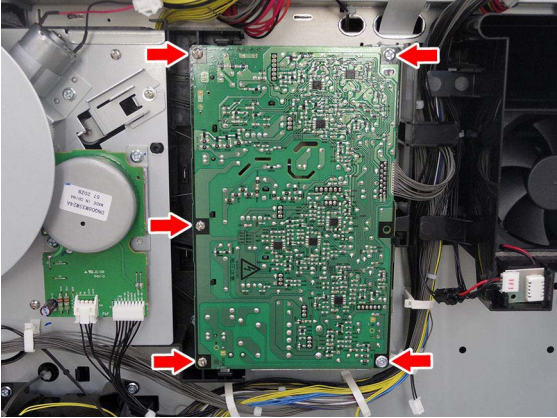


Fig. 9-20

- (3) Release 3 hooks and turn over the high-voltage transformer [1].

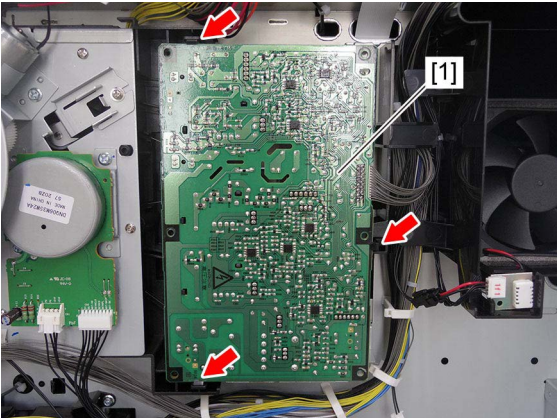


Fig. 9-21

- (4) Disconnect 1 connector and remove the high-voltage transformer [1].

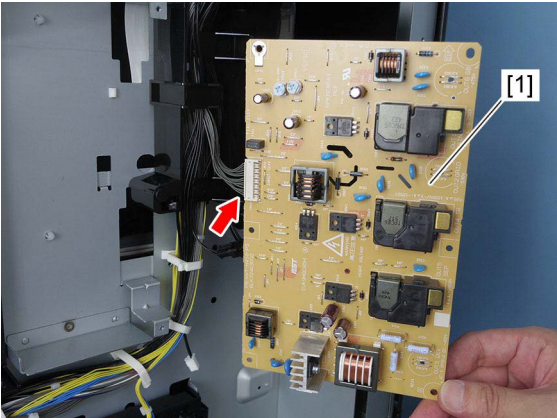


Fig. 9-22

## 9.1.9 SRAM

- (1) Remove the rear cover.  
📖 P. 4-8 “4.1.15 Rear cover”
- (2) Remove the HDD unit.  
📖 P. 9-2 “9.1.3 Hard disk (HDD)”
- (3) Remove the SRAM [2] from the SYS board [1].

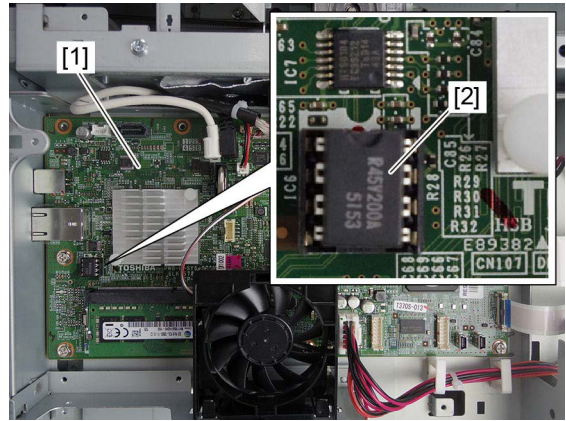


Fig. 9-23

### Notes:

- Be careful not to damage the SRAM when removing the SRAM from the SYS board.
- When installing the SRAM, pay attention to the orientation. Install the SRAM with its concave portion up.

## 9.1.10 Main memory (DIMM)

### Notes:

- When the SYS board or main memory has been replaced, be sure to perform the calibration of memory.
- When performing the calibration of memory, press the [ENERGY SAVER] button and turn the power ON.
- When the equipment is started up normally, the calibration has been completed.
- If the calibration is not performed, the equipment may be not started up normally.

- (1) Remove the SYS board cooling fan.  
📖 P. 9-1 “9.1.2 SYS board cooling fan (M6)”
- (2) Remove the HDD unit.  
📖 P. 9-2 “9.1.3 Hard disk (HDD)”
- (3) Release 2 latches and remove the main memory [2] from the SYS board [1].

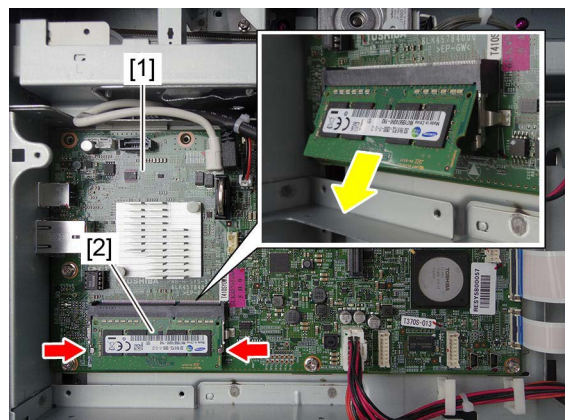



Fig. 9-24

### 9.1.11 EEPROM

- (1) Remove the rear cover.  
 P. 4-8 “4.1.15 Rear cover”
- (2) Remove the EEPROM [2] from the LGC board [1].

#### Notes:

- Be careful not to damage the EEPROM when removing it from the LGC board.
- When installing the EEPROM, pay attention to the orientation. Install the EEPROM with its concave portion up.

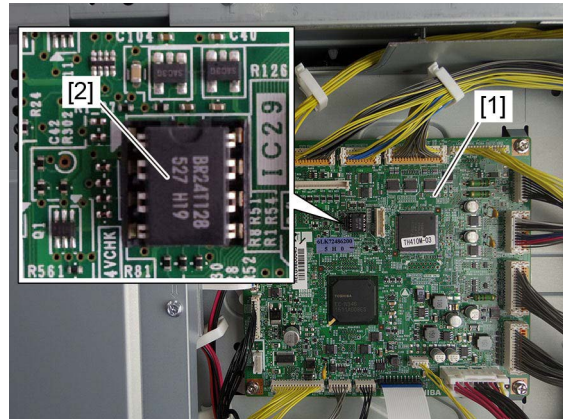




Fig. 9-25

### 9.1.12 Switching regulator cooling fan (M7)

- (1) Remove the rear cover.  
 P. 4-8 “4.1.15 Rear cover”
- (2) Remove the temperature/humidity sensor.  
 P. 4-110 “4.7.12 Temperature/humidity sensor (S19)”
- (3) Remove 2 screws and disconnect 1 connector [3], and then take off the switching regulator cooling fan [4].

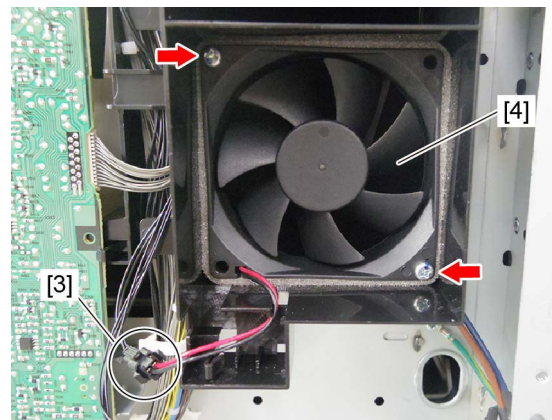


Fig. 9-26



### 9.1.13 DSDF I/F board

- (1) Remove the SYS board cover.  
☞ P. 9-1 “9.1.1 SYS board cover”
- (2) Remove 1 locking support and 2 screws, and then take off the DSDF I/F board.

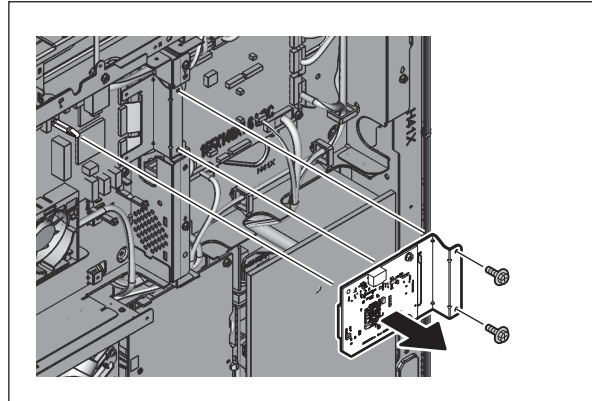








Fig. 9-27

## 9.2 Precautions and Procedures for Replacing PC Boards and HDD/SSD

### 9.2.1 Precautions when replacing PC boards

- If more than one of the LGC board and the SYS board require replacement, replace them in the following procedure.
  1. First, replace one of the board to be replaced.
  2. Turn the power ON and confirm that “READY” is displayed.
  3. Turn the power OFF.
  4. Replace another board that requires replacement.
  5. Repeat steps 2 to 4.
  6. Do not replace the LGC board and the EEPROM together.
- To replace the HDD/SSD, see the following procedure.  
 P. 9-18 “9.2.3 Precautions and procedures when replacing the HDD/SSD”
- To replace the SYS board, see the following procedure.  
 P. 9-22 “9.2.4 Precautions and procedures when replacing the SYS board”
- To replace the LGC board, see the following procedure.  
 P. 9-31 “9.2.6 Procedures when replacing the LGC board”
- To replace the SRAM, see the following procedures.  
 P. 9-26 “9.2.5 Precautions and procedure when replacing the SRAM”
- To replace the EEPROM, see the following procedures.  
 P. 9-31 “9.2.7 Procedures and settings when replacing EEPROM (for LGC board)”
- To replace the DSP board, see the following procedures.  
 P. 6-69 “6.11 Control Panel Calibration”

## 9.2.2 HDD/SSD fault diagnosis

This code displays the HDD/SSD operation history, which is recorded in the HDD/SSD, on the control panel. HDD/SSD failure can be diagnosed or predicted with the information displayed.

### 1. Display

The following screen is displayed with setting code FS-08-9065. You can also refer to the same information by perform HS-75-[SMART Info].

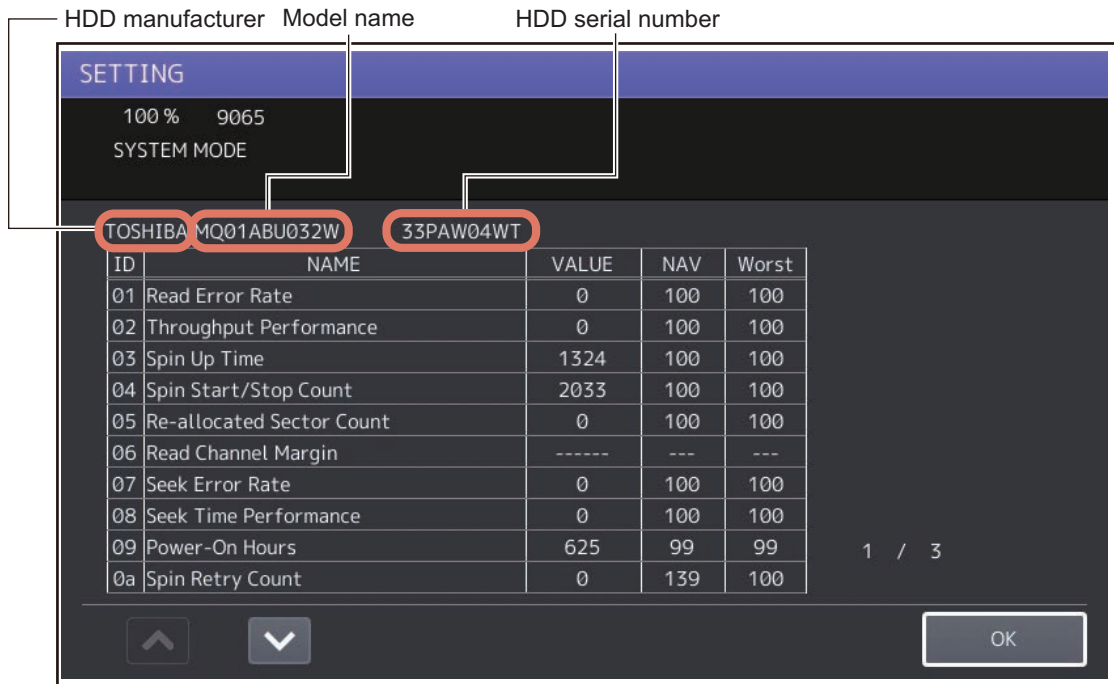


Fig. 9-28

- Items supported differ depending on the HDD/SSD manufacturer.
- “---” is displayed on the VALUE, NAV and Worst columns if items are not supported.

### 2. Usage

The combination of the values of ID=05 and c5 is used to diagnose whether or not the HDD/SSD has a physical failure when HDD/SSD failure is suspected (service call F100 to 108 or 120 occurred).

Result		Description	Diagnosis
ID	VALUE		
05	0	Low possibility of physical failure	HDD/SSD replacement is not required.
c5	0		
05	From 1 to 999	Defective sector has been reassigned and HDD/SSD is recovered.	HDD/SSD replacement is not required.
c5	0		
05	Any value	High possibility of defective sector existence. (There will be a possibility of physical failure depending on the use of HDD/SSD.)	HDD/SSD replacement is recommended.
c5	1 or more		
05	Either one is at least 1000.	High possibility of physical failure	HDD/SSD replacement is recommended.
c5			
05	All values are displayed as “-----”.	High possibility of physical failure (A HDD/SSD connector, harness or SYS board may be one of the causes.)	HDD/SSD replacement is recommended.
c5			

### 3. ID=05 and c5

ID	Name	Description	Remarks
05	Re-allocated Sector Count	The number of sectors reassigned	This value tends to increase at HDD/SSD failure.
c5	Current Pending Sector Count	The number of candidate sectors to be reassigned	This value tends to increase at HDD/SSD failure.

#### 4. Description of each ID

ID	Name	Meaning
01	Read Error Rate	This attribute is a measure of the read error rate.
02	Throughput Performance	This attribute is a measure of the throughput performance.
03	Spin Up Time	This attribute is a measure of how quickly the drive is able to spin up from a spun down condition.
04	Spin Start/Stop Count	This attribute is a measure of the total number of spin ups from a spun down condition.
05	Re-allocated Sector Count	This attribute is a measure of the total number of reallocated sectors.
07	Seek Error Rate	This is a measure of the seek error rate.
08	Seek Time Performance	This attribute is a measure of a drive's seek performance during normal online operations.
09	Power-On Hours	This attribute is a measure of the total time (hours or minutes depending on disk manufacturer) the drive has been on.
0a	Spin Retry Count	This attribute is a measure of the total number of spin retries.
0c	Power Cycle Count	This attribute is a measure of the number of times the drive has been turned on.
c0	Power off Retract Count	This attribute is a measure of the total number of emergency unloads.
c1	Load Cycle Count	This attribute is a measure of the total number of load/unloads.
c2	Temperature	This attribute is a measure of the temperature in the HDD/SSD.
c3	ECC On the Fly Count	This attribute is a measure of the total number of the ECC On the Fly.
c4	Reallocation Event Count	This attribute is a measure of the total number of the reallocation events.
c5	Current Pending Sector Count	This attribute is a measure of the total number of candidate sectors to be reallocated.
c6	Off-Line Scan Uncorrectable Sector Count	This attribute is a measure of the total number of uncorrectable sectors found during the off-line scan.
c7	Ultra DMA CRC Error Count (Rate)	This attribute is a measure of the total number of errors found in data transfer in the Ultra-DMA mode.
c8	Write Error Rate	This attribute is a measure of the write error rate.

#### Notes:

“Over-range” appears when the digits of the numbers obtained from HDD/SSD exceed the acceptable limit for being displayed on the touch panel. This is not shown as a failure.

## 9.2.3 Precautions and procedures when replacing the HDD/SSD

### Notes:

- Replacing ADI-HDD with SSD is not possible.
- Replacing ADI-HDD with SATA-HDD is not possible. When replacing ADI-HDD, replace it with another ADI-HDD.
- When the HDD/SSD is replaced, it is necessary to back up the data in the HDD/SSD before replacing and to recover them after replacing.
- To maintain the security, ask users to perform the backup/restore for users' data/information in the HDD/SSD. The service technician can perform them only when users permit it.
- Some data in the HDD/SSD cannot be backed up and can be kept only on the paper.
- Do not replace the HDD/SSD and the SRAM together.
- When the HDD is replaced, do not perform SRAM data formatting (Clear SRAM) before the normal start-up.
- When the HDD/SSD is replaced, do not restore the back-up file before the normal start-up.

A procedure for replacing the HDD/SSD is shown below.

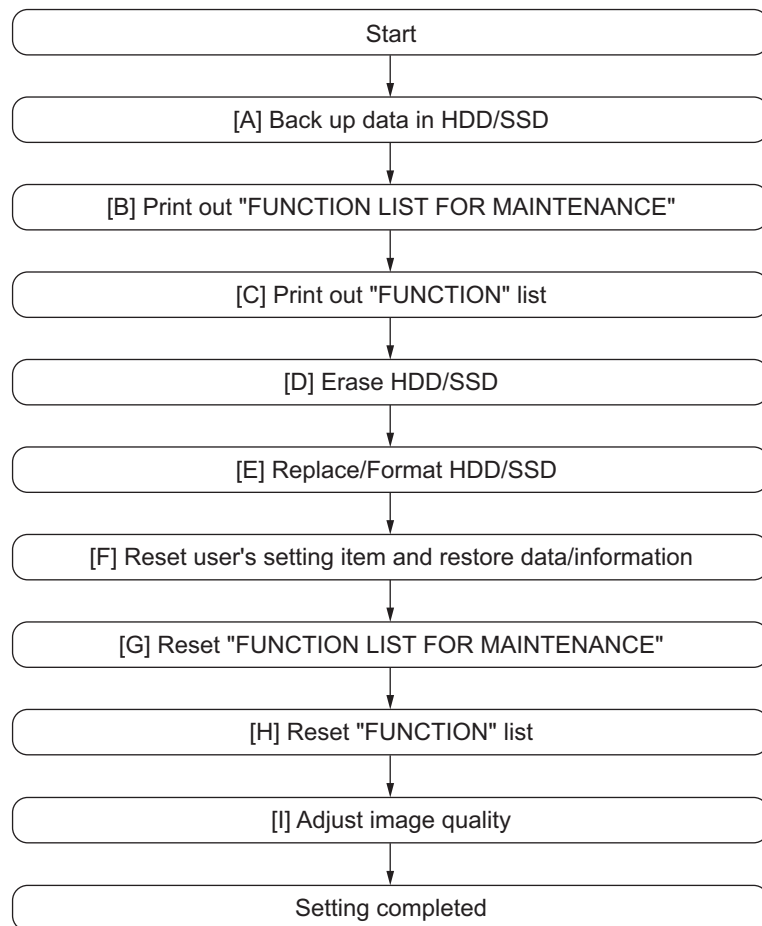


Fig. 9-29

## [A] Back up in HDD/SSD

Ask the user (machine administrator) to back up the data in the HDD/SSD. Refer to the table below for the type of data, availability and method of backup.

Type of data in HDD/SSD	Availability	Backup method
Image data in the e-Filing	HDD: Available SSD: Not available	Archive them in the “e-Filing” of TopAccess. As for the backup in Box data, all data (selectable by the box) can be backed up / restored in one go by using “e-Filing Backup/Restore Utility”.
F-code information, Template registration information, Address book data	Available	Export them in the [Administration] tab - [Maintenance] - [Export] of TopAccess.
User information, Combined information (User information + Role + Group), LDAP Role, Department information, Project code	Available	Export them in the [Administration] tab - [Export/Import] - [Export] of TopAccess.
Log data (Print, Scan, FAX (Transmission/Reception))	Available	Export them in the “Administrator” menu of TopAccess. (Import cannot be performed.)
Data in the shared folder (Scanned data, Saved data of copy / FAX transmission)	HDD: Available SSD: Not available	Copy them to the client computer via the network. (The data which have been copied to the client computer cannot be copied to the shared folder.)
Print waiting data (Copying data and FAX reception data that are waiting to be printed due to the paper run-out and jam, etc.)	Not available	Finish printing them after supplying paper or releasing the jam, etc. (The data cannot be left.)
Print job (Private print data, Schedule print data)	Not available	If any jobs are left, print them. (The data cannot be backed up.)
FAX saved data (Confidential / Bulletin board data)	Not available	Print them. (The data cannot be backed up.)
Registration data for FAX transmission (Delayed transmission / Recovery transmission)	Not available	The data cannot be backed up.

## [B] Print out “FUNCTION LIST FOR MAINTENANCE”

- (1) Perform FS-12 (12 FAX LIST PRINT MODE).
- (2) Select “Function list for Maintenance” and then press [PRINT].

## [C] Print out “FUNCTION” list

- (1) Press [USER FUNCTIONS] on the [HOME] screen.
- (2) Enter the password in [Administrator] tab and press [OK].

### Notes:

Explain the procedure to the user (machine administrator) and ask him/her to enter his/her password.

- (3) Press [LIST/REPORT] and then [LIST].
- (4) Press [FUNCTION]. The “FUNCTION” list is printed out.

## **[D] Erase HDD/SSD**


In case of the Secure HDD:

- (1) Perform HS-74-[Revert Factory Initial Status HDD] and then press [OK].
- (2) Turn the power OFF.

In case of Normal HDD/SSD:

- (1) Perform HS-73-[Erase HDD Security] and then press [OK].
- (2) Select any of "LOW", "MEDIUM", "HIGH" or "SIMPLE" and then press [OK].
- (3) Turn the power OFF.

## **[E] Replace / Format HDD**


- (1) Confirm that the power is turned OFF.
- (2) Replace the HDD.  
(Refer to  P. 9-2 "9.1.3 Hard disk (HDD)".)
- (3) Create the partitions on the HDD.
  1. Perform HS-73-[Format HDD] and then press [OK].
  2. When "Operation Complete" is displayed on the LCD, creating of the partitions is completed.

### **Remarks:**

When HS-[73 Firmware Assist]-[HDD Data Restore] is carried out instead of step (3), perform [HDD Data Restore] and then the following steps in [E].

(4) > (5) > (6) > (9) > (10) > (11) > (12)

In addition, skip [F] and perform the procedure from [G].

- (4) Turn the power OFF.
- (5) Format the service password.
  1. Perform HS-73-[Clear Service Tech Password] and then press [OK].
  2. When "Reset Complete" is displayed on the LCD, formatting of the service tech password is completed.
- (6) Turn the power OFF.
- (7) Update the system software using the USB device.  
See " P. 11-2 "11.2 Firmware Updating with USB Device"" for details.
- (8) Turn the power OFF.
- (9) When the Fax Board (GD-1370) is installed, perform [CUSTOM INITIALIZE] > [INIT MEMORY(FAX)] and [CLEAR DATA] in the FS-11 FAX CLEAR MODE. Then turn the power OFF.
- (10) Perform 08-9930 to check the version of the system software.  
Confirm the version displayed on the LCD, and then press [OK].
- (11) Initialization of NIC information (08-9083).
- (12) Turn the power OFF.



## [F] Reset user's setting items and restore data/information

Ask the user (machine administrator) to reset the user's setting items and to restore data or information. Refer to the following for the reset and restore:

Items to reset/restore	Method
Printer driver	Upload them in the "Administrator" menu of TopAccess.
F-code information, Template registering information, Address book data	Import them in the [Administration] tab - [Maintenance] - [Import] of TopAccess.
User information, Combined information (User information + Role + Group), LDAP Role, Department information, Project code	Import them in the [Administration] tab - [Export/Import] - [Import] of TopAccess.
Image data in the e-Filing	Upload them in the "e-Filing" of TopAccess.


\* When the SSL is enabled, perform the setting of the following items again with "Create self-certificate" of TopAccess.

Country/Region Name  
State or Province Name  
Locality Name  
Organization Name  
Organizational Unit Name  
Common Name  
Email Address


\* When wireless LAN is used, perform the setting again on the LCD panel. (only when security with a certificate is used)  
Also, upload the following certificate file with "Install Certificate for Wireless LAN" of TopAccess.

- CA certificate (PEM)
- CA certificate (DER)

## [G] Reset "FUNCTION LIST FOR MAINTENANCE"

- (1) Print out "FUNCTION LIST FOR MAINTENANCE" after the HDD formatting.  
 P. 9-19 "[B] Print out "FUNCTION LIST FOR MAINTENANCE""
- (2) Perform FS-13 (13 FAX Function Mode)
- (3) Compare the lists which were printed before and after the formatting to check the setting items having the different setting values. Set the value which was set before the formatting.
- (4) Turn the power OFF.

## [H] Reset "FUNCTION" list

Reset the initial setting of the fax function by referring to the "function list" which has been printed out.  
 P. 9-19 "[C] Print out "FUNCTION" list"

- (1) Press [USER FUNCTIONS].
- (2) Press [ADMIN], enter the password, and then press [OK].

### Notes:

Explain the user (machine administrator) about the next operation and ask him/her to enter his/her password.

- (3) Press [FAX] and then [TERMINAL ID] to set each item.

- (4) Press [INITIAL SETUP] to set each item.

### [I] Adjust image quality

- (1) Perform [FS-05-7311] to carry out “Automatic gamma adjustment <PPC>”.  
📖 P. 6-26 “6.2.1 Automatic gamma adjustment (600dpi)”
- (2) Turn the power OFF.

## 9.2.4 Precautions and procedures when replacing the SYS board

A procedure for SYS board replacement is shown below.

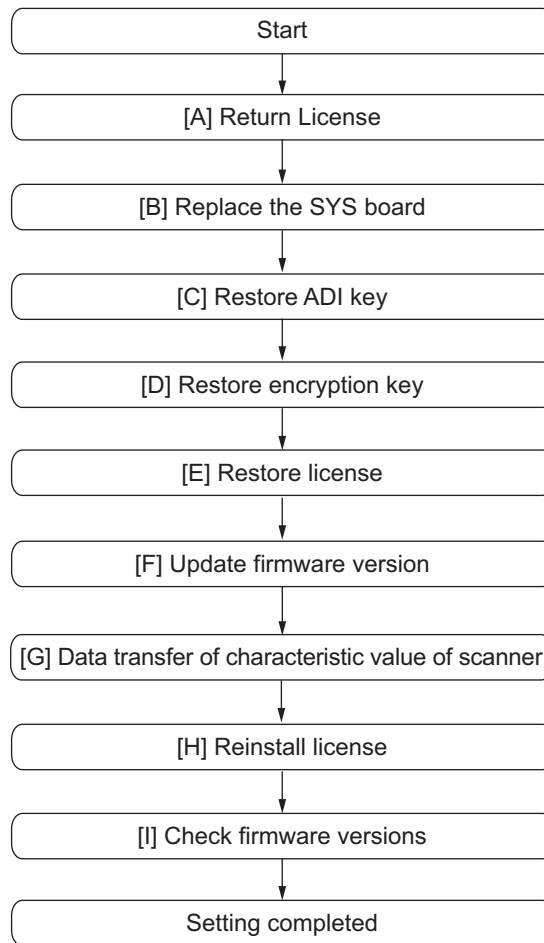


Fig. 9-30

#### Notes:

- [C] is required only for the equipment in which the Secure HDD has been installed.
- It is required to perform HDD formatting in equipment with the High Security Mode enabled. Therefore, perform the following items which are carried out at the HDD replacement in advance.
  - 📖 P. 9-19 “[A] Back up in HDD/SSD”
  - 📖 P. 9-19 “[B] Print out “FUNCTION LIST FOR MAINTENANCE””
  - 📖 P. 9-19 “[C] Print out “FUNCTION” list”
- Do not perform the following steps in [C] in the equipment with the High Security Mode enabled.

## [A] Return License

### Notes:

- If the 08 Setting Mode is not started up, “[A]Return License” can be omitted. In that case, reinstall the license with “[ 1 ]Re-registration when the board is replaced” if it is cleared since “[H] Reinstallation of License” cannot be performed.
- When installing the Data Overwrite Enabler (GP-1070) and security mode is setting High Security, set the security mode level (FS-08-8911) to “1” (Low level). Then restart the equipment.

- (1) Perform FS-08-3840.
- (2) Select the license to be returned, and then press [REMOVE].
- (3) Install the one-time dongle, which you used for uploading the selected license, in the equipment, and then press [OK].
- (4) The Remove screen is displayed, then press [YES]. If this screen is not displayed, check whether the one-time dongle is installed in the equipment properly.
- (5) After 10 to 40 seconds passes, the screen for notifying the success of performance is displayed. Then press [OK]. If this screen is not displayed or the screen for notifying the failure of performance is displayed, quit this operation by pressing [NO]/[CLOSE]. Then, check whether the one-time dongle, which you used for uploading the selected license, is installed in the equipment.
- (6) Check that the returned license is not displayed on the screen.


### Remarks:

- If there are any other licenses to be returned, repeat from step (2).
- If there is no more licenses to be returned, press [CLOSE], and then turn the power OFF.

## [B] Replace the SYS board

### Notes:

Before replacing the SYS board, perform the following procedure.

 P. 9-14 “9.2.1 Precautions when replacing PC boards”

- (1) Confirm that the power is turned OFF.
- (2) Replace the SYS board.
- (3) Install main memory (DIMM) to the new SYS board (from the old SYS board).
- (4) Install SRAM to the new SYS board (from the old SYS board).

### Notes:

When the combination of the main memory and the SYS board has been changed by replacing either of them, it is necessary to perform the calibration of the main memory at the next startup. To perform the calibration of the main memory, start up the equipment while pressing the [ENERGY SAVER] button.


E.g.:

To start up HS Menu, turn the power ON by pressing the [POWER] button while pushing the [HOME], [START] and [ENERGY SAVER] buttons simultaneously.

### [C] Restore ADI key

If the Secure HDD is installed, follow the steps below. To confirm the type of device, start up the equipment in the HS-74.

#### Notes:

Do not perform the following steps in  P. 9-24 “[C] Restore ADI key” in the equipment with the High Security Mode enabled.

- (1) Perform HS-73.
- (2) Press [Key Backup/Restore].
- (3) Press [ADIKey], and then press [Execute].
- (4) Wait until the restoring of the ADI key is completed. “Success” is displayed.
- (5) Turn the power OFF.

### [D] Restore encryption key

- (1) Perform HS-73.
- (2) Press [Key Backup/Restore].
- (3) Press [Key], and then press [Execute].
- (4) Wait until the restoring of the encryption key is completed. “Success” is displayed.
- (5) Restart the equipment after the restoring is completed. If you want to perform the restoring of the license, do not restart the equipment but perform from (2) in “[E] Restore license”.


### [E] Restore license

- (1) Perform HS-73.
- (2) Press [Key Backup/Restore].
- (3) Press [License] and then [Execute].
- (4) Wait until the restoring of the license is completed. “Success” is displayed.  
\* Confirm that “OK” is indicated in all of the FROM column and then reboot the equipment.



#### Notes:

For equipment with the High Security Mode enabled, continue by performing the following steps.

1. Create the partitions on the HDD.
  1. Perform HS-73 > [Format HDD] and then press [OK].
  2. When “Operation Complete” is displayed on the LCD, creating of the partitions is completed.
2. Turn the power OFF.
3. Format the service password.
  1. Perform HS-73 > [Clear Service Tech Password] and then press [OK].
  2. When “Reset Complete” is displayed on the LCD, formatting of the service tech password is completed.
4. Turn the power OFF.
5. Update the system software using a USB device.
6. Turn the power
7. When the Fax Board (GD-1370) is installed, perform [CUSTOM INITIALIZE] > [INIT MEMORY(FAX)] and [CLEAR DATA] in the FS-11 FAX CLEAR MODE. Then turn the power OFF.
8. Check the system software version (FS-08-8952).  
Confirm the version displayed on the LCD and then press [OK].

9. Format the NIC information (FS-08-9083).
10. Turn the power OFF.
11. Perform the procedure in  P. 12-14 "12.4.3 Procedure for entering the High Security Mode".

#### **[F] Update firmware version**

- (1) Update the version of system firmware using the USB device.  
 P. 11-2 "11.2 Firmware Updating with USB Device"
- (2) Update the version of scanner firmware with the USB device.  
 P. 11-2 "11.2 Firmware Updating with USB Device"

#### **[G] Data transfer of characteristic value of scanner**

- (1) Perform FS-05-3203
- (2) Turn the power OFF.

#### **[H] Reinstall license**

If the license was returned "[A]Return License", reinstall it with the following procedure.

- (1) Perform FS-08-3840.
- (2) Press [INSTALL].
- (3) Install the one-time dongle in the equipment (the one which you used for returning the selected license before replacing the equipment). Then press [OK].
- (4) Select the license to be installed, and then press [INSTALL].
- (5) The screen for notifying that the installation will be started is displayed. Then press [YES].
- (6) After 10 to 40 seconds have passed, the screen for notifying the success of the performance is displayed. Then press [OK]. If the screen for notifying a failure of the performance is displayed, quit this operation by pressing [NO]. Then check that the one-time dongle is installed properly in the equipment.
- (7) Check that the installed license is displayed on the license list.

#### **Remarks:**

If there are any other licenses to be installed, repeat from step (2).  
If there are no other licenses to be installed, press [CLOSE], and then turn the power OFF.

#### **[I] Check firmware versions**

- System firmware version (FS-08-9930)
- Scanner firmware version (FS-08-9902)

#### **Notes:**

If the security mode is changed from High Security to Low Security in the step "[A] Return License", set the value of FS-08-8911 to "3" (High Security).

## 9.2.5 Precautions and procedure when replacing the SRAM

### Notes:

- Do not replace the HDD and the SRAM together.
- Be careful not to damage the board when replacing the SRAM.
- When the SRAM is replaced, do not perform HDD partition creation (Format HDD) before the normal start-up.

A procedure for replacing the SRAM is shown below.

When disposing of the SRAM, perform the items in [P. 9-38](#) “9.3.4 Precautions when disposing of the SRAM”.

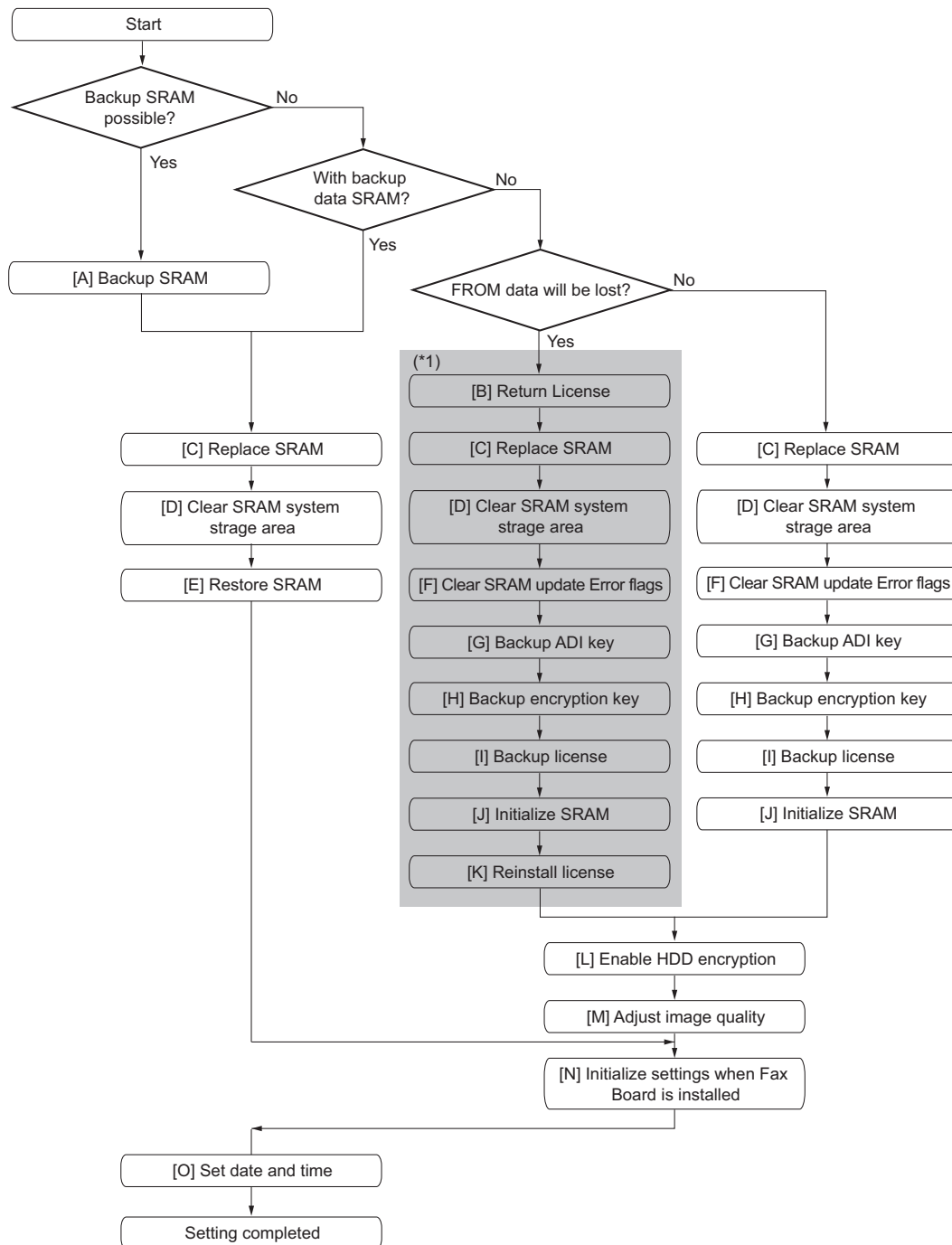



Fig. 9-31

**Notes:**

- [G], [H] and [I] are required only for the equipment in which the Secure HDD has been installed.
- [H] and [I] are required only for the equipment in which a Normal HDD has been installed.
- Use the flow (\*1) when securely returning and reinstalling the license. Returning and reinstalling the license is required when it has been lost. The examples are as below.
  - E.g. 1: When SRAM data are overwritten on the FROM mistakenly due to an incorrect operation during the backup of the license
  - E.g. 2: When the SYS board (SRAM) is damaged or the license data in the FROM are broken

**[A] Backup SRAM**

Perform a backup before replacing the SRAM.

 P. 12-2 “[A] Backup procedure”

**Notes:**

- If “[A] Backup SRAM” fails, proceed to “[B]Return License”.
- If “[A] Backup SRAM” succeeds, proceed to “[D]Clear SRAM system storage area”.

**[B] Return License****Notes:**


When installing the Data Overwrite Enabler (GP-1070) and security mode is setting High Security, set the security mode level (FS-08-8911) to “1” (Low level). Then restart the equipment.

- (1) Perform FS-08-3840.
- (2) Select the license to be returned, and then press [REMOVE].
- (3) Install the one-time dongle, which you used for uploading the selected license, in the equipment, and then press [OK].
- (4) The Remove screen is displayed, then press [YES]. If this screen is not displayed, check whether the one-time dongle is installed in the equipment properly.
- (5) After 10 to 40 seconds passes, the screen for notifying the success of performance is displayed. Then press [OK]. If this screen is not displayed or the screen for notifying the failure of performance is displayed, quit this operation by pressing [NO]/[CLOSE]. Then, check whether the one-time dongle, which you used for uploading the selected license, is installed in the equipment.
- (6) Check that the returned license is not displayed on the screen.

**Remarks:**

- If there are any other licenses to be installed, repeat from step (2).
- If there are no other licenses to be installed, press [CLOSE], and then turn the power OFF.

**[C] Replace SRAM**

- (1) Confirm that the power is turned OFF.
- (2) Take off the Fax Board (GD-1370) if it is installed.
- (3) Replace the SRAM.  
 P. 9-11 “9.1.9 SRAM”

**[D] Clear SRAM system storage area**

- (1) Perform HS-76.  
The authentication screen appears. Press [OK]. (Entry of a password is unnecessary.)
- (2) When “SRAM Clear Mode” appears on the LCD, press the [Clear SRAM].

- (3) When “SRAM Format Completed” is displayed on the LCD, initializing is completed.
- (4) Turn the power OFF.

#### **[E] Restore SRAM**

- (1) Perform HS-76.
- (2) When “SRAM Clear Mode” appears on the LCD screen, press [Set Serial Number].
- (3) Key in the serial number printed on the label attached to the rear cover of the equipment and then press [OK].
- (4) “Set Serial Number was completed.” is displayed.
- (5) Turn the power OFF.
- (6) If there are SRAM backup data, perform restoring.  
📖 P. 12-3 “[B] Restore procedure”
- (7) Turn the power OFF after the restoring of SRAM is completed.

#### **Remarks:**

When the restoration is completed successfully, proceed to “📖 P. 9-30 “[N] Initialize settings when FAX Board (GD-1370) is installed””.

#### **[F] Clear Software Update Error Flag**

- (1) Perform HS-73.
- (2) Press Clear Software Update Error Flag.
- (3) When “Operation Complete” is displayed on the LCD, clearing the flag is completed.
- (4) Turn the power OFF.

#### **[G] Backup ADI key (FROM > SRAM)**


If the Secure HDD is installed, follow the steps below.

- (1) Perform HS-73.
- (2) Press [Key Backup/Restore].
- (3) Press [ADIKey] and then [Execute].
- (4) Wait until the backup of the ADI key is completed. “Success” is displayed.
- (5) Restart the equipment after the backup is completed.  
If you want to perform the backup of the encryption key, do not restart the equipment but perform from (2) in 📖 P. 9-28 “[H] Backup encryption key (FROM > SRAM)”.
- (6) Turn the power OFF.

#### **[H] Backup encryption key (FROM > SRAM)**


- (1) Perform HS-73.
- (2) Press [Key Backup/Restore].
- (3) Press [Key] and then [Execute].



- (4) Wait until the backup of the encryption key is completed. "Operation Complete" is displayed.
- (5) Restart the equipment after the backup is completed. If you want to perform the backup of the license, do not restart the equipment but perform from (3) in  P. 9-29 "[I] Backup license (FROM > SRAM)".
- (6) Turn the power OFF.

#### **[I] Backup license (FROM > SRAM)**

##### **Notes:**

If "License SRAM to FROM" is performed by mistake, carry out the following procedure.  
 P. 9-36 "[ 1 ] Re-registration when the board is replaced"

- (1) Perform HS-73.
- (2) Press [Key Backup/Restore].
- (3) Press [License] and then [Execute].
- (4) Wait until the backup of the license is completed. "Success" is displayed.
- (5) Restart the equipment after the backup is completed.
- (6) Turn the power OFF.
  - \* After the restoring is completed, check that "OK" is indicated in SRAM column. Then, restart the equipment.

#### **[J] Initialize SRAM**

- (1) Perform FS-08.
- (2) Initialize the SRAM.
  1. When "SRAM REQUIRES INITIALIZATION" is displayed on the LCD, check the destination and then press the [START] button.  
If the destination is not correct, key in the correct one and then press the [START] button.
  2. After the confirmation message is displayed, press [OK].
- (3) Perform the initialization at the software version upgrade (FS-08-9030).
- (4) Initialize the NIC information (FS-08-9083).
- (5) Enter the serial number (FS-08-9601).  
Key in the serial number on the label attached to the rear cover of the equipment, and then press [OK].
- (6) Turn the power off.

#### **[K] Reinstall license**

If the license was returned in "[B]Return License", reinstall it with the following procedure.

- (1) Perform FS-08-3840.
- (2) Press [INSTALL].
- (3) Install the one-time dongle in the equipment (the one which you used for returning the selected license before replacing the equipment). Then press [OK].

- (4) Select the license to be installed, and then press [INSTALL].
- (5) The screen for notifying that the installation will be started is displayed. Then press [YES].
- (6) After 10 to 40 seconds have passed, the screen for notifying the success of the performance is displayed. Then press [OK]. If the screen for notifying a failure of the performance is displayed, quit this operation by pressing [NO]. Then check that the one-time dongle is installed properly in the equipment.
- (7) Check that the installed license is displayed on the license list.

**Remarks:**

If there are any other licenses to be installed, repeat from step (2).

If there are no other licenses to be installed, press [CLOSE], and then turn the power OFF.

**[L] Enable HDD encryption**


If the HDD encryption function is used, follow the procedure below.

**Notes:**

When the installation of the license of the Data Overwrite Enabler (GP-1070) is required, be sure to do this before HDD encryption is performed. However, it is not necessary to do so for the models (NAD) in which the Data Overwrite Enabler (GP-1070) is installed as a standard.

- (1) Perform FS-08-8911.
- (2) Enable the encryption function.
  - For enabling HDD encryption only  
Set the value of FS-08-8911 to "1", and then set the value of FS-08-9379 to "1" (Security priority) or "2" (Performance priority).
  - For high security mode  
Set the value of FS-08-8911 to "3".
- (3) Turn the power OFF.

**[M] Adjust image quality**

- (1) Perform FS-05-3203 (Data transfer of characteristic value of scanner).
- (2) Perform FS-05-7311 (Automatic gamma adjustment" <PPC>).  
 P. 6-26 "6.2.1 Automatic gamma adjustment (600dpi)"
- (3) Turn the power OFF.

**[N] Initialize settings when FAX Board (GD-1370) is installed**

- (1) Reinstall the FAX Board (GD-1370).
- (2) Perform FS-08-9001 (the destination of FAX).
- (3) Turn the power OFF.
- (4) Perform FS-11 > [CUSTOM INITIALIZE] > [INIT MEMORY(FAX)].
- (5) Perform restart the MFP.
- (6) Set the dial type according to these buttons: [USER FUNCTIONS] > [ADMIN] > [FAX] > [INITIAL SETUP]

## [O] Set date and time

Set the date and time according to these buttons.

[USER FUNCTIONS] > [ADMIN] > [GENERAL] > [CLOCK] > [DATE/TIME]

## 9.2.6 Procedures when replacing the LGC board

Be sure to follow the procedure below when replacing the LGC board.

- (1) Turn the power OFF.
- (2) Remove the LGC board.  
📖 P. 9-7 "9.1.6 LGC board"
- (3) Install the removed LGC board's EEPROM into the new LGC board.
- (4) Attach the new LGC board.

## 9.2.7 Procedures and settings when replacing EEPROM (for LGC board)

### Notes:

- Before replacing the EEPROM, make sure to print out the current List print.
- Be careful not to damage the EEPROM when replacing the EEPROM.

A procedure for replacing the EEPROM is shown below.

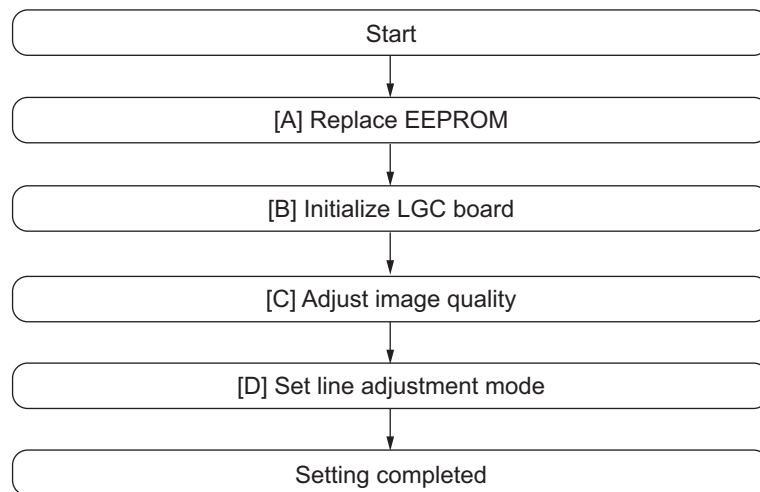


Fig. 9-32

### [A] Replace EEPROM

- (1) Confirm that the power is turned OFF.
- (2) Replace the EEPROM.  
📖 P. 9-12 "9.1.11 EEPROM"

## [B] Initialize LGC board

- (1) Check the destination printed on the white tape stuck on the equipment.
- (2) Perform “Destination display at SRAM initialization” (FS-08-9060).
- (3) Check whether the displayed destination (see the below figure) of the SRAM is the same as the one in step (1).

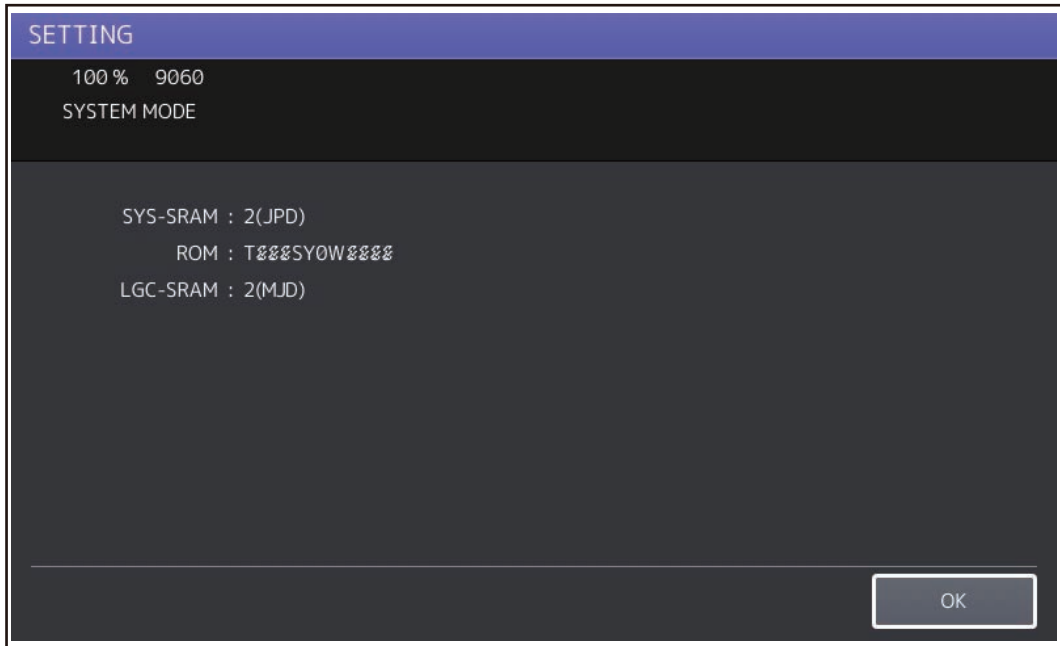


Fig. 9-33

### Remarks:

If the destinations are different, initialize the SRAM with reference to the following procedure.  
📖 P. 9-26 “9.2.5 Precautions and procedure when replacing the SRAM”

- (4) Perform “Printer all clear” (FS-08-9090).

### Notes:

Perform FS-08-9090 only when the EEPROM on the LGC board is replaced. Do not perform this code in other cases.

- (5) Press [INITIALIZE] to perform the initialization of the EEPROM.

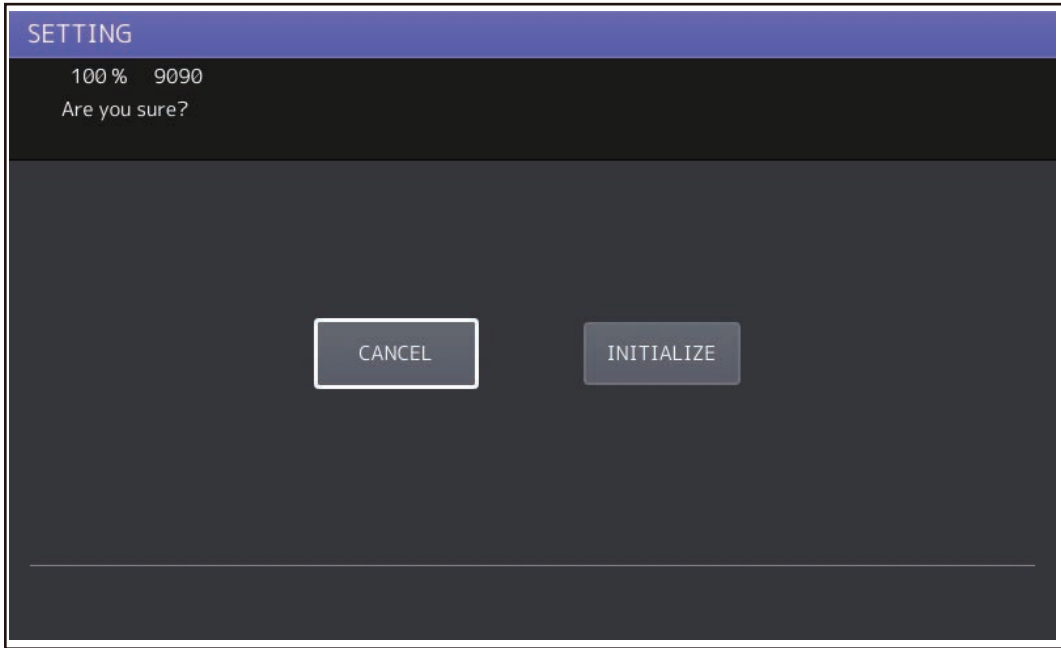


Fig. 9-34

- (6) Perform "Destination display at SRAM initialization" (FS-08-9060), and check whether the same destinations are displayed for the SRAM and the LGC board.

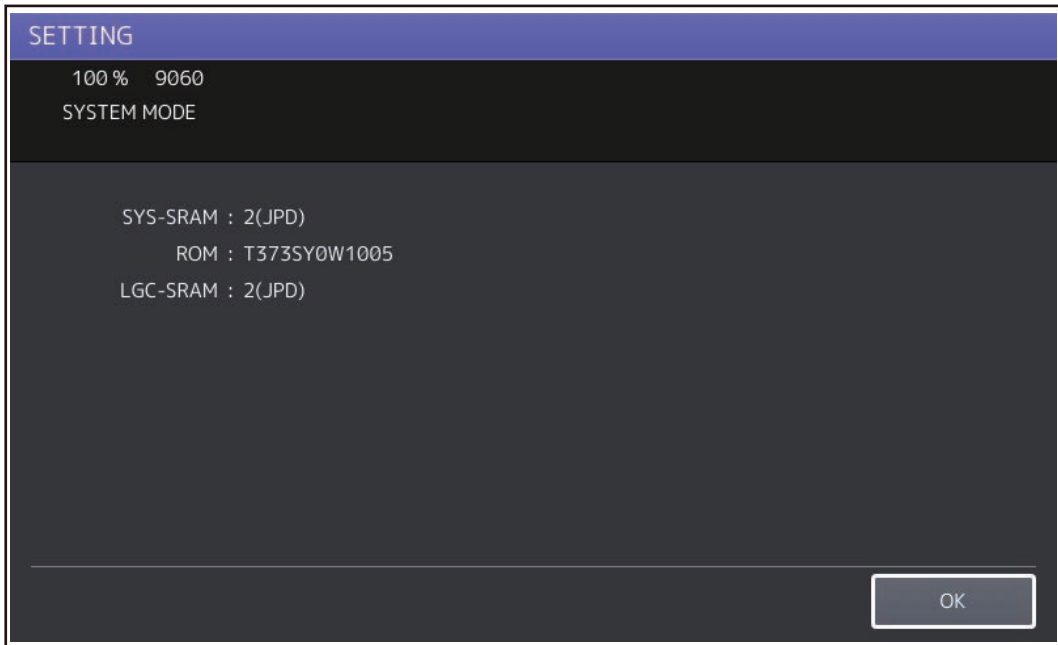


Fig. 9-35

**Remarks:**

If an error occurs during the initialization of the LGC board and the initialization fails, error messages are displayed on the touch panel. The error messages and the corresponding troubleshooting methods are shown below.

Error message	Troubleshooting
UNDEFINED MODEL	Since the LGC board probably has a problem, replace it with a new one by following the procedure below. 📖 P. 9-7 "9.1.6 LGC board"
UNDEFINED VERSION	Recheck the destination of the SRAM. Since the SRAM probably has a problem, replace it with a new one by following the procedure below. 📖 P. 9-11 "9.1.9 SRAM"
VERIFY ERROR	Check whether the EEPROM (for the LGC board) is connected properly.

**[C] Adjust image quality**

- (1) Reset the auto toner sensor.
  1. Turn the power OFF.
  2. Take off the developer unit.  
📖 P. 4-114 "4.8.1 Developer unit"
  3. Discharge developer material in developer unit and make sure that the developer unit is completely empty. Or prepare empty developer unit.  
📖 P. 4-116 "4.8.2 Removing developer material"
  4. Install the developer material in developer unit, and then install the developer unit to the equipment. (Do not install the toner cartridge at this time.)  
📖 P. 4-117 "4.8.3 Filling developer unit with developer material"
  5. Perform automatic adjustment of auto-toner sensor (FS-05-2000).
  6. Turn the power OFF.
  7. Install the toner cartridge.

**Remarks:**

You can reset the auto-toner sensor by directly entering the adjustment values for FS-05-2001 with the Adjustment mode data list, which has been printed during normal operation of equipment such as when it is setup, when preventive maintenance (PM) is performed or when developer material is replaced, etc.

- (2) Perform printer related adjustment and scanner related adjustment.
  - 📖 P. 6-10 "6.1.5 Image dimensional adjustment at the printing section"
  - 📖 P. 6-17 "6.1.6 Scanner related adjustment" (with out [A])

**[D] Set line adjustment mode**

- (1) Turn the power OFF.
- (2) Perform FS-08-9010.
- (3) Set "Line adjustment mode" to "0: For factory shipment".

**Notes:**

Since "1: For line" is set for "Line adjustment mode" in [B] Initialize LGC board in EEPROM (for LGC board) supplied as a service part, number of prints is not counted unless it is changed.

## 9.2.8 Procedures and settings when replacing the lens unit

When replacing the lens unit, follow the procedure below.

- (1) Confirm that the power is turned OFF.
- (2) Replace the lens unit.  
📖 P. 4-26 “4.3.6 Lens unit/CCD driving PC board”
- (3) Perform “Data transfer of characteristic value of scanner / SYS board > Lens unit (FS-05-3209)”.
- (4) Perform “Shading correction plate Automatic dust detection adjustment (FS-05-3218)”.
- (5) Turn the power OFF.

## 9.2.9 Firmware confirmation after the PC board/HDD/SSD replacement

After replacing the PC board/HDD/SSD, check the firmware version in the setting mode (08) and confirm if the firmware combination is correct.

Firmware	Code
System software	9900
System firmware	9930
Engine firmware	9901
Scanner firmware	9902
NIC firmware	9990
DF firmware	9903
Finisher firmware	9904
Hole Punch Unit firmware	9944
FAX board firmware (Line1)	9905
FAX board firmware (Line2)	9969

The installed ROM versions and the registered optional Electronic License Keys can be confirmed in the list print mode following the procedure below.

- (1) Perform [FS-30-111] to print out VERSION LIST.  
\* It is recommended to keep this list for future reinstallation such as the replacement of the SYS board.
- (2) Shut down the equipment.

## 9.2.10 License re-registration using the one-time dongle

### [ 1 ] Re-registration when the board is replaced

The license registered using the one-time dongle can be re-registered only in the same equipment. When the SYS board or FRAM is replaced, follow the procedures for re-registration given below.

- (1) Perform FS-08-3840.
- (2) Press [INSTALL].
- (3) Install the one-time dongle in the equipment (the one which you used for registering the selected license), and then press [OK].
- (4) Select the license to be installed, and then press the [INSTALL].
- (5) The screen for notifying that the installation will be started is displayed. Then press [YES].
- (6) After 10 to 40 seconds have passed, the screen for notifying the success of the performance is displayed. Then press [OK]. If the screen for notifying a failure of the performance is displayed, quit this operation by pressing [NO]. Then check that the one-time dongle, which you used for uploading the selected license, is installed in the equipment.
- (7) Check that the installed license is displayed on the license list.

#### Remarks:

If there are any other licenses to be returned, repeat from step (2). If there are no other licenses to be returned, press [CLOSE], and then turn the power OFF.

#### Notes:

This procedure is available only with the one-time dongle used for the previous registration, since the model information registered in it is utilized. Use the same one-time dongle and the equipment when registering the license.

### [ 2 ] Re-registration when the equipment is replaced due to malfunction

When the equipment has to be replaced due to a malfunction, return the license registered in the equipment to the one-time dongle and register it to the new equipment following the procedure below.

#### Notes:

It is not possible to re-register the license for the IPsec Enabler (GP-1080) into other equipment.

- (1) Perform FS-08-3840.
- (2) Select the license to be returned, and then press [REMOVE].
- (3) Install the one-time dongle in the equipment (the one which you used for uploading the selected license), and then press [OK].
- (4) The Remove screen is displayed. Then press [YES].  
If this screen is not displayed, check that the one-time dongle is installed in the equipment properly.
- (5) After 10 to 40 seconds have passed, the screen for notifying the success of the performance is displayed. Then press [OK].  
If the screen for notifying a failure of the performance is displayed, quit this operation by pressing [NO]. Then check that the one-time dongle, which you used for uploading the selected license, is installed in the equipment.



- (6) Check that the returned license is not displayed on the screen.

**Remarks:**

If there are any other licenses to be returned, repeat from step (2).

If there are no other licenses to be returned, press [CLOSE], and then turn the power OFF.

- (7) Replace the equipment.
- (8) Perform FS-08-3840.
- (9) Press the [INSTALL].
- (10) Install the one-time dongle in the equipment (the one which you used for returning the selected license before replacing the equipment). Then press [OK].
- (11) Select the license to be installed, and then press [INSTALL].
- (12) The screen for notifying that the installation will be started is displayed. Then press [YES].
- (13) After 10 to 40 seconds have passed, the screen for notifying the success of the performance is displayed. Then press [OK]. If the screen for notifying a failure of the performance is displayed, quit this operation by pressing [NO] button. Then check that the one-time dongle is installed properly in the equipment.
- (14) Check that the installed license is displayed on the license list.

**Remarks:**

If there are any other licenses to be installed, repeat from step (9). If there are no other licenses to be installed, press [CLOSE], and then turn the power OFF.

## 9.3 Precautions for Installation of GP-1070 and Disposal of HDD/SSD/Board

### 9.3.1 Precautions for Installation of GP-1070

When installing the Data Overwrite Enabler (GP-1070), perform the following setting:

HS-73 > [Erase HDD Securely]: HDD securely erasing

This setting is the overwriting method complying with DoD 5220.22-M.

1. LOW: This is the normal overwriting method. (This setting is used normally.)  
"00-FF-Random-Verify" Once
2. MEDIUM: This overwriting method is more secure than LOW. The erasing time is between and HIGH.  
"00-FF-Random" three times repeatedly -Verify
3. HIGH: This is the most secure overwriting method. It takes the longest time to erase data.  
"00-FF-Random" five times repeatedly -Verify
4. SIMPLE: This is the simple overwriting method. It takes the shortest time to erase data.  
Overwrite the Random data once

### 9.3.2 Precautions when disposing of the HDD/SSD

#### [ 1 ] When disposing of Secure HDD

When disposing of Secure HDD, perform the following setting:

HS-74 > [Revert factory initial status HDD]

#### [ 2 ] When disposing of Normal HDD/SSD

When disposing of Normal HDD/SSD, perform the following setting:

HS-73 > [Erase HDD Securely] (HDD securely erasing)

This setting is the overwriting method complying with DoD 5220.22-M.

1. LOW: This is the normal overwriting method. (This setting is used normally.)  
"00-FF-Random-Verify" Once
2. MEDIUM: This overwriting method is more secure than LOW. The erasing time is between and HIGH.  
"00-FF-Random" three times repeatedly -Verify
3. HIGH: This is the most secure overwriting method. It takes the longest time to erase data.  
"00-FF-Random" five times repeatedly -Verify
4. SIMPLE: This is the simple overwriting method. It takes the shortest time to erase data.  
Overwrite the Random data once

### 9.3.3 Precautions when disposing of the SYS board

When disposing of the SYS board, data clearing is not required since important data, such as user information, etc. are stored in the SRAM.

### 9.3.4 Precautions when disposing of the SRAM

When disposing of the SRAM, perform HS-73 > Erase SRAM Securely (SRAM securely erasing) for security reasons.

#### Notes:

If this is performed, the equipment cannot be started up.

## 10. REMOTE SERVICE

There are following functions as Remote Service.

1. Auto Supply Order  
Automatically orders the toner by FAX or E-mail.
2. Service Notification  
Notifies the status of the equipment to the service technician by FAX or E-mail.

To start in the self-diagnosis mode, turn OFF the power using the main power switch, then turn ON the power while two digital keys designated to each mode.

### 10.1 Auto Supply Order

#### 10.1.1 Outline

Automatically orders the toner.

1. Placing an Order  
There are two ways to place an order.
  - FAX  
Installation of the FAX board is required.  
If the FAX board has not been installed, it is regarded as OFF setting.
  - E-mail (E-mail body + TIFF image)
2. Order Intervals  
The Auto Supply Order is sent as indicated in the following steps.
  - (1) Toner empty occurs.
  - (2) The toner cartridge is replaced.
  - (3) The toner empty counter is incremented when the total number of prints or the pixel counter value exceeds the threshold set in the following self-diagnostic code.

Code	Details	Contents
FS-08-6506	Toner empty determination counter	Selects the counter to determine toner empty. 0: Output pages 1: Pixel counter
FS-08-6507	Threshold setting for toner empty determination (output pages)	Sets the number of output pages to determine toner empty. This setting is valid when "0" is set at FS-08-6506.
FS-08-6508	Threshold setting for toner empty determination (pixel counter)	Sets the number of the pixel counter value to determine toner empty. This setting is valid when "1" is set at FS-08-6506.

e.g.) When "0" is set for FS-08-6506 and "50" is set for FS-08-6507

The toner empty counter is incremented when 50 sheets are printed after the toner cartridge has been replaced.

- (4) When the accumulated number of toner empty times reaches the set condition, an order is placed automatically.
3. If Order Failure Occurs  
If some problems occur and the order cannot be placed after registering an order as a job, refer to the standard countermeasure for the FAX/E-mail transmission failure.

## 10.1.2 Setting item

To enable Auto Supply Order, the following settings are required.

### Notes:

When selecting E-mail to place an order, it is required that sending and receiving E-mails are available. Confirm the details to the administrator.

#### 1. Self-diagnosis (08) Setting

As the default setting, the Auto Supply Order setting screen is not displayed on the touch panel. To display it, switching the Valid/Invalid setting (08-9783) is required.

0: Valid (FAX/Internet FAX)

1: Valid (FAX/Internet FAX/HTTP)\*

2: Invalid (Default)

When changing the setting value from "2" (default) to "0", the Auto Supply Order setting screen is displayed. (\* HTTP has not been supported yet.)

#### 2. Touch Panel Setting

Each item is set from the Auto Supply Order screen on the touch panel.

Entering the password and customer information is required because the setting is made from the ADMIN screen. Setting it with the administrator is a must.

#### - Basic setting

[ADMIN] > [SERVICE] > [SUPPLY ORDER SETUP] > [ORDER INFORMATION]

AUTO SUPPLY ORDER	Ordered by: [FAX], [MAIL], [HTTP] (*1)
FAX NUMBER	FAX number of supplier (*2)
E-MAIL	E-mail address of supplier (*3)
CUSTOMER	Customer information
NAME	
TEL NUMBER	
E-MAIL	
ADDRESS	
SUPPLIER	Supplier information
NAME	
ADDRESS	
SERVICE TECHNICIAN	Service technician information
NUMBER	
NAME	
TEL NUMBER	
E-MAIL	

\*1 HTTP has not been supported yet.

\*2 The fax number of the supplier must be entered when an order is made by means of a fax.

\*3 The e-mail address of the supplier must be entered when an order is made by means of an e-mail.

- Detailed setting for the order  
[ADMIN] > [SERVICE] > [SUPPLY ORDER SETUP] > [TONER ORDERING]

**** TONER ORDER	Order information (TONER)
PART NUMBER	Part number to be ordered
CONDITION	The number of conditions (*)
QUANTITY	The quantity to be ordered
AUTO ORDER	ON/OFF setting of order for each part

\* The order is placed when the number of replacement reaches the number specified for the CONDITION.

- FAX number of this equipment (common information)  
[ADMIN] > [FAX] > [TERMINAL ID]

ID NAME	ID name of this equipment
FAX NUMBER	FAX number of this equipment

- E-mail information of this equipment (common information)  
[ADMIN] > [E-MAIL]

FROM ADDRESS	E-mail address of this equipment (*)
FROM NAME	E-mail user name of this equipment

\* When sending an E-mail, validity of the address is checked. If the address is invalid, it is not sent.

### 3. Output of setting list of the Auto Supply Order

1. Perform FS-12 (12 FAX LIST PRINT MODE).
2. Select "SUPPLY ORDER LIST" and then press [PRINT].

### 10.1.3 Setting procedure

- (1) Perform FS-08-9783 and set the setting value to "0".
- (2) Turn the power OFF and then back ON.
- (3) Press [USER FUNCTIONS] on the HOME screen.
- (4) Press [ADMIN] tab.
  - When the Administrator Password has been set, the ADMINISTRATOR PASSWORD screen is displayed.

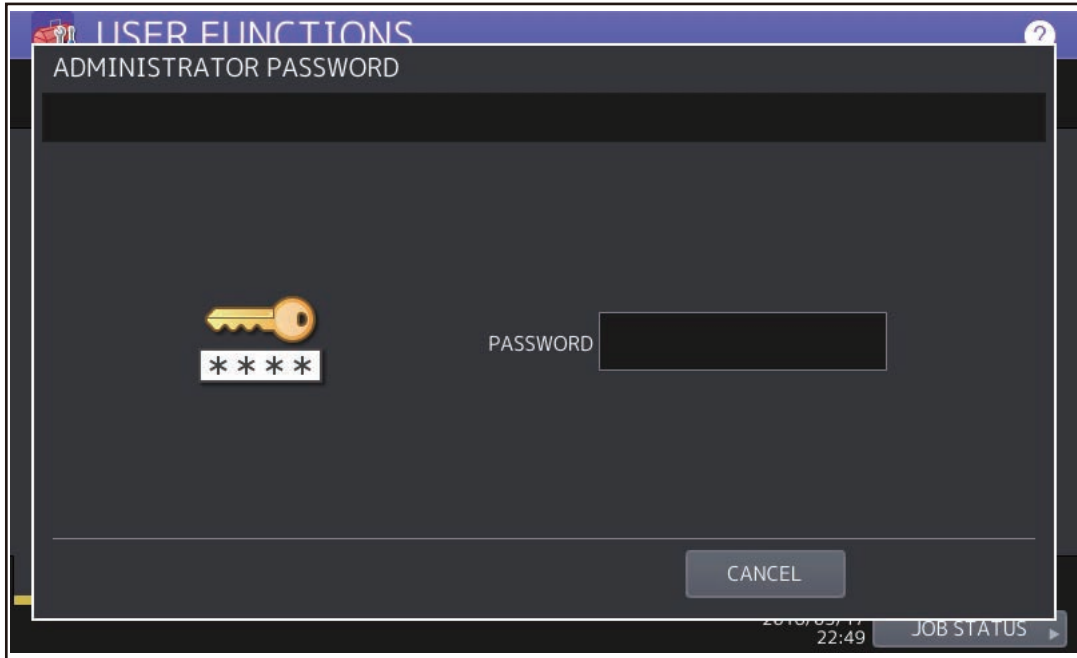


Fig.10-1

- (5) The keyboard appears upon your touching the entry box for a password. Enter the administrator password and then press [OK] or [CLOSE].
  - \* Confirm the password to the administrator.

(6) Press [Service] in the ADMIN screen.

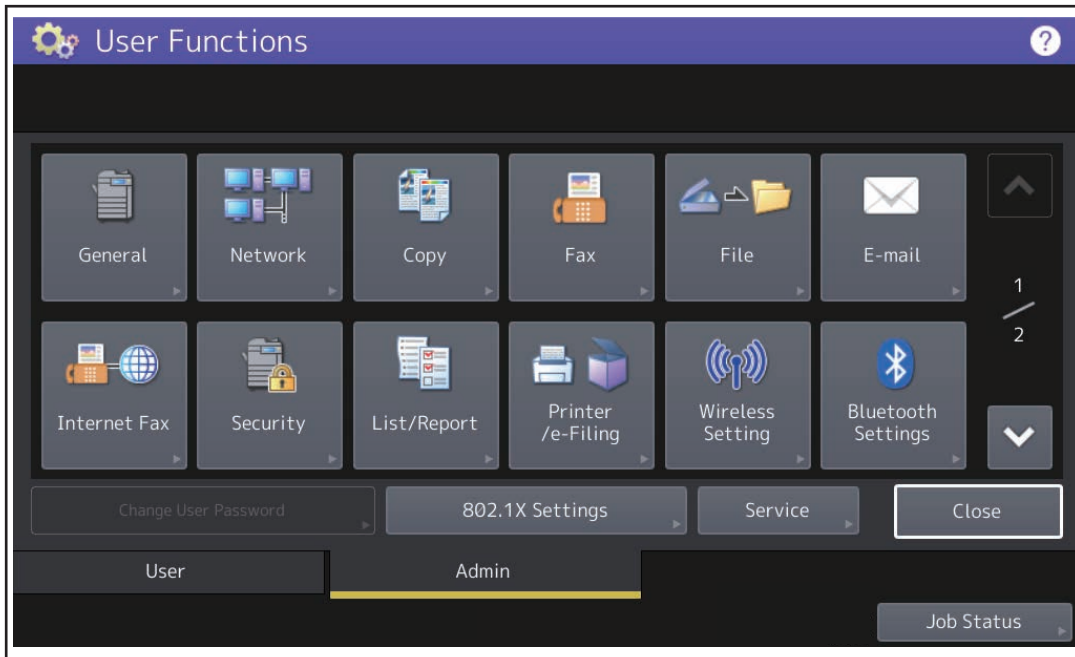


Fig.10-2

(7) The SERVICE screen is displayed.

(8) Press [SUPPLY ORDER SETUP].



Fig.10-3

(9) Press [ORDER INFORMATION].



Fig.10-4

(10) The ORDER INFORMATION screen is displayed.

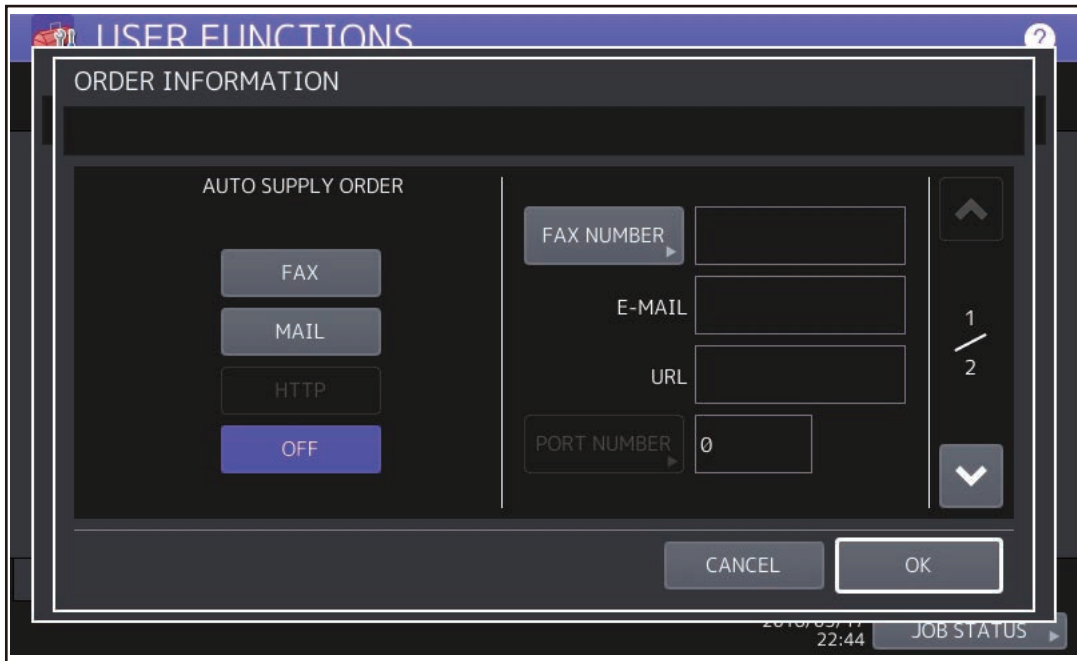


Fig.10-5



- (11) Press the buttons on the screen of ORDER INFORMATION to set the required item.  
 [FAX]/[MAIL]/[OFF] ---  
 Select [FAX] or [MAIL] for the transmitting way of order.  
 (HTTP has not been supported yet.)  
 [OFF]: Turn off the AUTO SUPPLY ORDER function.
- [FAX NUMBER] --- Input the FAX number of supplier.  
 (This must be entered when an order is transmitted by means of a fax.)
- [E-MAIL] --- Input the E-mail address of supplier.  
 (This must be entered when an order is transmitted by means of an e-mail.)
- (12) Press the scroll button.
- (13) The SUPPLIER screen is displayed.

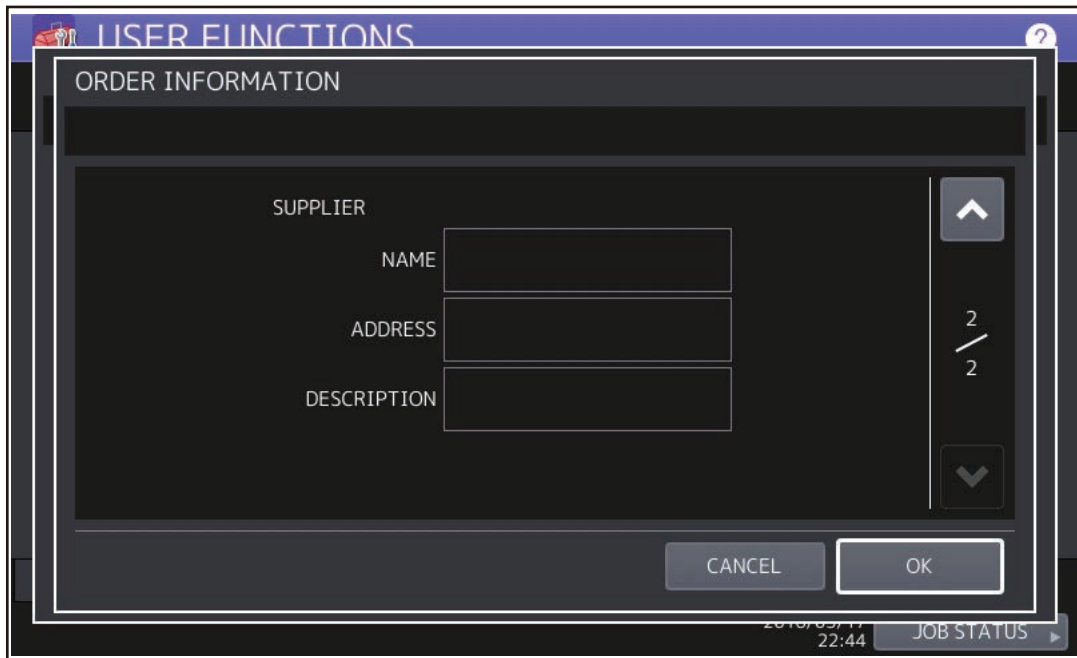


Fig.10-6

- (14) Press the buttons of the screen of SUPPLIER to set the required item.  
 [NAME] --- Input the name of supplier.  
 [ADDRESS] --- Input the address of supplier.  
 [DESCRIPTION] --- Input the remarks if necessary.
- (15) Press [OK].  
 Press [OK] to register the entered information and then the screen returns to the (7) SERVICE screen.  
 Press [CANCEL] to cancel the entered information and then the screen returns to the (7) SERVICE screen.

(16) The SERVICE screen is displayed.

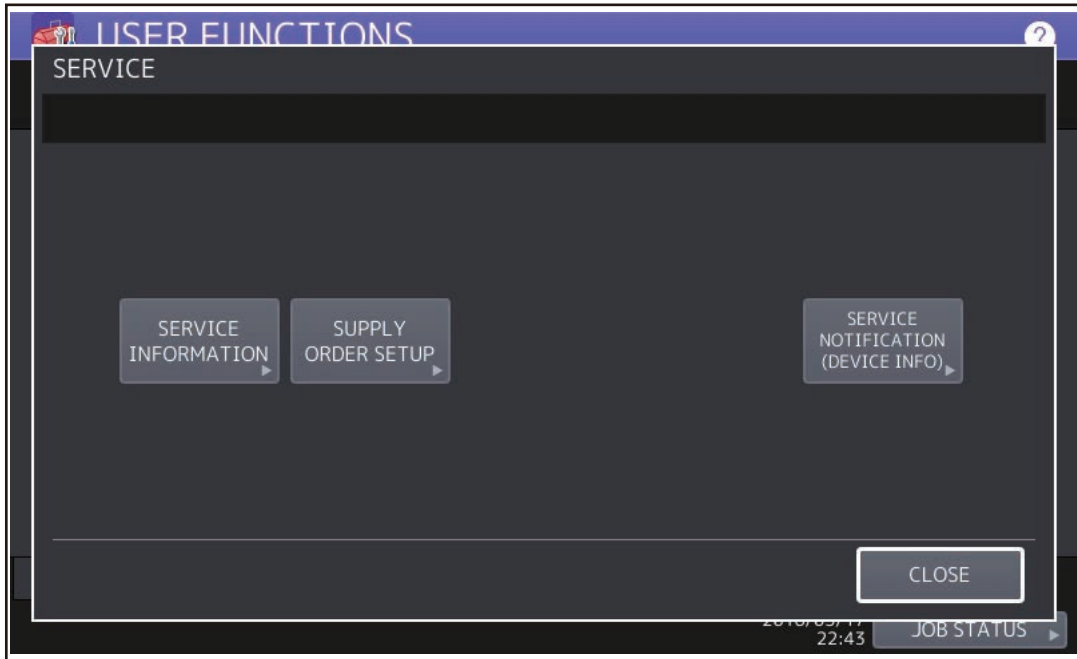


Fig.10-7

(17) Press [SERVICE INFORMATION].

(18) The SERVICE INFORMATION screen is displayed.

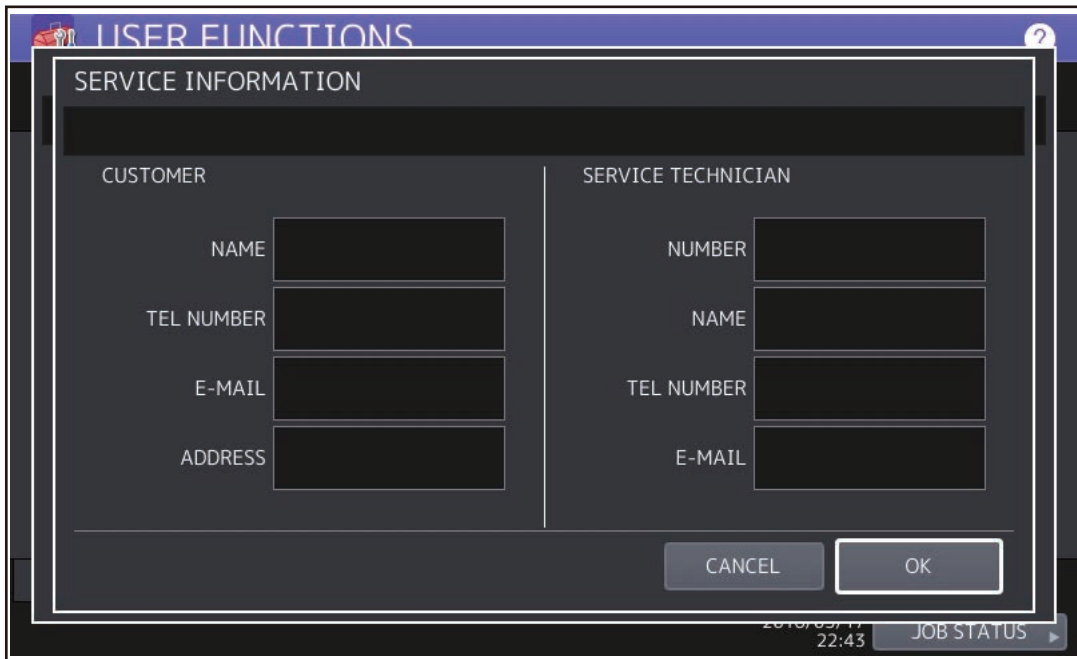


Fig.10-8

(19) Press the buttons of the screen of SERVICE INFORMATION to set the required item.

**CUSTOMER**

[NAME]: Input the name of customer.

[TEL NUMBER]: Input the telephone number of customer.

[E-MAIL]: Input the E-mail address of customer.

[ADDRESS]: Input the address of customer.

**SERVICE TECHNICIAN**

[NUMBER]: Input the number of SERVICE TECHNICIAN.

[NAME]: Input the name of SERVICE TECHNICIAN.

[TEL NUMBER]: Input the telephone number of SERVICE TECHNICIAN.

[E-MAIL]: Input the E-mail address of SERVICE TECHNICIAN.

(20) Press [OK] to register and complete the order information setting.

(21) The SERVICE screen is returned.

(22) Press [SUPPLY ORDER SETUP].



Fig.10-9

(23) Press [TONER ORDERING].



Fig.10-10

(24) Select the part to be ordered. (Press [TONER].)

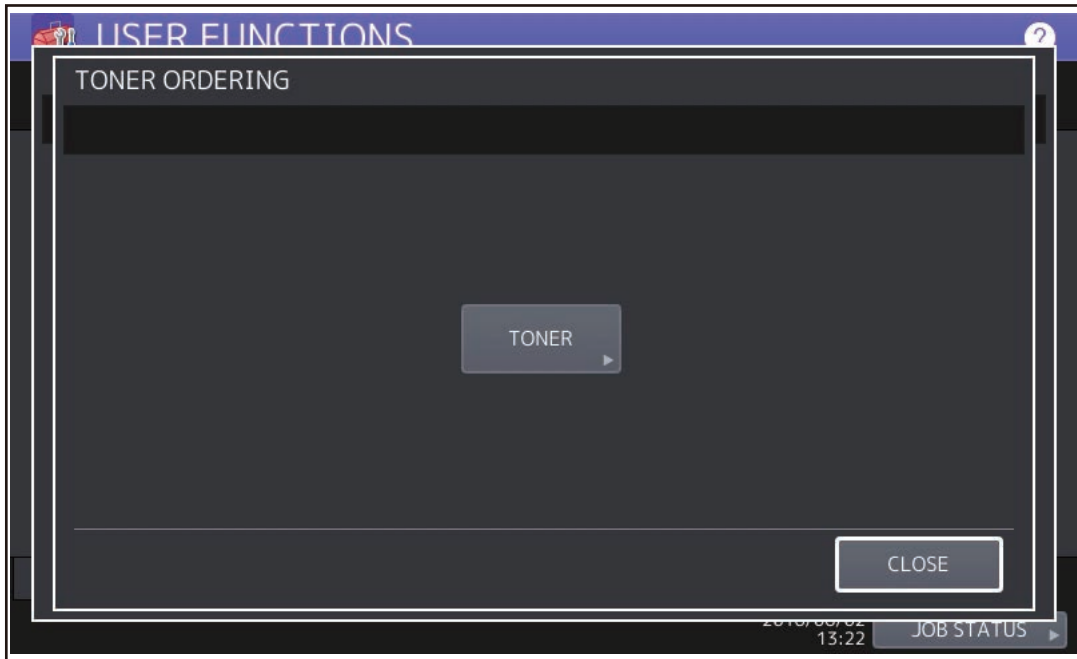


Fig.10-11

(25) Input the order information of TONER.

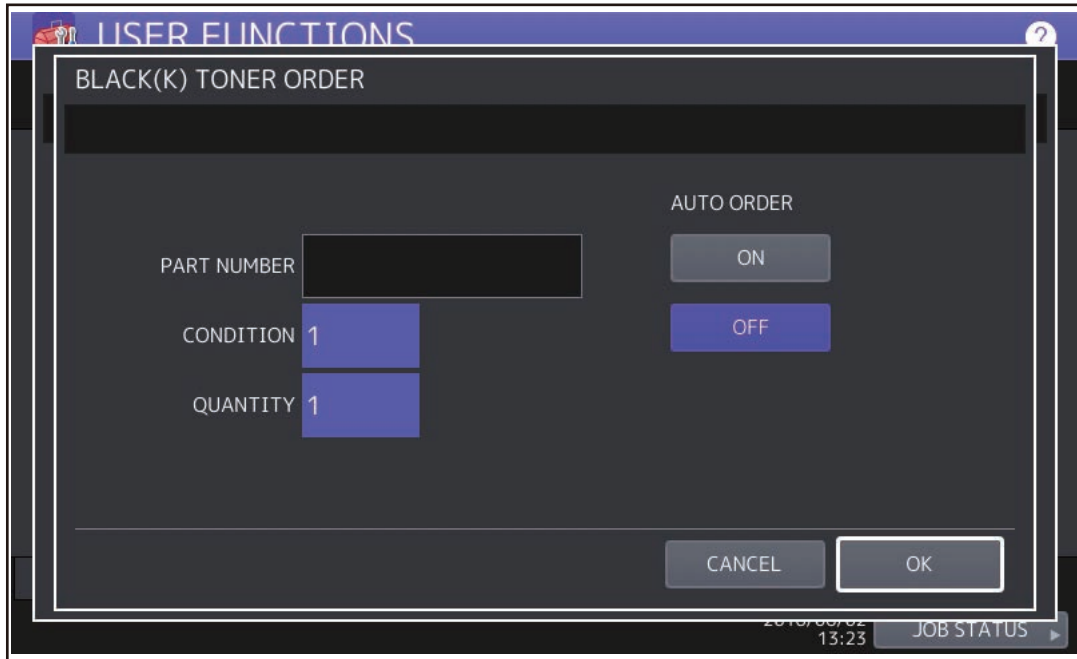


Fig.10-12

[PART NUMBER]: Toner number

[CONDITION]: The order is placed when the accumulated number of toner empty times reaches the value set in here.

[QUANTITY]: Quantity to be ordered

#### **AUTO ORDER**

[ON]/[OFF]: Allows you to select whether each part to be ordered is placed automatically or not.

(26) Press [OK] to register the setting of toner order.

(27) The screen returns to the TONER ORDERING.

(28) Press the [USER FUNCTION] button to be switched from the ADMIN screen on touch panel and returned to the BASIC screen, so that the setting of Auto Supply Order is finished.

**Notes:**

Auto Supply Order setting is also available from the following setting mode (08).

Items	08 code	Contents
The transmitting way of order [FAX] / [MAIL] / [OFF]	9750	0: Ordered by FAX 1: Ordered by E-mail 2: Ordered by HTTP 3: OFF
SUPPLIER [FAX NUMBER]	9751	Maximum 32 digits
SUPPLIER [E-MAIL]	9752	Maximum 192 letters
CUSTOMER [NAME]	9756	Maximum 50 letters
CUSTOMER [TEL NUMBER]	9757	Maximum 32 letters
CUSTOMER [E-MAIL]	9758	Maximum 192 letters
CUSTOMER [ADDRESS]	9759	Maximum 100 letters
SUPPLIER [NAME]	9764	Maximum 50 letters
SUPPLIER [ADDRESS]	9765	Maximum 100 letters
SERVICE TECHNICIAN [NUMBER]	9760	Maximum 5 digits
SERVICE TECHNICIAN [NAME]	9761	Maximum 50 letters
SERVICE TECHNICIAN [TEL NUMBER]	9762	Maximum 32 digits
SERVICE TECHNICIAN [E-MAIL]	9763	Maximum 192 letters
Remarks [DESCRIPTION]	9766	Maximum 128 letters
TONER [PART NUMBER]	9776	Maximum 20 digits
TONER [CONDITION]	9778	1-99
TONER [QUANTITY]	9777	1-99

(29) The SERVICE screen is returned.

(30) Press [SERVICE NOTIFICATION (DEVICE INFO)].

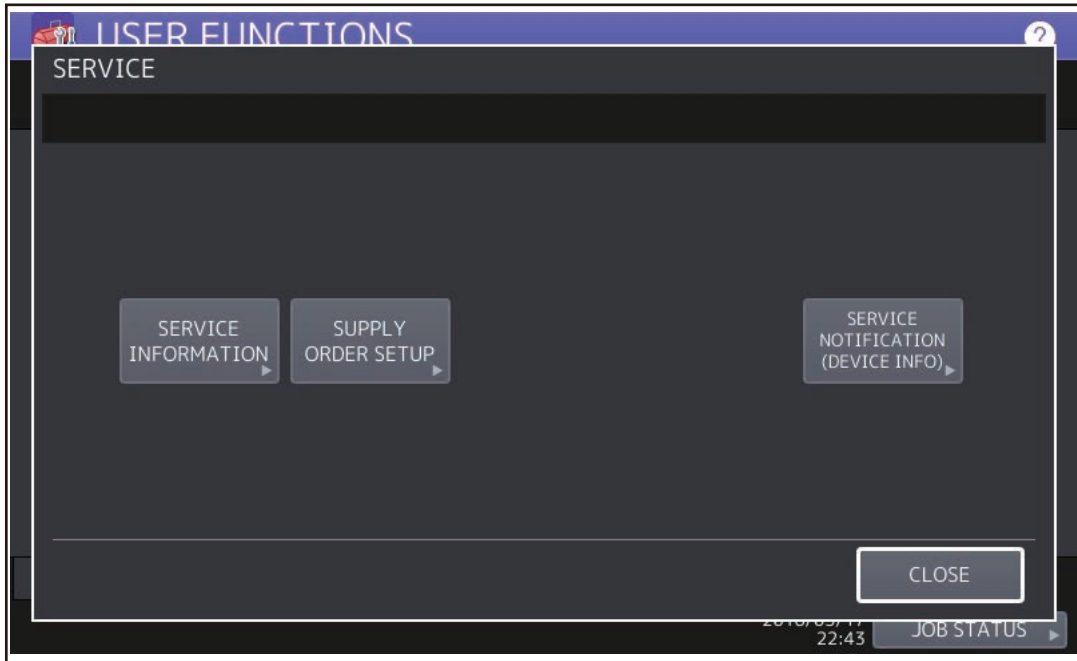


Fig.10-13

(31) Press [ON] or [OFF] in SERVICE NOTIFICATION (DEVICE INFO).  
When [OFF] is pressed, all functions related SERVICE NOTIFICATION (DEVICE INFO) become ineffective.

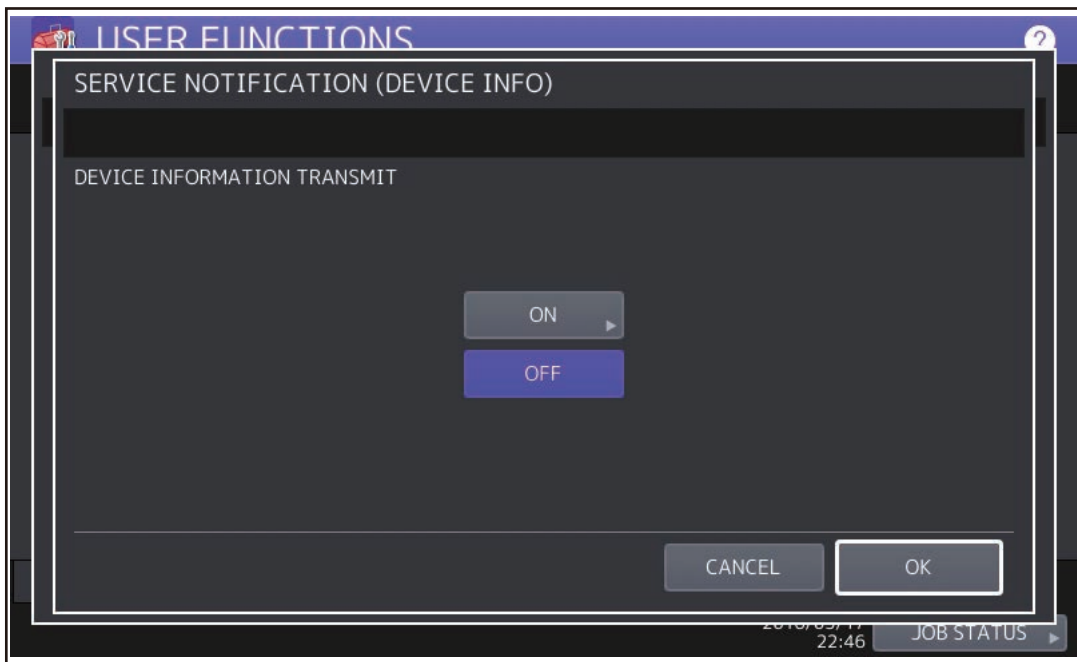


Fig.10-14

(32) When SERVICE NOTIFICATION (DEVICE INFO) is set to ON, the screen to set the notification date is displayed.

Then set the notification date with the following procedure.

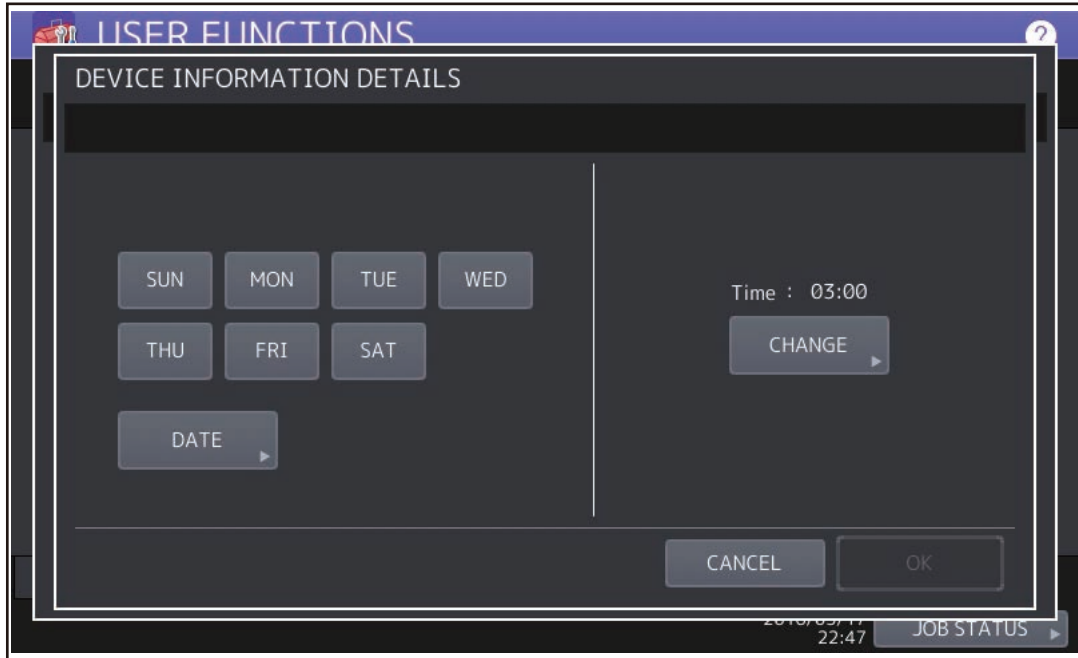


Fig.10-15

Set the date and time of the “DEVICE INFORMATION DETAILS”.

The following 3 items can be specified for the date setting, and more than one day of the week also can be selected.

- Day of the week (More than one day can be selected.)
- Notify Date 1
- Notify Date 2
  
- **Day of the week ([SUN] to [SAT])**  
Pressing [SUN] to [SAT] of the desired day makes transmission on every specified day. More than one day can be selected.
  - \* This does not affect the settings of “Notify Date 1” and “Notify Date 2”.
  
- **Notify Date 1 and Notify Date 2 ([DATE])**  
Pressing [DATE] sets up to 2 dates on which you want to send data.
  - \* This is not affected by the specified day of the week.



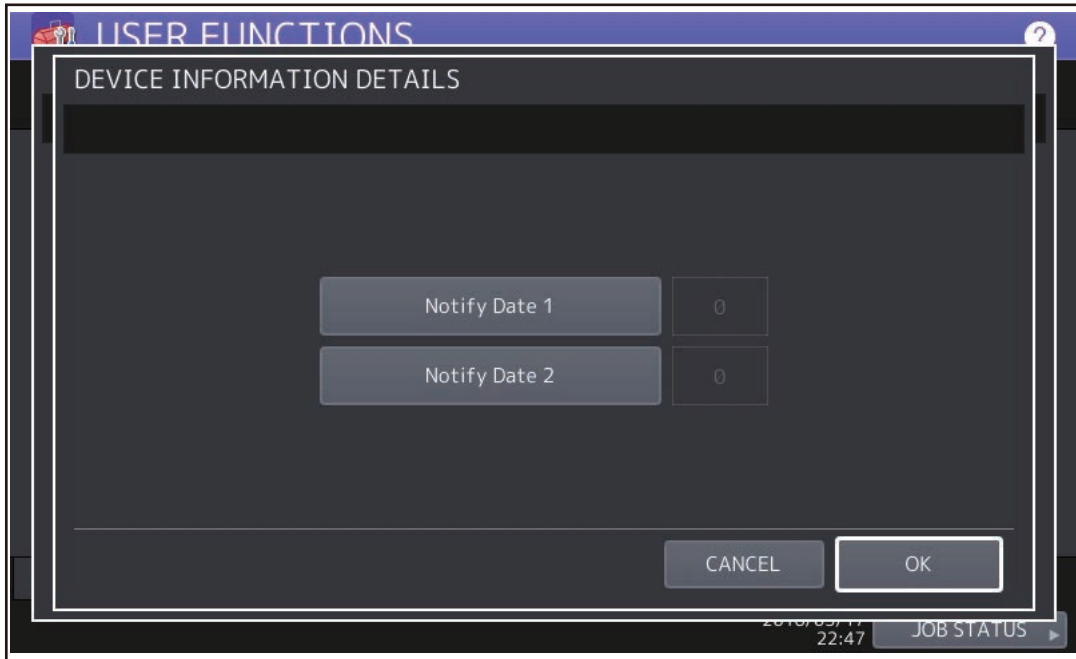


Fig.10-16

Key in the date (acceptable values: 0-31) in “Notify Date 1” or “Notify Date 2” and press [OK].

- **Time setting ([CHANGE])**

Pressing [CHANGE] sets the time at which you want to send data.

This is the time when data are sent with “Day of the week”, “Notify Date 1” and “Notify Date 2”.

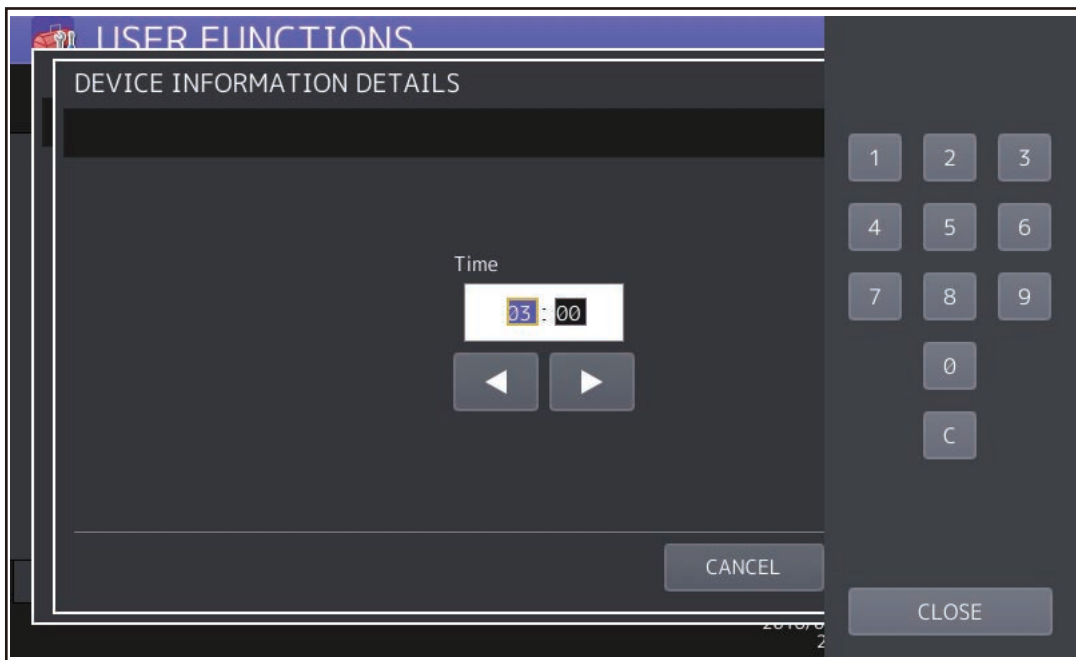


Fig.10-17

Key in the time (acceptable values: 00:00-23:59) in “Time”.

Key in the time in the hour column of “Time”, press the scroll button, key in the time in the minute column of “Time”.

After all the settings are completed, press [OK].

(33) Press [CLOSE]. The setting completes.

## 10.1.4 Order sheet format

The sample of order sheet is as follows.

- (1) FAX (This format is the same as that of TIFF image attached E-mail.)  
 \*1. Part not to be ordered is not output. (Less space between the lines)

DATE & TIME	:	99-99-'99 99:99
CUSTOMER NAME	:	XXXXXXXXXXXXXXXXXXXXXXXXXXXXXXXXXXXX
CUSTOMER ADDRESS	:	XXXXXXXXXXXXXXXXXXXXXXXXXXXXXXXXXXXX
CUSTOMER TEL NUMBER	:	XXXXXXXXXXXXXXXXXXXXXXXXXXXXXXXXXXXX
CUSTOMER E-MAIL ADDRESS	:	XXXXXXXXXXXXXXXXXXXXXXXXXXXXXXXXXXXX
SERVICE TECHNICIAN NUMBER	:	XXXXXXXXXXXXXXXXXXXXXXXXXXXXXXXXXXXX
SERVICE TECHNICIAN NAME	:	XXXXXXXXXXXXXXXXXXXXXXXXXXXXXXXXXXXX
SERVICE TECHNICIAN TEL NUMBER	:	XXXXXXXXXXXXXXXXXXXXXXXXXXXXXXXXXXXX
SERVICE TECHNICIAN E-MAIL	:	XXXXXXXXXXXXXXXXXXXXXXXXXXXXXXXXXXXX
SUPPLIER NAME	:	XXXXXXXXXXXXXXXXXXXXXXXXXXXXXXXXXXXX
SUPPLIER ADDRESS	:	XXXXXXXXXXXXXXXXXXXXXXXXXXXXXXXXXXXX

---

TONER CARTRIDGE	:	PART NUMBER	QUANTITY
		XXXXXXXXXXXX	99 (*1)

---

DESCRIPTION AREA .....

.....

DEVICE DESCRIPTION	:	XXXXXXXXXXXXXXXXXXXXXXXXXXXX
SERIAL NUMBER	:	XXXXXXXXXXXXXXXXXXXXXXXXXXXX
DEVICE FAX NUMBER	:	XXXXXXXXXXXXXXXXXXXXXXXXXXXX
DEVICE E-MAIL ADDRESS	:	XXXXXXXXXXXXXXXXXXXXXXXXXXXX

	TOTAL	BLACK	FULL COLOR
PRINT COUNTER	0	0	-----
SCAN COUNTER	0	0	0

TONER INFORMATION  
 BLACK REMAINING QUANTITY (%): 0000062

Fig.10-18

DESCRIPTION AREA:	Remarks
DEVICE DESCRIPTION:	Model name
SERIAL NUMBER:	Serial number
DEVICE FAX NUMBER:	Fax number
DEVICE E-MAIL ADDRESS:	E-mail address

(2) E-MAIL (TIFF image attached with the E-mail is the same format with that of the FAX order sheet.)

SUBJECT: SUPPLY ORDER REQUEST

\*1. Part not to be ordered is not output. (Less space between the lines)

```
Date&Time: '08-04-14 00:17
Service Number: a1 MachineName: TOSHIBA e-STUDIOxxx
SerialNumber: 1234567890
Device FAX Number: 456
Device Email: aaa@linux.nam1.local
OrderInformation:
BLACK PartNumber: BLACK-04 Quantity: 18 (*1)
CounterInformation:
PrintCounter(Small) FullColor: 0 TwinColor: 0 Black: 150 (*2)
PrintCounter(Large) FullColor: 0 TwinColor: 0 Black: 0 (*2)
ScanCounter FullColor: 0 TwinColor: 0 Black: 7 (*3)
```

Fig.10-19

Date&Time:	Order date and time
Service Number	Service engineer number
MachineName:	Model name (MFP model name)
SerialNumber:	Serial number
Device FAX Number:	Fax number
Device Email:	E-mail address
OrderInformation:	Order information
BLACK PartNumber:	Black toner cartridge part number
Quantity:	Order quantity
CounterInformation:	Counter information
PrintCounter (Small) FullColor: 0 TwinColor: 0 Black *2:	Print count (Small size) for Full color, Twin color and Black
PrintCounter (Large) FullColor: 0 TwinColor: 0 Black *2:	Print count (Large size) for Full color, Twin color and Black
ScanCounter FullColor: 0 TwinColor: 0 Black: Scan count *3	Scan count for Full color, Twin color and Black

\*2. "FullColor:0" and "TwinColor:0" do not change. The value for "Black:" is the counter value.

\*3. "TwinColor:0" does not change. The values for "FullColor:" and "Black:" are the counter values.

(3) Result list

\*1. Part not to be ordered is not output. (Less space between the lines)

```
SUPPLY ORDER FORM
CONFIRMATION
ORDER SUCCESSFUL

DATE & TIME :99-99-'99 99:99
CUSTOMER NAME :XXXXXXXXXXXXXXXXXXXXXXXXXXXXXXXXXXXX
CUSTOMER ADDRESS :XXXXXXXXXXXXXXXXXXXXXXXXXXXXXXXXXXXXXXXXXXXX
CUSTOMER TEL NUMBER :XXXXXXXXXXXXXXXXXXXXXXXXXXXXXXXXXXXXXXXXXXXX
CUSTOMER E-MAIL ADDRESS :XXXXXXXXXXXXXXXXXXXXXXXXXXXXXXXXXXXXXXXXXXXX
SERVICE TECHNICIAN NUMBER :XXXXXXXXXXXXXXXXXXXXXXXXXXXXXXXXXXXXXXXXXXXX
SERVICE TECHNICIAN NAME :XXXXXXXXXXXXXXXXXXXXXXXXXXXXXXXXXXXXXXXXXXXX
SERVICE TECHNICIAN TEL NUMBER :XXXXXXXXXXXXXXXXXXXXXXXXXXXXXXXXXXXXXXXXXXXX
SERVICE TECHNICIAN E-MAIL :XXXXXXXXXXXXXXXXXXXXXXXXXXXXXXXXXXXXXXXXXXXX
SUPPLIER NAME :XXXXXXXXXXXXXXXXXXXXXXXXXXXXXXXXXXXXXXXXXXXX
SUPPLIER ADDRESS :XXXXXXXXXXXXXXXXXXXXXXXXXXXXXXXXXXXXXXXXXXXX

-----
TONER CARTRIDGE : PART NUMBER QUANTITY
: XXXXXXXXXXXXX 99 (*1)

-----
DESCRIPTION AREA .....
.....

DEVICE DESCRIPTION :XXXXXXXXXXXXXXXXXXXXXXXXXXXX
SERIAL NUMBER :XXXXXXXXXXXXXXXXXXXXXXXXXXXX
DEVICE FAX NUMBER :XXXXXXXXXXXXXXXXXXXXXXXXXXXX
DEVICE E-MAIL ADDRESS :XXXXXXXXXXXXXXXXXXXXXXXXXXXX

PRINT COUNTER    TOTAL    BLACK    FULL COLOR
0                0        0        -----
SCAN COUNTER    0        0        0

TONER INFORMATION

BLACK REMAINING QUANTITY (%) : 00000059
```

Fig.10-20

ORDER SUCCESSFUL/FAILURE:	Automatic supply ordering: transmission success or failure
DATE & TIME:	Order date and time
CUSTOMER NAME:	Customer name
CUSTOMER ADDRESS:	Customer address
CUSTOMER TEL NUMBER:	Customer telephone number
CUSTOMER E-MAIL ADDRESS:	Customer E-mail address
SERVICE TECNICIAN NUMBER	Service technician number
SERVICE TECHNICIAN NAME	Service technician name
SERVICE TECHNICIAN TEL NUMBER:	Service technician telephone number
SERVICE TECHNICIAN E-MAIL:	Service technician E-mail address
SUPPLIER NAME:	Supplier name
SUPPLIER ADDRESS:	Supplier address
PART NUMBER:	Order part number
QUANTITY:	Order quantity
TONER CARTRIDGE:	Toner cartridge
DESCRIPTION AREA:	Remarks

DEVICE DESCRIPTION:	Model name (MFP model name)
SERIAL NUMBER:	Serial number
DEVICE FAX NUMBER:	Fax number
DEVICE E-MAIL ADDRESS:	E-mail address
PRINT COUNTER:	Print count
SCAN COUNTER:	Scan count
TOTAL:	Total
BLACK:	Black
FULL COLOR:	Full color
TONER INFORMATION	Black remaining quantity

## 10.2 Service Notification

### 10.2.1 Outline

This function automatically notifies the status of the equipment to the service technician by E-mail or FAX. The following 5 are the items to be notified.

- **Total Counter Transmit**  
When this function is effective, it notifies each counter information periodically (on the set date and time every month).
- **Service Call Transmit (E-mail only)**  
When this function is effective, it notifies the corresponding error code and such at a service call error.
- **PM Counter Transmit**  
When this function is effective, it notifies that the PM timing has come when the present PM count has reached to its setting value, or the present PM driving count has reached to its setting value.
- **Toner near-empty notification**  
If this function is effective, it notifies each counter information and toner cartridge information when toner near-empty occurs.
- **HDD alert notification**  
When this function is effective, it notifies an alert for backing up or replacing the HDD.

## 10.2.2 Setting

### Notes:

When using this function, it is required that sending and receiving E-mails or FAXes are available. Confirm the details to the administrator.

### [ 1 ] Preparation

If the menu display of this function is disabled (not displayed), set it to be enabled (displayed) with the following code.

FS-08-9604: Display set of the [Service Notification] button

0: Not displayed

1: Displayed

### [ 2 ] Setting procedure

- (1) Press [USER FUNCTIONS] on the HOME screen and select the [ADMIN] tab. Then, enter the password and press [OK].
  - Confirm the password to the administrator.

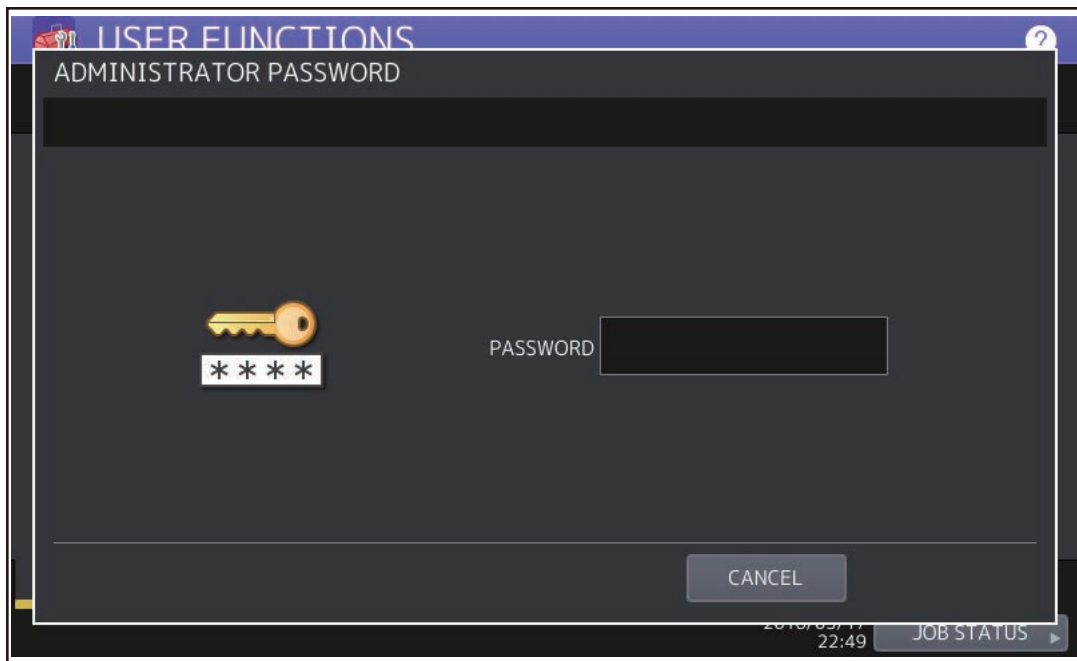


Fig.10-21

(2) Press [SERVICE].



Fig.10-22

(3) Press [SERVICE NOTIFICATION].



Fig.10-23



- (4) Press [E-MAIL] or [FAX].
  - When [OFF] is pressed, all functions related Service Notification become ineffective.

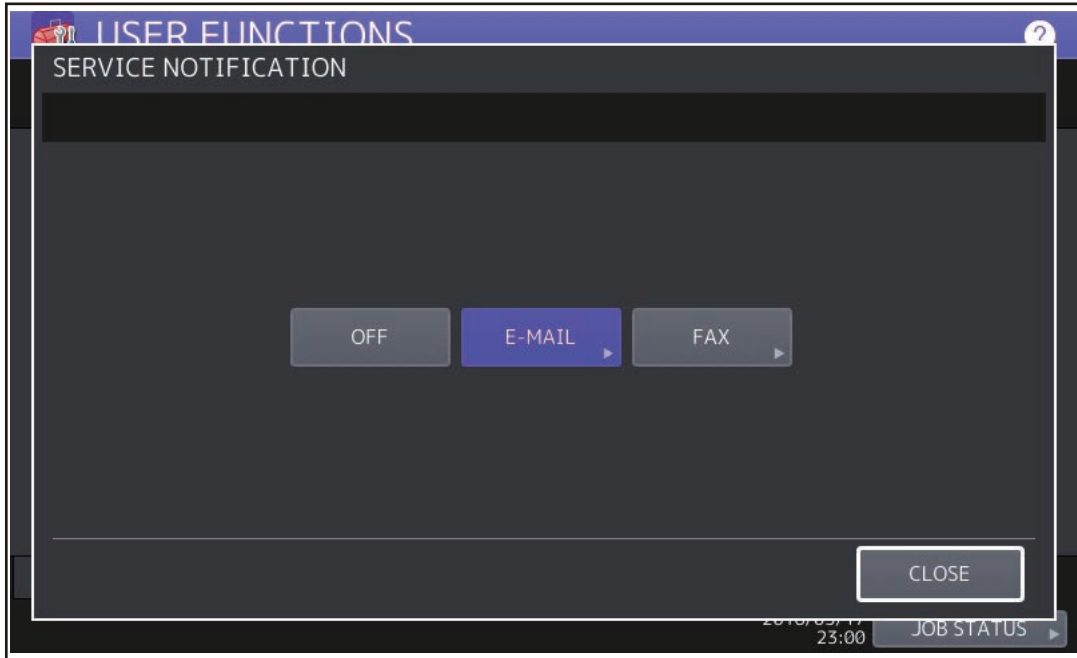


Fig.10-24

- (5) Enter the e-mail address or fax number of the destination and press [OK]. A maximum of 3 addresses can be set. (The keyboard appears upon your touching the entry box for an e-mail address.)



Fig.10-25

- Press [FAX NUMBER], key in the FAX number and then press [OK].

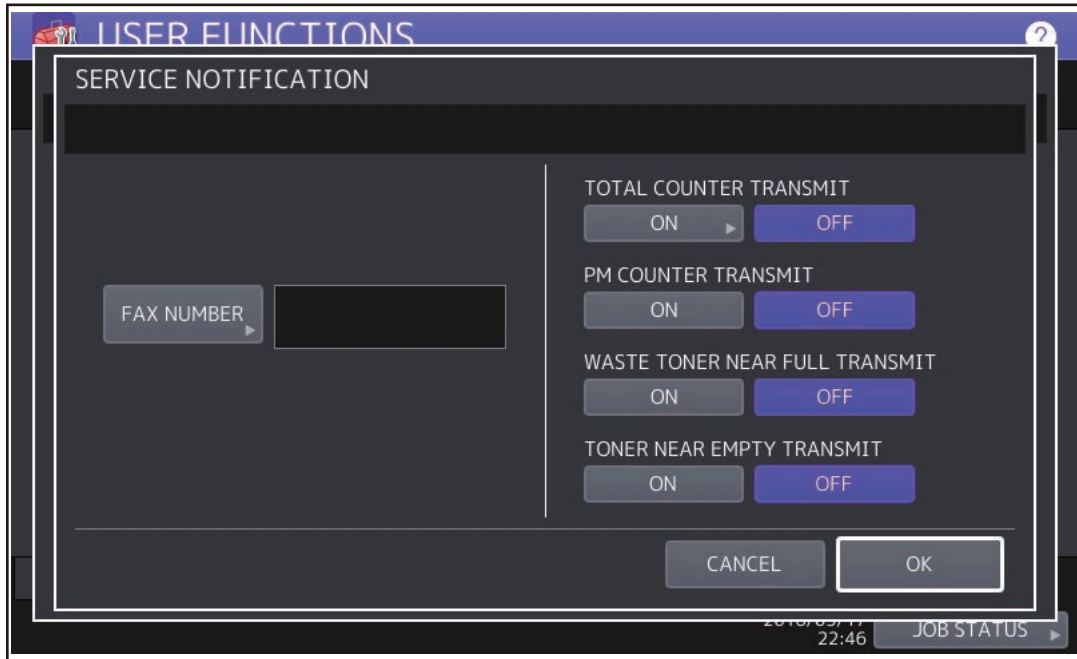


Fig.10-26

- (6) Press [ON] to notify or [OFF] not to notify each item for E-mail and FAX. When Total Count Transmit is set to ON, the screen to set the notification date is displayed. Then set the notification date with the following procedure.

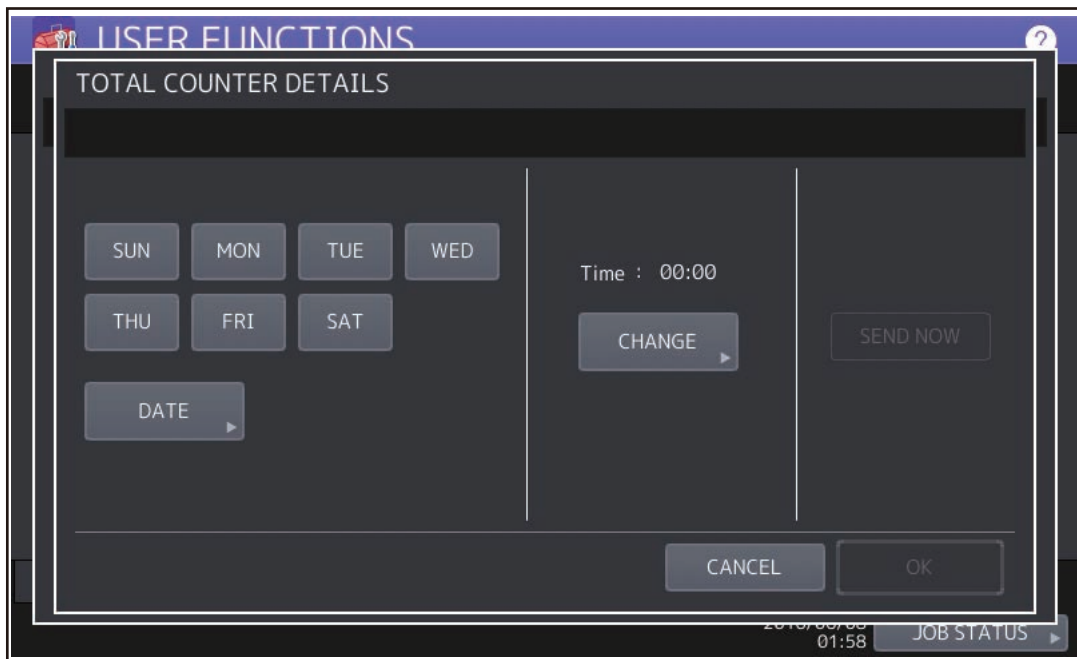


Fig.10-27

Set the date and time of the Total Counter.

The following 3 items can be specified for the date setting, and more than one day of the week also can be selected.

- Day of the week (More than one day can be selected.)

- Notify Date 1
- Notify Date 2

You can send the Total Counter immediately without the above settings by pressing [SEND NOW].

- **Day of the week ([Sunday] to [Saturday])**  
Pressing [SUN] to [SAT] of the desired day makes transmission on every specified day. More than one day can be selected.  
\* This does not affect the settings of “Notify Date 1” and “Notify Date 2”.
- **Notify Date 1 and Notify Date 2 ([DATE])**  
Pressing [DATE] sets up to 2 dates on which you want to send data.  
\* This is not affected by the specified day of the week.

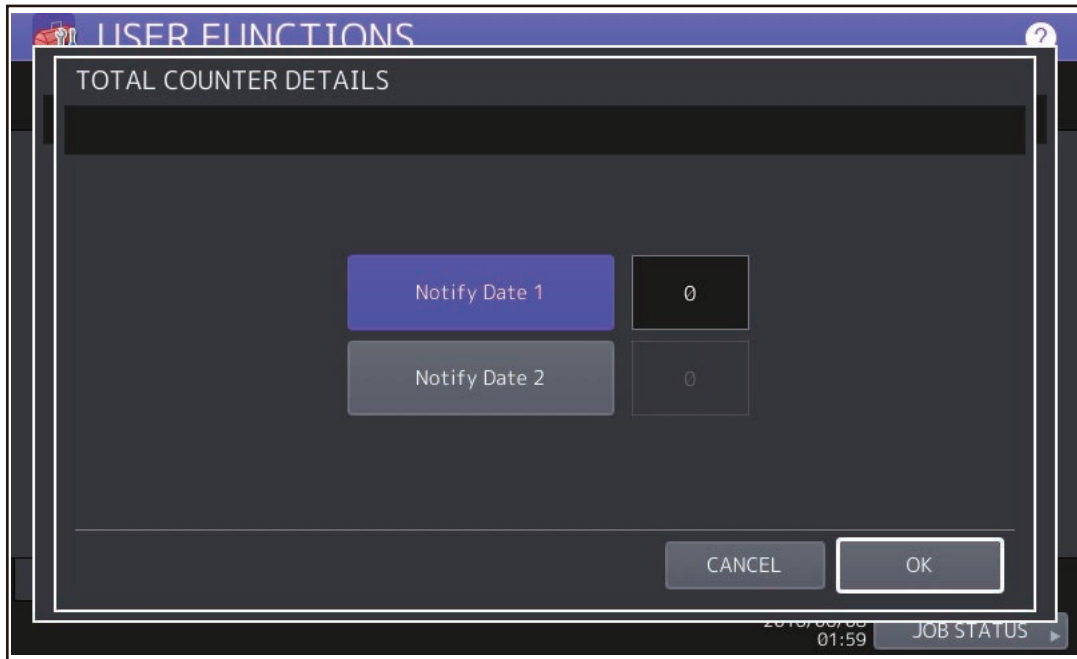


Fig.10-28

Key in the date (acceptable values: 0-31) in “Notify Date 1” or “Notify Date 2” and press [OK].

- **Time setting ([CHANGE])**

Pressing [CHANGE] sets the time at which you want to send data.

This is the time when data are sent with “Day of the week”, “Notify Date 1” and “Notify Date 2”.

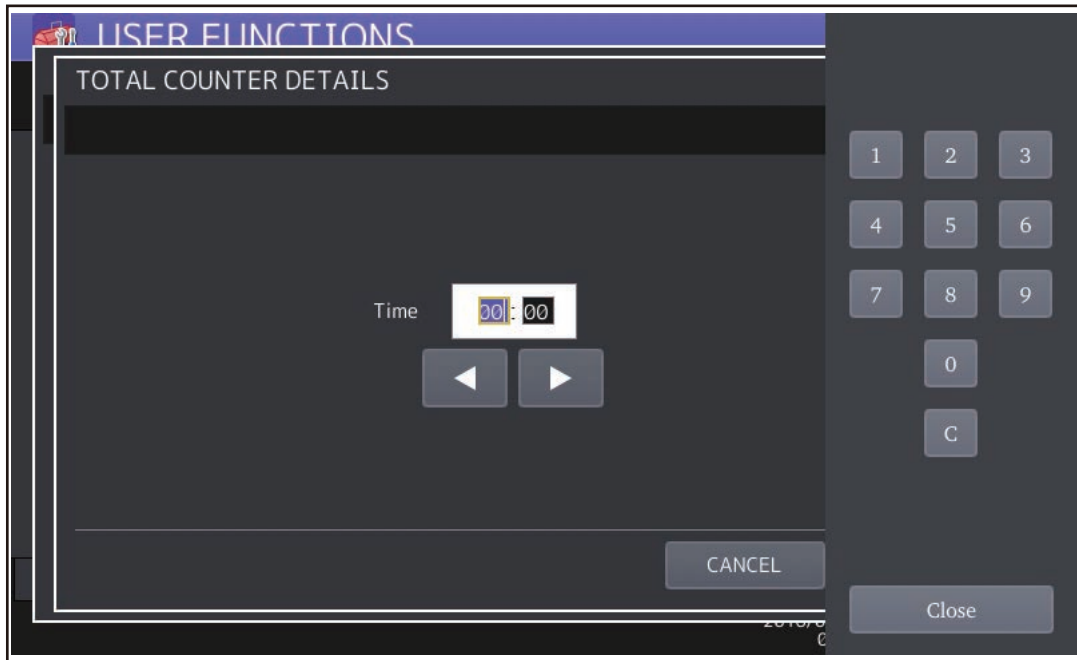


Fig.10-29

Key in the time (acceptable values: 00:00-23:59) in “Time”.

Key in the time in the hour column of “Time”, press the scroll button, key in the time in the minute column of “Time”.

After all the settings are completed, press [CLOSE].

(7) Press [OK]. The setting completes.

**Notes:**

- Service Notification setting is also available from the following setting mode (08).
- Set the service notification setting (FS-08-9793) to “1” or “2”. Then sets the items (self-diagnostic code) which you want to transmit to ON.

Items	08 code	Contents
Service Notification setting	9793	0: Invalid 1: Valid (E-mail) 2: Valid (Fax)
E-mail address 1	9794	Maximum 192 letters
E-mail address 2	9607	Maximum 192 letters
E-mail address 3	9608	Maximum 192 letters
FAX number	9784	Maximum 32 digits
Total Counter Transmit setting	9795	0: OFF (Invalid) 1: ON (Valid)
Total counter transmission date setting	9796	0 to 31
Total counter transmission date setting(2)	9880	0 to 31
Day of total counter data transmission	9881	1 byte 00000000(0)-01111111(127) From the 2nd bit - Sunday, Monday, Tuesday, Wednesday, Thursday, Friday, Saturday
Total counter transmission interval setting (Hour/Minute/Minute/Minute)	9606	00:00-23:59 (Hour/Minute/Minute/Minute)
Service Call Transmit setting	9605	0: OFF (Invalid) 1: ON (Valid)
PM Counter Transmit setting	9797	0: OFF (Invalid) 1: ON (Valid)
Toner near empty Transmit setting	FS-08-8538	0: OFF (Invalid) 1: ON (Valid)

### 10.2.3 Items to be notified

The items to be notified are shown below.

#### [ 1 ] Total Counter Transmit / PM Counter Transmit by E-mail

Subject: COUNTER NOTIFICATION

(In case of the PM Counter Transmit, it is shown as "PERIODICAL MAINTENANCE NOTIFICATION".)

1	Date	: 04/26/2008 12:34
2	Machine Model	: TOSHIBA e-STUDIO655
3	SerialNumber	: 1234567890
4	Total Counter	: 00004787
5	Supplier:	
	Name	: SUPPLIER_NAME
	Fax Number	: 1122334455
	E-Mail	: <u>Supplier_emailaddress@cccc.xxx</u>
	Address	: SUPPLIER_ADDRESS
6	Customer:	
	Name	: CUSTOMER_NAME
	Tel Number	: 1234567890
	E-Mail	: <u>customer_emailaddress@dddd.xxx</u>
	Address	: CUSTOMER_ADDRESS
7	Service Technician:	
	Number	: svc12
	Name	: SERVICE_TECHNICIAN_NAME
	Tel Number	: 0987654321
	E-Mail	: <u>svc@toshibatec.co.jp</u>
	ChargeCounterFormat:	
8	LargeSizeChargeCount	1
9	LargeSizeChargePaperDefinition	1
	PMCounterFormat:	
10	LargeSizePMCount	1
11	LargeSizePMPaperDefinition	0
	Charge Counter:	
		Large Small
	<Print Counter>	
	Black	-----
12	Copy	00000000 00000000
13	Print	00000000 00000000
14	List	00000000 00000000
15	FAX	00000000 00000000
	<Scan Counter>	
	Full Color	-----
16	Net Scan	00000000 00000000
	Black	-----
17	Copy Scan	00000000 00000000
18	FAX Scan	00000000 00000000
19	Net Scan	00000000 00000000
	<FAX Counter>	
20	Transmit	00000000 00000000
21	Receive	00000000 00000000

Fig.10-30

Periodical Maintenance Counter:			
		Pages	Drive Counts
22	K-EPU		
	Setting	00000000	00000000
23	Current	00000000	00000000
	K-Dev		
24	Setting	00000000	00000000
25	Current	00000000	00000000
	Others		
26	Setting	00000000	00000000
27	Current	00000000	00000000
28	Printer Error History:		
	Date	Time	ErrorCode Counter
	04/13/2008	16:44	F110 00000000
	04/12/2008	22:28	F110 00000000
	04/12/2008	22:23	F110 00000000
	03/15/2008	22:23	F110 00000000
	02/25/2008	11:12	F110 00000000
	(*1)		
29	Toner		Remaining Quantity (%)
	Black	00000000	

**Fig.10-31**

1. Date
2. Machine model name
3. Serial number
4. Total counter value
5. Supplier information
6. Customer information
7. Service technician information
8. Count setting of large-sized paper (Fee charging system counter)
9. Definition setting of large-sized paper (Fee charging system counter)
10. Count setting of large-sized paper (PM)
11. Definition setting of large-sized paper (PM)
12. Number of output pages in the Copier Function (BLACK)
13. Number of output pages in the Printer Function (BLACK)
14. Number of output pages at the List Print Mode (BLACK)
15. Number of output pages in the FAX Function (BLACK)
16. Number of scanning pages in the Network Scanning Function (Full color)
17. Number of scanning pages in the Copier Function (BLACK)
18. Number of scanning pages in the FAX Function (BLACK)
19. Number of scanning pages in the Network Scanning Function (BLACK)
20. Number of transmitted pages in the FAX Function (BLACK)
21. Number of received pages in the FAX Function (BLACK)
22. PM count setting value / PM driving count setting value [EPU (K)]
23. PM count present value / PM driving count present value [EPU (K)]
24. PM count setting value / PM driving count setting value [Developer material (K)]
25. PM count present value / PM driving count present value [Developer material (K)]
26. PM count setting value / PM driving count setting value [Other parts]
27. PM count present value / PM driving count present value [Other parts]
28. History of error
  - \*1 The latest 20 errors are displayed.
29. Toner remaining quantity (Black)

## [ 2 ] Total Counter Transmit / PM Counter Transmit by FAX

\*1 In case of the PM Counter Transmit, the title is replaced to "PERIODICAL MAINTENANCE NOTIFICATION".

Sheet 1

COUNTER NOTIFICATION (*1)	
1	DATE : 08/04/14 13:47
2	MACHINE MODEL : TOSHIBA e-STUDIO655
3	SERIAL NUMBER : 1234567890
4	TOTAL COUNTER : 00004787
5	CUSTOMER NAME : CUSTOMER_NAME
	CUSTOMER ADDRESS : CUSTOMER_ADDRESS
	CUSTOMER TEL NUMBER : 1234567890
	CUSTOMER E-MAIL ADDRESS : customer_emailaddress@dddd.xxx
6	SERVICE TECHNICIAN NUMBER : svc12
	SERVICE TECHNICIAN NAME : SERVICE_TECHNICIAN_NAME
	SERVICE TECHNICIAN TEL NUMBER : 0987654321
	SERVICE TECHNICIAN E-MAIL : svc@toshibatec.co.jp
7	SUPPLIER NAME : SUPPLIER_NAME
	SUPPLIER ADDRESS : SUPPLIER_ADDRESS
	SUPPLIER FAX NUMBER : 5544332211
	SUPPLIER E-MAIL : supplier_emailaddress@cccc.xxx

Fig.10-32

COUNTER NOTIFICATION (*1)										
CHARGE COUNTER FORMAT					PM COUNTER FORMAT					
8	LARGE SIZE CHARGE COUNT				: 1	LARGE SIZE PM COUNT				: 1
9	LARGE SIZE CHARGE PAPER DEFINITION				: 1	LARGE SIZE PM PAPER DEFINITION				: 0
CHARGE COUNTER					10	11				
PRINT COUNTER					SCAN COUNTER					
BLACK					FULL COLOR					
12	COPY	LARGE	SMALL		16	NET SCAN	LARGE	SMALL		
		00000000	00000000			00000000	00000000	00000000		
13	PRINT	00000000	00000000		BLACK					
14	LIST	00000000	00000000		17	COPY SCAN	LARGE	SMALL		
		00000000	00000000			00000000	00000000	00000000		
15	FAX	00000000	00000000		18	FAX SCAN	00000000	00000000		
		00000000	00000000		19	NET SCAN	00000000	00000000		
FAX COUNTER										
20	TRANSMIT	LARGE	SMALL							
		00000000	00000000							
21	RECEIVE	00000000	00000000							
		00000000	00000000							
PERIODICAL MAINTENANCE COUNTER										
22	SETTING VALUE	(K-EPU PAGES)	:	00000000	SETTING VALUE	(K-DEV DRIVE COUNTS)	:	00000000	28	
23	CURRENT VALUE	(K-EPU PAGES)	:	00000000	CURRENT VALUE	(K-DEV DRIVE COUNTS)	:	00000000	29	
24	SETTING VALUE	(K-EPU DRIVE COUNTS)	:	00000000	SETTING VALUE	(OTHERS PAGES)	:	00000000	30	
25	CURRENT VALUE	(K-EPU DRIVE COUNTS)	:	00000000	CURRENT VALUE	(OTHERS PAGES)	:	00000000	31	
26	SETTING VALUE	(K-DEV PAGES)	:	00000000	SETTING VALUE	(OTHERS DRIVE COUNTS)	:	00000000	32	
27	CURRENT VALUE	(K-DEV PAGES)	:	00000000	CURRENT VALUE	(OTHERS DRIVE COUNTS)	:	00000000	33	
PRINTER ERROR HISTORY										
34	DATE	TIME	ERROR CODE	COUNTER	DATE	TIME	ERROR CODE	COUNTER		
	08/04/13	16:44	F110	00000000	08/04/13	16:44	F110	00000000	(*2)	
	08/04/12	22:28	F110	00000000	08/04/13	16:44	F110	00000000		
	08/04/12	22:23	F110	00000000	08/04/13	16:44	F110	00000000		
	08/03/15	22:23	F110	00000000	08/04/13	16:44	F110	00000000		
	08/02/25	11:12	F110	00000000	08/04/13	16:44	F110	00000000		
	08/02/25	11:12	F110	00000000	08/04/13	16:44	F110	00000000		
TONER INFORMATION										
35	BLACK REMAINING QUANTITY (%)				:	00000059				

Fig.10-33

1. Date
2. Machine model name
3. Serial number
4. Total counter value
5. Customer information
6. Service technician information
7. Supplier information
8. Count setting of large-sized paper (Fee charging system counter)
9. Definition setting of large-sized paper (Fee charging system counter)
- 10.Count setting of large-sized paper (PM)
- 11.Definition setting of large-sized paper (PM)
- 12.Number of output pages in the Copier Function (BLACK)
- 13.Number of output pages in the Printer Function (BLACK)
- 14.Number of output pages at the List Print Mode (BLACK)
- 15.Number of output pages in the FAX Function (BLACK)
- 16.Number of scanning pages in the Network Scanning Function (Full color)



- 17.Number of scanning pages in the Copier Function (BLACK)
- 18.Number of scanning pages in the FAX Function (BLACK)
- 19.Number of scanning pages in the Network Scanning Function (BLACK)
- 20.Number of transmitted pages in the FAX Function (BLACK)
- 21.Number of received pages in the FAX Function (BLACK)
- 22.PM count setting value [EPU (K)]
- 23.PM count present value [EPU (K)]
- 24.PM driving count setting value [EPU (K)]
- 25.PM driving count present value [EPU (K)]
- 26.PM count setting value [Developer material (K)]
- 27.PM count present value [Developer material (K)]
- 28.PM driving count setting value [Developer material (K)]
- 29.PM driving count present value [Developer material (K)]
- 30.PM count setting value (Other parts)
- 31.PM count present value (Other parts)
- 32.PM driving count setting value (Other parts)
- 33.PM driving count present value (Other parts)
- 34.History of error
  - \*2 The latest 20 errors are displayed.
- 35.Toner remaining quantity (Black)

### [ 3 ] Toner near-empty notification by e-mail

Subject: Toner Near-Empty Notification

```
1  Date       : 04/26/2008 12:34
2  Machine Model : TOSHIBA e-STUDIO655
3  SerialNumber : 1234567890
4  Total Counter : 00004787
5  Supplier:
   Name       : SUPPLIER_NAME
   Fax Number : 1122334455
   E-Mail     : Supplier_emailaddress@cccc.xxx
   Address    : SUPPLIER_ADDRESS
6  Customer:
   Name       : CUSTOMER_NAME
   Tel Number : 1234567890
   E-Mail     : customer_emailaddress@dddd.xxx
   Address    : CUSTOMER_ADDRESS
7  Service Technician:
   Number    : svc12
   Name      : SERVICE_TECHNICIAN_NAME
   Tel Number : 0987654321
   E-Mail    : svc@toshibatec.co.jp
8  ChargeCounterFormat:
   LargeSizeChargeCount      1
9  LargeSizeChargePaperDefinition  1
10 PMCounterFormat:
   LargeSizePMCount          1
11 LargeSizePMPaperDefinition  0
   Charge Counter:
       Large Small
   <Print Counter>
   Black -----
12 Copy      00000000 00000000
13 Print     00000000 00000000
14 List      00000000 00000000
15 FAX       00000000 00000000
   <Scan Counter>
   Full Color -----
16 Net Scan  00000000 00000000
   Black -----
17 Copy Scan 00000000 00000000
18 FAX Scan  00000000 00000000
19 Net Scan  00000000 00000000
   <FAX Counter>
20 Transmit 00000000 00000000
21 Receive  00000000 00000000
```

Fig.10-34

Periodical Maintenance Counter:			
		Pages	Drive Counts
22	K-EPU		
	Setting	00000000	00000000
23	Current	00000000	00000000
24	K-EPU		
	Setting	00000000	00000000
25	Current	00000000	00000000
26	Others		
	Setting	00000000	00000000
27	Current	00000000	00000000
28	Printer Error History:		
	Date	Time	ErrorCode Counter
	04/13/2008	16:44	F110 00000000
	04/12/2008	22:28	F110 00000000
	04/12/2008	22:23	F110 00000000
	03/15/2008	22:23	F110 00000000
	02/25/2008	11:12	F110 00000000
29	Toner Cartridge Information:		
30	Toner Near-Empty Counter		
31	Setting		00000000
32	Current		00000000
	Toner Near-Empty Sensed		1
33	Point Of Destination		0
34	Used History		
35	Developer Counter		00000000
36	Developer Driving Time		00000000
37	Drum Driving Time		00000000
38	Toner Information:		
	Toner		
	Black		00000000

Fig.10-35

1. Date
2. Machine model name
3. Serial number
4. Total counter value
5. Supplier information
6. Customer information
7. Service technician information
8. Count setting of large-sized paper (Fee charging system counter)
9. Definition setting of large-sized paper (Fee charging system counter)
- 10.Count setting of large-sized paper (PM)
- 11.Definition setting of large-sized paper (PM)
- 12.Number of output pages in the Copier Function (BLACK)
- 13.Number of output pages in the Printer Function (BLACK)
- 14.Number of output pages at the List Print Mode (BLACK)
- 15.Number of output pages in the FAX Function (BLACK)
- 16.Number of scanning pages in the Network Scanning Function (Full color)
- 17.Number of scanning pages in the Copier Function (BLACK)
- 18.Number of scanning pages in the FAX Function (BLACK)
- 19.Number of scanning pages in the Network Scanning Function (BLACK)
- 20.Number of transmitted pages in the FAX Function (BLACK)
- 21.Number of received pages in the FAX Function (BLACK)
- 22.PM count setting value / PM driving count setting value [EPU (K)]
- 23.PM count present value / PM driving count present value [EPU (K)]

- 24. PM count setting value / PM driving count setting value [Developer material (K)]
- 25. PM count present value / PM driving count present value [Developer material (K)]
- 26. PM count setting value / PM driving count setting value [Other parts]
- 27. PM count present value / PM driving count present value [Other parts]
- 28. History error
- 29. Toner cartridge information
- 30. Toner near-empty counter
- 31. Setting value of toner cartridge rotation time counter
- 32. Current value of toner cartridge rotation time counter
- 33. Destination setting of toner cartridge
- 34. Usage History
- 35. Current value for total printed sheets of developer
- 36. Current value for developer driving time
- 37. Current value for drum driving time
  - \*1. The latest 20 errors are displayed.
- 38. Toner remaining quantity (Black)

## [ 4 ] Toner near-empty notification by FAX

Sheet 1

TONER NEAR-EMPTY NOTIFICATION (*1)	
1	DATE : 08/04/14 13:47
2	MACHINE MODEL : TOSHIBA e-STUDIO655
3	SERIAL NUMBER : 1234567890
4	TOTAL COUNTER : 00004787
5	CUSTOMER NAME : CUSTOMER_NAME
	CUSTOMER ADDRESS : CUSTOMER_ADDRESS
	CUSTOMER TEL NUMBER : 1234567890
	CUSTOMER E-MAIL ADDRESS : customer_emailaddress@dddd.xxx
6	SERVICE TECHNICIAN NUMBER : svc12
	SERVICE TECHNICIAN NAME : SERVICE_TECHNICIAN_NAME
	SERVICE TECHNICIAN TEL NUMBER : 0987654321
	SERVICE TECHNICIAN E-MAIL : svc@toshibatec.co.jp
7	SUPPLIER NAME : SUPPLIER_NAME
	SUPPLIER ADDRESS : SUPPLIER_ADDRESS
	SUPPLIER FAX NUMBER : 5544332211
	SUPPLIER E-MAIL : supplier_emailaddress@ccccc.xxx

Fig.10-36

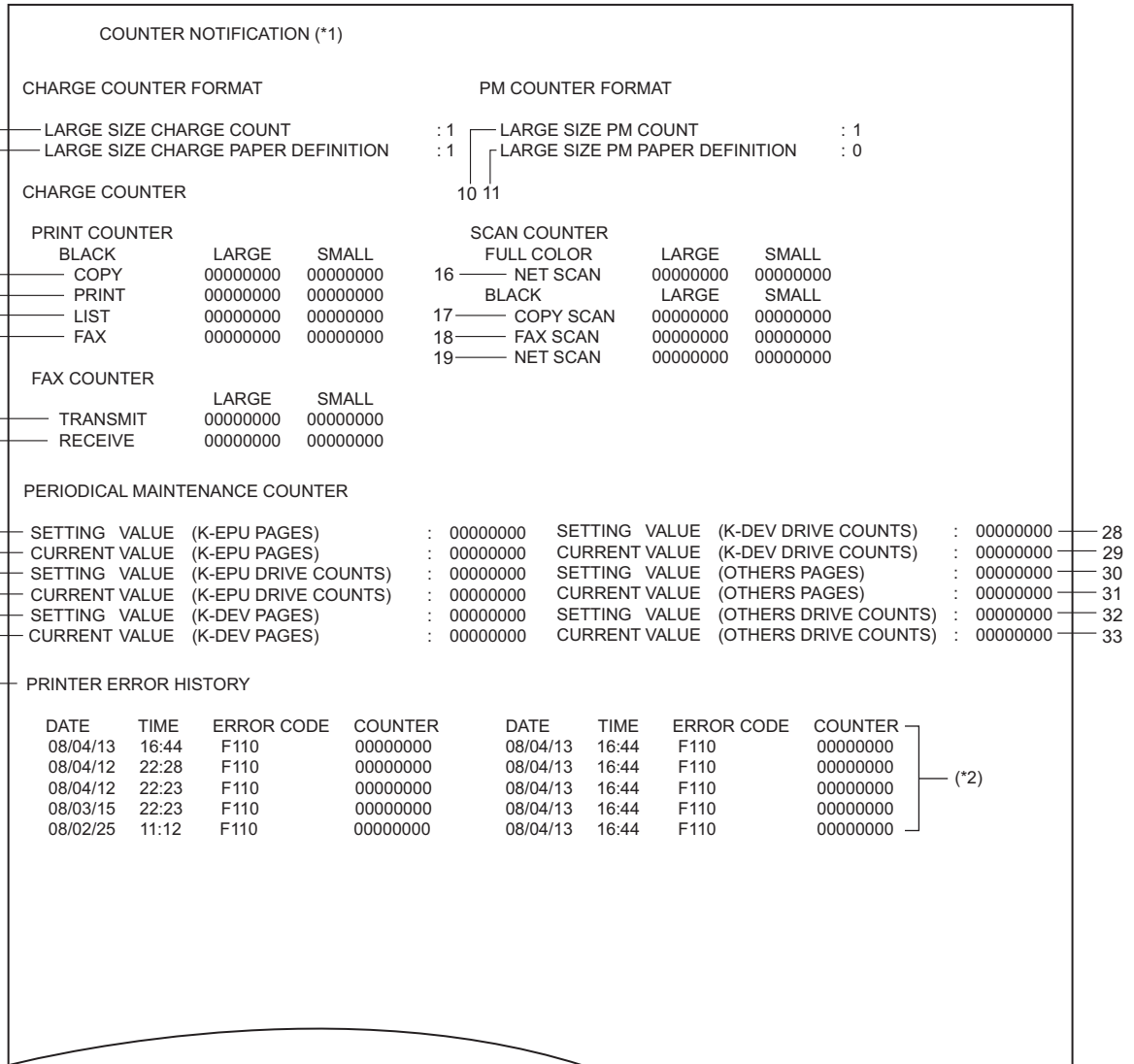


Fig.10-37

COUNTER NOTIFICATION (*1)							
PRINTER ERROR HISTORY							
DATE	TIME	ERROR CODE	COUNTER	DATE	TIME	ERROR CODE	COUNTER
08/04/13	16:44	F110	00000000	08/04/13	16:44	F110	00000000
08/04/12	22:28	F110	00000000	08/04/13	16:44	F110	00000000
08/04/12	22:23	F110	00000000	08/04/13	16:44	F110	00000000
08/03/15	22:23	F110	00000000	08/04/13	16:44	F110	00000000
08/02/25	11:12	F110	00000000	08/04/13	16:44	F110	00000000

(\*2)

34

35 Toner Cartridge Information:

36 Toner Near-Empty Counter

37 Setting 00000000

38 Current 00000000

Toner Near-Empty Sensed 1

39 Point Of Destination 0

40 Used History

41 Developer Counter 00000000

42 Developer Driving Time 00000000

43 Drum Driving Time 00000000

Fig.10-38

1. Date
2. Machine model name
3. Serial number
4. Total counter value
5. Customer information
6. Service technician information
7. Supplier information
8. Count setting of large-sized paper (Fee charging system counter)
9. Definition setting of large-sized paper (Fee charging system counter)
- 10.Count setting of large-sized paper (PM)
- 11.Definition setting of large-sized paper (PM)
- 12.Number of output pages in the Copier Function (BLACK)
- 13.Number of output pages in the Printer Function (BLACK)
- 14.Number of output pages at the List Print Mode (BLACK)
- 15.Number of output pages in the FAX Function (BLACK)
- 16.Number of scanning pages in the Network Scanning Function (Full color)
- 17.Number of scanning pages in the Copier Function (BLACK)
- 18.Number of scanning pages in the FAX Function (BLACK)
- 19.Number of scanning pages in the Network Scanning Function (BLACK)
- 20.Number of transmitted pages in the FAX Function (BLACK)
- 21.Number of received pages in the FAX Function (BLACK)
- 22.PM count setting value [EPU (K)]
- 23.PM count present value [EPU (K)]
- 24.PM driving count setting value [EPU (K)]
- 25.PM driving count present value [EPU (K)]
- 26.PM count setting value [Developer material (K)]
- 27.PM driving count present value [Developer material (K)]
- 28.PM driving count setting value [Developer material (K)]
- 29.PM driving count present value [Developer material (K)]

- 30.PM count setting value (Other parts)
  - 31.PM driving count present value (Other parts)
  - 32.PM driving count setting value (Other parts)
  - 33.PM driving count present value (Other parts)
  - 34.History of error
  - 35.Toner cartridge information
  - 36.Toner near-empty counter
  - 37.Setting value of toner cartridge rotation time counter
  - 38.Current value of toner cartridge rotation time counter
  - 39.Destination setting of toner cartridge
  - 40.Usage History
  - 41.Current value for total printed sheets of developer
  - 42.Current value for developer driving time
  - 43.Current value for drum driving time
- \*2 The latest 20 errors are displayed.



**[ 5 ] Service Call Transmit**  
**Subject: Service Call Notification**

1 — Date: 04/14/2008 13:47  
Machine Name: e-STUDIO3520C SerialNumber:1234567890  
2 3

4 — Function: Printer  
5 — Severity: Error  
6 — ErrorCode: XXXX  
7 — Message:  
XX

8 — Supplier:  
Name : SUPPLIER\_NAME  
Tel Number : 1122334455  
E-Mail : supplier\_emailaddress@cccc.xxx  
Address : SUPPLIER\_ADDRESS

9 — Customer:  
Name : CUSTOMER\_NAME  
Tel Number : 1234567890  
E-Mail : customer\_emailaddress@dddd.xxx  
Address : CUSTOMER\_ADDRESS

10 — Service Technician:  
Number : svc12  
Name : SERVICE\_TECHNICIAN\_NAME  
Tel Number : 0987654321  
E-Mail : svc@toshibatec.co.jp

11 — Printer Error History:

Date	Time	ErrorCode	Counter
04/13/2008	16:44	F110	} (*1)
04/12/2008	22:28	F110	
04/12/2008	22:23	F110	
03/15/2008	22:23	F110	
02/25/2008	11:12	F110	

12 — Toner Information

Toner	Remaining Quantity(%)
Black	00000000

**Fig.10-39**

1. Date (When an error occurs)
2. Machine model name
3. Serial number
4. Function: Fixed at "Printer"
5. Severity: Fixed at "Error"
6. Error code
7. Error message: The content of error is displayed.
8. Supplier information
9. Customer information
10. Service technician information

11. History of error

\*1 The latest 20 errors are displayed.

12. Toner remaining quantity (Black)

## [ 6 ] HDD alert notification by E-mail

Subject: HDD ALERT NOTIFICATION

```
Date : 99-99-'99 99:99
Machine Model : TOSHIBA e-STUDIOxxxx
Serial Number : 1234567890
F/W Ver. : XXXXXXXXXXXXXXXX
Total Counter : 00000000

Supplier:
  Name : XXXXXXXXXXXXXXXXXXXXXXXXXXXXXXXXXXXXXXXXXXXXXXXX
  Tel Number : XXXXXXXXXXXXXXXXXXXXXXXXXXXXXXXXXXXXXXXXXXXXXXXX
  E-Mail : XXXXXXXXXXXXXXXXXXXXXXXXXXXXXXXXXXXXXXXXXXXXXXXX
  Address : XXXXXXXXXXXXXXXXXXXXXXXXXXXXXXXXXXXXXXXXXXXXXXXX

Customer:
  Name : XXXXXXXXXXXXXXXXXXXXXXXXXXXXXXXXXXXXXXXXXXXXXXXX
  Tel Number : XXXXXXXXXXXXXXXXXXXXXXXXXXXXXXXXXXXXXXXXXXXXXXXX
  E-Mail : XXXXXXXXXXXXXXXXXXXXXXXXXXXXXXXXXXXXXXXXXXXXXXXX
  Address : XXXXXXXXXXXXXXXXXXXXXXXXXXXXXXXXXXXXXXXXXXXXXXXX

Service Technician:
  Number : XXXXXXXXXXXXXXXXXXXXXXXXXXXXXXXXXXXXXXXXXXXXXXXX
  Name : XXXXXXXXXXXXXXXXXXXXXXXXXXXXXXXXXXXXXXXXXXXXXXXX
  Tel Number : XXXXXXXXXXXXXXXXXXXXXXXXXXXXXXXXXXXXXXXXXXXXXXXX
  E-Mail : XXXXXXXXXXXXXXXXXXXXXXXXXXXXXXXXXXXXXXXXXXXXXXXX

HDD Model Number : TOSHIBAXXXXXXXXXXXXXXXXXXXXXXXXXXXXXX
HDD Serial Number : XXXXXXXXXXXXXXXXXXXXXXXX

SMART Information
  Start/Stop Count : 0
  Reallocated Sector Count : 0
  Power-On hours count : 0
  Drive Power Cycle Count : 0
  Shock Sense Count : 0
  Power-Off Retract Count : 0
  Load Cycle Count : 0
  Temperature(Minimum) : 0
  Temperature(Maximum) : 0
  Reallocated Sector Event : 0
  Current Pending Sector Count : 0
  CRC Error Count : 0
  Loaded Hours : 0

HDD Check Result : Please make a backup of HDD data.
```

Fig.10-40

# [ 7 ] HDD alert notification by Fax

Sheet 1

```
HDD ALERT NOTIFICATION

DATE : 99-99-'99 99:99
MACHINE MODEL : TOSHIBA e-STUDIOxxxx
SERIAL NUMBER : 1234567890
TOTAL COUNTER : 00000000
CUSTOMER NAME : XXXXXXXXXXXXXXXXXXXXXXXXXXXXXXXXXXXXXXXXXXXX
CUSTOMER ADDRESS : XXXXXXXXXXXXXXXXXXXXXXXXXXXXXXXXXXXXXXXXXXXX
CUSTOMER TEL NUMBER : XXXXXXXXXXXXXXXXXXXXXXXXXXXXXXXXXXXXXXXXXXXX
CUSTOMER E-MAIL ADDRESS : XXXXXXXXXXXXXXXXXXXXXXXXXXXXXXXXXXXXXXXXXXXX
SERVICE TECHNICIAN NUMBER : XXXXXXXXXXXXXXXXXXXXXXXXXXXXXXXXXXXX
SERVICE TECHNICIAN NAME : XXXXXXXXXXXXXXXXXXXXXXXXXXXXXXXXXXXX
SERVICE TECHNICIAN TEL NUMBER : XXXXXXXXXXXXXXXXXXXXXXXXXXXXXXXX
SERVICE TECHNICIAN E-MAIL : XXXXXXXXXXXXXXXXXXXXXXXXXXXXXXXX
SUPPLIER NAME : XXXXXXXXXXXXXXXXXXXXXXXXXXXXXXXXXXXXXXXXXXXX
SUPPLIER ADDRESS : XXXXXXXXXXXXXXXXXXXXXXXXXXXXXXXXXXXXXXXXXXXX
SUPPLIER FAX NUMBER : XXXXXXXXXXXXXXXXXXXXXXXXXXXXXXXXXXXXXXXXXXXX
SUPPLIER E-MAIL ADDRESS : XXXXXXXXXXXXXXXXXXXXXXXXXXXXXXXXXXXXXXXXXXXX
```

Fig.10-41

Sheet 2

```
HDD ALERT NOTIFICATION

HDD MODEL NUMBER : TOSHIBAXXXXXXXXXXXXXXXXXXXXXXXXXX
HDD SERIAL NUMBER : XXXXXXXXXXXXXXXXXXXXXXXX

SMART INFORMATION
START/STOP COUNT : 0
REALLOCATED SECTOR COUNT : 0
POWER-ON HOURS COUNT : 0
DRIVE POWER CYCLE COUNT : 0
SHOCK SENSE COUNT : 0
POWER-OFF RETRACT COUNT : 0
LOAD CYCLE COUNT : 0
TEMPERATURE(MINIMUM) : 0
TEMPERATURE(MAXIMUM) : 0
REALLOCATED SECTOR EVENT : 0
CURRENT PENDING SECTOR COUNT : 0
CRC ERROR COUNT : 0
LOADED HOURS : 0

HDD CHECK RESULT : PLEASE MAKE A BACKUP OF HDD DATA.
```

Fig.10-42

## 10.3 Remote Panel (VNC)

### 10.3.1 Outline

By using the Remote Panel (VNC: Virtual Network Computing) function, the control panel of equipment (\*) which is located in a remote place can be operated by a client computer or tablet.

\* Equipment whose IP address can be confirmed from a client computer or tablet to be operated

#### Notes:

- The VNC function is available with the SYS version TG01HD0W1500 or later.
- Be sure to obtain permission from the user beforehand to enable and use this function.
- If the user's permission can be obtained, ask that the equipment be operated with this function enabled and not disabled.
- The VNC client software needs to be installed in a client computer or tablet in order for you to perform the VNC connection with the equipment. (Recommended VNC client software: "UltraVNC")

The following items become operable in the VNC function.

- All the operations which are available on the control panel (operations of icons in the touch panel and hard keys)

#### Notes:

The pinch operation on the touch panel, [ON/OFF] button operation, LED lamp performance and Ten Key (option) operation are not supported.

- Shifting to the FS Menu from the normal mode
- Browsing and setting self-diagnostic codes in the FS Menu

### 10.3.2 Setting

#### [ 1 ] Setting the equipment

Set this function from TopAccess or [08 SETTING MODE].

#### [A] Setting from TopAccess

Access from TopAccess > [Administration] > [Setup] > [Network] and specify the items in VNC Setting as below.

Item name	Setting
Enable VNC Function	Select [Enable].
Old Password	Enter the old password for the VNC function.
New Password	Enter a new password for the VNC function.
Retype Password	Retype the new password for the VNC function.
Enable SSL/TLS	Select [Enable] or [Disable].

## [B] Setting from [08 SETTING MODE]

Code	Description	Setting
FS-08-8794	VNC connection of control panel	Set "1" (Allowed to connect).
FS-08-8559	Password at VNC connection	Enter a password for the VNC function.
FS-08-8699	SSL function setting	Set "1" (Enabled) or "2" (Disabled).

### Notes:

- "d9kvgn" has been given for the default password. Be sure to change this at the time of the first setting.
- To use "UltraVNC" for the VNC client software, set [Disable] in the [Enable SSL/TLS] option. To perform the VNC function by selecting [Enable] for the [Enable SSL/TLS] option, use a VNC client software which supports SSL/TLS.
- Specify a password with six or more and eight or less alphanumeric letters.
- When the "Enable" is selected for Enable VNC Function (FS-08-8794: 1), the equipment cannot shift to the Super Sleep mode.

## [ 2 ] Setting a client computer or tablet

Install the VNC client software.

### 10.3.3 Operation

#### [ 1 ] VNC connection between the equipment and a client computer or tablet

- (1) Start the VNC client software in the client computer or tablet.
- (2) Enter the IP address of the equipment to connect in the VNC Server field and press [Connect].

#### Remarks:

Select "Auto" for Quick Options.

- (3) Enter the password for the VNC connection and press [Log On].  
The control panel of the connected equipment is displayed.

#### Notes:

Only one client computer or tablet can be connected to one equipment unit.

#### [ 2 ] Operation of the equipment on the remote panel

The equipment can be operated by mouse clicking the button or icon on the control panel displayed on the client computer or tablet.

#### Notes:

- The pinch operation on the touch panel, [ON/OFF] button operation, LED lamp performance and Ten Key (option) operation are not supported.
- Operation on the control panel of the equipment is possible even during the VNC connection.
- The equipment does not shift to the Energy Saving mode or Sleep mode during the VNC connection.

### [ 3 ] Shifting to the FS Menu

- (1) Press the [Gear] icon with the mouse for at least 3 seconds.
- (2) Enter the service password on the login screen and press [OK].

**Important:**

Be sure to shift the equipment to the normal mode before quitting the VNC connection.

**Notes:**

- While the equipment is shifting to the FS Menu, jobs such as network printing, fax, internet fax and remote scanning are not accepted.
- If the equipment is rebooted when it is returned from the FS menu to the normal mode, the VNC connection is disconnected. To continue the operation, perform the VNC connection again.

## 10.4 Remote Service

### 10.4.1 Outline

When the remote management of the equipment is performed by e-BRIDGE CloudConnect, carry out the updating or setting change once a day or at the time of the rebooting of the equipment. Using the Remote Service function can immediately reflect the updating or setting change to the equipment, and thus the period to solve the problem can be shortened.

### 10.4.2 Setting

Set "1" (Enabled) for FS-08-3820 (e-BRIDGE CloudConnect function setting).

[Remote Service] is displayed in [User Functions -User-] > [Admin] > [General] on the touch panel.

### 10.4.3 Operation

After the setting, such as a policy, has been specified to the target equipment by means of e-BRIDGE CloudConnect, ask your user to press [Remote Service] and then press [Yes] on the connection confirmation screen.

**Notes:**

- During the connecting of the Remote Service function, an hourglass mark is displayed on the screen and the operation of other functions becomes impossible.
- When the Remote Service function is finished, the equipment will reboot.
- When this operation has been completed successfully, "Communication success" is displayed on the bottom left of the Home screen.
- If an error has occurred, check the message log of TopAccess and take an appropriate measure.





# 11. FIRMWARE UPDATING

## 11.1 Overview

When you want to update the firmware to the latest one or the equipment becomes inoperable due to some defect in the firmware, updating can be performed as follows.

### Equipment

Firmware	Updating method
System firmware	USB device
Engine firmware	
Scanner firmware	
System software	
NIC firmware	

### Options

Model name	Firmware	Updating method
Reversing Automatic Document Feeder (RADF) (MR-3031)	RADF firmware	USB device
Dual Scan Document Feeder (DSDF) (MR-4000)	DSDF firmware	
Finisher (MJ-1042)	Finisher firmware	
Finisher (MJ-1109)	Finisher firmware	
Finisher (MJ-1110)	Finisher firmware	
Hole Punch Unit (MJ-6105)	Hole punch unit firmware	
FAX Unit (GD-1370)	FAX board firmware (Line1)	
	FAX board firmware (Line2)	

#### Notes:

- Written firmware varies depending on the kinds of the boards provided as service parts. For updating, only the minimum firmware is installed on the system control PC board, logic PC board, scanning section control PC board and FAX board. The latest version of the firmware at the time of delivery is written on the RADF control PC board and finisher control PC board. When any of above boards is replaced with a new one in the field, check the other firmware version used and then update with a corresponding suitable version.
- “Can't fetch Ver.” is displayed in the Installed Version field when the version of the installed firmware cannot be acquired properly. For example, if [HS-49] is carried out without your performing the normal startup after updating, this message will appear for some firmware.

## 11.2 Firmware Updating with USB Device

The software and firmware can be updated by means of a USB device in which an update package is stored. All necessary files for updating are stored in the package provided, so be sure to save all of them in the model specific folder.

For the data file for each firmware, refer to the following tables.

### Notes:

When performing the update, use the latest program.

### 11.2.1 Updating methods

There are three types of updating methods by means of a USB device. The table below explains the differences.

Method	File	Explanation
Normal update	Standard package	Updating the file of a base version.
Differential items update	Differential items package	Updating the version by means of the package of only the files which have been changed from the base. This method is applied to the system firmware and the system software. Since only the files which have been changed are packaged, the data size is smaller than that for the standard package. This method cannot be used for the equipment whose HDD has been formatted.
Patch update	Patch	Updating can be done in a shorter time than the standard one. This method is applied to the system firmware and the system software only.

### 11.2.2 Firmware type and data file for updating

#### [A] Normal update

#### Equipment

Firmware	Stored	Data file name	Display
System firmware	System control PC board (SYS board)	TG01SF0Wxxxx.tar * xxxx is version.	SYSTEM FIRMWARE (OS Data)
System software	HDD	TG01HD0Wxxxx.tar * xxxx is version.	SYSTEM SOFTWARE (HD Data)
Engine firmware	Logic PC board (LGC board)	TK120MWW.xxx * xxx is version.	ENGINE FIRMWARE
Scanner firmware	System control PC board (SYS board)	TK100SLGWW.xxx * xxx is version.	SCANNER FIRMWARE
NIC firmware	System control PC board (SYS board)	T370NIC0Wxxxx.tar * xxxx is version.	NIC FIRMWARE

## Option

Firmware	Stored	Data file name	Display
RADF firmware	DLG board (MR-3031)	H617DFWW.0xxx * xxx is version.	RADF FIRMWARE
DSDf firmware	DLG board (MR-4000)	H616DFWW.xxx * xxx is version.	DSDf FIRMWARE
Finisher firmware (MJ-1042)	Finisher control PC board	FIN1042T.xxx * xxx is version.	FINISHER FIRMWARE
Finisher firmware (MJ-1109)	Finisher control PC board	FIN1109T.xxx * xxx is version.	FINISHER FIRMWARE
Finisher firmware (MJ-1110)	Finisher control PC board	FIN1110T.xxx * xxx is version.	FINISHER FIRMWARE
Hole punch unit firmware (MJ-6105)	Punch control PC board	PUN6105T.xxx * xxx is version.	PUNCH FIRMWARE
FAX firmware (GD-1370)	System control PC board (SYS board)	FAXH625T.xxx * xxx is version.	FAX FIRMWARE1, FAX FIRMWARE2

### [B] Patch update

Firmware	Stored	Data file name	Display
System firmware	System control PC board (SYS board)	TG01SFPWxxxx.tar * xxxx is version.	SYSTEM FIRMWARE (OS DATA)
System software	HDD	TG01HDPWxxxx.tar * xxxx is version.	SYSTEM SOFTWARE (HDD DATA)

### [C] Differential items update

Firmware	Stored	Data file name	Display
System firmware	System control PC board (SYS board)	TG01SFdWxxxx.tar * xxxx is version.	SYSTEM FIRMWARE (OS DATA)
System software	HDD	TG01HDdWxxxx.tar * xxxx is version.	SYSTEM SOFTWARE (HDD DATA)

### 11.2.3 Folder configuration of a USB device

#### [A] Normal update

Store the data file for updating in the model specific folder. This configuration is an example. The number of files differs depending on the installed option.

Model specific folder name	2018A_5018A
----------------------------	-------------

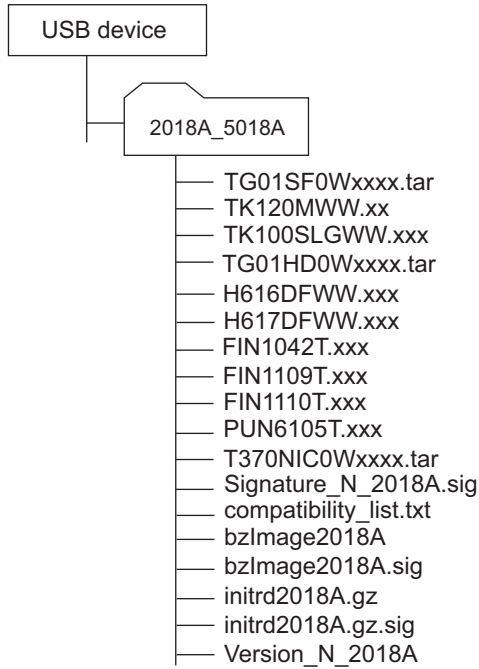


Fig.11-1

#### [B] Patch update

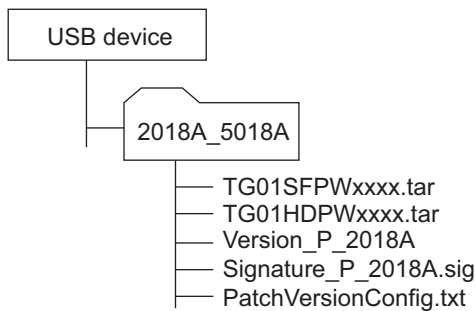


Fig.11-2

## [C] Differential items update

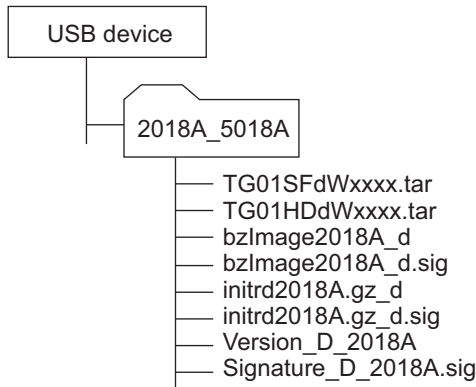


Fig.11-3

### Notes:

- Since the date and time set in the equipment are recorded in the firmware update log, make sure that they are correct before updating the firmware.
- Never change the model specific folder name, since it is used for identifying the data file when the data files used for updating multiple models are stored in the USB device.

### Important:

- Only the USB devices which meet the following conditions should be used for updating. Be careful since updating with any device other than the above is never guaranteed.
  - A combination USB device with a flash memory (to be connected directly to the USB port) and its capacity is 2GB or more.
  - Operation of the USB device used for updating has been confirmed at the input check of this equipment (03 Test mode). (P. 5-9 “5.4.2 Input check”)
  - USB devices which comply with the following standards regulated by USB-IF (USB Implementers Forum)
    - Class number: 8 (=08h) (Mass-storage class)
    - Sub-class number: 6 (=06h) (SCSI transfer command set)
    - Protocol number: 80 (=50h) (Bulk-Only)
- \* Most common USB devices comply with the specification above and can be used for updating. However, the operation in all the Multi Functional Digital Color Systems and Multi Functional Digital Systems is not necessarily guaranteed since the most of these devices are developed based on use in a PC environment (Windows or Macintosh). Therefore, check thoroughly that the device is operational in the equipment for which the updating will be performed when purchasing it.
- The USB devices complying with USB2.0 can be used for updating.
- Do not update the firmware by any storage device other than a flash memory (such as a USB connection type memory card reader, CD/DVD drive or hard disk), since it is never guaranteed.
- It is possible to store the model specific update program and the data file for updating directly in the root directory when you store the updating data file for one specific model in the USB device. However, if the model specific folder for the same model as that of the data file stored in the root directory already exists, this will have priority.

## 11.2.4 Update procedure

### Important:

- The file system of a USB device should be formatted in the FAT16 or FAT32 format. USB devices formatted in an NTFS or another format will not be able to be operated. The file system of a USB device can be confirmed by opening its property using Windows Explorer or such.
- Never shut down the equipment during the update. Firmware data and the following option data (if installed) could be damaged and may not be able to be operated properly.
  - Data Overwrite Enabler (GP-1070)
  - Meta Scan Enabler (GS-1010)
  - External Interface Enabler (GS-1020)
  - IPsec Enabler (GP-1080)
  - OCR Enabler (GS-1080/1085)
  - Multi Station Print Enabler (GS-1090/1095)

### [A] Updating firmware

- (1) Connect the USB device to the PC and write the model specific folder in which the data file is stored.  
Store the data file for updating in the model specific folder.
- (2) Press the [ON/OFF] button to shut down the equipment.
- (3) Connect the USB device [1] to the USB port [2].

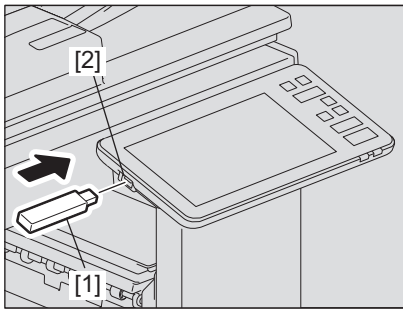


Fig.11-4

- (4) Start the HS Menu.

(5) Press [49 Firmware Update].

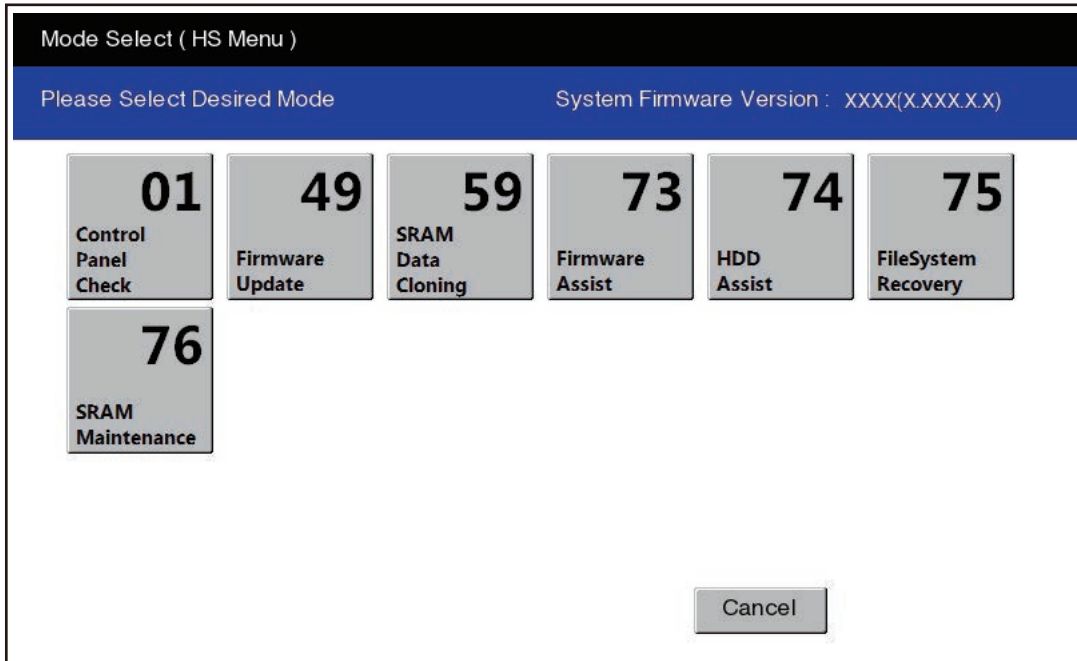


Fig.11-5

(6) Select the update type.  
Normal Update  
Patch Update  
Diff Update

**Notes:**

- The update file which is selected must be included in the model specific folder. There is no problem if updated files of different types are mixed.

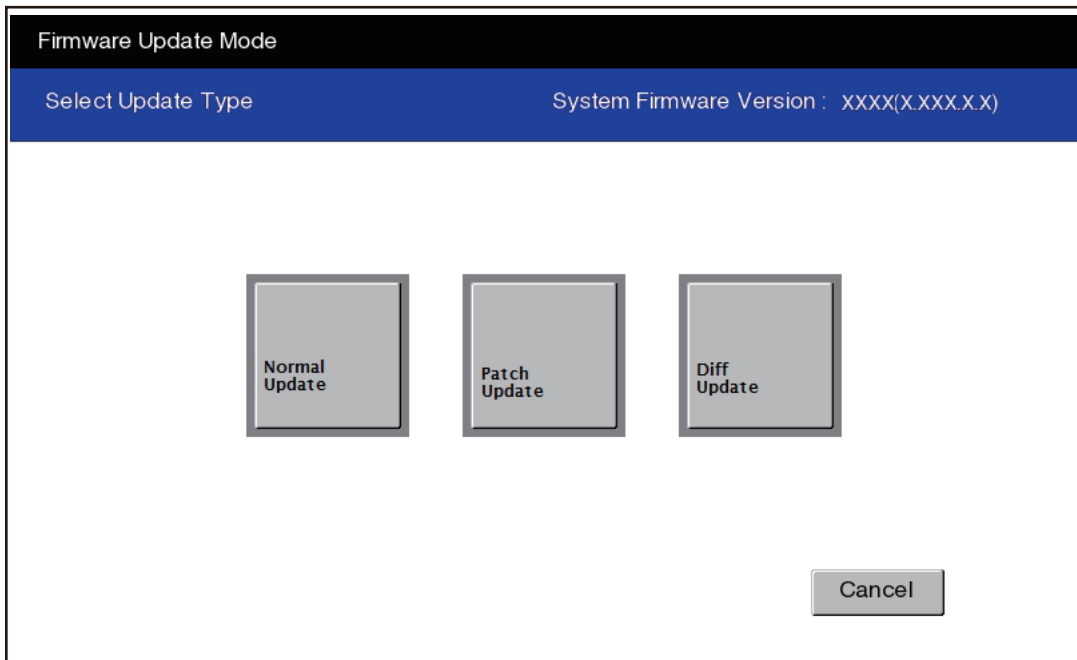


Fig.11-6

- The screen for selecting items to be updated is displayed.
  - Only the firmware which is included in the update file is displayed.
  - The firmware whose version is later than the current one is being selected to be updated if there is such in the update file.

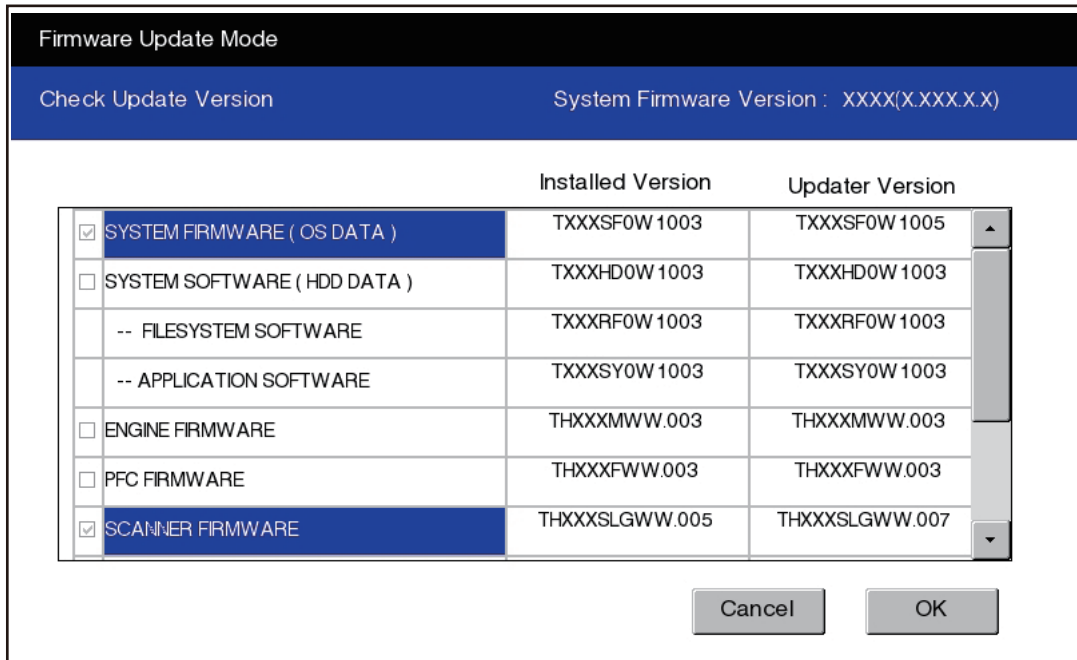


Fig.11-7

- The display of items on this screen varies depending on the types of data written on the USB device. Each item is displayed only when each data file is written on the USB device in the following conditions.

**[A] Normal update**

Item	Condition (xxx is version)
SYSTEM FIRMWARE (OS DATA)	TG01SF0Wxxxx.tar is written.
SYSTEM SOFTWARE (HDD DATA)	TG01HD0Wxxxx.tar is written.
ENGINE FIRMWARE	TK120MWW.xxx is written.
SCANNER FIRMWARE	TK100SLGWW.xxx is written.
RADF FIRMWARE	H617DFWW.0xxx is written. (When MR-3031 is connected)
DSDF FIRMWARE	H616DFWW.xxx is written. (When MR-4000 is connected)
NIC FIRMWARE	T370NIC0Wxxxx.tar is written.
FAX FIRMWARE	FAXH625TZxx is written. (When GD-1370 is connected.)
FINISHER FIRMWARE	FIN1042T.xxx is written. (When MJ-1042 is connected.) FIN1109T.xxx is written. (When MJ-1109 is connected.) FIN1110T.xxx is written. (When MJ-1110 is connected.)
PUNCH FIRMWARE	PUN6105T.xxx is written. (When MJ-6105 is connected.)

**[B] Patch update**

Item	Condition (xxx is version)
SYSTEM FIRMWARE (OS DATA)	TG01SFPWxxxx.tar is written.
SYSTEM SOFTWARE (HDD DATA)	TG01HDPWxxxx.tar is written.



**[C] Differential items update**

Item	Condition (xxx is version)
SYSTEM FIRMWARE (OS DATA)	TG01SFdWxxxx.tar is written.
SYSTEM SOFTWARE (HDD DATA)	TG01HDdWxxxx.tar is written.

**Notes:**

- If the USB device is not recognized properly, “USB device Not detected” message is displayed. In this case, disconnect the USB device and connect again within 3 minutes, or shut down the equipment and connect the device properly. Then repeat the procedure from (5).
- If any of the error messages below is displayed, confirm if the data file in the USB device is correct. Then repeat the procedure from (5).

Error number	Error message	Cause
01	Model specific update program XXXXXXXXXXXX is not stored.	No update file of this equipment exists in the USB storage.

(7) Select the item.

The item selected is highlighted and a check is marked at its left side. If you press the item once again, its selection is released.

Item	Remarks
SYSTEM FIRMWARE(OS Data)	Updating System firmware
SYSTEM SOFTWARE (HD Data)	Updating System software
ENGINE FIRMWARE	Updating Engine firmware
SCANNER FIRMWARE	Updating Scanner firmware
RADF FIRMWARE (DSDF FIRMWARE)	Updating RADF firmware (Updating DSDF firmware)
NIC FIRMWARE	Updating NIC firmware
FAX FIRMWARE	Updating FAX firmware
FINISHER FIRMWARE	Updating Finisher firmware
PUNCH FIRMWARE	Updating Punch firmware

(8) Press [OK].

Updating starts and the processing status is displayed on the screen.

Status display during update	Status display when update is completed
SYSTEM FIRMWARE(OS Data) update in progress	SYSTEM FIRMWARE(OS Data) Completed
SYSTEM SOFTWARE (HD Data) update in progress	SYSTEM SOFTWARE (HD Data) Completed
ENGINE FIRMWARE update in progress	ENGINE FIRMWARE Completed
SCANNER FIRMWARE update in progress	SCANNER FIRMWARE Completed
RADF FIRMWARE update in progress	RADF FIRMWARE Completed
NIC FIRMWARE update in progress	NIC FIRMWARE Completed
FAX FIRMWARE update in progress	FAX FIRMWARE Completed
FINISHER FIRMWARE update in progress	FINISHER FIRMWARE Completed
PUNCH FIRMWARE update in progress	PUNCH FIRMWARE Completed

(9) When updating is completed properly, the following message is displayed at the bottom of the LCD screen.

Normal update: Update successfully completed Restart the MFP

Patch update: Patch Update Successfully Restart the MFP

Differential items update: Differential Update Successfully Restart the MFP

**Notes: Troubleshooting when “Customized UI version is not compatible!” is displayed**

In the equipment with the customized UI installed, when its version is not compatible with that for the HDD DATA to be installed, “Customized UI version is not compatible!” is displayed and the updating will fail. To continue the updating, perform FS-08-3512 (Customized UI uninstallation).

**Notes: Troubleshooting when “Update Failed” is displayed**

- Even though an update fails, do not turn the power OFF until other updates are finished.
- “Update Failed.” is displayed at the bottom of the screen when the updating is not completed properly. “Failed” appears next to the failed item on the status display. If “Update Failed” appears at the bottom of the screen, turn OFF the power and then check the following items. After confirming and clearing the problems, restart updating from the beginning.
  - Does the USB device meet the conditions to be used for updating?
  - Is the data file written properly on the USB device?
  - Is the USB device installed properly?
  - Do the USB device and equipment operate properly?
  - When H05 error occurs and it does not clear after a USB media check, replace the main memory (DIMM).
- The integrity check system is automatically operated before firmware updating. During this operation, “Verifying Signature...” and “Progress: \*\*%” are displayed on the control panel. When the check is completed properly, no message for notifying the success will appear and the firmware updating will start. If it fails, “Invalid Signature” and “Copy Data with >valid signature in USB” will be shown. In that case, firmware updating cannot be performed, so turn the power OFF and disconnect the USB device. Check that there is no abnormality in the firmware data, and reperform the update.
- When a system firmware (OS Data) update error or system software (HD Data) update error occurs, “Update Failed” or “Failed” appears on the screen and the error number appears next to the message.

For details of each error, refer to the following tables.

System firmware update Error	
Error number	Error content
O01	FROM writing failed
O02	FROM verification error
O03	File operation error
O04	SRAM flag set error
O05	Electronic key data backup error
O06	Device error
O07	Signature Check Failed error
O08	Signature not present error

System software update Error	
Error number	Error content
H01	File creation error
H02	File decompression error (Out of free disk space on the HDD at file extraction)
H03	Partition mount error
H04	Other errors
H05	Signature Check Failed error
H06	Signature not present error
H07	Hard Disk Full Error

- When an Engine firmware update error, Scanner firmware update error, RADF/DSDF firmware update error, Punch firmware update error, Finisher firmware update error or FAX firmware update error occurs, “Update Failed” or “Failed” appears on the screen and the error number and error message appear next to the message. For details of each error, refer to the following tables.

Engine firmware update Error		
Error number	Error message	Error content
M01	Time out (When the download is requested)	Communication timeout (When the download is requested)
M02	Time out (When the download is written)	Communication timeout (When the download is written)
M03	Time out (When the download is finished)	Communication timeout (When the download is finished)
M04	Reception failed (When the download is requested)	Downloading request was denied. (When the download is requested)
M05	Deletion error (When the download is written)	Deletion error (When the download is written)
M06	Writing error (When the download is written)	Writing error (When the download is written)
M07	Checksum error (When the download is finished)	Checksum error (When the download is finished)
M08	Reception status code abnormality (When the download is requested)	Reception status code abnormality (When the download is requested)
M09	Reception status code abnormality (When the download is written)	Reception status code abnormality (When the download is written)
M10	Reception status code abnormality (When the download is finished)	Reception status code abnormality (When the download is finished)
M11	Version downgrade abnormality FAILED M11	Downgrade error (When the download is requested)
M00	Other error	Other error

Scanner firmware update Error		
Error number	Error message	Error content
S01	Time out (When the download is requested)	Communication timeout (When the download is requested)
S02	Time out (When the download is written)	Communication timeout (When the download is written)
S03	Time out (When the download is finished)	Communication timeout (When the download is finished)
S05	Deletion error (When the download is written)	Deletion error (When the download is written)
S06	Writing error (When the download is written)	Writing error (When the download is written)
S08	Reception status code abnormality (When the download is requested)	Reception status code abnormality (When the download is requested)
S09	Reception status code abnormality (When the download is written)	Reception status code abnormality (When the download is written)
S10	Reception status code abnormality (When the download is finished)	Reception status code abnormality (When the download is finished)
S00	Other error	Other error

NIC firmware update Error		
Error number	Error message	Error content
N01	Connection Failure	Communication timeout
N02	No Update Files	No Update Files
N03	Flash Write Error	Writing error

NIC firmware update Error		
Error number	Error message	Error content
N04	File decompression error	File decompression error
N05	Other Errors	Other error

RADF/DSDF firmware update Error		
Error number	Error message	Error content
R01	Time out (When the download is requested)	Communication timeout (When the download is requested)
R02	Time out (When the download is written)	Communication timeout (When the download is written)
R03	Time out (When the download is finished)	Communication timeout (When the download is finished)
R05	Deletion error (When the download is written)	Deletion error (When the download is written)
R06	Writing error (When the download is written)	Writing error (When the download is written)
R08	Reception status code abnormality (When the download is requested)	Reception status code abnormality (When the download is requested)
R09	Reception status code abnormality (When the download is written)	Reception status code abnormality (When the download is written)
R10	Reception status code abnormality (When the download is finished)	Reception status code abnormality (When the download is finished)
R11	ADF not connected	RADF/DSDF not installed
R12	ADF download error	Firmware for different model data connected
R13	RADF/DSDF Mismatch error	Firmware for different model data connected
R00	Other error	Other error

Punch firmware update Error		
Error number	Error message	Error content
U01	Time out (When the download is requested)	Communication timeout (When the download is requested)
U02	Time out (When the download is written)	Communication timeout (When the download is written)
U03	Time out (When the download is finished)	Communication timeout (When the download is finished)
U04	Reception failed (When the download is requested)	Downloading request was denied. (When the download is requested)
U05	Deletion error (When the download is written)	Deletion error (When the download is written)
U06	Writing error (When the download is written)	Writing error (When the download is written)
U07	Checksum error (When the download is finished)	Checksum error (When the download is finished)
U08	Reception status code abnormality (When the download is requested)	Reception status code abnormality (When the download is requested)
U09	Reception status code abnormality (When the download is written)	Reception status code abnormality (When the download is written)
U10	Reception status code abnormality (When the download is finished)	Reception status code abnormality (When the download is finished)
U00	Other error	Other error

Finisher firmware update Error		
Error number	Error message	Error content
F01	Time out (When the download is requested)	Communication timeout (When the download is requested)
F02	Time out (When the download is written)	Communication timeout (When the download is written)
F03	Time out (When the download is finished)	Communication timeout (When the download is finished)
F04	Reception failed (When the download is requested)	Downloading request was denied. (When the download is requested)
F05	Deletion error (When the download is written)	Deletion error (When the download is written)
F06	Writing error (When the download is written)	Writing error (When the download is written)
F07	Checksum error (When the download is finished)	Checksum error (When the download is finished)
F08	Reception status code abnormality (When the download is requested)	Reception status code abnormality (When the download is requested)
F09	Reception status code abnormality (When the download is written)	Reception status code abnormality (When the download is written)
F10	Reception status code abnormality (When the download is finished)	Reception status code abnormality (When the download is finished)
F00	Other error	Other error


FAX firmware update Error		
Error number	Error message	Error content
FX01	Communication Timeout (when download is requested)	Communication timeout (When the download is requested)
FX02	Communication Timeout (when data is downloaded)	Communication timeout (When the download is finished)
FX03	Download request Failed	Downloading request was denied. (When the download is requested)
FX04	Received failure during download request	Reception Error (When the download is requested)
FX05	Received failure during data download	Reception error (During data download)
FX06	File decompression error	File decompression error
FX07	Other Errors	Other error

(10) Check that [Automatic Initialization] is displayed and then remove the USB device.

(11) Press [Automatic Initialization]. The equipment is rebooted and the initialization of the updating data is carried out.

### **[B] Confirmation of the updated data**

After the updating is completed, check each data version in the 08 Setting Mode to confirm that the data were overwritten properly.

 P. 11-14 “11.3 Confirmation of the updated data”

### 11.3 Confirmation of the updated data

After the updating is completed, check each data version in 08 Setting Mode to confirm that the data were overwritten properly.

Firmware	Code
System software	9900
System firmware	9930
Engine firmware	9901
Scanner firmware	9902
NIC firmware	9990
DF firmware	9903
Finisher firmware	9904
Hole punch firmware	9944
FAX board firmware(Line1)	9905
FAX board firmware(Line2)	9969

## 12. BACKUP FUNCTION

### 12.1 Cloning (HS menu)

#### 12.1.1 General description

Cloning (HS menu) is a function that backs up user data, setting data and SRAM data into a USB storage device and also restores these data into the equipment.

This function backs up or restores the data of the same equipment (same serial number), and is performed when the SRAM is replaced.

#### 12.1.2 Precautions

- When the Security HDD is initialized or replaced, back up the SRAM data afterwards.
- It is assumed that cloning (HS menu) is to be performed when equipment is installed or options are installed. If the address book has been registered, do not perform restoring. Otherwise, registered or set data are lost.
- The USB storage device for the cloning (HS menu) must meet the following conditions. A cloning (HS menu) operation with any devices other than the following will not be guaranteed.
  - A combination USB storage device with a flash memory (to be connected directly to the USB port) and its capacity is 1GB or more.
  - A device compliant with the following specifications established by USB-IF (USB Implementers Forum)

Class number:	8 (=08h)	(Mass storage class)
Sub-Class number:	6 (=06h)	(SCSI transfer command set)
Protocol number:	80 (=50h)	(Bulk-only)

The USB storage device should be formatted in the FAT16 or FAT32. (Correct operation cannot be guaranteed if it is formatted in NTFS/exFAT.)

- Most of the common USB storage device are compliant with the above specifications and are therefore applicable to this cloning (HS menu). However, most of these devices were originally developed to be used in an environment for PCs (e.g. Windows or Macintosh) and thus operations exclusively with this equipment have not been fully guaranteed. Therefore, the user must thoroughly check in advance whether there will be any problem in operating with this equipment when one of these devices is adopted.
- The USB storage device compliant with both USB 1.1 and USB 2.0 can be used for this cloning (HS menu).
- Cloning (HS menu) with any storage devices other than a flash memory (e.g. USB-connectable memory card reader, CD/DVD drive, hard disk) will never be guaranteed. Therefore, never use them for this operation.
- Be sure to unplug the LAN cable and Fax line before data are backed up / restored. Also, do not use the RADF and open the cover, drawer, etc. during the cloning (HS menu).
- Data can be backed up / restored only for the same model and version. If the version is different, update the firmware and back up / restore data in the same version.
- Restore data to equipment which has the same options as when the data are backed up.
- Delete the backed up data in the USB storage device after the cloning (HS menu).

### 12.1.3 Backup files

The following files are saved in the root directory of the USB device by backing up.

Filename	Remark
Modelname_MFPSerialNo_yyyy-MM-dd_hh-mm	E.g.: When backup was performed at 13:59 on October 1st, 2016. Txxx_CUK911379_2016-10-01_13-59

### 12.1.4 Cloning procedure

#### [A] Backup procedure

- (1) Shut down the equipment.
- (2) Connect the USB storage device [1] to the USB port [2].

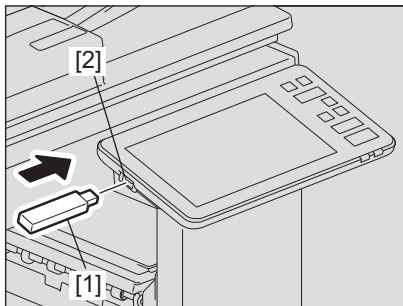


Fig.12-1

- (3) Perform HS-59-[Backup SRAM Data to USB].

**Notes:**

When "Operation Failed" is displayed, turn the power OFF and then reattempt the steps from (1).

- (4) Enter the password and press [OK].

**Remarks:**

- Maximum 15 characters
- This password will be used when the backed-up clone data are restored in the equipment.

- (5) "Backup successfully done" is displayed on the LCD when the backup has been properly completed.
- (6) Turn the power OFF.



## [B] Restore procedure

- (1) Shut down the equipment.
- (2) Connect the USB storage device [1] to the USB port [2].

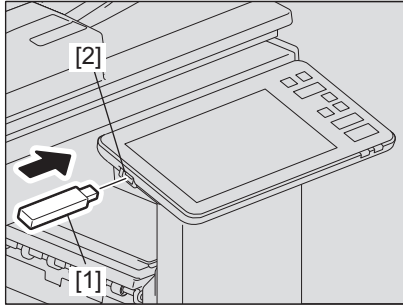


Fig.12-2

- (3) Perform HS-59-Restore SRAM Data from USB.
- (4) Enter the password which has been set in (4) of “[A] Backup procedure”, and press [OK].
- (5) Enter the serial number of the equipment and press [OK].

### Notes:

Use the serial number given on the label attached to the rear cover for the entry.

- (6) “Restore successfully done Restart the MFP” is displayed on the LCD when the restoring has been properly completed.
- (7) Then turn the power OFF.

### Notes:

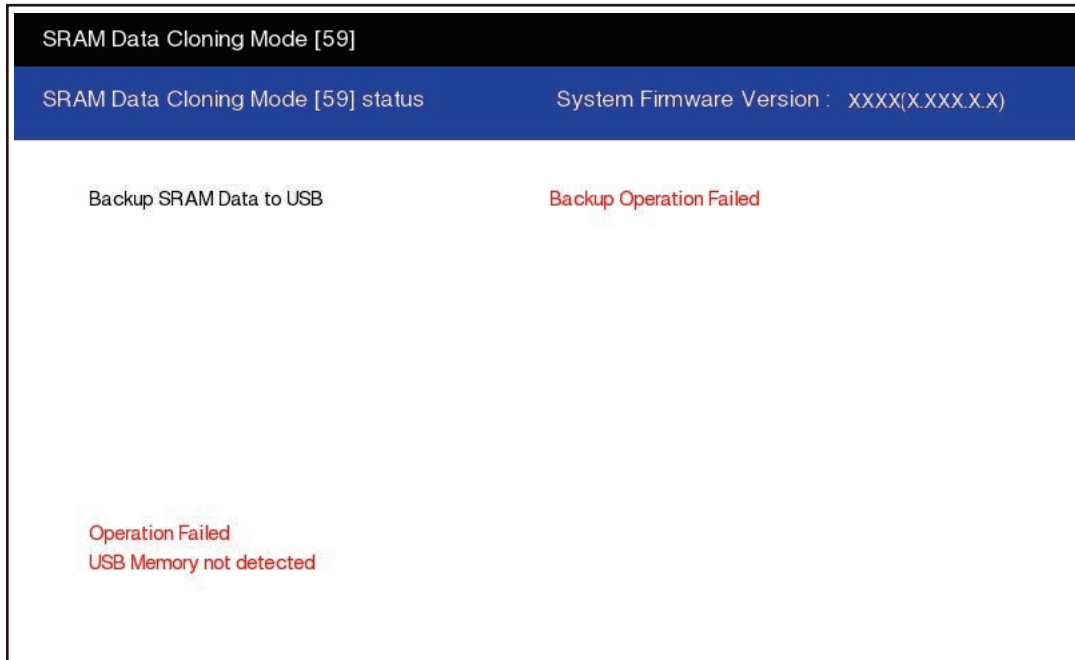
- When the back-up file is restored, do not perform HDD partition creation (Format HDD) before the normal start-up.
- When the backup data, which were created before the HDD has been initialized or replaced, are restored, do so also for ADIKey. (Only for a secure HDD)

**[C] Confirmation of the error**

“Operation Failed” is displayed on the lower left part of the LCD when the data have not been properly backed up or restored.

Moreover, details of an error are displayed under the above message.

(The following is an example screen when “USB Memory not detected” is displayed.)



**Fig.12-3**

In this case, turn the power OFF and then check the following items. After confirming and solving the problem, back up / restore the data again from the beginning.

- Does the USB storage device meet the conditions being used for this cloning?
- Is the updated program file written on the USB storage device properly?
- Is the USB storage device installed properly?
- Is the USB storage device or the equipment damaged?

<b>Backup</b>	
<b>Display content</b>	<b>Error content</b>
USB device not detected	The USB storage device has not been installed.
SRAM Device Not Connected	The SRAM has not been installed.
Backup not created	Creation of the Backup file of data of the SRAM has failed.
Encryption Failed	An encryption of the backup file has failed.
password Not Appended to Backup	Addition of the encryption password has failed.
MFP Serial Number Not Set	Acquisition of the MFP Serial No. has failed.


<b>Restore</b>	
<b>Display content</b>	<b>Error content</b>
USB device not detected	The USB storage device has not been installed.
SRAM Device Not Connected	The SRAM has not been installed.
Invalid Backup File	The SYS board has not been recognized.
No Backup File Exists	Backup file has not existed in the USB storage device.
Invalid password	An incorrect password has been entered.
Decryption Failed	Decoding of the backup file has failed.
Invalid MFP Serial Number: xxxxxxxx	An incorrect MFP Serial No. has been entered.
MFP Serial Number Not Set	Acquisition of the MFP Serial No. has failed.
Backup File Corrupted	A backup file has been damaged.

## 12.2 Cloning (FS menu)

### 12.2.1 General description

By means of cloning (FS menu) can store the MFP setting data and user information as a clone file into a USB storage device. In addition, the clone file created by another unit of the equipment can be installed in this one, resulting in making of the same conditions.

### 12.2.2 Precautions

- A clone file created by the following MFPs can be installed in this equipment.
  - e-STUDIO2010AC/2510AC
  - e-STUDIO2515AC/3015AC/3515AC/4515AC/5015AC
  - e-STUDIO5516AC/6516AC/7516AC
  - e-STUDIO2018A/2518A/3018A/3518A/4518A/5018A
  - e-STUDIO5518A/6518A/7518A/8518A
  - e-STUDIO2000AC/2500AC
  - e-STUDIO2505AC/3005AC/3505AC/4505AC/5005AC
  - e-STUDIO5506AC/6506AC/7506AC
  - e-STUDIO2008A/2508A/3008A/3508A/4508A/5008A
  - e-STUDIO5508A/6508A/7508A/8508A
  - e-STUDIO3508LP/4508LP/5008LP
  - e-STUDIO2050C/2550C
  - e-STUDIO2555C/3055C/3555C/4555C/5055C
  - e-STUDIO2555CSE/3055CSE/3555CSE/4555CSE/5055CSE
  - e-STUDIO5560C/6560C/6570C
  - e-STUDIO207L/257/307/357/457/507
  - e-STUDIO557/657/757/857
  - e-STUDIO307LP
  - e-STUDIO287CS/347CS/407CS
  - e-STUDIO287CSL/347CSL
  - e-STUDIO477S/527S
  - e-STUDIO477SL
  - e-STUDIO2040C/2540C/3040C/3540C/4540C
  - e-STUDIO5540C/6540C/6550C
  - e-STUDIO206L/256/306/356/456/506
  - e-STUDIO256SE/306SE/356SE/456SE/506SE
  - e-STUDIO556/656/756/856
  - e-STUDIO556SE/656SE/756SE/856SE
  - e-STUDIO306LP
- When a clone file created by this equipment is installed in another one, confirm the installation ability by referring to the Service Manual for the target model.
- When a clone file created by another unit of the equipment is installed in this one, settings and information about the functions which are not supported by this equipment will be disregarded.
- When cloning of user information is carried out by means of this function, ask your users to change the setting to [Enable] of [User Information Cloning] from [Administration] - [Setup] - [General settings] - [Device Information] via TopAccess.
- When cloning of the administrator password is carried out by means of this function, ask your users to change the setting to [Enable] of [Administrator's Password Cloning] from [Administration] - [Setup] - [General settings] - [Device Information] via TopAccess.
- Be sure to use a USB storage device which satisfies the conditions described in  P. 12-1 "12.1.2 Precautions".
- Delete a clone file stored in the USB storage device after the cloning.

- Notes for cloning
  - Cloning of the service password is achieved when it is carried out with an administrator setting from TopAccess or the control panel.  
For example, the service password is set in blank when cloning is carried out using a clone file of the equipment whose service password is blank.
  - When cloning is carried out from the FS menu, its performance is changed as below by setting to [Enable] or [Disable] in [Data Cloning Function] from [Administration] - [Setup] - [General Setting] - [Device Information] via TopAccess.  
[Disable] (default): Cloning of the service password is not achieved.  
[Enable]: Cloning of the service password is achieved.

### 12.2.3 Clone file creation procedure

- (1) Press [36 CLONING] in the FS menu.
- (2) Press [Create Clone File].
- (3) Select the categories to be included in the clone file.

**Notes:**

- If the following categories cannot be selected, ask your users to change the setting to [Enable] of [User Information Cloning] from [Administration] - [Setup] - [General settings] - [Device Information] via TopAccess.
  - User Management
  - Address Book
  - Address Book + Template + MailBoxes
- If Administrator's Password cannot be selected, ask your users to change the setting to [Enable] of [Administrator's Password Cloning] from [Administration] - [Setup] - [General settings] - [Device Information] via TopAccess.

- (4) Press [Save].
- (5) Enter a file name. Set a password if necessary.  
Once a password has been set, its entry is required when this clone file is installed in the equipment.
- (6) Press [Save].  
The clone file is stored by a file name with the extension ".enc" applied.

**Notes:**

Be sure to disconnect the USB storage device after the completion screen is displayed.

### 12.2.4 Clone file installation procedure

- (1) Press [36 CLONING] in the FS menu.
- (2) Press [Install Clone File].
- (3) Connect the USB storage device with the store clone file and press [OK].
- (4) Select the clone file to be installed.  
Enter the password if one has been set.
- (5) Press [Install].

**Notes:**

Be sure to disconnect the USB storage device after the completion screen is displayed.

## 12.3 AES Data Encryption Function Setting

### 12.3.1 General description

Data encryption is a function that encrypts data in the HDD to enhance the security. Note that this function may affect the equipment performance.

### 12.3.2 Precautions

When the data encryption function is set to be enabled, the data saved in the HDD before the encryption has been performed cannot be retrieved. Therefore when data encryption function needs to be enabled after the installation of the equipment, it is necessary to back up the data in the HDD before setting this function and then recover them after the setting.

- To ensure security, ask the user (machine administrator) to back up or restore the user's data and information in the HDD. A service technician can back up or restore them only when the user (machine administrator) permits it.
- Some data in the HDD cannot be backed up and can be left only on printouts.

When the data encryption function is enabled, the following items are restricted.

- FS-08-9112 (Auto Shut Off Mode timer setting (Sleep Mode)) is automatically set to "20: Not used".
- FS-08-9113 (Screen setting for automatic energy saver/automatic power OFF) is automatically set to "0: OFF".
- When the [ENERGY SAVER] button is pressed on the control panel, the equipment does not enter the sleep mode.
- Since the energy saver mode cannot be set using the control panel, set it in TopAccess. However, the setting of "Sleep/Auto Shut Off" cannot be changed in TopAccess and "Disable" is displayed.

### 12.3.3 Setting procedure

A procedure for setting the data encryption function is shown below.

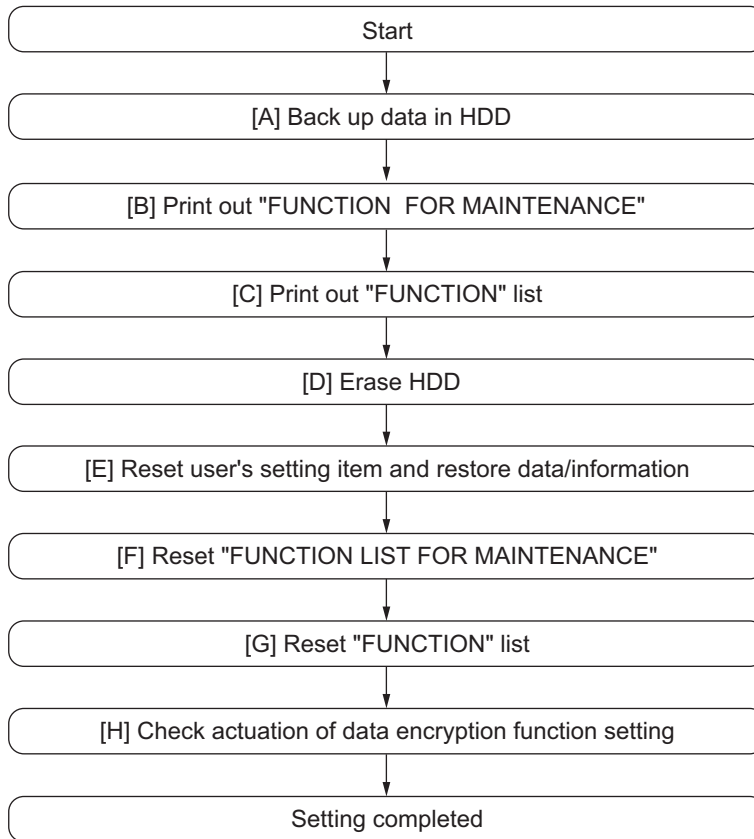


Fig.12-4

## [A] Back up in HDD

Ask the user (machine administrator) to back up the data in the HDD. Refer to the table below for the type of data, availability and method of backup.

Type of data in HDD	Availability	Backup method
Image data in the e-Filing	Available	Archive them in the “e-Filing” of TopAccess. As for the backup in Box data, all data (selectable by the box) can be backed up / restored in one go by using “e-Filing Backup/Restore Utility”.
F-code information, Template registration information, Address book data	Available	Export them up in the “Administrator” menu of TopAccess.
Department management data	Available	Export them in “Administrator” menu of TopAccess.
Log data (Print, Scan, FAX (Transmission/Reception)) / Message Log	Available	Export them in the “Log” menu of TopAccess. (Import cannot be performed.)
Data in the shared folder (Scanned data, Saved data of copy / FAX transmission)	Available	Copy them to the client computer via the network. (The data which have been copied to the client computer cannot be copied to the shared folder.)
Role information	Available	Export role information on the TopAccess menus. [User Management] tab > [Export]
Print waiting data (Copying data and FAX reception data that are waiting to be printed due to the paper run-out and jam, etc.)	Not available	Finish printing them after the paper supply and the jam release, etc. (The data cannot be kept.)
Print job (Private print data, Schedule print data)	Not available	If any jobs are left, print them. (The data cannot be backed up.)
FAX saved data (Confidential / Bulletin board data)	Not available	Print them. (The data cannot be backed up.)
Registration data for FAX transmission (Delayed transmission / Recovery transmission)	Not available	Print them. (The data cannot be backed up.)

## [B] Print out “FUNCTION LIST FOR MAINTENANCE”

- (1) Select “FAX LIST PRINT MODE” and then press [NEXT].
- (2) Select “Function list for Maintenance” and then press [PRINT].



**[C] Print out “FUNCTION” list**

- (1) Press [USER FUNCTIONS] on the HOME screen.
- (2) Press [ADMIN], enter the password, and then press [ENTER].
- (3) Press [LIST/REPORT] and then [LIST].
- (4) Press [FUNCTION]. The “FUNCTION” list is printed out.

**Notes:**

Explain the procedure to the user (machine administrator) and ask him/her to enter his/her password.

**[D] Enable data encryption function**

Perform the setting of the data encryption function in the code FS-08-9379. The setting values are shown below.

- 0: Encryption disabled
- 1: Encryption enabled (Security priority)
- 2: Encryption enabled (Performance priority)

Security priority: All user data are encrypted.

Performance priority: Encryption data are generated only in a copying or a printing process temporarily. All user data except files which are deleted in a corresponding process are encrypted.

**[E] Reset user’s setting items and restore data/information**

Ask the user (machine administrator) to reset the user’s setting items and to restore data or information. Refer to the following for the reset and restore:

Items to reset/restore	Method
Printer driver	Upload them in the “Administrator” menu of TopAccess.
F-code information, Template registering information, Address book data	Restore them in the “Administrator” menu of TopAccess.
Department management data	Import them in the “Administrator” menu of TopAccess.
Image data in the e-Filing	Restore them in the “e-Filing” of the TopAccess.
Role information	Import role information on the TopAccess menus. [User Management] tab > [User Confirm/Create/Modify] > [Role Information]


**Notes:**

- When the SSL is enabled, perform the setting of the following items again with “Create self-signed certificate” of TopAccess.
  - Country/Region Name
  - State or Province Name
  - Locality Name
  - Organization Name
  - Organizational Unit Name
  - Common Name
  - Email Address
- When the wireless LAN is used, recreate its setting. (only when security with a certificate is used) Also, upload the following certificate file with Security of TopAccess.
  - CA certificate
  - Device certificate

### [F] Reset “FUNCTION LIST FOR MAINTENANCE”

- (1) Print out the “FUNCTION LIST FOR MAINTENANCE” list after the formatting.  
For how to print it out, refer to [B] Print out “FUNCTION LIST FOR MAINTENANCE”.
- (2) Perform FS-13 FAX FUNCTION MODE.
- (3) Compare the lists which were printed before and after the formatting to check the setting items having the different setting values. Set the value which was set before the formatting
- (4) Turn the power OFF.

### [G] Reset “FUNCTION” list

Reset the fax function by referring to the “function list” that was printed out in  P. 12-11 “[C] Print out “FUNCTION” list”.

- (1) Press [USER FUNCTIONS] on the HOME screen.
- (2) Press [ADMIN], enter the password, and then press [ENTER].
- (3) Press [FAX] and then the [TERMINAL ID] to set each item.
- (4) Press [INITIAL SETUP] to set each item.

#### Notes:

Explain to the user (machine administrator) about the next operation and ask him/her to enter his/her password.

### [H] Check actuation of data encryption function setting

Check if the data encryption function is in operation.

Press [COUNTER] on the control panel. If a key-shaped icon is displayed at the top right of the screen, the data encryption function is in operation.

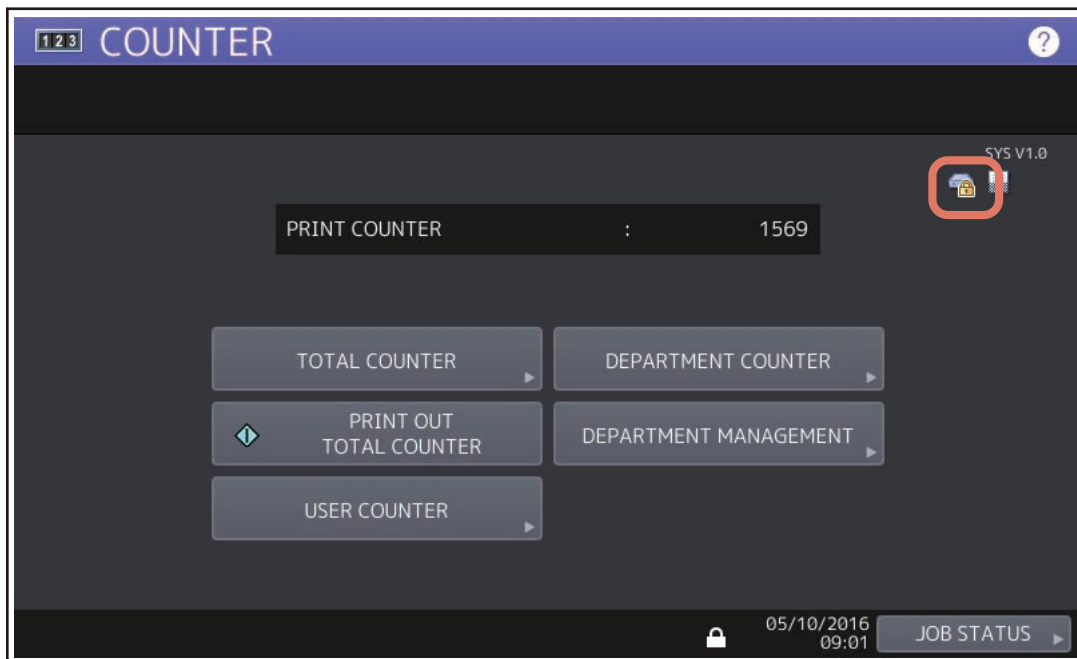




Fig.12-5

### **12.3.4 Procedure for disabling data encryption function**

The basic procedure is the same as the one for enabling this function. To disable it, set “0 (Invalid)” in the code FS-08-9379 at step  P. 12-11 “[D] Enable data encryption function”.

### **12.3.5 Procedure for discarding HDD when data encryption function is enabled**


Set the data encryption function disabled following the procedure shown in  P. 12-13 “12.3.4 Procedure for disabling data encryption function”. Then perform the code HS-73-[Erase HDD Securely] to completely erase the data in the HDD.

## 12.4 High Security Mode

### 12.4.1 General description

The High Security Mode is a security mode complying with CCC certification which is suitable for HCD-PP. To have the equipment enter this mode, follow the procedure and the precautions below.

### 12.4.2 Prior confirmation

- Confirm that the administrator for the equipment is authorized and ask him/her to observe the installation.
- To have the equipment enter the High Security Mode complying with CCC certification which is suitable for HCD-PP, the Fax Unit (GD-1370) is required. Confirm that this unit is installed in advance. Follow the Unpacking Instructions to install it. It is possible to have the equipment enter the High Security Mode without installing the Fax Unit. However, in such a case, the equipment is not judged as a digital MFP and thus it does not comply with the CCC certification.
- To avoid physical security problems, such as hardware removal or inappropriate disassembly at the installation site, take all necessary measures, such as checking who enters and leaves the site.
- Confirm that no received fax data or print jobs in progress exist. If there are any, be sure to print them all out before entering the High Security Mode.
- The HDD is initialized in the High Security Mode. Be sure first to back up user data such as documents, Address Book, templates or fax settings using the export function or the backup/restore utility of the TopAccess. Refer to items noted in  P. 12-8 "12.3 AES Data Encryption Function Setting".
- Make a note of the settings on the Administration tab page of the TopAccess in advance.
- Compatibility of cloning data is lost between the High Security Mode and the normal mode; therefore, cloning data cannot be imported.

Downloaded from	Downloaded to	Compatibility of cloning data
Normal mode	Normal mode	Yes
Normal mode	High Security Mode	No
High Security Mode	Normal mode	No
High Security Mode	High Security Mode	Yes

### 12.4.3 Procedure for entering the High Security Mode

- (1) Set the value of the code FS-08-8911 (Security mode level setting) to "3" (High). Then restart the equipment.
- (2) A key-shaped icon appears at the bottom of the touch panel, indicating that it is now in the High Security Mode.
- (3) Press [COUNTER] button on the control panel. If a key-shaped icon, indicating that the HDD data are being encrypted, a paper-shaped icon indicating that the Data Overwrite Enabler is operating normally and the version name of the installed system ROM (SYS V1.0) are displayed on the top right of the counter menu, this means the mode is operating normally.
- (4) Reset the user data backed up in advance.

## 12.4.4 Precautions

- In the High Security Mode, an integrity check system is operated at every restart. If F521 (integrity check error) is displayed, take the necessary measures following the troubleshooting procedure.
- When a self-diagnostic mode is started in the High Security Mode, an authentication screen appears. Enter the default user name and password as follows:  
Default user name: service  
Default password: #1048#
- If a password change screen appears, reset the password according to the rules below.
  - It must not include the user name.
  - It must be a combination of letters of the alphabet and numbers.
  - It must be 6 characters or more. (Maximum 64 characters)
  - The same character must not be repeated 4 times within the new password.
  - The old and the new passwords must not be the same.
- When the equipment is shifted to the High Security Mode, the contents for some codes will be changed as below.
  - The default value is changed.
  - The settings cannot be changed.
  - Some setting values cannot be selected.  
For details, refer to the “Self-diagnostic code list” (separate document).
- The HDD is initialized (and the saved user data are deleted) when the equipment returns to the normal mode from the High Security Mode. Be sure to back up user data before having it do so.
- In the above case, the password is not reset. The password setting can be changed with the code FS-08-8919.
- After the equipment enters the High Security Mode, ask the administrator for the equipment to select [FULL] and perform the Integrity check manually.

## 12.5 Decommissioning

### 12.5.1 General description

Decommissioning is the function which performs automatic batch processing of the user data deletion and settings formatting. This is used when the equipment is removed.

### 12.5.2 Functions

By performing decommissioning, automatic batch processing of the user data deletion and settings formatting can be carried out.

There are two ways for decommissioning; one is performed from the control panel on the equipment and the other is performed by remote operation using a remote maintenance service. In this manual, the way used for decommissioning from the control panel on the equipment is explained.

### 12.5.3 Precautions

- Deleted data and formatted setting values subjected to decommissioning cannot be returned to the original ones.
- The equipment cannot be operated while performing decommissioning.

**Remarks:**

- The firmware update log and the power ON/OFF log are not deleted.
- Installed licenses and applications are not deleted.
- The data of the NIC Config List and the Function List which a remote maintenance service obtains are formatted.

### 12.5.4 Procedures of decommissioning

#### [ 1 ] Performing of decommissioning

- (1) Confirm that no paper jams and errors have occurred and the equipment is not being operated.
- (2) Perform FS-08-8615.
- (3) Press [EXECUTION].

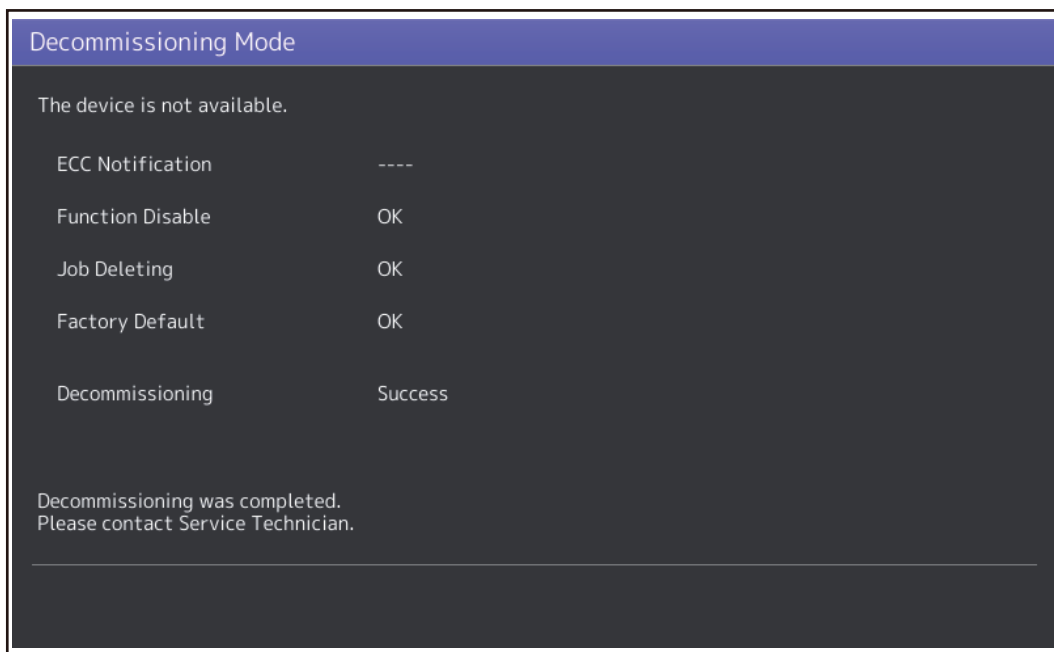


Fig.12-6

The equipment is rebooted. After this has happened, the state is changed to the decommissioning mode and the processing starts.

The equipment carries out the following items while performing decommissioning.

- Stopping the network function
- Prohibiting job reception and job execution
- Deleting pending jobs
- Returning the settings to the factory default ones
- Deleting users information, etc.

(4) When the processing is completed, “Success” or “Failed” is displayed.

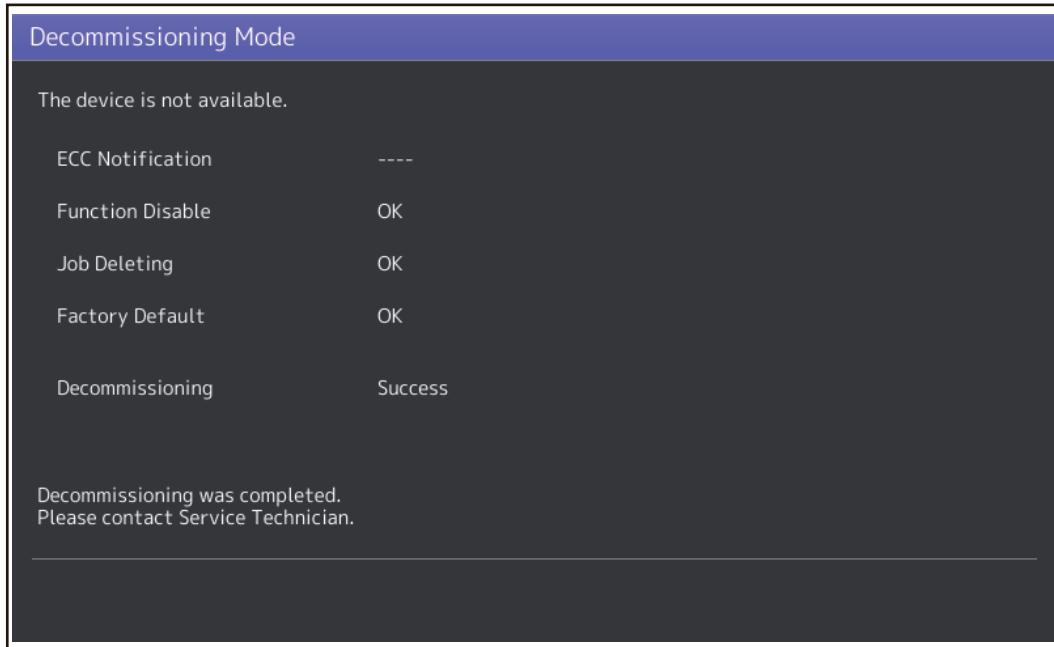


Fig.12-7

**Notes:**

When “Failed” is displayed, manually delete or format the data.

(5) After the processing is completed, the equipment is kept in the decommissioning mode state.

**Remarks:**

- The equipment will keep retaining the decommissioning mode until it is canceled.
- While the decommissioning mode is retained, the processing result keeps being displayed and receiving and executing of jobs are stopped. Only the [POWER] button is operable.

(6) To cancel the decommissioning mode, perform the procedure of [2].

**[ 2 ] Cancellation of decommissioning**

(1) Perform FS-08-8616.

(2) Press [EXECUTION].

The equipment is rebooted. After this has happened, the state is changed to the normal mode.

**Remarks:**

If the decommissioning mode cannot be canceled even though the procedure of [2] has been carried out, perform the following steps.

1. Perform FS-49.
2. Install the system software (HDD data).
3. The equipment is rebooted. Confirm that the state of the equipment is changed to the normal mode.





## 13. EXTERNAL COUNTERS

### 13.1 Outline

This chapter describes the interface between external counters, such as Coin Controller and Key copy counter.

### 13.2 Signal

#### 13.2.1 Connector

- Connector on the LGC board: CN313 (JST-made B20B-CZHK-B-1(LF)(SN)(V)) (Coin Controller)
- Connector on the SYS board: CN118 (JST-made B7B-PH-SM4) (Coin Controller)

#### 13.2.2 Coin controller

##### [ 1 ] Settings

1. Set the value of FS-08-9016 to "1" or "5".
2. Harness kit: GQ-1280

##### [ 2 ] Pin Layout

###### Notes:

Do not connect inductive loads to CTRON, such as a mechanical counter or a relay coil.

###### 1. LGC Board

Pin No.	I/O	Signal name	Function	Voltage level	Remarks
1 - 4	-	-	-	-	Not connect
5	Power	+24V	24V line	DC24V+10%, -5%	
6	Out	CTRON	Total Counter On Signal	Open Collector	L: ON IO (Max): 500mA
7	In	CTRCNT	Copy permission Signal 1	L=0V, H=DC3.3V	L: Allowed *1
8	Out	MCRUN	Ready to Copy Signal	Open Collector	L: Operating IO (Max): 40mA
9	Out	EXTCTR	Exit Sensor On Signal	Open Collector	L: ON IO (Max): 40mA
10	GND	PG	Power ground	0V	
11 - 18	-	-	-	-	Not connect
19	Power	+5V (Sleep)	5V line	DC5.1V	At the sleep mode: OFF
20	-	-	-	-	Not connect

\*1 When the coin controller outputs the CTRCNT signal, the controller should be driven by means of an open collector or open drain to prevent the inflow of current to the equipment.

## 2. SYS board

Pin No.	I/O	Signal name	Function	Voltage level	Remarks
1	Out	LARGE / SMALL	Paper size Signal	Open Collector	L: Large size IO (Max): 20mA
2	-	-	-	-	Not connect
3	-	-	-	-	Not connect
4	-	-	-	-	Not connect
5	-	-	-	-	Not connect
6	GND	GND	Signal Ground	0V	
7	-	-	-	-	Not connect

### [ 3 ] Details of the signals

#### 1. CTRON signal (output signal)

The CTRON signal is synchronized with an electronic counter of the equipment and it becomes "Low" when one sheet of paper is counted up. This signal is output from the LGC board.



Fig.13-1

#### 2. CTCRNT signal (input signal)

The CTCRNT signal enables to accept copies when the coin controller is connected, and copies can be accepted with "Low". In case of "High", "Set Key Counter" appears and copies cannot be made.

#### 3. MCRUN signal (output signal)

The MCRUN signal is changed to "Low" during copying. It becomes "Low" at 30 ms or more before the CTRON signal is turned ON, and "High" at 50 ms or more after the EXTCTR signal goes OFF. However, if copying is interrupted due to forced toner supply or similar, this signal is "High" until copying is made possible again.

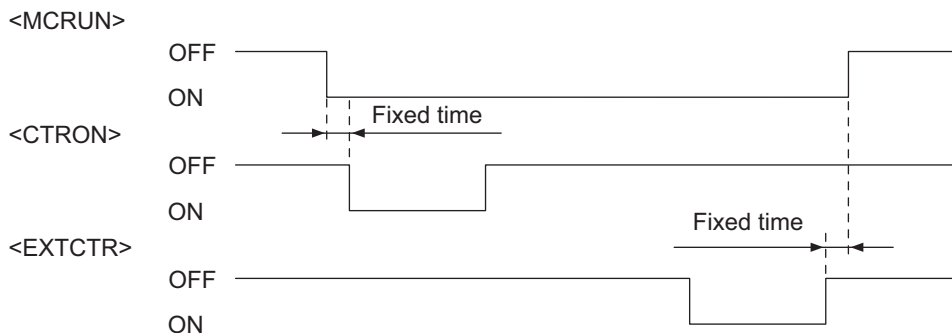


Fig.13-2

#### 4. EXTCTR signal (output signal)

The EXTCTR signal is synchronized with “Exit sensor ON” and becomes “Low” (ON) for 200 ms. The coin controller counts the number of times with this signal. This is the signal only for the coin controller.

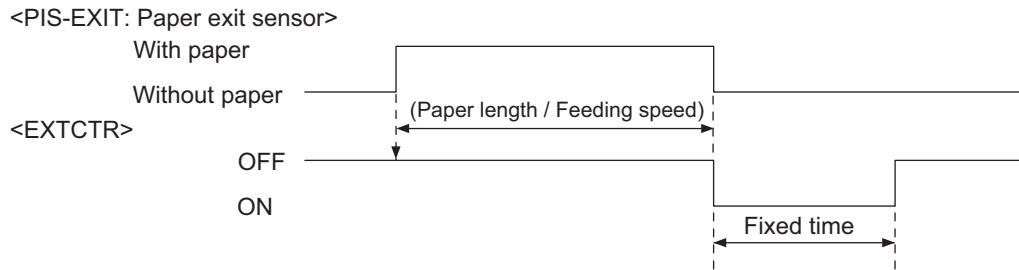


Fig.13-3

#### 5. LARGE/SMALL signal (output signal)

When large size paper (A3 / A3 wide / LD) is selected or paper size is not specified with the manual feeding, it outputs “Low” in real time. In other cases, it outputs “High”. The setting change for large size paper is performed with F/W.

This is the signal only for the coin controller.

### [ 4 ] Harness (GQ-1280)

Board	Connector	Pin No.	Signal name	Pin No.	Connector
SYS board (CN118)	Connector-2	1	LARGE / SMALL	7	Connector-3 (Coin controller)
		2	-	8	
		3	-	9	
		4	-	10	
		5	-	-	
		6	SG	12	
		7	-	-	
LGC board (CN313)	Connector-1	1	-	-	
		2	-	-	
		3	-	-	
		4	-	-	
		5	+24V	1	
		6	CTRON	2	
		7	CTRCNT	3	
		8	MCRUN	4	
		9	EXTCTR	5	
		10	PG	6	
		11	-	-	
		12	-	-	
		13	-	-	
		14	-	-	
15	-	-			
16	-	-			
17	-	-			
18	-	-			
19	+5VL	11			
20	-	-			

## 13.2.3 Key copy counter

### [ 1 ] Settings

1. Set the value of FS-08-9016 to "3".
2. Harness kit: -

### [ 2 ] Pin Layout

#### Notes:

Use 24V supplied from the equipment as power for the output signals (KCTRON) from the transistor.

1. LGC Board

Pin No.	I/O	Signal name	Function	Voltage level	Remarks
1	GND	SG	Signal Ground	0V	
2	In	CTRCNT	Copy permission Signal 1	L=0V, H=DC3.3V	L: Allowed *1
3	Power	+24V	24V line	DC24V+10%, -5%	
4	Out	KCTRON	Mechanical Counter On Signal	Open Collector	L: ON IO (Max): 500mA
5 - 20	-	-	-	-	Not connect

\*1 When the coin controller outputs the CTRCNT signal, the controller should be driven by means of an open collector or open drain to prevent the inflow of current to the equipment.

2. SYS board

Do not connect to the SYS board.

### [ 3 ] Details of the signals

1. CTRCNT signal (input signal)

The CTRCNT signal enables to accept copies when the coin controller is connected, and copies can be accepted with "Low". In case of "High", "Set Key Counter" appears and copies cannot be made.

2. KCTRON signal (output signal)

These signals are synchronized with the electronic counter of the equipment and they become "Low" when the counter is turned ON. They are the signals for driving a mechanical counter, and output from the LGC board.

They can drive inductive loads, such as a solenoid, using 24V supplied from the equipment. The interval between when they are turned ON and when this happens next must be at least 100 ms. "Single count" or "Double count" can be switched according to the paper size by setting "1" or "2" for FS-08-6010.

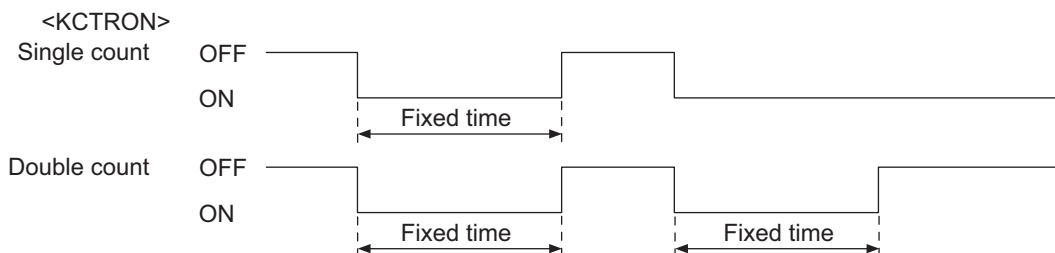


Fig.13-4

## 13.3 Notices

### 13.3.1 Setting code

Each signal will be enabled by configuring the setting code "FS-08-9016" (Externally installed counter).

FS-08-9016

- 0: No external counter (Default)
- 1: Coin controller
- 2: Copy key card (For Japan only)
- 3: Key copy counter
- 5: Coin controller supporting mixed-size

### 13.3.2 Setting value change and restrictions when using the card controller

1. Setting value
  - FS-08-9016 (Externally installed counter): Set to "2" (Copy key card).
  - FS-08-9017 (Setting for counter installed externally): It should be charged precisely according to the usage.  
Example: To charge only when copies are made, set to "1".
  - FS-08-6011 (Definition setting of large sized paper): Set to "0" if only A3 and LD are regarded as large size. Set to "1" if B4, LG, FOLIO and COMP are done so as well.

### 13.3.3 Setting value change and restrictions when using the coin controller

FS-08-9016 (Externally installed counter): Set to "1" (Coin controller) or "5" (Coin controller supporting mixed-size).

**Notes:**

- Mixed-size jobs will be supported by setting to "5". The switching process of the size signal is carried out for each page.
- Be sure to make the following charge settings appropriately according to the usage.
  - FS-08-9017 (Setting for counter installed externally): To charge only when copies are made, set to "1".
  - FS-08-6011 (Definition setting of large sized paper): Set to "0" if only A3 and LD are regarded as large size. Set to "1" if B4, LG, FOLIO and COMP are to be so as well.

### 13.3.4 Installation of external counter

It is not allowed to install more than one external counter (Key copy counter and Coin Controller) at the same time.

### **13.3.5 Setting value change and restrictions when using the key counter**

The Key copy counter used for current models is not supported in this equipment, but the circuit for driving the counter has been mounted. The mechanical counter can be used by setting as below, however the harness for connecting it has not been provided as an option.

#### **1. Setting value**

- FS-08-9016 (Externally installed counter): Set to "3" (Key copy counter).
- FS-08-9017 (Setting for counter installed externally): It should be charged precisely according to the usage.  
Example: To charge only when copies are made, set to "1".
- FS-08-6011 (Definition setting of large sized paper): Set to "0" if only A3 and LD are regarded as large size. Set to "1" if B4, LG, FOLIO and COMP are done so as well.

### **13.3.6 Restrictions when using the external counter**

The Job Skip function will be disabled when an external counter is installed (when a value other than "0" is set for FS-08-9016).

Therefore, if printing is attempted while a counter or a coin controller is used, all jobs stored in the HDD may be printed.

## 14. NOTES FOR THE INSTALLATION OF A CARD READER

- (1) The card reader to use in this equipment needs to satisfy all of the following conditions. However, the operation cannot be guaranteed even if all of these conditions are satisfied.
  1. Complying with the USB HID class and satisfying the following class codes
    - Class code: 0x03
    - Sub Class code: 0x00
    - Protocol code: 0x01
  2. An interface descriptor for the USB HID class needs to be single. (A card reader which consists of multiple HID classes, such as card reader and keyboard functions, cannot be used.)
  3. The USB VID/PID of the card reader has been registered in this equipment. For details about the registration of VID/PID, ask your service contact center.
- (2) When any problems concerning to a card reader have occurred, ask your service contact center to confirm whether the card reader satisfies the above conditions or not.





# 15. WIRE HARNESS CONNECTION DIAGRAMS

## 15.1 AC Wire Harness

NAD, MJD

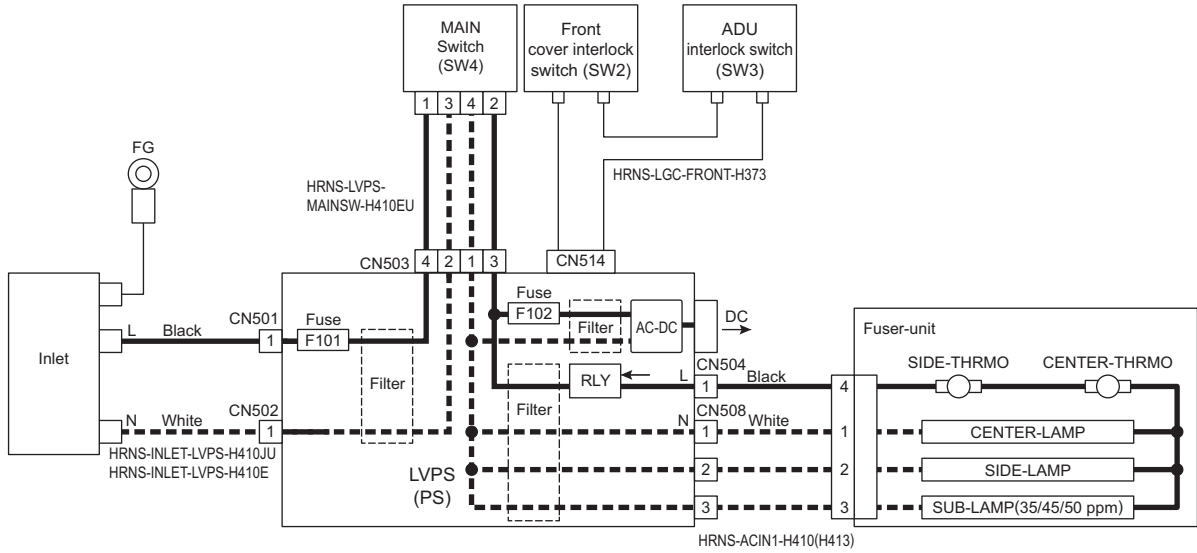


Fig.15-1

ARD, ASD, AUD, TWD

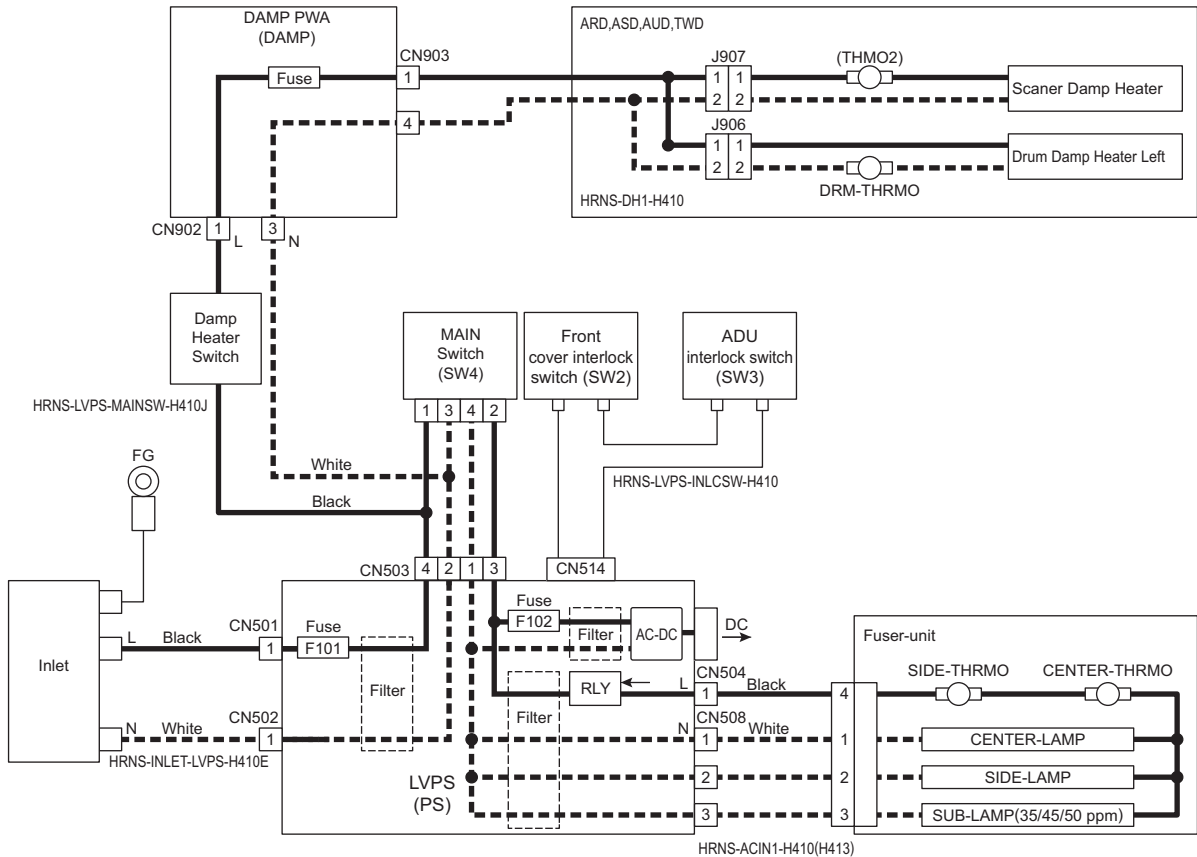


Fig.15-2

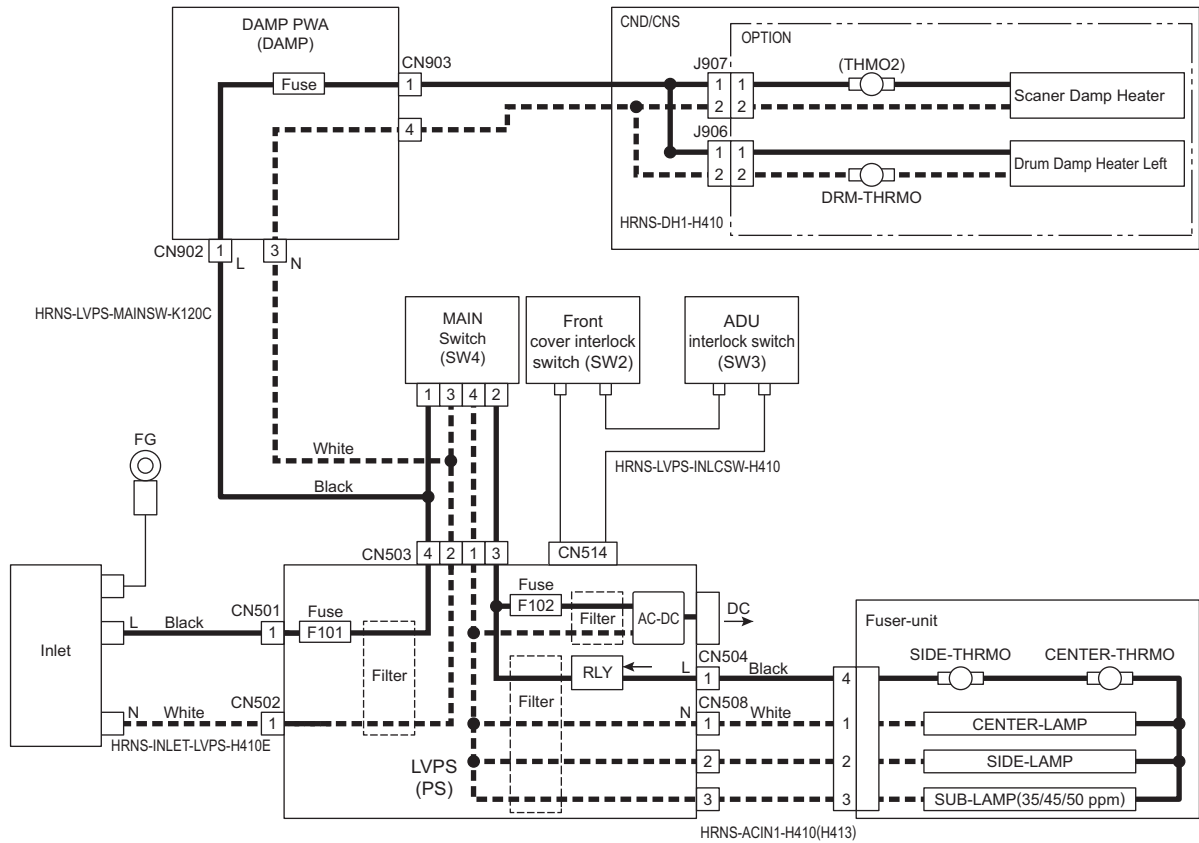


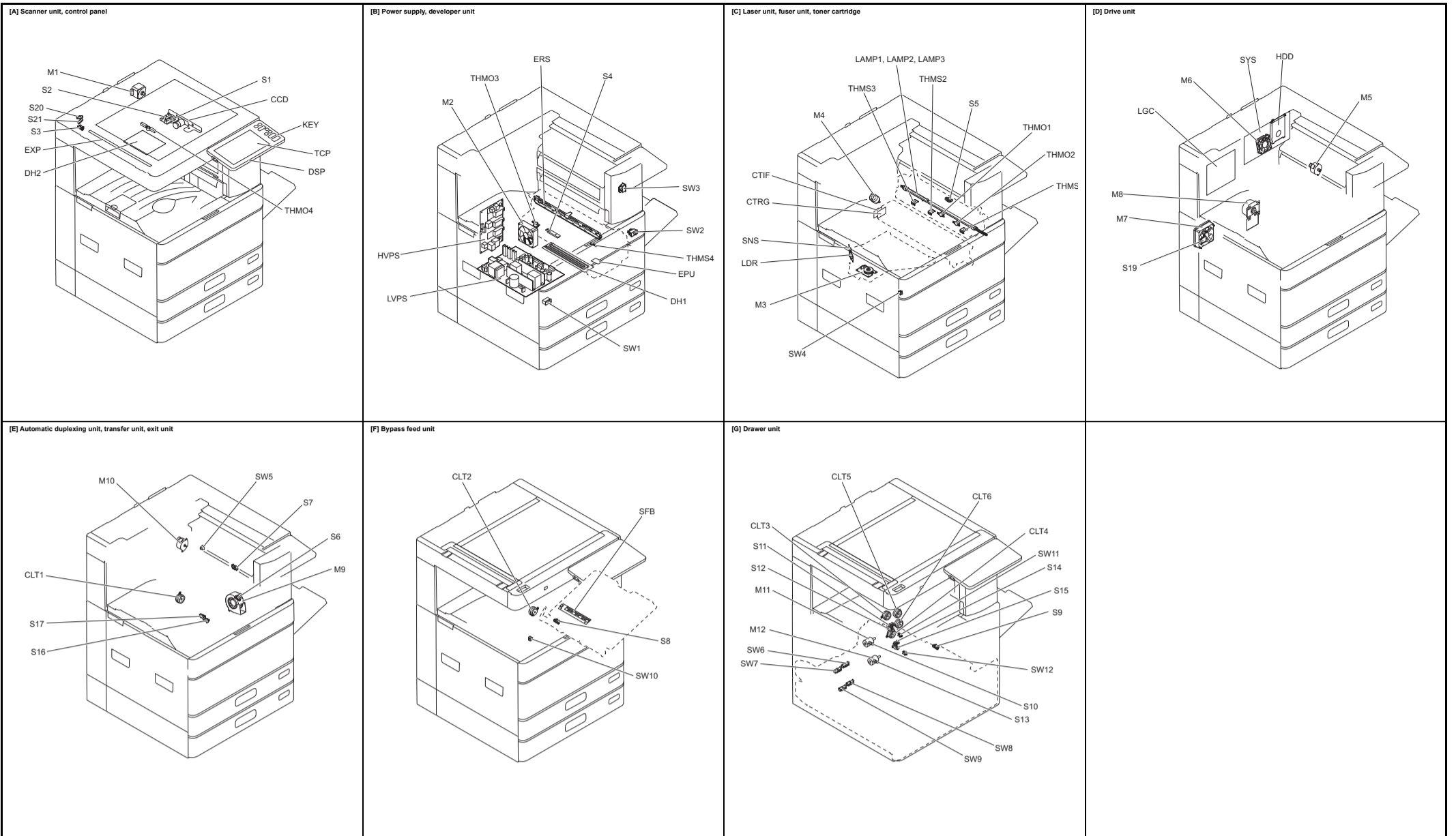
Fig.15-3

**Notes:**

- Front cover interlock switch (SW2) and ADU interlock switch (SW3) are the interlock switches with 12V DC.
- When the front cover interlock switch (SW2) or ADU interlock switch (SW3) is turned OFF, 24VD output will stop.



### 15.3 Electric Parts Layout (20ppm/25ppm/30ppm)



Symbol	Name	Figure	Wire harness location
M1	SCAN-MOT Scan motor	[A]	4-F
M2	PU-FAN Process unit fan	[B]	8-C
M3	POL-MOT Polygonal motor	[C]	7-E
M4	TRN-MOT Toner motor	[C]	7-E
M5	ADU-MOT ADU motor	[D]	6-B
M6	SYS-FAN-MOT SYS/HDD cooling fan	[D]	-
M7	POW-FAN Switching regulator cooling fan	[D]	8-C
M8	MAIN-MOT Main motor	[D]	7-E
M9	TRU-FAN TRU fan	[E]	7-B
M10	EXIT-MOT Exit motor	[E]	6-B
M11	TRAY-U-MOT Upper tray-up motor	[G]	8-A
M12	TRAY-L-MOT Lower tray-up motor	[G]	8-A

Symbol	Name	Figure	Wire harness location
S1-5	AP51-3, AP5-C, AP5-R Automatic original detection sensor	[A]	4-E
S6	HOME-SNR Carriage home position sensor	[A]	4-F
S7	PLTN-SNR Platen sensor	[A]	4-F
S8	ATTNR-SNR Auto-toner sensor	[B]	7-C
S9	EXIT-SW Exit sensor	[C]	8-E
S10	ADU-TR1-SNR ADU exit sensor	[E]	7-A
S11	ADU-TR2-SNR ADU entrance sensor	[E]	7-A
S12	SFB-EMP-SNR Bypass paper sensor	[F]	7-B
S13	FEED-COV-SNR Feed cover opening/closing sensor	[G]	6-E
S14	2ND-FEED-SNR 2nd transport sensor	[G]	8-B
S15	NEAR-EMP-U-SNR Upper drawer paper stock sensor	[G]	8-D
S16	TOP-U-SNR Upper drawer tray-up sensor	[G]	8-C
S17	EMP-U-SNR Upper drawer empty sensor	[G]	8-C
S18	NEAR-EMP-L-SNR Lower drawer paper stock sensor	[G]	8-D
S19	TOP-L-SNR Lower drawer tray-up sensor	[G]	8-D
S20	EMP-L-SNR Lower drawer empty sensor	[G]	8-D
S21	1ST-FEED-SNR 1st transport sensor	[E]	8-B
S22	RGST-SNR Registration sensor	[E]	8-B
S25	TEMP/HUM-SNR Temperature/humidity sensor	[D]	8-C
SW1	MAIN-SW Main power switch	[B]	-
SW2	FRNT-COV-INTLCK-SW Front cover interlock switch	[B]	-
SW3	ADU-INTLCK-SW ADU interlock switch	[B]	-
SW4	FRONT-COV-SW Front cover switch	[C]	6-C
SW5	ADU-COV-SW ADU opening/closing switch	[E]	7-B
SW6	CST-U-SW Upper drawer detection switch	[G]	8-D
SW7	CST-L-SW Lower drawer detection switch	[G]	8-E

Symbol	Name	Figure	Wire harness location
CLT1	ADU-CLT ADU clutch	[E]	7-A
CLT2	RGST-CLT Registration roller clutch	[E]	8-A
CLT3	SFB-CLT Bypass feed clutch	[F]	7-B
CLT4	CST-U-FEED-CLT Upper drawer feed clutch	[G]	8-C
CLT5	CST-L-FEED-CLT Lower drawer feed clutch	[G]	8-D
CLT6	TR-U-CLT High speed transport clutch	[G]	-
CLT7	TR-M-CLT Low speed transport clutch	[G]	-

Symbol	Name	Figure	Wire harness location
CCD	PWA-F-CCD CCD driving PC board (CCD board)	[A]	3-G
CTIF	PWA-F-CTIF Toner cartridge interface PC board (CTIF board)	[C]	7-E
CTRG	PWA-F-CTRG Toner cartridge PC board (CTRG board)	[C]	-
DSP	PWA-F-DSP Display PC board (DSP board)	[A]	1-G
EPU	PWB-F-EPU EPU board	[B]	7-C
FUS	PWA-F-FUS Fuse PC board (FUS board)	[D]	5-H
KEY	PWA-F-KEY Key control PC board (KEY board)	[A]	1-H
LDR	PWA-F-LDR Laser driving PC board (LDR board)	[C]	7-D
LGC	PWA-F-LGC Logic PC board (LGC board)	[D]	7-A
MOT	PWB-F-MOT MOT board	[D]	5-C
SFB	PWA-F-SFB Paper size detection board	[F]	7-B
SLG	PWA-F-SLG Scanning section control PC board (SLG board)	[A]	4-F
SNS	PWA-F-SNS H-sync signal detection PC board (SNS board)	[C]	7-D
SYS	PWA-F-SYS System control PC board (SYS board)	[D]	2-D

Symbol	Name	Figure	Wire harness location
DH1	SCN-LDH Scanner damp heater (Left)	[A]	-
DH2	SCN-RDH Scanner damp heater (Right)	[A]	-
DH3	DRM-DH Drum damp heater	[B]	-
ERS	LP-ERS Discharge LED	[B]	-
EXP	LP-EXP Exposure lamp	[A]	4-G
LAMP1	CNTR-LAMP Center heater lamp	[C]	-
LAMP2	SIDE-LAMP Side heater lamp	[C]	-

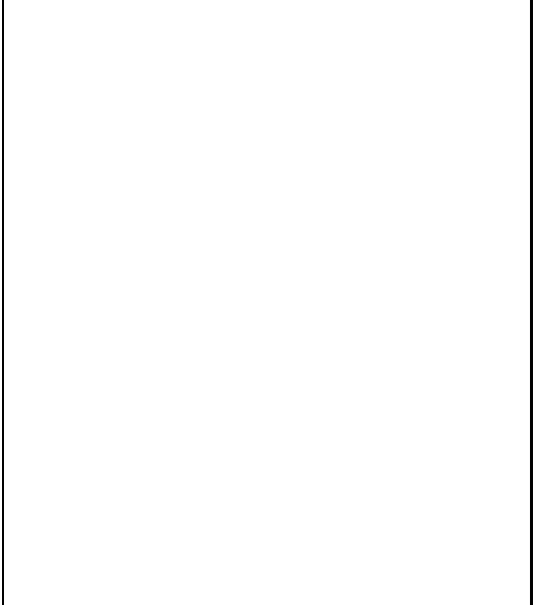
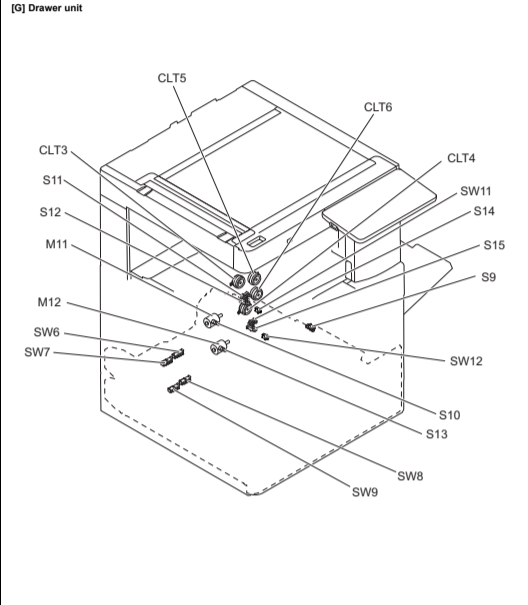
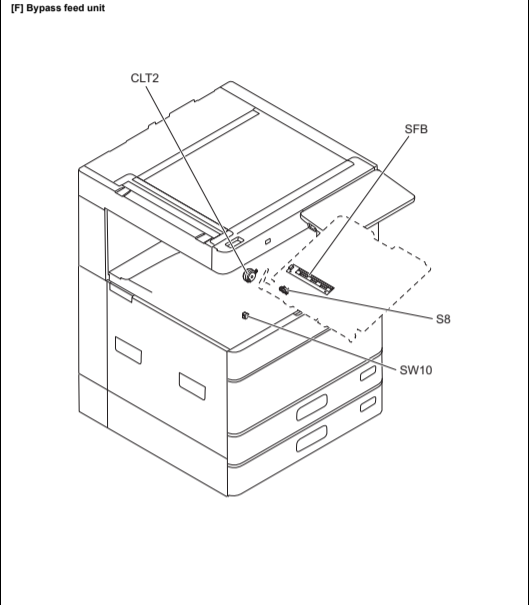
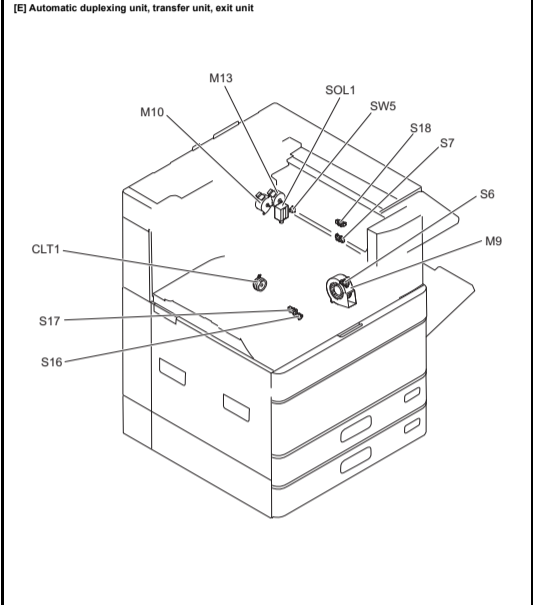
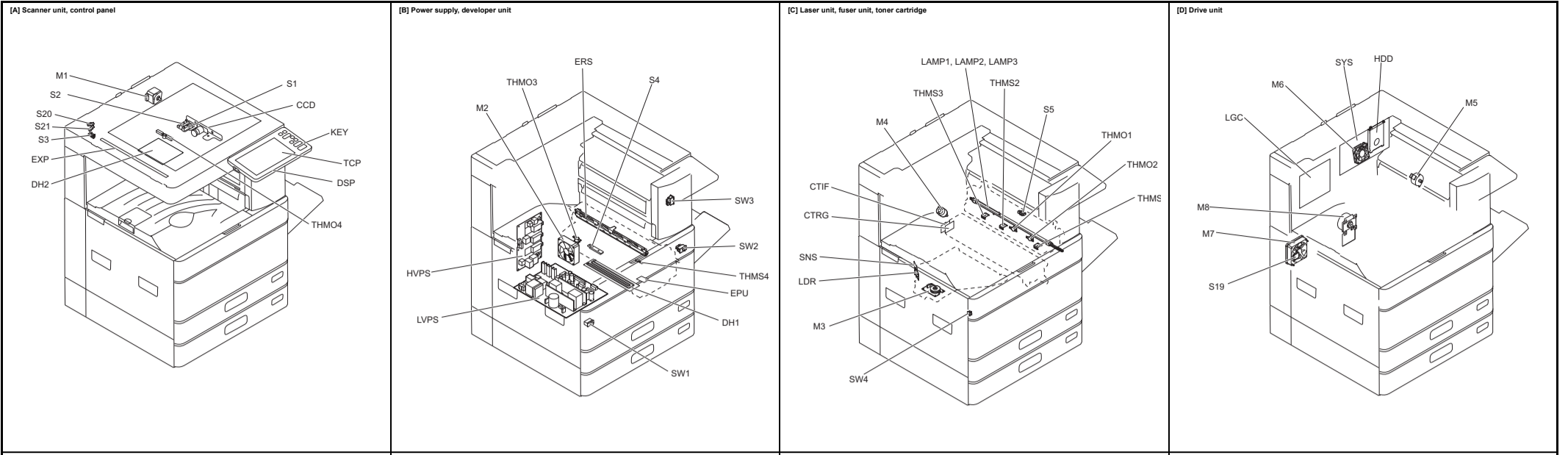
Symbol	Name	Figure	Wire harness location
THMO1	THERMO-FSR-C Fuser center thermostat	[C]	-
THMO2	THERMO-FSR-F Fuser front thermostat	[C]	-
THMO3	THERMO-DRM-DH Drum damp heater thermostat	[B]	-
THMO4	THERMO-SCN-DH Scanner damp heater thermostat	[A]	-
THMS1	THMS-C-HTR Center thermistor	[C]	8-E
THMS2	THMS-S-HTR Side thermistor	[C]	-
THMS3	THMS-EDG-HTR Edge thermistor	[C]	8-F
THMS4	THMS-DRM Drum thermistor	[B]	7-C

Symbol	Name	Figure	Wire harness location
HVT	PS-HVT High-voltage transformer	[B]	-

Symbol	Name	Figure	Wire harness location
TCP	Touch panel	[A]	1-G
HDD	Hard disk	[D]	3-F
INV	INV-EXP Inverter board	[A]	4-G
LVPS	Switching regulator (LVPS board)	[B]	5-H
LEDB	PWA-LED LED board	[A]	4-G



# 15.5 Electric Parts Layout (35ppm/45ppm/50ppm)



Symbol	Name	Figure	Wire harness location
M1	SCAN-MOT Scan motor	[A]	4-F
M2	PU-FAN Process unit fan	[B]	8-C
M3	POL-MOT Polygonal motor	[C]	7-E
M4	TRN-MOT Toner motor	[C]	7-E
M5	ADU-MOT ADU motor	[D]	5-C
M6	SYS-FAN-MOT SYS-HDD cooling fan	[D]	-
M7	POW-FAN Switching regulator cooling fan	[D]	8-C
M8	MAIN-MOT Main motor	[D]	7-E
M9	TRU-FAN TRU fan	[E]	7-B
M10	EXIT-MOT Exit motor	[E]	6-C
M11	TRAY-U-MOT Upper tray-up motor	[G]	8-A
M12	TRAY-L-MOT Lower tray-up motor	[G]	8-A
M13	OCT-GT-MOT offset gate motor	[E]	6-D
M14	REV-MOT Reverse motor	[E]	6-D

Symbol	Name	Figure	Wire harness location
S1-5	APSI-3, APS-C, APS-R Automatic original detection sensor	[A]	4-E
S6	HOME-SNR Carriage home position sensor	[A]	4-F
S7	PLTN-SNR Platen sensor	[A]	4-F
S8	ATTNR-SNR Auto-toner sensor	[B]	7-C
S9	EXIT-SW Exit sensor	[C]	8-E
S10	ADU-TR1-SNR ADU exit sensor	[E]	7-A
S11	ADU-TR2-SNR ADU entrance sensor	[E]	7-A
S12	SFB-EMP-SNR Bypass paper sensor	[F]	7-B
S13	FEED-COV-SNR Feed cover opening/closing sensor	[G]	6-E
S14	2ND-FEED-SNR 2nd transport sensor	[G]	8-B
S15	NEAR-EMP-U-SNR Upper drawer paper stock sensor	[G]	8-D
S16	TOP-U-SNR Upper drawer tray-up sensor	[G]	8-C
S17	EMP-U-SNR Upper drawer empty sensor	[G]	8-C
S18	NEAR-EMP-L-SNR Lower drawer paper stock sensor	[G]	8-D
S19	TOP-L-SNR Lower drawer tray-up sensor	[G]	8-D
S20	EMP-L-SNR Lower drawer empty sensor	[G]	8-D
S21	1ST-FEED-SNR 1st transport sensor	[E]	8-B
S22	RGST-SNR Registration sensor	[E]	8-B
S23	REV-SNR REV sensor	[E]	6-D
S24	OCT-HOME-SNR OCT home position sensor	[E]	6-D
S25	TEMPHUMI-SNR Temperature/humidity sensor	[D]	8-C
SW1	MAIN-SW Main power switch	[B]	-
SW2	FRNT-COV-INTLCK-SW Front cover interlock switch	[B]	-
SW3	ADU-INTLCK-SW ADU interlock switch	[B]	-
SW4	FRONT-COV-SW Front cover switch	[C]	6-C
SW5	ADU-COV-SW ADU opening/closing switch	[E]	7-B
SW6	CST-U-SW Upper drawer detection switch	[G]	8-D
SW7	CST-L-SW Lower drawer detection switch	[G]	8-E

Symbol	Name	Figure	Wire harness location
CLT1	ADU-CLT ADU clutch	[E]	7-A
CLT2	RGST-CLT Registration roller clutch	[E]	8-A
CLT3	SFB-CLT Bypass feed clutch	[F]	7-B
CLT4	CST-U-FEED-CLT Upper drawer feed clutch	[G]	8-C
CLT5	CST-L-FEED-CLT Lower drawer feed clutch	[G]	8-D
CLT6	TR-U-CLT High speed transport clutch	[G]	-
CLT7	TR-L-CLT Low speed transport clutch	[G]	-

Symbol	Name	Figure	Wire harness location
SOL1	REV-SOL REV gate solenoid	[E]	8-D

Symbol	Name	Figure	Wire harness location
CCD	PWA-F-CCD CCD driving PC board (CCD board)	[A]	3-G
CTIF	PWA-F-CTIF Toner cartridge interface PC board (CTIF board)	[C]	7-E
CTRG	PWA-F-CTRG Toner cartridge PC board (CTRG board)	[C]	-
DSP	PWA-F-DSP Display PC board (DSP board)	[A]	1-G
FUS	PWB-F-FUS Fuse PC board (FUS board)	[D]	5-H
KEY	PWA-F-KEY Key control PC board (KEY board)	[A]	1-H
LDR	PWA-F-LDR Laser driving PC board (LDR board)	[C]	7-D
LGC	PWA-F-LGC Logic PC board (LGC board)	[D]	7-A
MOT2	PWB-F-MOT2 MOT2 board	[D]	5-C
SFB	PWA-F-SFB Paper size detection board	[F]	7-B
SLG	PWA-F-SLG Scanning section control PC board (SLG board)	[A]	4-F
SNS	PWA-F-SNS H-sync signal detection PC board (SNS board)	[C]	7-D
SYS	PWA-F-SYS System control PC board (SYS board)	[D]	2-D

Symbol	Name	Figure	Wire harness location
DH1	SCN-L-DH Scanner lamp heater (Left)	[A]	-
DH2	SCN-R-DH Scanner lamp heater (Right)	[A]	-
DH3	DRM-DH Drum lamp heater	[B]	-
ERS	LP-ERS Discharge LED	[B]	-
EXP	LP-EXPO Exposure lamp	[A]	4-G
LAMP1	CNTR-LAMP Center heater lamp	[C]	-
LAMP2	SIDE-LAMP Side heater lamp	[C]	-
LAMP3	LAMP-TRIPLE Sub heater lamp	[C]	-

Symbol	Name	Figure	Wire harness location
THMO1	THERMO-FSR-C Fuser center thermostat	[C]	-
THMO2	THERMO-FSR-F Fuser front thermostat	[C]	-
THMO3	THERMO-DRM-DH Drum lamp heater thermostat	[B]	-
THMO4	THERMO-SCN-DH Scanner lamp heater thermostat	[A]	-
THMS1	THMS-C-HTR Center thermistor	[C]	8-E
THMS2	THMS-S-HTR Side thermistor	[C]	-
THMS3	THMS-EDG-HTR Edge thermistor	[C]	8-F
THMS4	THMS-DRM Drum thermistor	[B]	7-C

Symbol	Name	Figure	Wire harness location
HVT	PS-HVT High-voltage transformer	[B]	-

Symbol	Name	Figure	Wire harness location
TCP	TCP Touch panel	[A]	1-G
HDD	HDD Hard disk	[D]	3-F
INV	INV-EXP Inverter board	[A]	4-G
LVPS	PS-ACC Switching regulator (LVPS board)	[B]	5-H
LEDB	PWA-LED LED board	[A]	4-G

# APPENDIX

e-STUDIO2018A/2518A/3018A/3518A/4518A/5018A

MAINTENANCE CHECK LIST /  
 LISTE DE VERIFICATION D'ENTRETIEN /  
 LISTE DER WARTUNGSPRÜFUNG /  
 LISTA DE CONTROL DE MANTENIMIENTO

e-STUDIO2018A/2518A/3018A/3518A/4518A/5018A

REPLACEMENT PARTS AND SUPPLIES		COUNTER	TECHNICIAN	DATE
1.PICK UP ROLLER (1st CST.)	2018A			
2.FEED ROLLER (1st CST.)	2518A			
3.SEP ROLLER (1st CST.)	3018A			
4.PICK UP ROLLER (2nd CST.)	3518A			
5.FEED ROLLER (2nd CST.)	4518A			
6.SEP ROLLER (2nd CST.)	5018A			
7.FEED ROLLER (SFB)	80k			
8.SEP ROLLER (SFB)	160k			
9.PICK UP ROLLER (LCP)	240k			
10.FEED ROLLER (LCP)	320k			
11.SEP ROLLER (LCP)	400k			
12.PICK UP ROLLER (3rd CST.)	480k			
13.FEED ROLLER (3rd CST.)	560k			
14.SEP ROLLER (3rd CST.)	640k			
15.PICK UP ROLLER (4th CST.)	720k			
16.FEED ROLLER (4th CST.)	800k			
17.SEP ROLLER (4th CST.)				
18.PICK UP ROLLER (RADF/DADF)	2018A			
19.FEED ROLLER (RADF/DADF)	2518A			
20.SEP ROLLER (RADF/DADF)	3018A			
21.PICK UP ROLLER (RADF/DADF)	3518A			
22.FEED ROLLER (RADF/DADF)	4518A			
23.SEP ROLLER (RADF/DADF)	5018A			
24.REGISTRATION ROLLER FRONT SHEET (RADF)				

REPLACEMENT UNIT	CLEANING UNIT	REPLACEMENT PARTS AND SUPPLIES
1.PROCESS UNIT	1.CLEANER	1.MAIN BLADE (CLEANER)
2.FUSER UNIT	2.SCANNER	2.SEPARATION FINGER (DRUM)
	3.SFB	3.RECOVERY BLADE
	4.ADU	4.DRUM
	5.CHARGER	5.OZON FILTER
	6.SLIT GLASS	6.MAIN CHARGER NEEDLE
	7.FUSER	7.MAIN CHARGER GRID
	8.DEVELOPER	8.DEVELOPER MATERIAL
	9.PAPER FEED SECTION	9.FUSER ROLLER
	10.PFP	10.PRESS ROLLER
	11.RADF/DADF	11.SEPARATION FINGER (FUSER)
	12.LCF	12.TRANSFER ROLLER

2018A	2518A	3018A	3518A	4518A	5018A
80k	100k	120k	125k	150k	150k
160k	200k	240k	250k	300k	300k
240k	300k	360k	375k	450k	450k
320k	400k	480k	500k	600k	600k
400k	500k	600k	625k	750k	750k
480k	600k	720k	750k	900k	900k
560k	700k	840k	875k	1050k	1050k
640k	800k	960k	1000k	1200k	1200k
720k	900k	1080k	1125k	1350k	1350k
800k	1000k	1200k	1250k	1500k	1500k





# REVISION RECORD

Ver.02

Ver.02 <2020.09.18>	
Page	Contents
2-2	The description has been added. (Using a printer driver)
2-11	The description has been added. (Paper size of bypass feeding for using a printer driver)
5-28	The illustration has been changed. (Initialized display for FAX clear mode)
6-33	The error code "05-7026" has been deleted. The color mode "monochrome" has been renamed to "black". ([6.2] Background offsetting adjustment for DF)
6-33	The error code "05-7024" has been deleted. The color mode "monochrome" has been renamed to "black". ([6.2] Background offsetting adjustment in back side for DSDF)
6-44	The mistake has been corrected. ([6.4] Background offsetting adjustment for DF)
6-50	The mistake has been corrected. The error code "05-7026" has been deleted. ([6.5] Background offsetting adjustment for DF)
6-50	The error code "05-7023" has been added and the mistake has been corrected. ([6.5] Background offsetting adjustment in back side for DSDF)
6-91	The item has been added. (DSDF separation roller pressure force adjustment)
8-1	The overview description of the troubleshooting have been changed.
8-24	The item has been added. (F101-14)
8-28	The item of F901 has been divided into F901_0 to F901_3.
8-45	The item has been added. (5401 error)
8-45 to 8-46	The error messages have been changed. (5410 to 5417)
8-46	The error items have been deleted. (5418 and 5419)
8-65	The error items have been added. (7433 to 7435)
8-149	The procedure of the troubleshooting for E769 have been added.
8-185	The procedure of the troubleshooting for EF14 have been added.
8-193	The procedure of the troubleshooting for EF19 have been added.
8-203	The replacement parts of the troubleshooting for C260 have been added.
8-204	The description of the troubleshooting for C262 has been changed.
8-210	The number of the connector has been added. (The troubleshooting for C411 and C412)
8-218	The instructions of the replacement parts for F115 to F118 have been added.
8-218	The instructions of the replacement parts for F11A have been added.
8-219	The instructions of the replacement parts for F11B have been added.
8-221	The instructions of the replacement parts for F090 have been added.
8-222	The instructions of the replacement parts for F400 have been added.
8-223	The instructions of the replacement parts for E070 have been added.
8-224	The instructions of the replacement parts for E071 and E074 have been added.
8-250	The instructions of the replacement parts for F100_0 have been added.
8-251	The instructions of the replacement parts for F100_1 have been added.
8-252	The instructions of the replacement parts for F100_2 have been added.
8-253	The instructions of the replacement parts for F101_0 to F101_3 have been added.
8-254	The instructions of the replacement parts for F101_4 and F101_12 have been added.
8-255	The instructions of the replacement parts for F101_5 have been added.
8-256	The instructions of the replacement parts for F101_6 have been added.
8-257	The instructions of the replacement parts for F101_7 have been added.
8-258	The instructions of the replacement parts for F101_8 have been added.
8-259	The instructions of the replacement parts for F101_9 have been added.
8-260	The instructions of the replacement parts for F101_10 have been added.
8-261	The instructions of the replacement parts for F101_11 have been added.
8-262	The description of the troubleshooting for F101_13 has been corrected.
8-263	The item has been added. (F101_14)
8-264	The instructions of the replacement parts for F102 to F105 have been added.

Ver.02 <2020.09.18>	
Page	Contents
8-264	The instructions of the replacement parts for F106_0 have been added.
8-265	The instructions of the replacement parts for F106_1 have been added.
8-265	The instructions of the replacement parts for F106_2 have been added.
8-266	The instructions of the replacement parts for F106_3 have been added.
8-266 to 8-267	The instructions of the replacement parts for F106_4 have been added.
8-267	The instructions of the replacement parts for F106_5 have been added.
8-268	The instructions of the replacement parts for F106_6 to F106_UNDEF have been added.
8-268	The instructions of the replacement parts for F106_11 have been added.
8-269	The instructions of the replacement parts for F106_12 have been added.
8-269	The instructions of the replacement parts for F109_0 have been added.
8-270	The instructions of the replacement parts for F109_1 have been added.
8-270	The instructions of the replacement parts for F109_2 have been added.
8-271	The instructions of the replacement parts for F109_3 have been added.
8-272	The instructions of the replacement parts for F109_4 have been added.
8-274	The instructions of the replacement parts for F109_5 have been added.
8-275	The instructions of the replacement parts for F109_6 have been added.
8-275	The instructions of the replacement parts for F109_7 have been added.
8-276	The instructions of the replacement parts for F120 have been added.
8-276	The instructions of the replacement parts for F121 have been added.
8-277	The instructions of the replacement parts for F122 have been added.
8-277	The mistake of the troubleshooting for F124 has been corrected. The instructions of the replacement parts for F124 have been added.
8-277	The mistake of the troubleshooting for F125 has been corrected.
8-278	The instructions of the replacement parts for F125 have been added.
8-278	The mistake of the troubleshooting for F126 has been corrected. The instructions of the replacement parts for F126 have been added.
8-278	The mistake of the troubleshooting for F127 has been corrected. The instructions of the replacement parts for F127 have been added.
8-278	The instructions of the replacement parts for F128 have been added.
8-279	The instructions of the replacement parts for F130 have been added.
8-282	The instructions of the replacement parts for F700 have been added.
8-283	The instructions of the replacement parts for F800 have been added.
8-283	The instructions of the replacement parts for F901 have been added.
8-324	The error item and the measures have been changed. (5410)
8-324 to 8-325	The error item and the measures have been changed. (5411)
8-325	The error item and the measures have been changed. (5412)
8-325	The error item and the measures have been changed. (5413)
8-325	The error item and the measures have been changed. (5414)
8-325 to 8-326	The error item and the measures have been changed. (5415)
8-326	The error item and the measures have been changed. (5416)
8-326	The error item and the measures have been changed. (5417)
8-347	The description of the troubleshooting has been added. (7433)
8-347	The description of the troubleshooting has been added. (7434)
8-347	The description of the troubleshooting has been added. (7435)
8-359	The description of the troubleshooting for 80D1 has been corrected.
8-447	The description of the troubleshooting has been added. (Drum pitch fogging)
8-451	The item has been added. (If an image-related problem continues after performing all troubleshooting)
10-43 to 10-45	The item has been added. (Remote Panel VNC)
10-45	The item has been added. (Remote Service)

## Ver.01

Ver.01 <2019.09.10>	
Page	Contents
General precautions	A note has been added.
2-10	The description has been corrected. (System copy speed)
2-11	The mistake has been corrected. (Supported Client OS)
2-14	The description has been added.
2-16	The illustration has been changed. (Add option) Fig.2-2
2-17	Note has been added.
2-18 to 2-19	The description has been added. (Add option)
3-4	The illustration has been corrected. (Fig.3-3)
3-7	The illustration has been corrected. (Fig.3-6)
3-13	The description has been corrected.
3-16	The numbers for P-I has been added. (CTIF)
3-18	The description have been added. (Main memory, SRAM, EEPROM)
3-37	The illustration has been corrected. (Fig.3-20)
3-38	The illustration have been corrected. (Fig.3-21, Fig.3-22)
4-26	The illustration has been corrected. (Fig.4-64)
4-31	The notes has been added.
4-36	The notes has been corrected.
4-58	The procedure has been added. (Paper dust holder)
5-1	The description has been corrected. (HS Menu)
5-4	The illustration has been changed. (Fig.5-3)
5-5	The illustration has been changed. (Fig.5-4)
5-7	The illustration has been changed. (Fig.5-6)
5-22	The illustration has been changed. (Fig.5-18)
5-26	The illustration has been changed. (Fig.5-22)
5-27	The illustration has been changed. (Fig.5-23)
5-28	The illustration has been changed. (Fig.5-24)
5-29	The illustration has been corrected. (Fig.5-25) The description of step (2) has been added.
5-30	The illustration has been changed. (Fig.5-26)
5-31	The notes has been added.
5-35	The description has been corrected.
5-39	The notes has been changed.
5-46	The illustration has been corrected. (Fig.5-41) The description has been added.
6-10	The description has been corrected.
6-45	The description has been changed. (Adjustment of the capacity and image quality of SlimPDF)
6-69 to 6-71	The procedure has been added. (Control Panel Calibration)
7-17	The illustration has been corrected. (Fig.7-7)
7-30 to 7-31	The description has been added. (DSDf)
8-6 to 8-74	The description has been changed. (Error Code List)
8-75 to 8-105	The description has been added. (FAX error)
8-154 to 8-155	The description of the troubleshooting for E930 and E940 have been changed.
8-160	The description of the troubleshooting for EA23 has been changed.
8-190	The description of the troubleshooting for C010 has been changed.
8-192	The description of the troubleshooting for C040 has been changed.
8-197	The description of the troubleshooting for C1B0 has been changed.
8-199	The description of the troubleshooting for C262 has been changed.
8-200	The description of the troubleshooting for C270 has been changed.
8-200	The description of the troubleshooting for C280 has been changed.

Ver.01 <2019.09.10>	
Page	Contents
8-211	The description of the troubleshooting for C580 has been changed.
8-219	The description of the troubleshooting for F110 and F111 have been changed.
8-256	The description of the troubleshooting for F101_11 has been added.
8-261	The description of the troubleshooting for F106_12 has been changed.
8-271	The description of the troubleshooting for F150 has been changed.
8-289	The description of the troubleshooting for 2C50 has been changed.
8-294	The description of the troubleshooting for 2D50 has been added.
8-315	The description of the troubleshooting have been changed. (5410 and 5411)
8-316 to 8-317	The description of the troubleshooting have been changed. (5413 to 5417)
8-335	The description of the troubleshooting for 7301 has been added.
8-353 to 8-393	The troubleshooting have been added. (FAX error)
8-394	The description of the troubleshooting has been corrected.
8-397	The troubleshooting has been changed. (The equipment does not start after the power has been turned ON.)
8-404	The description of the troubleshooting has been changed. (Background fogging)
8-417	The description of the troubleshooting has been changed. (Black banding (in the feeding direction))
8-425	The description of the troubleshooting has been changed. (Jittering image)
8-426	The description of the troubleshooting has been changed. (Poor cleaning)
8-438 to 8-439	The description of the troubleshooting has been added. (Scanned image abnormality)
9-9	The notes has been added.
10-5	The illustration has been changed. (Fig.10-2)
12-16	The notes has been added.
14-1	The description has been added. (NOTES FOR THE INSTALLATION OF A CARD READER)
15-1	The illustration has been changed. (Fig.15-1, Fig.15-2)
15-2	The illustration has been changed. (Fig.15-3) / The notes has been added.
15-2	The illustration has been changed. (Fig.15-3) / The notes has been added.
15-3	The DC wire harness diagram has been corrected.

## Ver.00

Ver.00 <2018.06.20>	
Page	Contents
-	Initial release



**TOSHIBA**

**Toshiba Tec Corporation**

1-11-1, OSAKI, SHINAGAWA-KU, TOKYO, 141-8562, JAPAN