

# **SERVICE MANUAL**

MULTIFUNCTIONAL DIGITAL SYSTEMS  
**e-STUDIO200L/230/280**  
**e-STUDIO202L/232/282**  
**e-STUDIO203L/233/283**



## Trademarks

- The official name of Windows 95 is Microsoft Windows 95 Operating System.
- The official name of Windows 98 is Microsoft Windows 98 Operating System.
- The official name of Windows Me is Microsoft Windows Millennium Edition Operating System.
- The official name of Windows 2000 is Microsoft Windows 2000 Operating System.
- The official name of Windows XP is Microsoft Windows XP Operating System.
- Microsoft, Windows, Windows NT and the brand names and product names of other Microsoft products are trademarks or registered trademarks of Microsoft Corporation in the U.S. and/or other countries.
- Apple, AppleTalk, Macintosh, and Mac are trademarks of Apple Computer, Inc. in the U.S. and other countries.
- PostScript is a trademark of Adobe Systems Incorporated.
- NOVELL, NetWare, and NDS are trademarks or registered trademarks of Novell, Inc.
- Molykote is a registered trademark of Dow Corning Corporation.
- iCLASS is a trademark of HID Corporation.
- MIFARE is a trademark of Royal Philips Electronics.
- Other company names and product names in this manual are the trademarks of their respective companies.

©2004 - 2008 TOSHIBA TEC CORPORATION All rights reserved

Under the copyright laws, this manual cannot be reproduced in any form without prior written permission of TOSHIBA TEC CORPORATION. No patent liability is assumed, however, with respect to the use of the information contained herein.

# GENERAL PRECAUTIONS REGARDING THE SERVICE FOR e-STUDIO200L/202L/203L/230/232/233/280/282/283 SERIES

The installation and service should be done by a qualified service technician.

## 1) Transportation/Installation

- When transporting/installing the equipment, employ two persons and be sure to hold the positions as shown in the figure.  
The equipment is quite heavy and weighs approximately 75 kg (165.34 lb.) therefore pay full attention when handling it.

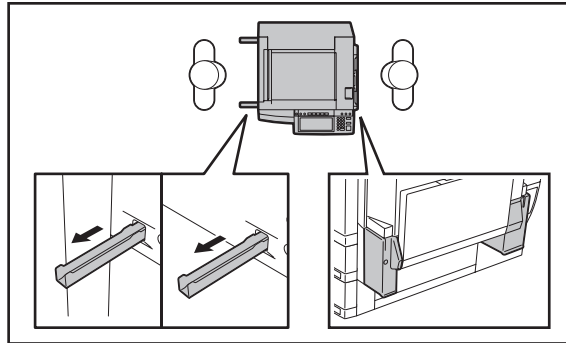

- Be sure not to hold the movable parts or units (e.g. the control panel, ADU or RADF) when transporting the equipment.
- Be sure to use a dedicated outlet with AC 110 V / 13.2 A, 115 V or 127 V / 12 A, 220-240 V or 240 V / 8 A for its power source.
- The equipment must be grounded for safety.
- Select a suitable place for installation. Avoid excessive heat, high humidity, dust, vibration and direct sunlight.
- Provide proper ventilation since the equipment emits a slight amount of ozone.
- To insure adequate working space for the copying operation, keep a minimum clearance of 80 cm (32") on the left, 80 cm (32") on the right and 10 cm (4") on the rear.
- The equipment shall be installed near the socket outlet and shall be accessible.
- Be sure to fix and plug in the power cable securely after the installation so that no one trips over it.

## 2) General Precautions at Service

- Be sure to turn the power OFF and unplug the power cable during service (except for the service should be done with the power turned ON).
- Unplug the power cable and clean the area around the prongs of the plug and socket outlet once a year or more. A fire may occur when dust lies on this area.
- When the parts are disassembled, reassembly is the reverse of disassembly unless otherwise noted in this manual or other related documents. Be careful not to install small parts such as screws, washers, pins, E-rings, star washers in the wrong places.
- Basically, the equipment should not be operated with any parts removed or disassembled.
- The PC board must be stored in an anti-electrostatic bag and handled carefully using a wristband since the ICs on it may be damaged due to static electricity.

**Caution: Before using the wristband, unplug the power cable of the equipment and make sure that there are no charged objects which are not insulated in the vicinity.**

- Avoid expose to laser beam during service. This equipment uses a laser diode. Be sure not to expose your eyes to the laser beam. Do not insert reflecting parts or tools such as a screwdriver on the laser beam path. Remove all reflecting metals such as watches, rings, etc. before starting service.
- Be sure not to touch high-temperature sections such as the exposure lamp, fuser unit, damp heater and areas around them.
- Be sure not to touch high-voltage sections such as the chargers, developer, high-voltage transformer, exposure lamp control inverter, inverter for the LCD backlight and power supply unit. Especially, the board of these components should not be touched since the electric charge may remain in the capacitors, etc. on them even after the power is turned OFF.
- Make sure that the equipment will not operate before touching potentially dangerous places (e.g. rotating/operating sections such as gears, belts pulleys, fans and laser beam exit of the laser optical unit).
- Be careful when removing the covers since there might be the parts with very sharp edges underneath.
- When servicing the equipment with the power turned ON, be sure not to touch live sections and rotating/operating sections. Avoid exposing your eyes to laser beam.
- Use designated jigs and tools.
- Use recommended measuring instruments or equivalents.
- Return the equipment to the original state and check the operation when the service is finished.
- Be very careful to treat the touch panel gently and never hit it. Breaking the surface could cause malfunctions.

## 3) Important Service Parts for Safety

- The breaker, door switch, fuse, thermostat, thermofuse, thermistor, IC-RAMs including lithium batteries, etc. are particularly important for safety. Be sure to handle/install them properly. If these parts are short-circuited and their functions become ineffective, they may result in fatal accidents such as burnout. Do not allow a short-circuit or do not use the parts not recommended by Toshiba TEC Corporation.

## 4) Cautionary Labels

- During servicing, be sure to check the rating plate and cautionary labels such as "Unplug the power cable during service", "CAUTION. HOT", "CAUTION. HIGH VOLTAGE", "CAUTION. LASER BEAM", etc. to see if there is any dirt on their surface and if they are properly stuck to the equipment.

5) **Disposal of the Equipment, Supplies, Packing Materials, Used Batteries and IC-RAMs**

- Regarding the recovery and disposal of the equipment, supplies, packing materials, used batteries and IC-RAMs including lithium batteries, follow the relevant local regulations or rules.

**Caution:**

Dispose of used batteries and IC-RAMs including lithium batteries according to this manual.

**Attention:**

Se débarrasser de batteries et IC-RAMs usés y compris les batteries en lithium selon ce manuel.

**Vorsicht:**

Entsorgung der gebrauchten Batterien und IC-RAMs (inclusive der Lithium-Batterie) nach diesem Handbuch.



# CONTENTS

|  |            |
|--|------------|
| <b>1. SPECIFICATIONS / ACCESSORIES / OPTIONS / SUPPLIES .....</b>      | <b>1-1</b> |
| 1.1 Specifications.....  | 1-1        |
| 1.2 Accessories .....  | 1-6        |
| 1.3 Options .....  | 1-7        |
| 1.3.1 e-STUDIO200L/230/230L/280/280S .....                             | 1-7        |
| 1.3.2 e-STUDIO202L/203L/232/232S/233/282/282S/283/283S .....           | 1-8        |
| 1.4 Supplies.....  | 1-10       |
| 1.4.1 e-STUDIO200L/230/230L/280/280S .....                             | 1-10       |
| 1.4.2 e-STUDIO202L/232/232S/282/282S .....                             | 1-10       |
| 1.4.3 e-STUDIO203L/233/283/283S .....                                  | 1-10       |
| 1.5 System List.....   | 1-11       |
| 1.5.1 e-STUDIO200L/230/230L/280/280S .....                             | 1-11       |
| 1.5.2 e-STUDIO202L/203L/232/232S/233/282/282S/283/283S .....           | 1-17       |
| <b>2. OUTLINE OF THE MACHINE .....</b>                                 | <b>2-1</b> |
| 2.1 Sectional View .....   | 2-1        |
| 2.2 Electric Parts Layout.....   | 2-4        |
| 2.3 Symbols and Functions of Various Components.....                   | 2-17       |
| 2.4 General Description .....  | 2-26       |
| 2.4.1 System block diagram .....                                       | 2-26       |
| 2.4.2 Construction of boards .....                                     | 2-28       |
| 2.5 Installation and Replacement of Covers and PC Boards.....          | 2-30       |
| 2.5.1 Covers .....   | 2-30       |
| 2.5.2 PC boards .....  | 2-41       |
| 2.6 Installation and Replacement of Options.....                       | 2-51       |
| <b>3. COPY PROCESS .....</b>   | <b>3-1</b> |
| 3.1 General Description of Copying Process.....                        | 3-1        |
| 3.2 Details of Copying Process.....                                    | 3-2        |
| 3.3 Comparison with e-STUDIO350/450 .....                              | 3-13       |
| <b>4. GENERAL OPERATION .....</b>                                      | <b>4-1</b> |
| 4.1 Overview of Operation .....  | 4-1        |
| 4.2 Description of Operation .....                                     | 4-2        |
| 4.2.1 Warming-up.....  | 4-2        |
| 4.2.2 Ready state (ready for copying) .....                            | 4-2        |
| 4.2.3 Drawer feed copying (Upper drawer paper feeding) .....           | 4-3        |
| 4.2.4 Bypass feed copying .....  | 4-5        |
| 4.2.5 Interruption copying.....  | 4-5        |
| 4.3 Detection of Abnormality.....                                      | 4-6        |
| 4.3.1 Types of abnormality .....                                       | 4-6        |
| 4.3.2 Description of abnormality .....                                 | 4-7        |
| 4.4 Flow Chart .....   | 4-12       |
| 4.4.1 Immediately after the power is turned ON.....                    | 4-12       |
| 4.4.2 Automatic paper feed copying.....                                | 4-14       |
| <b>5. CONTROL PANEL.....</b>   | <b>5-1</b> |
| 5.1 Control Panel and Display Panel .....                              | 5-1        |
| 5.2 Items Shown on the Control Panel .....                             | 5-2        |
| 5.2.1 Display.....   | 5-3        |
| 5.3 Relation between the Equipment State and Operator's Operation..... | 5-8        |
| 5.4 Description of Operation .....                                     | 5-12       |
| 5.4.1 Dot matrix LCD circuit .....                                     | 5-12       |
| 5.4.2 LED display circuit.....   | 5-15       |

|            |   |             |
|------------|---|-------------|
| 5.5        | Disassembly and Replacement .....               | 5-16        |
| <b>6.</b>  | <b>SCANNER .....</b>                            | <b>6-1</b>  |
| 6.1        | Function .....                                  | 6-1         |
| 6.2        | Construction .....                              | 6-2         |
| 6.3        | Description of Operation .....                  | 6-4         |
| 6.3.1      | Scan motor .....                                | 6-4         |
| 6.3.2      | Scanning drive circuit .....                    | 6-5         |
| 6.3.3      | Initialization at power-ON .....                | 6-7         |
| 6.4        | Control of Exposure Lamp .....                  | 6-8         |
| 6.4.1      | General description .....                       | 6-8         |
| 6.4.2      | Exposure lamp .....                             | 6-9         |
| 6.4.3      | Control circuit for the exposure lamp .....     | 6-10        |
| 6.5        | General Description of CCD Control .....        | 6-11        |
| 6.5.1      | Opto-electronic conversion .....                | 6-11        |
| 6.5.2      | Shading correction .....                        | 6-11        |
| 6.6        | Automatic Original Size Detection Circuit ..... | 6-12        |
| 6.6.1      | Principle of original size detection .....      | 6-12        |
| 6.6.2      | Process of detection of original size .....     | 6-13        |
| 6.7        | Disassembly and Replacement .....               | 6-17        |
| <b>7.</b>  | <b>IMAGE PROCESSING .....</b>                   | <b>7-1</b>  |
| 7.1        | General Description .....                       | 7-1         |
| 7.2        | Configuration .....                             | 7-3         |
| 7.3        | SLG Board .....                                 | 7-4         |
| 7.3.1      | Features .....                                  | 7-4         |
| 7.3.2      | Functions of image processing circuit .....     | 7-4         |
| 7.4        | LGC Board .....                                 | 7-8         |
| 7.4.1      | Features .....                                  | 7-8         |
| 7.4.2      | Functions of image processing circuit .....     | 7-8         |
| 7.5        | Laser Driving PC Board .....                    | 7-9         |
| <b>8.</b>  | <b>LASER OPTICAL UNIT .....</b>                 | <b>8-1</b>  |
| 8.1        | General Description .....                       | 8-1         |
| 8.2        | Structure .....                                 | 8-3         |
| 8.3        | Laser Diode .....                               | 8-6         |
| 8.4        | Polygonal Motor .....                           | 8-7         |
| 8.5        | Internal cooling fan-2 .....                    | 8-8         |
| 8.6        | Disassembly and Replacement .....               | 8-9         |
| <b>9.</b>  | <b>PAPER FEEDING SYSTEM .....</b>               | <b>9-1</b>  |
| 9.1        | Functions .....                                 | 9-1         |
| 9.2        | Operation .....                                 | 9-5         |
| 9.2.1      | Operation of bypass pickup roller .....         | 9-5         |
| 9.2.2      | Operation of drawer pickup roller .....         | 9-6         |
| 9.2.3      | Separation of paper .....                       | 9-7         |
| 9.2.4      | Operation of clutch .....                       | 9-8         |
| 9.2.5      | General operation .....                         | 9-9         |
| 9.3        | Drive Circuit of Tray-up Motor .....            | 9-11        |
| 9.4        | Disassembly and Replacement .....               | 9-13        |
| <b>10.</b> | <b>DRIVE SYSTEM .....</b>                       | <b>10-1</b> |
| 10.1       | General Description .....                       | 10-1        |
| 10.2       | Functions .....                                 | 10-2        |
| 10.3       | Main Motor .....                                | 10-3        |
| 10.3.1     | Main motor drive .....                          | 10-3        |
| 10.3.2     | Control signals .....                           | 10-4        |
| 10.4       | Disassembly and Replacement .....               | 10-5        |



|   |             |
|---|-------------|
| <b>11. DRUM RELATED SECTION .....</b>                             | <b>11-1</b> |
| 11.1 Configuration .....  | 11-1        |
| 11.2 Functions .....  | 11-2        |
| 11.3 High-Voltage Transformer Output Control Circuit.....         | 11-4        |
| 11.3.1 General description .....                                  | 11-4        |
| 11.3.2 Description of Operation.....                              | 11-5        |
| 11.4 Drum Temperature Detection Circuit.....                      | 11-6        |
| 11.4.1 General description .....                                  | 11-6        |
| 11.4.2 Construction .....   | 11-6        |
| 11.5 Temperature/Humidity Detection Circuit.....                  | 11-7        |
| 11.5.1 General description .....                                  | 11-7        |
| 11.5.2 Construction .....   | 11-7        |
| 11.6 Disassembly and Replacement .....                            | 11-8        |
| <b>12. DEVELOPMENT SYSTEM.....</b>                                | <b>12-1</b> |
| 12.1 Configuration .....  | 12-1        |
| 12.2 Functions .....  | 12-2        |
| 12.2.1 General description .....                                  | 12-2        |
| 12.2.2 Recovered toner supply mechanism .....                     | 12-3        |
| 12.3 Drive Circuit of Toner Motor.....                            | 12-4        |
| 12.4 Auto-Toner Circuit.....                                      | 12-6        |
| 12.4.1 General description .....                                  | 12-6        |
| 12.4.2 Function of auto-toner sensor .....                        | 12-7        |
| 12.5 Disassembly and Replacement .....                            | 12-9        |
| <b>13. FUSER UNIT .....</b>                                       | <b>13-1</b> |
| 13.1 General Description .....                                    | 13-1        |
| 13.2 Operation .....  | 13-2        |
| 13.3 Functions .....  | 13-3        |
| 13.4 Heater Control Circuit .....                                 | 13-5        |
| 13.4.1 Configuration .....  | 13-5        |
| 13.4.2 Temperature detection section .....                        | 13-6        |
| 13.5 Disassembly and Replacement .....                            | 13-11       |
| <b>14. PAPER EXIT SECTION .....</b>                               | <b>14-1</b> |
| 14.1 General Description .....                                    | 14-1        |
| 14.2 Functions .....  | 14-2        |
| 14.3 Control Circuit of Exit Motor.....                           | 14-3        |
| 14.4 Exit Motor Drive .....                                       | 14-4        |
| 14.5 Disassembly and Replacement .....                            | 14-5        |
| <b>15. AUTOMATIC DUPLEXING UNIT (ADU) (OPTION: MD-0102) .....</b> | <b>15-1</b> |
| 15.1 General Description .....                                    | 15-1        |
| 15.2 Description of Operations .....                              | 15-2        |
| 15.3 Drive of ADU.....  | 15-7        |
| 15.4 Flow Chart .....   | 15-8        |
| 15.5 Disassembly and Replacement .....                            | 15-10       |
| <b>16. POWER SUPPLY UNIT .....</b>                                | <b>16-1</b> |
| 16.1 Construction.....  | 16-1        |
| 16.2 Operation of DC Output Circuits.....                         | 16-2        |
| 16.3 Output Channel .....   | 16-3        |
| 16.4 Fuse.....  | 16-5        |
| 16.5 Configuration of Power Supply Unit.....                      | 16-6        |
| 16.6 Sequence of Power Supply .....                               | 16-7        |
| 16.7 AC Wire Harness .....  | 16-8        |
| <b>17. PC BOARDS .....</b>  | <b>17-1</b> |



# 1. SPECIFICATIONS / ACCESSORIES / OPTIONS / SUPPLIES

## 1.1 Specifications

Values in { } are for e-STUDIO200L/202L/203L and values in [ ] are for e-STUDIO280/280S/282/282S/283/283S in case that the specification is different among e-STUDIO200L/202L/203L, e-STUDIO230/230L/232/232S/233 and e-STUDIO280/280S/282/282S/283/283S.

- Copy process Indirect electrophotographic process (dry)
- Type Desktop type (console type: when paper feed pedestal (PFP) and large capacity feeder (LCF) are installed)
- Original table Fixed type (the left rear corner used as guide to place originals)
- Accepted originals Sheet, book and 3-dimensional object. The reversing automatic document feeder (RADF) only accepts paper which are not pasted or stapled. Carbon paper are not acceptable either.  
Maximum size: A3/LD

|         | Single - sided original                                 | Double - sided original                                |
|---------|---|--|
| MR-3016 | 50 ~ 127 g/m <sup>2</sup> (13 lb. Bond - 34 lb. Bond)   | 50 ~ 105 g/m <sup>2</sup> (13 lb. Bond - 28 lb. Bond)  |
| MR-3018 | 35 ~ 157 g/m <sup>2</sup> (9.3 lb. Bond - 58 lb. Cover) | 50 ~ 157 g/m <sup>2</sup> (13 lb. Bond - 58 lb. Cover) |

- Copy speed (Copies/min.)  
e-STUDIO200L/202L/203L

| Paper size             | Drawer | Bypass feed    |                    | PFP | LCF |
|------------------------|--------|----------------|--------------------|-----|-----|
|                        |        | Size specified | Size not specified |     |     |
| A4, LT, B5, A5-R, ST-R | 20     | 20             | 16                 | 20  | 20  |
| A4-R, B5-R, LT-R       | 19     | 19             | 16                 | 19  | –   |
| B4, LG                 | 18     | 18             | 16                 | 18  | –   |
| A3, LD                 | 16     | 16             | 16                 | 16  | –   |

e-STUDIO230/230L/232/232S/233

| Paper size             | Drawer | Bypass feed    |                    | PFP  | LCF |
|------------------------|--------|----------------|--------------------|------|-----|
|                        |        | Size specified | Size not specified |      |     |
| A4, LT, B5, A5-R, ST-R | 23     | 23             | 16                 | 23   | 23  |
| A4-R, B5-R, LT-R       | 21.5   | 21.5           | 16                 | 21.5 | –   |
| B4, LG                 | 18     | 18             | 16                 | 18   | –   |
| A3, LD                 | 16     | 16             | 16                 | 16   | –   |

e-STUDIO280/280S/282/282S/283/283S

| Paper size             | Drawer | Bypass feed    |                    | PFP  | LCF |
|------------------------|--------|----------------|--------------------|------|-----|
|                        |        | Size specified | Size not specified |      |     |
| A4, LT, B5, A5-R, ST-R | 28     | 28             | 16                 | 28   | 28  |
| A4-R, B5-R, LT-R       | 21.5   | 21.5           | 16                 | 21.5 | –   |
| B4, LG                 | 18     | 18             | 16                 | 18   | –   |
| A3, LD                 | 16     | 16             | 16                 | 16   | –   |

\* “–” means “Not acceptable”.

\* The copy speed in the above table are available when originals are manually placed for single side, multiple copying.

\* When the RADF is used, the copy speed of {20}23[28] sheets per minute is only available under the following conditions:

- Original/Mode: Single side original/A4/LT size. APS/automatic density are not selected.
- Number of sheets: {20}23[28] or more.
- Reproduction ratio: 100%

Copy speed for thick paper (Copies/min.)

e-STUDIO200L/202L/203L/230/232/233/280/282/283 series

Thick 1 (81 g/m<sup>2</sup> to 105 g/m<sup>2</sup>, 21.3 lb. Bond to 28 lb. Bond)

| Paper size             | Drawer       | Bypass feed    |                    | PFP          | LCF          |
|------------------------|--------------|----------------|--------------------|--------------|--------------|
|                        |              | Size specified | Size not specified |              |              |
| A4, LT, B5, A5-R, ST-R | {20} 23 [27] | {20} 23 [27]   | {15} 16 [16]       | {20} 23 [27] | {20} 23 [27] |
| A4-R, B5-R, LT-R       | {19} 21 [21] | {19} 21 [21]   | {15} 16 [16]       | {19} 21 [21] | {-} - [-]    |
| B4, LG                 | {18} 18 [18] | {18} 18 [18]   | {15} 16 [16]       | {18} 18 [18] | {-} - [-]    |
| A3, LD                 | {15} 16 [16] | {15} 16 [16]   | {15} 16 [16]       | {15} 16 [16] | {-} - [-]    |

Thick 2 (106 g/m<sup>2</sup> to 163 g/m<sup>2</sup>, 28 lb. Bond to 90 lb. Index)

| Paper size             | Drawer    | Bypass feed    |                    | PFP       | LCF       |
|------------------------|-----------|----------------|--------------------|-----------|-----------|
|                        |           | Size specified | Size not specified |           |           |
| A4, LT, B5, A5-R, ST-R | {-} - [-] | {20} 23 [27]   | {15} 16 [16]       | {-} - [-] | {-} - [-] |
| A4-R, B5-R, LT-R       | {-} - [-] | {19} 21 [21]   | {15} 16 [16]       | {-} - [-] | {-} - [-] |
| B4, LG                 | {-} - [-] | {18} 18 [18]   | {15} 16 [16]       | {-} - [-] | {-} - [-] |
| A3, LD                 | {-} - [-] | {15} 16 [16]   | {15} 16 [16]       | {-} - [-] | {-} - [-] |

Thick 3 (164 g/m<sup>2</sup> to 209 g/m<sup>2</sup>, 90 lb. Index to 115.7 lb. Index)

| Paper size             | Drawer    | Bypass feed    |                    | PFP       | LCF       |
|------------------------|-----------|----------------|--------------------|-----------|-----------|
|                        |           | Size specified | Size not specified |           |           |
| A4, LT, B5, A5-R, ST-R | {-} - [-] | {20} 23 [27]   | {15} 16 [16]       | {-} - [-] | {-} - [-] |
| A4-R, B5-R, LT-R       | {-} - [-] | {19} 21 [21]   | {15} 16 [16]       | {-} - [-] | {-} - [-] |
| B4, LG                 | {-} - [-] | {18} 18 [18]   | {15} 16 [16]       | {-} - [-] | {-} - [-] |
| A3, LD                 | {-} - [-] | {15} 16 [16]   | {15} 16 [16]       | {-} - [-] | {-} - [-] |

\* Only A4/LT size is available for the LCF.

\* The tolerance is within ±2.

\* System copy speed

| Copy mode  |        | Sec.                       |                                   |  |
|--|--------|----------------------------|-----------------------------------|--|
|  |        | e-STUDIO200L/<br>202L/203L | e-STUDIO230/230L/<br>232/232S/233 | e-STUDIO280/280S/<br>282/282S/283/283S |
| Single-sided originals<br>↓<br>Single-sided copies | 1 set  | 34.18                      | 31.5                              | 27.6                                   |
|  | 3 sets | 95.53                      | 84.8                              | 72.2                                   |
|  | 5 sets | 154.28                     | 136.2                             | 114.0                                  |
| Single-sided originals<br>↓<br>Double-sided copies | 1 set  | 37.44                      | 34.5                              | 31.6                                   |
|  | 3 sets | 96.81                      | 85.9                              | 73.4                                   |
|  | 5 sets | 155.54                     | 137.4                             | 116.4                                  |
| Double-sided originals<br>↓<br>Double-sided copies | 1 set  | 70.26                      | 64.8                              | 58.9                                   |
|  | 3 sets | 188.48                     | 167.7                             | 143.8                                  |
|  | 5 sets | 306.64                     | 270.6                             | 228.5                                  |
| Double-sided originals<br>↓<br>Single-sided copies | 1 set  | 64.65                      | 57.8                              | 50.5                                   |
|  | 3 sets | 184.73                     | 163.1                             | 137.3                                  |
|  | 5 sets | 302.58                     | 266.1                             | 222.1                                  |

- \* The system copy speed, including scanning time, is available when 10 sheets of A4/LT size original are set on RADF and one of the copy modes in the above table is selected. The period of time from pressing [START] to the paper exit completely out of the equipment based on the actually measured value.
- \* Upper drawer is selected and copying is at the non-sort mode.
- \* Automatic copy density, APS/AMS are turned off.
- \* Finisher is not installed.

•Copy paper

|               | Drawer  | ADU | PFP | LCF    | Bypass copy  | Remarks  |
|---------------|---|-----|-----|--------|--|--|
| Size          | A3 to A5-R, LD to ST-R, FOLIO, COMPUTER, 13"LG, 8.5" x 8.5", 8K, 16K, 16K-R |     |     | A4, LT | A3 to A5-R, LD to ST-R, FOLIO, COMPUTER, 13"LG, 8.5" x 8.5", 8K, 16K, 16K-R<br>(Non-standard or user-specified sizes can be set.)  |  |
| Weight        | 64 to 105 g/m <sup>2</sup><br>17 to 28 lb. Bond                             |     |     |        | 64 to 209 g/m <sup>2</sup> , 17 lb. Bond to 110 lb. Index<br>(Continuous feeding)<br>50 to 209 g/m <sup>2</sup> , 13 lb. Bond to 110 lb. Index<br>(Single paper feeding) |  |
| Special paper | -   |     |     |        | Tracing paper, labels, OHP film (thickness: 80 μm or thicker), tab paper, envelope (COM10, Monarch, DL, CHO-3, YOU-4)  | These special papers recommended by Toshiba Tec<br>CHO-3: 92 mm x 235 mm<br>YOU-4: 105 mm x 235 mm |

- First copy time ..... Approx. 5.4 sec. or less  
(A4/LT, upper drawer, 100%, original placed manually)
- Warming-up time ..... Approx. 25 sec. (temperature: 20°C)
- Multiple copying..... Up to 999 copies; Key in set numbers
- Reproduction ratio ..... Actual ratio: 100±0.5%  
Zooming: 25 to 400% in increments of 1%  
(25 to 200% when using RADF)
- Resolution/Gradation..... Scanning: 600 dpi x 600 dpi  
Printing: Equivalent to 2400 dpi x 600 dpi  
Gradation: 256 steps

- Eliminated portion.....Leading edges: 3.0±2.0 mm, Side/trailing edges: 2.0±2.0 mm (copy)  
Leading / trailing edges: 5.0±2.0 mm, Side edges: 5.0±2.0 mm (print)
  
- Paper feeding .....Standard drawers:  
1 or 2 drawers (stack height 60.5 mm, equivalent to 550 sheets;  
64 to 80 g/m<sup>2</sup> (17 to 22 lb. Bond)); Depends on destinations or  
versions.  
  
PFP:  
Option (One drawer or two: stack height 60.5 mm, equivalent to  
550 sheets; 64 to 80 g/m<sup>2</sup> (17 to 22 lb. Bond))  
  
LCF:  
Option (Stack height 137.5 mm x 2: equivalent to 2500 sheets;  
64 to 80 g/m<sup>2</sup> (17 to 22 lb. Bond))  
  
Bypass feeding:  
Stack height 11 mm: equivalent to 100 sheets; 64 to 80 g/m<sup>2</sup> (17  
to 22 lb. Bond)
  
- Capacity of originals in the reversing automatic document feeder (Option)  
.....A3 to A5-R, LD to ST-R:  
100 sheets / 80 g/m<sup>2</sup> (Stack height 16 mm or less)
  
- Automatic duplexing unit (ADU is available as standard equipment for some destinations or versions.)  
.....Stackless, Switchback type
  
- Toner supply .....Automatic toner density detection/supply  
Toner cartridge replacing method (There is a recovered toner supply  
mechanism.)
  
- Density control.....Automatic density mode and manual density mode selectable in 11  
steps
  
- Weight .....Approximately 75 kg (165.34 lb.): e-STUDIO200L/230/230L/280/280S  
Approximately 77 kg (169.75 lb.): e-STUDIO202L/203L/232/232S/233/  
282/282S/283 (include the developer material and drum) (The ADU  
and Drawer module are installed.)
  
- Power requirements .....AC 110 V / 13.2 A, 115 V or 127 V / 12 A  
220-240 V or 240 V / 8 A (50/60 Hz)  
\* The acceptable value of each voltage is ±10%.
  
- Power consumption .....1.5 kW or less (115 V series, 200 V series)  
\* The electric power is supplied to the RADF, (ADU), Finisher, Job Separator, Offset Tray, PFP and  
LCF through the equipment.
  
- Total counter .....Electronical counter

•Dimensions of the equipment..... See the figure below (W 637 x D 719 x H 739 (mm))  
\* When the tilt angle of the control panel is 45 degrees.

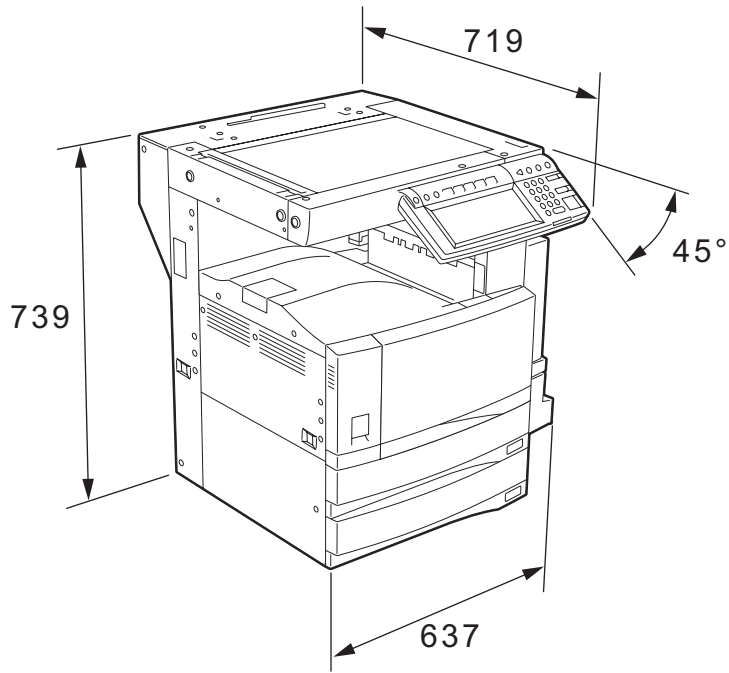

Fig. 1-1

## 1.2 Accessories

|   |                             |
|---|-----------------------------|
| Unpacking/setup instruction   | 1 set                       |
| Operator's manual   | 3 pcs. (except for MJD)     |
| Operator's manual pocket  | 1 pc.                       |
| Power cable   | 1 pc.                       |
| Warranty sheet  | 1 pc. (for NAD)             |
| Setup report  | 1 set (for NAD and MJD)     |
| Customer satisfaction card  | 1 pc. (for MJD)             |
| Drum (installed inside of the equipment)                                  | 1 pc.                       |
| Toner cartridge   | 1 pc. (except for NAD, MJD) |
| Developer material  | 1 pc. (except for NAD, MJD) |
| Control panel stopper   | 1 pc.                       |
| Blind seal  | 1 pc.                       |
| Rubber plug   | 5 pcs.                      |
| CD-ROM  | 4 pcs. *2                   |
| Transfer charger wire cleaner<br>(installed inside of the transfer cover) | 1 pc.                       |
| Paper stopper *1  | 1 pc.                       |
| Stopper bracket *1  | 1 pc.                       |

### Machine version

|      |                                       |
|------|---------------------------------------|
| NAD: | North America                         |
| ARD: | Argentina                             |
| ASD: | Central and South America / Hong Kong |
| AUD: | Australia                             |
| MJD: | Europe                                |
| ASU: | Asia                                  |
| SAD: | Saudi Arabia                          |
| IRD: | Iran                                  |
| CND: | China                                 |
| TWD: | Taiwan                                |
| JPD: | Japan                                 |
| KRD: | Korea                                 |

\*1: e-STUDIO200L/230/230L/280/280S only

\*2: In e-STUDIO202L/203L/232/232S/233/282/282S/283, 2 discs are included.



## 1.3 Options

### 1.3.1 e-STUDIO200L/230/230L/280/280S

|  |  |
|--|--|
| Platen Cover                               | KA-3511 PC/PC-C  |
| Reversing Automatic Document Feeder (RADF) | MR-3016  |
| Drawer Module                              | MY-1021/-C   |
| Paper Feed Pedestal (PFP)                  | KD-1011/-C   |
| Large Capacity Feeder (LCF)                | KD-1012 A4/LT/A4-C                                     |
| Finisher (Hanging type)                    | MJ-1022/-C   |
| Saddle stitch Finisher                     | MJ-1025/-C   |
| Hole Punch Unit                            | MJ-6005 N/E/F/S *1                                     |
| Staple Cartridge                           | STAPLE-1600 (for MJ-1022)<br>STAPLE-2000 (for MJ-1025) |
| Bridge Kit                                 | KN-3520/-C   |
| Job Separator                              | MJ-5004/-C   |
| Offset Tray                                | MJ-5005/-C   |
| Key copy Counter, Key copy counter socket  | MU-8, MU-10  |
| Work Tray                                  | KK-3511  |
| Damp Heater                                | MF-2320 U/E  |
| Fax Board                                  | GD-1150 NA/AU/EU/TW/C/AS                               |
| 2nd Line for Fax Board                     | GD-1160 NA/EU/TW/C                                     |
| Wireless LAN Adapter                       | GN-1010  |
| PCI Slot                                   | GO-1040/C  |
| Scrambler Board                            | GP-1030  |
| Printer Kit                                | GM-1020/GM-1030  |
| Printer/Scanner Kit                        | GM-2020/GM-2030  |
| Scanner upgrade Kit                        | GM-3020/GM-3030  |
| Parallel interface kit                     | GF-1140  |
| Desk                                       | MH-1700  |
| Harness kit for coin controller            | GQ-1020  |
| Automatic Duplexing Unit (ADU)             | MD-0102  |
| Slot cover                                 | KE-2330  |
| NIC board                                  | GF-1150  |
| Data overwrite kit                         | GP-1050  |

\* 1) N: North America    E: Europe    F: France    S: Sweden

#### Notes:

- The bridge unit (KN-3520) is necessary for installation of the finisher (MJ-1022, MJ-1025).
- The finisher (MJ-1025) is necessary for installation of the hole punch unit (MJ-6005N/E/F/S).
- The PCI slot (GO-1040) is necessary for installation of the scrambler board (GP-1030) and parallel interface kit (GF-1140).
- GM-1030/GM-2030/GM-3030 are exclusive for e-STUDIO200L.  
They do not operate with e-STUDIO230/230L/280/280S.

### 1.3.2 e-STUDIO202L/203L/232/232S/233/282/282S/283/283S

|  |  |
|--|--|
| Platen Cover                               | KA-3511PC/-C   |
| Reversing Automatic Document Feeder (RADF) | MR-3020  |
| Automatic Duplexing Unit (ADU)             | MD-0102  |
| Drawer module                              | MY-1021/-C   |
| Slot cover                                 | KE-2330  |
| Paper Feed Pedestal (PFP)                  | KD-1011/-C   |
| Large Capacity Feeder (LCF)                | KD-1012LT/A4/A4-C  |
| Finisher (Hanging type)                    | MJ-1022/-C   |
| Finisher (Console saddle stitcher type)    | MJ-1025  |
| Hole punch unit (for MJ-1025)              | MJ-6005N/E/F/S *1  |
| Staple cartridge                           | STAPLE-1600 (for MJ-1022)<br>STAPLE-2000 (for MJ-1025)                               |
| Bridge kit                                 | KN-3520/-C   |
| Job separator                              | MJ-5004/-C   |
| Offset tray                                | MJ-5005/-C   |
| Work tray                                  | KK-3511/-C   |
| Damp heater                                | MF-2320U/E   |
| Fax board                                  | GD-1150NA/EU/AU/AS/C/TW  |
| 2nd line for fax board                     | GD-1160NA/EU-N/C/TW  |
| Printer kit                                | GM-1070/1071/1080U/1081U   |
| Printer/Scanner kit                        | GM-2070/2071/2080U/2081U   |
| Scanner kit                                | GM-4070/GM-4080U   |
| Printer ELK                                | GM-1130 (e-STUDIO232/232S/233/282/282S/<br>283/283S)<br>GM-1140U (e-STUDIO202L/203L) |
| Printer/Scanner ELK                        | GM-2130 (e-STUDIO232/232S/233/282/282S/<br>283/283S)<br>GM-2140U (e-STUDIO202L/203L) |
| Scanner ELK                                | GM-4130 (e-STUDIO232/232S/233/282/282S/<br>283/283S)<br>GM-4140U (e-STUDIO202L/203L) |
| Memory                                     | GC-1230  |
| Scrambler board                            | GP-1040  |
| Wireless LAN module                        | GN-1041  |
| Bluetooth module                           | GN-2010  |
| Antenna                                    | GN-3010  |
| Data overwrite kit                         | GP-1060  |
| PCI slot                                   | GO-1060  |
| e-BRIDGE ID Gate (HID iClass)              | KP-2004  |
| e-BRIDGE ID Gate (MIFARE)                  | KP-2005  |
| Desk                                       | MH-1700  |
| Harness kit for coin controller            | GQ-1020  |

\* 1) N: North America E: Europe F: France S: Sweden

**Notes:**

1. The bridge kit (KN-3520) is necessary for installation of the finisher (MJ-1022 or MJ-1025).
2. The saddle stitch finisher (MJ-1025) is necessary for installation of the hole punch unit (MJ-6005N/E/F/S).
3. The PCI slot (GO-1060) is necessary for installation of the scrambler board (GP-1040).
4. The antenna (GN-3010) is necessary to enable the wireless LAN module (GN-1041) and Bluetooth module (GN-2010).
5. When the wireless LAN module (GN-1041) and the Bluetooth module (GN-2010) are installed, only 1 antenna (GN-3010) can be connected to each.
6. GM-1080U / GM-2080U / GM-4080U are exclusive to e-STUDIO202L. They do not operate with e-STUDIO232/232S/282/282S.
7. GM-1081U / GM-2081U / GM-4080U are exclusive to e-STUDIO202L/203L. They do not operate with e-STUDIO232/232S/233/282/282S/283.
8. The Printer kit (GM-1070/1080U) or Printer/Scanner kit (GM-2070/2080U) does not have a function for printing an XPS file.
9. To enable an XPS file to be printed by the Printer kit (GM-1071/1081U) or Printer/Scanner kit (GM-2071/1081U), the Memory (GC-1230) is required to be installed.
10. To enable an XPS file to be printed by the Printer ELK (GM-1130/1140U) or Printer/Scanner ELK (GM-2130/2140U), the Memory (GC-1230) is required to be installed.

## 1.4 Supplies

### 1.4.1 e-STUDIO200L/230/230L/280/280S

|                 |                       |
|-----------------|-----------------------|
| Drum            | OD-1600               |
| Toner cartridge | PS-ZT2320 /T/D/C/E *1 |
| Developer       | D-2320 /C             |

\* 1) T: Taiwan D: Asia C: China E: Europe NONE: North America

### 1.4.2 e-STUDIO202L/232/232S/282/282S

|                 |                       |
|-----------------|-----------------------|
| Drum            | OD-1600               |
| Toner cartridge | PS-ZT2340 /T/D/C/E *1 |
| Developer       | D-2340 /C             |

\* 1) T: Taiwan D: Asia C: China E: Europe NONE: North America

### 1.4.3 e-STUDIO203L/233/283/283S

|                 |                                  |
|-----------------|----------------------------------|
| Drum            | OD-1600                          |
| Toner cartridge | PS-ZT2840 /E *1<br>PS-ZT2340C *1 |
| Developer       | D-2340 /C                        |

\* 1) C: China E: Europe NONE: North America

# 1.5 System List

## 1.5.1 e-STUDIO200L/230/230L/280/280S

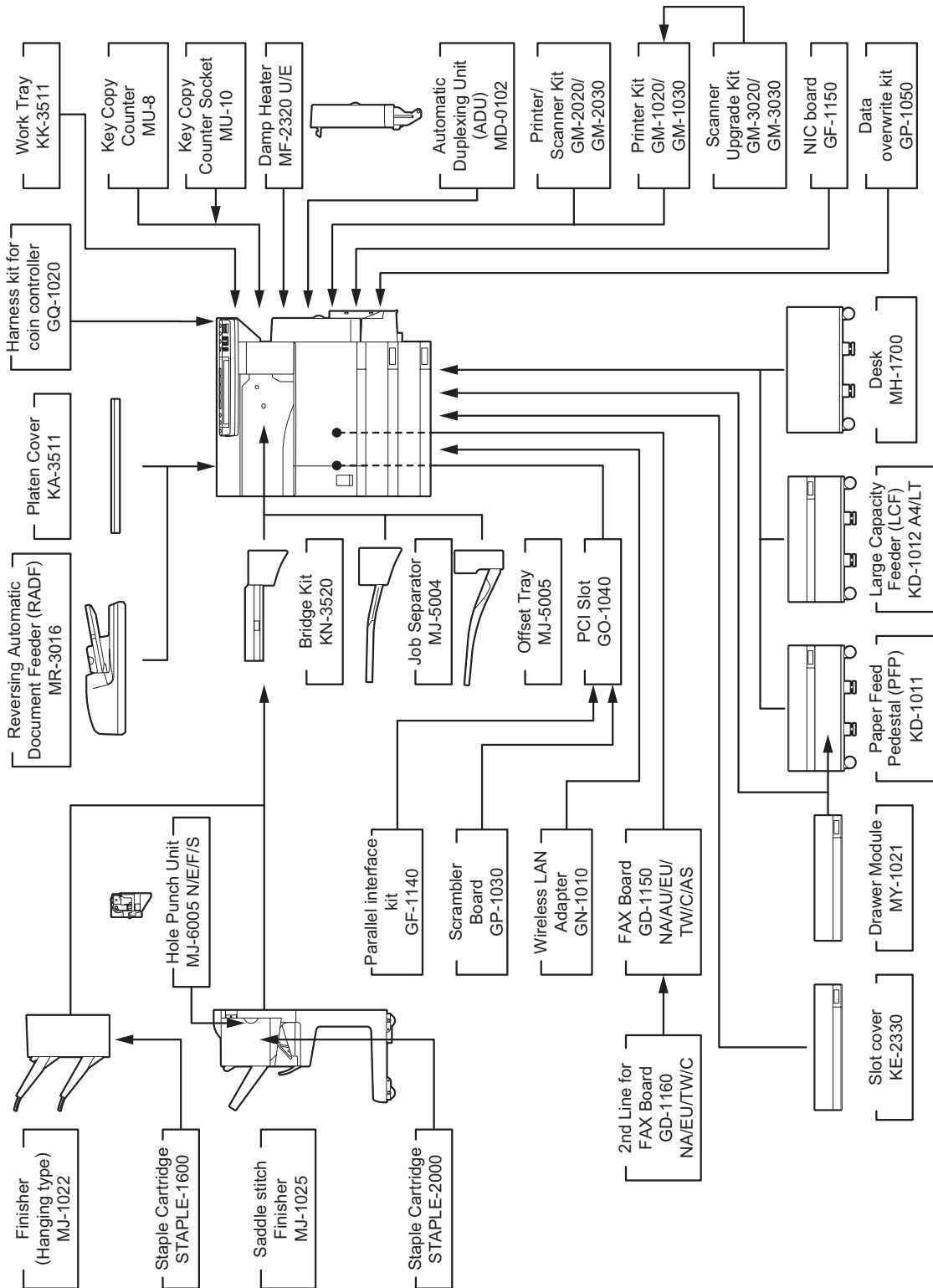

Fig. 1-2

## e-STUDIO280/280S

| Area                            | North America | Central and South America/<br>Hong Kong | Australia      | Europe         | Asia           |
|---------------------------------|---------------|---|----------------|----------------|----------------|
| Machine version (destination)   | NAD (115V)    | ASD (220-240V)                          | AUD (220-240V) | MJD (220-240V) | ASU (220-240V) |
| Model name                      | e-STUDIO280   | e-STUDIO280                             | e-STUDIO280    | e-STUDIO280    | e-STUDIO280    |
| Platen cover                    | KA-3511PC     | KA-3511PC                               | KA-3511PC      | KA-3511PC      | KA-3511PC      |
| RADF                            | MR-3016       | MR-3016                                 | MR-3016        | MR-3016        | MR-3016        |
| Drawer module (for Equipment)   | Standard      | MY-1021                                 | Standard       | Standard       | MY-1021        |
| Drawer module (for PFP)         | MY-1021       | MY-1021                                 | MY-1021        | MY-1021        | MY-1021        |
| Slot cover                      | -             | Standard                                | -              | -              | KE-2330        |
| ADU                             | Standard      | MD-0102                                 | Standard       | Standard       | MD-0102        |
| PFP                             | KD-1011       | KD-1011                                 | KD-1011        | KD-1011        | KD-1011        |
| LCF                             | KD-1012LT     | KD-1012A4                               | KD-1012A4      | KD-1012A4      | KD-1012A4      |
| Finisher (Hanging type)         | MJ-1022       | MJ-1022                                 | MJ-1022        | MJ-1022        | MJ-1022        |
| Staple cartridge (for MJ-1022)  | STAPLE-1600   | STAPLE-1600                             | STAPLE-1600    | STAPLE-1600    | STAPLE-1600    |
| Saddle stitch finisher          | MJ-1025       | MJ-1025                                 | MJ-1025        | MJ-1025        | MJ-1025        |
| Staple cartridge (for MJ-1025)  | STAPLE-2000   | STAPLE-2000                             | STAPLE-2000    | STAPLE-2000    | STAPLE-2000    |
| Hole punch unit                 | MJ-6005N      | MJ-6005E                                | MJ-6005E       | MJ-6005E/F/S   | MJ-6005E       |
| Bridge kit                      | KN-3520       | KN-3520                                 | KN-3520        | KN-3520        | KN-3520        |
| Job separator                   | MJ-5004       | MJ-5004                                 | MJ-5004        | MJ-5004        | MJ-5004        |
| Offset tray                     | MJ-5005       | MJ-5005                                 | MJ-5005        | MJ-5005        | MJ-5005        |
| Key copy counter                | MU-8          | MU-8                                    | MU-8           | MU-8           | MU-8           |
| Key copy counter socket         | MU-10         | MU-10                                   | MU-10          | MU-10          | MU-10          |
| Work tray                       | KK-3511       | KK-3511                                 | KK-3511        | KK-3511        | KK-3511        |
| Damp heater                     | MF-2320U      | Standard                                | Standard       | MF-2320E       | Standard       |
| Fax board                       | GD-1150NA     | GD-1150AS                               | GD-1150AU      | GD-1150EU      | GD-1150AS      |
| 2nd line for Fax board          | GD-1160NA     | GD-1160EU                               | GD-1160EU      | GD-1160EU      | GD-1160EU      |
| Wireless LAN adapter            | GN-1010       | GN-1010                                 | GN-1010        | GN-1010        | GN-1010        |
| PCI slot                        | GO-1040       | GO-1040                                 | GO-1040        | GO-1040        | GO-1040        |
| Scrambler board                 | GP-1030       | GP-1030                                 | GP-1030        | GP-1030        | GP-1030        |
| Parallel interface kit          | GF-1140       | GF-1140                                 | GF-1140        | GF-1140        | GF-1140        |
| NIC board                       | Standard      | GF-1150                                 | Standard       | Standard       | GF-1150        |
| Printer/Scanner kit             | GM-2020       | GM-2020                                 | GM-2020        | GM-2020        | GM-2020        |
| Printer kit                     | GM-1020       | GM-1020                                 | GM-1020        | GM-1020        | GM-1020        |
| Scanner upgrade kit             | GM-3020       | GM-3020                                 | GM-3020        | GM-3020        | GM-3020        |
| Desk                            | MH-1700       | MH-1700                                 | MH-1700        | MH-1700        | MH-1700        |
| Harness kit for coin controller | GQ-1020       | GQ-1020                                 | GQ-1020        | GQ-1020        | GQ-1020        |

| Area                            | Saudi Arabia | Iran           | China          |             | Taiwan      |
|---------------------------------|--------------|----------------|----------------|-------------|-------------|
| Machine version (destination)   | SAD (127V)   | IRD (220-240V) | CND (220-240V) |             | TWD (110V)  |
| Model name                      | e-STUDIO280  | e-STUDIO280    | e-STUDIO280S   | e-STUDIO280 | e-STUDIO280 |
| Platen cover                    | KA-3511PC    | KA-3511PC      | Standard       | Standard    | KA-3511PC   |
| RADF                            | MR-3016      | MR-3016        | MR-3016        | MR-3016     | MR-3016     |
| Drawer module (for Equipment)   | MY-1021      | Standard       | Standard       | Standard    | Standard    |
| Drawer module (for PFP)         | MY-1021      | MY-1021        | MY-1021        | MY-1021     | MY-1021     |
| Slot cover                      | KE-2330      | -              | -              | -           | -           |
| ADU                             | MD-0102      | Standard       | MD-0102        | Standard    | MD-0102     |
| PFP                             | KD-1011      | KD-1011        | KD-1011        | KD-1011     | KD-1011     |
| LCF                             | KD-1012A4    | KD-1012A4      | KD-1012-C      | KD-1012-C   | KD-1012A4   |
| Finisher (Hanging type)         | MJ-1022      | MJ-1022        | MJ-1022-C      | MJ-1022-C   | MJ-1022     |
| Staple cartridge (for MJ-1022)  | STAPLE-1600  | STAPLE-1600    | STAPLE-1600    | STAPLE-1600 | STAPLE-1600 |
| Saddle stitch finisher          | MJ-1025      | MJ-1025        | MJ-1025        | MJ-1025     | MJ-1025     |
| Staple cartridge (for MJ-1025)  | STAPLE-2000  | STAPLE-2000    | STAPLE-2000    | STAPLE-2000 | STAPLE-2000 |
| Hole punch unit                 | MJ-6005E     | MJ-6005E       | MJ-6005E       | MJ-6005E    | MJ-6005E    |
| Bridge kit                      | KN-3520      | KN-3520        | KN-3520-C      | KN-3520-C   | KN-3520     |
| Job separator                   | MJ-5004      | MJ-5004        | MJ-5004-C      | MJ-5004-C   | MJ-5004     |
| Offset tray                     | MJ-5005      | MJ-5005        | MJ-5005-C      | MJ-5005-C   | MJ-5005     |
| Key copy counter                | MU-8         | MU-8           | MU-8           | MU-8        | MU-8        |
| Key copy counter socket         | MU-10        | MU-10          | MU-10          | MU-10       | MU-10       |
| Work tray                       | KK-3511      | KK-3511        | KK-3511        | KK-3511     | KK-3511     |
| Damp heater                     | Standard     | Standard       | Standard       | Standard    | Standard    |
| Fax board                       | GD-1150NA    | N/A            | GD-1150C       | GD-1150C    | GD-1150TW   |
| 2nd line for Fax board          | GD-1160NA    | N/A            | GD-1160C       | GD-1160C    | GD-1160TW   |
| Wireless LAN adapter            | GN-1010      | GN-1010        | GN-1010        | GN-1010     | GN-1010     |
| PCI slot                        | GO-1040      | GO-1040        | GO-1040C       | GO-1040C    | GO-1040     |
| Scrambler board                 | GP-1030      | GP-1030        | GP-1030        | GP-1030     | GP-1030     |
| Parallel interface kit          | GF-1140      | GF-1140        | GF-1140        | GF-1140     | GF-1140     |
| NIC board                       | GF-1150      | Standard       | GF-1150        | Standard    | Standard    |
| Printer/Scanner kit             | GM-2020      | Standard       | GM-2020        | Standard    | GM-2020     |
| Printer kit                     | GM-1020      | GM-1020        | GM-1020        | GM-1020     | GM-1020     |
| Scanner upgrade kit             | GM-3020      | GM-3020        | GM-3020        | GM-3020     | GM-3020     |
| Desk                            | MH-1700      | MH-1700        | MH-1700        | MH-1700     | MH-1700     |
| Harness kit for coin controller | GQ-1020      | GQ-1020        | GQ-1020        | GQ-1020     | GQ-1020     |

## e-STUDIO230/230L

| Area                            | North America | Central and South America/<br>Hong Kong | Australia      | Europe         |              |
|---------------------------------|---------------|---|----------------|----------------|--------------|
| Machine version (destination)   | NAD (115V)    | ASD (220-240V)                          | AUD (220-240V) | MJD (220-240V) |              |
| Model name                      | e-STUDIO230   | e-STUDIO230                             | e-STUDIO230    | e-STUDIO230    | e-STUDIO230L |
| Platen cover                    | KA-3511PC     | KA-3511PC                               | KA-3511PC      | KA-3511PC      | KA-3511PC    |
| RADF                            | MR-3016       | MR-3016                                 | MR-3016        | MR-3016        | MR-3016      |
| Drawer module (for Equipment)   | Standard      | MY-1021                                 | Standard       | Standard       | MY-1021      |
| Drawer module (for PFP)         | MY-1021       | MY-1021                                 | MY-1021        | MY-1021        | MY-1021      |
| Slot cover                      | -             | Standard                                | -              | -              | Standard     |
| ADU                             | Standard      | MD-0102                                 | Standard       | Standard       | MD-0102      |
| PFP                             | KD-1011       | KD-1011                                 | KD-1011        | KD-1011        | KD-1011      |
| LCF                             | KD-1012LT     | KD-1012A4                               | KD-1012A4      | KD-1012A4      | KD-1012A4    |
| Finisher (Hanging type)         | MJ-1022       | MJ-1022                                 | MJ-1022        | MJ-1022        | MJ-1022      |
| Staple cartridge (for MJ-1022)  | STAPLE-1600   | STAPLE-1600                             | STAPLE-1600    | STAPLE-1600    | STAPLE-1600  |
| Saddle stitch finisher          | MJ-1025       | MJ-1025                                 | MJ-1025        | MJ-1025        | MJ-1025      |
| Staple cartridge (for MJ-1025)  | STAPLE-2000   | STAPLE-2000                             | STAPLE-2000    | STAPLE-2000    | STAPLE-2000  |
| Hole punch unit                 | MJ-6005N      | MJ-6005E                                | MJ-6005E       | MJ-6005E/F/S   | MJ-6005E     |
| Bridge kit                      | KN-3520       | KN-3520E                                | KN-3520        | KN-3520        | KN-3520      |
| Job separator                   | MJ-5004       | MJ-5004                                 | MJ-5004        | MJ-5004        | MJ-5004      |
| Offset tray                     | MJ-5005       | MJ-5005                                 | MJ-5005        | MJ-5005        | MJ-5005      |
| Key copy counter                | MU-8          | MU-8                                    | MU-8           | MU-8           | MU-8         |
| Key copy counter socket         | MU-10         | MU-10                                   | MU-10          | MU-10          | MU-10        |
| Work tray                       | KK-3511       | KK-3511                                 | KK-3511        | KK-3511        | KK-3511      |
| Damp heater                     | MF-2320U      | Standard                                | Standard       | MF-2320E       | MF-2320E     |
| Fax board                       | GD-1150NA     | GD-1150AS                               | GD-1150AU      | GD-1150EU      | GD-1150EU    |
| 2nd line for Fax board          | GD-1160NA     | GD-1160EU                               | GD-1160EU      | GD-1160EU      | GD-1160EU    |
| Wireless LAN adapter            | GN-1010       | GN-1010                                 | GN-1010        | GN-1010        | GN-1010      |
| PCI slot                        | GO-1040       | GO-1040                                 | GO-1040        | GO-1040        | GO-1040      |
| Scrambler board                 | GP-1030       | GP-1030                                 | GP-1030        | GP-1030        | GP-1030      |
| Parallel interface kit          | GF-1140       | GF-1140                                 | GF-1140        | GF-1140        | GF-1140      |
| NIC board                       | Standard      | GF-1150                                 | Standard       | Standard       | GF-1150      |
| Printer/Scanner kit             | GM-2020       | GM-2020                                 | GM-2020        | GM-2020        | GM-2020      |
| Printer kit                     | GM-1020       | GM-1020                                 | GM-1020        | GM-1020        | GM-1020      |
| Scanner upgrade kit             | GM-3020       | GM-3020                                 | GM-3020        | GM-3020        | GM-3020      |
| Desk                            | MH-1700       | MH-1700                                 | MH-1700        | MH-1700        | MH-1700      |
| Harness kit for coin controller | GQ-1020       | GQ-1020                                 | GQ-1020        | GQ-1020        | GQ-1020      |



| Area                            | Asia           | Saudi Arabia | China          | Taiwan      |
|---------------------------------|----------------|--------------|----------------|-------------|
| Machine version (destination)   | ASU (220-240V) | SAD (127V)   | CND (220-240V) | TWD (110V)  |
| Model name                      | e-STUDIO230    | e-STUDIO230  | e-STUDIO230    | e-STUDIO230 |
| Platen cover                    | KA-3511PC      | KA-3511PC    | Standard       | KA-3511PC   |
| RADF                            | MR-3016        | MR-3016      | MR-3016        | MR-3016     |
| Drawer module (for Equipment)   | MY-1021        | MY-1021      | Standard       | Standard    |
| Drawer module (for PFP)         | MY-1021        | MY-1021      | MY-1021        | MY-1021     |
| Slot cover                      | KE-2330        | KE-2330      | -              | -           |
| ADU                             | MD-0102        | MD-0102      | Standard       | MD-0102     |
| PFP                             | KD-1011        | KD-1011      | KD-1011        | KD-1011     |
| LCF                             | KD-1012A4      | KD-1012A4    | KD-1012A4      | KD-1012A4   |
| Finisher (Hanging type)         | MJ-1022        | MJ-1022      | MJ-1022-C      | MJ-1022     |
| Staple cartridge (for MJ-1022)  | STAPLE-1600    | STAPLE-1600  | STAPLE-1600    | STAPLE-1600 |
| Saddle stitch finisher          | MJ-1025        | MJ-1025      | MJ-1025        | MJ-1025     |
| Staple cartridge (for MJ-1025)  | STAPLE-2000    | STAPLE-2000  | STAPLE-2000    | STAPLE-2000 |
| Hole punch unit                 | MJ-6005E       | MJ-6005E     | MJ-6005E       | MJ-6005E    |
| Bridge kit                      | KN-3520        | KN-3520      | KN-3520-C      | KN-3520     |
| Job separator                   | MJ-5004        | MJ-5004      | MJ-5004-C      | MJ-5004     |
| Offset tray                     | MJ-5005        | MJ-5005      | MJ-5005-C      | MJ-5005     |
| Key copy counter                | MU-8           | MU-8         | MU-8           | MU-8        |
| Key copy counter socket         | MU-10          | MU-10        | MU-10          | MU-10       |
| Work tray                       | KK-3511        | KK-3511      | KK-3511        | KK-3511     |
| Damp heater                     | Standard       | Standard     | Standard       | Standard    |
| Fax board                       | GD-1150AS      | GD-1150NA    | GD-1150C       | GD-1150TW   |
| 2nd line for Fax board          | GD-1160EU      | GD-1160NA    | GD-1160C       | GD-1160TW   |
| Wireless LAN adapter            | GN-1010        | GN-1010      | GN-1010        | GN-1010     |
| PCI slot                        | GO-1040        | GO-1040      | GO-1040C       | GO-1040     |
| Scrambler board                 | GP-1030        | GP-1030      | GP-1030        | GP-1030     |
| Parallel interface kit          | GF-1140        | GF-1140      | GF-1140        | GF-1140     |
| NIC board                       | GF-1150        | GF-1150      | Standard       | Standard    |
| Printer/Scanner kit             | GM-2020        | GM-2020      | Standard       | GM-2020     |
| Printer kit                     | GM-1020        | GM-1020      | GM-1020        | GM-1020     |
| Scanner upgrade kit             | GM-3020        | GM-3020      | GM-3020        | GM-3020     |
| Desk                            | MH-1700        | MH-1700      | MH-1700        | MH-1700     |
| Harness kit for coin controller | GQ-1020        | GQ-1020      | GQ-1020        | GQ-1020     |

## e-STUDIO200L

| <b>Area</b>                     | <b>North America</b> | <b>Central and South America</b> |
|---------------------------------|----------------------|----------------------------------|
| Machine version (destination)   | NAD (115V)           | ASD (220-240V)                   |
| Model name                      | e-STUDIO200L         | e-STUDIO200L                     |
| Platen cover                    | KA-3511PC            | KA-3511PC                        |
| RADF                            | MR-3016              | MR-3016                          |
| Drawer module (for Equipment)   | MY-1021              | MY-1021                          |
| Drawer module (for PFP)         | MY-1021              | MY-1021                          |
| Slot cover                      | Standard             | Standard                         |
| ADU                             | MD-0102              | MD-0102                          |
| PFP                             | KD-1011              | KD-1011                          |
| LCF                             | KD-1012LT            | KD-1012A4                        |
| Finisher (Hanging type)         | MJ-1022              | MJ-1022                          |
| Staple cartridge (for MJ-1022)  | STAPLE-1600          | STAPLE-1600                      |
| Saddle stitch finisher          | MJ-1025              | MJ-1025                          |
| Staple cartridge (for MJ-1025)  | STAPLE-2000          | STAPLE-2000                      |
| Hole punch unit                 | MJ-6005N             | MJ-6005E                         |
| Bridge kit                      | KN-3520              | KN-3520                          |
| Job separator                   | MJ-5004              | MJ-5004                          |
| Offset tray                     | MJ-5005              | MJ-5005                          |
| Key copy counter                | MU-8                 | MU-8                             |
| Key copy counter socket         | MU-10                | MU-10                            |
| Work tray                       | KK-3511              | KK-3511                          |
| Damp heater                     | MF-2320              | Standard                         |
| Fax board                       | GD-1150NA            | GD-1150AS                        |
| 2nd line for Fax board          | GD-1160NA            | GD-1160EU                        |
| Wireless LAN adapter            | GN-1010              | GN-1010                          |
| PCI slot                        | GO-1040              | GO-1040                          |
| Scrambler board                 | GP-1030              | GP-1030                          |
| Parallel interface kit          | GF-1140              | GF-1140                          |
| NIC board                       | GF-1150              | GF-1150                          |
| Printer/Scanner kit             | GM-2030              | GM-2030                          |
| Printer kit                     | GM-1030              | GM-1030                          |
| Scanner upgrade kit             | GM-3030              | GM-3030                          |
| Desk                            | MH-1700              | MH-1700                          |
| Harness kit for coin controller | GQ-1020              | GQ-1020                          |

## 1.5.2 e-STUDIO202L/203L/232/232S/233/282/282S/283/283S

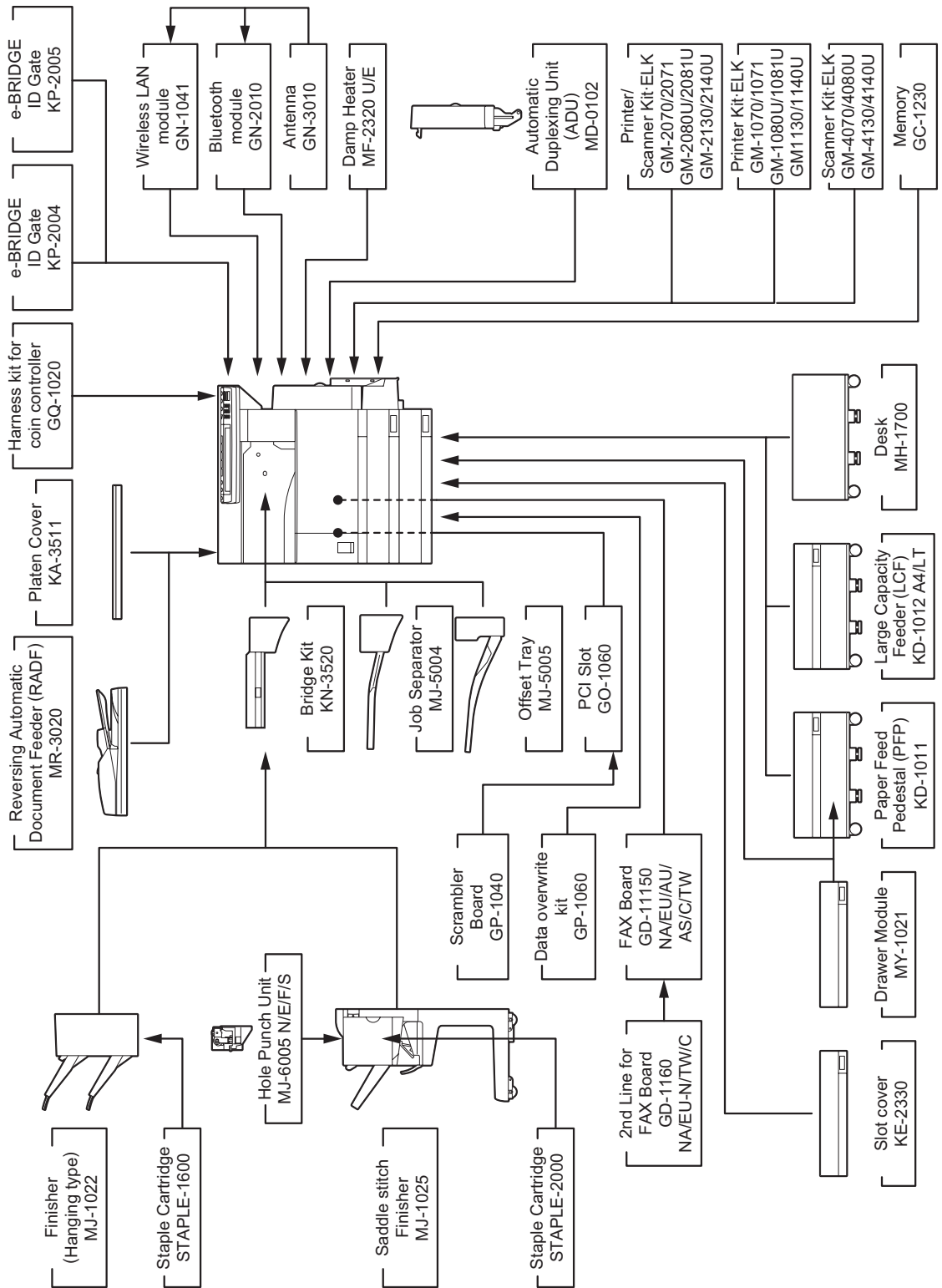

Fig. 1-3

## e-STUDIO282/282S/283/283S

| Area                            | North America    | Central and South America/Hong Kong | Argentina        | Australia      | Europe           |
|---------------------------------|------------------|-------------------------------------|------------------|----------------|------------------|
| Machine version (destination)   | NAD (115V)       | ASD (220-240V)                      | ARD (220-240V)   | AUD (220-240V) | MJD (220-240V)   |
| Model name                      | e-STUDIO 282/283 | e-STUDIO282                         | e-STUDIO 282/283 | e-STUDIO282    | e-STUDIO 282/283 |
| Platen cover                    | KA-3511PC        | KA-3511PC                           | KA-3511PC        | KA-3511PC      | KA-3511PC        |
| RADF                            | MR-3020          | MR-3020                             | MR-3020          | MR-3020        | MR-3020          |
| Drawer module (for Equipment)   | Standard         | MY-1021                             | MY-1021          | Standard       | Standard         |
| Drawer module (for PFP)         | MY-1021          | MY-1021                             | MY-1021          | MY-1021        | MY-1021          |
| Slot cover                      | -                | Standard                            | Standard         | -              | -                |
| ADU                             | Standard         | MD-0102                             | MD-0102          | Standard       | Standard         |
| PFP                             | KD-1011          | KD-1011-N                           | KD-1011          | KD-1011        | KD-1011          |
| LCF                             | KD-1012LT        | KD-1012A4                           | KD-1012A4        | KD-1012A4      | KD-1012A4        |
| Finisher (Hanging type)         | MJ-1022          | MJ-1022                             | MJ-1022          | MJ-1022        | MJ-1022          |
| Staple cartridge (for MJ-1022)  | STAPLE-1600      | STAPLE-1600                         | STAPLE-1600      | STAPLE-1600    | STAPLE-1600      |
| Saddle stitch finisher          | MJ-1025          | MJ-1025                             | MJ-1025          | MJ-1025        | MJ-1025          |
| Staple cartridge (for MJ-1025)  | STAPLE-2000      | STAPLE-2000                         | STAPLE-2000      | STAPLE-2000    | STAPLE-2000      |
| Hole punch unit                 | MJ-6005N         | MJ-6005E                            | MJ-6005E         | MJ-6005E       | MJ-6005E/F/S     |
| Bridge kit                      | KN-3520          | KN-3520                             | KN-3520          | KN-3520        | KN-3520          |
| Job separator                   | MJ-5004          | MJ-5004                             | MJ-5004          | MJ-5004        | MJ-5004          |
| Offset tray                     | MJ-5005          | MJ-5005                             | MJ-5005          | MJ-5005        | MJ-5005          |
| Work tray                       | KK-3511          | KK-3511                             | KK-3511          | KK-3511        | KK-3511          |
| Damp heater                     | MF-2320U         | Standard                            | Standard         | Standard       | MF-2320E         |
| Fax board                       | GD-1150NA        | GD-1150AS                           | GD-1150AS        | GD-1150AU      | GD-1150EU        |
| 2nd line for Fax board          | GD-1160NA        | GD-1160EU-N                         | GD-1160EU-N      | GD-1160EU-N    | GD-1160EU-N      |
| Wireless LAN module             | GN-1041          | GN-1041                             | GN-1041          | GN-1041        | GN-1041          |
| Bluetooth module                | GN-2010          | GN-2010                             | GN-2010          | GN-2010        | GN-2010          |
| Antenna                         | GN-3010          | GN-3010                             | GN-3010          | GN-3010        | GN-3010          |
| PCI slot                        | GO-1060          | GO-1060                             | GO-1060          | GO-1060        | GO-1060          |
| Scrambler board                 | GP-1040          | GP-1040                             | GP-1040          | GP-1040        | GP-1040          |
| Printer kit                     | GM-1070/1071     | GM-1070/1071                        | GM-1070/1071     | GM-1070/1071   | GM-1070/1071     |
| Printer/Scanner kit             | GM-2070/2071     | GM-2070/2071                        | GM-2070/2071     | GM-2070/2071   | GM-2070/2071     |
| Scanner kit                     | GM-4070          | GM-4070                             | GM-4070          | GM-4070        | GM-4070          |
| Data overwrite kit              | GP-1060          | GP-1060                             | GP-1060          | GP-1060        | GP-1060          |
| Desk                            | MH-1700          | MH-1700                             | MH-1700          | MH-1700        | MH-1700          |
| Harness kit for coin controller | GQ-1020          | GQ-1020                             | GQ-1020          | GQ-1020        | GQ-1020          |

| Area                            | Asia           | Saudi Arabia | China            |                    |
|---------------------------------|----------------|--------------|------------------|--------------------|
| Machine version (destination)   | ASU (220-240V) | SAD (127V)   | CND (220-240V)   |                    |
| Model name                      | e-STUDIO282    | e-STUDIO282  | e-STUDIO 282/283 | e-STUDIO 282S/283S |
| Platen cover                    | KA-3511PC      | KA-3511PC    | Standard         | Standard           |
| RADF                            | MR-3020        | MR-3020      | MR-3020          | MR-3020            |
| Drawer module (for Equipment)   | MY-1021        | MY-1021      | Standard         | Standard           |
| Drawer module (for PFP)         | MY-1021        | MY-1021      | MY-1021-C        | MY-1021-C          |
| Slot cover                      | KE-2330        | KE-2330      | -                | -                  |
| ADU                             | MD-0102        | MD-0102      | Standard         | MD-0102-C          |
| PFP                             | KD-1011        | KD-1011      | KD-1011-C        | KD-1011-C          |
| LCF                             | KD-1012        | KD-1012A4    | KD-1012A4-C      | KD-1012A4-C        |
| Finisher (Hanging type)         | MJ-1022        | MJ-1022      | MJ-1022-C        | MJ-1022-C          |
| Staple cartridge (for MJ-1022)  | STAPLE-1600    | STAPLE-1600  | STAPLE-1600      | STAPLE-1600        |
| Saddle stitch finisher          | MJ-1025        | MJ-1025      | MJ-1025          | MJ-1025            |
| Staple cartridge (for MJ-1025)  | STAPLE-2000    | STAPLE-2000  | STAPLE-2000      | STAPLE-2000        |
| Hole punch unit                 | MJ-6005E       | MJ-6005E     | MJ-6005E         | MJ-6005E           |
| Bridge kit                      | KN-3520        | KN-3520      | KN-3520-C        | KN-3520-C          |
| Job separator                   | MJ-5004        | MJ-5004      | MJ-5004-C        | MJ-5004-C          |
| Offset tray                     | MJ-5005        | MJ-5005      | MJ-5005-C        | MJ-5005-C          |
| Work tray                       | KK-3511        | KK-3511      | KK-3511-C        | KK-3511-C          |
| Damp heater                     | Standard       | Standard     | Standard         | Standard           |
| Fax board                       | GD-1150AS      | GD-1150NA    | GD-1150C         | GD-1150C           |
| 2nd line for Fax board          | GD-1160EU-N    | GD-1160NA    | GD-1160C         | GD-1160C           |
| Wireless LAN module             | GN-1041        | GN-1041      | GN-1041          | GN-1041            |
| Bluetooth module                | GN-2010        | GN-2010      | GN-2010          | GN-2010            |
| Antenna                         | GN-3010        | GN-3010      | GN-3010          | GN-3010            |
| PCI slot                        | GO-1060        | GO-1060      | GO-1060          | GO-1060            |
| Scrambler board                 | GP-1040        | GP-1040      | GP-1040          | GP-1040            |
| Printer kit                     | GM-1070/1071   | GM-1070/1071 | GM-1070/1071     | -                  |
| Printer/Scanner kit             | GM-2070/2071   | GM-2070/2071 | Standard         | -                  |
| Scanner kit                     | GM-4070        | GM-4070      | GM-4070          | -                  |
| Data overwrite kit              | GP-1060        | GP-1060      | GP-1060          | GP-1060            |
| Desk                            | MH-1700        | MH-1700      | MH-1700          | MH-1700            |
| Harness kit for coin controller | GQ-1020        | GQ-1020      | GQ-1020          | GQ-1020            |

| <b>Area</b>                     | <b>Taiwan</b> | <b>Korea</b>   |
|---------------------------------|---------------|----------------|
| Machine version (destination)   | TWD (110V)    | KRD (220-240V) |
| Model name                      | e-STUDIO282   | e-STUDIO282    |
| Platen cover                    | KA-3511PC     | Standard       |
| RADF                            | MR-3020       | MR-3020        |
| Drawer module (for Equipment)   | Standard      | Standard       |
| Drawer module (for PFP)         | MY-1021       | MY-1021        |
| Slot cover                      | -             | -              |
| ADU                             | MD-0102       | MD-0102        |
| PFP                             | KD-1011       | KD-1011        |
| LCF                             | KD-1012A4     | KD-1012A       |
| Finisher (Hanging type)         | MJ-1022       | MJ-1022        |
| Staple cartridge (for MJ-1022)  | STAPLE-1600   | STAPLE-1600    |
| Saddle stitch finisher          | MJ-1025       | MJ-1025        |
| Staple cartridge (for MJ-1025)  | STAPLE-2000   | STAPLE-2000    |
| Hole punch unit                 | MJ-6005E      | MJ-6005E       |
| Bridge kit                      | KN-3520       | KN-3520        |
| Job separator                   | MJ-5004       | MJ-5004        |
| Offset tray                     | MJ-5005       | MJ-5005        |
| Work tray                       | KK-3511       | KK-3511        |
| Damp heater                     | Standard      | Standard       |
| Fax board                       | GD-1150TW     | GD-1150AS      |
| 2nd line for Fax board          | GD-1160TW     | GD-1160EU-N    |
| Wireless LAN module             | GN-1041       | GN-1041        |
| Bluetooth module                | GN-2010       | GN-2010        |
| Antenna                         | GN-3010       | GN-3010        |
| PCI slot                        | GO-1060       | GO-1060        |
| Scrambler board                 | GP-1040       | GP-1040        |
| Printer kit                     | GM-1070/1071  | GM-1070/1071   |
| Printer/Scanner kit             | GM-2070/2071  | GM-2070/2071   |
| Scanner kit                     | GM-4070       | GM-4070        |
| Data overwrite kit              | GP-1060       | GP-1060        |
| Desk                            | MH-1700       | MH-1700        |
| Harness kit for coin controller | GQ-1020       | GQ-1020        |

## e-STUDIO232/232S/233

| Area                            | North America    | Central and South America/Hong Kong | Argentina        | Australia      | Europe           |
|---------------------------------|------------------|-------------------------------------|------------------|----------------|------------------|
| Machine version (destination)   | NAD (115V)       | ASD (220-240V)                      | ARD (220-240V)   | AUD (220-240V) | MJD (220-240V)   |
| Model name                      | e-STUDIO 232/233 | e-STUDIO232                         | e-STUDIO 232/233 | e-STUDIO232    | e-STUDIO 232/233 |
| Platen cover                    | KA-3511PC        | KA-3511PC                           | KA-3511PC        | KA-3511PC      | KA-3511PC        |
| RADF                            | MR-3020          | MR-3020                             | MR-3020          | MR-3020        | MR-3020          |
| Drawer module (for Equipment)   | Standard         | MY-1021                             | MY-1021          | Standard       | Standard         |
| Drawer module (for PFP)         | MY-1021          | MY-1021                             | MY-1021          | MY-1021        | MY-1021          |
| Slot cover                      | -                | Standard                            | Standard         | -              | -                |
| ADU                             | Standard         | MD-0102                             | MD-0102          | Standard       | Standard         |
| PFP                             | KD-1011          | KD-1011-N                           | KD-1011          | KD-1011        | KD-1011          |
| LCF                             | KD-1012LT        | KD-1012A4                           | KD-1012A4        | KD-1012A4      | KD-1012A4        |
| Finisher (Hanging type)         | MJ-1022          | MJ-1022                             | MJ-1022          | MJ-1022        | MJ-1022          |
| Staple cartridge (for MJ-1022)  | STAPLE-1600      | STAPLE-1600                         | STAPLE-1600      | STAPLE-1600    | STAPLE-1600      |
| Saddle stitch finisher          | MJ-1025          | MJ-1025                             | MJ-1025          | MJ-1025        | MJ-1025          |
| Staple cartridge (for MJ-1025)  | STAPLE-2000      | STAPLE-2000                         | STAPLE-2000      | STAPLE-2000    | STAPLE-2000      |
| Hole punch unit                 | MJ-6005N         | MJ-6005E                            | MJ-6005E         | MJ-6005E       | MJ-6005E/F/S     |
| Bridge kit                      | KN-3520          | KN-3520                             | KN-3520          | KN-3520        | KN-3520          |
| Job separator                   | MJ-5004          | MJ-5004                             | MJ-5004          | MJ-5004        | MJ-5004          |
| Offset tray                     | MJ-5005          | MJ-5005                             | MJ-5005          | MJ-5005        | MJ-5005          |
| Work tray                       | KK-3511          | KK-3511                             | KK-3511          | KK-3511        | KK-3511          |
| Damp heater                     | MF-2320U         | Standard                            | Standard         | Standard       | MF-2320E         |
| Fax board                       | GD-1150NA        | GD-1150AS                           | GD-1150AS        | GD-1150AU      | GD-1150EU        |
| 2nd line for Fax board          | GD-1160NA        | GD-1160EU-N                         | GD-1160EU-N      | GD-1160EU-N    | GD-1160EU-N      |
| Wireless LAN module             | GN-1041          | GN-1041                             | GN-1041          | GN-1041        | GN-1041          |
| Bluetooth module                | GN-2010          | GN-2010                             | GN-2010          | GN-2010        | GN-2010          |
| Antenna                         | GN-3010          | GN-3010                             | GN-3010          | GN-3010        | GN-3010          |
| PCI slot                        | GO-1060          | GO-1060                             | GO-1060          | GO-1060        | GO-1060          |
| Scrambler board                 | GP-1040          | GP-1040                             | GP-1040          | GP-1040        | GP-1040          |
| Printer kit                     | GM-1070/1071     | GM-1070/1071                        | GM-1070/1071     | GM-1070/1071   | GM-1070/1071     |
| Printer/Scanner kit             | GM-2070/2071     | GM-2070/2071                        | GM-2070/2071     | GM-2070/2071   | GM-2070/2071     |
| Scanner kit                     | GM-4070          | GM-4070                             | GM-4070          | GM-4070        | GM-4070          |
| Data overwrite kit              | GP-1060          | GP-1060                             | GP-1060          | GP-1060        | GP-1060          |
| Desk                            | MH-1700          | MH-1700                             | MH-1700          | MH-1700        | MH-1700          |
| Harness kit for coin controller | GQ-1020          | GQ-1020                             | GQ-1020          | GQ-1020        | GQ-1020          |

| Area                            | Asia           | Saudi Arabia | China            |              |
|---------------------------------|----------------|--------------|------------------|--------------|
| Machine version (destination)   | ASU (220-240V) | SAD (127V)   | CND (220-240V)   |              |
| Model name                      | e-STUDIO232    | e-STUDIO232  | e-STUDIO 232/233 | e-STUDIO232S |
| Platen cover                    | KA-3511PC      | KA-3511PC    | Standard         | Standard     |
| RADF                            | MR-3020        | MR-3020      | MR-3020          | MR-3020      |
| Drawer module (for Equipment)   | MY-1021        | MY-1021      | Standard         | Standard     |
| Drawer module (for PFP)         | MY-1021        | MY-1021      | MY-1021-C        | MY-1021-C    |
| Slot cover                      | KE-2330        | KE-2330      | -                | -            |
| ADU                             | MD-0102        | MD-0102      | Standard         | MD-0102-C    |
| PFP                             | KD-1011        | KD-1011      | KD-1011-C        | KD-1011-C    |
| LCF                             | KD-1012        | KD-1012A4    | KD-1012A4-C      | KD-1012A4-C  |
| Finisher (Hanging type)         | MJ-1022        | MJ-1022      | MJ-1022-C        | MJ-1022-C    |
| Staple cartridge (for MJ-1022)  | STAPLE-1600    | STAPLE-1600  | STAPLE-1600      | STAPLE-1600  |
| Saddle stitch finisher          | MJ-1025        | MJ-1025      | MJ-1025          | MJ-1025      |
| Staple cartridge (for MJ-1025)  | STAPLE-2000    | STAPLE-2000  | STAPLE-2000      | STAPLE-2000  |
| Hole punch unit                 | MJ-6005E       | MJ-6005E     | MJ-6005E         | MJ-6005E     |
| Bridge kit                      | KN-3520        | KN-3520      | KN-3520-C        | KN-3520-C    |
| Job separator                   | MJ-5004        | MJ-5004      | MJ-5004-C        | MJ-5004-C    |
| Offset tray                     | MJ-5005        | MJ-5005      | MJ-5005-C        | MJ-5005-C    |
| Work tray                       | KK-3511        | KK-3511      | KK-3511-C        | KK-3511-C    |
| Damp heater                     | Standard       | Standard     | Standard         | Standard     |
| Fax board                       | GD-1150AS      | GD-1150NA    | GD-1150C         | GD-1150C     |
| 2nd line for Fax board          | GD-1160EU-N    | GD-1160NA    | GD-1160C         | GD-1160C     |
| Wireless LAN module             | GN-1041        | GN-1041      | GN-1041          | GN-1041      |
| Bluetooth module                | GN-2010        | GN-2010      | GN-2010          | GN-2010      |
| Antenna                         | GN-3010        | GN-3010      | GN-3010          | GN-3010      |
| PCI slot                        | GO-1060        | GO-1060      | GO-1060          | GO-1060      |
| Scrambler board                 | GP-1040        | GP-1040      | GP-1040          | GP-1040      |
| Printer kit                     | GM-1070/1071   | GM-1070/1071 | GM-1070/1071     | -            |
| Printer/Scanner kit             | GM-2070/2071   | GM-2070/2071 | Standard         | -            |
| Scanner kit                     | GM-4070        | GM-4070      | GM-4070          | -            |
| Data overwrite kit              | GP-1060        | GP-1060      | GP-1060          | GP-1060      |
| Desk                            | MH-1700        | MH-1700      | MH-1700          | MH-1700      |
| Harness kit for coin controller | GQ-1020        | GQ-1020      | GQ-1020          | GQ-1020      |



| Area                            | Taiwan       | Korea          |
|---------------------------------|--------------|----------------|
| Machine version (destination)   | TWD (110V)   | KRD (220-240V) |
| Model name                      | e-STUDIO232  | e-STUDIO232    |
| Platen cover                    | KA-3511PC    | Standard       |
| RADF                            | MR-3020      | MR-3020        |
| Drawer module (for Equipment)   | Standard     | Standard       |
| Drawer module (for PFP)         | MY-1021      | MY-1021        |
| Slot cover                      | -            | -              |
| ADU                             | MD-0102      | MD-0102        |
| PFP                             | KD-1011-TW   | KD-1011        |
| LCF                             | KD-1012A4    | KD-1012A4      |
| Finisher (Hanging type)         | MJ-1022      | MJ-1022        |
| Staple cartridge (for MJ-1022)  | STAPLE-1600  | STAPLE-1600    |
| Saddle stitch finisher          | MJ-1025      | MJ-1025        |
| Staple cartridge (for MJ-1025)  | STAPLE-2000  | STAPLE-2000    |
| Hole punch unit                 | MJ-6005E     | MJ-6005E       |
| Bridge kit                      | KN-3520      | KN-3520        |
| Job separator                   | MJ-5004      | MJ-5004        |
| Offset tray                     | MJ-5005      | MJ-5005        |
| Work tray                       | KK-3511      | KK-3511        |
| Damp heater                     | Standard     | Standard       |
| Fax board                       | GD-1150TW    | GD-1150AS      |
| 2nd line for Fax board          | GD-1160TW    | GD-1160EU-N    |
| Wireless LAN module             | GN-1041      | GN-1041        |
| Bluetooth module                | GN-2010      | GN-2010        |
| Antenna                         | GN-3010      | GN-3010        |
| PCI slot                        | GO-1060      | GO-1060        |
| Scrambler board                 | GP-1040      | GP-1040        |
| Printer kit                     | GM-1070/1071 | GM-1070/1071   |
| Printer/Scanner kit             | GM-2070/2071 | GM-2070/2071   |
| Scanner kit                     | GM-4070      | GM-4070        |
| Data overwrite kit              | GP-1060      | GP-1060        |
| Desk                            | MH-1700      | MH-1700        |
| Harness kit for coin controller | GQ-1020      | GQ-1020        |

e-STUDIO202L/203L

| <b>Area</b>                     | <b>North America</b> | <b>Argentina</b>   |
|---------------------------------|----------------------|--------------------|
| Machine version (destination)   | NAD (115V)           | ARD (220-240V)     |
| Model name                      | e-STUDIO 202L/203L   | e-STUDIO 202L/203L |
| Platen cover                    | KA-3511PC            | KA-3511PC          |
| RADF                            | MR-3020              | MR-3020            |
| Drawer module (for Equipment)   | MY-1021              | MY-1021            |
| Drawer module (for PFP)         | MY-1021              | MY-1021            |
| Slot cover                      | Standard             | Standard           |
| ADU                             | MD-0102              | MD-0102            |
| PFP                             | KD-1011              | KD-1011-N          |
| LCF                             | KD-1012LT            | KD-1012A4          |
| Finisher (Hanging type)         | MJ-1022              | MJ-1022            |
| Staple cartridge (for MJ-1022)  | STAPLE-1600          | STAPLE-1600        |
| Saddle stitch finisher          | MJ-1025              | MJ-1025            |
| Staple cartridge (for MJ-1025)  | STAPLE-2000          | STAPLE-2000        |
| Hole punch unit                 | MJ-6005N             | MJ-6005E           |
| Bridge kit                      | KN-3520              | KN-3520            |
| Job separator                   | MJ-5004              | MJ-5004            |
| Offset tray                     | MJ-5005              | MJ-5005            |
| Work tray                       | KK-3511              | KK-3511            |
| Damp heater                     | MF-2320U             | Standard           |
| Fax board                       | GD-1150NA            | GD-1150AS          |
| 2nd line for Fax board          | GD-1160NA            | GD-1160EU-N        |
| Wireless LAN module             | GN-1041              | GN-1041            |
| Bluetooth module                | GN-2010              | GN-2010            |
| Antenna                         | GN-3010              | GN-3010            |
| PCI slot                        | GO-1060              | GO-1060            |
| Scrambler board                 | GP-1040              | GP-1040            |
| Printer kit                     | GM-1080U/<br>1081U   | GM-1080U/<br>1081U |
| Printer/Scanner kit             | GM-2080U/<br>2081U   | GM-2080U/<br>2081U |
| Scanner kit                     | GM-4080U             | GM-4080U           |
| Data overwrite kit              | GP-1060              | GP-1060            |
| Desk                            | MH-1700              | MH-1700            |
| Harness kit for coin controller | GQ-1020              | GQ-1020            |

## 2. OUTLINE OF THE MACHINE

### 2.1 Sectional View

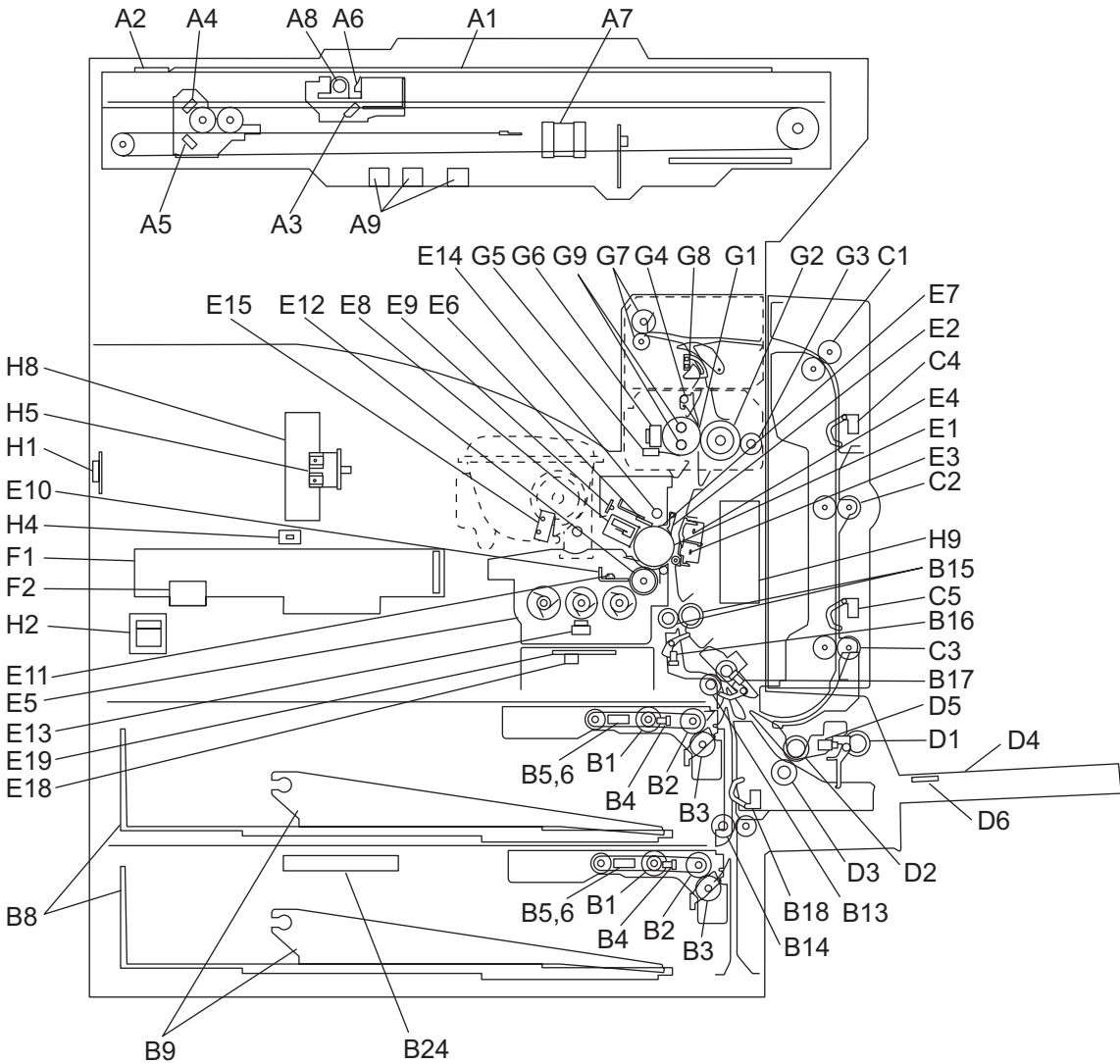

Fig. 2-1 Front side view

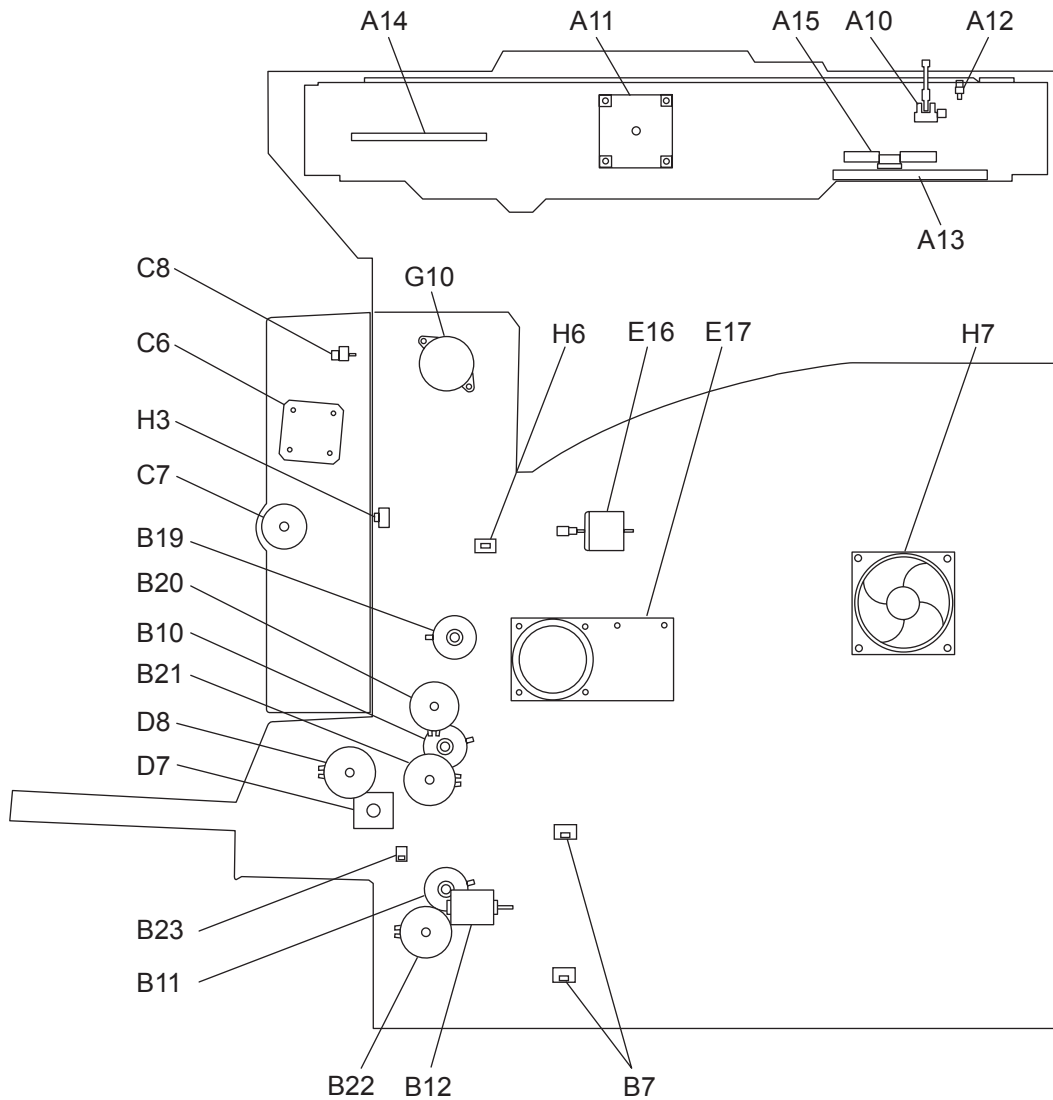

Fig. 2-2 Rear side view

|     |                                     |     |                                |
|-----|-------------------------------------|-----|--------------------------------|
| A1  | Original glass                      | A15 | Scanner damp heater thermostat |
| A2  | ADF original glass                  | B1  | Drawer pickup roller           |
| A3  | Mirror-1                            | B2  | Drawer feed roller             |
| A4  | Mirror-2                            | B3  | Drawer separation roller       |
| A5  | Mirror-3                            | B4  | Drawer tray-up sensor          |
| A6  | Reflector                           | B5  | Drawer empty sensor            |
| A7  | Lens                                | B6  | Drawer paper stock sensor      |
| A8  | Exposure lamp                       | B7  | Drawer detection switch        |
| A9  | Automatic original detection sensor | B8  | Drawer                         |
| A10 | Platen sensor                       | B9  | Drawer tray                    |
| A11 | Scan motor                          | B10 | Upper drawer feed clutch       |
| A12 | Carriage home position sensor       | B11 | Lower drawer feed clutch       |
| A13 | Scanner damp heater (Left)          | B12 | Tray-up motor                  |
| A14 | Scanner damp heater (Right)         | B13 | 1st transport roller           |

|     |                                   |     |  |
|-----|-----------------------------------|-----|--|
| B14 | 2nd transport roller              | E8  | Main charger                           |
| B15 | Registration roller               | E9  | Discharge LED                          |
| B16 | Registration sensor               | E10 | Doctor blade                           |
| B17 | 1st transport sensor              | E11 | Drum thermistor                        |
| B18 | 2nd transport sensor              | E12 | Developer sleeve (magnetic roller)     |
| B19 | Registration clutch               | E13 | Auto-toner sensor                      |
| B20 | Upper transport clutch            | E14 | Toner recovery auger                   |
| B21 | Middle transport clutch           | E15 | Toner cartridge installation switch    |
| B22 | Lower transport clutch            | E16 | Toner motor                            |
| B23 | Side cover opening/closing switch | E17 | Main motor                             |
| C1  | ADU upper transport roller        | E18 | Drum damp heater thermostat            |
| C2  | ADU middle transport roller       | E19 | Drum damp heater                       |
| C3  | ADU lower transport roller        | F1  | Laser unit                             |
| C4  | ADU entrance sensor               | F2  | Polygonal motor                        |
| C5  | ADU exit sensor                   | G1  | Heat roller                            |
| C6  | ADU motor                         | G2  | Pressure roller                        |
| C7  | ADU clutch                        | G3  | Cleaning roller                        |
| C8  | ADU opening/closing switch        | G4  | Separation finger for heat roller      |
| D1  | Bypass pickup roller              | G5  | Center/side/edge thermistor            |
| D2  | Bypass feed roller                | G6  | Fuser center/front thermostat          |
| D3  | Bypass separation roller          | G7  | Exit roller                            |
| D4  | Bypass tray                       | G8  | Exit sensor                            |
| D5  | Bypass paper sensor               | G9  | Heater Lamp (center/side)              |
| D6  | Paper size detection sensor       | G10 | Exit motor                             |
| D7  | Bypass pickup solenoid            | H1  | Temperature/humidity sensor            |
| D8  | Bypass feed clutch                | H2  | Main switch                            |
| E1  | Drum                              | H3  | Transfer cover opening/closing switch  |
| E2  | Separation finger                 | H4  | Front cover opening/closing switch     |
| E3  | Transfer charger                  | H5  | Cover opening/closing interlock switch |
| E4  | Separation charger                | H6  | Auger lock switch                      |
| E5  | Developer unit                    | H7  | Internal cooling fan-1                 |
| E6  | Cleaning blade                    | H8  | Internal cooling fan-2                 |
| E7  | Recovery blade                    | H9  | Exhaust fan                            |

## 2.2 Electric Parts Layout

### 1) Unit construction

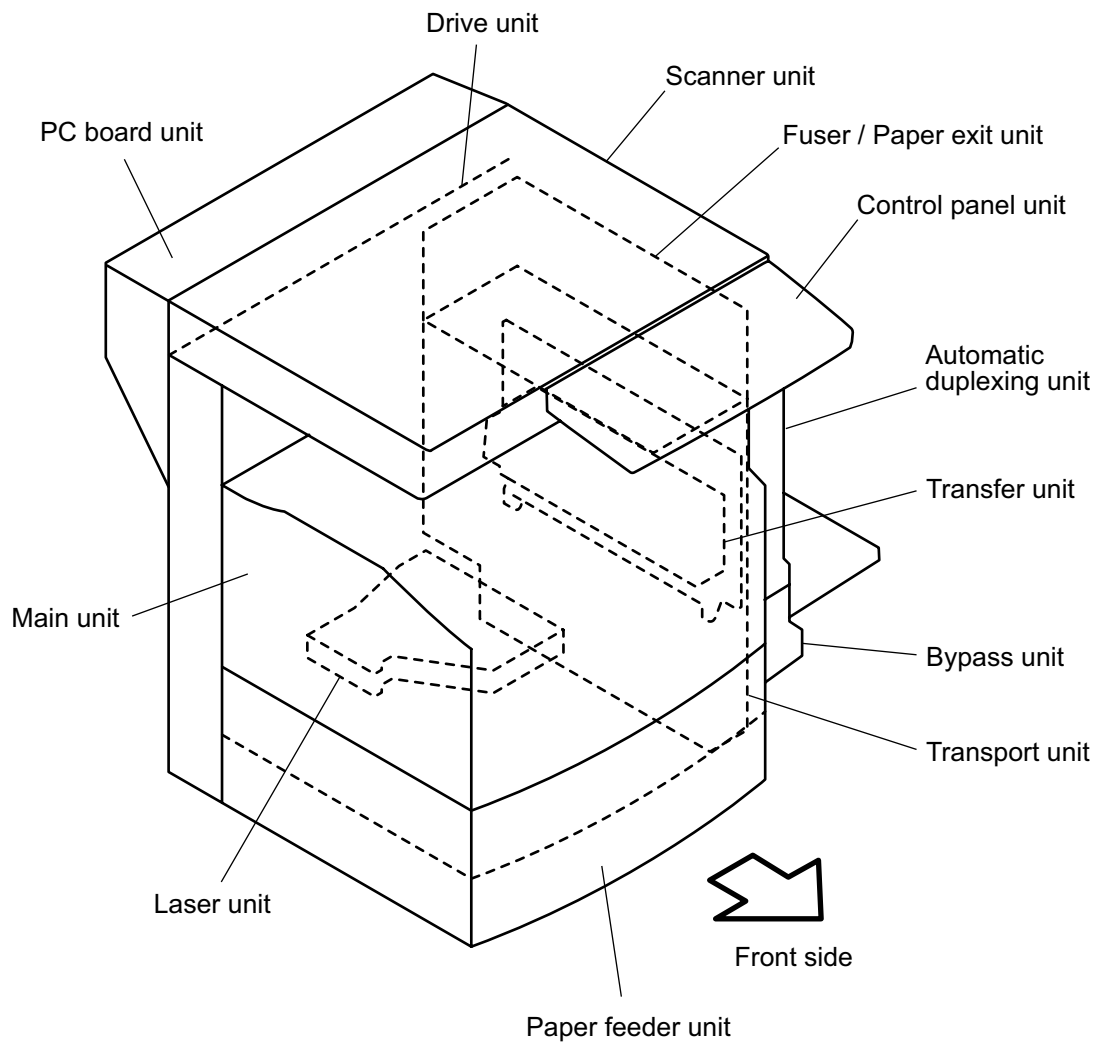

Fig. 2-3

- 2) Scanner unit
  - a. Motor, sensor, lamp
  - A4 series

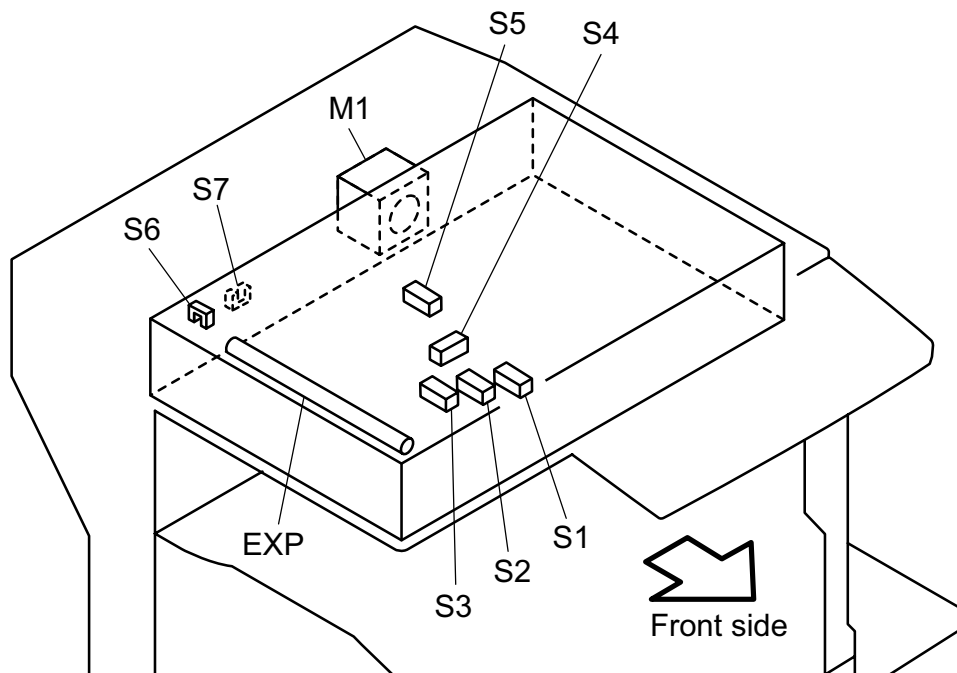

Fig. 2-4

LT series

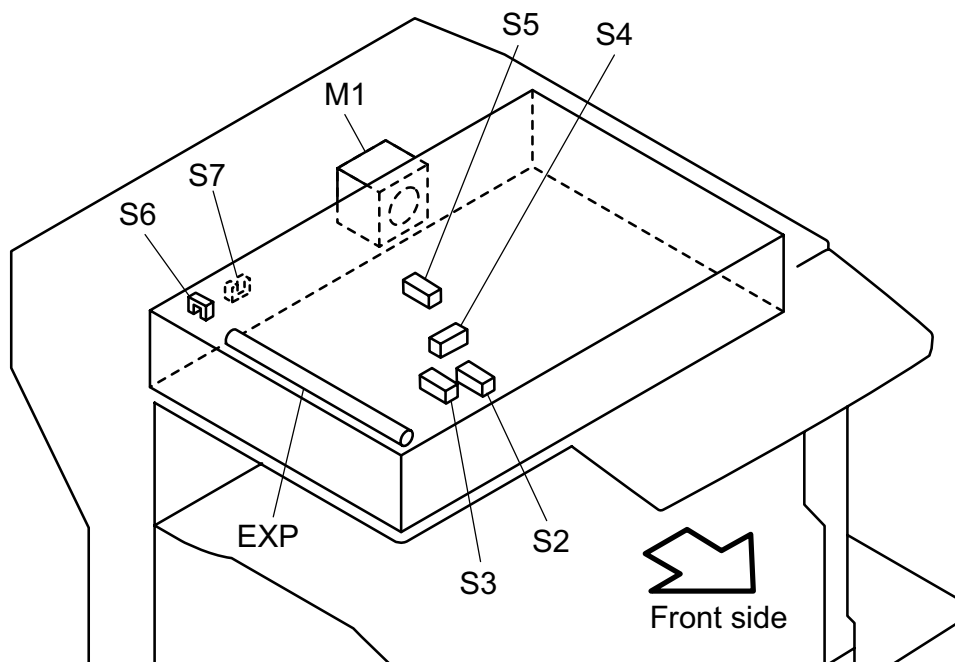

Fig. 2-5

b. PC board, heater, thermostat, other part

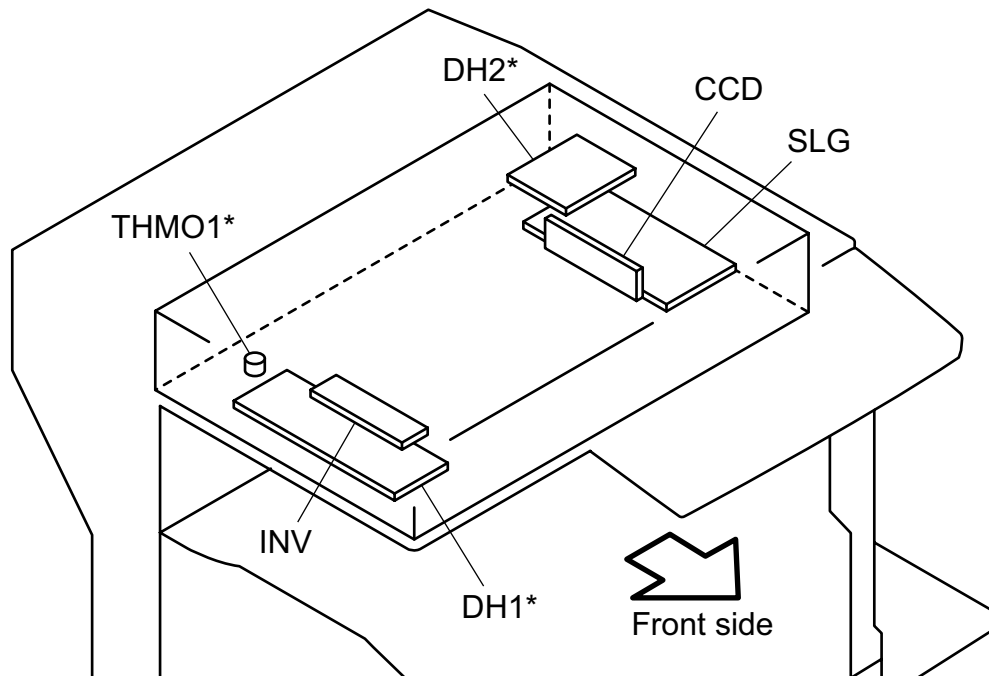

Fig. 2-6

\* ASD/AUD/CND/SAD/ASU/TWD/IRD/ARD/KRD models: Standard  
NAD/MJD models: Option



3) Control panel unit

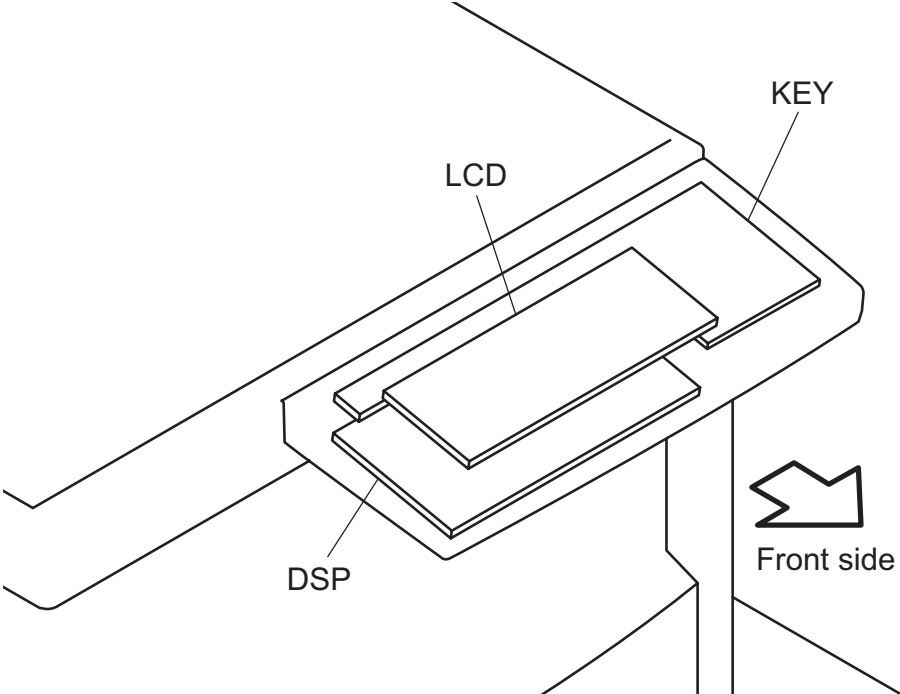

Fig. 2-7

4) Main unit  
a. Motor, sensor, switch, PC board

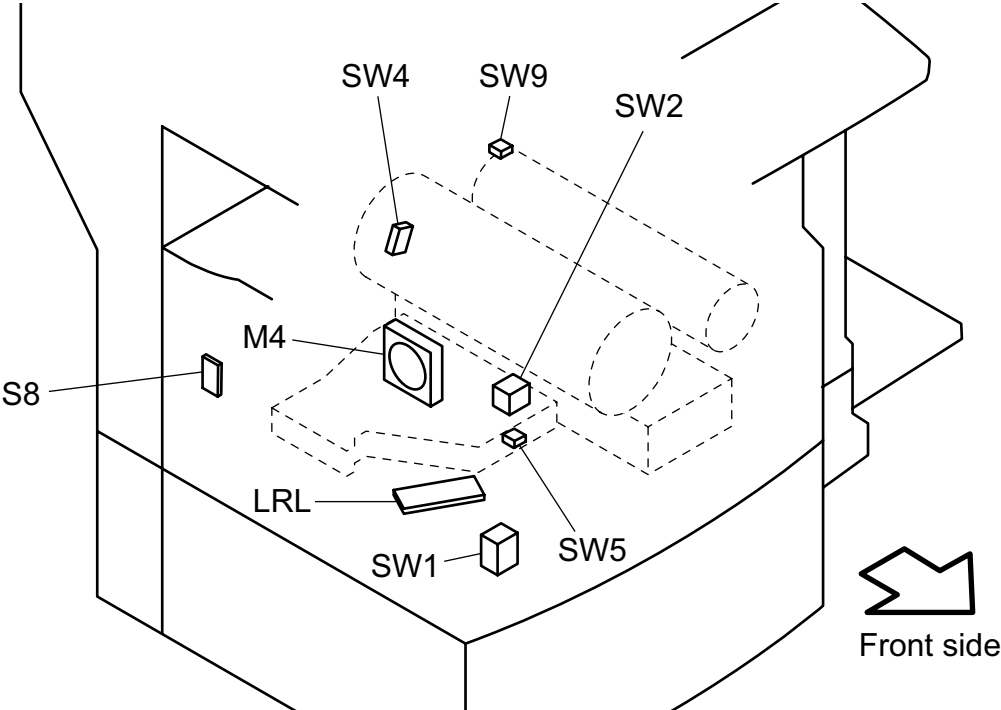

Fig. 2-8

b. PC board, sensor, lamp, heater, thermistor, thermostat

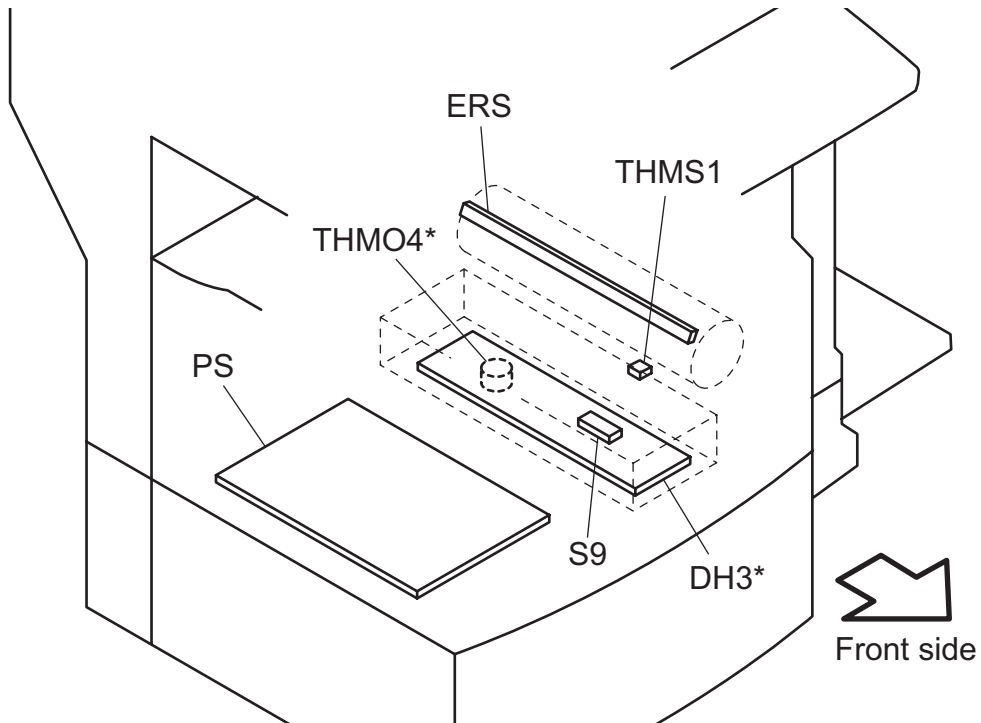

Fig. 2-9

\* ASD/AUD/CND/SAD/ASU/TWD/IRD/ARD/KRD models: Standard  
NAD/MJD models: Option

5) Laser unit

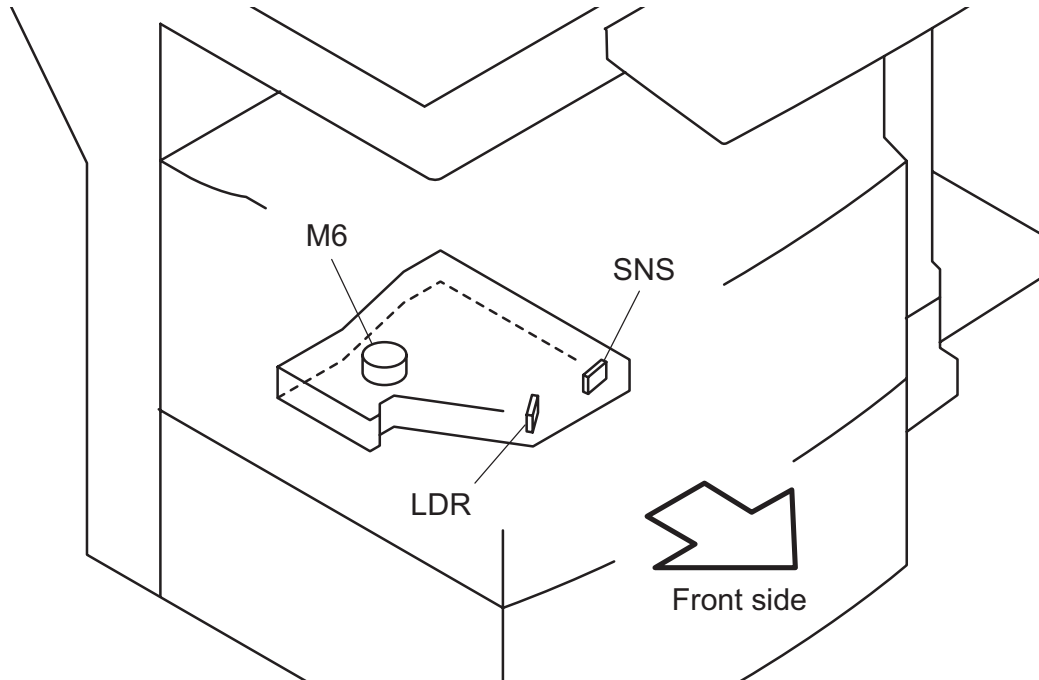

Fig. 2-10

6) Paper feeder unit

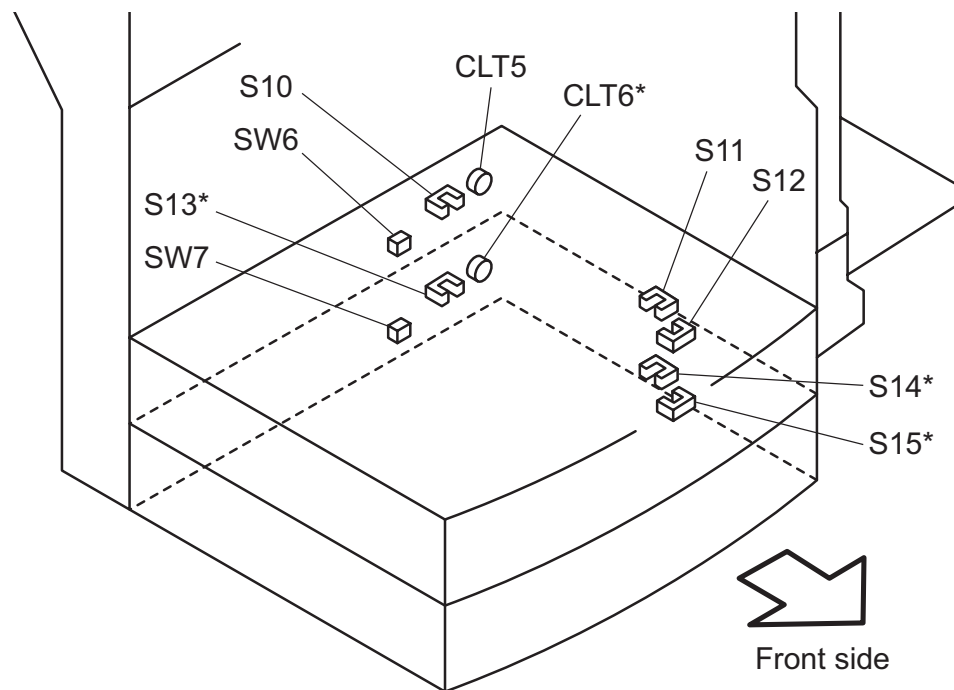

Fig. 2-11

\* e-STUDIO230/280/232/282 (NAD/AUD/MJD/IRD/CND/TWD/KRD), e-STUDIO233/283 (NAD/MJD/CND), e-STUDIO280S/282S/283S/232S (CND) models: Standard  
 e-STUDIO200L/202L (NAD/ASD/ARD), e-STUDIO203L (NAD/ARD), e-STUDIO230/280/232/282 (ASD/ASU/SAD/ARD), e-STUDIO233/283 (ARD), e-STUDIO230L (MJD) models: Option

7) Transport unit

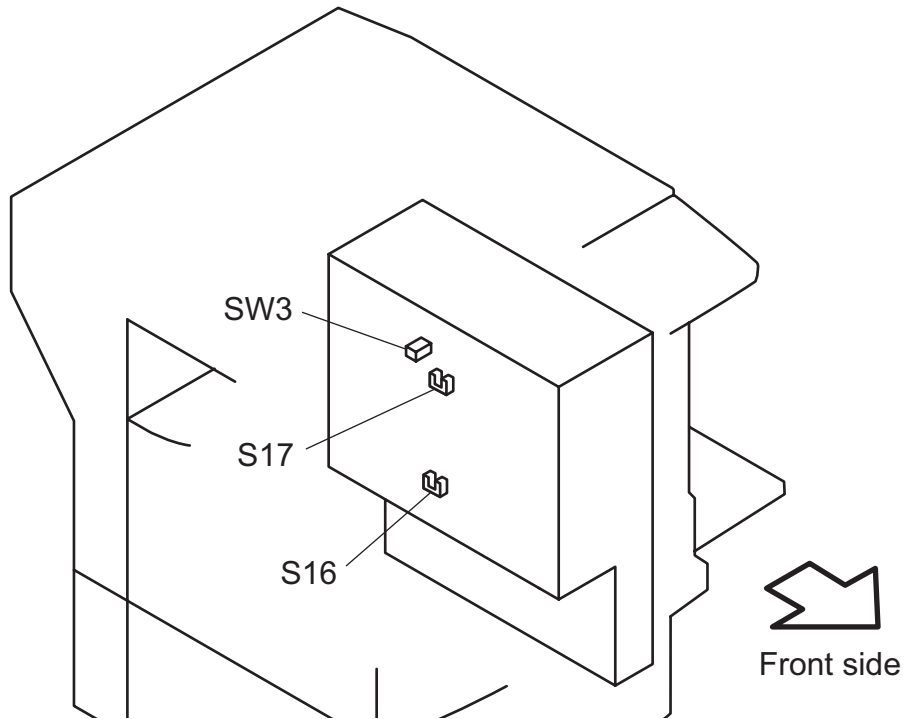

Fig. 2-12

8) Bypass unit

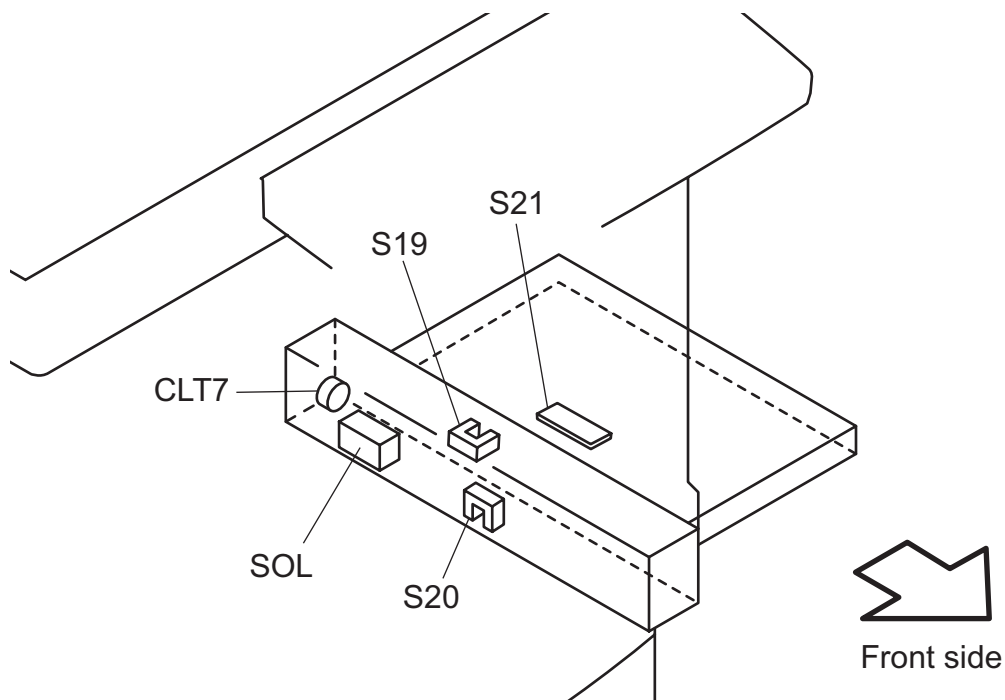

Fig. 2-13

9) Transfer unit

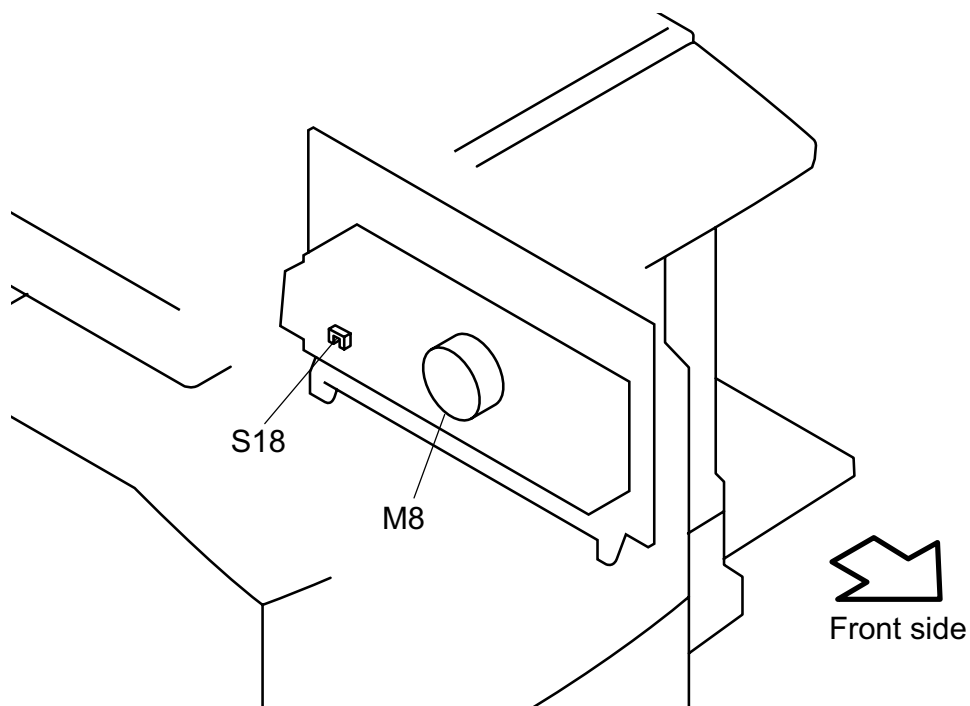

Fig. 2-14

10)Automatic duplexing unit

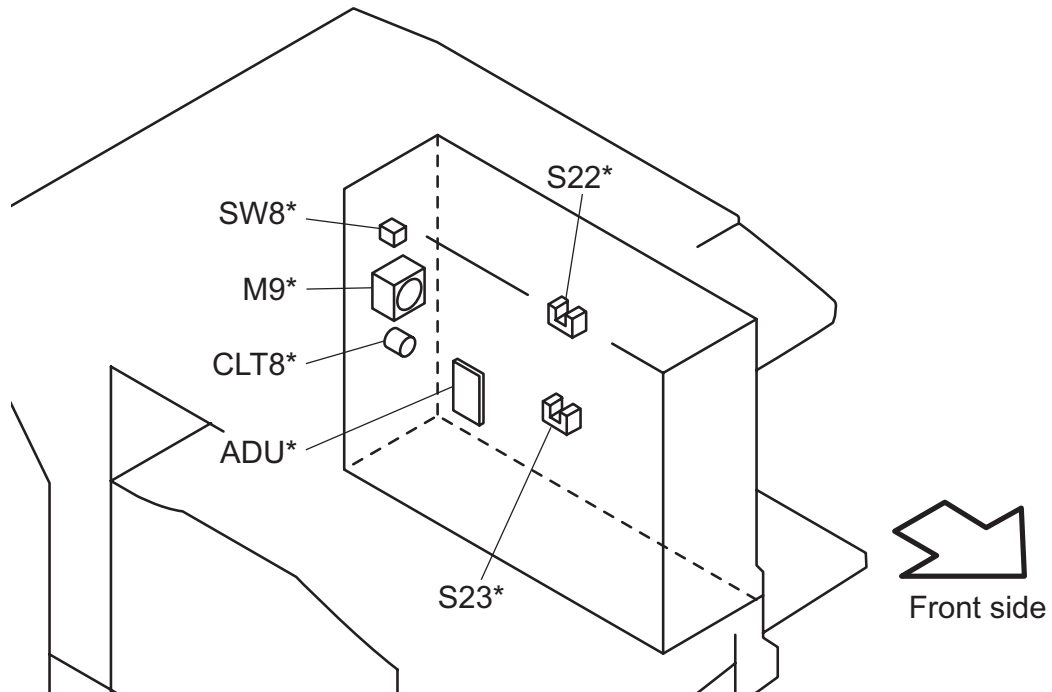

Fig. 2-15

- \* e-STUDIO230/280/232/282 (NAD/AUD/MJD/IRD/CND), e-STUDIO233/283 (NAD/MJD/CND) models: Standard
- e-STUDIO200L/202L (NAD/ASD/ARD), e-STUDIO203L (NAD/ARD), e-STUDIO230/280/232/282 (ASD/ASU/SAD/TWD/KRD), e-STUDIO233/283 (ARD), e-STUDIO230L (MJD), e-STUDIO280S/232S/282S/283S (CND) models: Option

11)Fuser/Paper exit unit

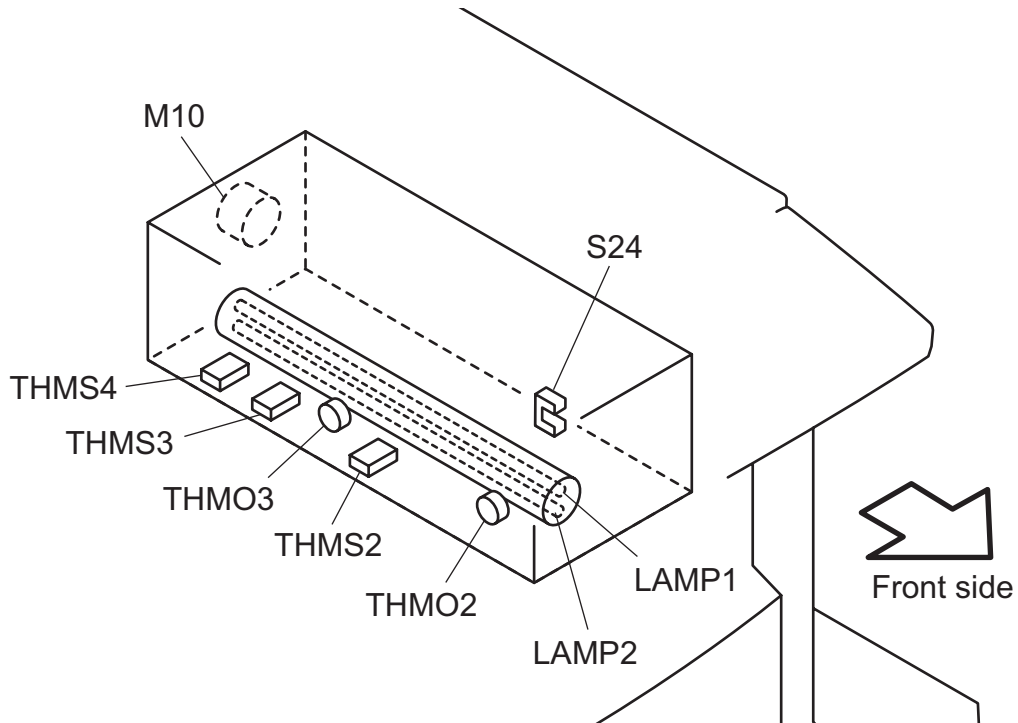

Fig. 2-16

12) Drive unit

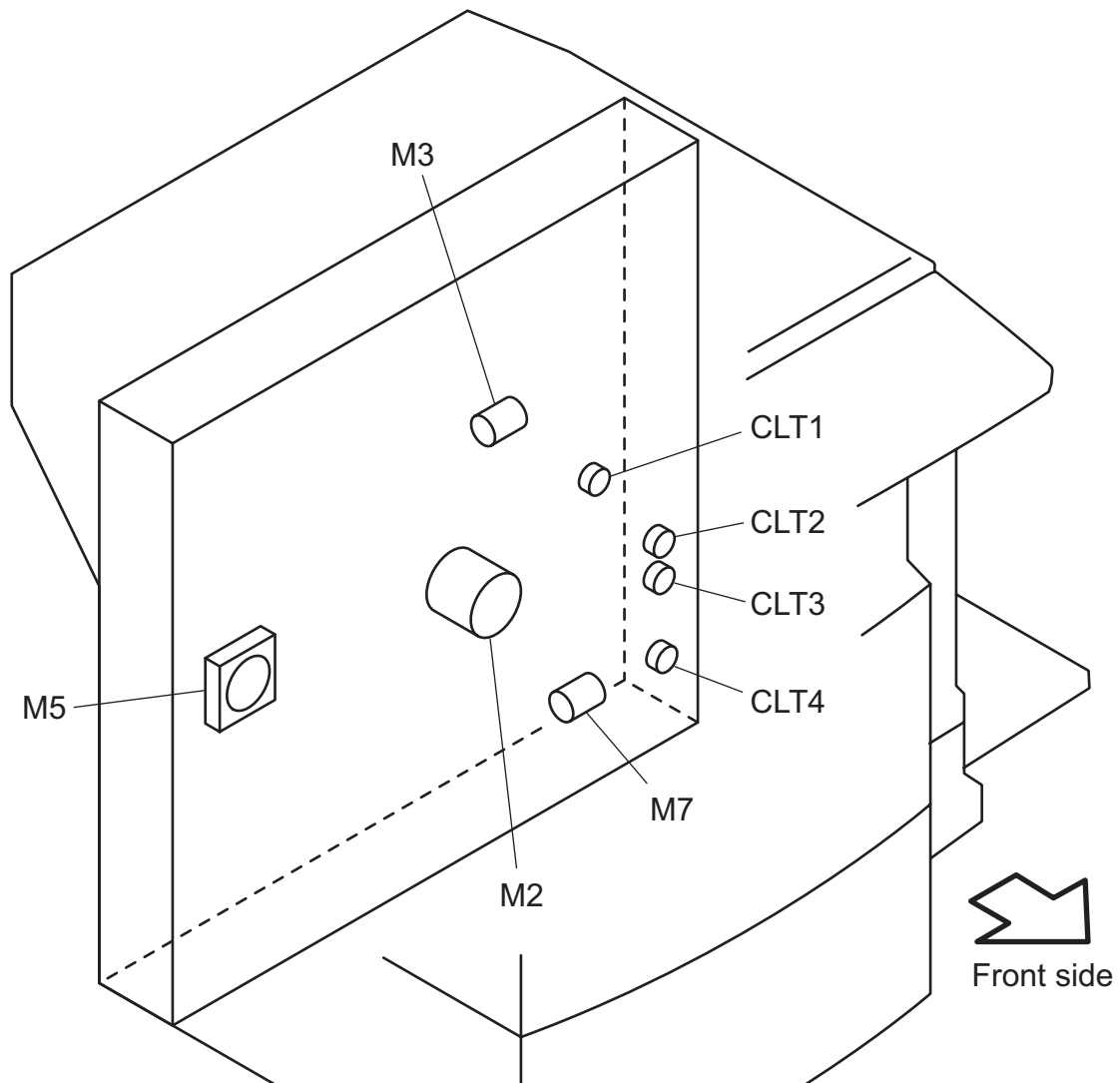

Fig. 2-17



13)PC board unit  
e-STUDIO200L/230/230L/280/280S

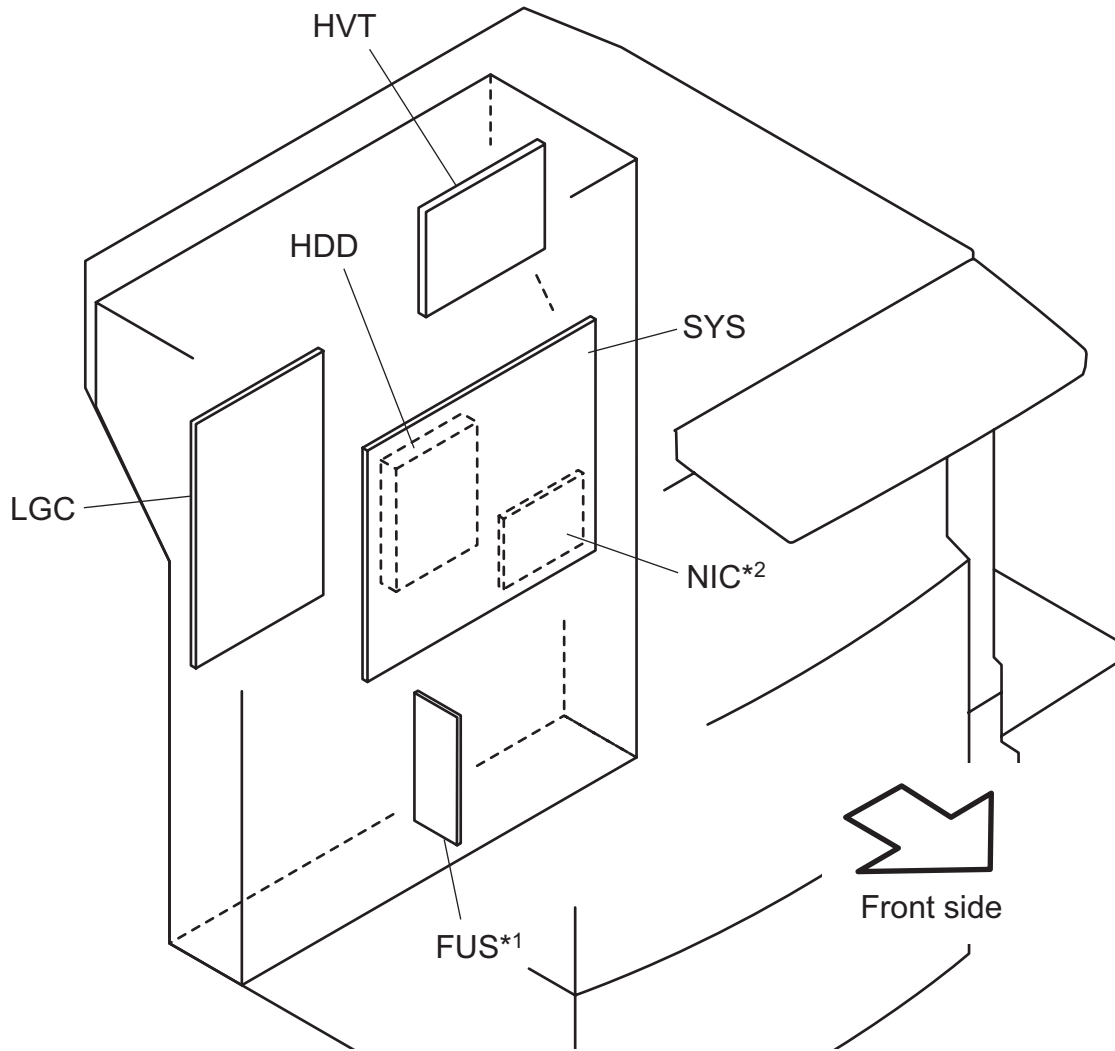

Fig. 2-18

\*1: ASD/AUD/CND/SAD/ASU/TWD/IRD models: Standard  
NAD/MJD models: Option

\*2: e-STUDIO230/280 (NAD/AUD/MJD/IRD/CND/TWD) models: Standard  
e-STUDIO200L (NAD/ASD), e-STUDIO230/280 (ASD/ASU/SAD), e-STUDIO230L (MJD),  
e-STUDIO280S (CND) models: Option

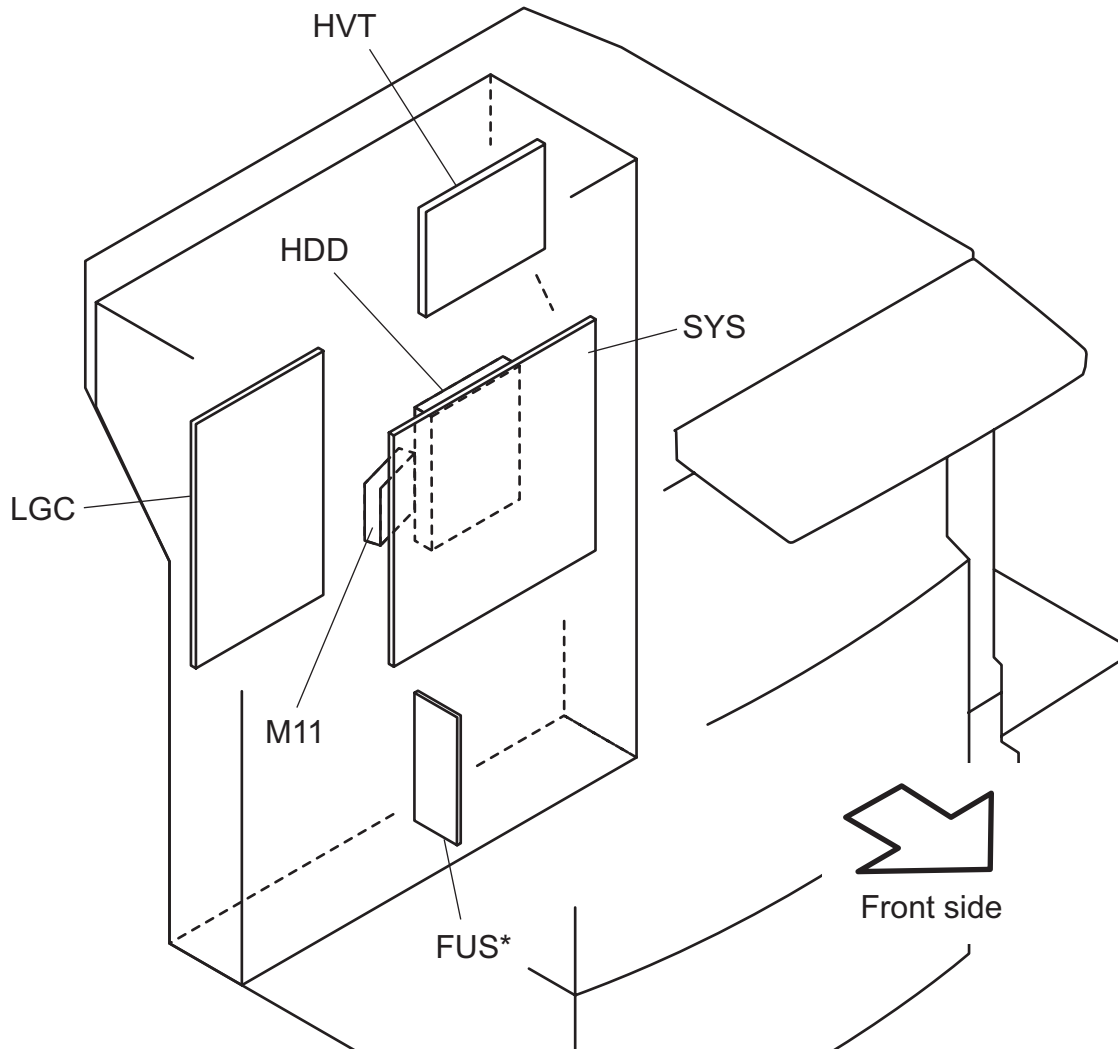

Fig. 2-19

\* ASD/AUD/CND/SAD/ASU/TWD/ARD/KRD models: Standard  
NAD/MJD models: Option

## 2.3 Symbols and Functions of Various Components

The column "P-I" shows the page and item number in the parts list.

### 1) Motors

| Symbol | Name                                   | Function  | Remarks                                     | P-I     |
|--------|--|---|---|---------|
| M1     | SCAN-MOT<br>Scan motor                 | Driving the carriages   | P.2-5<br>"Fig. 2-4",<br>P.2-5<br>"Fig. 2-5" | P14-I16 |
| M2     | MAIN-MOT<br>Main motor                 | Driving the drum, developer unit, fuser unit, registration roller, transport rollers, feed rollers and pickup rollers   | P.2-14<br>"Fig. 2-17"                       | P13-I16 |
| M3     | TNR-MOT<br>Toner motor                 | Supplying the toner   | P.2-14<br>"Fig. 2-17"                       | P13-I15 |
| M4     | MID-FAN-MOT<br>Internal cooling fan-1  | Cooling down the equipment inside   | P.2-7<br>"Fig. 2-8"                         | P10-I7  |
| M5     | REAR-FAN-MOT<br>Internal cooling fan-2 | Cooling down the laser unit and switching regulator   | P.2-14<br>"Fig. 2-17"                       | P6-I7   |
| M6     | M/DC-POL<br>Polygonal motor            | Driving the polygonal mirror  | P.2-9<br>"Fig. 2-10"                        | P10-I19 |
| M7     | TRY-MOT<br>Tray-up motor               | Driving the lifting movement of trays in upper/lower drawer   | P.2-14<br>"Fig. 2-17"                       | P16-I15 |
| M8     | EXIT-FAN-MOT<br>Exhaust fan            | Exhausting ozone  | P.2-11<br>"Fig. 2-14"                       | P12-I34 |
| M9     | ADU-MOT<br>ADU motor                   | Driving the automatic duplexing unit<br>* e-STUDIO230/280/232/282 (NAD/AUD/MJD/IRD/CND), e-STUDIO233/283 (NAD/MJD/CND) models: Standard<br>* e-STUDIO200L/202L (NAD/ASD/ARD), e-STUDIO203L (NAD/ARD), e-STUDIO230/280/232/282 (ASD/ASU/SAD/TWD/KRD), e-STUDIO233/283(ARD), e-STUDIO230L (MJD), e-STUDIO280S/232S/282S/283S (CND) models: Option | P.2-12<br>"Fig. 2-15"                       | P32-I18 |
| M10    | EXIT-MOT<br>Exit motor                 | Driving the exit roller   | P.2-13<br>"Fig. 2-16"                       | P31-I15 |
| M11    | HDD-FAN-MOT<br>HDD cooling fan         | Cooling down the HDD and SYS board.   | P.2-16<br>"Fig. 2-19"                       | P8-I15  |

## 2) Sensors and switches

| Symbol | Name  | Function   | Remarks                                     | P-I                                |
|--------|---|--|---|------------------------------------|
| S1-5   | APS1-3, APS-C, APS-R<br>Automatic original detection sensor | Original size detection  | P.2-5<br>"Fig. 2-4",<br>P.2-5<br>"Fig. 2-5" | S1-4:<br>P11-I17<br>S5:<br>P11-I18 |
| S6     | HOME-SNR<br>Carriage home position sensor                   | Carriage home position detection   | P.2-5<br>"Fig. 2-4",<br>P.2-5<br>"Fig. 2-5" | P11-I103                           |
| S7     | PLTN-SNR<br>Platen sensor                                   | Opening/closing detection of platen cover or RADF  | P.2-5<br>"Fig. 2-4",<br>P.2-5<br>"Fig. 2-5" | P14-I101                           |
| S8     | TEMP/HUMI-SNR<br>Temperature/humidity sensor                | Detecting the temperature and humidity of the outside air taken into the equipment   | P.2-7<br>"Fig. 2-8"                         | P10-I14                            |
| S9     | ATTNR-SNR<br>Auto-toner sensor                              | Detecting the density of toner in the developer unit   | P.2-8<br>"Fig. 2-9"                         | P28-I46                            |
| S10    | NEMP-U-SNR<br>Upper drawer paper stock sensor               | Paper amount detection in the upper drawer   | P.2-9<br>"Fig. 2-11"                        | P15-I104                           |
| S11    | CST-U-TRY-SNR<br>Upper drawer tray-up sensor                | Position detection of the lifting tray of the upper drawer   | P.2-9<br>"Fig. 2-11"                        | P15-I104                           |
| S12    | EMP-U-SNR<br>Upper drawer empty sensor                      | Paper presence/absence detection in the upper drawer   | P.2-9<br>"Fig. 2-11"                        | P15-I104                           |
| S13    | NEMP-L-SNR<br>Lower drawer paper stock sensor               | Paper amount detection in the lower drawer<br>* e-STUDIO230/280/232/282 (NAD/AUD/MJD/IRD/CND/TWD/KRD), e-STUDIO233/283 (NAD/MJD/CND), e-STUDIO280S/282S/283S/232S (CND) models: Standard<br>* e-STUDIO200L/202L (NAD/ASD/ARD), e-STUDIO203L (NAD/ARD), e-STUDIO230/280/232/282 (ASD/ASU/SAD/ARD), e-STUDIO233/283 (ARD), e-STUDIO230L (MJD) models: Option                 | P.2-9<br>"Fig. 2-11"                        | P15-I104                           |
| S14    | CST-L-TRY-SNR<br>Lower drawer tray-up sensor                | Position detection of the lifting tray of the lower drawer<br>* e-STUDIO230/280/232/282 (NAD/AUD/MJD/IRD/CND/TWD/KRD), e-STUDIO233/283 (NAD/MJD/CND), e-STUDIO280S/282S/283S/232S (CND) models: Standard<br>* e-STUDIO200L/202L (NAD/ASD/ARD), e-STUDIO203L (NAD/ARD), e-STUDIO230/280/232/282 (ASD/ASU/SAD/ARD), e-STUDIO233/283 (ARD), e-STUDIO230L (MJD) models: Option | P.2-9<br>"Fig. 2-11"                        | P15-I104                           |

| Symbol | Name  | Function  | Remarks               | P-I      |
|--------|---|---|-----------------------|----------|
| S15    | EMP-L-SNR<br>Lower drawer empty sensor            | Paper presence/absence detection in the lower drawer<br>* e-STUDIO230/280/232/282 (NAD/AUD/MJD/IRD/CND/TWD/KRD), e-STUDIO233/283 (NAD/MJD/CND), e-STUDIO280S/282S/283S/232S (CND) models: Standard<br>* e-STUDIO200L/202L (NAD/ASD/ARD), e-STUDIO203L (NAD/ARD), e-STUDIO230/280/232/282 (ASD/ASU/SAD/ARD), e-STUDIO233/283 (ARD), e-STUDIO230L (MJD) models: Option                      | P.2-9<br>"Fig. 2-11"  | P15-I104 |
| S16    | SIDE-COV-SNR<br>Side cover opening/closing sensor | Side cover opening/closing detection  | P.2-10<br>"Fig. 2-12" | P17-I101 |
| S17    | RGST-SNR<br>Registration sensor                   | Detecting the paper transport at the registration roller section  | P.2-10<br>"Fig. 2-12" | P21-I10  |
| S18    | FEED-SNR-1<br>1st transport sensor                | Detecting the transporting paper and jamming fed from the bypass, drawer, ADU   | P.2-11<br>"Fig. 2-14" | P12-I102 |
| S19    | SFB-SNR<br>Bypass paper sensor                    | Detecting presence/absence of paper on the bypass tray  | P.2-11<br>"Fig. 2-13" | P20-I104 |
| S20    | FEED-SNR-2<br>2nd transport sensor                | Detecting the transport paper and jamming fed from the lower drawer or PFP/LCF  | P.2-11<br>"Fig. 2-13" | P19-I13  |
| S21    | SFB-SIZE-SNR<br>Paper size detection sensor       | Detecting the width of paper on the bypass tray   | P.2-11<br>"Fig. 2-13" | P18-I12  |
| S22    | ADU-TRU-SNR<br>ADU entrance sensor                | Detecting the transporting paper at automatic duplexing unit entrance section<br>* e-STUDIO230/280/232/282 (NAD/AUD/MJD/IRD/CND), e-STUDIO233/283 (NAD/MJD/CND) models: Standard<br>* e-STUDIO200L/202L (NAD/ASD/ARD), e-STUDIO203L (NAD/ARD), e-STUDIO230/280/232/282 (ASD/ASU/SAD/TWD/KRD), e-STUDIO233/283 (ARD), e-STUDIO230L (MJD), e-STUDIO280S/232S/282S/283S (CND) models: Option | P.2-12<br>"Fig. 2-15" | P32-I31  |

| Symbol | Name  | Function  | Remarks               | P-I      |
|--------|---|---|-----------------------|----------|
| S23    | ADU-TRL-SNR<br>ADU exit sensor                          | Detecting the transporting paper in automatic duplexing unit<br>* e-STUDIO230/280/232/282 (NAD/AUD/MJD/IRD/CND), e-STUDIO233/283 (NAD/MJD/CND) models: Standard<br>* e-STUDIO200L/202L (NAD/ASD/ARD), e-STUDIO203L (NAD/ARD), e-STUDIO230/280/232/282 (ASD/ASU/SAD/TWD/KRD), e-STUDIO233/283(ARD), e-STUDIO230L (MJD), e-STUDIO280S/232S/282S/283S (CND) models: Option | P.2-12<br>"Fig. 2-15" | P32-I31  |
| S24    | EXIT-SNR<br>Exit sensor                                 | Detecting the transporting paper at the exit section  | P.2-13<br>"Fig. 2-16" | P31-I101 |
| SW1    | MAIN-SW<br>Main switch                                  | Turning ON/OFF of the equipment   | P.2-7<br>"Fig. 2-8"   | P5-I6    |
| SW2    | COV-INTLCK-SW<br>Cover opening/closing interlock switch | Controlling cutoff and supply of the AC input for DC power supply by opening/closing of the front cover or transfer guide.  | P.2-7<br>"Fig. 2-8"   | P5-I108  |
| SW3    | TR-COV-SW<br>Transfer cover opening/closing switch      | Transfer cover opening/closing switch   | P.2-10<br>"Fig. 2-12" | P6-I113  |
| SW4    | TNR-SW<br>Toner cartridge installation switch           | Toner cartridge presence/absence detection  | P.2-7<br>"Fig. 2-8"   | P6-I52   |
| SW5    | FRNT-COV-SW<br>Front cover opening/closing switch       | Detecting opening/closing of the front cover  | P.2-7<br>"Fig. 2-8"   | P5-I102  |
| SW6    | CST-U-SW<br>Upper drawer detection switch               | Detecting presence/absence of the upper drawer  | P.2-9<br>"Fig. 2-11"  | P6-I113  |
| SW7    | CST-L-SW<br>Lower drawer detection switch               | Detecting presence/absence of the lower drawer  | P.2-9<br>"Fig. 2-11"  | P6-I113  |
| SW8    | ADU-SET-SW<br>ADU opening/closing switch                | Automatic duplexing unit opening/closing detection<br>* e-STUDIO230/280/232/282 (NAD/AUD/MJD/IRD/CND), e-STUDIO233/283 (NAD/MJD/CND) models: Standard<br>* e-STUDIO200L/202L (NAD/ASD/ARD), e-STUDIO203L (NAD/ARD), e-STUDIO230/280/232/282 (ASD/ASU/SAD/TWD/KRD), e-STUDIO233/283(ARD), e-STUDIO230L (MJD), e-STUDIO280S/232S/282S/283S (CND) models: Option           | P.2-12<br>"Fig. 2-15" | P32-I43  |
| SW9    | AUG-LOCK-SW<br>Auger lock switch                        | Detecting lock of the toner recovery auger  | P.2-7<br>"Fig. 2-8"   | P6-I113  |

## 3) Electromagnetic clutches

| Symbol | Name                                       | Function   | Remarks               | P-I     |
|--------|--|--|-----------------------|---------|
| CLT1   | RGST-CLT<br>Registration roller clutch     | Driving the registration roller  | P.2-14<br>"Fig. 2-17" | P21-I26 |
| CLT2   | TR-U-CLT<br>Upper transport clutch         | Driving with high speed for the 1st transport roller   | P.2-14<br>"Fig. 2-17" | P21-I24 |
| CLT3   | TR-M-CLT<br>Middle transport clutch        | Driving with low speed for the 1st/2nd transport roller  | P.2-14<br>"Fig. 2-17" | P7-I8   |
| CLT4   | TR-L-CLT<br>Lower transport clutch         | Driving with high speed for the 2nd transport roller   | P.2-14<br>"Fig. 2-17" | P7-I8   |
| CLT5   | CST-U-FEED-CLT<br>Upper drawer feed clutch | Driving the upper drawer pickup roller   | P.2-9<br>"Fig. 2-11"  | P15-I11 |
| CLT6   | CST-L-FEED-CLT<br>Lower drawer feed clutch | Driving the lower drawer pickup roller<br>* e-STUDIO230/280/232/282 (NAD/AUD/MJD/IRD/CND/TWD/KRD), e-STUDIO233/283 (NAD/MJD/CND), e-STUDIO280S/282S/283S/232S (CND) models: Standard<br>* e-STUDIO200L/202L (NAD/ASD/ARD), e-STUDIO203L (NAD/ARD), e-STUDIO230/280/232/282 (ASD/ASU/SAD/ARD), e-STUDIO233/283 (ARD), e-STUDIO230L (MJD) models: Option | P.2-9<br>"Fig. 2-11"  | P15-I11 |
| CLT7   | SFB-FEED-CLT<br>Bypass feed clutch         | Driving the bypass pickup roller and bypass feed roller  | P.2-11<br>"Fig. 2-13" | P20-I18 |
| CLT8   | ADU-CLT<br>ADU clutch                      | Driving the ADU<br>* e-STUDIO230/280/232/282 (NAD/AUD/MJD/IRD/CND), e-STUDIO233/283 (NAD/MJD/CND) models: Standard<br>* e-STUDIO200L/202L (NAD/ASD/ARD), e-STUDIO203L (NAD/ARD), e-STUDIO230/280/232/282 (ASD/ASU/SAD/TWD/KRD), e-STUDIO233/283(ARD), e-STUDIO230L (MJD), e-STUDIO280S/232S/282S/283S (CND) models: Option                             | P.2-12<br>"Fig. 2-15" | P32-I16 |

## 4) Solenoids

| Symbol | Name                              | Function                         | Remarks               | P-I     |
|--------|-----------------------------------|----------------------------------|-----------------------|---------|
| SOL    | SFB-SOL<br>Bypass pickup solenoid | Driving the bypass pickup roller | P.2-11<br>"Fig. 2-13" | P19-I11 |

5) PC boards

| Symbol | Name   | Function  | Remarks               | P-I              |
|--------|--|---|-----------------------|------------------|
| ADU    | PWA-F-ADU<br>ADU driving PC board (ADU board)                | Controlling the automatic duplexing unit<br>* e-STUDIO230/280/232/282 (NAD/AUD/MJD/IRD/CND), e-STUDIO233/283 (NAD/MJD/CND) models: Standard<br>* e-STUDIO200L/202L (NAD/ASD/ARD), e-STUDIO203L (NAD/ARD), e-STUDIO230/280/232/282 (ASD/ASU/SAD/TWD/KRD), e-STUDIO233/283(ARD), e-STUDIO230L (MJD), e-STUDIO280S/232S/282S/283S (CND) models: Option | P.2-12<br>"Fig. 2-15" | P32-I30          |
| CCD    | PWA-F-CCD<br>CCD driving PC board (CCD board)                | Controlling CCD and outputting the analog signal  | P.2-6<br>"Fig. 2-6"   | P11-I16          |
| DSP    | PWA-F-DSP<br>Display PC board (DSP board)                    | Controlling LCD and the touch panel on the control panel  | P.2-7<br>"Fig. 2-7"   | P3-I26           |
| FUS    | PWA-F-FUS<br>Fuse PC board (FUS board)                       | Supplying the power to each damp heater<br>* ASD/AUD/CND/SAD/ASU/TWD/IRD/ARD/KRD models: Standard<br>* NAD/MJD models: Option   | P.2-15<br>"Fig. 2-18" | P8-I5            |
| KEY    | PWA-F-KEY<br>Key control PC board (KEY board)                | Detecting the button entry and controlling LED on the control panel   | P.2-7<br>"Fig. 2-7"   | P3-I25           |
| LDR    | PWA-F-LDR<br>Laser driving PC board (LDR board)              | Driving the laser diode   | P.2-9<br>"Fig. 2-10"  | P10-I19          |
| LGC    | PWA-F-LGC<br>Logic PC board (LGC board)                      | Controlling the print engine section  | P.2-15<br>"Fig. 2-18" | P9-I10           |
| LRL    | PWA-F-LRL<br>Laser control signal relay PC board (LRL board) | Relaying the control signals of the laser unit  | P.2-7<br>"Fig. 2-8"   | P10-I3           |
| NIC    | PWA-F-NIC<br>NIC board                                       | Network connection interface<br>* e-STUDIO230/280 (NAD/AUD/MJD/IRD/CND/TWD) models: Standard<br>* e-STUDIO200L (NAD/ASD), e-STUDIO230/280 (ASD/ASU/SAD), e-STUDIO230L (MJD), e-STUDIO280S (CND) models: Option  | P.2-15<br>"Fig. 2-18" | P8-I29           |
| SLG    | PWA-F-SLG<br>Scanning section control PC board (SLG board)   | Controlling the original scanning section and RADF  | P.2-6<br>"Fig. 2-6"   | P11-I15          |
| SNS    | PWA-F-SNS<br>H-sync signal detection PC board (SNS board)    | Detection of the laser beam position  | P.2-9<br>"Fig. 2-10"  | P10-I19          |
| SYS    | PWA-F-SYS<br>System control PC board (SYS board)             | Controlling the whole system and image processing   | P.2-15<br>"Fig. 2-18" | P8-I20/<br>P8-I1 |



## 6) Lamps and heaters

| Symbol | Name                                    | Function  | Remarks                                     | P-I     |
|--------|---|---|---|---------|
| DH1    | SCN-L-DH<br>Scanner damp heater (Left)  | Preventing condensation of the mirrors of the carriages<br>* ASD/AUD/CND/SAD/ASU/TWD/IRD/ARD/KRD models: Standard<br>* NAD/MJD models: Option | P.2-6<br>"Fig. 2-6"                         | P11-I37 |
| DH2    | SCN-R-DH<br>Scanner damp heater (Right) | Preventing condensation of the lens<br>* ASD/AUD/CND/SAD/ASU/TWD/IRD/ARD/KRD models: Standard<br>* NAD/MJD models: Option                     | P.2-6<br>"Fig. 2-6"                         | P11-I38 |
| DH3    | DRM-DH<br>Drum damp heater              | Preventing condensation of the drum<br>* ASD/AUD/CND/SAD/ASU/TWD/IRD/ARD/KRD models: Standard<br>* NAD/MJD models: Option                     | P.2-8<br>"Fig. 2-9"                         | P5-I19  |
| ERS    | LP-ERS<br>Discharge LED                 | Removing the residual charge from the drum surface  | P.2-8<br>"Fig. 2-9"                         | P27-I13 |
| EXP    | LP-EXPO<br>Exposure lamp                | Exposing the original to the light  | P.2-5<br>"Fig. 2-4",<br>P.2-5<br>"Fig. 2-5" | P23-I6  |
| LAMP1  | CNTR-LAMP<br>Center heater lamp         | Heating the center section of fuser roller  | P.2-13<br>"Fig. 2-16"                       | P30-I37 |
| LAMP2  | SIDE-LAMP<br>Side heater lamp           | Heating the section of both sides of fuser roller   | P.2-13<br>"Fig. 2-16"                       | P30-I38 |

## 7) Thermistors and thermostats

| Symbol | Name  | Function   | Remarks               | P-I     |
|--------|---|--|-----------------------|---------|
| THMO1  | THERMO-SCN-DH<br>Scanner damp heater thermostat | Controlling the temperature of the scanner damp heater<br>* ASD/AUD/CND/SAD/ASU/TWD/<br>IRD/ARD/KRD models: Standard<br>* NAD/MJD models: Option | P.2-6<br>"Fig. 2-6"   | P11-I37 |
| THMO2  | THERMO-FSR-F<br>Fuser front thermostat          | Preventing overheating in the fuser unit   | P.2-13<br>"Fig. 2-16" | P30-I10 |
| THMO3  | THERMO-FSR-C<br>Fuser center thermostat         | Preventing overheating in the fuser unit   | P.2-13<br>"Fig. 2-16" | P30-I10 |
| THMO4  | THERMO-DRM-DH<br>Drum damp heater thermostat    | Controlling the temperature of the drum damp heater<br>* ASD/AUD/CND/SAD/ASU/TWD/<br>IRD/ARD/KRD models: Standard<br>* NAD/MJD models: Option    | P.2-8<br>"Fig. 2-9"   | P5-I19  |
| THMS1  | THMS-DRM<br>Drum thermistor                     | Detecting the temperature at the drum surface  | P.2-8<br>"Fig. 2-9"   | P28-I49 |
| THMS2  | THMS-C-HTR<br>Center thermistor                 | Detecting the surface temperature at fuser roller center<br>(for controlling the temperature of the center heater lamp)                          | P.2-13<br>"Fig. 2-16" | P30-I40 |
| THMS3  | THMS-S-HTR<br>Side thermistor                   | Detecting the surface temperature at the rear side of the fuser roller<br>(for controlling the temperature of the side heater lamp)              | P.2-13<br>"Fig. 2-16" | P30-I40 |
| THMS4  | THMS-EDG-HTR<br>Edge thermistor                 | Detecting the surface temperature at the edge of the fuser roller<br>(for preventing overheating)  | P.2-13<br>"Fig. 2-16" | P30-I40 |

## 8) Transformer

| Symbol | Name                               | Function   | Remarks               | P-I   |
|--------|------------------------------------|--|-----------------------|-------|
| HVT    | PS-HVT<br>High-voltage transformer | Generating high-voltage and supplying it to the following sections<br>• Needle electrode<br>• Main charger grid<br>• Developer bias<br>• Transfer bias<br>• Separation bias<br>• Transfer guide bias | P.2-15<br>"Fig. 2-18" | P6-I1 |

## 9) Others

| Symbol | Name                          | Function  | Remarks               | P-I                |
|--------|-------------------------------|---|-----------------------|--------------------|
| LCD    | LCD<br>LCD panel              | Displaying and entering each information                                | P.2-7<br>"Fig. 2-7"   | P3-I19             |
| HDD    | HDD<br>Hard disk              | Storing the program data and image data                                 | P.2-15<br>"Fig. 2-18" | P8-I39/<br>P8-I101 |
| INV    | INV-EXP<br>Inverter board     | Controlling the exposure lamp   | P.2-6<br>"Fig. 2-6"   | P23-I7             |
| PS     | PS-ACC<br>Switching regulator | Generating DC voltage and supplying it to each section of the equipment | P.2-8<br>"Fig. 2-9"   | P10-I16            |

## 2.4 General Description

### 2.4.1 System block diagram

#### e-STUDIO200L/230/230L/280/280S

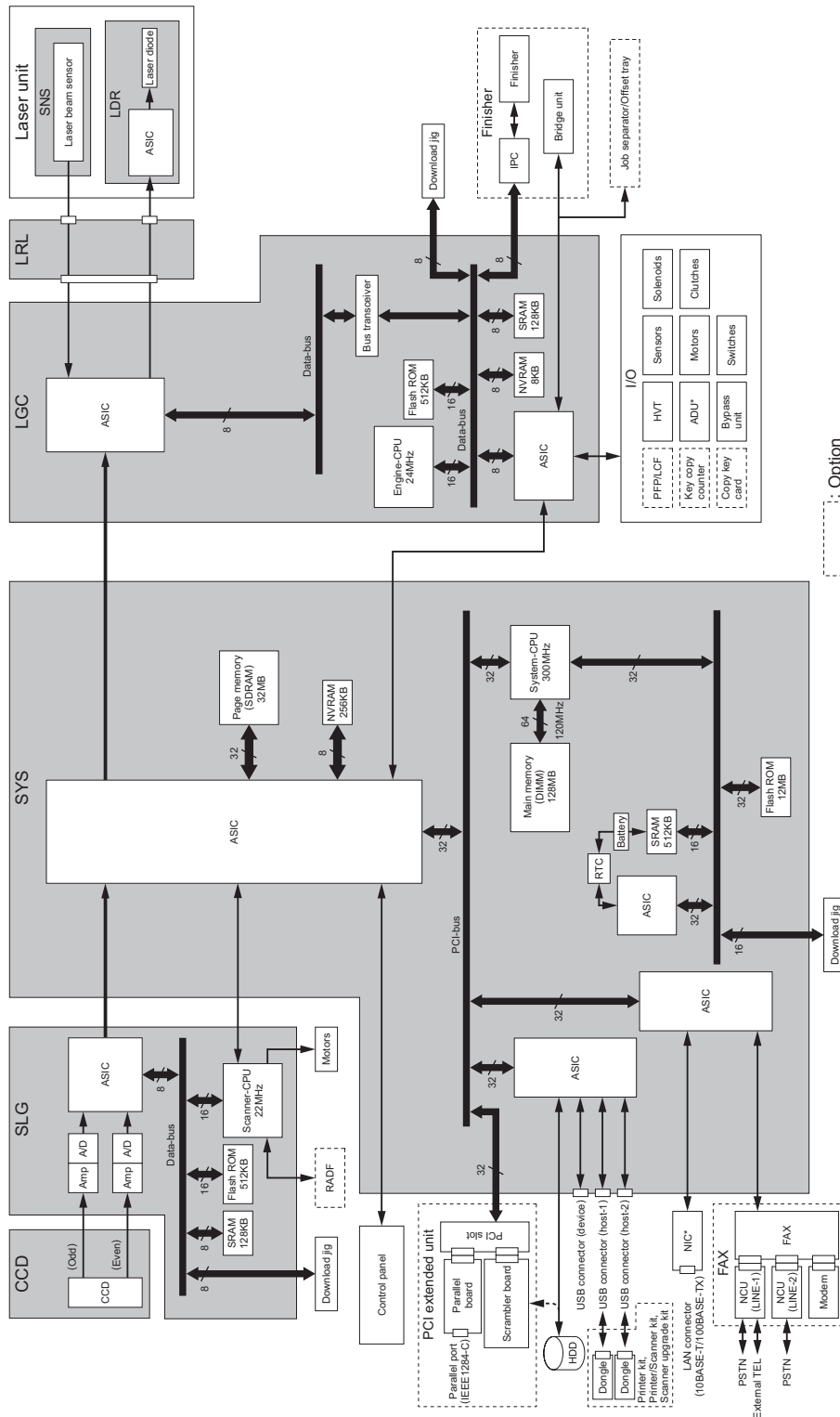

\*ADU and NIC are available as an option for some models or destinations.

Fig. 2-20

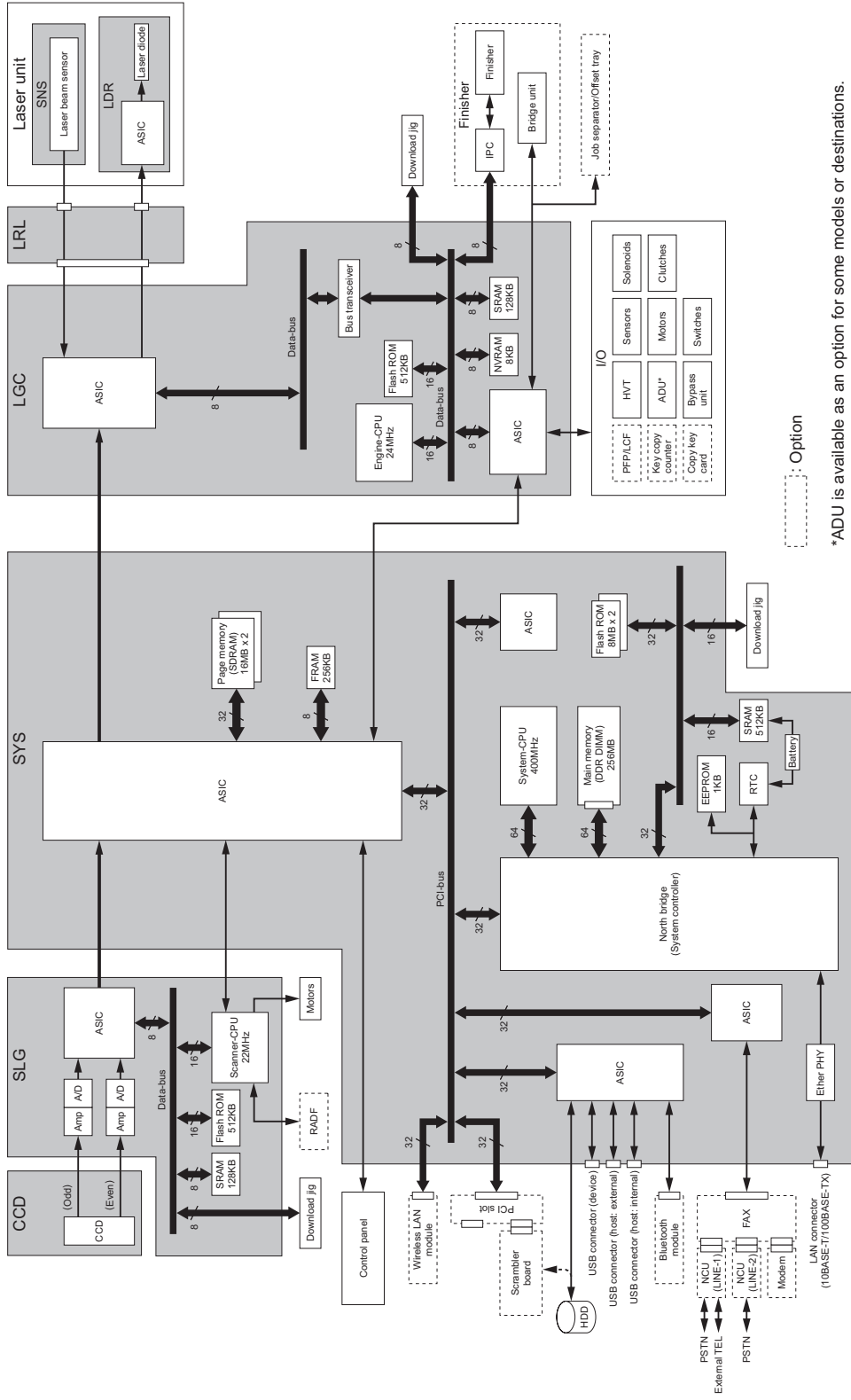

\*ADU is available as an option for some models or destinations.

Fig. 2-21

## 2.4.2 Construction of boards

### [ 1 ] Construction diagram of boards

This system consists of the following including the SYS board as a main board.

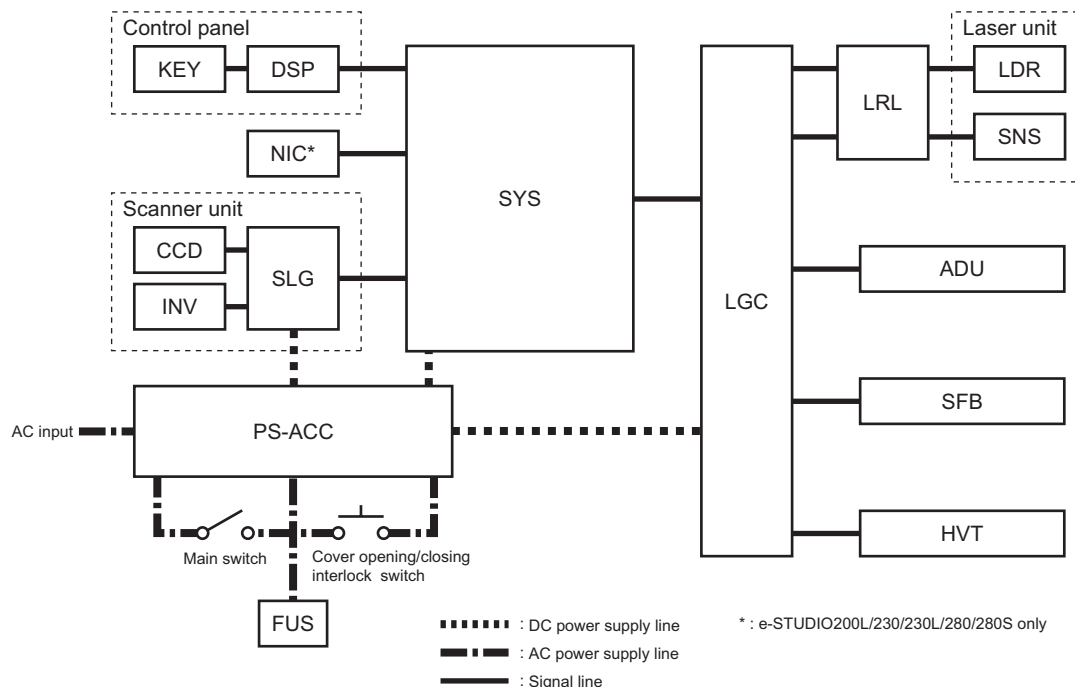

Fig. 2-22

### [ 2 ] Function of each board

- **CCD board:**  
This is the board to convert the reflected light by the original to electrical signals. It consists of the CCD, and its peripheral circuitry. The CCD converts the reflected light by the original to analog signal and outputs it to the SLG board.
- **SLG board:**  
This is the board to mainly control the scanning function (scanner unit) and consists of the Scanner-CPU, ASIC, memory (Flash ROM and SRAM), A/D converter, driver for motor drive, etc. When scanning the original, the exposure lamp and scan motor are driven by the command from the Scanner-CPU. The analog signal output from the CCD board is then converted to digital signal by the A/D converter. Image processing is performed by ASIC.
- **INV board:**  
This is the board on which the lighting control circuit of the exposure lamp is mounted. The exposure lamp lights by the command from the Scanner-CPU.
- **DSP board:**  
This is the board to mainly control the control panel. The panel processing CPU detecting the input from each button and touch panel, and the lighting control circuit for the backlight of the LCD are mounted. And it relays the control signal of the control panel from the SYS board to the LCD and KEY board.
- **KEY board:**  
This is the board on which each button switch and each LED on the control panel are mounted.

- **LDR board:**  
This is the board on which the laser diode and the ASIC are mounted. The laser is emitted based on the output image data signal from the ASIC on the LGC board.
- **SNS board:**  
This is the board on which the light sensor for detecting the radiating position of the laser is mounted.  
It outputs the H-sync signal to ASIC on the LGC board.
- **LRL board:**  
This is the board to relay each signal transmitted between the LGC board and laser unit (LDR and SNS boards).
- **ADU board:**  
This is the board to relay each signal between the ASIC on the LGC board and the electric parts (motor, sensor, clutch) in the ADU.
- **SYS board:**  
This is the main board taking a leading part in all systems. It consists of the System-CPU, ASIC, memory (DIMM, SDRAM, Flash ROM, SRAM, NVRAM), RTC (Real Time Clock IC), etc. The System-CPU controls each ASIC to perform the control of the image processing, image memory (page memory, main memory, HDD), external interface (IEEE-1284, USB, PCI), NIC and FAX.  
Based on the input data from the control panel, the System-CPU communicates with the Scanner-CPU on the SLG board and Engine-CPU on the LGC board, and then issues an operation command to the scanner and printer engine section.
- **LGC board:**  
This is the board to mainly control the printing function (printer engine). It consists of the Engine-CPU, ASIC, memory (Flash ROM, SRAM, NVRAM), driver for motor drive, etc. The Engine-CPU controls each ASIC to drive I/O (for the electrical parts) of each section in the system. It leads to the operation of the laser unit, developer unit, drum, drawers, bypass unit, ADU, etc. Thus printing is performed.
- **NIC board (e-STUDIO200L/230/230L/280/280S):**  
This is the interface board to connect this equipment to the LAN environment (10BASE-T, 100BASETX) to communicate with PCs, etc.
- **FIL board:**  
This is the board to cut off the noise of AC power from outside, and supply the driving AC power to the damp heater for condensation prevention of each section (scanner and drum).
- **FUS board:**  
This is the board to provide the AC electric power for driving to the damp heater for preventing of the condensation of each section (scanner and drum).
- **HVT:**  
This is the board to generate the DC high voltage from +24V to provide the bias to the section of the main charger, developer, transfer, and separation.
- **PS-ACC:**  
This is the unit to generate each DC voltage, which is used in the equipment, from external AC electric power input. And then it is provided to each electrical part.

## 2.5 Installation and Replacement of Covers and PC Boards

### 2.5.1 Covers

#### [A] Front cover

- (1) Open the front cover.

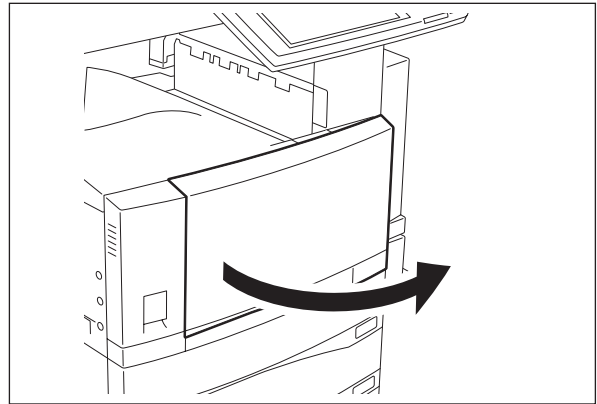

Fig. 2-23

- (2) Turn 2 hinge pins to point at the front side and pull them out upward.
- (3) Take off the front cover.

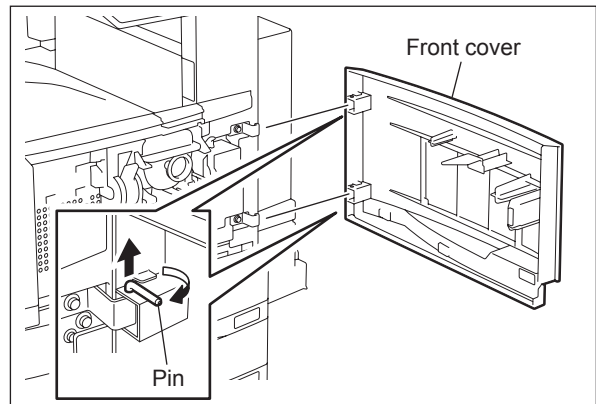
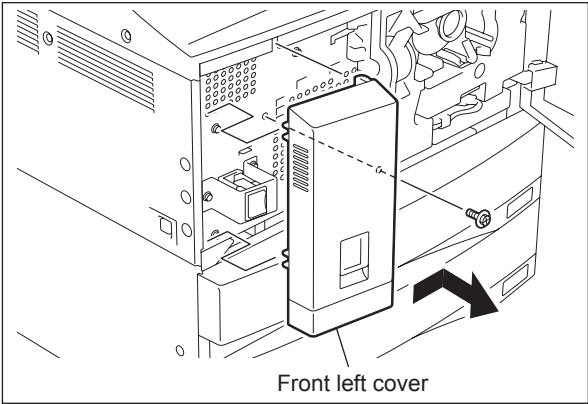

Fig. 2-24



**[B] Front left cover**

- (1) Open the front cover.
- (2) Remove 1 screw. Pull out the front left cover to the front side, and then take it off by sliding it to the right side.



**Fig. 2-25**

**[C] Rear cover**

- (1) Remove 7 screws and take off the rear cover.

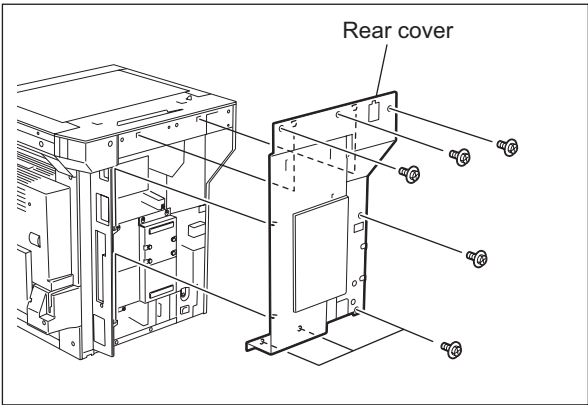

**Fig. 2-26**

### [D] Left upper cover

- (1) Remove 2 screws and take off the left upper cover.

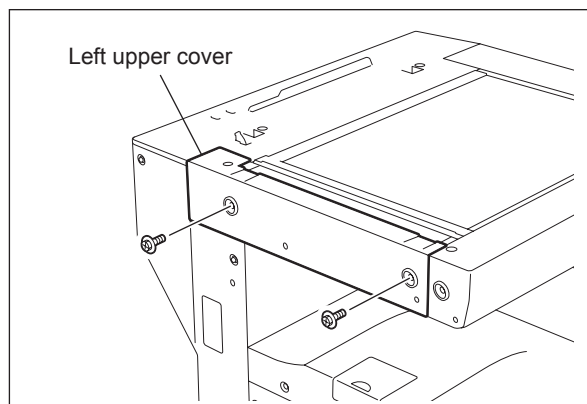

Fig. 2-27

### [E] Front upper cover

- (1) Take off the left upper cover (P.2-32 "[D] Left upper cover").
- (2) Remove 2 screws and take off the front upper cover.

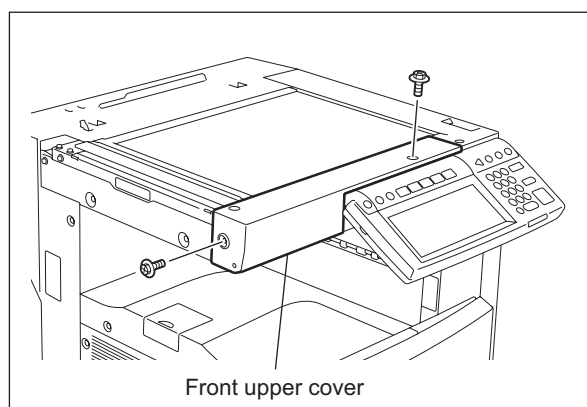
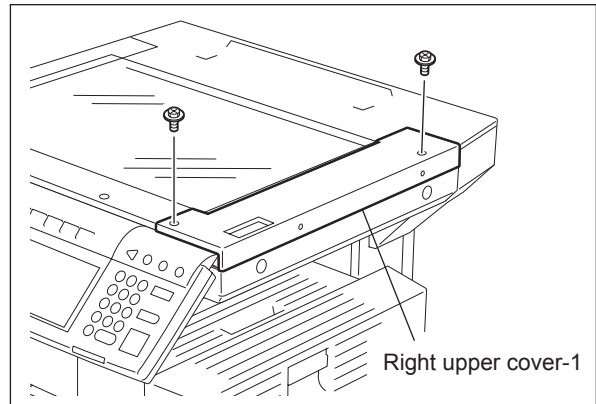

Fig. 2-28

**[F] Right upper cover-1**

- (1) Remove 2 screws and take off the right upper cover-1.

**Fig. 2-29****[G] Right upper cover-2**

- (1) Take off the right upper cover-1 (P.2-33 "[F] Right upper cover-1").
- (2) Remove 2 screws and take off the right upper cover-2.

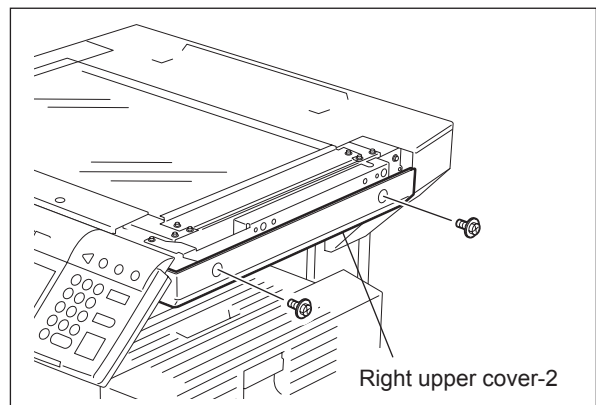
**Fig. 2-30**

### [H] Right upper cover-3

- (1) Take off the rear cover  
( P.2-31 "[C] Rear cover").
- (2) Remove 1 screw and take off the right upper cover-3.

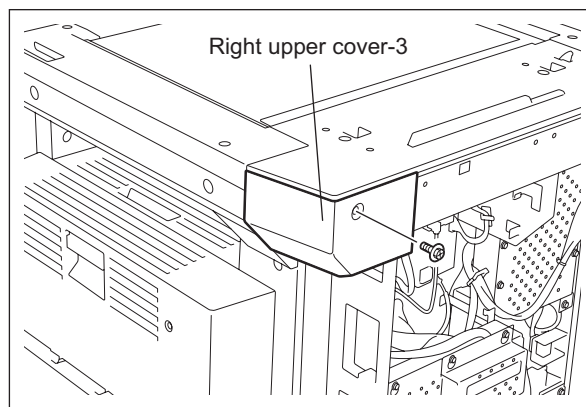



Fig. 2-31

### [I] Upper rear cover

- (1) Take off the RADF or Platen Cover.
- (2) Take off the left upper cover  
( P.2-32 "[D] Left upper cover").
- (3) Take off the right upper cover-1  
( P.2-33 "[F] Right upper cover-1").
- (4) Remove 2 screws and take off the upper rear cover.

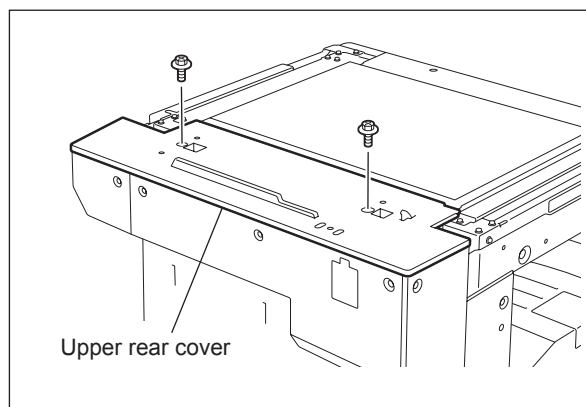



Fig. 2-32

### [J] Left rear cover

- (1) Take off the left upper cover  
( P.2-32 "[D] Left upper cover").
- (2) Remove 4 screws and take off the left rear cover.

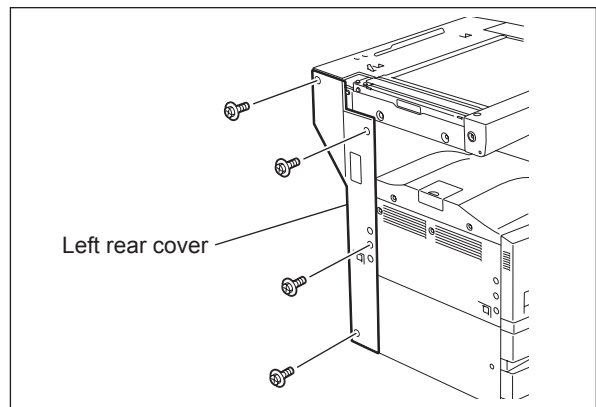

Fig. 2-33

### [K] Inner tray

- (1) Open the front cover.
- (2) Open the exit cover.
- (3) Remove 2 screws and take off the inner tray.

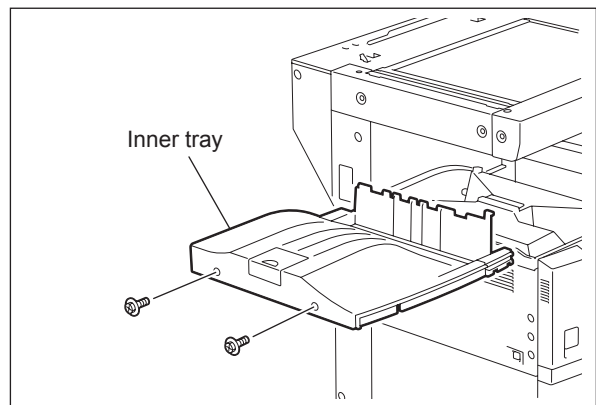

Fig. 2-34

## [L] Left cover

- (1) Remove 3 screws and take off the left cover.

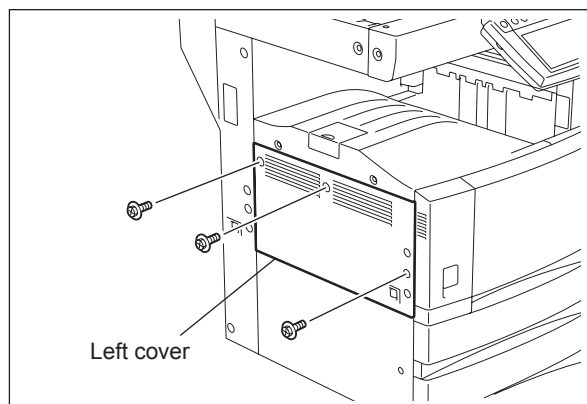

Fig. 2-35

## [M] Tray back cover

- (1) Take off the left rear cover (P.2-35 "[J] Left rear cover").
- (2) Take off the inner tray (P.2-35 "[K] Inner tray").
- (3) Open the exit cover.
- (4) Take off the tray back cover.

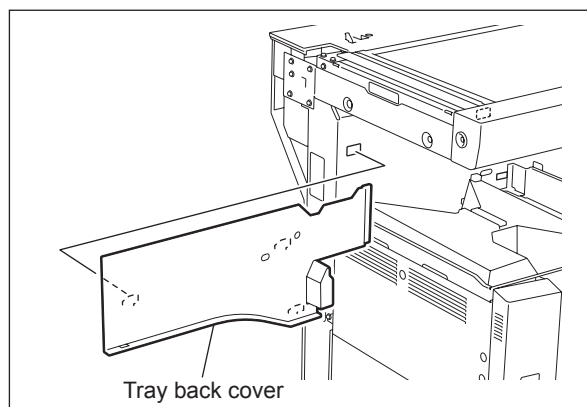



Fig. 2-36

## [N] Right rear cover

- (1) Take off the right upper cover-3  
( P.2-34 "[H] Right upper cover-3").
- (2) Open the transfer cover.
- (3) Remove 2 screws and take off the right rear cover.

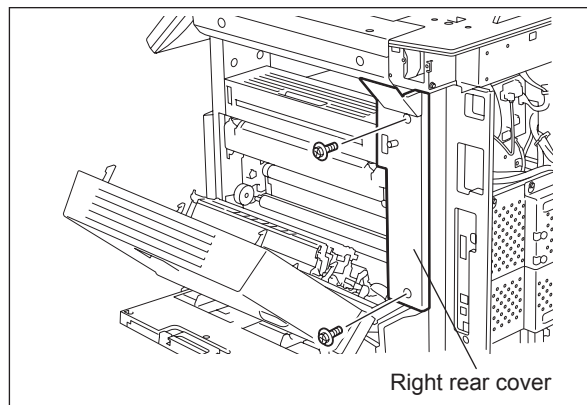



Fig. 2-37

## [O] Connecting port cover

### [O-1] e-STUDIO200L/230/230L/280/280S

- (1) Take off the right rear cover  
( P.2-37 "[N] Right rear cover").
- (2) Remove 1 screw and take off the connecting port cover.

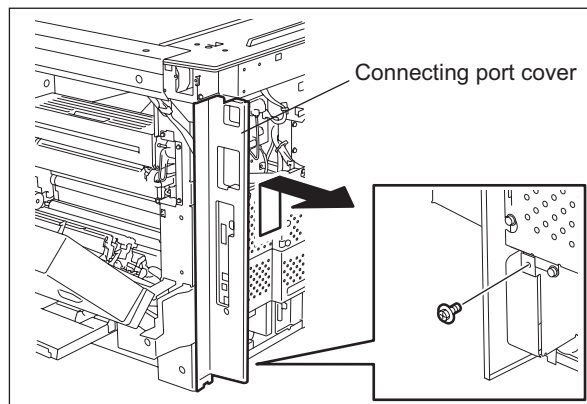

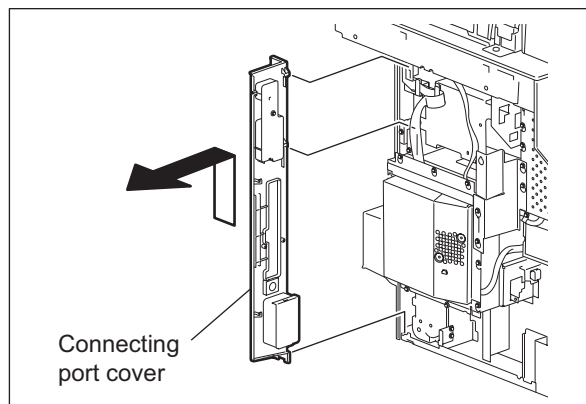

Fig. 2-38

**[O-2] e-STUDIO202L/203L/232/233/232S/282/283/282S/283S**

- (1) Take off the right upper cover-3  
( P.2-34 "[H] Right upper cover-3").
- (2) Remove the connecting port cover while releasing 2 hooks.



**Fig. 2-39**

**[P] Right front hinge cover**

- (1) Pull out the upper and lower drawers.
- (2) Remove 2 screws and take off the right front hinge cover.

**Note:**

When the ADU is installed, refer to chapter 15.5 ( P.15-10 "[A] Automatic Duplexing Unit (ADU)").

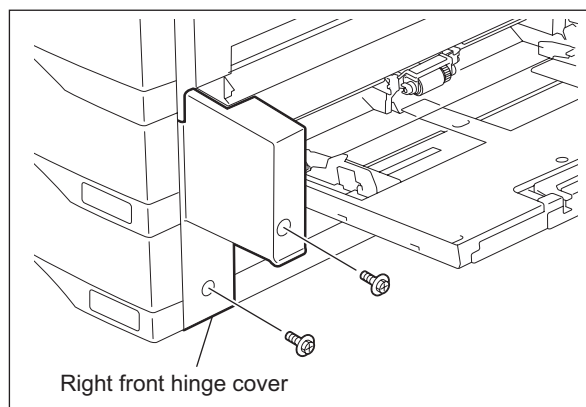

**Fig. 2-40**



**[Q] Right rear hinge cover**

- (1) Remove 2 screws and take off the right rear hinge cover.

**Note:**

When the ADU is installed, refer to chapter 15.5 (P.15-10 "[A] Automatic Duplexing Unit (ADU)")

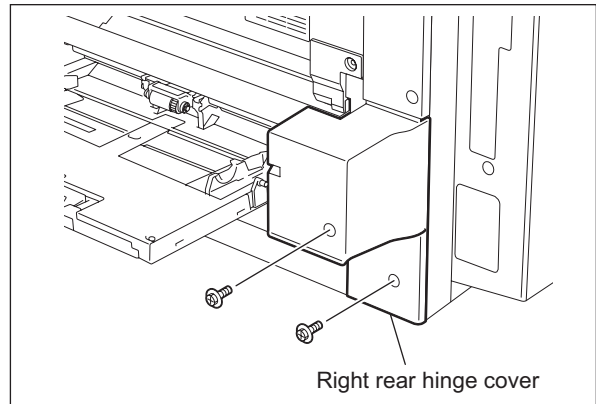

**Fig. 2-41**

**[R] Bypass upper cover**

**Note:**

- e-STUDIO200L (NAD/ASD),
- e-STUDIO230L (MJD),
- e-STUDIO230/280 (ASD/ASU/SAD/TWD)
- e-STUDIO202L/203L (NAD/ARD),
- e-STUDIO232 (ASD/ASU/SAD/CND/TWD/KRD/ARD),
- e-STUDIO233 (CND/ARD),
- e-STUDIO282 (ASD/ASU/SAD/CND/TWD/KRD/ARD),
- e-STUDIO283 (CND/ARD)

- (1) Remove 1 screw, take off the harness cover.
- (2) Take off the right front hinge cover. (P.2-38 "[P] Right front hinge cover")
- (3) Take off the right rear hinge cover. (P.2-39 "[Q] Right rear hinge cover")

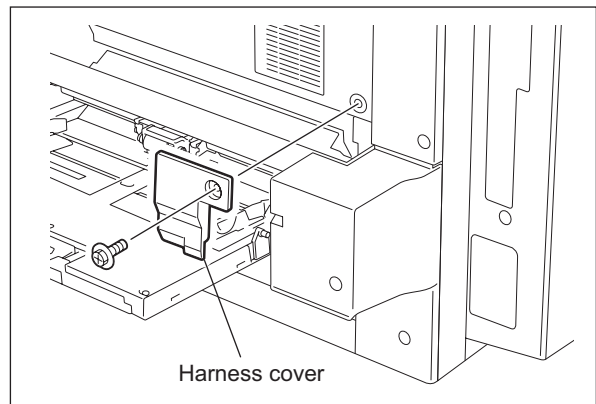

**Fig. 2-42**

- (4) Remove 2 screws, take off the bypass upper cover.

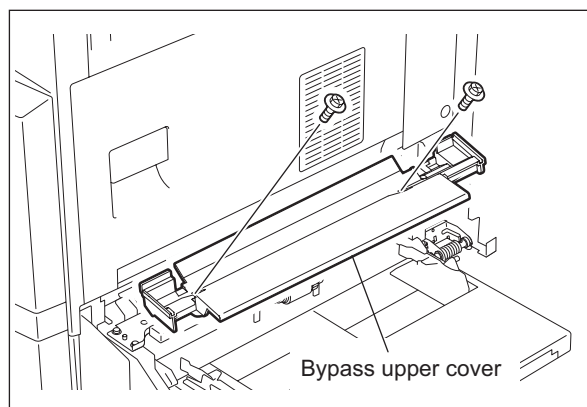

**Fig. 2-43**

## 2.5.2 PC boards

**Note:**

When the PC board/HDD is replaced, refer to each CAUTIONS of TROUBLESHOOTING in the SERVICE HANDBOOK.

### [A] Hard disk (HDD)

#### [A-1] e-STUDIO200L/230/230L/280/280S

- (1) Take off the rear cover  
( P.2-31 "[C] Rear cover").
- (2) Loosen 4 screws and take off the bridge bracket.

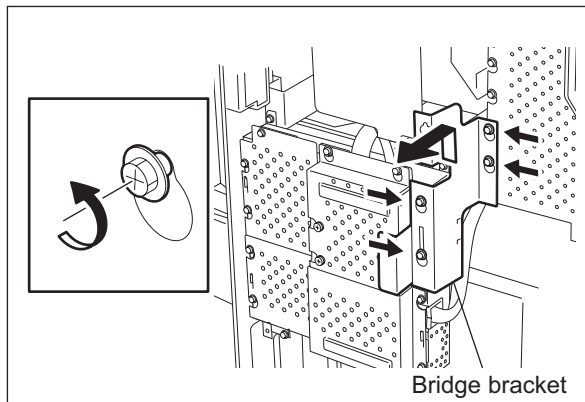

Fig. 2-44

- (3) Loosen 6 screws and take off the SYS board lower cover.

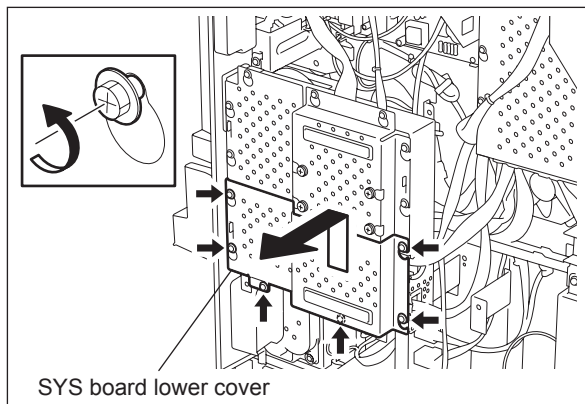

Fig. 2-45

- (4) Loosen 5 screws, disconnect 2 connectors and take off the SYS board upper cover.

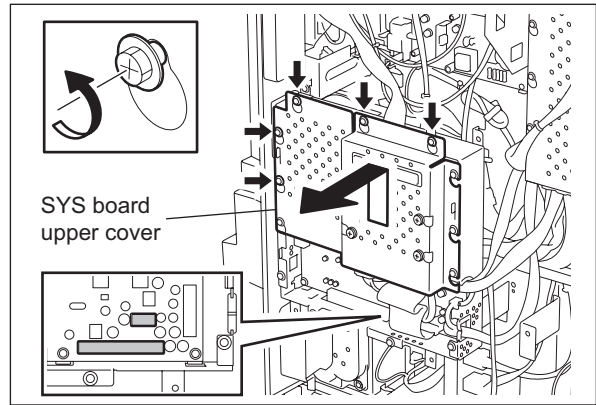

Fig. 2-46

- (5) Remove 4 screws and take off the HDD from the SYS board upper cover.

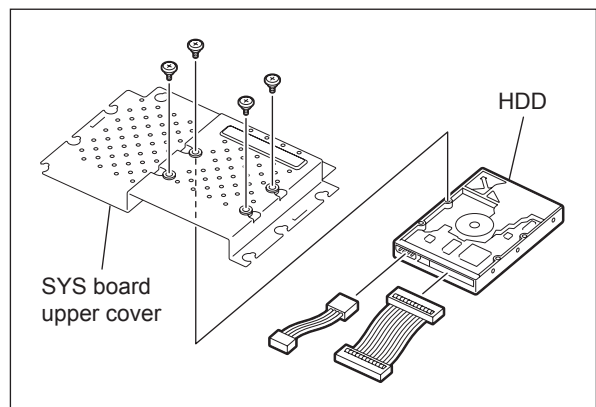

Fig. 2-47

**[A-2] e-STUDIO202L/203L/232/233/232S/282/283/282S/283S**

- (1) Take off the rear cover (see P.2-31 "[C] Rear cover").
- (2) Loosen 4 screws and take off the bridge bracket.

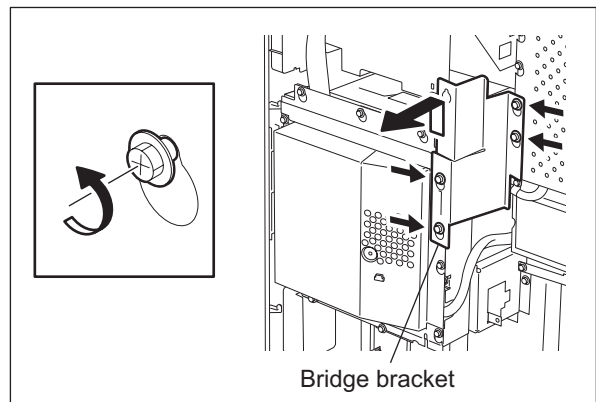

Fig. 2-48

(3) Disconnect 1 connector.

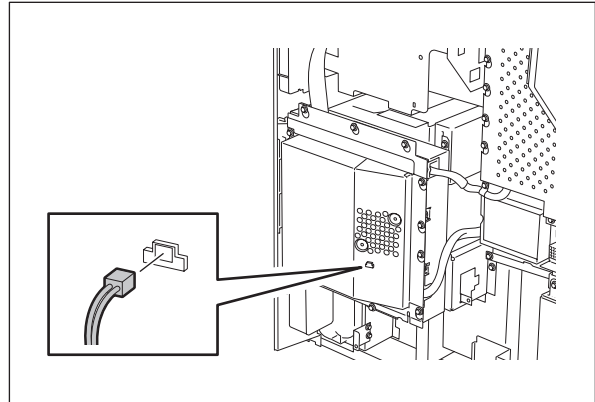

Fig. 2-49

(4) Loosen 11 screws and take off the SYS board cover.

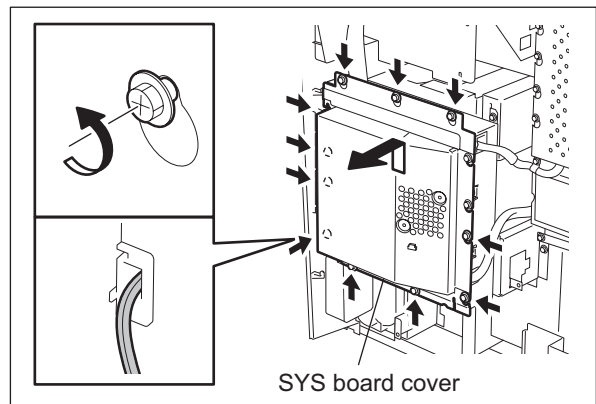

Fig. 2-50

(5) Remove 4 screws. Disconnect 2 connectors while removing the HDD with the bracket.

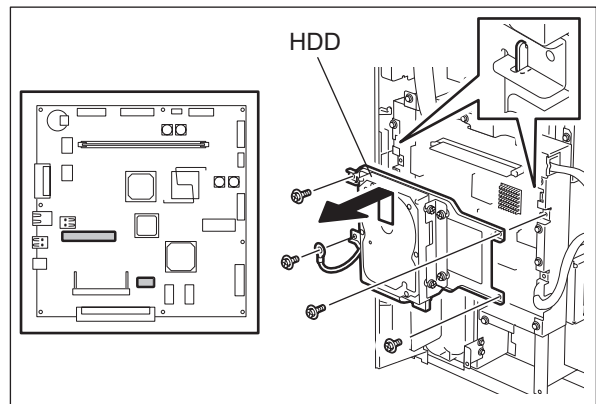

Fig. 2-51

- (6) Remove 4 screws and take off the HDD from the bracket. Disconnect 2 connectors. Remove 1 screw and take off the ground wire.

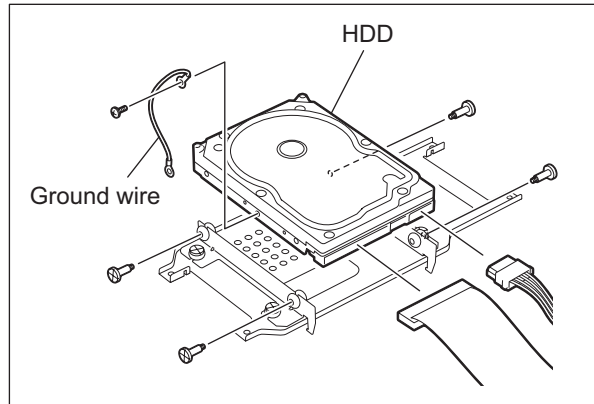

Fig. 2-52

- (7) Disconnect 1 connector. Remove 2 screws and take off the HDD cooling fan from the SYS board cover.

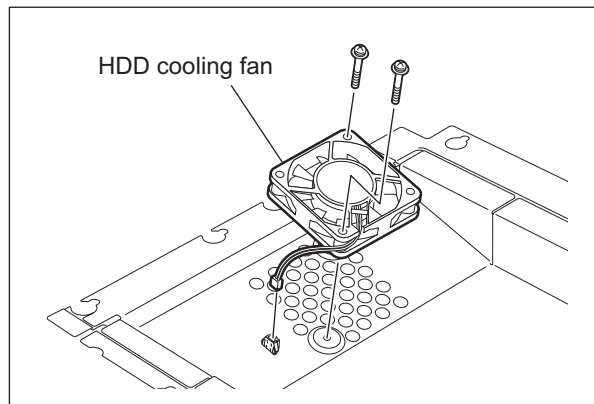

Fig. 2-53

### [B] NIC board (GF-1150)

e-STUDIO200L/230/230L/280/280S only

- (1) Take off the SYS board lower cover and SYS board upper cover (P.2-41 "[A] Hard disk (HDD)").
- (2) Release 2 locking supports, remove 2 screws, and then take off the NIC board.

**Note:**

NIC board is available as an option (GF-1150) for some destinations or versions.

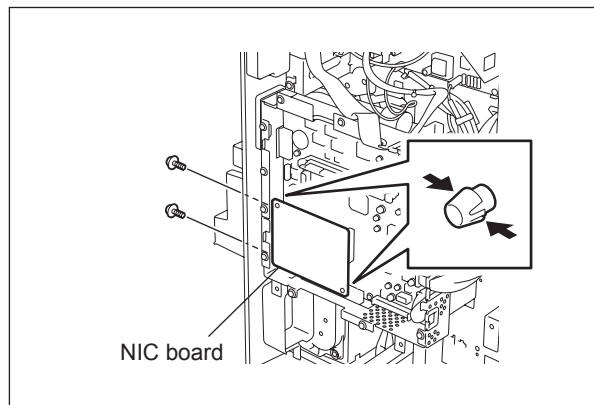

Fig. 2-54

### [C] System control PC board (SYS board)

#### [C-1] e-STUDIO200L/230/230L/280/280S

- (1) Take off the SYS board upper cover and SYS board lower cover (P.2-41 "[A] Hard disk (HDD)").
- (2) Take off the NIC board (P.2-44 "[B] NIC board (GF-1150)").
- (3) Disconnect 4 connectors, remove 8 screws, and then take off the SYS board.

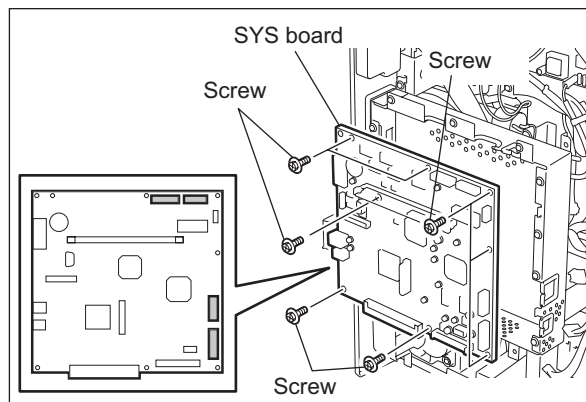

Fig. 2-55

#### [C-2] e-STUDIO202L/203L/232/233/232S/282/283/282S/283S

- (1) Take off the SYS board cover (P.2-41 "[A] Hard disk (HDD)").
- (2) Disconnect 4 connectors, remove 8 screws, and then take off the SYS board.

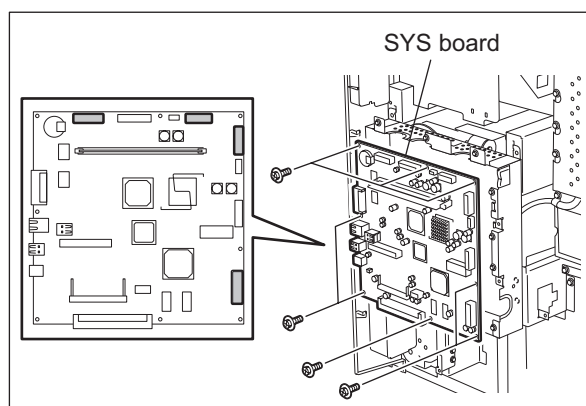
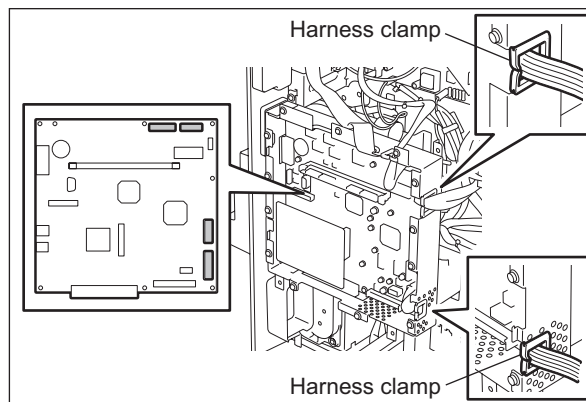

Fig. 2-56

**[D] SYS board case**

**[D-1] e-STUDIO200L/230/230L/280/280S**

- (1) Take off the SYS board upper cover and SYS board lower cover (P.2-41 "[A] Hard disk (HDD)").
- (2) Disconnect 4 connectors and release the harness from 3 harness clamps.



**Fig. 2-57**

- (3) Remove 5 screws and take off the SYS board case.

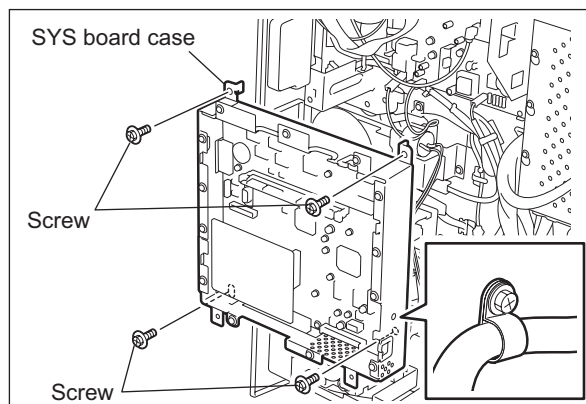
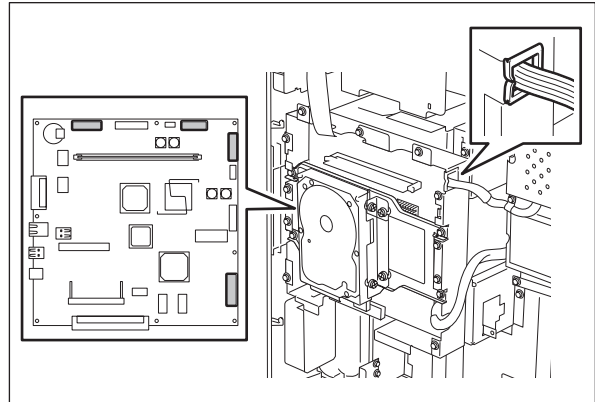

**Fig. 2-58**



**[D-2] e-STUDIO202L/203L/232/233/232S/282/283/282S/283S**

- (1) Take off the SYS board cover (📖 P.2-41 "[A] Hard disk (HDD)").
- (2) Disconnect 4 connectors and release the harness from 1 harness clamp.



**Fig. 2-59**

- (3) Remove 5 screws and take off the SYS board case.

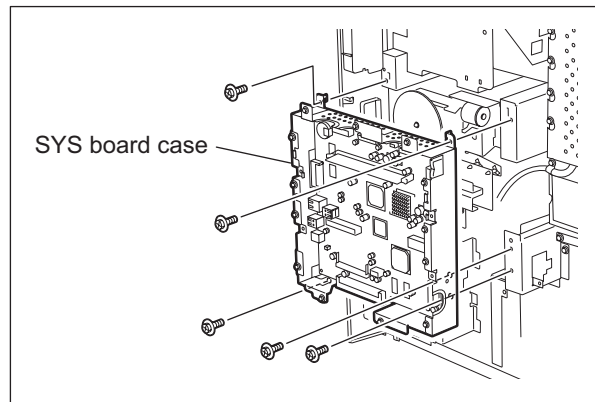

**Fig. 2-60**

**[E] Logic PC board (LGC board)**

- (1) Take off the rear cover (📖 P.2-31 "[C] Rear cover").
- (2) Loosen 4 screws and take off the bridge bracket.

**Note:**

The LGC boards of e-STUDIO200L/230/230L/280/280S and e-STUDIO202L/203L/232/233/232S/282/283/282S/283S are different in appearance.

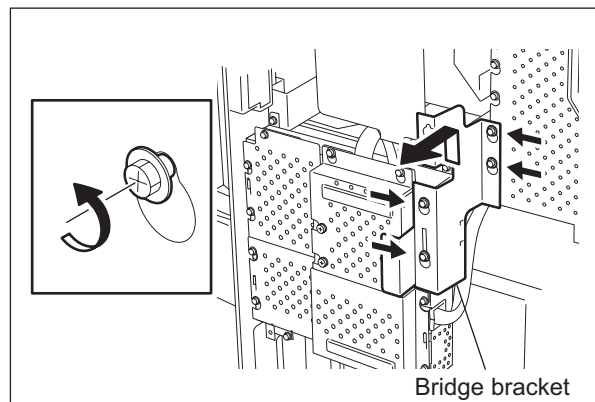

**Fig. 2-61**

- (3) Loosen 6 screws, remove 1 screw, and then take off the LGC board cover.

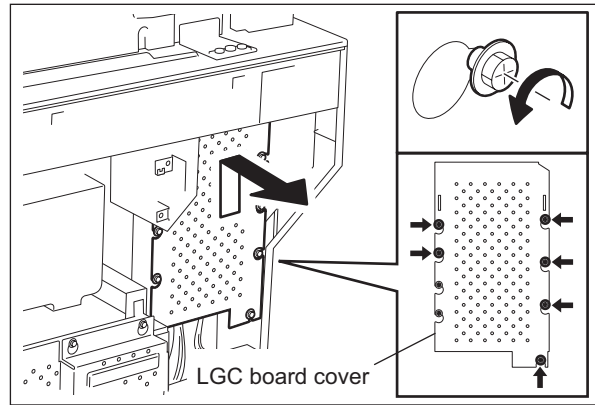

Fig. 2-62

- (4) Disconnect 12 connectors and release the harness from 5 harness clamps.

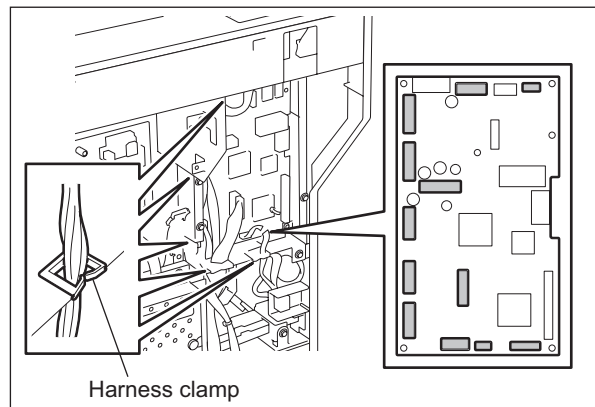

Fig. 2-63

- (5) Remove 4 screws, release 1 locking support, and then take off the LGC board.

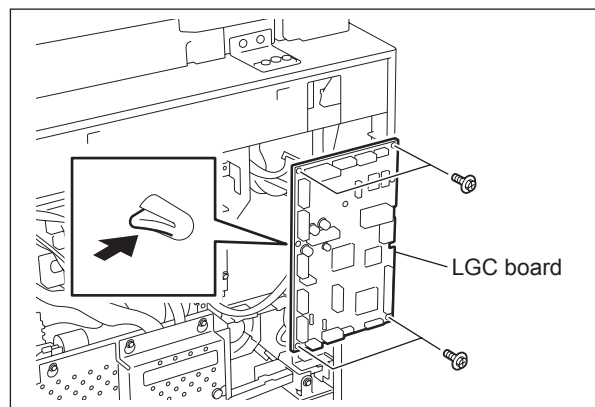

Fig. 2-64

## [F] High-voltage transformer

- (1) Take off the connecting port cover (P.2-37 "[O] Connecting port cover").
- (2) Release the harness from 6 harness clamps.
- (3) Remove 4 screws and take off the high-voltage transformer cover.

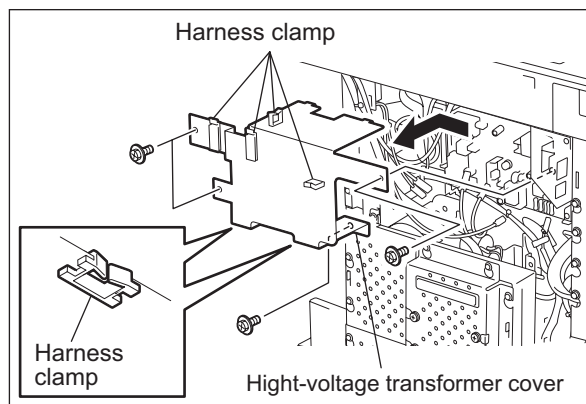

Fig. 2-65

- (4) Disconnect 7 connectors. Remove 2 screws, release 2 locking supports, and then take off the high-voltage transformer.

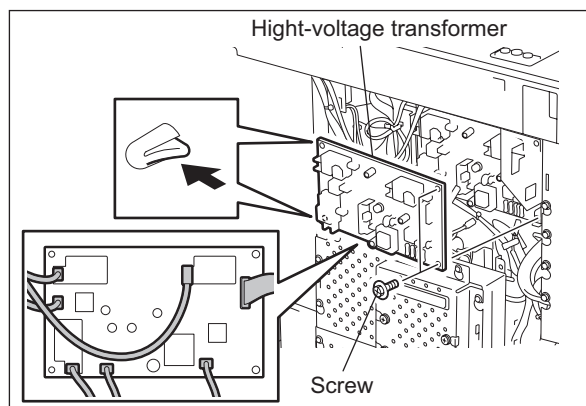

Fig. 2-66

## [G] Switching power supply

- (1) Take off the left rear cover (P.2-35 "[J] Left rear cover").
- (2) Take off the left cover (P.2-36 "[L] Left cover").
- (3) Remove 2 screws and pull out the switching power supply.
- (4) Disconnect 7 connectors, release the harness from 4 harness clamps.

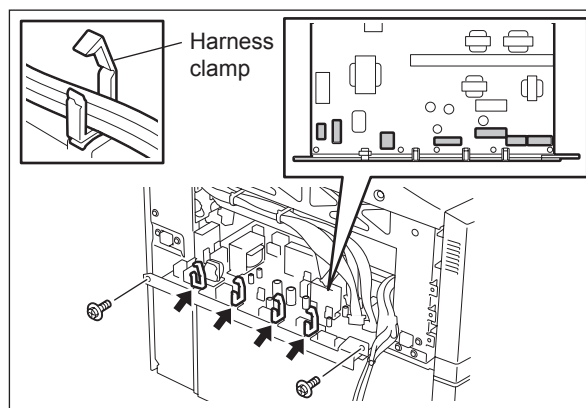

Fig. 2-67

(5) Take off the switching power supply.

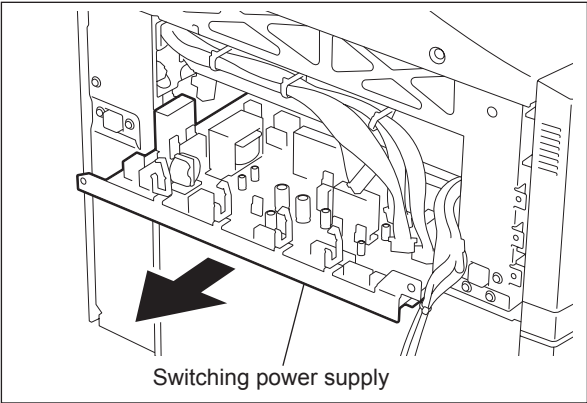

Fig. 2-68

## 2.6 Installation and Replacement of Options

### [A] MR-3016 (Reversing Automatic Document Feeder (RADF))

- (1) Turn the power OFF and unplug the power cable.
- (2) Take off the connector cover.

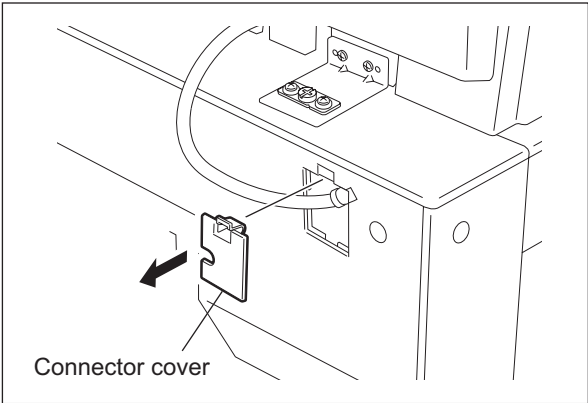

Fig. 2-69

- (3) Disconnect the connector.

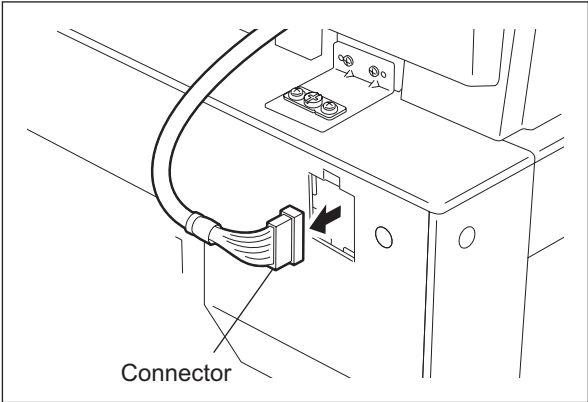
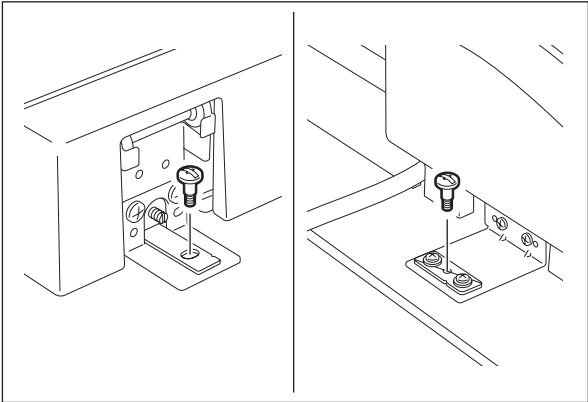

Fig. 2-70

- (4) Remove 2 screws on the rear side.



(5) Open the RADF.

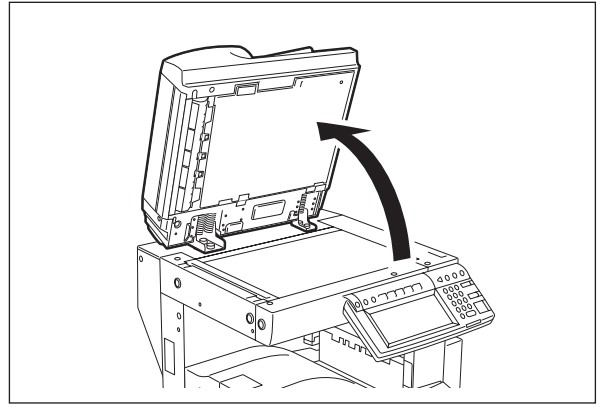

Fig. 2-72

(6) Remove 2 screws on the front side.

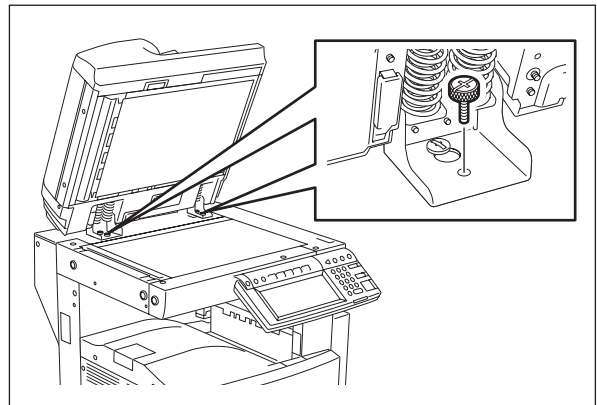

Fig. 2-73

(7) Slide the RADF backward and take it off by lifting it up.

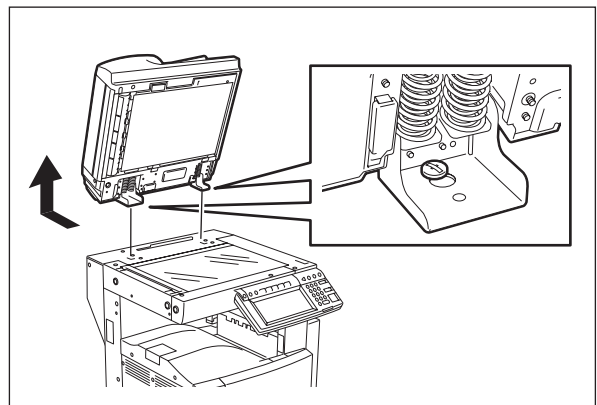
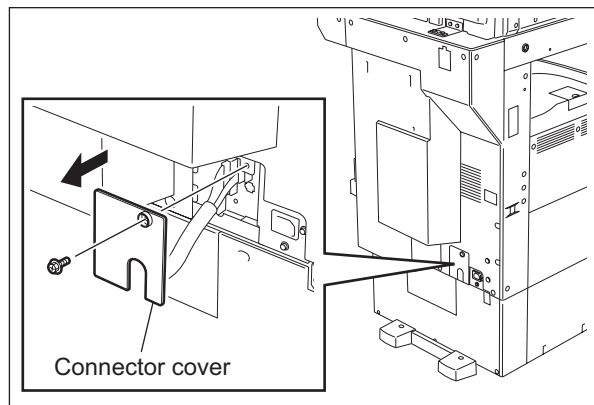

Fig. 2-74

**[B] KD-1011 (Paper Feed Pedestal (PFP))**

- (1) Turn the power OFF and unplug the power cable.
- (2) Remove 1 screw and take off the connector cover.



**Fig. 2-75**

- (3) Remove 1 screw and the ground wire, and then disconnect 2 connectors (3 connectors if the optional damp heater is installed).

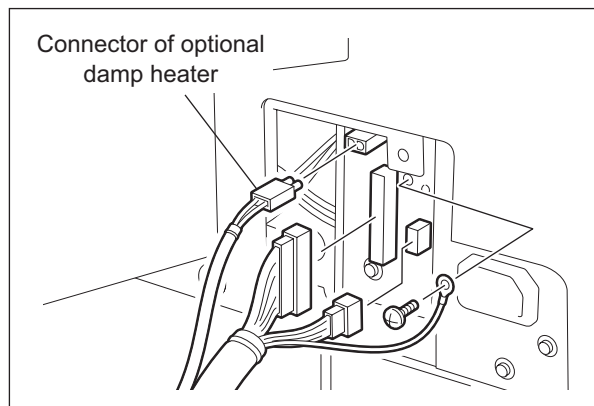

**Fig. 2-76**

- (4) Take off the lower drawer of the equipment and PFP upper drawer.

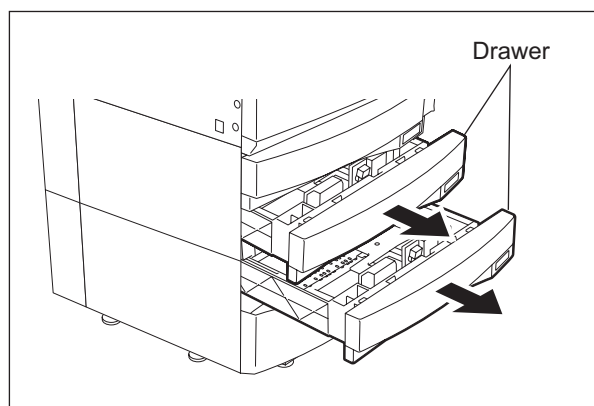

**Fig. 2-77**

- (5) Remove 2 screws and take off 2 fixing brackets on the rear side.

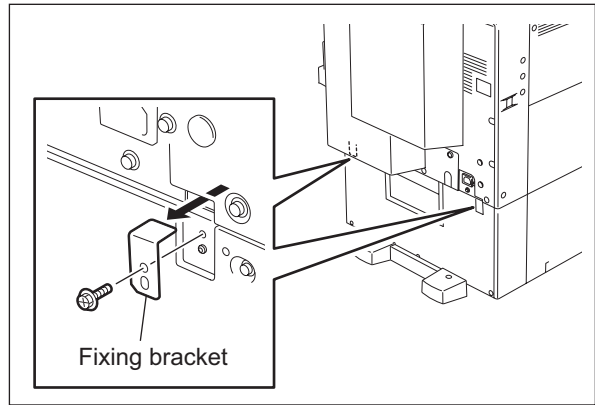

Fig. 2-78

- (6) Remove 4 screws and take off 2 fixing brackets on the front side.

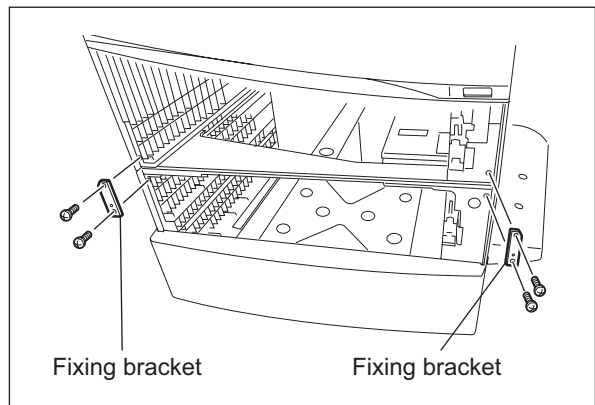

Fig. 2-79

- (7) Lift up the equipment and take off the PFP.

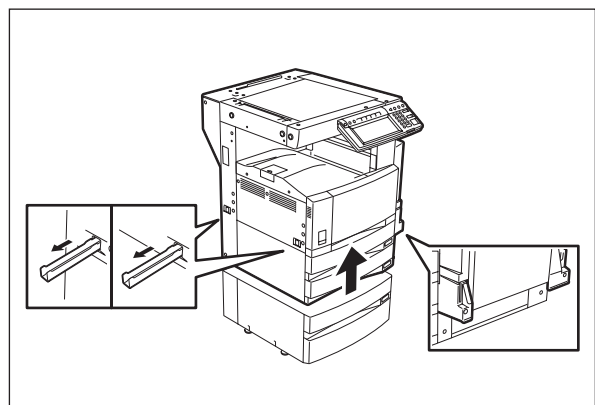
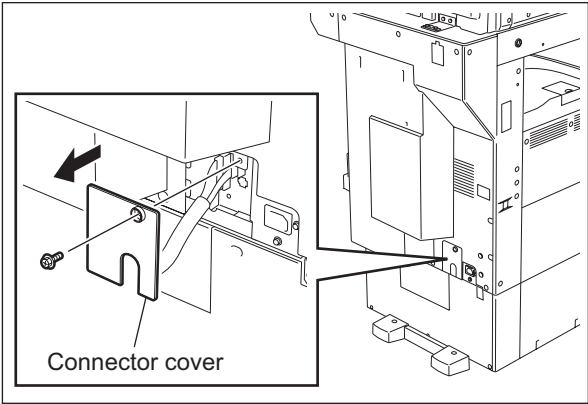

Fig. 2-80



**[C] KD-1012 (Large Capacity Feeder (LCF))**

- (1) Turn the power OFF and unplug the power cable.
- (2) Remove 1 screw and take off the connector cover.



**Fig. 2-81**

- (3) Remove 1 screw and the ground wire, and then disconnect 2 connectors.

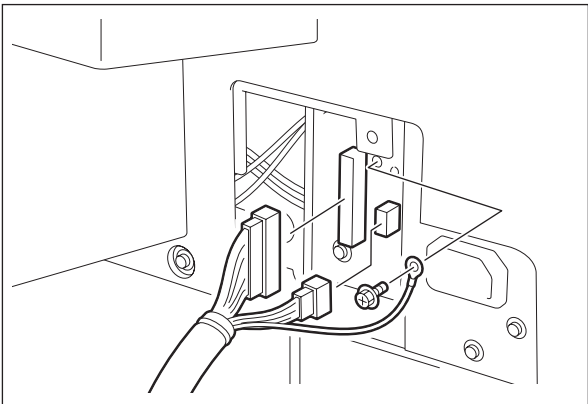

**Fig. 2-82**

- (4) Take off the lower drawer of the equipment.

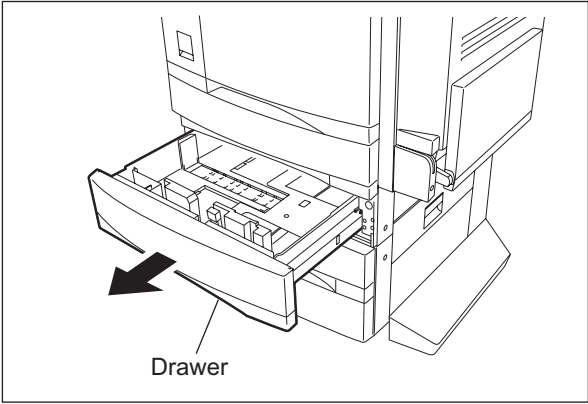

**Fig. 2-83**

- (5) Pull out the LCF drawer.

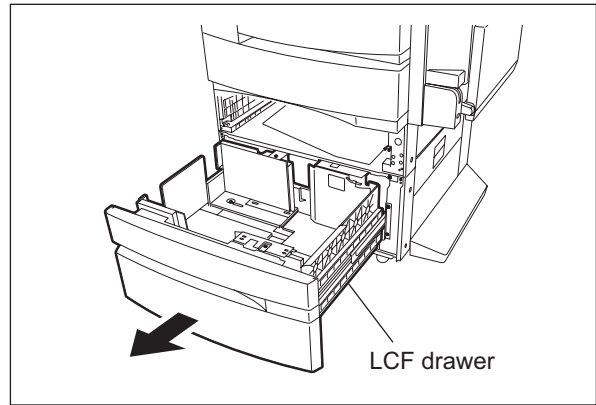

**Fig. 2-84**

- (6) Remove 2 screws and take off 2 fixing brackets on the rear side.

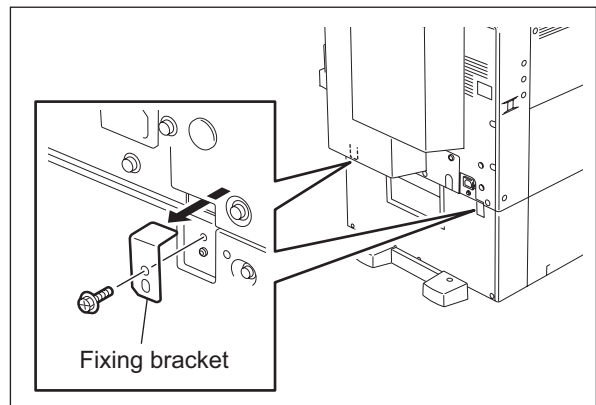

**Fig. 2-85**

- (7) Remove 4 screws and take off 2 fixing brackets on the front side.

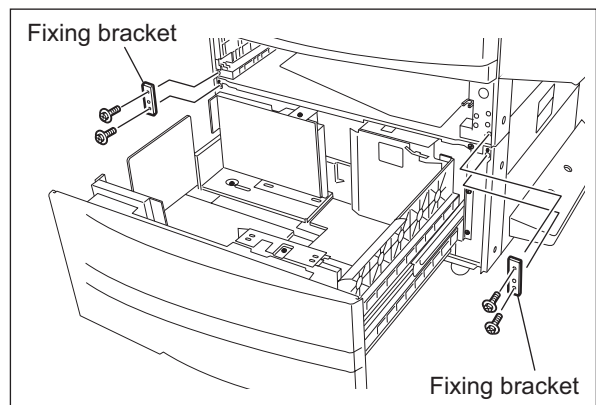

**Fig. 2-86**

(8) Lift up the equipment and take off the LCF.

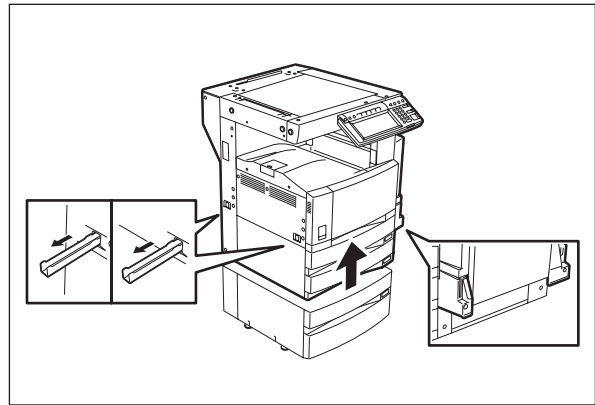

Fig. 2-87

**[D] MJ-1022 (Hanging finisher)**

**[D-1] When PFP/LCF is not installed**

- (1) Turn the power OFF and unplug the power cable.
- (2) Take off the connector cover and disconnect the connector.

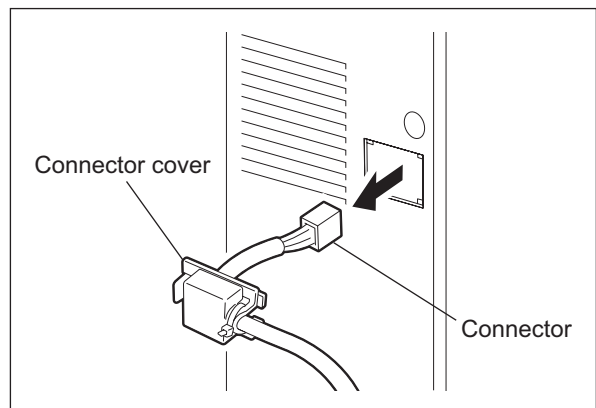

Fig. 2-88

- (3) Remove 2 screws and take off the safety bracket on the rear side and the cover.

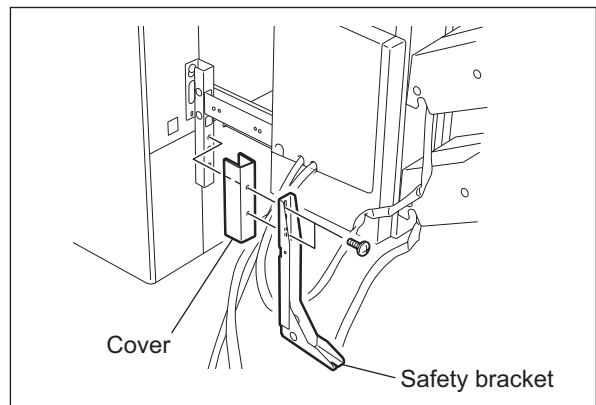

Fig. 2-89

- (4) Remove 2 screws and take off the safety bracket on the front side and the cover.

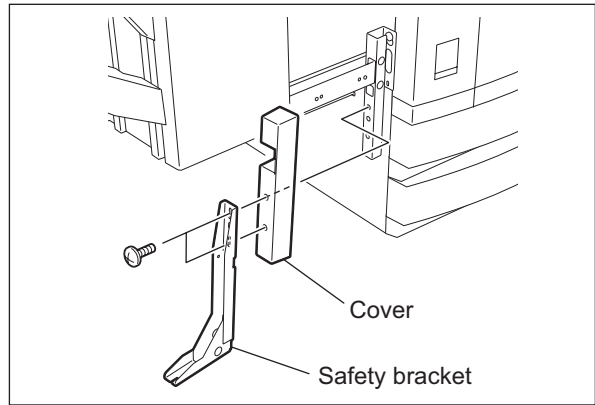

Fig. 2-90

- (5) Remove 2 screws.

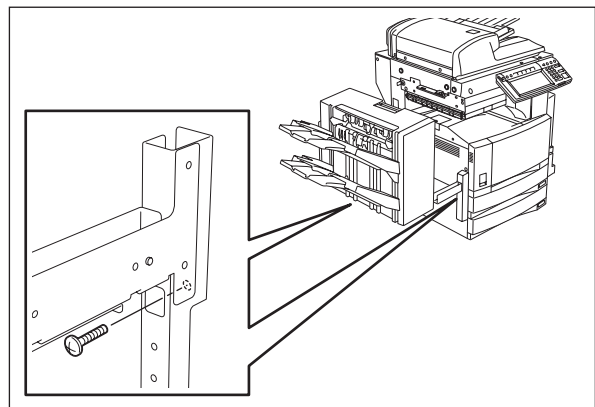

Fig. 2-91

- (6) Lift up the finisher and take it off.

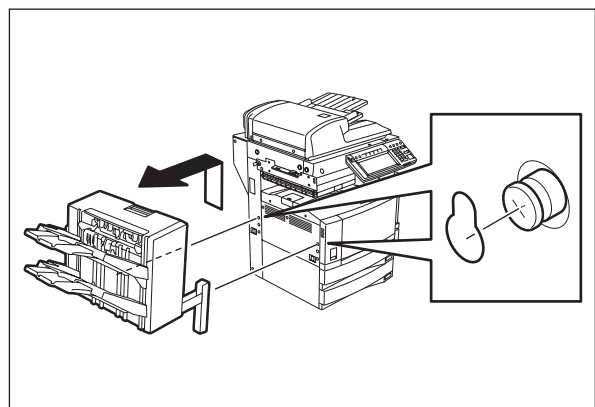
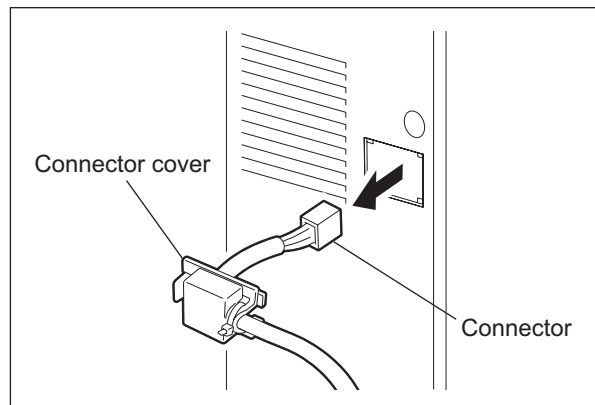

Fig. 2-92

**[D-2] When PFP/LCF is installed**

- (1) Turn the power OFF and unplug the power cable.
- (2) Take off the connector cover and disconnect the connector.



**Fig. 2-93**

- (3) Remove 2 screws and take off the cover on the rear side.

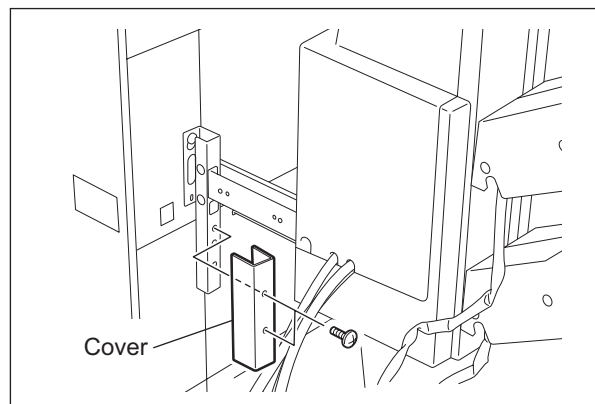

**Fig. 2-94**

- (4) Remove 2 screws and take off the cover on the front side.

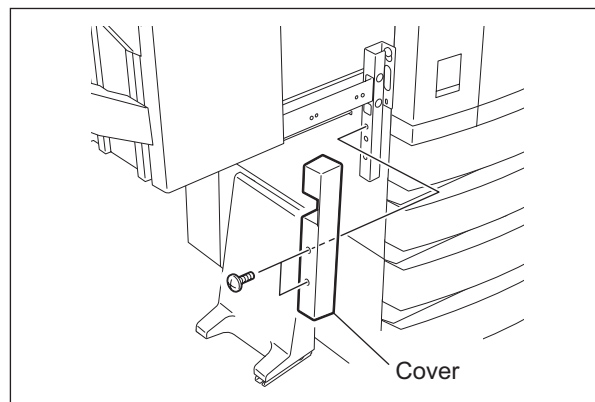

**Fig. 2-95**

- (5) Remove 2 screws.

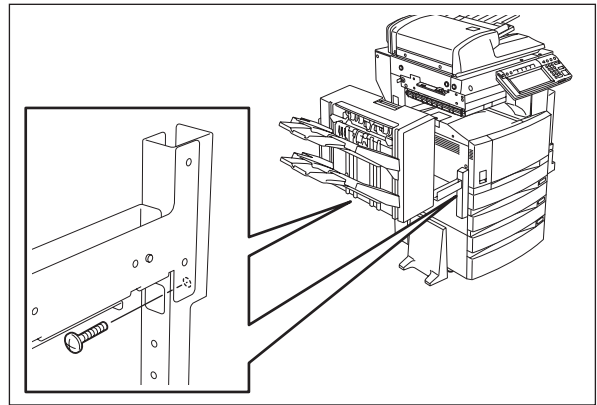

Fig. 2-96

- (6) Lift up the finisher and take it off.

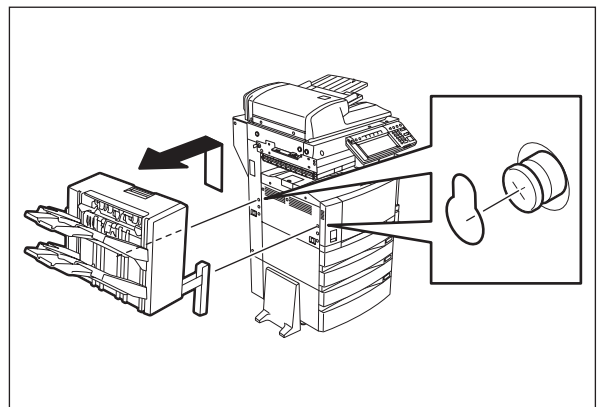

Fig. 2-97

**[E] MJ-1025 (Saddle stitch finisher)**

- (1) Turn the power OFF and unplug the power cable.
- (2) Take off the connector cover and disconnect the connector.

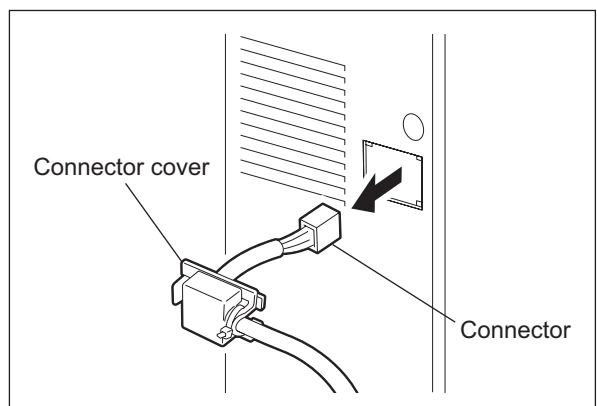

Fig. 2-98

- (3) Pull out the finisher while pushing the lever.

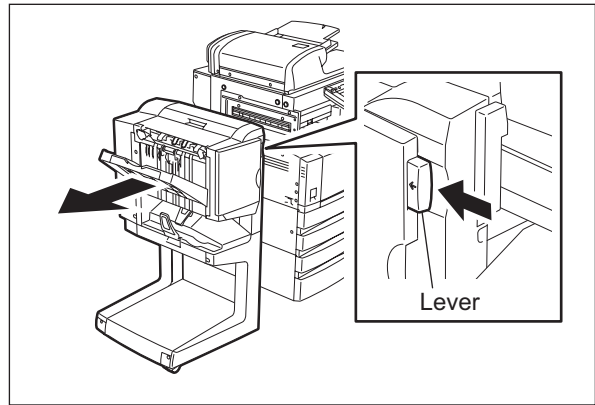

Fig. 2-99

- (4) Remove 1 screw and take off the finisher from the rail.

**Note:**

Be careful not to fell the finisher when moving the finisher unit only.

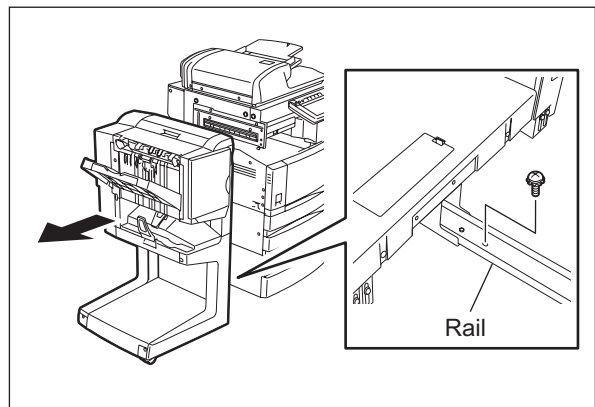

Fig. 2-100

**[F] KN-3520 (Bridge unit)**

- (1) Turn the power OFF and unplug the power cable.
- (2) Pull out the finisher from the equipment.
- (3) Remove the stopper.

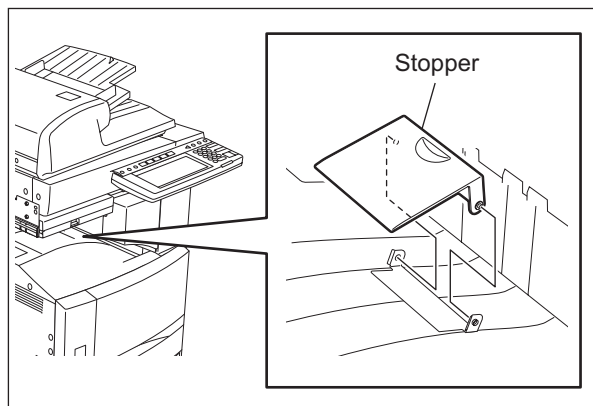
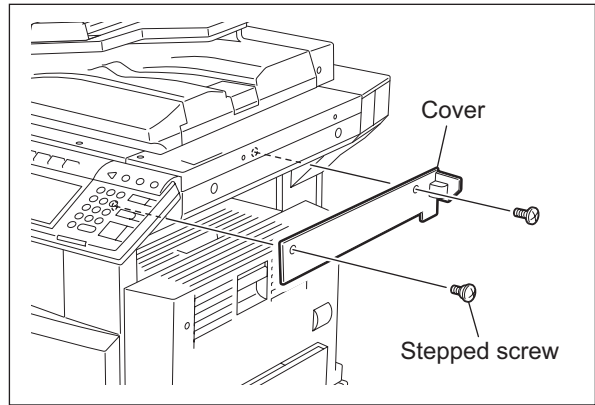

Fig. 2-101

- (4) Remove 2 screws and take off the cover.



**Fig. 2-102**

- (5) Disconnect 1 connector.

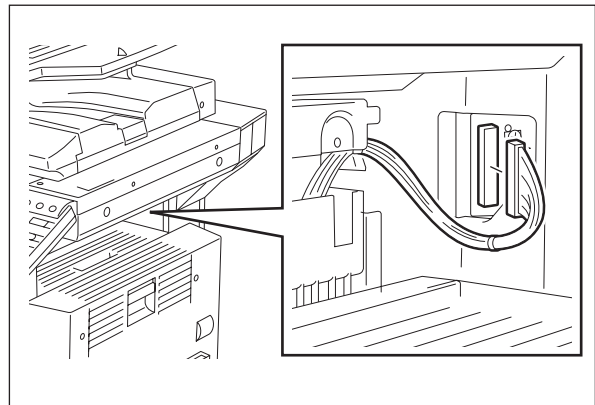

**Fig. 2-103**

- (6) Open the bridge unit. Remove 1 screw and take off the cover.

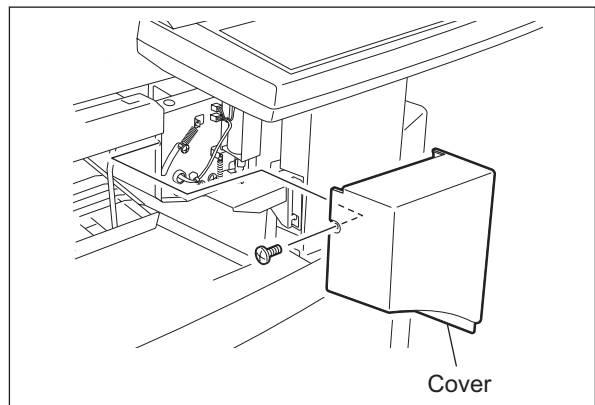

**Fig. 2-104**



(7) Close the bridge unit and remove 1 screw.

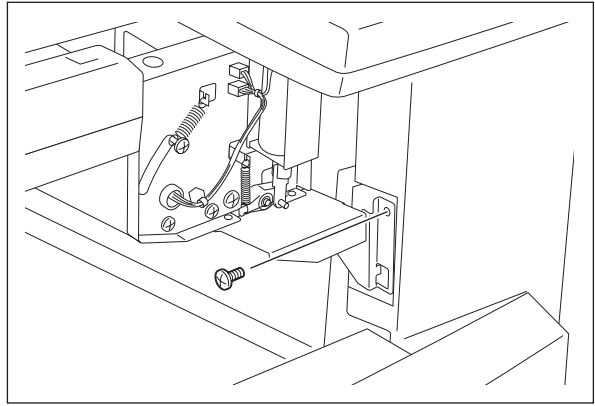

Fig. 2-105

(8) • When MJ-1022 is installed; Remove 4 screws and take off the bracket.

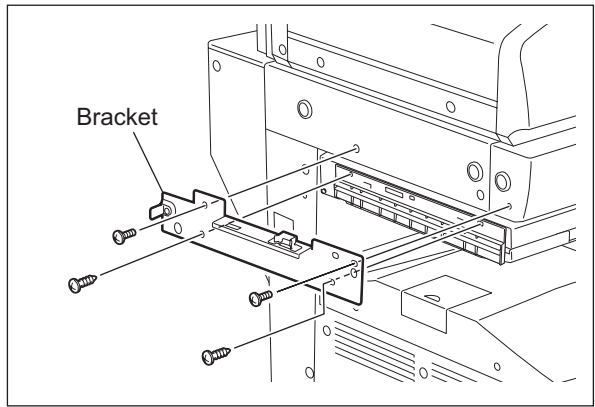

Fig. 2-106

• When MJ-1025 is installed; Remove 5 screws and take off the bracket.

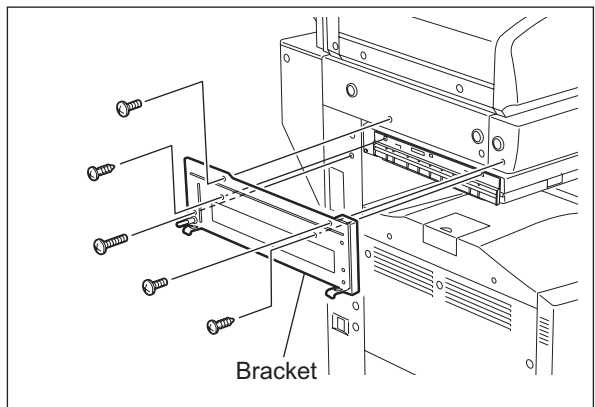

Fig. 2-107

- (9) Take off the guide.

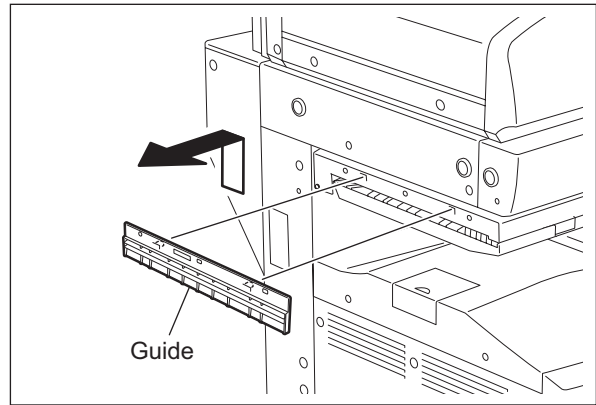

Fig. 2-108

- (10) Lift up the bridge unit and release the hook.  
Take off the bridge unit toward the front.

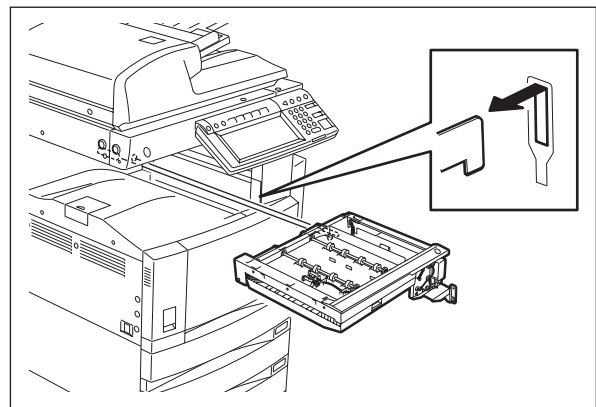

Fig. 2-109

**[G] MJ-5004 (Job separator)**

- (1) Turn the power OFF and unplug the power cable.  
(2) Take off the tray.

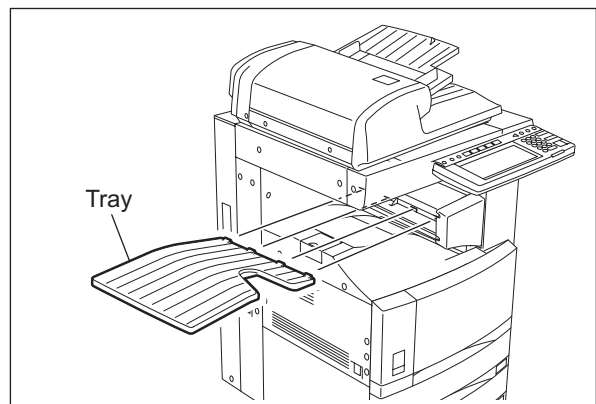

Fig. 2-110

(3) Remove 2 screws and take off the cover.

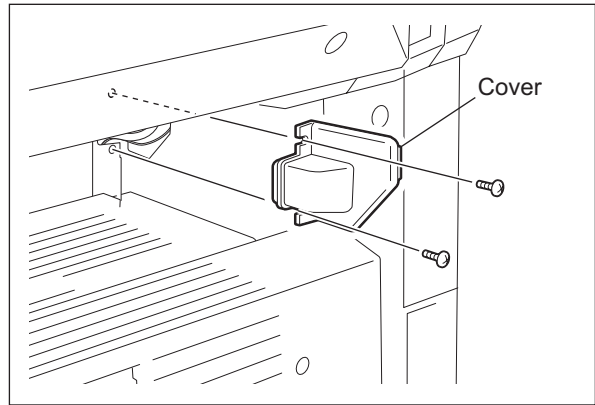

Fig. 2-111

(4) Disconnect 2 connectors.

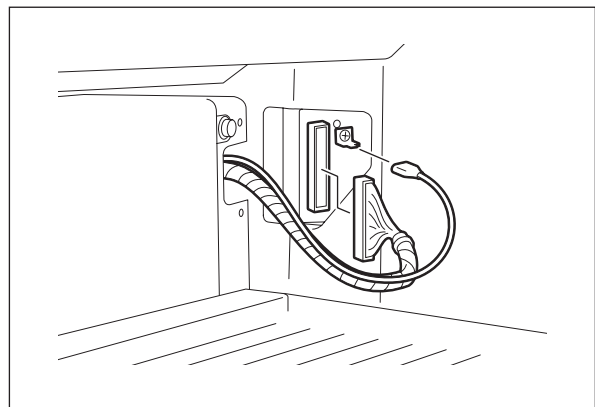

Fig. 2-112

(5) Loosen 2 screws and take off the cover.

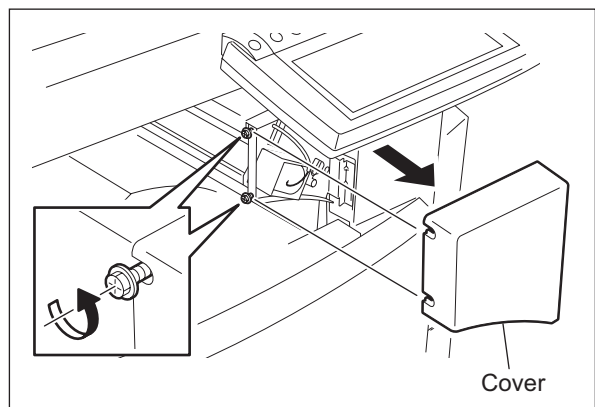

Fig. 2-113

- (6) Remove 1 screw. Lift up the job separator and release the hook. Take off the job separator toward the front.

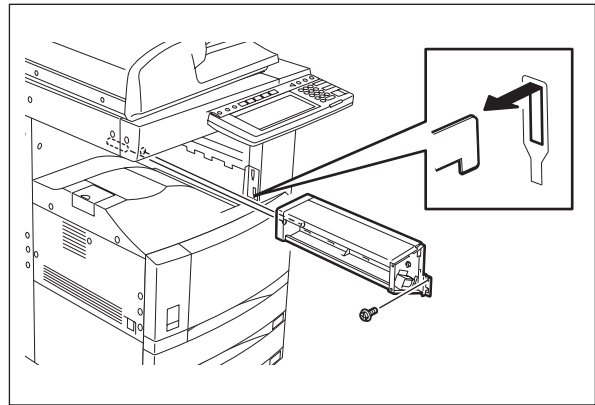

Fig. 2-114

**[H] MJ-5005 (Offset tray)**

- (1) Turn the power OFF and unplug the power cable.  
(2) Take off the tray.

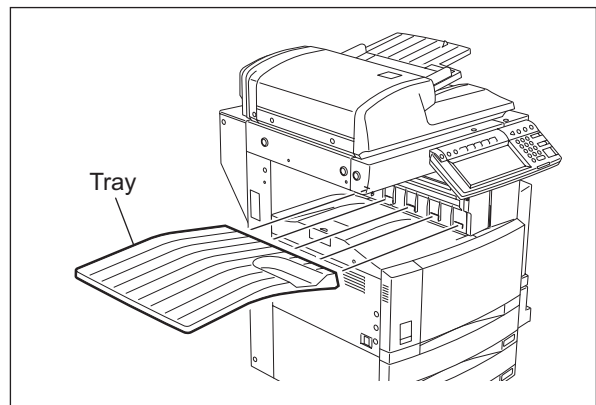

Fig. 2-115

- (3) Remove 2 screws and take off the cover.

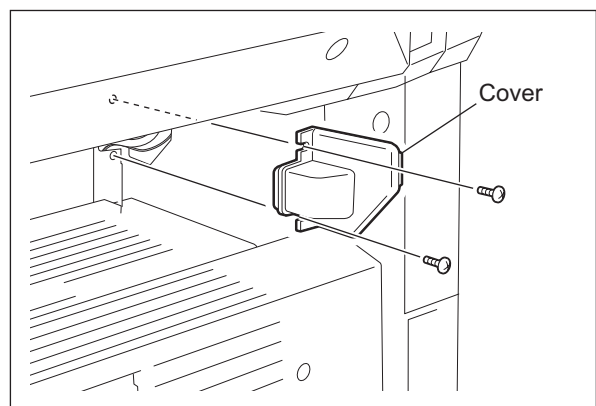

Fig. 2-116

- (4) Disconnect 2 connectors.

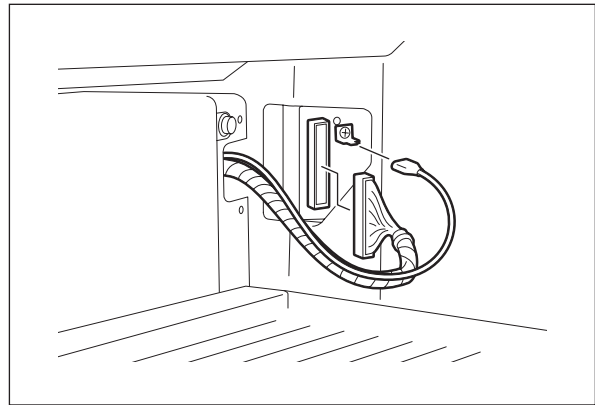

Fig. 2-117

- (5) Open the front cover.
- (6) Remove the inner tray attachment cover.

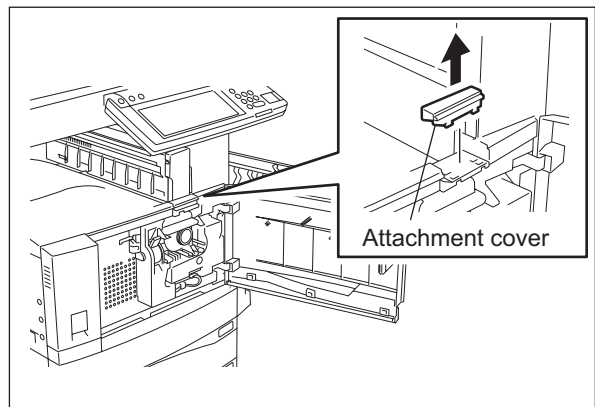

Fig. 2-118

- (7) Remove 1 screw and take off the cover.

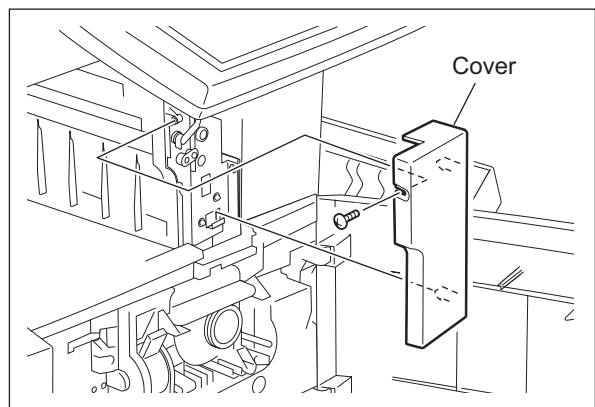

Fig. 2-119

- (8) Lift up the offset tray and release the hook.  
Take off the offset tray toward the front.

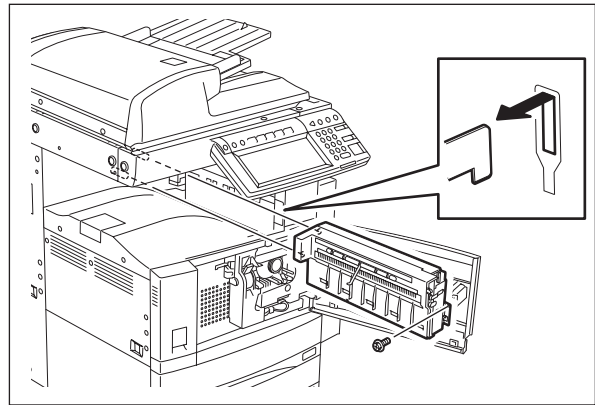

Fig. 2-120

**[I] MD-0102 (Automatic Duplexing Unit (ADU))**

- Refer to chapter 15.5 for taking off the ADU. (P.15-10 "[A] Automatic Duplexing Unit (ADU)")
- The ADU is available as standard equipment for some destinations or versions.

**[J] MR-3020 (Reversing Automatic Document Feeder (RADF))**

- (1) Turn the power OFF and unplug the power cable.
- (2) Take off the connector cover.

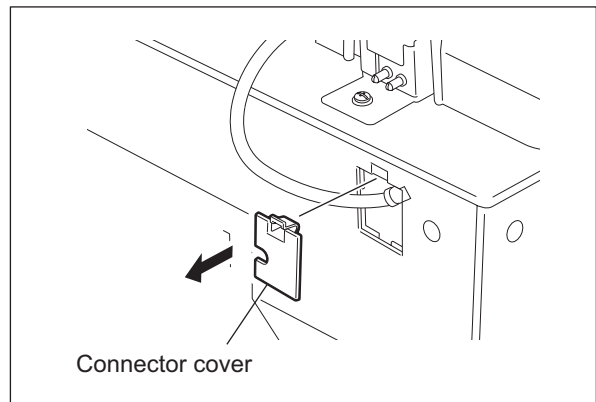

Fig. 2-121

(3) Disconnect the connector.

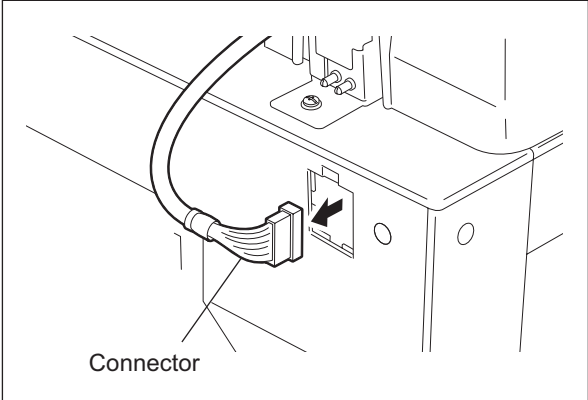

Fig. 2-122

(4) Remove 1 screw and 1 washer on the rear side.

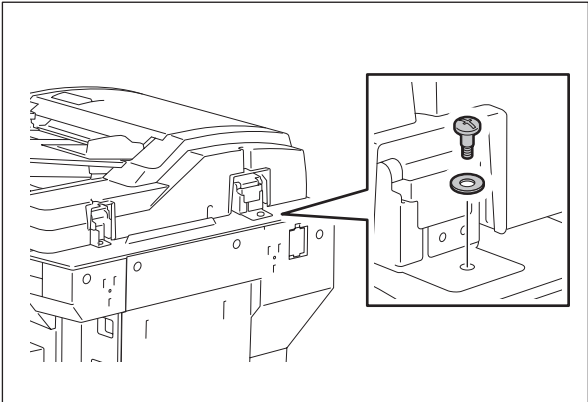

Fig. 2-123

(5) Remove 1 screw on the rear side.

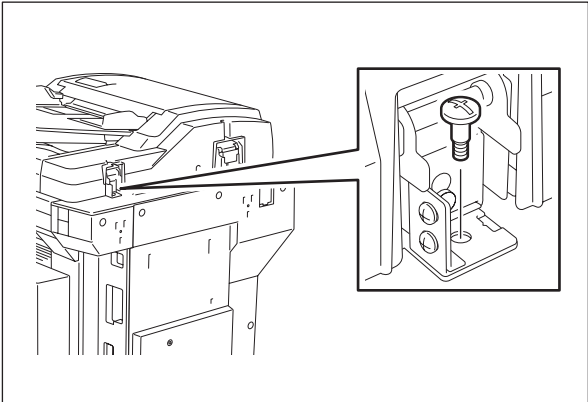

Fig. 2-124

(6) Open the RADF.

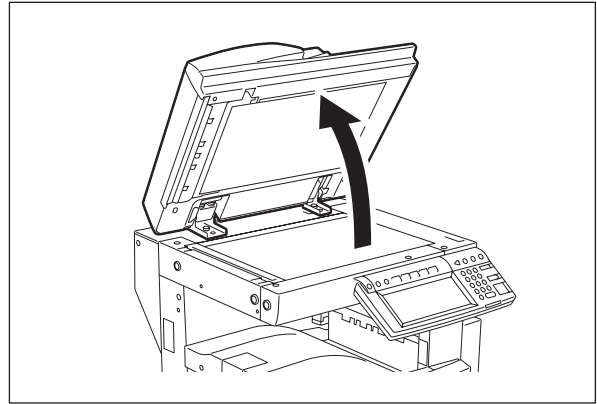

Fig. 2-125

(7) Remove 2 screws on the front side.

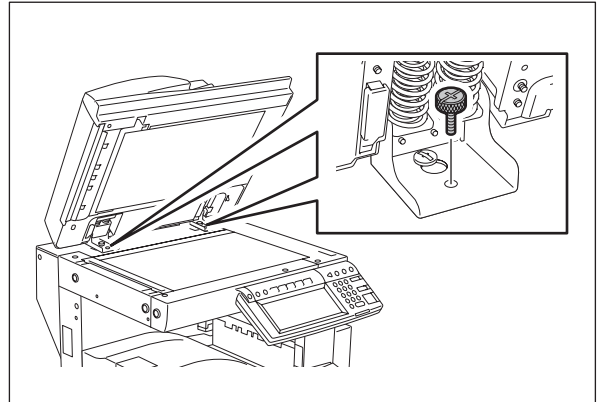

Fig. 2-126

(8) Slide the RADF backward and take it off by lifting it up.

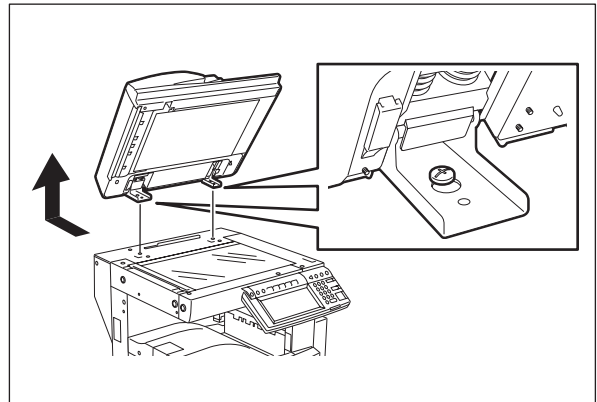

Fig. 2-127



### 3. COPY PROCESS

#### 3.1 General Description of Copying Process

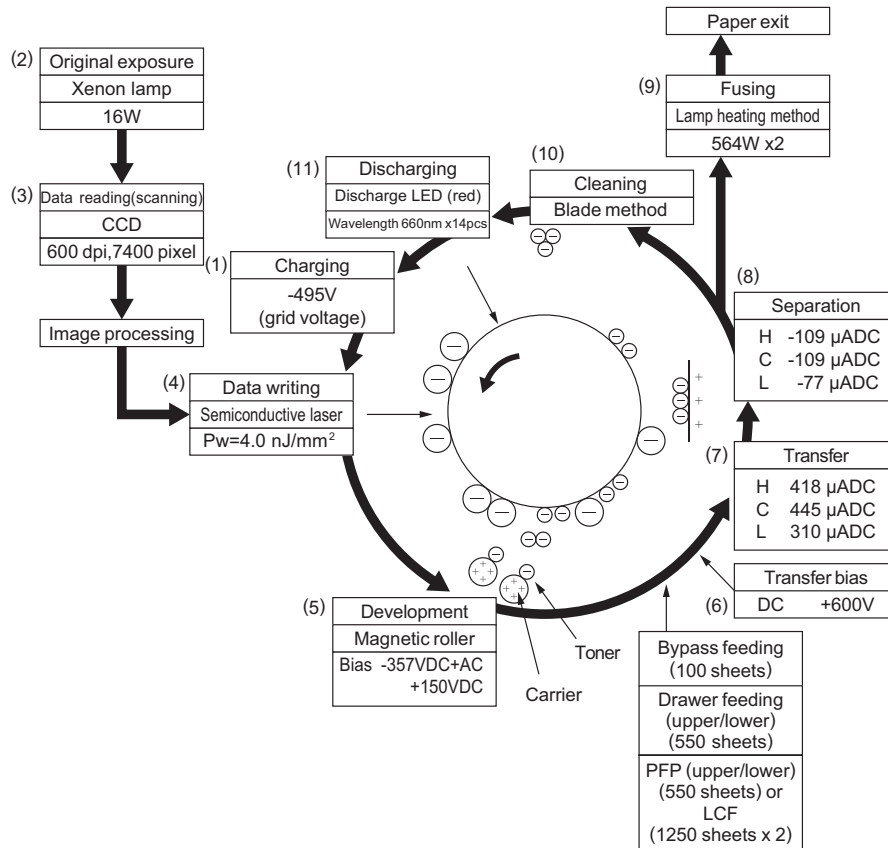

Fig. 3-1

- |  |   |
|--|---|
| <p>(1) Charging: Applies negative charge on the surface of the photoconductive drum.</p> <p>↓</p> <p>(2) Original exposure: Converts images on the original into optical signals.</p> <p>↓</p> <p>(3) Data reading: The optical signals are converted into electrical signals.</p> <p>↓</p> <p>(4) Data writing: The electrical signals are converted into light signal (laser emission) which exposes the surface of the photoconductive drum.</p> <p>↓</p> <p>(5) Development: Negatively-charged toner adheres to the photoconductive drum and forms visible image.</p> <p>↓</p> <p>(6) Transfer bias: Improves transfer efficiency.</p> <p>↓</p> | <p>(7) Transfer: Transfers the visible toner image on the photoconductive drum onto paper.</p> <p>↓</p> <p>(8) Separation: Separates paper with the toner image from the photoconductive drum.</p> <p>↓</p> <p>(9) Fusing: Fuses the toner image onto the paper by applying heat and pressure.</p> <p>↓</p> <p>(10) Cleaning: Scrapes off the residual toner from the drum.</p> <p>↓</p> <p>(11) Discharging: Eliminates the residual negative charge from the surface of the photoconductive drum.</p> |
|--|---|

## 3.2 Details of Copying Process

### 1) Photoconductive drum

The photoconductive drum consists of two layers. The outer layer is a photoconductive layer made of an organic photoconductive carrier (OPC), and the inner layer is an aluminum conductive base in a cylindrical form. The photoconductor has the following property: when it is exposed to light, the electrical resistance it possesses increases or decreases according to the strength of the light.

Example:

- Strong light  
Resistance is decreased (works as a conductor.)
- Weak light  
Resistance is increased (works as an insulator.)

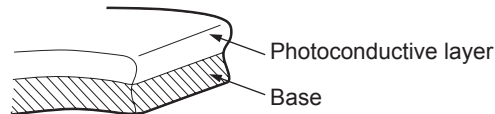

Structure of the photoconductive drum  
(Example of OPC)

Fig. 3-2

[Formation of electrostatic latent image]

In the processes of charging, data reading, data writing, discharging described later, negative potential of the areas on the drum corresponding to black areas of the original are eliminated, while the areas on the drum corresponding to white areas retains the negative charge.

As this image on the drum formed by the negative potential is not visible, it is called an "electrostatic latent image."

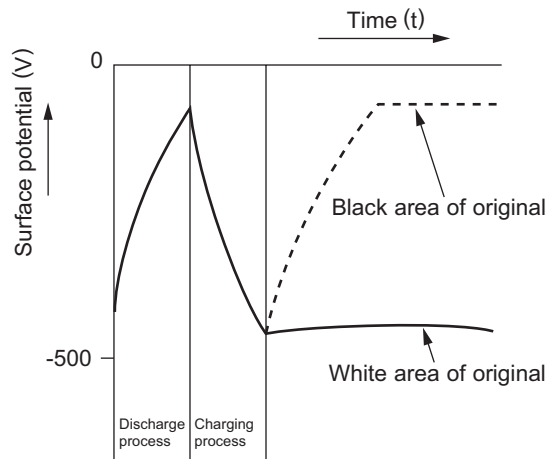

Electric potential of the photoconductive drum

Fig. 3-3

2) Charging

Charging is the process to apply charge evenly on the drum surface.

The needle electrode produces negative corona discharge is controlled by the grid, allowing the drum surface to be evenly charged with the negative potential.

The surface potential on the drum is determined by the grid potential and is controlled to a certain value by the grid control circuit.

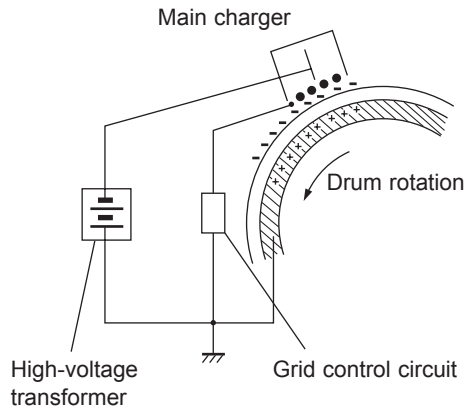

Fig. 3-4

3) Data reading (scanning)

Data reading is the process of illuminating the original with light and converting the reflected light into electrical signals.

The light reflected from the original is directed to the charge coupled device (CCD) and this optical image information is converted into electrical signals (image signals), which are then transmitted to the image processing section.

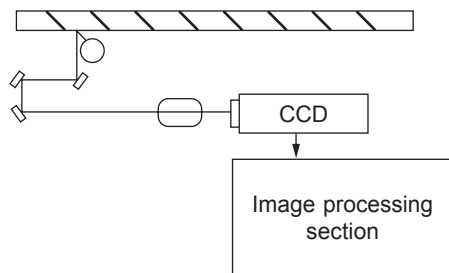

Fig. 3-5

(Example)

| CCD light receiving amount | Value of image signals to be output |
|----------------------------|-------------------------------------|
| Light                      | 255                                 |
| Dark                       | 0                                   |

} Difference between "light" and "dark" is divided into 256 steps.

Fig. 3-6

#### 4) Data writing

Data writing is the process of converting the image signals sent from the image processing section into optical signal and exposing the drum surface with the light.

Semiconductive laser element converts image signals transmitted from the image processing section into optical signal (laser emission) to expose the drum surface and form an electrostatic latent image on it.

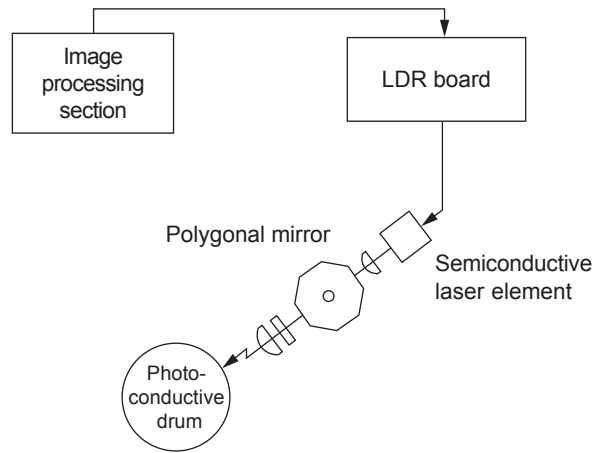

**Fig. 3-7**

5) Development

Development is the process of making the electrostatic latent images visible to the eye (visible images).

Developer material is supplied to the photoconductive drum surface by the magnetic roller.

The toner in the developer material adheres to the areas on the drum surface where the potential is lower than the developer bias which is applied to the magnetic roller (reverse development method).

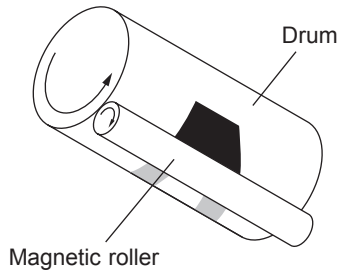

Fig. 3-8

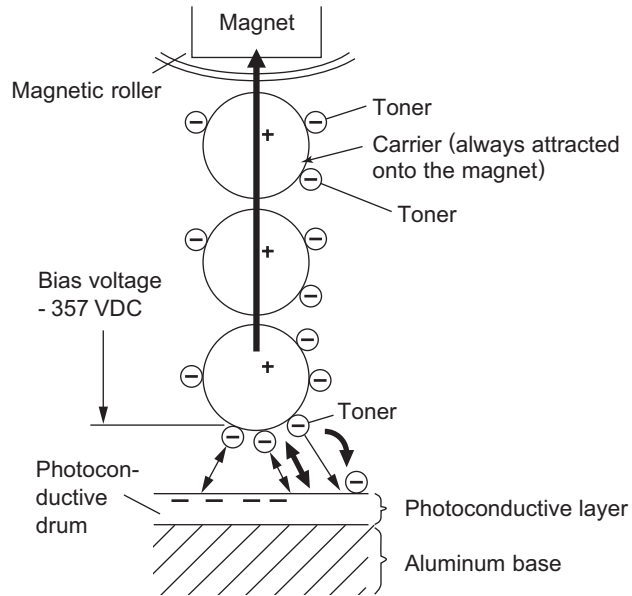

Fig. 3-9

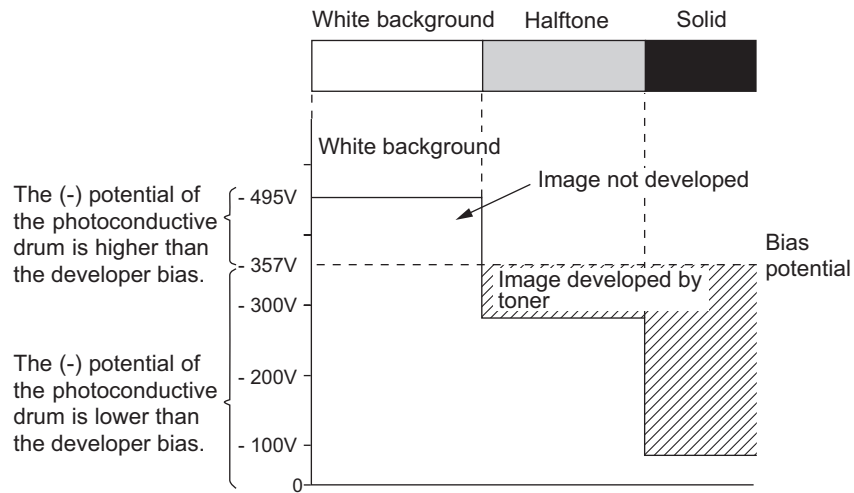

Fig. 3-10

- Switching of developer bias polarity  
With the area which has no negative charge, background fogging is decreased by switching the bias to the positive polarity (approx. +150 V).
- Charging AC bias  
To obtain the stable development characteristics, AC bias (approx. 1,100 V) is charged to the development bias (DC bias).

- Developer material

The developer material consists of a mixture of the toner and carrier. The toner is charged to the negative polarity and the carrier to positive polarity due to the friction with each other caused by mixing.

- Toner: Mainly consists of the resin and carbon.  
 Carrier: Consists of the ferrite and resin coating on its surface to provide consistent frictional electrification.

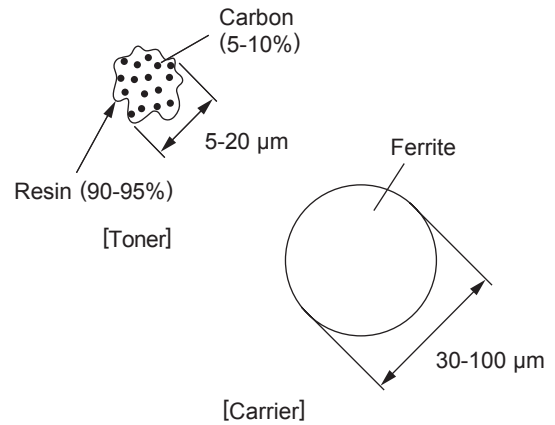

Fig. 3-11

**Note:**

If the developer material is used for a long time (beyond its normal life span), the toner is caked onto the carrier.



The charging performance of the carrier is lowered.

- Symptom:
1. Image density is lowered.
  2. Toner scattering occurs.
  3. Background fogging occurs.

Solution: Replace the developer material.

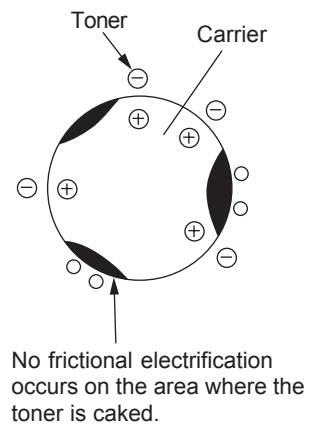

Fig. 3-12

- Magnetic roller  
Magnetic brush development  
The south and north poles are arranged inside the magnetic roller as shown in the right figure.  
The developer material forms a brush-like fluff which contacts the photoconductive drum surface.  
↓  
This is caused by the magnetic force lines between the south and north poles.

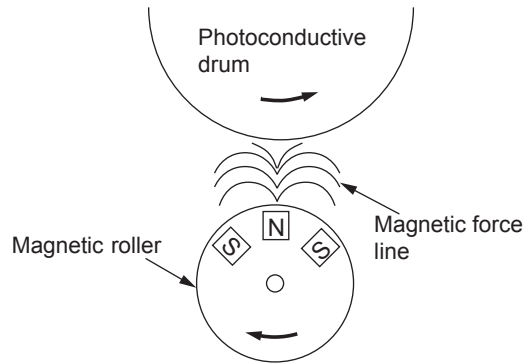

Fig. 3-13

- **Additional Explanation**

The life of the toner cartridge (number of output pages) varies depending on the following conditions.

Coverage of originals (printing image ratio of the original size) and density of original background

Size and density of originals

The existence of solid black when making prints (when a book is copied and the original cover is partially opened)

Temperature and humidity in the room when making prints.

Prints density and image quality mode

As indicated in the figure below, the life of the toner cartridge varies depending on the copy mode and coverage of originals.

A full block in the figure below denotes approx. 5,000 output pages.

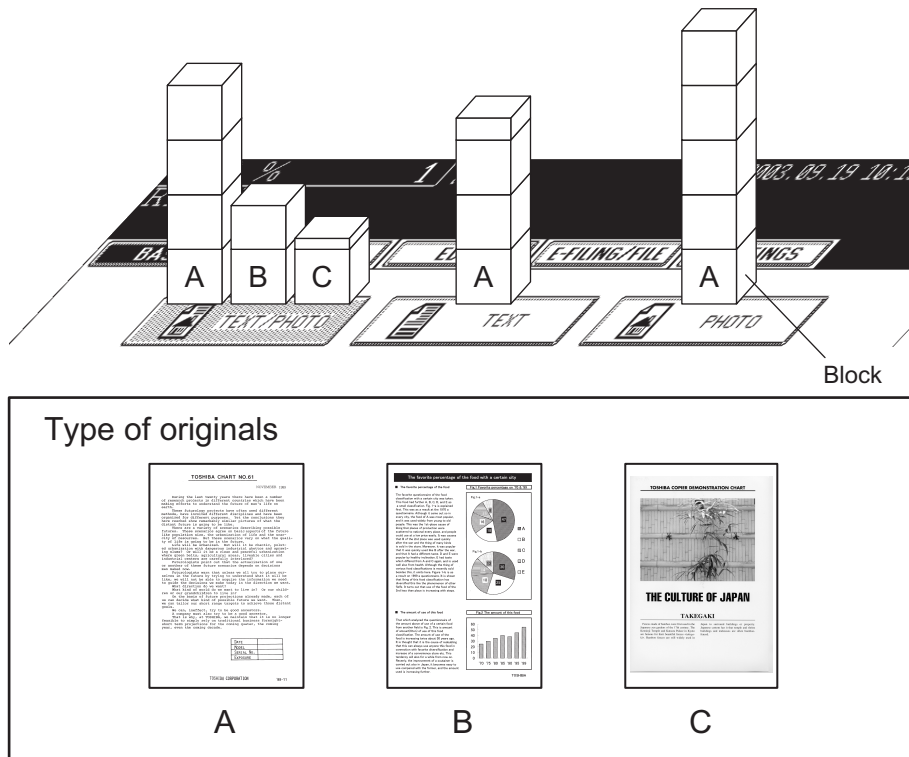

Fig. 3-14



6) Transfer

Transfer is the process of transferring the toner image (visible image) formed on the drum surface onto paper.

Method: A paper passing the side of the drum is charged to the opposite polarity to the that of toner by the corona discharge of the transfer charger.



The toner moves from the drum surface onto the paper.

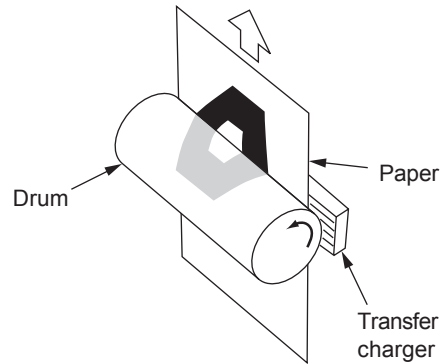

Fig. 3-15

- For smooth transfer

In the transfer bias processing of this equipment, bias voltage (+600 VDC) is applied to the registration roller and transfer unit transport guide to prevent the charge produced by the transfer charger from flowing into the transfer unit transport guide through the paper. Output is controlled as follows to realizes the desirable transability.

| Paper position against transfer point                   | Transfer output   |
|---|-------------------|
| From leading edge to 11 mm from leading edge            | (H) 418 $\mu$ ADC |
| From 11 mm from leading edge to 5 mm from trailing edge | (C) 445 $\mu$ ADC |
| From 5 mm from trailing edge to trailing edge           | (L) 310 $\mu$ ADC |

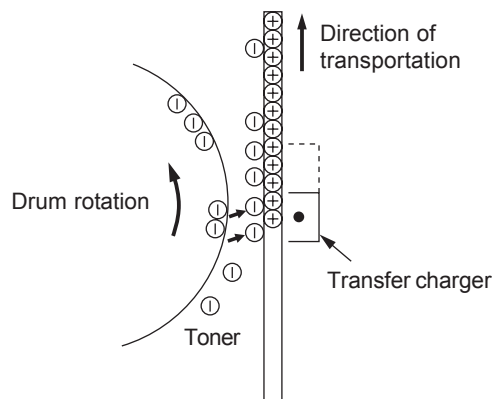

Fig. 3-16

7) Separation

Separation is the process of separating paper which is temporarily adhering to the drum due to the static electricity during the transfer process.

Method: Apply negative DC bias to the separation charger.

- ↓
- The positive charge on the paper is decreased.
- ↓
- The electrostatic adherence force between the paper and drum becomes weak.
- ↓
- The paper is separated from the drum by its own stiffness.

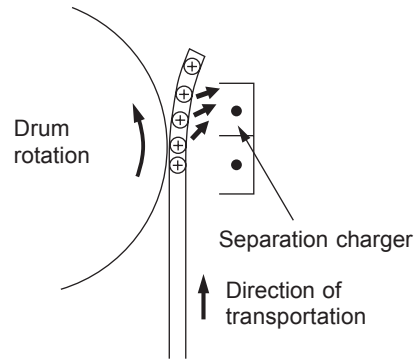

Fig. 3-17

- Output is controlled as follows to realizes the desirable separability.

| Paper position against transfer point                  | Separation output  |
|--|--------------------|
| From leading edge to 11mm from leading edge            | (H) -109 $\mu$ ADC |
| From 11mm from leading edge to 46mm from leading edge  | (L) -77 $\mu$ ADC  |
| From 46mm from leading edge to 48mm from trailing edge | (C) -109 $\mu$ ADC |
| From 48mm from trailing edge to trailing edge          | (L) -77 $\mu$ ADC  |

Paper may not be separated from the drum surface because of moisture or malfunction of the transfer/separation charger during printing. As the result, the paper enters into the cleaner and causes jamming. To prevent this, a separation finger is used to forcibly separate the paper which was left around the drum.

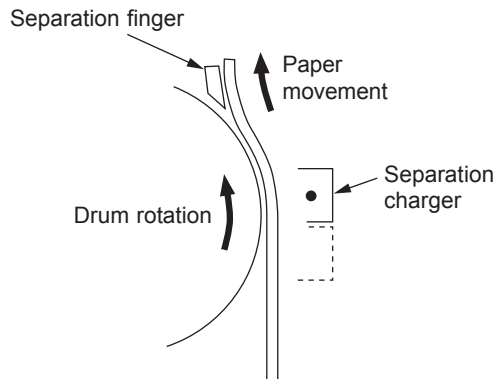

Fig. 3-18

8) Fusing

Fusing is the process of melting the toner on the paper and fixing it firmly on the paper.

Method: The melting point of the toner (main ingredient: resin) is 90-100°C.

(Heat) Toner is melted by the heat of the surface of the fuser roller.

+

(Pressure) The pressure roller is pressed against the fuser roller by the springs to increase the adherence of the melted toner onto the paper.

Heat and pressure are applied to the paper when it passes between the fuser roller and pressure roller.

(Fusing) The toner is fused on the paper.

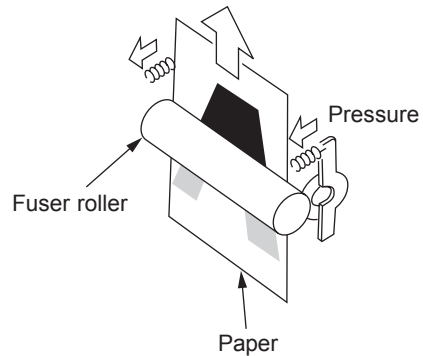

Fig. 3-19

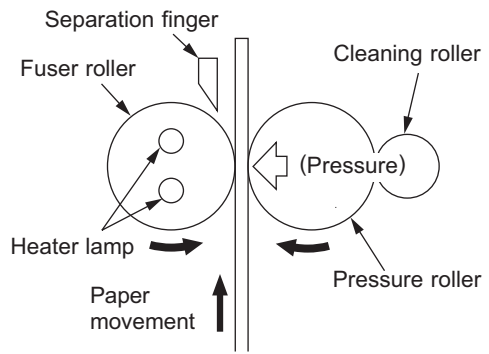

Fig. 3-20

9) Cleaning

Cleaning is the process of removing the residual toner from the photoconductive drum.

The edge of the urethane rubber cleaning blade is pressed against the photoconductive drum surface to scrape off the residual toner on it. The toner is then caught by the recovery blade.

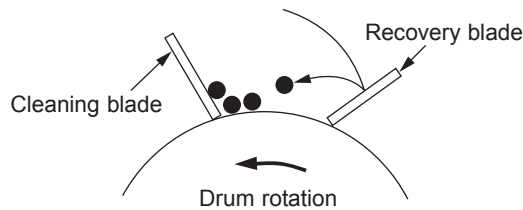

Fig. 3-21

## 10) Discharging

Discharging is the process of eliminating the negative charge remaining on the photoconductive drum before the next charging process.

If the residual charge is not eliminated, the following phenomenon occurs:

Negative charge remaining on the photoconductive drum surface causes uneven application of the charge for the next printing.



The next print will have a double image. (The preceding image appears.)



Solution:

The entire surface of the photoconductive drum is illuminated with light by the discharge LED array.



The photoconductive drum becomes electrically conductive.



All of the negative charge remaining on the photoconductive drum is conducted to the ground.



Preparation for the next printing is completed.

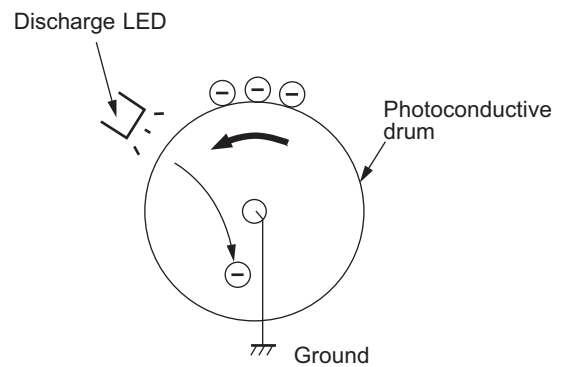

Fig. 3-22

### 3.3 Comparison with e-STUDIO350/450

| Process   | e-STUDIO350/450  | e-STUDIO200L/202L/203L/230/230L/<br>232/233/232S/280/280S/282/283/<br>282S/283S   |
|---|--|---|
| 1. Photoconductive drum<br>• Sensitivity<br>• Surface potential   | OD-3500 (OPC ø60)<br>Highly sensitized/durable drum<br>-750 V  | OD-1600 (OPC ø30)<br>←<br>-475 V  |
| 2. Charging<br>• Grid voltage   | Scoro-tron method<br>-790 V  | ←<br>-495 V   |
| 3. Data writing<br>• Light source<br>• Light amount   | Semiconductor laser (Adjustment not required)<br>4.3 nJ/mm <sup>2</sup>  | ←<br>4.0 nJ/mm <sup>2</sup>   |
| 4. Development<br>• Magnetic roller<br>• Auto-toner<br>• Toner supply<br>• Toner-empty detection<br>• Toner<br><br>• Developer material<br>• Developer bias | One magnetic roller<br>Magnetic bridge-circuit method<br>Toner cartridge<br>Density detection method<br>T-3520, T-3520E, T-3520D, T-3520C,<br>T-3520T<br><br>D-3500, D-3500C<br>DC-550 V Adjustable output (during printing)<br><br>DC+150 V Fixed (others)  | ←<br>←<br>←<br>←<br>T-2320, T-2320E, T-2320D, T-2320C,<br>T-2320T (e-STUDIO200L/230/230L/<br>280/280S)<br>T-2340, T-2340E, T-2340D, T-2340C,<br>T-2340T (e-STUDIO202L/232/232S/<br>282/282S)<br>T-2840, T-2840E, T-2340C<br>(e-STUDIO203L/233/283/283S)<br>D-2320, D-2320C<br>DC-357 V Adjustable output<br>(during printing)<br>AC 1100 V (Adjustment not required,<br>during printing)<br>← |
| 5. Transfer<br>• Transfer bias  | Adjustable output (Constant current)<br>+580 V (Adjustment not required)   | ←<br>+600 V (Adjustment not required)   |
| 6. Separation   | AC: Adjustable output<br>(Constant voltage)<br>DC: Adjustment not required   | ←<br>←  |
| 7. Discharge<br>• Discharging position<br>• Discharge LED   | Exposure after cleaning<br>Red LED   | ←<br>←  |
| 8. Cleaning<br>• Method<br>• Recovered toner  | Cleaning blade<br>Not reusable   | ←<br>Reuse (There is the recovered toner supply mechanism.)   |
| 9. Fusing<br>• Method<br><br>• Cleaning<br>• Heater   | Long-life fuser roller method<br>Fuser roller:<br>Thin roller coated with fluoroplastic (ø40)<br>Pressure roller:<br>PFA tube roller (ø30)<br>Cleaning roller for pressure roller (ø14)<br>IH coil (Induction-heating method)<br>Turned ON/OFF by thermistor | ←<br>←<br>Thin roller coated with fluoroplastic (ø30)<br>←<br>←<br>Cleaning roller for pressure roller (ø16)<br>Heater lamp   |



## 4. GENERAL OPERATION

### 4.1 Overview of Operation

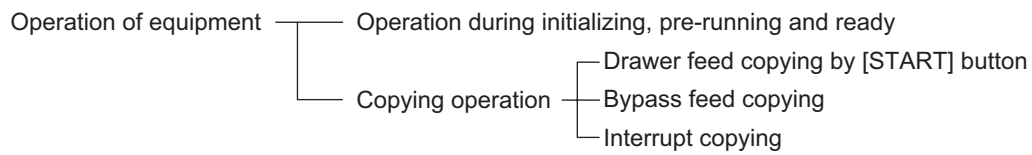

## 4.2 Description of Operation

### 4.2.1 Warming-up

#### 1) Initialization

Power ON

- Heater lamp ON
- Set number "1" reproduction ratio "100%" and "WAIT WARMING UP" are displayed
- Fan motors ON
- Initialization of scanning system
  - The carriage moves to the home position.
  - The carriage moves to the peak detection position.
  - The exposure lamp is turned ON.
  - Peak detection (white color is detected by the shading correction plate)
  - The exposure lamp is turned OFF.
- "READY (WARMING UP)" is displayed

#### 2) Pre-running operation

The pre-running operation is started when the temperature of the fuser roller surface reaches a certain temperature.

- The main motor is turned ON.
  - Fuser roller rotated
  - Drum rotated
- Initialization of feeding system
  - Each drawer tray goes up.
- Pre-running operation stops after five seconds.

#### 3) When the surface temperature of the fuser roller becomes sufficient for fusing,

- "READY" is displayed.

### 4.2.2 Ready state (ready for copying)

Buttons on the control panel enabled

- When no button is pressed for a certain period of time,
  - Set number "1" and reproduction ratio "100%" are displayed. Equipment returns to the normal ready state.



### 4.2.3 Drawer feed copying (Upper drawer paper feeding)

- 1) Press the [START] button
  - “READY” changes to “COPYING”
  - Exposure lamp ON
  - Scan motor ON → carriages -1 and -2 move forward
  - Polygonal motor rotates in high speed
  - Main motor and exit motor ON
  - The drum, fuser unit, developer unit and exit roller are driven.
- 2) Drawer paper feeding
  - Main charger, developer bias and discharge LED ON. Fans are rotated in high speed. Drawer feed clutch ON.
  - The pickup roller, feed roller, separation roller and transport roller start to rotate.
  - Paper reaches the 1st transport sensor
  - The 1st transport sensor is turned ON.
  - Paper reaches the registration roller.
  - The registration sensor is turned ON and aligning is performed.
  - Drawer feed clutch OFF after a certain period of time
- 3) After the carriage operation:
  - Registration clutch ON after a certain period of time → paper is transported to the transfer area.
  - Copy counter operates
- 4) After the registration clutch is turned ON:
  - Transfer charger ON after a certain period of time
  - Copy counter operates
- 5) Completion of scanning
  - Scan motor OFF
  - Exposure lamp OFF
  - Registration clutch OFF (after the trailing edge of the paper passed the registration roller)
  - “READY (PRINTING)” is displayed
- 6) Paper exit
  - Exit sensor detects the trailing edge of the paper
  - Main charger, developer bias and discharge LED OFF
  - Polygonal motor, main motor and exit motor OFF
  - Drum, fuser unit and developer unit stop
  - Fans return to the ready rotation
  - “READY” is displayed and the equipment enters the ready mode

Timing chart for copying one A4 size sheet fed from the upper drawer

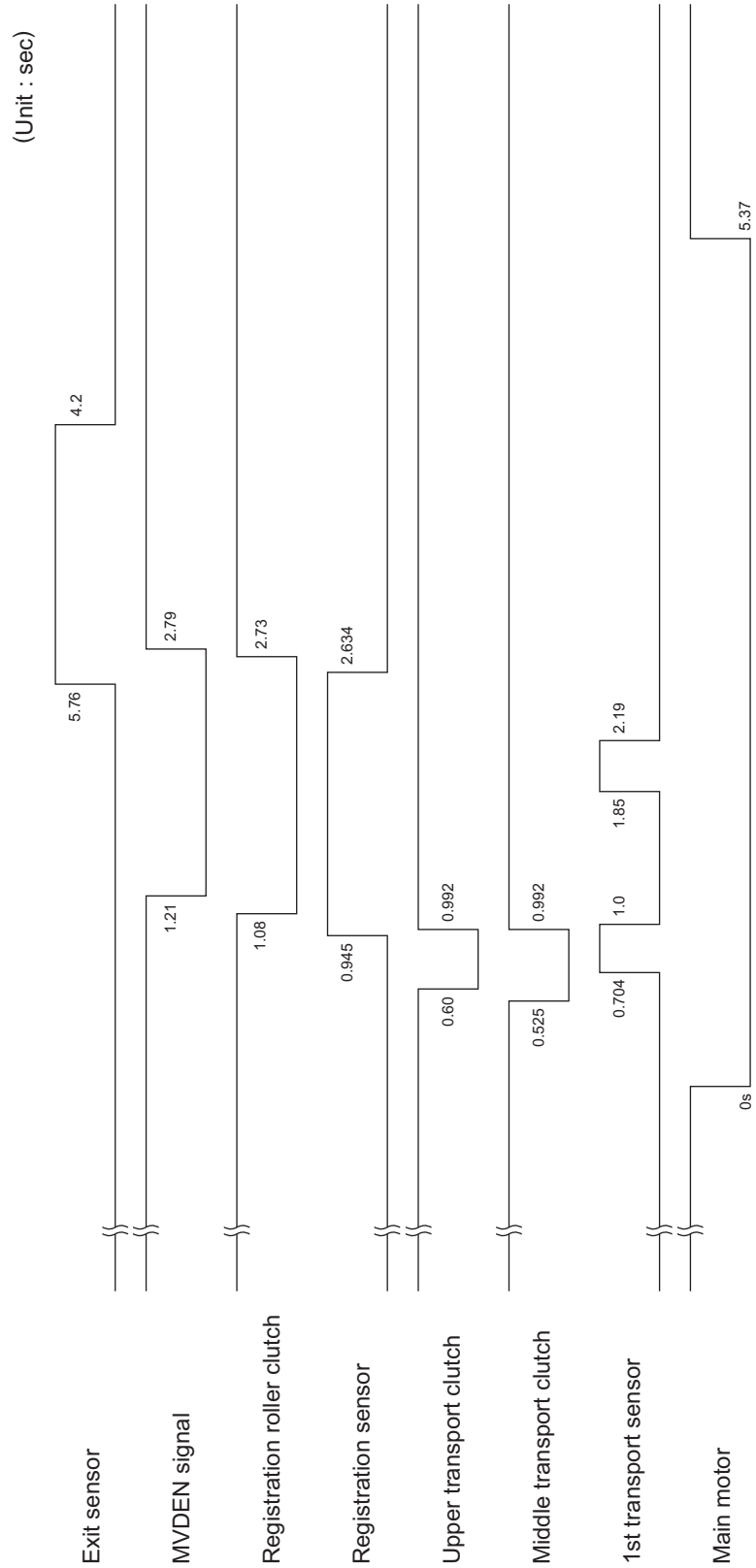

#### 4.2.4 Bypass feed copying

- 1) Insert a sheet of paper into the bypass tray.
  - Bypass paper sensor ON
  - "Ready for bypass feeding" is displayed.
- 2) Press the [START] button
  - "Ready for bypass feeding" changes to "COPYING"
  - Exposure lamp ON
  - Scan motor ON → Carriages -1 and -2 move forward
  - Polygonal motor rotates in high speed
  - Main motor and exit motor ON
  - The drum, fuser unit, developer unit and exit roller are driven.
- 3) Bypass feeding
  - Main charger, developer bias and discharge LED ON. Fans are rotated in high speed.
  - Bypass feed clutch ON
  - The bypass pickup roller start to rotate.
  - The bypass pickup roller is lowered.
  - The bypass feed roller start to rotate.
  - Aligning operation
  - Paper reaches the registration roller
  - After a certain period of time, the bypass feed clutch OFF
- 4) Hereafter, the operation 3) through 6) of  P.4-3 "4.2.3 Drawer feed copying (Upper drawer paper feeding)" is repeated.

#### 4.2.5 Interruption copying

- 1) Press the [INTERRUPT] button
  - LED "INTERRUPT" ON
  - Copying operation in progress is temporarily stopped. Carriages -1 and -2 return to appropriate positions.
  - "Job interrupted job 1 saved" is displayed.
  - Automatic density and reproduction ratio 100% are set (The set number remains the same)
- 2) Select the desired copy condition
- 3) After the interruption copying is finished:
  - LED "INTERRUPT" OFF by pressing the [INTERRUPT] button
  - Equipment returns to the status before the interruption
  - "Ready to resume job 1" is displayed
- 4) Press the [START] button
  - The copying operation before the interruption is resumed.

## 4.3 Detection of Abnormality

When something abnormal has occurred in the equipment, the symbols corresponding to the type of abnormality are displayed.

### 4.3.1 Types of abnormality

- 1) Abnormality cleared without turning OFF the door switch
  - (A) Add paper
  - (B) Pick-up failure in bypass
  - (C) Set key copy counter
  
- 2) Abnormality not cleared without turning OFF the door switch
  - (D) Misfeed in equipment
  - (E) Replace the toner cartridge
  - (F) Developer unit not installed properly
  
- 3) Abnormality not cleared without turning OFF the main switch
  - (G) Call for service

### 4.3.2 Description of abnormality

#### (A) Add paper

- Drawer empty sensor detects the presence or absence of paper.

[When drawer is not installed]

No drawer detected



Tray not going up (drawer empty sensor OFF)



“Add paper” displayed



[START] button disabled

[When drawer is installed]



Drawer detected



Tray going up (drawer empty sensor OFF)



“Add paper” displayed



[START] button disabled

- When the power is turned ON or the LCF drawer is inserted (when the power is turned ON or equipment drawer / PFP drawers are inserted), LCF (PFP/equipment) performs initialization.



Detects the presence of paper

Tray-up motor ON – The tray goes up

At this time, the tray-up sensor and empty sensor are OFF.

→ When the tray-up sensor is not turned ON in a fixed period of time, it means that the tray is in abnormal condition.

→ “Add paper” is displayed regardless of presence/absence of paper.

→ Cleared by turning the power ON/OFF

→ Tray-up sensor is turned ON in a fixed period of time.

- The tray motor stops.

At this time, if the empty sensor is ON: It is judged that there is paper.

OFF: It is judged that there is no paper.



Drawer area of the LCD panel blinks (When the drawer is selected)

- When the paper in the drawer runs out during copying,

→ The tray-up sensor turned OFF

→ The tray-up motor turned ON → Tray goes up

The tray-up sensor turned ON → Tray-up motor stopped.

- Empty sensor turned OFF during the copying in spite of the tray-up sensor is ON



It is judged that there is no paper.



Drawer area of the LCD panel blinks (When the drawer is selected)



The copying operation is stopped.

(B) Pick-up failure in bypass ( 8V )

- During bypass feeding  
Bypass feed clutch ON



1st transport sensor is not turned ON in a fixed period of time



Clear paper symbol is displayed ( 8V ): E120



Copying operation is disabled



Solution: The bypass paper sensor is turned OFF by removing the paper from the bypass tray.

(C) Set key copy counter

- When the key copy counter (optional) is pulled out from the equipment which installs it:

“Set key copy counter” displayed



Copying operation disabled

- When the counter is pulled out during copying:

Copying is stopped when the key copy counter is pulled out.



“Set key copy counter” displayed



Copying operation disabled

(D) Misfeed in equipment ( 8V )

- Exit sensor detects jamming of the leading edge of paper.



Registration clutch ON



Exit sensor ON

If the exit sensor is not turned ON after 1.808 sec,



Paper jam (E010) → The copying operation is stopped.

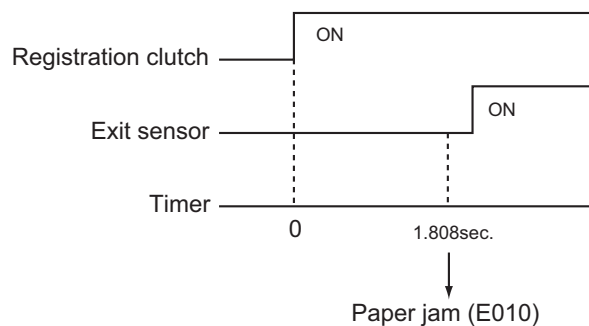

Fig. 4-1

- Exit sensor detects jamming of the tailing edge of paper.

↓

Registration clutch OFF

↓ Less than 1.759 sec.

Exit sensor OFF

If the exit sensor is not turned OFF after 1.759 sec,

↓

Paper jam (E020) → The copying operation is stopped.

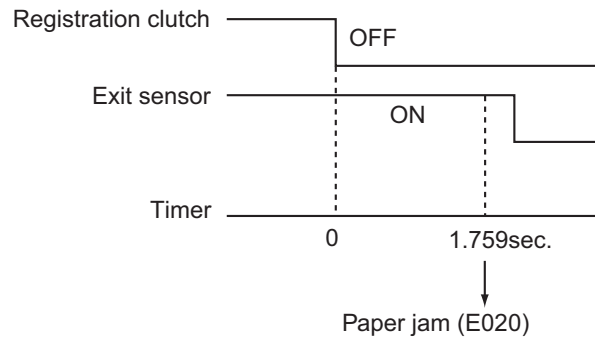

Fig. 4-2

- Immediately after the power ON

↓

Any of all sensors on paper transport path detects paper (ON)

↓

Paper jam (E030)

- Front cover is opened during copying

↓

Paper jam (E410)

- Registration sensor detects jamming of the leading edge of paper:  
Registration sensor is not turned ON in a fixed period of time after the leading edge of paper passed the 1st transport roller.

↓

Paper jam (E200, E210, E270, E280, E300, E330 and E3C0)

- During paper feeding from ADU:  
1st transport sensor is not turned ON in a fixed period of time after the ADU clutch is turned ON.

↓

Paper jam (E110)

- During paper transporting from ADU:  
ADU entrance/exit sensors do not detect the paper at the fixed timing

↓

Paper jam (E510 or E520)



- The 1st/2nd transport sensor and each sensors of PFP/LCF are not turned ON in a fixed period of time after the feed clutch is turned ON



Paper jam (E220, E310, E320, E340–E360, E3D0 and E3E0: Error code differs depending on the paper source.) Refer to the error code table in the Service Handbook.

(E) Replace the toner cartridge (  )

- Toner density becomes low



Auto-toner sensor detects the absence of the toner



Control circuit → “Install new toner cartridge” displayed: the copying operation disabled

Solution: Open the front cover and replace the toner cartridge with a new one.  
Toner is supplied → copying operation enabled.

(F) Developer unit not installed properly

- Disconnection of the connectors of the developer unit



“Developer unit not installed” is displayed.

Solution: Connect the connectors of the developer unit and close the front cover.

(G) Call for service

Error code is displayed instead of the set number by pressing the [CLEAR] button and [8] button simultaneously when the “Call for service” is blinking.  
Refer to the error code table in the Service Handbook.

## 4.4 Flow Chart

### 4.4.1 Immediately after the power is turned ON

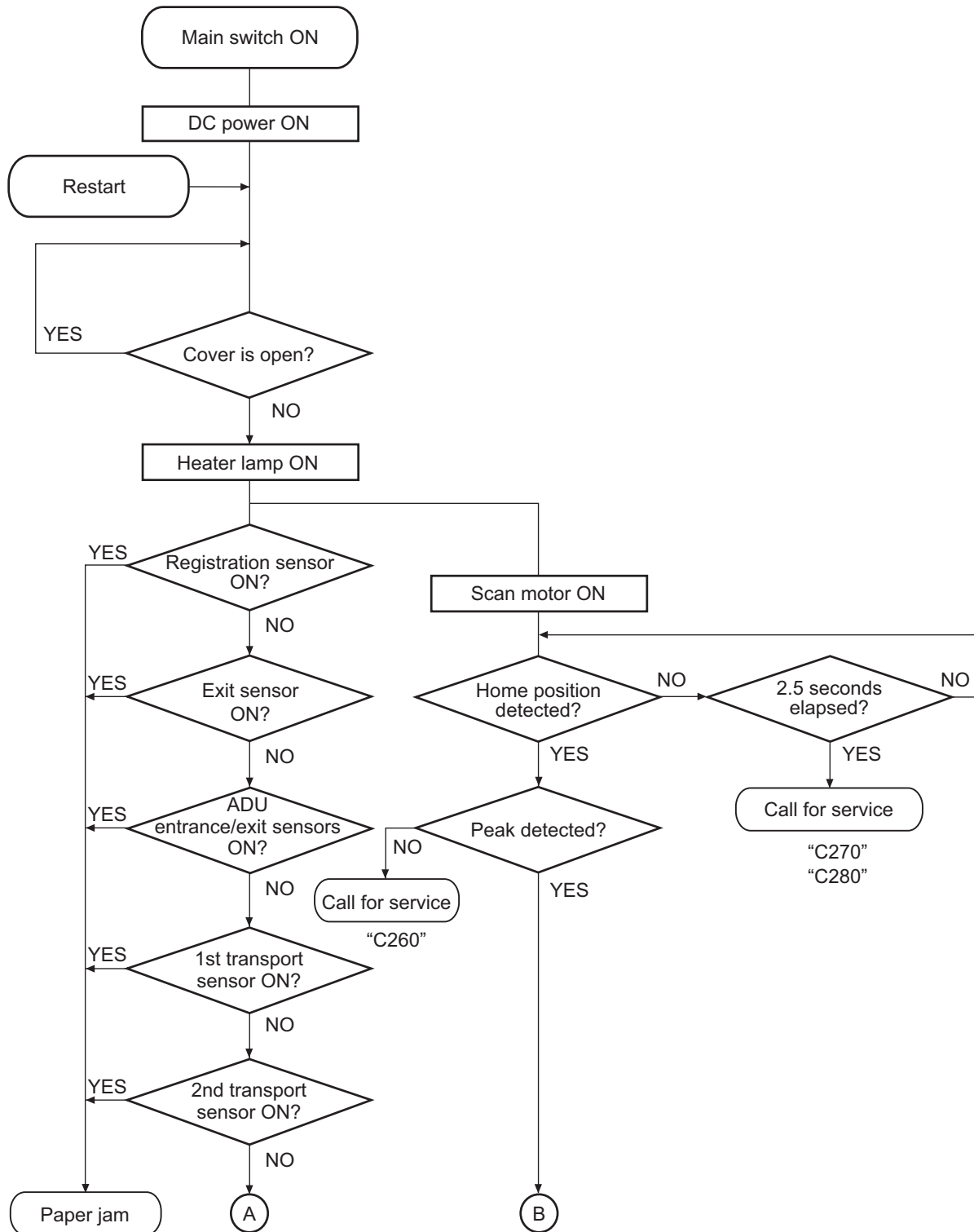

Fig. 4-3

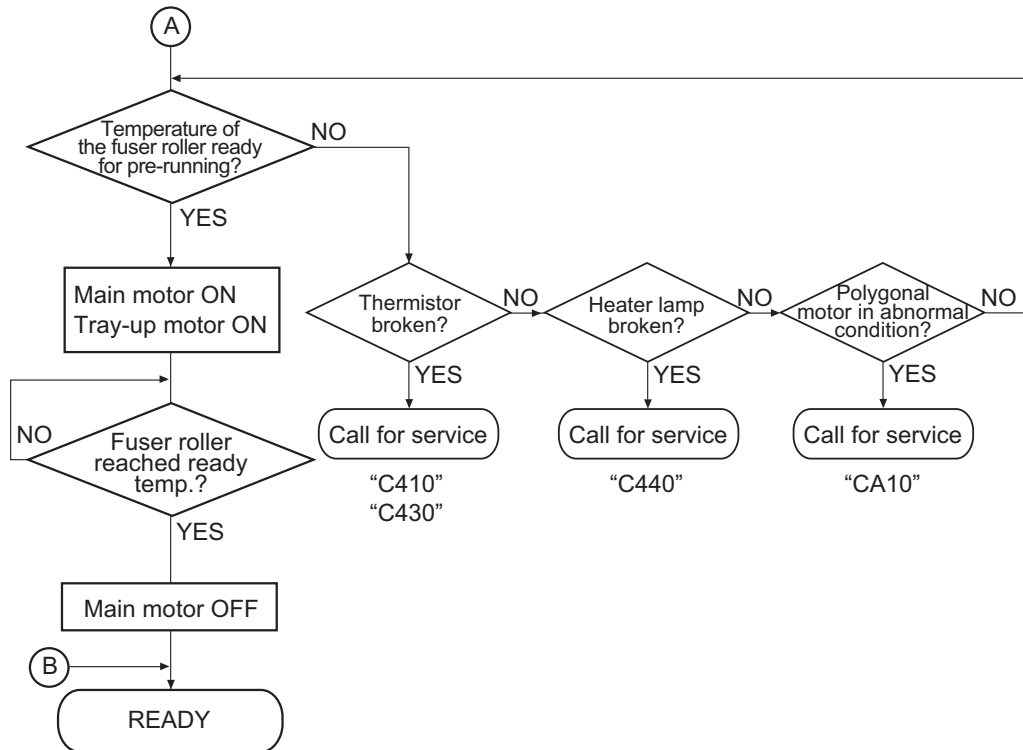

Fig. 4-4

## 4.4.2 Automatic paper feed copying

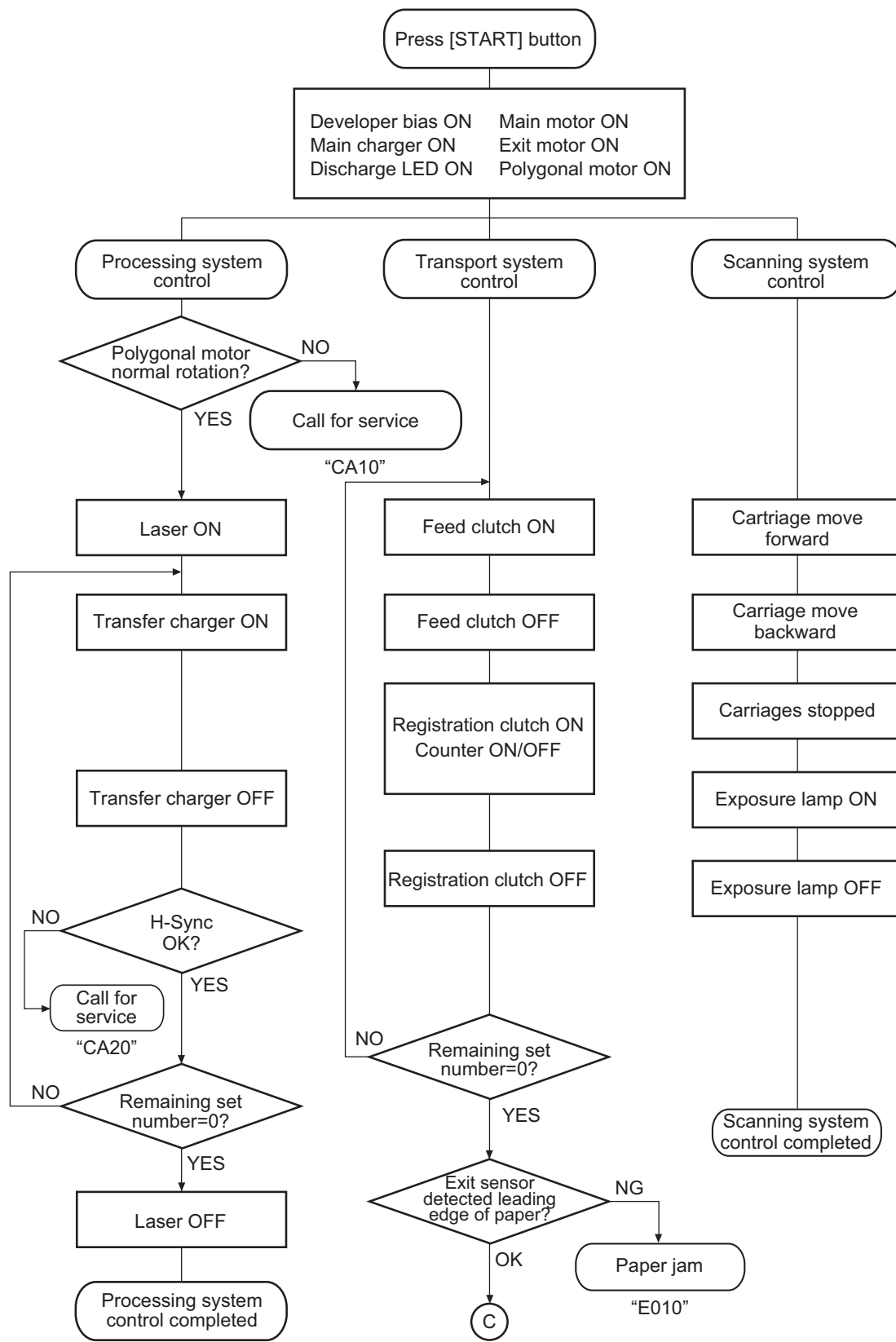

Fig. 4-5

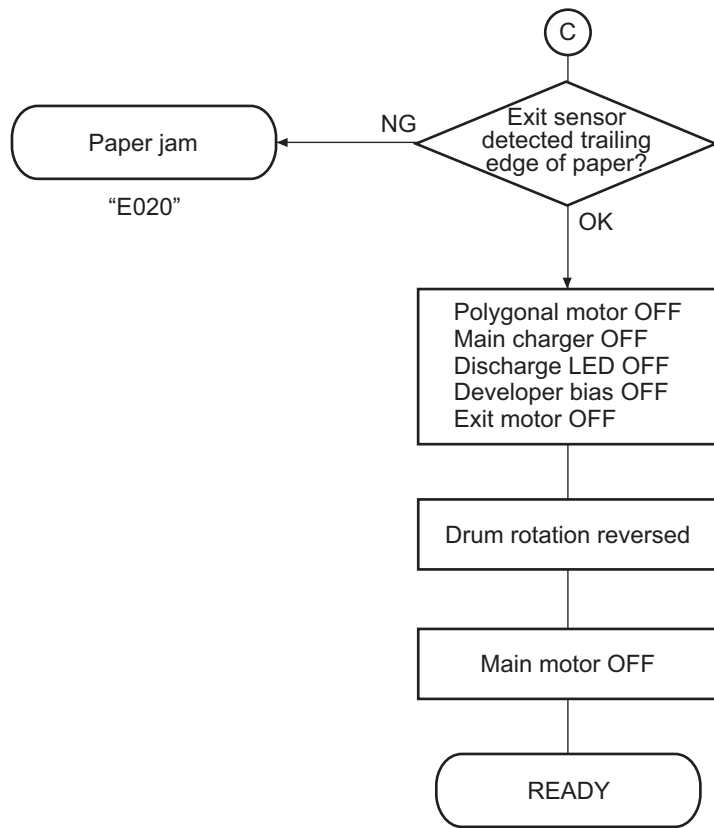

Fig. 4-6



# 5. CONTROL PANEL

## 5.1 Control Panel and Display Panel

The control panel consists of button switches and touch-panel switches to operate equipment and select various modes, and LEDs and an LCD to display the state of the equipment or the messages. When the operator's attention is required, graphic symbols appear with messages explaining the condition of the equipment in the LCD panel.

This equipment has a movable control panel which enables to adjust its angle to the operator. It also has improved its operability and visibility with the enlarged LCD panel.

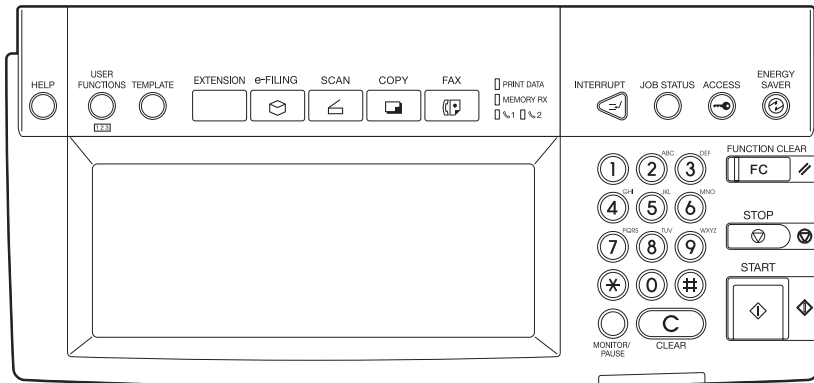

Fig. 5-1

# 5.2 Items Shown on the Control Panel

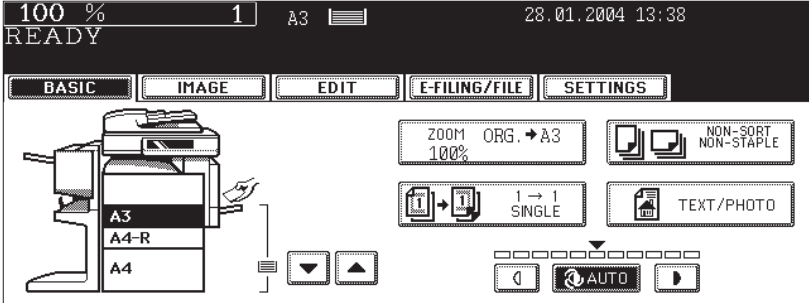

Fig. 5-2

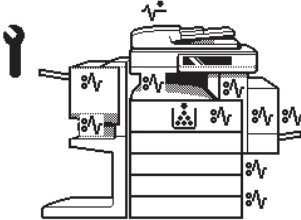

Fig. 5-3



## 5.2.1 Display

| No. | Message  | State of equipment   | Note   |
|-----|--|--|--|
| 1   | -  | Power is OFF (at Sleep Mode)   | Press [START] button or [FUNCTION] button to clear   |
| 2   | Saving energy - press START button             | At Energy Saving Mode  | Press [START] button to clear  |
| 3   | Wait Warming Up                                | Scanner warming up<br>• Displayed until the equipment becomes ready to start scanning          | Auto Start can be set  |
| 4   | Wait Warming Up Auto Start                     | Scanner warming up<br>• Displayed when Auto Start is set                                       | Press [STOP] button to clear the Auto Start  |
| 5   | WAIT   | Displayed when performing the controlling function to keep the equipment at the best condition |  |
| 6   | Wait adding toner                              | Supplying toner<br>• Equipment becomes the toner supply state                                  | Recovers when the toner supply has finished  |
| 7   | Performing Auto Calibration                    | Displayed at image quality control   | Recovers when the image quality control has finished                                       |
| 8   | READY  | Ready for copying<br>• Waiting for the operation   |  |
| 9   | READY<br>Press START button to copy            | Copying job interrupted  | Press [START] button to resume copying or press [MEMORY CLEAR] button to delete the job    |
| 10  | READY<br>(WARMING UP)                          | Scanner warming up   |  |
| 11  | READY<br>(PRINTING)                            | Printing out the data<br>• Scanning is enabled   |  |
| 12  | READY<br>(ADDING TONER)                        | Supplying toner<br>• Scanning is enabled   |  |
| 13  | READY<br>(INNER TRAY FULL)                     | Inner tray in the equipment is full<br>• Scanning is enabled                                   | - When the bridge unit is installed<br>- Resumes printing by removing papers from the tray |
| 14  | READY<br>(CHECK STAPLER)                       | No staples in finisher<br>• Scanning is enabled  | Cleared by supplying the staples   |
| 15  | READY<br>(CHECK STAPLER)                       | Stapling jam occurred in finisher  |  |
| 16  | READY (ADD PAPER)<br>Press JOB STATUS button   | No paper in drawer<br>• Scanning is enabled  | Cleared by supplying papers  |
| 17  | READY<br>(FINISHER FULL)                       | Finisher is full of paper<br>• Scanning is enabled   | Resumes printing by removing paper from the finisher                                       |
| 18  | READY<br>(HOLE PUNCH DUST BIN IS FULL)         | Punching dust box is full<br>• Scanning is enabled   | Resumes printing by removing punching dust from the dust box                               |
| 19  | READY<br>(SADDLE STITCH TRAY FULL)             | Saddle stitcher tray is full of paper<br>• Scanning is enabled                                 |  |
| 20  | READY<br>(CHANGE DRAWER TO CORRECT PAPER SIZE) | Incorrect paper size setting   |  |
| 21  | Ready for bypass feeding                       | Paper is set on the bypass tray  |  |
| 22  | COPYING  | At the copying state   |  |
| 23  | Auto Start                                     | Auto Start is set during printing  | Cleared by pressing [RESET] button or [STOP] button  |

| No. | Message  | State of equipment  | Note                                  |
|-----|--|---|---------------------------------------|
| 24  | Close Large Capacity Feeder                            | LCF drawer is not installed when feeding from LCF is set  | Cleared by installing LCF drawer      |
| 25  | Close Large Capacity Feeder Door                       | LCF cover is open when feeding from LCF is set  | Cleared by closing the cover          |
| 26  | Place Doc. Feeder in the down position                 | RADF is open when original is placed on RADF  | Cleared by closing RADF               |
| 27  | Insert key copy counter                                | Key copy counter not inserted   | Cleared by inserting key copy counter |
| 28  | Place originals in the document feeder                 | Displayed when the conditions are set and START button is pressed with no original placed   | Cleared by setting the original       |
| 29  | Change direction of original                           | Displayed when the direction of original placed is different from the setting   |                                       |
| 30  | PRESS [BASIC] and select normal paper size             | Displays the warning that the copy is not enabled when any drawer but bypass feed is selected at Cover Sheet Copying Mode or Sheet Insertion Mode |                                       |
| 31  | %d originals are scanned Start copy job from next page | Paper jam occurred during copying (RADF scanning)   |                                       |
| 32  | Add paper  | Displayed when the paper in selected drawer is running out  |                                       |
| 33  | Cannot duplex this size                                | Displayed when the paper size which is not specified for duplex copying is set  |                                       |
| 34  | Cannot use this media type                             | Displayed when the paper size which is not specified for the functions such as stapling or hole punching is set                                   |                                       |
| 35  | Set standard size                                      | Displayed when the paper size which is not acceptable is set (depends on the setting)   | Re-set the paper size                 |
| 36  | Cannot staple this paper type                          | Displayed when the paper type which can not be stapled is set at Cover Sheet Copying Mode/Sheet Insertion Mode                                    | Re-set the paper type                 |
| 37  | Cannot duplex copy                                     | Displayed when the paper type which can not be duplexed is set at Cover Sheet Copying Mode/Sheet Insertion Mode                                   | Re-set the paper type                 |
| 38  | Cannot use transparency film                           | Displayed when the paper type which can not be punched is set at Cover Sheet Copying Mode/Sheet Insertion Mode                                    | Re-set the paper type                 |
| 39  | Copy size: A4/LT only                                  | Displayed when the paper size which is not specified for "Book-type duplex copying" or "Dual-page" is set   |                                       |
| 40  | Copy size: A4/LT and A4-R/LT-R                         | Displayed when the paper size which is not specified for "Rotate Sort"  |                                       |
| 41  | CHANGE DRAWER TO CORRECT PAPER SIZE                    | Displayed when the selected paper size is not in the drawer   |                                       |
| 42  | Change the paper type                                  | Displayed when the selected media type is not in the drawer   |                                       |
| 43  | Select a paper size for bypass feeding                 | Displayed when paper size needs to be specified for bypass feeding such as duplex copying   |                                       |

| No. | Message   | State of equipment  | Note  |
|-----|---|---|---|
| 44  | Place the blank sheets in bypass tray and select the paper size     | Displayed when no paper is in the selected feeder at Cover Sheet Copying Mode   |   |
| 45  | Place the blank sheets in the same direction as the originals       | Displayed when the direction of cover page is different from that of other pages at Cover Copying Mode                  |   |
| 46  | Place the same size blank sheets as the originals                   | Displayed when the paper size of cover page is different from that of other pages at Cover Copying Mode                 |   |
| 47  | Place insertion sheets in the bypass tray and select the paper size | Displayed when no insertion sheet is in the selected drawer at Sheet Insertion Mode                                     |   |
| 48  | Select the same size insert1 sheets as the originals                | Displayed when the size of insertion sheet (sheet 1) is different from that of other pages at Sheet Insertion Mode      |   |
| 49  | Select the same size insert2 sheets as the originals                | Displayed when the size of insertion sheet (sheet 2) is different from that of other pages at Sheet Insertion Mode      |   |
| 50  | Set insert1 sheets in the same direction as the originals           | Displayed when the direction of insertion sheet (sheet 1) is different from that of other pages at Sheet Insertion Mode |   |
| 51  | Set insert2 sheets in the same direction as the originals           | Displayed when the direction of insertion sheet (sheet 2) is different from that of other pages at Sheet Insertion Mode |   |
| 52  | READY<br>(CHANGE THE PAPER TYPE)                                    | Displays when the printing is stopped because of media type mismatch  |   |
| 53  | Set transparency film in A4/LT direction                            | Displayed when the selected paper size is other than A4/LT at OHP mode  |   |
| 54  | CHECK PAPER IN LARGE CAPACITY FEEDER                                | Papers in LCF are set incorrectly   |   |
| 55  | CANNOT PUNCH THIS SIZE PAPER  | Displayed when the selected paper size is not specified for hole punching   |   |
| 56  | Remove paper from the finisher                                      | Displayed when the paper sizes are mixed at Staple Sorting Mode   |   |
| 57  | Cannot staple this size   | Displayed when the paper size is not specified for stapling at Staple Sorting Mode                                      |   |
| 58  | Remove paper from the finisher                                      | Finisher is full of papers  |   |
| 59  | Examine stapler   | Trouble in the stapler unit in finisher   |   |
| 60  | Check staple cartridge  | No stapler in finisher section  |   |
| 61  | Job interrupted job 1 saved   | Interrupt copying is accepted   |   |
| 62  | Ready to resume job 1   | Interrupt copying is cancelled (finished)   |   |
| 63  | Cannot use AMS mode   | Displayed when reproduction ratio is set to be over 200% at AMS Mode on RADF  | Set the reproduction ratio 200% or below manually |
| 64  | More than 200% is not available                                     | Displayed when reproduction ratio is set manually to be over 200% on RADF   | Set the reproduction ratio 200% or below          |

| No. | Message  | State of equipment  | Note   |
|-----|--|---|--|
| 65  | Updated the template setting   | Displayed when the template stored is recalled by pressing [TEMPLATE] button                        |  |
| 66  | Enter Department Code  | Displayed when a button is pressed while the department management setting is available             |  |
| 67  | Cannot copy<br>Check DEPARTMENT COUNTER  | Displayed when the number of print-outs exceeds the limit number of department counter              |  |
| 68  | Not enough memory to store original(s)<br>Will you print out stored originals?   | Displayed when confirming the user to print out the data as much as stored at memory-full state     |  |
| 69  | Not enough memory to store original(s)<br>Will you enable stored originals?      | Displayed when confirming the user to send the FAX data as much as stored at memory-full state      | Displayed only in FAX Function   |
| 70  | Not enough memory to store original(s)<br>Will you save stored originals?        | Displayed when confirming the user to save the scanning data as much as stored at memory-full state | Displayed only in Scanning Function  |
| 71  | The number of originals exceeds the limits Will you copy stored originals?       | Displayed when confirming the user to print out the data as much as stored at memory-full state     |  |
| 72  | The number of originals exceeds the limits.<br>Will you enable stored originals? | Displayed when confirming the user to send the FAX data as much as stored at memory-full state      | Displayed only in FAX Function   |
| 73  | The number of originals exceeds the limits.<br>Will you save stored originals?   | Displayed when confirming the user to save the scanning data as much as stored at memory-full state | Displayed only in Scanning Function  |
| 74  | Install new toner cartridge  | No toner in the cartridge   | Displayed when toner is running out.<br>Copying not enabled                        |
| 75  | Time for periodic maintenance  | PM cycle<br>• Displayed at the time for maintenance<br>• Copying is available                       | Maintenance and inspection are performed by qualified service technician           |
| 76  | Please try again after a while   | Displayed when the Department Code can no be keyed in immediately after power-ON.                   | Leave it for a while and key in the code again                                     |
| 77  | Misfeed in copier  | Paper jam in the equipment<br>• Displayed when paper jam occurred in the equipment                  | Remove the paper in the equipment according to the messages displayed on the panel |
| 78  | Call for service   | Displayed when motor, sensor, switch, etc. do not work properly                                     | Turn OFF the power and solve the problem, then turn ON the power.                  |
| 79  | Cannot use envelope  | Displayed when envelope cannot be set for duplex copy   | Re-set   |
| 80  | Size must be ENVELOPE;<br>Type is ENVELOPE                                       | Displayed when envelope is set for media type, but not for the size of the paper                    | Re-set the paper size  |
| 81  | Type must be ENVELOPE;<br>Size is ENVELOPE                                       | Displayed when envelope is set for the size of the paper, but not for the media type                | Re-set the media type  |
| 82  | Press START button to copy after changing setting                                | Displayed when the build job is set   |  |

| No. | Message   | State of equipment   | Note                                |
|-----|---|--|-------------------------------------|
| 83  | The number of builds exceeds the limits will you copy stored originals? | Displayed when the number of builds exceeds the limits                     | Select either printing or canceling |
| 84  | The number of builds exceeds the limits will you save stored originals? | Displayed when the number of builds exceeds the limits                     | Select either printing or saving    |
| 85  | This setting cannot be changed now                                      | Displayed when the setting is changed during the build job is discontinued |                                     |

## 5.3 Relation between the Equipment State and Operator's Operation

|   | During READY status   | During warming-up   | Auto job start reserved  | Scanning original/ Scanning original and printing out the copy                                   |
|---|---|---|--------------------------|--|
| Press [ENERGY SAVER] button                                 | Switches to energy saving mode  | Display not changed   | Display not changed      | Display not changed  |
| Press [ACCESS] button                                       | Displays department code entry screen (when department management is available)                 | Displays department code entry screen (when department management is available)                 | Display not changed      | Display not changed  |
| Press [JOB STATUS] button                                   | Displays print job list screen  | Display not changed   | Display not changed      | Displays print job list screen   |
| Press [INTERRUPT] button                                    | Switches to interrupt mode  | Display not changed   | Display not changed      | Display not changed (LED blinking)   |
| Press [FUNCTION CLEAR] button after setting the copy mode   | Copy mode is cleared after the copy mode is set   | Copy mode is cleared after the copy mode is set   | Auto job start cancelled | Display not changed  |
| Press [STOP] button   | Display not changed   | Display not changed   | Auto job start cancelled | Scanning or printing out stops, and "READY Press START to copy" and "MEMORY CLEAR" are displayed |
| Press [CLEAR] button after setting the copy mode            | Number of printouts changes to 1 while the setting remains unchanged after the copy mode is set | Number of printouts changes to 1 while the setting remains unchanged after the copy mode is set | Display not changed      | Display not changed  |
| Press [CLEAR] button after keying in numbers (digital keys) | Number keyed in changes to 1 after being entered  | Number keyed in changes to 1 after being entered  | Display not changed      | Display not changed  |
| Press [MONITOR/ PAUSE]                                      | Display not changed   | Display not changed   | Display not changed      | Display not changed  |
| Press [FAX] button  | Displays FAX screen   | Display not changed   | Display not changed      | Display not changed  |
| Press [COPY] button   | Display not changed   | Display not changed   | Display not changed      | Display not changed  |
| Press [SCAN] button   | Displays SCAN screen  | Display not changed   | Display not changed      | Display not changed  |
| Press [e-FILING]  | Displays e-FILING   | Display not changed   | Display not changed      | Display not changed  |
| Press [EXTENSION] button                                    | Display not changed   | Display not changed   | Display not changed      | Display not changed  |
| Press [TEMPLATE] button                                     | Displays TEMPLATE screen  | Display not changed   | Display not changed      | Display not changed  |
| Press [USER FUNCTIONS] button                               | Displays USER FUNCTIONS screen  | Display not changed   | Display not changed      | Display not changed  |

|  | <b>During READY status</b> | <b>During warming-up</b>                  | <b>Auto job start reserved</b> | <b>Scanning original/<br/>Scanning original and printing out the copy</b> |
|--|----------------------------|---|--------------------------------|---|
| Press [HELP] button                                | Displays HELP screen       | Displays HELP screen                      | Display not changed            | Display not changed   |
| Press [START] button with the original set on RADF | Displays "COPYING"         | "Wait Warming Up Auto Start" is displayed | Display not changed            | Display not changed   |

|   | Printing out the copy   | During paper jam    | When interrupting   | When displaying HELP screen   | During energy saving mode                               |
|---|---|---------------------|---|---|---|
| Press [ENERGY SAVER] button                                 | Display not changed   | Display not changed | Display not changed   | Switches to energy saving mode  | Energy saving mode is cleared and displays BASIC screen |
| Press [ACCESS] button                                       | Displays department code entry screen (when department management is available)                 | Display not changed | Displays department code entry screen (when department management is available)                 | Displays department code entry screen (when department management is available)                 | Display not changed                                     |
| Press [JOB STATUS] button                                   | Displays print job list screen  | Display not changed | Displays print job list screen  | Displays print job list screen  | Display not changed                                     |
| Press [INTERRUPT] button                                    | Display not changed (LED blinking)  | Display not changed | Returns to the status before interrupting   | Switches to interrupting mode   | Display not changed                                     |
| Press [FUNCTION CLEAR] button after setting the copy mode   | Copy mode is cleared after the copy mode is set   | Display not changed | Copy mode is cleared after the copy mode is set   | Displays BASIC screen after the copy mode is set and then cancelled                             | Display not changed                                     |
| Press [STOP] button   | Printing out stops, and "READY Press START to copy" and "MEMORY CLEAR" are displayed            | Display not changed | Display not changed   | Display not changed   | Display not changed                                     |
| Press [CLEAR] button after setting the copy mode            | Number of printouts changes to 1 while the setting remains unchanged after the copy mode is set | Display not changed | Number of printouts changes to 1 while the setting remains unchanged after the copy mode is set | Number of printouts changes to 1 while the setting remains unchanged after the copy mode is set | Display not changed                                     |
| Press [CLEAR] button after keying in numbers (digital keys) | Number keyed in changes to 1 after being entered  | Display not changed | Number keyed in changes to 1 after being entered  | Number keyed in changes to 1 after being entered  | Display not changed                                     |
| Press [MONITOR/PAUSE]                                       | Display not changed   | Display not changed | Display not changed   | Display not changed   | Display not changed                                     |
| Press [FAX] button  | Displays FAX screen   | Display not changed | Display not changed   | Displays FAX screen   | Displays FAX screen                                     |
| Press [COPY] button   | Display not changed   | Display not changed | Display not changed   | Display not changed   | Displays COPY screen                                    |
| Press [SCAN] button   | Displays SCAN screen  | Display not changed | Display not changed   | Displays SCAN screen  | Displays SCAN screen                                    |
| Press [e-FILING]  | Displays e-FILING screen  | Display not changed | Display not changed   | Displays e-FILING screen  | Displays e-FILING screen                                |
| Press [EXTENSION] button                                    | Display not changed   | Display not changed | Display not changed   | Display not changed   | Display not changed                                     |



|  | <b>Printing out the copy</b>               | <b>During paper jam</b> | <b>When interrupting</b>                   | <b>When displaying HELP screen</b>          | <b>During energy saving mode</b>                        |
|--|--|-------------------------|--|---|---|
| Press [TEMPLATE] button                            | Displays TEMPLATE screen                   | Display not changed     | Display not changed                        | Displays TEMPLATE screen                    | Display not changed                                     |
| Press [USER FUNCTIONS] button                      | Displays USER FUNCTIONS screen             | Display not changed     | Display not changed                        | Displays USER FUNCTIONS screen              | Display not changed                                     |
| Press [HELP] button                                | Displays HELP screen                       | Display not changed     | Displays HELP screen                       | Switches to the screen previously displayed | Display not changed                                     |
| Press [START] button with the original set on RADF | Displays "COPYING" and RADF starts feeding | Display not changed     | Displays "COPYING" and RADF starts feeding | Displays "COPYING" and RADF starts feeding  | Energy saving mode is cleared and displays BASIC screen |

## 5.4 Description of Operation

### 5.4.1 Dot matrix LCD circuit

#### 1) Structure

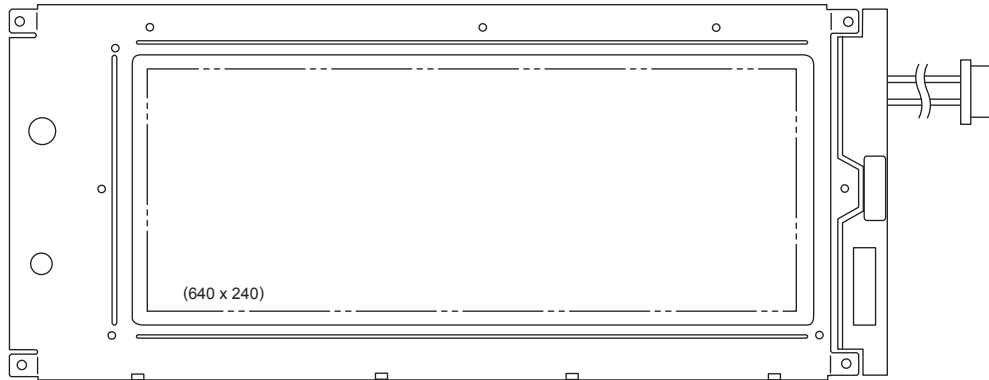

Fig. 5-4

The LCD panel is an STN blue mode transmissive type LCD with 640x240-dot display capacity. It consists of a driver LSI, frame, printed circuit board, and lateral type CCFL backlight.

- \* STN: Super Twisted Nematic
- \* CCFL: Cold Cathode Fluorescent Lamp

#### 2) Block diagram

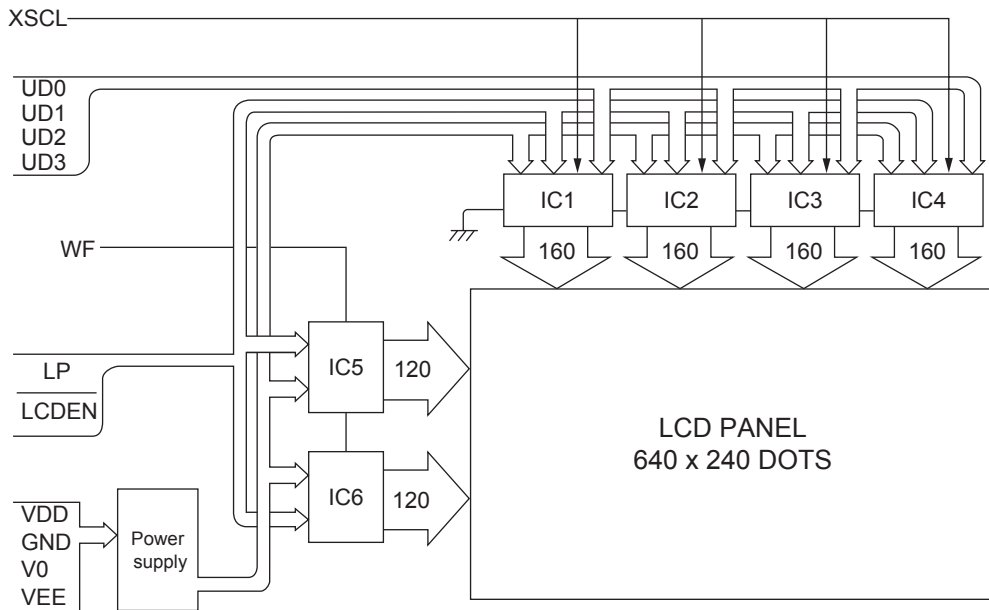

Fig. 5-5

3) System diagram

Signals flowing between the control panel and the SYS board are indicated in the chart below. When the panel processing CPU detects that the control panel is operated, the operational contents are transmitted to the SYS board through the serial data. The state of the equipment and the messages from the SYS board are received by the LCD controller and then displayed on the LCD. The LED and buzzers are switched to ON/OFF with the signals from the SYS board.

The control methods of the LED and buzzers differ depending on the model:

e-STUDIO200L/230/230L/280/280S: They are switched to ON/OFF with control signals from the SYS board.

e-STUDIO202L/203L/232/233/232S/282/283/282S/283S: They are switched to ON/OFF with the signals output from the panel processing CPU, based on serial data transmitted from the SYS board.

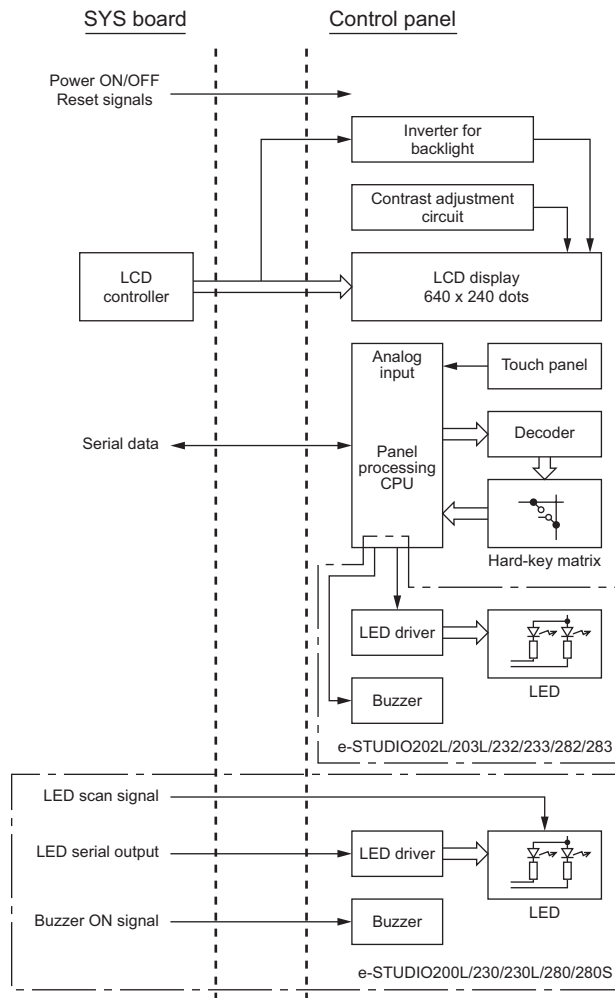

#### 4) Data Transmission

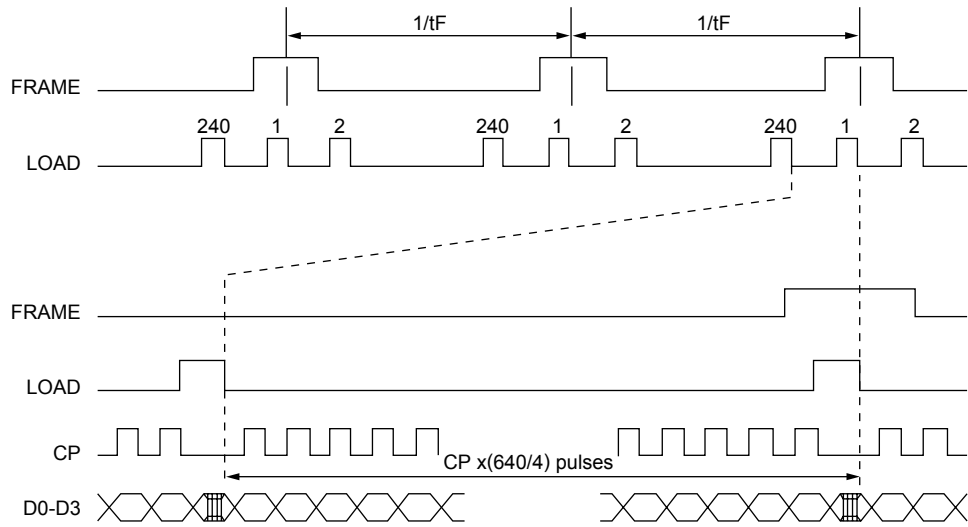

**Fig. 5-6**

## 5.4.2 LED display circuit

- 1) Method of LED display
- ex) Displaying "COPY".

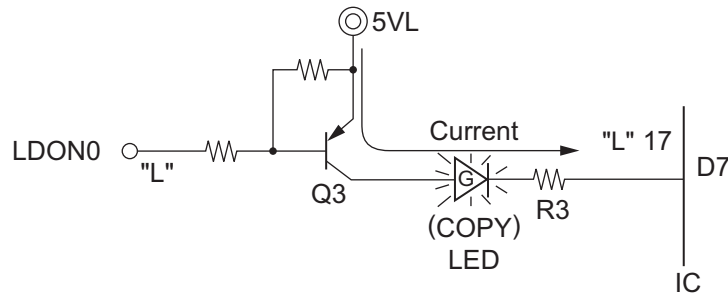

Fig. 5-7

Transistor is turned ON when the LDON 0 signal becomes "L" level.

Also, when IC pin 17 changes to "L", the current flows from 5V via the transistor to the LED ("COPY") to turn ON the LED ("COPY").

|                               |
|-------------------------------|
| Conditions to turn ON the LED |
|-------------------------------|

- (a) The transistor (Q3) connected to the LED anode is ON.
  - (b) The output from the cathode side of the LED is "L" level.
- The LED turns ON when the conditions (a) and (b) are met.

# 5.5 Disassembly and Replacement

**Note:**  
When taking off the control panel, check the position of the stopper; if the stopper is at the position "B", remove the stopper or move it to the position "A".

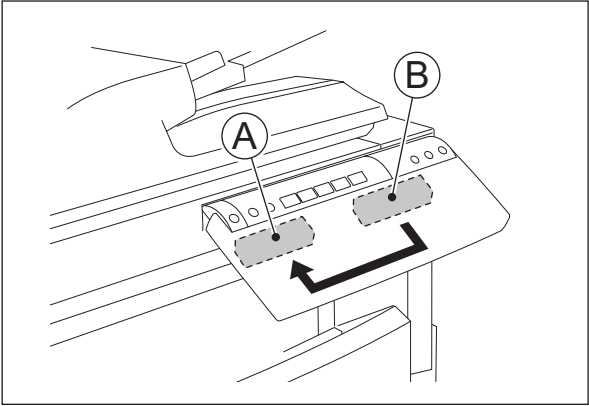

Fig. 5-8

## [A] Stopper

- (1) Slide the stopper and pull it out.

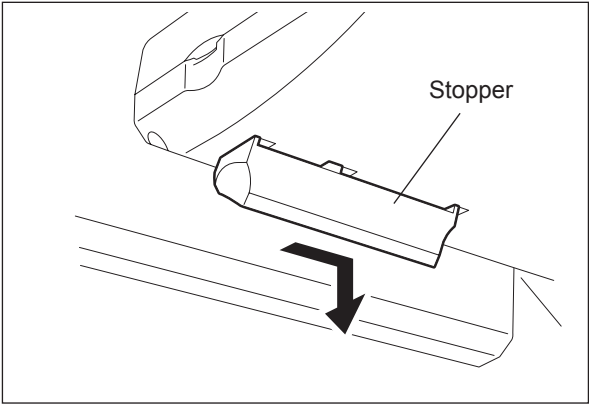

Fig. 5-9

## [B] Control panel unit

- (1) Take off the front upper cover, right upper cover-1 and right upper cover-2 (P.2-32 "[E] Front upper cover", P.2-33 "[F] Right upper cover-1", P.2-33 "[G] Right upper cover-2").
- (2) Disconnect 1 connector.
- (3) Remove 2 screws and 2 harness clamps. Then release the harness from 3 harness clamps.

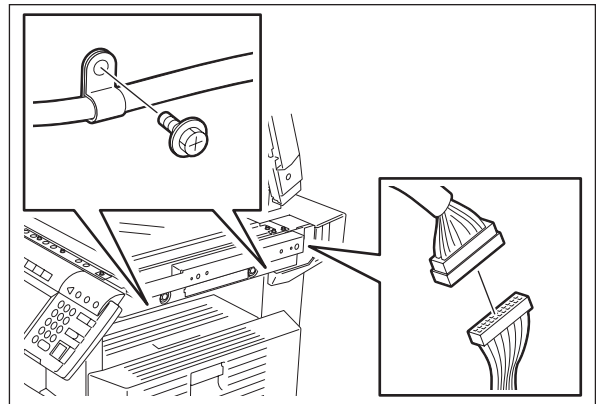

Fig. 5-10

- (4) Lower the control panel unit and remove 4 screws.
- (5) Take off the control panel unit while sliding it.

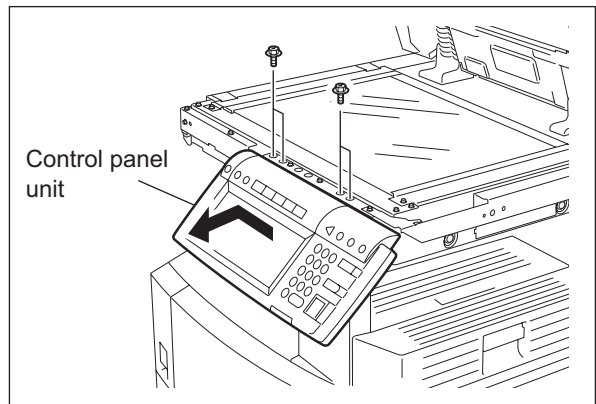
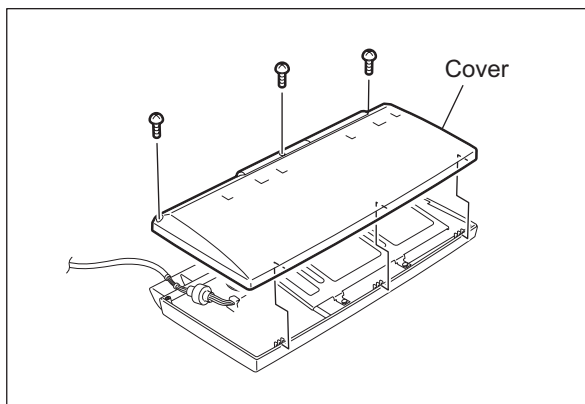

Fig. 5-11

**[C] Display PC board (DSP board)/Key control PC board (KEY board)/LCD**

- (1) Take off the control panel unit  
( P.5-17 "[B] Control panel unit").
- (2) Remove 3 screws and take off the cover.



**Fig. 5-12**

- (3) Remove 5 screws and take off the hinge bracket.

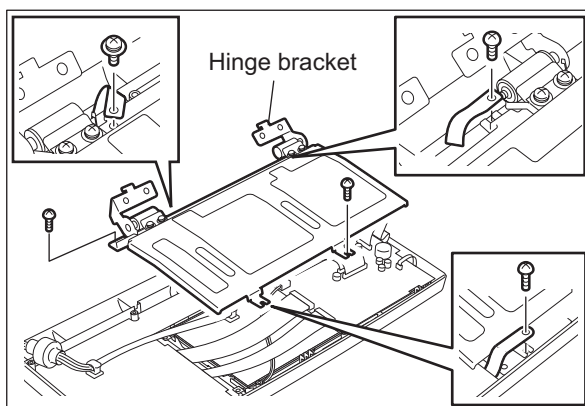

**Fig. 5-13**

- (4) Disconnect 5 connectors.
- (5) Release the harness from 2 harness clamps.
- (6) Remove 1 screw and take off the DSP board.

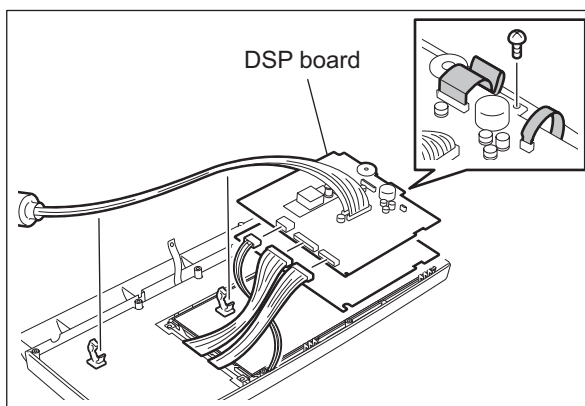

**Fig. 5-14**



(7) Remove 4 screws and take off the LCD.

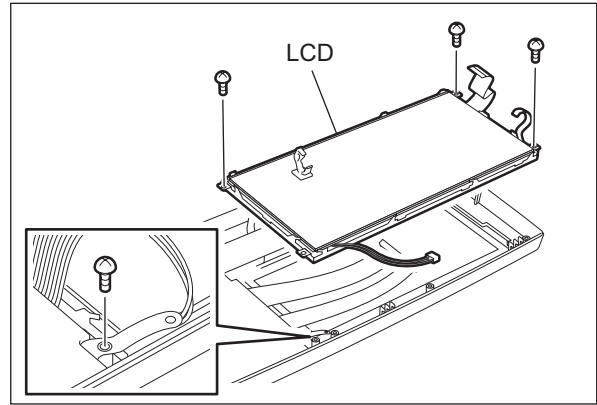

Fig. 5-15

(8) Remove 16 screws and take off the KEY board.

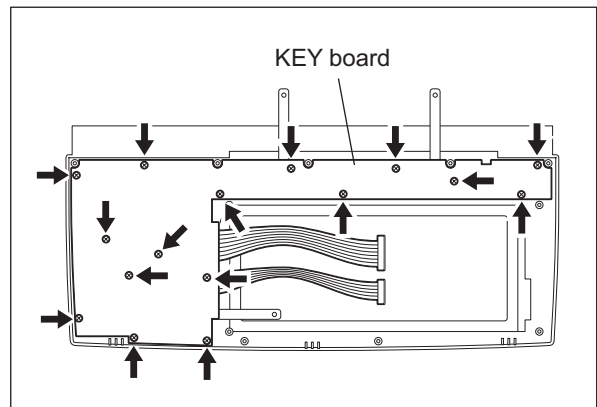

Fig. 5-16



## 6. SCANNER

### 6.1 Function

In the scanning section of this equipment, the surface of an original is irradiated with a direct light and the reflected light is led through mirrors, a lens and a slit to the CCD where optical-to-electrical conversion is performed, converting the optical image data into an electrical (analog) signal. This analog signal is changed to a digital signal, which then performs various corrective processes necessary for image formation. After that, an arithmetic operation is performed on the digital signal, which is then transmitted to the data writing section.

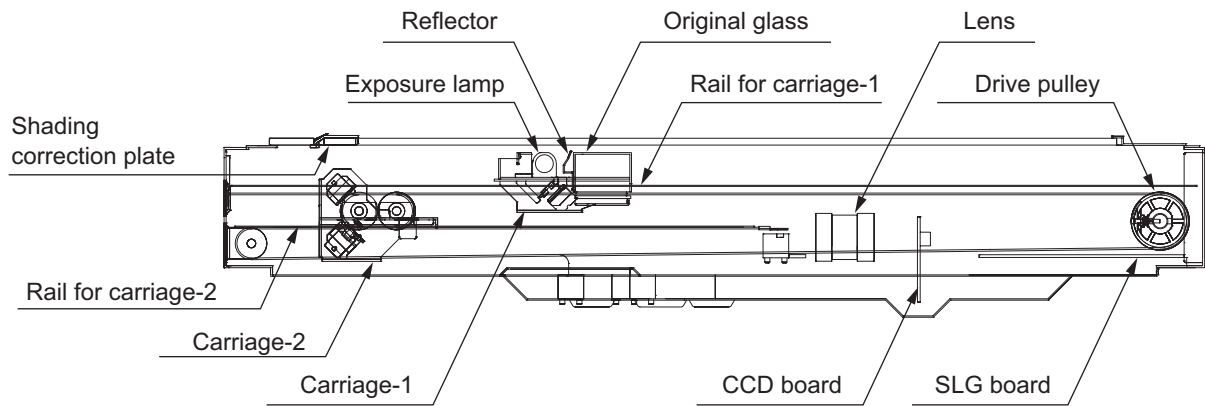

Fig. 6-1

## 6.2 Construction

The construction and purpose of the scanning system are shown below.

### 1) Original glass

This is a glass on which original is placed. The light from the exposure lamp is irradiated to the original through this glass.

### 2) Carriage-1

The carriage-1 consists of the exposure lamp, inverter board, reflector, mirror-1, etc. It is driven by the scan motor and scans an original on the glass.

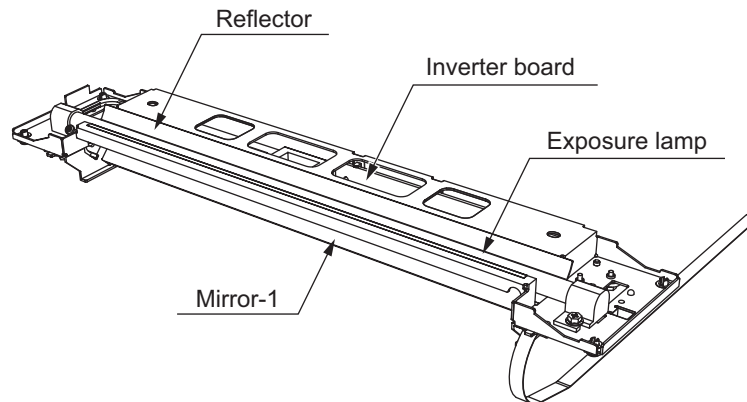

Fig. 6-2

- Exposure lamp  
This lamp is a light source to irradiate the original on the glass (one 16 W xenon lamp).
- Inverter board  
This inverter board controls lighting of the xenon lamp.
- Reflector  
This is a reflecting plate to efficiently lead the light from the exposure lamp to the surface of the original on the glass.
- Mirror-1  
This mirror leads the light reflected from the original to the mirror-2 described later.

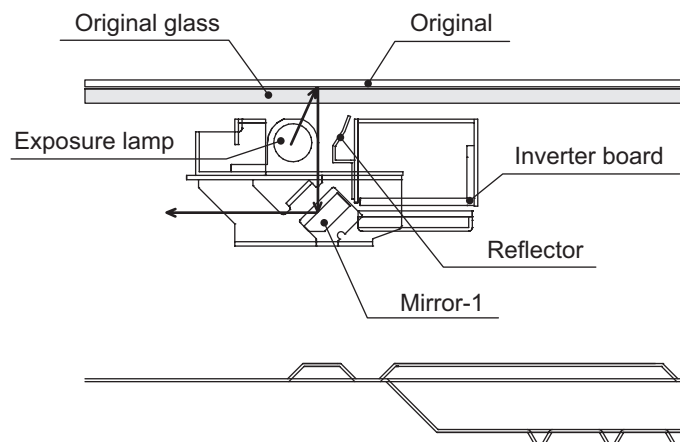

Fig. 6-3

3) Carriage-2

The carriage-2 consists of the mirror-2, mirror-3, etc. and leads the reflected light from the mirror-1 through the mirrors-2 and -3 to the lens.

This carriage is also driven by the scan motor as in the same manner of the carriage-1 at half the scanning speed of the carriage-1. (The scanning distance is also half that of the carriage-1.)

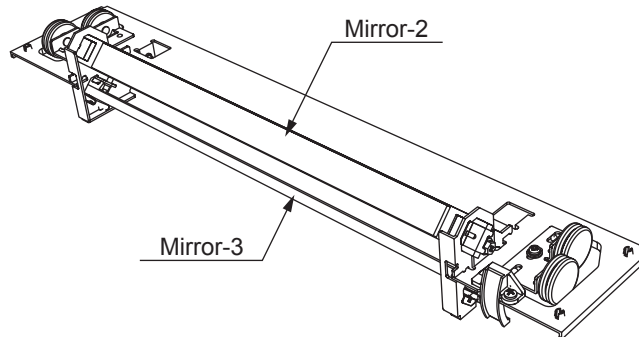

Fig. 6-4

4) Lens unit

The light reflected from the mirror-3 is led to the CCD placed at the focal point of the lens which is fixed at this position.

5) CCD driving PC board (CCD board)

This is a board to convert the optical image signal which has been converted by the CCD into an analog signal.

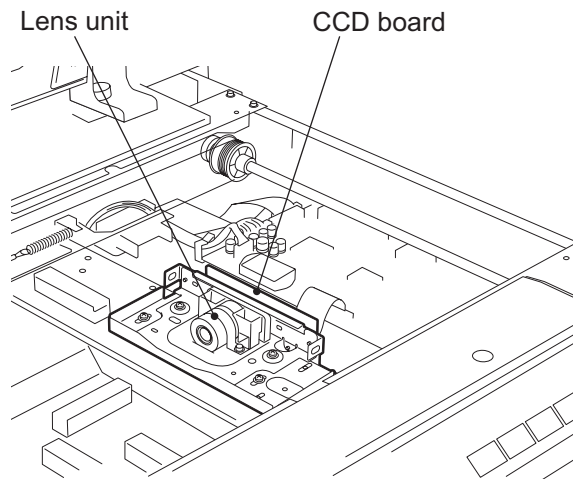

Fig. 6-5

6) Automatic original detection sensor (APS sensor)

The size of an original placed on the glass is instantly detected using the APS sensor fixed on the base frame without moving the carriage-1.

## 6.3 Description of Operation

### 6.3.1 Scan motor

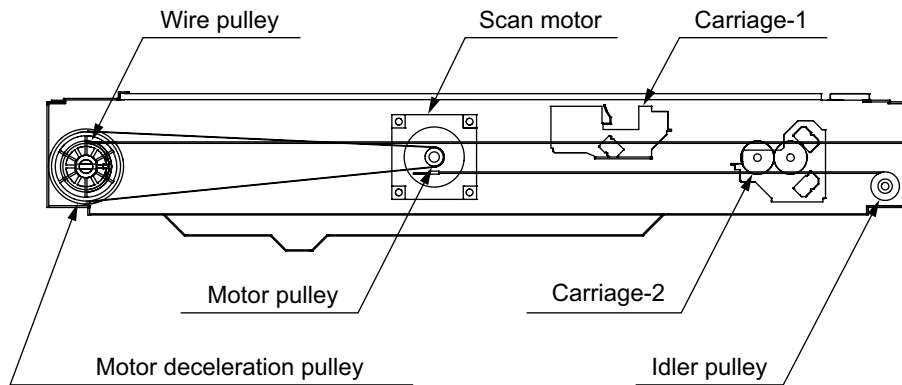

Fig. 6-6

- Scanning an original on the original glass  
This motor drives the carriages-1 and -2 through the timing belt and carriage wire. First, the scan motor drives the carriages-1 and -2 to their respective home position. The home position is detected when the carriage-1 passes the carriage home position sensor. When [START] is pressed, both of the carriages start to move and scan the original on the glass.
- Scanning an original on the RADF  
The carriage-1 stays at the shading position during shading correction, and at the scanning position during scanning operation.

### 6.3.2 Scanning drive circuit

The scan motor is a 2-phase stepping motor and driven by the motor driver (IC16).

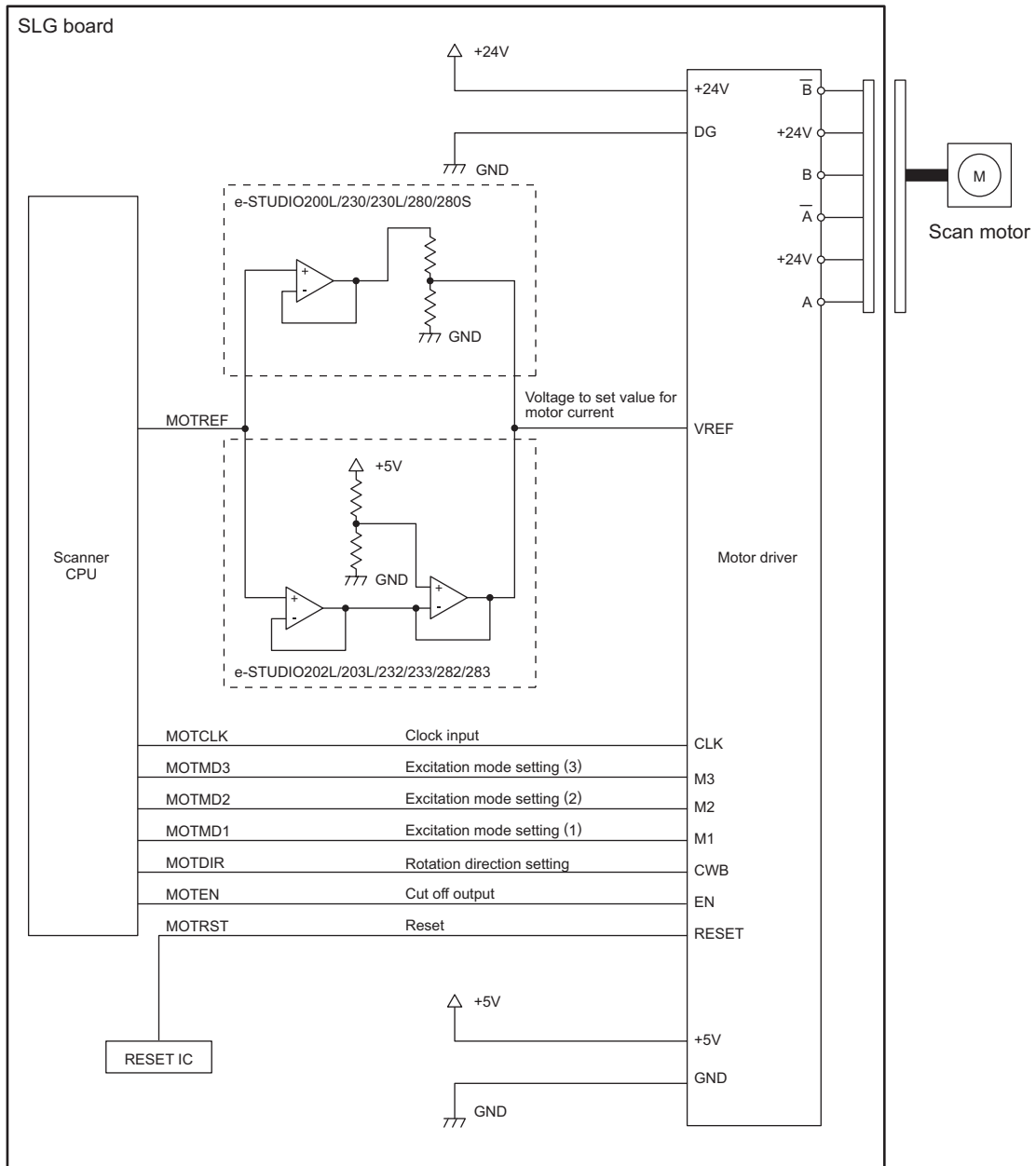

Fig. 6-7

Input/output signals

|  |              |       |   |
|--|--------------|-------|---|
| Clock input                                | MOTCLK       | Input | Motor is rotated by setting number of pulses.<br>* Internal circuit of the motor driver works when the first pulse becomes ON and the last pulse becomes OFF.   |
| Set the direction of motor rotation        | MOTDIR       | Input | The direction of the motor rotation is determined by setting the level of signal.<br>“L” ..... Clockwise direction (as seen from the output shaft)<br>“H” .... Counterclockwise direction (as seen from the output shaft)<br><b>Note:</b><br>Do not change the rotation direction within 7μsec. before the first pulse of the MOTCLK becomes ON and after the last pulse becomes OFF. |
| Cut off the drive output                   | MOTEN        | Input | Excitation drive is turned ON/OFF.<br>“H” .... Normal operation (Excited)<br>“L” ..... Excitation drive is forcibly shut off (Not excited)  |
| Voltage to set value for the motor current | MOTREF       | Input | Motor wire current value is set in the range of 0 to 1.7 (A)/phase by applying the analog voltage 0 to 5 (V).   |
| Set the excitation mode (1) to (3)         | MOTMD 1 to 3 | Input | Set the excitation mode.<br><b>Note:</b><br>Do not change the setting within 7μsec. after the first pulse of the MOTCLK becomes ON and the last pulse becomes OFF.  |
| Reset                                      | MOTRST       | Input | Reset for the whole system<br>Internal circuit of the driver is initialized by setting the motor to “L” level (pulse interval: 10μsec. or more).<br>The motor drive circuit is automatically reset when the power is turned ON.   |



### 6.3.3 Initialization at power-ON

The carriages move to their home positions and perform the peak detection. Then they move to the carriage waiting positions and wait.

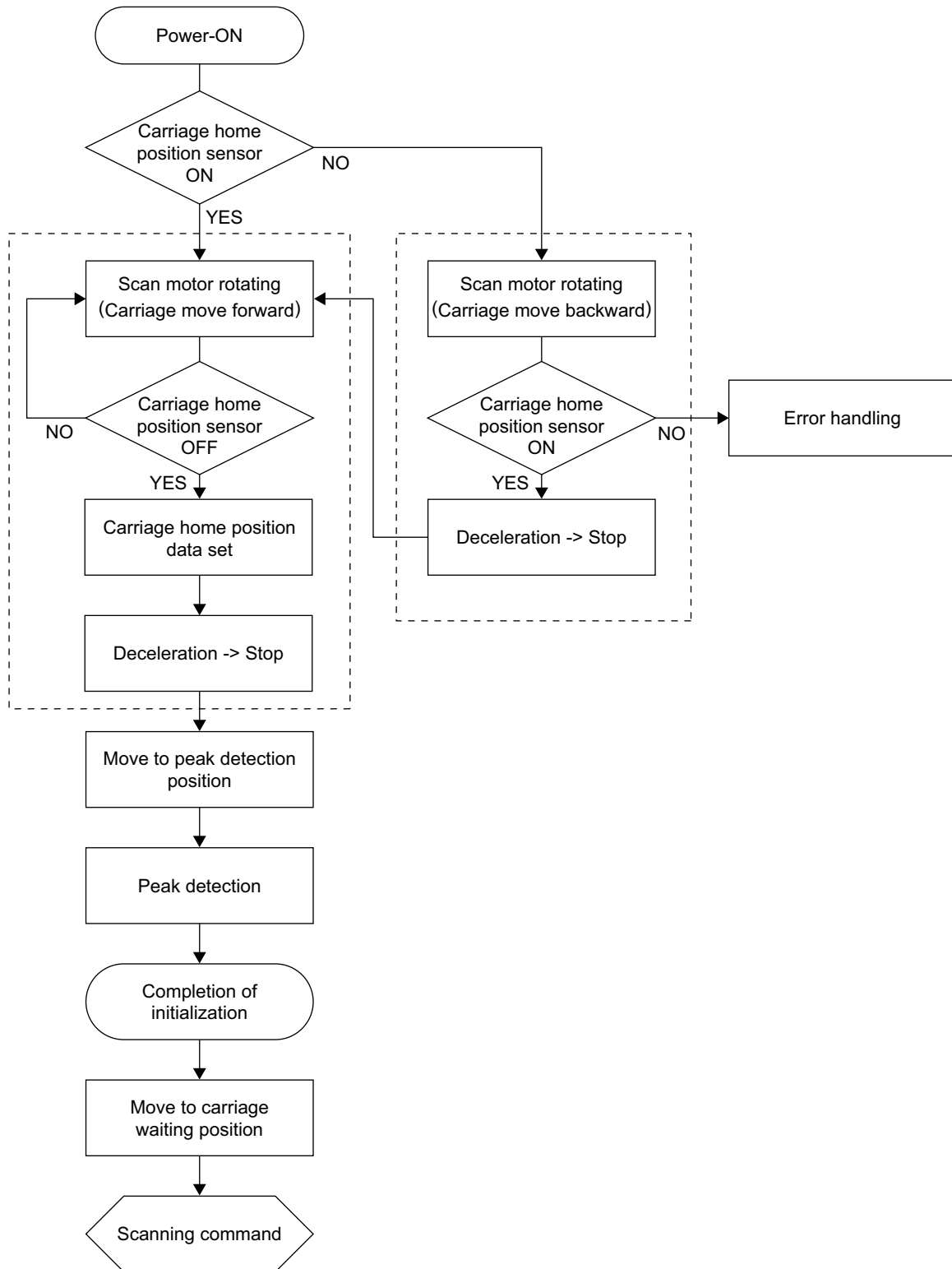

Fig. 6-8

## 6.4 Control of Exposure Lamp

### 6.4.1 General description

The control circuit for the exposure lamp consists of the following three blocks:

- 1) Lighting device for the exposure lamp (Inverter)  
This device turns the exposure lamp (xenon lamp) ON/OFF.
- 2) CCD circuit  
This circuit converts the light amount reflected from the original surface and shading correction plate to electrical signals. The exposure amount is controlled in two ways:
  - White reference formation – reads the light amount reflected from the white shading correction plate
  - Black reference formation – reads the light amount at the specified position with the exposure lamp lights OFF
- 3) Image processing circuit  
A series of image processes such as a gamma correction and a shading correction are applied on the output signal from the CCD. The signal is then digitized and output from this circuit.

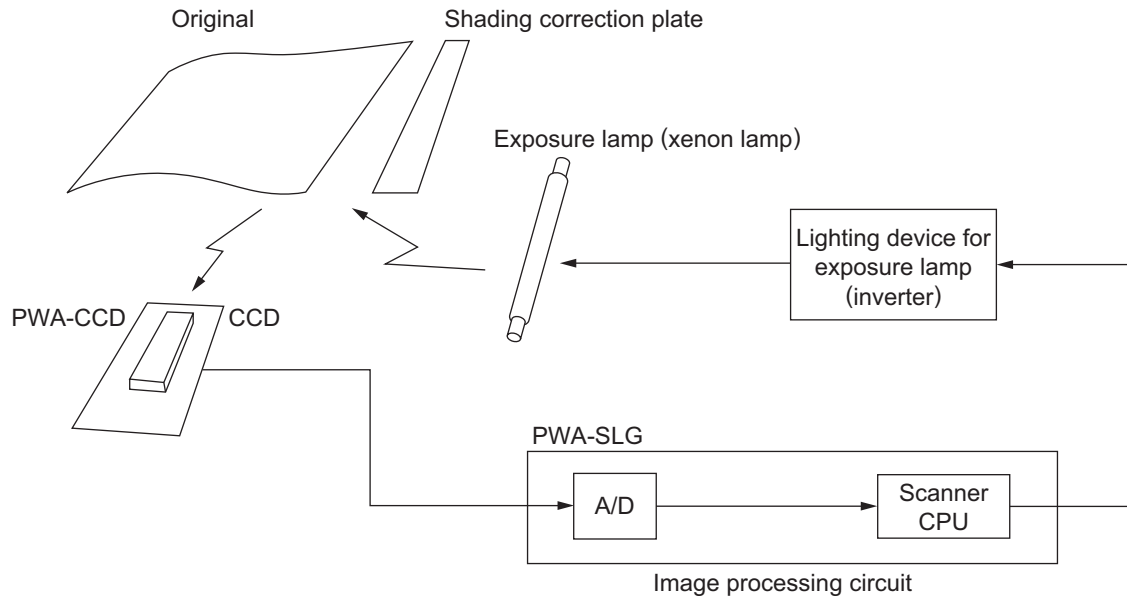

Fig. 6-9

## 6.4.2 Exposure lamp

An external electrode type xenon fluorescent lamp is used as the exposure lamp in this equipment.

### 1) Structure

Fluorescer is applied on the internal surface of the lamp pipe (except a part to be an opening) which is filled with xenon gas.

A pair of the external electrodes covered by film with the adhesive agent is attached over the pipe.

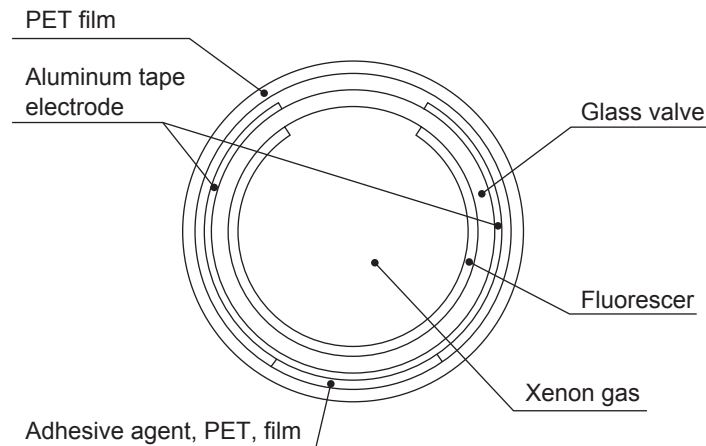
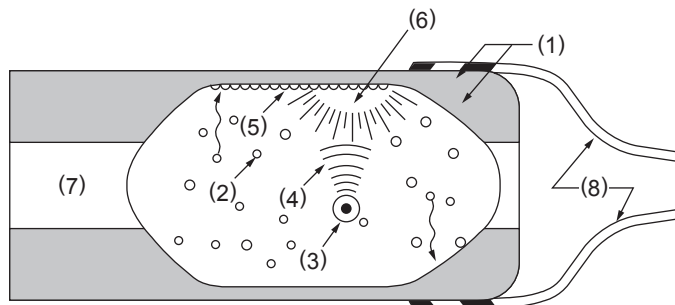

Fig. 6-10

### 2) Behavior inside the lamp

Electrons inside the pipe are led to the electric field by applying voltage to a pair of the external electrodes, and discharging starts. The electrons then flow and clash with a xenon atom inside the pipe to excite it, and generate an ultraviolet ray. This ultraviolet ray converts the fluorescer into visible light.



- (1)Electrode (2)Electron (3)Xenon atom (4)Ultraviolet ray (5)Fluorescer  
 (6)Visible light (irradiated from the opening to outside the pipe)  
 (7)Opening (8)Harness

Fig. 6-11

### 6.4.3 Control circuit for the exposure lamp

SLG board

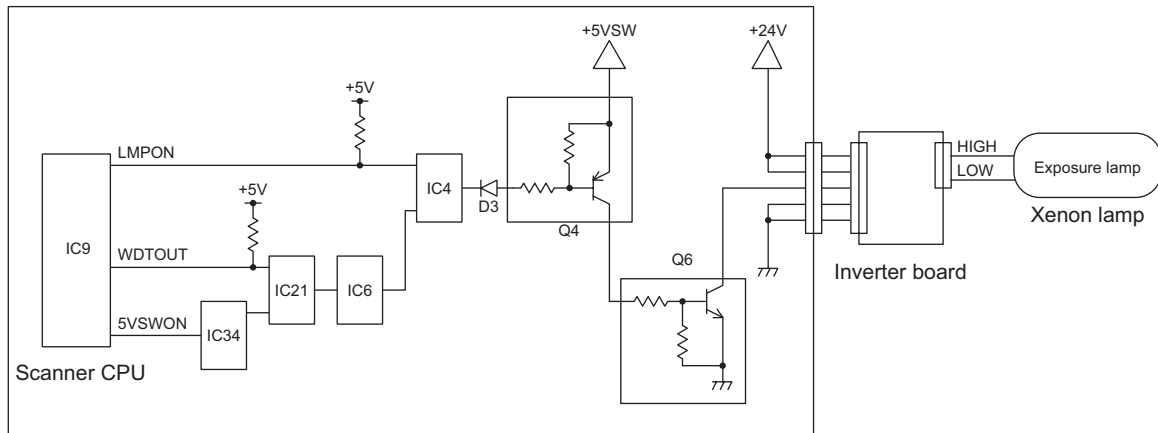

Fig. 6-12

Working conditions

|            |        |     |   |   |                         |                                       |
|------------|--------|-----|---|---|-------------------------|---------------------------------------|
| LMPON      | L      | -   | - | - | Exposure lamp ON signal | Lamp turns ON at "L"                  |
| 5VSW ON    | L      | H   | - | - | 5V SW ON signal         | Controls 5VSW at CPU.<br>Normally "L" |
| WDTOUT     | H      | -   | L | - | Watchdog timer signal   | Level "L" when CPU is out of control  |
| Xenon lamp | O<br>N | OFF |   |   |                         |                                       |

## 6.5 General Description of CCD Control

### 6.5.1 Opto-electronic conversion

A CCD (Charge-Coupled Device) is used to produce an electrical signal corresponding to the amount of light reflected from the original. The CCD is a one-chip opto-electronic conversion device, comprised of several thousand light-receiving elements arranged in a line, each one of them is a few micron square. This equipment has a CCD which has 7,400 light-receiving elements.

Each element of the light-receiving section consists of semiconductive layers P and N. When the light irradiates the element, light energy produces a minus (-) charge in the layer P; the amount of the charge produced is proportional to the energy and irradiating time. The charge produced in the light-receiving section is then sent to the transfer section where it is shifted by transfer clock from left to right as shown in the figure below, and is finally output from the CCD. At this time, to increase the transfer speed of the CCD, image signals in the even-number and odd-number elements are separated and output in parallel via two channels.

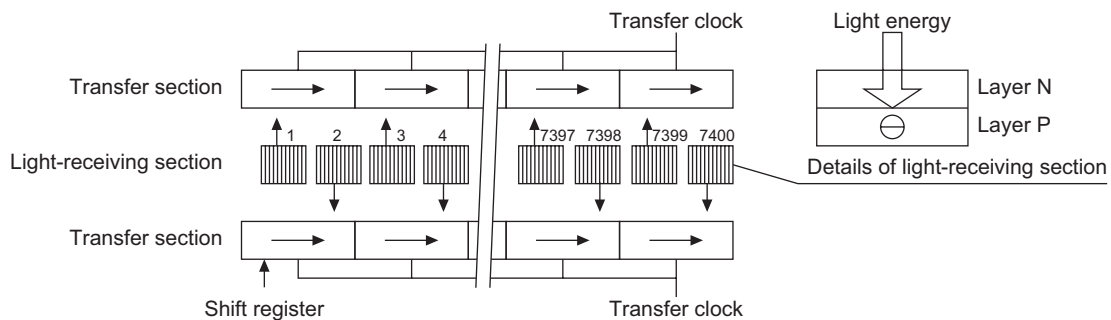

Fig. 6-13

### 6.5.2 Shading correction

Signal voltages read by the CCD have the following characteristics:

- 1) The light source has a variation in its light distribution.
- 2) Since the light beams reflected from the original are converged using a lens, the light path is the shortest at the center of the CCD and the longest at the ends. This causes a difference in the amount of light reaching the CCD (i.e. the light amount is maximum at the center of CCD, gradually decreases toward the ends).
- 3) Each of 7,400 elements varies in opto-electronic conversion efficiency.

These differences need to be corrected and this correction is referred to as a shading correction. The shading correction is performed by applying a normalization process using the following formula on the black data and white data obtained in advance to correct the lighting variance and element variation of the image data.

$$I = k \times \frac{(S - K)}{(W - K)}$$

- k : Coefficient  
 S : Image data before correction  
 K : Black data (stored in "black" memory)  
 W : White data (stored in "white" memory)

# 6.6 Automatic Original Size Detection Circuit

This circuit detects the size of the original (standard sizes only) using the reflection-type photosensors arranged on the base frame of the scanner unit.

## 6.6.1 Principle of original size detection

The reflection-type photosensors are placed on the base frame of the scanner unit as shown in the Fig. 6-14. Each sensor consists of an infrared LED (Light Emitting Diode) on the light-emitting side, and a phototransistor on the light-receiving side.

When there is an original on the original glass, the light beams from the LEDs are reflected by the original and led to the phototransistors. This means that the presence of the original is detected by the presence of reflection.

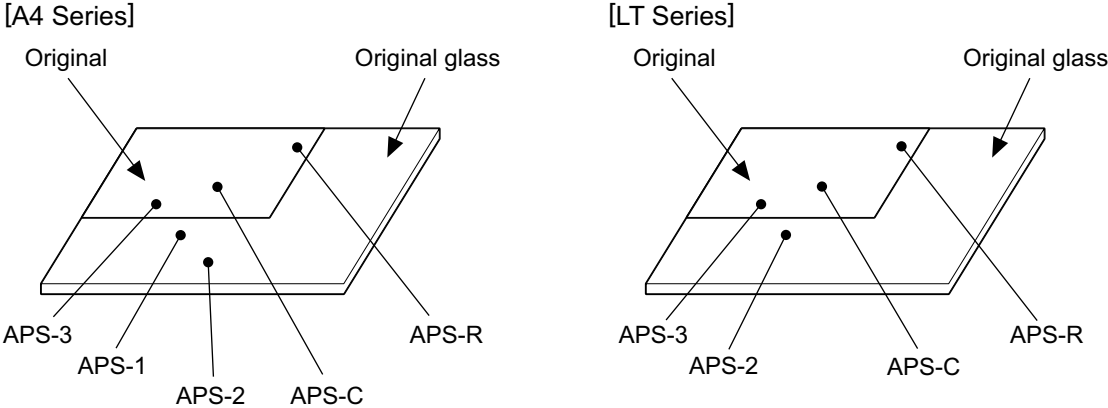

Fig. 6-14

### 6.6.2 Process of detection of original size

- 1) When the equipment is in the APS mode, the carriage-1 is set at its home position.
- 2) When the platen cover is opened, the sensors receive the light reflected from the original and if the conditions for original size shown in a matrix of 4) are met, the size of the original is instantly detected.
- 3) The output signal from each sensor is input to CPU on the SLG board to determine the size of the original.

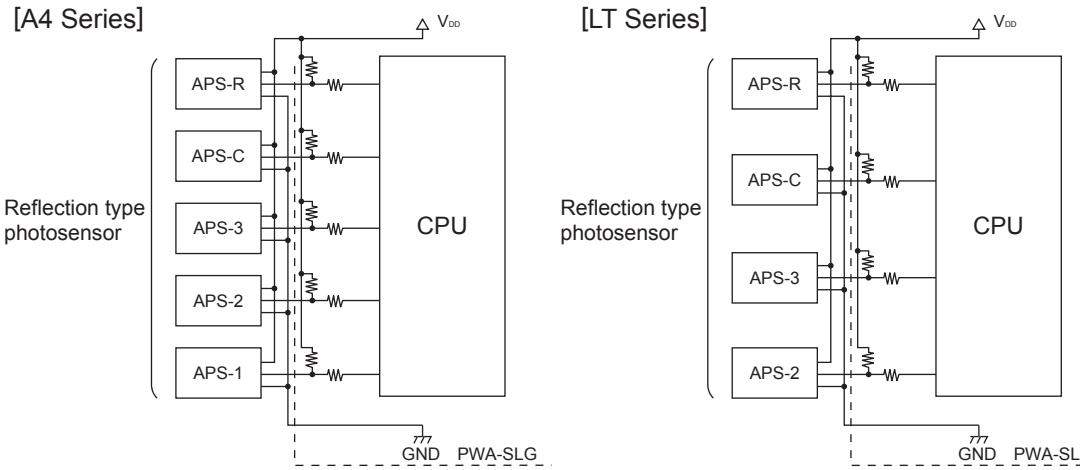
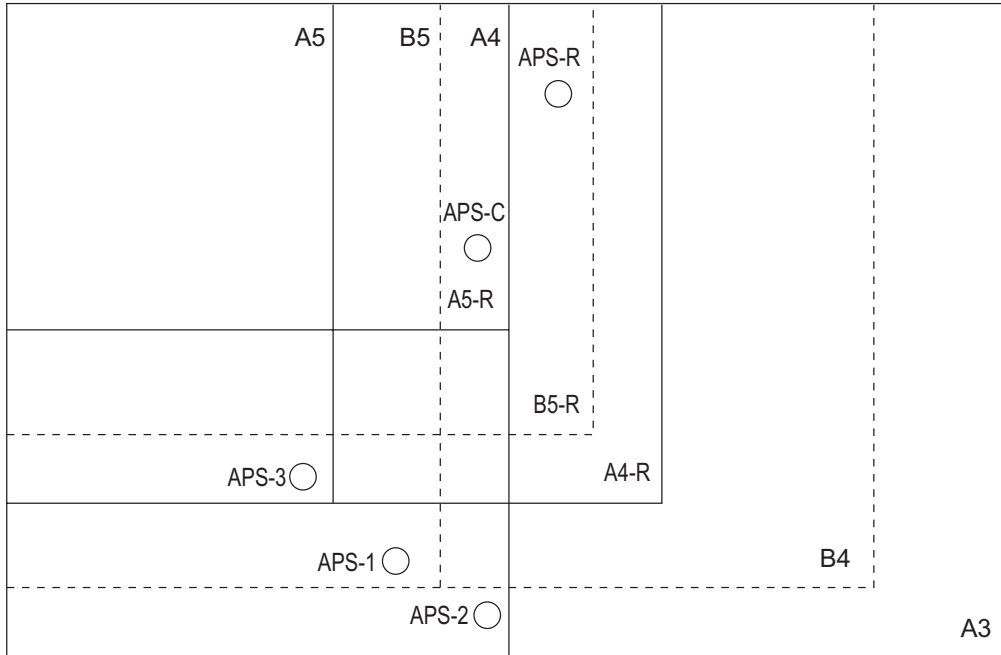

Fig. 6-15

**[A4 Series]**



**Fig. 6-16**

**[LT Series]**

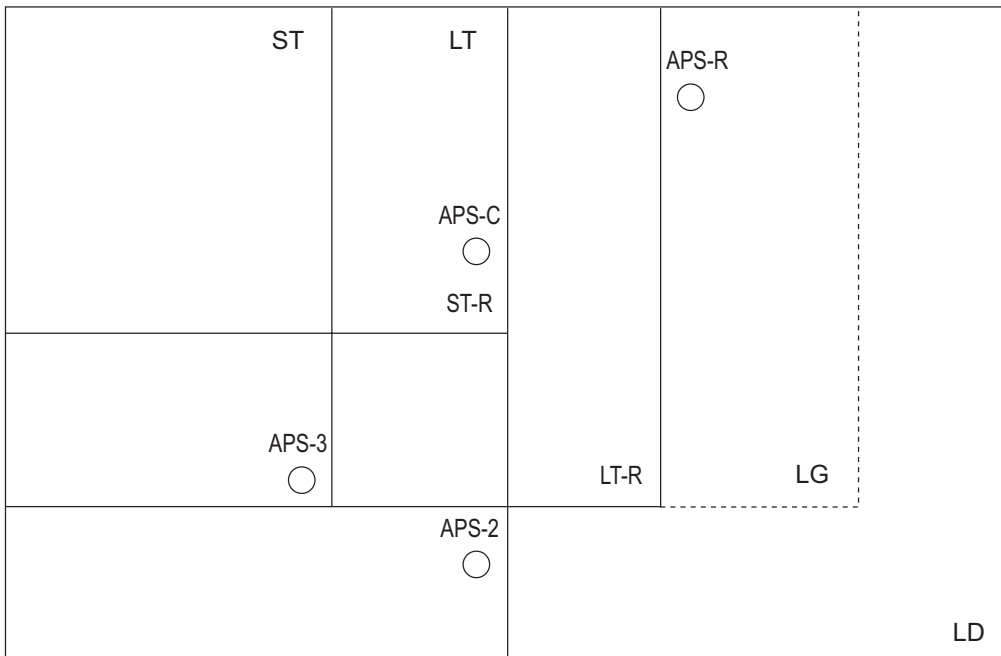

**Fig. 6-17 Sensor detection points**



- 4) The original size is determined by the combination of the signals output from each detection point. Combination charts for size determination of A4 series and LT series are as follows.

**[A4 Series]**

| Size judgement | APS-C | APS-R | APS-1 | APS-2 | APS-3 |
|----------------|-------|-------|-------|-------|-------|
| A3             | 0     | 0     | 0     | 0     | 0     |
| A4             | 0     | 1     | 0     | 0     | 0     |
| B4             | 0     | 0     | 0     | 1     | 0     |
| B5             | 1     | 1     | 0     | 1     | 0     |
| A4-R           | 0     | 0     | 1     | 1     | 0     |
| A5             | 1     | 1     | 1     | 1     | 0     |
| B5-R           | 0     | 0     | 1     | 1     | 1     |
| A5-R           | 0     | 1     | 1     | 1     | 1     |

**[LT Series]**

| Size judgement | APS-C | APS-R | APS-2 | APS-3 |
|----------------|-------|-------|-------|-------|
| LD             | 0     | 0     | 0     | 0     |
| LT             | 0     | 1     | 0     | 0     |
| LG             | 0     | 0     | 1     | 0     |
| LT-R           | 0     | 1     | 1     | 0     |
| ST             | 1     | 1     | 1     | 0     |
| ST-R           | 0     | 1     | 1     | 1     |

| Code | Output signal | Original      |
|------|---------------|---------------|
| 1    | H             | Not available |
| 0    | L             | Available     |

- \* When the platen sensor is OFF,
- The following is judged by the signals output from the APS sensors.
    - Size determined (The combination of the signals satisfies any in the above chart.)  
: The size is displayed on the control panel and a specific paper size or reproduction ratio is selected.
    - Size not determined (The combination of the signals does not satisfy any in the above chart.)  
: The size of the original immediately before the output signal change (or the state that there is no original) remains.
    - No original (The output signals from all sensors are level "H".)  
: The reproduction ratio and paper size are not selected.
  - The size change is always observed and detected.
  - The carriage-1 stays at the waiting position even if the reproduction ratio changes corresponding to the change of the original size.
- \* When the platen sensor is ON,  
The size of the original immediately before the platen sensor is turned ON (or the state that there is no original) remains regardless of the output signals of APS sensors.

### About the reflection-type photosensor

The reflection-type photosensor is comprised of an infrared LED (Light Emitting Diode) and a phototransistor. The sensor detects an original with a pulse modulation of LED.

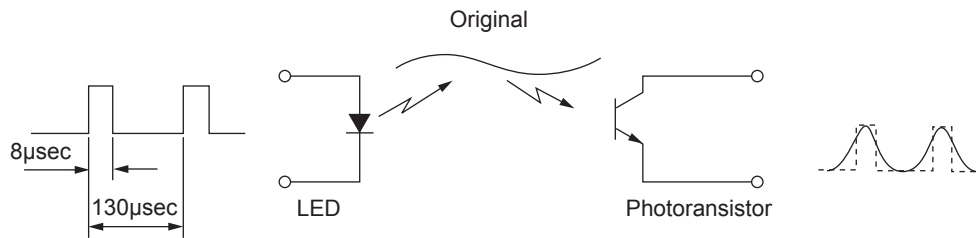



Fig. 6-18

The LED is driven by a pulse having a 130 μsec cycle and an 8 μsec ON time. When the phototransistor receives the same signal as this pulse, it is determined that there is an original. The pulse modulation is performed inside the reflection-type phototransistor.

## 6.7 Disassembly and Replacement

### [A] Original glass

- (1) Take off the right upper cover-1  
( P.2-33 "[F] Right upper cover-1").
- (2) Remove 2 screws and take off the fixing bracket.

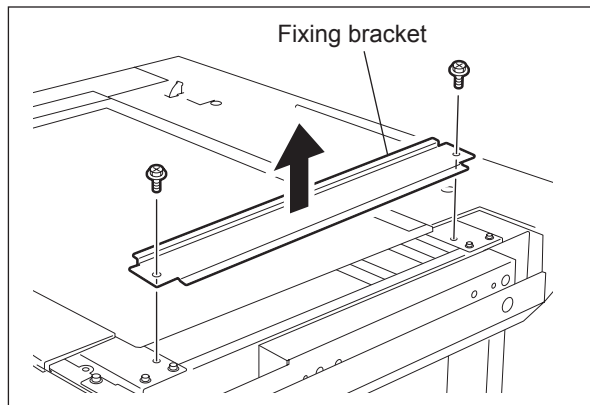

Fig. 6-19

- (3) Take off the original glass.

**Note:**

When installing, fit 2 small protrusions of the original glass in the groove of the equipment and fix the original glass with the fixing bracket by pushing it to the left rear direction.

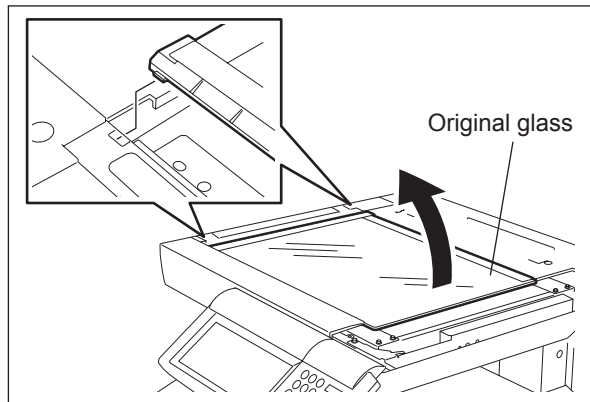



Fig. 6-20

## [B] Lens cover

- (1) Take off the original glass  
( P.6-17 "[A] Original glass").
- (2) Remove 6 screws and take off the lens cover.

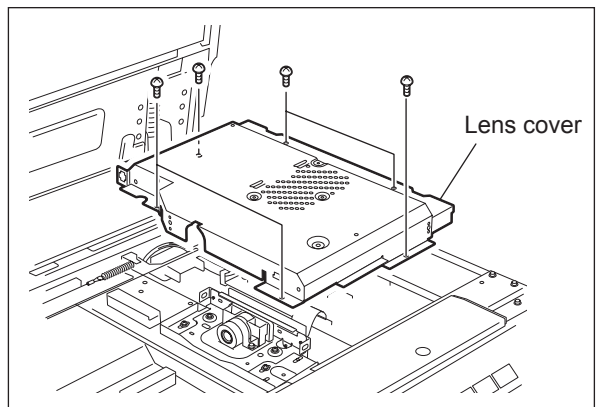



Fig. 6-21

## [C] Automatic original detection sensor (APS sensor)

### [C-1] A4 series

- (1) Take off the lens cover  
( P.6-18 "[B] Lens cover").
- (2) Disconnect 1 connector from the SLG board.
- (3) Remove 6 harness clamps.

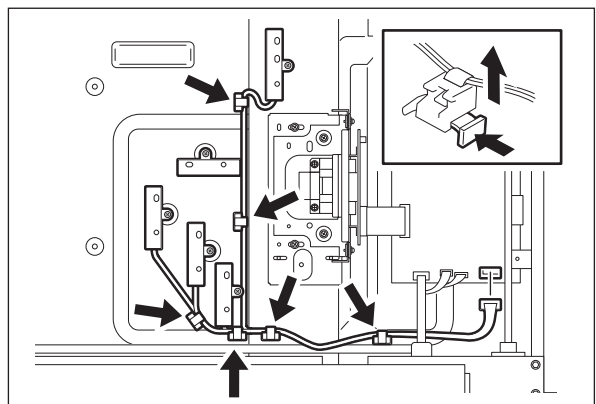

Fig. 6-22

- (4) Take off 5 APS sensors by removing 1 screw each.

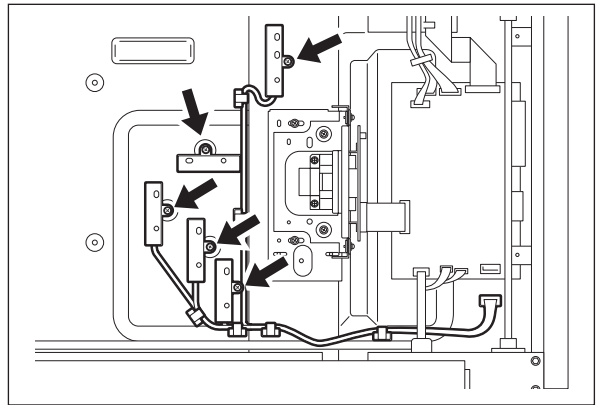

Fig. 6-23

**[C-2] LT series**

- (1) Take off the lens cover  
(P.6-18 "[B] Lens cover").
- (2) Disconnect 1 connector from the SLG board.
- (3) Remove 6 harness clamps.

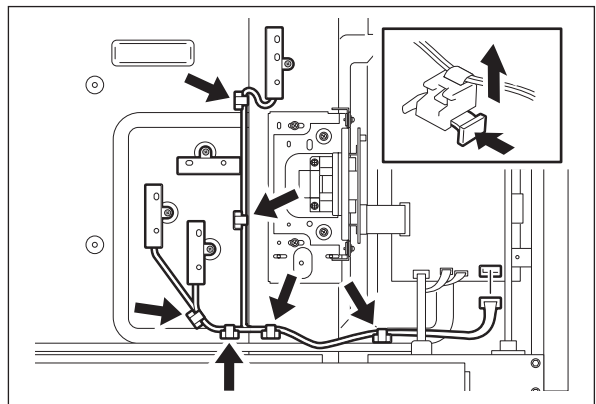

Fig. 6-24

- (4) Take off 4 APS sensors by removing 1 screw each.

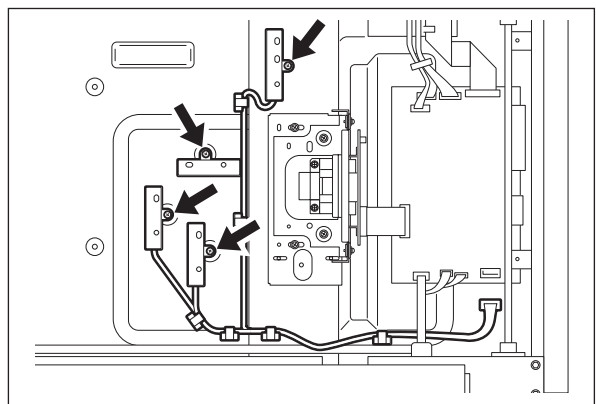



Fig. 6-25

## [D] Lens unit

- (1) Take off the lens cover  
( P.6-18 "[B] Lens cover").
- (2) Disconnect 1 connector form the SLG board.
- (3) Remove 2 screws and take off the lens unit.

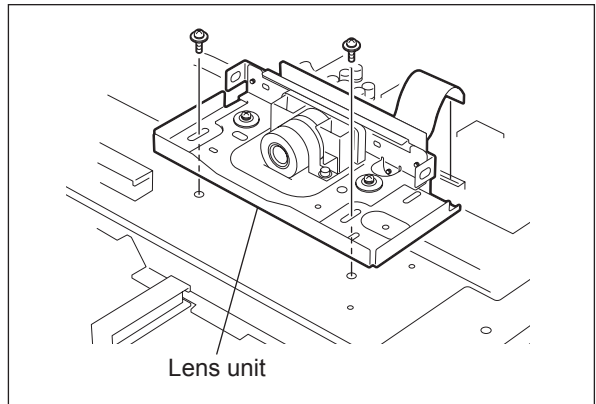

Fig. 6-26

### Notes:

1. When installing, fix the lens unit with the screws while pushing the unit to the rear side.
2. Refer to "3.7.2 Lens Unit" in the Service Handbook for the adjustment method.
3. Never attempt to loosen the screws (8 pc.) of the lens unit denoted with arrows.

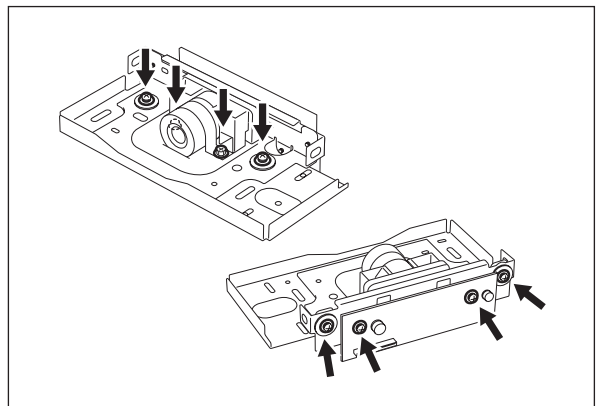

Fig. 6-27

4. Handle the unit with extra care. Do not touch the adjusted area or lens. (Hold the unit as shown in the figure at right.)

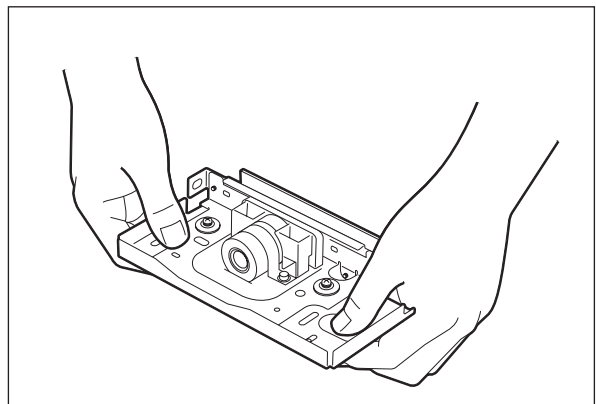



Fig. 6-28

## [E] Exposure lamp

- (1) Take off the original glass  
( P.6-17 "[A] Original glass").
- (2) Take off the front upper cover  
( P.2-32 "[E] Front upper cover").
- (3) Move the carriage-1 to the center position where the side of the frame is cut out.

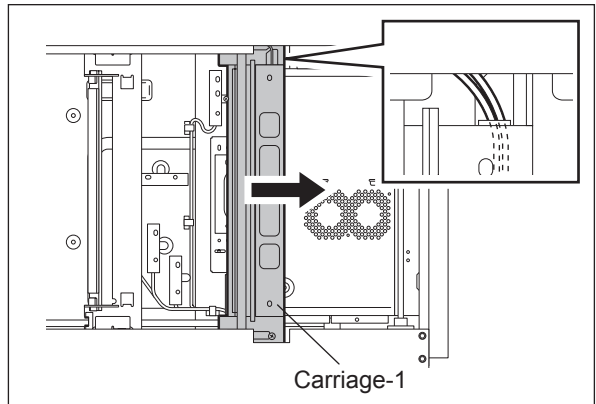

Fig. 6-29

### Note:

Rotate the drive pulley to move the carriage.

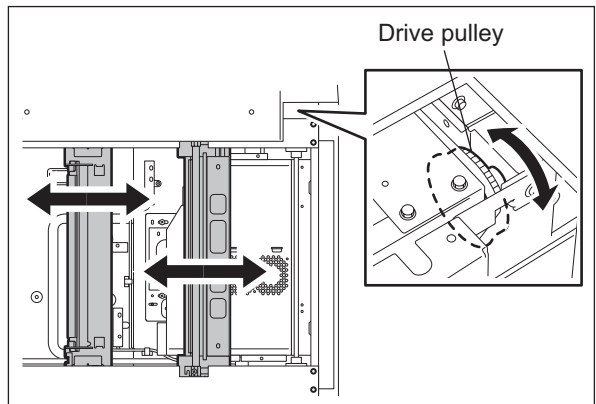

Fig. 6-30

- (4) Disconnect 1 connector from the inverter board. Pull out the harness from 2 harness clamps and the frame of the carriage.

### Note:

When disconnecting the connector, make sure not to overload the carriage frame.

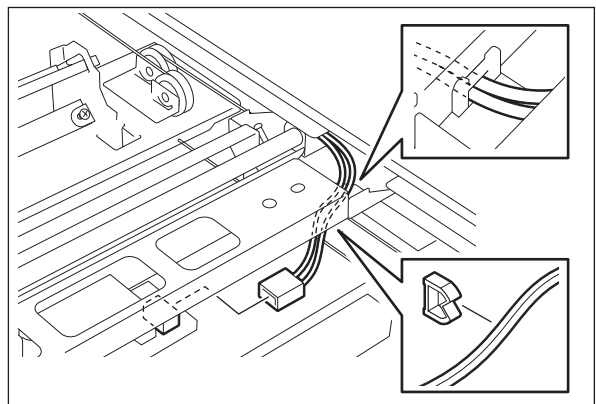
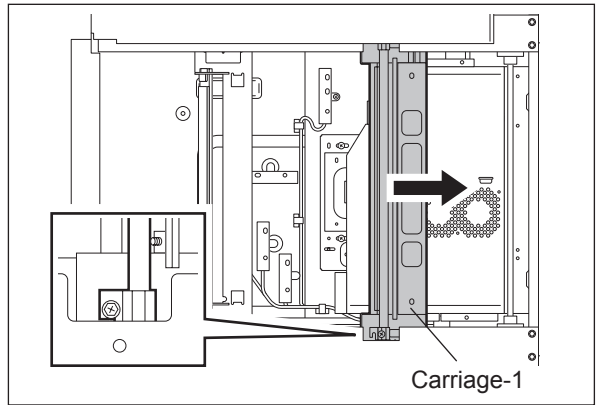

Fig. 6-31

- (5) Move the carriage-1 to the position where the exposure lamp is seen through the cutout of the frame.

**Note:**

Rotate the drive pulley to move the carriage.

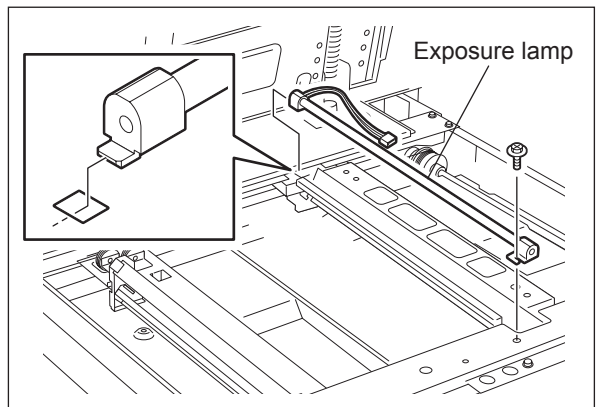

**Fig. 6-32**

- (6) Remove 1 screw. Lift up the exposure lamp and take it off by pulling out toward you.

**Note:**

Make sure to hold only the black molded part of the exposure lamp. Do not touch any other part than this black molded part.



**Fig. 6-33**

**[F] Carriage-1**

- (1) Take off the original glass (P.6-17 "[A] Original glass").
- (2) Take off the front upper cover and upper rear cover (P.2-32 "[E] Front upper cover", P.2-34 "[I] Upper rear cover").
- (3) Move the carriage-1 to the position shown in the figure at right, and match the positions of each hole and screw. Remove 2 screws.

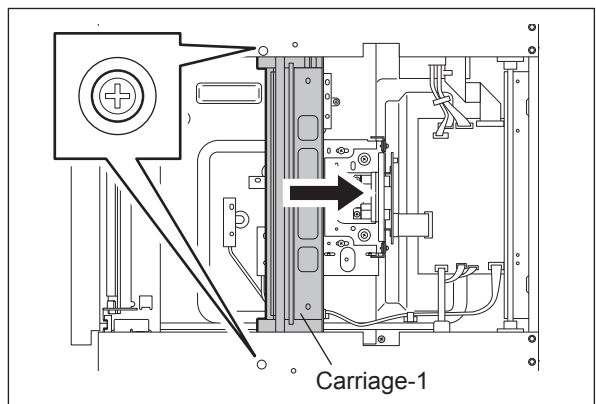

**Fig. 6-34**



- (4) Move the carriage-1 to the cutout part. Pull down each bracket fixing the wire from the hole of the frame on both ends of the carriage-1.

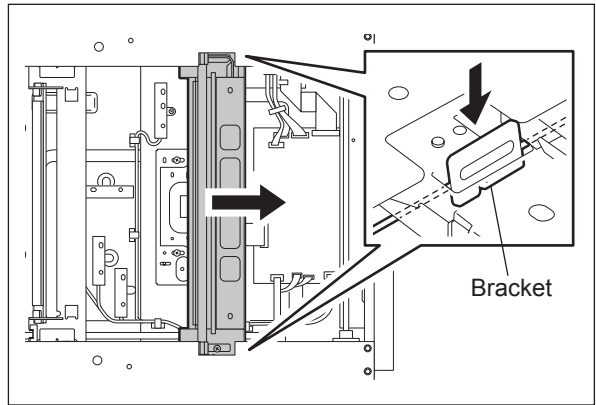

Fig. 6-35

- Note:**  
Rotate the drive pulley to move the carriage.

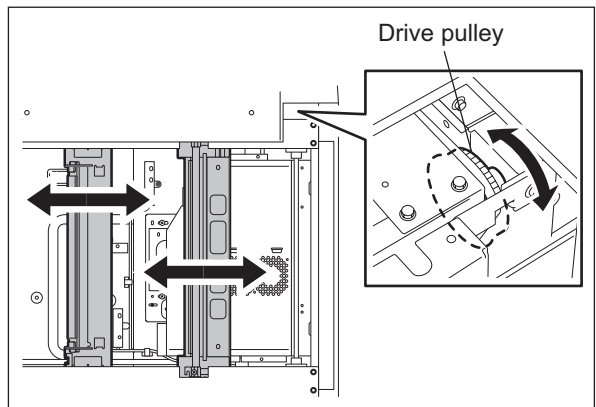

Fig. 6-36

- (5) Disconnect 1 connector from the SLG board. Remove 2 seals and release the lamp harness.

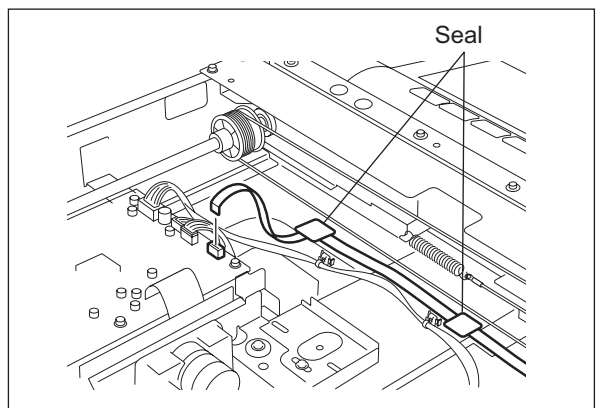
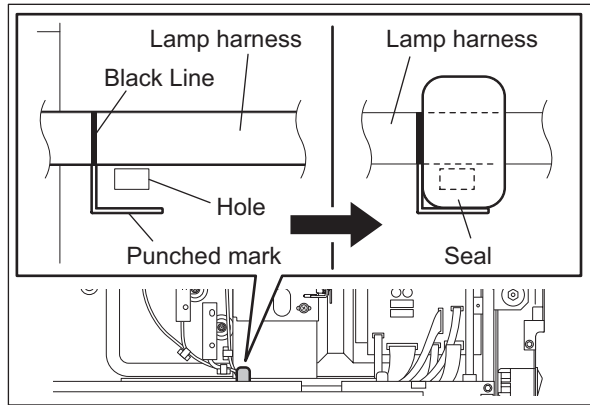

Fig. 6-37

**Notes:**

Be sure to install the lamp harness by following the procedure below.

1. Using alcohol, clean the area where the seal is to be attached.
2. Align the black line on the lamp harness with the position as shown in the figure, and fix it with a seal.



**Fig. 6-38**

3. Align the bent portion of the lamp harness with the position as shown in the figure, and fix it with a seal.
4. After the installation, move carriage-1 towards the left and confirm that there is no abnormality in the lamp harness, such as twisting.

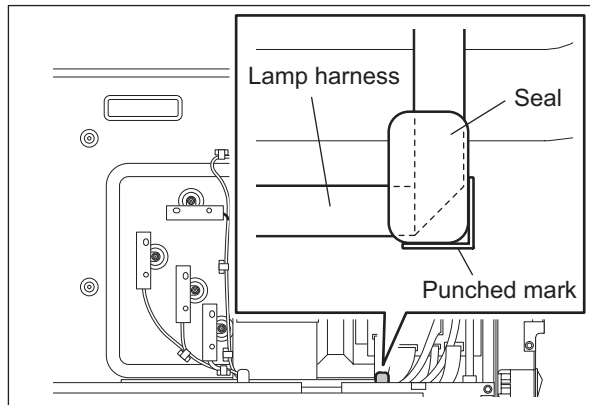

**Fig. 6-39**

- (6) Rotate the carriage-1 in the direction shown in the figure at right, not to touch the mirror. Then take out the carriage-1.

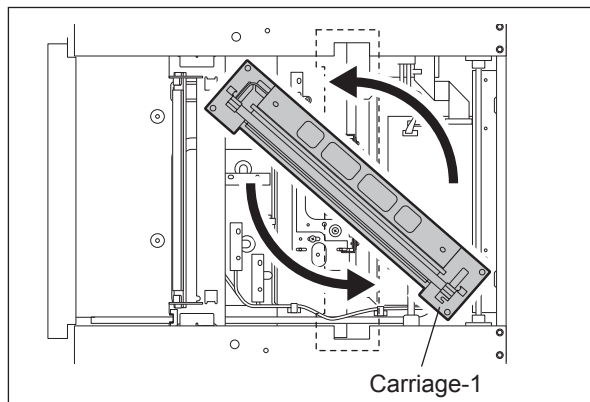

**Fig. 6-40**

**Notes:**

1. When installing the carriage-1, fix the bracket temporarily at the position (A). Then move it to the direction (B) slowly, push it to the end of frame and fix at this position with the screws.
2. Refer to the "3.7.1 Carriages" in the Service Handbook
3. Rotate the drive pulley to move the carriage.

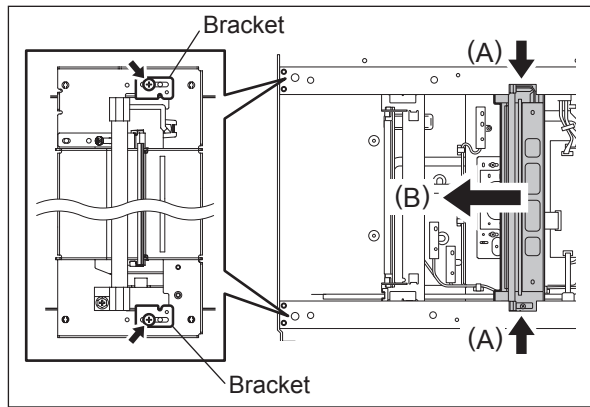

**Fig. 6-41**

**[G] Mirror-1**

- (1) Take off the carriage-1  
( P.6-22 "[F] Carriage-1").

**Note:**

When replacing the mirror-1, replace it together with the carriage-1. The mirror-1 should not be removed separately.

**[H] Inverter board**

- (1) Take off the carriage-1  
( P.6-22 "[F] Carriage-1").
- (2) Disconnect 2 connectors.
- (3) Remove 2 screws and take off the inverter board.

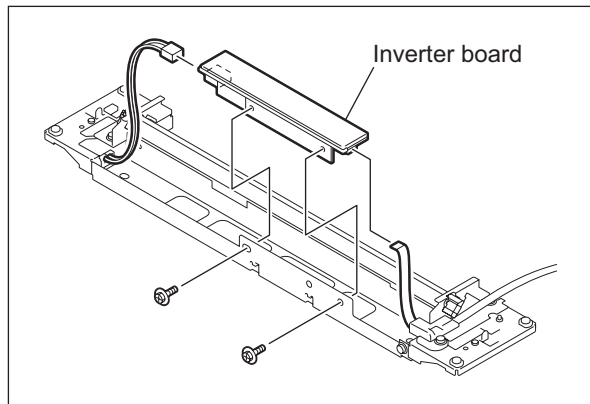

**Fig. 6-42**

## [I] Carriage wire / Carriage-2

- (1) Take off the carriage-1  
( P.6-22 "[F] Carriage-1").
- (2) Install the wire holder jig to each pulley on front and rear sides, not to loosen the carriage wire.

**Note:**

Refer to "3.7.1 Carriages" in the Service Handbook for the installation direction of the wire holder jig.

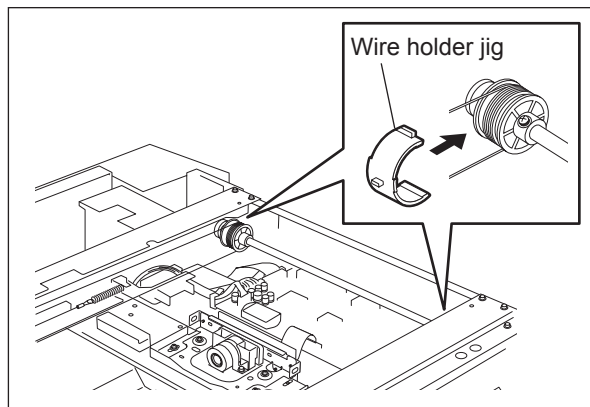

Fig. 6-43

- (3) Remove the tension springs on both front and rear sides.
- (4) Remove the carriage wires on both front and rear sides.

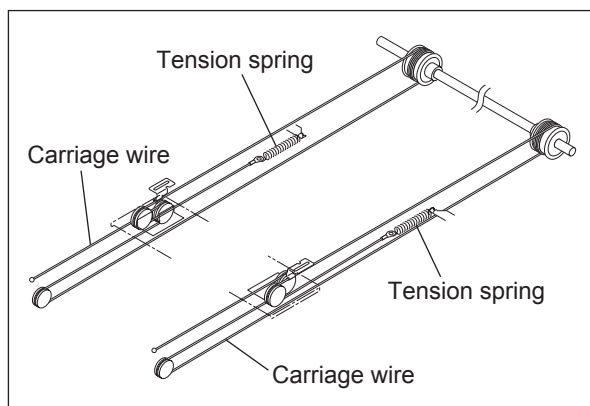

Fig. 6-44

- (5) Rotate the carriage-2 in the direction where the inside of the frame is dented shown in the figure at right, not to touch the mirror. Then take off the carriage-2.

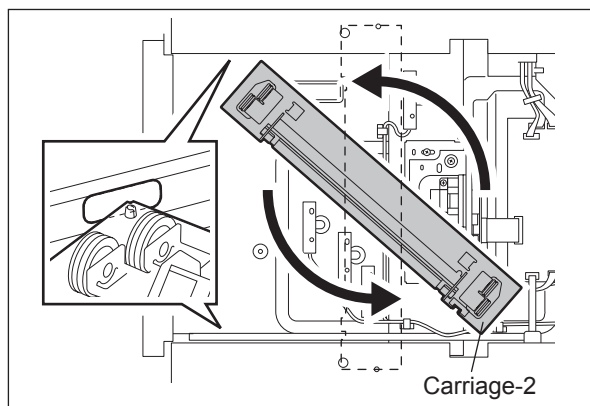



Fig. 6-45



## [J] Mirrors-2 and -3

- (1) Take off the carriage-2  
( P.6-26 "[I] Carriage wire / Carriage-2").

### Note:

When replacing the mirrors-2 and -3, replace them together with the carriage-2. The mirrors-2 and -3 should not be removed separately.

## [K] Platen sensor

- (1) Take off the rear cover an upper rear cover ( P.2-31 "[C] Rear cover",  P.2-34 "[I] Upper rear cover").
- (2) Disconnect 1 connector from the platen sensor on the left rear position of the equipment upper side.
- (3) Release the latches of the sensor and take off the platen sensor.

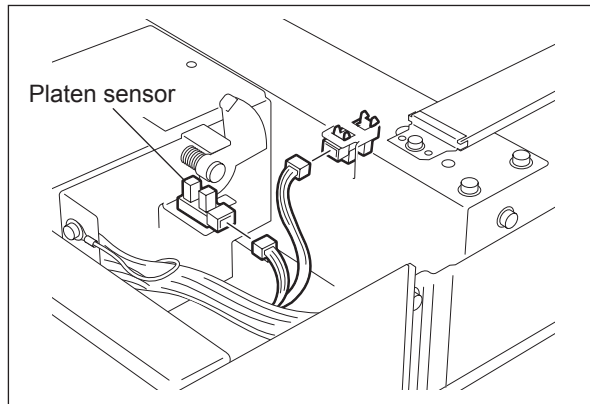



Fig. 6-46

## [L] Carriage home position sensor

- (1) Take off the rear cover upper rear cover ( P.2-31 "[C] Rear cover",  P.2-34 "[I] Upper rear cover").
- (2) Disconnect 1 connector from the carriage home position sensor on the left rear position of the equipment upper side.
- (3) Release the latches of the sensor and take off the carriage home position sensor.

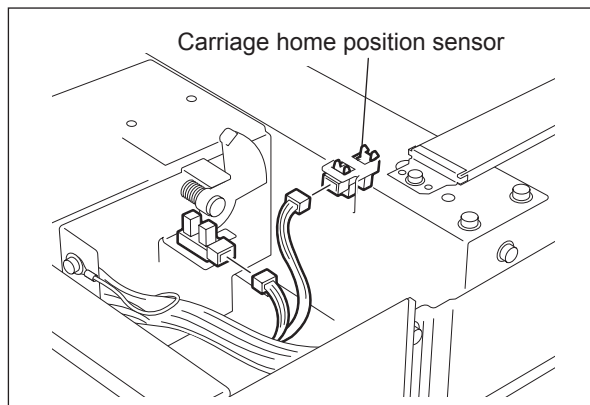

Fig. 6-47

## [M] Scan motor

- (1) Take off the rear cover upper rear cover (P.2-31 "[C] Rear cover", P.2-34 "[I] Upper rear cover").
- (2) Disconnect the connector of scan motor.

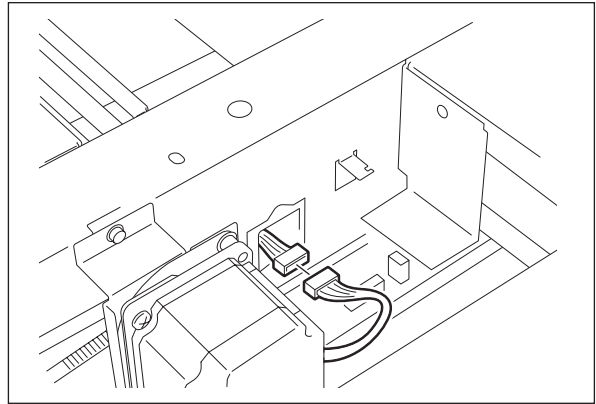

Fig. 6-48

- (3) Remove 3 screws and take off the scan motor.

### Note:

When installing, use a stepped screw to fix the left rear point.

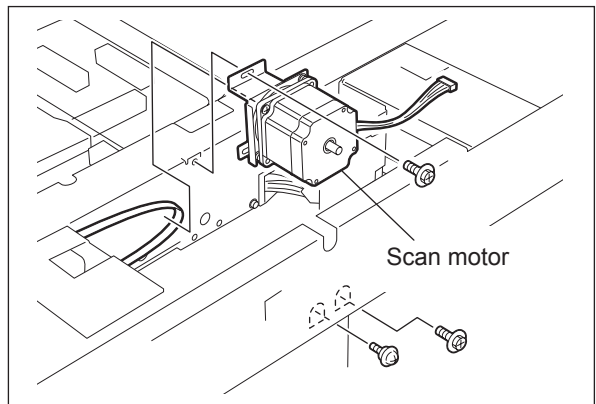

Fig. 6-49

### Notes:

When installing the scan motor, use the belt tension jig (spring). The procedure is as follows.

1. Fix the screw A.
2. Temporarily fix the screw B and C.
3. Hook the belt tension jig to the motor bracket and the flame.
4. The scan motor is pulled by the belt tension jig. Fix the screw B and then C at the stopped position.
5. Remove the belt tension jig.

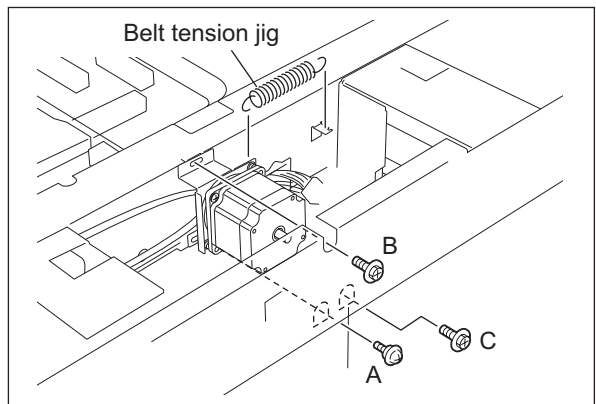



Fig. 6-50

## [N] Scanning section control PC board (SLG board)

- (1) Take off the lens cover  
( P.6-18 "[B] Lens cover")
- (2) Disconnect 8 connectors from the SLG board.
- (3) Remove 6 screws and take off the SLG board.

**Note:**

The SLG board for e-STUDIO200L/230/280 series and the one for e-STUDIO202L/203L/232/233/282/283 series are different. To avoid confusion, the color of the connector CN19 on the SLG board for e-STUDIO202L/203L/232/233/282/283 series is yellow.

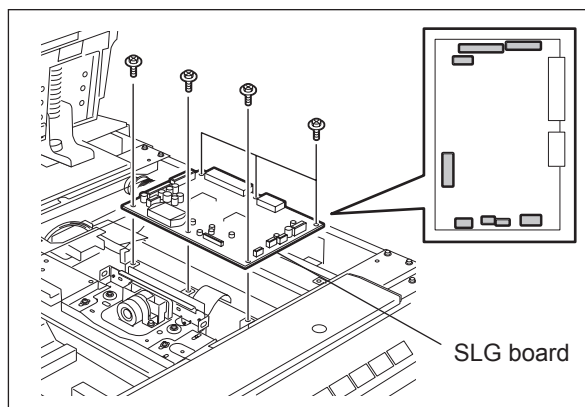

Fig. 6-51





# 7. IMAGE PROCESSING

## 7.1 General Description

The following diagram shows the process of the equipment from scanning of original to writing data on the photoconductive drum surface.

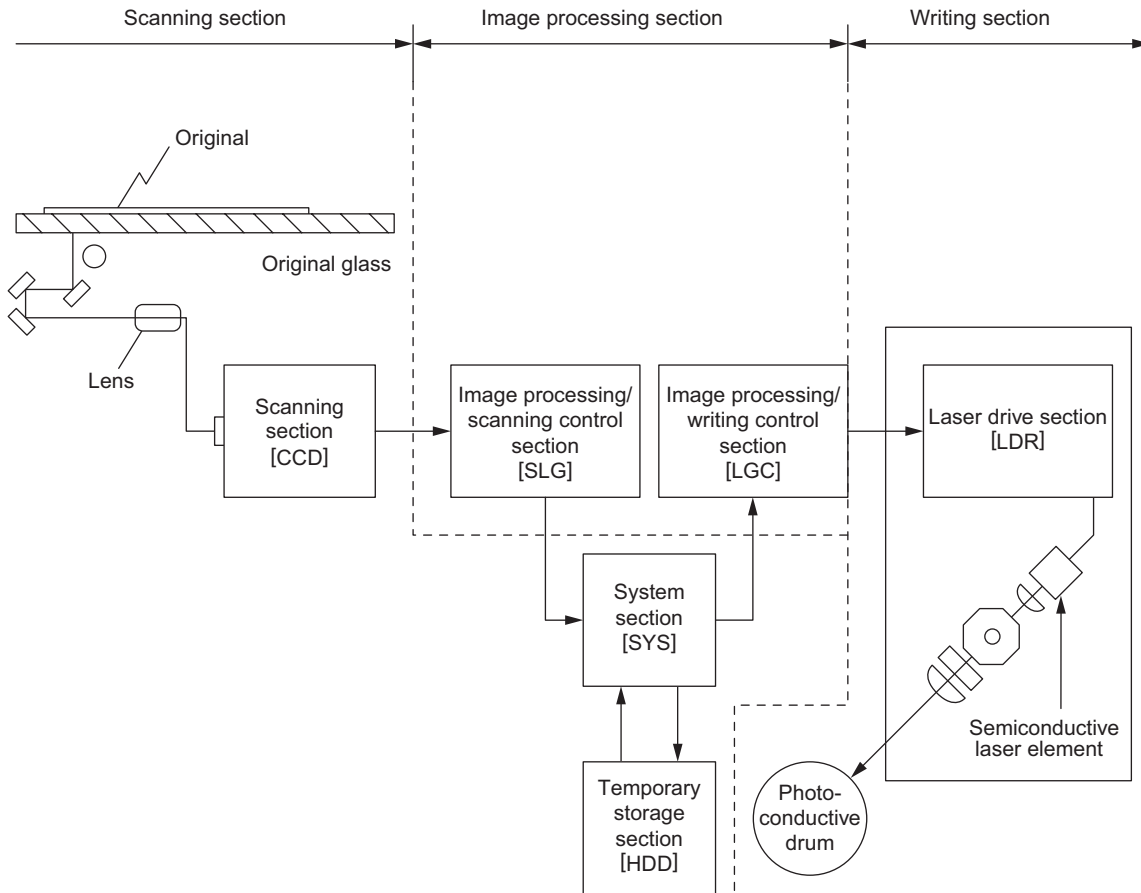

Fig. 7-1

The followings are the boards used for image processing.

| Board     | Function  |
|-----------|---|
| SLG board | High quality image processing, image memory editing, editing processing, gamma correction, gradation processing, scanner high quality image processing and external output system interface |
| LGC board | Smoothing processing, external input system interface, image area control, laser related control and printer high quality image processing  |

Image of an original placed on the original table is scanned by the optical system. The CCD (Charge Coupled Device) reads the optical image signals and converts them into the electrical signals. The electrical signals are amplified and undergo analog-to-digital conversion, then are changed into digital signals. Shading correction (correction of variance in CCD elements and the light source) is performed and the digital signal is output as an image signal from the scanning section.

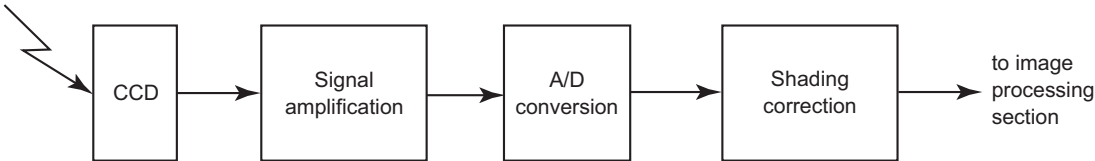

Fig. 7-2

The image processing section inputs the image signal from the scanning section and applies various image processing on the signal, then transmits the output result to the writing section. Images are processed by the SLG board and LGC board in this equipment. The image signal read in the scanning function is processed in SLG board and the printer image signal is processed in the SYS board.

## 7.2 Configuration

The following diagram shows the image processing section of this equipment.

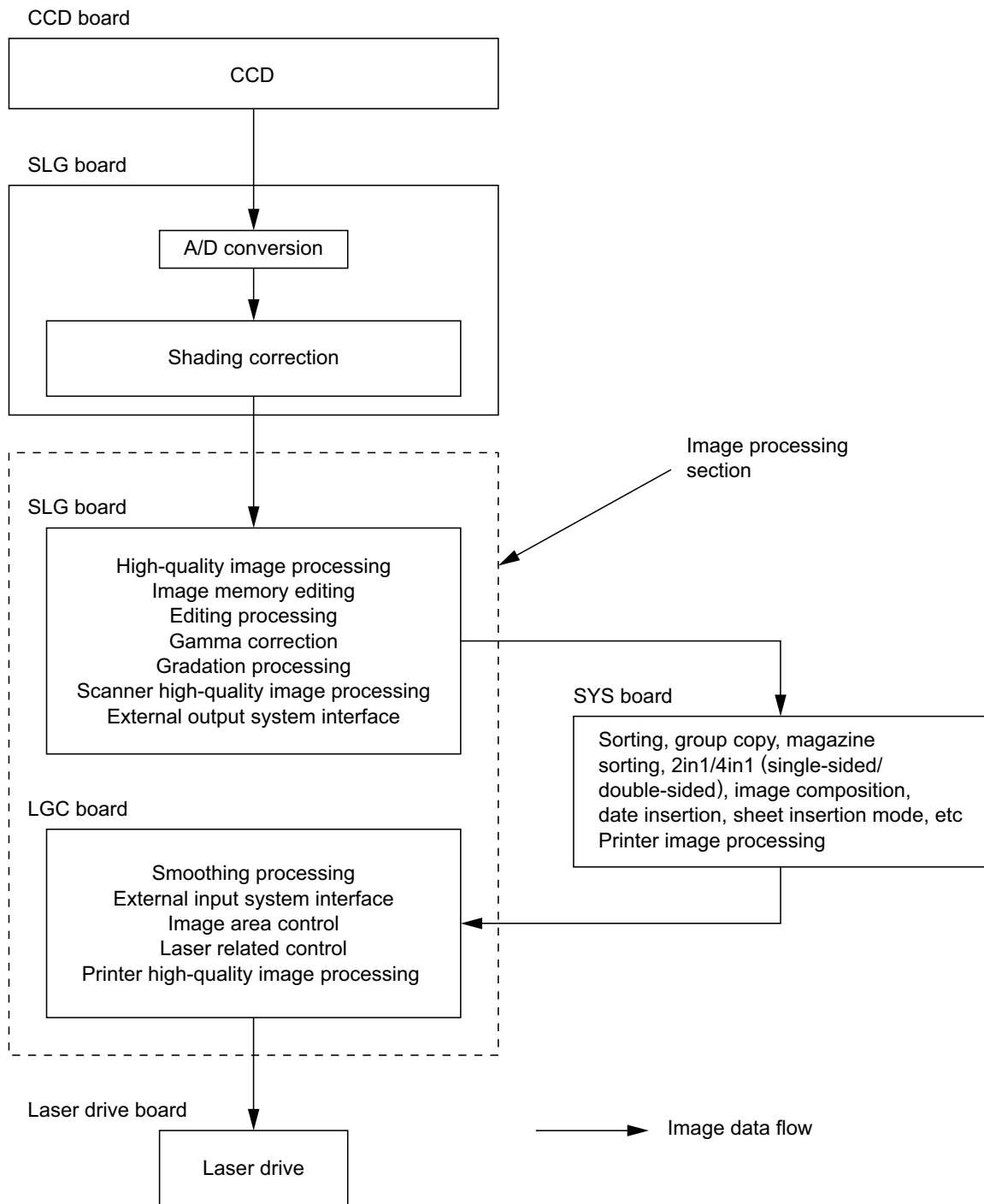

Fig. 7-3

## 7.3 SLG Board

### 7.3.1 Features

- 1) The image processing section on the SLG board is controlled by the CPU on the SLG board.
- 2) The image processing section on the SLG board realizes the following when functioning the equipment:
  - High quality image processing
  - Image memory editing
  - Editing processing
  - Gamma correction
  - Gradation processing
  - External output system interface

### 7.3.2 Functions of image processing circuit

The image processing section mounted on the SLG board realizes the followings:

- 1) High quality image processing
  - Background processing function (Range correction)  
This function removes undesirable background so that the original can be reproduced appropriately. By using the background adjustment function while manually adjusting the image density, undesirable background of the original can be removed if any, and some necessary but disappeared background can be recovered. By using this function, it is possible to cut the background density down to zero when copying originals which have a certain level of background density, such as newspapers.

<Example>

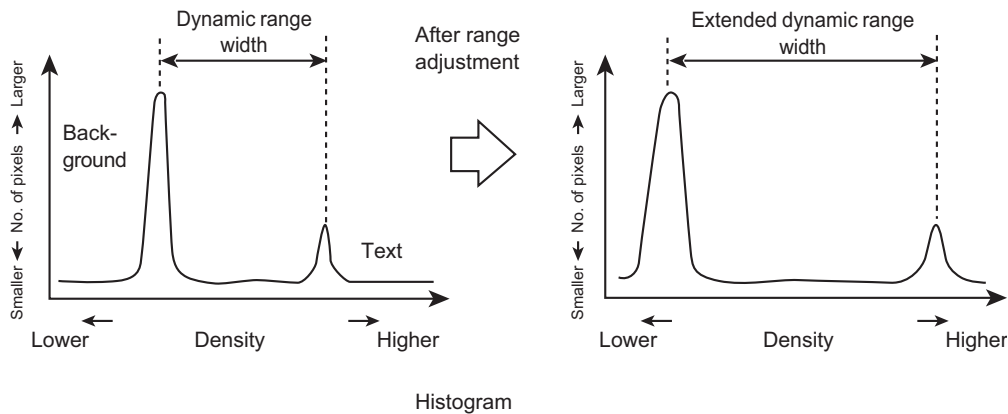

Fig. 7-4

- Filtering  
This function is enabled by low-pass filter processing and high-pass filter processing.

**Low-pass filter processing**

This processing removes image/electrical noise and decreases moire by performing averaging operation between the image signals of the targeted pixel and those of the neighboring pixels to enhance the reproducibility of original.

<Example>

Density of the targeted pixel position is X. Density of pixel positions at front and back of the targeted pixel are “a” and “b” respectively. X is converted to X’ through the low pass filtering.

When the matrix is (3 x 1):

$$\begin{array}{|c|c|c|} \hline a & x & b \\ \hline \end{array} \quad x' = \frac{a+b+x}{3}$$

The above averaging operation is performed for all the pixels to accomplish the high reproducibility of original.

(The following is the case that the low pass filtering is applied on the primary scanning pixel.)

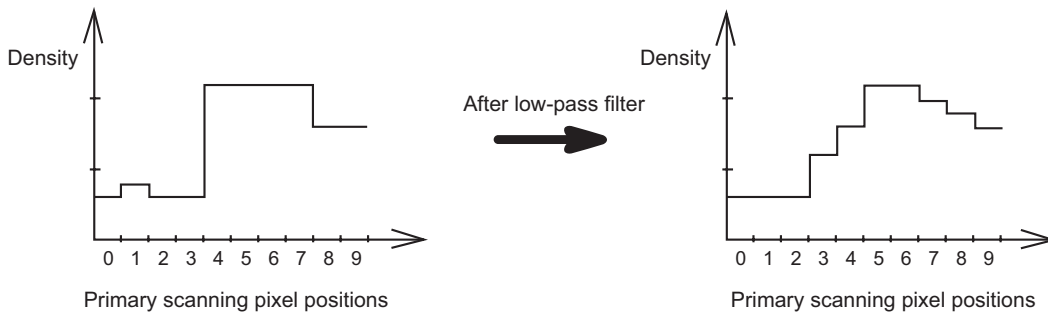

Fig. 7-5

**High-pass filter processing**

Character outline blurs when the original, such as text, with big difference in density among the pixels is optically scanned and output from the CCD. Characteristic of the lens and other factors cause this phenomenon. In this equipment, processing such as edge enhancement is applied between the targeted pixel and the neighboring pixels to eliminate this phenomenon and realize high reproducibility of original.

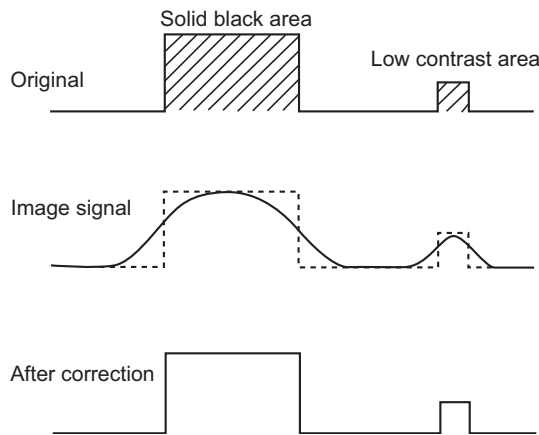

Fig. 7-6

## 2) Image memory editing

This function performs editing such as enlargement/reduction, mirror imaging, etc., by using a line memory. Pixel data for one line in the primary scanning direction is stored in the line memory and the memory is renewed at each line.

### - Enlargement/Reduction

Enlargement/Reduction is accomplished by using the line memory control function in the process of the image processing operation.

#### <Example> Enlargement

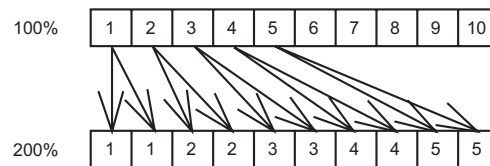

#### <Example> Reduction

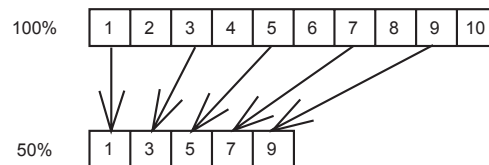

Fig. 7-7

### - Mirror imaging

This is accomplished by reading and outputting data from its end.

## 3) Editing processing

This function performs trimming and masking.

### - Trimming

Using rectangular area signals, the image signals inside the rectangular area are left and the other image signals are eliminated.

### - Masking

Using rectangular area signals, the image data inside the rectangular area are erased.

### - Negative/positive reversing

This function reverses the entire data from negative to positive or vice versa.

## 4) Gamma correction

This function corrects the input/output characteristics of the scanner/printer and adjusts the image signals so that the input/output characteristics would match with the copy mode.

## 5) Gradation processing

This function switches the type of gradation processing depending on the copy mode: A type which selects the printer characteristics giving the priority to resolution such as for text data, and another which selects the printer characteristics giving the priority to gradation reproducibility such as for photographic images.

- 6) External output system interface  
This function controls the output of the output interface.
- 7) Scanner high quality image processing  
This function corrects the image signals scanned by the scanner and reproduces them in a higher image quality.

## 7.4 LGC Board

### 7.4.1 Features

- 1) The image processing section on the LGC board is controlled by the CPU mounted on the LGC board.
- 2) The image processing functions of the LGC board realizes the followings:
  - Smoothing processing
  - External input system interface
  - Image area control
  - Laser related control
  - Printer high quality processing

### 7.4.2 Functions of image processing circuit

The image processing section mounted on the LGC board realizes the followings:

- 1) Smoothing processing  
This function removes jaggy area, and output images after processing the smoothing the character outline.
- 2) External input system interface  
This function controls the input of the input interface.
- 3) Image area control  
This function sets the effective image area in horizontal and vertical directions to be output.
- 4) Laser related control  
This function performs the APC (Auto Power Control).
- 5) Printer high quality processing  
This function reproduces the image signals output from the printer controller sharper.



## 7.5 Laser Driving PC Board

Image signals processed on the LGC board are then processed by ASIC for writing control and Laser driving PC board. The signal is then laser controlled and written on the drum.

- 1) Setting of effective image area
  - Top, bottom, left and right margins
- 2) Horizontal synchronization signal (H-sync) clock generation section
  - Reference clock signal in the printer section synchronized with H-sync and its signal.
- 3) Laser drive section
  - ON/OFF control of the semiconductive laser and APC (Auto Power Control).



# 8. LASER OPTICAL UNIT

## 8.1 General Description

The laser optical unit radiates the laser beam onto the photoconductive drum responding to the digital image signals transmitted from the scanner, printer controller, etc. to form a latent image. The image signal is converted into the light emission signal of the laser diode on the laser driving PC board, then radiated on the drum through the optical devices such as cylinder lens, polygonal mirror and f  $\theta$  lenses. The unit must not be disassembled in the field as they are very sensitive to dust and finely adjusted at the factory.

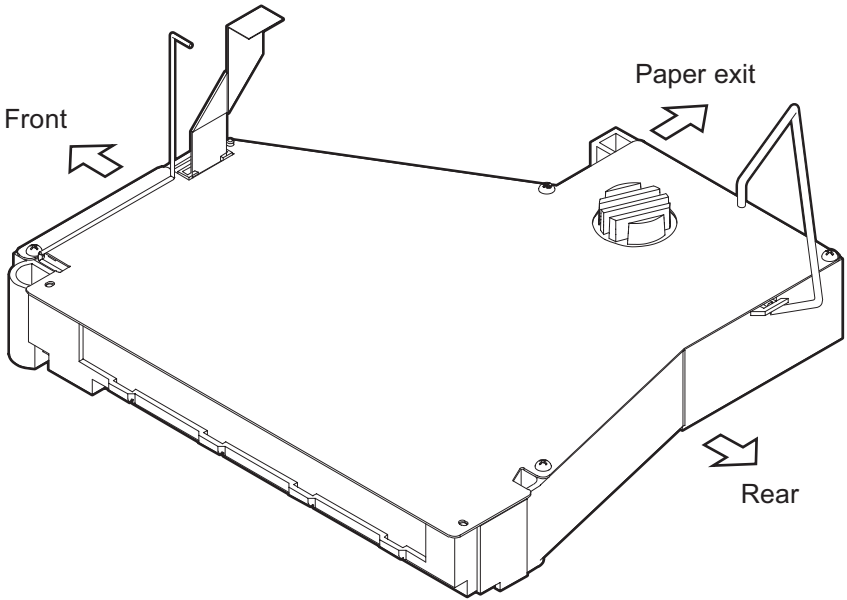
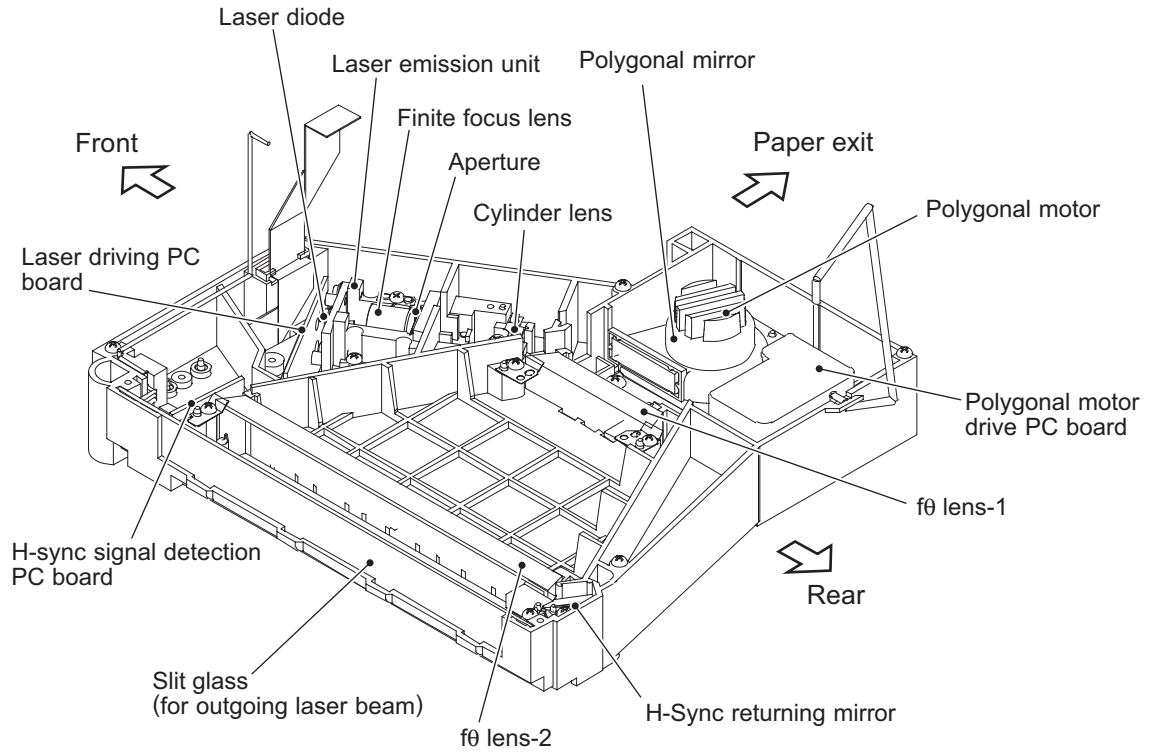

Fig. 8-1



**Fig. 8-2**

## 8.2 Structure

### 1) Laser emission unit

This unit consists of the laser diode, finite focus lens, aperture and cylinder lens.

#### - Laser diode

This laser diode features low droop, small laser variation and low threshold current.

The aperture determines the shape of the laser beam at the laser emission position of the primary scanning and secondary scanning directions.

The laser diode radiates the laser beam responding to the laser emission control (ON/OFF) signal from the laser driving PC board. Laser beam which passed through the finite focus lens is focused on the drum surface.

#### - CAUTION

The beam of the semiconductor laser is very weak (about 5 mW), however, the focused parallel rays create great energy which is hazardous.

Some materials of the components of the laser optical unit are metal. Since the unit is in a sealed container, there is no danger of laser leakage during normal operation.

#### Note:

The laser beam is not visible. Pay the closest attention when handling the laser unit components or performing operations such as adjustment of the laser beam, and this kind of operation is very dangerous and must be performed only by specially trained staff.

The warning label shown below is attached on the inner housing at the front side of the equipment.

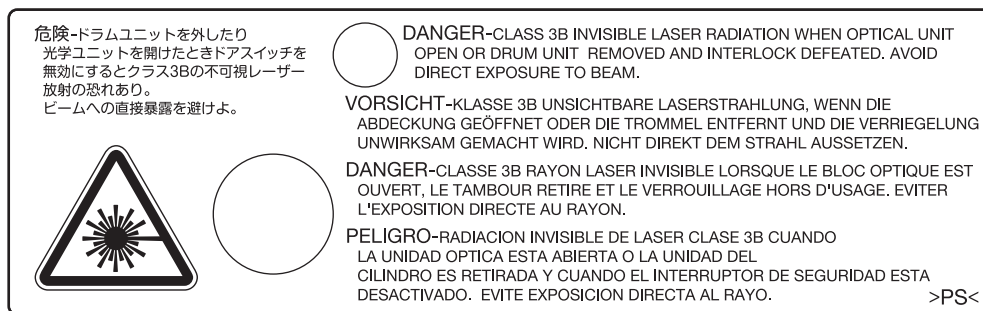

Fig. 8-3

#### [CAUTION]

- Do not bring tools close to the path of the laser beam.
- Take off your watches, rings, bracelets, etc. before handling the unit.

## 2) Polygonal motor unit

This unit consists of the polygonal motor, polygonal mirror and polygonal mirror cover.

### a. Polygonal motor

This motor rotates the polygonal mirror at high speed.

The DC motor controls the rotation speed of this motor as follows:

During printing: 23,562.992 rpm (600 dpi)  
: 24,095.503 rpm (FAX 15.4 × 16.0 dot/mm)  
: 23,191.921 rpm (FAX 16.0 × 15.4 dot/mm)

### b. Polygonal

One laser beam emitted from the laser diode is reflected by this mirror. Since the polygonal mirror is rotated by the polygonal motor, the reflected laser beam moves in sync with the rotation. The direction of the movement is the primary scanning direction of the image. One scan is performed on one plane of the polygonal mirror.

Since the polygonal mirror has eight planes, eight scans are performed in one rotation of the polygonal mirror.

### c. Polygonal mirror cover

The polygonal mirror cover reduces the windage loss and noise, prevents adhesion of foreign matter onto the mirror surface and releases heat.

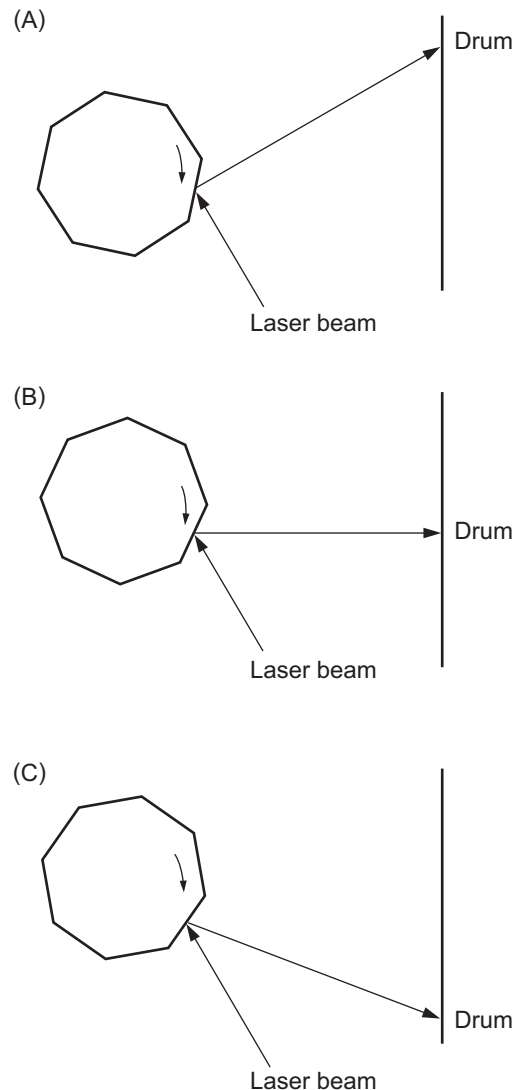

**Fig. 8-4**

One scan is completed by completion of steps (A) to (C). One scan is performed on one plane of the polygonal-mirror. Eight scans can be made with one rotation of the polygonal mirror.

3)  $f\theta$  lenses-1 and -2

These two lenses perform the following adjustment on the laser beam reflected by the polygonal mirror.

a. Uniform-velocity scanning

Since the polygonal mirror is rotating at a uniform velocity, the laser beam reflected from the mirror is scanned over the drum surface at a uniform angle; namely, the pitch between the dots on the drum is wider at both ends than at the center of the scanning range. The  $f\theta$  lenses help to correct this difference, making all the dot-to-dot pitches equal on the drum surface.

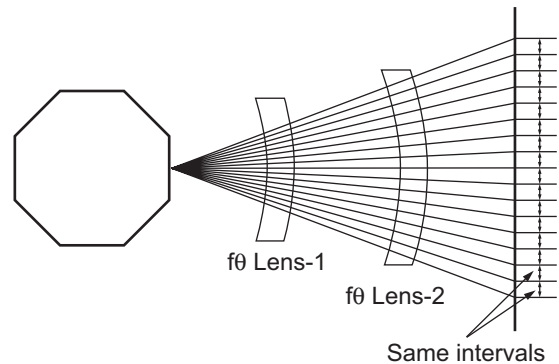
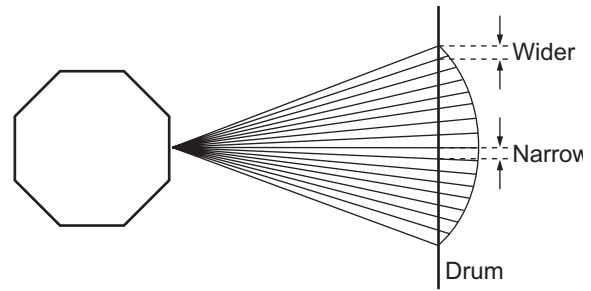

Fig. 8-5

b. Face tilt correction

The reflecting plane of the polygonal mirror is slightly tilted to one side against the perfect vertical. Horizontal deviation of the laser beam which is caused by the tilt is corrected.

c. Sectional shape of laser beam

The shape of the laser beam spotted on the drum is adjusted.

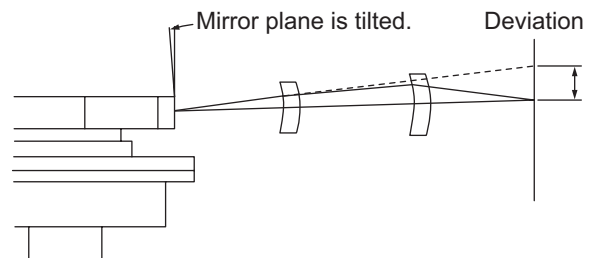

Fig. 8-6

4) H-sync signal detection PC board

The laser beam which has started being scanned from one of the reflecting plane of the polygonal mirror is reflected by the H-sync detection mirror and it enters the PIN diode on the H-sync signal detection PC board. The primary scanning synchronization signal is generated based on this reflection.

5) Laser driving PC board (LDR board)

This control board has the following functions:

- APC function (adjusts disparity of the laser intensity caused by temperature)
- Laser emission function

6) Slit glass

The slit glass is located where the laser beam is output from the laser optical unit, and it protects the unit from dust.

### 8.3 Laser Diode

The laser used in this equipment is an AlGaAs type semiconductive laser. It is generated in the single-horizontal mode, and its wavelength is approx. 785 nm. This semiconductive laser has 5 mW of rated DC power output and the laser intensity is controlled by using the output from the PIN diode for monitoring light output in the semiconductive laser.

The relation between the current and optical output of the semiconductive laser is as shown at right.

Light emission is started when the forward current reaches or becomes larger than the threshold current, and then outputs the monitor current which is proportionate to the optical output. The threshold current and monitor current vary depending on each semiconductive laser. Therefore, optical output has to be adjusted to maintain a constant value.

Since the optical output of the semiconductive laser is decreased as the temperature of the laser rises, APC (Auto Power Control) needs to be performed to maintain a constant optical output.

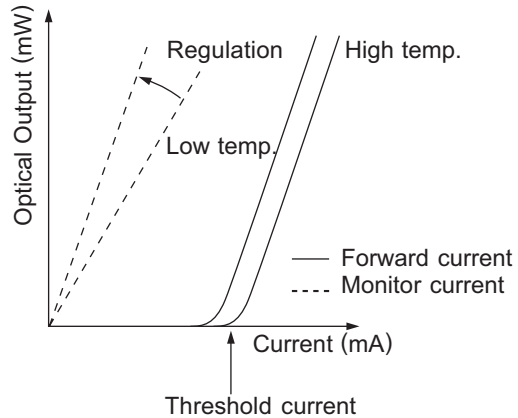

Fig. 8-7

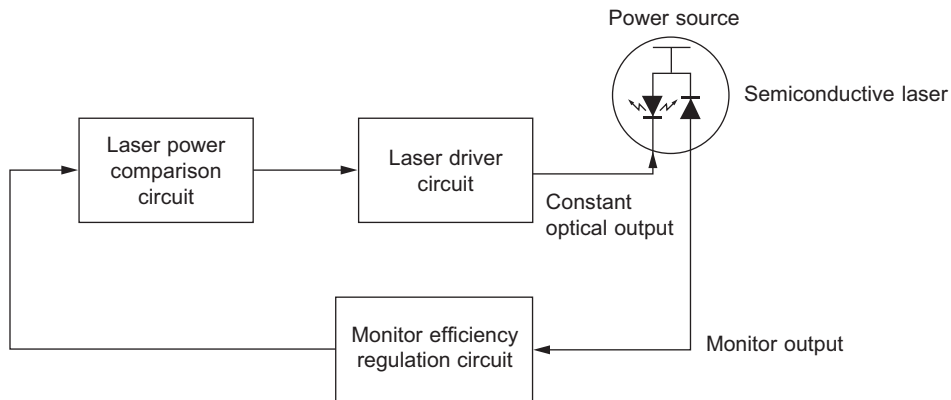

Fig. 8-8

Fig. 8-8 shows a block diagram of the semiconductive laser control circuit. The semiconductive laser performs a monitor efficiency regulation (the process to control monitor current for the light amount), and laser itself is adjusted to initial output emission of approx. 1.31 mW (approx. 261  $\mu$ W on the drum surface).

The regulated voltage of the monitor output is fed back to the laser power comparison circuit. This monitor output voltage is compared with the laser power voltage set for the control circuit for every scanning.

The laser driver circuit increases the forward current when the laser power is insufficient, and decreases the current when the power is excessive to maintain a constant optical output.



## 8.4 Polygonal Motor

### 1) Drive circuit of the polygonal motor

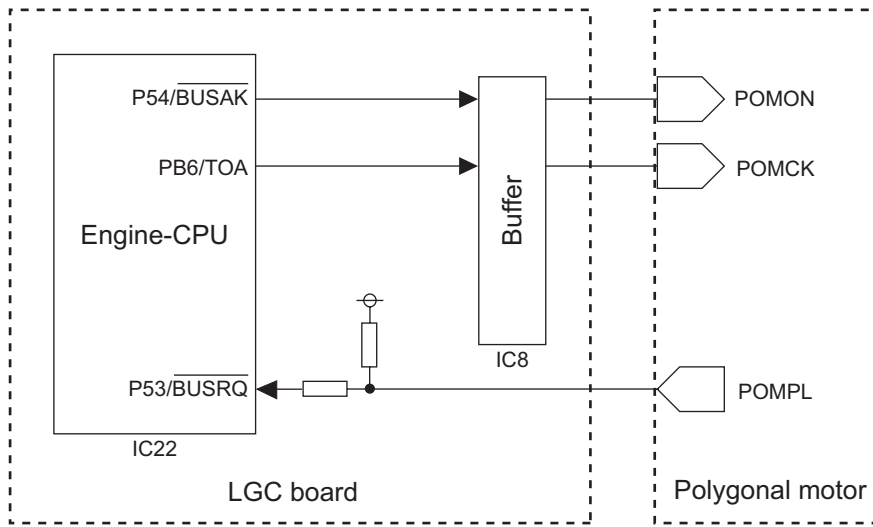

Fig. 8-9

### 2) Control signal

The polygonal motor is a DC motor which is PLL-controlled by clock signals. The signals from LGC board control the polygonal motor.

| Signal | Level "L"       | Level "H"         | Remarks                                |
|--------|-----------------|-------------------|--|
| POMON  | ON              | OFF               | Polygonal motor ON signal              |
| POMCK  | -               | -                 | Polygonal motor reference clock signal |
| POMPL  | Normal rotation | Abnormal rotation | Polygonal motor PLL signal             |

## **8.5 Internal cooling fan-2**

The internal cooling fan-2 is a DC fan motor for cooling down the laser optical unit and the switching power supply. It discharges the heat generated by the polygonal motor and the switching power supply. It is controlled to switch rotating in high speed, low speed or stopping according to the condition of the equipment.

## 8.6 Disassembly and Replacement

### [A] Laser optical unit

- (1) Take off the toner cartridge.
- (2) Take off the inner tray and tray back cover (P.2-35 "[K] Inner tray", P.2-36 "[M] Tray back cover").
- (3) Lift the duct and disconnect 1 connector.

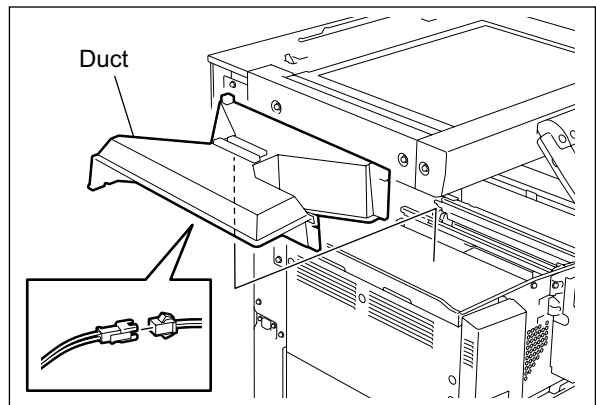

Fig. 8-10

- (4) Remove 2 screws and take off the plate.

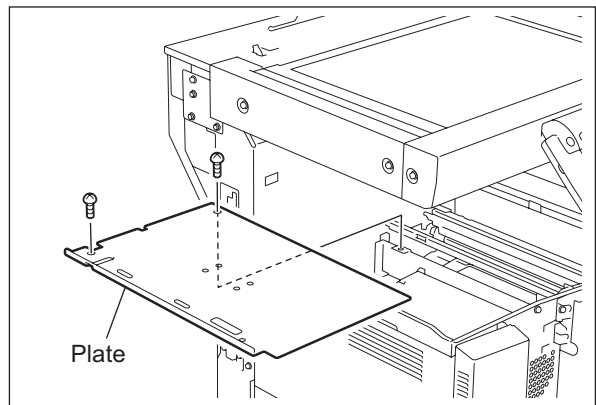

Fig. 8-11

- (5) Disconnect 1 connector from the rear frame. Disconnect 2 connectors from the LRL board.

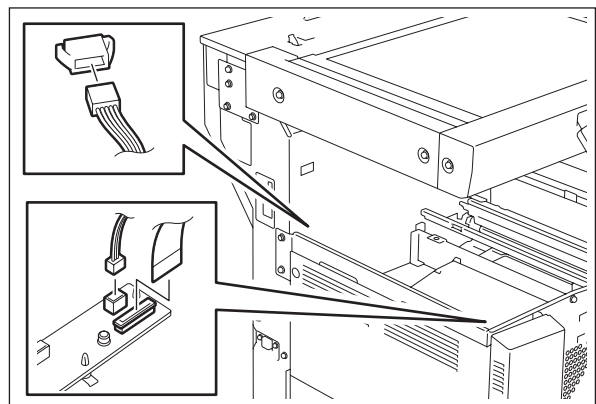

Fig. 8-12

- (6) Remove 3 screws with spring. Then take off the laser optical unit.

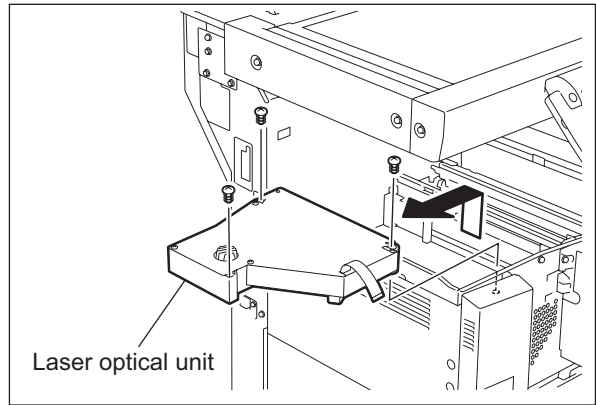



Fig. 8-13

**[B] Laser control signal relay PC board (LRL board)**

- (1) Take off the plate  
( P.8-9 "[A] Laser optical unit").

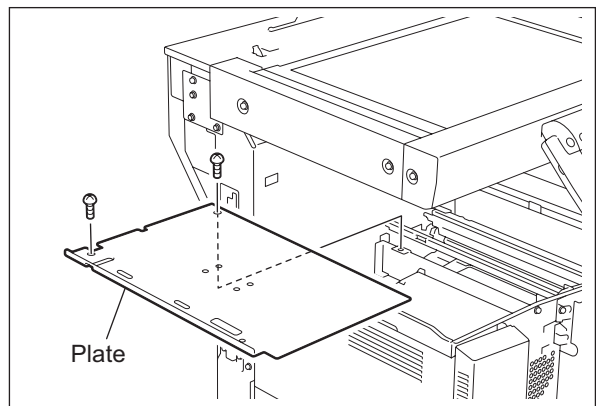

Fig. 8-14

- (2) Disconnect 3 connectors from the LRL board. Remove 1 screw and release 2 locking supports, then take off the LRL board.

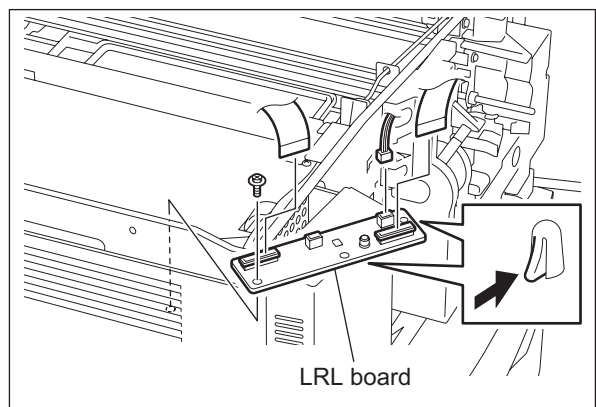



Fig. 8-15

### [C] Internal cooling fan-2

- (1) Take off the rear cover  
( P.2-31 "[C] Rear cover").
- (2) Remove 1 screw and take off the harness clamp. Take off the duct upper cover and ozone filter.

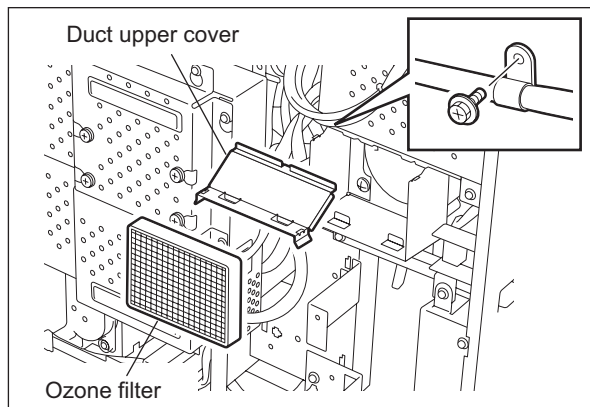

Fig. 8-16

- (3) Disconnect 1 connector and remove 2 screws, and then take off the duct and the internal cooling fan-2.

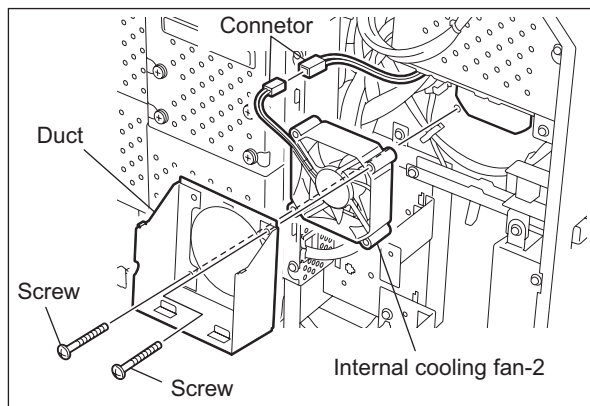

Fig. 8-17



## 9. PAPER FEEDING SYSTEM

### 9.1 Functions

The purpose of this system is to pick up a sheet of paper from the drawer or bypass tray and transport it to the transfer position. The paper feeding system mainly consists of the pickup roller, feed roller, separation roller, transport roller, registration roller, bypass paper sensor, drawer empty sensor, drawer paper stock sensor, feed sensor, registration sensor and the drive system for these components. This manual explains the paper feeding system assuming that the lower drawer (drawer module) is installed although it is available as only an option (MY-1021) depending on the destination or version.

Sectional view of paper feeding section (Front side)

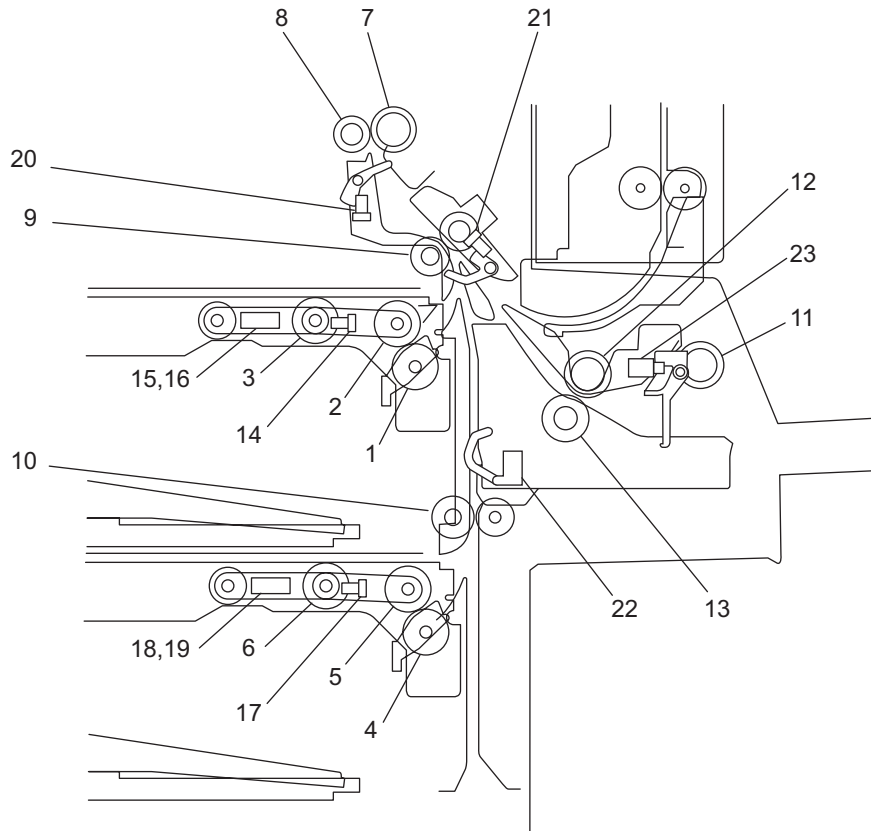

Fig. 9-1

| No. | Name                           | No. | Name                            |
|-----|--------------------------------|-----|---------------------------------|
| 1   | Upper drawer separation roller | 13  | Bypass separation roller        |
| 2   | Upper drawer feed roller       | 14  | Upper drawer tray-up sensor     |
| 3   | Upper drawer pickup roller     | 15  | Upper drawer empty sensor       |
| 4   | Lower drawer separation roller | 16  | Upper drawer paper stock sensor |
| 5   | Lower drawer feed roller       | 17  | Lower drawer tray-up sensor     |
| 6   | Lower drawer pickup roller     | 18  | Lower drawer empty sensor       |
| 7   | Registration roller (rubber)   | 19  | Lower drawer paper stock sensor |
| 8   | Registration roller (metal)    | 20  | Registration sensor             |
| 9   | 1st transport roller           | 21  | 1st transport sensor            |
| 10  | 2nd transport roller           | 22  | 2nd transport sensor            |
| 11  | Bypass pickup roller           | 23  | Bypass paper sensor             |
| 12  | Bypass feed roller             |     |                                 |

Paper feeding section drive system (Rear side)

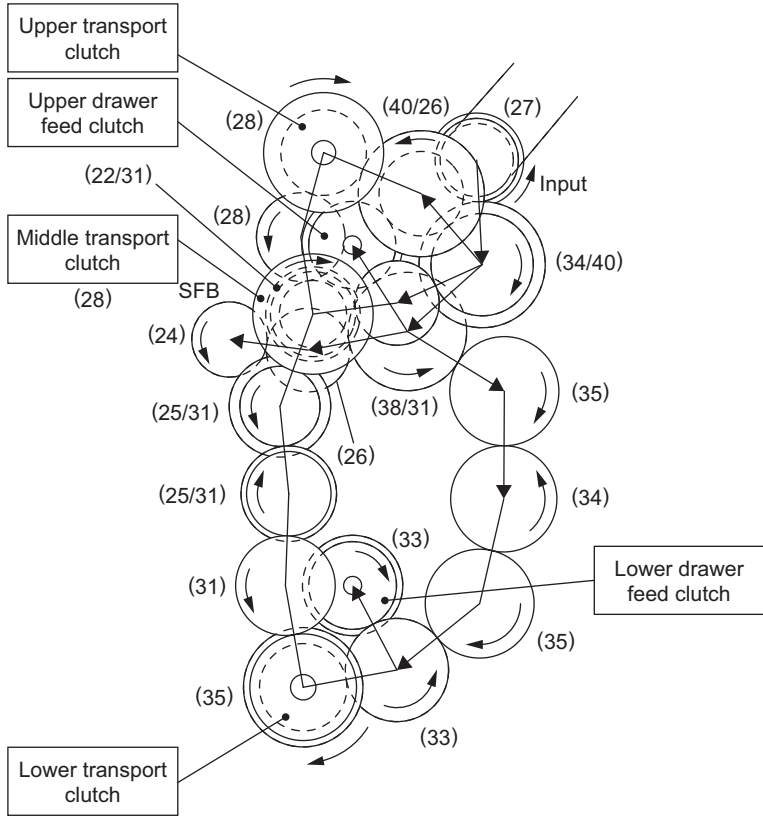

Fig. 9-2



- 1) Pickup roller  
This roller moves up and down to draw out a sheet of paper from the bypass tray or the drawer, and transport it to the feed roller.
- 2) Feed roller  
This roller transports the paper from the pickup roller to the registration roller.
- 3) Separation roller  
This roller is mounted against the feed roller. When two sheets of paper or more are transported from the pickup roller, the load of the torque limiter (spring) of the separation roller is greater than the frictional force between the sheets. As the result, the separation roller is stopped and the lower sheet of paper is not transported any further. When only one sheet of paper is transported from the pickup roller, the separation roller is forced to rotate following the feed roller.
- 4) 1st transport roller  
This roller relays the paper transported from the drawer, bypass unit, ADU to secure the transport performance in the registration roller. After the paper is aligned in the registration roller, it is transported in the 1st transport roller at the same speed (low speed) as that of registration roller.
- 5) 2nd transport roller  
This roller transports the paper from the lower drawer or PFP/LCF to the 1st transport roller.
- 6) Registration roller  
Paper transported from the 1st transport roller is pushed against the registration rollers, which aligns the leading edge of paper. The registration roller then rotates to transport the paper to the transfer section.
- 7) Bypass paper sensor  
This sensor detects whether paper is set in the bypass tray or not. If it is, bypass feeding is performed in preference to drawer feeding. And also detects whether paper has been transported from the bypass tray or not. In other words, whether the leading/trailing edge of paper has passed the feed sensor or not. This sensor is utilized to detect the jams such as paper misfeeding in the bypass unit.
- 8) Drawer empty sensor  
This is a transmissive-type sensor which detects the presence/absence of paper in the drawer using an actuator. When there is no paper in the drawer, the actuator blocks the light path of the sensor. Then the sensor determines that there is no paper.
- 9) Drawer paper stock sensor  
This is a transmissive-type sensor which detects the amount of paper remaining in the drawer using an actuator. When the remaining paper has become around 100 sheets, the actuator blocks the light path of the sensor to notify that the paper quantity is getting less.
- 10) Feed sensor  
This sensor detects whether the leading/trailing edge of paper has passed the feed roller or not. It also detects jams such as paper misfeeding.
- 11) Registration sensor  
This sensor detects whether the leading edge of the paper has reached the registration roller or not, and the trailing edge of paper has passed the registration roller or not.
- 12) Upper transport clutch  
Drives the 1st transport roller at high speed by transmitting the drive from the main motor.

13) Lower transport clutch

Drives the 2nd transport roller at high speed by transmitting the drive from the main motor.

14) Middle transport clutch

Switches the high speed of the 1st transport roller or the 2nd transport roller to the low speed. Turning ON this clutch makes the 1st transport roller or the 2nd transport roller drive at low speed (the same speed as that of registration roller)

15) Registration roller clutch

Drives the registration roller.

## 9.2 Operation

### 9.2.1 Operation of bypass pickup roller

When the paper is set on the bypass tray, the bypass feed sensor detects the presence of the paper. Then the bypass pickup solenoid is turned ON and the pickup arm falls by its own weight. At this time, when the bypass feed clutch is turned ON, the drive from the main motor is transmitted to the pickup roller through the gears and shaft. Then the paper is picked up.

The paper picked up is transported to the transport path in the equipment by the bypass feed roller. When there is no paper remaining on the bypass tray, the bypass pickup solenoid is turned OFF and the pickup roller returns by the spring force.

The separation roller works not to transport paper more than one sheet at a time.

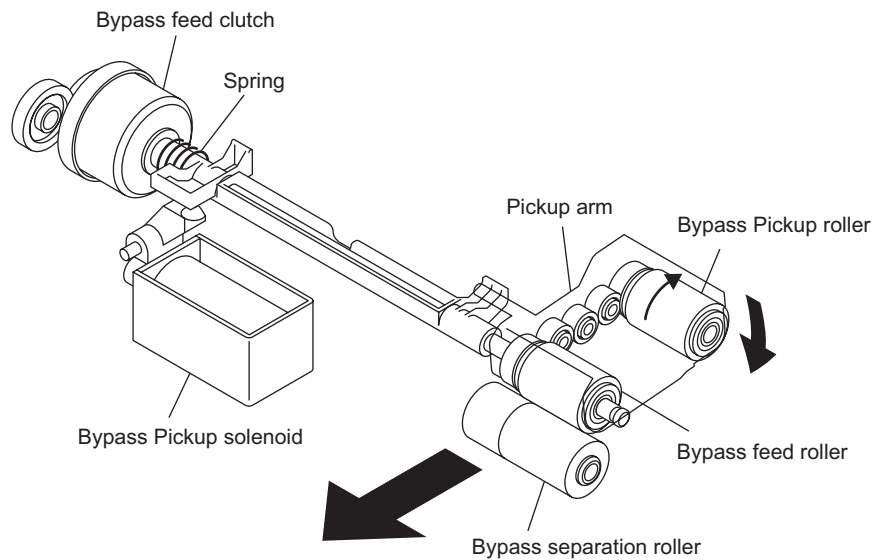

Fig. 9-3

### 9.2.2 Operation of drawer pickup roller

When the drawer is inserted, the pickup roller and roller holder fall by the spring force. Then the drawer tray lifts up and paper feeding is enabled.

When the drawer feed clutch is turned ON, the drive from the main motor is transmitted. Then the feed roller and pickup roller rotate to transport the paper from the drawer.

The separation roller under the feed roller prevents multiple transporting of paper.

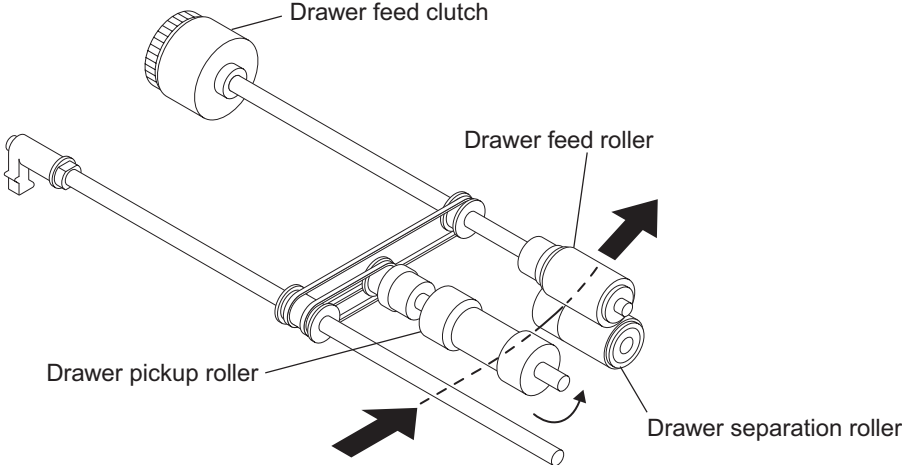

Fig. 9-4

### 9.2.3 Separation of paper

The separation roller in this equipment works to separate the sheets of paper being fed. The separation roller section consists of the feed roller, separation roller, spring joint, etc. The feed roller rotates in the direction of the white arrow (shown below in the figure at right) at the same timing as the pickup roller rotation when the feed clutch is turned ON.

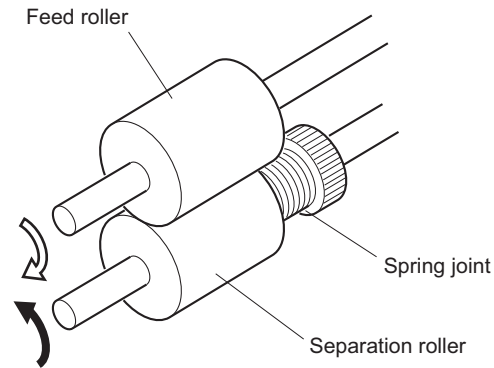

Fig. 9-5

When two sheets of paper are transported (shown in the figure at right), the lower sheet is braked by the separation roller and not transported any further and the upper sheet is transported in the direction of black arrow since the frictional force between two sheets is small.

(Example)

When only one sheet enters into the separation roller section:

Since the transporting force of the feed roller is greater than the braking force of the separation roller, these two rollers rotate together to transport the sheet to the registration roller.

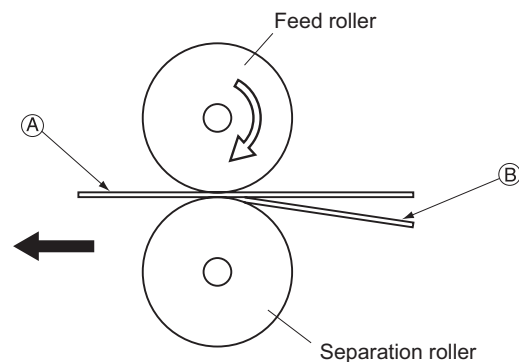

Fig. 9-6

When two sheets enter into the separation roller section:

Since the transporting force of the feed roller and the braking force of the separation roller are greater than the frictional force between two sheets, the sheet A is transported in the direction of the black arrow and the sheet B is braked by the separation roller and is not transported any further.

## 9.2.4 Operation of clutch

The power ON/OFF of each transport clutch and the operation of each transport roller are as follows.

| 1st transport roller | 2nd transport roller | Upper transport clutch | Middle transport clutch | Lower transport clutch |
|----------------------|----------------------|------------------------|-------------------------|------------------------|
| Low speed            | Low speed            | OFF                    | ON                      | OFF                    |
| Low speed            | High speed           | OFF                    | ON                      | ON                     |
| High speed           | High speed           | ON                     | OFF                     | OFF                    |
| Stop                 | Stop                 | OFF                    | OFF                     | OFF                    |

## 9.2.5 General operation

### [A] From power-ON to ready status

- When the equipment is turned ON, the tray-up motor starts to rotate forward and the upper drawer tray starts to rise. When the tray has risen and the tray-up sensor is turned ON (L→H), the tray-up motor is turned OFF, then the tray stops to rising. At this time, if the empty sensor is OFF (L), it is judged that there is no paper in the drawer. If the empty sensor is ON (H), there is paper in the drawer. The tray stops at raised position regardless of the presence/absence of paper.  
The tray-up motor then starts to rotate in reverse and the lower drawer tray starts to rise. The lower drawer tray is stopped in the same manner as the upper drawer tray, and the empty sensor detects if there is paper in the drawer.
- If the drawer is not completely inserted when the equipment is turned ON, the tray in that drawer does not rise. When the drawer is inserted completely, the tray is raised and checks the presence/absence of paper.
- If either of the feed sensors is ON (= there is paper on the transport path) at power-ON, it is determined that a paper jam has occurred and no operation is enabled until the jammed paper is removed.

### [B] Ready status

- After the tray is moved up to check the presence/absence of paper as described above, the equipment enters the ready state. During the ready mode, the tray stays at the raised position.
- When a drawer is inserted or removed in the ready state, the tray is raised again and checks the presence/absence of paper.

### [C] Bypass feeding

- The bypass paper sensor detects paper in the bypass tray.
- The bypass pickup roller is lowered when the bypass pickup solenoid is turned ON.
- The bypass feed clutch is turned ON, and then the bypass pickup roller and bypass feed roller are rotated.
- Paper feeding is started and the bypass feed sensor detects the passing of paper.
- The leading edge of paper turns the registration sensor ON and the paper is aligned by the registration rollers.
- The bypass feed clutch is turned OFF, causing the bypass pickup roller and bypass feed roller to stop rotating.
- The bypass pickup solenoid is turned OFF, and the bypass pickup roller moves up.
- The registration clutch is turned ON, and the paper is transported to the transfer unit.

## [D] Paper feeding

- Lower drawer
  - The feed clutch and transport clutches (upper, lower) are turned ON, and the pickup roller, feed roller and transport roller rotate to start paper feeding.
  - The leading edge of paper turns the 2nd transport sensor ON, and the feed clutch is turned OFF. (Pick-up roller and feed roller stop rotating.)
  - The leading edge of paper turns the registration sensor ON and the paper is aligned by the registration rollers.
  - The transport clutch (upper, lower) are turned OFF, and the transport roller stop rotating.
  - The registration clutch and transport clutch (middle) are turned ON, and the paper is transported to the transfer unit.
- Upper drawer
  - The feed clutch is turned ON and the pickup roller and feed roller rotate to start paper feeding.
  - The leading edge of paper turns the registration sensor ON, and the paper is aligned by the registration rollers.
  - The feed clutch is turned OFF and the pickup roller and feed roller to stop rotating.
  - The registration clutch is turned ON, and the paper is transported to the transfer unit.



### 9.3 Drive Circuit of Tray-up Motor

The tray-up motor (brush motor) is a motor to lift or lower the tray in the upper/lower drawer. The tray-up motor is driven by the motor driver TA8428 (LGC board: IC17).

Circuit diagram of the tray-up motor

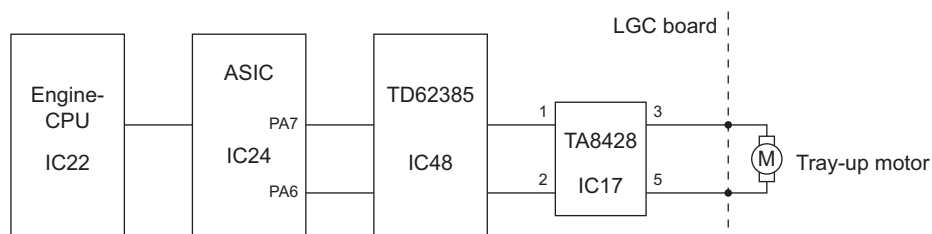

Fig. 9-7

The motor rotates or stops by the control signals from ASIC.

- When the PA7 (CLTRM-1A) of the ASIC becomes “H” and PA6 (CLTRM-0A) becomes “L” levels, current flows into the motor coil and the motor is rotated.
- When both of PA7 (CLTRM-1A) and PA6 (CLTRM-0A) of the ASIC become “H” level, the motor is braked and stopped.
- When both of PA7 (CLTRM-1A) and PA6 (CLTRM-0A) of ASIC become “L” level, the motor waits for the next command (the motor is stopped).

The block diagram of TA8428 and the operation of the control logic are shown below.

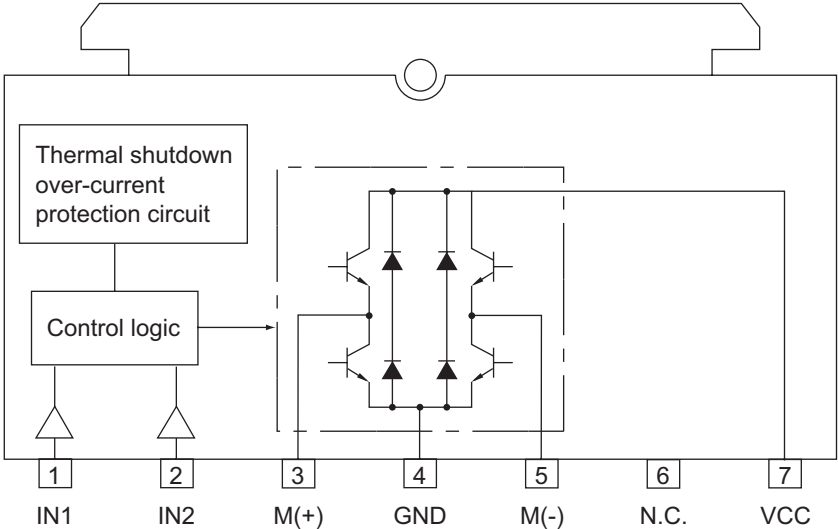

Fig. 9-8

| Input |     | Output                  |       | State |
|-------|-----|-------------------------|-------|-------|
| IN1   | IN2 | M (+)                   | M (-) |       |
| H     | H   | L                       | L     | Brake |
| L     | H   | L                       | H     | CCW   |
| H     | L   | H                       | L     | CW    |
| L     | L   | OFF<br>(High impedance) |       | Stop  |

## 9.4 Disassembly and Replacement

### [A] Bypass pickup roller

- (1) Remove 1 clip.
- (2) Pull out the shaft and take off the bypass pickup roller.

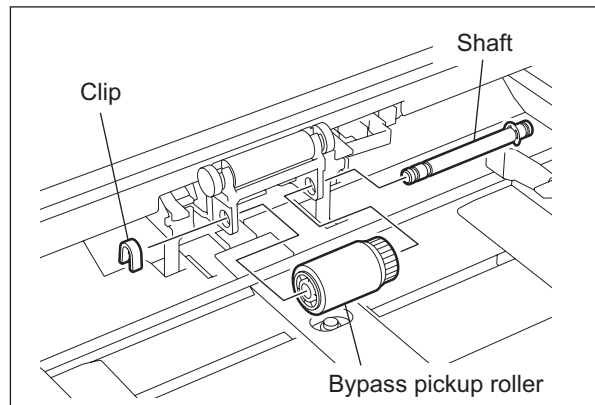





Fig. 9-9

### [B] Bypass feed unit

- (1) If the ADU is not installed, take off the right front hinge cover, the right rear hinge cover and the bypass upper cover ( P.2-38 "[P] Right front hinge cover",  P.2-39 "[Q] Right rear hinge cover",  P.2-39 "[R] Bypass upper cover").  
If the ADU is installed, take off the ADU ( P.15-10 "[A] Automatic Duplexing Unit (ADU)").
- (2) Remove 1 spring.
- (3) Disconnect the connector of the bypass feed clutch.

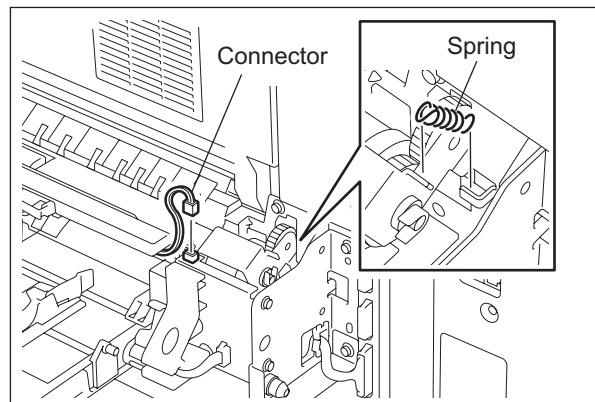

Fig. 9-10

- (4) Remove 3 screws and take off the bypass feed unit.

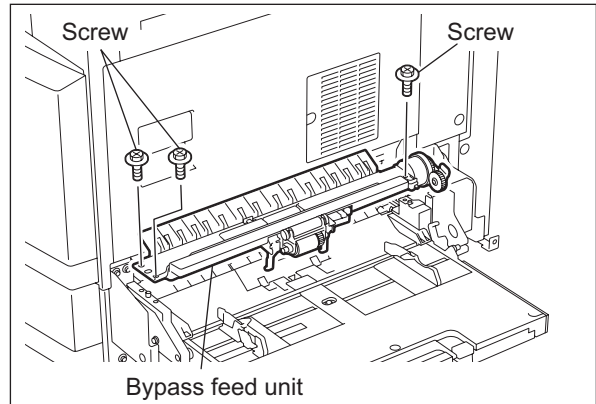

Fig. 9-11

**[C] Bypass separation roller (PM)**

- (1) Take off the bypass feed unit  
(P.9-13 "[B] Bypass feed unit").  
(2) Remove 1 screw and take off the bypass separation roller cover.

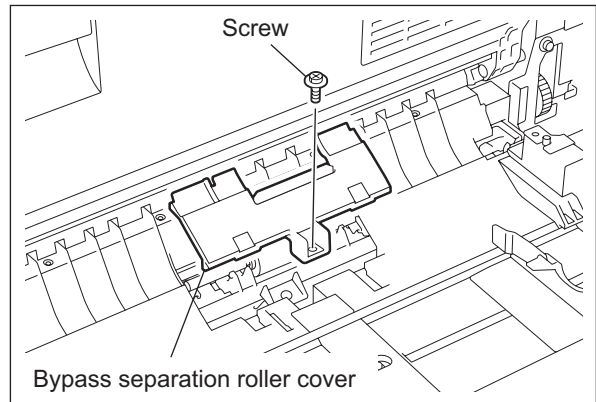

Fig. 9-12

- (3) Take off the bypass separation roller unit.

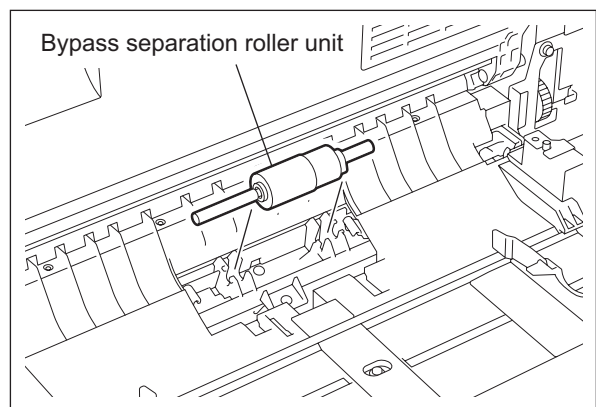

Fig. 9-13

- (4) Take off the cover, arbor, clutch spring and bypass separation roller from the shaft.

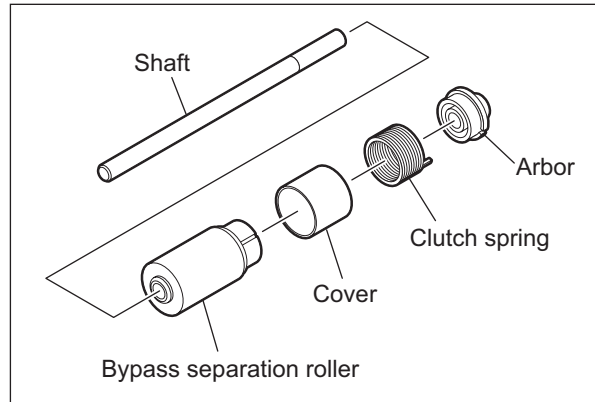

Fig. 9-14

**[D] Bypass feed roller (PM)**

- (1) Take off the bypass feed unit  
( P.9-13 "[B] Bypass feed unit").  
(2) Remove 2 screws and take off the upper guide.

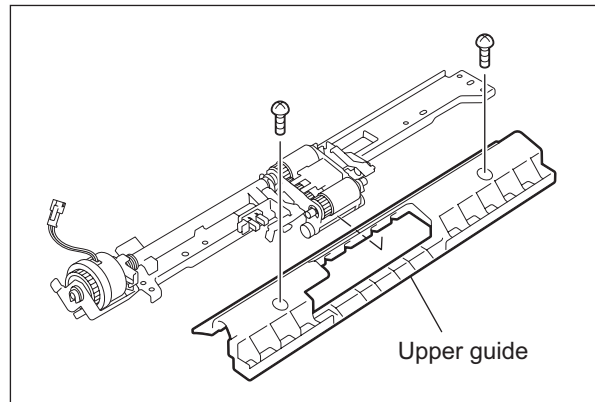

Fig. 9-15

- (3) Lift up the arm, remove 1 screw, and then take off the bracket.

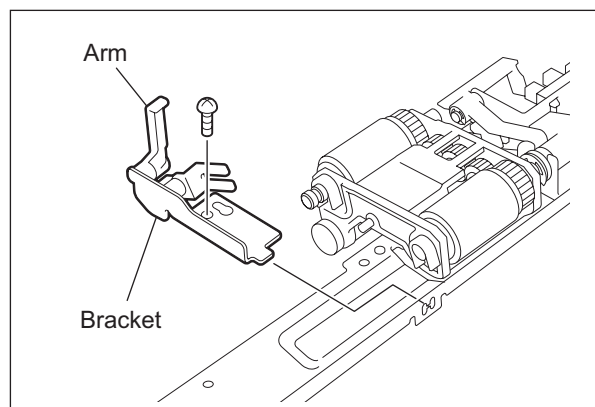

Fig. 9-16

- (4) Remove 1 clip and take off the bypass feed roller unit from the shaft. Then take off the bypass feed roller.

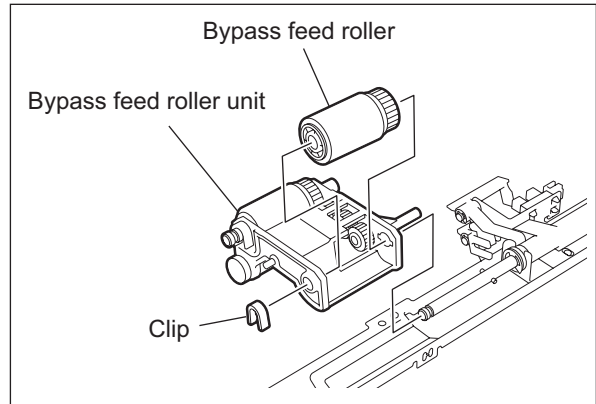

Fig. 9-17

### [E] Bypass paper sensor

- (1) Take off the bypass feed unit (P.9-13 "[B] Bypass feed unit").
- (2) Remove 2 screws and take off the upper guide.

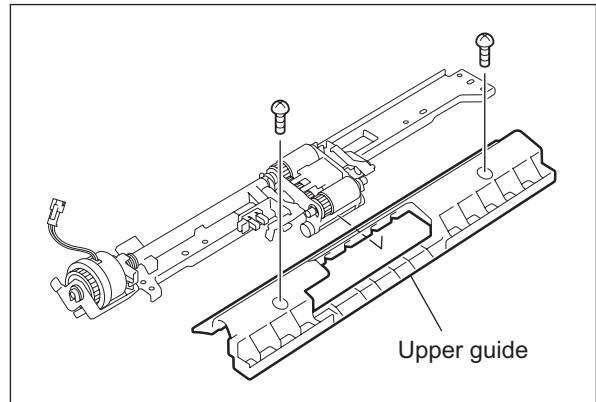

Fig. 9-18

- (3) Release the latches and take off the bypass paper sensor.

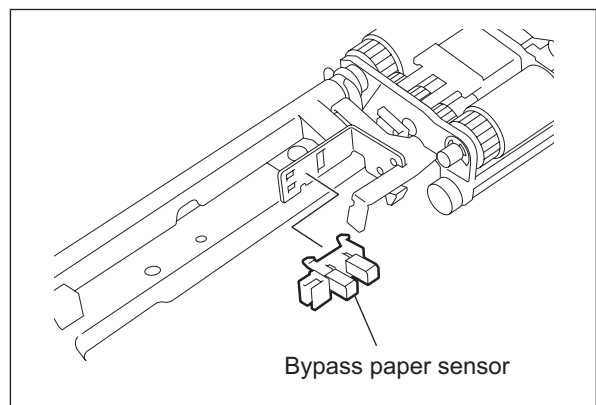



Fig. 9-19

## [F] Bypass feed clutch

- (1) Take off the bypass feed unit  
( P.9-13 "[B] Bypass feed unit").
- (2) Remove 1 clip. Take off the bypass feed clutch together with the bushing and bracket.

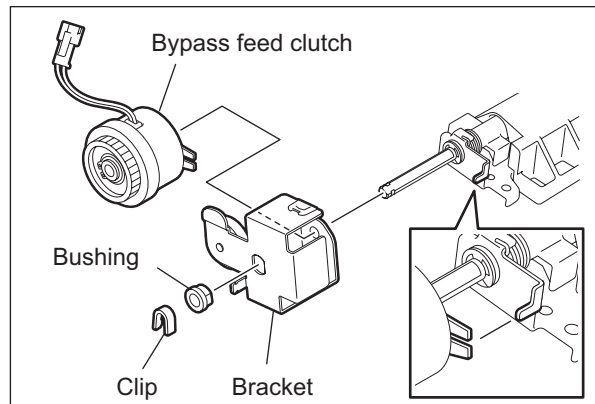





Fig. 9-20

## [G] Bypass unit

- (1) If the ADU is not installed, take off the right front hinge cover, the right rear hinge cover and the bypass upper cover  
( P.2-38 "[P] Right front hinge cover",  P.2-39 "[Q] Right rear hinge cover",  P.2-39 "[R] Bypass upper cover").  
If the ADU is installed, take off the ADU  
( P.15-10 "[A] Automatic Duplexing Unit (ADU)").
- (2) Open the side cover.
- (3) Disconnect 2 connectors. Remove 5 screws and take off the bypass unit.

**Note:**

Make sure to let the disconnected connector (A) (harness) through the hole (B).

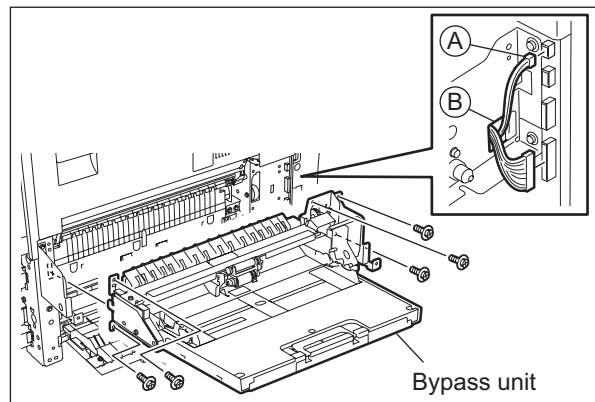



Fig. 9-21

## [H] Bypass tray

- (1) Take off the bypass unit  
( P.9-17 "[G] Bypass unit").
- (2) Disconnect 1 connector. Remove 2 screws and take off the bypass tray.

**Note:**

The bypass tray is removable without taking off the bypass unit from the equipment.

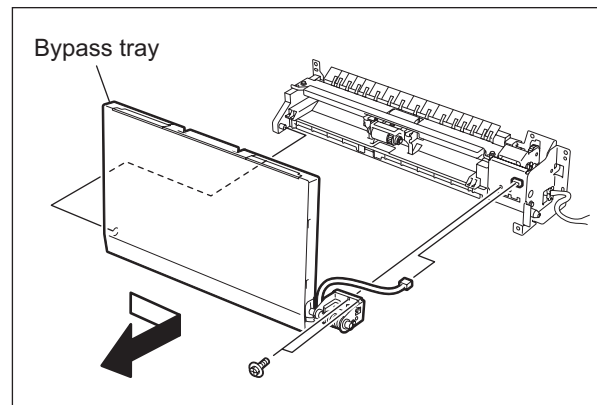

Fig. 9-22

- (3) Pull out the hinge assembly from the bypass tray.

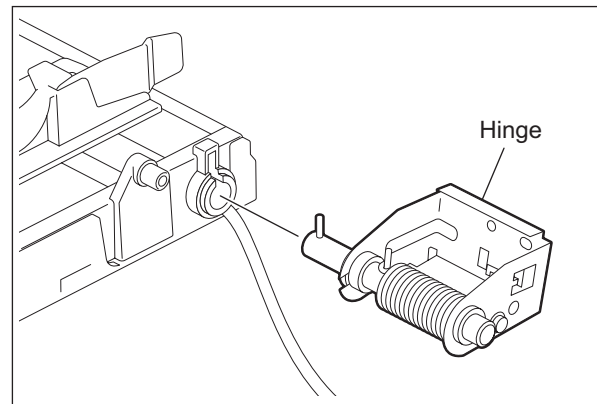



Fig. 9-23

## [I] Paper size detection sensor

- (1) Take off the bypass tray.  
( P.9-18 "[H] Bypass tray").
- (2) Remove 3 screws and take off the bypass tray upper cover.

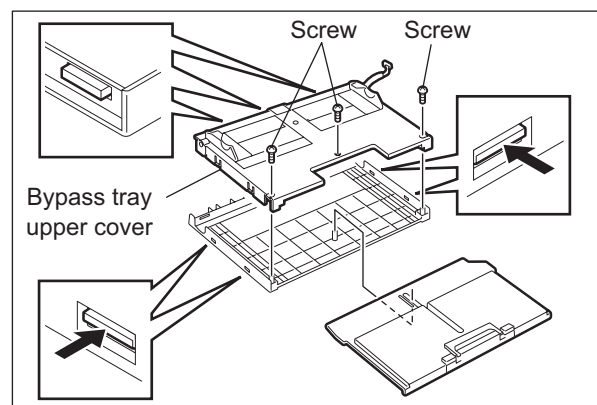

Fig. 9-24



- (3) Remove 1 screw and take off the paper size detection sensor.

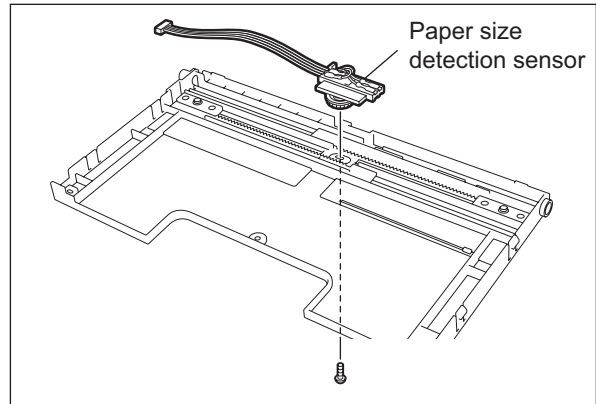

Fig. 9-25

**[J] 2nd transport sensor / Bypass pickup solenoid**

- (1) Take off the bypass unit  
( P.9-17 "[G] Bypass unit").
- (2) Take off the bypass tray  
( P.9-18 "[H] Bypass tray").
- (3) Take off the bypass feed unit  
( P.9-13 "[B] Bypass feed unit").
- (4) Remove 1 screw and take off the bypass separation roller cover  
( P.9-14 "[C] Bypass separation roller").
- (5) Remove 2 screws and take off the 2nd transport sensor cover.

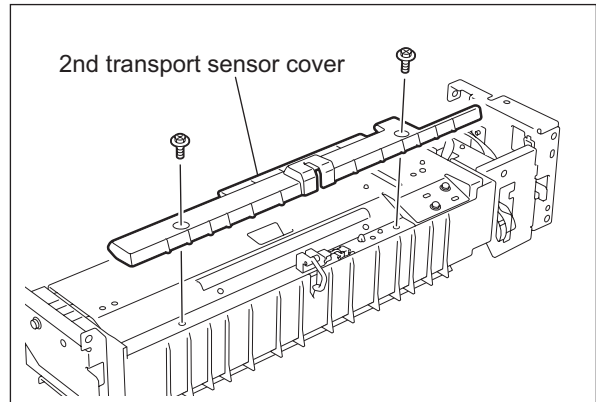

Fig. 9-26

- (6) Remove 3 screws and take off the bypass unit lower cover.

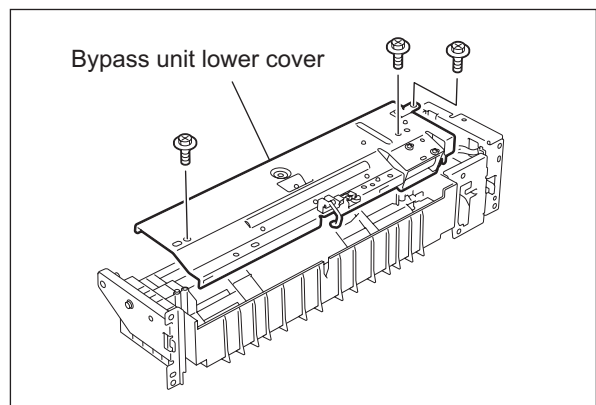

Fig. 9-27

- (7) Disconnect 1 connector. Release the latches and take off the 2nd transport sensor.

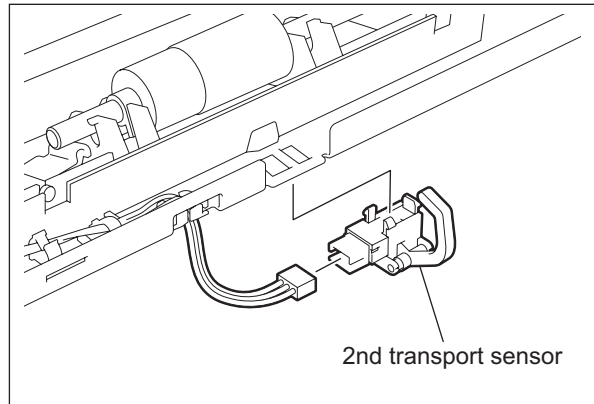

Fig. 9-28

- (8) Disconnect 1 connector. Remove 2 screws and take off the bypass pickup solenoid and solenoid arm.

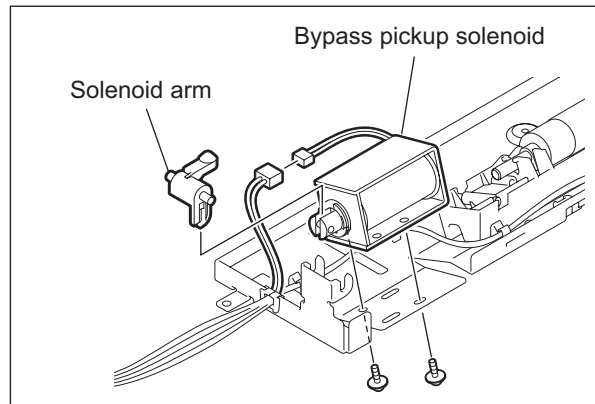

Fig. 9-29

### [K] Drawer feeding unit

- (1) Take off the drawer.  
(2) Remove 1 screw and take off the drawer feeding unit by sliding it to the front side.

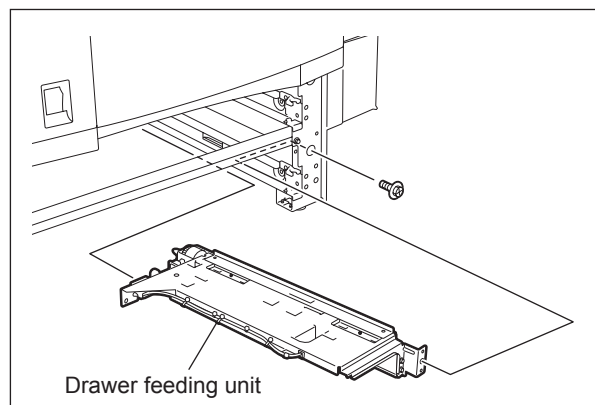

Fig. 9-30

## [L] Tray-up sensor

- (1) Take off the drawer feeding unit (P.9-20 "[K] Drawer feeding unit").
- (2) Disconnect the connector and release the latches to take off the tray-up sensor.

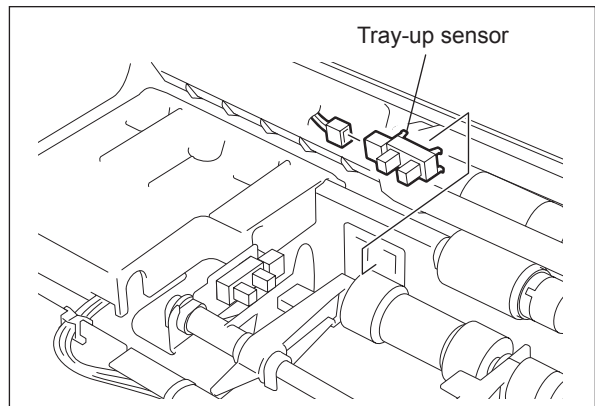

Fig. 9-31

## [M] Empty sensor

- (1) Take off the drawer feeding unit (P.9-20 "[K] Drawer feeding unit").
- (2) Disconnect the connector and release the latches to take off the empty sensor.

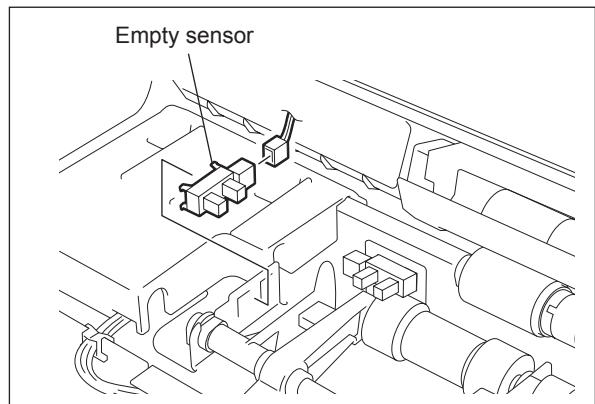

Fig. 9-32

## [N] Paper stock sensor

- (1) Take off the drawer feeding unit (P.9-20 "[K] Drawer feeding unit").
- (2) Pull up the paper stock sensor arm.
- (3) Disconnect the connector and release the latches to take off the paper stock sensor.

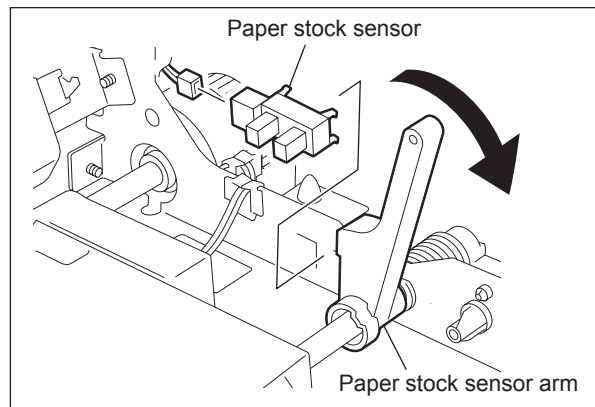

Fig. 9-33

## [O] Separation roller

- (1) Take off the drawer feeding unit (P.9-20 "[K] Drawer feeding unit").
- (2) Remove 1 screw and take off the separation roller holder.

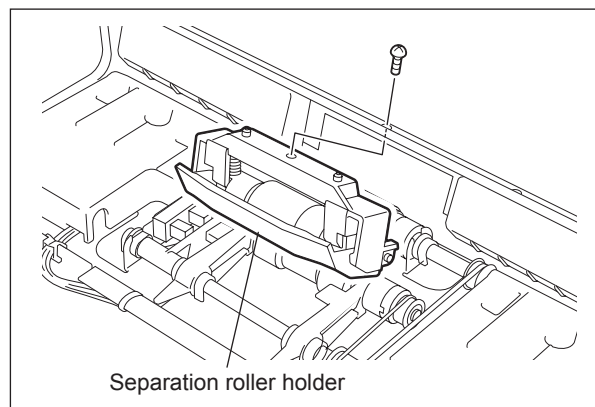

Fig. 9-34

- (3) Detach the lever from the holder and take off the separation roller with the shaft.

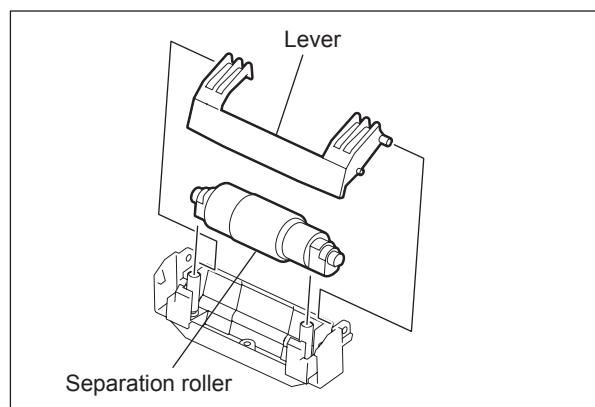

Fig. 9-35

- (4) Detach the cover, arbor and clutch spring from the shaft, and then take off the separation roller.

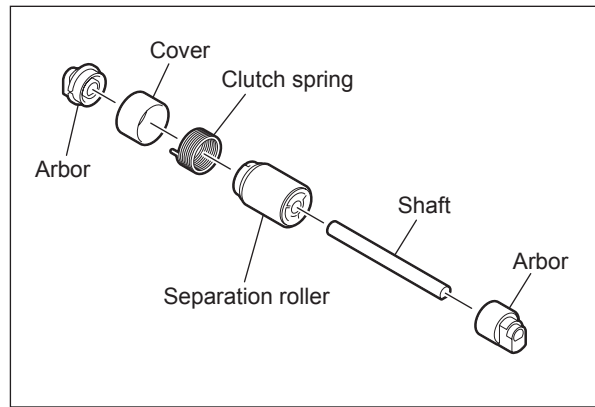



Fig. 9-36

**[P] Feed roller **

- (1) Take off the drawer feeding unit ( P.9-20 "[K] Drawer feeding unit").
- (2) Take off the separation roller holder ( P.9-22 "[O] Separation roller").
- (3) Remove the clip and take off the feed roller.

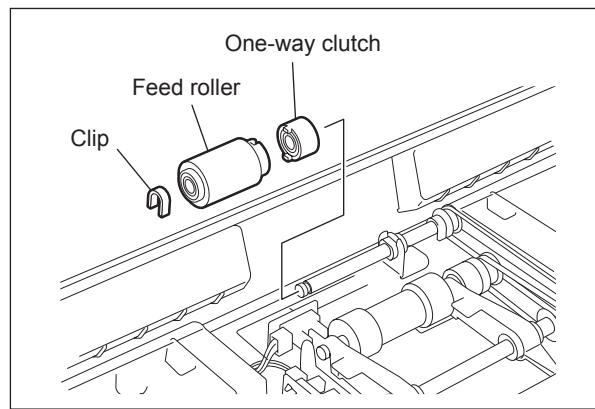



Fig. 9-37

**[Q] Pickup roller **

- (1) Take off the drawer feeding unit ( P.9-20 "[K] Drawer feeding unit").
- (2) Remove the pickup roller assembly from the pickup arms. Take off the timing belt and then take off the pickup roller assembly.

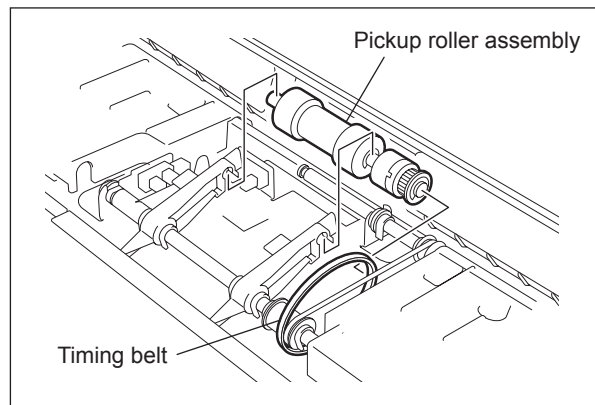

Fig. 9-38

- (3) Remove the pulley, one-way clutch and 3 E-rings. Then take off the pickup roller.

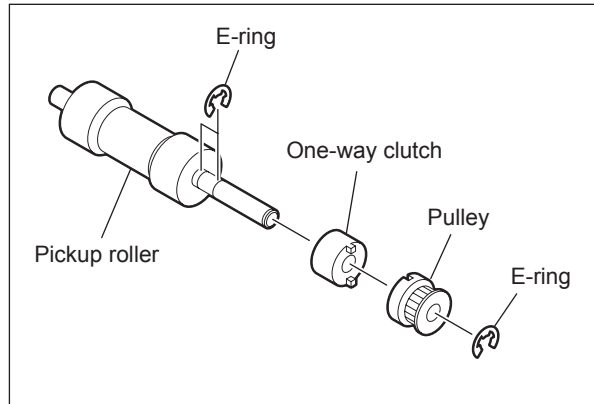

Fig. 9-39

**[R] Drawer feed clutch**

- (1) Take off the drawer feeding unit (P.9-20 "[K] Drawer feeding unit").
- (2) Disconnect the connector and release the harness from the harness clamp.

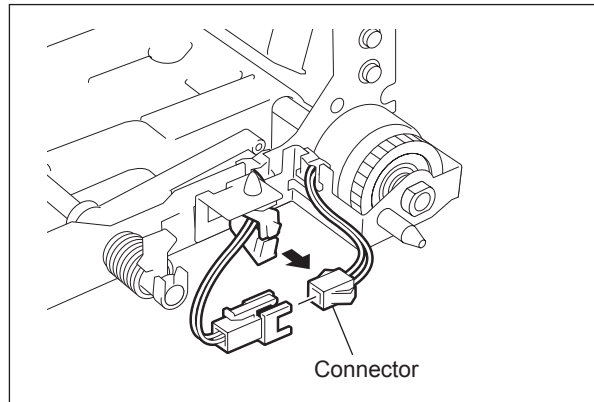

Fig. 9-40

- (3) Remove 2 screws and take off the clutch bracket and bushing.

**Note:**

Match the protruding portion of the clutch with the position shown in the figure for assembling.

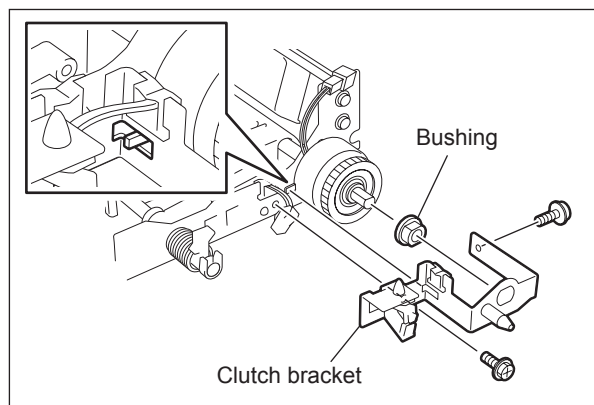

Fig. 9-41

- (4) Loosen 1 setscrew and take off the drawer feed clutch.

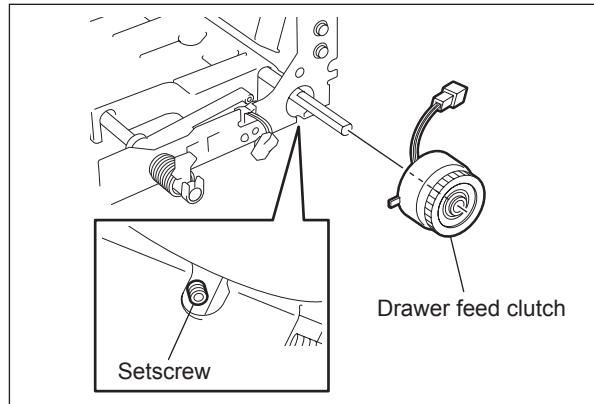

Fig. 9-42

**Note:**

Attach the clutch to the shaft referring to the figure at right.

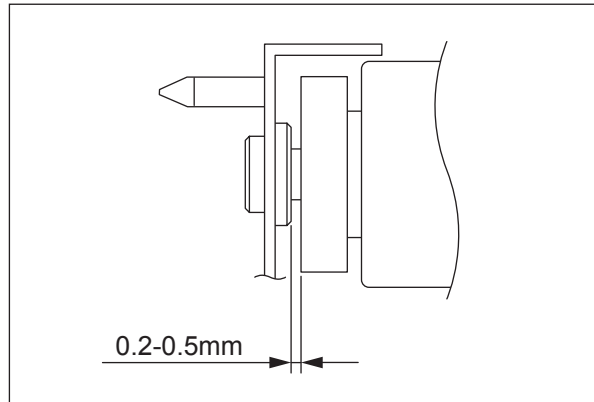

Fig. 9-43

**[S] Registration roller clutch**

- (1) Take off the main motor drive unit (P.10-5 "[B] Main motor drive unit").
- (2) Loosen 2 setscrews. Disconnect 1 connector and take off the registration roller clutch.

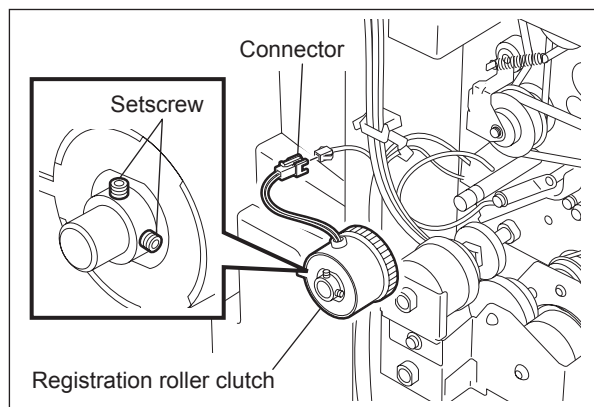



Fig. 9-44

## [T] Tray drive unit / Tray-up motor

- (1) Take off the SYS board case  
( P.2-46 "[D] SYS board case").
- (2) Take off the right rear hinge cover  
( P.2-39 "[Q] Right rear hinge cover").
- (3) Remove 4 screws and disconnect 1 connector. Release the harness from 2 harness clamps and take off the tray drive unit with the bracket.

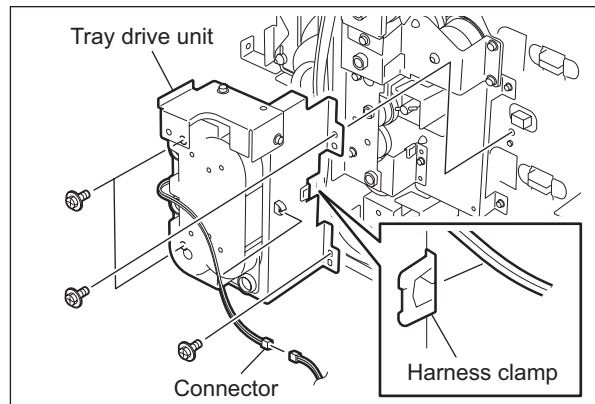

Fig. 9-45

- (4) Remove 2 screws and take off the bracket fixing the PCI slot.
- (5) Remove 4 screws and take off the tray drive unit from the bracket.

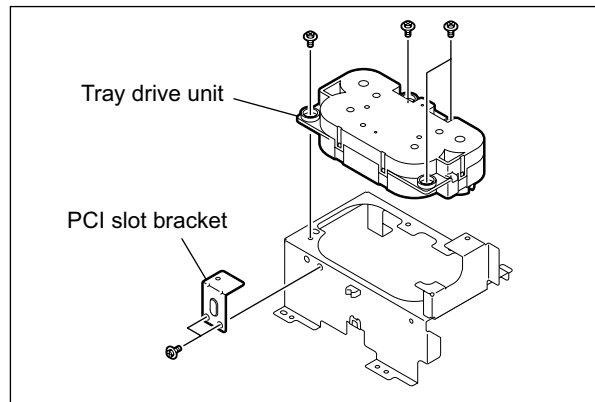

Fig. 9-46

- (6) Place the unit with its coupling up and release 6 latches to take off the cover.

### Note:

Be careful in taking off the cover because there is a spring in the tray drive unit.

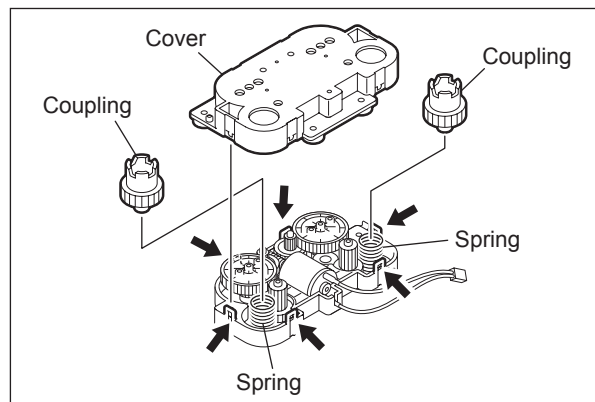

Fig. 9-47



- (7) Take off the tray-up motor.

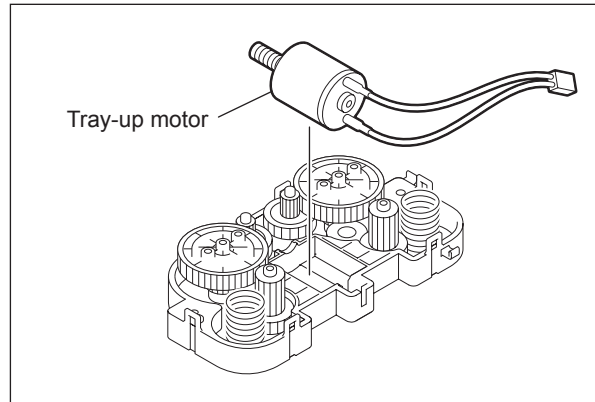

Fig. 9-48

**Note:**

Match the boss of the gear with the hole of the cover when installing the motor.

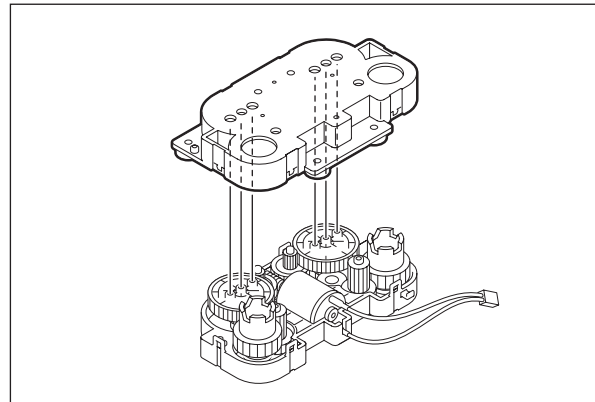

Fig. 9-49

**[U] Transport drive unit / Upper transport clutch / Middle transport clutch / Lower transport clutch**

- (1) Take off the right upper cover-3, connecting port cover and right rear hinge cover (P.2-34 "[H] Right upper cover-3", P.2-37 "[O] Connecting port cover", P.2-39 "[Q] Right rear hinge cover").
- (2) Take off the tray drive unit (P.9-26 "[T] Tray drive unit / Tray-up motor").
- (3) Take off the main motor drive unit (P.10-5 "[B] Main motor drive unit").
- (4) Remove 1 screw and take off the bracket fixing the upper transport clutch and 1 bushing.

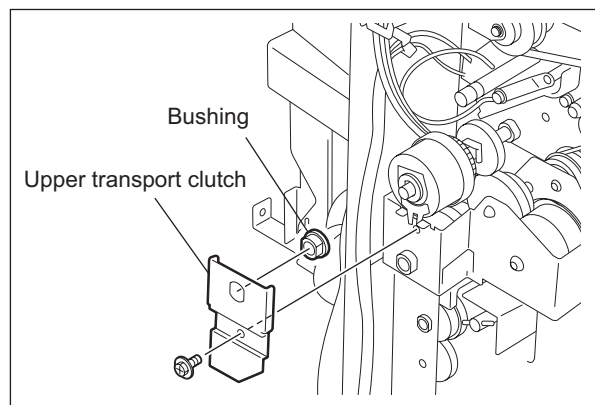
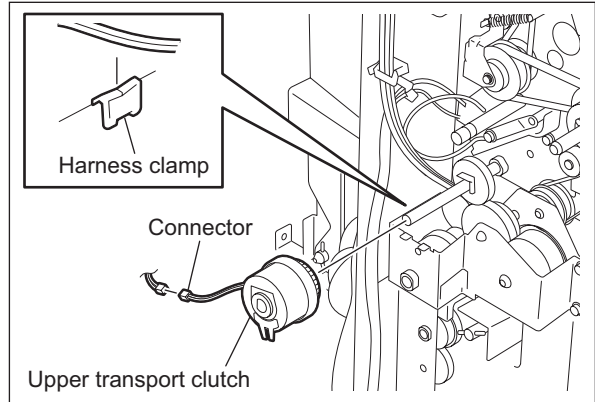

Fig. 9-50

- (5) Disconnect 1 connector and release the harness from 1 harness clamp. Then take off the upper transport clutch.



**Fig. 9-51**

- (6) Remove 3 screws. Release the harness from 1 harness clamp and take off the fixing bracket.

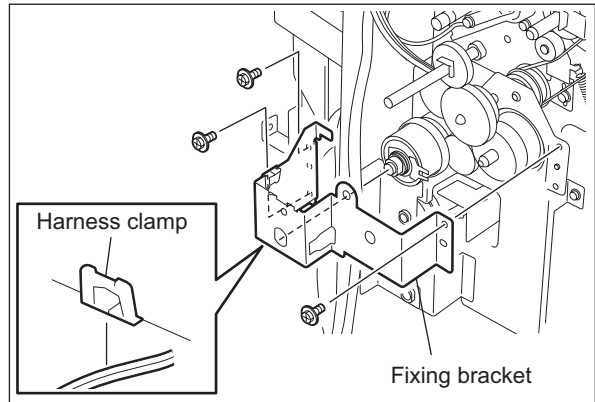

**Fig. 9-52**

- (7) Disconnect 1 connector. Take off 1 bushing and middle transport clutch.

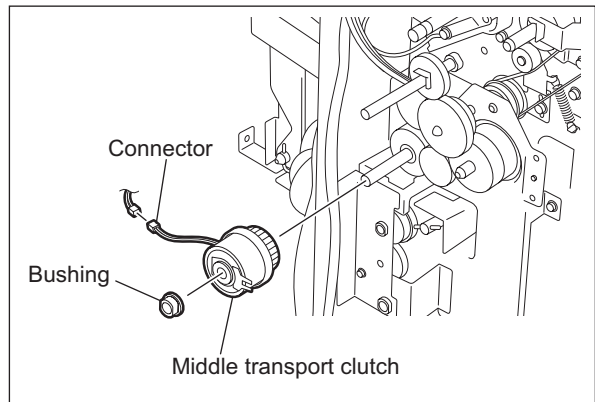

**Fig. 9-53**

- (8) Remove 3 screws and take off the fixing bracket.

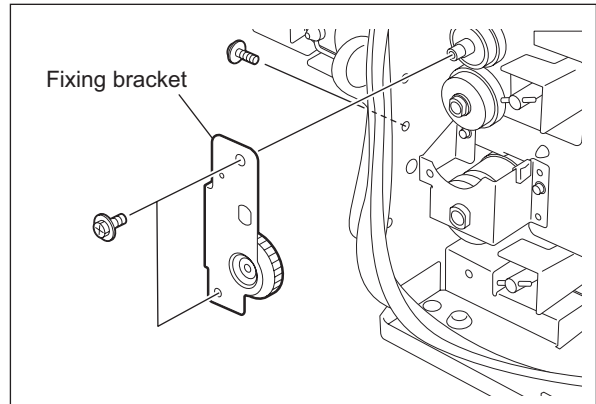

Fig. 9-54

- (9) Remove 2 screws and disconnect 1 connector. Release the harness from 1 harness clamp and then take off the bracket fixing the lower transport clutch and 1 bushing.

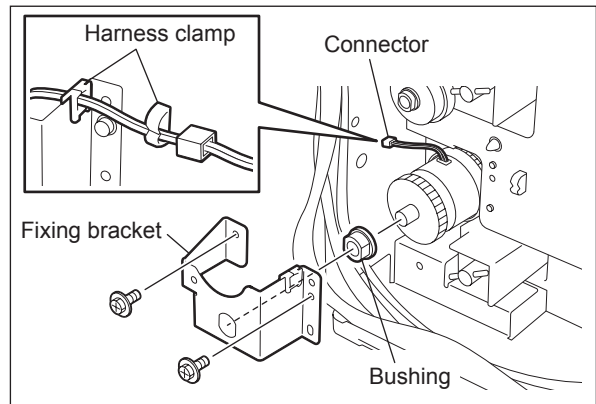

Fig. 9-55

- (10) Take off the lower transport clutch and 1 bushing.

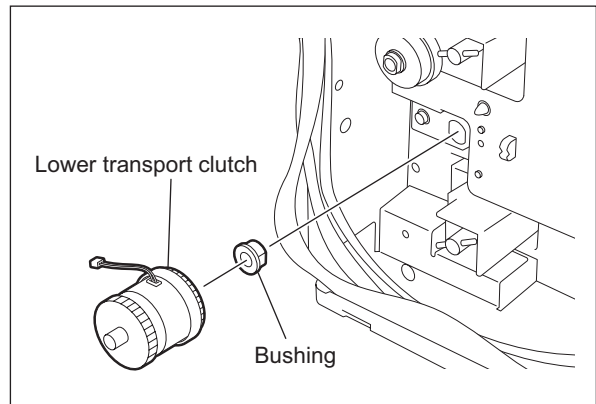
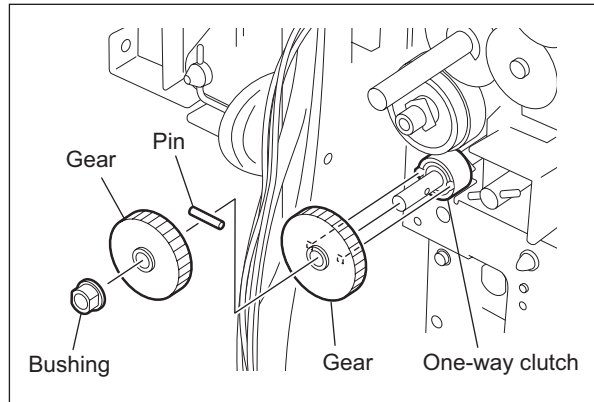

Fig. 9-56

- (11) Remove 1 each of the bushing, gear, pin and gear in order.

**Note:**

When installing the gear, engage the convexity of the one-way clutch and concavity of the gear.



**Fig. 9-57**

- (12) Remove 4 screws and take off the transport drive unit.

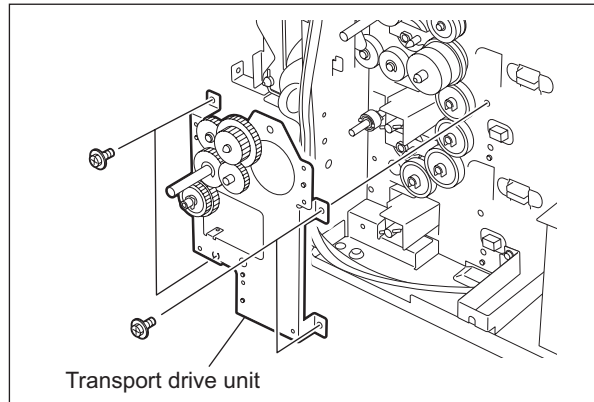

**Fig. 9-58**

**[V] Side cover opening/closing detection sensor**

- (1) Take off the ADU (P.15-10 "[A] Automatic Duplexing Unit (ADU)").
- (2) Take off the bypass unit (P.9-17 "[G] Bypass unit").
- (3) Release the latches and take off the side cover opening/closing detection sensor.

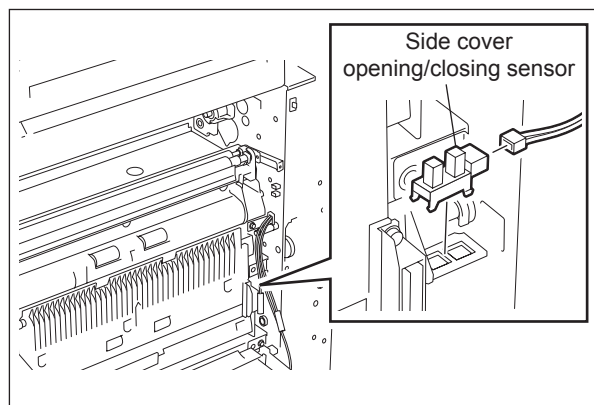

**Fig. 9-59**

## [W] Registration roller

- (1) Take off the front cover  
(☞ P.2-30 "[A] Front cover").
- (2) Take off the process unit  
(☞ P.11-8 "[A] Process unit").
- (3) Take off the ADU  
(☞ P.15-10 "[A] Automatic Duplexing Unit (ADU)").
- (4) Take off the bypass unit  
(☞ P.9-17 "[G] Bypass unit").
- (5) Take off the transfer unit  
(☞ P.11-17 "[O] Transfer unit").
- (6) Take off the SYS board case  
(☞ P.2-46 "[D] SYS board case").
- (7) Take off the connecting port cover  
(☞ P.2-37 "[O] Connecting port cover").
- (8) Take off the main motor drive unit  
(☞ P.10-5 "[B] Main motor drive unit").
- (9) Take off the registration roller clutch  
(☞ P.9-25 "[S] Registration roller clutch").
- (10) Remove 2 screws and take off the terminal holder.
- (11) Release the latch and knob.

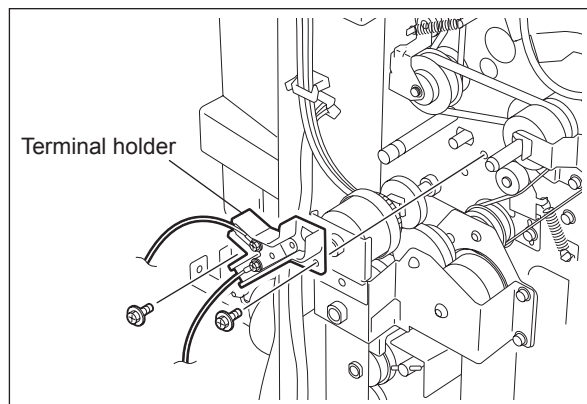

Fig. 9-60

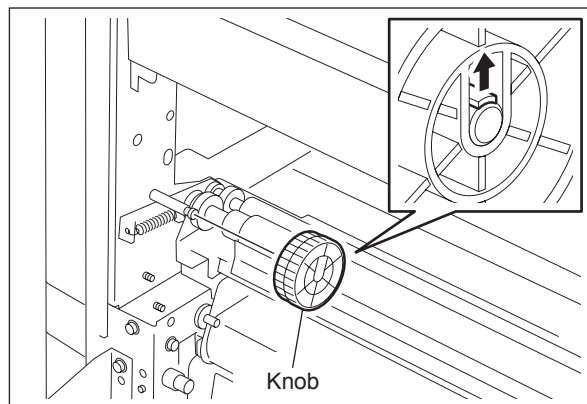
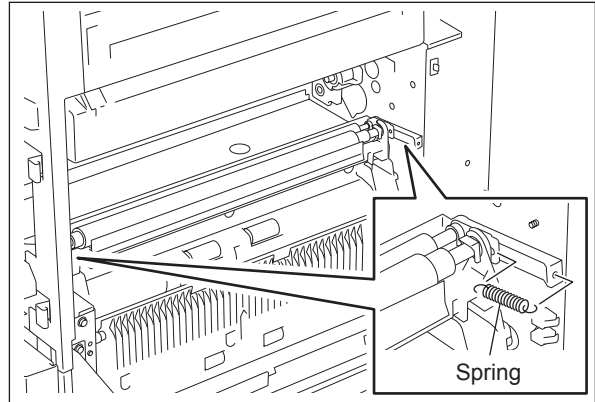

Fig. 9-61

- (12) Remove 2 springs of both front and rear sides.



**Fig. 9-62**

- (13) Remove 2 screws and take off the registration guide R.

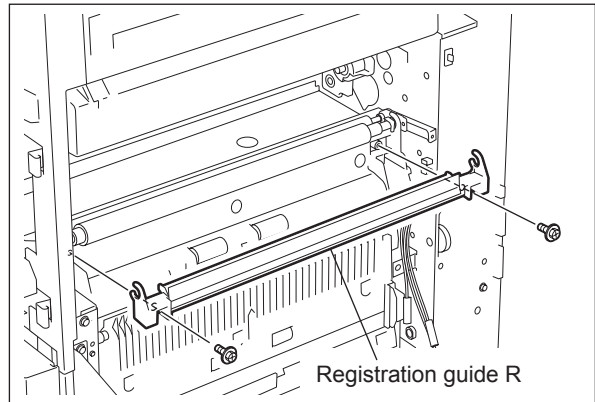

**Fig. 9-63**

- (14) Remove the clip of registration roller (rubber).

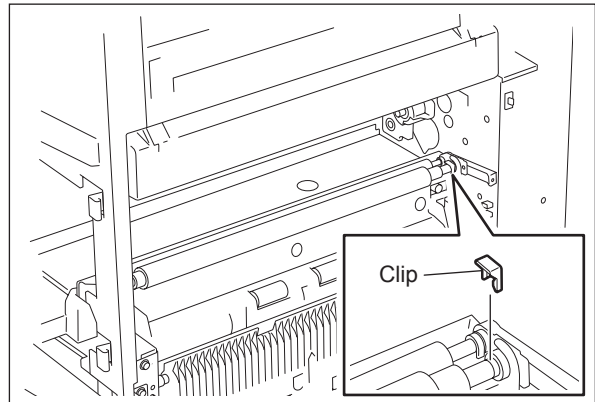

**Fig. 9-64**

- (15) Slide the registration roller (rubber) to the rear side. Then remove the gear.

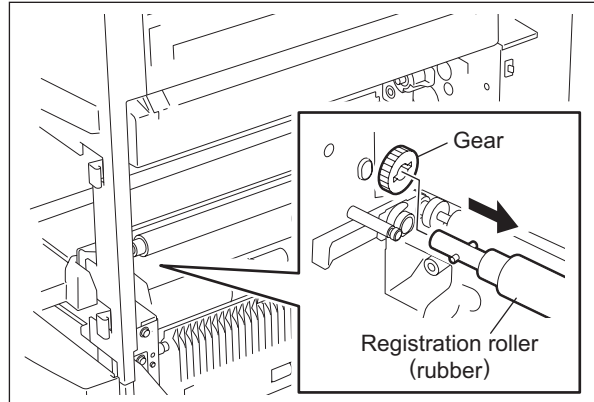

Fig. 9-65

- (16) Pull out the registration roller (rubber) to the front side.

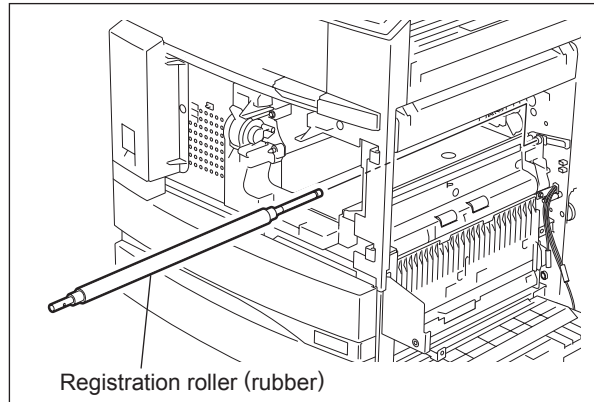

Fig. 9-66

- (17) Remove the clip of registration roller (metal).

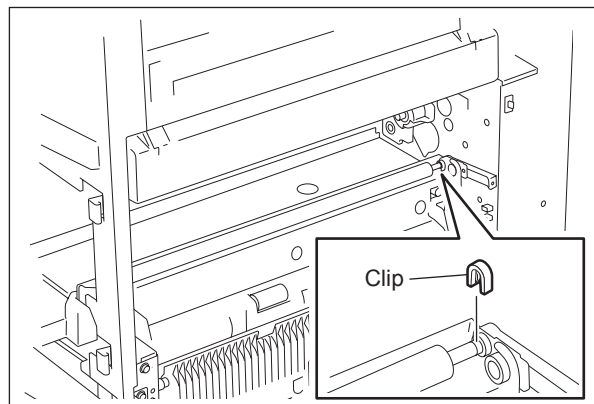

Fig. 9-67

- (18) Slide the registration roller (metal) to the rear side. Then remove the gear.

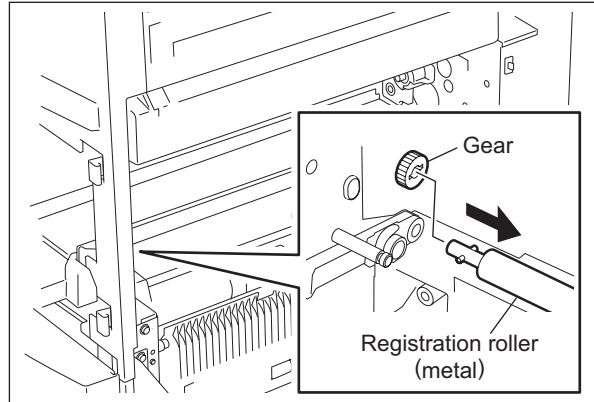

Fig. 9-68

- (19) Pull out the registration roller (metal) to the front side.

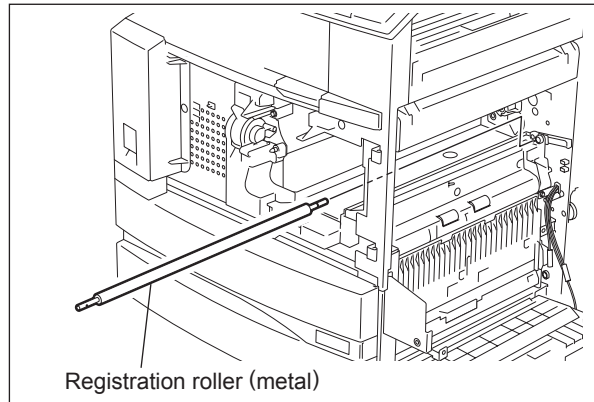



Fig. 9-69

### [X] Registration sensor

- (1) Take off the registration rollers (rubber one and metal one)  
( P.9-31 "[W] Registration roller").
- (2) Disconnect 1 connector and remove 3 screws and take off the registration guide L.

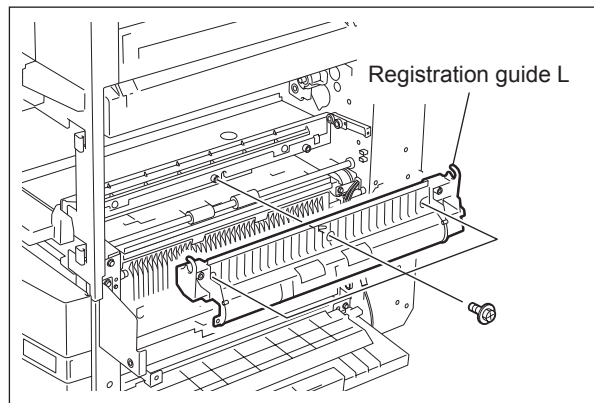

Fig. 9-70



- (3) Disconnect 1 connector and release the latches. Then take off the registration sensor.

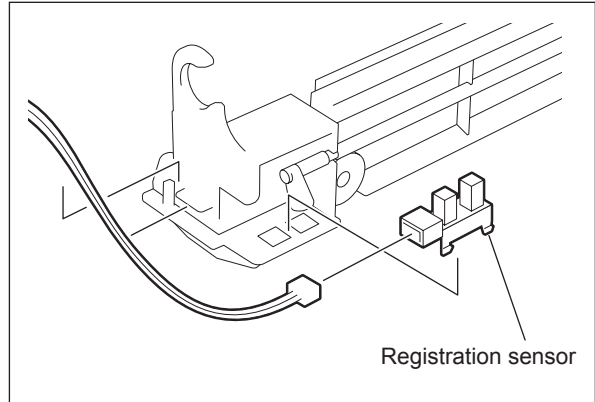

Fig. 9-71



# 10. DRIVE SYSTEM

## 10.1 General Description

The drive system drives the drum, developer unit, cleaner unit, fuser unit, transport roller, feed roller (upper/lower drawer and bypass unit) and registration roller.

The drive system is driven by the rotation of the main motor.

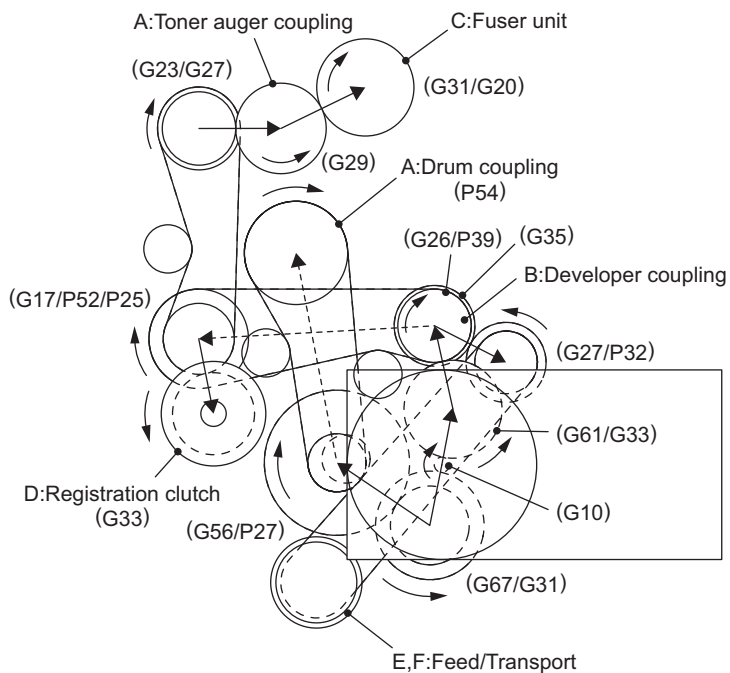

Fig. 10-1

## 10.2 Functions

- A: Drum cleaner unit drive ..... Drives the drum by transmitting the rotation of the main motor through the gears to the drum flange gear. Also, drives the toner recovery auger to transport the used toner to the developer unit.
- B: Developer unit drive..... Drives the developer unit by transmitting the rotation of the main motor through the gears to the developer unit gears.
- C: Fuser unit drive..... Drives the fuser unit by transmitting the rotation of the main motor through the gears and timing belt to the fuser unit gears. The bridge unit, the job separator and the offset tray are driven by transmitting from the fuser unit.
- D: Registration roller drive ..... Drives the registration rollers by transmitting the rotation of the main motor through the gears and clutches.
- E: Transport roller drive..... Drives the transport roller by transmitting the rotation of the main motor through the gears and clutches.
- F: Feed roller drive..... Drives the cassette feed roller by transmitting the rotation of the main motor through the gears and clutches.

## 10.3 Main Motor

### 10.3.1 Main motor drive

The main motor consists of the motor and the drive board combined with the motor, and its rotation is controlled by control signals (three) and reference frequency.

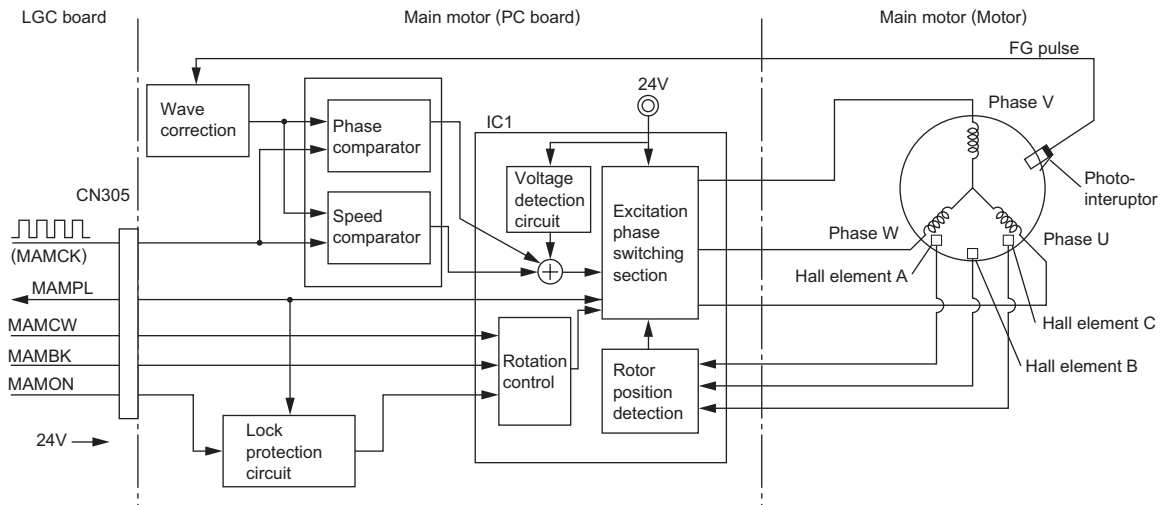

Fig. 10-2

- 1) LGC board outputs the control signals for the main motor rotation. (MAMCW: Motor rotation direction setting, MAMON: Motor rotation command)
- 2) The excitation phase switching section excites each phase of the main motor. → The main motor is rotated.
- 3) Hall elements A, B and C detect the rotation position of the motor (rotor).
- 4) The excitation phase switching section switches the excitation of each phase. (The motor keeps rotating by repeating from 2) to 4).)
- 5) An FG pulse is generated by the FG pattern of the encoder attached to the main motor.
- 6) The FG pulse and the reference frequency from the LGC board are compared in terms of the phase and speed, and the difference is added to the IC1. The fluctuations in the power supply voltage is also added to the value. (Signal generation)
- 7) In accordance with the signal obtained in the step 6), the excitation phase switching section changes the switching timing. i.e. The FG pulse and reference frequency are controlled to be equal. → The main motor rotates at a fixed speed. (Locked range)
- 8) When the main motor enters the locked range, the excitation phase switching section outputs the MAMPL signal to the LGC board. ("L" level)
- 9) When the MAMBK from the LGC board becomes "L" level, the main motor is braked. When the MAMON signal becomes "H" level, the main motor is stopped.

## 10.3.2 Control signals

- 1) MAMCW signal (LGC → MTR: Input)  
This is a signal to switch the direction of the main motor rotation. When this signal becomes “H” level, the main motor rotates clockwise as seen from the rear side, and drives the developer unit, drum, fuser unit, etc. to the appropriate direction.
- 2) MAMPL signal (MTR → LGC: Output)  
When the difference of the FG pulse cycle against the reference frequency is within  $\pm 6.25\%$ , it is specified that the motor is in a lock range (normal rotation), and this MAMPL signal becomes “L” level. At this time, the LED “D4” is lit.
- 3) MAMCK signal (LGC → MTR: Input)  
This is a reference clock signal to rotate the main motor at a fixed speed.
- 4) MAMBK signal (LGC → MTR: Input)  
This is a signal to stop the main motor.  
When it becomes “L” level, the main motor is braked.
- 5) MAMON signal (LGC → MTR: Input)  
This is a signal to turn ON/OFF the main motor. When it becomes “L” level, the motor is rotated.

### Signal level of the motor circuit

| Signal | Level “H”              | Level “L”       |
|--------|------------------------|-----------------|
| MAMCW  | CCW direction          | CW direction    |
| MAMPL  | Abnormal rotation      | Normal rotation |
| MAMCK  | Reference clock signal |                 |
| MAMBK  | Brake OFF              | Brake ON        |
| MAMON  | Motor OFF              | Motor ON        |

\* The signal names are for the connector CN305 (LGC board).

## 10.4 Disassembly and Replacement

### [A] Main motor

- (1) Take off the SYS board case  
( P.2-46 "[D] SYS board case").
- (2) Disconnect 1 connector. Remove 2 screws, release 2 locking supports, and then take off the main motor.

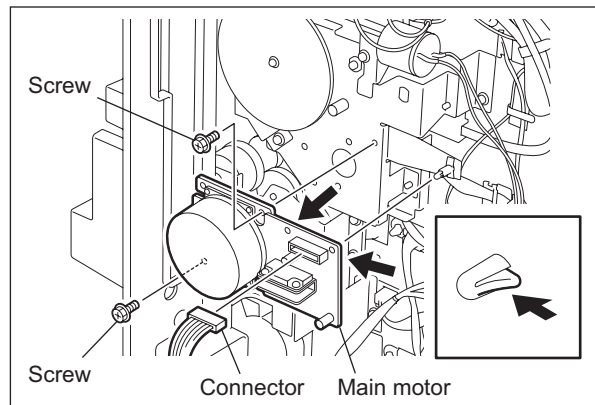





Fig. 10-3

### [B] Main motor drive unit

- (1) Take off the process unit  
( P.11-8 "[A] Process unit").
- (2) Take off the SYS board case  
( P.2-46 "[D] SYS board case").
- (3) Take off the connecting port cover  
( P.2-37 "[O] Connecting port cover").
- (4) Remove 1 screw and take off the flywheels.

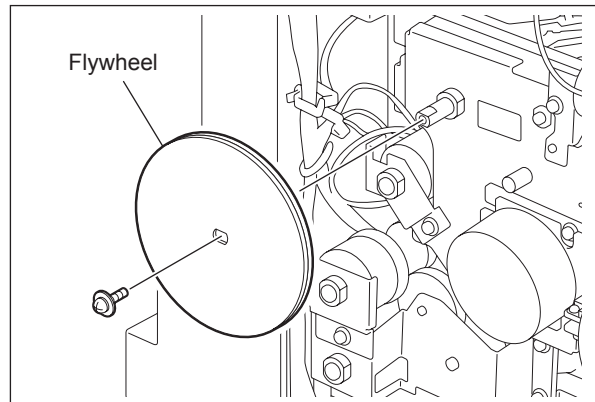

Fig. 10-4

- (5) Remove 1 screw. Take off the bracket fixing the registration clutch and bushing.

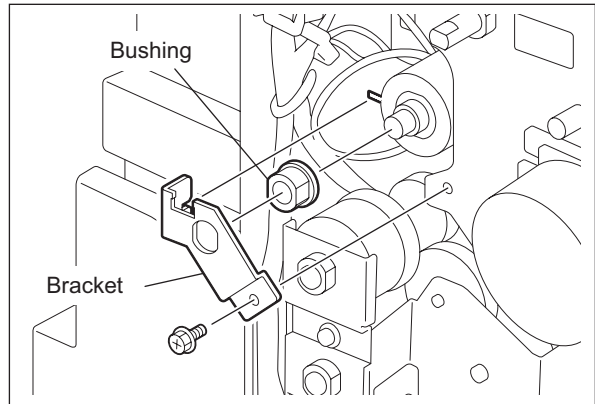

Fig. 10-5

- (6) Disconnect 2 connectors, remove 3 screws, and then take off the main motor drive unit.

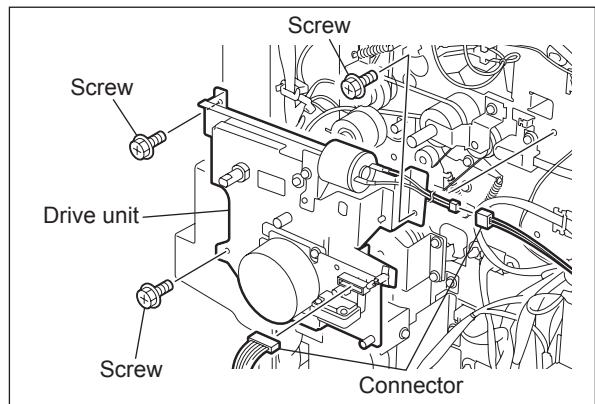

Fig. 10-6

- (7) Loosen 1 fixing screw of the tensioner and remove the tension spring.

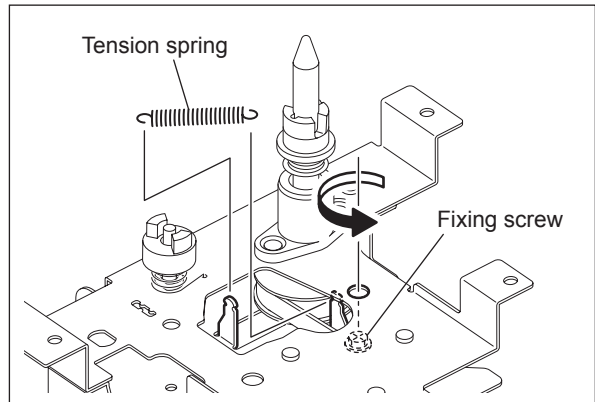

Fig. 10-7



- (8) Remove 3 screws. Take off the main motor drive unit front bracket while removing the timing belt, gear, pin and bushing.

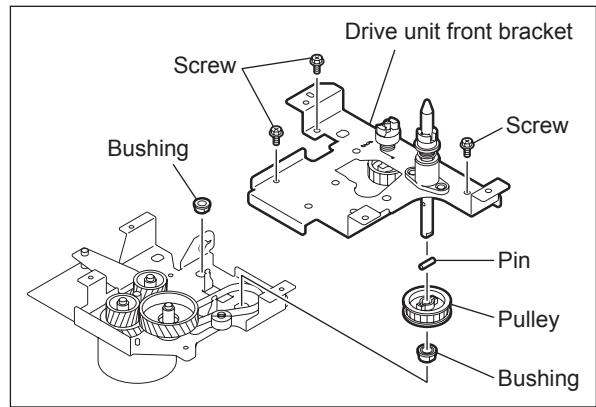

Fig. 10-8

- (9) Take off the gear and timing belt from the main motor drive unit rear bracket.

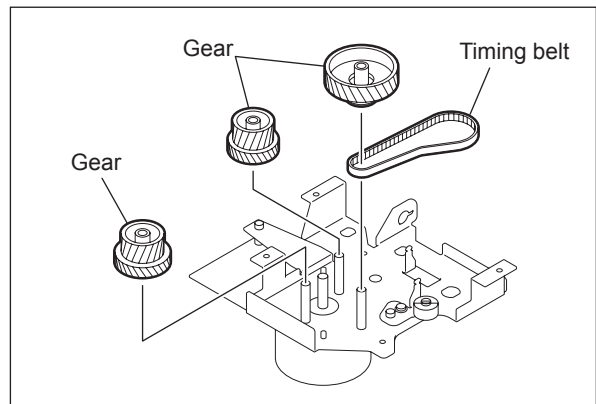

Fig. 10-9

**Note:**

When assembling the main motor drive unit, assemble it while the fixing screw is loosened. Then hook the tension spring and tighten the fixing screw of the tensioner.

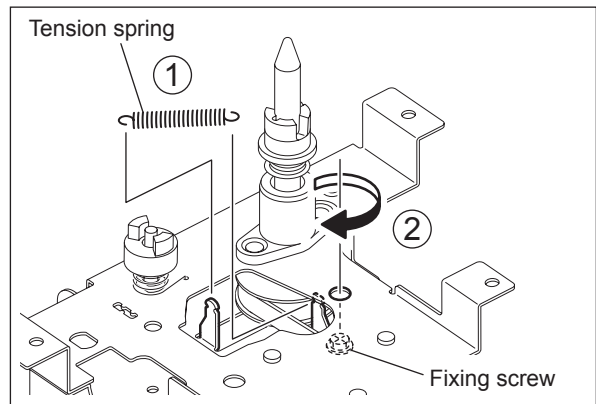



Fig. 10-10

### [C] Toner motor

- (1) Take off the main motor drive unit  
( P.10-5 "[B] Main motor drive unit").
- (2) Remove 1 screw, and take off the toner motor.

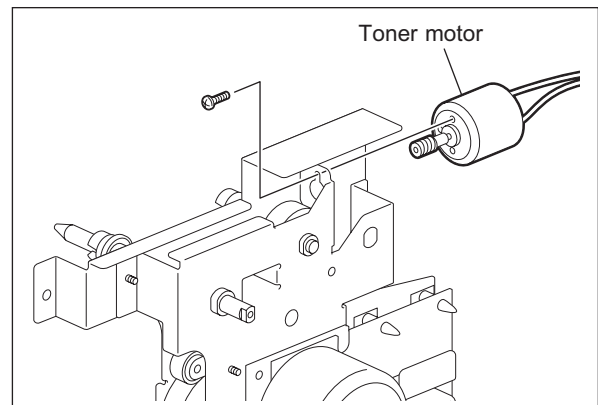

Fig. 10-11

# 11. DRUM RELATED SECTION

## 11.1 Configuration

This chapter explains about the area around the drum, drum itself, image processing, their parts and control circuits.

This area mainly consists of the following components:

- Drum cleaner unit
  - Drum
  - Main charger
  - Cleaner
    - Cleaning blade
    - Toner recovery blade
    - Toner recovery auger
  - Discharge LED
- Transfer / Separation charger
  - Transfer guide
  - Transfer charger
  - Separation charger
- Exhaust fan
- Drum thermistor (📖 P.12-1 "12. DEVELOPMENT SYSTEM")
- High-voltage transformer
- Temperature/humidity sensor
- Internal cooling fan

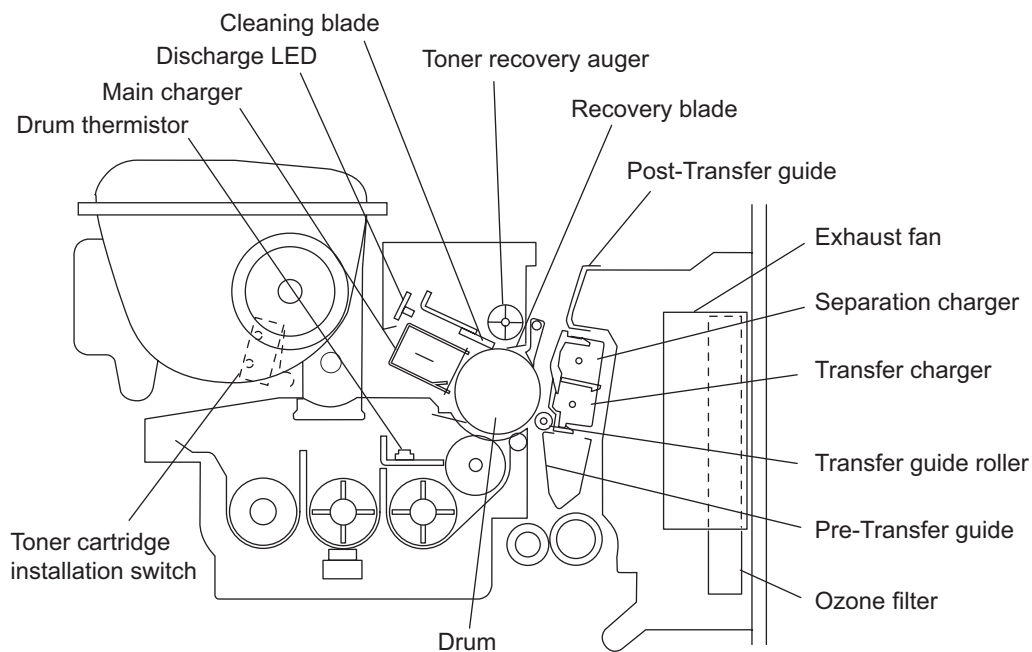

Fig. 11-1

## 11.2 Functions

### 1) Drum

The drum is made of a cylindrical aluminum base coated with thin film of organic photoconductive substance.

The photoconductive object becomes insulative (the electrical resistance is high) when it is not exposed to the light and electrically conductive (the electrical resistance is low) when it is exposed to the light. This object is called a photoconductor.

### 2) Main charger

The main charger in this equipment consists of a metal rod with U-shaped section, insulated blocks at both ends of the rod and a needle electrode attached between them.

When a high voltage is applied to the needle electrode, the air around it is charged (ionized). The ionized air then flows into the drum causing it to be charged. This phenomenon is called "corona discharge". At the same time, a control bias is applied to the main charger grid to control the charging amount.

In a dark place, negative charge is evenly applied onto the drum surface by the corona discharge and this grid. In addition, a cleaner is installed to clean up the dust attached on the needle electrode.

#### - Needle electrode

The needle electrode has aligned needles and their points perform the corona discharge. These points (electrodes) discharge toward the drum in one direction to realize the more efficient discharging comparing to the charger wire which discharges in a radial direction. Therefore, the needle electrode enables to reduce the ozone amount.

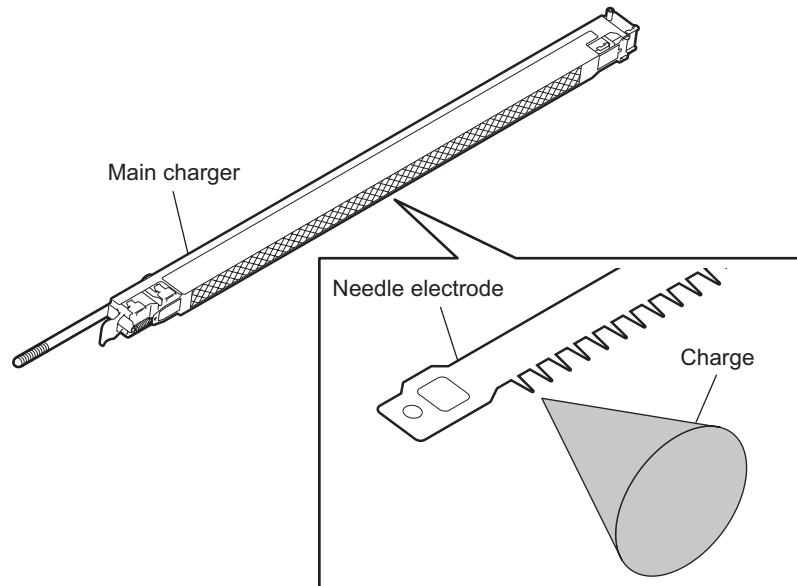

Fig. 11-2

- 3) Drum cleaner
  - Cleaning blade  
This blade is pressed against the drum surface and scrapes off the residual toner from the drum surface.
  - Recovery blade  
This blade catches the toner scraped off by the cleaning blade.
  - Toner recovery auger  
This auger carries the residual toner scraped off to the developer unit and reuses the toner.
- 4) Transfer/Separation charger
  - Transfer guide  
This guide leads the paper transported from the feeding unit to the transfer section. Positive (+) bias voltage is applied to the registration roller and post-transfer guide to prevent the transferability from being lowered under conditions such as high humidity.
  - Transfer charger  
The transfer charger applies a charge (positive (+) charge) which is contrary to the charging polarity of the toner to the back of the paper. The toner image is transferred electrostatically on the paper by performing this corona discharge.
  - Separation charger  
After the transfer process, the corona discharge applies a negative charge (DC) on the back of the paper to separate the paper adhering to the drum surface by an electrostatic force.
- 5) Exhaust fan  
The exhaust fan cools down the inside of the equipment. The air to exhaust includes the ozone generated by the corona discharge, and this ozone is removed by the ozone filter. The exhaust fan also helps the paper separation by absorbing the paper to post-transfer guide.
- 6) Discharge LED  
Discharging is a process to decrease or eliminate the electrical potential of the drum surface. The electrical resistance of the photosensitive layer is decreased by the light irradiation, and the residual charge on the drum surface is neutralized and eliminated. The electrical potential of the drum surface is fixed to a certain amount before the drum is charged.
- 7) Drum thermistor  
The drum thermistor detects the drum surface temperature, and thus each rotation speed of the exhaust fan and internal cooling fan-1 is controlled when the equipment is in the ready status.
- 8) High-voltage transformer  
This is a board to generate the output control voltage of the main charger, main charger grid, transfer charger, separation charger, developer bias and pre/post-transfer guide bias.
- 9) Temperature/Humidity sensor  
This sensor and drum thermistor detect the temperature and humidity inside of the equipment since the drum, developer material and paper are affected by environmental elements such as temperature or humidity. Thus the main charger grid, transfer/separation charger, transfer guide bias, developer bias, laser output and auto-toner output are controlled to be at their optimum states.
- 10) Internal cooling fan-1  
This fan cools down the inside of the equipment, drum cleaning unit and developer unit.

## 11.3 High-Voltage Transformer Output Control Circuit

### 11.3.1 General description

The high-voltage transformer is controlled by the ON/OFF signal of each bias output from the ASIC on the LGC board, reference voltage  $V_c$  output through D/A converter, etc. The high-voltage transformer then generates the output current/voltage of each bias according to the +24V voltage (+24VD2) input.

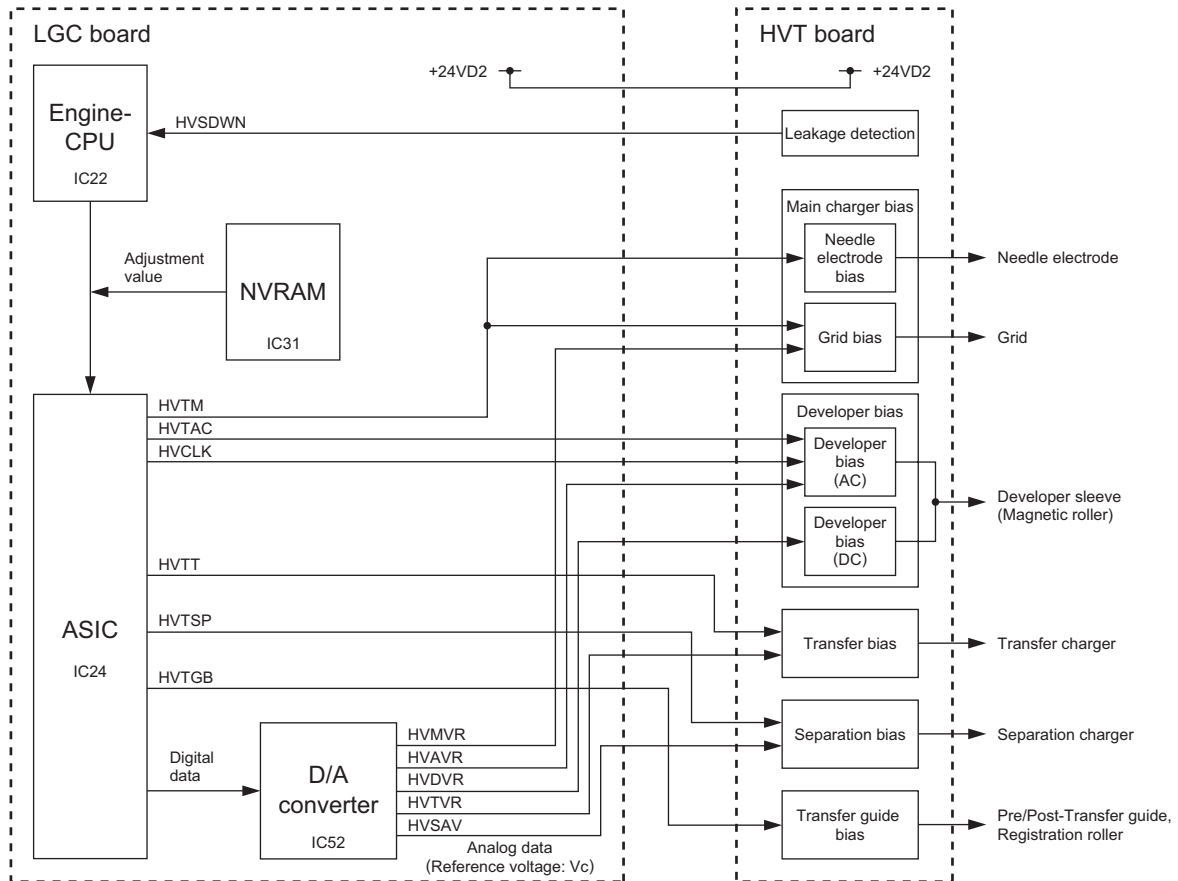

Fig. 11-3

## 11.3.2 Description of Operation

The function and operation of each signal is as follows.

### **ON/OFF signal (HVTM / HVTAC / HVTT / HVTGB / HVTSP):**

ON/OFF signals are for each output of the main charger (needle electrode / grid), developer bias (AC), transfer charger, transfer guide bias and separation charger. When these signals become "L" level, the generation circuit of each bias on the high-voltage transformer turns ON to generate an output current/voltage.

- \* The negative DC component of the developer bias is turned ON/OFF by switching a reference voltage (HVDVR) separately. The positive DC component of the developer bias is output only when the reference voltage (HVDVR) is under 0.6 V and also the developer bias (AC) ON/OFF signal (HVTAC) is ON.

### **Reference voltage Vc (HVMVR / HVAVR / HVDVR / HVTVR / HVSAV):**

The reference voltage is an analog voltage which is the reference of each output of the main charger grid, developer bias (AC/DC), transfer charger and separation charger. Each output of the high-voltage transformer can be linearly changed by switching these reference voltages.

The output operation of the reference voltage is as follows.

- Outputs the adjustment values of the main charger, transfer charger, separation charger and developer bias in the NVRAM to ASIC.  
↓
  - Outputs the reference voltage data from the ASIC to a D/A converter.  
↓
  - Outputs the reference voltage Vc of each bias to the high-voltage transformer.  
↓
  - The high-voltage transformer generates the output current/voltage which is proportional to the reference voltage.
- \* The reference voltage Vc is adjusted in the Adjustment Mode (05).
  - \* The output values of the main charger (needle electrode) and transfer guide bias are fixed when the high-voltage transformer is shipped from the factory.

### **Developer bias (AC) generation clock (HVCLK):**

This clock signal is a reference of AC component of the developer bias.

### **High-voltage transformer leakage detection signal (HVSDWN):**

This signal is for the abnormality (leakage) detection of the high-voltage transformer output. This signal becomes "L" level at the occurrence of abnormality.

## 11.4 Drum Temperature Detection Circuit

### 11.4.1 General description

If the temperature of the drum and its surrounding area becomes too high, the property of the toner which is recovered by the drum cleaner easily changes. To prevent this, the drum thermistor detects the surface temperature of the drum. Based on the result, it controls the exhaust fan and internal cooling fan-1 to cool down the inside of the equipment.

### 11.4.2 Construction

The configuration of the drum surface temperature detection circuit is shown below. The input voltage from the drum thermistor is converted by an A/D converter in the Engine-CPU on the LGC board. The drum thermistor is a device whose resistance decreases as the temperature rises. Namely, the input voltage to the Engine-CPU becomes smaller along with the rise of the temperature.

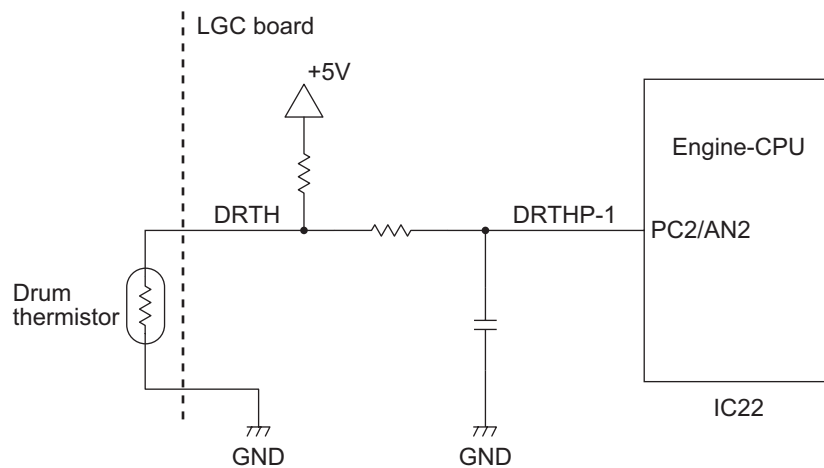

Fig. 11-4



## 11.5 Temperature/Humidity Detection Circuit

### 11.5.1 General description

To prevent a deterioration of printing quality by the variation of the temperature and humidity where the equipment is installed, the temperature/humidity sensor detects the temperature and humidity of the outside air taken into the equipment. Based on the result of the detection, this circuit corrects each output of main charger bias, developer bias, transfer bias and separation bias, output of the auto-toner sensor and output of the laser.

### 11.5.2 Construction

The configuration of the temperature/humidity detection circuit is shown below. The analog-signal voltage output from the temperature/humidity sensor is converted by the A/D converter in the Engine-CPU on the LGC board. The higher the temperature is, the higher the output voltage of this sensor becomes, and the higher the humidity is, the higher the output voltage of this sensor becomes.

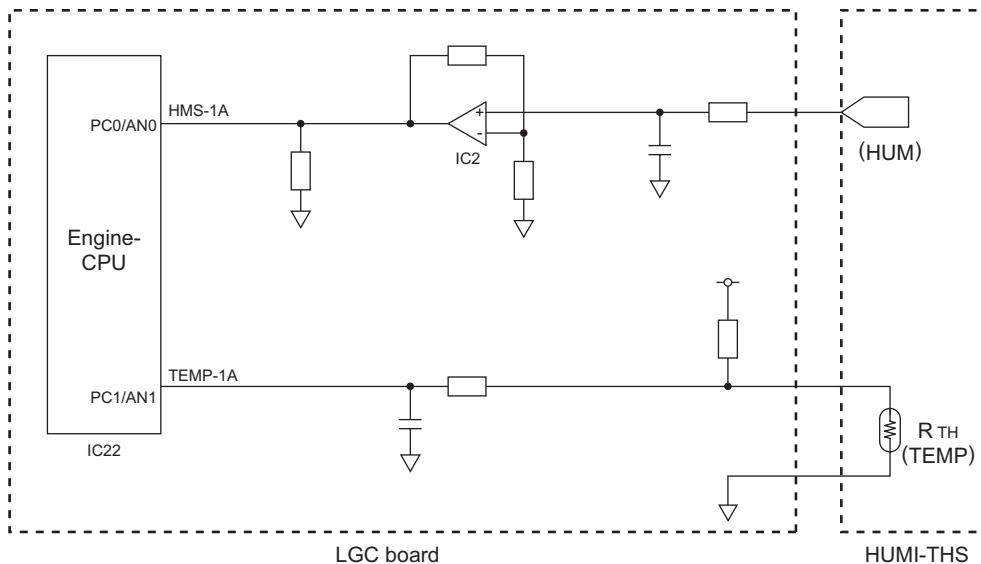

Fig. 11-5

## 11.6 Disassembly and Replacement

### [A] Process unit

- (1) Open the bypass tray, ADU and transfer cover.
- (2) Open the front cover and take off the toner cartridge.
- (3) Disconnect 1 connector. Loosen 2 screws and pull out the process unit.

**Note:**

When installing the process unit, make sure that the connector (harness) is not caught under the developer unit.

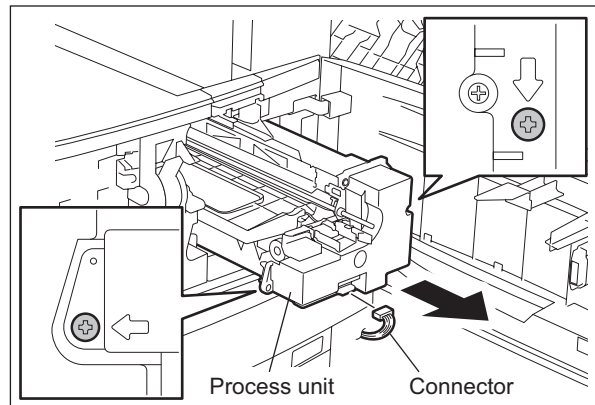



Fig. 11-6

## [B] Drum cleaner unit

- (1) Take out the process unit  
( P.11-8 "[A] Process unit").
- (2) Disconnect 2 connectors and remove 2 screws.
- (3) Release 1 latch. Then pull out the process unit front cover and take it off.

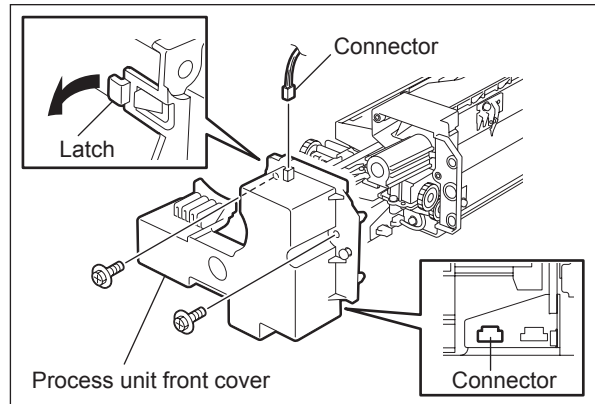

Fig. 11-7

### Note:

When installing the process unit front cover, wire the harness correctly in order not to contact the gears and harness of the process unit front cover each other.

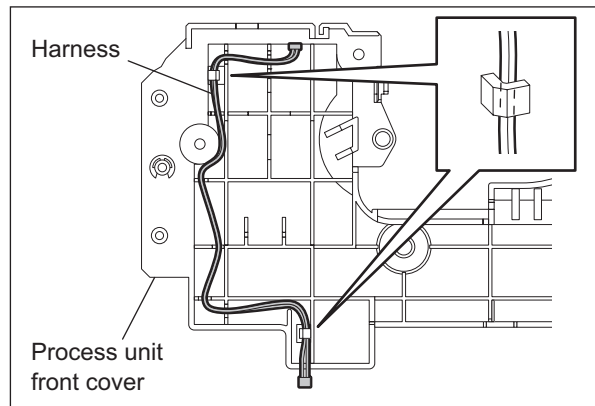

Fig. 11-8

- (4) Lift up the drum cleaner unit and take it off.

**Notes:**

1. Be careful not to touch or scratch the drum surface at this time.

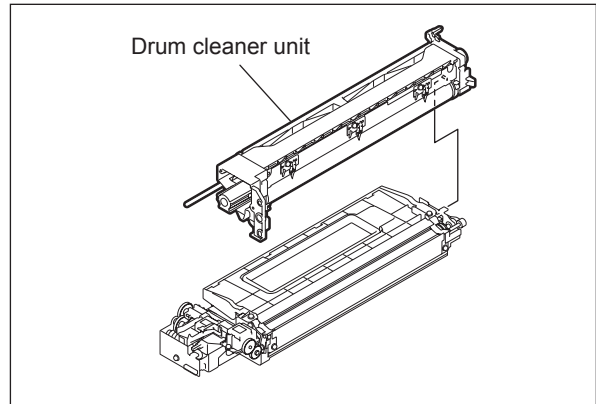

Fig. 11-9

2. Do not deform the Guide Mylar by touching this.

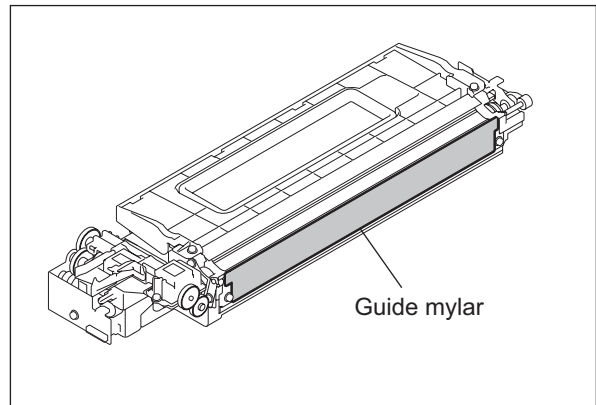

Fig. 11-10

**[C] Discharge LED**

- (1) Take off the drum cleaner unit (P.11-9 "[B] Drum cleaner unit").
- (2) Release 1 latch and take off the discharge LED unit.

**Note:**

Be careful not to touch or scratch the drum surface at this time.

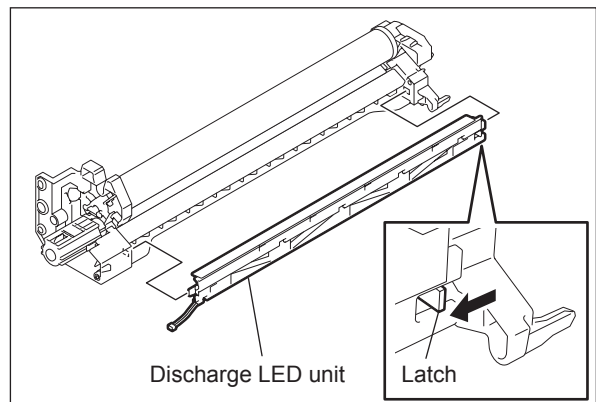

Fig. 11-11

- (3) Release the harness from the harness clamp and pull out the discharge LED.

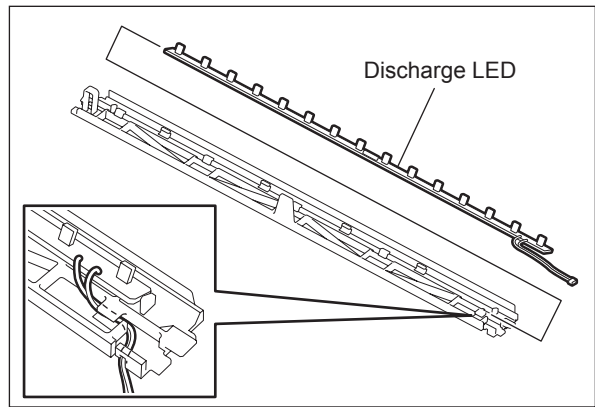

Fig. 11-12

#### [D] Main charger

- (1) Take off the discharge LED unit (P.11-10 "[C] Discharge LED").
- (2) Pull out the main charger and take it off by sliding it to the rear side.

**Note:**

Be careful not to touch or scratch the drum surface at this time.

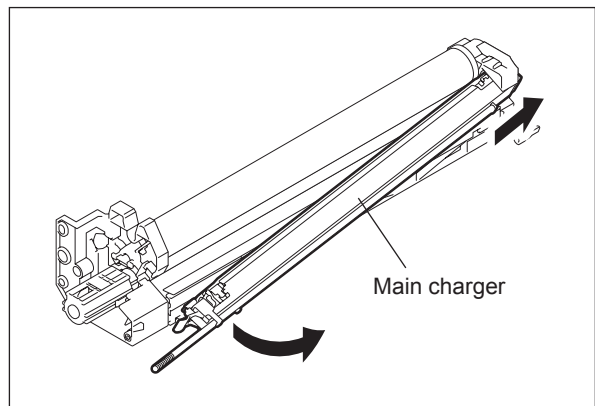

Fig. 11-13

#### [E] Main charger grid

- (1) Take off the main charger (P.11-11 "[D] Main charger").
- (2) Remove the spring and take off the main charger grid.

**Note:**

Do not touch the mesh area of the grid.

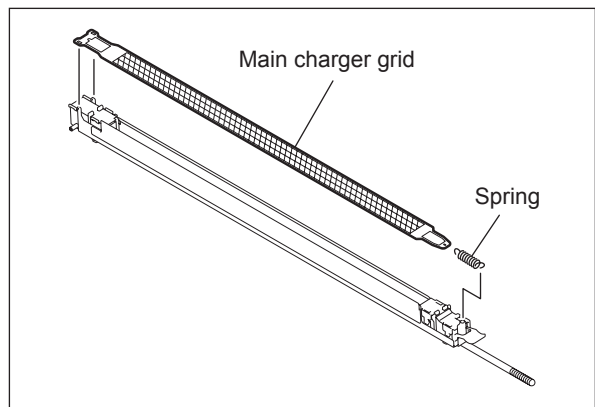



Fig. 11-14

## [F] Main charger cleaner

- (1) Take off the main charger  
( P.11-11 "[D] Main charger").
- (2) Release the hook of the cleaning shaft. Then rotate the shaft at 90 degrees to take it off.

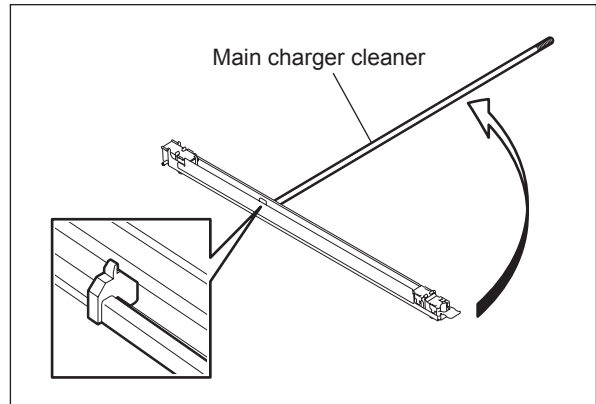



Fig. 11-15

## [G] Needle electrode

- (1) Take off the main charger grid and main charger cleaner  
( P.11-11 "[E] Main charger grid",  
 P.11-12 "[F] Main charger cleaner").
- (2) Take off the terminal covers of both front and rear sides.

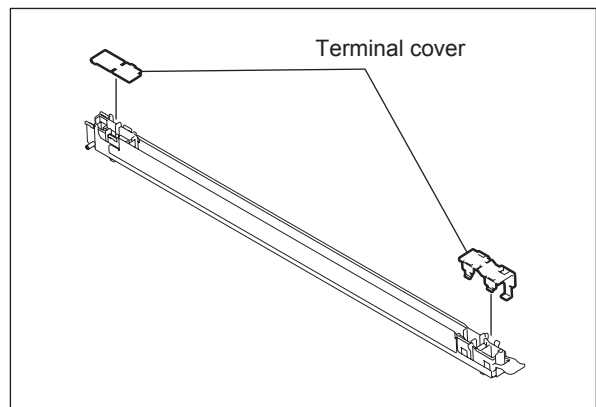

Fig. 11-16

- (3) Remove the terminal and spring. Then take off the needle electrode.

### Notes:

1. Do not touch the needle electrode directly with bare hands.
2. Make sure not to hold or bend the needle electrode.

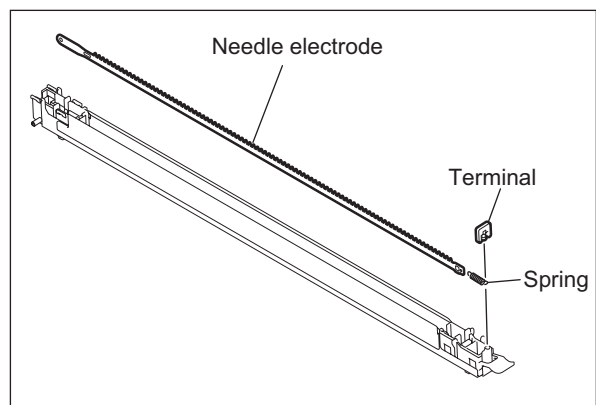



Fig. 11-17

## [H] Drum

- (1) Take off the main charger  
( P.11-11 "[D] Main charger").
- (2) Rotate the lever while pushing its latch and pull it out.
- (3) Take off the drum.

### Notes:

1. Be careful not to touch, spit or scratch the drum surface.
2. Avoid direct light. Place the drum in a dark place immediately after taking off.
3. Be careful not to touch or scratch the edge of the cleaning blade.

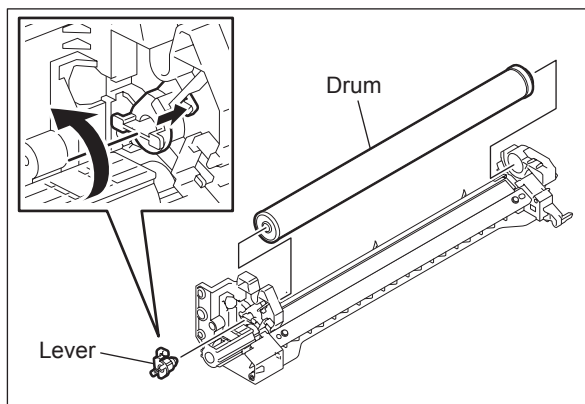



Fig. 11-18

## [I] Drum cleaning blade

- (1) Take off the drum  
( P.11-13 "[H] Drum").
- (2) Remove 2 screws and take off the drum cleaning blade.

### Note:

Be careful not to touch or scratch the edge of the drum cleaning blade.

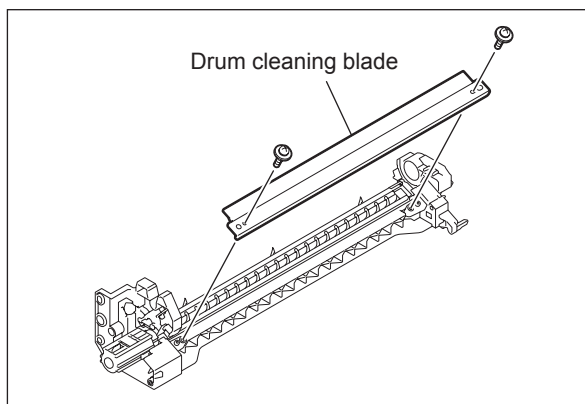



Fig. 11-19

## [J] Drum separation finger

- (1) Take off the drum  
( P.11-13 "[H] Drum").
- (2) Remove 1 screw of each unit to take off the drum separation finger units (3 pc.).

### Notes:

1. When replacing the drum separation fingers, make sure that the drum has been taken off first since the fingers may scratch the drum surface.
2. In e-STUDIO202L/203L/232/233/232S/282/283/282S/283S, 2 drum separation finger units are installed.

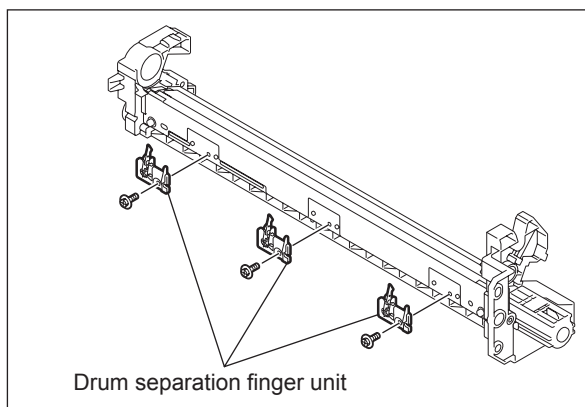

Fig. 11-20

- (3) Remove the spring and take off the drum separation fingers.

### Note:

When the drum separation fingers have been replaced, check if the pressure movement is normal by moving them with your hands.

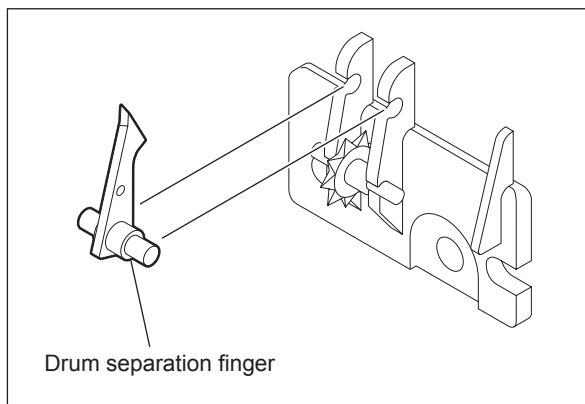



Fig. 11-21

## [K] Recovery blade

- (1) Take off 3 drum separation finger units  
( P.11-14 "[J] Drum separation finger").
- (2) Remove 2 screws, and take off the whole recovery blade with the bracket.

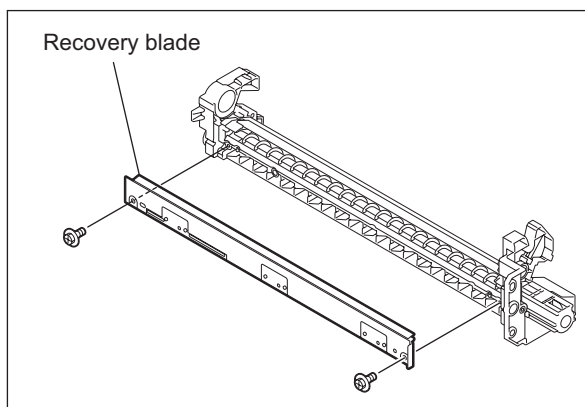

Fig. 11-22



## [L] Ozone filter

- (1) Open the bypass tray and ADU.

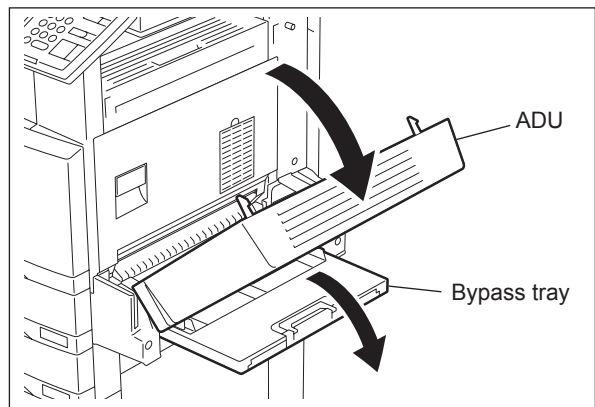

Fig. 11-23

- (2) Remove 1 screw and take off the ozone filter cover.
- (3) Take off the ozone filter.

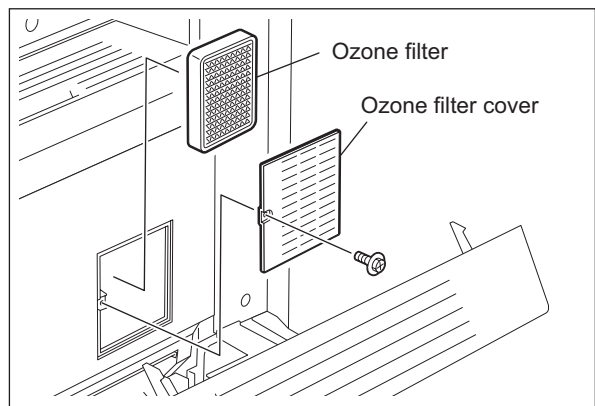

Fig. 11-24

## [M] Transfer/Separation charger

- (1) Open the bypass tray, ADU and transfer cover.
- (2) Release the latch and take off the transfer and separation chargers.

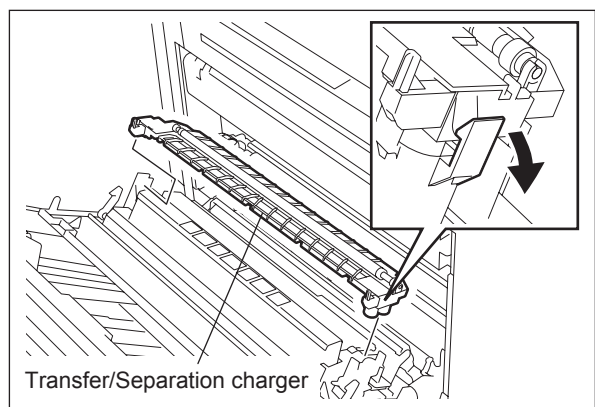



Fig. 11-25

**[N] Charger wire** 

\* Length: 353 mm (tungsten wire), diameter: 0.06 mm

- (1) Take off the transfer/separation charger  
( P.11-15 "[M] Transfer/Separation charger").
- (2) Release 9 latches and take off the separation supporter.

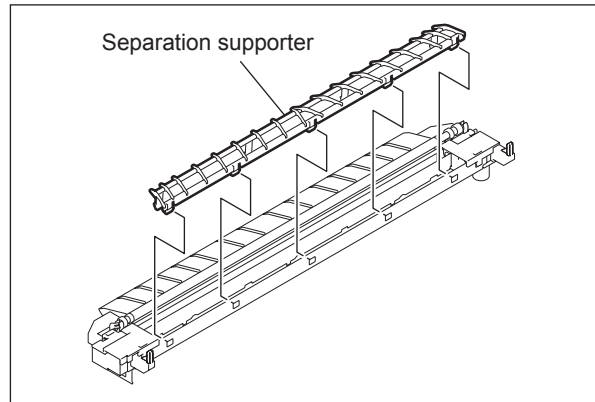

Fig. 11-26

- (3) Release 2 latches and take off the terminal cover on the front side.
- (4) Release 1 latch and take off the terminal cover on the rear side.

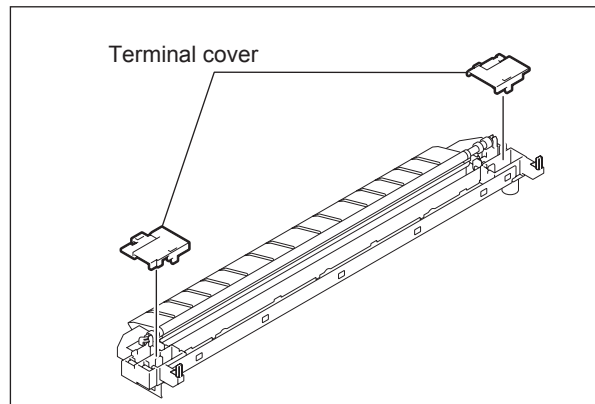

Fig. 11-27

- (5) Remove the terminal and spring. Then take off the transfer charger wire.
- (6) Remove the cushioning material, disconnect the terminal and remove the spring. Then take off the separation charger wire.

**Notes:**

1. Insert the wire securely into the V-grooves of the front and rear sides.
2. Do not twist the wire.
3. Do not touch the wire directly with bare hands.

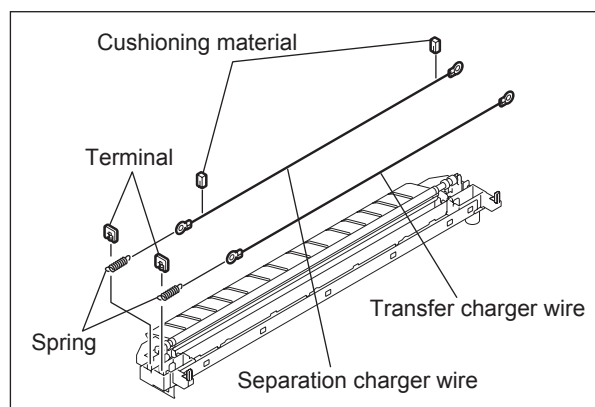

Fig. 11-28

## [O] Transfer unit

### Note:

When taking off the transfer unit, take off the process unit first to prevent the drum from light.

- (1) If the ADU is not installed, take off the right front hinge cover, the right rear hinge cover and the bypass upper cover (see P.2-38 "[P] Right front hinge cover", P.2-39 "[Q] Right rear hinge cover", P.2-39 "[R] Bypass upper cover").  
If the ADU is installed, take off the ADU (see P.15-10 "[A] Automatic Duplexing Unit (ADU)").
- (2) Take off the bypass unit (see P.9-17 "[G] Bypass unit").
- (3) Release 1 latch and take off the transport guide.

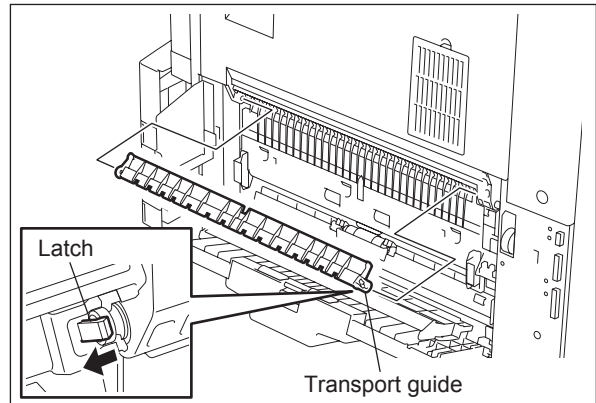

Fig. 11-29

- (4) Open the transfer unit and disconnect 5 connectors.

### Note:

When installing the unit, do not connect the connectors in the wrong places.

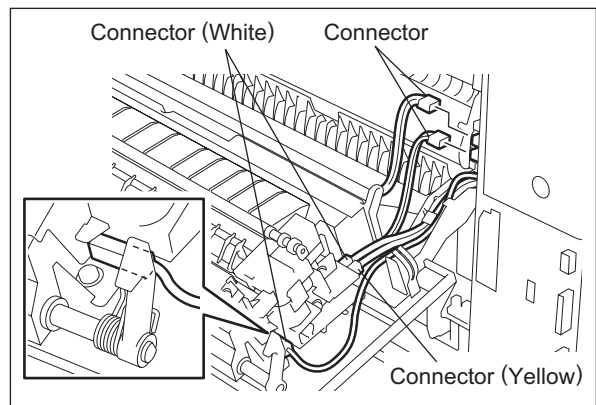

Fig. 11-30

- (5) Slide the transfer unit to the rear side to displace the supporting point on the front side. Then take off the transfer unit.

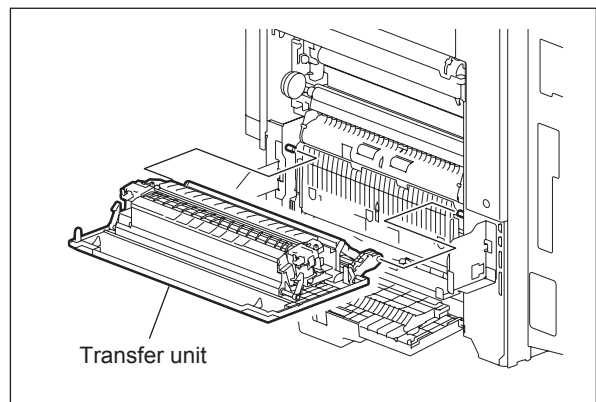



Fig. 11-31

## [P] 1st transport sensor

- (1) Take off the transfer unit  
( P.11-17 "[O] Transfer unit").
- (2) Extend the holder part to release the hook of the protrusion.
- (3) Rotate the guide and lift it up to take off.

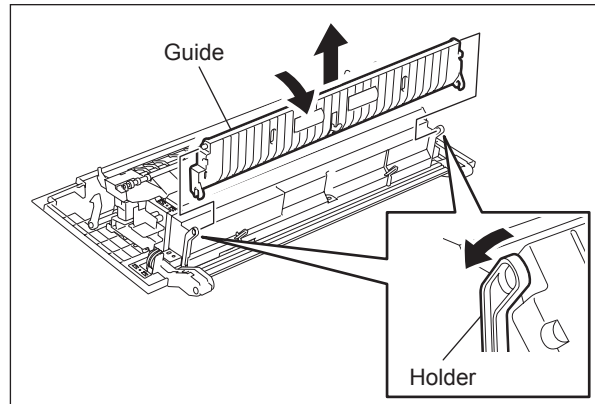

Fig. 11-32

- (4) Disconnect 1 connector, release the latch, and then take off the 1st transport sensor.

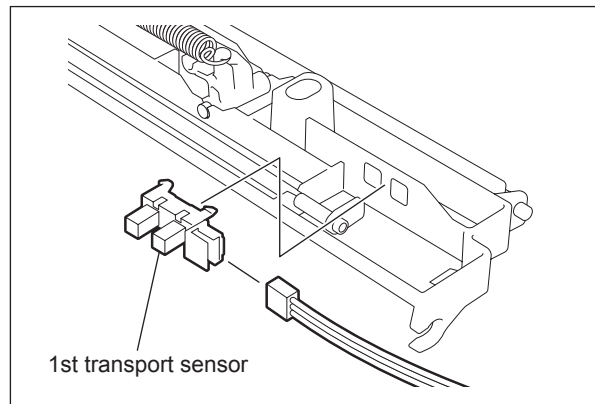





Fig. 11-33

## [Q] Exhaust fan

- (1) Take off the ozone filter  
( P.11-15 "[L] Ozone filter").
- (2) Take off the transfer/separation charger ( P.11-15 "[M] Transfer/Separation charger").
- (3) Take off the transfer unit  
( P.11-17 "[O] Transfer unit").
- (4) Take off the guide  
( P.11-18 "[P] 1st transport sensor").
- (5) Remove the plate spring.

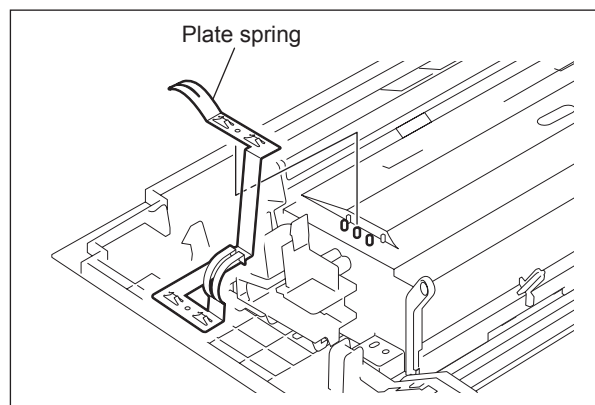

Fig. 11-34

- (6) Remove 2 springs and 5 screws.
- (7) Take off the case while pulling the opening/closing lever.

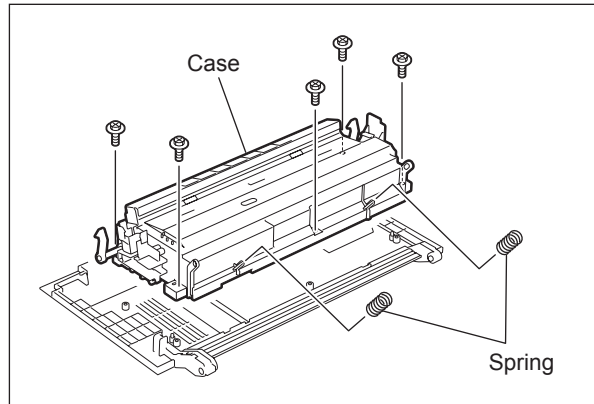

Fig. 11-35

- (8) Remove 2 screws and take off the duct.

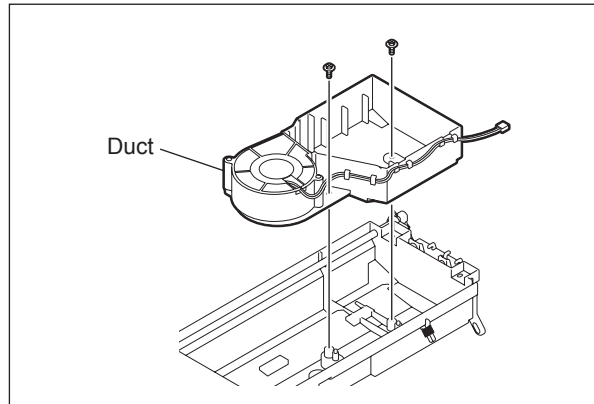

Fig. 11-36

- (9) Remove the two-sided tape and take off the exhaust fan.

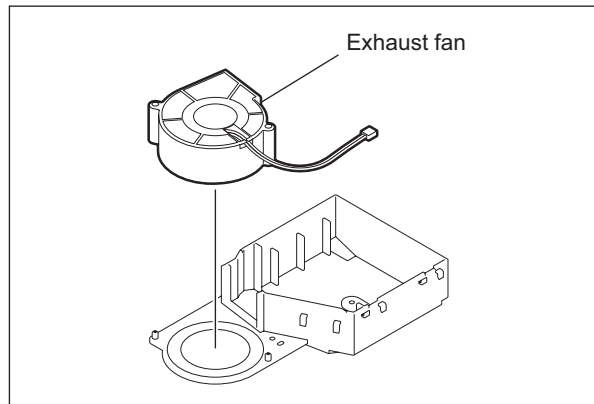



Fig. 11-37

## [R] Temperature/humidity sensor

- (1) Take off the inner tray  
( P.2-35 "[K] Inner tray").
- (2) Lift the duct and disconnect 1 connector.

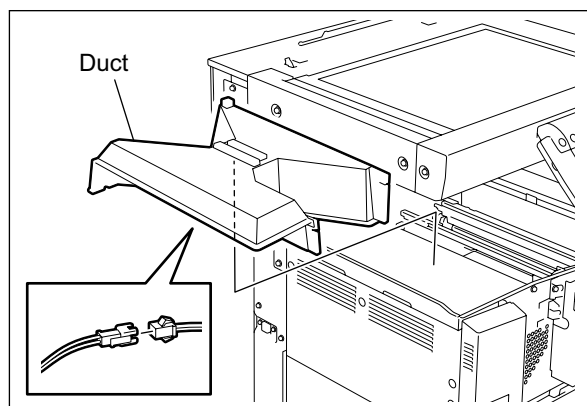

Fig. 11-38

- (3) Disconnect 1 connector, remove 1 screw and take off the temperature/humidity sensor cover.

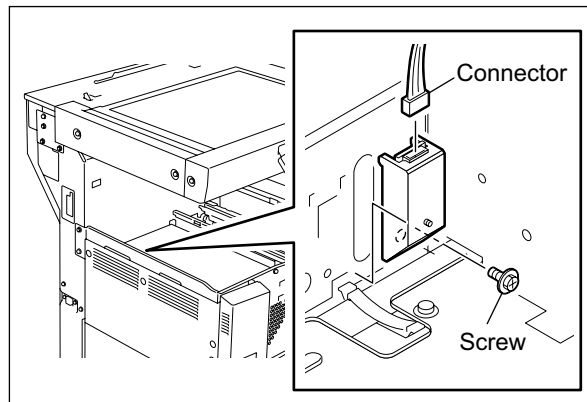

Fig. 11-39

- (4) Remove 1 screw and take off the temperature/humidity sensor.

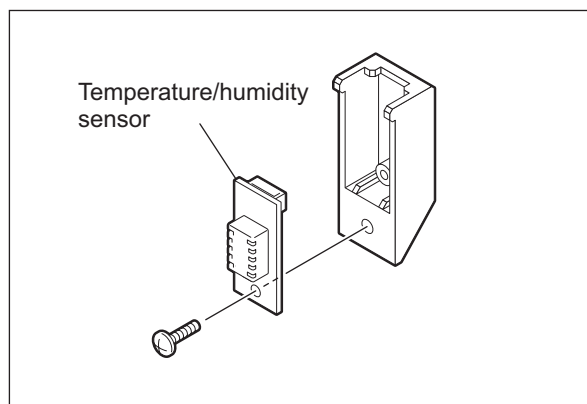

Fig. 11-40

## 12. DEVELOPMENT SYSTEM

### 12.1 Configuration

The developer unit in this equipment has a recovered toner supply mechanism which recovers the recovered toner scraped off by the drum cleaning blade and recycles the recovered toner. The developer unit is driven by the main motor to rotate the mixers and developer sleeve.

Development system consists of the following unit, components and control circuits.

- Toner cartridge drive unit / Toner cartridge installation switch
- Temperature/humidity sensor ( P.11-1 "11. DRUM RELATED SECTION")
- Developer unit
  - Developer material
  - Mixers -1, -2 and -3
  - Developer sleeve (magnetic roller)
  - Doctor blade
  - Auto-toner sensor
  - Drum thermistor ( P.11-1 "11. DRUM RELATED SECTION")
  - Recovered toner supply mechanism (paddle, toner recycling auger)
  - Toner recovery roller

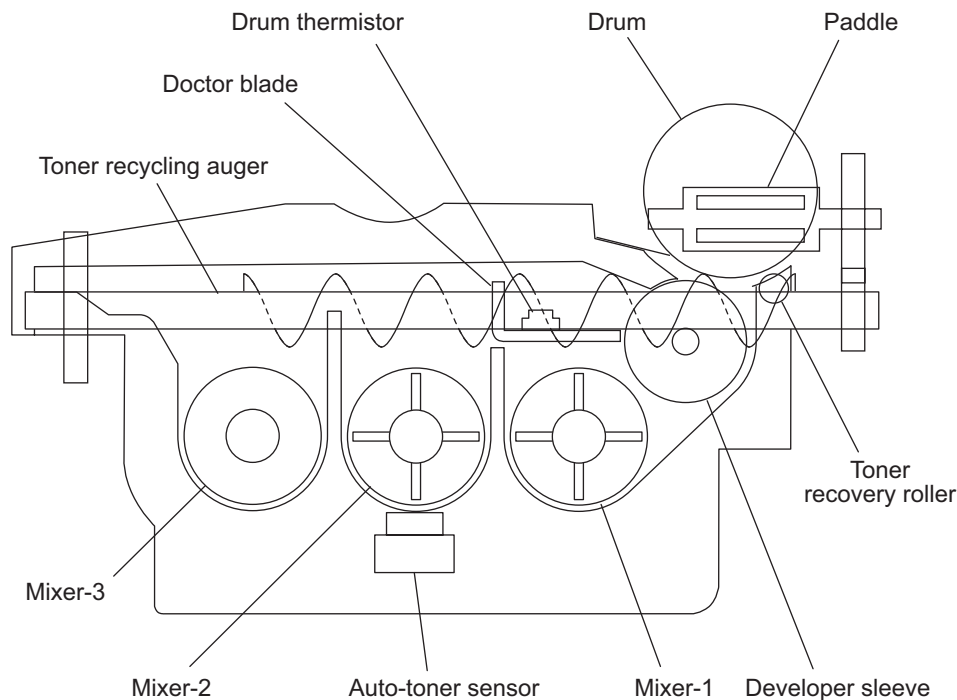

Fig. 12-1

## 12.2 Functions

### 12.2.1 General description

#### 1) Toner cartridge drive unit / Toner cartridge installation switch

The toner cartridge is filled with toner. The toner motor drives the cartridge to supply the toner to the developer unit.

The toner cartridge installation switch detects whether the toner cartridge is installed.

#### 2) Developer unit

##### - Developer material

The developer material is made of a mixture of the carrier and toner.

The carrier is an electrical conductive ferrite whose size is 30  $\mu\text{m}$  to 100  $\mu\text{m}$ . The toner is a resin particle whose size is 5  $\mu\text{m}$  to 20  $\mu\text{m}$ .

The developer material needs periodic replacement since its quality is deteriorated by long use.

##### - Mixers-1, -2 and -3

Friction is generated by mixing the developer material. The carrier is charged to (+) and the toner to (-), and the image is formed on the drum surface by the static electricity caused by the friction. The mixer-3 is mounted exclusively for the recovered toner to mix it with sufficient time.

##### - Developer sleeve (Magnetic roller)

This is an aluminum roller with a magnet inside. The magnet works to absorb the developer material and forms the magnetic brush. The magnet is fixed and only the sleeve around is rotated. This rotation makes the magnetic brush of the developer sleeve sweep over the drum surface and perform development.

##### - Doctor blade

Doctor blade controls the amount of the developer material transported by the developer sleeve so that the magnetic brush of the developer material contacts with the drum surface properly.

##### - Auto-toner sensor

The carrier and the toner (toner density) in the developer material should be always fixed to a certain ratio to output normal images. The auto-toner sensor detects the inclusion ratio of the toner in the developer material by using a magnetic bridge circuit. When the quantity of toner becomes insufficient, the toner motor is driven to supply the toner from the toner cartridge.

##### - Recovered toner supply mechanism

The recovered toner transported from the drum cleaner is transported into the developer unit by the paddle and the toner recycling auger on the front side of the developer unit. The drive of the toner recycling auger is transmitted by the mixer-3.



## 12.2.2 Recovered toner supply mechanism

The toner scraped off by the drum cleaning blade is transported by the toner recovery auger, paddle and toner recycling auger to be recycled, and then returned to the developer unit. Then the recovered toner in the developer unit is mixed with developer material by the mixer-3. The mixer-3 is mounted exclusively for the recovered toner to mix it with sufficient time.

On the other hand, the toner (fresh) transported into the developer unit from the toner cartridge is mixed by the mixer-2. Then the toner (fresh) and recovered toner are mixed together and further transported to the mixer-1. They are further mixed and transported to the developer sleeve by the mixer-1.

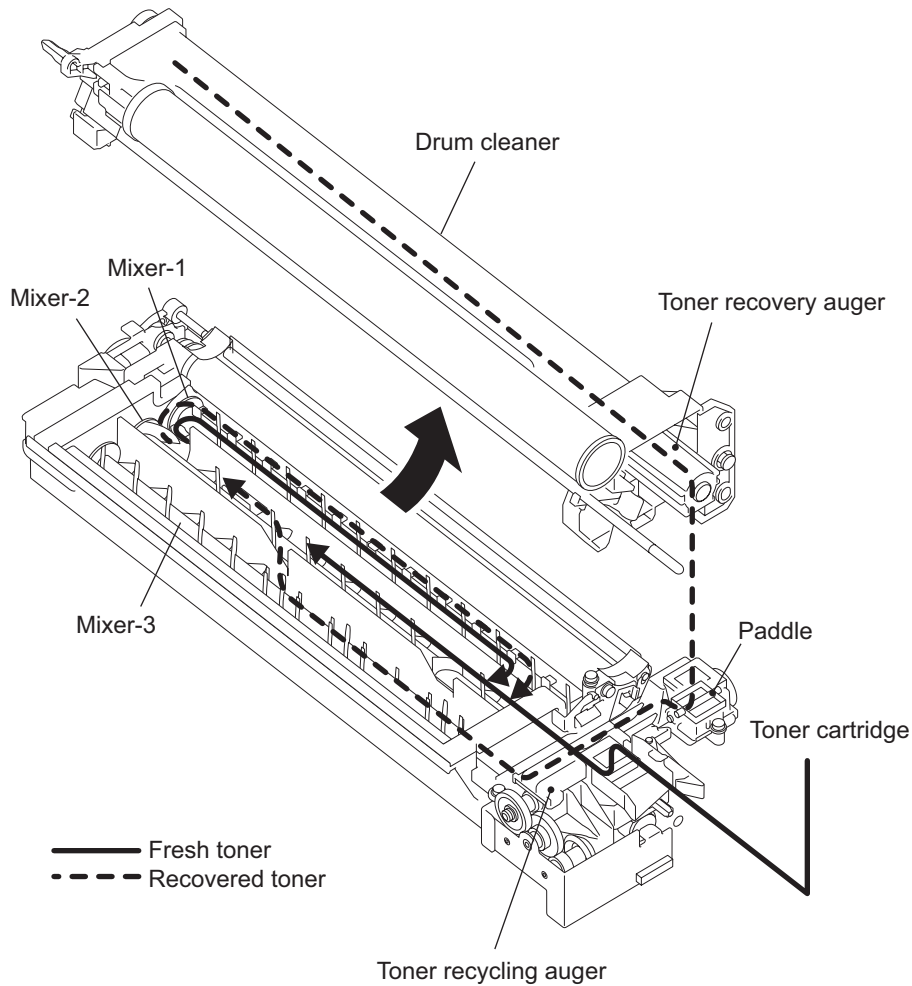

Fig. 12-2

## 12.3 Drive Circuit of Toner Motor

The toner motor (brush motor) is a motor to supply toner from the toner cartridge to the developer unit. The toner is driven by the motor driver TA8428 (LGC board: IC1).

Circuit diagram of the toner motor

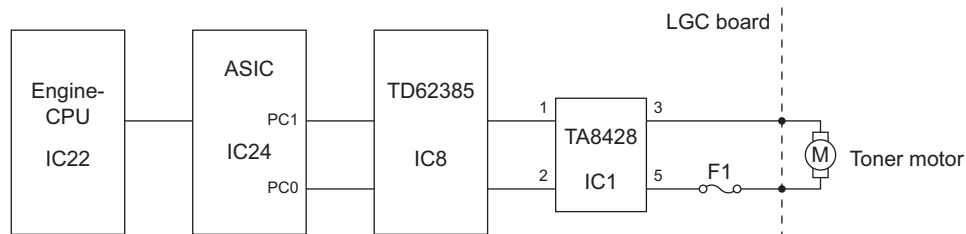

Fig. 12-3

The motor rotates or stops by the control signals from ASIC.

- When the PC1 (TNRM-1A) of the ASIC becomes “H” and PC0 (TNRM-0A) becomes “L” levels, current flows into the motor coil and the motor is rotated.
- When both of PC1 (TNRM-1A) and PC0 (TNRM-0A) of the ASIC become “H” level, the motor is braked and stopped.
- When both of PC1 (TNRM-1A) and PC0 (TNRM-0A) of ASIC become “L” level, the motor waits for the next command (the motor is stopped).

The block diagram of TA8428 and the operation of the control logic are shown below.

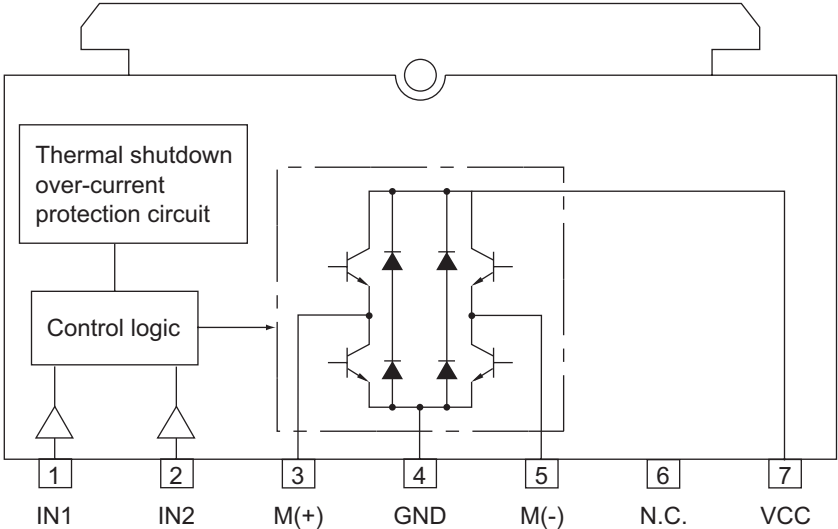

Fig. 12-4

| Input |     | Output                  |       | State |
|-------|-----|-------------------------|-------|-------|
| IN1   | IN2 | M (+)                   | M (-) |       |
| H     | H   | L                       | L     | Brake |
| L     | H   | L                       | H     | CCW   |
| H     | L   | H                       | L     | CW    |
| L     | L   | OFF<br>(High impedance) |       | Stop  |

## 12.4 Auto-Toner Circuit

### 12.4.1 General description

1) Function of the auto-toner circuit

- Detects the toner density in the developer material, and supplies toner when the density is lowered to a certain level.
- Detects that there is no toner left in the cartridge (toner-empty detection).

2) The auto-toner circuit consists of the following:

- Auto-toner sensor:  
Detects the toner density.
- Control section:  
Controls the toner density so that the toner in the developer material is fixed to certain ratio.
- Toner motor:  
Supplies toner to the developer material.
- LCD panel:  
Indicates toner-empty information.

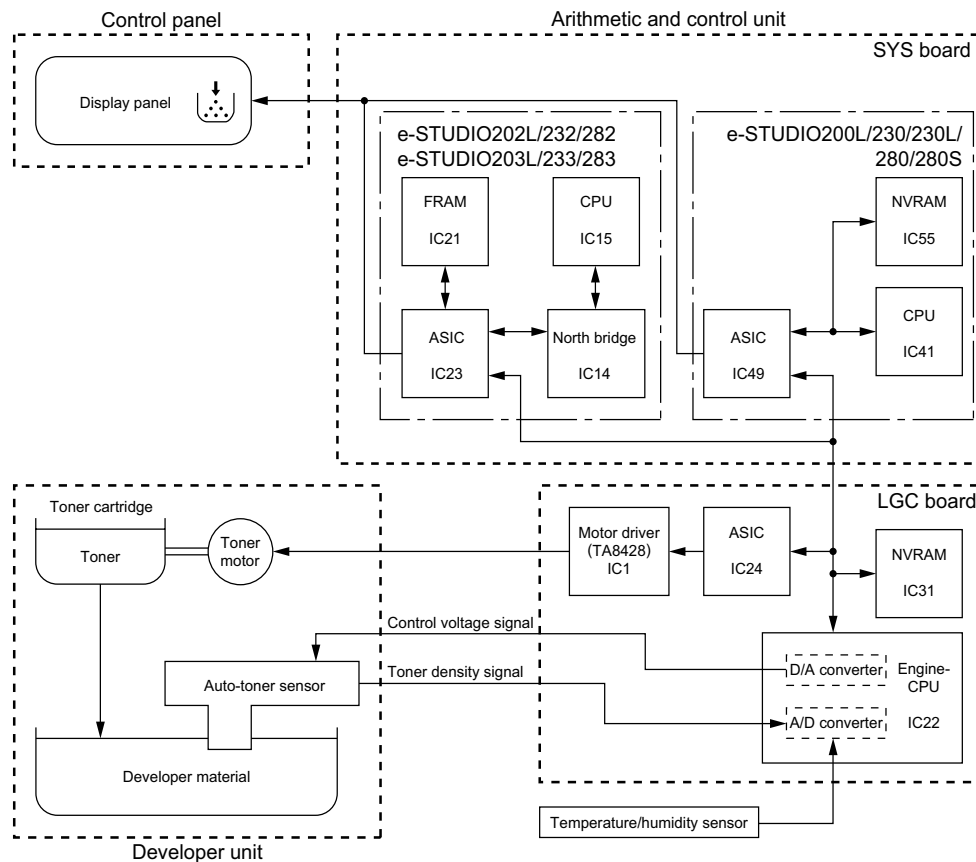

Fig. 12-5

## 12.4.2 Function of auto-toner sensor

### 1) Function

- Initialization adjustment function - At the first use of the equipment or when the developer material is replaced with a new one.

Automatically adjusts the output value of the auto-toner sensor responding to humidity (input value to the engine CPU) for the toner density of the new developer material so that it stays in range of 2.34 to 2.46 V.

- Stabilizing the toner density - During the printing operation  
Maintains the toner density to a certain ratio as follows.

Toner is consumed.

→ The toner density is lowered.

→ Change in the auto-toner sensor output responding to humidity is detected.

→ The toner motor is driven.

→ Toner is supplied from the toner cartridge to the developer unit.

- Toner-empty detection and recovery:

Detects that there is no toner in the toner cartridge:

The toner motor is driven.

→ The auto-toner sensor output does not change.

→ The toner density does not change.

→ It is determined there is no toner in the cartridge (toner empty).

Recovering from the toner-empty state:

The toner motor is driven.

→ Toner is supplied from toner cartridge.

→ The auto-toner sensor output changes.

→ The toner density returns to normal value.

→ The toner-empty state is cleared.

## 2) Function of auto-toner sensor

- The auto-toner sensor consists of the following circuits:

### Drive winding:

A magnetic head (primary side) with a high-frequency magnetic field, which forms a magnetic circuit in the developer material.

### Detection winding:

Receives the change in the magnetic resistance of the developer material through the magnetic circuit (secondary side).

### DC conversion circuit:

Converts a high-frequency output from the detection winding into a DC signal (auto-toner output  $V_{ATS}$ ).

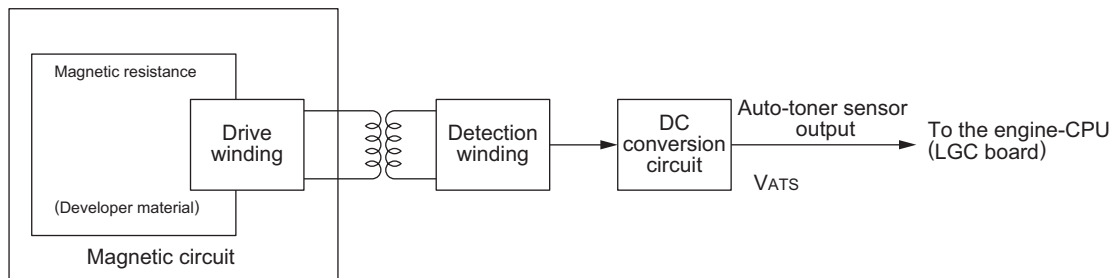

Fig. 12-6

- When the toner density is low

The ratio of the toner against the carrier in the developer material decreases.

- The magnetic resistance decreases.
- The detection output increases.
- The auto-toner output  $V_{ATS}$  increases.

- When the toner density is high

The ratio of the toner against the carrier in the developer material increases.

- The magnetic resistance increases.
- The detection output decreases.
- The auto-toner output  $V_{ATS}$  decreases.

## 12.5 Disassembly and Replacement

### [A] Process unit

**Note:**

Make sure to perform "05-280" and take off the process unit before the developer material is replaced.

- (1) Open the bypass tray, ADU and transfer cover.
- (2) Open the front cover and take off the toner cartridge.
- (3) Disconnect 1 connector. Loosen 2 screws and pull out the process unit.

**Note:**

When installing the process unit, make sure that the connector (harness) is not caught under the developer unit.

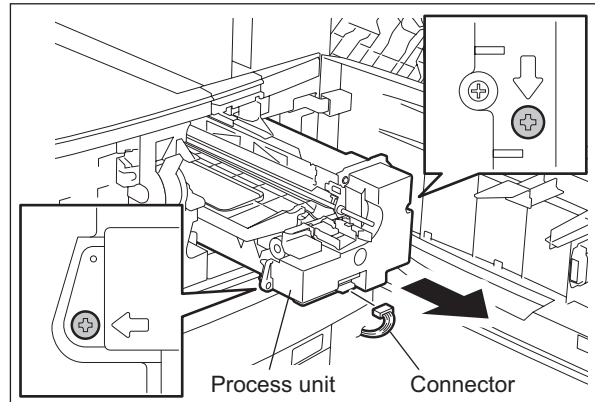



Fig. 12-7

## [B] Developer unit

- (1) Take out the process unit  
( P.12-9 "[A] Process unit").
- (2) Take out the drum cleaner unit from the process unit so that only the developer unit will be left in it  
( P.11-9 "[B] Drum cleaner unit").

### Notes:

1. Be careful not to touch or scratch the drum surface at this time.
2. Do not deform the Guide Mylar by touching this.

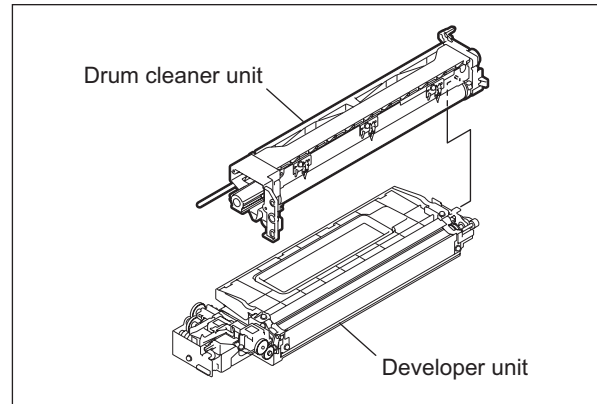

Fig. 12-8

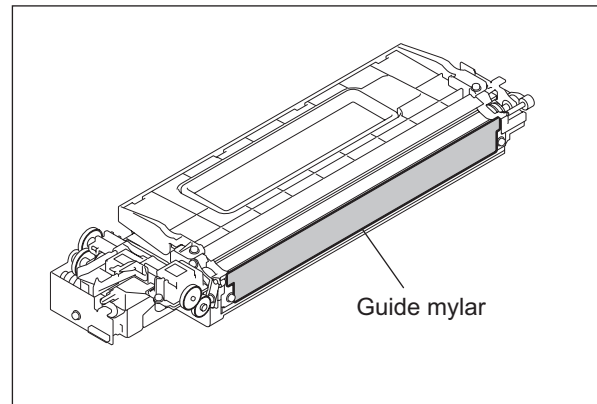



Fig. 12-9

## [C] Removing developer material

- (1) Take out the developer unit  
( P.12-10 "[B] Developer unit").
- (2) Remove 2 screws and slide the developer unit upper cover to the direction of the arrow and take it off.

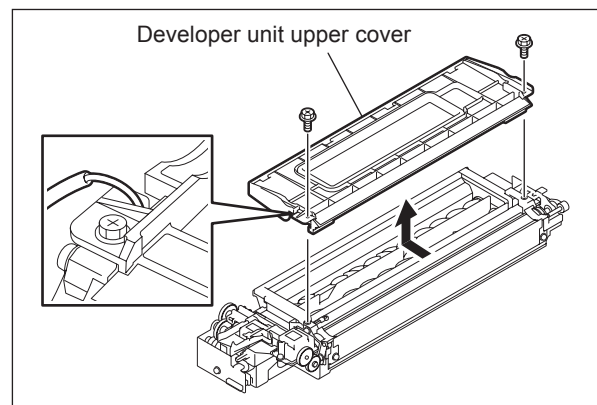

Fig. 12-10



**Note:**

When installing the developer unit upper cover, make sure that the side seal comes between the developer unit upper cover and rubber seal on the cover.

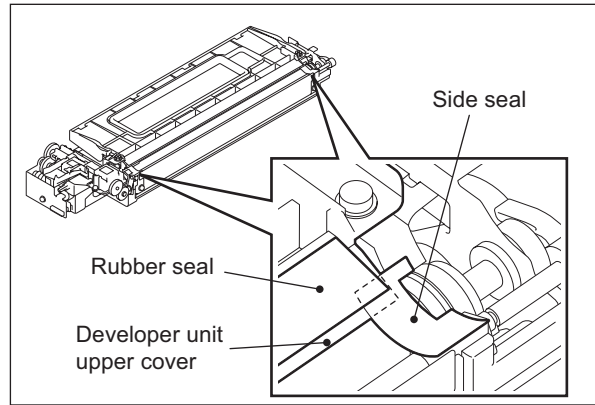

Fig. 12-11

- (3) Remove the developer material from rear side.

**Note:**

When removing the developer material, be careful not to drop the developer material on the gears of the developer unit.

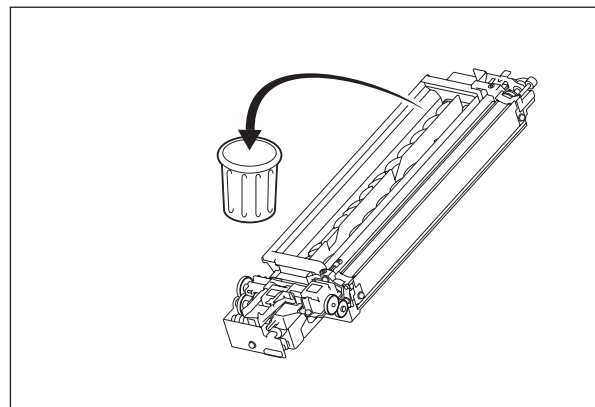

Fig. 12-12

**[D] Filling developer unit with developer material**

- (1) Install the developer nozzle jig on the developer bottle.
- (2) Rotate the gear on the rear side of the developer unit to the direction of the arrow while filling the developer unit with the developer material. Spread out the developer material over the developer sleeve.

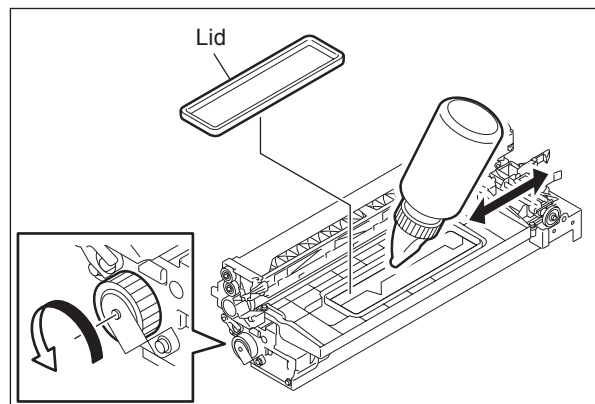

Fig. 12-13

### [E] Auto-toner sensor

- (1) Remove the developer material (P.12-10 "[C] Removing developer material").
- (2) Place the developer unit upside down. Disconnect 1 connector, remove 1 screw, and then take off the auto-toner sensor.

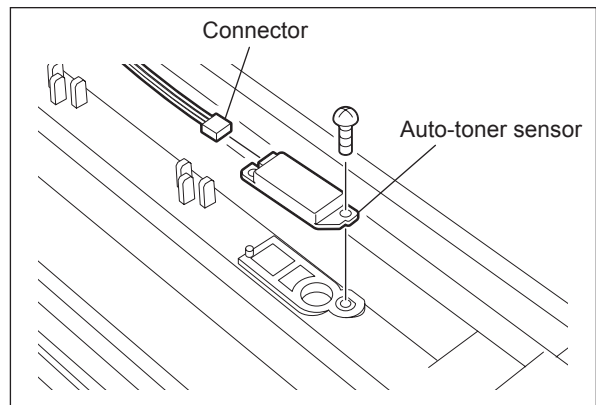

Fig. 12-14

### [F] Drum thermistor

- (1) Remove the developer material (P.12-10 "[C] Removing developer material").
- (2) Disconnect 1 connector, remove 1 screw and take off the drum thermistor.

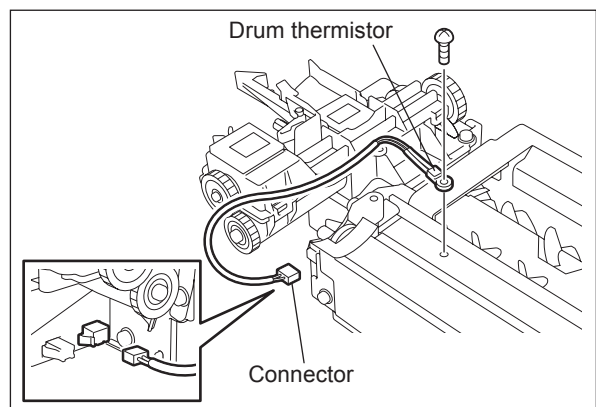
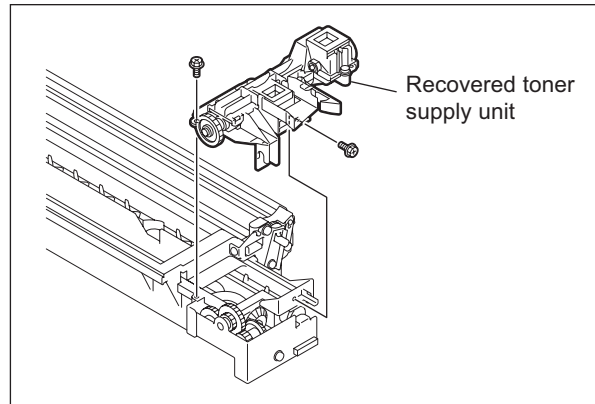

Fig. 12-15

**[G] Guide roller / Developer sleeve**

- (1) Remove the developer material (P.12-10 "[C] Removing developer material").
- (2) Remove 2 screws and take off the recovered toner supply unit.



**Fig. 12-16**

- (3) Remove 1 screw. Disconnect 1 connector while taking off the recovered toner drive unit. Remove 1 gear.

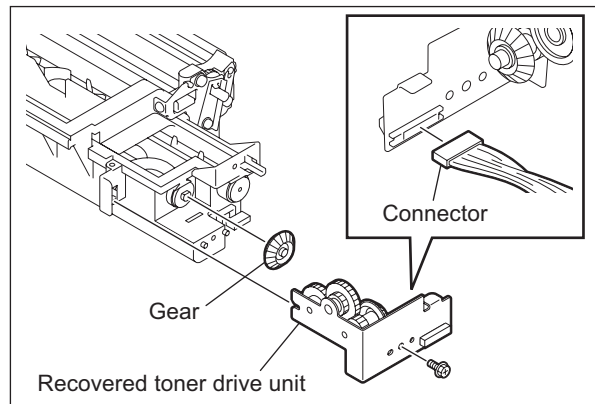

**Fig. 12-17**

- (4) Remove 2 plate springs fixing the doctor sleeve on its both ends.

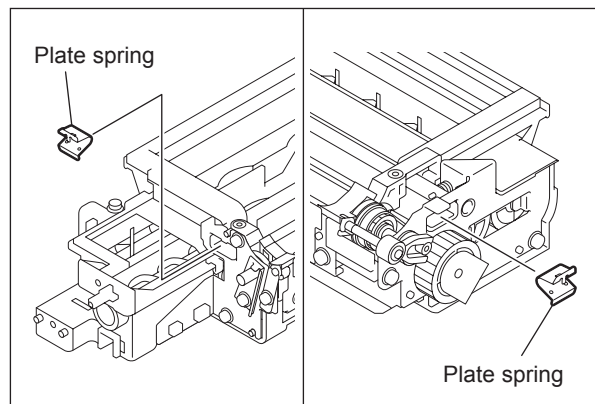

**Fig. 12-18**

- (5) Remove 2 screws on both ends of the doctor sleeve and remove 2 coil springs.

**Note:**

When the screws on both ends of the doctor sleeve are removed, be sure to adjust the doctor sleeve gap ( $0.45 \pm 0.05$  mm) after assembling.

(Refer to Service Handbook Chap. 3.9)

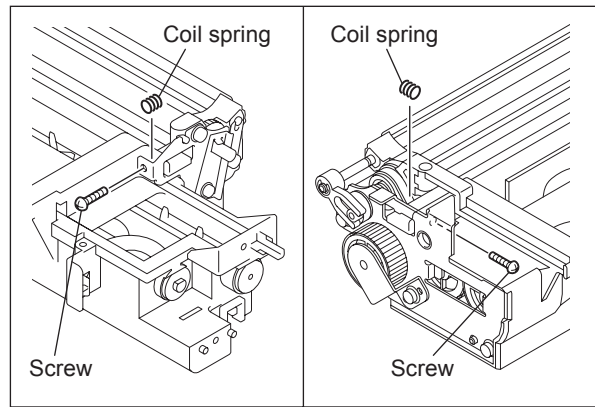

Fig. 12-19

- (6) Remove 1 screw and plate spring.  
(7) Remove 1 screw and take off the polarity adjustment lever.

**Note:**

Make a note of the position where the polarity adjustment lever is pointing. (Mark the position if needed.) When reassembling, match the polarity adjustment lever with the previously marked position on the scale.

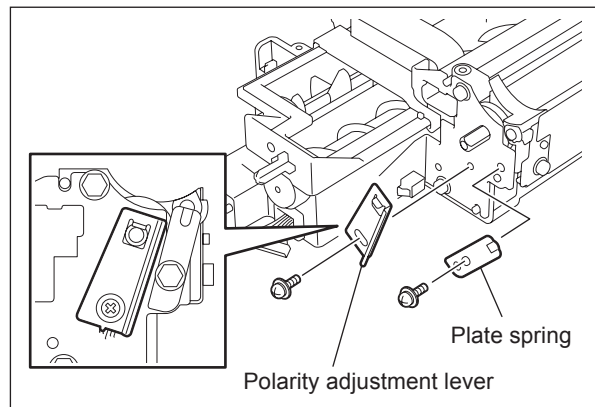

Fig. 12-20

- (8) Remove 2 screws and take off the bracket.

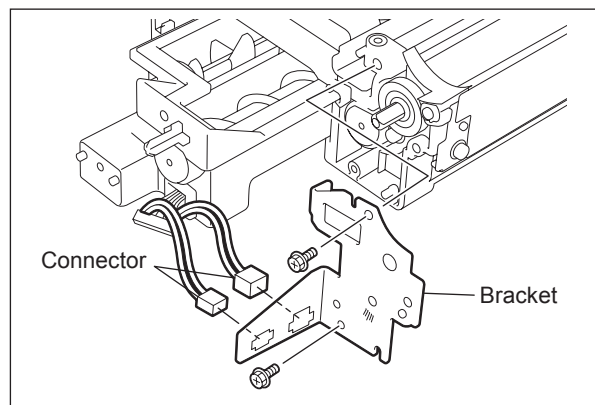

Fig. 12-21

- (9) Remove 1 E-ring and take off the guide roller on the front side.

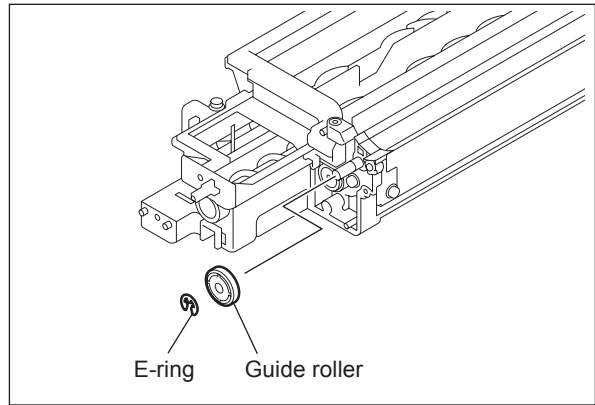

Fig. 12-22

- (10) Remove 1 E-ring. Remove the arm and cam.

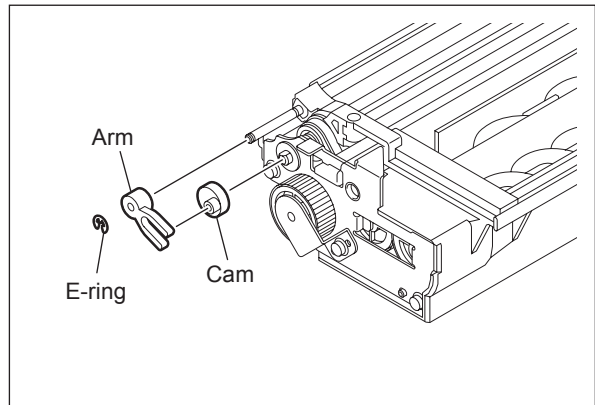

Fig. 12-23

- (11) Remove 1 screw and the gear.

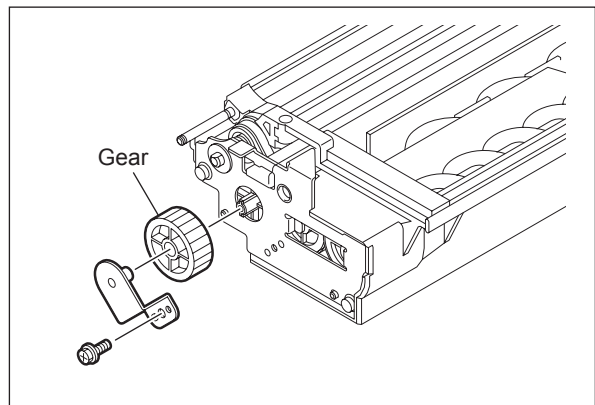

Fig. 12-24

- (12) Remove 2 screws. Take off 1 bearing and the bracket.

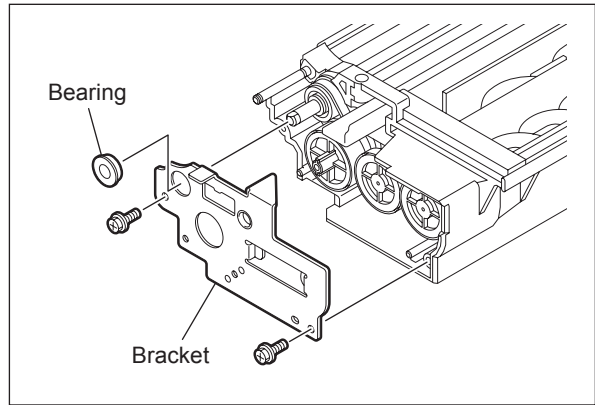

Fig. 12-25

- (13) Take off 3 gears and 1 timing belt.

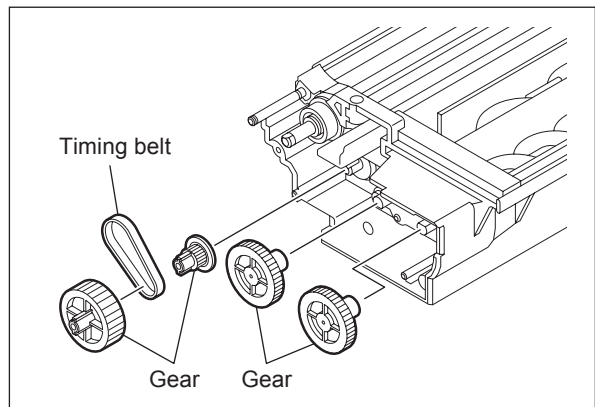

Fig. 12-26

- (14) Remove 1 E-ring, 1 pin and 1 pulley.  
(15) Take off the guide roller on the rear side.

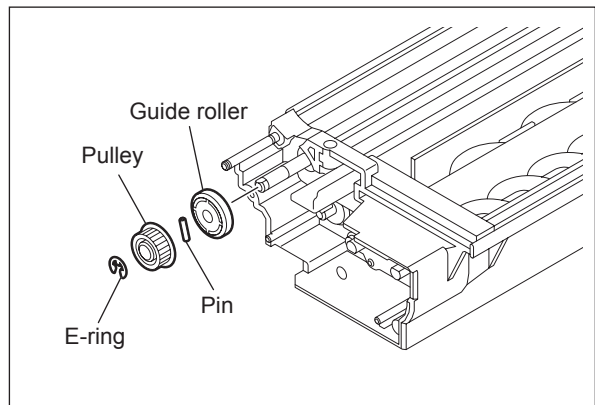

Fig. 12-27

- (16) Remove the seal on the front side. Remove 1 E-ring and 1 bushing.

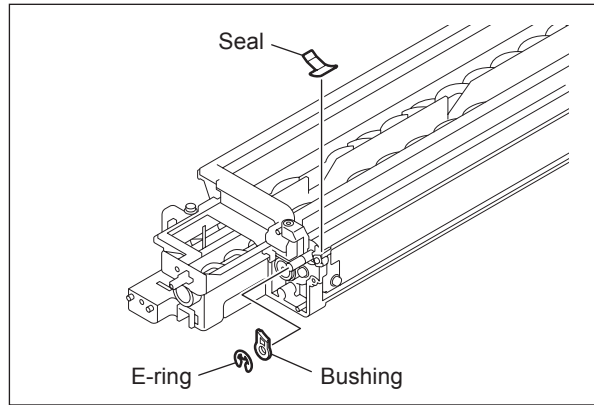

Fig. 12-28

- (17) Take off the developer sleeve.

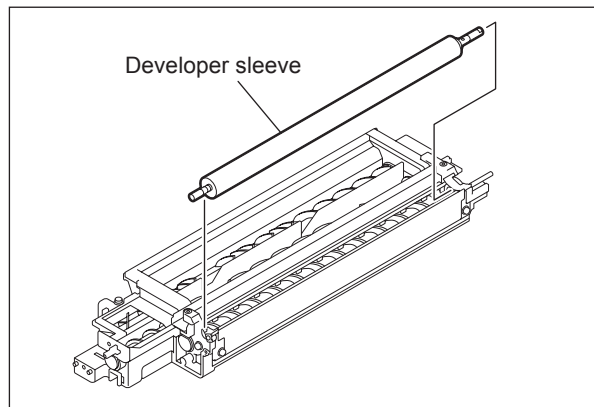



Fig. 12-29

## [H] Mixer

- (1) Take off the developer sleeve  
( P.12-13 "[G] Guide roller / Developer sleeve").
- (2) Take off the doctor sleeve.

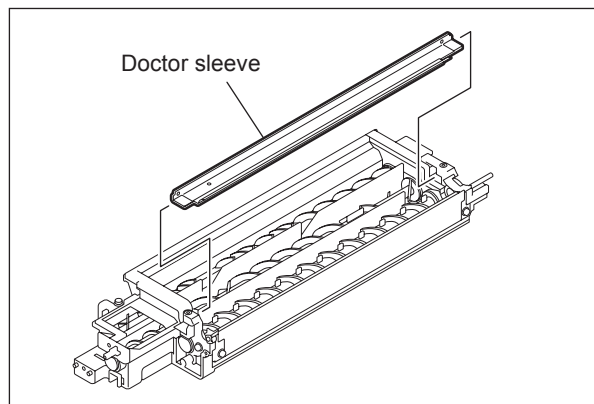

Fig. 12-30

- (3) Remove 1 screw and take off the tensioner bracket.
- (4) Remove 2 screws and take off the holder.

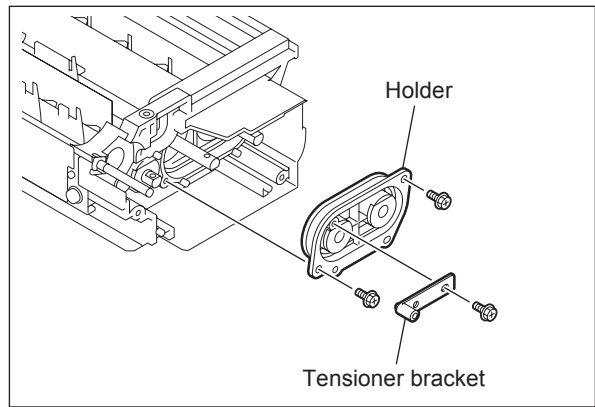



Fig. 12-31

- (5) Remove 2 bushings and 2 oil seals from the holder.  
 (Replacement of Oil Seal:  P.12-20 "[Replacement of Oil Seal]")

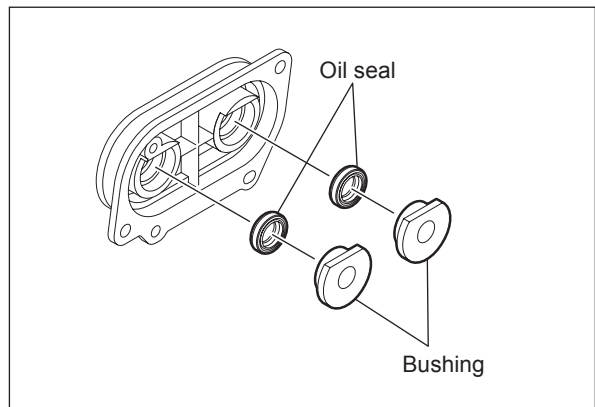

Fig. 12-32

- (6) Take off the mixers-2 and -3.

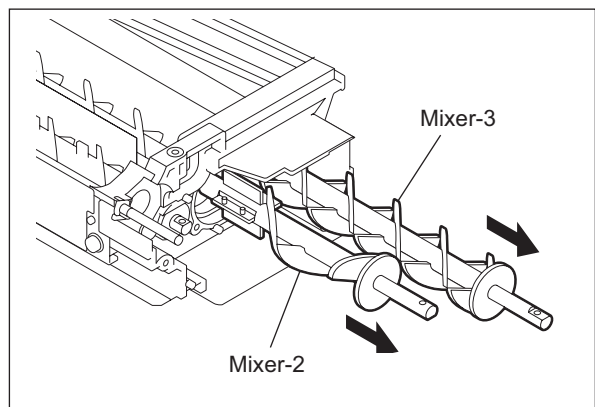



Fig. 12-33



- (7) Remove 2 bushings and 2 oil seals on the rear side.  
 (Replacement of Oil Seal:  P.12-20 "[I] Replacement of Oil Seal")

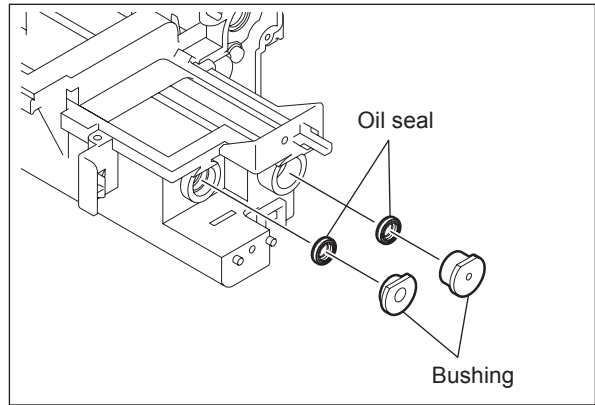



Fig. 12-34

- (8) Remove the end section of the mixer-1.  
 (9) Remove the bushing and oil seal.  
 (Replacement of Oil Seal:  P.12-20 "[I] Replacement of Oil Seal")

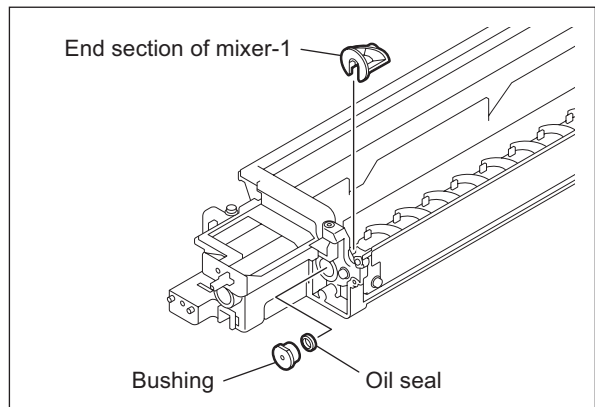

Fig. 12-35

- (10) Take off the mixer-1.

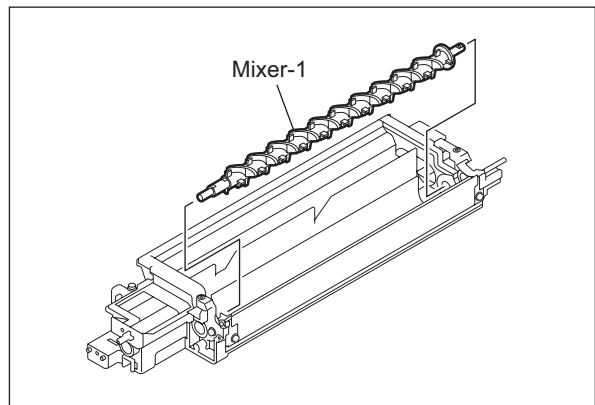



Fig. 12-36

- (11) Remove the bushing on the rear side.
- (12) Remove the oil seal.  
(Replacement of Oil Seal:  P.12-20 "[I] Replacement of Oil Seal")

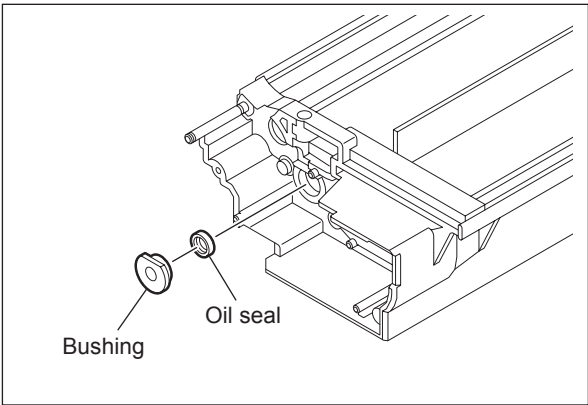

Fig. 12-37

**[I] Replacement of Oil Seal**

- (1) Insert a fine screwdriver into the depression of the oil seal to take it out.
- (2) Push in a new oil seal parallel to the frame or bushing (shown figure at right).
- (3) Apply the grease (Alvania No.2; amount of 2 rice grains) on entire surface of the oil seal evenly.

**Note:**  
Wipe off the excessive grease.

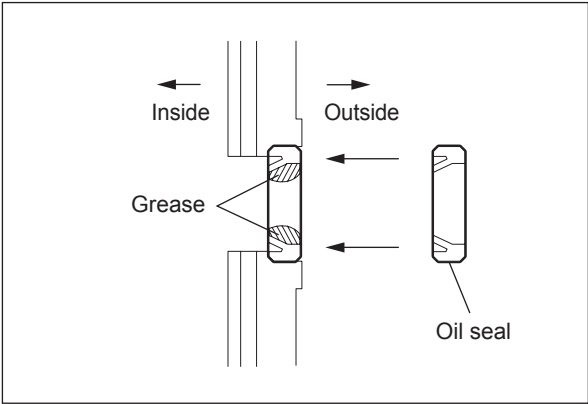

Fig. 12-38

## 13. FUSER UNIT

### 13.1 General Description

In the fuser unit, toner is fused by applying heat and pressure on the transferred image on the transported paper. The paper is then transported to the paper exit section after completion of fusing. The fuser unit consists of the heater lamps, fuser roller, pressure roller, separation fingers, cleaning roller, thermistors, thermostat, etc.

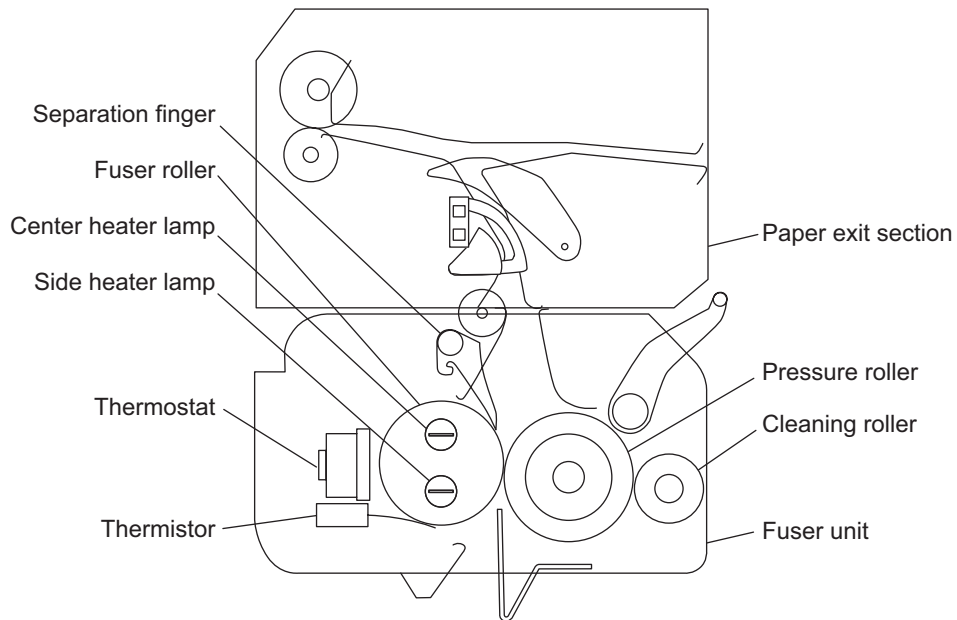

Fig. 13-1

## 13.2 Operation

The fuser roller is pressed with the spring force from the pressure roller side, and is rotated by the main motor drive. Then the paper transported to the fuser unit is held between the fuser roller and pressure roller and the toner is fused on the paper with heat and pressure. After this, the separation fingers separate the paper from the fuser roller or pressure roller. Then the paper is transported to the inner tray, paper exiting options or ADU through the exit roller. In addition, the heater lamps in the fuser roller do not structurally rotate.

2 heater lamps having different functions each other are installed; one applies heat to the center part of the fuser roller and the other one applies heat to both ends of the roller.

The thermistors control the temperature of fuser roller and detect temperature abnormalities. If the temperature becomes excessively high, the thermostat is opened to stop the power supply to the heater lamps.

## 13.3 Functions

### 1) Heater lamp

The heater lamps are halogen lamps to apply heat to the fuser roller. The fuser unit in this equipment has 2 heater lamps with different functions each other. One has a coil wound up on its center and this part generates heat. The other one has coils wound up on its both ends and these parts generate heat. The one has a coil on its center is called the center heater lamp and the one has coils on its both ends is called the side heater lamp.

The heater lamps are fixed on the inside of the fuser roller to heat it up. The heater lamps do not rotate even when the fuser roller is rotating.

### 2) Fuser roller

The fuser roller applies heat onto the paper and is heated by the heater lamps installed inside of the fuser roller. The heat from this roller fuses toner onto the paper. The fuser roller in this equipment is a thin roller which enhances heat conduction, and thus the warming-up time is shortened.

### 3) Pressure roller

The pressure roller is a sponge roller which assures the nip amount of the fuser roller. The pressure from the spring presses the paper onto the fuser roller to fuse the toner onto the paper efficiently. A sponge roller with a lower hardness is adopted for the pressure roller in this fuser unit to enable envelopes to pass through.

### 4) Separation fingers

The separation fingers are installed, five above the pressure roller and six above the fuser roller, in order to separate the paper adhered on each roller.

### 5) Cleaning roller

The cleaning roller is an aluminum roller which removes the residual toner or paper dust adhered on the fuser roller. The cleaning process is performed as follows:

1. The stain (residual toner) adheres on the fuser roller.
2. The stain (residual toner) on the fuser roller is transferred to the pressure roller.
3. The stain (residual toner) on the pressure roller is then transferred to the cleaning roller and is caked on the cleaning roller.

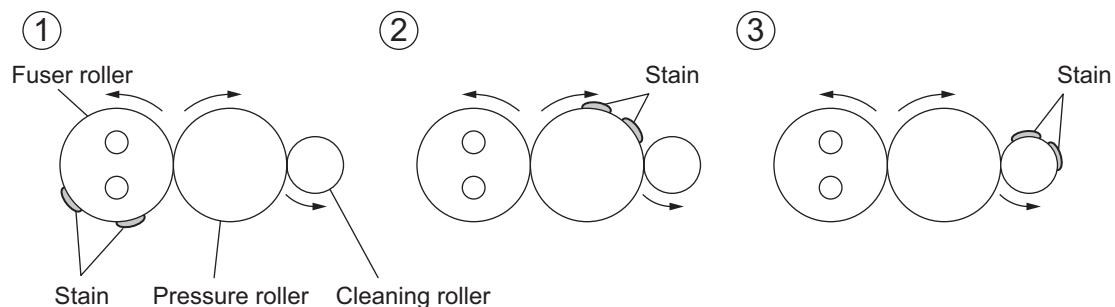

Fig. 13-2

The stain (residual toner) tends to remain more on the cleaning roller than on the fuser roller or pressure roller.

Therefore, the stain (residual toner) once adhered on the cleaning roller does not adhere again on the pressure roller or fuser roller.

6) Center thermistor / Side thermistor

This thermistor detects the temperature of the fuser roller to maintain it in a certain temperature range (actually around 180°C) between the lower limit causing the poor fusing and the upper limit causing the high temperature offsetting. When the temperature of the fuser roller is lower than the preset temperature, it turns ON the power supply to the heater lamps, and when it is higher than the preset temperature, it cuts off the supply.

The center thermistor detects the temperature of the center part of the fuser roller, and the side thermistor detects the temperature of one side of fuser roller and control the both sides.

7) Edge thermistor

It detects the temperature abnormality at the both ends of the fuser roller. This area may be overheated without heat absorption by paper since paper does not pass through this area. This thermistor is not related to the temperature control of the fuser roller.

8) Thermostat

The thermostat cuts off the power supply to the heater lamps by opening itself if the fuser roller becomes abnormally hot as a result of the problem such as thermistor malfunction. The thermostat for this equipment is used to prevent abnormal operation. When the thermostat detects any abnormality, it must be replaced as well as the other damaged parts in the fuser unit.

## 13.4 Heater Control Circuit

### 13.4.1 Configuration

In this equipment, the surface temperature of the fuser roller is controlled by turning ON/OFF 2 heater lamps (center and side) which have different heat-generating positions with the command from the engine-CPU on the LGC board. The surface temperature of the fuser roller is detected by 3 thermistors (center, side and edge) and then the information of the temperature is transmitted to the engine-CPU and each control circuit. Based on the detected temperature, the engine-CPU transmits the control signal of the heater lamp to the control circuit (TRC: Triac) of each heater lamp on the switching regulator via the temperature control circuit. The power supply to each fuser roller is thus controlled by driving TRC. The temperature control circuit detects the overheating of the fuser roller. In case that the surface temperature of the fuser roller has exceeded the specified temperature, the temperature control circuit transmits an overheat detection signal to the engine CPU and turns the heater lamp OFF.

If the temperature control circuit does not function for some reason and the fuser roller is abnormally overheated as the result, a forcible power-OFF circuit transmits a reset signal to the power switch to turn the power OFF forcibly. In addition, if these control circuits do not function with thermistor abnormality or other reasons and the fuser roller is abnormally overheated as the result, 2 thermostats (front and center ones in the fuser unit) shut off the power supply to the heater lamps to protect the equipment.

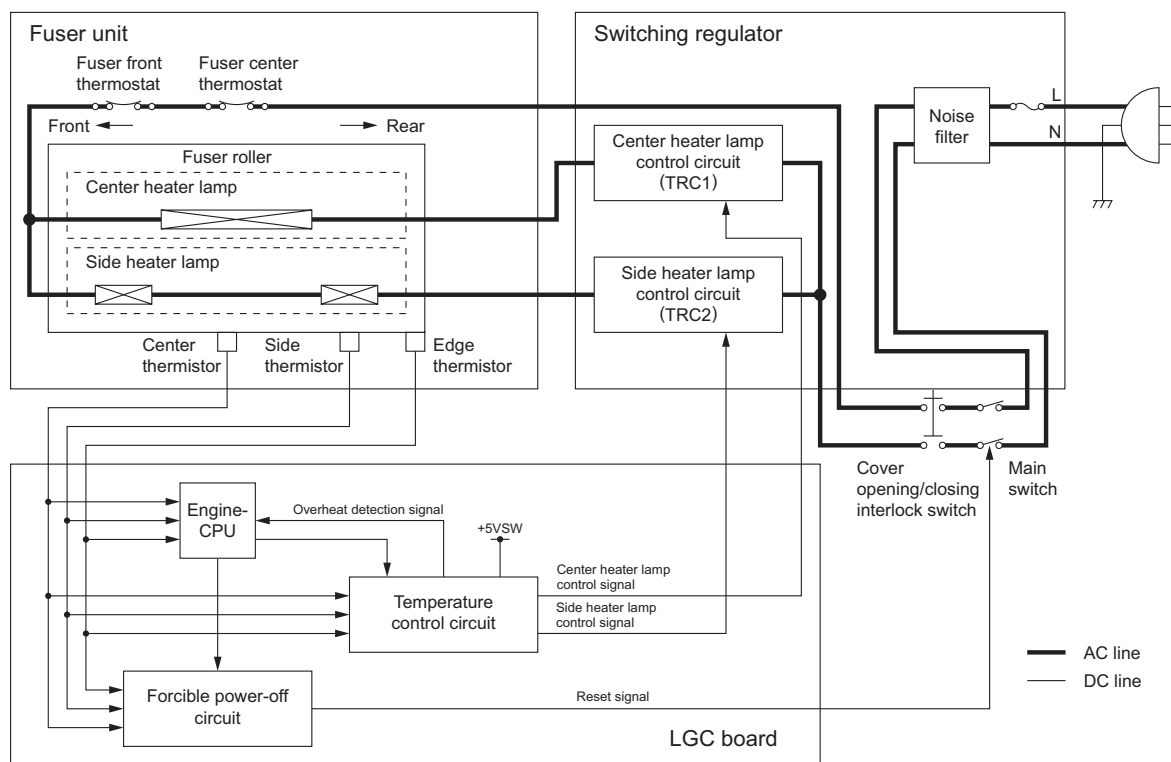

Fig. 13-3

## 13.4.2 Temperature detection section

To maintain the surface temperature of the fuser roller at a certain level, 3 thermistors (center, side and edge) detect the surface temperature of the fuser roller to turn ON/OFF and control 2 heater lamps (center and side).

1) Relation between the thermistor output voltage and surface temperature of the fuser roller

| Output voltages of thermistors [V] | Surface temperatures of fuser roller [°C] |
|------------------------------------|---|
| Approx. 0.5                        | 40  |
| Approx. 1.9                        | 100                                       |
| Approx. 3.8                        | 180                                       |

2) Control of the surface temperature of the fuser roller

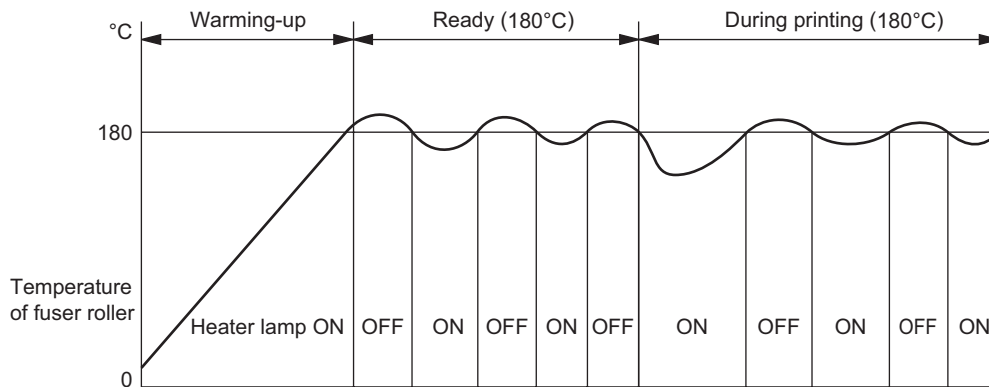

Fig. 13-4

### Remark:

During warming-up, 2 heater lamps (center and side) are turned ON to raise the surface temperature of the fuser roller. During ready and printing status, each heater lamp is turned ON/OFF alternately to maintain the surface temperature of the fuser roller at a certain level (setting temperature of each status).

3) Temperature control for the both ends of the fuser roller

During continuous printing, the temperature of the end of the fuser roller (area where the paper does not pass on) generally tends to be higher than that of other areas (areas where the paper passes on). For this reason, the edge thermistor detects the temperature of the end of the fuser roller. When this thermistor detects the abnormal temperature (230°C), the heater lamp is turned OFF regardless of the temperature of the area where the paper passes on.



#### 4) Temperature control at Energy Saving Mode

This equipment has the following two types of temperature control for saving energy and returns to ready status to perform printing in each mode upon printing request.

The period of time from the printing request to this mode can be set in "Setting Mode (08)" or by an administrator.

##### Administrator setting procedure:

[USER FUNCTIONS] button → [ADMIN] (input of administrator's password) → [GENERAL] → [ENERGY SAVER]

##### Auto Power Save Mode (Setting Mode (08-205)):

When the printing is not performed in a specified period of time (default setting: 15 min.) after the previous printing is completed, the equipment enters to Auto Power Save Mode to turn OFF the heater lamp.

##### Auto Shut Off Mode (Setting Mode (08-206)):

When the printing is not performed in a specified period of time (default setting: 60 min (e-STUDIO230/232/233/280/282/283 series<sup>\*1</sup>), 30 min (e-STUDIO200L/202L/203L series)). after the equipment entered to Auto Power Save Mode, the equipment then enters to Auto Shut Off Mode to turn OFF the heater lamp.

\*1 For e-STUDIO232/233/282/283 for MJD, "40 minutes" is set by default.

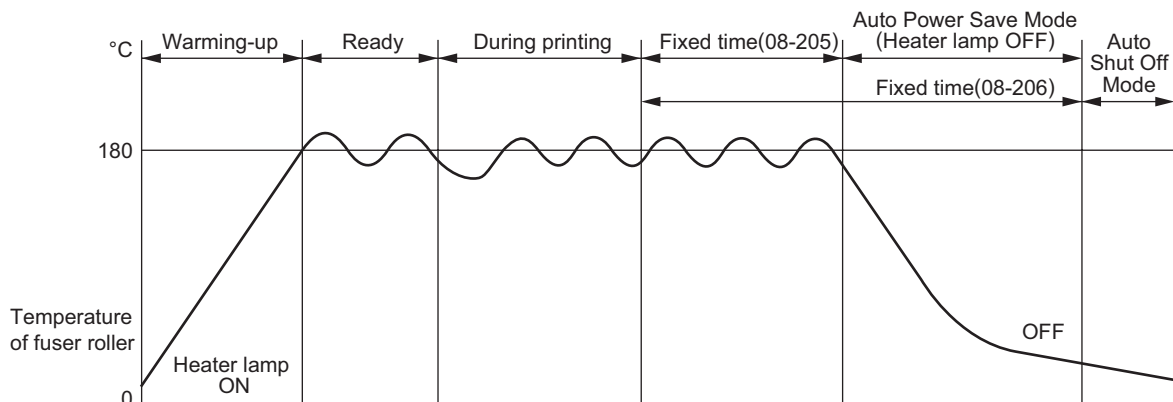

Fig. 13-5

## 5) Fuser unit error status counter control

- To enhance the safety of the fusing section unit, engine-CPU provides the following protection: When the third [C410] error has occurred after two consecutive [C410] errors, the heater lamp is not turned ON and error [C410] is displayed immediately even if an operator turns OFF the power and back ON. However, if the equipment goes into a ready state normally with the fuser unit error status counter "1" or below, the counter is cleared to "0".
- If the error codes [C410] to [C450] are displayed and still not cleared even though the thermistor, thermostat and heater lamp have been repaired (and the power ON/OFF does not clear the error), check the Setting Mode (08-400) to set the fuser unit error status counter to "0".

### Remark:

The fuser unit error status counter (Setting Mode (08-400)) never has values other than 0-9.

- If the heater lamp does not turn ON and the service call [C410] is displayed immediately after the power is ON, ensure the fuser unit error status counter is "2" or over. If it is "2" or over, be sure to check the thermistor, thermostat and heater lamp. Reset the counter to "0" after repairing them, then turn ON the power.
- If the fuser unit error status counter is "10" or over (e.g., 21), the data in NVRAM or NVRAM itself may possibly have been ruined due to causes such as leakage from the chargers. Check the bias, high-voltage transformers and charge wires to see if any of them is defective, and also look through all the data in the NVRAM.
- When the thermistors detect overheating, the engine-CPU decides the error code and counter value of the fuser unit error status. After turning OFF each output (the heater lamp, exposure lamp, control panel display, motors and so on), the engine-CPU turns OFF the power to protect the fuser unit.

Error code: C440 ([C] and [8])

Counter value of the fuser unit error status: 9 (08-400)

Thermistors continue detecting the abnormal temperature even after the error codes and counter values are decided. Even if the power is turned ON immediately, it is automatically turned OFF again when the surface temperature of the fuser roller is still higher than the abnormal temperature detected.

Wait until the surface temperature of the fuser roller is lowered enough, and turn ON the power to check the counter value while it is turned OFF again. After confirming that it is the fuser unit abnormality, correct the abnormality and reset the counter value (08-400) to "0" to start up the equipment normally.

### 6) Temperature detection configuration

Thermistor is a device whose resistance decreases as it detects a higher temperature. Thus its input voltage to engine-CPU changes and then engine-CPU judges whether this change is normal or abnormal. If one of the fuser roller thermistors is broken, the control circuit judges that the fuser roller temperature is extremely low and keeps turning the heater lamp ON. As a result, the fuser roller temperature rises, and possibly activates the thermostat which is a safety protection device. To prevent this in advance, engine-CPU works to detect whether each thermistor is broken or not. Also, the thermistors constantly check the temperature of heater lamp to prevent it from excessive heating by LGC circuit abnormality or thermistor abnormality. The thermistors automatically turn OFF the power when the temperature of heater lamp exceeds the specified temperature.

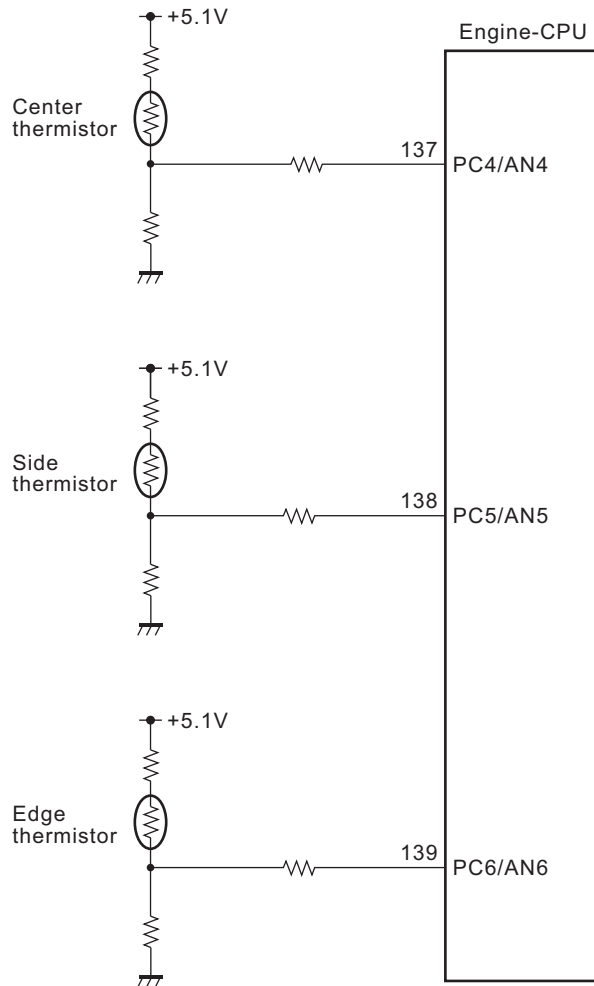

Fig. 13-6

7) Abnormality detection by the thermistors

The following table shows the conditions judging the fuser roller temperature abnormality and detecting timing.

| Checking timing                             | Priority | Temperature judged   |                      |                 | Error-judging timing | Error code     |      |
|---|----------|----------------------|----------------------|-----------------|----------------------|----------------|------|
|   |          | Center thermistor    | Side thermistor      | Edge thermistor |                      |                |      |
| Power ON                                    | 1        | 230°C or above       | -                    | -               | Power ON             | C440           |      |
|   |          | -                    | 230°C or above       | -               |                      |                |      |
|   | 2        | 40°C or below        | 150°C or above       | -               |                      | C430           |      |
|   |          | 150°C or above       | 40°C or below        | -               |                      |                |      |
| Detecting 40°C                              | 1        | 230°C or above       | -                    | -               | On usual             | C440           |      |
|   |          | -                    | 230°C or above       | -               |                      |                |      |
|   | 2        | 40°C or below        | -                    | -               |                      | Specified time | C410 |
|   |          | -                    | 40°C or below        | -               |                      |                |      |
| Detecting 100°C                             | 1        | 230°C or above       | -                    | -               | On usual             | C440           |      |
|   |          | -                    | 230°C or above       | -               |                      |                |      |
|   | 2        | 40°C or below        | 150°C or above       | -               |                      | C430           |      |
|   |          | 150°C or above       | 40°C or below        | -               |                      |                |      |
|   | 3        | 100°C or below       | -                    | -               | Specified time       | C440           |      |
|   |          | -                    | 100°C or below       | -               |                      |                |      |
| Detecting ready temperature                 | 1        | 230°C or above       | -                    | -               | On usual             | C440           |      |
|   |          | -                    | 230°C or above       | -               |                      |                |      |
|   | 2        | 40°C or below        | 150°C or above       | -               |                      | C430           |      |
|   |          | 150°C or above       | 40°C or below        | -               |                      |                |      |
|   | 3        | Ready temp. or below | -                    | -               | Specified time       | C440           |      |
|   |          | -                    | Ready temp. or below | -               |                      |                |      |
| During ready status / In Energy Saving Mode | 1        | 230°C or above       | -                    | -               | On usual             | C440           |      |
|   |          | -                    | 230°C or above       | -               |                      |                |      |
|   | 2        | 40°C or below        | 150°C or above       | -               |                      | C430           |      |
|   |          | 150°C or above       | 40°C or below        | -               |                      |                |      |
|   | 3        | 40°C or below        | -                    | -               | C440                 |                |      |
|   |          | -                    | 40°C or below        | -               |                      |                |      |
| During printing                             | 1        | 230°C or above       | -                    | -               | On usual             | C440           |      |
|   |          | -                    | 230°C or above       | -               |                      |                |      |
|   |          | -                    | -                    | 230°C or above  |                      |                |      |
|   |          | 40°C or below        | -                    | -               |                      |                |      |
|   | 2        | -                    | 40°C or below        | -               |                      | C450           |      |
|   |          | -                    | -                    | 40°C or below   |                      |                |      |
| At paper jam                                | 1        | 230°C or above       | -                    | -               | On usual             | C440           |      |
|   |          | -                    | 230°C or above       | -               |                      |                |      |
| In Self-diagnosis Mode                      | 1        | 230°C or above       | -                    | -               | On usual             | C440           |      |
|   |          | -                    | 230°C or above       | -               |                      |                |      |

\* The figures in the "priority" section denote the priority of error checking.

## 13.5 Disassembly and Replacement

### [A] Fuser unit

- (1) Take off the right rear cover (P.2-37 "[N] Right rear cover").
- (2) Disconnect 2 connectors, remove 2 screws, and then take off the fuser unit.

**Notes:**

1. Be careful when handling the fuser unit as it may become very hot.

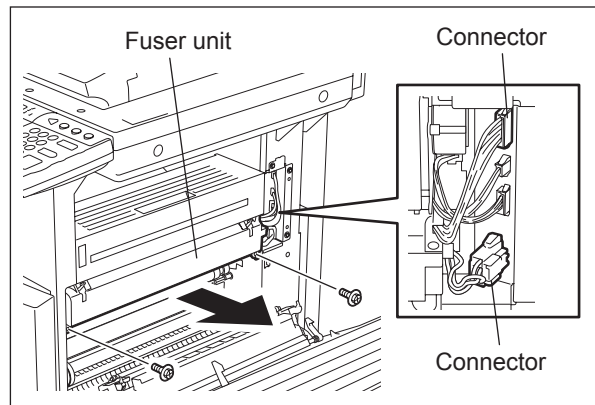

Fig. 13-7

2. Be careful not to hold the center part (shaded part in the figure at right).

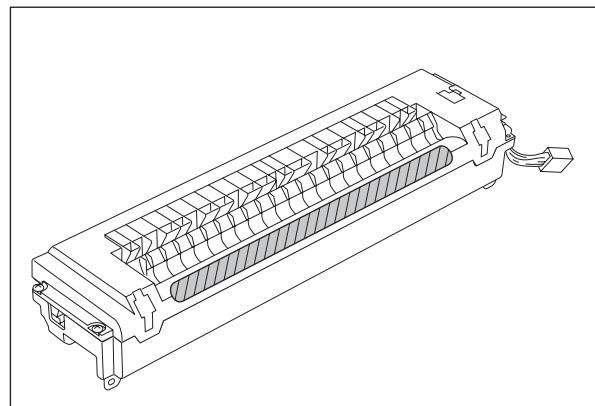



Fig. 13-8

## [B] Fuser unit upper cover

- (1) Take off the fuser unit  
( P.13-11 "[A] Fuser unit").
- (2) Release the harness from the harness clamp. Remove 4 screws and take off the fuser unit upper cover.

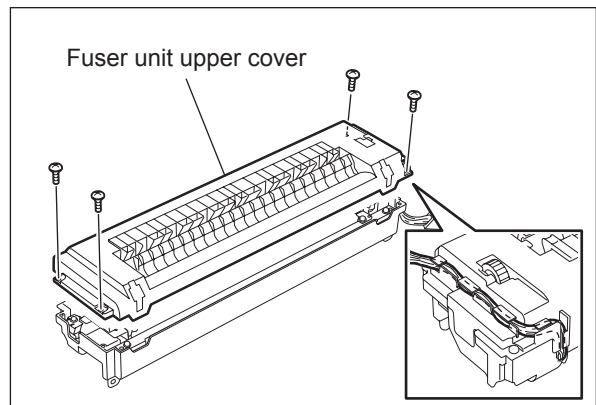



Fig. 13-9

## [C] Separation finger

- (1) Take off the fuser unit upper cover  
( P.13-12 "[B] Fuser unit upper cover").
- (2) Remove 6 springs and take off 6 separation fingers.

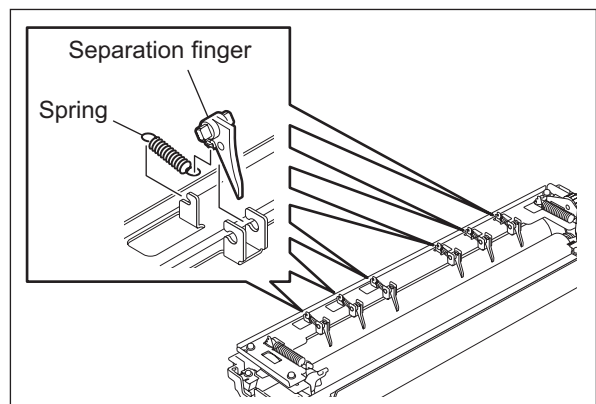



Fig. 13-10

## [D] Heater lamp

- (1) Take off the fuser unit upper cover  
( P.13-12 "[B] Fuser unit upper cover").
- (2) Remove 2 springs.

**Note:**

When installing the spring, catch the spring on the lower hook.

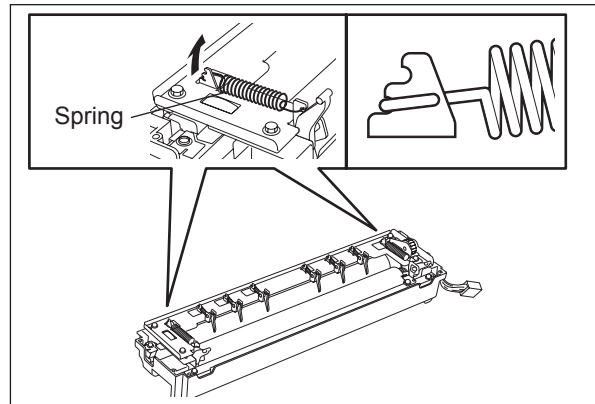

Fig. 13-11

- (3) Remove 4 screws and take off the separation finger bracket.

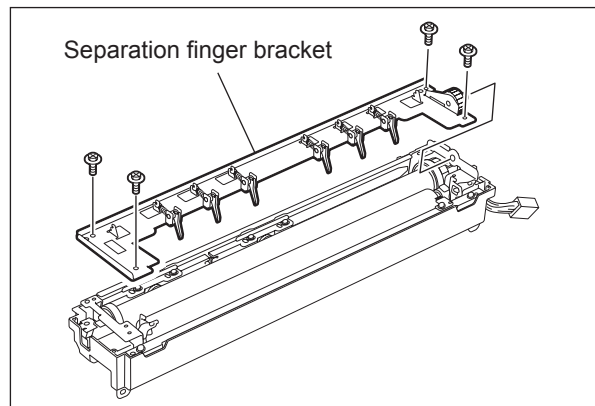

Fig. 13-12

- (4) Remove 2 screws of each the center heater lamp and the side heater lamp.

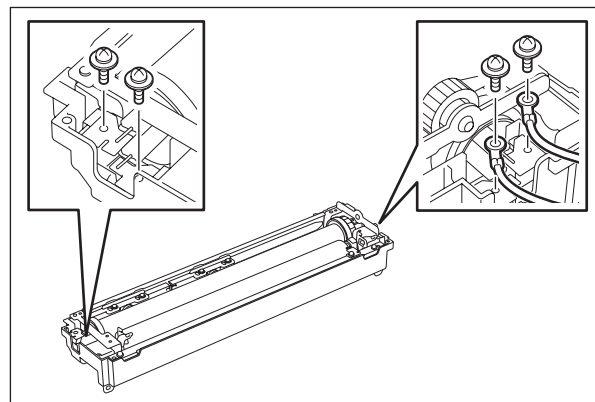

Fig. 13-13

- (5) Pull out the upper heater lamp and the lower heater lamp.

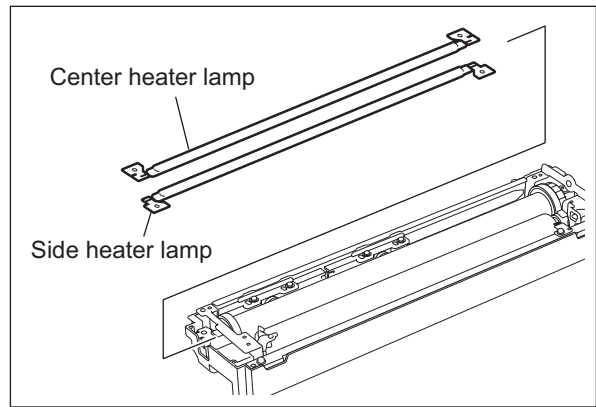

Fig. 13-14

**Notes:**

1. When installing the heater lamps, do not mix up the upper side and lower side. The upper heater lamp has the coil wound up on its center part and the lower heater lamp has the coil wound up on its both ends.
2. Install the heater lamps on their welded sides on upper.
3. Do not touch the lamps directly with bare hands.
4. Distinguish the harnesses by their terminals:  
The M3 one is for the center heater lamp and the M4 one is for the side heater lamp.

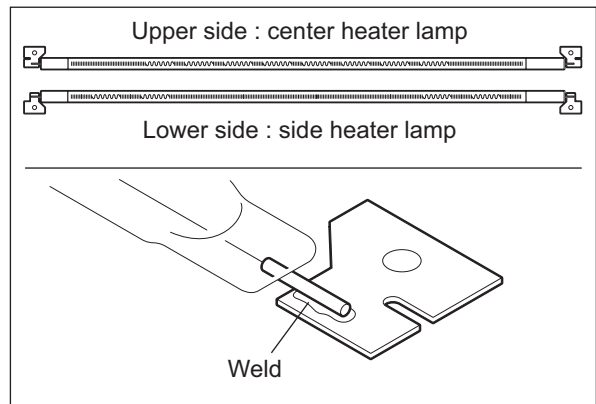

Fig. 13-15

**[E] Fuser roller**

- (1) Take off the center heater lamp and side heater lamp (P.13-13 "[D] Heater lamp").
- (2) Take out the fuser roller upward.

**Notes:**

1. When installing the fuser roller, move the bearings on both ends outward so that the bearings will be engaged into the frames.
2. Be careful not to deform the fuser roller by pushing strongly.

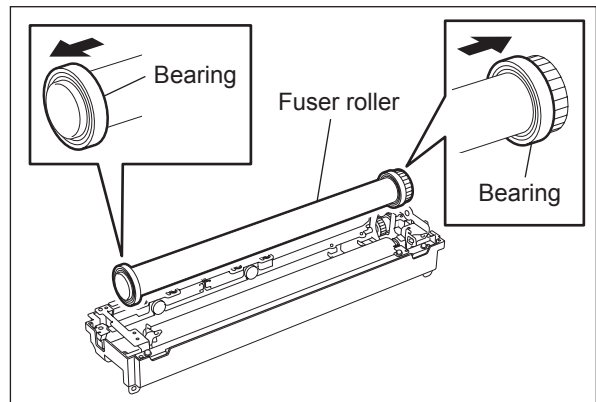

Fig. 13-16



- (3) Remove 1 C-ring and 1 bearing from the fuser roller front side.
- (4) Remove 1 C-ring, 1 gear and 1 bearing from the fuser roller rear side.

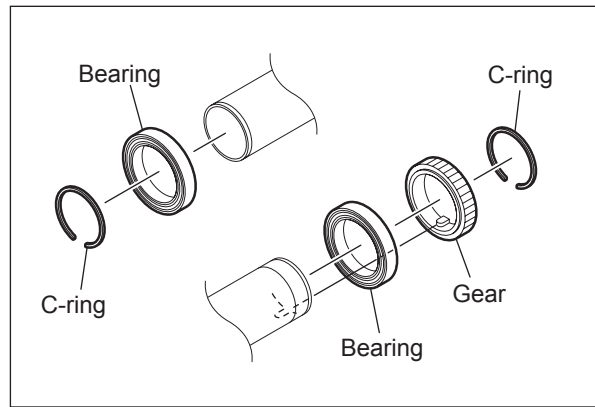



Fig. 13-17

### [F] Pressure roller

- (1) Take off the fuser roller  
( P.13-14 "[E] Fuser roller").
- (2) Place the fuser unit with the pressure roller on its bottom. Remove 2 screws and take off the fuser unit entrance guide.

**Note:**

Install the fuser unit entrance guide by fixing the screws in the holes marked by the arrows. However, if paper wrinkling occurs during duplex copying, use the holes not marked by the arrows to reduce this.

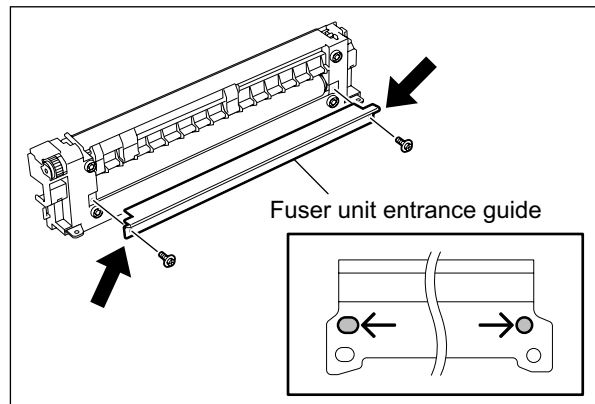

Fig. 13-18

- (3) Take off the pressure roller. Remove 2 E-rings and the bearings on both ends of the pressure roller.

**Note:**

The pressure roller is quite heavy. Do not drop the roller when lifting up.

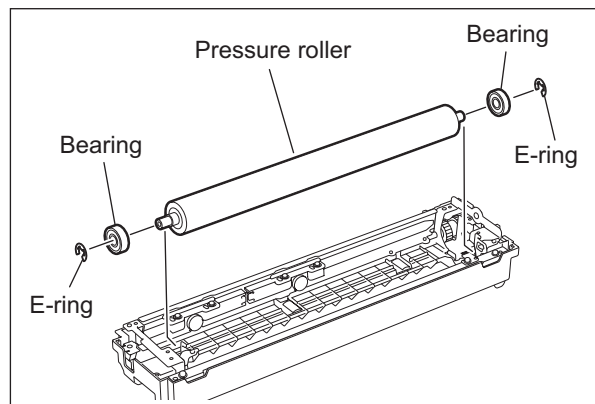



Fig. 13-19

### [G] Cleaning roller

- (1) Take off the pressure roller  
( P.13-14 "[E] Fuser roller").
- (2) Remove 2 screws and take off the cleaning unit.

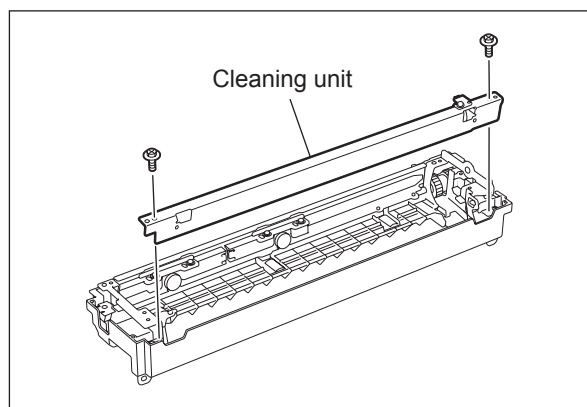

Fig. 13-20

- (3) Press down the holder and take off the cleaning roller.

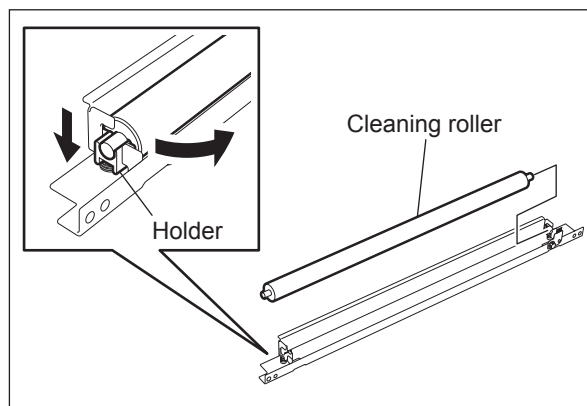

Fig. 13-21

### [H] Thermistor

- (1) Place the fuser unit upside down.
- (2) Release the latch and take off the harness cover.

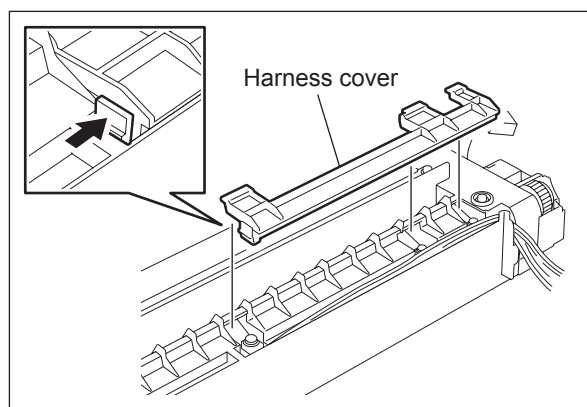

Fig. 13-22

- (3) Take out the thermistor by removing 1 screw each.

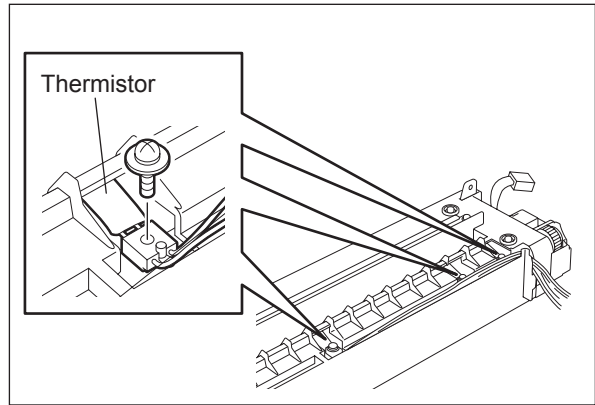

Fig. 13-23

**Note:**

When installing the thermistors, check the length of the harness first and distinguish the installation positions of the side thermistor and edge thermistor by the length of each harness.

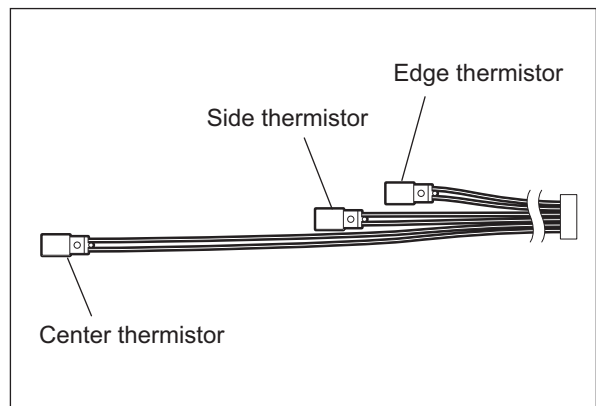

Fig. 13-24

**[I] Thermostat**

- (1) Take off the pressure roller (P.13-15 "[F] Pressure roller").
- (2) Place the fuser unit upside down. Release the latch and take off the harness cover.

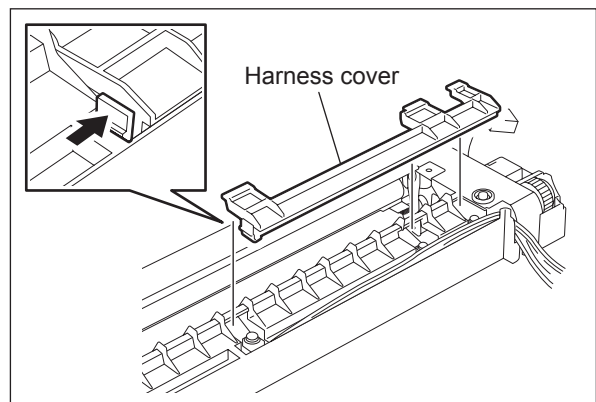

Fig. 13-25

- (3) Remove 4 screws (2 of them on the front side are the stepped screws) and take off the fuser unit lower cover.

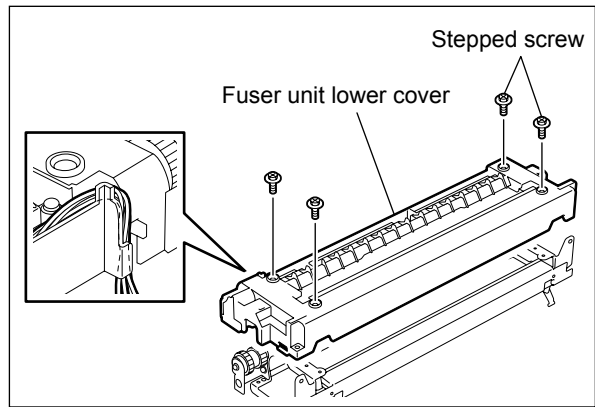

Fig. 13-26

- (4) Take off 2 thermostats by removing 2 screws each.

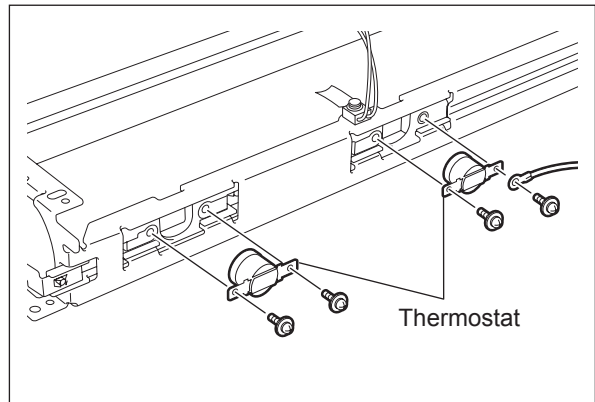

Fig. 13-27

**Note:**

The gap between the fuser roller and thermostat is adjusted to be  $2.3 \pm 0.2$  mm with the screw in the figure at right. Therefore, make sure not to loosen 4 screws shown in the figure at right.

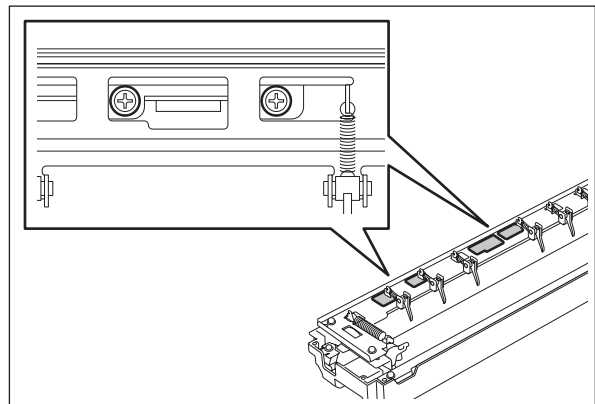

Fig. 13-28

## 14. PAPER EXIT SECTION

### 14.1 General Description

In the paper exit section, a sheet of paper with the toner fused on is transported to the inner tray, paper exit options or Automatic Duplexing Unit (ADU). The paper exit section consists of the guide and roller to transport the paper, motor to drive this roller and sensor to detect the transporting status of the paper.

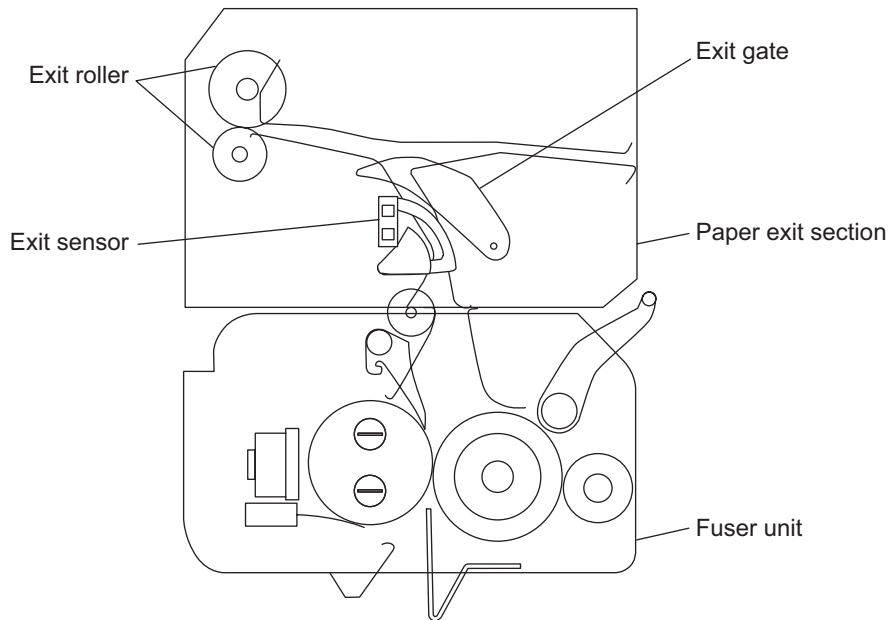

Fig. 14-1

## 14.2 Functions

### 1) Exit sensor

The exit sensor detects if the leading or trailing edge of the paper has reached to the exit roller. This sensor is also used for the detection of a paper jam in the fuser unit and paper exit section, and the detection of the trailing edge of the reversed paper at duplex printing as well.

### 2) Exit motor

The exit motor is a stepping motor which drives the exit roller. This motor rotates reversely to switch-back the exit roller when the paper is transported to the ADU.

In this equipment, the transport speed in the ADU is about three times as fast as that of print processing to enhance the productivity of duplex printing. For that purpose, the transport speed starts increasing when the trailing edge of the paper has passed the fuser roller in the fuser unit.

### 3) Exit roller

The exit roller transports the paper from the fuser unit to the inner tray, paper exit options or ADU. This roller is driven by the exit motor.

### 14.3 Control Circuit of Exit Motor

The following is the control circuit of the exit motor.

The exit motor is a stepping motor. The motor is turned ON/OFF and the direction of its rotation is switched by controlling the output timing of pulse signal (A0·A1·B0·B1).

VREF is the reference voltage for the current control of the motor.

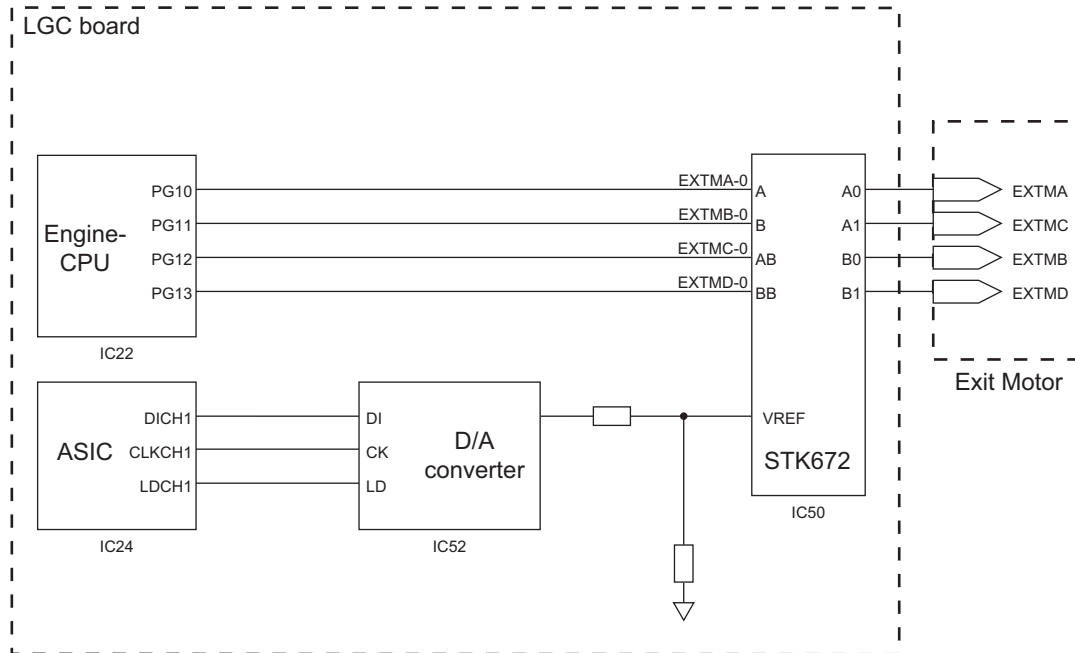

Fig. 14-2

# 14.4 Exit Motor Drive

The diagram shown below is the layout of the driving gears of the exit roller.

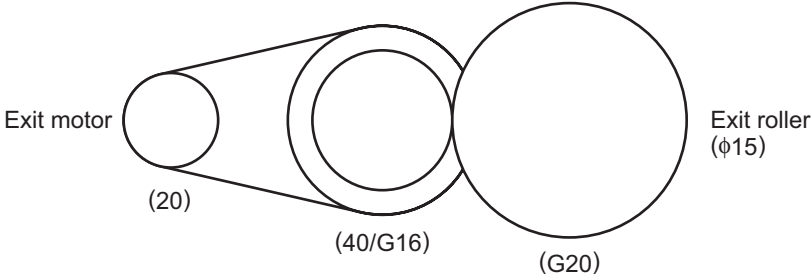

Fig. 14-3



## 14.5 Disassembly and Replacement

### [A] Exit cover

- (1) Open the exit cover.
- (2) Remove 1 clip and take off the exit cover.

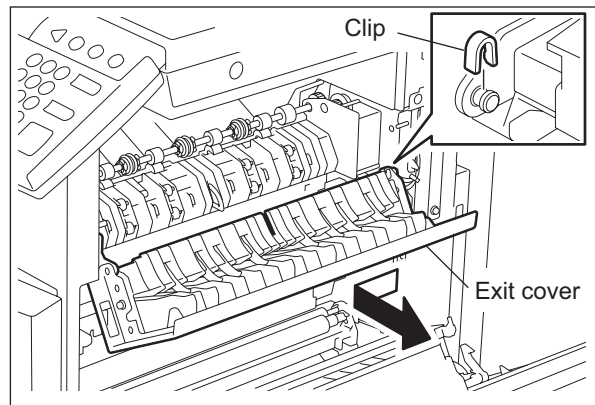

Fig. 14-4

### [B] Paper exit unit

- (1) Take off the right rear cover (P.2-37 "[N] Right rear cover").
- (2) Take off the exit cover (P.14-5 "[A] Exit cover").
- (3) Remove 2 connectors, remove 3 screws and then take off the paper exit unit.

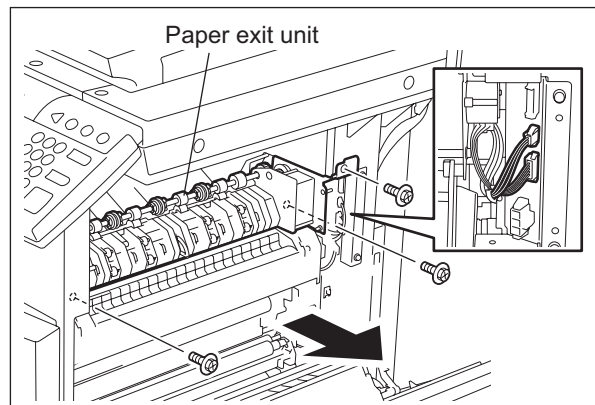

Fig. 14-5

### [C] Paper exit drive unit

- (1) Take off the paper exit unit (P.14-5 "[B] Paper exit unit").
- (2) Release the harness from 2 harness clamps.
- (3) Remove 3 screws and take off the paper exit drive unit.

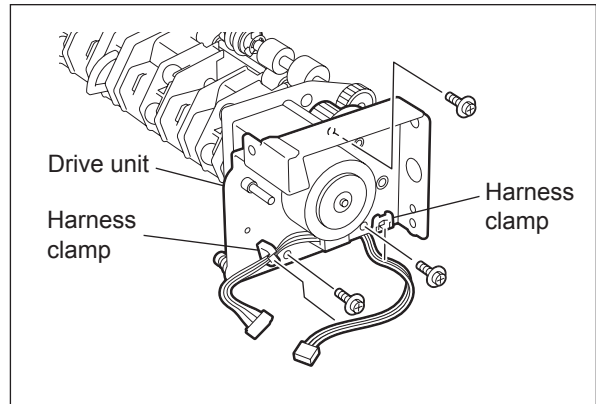

Fig. 14-6

- (4) Remove 3 gears and take off the timing belt. And then slide the exit motor to the hole and take it off.

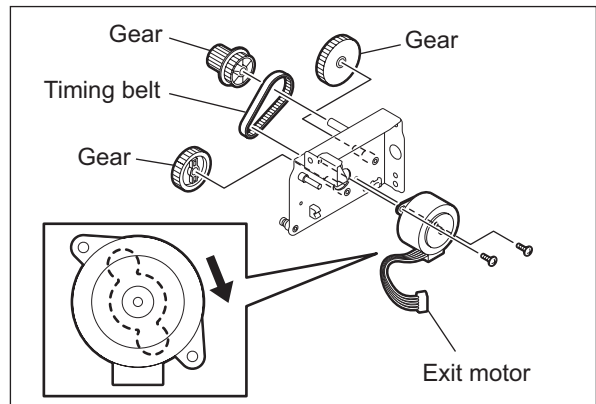

Fig. 14-7

### [D] Exit sensor

- (1) Take off the paper exit unit (P.14-5 "[B] Paper exit unit").
- (2) Disconnect 1 connector and take off the exit sensor.

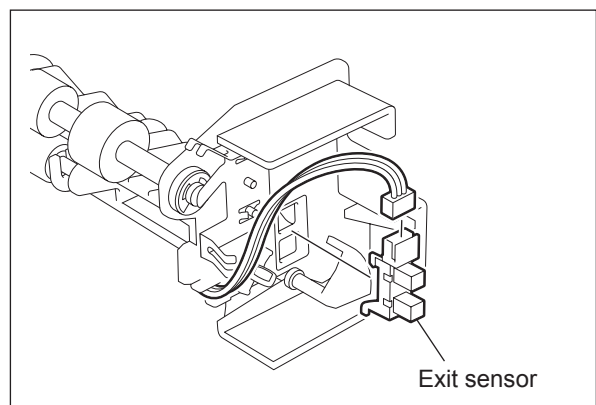

Fig. 14-8

## [E] Exit roller

- (1) Take off the paper exit unit.  
(P.14-5 "[B] Paper exit unit").
- (2) Remove 2 springs.

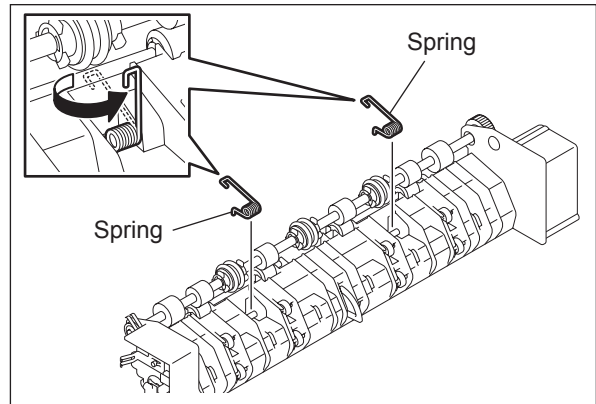

Fig. 14-9

- (3) Remove the plate spring.

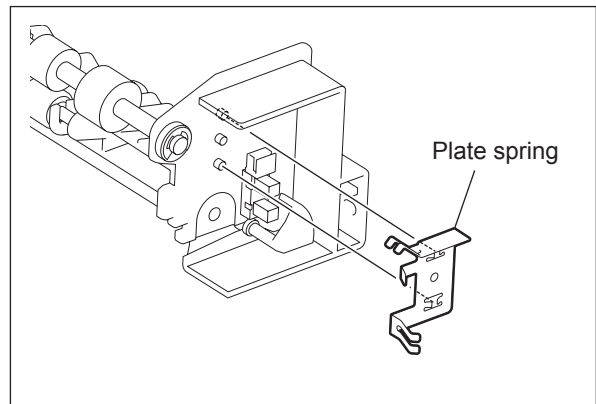

Fig. 14-10

- (4) Remove 1 E-ring and 1 bearing on the front side. Remove 1 E-ring, 1 gear and 1 bearing on the rear side.
- (5) Take off the exit roller.

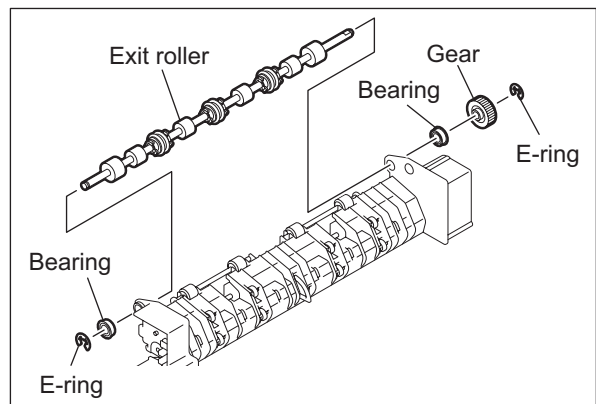

Fig. 14-11



## 15. AUTOMATIC DUPLEXING UNIT (ADU) (OPTION: MD-0102)

### 15.1 General Description

The Automatic Duplexing Unit (ADU) is a unit to reverse a sheet of paper at duplex copying.

A switchback method using the exit roller is adopted for the ADU of this equipment. Immediately after the printing of one side (fusing process) is completed, the paper is switchbacked by the exit roller. The paper being reversed is then transported to the 1st transport roller for the printing of the other side.

In this ADU, the transport of the switchbacked paper again accelerates and this speed is maintained to enhance the productivity of duplex printing.

The ADU mainly consists of the transport rollers and their drive system, paper guide and ADU entrance/exit sensor.

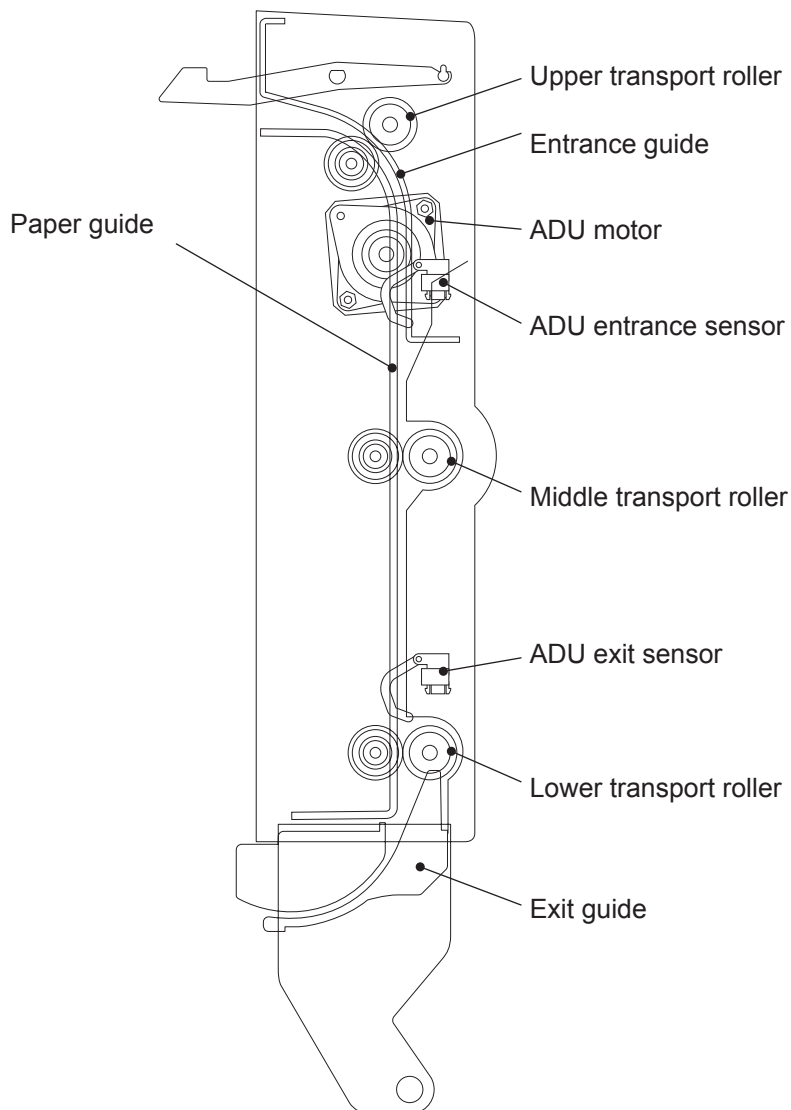

Fig. 15-1

## 15.2 Description of Operations

The back side printing (recording data of the back side of paper) is performed first by selecting duplex printing mode and pressing the [START] button. When the trailing edge of the paper passes the exit gate, the paper is switchbacked by the exit roller and transported into the ADU (the exit gate is closed with its own weight), and then the switchbacked paper is transported with acceleration. The transportation decelerates in front of the ADU exit sensor. The front side printing (recording data of the front side of paper) is performed at the registration section. The paper passes through the exit gate again and is transported to the inner tray to complete duplex printing.

There are three methods of judging a paper jam: (1) whether the ADU entrance sensor is turned ON or not in a specified period of time after the switchback to the ADU started (E510). (2) whether the ADU exit sensor is turned ON or not in a specified period of time after the ADU entrance sensor is turned ON (E520). (3) whether the registration sensor is turned ON or not in a specified period of time after the paper feeding from the ADU to the equipment (E110).

If the ADU is opened during duplex printing, the ADU motor and ADU clutch are stopped, namely, ADU open jam occurs (E430).

The equipment is never to be stopped during printing by interruption in any case except paper jam or service call.

The operation of the duplex printing differs depending on the size of the paper; single-paper circulation and alternateness circulation. The figures in the following pages show the circulating operations during duplex copying. The numbers in the figures indicate the page numbers.

1) Single-paper circulation

With the paper larger than A4/LT size, duplex printing (back-side printing → front-side printing) is performed for one sheet at a time as shown below.

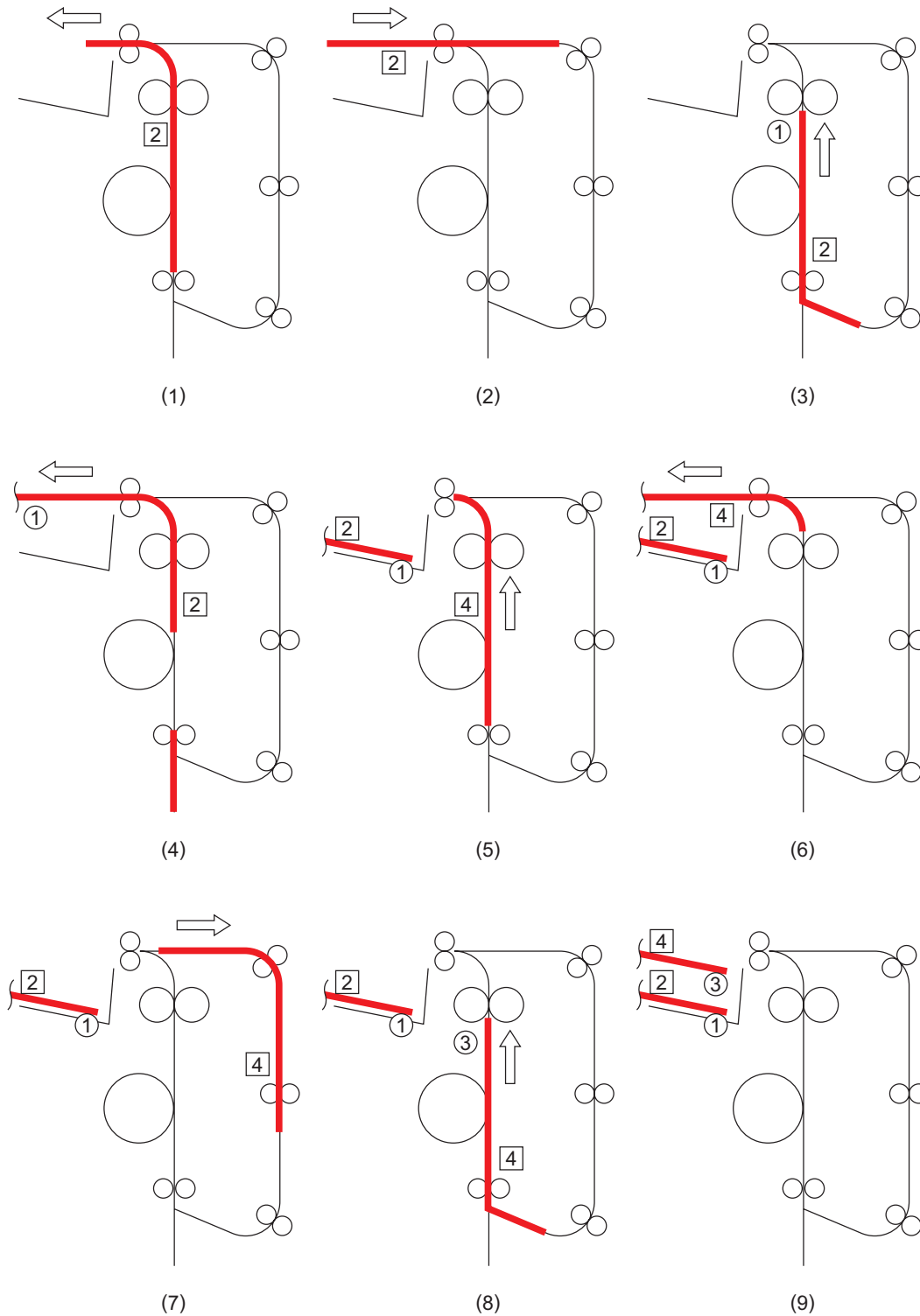

Fig. 15-2

2) Double-paper alternateness circulation

With A4/LT size paper or smaller, duplex printing is performed for two sheets at a time as shown below.

Back side of the 1st sheet → Back side of the 2nd sheet → Front side of the 1st sheet → Front side of the 2nd sheet

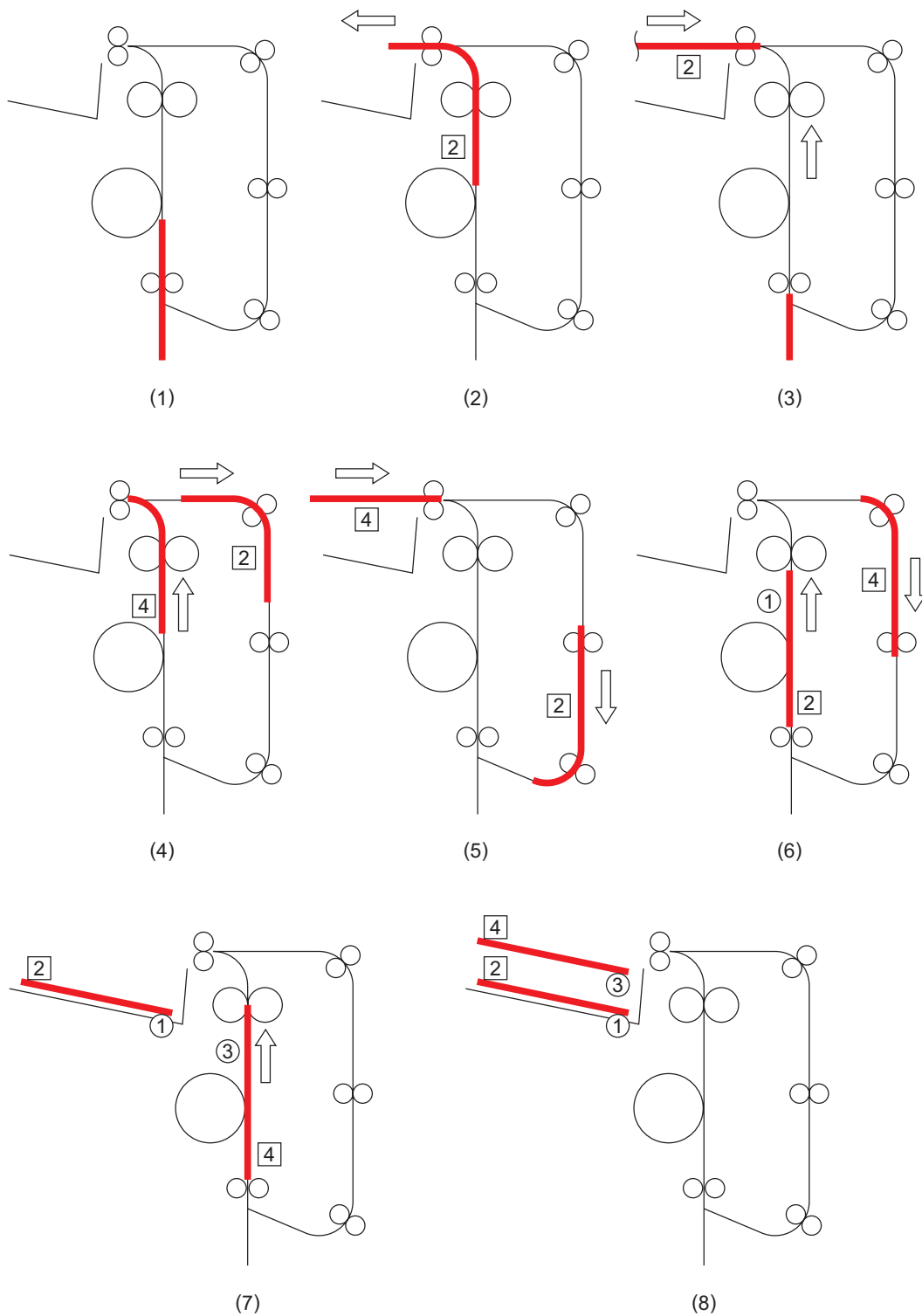

Fig. 15-3



Timing chart for duplex copying from upper drawer (A4, 4 sheets)

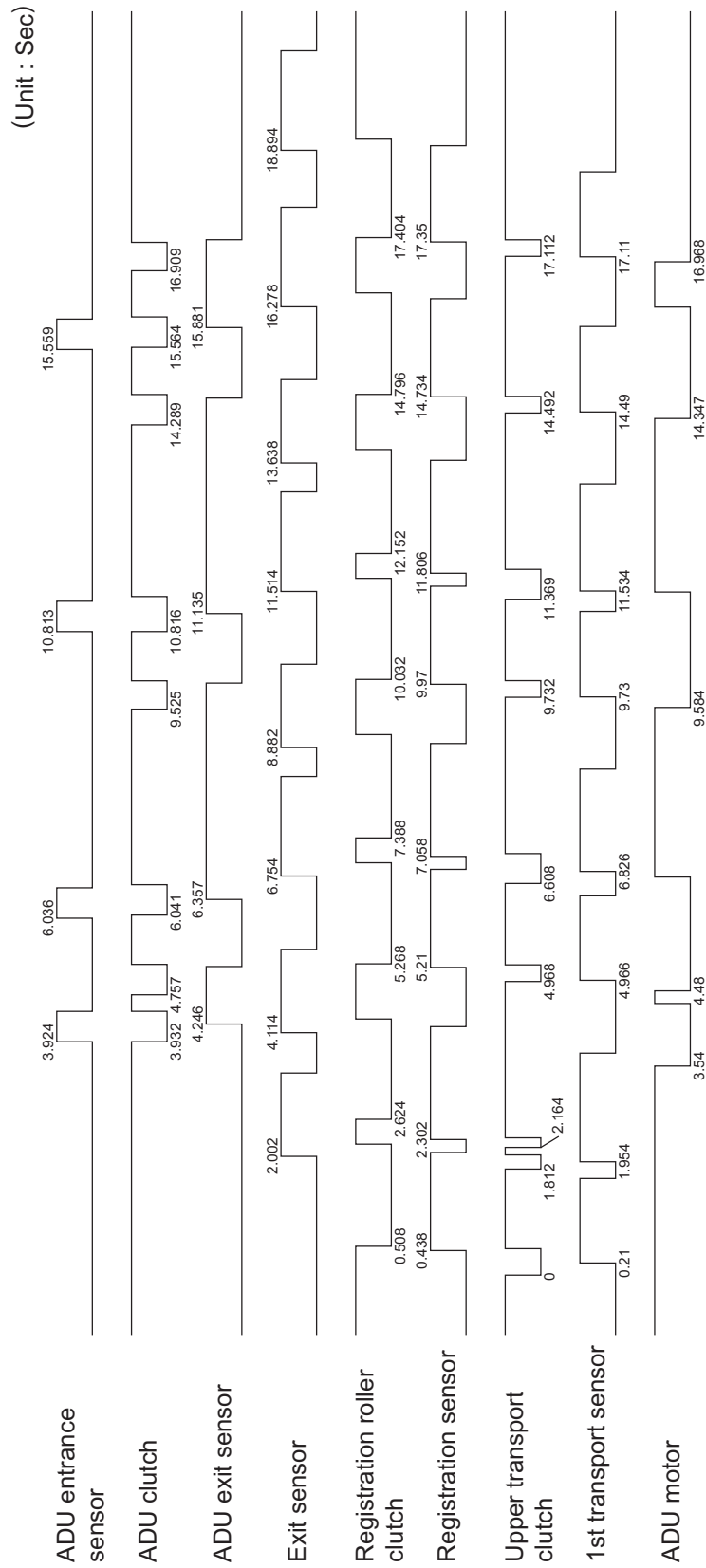

Fig. 15-4

Timing chart for duplex copying from upper drawer (A3, 1 sheet)

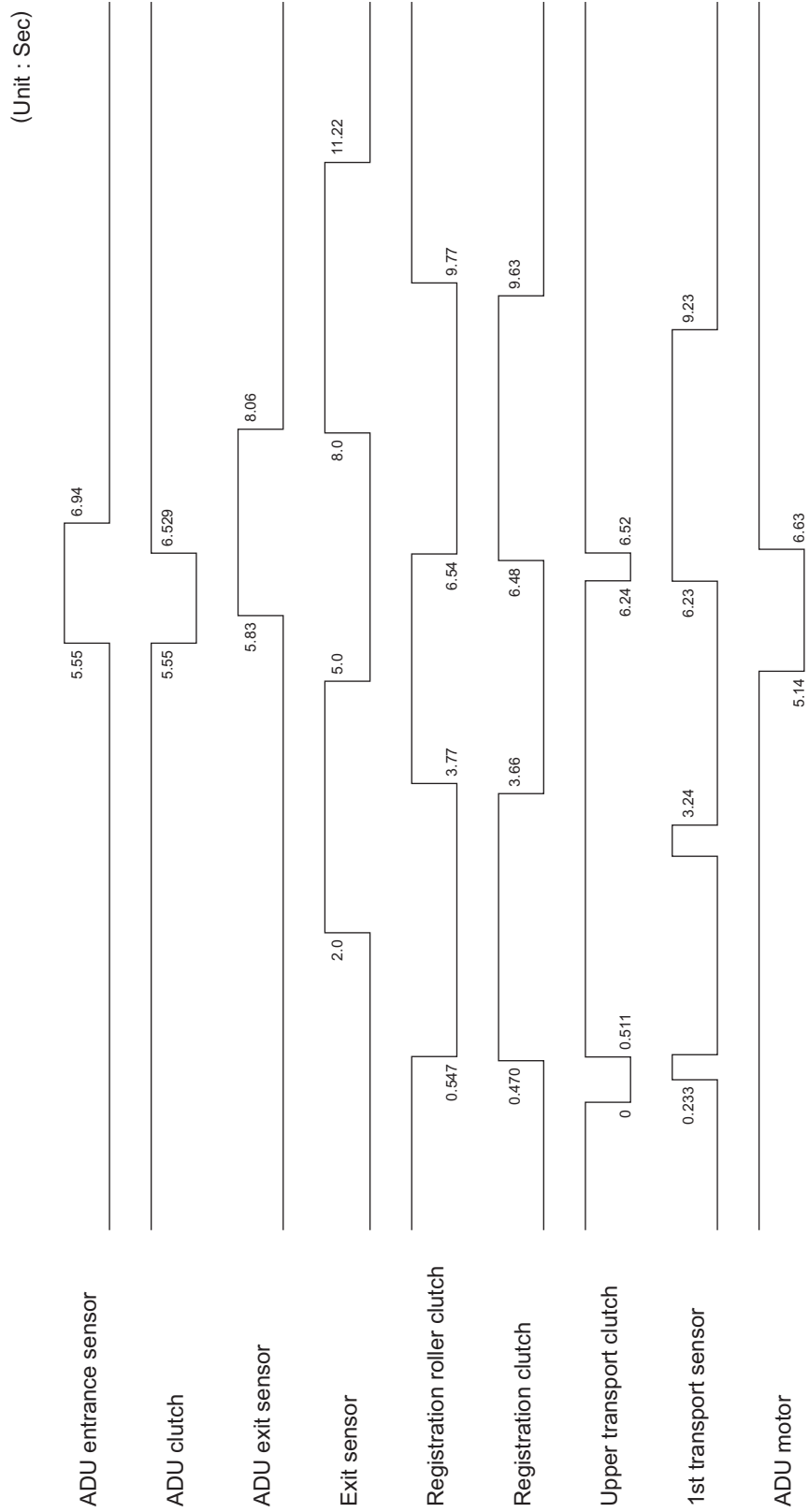

Fig. 15-5

### 15.3 Drive of ADU

When the ADU motor rotates in the direction A, the upper transport roller is rotated with the drive of the gears and belt, and thus the paper is transported. When the ADU clutch is turned ON, the middle transport roller and lower transport roller are rotated.

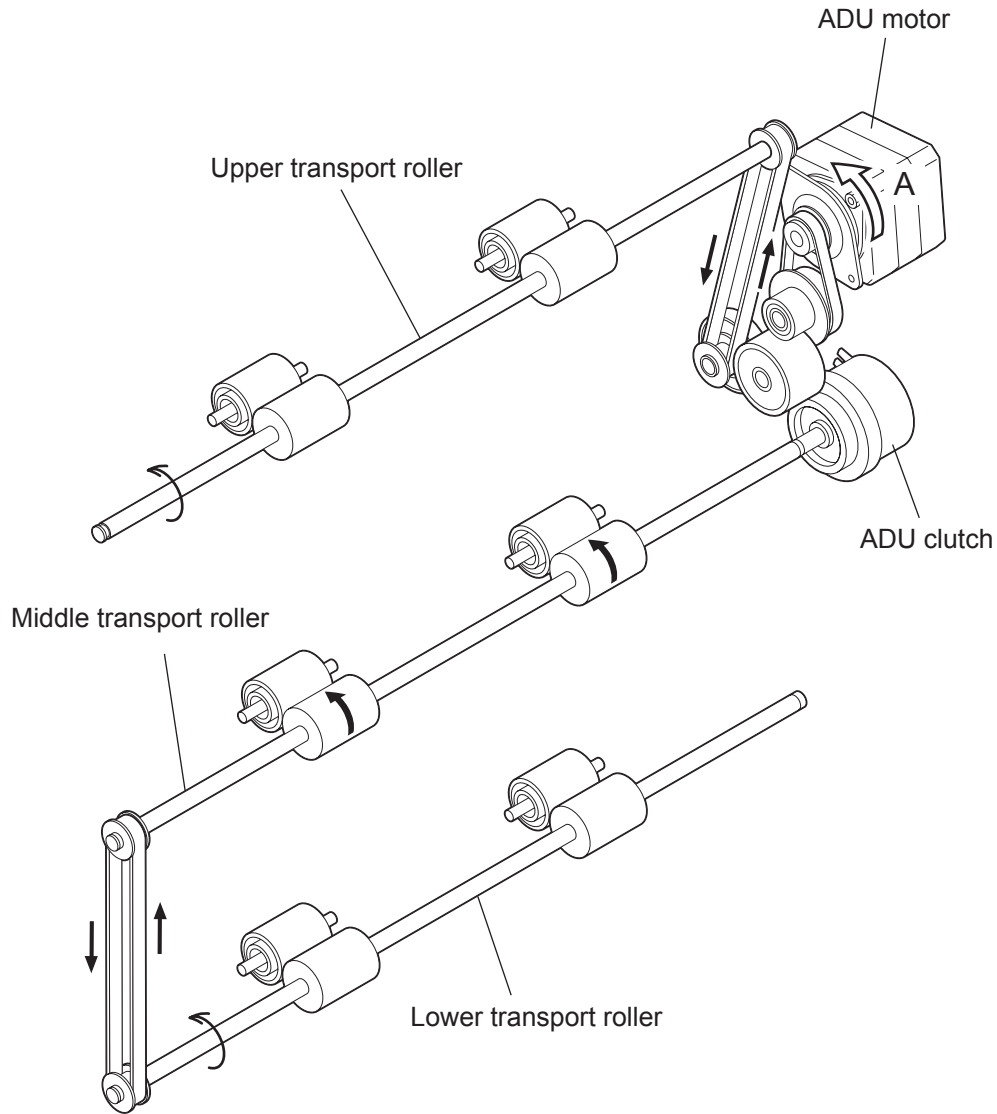

Fig. 15-6

## 15.4 Flow Chart

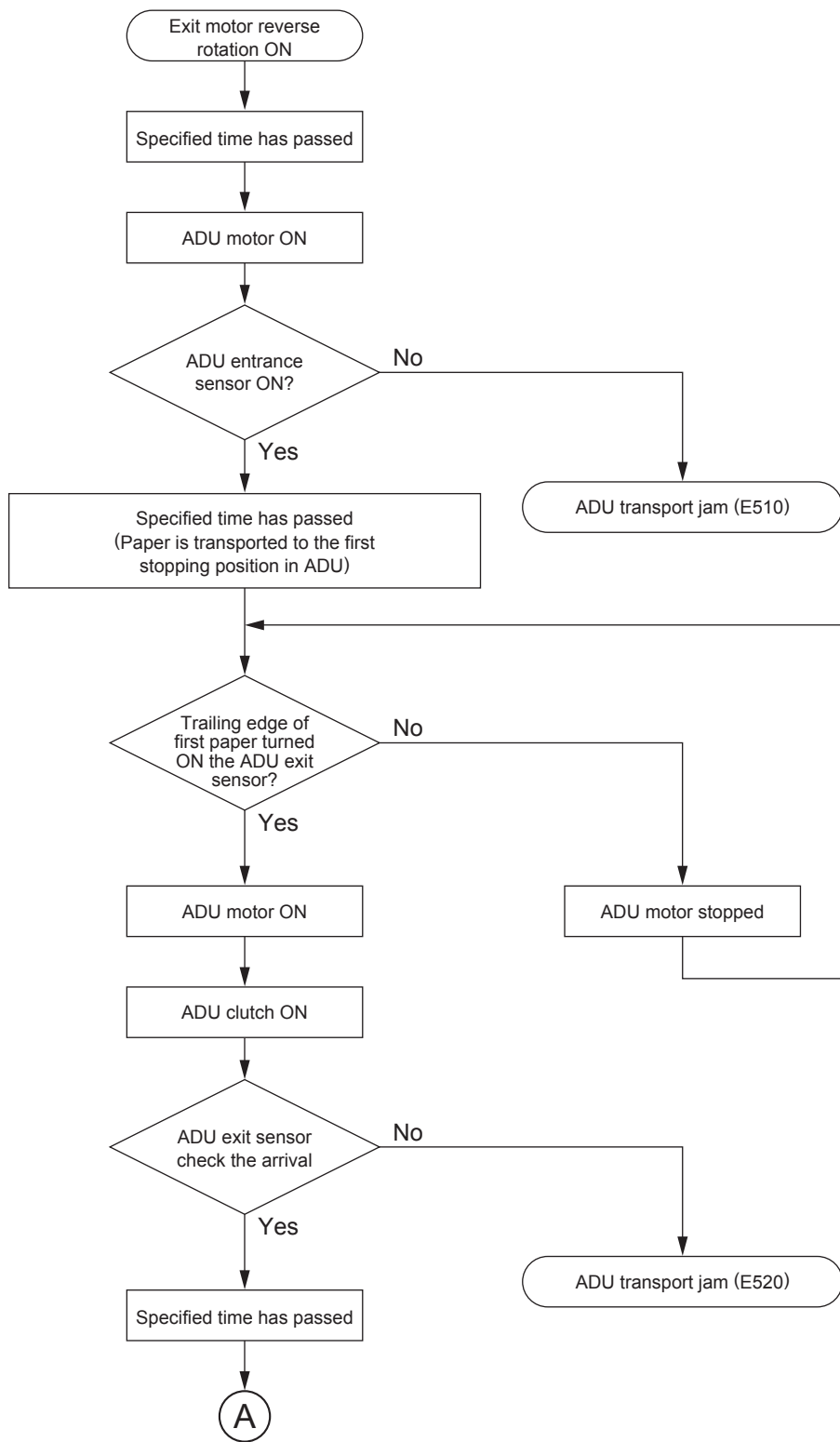

Fig. 15-7

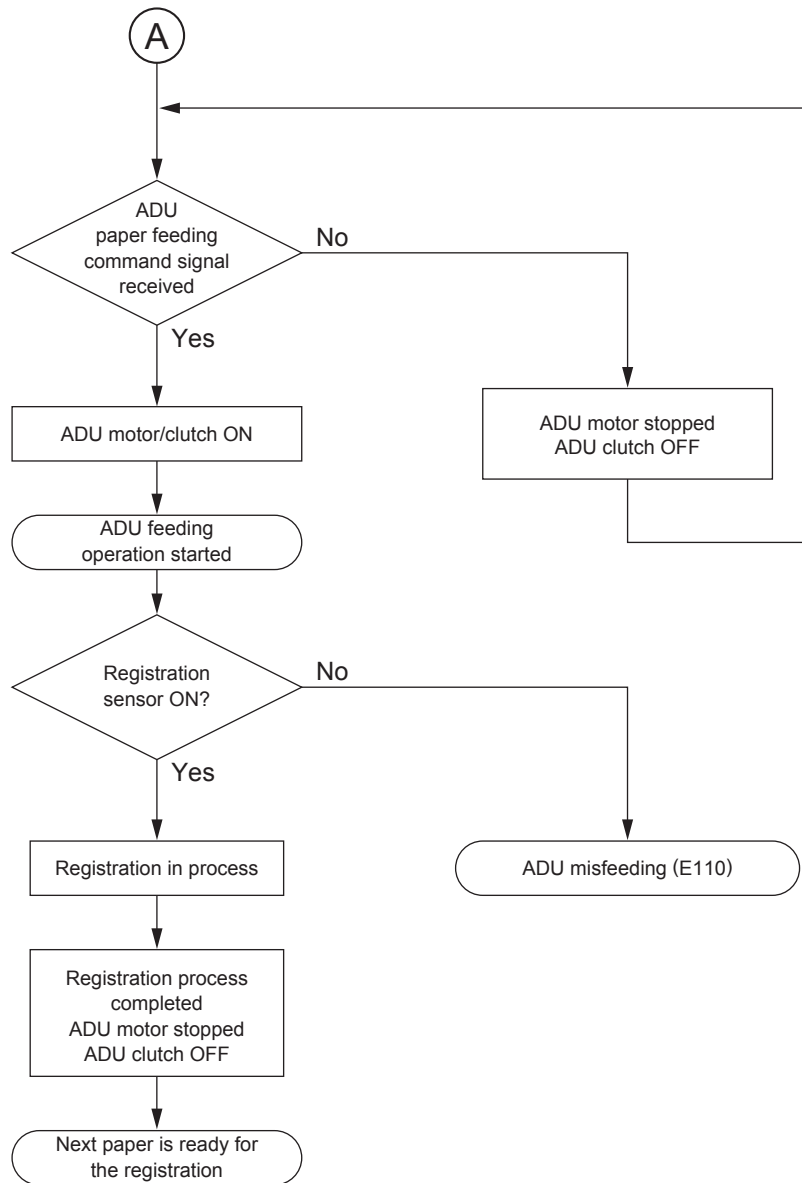

Fig. 15-8

## 15.5 Disassembly and Replacement

### [A] Automatic Duplexing Unit (ADU)

- (1) Pull out the upper and lower drawers.
- (2) Remove 2 screws and take off the right front hinge cover.

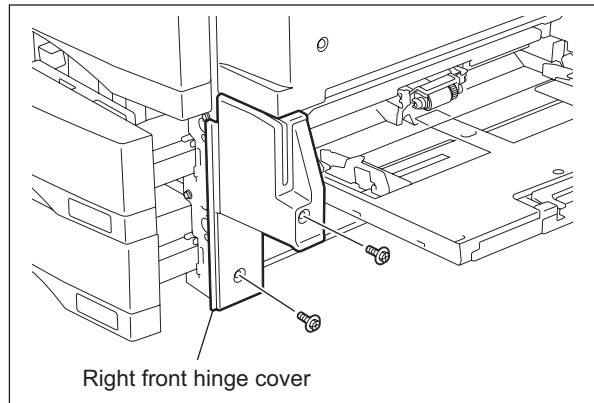

Fig. 15-9

- (3) Remove 2 screws and take off the right rear hinge cover.

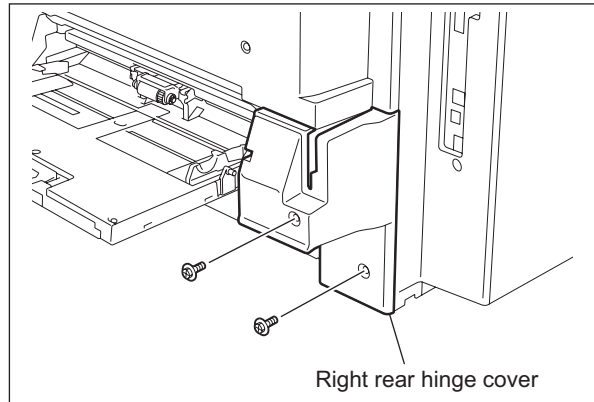

Fig. 15-10

- (4) Disconnect 2 connectors. Remove 1 screw and 1 ground wire.

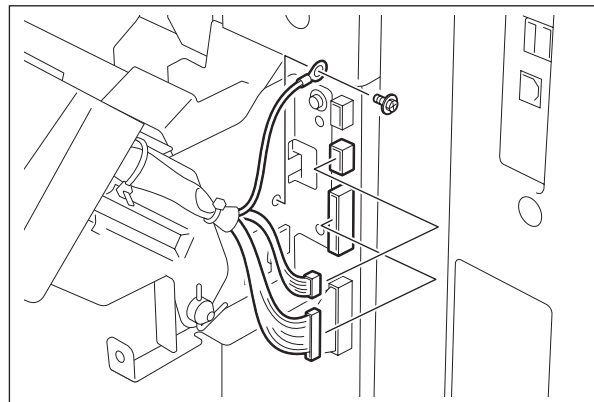

Fig. 15-11

- (5) Turn the hinge pin to point at the front side and pull it out downward. Open the ADU and take it off by sliding it to the rear side.

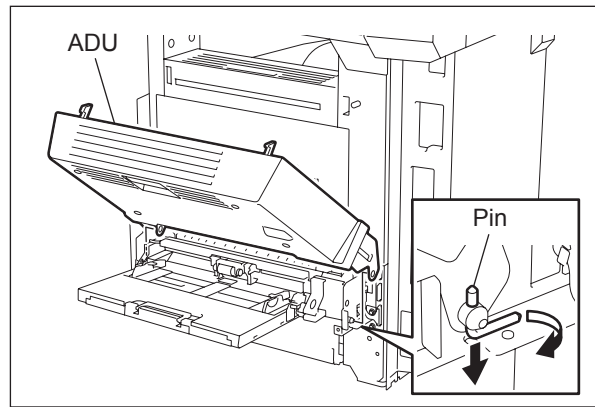

Fig. 15-12

**[B] ADU inside rear cover**

- (1) Take off the ADU (P.15-10 "[A] Automatic Duplexing Unit (ADU)").
- (2) Remove 2 screws and take off the ADU inside rear cover.

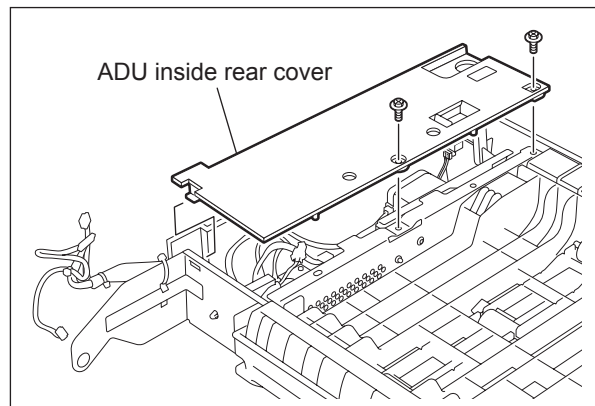

Fig. 15-13

**[C] ADU opening/closing switch**

- (1) Take off the ADU inside rear cover (P.15-11 "[B] ADU inside rear cover").
- (2) Disconnect 1 connector. Release the latches and take off the ADU opening/closing switch.

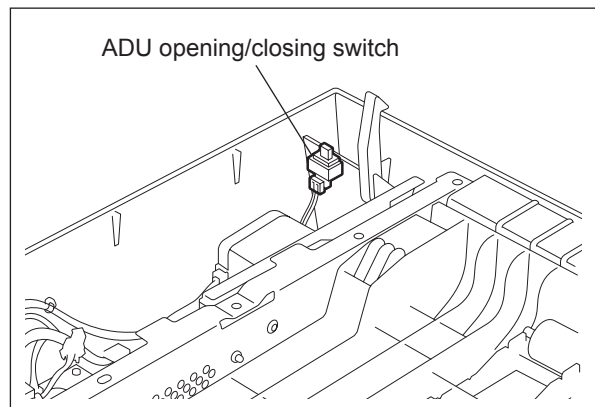

Fig. 15-14

#### [D] ADU driving PC board (ADU board)

- (1) Take off the ADU inside rear cover (P.15-11 "[B] ADU inside rear cover").
- (2) Disconnect 6 connectors from the ADU board. Release the latch and take off the ADU board.

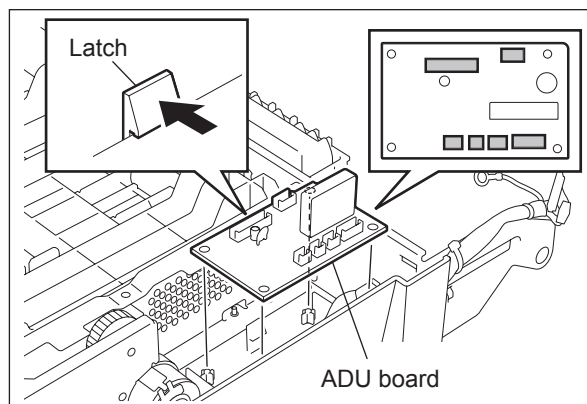

Fig. 15-15

#### [E] ADU cover

- (1) Take off the ADU inside rear cover (P.15-11 "[B] ADU inside rear cover").
- (2) Disconnect 3 connectors from the ADU board.

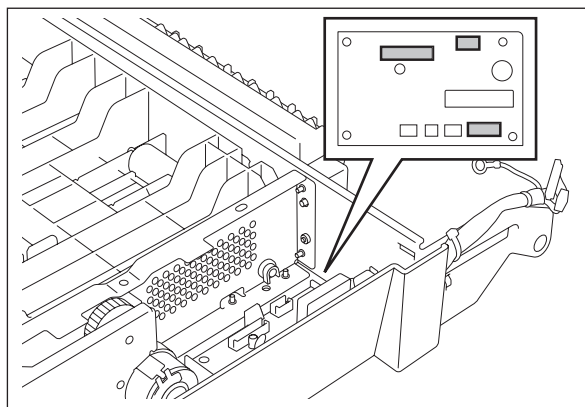

Fig. 15-16

- (3) Remove 4 screws and take off the ADU cover.

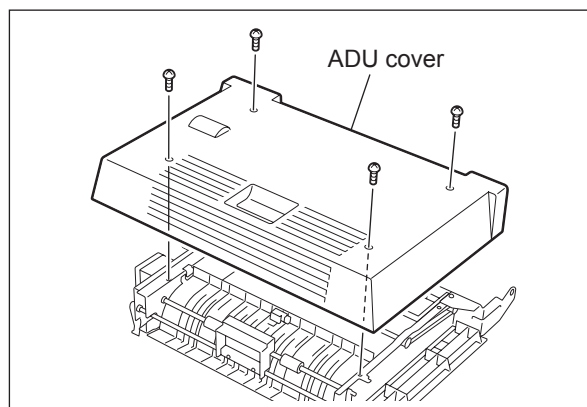



Fig. 15-17



## [F] ADU clutch

- (1) Take off the ADU cover  
( P.15-12 "[E] ADU cover").
- (2) Remove 1 E-ring and disconnect 1 connector. Then take off the ADU clutch.

**Note:**

When installing the E-ring, make sure that the latches of both ends of E-ring are on the flat part of the shaft.

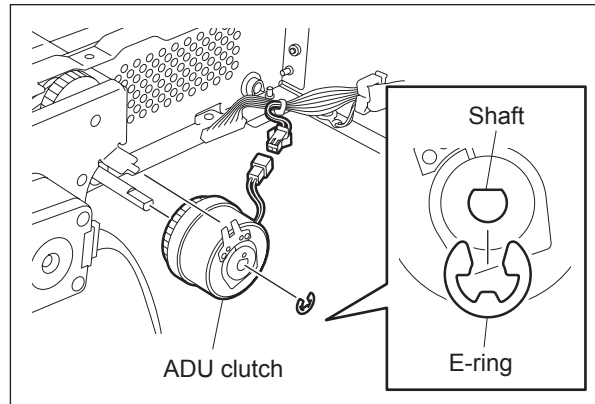



Fig. 15-18

## [G] ADU motor / ADU drive unit

- (1) Take off the ADU clutch  
( P.15-13 "[F] ADU clutch").
- (2) Remove the spring.

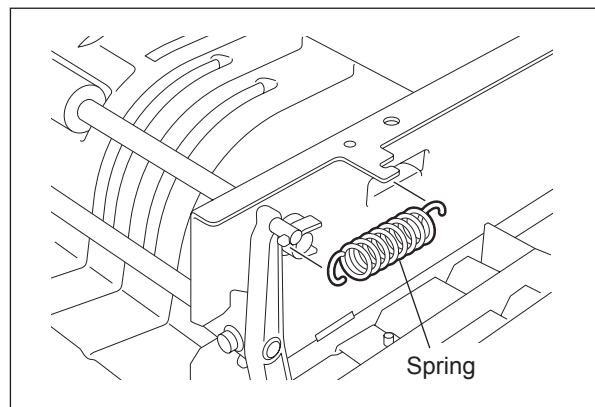

Fig. 15-19

- (3) Remove 1 screw and take off the ADU rear latch.

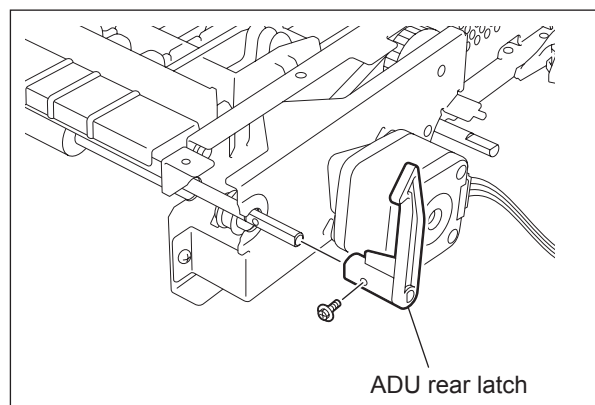

Fig. 15-20

- (4) Remove 2 screws and take off the ADU drive unit.

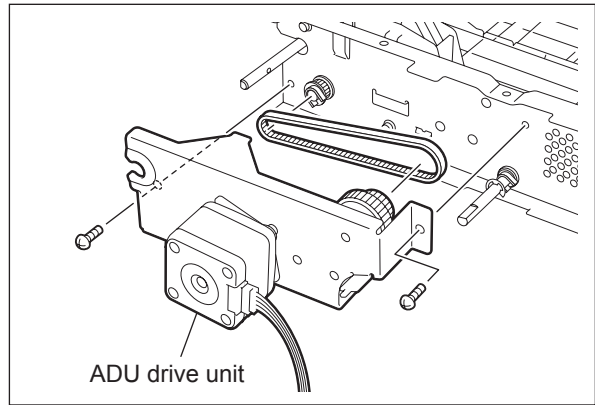

Fig. 15-21

- (5) Remove 2 screws and take off the ADU motor.

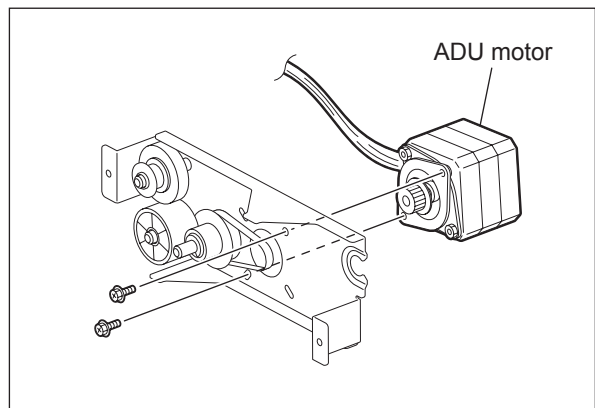

Fig. 15-22

- (6) Take off the timing belt. Remove E-ring. Then take off the gears from the ADU drive unit.

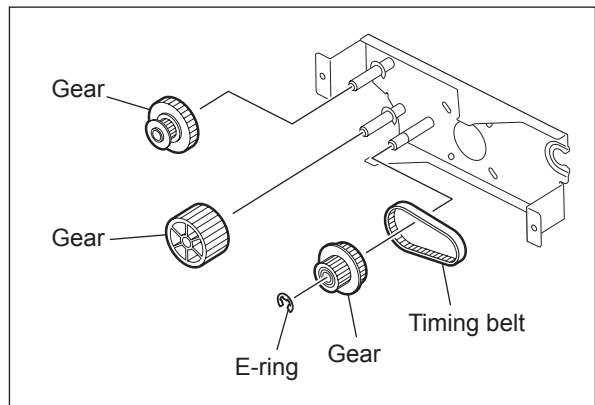



Fig. 15-23

## [H] Upper transport roller

- (1) Take off the ADU drive unit  
( P.15-13 "[G] ADU motor / ADU drive unit").

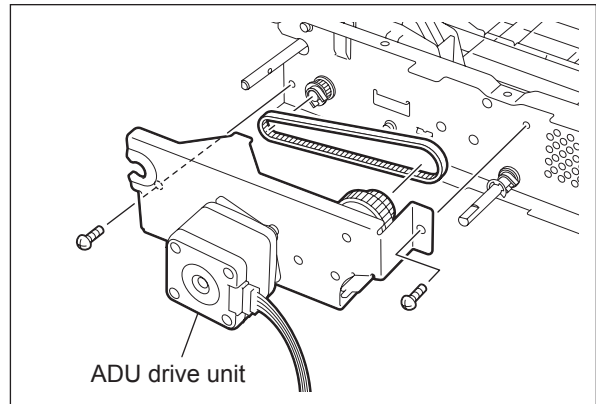

Fig. 15-24

- (2) Remove 1 clip on the rear side. Then remove 1 pulley and 1 pin.

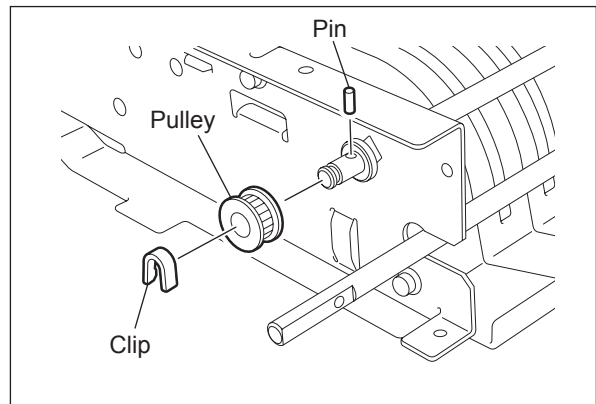

Fig. 15-25

- (3) Remove 1 clip on the front side. Then take off 2 bushings and upper transport roller.

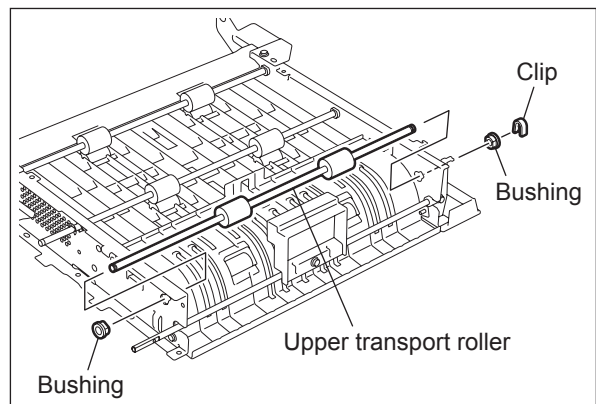



Fig. 15-26

## [I] Middle transport roller

- (1) Take off the ADU drive unit  
( P.15-13 "[G] ADU motor / ADU drive unit").

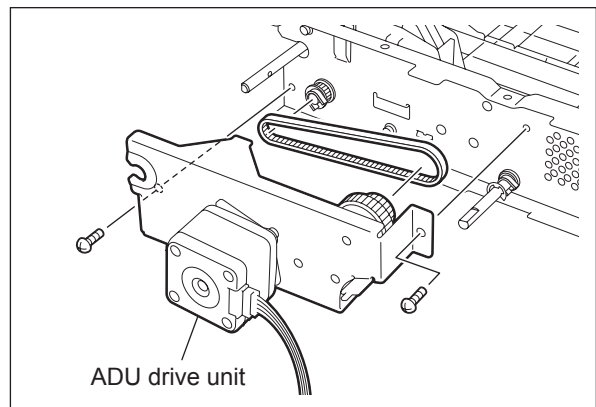

Fig. 15-27

- (2) Remove 2 clips, 2 pulleys and 2 pins on the front side. Then take off the timing belt.

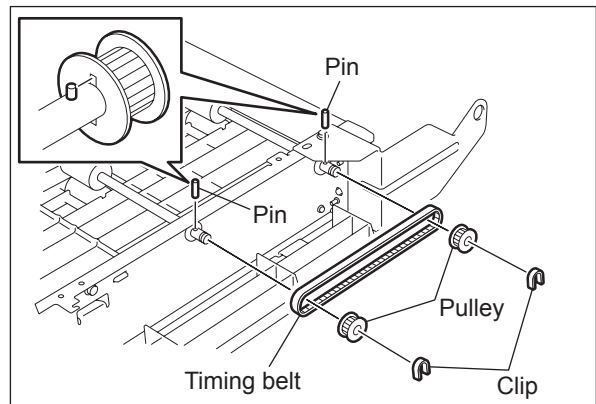

Fig. 15-28

- (3) Remove 1 E-ring and 1 clip on the rear side.
- (4) Take off 2 bushings and middle transport roller.

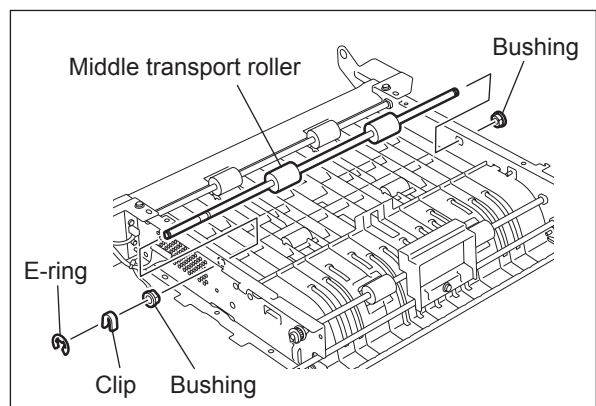



Fig. 15-29

## [J] Lower transport roller

- (1) Take off the ADU cover  
( P.15-12 "[E] ADU cover").
- (2) Remove 2 screws and take off the exit guide.

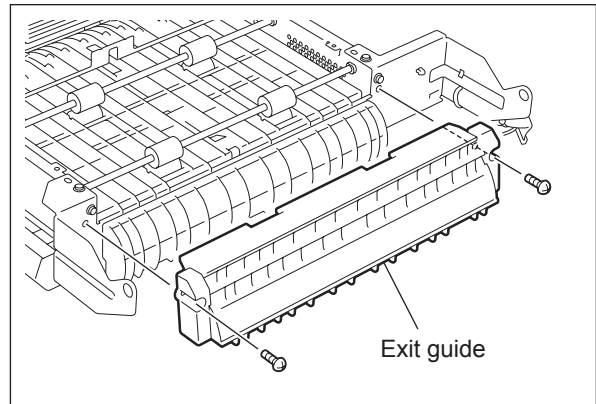

Fig. 15-30

- (3) Remove 2 clips, 2 pulleys and 2 pins on the front side. Then take off the timing belt.

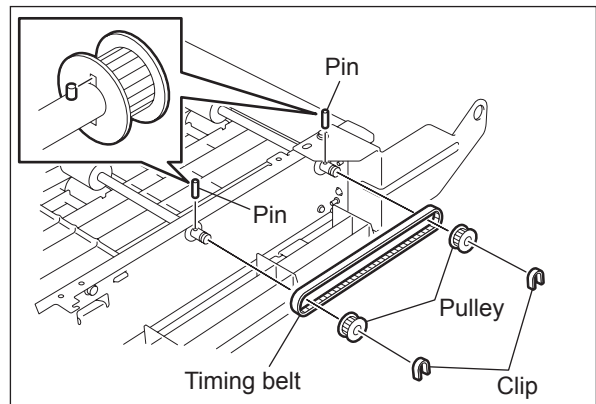

Fig. 15-31

- (4) Remove 1 clip on the rear side. Take off 2 bushings and lower transport roller.

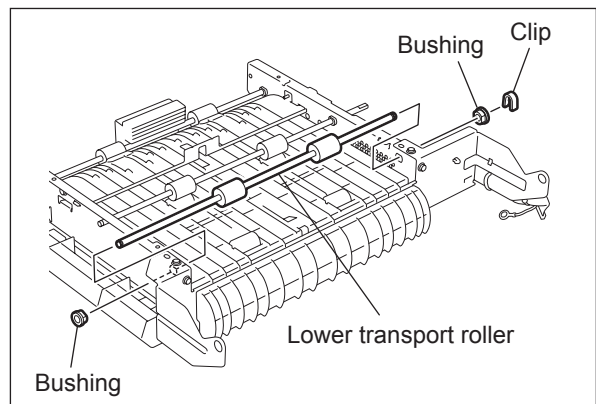



Fig. 15-32

### [K] ADU entrance sensor

- (1) Take off the ADU cover  
( P.15-12 "[E] ADU cover").
- (2) Disconnect 1 connector. Release the latches and take off the ADU entrance sensor.

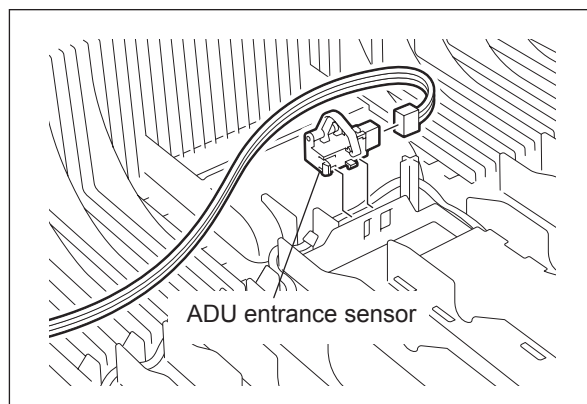



Fig. 15-33

### [L] ADU exit sensor

- (1) Take off the ADU cover  
( P.15-12 "[E] ADU cover").
- (2) Take off the sheet.

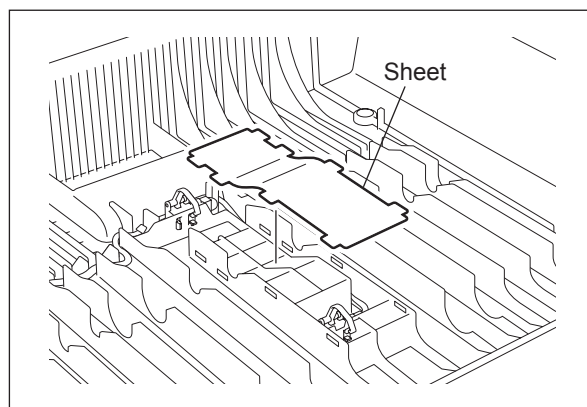

Fig. 15-34

- (3) Disconnect 1 connector. Release the latches and take off the ADU exit sensor.

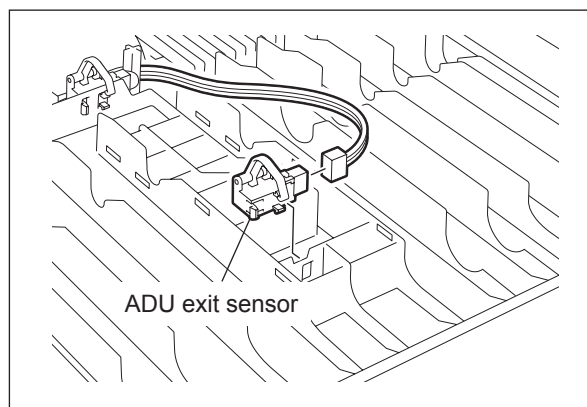

Fig. 15-35

## 16. POWER SUPPLY UNIT

### 16.1 Construction

The power supply unit consists of the AC filter, insulation type DC output circuit, heater lamp control circuit and damp heater power supply circuit.

1) AC filter

Eliminates noise from the outside and prevents the noise generated by the equipment from leaking to the outside.

2) DC output circuits

Converts AC voltage input from outside to DC voltage and supplies it to each electric part. The DC voltage is divided into the following two lines.

a. Main line: Power supply used in the entire equipment during image forming process. Five kinds of voltage (+3.3V, +5.1V, +12V, -12V and +24V) are output when the main switch of the equipment is turned ON.

b. Door switch line :Power supply used in the entire equipment during image forming process, being supplied via the door switch. Two kinds of voltage (+5.1VD and +24VD) are output only when the main switch of the equipment is turned ON and two doors (front cover and transfer guide) are closed.

3) Heater lamp control circuit

TRC (Triac) is driven by the heater control signal (HTR1ON/HTR2ON) from the LGC board and then AC power is supplied to each heater lamp (center and side) in the fuser unit.

4) Damp heater power supply circuit

AC power input from outside is output directly to the FUS board and then supplied to the Damp Heater in each section in the equipment. The Damp Heater (including the FUS board) is an option in NAD/MJD model, and is installed as standard device in other models.

## 16.2 Operation of DC Output Circuits

### 1) Starting line output

When the main switch of the equipment is turned ON, power starts supplying to all the lines only when two doors (front cover and transfer guide) are closed.

### 2) Stopping line output

When the main switch of the equipment is turned OFF, PWR-DN signal is output after the instantaneous outage insurance time (20 ms or more) elapses and then the supply of each voltage stops. If the supply of voltage of the main line (+3.3VA, +5.1VA, +12VA, -12VA) stops earlier than the 24V line does, it may cause the damage of the electron device on each control circuit. To prevent this, the supply of these voltages stops after the PWR-DN signal is output and the minimum retaining time (+3.3VA/+5.1VA: 50 ms or more, +12VA/-12VA: 5 ms or more) elapses.

### 3) Output protection

Each output system includes an overcurrent and overvoltage protection circuits (a fuse and internal protection circuit). This is to prevent the defectives (damage or abnormal operation of the secondary circuit) which may be caused by an overcurrent due to a short circuit or an overvoltage due to a short circuit between different voltages. If the protection circuit is activated (except the case the fuse is blown out), remove the causes such as short-circuit. Turn ON the power again 1 minute later to clear the overcurrent protection.



## 16.3 Output Channel

The followings are five output channels which are not linked with the door switch.

### 1) +3.3V

- +3.3VA : CN705 Pins 13, 14, 15 and 16  
Output to the SYS board
- +3.3VB : CN705 Pins 19 and 20  
Output to the SYS board
- +3.3VB : CN706 Pin 30  
Output to the LGC board
- +3.3VB : CN708 Pins 9 and 10  
Output to the SLG board

### 2) +5.1V

- +5.1VA : CN705 Pins 24 and 26  
Output to the SYS board
- +5.1VB : CN705 Pin 25  
Output to the SYS board
- +5.1VB : CN706 Pin 26  
Output to the FUS board
- +5.1VB : CN706 Pins 27 and 28  
Output to the LGC board, PFP/ LCF (via LGC board),  
Bridge unit / Job separator / Offset tray (via LGC board)
- +5.1VB : CN707 Pin 4  
Output to the finisher
- +5.1VB : CN708 Pins 3 and 4  
Output to the SLG board
- +5.1VB : CN708 Pins 5 and 6  
Output to the RADF

### 3) +12V

- +12VA : CN705 Pin 7  
Output to the SYS board
- +12VB : CN705 Pin 5  
Output to the SYS board
- +12VB : CN706 Pin 22  
Output to the LGC board
- +12VB : CN708 Pin 13  
Output to the SLG board

### 4) -12V

- 12VA : CN705 Pin 9  
Output to the SYS board
- 12VB : CN705 Pin 3  
Output to the SYS board

### 5) +24V

- +24VB : Not used

The followings are two output channels which are linked with the door switch.

1) +5.1V

+5.1VD : CN706 Pin 2  
Output to the LGC board

2) +24V

+24VD1 : CN706 Pins 11, 12, 13 and 14  
Output to the LGC board, PFP/LCF (via LGC board)  
+24VD1 : CN707 Pins 15 and 16  
Output to the main motor  
+24VD2 : CN706 Pins 5 and 6  
Output to the LGC board, High-voltage transformer (via LGC board),  
Bridge unit / Job separator / Offset tray (via LGC board)  
+24VD2 : CN707 Pins 11 and 12  
Output to the ADU board  
+24VD3 : CN708 Pins 23 and 24  
Output to the RADF  
+24VD4 : CN708 Pins 19 and 20  
Output to the SLG board  
+24VD5 : CN707 Pin 8  
Output to the finisher

<<Output connector>>

Not linked with the door switch

| Connector | Destination  | Voltage   |
|-----------|--|---|
| CN705     | For the SYS board  | +3.3VA, +3.3VB, +5.1VA, +5.1VB,<br>+12VA, +12VB, -12VA, -12VB |
| CN706     | For the LGC board, FUS board, PFP/LCF (via LGC board), Bridge unit / Job separator / Offset tray (via LGC board) | +3.3VB, +5.1VB, +12VB   |
| CN707     | For the finisher   | +5.1VB  |
| CN708     | For the SLG board, RADF  | +3.3VB, +5.1VB, +12VB   |

Linked with the door switch

| Connector | Destination   | Voltage                |
|-----------|---|------------------------|
| CN706     | For the LGC board, High-voltage transformer (via LGC board), PFP/LCF (via LGC board), Bridge unit / Job separator / Offset tray (via LGC board) | +5.1VD, +24VD1, +24VD2 |
| CN707     | For the ADU board, finisher   | +24VD1, +24VD2, +24VD5 |
| CN708     | For the SLG board, RADF   | +24VD3, +24VD4         |

## 16.4 Fuse

When the power supply secondary fuse is blown out, confirm that there is no abnormality with each part using the following table.

| Voltage | Board/Unit                                | Part                             | Fuse type             |
|---------|---|----------------------------------|-----------------------|
| +24VD1  | LGC                                       | Main motor                       | F3:8A (Semi time-lag) |
|         |   | Toner motor                      |                       |
|         |   | Polygonal motor                  |                       |
|         |   | Tray-up motor                    |                       |
|         |   | Internal cooling fan 1           |                       |
|         |   | Internal cooling fan 2           |                       |
|         |   | Auto-toner sensor                |                       |
|         |   | Upper drawer feed clutch         |                       |
|         |   | Lower drawer feed clutch         |                       |
|         |   | Registration roller clutch       |                       |
|         |   | Upper transport clutch           |                       |
|         |   | Middle transport clutch          |                       |
|         |   | Lower transport clutch           |                       |
|         |   | Discharge LED                    |                       |
|         |   | Main switch                      |                       |
|         | PFP/LCF                                   |                                  |                       |
| +24VD2  | LGC                                       | Exit motor                       | F5:8A (Semi time-lag) |
|         |   | ADU motor                        |                       |
|         |   | Exhaust fan                      |                       |
|         |   | Bypass feed clutch               |                       |
|         |   | ADU clutch                       |                       |
|         |   | Bypass pickup solenoid           |                       |
|         |   | High-voltage transformer         |                       |
|         |   | Key copy counter / Copy key card |                       |
|         | Bridge unit / Job separator / Offset tray |                                  |                       |
| +24VD3  | RADF                                      |                                  | F6:4A (Semi time-lag) |
| +24VD4  | SLG                                       | Scan motor                       | F5:8A (Semi time-lag) |
|         |   | Exposure lamp (Inverter board)   |                       |
| +24VD5  | Finisher                                  |                                  | F4:5A (Semi time-lag) |

# 16.5 Configuration of Power Supply Unit

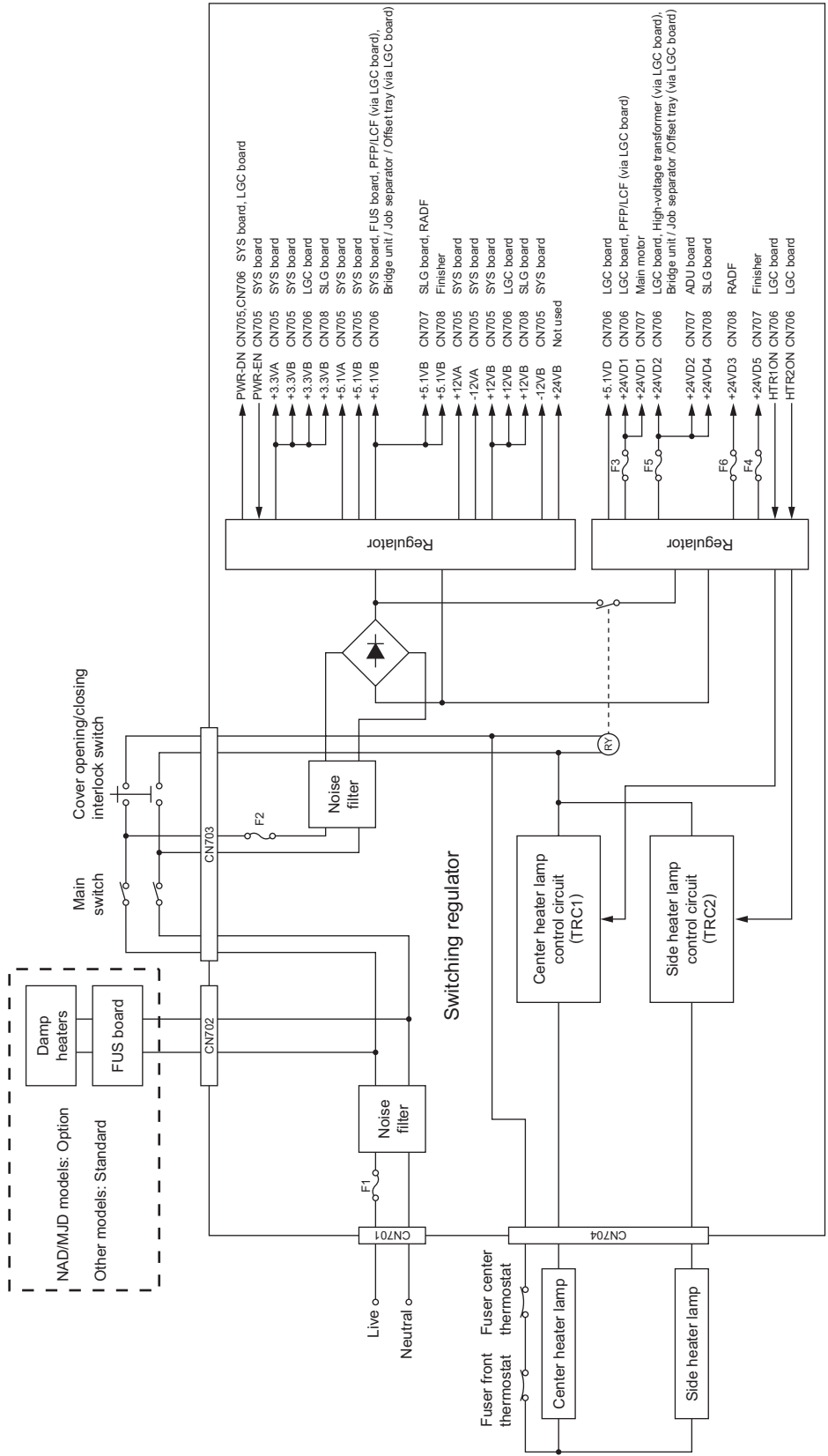

Fig. 16-1

## 16.6 Sequence of Power Supply

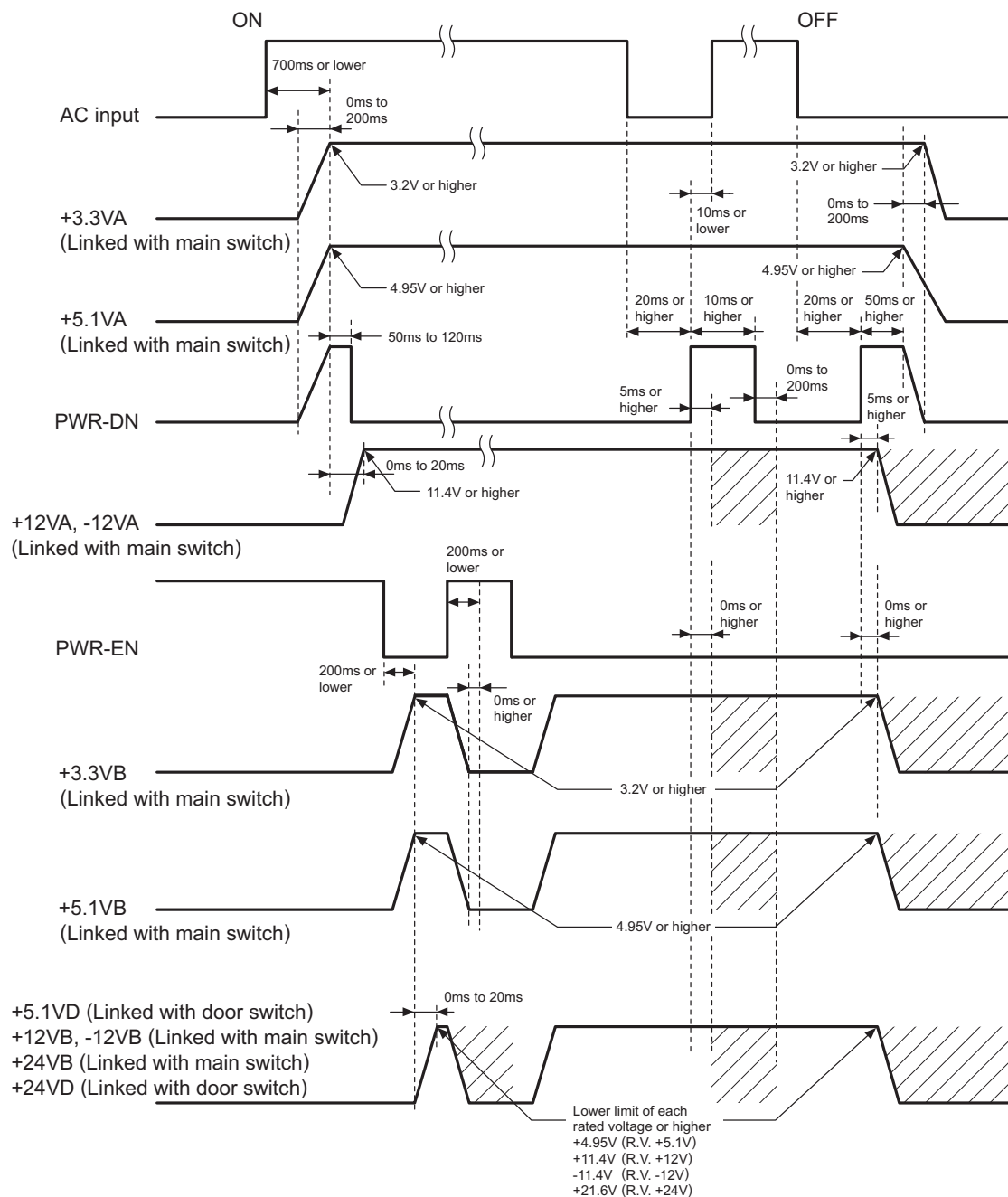

Fig. 16-2

# 16.7 AC Wire Harness

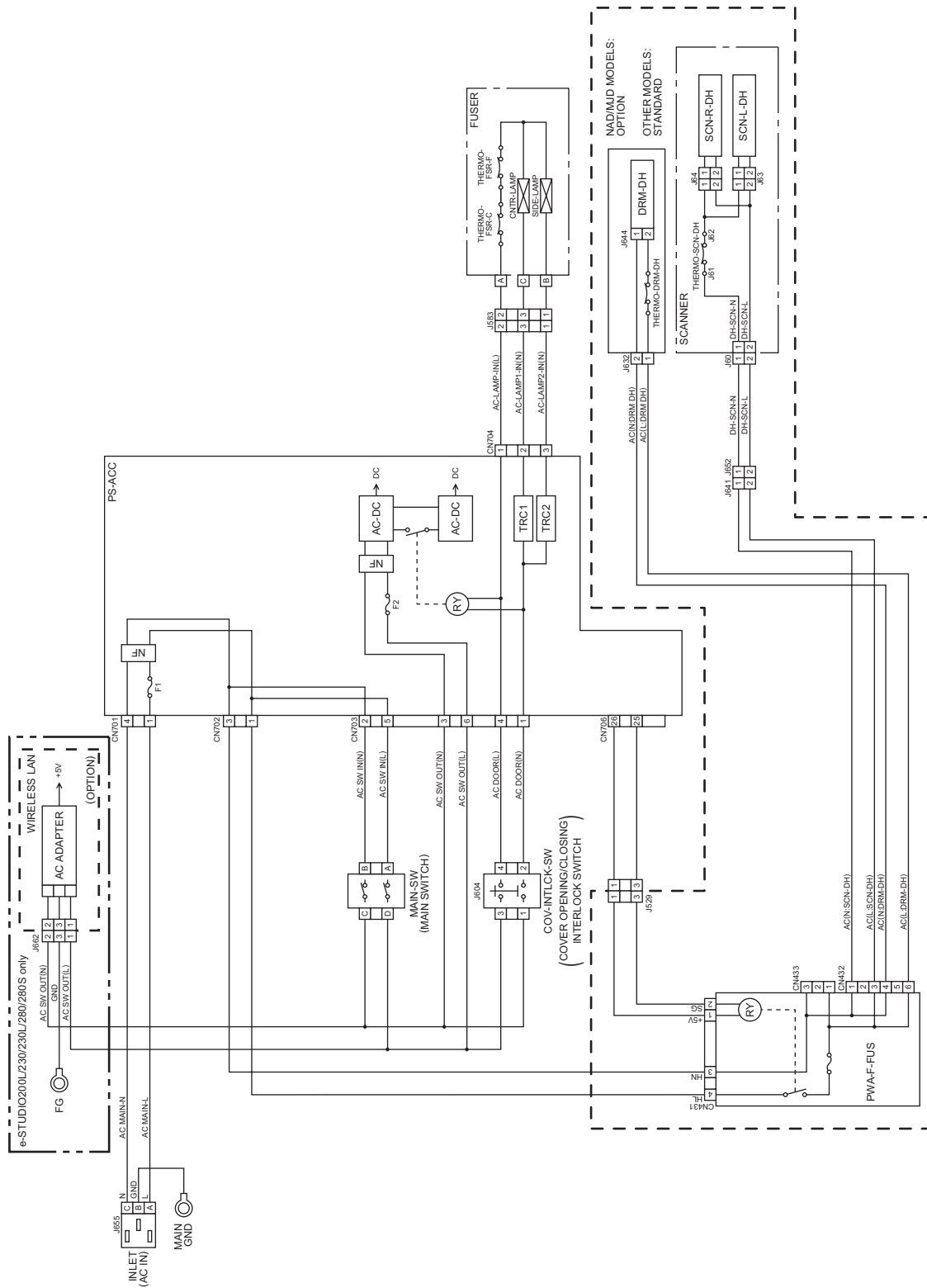
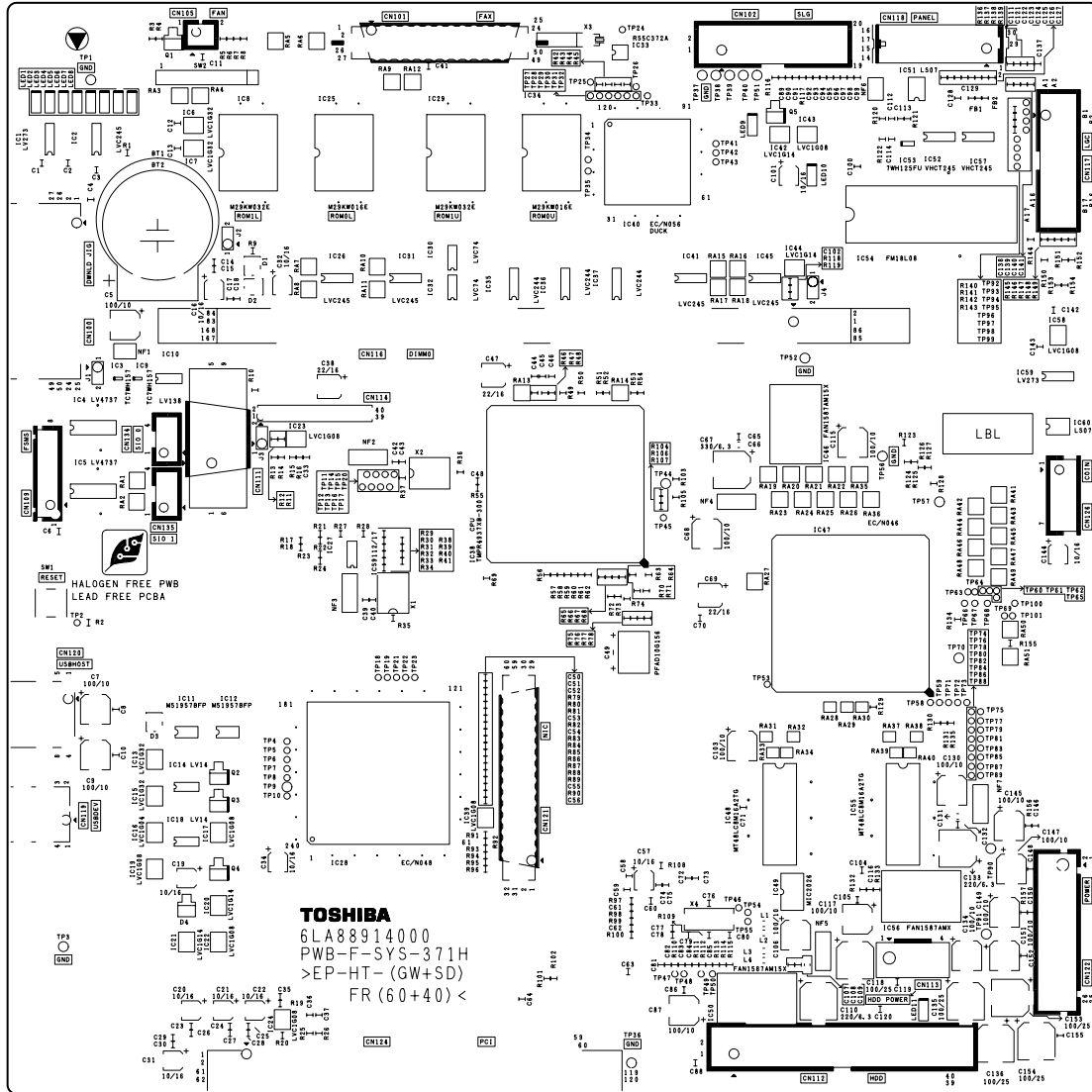
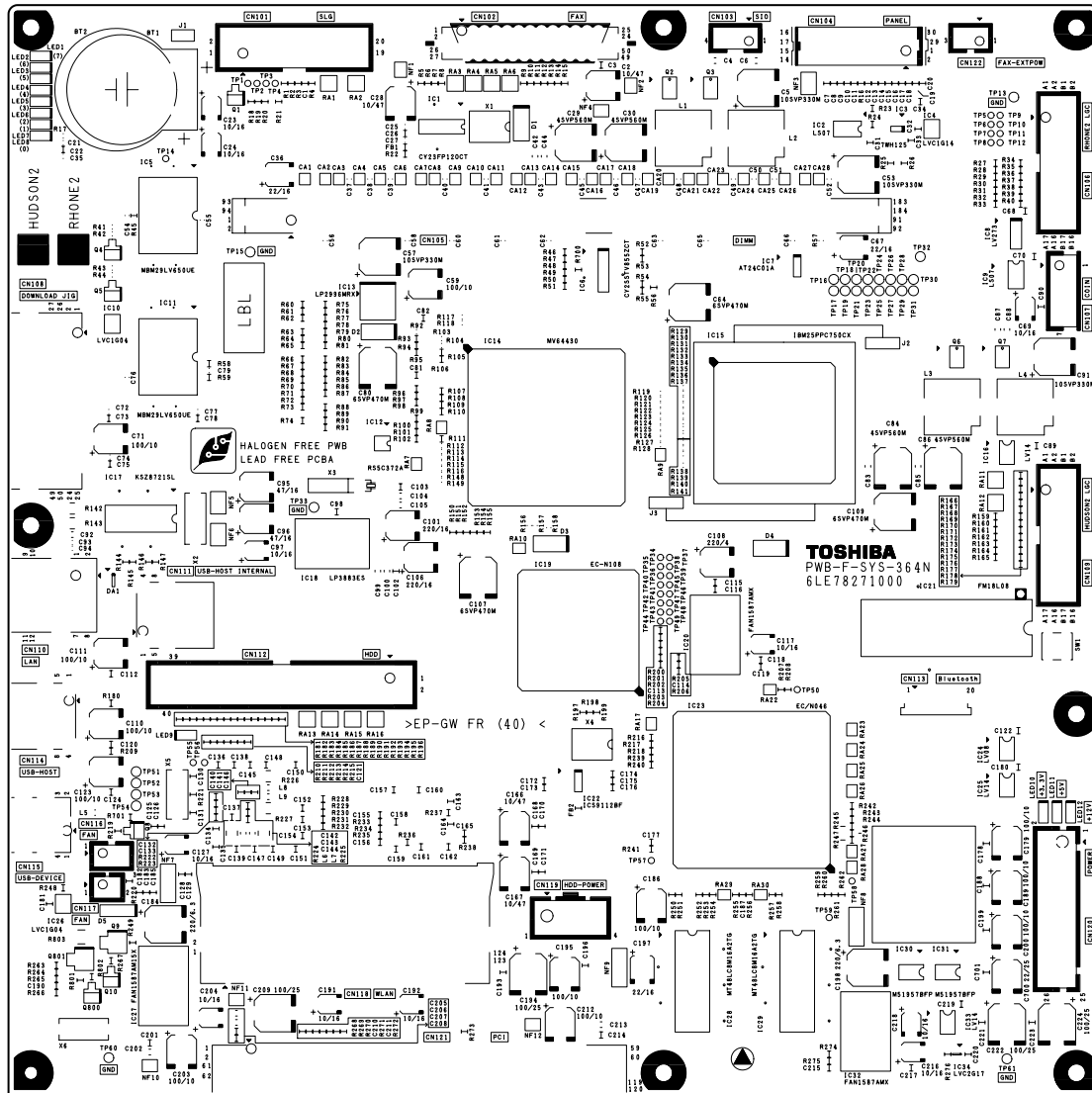

Fig. 16-3

# 17. PC BOARDS

## 1) PWA-F-SYS e-STUDIO200L/230/230L/280/280S







2) PWA-F-LGC  
e-STUDIO200L/230/230L/280/280S

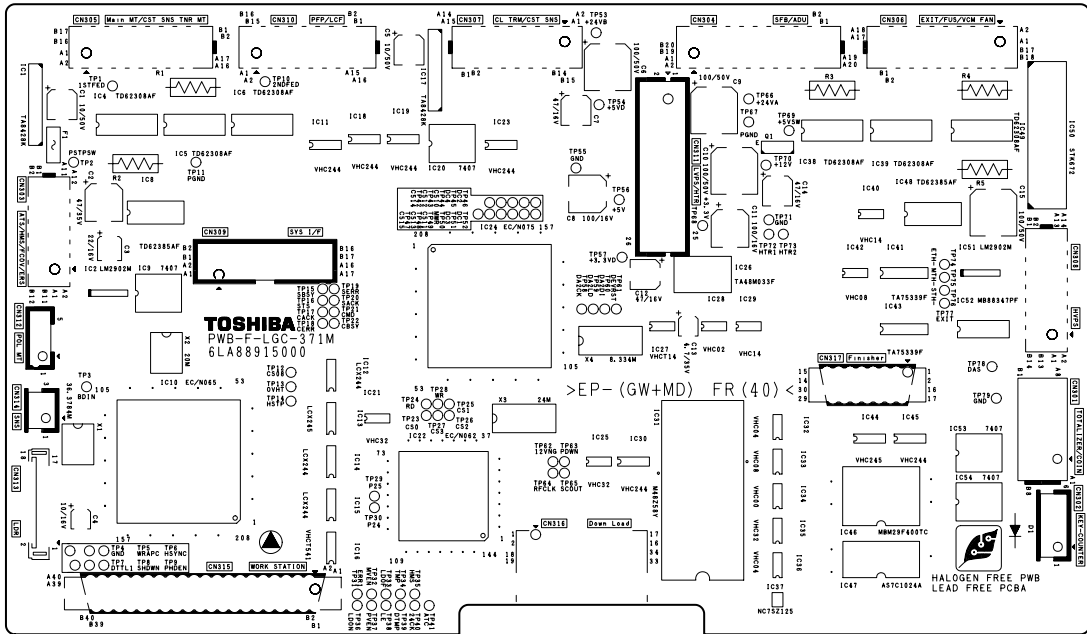

e-STUDIO202L/203L/232/233/232S/282/283/282S/283S

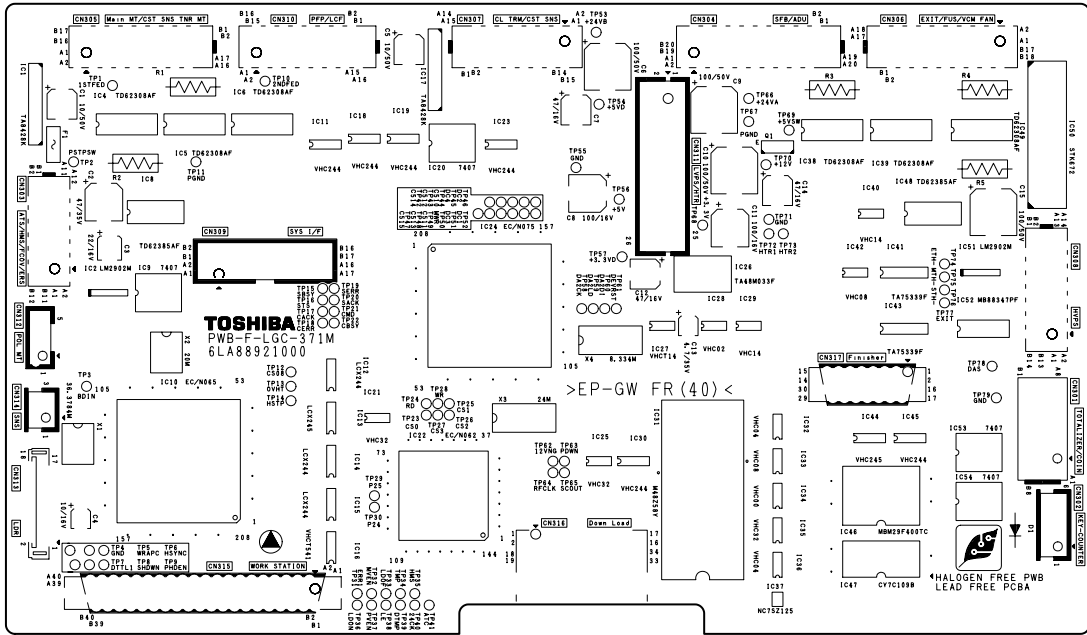

3) PWA-F-SLG  
e-STUDIO200L/230/230L/280/280S

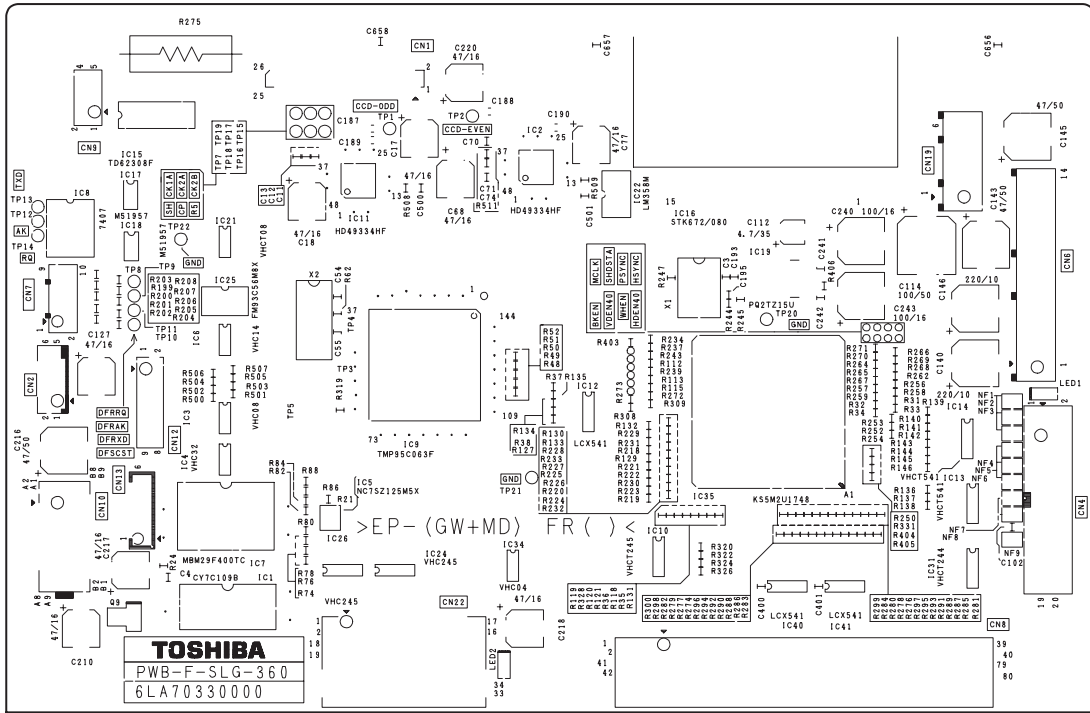

e-STUDIO202L/203L/232/233/232S/282/283/282S/283S

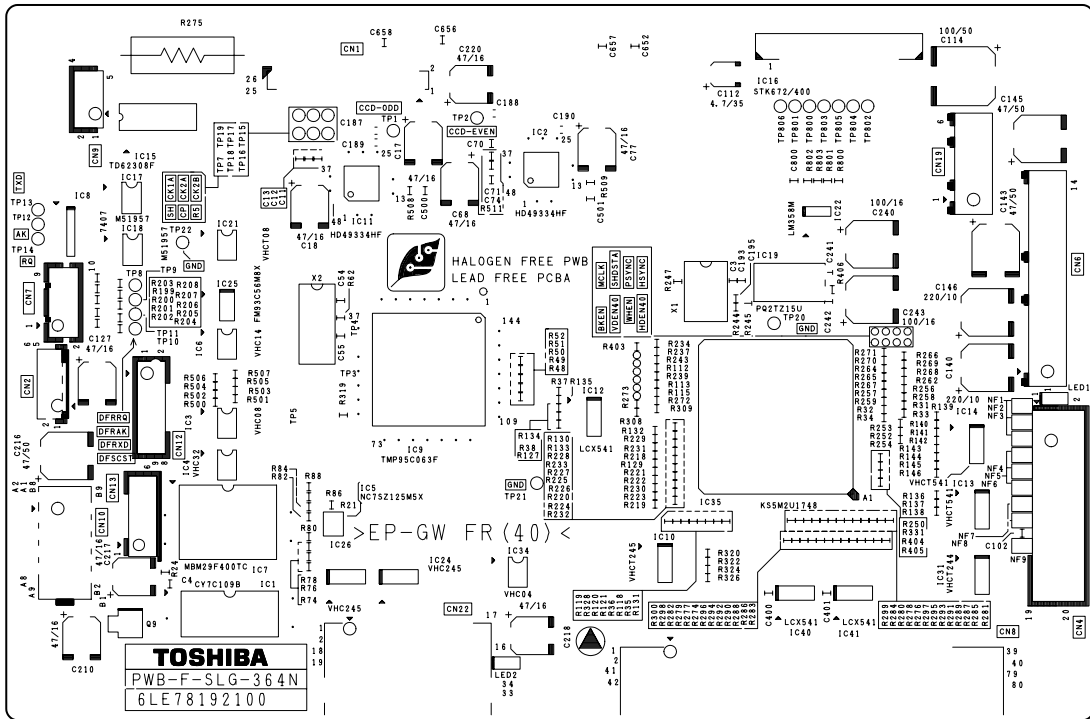

4) PWA-F-CCD  
e-STUDIO200L/230/230L/280/280S

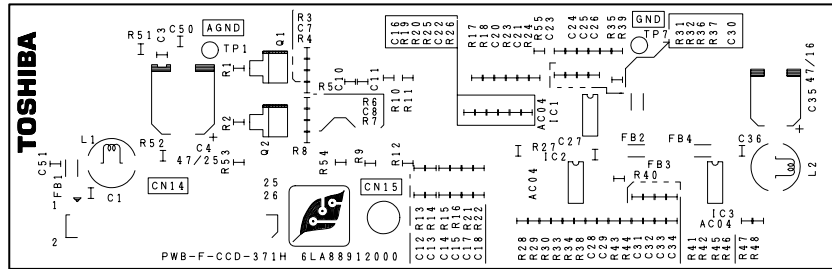

e-STUDIO202L/203L/232/233/232S/282/283/282S/283S

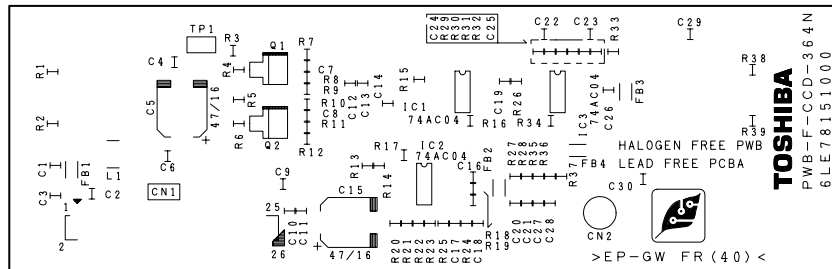

5) PWA-F-LRL

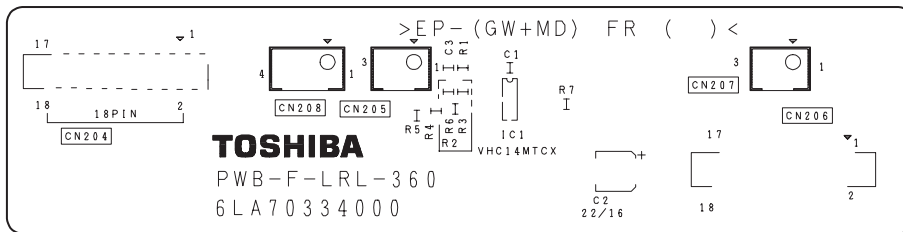

6) PWA-F-LDR

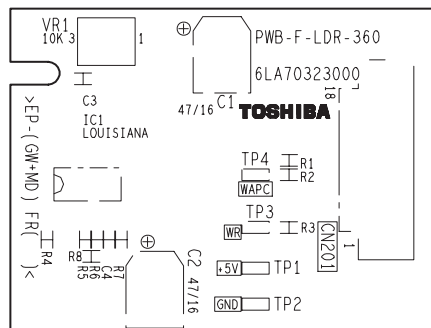

## 7) PWA-F-SNS

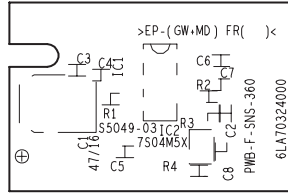

## 8) PWA-F-ADU

- \* e-STUDIO200L/230/280 series  
e-STUDIO230/280 (NAD/AUD/MJD/IRD/CND) models: Standard,  
e-STUDIO200L (NAD/ASD), e-STUDIO230/280 (ASD/ASU/SAD/TWD), e-STUDIO230L (MJD),  
e-STUDIO280S (CND) models: Option
- \* e-STUDIO202L/232/282 series  
e-STUDIO232/282 (NAD/MJD/AUD) models: Standard,  
Other models: Option
- \* e-STUDIO203L/233/282 series  
e-STUDIO233/283 (NAD/MJD/CND) models: Standard,  
Other models: Option

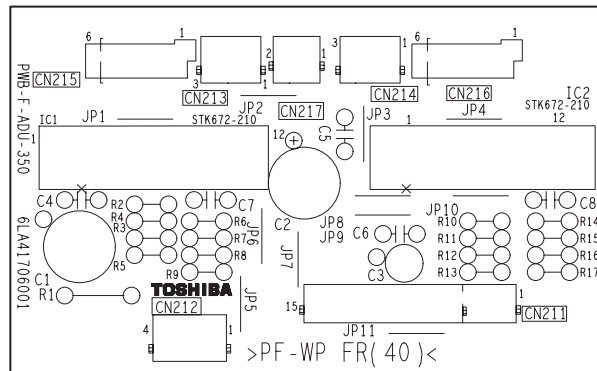

9) PWA-F-DSP  
e-STUDIO200L/230/230L/280/280S

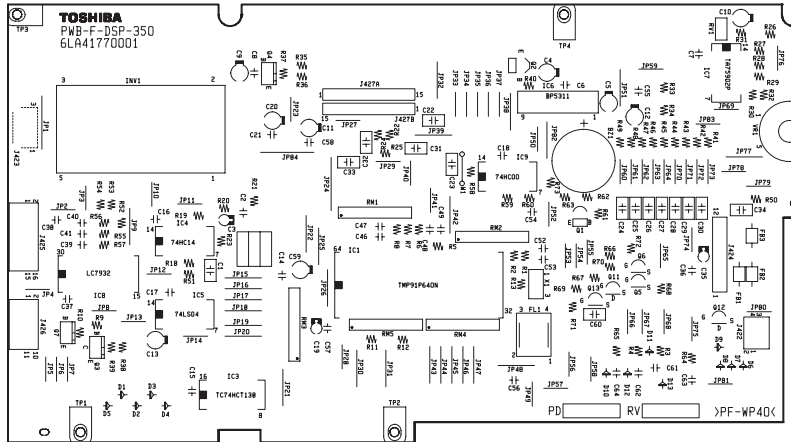

e-STUDIO202L/203L/232/233/232S/282/283/282S/283S

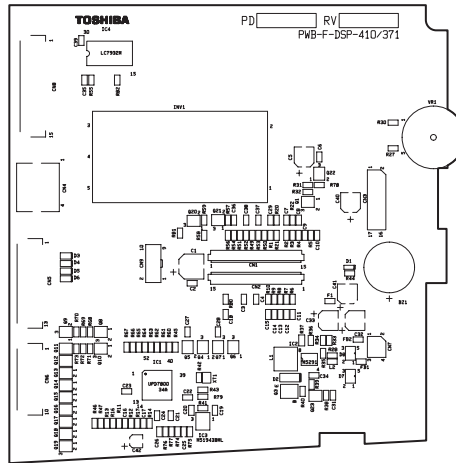

10)PWA-F-KEY  
e-STUDIO200L/230/230L/280/280S

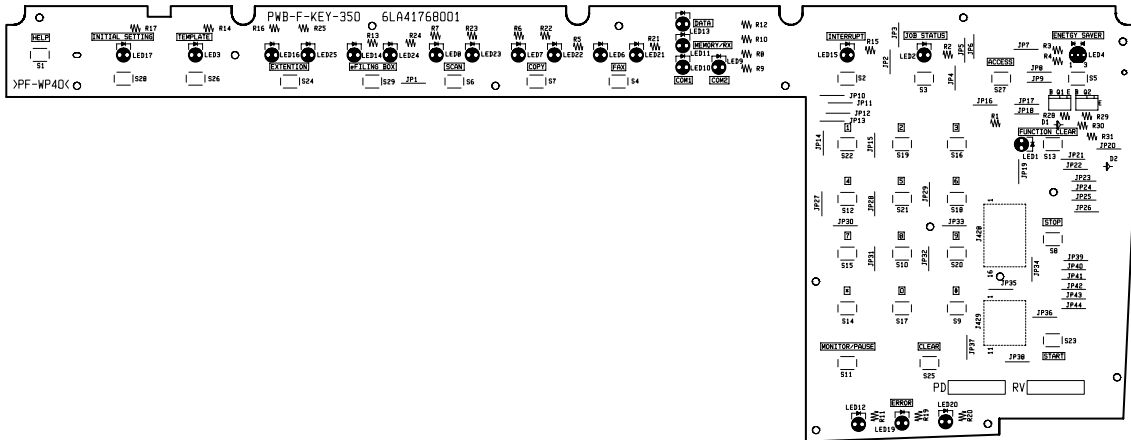

e-STUDIO202L/203L/232/233/232S/282/283/282S/283S

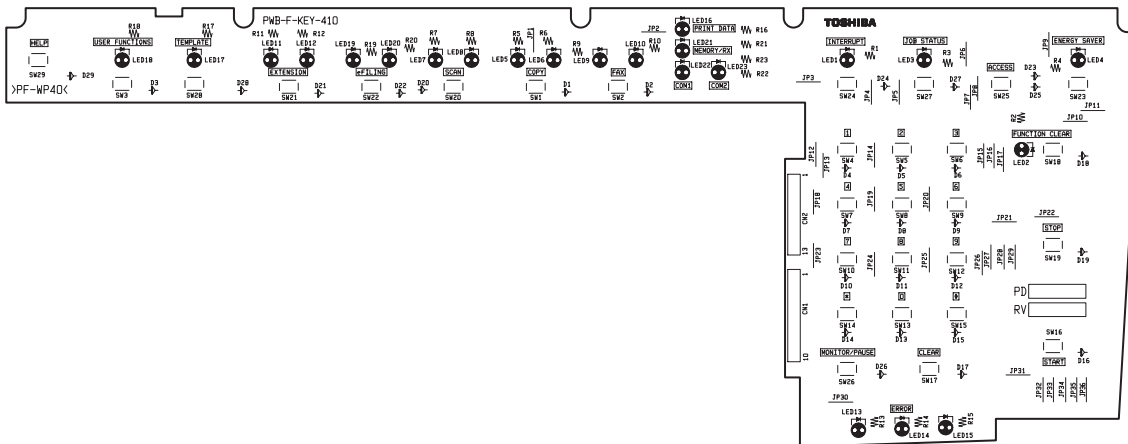

11)PWA-F-FUS

\* ASD/AUD/SAD/ASU/TWD/CND/IRD/ARD/KRD models: Standard, NAD/MJD models: Option

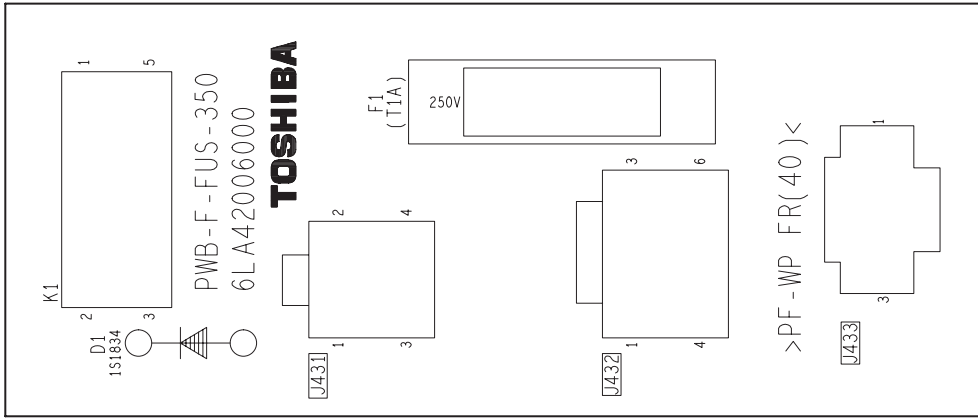

12)PWA-F-NIC (e-STUDIO200L/230/230L/280/280S only)

\* e-STUDIO230/280 (NAD/AUD/MJD/IRD/CND/TWD) models: Standard,  
e-STUDIO200L (NAD/ASD), e-STUDIO230/280 (ASD/ASU/SAD), e-STUDIO230L (MJD),  
e-STUDIO280S (CND) models: Option

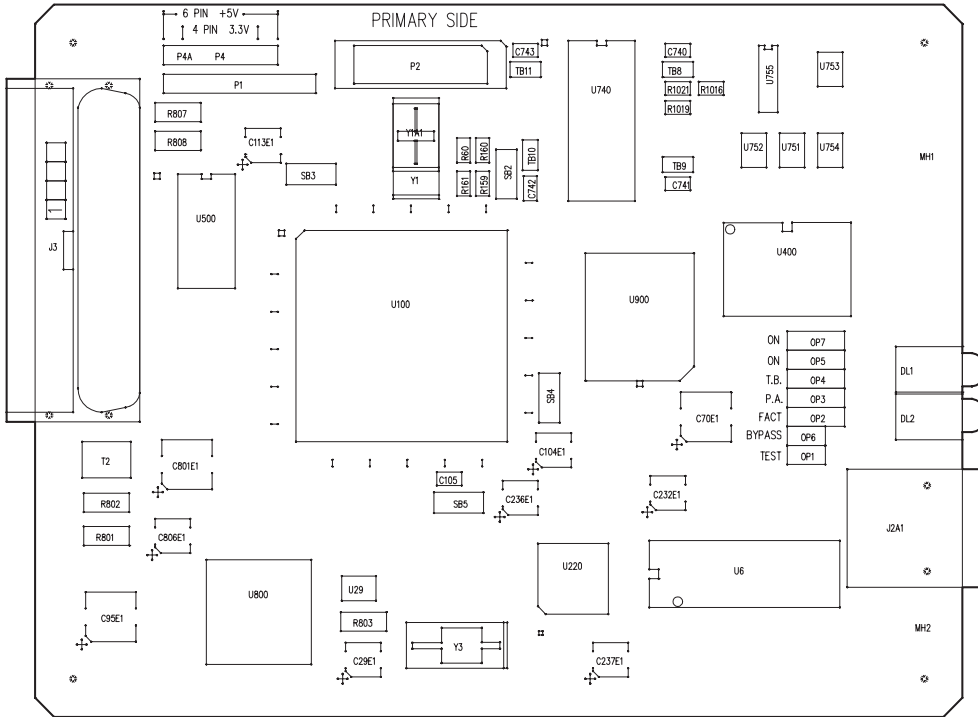







**TOSHIBA**

**TOSHIBA TEC CORPORATION**

2-17-2, HIGASHIGOTANDA, SHINAGAWA-KU, TOKYO, 141-8664, JAPAN