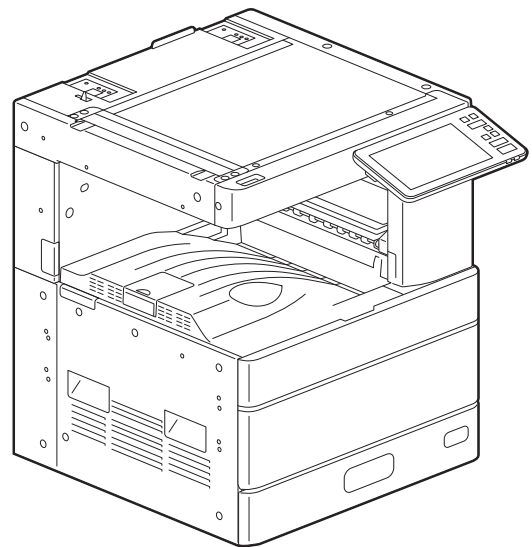


# TOSHIBA

# SERVICE MANUAL

## MULTIFUNCTIONAL DIGITAL COLOR SYSTEMS **e-STUDIO2000AC/2500AC**



Model: FC-2000AC  
Publish Date: March 2016  
File No. SME150006E0  
R150521Q2805-TTEC  
Ver05 F\_2019-03

## Trademarks

- The official name of Windows® Vista is Microsoft Windows Vista Operating System.
- The official name of Windows® 7 is Microsoft Windows 7 Operating System.
- The official name of Windows® 8.1 is Microsoft Windows 8.1 Operating System.
- The official name of Windows® 10 is Microsoft Windows 10 Operating System.
- The official name of Windows Server® 2008 is Microsoft Windows Server 2008 Operating System.
- The official name of Windows Server® 2012 is Microsoft Windows Server 2012 Operating System.
- Microsoft, Windows, Windows NT, and the brand names and product names of other Microsoft products are trademarks of Microsoft Corporation in the US and other countries.
- Apple, AppleTalk, Macintosh, Mac, Mac OS, Safari, iPhone, iPod touch, TrueType, AirPrint, AirPrint logo, and iPad are trademarks of Apple Inc.
- IOS is a trademark or registered trademark of Cisco in the U.S. and other countries and is used under license.
- Adobe, Acrobat, Reader, and PostScript are trademarks of Adobe Systems Incorporated.
- Mozilla®, Firefox® and the Firefox logo® are trademarks or registered trademarks of Mozilla Foundation in the U.S. and other countries.
- IBM, AT and AIX are trademarks of International Business Machines Corporation.
- NOVELL®, NetWare® and NDS® are trademarks of Novell, Inc.
- FLOIL® is a registered trademark of Kanto Kasei CO., Ltd.
- MOLYKOTE® is a registered trademark of Dow Corning Corporation.
- KAPTON® is a registered trademark of E. I. du Pont de Nemours and Company.
- Sankol® is a registered trademark of SANKEIKAGAKU CO.,Ltd.
- e-STUDIO, e-BRIDGE, and TopAccess are trademarks of Toshiba Tec Corporation.
- Other company names and product names in this manual are the trademarks of their respective companies.

© 2016-2019 Toshiba Tec Corporation All rights reserved

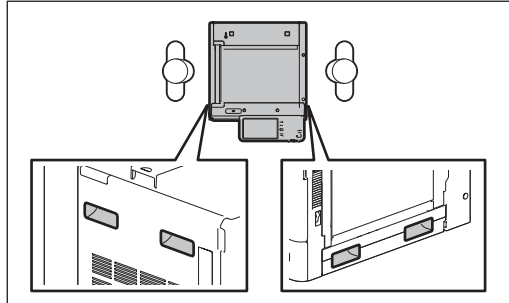
Under the copyright laws, this manual cannot be reproduced in any form without prior written permission of Toshiba Tec Corporation.

# GENERAL PRECAUTIONS REGARDING THE SERVICE FOR THIS EQUIPMENT

**The installation and service shall be done by a qualified service technician.**

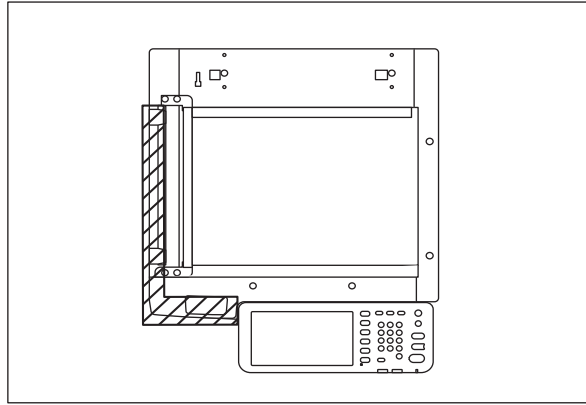
## 1. Transportation/Installation

- When transporting/installing the equipment, employ two persons and be sure to hold the positions as shown in the figure.  
The equipment is quite heavy and weighs approximately 60 kg (132.27 lb.), therefore pay full attention when handling it.



- Be sure not to hold the movable parts or units (e.g. the control panel, ADU or RADF) when transporting the equipment.
- Be sure to use a dedicated outlet with AC 110V/15A, 120V/12A, 220-240V/8A for its power source.
- The equipment must be grounded for safety.
- Select a suitable place for installation. Avoid excessive heat, high humidity, dust, vibration and direct sunlight.
- Provide proper ventilation since the equipment emits a slight amount of ozone.
- To insure adequate working space for the copying operation, keep a minimum clearance of 30 cm (11.8") on the left, 80 cm (32") on the right and 20 cm (7.9") on the rear.
- The equipment shall be installed near the socket outlet and shall be easily accessible.
- Be sure to fix and plug in the power cable securely after the installation so that no one trips over it.
- If the unpacking place and where the equipment is to be installed differ, perform image quality adjustment (automatic gamma adjustment) according to the temperature and humidity of the place of installation and the paper to be used.
- When the equipment is used after the option is removed, be sure to install the parts or the covers which have been taken off so that the inside of the equipment is not exposed.
- Do not use an ozone generator near the MFP. Or, place any ozone generator as far away from the MFP as possible.

- Do not lift the machine by the areas in the figure that are shaded when lifting it.



## 2. General Precautions at Service

- Be sure to turn the power OFF and unplug the power cable during service (except for the service should be done with the power turned ON).
- After the power cable is disconnected, an electric charge may remain in the boards of the equipment. Therefore, be sure to disconnect or connect the connectors when about 1 minute (e.g.: the time for taking off the rear cover) has passed after the power cable is disconnected.
- Unplug the power cable and clean the area around the prongs of the plug and socket outlet once a year or more. A fire may occur when dust lies on this area.
- When the parts are disassembled, reassembly is the reverse of disassembly unless otherwise noted in this manual or other related documents. Be careful not to install small parts such as screws, washers, pins, E-rings, star washers, harnesses in the wrong places.
- Basically, the equipment should not be operated with any parts removed or disassembled.
- The PC board must be stored in an anti-electrostatic bag and handled carefully using an antistatic wrist strap since the ICs on it may be damaged due to static electricity.

Caution: Before using the antistatic wrist strap, unplug the power cable of the equipment and make sure that there are no charged objects which are not insulated in the vicinity.

- Be sure not to touch high-temperature sections such as the fuser unit, damp heater and areas around them.
- Be sure not to touch high-voltage sections such as the chargers, transfer belt, 2nd transfer roller, developer, high-voltage transformer, and power supply unit. Especially, the board of these components should not be touched since the electric charge may remain in the capacitors, etc. on them even after the power is turned OFF.
- Make sure that the equipment will not operate before touching potentially dangerous places (e.g. rotating/operating sections such as gears, belts pulleys, and fans).
- Be careful when removing the covers since there might be the parts with very sharp edges underneath.
- When servicing the equipment with the power turned ON, be sure not to touch live sections and rotating/operating sections.
- Use designated jigs and tools.
- Use recommended measuring instruments or equivalents.
- Return the equipment to the original state and check the operation when the service is finished.
- Be very careful to treat the touch panel gently and never hit it. Breaking the surface could cause malfunctions.
- Do not leave plastic bags where children can get at them. This may cause an accident such as suffocation if a child puts his/her head into a bag. Plastic bags of options or service parts must be brought back.
- There is a risk of an electric shock or fire resulting from the damage to the harness covering or conduction blockage. To avoid this, be sure to wire the harness in the same way as that before disassembling when the equipment is assembled/disassembled.

### 3. General operations

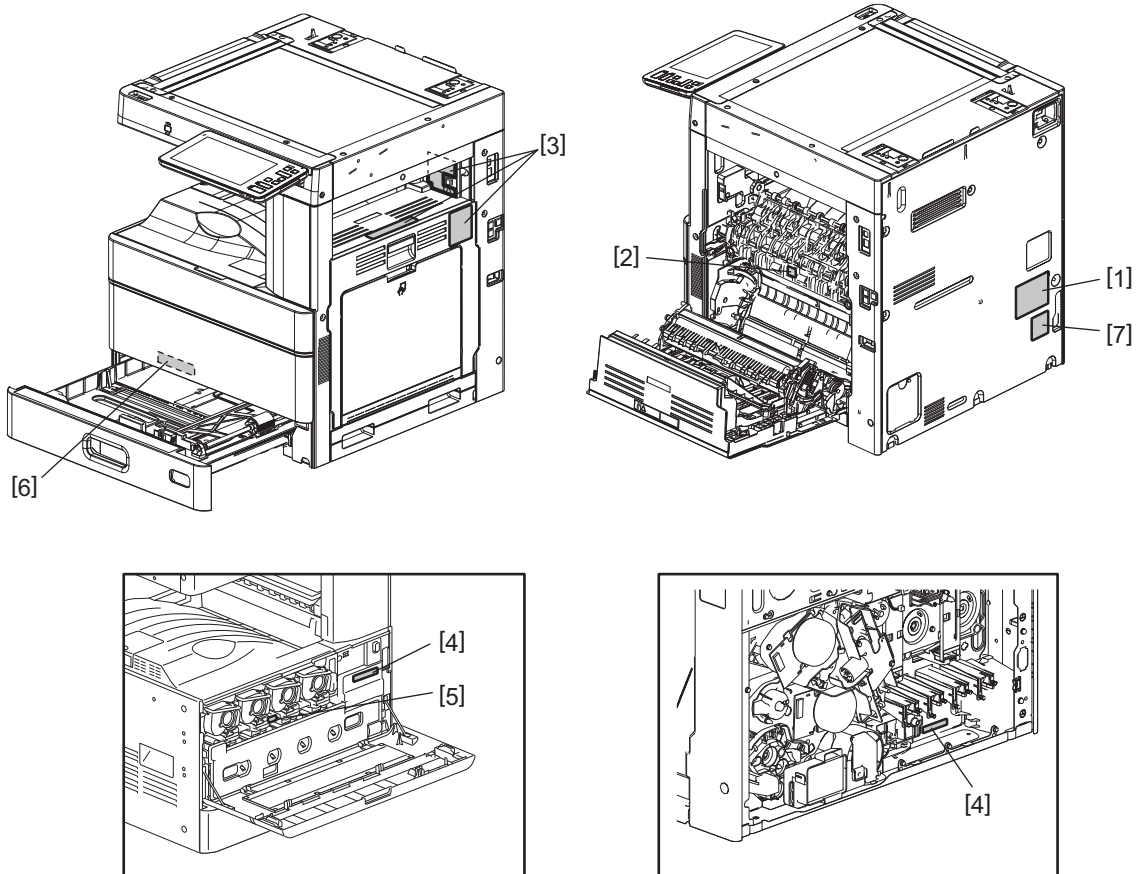
- Check the procedures and perform them as described in the Service Manual.
- Make sure you do not lose your balance.
- Avoid exposure to your skin and wear protective gloves as needed.

### 4. Important Service Parts for Safety

- The breaker, door switch, fuse, thermostat, thermofuse, thermistor, batteries, IC-RAMs including lithium batteries, etc. are particularly important for safety. Be sure to handle/install them properly. If these parts are short-circuited and their functions become ineffective, they may result in fatal accidents such as explosion or fire. Avoid short-circuiting and do not use parts not recommended by Toshiba Tec Corporation.

### 5. Cautionary Labels

- During servicing, be sure to check the rating label and cautionary labels to see if there is any dirt on their surface and if they are properly stuck to the equipment.



- [1] Rating label
- [2] Warning for high temperature area (fuser unit)
- [3] Warning for high temperature area
- [4] Machine serial number label
- [5] Warning for high voltage area
- [6] Warning for high temperature area
- [7] Warning for service

### 6. Disposal of the Equipment, Supplies, Packing Materials, Used Batteries and IC-RAMs

- Regarding the recovery and disposal of the equipment, supplies, packing materials, used batteries and IC-RAMs including lithium batteries, follow the relevant local regulations or rules.

**Caution:**

Dispose of used batteries and IC-RAMs including lithium batteries according to this manual.

**Attention:**

Se débarrasser de batteries et IC-RAMs usés y compris les batteries en lithium selon ce manuel.

**Vorsicht:**

Entsorgung der gebrauchten Batterien und IC-RAMs (inclusive der Lithium-Batterie) nach diesem Handbuch.

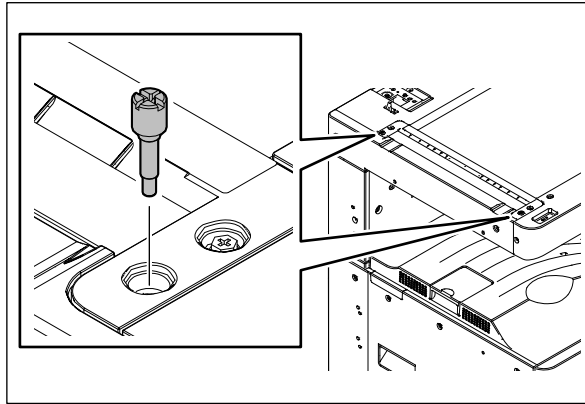
## 1. Precautions for Transporting Equipment Once Unpacked

### 1.1 General Description

It is recommended to follow the procedure below when you transport equipment that has already been unpacked but has not been packed again. Note that the following procedure cannot guarantee the operation of the transported equipment.

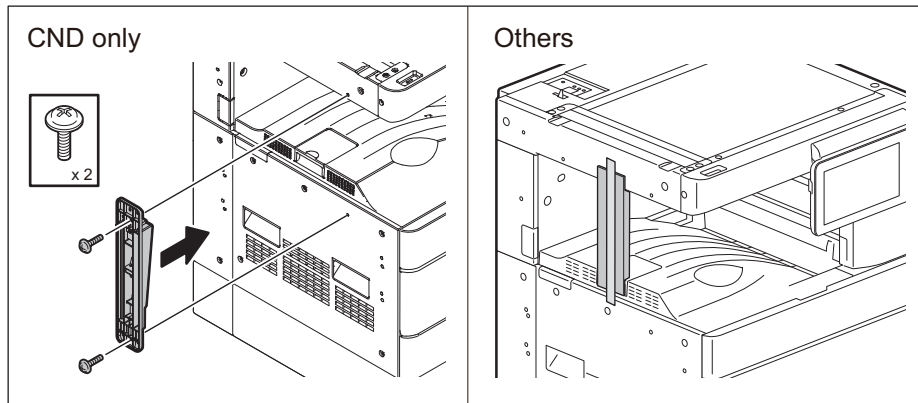
#### [A] Fixing the carriage

- (1) Perform the PM code: FS-03-261 (Scan motor ON Automatically stops at limit position) so that the carriage is moved to the fixing position.
- (2) Tighten the 2 screws to fix the carriage.



#### [B] Attach the packing material (scanner supporting member)

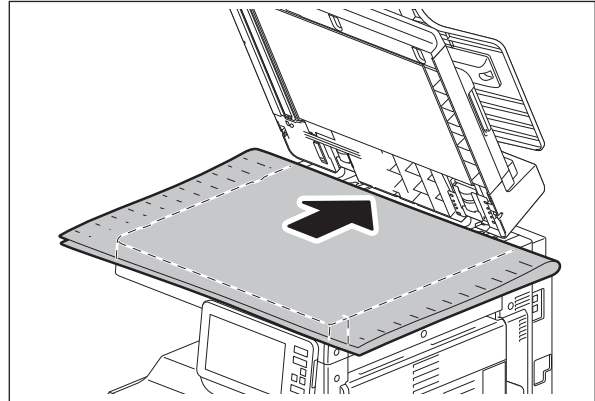
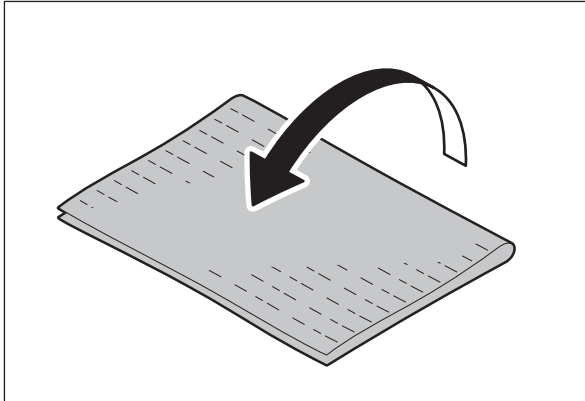
- (1) Attach the packing material under the scanner (if it is still kept immediately after the setup).



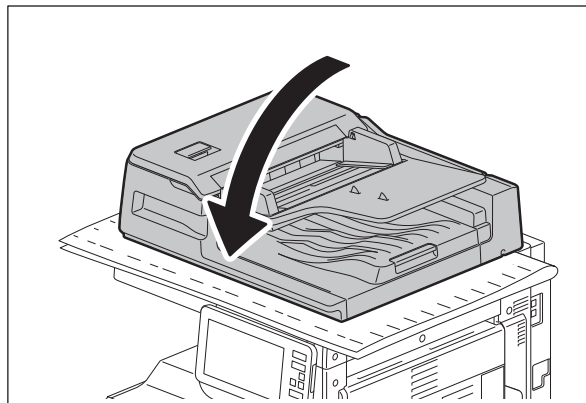
**[C] Attach the cushioning material**

When transporting the equipment with the DSDF installed, be sure to attach the cushioning material as below to prevent the cover in the scanner section from being scratched by the protrusion of the DSDF cover.

- (1) Fold the cushioning material (packing material) in two. (Utilize the packing material used in the scanner section, if available.) Place it on the upper surface of the scanner section so that it is covered.



- (2) While paying attention to ensure that the cushioning material is not moved, slowly close the DSDF.



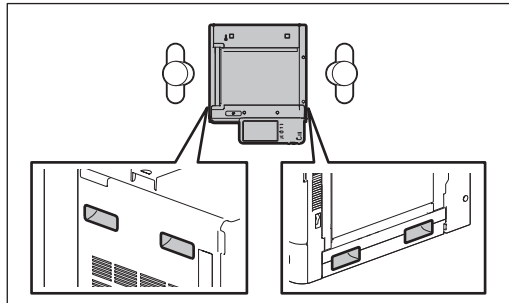


# ALLGEMEINE SICHERHEITSMASSNAHMEN IN BEZUG AUF DIE WARTUNG

**Die Installation und die Wartung sind von einem qualifizierten Service-Techniker durchzuführen.**

## 1. Transport/Installation

- Zum Transportieren/Installieren des Gerätes werden 2 Personen benötigt. Nur an den in der Abbildung gezeigten Stellen tragen.  
Das Gerät ist sehr schwer und wiegt etwa 60 kg; deshalb muss bei der Handhabung des Geräts besonders aufgepasst werden.



- Beim Transportieren des Geräts nicht an den beweglichen Teilen oder Einheiten (z.B. das Bedienungsfeld, die Duplexeinheit oder die automatische Dokumentenzuführung) halten.
- Eine spezielle Steckdose mit Stromversorgung von AC 110V/15A, 120V/12A, 220-240V/8A als Stromquelle verwenden.
- Das Gerät ist aus Sicherheitsgründen zu erden.
- Einen geeigneten Standort für die Installation wählen. Standorte mit zuviel Hitze, hoher Luftfeuchtigkeit, Staub, Vibrieren und direkter Sonneneinstrahlung sind zu vermeiden.
- Für ausreichende Belüftung sorgen, da das Gerät etwas Ozon abgibt.
- Um einen optimalen Kopierbetrieb zu gewährleisten, muss ein Abstand von mindestens 80 cm links, 80 cm rechts und 20 cm dahinter eingehalten werden.
- Das Gerät ist in der Nähe der Steckdose zu installieren; diese muss leicht zu erreichen sein.
- Nach der Installation muss das Netzkabel richtig hineingesteckt und befestigt werden, damit niemand darüber stolpern kann.
- Falls der Auspackungsstandort und der Installationsstandort des Geräts verschieden sind, die Bildqualitätsjustierung (automatische Gammajustierung) je nach der Temperatur und Luftfeuchtigkeit des Installationsstandorts und der Papiersorte, die verwendet wird, durchführen.

## 2. Allgemeine Sicherheitsmassnahmen in bezug auf die Wartung

- Während der Wartung das Gerät ausschalten und das Netzkabel herausziehen (ausser Wartung, die bei einem eingeschalteten Gerät, durchgeführt werden muss).
- Das Netzkabel herausziehen und den Bereich um die Steckerpole und die Steckdose die Umgebung in der Nähe von den Steckerzacken und der Steckdose wenigstens einmal im Jahr reinigen. Wenn Staub sich in dieser Gegend ansammelt, kann dies ein Feuer verursachen.
- Wenn die Teile auseinandergenommen werden, wenn nicht anders in diesem Handbuch usw erklärt, ist das Zusammenbauen in umgekehrter Reihenfolge durchzuführen. Aufpassen, dass kleine Teile wie Schrauben, Dichtungsringe, Bolzen, E-Ringe, Stern-Dichtungsringe, Kabelbäume nicht an den verkehrten Stellen eingebaut werden.
- Grundsätzlich darf das Gerät mit entfernten oder auseinandergenommenen Teilen nicht in Betrieb genommen werden.
- Das PC-Board muss in einer Anti-elektrostatischen Hülle gelagert werden. Nur Mit einer Manschette bei Betätigung eines Armbandes anfassen, sonst könnte es sein, dass die integrierten Schaltkreise durch statische Elektrizität beschädigt werden.

Vorsicht: Vor Benutzung der Manschette der Betätigung des Armbandes, das Netzkabel des Gerätes herausziehen und prüfen, dass es in der Nähe keine geladenen Gegenstände, die nicht isoliert sind, gibt.

- Auf keinen Fall Hochtemperaturbereiche, wie die Fixiereinheit, die Heizquelle und die umliegenden Bereiche, berühren.
- Auf keinen Fall Hochspannungsbereiche, wie die Ladeeinheiten, das Transferband, die zweite Transferwalze, die Entwicklereinheit, den Hochspannungstransformator und das Netzgerät, berühren. Insbesondere sollten die Platinen dieser Komponenten nicht berührt werden, da die Kondensatoren usw. auch nach dem Ausschalten des Geräts noch elektrisch geladen sein können.
- Vor dem Berühren potenziell gefährlicher Bereiche (z. B. drehbare oder betriebsrelevante Bereiche, wie Zahnräder, Riemen, Riemenscheiben und Lüfter) sicherstellen, dass das Gerät sich nicht bedienen lässt.
- Beim Entfernen von Abdeckungen vorsichtig vorgehen, da sich darunter scharfkantige Komponenten befinden können.
- Beim Entfernen von Abdeckungen vorsichtig vorgehen, da sich darunter scharfkantige Komponenten befinden können.
- Ausschließlich vorgesehene Werkzeuge und Hilfsmittel verwenden.
- Empfohlene oder gleichwertige Messgeräte verwenden.
- Nach Abschluss der Wartungsarbeiten das Gerät in den ursprünglichen Zustand zurück versetzen und den einwandfreien Betrieb überprüfen.
- Das berührungsempfindliche Bedienungsfeld stets vorsichtig handhaben und keinen Stößen aussetzen. Wenn die Oberfläche beschädigt wird, kann dies zu Funktionsstörungen führen.
- Bewahren Sie Kunststofftüten kindersicher auf. Es besteht Erstickungsgefahr, wenn sich Kinder beim Spielen eine Kunststofftüte über den Kopf ziehen. Bitte nehmen Sie die Kunststofftüten von Optionen oder Serviceparts wieder zurück.
- Wenn der Schutzmantel eines Kabels oder die Steckerisolierung beschädigt werden, besteht Brandgefahr oder die Gefahr eines elektrischen Schlags. Um dies zu vermeiden, sollten Kabel in der gleichen Weise verlegt werden, wie sie vor der Demontage/dem Transport verlegt waren.

## 3. Allgemeine Sicherheitsmassnahmen

- Die Verfahren sind zu überprüfen und wie im Wartungshandbuch beschrieben durchzuführen.
- Vorsichtig, dass Sie nicht umfallen.
- Um Aussetzung zur Haut zu vermeiden, tragen Sie wenn nötig Schutzhandschuhe.

#### 4. Sicherheitsrelevante Wartungsteile

- Der Leistungsschutzschalter, der Türschalter, die Sicherung, der Thermostat, die Thermosicherung, der Thermistor, der Akkus, die IC-RAMs einschließlich der Lithiumakkus usw. sind besonders sicherheitsrelevant. Sie müssen unbedingt korrekt gehandhabt und installiert werden. Wenn diese Teile kurzgeschlossen und funktionsunfähig werden, kann dies zu schwerwiegenden Schäden, wie einer Explosion oder einem Abbrand, führen. Kurzschlüsse sind zu vermeiden, und es sind ausschließlich Teile zu verwenden, die von der Toshiba Tec Corporation empfohlen sind.

#### 5. Warnetiketten

- Im Rahmen der Wartung unbedingt das Leistungsschild und die Etiketten mit Warnhinweisen überprüfen [z. B. „Unplug the power cable during service“ („Netzkabel vor Beginn der Wartungsarbeiten abziehen“), „CAUTION. HOT“ („VORSICHT, HEISS“), „CAUTION. HIGH VOLTAGE“ („VORSICHT, HOCHSPANNUNG“)], um sicherzustellen, dass sie nicht verschmutzt sind und korrekt am Gerät angebracht sind.

#### 6. Entsorgung des Geräts, der Verbrauchs- und Verpackungsmaterialien, alter Akkus und IC-RAMs

- In Bezug auf die Entsorgung und Wiederverwertung des Geräts, der Verbrauchs- und Verpackungsmaterialien, alter Akkus und IC-RAMs, einschließlich Lithiumakkus, sind die einschlägigen nationalen oder regionalen Vorschriften zu befolgen.

**Caution:**

Dispose of used batteries and IC-RAMs including lithium batteries according to this manual.

**Attention:**

Se débarrasser de batteries et IC-RAMs usés y compris les batteries en lithium selon ce manuel.

**Vorsicht:**

Entsorgung der gebrauchten Batterien und IC-RAMs (inclusive der Lithium-Batterie) nach diesem Handbuch.



# CONTENTS

<b>1. FEATURE</b> .....	<b>1-1</b>
1.1 Main Features of this Equipment .....	1-1
<b>2. SPECIFICATIONS/ACCESSORIES/OPTIONS/SUPPLIES</b> .....	<b>2-1</b>
2.1 Specifications .....	2-1
2.1.1 General .....	2-1
2.1.2 Copy .....	2-4
2.1.3 Print .....	2-7
2.1.4 Scan .....	2-7
2.1.5 Internet Fax .....	2-8
2.1.6 Network Fax (Option) .....	2-9
2.2 Accessories .....	2-10
2.3 System List .....	2-11
2.4 Option List .....	2-14
2.5 Supplies .....	2-15
<b>3. OUTLINE OF THE MACHINE</b> .....	<b>3-1</b>
3.1 Sectional View .....	3-1
3.1.1 Front side .....	3-1
3.1.2 Rear side .....	3-3
3.2 Electric Parts Layout .....	3-4
3.3 Symbols and Functions of Various Components .....	3-14
3.3.1 Motors, fans .....	3-14
3.3.2 Sensors and switches .....	3-14
3.3.3 Electromagnetic spring clutches .....	3-17
3.3.4 Solenoids .....	3-17
3.3.5 PC boards .....	3-17
3.3.6 Lamps and heaters .....	3-18
3.3.7 Thermistors, thermostats .....	3-18
3.3.8 Others .....	3-19
3.4 Copy Process .....	3-20
3.5 Comparison with e-STUDIO2050C/2550C/2051C/2551C .....	3-21
3.6 General Operation .....	3-24
3.6.1 Overview of Operation .....	3-24
3.6.2 Description of Operation .....	3-25
3.6.3 Detection of Abnormality .....	3-29
3.6.4 Hibernation function .....	3-36
3.7 Control Panel .....	3-37
3.7.1 General Description .....	3-37
3.8 Scanner .....	3-38
3.8.1 General Description .....	3-38
3.8.2 Construction .....	3-39
3.8.3 Functions .....	3-40
3.8.4 Description of Operation .....	3-42
3.8.5 Process of detection of original size .....	3-43
3.9 Writing Section .....	3-45
3.9.1 General Description .....	3-45
3.9.2 General description of LED printer head .....	3-46
3.9.3 LED printer head lifting mechanism .....	3-47
3.10 Driving Section .....	3-48
3.10.1 Drum TBU drive unit .....	3-49
3.10.2 Feeding/developing drive unit .....	3-50
3.10.3 Monochrome/color switching mechanism .....	3-51
3.11 Paper Feeding System .....	3-52
3.11.1 General Descriptions .....	3-52
3.11.2 Composition .....	3-53

3.11.3	Functions .....	3-54
3.11.4	Description of Operation .....	3-55
3.12	Process Unit Related Section .....	3-61
3.12.1	General description .....	3-61
3.12.2	Composition .....	3-63
3.12.3	Functions .....	3-64
3.12.4	Drum driving sleep mode .....	3-66
3.13	Developer Unit .....	3-67
3.13.1	General Description .....	3-67
3.13.2	Composition .....	3-68
3.13.3	Functions .....	3-69
3.13.4	Functions of the toner cartridge PC board (CTRG) .....	3-70
3.13.5	Waste toner box .....	3-73
3.14	Transfer Unit .....	3-74
3.14.1	General Descriptions .....	3-74
3.14.2	Composition .....	3-75
3.15	Image Quality Control .....	3-76
3.15.1	General Description .....	3-76
3.16	Fuser unit / Paper exit section .....	3-77
3.16.1	General Description .....	3-77
3.16.2	Composition .....	3-78
3.16.3	Electric Circuit Description .....	3-79
3.17	Automatic Duplexing Unit (ADU) .....	3-84
3.17.1	General Description .....	3-84
3.17.2	Composition .....	3-85
3.17.3	Drive of ADU .....	3-86
3.17.4	Description of Operations .....	3-87
3.18	Power Supply Unit .....	3-88
3.18.1	General description .....	3-88
3.18.2	Functions .....	3-88
3.18.3	Operation of DC Output Circuits .....	3-89
3.18.4	Output Channel .....	3-91
3.18.5	Fuse .....	3-92
<b>4.</b>	<b>DISASSEMBLY AND REPLACEMENT .....</b>	<b>4-1</b>
4.1	Covers .....	4-1
4.1.1	Front cover .....	4-1
4.1.2	Left cover .....	4-1
4.1.3	Receiving tray .....	4-2
4.1.4	Tray rear cover .....	4-2
4.1.5	Left top cover .....	4-3
4.1.6	Left rear cover .....	4-3
4.1.7	Receiving rear cover .....	4-3
4.1.8	Right top cover .....	4-4
4.1.9	Control panel lower cover .....	4-4
4.1.10	Right front cover .....	4-5
4.1.11	Right rear cover .....	4-5
4.1.12	Front top cover .....	4-5
4.1.13	Front right cover .....	4-6
4.1.14	Rear top cover .....	4-6
4.1.15	Rear cover .....	4-6
4.1.16	Front cover switch (SW1) .....	4-7
4.1.17	Front cover interlock switch (SW2) .....	4-8
4.2	Control Panel .....	4-9
4.2.1	Control panel unit .....	4-9
4.2.2	KEY board/button .....	4-12
4.2.3	DSP board .....	4-13
4.3	Scanner Unit .....	4-16
4.3.1	Original glass .....	4-19

4.3.2	Lens cover .....	4-20
4.3.3	Automatic original detection sensor-1 (S24).....	4-20
4.3.4	Automatic original detection sensor-2 (S25).....	4-20
4.3.5	Lens unit/CCD driving PC board.....	4-21
4.3.6	Carriage home position sensor (S23).....	4-23
4.3.7	Exposure lamp (EXP) .....	4-24
4.3.8	Scan motor (M1).....	4-25
4.3.9	Platen sensor (S21, S22).....	4-27
4.3.10	Carriage-1 .....	4-28
4.3.11	Carriage wire, carriage-2 .....	4-31
4.3.12	Scanner damp heater .....	4-34
4.4	Writing Section.....	4-35
4.4.1	LED Tray.....	4-35
4.4.2	Discharge LED.....	4-38
4.4.3	LED printer head.....	4-39
4.4.4	LED gap spacer .....	4-46
4.5	Paper Feeding System.....	4-47
4.5.1	Bypass unit .....	4-47
4.5.2	Bypass feed roller .....	4-48
4.5.3	Bypass separation roller .....	4-51
4.5.4	Paper width detection PC board (S17) .....	4-52
4.5.5	Bypass feed sensor (S16) .....	4-52
4.5.6	Side cover switch (SW5).....	4-54
4.5.7	Registration sensor (S19), feed sensor (S20) .....	4-55
4.5.8	Registration roller (on the equipment side).....	4-57
4.5.9	Registration roller (on the ADU side).....	4-57
4.5.10	Drawer feed roller .....	4-59
4.5.11	Drawer separation pad .....	4-60
4.5.12	1st drawer empty sensor (S5).....	4-61
4.5.13	1st drawer size detection switch-1, -2 (SW6, SW7).....	4-61
4.5.14	1st drawer detection switch (SW8) .....	4-63
4.5.15	Registration clutch (CLT1).....	4-63
4.5.16	Feed clutch (CLT2).....	4-64
4.5.17	Paper feed drive gear .....	4-65
4.6	Developer Unit, Cleaner.....	4-67
4.6.1	Waste toner box.....	4-67
4.6.2	Developer unit.....	4-68
4.6.3	Developer material.....	4-69
4.6.4	Doctor blade .....	4-74
4.6.5	Side seal .....	4-74
4.6.6	Auto-toner sensor (S1, S2, S3, S4) .....	4-75
4.6.7	Developer sleeve .....	4-75
4.6.8	Mixer .....	4-77
4.6.9	Replacement of oil seal .....	4-78
4.6.10	Cleaner unit .....	4-78
4.6.11	Main charger.....	4-79
4.6.12	Drum and bushing .....	4-81
4.6.13	Drum cleaning blade.....	4-83
4.6.14	Side seal .....	4-84
4.6.15	Waste toner unit gear .....	4-85
4.6.16	Main charger grid.....	4-85
4.6.17	Main charger cleaner .....	4-87
4.6.18	Needle electrode.....	4-88
4.6.19	New/old drum detection switches (SW9, SW10, SW11, SW12) and new/old developer unit detection switches (SW13, SW14, SW15, SW16) .....	4-88
4.6.20	Drum thermistor (THM4).....	4-92
4.6.21	Waste toner paddle rotation detection sensor (S9) .....	4-93
4.6.22	Waste toner paddle motor (M7).....	4-93

4.6.23	Drum switching unit .....	4-96
4.6.24	Drum switching detection sensor (S11) .....	4-97
4.6.25	Drum switching motor (M3).....	4-98
4.6.26	Paper feeding/developer unit drive motor (M2) .....	4-100
4.6.27	Paper feeding/developer drive unit .....	4-100
4.6.28	Developer unit (K) drive gear .....	4-102
4.6.29	Toner motor assembly .....	4-103
4.6.30	Toner motor (M8, M9, M10, M11) .....	4-104
4.6.31	Ozone filter .....	4-106
4.6.32	Ozone exhaust fan (F2) .....	4-106
4.6.33	Switching regular cooling fan (F3) .....	4-107
4.6.34	Drum drive gear .....	4-108
4.6.35	Developer drive gear .....	4-109
4.6.36	Main power switch (SW4) .....	4-110
4.6.37	Temperature/humidity sensor (S10) .....	4-110
4.6.38	Drum damp heater (Right) .....	4-111
4.6.39	Drum damp heater (Left) .....	4-112
4.7	Transfer Units (TBU, TRU).....	4-115
4.7.1	Transfer belt cleaning unit .....	4-115
4.7.2	Transfer belt cleaning blade/blade seal/recovery blade .....	4-115
4.7.3	Transfer belt unit (TBU) .....	4-117
4.7.4	Transfer belt .....	4-118
4.7.5	Cleaner unit facing roller .....	4-121
4.7.6	Drive roller .....	4-122
4.7.7	1st transfer roller .....	4-122
4.7.8	2nd transfer roller.....	4-124
4.7.9	2nd transfer roller unit (TRU) .....	4-126
4.7.10	Paper clinging detection sensor (S18).....	4-127
4.7.11	1st transfer contact/release clutch (CLT3).....	4-127
4.7.12	1st transfer roller status detection sensor (S12) .....	4-128
4.7.13	Drum/TBU motor (M6) .....	4-130
4.7.14	Drum TBU drive unit .....	4-130
4.8	Image Quality Control .....	4-134
4.8.1	Image quality control unit.....	4-134
4.8.2	Paper dust holder .....	4-134
4.8.3	Image position aligning sensor (Front) (S7).....	4-135
4.8.4	Image position aligning sensor (Rear)/Image quality sensor (S8) .....	4-136
4.8.5	Registration sensor (S6).....	4-136
4.9	Fuser Unit.....	4-137
4.9.1	Fuser unit.....	4-137
4.9.2	Front side cover .....	4-143
4.9.3	Rear side cover.....	4-143
4.9.4	Fuser roller cover.....	4-143
4.9.5	Paper entrance guide .....	4-144
4.9.6	Fuser roller separation finger .....	4-144
4.9.7	Paper exit sensor (S13).....	4-145
4.9.8	Fuser roller center thermostat (THMO1)/ fuser roller rear thermostat (THMO2) .....	4-146
4.9.9	Fuser roller center thermistor (THM1)/fuser roller side thermistor (THM2)/fuser roller edge thermistor (THM3).....	4-147
4.9.10	Center heater lamp (LAMP1), Side heater lamp (LAMP2) .....	4-148
4.9.11	Pressure roller .....	4-150
4.9.12	Fuser roller.....	4-152
4.9.13	Paper exit unit.....	4-153
4.9.14	Exit roller.....	4-154
4.9.15	Exit motor (M5) .....	4-155
4.9.16	Fuser motor (M4) .....	4-158
4.9.17	Fuser drive unit .....	4-159



4.10	Automatic Duplexing Unit (ADU).....	4-161
4.10.1	Automatic duplexing unit (ADU).....	4-161
4.10.2	Bypass feed clutch (CLT4) .....	4-163
4.10.3	Transport unit.....	4-164
4.10.4	ADU guide assembly .....	4-166
4.10.5	ADU middle cover.....	4-167
4.10.6	ADU control board (ADU) .....	4-167
4.10.7	ADU drive unit/ADU entrance sensor (S14)/ ADU exit sensor (S15)/ADU motor (M12).....	4-167
4.10.8	Side cover interlock switch (SW3) .....	4-170
4.11	Removal and Installation of Options .....	4-171
4.11.1	Reversing Automatic Document Feeder .....	4-171
4.11.2	Paper Feed Pedestal .....	4-173
4.11.3	Large Capacity Feeder .....	4-176
4.11.4	Paper Feed Unit.....	4-179
4.11.5	Bridge Kit .....	4-183
4.11.6	Inner Finisher .....	4-185
4.11.7	Saddle Stitch Finisher .....	4-188
4.11.8	Saddle stitch finisher (Hole punch unit) .....	4-190
4.11.9	Job Separator .....	4-192
<b>5.</b>	<b>SELF-DIAGNOSTIC MODE .....</b>	<b>5-1</b>
5.1	Overview .....	5-1
5.2	Description Rule for Each Menu and Mode .....	5-4
5.3	Service UI.....	5-7
5.3.1	Overview.....	5-7
5.3.2	Operation procedure.....	5-7
5.3.3	Starting the FS Menu from the normal mode.....	5-7
5.4	03 TEST MODE .....	5-9
5.4.1	Output check.....	5-9
5.4.2	Input check .....	5-9
5.5	04 TEST PRINT MODE .....	5-10
5.6	05 ADJUSTMENT MODE .....	5-10
5.6.1	TEST PRINT .....	5-10
5.7	08 SETTING MODE.....	5-10
5.8	20 PM SUPPORT MODE.....	5-10
5.9	30 LIST PRINT MODE .....	5-11
5.9.1	Operation procedure.....	5-11
5.9.2	List Printing .....	5-12
5.10	31 CHART OUTPUT MODE .....	5-26
5.11	FAX .....	5-27
5.11.1	11 FAX CLEAR MODE .....	5-27
5.11.2	12 FAX LIST PRINT MODE.....	5-30
5.11.3	13 FAX FUNCTION MODE .....	5-30
5.11.4	19 RAM EDIT MODE.....	5-30
5.12	35 DATA BACKUP/RESTORE MODE.....	5-31
5.13	36 CLONING.....	5-32
5.14	37 LICENSE MANAGEMENT .....	5-32
5.15	01 Control Panel Check Mode .....	5-32
5.15.1	Screen transition.....	5-32
5.15.2	Checking of the LCD back light and LEDs.....	5-33
5.15.3	Checking of the LCD display, hard keys and digital keys .....	5-33
5.15.4	Checking of the LCD touch sensor and USB storage device connection .....	5-34
5.16	73 Firmware Assist Mode.....	5-35
5.16.1	Overview.....	5-35
5.16.2	Operation procedure .....	5-35
5.16.3	Functions .....	5-36
5.17	74 HDD Assist Mode.....	5-40
5.17.1	Overview.....	5-40

5.17.2	Operation procedure .....	5-40
5.17.3	Functions .....	5-41
5.18	75 File System Recovery Mode .....	5-43
5.18.1	Overview .....	5-43
5.18.2	Operation procedure .....	5-43
5.18.3	Functions .....	5-44
5.19	76 SRAM Maintenance Mode .....	5-50
5.19.1	Overview .....	5-50
5.19.2	Operation procedure .....	5-50
5.19.3	Functions .....	5-51
5.20	Pixel Counter .....	5-53
5.20.1	Outline .....	5-53
5.21	Batch Setting for Self-Diagnostic Codes .....	5-64
5.21.1	General description .....	5-64
5.21.2	Applicable codes .....	5-64
5.21.3	Setting files .....	5-64
5.21.4	Result files .....	5-65
5.21.5	Operation procedure .....	5-66
<b>6.</b>	<b>SETTING / ADJUSTMENT .....</b>	<b>6-1</b>
6.1	Image Related Adjustment .....	6-1
6.1.1	Adjustment Order .....	6-1
6.1.2	Adjustment of the Auto-Toner Sensor .....	6-2
6.1.3	Performing Image Quality Control .....	6-4
6.1.4	Adjustment of Color Registration Control .....	6-5
6.1.5	Image Dimensional Adjustment .....	6-6
6.1.6	Paper alignment at the registration roller .....	6-8
6.1.7	Image dimensional adjustment at the printing section .....	6-12
6.1.8	Image dimensional adjustment at the scanning section .....	6-18
6.1.9	Image dimensional adjustment in the copy/printer/fax function .....	6-26
6.2	Image Quality Adjustment (Copying Function) .....	6-27
6.2.1	Automatic gamma adjustment .....	6-27
6.2.2	Density adjustment .....	6-29
6.2.3	Gamma balance adjustment .....	6-30
6.2.4	Color balance adjustment .....	6-31
6.2.5	Background adjustment .....	6-33
6.2.6	Judgment threshold for ACS (common for copy and scan) .....	6-33
6.2.7	Sharpness adjustment .....	6-34
6.2.8	Setting range correction .....	6-35
6.2.9	Adjustment of smudged/faint text .....	6-35
6.2.10	Color Adjustment of Marker .....	6-36
6.2.11	Emission level adjustment .....	6-37
6.2.12	Maximum toner density adjustment to paper type .....	6-38
6.2.13	Maximum text density adjustment .....	6-38
6.2.14	Text/Photo reproduction level adjustment .....	6-39
6.2.15	Black header density level adjustment .....	6-39
6.2.16	Black area adjustment in twin color copy mode .....	6-40
6.2.17	Judgment threshold adjustment for blank originals (common for copy and scan) .....	6-40
6.2.18	Background offsetting adjustment for DF (common for copy, scan and fax) .....	6-40
6.2.19	Twin color copy / mono color copy adjustment .....	6-41
6.2.20	Maximum density adjustment for each paper type .....	6-42
6.2.21	Color reproduction selection .....	6-43
6.2.22	Hue adjustment .....	6-44
6.2.23	Saturation adjustment .....	6-47
6.2.24	ADF noise reduction .....	6-48
6.3	Image Quality Adjustment (Printing Function) .....	6-49
6.3.1	Automatic gamma adjustment .....	6-49
6.3.2	Gamma balance adjustment (Black Mode) .....	6-52

6.3.3	Color balance adjustment .....	6-54
6.3.4	Fine line/text density adjustment .....	6-56
6.3.5	Upper limit value in the Toner Saving Mode.....	6-56
6.3.6	Maximum toner density adjustment .....	6-57
6.3.7	Fine line enhancement switchover .....	6-57
6.3.8	“PureBlack/PureGray” threshold adjustment (PCL).....	6-58
6.3.9	“PureBlack/PureGray” threshold adjustment (Twin color mode) .....	6-58
6.3.10	“PureBlack/PureGray” threshold adjustment (PS).....	6-58
6.3.11	“PureBlack/PureGray” threshold adjustment (XPS).....	6-59
6.3.12	Toner limit threshold adjustment.....	6-59
6.3.13	Sharpness adjustment .....	6-60
6.3.14	Thin line width lower limit adjustment .....	6-61
6.3.15	Background adjustment .....	6-61
6.3.16	Color/black judgment setting for twin color printing images.....	6-61
6.3.17	Emission level adjustment .....	6-62
6.3.18	Density adjustment of graphic lines (1200 dpi).....	6-63
6.3.19	Gradation switching for black mode printing text .....	6-64
6.3.20	Color reproduction switching (Twin color printing).....	6-64
6.3.21	Auto Trapping adjustment.....	6-65
6.3.22	Adjustment of smudged text in black (600dpi).....	6-65
6.4	Image Quality Adjustment (Scanning Function).....	6-66
6.4.1	Gamma balance adjustment.....	6-66
6.4.2	RGB Color balance adjustment .....	6-66
6.4.3	Density adjustment .....	6-67
6.4.4	Background adjustment (Color).....	6-68
6.4.5	Background adjustment (Black/Grayscale).....	6-68
6.4.6	Judgment for ACS adjustment (common for copy and network scan).....	6-68
6.4.7	Sharpness adjustment .....	6-69
6.4.8	Contrast adjustment.....	6-69
6.4.9	Fine adjustment of black density .....	6-70
6.4.10	RGB conversion method selection .....	6-70
6.4.11	Adjustment of saturation .....	6-71
6.4.12	Background offsetting adjustment for DF (common for copy, scan and fax) ...	6-71
6.4.13	Adjustment of the capacity and image quality of SlimPDF .....	6-72
6.4.14	Surrounding void amount adjustment .....	6-72
6.4.15	Judgment threshold adjustment for blank originals (common for copy and scan) .....	6-73
6.4.16	JPEG compression level adjustment .....	6-73
6.4.17	ADF noise reduction .....	6-74
6.5	Image Quality Adjustment (FAX Function).....	6-75
6.5.1	Density adjustment .....	6-75
6.5.2	Emission level adjustment .....	6-76
6.5.3	Background offsetting adjustment for DF (common for copy, scan and fax) ...	6-76
6.6	Scanner.....	6-77
6.6.1	Adjustment carriages-1 positions.....	6-77
6.6.2	Position adjustment of CCD lens unit .....	6-78
6.6.3	Belt tension adjustment of the Scan motor .....	6-78
6.7	Writing Section .....	6-79
6.7.1	Image Adjustment in the Writing Section .....	6-79
6.8	Paper Feeding System.....	6-80
6.8.1	Adjusting the clearance of the paper and side guides .....	6-80
6.8.2	Separation roller pressure force adjustment (PFU/PFP) .....	6-81
6.9	Process Unit Related Section .....	6-82
6.9.1	High-Voltage Transformer Setting .....	6-82
6.10	Developer Unit .....	6-83
6.10.1	Adjustment of the Auto-Toner Sensor .....	6-83
6.10.2	Adjustment of the doctor-to-sleeve gap .....	6-83
6.11	Image Quality Control .....	6-85

6.11.1	Performing Image Quality Control .....	6-85
6.12	Fuser Unit / Paper Exit Section .....	6-85
6.12.1	Adjustment of the non-contact thermistor Gap .....	6-85
6.12.2	Correction of Performing non-contact thermistor .....	6-88
6.12.3	Adjustment of the thermostat Gap .....	6-89
6.13	Adjustment of the RADF .....	6-91
6.13.1	Adjustment of RADF position .....	6-91
6.13.2	Adjustment of RADF height .....	6-96
6.13.3	Adjustment of skew .....	6-98
6.13.4	Adjustment of the leading edge position .....	6-101
6.13.5	Adjustment of horizontal position .....	6-103
6.13.6	Adjustment of copy ratio .....	6-104
6.13.7	RADF Separation roller pressure force adjustment .....	6-105
6.14	Adjustment of the Inner Finisher .....	6-107
6.14.1	Alignment position adjustment .....	6-107
6.14.2	Stapling position adjustment .....	6-108
6.14.3	Punch hole position adjustment .....	6-111
6.15	Adjustment of the Console Finisher .....	6-112
6.15.1	Adjusting the alignment position .....	6-112
6.15.2	Adjusting the stapling position .....	6-115
6.16	Adjustment of the Saddle Stitch Finisher .....	6-117
6.16.1	Adjusting the Alignment Position .....	6-117
6.16.2	Adjusting the Stapling Position .....	6-120
6.16.3	Stapling/folding position adjustment in saddle stitch unit .....	6-122
6.16.4	Folding position adjustment .....	6-124
6.16.5	Stapling position adjustment .....	6-124
6.16.6	Saddle Stitch Skew Adjustment .....	6-125
6.17	Adjustment of Hole punch unit .....	6-126
6.17.1	Destination setting of hole punch control PC board .....	6-126
6.17.2	Stopping Position Adjustment (MJ-6105) .....	6-127
<b>7.</b>	<b>PREVENTIVE MAINTENANCE (PM).....</b>	<b>7-1</b>
7.1	General Description .....	7-1
7.2	PM Display .....	7-1
7.2.1	General Description .....	7-1
7.2.2	PM Display Conditions .....	7-1
7.2.3	PM Display Contents .....	7-3
7.2.4	Counter Clearing .....	7-4
7.3	General Descriptions for PM Procedure .....	7-5
7.4	PM Support Mode .....	7-6
7.4.1	General Description .....	7-6
7.4.2	Operational flow .....	7-6
7.4.3	Operational screen .....	7-7
7.4.4	Access tree .....	7-10
7.5	Work flow of parts replacement .....	7-12
7.6	Preventive Maintenance Checklist .....	7-13
7.6.1	Feed unit .....	7-14
7.6.2	Bypass feed unit .....	7-15
7.6.3	Main charger .....	7-16
7.6.4	Drum unit, Cleaner related section .....	7-18
7.6.5	Developer unit (K, Y, M, and C) .....	7-21
7.6.6	Transfer belt unit / Transfer belt cleaning unit .....	7-25
7.6.7	Image quality control unit .....	7-27
7.6.8	2nd transfer roller unit .....	7-28
7.6.9	Fuser unit .....	7-29
7.6.10	RADF .....	7-30
7.6.11	PPF .....	7-31
7.6.12	LCF .....	7-32
7.6.13	PFU .....	7-33

7.6.14	JSP .....	7-34
7.6.15	Inner Finisher .....	7-35
7.6.16	Saddle stitch finisher / Finisher .....	7-36
7.6.17	Hole punch unit (MJ-6105) .....	7-41
7.7	Machine Refreshing Checklist.....	7-42
7.8	Storage of Supplies and Replacement Parts .....	7-51
7.9	PM KIT .....	7-52
7.10	Machine Refreshing Kit .....	7-53
7.11	Maintenance Part List .....	7-54
7.12	Grease List.....	7-56
<b>8.</b>	<b>ERROR CODE AND TROUBLESHOOTING .....</b>	<b>8-1</b>
8.1	General Descriptions.....	8-1
8.1.1	If a problem continues even after performing all troubleshooting .....	8-1
8.1.2	Collection of debug logs with a USB device .....	8-2
8.1.3	Traceability label.....	8-3
8.2	Error Code List .....	8-6
8.2.1	Jam .....	8-6
8.2.2	Service call .....	8-19
8.2.3	Error in Internet FAX / Scanning Function .....	8-34
8.2.4	Printer function error .....	8-52
8.2.5	TopAccess related error/Communication error with external application .....	8-59
8.2.6	MFP access error .....	8-63
8.2.7	Maintenance error.....	8-70
8.2.8	Network error .....	8-77
8.2.9	Notification .....	8-82
8.2.10	FAX error .....	8-87
8.2.11	Error history .....	8-98
8.3	Diagnosis and Prescription for Each Error Code .....	8-100
8.3.1	Check item .....	8-100
8.3.2	Paper transport jam (paper exit section).....	8-100
8.3.3	Paper misfeeding.....	8-103
8.3.4	Paper transport jam .....	8-108
8.3.5	Other paper jam .....	8-117
8.3.6	Cover open jam .....	8-125
8.3.7	RADF jam .....	8-129
8.3.8	Paper jam in bridge unit.....	8-134
8.3.9	Paper jam in job separator.....	8-136
8.3.10	Paper jam in finisher section.....	8-137
8.3.11	Paper jam in saddle stitcher section .....	8-154
8.3.12	Paper jam in puncher unit.....	8-158
8.3.12a	Scanning of an original from the DF is stopped.....	8-158a
8.3.13	Other paper jam.....	8-160
8.3.14	Drive system related service call .....	8-176
8.3.15	Paper feeding system related service call .....	8-178
8.3.16	Scanning system related service call.....	8-184
8.3.17	Fuser unit related service call .....	8-190
8.3.18	Communication related service call .....	8-194
8.3.19	RADF related service call .....	8-198
8.3.20	Circuit related service call.....	8-200
8.3.21	LED printer head related service call.....	8-205
8.3.22	Finisher related service call .....	8-209
8.3.23	Image control related service call .....	8-235
8.3.24	Copy process related service call .....	8-254
8.3.25	Other service call .....	8-267
8.3.26	Error in Internet FAX / Scanning Function .....	8-305
8.3.27	Printer function error .....	8-316
8.3.28	TopAccess related error/Communication error with external application .....	8-319
8.3.29	MFP access error .....	8-325
8.3.30	Maintenance error.....	8-331

8.3.31	Network error .....	8-337
8.3.32	FAX error .....	8-349
8.4	Other errors.....	8-361
8.4.1	Equipment operation disabled after the installation of option(s).....	8-361
8.4.2	Wireless LAN connection disabled .....	8-361
8.4.3	"Invalid Department Code" is displayed.....	8-361
8.4.4	Paper folded on the leading edge.....	8-361
8.4.5	Toner cartridge unrecognized.....	8-361
8.4.6	Ethernet disabled in half-duplex communication .....	8-361
8.4.7	The equipment does not start after the power has been turned ON.....	8-362
8.4.8	Countermeasure to Sudden Power Failure .....	8-368
8.4.9	"Authentication Failed" is displayed .....	8-370
8.4.10	Error code "M00" is displayed while updating firmware .....	8-370
8.4.11	"Fax line1 is out of order." or "Fax line2 is out of order." is displayed.....	8-370
8.4.12	"Latch the developer unit (Yellow, Magenta, Cyan, Black)" remains displayed.....	8-371
8.5	Troubleshooting for the Image .....	8-372
8.5.1	Color deviation.....	8-372
8.5.2	Uneven pitch and jitter image .....	8-374
8.5.3	Poor image density, color reproduction and gray balance.....	8-376
8.5.4	Background fogging 1 .....	8-378
8.5.5	Background fogging 2 (1200 dpi printing).....	8-380
8.5.6	Moire /lack of sharpness.....	8-381
8.5.7	Toner offset.....	8-383
8.5.8	Blurred image .....	8-385
8.5.9	Poor fusing.....	8-386
8.5.10	Blank print.....	8-388
8.5.11	Solid print.....	8-390
8.5.12	White banding (in feeding direction) .....	8-392
8.5.13	White banding (at right angles to feeding direction) .....	8-394
8.5.14	Skew (slantwise copying) .....	8-395
8.5.15	Color banding (in feeding direction).....	8-397
8.5.16	Color banding (at right angles to feeding direction) .....	8-399
8.5.17	White spots .....	8-400
8.5.18	Poor transfer .....	8-402
8.5.19	Uneven image density 1 (in feeding direction).....	8-404
8.5.20	Uneven image density 1 (at right angles to feeding direction).....	8-406
8.5.21	Uneven image density 2 .....	8-407
8.5.22	Faded image (low density, roughness).....	8-409
8.5.23	Image dislocation in feeding direction.....	8-411
8.5.24	Image jittering .....	8-412
8.5.25	Poor cleaning.....	8-413
8.5.26	Uneven light distribution .....	8-416
8.5.27	Blotched image .....	8-417
8.5.28	Stain on the paper back side .....	8-418
8.5.29	White void in the halftone .....	8-420
8.5.30	Paper wrinkle .....	8-423
8.5.31	Staining at the leading/trailing edge.....	8-425
8.5.32	Faint image .....	8-426
8.5.33	Toner scattering.....	8-427
8.5.34	Feathered image.....	8-429
8.5.35	Image Skewing on Paper Trailing Edge .....	8-430
<b>9.</b>	<b>REPLACEMENT OF PC BOARDS/HDD .....</b>	<b>9-1</b>
9.1	Removal and Installation of PC Boards/HDD.....	9-1
9.1.1	SYS board cover.....	9-1
9.1.2	SYS board cooling fan (F1) .....	9-1
9.1.3	Hard disk (HDD) .....	9-2
9.1.4	SYS board .....	9-3

9.1.5	LGC board .....	9-5
9.1.6	Switching regulator .....	9-8
9.1.7	High-voltage transformer (HVT).....	9-9
9.1.8	SRAM .....	9-10
9.1.9	Main memory (DIMM).....	9-10
9.1.10	EEPROM .....	9-10
9.1.11	CFD board .....	9-11
9.1.12	CTIF board.....	9-11
9.1.13	DAMP board .....	9-11
9.2	Precautions, Procedures and Settings for Replacing PC Boards and HDD .....	9-14
9.2.1	Precautions when replacing PC boards.....	9-14
9.2.2	HDD fault diagnosis .....	9-15
9.2.3	Precautions and procedures when replacing the HDD .....	9-17
9.2.4	Precautions and procedures when replacing the SYS board .....	9-21
9.2.5	Precautions and procedure when replacing the SRAM .....	9-25
9.2.6	Procedures when replacing the LGC board.....	9-30
9.2.7	Procedures and settings when replacing EEPROM .....	9-30
9.2.8	Procedures and settings when replacing the Lens unit .....	9-33
9.2.9	Firmware confirmation after the PC board/HDD replacement .....	9-34
9.2.10	License re-registration using the one-time dongle .....	9-34
9.3	Precautions for Installation of GP-1070 and Disposal of HDD/Board .....	9-36
9.3.1	Precautions for Installation of GP-1070 .....	9-36
9.3.2	Precautions when disposing of HDD .....	9-36
9.3.3	Precautions when disposing of the SYS board.....	9-36
9.3.4	Precautions when disposing of the SRAM.....	9-36
<b>10.</b>	<b>REMOTE SERVICE.....</b>	<b>10-1</b>
10.1	Auto Supply Order.....	10-1
10.1.1	Outline .....	10-1
10.1.2	Setting Item.....	10-2
10.1.3	Setting procedure .....	10-4
10.1.4	Order Sheet Format.....	10-18
10.2	Service Notification .....	10-22
10.2.1	Outline .....	10-22
10.2.2	Setting.....	10-22
10.2.3	Items to be notified .....	10-30
<b>11.</b>	<b>FIRMWARE UPDATING .....</b>	<b>11-1</b>
11.1	Overview .....	11-1
11.2	Firmware Updating with USB Device .....	11-2
11.2.1	Updating methods.....	11-2
11.2.2	Firmware type and data file name for updating .....	11-2
11.2.3	Folder configuration of a USB device .....	11-4
11.2.4	Update procedure .....	11-6
11.3	Confirmation of the updated data.....	11-15
<b>12.</b>	<b>BACKUP FUNCTION.....</b>	<b>12-1</b>
12.1	Cloning (HS Menu).....	12-1
12.1.1	General description.....	12-1
12.1.2	Precautions .....	12-1
12.1.3	Backup files .....	12-2
12.1.4	Cloning procedure .....	12-2
12.2	Cloning (FS menu).....	12-6
12.2.1	General description.....	12-6
12.2.2	Precautions .....	12-6
12.2.3	Clone file creation procedure.....	12-7
12.2.4	Clone file installation procedure.....	12-7
12.3	AES Data Encryption Function Setting .....	12-8
12.3.1	General description.....	12-8
12.3.2	Precautions .....	12-8

12.3.3	Setting procedure .....	12-9
12.3.4	Procedure for disabling data encryption function.....	12-13
12.3.5	Procedure for discarding HDD when data encryption function is enabled ....	12-13
12.4	High Security Mode.....	12-14
12.4.1	General description.....	12-14
12.4.2	Prior confirmation .....	12-14
12.4.3	Procedure for entering the High Security Mode .....	12-14
12.4.4	Precautions.....	12-15
<b>13.</b>	<b>EXTERNAL COUNTERS .....</b>	<b>13-1</b>
13.1	Outline.....	13-1
13.2	Signal .....	13-1
13.2.1	Connector .....	13-1
13.2.2	Coin Controller.....	13-1
13.2.3	Key copy counter .....	13-5
13.3	Notices.....	13-6
13.3.1	Setting code.....	13-6
13.3.2	Setting value change and restrictions when using the Card Controller .....	13-6
13.3.3	Setting value change and restrictions when using the coin controller .....	13-6
13.3.4	Installation of External Counter.....	13-6
13.3.5	Setting value .....	13-7
13.3.6	Restrictions when using the external counter .....	13-7
<b>14.</b>	<b>NOTES FOR THE INSTALLATION OF A CARD READER .....</b>	<b>14-1</b>
<b>15.</b>	<b>WIRE HARNESS CONNECTION.....</b>	<b>15-1</b>
15.1	AC Wire Harness .....	15-1
15.2	DC Wire Harness / Electric Parts Layout .....	15-3
15.2.1	DC Wire Harness.....	15-3
15.2.2	Electric Parts Layout.....	15-4
	<b>REVISION RECORD .....</b>	<b>1-1</b>



# 1. FEATURE

## 1.1 Main Features of this Equipment

- **Adopting a capacitive touch panel**  
Digital keys are provided as an option instead of being located on the control panel. The user interface is changed, consequently transition operation to the self-diagnosis mode is updated.
- **All models standard equipped with HDD**  
All models are standard equipped with HDD instead of SSD.
- **Abolishing the use of the download jig**  
The use of the download jig is abolished. Instead, a USB device is used for all firmware updates.
- **Envelope-specific drawer**  
An envelope-specific drawer is adopted as an option.
- **Fax**  
An optional fax is provided as a board instead of a unit for current models. The same board is used for either Line 1 or Line 2.



## 2. SPECIFICATIONS/ACCESSORIES/OPTIONS/SUPPLIES

Notes: In this document, a model name is replaced with an alias as follows:

Model name	Alias
e-STUDIO2000AC	20ppm
e-STUDIO2500AC	25ppm

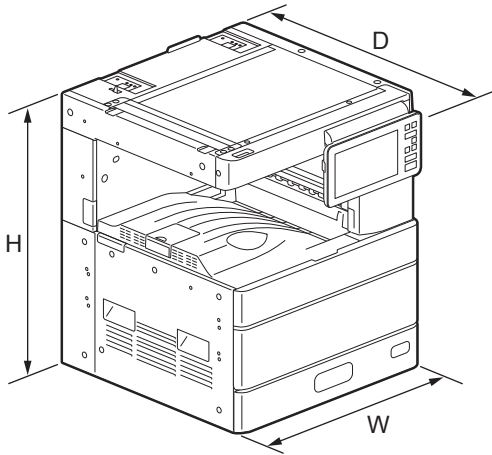
### 2.1 Specifications

#### 2.1.1 General

Type	Desktop type (Console type: when optional Paper Feed Pedestal (PFP) or optional Large Capacity Feeder (LCF) is installed.)	
Original glass	Fixed	
Color	Full color, Twin color, Mono color	
Copy process	Indirect electrophotographic method (dry)	
Developing system	2-component magnetic brush developing	
Fixing method	Roller fusing system	
Photosensor type	OPC	
Original scanning sensor	Linear CCD sensor	
Scanning light source	LED	
Resolution	Scanning	600 dpi x 600 dpi
	Writing	600 dpi x 600 dpi (color print / Photo / gray scale)
Gradation	256	
Paper feeding	1 drawer + Bypass feeding 1 drawer + Bypass feeding + PFU (optional) 1 drawer + Bypass feeding + PFU+ PFP 1 drawer (optional) 1 drawer + Bypass feeding + PFU+ PFP 2 drawers (optional) 1 drawer + Bypass feeding + PFU+ LCF (optional)	
Paper supply	Drawer	Stack height 28 mm, Approx. 250 sheets (80 g/m <sup>2</sup> , 21.3 lb. Bond), Approx. 200 sheets (105 g/m <sup>2</sup> , 28 lb. Bond)
	Bypass feeding	Stack height 11 mm, Approx. 100 sheets (80 g/m <sup>2</sup> , 21.3 lb. Bond), Approx. 80 sheets (105 g/m <sup>2</sup> , 28 lb. Bond)
	PFU (optional)	Stack height 60.5 mm, Approx. 550 sheets (80 g/m <sup>2</sup> , 21.3 lb. Bond), Approx. 500 sheets (105 g/m <sup>2</sup> , 28 lb. Bond)
	PFP (optional)	Stack height 60.5 mm, Approx. 550 sheets (80 g/m <sup>2</sup> , 21.3 lb. Bond), Approx. 500 sheets (105 g/m <sup>2</sup> , 28 lb. Bond)
	LCF (optional)	Stack height 110 mm, Approx. 2000 sheets (80 g/m <sup>2</sup> , 21.3 lb. Bond), Approx. 1660 sheets (105 g/m <sup>2</sup> , 28 lb. Bond)
	Envelope Drawer (optional)	Plain paper: Approx. 550 sheets (80 g/m <sup>2</sup> , 21.3 lb. Bond), Approx. 500 sheets (105 g/m <sup>2</sup> , 28 lb. Bond)) Envelope: Stack height 505 mm (Approx. 60 envelopes)

Paper size	Drawer	A3, A4, A4-R, A5-R, B4, B5, B5-R, FOLIO, 8K, 16K, 16K-R, LD, LG, LT, LT-R, ST-R, COMPUTER, 13"LG, 8.5" x 8.5",
	Bypass feeding	A3, A4, A4-R, A5-R, A6, B4, B5, B5-R, FOLIO, 8K, 16K, 16K-R, LD, LG, LT, LT-R, ST-R, COMPUTER, 13"LG, 8.5" x 8.5" Non-standard: Paper size within 100 - 297 mm (3.9 - 11.7") (Length), 148 - 432 mm (5.8 - 17") (Width)
	PFU (optional)	A3, A4, A4-R, A5-R, B4, B5, B5-R, FOLIO, 8K, 16K, 16K-R, LD, LG, LT, LT-R, ST-R, COMPUTER, 13"LG, 8.5" x 8.5",
	Drawers / PFP (optional)	A3, A4, A4-R, A5-R, B4, B5, B5-R, FOLIO, 8K, 16K, 16K-R, LD, LG, LT, LT-R, ST-R, COMPUTER, 13"LG, 8.5" x 8.5",
	LCF (optional)	A4, LT
	Envelope Drawer (optional)	Plain paper: A4-R, A5-R, B5-R, 16K-R, LG, LT-R, ST-R, 13" LG Envelope DL (110 x 220 mm), Envelope Com10 (4 1/8 x 9 1/2"), Envelope Monarch (3 7/8 x 7 1/2"), Envelope Cho-3 (120 x 235 mm), Envelope You-4 (105 x 235 mm), Envelope KAKU-2 (240 x 332 mm) Non-standard envelope: Paper size within 100 - 240 mm (3.9 - 9.45") (Length), 162 - 380 mm (6.38 - 14.9") (Width)
Paper type	Drawer	Plain paper, Recycled paper, Thick, Thick 1
	Bypass feeding	Plain paper, Recycled paper, Thick, Thick 1, Thick 2, Sticker labels, OHP film, Tab paper, Water proof paper
	PFU (optional)	Plain paper, Recycled paper, Thick, Thick 1
	PFP (optional)	Plain paper, Recycled paper, Thick, Thick 1
	LCF (optional)	Plain paper, Recycled paper, Thick
	Envelope Drawer (optional)	Plain paper, Envelope, Thick 1
Paper weight	Drawer / PFU (optional)/ PFP (optional)	60 g/m <sup>2</sup> to 163 g/m <sup>2</sup> (16 lb. Bond to 90 lb. Index)
	Bypass feeding	60 g/m <sup>2</sup> to 209 g/m <sup>2</sup> (16 lb. Bond to 110 lb. Index)
	LCF (optional)	64 g/m <sup>2</sup> to 105 g/m <sup>2</sup> (17 lb. Bond to 28 lb. Bond)
	Envelope Drawer (optional)	60 g/m <sup>2</sup> to 163 g/m <sup>2</sup> (16 lb. Bond to 90 lb. Index)
Automatic duplexing unit	Type	Stackless, Switchback type
	Acceptable paper size	A3, A4, A4-R, A5-R, B4, B5, B5-R, FOLIO, 8K, 16K, 16K-R, LD, LG, LT, LT-R, ST-R, COMPUTER, 13"LG, 8.5" x 8.5"
	Acceptable paper weight	60 g/m <sup>2</sup> to 163 g/m <sup>2</sup> (17 lb. Bond to 90 lb. Index)
Toner supply		Automatic toner density detection/supply
Density control		Automatic density mode and manual density mode selectable in 11 steps
Total counter		Electronic counter
Memory (RAM)	Main memory	4 GB (including page memory)
	Page Memory	(including main memory)
HDD		320 GB
Account Codes		1000 codes
Department Codes		1000 codes

Machine version	NAD: North America, Brazil MJD: Europe AUD: Australia ASD: Asia, Hong Kong, Latin America TWD: Taiwan CND: China ARD: Argentina JPD: Japan
Warm-up time	Approx. 21 sec. (100 V/200 V series) <Stand-alone, temperature: 20°C> Start-up without hibernation: Approx. 70 sec. (100 V / 200 V series) <Stand-alone, temperature: 20°C> *Varies depending on the settings, use conditions, and quality maintenance behavior such as toner refill.
Recovery from sleep	Approx. 15 sec. (100V series) / Approx. 12.5 sec. (200V series) <Stand-alone, temperature: 20°C> *Varies depending on the settings, use conditions, and quality maintenance behavior such as toner refill.
Power requirements	AC 110 V / 13.2 A, 120V / 12 A 220-240 V / 8 A (50/60 Hz) * The acceptable value of each voltage is ± 10%.
Power consumption	1.5 kW or less (100 V, 120 V) 2.0 kW or less (200 V series) * The electric power is supplied to the RADF, Finisher, PFU, PFP and LCF through the equipment.
Weight	Approx. 60 kg (132.27 lb.)
Dimensions of the equipment	W 575 x D 590 x H 662 (mm) * When the tilt angle of the control panel is 90 degrees.



## 2.1.2 Copy

### [ 1 ] Copy specifications

Storage capacity		Max. 1000 sheets or until the memory is full
Original glass	Original scanning system	Flat surface scanning system (the left rear corner used as guide to place originals)
	Original type	Sheets, books
	Original size	Max. A3/LD
Reversing Automatic Document Feeder (optional)	Original scanning system	Fixed scanning system by feeding the original (the center used as guide to place originals)
	Original type	Sheets (carbon, bounded or stapled originals cannot be accepted)
	Original size	A3, A4, A4-R, A5-R, B4, B5, B5-R, FOLIO, LD, LG, LT, LT-R, ST-R, COMPUTER
	Original paper weight	Single-sided copy: 35-157g/m <sup>2</sup> (9.3 lb. Bond - 58 lb. Cover) Double-sided copy: 50-157g/m <sup>2</sup> (13.3 lb. Bond - 58 lb. Cover)
	Original capacity	Max. 100 sheets (80 g/m <sup>2</sup> ) (Stack height 16 mm)
Eliminated portion	Black copy	Leading edges: 4.2 +2.8/-1.2 mm, Trailing edges: 3.0 ± 2.0 mm, Side edges: 2.0 ± 2.0 mm
	Color copy	Leading edges: 5.0 ± 2.0 mm, Trailing edges: 3.0 ± 2.0 mm, Side edges: 2.0 ± 2.0 mm
Multiple copying		Up to 999 copies

### [ 2 ] First copy time

20ppm	Black	Approx. 7.1 sec.
25ppm	Color	Approx. 9.5 sec.

### [ 3 ] Copy speed (Copies/min.)

#### [ 3-1 ] Plain paper / Thick

- Plain paper: 60 g/m<sup>2</sup> to 80 g/m<sup>2</sup> (16 lb. Bond to 21 lb. Bond)
- Thick: 81 g/m<sup>2</sup> to 105 g/m<sup>2</sup> (22 lb. Bond to 28 lb. Bond)

#### 20ppm

Paper supply Paper size	Drawer	Bypass feed		PFP	LCF (A4/LT only)
		Size specified	Size not specified		
A4, LT	20 (20)	20 (20)	9 (9)	20 (20)	20 (20)
B5, A5-R, ST-R					-
A4-R, B5-R, LT-R	15 (15)	15 (15)	9(9)	15 (15)	-
B4, LG, FOLIO, COMPUTER	12 (12)	12 (12)	9 (9)	12 (12)	-
A3, LD	10 (10)	10 (10)	9 (9)	10 (10)	-

25ppm

Paper supply Paper size	Drawer	Bypass feed		PFP	LCF (A4/LT only)
		Size specified	Size not specified		
A4, LT	25 (25)	25 (25)	11 (11)	25 (25)	25 (25)
B5, A5-R, ST-R					-
A4-R, B5-R, LT-R	18(18)	18(18)	11 (11)	20 (20)	-
B4, LG, FOLIO, COMPUTER	15 (15)	15 (15)	11 (11)	17 (17)	-
A3, LD	12 (12)	12 (12)	11 (11)	15 (15)	-

- \* “-” means “Not acceptable”.
- \* When originals are manually placed for single-sided, continuous copying.
- \* Plain paper is selected for the paper type.
- \* When the Reversing Automatic Document Feeder is used, the copying speeds of the equipment is only possible under the following conditions:
  - Original: A4 or LT (single-sided)
  - Mode: APS and Automatic density not selected, Plain paper mode
  - Reproduction ratio: 100%
- \* The values in ( ) can be realized in the color mode.

[ 3-2 ] Thick 1/Thick 2

- Thick 1: 106 g/m<sup>2</sup> to 163 g/m<sup>2</sup> (90 lb. Index)
- Thick 2: 164 g/m<sup>2</sup> to 209 g/m<sup>2</sup> (110 lb. Index)

20ppm/25ppm

Paper supply Paper size	Drawer	Bypass feed		PFP	LCF (A4/LT only)
		Size specified	Size not specified		
A4, LT	17.5 (17.5)	16.5 (16.5)	7 (7)	16.5 (16.5)	-
B5, A5-R, ST-R					-
A4-R, B5-R, LT-R	13 (13)	12.5 (12.5)	7 (7)	12.5 (12.5)	-
B4, LG, FOLIO, COMPUTER	10.5 (10.5)	10 (10)	7 (7)	10 (10)	-
A3, LD	8.5 (8.5)	8 (8)	7 (7)	8 (8)	-

- \* “-” means “Not acceptable”.
- \* When originals are manually placed for single-sided, continuous copying.
- \* The values in ( ) can be realized in the color mode.

### [ 3-3 ] OHP film

20ppm/25ppm

Paper supply Paper size	Drawer	Bypass feed		PFP	LCF (A4/LT only)
		Size specified	Size not specified		
A4, LT	-	14.5 (14.5)	-	-	-
A3, LD	-	7.5 (7.5)	-	-	-

\* “-” means “Not acceptable”.

\* When originals are manually placed for single-sided, continuous copying.

\* The values in ( ) can be realized in the color mode.

### [ 4 ] System copy speed

Copy mode		Sec.	
		20ppm	25ppm
Single-sided originals ↓ Single-sided copies	1 set	35.3 (38.0)	30.0 (32.7)
	3 sets	97.1 (99.9)	80.2 (82.9)
	5 sets	157.1 (159.9)	127.8 (130.2)
Single-sided originals ↓ Double-sided copies	1 set	39.0 (42.0)	37.0 (39.9)
	3 sets	98.9 (100.9)	89.3 (92.3)
	5 sets	158.1 (160.0)	141.9 (143.8)
Double-sided originals ↓ Double-sided copies	1 set	70.5 (73.4)	64.5 (68.2)
	3 sets	188.2 (191.7)	168.6 (172.3)
	5 sets	306.9 (310.1)	273.2 (276.4)
Double-sided originals ↓ Single-sided copies	1 set	67.5 (69.1)	56.7 (58.3)
	3 sets	186.0 (187.4)	152.2 (153.6)
	5 sets	304.6 (305.7)	247.4 (248.5)

\* The values in ( ) are the speeds of when in the color mode.

\* Shows the period of time from when the [START] button is pressed until the message “Ready” is displayed. (10 sheets of A4/LT size original are set on the RADF and one of the copy modes above is selected.)

\* Setting: when in the Text/Photo mode with Automatic density and APS/AMS set to OFF, or when in the sort mode with paper fed from the 1st drawer.

\* The Saddle Stitch Finisher and hole punch unit not installed.



## 2.1.3 Print

Supported Page Description Language (Printer Driver)		PCL6, PostScript 3 emulation, XPS
Supported Page Description Language (RIP)		PCL6, PostScript 3 emulation, XPS, PCL5e, PCL5c, PDF (emulation)
Supported Client OS		Windows Vista / Windows 7 / Windows 8.1 / Windows Server 2008 / Windows Server 2012 Mac OS X 10.4 or later Solaris v2.6/2.7/7.8/8/9/10 HP-UX ver.10.20/11.x, HP-UX64 ver.11.31 AIX 4.3.3 Red Hat 7.x/8.x/9.x, Red Hat Enterprise WS2, SuSE Linux 7.x/8.x/9.x, Mandrake Linux 7.x/8.x/9.x and Turbolinux 8/10 SCO UnixWare 7, SCO Open UNIX 8, CUPS
Resolution	Black	600 x 600 dpi, 5bit 600 x 1200dpi, 1bit (20ppm/25ppm PS only)
	Color	600 x 600 dpi, 5bit 600 x 1200dpi, 1bit (20ppm/25ppm PS only)
Eliminated portion	Black / Color	Leading edges: 4.2 +2.8/-1.2 mm, Trailing edges: 4.2 +1.2/-2.8 mm, Side edges: 4.2 ±2.0 mm
Interface	Standard	Ethernet (1000BASE-T/100BASE-TX/10BASE-T), USB 2.0 (High speed)
	Optional	Wireless LAN (IEEE 802.11b/g/n) Bluetooth V3.0 (HCRP/BIP/OPP/FTP/HID)

## 2.1.4 Scan

Scanning speed (A4/LT)	Color / Black / Gray scale	RADF 73 spm (200 dpi / 300 dpi) 50 spm (600 dpi)
Resolution		100, 150, 200, 300, 400 and 600 dpi
Scan mode		Black, Gray scale, Color and ACS (Auto color Selection)
File formats		JPEG, Multi/Single page TIFF, Multi/Single page PDF, Slim PDF, Multi/Single page XPS

\* When scanning single-sided A4/LT landscape originals using RADF

## 2.1.5 Internet Fax

### [ 1 ] Internet FAX transmission

Resolution	TX Resolution < dots/mm >	Standard (8 x 3.85), Fine (8 x 7.7),
Scanning	Original Document Size	A3, B4, A4, A4-R, A5, B5, B5-R, A5-R, LT, LT-R, LG, LD, ST, ST-R, Computer, Folio
	Speed	0.7 sec. (per page/A4) Max. 50 spm (ITU-T No.1, A4, 8 x 3.85, Text mode)
	Gray scale	256 levels (Error Diffusion)
Address book	Address Book	400 stations
	Group	Max. 40 stations
Transmission Features	Broadcast transmission	Max. 80 destinations/job. (Fax number and E-mail address are available to registered in same job.)
	Message size limitation	Max. 100MB
	Message division	Page by page

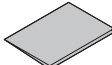

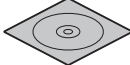
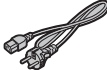

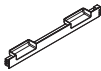
### [ 2 ] Internet FAX receiving

Format of receive attachment	TIFF-FX (Profile S, F, J)
------------------------------	---------------------------

## 2.1.6 Network Fax (Option)

Compatibility		Super G3, G3 (ITU-T.30) Internet Fax (Simple mode) (ITU-T.37)
TX Resolution	PSTN	Standard: 200 x 100 dpi, Fine: 200 x 200 dpi, Super Fine: 200 x 400 dpi, Ultra Fine: 400 x 400 dpi
	Internet Fax	200 dpi x 200 dpi
Original Document Size		A3, A4, A5, B4, B5, FOLIO, LD, LG, LT, ST, COMPUTER
Mail Box	User defined	Max. 300 boxes
Routed document format	Send to e-Filing	MMR
	Send to File (SMB)	Single TIFF, Multi-TIFF, Single PDF, Multi PDF
	Send to FTP	Single TIFF, Multi-TIFF, Single PDF, Multi PDF
	Send to E-mail	Single TIFF, Multi-TIFF, Single PDF, Multi PDF
	Send to I-Fax	TIFF-S
	Send to PSTN-FAX	MMR

## 2.2 Accessories

Unpacking/Setup instruction		1 set
Operator's manual		1 set - Safety Information: 1 manual - Quick Start Guide: 1 manual
DVD		1 pc. Client Utilities / User Documentation DVD
Power cable		1 pc.
Warranty sheet		1 pc. (for NAD)
Setup report		1 set (for NAD, MJD and CND)
Rubber plug		2 pcs.
Developer material (Y, M, C, K)		Developer material is pre-filled in each developer unit.
Toner (Y, M, C, K)		1 set (for AUD and CND)
Approval sheet		1 set (for CND)
Right lower cover		1 pc.

\* Machine version

NAD:	North America, Brazil
MJD:	Europe
AUD:	Australia
ASD:	Asia, Hong Kong, Latin America
TWD:	Taiwan
CND:	China
ARD:	Argentina
JPD:	Japan

Notes:

Check that the above accessories are correctly co-packed at the time of unpacking.

## 2.3 System List

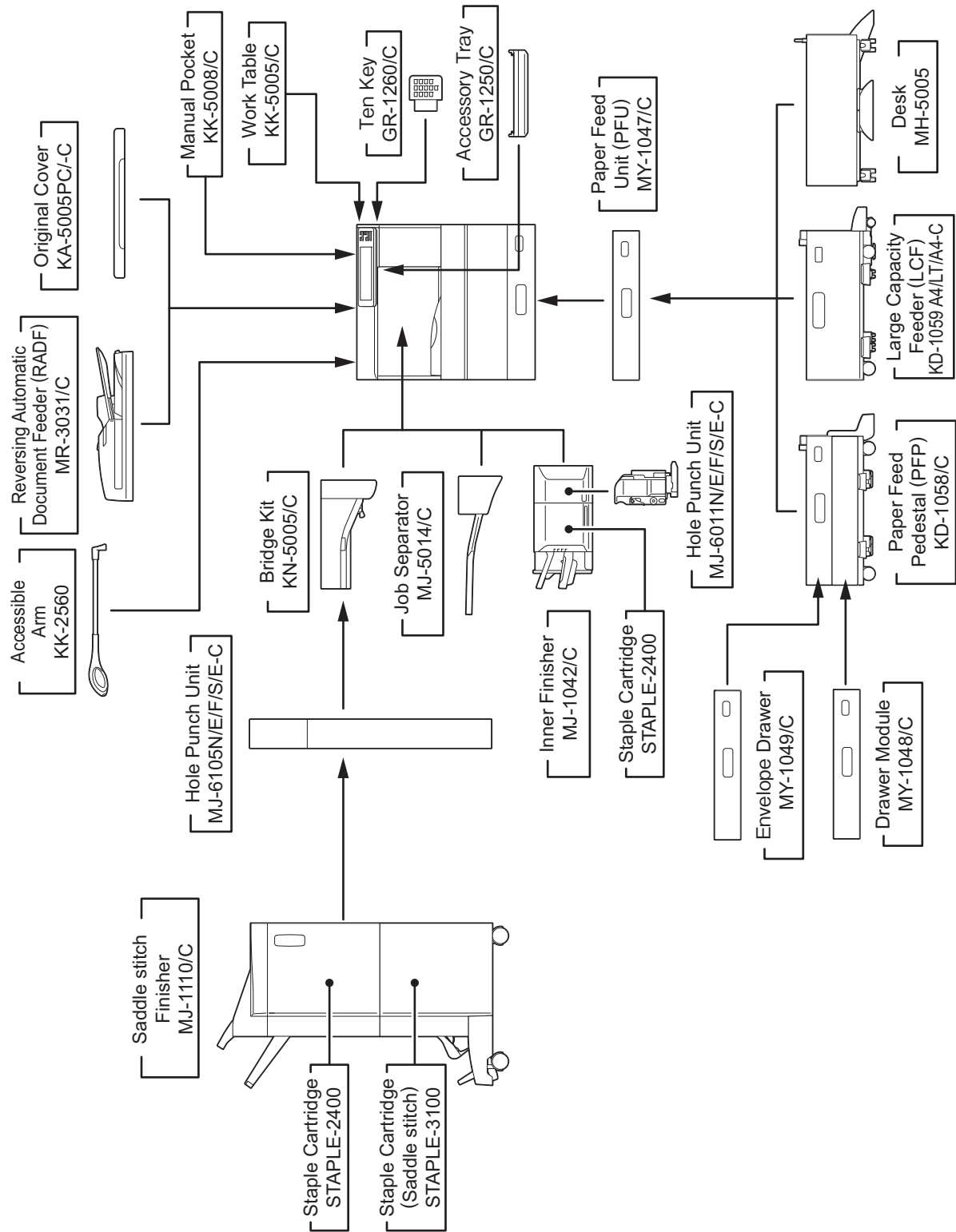


Fig. 2-1

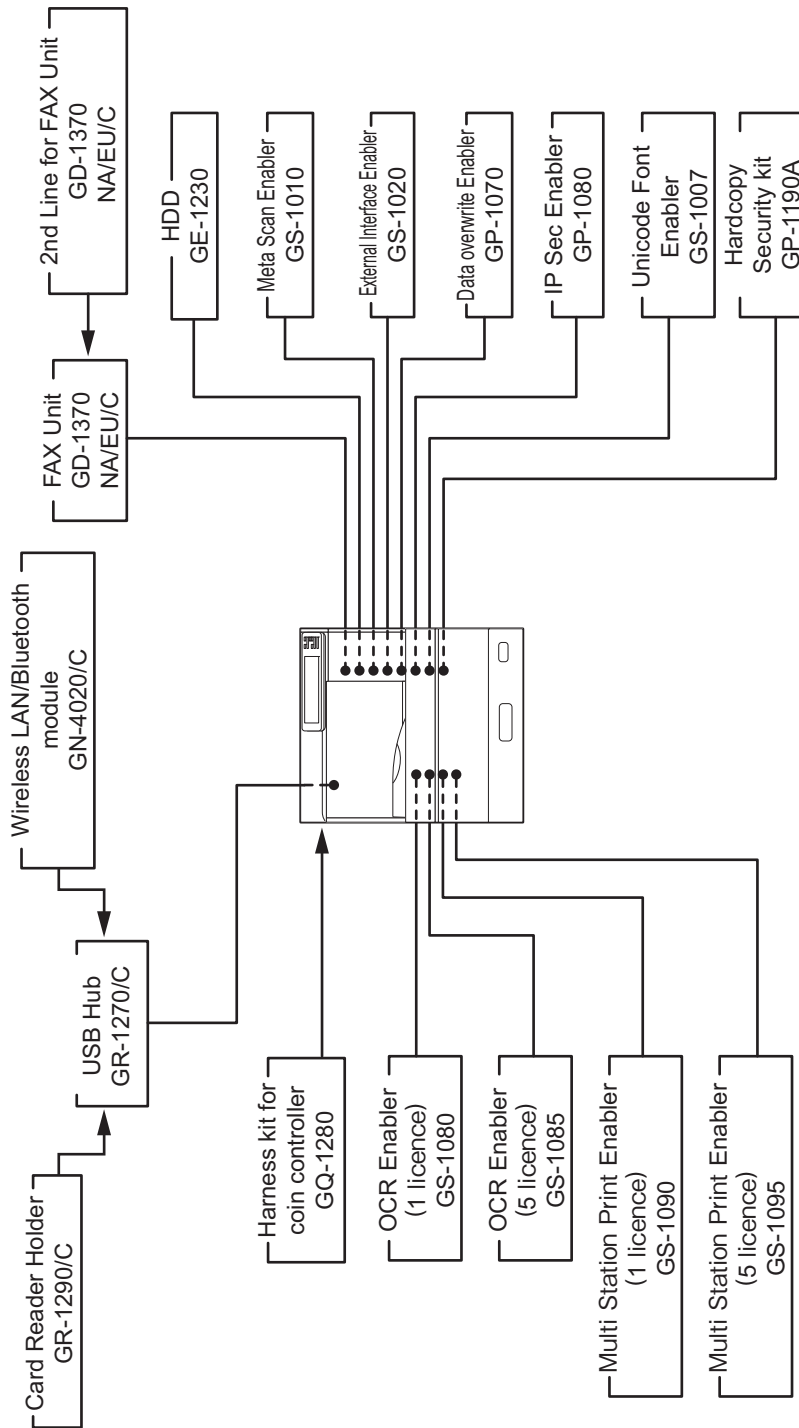


Fig. 2-2

**Notes:**









- The bridge kit (KN-5005/C) is necessary for installation of the finisher (MJ-1110/C).
- The finisher (MJ-1042) is necessary for installation of the hole punch unit (MJ-6011N/E/F/S/E-C).
- The finisher (MJ-1110/C) is necessary for installation of the hole punch unit (MJ-6105N/E/F/S/E-C).
- The USB Hub (GR-1270/C) is necessary for installation of the Wireless LAN / Bluetooth module (GN-4020/C).
- The USB Hub (GR-1270/C) is necessary for installation of the Card Reader Holder (GR-1290/C).
- GE-1230 is FIPS SED.
- Install the Ten Key (GR-1260) first when it is done together with the Accessory Tray (GR-1250).
- The envelope drawer (MY-1049/C) is necessary for installation of the paper feed pedestal (KD-1058/C).
- The envelope drawer (MY-1049/C) can be installed as the 3rd or 4th drawer.

## 2.4 Option List

Model Name	Option
MR-3031/C	Reversing Automatic Document Feeder (RADF)
KA-5005PC/PCC	Original Cover
KD-1058/C	Paper Feed Pedestal (PFP)
MY-1047/C	Paper Feed Unit (PFU)
MY-1048/C	Drawer Module
MY-1049/C	Envelope Drawer
KD-1059LT/A4/C	Large Capacity Feeder (LCF)
MH-5005	Desk
KK-5008/C	Operator's manual pocket
KK-5005/C	Work Table
KK-2560	Accessible Arm
MJ-5014/C	Job Separator
KN-5005/C	Bridge Kit
MJ-1042/C	Inner Finisher
MJ-6011E/N/F/S/E-C	Hole Punch Unit (for MJ-1042/C)
MJ-1110/C	Saddle Stitch Finisher
MJ-6105/E/N/F/S/E-C	Hole Punch Unit (for MJ-1110/C)
STAPLE-2400	Staple Cartridge (for MJ-1042/C, MJ-1110/C)
STAPLE-3100	Staple Cartridge (for MJ-1110/C saddle stitch)
GD-1370NA/EU/C	Fax Unit / 2nd Line for FAX Unit
GR-1250/C	Accessory Tray
GR-1260/C	Ten Key
GR-1270/C	USB Hub
GR-1290/C	Card Reader Holder
GN-4020/C	Wireless LAN / Bluetooth Module
GQ-1280	Harness Kit for coin controller
GE-1230	HDD (FIPS Hard Disk)
GP-1190A	Hardcopy Security Kit
GS-1010	Meta Scan Enabler
GS-1020	External Interface Enabler
GP-1080	IPSec Enabler
GP-1070	Data Overwrite Enabler
GS-1007	Unicode Font Enabler
GS-1080	OCR Enabler (1 licence)
GS-1085	OCR Enabler (5 licences)
GS-1090	Multi Station Print Enabler (1 licence)
GS-1095	Multi Station Print Enabler (5 licences)



## 2.5 Supplies

Drum 	OD-FC30N
Developer material (K) 	D-FC30-K
Developer material (Y) 	D-FC30-Y
Developer material (M) 	D-FC30-M
Developer material (C) 	D-FC30-C
Toner cartridge (K) 	PS-ZTFC200UK(1) (for North America, Central and South America) PS-ZTFC200EK(1) (for Europe) PS-ZTFC200PK(1) (for Asia and Australia) PS-ZTFC200PKM(1) (for Asia and Australia) PS-ZTFC505CK(1) (for China) PS-ZTFC505CKS(1) (for China) PS-ZTFC505TK(1) (for Taiwan)
Toner cartridge (Y) 	PS-ZTFC200UY(1) (for North America, Central and South America) PS-ZTFC200EY(1) (for Europe) PS-ZTFC200PY(1) (for Asia and Australia) PS-ZTFC200PYM(1) (for Asia and Australia) PS-ZTFC505CY(1) (for China) PS-ZTFC505CYS(1) (for China) PS-ZTFC505TY(1) (for Taiwan)
Toner cartridge (M) 	PS-ZTFC200UM(1) (for North America, Central and South America) PS-ZTFC200EM(1) (for Europe) PS-ZTFC200PM(1) (for Asia and Australia) PS-ZTFC200PMM(1) (for Asia and Australia) PS-ZTFC505CM(1) (for China) PS-ZTFC505CMS(1) (for China) PS-ZTFC505TM(1) (for Taiwan)

<p>Toner cartridge (C)</p> 	<p>PS-ZTFC200UC(1) (for North America, Central and South America)  PS-ZTFC200EC(1) (for Europe)  PS-ZTFC200PC(1) (for Asia and Australia)  PS-ZTFC200PCM(1) (for Asia and Australia)  PS-ZTFC505CC(1) (for China)  PS-ZTFC505CCS(1) (for China)  PS-ZTFC505TC(1) (for Taiwan)</p>
<p>Waste toner box</p> 	<p>PS-TBFC30 (except for Europe and China)  PS-TBFC30E (for Europe)  PS-TBFC30C (for China)</p>

# 3. OUTLINE OF THE MACHINE

## 3.1 Sectional View

### 3.1.1 Front side

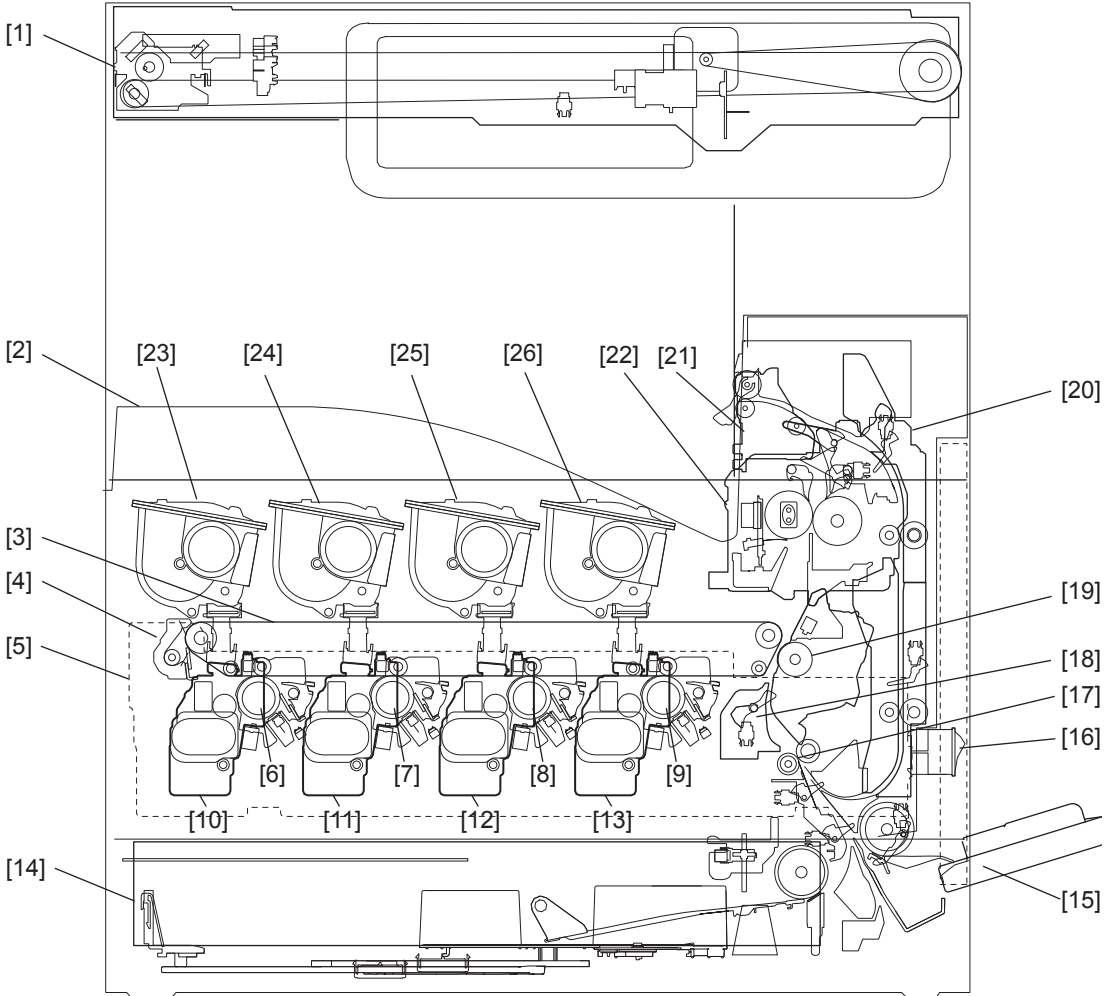


Fig. 3-1

1	Scanner unit	14	1st drawer
2	Inner tray	15	Bypass tray
3	Transfer belt	16	Main power switch
4	Transfer belt cleaning unit	17	Registration roller
5	Waste toner box	18	Image quality control unit
6	Drum (Y)	19	2nd transfer roller
7	Drum (M)	20	Automatic duplexing unit (ADU) *1
8	Drum (C)	21	Exit unit
9	Drum (K)	22	Fuser unit
10	Developer unit (Y)	23	Toner (Y)
11	Developer unit (M)	24	Toner (M)
12	Developer unit (C)	25	Toner (C)
13	Developer unit (K)	26	Toner (K)

\*1: L25ppm: Option

### 3.1.2 Rear side

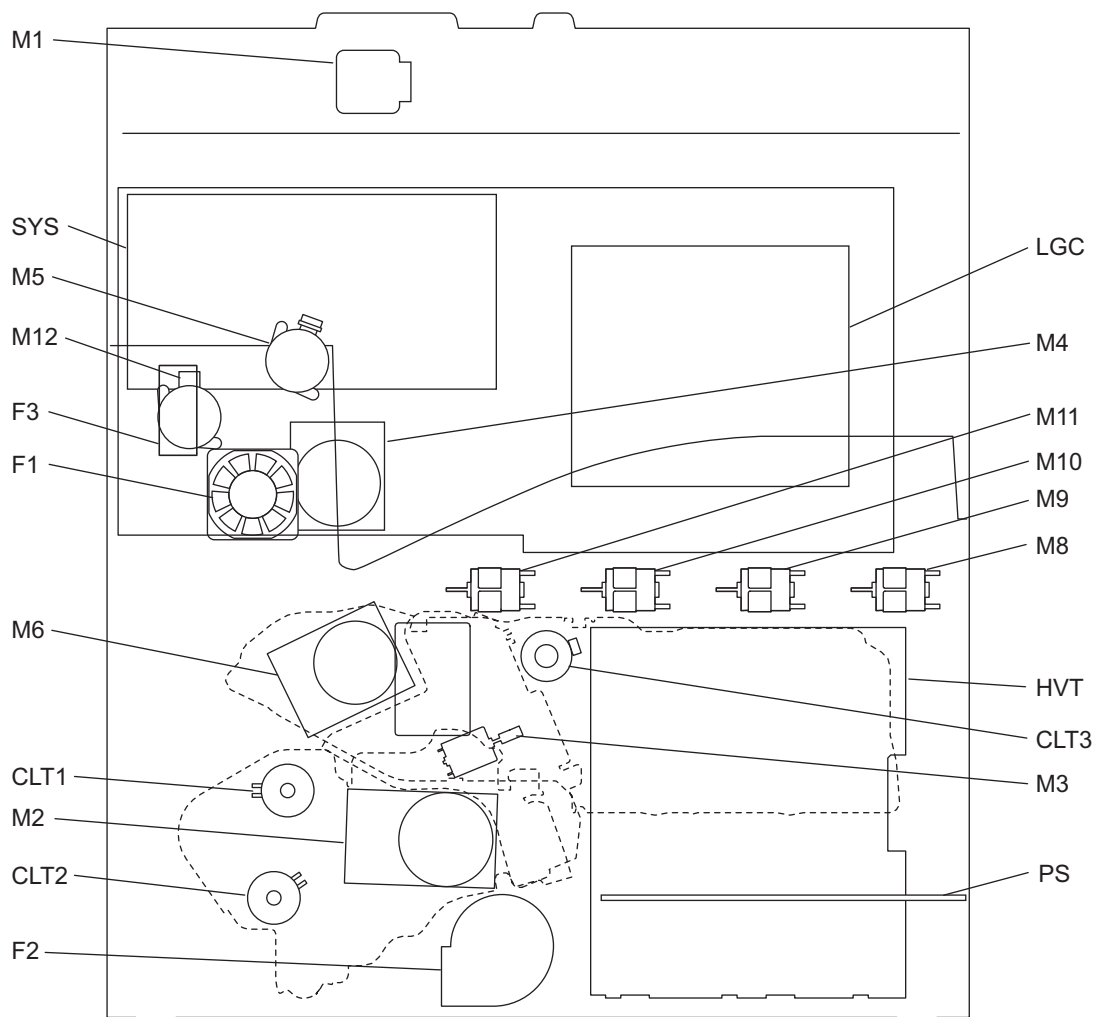


Fig. 3-2

M1	Scan motor	CLT1	Registration clutch
M2	Feed/Developer motor	CLT2	Feed clutch
M3	Mono/color switching motor	CLT3	1st transfer clutch
M4	Fuser motor	F1	SYS board cooling fan
M5	Exit/Rev motor	F2	Ozone exhaust fan
M6	Drum/TBU motor	F3	Ozone suctioning fan
M8	Toner motor-Y	SYS	System control PC board (SYS board)
M9	Toner motor-M	LGC	Logic PC board (LGC board)
M10	Toner motor-C	HVT	High-voltage transformer
M11	Toner motor-K	PS	Switching regulator
M12	ADU motor		

### 3.2 Electric Parts Layout

#### [A] Scanner unit, control panel

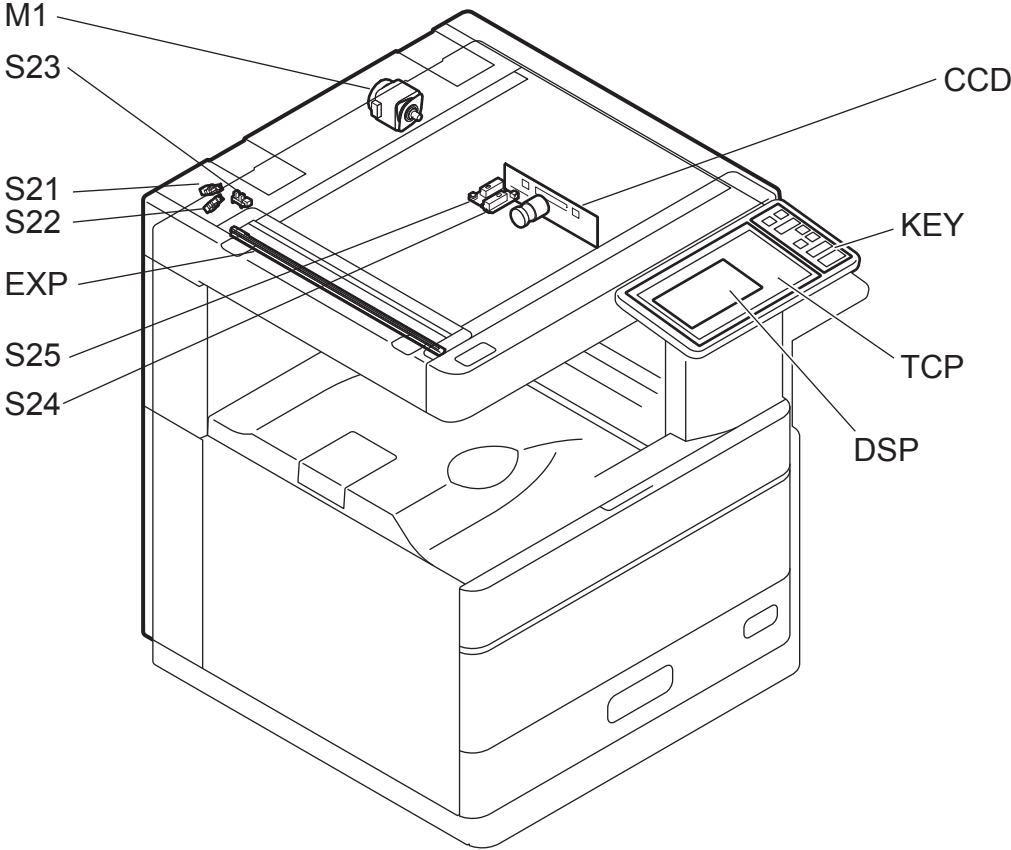


Fig. 3-3

[B] Toner cartridge, waste toner box

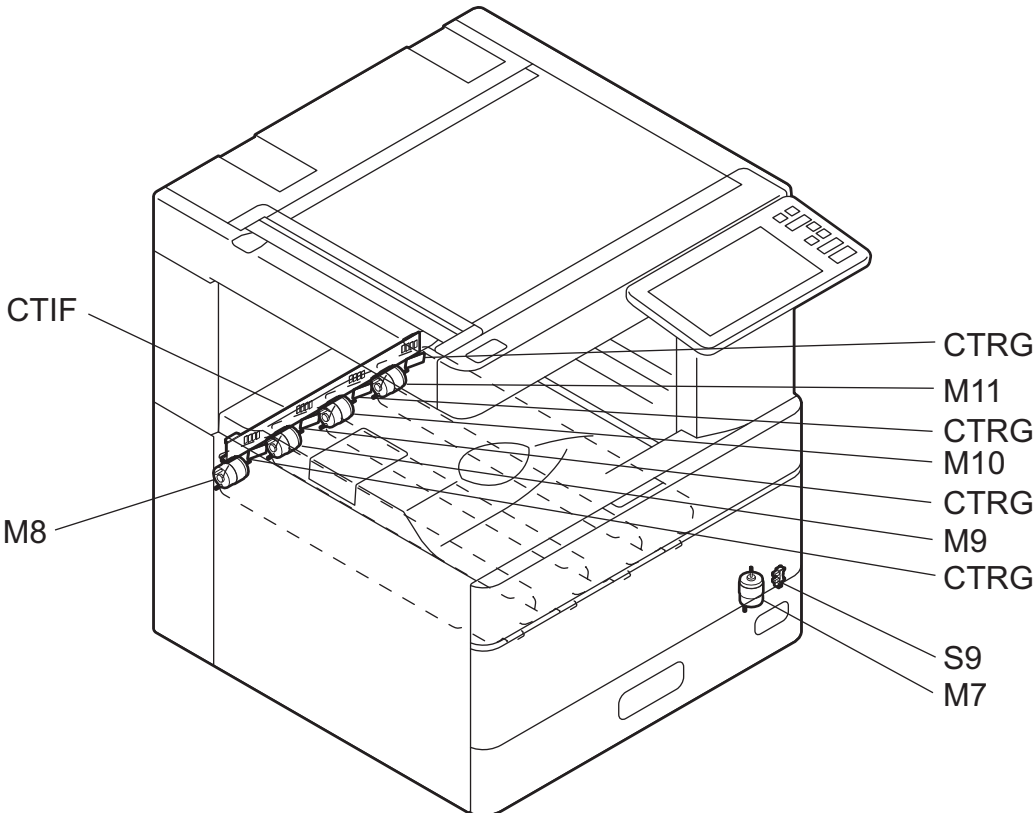


Fig. 3-4

[C] Developer unit

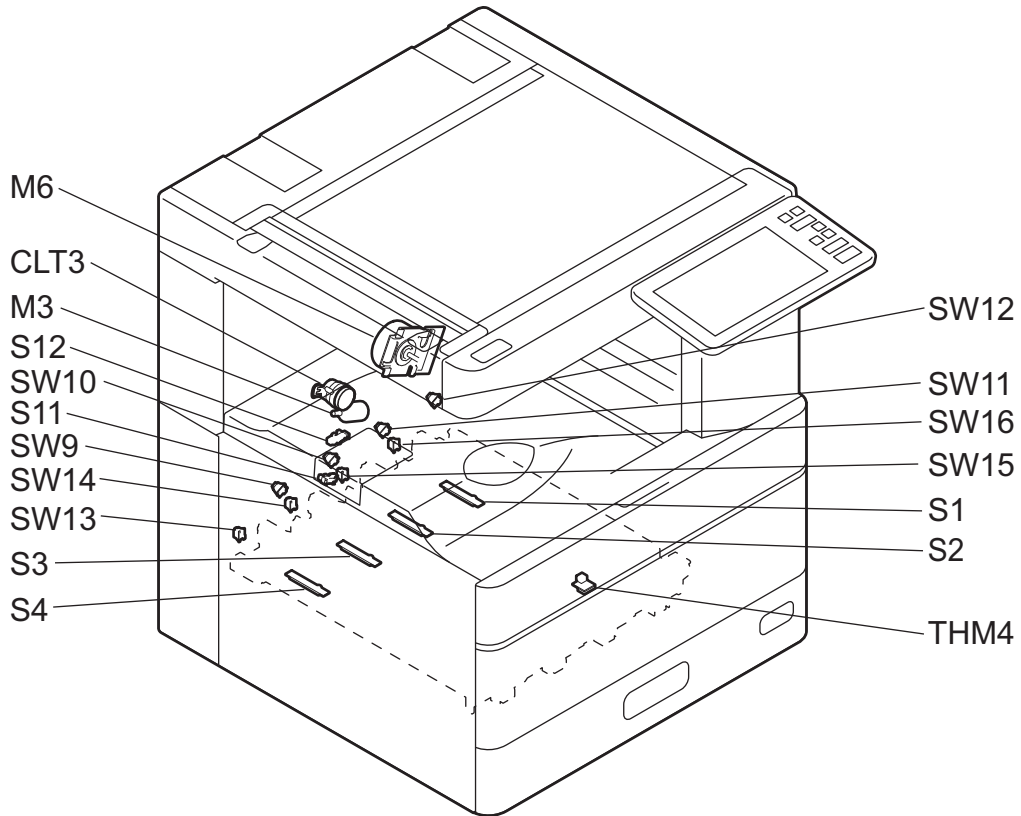


Fig. 3-5



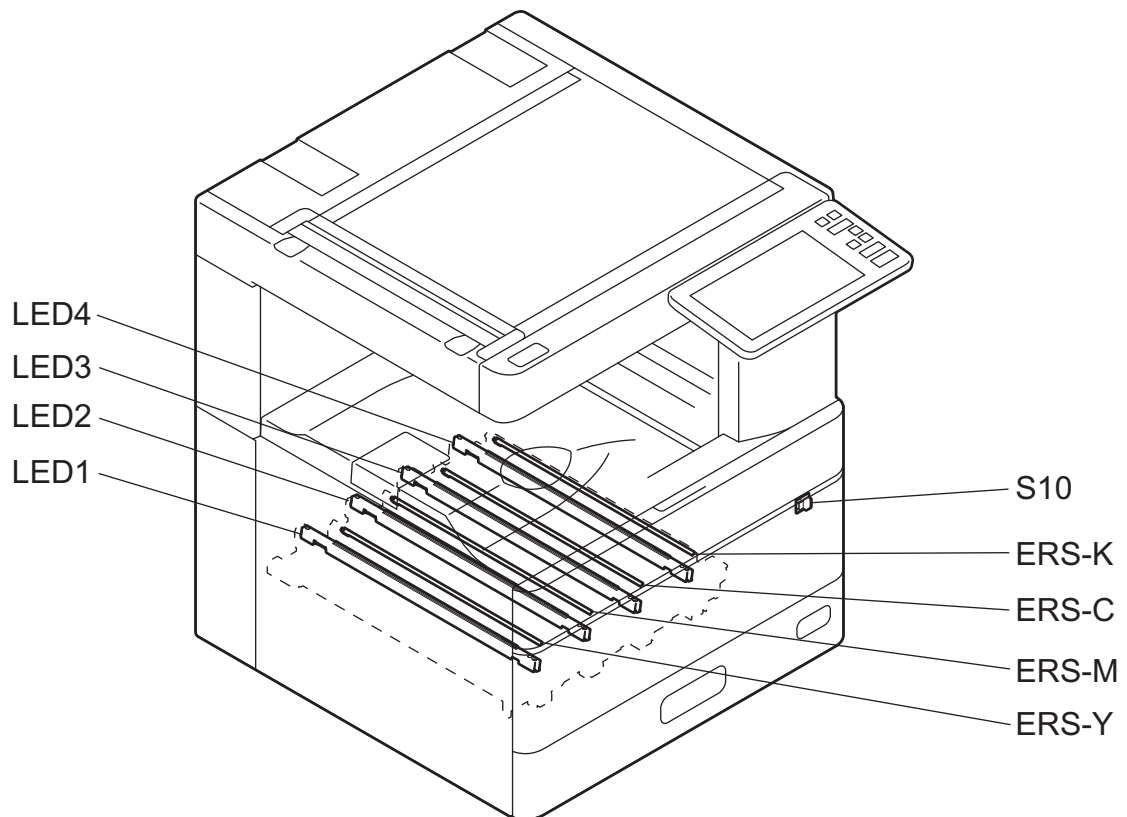


Fig. 3-6

[E] Fuser unit

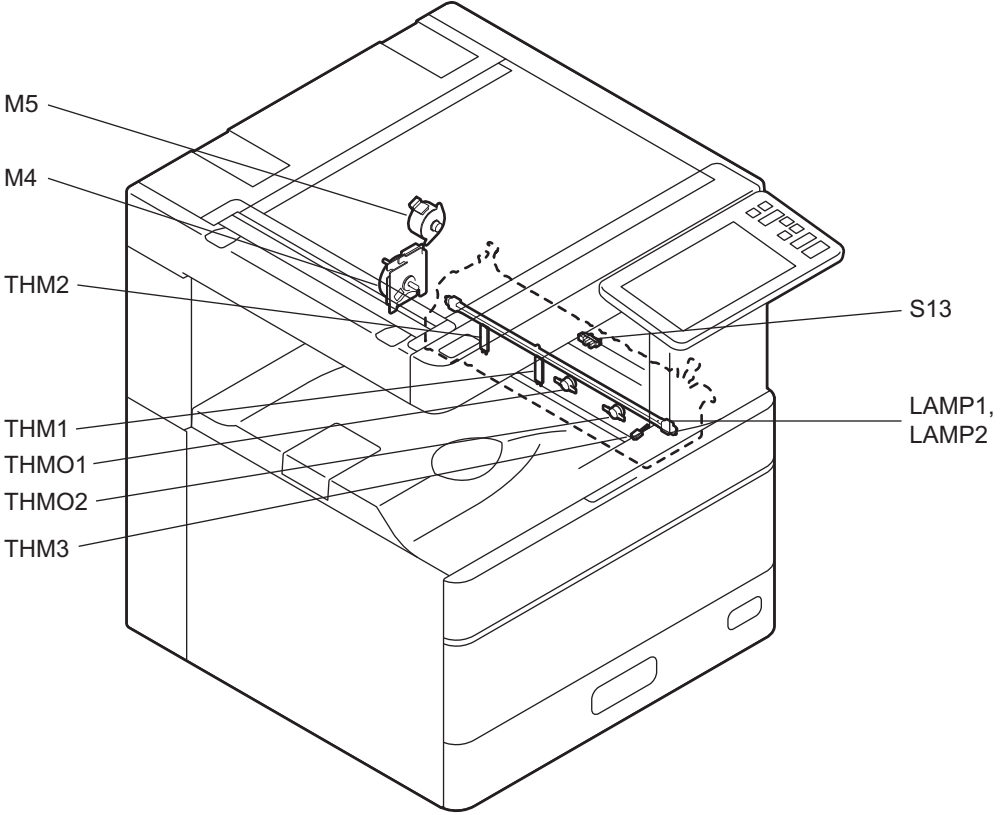


Fig. 3-7

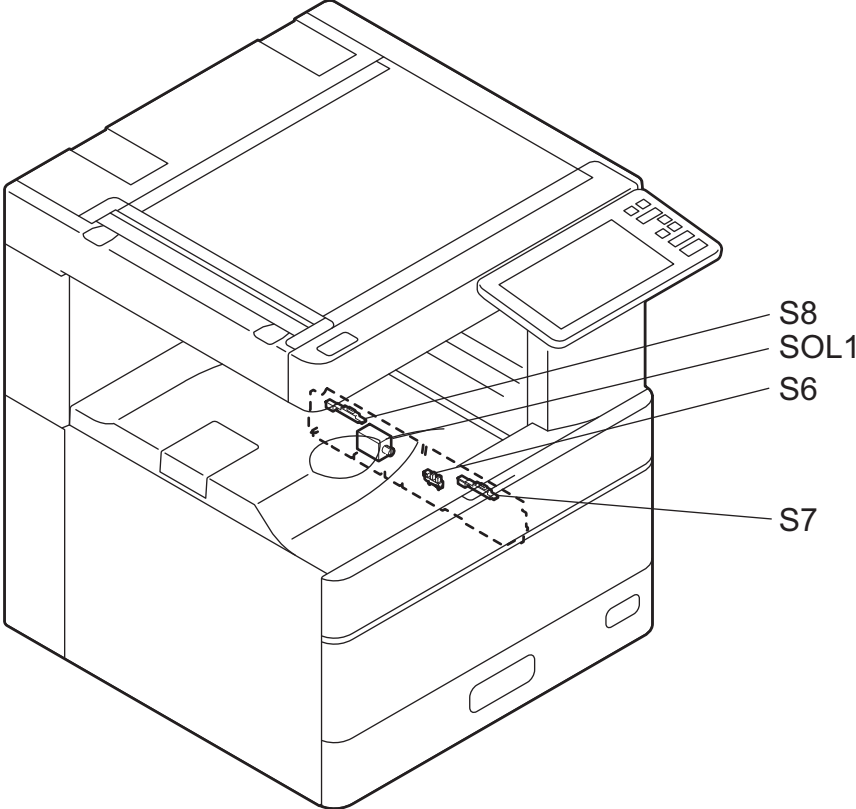


Fig. 3-8

[G] Paper feeding unit

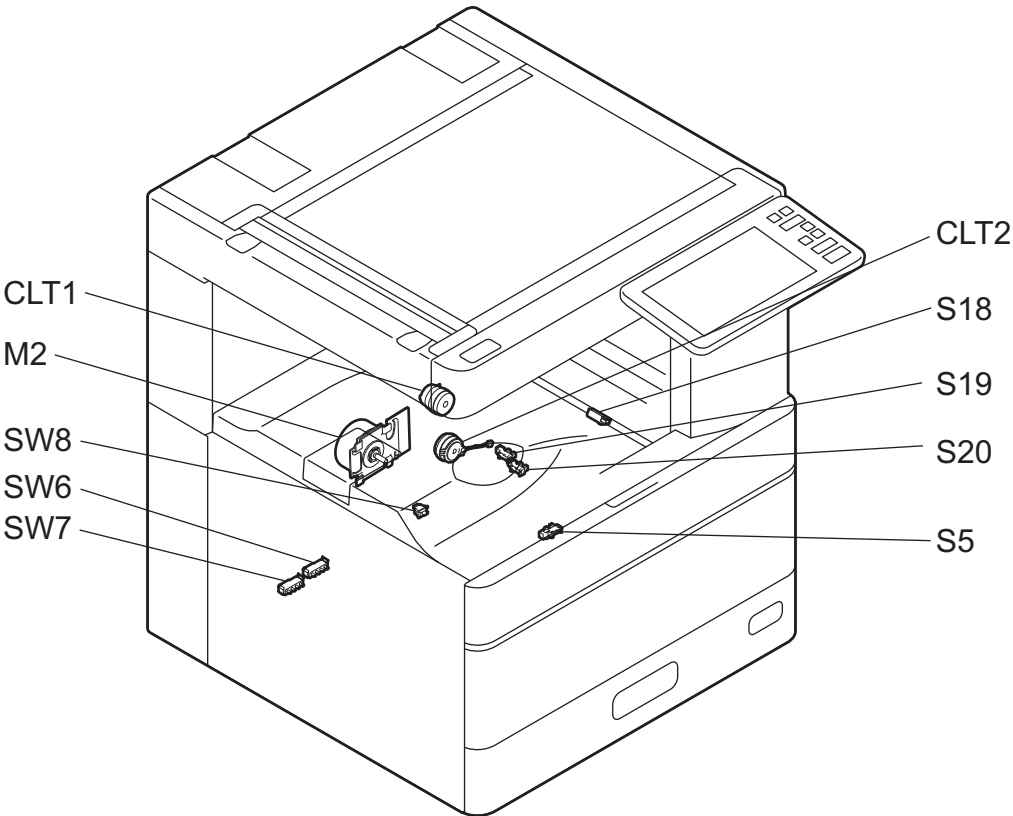


Fig. 3-9

[H] Automatic duplexing unit, bypass feed unit

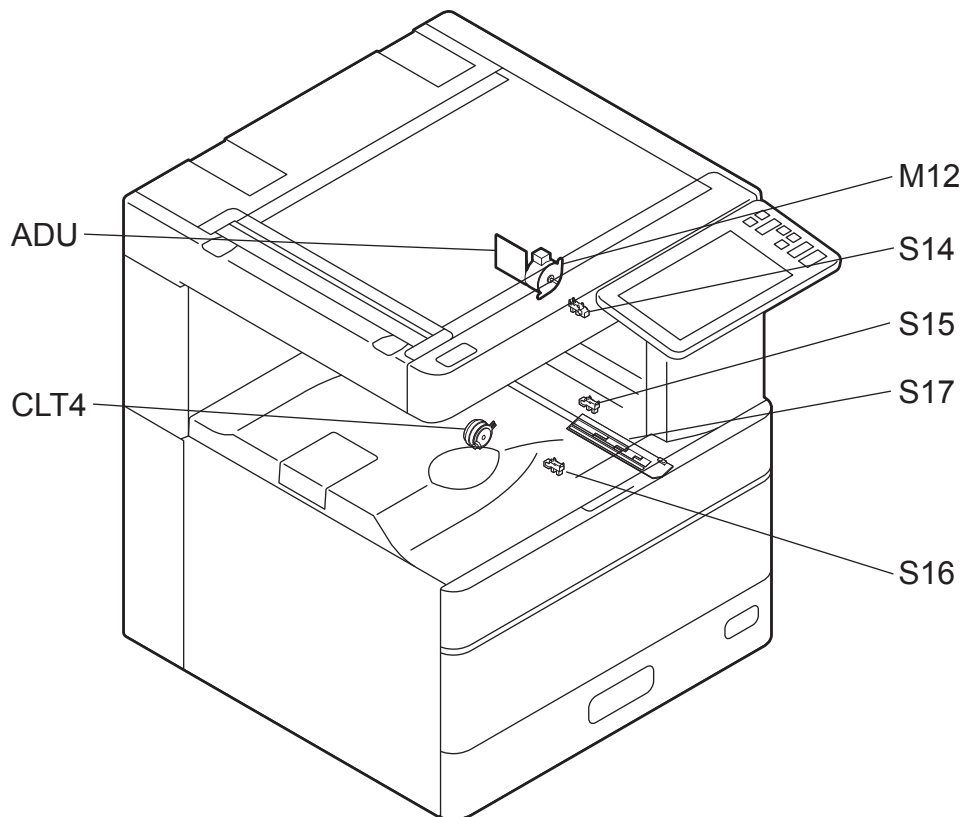


Fig. 3-10

[I] PC board, power supply

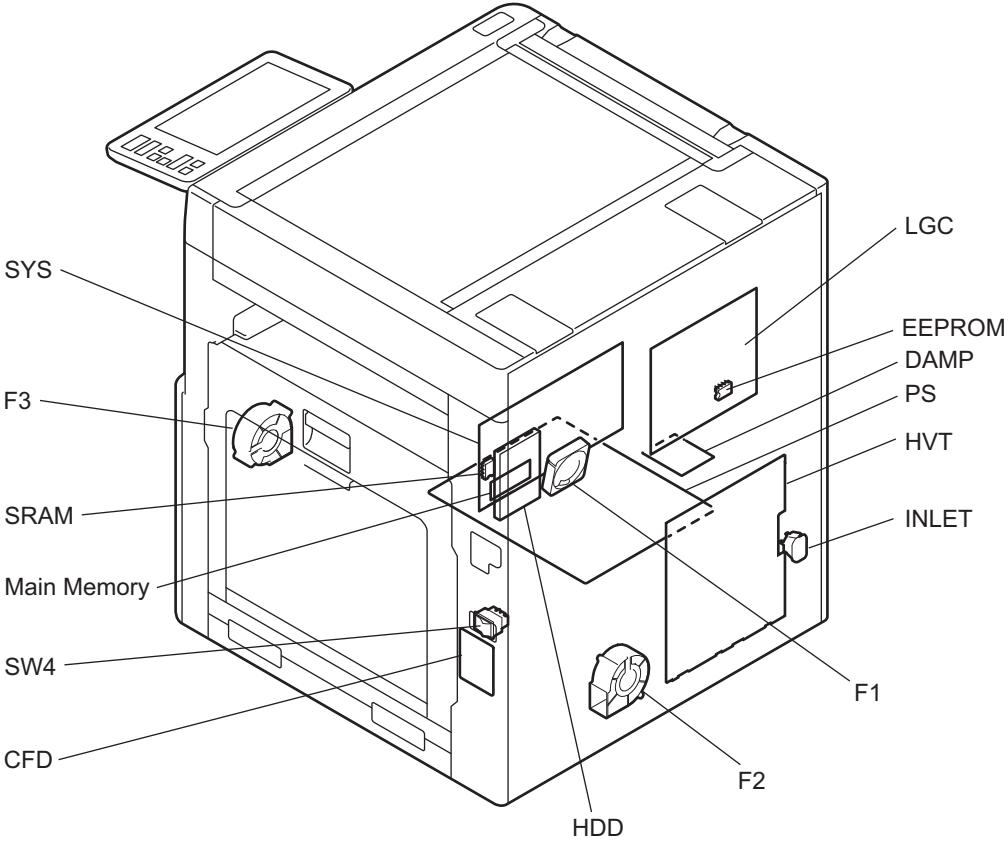


Fig. 3-11

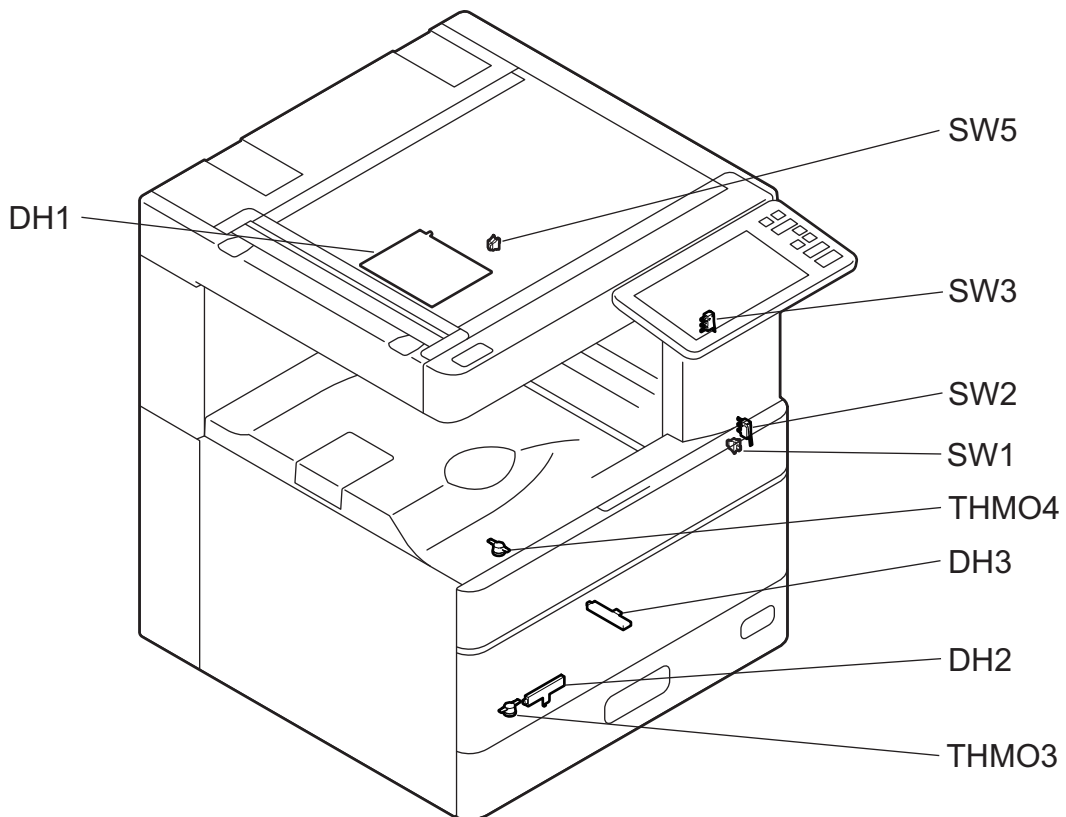


Fig. 3-12

### 3.3 Symbols and Functions of Various Components

The column "P-I" shows the page and item number in the parts list.

#### 3.3.1 Motors, fans

Symbol	Name	Function	Remarks	P-I
M1	SCAN-MOT Scan motor	Driving the carriages	Fig. 3-3	19-8
M2	FEED/DEV-MOT Paper feeding/developer unit drive motor	Driving the registration rollers, feed roller and developer unit	Fig. 3-3	17-35
M3	DRM-SW-MOT Mono/color switching motor	Transmitting/releasing the drive to the Y/M/C drums	Fig. 3-5	17-39
M4	FUS-MOT Fuser motor	Driving the fuser	Fig. 3-7	18-7
M5	EXIT-MOT Exit motor	Driving the exit roller	Fig. 3-7	18-14
M6	DRM/TBU-MOT Drum / TBU motor	Driving the drum Driving the transfer belt	Fig. 3-5	15-43
M7	USD-TNR-MOT Waste toner paddle motor	Driving the paddle in the waste toner box (agitating the accumulated waste toner)	Fig. 3-4	24-9
M8	TNR-MOT-Y Toner motor-Y	Transporting toner from the Y toner cartridge to the developer unit	Fig. 3-4	36-7
M9	TNR-MOT-M Toner motor-M	Transporting toner from the M toner cartridge to the developer unit	Fig. 3-4	36-7
M10	TNR-MOT-C Toner motor-C	Transporting toner from the C toner cartridge to the developer unit	Fig. 3-4	36-7
M11	TNR-MOT-K Toner motor-K	Transporting toner from the K toner cartridge to the developer unit	Fig. 3-4	36-7
M12	ADU-MOT ADU motor	Driving the automatic duplexing unit	Fig. 3-10	41-16
F1	SYS-FAN-MOT SYS cooling fan	Cooling down the SYS board	Fig. 3-11	9-5
F2	OZN-FAN-MOT Ozone exhaust fan	Suctioning ozone generated at charging	Fig. 3-11	7-6
F3	PS-FAN-MOT PS cooling/Ozone suctioning fan	Cooling down the switching regulator	Fig. 3-11	5-6

#### 3.3.2 Sensors and switches

Symbol	Name	Function	Remarks	P-I
S1	ATTNR-SNR-K Auto-toner sensor-K	Detecting the toner density in the K developer unit	Fig. 3-5	33-4
S2	ATTNR-SNR-C Auto-toner sensor-C	Detecting the toner density in the C developer unit	Fig. 3-5	33-4



Symbol	Name	Function	Remarks	P-I
S3	ATTNR-SNR-M Auto-toner sensor-M	Detecting the toner density in the M developer unit	Fig. 3-5	33-4
S4	ATTNR-SNR-Y Auto-toner sensor-Y	Detecting the toner density in the Y developer unit	Fig. 3-5	33-4
S5	CST1-EMP-SNR 1st drawer empty sensor	Detecting the presence of paper in the 1st drawer	Fig. 3-9	4-6
S6	RGST-PASS-SNR Registration pass sensor	Detecting paper transport at the registration roller section	Fig. 3-8	14-5
S7	IMG-POS-SNR-F Image position aligning sensor (Front)	Detecting the density of a toner image (test pattern) developed on the transfer belt surface (front)	Fig. 3-8	14-6
S8	IMG-POS-SNR-R Image position aligning sensor (Rear)/Image quality sensor	Detecting the density of a toner image (test pattern) developed on the transfer belt surface (rear) Detecting the rear side position a toner image (test pattern) developed on the transfer belt	Fig. 3-8	14-6
S9	USD-TNR-PDL-SNR Waste toner paddle rotation detection sensor	Detecting the rotation status of the waste toner paddle (Detecting the waste toner full)	Fig. 3-4	24-4
S10	TEMP/HUMI-SNR Temperature/humidity sensor	Detecting the ambient temperature/humidity of the equipment	Fig. 3-6	5-34
S11	DRM-SW-SNR Drum switching detection sensor	Detecting contact/release status of the drive to the Y/M/C drums	Fig. 3-5	17-36
S12	1ST-TRNS-SW-SNR 1st transfer roller status detection sensor	Detecting contact/release status of the 1st transfer roller for each color	Fig. 3-5	16-5
S13	EXIT-SNR Exit sensor	Detecting paper exit	Fig. 3-7	39-25
S14	ADU-U-SNR ADU entrance sensor	Detecting transported paper at the automatic duplexing unit entrance section	Fig. 3-10	41-19
S15	ADU-L-SNR ADU exit sensor	Detecting transported paper inside the automatic duplexing unit	Fig. 3-10	41-19
S16	SFB-FEED-SNR Bypass feed sensor	Detecting transported paper fed from the bypass feed unit	Fig. 3-10	42-9
S17	PWA-F-SFB Paper width detection PC board (SFB board)	Detecting the width of paper on the bypass tray	Fig. 3-10	20-6
S18	CLNG-SNR Paper clinging detection sensor	Detecting whether the paper is clinging to the transfer belt or not	Fig. 3-9	14-19
S19	RGST-SNR Registration sensor	Detecting paper transport at the registration roller section	Fig. 3-9	13-5
S20	TRANS-SNR Feed sensor	Detecting paper transport at the from the bypass feed unit, drawer, and ADU.	Fig. 3-9	13-5
S21	PLTN-SNR1 Platen sensor-1	Detecting the opening/closing status of the platen cover or RADF	Fig. 3-3	19-13
S22	PLTN-SNR2 Platen sensor-2	Detecting the opening/closing status of the platen cover or RADF	Fig. 3-3	19-13

Symbol	Name	Function	Remarks	P-I
S23	HOME-SNR Carriage home position sensor	Detecting the carriage home position	Fig. 3-3	10-5
S24	APS1 Automatic original detection sensor-1	Detecting original size	Fig. 3-3	10-12
S25	APS2 Automatic original detection sensor-2	Detecting original size (for LT size)	Fig. 3-3	10-12
SW1	FRT-COV-SW Front cover switch	Detecting the opening/closing status of the front cover	Fig. 3-12	24-20
SW2	F-COV-INTLCK-SW Front cover interlock switch	Supplying or shutting off AC power to the switching regulator (voltage-generating circuit interlocked with these covers) according to the opening/closing status of the front cover or automatic duplexing unit (Cover open: Shut off)	Fig. 3-12	5-10
SW3	S-COV-INTLCK-SW Side cover interlock switch	Supplying or shutting off AC power to the switching regulator (voltage-generating circuit interlocked with these covers) according to the opening/closing status of the front cover or automatic duplexing unit (Cover open: Shut off)	Fig. 3-12	5-10
SW4	MAIN-SW Main power switch	Turning the power of the equipment ON/OFF	Fig. 3-11	6-3
SW5	SIDE-COV-SW Side cover switch	Detecting the opening/closing status of the side cover	Fig. 3-12	7-23
SW6	CST-SIZE1-SW 1st drawer size detection switch-1	Detecting the size of paper	Fig. 3-9	7-2
SW7	CST-SIZE2-SW 1st drawer size detection switch-2	Detecting the size of paper	Fig. 3-9	7-2
SW8	CST1-SW 1st drawer detection switch	Detecting the presence of the 1st drawer	Fig. 3-9	6-39
SW9	Y-DRUM-SW Y drum old/new detection switch	Detecting whether the Y drum is the old or the new one	Fig. 3-5	31-2
SW10	M-DRUM-SW M drum old/new detection switch	Detecting whether the M drum is the old or the new one	Fig. 3-5	31-2
SW11	C-DRUM-SW C drum old/new detection switch	Detecting whether the C drum is the old or the new one	Fig. 3-5	31-2
SW12	K-DRUM-SW K drum old/new detection switch	Detecting whether the K drum is the old or the new one	Fig. 3-5	31-2
SW13	Y-DEV-SW Y developer unit old/new detection switch	Detecting whether the Y developer unit is the old or the new one	Fig. 3-5	31-2
SW14	M-DEV-SW M developer unit old/new detection switch	Detecting whether the M developer unit is the old or the new one	Fig. 3-5	31-2
SW15	C-DEV-SW C developer unit old/new detection switch	Detecting whether the C developer unit is the old or the new one	Fig. 3-5	31-2

Symbol	Name	Function	Remarks	P-I
SW16	K-DEV-SW K developer unit old/new detection switch	Detecting whether the K developer unit is the old or the new one	Fig. 3-5	31-2

### 3.3.3 Electromagnetic spring clutches

Symbol	Name	Function	Remarks	P-I
CLT1	RGST-CLT Registration clutch	Driving the registration roller	Fig. 3-9	17-45
CLT2	FEED-CLT Feed clutch	Driving the feed roller of the 1st drawer	Fig. 3-9	17-15
CLT3	1ST-TRNS-CLT 1st transfer contact/release clutch	Driving the contacting/releasing of the transfer belt and the drum	Fig. 3-5	15-40
CLT4	SFB-FEED-CLT Bypass feed clutch	Driving the feed roller of the bypass feed unit	Fig. 3-10	21-13

### 3.3.4 Solenoids

Symbol	Name	Function	Remarks	P-I
SOL1	SNR-SHUT-SOL Sensor shutter solenoid	Driving the sensor shutter of the image position aligning sensor (front / rear) and image quality sensor	Fig. 3-8	14-32

### 3.3.5 PC boards

Symbol	Name	Function	Remarks	P-I
CCD	PWA-F-CCD CCD driving PC board (CCD board)	Scanning originals with CCD	Fig. 3-3	10-9
DSP	PWA-F-DSP Display PC board (DSP board)	Controlling the whole control panel	Fig. 3-3	3-15
KEY	PWA-F-KEY Key PC board (KEY board)	Controlling the key switches and LEDs	Fig. 3-3	3-14
CTIF	PWA-F-CTIF Toner cartridge interface PC board (CTIF board)	Interface for detecting the toner cartridge (Detecting the CTRG board)	Fig. 3-4	36-2
CTRG	PWA-F-CTRG Toner cartridge PC board (CTRG board))	Storing the status of the toner cartridge	Fig. 3-4	-
ADU	PWA-F-ADU ADU control PC board (ADU board)	Controlling the automatic duplexing unit	Fig. 3-10	41-1
CFD	PWA-F-CFD Feed control PC board (CFD board)	Controlling the feed section	Fig. 3-11	6-1
SYS	PWA-F-SYS System control PC board (SYS board)	Controlling the whole system and image processing Controlling the scanning section	Fig. 3-11	9-2
LGC	PWA-F-LGC Logic PC board (LGC board)	Controlling the print engine section	Fig. 3-11	9-30

Symbol	Name	Function	Remarks	P-I
DAMP	PWA-H-DAMP DAMP board (DAMP board)	Power supplying to each damp heater (AUD, ASD, ARD, TWD, CND)	Fig. 3-11	9-24

### 3.3.6 Lamps and heaters

Symbol	Name	Function	Remarks	P-I
EXP	LP-EXPO Exposure lamp	Exposing originals	Fig. 3-3	11-3
LED1	LP-LED-Y LED printer head-Y	Exposing the Y drum	Fig. 3-6	31-21
LED2	LP--LED-M LED printer head-M	Exposing the M drum	Fig. 3-6	31-21
LED3	LP--LED-C LED printer head-C	Exposing the C drum	Fig. 3-6	31-21
LED4	LP--LED-K LED printer head-K	Exposing the K drum	Fig. 3-6	31-21
ERS-Y	LP-ERS-Y Discharge LED-Y	Eliminating residual charge on the Y drum surface	Fig. 3-6	31-15
ERS-M	LP-ERS-M Discharge LED-M	Eliminating residual charge on the M drum surface	Fig. 3-6	31-15
ERS-C	LP-ERS-C Discharge LED-C	Eliminating residual charge on the C drum surface	Fig. 3-6	31-15
ERS-K	LP-ERS-K Discharge LED-K	Eliminating residual charge on the K drum surface	Fig. 3-6	31-15
LAMP1	LP-HTR-C Center heater lamp	Heating the center section of the fuser roller	Fig. 3-7	37-8
LAMP2	LP-HTR-S Side heater lamp	Heating the section of the both sides of the fuser roller	Fig. 3-7	37-8
DH1	SCN-DH-L Scanner damp heater	Preventing condensation of the mirrors of the scanner	Fig. 3-12	10-17
DH2	DRM-DH-L Drum damp heater (Left)	Preventing condensation of the drum	Fig. 3-12	4-20
DH3	DRM-DH-R Drum damp heater (Right)	Preventing condensation of the drum	Fig. 3-12	4-19

### 3.3.7 Thermistors, thermostats

Symbol	Name	Function	Remarks	P-I
THM1	THMS-FR-C Fuser roller center thermistor	Detecting the surface temperature of the center of the fuser roller	Fig. 3-7	38-4
THM2	THMS-FR-S Fuser roller side thermistor	Detecting the surface temperature of the side of the fuser roller	Fig. 3-7	38-4
THM3	THMS-FR-E Fuser roller edge thermistor	Detecting the surface temperature of the front end of the fuser roller	Fig. 3-7	38-4
THM4	THMS-DRM Drum thermistor	Detecting the surface temperature of the drum	Fig. 3-5	31-11
THMO1	THERMO-FR-C Fuser roller center thermostat	Preventing overheating of the center portion of the fuser roller	Fig. 3-7	37-6

Symbol	Name	Function	Remarks	P-I
THMO2	THERMO-FR-S Fuser roller rear thermostat	Preventing overheating of the rear portion of the fuser roller	Fig. 3-7	37-6
THMO3	THERMO-DRM-DH-L Drum damp heater thermostat (Left)	Controlling the temperature of the drum damp heater	Fig. 3-12	4-22
THMO4	THERMO-DRM-DH-R Drum damp heater thermostat (Right)	Controlling the temperature of the drum damp heater	Fig. 3-12	4-21

### 3.3.8 Others

Symbol	Name	Function	Remarks	P-I
TCP	TCP Touch panel	Displaying and entering various kinds of information	Fig. 3-3	3-1
EEPROM	EEPROM Electrically Erasable Programmable Read Only Memory	Storing the setting or adjustment value, etc. used for the control by the logic PC board	Fig. 3-11	9-31
SRAM	SRAM	Storing the setting or program, etc. used for the control by the system PC board	Fig. 3-11	
HDD	HDD Hard disk	Saving programs and data	Fig. 3-11	9-3
Main memory	Main memory	Saving data and programs temporarily (Also used as page memory in this equipment.)	Fig. 3-11	9-32
PS	PS-ACC Switching regulator	Generating DC voltage and supplying it to each section of the equipment	Fig. 3-11	4-17
HVT	PS-HVT High-voltage transformer	Generating high-voltage and supplying it to the following sections <ul style="list-style-type: none"> <li>• Main charger needle electrode</li> <li>• Main charger grid</li> <li>• Developer bias</li> <li>• Transfer bias</li> </ul>	Fig. 3-11	8-17

### 3.4 Copy Process

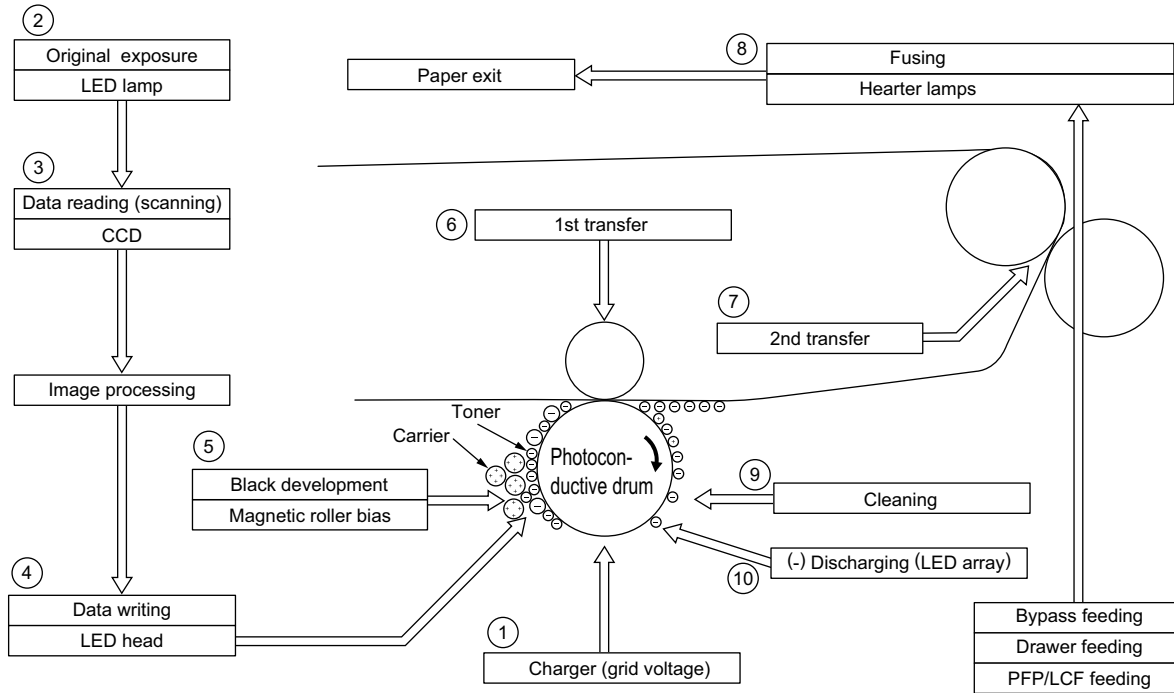


Fig. 3-13

- |  |  |
|--|--|
| <p>(1) Charging: Places a negative charge on the surface of the photoconductive drum.</p> <p style="text-align: center;">↓</p> <p>(2) Original exposure: Converts images on the original into optical signals.</p> <p style="text-align: center;">↓</p> <p>(3) Data reading: The optical image signals are read into CCD and converted into electrical signals.</p> <p style="text-align: center;">↓</p> <p>(4) Data writing: The electrical image signals are changed to light signals (by LED emission) which expose the surface of the photoconductive drum.</p> <p style="text-align: center;">↓</p> <p>(5) Development: Negatively-charged toner is made to adhere to the photoconductive drum, producing a visible image.</p> <p style="text-align: center;">↓</p> | <p>(6) 1st transfer: Transfers the visible image (toner) on photoconductive drum to the transfer belt.</p> <p style="text-align: center;">↓</p> <p>(7) 2nd transfer: Transfers the visible image (toner) on the transfer belt to paper.</p> <p style="text-align: center;">↓</p> <p>(8) Fusing: Fuses the toner image to the paper by applying heat and pressure.</p> <p style="text-align: center;">↓</p> <p>(9) Blade cleaning: While scraping off the residual toner from the drum by the blade.</p> <p style="text-align: center;">↓</p> <p>(10) (-) Discharging: Eliminates the residual (-) charge from the surface of the photoconductive drum.</p> |
|--|--|

### 3.5 Comparison with e-STUDIO2050C/2550C/2051C/2551C

Process		e-STUDIO2050C/2550C/2051C/ 2551C	20ppm/25ppm
1. Photoconductive drum	Drum	OD-FC30 (OPC drum)	←
	Sensitivity	Highly sensitized drum (ø30)	←
2. Charging		Scorotron type -300 to -1100 V (grid voltage) (adjusting by image quality control)	←
3. Data writing	Light source	LED printer head	←
	Light amount	-	←
4. Image control		Image quality control by detecting toner adhesion amount	←

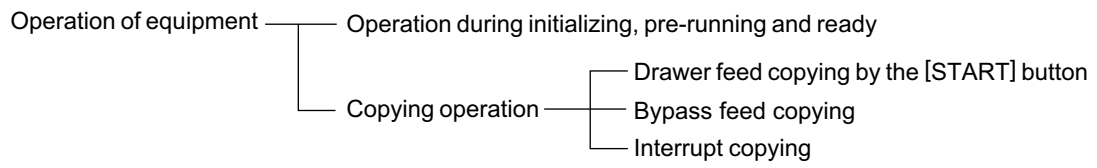
Process		e-STUDIO2050C/2550C/2051C/ 2551C	20ppm/25ppm
5. Development	Magnetic roller	One magnetic roller	←
	Auto-toner detection	Magnetic bridge-circuit method	←
	Toner supply	Toner cartridge replacing method	←
	Toner-empty detection	Density detection method	←
	Toner	NAD/NAH T-FC30-K, T-FC30-Y T-FC30-M, T-FC30-C MJD T-FC30E-K, T-FC30E-Y T-FC30E-M, T-FC30E-C CND T-FC30C-K, T-FC30C-Y T-FC30C-M, T-FC30C-C OthersT-FC30D-K, T-FC30D-Y T-FC30D-M, T-FC30D-C (K: Black, Y: Yellow, M: Magenta, C: Cyan)	NAD: PS-ZTFC200UK(1) PS-ZTFC200UY(1) PS-ZTFC200UM(1) PS-ZTFC200UC(1) MJD: PS-ZTFC200EK(1) PS-ZTFC200EY(1) PS-ZTFC200EM(1) PS-ZTFC200EC(1) CND: PS-ZTFC505CK(1), PS- ZTFC505CKS(1) PS-ZTFC505CY(1), PS- ZTFC505CYS(1) PS-ZTFC505CM(1), PS- ZTFC505CMS(1) PS-ZTFC505CC(1), PS- ZTFC505CCS(1) TWD: PS-ZTFC505TK(1) PS-ZTFC505TY(1) PS-ZTFC505TM(1) PS-ZTFC505TC(1) Others: PS-ZTFC200PK(1), PS- ZTFC200PKM(1) PS-ZTFC200PY(1), PS- ZTFC200PYM(1) PS-ZTFC200PM(1), PS- ZTFC200PMM(1) PS-ZTFC200PC(1), PS- ZTFC200PCM(1) (K: Black, Y: Yellow, M: Magenta, C: Cyan)
	Developer material	D-FC30-K (black) D-FC30-Y (yellow) D-FC30-M (magenta) D-FC30-C (cyan)	D-FC505-K (Black) D-FC505-Y (Yellow) D-FC505-M (Magenta) D-FC505-C (Cyan)
	Developer bias	DC -200 to -900V (adjusting by image quality control)	←
6. Transfer	1st transfer	Transfer belt method	←
	2nd transfer:	Transfer roller method	←
7. Separation		Self-separation by transfer belt and 2nd transfer roller	←
8. Photoconductive drum cleaning	Method	Blade cleaning	←
	Recovered toner	Non-reusable	←



Process		e-STUDIO2050C/2550C/2051C/ 2551C	20ppm/25ppm
9. Transfer belt cleaning		Blade cleaning	←
10. Discharge		LED array (red)	←
11. Fusing	Method	Roller fusing system	←
		Fuser roller: Aluminum rubber coated roller, (Surface-PFA tube)(ø30) (Heater lamp: 570 W x 2))	←
		Pressure roller: Silicon rubber roller, (Surface-PFA tube)(ø30)	←
	Cleaning	None	←
	Heater temperature	ON/OFF control and power control by thermistor	←
	Heater	Heater lamp	←

## 3.6 General Operation

### 3.6.1 Overview of Operation



## 3.6.2 Description of Operation

### [ 1 ] Warming-up

#### 1. Initialization

- Power ON
- Heater lamps (LAMP1, LAMP2) ON
- “Wait Warming Up” are displayed.
- Fan motors ON
- Initialization of feeding system
  - Each drawer tray goes up.
  - Pre-running operation is stopped after five seconds.
  - Drum/TBU motor (M6) is turned ON.
  - Mono/color switching motor (M3) is turned ON and OFF.
  - Cleaning of transfer belt
  - (Performs color registration control.)\*<sup>1</sup>
  - (Performs image quality control.)\*<sup>1</sup>
  - Drum/TBU motor (M6) is turned OFF.
- Initialization of scanning system
  - The carriage moves to the home position.
  - The carriage moves to the peak detection position.
  - The exposure lamp (EXP) is turned ON.
  - Peak detection (white color is detected by the shading correction plate)
  - The exposure lamp (EXP) is turned OFF.
  - Pre-scanning <forward/backward> moves by 420 mm <A3 (landscape)>.
  - “READY (WARMING UP)” is displayed.

#### 2. Pre-running operation

Pre-running operation is started when the temperature of the fuser roller surface reaches a certain level.

- Fuser motor (M4) is turned ON.
- Fuser roller rotation.
- Fuser motor (M4) is turned OFF.
- Fuser roller rotation stop.

#### 3. When the temperature of the fuser roller surface becomes sufficient for fusing,

- “READY” is displayed.

\*1: Image quality control and color registration control should be performed only at change of environment or periodical performing timing.

### [ 2 ] Ready (ready for copying)

- Buttons on the control panel enabled
- When no button is pressed for a certain period of time,
  - Set number “1” and reproduction ratio “100%” are displayed. Equipment returns to the normal ready state.

### [ 3 ] Drawer feed copying (1st drawer paper feeding)

1. Press the [START] button ON
  - “READY” changes to “COPYING”
  - Exposure lamp (EXP) turned ON
  - Scan motor (M1) turned ON → Carriages-1 and -2 move forward
  - Drum/TBU motor (M6), Paper feeding/developer unit drive motor (M2), and fuser motor (M4) turned ON
  - Drum, transfer belt, fuser unit, and developer unit are driven
2. Drawer paper feeding
  - Fans rotated at high speed and feed clutch (CLT2) turned ON
  - Feed roller start to rotate
  - Paper reaches the feed sensor (S20)
  - Feed sensor (S20) is turned ON
  - Paper reaches the registration roller
  - Registration sensor (S19) is turned ON and aligning is performed
  - Feed clutch (CLT2) is turned OFF after a certain period of time
3. A certain period of time passed after the carriage operation
  - Registration clutch (CLT1) is turned ON → Paper is transported to the transfer area
  - Copy counter operates
4. Completion of scanning
  - Exposure lamp (EXP) turned OFF
  - Scan motor (M1) turned OFF
  - Registration clutch (CLT1) is turned OFF (after the trailing edge of the paper passed the registration roller)
  - “READY (PRINTING)” is displayed
5. Printing operation
  - 1) **Color printing operation**
    - Mono/color switching motor (M3) turned ON
    - The drum switching detection sensor (S19) checks whether the equipment is in the color or black printing status, and if it is in the black printing status, the motor (M3) is turned ON to switch the status to color printing.
    - Drum/TBU motor (M6), discharge LED-Y, -M, -C, -K (ERS) turned ON
    - Main charger bias turned ON
    - 1st transfer contact/release clutch (CLT3) turned ON
    - Contact the 1st transfer rollers (Y, M and C) to the transfer belt
    - YMCK developer bias (DC) and Paper feeding/developer unit drive motor (M2) turned ON
    - 2nd transfer bias turned ON
    - LED emission (yellow image)
    - 1st transfer bias (Y) turned ON
    - 1st transfer of yellow image (Yellow image is transferred to the transfer belt)
    - 1st transfer bias (Y) turned OFF
    - LED emission (magenta image)
    - 1st transfer bias (M) turned ON
    - 1st transfer of magenta image (Magenta image is transferred to the transfer belt)
    - 1st transfer bias (M) turned OFF
    - LED emission (cyan image)
    - 1st transfer bias (C) turned ON
    - 1st transfer of cyan image (Cyan image is transferred to the transfer belt)
    - 1st transfer bias (C) turned OFF
    - LED emission (black image)
    - 1st transfer bias (K) turned ON
    - 1st transfer of black image (Black image is transferred to the transfer belt)
    - 1st transfer bias (K) turned OFF

- 1st transfer contact/release clutch (CLT3) turned ON
- Release the 1st transfer rollers (Y, M and C) from the transfer belt
- 2nd transfer of YMCK image (YMCK image on the transfer belt is transferred to the paper)
- Main charger turned OFF
- Paper feeding/developer unit drive motor (M2) and developer bias (YMC and K) turned OFF
- 2nd transfer bias turned OFF
- Drum/TBU motor (M6), discharge LED-Y, -M, -C, -K (ERS) turned OFF

## 2) Black printing operation

- Mono/color switching motor (M3) turned ON
- The drum switching detection sensor (S19) checks whether the equipment is in the color or black printing status, and if it is in the color printing status, the motor (M3) is turned ON to switch the status to black printing.
- Drum/TBU motor (M6), discharge LED-K (ERS) turned ON
- Main charger bias turned ON
- K developer bias (DC) and Paper feeding/developer unit drive motor (M2) turned ON
- 2nd transfer bias turned ON
- LED emission (black image)
- 1st transfer bias (K) turned ON
- 1st transfer of black image (Black image is transferred to the transfer belt)
- 1st transfer bias (K) turned OFF
- 2nd transfer of K image (K image on the transfer belt is transferred to the paper)
- Main charger turned OFF
- Paper feeding/developer unit drive motor (M2) turned OFF
- 2nd transfer bias turned OFF
- Drum/TBU motor (M6), discharge LED-K (ERS) turned OFF

## 6. Paper exiting

- The exit sensor (S13) detects the leading edge of the paper
- Exit motor (M5) turned ON
- The exit sensor (S13) detects the trailing edge of the paper
- Discharge LED (ERS) turned OFF
- Drum/TBU motor (M6), Paper feeding/developer unit drive motor (M2), fuser motor (M4) and exit motor (M5) turned OFF
- The polygonal motor (M4) rotates at low speed.
- Drum, fuser unit and developer unit are stopped
- Fans return to rotate at the normal rotation speed
- "READY" is displayed and the equipment enters into ready mode

#### **[ 4 ] Bypass feed copying**

1. Insert a paper into the bypass tray.
  - Bypass paper sensor (S16) is turned ON.
  - “Ready for bypass feeding” is displayed.
  - Carriages move to the home position.
2. Press the [START] button ON
  - “Ready for bypass feeding” changes to “COPYING”.
  - Exposure lamp (EXP) ON
  - Scan motor (M1) ON→Carriages-1 and -2 move forward.
  - Drum/TBU motor (M6), Paper feeding/developer unit drive motor (M2), and fuser motor (M4) turned ON
  - The drum, transfer belt, fuser unit and developer unit are driven.
3. Bypass feeding
  - Fans rotate at high speed.
  - Bypass feed clutch (CLT4) turned ON.
  - The bypass feed roller is lowered.
  - Aligning operation
  - Paper reaches the registration roller.
  - After a certain period of time, the bypass feed clutch (CLT4) turned OFF.
4. Hereafter, operations (3) through (6) of “5.2.3Drawer feed copying (1st drawer paper feeding)” are repeated.

#### **[ 5 ] Interruption copying**

1. Press the [INTERRUPT] button
  - Copying operation in progress is temporarily stopped, and the carriages-1 and -2 return to appropriate positions.
  - “Job interrupted job 1 saved” is displayed.
  - Automatic density and reproduction ratio 100% are set. Set number remains the same.
2. Select the desired copy condition
3. After interruption copying is finished:
  - The equipment returns to the status before the interruption by pressing the [INTERRUPT] button.
4. Press the [START] button
  - The copying operation before the interruption is resumed.

### 3.6.3 Detection of Abnormality

When something abnormal has occurred in the equipment, symbols corresponding to the type of abnormality are displayed.

#### [ 1 ] Types of abnormality

1. Abnormality cleared without turning OFF the door switch
  - (A) Add paper
  - (B) Paper misfeed in bypass
  
2. Abnormality not cleared without turning OFF the door switch
  - (C) Misfeed in equipment
  - (D) No toner in the cartridge
  - (E) EPU not installed properly
  - (F) Waste toner box replacement
  
3. Abnormality not cleared without turning OFF the [ON/OFF] button
  - (G) Call for service

## [ 2 ] Description of abnormality

### [A] Add paper

[In case of the equipment drawer or PFP drawer] (When drawer is not installed)

Drawer not detected



Drawer is not installed:  
Drawer is installed but there is no paper in it:



No paper



A signal sent to the control circuit



Drawer area of the control panel blinks  
(When the drawer is selected)



[START] button is disabled.

[In case of the PFU, PFP or LCF drawers] (When drawer is installed)

Based on the combination of the tray-up motor (M21) movement and the status of tray-up sensor and empty sensor, CPU detects the presence of paper.

- When the power is turned ON or LCF drawer is inserted (When the power is turned ON or equipment/PFP drawers are inserted). LCF performs initialization.



Detects the presence of paper  
Tray-up motor ON - The tray goes up

- When the tray-up sensor is not turned ON in a fixed period of time it means that the tray is in abnormal condition  
“Add paper” is displayed regardless of presence/absence of paper.

→ Cleared by turning the power ON/OFF



- Tray-up sensor is turned ON in a fixed period of time
  - The tray-up motor stops.

At this time, if the empty sensor is ON: It is judged that there is paper.

OFF: It is judged that there is no paper.



Drawer area of the control panel  
blinks.  
(When the drawer is selected)

- When the paper in the drawer gets short during copying,
  - The tray-up sensor turned OFF
  - The tray-up motor turned ON - Tray goes up
  - Tray-up sensor turned ON
  - Tray-up motor stopped
  
- Empty sensor turned OFF during the copying in spite of the tray-up sensor is ON



It is judged that there is no paper.



Drawer area of the control panel blinks.  
(When the drawer is selected)



The copying operation is stopped.

## **[B] Paper misfeed in bypass**

During bypass feeding  
Bypass feed clutch (CLT4) is turned ON



Registration sensor (S19) is turned ON  
\* Registration sensor (S19) is not turned ON in a fixed period of time (E120)



Bypass misfeeding



Bypass misfeed symbol is displayed



The copying operation is disabled.



Solution: The bypass sensor (S16) is turned OFF by removing the paper from the bypass tray.

**[C] Misfeed in equipment**

- Exit sensor (S13) detects jamming of the leading edge of paper

↓

Registration clutch (CLT1) turned ON

↓ Fixed time

Exit sensor (S13) turned ON  
If the exit sensor (S13) is not turned ON after a fixed time,

↓

Paper jam (E010) The copying operation is stopped.

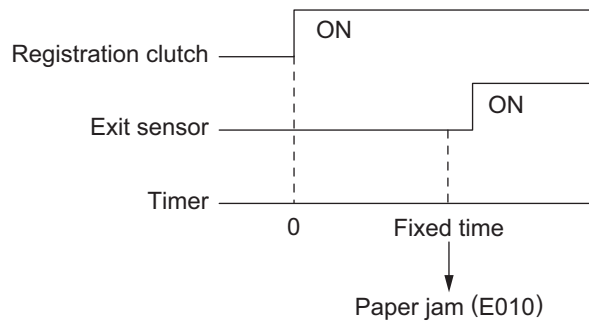


Fig. 3-14

- Exit sensor (S13) detects jamming of the trailing edge of paper

Registration clutch (CLT1) turned OFF

↓ Fixed time.

Exit sensor (S13) turned OFF  
If the exit sensor (S13) is not turned OFF a fixed time

↓

Paper jam (E020) The copying operation is stopped.

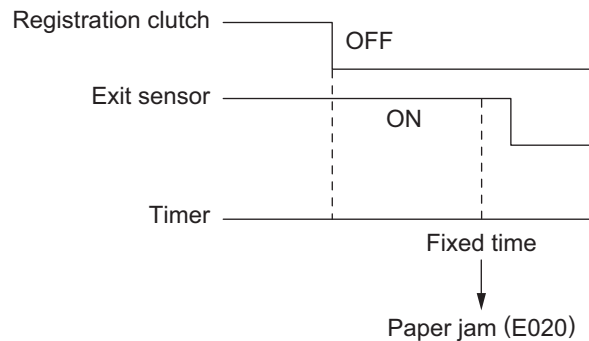


Fig. 3-15

- Immediately after the power ON

↓

Any of all sensors on paper transport path detects paper (ON)

↓

Paper jam (E030)

- Front cover is opened during copying

↓

Paper jam (E410)

- Registration sensor (S19) detects jamming of the leading edge of paper:  
The registration sensor (S19) is not turned ON in a fixed period of time after the leading edge of paper passed the transport roller.



Paper jam (E120, E200, E210, E300, E330 and E3C0)

- During paper feeding from ADU:  
The registration sensor (S19) is not turned ON in a fixed period of time after the ADU clutch (CLT7) is turned ON.



Paper jam (E110)

- During paper transporting from ADU:  
ADU entrance/exit sensors (S14/S15) do not detect the paper at the fixed timing



Paper jam (E510 and E520)

- During paper feeding from the equipment or PFP:  
The registration sensor (S19) is not turned ON in a fixed period of time after the feed clutch is turned ON.



Paper jam (E220, E310, E320, E340 to E360, E3D0 and E3E0: Error code defers depending on the paper source.)

## **[D] No toner in the cartridge**

Toner density becomes low



Auto-toner sensor (S1/S2/S3/S4) detects the absence of the toner



Control circuit → “Install new \*\* toner cartridge” is displayed: the copying operation disabled

Solution    Open the front cover and replace the toner cartridge with new one.  
:            Toner is supplied → copying operation enabled

**[E] EPU not installed properly**

Disconnection of the connectors of the EPU



“Latch the developer unit” is displayed.

Solution: Install the EPU and close the front cover.

**[F] Waste toner box replacement**

- Waste toner box is full of used toner



Rotation of the paddle has not been detected for a specified period



“Dispose of used toner” is displayed

- Waste toner box full is detected during printing




Printing is stopped after the paper being printed is exited

Solution: Replace the waste toner box with new one and close the front cover.


**[G] Call for service**

Check the error code displayed on the control panel when “Call for service” appears, and handle the abnormality in reference to the error code table.

 P. 8-6 "8.2 Error Code List"

### 3.6.4 Hibernation function

A hibernation function is embedded in this equipment. This function allows the equipment to store the last status of the system in the HDD immediately before the power is turned OFF, and to restart from this stored status at the next boot-up.

For warming-up time, refer to  P. 2-1 "2.1.1 General"

If hibernation is not performed when the power is turned OFF or the equipment boots up immediately after the settings, warming-up takes longer. It differs depending on the usage conditions; warming-up will take approx. 30 to 150 sec.

The following are the conditions which necessitate a longer warming-up time.

- Rebooting from TopAccess
- First booting after power interruption
- First booting after a self-diagnosis code is changed in the Service UI
- First booting after the power is turned OFF with the main power switch during the super sleep mode
- Installing options or finishers
- First booting after an option or a finisher is removed
- During toner supply
- Operating while "READY (WARMING UP)" is still on the control panel
- Shutting down during network initialization
- First booting after the power is turned OFF in a procedure other than the correct one described in the Quick Start Guide

## 3.7 Control Panel

### 3.7.1 General Description

The control panel consists of button switches and touch-panel to operate the equipment and select various modes, and LEDs to display the state of the equipment.

When the operator's attention is required, graphic symbols light or blink with messages explaining the condition of the equipment in the LCD panel. When paper jams and "Call for service" occur, error codes are also displayed to notify users of the problem.

A 9-inch capacitive touch panel is used in this equipment, resulting in the improvement of operability.

The [ON/OFF] button is placed on the control panel, and this button is used instead of the main power switch to turn the power ON/OFF. Press this button to turn the power of the equipment ON/OFF.

The digital keys are displayed on the touch panel instead of being located on the control panel. In addition to this, a digital key pad can be installed optionally for a user who wants to carry out the button operation by means of the actual keys.

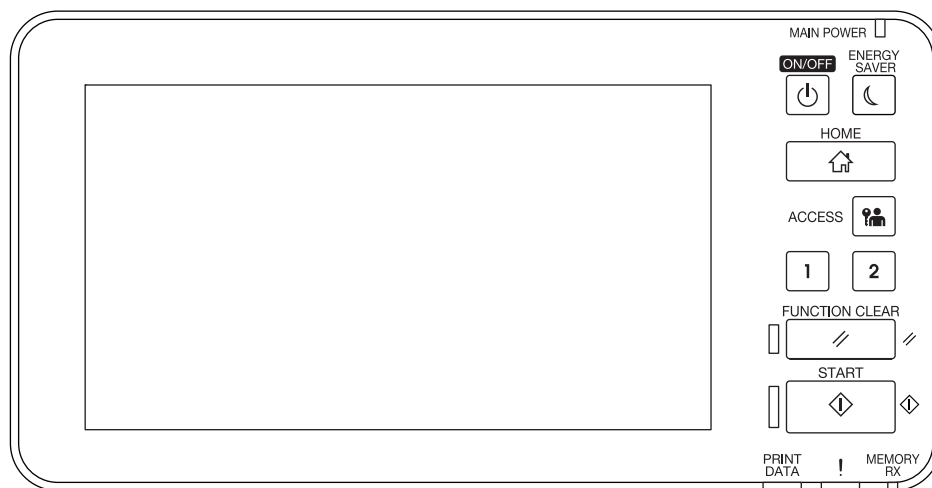


Fig. 3-16

## 3.8 Scanner

### 3.8.1 General Description

In the scanning section of this equipment, the surface of an original is irradiated with a direct light and the reflected light is led through mirrors, a lens and a slit to CCD where optical-to-electrical conversion is performed, converting the optical image data into an electrical (analog) signal. This analog signal is changed to a digital signal, which then undertakes various corrective processes necessary for image formation. After that, arithmetic operation is performed on the digital signal, which is then transmitted to the data writing section.

In this equipment, a reduction-type CCD for color processing is used. What this CCD differs from black-and-white CCDs is that its devices are arranged in 3 lines and covered with color filters (Red, Green, and Blue). These lines are composed with 3-line color devices and black-and-white device with no filter.

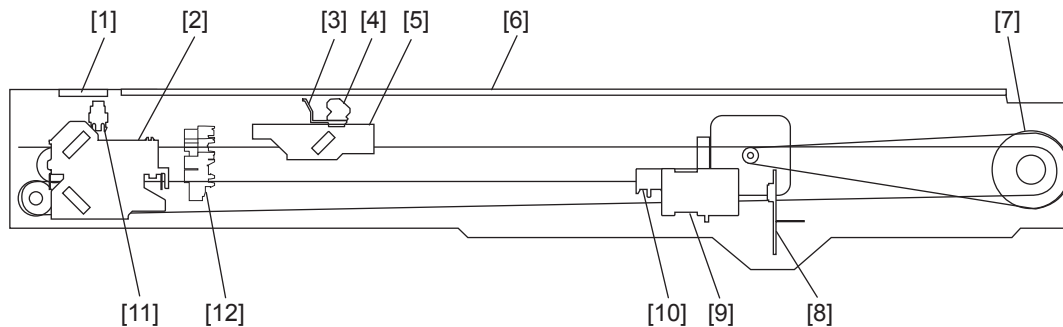


Fig. 3-17

- [1] ADF original glass
- [2] Carriage-2
- [3] Reflector
- [4] Exposure lamp
- [5] Carriage-1
- [6] Original glass
- [7] Drive pulley
- [8] CCD board
- [9] Lens
- [10] Automatic original detection sensor
- [11] Carriage home position sensor
- [12] Platen sensor



### 3.8.2 Construction

Scanner		
Original glass	Original glass	
	ADF original glass	
Carriage-1	Exposure lamp (EXP)	
	Reflector	
	Mirror-1	
Carriage-2	Mirror-2	
	Mirror-3	
Lens unit	Lens	
	CCD driving PC board (CCD)	
Automatic original detection sensor (S24, S25)		
Driving section	Scan motor (M1)	<ul style="list-style-type: none"> <li>• 2-phase stepping motor</li> <li>• Driving the carriage-1 and carriage-2</li> </ul>
Other	Carriage home position sensor (S23)	
	Platen sensor (S21)	
	Platen sensor (S22)	

### 3.8.3 Functions

The following shows the construction and purpose of the scanning system:

#### 1. Original glass

This is a glass for placing original. The light from the exposure lamp (EXP) is irradiated to the original through this glass.

The ADF original glass is used when original is read with the Automatic Document Feeder. Original is transported on the ADF original glass by the Automatic Document Feeder, and the transported original is read under the ADF original glass by the carriage. Do not use such solvents as alcohol when cleaning the surface of the ADF original glass, because it is coated so as not to be scratched by originals.

#### 2. Carriage-1

Carriage-1 consists of the exposure lamp (EXP), reflector, mirror-1, etc. It is driven by the scan motor (M1) and scans an original on the glass.

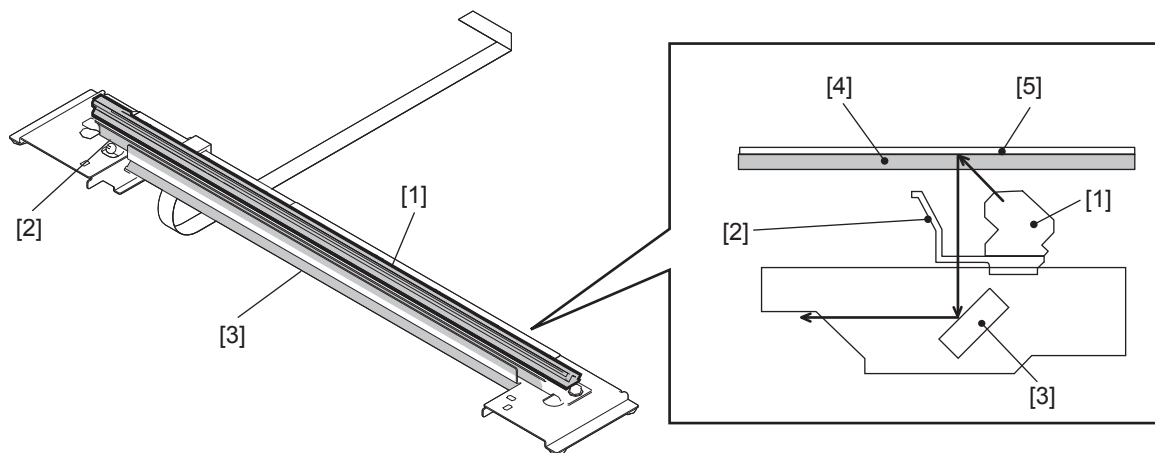


Fig. 3-18

- [1] Exposure lamp
- [2] Reflector
- [3] Mirror-1
- [4] Original glass
- [5] Original

- Exposure lamp (EXP)  
This lamp is the light source to irradiate the original on the glass. (LED lamp)
- Reflector  
This is a plate to efficiently direct the light from the exposure lamp (EXP) to the surface of the original on the glass.
- Mirror-1  
This mirror directs the light reflected from the original to the mirror-2 described later.

3. Carriage-2

Carriage-2 mainly consists of the mirror-2, mirror-3, etc. and directs the reflected light from the mirror-1 through the mirrors-2 and -3 to the lens.

This carriage is driven by the same scan motor (M1) as that for the carriage-1 at half the scanning speed of the carriage-1 (The scanning distance is also half that of the carriage-1).

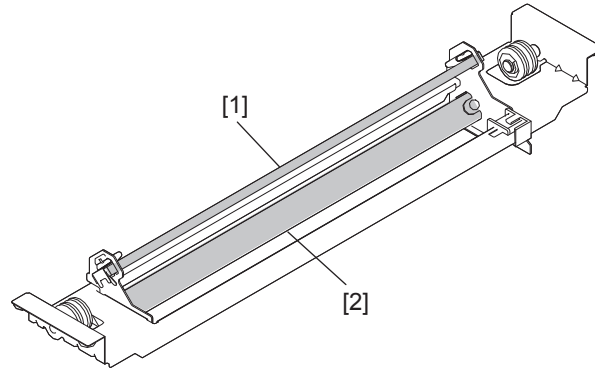


Fig. 3-19

[1] Mirror-2

[2] Mirror-3

4. Lens unit

The light reflected from the mirror-3 is led to the CCD placed at the focal point of the lens which is fixed in a position.

5. CCD driving PC board (CCD)

Processes such as signal amplification, signal integration and A/D conversion are applied on the electrical signal which was converted by CCD.

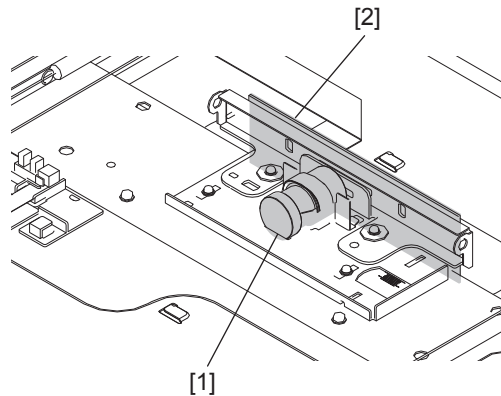


Fig. 3-20

[1] Lens

[2] CCD board

6. Automatic original detection sensor (S24, S25)

The size of an original placed on the glass is instantly detected using the automatic original detection sensors (S24, S25) fixed on the base frame without moving the carriage-1.

## 3.8.4 Description of Operation

### [ 1 ] Scanning operation

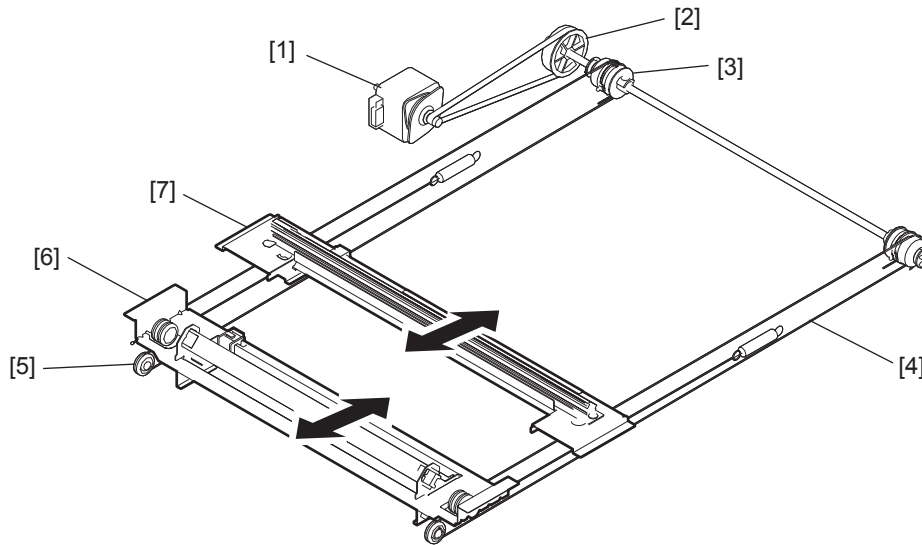


Fig. 3-21

- [1] Scan motor
- [2] Drive pulley
- [3] Wire pulley
- [4] Wire
- [5] Idler pulley
- [6] Carriage-2
- [7] Carriage-1

- Scanning of an original placed on the original glass  
This motor drives the carriages-1 and -2 through the timing belt and carriage wire. First, the scan motor drives the carriages-1 and -2 to their respective home positions. The home positions are detected when the carriage-1 passes the home position sensor (S23). When the [START] button is pressed, the both carriages start to move and scan the original on the glass.
- Scanning of an original placed on the RADF  
The carriage-1 stays at the shading position during shading correction, and at the scanning position during scanning operation.
- Carriage speed  
The Carriage speed of the original placed on the original glass in the color mode is the same as that in the black mode.

### 3.8.5 Process of detection of original size

In this equipment, detection of original sizes is performed with the combination of a CCD and the automatic original detection sensors-1 and -2 (S24 and S25).

A size in the primary scanning direction is detected by the CCD while that in the secondary scanning direction is detected by the sensors.

#### [ 1 ] Original size detection procedure

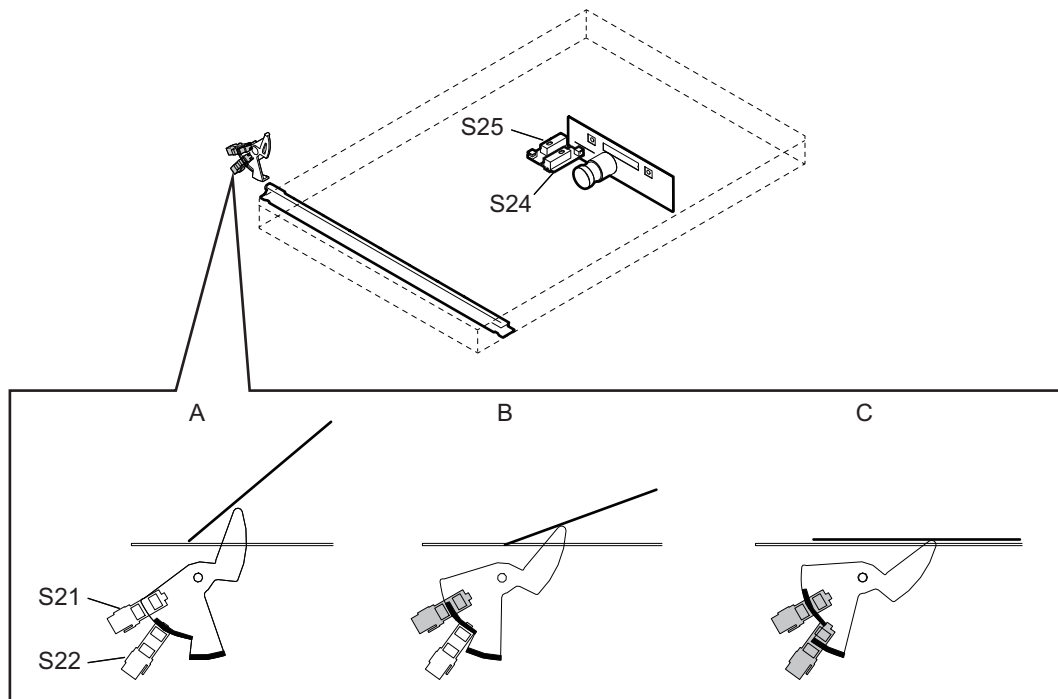


Fig. 3-22

A: Platen cover (or RADF) fully opened

When the platen cover is fully opened, the original size is not detected.

B: Platen cover (or RADF) opened by 25 degrees - Detected by the platen sensor-1 (S21)

When this status is detected, the exposure lamp of the scanner emits light and the presence/absence of the original in the secondary scanning direction and the paper size of the original in the primary scanning direction are detected by the automatic original detection sensor. (As for the LT series, two automatic original detection sensors are used.

C: Platen cover (or RADF) closed - Detected by the platen sensors-1 and -2 (S21 and S22)

This status is detected by the platen sensors-1 and -2. The exposure lamp of the scanner emits light for a short time and the sensors detect the length of the original in the primary scanning direction again.

#### Remarks:

When the platen cover (or the RADF) is fully closed or closed by 25 degrees or less, the exposure lamp emits light as follows. Light emitted -> OFF -> light emitted -> OFF -> carriage moved. If the connectors are connected to the platen sensor-1 (S21) and -2 (S22) in reverse, the exposure lamp emits light as follows. Light emitted -> OFF -> carriage moved -> light emitted. When the following phenomena have occurred, the platen sensor-1 (S21) may be damaged. In such a case, check the sensors and harnesses.

- The exposure lamp does not emit light even when the platen cover is opened by 25 degrees.
- The detected paper size of the original is not correct.

## [ 2 ] Detection points

### Sensor detection points [A4, K Series]

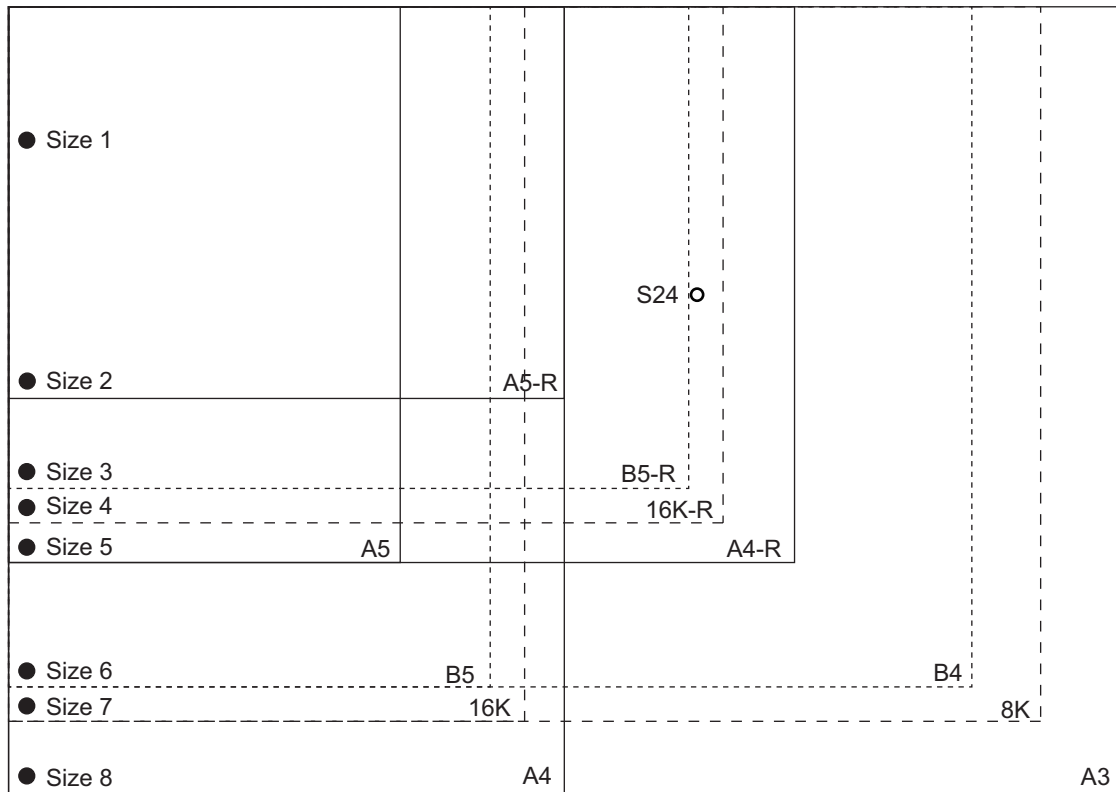


Fig. 3-23

### Sensor detection points [LT Series]

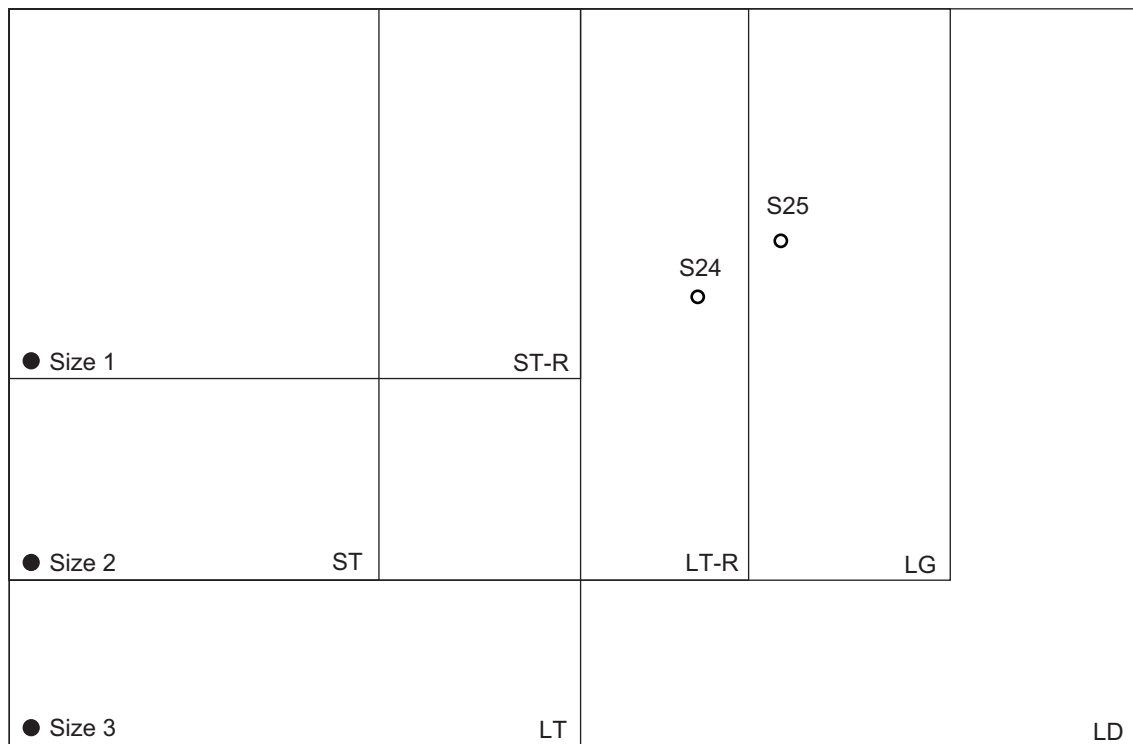


Fig. 3-24

## 3.9 Writing Section

### 3.9.1 General Description

The writing section of this equipment uses LED printer heads.

An LED printer head is mounted on each of Y, M, C and K drums. The emission of the LED printer head generates (exposes) latent images on the corresponding drum.

The LED gap spacer keeps a specified distance between the LED printer head and the drum.

The writing section radiates the LED light onto the photoconductive drum responding to the digital image signals transmitted from the scanner, USB, network, etc. to create the latent image.

3

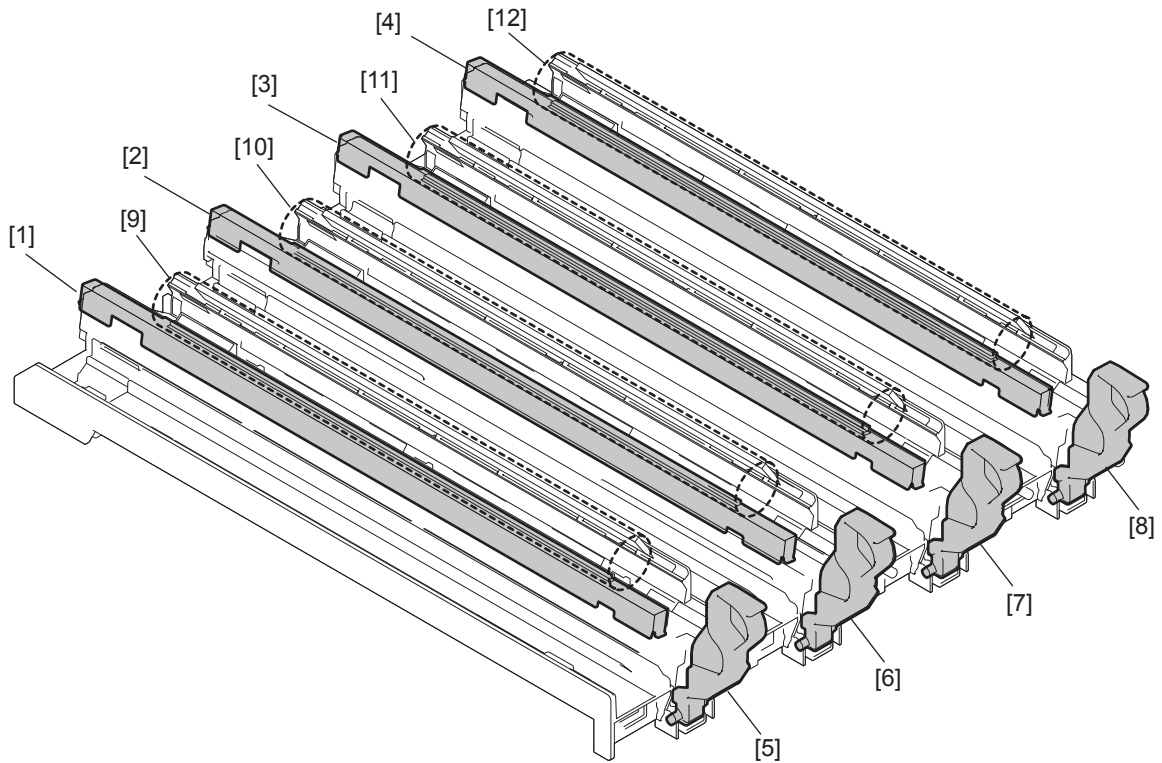


Fig. 3-25

- [1] LED printer head-Y
- [2] LED printer head-M
- [3] LED printer head-C
- [4] LED printer head-K
- [5] LED printer head contact/release lever (Y)
- [6] LED printer head contact/release lever (M)
- [7] LED printer head contact/release lever (C)
- [8] LED printer head contact/release lever (K)
- [9] Y drum
- [10] M drum
- [11] C drum
- [12] K drum

### 3.9.2 General description of LED printer head

An LED printer head, which uses an LED (light-emitting diode) as a light source, is equipped for each color, Y, M, C and K.

The LED light from the LED printer head is emitted to the drum through a lens.

A gap between the LED printer head and the drum in each color is kept constant with an LED gap spacer.

If this gap is not at the specified value, a focus error may occur, resulting blurring on images.

Therefore an LED gap spacer is a PM part due to possible difference in the gap caused by friction.

Also a dirty lens may cause image troubles such as blurring.

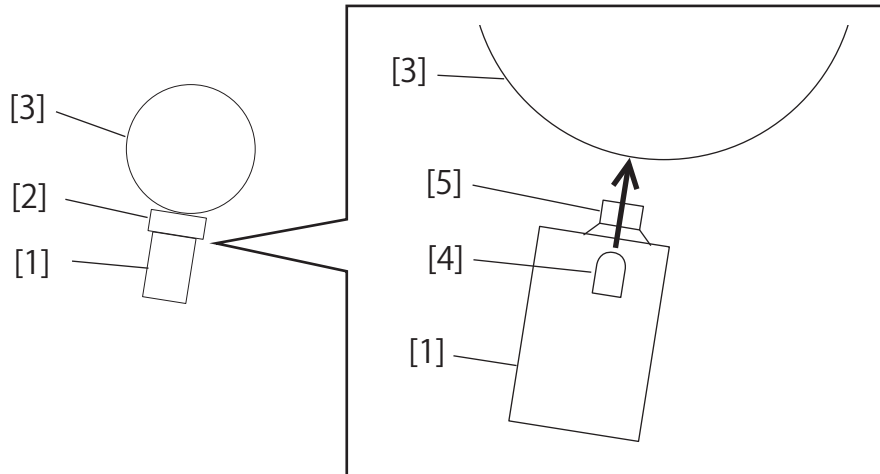


Fig. 3-26

- [1] LED printer head
- [2] LED gap spacer (front/rear)
- [3] Drum
- [4] LED
- [5] Lens

\*An LED and a lens cannot be disassembled as they are the components of an LED printer head.

Two harnesses are connected to each LED printer head from the LGC board.

One is for power supply and the other is for control signals.

If any of them is disconnected (or has a loose connection), an image trouble may occur.

When a control signal is sent from the LGC board, the LED of the LED printer head is lit and emits light to the drum for exposure.

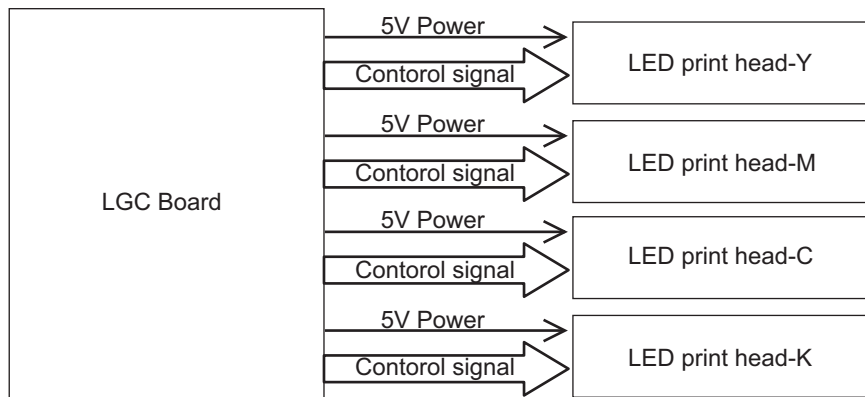


Fig. 3-27



### 3.9.3 LED printer head lifting mechanism

The LED printer head is contacted or released by the LED printer head contact/release lever.

When this lever is held down to the front side of this equipment, the link arm is slid to the front side together with the lever.

Since the LED printer head is positioned by the guide of the link arm, it is lowered (released) as the guide is lowered.

A gap between the LED printer head and the drum in a contacting status is kept at a specified value by the LED gap spacer.

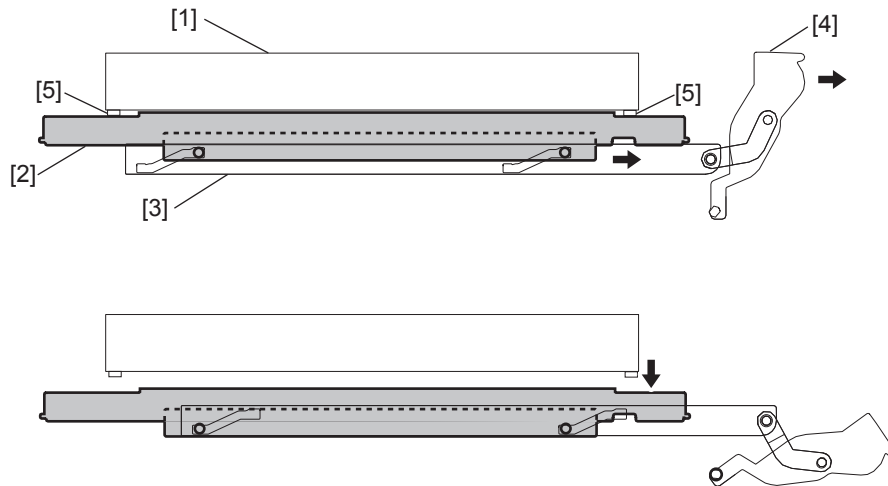


Fig. 3-28

- [1] Drum
- [2] LED printer head
- [3] Link arm
- [4] LED printer head contact/release lever
- [5] LED gap spacer

### 3.10 Driving Section

The driving section of this equipment consists of 3 units.

- Drum TBU drive unit
- Monochrome/color switching unit
- Feeding/developing drive unit

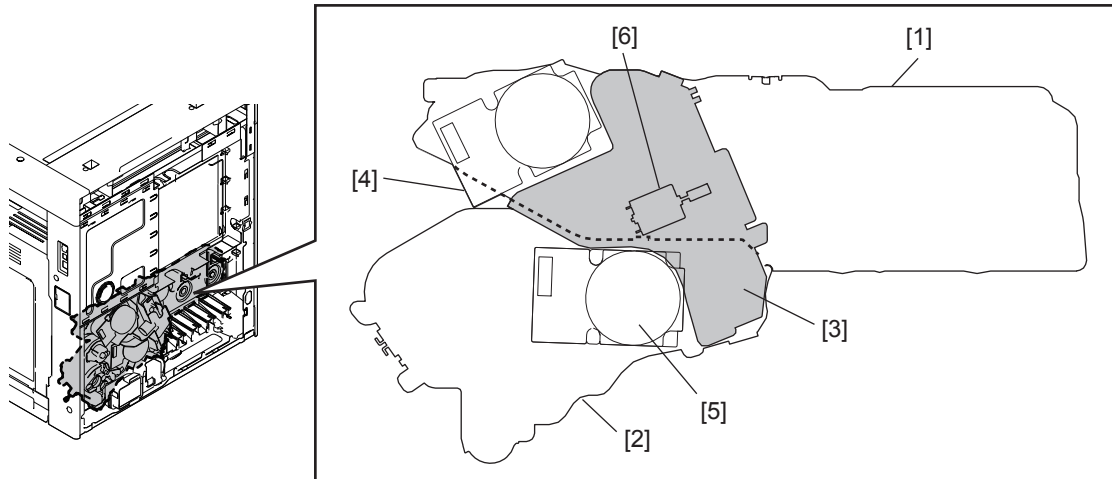


Fig. 3-29

- [1] Drum TBU drive unit
- [2] Paper feed development drive unit
- [3] Monochrome/color switching unit
- [4] Drum/TBU motor
- [5] Paper feeding/developer unit drive motor
- [6] Mono/color switching motor

### 3.10.1 Drum TBU drive unit

The drum TBU drive unit is driven by the drum TBU motor to drive Y, M, C and K drums and the transfer belt unit (TBU).  
It also drives the contacting and releasing of the transfer belt.

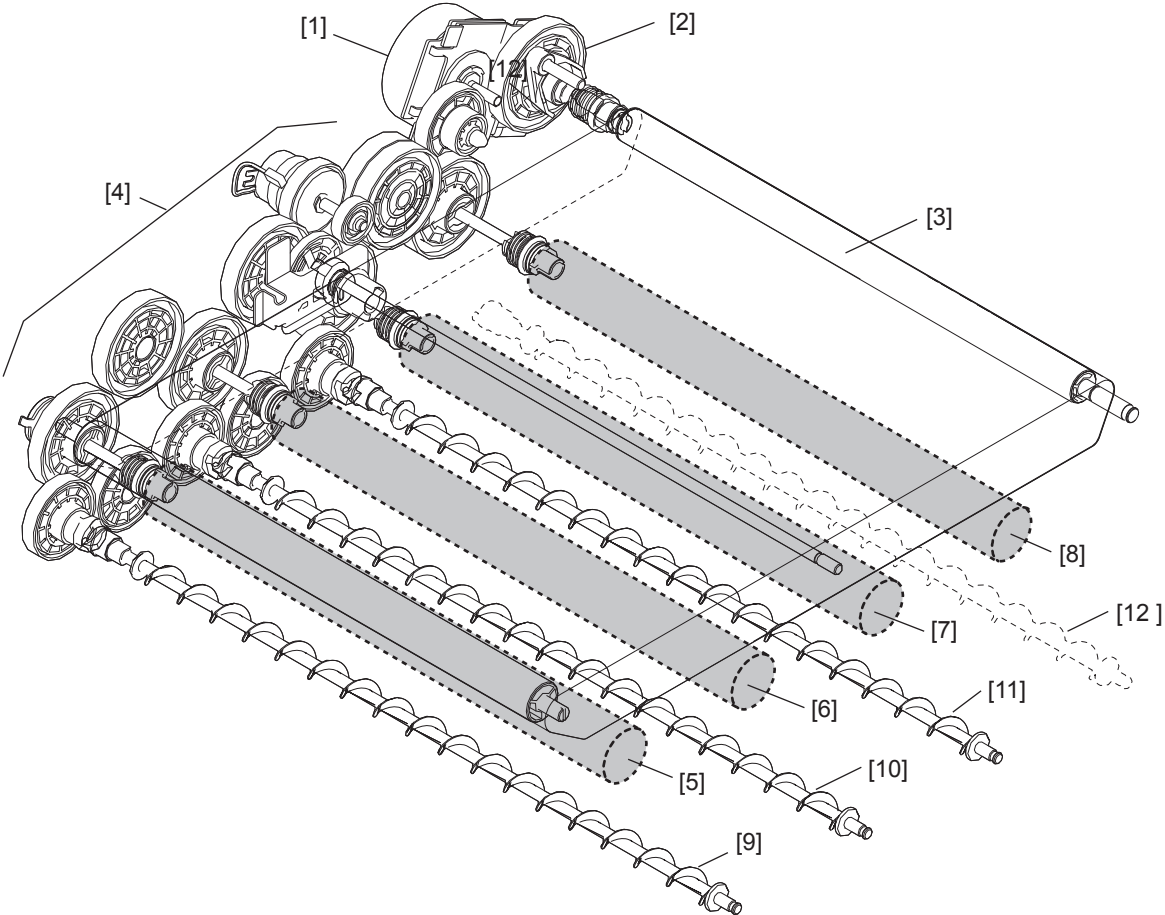


Fig. 3-30

- [1] Drum TBU motor
- [2] Drum TBU motor gear
- [3] TBU drive roller
- [4] Gear (row of gears)
- [5] Y drum
- [6] M drum
- [7] C drum
- [8] K drum
- [9] Y mixer
- [10] M mixer
- [11] C mixer
- [12] K mixer

### 3.10.2 Feeding/developing drive unit

The feeding/developing drive unit is driven by the paper feeding/developer unit drive motor to drive the developer unit and the paper feeding section.

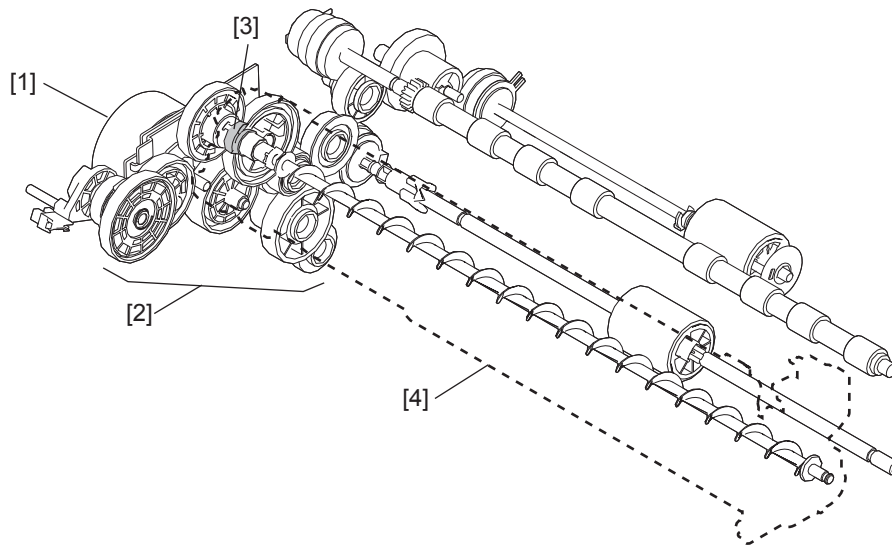


Fig. 3-31

- [1] Paper feeding/developer unit drive motor
- [2] Gear (row of gears)
- [3] Coupling
- [4] K developer unit

### 3.10.3 Monochrome/color switching mechanism

The feeding/developing drive unit is driven by the paper feeding/developer unit drive motor to drive the developer unit and the paper feeding section.

Switching of the monochrome and color modes is performed by the monochrome/color switching unit. In the monochrome mode, the switching plate is positioned at "A" in the figure below and the monochrome/color switching sensor (S11) is OFF.

At this time, the drive gears of the drum and the developer unit are not engaged. (Monochrome mode operation)

When the mono/color switching motor (M3) starts rotating, the switching plate is moved and the monochrome/color switching sensor (S11) is turned ON.

The coupling cam is rotated with a movement of the switching plate and then the idling gear and the color drive gear are engaged.

Thus the rotation of the motor is transmitted to each gear in the color drive gear rows.

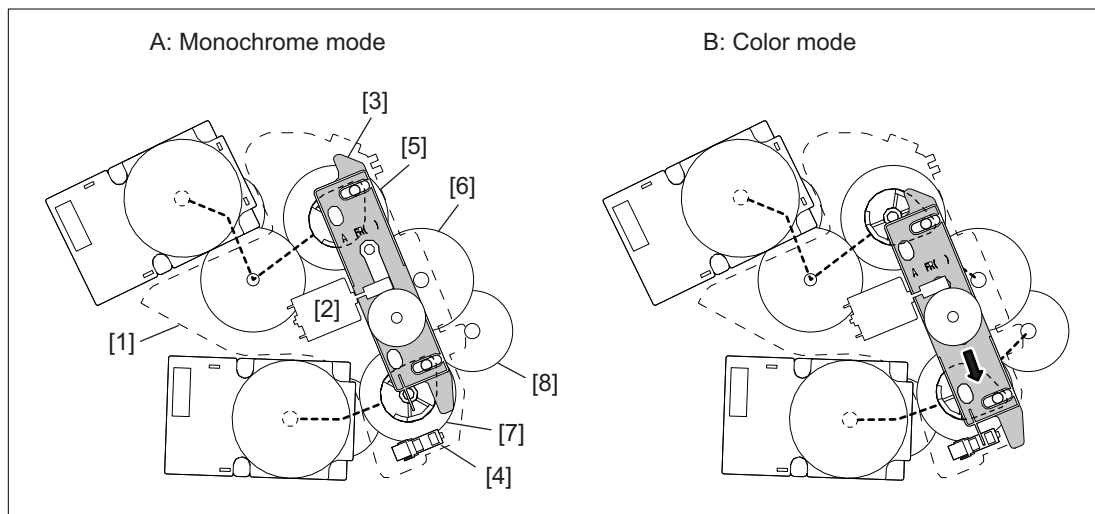


Fig. 3-32

- [1] Monochrome/color switching unit
- [2] Mono/color switching motor (M3)
- [3] Switching plate
- [4] Monochrome/color switching sensor (S11)
- [5] Color coupling gear (driving the drum)
- [6] Color drive gear (driving the drum)
- [7] Color coupling gear (driving the developer unit)
- [8] Color drive gear (driving the developer unit)

## 3.11 Paper Feeding System

### 3.11.1 General Descriptions

This chapter explains how the system works to pick up paper from the drawer or bypass tray and transport it to the 2nd transfer position.

The paper feeding system mainly consists of the feed roller, registration roller, bypass paper sensor (S16), drawer empty sensor (S5), bypass feed sensor (S16), registration sensor (S19) and drive system for these components. The feed/DEV motor (M2) drives the above rollers.

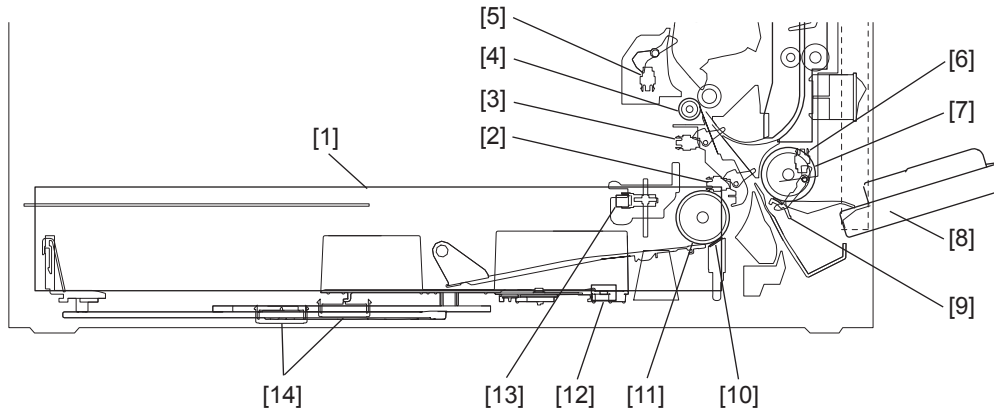


Fig. 3-33

- [1] Drawer
- [2] Feed sensor
- [3] Registration sensor
- [4] Registration roller
- [5] Registration pass sensor
- [6] Bypass feed roller
- [7] Bypass feed sensor
- [8] Bypass tray
- [9] Separation pad
- [10] Bypass separation pad
- [11] Paper feed roller
- [12] 1st drawer detection switch
- [13] 1st drawer empty sensor
- [14] 1st drawer size detection switch

### 3.11.2 Composition

Feeding system		
Feed clutch		CLT2
1st drawer empty sensor		S5
1st drawer detection switch		SW8
Bypass unit	Bypass feed roller	PM parts
	Bypass separation pad	PM parts
	Bypass paper sensor	S16
	Bypass tray slide guide width detection PC board	SFB
	Bypass feed clutch	CLT4
Feed/DEV motor		M2
Registration clutch		CLT1
Registration roller		
Registration sensor		S19

### 3.11.3 Functions

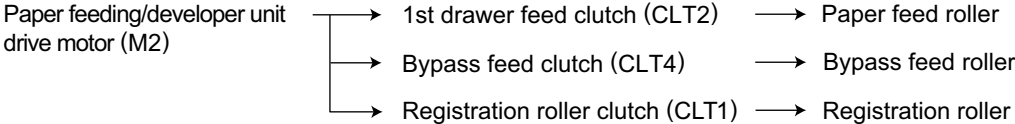
1. Feed roller (Drawers and bypass feed)  
This roller is placed against the separation roller. It transports the paper from the pick-up roller to the transport roller.
2. Separation pad (Drawer and bypass feed)  
When two or more sheets of paper are transported from the feed roller, since the resistance force of the separation pad is larger than the frictional force between the sheets, the lower sheets are not transported any further.
3. Registration roller  
Paper transported from the transport roller is pushed against the registration roller which aligns the leading edge of the paper.  
Then, the registration rollers rotate to transport the paper to the transfer unit.
4. Bypass paper sensor (S16)  
This sensor detects if paper is set in the bypass tray. If it is, bypass feeding always comes before drawer feeding.
5. Empty sensor (S5)  
This is a transmissive-type sensor and detects the availability of paper in the drawer by using an actuator. When there is no paper in the drawer, the actuator blocks the light path of the sensor, and the sensor determines that there is no paper.
6. Registration sensor (S19)  
This sensor detects that the leading edge of the paper has reached the registration roller and the trailing edge of the paper has passed the registration roller.
7. Drawer detection switch (SW8)  
This switch detects if the drawer is fully inserted.
8. Drawer feed clutch (CLT2)  
This is a clutch used to transmit the drive from the feed/dev motor to the feed roller.  
When the clutch is turned ON, the feed roller rotates at high speed to transport paper.
9. Feed/dev motor (M2)  
This motor drives the registration roller and transport rollers of the drawers and bypass tray.
10. Registration clutch (CLT1)  
This is an electromagnetic clutch which drives the registration roller.  
When the registration clutch (CLT1) is turned ON, the drive is transmitted from the paper feeding/ developer unit drive motor to rotate the registration roller.
11. Paper width detection board (SFB)  
This sensor works directly with the sidewalls of the bypass tray to detect the paper width on the tray.



### 3.11.4 Description of Operation

#### [ 1 ] Drive of rollers

The drive of each motor in the paper feeding area activates the paper transfer roller as follows.



## [ 2 ] Operation of drawer pick-up roller

When the drawer is inserted into the equipment, the lock located in the center of the drawer is released, and the tray in the drawer is lifted up by the spring.

This makes the paper set in the tray contact the pick-up roller when it is rotated.

The driving force of the Feed/DEV motor is transmitted through the feed clutch to the pick-up roller.

This feeding system has no mechanism specific for detecting the transported paper.

Therefore, whether the paper has been transported to the registration sensor within a specified period of time or not is substituted for the paper jam detection.

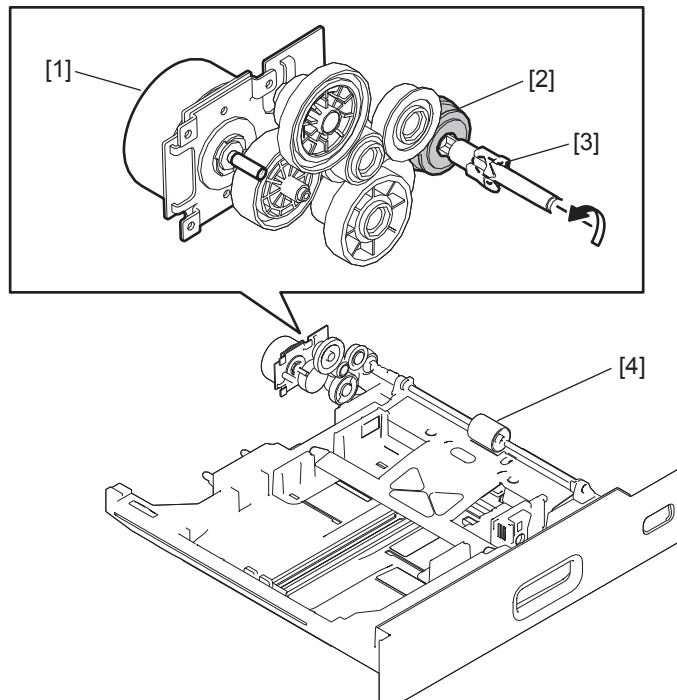


Fig. 3-34

- [1] Paper feeding/developer unit drive motor (M2)
- [2] Feed clutch (CLT2)
- [3] Coupling
- [4] Feed roller

**[ 3 ] Separation of paper**

This model is equipped with a separation pad which works to prevent multiple paper feeding. The separation pad is pushed to the paper feed roller by the spring force.

When two or more sheets of paper are fed, since the friction between two sheets of paper is smaller than that between a sheet and the separation pad, the lower sheets are not transported any further while the uppermost one is transported by the paper feed roller.

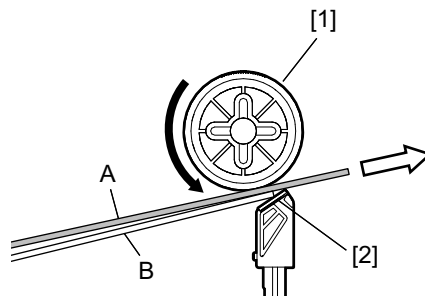


Fig. 3-35

- [1] Feed roller
- [2] Separation pad
- [3] Spring

#### [ 4 ] Operation of bypass feed roller

The driving force transmitted through the bypass feed clutch (CLT4) is transmitted to the bypass feed roller through the shaft. The roller is rotated by this driving force.

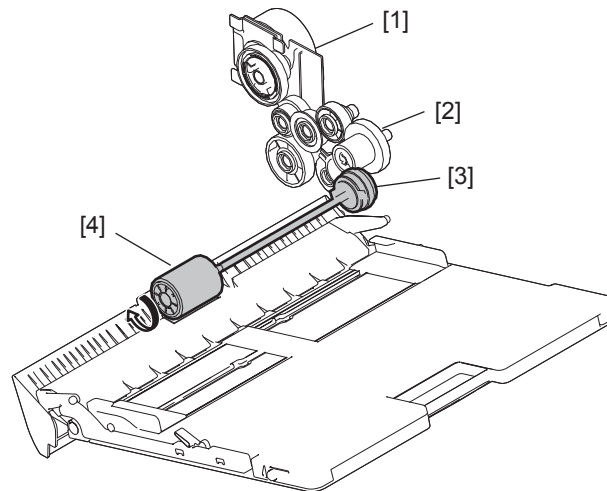


Fig. 3-36

- [1] Paper feeding/developer unit drive motor
- [2] Gear
- [3] Bypass feed clutch
- [4] Bypass feed roller

## [ 5 ] Separation of paper

This model is equipped with a separation roller which works to prevent multiple paper feeding. The separation roller is pushed to the paper feed roller by the spring force.

When two or more sheets of paper are fed, since the friction between two sheets of paper is smaller than that between a sheet and the separation roller, the lower sheets are not transported any further while the uppermost one is transported by the paper feed roller.

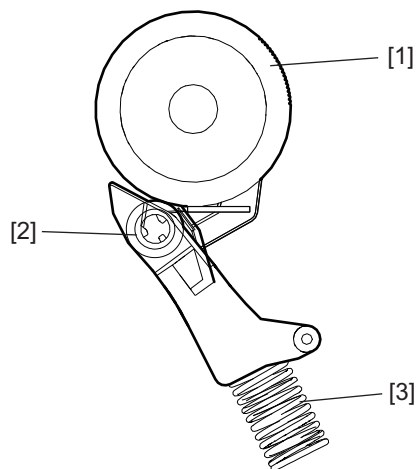


Fig. 3-37

- [1] Bypass feed roller
- [2] Bypass separation roller
- [3] Spring

## [ 6 ] General operation

### [A] From power-ON to ready status

1. If either of the sensors on the transport path is ON (means there is paper on the transport path) when the equipment is turned ON, it is determined that a paper jam has occurred and no operation is enabled until the paper is removed.

### [B] Ready status

1. When a drawer is inserted or removed at ready status, to check the availability of paper.

### [C] Bypass feeding

- The bypass paper sensor (S16) detects availability of paper.
- The bypass feed clutch (CLT4) is turned ON and then the bypass pick-up roller, bypass feed roller and bypass transport roller are rotated and start feeding.
- The leading edge of paper turns ON the registration sensor (S19) and the paper is aligned by the registration roller.
- The bypass feed clutch (CLT4) is turned OFF, and then the bypass pick-up roller, bypass feed roller and bypass transport roller are stopped.
- The registration clutch (CLT1) is turned ON and the paper is transported to the 2nd transfer position.

### [D] Drawer feeding

#### [D-1] 1st drawer

- The feed clutch (CLT3) is turned ON, and the feed roller is rotated to start feeding paper.
- Passing of the leading edge of the paper turns ON the registration sensor (S19) and the paper is aligned by the registration roller.
- The registration clutch (CLT1) is turned ON and the paper is transported to the 2nd transfer position.

## **[ 7 ] Drawer damp heater**

The drawer damp heater is located at the middle of the upper and lower drawers. It allows the prevention of an increase in the humidity by reducing the temperature alternation in the drawers. AC power is connected in the drawer damp heater via its switch. The drawer damp heater can go into its operable status at any of the following points when its switch is turned ON while the power cable of the equipment is connected and AC power is supplied.

- When the main power switch is turned OFF
- When the [ON/OFF] button on the control panel is turned OFF
- At the sleep mode
- At the super sleep mode

A heater whose maximum permissible power is 10.8 W is used in the drawer damp heater.

## **[ 8 ] Envelope drawer**

The envelope drawer is an option so that a standard envelope can be fed from the drawer. Different side walls compared to those for current drawers are adopted. These side walls are positioned by being aligned to the width of an envelope and they have the function of holding envelopes.

By using the drawer paper size detection sensors 1 and 2, the level where the envelope drawer is installed is detected. Since the size of the paper in the envelope drawer is not detected automatically, it is necessary to set the size manually.

## 3.12 Process Unit Related Section

### 3.12.1 General description

There are 4 cleaner units and 4 developer units, corresponding to the image forming process of the Y, M, C and K colors. The main charger unit is installed with the cleaner units, while the discharge LEDs are installed on the equipment side (LED tray).

This chapter explains about the process unit and parts around this unit which are provided for image formation. Except the developer unit, which is one of units composing the process unit, is described in Ch3.13 in detail.

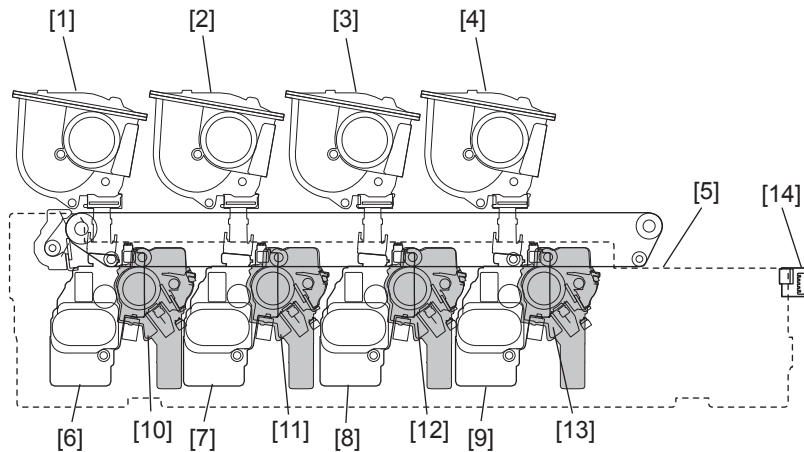
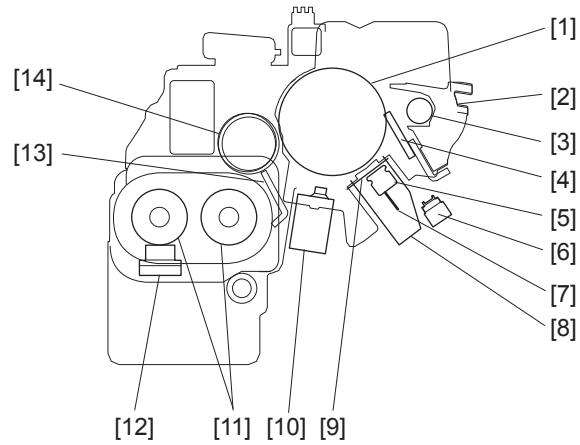


Fig. 3-38

- [1] Toner (Y)
- [2] Toner (M)
- [3] Toner (C)
- [4] Toner (K)
- [5] Waste toner box
- [6] Developer unit (Y)
- [7] Developer unit (M)
- [8] Developer unit (C)
- [9] Developer unit (K)
- [10] Process unit (Y)
- [11] Process unit (M)
- [12] Process unit (C)
- [13] Process unit (K)
- [14] Temperature/Humidity sensor



**Fig. 3-39**

- [1] Drum
- [2] Drum cleaner unit
- [3] Toner recovery auger
- [4] Cleaning blade
- [5] Needle electrode cleaner
- [6] Discharge LED
- [7] Needle electrode
- [8] Main charger unit
- [9] Main charger grid
- [10] LED printer head
- [11] Mixer
- [12] Auto-toner sensor
- [13] Doctor blade
- [14] Developer sleeve (Magnetic roller)



### 3.12.2 Composition

Process unit (Y, M, C, K)	Drum cleaner unit	Drum	PM parts
		Cleaning blade	PM parts
		Recovery blade	
		Toner recovery auger	
	Main charger unit	Main charger grid	PM parts
		Needle electrode	PM parts
		Needle electrode cleaner	PM parts
		Charger duct	
Developer unit		Ch3.13	
Discharge LED		ERS-Y, -M, -C, -K	
Temperature/Humidity sensor		S10	
Ozone filter			
Ozone exhaust fan		F2	
High-voltage transformer			
Drum/TBU motor		M6	
Mono/color switching motor		M3	
Drum thermistor		THM4	

### 3.12.3 Functions

#### 1. Drum

Drum is made of a cylindrical aluminum base coated with thin film of organic photoconductive substance. Photoconductive object becomes insulative (high electrical resistance) when it is not exposed to lights and becomes conductive (low electrical resistance) when it is exposed to lights. This object is called photoconductor.

#### 2. Drum cleaner unit

- Cleaning blade  
This blade is pressed against the drum surface with a constant force and scrapes off the residual toner on the drum surface.
- Recovery blade  
This blade prevents the toner which was scraped off by the cleaning blade from being scattered to the outside.
- Toner recovery auger  
This auger carries the residual toner scraped off to the waste toner box.

#### 3. Main charger

The main charger in this equipment consists of a metal rod with U-shaped section, insulated terminals at both ends of the rod and a needle electrode attached between them. When a high voltage is applied to the needle electrode, the air around it is charged (ionized). The ionized air then flows into the drum causing it to be charged. This phenomenon is called "corona discharge". At the same time, a control bias is applied to the main charger grid to control the charging amount. In a dark place, negative charge is evenly applied onto the drum surface by the corona discharge and this grid. In addition, a cleaner is installed to clean up the dust attached on the needle electrode.

- Needle electrode  
The needle electrode has aligned needles and their points perform the corona discharge. These points (electrodes) discharge toward the drum in one direction to realize the more efficient discharging comparing to the charger wire which discharges in a radial direction. Therefore, the needle electrode enables to reduce the ozone amount.

#### 4. Drum thermistor (THM4)

Since the photoconductive characteristic of the drum surface changes depending on the temperature of the drum surface, the drum thermistor detects the temperature of the drum surface and controls to gain the charging potential according to the environment.

#### 5. Discharge LED (ERS-Y, ERS-M, ERS-C, ERS-K)

Discharge is a process to decrease or eliminate the charge on the drum surface. The residual charge on the drum surface is neutralized and eliminated (cleaned). Electrical potential of the drum surface is fixed to a certain amount before the drum is charged.

#### 6. Temperature/humidity sensor (S10)

This sensor measures the environment inside the equipment. The values of the temperature and humidity detected inside the equipment are output to the LGC board.

#### 7. Ozone filter

Ozone produced by corona discharge of the main charger is exhausted through this filter. The catalyzer of the ozone filter degrades the ozone.

#### 8. Ozone exhaust fan (F2)

This fan exhausts air through the ozone filter-1.

9. High-voltage transformer (HVT)

A circuit generates the output control voltage  $V_c$  of the main charger bias, main charger grid bias, 1st transfer roller bias, 2nd transfer roller bias and developer bias.

10. Drum/TBU motor (M6)

This motor drives each drum and toner recovery auger. The drive of the motor is transmitted to each drum by gears in the following 2 lines: Drum/TBU motor → K drum → C drum → Y drum

The gears and drum couplings are assembled with high precision in order to improve accuracy of color overlay.

11. Mono/color switching motor (M3)

This motor switches ON/OFF the transmission of drive to the Y, M, C drums. The drum switching sensor detects the phase of the guide to control the mono/color switching motor, and checks whether the drive is transmitted to the Y, M, C drums or not.

### 3.12.4 Drum driving sleep mode

When the conditions of the accumulated number of outputs are met, the equipment is shifted to the drum driving sleep mode, in which the photoconductive drum is rotated without exposure several times. This mode prevents the photoconductive drum from being contaminated with ozone exhausted inside of the equipment.

#### [ 1 ] Function

In the standby mode, the photoconductive drum is rotated without exposure according to the specified number of times. The more rotations without exposure increase, the more drive count increases. Consequently, this may reduce the life of the drum.

To prevent a reduction in the life, the drum is rotated without exposure normally once. It is rotated without exposure several times only under certain conditions.

#### [ 2 ] Drum driving sleep mode related codes

FS-08-2380	Control for drum rotation without exposure at standby	Sets ON or OFF for the control of the photoconductive drum rotation without exposure in the standby mode after printing is finished.
FS-08-2381	Starting time of drum rotation without exposure at standby	Sets the time to start the 1st rotation of the photoconductive drum without exposure in the standby mode after printing is finished.
FS-08-2382	Control of drum rotation without exposure at standby: Rotation interval	Sets the rotation interval of the photoconductive drum without exposure between the 1st and 2nd rotations and subsequent intervals.
FS-08-2383	Control of drum rotation without exposure at standby: Maximum number of rotations	Sets the maximum number of rotations allowed without exposure.
FS-08-2385	Accumulated number of outputs to shift to drum driving sleep mode	Sets the number of outputs to shift to the drum driving sleep mode.

#### [ 3 ] The drum driving sleep mode setting

##### [ 3-1 ] Case in which the equipment needs to be shifted to the drum driving sleep mode frequently

When uneven density image problem in 94 mm pitch (the circumference of the drum) must be corrected

- Set a value smaller than "7" (default) for FS-08-2385.

##### Notes:

If MCV (monthly copy volume) is relatively small, the drive count tends to increase quickly when you set the equipment to shift the drum driving sleep mode often, resulting in a shorter life

##### [ 3-2 ] Case in which the equipment needs to be shifted to the drum driving sleep mode frequently

A: When uneven density image problem in 94 mm pitch (the circumference of the drum) must be corrected

- The ozone exhaust fan keeps rotating for 1 minute after printing is finished. The rotation noise is not so annoying during this period. Therefore set "0" or "1" for FS-08-2383 so that the rotation of all drums without exposure will be finished within 1 minute.

B: When MCV is relatively small (e.g.; 1k)

- Set "20" for FS-08-2385 to reduce the number of times to shift the drum driving sleep mode, or set "0" or "1" for FS-08-2383 to reduce the number of drum rotations without exposure.

## 3.13 Developer Unit

### 3.13.1 General Description

This chapter describes the development (developer unit) which is a process of making toner adhere to the drum.

The developer material which is comprised of a mixture of toner and carrier, and is filled in the developer unit of each color. The toner is charged to a negative polarity and the carrier to a positive polarity, due to the friction with each other caused by mixing in the developer unit. The charged toner is supplied to the photoconductive drum surface by means of a magnetic roller, allowing it to adhere to the areas on the drum surface where the potential is lower than the developer bias which is applied to the magnetic roller. Through this process, the latent images are formed on the photoconductive drum surface.

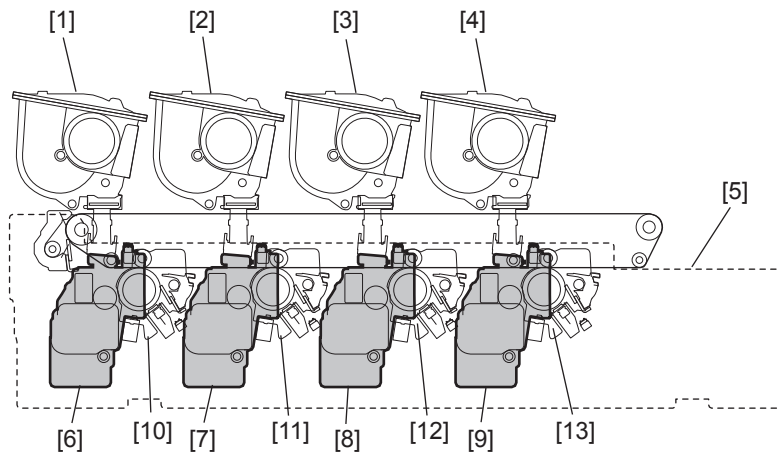


Fig. 3-40

- [1] Toner (Y)
- [2] Toner (M)
- [3] Toner (C)
- [4] Toner (K)
- [5] Waste toner box
- [6] Developer unit (Y)
- [7] Developer unit (M)
- [8] Developer unit (C)
- [9] Developer unit (K)
- [10] Process unit (Y)
- [11] Process unit (M)
- [12] Process unit (C)
- [13] Process unit (K)

### 3.13.2 Composition

Process unit (Y, M, C, K)	Drum cleaner unit		Ch3.12	
	Main charger unit		Ch3.12	
	Developer unit	Developer material		PM parts
		Mixer		
		Developer sleeve (Magnetic roller)		
		Doctor blade		
Auto-toner sensor		S1, S2, S3, S4		
Paper feeding/ developer unit drive motor			M2	

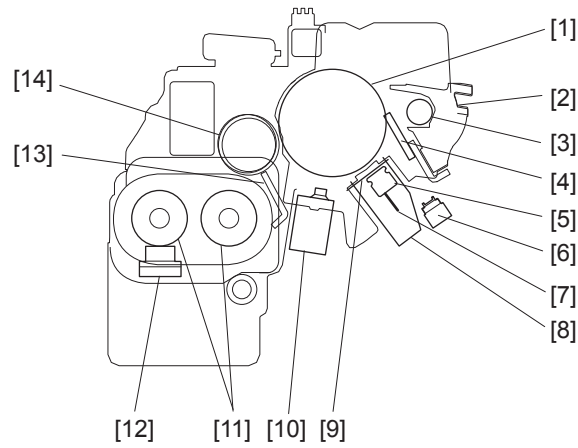


Fig. 3-41

### 3.13.3 Functions

1. Developer material  
The developer material consists of the carrier and toner. Since the developer material deteriorates after a long time use, periodic replacements are needed.
2. Mixer  
The carrier and toner are frictionized each other when the developer material is stirred. Then the carrier is positively charged (+) and the toner is negatively charged (–), and the toner is adhered by the electrostatic force.
3. Developer sleeve (Magnetic roller)  
These aluminum rollers have magnets inside. The developer material is pulled by these magnets to form a magnetic brush. The magnets are fixed at their position so only the sleeve rotates. By this rotation, the developer material is transported to the developer sleeve.  
Then the magnetic brush formed at the developer sleeve sweeps over the drum surface and thus development is performed.
4. Doctor blade  
The doctor blade controls the amount of the developer material from the developer sleeve so that the magnetic brush of the developer material can contact with the drum surface properly.
5. Auto-toner sensor (S1, S2, S3, S4)  
To print out a precise image, the proportion (toner density ratio) of the carrier and the toner in the developer material needs to be always constant. The magnetic bridge circuit in the black auto-toner sensor detects the toner ratio in the developer material. This sensor supplies the toner from the toner cartridge.
6. Paper feeding/developer unit drive motor (M2)  
This motor rotates the Y, M, C, K developer units. The drive of the motor is transmitted to each developer unit by gears in the following 2 lines: Developer motor → K developer unit, developer motor → C developer unit → M developer unit → Y developer unit
7. Toner motor (M8, M9, M10, M11)  
These motors drive the paddles and auger in the toner cartridge and transport the toner filled in the cartridge to the developer unit. Each toner cartridge of Y, M, C and K mounts one toner motor correspondingly.
8. Waste toner paddle motor (M7)  
This motor rotates the paddles mounted in the Waste toner box to level the Waste toner accumulated in the waste toner box.
9. Waste toner box  
This collects the residual toner scraped off on the drum surface by the cleaning blade and residual toner scraped off on the transfer belt by the transfer belt cleaning blade.

### 3.13.4 Functions of the toner cartridge PC board (CTRG)

An IC chip is embedded in this board. Data such as identification information for the recommended Toshiba toner cartridge, thresholds to determine if the cartridge is nearly empty, and controlling data for the image quality to be optimal according to the toner characteristics are written in this chip. To measure the amount of toner remaining in the cartridge, when the value of the counter for the period of the toner cartridge rotation time is updated, this equipment writes the updated value into the toner cartridge PC board (CTRG).

These data written in the toner cartridge PC board (CTRG) enable the functions below, and accordingly this equipment operates as shown below.

Data reading is performed every time when the power is turned ON, the front cover is closed, a job is finished and the equipment has recovered from the sleep mode.

#### [ 1 ] Data read by the toner cartridge PC board (CTRG)

- Data to identify recommended Toshiba toner cartridges
- Thresholds to determine if the toner cartridge is nearly empty
- Value of the counter for the period of the toner cartridge rotation time
- Data for optimizing image quality
- Threshold of toner remaining displays

#### [ 2 ] Functions

- Cartridge detecting function  
This function checks whether the toner cartridge is inserted correctly or not, and whether the recommended toner cartridge is used or not.
- Toner remaining check function  
This function notifies the user of the near-empty status of toner. Normally, the message (Toner is low) is displayed when the toner is running out, and (Toner empty) when the toner cartridge is empty.
- Toner remaining check notification function  
Upon detecting the near-empty status of toner, this function automatically notifies your service representative.
- Image optimization function  
This function controls the quality of images to be optimal according to the characteristics of the toner used.
- Toner remaining display function  
This function displays the remaining toner amount from 0% to 100%.

#### [ 3 ] Operations

A sign indicating that the toner cartridge is nearly empty appears in the following cases:

- The counter value for the toner cartridge rotation time has exceeded the threshold previously written in the toner cartridge PC board (CTRG). (Related code: FS-08-5155)
- The remaining amount of toner is equal to or less than the set amount (percentage or number of sheets). (Related code: FS-08-5155, FS-08-5810, FS-08-5811)

When a used cartridge refilled with new toner is used, a sign indicating that the toner cartridge is empty appears because information for determining the empty status is already written in the toner cartridge PC board (CTRG).

When a non-recommended toner cartridge is used, "Toner not recognized" appears on the control panel, and then the equipment may stop normal operations. The toner remaining display function, the toner remaining check function, the automatic remote supply order to Toshiba sales representatives and the image optimization function may also be disabled.

The self-diagnosis codes to adjust the timing for displaying the toner near-empty status are as follows.



- Toner near-empty status threshold setting (FS-08-5155)  
<Setting value>  
0: The period from the appearance of the toner near-empty sign to the actual complete consumption of the toner is set to long.  
1: Normal (Default)  
2: The period from the appearance of the toner near-empty sign to the actual complete consumption of the toner is set to short.  
4: Toner near-empty status threshold value: (%)  
5: Toner near-empty status threshold value: (Number of sheets)
- Toner near-empty status threshold value setting (%) (FS-08-5810)  
Use this code to specify the threshold value (unit: %) for displaying the toner near-empty status. This code is used when the value of FS-08-5155 is set to "4".  
Sub-code 0: K, sub-code 1: Y, sub-code 2: M, sub-code 3: C
- Toner near-empty status threshold value setting (number of sheets) (FS-08-5811)  
Use this code to specify the threshold value (unit: number of sheets) for displaying the toner near-empty status. This code is used when the value of FS-08-5155 is set to "5".  
Sub-code 0: K, sub-code 1: Y, sub-code 2: M, sub-code 3: C
- Fine adjustment of threshold value for displaying the toner remaining amount / toner near-empty (FS-08-5156)  
Performs fine adjustment of the threshold value for displaying the toner remaining amount and toner near-empty.  
Display threshold value = Default threshold value x setting value/100 (Unit: %)

#### [ 4 ] Toner near-empty / toner empty display adjustment

The toner empty appears when the auto-toner sensor in the developer unit detects that the level amount of toner in the developer unit has actually become low. The toner remaining amount is displayed by means of calculating it by counting the value of the counter for the period of the toner motor rotation time. Then the toner near-empty appears when the calculated toner remaining amount has reached the specified value (the toner amount which can print approx. 1,000 sheets of paper when an image whose print ratio is 6% is printed with the A4/LT equivalent paper size).

The relationship between the period of the toner motor rotation time and the actual toner consumption amount varies depending on the printed images and usage conditions. Therefore, the displaying of the toner remaining amount can be adjusted by the codes shown below. However, it is recommended to handle the toner remaining amount as the reference since the printed images and usage conditions are always unstable and there will be variations in the systems.

1. Fine adjustment of the toner remaining amount display  
When the displayed toner remaining amount is decreased more quickly than that for the actual toner (when "1%" is being displayed for a long time), set a value in FS-08-5156 larger than the default one. When the displayed toner remaining amount is decreased more slowly than that for the actual toner (when the toner near-empty appears before "1%" is displayed), set a value in FS-08-5156 than smaller the default one.
2. Toner near-empty setting change
  - Setting change of the period from the toner near-empty to the toner empty  
When the period is made longer, set "0" in FS-08-5155. When the period is made shorter, set "2" in FS-08-5155.
  - Setting change of the toner near-empty threshold value  
When the threshold value (default: printing approx. 1,000 sheets of paper is available when an image whose print ratio is 6% is printed with the A4/LT equivalent paper size) used to designate toner near-empty is changed, perform the following setting change.

When the change is made by using the toner remaining amount (%), set "4" in FS-08-5155 and exchange the value of FS-08-5810. In order to designate the toner near-empty while the toner remaining amount is greater than the default value, set a larger value in FS-08-5810.

When the change is made by using the available remaining number of print sheets, set "5" in FS-08-5155 and exchange the value of FS-08-5811. In order to designate the toner near-empty while the available remaining number of print sheets is greater than the default value (printing approx. 1,000 sheets of paper is available when an image whose print ratio is 6% is printed with the A4/LT equivalent paper size), set a larger value in FS-08-5811.

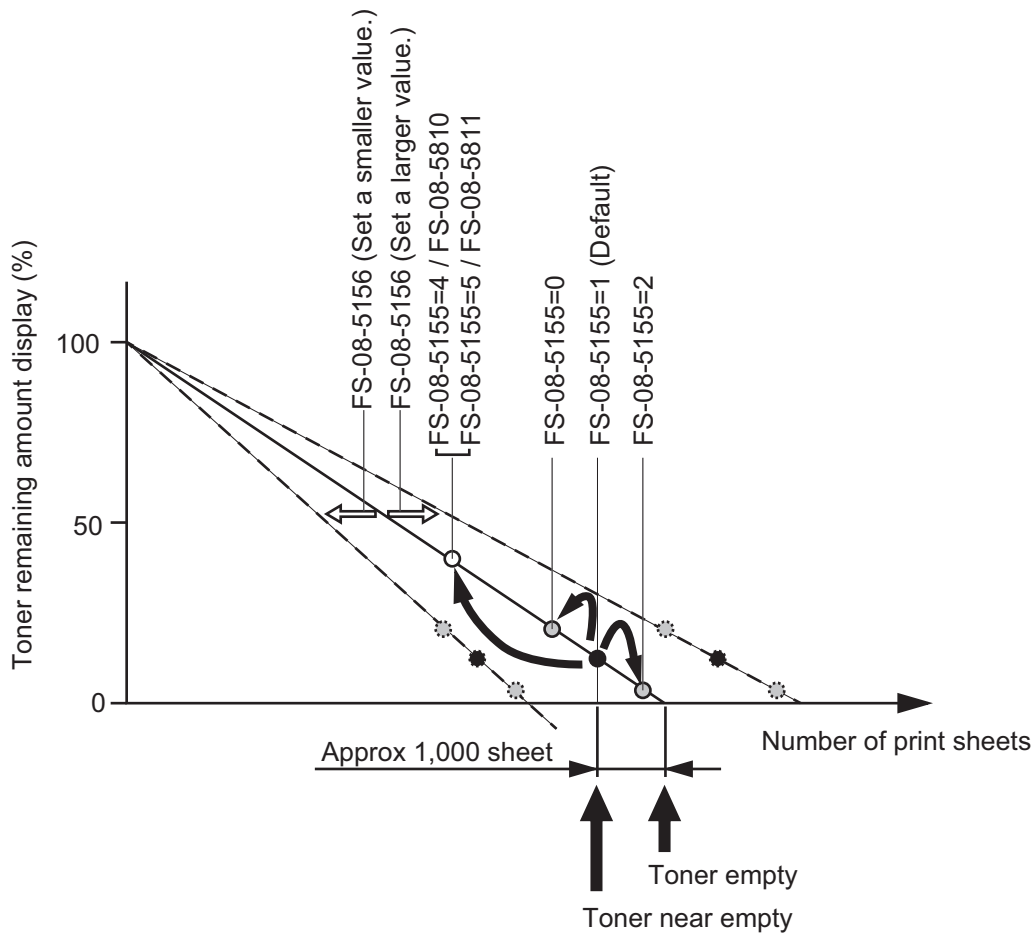


Fig. 3-42

**Notes:**

- Do not perform the change operations 1 (Fine adjustment of the toner remaining amount display) and 2 (Toner near-empty setting change) simultaneously. Otherwise, the desired results may not be obtained. If the change is required by the combination of the operations 1 (Fine adjustment of the toner remaining amount display) and 2 (Toner near-empty setting change), only perform either of them first. Then change the setting for another one while checking the results.
- The values of the toner remaining amount and the number of print sheets are the reference. They will vary depending on the printed images and usage conditions.

### 3.13.5 Waste toner box

The waste toner box is installed inside of the front cover, and collects waste toner discharged from a cleaner for each color and the transfer belt cleaner.

The front cover is designed not to be closed without installing the waste toner box in this equipment.

The paddle embedded in the waste toner box is rotated by the waste toner paddle motor (M7).

The rotation status of the paddle is detected by the waste toner paddle rotation detection sensor (S9).

In this equipment, a sensor detecting the full status of waste toner is not equipped.

Instead, the waste toner box full is judged when the waste toner has been accumulated in the box and the rotation of the paddle has not been detected for a specified period.

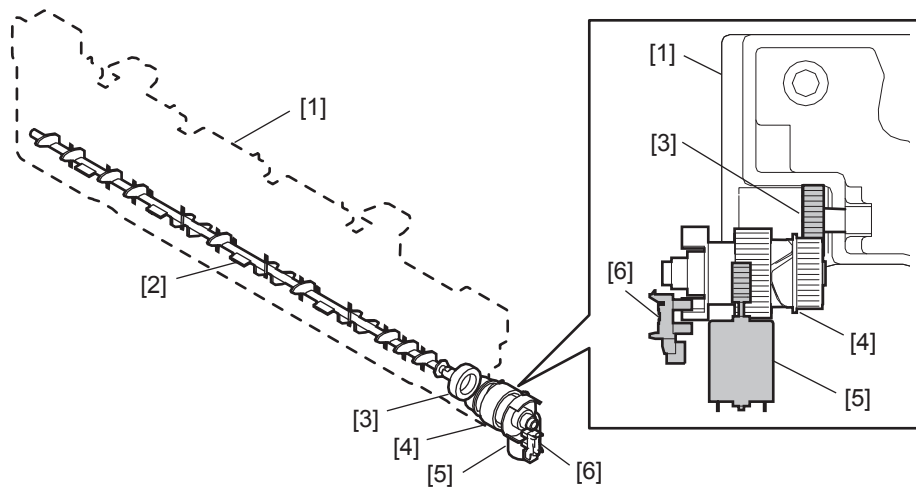


Fig. 3-43

- [1] Waste toner box
- [2] Paddle
- [3] Gear (Paddle)
- [4] Gear
- [5] Waste toner paddle motor (M7)
- [6] Waste toner paddle rotation detection sensor (S9)

## 3.14 Transfer Unit

### 3.14.1 General Descriptions

Transfer is a process of decaling a toner image from the photoconductive drum onto paper. A toner image formed on the photoconductive drum is temporarily transferred onto the transfer belt, and the toner image is then transferred from the transfer belt onto paper. The first transfer from the drum to the transfer belt is called the 1st transfer, and the second transfer from the transfer belt to paper is called the 2nd transfer. To form a color image, the images of yellow (Y), magenta (M), cyan (C) and black (K) are transferred and overlaid on the transfer belt in order, and then the overlaid images are transferred onto paper.

After the completion of the 2nd transfer, the residual toner on the transfer belt is scraped off by the transfer belt cleaning blade and then transported to the waste toner box.

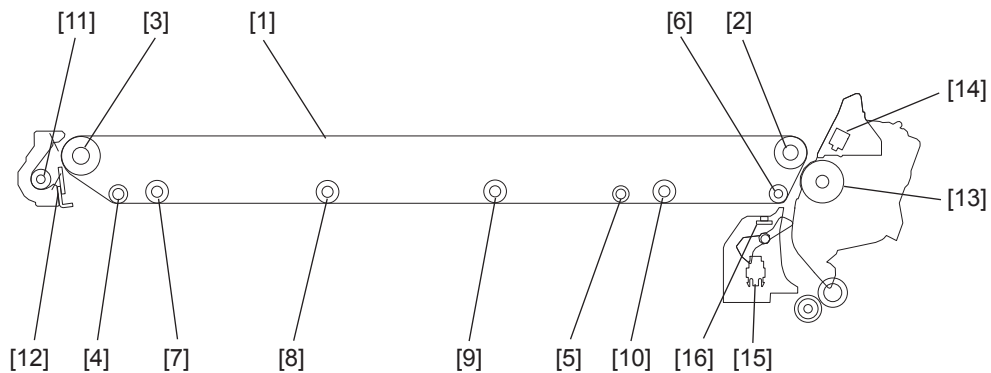


Fig. 3-44

- [1] Transfer belt
- [2] TBU drive roller
- [3] Cleaner unit facing roller
- [4] Lift roller
- [5] Winding roller (K)
- [6] Belt clinging roller before 2nd transfer
- [7] 1st transfer roller (Y)
- [8] 1st transfer roller (M)
- [9] 1st transfer roller (C)
- [10] 1st transfer roller (K)
- [11] Waste toner auger
- [12] Transfer belt cleaning blade
- [13] 2nd transfer roller
- [14] Paper clinging detection sensor
- [15] Registration reach sensor

### 3.14.2 Composition

Transfer belt unit	Transfer belt	
	1st transfer roller	Y, M, C, K
	Drive roller	
	Tension roller	
	TBU drive roller	
	Lift roller	
	Idling roller	
	1st transfer roller cam motor	M8
	1st transfer roller status detection sensor	S15
	Transfer belt cleaning unit	Transfer belt cleaning blade
Waste toner auger		
2nd transfer unit	2nd transfer roller	PM parts
	Paper clinging detection sensor	S18
Image position aligning sensor (Front) Image position aligning sensor (Rear)/Image quality sensor		S7 / S8

## 3.15 Image Quality Control

### 3.15.1 General Description

Two image position aligning sensors are mounted inside of the 2nd transfer front guide beneath the transfer belt.

The image position aligning sensor on the rear side combines its own functions with those of the image quality sensors.

At this control, image forming conditions are automatically adjusted so as to minimize the change in the image density or tone reproduction caused by the fluctuation of working environment or life of supply items.

At first, the image quality sensor (S8) operates to output reflected light amount voltage when no toner image is formed on the transfer belt. The output voltage is then converted analog-to-digital to be output as the reflected light amount signal. The light source amount voltage of the sensor is adjusted to correspond with the value set in advance and the output value of reflected light amount signal at this adjustment is stored. This output value is considered as the reading of the belt surface. Next, the sensor outputs the reflected light amount signal when a test pattern is developed on the transfer belt. This output value is considered as the reading of the toner image.

The difference between the reading of the transfer belt and that of the toner image is defined as toner adhesion amount. Image forming conditions are determined in approximating this toner adhesion amount to the value set in advance.

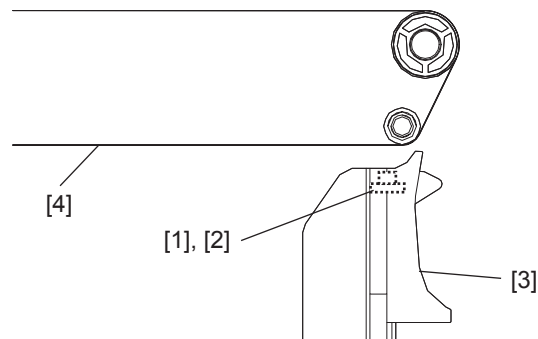


Fig. 3-45

- [1] Image position aligning sensor (Front)
- [2] Image position aligning sensor (Rear)/Image quality sensor
- [3] 2nd transfer front guide
- [4] Transfer belt

## 3.16 Fuser unit / Paper exit section

### 3.16.1 General Description

Toner is fused by applying heat and pressure on the transferred image on the paper which is transported to the fuser unit. The paper is then transported to the inner tray, paper exiting options or ADU. The fuser unit consists of the heater lamps, heat roller, fuser roller, pressure roller, separation fingers, thermistors, thermostats, etc.

The heat roller, fuser roller and pressure roller in the fuser unit are driven by the fuser motor, and the exit roller is driven by the exit motor.

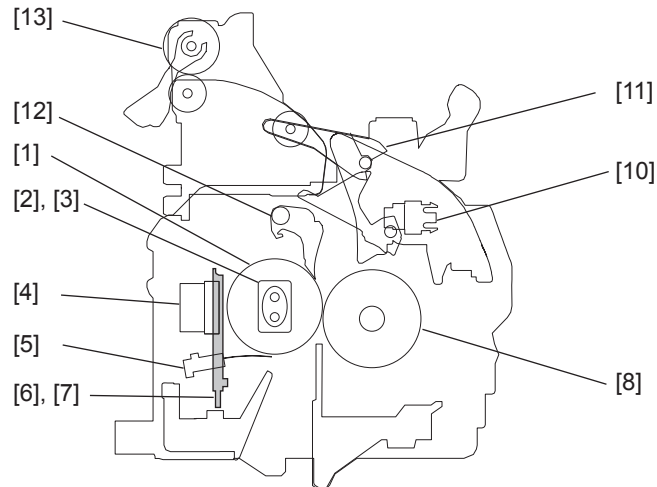


Fig. 3-46

- [1] Fuser roller
- [2] Side heater lamp
- [3] Center heater lamp
- [4] Fuser roller center thermostat, Fuser roller side thermostat
- [5] Fuser roller edge thermistor
- [6] Fuser roller center thermistor
- [7] Fuser roller side thermistor
- [8] Pressure roller
- [10] Exit sensor
- [11] Exit/reverse gate
- [12] Fuser roller separation finger
- [13] Exit roller

### 3.16.2 Composition

Center heater lamp	LAMP1 (570 W)
Side heater lamp	LAMP2 (570 W)
Fuser roller center thermistor	THM1
Fuser roller side thermistor	THM2
Fuser roller edge thermistor	THM3
Fuser roller center thermostat	THMO1
Fuser roller rear thermostat	THMO2
Fuser roller	
Pressure roller	
Separation finger	
Fuser motor	M4
Exit sensor	S13
Exit roller	
Exit motor	M5



### 3.16.3 Electric Circuit Description

#### [ 1 ] Fuser unit control circuit

##### [ 1-1 ] Configuration

In this equipment, 2 heater lamps (center, side) which have different heat-generating positions are installed in the heat roller to heat up the fuser roller. The fusing temperature is controlled by turning ON/OFF these heater lamps with the command from the ASIC on the LGC board.

The surface temperature of the fuser roller is detected by a thermistor. And then the information of these temperatures is input to the ASIC through an A/D converter.

Based on the detected temperature, the ASIC transmits the control signal of the heater lamp to the drive circuit (TRC: Triac) of each heater lamp on the switching regulator via the heater lamp control circuit. The power supply to each heater lamp is thus controlled by driving TRC.

The forcible power-OFF circuit detects the overheating of the fuser roller by each thermistor. In case that the surface temperature of the fuser roller has exceeded the specified temperature, the forcible power-OFF circuit transmits an overheat detection signal to the ASIC and the heater lamp control circuit and transmits a reset signal to the relay in the power supply unit to turn the relay OFF forcibly.

In addition, if these control circuits do not function due to thermistor abnormality or for other reasons and the fuser roller is abnormally overheated as the result, 2 thermostats shut off the power supply to the heater lamps to protect the equipment.

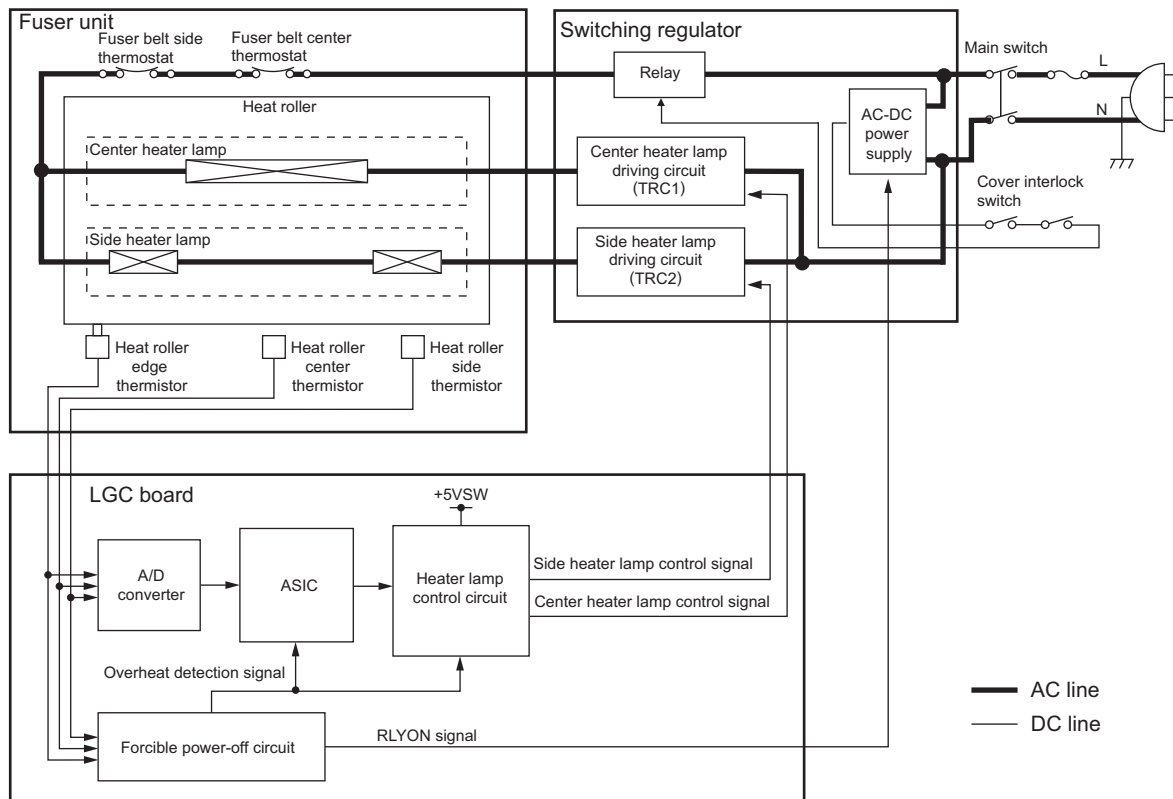


Fig. 3-47

## [ 1-2 ] Temperature detection section

### Fuser unit error status counter control

- To enhance the safety of the fusing section unit, engine CPU provides the following protection:  
When the third [C411], [C445], [C450] error have occurred after two consecutive [C411] errors, the heater lamp is not turned ON and error [C412] is displayed immediately even if an operator turns OFF the power and back ON. However, if the equipment goes into a ready state normally with the fuser unit error status counter "1" or below, the counter is cleared to "0".
- If the error codes [C411] to [C452] are displayed and still not cleared even though the thermistor, thermostat and heater lamp have been repaired (and the power ON/OFF does not clear the error), check the fuser unit error status counter (FS-08-2002) to clear the value to "0".

### Remarks:

The fuser unit error status counter (Setting Mode (08-2002)) never has values other than 0 to 62.

- If the heater lamps do not turn ON and the service call [C411] or [C412] is displayed immediately after the power is ON, ensure the fuser unit error status counter is "62" or over. If it is "62" or over, be sure to check the thermistor, thermostat and heater lamp. Reset the counter to "0" after repairing them, then turn ON the power.
- If the fuser unit error status counter is "62" or more, EEPROM or its data may have been ruined due to leakage from the chargers.  
Check the bias, high-voltage transformers and needle electrodes for defects, and also look through all the data in EEPROM.
- When the thermistors detect overheating, the engine CPU decides the error code and counter value of the fuser unit error status. After turning OFF each output (the heater lamp, exposure lamp, control panel display, motors and so on), the engine CPU turns OFF the power to protect the fuser unit.

Error code: C449

Fuser unit error status counter (FS-08-2002): 8, 9, 18 to 23, 25 to 29

Thermistors continue detecting the abnormal temperature even after the error codes and counter values are decided. Even if the power is turned ON immediately, it is automatically turned OFF again when the surface temperature of the fuser belt is still higher than the abnormal temperature detected.

Wait until the surface temperature of the fuser belt is lowered enough, and turn ON the power to check the counter value while it is turned OFF again. After confirming that it is the fuser unit abnormality, correct the abnormality and reset the counter value (08-2002) to "0" to start up the equipment normally.

### **Temperature detection circuit**

The thermistor is a device whose resistance varies according to the detected temperature. The ASIC detects voltages output from this devices, and judges whether the operation of the fuser unit is normal or abnormal from the changes in voltages.

If one of the thermistors is broken, the control circuit judges that the temperature of the fuser belt or pressure roller is extremely low and keeps turning the heater lamps ON. As a result, the temperature of the fuser belt or pressure roller rises, and possibly activates the thermostat which is a safety protection device. To prevent this in advance, the ASIC works to detect whether each thermistor is broken or not. Also, the control circuit constantly checks the temperature of the heat roller and the pressure roller to prevent them from excessive heating by circuit abnormality or thermistor abnormality, and automatically shuts OFF the power when one of these temperatures exceeds the specified temperature.

## Abnormality detection by the thermistors

The following table shows the conditions for judging the temperature abnormality of the fuser roller, and the detecting timing.

Check timing	Error code	Counter	Temperature judged			Error judging timing
			Fuser roller thermistor			
			Center	Side	Edge	
Power ON	C449	9	200°C or above	200°C or above	230°C or above	Power ON
	C412	4	40°C or below	150°C or above	---	
			150°C or above	40°C or below	---	
			150°C or above	---	40°C or below	
			---	150°C or above	40°C or below	
Detecting 40°C	C449	19	200°C or above	200°C or above	230°C or above	On usual
	C411	(1)	40°C or below	40°C or below	40°C or below	
	C412	2				
	C450	(38)	The temperature of the fuser unit edge section is 50°C higher or more than that of the fuser unit center section for more than 2 seconds.			
	C451	41				
	C450	(48)	The temperature of the fuser unit side section is 50°C higher or more than that of the fuser unit center section for more than 2 seconds.			
C452	50					
Ready temperature is detected (Center or Side)	C449	22	200°C or above	200°C or above	230°C or above	On usual
	C445	(5)	Ready temperature or below	Ready temperature or below	Ready temperature or below	
	C446	6				
	C450	(38)	The temperature of the fuser unit edge section is 50°C higher or more than that of the fuser unit center section for more than 2 seconds.			
	C451	41				
	C450	(48)	The temperature of the fuser unit side section is 50°C higher or more than that of the fuser unit center section for more than 2 seconds.			
C452	50					
During ready	C449	23	200°C or above	200°C or above	230°C or above	On usual
	C447	7	40°C or below	40°C or below	40°C or below	
During printing	C449	25	200°C or above	200°C or above	230°C or above	On usual
	C447	24	40°C or below	40°C or below	40°C or below	
At energy saving mode	C449	27	200°C or above	200°C or above	230°C or above	On usual

Check timing	Error code	Counter	Temperature judged			Error judging timing
			Fuser roller thermistor			
			Center	Side	Edge	
At paper jam	C449	29	200°C or above	200°C or above	230°C or above	On usual

\* The figures in the "Condition" field denote the priority of error checking.

\* The figures in the "Error code" and "Counter" fields with parentheses denote that an error status has not yet been determined (= error status is detected only once).

# 3.17 Automatic Duplexing Unit (ADU)

## 3.17.1 General Description

The Automatic Duplexing Unit (ADU) is a unit to automatically print on both sides of paper. A switchback method using the exit roller is adopted for the ADU of this equipment.

A sheet of paper is switchbacked by the exit roller right after the printing operation (fusing operation) on one side is completed, and the reversed sheet is transported to the registration section for the other side of the sheet to be printed.

The ADU mainly consists of the transport rollers and their drive system, paper guide and ADU entrance / exit sensor.

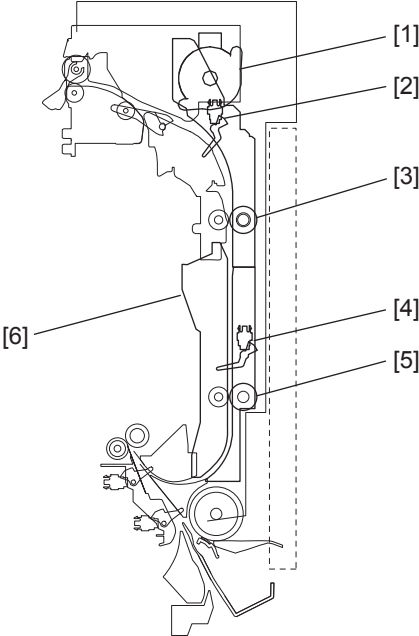


Fig. 3-48

- [1] ADU motor
- [2] ADU entrance sensor
- [3] Upper transport roller
- [4] ADU exit sensor
- [5] Lower transport roller
- [6] Paper guide

### 3.17.2 Composition

Automatic Duplexing Unit (ADU)	
ADU motor	M12: Stepping motor
ADU entrance sensor	S14
ADU exit sensor	S15
Side cover opening/closing switch	SW5
ADU driving PC board	ADU
Upper transport roller	
Lower transport roller	

### 3.17.3 Drive of ADU

When the ADU motor (M12) rotates, the upper transport roller and lower transport roller are rotated driven by the gears and belt.

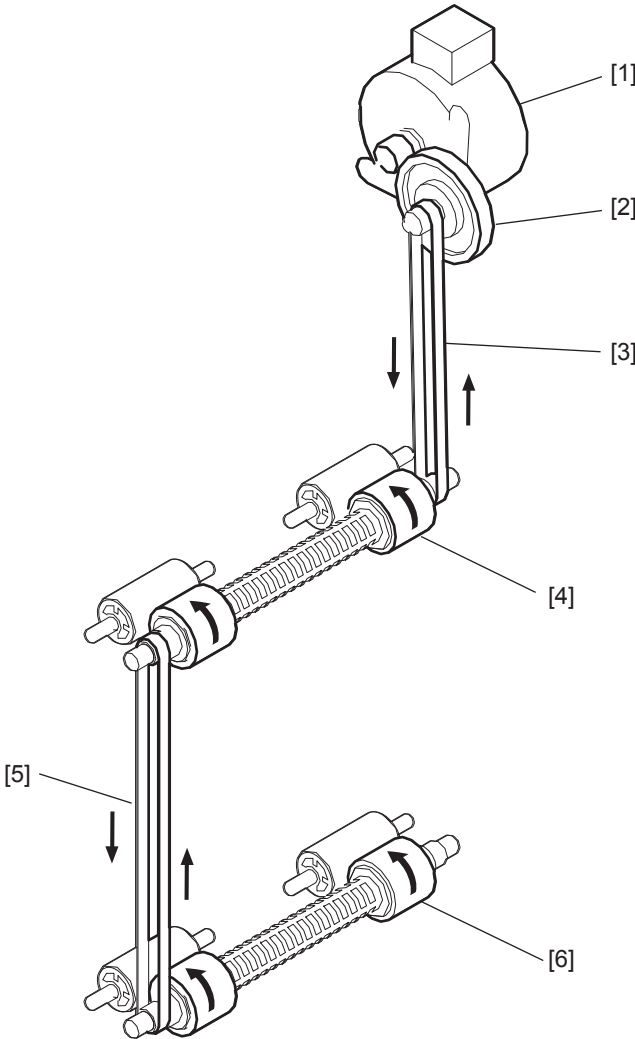


Fig. 3-49

- [1] ADU motor
- [2] Gear
- [3] Timing belt
- [4] Upper transport roller
- [5] Timing belt



### 3.17.4 Description of Operations

The back side printing (recording data of the back side of paper) is performed first by selecting duplex printing mode and pressing the [START] button. When the trailing edge of the paper passes the exit gate, the paper is switchbacked by the exit roller and transported into the ADU (the exit gate is closed with its own weight), and then the switchbacked paper is transported with acceleration. The transportation decelerates when the ADU exit sensor (S15) detects the paper. The front side printing (recording data of the front side of paper) is performed at the registration section. The paper passes through the exit gate again and is transported to the inner tray to complete duplex printing.

There are three methods of judging a paper jam: (1) whether the ADU entrance sensor (S14) is turned ON or not in a specified period of time after the switchback to the ADU started (E510). (2) whether the ADU exit sensor (S15) is turned ON or not in a specified period of time after the ADU entrance sensor (S14) is turned ON (E520). (3) whether the registration sensor (S19) is turned ON or not in a specified period of time after the paper feeding from the ADU to the equipment (E110).

If the ADU is opened during duplex printing, the ADU motor (M12) is stopped, namely, ADU open jam occurs (E430).

The equipment is never to be stopped during printing by interruption in any case except paper jam or service call, if paper remains in the ADU.

The operation of the duplex printing differs depending on the size of the paper; single-paper circulation and alternateness circulation. The figures in the following pages show the circulating operations during duplex copying. The numbers in the figures indicate the page numbers.

## 3.18 Power Supply Unit

### 3.18.1 General description

The power supply unit consists of AC filters, insulation-type DC output circuits and heater lamp control circuits in order to supply stable DC and AC voltage to each electric part of this equipment.

### 3.18.2 Functions

The power supply unit consists of the AC filter, insulation type DC output circuits and heater lamp control circuit.

1. AC filter  
Eliminates noise from the outside and prevents the noise generated by the equipment from leaking to the outside.
2. DC output circuits  
Converts AC voltage input from outside to DC voltage and supplies it to each electric part. The DC voltage is divided into the following two lines.
  - a. Main power switch line:  
Power supply used in the entire equipment during image forming process. Two kinds of voltage (+5VS and +12 VA) are output when the main power switch of the equipment is turned ON.
  - b. Cover switch line:  
Power supply used in the entire equipment during image forming process, being supplied via the cover switch. The voltage (+24 VD) is output only when the main power switch of the equipment is turned ON and two covers (front cover and automatic duplexing unit) are closed.
3. Heater lamp control circuit  
TRC (Triac) is driven by the heater control signal (SLAMP-ON, CLAMP-ON) from the LGC board and then AC power is supplied to each heater lamp (center heater lamp, side heater lamp) in the fuser unit.

### 3.18.3 Operation of DC Output Circuits

#### 1. Starting operation of the equipment

When the main switch of the equipment is turned ON, power starts supplying to all the lines only when two doors (front cover and ADU) are closed

#### 2. Stopping line output

When the main switch of the equipment is turned OFF, PWR-DN signal is output after the instantaneous outage insurance time elapses and then the supply of each voltage stops. If the supply of voltage of the main line (+5VS, +12VA) stops earlier than the 24V line does, it may cause the damage of the electron device on each control circuit. To prevent this, the supply of these voltages stops after the PWR-DN signal is output and the minimum retaining time elapses.

#### 3. Output protection

Each output system includes an overcurrent and overvoltage protection circuits (a fuse and internal protection circuit). This is to prevent the defectives (damage or abnormal operation of the secondary circuit) which may be caused by an overcurrent due to a short circuit or an overvoltage due to a short circuit between different voltages. If the protection circuit is activated (except the case the fuse is blown out), remove the causes such as short-circuit. Turn ON the power again to clear the overcurrent protection.

#### 4. Recovering from super sleep mode (normal starting))

When the [ENERGY SAVER] button on the control panel is pressed during the super sleep mode, a super sleep mode shifting/recovering signal (SYS-EN) is output from the SYS board and then voltage starts being supplied to all the lines, if no error was detected.

#### 5. Recovering from super sleep mode (when receiving a packet)

When a packet from a network is received during the super sleep mode, the mode is shifted to the sleep mode.

When packets are received frequently, a control is performed to keep the sleep mode for a specified period. It will be cleared when the power is turned OFF and then back ON.

#### 6. Shifting to super sleep mode (normal stopping)

When the [ENERGY SAVER] button on the control panel is pressed while the main switch of the equipment is toggled ON, a super sleep mode shifting/recovering signal (SYS-EN) is output from the SYS board after the initialization is finished and then all lines for output voltage except +5VS are closed.

The Super sleep mode is disabled under the following conditions.

- When the Super sleep mode is set to be disabled on the control panel, TopAccess and with the code FS-08-8543
- When the Wireless LAN Module, Bluetooth Module, e-BRIDGE ID Gate or Data Overwrite Enabler is installed, or when the IPsec Enabler is installed and its function is set to be enabled
- When operation is being performed in the self-diagnosis mode (Disabled until the main switch is turned OFF)

## 7. State of the power supply

- Power OFF

The main switch of the equipment is turned OFF. Since DC voltage is not supplied to each board, the equipment is not operable.

- Normal state (including Energy saving mode)

The main switch of the equipment is turned ON and DC voltage is supplied to each board. When the cover of the equipment is closed, 24V DC voltage is supplied and the equipment enters into the ready/printing state.

- Sleep mode

Since +24VD DC voltages are not supplied but +12VA and +5VS DC voltages only, the equipment does not enter into the ready state.

- Super Sleep mode

Only +5VS DC voltages are output from the power supply unit. The [ENERGY SAVER] button is monitored and the LED of the main switch is lit.

### 3.18.4 Output Channel

The following are output channels for the main power switch line.

main power switch line

Connector	Pin No.	Voltage	Destination
CN511	5	+5VS	SYS board DF (via SYS board)
	6		
	9	+12VA	
	10		
CN512	5	+12VA	LGC board
	6		
CN514	1	+12VA	Cover switch

The following are output channels for the cover switch line.

Cover switch line

Connector	Pin No.	Voltage	Destination
CN512	15	+24VD1	LGC board
	16		
	19	+24VD2	
	20		
CN513	3	+24VD3	SYS board
CN516	2	+24VD5	Finisher

### 3.18.5 Fuse

When the power supply secondary fuse is blown out, confirm that there is no abnormality with each part using the following table.

Voltage	Board/Unit	Part		Fuse type
+24VD1	LGC board	Fuser motor	M4	F201: 4A
		Exit motor	M5	
		ADU motor	M12	
		Bypass feed clutch	CLT4	
		Bridge kit, Job Separator	-	
		Key copy counter, coin controller	-	
		PFU, PFP, LCF	-	
+24VD2	LGC board	Auto-toner sensor-K	S1	F202: 4A
		Auto-toner sensor-C	S2	
		Auto-toner sensor-M	S3	
		Auto-toner sensor-Y	S4	
		Discharge LED-Y	ERS-Y	
		Discharge LED-M	ERS-M	
		Discharge LED-C	ERS-C	
		Discharge LED-K	ERS-K	
		Paper feeding/developer unit drive motor	M2	
		Mono/color switching motor	M3	
		Drum / TBU motor	M6	
		Waste toner paddle motor	M7	
		Toner motor-Y	M8	
		Toner motor-M	M9	
		Toner motor-C	M10	
		Toner motor-K	M11	
		Sensor shutter solenoid	SOL1	
		Registration clutch	CLT1	
		Feed clutch	CLT2	
		1st transfer contact/release clutch	CLT3	
Ozone exhaust fan	F2			
PS cooling/Ozone suctioning fan	F3			
High-voltage transformer	HVT			
+24VD3	SYS board	Scan motor	M1	F203: 4A
+24VD5	PFC board	-	-	F205: 4A

#### Primary fuse

Part		Fuse type
MFP	-	F101
Switching regulator	PS	F102

## 4. DISASSEMBLY AND REPLACEMENT

### 4.1 Covers

#### 4.1.1 Front cover

- (1) Open the front cover.
- (2) Remove 2 screws and pull out the front cover [1] at an angle toward the lower-front side.

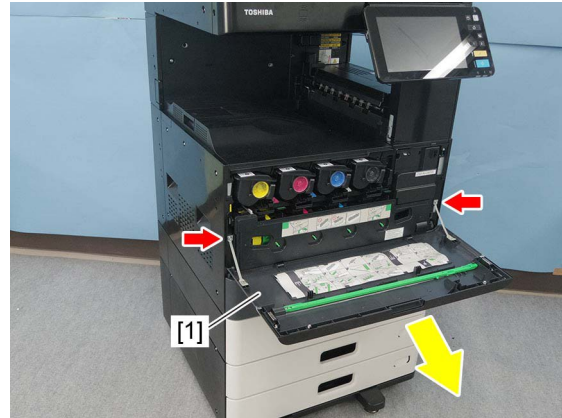


Fig. 4-1

#### 4.1.2 Left cover

- (1) Open the front cover and pull out the 1st drawer.
- (2) Remove 8 screws and take off the left cover [1].  
[2] M4x8  
[3] M3x8

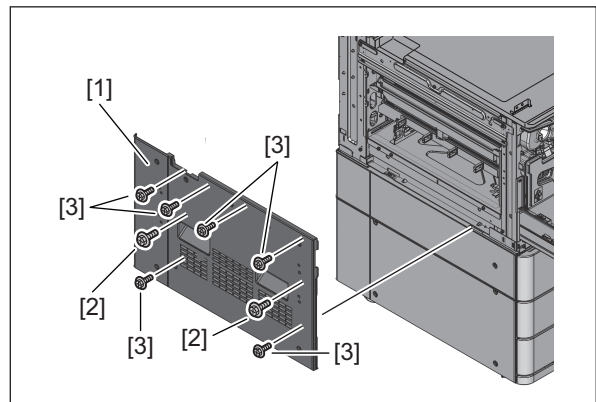


Fig. 4-2

### 4.1.3 Receiving tray

- (1) Remove the left cover.  
📖 P. 4-1 "4.1.2 Left cover"
- (2) Remove the receiving tray [1].



Fig. 4-3

### 4.1.4 Tray rear cover

- (1) Remove the receiving tray.  
📖 P. 4-2 "4.1.3 Receiving tray"
- (2) Remove the left-rear cover.  
📖 P. 4-3 "4.1.6 Left rear cover"
- (3) Take off the connector cover.  
📖 P. 4-3 "4.1.7 Receiving rear cover"
- (4) Remove 1 screw and take off the tray rear cover [1] by sliding it to the left.

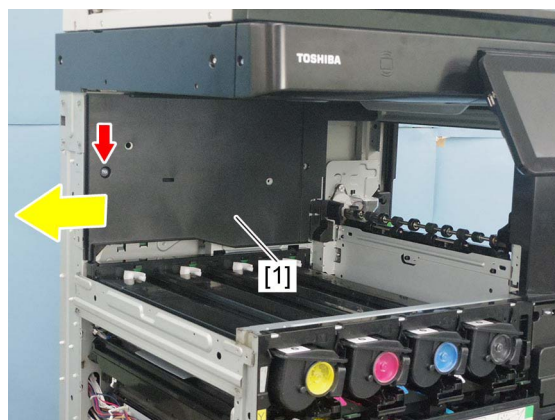


Fig. 4-4

#### Notes:

When installing, attach the latch [2] to the hole [3] of the frame.

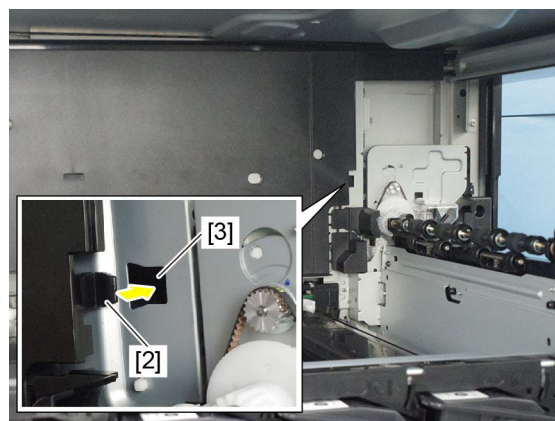


Fig. 4-5



### 4.1.5 Left top cover

- (1) Remove 2 screws and take off the left top cover [1].

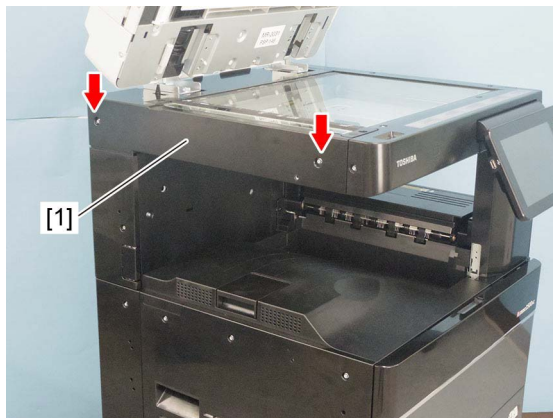



Fig. 4-6

### 4.1.6 Left rear cover

- (1) Remove the left cover.  
 P. 4-1 "4.1.2 Left cover"
- (2) Remove 1 screw and take off the left rear cover [1] by lifting it up.

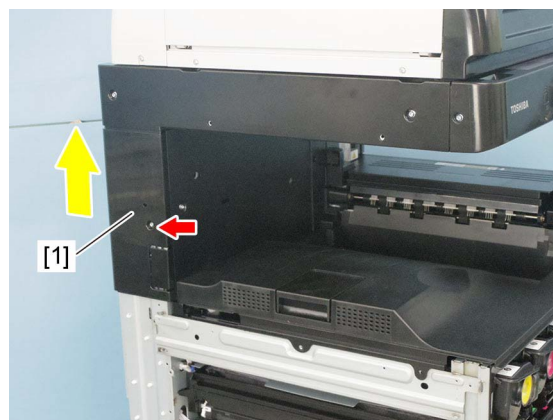


Fig. 4-7

### 4.1.7 Receiving rear cover

- (1) Open the side cover.
- (2) Remove 1 screw and take off the receiving rear cover [1].



Fig. 4-8

### 4.1.8 Right top cover

- (1) Remove 3 screws and take off the top right cover [1] by lifting it up.

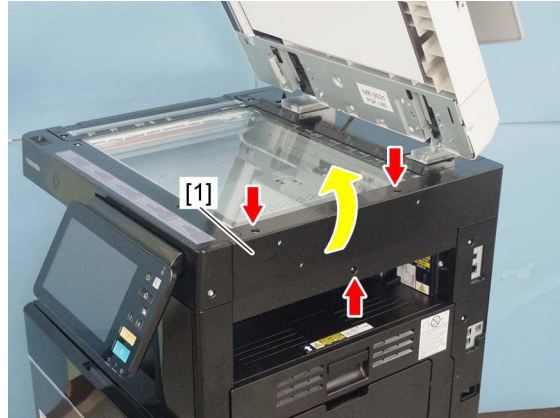


Fig. 4-9

### 4.1.9 Control panel lower cover

- (1) Make the control panel [1] level.



Fig. 4-10

- (2) Remove 2 screws and take off the control panel lower cover [2].

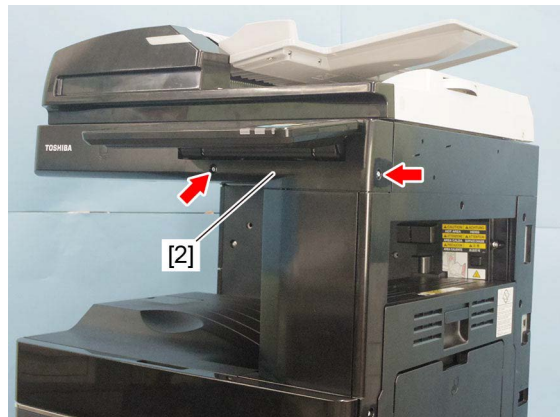


Fig. 4-11

### 4.1.10 Right front cover

- (1) Take off the control panel lower cover.  
 P. 4-4 "4.1.9 Control panel lower cover"
- (2) Take off the front cover.  
 P. 4-1 "4.1.1 Front cover"
- (3) Remove 1 screw and take off the right front cover [1].

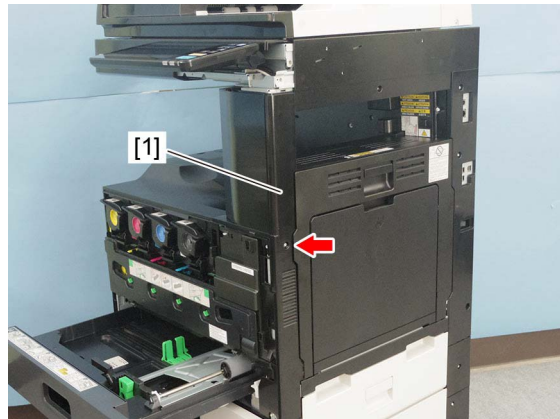


Fig. 4-12

### 4.1.11 Right rear cover

- (1) Remove 3 screws and take off the right rear cover [1].

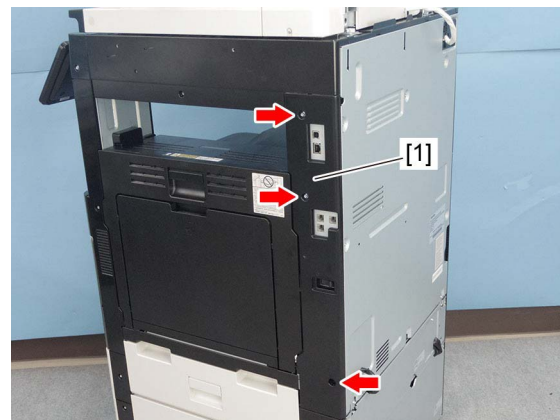


Fig. 4-13

### 4.1.12 Front top cover

- (1) Remove 2 caps.
- (2) Remove 3 screws and take off the front top cover [1] by sliding it toward the left side.

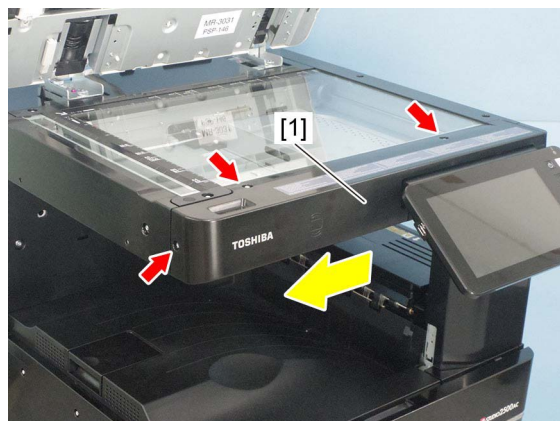


Fig. 4-14

### 4.1.13 Front right cover

- (1) Remove the control panel lower cover.  
☞ P. 4-4 "4.1.9 Control panel lower cover"
- (2) Open the front cover.
- (3) Remove 1 screw and take off the front right cover [1] by lifting it up.

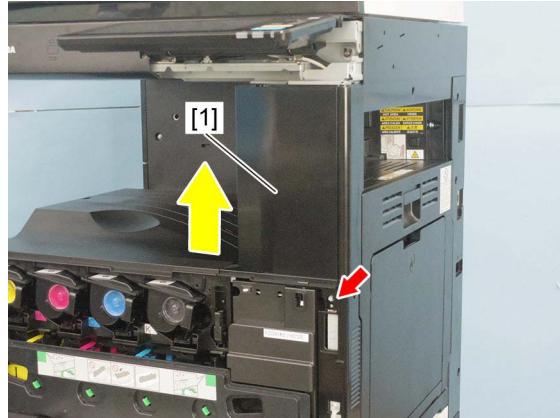


Fig. 4-15

### 4.1.14 Rear top cover

- (1) Remove the RADF or the platen cover.
- (2) Remove the left top cover.  
☞ P. 4-3 "4.1.5 Left top cover"
- (3) Remove the right top cover.  
☞ P. 4-4 "4.1.8 Right top cover"
- (4) Remove 2 screws and take off the rear top cover [1].

**Notes:**

If the platen cover is installed, remove 2 brackets.

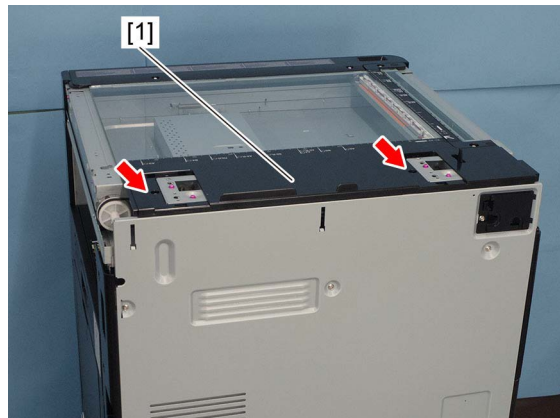


Fig. 4-16

### 4.1.15 Rear cover

- (1) Remove 5 screws and take off the rear cover [1].

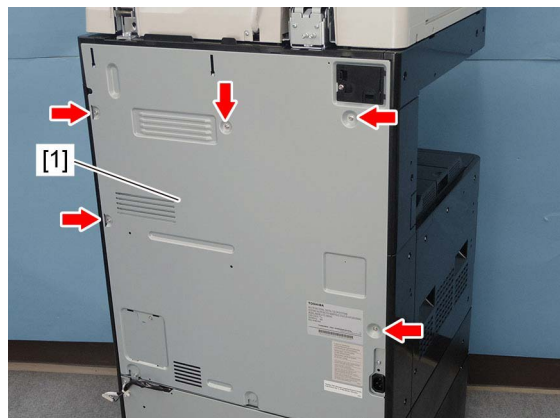


Fig. 4-17

## 4.1.16 Front cover switch (SW1)

- (1) Remove the front cover.  
 P. 4-1 "4.1.1 Front cover"
- (2) Remove the drawer.
- (3) Remove the right front cover.  
 P. 4-5 "4.1.10 Right front cover"
- (4) Remove the waste toner box.  
 P. 4-67 "4.6.1 Waste toner box"
- (5) Remove 6 screws of the inner cover [1].

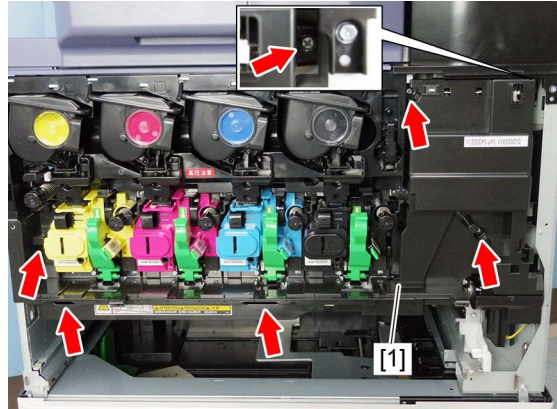


Fig. 4-18

- (6) Disconnect 1 connector and remove the inner cover [1].

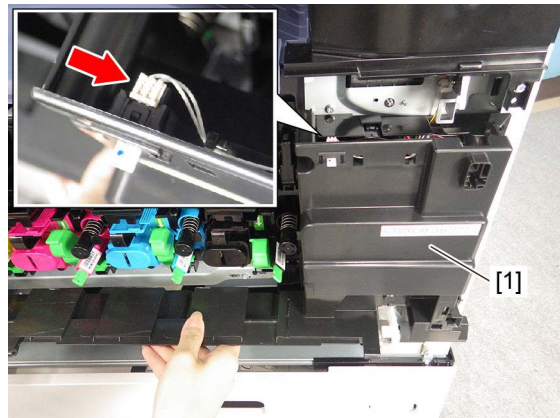


Fig. 4-19

- (7) Release the 2 latches and remove the front cover switch [2].

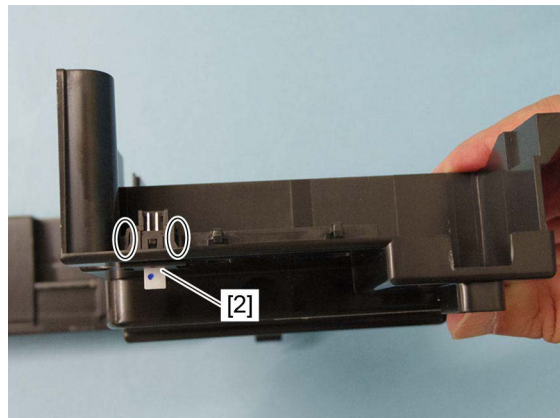


Fig. 4-20

## 4.1.17 Front cover interlock switch (SW2)

### Notes:

If the interlock switch is not installed appropriately when it is replaced or installed, it may not work normally. If you carry out the maintenance of the equipment in such a situation, you could get an electric shock by touching live sections or be injured by touching moving sections. Therefore, to avoid this, be sure to perform correct handling and installation.

- (1) Remove the inner cover.  
P. 4-7 "4.1.16 Front cover switch (SW1)"
- (2) Remove 1 screw and take off the bracket [1].

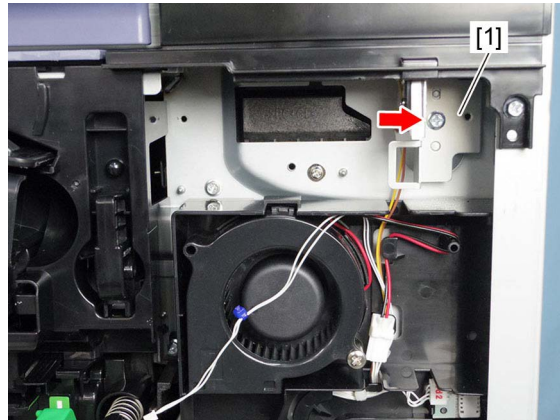


Fig. 4-21

- (3) Remove 2 screws and disconnect 2 connectors [2], and then take off the front cover interlock switch [3].

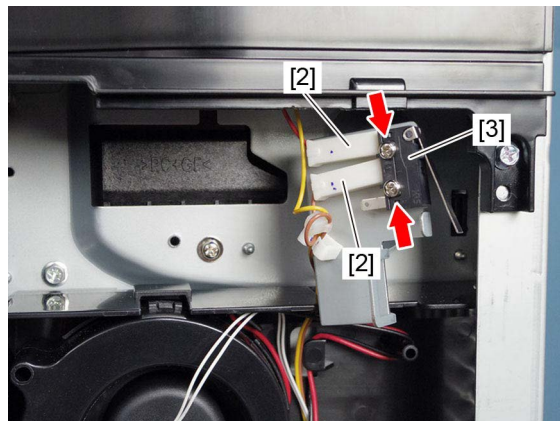



Fig. 4-22

## 4.2 Control Panel

### 4.2.1 Control panel unit

- (1) Remove the front top cover.  
 P. 4-5 "4.1.12 Front top cover"
- (2) Lower the control panel unit [1].

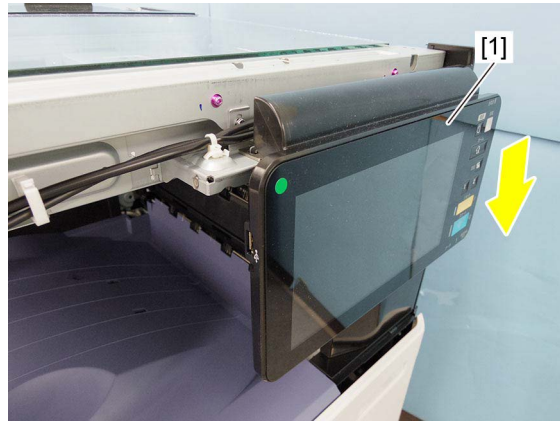


Fig. 4-23

- (3) Remove 1 screw and take off the ground wire [2].



Fig. 4-24

- (4) Remove 2 screws. Remove the control panel unit [1] by sliding it.

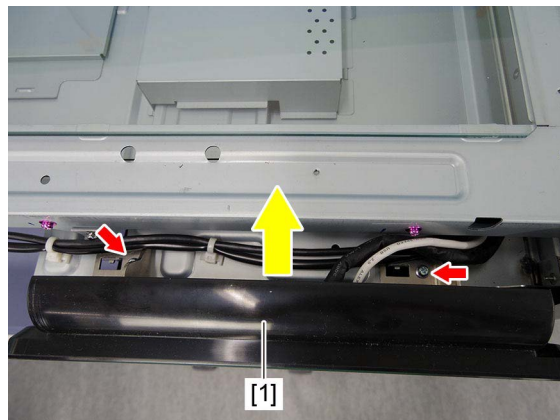


Fig. 4-25

(5) Remove 4 screws.

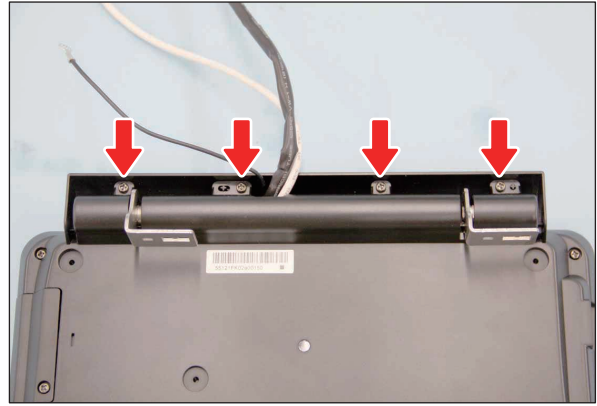


Fig. 4-26

(6) Raise 2 hinges and remove the hinge cover [3].

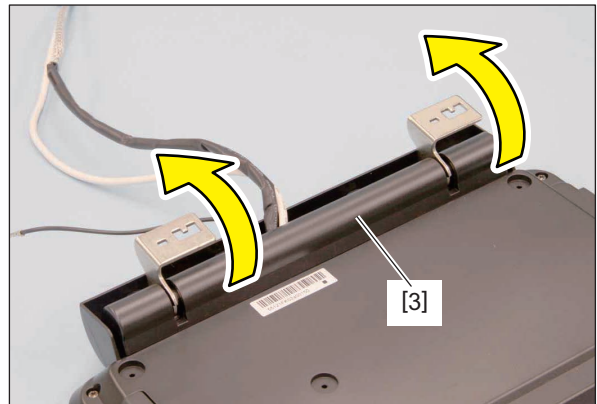


Fig. 4-27



Fig. 4-28



- (7) Remove 6 screws and take off the cover [4].

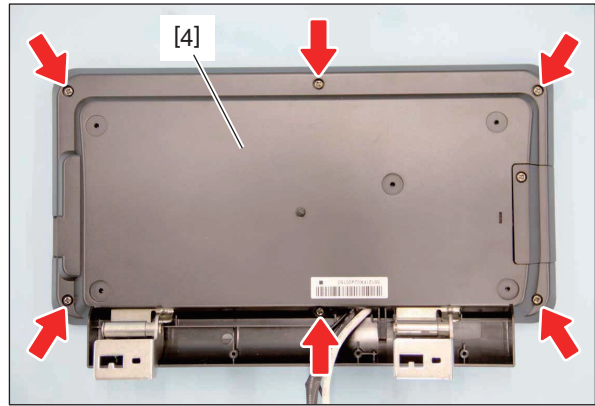


Fig. 4-29

- (8) Remove the harness from 3 hooks and disconnect connector [5] and [6], and then remove the USB harness/signal harness [7].

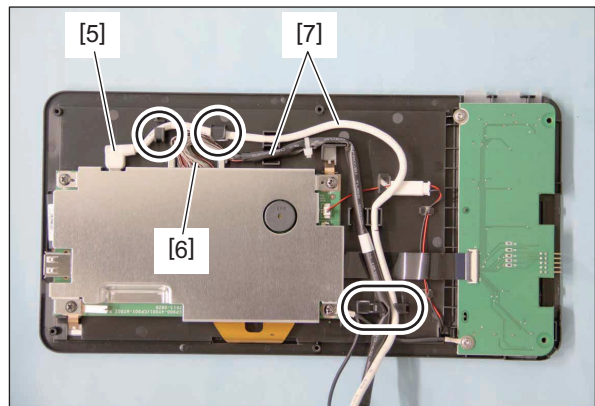


Fig. 4-30

**Notes:**

When disconnecting the connector [6], release the lock and disconnect it.

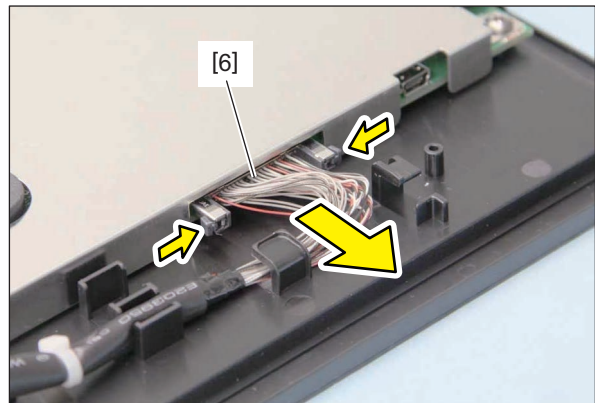


Fig. 4-31

## 4.2.2 KEY board/button

- (1) Remove the control panel unit.  
P. 4-9 "4.2.1 Control panel unit"
- (2) Disconnect the connector [1], remove 2 screws, and take off the ground wire [3], and then take off the key PC board [2].

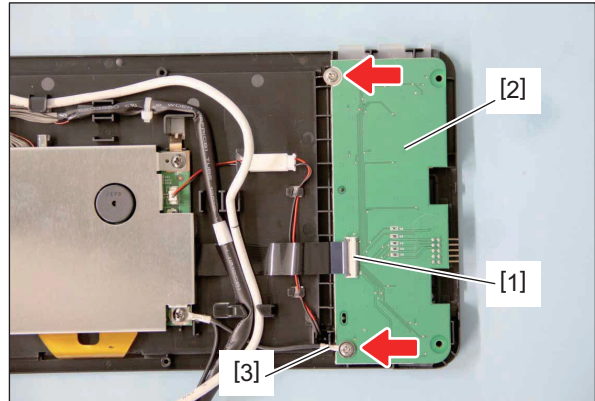


Fig. 4-32

### Notes:

When disconnecting the connector [1], release the lock by raising the latch and disconnect it.

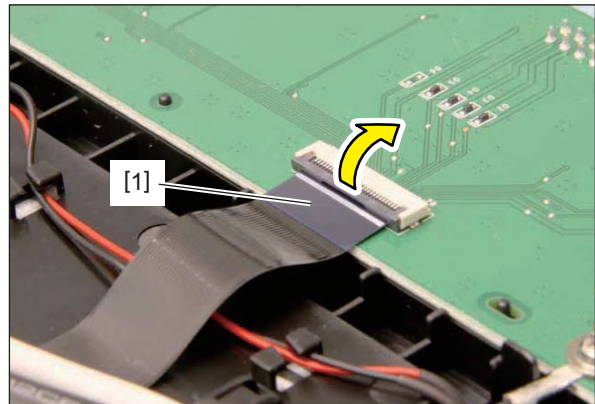


Fig. 4-33

(3) Remove 6 buttons [4].

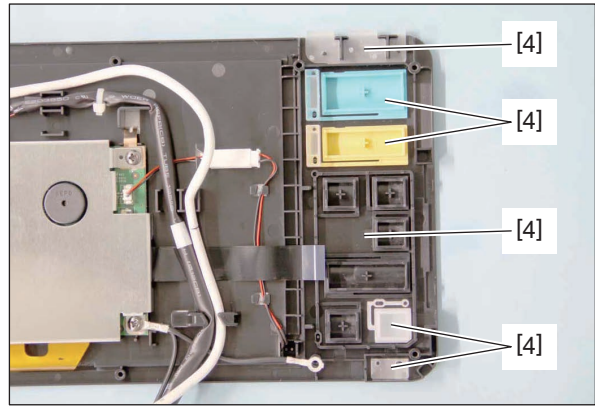


Fig. 4-34



Fig. 4-35

### 4.2.3 DSP board

- (1) Remove the control panel unit.  
📖 P. 4-9 "4.2.1 Control panel unit"
- (2) Remove 4 screws, and then take off the ground wire [2] and the bracket [1].

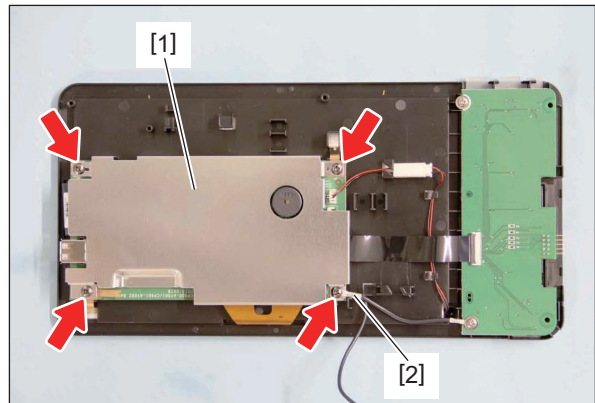


Fig. 4-36

- (3) Remove the leaf spring [3] and [4].  
Disconnect 1 connector and remove the flat cable [5], [6], and [7], and then remove the DSP board [8].

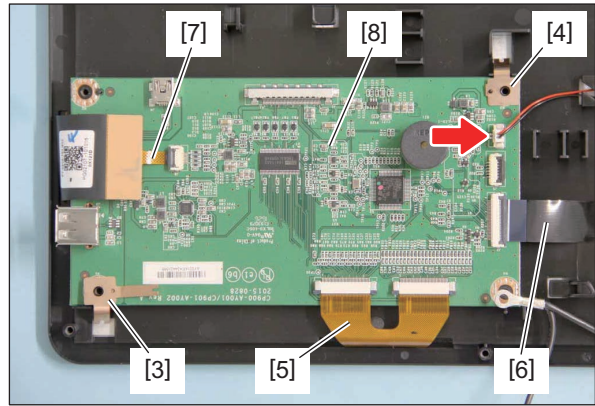


Fig. 4-37

**Notes:**

- When removing the flat cable [5], release the lock by pulling the 4 latches toward the direction of the arrow shown in the figure, and then pulling it out.

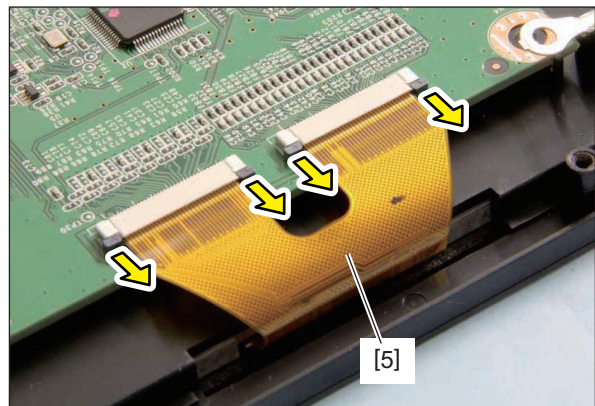


Fig. 4-38

- When removing the flat cable [6], release the lock by raising the latch [9] and remove the flat cable.

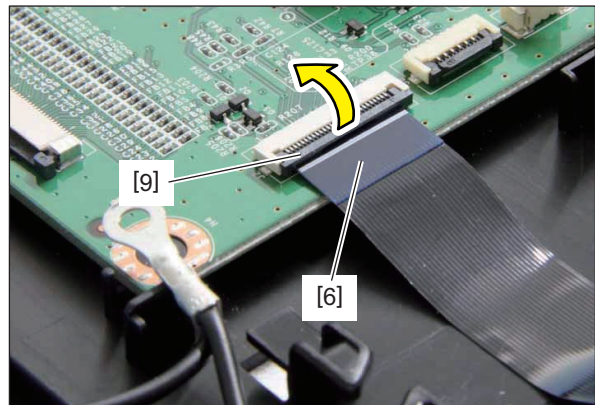


Fig. 4-39

- When removing the flat cable [7], release the lock by raising the latch [10] and remove the flat cable.

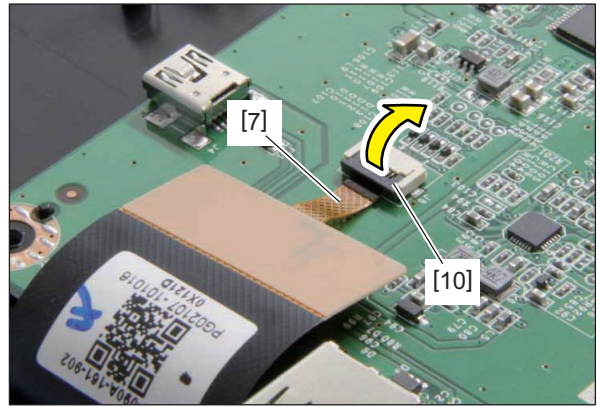


Fig. 4-40

## 4.3 Scanner Unit

### Notes:

1. Since the scanner section is assembled with high precision, be sure not to perform any disassembling other than that instructed in the Service Manual.
2. Precautions for the scanner fixing screw are shown below.
  - Since the scanner unit is adjusted, do not loosen the 5 scanner fixing screws shown in the figures below.

2 screws on the right-hand surface of the equipment

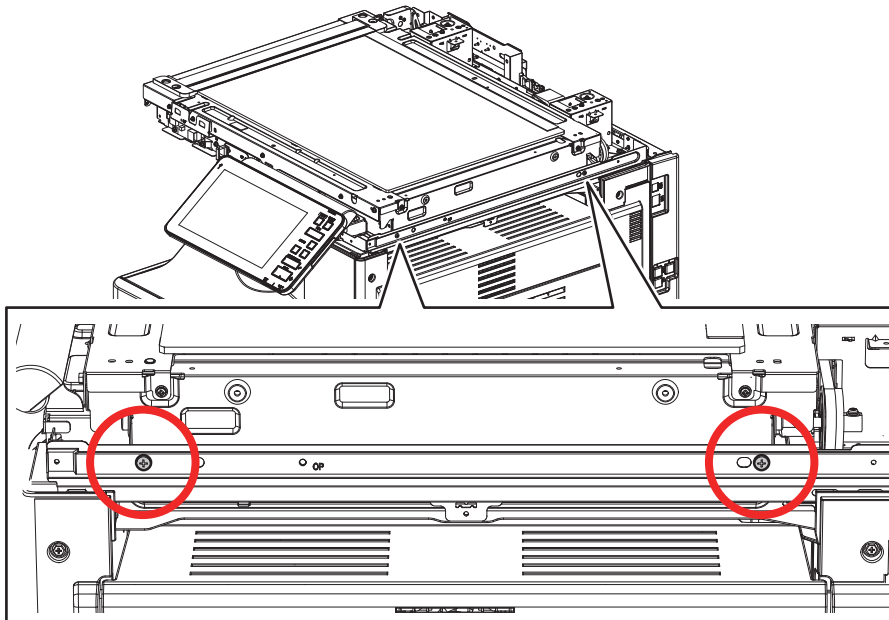


Fig. 4-41

3 screws on the left-hand surface of the equipment

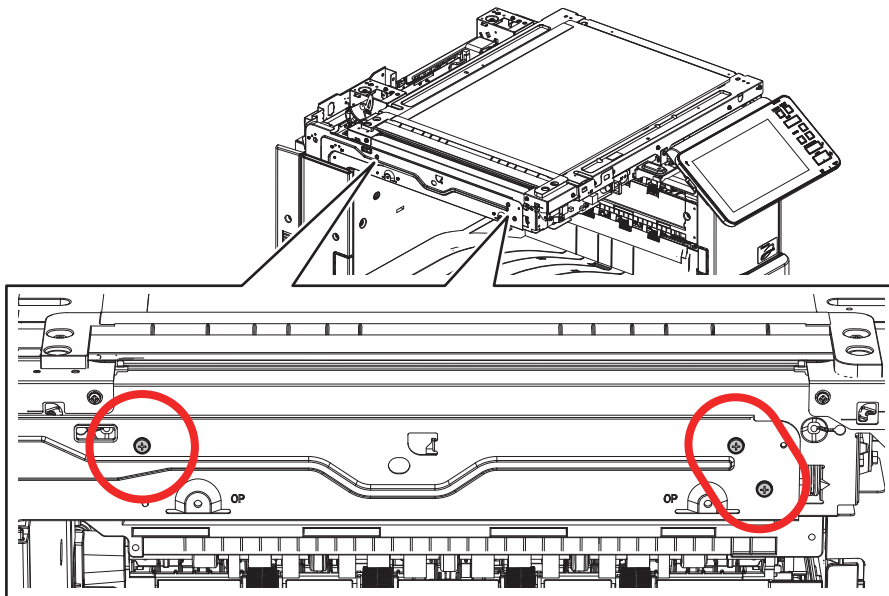


Fig. 4-42

- Make sure the followings before loosening the scanner fixing screw, if it is unavoidable.

Draw the mark-off lines [1] aligning with the edge of the hole on the rear side of the right-hand surface.

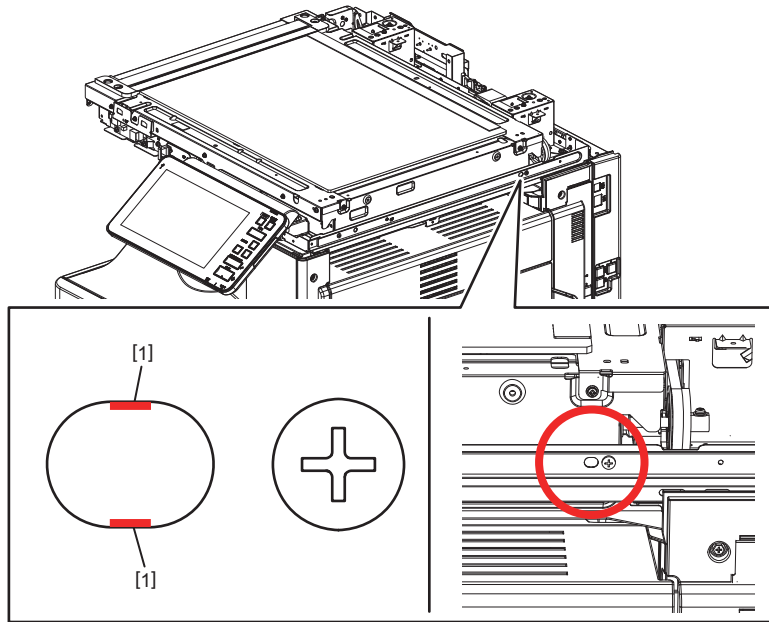


Fig. 4-43

Draw a mark-off line [2] on the edge of the front side frame on the left-hand surface.

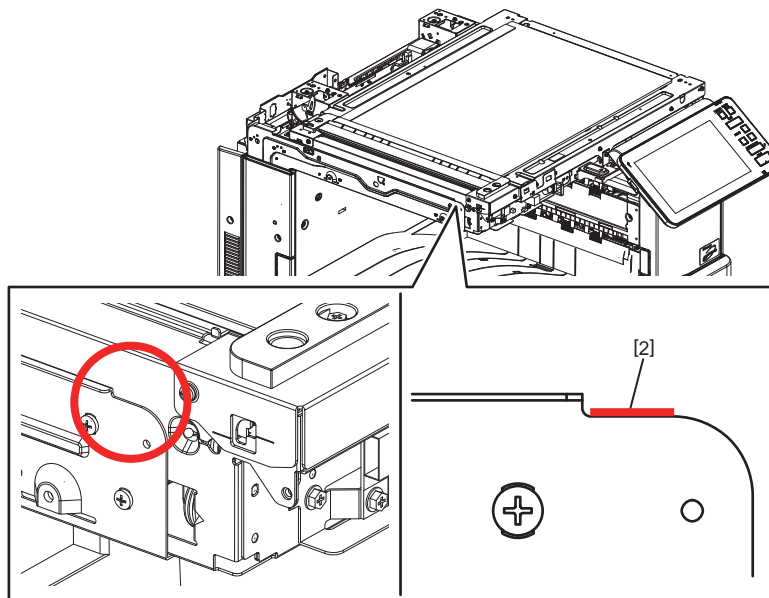


Fig. 4-44

Draw a mark-off line [3] on the edge of the rear side frame on the left-hand surface.

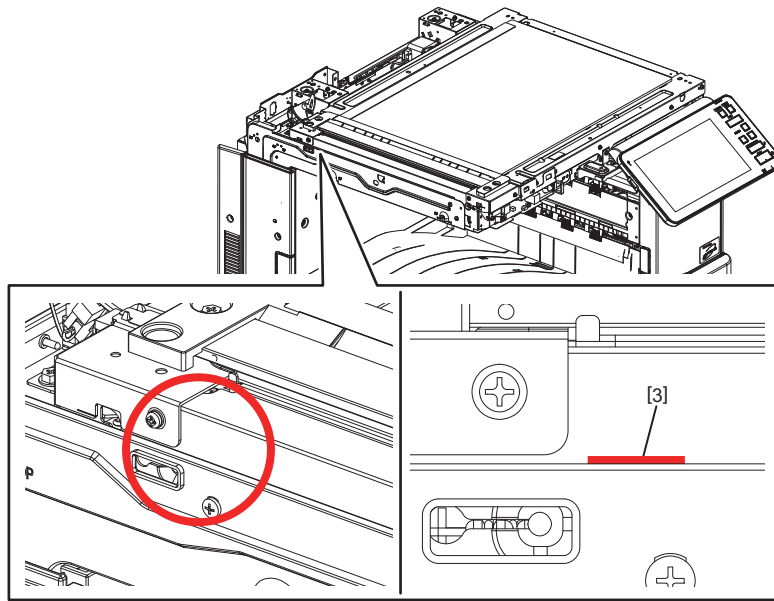


Fig. 4-45

- When tightening the scanner fixing screws, align the scanner unit [4] with each mark-off line. Be sure to install the scanner unit [4] in the same position in which it was removed. In addition, the rear left/right side of the scanner unit [4] touch the DF bracket [5] and [6].

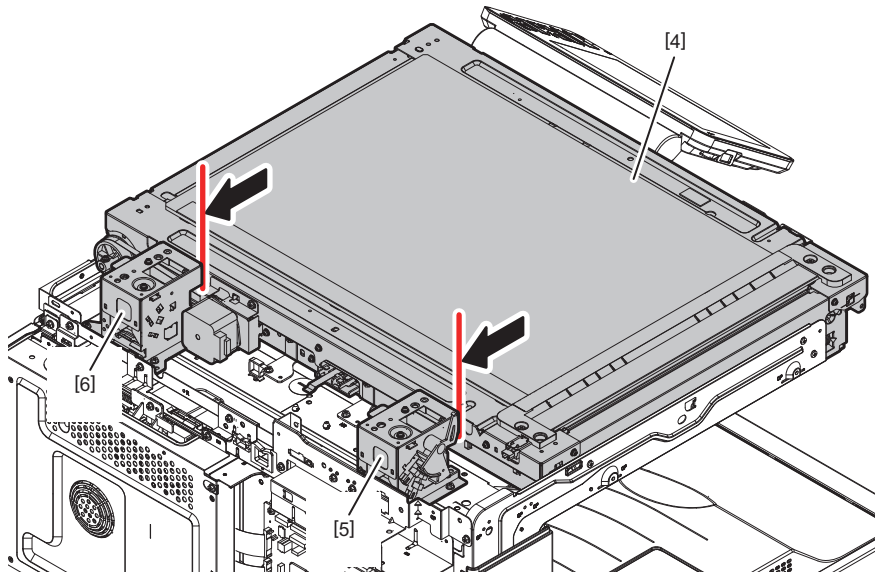


Fig. 4-46



- If image distortion occurs after tightening the scanner fixing screws, adjust the image distortion according to the following procedure.
  1. Loosen the 3 screws on the left-hand surface.
  2. Move the front left side of the scanner unit up and down.

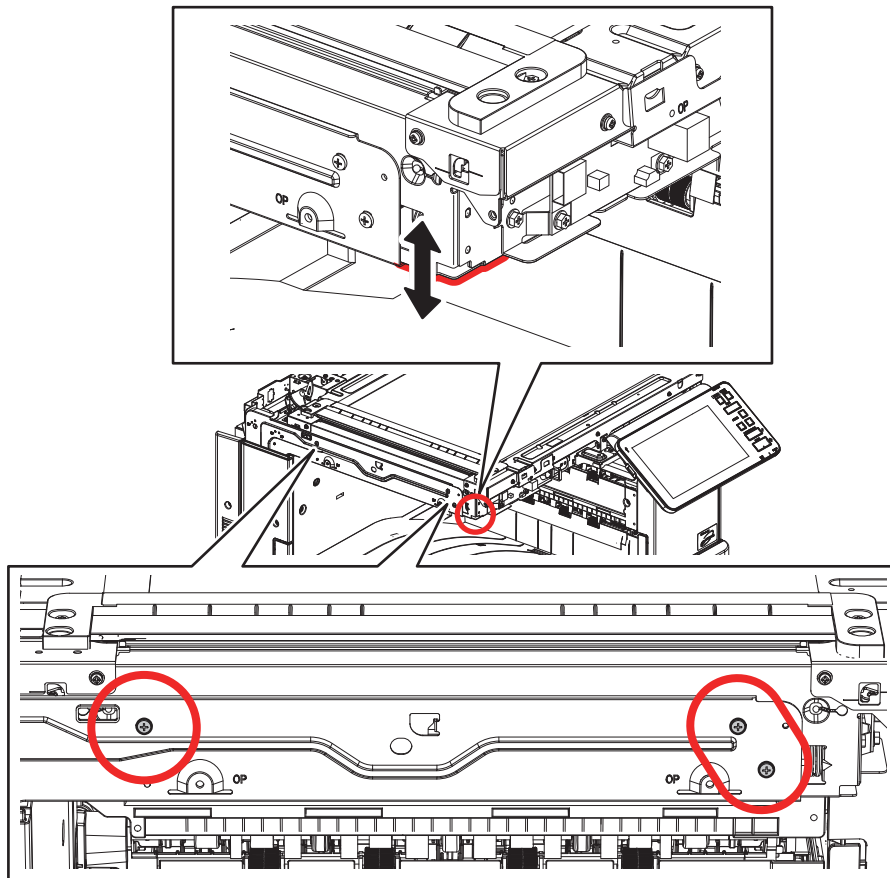


Fig. 4-47

### 4.3.1 Original glass

- (1) Remove the right top cover.  
 P. 4-4 "4.1.8 Right top cover"
- (2) Remove 2 screws and take off the original glass [1] and ADF original glass [2].

**Notes:**

- Make sure that the ADF original glass [2] is securely inserted into the groove of the fixing part of the original glass [1].
- Securely insert 2 pins of the original glass [1] into the holes in the frame.

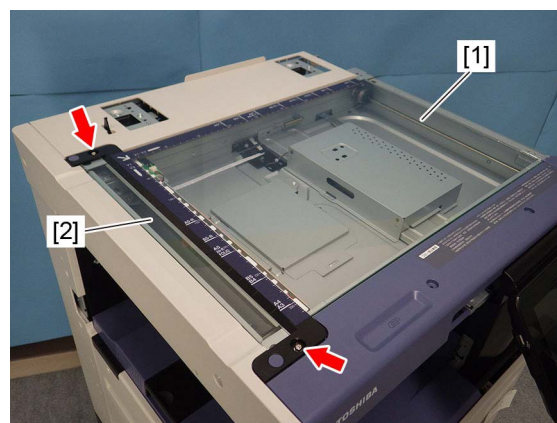



Fig. 4-48

### 4.3.2 Lens cover

- (1) Remove the original glass.  
 P. 4-19 "4.3.1 Original glass"
- (2) Take off the lens cover [1] by sliding it toward the left side.

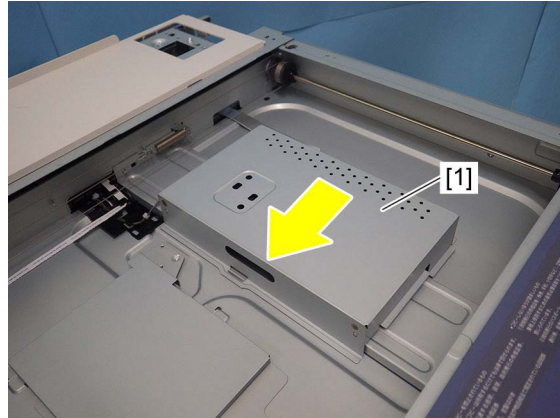



Fig. 4-49

### 4.3.3 Automatic original detection sensor-1 (S24)

- (1) Remove the lens cover.  
 P. 4-20 "4.3.2 Lens cover"
- (2) Remove 1 screw and disconnect 1 connector [1], and then take off the automatic original detection sensor-1 [2].

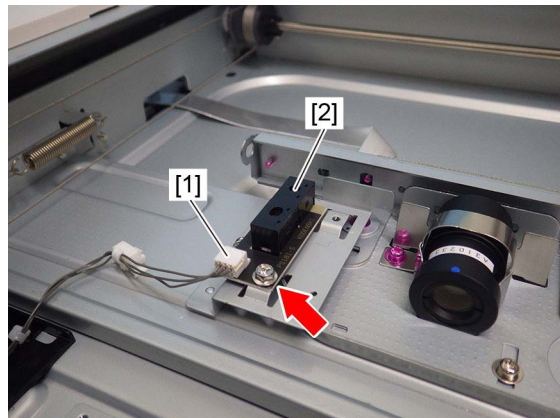



Fig. 4-50

### 4.3.4 Automatic original detection sensor-2 (S25)

- (1) Remove the lens cover.  
 P. 4-20 "4.3.2 Lens cover"
- (2) Remove 1 screw and disconnect 1 connector [1], and then take off the automatic original detection sensor-2 [2].

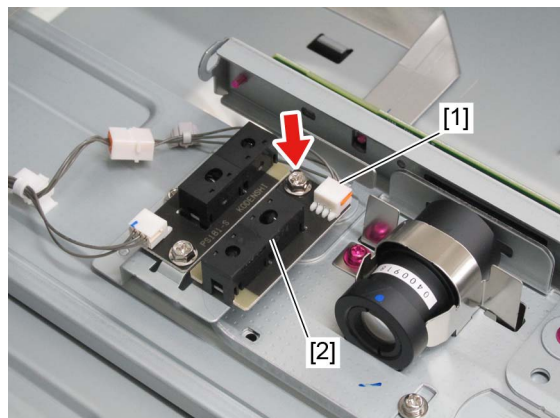


Fig. 4-51

### 4.3.5 Lens unit/CCD driving PC board

- (1) Remove 1 screw and take off the automatic original detection sensor with the bracket [1].

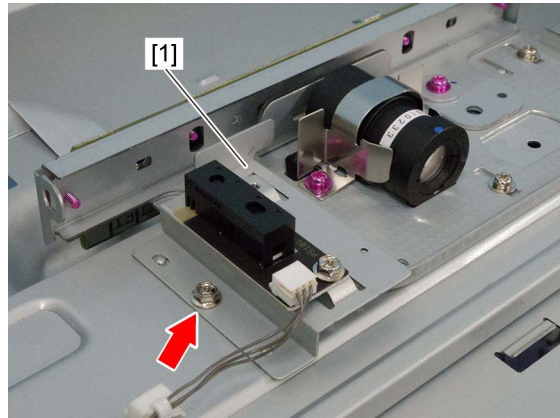


Fig. 4-52

- (2) Release the lock by tilting the flap and remove 1 flat cable [2].

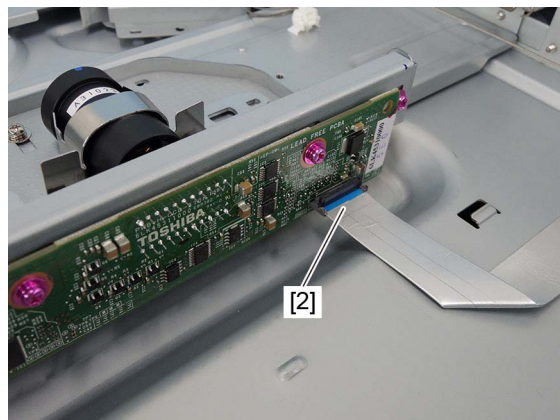


Fig. 4-53

#### Notes:

- When removing the flat cable [2], change the lever position so that the connector is released, and remove the flat cable by lifting it up slightly (approx. 7 degrees) as shown in the right figure.
- When connecting the flat cable [2] to the connector, insert the flat cable straightly and lock it securely. Confirm that the tabs are in the positions shown in the right figure.

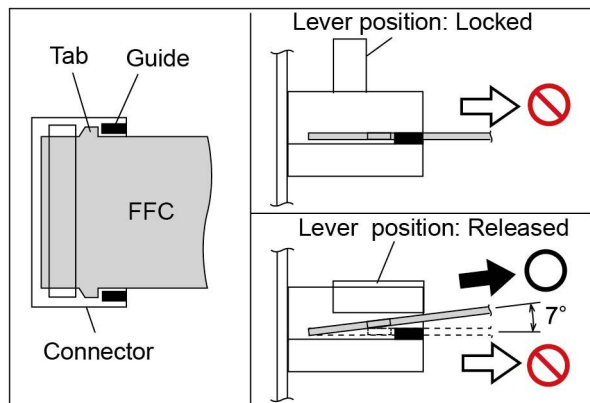
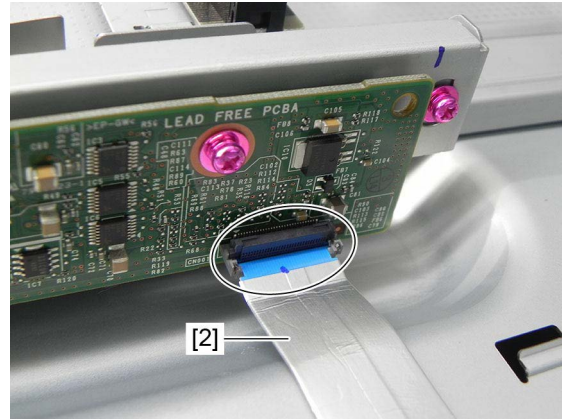


Fig. 4-54

**Notes:**

- When installing the flat cable [2], do not push it in strongly.
- When installing the flat cable [2], be careful not to insert it at an angle.
- Do not apply pressure to or damage the edge of the flat cable [2].

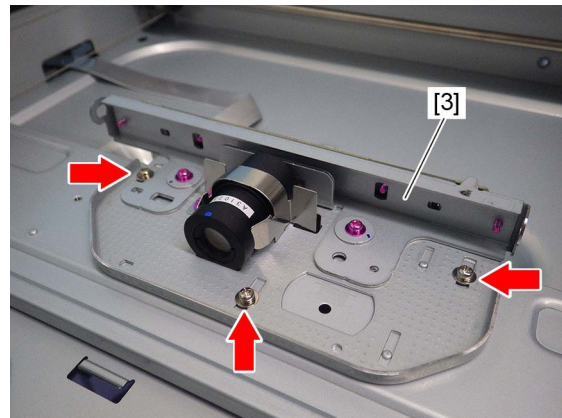


**Fig. 4-55**

- (3) Remove 3 screws and take off the CCD lens unit [3].

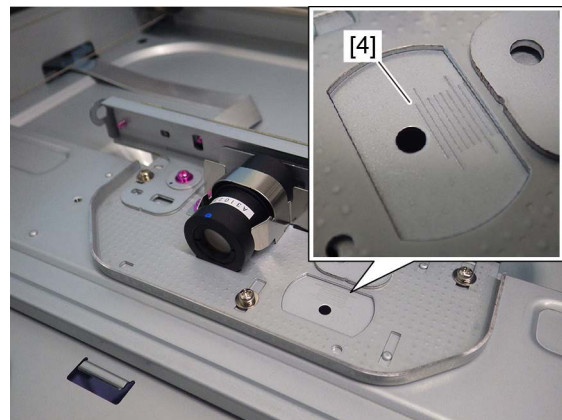
**Notes:**

1. The CCD lens unit is adjusted finely, so the re-adjustment or replacement of some parts are impossible in the field. The lens unit must be replaced on a unit basis.
2. Handle the lens unit with care. Do not hold the adjustment unit or lens.



**Fig. 4-56**

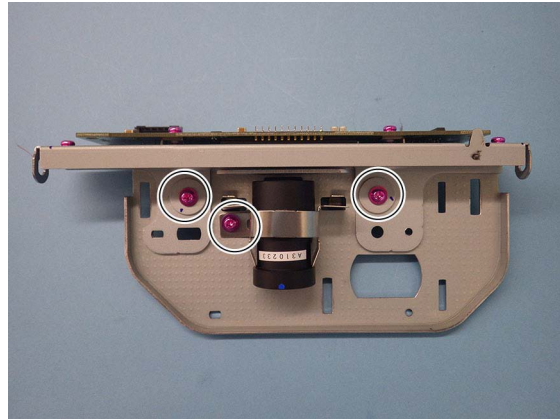
3. Count the number of lines [4] and write it down for later reference before removing the CCD lens unit. When installing the CCD lens unit, the same number of lines needs to be visible.



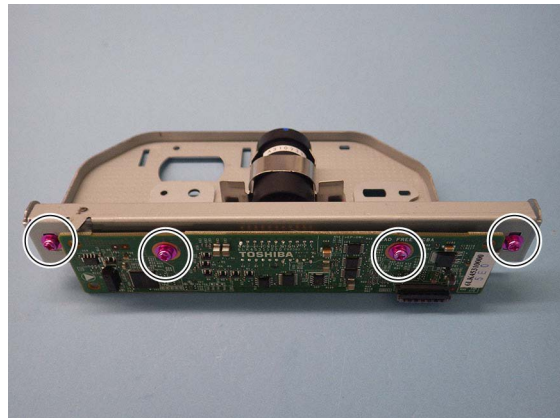
**Fig. 4-57**

**Notes:**

When replacing the lens unit, do not touch the screws (7 places).



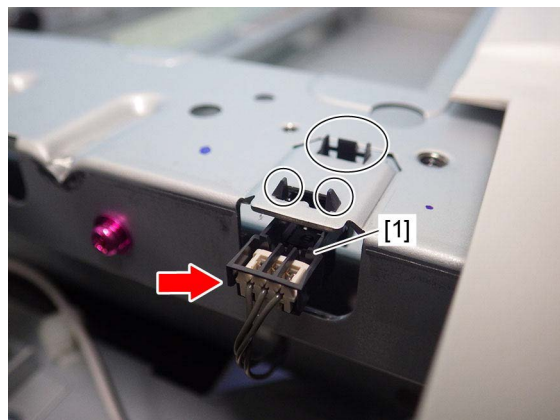
**Fig. 4-58**



**Fig. 4-59**

### 4.3.6 Carriage home position sensor (S23)

- (1) Remove the original glass.  
📖 P. 4-19 "4.3.1 Original glass"
- (2) Remove the rear top cover.  
📖 P. 4-6 "4.1.14 Rear top cover"
- (3) Disconnect the 1 connector, and release 3 latches and remove carriage home position sensor [1].



**Fig. 4-60**

### 4.3.7 Exposure lamp (EXP)

- (1) Remove the original glass and front top cover.  
P. 4-19 "4.3.1 Original glass"  
P. 4-5 "4.1.12 Front top cover"
- (2) Move carriage-1 [1] to a place where you can see the exposure lamp mounting screw through the frame hole.

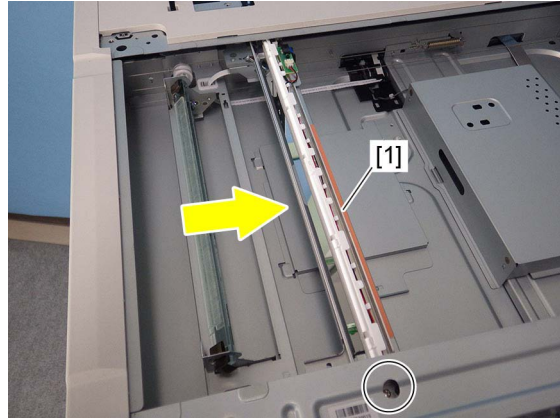


Fig. 4-61

**Notes:**

To move the carriage, manually rotate the drive pulley.



Fig. 4-62

- (3) Remove 1 screw.

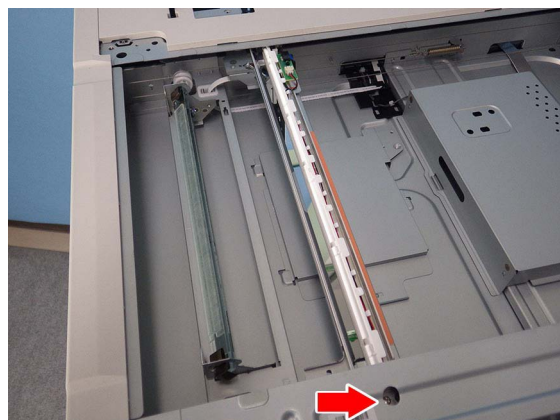


Fig. 4-63

- (4) Disconnect the connector [3] by sliding the front side of the exposure lamp [2] toward the direction of the arrow shown in the figure. Remove the exposure lamp [2] from the front side.

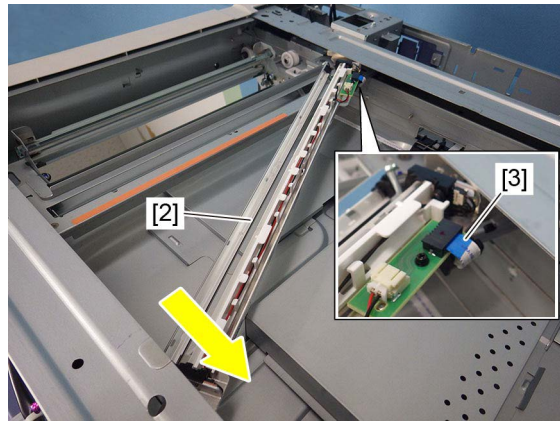


Fig. 4-64

**Notes:**

After replacing the exposure lamp, be sure to perform FS-05-3270.



Fig. 4-65

### 4.3.8 Scan motor (M1)

- (1) Take off the rear top cover.  
P. 4-6 "4.1.14 Rear top cover"
- (2) Remove the rear cover.  
P. 4-6 "4.1.15 Rear cover"
- (3) Disconnect 1 connector.

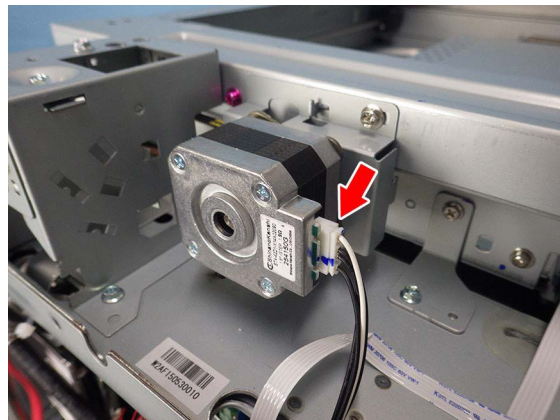


Fig. 4-66

- (4) Remove 2 screws and take off the scan motor assembly [1].

**Notes:**

When installing the scan motor, use the belt tension jig.

📖 P. 6-78 "6.6.3 Belt tension adjustment of the Scan motor"

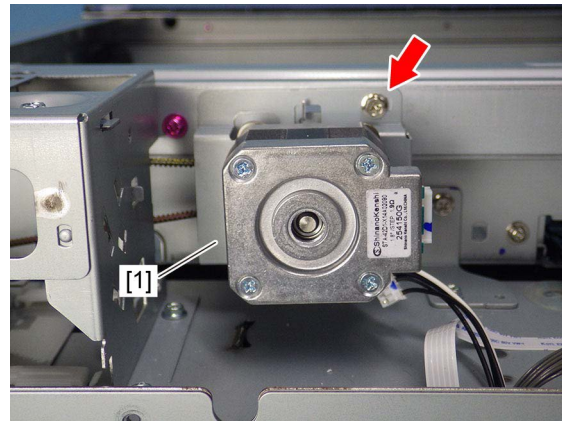


Fig. 4-67

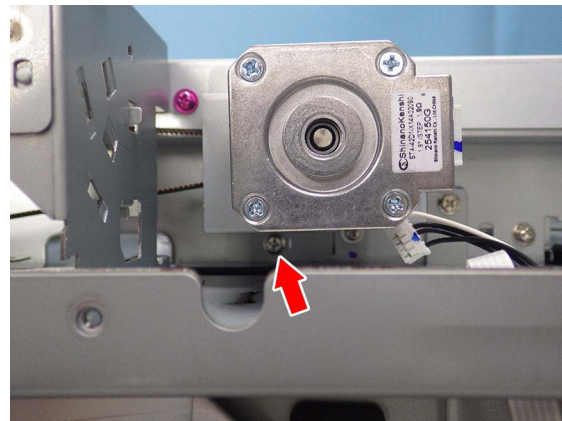


Fig. 4-68

- (5) Remove 2 screws and take off the scan motor [2].

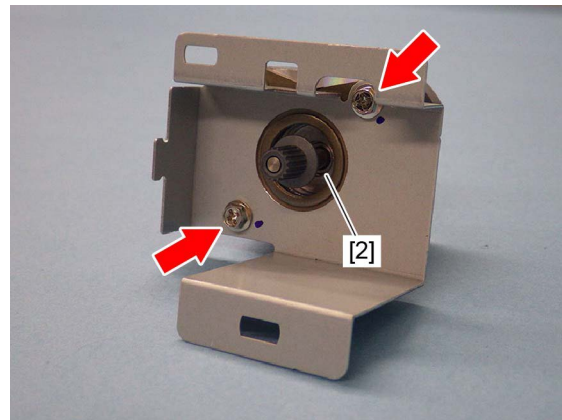



Fig. 4-69



### 4.3.9 Platen sensor (S21, S22)

- (1) Remove the rear top cover.  
 P. 4-6 "4.1.14 Rear top cover"
- (2) Remove 5 screws.

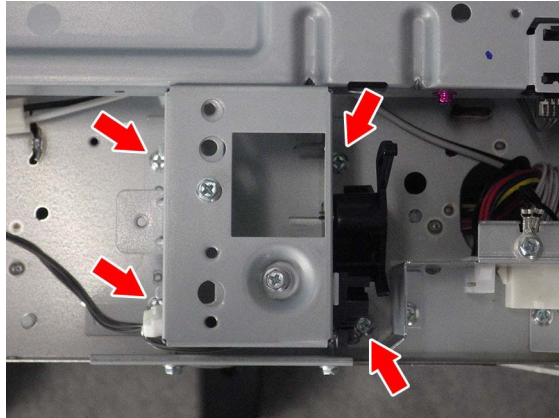


Fig. 4-70

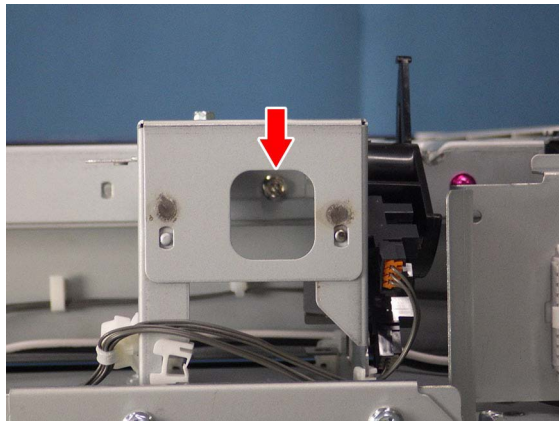


Fig. 4-71

- (3) Disconnect 2 connectors and take off the platen sensor assembly [1].

**Notes:**

When installing, be careful not to connect each different connector.

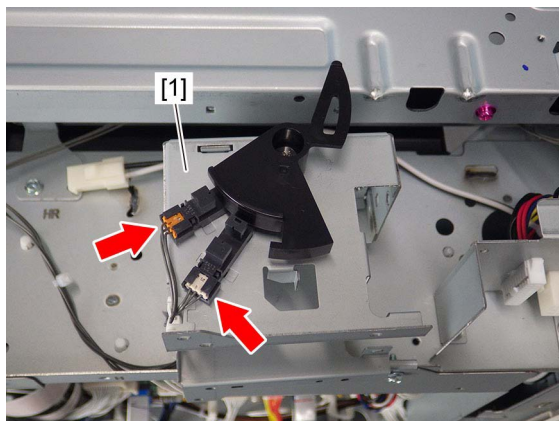


Fig. 4-72

- (4) Release each 3 latch and remove the platen sensor-1 [2] and -2 [3].

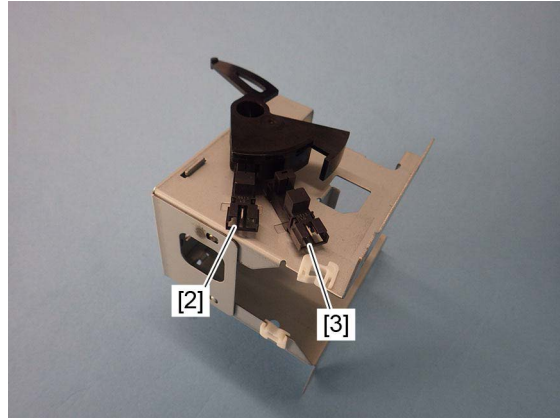





Fig. 4-73

### 4.3.10 Carriage-1

- (1) Remove the original glass.  
 P. 4-19 "4.3.1 Original glass"
- (2) Remove the rear top cover.  
 P. 4-6 "4.1.14 Rear top cover"
- (3) Remove the front top cover.  
 P. 4-5 "4.1.12 Front top cover"
- (4) Move carriage-1 [1] to the leftmost side.

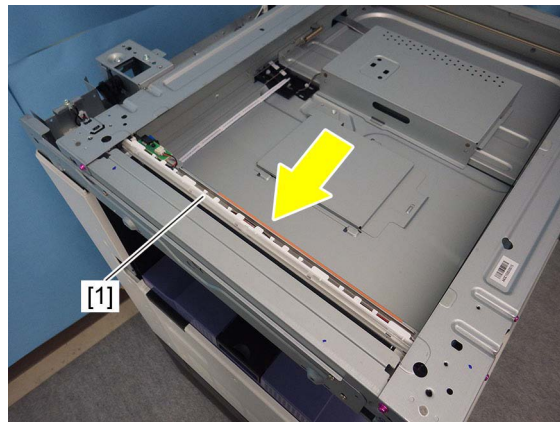


Fig. 4-74

**Notes:**

To move the carriage, manually rotate the drive pulley.

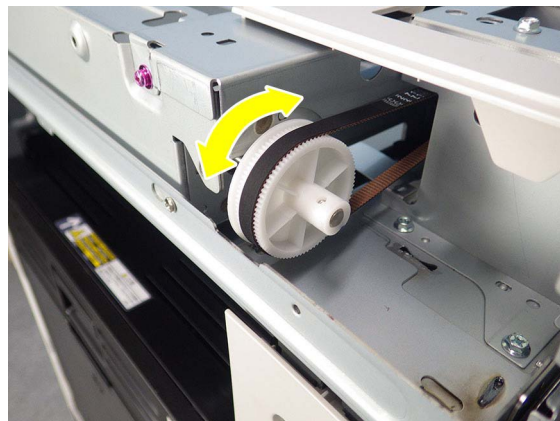


Fig. 4-75

- (5) Remove 2 screws.

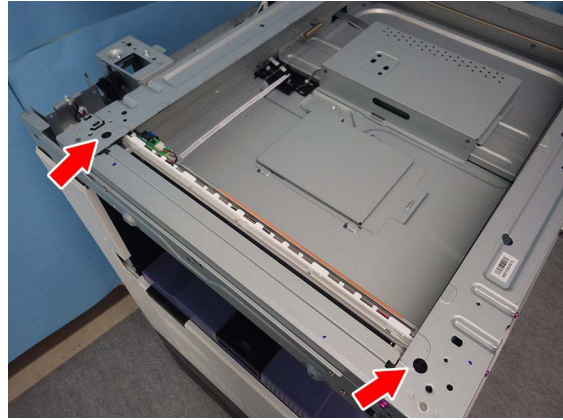


Fig. 4-76

- (6) Slide the front of the carriage-1 [1] toward the direction of the arrow shown in the figure, while trying not to touch the mirror [2].

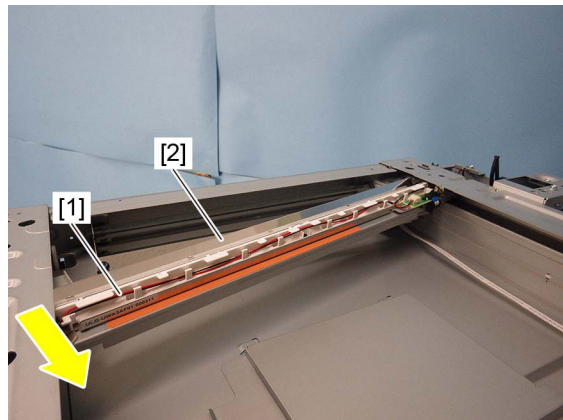


Fig. 4-77

- (7) Release the harness from the harness guide [3] and disconnect 1 connector [4].

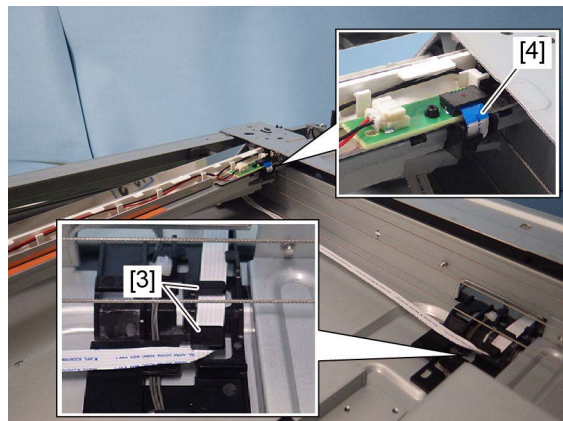


Fig. 4-78

(8) Remove the carriage-1 [1].

**Notes:**

After connecting the exposure lamp harness, move carriage-1 to the leftmost side and check the lamp harness for any twists.

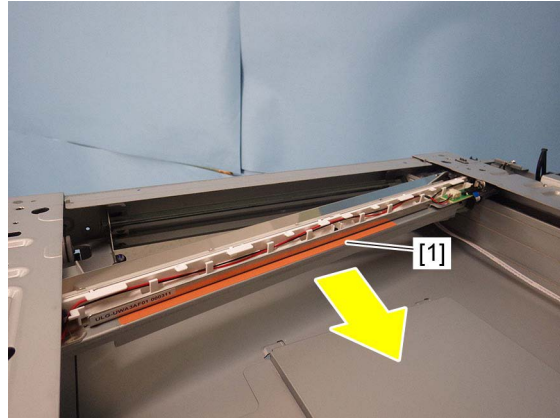


Fig. 4-79

**Notes:**

When installing carriage-1, make sure that the wires are placed on the front and rear notches of carriage-1 and fix them with screws.



Fig. 4-80



Fig. 4-81

### 4.3.11 Carriage wire, carriage-2

**Notes:**

- When replacing the carriage wire with a new one, replace the front and rear at the same time.
- When replacing the carriage wire with a new one, set the value of FS-08-6123 to "0".

**[A] Carriage wire, carriage-2**

- (1) Remove carriage-1.  
📖 P. 4-28 "4.3.10 Carriage-1"
- (2) Move carriage-2 to the center.
- (3) Attach the wire holder jig to the pulley to prevent the wire from coming loose.

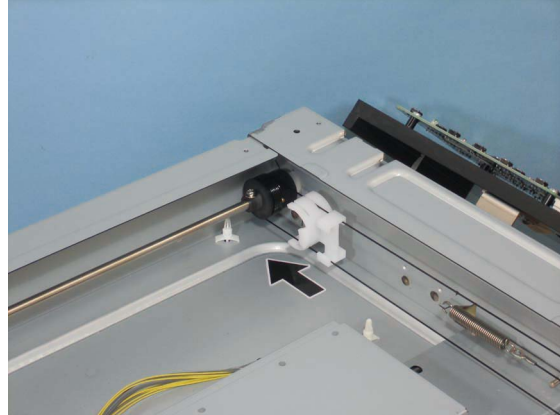


Fig. 4-82

**Notes:**

1. When attaching the wire holder jig [1], make sure that the wire has not shifted or become loose.
2. The wire should come out of the slot of the wire holder jig [1] and be passed under the jig arm [2].
3. When installing the wire holder jig, be careful of the orientation.

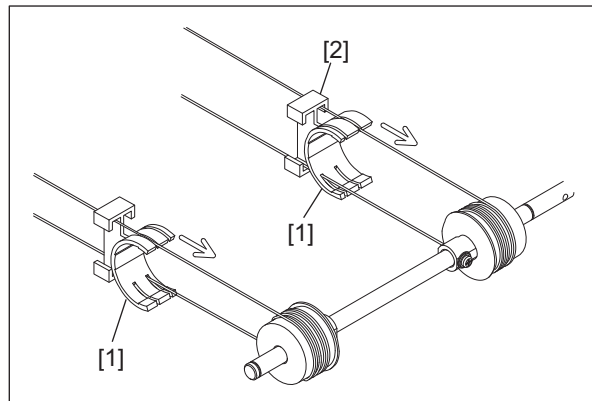


Fig. 4-83

- (4) Remove the tension springs [1] in the front and rear sides.
- (5) Remove the carriage wire.

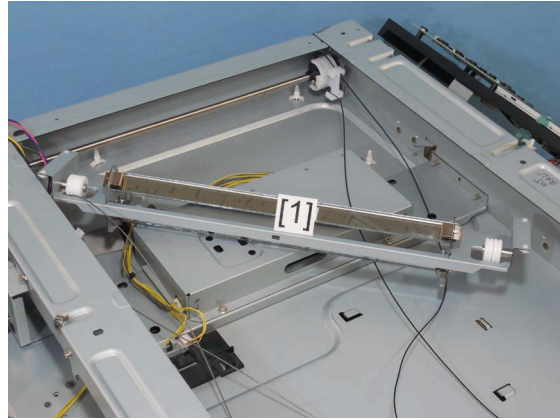


Fig. 4-84

- (6) Rotate carriage-2 [1] in the direction shown in the figure, while trying not to touch the mirror. Then remove carriage-2 [1].

**Notes:**

Replace mirror-2 and -3 together with carriage-2 [1]. Do not remove mirror-2 and -3.



**Fig. 4-85**

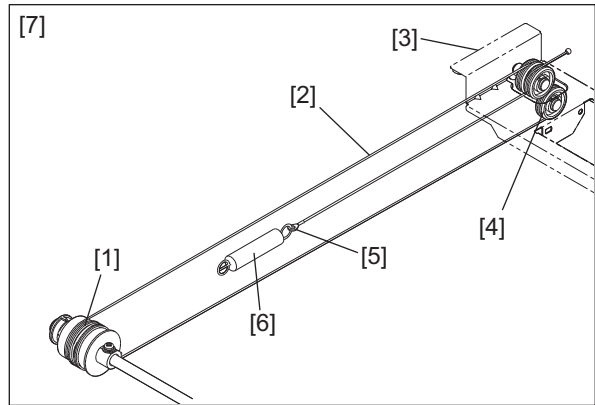
**[B] Installing the carriage wire**

- (1) As shown on the right, replace the carriage wire and install a new wire.

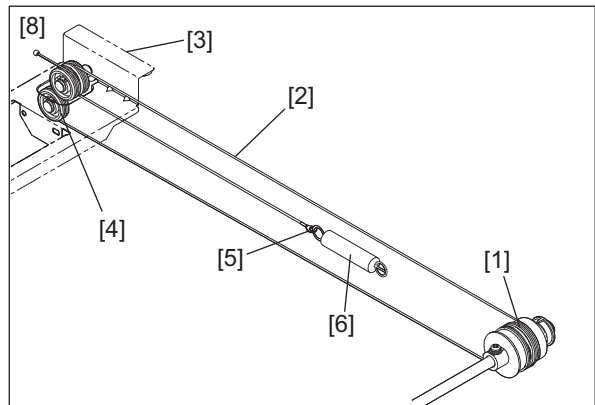
- [1] Wire pulley
- [2] Carriage wire
- [3] Carriage-2
- [4] Idler pulley
- [5] Hook
- [6] Tension spring
- [7] Front side
- [8] Rear side

**Notes:**

It is not necessary to adjust the carriage wire tension since a certain tension is applied to the carriage wires through the tension springs. Make sure the tension applied to the wire is normal.



**Fig. 4-86**



**Fig. 4-87**

### [C] Winding on the wire pulley

- (1) Pull the  $\phi 3$  ball terminal [1] located at the center of the wire into a hole on the wire pulley. One end of the wire with the hook [2] attached comes to the outside.
- (2) Wind the wires around the wire pulleys of the front side [3] and rear side [4]. The number of turns to be wound are as follows: 3 [5] toward the opposite side (outside) of the pulley boss, and 3 [6] toward the pulley boss side (inside).  
[7] Black  
[8] Silver

#### Notes:

When winding the wire onto the pulley, be sure to note the following.

- Do not twist the wire.
- Wind the wires tightly so that they are in complete contact with the surface of the pulleys.
- Each turn should be pushed against the previously wound turn so that there is no space between them.

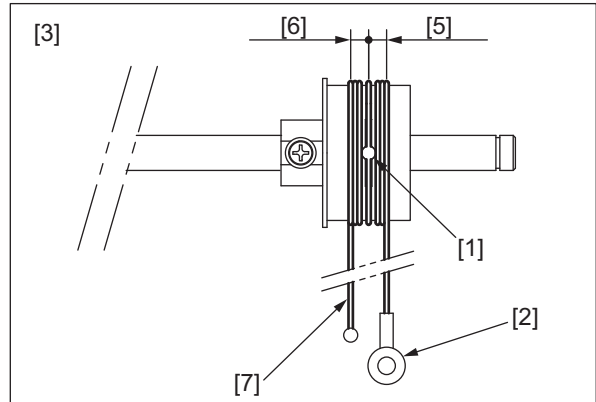


Fig. 4-88

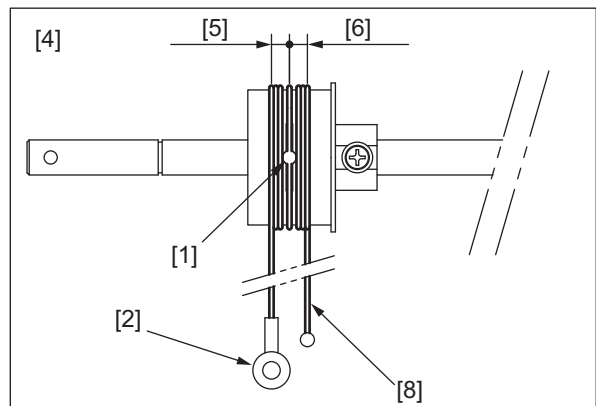


Fig. 4-89

- (3) After winding the wires around the pulleys, attach the wire holder jigs to prevent the wire from coming loose.

#### Notes:

1. When attaching the wire holder jig [1], make sure that the wire has not shifted or become loose.
2. The wire should come out of the slot of the wire holder jig [1] and be passed under the jig arm [2].
3. When installing the wire holder jig, be careful of the orientation.

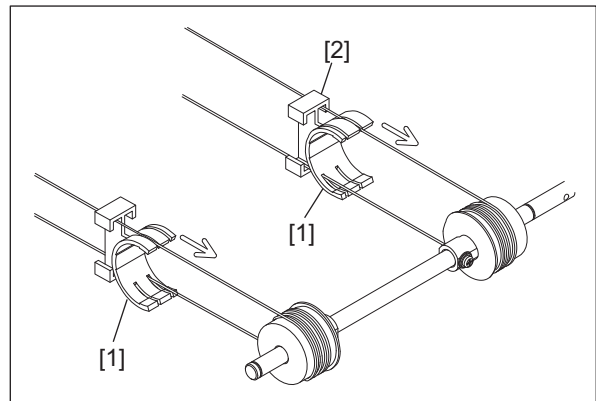




Fig. 4-90

### 4.3.12 Scanner damp heater

- (1) Remove the rear cover.  
 P. 4-6 "4.1.15 Rear cover"
- (2) Remove the original glass.  
 P. 4-19 "4.3.1 Original glass"
- (3) Disconnect 1 connector.

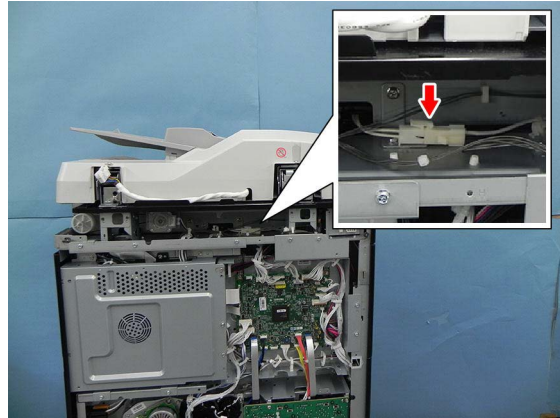


Fig. 4-91

- (4) Remove the scanner damp heater [1].

**Notes:**

- Be sure that the fasten terminal of the thermostat is connected securely.
- Be sure that the thermostat is attached to the plate.

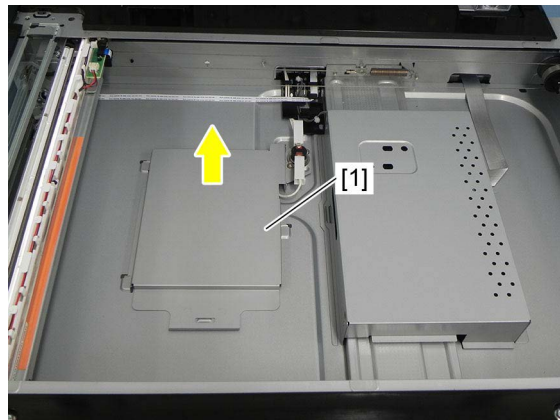


Fig. 4-92

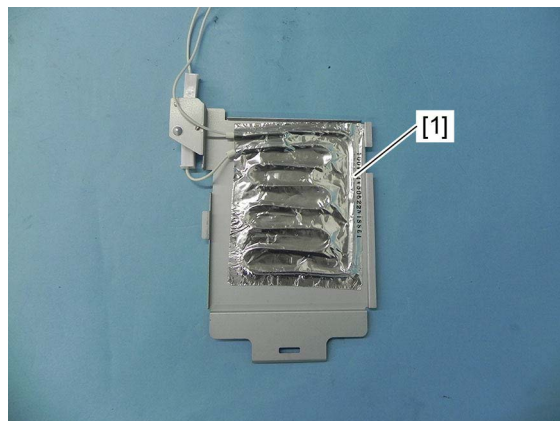


Fig. 4-93



## 4.4 Writing Section

### 4.4.1 LED Tray

- (1) Remove the cleaner unit.  
📖 P. 4-78 "4.6.10 Cleaner unit"
- (2) Remove the high-voltage transformer.  
📖 P. 9-9 "9.1.7 High-voltage transformer (HVT)"
- (3) Disconnect 5 connectors. Release the lock by tilting the flap and remove 4 flat cables [1].

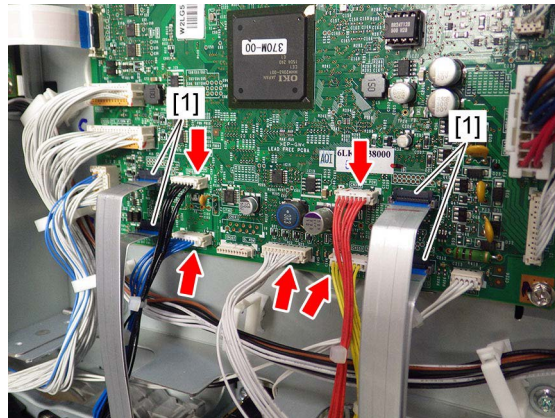


Fig. 4-94

#### Notes:

- When removing the flat cable [1], change the lever position so that the connector is released, and remove the flat cable by lifting it up slightly (approx. 7 degrees) as shown in the right figure.
- When connecting the flat cable [1] to the connector, insert the flat cable straightly and lock it securely. Confirm that the tabs are in the positions shown in the right figure.

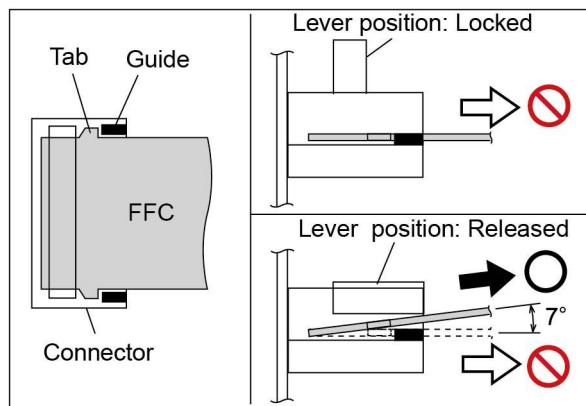


Fig. 4-95

#### Notes:

- When installing the flat cable [1], do not push it in strongly.
- When installing the flat cable [1], be careful not to insert it at an angle.
- Do not apply pressure to or damage the edge of the flat cable [1].

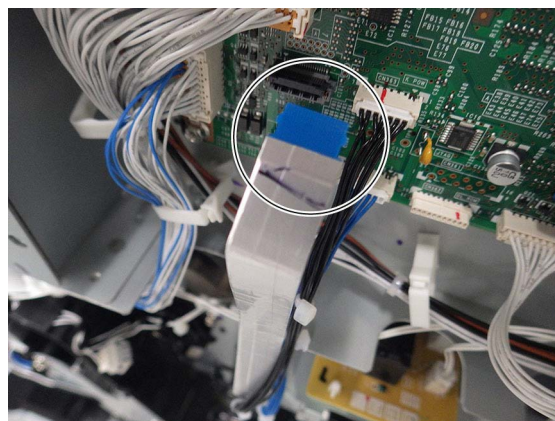


Fig. 4-96

- (4) Slide the harness guides [2] upward and tilt them to the near side.

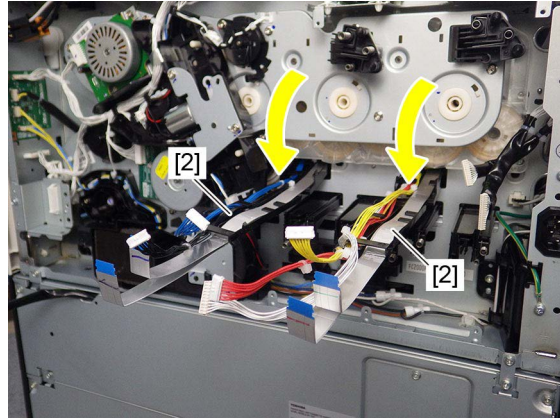


Fig. 4-97

- (5) Install the harness holding jig [3].

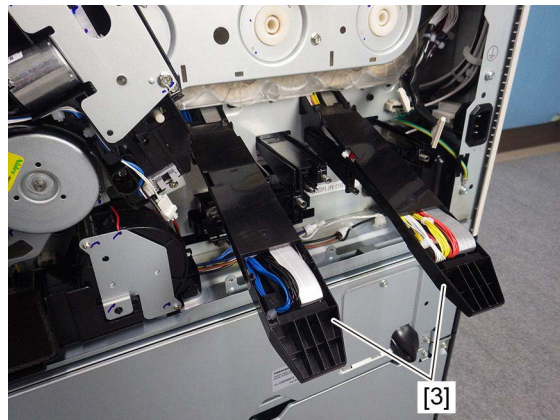


Fig. 4-98

**Notes:**

Store the connector inside the jig.

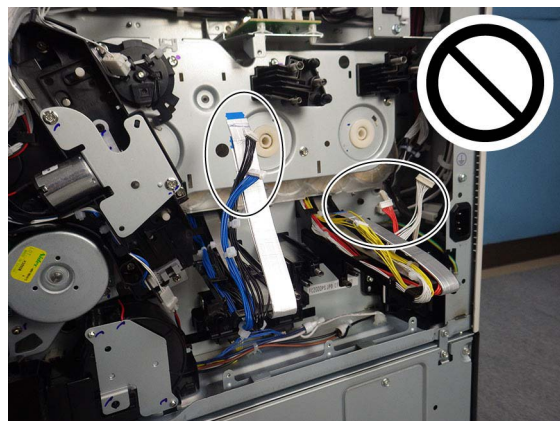


Fig. 4-99

- (6) Remove 4 screws and pull out the LED tray [4] while lifting it up by holding the levers on both sides.

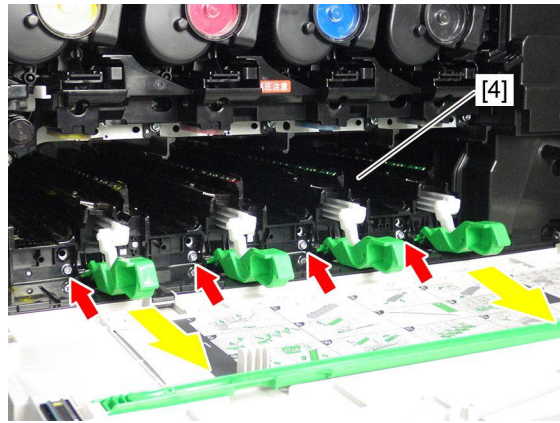


Fig. 4-100

- (7) Remove the LED tray [4] while holding both sides.

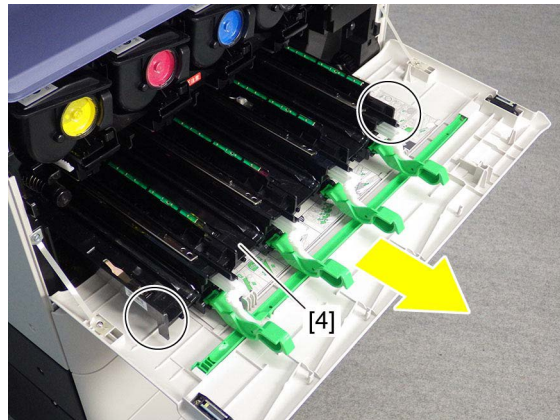


Fig. 4-101

**Notes:**

- Always hold both sides of the LED tray, and be careful not to touch the LED [5].
- Be careful not to leave any fingerprints on the lens of the LED printer head.
- The LED tray is a precision unit, so be careful when handling it so that it is not subjected to impact or vibration.
- The LED printer head is an electrical part, so be careful of static electricity when handling it. In particular, exercise great care when handling the LED printer head connector part.
- When installing the LED tray, attach the harness holding the jig and pass the harness through the hole in the frame.
- When installing the LED tray, mount the attachment screw from the left side.

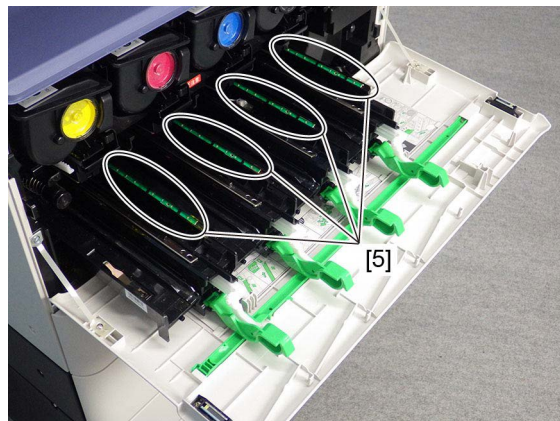



Fig. 4-102

## 4.4.2 Discharge LED

- (1) Remove the LED tray.  
 P. 4-35 "4.4.1 LED Tray"
- (2) Slide the discharge LED [1] to the front side and remove it by releasing the hook.

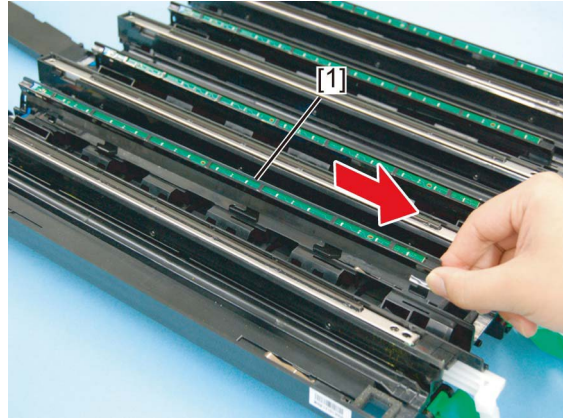


Fig. 4-103

- (3) Disconnect the 1 connector [1].

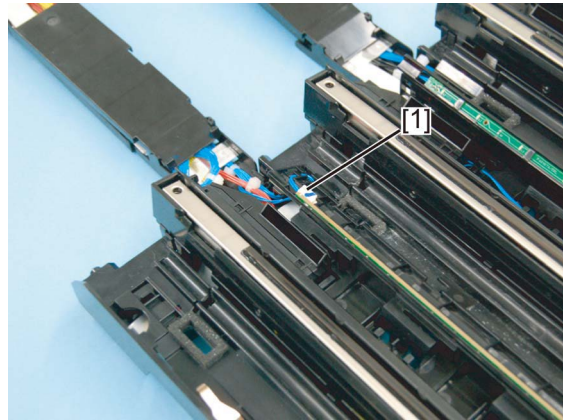


Fig. 4-104

- (4) Remove the discharge LED [1].

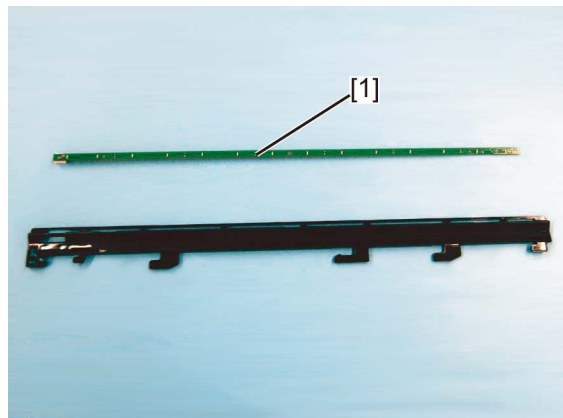


Fig. 4-105

### 4.4.3 LED printer head

**Notes:**

- The LED printer head is an electrical part, so be careful of static electricity when handling it. In particular, exercise great care when handling the LED printer head connector part.
- If you accidentally touch the LED printer head, clean it using a dry cloth to remove stains. If grease adhered to the LED printer head, clean it with alcohol.

- (1) Remove the LED tray.  
📖 P. 4-35 "4.4.1 LED Tray"
- (2) Release 2 latches and remove the harness cover [1].

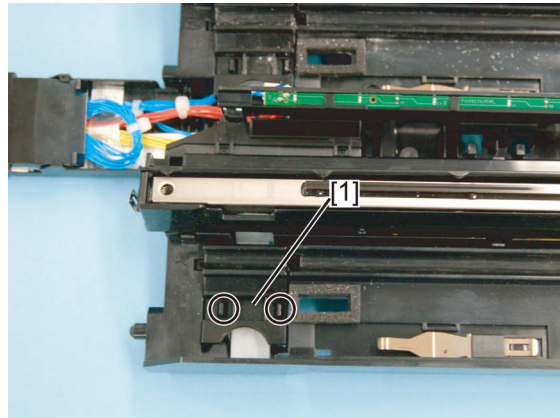


Fig. 4-106

- (3) Remove the LED printer head contact/release lever link [1] and lever [2].

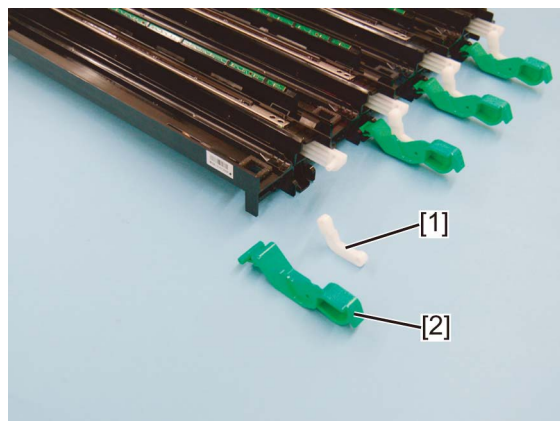


Fig. 4-107

- (4) Press the contact/release arm [1] to place the LED printer head [2] into the contact state.

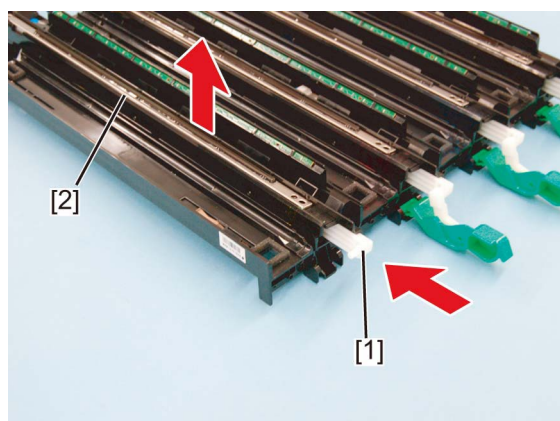


Fig. 4-108

- (5) Release 3 latches [1] on the right, and then tilt the LED printer head unit [1] toward the left side to remove it.

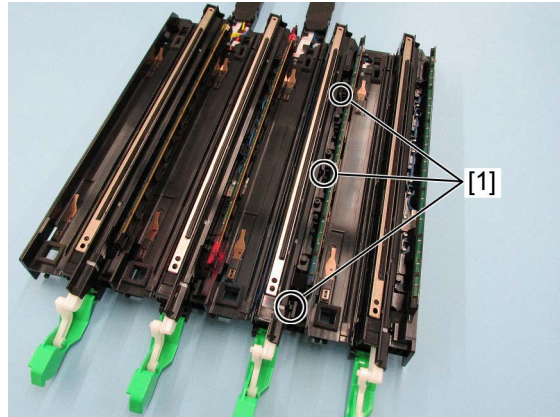


Fig. 4-109

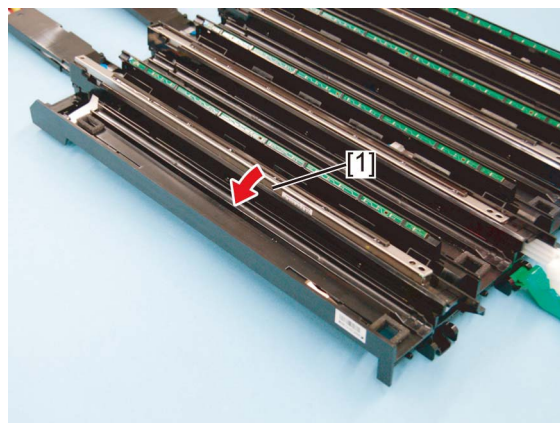


Fig. 4-110

**Notes:**

- Make sure that the plate spring [1] on the front of the LED printer head unit is placed in the groove [2].

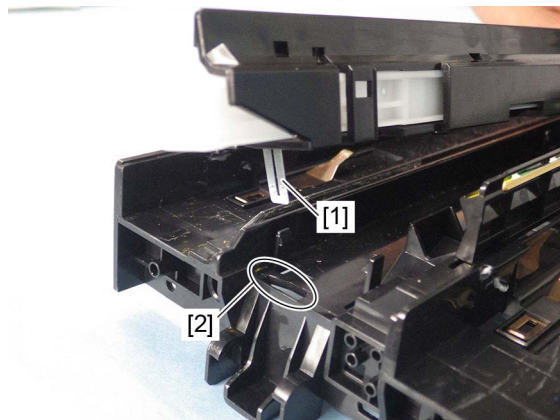


Fig. 4-111

- Before installing the LED printer head unit, pull out the contact/release arm.

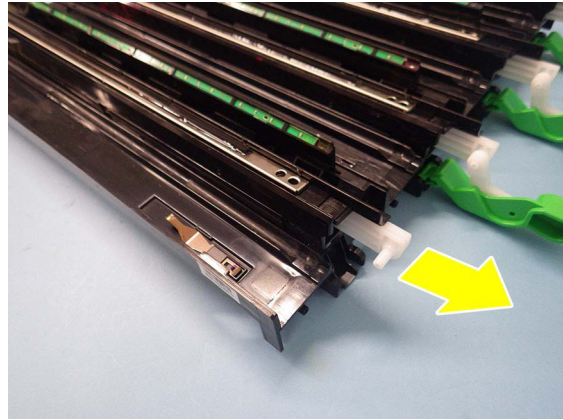


Fig. 4-112

- Before installing the LED printer head unit, mount the link alone.  
[1] LED printer head contact/release lever link  
[2] Lever

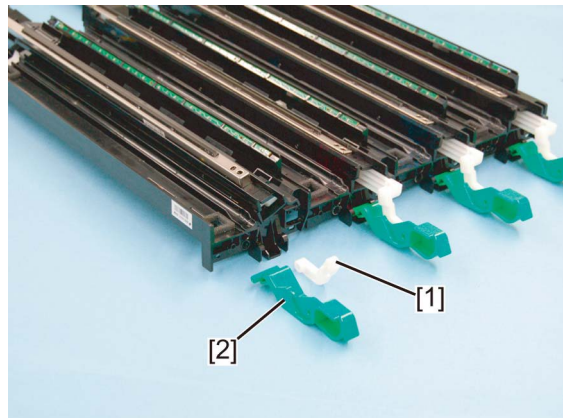


Fig. 4-113

- Make sure that the duct in the rear side is securely positioned without any clearance.



Fig. 4-114

- When installing the LED printer head unit, push both sides [1] and then the center part [2] of the head inside. Then, make sure that the head is securely installed.
- After the link has been installed, check the contact/release operations.

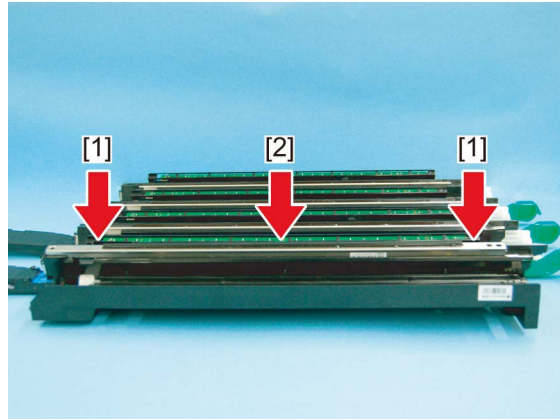


Fig. 4-115

- (6) Remove the LED printer head side cover [1].

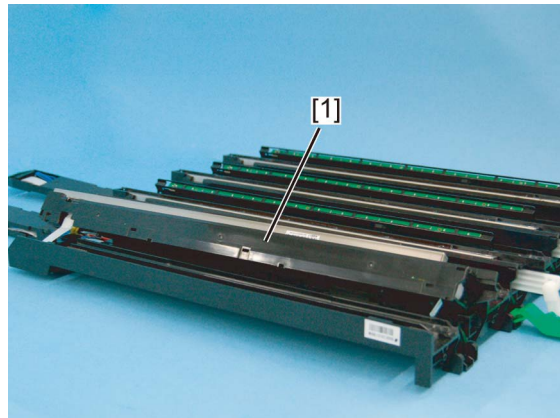


Fig. 4-116

- (7) Release the lock by tilting the flap. Remove the flat cable [1].

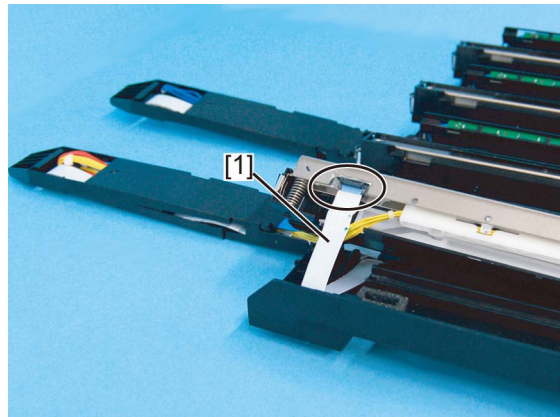


Fig. 4-117



**Notes:**

- When removing the flat cable [1], change the lever position so that the connector is released, and remove the flat cable by lifting it up slightly (approx. 7 degrees) as shown in the right figure.
- When connecting the flat cable [1] to the connector, insert the flat cable straightly and lock it securely. Confirm that the tabs are in the positions shown in the right figure.

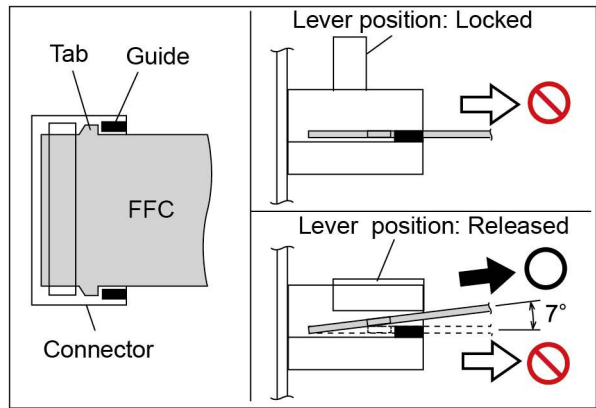


Fig. 4-118

**Notes:**

- When installing the flat cable [1], do not push it in strongly.
- When installing the flat cable [1], be careful not to insert it at an angle.
- Do not apply pressure to or damage the edge of the flat cable [1].

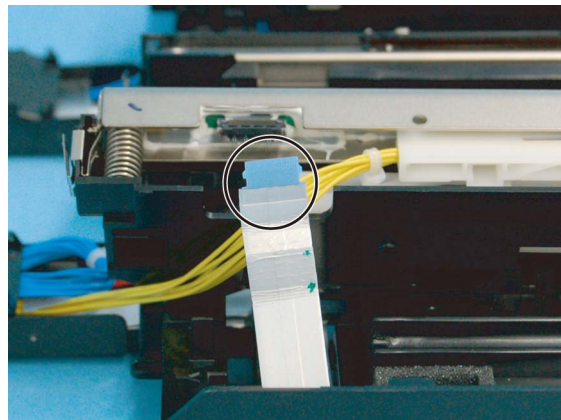


Fig. 4-119

- (8) Release 6 latches and remove the LED printer head [1].

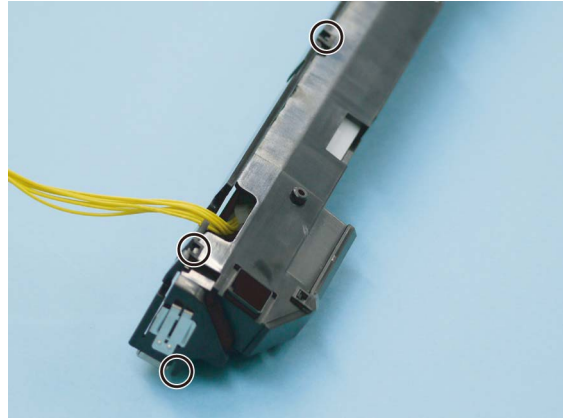


Fig. 4-120

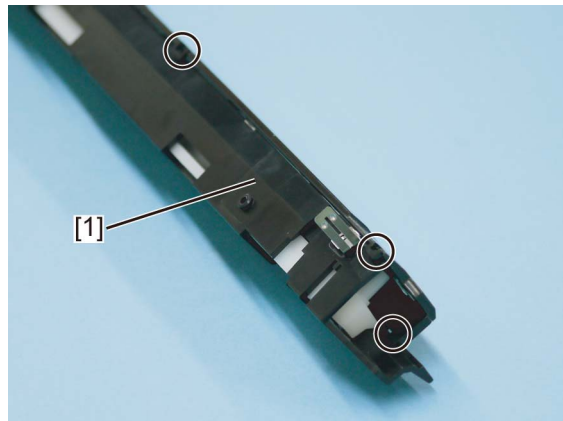


Fig. 4-121

**Notes:**

When installing the LED printer head, make sure that the flanges [1] in the front and rear sides of the LED printer head are inside the flat spring [2].

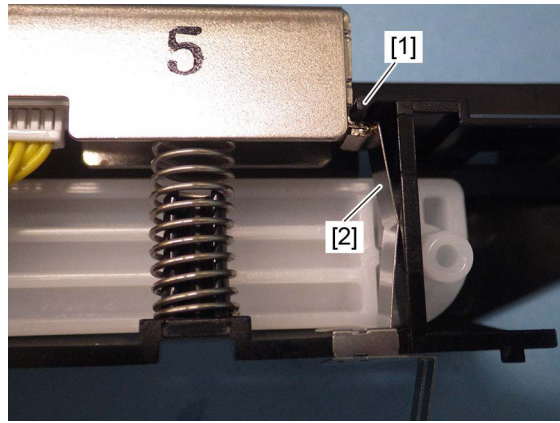


Fig. 4-122

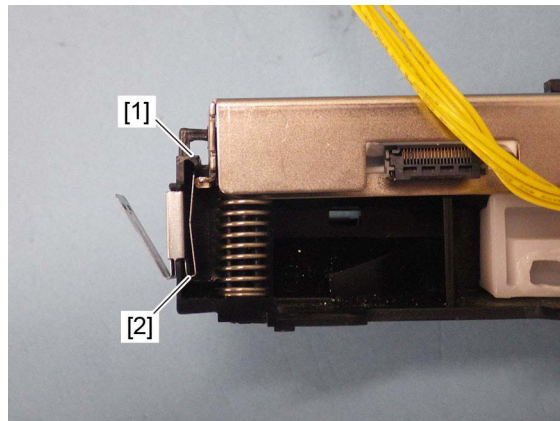


Fig. 4-123

- (9) Remove the harness holder [1], 1 connector [2], and LED printer head [3].

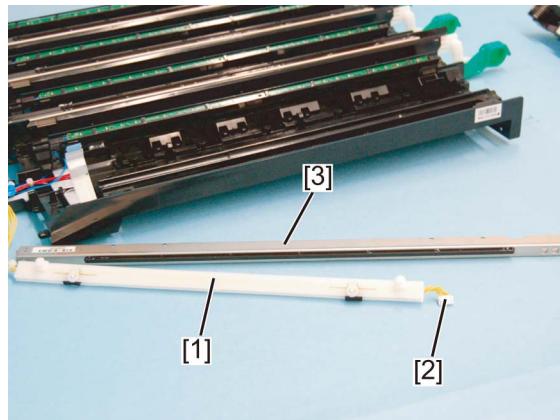



Fig. 4-124

#### 4.4.4 LED gap spacer<sup>TM</sup>

- (1) Remove the drum.  
 P. 4-81 "4.6.12 Drum and bushing"
- (2) Remove the LED gap spacer [1] in the front side and the LED gap spacer [2] in the rear side.

**Notes:**

When attaching the LED gap spacer, make sure that it is placed in the correct orientation.

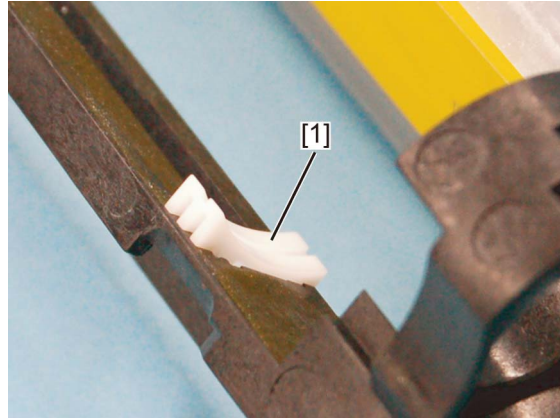


Fig. 4-125

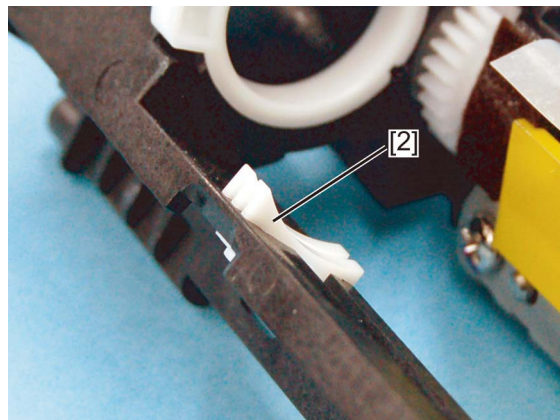


Fig. 4-126

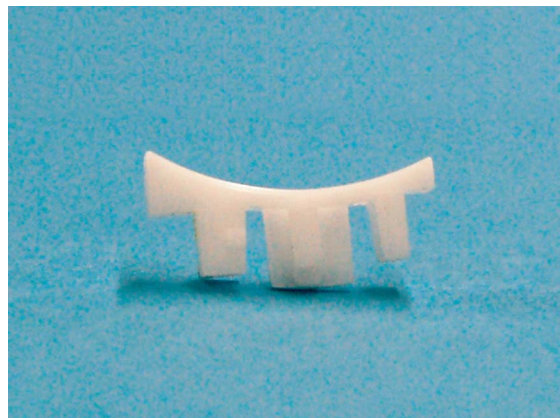


Fig. 4-127

## 4.5 Paper Feeding System

### 4.5.1 Bypass unit

- (1) Remove the right front cover.  
📖 P. 4-5 "4.1.10 Right front cover"
- (2) Remove the right rear cover.  
📖 P. 4-5 "4.1.11 Right rear cover"
- (3) Remove 4 screws and take off the stay [1].

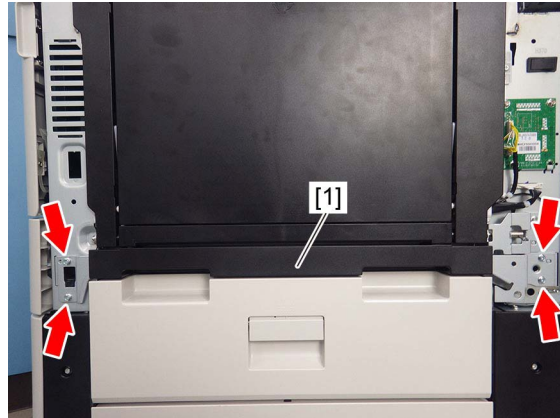


Fig. 4-128

- (4) To release the bypass unit [2], move the projection portion [3] on the front side and the rear side of the bypass unit [2] to the wider part [5] of the groove of the hinge stoppers [4].

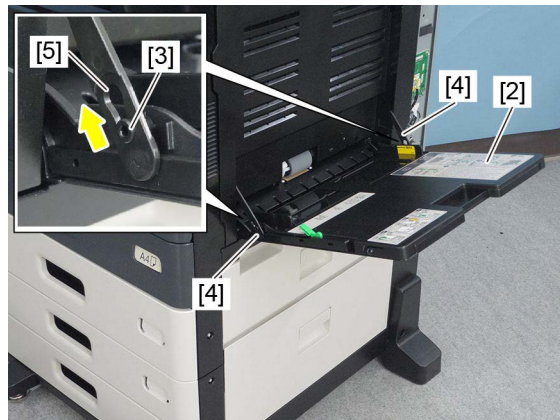


Fig. 4-129

- (5) Remove the arm [6] and paper holder release lever [7].

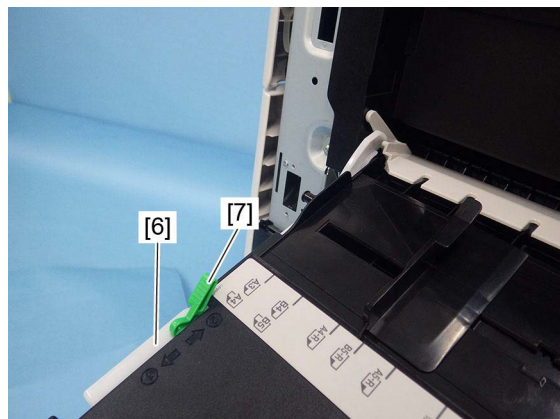


Fig. 4-130

- (6) Disconnect 1 connector and remove the bypass unit [2].

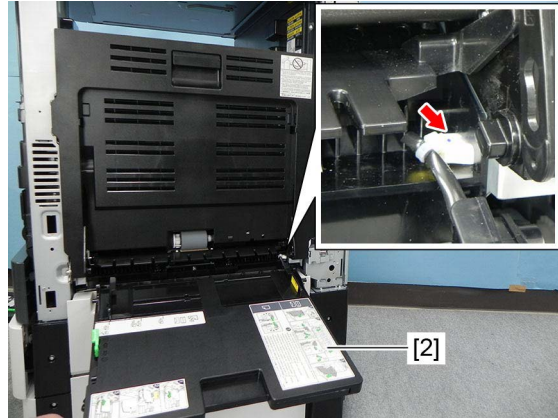


Fig. 4-131

#### 4.5.2 Bypass feed roller<sup>PM</sup>

- (1) Open the bypass tray.
- (2) Tip the paper holder release lever [1] outward to release the pressure.

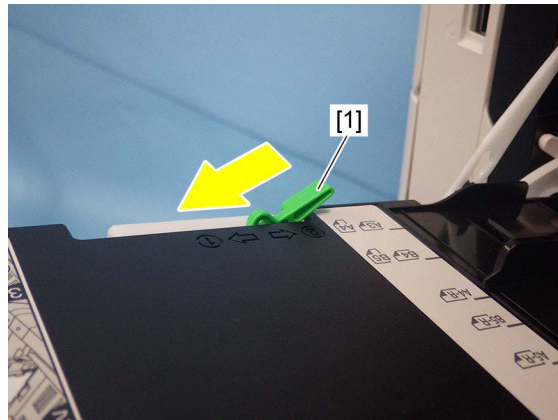


Fig. 4-132

- (3) Remove the stopper [2] while pulling out it.

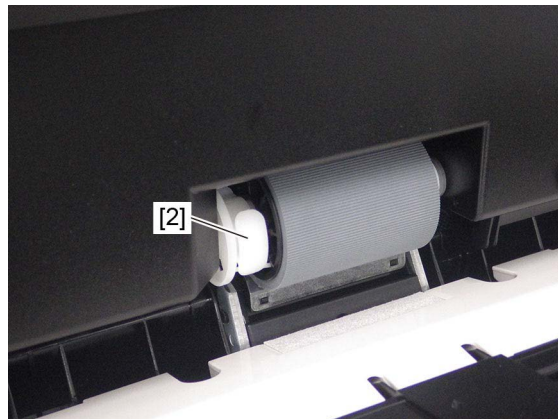


Fig. 4-133

- (4) Press the collar [3] toward the rear side and release the lock.

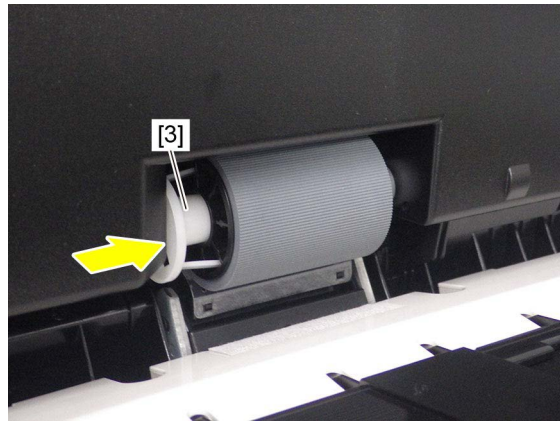


Fig. 4-134

- (5) Remove the bypass feed roller [4] while pulling out it.

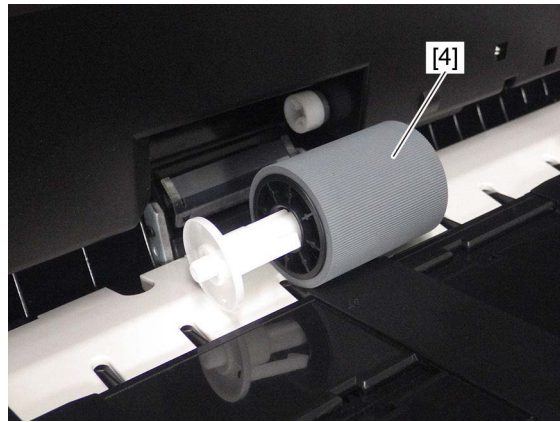


Fig. 4-135

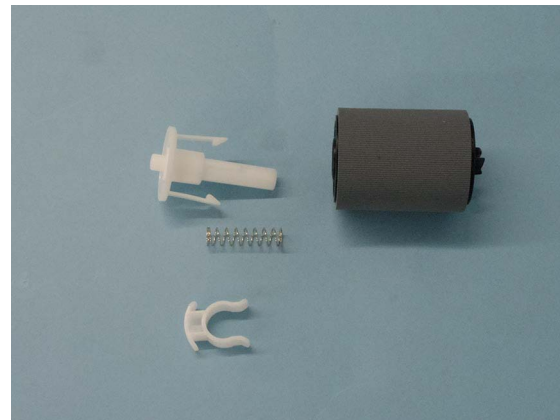
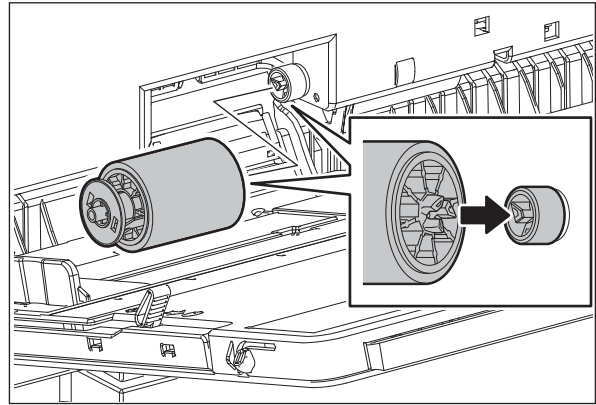


Fig. 4-136

**Notes:**

When installing the bypass feed roller, fit the convex portion on the roller with the concave portion on the equipment.



**Fig. 4-137**



### 4.5.3 Bypass separation roller<sup>PM</sup>

- (1) Remove the bypass feed roller.  
📖 P. 4-48 "4.5.2 Bypass feed roller"
- (2) Lift the bypass separation roller [1] to remove it.

**Notes:**

- When installing/removing, do not twist the film.
- Handle the bypass separation roller with care so that no dirt, oils or stains adhere.
- Be careful not to drop the parts inside the equipment.



Fig. 4-138



Fig. 4-139



Fig. 4-140

**Notes:**

When replacing the parts or performing machine refreshment, apply 1 rice-sized grain of white grease (Molykote HP-300) to the bushings [2] of the bypass separation roller.

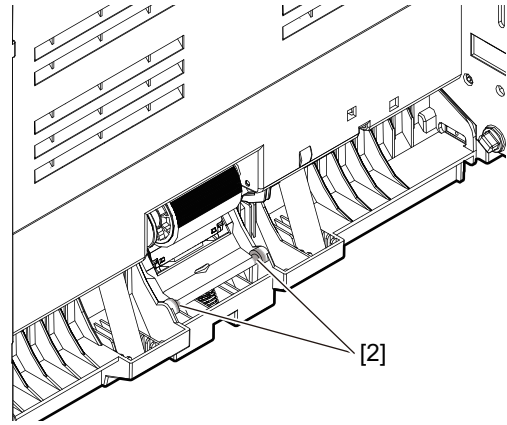



Fig. 4-141

#### 4.5.4 Paper width detection PC board (S17)

- (1) Take off the paper width detection PC board cover.  
 P. 4-47 "4.5.1 Bypass unit"
- (2) Disconnect 1 connector and remove the paper width detection PC board [1].

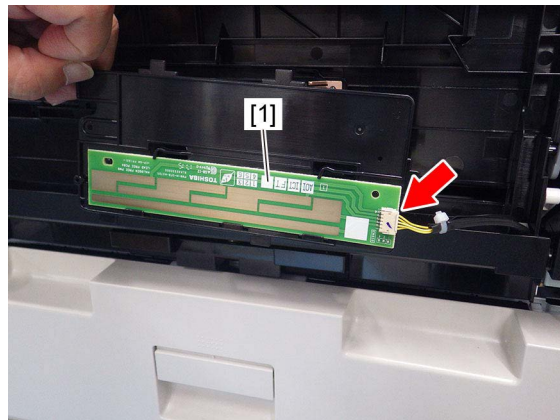



Fig. 4-142

#### 4.5.5 Bypass feed sensor (S16)

- (1) Remove the transport unit.  
 P. 4-164 "4.10.3 Transport unit"
- (2) Remove the stopper [1].

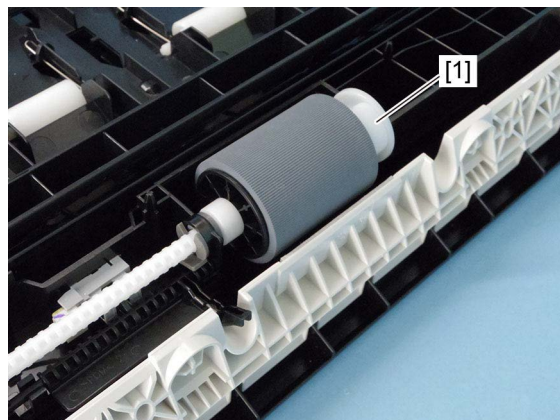


Fig. 4-143

- (3) Press the collar [2] toward the rear side and release the lock.
- (4) Remove the bypass feed roller [3] while pulling out it.

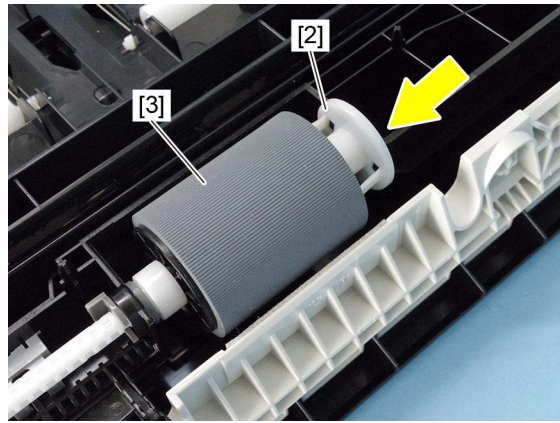


Fig. 4-144

- (5) Remove the clip [4]. Remove the shaft [5] by sliding it toward the front side. Remove the collar [2].

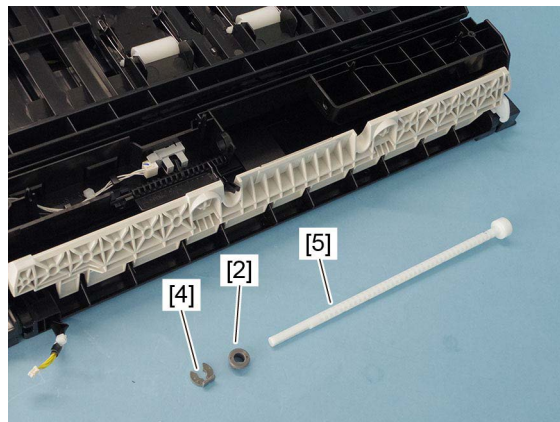


Fig. 4-145

- (6) Release the harness from the harness guide, and disconnect 1 connector [6]. Remove the bypass feed sensor [7] and sensor arm [8].

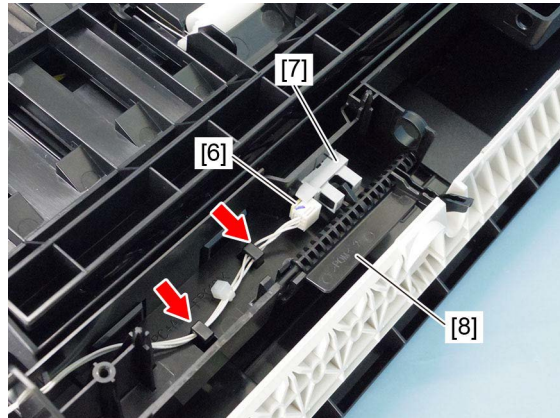


Fig. 4-146

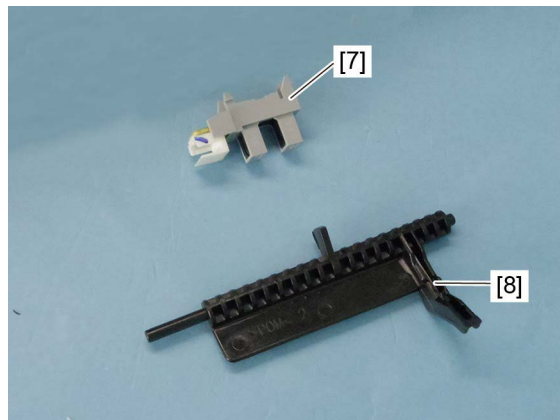


Fig. 4-147

#### 4.5.6 Side cover switch (SW5)

- (1) Open the side cover.  
(2) Release 2 hooks and pull out the side cover switch [1]. Disconnect 1 connector and remove the side cover switch [1].

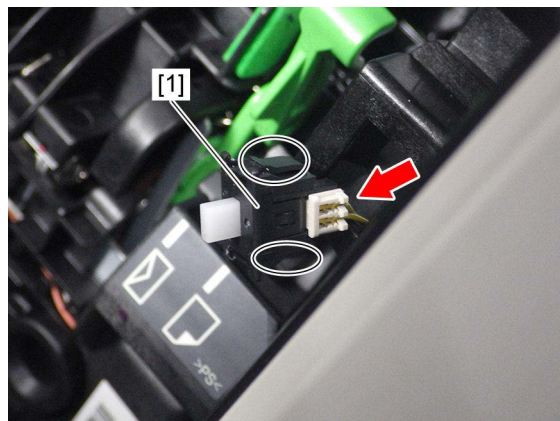


Fig. 4-148

## 4.5.7 Registration sensor (S19), feed sensor (S20)

- (1) Remove the registration roller.  
📖 P. 4-57 "4.5.8 Registration roller (on the equipment side)"
- (2) Remove the automatic duplexing unit (ADU).  
📖 P. 4-161 "4.10.1 Automatic duplexing unit (ADU)"
- (3) Disconnect 1 connector from the CFD board.

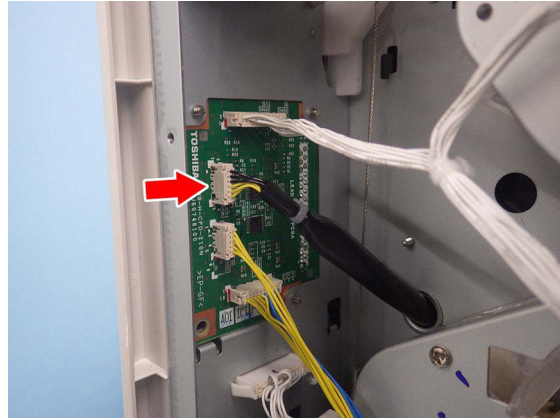


Fig. 4-149

- (4) Remove the harness from the guide.

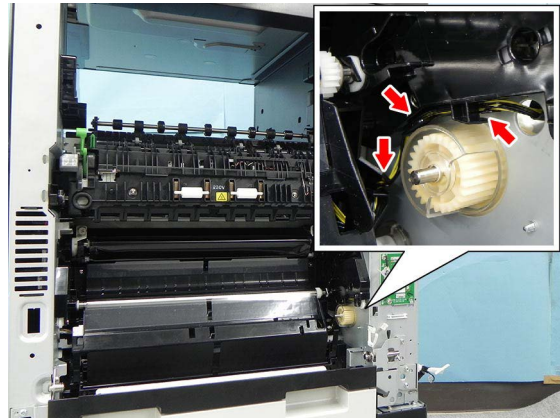


Fig. 4-150

- (5) Remove 1 screw.

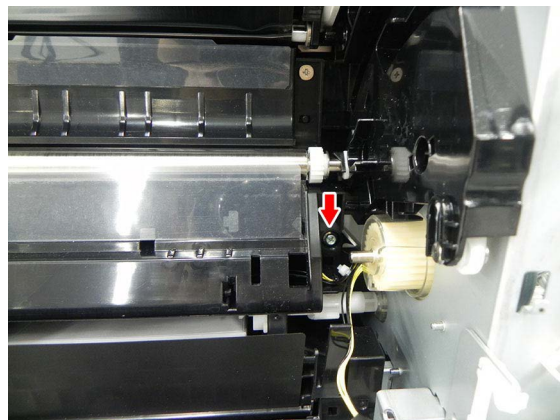


Fig. 4-151

- (6) Push the hook [1] and remove the paper guide [2] by sliding it toward the front side.

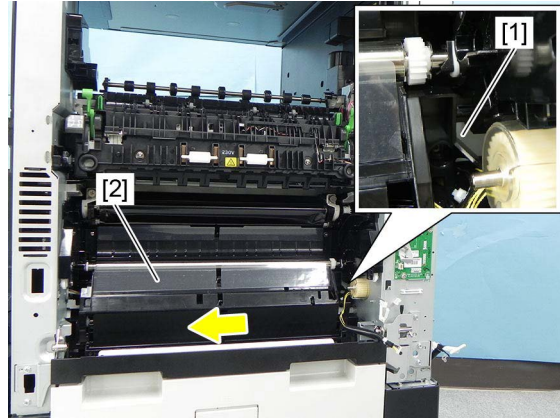


Fig. 4-152

- (7) Release 2 latches and remove the sensor bracket [3].

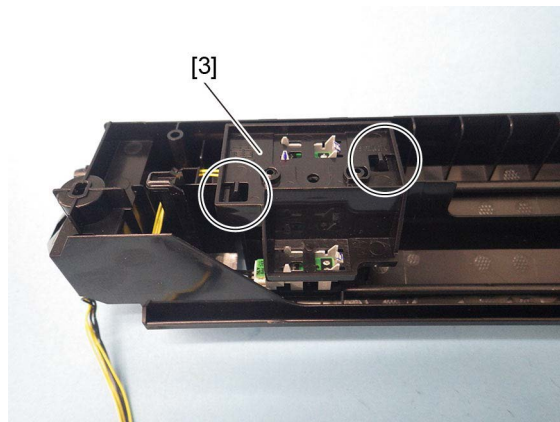


Fig. 4-153

- (8) Release each 3 latch and remove the feed sensor [4] and registration sensor [5].

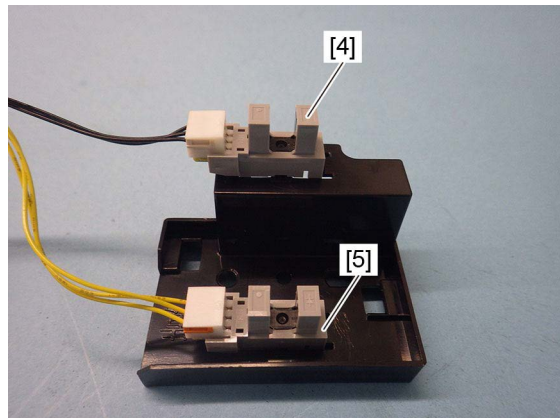


Fig. 4-154

## 4.5.8 Registration roller (on the equipment side)

- (1) Remove the rear cover.  
📖 P. 4-6 "4.1.15 Rear cover"
- (2) Remove the registration clutch.  
📖 P. 4-63 "4.5.15 Registration clutch (CLT1)"
- (3) Open the side cover.
- (4) Remove the clip [1]. Slide the shaft toward the rear side and remove the front shaft, and then take off the registration roller shaft [2].

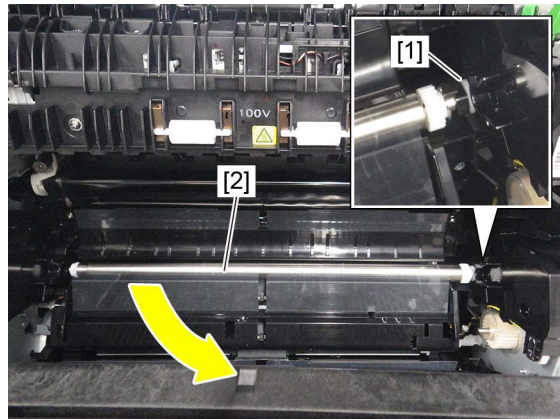


Fig. 4-155

- (5) Remove the 2 bushings [3], E-ring [4], gear [5] and pin [6].

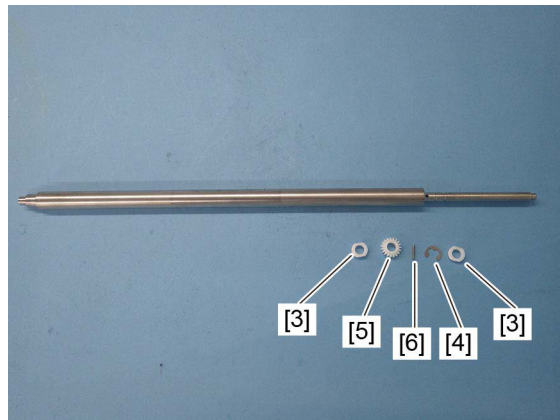


Fig. 4-156

## 4.5.9 Registration roller (on the ADU side)

- (1) Remove the 2nd transfer roller unit (TRU).  
📖 P. 4-126 "4.7.9 2nd transfer roller unit (TRU)"
- (2) Remove 1 screw. While compressing the spring, slide the holder [1] in the direction indicated by the arrow to align it with the notch [2]. Then take off the holder [1] and the spring.

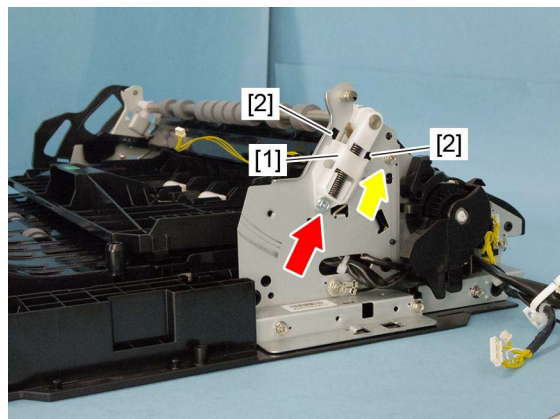


Fig. 4-157

- (3) Remove 1 screw. While compressing the spring, slide the holder [3] in the direction indicated by the arrow to align it with the notch [4]. Then take off the holder [3] and the spring.

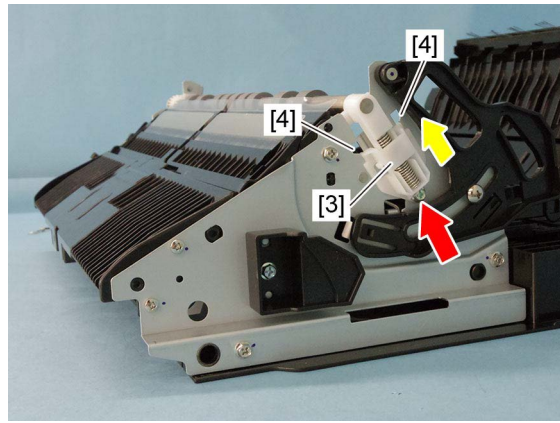


Fig. 4-158

- (4) Remove the holder, bushing, gear, and leaf spring.

**Notes:**

When assembling, attach the black spring on the rear side and silver spring on the front side.



Fig. 4-159

**Notes:**

Install the gear, bushing, and leaf spring in the orientation shown in the figure.

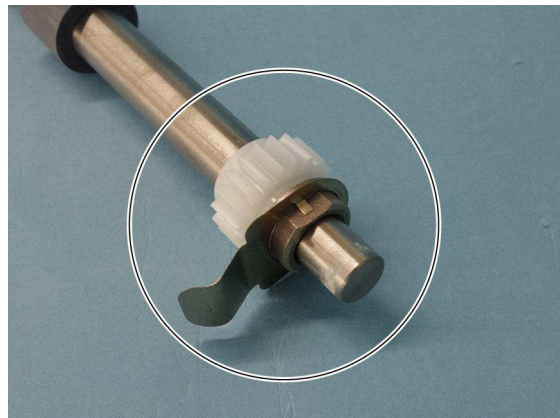


Fig. 4-160



#### 4.5.10 Drawer feed roller

- (1) Remove the drawer.
- (2) Release the hook and remove the roller shaft [2] by sliding 2 collars [1] toward each other.

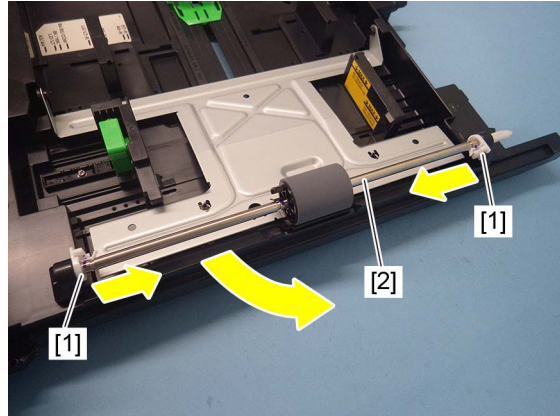


Fig. 4-161

- (3) Remove 2 collars [1] and the paper feed roller [3].

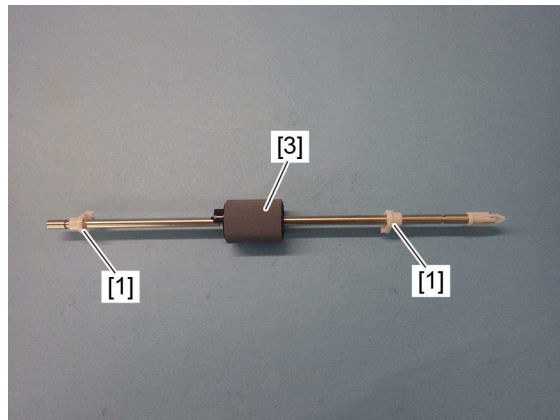



Fig. 4-162



Fig. 4-163

## 4.5.11 Drawer separation pad

- (1) Remove the drawer feed roller.  
 P. 4-59 "4.5.10 Drawer feed roller"
- (2) Place the drawer face down and remove 2 latches [1] at the bottom.

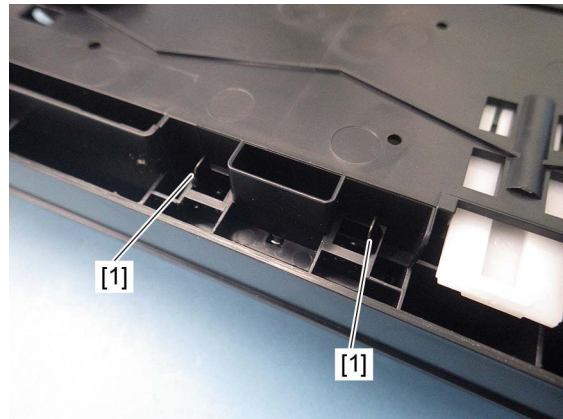


Fig. 4-164

- (3) Remove the drawer separation pad [2].

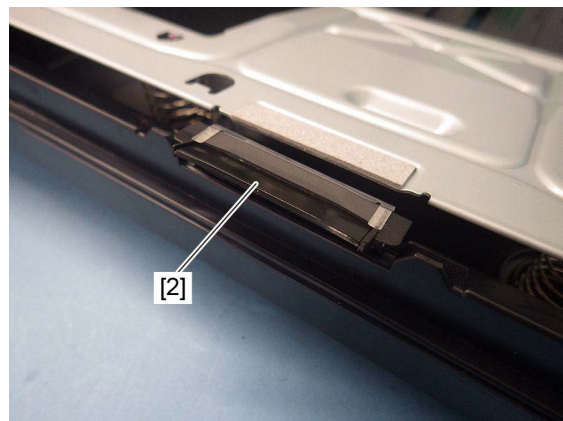


Fig. 4-165



Fig. 4-166

#### 4.5.12 1st drawer empty sensor (S5)

- (1) Remove the paper guide.  
📖 P. 4-55 "4.5.7 Registration sensor (S19), feed sensor (S20)"
- (2) Remove 1 screw and disconnect the connector [1], and then take off the 1st drawer empty sensor holder [2].

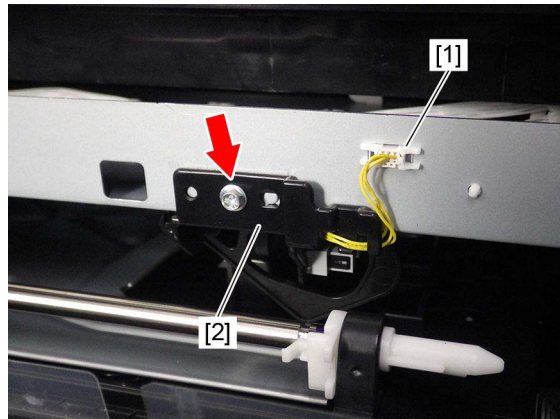


Fig. 4-167

- (3) Disconnect the connector and release 3 latches, and then remove the empty sensor [3].

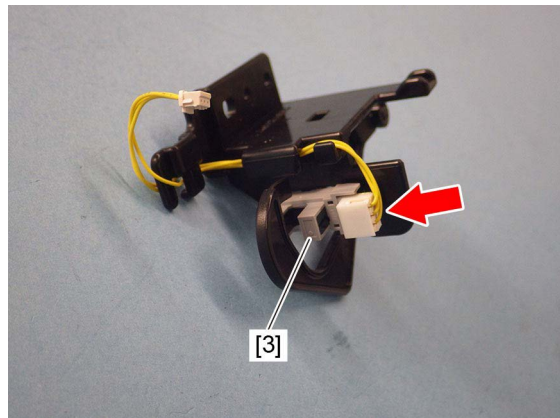


Fig. 4-168

#### 4.5.13 1st drawer size detection switch-1, -2 (SW6, SW7)

- (1) Pull out the drawer.
- (2) Remove the HVT board.  
📖 P. 9-9 "9.1.7 High-voltage transformer (HVT)"
- (3) Remove the spring and take off the switch bracket [1].

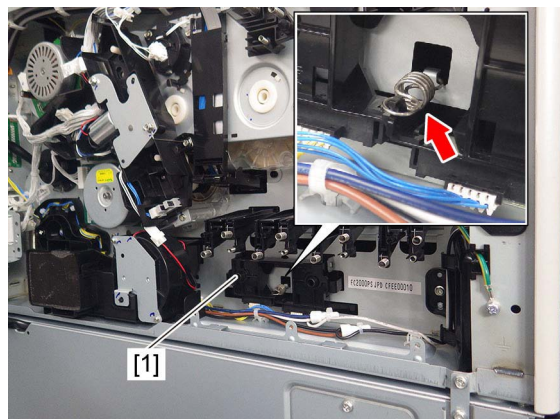


Fig. 4-169

- (4) Disconnect 2 connectors from the switch bracket [1].

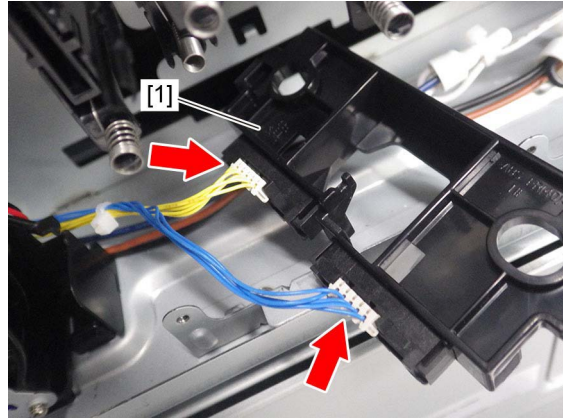


Fig. 4-170

- (5) Release 2 latches and remove the 1st drawer size detection switch-1 [2] and -2 [3].

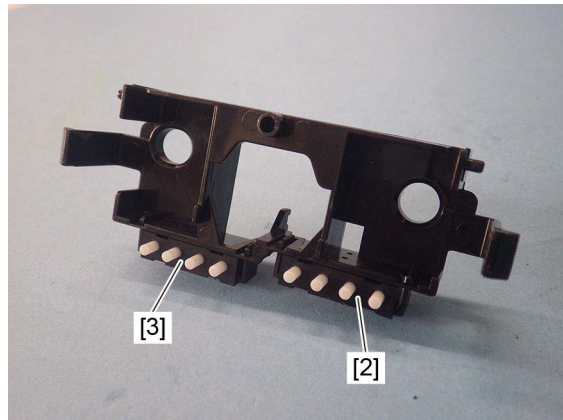


Fig. 4-171

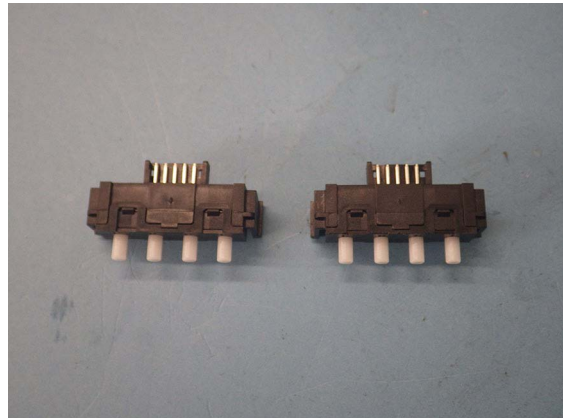


Fig. 4-172

#### 4.5.14 1st drawer detection switch (SW8)

- (1) Remove the ozone exhaust fan.  
📖 P. 4-106 "4.6.32 Ozone exhaust fan (F2)"
- (2) Disconnect the connector and remove the 1st drawer detection switch [1].

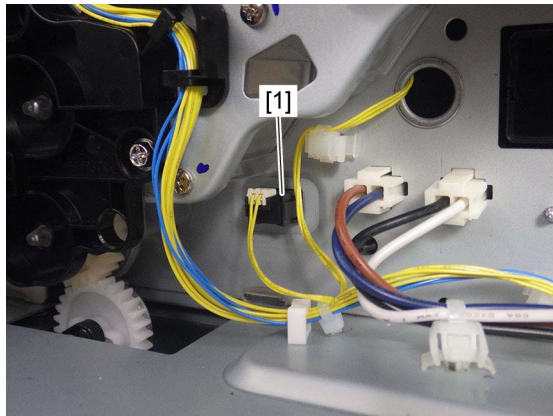


Fig. 4-173

#### 4.5.15 Registration clutch (CLT1)

- (1) Remove the rear cover.  
📖 P. 4-6 "4.1.15 Rear cover"
- (2) Remove 1 screw and release 2 latches [1] of the hook. Then, remove the registration clutch cover [2].

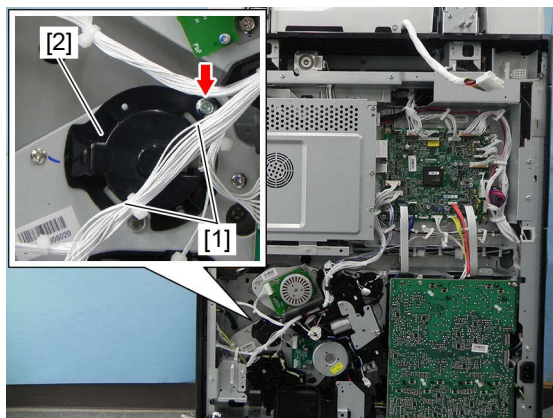


Fig. 4-174

- (3) Disconnect 1 connector and remove the registration clutch [3].

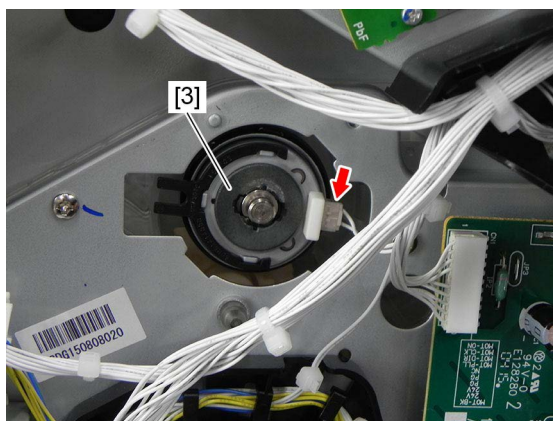


Fig. 4-175

**Notes:**

When installing the registration clutch, align the clutch stopper with the frame projection.

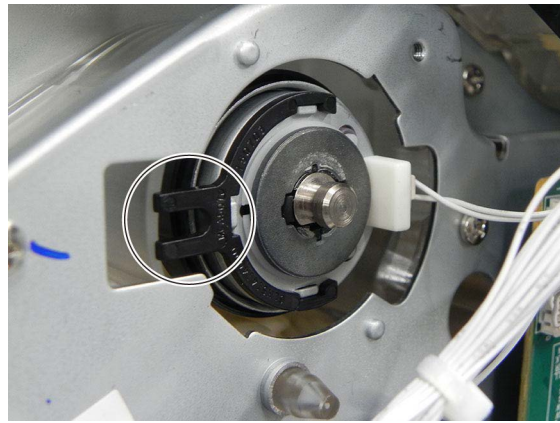


Fig. 4-176

### 4.5.16 Feed clutch (CLT2)

- (1) Remove the paper feeding/developer drive unit.  
P. 4-100 "4.6.27 Paper feeding/developer drive unit"
- (2) Remove 2 screws and then take off the feed clutch cover [1].

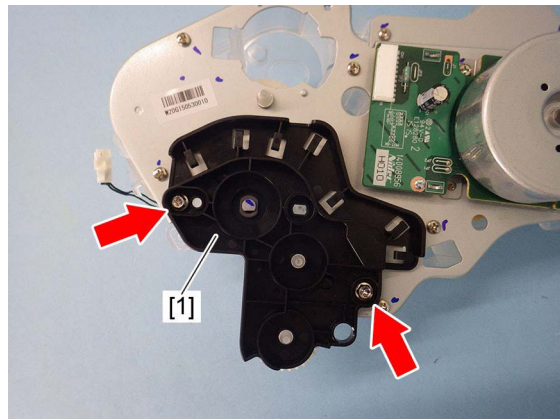


Fig. 4-177

- (3) Remove 2 gears [2] and bushings [3], and then take off the feed clutch [4].

**Notes:**

When installing the clutch, attach a rotation stopper.

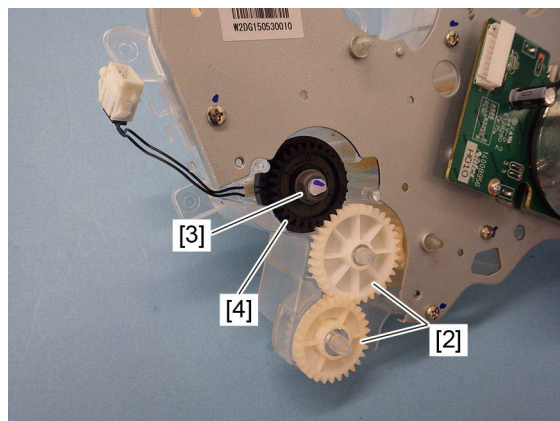


Fig. 4-178

## 4.5.17 Paper feed drive gear

- (1) Remove the paper feeding/developer drive unit.  
P. 4-100 "4.6.27 Paper feeding/developer drive unit"
- (2) Remove the paper feed development motor [1].  
P. 4-100 "4.6.26 Paper feeding/developer unit drive motor (M2)"

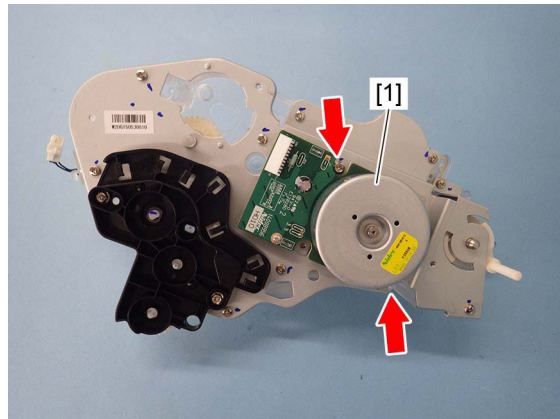


Fig. 4-179

- (3) Remove 2 screws and take off the spring.

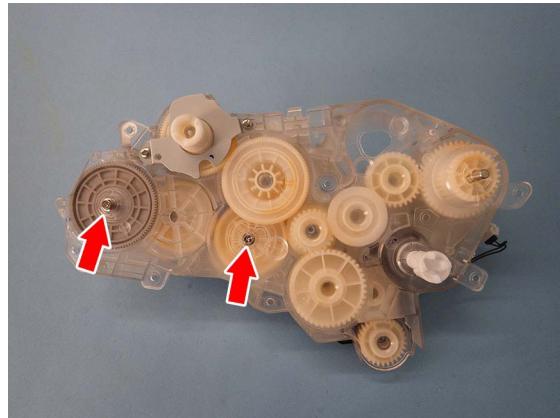


Fig. 4-180

- (4) Remove 9 screws and take off the paper feed drive gear cover [2].

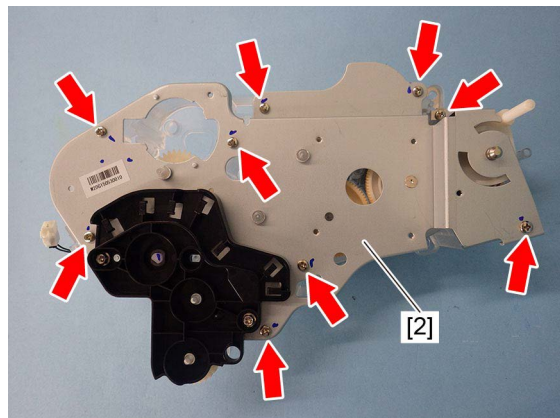


Fig. 4-181

(5) Remove the paper feed drive gear.

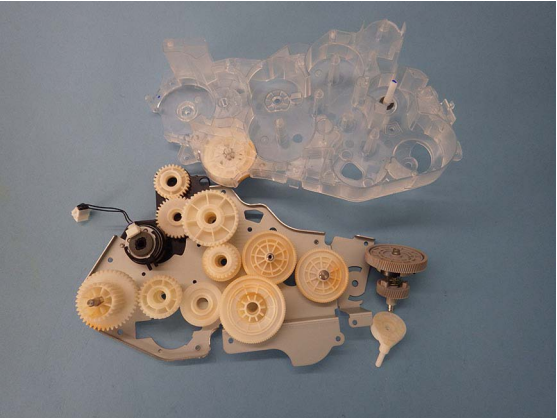


Fig. 4-182



## 4.6 Developer Unit, Cleaner

### 4.6.1 Waste toner box

- (1) Open the front cover.
- (2) Press down 2 hooks and remove the waste toner box [1].



Fig. 4-183

**Notes:**

Put the waste toner box level.

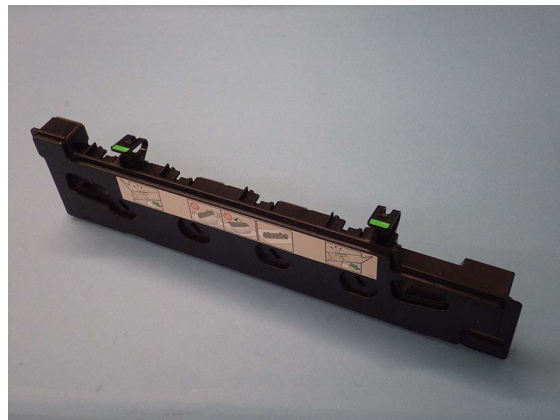


Fig. 4-184

**Notes:**

Do not tilt the waste toner box.

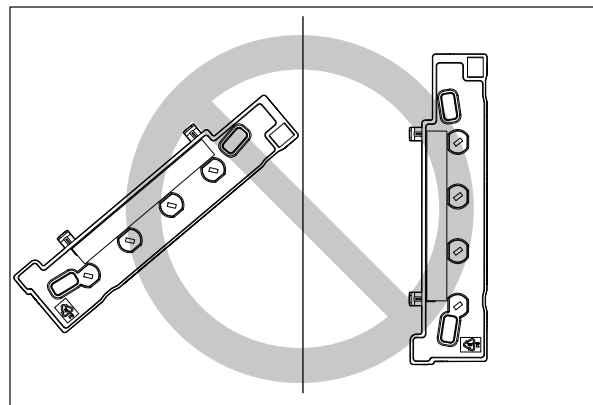



Fig. 4-185

## 4.6.2 Developer unit

- (1) Remove the waste toner box.  
 P. 4-67 "4.6.1 Waste toner box"
- (2) Press down the lever [1]. Put your finger into the knob [3] and pull the knob toward the front while pressing down the developer unit cover lever [2]. Then remove the developer unit [4] carefully.

**Notes:**

If the lid of the developer unit is not closed while you take out the unit, close it by hand. Toner may spill from the developer unit if it is tilted with the lid open.

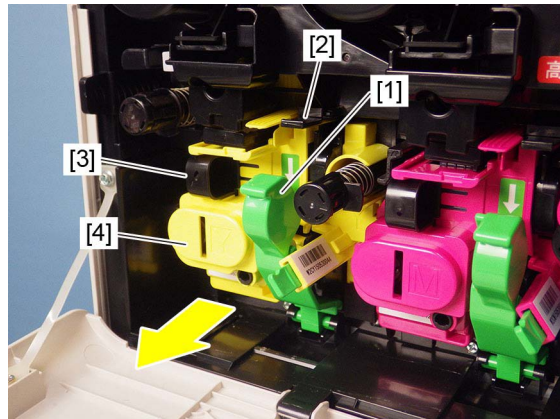


Fig. 4-186

**Notes:**

Do not peel off the film [1] on the upper part of the developer unit.

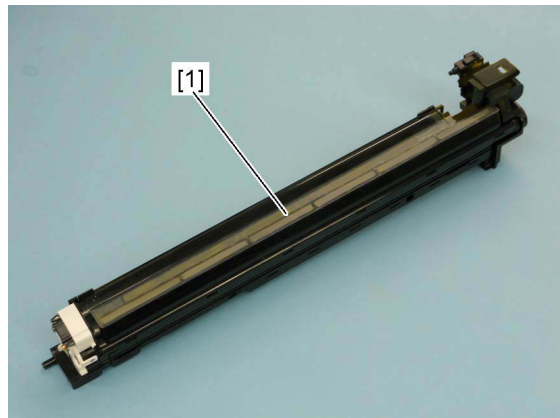


Fig. 4-187

**Notes:**

- When installing the developer unit, insert it carefully keeping it horizontal.
- If it is tilted (especially if its leading edge is upward), the upper part of the unit will catch the edge of the transfer belt. Pushing it will damage the belt.

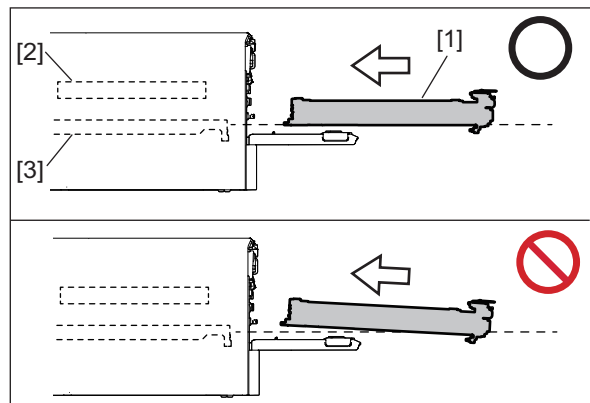


Fig. 4-188

### 4.6.3 Developer material

#### [A] Removing developer material

- (1) Remove the developer unit.  
☞ P. 4-68 "4.6.2 Developer unit"
- (2) Push the hook and take off the knob [1] by sliding it to the right.

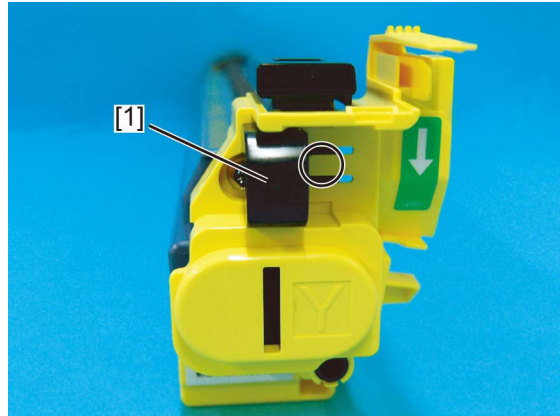


Fig. 4-189

- (3) Remove 1 screw.
- (4) Release the 1 hook [1], and remove the developer unit cover [2].

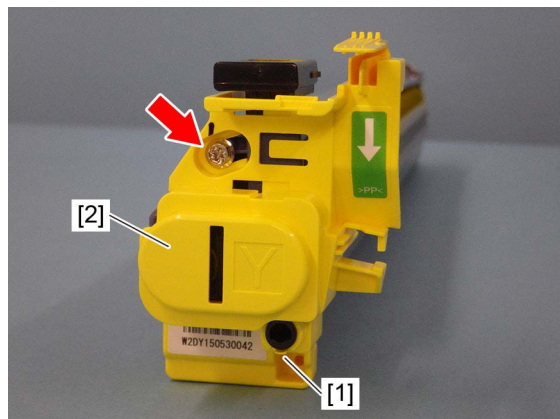


Fig. 4-190

- (5) Lift the latch [1] on the front side of the upper cover and release the latch [2] from the developer case and developer sleeve shaft.

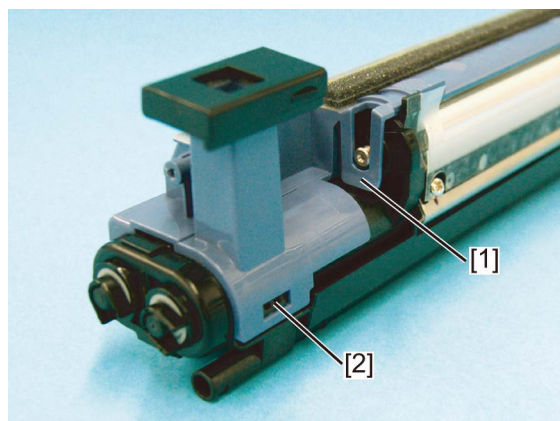


Fig. 4-191

- (6) Release 6 latches at the side of the upper cover.



Fig. 4-192

- (7) Release the 2 latches in the rear side of the upper cover.

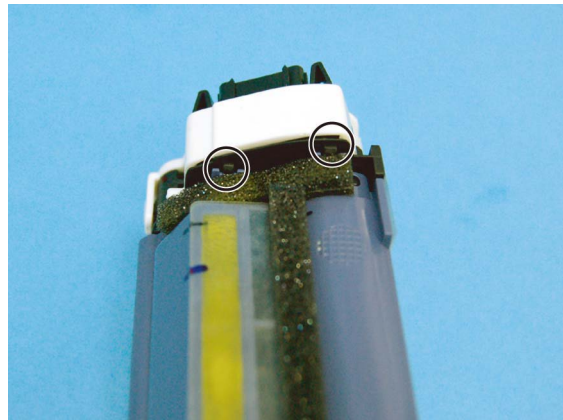


Fig. 4-193

- (8) Remove the upper cover [1].

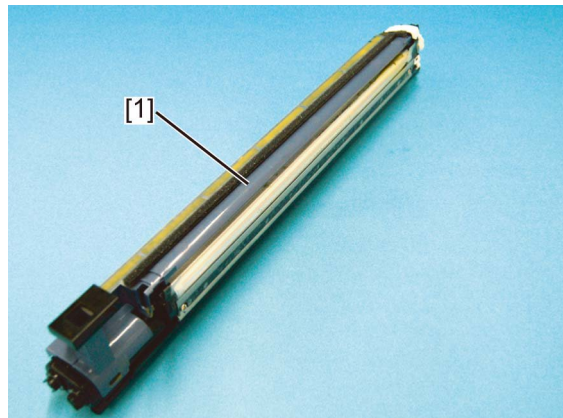


Fig. 4-194

(9) Discharge the developer material.

**Notes:**

- Make sure not to have developer material adhering to the drive gears or bushings.
- If the developer material on the developer sleeve is hard to come off, use a brush (jig) to clean it off.  
4407915710 BRUSH-33

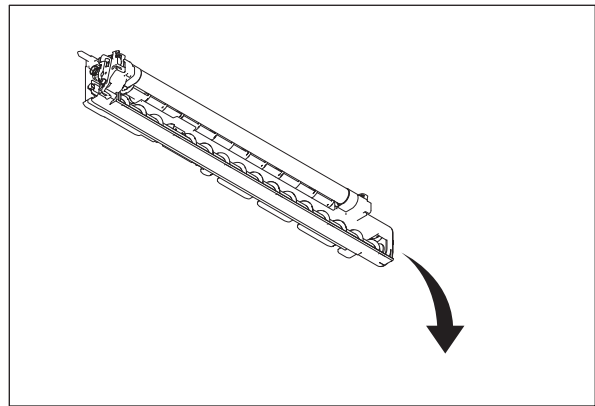


Fig. 4-195

**[B] Filling developer unit with developer material**

- (1) Shake the developer material bag and open it.
- (2) Pour in the developer until the mixer [1] under the developer sleeve is full.

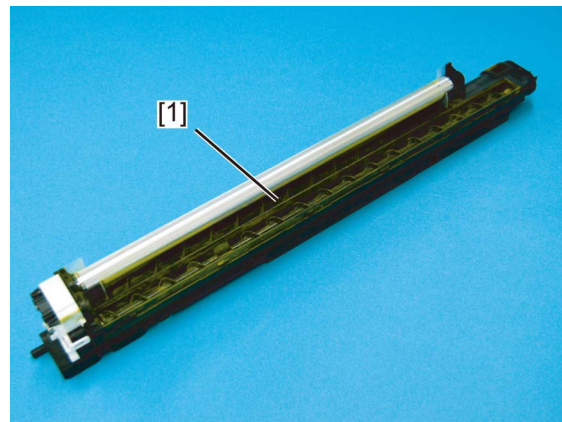


Fig. 4-196

- (3) Turn the knob [1] in the direction of the arrow shown on the cover until the developer material is evenly adhered to the surface of the developer sleeve.

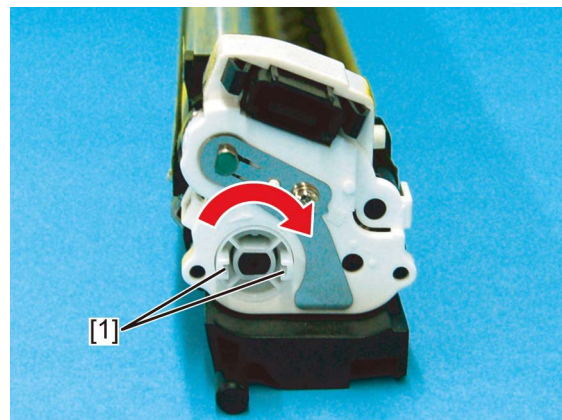


Fig. 4-197

- (4) Lift the rear side of the developer unit up and move the developer material to the front side of the mixer under the developer sleeve.



Fig. 4-198

- (5) Pour in more developer until the mixer [1] under the developer sleeve is full.

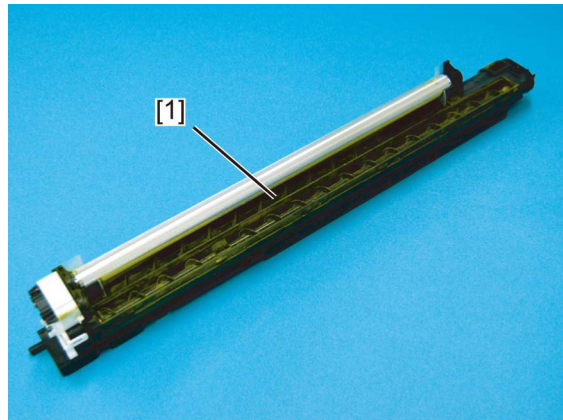


Fig. 4-199

- (6) Pour all the remaining developer material into another mixer [1].

**Notes:**

- Fill the developer material in the mixer section under the developer sleeve as much as possible.
- Check if the developer does not adhere to the joint of the upper cover.

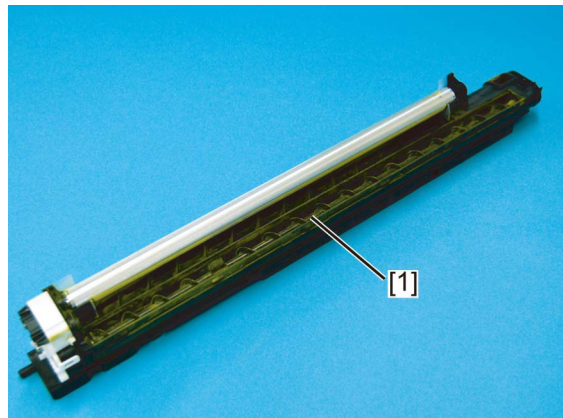


Fig. 4-200

(7) Install the upper cover.

**Notes:**

After the installation, check that all the protrusions and latches are fitted and locked securely.



Fig. 4-201

**Notes:**

Do not install the upper cover from the rear side by tilting it as shown in the figure.

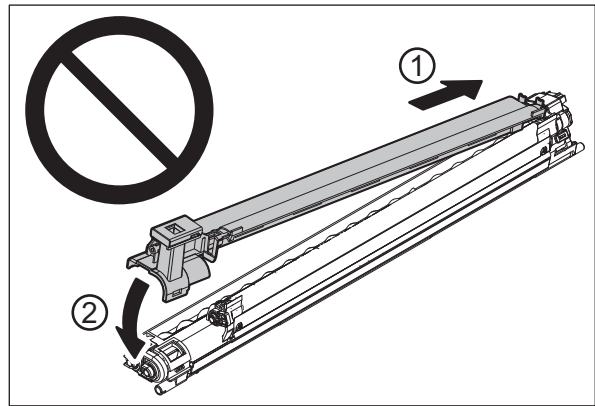


Fig. 4-202

**Notes:**

Hook the latches, and then install the cover while holding it from above.

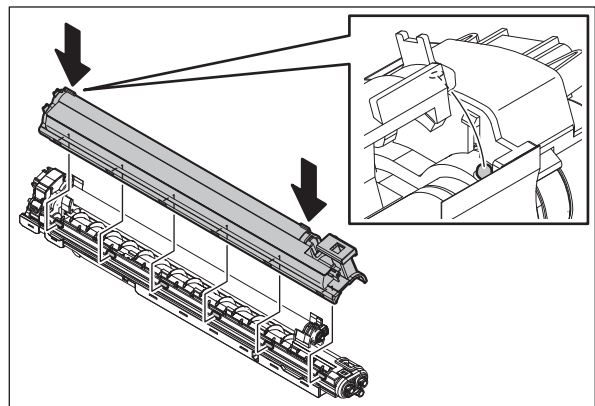


Fig. 4-203

**Notes:**

Check that the seal material is not folded down. The folding allowance shall be 0.7 mm or less.

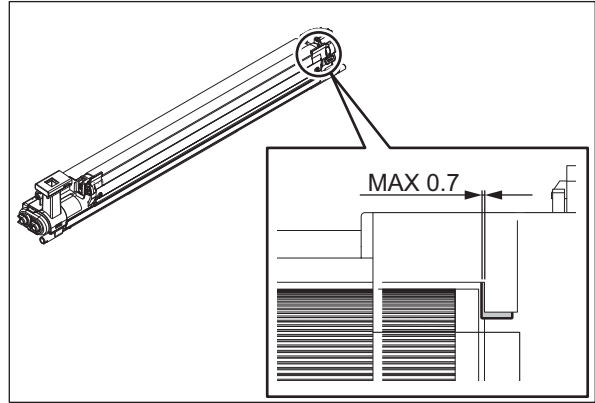


Fig. 4-204

### 4.6.4 Doctor blade

- (1) Discharge the developer material.  
 P. 4-69 "4.6.3 Developer material"
- (2) Remove 2 screws and take off the doctor blade [1].

**Notes:**

Adjust the gap between the developer sleeve and the doctor blade after the installation.  
 P. 6-83 "6.10.2 Adjustment of the doctor-to-sleeve gap"

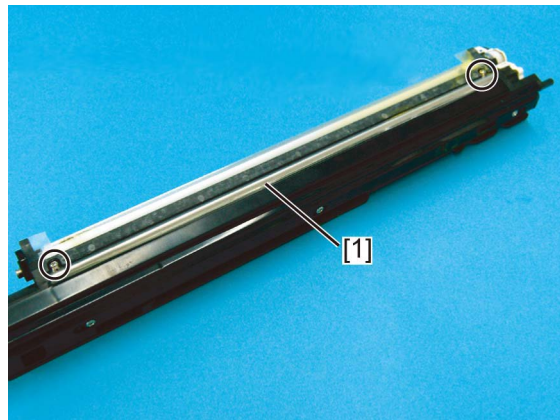


Fig. 4-205

### 4.6.5 Side seal

- (1) Remove the doctor blade.  
 P. 4-74 "4.6.4 Doctor blade"
- (2) Remove the side seal [1].

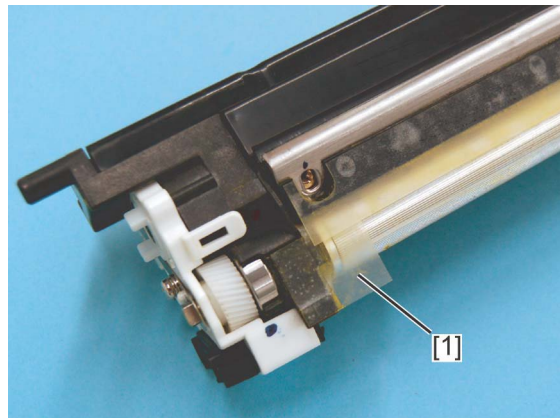


Fig. 4-206



## 4.6.6 Auto-toner sensor (S1, S2, S3, S4)

The auto-toner sensor is installed in the developer unit (Y, M, C, K).

Developer unit (K): Auto-toner sensor (S1)

Developer unit (C): Auto-toner sensor (S2)

Developer unit (M): Auto-toner sensor (S3)

Developer unit (Y): Auto-toner sensor (S4)

- (1) Remove the corresponding the developer unit, and then discharge the developer material out of the unit.  
📖 P. 4-68 "4.6.2 Developer unit"  
📖 P. 4-69 "4.6.3 Developer material"
- (2) Remove 3 screws and take off the auto-toner sensor cover [1].

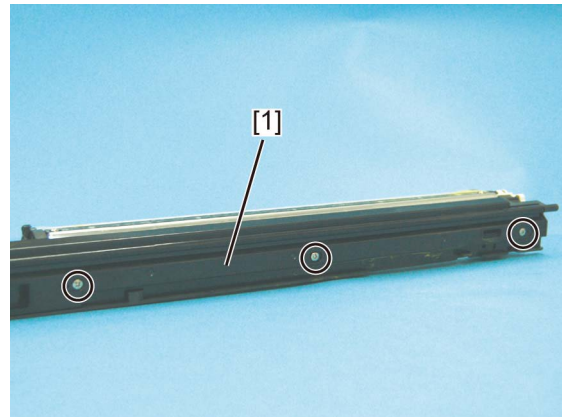


Fig. 4-207

- (3) Disconnect the 1 connector [1].
- (4) Lift the rib up and remove the auto-toner sensor [2] by turning it clockwise.

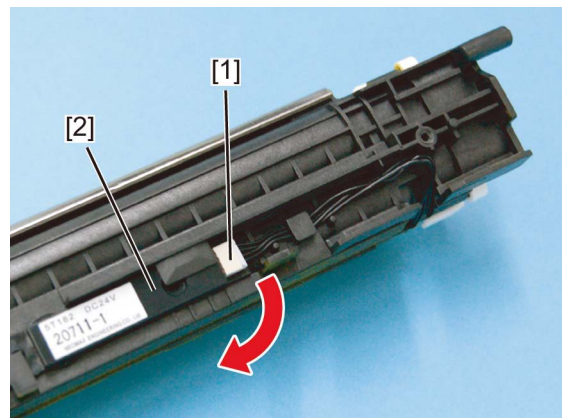


Fig. 4-208

## 4.6.7 Developer sleeve

- (1) Discharge the developer material.  
📖 P. 4-69 "4.6.3 Developer material"
- (2) Remove 1 screw and take off the pole position adjustment plate [1].

### Notes:

Before disassembling, record (mark if any) the scale pointed by the pole position adjustment plate. Then match the pole position adjustment plate at the scale previously recorded when reassembling.

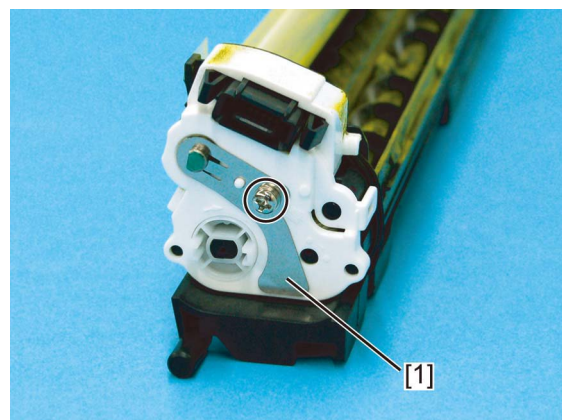


Fig. 4-209

- (3) Release 2 latches and remove the gear cover [1].

**Notes:**

When installing, align the idler gear shaft to the hole of the gear holder.

- (4) Disconnect the 1 connector [2] from the gear cover.

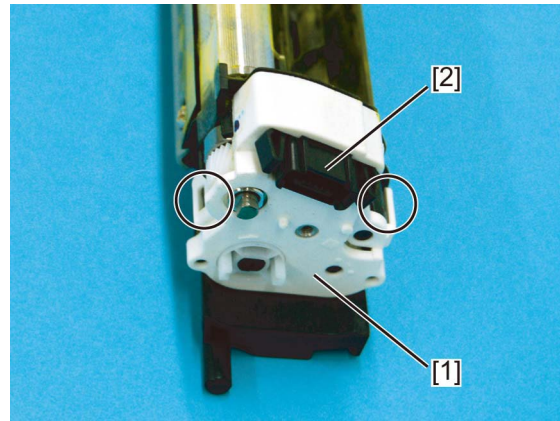


Fig. 4-210

- (5) Remove the C-ring, drive gear, idler shaft, and idler gear.

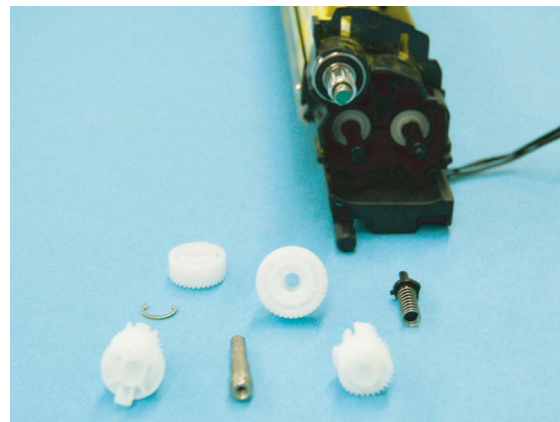


Fig. 4-211

- (6) Remove the bearing [1], bearing holder [2], bushing [3], and developer sleeve [4].

**Notes:**

Adjust the gap between the developer sleeve and the doctor blade after the installation.

📖 P. 6-83 "6.10.2 Adjustment of the doctor-to-sleeve gap"

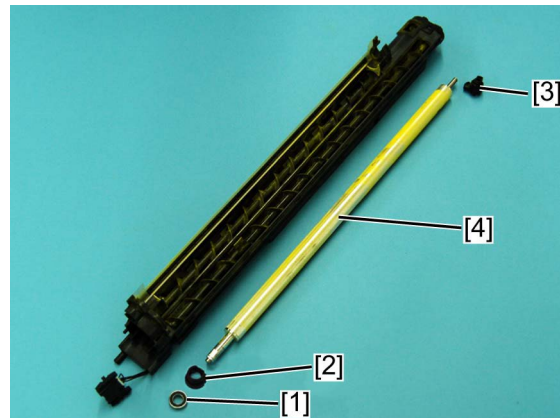



Fig. 4-212

## 4.6.8 Mixer

- (1) Remove the developer sleeve.  
 P. 4-75 "4.6.7 Developer sleeve"
- (2) Remove 2 clips [1], 2 bushings [2] and the front bushing holder [3].

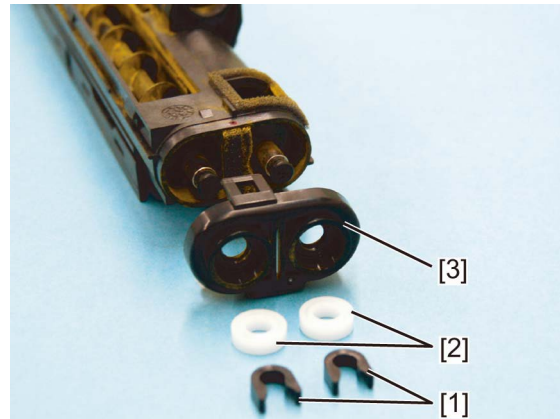


Fig. 4-213

- (3) Remove the separator [1], mixer [2], and bushing [3] from the front side.

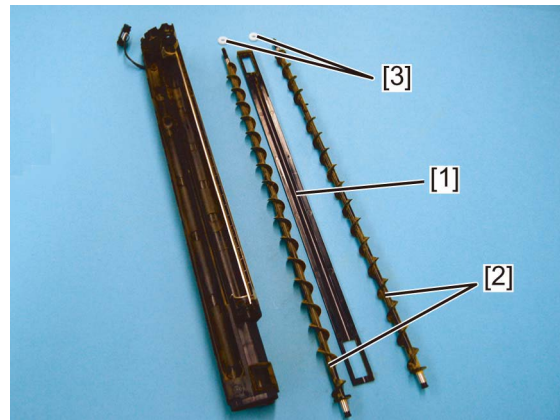


Fig. 4-214

### Notes:

When installing a separator, turn the short collar [1] side to the left.

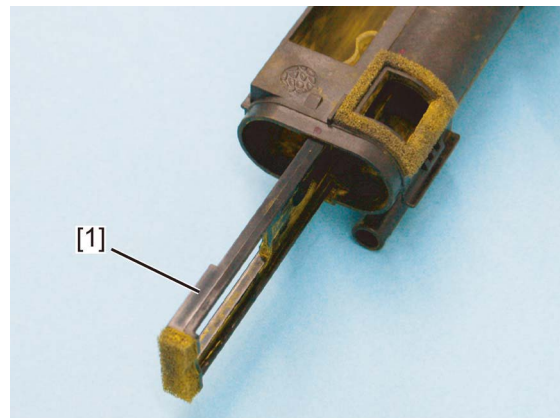


Fig. 4-215

## 4.6.9 Replacement of oil seal

- (1) Insert a fine screwdriver into the depression of the oil seal to take it out.
- (2) Push in a new oil seal parallel to the frame or bushing (shown figure at right).

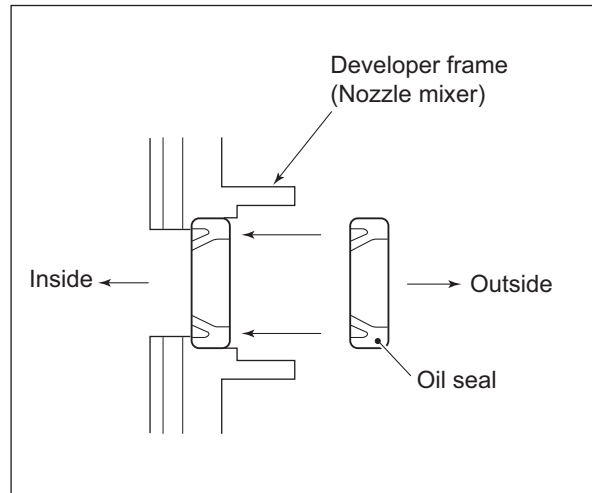


Fig. 4-216

## 4.6.10 Cleaner unit

- (1) Remove the developer unit.  
P. 4-68 "4.6.2 Developer unit"
- (2) Press down the lever [1] and take off the cleaner unit [2].

### Notes:

- Before removing the cleaner unit, be sure to take off the developer unit for the corresponding color.
- When installing the cleaner, make sure to correspond to the color.

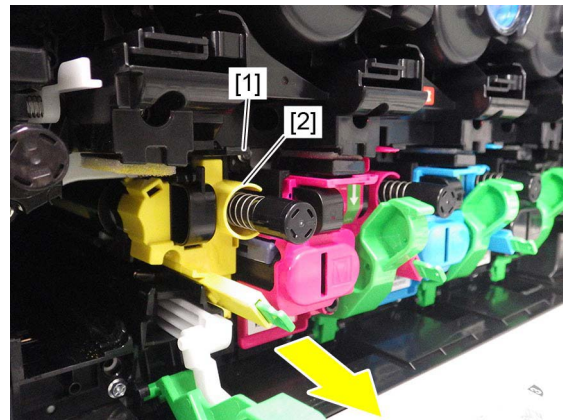


Fig. 4-217

### Notes:

To remove the cleaner unit for black (K), pull the TBU release lever [3], turn it clockwise to release the lock, and then pull out the cleaner unit.

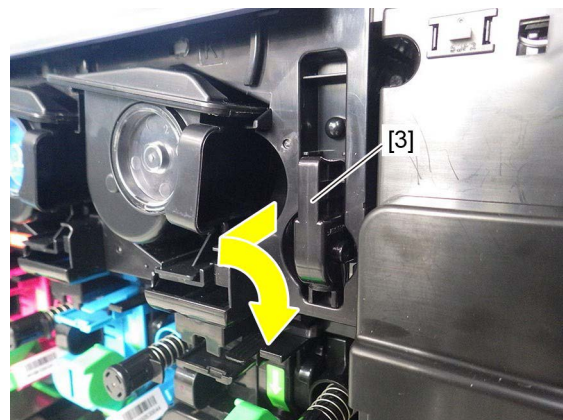
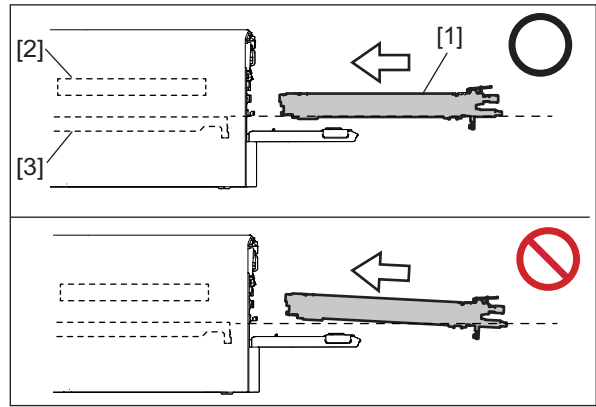


Fig. 4-218


**Notes:**

- When installing the cleaner unit [1], insert it carefully keeping it horizontal [3].
- If it is tilted (especially if its leading edge is upward), the upper part of the unit will catch the edge of the transfer belt [2]. Pushing it will damage the belt.



**Fig. 4-219**

### 4.6.11 Main charger

- (1) Remove the cleaner unit.  
 P. 4-78 "4.6.10 Cleaner unit"
- (2) Remove 1 screw.



**Fig. 4-220**

- (3) Release 2 latches [1] and remove the cleaner cover [2].

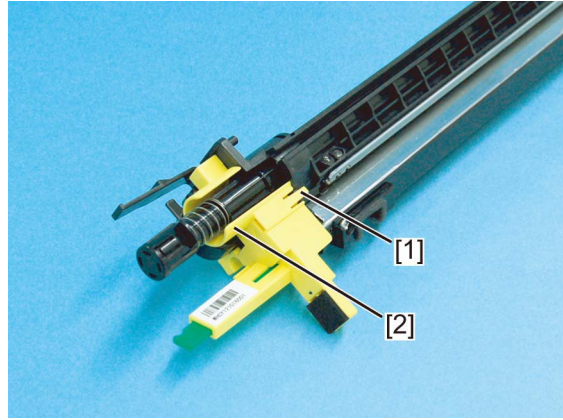


Fig. 4-221

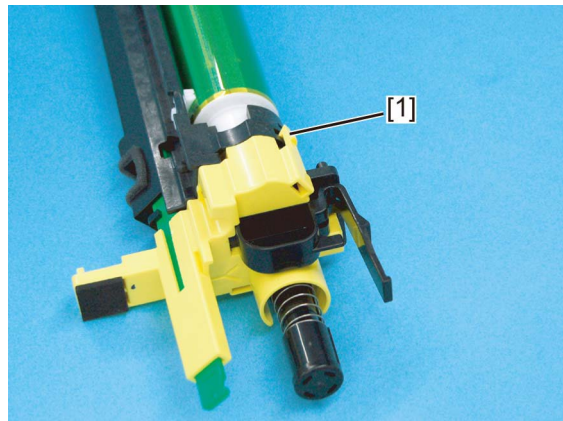


Fig. 4-222

- (4) Pull down the main charger [1] and release 2 latches [2].

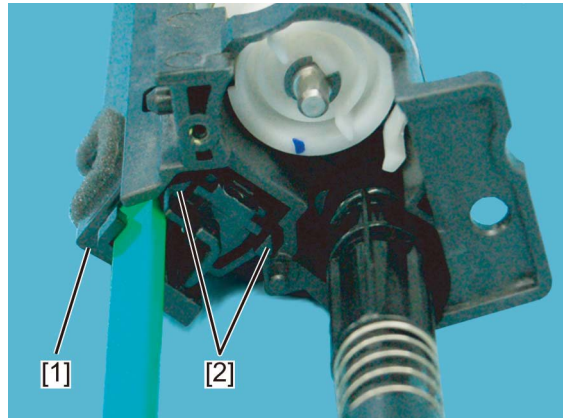


Fig. 4-223

- (5) Remove the main charger [1].

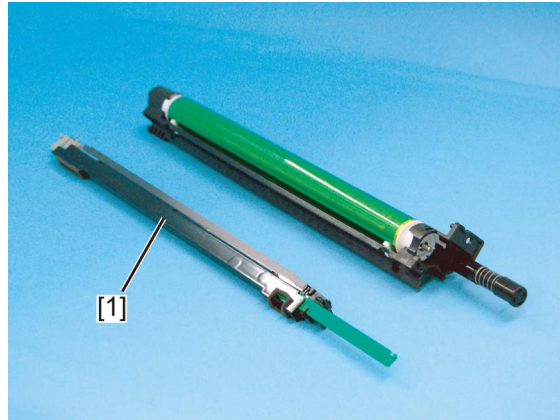


Fig. 4-224

#### 4.6.12 Drum



- (1) Remove the main charger.  
 P. 4-79 "4.6.11 Main charger"
- (2) Turn the bushing [1] clockwise and release the lock.

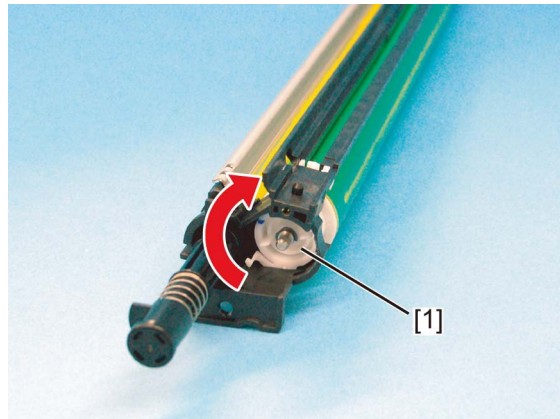


Fig. 4-225

- (3) Remove the bushing [1].

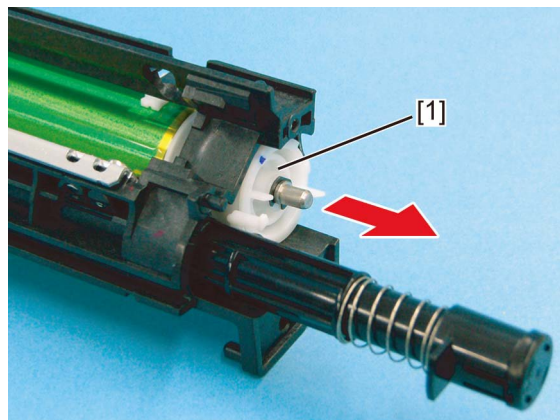


Fig. 4-226

- (4) Remove the drum [1] and bushing [2] from the cleaner.

**Notes:**

- Be sure not to touch, spit or scratch on the drum surface.
- Avoid a direct sunlight onto the drum. Move it to a dark place as soon as it is taken off.
- Be sure not to touch or scratch the edge of the drum cleaning blade.

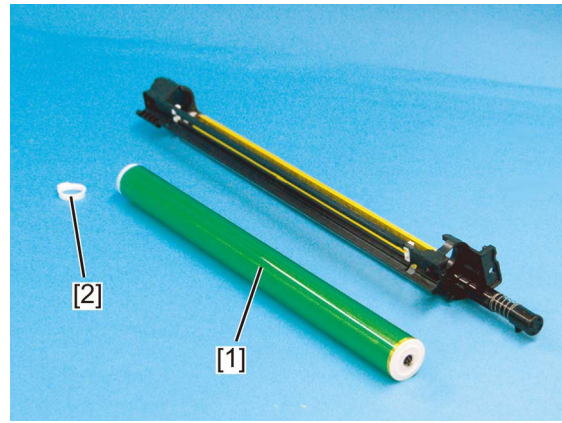


Fig. 4-227

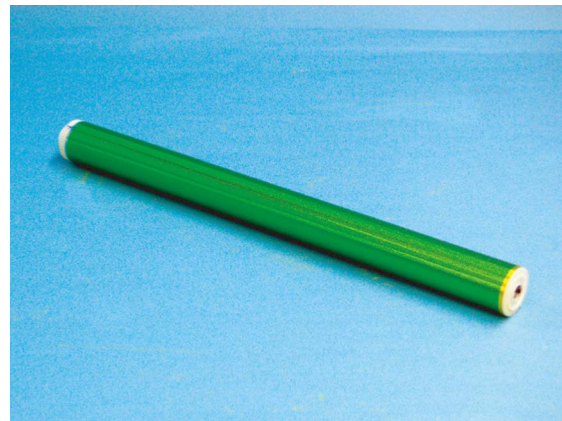



Fig. 4-228



Fig. 4-229



### 4.6.13 Drum cleaning blade

- (1) Remove the drum.  
 P. 4-81 "4.6.12 Drum and bushing"
- (2) Remove 2 screws and take off the drum cleaning blade [1].

**Notes:**

Be sure not to touch or scratch the edge of the cleaning blade.

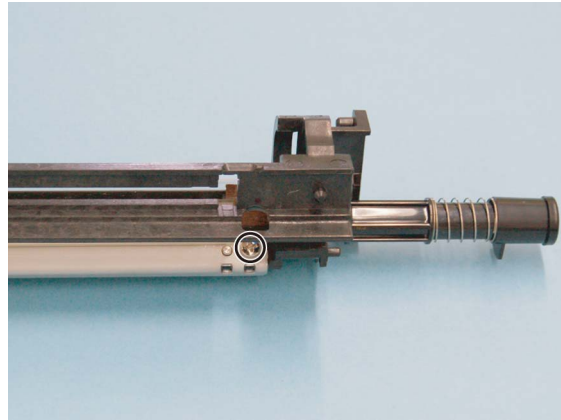


Fig. 4-230

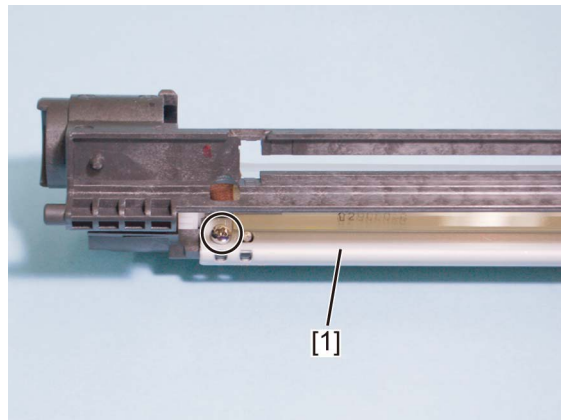



Fig. 4-231



Fig. 4-232

## 4.6.14 Side seal

- (1) Remove the drum cleaning blade.  
 P. 4-83 "4.6.13 Drum cleaning blade"
- (2) Remove the side seal [1].

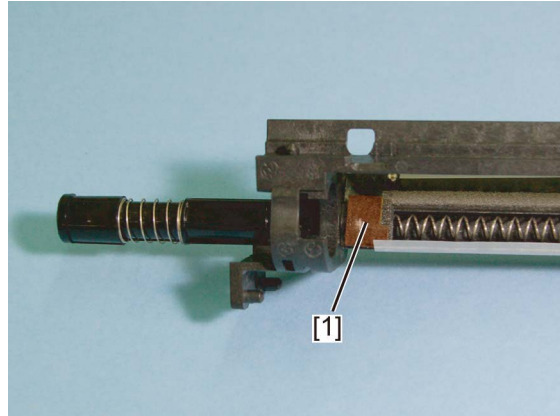


Fig. 4-233

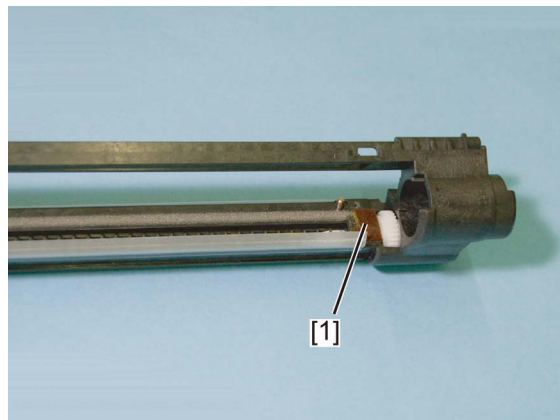


Fig. 4-234

### Notes:

Make sure to attach the side seals as shown in the figure.

- From the case edge: 0 to 0.3 mm (Protruding from the case is unallowable.)
- Gap between the blade: 0 to 0.3 mm (Overlapping is unallowable.)

[1] Side seal

[2] Blade

[3] Case

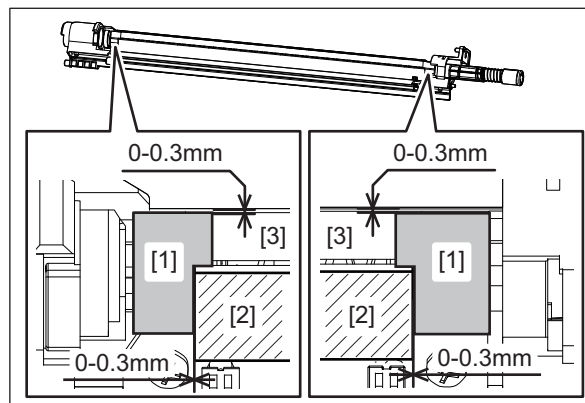


Fig. 4-235

## 4.6.15 Waste toner unit gear

- (1) Remove the cleaner unit.  
📖 P. 4-78 "4.6.10 Cleaner unit"
- (2) Remove the C-ring [1], washer [2], spring [3], bushing [4], and waste toner unit gear [5].

### Notes:

To remove the gear, and release the lock by raising the latch.

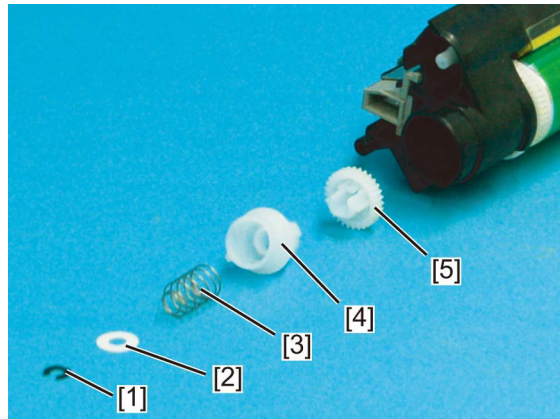


Fig. 4-236

## 4.6.16 Main charger grid

- (1) Remove the main charger.  
📖 P. 4-79 "4.6.11 Main charger"
- (2) Pull the lever [1].

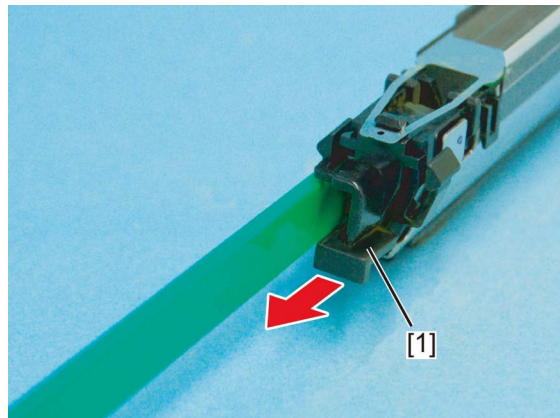


Fig. 4-237

(3) Remove the main charger grid [1].

**Notes:**

- Do not touch the mesh area of the grid.
- When installing the grid, be careful not to let the urethane sheet adhered to the charge case get caught in it.

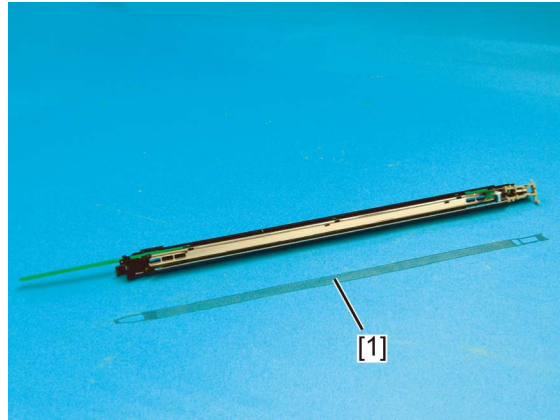


Fig. 4-238

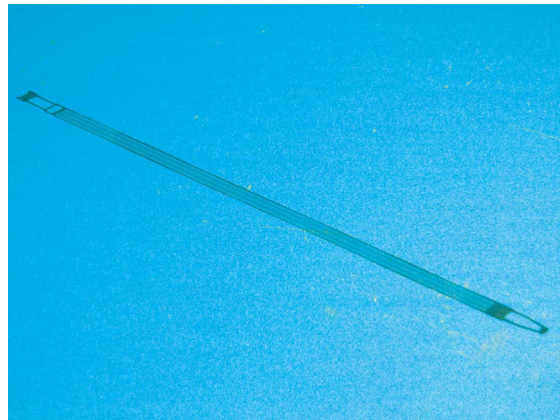



Fig. 4-239

- There are 2 holes on the rear side of the main charger grid for determining which is the front or back surface. Be sure to place the grid so that the 2 holes come as shown in the figure.



Fig. 4-240

## 4.6.17 Main charger cleaner

- (1) Remove the main charger grid.  
 P. 4-85 "4.6.16 Main charger grid"
- (2) Release the latch [1] and remove the main charger cleaner [2].

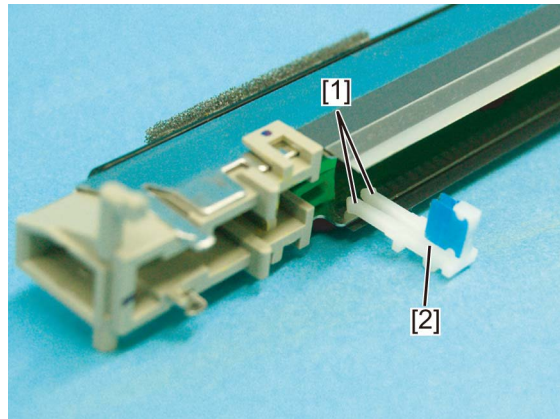


Fig. 4-241

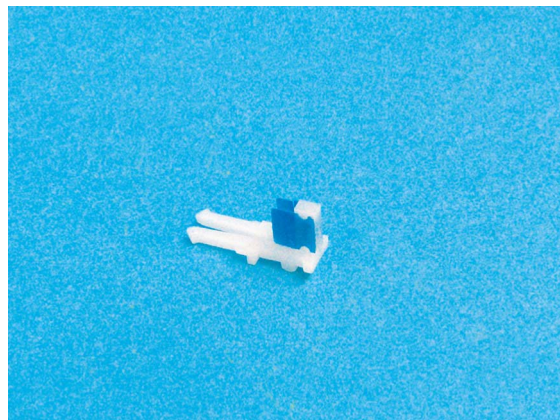


Fig. 4-242

## 4.6.18 Needle electrode

- (1) Remove the main charger cleaner.  
P. 4-87 "4.6.17 Main charger cleaner"
- (2) Pull out the lever [1] and remove the needle electrode [2] together with the lever [1].

### Notes:

When installing the needle electrode, be sure of the following:

- Be sure that its needle comes at its top side.
- Hook the needle electrode and the spring on both front and rear terminals securely.
- Do not twist the needle electrode.
- Do not touch the needle electrode directly with bare hands.

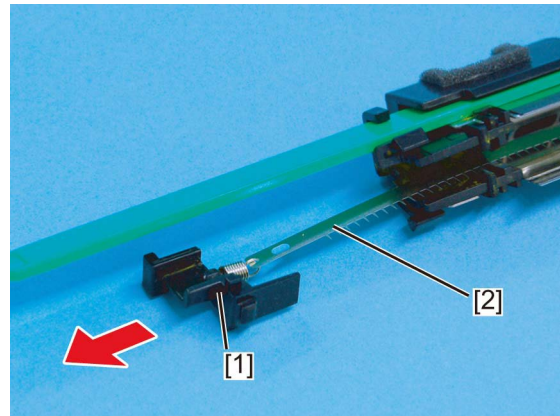


Fig. 4-243

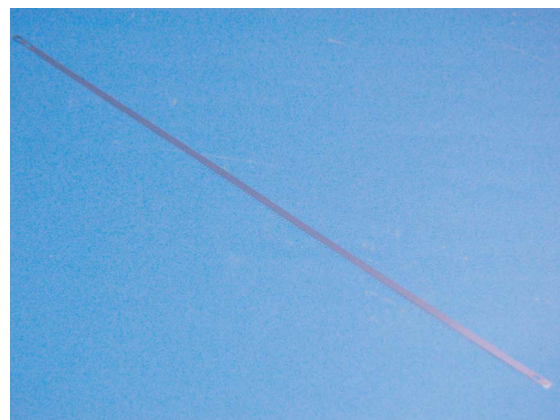


Fig. 4-244

## 4.6.19 New/old drum detection switches (SW9, SW10, SW11, SW12) and new/old developer unit detection switches (SW13, SW14, SW15, SW16)

- (1) Remove the drum TBU drive unit.  
P. 4-130 "4.7.14 Drum TBU drive unit"
- (2) Remove the front right cover.  
P. 4-6 "4.1.13 Front right cover"
- (3) Remove the transfer belt unit.  
P. 4-117 "4.7.3 Transfer belt unit (TBU)"
- (4) Remove The Cleaner Unit.  
P. 4-78 "4.6.10 Cleaner unit"
- (5) Remove The Toner Motor Assembly.  
P. 4-103 "4.6.29 Toner motor assembly"
- (6) Remove 3 screws, release 5 upper latches, and then take off the toner cartridge holder [1].

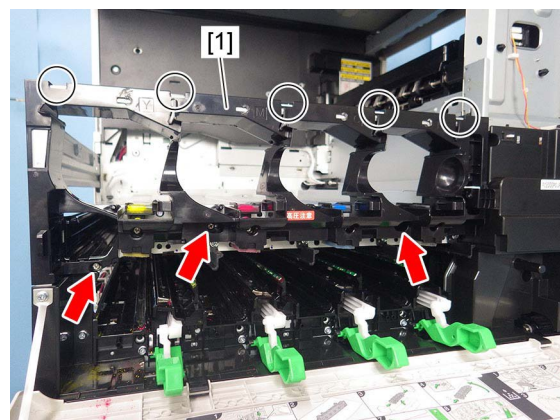


Fig. 4-245

(7) Remove 3 screws.

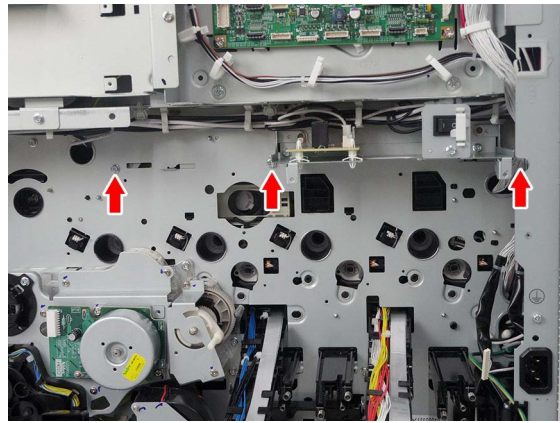


Fig. 4-246

- (8) Release the harness from the harness clamp [2].
- (9) Remove 3 screws. Release the lock by sliding the top frame of toner cartridge [3] leftward. Then take off it.

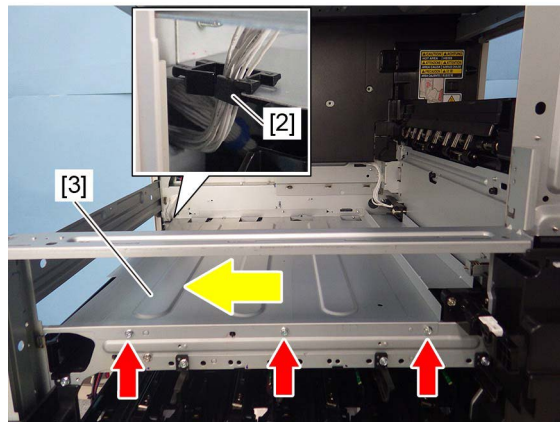


Fig. 4-247

(10) Remove 2 screws and take off the transfer belt cleaner guide (upper) [4].

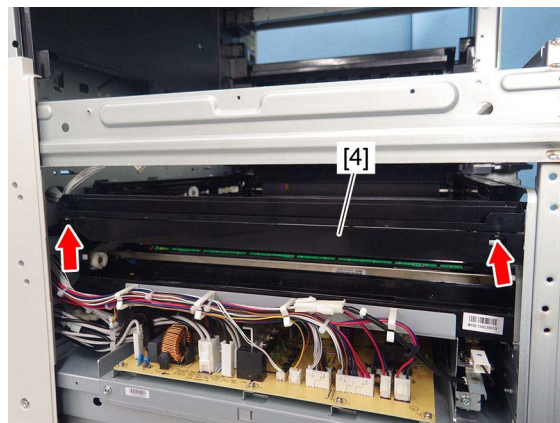


Fig. 4-248

- (11) Remove 1 screw and take off the transfer belt cleaner guide (lower) [5].

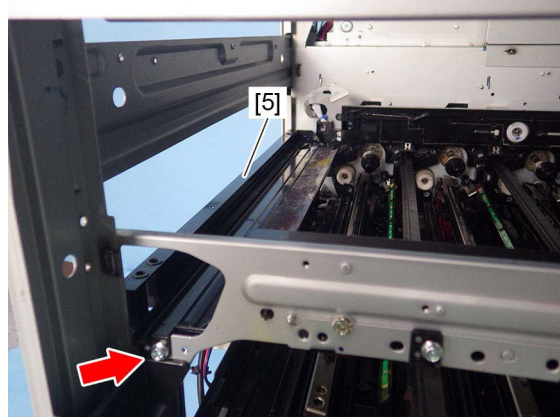


Fig. 4-249

- (12) Remove 2 screws and take off the transfer belt rail (rear) [6].

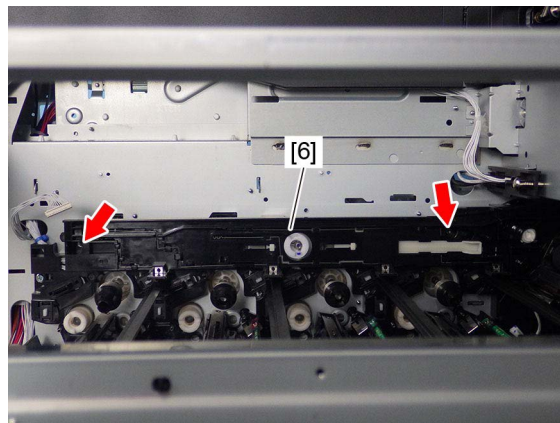


Fig. 4-250

- (13) Remove 4 screws and take off 4 cleaner unit rails [7].

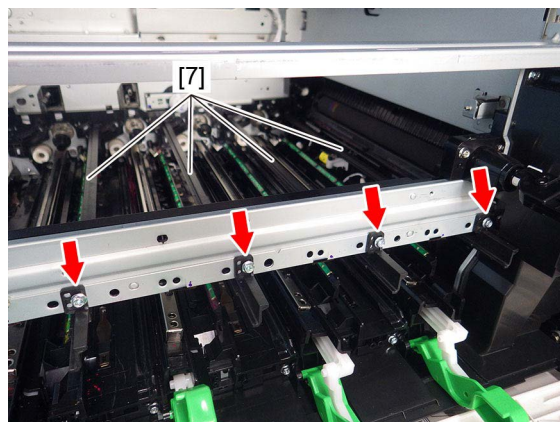


Fig. 4-251



- (14) Remove 2 screws and take off the switch base [8].



Fig. 4-252

- (15) Release the latches, and remove the new/old drum detection switch [9] and new/old developer unit detection switch [10] from the switch base.

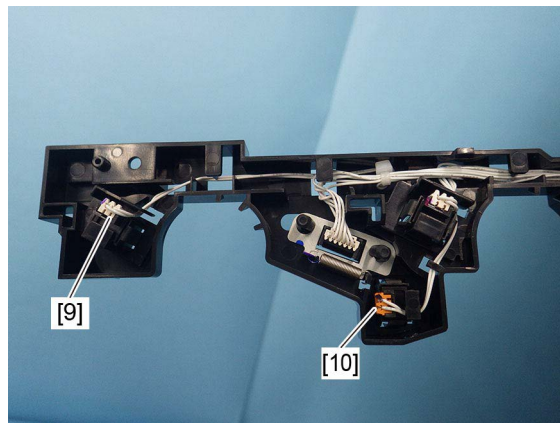


Fig. 4-253

- (16) Disconnect the connector, and remove the new/old drum detection switch [9] and new/old developer unit detection switch [10].

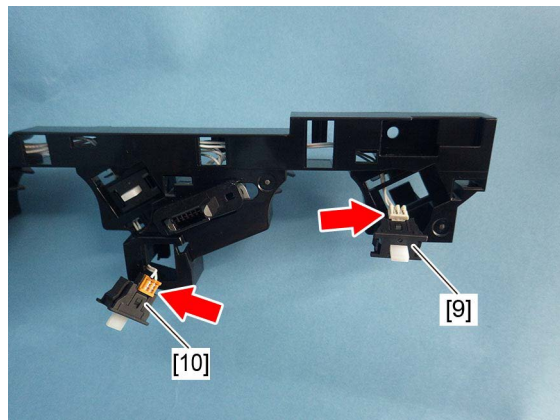


Fig. 4-254

#### New/old drum detection switches

- Y (SW9)
- M (SW10)
- C (SW11)
- K (SW12)

#### New/old developer unit detection switches

- Y (SW13)
- M (SW14)
- C (SW15)
- K (SW16)

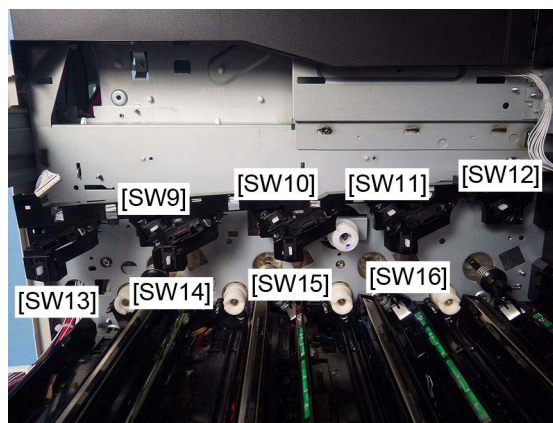



Fig. 4-255

### 4.6.20 Drum thermistor (THM4)

- (1) Remove the discharge LED (C).  
 P. 4-38 "4.4.2 Discharge LED"
- (2) Remove 1 screw and disconnect the connector [1], and then take off the drum thermistor [2].

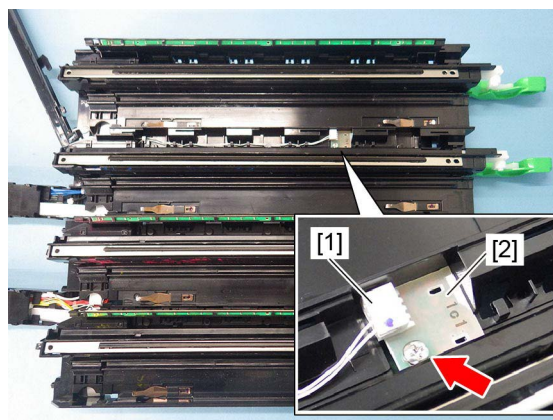


Fig. 4-256

## 4.6.21 Waste toner paddle rotation detection sensor (S9)

- (1) Remove the waste toner paddle motor unit.  
P. 4-93 "4.6.22 Waste toner paddle motor (M7)"
- (2) Release 3 latches and disconnect 1 connector, and then remove the waste toner paddle rotation detection sensor [1].

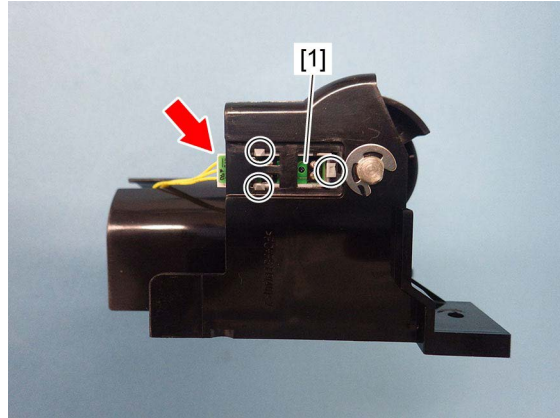


Fig. 4-257

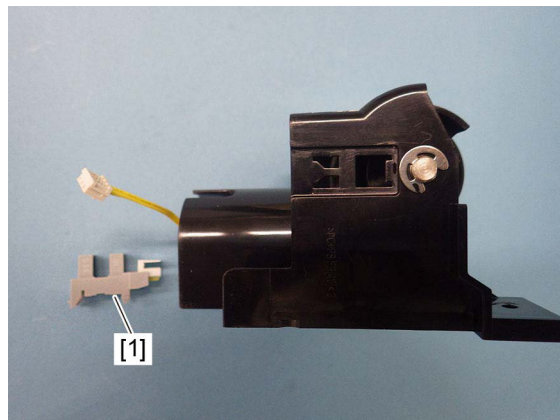


Fig. 4-258

## 4.6.22 Waste toner paddle motor (M7)

- (1) Remove the inner cover.  
P. 4-7 "4.1.16 Front cover switch (SW1)"
- (2) Remove 3 screws and disconnect 1 connector [1], and then remove the waste toner paddle motor unit [2].
- (3) Remove the waste toner paddle rotation detection sensor (S9).  
P. 4-93 "4.6.21 Waste toner paddle rotation detection sensor (S9)"

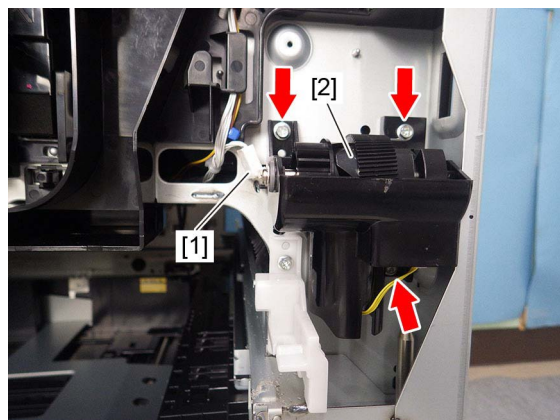


Fig. 4-259

(4) Remove 1 E-ring [3] and gear [4].

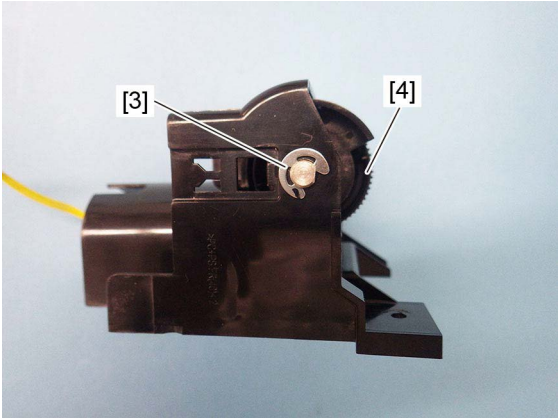


Fig. 4-260

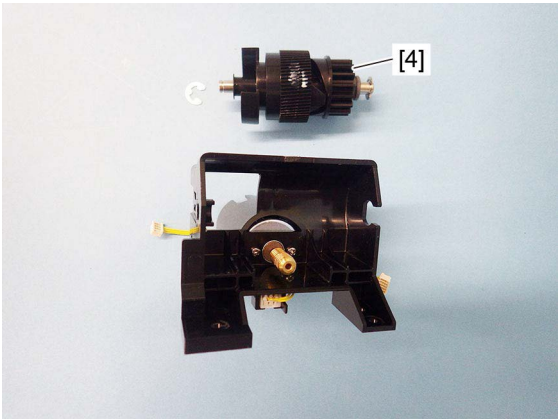


Fig. 4-261

- (5) Remove 2 screws and disconnect 1 connector [5], and then take off the waste toner paddle motor [6].

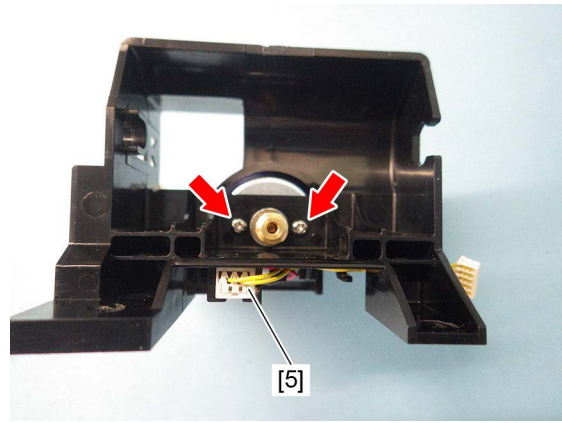


Fig. 4-262

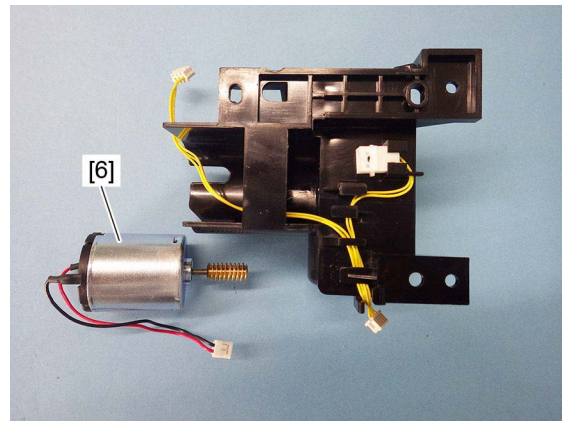


Fig. 4-263

**Notes:**

Wire the motor harness through hooks during assembly.  
Make sure that the harness does not come up on the area in the red frame.

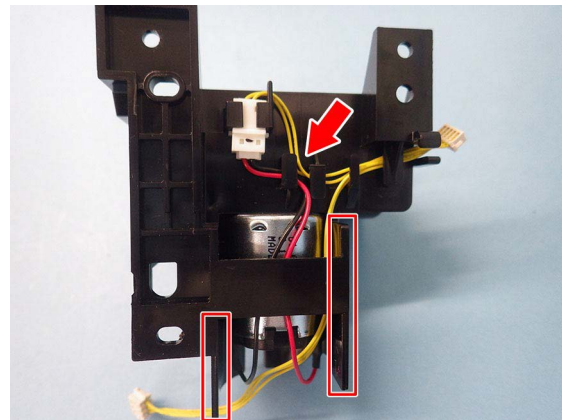




Fig. 4-264

## 4.6.23 Drum switching unit

- (1) Remove the rear cover.  
 P. 4-6 "4.1.15 Rear cover"
- (2) Remove the registration clutch.  
 P. 4-63 "4.5.15 Registration clutch (CLT1)"
- (3) Release the harness from the harness guide.

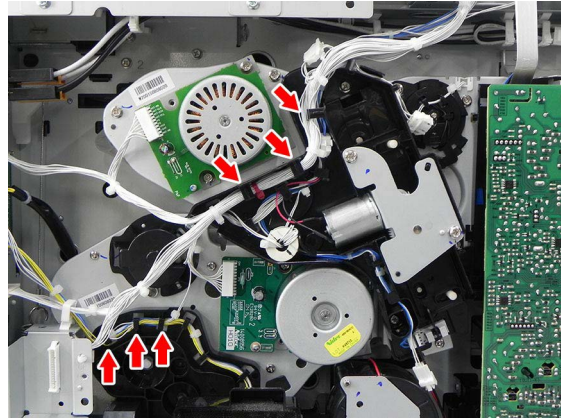


Fig. 4-265

- (4) Disconnect 2 connectors and release the harness from the harness clamp [1].

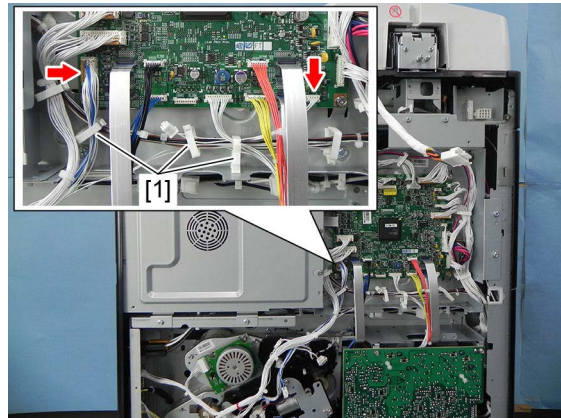


Fig. 4-266

- (5) Remove 1 screw and take off the bracket [2].

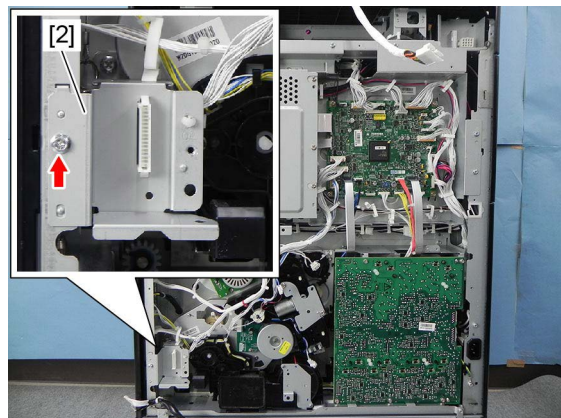


Fig. 4-267

- (6) Disconnect 3 connectors.

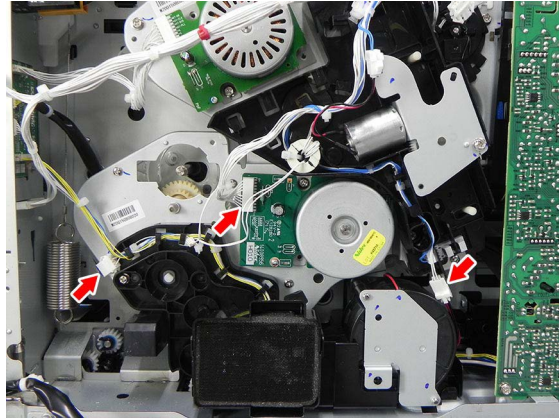


Fig. 4-268

- (7) Remove 3 screws and take off the drum switching unit [3].

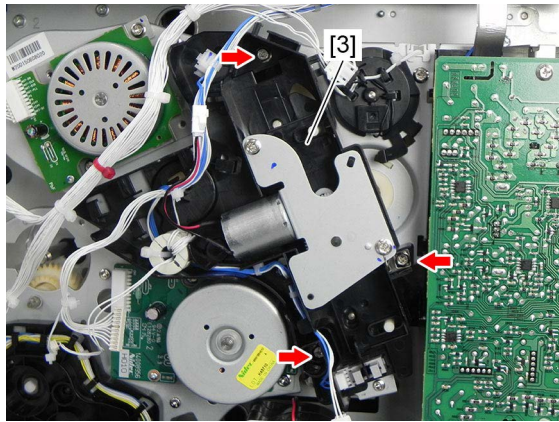


Fig. 4-269

#### 4.6.24 Drum switching detection sensor (S11)

- (1) Remove the drum switching unit.  
P. 4-96 "4.6.23 Drum switching unit"
- (2) Disconnect 1 connector and remove the drum switching detection sensor [1].

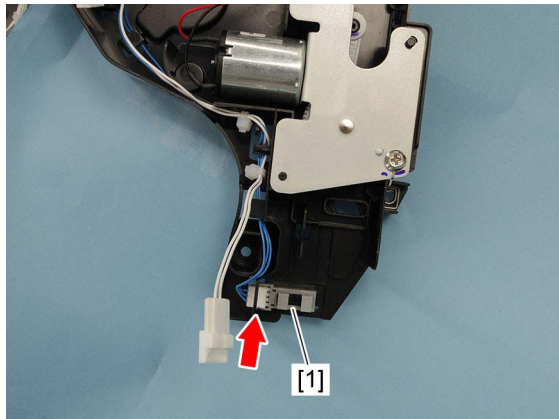



Fig. 4-270

## 4.6.25 Drum switching motor (M3)

- (1) Remove the rear cover.  
 P. 4-6 "4.1.15 Rear cover"
- (2) Disconnect 1 connector and release the harness from the harness guide [1].

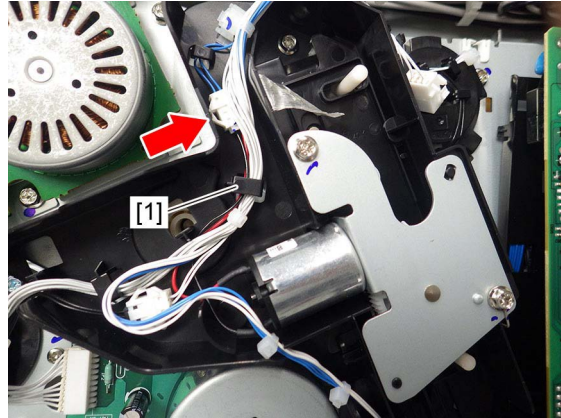


Fig. 4-271

- (3) Remove 2 screws and take off the drum switching motor bracket [2].

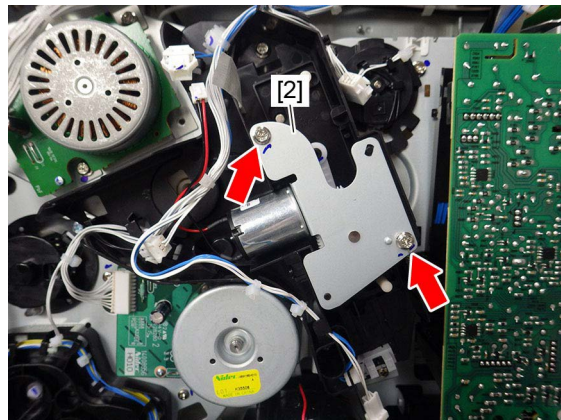


Fig. 4-272



- (4) Remove the arm [3].

**Notes:**

When installing the drum switching motor bracket, put the gear projection [5] into the arm hole [4].

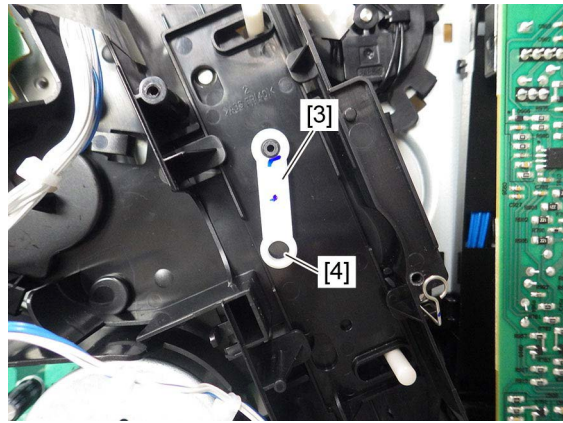


Fig. 4-273

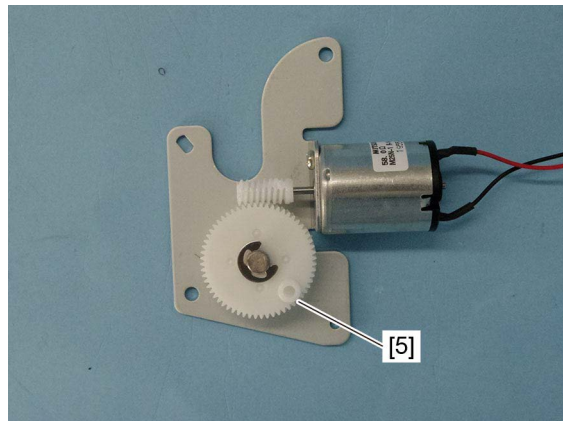


Fig. 4-274

- (5) Remove the E-ring [6] and gear [7].

**Notes:**

Before removing the gear, place a marking so that it can be re-assembled at the same position.

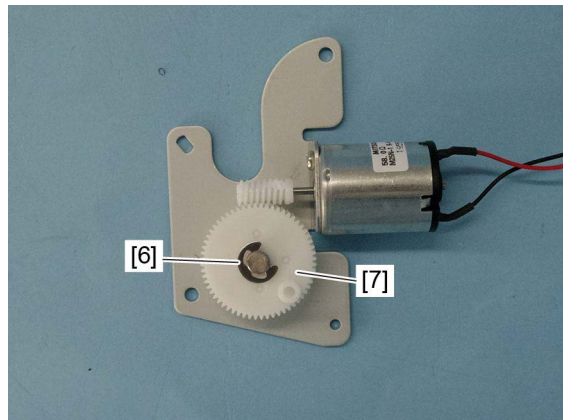


Fig. 4-275

- (6) Remove 1 screw and take off the drum switching motor [8].

**Notes:**

Pay attention to the size (length) of the screws. If incorrect ones are used, the motor could be damaged.

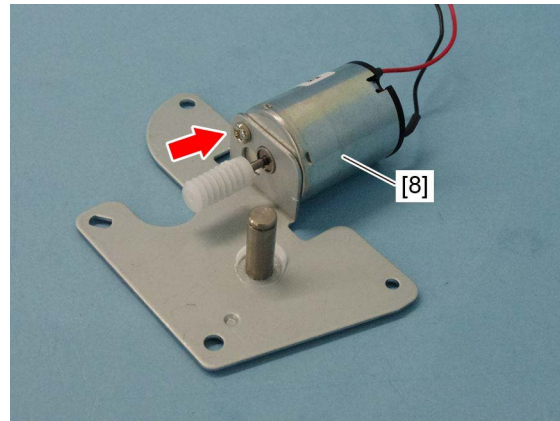


Fig. 4-276

#### 4.6.26 Paper feeding/developer unit drive motor (M2)

- (1) Remove the rear cover.  
📖 P. 4-6 "4.1.15 Rear cover"
- (2) Remove 2 screws and disconnect 1 connector [1], and then take off the paper feeding/developer unit drive motor [2].

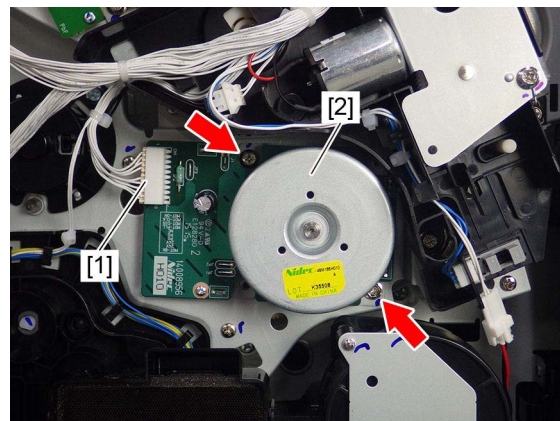


Fig. 4-277

#### 4.6.27 Paper feeding/developer drive unit

- (1) Remove the drum TBU drive unit.  
📖 P. 4-130 "4.7.14 Drum TBU drive unit"
- (2) Remove the ozone exhaust fan duct.  
📖 P. 4-106 "4.6.32 Ozone exhaust fan (F2)"
- (3) Remove the registration clutch.  
📖 P. 4-63 "4.5.15 Registration clutch (CLT1)"
- (4) Disconnect 2 connectors.

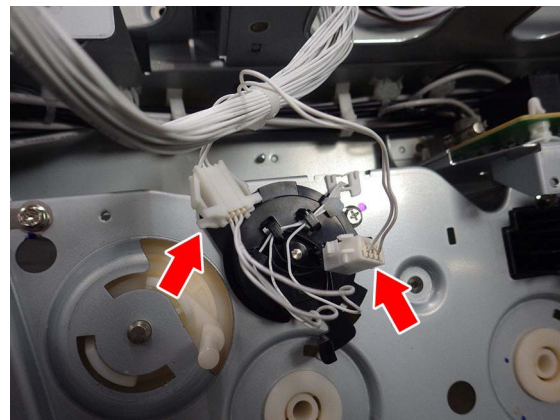


Fig. 4-278

- (5) Disconnect 2 connectors from the LGC board.

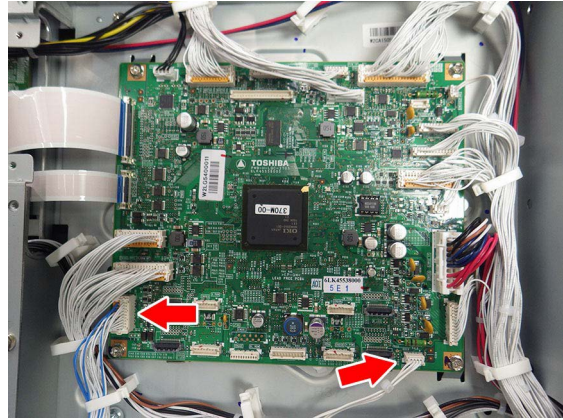


Fig. 4-279

- (6) Disconnect 2 connectors from the CFD board.

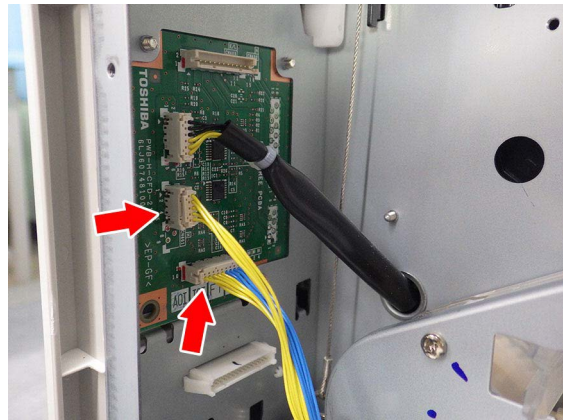


Fig. 4-280

- (7) Release the harness from the harness guide [1] and remove 7 screws, and then take off the paper feeding/developer drive unit [2].

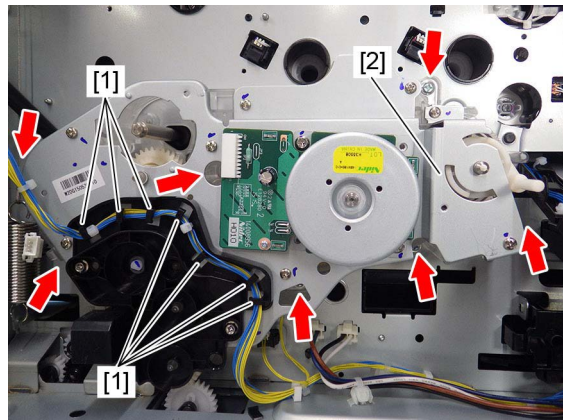


Fig. 4-281

**Notes:**

If an optional PFU is installed, press the drive gear [3] down and install the drive unit.

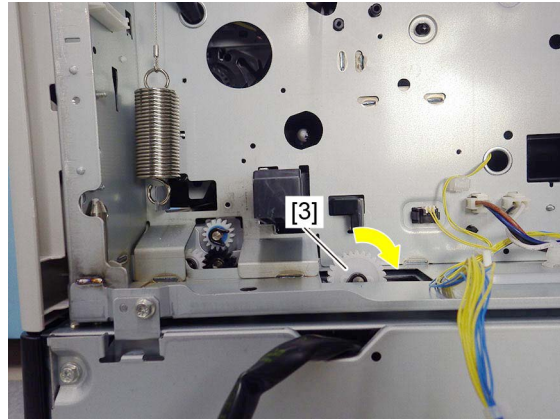


Fig. 4-282

### 4.6.28 Developer unit (K) drive gear

- (1) Remove the paper feeding/developer drive unit.  
P. 4-100 "4.6.27 Paper feeding/developer drive unit"
- (2) Remove 2 screws and take off the developer unit (K) drive gear cover [1].

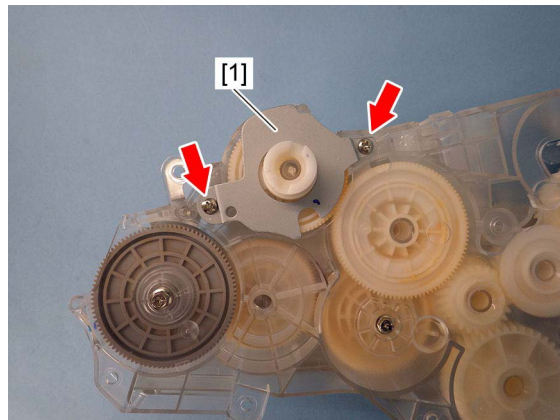


Fig. 4-283

- (3) Remove the developer unit (K) drive gear [2].

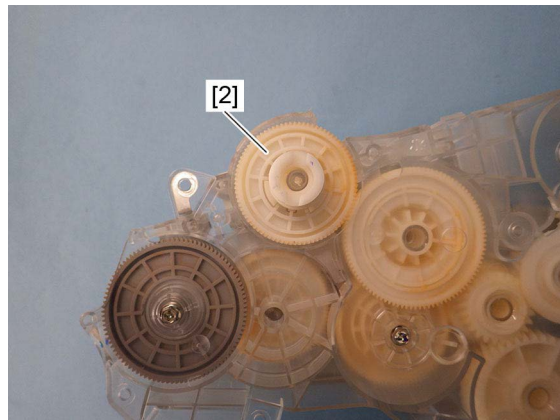


Fig. 4-284

## 4.6.29 Toner motor assembly


The toner motor is installed depending on toner cartridge (Y, M, C, K).

Toner cartridge (Y): Toner motor (M8)

Toner cartridge (M): Toner motor (M9)

Toner cartridge (C): Toner motor (M10)

Toner cartridge (K): Toner motor (M11)

- (1) Remove the receiving tray.  
 P. 4-2 "4.1.3 Receiving tray"
- (2) Pull out the toner cartridge.
- (3) Release the latch and remove 5 toner cartridge rails [1].

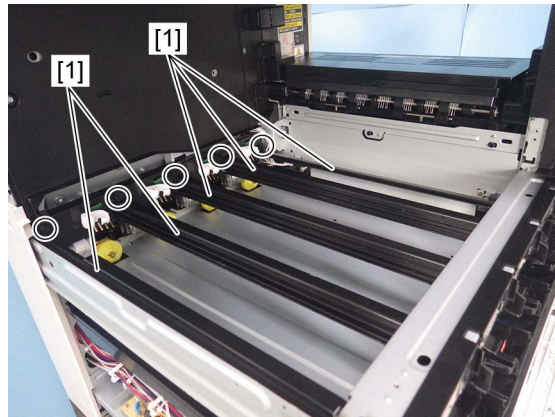


Fig. 4-285

### Notes:

When installing the toner cartridge rail, securely align at the position at which the frame matches the rail groove.

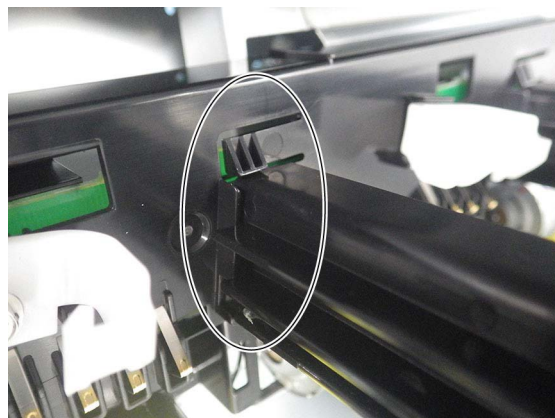


Fig. 4-286

- (4) Remove 2 screws and release 2 hooks [2], and then lift the toner motor assembly [3].

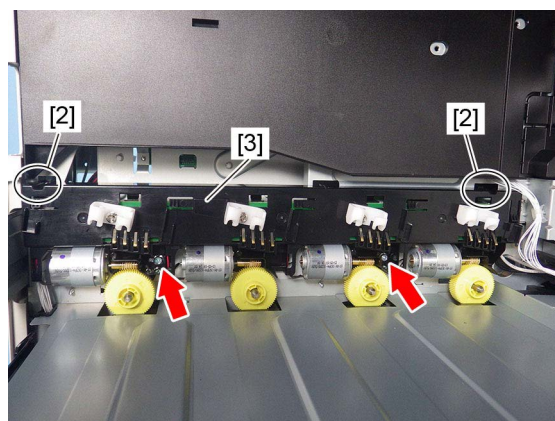


Fig. 4-287

- (5) Disconnect the connector and remove the toner motor assembly [3].

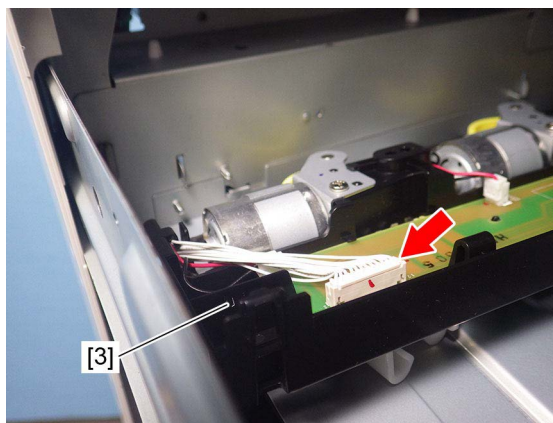


Fig. 4-288

#### 4.6.30 Toner motor (M8, M9, M10, M11)

- (1) Remove the toner motor assembly.  
📖 P. 4-103 "4.6.29 Toner motor assembly"  
(2) Release 2 latches and remove the gear [1].

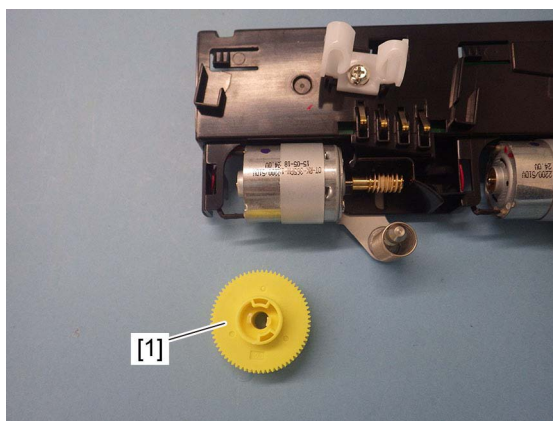


Fig. 4-289

- (3) Remove 1 screw and disconnect the connector [2], and then take off the motor bracket [3].

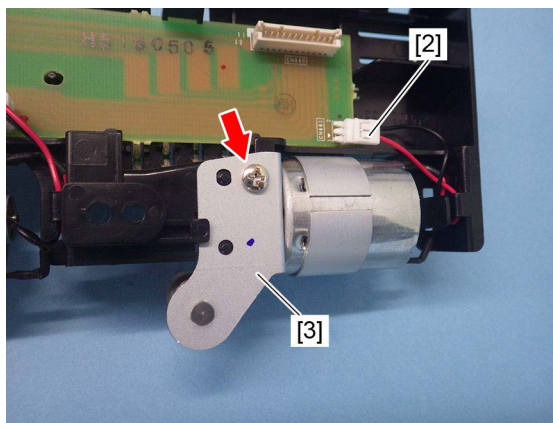


Fig. 4-290

- (4) Remove 2 screws and take off the toner motor [4].

**Notes:**

Pay attention to the size (length) of the screws. If incorrect ones are used, the motor could be damaged.

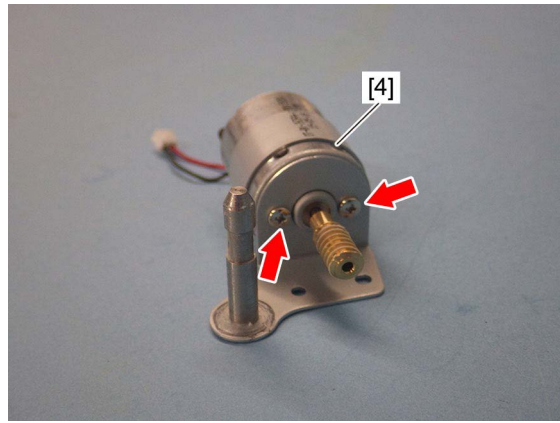


Fig. 4-291

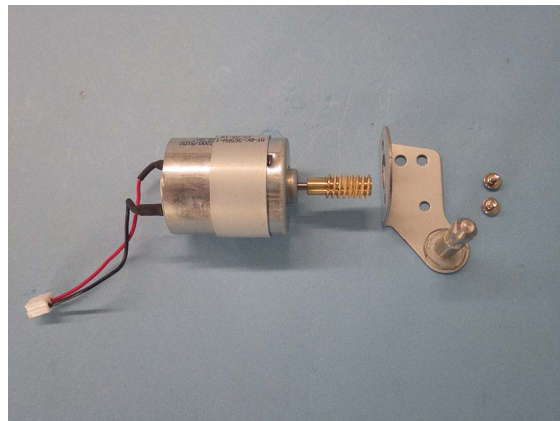



Fig. 4-292

### 4.6.31 Ozone filter

- (1) Remove the rear cover.  
 P. 4-6 "4.1.15 Rear cover"
- (2) Remove the ozone filter [1].

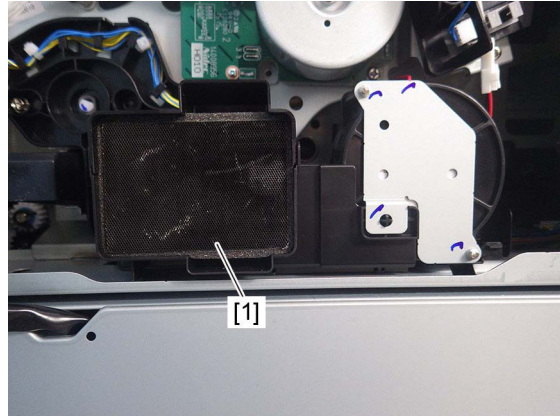



Fig. 4-293



Fig. 4-294

### 4.6.32 Ozone exhaust fan (F2)

- (1) Remove the rear cover.  
 P. 4-6 "4.1.15 Rear cover"
- (2) Disconnect 1 connector and release 1 hook [1], and then remove the ozone exhaust fan duct [2].

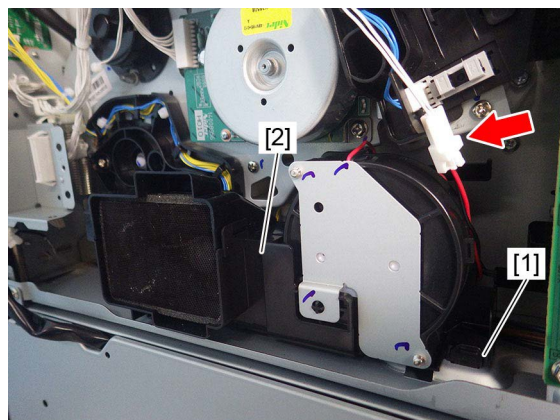


Fig. 4-295



- (3) Remove 2 screws, release the harness from the guide, and then take off the ozone exhaust fan [3] and bracket [4].

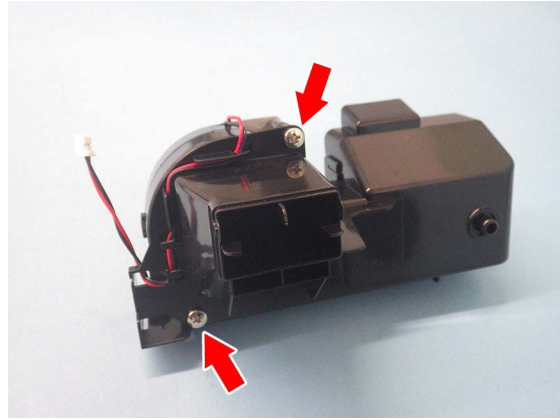


Fig. 4-296

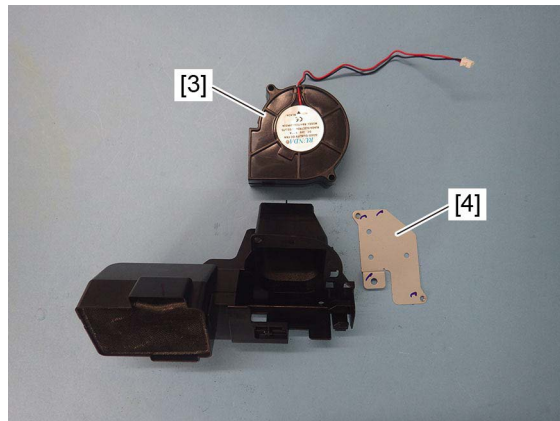



Fig. 4-297

### 4.6.33 Switching regular cooling fan (F3)

- (1) Remove the inner cover.  
 P. 4-7 "4.1.16 Front cover switch (SW1)"
- (2) Disconnect 1 connector and remove the inner cover [1].
- (3) Remove 1 screw and disconnect 1 connector [1]. Release the harness from the guide and remove the switching regular cooling fan [2].

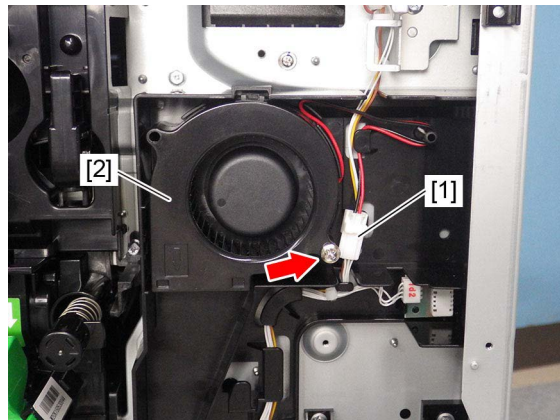


Fig. 4-298

### 4.6.34 Drum drive gear

- (1) Remove the drum TBU drive unit.  
📖 P. 4-130 "4.7.14 Drum TBU drive unit"
- (2) Remove the drum TBU motor [1] and the 1st transfer contact/release clutch [2].  
📖 P. 4-130 "4.7.13 Drum/TBU motor (M6)"  
📖 P. 4-127 "4.7.11 1st transfer contact/release clutch (CLT3)"

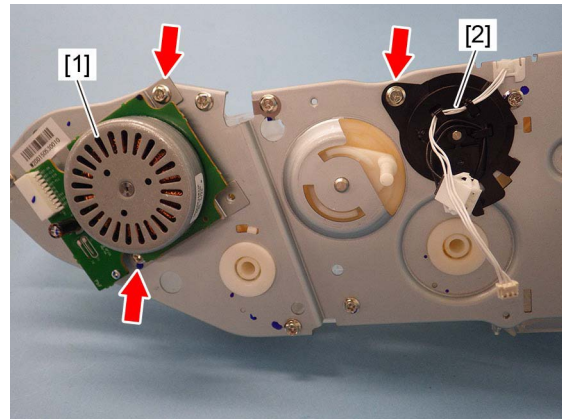


Fig. 4-299

- (3) Remove 8 screws and take off the drum drive gear cover [3].

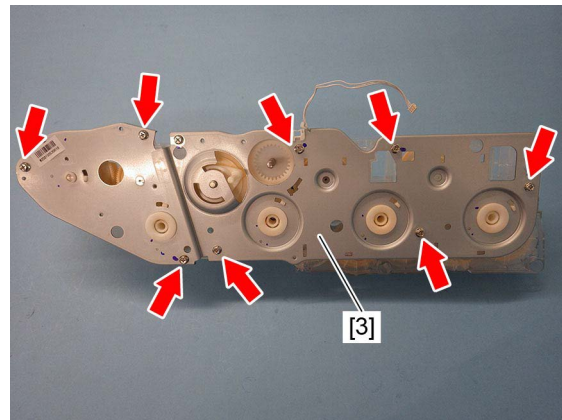


Fig. 4-300

#### Notes:

When installing the drum drive gear cover, make sure that the spring is engaged with the concave portion of the gear.

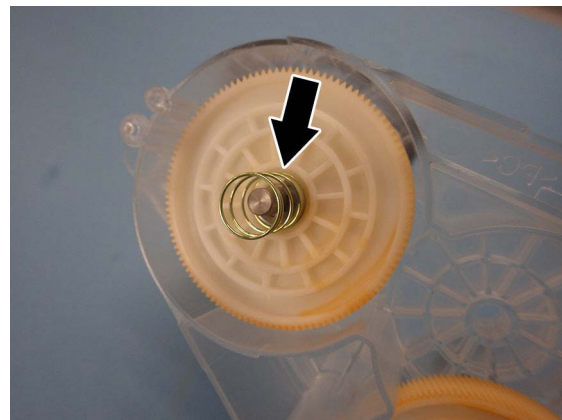


Fig. 4-301

**Notes:**

Put the ground cable into the hole so as not to deform.

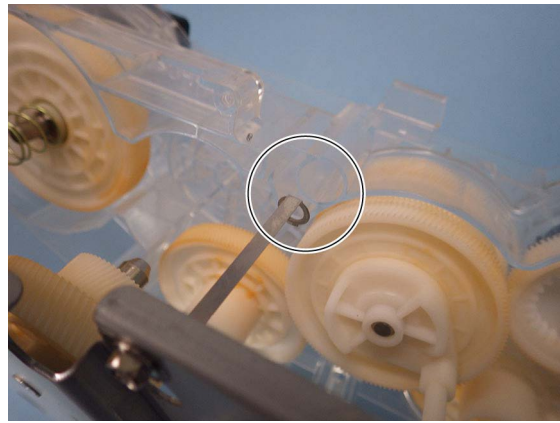


Fig. 4-302

- (4) Remove the drum drive gear.

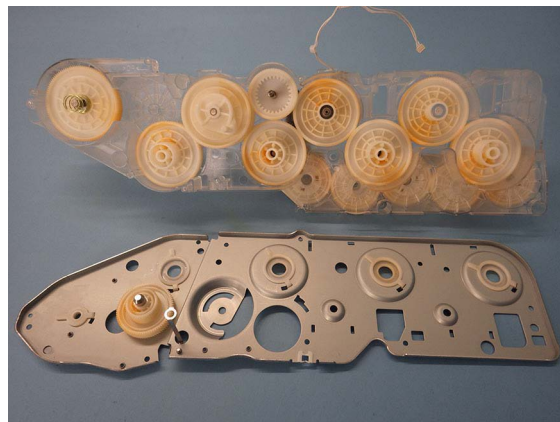


Fig. 4-303

### 4.6.35 Developer drive gear

- (1) Remove the drum TBU drive unit.  
P. 4-130 "4.7.14 Drum TBU drive unit"
- (2) Remove 3 screws and take off the developer drive gear cover [1].

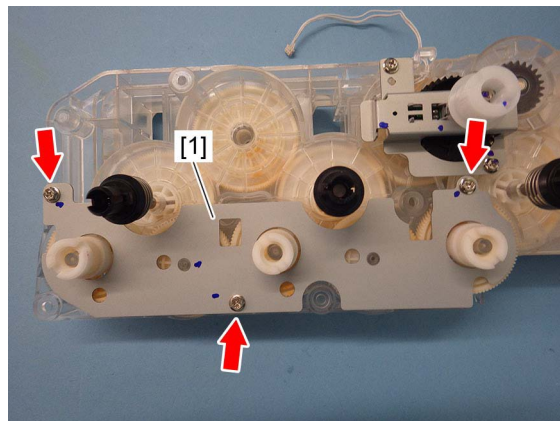


Fig. 4-304

- (3) Remove the developer drive gear.

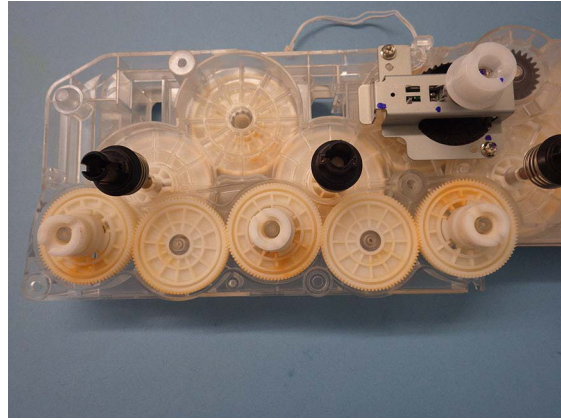


Fig. 4-305

#### 4.6.36 Main power switch (SW4)

- (1) Remove the rear cover.  
P. 4-6 "4.1.15 Rear cover"
- (2) Disconnect 4 connectors [1] and remove the main power switch [2].

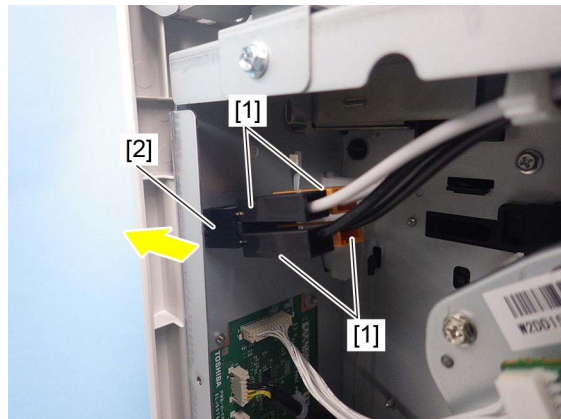


Fig. 4-306

#### 4.6.37 Temperature/humidity sensor (S10)

- (1) Remove the inner cover.  
P. 4-7 "4.1.16 Front cover switch (SW1)"
- (2) Disconnect 1 connector and remove the temperature/humidity sensor [1].

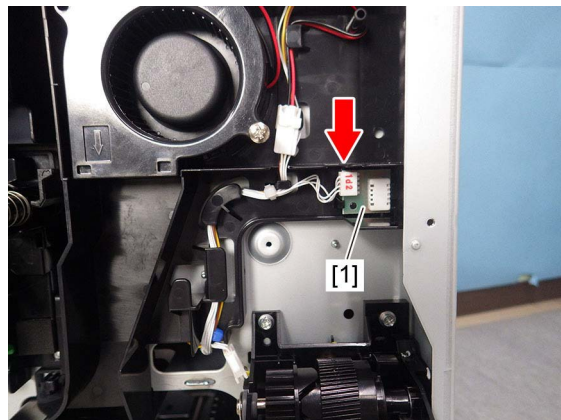


Fig. 4-307

#### 4.6.38 Drum damp heater (Right)

- (1) Remove the drawer.
- (2) Remove 1 screw and take off the cover [1].

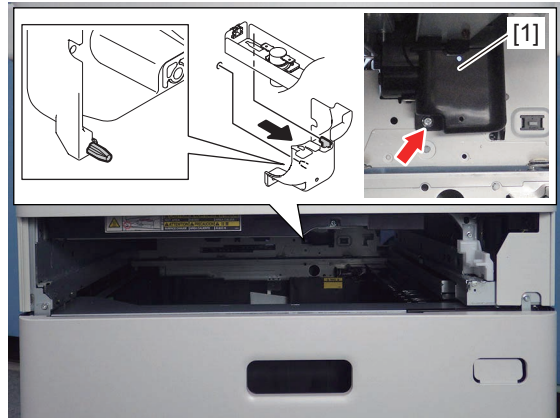


Fig. 4-308

- (3) Disconnect 1 connector [3] and remove 1 screw.

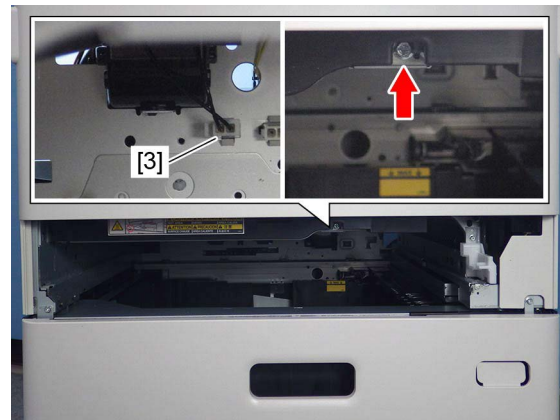


Fig. 4-309

- (4) As shown in the figure, slide the drum damp heater (right) [2] and take it off.

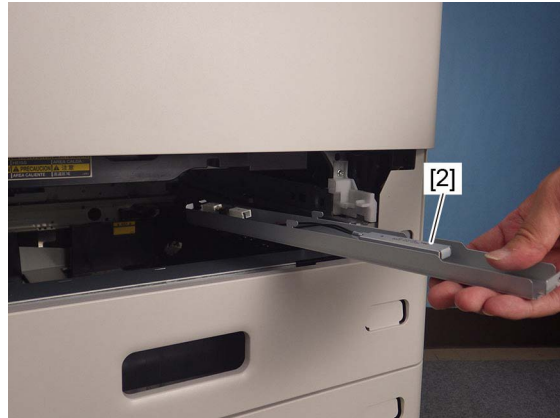


Fig. 4-310

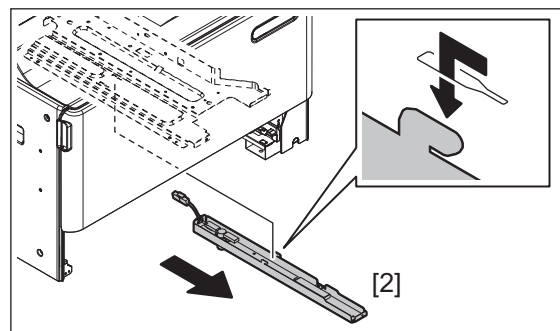


Fig. 4-311

#### 4.6.39 Drum damp heater (Left)

- (1) Remove the left cover.  
📖 P. 4-1 "4.1.2 Left cover"
- (2) Disconnect 1 connector

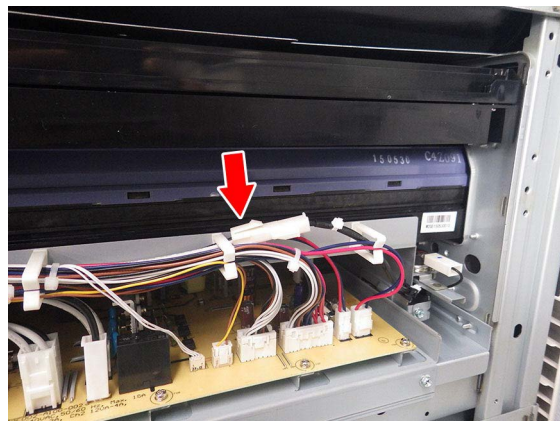


Fig. 4-312

(3) Remove 1 screw.

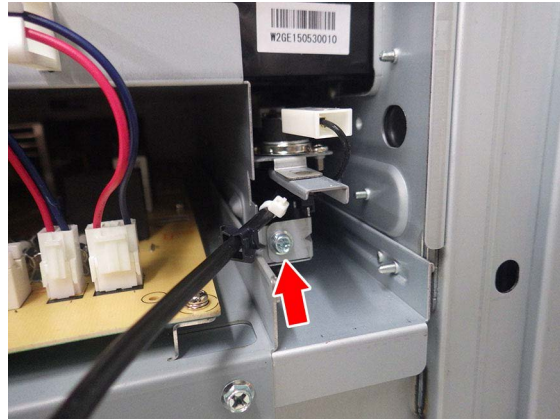


Fig. 4-313

(4) As shown in the figure, slide the drum damp heater (right) [1] and take it off.

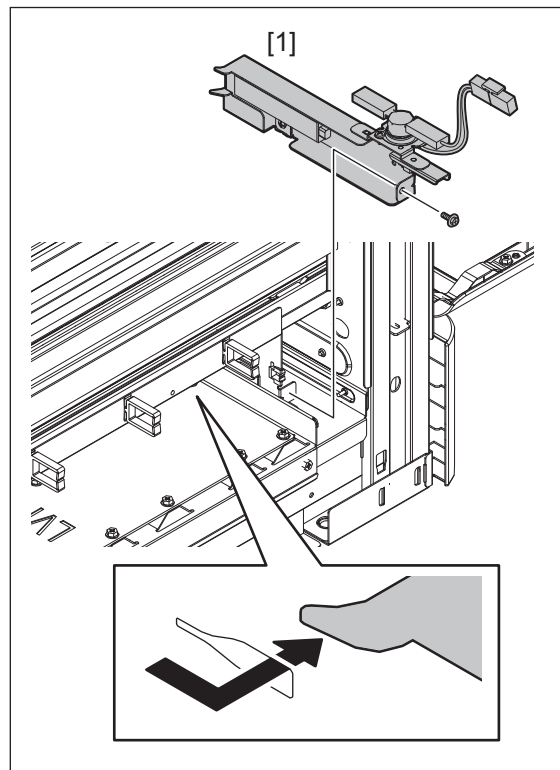
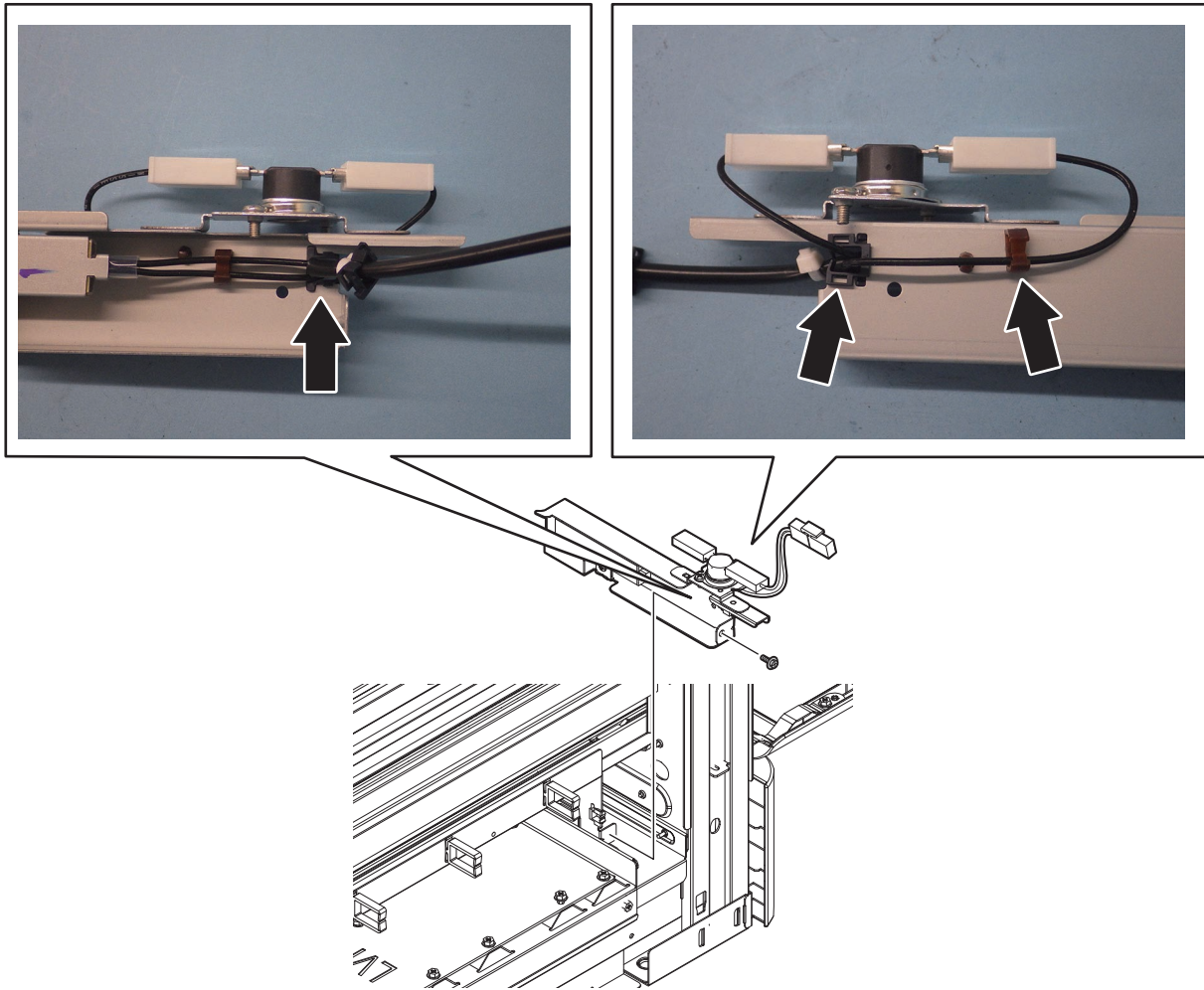


Fig. 4-314

**Notes:**

Be sure to pass the harness for the damp heater through the clamps.



**Fig. 4-315**

**Notes:**

If the thermostat is not installed appropriately when it is replaced or installed, it may not work normally. If you carry out the maintenance of the equipment in such a situation, you could get an electric shock by touching live sections or be injured by touching moving sections. Therefore, to avoid this, be sure to perform correct handling and installation.



## 4.7 Transfer Units (TBU, TRU)

### 4.7.1 Transfer belt cleaning unit

- (1) Remove the waste toner box.  
☞ P. 4-67 "4.6.1 Waste toner box"
- (2) Hold the lever [1] and pull the transfer belt cleaning unit [2] toward the front side to remove it.

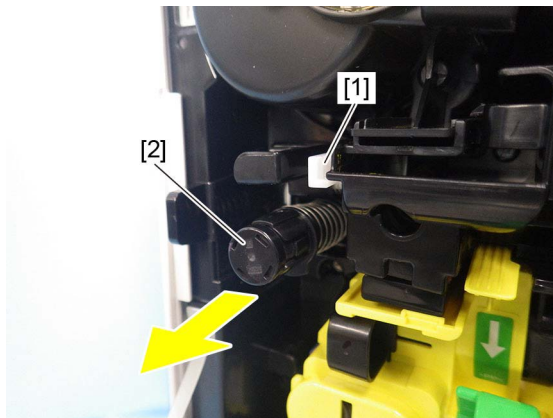


Fig. 4-316

### 4.7.2 Transfer belt cleaning blade/blade seal/recovery blade<sup>PM</sup>

- (1) Remove the transfer belt cleaning unit.  
☞ P. 4-115 "4.7.1 Transfer belt cleaning unit"
- (2) Remove 2 screws and take off the transfer belt cleaning blade [1].

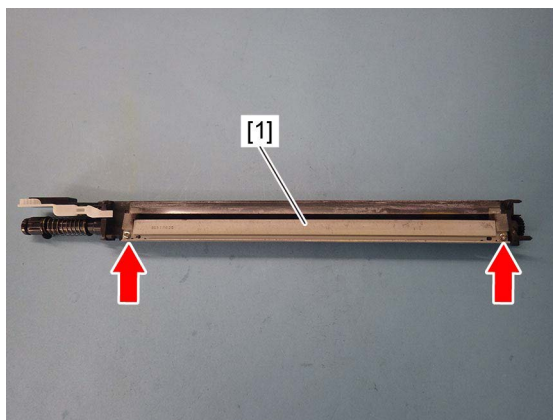


Fig. 4-317

- (3) Remove the front and rear blade seals.

**Notes:**

After the blade seals have been attached, be sure that no gap is left between the blade seals and the edge of the transfer belt cleaning blade.



Fig. 4-318

(4) Remove the recovery blade [1].



Fig. 4-319

Transfer belt cleaning blade



Fig. 4-320

Blade seal



Fig. 4-321

Recovery blade



Fig. 4-322

### 4.7.3 Transfer belt unit (TBU)

**Notes:**

You are recommended to wear gloves so that you do not touch the surface of the transfer belt with bare hands.

- (1) Remove the transfer belt cleaning unit.  
P. 4-115 "4.7.1 Transfer belt cleaning unit"
- (2) Pull the TBU release lever [1] and turn it clockwise to release the 1st transfer roller.

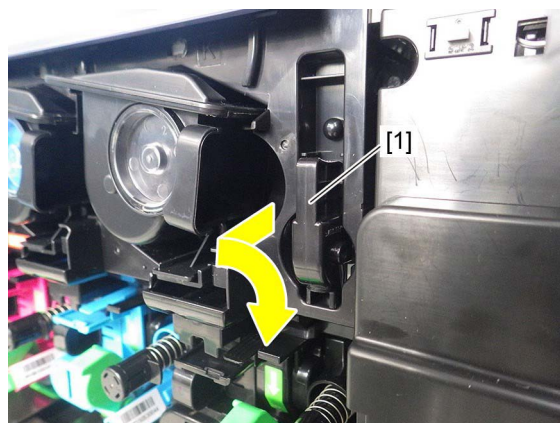


Fig. 4-323

- (3) Open the side cover and lower the 2nd transfer roller unit (TRU) [2].

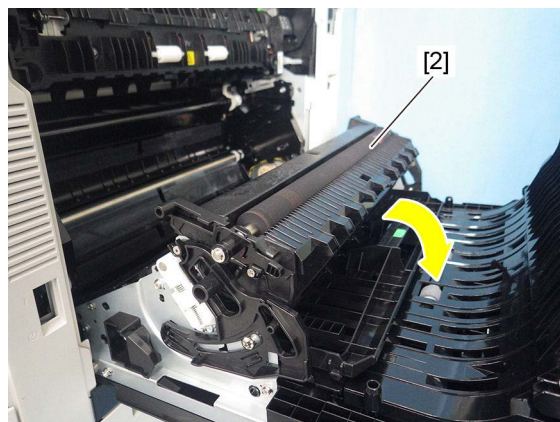


Fig. 4-324

- (4) Pull the lever [3]. Loosen 2 screws to lower it and pull out the transfer belt unit [4].

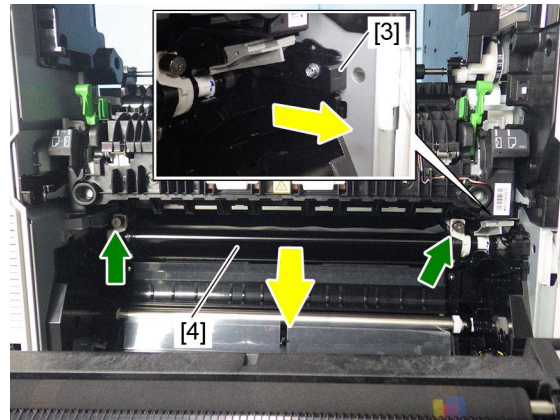


Fig. 4-325

**Notes:**

- Be careful not to generate any friction between the transfer belt and the 2nd transfer roller unit when pulling out the transfer belt unit.
- When installing the transfer belt unit, make sure that the lever [3] is pulled out.
- When installing the transfer belt unit, push the handle unit [6] inside while the screw [5] is lowered.

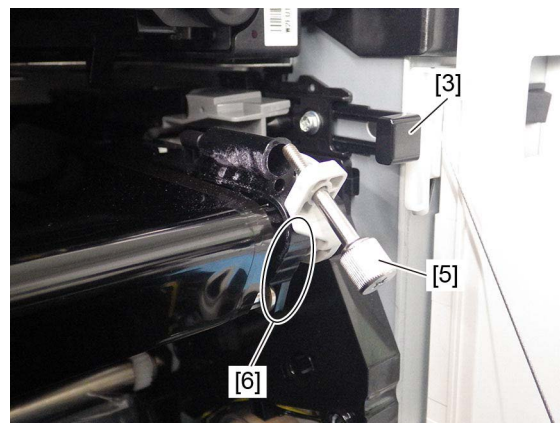


Fig. 4-326

#### 4.7.4 Transfer belt

**Notes:**

You are recommended to wear gloves so that you do not touch the surface of the transfer belt with bare hands.

- (1) Remove the transfer belt unit.  
📖 P. 4-117 "4.7.3 Transfer belt unit (TBU)"
- (2) Remove the spring [2] and the front tensioner [1].

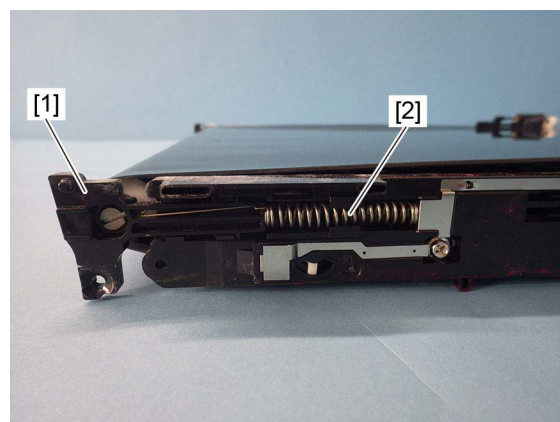


Fig. 4-327

- (3) Remove the spring [1] on the rear side.

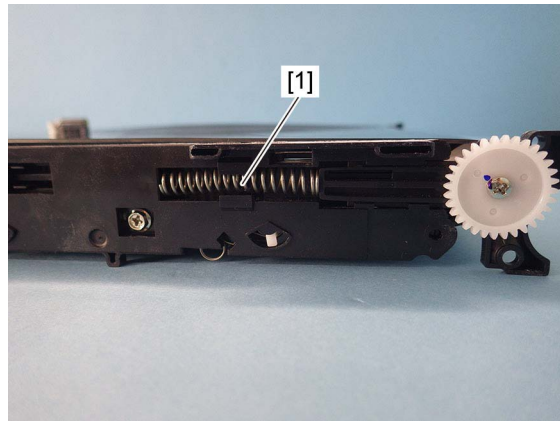


Fig. 4-328

- (4) Remove 1 screw and take off the front drive roller bracket [1].

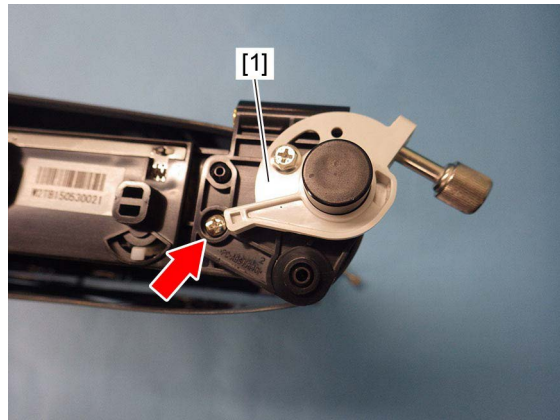


Fig. 4-329

- (5) Using the material that is packed with the transfer belt (service part), stand the transfer belt unit [1] on the waste toner box [2].

**Notes:**

Use 1 piece of white urethane foam (138 x 138 x 25 mm) with a 30 mm diameter hole.

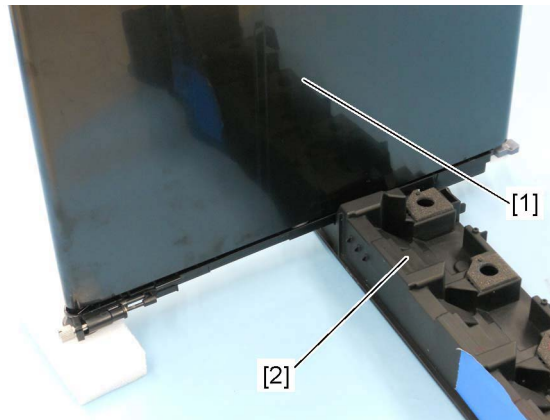


Fig. 4-330

**Notes:**

When installing, make sure that the  $\triangle$  mark [1] of the transfer belt unit is aligned with the  $\triangle$  mark [2] of the waste toner box.

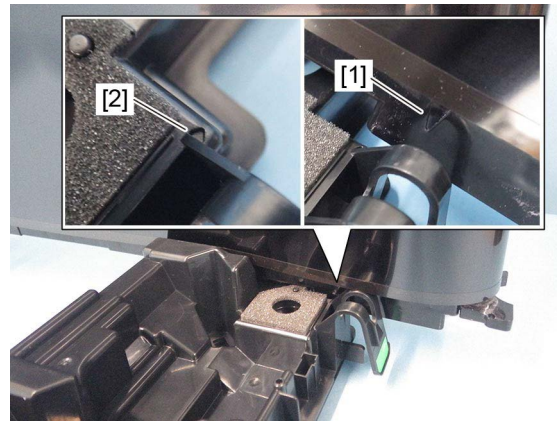


Fig. 4-331

- (6) Remove the transfer belt [1] upward.

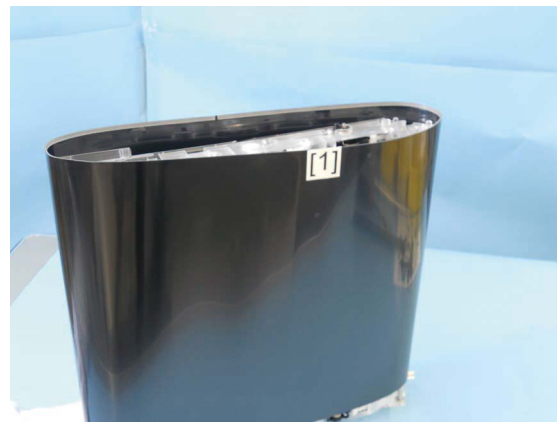


Fig. 4-332

**Notes:**

- When installing the transfer belt, place the side with the serial number facing upward (front side).
- Install the transfer belt in the middle so that it does not move to one side.
- Do not touch the belt surface directly with bare hands.
- Be sure not to scratch the belt surface.
- Check if the rib on both ends of the transfer belt does not run on the rollers.



Fig. 4-333

## 4.7.5 Cleaner unit facing roller

- (1) Remove the transfer belt.  
📖 P. 4-118 "4.7.4 Transfer belt"
- (2) Remove 1 screw, 1 gear [1], 1 tensioner [2], 1 bushing [3], and 2 guides [4], and then take off the cleaner unit facing roller [5].

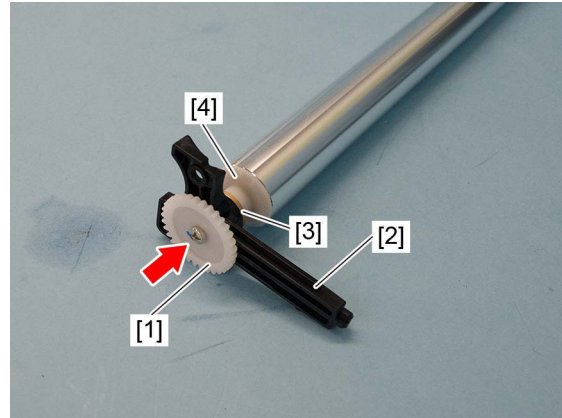


Fig. 4-334



Fig. 4-335

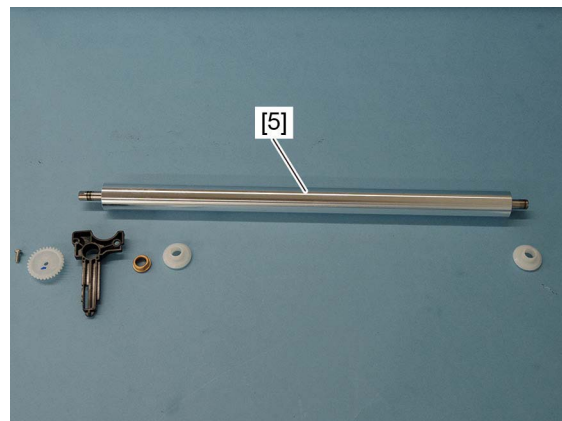



Fig. 4-336

## 4.7.6 Drive roller

- (1) Remove the transfer belt.  
 P. 4-118 "4.7.4 Transfer belt"
- (2) Remove the drive roller [1].

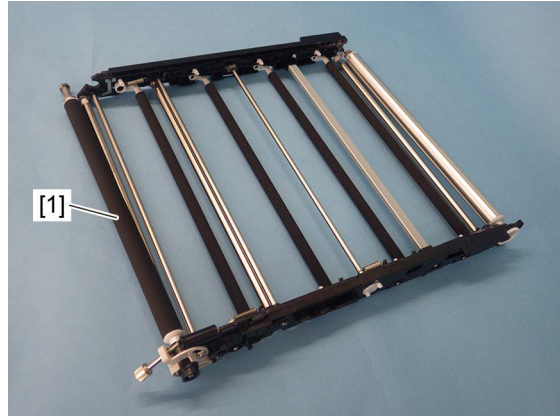


Fig. 4-337

### Notes:

When installing the driver roller, correctly attach the spring [2] on the rear drive roller shaft.

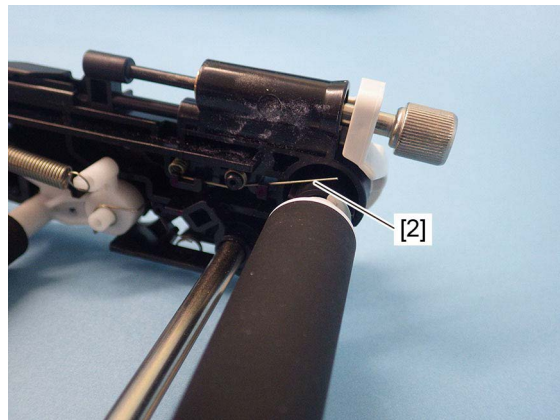



Fig. 4-338

## 4.7.7 1st transfer roller

- (1) Remove the transfer belt.  
 P. 4-118 "4.7.4 Transfer belt"
- (2) Place the transfer belt frame upside down.
- (3) Turn the coupling to place the 1st transfer roller into the contact state.

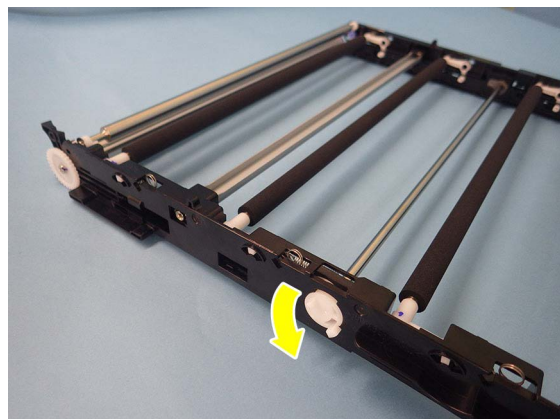


Fig. 4-339



- (4) Remove the rear shaft [2] on the 1st transfer roller [1].
- (5) Pull the 1st transfer roller [1] toward the rear side to remove it.

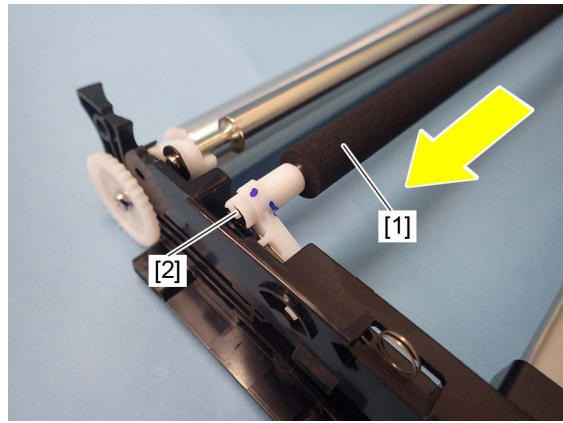


Fig. 4-340



Fig. 4-341

## 4.7.8 2nd transfer roller

- (1) Open the side cover.
- (2) Raise the stopper and remove the 2nd transfer roller assembly [1].

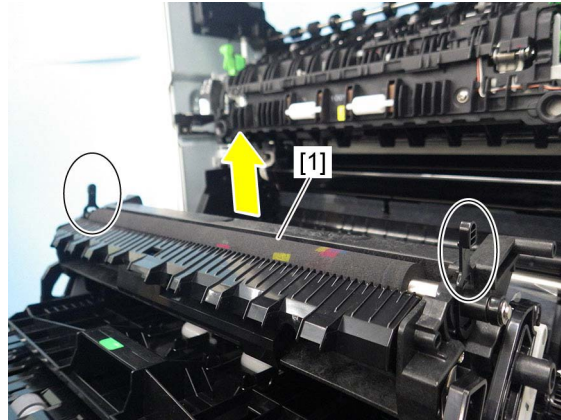
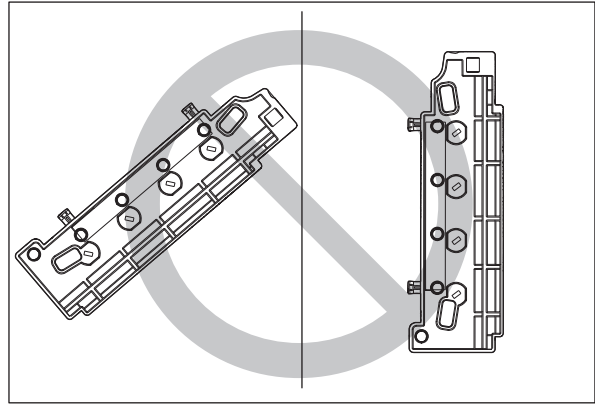


Fig. 4-342

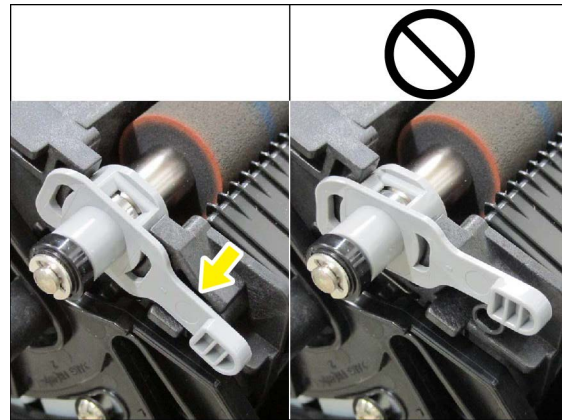


**Notes:**

- Be sure that the stopper is attached securely.

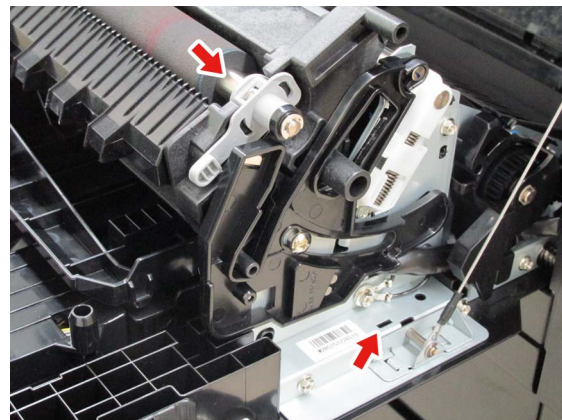


**Fig. 4-343**



**Fig. 4-344**

- After replacing the 2nd transfer roller, check that the 2nd transfer roller shaft is securely grounded via the ADU rear frame (metal plate).



**Fig. 4-345**

## 4.7.9 2nd transfer roller unit (TRU)

- (1) Open the side cover.
- (2) Remove 1 screw and take off the harness cover [1].

**Notes:**

When installing the harness cover, be careful not to let the harness get caught in it.

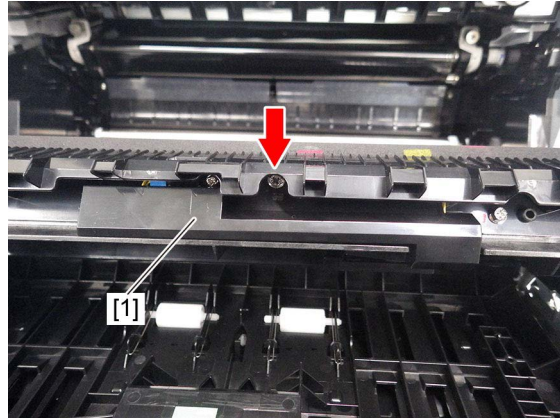


Fig. 4-346

- (3) Disconnect 1 connector [2] and remove 1 screw and 1 clip [3], and then remove the 2nd transfer roller unit [4].

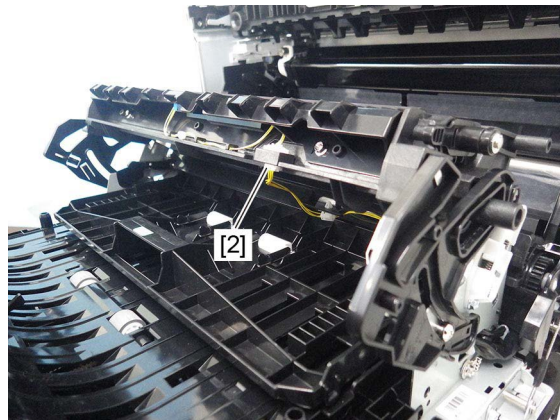


Fig. 4-347

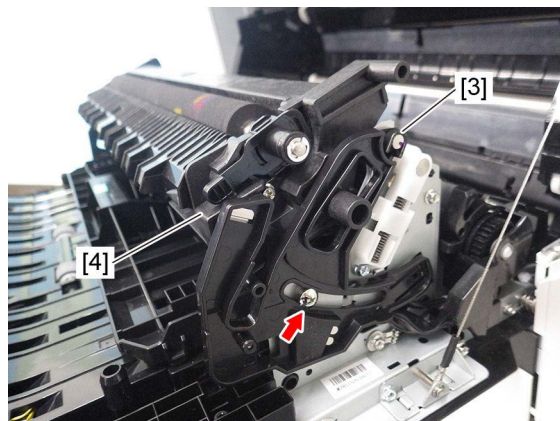


Fig. 4-348

## 4.7.10 Paper clinging detection sensor (S18)

- (1) Remove the 2nd transfer roller unit.  
P. 4-126 "4.7.9 2nd transfer roller unit (TRU)"
- (2) Disconnect 1 connector [3] and remove 1 screw. Take off the paper clinging detection sensor (S18) [1].

**Notes:**

When installing, hook the harness to 3 hooks [2].

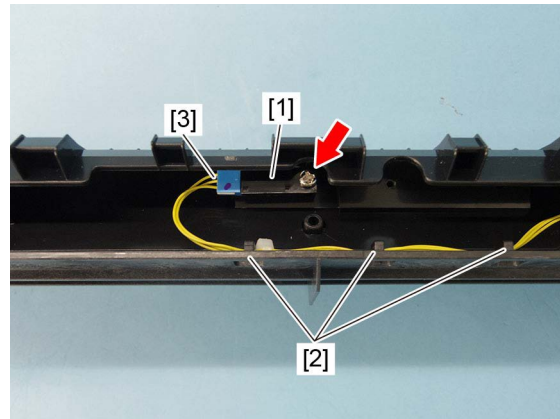


Fig. 4-349

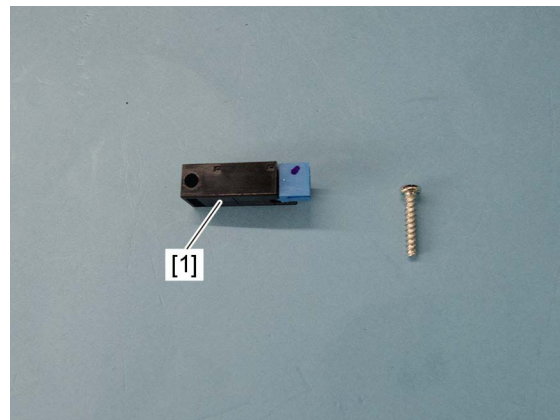


Fig. 4-350

## 4.7.11 1st transfer contact/release clutch (CLT3)

- (1) Remove the rear cover.  
P. 4-6 "4.1.15 Rear cover"
- (2) Remove 1 screw and release the harness from the harness guide [1].

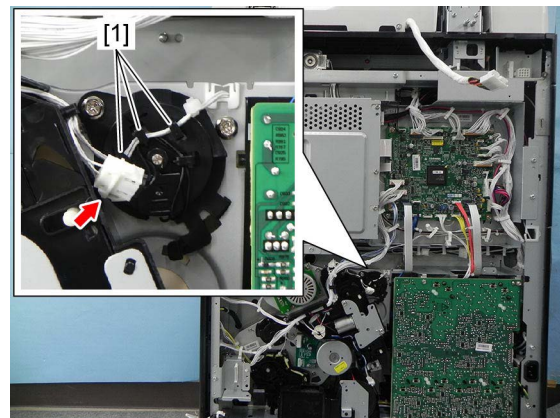


Fig. 4-351

- (3) Remove the 1st transfer contact/release clutch cover [2] by rotating it clockwise.

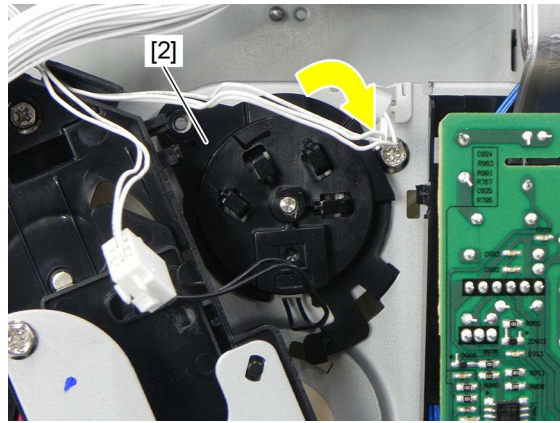


Fig. 4-352

- (4) Disconnect 1 connector and remove the 1st transfer contact/release clutch [3].

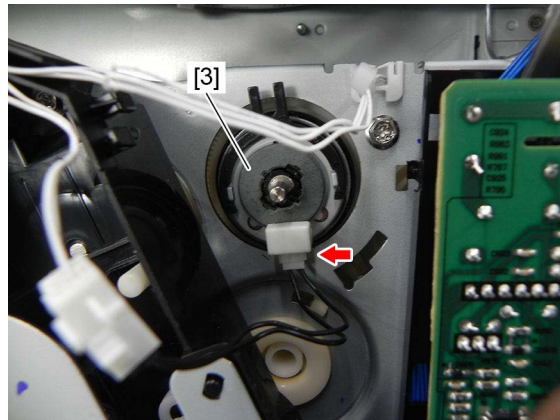


Fig. 4-353

#### 4.7.12 1st transfer roller status detection sensor (S12)

- (1) Remove the drum TBU drive unit.  
📖 P. 4-130 "4.7.14 Drum TBU drive unit"  
(2) Remove 2 screws and take off the 1st transfer contact/release gear unit [1].

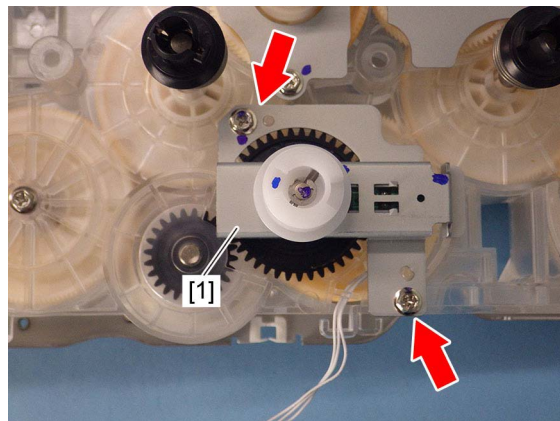
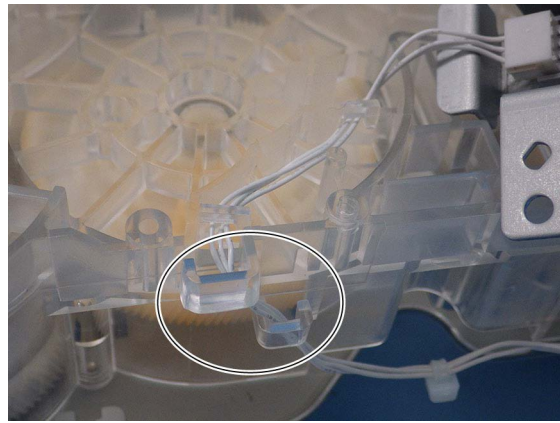


Fig. 4-354

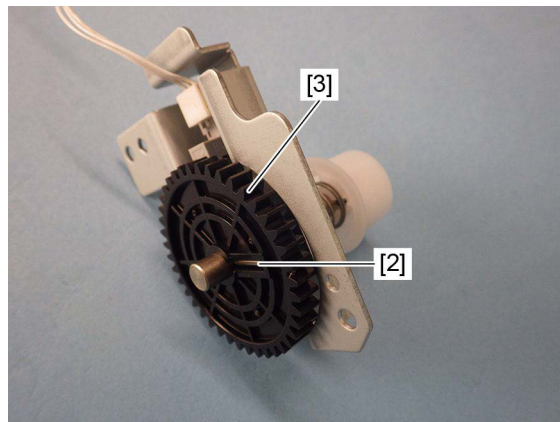
**Notes:**

When installing the 1st transfer roller status detection sensor, pass the harness through the harness guide.



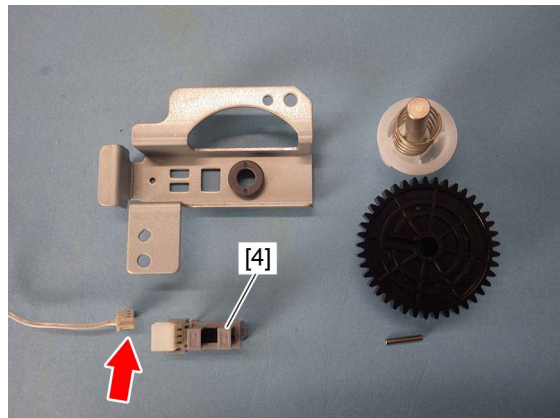
**Fig. 4-355**

- (3) Remove the pin [2] and gear [3].



**Fig. 4-356**

- (4) Release 3 latches and remove the 1st transfer roller status detection sensor [4], and then disconnect the connector.



**Fig. 4-357**

### 4.7.13 Drum/TBU motor (M6)

- (1) Remove the rear cover.  
 P. 4-6 "4.1.15 Rear cover"
- (2) Remove 2 screws and disconnect 1 connector [1], and then take off the drum/TBU motor [2].

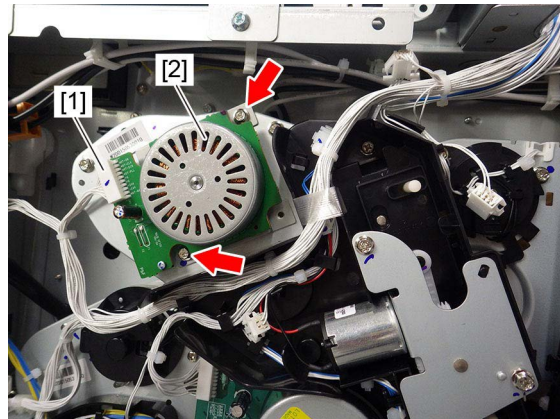


Fig. 4-358

### 4.7.14 Drum TBU drive unit

- (1) Remove the high-voltage transformer.  
 P. 9-9 "9.1.7 High-voltage transformer (HVT)"
- (2) Disconnect 5 connectors. Release the lock by tilting the flap and remove 4 flat cables [1].

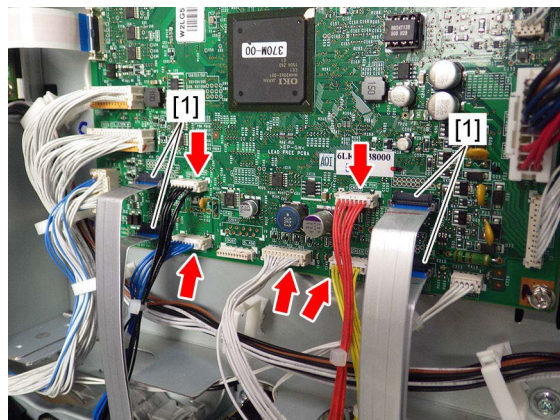


Fig. 4-359

#### Notes:

- When removing the flat cable [1], change the lever position so that the connector is released, and remove the flat cable by lifting it up slightly (approx. 7 degrees) as shown in the right figure.
- When connecting the flat cable [1] to the connector, insert the flat cable straightly and lock it securely. Confirm that the tabs are in the positions shown in the right figure.

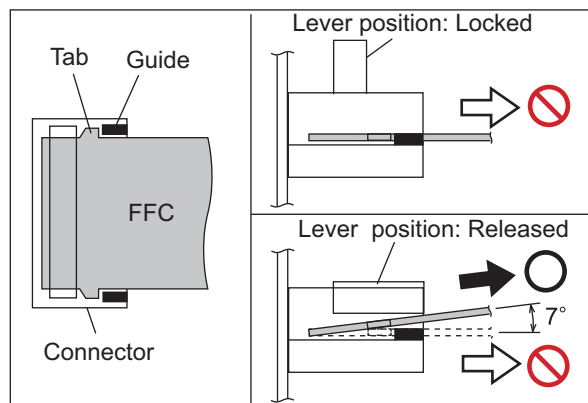
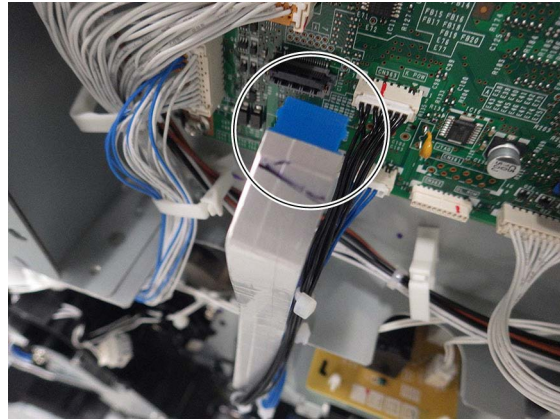


Fig. 4-360



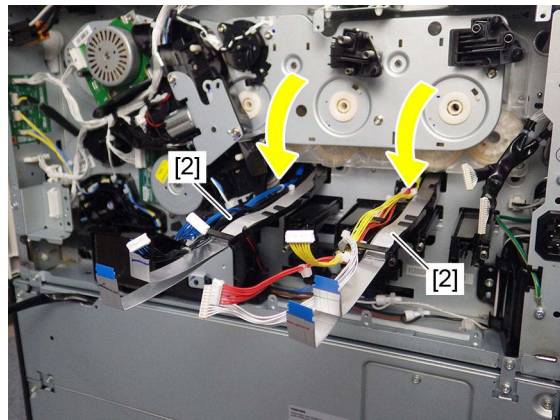
**Notes:**

- When installing the flat cable [1], be careful not to insert it at an angle.
- Do not apply pressure to or damage the edge of the flat cable [1].
- When installing the flat cable [1], do not push it in strongly.



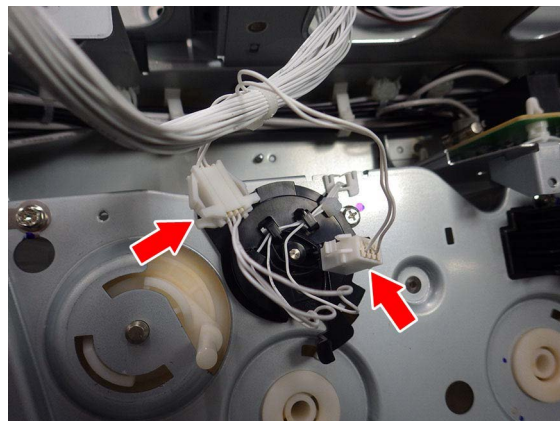
**Fig. 4-361**

- (3) Slide the harness guides [2] upward and tilt them to the near side.



**Fig. 4-362**

- (4) Remove the drum switching unit.  
📖 P. 4-96 "4.6.23 Drum switching unit"
- (5) Disconnect 2 connectors.



**Fig. 4-363**

- (6) Remove 2 power supply terminals [3].

**Notes:**

The number of the springs for the left side power supply terminal differs from the one for the right side power supply terminal.

Left side (see from rear side): 3 springs

Right side (see from rear side): 2 springs

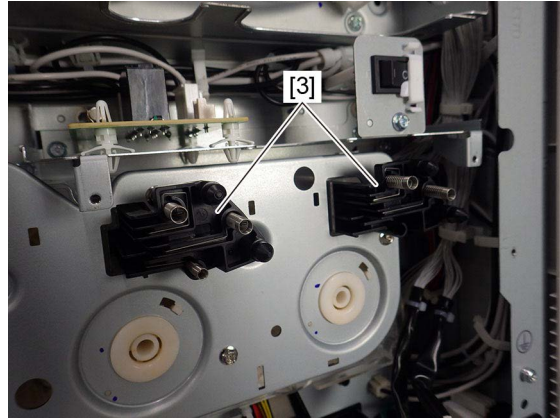


Fig. 4-364

- (7) Remove 7 screws, release the upper hook, and then take off the drum TBU drive unit [4].

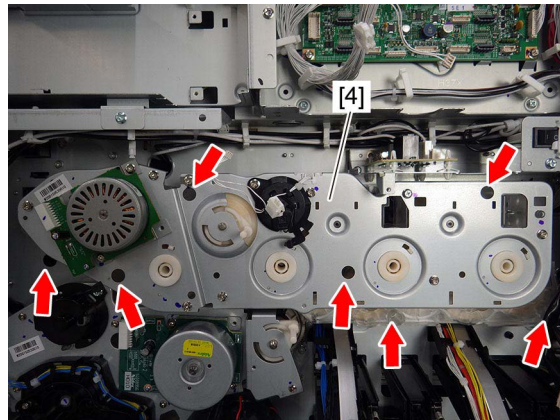


Fig. 4-365

**Notes:**

When installing the drum TBU drive unit, insert the protrusion of the transfer belt drive shaft release arm into the hole in the lever.

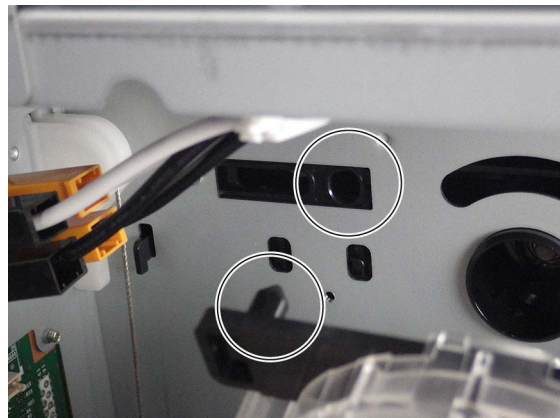


Fig. 4-366

(8) Remove the transfer belt drive shaft release arm [5].

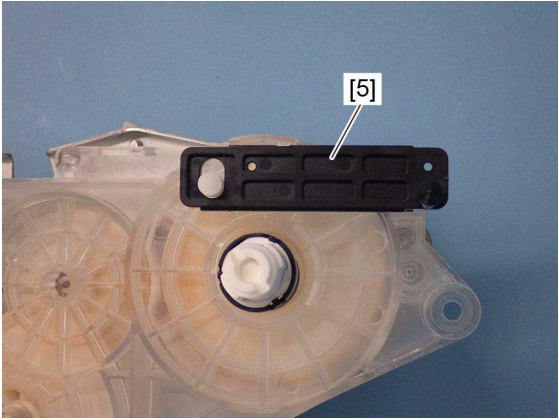




Fig. 4-367

## 4.8 Image Quality Control

### 4.8.1 Image quality control unit

- (1) Open the side cover.
- (2) Remove the transfer belt unit.  
 P. 4-117 "4.7.3 Transfer belt unit (TBU)"
- (3) Remove the Registration roller (on the equipment side).  
 P. 4-57 "4.5.8 Registration roller (on the equipment side)"
- (4) Remove 2 screws. Disconnect 1 connector [1] and take off the image quality control unit [2].

**Notes:**

The attachment screw on the rear side is a shoulder screw, so exercise care when handling it during installation.

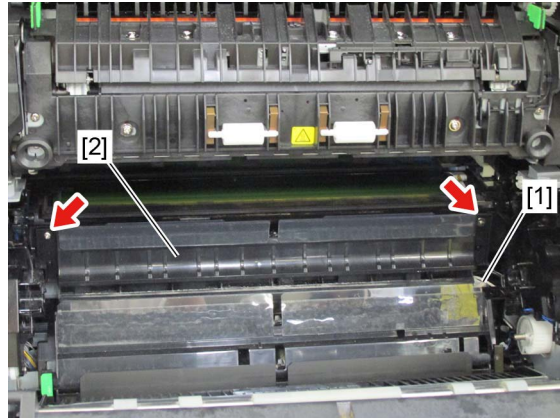



Fig. 4-368

### 4.8.2 Paper dust holder

- (1) Remove the image quality control unit.  
 P. 4-134 "4.8.1 Image quality control unit"
- (2) Remove 3 screws.

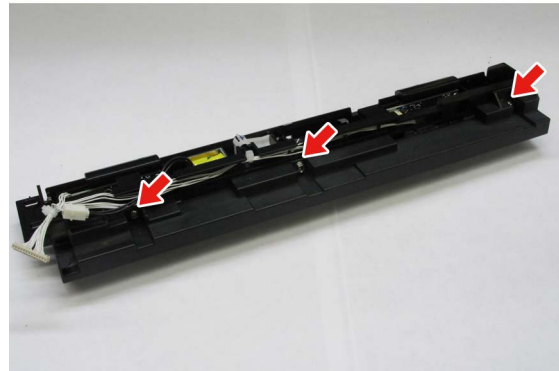


Fig. 4-369

- (3) Remove the paper dust holder [1].

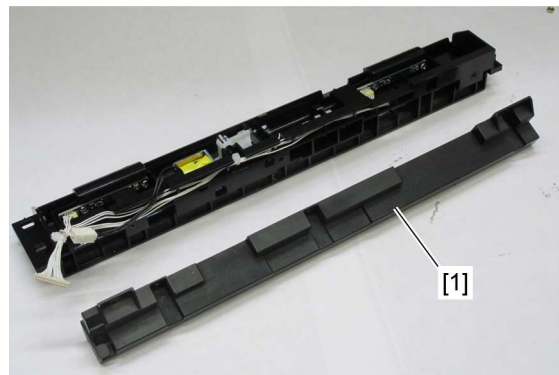


Fig. 4-370

### 4.8.3 Image position aligning sensor (Front) (S7)

- (1) Remove the image quality control unit.  
📖 P. 4-134 "4.8.1 Image quality control unit"
- (2) Remove 2 screws and disconnect 1 connector [1], and then take off the Image position aligning sensor (Front) [2].

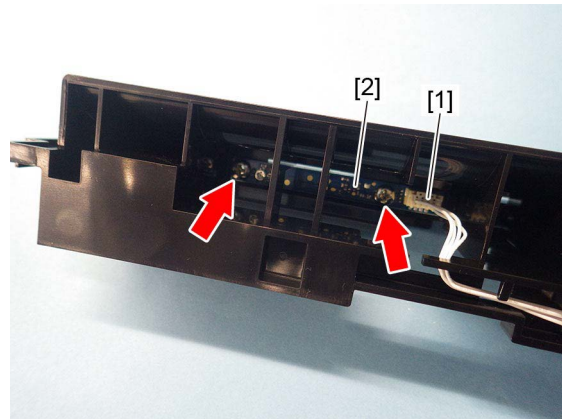


Fig. 4-371

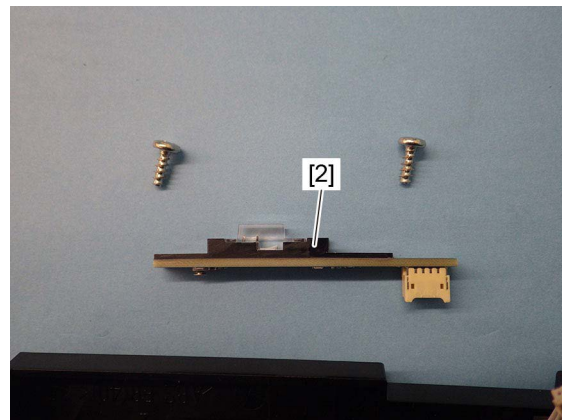


Fig. 4-372

#### 4.8.4 Image position aligning sensor (Rear)/Image quality sensor (S8)

- (1) Remove the image quality control unit.  
📖 P. 4-134 "4.8.1 Image quality control unit"
- (2) Remove 2 screws and disconnect 1 connector [1], and then take off the image position aligning sensor (Rear)/image quality sensor [2].

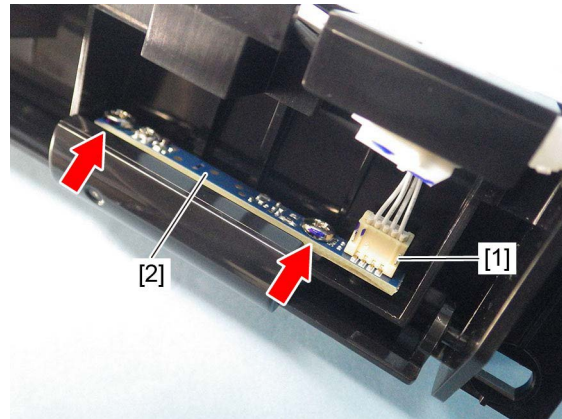


Fig. 4-373

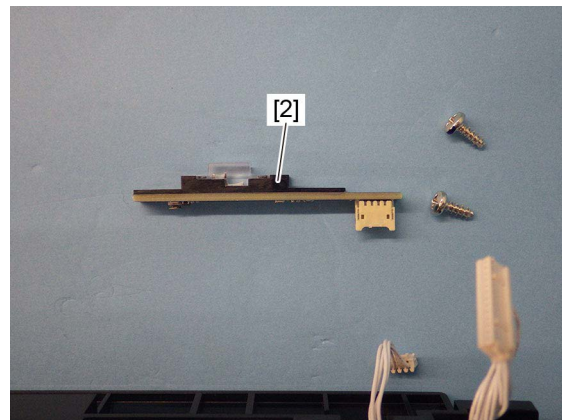


Fig. 4-374

#### 4.8.5 Registration sensor (S6)

- (1) Remove the image quality control unit.  
📖 P. 4-134 "4.8.1 Image quality control unit"
- (2) Release 3 latches and remove the registration sensor [1], and then disconnect the connector.

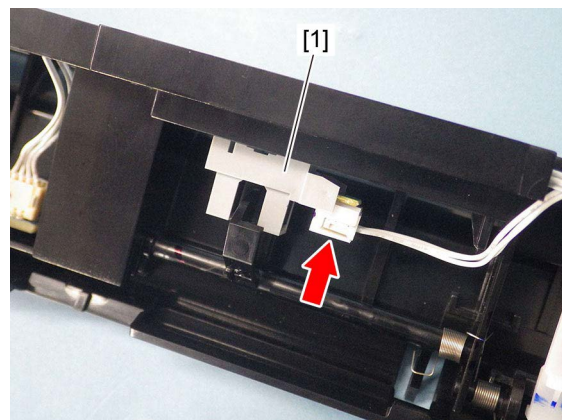


Fig. 4-375

## 4.9 Fuser Unit

### 4.9.1 Fuser unit

**Notes:**

- Be sure that the temperature of the fuser unit has lowered enough before removing it. If the unit still heated should be removed, wear a pair of gloves before working.
- When a new fuser unit is installed, be sure to check whether the fuser-related life counter values have been cleared in the list printing mode or the setting mode (08).
- When disassembling the fuser unit or replacing any parts in it, be sure that the wire harness is correctly set, and also be careful not to catch it between other parts.

- a. Check the harness wiring to prevent the cover from catching the harnesses.
- b. Be sure to wire the harness for the paper exit sensor as shown below and not to let it catch in the harness holder [1].

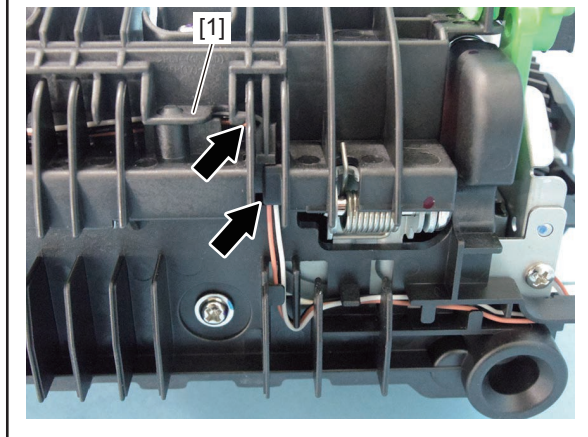
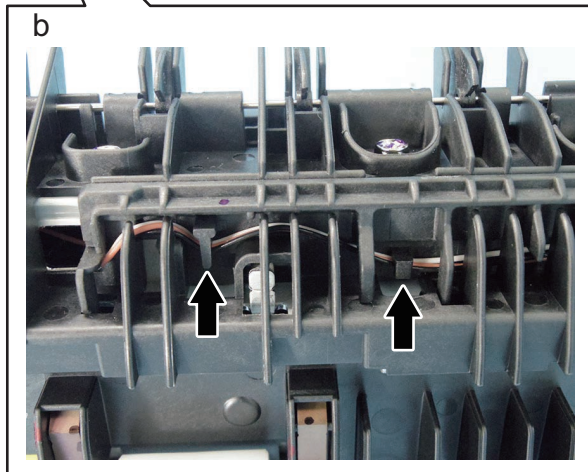
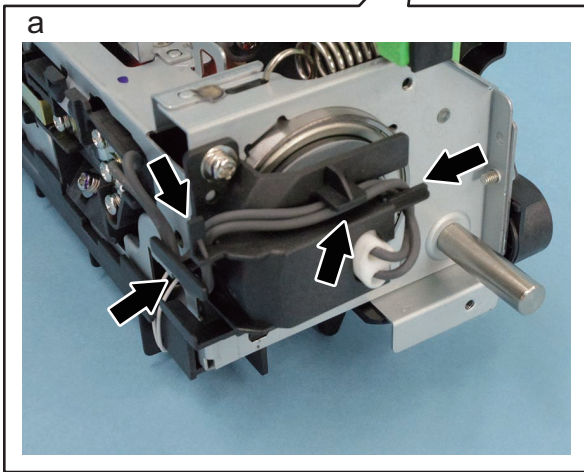
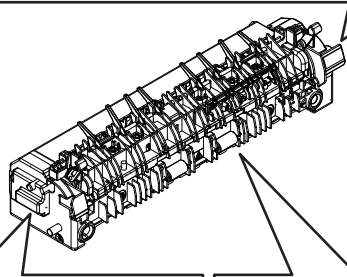
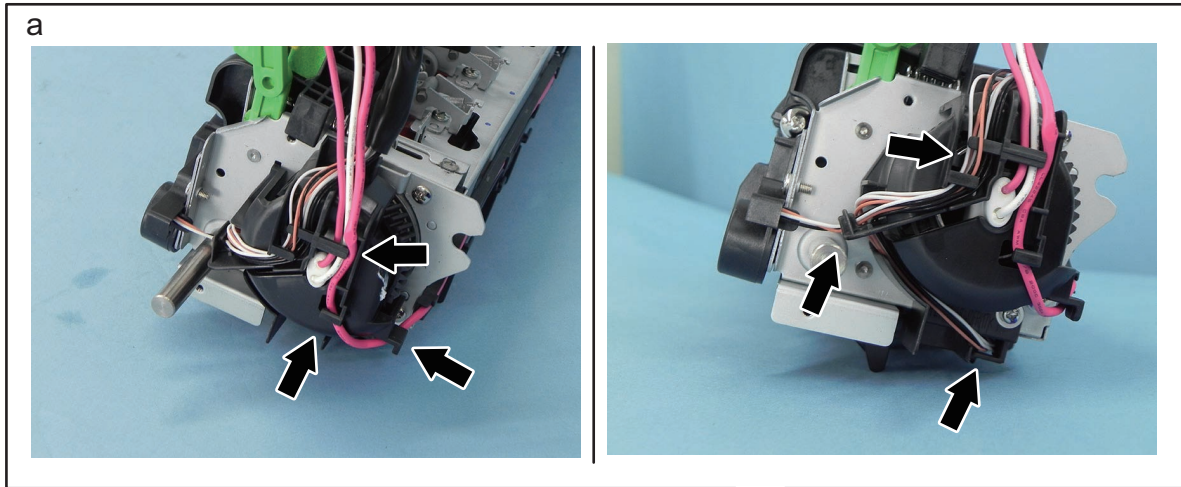


Fig. 4-376

c. Be sure to wire the harness for the fuser roller thermostat along the hooks of the harness holder [2] as shown below.



d. Be sure to wire the harnesses for the fuser roller thermistor along all the hooks of the harness holder [1] as shown below.

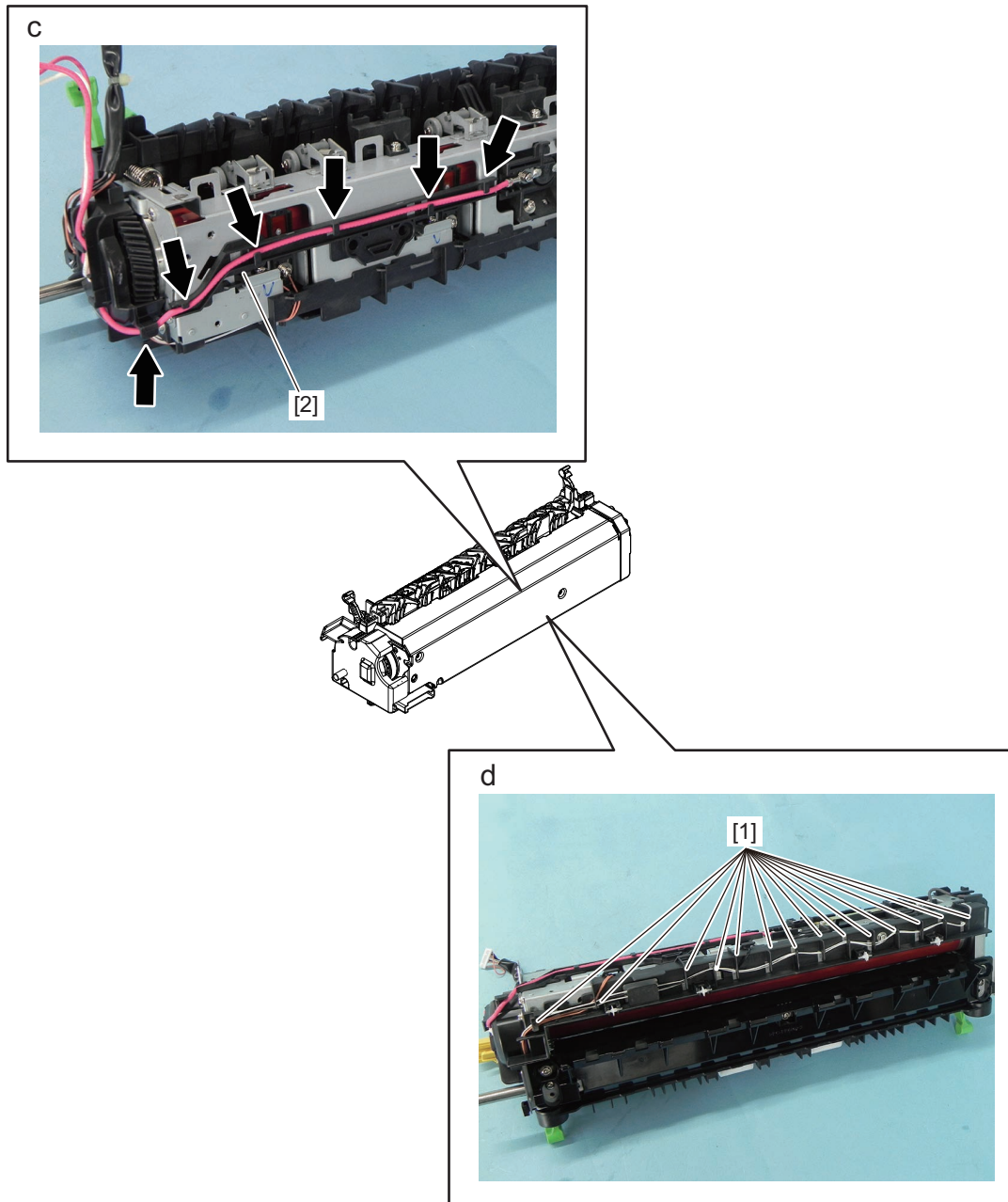
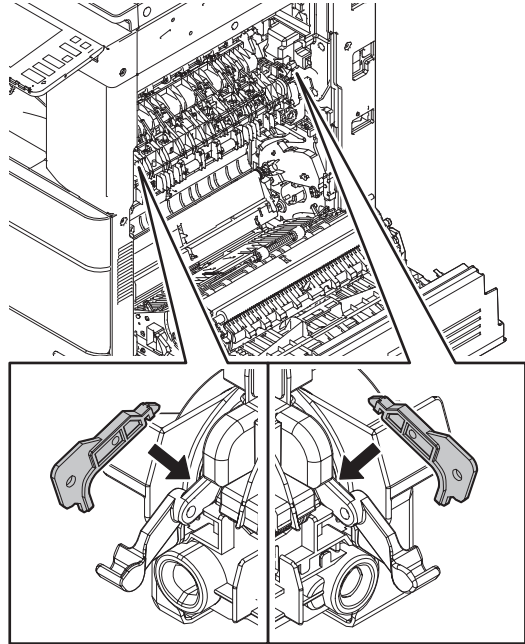


Fig. 4-377

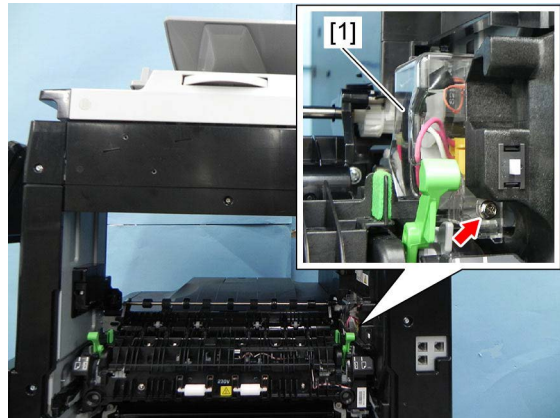
**Notes:**

If the equipment and the fuser unit are left unused for a long time, install the pressure release parts (SPACER-PRS-INI) to release the pressure of the fuser unit.



**Fig. 4-378**

- (1) Open the side cover.
- (2) Remove 1 screw and take off the connector cover [1].



**Fig. 4-379**

- (3) Disconnect 2 connectors.



**Fig. 4-380**

- (4) Press down the lever [2] and remove the fuser unit [3].

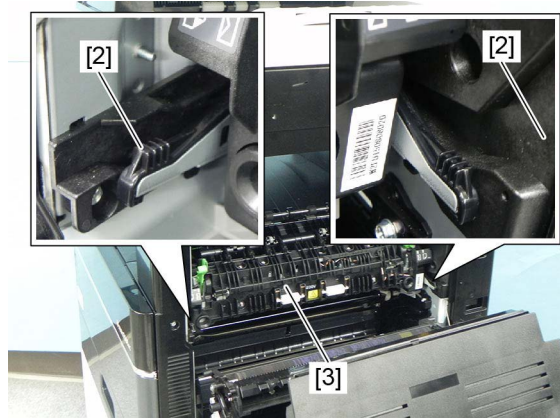
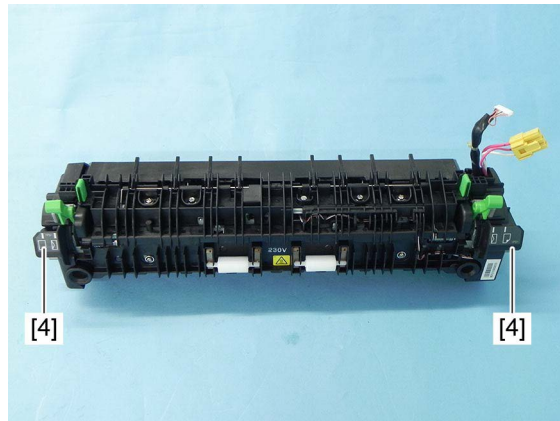


Fig. 4-381

**Notes:**

- The fuser unit is extremely hot. When removing the fuser unit, hold the handles [4] of the unit to avoid a direct touch on the unit.

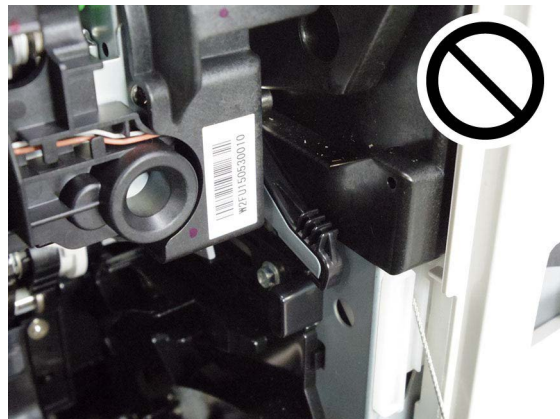


**Fig. 4-382**

- When installing the fuser unit, be sure to press it in until the lever goes up. If the lever goes down, the fuser unit has not been correctly installed.



**Fig. 4-383**



**Fig. 4-384**

## 4.9.2 Front side cover

- (1) Remove the fuser unit.  
📖 P. 4-137 "4.9.1 Fuser unit"
- (2) Remove 2 screws and take off the front side cover [1].

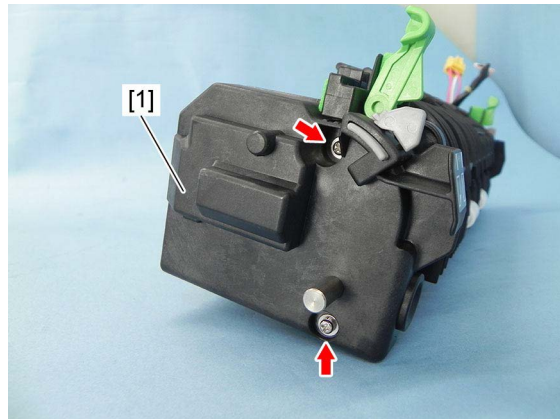


Fig. 4-385

## 4.9.3 Rear side cover

- (1) Remove the fuser unit.  
📖 P. 4-137 "4.9.1 Fuser unit"
- (2) Remove 2 screws and take off the rear side cover [1].

### Notes:

When installing the cover, put the harness into the harness guide so that it will not be pinched by the cover.

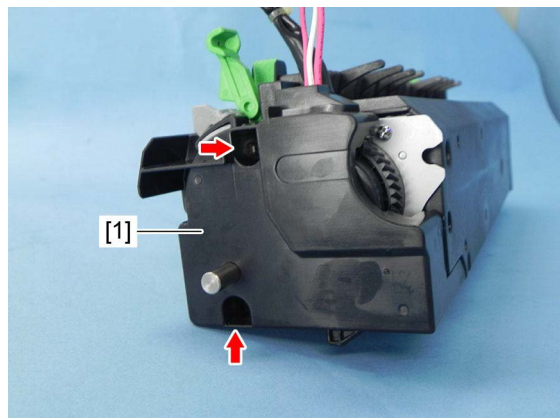


Fig. 4-386

## 4.9.4 Fuser roller cover

- (1) Remove the fuser unit.  
📖 P. 4-137 "4.9.1 Fuser unit"
- (2) Remove 2 screws and take off the fuser roller cover [1].

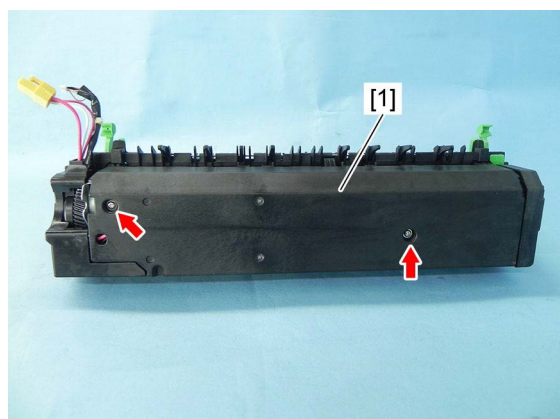




Fig. 4-387

## 4.9.5 Paper entrance guide

- (1) Remove the front side cover.  
 P. 4-143 "4.9.2 Front side cover"
- (2) Remove the rear side cover.  
 P. 4-143 "4.9.3 Rear side cover"
- (3) Remove 2 screws and take off the paper entrance guide [1].

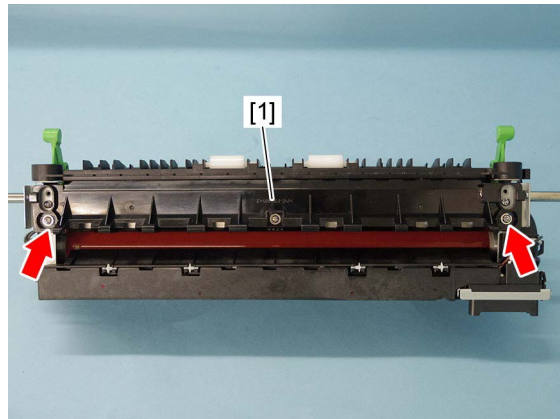


Fig. 4-388

- (4) Remove 1 screw and take off the brush [2].

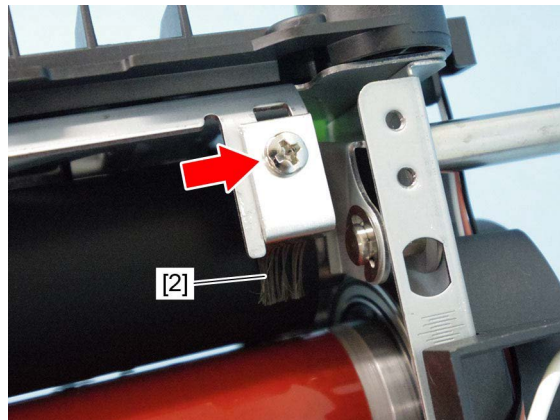



Fig. 4-389

## 4.9.6 Fuser roller separation finger

- (1) Remove the fuser roller cover.  
 P. 4-143 "4.9.4 Fuser roller cover"
- (2) Remove 5 springs [1] and take off 5 separation fingers [2].

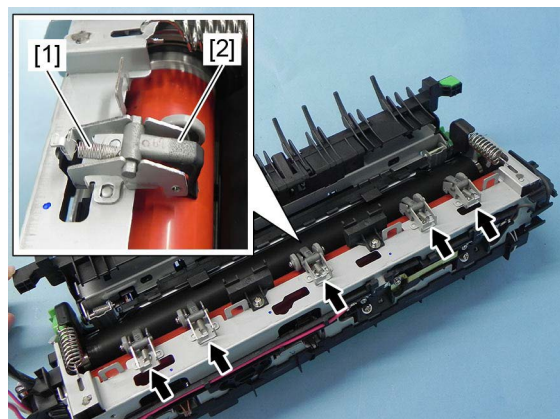



Fig. 4-390

## 4.9.7 Paper exit sensor (S13)

- (1) Remove the fuser unit.  
 P. 4-137 "4.9.1 Fuser unit"
- (2) Remove the harness holder [1].

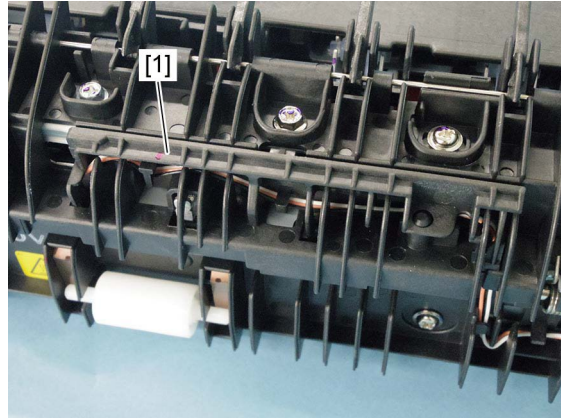


Fig. 4-391

- (3) Release the harness [2] from the harness guide.

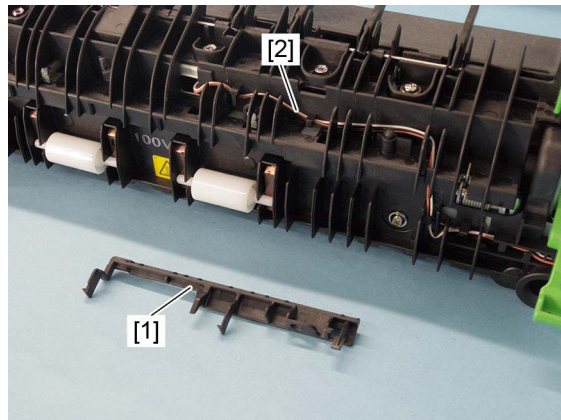


Fig. 4-392

- (4) Remove 2 screws. Open the reverse guide, and then take off the sensor cover [3].

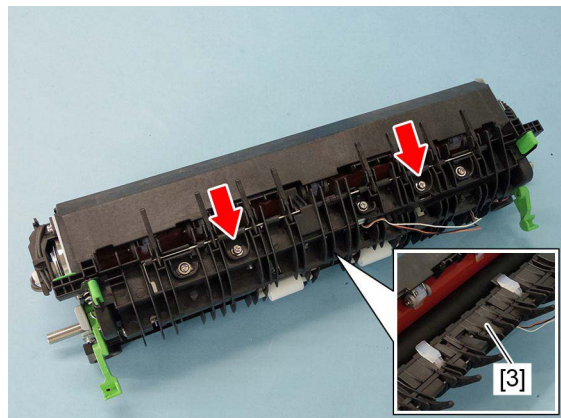


Fig. 4-393

- (5) Remove 3 screws and take off the reverse guide [4].

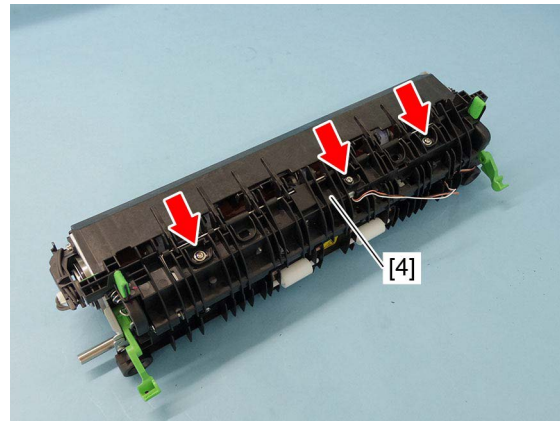


Fig. 4-394

- (6) Disconnect the connector and take off the paper exit sensor [5].

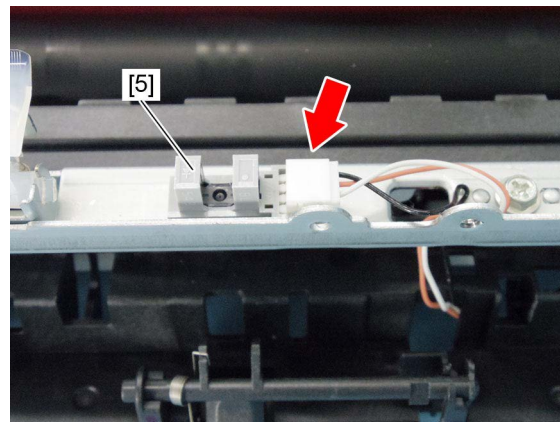



Fig. 4-395


#### 4.9.8 Fuser roller center thermostat (THMO1)/ fuser roller rear thermostat (THMO2)

**Notes:**

If the thermostat is not installed appropriately when it is replaced or installed, it may not work normally. If you carry out the maintenance of the equipment in such a situation, they may result in fatal accidents such as explosion or fire. Therefore, to avoid this, be sure to perform correct handling and installation.

- (1) Remove the fuser roller cover.  
 P. 4-143 "4.9.4 Fuser roller cover"
- (2) Remove 6 screws, and then take off the sensor thermostat [1] and side thermostat [2].

**Notes:**

- When installing, be sure that the gap between the thermostat and fuser roller is 1.2 to 1.8 mm.
- After replacing the center and side thermostats, adjust the gap between the thermostats and the fuser roller.  
 P. 6-89 "6.12.3 Adjustment of the thermostat Gap"

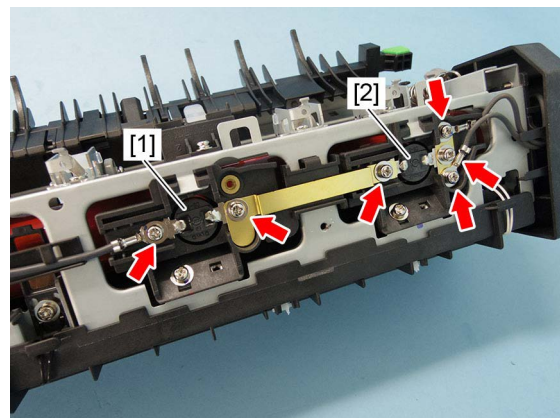


Fig. 4-396



## 4.9.9 Fuser roller center thermistor (THM1)/fuser roller side thermistor (THM2)/fuser roller edge thermistor (THM3)

### Notes:

If the thermistor is not installed appropriately when it is replaced or installed, it may not work normally. If you carry out the maintenance of the equipment in such a situation, they may result in fatal accidents such as explosion or fire. Therefore, to avoid this, be sure to perform correct handling and installation.

- (1) Remove the rear side cover.  
📖 P. 4-143 "4.9.3 Rear side cover"
- (2) Remove the fuser roller cover.  
📖 P. 4-143 "4.9.4 Fuser roller cover"
- (3) Release the harness from the harness guide.

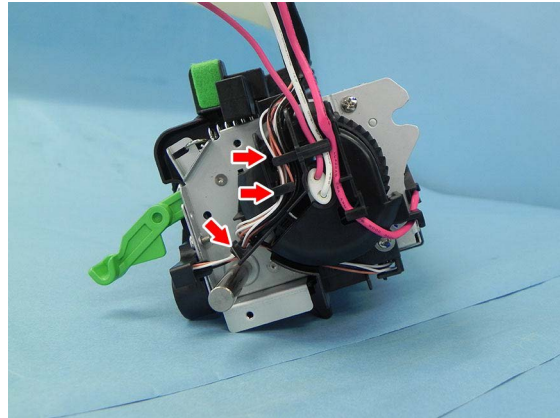


Fig. 4-397

- (4) Remove 1 screw, release the harness from the guides, and then take off the harness guide [1].

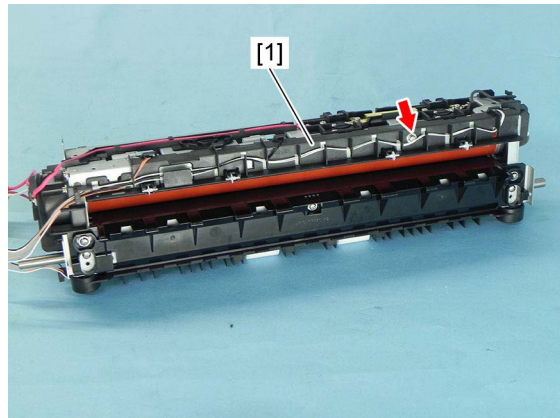


Fig. 4-398

- (5) Remove 1 screw and take off the edge thermistor [2].

### Notes:

- Before installing the fuser roller edge thermistor, assemble the fuser roller.
- When installing, be careful not to deform the thermistor. Also, make sure that the thermistor is in touch with the fuser roller.
- After replacing the thermistor, be sure to adjust the non-contact thermistor gap and calibrate the non-contact thermistor.

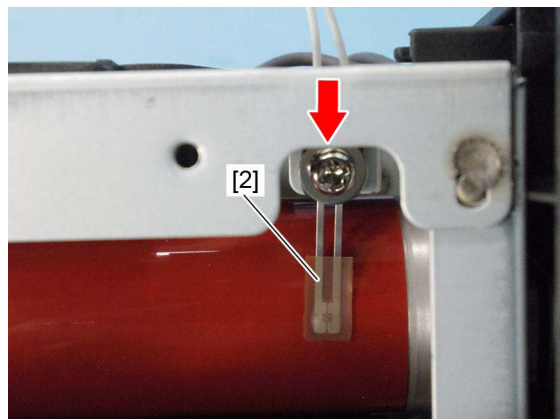


Fig. 4-399

- (6) Remove 2 screws, and then take off the center thermistor [3] and side thermistor [4].

**Notes:**

- When installing, be careful not to cause any deformation to occur to the thermistor.
- After replacing the center and side thermistors, adjust the gap between the thermistor and the fuser roller. And, be sure that the gap between the thermistor and fuser roller is 0.5 to 1.0 mm. See the external document.: 6.12.1 Adjustment of the non-contact thermistor Gap
- After replacing the thermistor, be sure to adjust the non-contact thermistor gap and calibrate the non-contact thermistor.

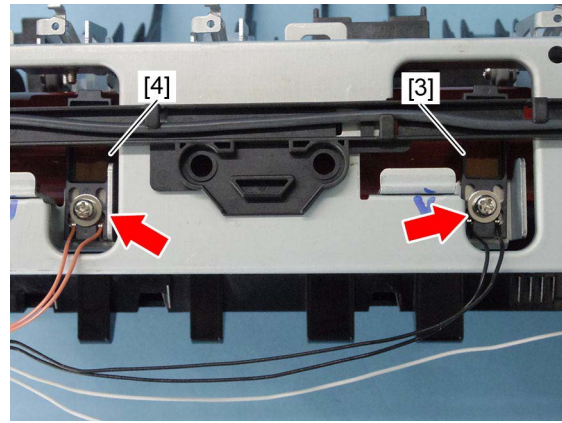


Fig. 4-400

#### 4.9.10 Center heater lamp (LAMP1), Side heater lamp (LAMP2)

- (1) Remove the front side cover.  
P. 4-143 "4.9.2 Front side cover"
- (2) Remove the rear side cover.  
P. 4-143 "4.9.3 Rear side cover"
- (3) Remove the fuser roller cover.  
P. 4-143 "4.9.4 Fuser roller cover"
- (4) Remove 3 screws and take off the harness of the thermostat.

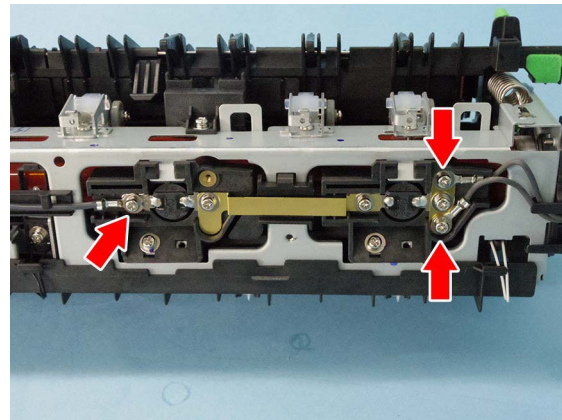


Fig. 4-401

- (5) Remove 1 screw and release the harness from the harness guide [1].

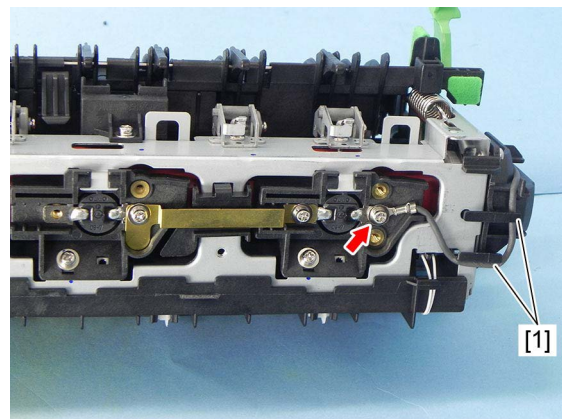


Fig. 4-402

- (6) Remove 1 screw and take off the front lamp holder [2].

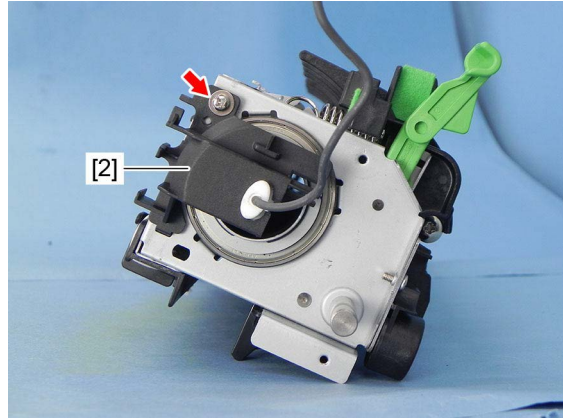


Fig. 4-403

- (7) Remove 1 screw and release the harness from the harness guide [3].

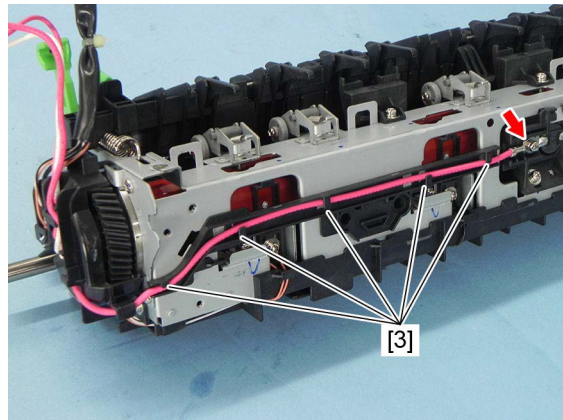


Fig. 4-404

- (8) Release the harness from the harness guide.

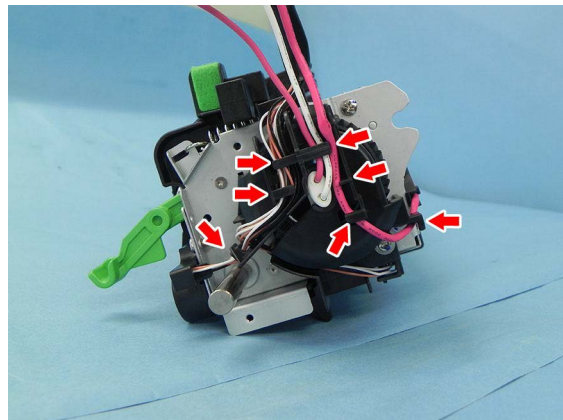


Fig. 4-405

- (9) Remove 1 screw and take off the rear lamp holder [4].

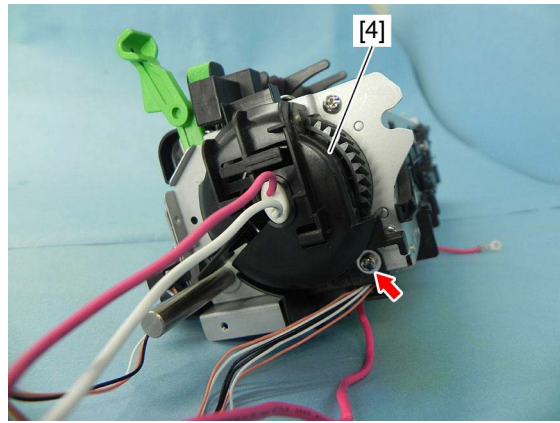


Fig. 4-406

- (10) Remove the heater lamp [5].

**Notes:**

- Do not touch the heater lamp directly with your hands.

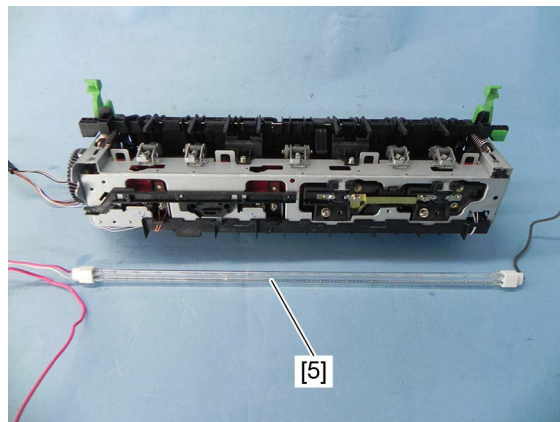


Fig. 4-407

### 4.9.11 Pressure roller

- (1) Remove the harness holder [1].

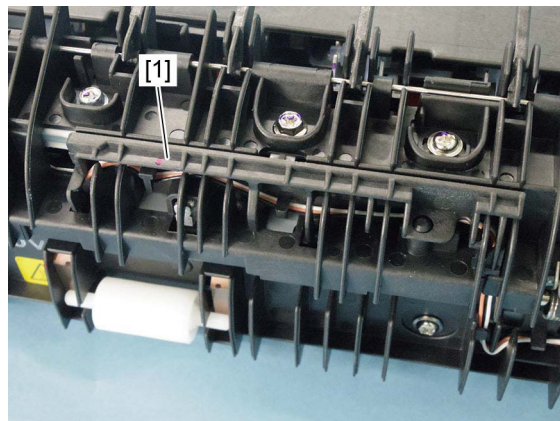


Fig. 4-408

- (2) Release the harness [2] from the harness guide.

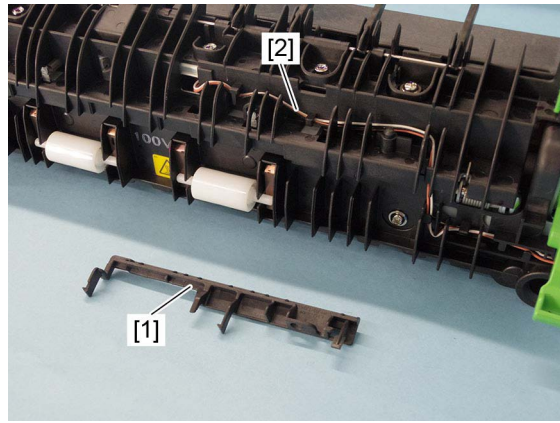


Fig. 4-409

- (3) Remove 2 screws and take off the pressure roller cover [3].

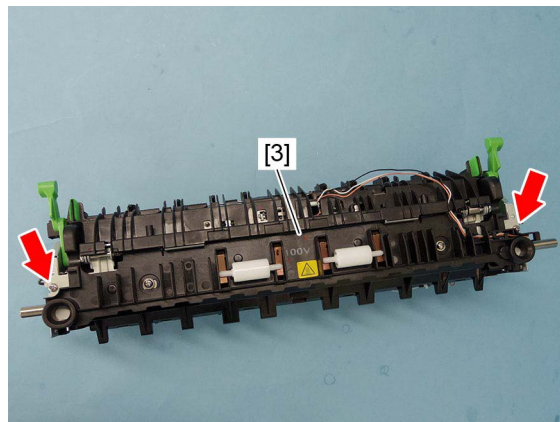


Fig. 4-410

- (4) Remove [4] 2 springs.

**Notes:**

- After replacing the springs, adjust the gap between the thermistor and the fuse roller. And, be sure that the gap between the thermistor and fuser roller is 0.5 to 1.0 mm.  
See the external document.: 6.12.1 Adjustment of the non-contact thermistor Gap
- After adjusting the gap, be sure to calibrate the fuser thermistor.

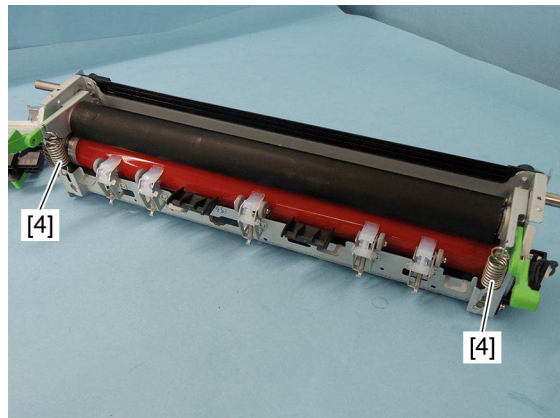


Fig. 4-411

- (5) Remove 2 levers [5] and the pressure roller [6].

**Notes:**

- After replacing the pressure roller, adjust the gap between thermistor and the fuser roller. And, be sure that the gap between the thermistor and fuser roller is 0.5 to 1.0 mm.  
See the external document.: 6.12.1 Adjustment of the non-contact thermistor Gap
- After adjusting the gap, be sure to calibrate the fuser thermistor.

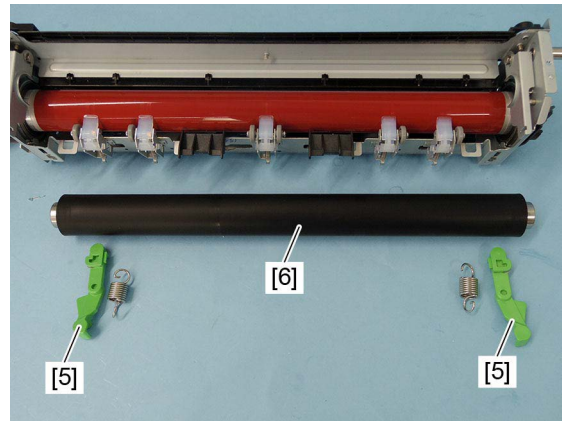


Fig. 4-412

### 4.9.12 Fuser roller

- (1) Remove the paper entrance guide.  
P. 4-144 "4.9.5 Paper entrance guide"
- (2) Remove the pressure roller.  
P. 4-150 "4.9.11 Pressure roller"
- (3) Remove the heater lamp.  
P. 4-148 "4.9.10 Center heater lamp (LAMP1), Side heater lamp (LAMP2)"
- (4) Remove the E-ring [1] and the pressure roller release lever [2].
- (5) Remove 5 fuser roller separation fingers [3].

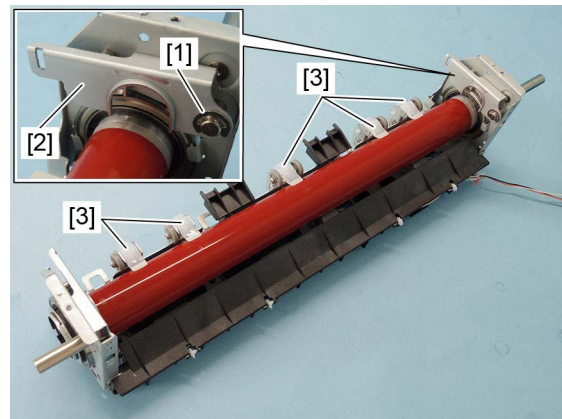


Fig. 4-413

- (6) Remove the C-ring [4], drive gear [5], collar [6], bearing [7], and washer [8], and then take off the fuser roller [9].

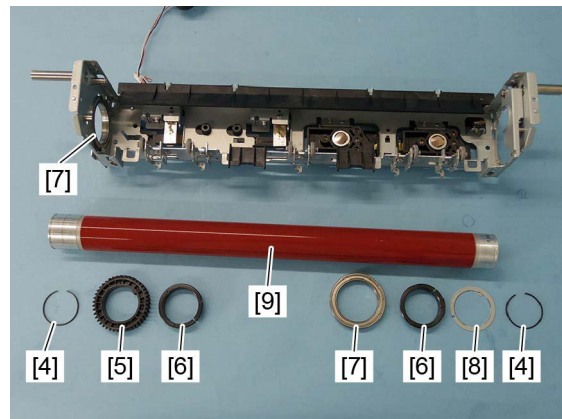


Fig. 4-414

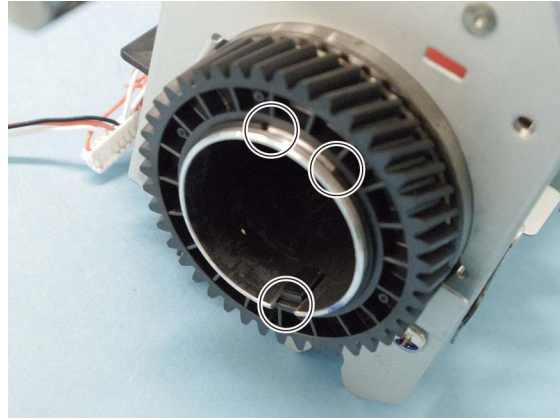
**Notes:**

- Be careful not to damage the fuser roller.
- When removing or installing the C-ring, be careful not change its shape by forcefully opening it excessively.
- Be sure to fit the C-ring to the groove on the fuser roller. (Make sure that the 2 opening ends and the center part of the C-ring are firmly positioned in the groove.)
- After replacing the fuser roller, adjust the gap between the thermistors and fuser roller.

And, be sure that the gap between the thermistor and fuser roller is 0.5 to 1.0 mm.

📖 P. 6-85 "6.12.1 Adjustment of the non-contact thermistor Gap"

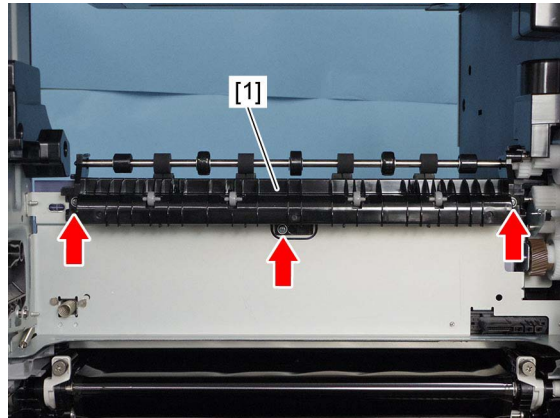
- After adjusting the gap, be sure to calibrate the fuser thermistor.



**Fig. 4-415**

### 4.9.13 Paper exit unit

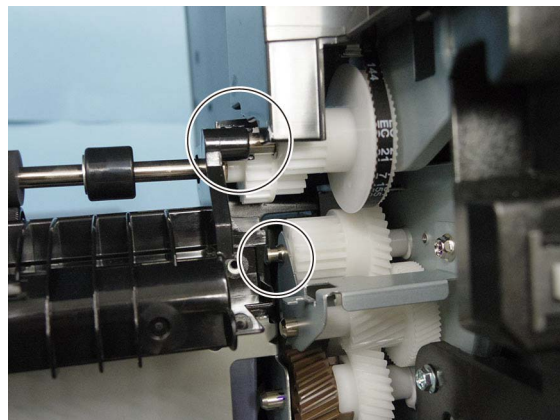
- (1) Remove the fuser unit.  
📖 P. 4-137 "4.9.1 Fuser unit"
- (2) Remove 3 screws and take off the paper exit unit [1].



**Fig. 4-416**

**Notes:**

When installing the paper exit unit, align the protrusion on the rear of the bottom of the screw hole with the frame hole, and fit the drive gear shaft into the bearing.



**Fig. 4-417**

## 4.9.14 Exit roller

- (1) Remove the paper exit unit.  
📖 P. 4-153 "4.9.13 Paper exit unit"
- (2) Remove the E-ring [1], gear [2], and bushing [3], then take off the exit roller [4].

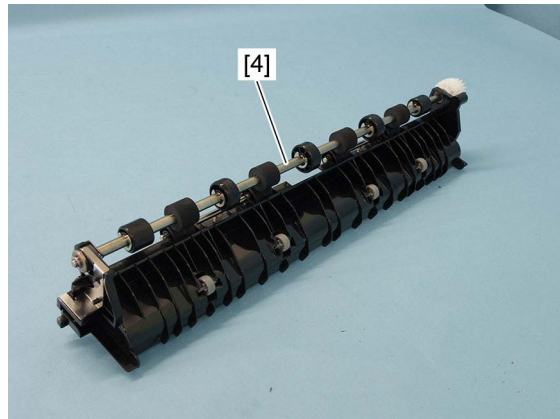


Fig. 4-418

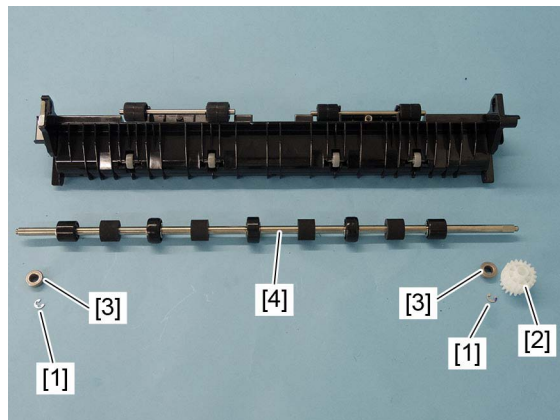


Fig. 4-419

- (3) Remove the idling roller [5] and spring [6].

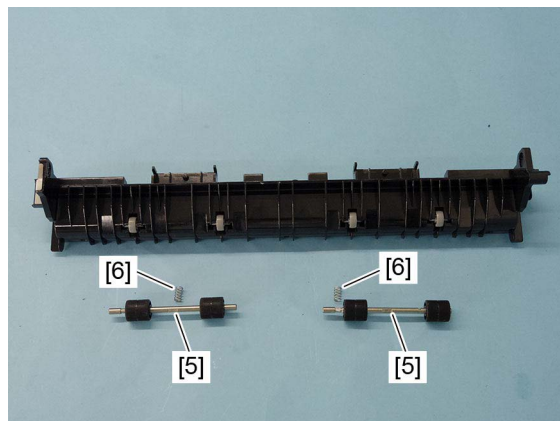


Fig. 4-420



**Notes:**

When replacing the idling roller or idling roller shaft, apply 1 rice sized grain of white grease (Molykote EM-30L) to the 2 place [7] shown in the figure 1 lap evenly.

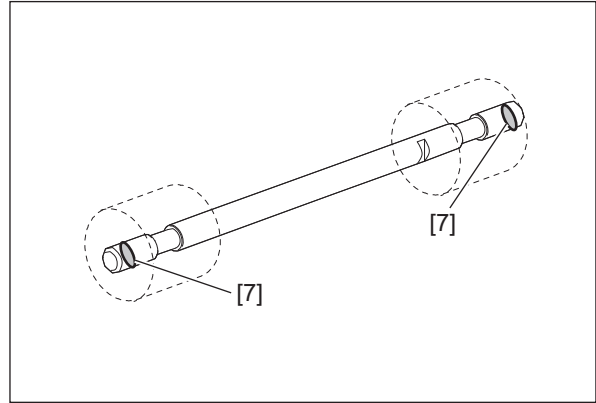


Fig. 4-421

### 4.9.15 Exit motor (M5)

- (1) Remove the right rear cover.  
 P. 4-5 "4.1.11 Right rear cover"
- (2) Remove the paper exit unit.  
 P. 4-153 "4.9.13 Paper exit unit"
- (3) Remove 1 screw and take off the exit motor cover [1].



Fig. 4-422

- (4) Remove 1 screw, take off the exit motor assembly [2], and disconnect the connector.

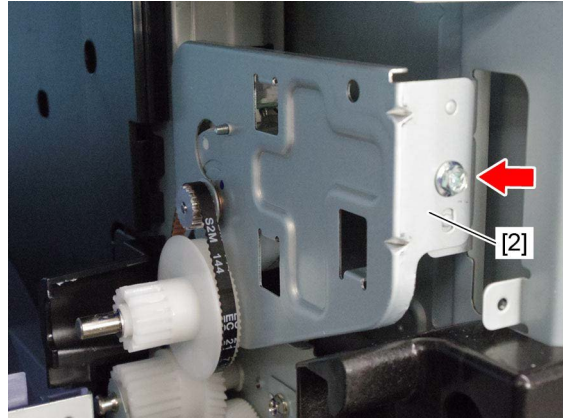


Fig. 4-423



Fig. 4-424

(5) Remove the belt [3].

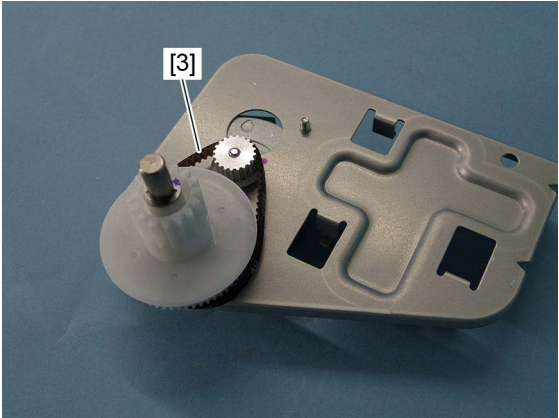


Fig. 4-425

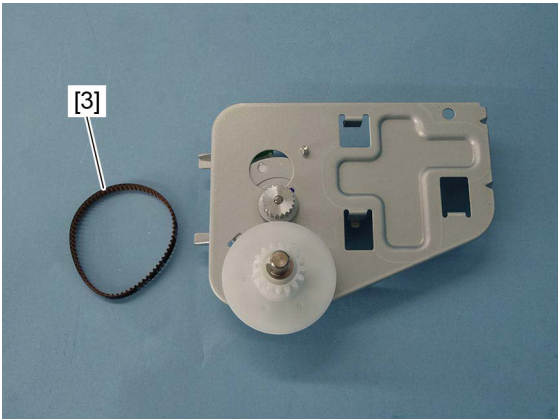


Fig. 4-426

- (6) Remove 2 screws, and take off the exit motor [5] by letting the gear [4] out of the large hole in the bracket.

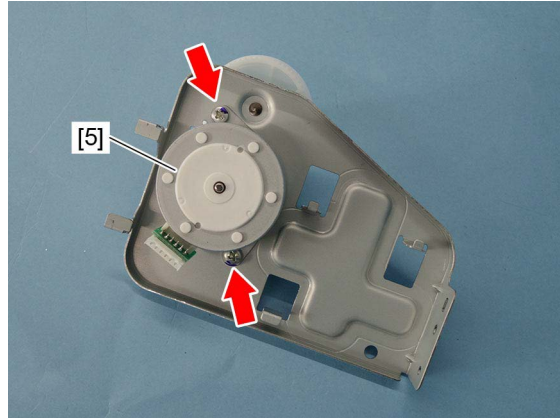


Fig. 4-427

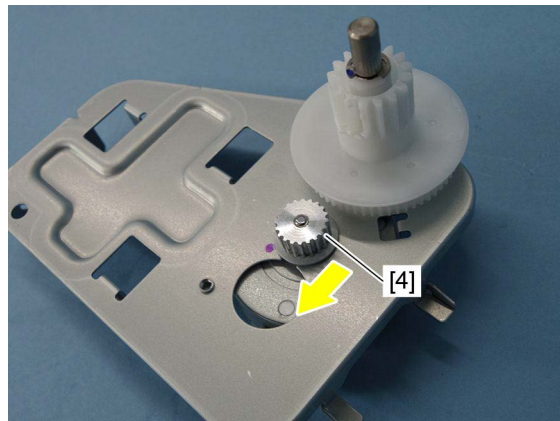


Fig. 4-428

#### 4.9.16 Fuser motor (M4)

- (1) Remove the SYS board.  
📖 P. 9-3 "9.1.4 SYS board"
- (2) Remove 2 clamps [2] and 6 screws, and then take off the fuser motor cover [1].

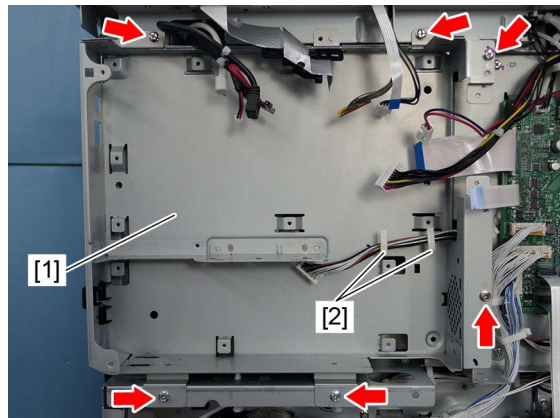


Fig. 4-429

- (3) Remove 2 screws and disconnect 1 connector [3], and then take off the fuser motor [4].

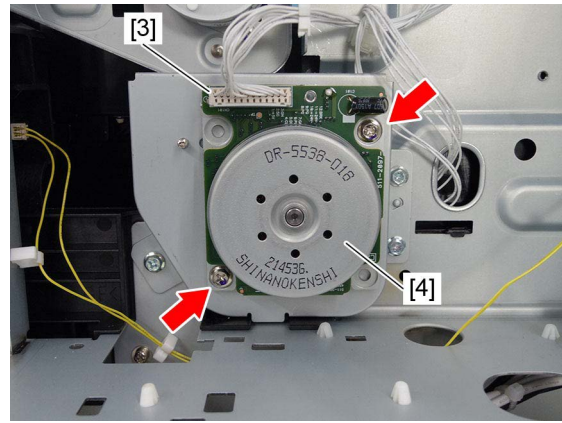


Fig. 4-430

### 4.9.17 Fuser drive unit

- (1) Remove the fuser unit.  
P. 4-137 "4.9.1 Fuser unit"
- (2) Remove the fuser motor cover.  
P. 4-158 "4.9.16 Fuser motor (M4)"
- (3) Remove 3 screws and disconnect 1 connector [1], and then remove the fuser drive unit [2].

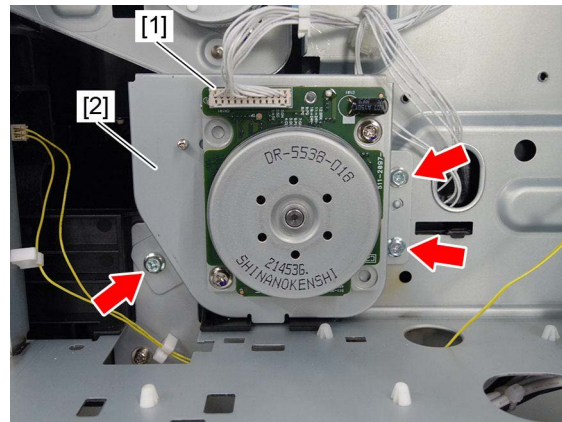


Fig. 4-431

#### Notes:

Exercise care to ensure the inside gear [3] does not drop.

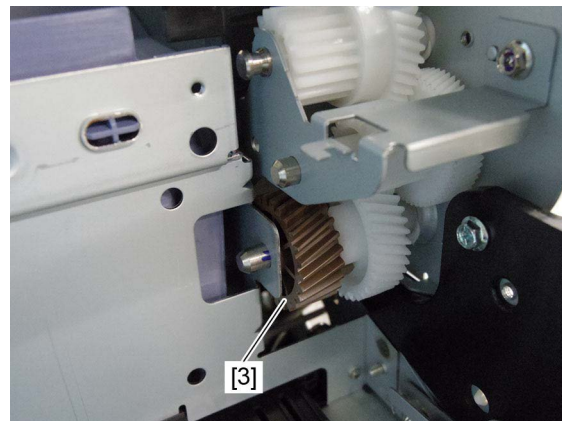
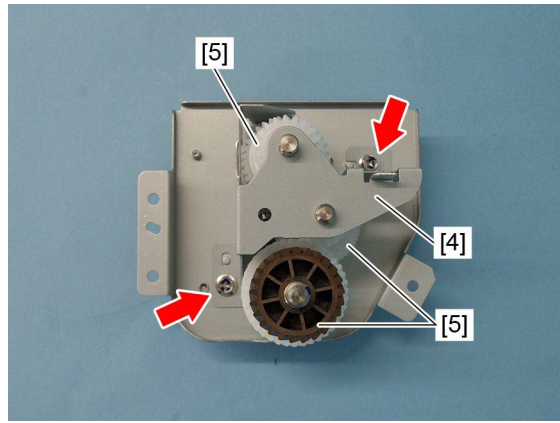
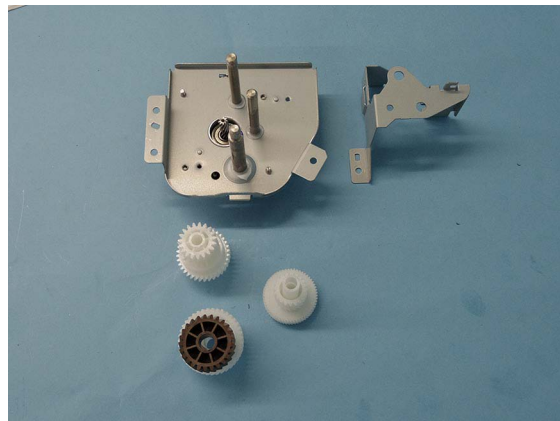


Fig. 4-432

- (4) Remove the 2 screws, and then take off the bracket [4] and fuser drive gear [5].



**Fig. 4-433**



**Fig. 4-434**

## 4.10 Automatic Duplexing Unit (ADU)

### 4.10.1 Automatic duplexing unit (ADU)

- (1) Open the side cover.
- (2) Remove the right top cover.  
📖 P. 4-4 "4.1.8 Right top cover"
- (3) Remove the right front cover.  
📖 P. 4-5 "4.1.10 Right front cover"
- (4) Remove the right rear cover.  
📖 P. 4-5 "4.1.11 Right rear cover"
- (5) Disconnect 3 connectors [2] and take off the ground cable fixing screw, and then release the harness from the harness clamps [1].

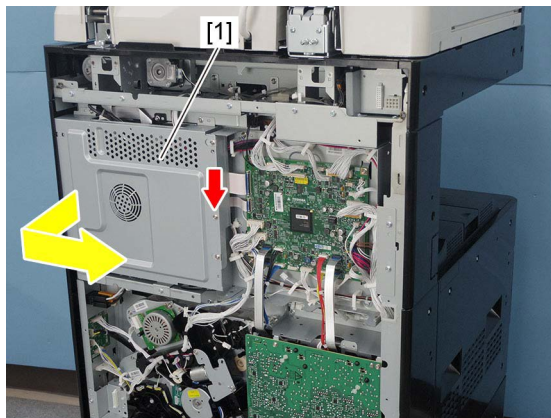


Fig. 4-435

- (6) Remove 1 screw and take off the wire end bracket [3] by holding up the automatic duplexing unit and sliding the bracket toward the rear side.

**Notes:**

When removing/attaching the wire end bracket, be sure to hold up the automatic duplexing unit so that the opening angle becomes smaller.

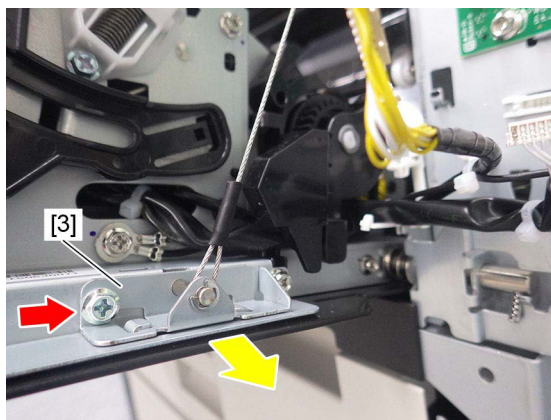


Fig. 4-436

**Notes:**

After removing the wire end bracket, hang it on the hook of the frame so that the spring of the wire does not come off.

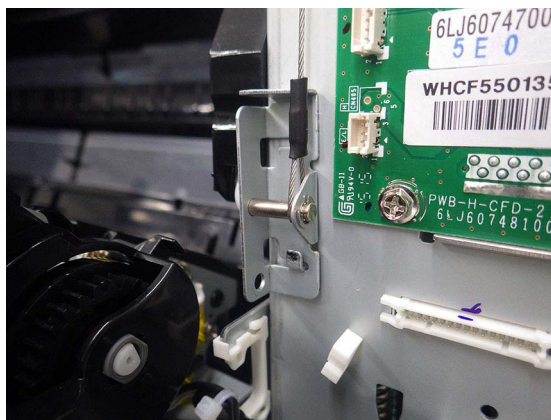


Fig. 4-437

- (7) Raise the rear hinge [4] and slide it outward, and then remove the rear shaft.

**Notes:**

During installation, turn the rear hinge downward, and then install the right rear cover.

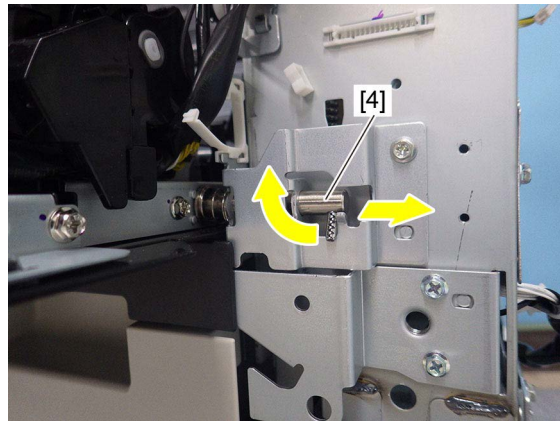


Fig. 4-438

- (8) Slightly lift up the automatic duplexing unit [5] and remove it while sliding it toward the rear side.



Fig. 4-439

**Notes:**

When installing the automatic duplexing unit, fit the boss to the hole in the front hinge.

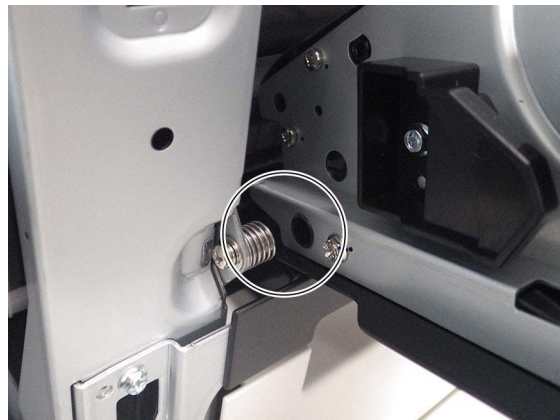


Fig. 4-440



## 4.10.2 Bypass feed clutch (CLT4)

- (1) Remove the automatic duplexing unit.  
☞ P. 4-161 "4.10.1 Automatic duplexing unit (ADU)"
- (2) Remove 1 screw and take off the clutch cover [1].

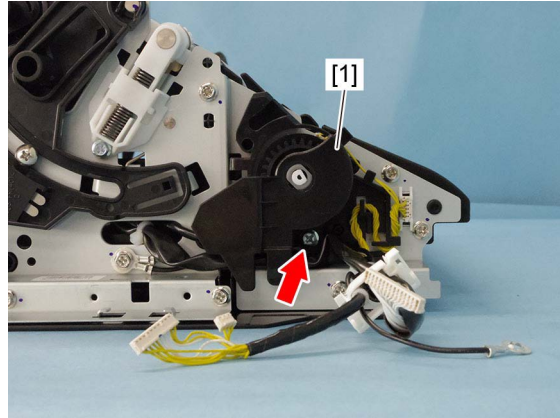


Fig. 4-441

- (3) Disconnect 1 connector and remove the bypass feed clutch [2].

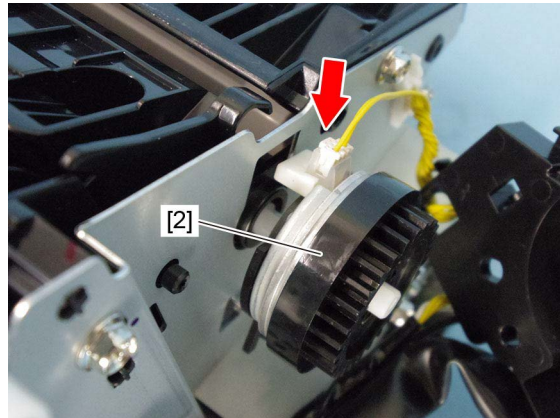


Fig. 4-442

### Notes:

When installing the clutch, attach a rotation stopper.

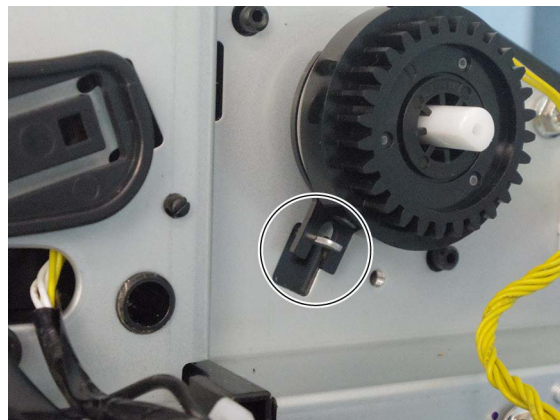


Fig. 4-443

### 4.10.3 Transport unit

- (1) Remove the feed clutch.  
☞ P. 4-163 "4.10.2 Bypass feed clutch (CLT4)"
- (2) Remove the transport roller.  
☞ P. 4-57 "4.5.9 Registration roller (on the ADU side)"
- (3) Disconnect 1 connector.

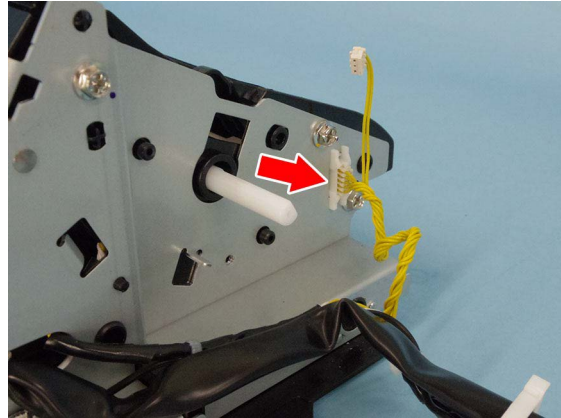


Fig. 4-444

- (4) Remove 7 screws and disconnect the ground cable, and then take off the rear bracket [1] of the transport unit.

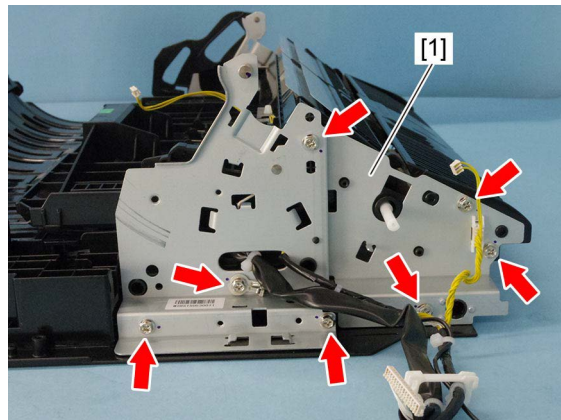


Fig. 4-445

- (5) Disconnect the 1 connector [2].

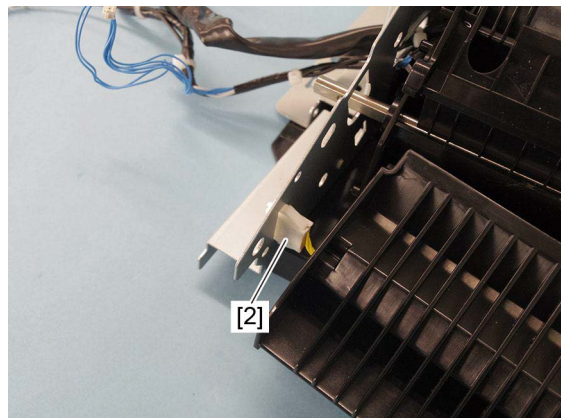


Fig. 4-446

- (6) Remove 1 screw and take off the stopper [3].

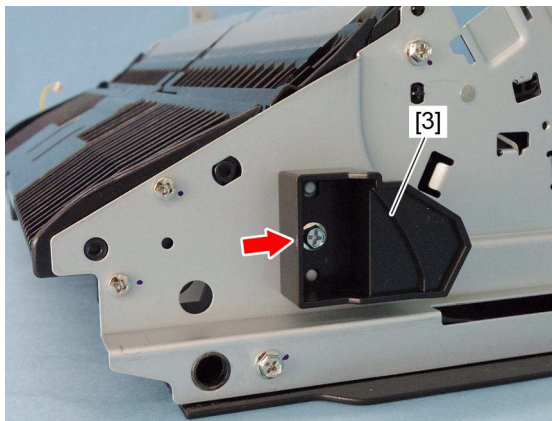


Fig. 4-447

- (7) Remove 5 screws and take off the front bracket [4] of the transport unit.

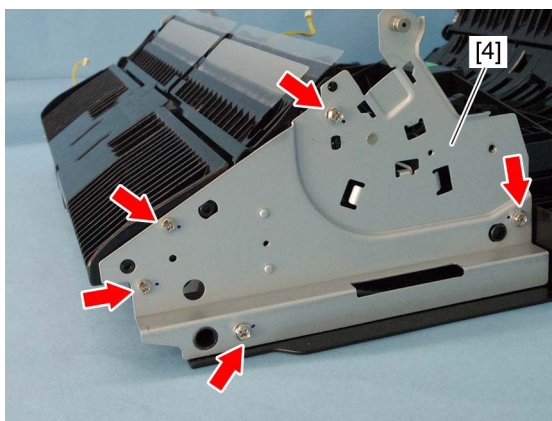


Fig. 4-448

- (8) Remove the bypass separation roller [6], 3 springs [7], paper guide (lower) [8], and paper guide (upper) [9].

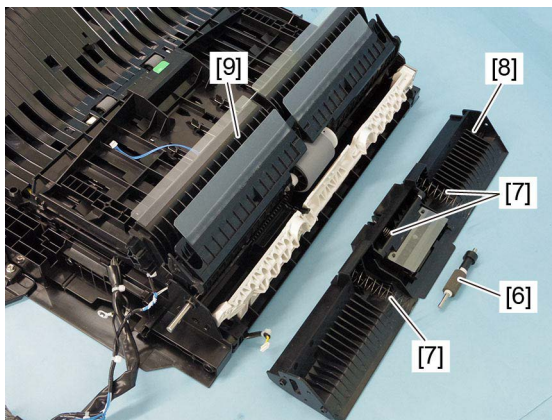


Fig. 4-449

- (9) Remove 2 screws and take off the paper guide (middle) [10].

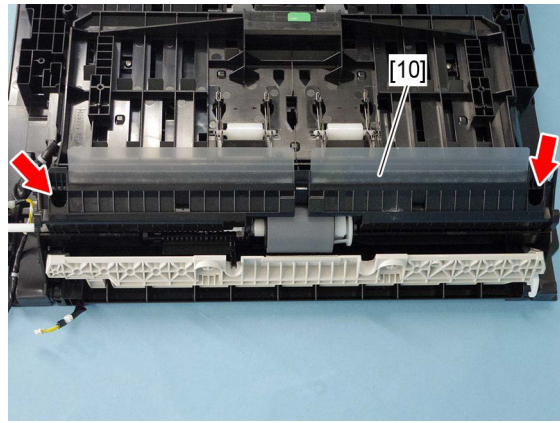


Fig. 4-450

#### 4.10.4 ADU guide assembly

- (1) Remove the transport unit.  
P. 4-164 "4.10.3 Transport unit"
- (2) Remove the ADU middle cover.  
P. 4-167 "4.10.5 ADU middle cover"
- (3) Remove 4 screws and take off the ADU guide assembly [1].

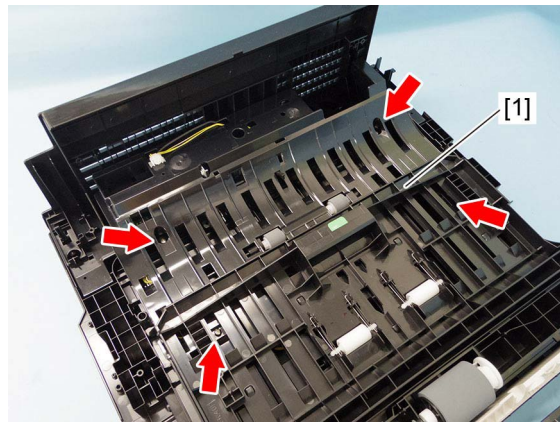


Fig. 4-451

- (4) Remove 2 screws and take off the ADU upper cover [2].

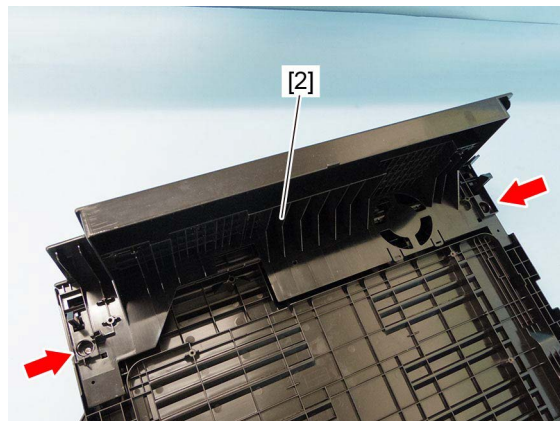


Fig. 4-452

#### 4.10.5 ADU middle cover

- (1) Remove the automatic duplexing unit.  
📖 P. 4-161 "4.10.1 Automatic duplexing unit (ADU)"
- (2) Remove 2 screws and take off the ADU middle cover [1].

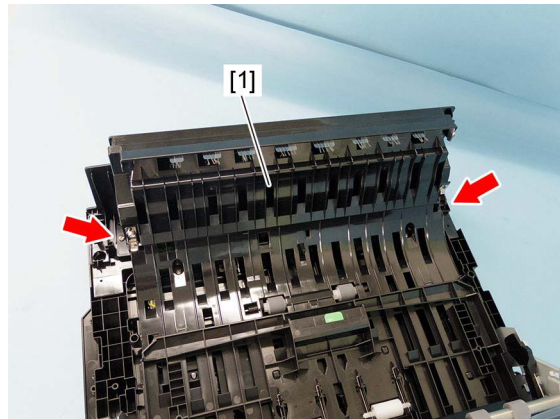


Fig. 4-453

#### 4.10.6 ADU control board (ADU)

- (1) Remove the ADU guide assembly.  
📖 P. 4-166 "4.10.4 ADU guide assembly"
- (2) Disconnect 3 connectors and remove the ADU control board (ADU) [1].

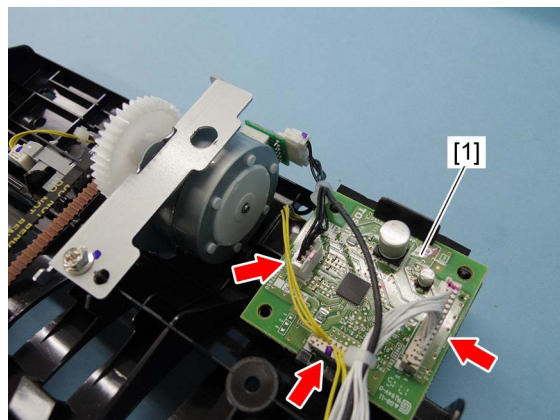


Fig. 4-454

#### 4.10.7 ADU drive unit/ADU entrance sensor (S14)/ ADU exit sensor (S15)/ADU motor (M12)

- (1) Remove the ADU guide assembly.  
📖 P. 4-166 "4.10.4 ADU guide assembly"
- (2) Disconnect the connector [1] of the ADU control board (ADU) and the connector [2] of the ADU motor (M12).
- (3) Remove 2 screws and take off the ADU motor assembly [3].
- (4) Disconnect the connector [4] and take off the ADU exit sensor (S15) [5].

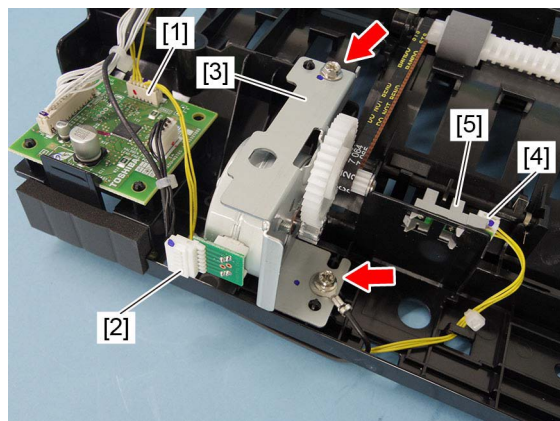


Fig. 4-455

- (5) Remove the E-ring [6] and gear [7] from the ADU motor assembly.

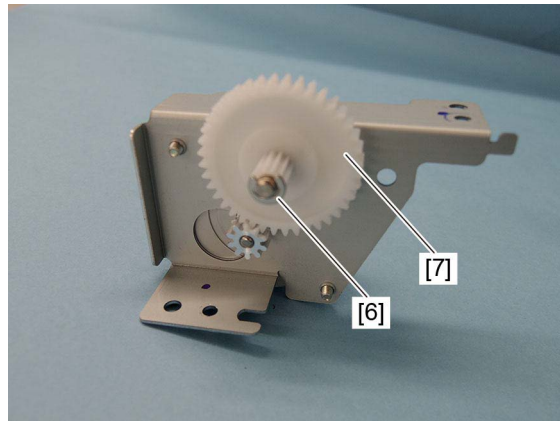


Fig. 4-456

- (6) Remove 2 screws and take off the ADU motor (M12) [8].

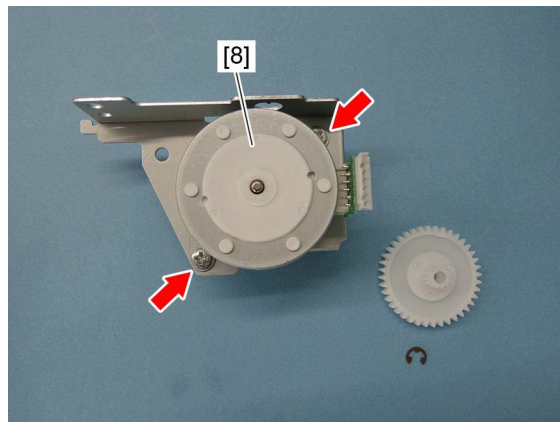


Fig. 4-457

- (7) Remove the ADU entrance sensor (S14) [9]. Remove the ADU transport roller [10] and drive belt [11].

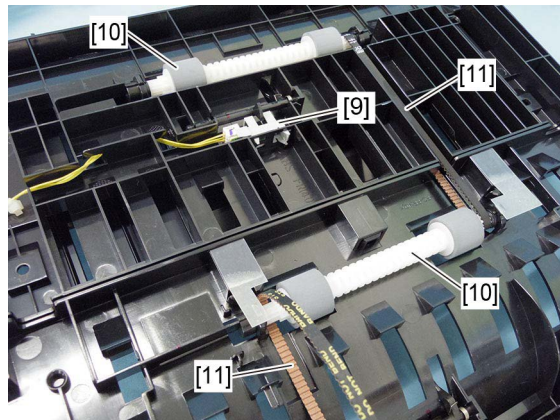
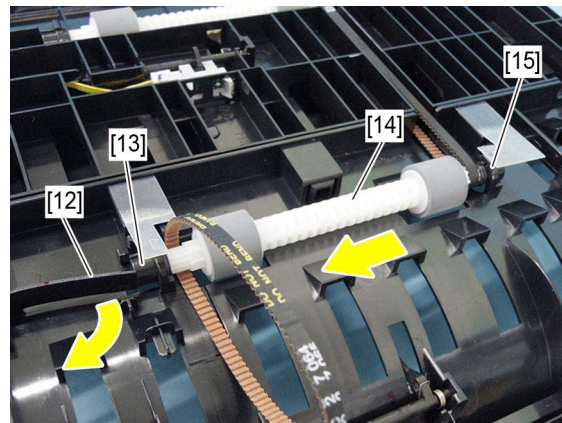


Fig. 4-458

**Notes:**

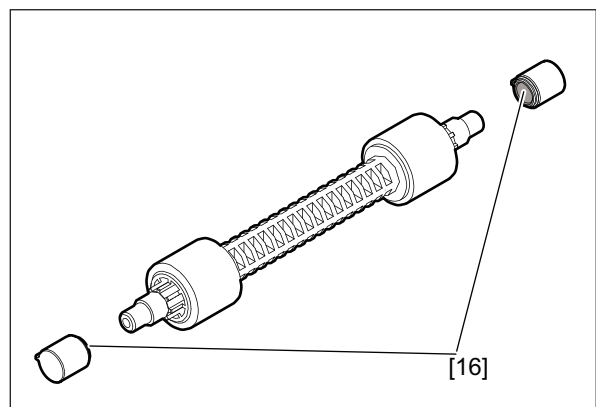
- When taking off the transport roller, bend the rib [12] to remove the collar [13], slide the shaft [14] onto the rib, and then take off the collar [15] on the opposite side to pull out the shaft.
- Be sure to attach the belt when carrying out installation.



**Fig. 4-459**

**Notes:**

- When replacing both the transport roller and the collar, or performing machine refreshment, apply an appropriate amount of white grease (Molykote EM-30L) inside of the collars [16]. When applying the grease, make sure that the grease is not running over.
- Grease might run out before the machine refreshment depending on frequency of use, apply an appropriate amount of grease as necessary.



**Fig. 4-460**

## 4.10.8 Side cover interlock switch (SW3)

### Notes:

If the interlock switch is not installed appropriately when it is replaced or installed, it may not work normally. If you carry out the maintenance of the equipment in such a situation, you could get an electric shock by touching live sections or be injured by touching moving sections. Therefore, to avoid this, be sure to perform correct handling and installation.

- (1) Open the side cover.
- (2) Remove 2 screws and take off the side cover interlock switch cover [1].

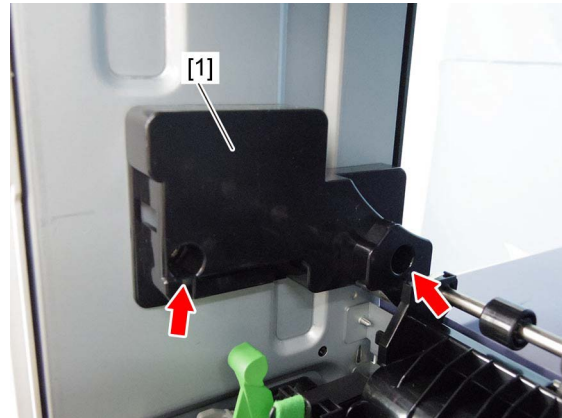


Fig. 4-461

- (3) Release the latches and take off the side cover interlock switch [2], and then disconnect 2 connectors [3].

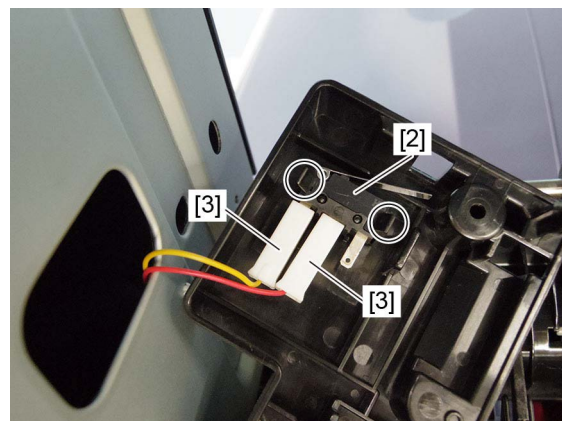


Fig. 4-462



## 4.11 Removal and Installation of Options

### Important:

- Before installing or removing options, turn the main power switch off and disconnect the power cable from the outlet.

### 4.11.1 Reversing Automatic Document Feeder

- (1) Press the [Power] button on the control panel to shut it down.
- (2) Turn the main power switch of the equipment off.
- (3) Disconnect the power cable.
- (4) Take off the connector cover.

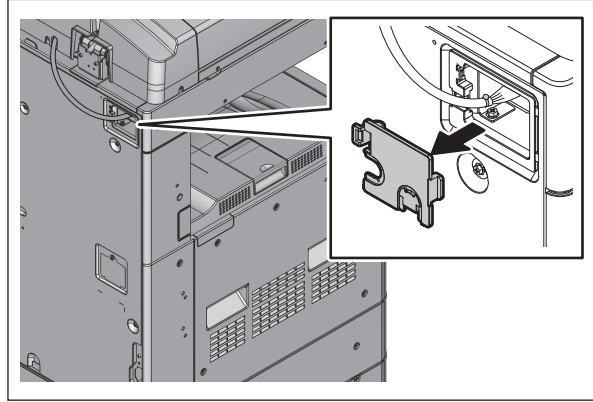


Fig. 4-463

- (5) Disconnect 1 connector.

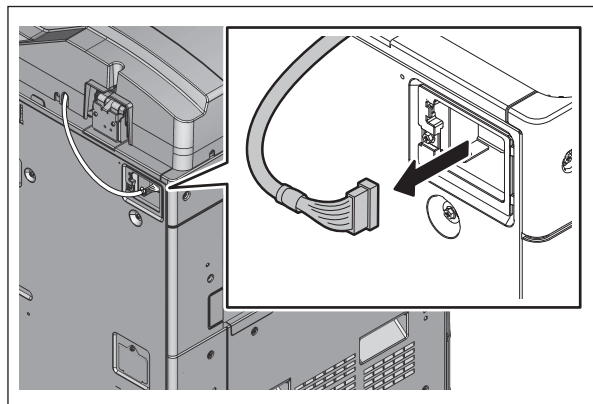


Fig. 4-464

- (6) Install the connector cover.

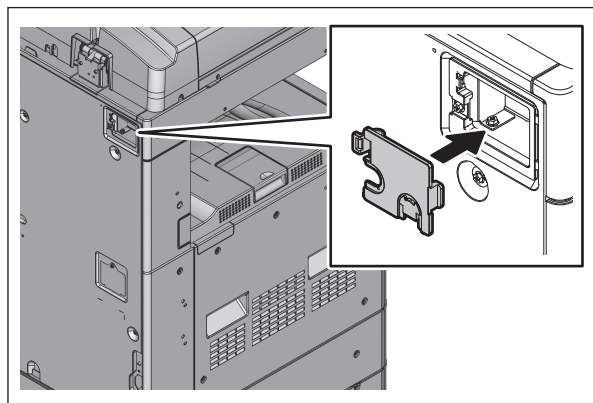


Fig. 4-465

- (7) Remove 2 screws and take off 1 bracket.

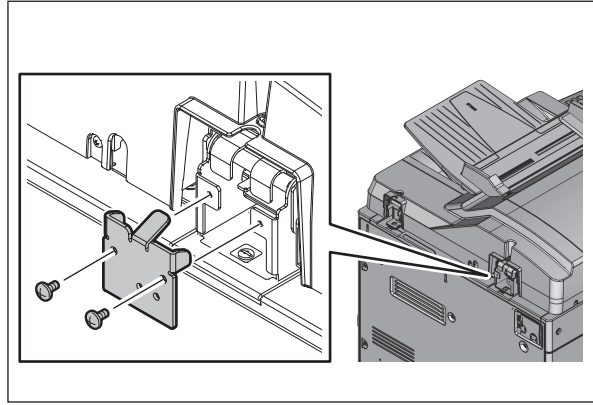


Fig. 4-466

- (8) Remove 2 screws and 1 washer.

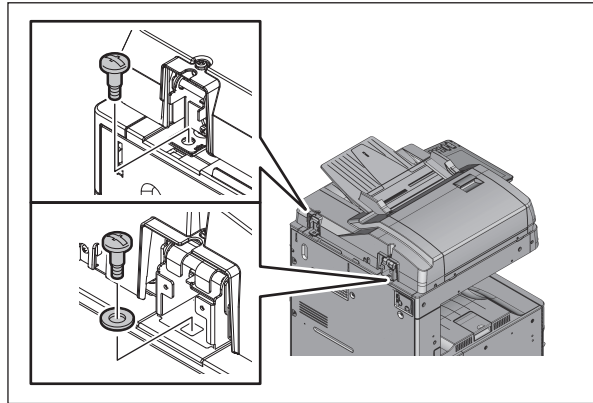


Fig. 4-467

- (9) Open the reversing automatic document feeder. Remove 2 screws.

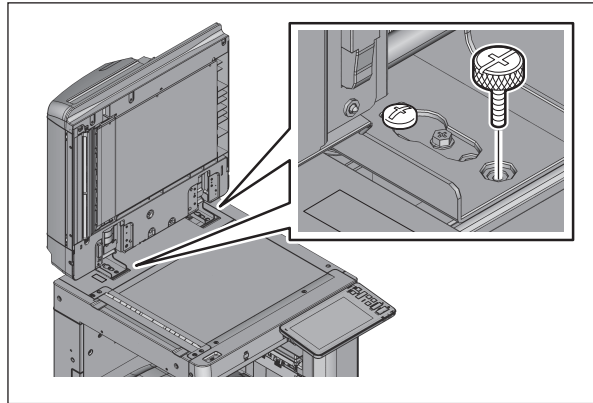


Fig. 4-468

- (10) Remove the reversing automatic document feeder by sliding it toward the rear side.

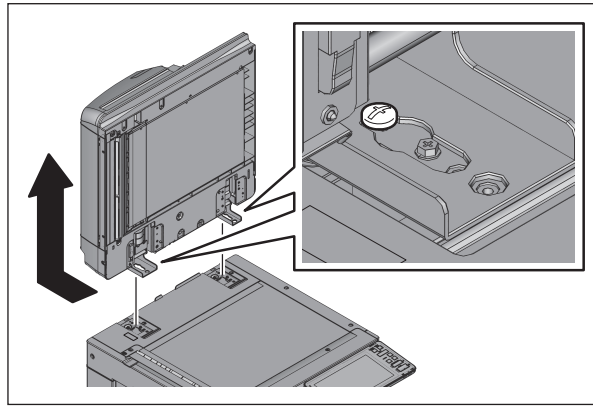


Fig. 4-469

### 4.11.2 Paper Feed Pedestal

- (1) Press the [Power] button on the control panel to shut it down.
- (2) Turn the main power switch of the equipment off.
- (3) Disconnect the power cable.
- (4) Remove 1 screw and take off the cover.

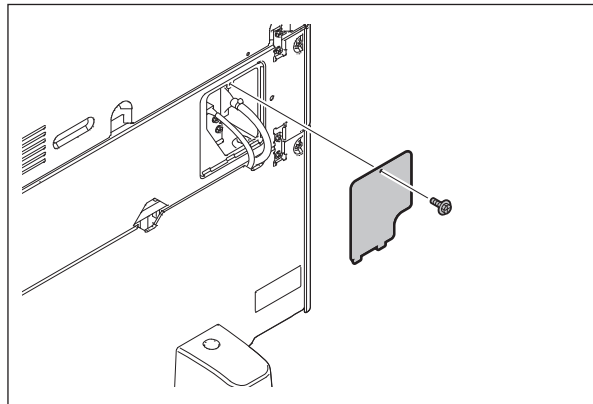


Fig. 4-470

- (5) Remove 1 screw and disconnect the ground cable. Disconnect 1 connector.

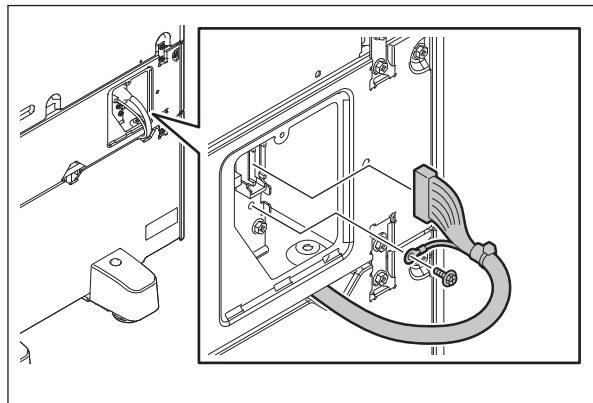
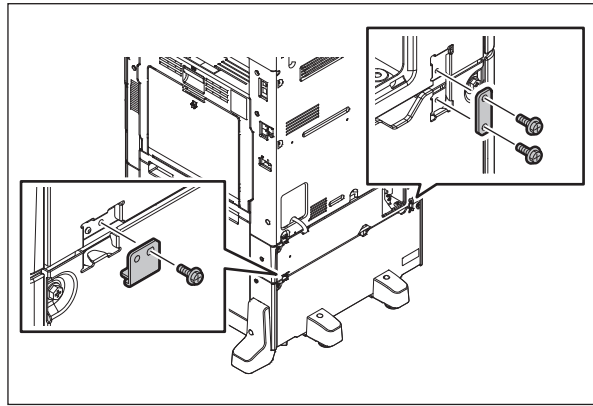


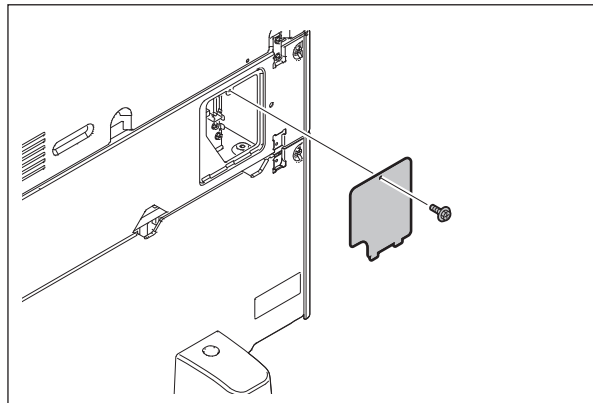
Fig. 4-471

- (6) Remove 3 screws and take off 2 fixing brackets on the rear side.



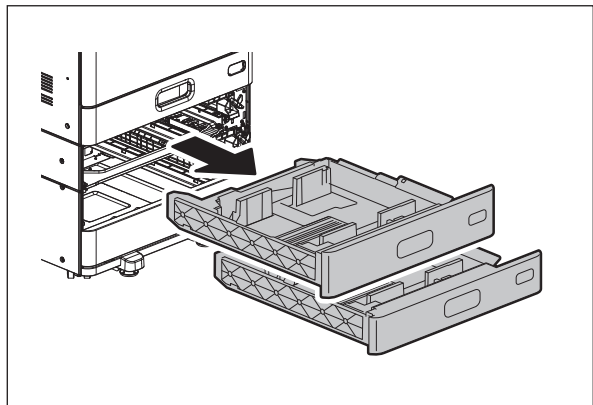
**Fig. 4-472**

- (7) Install the cover.



**Fig. 4-473**

- (8) Pull out the drawer.



**Fig. 4-474**

- (9) Remove 3 screws and take off 2 fixing brackets on the front side.

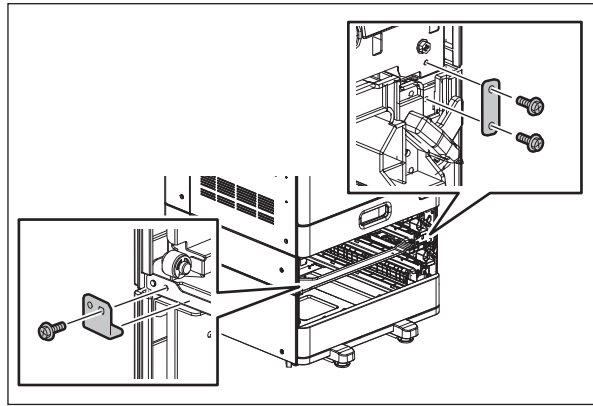


Fig. 4-475

- (10) Install the drawer.

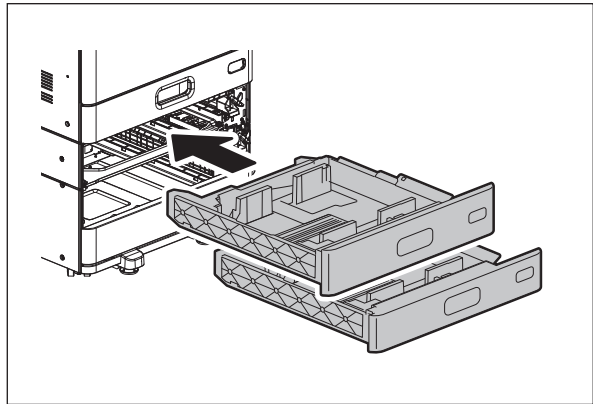


Fig. 4-476

- (11) Lift the equipment up and remove the paper feed pedestal.

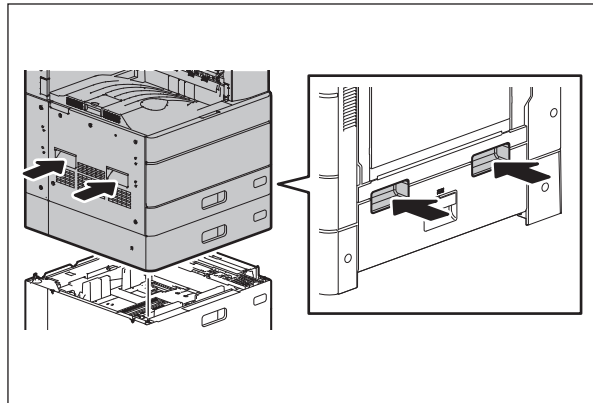


Fig. 4-477

### 4.11.3 Large Capacity Feeder

- (1) Press the [Power] button on the control panel to shut it down.
- (2) Turn the main power switch of the equipment off.
- (3) Disconnect the power cable.
- (4) Remove 1 screw and take off the cover.

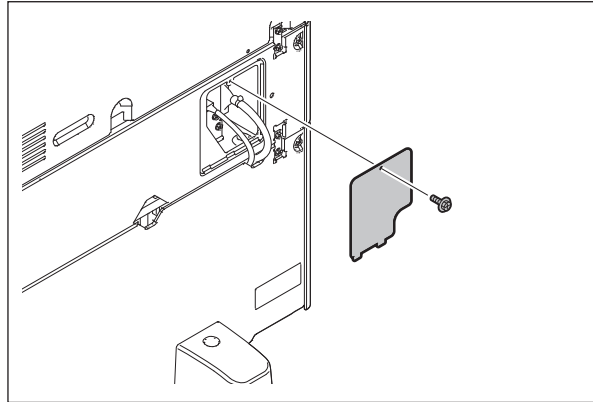


Fig. 4-478

- (5) Disconnect 2 connectors. Remove 1 screw and disconnect the ground cable.  
[1] Damp heater harness  
[2] Signal harness

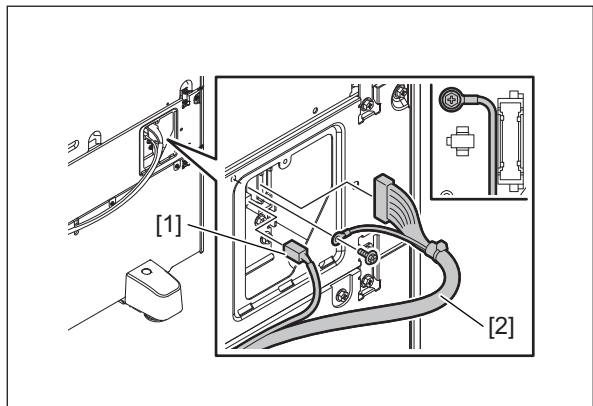


Fig. 4-479

- (6) Remove 3 screws and take off 2 fixing brackets on the rear side.

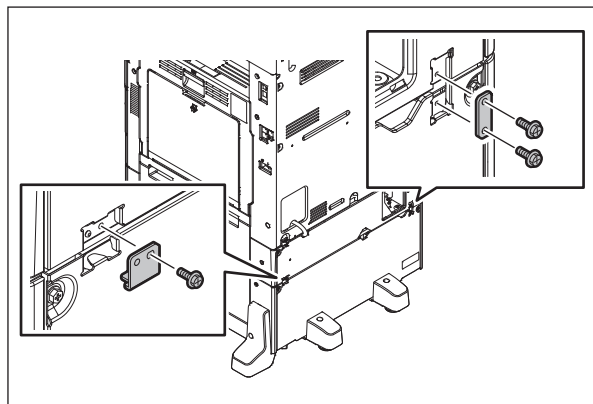


Fig. 4-480

(7) Install the cover.

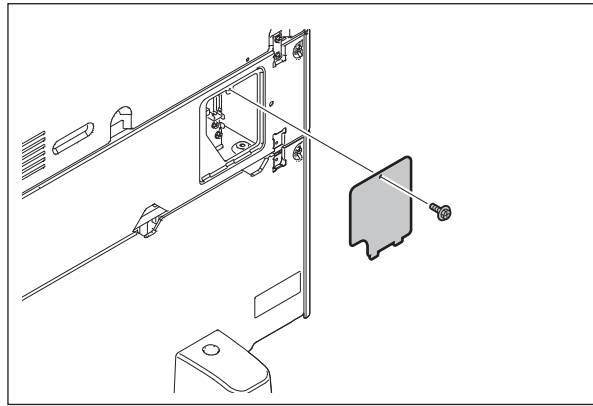


Fig. 4-481

(8) Pull out the drawer.

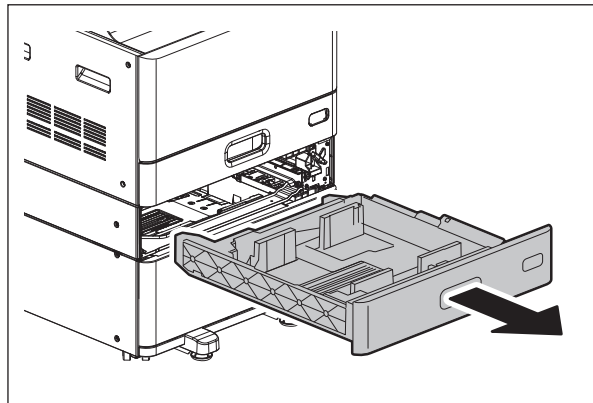


Fig. 4-482

(9) Pull out the large capacity feeder drawer.

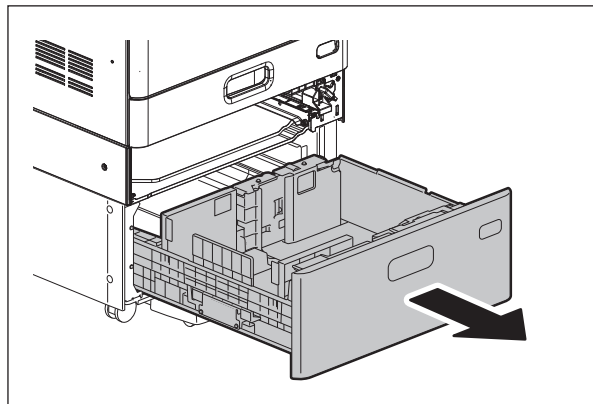
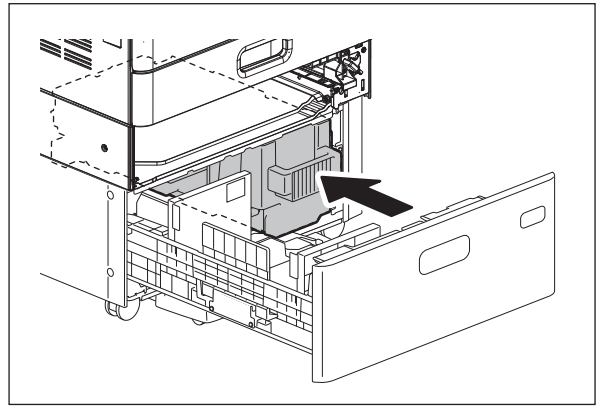


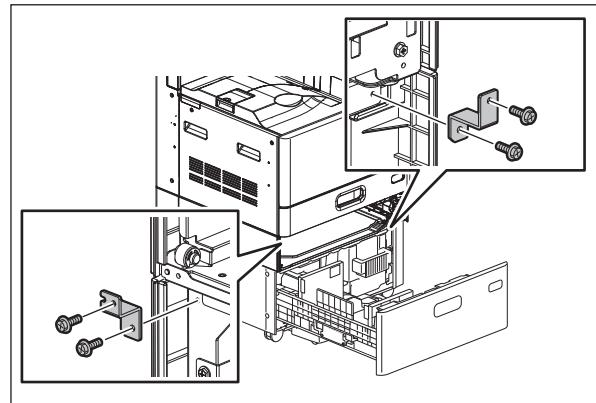
Fig. 4-483

(10) Install the right drawer.



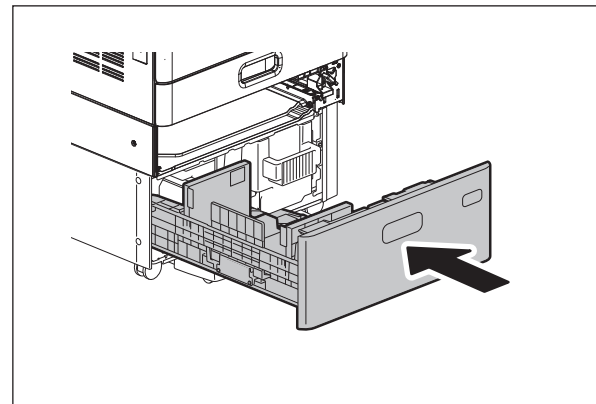
**Fig. 4-484**

(11) Remove 4 screws and take off 2 fixing brackets on the front side.



**Fig. 4-485**

(12) Install the large capacity feeder drawer.



**Fig. 4-486**



(13) Install the drawer.

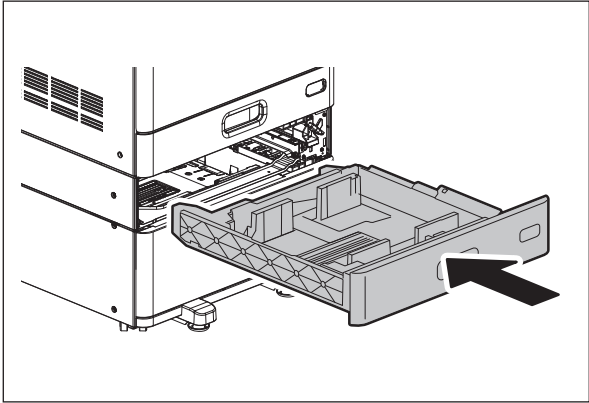


Fig. 4-487

(14) Lift the equipment up and remove the large capacity feeder.

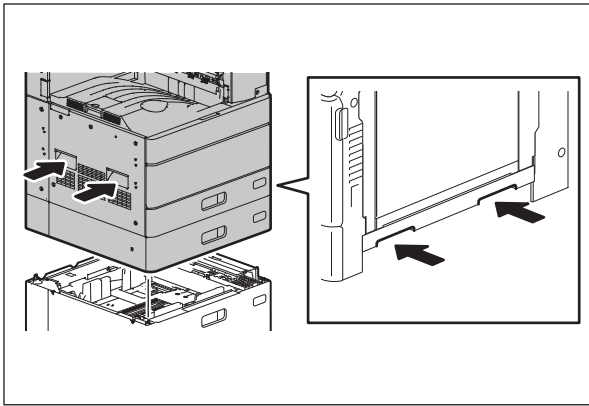


Fig. 4-488

### 4.11.4 Paper Feed Unit

- (1) Press the [Power] button on the control panel to shut it down.
- (2) Turn the main power switch of the equipment off.
- (3) Disconnect the power cable.
- (4) Pull out the drawer.

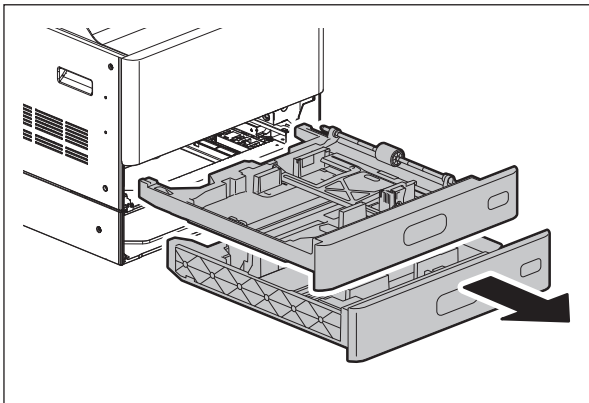


Fig. 4-489

- (5) Remove 1 screw and take off the damp heater connector cover.

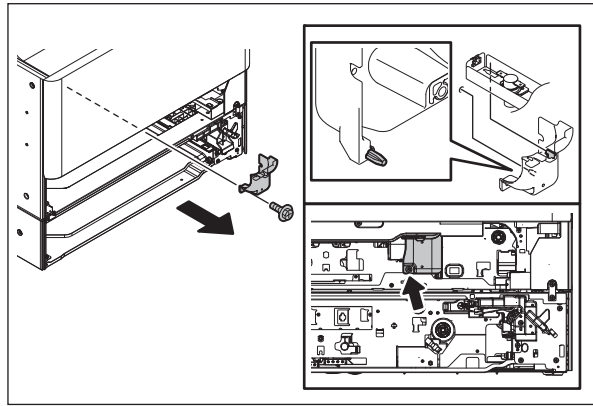


Fig. 4-490

- (6) Disconnect the damp heater connector.

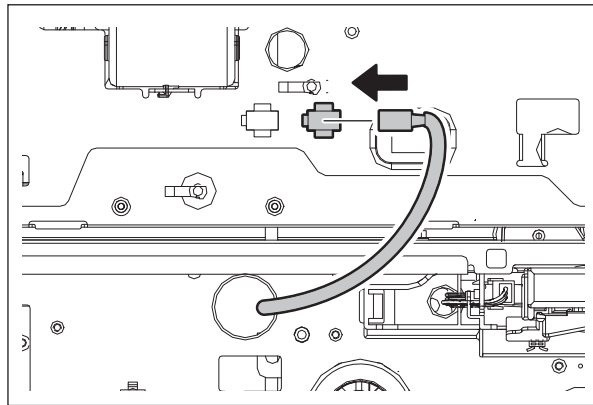


Fig. 4-491

- (7) Install the damp heater connector cover.

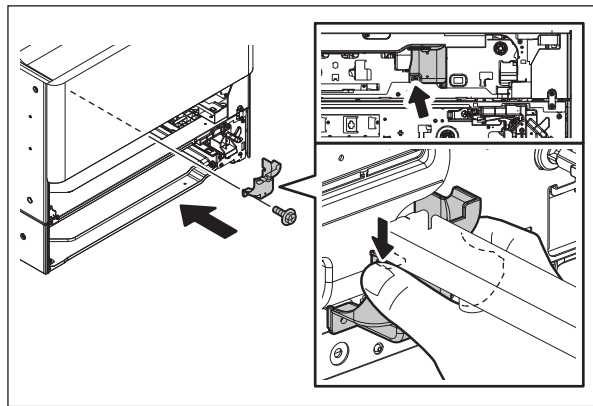


Fig. 4-492

(8) Remove 1 screw and take off the PFC cover.

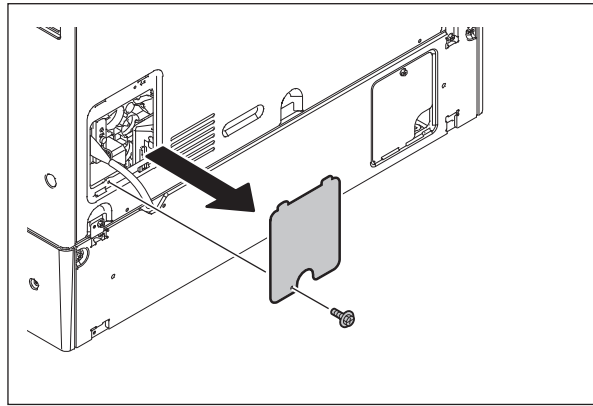


Fig. 4-493

(9) Remove 1 screw and disconnect the ground cable. Disconnect 1 connector.

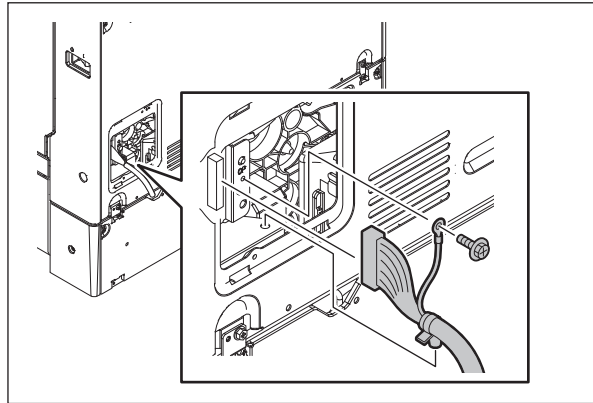


Fig. 4-494

(10) Install the PFC cover.

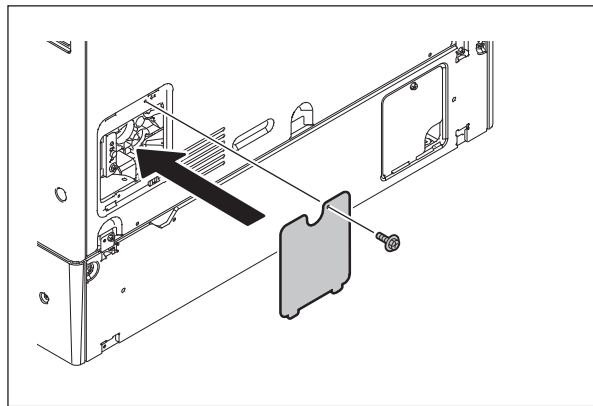


Fig. 4-495

- (11) Remove 3 screws and take off 2 fixing brackets on the rear side.

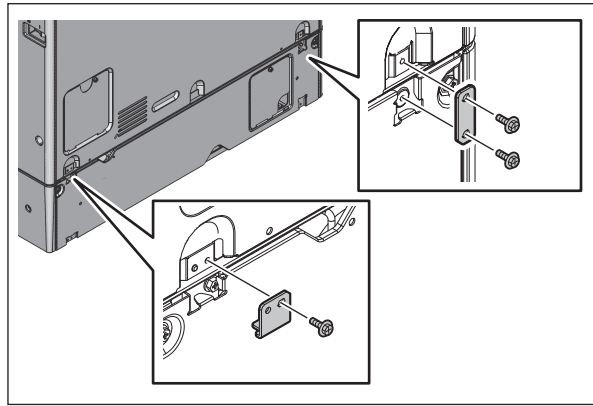


Fig. 4-496

- (12) Remove 3 screws and take off 2 fixing brackets on the front side.

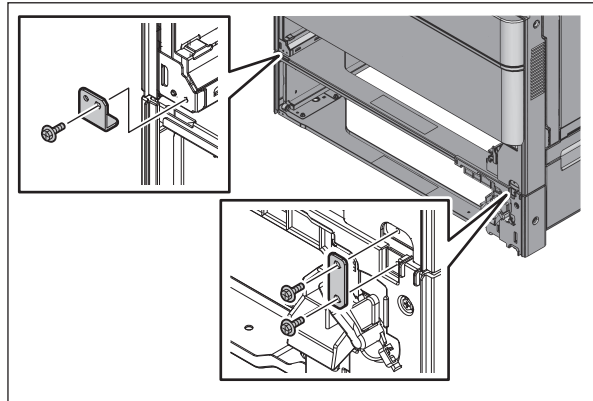


Fig. 4-497

- (13) Lift the equipment up and remove the paper feed unit.

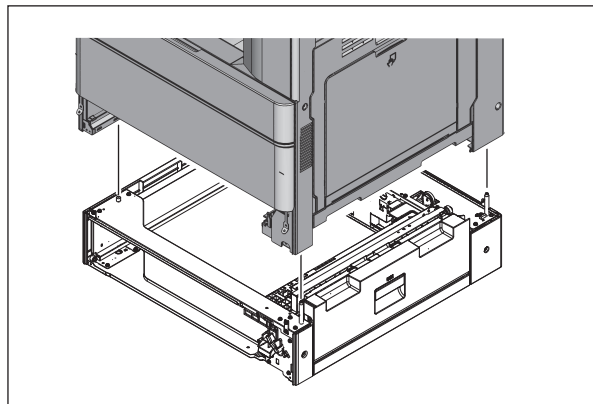


Fig. 4-498

## 4.11.5 Bridge Kit

- (1) Press the [Power] button on the control panel to shut it down.
- (2) Turn the main power switch of the equipment off.
- (3) Disconnect the power cable.
- (4) Open the side cover. Remove 1 screw and take off the connector cover.

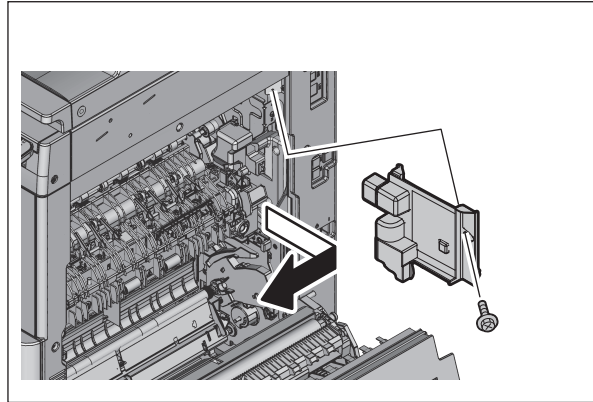


Fig. 4-499

- (5) Disconnect 1 connector.

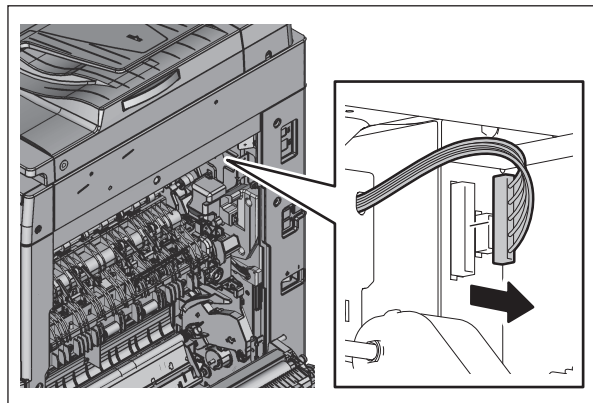


Fig. 4-500

- (6) Remove 1 screw and take off the front cover of the bridge kit.

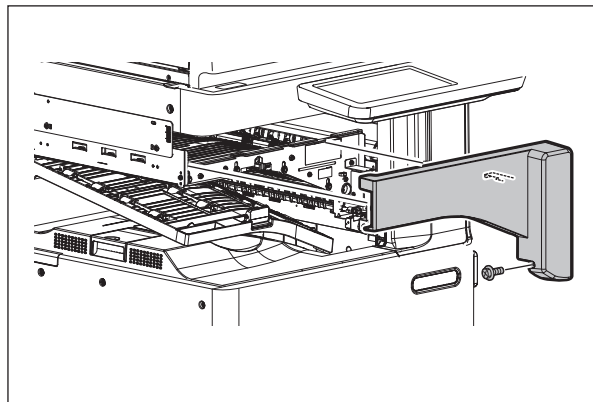


Fig. 4-501

(7) Remove 1 screw.

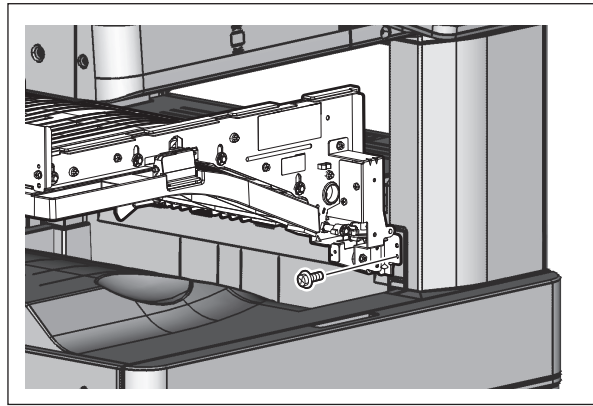


Fig. 4-502

(8) Remove 2 screws and take off the fixing bracket.

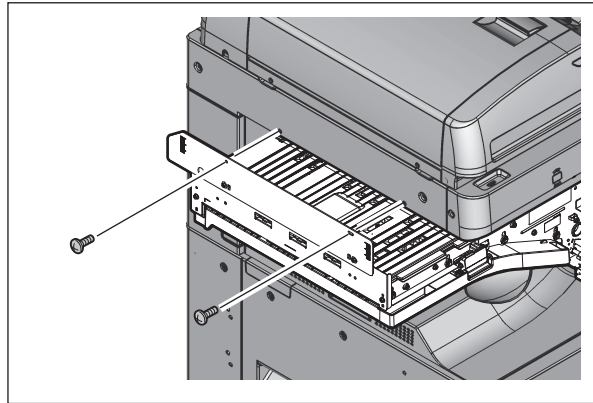


Fig. 4-503

(9) Lift the bridge kit up to pull out the hook, and pull the bridge kit toward the front side to remove it.

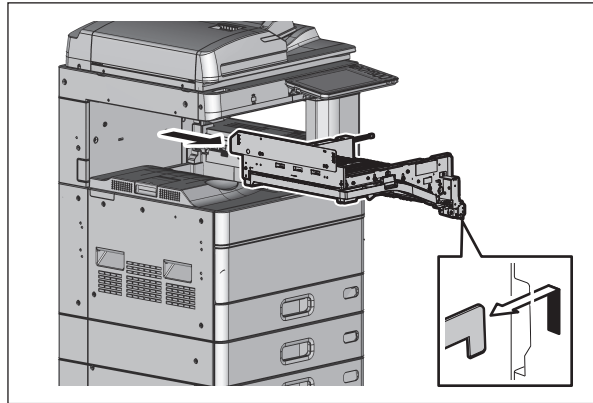


Fig. 4-504

## 4.11.6 Inner Finisher

- (1) Press the [Power] button on the control panel to shut it down.
- (2) Turn the main power switch of the equipment off.
- (3) Disconnect the power cable.
- (4) Remove the connector cover.

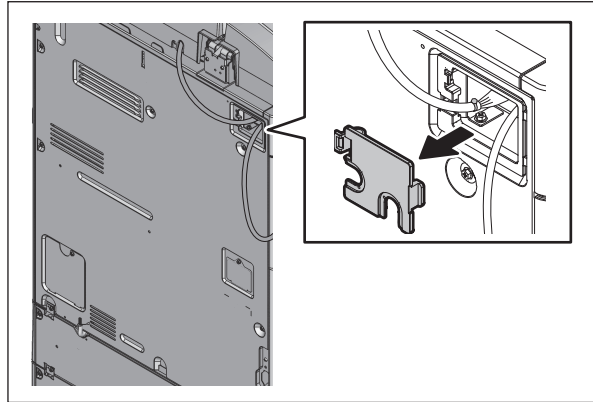


Fig. 4-505

- (5) Disconnect the connector.

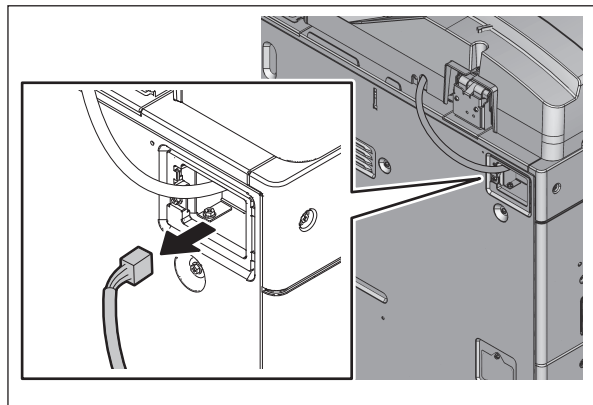


Fig. 4-506

- (6) Install the connector cover.

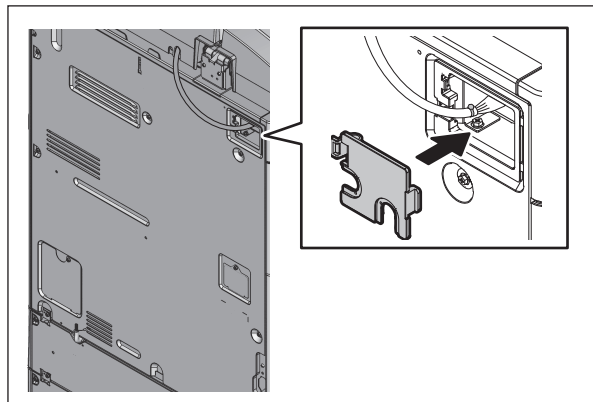
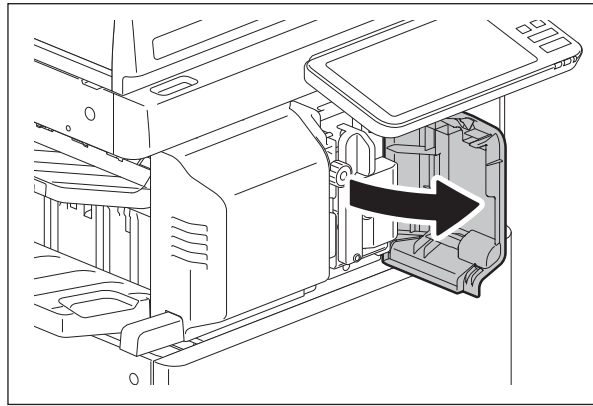


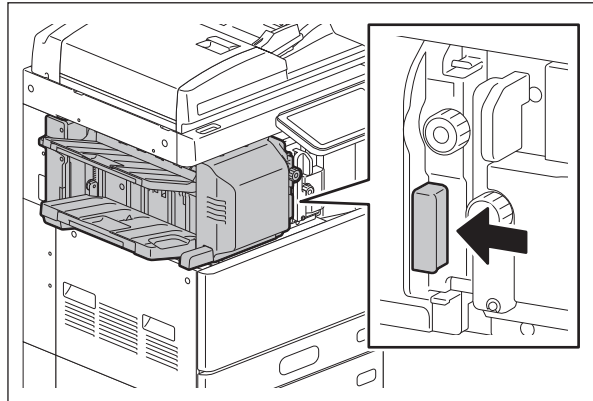
Fig. 4-507

(7) Open the finisher cover.



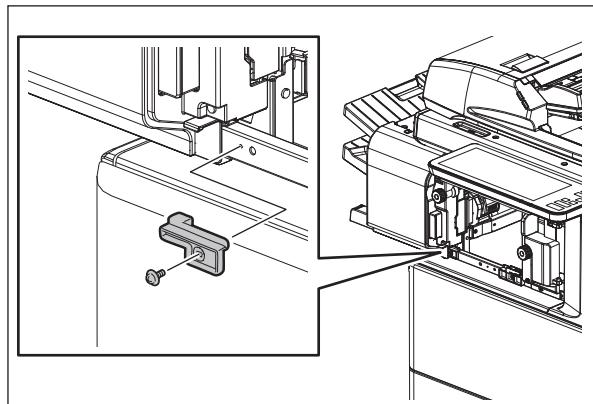
**Fig. 4-508**

(8) Press the button to release the lock. Pull out the finisher.



**Fig. 4-509**

(9) Remove 1 screw and take off 1 bracket.



**Fig. 4-510**



(10) Return the finisher to the installation position temporarily by sliding it.

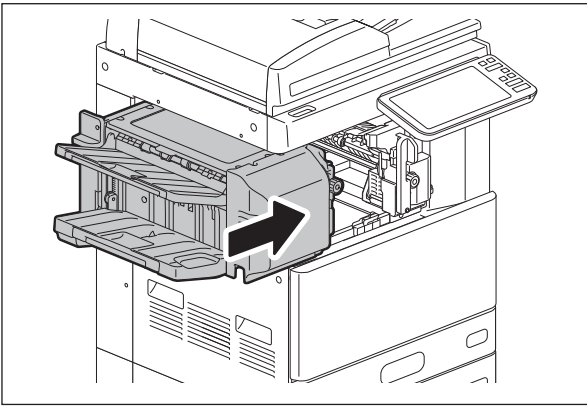


Fig. 4-511

(11) Remove 3 screws and take off the cover.

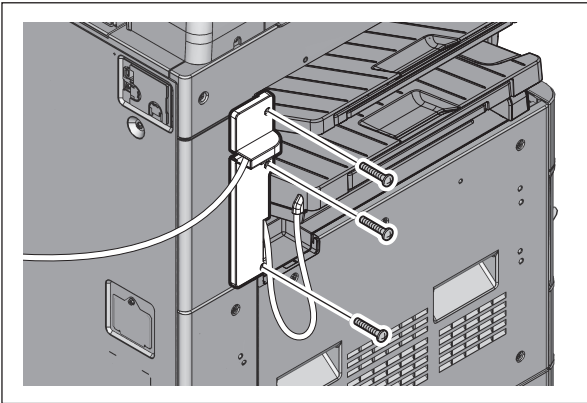


Fig. 4-512

(12) Remove 1 screw.

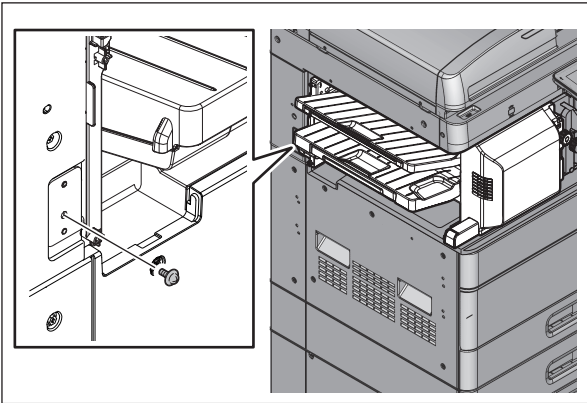


Fig. 4-513

(13) Remove the finisher.

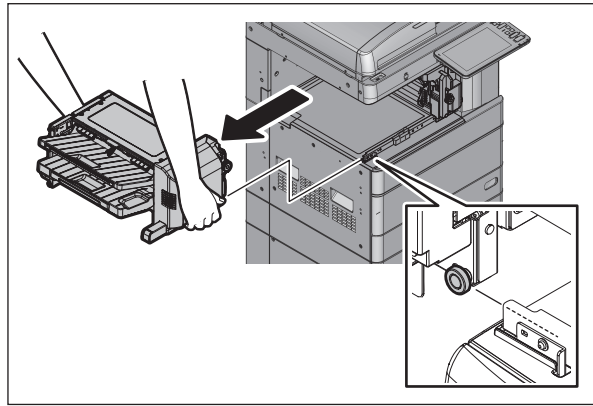


Fig. 4-514

#### 4.11.7 Saddle Stitch Finisher

- (1) Press the [Power] button on the control panel to shut it down.
- (2) Turn the main power switch of the equipment off.
- (3) Disconnect the power cable.
- (4) Remove the connector cover.

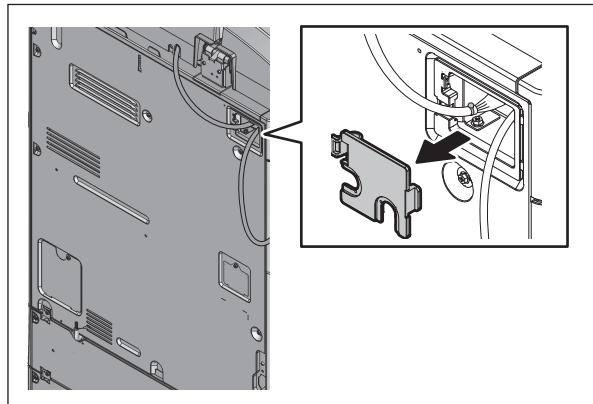


Fig. 4-515

- (5) Disconnect the connector.

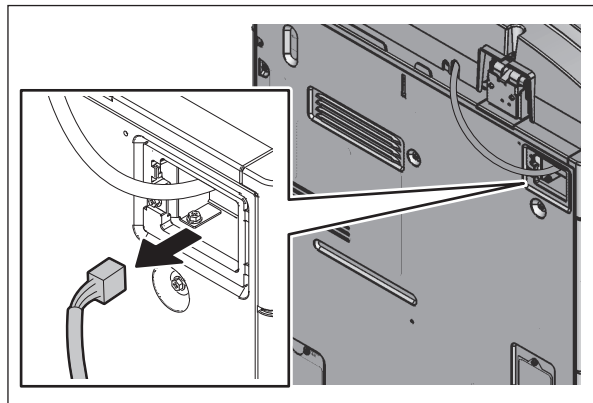


Fig. 4-516

(6) Install the connector cover.

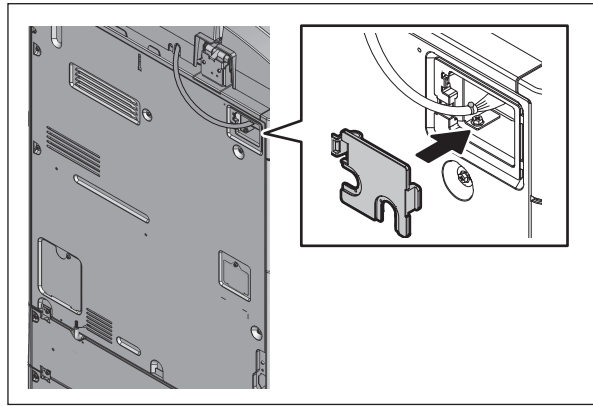


Fig. 4-517

(7) Open the finisher cover and remove 1 fixing screw. Pull out the lever.

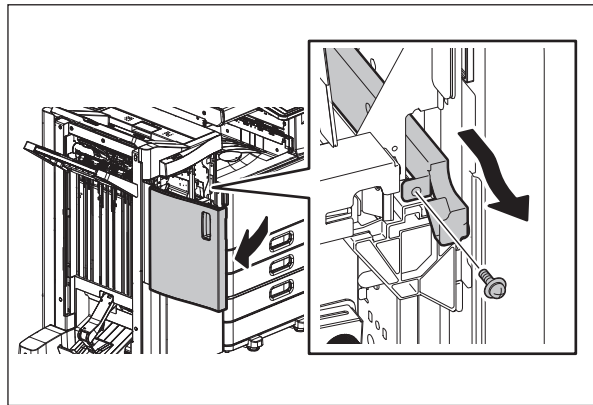


Fig. 4-518

(8) Remove the finisher.

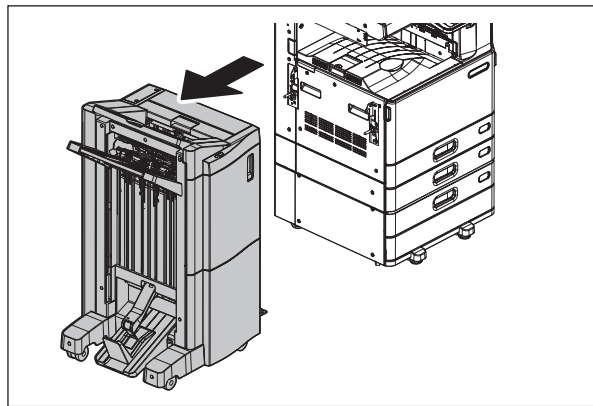


Fig. 4-519

### 4.11.8 Saddle stitch finisher (Hole punch unit)

- (1) Press the [Power] button on the control panel to shut it down.
- (2) Turn the main power switch of the equipment off.
- (3) Disconnect the power cable.
- (4) Take off the connector cover.

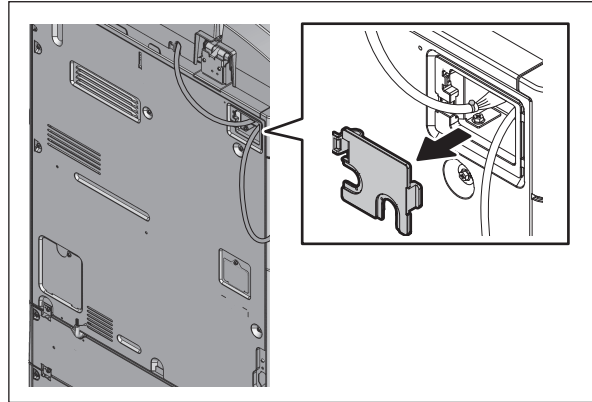


Fig. 4-520

- (5) Disconnect 1 connector.

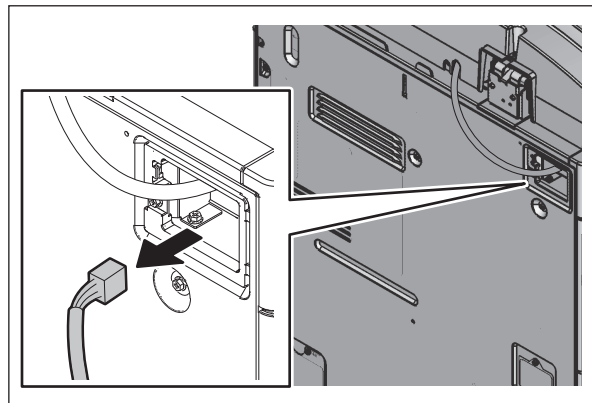


Fig. 4-521

- (6) Install the connector cover.

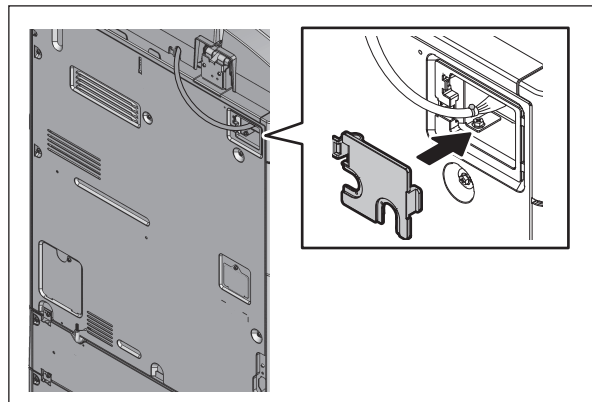


Fig. 4-522

- (7) Take off the cover of the hole punch unit lower side.

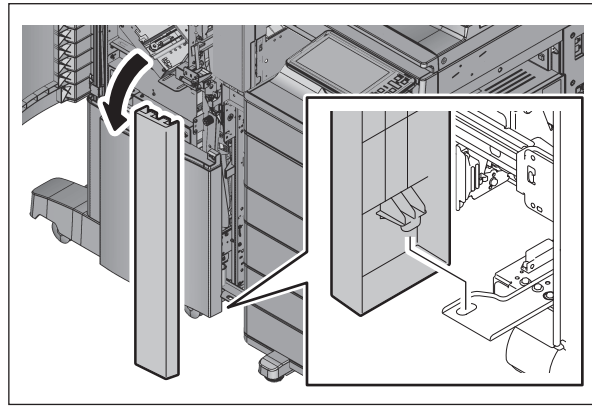


Fig. 4-523

- (8) Open the finisher cover and remove 1 fixing screw. Pull out the lever.

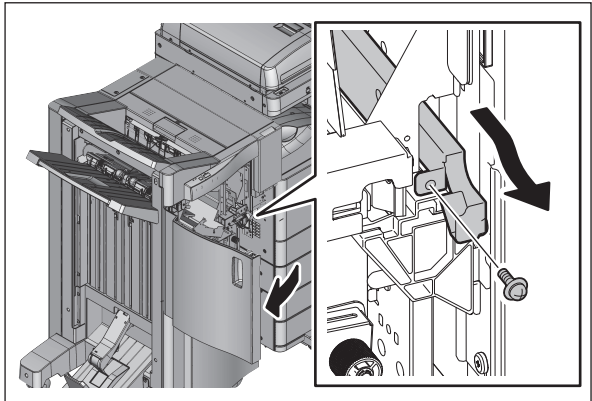


Fig. 4-524

- (9) Take off the finisher with the hole punch unit.

**Notes:**

Be careful not to fell the finisher when moving only the finisher unit.

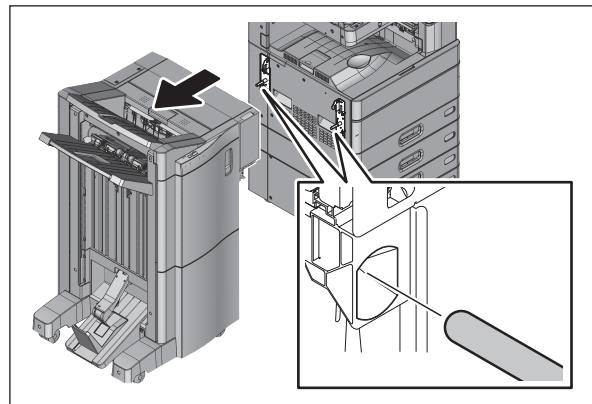


Fig. 4-525

## 4.11.9 Job Separator

- (1) Press the [Power] button on the control panel to shut it down.
- (2) Turn the main power switch of the equipment off.
- (3) Disconnect the power cable.
- (4) Remove the tray.

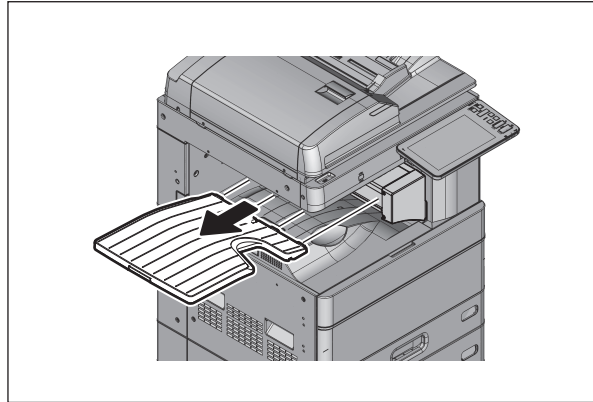


Fig. 4-526

- (5) Open the side cover. Remove 1 screw and take off the connector cover.

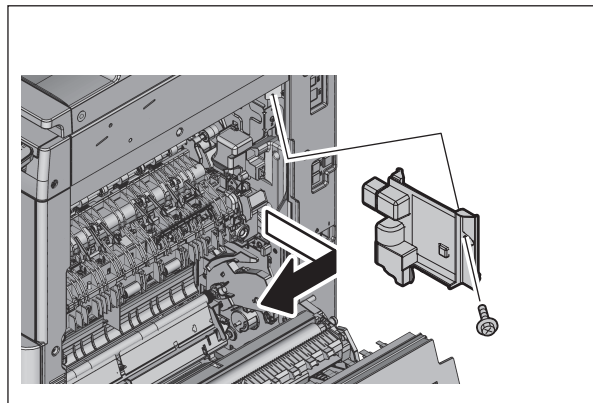


Fig. 4-527

- (6) Disconnect 2 connectors.

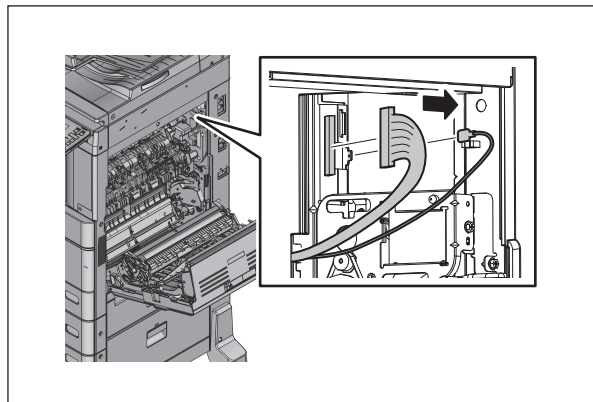


Fig. 4-528

- (7) Loosen 2 screws and take off the front cover of inner tray.

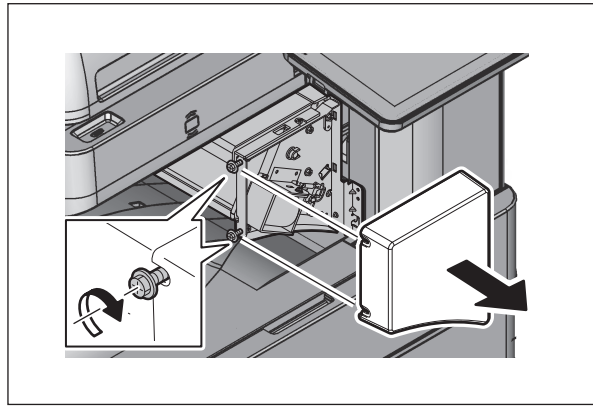


Fig. 4-529

- (8) Remove 1 screw. Lift up the job separator and release the hook. Take off the job separator toward the front.

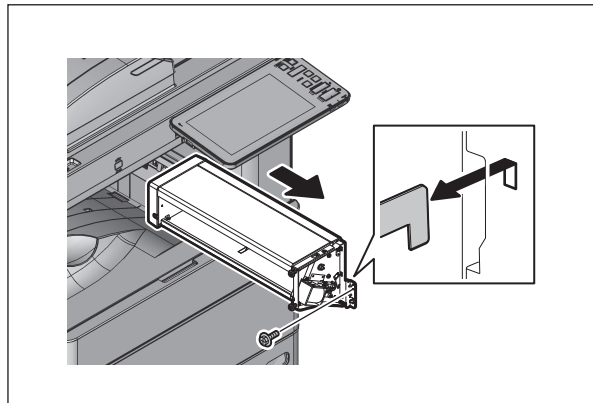


Fig. 4-530





## 5. SELF-DIAGNOSTIC MODE

### 5.1 Overview

This equipment consists of two servicing menus whose start-up method differs. Setting and adjustment can be performed by entering into a mode such as [05 ADJUSTMENT MODE] or [49 Firmware Update] from each menu.

- **FS Menu**

Mode		Contents
03 TEST MODE		Checks the status of input/output signals.
04 TEST PRINT MODE		Outputs the test patterns.
05 ADJUSTMENT MODE		Adjusts various items.
08 SETTING MODE		Sets various items.
20 PM SUPPORT MODE		Clears each counter.
30 LIST PRINT MODE		Prints various lists or outputs them in a CSV format.
31 CHART PRINT MODE		Prints the charts.
FAX	11 FAX CLEAR MODE	Sets the fax board.
	12 FAX LIST PRINT MODE	Outputs the contents set for the fax functions.
	13 FAX FUNCTION MODE	Sets the fax functions.
	19 RAM EDIT MODE	This is the mode for the special settings. (This is not used generally.)
35 DATA BACKUP/RESTORE MODE		This function backs up or restores the data.
36 CLONING		Creates and installs clone files.
37 LICENSE MANAGEMENT		Manages the license of applications.

- **HS Menu**

Mode		Contents
01 Control Panel Check		Checks various contents regarding the LCD, LED, hard keys and digital keys on the control panel.
49 Firmware Update		Performs firmware update with a USB storage device.
59 SRAM Data Cloning		Backs up the SRAM data to a USB storage device.
73 Firmware Assist		Clears error flags or SRAM, or safely deletes data in the HDD or SRAM to support the replacement of the SYS board, SRAM or HDD.
74 HDD Assist		Assists the Security HDD by checking the type of the mounted HDD or removing keys.
75 File System Recovery		Checks, recovers or initializes the file system (HDD).
76 SRAM Maintenance		Recovers the equipment from particular errors such as F800 or F900.

\* Only the modes which are available for this equipment are displayed on each menu.

**[A] Starting each Menu**

Menu			Mode*1		Operation			
FS Menu [FUNCTION CLEAR] + [START] + [POWER ON]	→	Enter a service password and press [OK].	→	03 TEST MODE	→	SELF-DIAGNOSIS CODE		
				04 TEST PRINT MODE	→	SELF-DIAGNOSIS CODE		
				05 ADJUSTMENT MODE	→	CLASSIC*2	→	SELF-DIAGNOSIS CODE
				08 SETTING MODE	→	CLASSIC*2	→	SELF-DIAGNOSIS CODE
				20 PM SUPPORT MODE	→			5.8
				30 LIST PRINT MODE	→			5.9
				31 CHART PRINT MODE	→			5.10
				FAX • 11 FAX CLEAR MODE • 12 FAX LIST PRINT MODE • 13 FAX FUNCTION MODE • 19 RAM EDIT MODE*3	→			SELF-DIAGNOSIS CODE
				35 DATA BACKUP/RESTORE MODE	→			5.12
				36 CLONING	→			5.13
				37 LICENSE MANAGEMENT	→			5.14
HS Menu [HOME] + [START] + [POWER ON]	→	Enter a service password and press [OK].	→	01 Control Panel Check	→	5.15		
				49 Firmware Update	→	11.2.4		
				59 SRAM Data Cloning	→	12.1.4		
				73 Firmware Assist	→	5.16		
				74 HDD Assist	→	5.17		
				75 File System Recovery	→	5.18		
				76 SRAM Maintenance	→	5.19		

\*1 FS menu: Select the mode and press [NEXT].

HS menu: Select the icon of the mode.

\*2 Press [CLASSIC] displayed at the upper right of the menu.

\*3 This is not used generally.

## [B] Cancellation of the self-diagnostic mode

The modes, which can be entered from [FS Menu], can be canceled by the following methods.

- When [FS Menu] is displayed on the screen:  
Press [FS Menu] to return to the menu screen. Press [NORMAL].  
The self-diagnostic mode finishes and the [HOME] screen appears. Rebooting/non-rebooting of the equipment will be performed depending on the mode worked and the code operated.
- When only [Return] is displayed on the screen:  
Press [Return] for several times until [FS Menu] is displayed on the screen. When [FS Menu] appears, press it.
- When neither [Return] nor [FS Menu] are not displayed on the screen:  
Press the [ON/OFF] button and perform the shut-down operation on the screen displayed.

To cancel the modes, which can be entered from [HS Menu] press the [ON/OFF] button for a few seconds to shut down the equipment.

## [C] State transition diagram of self-diagnosis modes

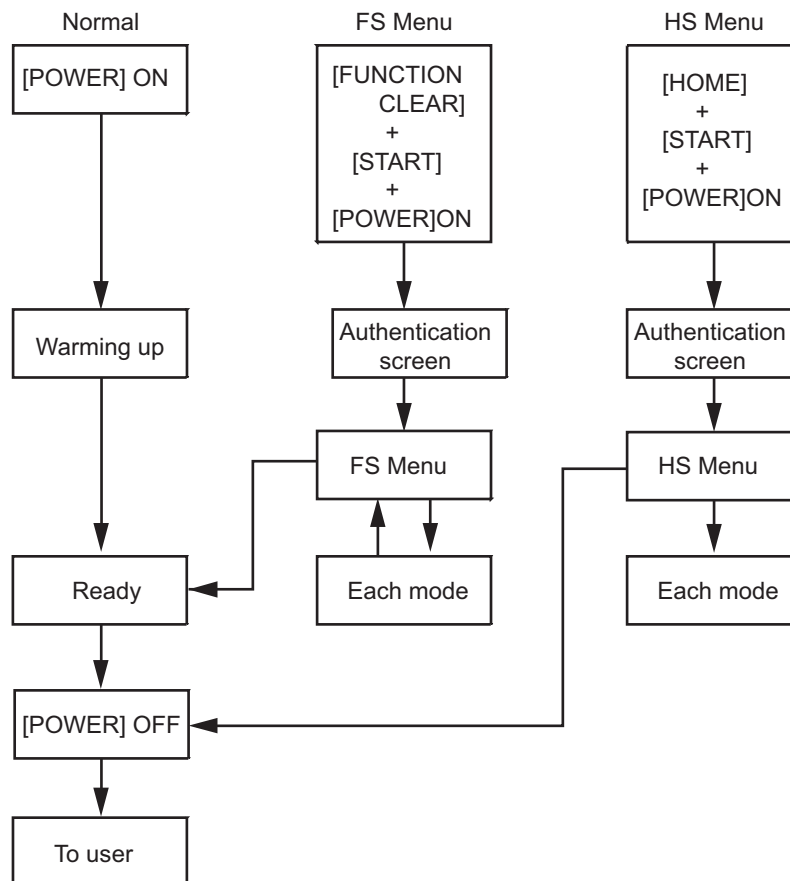


Fig.5-1

\* Be sure to cancel the self-diagnostic mode before customers start using the equipment.

## [D] Changing/setting of the service password

- (1) The [SETTINGS] screen is displayed by press [SETTINGS] on [FS Menu].
- (2) Press [Service Password] to change or reset the service password.

## 5.2 Description Rule for Each Menu and Mode

The description of the self-diagnostic code in this document complies with the rule below.

### Example

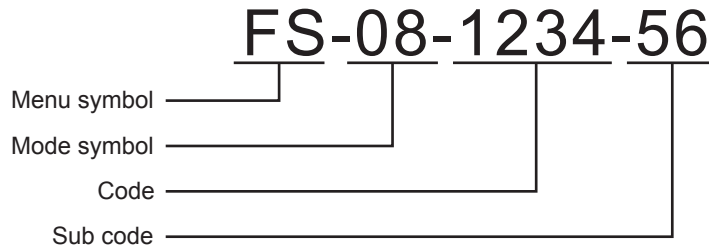


Fig.5-2

1. Symbol for the menu  
FS: FS Menu (Starting by pressing the [ON/OFF] button while pushing the [FUNCTION CLEAR] and [START] buttons simultaneously.)  
HS: HS Menu (Starting by pressing the [ON/OFF] button while pushing the [HOME] and [START] buttons simultaneously.)
2. Symbol for the mode  
The first two digits of each mode
3. Code  
The number of the code
4. Sub code  
This will only be given when a sub code exists.

### [A] FS Menu

#### [05 ADJUSTMENT MODE] or [08 SETTING MODE]:

[FS-05-1234-56] or [Performs FS-05-1234-56] is taken for explanation purposes.

- (1) Start FS Menu by pressing the [ON/OFF] button while pushing the [FUNCTION CLEAR] and [START] buttons simultaneously.

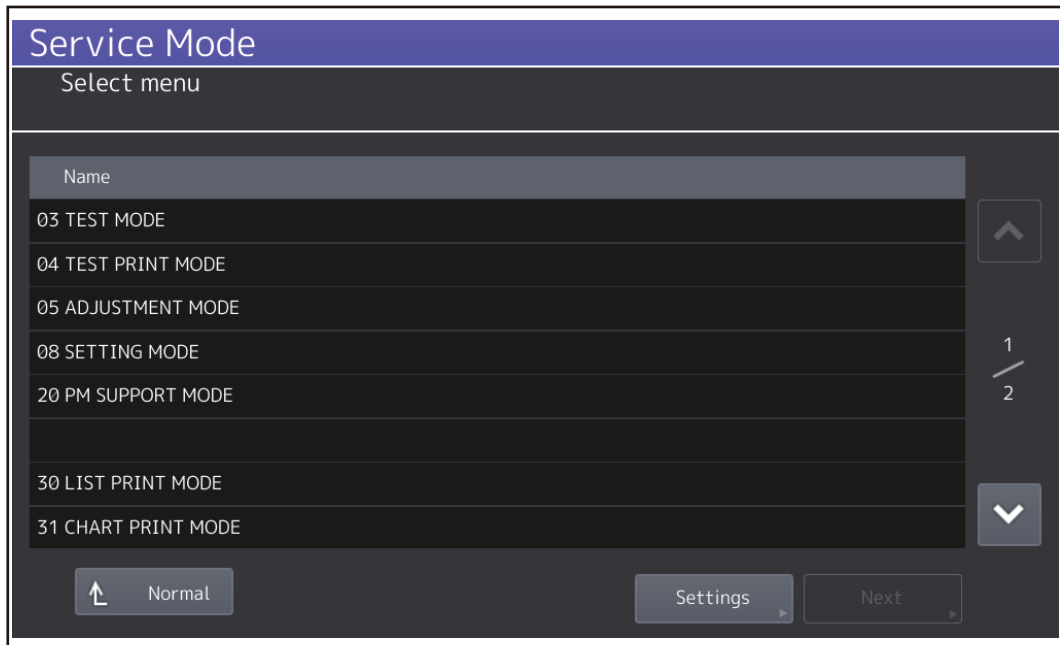


Fig.5-3

- (2) Select [05 ADJUSTMENT MODE] and press [NEXT].

- (3) Press [CLASSIC] on the upper right of the menu to display the adjustment mode menu.

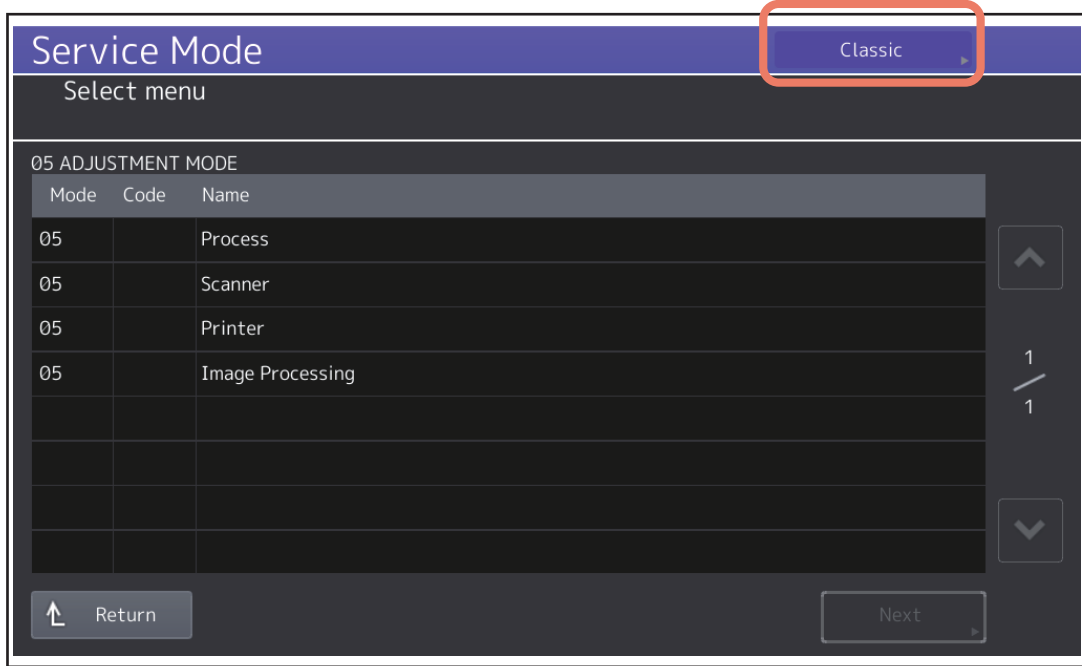


Fig.5-4

- (4) By using the digital keys displayed on the screen, enter [1], [2], [3], [4] and then press the [START] button. Enter the sub codes [5] and [6] and then press the [START] button.
- (5) Carry out the adjustment by following the instructions displayed on the screen or press the [START] button.

**[03 TEST MODE]:**

The key-pressing procedure for the modes, which are set by the combination of the [F1], [F2] and [F3] keys, are described as below.

[F1: ON]: Only F1 is turned ON.

[F1, 2: ON]: F1 and F2 are turned ON.

\* The number of the [F] key, which is turned ON, is depicted by dividing with "," (commas) as above.

[F1, 2, 3: ON]: All of the [F] keys are turned ON.

[F: OFF]: All of the [F] keys are turned OFF.

**Example:**

[FS-03-F:OFF-9-A]: Turn OFF all of the [F] keys in the FS-03 mode, select [9] and then [A].

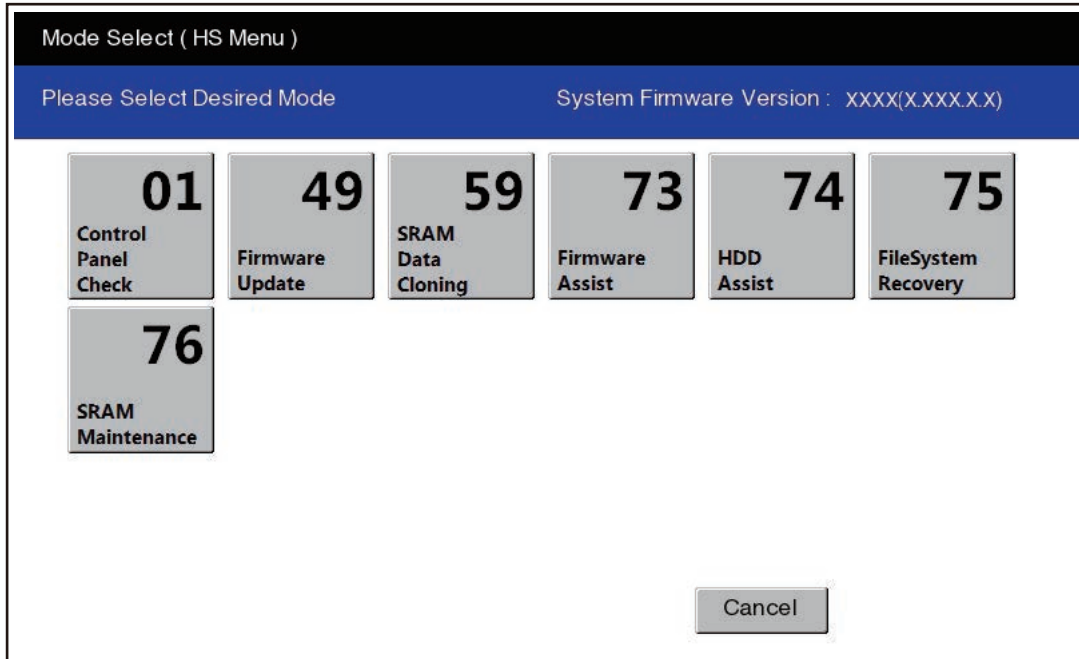
[FS-03-F1:ON-9-A]: Turn ON the [F1] key in the FS-03 mode, select [9] and then [A].

**[FAX]:**

In case of [FS-11], [FS-12] or [FS-13] is given in the explanations, select [FAX] in the [FS Menu] and then press [NEXT] to choose each mode.

**[B] HS Menu**

- (1) Start HS Menu by pressing the [ON/OFF] button while pushing the [HOME] and [START] buttons simultaneously.



**Fig.5-5**

- (2) Press the icon to operate.
- (3) Follow the instructions displayed on the screen.

**[C] When a particular setting condition is applied:**

The setting value is given at the end of the description by dividing with ":" (colons).

**Example:**

[FS-08-8911:3]: "3" is set for FS-08-8911.

## 5.3 Service UI

### 5.3.1 Overview

Each mode of the self-diagnostic codes can be used by selecting the keyword of the screen in the Service UI.

The codes which are used frequently can be selected in the Service UI.

The Service UI can be used in the following modes in the FS Menu.

- 05 ADJUSTMENT MODE
- 08 SETTING MODE

**Notes:**

Not all codes can be used in the Service UI.

For the codes available with the Service UI, refer to the "Self-diagnostic code list" (separate document).

### 5.3.2 Operation procedure

- (1) Start the FS Menu. Select the mode of the above Service UI and press [NEXT].
- (2) Select the item whose setting is to be changed and press [NEXT] until the code number is displayed. Press [OK]. The display shifts to the classic screen of the selected code.

### 5.3.3 Starting the FS Menu from the normal mode

If the [Tool] icon is displayed on the USER FUNCTIONS menu of the normal mode, the FS Menu can be started.

- (1) Turn the power ON.
- (2) Enter the user name and password if necessary. \*
- (3) Press [USER FUNCTIONS] on the HOME screen.
- (4) Press the [Tool] icon on the upper left of the screen for at least 3 seconds.

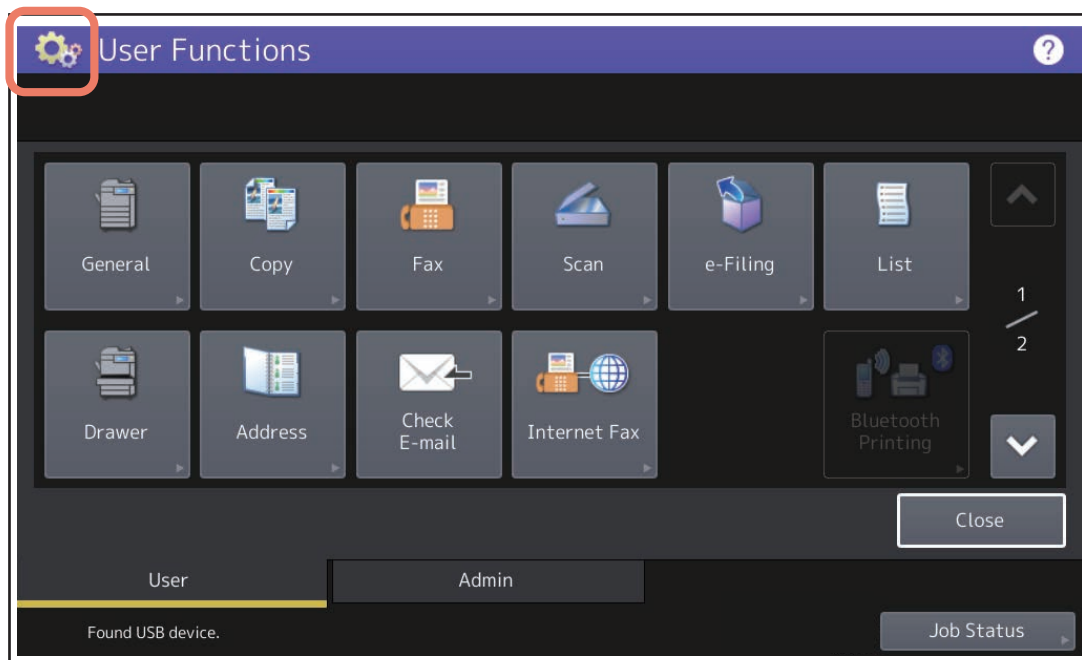


Fig.5-6

(5) Enter the service password and press [OK].  
The FS Menu appears.

\* When "3" is set for FS-08-8911 (security mode), the authentication screen is always displayed.

**Notes:**

- The service password needs to be changed to log in for the first time.
- In case the password is forgotten, ask the administrator to reset the service password.
- Note that the user data are deleted at that time.



## 5.4 03 TEST MODE

### 5.4.1 Output check

The status of the output signal can be checked.

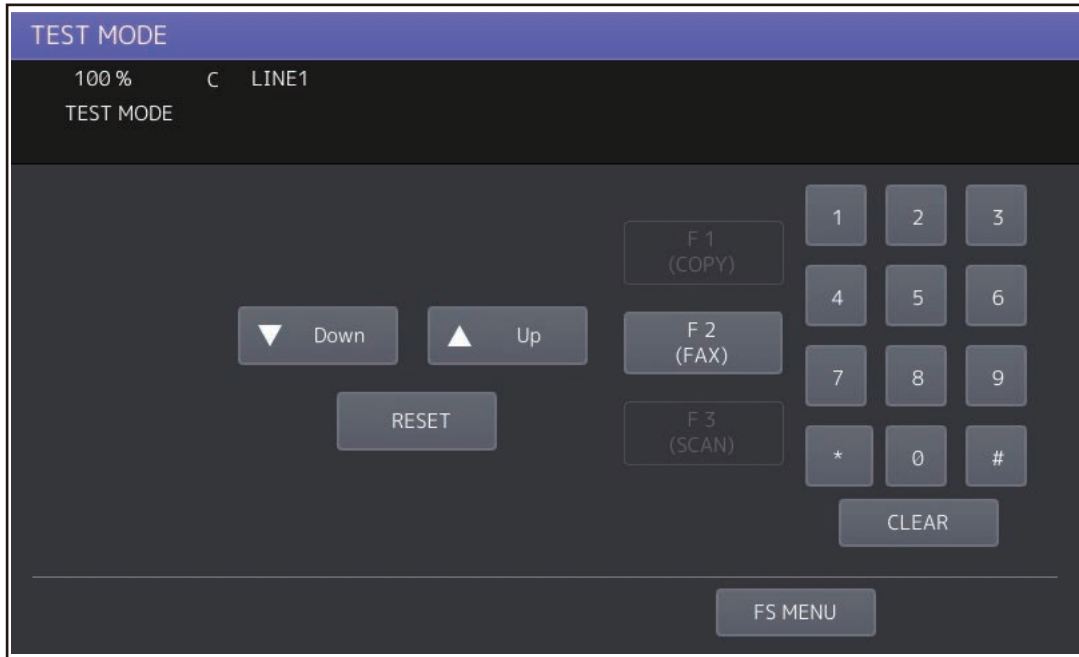


Fig.5-7

Operation procedure: Refer to SELF-DIAGNOSIS CODE.

### 5.4.2 Input check

The status of each input signal can be checked by operating the [F1], [F2], [F3] and the digital keys.



Fig.5-8

Operation procedure: Refer to SELF-DIAGNOSIS CODE.

## 5.5 04 TEST PRINT MODE

The embedded test pattern can be printed out.

Operation procedure: Refer to SELF-DIAGNOSIS CODE.

## 5.6 05 ADJUSTMENT MODE

Various adjustments and test printing can be performed.

Operation procedure: Refer to SELF-DIAGNOSIS CODE.

### 5.6.1 TEST PRINT

One sheet of the test print for various patterns can be printed out by entering 1 to 3-digit code and pressing [TEST PRINT] in the [CLASSIC] Mode standby screen in the [05 ADJUSTMENT MODE].

Operation procedure: Refer to SELF-DIAGNOSIS CODE.

## 5.7 08 SETTING MODE

Various settings can be set.

Operation procedure: Refer to SELF-DIAGNOSIS CODE.

## 5.8 20 PM SUPPORT MODE

 P. 7-6 "7.4 PM Support Mode"

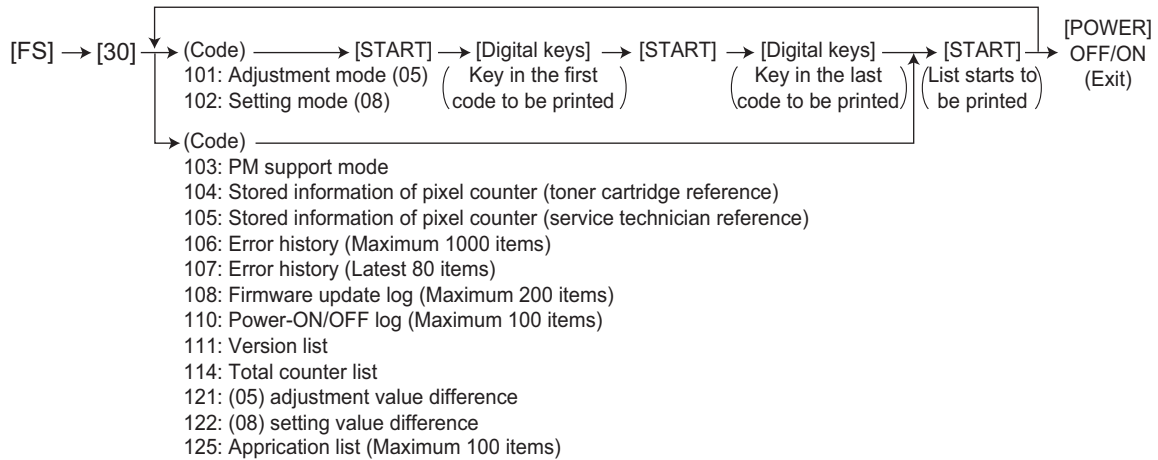
### <Operation procedure>

[FS] → [20] → (Operation started) → Exit

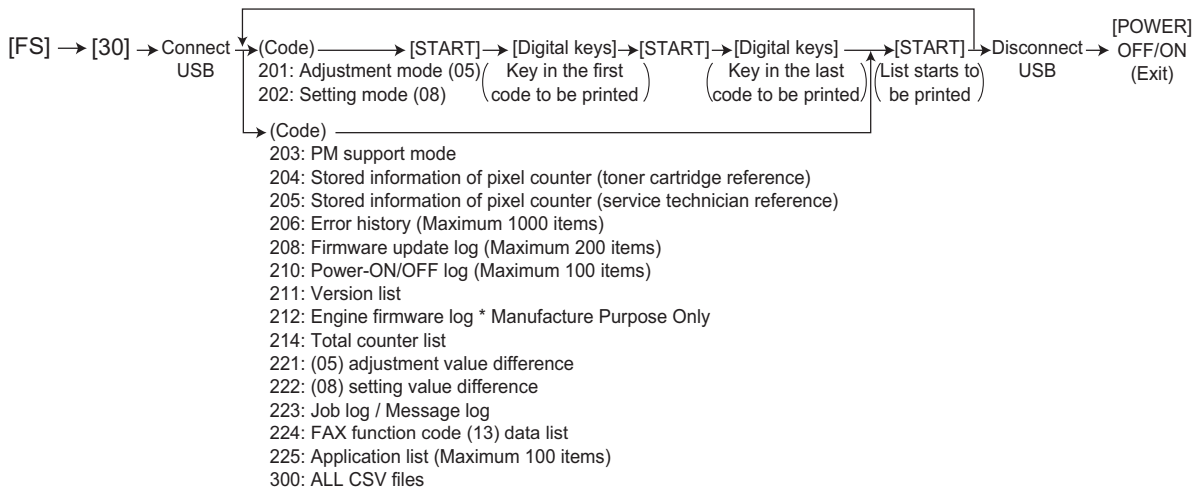
## 5.9 30 LIST PRINT MODE

### 5.9.1 Operation procedure

#### [ 1 ] Print out



#### [ 2 ] CSV output (USB)



#### Notes:

##### Precautions when storing information into USB device

- When storing the setting information of the equipment into a USB device, be sure to obtain permission from a user in advance.
- When storing the setting information of the equipment into a USB device, the information is printed out in a CSV format. Handle and manage the information with extra care.
- Do not lose or leak the setting information of the equipment.
- Do not use the setting information of the equipment for purposes other than maintenance or product services.
- Provide the information promptly if a user requires so.
- The buttons on the control panel keep blinking while data are being stored in the USB device. Do not disconnect the USB device while data are being stored.

## Tips

In the USB storage procedure above, lists are stored in a CSV format. The names of the CSV files are shown below.

201:ADJUSTMENT\_LIST\_serial\_date and time(YYYYMMDDHHMMSS).csv  
 202:SETTING\_LIST\_serial\_date and time(YYYYMMDDHHMMSS).csv  
 203:PM\_LIST\_serial\_date and time(YYYYMMDDHHMMSS).csv  
 204:PIXEL\_TONER\_LIST\_serial\_date and time(YYYYMMDDHHMMSS).csv  
 205:PIXEL\_SERVICE\_LIST\_serial\_date and time(YYYYMMDDHHMMSS).csv  
 206:ERROR\_LOG\_serial\_date and time(YYYYMMDDHHMMSS).csv  
 208:FW\_UPGRADE\_LOG\_serial\_date and time(YYYYMMDDHHMMSS).csv  
 210:POWER\_ONOFF\_LOG\_serial\_date and time(YYYYMMDDHHMMSS).csv  
 211:VERSION\_LIST\_serial\_date and time(YYYYMMDDHHMMSS).csv  
 212:ENG\_FW\_LOG\_serial\_date and time(YYYYMMDDHHMMSS).csv  
 214:TOTAL\_COUNTER\_LIST\_serial\_date and time(YYYYMMDDHHMMSS).csv  
 221:05DIFFERENCE\_CODE\_LIST\_serial\_date and time(YYYYMMDDHHMMSS).csv  
 222:08DIFFERENCE\_CODE\_LIST\_serial\_date and time(YYYYMMDDHHMMSS).csv  
 223:JOB\_LOG\_serial\_date and time(YYYYMMDDHHMMSS) (encrypted file)/MESSAGE\_LOG\_serial\_date and time(YYYYMMDDHHMMSS) (encrypted file)  
 224:FAX\_FUNCTION\_LIST\_Serial No.\_Date(YYYYMMDDHHMMSS).csv  
 225:APPLICATION\_LIST\_serial\_date and time(YYYYMMDDHHMMSS).csv

## 5.9.2 List Printing

Lists below are output in the list print mode.

List data are printed out or output in a CSV format by storing them in a USB device. Paper sizes available for this printing are A4 or LT or larger. This section introduces a sample of each list.

Perform [FS-30] to start the list print mode.

Lists	List code	
	Printout	CSV file output
Adjustment mode (05) data list	101	201
Setting mode (08) data list	102	202
PM support mode data list	103	203
Pixel counter list (toner cartridge reference)	104	204
Pixel counter list (service call reference)	105	205
Error history list	106 (Maximum 1000 items)	206 (Maximum 1000 items)
Error history list	107 (Latest 80 items)	-
Firmware upgrade log	108 (Maximum 200 items)	208 (Maximum 200 items)
Power ON/OFF log	110 (Maximum 100 items)	210 (Maximum 100 items)
Version list	111	211
Engine firmware log	-	212
Total counter list	114	214
(05) adjustment value difference	121	221
(08) setting value difference	122	222
Application list	125 (Maximum 100 items)	225 (Maximum 100 items)
Job log/Message log	-	223
FAX Function mode (13) data list	-	224
Output all CSV files	-	300 *

\*: (05) adjustment value difference and (08) setting value difference are not output.

- 05 ADJUSTMENT MODE

05 ADJUSTMENT MODE DATA LIST				S/N: xxxxxxxx		TOTAL: 9999999	
20xx-xx-xx xx:xx				TOSHIBA e-STUDIOxxx		DF TOTAL: 9999999	
CODE	DATA	CODE	DATA	CODE	DATA	CODE	DATA
2000	128	3860-0	88	4830	128	5920	128
.	.	.	.	.	.	.	.
.	.	.	.	.	.	.	.
.	.	.	.	.	.	.	.
.	.	.	.	.	.	.	.
.	.	.	.	.	.	.	.
.	.	.	.	.	.	.	.
.	.	.	.	.	.	.	.
.	.	.	.	.	.	.	.
.	.	.	.	.	.	.	.
.	.	.	.	.	.	.	.
.	.	.	.	.	.	.	.
.	.	.	.	.	.	.	.
.	.	.	.	.	.	.	.

Fig.5-9

The selected adjustment codes and the current adjustment value for each code are output in a list.

- 08 SETTING MODE

08 SETTING MODE		DATA LIST		S/N: xxxxxxxx		TOTAL: 999999	
20xx-xx-xx xx:xx				TOSHIBA e-STUDIOxxx		DF TOTAL: 999999	
CODE	DATA	CODE	DATA	CODE	DATA	CODE	DATA
2010	2	2880	12	3040	0	3070-3	0
.	.	.	.	.	.	.	.
.	.	.	.	.	.	.	.
.	.	.	.	.	.	.	.
.	.	.	.	.	.	.	.
.	.	.	.	.	.	.	.
.	.	.	.	.	.	.	.
.	.	.	.	.	.	.	.
.	.	.	.	.	.	.	.
.	.	.	.	.	.	.	.
.	.	.	.	.	.	.	.
.	.	.	.	.	.	.	.
.	.	.	.	.	.	.	.
.	.	.	.	.	.	.	.

Fig.5-10

The selected setting codes and the current setting value for each code are output in a list.

- 13 FAX FUNCTION MODE

```
13 FAX FUNCTION LIST FOR MAINTENANCE, VERSION x.x.x
20xx/xx/xx xx:xx:xx
TOSHIBA e-STUDIOxxxx
Cxxxxxxxx
FIN S/N-xxxxxxxx
TOTAL, 99999999, 99999999, 99999999, DF TOTAL, 99999999
CODE, SUB, DATA,
100, , 0
101, , 1
102, , 2
103, , 3
104, , 4
105, , 5
106, , 6
107, , 7
108, , 8
109, , 9
110, , 0
111, , 1
112, , 2
. .
. .
. .
. .
. .
. .
```

Fig.5-11

The selected setting codes and the current setting value for each code are output in a list.

- 20 PM SUPPORT MODE

PM SUPPORT CODE LIST				
		S/N: xxxxxxxx	TOTAL:	9999999
20xx-xx-xx xx:xx		TOSHIBA e-STUDIOxxx	DF TOTAL:	9999999
UNIT	OUTPUT PAGES/ DEVELOP COUNTS	PM OUTPUT PAGE/ DEVELOP COUNTS	DRIVE COUNTS	PM DRIVE COUNTS
DRUM (K)	2516	70000	11735	170000
DRUM BLADE (K)	2516	70000	11735	170000
GRID (K)	2516	70000	11735	170000
MAIN CHARGER NEEDLE (K)	2516	70000	11735	170000
CHARGER CLEANING PAD (K)	2516	70000	11735	170000
DRUM (Y)	411	70000	8625	170000
DRUM BLADE (Y)	411	70000	8625	170000
GRID (Y)	411	70000	8625	170000
MAIN CHARGER NEEDLE (Y)	411	70000	8625	170000
CHARGER CLEANING PAD (Y)	411	70000	8625	170000
DRUM (M)	411	70000	8625	170000
DRUM BLADE (M)	411	70000	8625	170000
GRID (M)	411	70000	8625	170000
MAIN CHARGER NEEDLE (M)	411	70000	8625	170000
CHARGER CLEANING PAD (M)	411	70000	8625	170000
.	.	.	.	.
.	.	.	.	.
.	.	.	.	.

Fig.5-12

The number of pages currently output (OUTPUT PAGES/DEVELOP COUNTS), the recommended number of output pages for PM (PM OUTPUT PAGES/DEVELOP COUNTS), the current drive count (DRIVE COUNTS) and the recommended drive count for PM (PM DRIVE COUNTS) are output together with PM units. Use this list for confirming the PM units to be replaced at each PM. See the following page for PM:

📖 P. 7-1 "7. PREVENTIVE MAINTENANCE (PM)"




- Stored information of pixel counter (toner cartridge reference)

PIXEL COUNTER CODE LIST							
				S/N: xxxxxxxx	TOTAL:	9999999	
				TOSHIBA e-STUDIOxxx	DF TOTAL:	9999999	
20xx-xx-xx xx:xx							
TONERCARTRIDGE							
No	DATE	COLOR		PPC	PRN	FAX	TOTAL
0	20xx-xx-xx	Y	Print Count[LT/A4]	181	45	---	226
1	20xx-xx-xx	Y	Average Pixel Count[%]	2.70	1.74	---	2.51
2	20xx-xx-xx	Y	Latest Pixel Count[%]	6.15	0.39	---	0.39
3	20xx-xx-xx	M	Print Count[LT/A4]	181	45	---	226
4	20xx-xx-xx	M	Average Pixel Count[%]	6.11	2	---	5.29
5	20xx-xx-xx	M	Latest Pixel Count[%]	6.82	2.15	---	2.15
6	20xx-xx-xx	C	Print Count[LT/A4]	181	45	---	226
7	20xx-xx-xx	C	Average Pixel Count[%]	5.46	2	---	4.81
8	20xx-xx-xx	C	Latest Pixel Count[%]	6.42	2.73	---	2.73
9	20xx-xx-xx	K	Print Count[LT/A4]	278	145	9	432
10	20xx-xx-xx	K	Average Pixel Count[%]	6.15	3.86	23.25	5.74
11	20xx-xx-xx	K	Latest Pixel Count[%]	7.32	2.19	6.25	2.19

Fig.5-13

Pixel counter data (toner cartridge reference) are output in a list. See the following page for the pixel counter:


 P. 5-53 "5.20 Pixel Counter"

- Stored information of pixel counter (service technician reference)

PIXEL COUNTER CODE LIST						
		S/N: xxxxxxxx		TOTAL:		9999999
		TOSHIBA e-STUDIOxxx		DF TOTAL:		9999999
20xx-xx-xx xx:xx						
SERVICEMAN						
No	DATE	COLOR	PPC	PRN	FAX	TOTAL
0	20xx-xx-xx	F Print Count[LT/A4]	181	45	---	226
1	20xx-xx-xx	F Average Pixel Count[%]	4.95	2.34	---	4.43
2	20xx-xx-xx	F Latest Pixel Count[%]	8.36	2.34	---	2.34
3	20xx-xx-xx	Y Print Count[LT/A4]	181	45	---	226
4	20xx-xx-xx	Y Average Pixel Count[%]	2.7	1.74	---	2.51
5	20xx-xx-xx	Y Latest Pixel Count[%]	6.15	0.39	---	0.39
6	20xx-xx-xx	M Print Count[LT/A4]	181	45	---	226
7	20xx-xx-xx	M Average Pixel Count[%]	6.11	2	---	5.29
8	20xx-xx-xx	M Latest Pixel Count[%]	6.82	2.15	---	2.15
9	20xx-xx-xx	C Print Count[LT/A4]	181	45	---	226
10	20xx-xx-xx	C Average Pixel Count[%]	5.46	2.18	---	4.81
11	20xx-xx-xx	C Latest Pixel Count[%]	6.42	2.73	---	2.73
12	20xx-xx-xx	K Print Count[LT/A4]	181	45	---	226
13	20xx-xx-xx	K Average Pixel Count[%]	5.51	3.43	---	5.10
14	20xx-xx-xx	K Latest Pixel Count[%]	14.05	4.10	---	4.10
15	20xx-xx-xx	K Print Count[LT/A4]	97	100	9	206
16	20xx-xx-xx	K Average Pixel Count[%]	7.36	4.06	23.25	6.45
17	20xx-xx-xx	K Latest Pixel Count[%]	7.32	2.19	6.25	2.19

Fig.5-14

Pixel counter data (service call reference) are output in a list. See the following page for the pixel counter:

 P. 5-53 "5.20 Pixel Counter"

- Error history

ERROR HISTORY LIST						
					S/N: xxxxxxxx	TOTAL: 9999999
					TOSHIBA e-STUDIOxxx	DF TOTAL: 9999999
20xx-xx-xx xx:xx						
CODE	COUNTER	DATE	TIME	ZOOM_XY	ABCD_EFGH_IJLO_PQ_R	
F110	00000000	xxx-xx-xx	xx:xx:xx	000 000	0000_0000_0000_00_0000000000	
F110	00000000	xxx-xx-xx	xx:xx:xx	000 000	0000_0000_0000_00_0000000000	
F110	00000000	xxx-xx-xx	xx:xx:xx	000 000	0000_0000_0000_00_0000000000	
F110	00000000	xxx-xx-xx	xx:xx:xx	000 000	0000_0000_0000_00_0000000000	
EAD0	00000000	xxx-xx-xx	xx:xx:xx	000 000	0000_0000_0000_00_0000000000	
E860	00000000	xxx-xx-xx	xx:xx:xx	000 000	0000_0000_0000_00_0000000000	
E731	00000000	xxx-xx-xx	xx:xx:xx	000 000	0000_0000_0000_00_0000000000	
E090	00000000	xxx-xx-xx	xx:xx:xx	000 000	0000_0000_0000_00_0000000000	
E870	00000000	xxx-xx-xx	xx:xx:xx	000 000	0000_0000_0000_00_0000000000	
E724	00000000	xxx-xx-xx	xx:xx:xx	000 000	0000_0000_0000_00_0000000000	

Fig.5-15

The error history is output. See the following page for the parameters for each error:

 P. 8-52 "8.2.4 Printer function error"

- Firmware update log

```

FW UPGRADE LOG

S/N: xxxxxxxx          TOTAL:    9999999
TOSHIBA e-STUDIOxxx  DF TOTAL:  9999999

20xx-xx-xx xx:xx

MANUFACTURE DATE  20xx-xx-xx
UNPACKING DATE   20xx-xx-xx

USER  ROM/VERSION  DATE    TOTAL  COPY(B) COPY(2) COPY(C) PRINT(B) PRINT(2) PRINT(C) LIST  FAX  STATUS
Service Txxxxxx-xxxx 20xx-xx-xx 99999999 99999999 99999999 99999999 99999999 99999999 99999999 99999999 99999999 99999999 OK
Service Txxxxxx-xxxx 20xx-xx-xx 99999999 99999999 99999999 99999999 99999999 99999999 99999999 99999999 99999999 99999999 OK
Service Txxxxxx-xxxx 20xx-xx-xx 99999999 99999999 99999999 99999999 99999999 99999999 99999999 99999999 99999999 99999999 OK
.         .         .         .         .         .         .         .         .         .         .         .         .
.         .         .         .         .         .         .         .         .         .         .         .         .
.         .         .         .         .         .         .         .         .         .         .         .         .
.         .         .         .         .         .         .         .         .         .         .         .         .
.         .         .         .         .         .         .         .         .         .         .         .         .
.         .         .         .         .         .         .         .         .         .         .         .         .

```

Fig.5-16

Firmware update logs are output.

- MANUFACTURE DATE: the date of manufacture / UNPACKING DATE: the date that the equipment was unpacked.
- Only the versions of ROMs updated with USB device are output.

Item	Content
USER	User who updated firmware
ROM/VERSION	Version of firmware
DATE	Date that firmware was updated
TOTAL	Total counter data when firmware was updated
COPY (B)	Copier counter data (black) when firmware was updated
COPY (2)	Copier counter data (twin color) when firmware was updated
COPY (C)	Copier counter data (full color) when firmware was updated
PRINT (B)	Printer counter data (black) when firmware was updated
PRINT (2)	Printer counter data (twin color) when firmware was updated
PRINT (C)	Printer counter data (full color) when firmware was updated
LIST	List print counter data when firmware was updated
FAX	Fax print counter data when firmware was updated
STATUS	Result of update

- Power-ON/OFF log

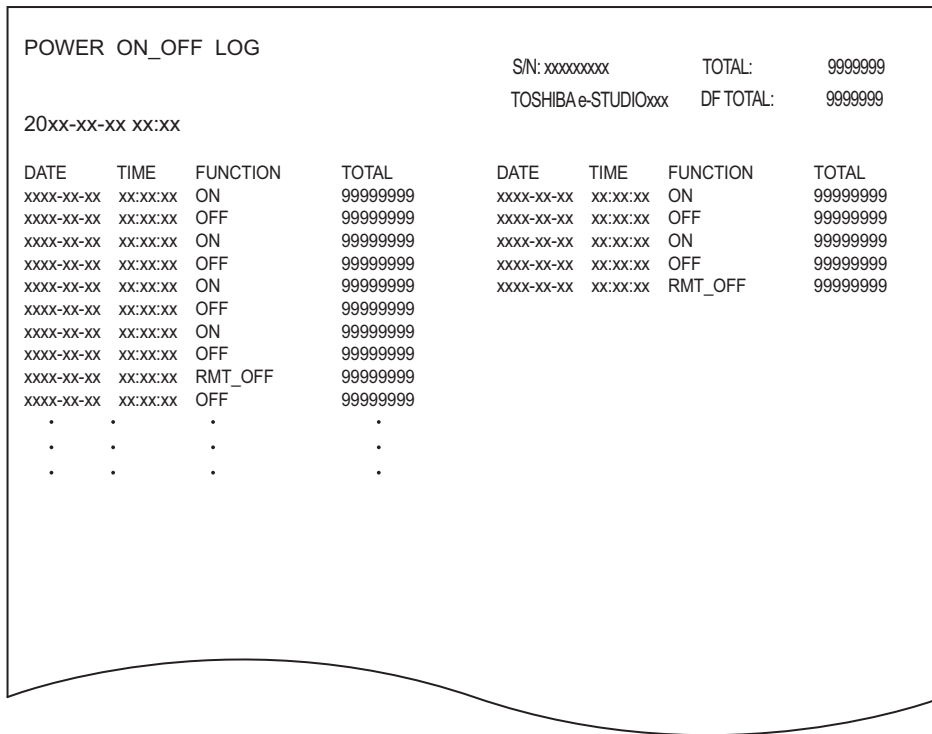


Fig.5-17

Power ON/OFF logs are output.

- Note that cases that the power was turned OFF with the main switch (not with the [ON/OFF] button on the control panel) will not be displayed.

Item	Content
DATE	Date that the power was turned ON or OFF
TIME	Time that the power was turned ON or OFF
FUNCTION	Whether the power was turned ON or OFF, or if it was turned ON or OFF with a remote reset function
TOTAL	Total counter data when the power was turned OFF and then back ON

- Version list

```

VERSION LIST
S/N: xxxxxxxx          TOTAL:      9999999
TOSHIBA e-STUDIOxxx   DF TOTAL:   9999999

20xx-xx-xx xx:xx

SYSTEM FIRMWARE ROM VERSION      : Txxxxxxxxxxxx
SYSTEM FIRMWARE INTERNAL ROM VERSION: Vx.x.x.xx.xx
PRINTER ROM VERSION              : xxxM-xxx
SCANNER ROM VERSION              : xxxS-xxx
PFC ROM VERSION                  : xxxF-xxx
RADF ROM VERSION                 : DF-xxx
FINISHER STACKER ROM VERSION     : FIN-
FINISHER PUNCH ROM VERSION      : PUN-
FAX BOARD FIRMWARE ROM VERSION   : Fxx-xxx
SYSTEM FIRMWARE INTERNAL OS VERSION : Vx.xxx.x.x
HDD DATA VERSION                : Txxxxxxxxxxxx
SYSTEM FIRMWARE OS VERSION       : Txxxxxxxxxxxx
NIC FIRMWARE ROM VERSION         : XXXXXXXXXXXX
LANGUAGE VERSION
  English(US)                    : xxx.xxx  xxx xxx xx xx:xx:xx xxxx
  .                                .
  .                                .
  .                                .

CAPACITY OF HDD                  : xx.x GB
DEVICE INFORMATION OF HDD       : xxx xxxxxxx-xxxxxx
SERIAL NUMBER OF HDD            : xx-xxxxxxxxxxxx
MEMORY SIZE                      : xxxx MB / xxxx MB
INSTALLED ELK NAME              : Data overwrite enabler
                                IPSec enabler
                                Meta scan enabler
                                External interface enabler
                                .
                                .
                                .

```

Fig.5-18

The list of versions is output.

**Notes:**

Some of the characters in the fonts that are used to print the version list are not supported. As a result, the language names under LANGUAGE VERSION may not be printed correctly when printing the version list.

- Engine firmware log

```
ENGINE FW LOG
20xx/xx/xx xx:xx
TOSHIBA e-STUDIOxxxx
Cxxxxxxxx
FIN S/N-xxxxxxxx
TOTAL, 9999999, DF TOTAL, 9999999
```

CODE	SUB	DATA
4624	0	0
4624	1	0
4624	2	58
4624	3	3
4624	4	58
4624	5	3
4624	6	0
4624	7	56
4624	8	3
4624	9	0
4624	10	41
4624	11	1
4624	12	29
4624	13	7
4624	14	0
4624	15	0
4624	16	0
4624	17	0
4624	18	0
4624	19	0
4624	20	0
.	.	.
.	.	.
.	.	.
.	.	.
.	.	.

Fig.5-19

The file of the engine firmware log is output (but it is not printed out).

- Total counter list

TOTAL COUNTER LIST		S/N: xxxxxxxx	TOTAL:	9999999
20xx-xx-xx xx:xx		TOSHIBA e-STUDIOxxx	DFTOTAL:	9999999
PRINT COUNTER				
TOTAL	FULL COLOR TWIN/MONO COLOR BLACK TOTAL			
COPY	37	0	1	38
FAX	0	0	0	0
PRINTER	122	0	60	182
LIST	0	0	0	0
TOTAL	159	0	61	220
COPY	FULL COLOR TWIN/MONO COLOR BLACK TOTAL			
SMALL	37	0	1	38
LARGE	0	0	0	0
TOTAL	37	0	1	38
FAX	FULL COLOR TWIN/MONO COLOR BLACK TOTAL			
SMALL	0	0	0	0
LARGE	0	0	0	0
TOTAL	0	0	0	0
PRINTER	FULL COLOR TWIN/MONO COLOR BLACK TOTAL			
SMALL	118	0	60	178
LARGE	4	0	0	4
TOTAL	122	0	60	182
LIST	FULL COLOR TWIN/MONO COLOR BLACK TOTAL			
SMALL	0	0	0	0
LARGE	0	0	0	0
TOTAL	0	0	0	0
CALIBRATION COUNTER : 0				
SCAN COUNTER				
TOTAL	FULL COLOR TWIN/MONO COLOR BLACK TOTAL			
COPY	7	0	1	8
FAX	0	0	0	0
NETWOF	0	0	0	0
TOTAL	7	0	1	8
COPY	FULL COLOR TWIN/MONO COLOR BLACK TOTAL			
SMALL	7	0	1	8
LARGE	0	0	0	0
TOTAL	7	0	1	8
FAX	FULL COLOR TWIN/MONO COLOR BLACK TOTAL			
SMALL	0	0	0	0
LARGE	0	0	0	0
TOTAL	0	0	0	0
NETWORK	FULL COLOR TWIN/MONO COLOR BLACK TOTAL			
SMALL	0	0	0	0
LARGE	0	0	0	0
TOTAL	0	0	0	0

Fig.5-20

The list of total counter is output.



- (05) adjustment value/(08) setting value difference

05 DIFFERENCE LIST			S/N: xxxxxxxx      TOTAL:      9999999		
xx-xx-xx xx:xx			TOSHIBA e-STUDIOxxxx    DF TOTAL:      9999999		
CODE	BACKUP	CURRENT	CODE	BACKUP	CURRENT
* 2400	128	160			
.	.	.			
.	.	.			
.	.	.			
.	.	.			
.	.	.			
.	.	.			
.	.	.			
.	.	.			
.	.	.			
.	.	.			
.	.	.			

Fig.5-21

The value differences between the factory default and the current value of [05 Adjustment mode] and [08 Setting mode] in the FS Menu can be printed or output with a CSV file.

The mark "\*" or "+" will be added to the left side of the code in the following cases.

"\*": If there is a difference

"+": If there is no backed up value

**Notes:**

- Back-up data of the factory default are automatically created when the automatic gamma adjustment of the easy set-up mode has been completed during the unpacking and setting up of the equipment. The back-up file will be retained even if the system firmware is upgraded. However, the file will be deleted when the HDD is formatted or replaced.
- When the easy set-up mode is restarted while a specified value such as 4 through 9 is set for FS-08-9022 (Production process management status for easy setup), the back-up file stored during unpacking and setting-up is deleted after the completion of the automatic gamma adjustment and a new one is created while the value as of then is stored.
- When no back-up file exists  
 When FS-30-121 (122) is performed, the equipment returns to the ready state of the 30 LIST PRINT MODE without performing printing.  
 When FS-30-221 (222) is performed, the equipment returns to the ready state of the 30 LIST PRINT MODE and the error message "The file cannot be saved." appears on the panel.

## 5.10 31 CHART OUTPUT MODE

Various charts can be output.

- (1) Select [31 CHART OUTPUT MODE] in the FS Menu and press [NEXT].

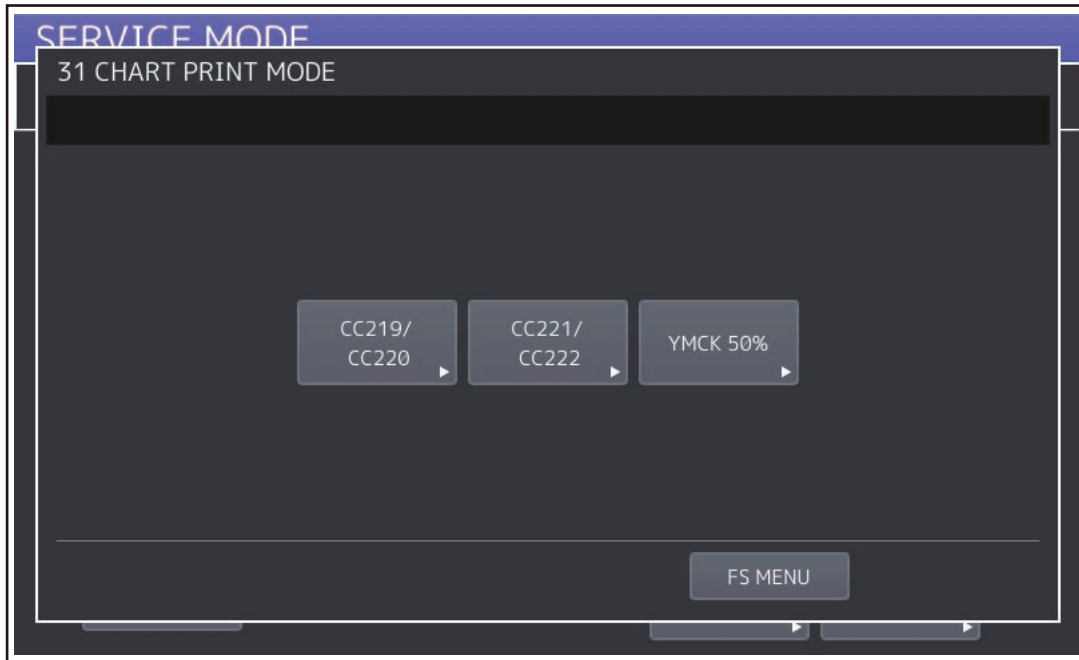


Fig.5-22

- (2) Press the type of the chart to be output.
- (3) Specify the output settings and press [PRINT].

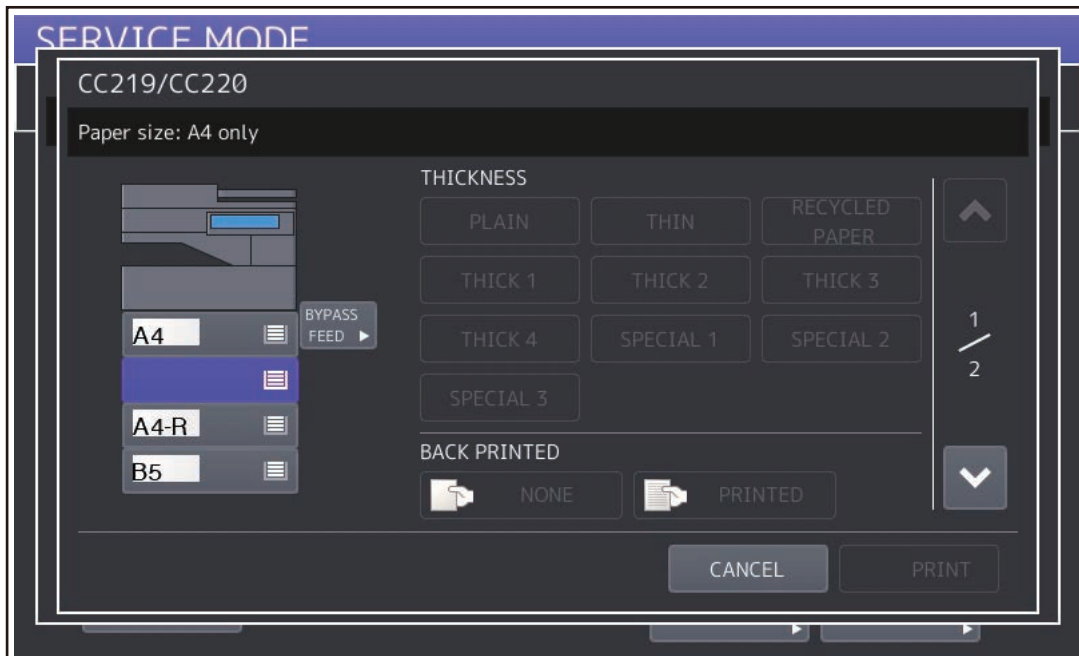


Fig.5-23

## 5.11 FAX

Adjustment and setting of the fax functions can be performed.

Select [FAX] in the FS Menu and press [NEXT]. The following modes are displayed.

11 FAX CLEAR MODE

12 FAX LIST PRINT MODE

13 FAX FUNCTION MODE

19 RAM EDIT MODE

### Notes:

The data automatically received during the self-diagnostic mode are sometimes not printed.

Therefore, be sure to disconnect the modular code form the line connector (LINE1, LINE2) of the equipment before starting the self-diagnostic mode. After the equipment is released from the self-diagnostic mode, reconnect the modular code.

### 5.11.1 11 FAX CLEAR MODE

- (1) Select [FAX] in the FS Menu and press [NEXT]. Select [11 FAX CLEAR MODE] and press [NEXT].

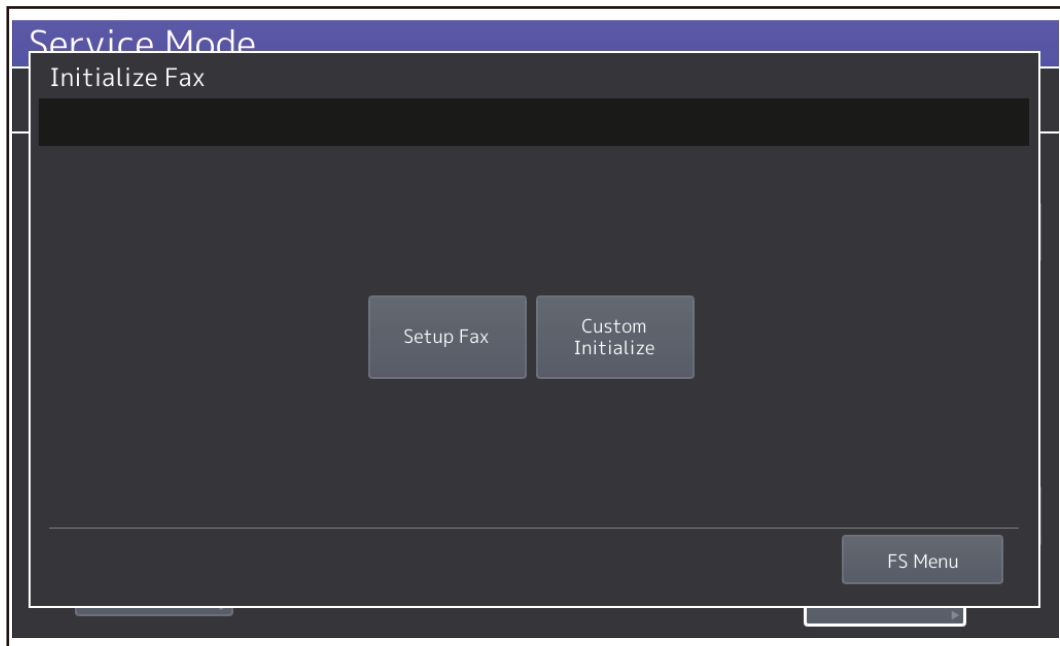


Fig.5-24

[SET UP FAX] and [CUSTOM INITIALZE] are displayed.

## [A] FAX Set-up

The destination of the fax can be set.

- (1) Press [SETUP FAX].
- (2) Select the destination and press [OK].

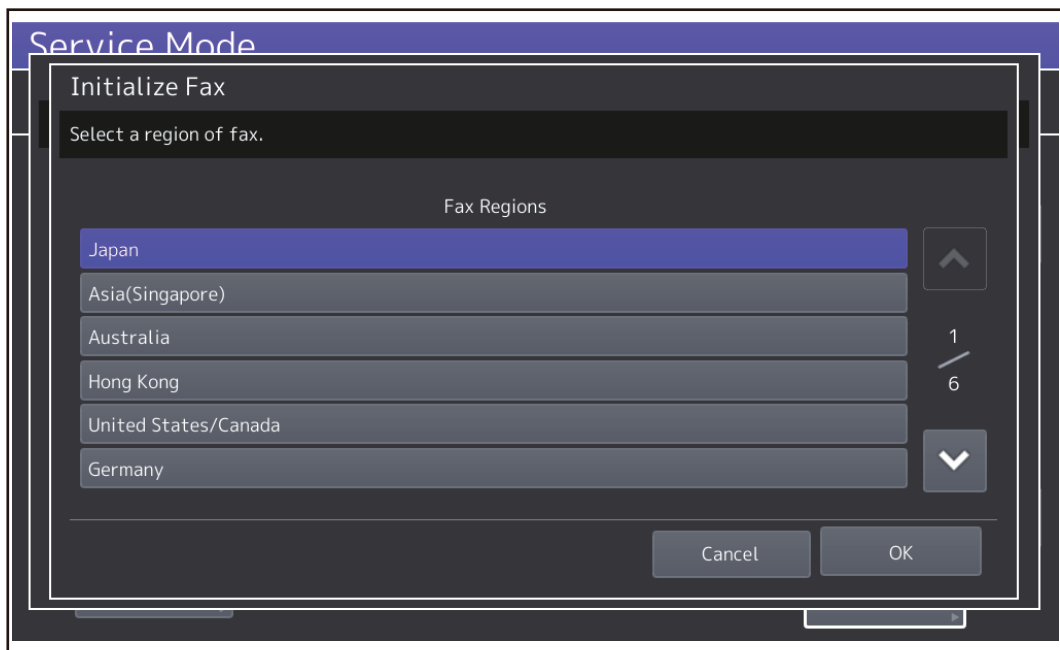


Fig.5-25

## [B] [CUSTOM INITIALZE]

Various FAX memories are initialized in the FAX clearing mode

- Memory Areas
  - User registration area (SRAM)
    - ID registration area
    - Home position
  - Image data area (HDD, SRAM)
    - Transmission file
    - Reception file
    - Image data file management area
    - F-code box information
  - System setting area (NVRAM)
    - Settings in the [13 FAX FUNCTION MODE] Areas 100 - 999

### <Operation procedure>

- (1) Press [CUSTOM INITIALZE].

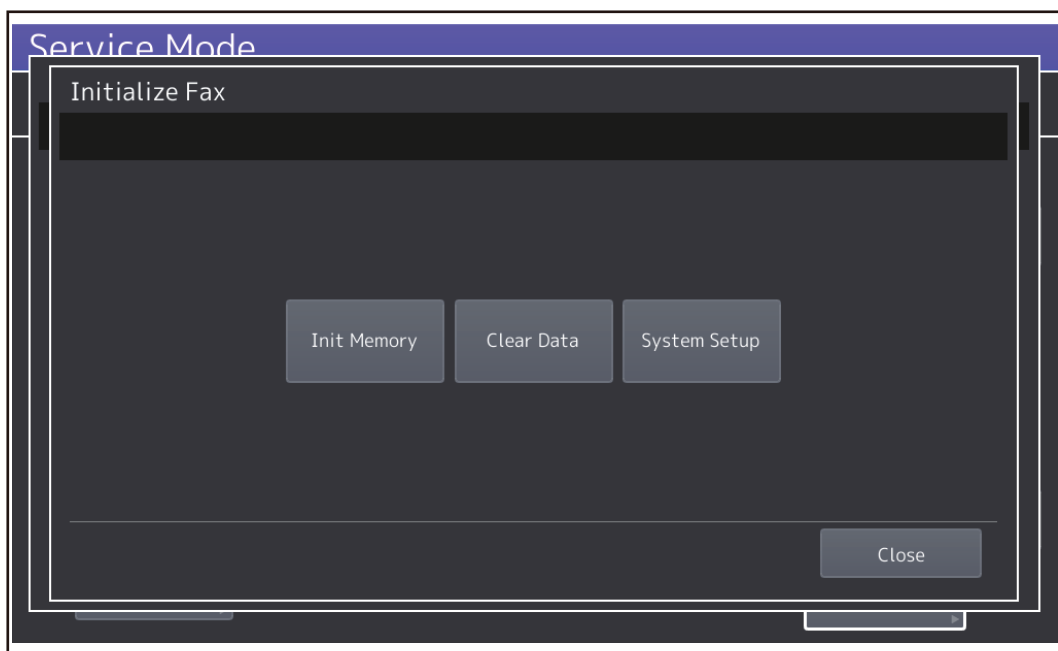


Fig.5-26

- (2) Select the mode.
  - [INIT MEMORY]: Initializes the user registration area (SRAM) so that there are no data stored. Initializes the system setting area (NVRAM) so that its value is reset to the default setting.
  - [CLEAR DATA]: Initializes the image data area (HDD, SRAM) so that there are no data stored.
  - [SYSTEM SETUP]: Initializes the system setting area (NVRAM) so that its value is reset to the default setting.

## 5.11.2 12 FAX LIST PRINT MODE

The setting contents of the fax function can be output.

- (1) Select [FAX] in the FS Menu and press [NEXT]. Select [12 FAX LIST PRINT MODE] and press [NEXT].

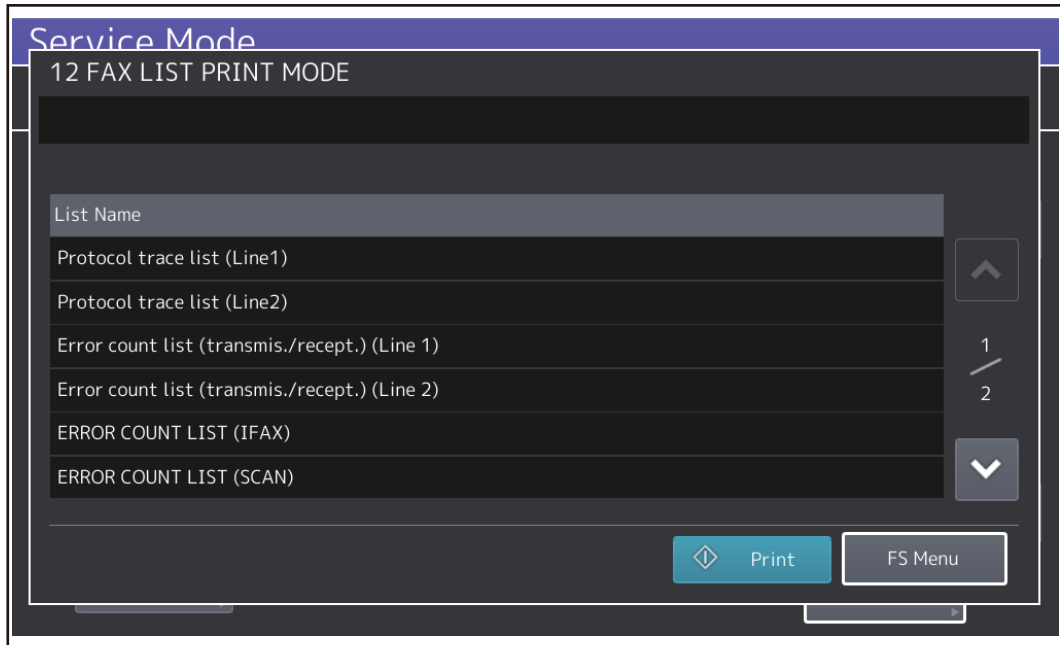


Fig.5-27

- (2) Select the list and press [PRINT].  
The names of the lists in [12 FAX LIST PRINT MODE] are shown below.
  - Protocol trace list (Line1)
  - Protocol trace list (Line2)
  - Error count list (transmis./recept.) (Line 1)
  - Error count list (transmis./recept.) (Line 2)
  - ERROR COUNT LIST (IFAX)
  - ERROR COUNT LIST (SCAN)
  - Function List for Maintenance
  - Memory dump list (system)
  - Memory dump list (FAX/LINE1)
  - Memory dump list (FAX/LINE2)
  - SUPPLY ORDER LIST

## 5.11.3 13 FAX FUNCTION MODE

Various fax functions can be set.

Operation procedure: Refer to SELF-DIAGNOSIS CODE.

## 5.11.4 19 RAM EDIT MODE

This is a mode for the special adjustments and settings. (This is not used generally.)

## 5.12 35 DATA BACKUP/RESTORE MODE

This function can save (back up) a back-up file of the MFP setting data in a USB media or external server, or can restore the stored (backed up) file into the equipment.

- (1) Select [35 DATA BACKUP/RESTORE MODE] in the FS Menu and press [NEXT].

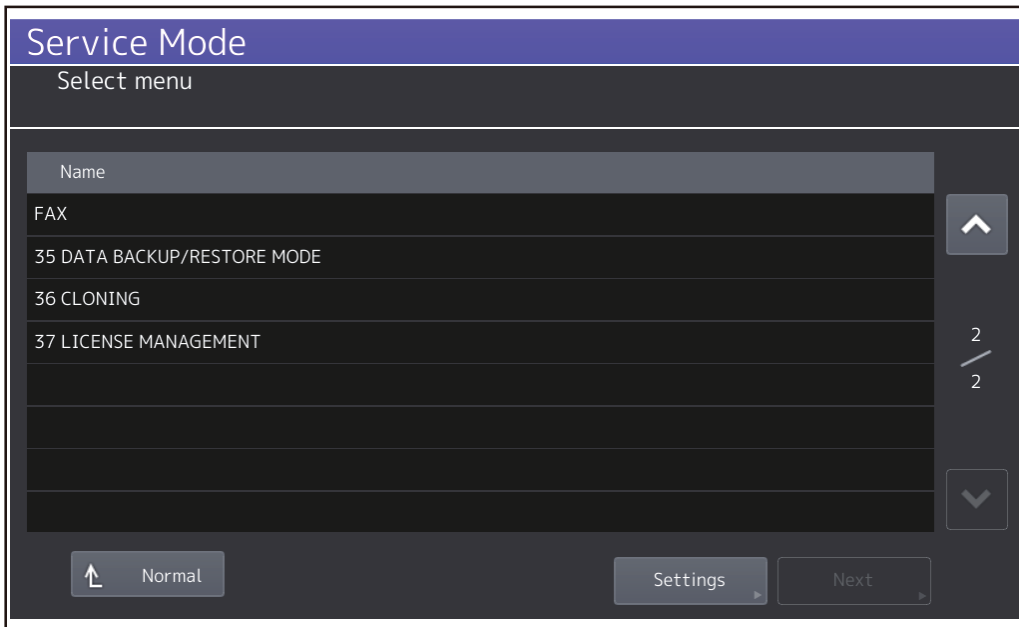


Fig.5-28

- (2) [Data Backup] and [Data Restore] are displayed.

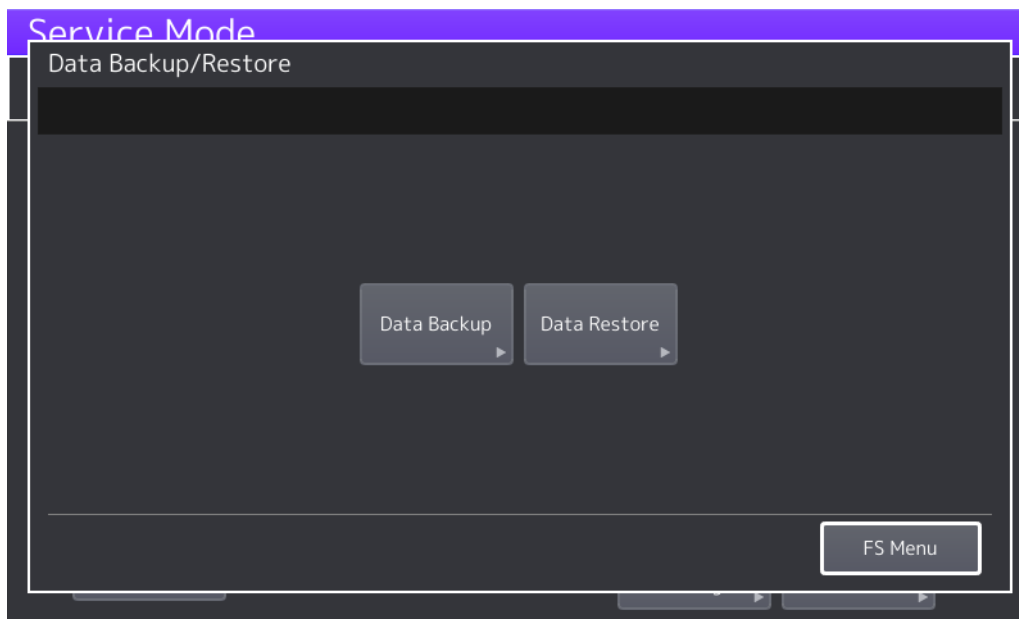


Fig.5-29


- (3) Select [Data Backup] or [Data Restore] and press [Next]. Press [USB Media].
- (4) Insert a USB storage device into the equipment and press [OK]. Backing up or restoring of the data starts.

### Tips

For details, refer to the "HDD Data Back-up/Restore Instruction Manual" (separate document).

## 5.13 36 CLONING

This function can create a clone file including the MFP setting data and user information or can install the clone file in this equipment.

For details, see  P. 12-6 "12.2 Cloning (FS menu)".

## 5.14 37 LICENSE MANAGEMENT

This function can register or delete the application license.

For details, refer to the "License Management MANUAL" (separate document).

## 5.15 01 Control Panel Check Mode

The following items can be checked with this mode.

- LCD back light blinking and brightness
- LCD display
- Confirmation of hard keys (buttons on the control panel) performance
- LEDs blinking
- Performance of digital keys (ten key option)
- LCD touch sensor
- USB storage device connection

### Notes:

- To check the performance of the digital keys, connect the ten key option before starting this mode.
- It is not possible to return to the HS Menu from [01 Control Panel Check]. To quit [01 Control Panel Check], display the LCD backlight check screen (Fig. A) and then press the [ON/OFF] button for a few seconds to shut down.

### 5.15.1 Screen transition

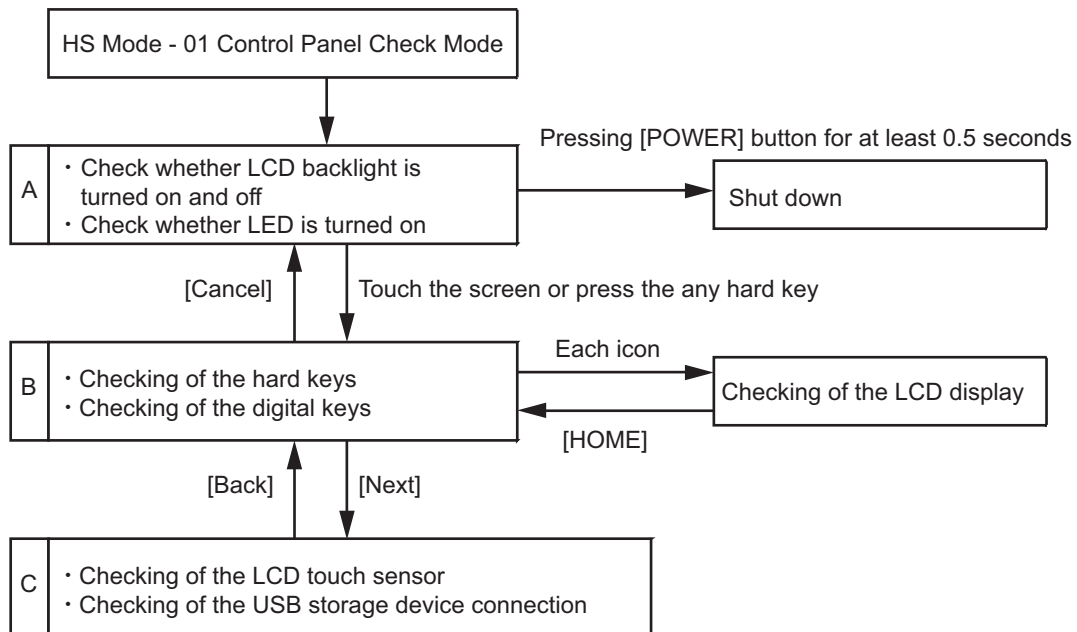


Fig.5-30



## 5.15.2 Checking of the LCD back light and LEDs

By pressing [01 Control Panel Check], the LCD back light blinks in 3-second intervals. Moreover, all LEDs are lit.

### Tips

- By touching the screen or pressing any hard key, the screen is shifted to the hard key confirmation screen.

## 5.15.3 Checking of the LCD display, hard keys and digital keys

### [A] Checking of the LCD display

By pressing the icon on the touch panel, the LCD display (Picture 1-15) confirmation screen is displayed.

### Tips

- The screen is returned to this one when the [HOME] button is pressed on each screen.

### [B] Checking of the hard keys

By pressing each hard key, a particular text is displayed and the blinking condition of the LED is changed.

The following table shows each text and performance when the key is pressed.

Hard key	Text	Performance
ON/OFF (Pressing for at least 0.5 seconds)	MAIN POWER	The [MEMORY RX] LED is turned OFF.
ENERGY SAVER	ENERGY SAVER	The [ENERGY SAVER] LED is turned OFF.
ACCESS	ACCESS	The [PRINT DATA] LED is turned OFF.
HOME	HOME	The [!] LED is turned OFF.
Programmable key 1	P-1	The LCD back light is made darker by each pressing. (10 levels)
Programmable key 2	P-2	The LCD back light is made lighter by each pressing. (10 levels)
FUNCTION CLEAR	FUNCTION CLEAR	The [FUNCTION CLEAR] LED is turned OFF.
START	START	The [START] LED is turned OFF.

The text is displayed only while the key is being pressed. Each LED is turned OFF only while the key is being pressed.

### [C] Checking of the digital keys for Ten Key option

By pressing each digital key, a particular text is displayed. The following table shows each text when the key is pressed.

digital key	Text
1	OP-1
2	OP-2
3	OP-3
4	OP-4
5	OP-5
6	OP-6
7	OP-7
8	OP-8
9	OP-9
0	OP-0
*	OP-*
#	OP-#
C	OP-CLEAR

#### Tips

- By pressing each icon on screen, the LCD display confirmation screen is displayed.
- The screen is shifted to the LCD touch sensor and USB storage device confirmation screen by your pressing [NEXT].

## 5.15.4 Checking of the LCD touch sensor and USB storage device connection

The screen is shifted to the LCD touch sensor and USB storage device confirmation screen by pressing [NEXT].

### [A] Checking of the LCD touch sensor

It can be checked whether the operations of swipe, pinch-out (enlargement) and pinch-in (reduction) are correctly detected on the screen. When the above operation is performed on the screen, an arrow which indicates the one detected by the touch sensor and a message are displayed.

Moreover, when any of [LH], [LL], [RH] or [RL] located on each corner of the screen is pressed, the calibration condition of the touched position can be checked.

### [B] Checking of the USB storage device connection

[USB Connection Failed] is displayed.

It can be checked whether a USB storage device inserted into the USB port is connected properly. Install a USB storage device and press the [START] button.

When a USB storage device is connected properly, [USB Connection Success] is displayed. If not, [USB Connection Failed] is displayed.

#### Tips:

It is not possible to return to the HS Menu from [01 Control Panel Check]. Return to the LCD back light blinking and brightness screen to shut down the equipment by pressing the [POWER] button for a few seconds.

## 5.16 73 Firmware Assist Mode

### 5.16.1 Overview

This mode enables you to operate the HDD partition, formatting SRAM data, delete the HDD/SRAM data and backup/restore the encryption key and license.

The Functions in this mode are below.

Functions	Content
Clear Software Update Error Flag	Clearing update error flag
Format Root Partition	Formatting data storage partition
Format HDD	Creating HDD partition
Key Backup/Restore	Backing up/restoring encryption key and license
Erase HDD Securely	Erasing HDD securely
Clear Service Tech Password	Clearing service password
Disable Fast boot	Disabling faster start
Clear SRAM	Formatting SRAM data
Erase SRAM Securely	Erasing SRAM securely
Format HDD Without Key Generation	Creating HDD partition without having upgraded the key
HDD Data Restore	Performing formatting, backup data restoring and firmware upgrading in series

### 5.16.2 Operation procedure

- (1) Perform [HS-73] by pressing [73 Firmware Assist].  
The following screen is displayed.

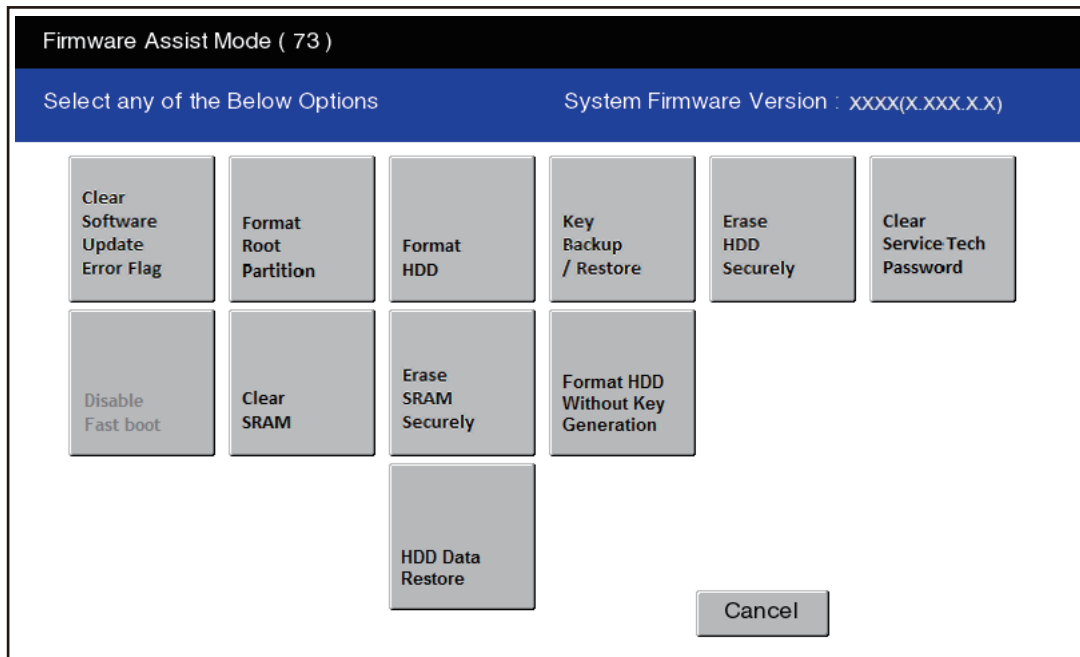


Fig.5-31

- (2) Press the icon to operate.

## 5.16.3 Functions

### [A] Clearing update error flag (Clear Software Update Error Flag)

Even if the firmware downloading has been completed normally, the Recovery Mode may accidentally start up and an F600 error occurs when the power is turned ON again. In this case, clear the Update Error flags used in the download process with this function. (Normally, the flags are automatically cleared in the download process.)

Also in the case the Recovery Mode accidentally starts up after the replacement of SRAM, the flags are cleared with this function.

### [B] Formatting data storage partition (Format Root Partition)

When a defect occurs on the UI data, etc. which are stored in the HDD, the partition with the stored UI data, etc. is formatted with this function.

Do not use this function since it is not normally necessary. HDD data must be installed after performing this function.

### [C] Creating HDD partition (Format HDD)

When the HDD is replaced or UI data, etc. are downloaded using the USB storage, it is necessary to format a partition in the HDD before downloading. In this case, the partition is created in the HDD with this function.

#### Notes:

- Perform the HDD partition formatting only when a new HDD is installed since all data in the current HDD are erased by this operation.
- When this operation has been done, do not perform SRAM data formatting (Clear SRAM) before the normal start-up.

### [D] Backing up/restoring encryption key and license (Key Backup Restore)

When the SRAM or the SYS board is replaced or initialized, the encryption key and license are erased. Therefore, they need to be backed up or restored with this function.

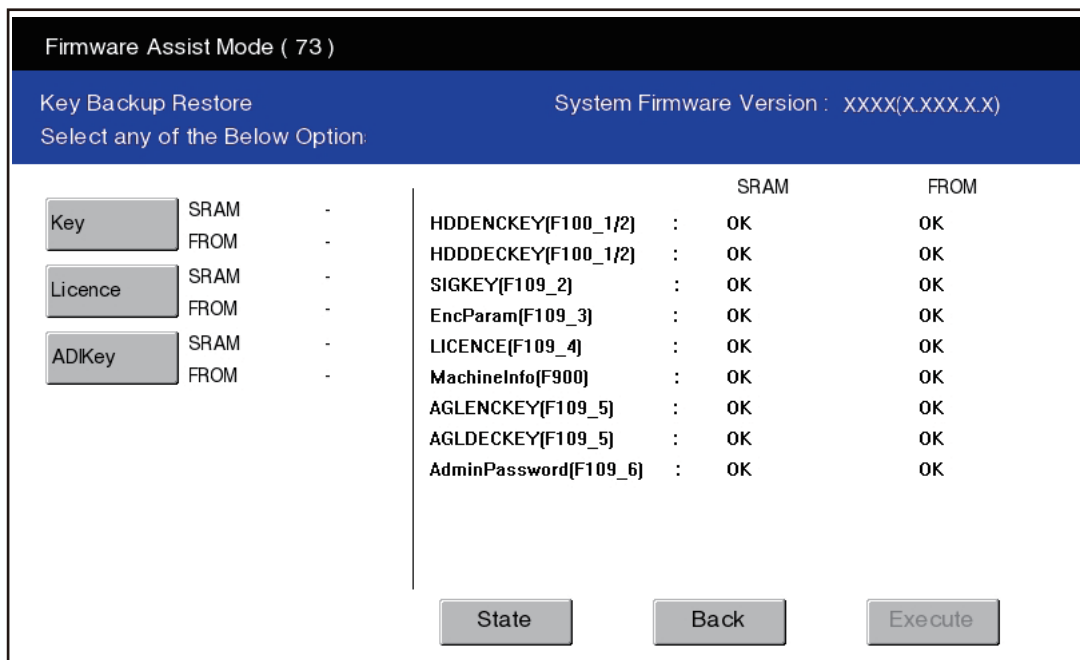


Fig.5-32

The following table shows the relationship between each Key or License and icon.

Key or License name	Icon
HDDENCKEY [F100_1/2]	Key
HDDDECKEY [F100_1/2]	Key
SIGKEY [F109_2]	Key
EncParam [F109_3]	Key
LICENSE [F109_4]	License
MachineInfo [F900]	Key
AGLENCKEY [F109_5]	ADiKey
AGLDECKEY [F109_5]	ADiKey
AdminPassword [F109_6]	ADiKey

- \* When "KeyBroken" or "KeyNull" is displayed on the SRAM row:  
Backs up the encryption Key or License in SRAM when the icon is pressed
- \* When "KeyBroken" or "KeyNull" is displayed on the FROM row:  
Recovers the encryption Key or License in SRAM when the icon is pressed

### [E] Erasing HDD securely (Erase HDD Securely)

This function is used when installing Data Overwrite Enabler (GP-1070) or before discarding the HDD. It overwrites all the used areas on the HDD with the selected data, and makes it unusable. After selecting this function, specify the level below to be overwritten. This setting is the overwriting method complying with DoD 5220.22-M.

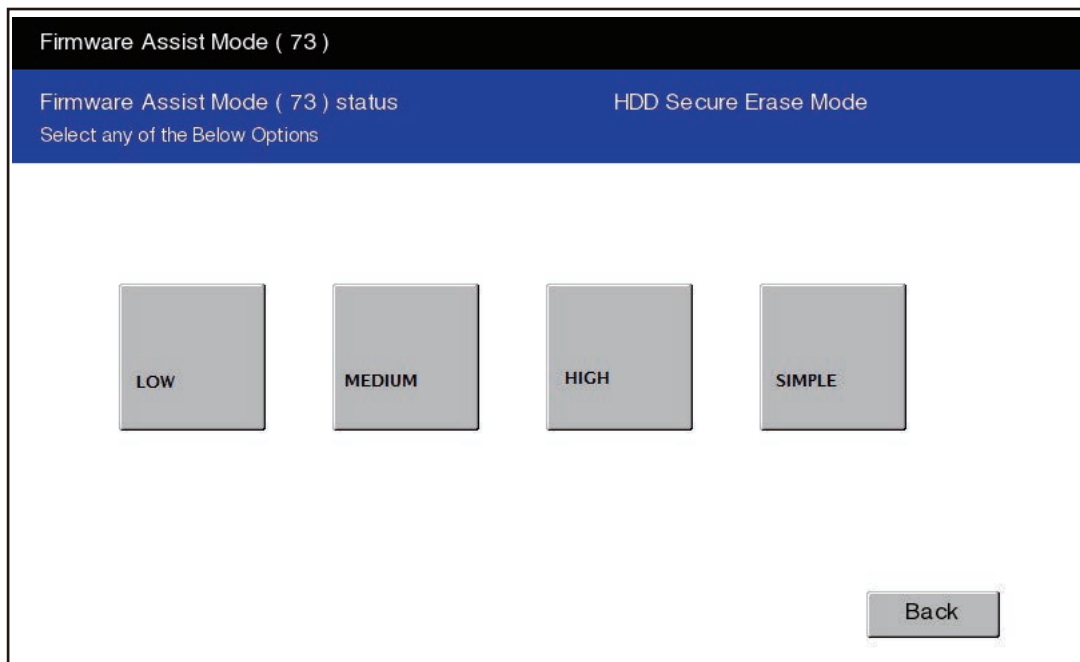


Fig.5-33

**LOW** (Normally use this setting.)  
This is the standard overwriting method.  
"00-FF-Random-Verify" Once

**MEDIUM**  
This overwriting method is more secure than LOW. The erasing time is between LOW and HIGH.  
"00-FF-Random" three times repeatedly -Verify

**HIGH**  
This is the most secure overwriting method. It takes the longest time to erase data.  
"00-FF-Random" five times repeatedly -Verify

## SIMPLE

This is the simple overwriting method. It takes the shortest time to erase data.  
Overwrite the Random data once

The reconfirmation screen is displayed when the icon is pressed.

Press [OK]: Processing starts.

Press [Back]: The screen returns to the previous one.

### Notes:

When this operation has been done, do not perform SRAM data formatting (Clear SRAM) before the normal start-up.

## [F] Formatting SRAM data (Clear SRAM)

When SRAM is replaced with a new one, abnormal values may be written in the new SRAM. SRAM data must be formatted with this function for such case.

### Notes:

- This function is required only when a new SRAM is installed.
- Do not perform this function in cases other than the installation of a new SRAM because all data in the SRAM will be deleted with this function.
- When this operation has been done, do not perform HDD partition creation (Format HDD) before the normal start-up.

## [G] Erasing SRAM securely (Erase SRAM Securely)

This function is used before discarding the SRAM.

It overwrites all the used areas on the SRAM with the selected data, and makes it unusable.

Immediately after selecting this function, the processing starts and is completed.

## [H] Clearing service password (Clear Service Tech Password)

This function is needed after the HDD is replaced.

When the HDD is replaced, the service password stored in the new one is set as a blank. Therefore, its service password is copied to the SRAM so that both passwords become the same with this function.

The setting is enabled when the equipment is started up in the normal mode after performing this function.

## [I] Disable Fast boot

This function disables faster boot (\*). Therefore, this can be operated while faster start is enabled.

- \* Faster start: The start-up method which can shorten the time for starting by approx. 5 seconds by starting up the equipment in the normal mode or while selecting the menu from the exclusive file. (There is no effect on the recovery from hibernation.)

Once the power is turned ON while the [HOME], [RESET] and [START] buttons are pressed simultaneously, a file for faster start is created and it becomes available. It will take approx. 3 minutes to create a file for faster start. When the file creation is completed, the equipment will automatically start in the normal mode.

- \* Faster start can also be disabled by the following operations.
  - Firmware update
  - HS-73 → [Format HDD]
  - Data Overwrite Enabler (GP-1070) installation or settings change
  - Security level change
  - HS-75 → [Initialize HDD]
  - HS-59 → [Restore SRAM Data from USB]

## **[J] Format HDD Without Key Generation (Create an HDD partition without having upgraded the key)**

This function is used when an HDD partition is created by means of HDDDATACOPYTOOL. An HDD partition can be created without having upgraded the key for ADI-HDD.

### **Notes:**

- Be sure to use this function only when in an operation carried out by means of HDDCOPYTOOL.
- Do not perform this function in cases other than the installation of a new HDD because all data in it will be deleted with this function.
- When this operation has been done, do not perform SRAM data formatting (Clear SRAM) before the normal startup.

## **[K] HDD Data Restore (Restoring HDD Data)**

This function performs formatting, backup data restoring and firmware upgrading in series.

### **Notes:**

- Perform this function only after the HDD is replaced or when there will be no problem even if all the information in the HDD is erased.
- Perform this function only when a USB storage device (\*), in which the backup data and the firmware standard package are stored, is prepared.
  - \* It is available even if these 2 files are stored in different USB storage devices separately.

- (1) Install the USB storage device with the backup data stored in the equipment.
- (2) Install the USB storage device with the backup data stored in the equipment.
  - Format the HDD and restore the backup data.
  - If the firmware standard package is stored in this USB storage device, continuously upgrade the firmware.
  - If the firmware standard package is not stored in this USB storage device, an error appears. In such a case, install the USB storage device with the firmware standard package stored in the equipment and press [OK]. Firmware upgrading will start.
  - After upgrading is completed, reboot the equipment.

## 5.17 74 HDD Assist Mode

### 5.17.1 Overview

This mode is available only when the security HDD (Secure HDD) is mounted in the equipment. It enables you to check the type of the mounted HDD, revert the Secure HDD to the factory default.

Functions of 74 HDD Assist mode

- Checks the type (Secure/Normal) of the mounted HDD.
- Disposes of Secure HDD data safely without any of leakage.
- Deletes image data when reusing a used Secure HDD.

### 5.17.2 Operation procedure

- (1) Perform [HS-74] by pressing [74 HDD Assist].  
Then, the type of the mounted HDD appears on the screen.

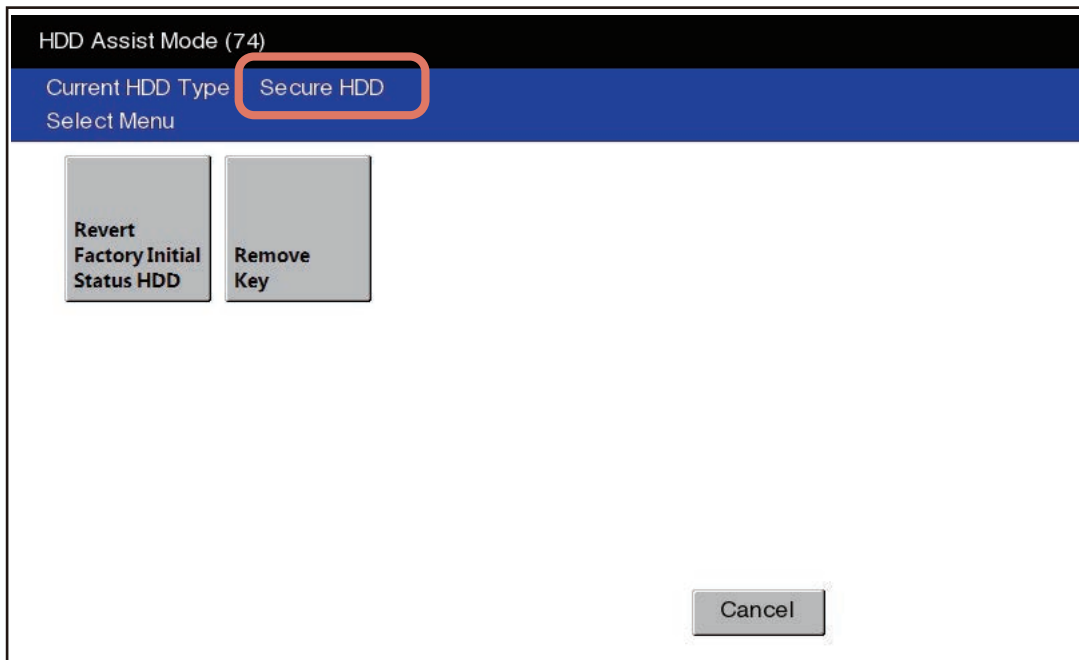


Fig.5-34

When a security HDD is mounted: Secure HDD

When a normal HDD is mounted: Normal HDD

- (2) Press the icon to operate.

#### Tips

If the HDD type cannot be identified, "Unknown HDD" may appear on the screen.  
Refer to [P. 8-281](#) "[F106\_1] Secure HDD error: HDD type detection error"

#### Notes:

When "Normal HDD" is displayed, items 1 and 2 are not selectable.

If you select any of 1 and 2 and press the [START] button, the error message "Operation Failed. Press SoftPower Key to Switch Off." appears.



## 5.17.3 Functions

### [A] Revert Factory Initial Status HDD

Select this to dispose of the Secure HDD as well as the equipment.

This operation requires only a few seconds; however, in order to make the HDD usable again, you need to perform [Format HDD] (creating HDD partition) in HS-73 and reinstall the HDD data with HS-49.

The following screen is displayed when [Revert Factory Initial Status HDD] is pressed.

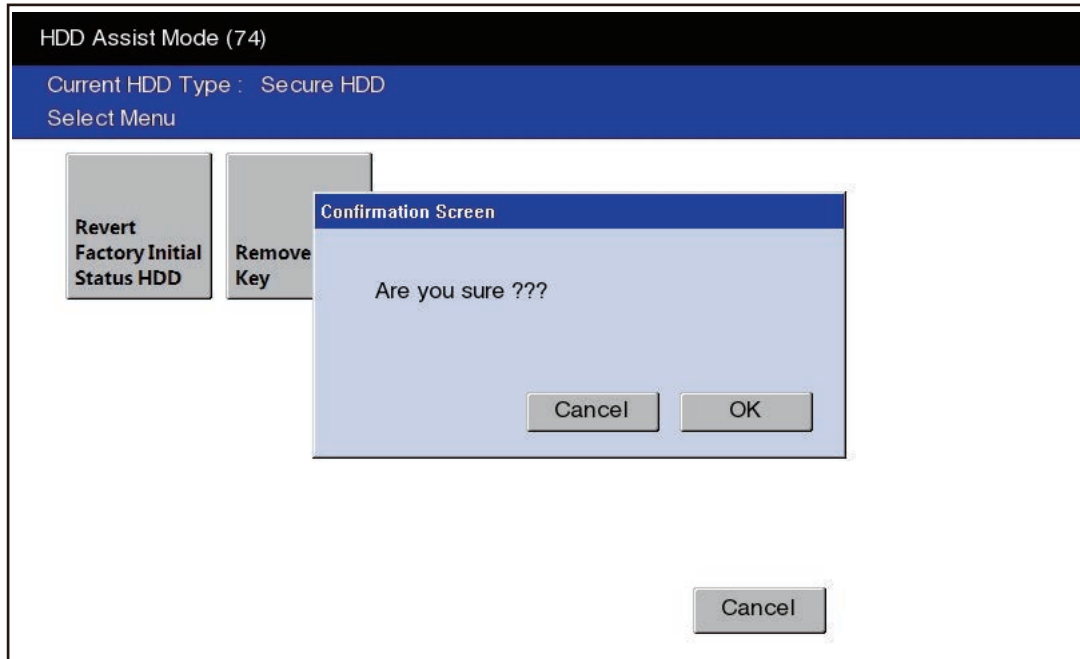


Fig.5-35

Press [OK] to carry out the operation.

When the operation is finished, the result appears on the menu.

#### Notes:

- If the equipment is started in the normal mode with this condition, an HDD mounting error occurs.
- After this has been performed, formatting of the HDD and reinstallation of applications are necessary.

## [B] Remove Key

Select this to reuse the Secure HDD as well as the equipment.

When this item is selected, image data in the HDD are deleted.

This operation requires only a few seconds; however, in order to make the HDD usable again, you need to perform [Format HDD] (creating HDD partition) in HS-73 and reinstall the HDD data with HS-49.

The following screen is displayed when [Remove Key] is pressed.

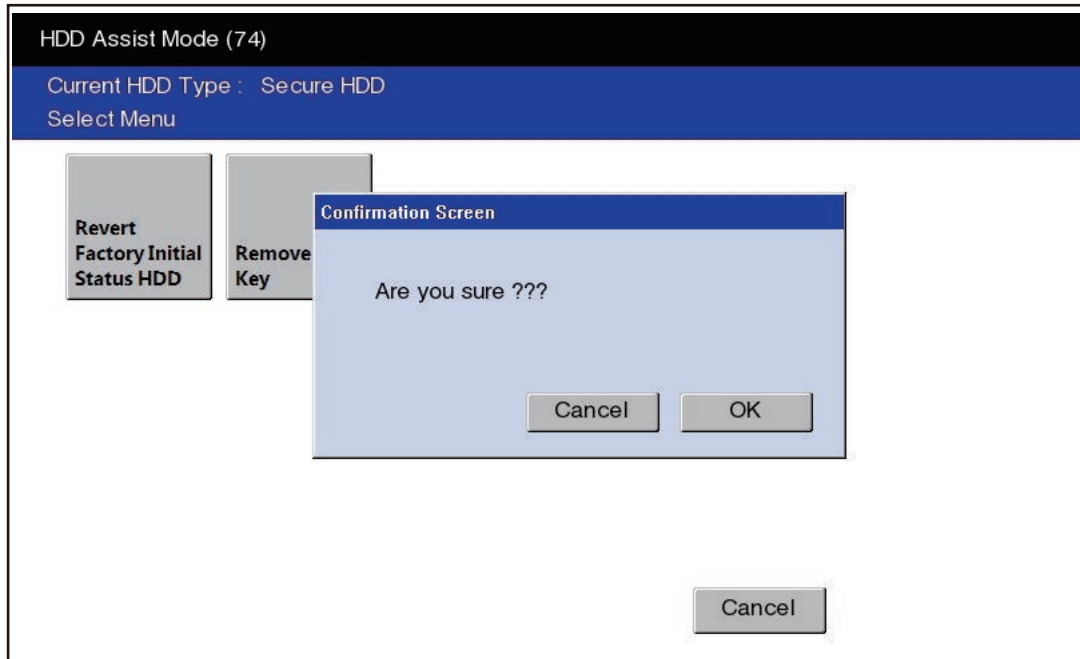


Fig.5-36

Press [OK] to carry out the operation.

When the operation is finished, the result appears on the menu.

### Notes:

- If the equipment is started in the normal mode with this condition, an HDD mounting error occurs.
- After this has been performed, formatting of the HDD and reinstallation of applications are necessary.

## 5.18 75 File System Recovery Mode

### 5.18.1 Overview

This is a mode to check if there is any damage to the file system (HDD) and recover it if necessary. Use this mode only in the following cases.

- There is a possibility of damage to the file system (HDD).
- There is an apparent damage to the file system (HDD), requiring recovery or initialization.

This mode enables you to have the following functions.

Functions	Content
Check F/S	Checks the file system.
Recovery F/S	Recovers the file system.
Initialize HDD	Initializes partitions in the HDD.
Initialize DB	Initializes database (LDAP DB / log DB / language DB / AppMgmt DB / HomeScreen DB / JobHistory DB / AppLicense DB).
SMART Info	Displays the various information in the HDD.
DISK Info	Displays the usage rate of HDD.
HDD Utility	Initializes log files.

### 5.18.2 Operation procedure

- (1) Perform [HS-75] by pressing [75 File System Recovery].  
The following screen appears.

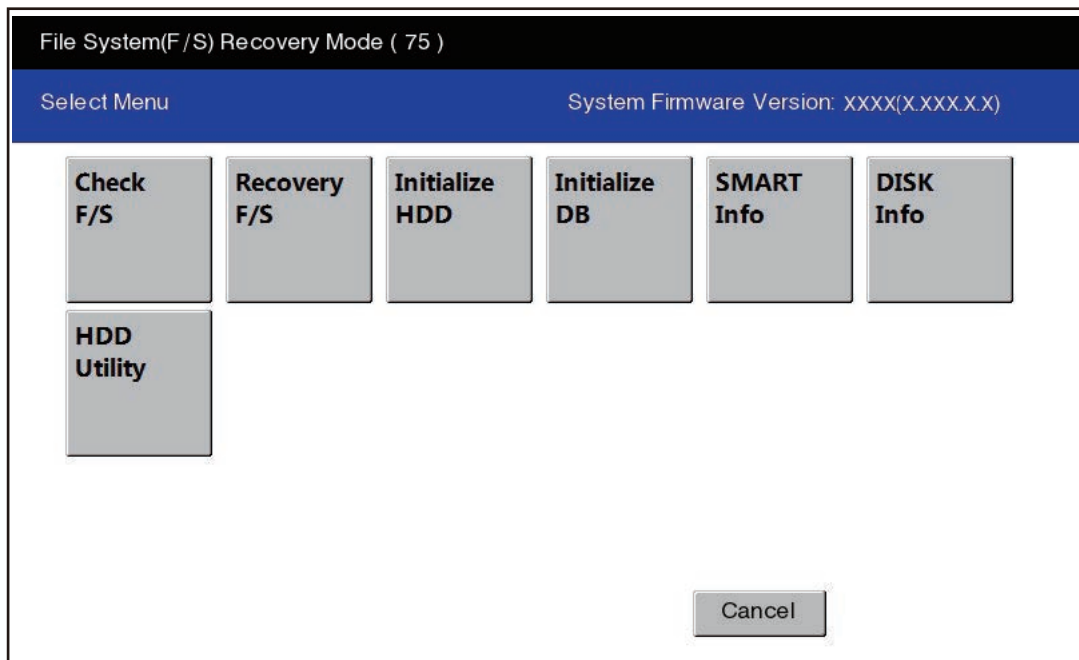


Fig.5-37

(2) Press the icon to operate.

**Notes:**

- Do not turn the power OFF with the [MAIN POWER] button after the processing has started (while the processing is being performed).
- After the processing is completed, a beep sounds 4 times and either "Completed" or "Failed" appears on the screen.

### 5.18.3 Functions

#### [A] Check of the File System (Check F/S)

In case that particular service calls occur or there is a possibility of damage to the file system, the status of each partition in the HDD can be checked.

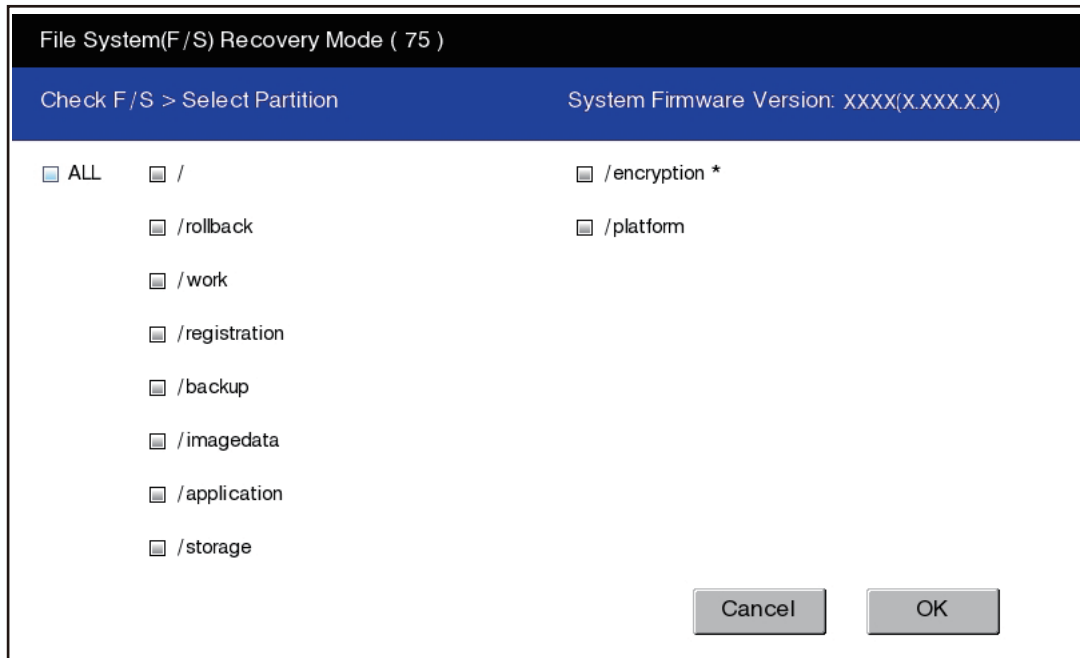


Fig.5-38

Explanation for each item

ALL: Checks all partitions.

/: Checks root partition only.

Others: Checks each partition shown above.

**Tips**

More than one partition can be selected. (A check mark is displayed at the selected item.)

\* If damage is discovered, recover or initialize the file system (HDD).

## [B] Recovery of the File System (Recovery F/S)

In case that an error occurs during the file system check, each partition can be recovered.

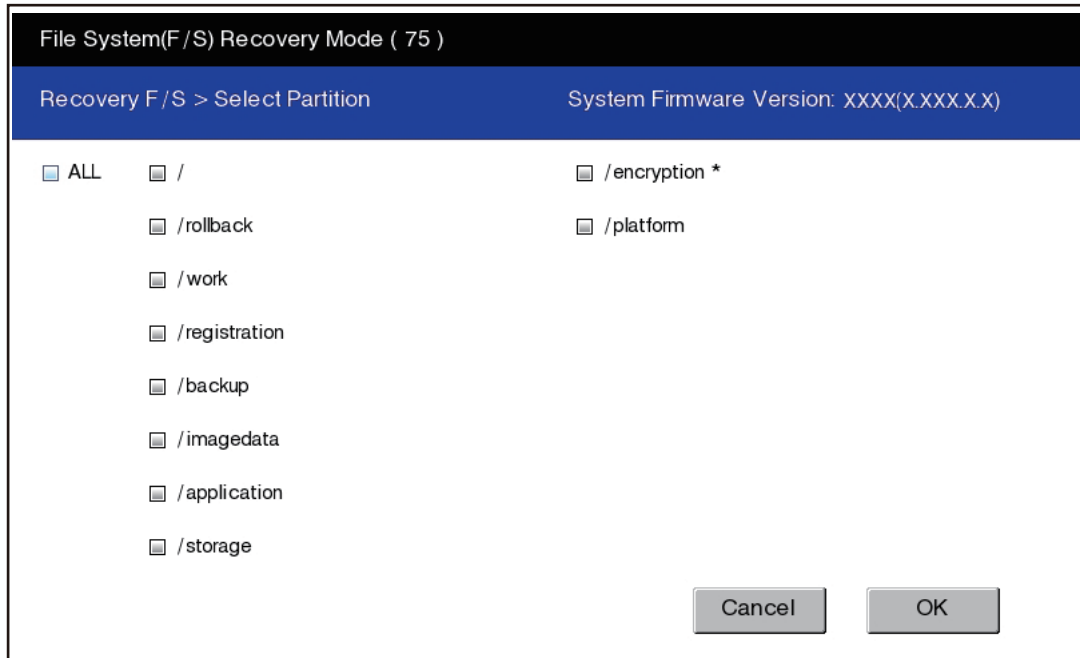


Fig.5-39

Explanation for each item

ALL: Recovers all partitions.

/: Recovers root partition only.

Others: Recovers each partition shown above.

### Tips

More than one partition can be selected. (A check mark is displayed at the selected item.)

\* If an error occurs during recovery, initialize the file system (HDD).

### [C] Initialize the File System (Initialize HDD)

In case that an error occurs during the file system check and the partition cannot be recovered with the recovery, each partition can be initialized.

It is recommended to export the user information such as address book before performing this function.

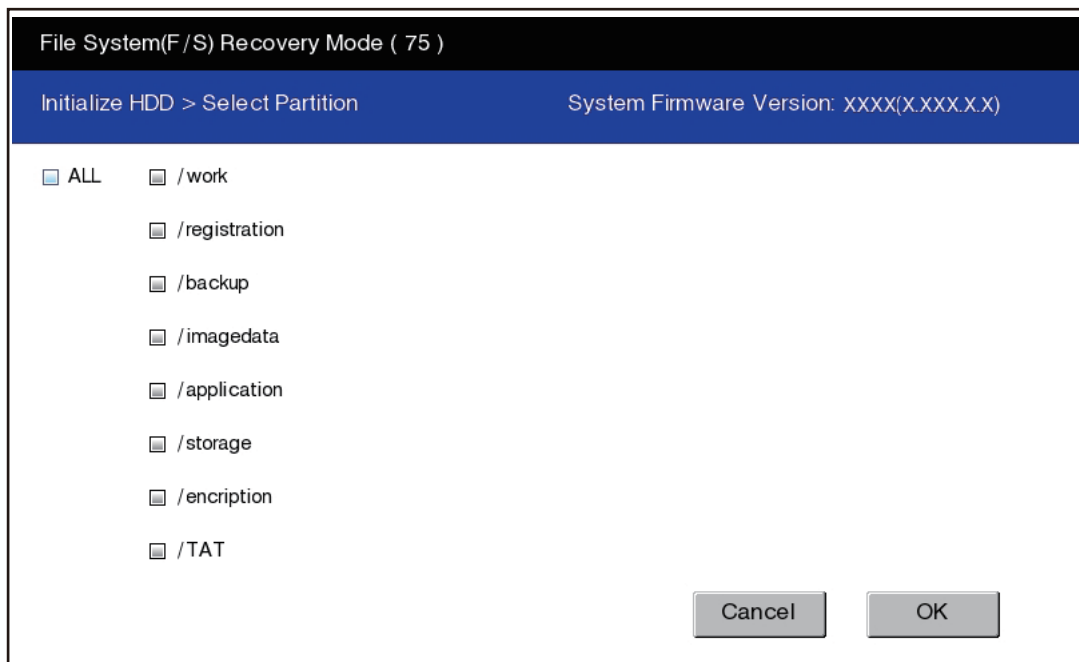


Fig.5-40

Explanation for each item

ALL: Initializes partitions other than root one and creates initial files.

Others: Initializes each partition.

#### Tips

More than one partition can be selected. (A check mark is displayed at the selected item.)

#### Notes:

- If initialization is carried out by selecting [ALL] or [/encription], applications and OS data in the equipment are also initialized. In this case, the applications and the file system must be reinstalled. Install the system software (HDD DATA) by performing [49] → [4] after initialization.
- If [ALL] is selected, minimal data necessary for normal startup are automatically recovered.
- If initialization is carried out by selecting [ALL], the log database is also initialized. Back up the data before initializing if necessary.
- If [ALL] is selected, do not perform SRAM data formatting (Clear SRAM) before the normal start-up.

## [D] Initialize the DB (Initialize DB)

In case that particular service calls occur or there is a possibility of damage to the databases, each one can be initialized.

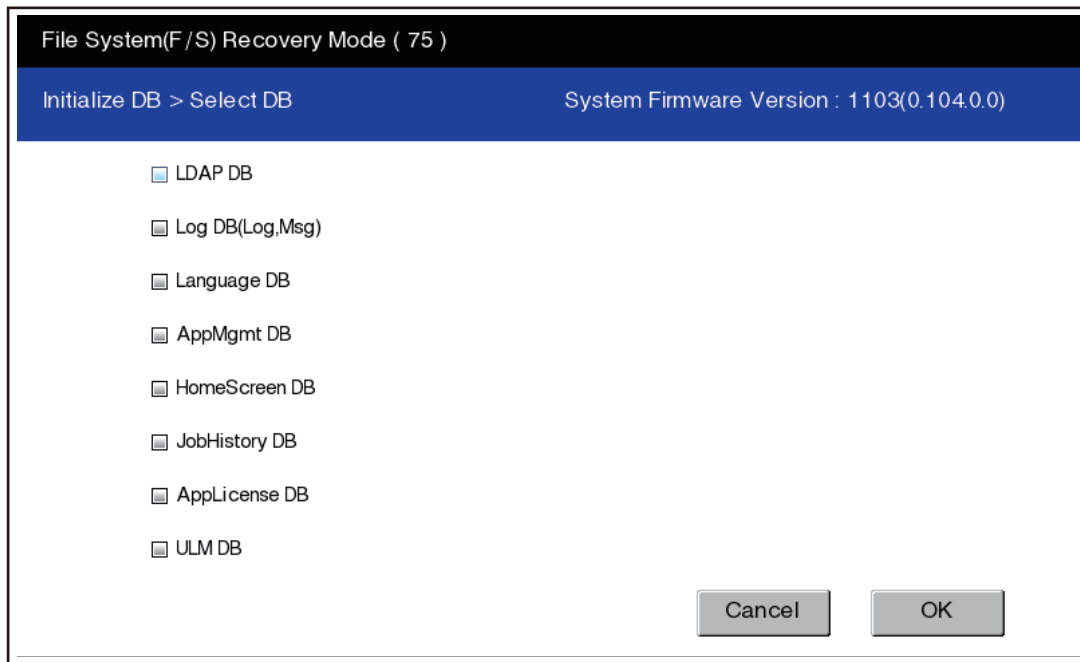


Fig.5-41

### Explanation for each item

LDAP DB: Initializes address book data and the user information database.

Log DB(Log,Msg): Initializes job log data and the message database.

Language DB: Initializes the language database.

AppMgmt DB: Initializes the application database.

HomeScreen DB: Initializes the home screen database.

JobHistory DB: Initializes the job history database.

AppLicense DB: Initializes the application license database.

ULM DB: Initializes the application license management database.

### Tips

Once the databases are selected, they are initialized.

### [E] Displaying various data in the HDD (SMART Info)

Various data in the HDD can be displayed. (Data equivalent to the setting contents of FS-08-9065 are displayed.)

When this item is selected, data in the HDD embedded in the equipment are displayed. "---" is displayed for the items not supported.

ID	NAME	VALUE	NAV	Worst
01	Read Error Rate	0	100	100
02	Throughput Performance	0	100	100
03	Spin Up Time	1330	100	100
04	Spin Start /Stop Count	2007	100	100
05	Re-allocated Sector Count	0	100	100
06	Read Channel Margin	-----	----	----
07	Seek Error Rate	0	100	100
08	Seek Time Performance	0	100	100
09	Power-On Hours	618	99	99
0a	Spin Retry Count	0	139	100
0b	Calibration Retry Count	-----	----	----
0c	Power Cycle Count	1962	100	100
bf	Shock Sense Count	2	100	100
c0	Power-Off Retract Count	900	99	99
c1	Load Cycle Count	2288	100	100
c2	Temperature	31	100	100
c3	ECC On the Fly Count	-----	----	----
c4	Re-allocation Event Count	0	100	100
c5	Current Pending Sector Count	0	100	100
c6	Off-Line Scan Unc Sector Count	0	100	100

Model : TOSHIBA XXXXXXXXXXXX  
Serial : XXXXXXXXXXXX

NextPage Back

Fig.5-42

#### Tips

NAV: Normalized Attribute Value

Indicates the value of the specified HDD condition as compared to the manufacturer's optimum value.

Worst: Worst Ever Normalized Attribute Value

Indicates the worst value of NAV permitted by the manufacturer.

#### Notes:

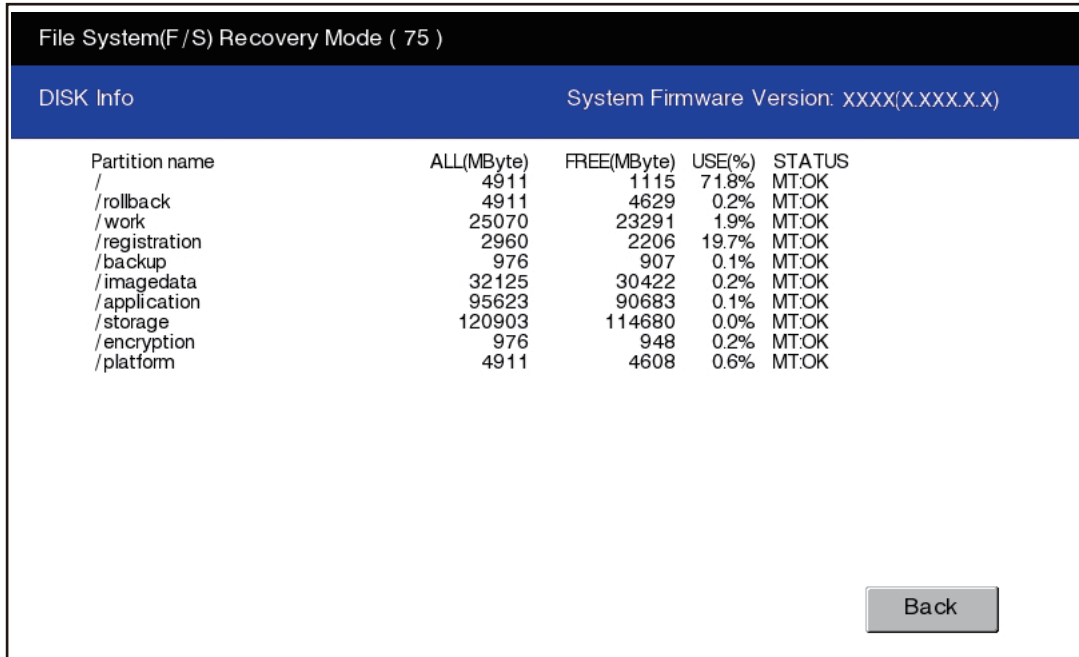
The values of NAV and Worst should be treated as a rough reference since their basis may differ depending on the specification of HDD manufacturers.



**[F] Displaying usage rate of each partition (DISK Info)**

The usage rate of each partition can be checked.

When this item is selected, the usage rate of each partition is displayed.



File System(F/S) Recovery Mode ( 75 )

DISK Info System Firmware Version: XXXX(X.XXX.X.X)

Partition name	ALL(MByte)	FREE(MByte)	USE(%)	STATUS
/	4911	1115	71.8%	MT:OK
/rollback	4911	4629	0.2%	MT:OK
/work	25070	23291	1.9%	MT:OK
/registration	2960	2206	19.7%	MT:OK
/backup	976	907	0.1%	MT:OK
/imagedata	32125	30422	0.2%	MT:OK
/application	95623	90683	0.1%	MT:OK
/storage	120903	114680	0.0%	MT:OK
/encryption	976	948	0.2%	MT:OK
/platform	4911	4608	0.6%	MT:OK

Back

Fig.5-43

**[G] Initialization of log file (HDD Utility)**

Log files for researching can be deleted. Since only a certain amount of log files for researching is usually stored in the work area of an HDD, the use of this mode is not necessary. In case the performance level of the equipment is lowered (e.g.: the response of the control panel becomes extremely slow), make use of this mode. This phenomenon may be resolved.

## 5.19 76 SRAM Maintenance Mode

### 5.19.1 Overview

This is a mode in which you can clear particular errors such as F800 or F900.  
The processing contents of this mode are the same as those for [Clear SRAM] in [HS-73].

Functions of 76 SRAM Maintenance mode

- Sets the serial number of this equipment.
- Clears F800 error.
- Clears F900 error.

### 5.19.2 Operation procedure

- (1) Perform [HS-76] by pressing [76 SRAM Maintenance].  
Then the following screen is displayed.

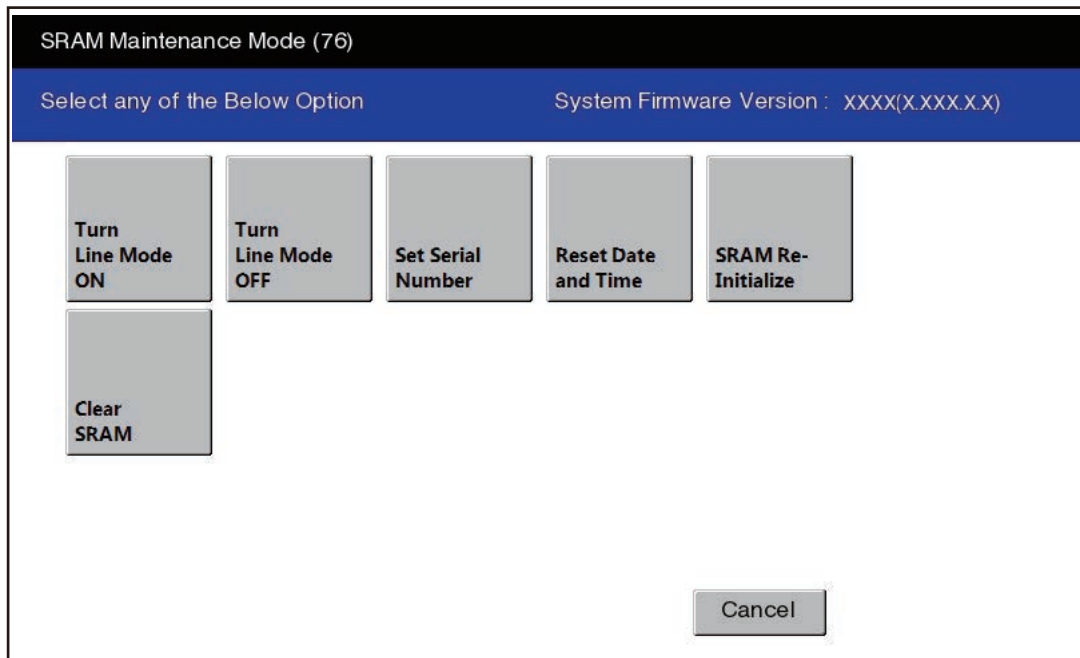


Fig.5-44

- (2) Press the icon to operate.

#### Notes:

- [Turn Line Mode ON] or [Turn Line Mode OFF] starts once each icon is pressed.
- When [Reset Date and Time], [SRAM Re-Initialize] or [Clear SRAM] is pressed, the confirmation screen appears.

### 5.19.3 Functions

#### [A] Turn Line Mode ON (Manufacturing mode ON)


The equipment enters into the manufacturing mode.

#### [B] Turn Line Mode OFF (Manufacturing mode OFF)

The equipment enters into the service mode.

#### [C] Set Serial Number

When replacing SYS-SRAM, select this to set the serial number of the equipment since it must be done in advance of recovery from SRAM backup data.

- Clear SRAM first and then set the serial number in this mode.
- Recover from SRAM backup data after setting the serial number.  
Refer to  P. 12-2 "12.1.4 Cloning procedure"

Key in the serial number of this equipment and press [OK].

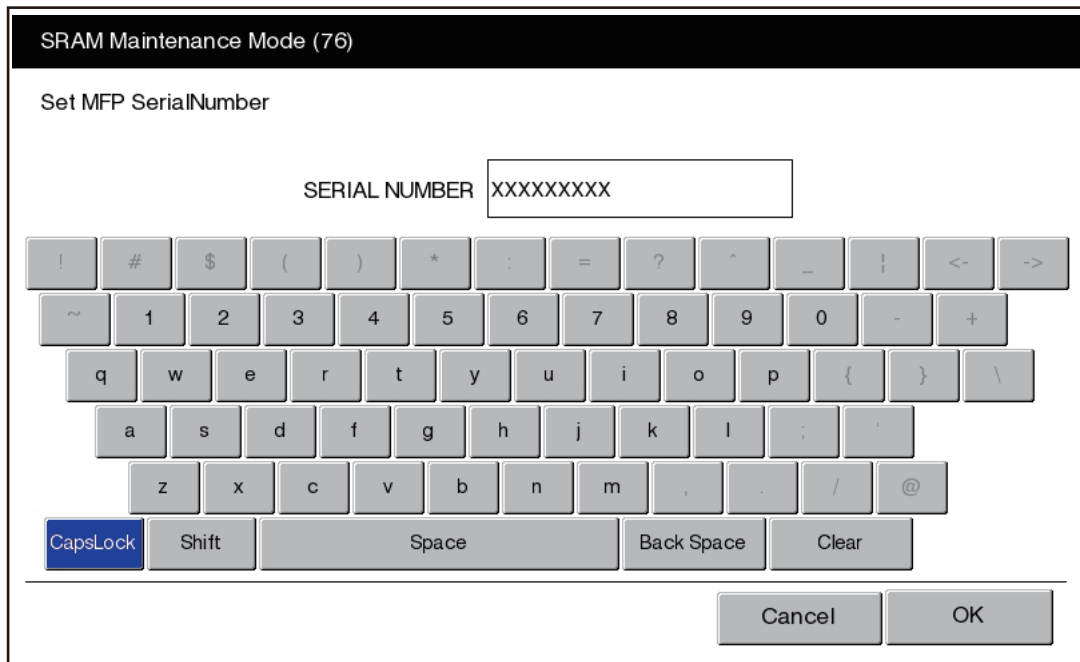


Fig.5-45


#### [D] Reset Date and Time

Select this to clear an F800 error which occurred when the date and time were set as after the end of the year 2037 or when the actual end of the year 2037 has come.

- After selecting this, start the equipment in the normal mode to reset the date and time.

#### [E] SRAM Re-Initialize

Since an F900 error cannot be cleared in the 73 Firmware Assist mode, use this function to clear the error in the following cases:


- When the SRAM and the SYS board are replaced at the same time
- When the SRAM is initialized with wrong destination at the replacement of the SRAM  
Refer to  P. 9-25 "9.2.5 Precautions and procedure when replacing the SRAM".

**[F] Clear SRAM**

Select this to clear all SRAM data when replacing SYS-SRAM.

Replace the SRAM and then clear the SRAM data.

After clearing the SRAM data, initialize SRAM following its replacement procedure.

Refer to  P. 9-25 "9.2.5 Precautions and procedure when replacing the SRAM".

**Notes:**

When this operation has been done, do not perform HDD partition creation (Format HDD) before the normal start-up.

## 5.20 Pixel Counter

### 5.20.1 Outline

#### [ 1 ] Outline

Pixel counter is a function that counts the number of dots emitted by writing light source and converts it into the print ratio (%) per standard paper size. This "Print ratio (%) per standard paper size" is called Pixel count (%).

This function enables you to know how each user uses the equipment and to grasp the tendency of toner consumption (number of output pages per cartridge).

However, since some of the factors in "2" below are not taken into account by the pixel counter, its accuracy does sometimes not match the actual toner consumption.

#### [ 2 ] Factors affecting toner consumption

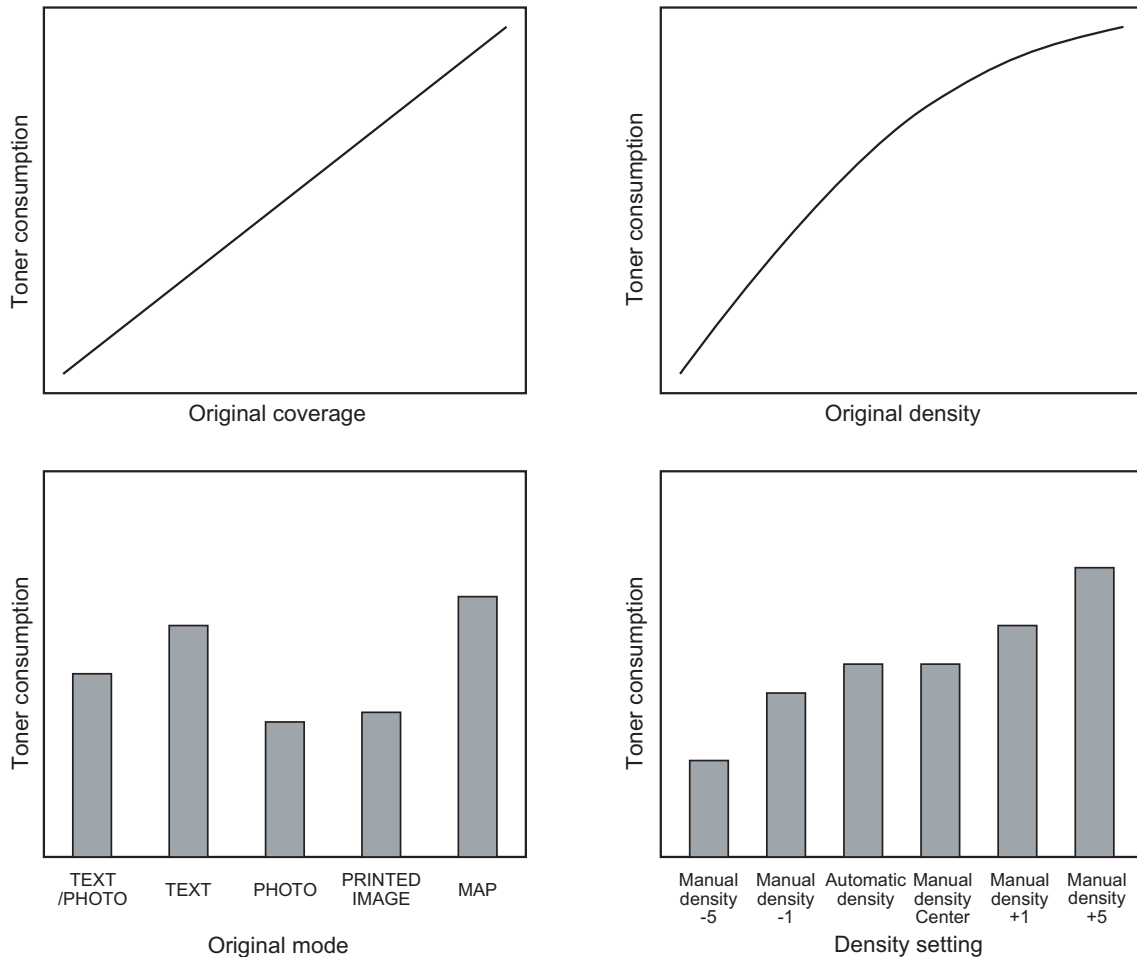
Standard number of output pages per cartridge shows the average number of output pages under the condition that the data of print ratio 5% is printed on the standard paper size (A4/LT) at a normal temperature and humidity.

However, users do not always print under the above condition. As for the type of original, copy/print mode and environment, each user has different tendency, and as a result, the number of output pages per cartridge becomes different depending on the user.

The major factors affecting toner consumption are as follows:

- Original/Data coverage
- Original/Data density
- Original/Print mode
- Density setting
- Print Pattern  
Character images (e.g. Text) consume more toner than solid images even though they may have the same density. This is due to the "edge effect".
- Number of pages per job  
Toner consumption testing is made in the "continuous running mode". More toner is required when printing in the non-continuous running mode.
- Number of image quality control  
Image quality control is performed automatically when the device is switched on, when it returns from sleep mode, and also during continuous running. Toner consumption may vary depending on the number of image quality adjustments performed during operation.
- Paper  
The size, feeding direction and type of paper influence toner consumption.
- Environmental conditions  
Temperature and Humidity affect toner consumption.
- Others  
In addition to the above, there are other factors that may influence toner consumption. These include variations between individual products, life of consumable, bias voltages, Drum surface potential, etc.

The general relations between the above 4 factors and toner consumption per output page in the copy function are as follows:



**Fig.5-46 Factors affecting toner consumption and the tendency**

### [ 3 ] Details of pixel counter

- Toner cartridge reference and service technician reference  
The pixel counter function in this equipment has 2 references, toner cartridge reference and service technician reference.

#### **Toner cartridge reference**

This is a system that accumulates data between the installation of a new toner cartridge and next installation.

The installation of new toner cartridge is judged when the total number of pixel count or output pages after the detection of toner cartridge empty has exceeded the threshold.

The threshold to be used is selectable in the FS-08-6506 between the pixel count and output pages (0: Output pages 1: Pixel counter). The threshold of pixel count is set in the FS-08-6508 and that of output pages is set in the FS-08-6507. When the new toner cartridge is judged as installed, the data related with the previous cartridge is cleared and replaced with the data after the installation of new cartridge. Clearing of the counter of the toner cartridge reference is performed in the FS-08-6503.

#### **Service technician reference**

This is a system that accumulates data between clearing the counter of the service technician reference by service technician and subsequently clearing the same counter.

Clearing of the counter of the service technician reference is performed in the FS-08-6502.

- **Print count (number of output pages)**  
The number of output pages shown at the pixel counter is counted after converting all paper sizes to the standard paper size (A4/LT). Printing on other than the standard size is converted by paper area ratio. The standard paper size is set in the FS-08-6500.

The examples of conversion are as follows:

**Ex.)**

When printing on A4/LT size:

Counts the number of output pages as the print count.

When printing on A3/LD size:

Counts the number of output pages multiplied by 2 as the print count. (Area ratio to A4/LT: 200%)

When printing on B4 size:

Counts the number of output pages multiplied by 1.49 as the print count. (Area ratio to A4: 149%)

When printing on LG size:

Counts the number of output pages multiplied by 1.27 as the print count. (Area ratio to LT: 127%)

- **Pixel count (%)**  
Pixel count (%) shows the ratio of the emitting pixels of the writing light source to all pixels on standard paper.  
The examples of pixel count are as follows:

**Notes:**

In the following examples, 'solid copy' is considered to be 100%. But since the image has 4 margins, it never becomes 100% actually.

**Ex.)**

Printing 5 pages on A4/LT size with solid copy (writing light source emit to all pixels.)

→ Pixel count: 100%, Print count: 5

Printing 5 pages on A4/LT size with blank copy (writing light source never emit.)

→ Pixel count: 0%, Print count: 5

Printing 2 pages on A4/LT size with solid copy (writing light source emit to all pixels.)

Printing 2 pages on A4/LT size with blank copy (writing light source never emit.)

→ Pixel count: 50%, Print count: 4

Printing 3 pages on A4/LT size with 6% of writing light source emission

Printing 1 page on A4/LT size with 2% of writing light source emission

→ Pixel count: 5%, Print count: 4

Printing 2 pages on A3/LD size with solid copy (writing light source emit to all pixels.)

→ Pixel count: 100%, Print count: 4

Printing 2 pages on A3/LD size with 6% of writing light source emission

→ Pixel count: 6%, Print count: 4

- **Average pixel count (%) and latest pixel count (%)**  
There are 2 types of the value calculated as the pixel count, average pixel count (%) and latest pixel count (%).

**Average pixel count (%)**

The average value of all pixel count data after each reference data is cleared is calculated and displayed.

**Latest pixel count (%)**

The value is displayed for printing just before the pixel counter is confirmed.

- Type of calculated data  
 Since this is multifunctional and color equipment, the data of pixel count is calculated for each function and color.  
 The following list is the information that can be confirmed by LCD screen. But actually, more information can be confirmed by the FS-08.  
 See after-mentioned "5)-Display in the FS-08 for details.

**Type of calculated data**

	Toner cartridge reference				Service technician reference					
	Yellow	Magenta	Cyan	Black	Full color/Twin color					Black
					Total	Yellow	Magenta	Cyan	Black	
Copier function	Yes	Yes	Yes	Yes	Yes	Yes	Yes	Yes	Yes	Yes
Printer function	Yes	Yes	Yes	Yes	Yes	Yes	Yes	Yes	Yes	Yes
FAX function	No	No	No	Yes	No	No	No	No	No	Yes
Total	Yes	Yes	Yes	Yes	Yes	Yes	Yes	Yes	Yes	Yes

Yes: With data  
 No: Without data

- Setting related with the pixel counter function

**Standard paper size setting**

The standard paper size (A4 or LT) to convert it into the pixel count is selected (FS-08-6500).

**Pixel counter display setting**

Whether or not to display the pixel counter on the LCD screen is selected (FS-08-6504).

**Display reference setting**

The reference when displaying the pixel counter on the LCD screen (toner cartridge reference or service technician reference) is selected (FS-08-6505).

**Determination counter of toner empty**

This is the counter to determine the replacement of new toner cartridge after the toner empty is detected.

After the toner empty is detected by the auto-toner sensor, this counter checks if toner empty is not detected one more time while the specified number of pixel count or output pages is counted.

**Pixel counter clearing**

There are 3 types for the pixel count clear as follows:

FS-08-6501: All information related to the pixel count is cleared.

FS-08-6502: All information related to the service technician reference pixel count is cleared.

FS-08-6503: All information related to the toner cartridge reference pixel count is cleared.



#### [ 4 ] Relation between pixel count and toner consumption

The user's printing out the image with large coverage or high density may cause the large value of pixel count. And the setting that toner consumption becomes high in the original mode or density setting may cause it as well.

In this case, the replacement cycle of toner cartridge is faster than the standard number of output pages. Therefore, this trend needs to be grasped for the service.

The relation between pixel count and number of output pages per cartridge is as follows:

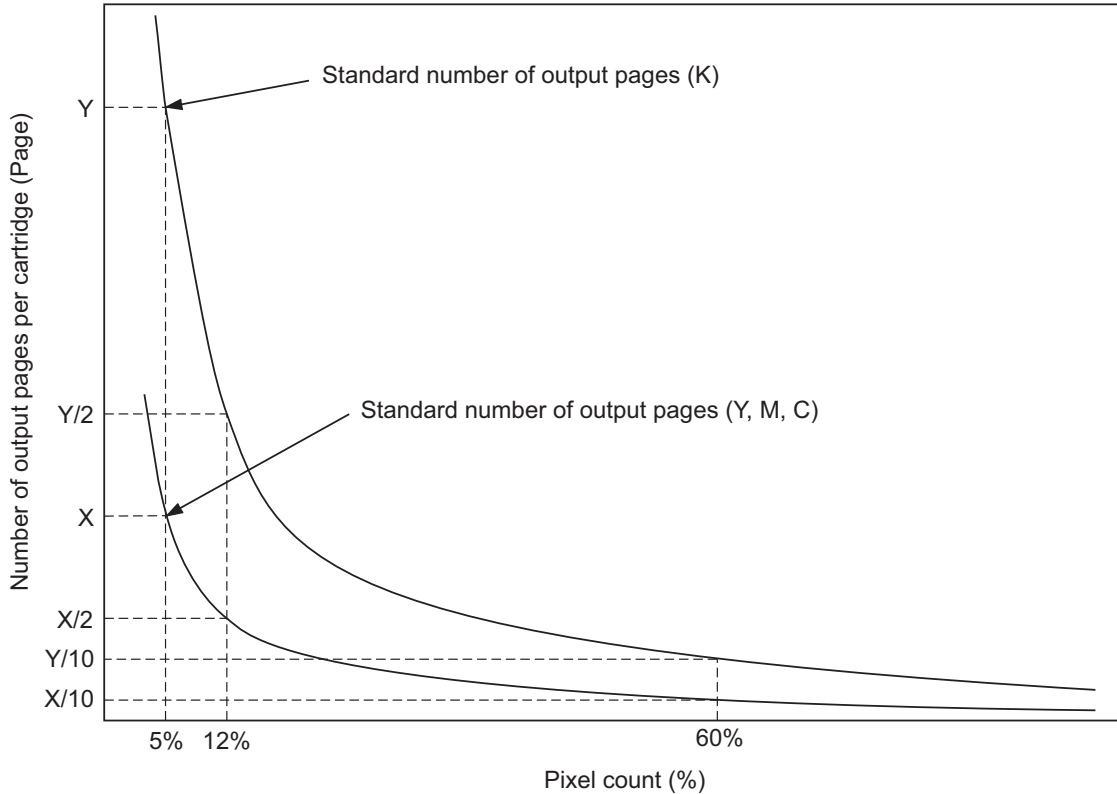


Fig.5-47 Pixel count and number of output pages per cartridge

#### [ 5 ] Pixel counter confirmation

- Display on LCD screen

Whether or not to display the pixel counter on the LCD screen is selected (0: Displayed, 1: Not displayed) in the setting mode (FS-08-6504), and whether or not to display it at the service technician reference or toner cartridge reference is selected (0: Service technician reference, 1: Toner cartridge reference) in the FS-08-6504.

The following screen is displayed when the buttons, [COUNTER] and [PIXEL COUNTER] are pressed in this order after "Displayed" is selected with the code above and the power is, as usual, turned ON. (The displayed buttons are depending on the FS-08-6505.)

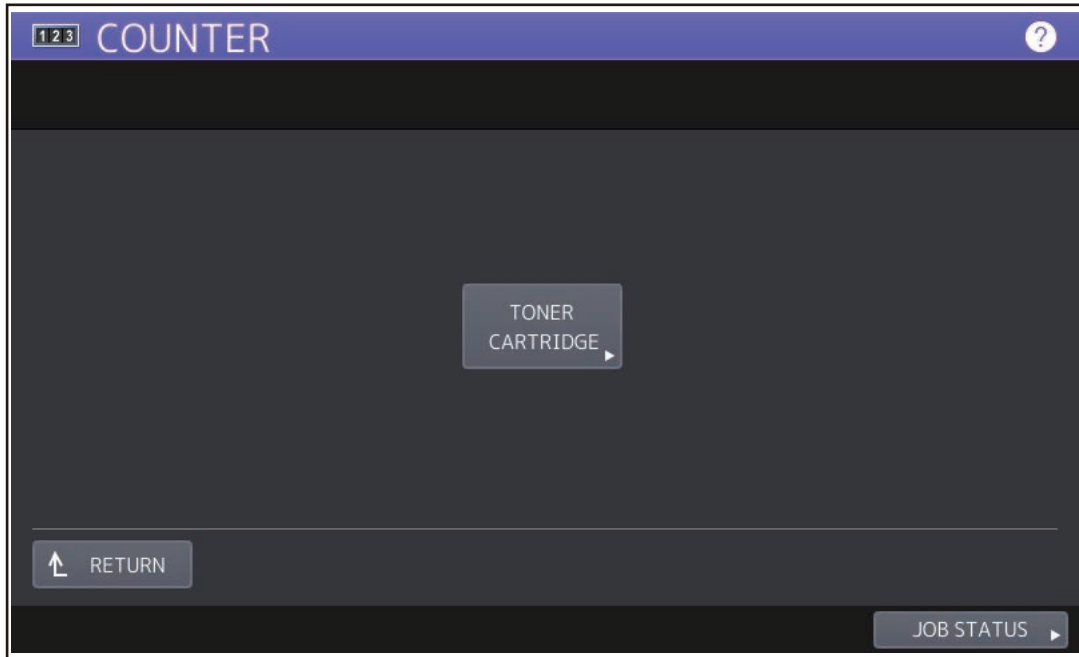


Fig.5-48

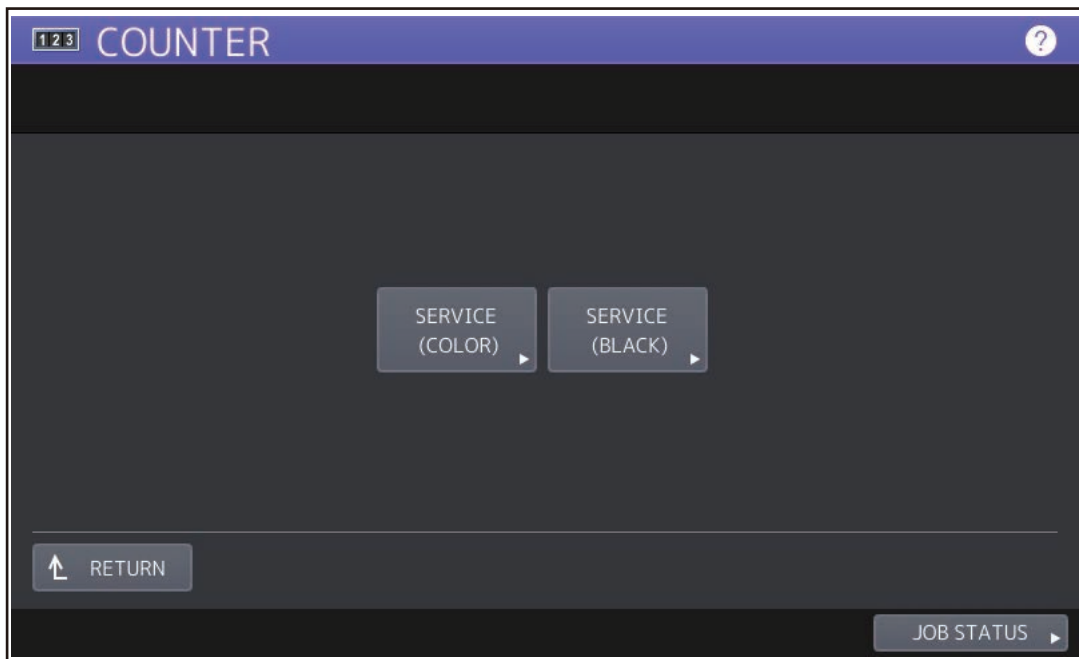


Fig.5-49 Reference selection screen

When selecting and pressing the button in the above screen, each pixel counter screen is displayed.  
[TONER CARTRIDGE]: Information screen of toner cartridge reference is displayed.  
[SERVICE (COLOR)]: Information screen of service technician reference (full color) is displayed.  
[SERVICE (BLACK)]: Information screen of service technician reference (black) is displayed.

The following screen is displayed when pressing [TONER CARTRIDGE].

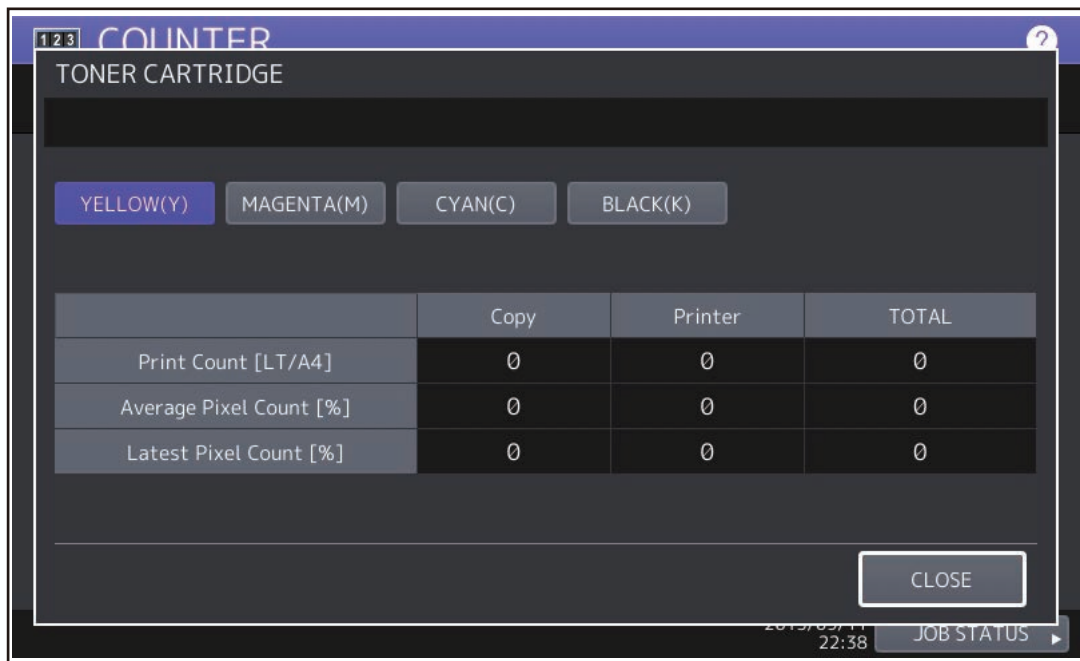


Fig.5-50 Information screen of toner cartridge reference

The following screen is displayed when pressing [SERVICE (COLOR)].

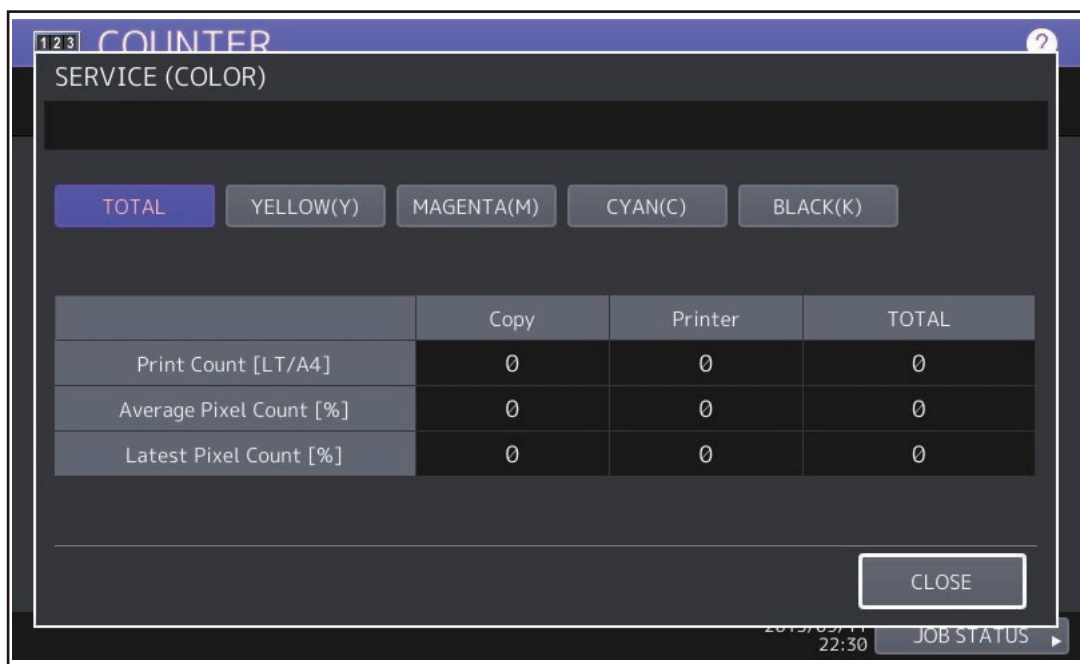


Fig.5-51 Information screen of service technician reference (full color)

The following screen is displayed when pressing the [SERVICE (BLACK)] button.

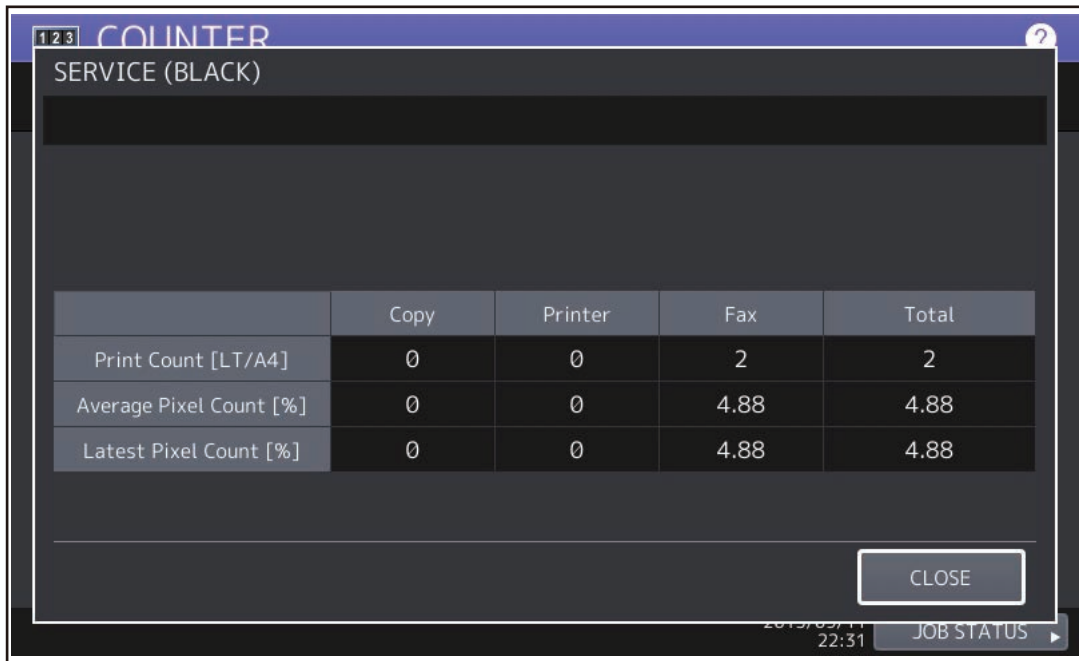


Fig.5-52 Information screen of service technician reference (black)

- Data list printing

The data for pixel counter can be printed in FS-30 LIST PRINT MODE.

FS-30-104: The data of the toner cartridge reference is printed.

FS-30-105: The data of service technician reference is printed.

PIXEL COUNTER CODE LIST				S/N: xxxxxxxx	TOTAL: 9999999	
				TOSHIBA e-STUDIOxxx	DF COUNTER: 9999999	
'08-02-08 20:13						
TONERCARTRIDGE						
No	DATE	COL.		PPC	PRN	FAX TOTAL
0	20080208	Y	Print Count[LT/A4]	181	45	--- 226
1	20080208	Y	Average Pixel Count[%]	2.70	1.74	--- 2.51
2	20080208	Y	Latest Pixel Count[%]	6.15	0.39	--- 0.39
3	20080208	M	Print Count[LT/A4]	181	45	--- 226
4	20080208	M	Average Pixel Count[%]	6.11	2	--- 5.29
5	20080208	M	Latest Pixel Count[%]	6.82	2.15	--- 2.15
6	20080208	C	Print Count[LT/A4]	181	45	--- 226
7	20080208	C	Average Pixel Count[%]	5.46	2	--- 4.81
8	20080208	C	Latest Pixel Count[%]	6.42	2.73	--- 2.73
9	20080208	K	Print Count[LT/A4]	278	145	9 432
10	20080208	K	Average Pixel Count[%]	6.15	3.86	23.25 5.74
11	20080208	K	Latest Pixel Count[%]	7.32	2.19	6.25 2.19

Fig.5-53 Data list of toner cartridge reference

## PIXEL COUNTER CODE LIST

S/N: xxxxxxxx

TOTAL: 9999999

TOSHIBAe-STUDIOxxx

DF COUNTER: 9999999

'08-02-08 20:13

## SERVICEMAN

No	DATE	COL.		PPC	PRN	FAX	TOTAL
0	20080208	F	Print Count[LT/A4]	181	45	---	226
1	20080208	F	Average Pixel Count[%]	4.95	2.34	---	4.43
2	20080208	F	Latest Pixel Count[%]	8.36	2.34	---	2.34
3	20080208	Y	Print Count[LT/A4]	181	45	---	226
4	20080208	Y	Average Pixel Count[%]	2.7	1.74	---	2.51
5	20080208	Y	Latest Pixel Count[%]	6.15	0.39	---	0.39
6	20080208	M	Print Count[LT/A4]	181	45	---	226
7	20080208	M	Average Pixel Count[%]	6.11	2	---	5.29
8	20080208	M	Latest Pixel Count[%]	6.82	2.15	---	2.15
9	20080208	C	Print Count[LT/A4]	181	45	---	226
10	20080208	C	Average Pixel Count[%]	5.46	2.18	---	4.81
11	20080208	C	Latest Pixel Count[%]	6.42	2.73	---	2.73
12	20080208	K	Print Count[LT/A4]	181	45	---	226
13	20080208	K	Average Pixel Count[%]	5.51	3.43	---	5.10
14	20080208	K	Latest Pixel Count[%]	14.05	4.10	---	4.10
15	20080208	K	Print Count[LT/A4]	97	100	9	206
16	20080208	K	Average Pixel Count[%]	7.36	4.06	23.25	6.45
17	20080208	K	Latest Pixel Count[%]	7.32	2.19	6.25	2.19

Fig.5-54 Data list of service technician reference

- Display in the FS-08 SETTING MODE  
Information of pixel count can be also checked in the 08 SETTING MODE.

**Print count, pixel count**

**Pixel count code table (toner cartridge reference)**

		Full color/Twin color				Black	Black (at color) + Black
		Yellow	Magenta	Cyan	Black		
Copier function	Print count (page)	6567	6569	6571	6562	6563	-
	Average pixel count (%)	6619	6620	6621	6622	6623	6624
	Latest pixel count (%)	6636	6637	6638	6639	6724	-
Printer function	Print count (page)	6568	6570	6572	6564	6565	-
	Average pixel count (%)	6625	6626	6627	6628	6629	6630
	Latest pixel count (%)	6640	6641	6642	6643	6725	-
FAX function	Print count (page)	-	-	-	-	6566	-
	Average pixel count (%)	-	-	-	-	6635	-
	Latest pixel count (%)	-	-	-	-	6644	-
Total	Average pixel count (%)	6631	6632	6633	-	-	6634

**Pixel count code table (service technician reference)**

		Full color/Twin color					Black
		Total	Yellow	Magenta	Cyan	Black	
Copier function	Print count (page)	6557	-	-	-	-	6558
	Average pixel count (%)	6587	6588	6589	6590	6591	6602
	Latest pixel count (%)	6606	6607	6608	6609	6610	6616
Printer function	Print count (page)	6559	-	-	-	-	6560
	Average pixel count (%)	6592	6593	6594	6595	6596	6603
	Latest pixel count (%)	6611	6612	6613	6614	6615	6617
FAX function	Print count (page)	-	-	-	-	-	6561
	Average pixel count (%)	-	-	-	-	-	6604
	Latest pixel count (%)	-	-	-	-	-	6618
Total	Average pixel count (%)	6597	6598	6599	6600	6601	6605

**Other information**

Toner cartridge replacement counter.

The toner cartridge replacement count is displayed.

- FS-08-6573: Toner cartridge Y
- FS-08-6574: Toner cartridge M
- FS-08-6575: Toner cartridge C
- FS-08-6576: Toner cartridge K

Toner cartridge reference count started date

The toner cartridge reference count started date is displayed.

- FS-08-6519: Toner cartridge Y
- FS-08-6520: Toner cartridge M
- FS-08-6521: Toner cartridge C
- FS-08-6522: Toner cartridge K

Service technician reference cleared date

The service technician reference cleared date (FS-08-6510) is displayed.

The date (FS-08-6502 was performed) is stored.

Toner cartridge reference cleared date

The toner cartridge reference cleared date is displayed.

The date (FS-08-6503 was performed) is stored.

- FS-08-6511: Toner cartridge Y
- FS-08-6512: Toner cartridge M
- FS-08-6513: Toner cartridge C
- FS-08-6514: Toner cartridge K

## 5.21 Batch Setting for Self-Diagnostic Codes

### 5.21.1 General description

The setting files encrypted in which each setting value has been written can be stored in a USB storage device. Installing this USB storage device in the equipment and reading a setting file enables the batch setting for the self-diagnostic codes.

- After the batch setting is performed, a result file is stored in the USB storage device.
- A maximum of 100 codes can be set in one file. If a code has sub codes, each of them is counted as one code.

**Notes:**

This function is not available if an automatic execution script such as a log collection is stored in a USB storage device.

### 5.21.2 Applicable codes

This function is available for the codes, whose values can be set by the service technicians, FS-05/08/13.

**Notes:**

- The codes only displaying the values and the ones acquiring or clearing the values by automatic execution are not included.
- When a value of the code which exchanges another one sequentially is changed, another one is altered in conjunction with it.
- Setting of the codes FS-08-8911 and FS-08-9000 is not possible.

### 5.21.3 Setting files

#### [ 1 ] Setting files

An encrypted file in which the setting values for each code to be changed is written in an XML format. A maximum of 100 codes can be set in one file. If a code has sub codes, each of them is counted as one code.

File name: Apply a name by employing the usable characters for an FAT32 format (extension: .diag).

File format: xml format

**Notes:**

- A setting file has to be encrypted by a dedicated encryption tool to be stored in a USB storage device.
- A setting file has to be located in the 1st or 2nd layer of the root folder of a USB storage device. (Do not locate it in the 3rd or lower layer.)
- No other automatic execution script has to be located in the same layer in which a setting file is stored.

#### [ 2 ] Example

```
<Policy>
  <Data>
    <Category-05/>
    <Category-08>
      <Code>
        <MainCode>8724</MainCode>
        <Value>1</Value>
      </Code>
      <Code>
        <MainCode>9240</MainCode>
        <Value>2</Value>
      </Code>
      <Code>
```



```

        <MainCode>9264</MainCode>
        <SubCode>1</SubCode>
        <Value>1</Value>
    </Code>
</Category-08>
<Category-13/>
</Data>
</Policy>

```

#### Notes:

- The setting value of the code in step 10 is written by inserting a comma to divide the values.  
E.g.: 08-4106 <Value>128,128</Value>
- Setting is carried out in order of written.
- The read-only codes and the execution codes are skipped to continue the processing if they are included.
- Even if writing of the setting value has failed, the processing will not stop and writing into the setting file will continue to its end.

After the processing has been completed, the result of writing of all codes is stored in a result file and then a message indicating partial success will be displayed.

- Storing of a result file is not desired, add "<ResultFile>>false</ResultFile>" under "<Policy>".

#### Example

```

<Policy>
  <ResultFile>>false</ResultFile>
  <Data>
    <Category-05/>
    <Category-08>
      <Code>
        <MainCode>8724</MainCode>
        <Value>1</Value>
      </Code>

```

## 5.21.4 Result files

### [ 1 ] Result files

A file in which success or failure of the replacement of the setting values for each code included in the setting files is written. A result file is stored in a USB storage device after this code is performed.

File name: DIG\_RESULT\_XXXX\_yymmddhhmmss.xml (XXXX: Serial No.)

File format: xml format

### [ 2 ] Example

```

<Policy>
  <Data>
    <Category-05/>
    <Category-08>
      <Code>
        <MainCode>8724</MainCode>
        <RESULT>SUCCESS</RESULT>
      </Code>
      <Code>
        <MainCode>9240</MainCode>
        <RESULT>FAILED</RESULT>
      </Code>
      <Code>
        <MainCode>9264</MainCode>
        <SubCode>1</SubCode>
        <RESULT>UNSPECIFIED</RESULT>
      </Code>
    </Category-08>

```

```
<Category-13/>
</Data>
```

```
</Policy>
```

- \* SUCCESS Values are updated successfully.
- \* FAILED Update of values fails.
- \* UNSPECIFIED No codes written exist.  
A value to be set is outside the assignable range.

**Notes:**

- A result file is stored in the root folder of a USB storage device.
- As for the codes whose values have been altered caused by batch setting of another one, their items, such as the code number, value changed and success/failure of the change, are not described in a result file.
- In case an unavailable code for writing is included in the setting file, the processing will continue and then a message indicating partial success will be displayed after the setting of all codes has been completed. Unavailable codes for writing are displayed in the list by pressing [View]. When [OK] is pressed on the screen of the message indicating partial success or the list screen, the display is returned to the BASIC screen.

### 5.21.5 Operation procedure

1. Enter into the Classic mode with [FS-08].
2. Install a USB storage device, in which setting files are stored, in the MFP.
3. Key in [3673] and then press the [START] button.
4. Select a setting file.

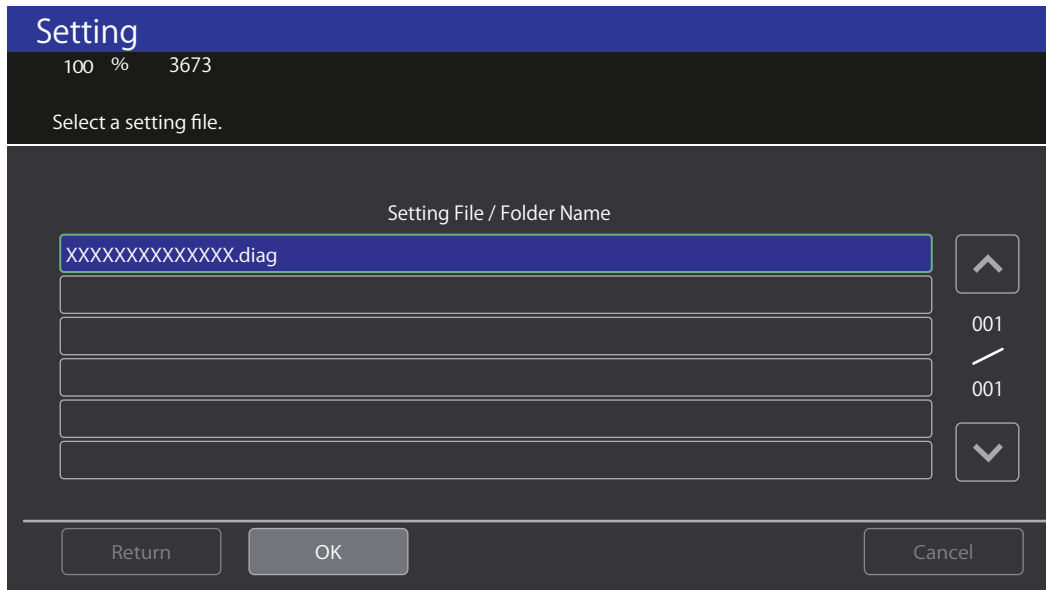


Fig.5-55

5. Press [OK].
6. Setting for all codes included in the setting file are completed, the BASIC screen of the 08 mode appears.
7. Remove the USB storage device.

# 6. SETTING / ADJUSTMENT

## 6.1 Image Related Adjustment

### 6.1.1 Adjustment Order

This chapter mainly explains the procedures for image related adjustment. When replacing components which have other specified instructions for adjustment, those specified instructions are to be obeyed in priority.

In the following diagram, the solid lines with arrow lead to essential adjustments, while the dotted lines lead to adjustments to be performed if necessary.

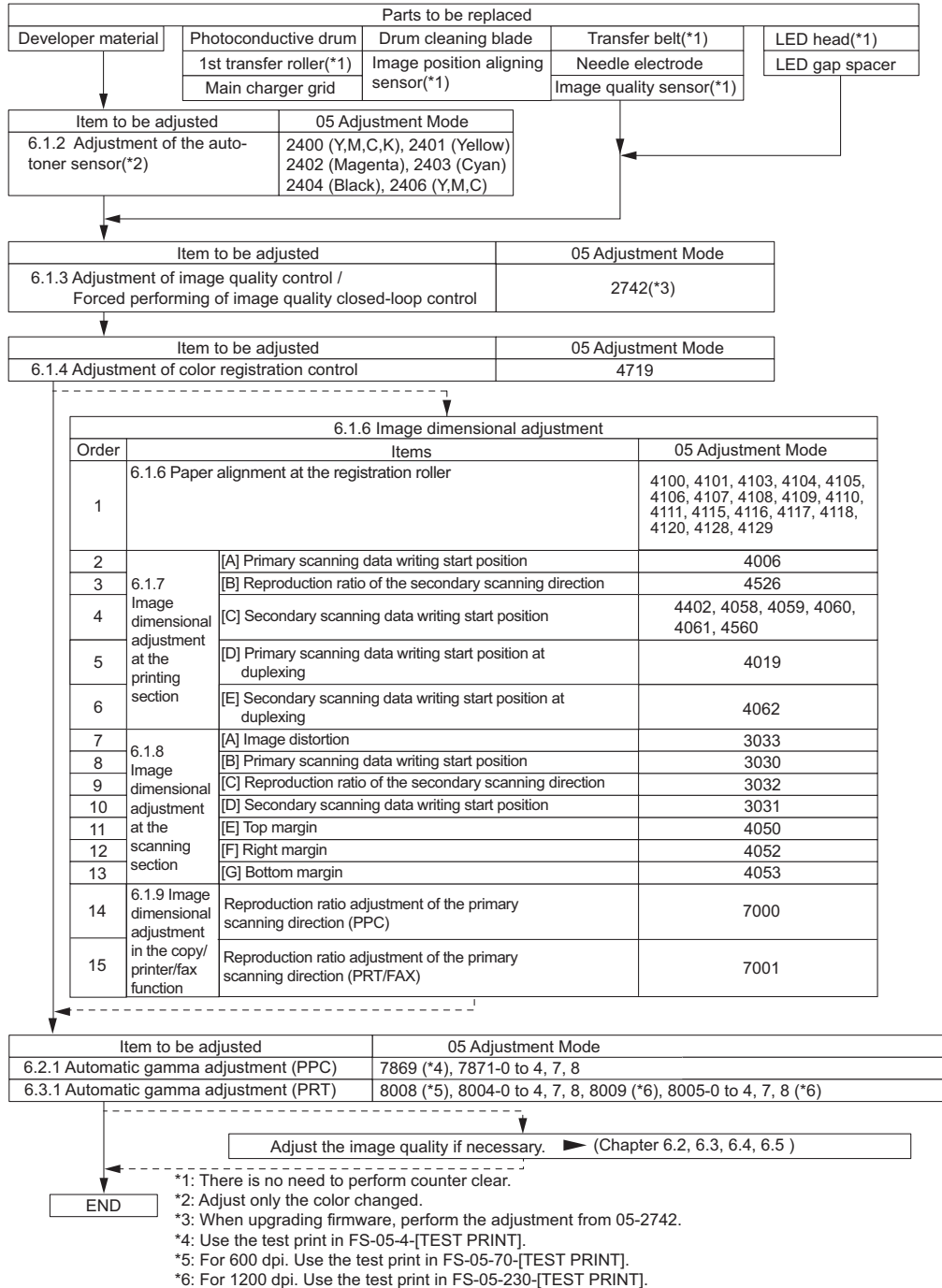


Fig.6-1

## 6.1.2 Adjustment of the Auto-Toner Sensor

When the developer material is replaced, adjust the auto-toner sensor in the following procedure. If the value of FS-08-2707 (toner density ratio manual offset control) of the replacing developer material has been changed from "0" (default), return the sub code value of the corresponding color to "0".

- (1) Install the cleaner unit and developer unit.

### Notes:

Do not install the toner cartridge.

- (2) Perform FS-05. The following message will be displayed.

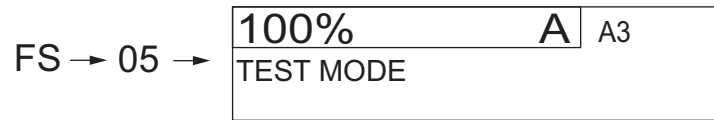


Fig.6-2

- (3) Key in a code and press the [START] button.

Code 2400: All developer materials	2401: Developer material Y	2402: Developer material M
2403: Developer material C	2404: Developer material K	2406: Developer material YMC

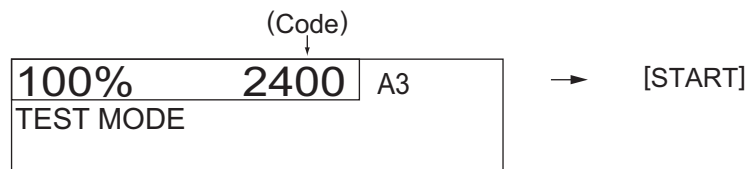
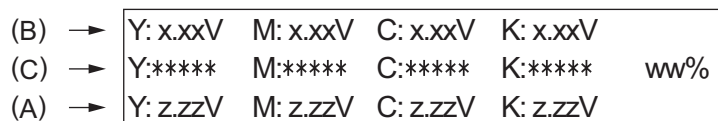


Fig.6-3

- (4) The message below will be displayed approx. 2 minutes later and the adjustment starts:
  - During the adjustment, "Current sensor voltage (V)" shown in (B) automatically changes and gradually approaches to "Target value (V) for adjustment reference voltage" shown in (A).



(B): Current sensor voltage (V)

(C): Adjustment value, Humidity (%)

(A): Target value (V) for adjustment reference voltage

Fig.6-4

- (5) When the "Current sensor voltage (V)" in (B) is converged and the "Sensor output control value (bit value)" corresponding to the value for initial developer material is displayed in (C), the adjustment is completed.
  - When the adjustment is completed, [OK] is displayed on the screen.

(B) →	Y: x.xxV	M: x.xxV	C: x.xxV	K: x.xxV
(C) →	Y: yyy	M: yyy	C: yyy	K: yyy
(A) →	Y: z.zzV	M: z.zzV	C: z.zzV	K: z.zzV

(B): Current sensor voltage (V)

(C): Sensor output control value (bit value)

(A): Target value (V) for adjustment reference voltage

**Fig.6-5**

**Notes:**

The values in (A), (B) and (C) vary with humidity.

(6) Press [OK] to store the adjustment result in the memory.

(7) Turn the power OFF and install the toner cartridges.

**Notes:**

When "Waste toner box replacement" is displayed at adjustment, follow the steps below.

<When "Waste toner box replacement" is displayed>

1. Replace the waste toner box with a new one and close the front cover.
2. Key in [4833] (Recovery from toner empty/waste toner full).
3. Check that "WAIT" is displayed.


### 6.1.3 Performing Image Quality Control

- (1) When unpacking  
Prior to image dimensional adjustment, perform the “Forced performing of image quality closed-loop control (FS-05-2742)” procedure.
- (2) When any of the following parts is replaced, be sure to perform the “Forced performing of image quality closed-loop control (FS-05-2742)” procedure.
  - Photoconductive drum
  - Developer material
  - LED printer head
  - LED gap spacer
  - Transfer belt
  - 1st transfer roller
  - Drum cleaning blade
  - Needle electrode
  - Main charger grid
  - Image position aligning sensor (Front)
  - Image position aligning sensor (Rear)/Image quality sensor

**Notes:**


When performing “Automatic gamma adjustment” in addition, “Forced performing of image quality closed-loop control (FS-05-2742)” should be done first.

- (3) When performing “Automatic gamma adjustment” in cases no parts written above are replaced, do the “Forced performing of image quality closed-loop control (FS-05-2742)” procedure before “Automatic gamma adjustment”.

Code	Item to be adjusted	Contents
2742	Forced performing of image quality closed-loop control	<p>&lt;Procedure&gt;</p> <ol style="list-style-type: none"> <li>1. Perform FS-05-2742.</li> <li>2. “WAIT” is displayed.</li> <li>3. When the adjustment finishes normally, the equipment returns to the initial state of Adjustment Mode.</li> </ol> <p>When an error occurs</p> <p>&lt;When “Waste toner box replacement” is displayed&gt;</p> <ol style="list-style-type: none"> <li>1. Replace the waste toner box with a new one and close the front cover.</li> <li>2. Key in [4833] (Recovery from toner empty/waste toner full).</li> <li>3. Check that “WAIT” is displayed.</li> </ol> <p>&lt;When toner empty is displayed&gt;</p> <ol style="list-style-type: none"> <li>1. Replace the empty toner cartridge with a new one and close the front cover.</li> <li>2. Key in [4833] (Recovery from toner empty/waste toner full).</li> <li>3. Check that “WAIT” is displayed.</li> </ol> <p>&lt;Other abnormalities&gt;</p> <p>Take the appropriate action described in Troubleshooting.</p> <p> P. 8-1 "8. ERROR CODE AND TROUBLESHOOTING"</p>

## 6.1.4 Adjustment of Color Registration Control

After having finished the “Forced performing of image quality closed-loop control (FS-05-2742)” procedure, perform the “Forced performing of color registration control adjustment (FS-05-4719)” procedure.

Code	Item to be adjusted	Contents
4719	Forced performing of color registration control	<p>&lt;Procedure&gt;</p> <ol style="list-style-type: none"> <li>1. Perform FS-05-4719.</li> <li>2. When the adjustment finishes normally, the equipment returns to the initial state of Adjustment Mode.</li> </ol> <p>If the following errors are displayed after performing FS-05-4719, clear the error by following the steps below, and then perform FS-05-4719 again.</p> <p>&lt;When “Waste toner box replacement” is displayed&gt;</p> <ol style="list-style-type: none"> <li>1. Replace the waste toner box with a new one and close the front cover.</li> <li>2. Key in [4833] (Recovery from toner empty/waste toner full).</li> <li>3. Check that “WAIT” is displayed.</li> </ol> <p>&lt;When toner empty is displayed&gt;</p> <ol style="list-style-type: none"> <li>1. Replace the empty toner cartridge with a new one and close the front cover.</li> <li>2. Key in [4833] (Recovery from toner empty/waste toner full).</li> <li>3. Check that “WAIT” is displayed.</li> </ol> <p>&lt;Other abnormalities&gt;</p> <p>Take the appropriate action described in Troubleshooting.   P. 8-1 "8. ERROR CODE AND TROUBLESHOOTING"</p>

## 6.1.5 Image Dimensional Adjustment

There are several adjustment items in the image dimensional adjustment, as listed below. Prior to this image dimensional adjustment, perform "Forced performing of image quality closed-loop control (FS-05-2742)" and "Forced performing of color registration control (FS-05-4719)".

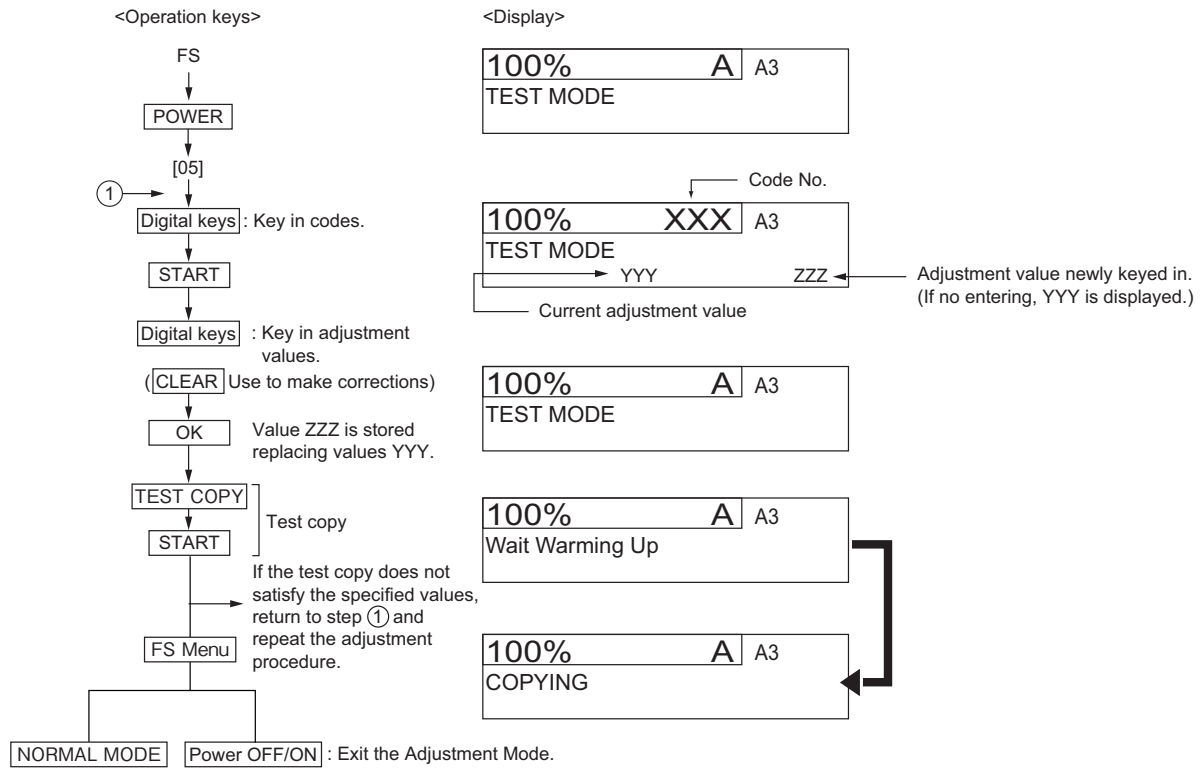
When adjusting these items, the following adjustment order should strictly be observed.

Item to be adjusted		Code in 05 Adjustment Mode
1. Paper alignment at the registration roller		4100, 4101, 4103, 4104, 4105, 4106, 4107, 4108, 4109, 4110, 4111, 4115, 4116, 4117, 4118, 4120, 4128, 4129
2. Printer-related image dimensional adjustment	Primary scanning data writing start position	4006
	Reproduction ratio of the secondary scanning direction (Fine adjustment of transfer belt motor rotation speed)	4526
	Primary scanning data writing start position	4402, 4058, 4059, 4060, 4560, 4061
	Primary scanning data writing start position at duplexing	4019
	Secondary scanning data writing start position at duplexing	4062
3. Scanner-related image dimensional adjustment	Image distortion	3033
	Primary scanning data writing start position	3030
	Reproduction ratio of the secondary scanning direction	3032
	Secondary scanning data writing start position	3031
	Top margin	4050
	Right margin	4052
	Bottom margin	4053
4. Image dimensional adjustment in the copy/printer/fax function	Reproduction ratio adjustment of the primary scanning direction (PPC)	7000
	Reproduction ratio adjustment of the primary scanning direction (PRT/FAX)	7001



**[Procedure to key in adjustment values]**

In accordance with the procedure described below, adjust the value of each item so that the measured values obtained from test copies satisfy the specification. By pressing [TEST COPY] in the ready state of 05 Adjustment Mode, single sided test copying in the normal copy mode can be performed.



**Fig.6-6**

# 6.1.6 Paper alignment at the registration roller

## [A] Adjustment with touch panel

Paper alignment at the registration roller can be adjusted in the following procedure by performing the code FS-05-4579.

- (1) Select the drawer.

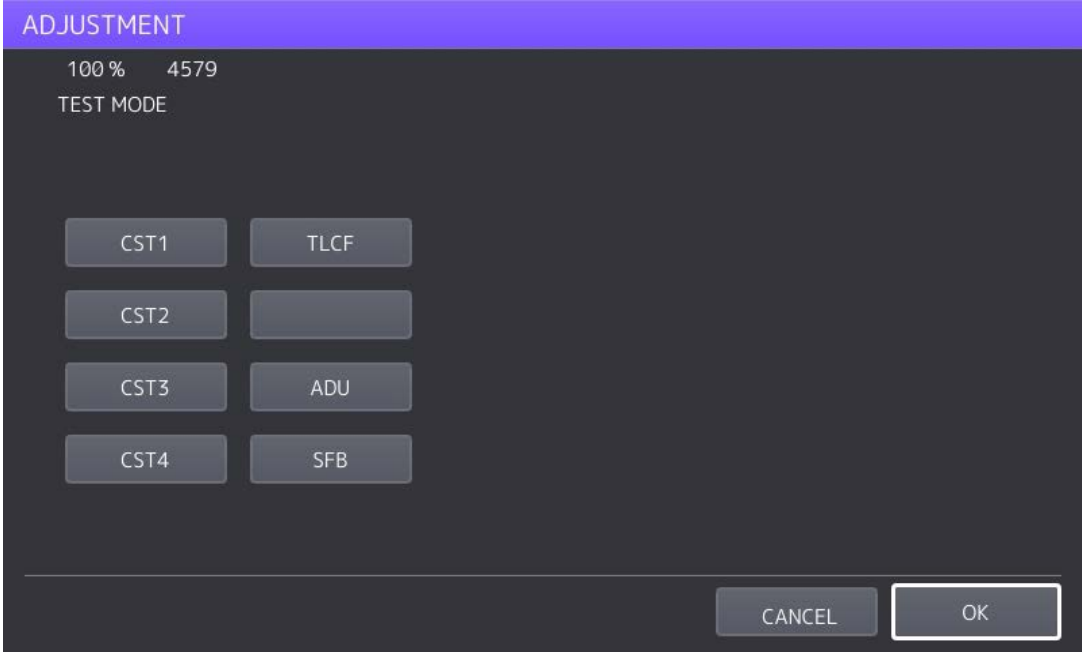


Fig.6-7

- (2) Select the paper size.

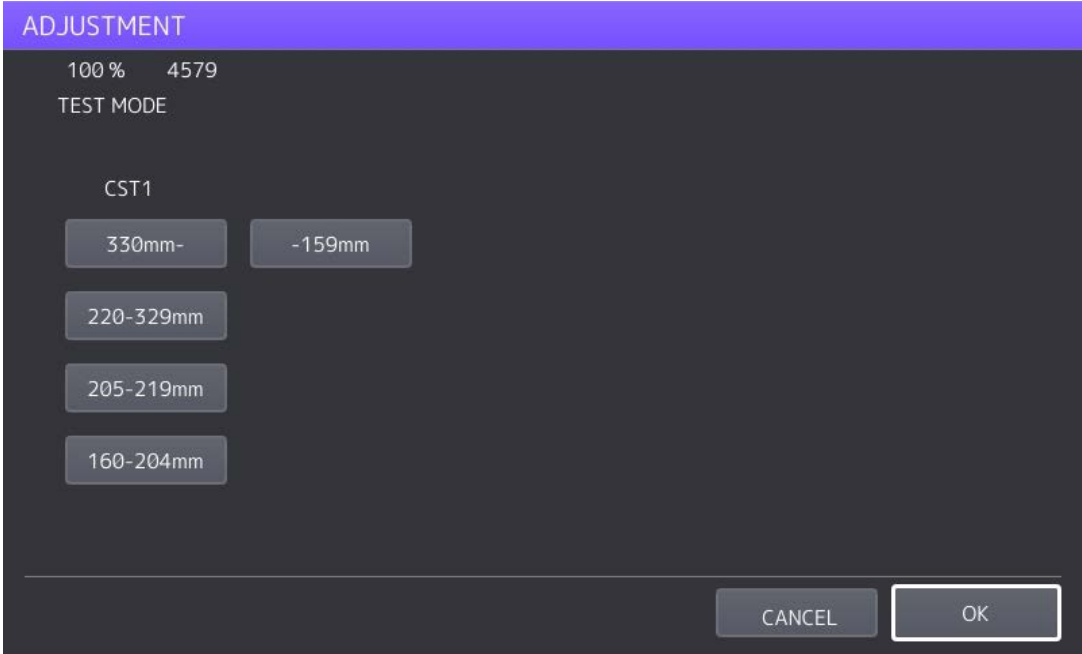


Fig.6-8

(3) Select the media type.

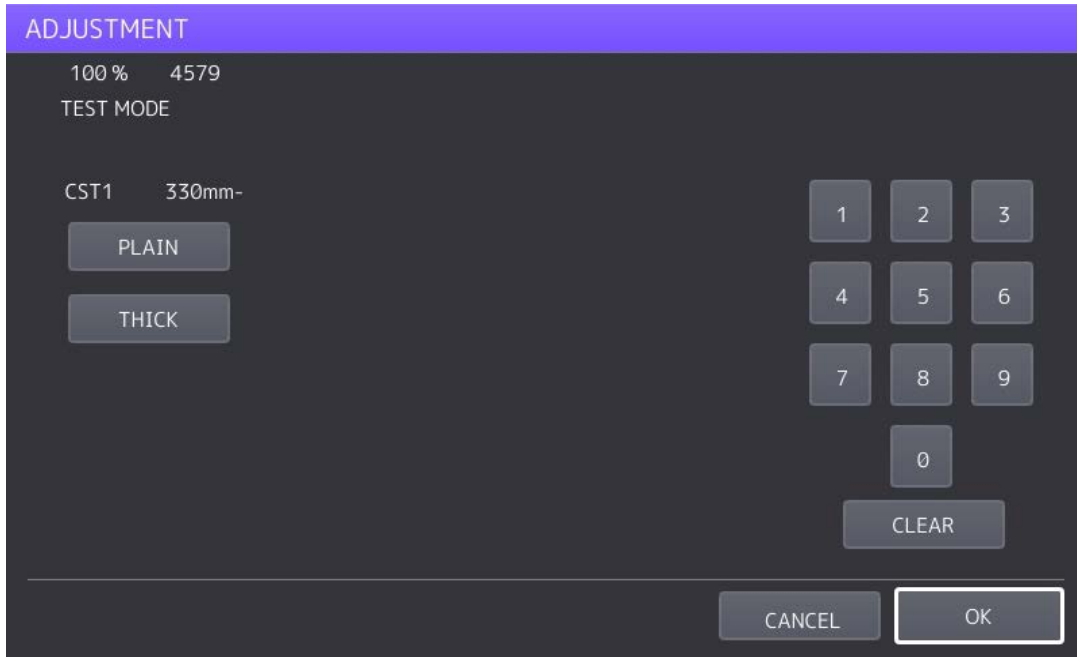


Fig.6-9

(4) Key in the adjustment value.

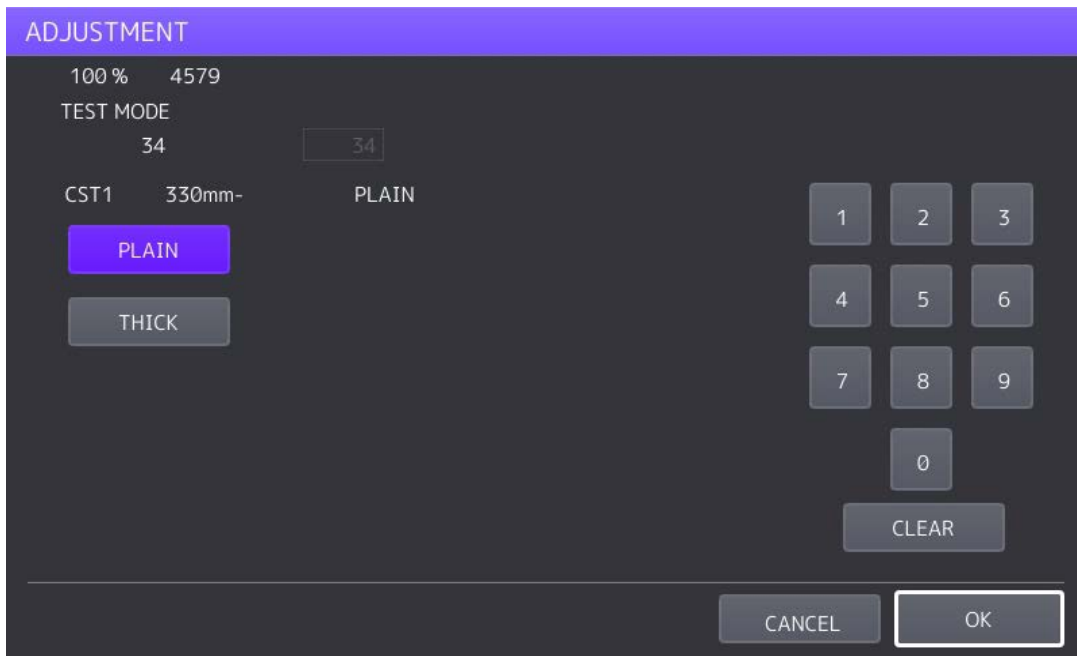


Fig.6-10

(5) Press [OK] to finish the adjustment.

\* Press the [FUNCTION CLEAR] to return to the previous menu.

**[B] Adjustment by direct code entry**

The aligning amount is adjusted by using the following codes in 05 Adjustment Mode.

Drawer	Code	Sub code	Paper size (Select the paper size with the sub code.)	Paper type*
1st drawer (CST1)	4100	0,1,2,3,4	0: 330 mm or longer (13.0 inches or longer) 1: 220–329 mm (8.7–12.9 inches) 2: 205–219 mm (8.1–8.6 inches) 3: 160-204 mm (6.3–8.0 inches) 4: 159 mm or shorter (6.26 inches or shorter)	Plain/Recycled/Thick
	4115	0,1,2,3,4		Thick1
2nd drawer (CST2)	4101	0,1,2,3,4		Plain/Recycled/Thick
	4116	0,1,2,3,4		Thick1/Envelope
3rd drawer (CST3)	4108	0,1,2,3,4		Plain/Recycled/Thick
	4117	0,1,2,3,4		Thick1/Envelope
4th drawer (CST4)	4109	0,1,2,3,4		Plain/Recycled/Thick
	4118	0,1,2,3,4		Thick1/Envelope
Bypass feed	4103	0,1,2,3,4		Plain/Recycled/Thick
	4104	0,1,2,3,4		Thick1
	4105	0,1,2,3,4		Thick2
	4107	0,1,2,3,4		OHP
	4128	0,1,2,3,4	Special1	
	4129	0,1,2,3,4	Thick2/Envelope	
ADU	4110	0,1,2,3,4	0: 330 mm or longer (13.0 inches or longer) 1: 220–329 mm (8.7–12.9 inches) 2: 205–219 mm (8.1–8.6 inches) 3: 160-204 mm (6.3–8.0 inches) 4: 159 mm or shorter (6.26 inches or shorter)	Plain/Recycled/Thick
	4120	0,1,2,3,4		Thick1/Special1/Special2
LCF	4111	-		Plain

\*Weight:

Plain: 60 to 80 g/m<sup>2</sup> (16 lb. Bond to 22 lb. Bond)

Thick: 81 to 105 g/m<sup>2</sup> (22 lb. Bond to 28 lb. Bond)

Thick1: 106 to 163 g/m<sup>2</sup> (28 lb. Bond to 60 lb. Cover (90 lb. Index))

Thick2: 164 to 209 g/m<sup>2</sup> (61 lb. Cover to 77.3 lb. Cover (115.7 lb. Index))

<Procedure>

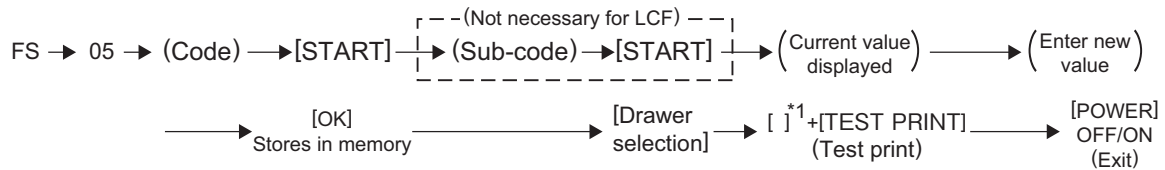


Fig.6-11

- (\*1) 1: Single-sided grid pattern in Black Mode
- 3: Double-sided grid pattern in Black Mode
- 55: Grid pattern of thick paper 2 in Full Color Mode
- 57: Grid pattern of OHP film in Full Color Mode
- 58: Single-sided grid pattern of thick paper 2 in Black Mode
- 60: Single-sided grid pattern of OHP film in Black Mode
- 98: Single-sided grid pattern in K(4)\* Mode


K(4)\*: System in which the test pattern is printed only in the black mode, though the four color developers (Y, M, C, K) are contacted to the transfer belt.


**Notes:**

If the aligning amount is too large, abnormal noise (paper-folding noise) or actual paper folding may occur during paper feeding. If the aligning amount is too small, on the other hand, a skew, an image dislocation in feeding direction, E010 (Jam not reaching the exit sensor), E011 (Transfer belt paper-clinging jam), or E013 (The paper jam occurred between the registration pass sensor and the paper clinging detection sensor) may occur. Pay attention to the above and select the appropriate value.

## 6.1.7 Image dimensional adjustment at the printing section

This adjustment is performed by using the chart output from the equipment. Select the appropriate chart in accordance with the adjustment orientation. Moreover, after performing this adjustment, check that no gap has occurred in the following adjustments.

Scanner:  P. 6-14 "[B] Reproduction ratio of the secondary scanning direction (Fine adjustment of transfer belt motor rotation speed)"

RADF:  P. 6-104 "6.13.6 Adjustment of copy ratio"

Type 1: Adjustment to make the size of an image match

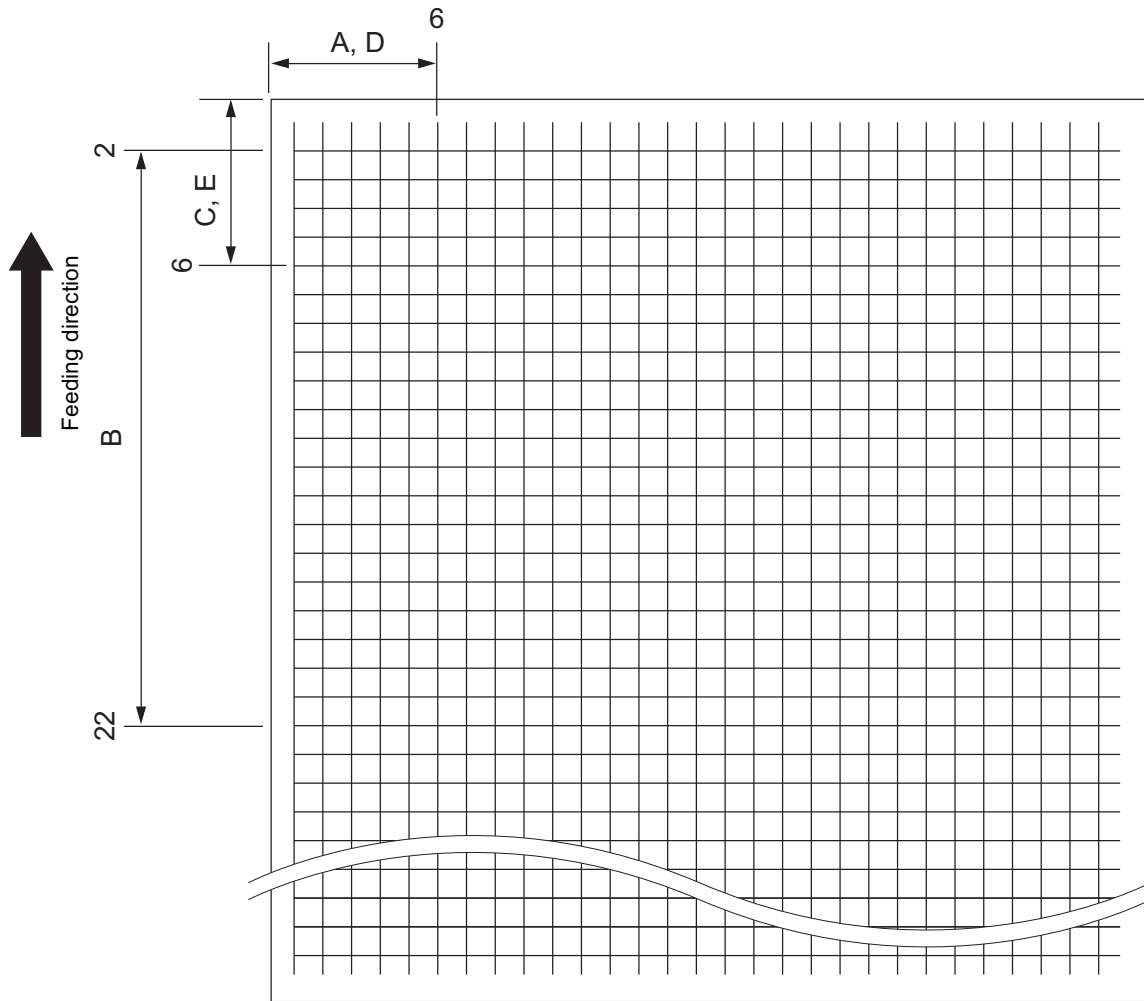







Fig.6-12

	Adjustment Tolerance	Detail of adjustment
A	52 ± 0.5mm	 P. 6-14 "[A] Primary scanning data writing start position"
B	200 ± 0.5mm	 P. 6-14 "[B] Reproduction ratio of the secondary scanning direction (Fine adjustment of transfer belt motor rotation speed)"
C	52 ± 0.5mm	 P. 6-15 "[C] Secondary scanning data writing start position"
D	52 ± 0.5mm	 P. 6-16 "[D] Primary scanning data writing start position at duplexing"
E	52 ± 0.5mm	 P. 6-17 "[E] Secondary scanning data writing start position at duplexing"

Type 2: Adjustment to make the void width match

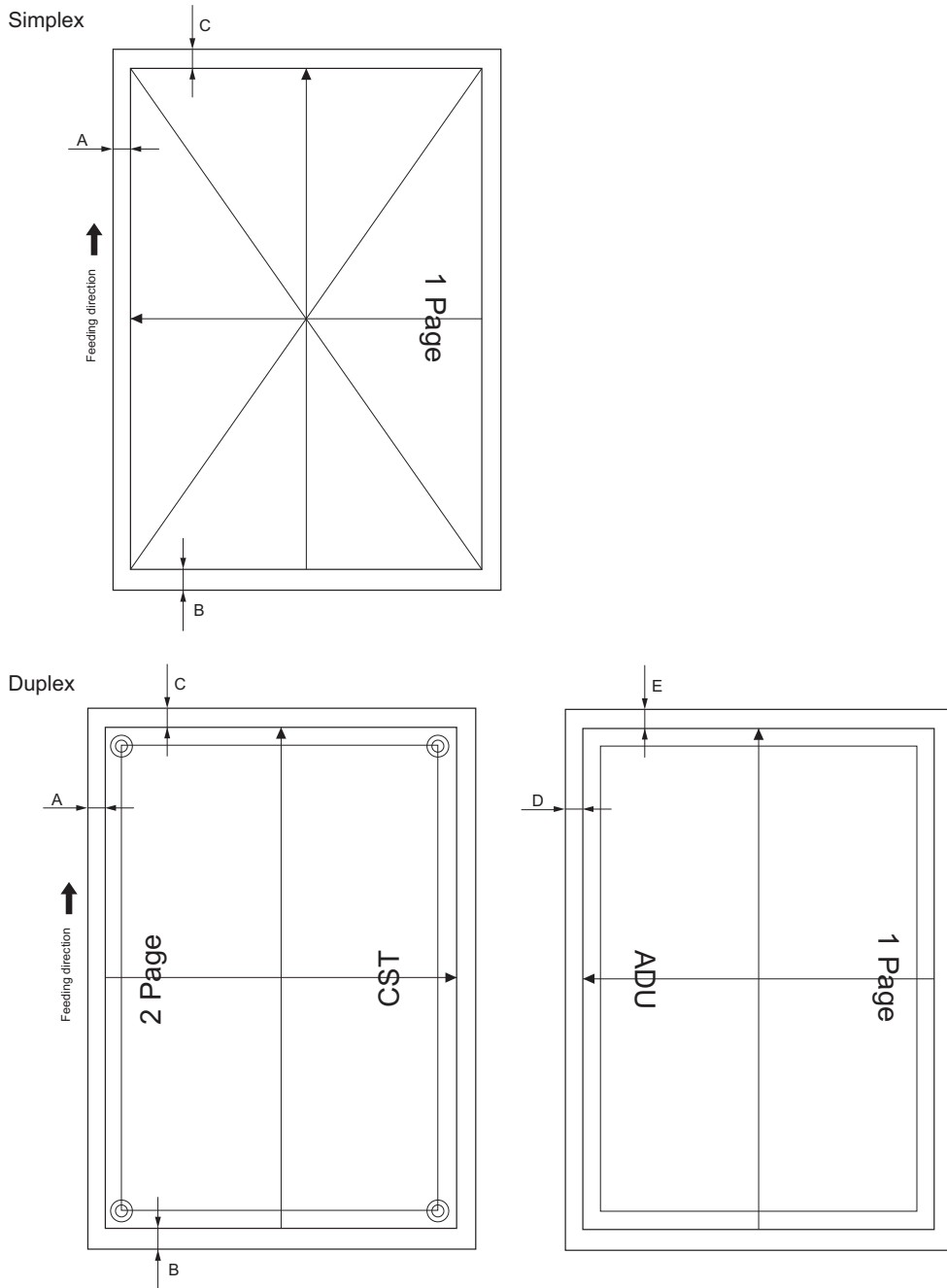


Fig.6-13

	Adjustment Tolerance	Detail of adjustment	Chart
A	4.2 ± 0.5mm	📖 P. 6-14 "[A] Primary scanning data writing start position"	05-315
B	4.2 ± 0.5mm	📖 P. 6-14 "[B] Reproduction ratio of the secondary scanning direction (Fine adjustment of transfer belt motor rotation speed)"	
C	4.2 ± 0.5mm	📖 P. 6-15 "[C] Secondary scanning data writing start position"	
D	4.2 ± 0.5mm	📖 P. 6-16 "[D] Primary scanning data writing start position at duplexing"	05-316
E	4.2 ± 0.5mm	📖 P. 6-17 "[E] Secondary scanning data writing start position at duplexing"	

### [A] Primary scanning data writing start position

- (1) Print out the chart in the ready state of FS-05 (Classic mode).  
Press FS-05-98 or FS-05-315 → [TEST PRINT]  
\* Use A3/LD from the 2nd drawer.
- (2) Check that the distance A of each chart is within the acceptable range.  
05-98:  $52 \pm 0.5\text{mm}$   
05-315:  $4.2 \pm 0.5\text{mm}$
- (3) If not, use the following procedure to change the values and measure the distance A.

<Procedure>

FS-05-4006 → [START]

→ (Key in a value (acceptable values: 0 to 255))

→ [OK] (Stored in the memory)

→ "100% A" is displayed → Key in the chart number

→ [TEST PRINT] → (A chart is printed out.)

\* The larger the adjustment value is, the longer the distance A becomes (approx. 0.04 mm/step).

#### Notes:

Make sure the first line of the grid pattern (05-98) is printed out since the line is occasionally vanished.

### [B] Reproduction ratio of the secondary scanning direction (Fine adjustment of transfer belt motor rotation speed)

Code	Sub code	Function	Remarks
4526	0	PRT/PPC (Normal speed)	When the value increases, the reproduction ratio in the secondary scanning direction becomes larger. 0.056%/step
	4	PRT/PPC (Reduced speed)	

If the sub code "0" of FS-05-4526 is adjusted, the adjustment values of sub code 4 is also changed automatically, being operated with the adjusted value, according to the proper parameter.

#### [B-1] Confirmation of FS-05-4526-0

1. Print out the chart in the ready state of FS-05 (Classic mode).  
Press FS-05-98 or FS-05-315 → [TEST PRINT]  
\* Use A3/LD from the 2nd drawer.
2. Check that the distance B of each chart is within the acceptable range.  
05-98:  $200 \pm 0.5\text{mm}$  \*  
05-315:  $4.2 \pm 0.5\text{mm}$   
\* For A3/LD, it is recommended to adjust the distance B above within the range of 199.5 mm and 200 mm otherwise the margin of the trailing edge may be deleted.
3. If not, perform the procedure in "[B-2] Adjustment of FS-05-4526-0" to change the values and measure the distance B again.
4. Perform the color registration (4719) after the adjustment.

#### Notes:

Make sure the first line of the grid pattern (05-98) is printed out since the line is occasionally vanished.



**[B-2] Adjustment of FS-05-4526-0**

- FS-05 -4526 → [START] → (Key in the sub-code [0])
- [START] → (Key in a value (acceptable values: 0 to 255))
- [OK] (Stored in the memory)
- \* When the measured value is not within the acceptable range, the trailing edge area of the image may be out of position for the paper length or the density at the trailing edge area of the image may become lower. To avoid this, perform the adjustment while checking the image.
- "100% A" is displayed → Key in the chart number
- [TEST PRINT] → (A chart is printed out.)
- \* The larger the adjustment value is, the longer the distance B becomes (0.056%/step).
- (Key in the code [4719]) → [START] → (Enforced color registration)

**Notes:**

- The setting value specified in FS-05-4526-0 is reflected to the charts printed out by FS-05-98, FS-05-3, FS-05-315 and FS-05-316. The adjustment result of FS-05-4526-4 cannot be confirmed by means of these charts.
- When "FS-05-4526-0" is performed, a proper value is automatically calculated for the size of an image in each function mode (copy/printer/Fax) or at each speed (normal speed/reduced speed/high speed). The speed of the transfer belt motor is also adjusted. Therefore, use the above default value other than the sub code "0," unless otherwise required.

**[C] Secondary scanning data writing start position**

Performing the code FS-05-4402 covers this adjustment for all paper sources. The adjustment for each paper source is also available.

For all paper sources

Code	Paper size	Acceptable value	Remarks
4402	A3/LD	0 to 200	Perform the adjustment for all paper sources.

For each paper source

Order for adjustment	Paper source	Code	Paper size	Acceptable value	Remarks
1	1st drawer	4058	A4/LT	0 to 100	
2	2nd drawer	4059	A3/LD	0 to 100	
3	LCF*	4561	A4/LT	0 to 100	
4	3rd drawer	4060	A4/LT	0 to 100	
5	4th drawer	4560	A4/LT	0 to 100	
6	Bypass feed	4061	A4/LT	0 to 100	

\* When the LCF is installed, adjustment of the PFP (the 3rd and 4th drawers) is unnecessary. When the PFP is installed, adjustment of the LCF is unnecessary.

- (1) Print out the chart in the ready state of FS-05 (Classic mode).  
Press FS-05-98 or FS-05-315 → [TEST PRINT]  
\* Use A3/LD from the 2nd drawer.
- (2) Check that the distance C of each chart is within the acceptable range.  
05-98: 52 ± 0.5mm  
05-315: 4.2 ± 0.5mm
- (3) If not, use the following procedure to change values and measure the distance C again.  
<Procedure>  
FS-05 → (Key in the code shown above) → [START]  
→ (Key in an acceptable value shown above)  
→ [OK] (Stored in the memory)  
→ "100% A" is displayed → Key in the chart number  
→ [TEST PRINT] → (A chart is printed out.)  
\* The larger the adjustment value is, the longer the distance C becomes (approx. 0.10 mm/step).

**Notes:**

Make sure the first line of the grid pattern (05-98) is printed out since the line is occasionally vanished.

**[D] Primary scanning data writing start position at duplexing****Notes:**

Make sure the first line of the grid pattern (05-3) is printed out since the line is occasionally vanished.

**[D-1] Adjustment for long-sized paper**

- (1) Print out the chart in the ready state of FS-05 (Classic mode).  
Press FS-05-3 or FS-05-316 → [TEST PRINT]  
\* Use A3/LD from the 2nd drawer.
- (2) Check that the distance D of each chart is within the acceptable range.  
05-3:  $52 \pm 0.5\text{mm}$   
05-316:  $4.2 \pm 0.5\text{mm}$
- (3) If not, use the following procedure to change values and measure the distance D again.  
<Procedure>  
FS-05 -4019 → [START] → [0] → [START]  
→ (Key in a value (acceptable values: 0 to 255))  
→ [OK] (Stored in the memory)  
→ "100% A" is displayed → Key in the chart number  
→ [TEST PRINT] → (A chart is printed out.)  
\* The larger the adjustment value is, the longer the distance D becomes (approx. 0.04 mm/step).

**[D-2] Adjustment for short-sized paper**

- (1) Print out the chart in the ready state of FS-05 (Classic mode).  
Press FS-05-3 or FS-05-316 → [TEST PRINT]  
\* Use A4/LT from the 1st drawer.
- (2) Check that the distance D of each chart is within the acceptable range.  
05-3:  $52 \pm 0.5\text{mm}$   
05-316:  $4.2 \pm 0.5\text{mm}$
- (3) If not, use the following procedure to change values and measure the distance D again.  
<Procedure>  
FS-05 -4019 → [START] → [1] → [START]  
→ (Key in a value (acceptable values: 0 to 255))  
→ [OK] (Stored in the memory)  
→ "100% A" is displayed → Key in the chart number  
→ [TEST PRINT] → (A chart is printed out.)  
\* The larger the adjustment value is, the longer the distance D becomes (approx. 0.04 mm/step).

**[D-3] Adjustment for medium-sized paper (Length: 220 mm to 329 mm)**

- (1) Print out the chart in the ready state of FS-05 (Classic mode).  
Press FS-05-3 or FS-05-316 → [TEST PRINT]  
\* Use A4/LT from the 1st drawer.
- (2) Check that the distance D of each chart is within the acceptable range.  
05-3:  $52 \pm 0.5\text{mm}$   
05-316:  $4.2 \pm 0.5\text{mm}$
- (3) If not, use the following procedure to change values and measure the distance D again.  
<Procedure>  
FS-05 -4019 → [START] → [2] → [START]  
→ (Key in a value (acceptable values: 0 to 255))  
→ [OK] (Stored in the memory)  
→ "100% A" is displayed → Key in the chart number

→ [TEST PRINT] → (A chart is printed out.)

- \* The larger the adjustment value is, the longer the distance D becomes (approx. 0.04 mm/step).

### [E] Secondary scanning data writing start position at duplexing

- (1) Print out the chart in the ready state of FS-05 (Classic mode).  
Press FS-05-3 or 05-316 → [TEST PRINT]  
\* Use A3/LD from the 2nd drawer.
- (2) Check that the distance E of each chart is within the acceptable range.  
05-3:  $52 \pm 0.5\text{mm}$   
05-316:  $4.2 \pm 0.5\text{mm}$
- (3) If not, use the following procedure to change the values and measure the distance E again.

<Procedure>

Press FS-05-4062 → [START]

→ Key in a value (acceptable values: 0 to 255) → [OK] (Stored in the memory)

→ "100% A" is displayed → Key in the chart number → [TEST PRINT]

→ (A chart is printed out.)

- \* The larger the adjustment value is, the longer the distance E becomes (approx. 0.10 mm/step).

#### Notes:

Make sure the first line of the grid pattern (05-3) is printed out since the line is occasionally vanished.

### <Adjustment procedure summarization for A to E>

Type 1: Adjustment to make the size of an image match

FS-05 → [98] ([3] for duplexing) → [TEST PRINT]

A:	FS-05-4006 (2nd drawer, A3/LD)	→	$52 \pm 0.5$ mm (0.04 mm/step)
B:	FS-05-4526-0 (2nd drawer, A3/LD)	→	$200 \pm 0.5$ mm (0.1 mm/step)
C:	FS-05-4402 (2nd drawer, A3/LD)	→	$52 \pm 0.5$ mm (0.1 mm/step)
	FS-05-4058 (1st drawer, A4/LT)		
	FS-05-4059 (2nd drawer, A3/LD)		
	FS-05-4060 (3rd drawer, A4/LT)		
	FS-05-4560 (4th drawer, A4/LT)		
	FS-05-4061 (Bypass feed, A4/LT)		
D:	FS-05-4019-0 (2nd drawer, A3/LD), FS-05-4019-1 (1st drawer, A4/LT) FS-05-4019-2 (A4-R/LT-R)	→	$52 \pm 0.5$ mm (0.04 mm/step)
E:	FS-05-4062 (2nd drawer, A3/LD)	→	$52 \pm 0.5$ mm (0.1 mm/step)

Type 2: Adjustment to make the void width match

FS-05 → 315(316 for duplexing) → [TEST PRINT]

A:	FS-05-4006 (2nd drawer, A3/LD)	→	$4.2 \pm 0.5$ mm (0.04 mm/step)
B:	FS-05-4526-0 (2nd drawer, A3/LD)	→	$4.2 \pm 0.5$ mm (0.1 mm/step)
C:	FS-05-4402 (2nd drawer, A3/LD)	→	$4.2 \pm 0.5$ mm (0.1 mm/step)
	FS-05-4058 (1st drawer, A4/LT)		
	FS-05-4059 (2nd drawer, A3/LD)		
	FS-05-4060 (3rd drawer, A4/LT)		
	FS-05-4560 (4th drawer, A4/LT)		
	FS-05-4061 (Bypass feed, A4/LT)		

D:	FS-05-4019-0 (2nd drawer, A3/LD), FS-05-4019-1 (1st drawer, A4/LT) FS-05-4019-2 (A4-R/LT-R)	→	4.2±0.5 mm (0.04 mm/step)
E:	FS-05-4062 (2nd drawer, A3/LD)	→	4.2±0.5 mm (0.1 mm/step)

## 6.1.8 Image dimensional adjustment at the scanning section

### [A] Image distortion

#### Notes:

- The specification of the distortion is 1 mm to 200 mm when a drawer equipped as standard is used, and is 3 mm to 200 mm when an optional drawer (PFU, PFP and LCF) is used.
- Do not perform this adjustment when the distortion is within the above value. If the adjustment has failed, fogging or a C260 error will occur.
- This adjustment is for the distortion in the scanning section. Therefore, do not use this to correct paper skew at paper feeding.
- When performing the adjustment, marginally rotate the screw by approximately one quarter while checking the image.

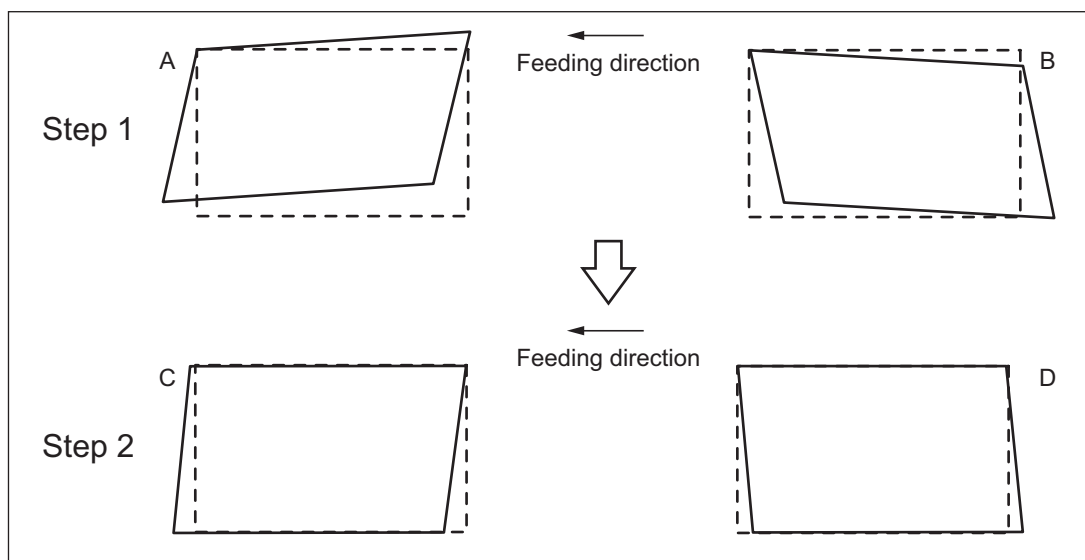


Fig.6-14

- (1) Perform FS-05.
- (2) Press [TEST COPY] → [START] button to make a copy of any image on a sheet of A3/LD paper.
- (3) Key in [3033] and press the [START] button to move the carriage to the adjustment position.

- (4) Make an adjustment in the order of step 1 and 2.

#### Step 1

In case of A:

Tighten the mirror-3 adjustment screw (Rear) [1] (CW).

In case of B:

Loosen the mirror-3 adjustment screw (Rear) [1] (CCW).

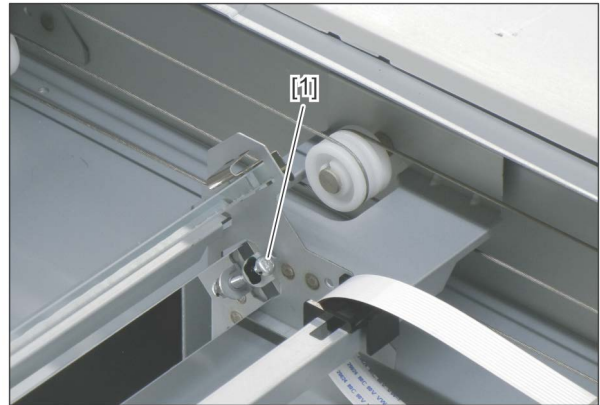


Fig.6-15

#### Step 2

In case of C:

Tighten the mirror-1 adjustment screw (Rear) [1] (CW).

In case of D:

Loosen the mirror-1 adjustment screw (Rear) [1] (CCW).

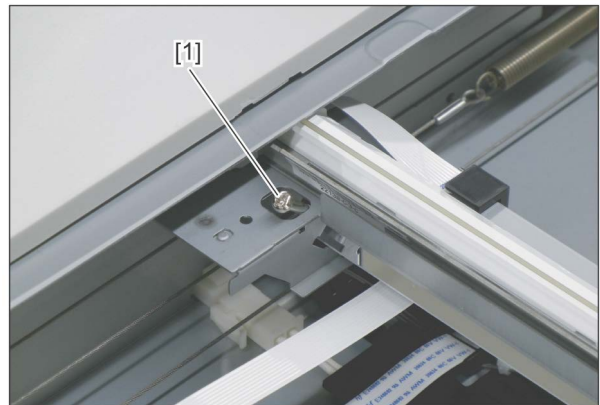



Fig.6-16

- (5) Apply the screw locking agents to the adjustment screws. (2 areas)
- Recommended screw lock agent  
Manufacturer: Three Bond  
Product name: 1401E

The following adjustments (B) to (D) should be performed with Test Chart No. TCC-1/TCC-2.  
 P. 6-24 " Adjustments and Checks using Test Chart No. TCC-1/TCC-2"

#### [B] Primary scanning data writing start position

- (1) Perform FS-05. → (05 Adjustment Mode)
- (2) Place Test Chart No. TCC-1/TCC-2 on the original glass (with the arrow positioned at the left rear side).
- (3) Press [TEST COPY] → [START] to make a copy at the mode of A4/LT, 100%, Full color and Text/Photo.
- (4) Measure the distance B from the left paper edge to the 5 mm line of left grid pattern on the copy with a ruler.
- (5) Check if the distance B is within  $5 \pm 0.5$  mm.
- (6) If not, use the following procedure to change values and repeat step (3) to (5). above.  
<Procedure>  
FS-05-3030 → [START]  
→ (Key in a value (acceptable values: 0 to 255))  
→ [OK] (Stored in the memory)  
\* The larger the adjustment value is, the longer the distance B becomes (approx. 0.04 mm/step).

### **[C] Reproduction ratio of the secondary scanning direction**

- (1) Perform FS-05. → (05 Adjustment Mode)
- (2) Place Test Chart No. TCC-1/TCC-2 on the original glass (with the arrow positioned at the left rear side).
- (3) Press [TEST COPY] → [START] to make a copy at the mode of A4/LT, 100%, Full color and Text/Photo.
- (4) Measure the distance C between M3 and M4 on the copy with a ruler.
- (5) Check if the distance C is within  $150 \pm 0.5$  mm.
- (6) If not, use the following procedure to change values and repeat step (3) to (5) above.  
<Procedure>  
FS-05-3032 → [START]  
→ (Key in a value (acceptable values: 63 to 193))  
→ [OK] (Stored in the memory)  
\* The smaller the adjustment value is, the smaller the ratio becomes (approx. 0.018%/step).

### **[D] Secondary scanning data writing start position**

- (1) Perform FS-05. → (05 Adjustment Mode)
- (2) Place Test Chart No. TCC-1/TCC-2 on the original glass (with the arrow positioned at the left rear side).
- (3) Press [TEST COPY] → [START] to make a copy at the mode of A4/LT, 100%, Full color and Text/Photo.
- (4) Measure the distance D from the top paper edge to the 10 mm line of top grid pattern on the copy with a ruler.
- (5) Check if the distance D is within  $10 \pm 0.5$  mm.
- (6) If not, use the following procedure to change values and repeat step 3. to 5. above.  
<Procedure>  
FS-05-3031 → [START]  
→ (Key in a value (acceptable values: 90 to 166))  
→ [OK] (Stored in the memory)  
\* The larger the adjustment value is, the longer the distance D becomes (approx. 0.08 mm/step).

**[E] Top margin**

- (1) Perform FS-05. → (05 Adjustment Mode)
- (2) Open the platen cover or DF.
- (3) Press [TEST COPY] → [START] to make a copy at the mode of A3/LD, 100%, Full color, Text/Photo and 2nd drawer.
- (4) Measure the blank area E at the leading edge of the copied image.
- (5) Check if the blank area E is within the range.

Function	Black	Color
Copy	4.2 mm + 2.8 mm / -1.2 mm	5 - 1.0 mm, 5 + 2.0 mm (4.0 to 7.0 mm)

- (6) If not, use the following procedure to change values and repeat the steps 3. to 5. above.

<Procedure>

FS-05-4050 → [START]

→ (Key in a value (acceptable values: 0 to 255))

→ [OK] (Stored in the memory)

→ ("100% A" is displayed.)

\* The larger the adjustment value is, the wider the blank area becomes (approx. 0.04 mm/step).

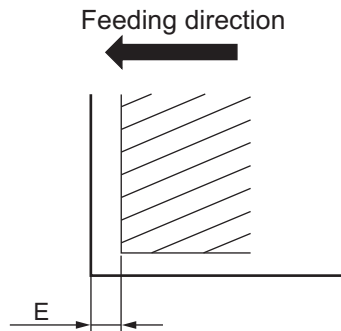


Fig.6-17

**Notes:**

Paper jams tend to occur in equipment in which thin paper such as 64g/m<sup>2</sup> (17lb. Bond) paper is used or a large amount of high density images such as pictures are output. For this equipment, we recommend that you adjust the top margin "in the plus direction" in order to prevent paper jamming.

Range of top margin adjustment (e.g.)

Function	Black	Color
Copy	4.2 - 7.0 mm	5.0 - 7.0 mm

## [F] Right margin

- (1) Perform FS-05. → (05 Adjustment Mode)
- (2) Open the platen cover or DF.
- (3) Press [TEST COPY] → [START] to make a copy at the mode of A3/LD, 100%, Full color, Text/Photo and 2nd drawer.
- (4) Measure the blank area F at the right side of the copied image.
- (5) Check if the blank area F is within the range.

Function	Black	Color
Copy	2±2.0 mm	2±2.0 mm

- (6) If not, use the following procedure to change values and repeat the steps (3) to (5) above.

<Procedure>

FS-05-4052 → [START]

→ (Key in a value (acceptable values: 0 to 255))

→ [OK] (Stored in the memory).

→ ("100% A" is displayed.)

\* The larger the adjustment value is, the wider the blank area at the right side becomes (approx. 0.04 mm/step).

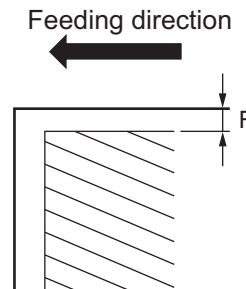


Fig.6-18



## [G] Bottom margin

- (1) Perform FS-05. → (05 Adjustment Mode)
- (2) Open platen cover or DF.
- (3) Press the [TEST COPY] → [START] to make a copy at the mode of A3/LD, 100%, Full color, Text/Photo and 2nd drawer.
- (4) Measure the blank area G at the trailing edge of the copied image.
- (5) Check if the blank area G is within the range.

Function	Black	Color
Copy	3±2.0 mm	3±2.0 mm

- (6) If not, use the following procedure to change values and repeat the steps (3) to (5) above.

<Procedure>

FS-05-4053 → [START]

→ (Key in value (acceptable values: 0 to 255))

→ [OK] (stored in the memory)

→ ("100% A" is displayed.)

\* The larger the adjustment value is, the wider the blank area at the trailing edge becomes (approx. 0.04 mm/step).

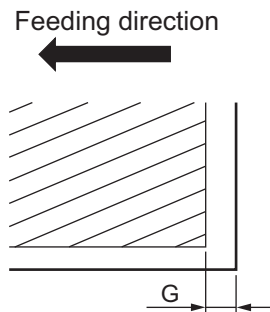


Fig.6-19

## Adjustments and Checks using Test Chart No. TCC-1/TCC-2

Following items can be checked with the Test Chart No. TCC-1/TCC-2.

1. Points to be measured in the chart

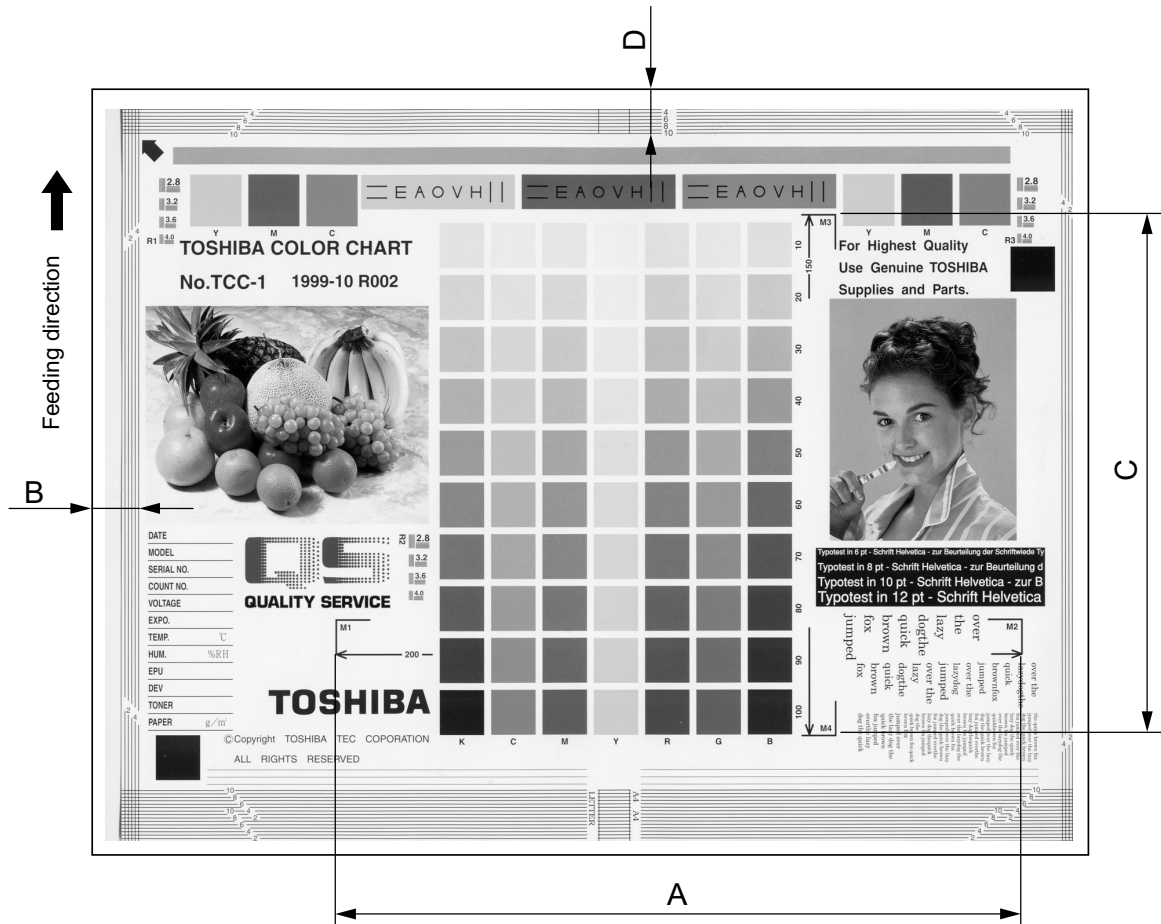


Fig.6-20

<Adjustment order>

FS-05 → (Chart TCC-1/TCC-2) → [TEST COPY] → [START] (A3/LD, 100%, Full color and Text/Photo)

- B: FS-05-3030 → 5±0.5 mm (0.04 mm/step)
- C: FS-05-3032 → 150±0.5 mm (0.03 mm/step)
- D: FS-05-3031 → 10±0.5 mm (0.08 mm/step)

## 2. Checking areas of the chart and their descriptions

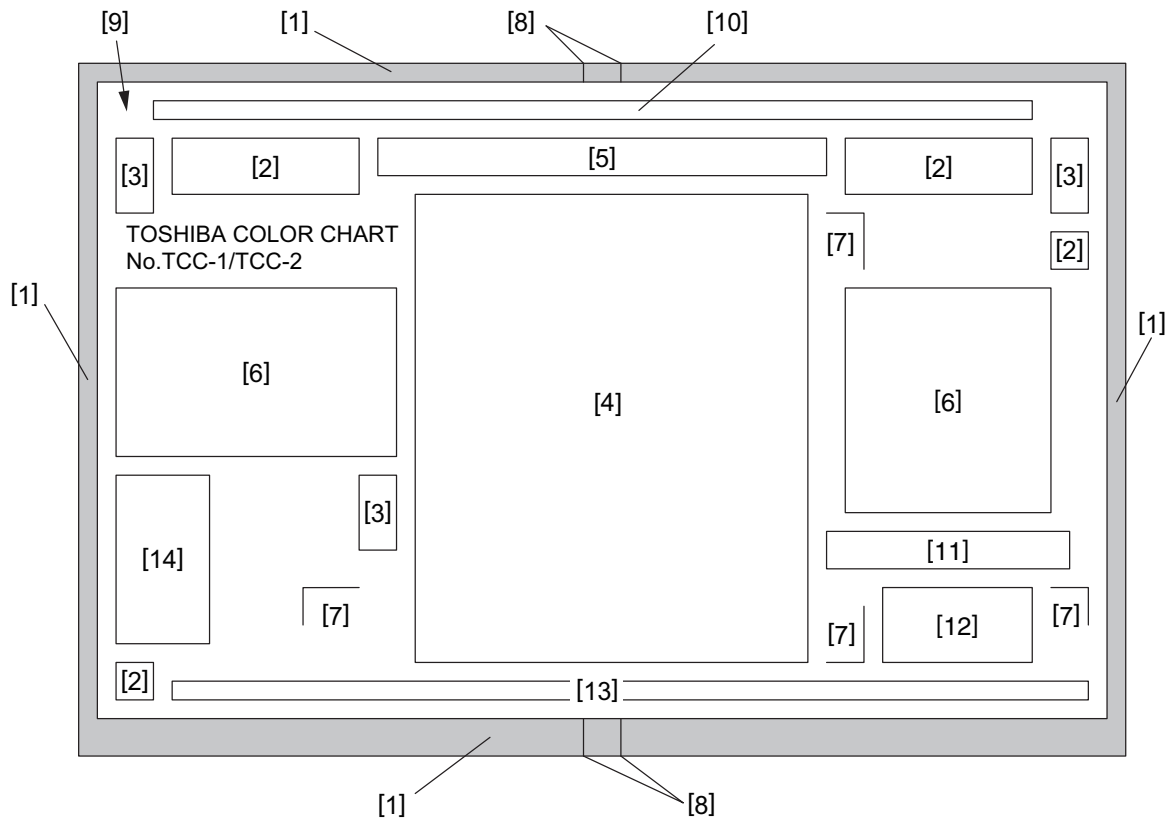


Fig.6-21

- |      |                               |   |
|------|-------------------------------|---|
| [1]  | Grid patterns                 | : For adjusting margin (void) and scanner section   |
| [2]  | YMCK patches                  | : For checking uniformity   |
| [3]  | Resolution patterns           | : For checking resolution   |
| [4]  | Gradation pattern             | : Gradation pattern of seven colors (Y, M, C, R, G, B and K)<br>Coverage: 10-100%<br>For adjusting the halftone reproduction and gray balance |
| [5]  | Color registration pattern    | : For checking color registration   |
| [6]  | Pictures                      | : For checking color reproduction and moire   |
| [7]  | Magnification lines           | : For checking the magnification error of primary and secondary scanning directions   |
| [8]  | Center lines                  | : Center lines for A4/LT sizes  |
| [9]  | Arrow                         | : A mark for placing the chart properly onto the original glass (place it to the left rear corner of the original glass.)                     |
| [10] | Halftone band                 | : For checking uniformity   |
| [11] | White text on the black solid | : For checking the reproduction of white text on black solid  |
| [12] | Text                          | : For checking reproduction of text   |
| [13] | Thin lines                    | : For checking reproduction of the thin lines (line width: 100μm)   |
| [14] | Note area                     | : For recording the date, conditions, etc.  |

## 6.1.9 Image dimensional adjustment in the copy/printer/fax function

### [ 1 ] Reproduction ratio adjustment of the primary scanning direction

The reproduction ratio in the primary scanning direction of the printed image can be adjusted as follows:

<05 Adjustment Mode>

Code	Function	Remarks
7000	PPC	The larger the value is, the larger the reproduction ratio in the primary scanning direction becomes. (0.1%/step) Acceptable values: 0 to 255 (Default: 128)
7001	PRT/FAX	The larger the value is, the larger the reproduction ratio in the primary scanning direction becomes. (0.1%/step) Acceptable values: 128 to 255 (Default: 128)

Make a test copy and compare the image obtained with the current settings; if necessary, make adjustments according to the following procedure:

#### Notes:

- Since the reproduction ratio may vary due to expansion and contraction of the paper immediately after the image is printed out, it is recommended to measure its dimension after at least 3 minutes have passed.
- This adjustment may cause image troubles such as moire, disappearance or breaking of thin lines on the printed image. Therefore check if there is no such image trouble while you are performing the adjustment.

<Procedure>

- (1) Perform FS-05.
- (2) Key in a code and press the [START] button.
- (3) Key in the adjustment value. (To correct a value, press [CLEAR].)
- (4) Press [OK] to store the value. → The equipment goes back to the ready state.
- (5) Make a test copy and check the image copied. To check the printed image, turn off the power and then back on, and then print the image. If the image is not in the desired reproduction ratio, repeat steps (2) to (4).



## 6.2 Image Quality Adjustment (Copying Function)

### 6.2.1 Automatic gamma adjustment

When the reproduction of gradation is not appropriate, the gradation reproducibility of all colors Y, M, C and K can be corrected by performing this automatic gamma adjustment. In case the gradation reproduction of the image checked is not satisfactory, make this adjustment as described below at parts replacement.

- (1) When unpacking or any of the following parts has been replaced, be sure to make this adjustment:
  - Photoconductive drum
  - Developer material
  - LED printer head
  - LED gap spacer
  - Transfer belt
  - 1st transfer roller
  - Drum cleaning blade
  - Needle electrode
  - Main charger grid
  - Image position aligning sensor (Front)
  - Image position aligning sensor (Rear)/Image quality sensor
  - SRAM
  - EEPROM (LGC board)
  - HDD
  
- (2) When any of the following parts are replaced or adjusted, make a copy and check the image to determine if adjustment is necessary:
  - 2nd transfer roller

#### Notes:

Be sure that this adjustment be made after performing the image adjustment in  P. 6-4 "6.1.3 Performing Image Quality Control" and  P. 6-6 "6.1.5 Image Dimensional Adjustment".

#### <Procedure>

- (1) Perform FS-05. → 05 Adjustment Mode
- (2) Select the A4/LT/A3/LD drawer. Key in the pattern number and press [TEST PRINT] to output a "Patch chart for gamma adjustment".

#### <Adjustment Mode (05)>

Pattern No.	Pattern No.	Remark	Paper type
4	Color/black integrated	When performing code FS-05-7869	All paper types
200	Color/black integrated	When performing code FS-05-7871-0	Plain paper
202	Color/black integrated	When performing code FS-05-7871-1	Thick paper
204	Color/black integrated	When performing code FS-05-7871-2	Recycled paper
206	Color/black integrated	When performing code FS-05-7871-3	Thick paper 1
208	Color/black integrated	When performing code FS-05-7871-4	Thick paper 2
214	Color/black integrated	When performing code FS-05-7871-7	Special paper 1
216	Color/black integrated	When performing code FS-05-7871-8	Special paper 2

- (3) Place the patch chart for adjustment printed in step (2) face down on the original glass. Place the chart aligning its side with 2 black squares against the original scale.

- (4) Key in a code and press the [START] button.  
 → The scanner reads the chart automatically and performs automatic gamma adjustment calculation (approx.30 sec.).

<05 Adjustment Mode>

Code	Item to be adjusted	Contents
7869 (7871)	Automatic gamma adjustment	When the reproduction of gradation is not appropriate, the gradation reproducibility of all colors Y, M, C and K can be corrected by performing this automatic gamma adjustment. The result of 7869 is applied to all paper types. The result of 7871 is applied to the specified paper type.

- (5) When the adjustment has finished normally, press [OK] to have the adjustment results reflected. (To cancel the reflection of adjustment results, press [CANCEL].)  
 In the case of an abnormal ending, "ADJUSTMENT ERROR" is shown.  
 Press [CANCEL] to clear the error display. When it is cleared, the control panel display will return to the ready state. Then, check if the patch chart on the original glass is placed in the wrong direction or if it is placed inclined on the original glass, and then repeat step (3) and afterward.

**Remarks:**

To select the paper type for the automatic gamma adjustment in user calibration, change the code below to "1". (copy/print)

Code	Remarks
FS-08-9059	0: No paper selecting buttons displayed 1: Paper selecting buttons displayed. (For both Copy and Printer)

## 6.2.2 Density adjustment

Adjusts the center density.

<05 Adjustment Mode>


Color mode	Original mode							Item to be adjusted	Remarks
	Text/Photo	Text	Printed Image	Photo	Map	Custom Mode	Red Seal Color Mode		
Full color	7713	7714	7715	7716	7717	7718	7719	Manual density mode center value	The larger the value is, the darker the image becomes. Acceptable values: 0 to 255 (Default: 128)
	7720	7721	7722	7723	7724	7725	7726	Automatic density	
Twin color	7733	7734	7735	-	-	-	-	Manual density mode center value	
	7736	7737	7738	-	-	-	-	Automatic density	
Mono color	7727	7728	7729	-	-	-	-	Manual density mode center value	
	7730	7731	7732	-	-	-	-	Automatic density	

<05 Adjustment Mode>

Color mode	Original mode					Item to be adjusted	Remarks
	Text/Photo	Text	Photo	Gray scale	Custom Mode		
Black	7114	7115	7116	7138	7134	Manual density mode center value	The larger the value is, the darker the image becomes. Acceptable values: 0 to 255 (Default: 128)
	7123	7124	7125	7141	7137	Automatic density mode	

Make a test copy and compare the image obtained with the current settings; if necessary, make adjustments according to the following procedure.

### Notes:

Be sure that this adjustment is made after performing  P. 6-27 "6.2.1 Automatic gamma adjustment".

<Procedure>

- (1) Perform FS-05.
- (2) Key in a code and press the [START] button.
- (3) Key in an adjustment value.  
(To correct the value once keyed in, press [CLEAR].)
- (4) Press [OK] to store the value. → The equipment goes back to the ready state.
- (5) Press [TEST COPY] and then press the [START] button to make a test copy.
- (6) If the desired image quality has not been attained, repeat step (2) to (5).

### Notes:

To check an image of [User Custom] and [Red Seal], use the one copied in the normal startup.

### 6.2.3 Gamma balance adjustment


The density adjustment at the Black Mode is performed by selecting its density area from the following: low density, medium density and high density.

<05 Adjustment Mode>

Color mode	Original mode					Item to be adjusted	Remarks
	Text/Photo	Text	Photo	Gray scale	Custom mode		
Black	7190-0	7191-0	7192-0	7193-0	7189-0	Low density	The larger the value is, the density of the item to be adjusted becomes darker. Acceptable values: 0 to 255 (Default: 128)
	7190-1	7191-1	7192-1	7193-1	7189-1	Medium density	
	7190-2	7191-2	7192-2	7193-2	7189-2	High density	

Make a test copy and compare the image obtained with the current settings; if necessary, make adjustments according to the following procedure.

**Notes:**

Be sure that this adjustment is made after performing  P. 6-27 "6.2.1 Automatic gamma adjustment".

<Procedure>

The procedure is the same as that of  P. 6-31 "6.2.4 Color balance adjustment".

**Notes:**

To check an image of [User Custom] and [Red Seal], use the one copied in the normal startup.



## 6.2.4 Color balance adjustment


The color balance is adjusted by adjusting the density of each color at the Full Color Mode. The adjustment is performed by selecting its density area from the following: low density, medium density and high density.

<05 Adjustment Mode>

Color	Original mode							Item to be adjusted	Remarks
	Text/Photo	Text	Printed Image	Photo	Map	Custom mode	Red Seal Color		
Yellow	7960-0	7961-0	7962-0	7963-0	7964-0	7980-0	7984-0	Low density	The larger the value is, the darker the color to be adjusted becomes. Acceptable values: 0 to 255 (Default: 128)
	7960-1	7961-1	7962-1	7963-1	7964-1	7980-1	7984-1	Medium density	
	7960-2	7961-2	7962-2	7963-2	7964-2	7980-2	7984-2	High density	
Magenta	7965-0	7966-0	7967-0	7968-0	7969-0	7981-0	7985-0	Low density	
	7965-1	7966-1	7967-1	7968-1	7969-1	7981-1	7985-1	Medium density	
	7965-2	7966-2	7967-2	7968-2	7969-2	7981-2	7985-2	High density	
Cyan	7970-0	7971-0	7972-0	7973-0	7974-0	7982-0	7986-0	Low density	
	7970-1	7971-1	7972-1	7973-1	7974-1	7982-1	7986-1	Medium density	
	7970-2	7971-2	7972-2	7973-2	7974-2	7982-2	7986-2	High density	
Black	7975-0	7976-0	7977-0	7978-0	7979-0	7983-0	7987-0	Low density	
	7975-1	7976-1	7977-1	7978-1	7979-1	7983-1	7987-1	Medium density	
	7975-2	7976-2	7977-2	7978-2	7979-2	7983-2	7987-2	High density	

Make a test copy and compare the image obtained with the current settings; if necessary, make adjustments according to the following procedure.

### Notes:

Be sure that this adjustment is made after performing  P. 6-27 "6.2.1 Automatic gamma adjustment".

Changing the adjustment setting influences the adjacent density area slightly.

E.g.: When the value of the medium density is larger, the adjacent areas in the low density and high density range will become slightly darker.

<Procedure>

- (1) Perform FS-05.
- (2) Key in the code of the mode to be adjusted (color and original mode) and press the [START] button.
- (3) Select the density area to be adjusted with digital keys (0, 1 or 2), and press the [START] button.  
0: Low density  
1: Medium density  
2: High density
- (4) Key in an adjustment value. (To correct the value once keyed in, press [CLEAR].)

- (5) Press [OK] to store the value in memory.  
→ The equipment goes back to the ready state.
- (6) For resetting the value, repeat step (2) to (5).
- (7) Press [TEST COPY] and then press the [START] button to make a test copy.
- (8) If the desired image quality has not been attained, repeat step (2) to (7).

**Notes:**

To check an image of [User Custom] and [Red Seal], use the one copied in the normal startup.  
<Range of the density area (low density, medium density, high density)>

The color from 10 to 30 (low density), from 40 to 70 (medium density) and from 80 to 100 (high density) in No. TCC-1/TCC-2 chart can be used as a guide for the range of the density area influenced by the change of the adjustment value (low density, medium density, high density).



Fig.6-22

## 6.2.5 Background adjustment

The density of the background can be adjusted as follows.

<05 Adjustment Mode>

Color mode	Original mode								Remarks
	Text/Photo	Text	Printed Image	Photo	Map	Custom mode	Gray scale	Red Seal Color Mode	
Full color	7656	7657	7658	7659	7660	7661	---	7662	The larger the value is, the darker the background becomes. Acceptable values: 0 to 255 (Default: 128)
Mono color	7707	7708	7709	---	---	---	---	---	
Twin color	7710	7711	7712	---	---	---	---	---	
Black (Auto/Manual)	7100	7101	---	7102	---	7106	7105	---	
Black (Manual)	7086	---	---	---	---	---	---	---	

Make a test copy and compare the image obtained with the current settings; if necessary, make adjustment using the following procedure.

<Procedure>

The procedure is the same as that of  P. 6-29 "6.2.2 Density adjustment".

### Notes:

To check an image of [User Custom] and [Red Seal], use the one copied in the normal startup.

## 6.2.6 Judgment threshold for ACS (common for copy and scan)

Judgment levels for automatically identifying whether an original is color or black are adjusted. This adjustment is for judgment levels when "Auto Color" is selected as a color mode. The same adjustment value is simultaneously applied to all cases of originals on the original glass for copier functions and network scanning functions, and those placed on the DF.

<05 Adjustment Mode>

Code	Item to be adjusted	Contents
7630	Judgment threshold for ACS	The larger the value is, the more an original tends to be judged as black even at the Auto Color Mode. The smaller value is, the more it tends to be judged as color. Acceptable values: 0 to 255 (Default: 70)

Make a test copy and compare the image obtained with the current settings; if necessary and make adjustment.

<Procedure>

The procedure is the same as that of  P. 6-29 "6.2.2 Density adjustment".

## 6.2.7 Sharpness adjustment

If you want to make copy images look softer or sharper, perform the following adjustment. The adjustment can be made for each of the color modes and original modes independently.

<05 Adjustment Mode>

Code	Color mode	Original mode	Contents
7796	Full Color	Text/Photo	The larger the value is, the sharper the image becomes; while the smaller the value is, the softer the image becomes. The smaller the value is, the less moire tends to appear. Acceptable values: 0 to 255 (Default: 128)
7797		Text	
7798		Printed Image	
7799		Photo	
7800		Map	
7795		Custom mode	
7794		Red Seal Color Mode	
7801	Mono color	Text/Photo	
7802		Text	
7803		Printed Image	
7804	Twin color	Text/Photo	
7805		Text	
7806		Printed Image	
7056	Black	Text/Photo	
7057		Text	
7058		Photo	
7249		Custom mode	
7061		Gray scale	

Make a test copy and compare the image obtained with the current settings; if necessary, make adjustment.

**Notes:**

You have to make adjustment by balancing between moire and sharpness.

<Procedure>

The procedure is the same as that of  P. 6-29 "6.2.2 Density adjustment".

**Notes:**

To check an image of [User Custom], use the one copied in the normal startup.

## 6.2.8 Setting range correction

The values of the background peak/text peak in the range correction at the Black Mode can be switched to "varied" or "fixed" in the following codes.

If they are fixed, the range correction is performed with standard values.

The values of the background peak affects the reproduction of the background density, and the values of the text peak affects that of the text density.

<05 Adjustment Mode>

Original mode	Original mode			Item to be adjusted	Remarks
	Text/Photo	Text	User Custom		
Black	7286	7287	7237	Manual density mode	0: Background peak / fixed 1: Background peak / varied

Make a test copy and compare the image obtained with the current settings; if necessary, make adjustment.

<Procedure>

The procedure is the same as that of  P. 6-29 "6.2.2 Density adjustment".

**Notes:**

To check an image of [User Custom], use the one copied in the normal startup.

## 6.2.9 Adjustment of smudged/faint text

The smudge/faint text at a Black Mode can be set at the following codes.

<05 Adjustment Mode>

Color mode	Original mode			Item to be adjusted	Remarks
	Text/Photo	Text	Custom mode		
Black	7097	7098	7252	Adjustment of smudged/ faint text	When the value decreases, the faint text is improved. When the value increases, the smudged text is improved. Acceptable values: 0 to 4 (Default: 2)

Make a test copy and compare the image obtained with the current settings; if necessary, make adjustment.

**Notes:**

Remember the image specifications and life span of the replacing parts may not meet the standard when the setting value is changed from the default value.

<Procedure>

The procedure is the same as that of  P. 6-29 "6.2.2 Density adjustment".

**Notes:**

To check an image of [User Custom], use the one copied in the normal startup.

## 6.2.10 Color Adjustment of Marker

The color of the one touch adjustment “MARKER” can be adjusted so that any marker colors already on the original can be distinguished.

<05 Adjustment Mode>

Code	Item to be adjusted	Relation between the adjustment value and the color (Acceptable values: 0 to 6)		
		0 to 2	3 (Default)	4 to 6
7850-0	Yellow	The smaller the value is, the more reddish the color becomes.	Yellow	The larger the value is, the more greenish the color becomes.
7850-1	Magenta	The smaller the value is, the more bluish the color becomes.	Magenta	The larger the value is, the more reddish the color becomes.
7850-2	Cyan	The smaller the value is, the more greenish the color becomes.	Cyan	The larger the value is, the more bluish the color becomes.
7850-3	Red	The smaller the value is, the closer to Magenta the color becomes.	Red	The larger the value is, the more yellowish the color becomes.
7850-4	Green	The smaller the value is, the more yellowish the color becomes.	Green	The larger the value is, the closer to Cyan the color becomes.
7850-5	Blue	The smaller the value is, the closer to Cyan the color becomes.	Blue	The larger the value is, the closer to Magenta the color becomes.

### Notes:

The color may not always be reproduced precisely due to the characteristics of the fluorescent ink.

<Procedure>

- (1) Perform FS-05.
- (2) Key in a code and press the [START] button.
- (3) Key in a sub-code and press the [START] button.
- (4) Key in an adjustment value.  
(To correct a value once keyed in, press [CLEAR].)
- (5) Press [OK] to store the value. → The equipment goes back to the ready state.
- (6) Turn the power OFF and back ON in the normal mode. Then make a copy in the one touch adjustment “MARKER” mode.
- (7) If the desired image quality has not been attained, repeat step (1) to (6).

## 6.2.11 Emission level adjustment

The emission level in the black mode can be adjusted as follows. This adjustment adjusts the dot size.

<05 Adjustment Mode>

Text/ Photo	Text	Item to be adjusted	Remarks
7218-0	7219-0	Emission level 0/4	The smaller the value is, the smaller the emission level becomes. Therefore, the smaller dot is reproduced accordingly. Acceptable values: 0 to 255 (Default: Level 0/4: 0, Level 1/4: 63, Level 2/4: 127, Level 3/4: 191, Level 4/4: 255)
7218-1	7219-1	Emission level 1/4	
7218-2	7219-2	Emission level 2/4	
7218-3	7219-3	Emission level 3/4	
7218-4	7219-4	Emission level 4/4	

Make a test copy and compare the image obtained with the current settings; if necessary, make adjustments according to the following procedure.

<Procedure>

- (1) Perform FS-05.
- (2) Key in a code and press the [START] button.
- (3) Key in a sub-code and press the [START] button.
- (4) Key in an adjustment value.  
(To correct a value once keyed in, press [CLEAR].)
- (5) Press [OK] to store the value. → The equipment goes back to the ready state.
- (6) Press [TEST COPY] and then press the [START] button to make a test copy.
- (7) If the desired image quality has not been attained, repeat step (2) to (6).

### Notes:

- Change the setting value increment of 8 as a guide.
- Be sure to confirm the image when the setting value is changed.
- The setting value must increase as the emission level number (0 to 4) becomes higher. Do not increase this order when setting the values.
- Usually, emission level 4 / 4 is most effective in the black mode.

## 6.2.12 Maximum toner density adjustment to paper type

The maximum toner adhesion amount can be adjusted for each paper type. It is used when offsetting occurs.

<05 Adjustment Mode>

Code	Paper type	Remarks
7913-0	Plain paper	The smaller the value is, the toner amount adhered decreases of the high density area (ex. prevention of fusing offsetting, jam in the fuser unit, etc.). Acceptable values: 0 to 255 <Default value> 128
7913-1	Thick paper	
7913-2	Recycled paper	
7913-3	Thick paper 1	
7913-4	Thick paper 2	
7913-7	Special paper 1	
7913-8	Special paper 2	
7913-11	Envelop	
7913-12	OHP film	

### Notes:

Even if a large value is set, the image does not drastically appear dark (the amount of toner adhering is not increased).

<Procedure>

The procedure is the same as that of  P. 6-29 "6.2.2 Density adjustment".

## 6.2.13 Maximum text density adjustment


The maximum text density in each color in the full color mode (Text/Photo, Text, Map mode) can be adjusted.

<05 Adjustment Mode>

Color	Code	Item to be adjusted	Remarks
Yellow	7889	Maximum text density	The larger the value is, the darker the maximum text density of each color to be adjusted becomes. Acceptable values: 0 to 10 (Default: 5)
Magenta	7890		
Cyan	7891		
Black	7892		

Make a test copy and compare the image obtained with the current settings; if necessary, make adjustments according to the following procedure.

### Notes:

Be sure that this adjustment is made after performing  P. 6-27 "6.2.1 Automatic gamma adjustment".

<Procedure>

The procedure is the same as that of  P. 6-29 "6.2.2 Density adjustment".



## 6.2.14 Text/Photo reproduction level adjustment

Text/Photo reproduction level at the Full color mode and Auto color mode can be adjusted. Text/Photo reproduction level adjustment can be switched to "Photo oriented 1", "Photo oriented 2", "Text oriented 1" or "Text oriented 2" in the following codes.

<05 Adjustment Mode>

Mode			Item to be adjusted	Contents
Text/Photo	Custom mode (Text/Photo base)	Red Seal Color Mode		
7840	7841	7842	Text/Photo reproduction level adjustment	0, 5: Default The smaller the value, the higher the printed image reproduction level becomes (Photo oriented). The larger the value, the higher the text reproduction level becomes (Text oriented).

### Notes:

- The text reproduction level is lower when the mode is switched from the default value to the Photo oriented.
- When you change the setting from the default value to Text oriented, noise occurs in a printed photo with a few lines.
- The codes for the user custom setting are enabled only when the base original mode of the user custom mode is Text/Photo.

<Procedure>

The procedure is the same as that of  P. 6-29 "6.2.2 Density adjustment".

### Notes:

To check an image of [User Custom] and [Red Seal], use the one copied in the normal startup.

## 6.2.15 Black header density level adjustment

The density level of headers in the black mode is adjusted.

<05 Adjustment Mode>

Mode	Code	Original mode	Remarks
Full Color	7811	Text/Photo	The larger the value is, the darker the black headers become but the dark areas in a photo become easily smudged.
	7812	Text	
	7816	Custom mode	The smaller the value is, the lighter the black headers become but the dark areas in a photo do not smudge easily. Acceptable values: 0 to 8 (Default: 0) If the value is set to "0", the settings will become to the equivalent ones to the following setting values.
	7817	Red Seal Color Mode	

Make a test copy and compare the image obtained with the current settings; if necessary, make adjustment.

<Procedure>

The procedure is the same as that of  P. 6-29 "6.2.2 Density adjustment".

**Notes:**

To check an image of [User Custom] and [Red Seal], use the one copied in the normal startup.

## 6.2.16 Black area adjustment in twin color copy mode

<05 Adjustment Mode>

Mode	Code	Item to be adjusted	Remarks
Twin color mode with selected colors	7641-0	High density	The larger the value is, the larger the area recognized as black in the original becomes. The smaller the value is, the larger the area recognized as the color other than black becomes. Acceptable values: 0 to 255 (Default: 128)
	7641-1	Medium density	
	7641-2	Low density	
Twin color mode (Black and red)	7642-0	High density	The larger the value is, the larger the black area becomes. The smaller the value is, the larger the red area becomes. Acceptable values: 0 to 255 (Default: 128)
	7642-1	Medium density	
	7642-2	Low density	

<Procedure>

The procedure is the same as that of  P. 6-31 "6.2.4 Color balance adjustment".

## 6.2.17 Judgment threshold adjustment for blank originals (common for copy and scan)

The judgment level is adjusted for automatic identification of whether the original set is blank or not.

This adjustment is made when "OMIT BLANK PAGE" is selected on the control panel.

The adjustment value is simultaneously applied to all modes at PPC and scanning.

<05 Adjustment Mode>

Code	Item to be adjusted	Remarks
7618	Judgment threshold adjustment for blank original	The larger the value is, the more an original tends to be judged as a blank sheet. Acceptable values: 0 to 255 (Default: 128)

<Procedure>

The procedure is the same as that of  P. 6-29 "6.2.2 Density adjustment".

## 6.2.18 Background offsetting adjustment for DF (common for copy, scan and fax)

The background level for scanning originals with the DF is adjusted when the background fogging at the scanning of a manually-set original and an original used with the DF is different. This is to adjust the level of the background image removed when the scanning of the originals with the DF is performed.

<05 Adjustment Mode>

Color mode	Code	Remarks
Color	7026	The larger the value is, the darker the background density becomes. Acceptable values: 0 to 255 (Default: 128)
Black	7025	

<Procedure>

The procedure is the same as that of  P. 6-29 "6.2.2 Density adjustment".

## 6.2.19 Twin color copy / mono color copy adjustment

The density of the color specified on the touch panel is adjusted in the monochrome copy or twin color copy mode. This adjustment is reflected to both monochrome and twin color copying.

<05 Adjustment Mode>

Code	Subcode				Remarks
	Y	M	C	K	
Magenta	7644-0	7644-1	7644-2	7644-3	The larger the value is, the darker the density becomes, and the smaller the value is, the lighter the density becomes. When "255" is set, the specified solid color is used for printing. When "0" is set, nothing is printed. For example, in case of "Red", the color when "Red" is specified becomes blue if you set as follows: (Y) 7649-0=0 (M) 7649-1=128 (C) 7649-2=255 Acceptable value: 0 to 255 (Default: 128) <b>Notes:</b> <ul style="list-style-type: none"> <li>If a large value is set for all of YMCK, offsetting may occur. Make an adjustment while checking the image.</li> <li>If "0" is set for all four colors of YMCK, when a color is specified for the adjustment item, nothing is printed.</li> </ul>
Yellow	7645-0	7645-1	7645-2	7645-3	
YellowGreen	7646-0	7646-1	7646-2	7646-3	
Cyan	7647-0	7647-1	7647-2	7647-3	
Pink	7648-0	7648-1	7648-2	7648-3	
Red	7649-0	7649-1	7649-2	7649-3	
Orange	7650-0	7650-1	7650-2	7650-3	
Green	7651-0	7651-1	7651-2	7651-3	
Blue	7652-0	7652-1	7652-2	7652-3	
Purple	7653-0	7653-1	7653-2	7653-3	

<Procedure>

- (1) Perform FS-05.
- (2) Key in the code of the mode to be adjusted (color and original mode) and press the [START] button.
- (3) Select the density area to be adjusted with digital keys (0, 1, 2 or 3), and press the [START] button.  
 0: Y  
 1: M  
 2: C  
 3: K
- (4) Key in an adjustment value. (To correct the value once keyed in, press [CLEAR].)
- (5) Press [OK] to store the value in memory.  
 → The equipment goes back to the ready state.
- (6) For resetting the value, repeat step (2) to (5).
- (7) Turn ON the power of the equipment and make a copy.
- (8) If the desired image quality has not been attained, repeat step (1) to (7).

## 6.2.20 Maximum density adjustment for each paper type

The maximum density for each paper type can be adjusted collectively.

<05 Adjustment Mode>

Code	Paper type	Remarks
7902	Plain paper	The smaller the value is, the lower the density of the whole image becomes. Acceptable values: 0 to 255 (Default: Plain paper: 255, Thick paper: 255, Recycled paper: 255, Thick paper 1: 255, Thick paper 2: 255, Special paper 1: 255, Special paper 2: 255, Envelope: 255, OHP film: 240, User Media Type1 to 10: 255)
7903	Thick paper	
7904	Recycled paper	
7905	Thick paper 1	
7906	Thick paper 2	
7909	Special paper 1	
7910	Special paper 2	
7901	Envelope	
7911	OHP film	
7912-0	User Media Type1	
7912-1	User Media Type2	
7912-2	User Media Type3	
7912-3	User Media Type4	
7912-4	User Media Type5	
7912-5	User Media Type6	
7912-6	User Media Type7	
7912-7	User Media Type8	
7912-8	User Media Type9	
7912-9	User Media Type10	

### Notes:

Be aware that if too small a value is set, a faint image occurs.

<Procedure>

The procedure is the same as that of  P. 6-29 "6.2.2 Density adjustment".



## 6.2.21 Color reproduction selection

When the custom mode is selected, the color reproduction can be adjusted as follows.

<05 Adjustment Mode>

Code	Original mode	Remarks
7690	Custom mode	0: Same as Text/Photo, printed image, text, map mode 1: Same as Photo mode 2: Same as Red seal color mode 3: The gray level becomes a more bluish one than the one specified in the setting value "0". 4: The highlight reproduction becomes more emphasized than the one specified in the setting value"0". (Default value: 0)

### Notes:

- Be sure that this adjustment is made after performing  P. 6-27 "6.2.1 Automatic gamma adjustment".
- When fine adjustment of the highlight is carried out while the setting value "4" is selected, perform  P. 6-33 "6.2.5 Background adjustment".

<Procedure>

- (1) Perform FS-05.
- (2) Key in a code and press the [START] button.
- (3) Key in an adjustment value.  
(To correct a value once keyed in, press [CLEAR].)
- (4) Press [OK] to store the value. → The equipment goes back to the ready state.
- (5) Start up the equipment in the normal mode and make a copy.
- (6) If the desired image quality has not been attained, repeat step (2) to (5).

## 6.2.22 Hue adjustment

The hue in the full color mode can be adjusted as follows.


<05 Adjustment Mode>

Code	Original mode	Item to be adjusted	Description	Remarks
7665-0	Text/Photo	Red	The larger the value, the darker the yellow becomes. The smaller the value, the darker the magenta becomes.	Acceptable value: 0 to 255 Default value: 128
7665-1	Text/Photo	Yellow	The larger the value, the darker the green becomes. The smaller the value, the darker the red becomes.	
7665-2	Text/Photo	Green	The larger the value, the darker the cyan becomes. The smaller the value, the darker the yellow becomes.	
7665-3	Text/Photo	Cyan	The larger the value, the darker the blue becomes. The smaller the value, the darker the green becomes.	
7665-4	Text/Photo	Blue	The larger the value, the darker the magenta becomes. The smaller the value, the darker the cyan becomes.	
7665-5	Text/Photo	Magenta	The larger the value, the darker the red becomes. The smaller the value, the darker the blue becomes.	
7666-0	Text	Red	The larger the value, the darker the yellow becomes. The smaller the value, the darker the magenta becomes.	
7666-1	Text	Yellow	The larger the value, the darker the green becomes. The smaller the value, the darker the red becomes.	
7666-2	Text	Green	The larger the value, the darker the cyan becomes. The smaller the value, the darker the yellow becomes.	
7666-3	Text	Cyan	The larger the value, the darker the blue becomes. The smaller the value, the darker the green becomes.	
7666-4	Text	Blue	The larger the value, the darker the magenta becomes. The smaller the value, the darker the cyan becomes.	
7666-5	Text	Magenta	The larger the value, the darker the red becomes. The smaller the value, the darker the blue becomes.	
7667-0	Printed image	Red	The larger the value, the darker the yellow becomes. The smaller the value, the darker the magenta becomes.	
7667-1	Printed image	Yellow	The larger the value, the darker the green becomes. The smaller the value, the darker the red becomes.	
7667-2	Printed image	Green	The larger the value, the darker the cyan becomes. The smaller the value, the darker the yellow becomes.	
7667-3	Printed image	Cyan	The larger the value, the darker the blue becomes. The smaller the value, the darker the green becomes.	
7667-4	Printed image	Blue	The larger the value, the darker the magenta becomes. The smaller the value, the darker the cyan becomes.	
7667-5	Printed image	Magenta	The larger the value, the darker the red becomes. The smaller the value, the darker the blue becomes.	

Code	Original mode	Item to be adjusted	Description	Remarks
7668-0	Photo	Red	The larger the value, the darker the yellow becomes. The smaller the value, the darker the magenta becomes.	Acceptable value: 0 to 255 Default value: 128
7668-1	Photo	Yellow	The larger the value, the darker the green becomes. The smaller the value, the darker the red becomes.	
7668-2	Photo	Green	The larger the value, the darker the cyan becomes. The smaller the value, the darker the yellow becomes.	
7668-3	Photo	Cyan	The larger the value, the darker the blue becomes. The smaller the value, the darker the green becomes.	
7668-4	Photo	Blue	The larger the value, the darker the magenta becomes. The smaller the value, the darker the cyan becomes.	
7668-5	Photo	Magenta	The larger the value, the darker the red becomes. The smaller the value, the darker the blue becomes.	
7669-0	Map	Red	The larger the value, the darker the yellow becomes. The smaller the value, the darker the magenta becomes.	
7669-1	Map	Yellow	The larger the value, the darker the green becomes. The smaller the value, the darker the red becomes.	
7669-2	Map	Green	The larger the value, the darker the cyan becomes. The smaller the value, the darker the yellow becomes.	
7669-3	Map	Cyan	The larger the value, the darker the blue becomes. The smaller the value, the darker the green becomes.	
7669-4	Map	Blue	The larger the value, the darker the magenta becomes. The smaller the value, the darker the cyan becomes.	
7669-5	Map	Magenta	The larger the value, the darker the red becomes. The smaller the value, the darker the blue becomes.	
7670-0	Custom	Red	The larger the value, the darker the yellow becomes. The smaller the value, the darker the magenta becomes.	
7670-1	Custom	Yellow	The larger the value, the darker the green becomes. The smaller the value, the darker the red becomes.	
7670-2	Custom	Green	The larger the value, the darker the cyan becomes. The smaller the value, the darker the yellow becomes.	
7670-3	Custom	Cyan	The larger the value, the darker the blue becomes. The smaller the value, the darker the green becomes.	
7670-4	Custom	Blue	The larger the value, the darker the magenta becomes. The smaller the value, the darker the cyan becomes.	
7670-5	Custom	Magenta	The larger the value, the darker the red becomes. The smaller the value, the darker the blue becomes.	
7671-0	Red seal color	Red	The larger the value, the darker the yellow becomes. The smaller the value, the darker the magenta becomes.	
7671-1	Red seal color	Yellow	The larger the value, the darker the green becomes. The smaller the value, the darker the red becomes.	

Code	Original mode	Item to be adjusted	Description	Remarks
7671-2	Red seal color	Green	The larger the value, the darker the cyan becomes. The smaller the value, the darker the yellow becomes.	Acceptable value: 0 to 255 Default value: 128
7671-3	Red seal color	Cyan	The larger the value, the darker the blue becomes. The smaller the value, the darker the green becomes.	
7671-4	Red seal color	Blue	The larger the value, the darker the magenta becomes. The smaller the value, the darker the cyan becomes.	
7671-5	Red seal color	Magenta	The larger the value, the darker the red becomes. The smaller the value, the darker the blue becomes.	

**Notes:**

Be sure that this adjustment is made after performing  P. 6-27 "6.2.1 Automatic gamma adjustment".

<Procedure>

- (1) Perform FS-05.
- (2) Key in a code and press the [START] button. (e.g. 7665)
- (3) Key in a value to adjust the color.
  - 0: Red
  - 1: Yellow
  - 2: Green
  - 3: Cyan
  - 4: Blue
  - 5: Magenta
 (To correct a value once keyed in, press [CLEAR].)
- (4) Press [OK] to store the value. → The equipment goes back to the ready state.
- (5) Repeat step (2) to (4) to make the setting again.
- (6) Press [TEST COPY] and then press the [START] button to make a test copy.
- (7) If the desired image quality has not been attained, repeat step (2) to (6).

**Notes:**

To check an image of [User Custom] and [Red Seal], use the one copied in the normal startup.




## 6.2.23 Saturation adjustment

The saturation of the copied image in the color copying function can be adjusted as follows.

<05 Adjustment Mode>

Code	Original mode	Item to be adjusted	Description	Remarks
7675-0	Text/Photo	Red	Input the larger value to increase the saturation, and input the smaller value to decrease the saturation.	Acceptable value: 0 to 255 Default value: 128
7675-1	Text/Photo	Yellow		
7675-2	Text/Photo	Green		
7675-3	Text/Photo	Cyan		
7675-4	Text/Photo	Blue		
7675-5	Text/Photo	Magenta		
7676-0	Text	Red		
7676-1	Text	Yellow		
7676-2	Text	Green		
7676-3	Text	Cyan		
7676-4	Text	Blue		
7676-5	Text	Magenta		
7677-0	Printed image	Red		
7677-1	Printed image	Yellow		
7677-2	Printed image	Green		
7677-3	Printed image	Cyan		
7677-4	Printed image	Blue		
7677-5	Printed image	Magenta		
7678-0	Photo	Red		
7678-1	Photo	Yellow		
7678-2	Photo	Green		
7678-3	Photo	Cyan		
7678-4	Photo	Blue		
7678-5	Photo	Magenta		
7679-0	Map	Red		
7679-1	Map	Yellow		
7679-2	Map	Green		
7679-3	Map	Cyan		
7679-4	Map	Blue		
7679-5	Map	Magenta		
7680-0	Custom	Red		
7680-1	Custom	Yellow		
7680-2	Custom	Green		
7680-3	Custom	Cyan		
7680-4	Custom	Blue		
7680-5	Custom	Magenta		
7681-0	Red seal color	Red		
7681-1	Red seal color	Yellow		
7681-2	Red seal color	Green		
7681-3	Red seal color	Cyan		
7681-4	Red seal color	Blue		
7681-5	Red seal color	Magenta		

### Notes:

Be sure that this adjustment is made after performing  P. 6-27 "6.2.1 Automatic gamma adjustment".

<Procedure>

- (1) Perform FS-05.
- (2) Key in a code and press the [START] button. (e.g. 7675)
- (3) Key in a value to adjust the color.
  - 0: Red
  - 1: Yellow
  - 2: Green
  - 3: Cyan
  - 4: Blue
  - 5: Magenta(To correct a value once keyed in, press [CLEAR].)
- (4) Press [OK] to store the value. → The equipment goes back to the ready state.
- (5) Repeat step (2) to (4) to make the setting again.
- (6) Press [TEST COPY] and then press the [START] button to make a test copy.
- (7) If the desired image quality has not been attained, repeat step (2) to (6).

**Notes:**

To check an image of [User Custom] and [Red Seal], use the one copied in the normal startup.

## 6.2.24 ADF noise reduction

The noise reduction level for streaks can be adjusted with the following codes when a scan job is performed using the ADF.

<05 Adjustment Mode>

Color mode	Original mode			Item to be adjusted	Remarks
	Text/Photo	Text	Custom mode		
Black	7151	7152	7150	ADF noise reduction level setting	When the value decreases, the effect of reducing streaks (set with FS-08-7617) becomes larger. When the value increases, the effect of reducing streaks (set with FS-08-7617) becomes smaller. When "0" is set, this function is disabled. Acceptable values: 0 to 200 (Default: 100)

When [FULL COLOR] or [AUTO COLOR] is selected for the color mode, the ADF noise reduction function for streaks can be set to enable or disable with the following codes.

Color mode	Original mode			Item to be adjusted	Remarks
	Text/Photo	Text	Custom mode		
Color	7694	-	7693	ADF noise reduction	Enable/Disable setting 0: Disabled 1: Enabled (Default: 1) FS-05-7693 is available only when "1" (TEXT/PHOTO base" is set for FS-08-7614.

**Notes:**

- Remember the image specifications and life span of the replacing parts may not meet the standard when the setting value is changed from the default value.
- If too small a value is set, the text may not be printed clearly.

<Procedure>

The procedure is the same as that of  P. 6-29 "6.2.2 Density adjustment".

**Notes:**

To check an image of [User Custom], use the one copied in the normal startup.


## 6.3 Image Quality Adjustment (Printing Function)

### 6.3.1 Automatic gamma adjustment

When the reproduction of gradation is not appropriate, the gradation reproducibility of all colors Y, M, C and K can be corrected by performing this automatic gamma adjustment. In case the gradation reproduction of the image checked is not satisfactory, make this adjustment as described below at parts replacement.

1. When unpacking or any of the following parts has been replaced, be sure to make this adjustment:
  - Photoconductive drum
  - Developer material
  - LED printer head
  - LED gap spacer
  - Transfer belt
  - 1st transfer roller
  - Drum cleaning blade
  - Needle electrode
  - Main charger grid
  - Image position aligning sensor (Front)
  - Image position aligning sensor (Rear)/Image quality sensor
  - SRAM
  - EEPROM (LGC board)
  - HDD
  
2. When any of the following parts are replaced or adjusted, make a print and check the image to determine if adjustment is necessary:
  - 2nd transfer roller
  - Screen switchover (for color: FS-08-8110, for black: FS-08-7310)

**Notes:**

Be sure to perform this adjustment after performing  P. 6-4 "6.1.3 Performing Image Quality Control".

<Procedure>

- (1) Perform FS-05. → 05 Adjustment Mode
- (2) Select the A4/LT/A3/LD drawer. Key in the pattern number and press [TEST PRINT] to output a "Patch chart for adjustment".

#### 600dpi

Pattern No.	Paper type	Remarks
70	Plain paper	Used when the code 8004-0 is performed
72	Thick paper	Used when the code 8004-1 is performed
74	Recycled paper	Used when the code 8004-2 is performed
76	Thick paper 1	Used when the code 8004-3 is performed
78	Thick paper 2	Used when the code 8004-4 is performed
84	Special paper 1	Used when the code 8004-7 is performed
86	Special paper 2	Used when the code 8004-8 is performed

#### 1200dpi

Pattern No.	Paper type	Remarks
230	Plain paper	Used when the code 8005-0 is performed
232	Thick paper	Used when the code 8005-1 is performed
234	Recycled paper	Used when the code 8005-2 is performed
236	Thick paper 1	Used when the code 8005-3 is performed
238	Thick paper 2	Used when the code 8005-4 is performed
244	Special paper 1	Used when the code 8005-7 is performed
246	Special paper 2	Used when the code 8005-8 is performed

- (3) Place the patch chart for adjustment printed in step (2) face down on the original glass, with its side, on which two black squares are present, aligned against the original scale.
- (4) Key in a code and press the [START] button. → The scanner reads the chart automatically and performs automatic gamma adjustment calculation (approx. 30 sec.).

#### 600dpi

Code	Paper type	Remarks
8004-0	Plain paper	When the reproduction of gradation is not appropriate, the gradation reproducibility of all colors Y, M, C and K can be corrected by performing this automatic gamma adjustment.
8004-1	Thick paper	
8004-2	Recycled paper	
8004-3	Thick paper 1	
8004-4	Thick paper 2	
8004-7	Special paper 1	
8004-8	Special paper 2	
8008	All paper types	

\* If the code FS-05-8008 is performed, the adjustment will be applied to all paper types.

#### 1200dpi

Code	Paper type	Remarks
8005-0	Plain paper	When the reproduction of gradation is not appropriate, the gradation reproducibility of all colors Y, M, C and K can be corrected by performing this automatic gamma adjustment.
8005-1	Thick paper	
8005-2	Recycled paper	
8005-3	Thick paper 1	
8005-4	Thick paper 2	
8005-7	Special paper 1	
8005-8	Special paper 2	
8009	All paper types	

\* If the code FS-05-8009 is performed, the adjustment will be applied to all paper types.

- (5) When the adjustment has finished normally, press [OK] to have the adjustment results reflected. (To cancel the reflection of adjustment results, press [CANCEL].)  
 In the case of an abnormal ending, "ADJUSTMENT ERROR" is shown. Press [CANCEL] to clear the error display.  
 When it is cleared, the control panel display will return to the ready state. Then, check if the patch chart on the original glass is placed in the wrong direction or if it is placed inclined on the original glass, and then repeat step (3) and afterward.

To select the paper type for the automatic gamma adjustment in user calibration, change the code below to "1". (copy/print)

Code	Remarks
FS-08-9059	0: No paper selecting buttons displayed 1: Paper selecting buttons displayed. (For both Copy and Printer)

## 6.3.2 Gamma balance adjustment (Black Mode)

The gamma balance is adjusted by adjusting the density at the Black Mode. The adjustment is performed by selecting its density area from the following: low density, medium density, and high density.

When "Black" (600 dpi) is set for the color mode and "Auto" is selected for the halftone setting, the gamma balance can be adjusted in each area of Text, Graphics and Image.


<05 Adjustment Mode>

Color mode	Smooth	Detail	Smooth	Detail	Smooth	Detail	Remarks
	(PS)	(PS)	(PCL)	(PCL)	(XPS)	(XPS)	
Black (600dpi)	7315-0	7316-0	7317-0	7318-0	7319-0	7320-0	The larger the value is, the density of the item to be adjusted becomes darker. Acceptable values: 0 to 255 (Default: 128)
	7315-1	7316-1	7317-1	7318-1	7319-1	7320-1	
	7315-2	7316-2	7317-2	7318-2	7319-2	7320-2	
Black (1200dpi)	7309-0	7310-0	---	---	---	---	The larger the value is, the density of the item to be adjusted becomes darker. Acceptable values: 0 to 255 (Default: 128)
	7309-1	7310-1	---	---	---	---	
	7309-2	7310-2	---	---	---	---	

Color mode	Auto (PS)			Auto (PCL)			Remarks
	Smooth (PS)	Detail (PS)	Smooth (PCL)	Detail (PCL)	Smooth (XPS)	Detail (XPS)	
Black (600dpi)	7360-0	7361-0	7362-0	7363-0	7364-0	7365-0	The larger the value is, the density of the item to be adjusted becomes darker. Acceptable values: 0 to 255 (Default: 128)
	7360-1	7361-1	7362-1	7363-1	7364-1	7365-1	
	7360-2	7361-2	7362-2	7363-2	7364-2	7365-2	

Color mode	Auto (XPS)			Remarks
	Smooth (PS)	Detail (PS)	Smooth (PCL)	
Black (600dpi)	7366-0	7367-0	7368-0	The larger the value is, the density of the item to be adjusted becomes darker. Acceptable values: 0 to 255 (Default: 128)
	7366-1	7367-1	7368-1	
	7366-2	7367-2	7368-2	

### Notes:


- Be sure that this adjustment be made after performing  P. 6-49 "6.3.1 Automatic gamma adjustment".
- Changing the adjustment setting influences the adjacent density area slightly.  
E.g.: When the value of the medium density is larger, the adjacent areas in the low density and high density range will become slightly darker.

<Procedure>

- (1) Perform FS-05.
- (2) Key in the codes to be adjusted (language and screen) and press the [START] button.
- (3) Key in the value corresponding to the density area to be adjusted (0, 1 or 2) and press the [START] button.  
0: Low density 1: Medium density 2: High density/Highest density
- (4) Key in the adjustment value. (To correct the value once keyed in, press [CLEAR].)
- (5) Press [OK] to store the value in memory. → The equipment goes back to the ready state.
- (6) For resetting the value, repeat step (2) to (5).
- (7) Let the equipment restart and perform the printing job.

(8) If the image density has not been attained, repeat step (1) to (7)

<Range of the density area (low density, medium density, high density)>

The color from the 1st to the 7th stage (low density), from the 8th to the 11th stage (medium density) and from the 12th to the 13th stage (high density) in "Patch chart for gamma adjustment ([71] [TEST PRINT])" output as a confirmation in  P. 6-49 "6.3.1 Automatic gamma adjustment" can be used as a guide for the range of the density area (low density, medium density, high density) influenced by the change of the adjustment value.

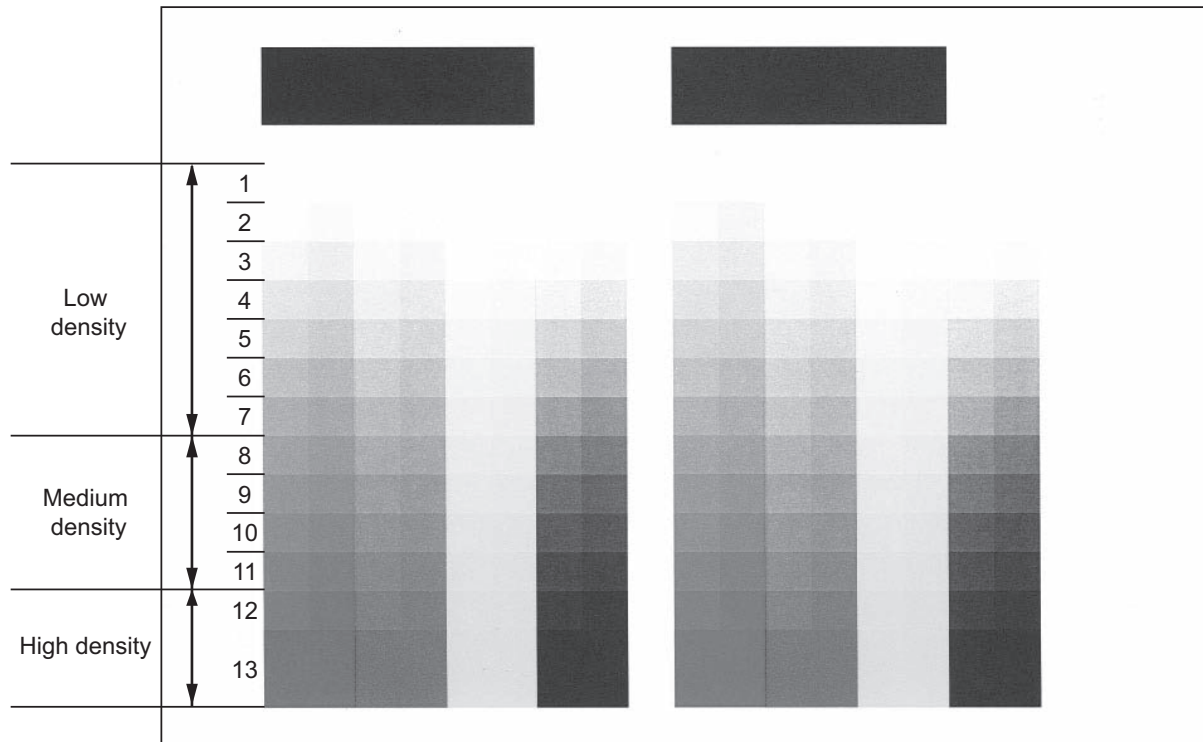


Fig.6-23

### 6.3.3 Color balance adjustment

The color balance is adjusted by adjusting the density of each color. The adjustment is performed by selecting its density area from the following: low density, medium density, and high density.

<05 Adjustment Mode>


For color printing

Color	PS		PCL		XPS		Remarks
	Smooth	Detail	Smooth	Detail	Smooth	Detail	
Yellow (600dpi)	8050-0	8054-0	8058-0	8062-0	8042-0	8046-0	The larger the value is, the darker the color to be adjusted becomes. Acceptable values: 0 to 255 (Default: 128) Sub code 0: low density Sub code 1: medium density Sub code 2: high density
	8050-1	8054-1	8058-1	8062-1	8042-1	8046-1	
	8050-2	8054-2	8058-2	8062-2	8042-2	8046-2	
Magenta (600dpi)	8051-0	8055-0	8059-0	8063-0	8043-0	8047-0	
	8051-1	8055-1	8059-1	8063-1	8043-1	8047-1	
	8051-2	8055-2	8059-2	8063-2	8043-2	8047-2	
Cyan (600dpi)	8052-0	8056-0	8060-0	8064-0	8044-0	8048-0	
	8052-1	8056-1	8060-1	8064-1	8044-1	8048-1	
	8052-2	8056-2	8060-2	8064-2	8044-2	8048-2	
Black (600dpi)	8053-0	8057-0	8061-0	8065-0	8045-0	8049-0	
	8053-1	8057-1	8061-1	8065-1	8045-1	8049-1	
	8053-2	8057-2	8061-2	8065-2	8045-2	8049-2	
Yellow (1200dpi)	8268-0	8272-0	---	---	---	---	
	8268-1	8272-1	---	---	---	---	
	8268-2	8272-2	---	---	---	---	
Magenta (1200dpi)	8269-0	8273-0	---	---	---	---	
	8269-1	8273-1	---	---	---	---	
	8269-2	8273-2	---	---	---	---	
Cyan (1200dpi)	8270-0	8274-0	---	---	---	---	
	8270-1	8274-1	---	---	---	---	
	8270-2	8274-2	---	---	---	---	
Black (1200dpi)	8271-0	8275-0	---	---	---	---	
	8271-1	8275-1	---	---	---	---	
	8271-2	8275-2	---	---	---	---	




Color specified for twin color print	Item to be adjusted				Remarks
	Black	Yellow	Magenta	Cyan	
Black	8023-0	-	-	-	The larger the value is, the darker the color to be adjusted becomes. Acceptable values: 0 to 255 (Default: 128) Sub code 0: low density Sub code 1: medium density Sub code 2: high density
	8023-1	-	-	-	
	8023-2	-	-	-	
Cyan	-	8024-0	8025-0	8026-0	
	-	8024-1	8025-1	8026-1	
	-	8024-2	8025-2	8026-2	
Magenta	-	8027-0	8028-0	8029-0	
	-	8027-1	8028-1	8029-1	
	-	8027-2	8028-2	8029-2	
Yellow	-	8030-0	8031-0	8032-0	
	-	8030-1	8031-1	8032-1	
	-	8030-2	8031-2	8032-2	
Red	-	8033-0	8034-0	8035-0	
	-	8033-1	8034-1	8035-1	
	-	8033-2	8034-2	8035-2	
Green	-	8036-0	8037-0	8038-0	
	-	8036-1	8037-1	8038-1	
	-	8036-2	8037-2	8038-2	
Blue	-	8039-0	8040-0	8041-0	
	-	8039-1	8040-1	8041-1	
	-	8039-2	8040-2	8041-2	



**Notes:**

- Be sure that this adjustment be made after performing  P. 6-49 "6.3.1 Automatic gamma adjustment".
- Changing the adjustment setting influences the adjacent density area slightly.  
E.g.: When the value of the medium density is larger, the adjacent areas in the low density and high density range will become slightly darker.

## &lt;Procedure&gt;

The procedure is the same as that of  P. 6-52 "6.3.2 Gamma balance adjustment (Black Mode)".

## &lt;Range of the density area (low density, medium density, high density)&gt;

The color from the 1st to the 7th stage (low density), from the 8th to the 11th stage (medium density), from the 12th to the 13th stage (high density) in "Patch chart for gamma adjustment ([71] [TEST PRINT])" output in  P. 6-49 "6.3.1 Automatic gamma adjustment" can be used as a guide for the range of the density area influenced by the adjustment with the printer driver and the change of the adjustment value (low density, medium density, and high density (Refer to  P. 6-53 "Fig.6-23").

### 6.3.4 Fine line/text density adjustment

The density of fine lines and small characters can be adjusted in the following codes.

<05 Adjustment Mode>

Printer Driver	General	Photographic	Presentation	Line art	Twin color	Monochrome	Remarks
PS	8130-0	8130-1	8130-2	8130-3	8133	7340	The larger the value is, the darker the density of the fine lines and small characters becomes. The smaller the value is, the lighter the density of the fine lines and small characters becomes. Acceptable values: 0 to 8 (Default: 0)
PCL	8131-0	8131-1	8131-2	8131-3	8134	7341	
XPS	8132-0	8132-1	8132-2	8132-3	8135	7342	

<Procedure>

- (1) Perform FS-05.
- (2) Key in the codes to be adjusted and press the [START] button.
- (3) Key in the adjustment value. (To correct the value once keyed in, press [CLEAR].)
- (4) Press [OK] to store the value in memory. → The equipment goes back to the ready state.
- (5) For resetting the value, repeat step (2) to (4).
- (6) Let the equipment restart and perform the printing job.
- (7) If the desired image has not been attained, repeat step (1) to (6).


### 6.3.5 Upper limit value in the Toner Saving Mode

The upper limit value of the density when "Toner save" is selected in the Custom tab of the printer driver can be adjusted.

<05 Adjustment Mode>

Color	PS	PCL	XPS	1200dpi	Remarks
Monochrome	7307-0	7307-1	7307-2	7302	The smaller the value is, the lighter the density of image becomes. Acceptable values: 0 to 255 (Default: 176)
Except monochrome	8160-0	8160-1	8160-2	8161	

<Procedure>

The procedure is the same as that of  P. 6-52 "6.3.2 Gamma balance adjustment (Black Mode)".


### 6.3.6 Maximum toner density adjustment

The maximum toner amount adhering to the OHP and the User Media Type1 to 10 can be controlled.

<05 Adjustment Mode>

Color	Code	Media Type	Remarks
Color (600dpi)	8144-0	User Media Type1	The smaller the value is, the toner amount adhered decreases of the high density area (ex. prevention of fusing offsetting, etc.). Acceptable values: 0 to 255 (Default: OHP:200, Other the OHP:255)
	8144-1	User Media Type2	
	8144-2	User Media Type3	
	8144-3	User Media Type4	
	8144-4	User Media Type5	
	8144-5	User Media Type6	
	8144-6	User Media Type7	
	8144-7	User Media Type8	
	8144-8	User Media Type9	
	8144-9	User Media Type10	
	8145	OHP	
Color (1200dpi)	8148-0	User Media Type1	
	8148-1	User Media Type2	
	8148-2	User Media Type3	
	8148-3	User Media Type4	
	8148-4	User Media Type5	
	8148-5	User Media Type6	
	8148-6	User Media Type7	
	8148-7	User Media Type8	
	8148-8	User Media Type9	
	8148-9	User Media Type10	
	8149	OHP	

<Procedure>

The procedure is the same as that of  P. 6-56 "6.3.4 Fine line/text density adjustment".

**Notes:**

The larger the value is, the more frequently fusing offsetting occurs.


### 6.3.7 Fine line enhancement switchover

The setting of the thin line enhancement is changed.

<05 Adjustment Mode>

Printer Driver	Monochrome	Full Color	Twin color	Remarks
PS	7322-0	8102-0	8101-0	Whether fine lines are enhanced or not can be switched. 0: OFF 1: ON Acceptable values: 0 to 1 (Default: 1)
PCL	7322-1	8102-1	8101-1	
XPS	7322-2	8102-2	8101-2	

<Procedure>


The procedure is the same as that of  P. 6-52 "6.3.2 Gamma balance adjustment (Black Mode)".

### 6.3.8 “PureBlack/PureGray” threshold adjustment (PCL)

<05 Adjustment Mode>

Original mode				Item to be adjusted	Remarks
General	Photographic	Presentation	Line art		
8210-0	8210-1	8210-2	8210-3	Text	The larger the value is, the wider the color range to be printed only with the black toner becomes. The smaller the value is, the narrower this color range becomes. Acceptable values: 1 to 255
8211-0	8211-1	8211-2	8211-3	Graphics	
8212-0	8212-1	8212-2	8212-3	Image	

<Procedure>


The procedure is the same as that of  P. 6-52 "6.3.2 Gamma balance adjustment (Black Mode)".

### 6.3.9 “PureBlack/PureGray” threshold adjustment (Twin color mode)

<05 Adjustment Mode>

Code	Item to be adjusted	Remarks
8213	Text	The larger the value is, the wider the color range to be printed only with the black toner becomes. The smaller the value is, the narrower this color range becomes. Acceptable values: 1 to 255
8214	Graphics	
8215	Image	

<Procedure>


The procedure is the same as that of  P. 6-56 "6.3.4 Fine line/text density adjustment".

### 6.3.10 “PureBlack/PureGray” threshold adjustment (PS)

<05 Adjustment Mode>

Original mode					Item to be adjusted	Remarks
General	Photographic	Presentation	Line art	Color profile		
8252-0	8252-1	8252-2	8252-3	8252-4	Text	The larger the value is, the wider the color range to be printed only with the black toner becomes. The smaller the value is, the narrower this color range becomes. Acceptable values: 1 to 255
8253-0	8253-1	8253-2	8253-3	8253-4	Graphics	
8254-0	8254-1	8254-2	8254-3	8254-4	Image	

<Procedure>


The procedure is the same as that of  P. 6-52 "6.3.2 Gamma balance adjustment (Black Mode)".

## 6.3.11 “PureBlack/PureGray” threshold adjustment (XPS)

<05 Adjustment Mode>

Original mode					Item to be adjusted	Remarks
General	Photographic	Presentation	Line art	Color profile		
8249-0	8249-1	8249-2	8249-3	8249-4	Text	The larger the value is, the wider the color range to be printed only with the black toner becomes. The smaller the value is, the narrower this color range becomes. Acceptable values: 1 to 255
8250-0	8250-1	8250-2	8250-3	8250-4	Graphics	
8251-0	8251-1	8251-2	8251-3	8251-4	Image	

<Procedure>

The procedure is the same as that of  P. 6-52 "6.3.2 Gamma balance adjustment (Black Mode)".


6

## 6.3.12 Toner limit threshold adjustment

<05 Adjustment Mode>

Smooth/Auto (PS/PCL/XPS)	Detail (PS/PCL/XPS)	Smooth (1200dpi)	Detail (1200dpi)	Paper type	Remarks
8071-0	8070-0	8090-0	8089-0	Plain paper	When you set a larger value, the density becomes high in some parts of the high density area since the maximum amount of toner adhering increases. When you set a smaller value, the reproduction of the gradation tends to be reduced since the maximum amount of toner adhering decreases and the maximum density becomes low. Be aware that if too large a value is set, offsetting occurs.  Acceptable values: 0 to 255 (Default: 128)
8071-1	8070-1	8090-1	8089-1	Thick paper	
8071-2	8070-2	8090-2	8089-2	Recycled paper	
8071-3	8070-3	8090-3	8089-3	Thick paper 1	
8071-4	8070-4	8090-4	8089-4	Thick paper 2	
8071-7	8070-7	8090-7	8089-7	Special paper 1	
8071-8	8070-8	8090-8	8089-8	Special paper 2	
8071-11	8070-11	8090-11	8089-11	Envelope	
8071-12	8070-12	8090-12	8089-12	OHP film	

<Procedure>

The procedure is the same as that of  P. 6-52 "6.3.2 Gamma balance adjustment (Black Mode)".

### 6.3.13 Sharpness adjustment

This adjustment is applied when images need to be softer or sharper.  
The adjustment for each original mode is available.

<05 Adjustment Mode>

Item to be adjusted	MonoChrome <sup>*1</sup>	Color					Twin color	Remarks
		General <sup>*2</sup>	Photo	Presentation	Line art <sup>*2</sup>	Red Seal Color <sup>*2</sup>		
Text	8118-0	8110-0	8111-0	8112-0	8113-0	8109-0	8108-0	The larger the value is, the sharper the image becomes. The smaller the value is, the softer the image becomes. Acceptable values: 0 to 255 (Default: 128)
Graphics	8118-1	8110-1	8111-1	8112-1	8113-1	8109-1	8108-1	
Image	8118-2	8110-2	8111-2	8112-2	8113-2	8109-2	8108-2	


\*1: Items which are adjusted when the value of FS-05-7322 is "0"  
The items which are adjusted when the value of FS-05-7322 is "1" are as below.

Item to be adjusted	Monochrome
Text/Others	8118-0
Thin text	8118-1
Image	8118-2

\*2: Items which are adjusted when the value of FS-05-8102 is "0"  
The items which are adjusted when the value of FS-05-8102 is "1" are as below.

Item to be adjusted	General	Line art	Red Seal Color
Text/Others	8110-0	8113-0	8109-0
Thin text	8110-1	8113-1	8109-1
Image	8110-2	8113-2	8109-2

<Procedure>

The procedure is the same as that of  P. 6-52 "6.3.2 Gamma balance adjustment (Black Mode)".

**Notes:**


To check an image of [Red Seal], use the one copied in the normal startup.

### 6.3.14 Thin line width lower limit adjustment

<05 Adjustment Mode>

Mode	Code	Remarks
600dpi	8240	Sets the lower limit value of the thin line width when "Distinguish Thin Lines" is selected in the screen selecting menu of the printer driver. The larger the value is, the thicker (darker) the thin line becomes. Acceptable values: 1 to 9 (Default: 2)
1200dpi	8241	

<Procedure>

The procedure is the same as that of  P. 6-56 "6.3.4 Fine line/text density adjustment".


### 6.3.15 Background adjustment

The density of background can be adjusted as follows.

<05 Adjustment Mode>

Mode	PS		PCL		XPS		1200dpi		Remarks
	Smooth	Detail	Smooth	Detail	Smooth	Detail	Smooth	Detail	
Color	8010-0	8013-0	8010-1	8013-1	8010-2	8013-2	8016	8017	The larger the value is, the darker the background becomes. The smaller the value is, the lighter the background becomes. Acceptable values: 0 to 255 (default: 128)
Twin Color	8011-0	8014-0	8011-1	8014-1	8011-2	8014-2	-	-	
Black	8012-0	8015-0	8012-1	8015-1	8012-2	8015-2	8018	8019	

<Procedure>

The procedure is the same as that of  P. 6-52 "6.3.2 Gamma balance adjustment (Black Mode)".


### 6.3.16 Color/black judgment setting for twin color printing images

The color reproduction of the image object is specified in the twin color mode.

<05 Adjustment Mode>

Code	Remarks
8218	0: Reproduced with black and the specified color 1: Reproduced with black only Acceptable values: 0 to 1 (Default: 0)

<Procedure>

The procedure is the same as that of  P. 6-56 "6.3.4 Fine line/text density adjustment".

### 6.3.17 Emission level adjustment

The emission level in the e-Filing printing (Monochrome/binary), the Network FAX and the Internet FAX can be adjusted as follows. This adjustment adjusts the dot size.

<05 Adjustment Mode>

Code	Item to be adjusted	Function	Remarks
7350-0	Emission level 0/4	Network FAX, Internet FAX	The smaller the value is, the smaller the emission level becomes. Therefore, the smaller dot is reproduced accordingly. Acceptable values: 0 to 255 (Default Level 0/4: 0, Level 1/4: 63, Level 2/4: 127, Level 3/4: 191, Level 4/4: 255)
7350-1	Emission level 1/4		
7350-2	Emission level 2/4		
7350-3	Emission level 3/4		
7350-4	Emission level 4/4		
7356-0	Emission level 0/4	e-Filing printing (Monochrome/binary)	
7356-1	Emission level 1/4		
7356-2	Emission level 2/4		
7356-3	Emission level 3/4		
7356-4	Emission level 4/4		

<Procedure>

The procedure is the same as that of  P. 6-37 "6.2.11 Emission level adjustment".

#### Notes:

- Change the setting value increment of 8 as a guide.
- Be sure to confirm the image when the setting value is changed.
- The setting value must increase as the emission level number (0 to 4) becomes higher. Do not increase this order when setting the values.
- Usually, emission level 4/4 is most effective in the black mode.
- It is not applied to the images printed in the black mode by the printer driver.



### 6.3.18 Density adjustment of graphic lines (1200 dpi)

This adjustment is available regardless of whether "Distinguish Thin Lines" of the printer driver is selected or not.

<05 Adjustment Mode>

#### Density adjustment

Color mode	Code	Remarks
Color/Black	8242-0	The density of the line in Black in the line density range specified by "FS-05-8243-0" or "FS-05-8243-1" can be adjusted.  The larger the value is, the darker the line density becomes. Acceptable value: 0 to 5 (Default: 3)
	8242-1	The density of the line in Yellow, Magenta, Cyan, and Black in the line density range specified by "FS-05-8243-2" or "FS-05-8243-3" can be adjusted.  The larger the value is, the darker the line density becomes. Acceptable value: 0 to 5 (Default: 1)


#### Effective range

Color mode	Code	Remarks
Color/Black	8243-0	The effective range (lower limit) of the density adjustment for the line in Black can be set.  Acceptable value: 0 to 255 (Default: 1)
	8243-1	The effective range (upper limit) of the density adjustment for the line in Black can be set.  Acceptable value: 0 to 255 (Default: 200)
	8243-2	The effective range (lower limit) of the density adjustment for the line in Yellow, Magenta, Cyan, and Black can be set.  Acceptable value: 0 to 255 (Default: 1)
	8243-3	The effective range (upper limit) of the density adjustment for the line in Yellow, Magenta, Cyan, and Black can be set.  Acceptable value: 0 to 255 (Default: 255)

#### Notes:

Be sure to set the values of the upper and lower limit properly so that they are not set in reverse.  
The line density adjustment codes with black (8242-0, 8243-0 and 8243-1) are in common for both the color and black modes.

<Procedure>

The procedure is the same as that of  P. 6-52 "6.3.2 Gamma balance adjustment (Black Mode)".


### 6.3.19 Gradation switching for black mode printing text

The gradation level of the TEXT object in black mode printing can be switched.

<05 Adjustment Mode>

Mode	PS	PCL	XPS	Remarks
Monochrome (600dpi)	7386-0	7386-1	7386-2	0: Text reproduction priority (Text with medium density will be reproduced darker.)
Monochrome (1200dpi)	7387	-	-	1: Gradation reproduction priority (Text with medium density will be reproduced lighter.) Acceptable values: 0 to 1 (Default: 0)

<Procedure>

The procedure is the same as that of  P. 6-56 "6.3.4 Fine line/text density adjustment".


### 6.3.20 Color reproduction switching (Twin color printing)

The color reproduction level in twin color printing can be switched.

<05 Adjustment Mode>

Code	Item to be adjusted	Remarks
8002	Color reproduction switching (Twin color printing)	0: Gradation priority Printing is performed in a natural gradation. This setting is suitable for printing an original such as a leaflet including photos. 1: Text reproduction priority Colored lines and text are printed in a clear shape. This setting is suitable for printing an original such as a form. Acceptable values: 0 to 1 (Default: 0)

<Procedure>

The procedure is the same as that of  P. 6-56 "6.3.4 Fine line/text density adjustment".

### 6.3.21 Auto Trapping adjustment

White voids in the background caused by an off registration of text or graphics can be reduced.


<05 Adjustment Mode>

Code	Item to be adjusted	Remarks
8244-0	Number of pixels to perform trapping (dot)	When a larger value is set, it will get stronger against a wider gap (off registration); however, overlapped areas will become more conspicuous. Acceptable values: 1 to 3 (Default: 2)
8244-1	Color brightness of trapped areas (%)	The smaller the value is, the darker the color becomes. In this case, gaps will not become conspicuous; however, overlapped areas will become more conspicuous. Acceptable values: 0 to 255 (Default: 128)
8245	Enable/disable switching of trapping process at direct printing	Acceptable values: 0 to 1 (Default: 0)

#### Notes:

- This is available only in full color printing.
- The settings of 05-8244 are reflected when AutoTrapping is enabled in a printer driver.
- The settings of 05-8244 are common for PCL, PS and XPS (excluding 1200dpi printing at PS).
- Direct printing: Printing process which does not use (pass through) a printer driver.

<Procedure>

The procedure is the same as that of  P. 6-52 "6.3.2 Gamma balance adjustment (Black Mode)".


### 6.3.22 Adjustment of smudged text in black (600dpi)

Smudged text in black can be adjusted.

<05 Adjustment Mode>

Mode	PS	PCL	XPS	Remarks
Color	8121	8122	8123	When a larger value is set, black text becomes thinner. When a smaller value is set, it becomes thicker. Acceptable values: 0 to 9 (Default: 5)
Twin Color	8124	8125	8126	
Monochrome	7325	7326	7327	

<Procedure>

The procedure is the same as that of  P. 6-56 "6.3.4 Fine line/text density adjustment".

## 6.4 Image Quality Adjustment (Scanning Function)

### 6.4.1 Gamma balance adjustment

The gamma balance at the Black Mode is adjusted by adjusting the density. The adjustment is performed by selecting its density area from the following: low density, medium density and high density.

<05 Adjustment Mode>

Black			Gray Scale	Item to be adjusted	Remarks
Original mode					
Text/Photo	Photo	Custom mode			
7485-0	7487-0	7480-0	7488-0	Low density	The larger the value is, the density of the item to be adjusted becomes darker. Acceptable values: 0 to 255 (Default: 128)
7485-1	7487-1	7480-1	7488-1	Medium density	
7485-2	7487-2	7480-2	7488-2	High density	

<Procedure>

- (1) Perform FS-05.
- (2) Key in the code corresponding to the desired original mode and press the [START] button.
- (3) Key in the value corresponding to the density area to be adjusted (0, 1 or 2) and press the [START] button.  
0: Low density (L), 1: Medium density (M), 2: High density (H)
- (4) Key in the adjustment value. (To correct the value once keyed in, press [CLEAR].)
- (5) Press [OK] to store the value in memory.  
→ The equipment goes back to the ready state.
- (6) For resetting the value, repeat step (2) to (5).
- (7) Let the equipment restart and perform the scanning job.
- (8) If the desired image has not been attained, repeat step (1) to (7).

### 6.4.2 RGB Color balance adjustment

The color balance of the images scanned in the color mode can be adjusted.

<05 Adjustment Mode>

Original mode	Item to be adjusted			Remarks
	Red	Green	Blue	
Text/Photo	8425-0	8425-1	8425-2	When a larger value is set, red becomes darker. When a smaller value is set, it becomes lighter. Acceptable values: 0 to 255 (Default: 128)
Text	8426-0	8426-1	8426-2	
Photo	8427-0	8427-1	8427-2	
Custom	8428-0	8428-1	8428-2	

<Procedure>

- (1) Perform FS-05.
- (2) Key in the code corresponding to the desired original mode and press the [START] button.
- (3) Key in the value corresponding to the sub code to be adjusted (0, 1 or 2) and press the [START] button.  
0: Red, 1: Green, 2: Blue
- (4) Key in the adjustment value. (Acceptable values: 0 to 255)  
(To correct the value once keyed in, press [CLEAR].)
- (5) Press [OK] to store the value in a memory.  
→ The equipment goes back to the ready state.
- (6) Turn the power ON again. Scan an original and check the images.

(7) If the desired image has not been attained, repeat step (1) to (6).

### 6.4.3 Density adjustment

Adjusts the center density.

<05 Adjustment Mode>

Color Mode	Original mode				Item to be adjusted	Remarks
	Text/Photo	Text	Photo	Custom mode		
Color	8339	8340	8341	8380	Manual density center value/ Automatic density	The larger the value is, the darker the image becomes. Acceptable values: 0 to 255 (Default: 128)

<05 Adjustment Mode>

Mode	Original mode				Gray Scale	Item to be adjusted	Remarks
	Text/Photo	Text	Photo	Custom mode			
Black	7444	7445	7446	7475	7447	Manual density center value	The larger the value is, the darker the image becomes. Acceptable values: 0 to 255 (Default: 128)
	7456	7457	7458	7478	7459	Automatic density	

<Procedure>

- (1) Perform FS-05.
- (2) Key in a code and press the [START] button.
- (3) Key in an adjustment value (acceptable values: 0 to 255).  
(To correct a value once keyed in, press [CLEAR].)
- (4) Press [OK] to store the value in memory.  
→ The equipment goes back to the ready state.
- (5) Let the equipment restart and perform the scanning.
- (6) If the desired image quality has not been attained, repeat step (1) to (5).

## 6.4.4 Background adjustment (Color)

The adjustment level of background center value is adjusted.

<05 Adjustment Mode>

Code	Original mode	Remarks
8309	Text/Photo	The smaller the value is, the background becomes lighter. Acceptable values: 0 to 255 (Default: 128)
8310	Text	
8311	Photo	
8370	Custom mode	

<Procedure>

- (1) Perform FS-05.
- (2) Key in the codes and press the [START] button.
- (3) Key in the adjustment values. Acceptable values: 0 to 255. (To correct the value once keyed in, press [CLEAR].)
- (4) Press [OK] to store the value in memory. → The equipment goes back to the ready state.
- (5) Let the equipment restart and perform the scanning job.
- (6) If the desired image has not been attained, repeat step (1) to (5).

## 6.4.5 Background adjustment (Black/Grayscale)

The density of background can be adjusted as follows.

<05 Adjustment Mode>

Code	Color mode	Original mode	Remarks
7436	Black	Text/Photo	The smaller the value is, the background becomes lighter. Acceptable values: 0 to 255 (Default: 128)
7437		Text	
7438		Photo	
7441		Custom mode	
7439	Grayscale	-	

<Procedure>

The procedure is the same as that of  P. 6-67 "6.4.3 Density adjustment".

## 6.4.6 Judgment for ACS adjustment (common for copy and network scan)

The judgment level is adjusted for the automatic identification of whether the original set on the glass is black or color. Namely, this is to adjust the judgment level used when "Auto Color" is selected at color modes. The same adjustment value is simultaneously applied to all cases of originals on the original glass for copier functions and network scanning functions, and those placed on the DF.

<05 Adjustment Mode>

Code	Item to be adjusted	Contents
7630	Judgment for ACS adjustment	The larger the value is, the more an original tends to be judged as black even at the Auto Color Mode. The smaller the value is, the more it tends to be judged as color. Acceptable values: 0 to 255 (Default: 70)

<Procedure>:

The procedure is the same as that of  P. 6-67 "6.4.3 Density adjustment".

## 6.4.7 Sharpness adjustment

If you want to make scan images look softer or sharper, perform the following adjustment. The adjustment can be made for each of the color modes and original modes independently.

<05 Adjustment Mode>

Code	Color mode	Original mode	Contents
8354	Full Color	Text/Photo	The larger the value is, the sharper the image becomes; while the smaller the value is, the softer the image becomes. The smaller the value is, the less moire tends to appear.
8335		Text	
8336		Photo	
8375		Custom mode	
7430	Black	Text/Photo	The acceptable values are 0 to 255. The center value is 128.
7431		Text	
7432		Photo	
7470		Custom mode	
7433	Gray Scale	-	

### Notes:

You have to make adjustment by balancing between moire and sharpness.

<Procedure>

The procedure is the same as that of  P. 6-67 "6.4.3 Density adjustment".

## 6.4.8 Contrast adjustment

The contrast of the images scanned in the color mode can be adjusted.

<05 Adjustment Mode>

Original mode	Code	Remarks
Text/Photo	8419	When a larger value is set, the contrast becomes higher. When a smaller value is set, it becomes lower. Acceptable values: 0 to 255 (Default: 128)
Text	8420	
Photo	8421	
Custom	8422	

<Procedure>

- (1) Perform FS-05.
- (2) Key in the code corresponding to the desired original mode and press the [START] button.
- (3) Key in the adjustment value. (Acceptable values: 0 to 255)  
(To correct the value once keyed in, press [CLEAR].)
- (4) Press [OK] to store the value in a memory.  
→ The equipment goes back to the ready state.
- (5) Turn the power ON again. Scan an original and check the images.
- (6) If the desired image has not been attained, repeat step (1) to (5).

## 6.4.9 Fine adjustment of black density

The density of black side on scanned image is adjusted at color-scanning.

<05 Adjustment Mode>

Code	Original mode	Remarks
8314	Text/Photo	The larger the value is, the black side of the image becomes darker. Acceptable values: 0 to 4 (Default: 1)
8315	Text	The larger the value is, the black side of the image becomes darker. Acceptable values: 0 to 4 (Default: 0)
8316	Photo	
8371	Custom mode	

### Notes:

Be careful for the value not to be too large since the gradation is reproduced worse in darker side.

<Procedure>

- (1) Perform FS-05.
- (2) Key in the codes and press the [START] button.
- (3) Key in the adjustment values. Acceptable values: 0 to 4. (To correct the value once keyed in, press [CLEAR].)
- (4) Press [OK] to store the value in memory. → The equipment goes back to the ready state.
- (5) Let the equipment restart and perform the scanning job.
- (6) If the desired image has not been attained, repeat step (1) to (5).

## 6.4.10 RGB conversion method selection

The color space conversion method of image is decided at color-scanning.

<05 Adjustment Mode>

Code	Original mode	Remarks
8319	Text/Photo	0: sRGB, 1: AppleRGB, 2: ROMMRGB, 3: AdobeRGB (Default: 0)
8320	Text	
8321	Photo	
8372	Custom mode	

<Procedure>

- (1) Perform FS-05.
- (2) Key in the codes and press the [START] button.
- (3) Key in the adjustment values. Acceptable values: 0 to 3. (To correct the value once keyed in, press [CLEAR].)
- (4) Press [OK] to store the value in memory. → The equipment goes back to the ready state.
- (5) Let the equipment restart and perform the scanning job.
- (6) If the desired image has not been attained, repeat step (1) to (5).



## 6.4.11 Adjustment of saturation

The saturation of the scanned image is adjusted for color-scanning.

<05 Adjustment Mode>

Code	Original mode	Remarks
8324	Text/Photo	The larger the value is, the brighter the image becomes. The smaller the value is, the duller the image becomes. Acceptable values: 0 to 255 (Default: 128)
8325	Text	
8326	Photo	
8373	Custom mode	

<Procedure>

- (1) Perform FS-05.
- (2) Key in the codes and press the [START] button.
- (3) Key in the adjustment values. Acceptable values: 0 to 255.  
(To correct the value once keyed in, press [CLEAR].)
- (4) Press [OK] to store the value in the memory. → The equipment goes back to the ready state.
- (5) Let the equipment restart and perform the scanning job.
- (6) If the desired image has not been attained, repeat step (1) to (5).

## 6.4.12 Background offsetting adjustment for DF (common for copy, scan and fax)

The background level for scanning originals with the DF is adjusted when the background fogging at the scanning of a manually-set original and an original used with the DF is different. This is to adjust the level of the background image removed when the scanning of the originals with the DF is performed.

<05 Adjustment Mode>

Color mode	Code	Remarks
Color	7026	The larger the value is, the darker the background density becomes. Acceptable values: 0 to 255 (Default: 128)
Black	7025	

<Procedure>

The procedure is the same as that of  P. 6-67 "6.4.3 Density adjustment".

### 6.4.13 Adjustment of the capacity and image quality of SlimPDF

The compression quality or the resolution is adjusted to reduce the file capacity of a SlimPDF or improve its quality.

<05 Adjustment Mode>

Code	Item to be adjusted	Remarks
9104	Compression quality of SlimPDF background processing	The smaller the value, the less the file capacity and the lower the image quality becomes. The larger the value, the greater the file capacity and the higher the image quality becomes. Acceptable values: 0 to 10 (Default: 5)
9107	Resolution of SlimPDF background processing	The smaller the value, the less the file capacity and the lower the image quality becomes. The larger the value, the greater the file capacity and the higher the image quality becomes. 0: 75dpi 1: 100dpi 2: 150dpi 3: 200dpi Acceptable values: 0 to 3 (Default: 1)

<Procedure>

- (1) Perform FS-05.
- (2) Key in the codes to be adjusted and press the [START] button.
- (3) Key in the adjustment value. (To correct a value once keyed in, press [CLEAR].)
- (4) Press [OK] to store the value in memory. → The equipment goes back to the ready state.
- (5) Let the equipment restart. Acquire the SlimPDF file and check it.
- (6) If the desired image quality has not been attained, repeat step (1) to (5).

### 6.4.14 Surrounding void amount adjustment

The void amount around the network scanned image is adjusted.

In network scanning, since the void amount is very small in stored images, a shadow may appear around the scanned image due to the subtle difference in the original sizes. This shadow can be eliminated by adjusting the setting value.

The setting value is applied to all resolutions and color modes.

<05 Adjustment Mode>

Code	Item to be adjusted	Remarks
7489	Surrounding void amount adjustment	When the value increases, the blank area around the scanned image becomes wider, and the data on the image decrease. Acceptable values: 0 to 255 (Default: 0) The setting value "1" is equal to 1 dot with 600 dpi. (The value "24" is equal to approx. 1 mm.)

<Procedure>

The procedure is the same as that of  P. 6-67 "6.4.3 Density adjustment".

## 6.4.15 Judgment threshold adjustment for blank originals (common for copy and scan)

The judgment level is adjusted for automatic identification of whether the original set is blank or not. This adjustment is made when "OMIT BLANK PAGE" is selected on the control panel. The adjustment value is simultaneously applied to all modes at PPC and scanning.

<05 Adjustment Mode>

Code	Item to be adjusted	Remarks
7618	Judgment threshold adjustment for blank original	The larger the value is, the more an original tends to be judged as a blank sheet. Acceptable values: 0 to 255 (Default: 128)

<Procedure>

The procedure is the same as that of  P. 6-67 "6.4.3 Density adjustment".

## 6.4.16 JPEG compression level adjustment

The compression level for saving the scanned data in the JPEG format can be adjusted as follows.

<05 Adjustment Mode>

Code	Item to be adjusted	Remarks
8304-0	High quality	The larger the value is, the better the quality becomes, and the larger the size of file becomes. Acceptable values: 0 to 255 (Default: 128)
8304-1	Standard	
8304-2	Low quality	

<Procedure>

The procedure is the same as that of  P. 6-67 "6.4.3 Density adjustment".

## 6.4.17 ADF noise reduction

The noise reduction level for streaks can be adjusted with the following codes when a scan job is performed using the ADF

<05 Adjustment Mode>

Color				Item to be adjusted	Remarks
Original mode					
Text/ Photo	Text	Photo	Custom mode		
8413	8414	8415	8412	ADF noise reduction level setting	When the value decreases, the effect of reducing streaks becomes larger. When the value increases, the effect of reducing streaks becomes smaller. When "0" is set, this function is disabled. Acceptable values: 0 to 200 (Default: 100)

Black					Item to be adjusted	Remarks
Original mode				Gray scale		
Text/ Photo	Text	Photo	Custom mode			
7401	7402	7403	7400	7404	ADF noise reduction level setting	When the value decreases, the effect of reducing streaks becomes larger. When the value increases, the effect of reducing streaks becomes smaller. When "0" is set, this function is disabled. Acceptable values: 0 to 200 (Default: 100)

### Notes:

- Remember the image specifications and life span of the replacing parts may not meet the standard when the setting value is changed from the default value.
- If too small a value is set, the text may not be printed clearly.

<Procedure>

The procedure is the same as that of  P. 6-67 "6.4.3 Density adjustment".

## 6.5 Image Quality Adjustment (FAX Function)

### 6.5.1 Density adjustment

Adjusts the center density.

<05 Adjustment Mode>

Color mode	Original mode			Item to be adjusted	Remarks
	Text/Photo	Text *	Photo		
Black	7533	7534	7535	Manual density center value	[TEXT/PHOTO], [PHOTO]: The larger the value is, the darker the image becomes. [Text]: The larger the value is, the lighter the image becomes. Acceptable values: 0 to 255 (Default: 128)
	7542	-	7543	Automatic density mode	The larger the value is, the darker the image becomes. Acceptable values: 0 to 255 (Default: 128)

\* Since the gradation in this mode is reproduced in a binary image (black and white), this adjustment should be a simple binary threshold adjustment.

<Procedure>

- (1) Perform FS-05.
- (2) Key in a code and press the [START] button.
- (3) Key in an adjustment value.  
(To correct the value once keyed in, press [CLEAR].)
- (4) Press [OK] to store the value. → The equipment goes back to the ready state.
- (5) Turn the power OFF.

<Confirmation>

If possible, perform a Fax transmission and check the adjusted density with the image on the recipient's side.

## 6.5.2 Emission level adjustment

The emission level in the fax function can be set. In this setting the size of dots is adjusted.

<05 Adjustment Mode>

Code	Item to be adjusted	Remarks
7595-0	Emission level 0/4	The smaller the value is, the smaller the emission level becomes. Therefore, the smaller dot is reproduced accordingly. Acceptable values: 0 to 255 (Default: Level 0/4: 0, Level 1/4: 63, Level 2/4: 127, Level 3/4: 191, Level 4/4: 255)
7595-1	Emission level 1/4	
7595-2	Emission level 2/4	
7595-3	Emission level 3/4	
7595-4	Emission level 4/4	

<Procedure>

The procedure is the same as that of  P. 6-37 "6.2.11 Emission level adjustment".

<Confirmation>

Check the emission level setting with the actual fax data received, if possible.

### Notes:

- Change the setting value increment of 8 as a guide.
- Be sure to confirm the image when the setting value is changed.
- The setting value must increase as the emission level number (0 to 4) becomes higher. Do not increase this order when setting the values.
- Usually, emission level 4 / 4 is the most effective in the black mode.

## 6.5.3 Background offsetting adjustment for DF (common for copy, scan and fax)

The background level for scanning originals with the DF is adjusted when the background fogging at the scanning of a manually-set original and an original used with the DF is different. This is to adjust the level of the background image removed when the scanning of the originals with the DF is performed.

<05 Adjustment Mode>

Color mode	Code	Remarks
Black	7025	The larger the value is, the darker the background density becomes. Acceptable values: 0 to 255 (Default: 128)

<Procedure>

The procedure is the same as that of  P. 6-29 "6.2.2 Density adjustment".

## 6.6 Scanner

### 6.6.1 Adjustment carriages-1 positions

- (1) Take off the RADF.  
📖 P. 4-171 "4.11.1 Reversing Automatic Document Feeder"
- (2) Take off the right top cover.  
📖 P. 4-4 "4.1.8 Right top cover"
- (3) Take off the original glass.  
📖 P. 4-19 "4.3.1 Original glass"
- (4) Take off the left top cover.  
📖 P. 4-3 "4.1.5 Left top cover"
- (5) Move the carriage-1[1] toward the exit side.

**Notes:**

Rotate the drive pulley to move the carriage.

- (6) Loosen the 2 fixing screws of the wire. Tighten the screws by aligning the sections [5] and [6] of the carriage-1 with the inside of the exit side frame [2].

**Notes:**

Confirm that they are aligned properly through the windows [3] and [4] of the exit side frame [2].

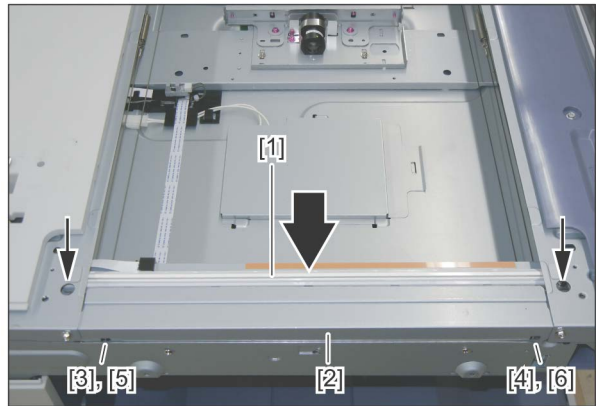


Fig.6-24

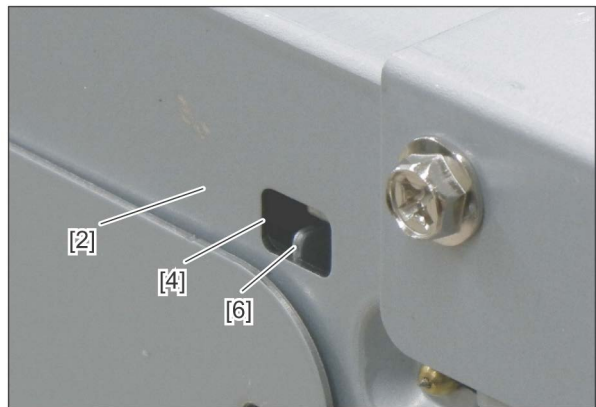




Fig.6-25

## 6.6.2 Position adjustment of CCD lens unit

Count the number of lines and write it down for later reference before removing the CCD lens unit. When installing the CCD lens unit, the same number of lines needs to be visible.

 P. 4-21 "4.3.5 Lens unit/CCD driving PC board"

## 6.6.3 Belt tension adjustment of the Scan motor

- (1) Take off the rear cover.  
 P. 4-6 "4.1.15 Rear cover"
- (2) Hook the belt tension jig[1] to the motor bracket[2] and hook section of the frame[3].
- (3) Loosen the screws [4] and [5].
- (4) The scan motor [6] is pulled by the belt tension jig [1]. When it is stopped, tighten the screws in order of [4] and [5].
- (5) Remove the belt tension jig[1].

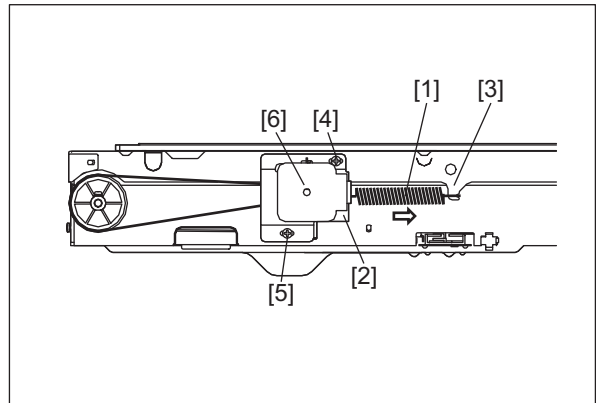





Fig.6-26



## 6.7 Writing Section

### 6.7.1 Image Adjustment in the Writing Section

Refer to the following pages for details.

-  P. 6-14 "[A] Primary scanning data writing start position"
-  P. 6-15 "[C] Secondary scanning data writing start position"
-  P. 6-16 "[D] Primary scanning data writing start position at duplexing"

## 6.8 Paper Feeding System

### 6.8.1 Adjusting the clearance of the paper and side guides

If the clearance between the paper and the side guides is too wide, it can be adjusted to between 0 and 1 mm using the following procedure (the clearance between the paper and the guides is 1 to 2 mm including both front and rear sides).

<Procedure>

- (1) Take out the drawer.
- (2) Move the side guide[1]. Loosen 2 screws.

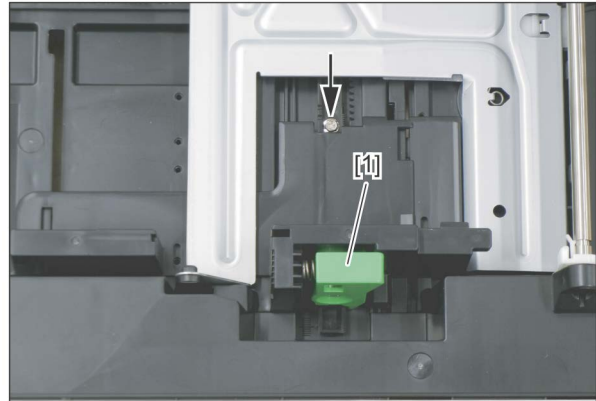


Fig.6-27

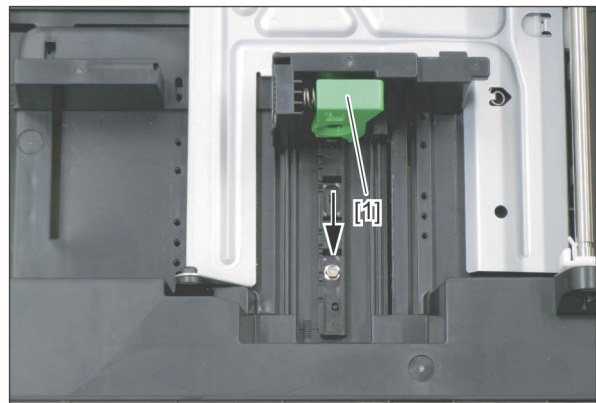


Fig.6-28

- (3) Move the side guide adjustment piece[1] to the front and tighten the screws (by 0.5 mm).

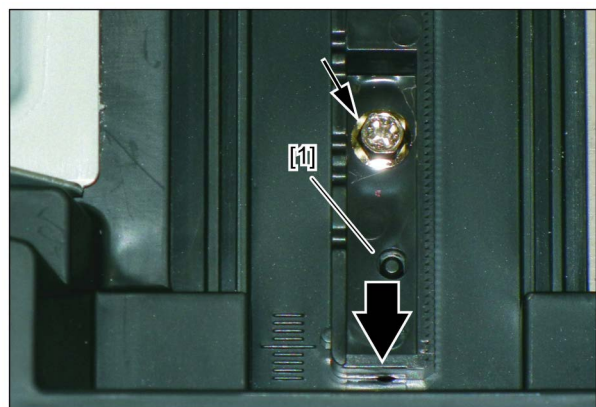


Fig.6-29

## 6.8.2 Separation roller pressure force adjustment (PFU/PFP)

Generally paper jams and multiple feeding often occur as the life end of the roller approaches. However, if they often occur even though its life has not yet reached its replacement timing, or if the life end comes much earlier than the scheduled replacement timing, the jams and multiple feeding can be suppressed by adjusting the pressure force of the separation roller.

In this method, however, when the roller life becomes longer, jams and multiple feeding may occur frequently, and when the jams and multiple feeding are suppressed, the roller life may become shorter. Therefore, perform this adjustment while checking the status carefully, and if necessary, give a sufficient explanation to users.

<Adjustment procedure>

- (1) Take off the drawer feeding unit.
- (2) Remove 1 screw, and then screw it temporarily into the oblong hole which is located next to it.

**Notes:**

Make a mark for the installation position of the holder [1] in advance.

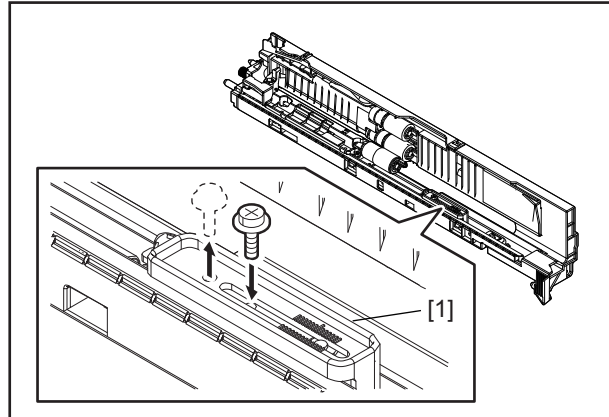


Fig.6-30

- (3) Move the holder [1].

**Remarks:**

- Moving in the direction of A: The roller life will become longer (but multiple feeding may occur frequently).
- Moving in the direction of B: Multiple feeding will be suppressed (but the roller life may become shorter).

**Notes:**

The recommended moving distance of the holder [1] is within 1 or 2 scale marks.

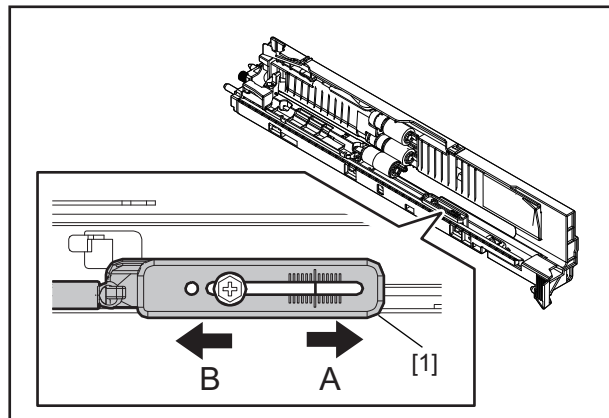


Fig.6-31

## 6.9 Process Unit Related Section

### 6.9.1 High-Voltage Transformer Setting

The high-voltage transformers (PS-HVT) supply high-voltage to the parts related to charging, development, transfer and Discharging blade.

The high-voltage transformer has the following high-voltage outputs.

CH1	1	Main charger bias (Y)
	2	Main charger bias (M)
	3	Main charger bias (C)
	4	Main charger bias (K)
CH2	1	Main charger grid bias (Y)
	2	Main charger grid bias (M)
	3	Main charger grid bias (C)
	4	Main charger grid bias (K)
CH3	1	Developer bias (Y)
	2	Developer bias (M)
	3	Developer bias (C)
	4	Developer bias (K)
CH4	1	1st transfer roller bias (Y)
	2	1st transfer roller bias (M)
	3	1st transfer roller bias (C)
	4	1st transfer roller bias (K)
CH5	-	2nd transfer roller bias

**Notes:**

Never move the variable resistance on the board since the output adjustment has been performed at the shipment for the high-voltage transformer supplied as a service part. Also do not perform the setting change when the high-voltage power supply is replaced.

## 6.10 Developer Unit

### 6.10.1 Adjustment of the Auto-Toner Sensor

When the developer material is replaced, adjust the auto-toner sensor.

📖 P. 6-2 "6.1.2 Adjustment of the Auto-Toner Sensor"

### 6.10.2 Adjustment of the doctor-to-sleeve gap

For the adjustment of the doctor-to-sleeve gap, perform the same procedure for the Y, M, C and K developer units.

Adjustment tool to use: Doctor-sleeve gap jig

<Adjustment procedure>

- (1) Take out the developer unit. Then discharge the developer material.  
📖 P. 4-69 "4.6.3 Developer material"
- (2) Loosen 2 doctor blade fixing screws[1].

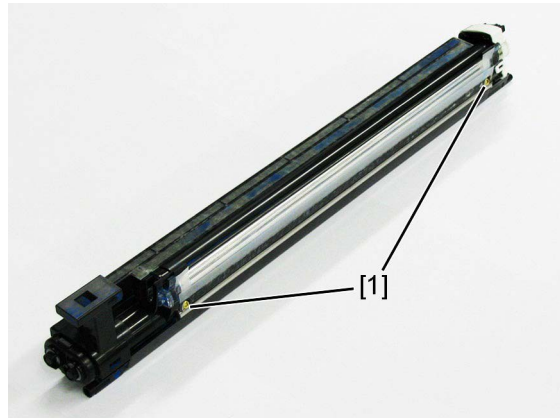


Fig.6-32

- (3) Insert the doctor-sleeve gap jig[1] to adjust the gap.  
Insert the gauge "0.60" of the doctor-sleeve gap jig between the developer sleeve and the doctor blade to adjust the gap, and tighten the screws.

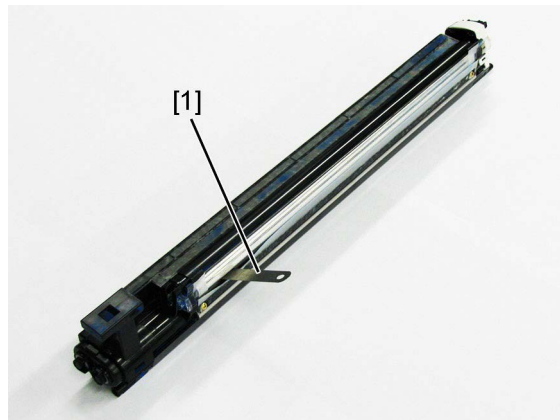
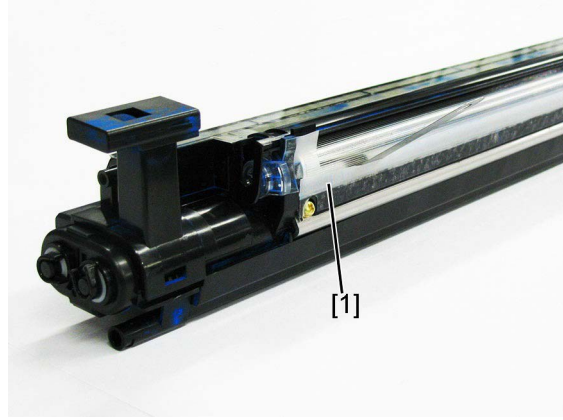


Fig.6-33

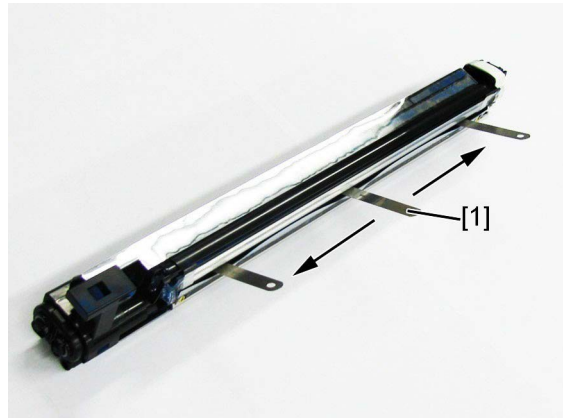
**Notes:**

Flip up protection sheet[1] for the doctor blade from the sleeve before inserting the gauge. Also, be sure not to damage the protection sheet[1].



**Fig.6-34**

- (4) Insert the gauge "0.55" of the doctor-sleeve gap jig[1] between the developer sleeve and the doctor blade to make sure that the gauge can move smoothly in the front/rear direction and the gauge "0.65" cannot be inserted into the gap.





**Fig.6-35**

## 6.11 Image Quality Control

### 6.11.1 Performing Image Quality Control

When the image position aligning sensor (front) or image position aligning sensor (rear)/image quality sensor is replaced, perform the image quality control and adjustment of color registration control.

 P. 6-4 "6.1.3 Performing Image Quality Control"

 P. 6-5 "6.1.4 Adjustment of Color Registration Control"

## 6.12 Fuser Unit / Paper Exit Section

### 6.12.1 Adjustment of the non-contact thermistor Gap

Perform this adjustment when the following parts are replaced or disassembled.





- Fuser roller
- Pressure roller
- Center thermistor (Non-contact thermistor)
- Side thermistor (Non-contact thermistor)
- Front thermistor
- Pressure spring

Adjustment tool to use: Non-contact thermistor/thermostat gap jig (Thin side)

**Notes:**

- Wait until the fuser unit is completely cooled down, and then start the adjustment.
- Place the fuser unit on a flat surface.
- Make sure that the pressure roller is pressed.
- Be careful not to damage the fuser roller and jig.
- Perform non-contact thermistor correction after the adjustment.

<Adjustment procedure>

- (1) Take off the fuser unit.  
 P. 4-137 "4.9.1 Fuser unit"
- (2) Take off the front side cover, rear side cover, and heat roller cover.  
 P. 4-143 "4.9.2 Front side cover"  
 P. 4-143 "4.9.3 Rear side cover"  
 P. 4-143 "4.9.4 Fuser roller cover"

- (3) Take off the heat roller separation finger installed in the window in which the side thermistor [1] can be seen.  
📖 P. 4-144 "4.9.6 Fuser roller separation finger"
- (4) Remove 1 screws and take off the bracket [2].

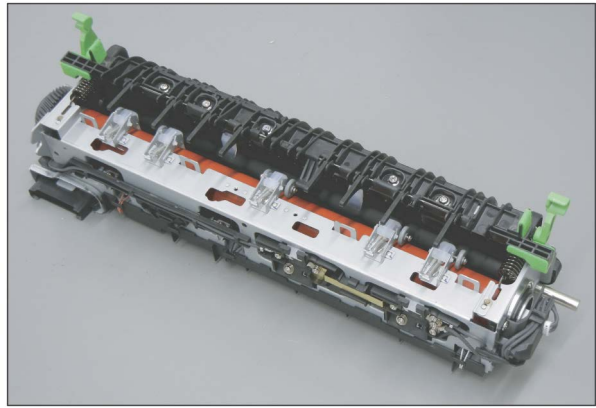


Fig.6-36

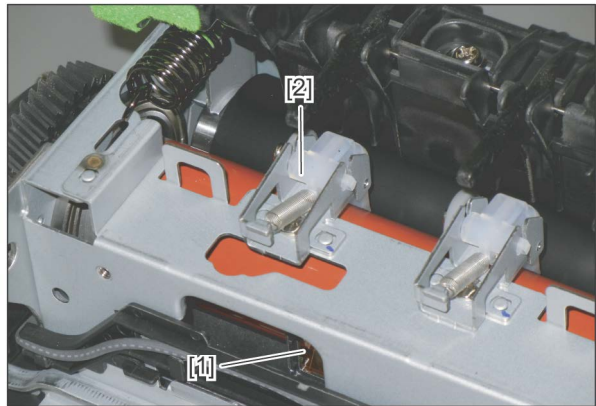


Fig.6-37

- (5) Insert the jig [2] between the side thermistor [3] and the fuser roller [4] through the window [1] in which the side thermistor [3] can be seen. Then confirm that the portion of the jig coming out of the window falls within the specified range of the scales.

**Notes:**

- The jig should be inserted under its own weight.

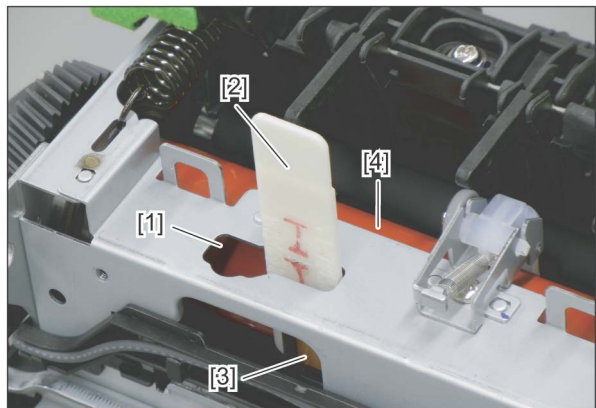


Fig.6-38



- (6) If the gap is out of the specified value, loosen 1 screw of the side thermistor [1], adjust the gap and then tighten the screw. Repeat the confirmation of step 5 until the portion falls within the specified range.

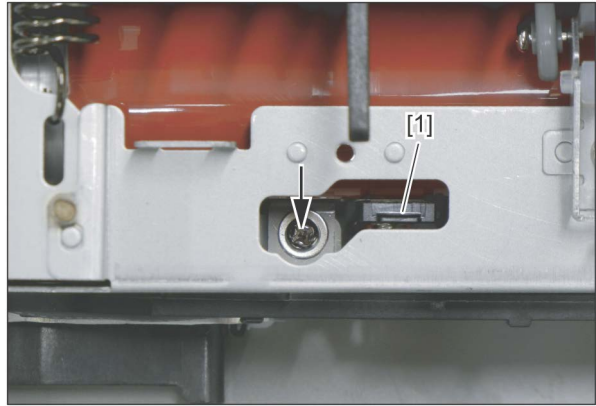


Fig.6-39

- (7) Check the gap between the center thermistor [1] and the fuser roller in the same manner. Adjust it if needed.

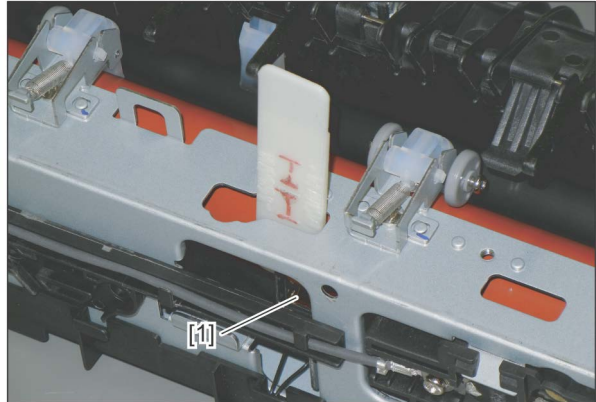




Fig.6-40

- (8) Perform non-contact thermistor correction.  
📖 P. 6-88 "6.12.2 Correction of Performing non-contact thermistor"

## 6.12.2 Correction of Performing non-contact thermistor

Since the center thermistor and the side thermistor are non-contact thermistors, the temperature detected or controlled by these thermistors may differ depending on the gap between the fuser roller and these thermistors. Therefore they must be corrected.

- (1) When unpacking  
Perform the "Forced performing of non-contact thermistor correction (FS-05-5990)" procedure before you start printing (or gamma adjustment).
- (2) When any of the following parts is replaced, be sure to perform the "Forced performing of non-contact thermistor correction (FS-05-5990)" procedure.
  - Fuser unit
  - Heater lamp
  - Fuser roller
  - Pressure roller
  - Center thermistor (Non-contact thermistor)
  - Side thermistor (Non-contact thermistor)
  - Front thermistor
  - Pressure spring
  - EEPROM
- (3) Procedure

Code	Item to be adjusted	Contents
5990	Forced performing of non-contact thermistor correction	1. Perform the FS-05-5990. 2. "WAIT" is displayed. 3. When the adjustment finishes normally, the equipment returns to the initial state of Adjustment Mode.  When an error occurs Refer to the C4F0 and C4F1.  P. 8-192 " [C4F0] Center thermistor error correction"  P. 8-192 " [C4F1] Side thermistor error correction"

### 6.12.3 Adjustment of the thermostat Gap

Perform this adjustment when the following parts are replaced or disassembled.

- Fuser roller
- Center thermostat
- Side thermostat

Adjustment tool to use: Non-contact thermistor/thermostat gap jig (Thick side)

#### Notes:

- Wait until the fuser unit is completely cooled down, and then start the adjustment.
- Place the fuser unit on a flat surface.
- Make sure that the pressure roller is pressed.
- Be careful not to damage the fuser roller and jig.

<Adjustment procedure>

- (1) Take off the fuser unit.  
📖 P. 4-137 "4.9.1 Fuser unit"
- (2) Take off the front side cover, rear side cover, and heat roller cover.  
📖 P. 4-143 "4.9.2 Front side cover"  
📖 P. 4-143 "4.9.3 Rear side cover"  
📖 P. 4-143 "4.9.4 Fuser roller cover"
- (3) Take off the heat roller separation finger installed in the window in which the side thermostat[1] can be seen.  
📖 P. 4-144 "4.9.6 Fuser roller separation finger"
- (4) Remove 1 screws and take off the bracket [2].

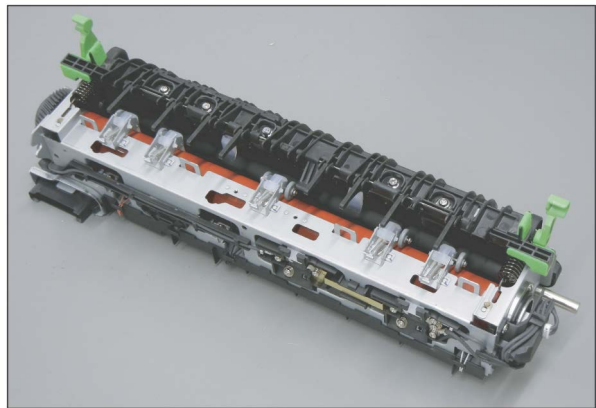


Fig.6-41

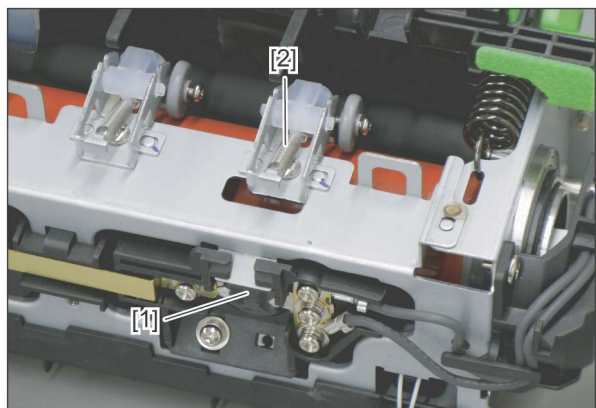
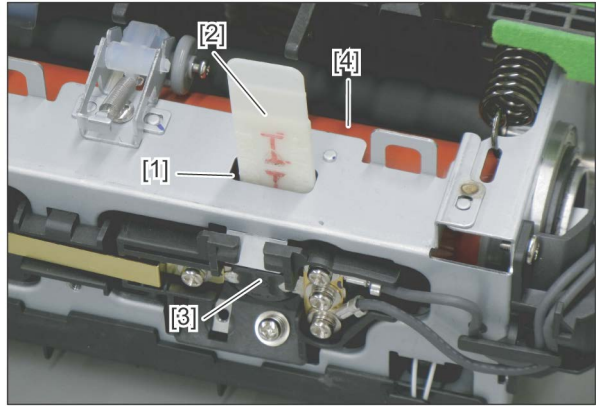


Fig.6-42

- (5) Insert the jig [2] between the side thermostat [3] and the fuser roller [4] through the window [1] in which the side thermostat [3] can be seen. Then confirm that the portion of the jig coming out of the window falls within the specified range of the scales.

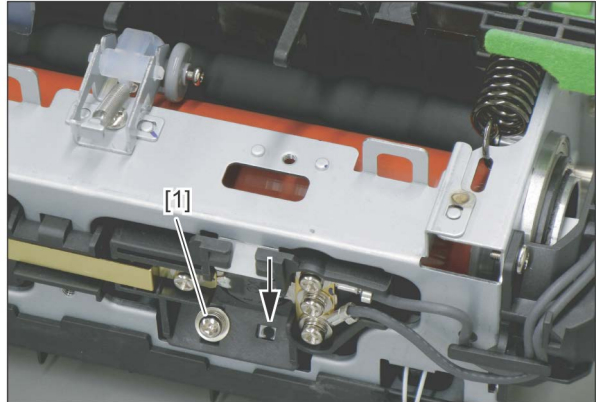
**Notes:**

- The jig should be inserted under its own weight.



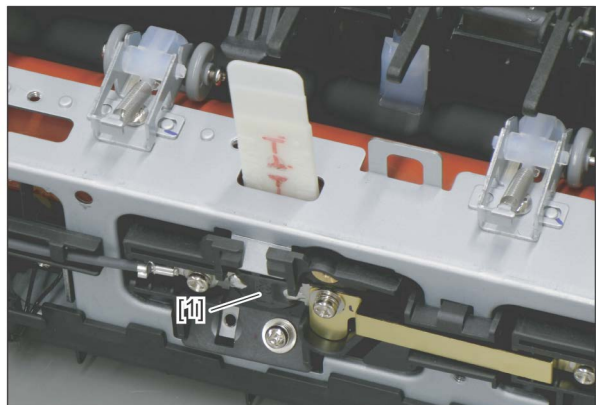
**Fig.6-43**

- (6) If the gap is not at the specified value, remove 1 screw of the side thermostat and screw it in the adjustment hole [1]. Then adjust the gap and tighten the screw. Repeat the confirmation of step 5 until the portion falls within the specified range.



**Fig.6-44**

- (7) Check the gap between the center thermostat [1] and the fuser roller as in the same manner. Adjust it if needed.



**Fig.6-45**

## 6.13 Adjustment of the RADF

### 6.13.1 Adjustment of RADF position

Perform this adjustment when the RADF is not installed in the correct position.

**Notes:**

Check if the image adjustment for the equipment is performed properly before this adjustment of the RADF.

**[A] Checking**

- (1) Open the RADF and install 2 positioning pins (the positioning pins are installed to the back side of the hinge which is on the left side of the RADF).

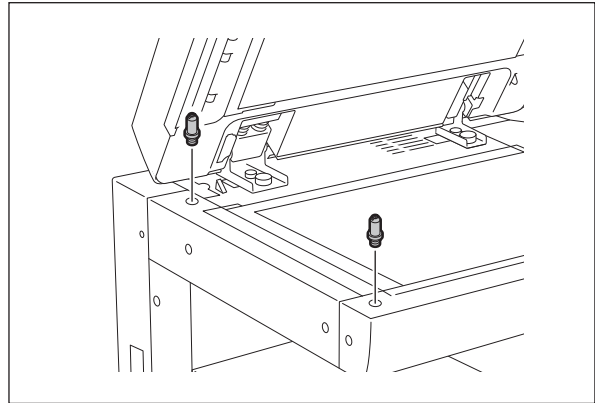


Fig.6-46

- (2) Remove the platen sheet.

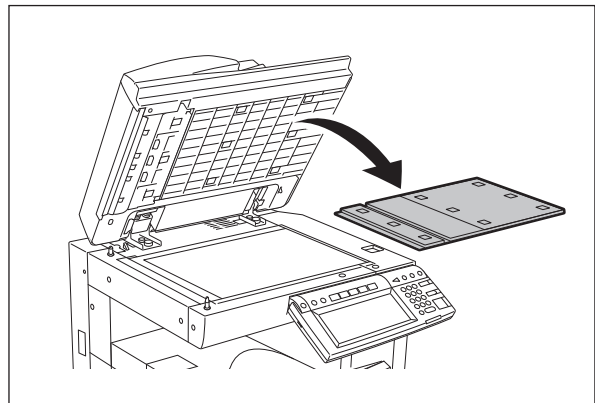


Fig.6-47

- (3) Close the RADF and check if the positioning pins fit the holes on the RADF.

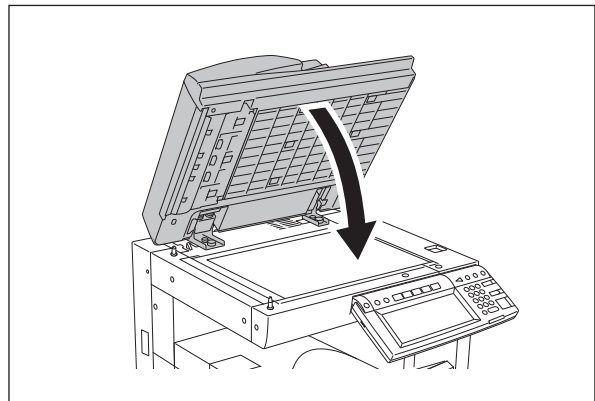


Fig.6-48

## [B] Adjustment

If the pins cannot be fitted into the holes, perform the adjustment according to the following procedure.

- (1) Remove the right-hand hinge screw at the rear side.

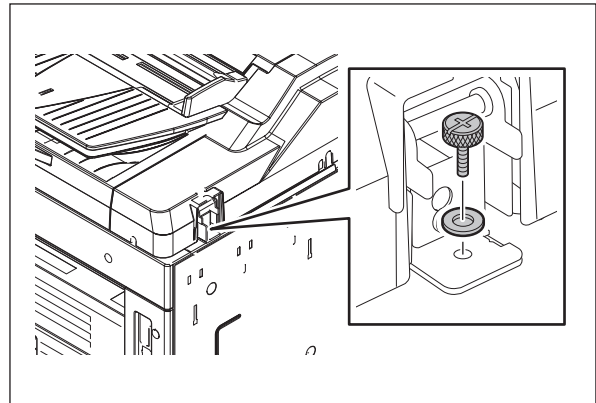


Fig.6-49

- (2) Remove the bracket on the left-hand hinge.

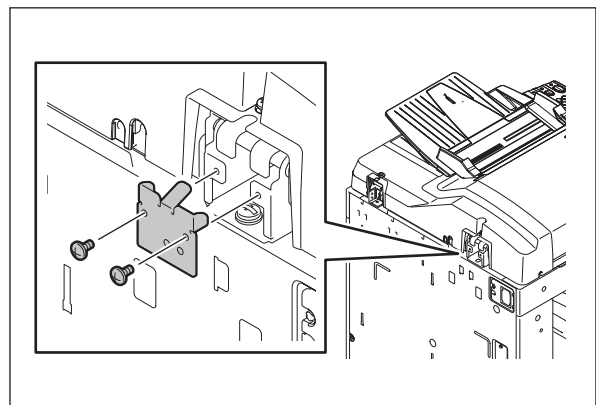


Fig.6-50

- (3) Loosen the left-hand hinge screw at the rear side.

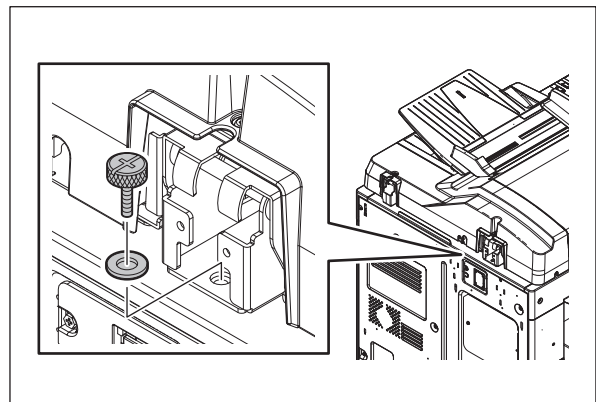
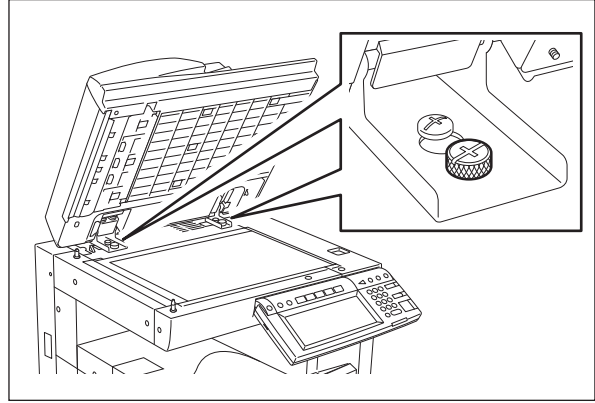


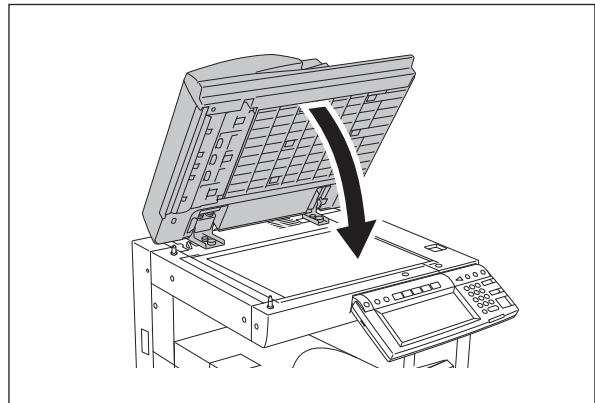
Fig.6-51

- (4) Loosen the hinge screws at the front side.



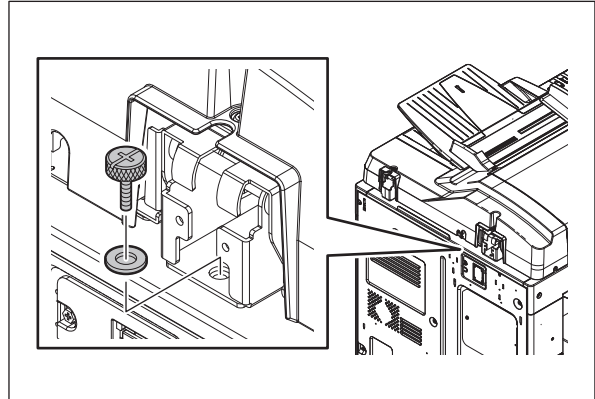
**Fig.6-52**

- (5) Position the pins with the holes on the RADF by moving it so that the pins fit into the holes when the RADF is closed.



**Fig.6-53**

- (6) Tighten the left-hand hinge screw at the rear side.



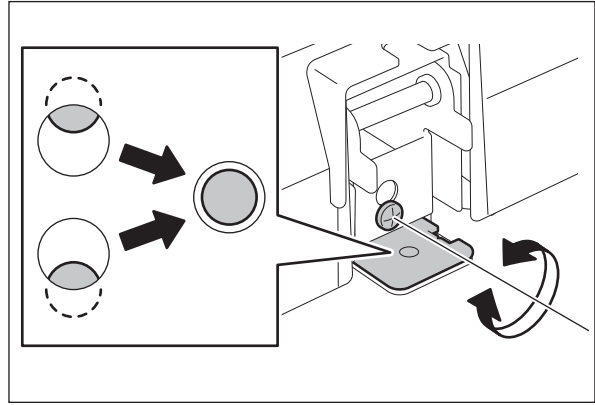
**Fig.6-54**

(7) Match the screw hole positions.

**Notes:**

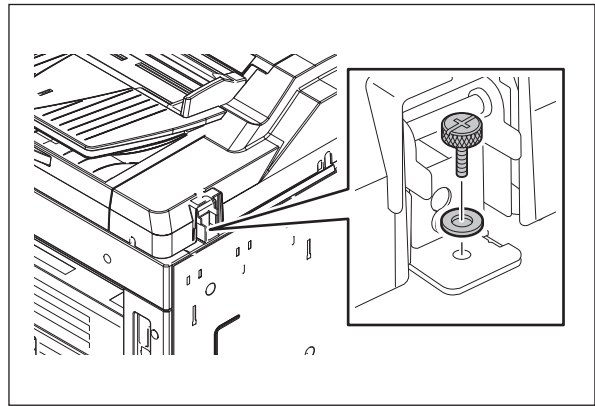
Turn it clockwise: It moves toward the rear side.

Turn it counterclockwise: It moves toward the front side.



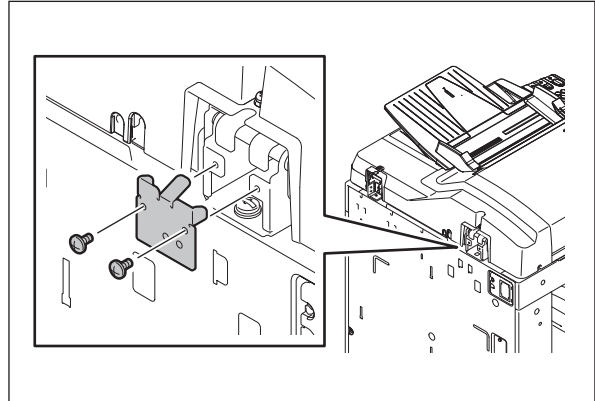
**Fig.6-55**

(8) Install the right-hand hinge screw at the rear side.



**Fig.6-56**

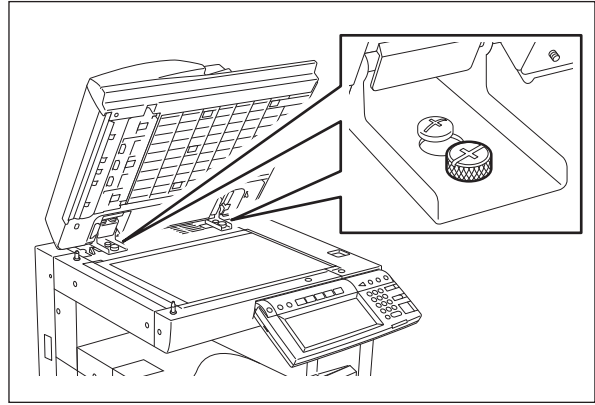
(9) Install the bracket on the left-hand hinge.



**Fig.6-57**

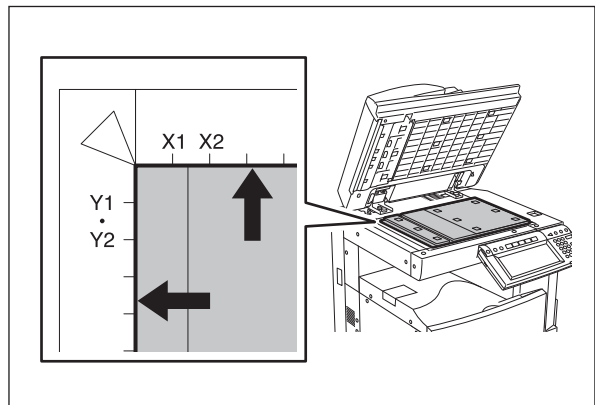


(10) Tighten the hinge screws at the front side.



**Fig.6-58**

(11) Place the platen sheet on the original glass and align it to the top left corner.  
Close the RADF gently and open it to check if the platen sheet is attached properly.



**Fig.6-59**

## 6.13.2 Adjustment of RADF height

### Notes:

Check if the image adjustment for the equipment is performed properly before this adjustment of the RADF.

### [A] Checking

- (1) Close the RADF.
- (2) Light the exposure lamp.
  - Performs FS-03.
  - Key in [267] and then press the [START] button. The exposure lamp is turned ON for a given length of time.
- (3) Visually check the gap between platen guide holder "A" and upper surface of the original glass "B" from the left hand side of the equipment. If the value is not within the tolerance, perform the adjustment according to the following procedure.

[Tolerance of the gap]

Rear side: 0 - 0.5 mm

Front side: 0 mm

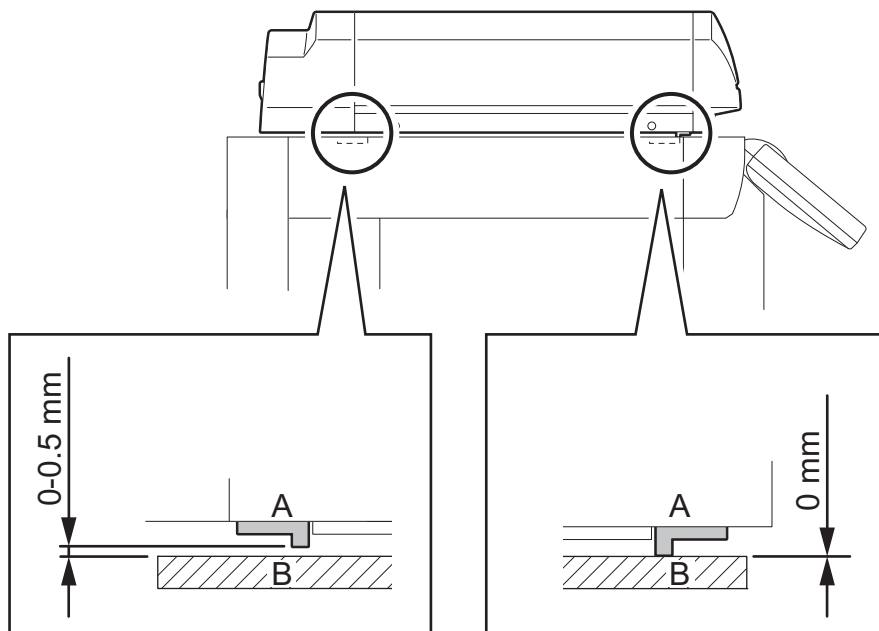


Fig.6-60

## [B] Adjustment

- (1) Close the RADF.
- (2) Adjust it by turning the adjustment screws on the hinges.
  - Adjust the height on the rear side by means of the screw on the hinge on the exit side of the RADF.

Turn it clockwise ..... Heightened  
Turn it counterclockwise ..... Lowered

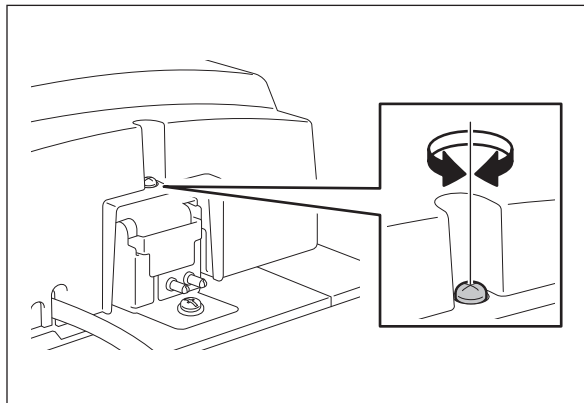


Fig.6-61

- Adjust the gap on the rear side by means of the screw on the hinge on the feed side of the RADF.

Turn it clockwise ..... Lowered  
Turn it counterclockwise ..... Heightened

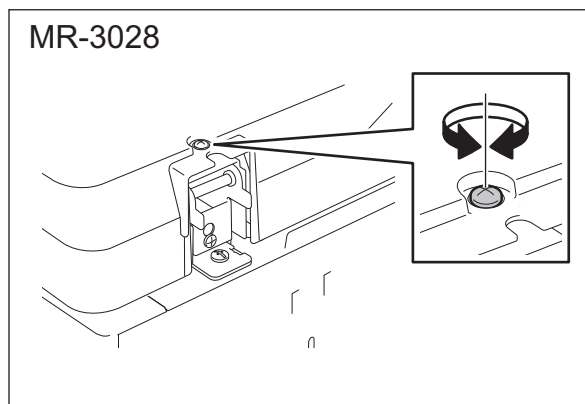


Fig.6-62

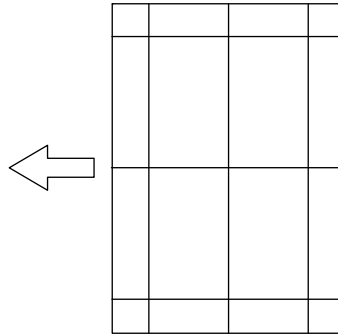
### 6.13.3 Adjustment of skew

**Notes:**

Check if the image adjustment for the equipment is performed properly before this adjustment of the RADF. Also, the RADF position and height shall be adjusted properly.

**[A] Checking**

Check the image using the chart (original) with vertical and horizontal lines in the following procedure.



**Fig.6-63 Chart (Original)**

Simplex copying:

- (1) Place the chart provided as an original with its face up on the original tray of the RADF, select [Sort] and [1 → 1 Simplex] and then press the [START] button.
- (2) Superimpose the chart on the copy and check the inclination of the copy image.

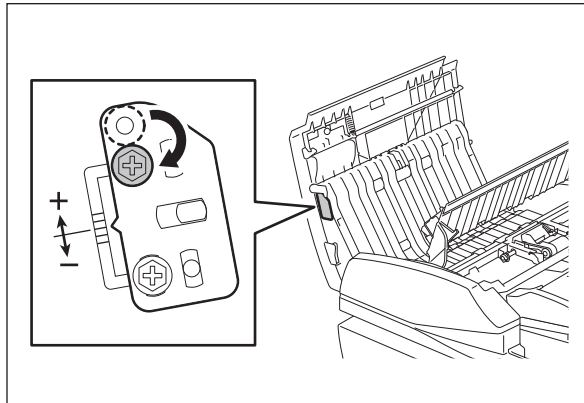
Duplex copying:

- (1) Place the chart provided as an original with its face down on the original tray of the RADF, select [Sort] and [2 → 2 Duplex] and then press the [START] button.
- (2) Superimpose the chart on the copy and check the inclination of the copy image.

**[B] Adjustment**

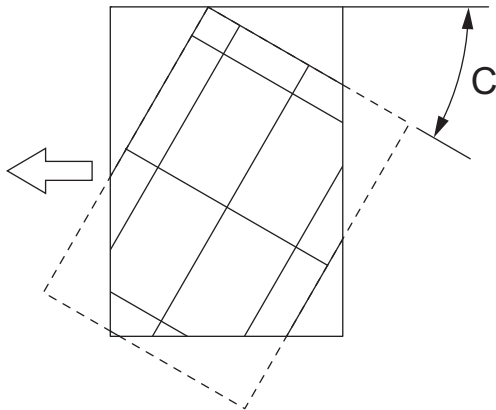
Simplex copying:

- (1) Shift the aligning plate with the scale as the guide shown in the figure below to adjust the skew.



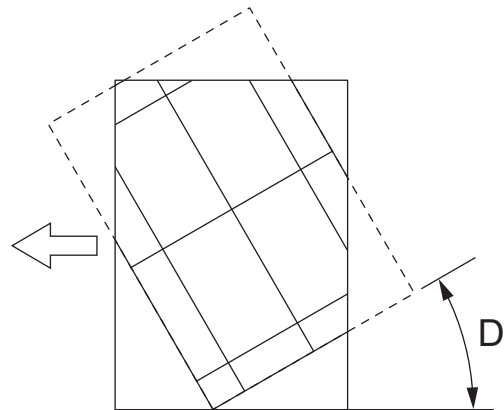
**Fig.6-64**

- (2) If the image skew is "C" as shown in the figure below, shift the aligning plate in the direction of "+", and if "D", shift it to "-".



**Fig.6-65**

Shift the aligning plate in the direction of "+".

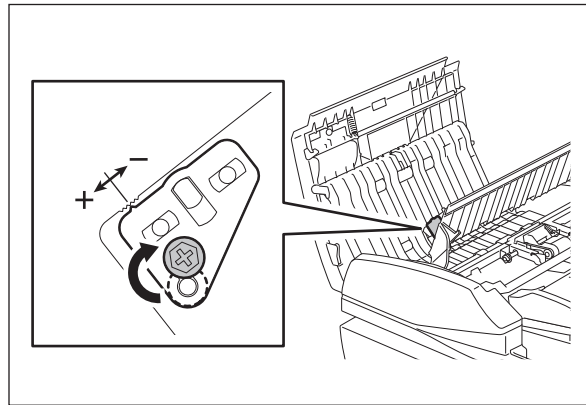


**Fig.6-66**

Shift the aligning plate in the direction of "-".

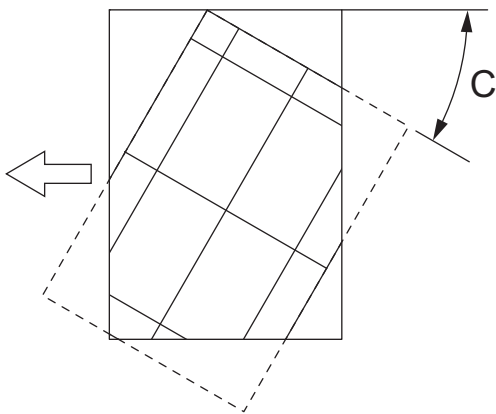
Duplex copying:

- (1) Shift the aligning plate with the scale as the guide shown in the figure below to adjust the skew.



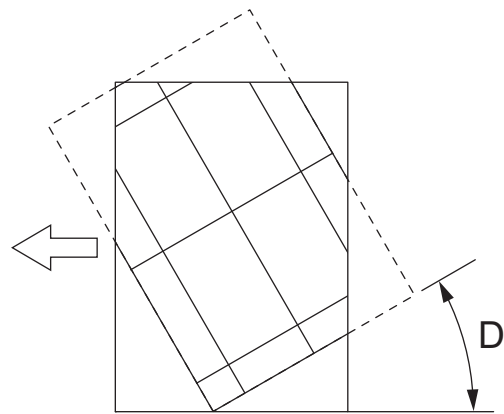
**Fig.6-67**

- (2) If the image skew is "C" as shown in the figure below, shift the aligning plate in the direction of "-", and if "D", shift it to "+".



**Fig.6-68**

Shift the aligning plate in the direction of "-".



**Fig.6-69**

Shift the aligning plate in the direction of "+".

## 6.13.4 Adjustment of the leading edge position

### Notes:

Check if the image adjustment for the equipment is performed properly before this adjustment of the RADF. Also, the RADF position and height shall be adjusted properly.

### [A] Checking

Check the image using the chart (original) with vertical and horizontal lines in the following procedure.

#### Simplex copying:

- (1) Place the chart provided as an original with its face up on the original tray of the RADF, select [Sort] and [1 → 1 Simplex] and then press the [START] button.
- (2) Superimpose the chart on the copy and check the leading edge E of the chart and F of the copy.

#### Duplex copying:

- (1) Place the chart provided as an original with its face down on the original tray of the RADF, select [Sort] and [2 → 2 Duplex] and then press the [START] button.
- (2) Superimpose the chart on the copy and check the leading edge E of the chart and F of the copy.

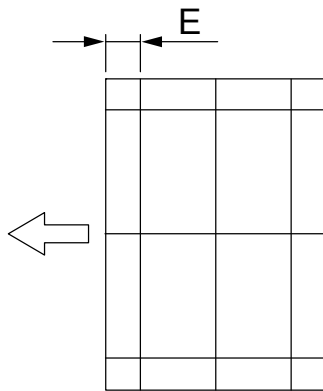


Fig.6-70 Chart (Original)

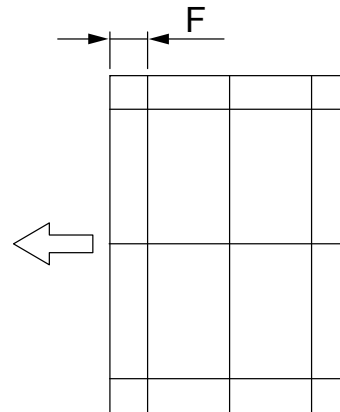


Fig.6-71 Copy

## [B] Adjustment

### Simplex copying:

- (1) Performs FS-05-3044.
- (2) Enter the value.
  - If the leading edge (F) margin of the copy image is larger than the (E) margin of the chart, enter a value smaller than the current one.

**Notes:**

Changing one value shifts the copy image by 0.1 mm.

- If the leading edge (F) margin of the copy image is smaller than the (E) margin of the chart, enter a value larger than the current one.

**Notes:**

Changing one value shifts the copy image by 0.1 mm.

- (3) Press [OK].

### Duplex copying:

- (1) Performs FS-05-3045.
- (2) Enter the value.
  - If the leading edge (F) margin of the copy image is larger than the (E) margin of the chart, enter a value smaller than the current one.

**Notes:**

Changing one value shifts the copy image by 0.1 mm.

- If the leading edge (F) margin of the copy image is smaller than the (E) margin of the chart, enter a value larger than the current one.

**Notes:**

Changing one value shifts the copy image by 0.1 mm.

- (3) Press [OK].



## 6.13.5 Adjustment of horizontal position

### Notes:

Check if the image adjustment for the equipment is performed properly before this adjustment of the RADF. Also, the RADF position and height shall be adjusted properly.

### [A] Checking

Check the image using the chart (original) with a center line in the following procedure.

- (1) Place the chart provided as an original with its face up on the original tray of the RADF.
- (2) Select the [Sort] and then press the [START] button.
- (3) Fold the copy in half and check if the center line is misaligned.

### [B] Adjustment

- (1) Performs FS-05-3043.
  - If the center line of the copy image is shifted to the front side of the equipment, enter a value larger than the current one.

### Notes:

Changing one value shifts the copy image by 0.042 mm.

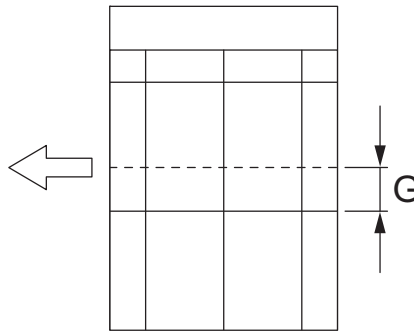


Fig.6-72

- If the center line of the copy image is shifted to the rear side of the equipment, enter a value smaller than the current one.

### Notes:

Changing one value shifts the copy image by 0.042 mm.

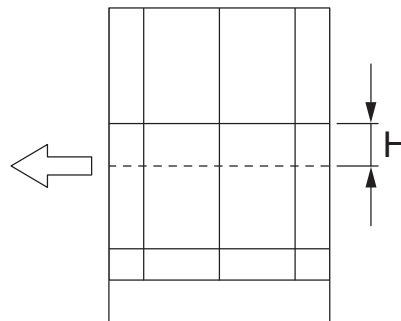


Fig.6-73

- (2) Press [OK].

## 6.13.6 Adjustment of copy ratio

### Notes:

Check if the image adjustment for the equipment is performed properly before this adjustment of the RADF. Also, the RADF position and height shall be adjusted properly.

### [A] Checking

Check the image using the chart (original) with vertical and horizontal lines in the following procedure.

- (1) Place the chart provided as an original with its face up on the original tray of the RADF.
- (2) Select the [Sort] and then press the [START] button.
- (3) Superimpose the chart on the copy and check the image dimension "1".

### [B] Adjustment

- (1) Performs FS-05-3042.
  - If the copy image dimension "1" is larger than the chart dimension, enter a value smaller than the current one.
  - If the copy image dimension "1" is smaller than the chart dimension, enter a value larger than the current one.

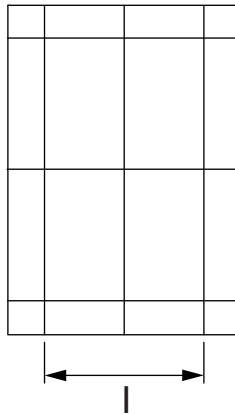


Fig.6-74

### Notes:

When the value increases by "1", the reproduction ratio of the secondary scanning direction when using the RADF increases by approx. 0.1%.

- (2) Press [OK].

### 6.13.7 RADF Separation roller pressure force adjustment

In some cases the life of the separation roller may be shortened or paper jams (E712, E721) and multiple feeding (E724) may occur regardless of the operation frequency of the equipment. This comes from the weight or edge status of paper used and the amount of paper dust.

Generally paper jams and multiple feeding often occur as the life end of the roller approaches.

However, if they often occur even though its life has not yet reached its replacement timing, or if the life end comes much earlier than the scheduled replacement timing, the jams and multiple feeding can be suppressed by adjusting the pressure force of the separation roller.

In this method, however, when the roller life becomes longer, jams and multiple feeding may occur frequently, and when the jams and multiple feeding are suppressed, the roller life may become shorter. Therefore, perform this adjustment while checking the status carefully, and if necessary, give a sufficient explanation to users.

#### [A] Adjustment procedure

- (1) Open the jam access cover.
- (2) Take off the paper feeder unit [1].

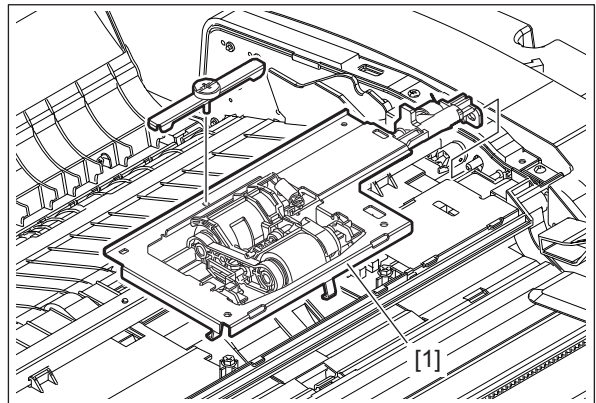


Fig.6-75

- (3) Remove 2 screws. Lift up the feeder upper guide [2] by sliding it to the right.

**Notes:**

Do not pull the harness too strong.

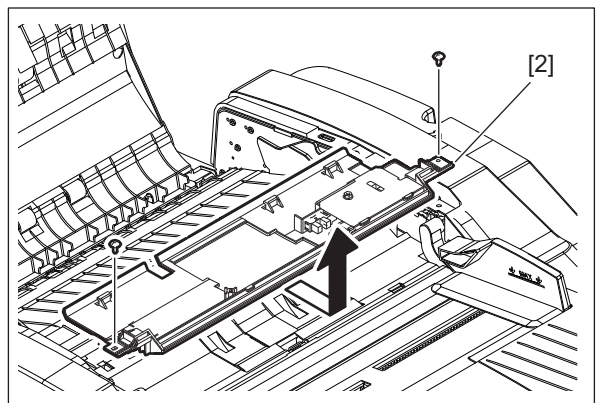


Fig.6-76

- (4) Take off the separation roller holder [3].

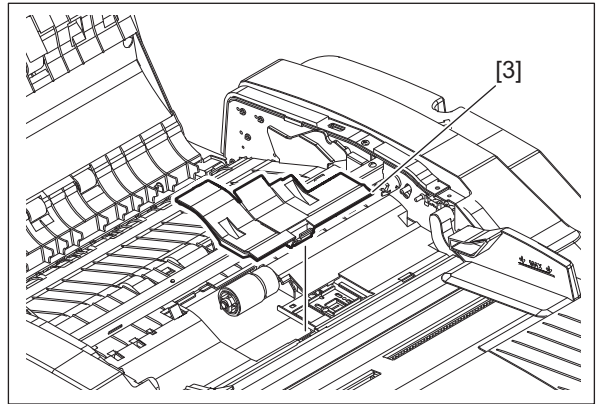


Fig.6-77

- (5) While holding the bracket [5] with your hand, remove the screw [4].

**Notes:**

When installing or taking off the bracket [5], keep it setting up because it is tensed with a spring to L direction.

- (6) Move the bracket [5].
- Move to the direction R: Paper jams (E712, E721) will be suppressed. The roller life will become longer (but multiple feeding may occur frequently).
  - Move to the direction L: Multiple feeding will be suppressed (but the roller life may become shorter).
  - The upper limit of the movement of the bracket for the adjustment is 1 scale. If the bracket is moved by 2 scales, deterioration of the pressure spring may occur.
- (7) Tighten the screw [4].

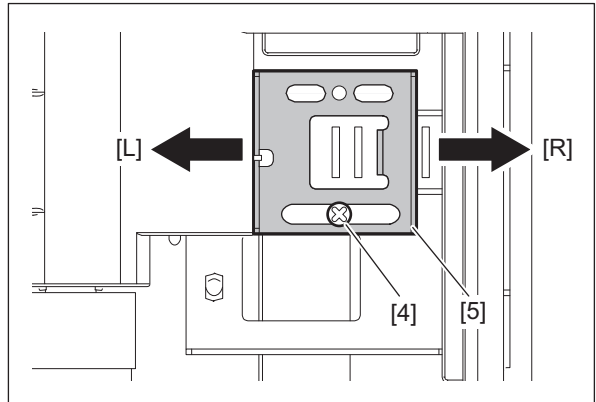


Fig.6-78

## 6.14 Adjustment of the Inner Finisher

### Notes:

- Before performing each adjustment, make sure that all covers (incl. those of the finisher and equipment) are closed. Otherwise, no power is supplied to the Finisher and the adjustment may not be performed properly.
- Do not enter a value which exceeds the range of the adjustment value. Although such value can be entered depending on the models, adjustment will be performed with the default value.

### 6.14.1 Alignment position adjustment

#### [A] Alignment position adjustment (front)

This adjustment is performed in the Adjustment Mode (FS-05-4822-0) of the equipment.

Adjustment scale	0.2mm	
Adjustable range	-3.4 mm to 3.4 mm	
Adjustment value	-17 to 17 (Default value: 0)	
Adjustment direction	Increasing the value	The alignment plate moves to the center.
	Decreasing the value	The alignment plate moves to the edge of paper.

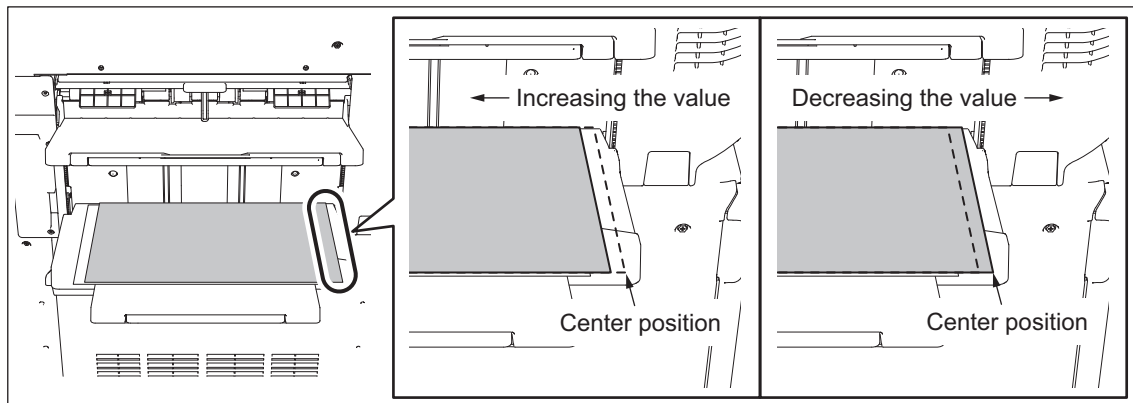


Fig.6-79

## [B] Alignment position adjustment (rear)

This adjustment is performed in the Adjustment Mode (FS-05-4822-1) of the equipment.

Adjustment scale	0.2mm	
Adjustable range	-3.4 mm to 3.4 mm	
Adjustment value	-17 to 17 (Default value: 0)	
Adjustment direction	Increasing the value	The alignment plate moves to the center.
	Decreasing the value	The alignment plate moves to the edge of paper.

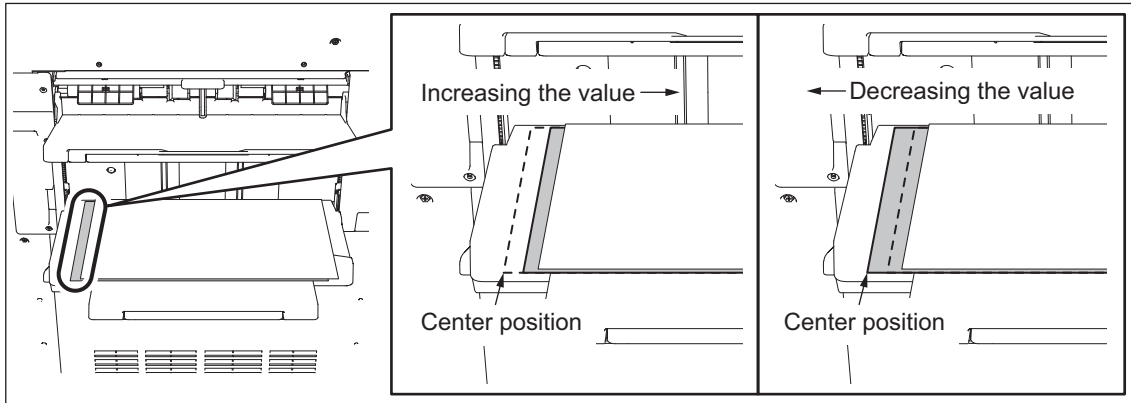


Fig.6-80

## 6.14.2 Stapling position adjustment

### [A] Stapling position adjustment (rear 1-point / paper output direction: portrait)

This adjustment is performed in the Adjustment Mode (FS-05-4823-0) of the equipment.

Adjustment scale	0.2mm	
Adjustable range	-3.4 mm to 3.4 mm	
Adjustment value	-17 to 17 (Default value: 0)	
Adjustment direction	Increasing the value	The distance between the stapling position and the edge of the paper becomes longer
	Decreasing the value	The distance between the stapling position and the edge of the paper becomes shorter.

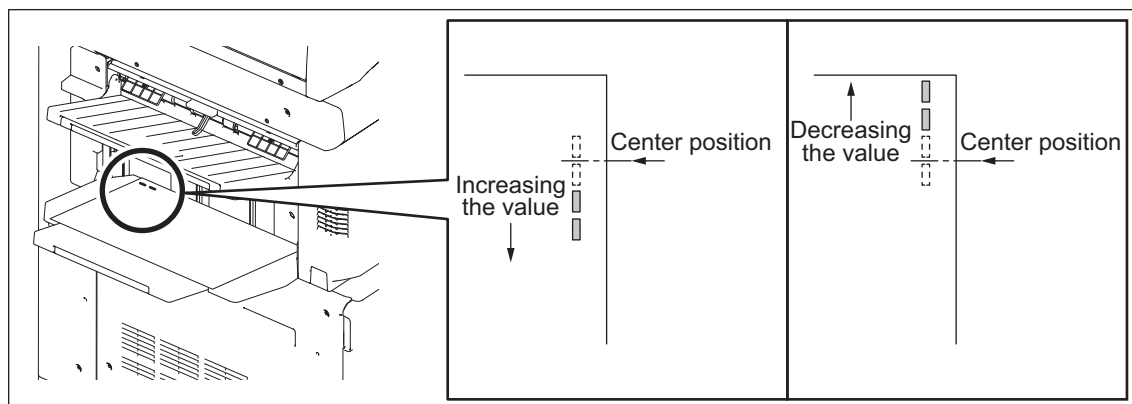


Fig.6-81

**[B] Stapling position adjustment (rear 1-point / paper output direction: landscape)**

This adjustment is performed in the Adjustment Mode (FS-05-4823-1) of the equipment.

Adjustment scale	0.2mm	
Adjustable range	-3.4mm to 3.4 mm	
Adjustment value	-17 to 17 (Default value: 0)	
Adjustment direction	Increasing the value	The distance between the stapling position and the edge of the paper becomes longer
	Decreasing the value	The distance between the stapling position and the edge of the paper becomes shorter.

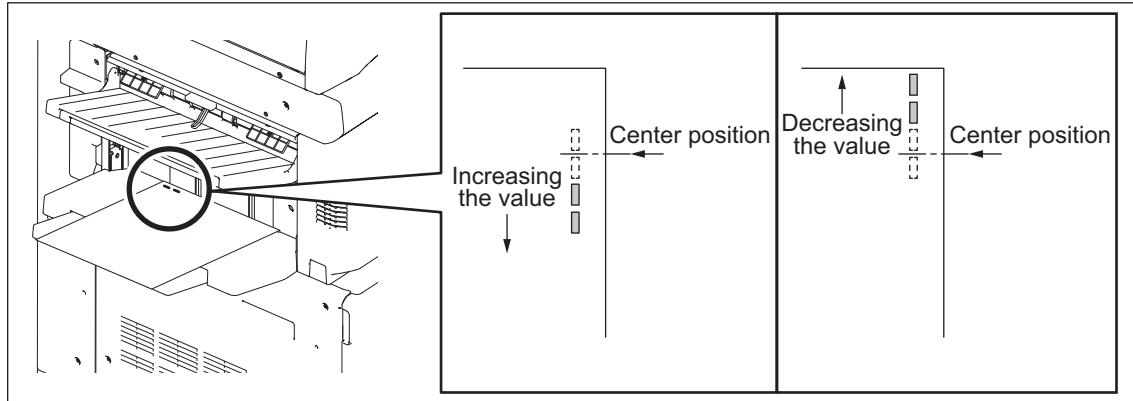


Fig.6-82

**[C] Stapling position adjustment (front 1-point / paper output direction: portrait)**

This adjustment is performed in the Adjustment Mode (FS-05-4823-2) of the equipment.

Adjustment scale	0.2mm	
Adjustable range	-3.4 mm to 3.4 mm	
Adjustment value	-17 to 17 (Default value: 0)	
Adjustment direction	Increasing the value	The distance between the stapling position and the edge of the paper becomes shorter.
	Decreasing the value	The distance between the stapling position and the edge of the paper becomes longer.

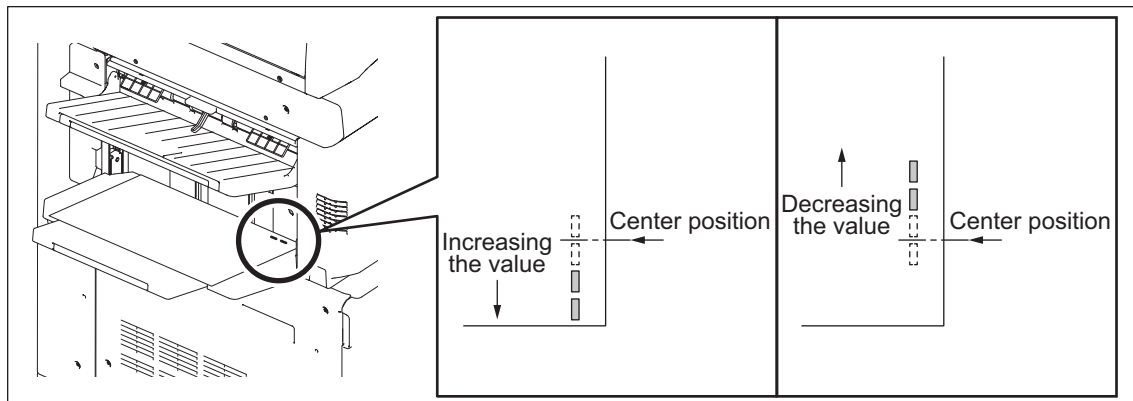


Fig.6-83

**[D] Stapling position adjustment (front 1-point / paper output direction: landscape)**

This adjustment is performed in the Adjustment Mode (FS-05-4823-3) of the equipment.

Adjustment scale	0.2mm	
Adjustable range	-3.4 mm to 3.4 mm	
Adjustment value	-17 to 17 (Default value: 0)	
Adjustment direction	Increasing the value	The distance between the stapling position and the edge of the paper becomes shorter.
	Decreasing the value	The distance between the stapling position and the edge of the paper becomes longer.

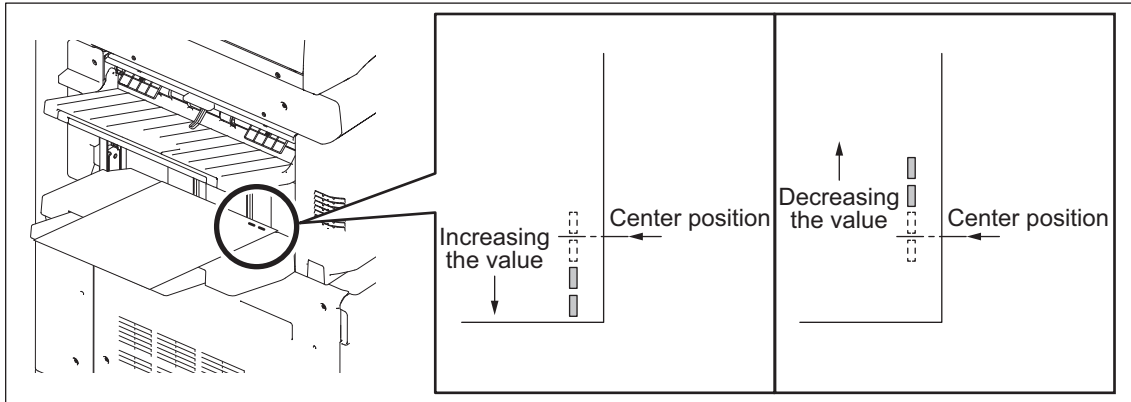


Fig.6-84

**[E] Stapling position adjustment (center 2-point)**

This adjustment is performed in the Adjustment Mode (FS-05-4823-4) of the equipment.

Adjustment scale	0.2mm	
Adjustable range	-3.4 mm to 3.4 mm	
Adjustment value	-17 to 17 (Default value: 0)	
Adjustment direction	Increasing the value	The stapling position moves farther to the front side from the center position.
	Decreasing the value	The stapling position moves farther to the rear side from the center position.

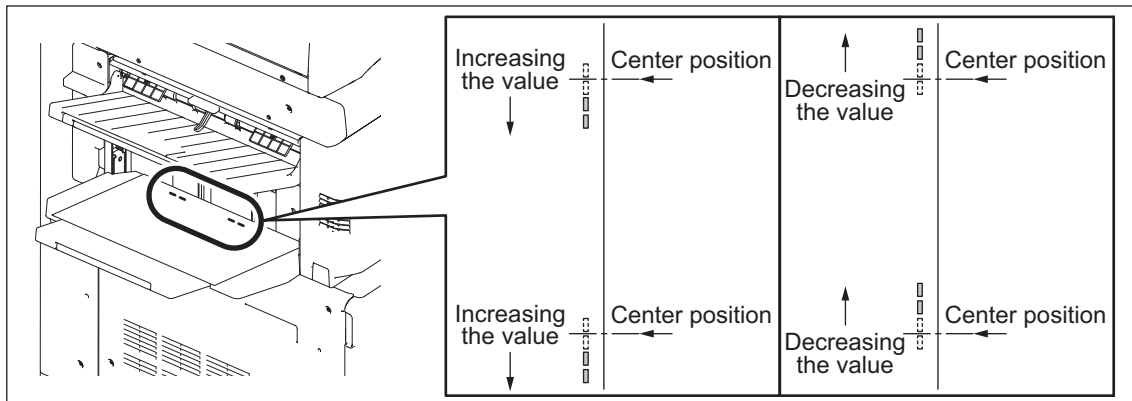


Fig.6-85



### 6.14.3 Punch hole position adjustment

This adjustment is performed in the Adjustment Mode (FS-05-4825) of the equipment.

Adjustment scale	0.2mm	
Adjustable range	-3.4 mm to 2.4 mm	
Adjustment value	-17 to 12 (Default value: 0)	
Adjustment direction	Increasing the value	The distance between the punch hole and the trailing edge of the paper becomes shorter.
	Decreasing the value	The distance between the punch hole and the trailing edge of the paper becomes longer.

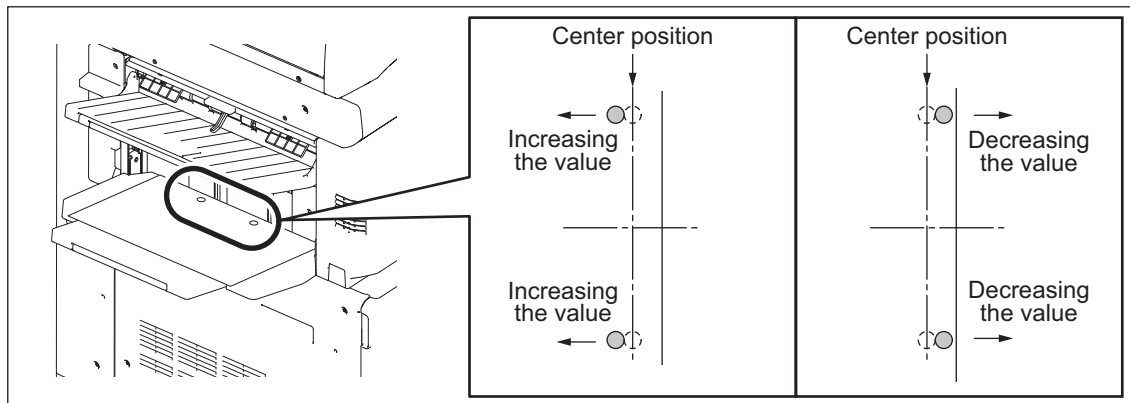


Fig.6-86

## 6.15 Adjustment of the Console Finisher

### Notes:

Before performing each adjustment, make sure that all covers (incl. those of the finisher and host machine) are closed. Otherwise, the power is not supplied to the finisher and the adjustment may not be performed properly.

### 6.15.1 Adjusting the alignment position

Perform this adjustment after replacing the Finisher control board or when the alignment position must be changed for some reason.

#### [A] Reading/writing of the adjustment value with the self-diagnostic mode

If the adjustment values can be confirmed from the pre-change board, check them from the connected equipment and then set them into the post-change board.

A4-size adjustment value check: Perform FS-05-4838-1.

LT-size adjustment value check: Perform FS-05-4838-2.

Item to be adjusted		Code	Remarks
Horizontal position of the paper	A-series paper	FS-05-4838-1	Adjusts the horizontal position of the paper. When a positive value is set, the pitch of the alignment plate becomes smaller. When a negative value is set, the pitch of the alignment plate becomes larger. 0: Finisher not installed 1: -2.10mm 2: -1.68mm 3: -1.26mm 4: -0.84mm 5: -0.42mm 6: 0.00mm 7: +0.42mm 8: +0.84mm 9: +1.26mm 10: +1.68mm 11: +2.10mm
	LT-series paper	FS-05-4838-2	

If the adjustment values cannot be confirmed, perform the adjustment in the following procedure.

#### [B] Adjustment with DIP-SW

Adjustment must be performed with 2 types of adjustment sheets for the A4 and LT series.

The adjustment value of A4 will be applied to the operation with A3, A4, A4-R, B4, B5, FOLIO, 8K, 16K. The adjustment value of LT will be applied to the operation with LD, LG, LT, LT-R, COMP, 13 LG, 8.5" SQ.

- (1) Turn OFF the power of the equipment.
- (2) Remove 1 screw and take off the board access cover [1].
- (3) Set the SW1 [2] on the Finisher control board as shown in the figures below.

Adjusting for A4 size paper: Turn ON pin 2 and 4.

Adjusting for LT size paper: Turn ON pin 1, 2, and 4.

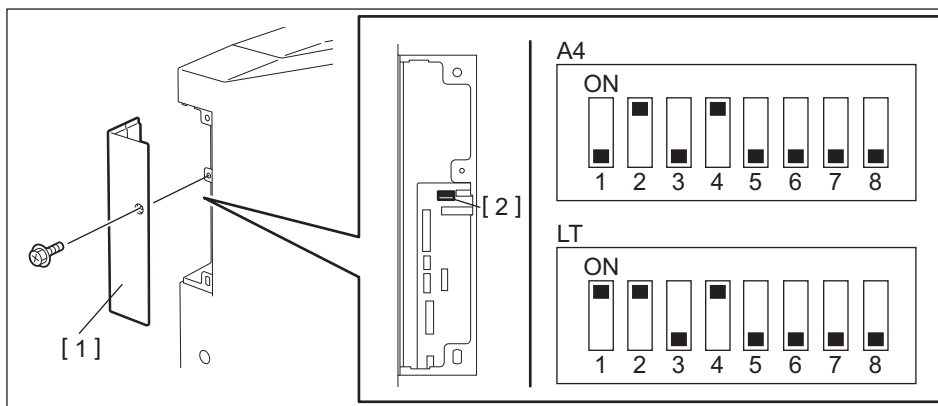


Fig.6-87

- (4) Start the equipment in the HS mode.  
The alignment plate moves to the SW1 set position and then stops.
- (5) Press the [Button1] to adjust the alignment position.  
Every time [Button1] is pressed, the alignment plate shifts by 0.42 mm. (The gap between the alignment plates becomes narrower.)

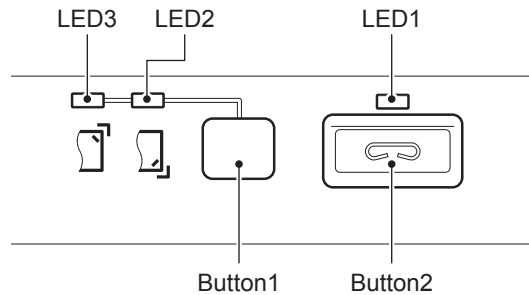


Fig.6-88

- (6) Place the adjustment sheet [1] on the process tray and adjust the position to make the gap between paper and the alignment plate [2] "0".  
Then setting is performed at a value that is one smaller than the adjustment value.

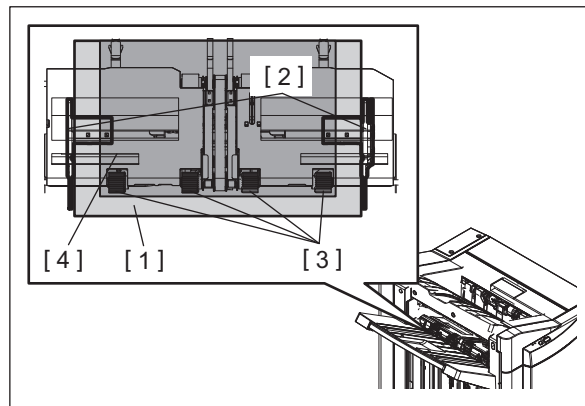


Fig.6-89

**Remarks:**

- Use an adjustment sheet [1] made of plastic resin which is light and accurate in measurement (e.g. OHP film).
- To reduce frictional resistance with the vertical alignment roller [3] on the process tray, place a sheet of B5 paper [4] beneath the adjustment sheet [1] on the vertical alignment roller [3].
- Confirm the gap between paper and the alignment plate [2] by moving the adjustment sheet [1] forward and backward.

- (7) When the adjustment is completed, press the [Button2] on the finisher control panel to store the adjustment value in memory.  
 When the value is stored normally, the [LED1] on the control panel will blink for a number of times that corresponds to the adjustment value set for the equipment.  
 See the following table for the number of times the [LED1] blinks and its corresponding moved amount (mm).

Number of Blinking	Distance from the center value (mm)
1	-2.10
2	-1.68
3	-1.26
4	-0.84
5	-0.42
6	Center value (0.00)
7	+0.42
8	+0.84
9	+1.26
10	+1.68
11	+2.10

- (8) Turn OFF the power of the equipment.
- (9) Turn OFF all bits of the SW1 on the Finisher control board.
- (10) Install the board access cover.

## 6.15.2 Adjusting the stapling position

Perform this adjustment after replacing the Finisher control board or when the stapling position must be changed for some reason.

### [A] Reading/writing of the adjustment value with the self-diagnostic mode

If the adjustment values can be confirmed from the pre-change board, check them from the connected equipment and then set them into the post-change board.

Adjustment value check (common for A4-size and LT-size): Perform FS-05-4838-3.

Item to be adjusted	Code	Remarks
Stapling position	FS-05-4838-3	Adjusts the stapling position. When a positive value is set, it shifts toward the rear side. When a negative value is set, it shifts toward the front side. 0: Finisher not installed 1: -2.16mm 2: -1.89mm 3: -1.62mm 4: -1.35mm 5: -1.08mm 6: -0.81mm 7: -0.54mm 8: -0.27mm 9: ±0.00mm 10: +0.27mm 11: +0.54mm 12: +0.81mm 13: +1.08mm 14: +1.35mm 15: +1.62mm 16: +1.89mm 17: +2.16mm

If the adjustment values cannot be confirmed, perform the adjustment in the following procedure.

### [B] Adjustment with DIP-SW

- (1) Turn OFF the power of the equipment.
- (2) Remove 1 screw and take off the board access cover [1].
- (3) Set the SW1 [2] on the Finisher control board as shown in the figures below.

When adjusting the rear side for A4 size paper: Turn ON pin 1, 3, and 4.	When adjusting the rear side for LT size paper: Turn ON pin 1, 2, 3, and 4.
When adjusting the front side for A4 size paper: Turn ON pin 3 and 4.	When adjusting the front side for LT size paper: Turn ON pin 2, 3, and 4.

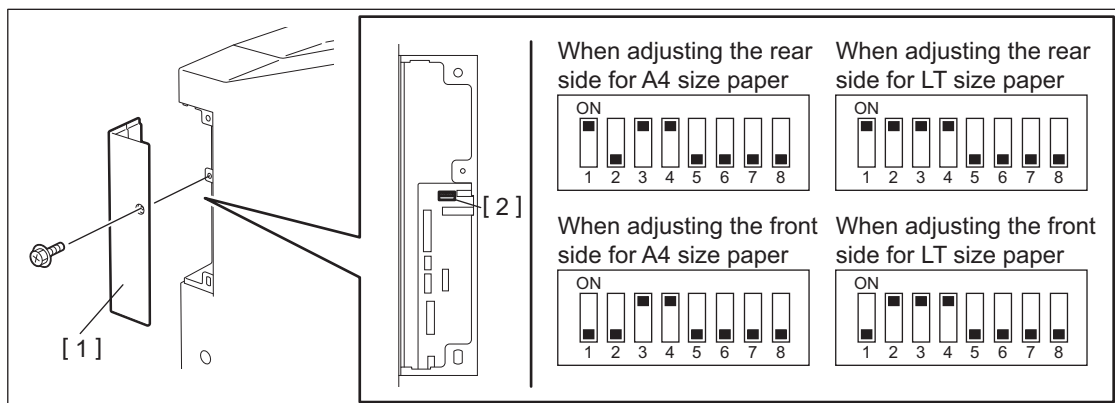


Fig.6-90

### Remarks:

Although there are four setting types for the SW1 as shown above, perform only one of them since the adjustment values are used in common.

- (4) Start the equipment in the HS mode.  
The staple unit moves to the rear or front side stapling position and stops. (It stops at the position of -2.16 mm (at the front side) from the center value of the adjustment range.)
- (5) Press [Button 1] to adjust the stapling position.  
Every time [Button 1] is pressed, the staple unit shifts by +0.27 mm (toward the rear side).  
Adjustment range is from -2.16 to +2.16 mm. If [Button 1] is pressed when the alignment position is at +2.16 mm, the unit will return to -2.16 mm.

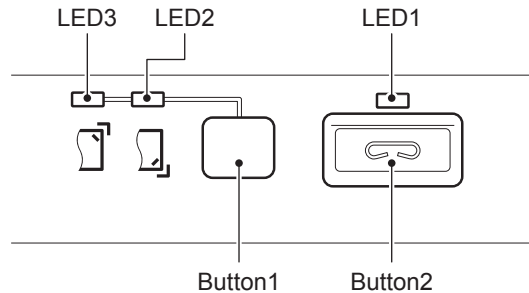


Fig.6-91

- (6) When the adjustment is completed, press [Button 2] on the finisher control panel to store the adjustment value in memory without sheets on the finishing tray.  
When the value is stored normally, [LED 1] on the control panel will blink for a number of times that corresponds to the adjustment value set for the equipment.  
See the following table for the number of times [LED 1] blinks and its corresponding adjustment value.

Number of blinking	Distance from the center value (mm)
1	-2.16
2	-1.89
3	-1.62
4	-1.35
5	-1.08
6	-0.81
7	-0.54
8	-0.27
9	Center value (0.00)
10	+0.27
11	+0.54
12	+0.81
13	+1.08
14	+1.35
15	+1.62
16	+1.89
17	+2.16

- (7) Turn OFF the power of the equipment.
- (8) Turn OFF all bits of the SW1 on the Finisher control board.
- (9) Install the board access cover.

## 6.16 Adjustment of the Saddle Stitch Finisher

### Notes:

Before performing each adjustment, make sure that all covers (incl. those of the finisher and host machine) are closed. Otherwise, the power is not supplied to the finisher and the adjustment may not be performed properly.

### 6.16.1 Adjusting the Alignment Position

Perform this adjustment after replacing the Finisher control board or when the alignment position must be changed for some reason.

#### [A] Reading/writing of the adjustment value with the self-diagnostic mode

If the adjustment values can be confirmed from the pre-change board, check them from the connected equipment and then set them into the post-change board.

A4-size adjustment value check: Perform FS-05-4838-1.

LT-size adjustment value check: Perform FS-05-4838-2.

Item to be adjusted		Code	Remarks
Horizontal position of the paper	A-series paper	FS-05-4838-1	Adjusts the horizontal position of the paper. When a positive value is set, the pitch of the alignment plate becomes smaller. When a negative value is set, the pitch of the alignment plate becomes larger. 0: Finisher not installed 1: -2.10mm 2: -1.68mm 3: -1.26mm 4: -0.84mm 5: -0.42mm 6: 0.00mm 7: +0.42mm 8: +0.84mm 9: +1.26mm 10: +1.68mm 11: +2.10mm
	LT-series paper	FS-05-4838-2	

If the adjustment values cannot be confirmed, perform the adjustment in the following procedure.

#### [B] Adjustment with DIP-SW

Adjustment must be performed with 2 types of adjustment sheets for the A4 and LT series.

The adjustment value of A4 will be applied to the operation with A3, A4, A4-R, B4, B5, FOLIO, 8K, 16K.

The adjustment value of LT will be applied to the operation with LD, LG, LT, LT-R, COMP, 13 LG, 8.5" SQ.

- (1) Turn OFF the power of the equipment.
- (2) Remove 2 screws and take off the board access cover [1].

- (3) Set the SW1 on the Finisher control board as shown in the figures below.

Adjusting for A4 size paper:

Turn ON pin 2 and 4.

Adjusting for LT size paper:

Turn ON pin 1, 2, and 4.

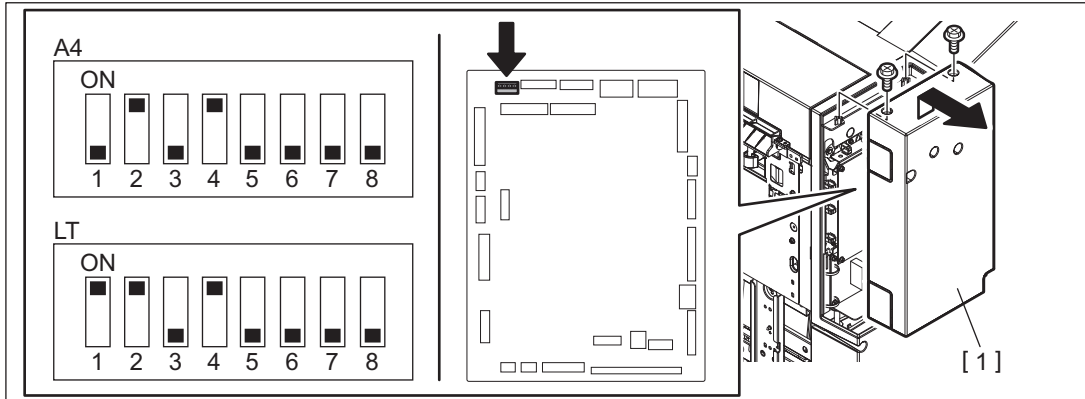


Fig.6-92

- (4) Start the equipment in the HS mode.  
The alignment plate moves to the SW1 set position and then stops.
- (5) Press [Button1] to adjust the alignment position.  
Every time [Button1] is pressed, the alignment plate shifts by 0.42 mm. (The gap between the alignment plates becomes narrower.)

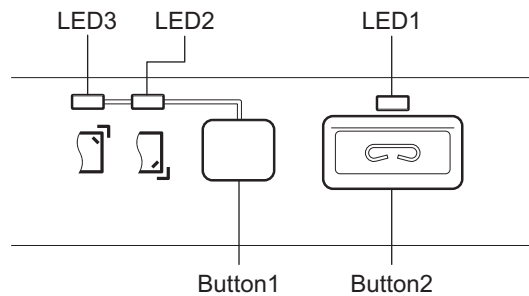


Fig.6-93

- (6) Place the adjustment sheet [1] on the process tray and adjust the position to make the gap between paper and the alignment plate [2] "0".  
Then setting is performed at a value that is one smaller than the adjustment value.

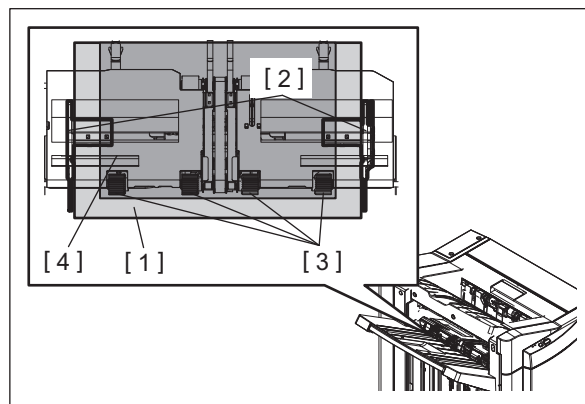


Fig.6-94



**Remarks:**

- Use an adjustment sheet [1] made of plastic resin which is light and accurate in measurement (e.g. OHP film).
- To reduce frictional resistance with the vertical alignment roller [3] on the process tray, place a sheet of B5 paper [4] beneath the adjustment sheet [1] on the vertical alignment roller [3].
- Confirm the gap between paper and the alignment plate [2] by moving the adjustment sheet [1] forward and backward.

(7) When the adjustment is completed, press the [Button2] on the finisher control panel to store the adjustment value in memory.

When the value is stored normally, the [LED1] on the control panel will blink for a number of times that corresponds to the adjustment value set for the equipment.

See the following table for the number of times [LED1] blinks and its corresponding moved amount (mm).

Number of Blinking	Distance from the center value (mm)
1	-2.10
2	-1.68
3	-1.26
4	-0.84
5	-0.42
6	Center value (0.00)
7	+0.42
8	+0.84
9	+1.26
10	+1.68
11	+2.10

(8) Turn OFF the power of the equipment.

(9) Turn OFF all bits of the SW1 on the Finisher control board.

(10) Install the board access cover.

## 6.16.2 Adjusting the Stapling Position

Perform this adjustment after replacing the Finisher control board or when the stapling position must be changed for some reason.

### [A] Reading/writing of the adjustment value with the self-diagnostic mode

If the adjustment values can be confirmed from the pre-change board, check them from the connected equipment and then set them into the post-change board.

Adjustment value check (common for A4-size and LT-size): Perform FS-05-4838-3.

Item to be adjusted	Code	Remarks
Stapling position	FS-05-4838-3	<p>Adjusts the stapling position. When a positive value is set, it shifts toward the rear side. When a negative value is set, it shifts toward the front side.</p> <p>0: Finisher not installed            1: -2.16mm 2: -1.89mm 3: -1.62mm 4: -1.35mm            5: -1.08mm 6: -0.81mm 7: -0.54mm 8: -0.27mm            9: ±0.00mm 10: +0.27mm 11: +0.54mm 12: +0.81mm            13: +1.08mm 14: +1.35mm 15: +1.62mm 16: +1.89mm            17: +2.16mm</p>

If the adjustment values cannot be confirmed, perform the adjustment in the following procedure.

### [B] Adjustment with DIP-SW

- (1) Turn OFF the power of the equipment.
- (2) Remove 2 screws and take off the board access cover [1].
- (3) Set the SW1 on the Finisher control board as shown in the figures below.

When adjusting the rear side for A4 size paper: Turn ON pin 1, 3, and 4.	When adjusting the rear side for LT size paper: Turn ON pin 1, 2, 3, and 4.
When adjusting the front side for A4 size paper: Turn ON pin 3 and 4.	When adjusting the front side for LT size paper: Turn ON pin 2, 3, and 4.

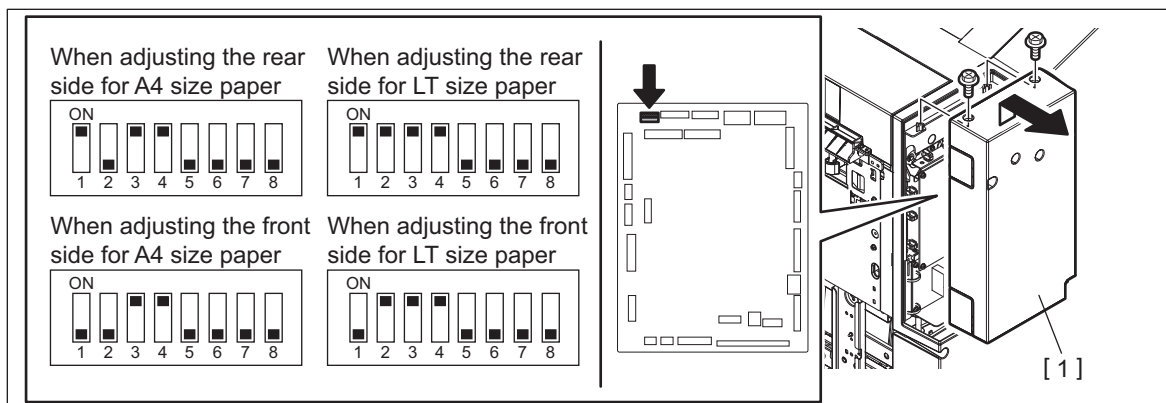


Fig.6-95

### Remarks:

Although there are four setting types for the SW1 as shown above, perform only one of them since the adjustment values are used in common.

- (4) Start the equipment in the HS mode.  
The staple unit moves to the rear or front side stapling position and stops. (It stops at the position of -2.16 mm (at the front side) from the center value of the adjustment range.)
- (5) Press [Button 1] to adjust the stapling position.  
Every time [Button 1] is pressed, the staple unit shifts by +0.27 mm (toward the rear side).  
Adjustment range is from -2.16 to +2.16 mm. If [Button 1] is pressed when the alignment position is at +2.16 mm, the unit will return to -2.16 mm.

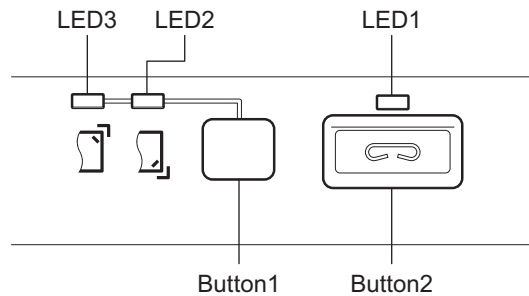


Fig.6-96

- (6) When the adjustment is completed, press [Button 2] on the finisher control panel to store the adjustment value in memory without sheets on the finishing tray.  
When the value is stored normally, [LED 1] on the control panel will blink for a number of times that corresponds to the adjustment value set for the equipment.  
See the following table for the number of times [LED 1] blinks and its corresponding adjustment value.

Number of blinking	Distance from the center value (mm)
1	-2.16
2	-1.89
3	-1.62
4	-1.35
5	-1.08
6	-0.81
7	-0.54
8	-0.27
9	Center value (0.00)
10	+0.27
11	+0.54
12	+0.81
13	+1.08
14	+1.35
15	+1.62
16	+1.89
17	+2.16

- (7) Turn OFF the power of the equipment.
- (8) Turn OFF all bits of the SW1 on the Finisher control board.
- (9) Install the board access cover.

### 6.16.3 Stapling/folding position adjustment in saddle stitch unit

Perform this adjustment when the saddle control PC board was replaced or the stapling/folding position must be changed for some reason.

Prepare 2 types of booklet samples using the main unit and use them for adjustment accordingly.

- (1) Create 2 types of booklet samples (1 set each) using the main unit.

	Sample 1	Sample 2
Media type	Recommended paper	Recommended paper
Paper size	A4	A3
Number of sheet	5 sheets	5 sheets

- (2) Measure the stapling and folding positions of the samples, and then perform adjustment accordingly.  
For stapling and folding, paper on the stacker of the stacker unit is moved to an exclusive mechanism for stapling or folding. Therefore adjustment must be performed individually for the folding stopping position of the stacker and the stapling stopping position.

\*Check the folding position at the centerfold page of the sample.

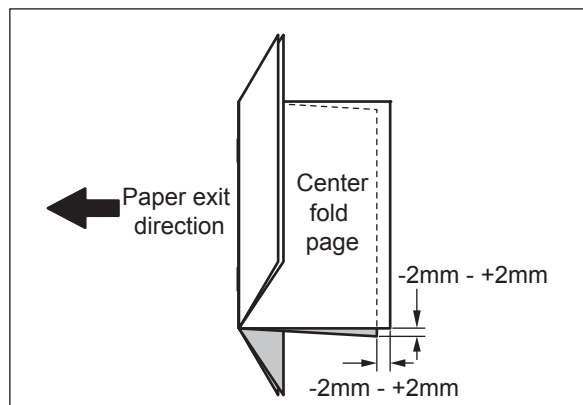


Fig.6-97

\* Check the stapling position at the centerfold page of the sample.

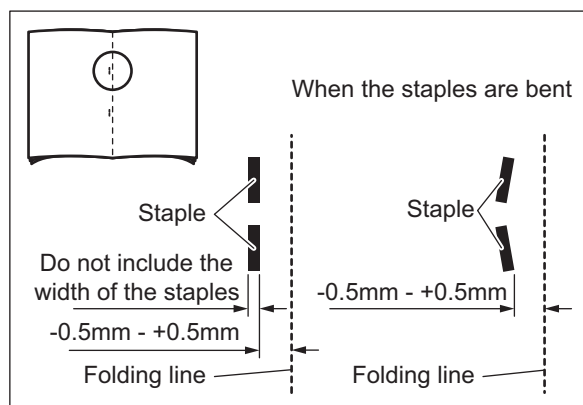
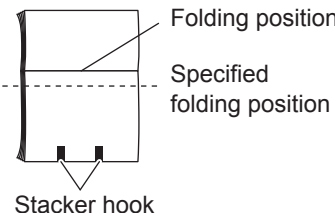
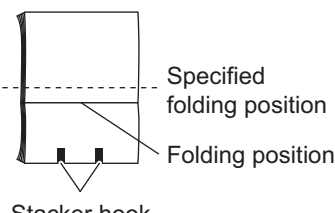
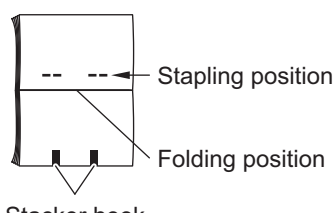
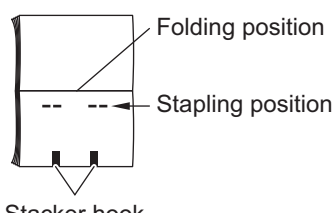


Fig.6-98

**Notes:**

Perform adjustment for the folding position first because the stapling position must be adjusted referring to the folding line.

Phenomenon	Contents	Adjustment
 <p><b>Fig.6-99</b></p>	<p>When the folding position is deviated from the specified one by more than -2.0 mm</p>	<p>Increase the value of the folding position adjustment in order to move the folding stopping position (the position of the stacker hooks) of the stacker upward.            P. 6-124 "[A] Adjustment with self-diagnostic mode"</p>
 <p><b>Fig.6-100</b></p>	<p>When the folding position is deviated from the specified one by more than 2.0 mm</p>	<p>Decrease the value of the folding position adjustment in order to move the folding stopping position (the position of the stacker hooks) of the stacker downward.            P. 6-124 "[A] Adjustment with self-diagnostic mode"</p>
 <p><b>Fig.6-101</b></p>	<p>When the stapling position is deviated from the specified one more than -0.50 mm</p>	<p>Decrease the value of the stapling position adjustment in order to move the stapling stopping position (the position of the stacker hooks) of the stacker downward.            P. 6-124 "[A] Adjustment with self-diagnostic mode"</p>
 <p><b>Fig.6-102</b></p>	<p>When the stapling position is deviated from the specified one more than 0.50 mm</p>	<p>Increase the value of the stapling position adjustment in order to move the stapling stopping position (the position of the stacker hooks) of the stacker upward.            P. 6-124 "[A] Adjustment with self-diagnostic mode"</p>

## 6.16.4 Folding position adjustment

### [A] Adjustment with self-diagnostic mode

Perform the adjustment from the connected equipment.

If the adjustment values can be confirmed from the pre-change board, check them from the connected equipment and then set them into the post-change board.

LD-size and A3-size adjustment value check: Perform FS-05-4838-6.

LG-size, B4-size, A4R-size, and 8K-size adjustment value check: Perform FS-05-4838-7.

Item to be adjusted		Code	Remarks
Saddle stitch folding position	A3,LD	FS-05-4838-6	Adjusts the saddle stitch folding position in the paper feeding direction. When a positive value is set, it shifts toward the trailing edge of the paper (stacker hook side). When a negative value is set, it shifts toward the leading edge of the paper. 0: Finisher not installed 1: -1.4mm 2: -1.2mm 3: -1.0mm 4: -0.8mm 5: -0.6mm 6: -0.4mm 7: -0.2mm 8: 0.0mm 9: +0.2mm 10: +0.4mm 11: +0.6mm 12: +0.8mm 13: +1.0mm 14: +1.2mm 15: +1.4mm
	Other than A3 and LD	FS-05-4838-7	

## 6.16.5 Stapling position adjustment

### [A] Adjustment with self-diagnostic mode

Perform the adjustment from the connected equipment.

If the adjustment values can be confirmed from the pre-change board, check them from the connected equipment and then set them into the post-change board.

LD-size and A3-size adjustment value check: Perform FS-05-4838-4.

LG-size, B4-size, A4R-size, and 8K-size adjustment value check: Perform FS-05-4838-5.

Item to be adjusted		Code	Remarks
Saddle stitch stapling position	A3,LD	FS-05-4838-4	Adjusts the saddle stitch stapling position in the paper feeding direction. When a positive value is set, it shifts toward the trailing edge of the paper (stacker hook side). When a negative value is set, it shifts toward the leading edge of the paper. 0: Finisher not installed 1: -2.8mm 2: -2.4mm 3: -2.0mm 4: -1.8mm 5: -1.2mm 6: -0.8mm 7: -0.4mm 8: 0.0mm 9: +0.4mm 10: +0.8mm 11: +1.2mm 12: +1.6mm 13: +2.0mm 14: +2.4mm 15: +2.8mm
	Other than A3 and LD	FS-05-4838-5	

## 6.16.6 Saddle Stitch Skew Adjustment

Perform this adjustment when the folding position for saddle stitching is tilted.

- (1) Turn OFF the power of the equipment.
- (2) Open the cover, pull out the saddle stitch section, and then loosen the 2 screws.

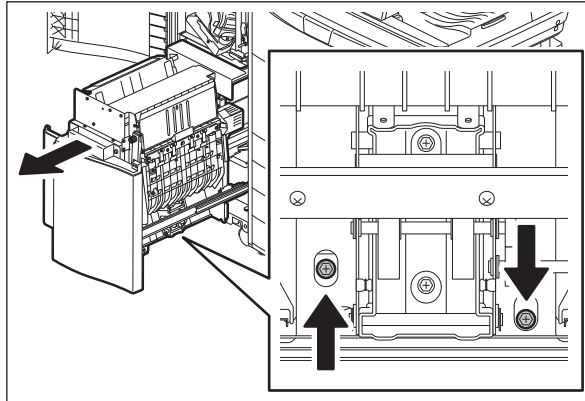


Fig.6-103

- (3) Rotate the adjustment screw slightly.

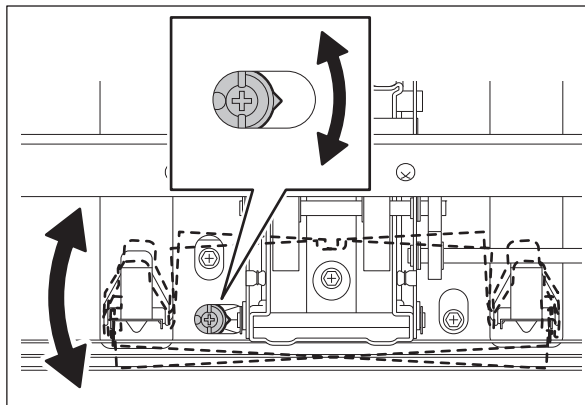


Fig.6-104

- (4) Tighten the 2 screws, return the saddle stitch section, and then close the cover.

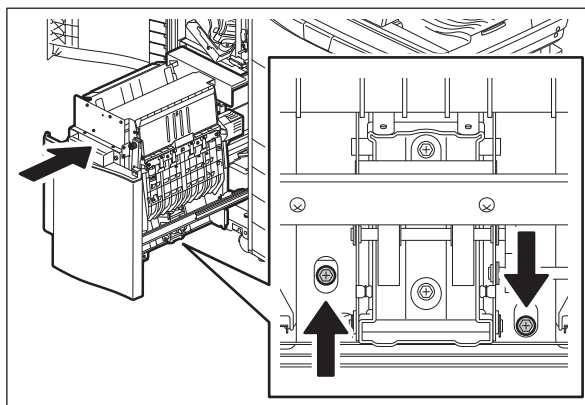


Fig.6-105

## 6.17 Adjustment of Hole punch unit

### 6.17.1 Destination setting of hole punch control PC board

This setting is performed when the hole punch control PC board (HP) [1] is replaced with a DIP switch [2] on it.

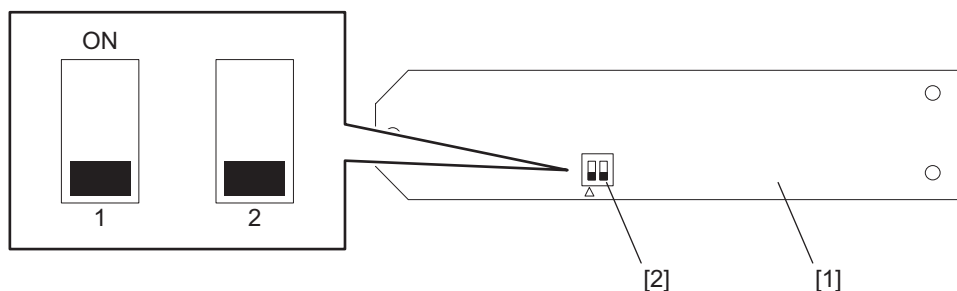


Fig.6-106

Refer to the table below for the destination settings.

Destination	Number of punch holes	DIP switch	
		1	2
MJ-6011E (Europe/Japan/China)	2 holes	OFF	OFF
MJ-6011N (North America)	2/3 holes	ON	OFF
MJ-6011F (France)	4 holes	OFF	ON
MJ-6011S (Sweden)	4 holes	ON	ON



## 6.17.2 Stopping Position Adjustment (MJ-6105)

This adjustment can change the position where paper transport stops during the punching operation. Perform this adjustment when you adjust the punching position on the paper in the transporting direction.

### [A] Adjustment with self-diagnostic mode

Item to be adjusted	Code	Remarks
Hole punch position	FS-05-4838-0	Adjusts the hole punch position in the paper feeding direction. When a positive value is set, it shifts toward the feeding side. When a negative value is set, it shifts toward the exit side. 0: Finisher not installed 1: -1.10mm 2: -0.88mm 3: -0.66mm 4: -0.44mm 5: -0.22mm 6: 0.00mm 7: +0.22mm 8: +0.44mm 9: +0.66mm 10: +0.88mm 11: +1.10mm

### [B] Adjustment with DIP-SW

If the adjustment values can be confirmed from the pre-change board, check them from the connected equipment and then set them into the post-change board.

Adjustment value check: Perform FS-05-4838-0.

If the adjustment values cannot be confirmed, perform the adjustment in the following procedure.

- (1) Turn the power of the equipment OFF.
- (2) Take off the board access cover [1] of the Finisher. Then set SW1 (DIP-SW) [2] on the finisher control PC board as shown below.

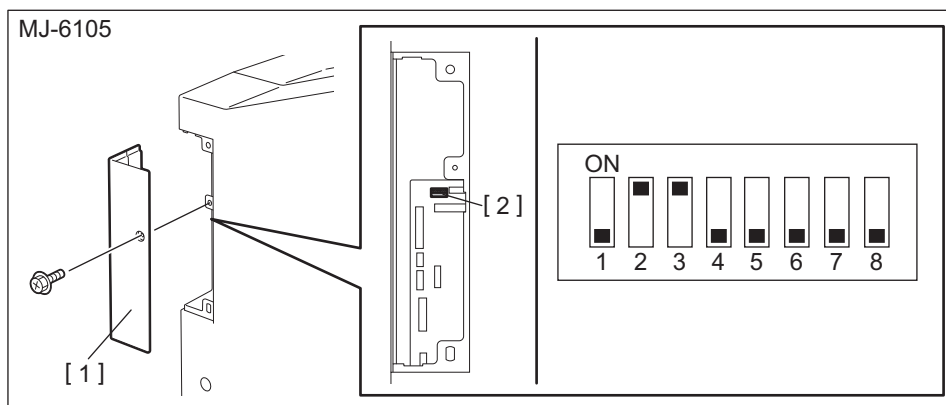


Fig.6-107

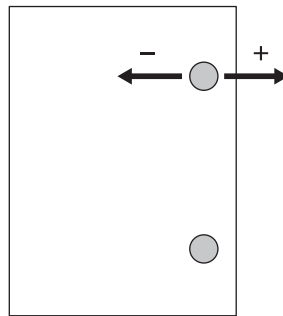
- (3) Turn the power of the equipment ON. The finisher enters into the stopping position adjustment mode.
- (4) LED1 on the finisher control panel blinks. The number of times it blinks indicates the current adjustment value.

- (5) Press Button1 on the finisher control panel to change the adjustment value. The number of times LED1 blinks changes in ascending order (e.g. 1, 2, 3... 11) each time you press Button1.

Number of LED1's blinking	Adjustment Value (Steps from the center value)	Distance from the center value
1	-5	1.10 mm
2	-4	0.88 mm
3	-3	0.66 mm
4	-2	0.44 mm
5	-1	0.22 mm
6	0	0 mm (Center value)
7	+1	0.22 mm
8	+2	0.44 mm
9	+3	0.66 mm
10	+4	0.88 mm
11	+5	1.10 mm

**Notes:**

When the adjustment value goes further in minus numbers in the table above, the distance between the paper edge and the holes becomes wider. When it goes further in plus numbers, this distance becomes narrower.



- (6) When the value change is completed, press Button2 on the finisher control panel to determine the adjustment value. (The adjustment value is written into the flash ROM.)
- (7) Turn the power of the equipment OFF.
- (8) Turn all the bits of SW1 (DIP-SW) on the finisher control PC board OFF.
- (9) Install the board access cover of the Finisher.

## 7. PREVENTIVE MAINTENANCE (PM)

### 7.1 General Description

The purpose of preventive maintenance (PM) is to maintain the quality level of this equipment by periodically inspecting and cleaning this equipment and also replacing the parts whose replacement timing has come according to the maintenance contract. There are PM kits packaged for each unit or a group of parts with the same replacement number of output pages, allowing you to carry out efficient parts replacement.

### 7.2 PM Display

#### 7.2.1 General Description

The maintenance timing for the PM parts of the process unit, such as the drum and developer material, and the PM parts of the units other than the process unit, such as the 2nd transfer roller varies depending on the conditions of the use, such as the ratio of color/black printing. Therefore, this equipment shows the appropriate maintenance timing of each part on the control panel LCD.

#### 7.2.2 PM Display Conditions

The conditions of the PM display consist of the codes of the 08 SETTING MODE for “the setting value treated as a threshold of the PM display”, “the counter indicating the current number of prints and driving time” and “the setting value which determines the display conditions”.

The PM timing is displayed when the counter exceeds the setting value according to the display condition based on “the setting value which determines the display conditions”.

- Setting value treated as a threshold of the PM display

**Notes:**

When “0” is entered as the setting value, PM timing is not displayed.

FS-08-6190: Setting value of PM counter [process unit (K)]

FS-08-6191: Setting value of PM time counter [process unit (K)]

FS-08-6192: Setting value of PM counter [process unit (Y)]

FS-08-6193: Setting value of PM time counter [process unit (Y)]

FS-08-5550: Setting value of PM counter [process unit (M)]

FS-08-5551: Setting value of PM time counter [process unit (M)]

FS-08-5552: Setting value of PM counter [process unit (C)]

FS-08-5553: Setting value of PM time counter [process unit (C)]

FS-08-5554: Setting value of PM counter [developer material (K)]

FS-08-5555: Setting value of PM time counter [developer material (K)]

FS-08-5556: Setting value of PM counter [developer material (Y)]

FS-08-5557: Setting value of PM time counter [developer material (Y)]

FS-08-5558: Setting value of PM counter [developer material (M)]

FS-08-5559: Setting value of PM time counter [developer material (M)]

FS-08-5560: Setting value of PM counter [developer material (C)]

FS-08-5561: Setting value of PM time counter [developer material (C)]

FS-08-5562: Setting value of PM counter [parts other than the PM parts of the process unit]

FS-08-5563: Setting value of PM time counter [parts other than the PM parts of the process unit]

- Counter indicating the current number of prints and driving time

FS-08-6194: Current value of PM counter [process unit (K)]

FS-08-6195: Current value of PM time counter [process unit (K)]

FS-08-6196: Current value of PM counter [process unit (Y)]

FS-08-6197: Current value of PM time counter [process unit (Y)]

FS-08-5564: Current value of PM counter [process unit (M)]

FS-08-5565: Current value of PM time counter [process unit (M)]

FS-08-5566: Current value of PM counter [process unit (C)]  
FS-08-5567: Current value of PM time counter [process unit (C)]  
FS-08-5568: Current value of PM counter [developer material (K)]  
FS-08-5569: Current value of PM time counter [developer material (K)]  
FS-08-5570: Current value of PM counter [developer material (Y)]  
FS-08-5571: Current value of PM time counter [developer material (Y)]  
FS-08-5572: Current value of PM counter [developer material (M)]  
FS-08-5573: Current value of PM time counter [developer material (M)]  
FS-08-5574: Current value of PM counter [developer material (C)]  
FS-08-5575: Current value of PM time counter [developer material (C)]  
FS-08-5576: Current value of PM counter [parts other than the PM parts of the process unit]  
FS-08-5577: Current value of PM time counter [parts other than the PM parts of the process unit]

- Setting value which determines the display conditions

FS-08-6198: Switching of output pages/driving counts at PM [process unit (K)]  
FS-08-5578: Switching of output pages/driving counts at PM [process unit (Y)]  
FS-08-5579: Switching of output pages/driving counts at PM [process unit (M)]  
FS-08-5580: Switching of output pages/driving counts at PM [process unit (C)]  
FS-08-5581: Switching of output pages/driving counts at PM [developer material (K)]  
FS-08-5582: Switching of output pages/driving counts at PM [developer material (Y)]  
FS-08-5583: Switching of output pages/driving counts at PM [developer material (M)]  
FS-08-5584: Switching of output pages/driving counts at PM [developer material (C)]  
FS-08-5585: Switching of output pages/driving counts at PM [parts other than the PM parts of the process unit]

## 7.2.3 PM Display Contents

When the counter value exceeds the setting value, the equipment notifies you of when the maintenance time has come by displaying the message “Time for periodic maintenance \*\*\*\*” on the control panel LCD. “\*\*\*\*” in the message is a 4-digit hexadecimal number code. This number is allocated in the following manner, therefore the parts needing maintenance can be identified.

PM parts of the process unit (K)	: 0008
PM parts of the process unit (Y)	: 0001
PM parts of the process unit (M)	: 0002
PM parts of the process unit (C)	: 0004
Developer material (K)	: 0080
Developer material (Y)	: 0010
Developer material (M)	: 0020
Developer material (C)	: 0040
Parts other than the PM parts of the process unit	: 0100

If multiple parts have reached the maintenance time, the sum of the corresponding code values listed above is displayed in hexadecimal numbers.

For example, if the PM parts of the process units (K) and (C) and the developer materials (K) and (C) reach the maintenance time, the 4-digit hexadecimal number code will be “00CC” in hexadecimal numbers: 0008+0004+0080+0040=00CC.

4th digit	3rd digit		2nd digit		1st digit	
	None	Part (2nd transfer roller)	Developer material		Photoconductive drum	
	Hexadecimal number code	Explanation	Hexadecimal number code	Explanation	Hexadecimal number code	Explanation
Always “0”	0	No maintenance required	0	No maintenance required	0	No maintenance required
	1	Maintenance required	1	Y	1	Y
			2	M	2	M
			3	M+Y	3	M+Y
			4	C	4	C
			5	Y+C	5	Y+C
			6	C+M	6	C+M
			7	Y+M+C	7	Y+M+C
			8	K	8	K
			9	K+Y	9	K+Y
			A	K+M	A	K+M
			B	K+M+Y	B	K+M+Y
			C	K+C	C	K+C
			D	K+Y+C	D	K+Y+C
			E	K+C+M	E	K+C+M
		F	K+Y+M+C	F	K+Y+M+C	

## 7.2.4 Counter Clearing

The counter indicating “current number of prints and driving time” used for the PM display function is reset by entering “0” in it or clearing it in the PM support mode.

### Notes:

Even if “0” is entered in the PM management setting value of the 08 SETTING MODE, the corresponding counter for the PM display is not reset. Be sure to clear the counter in the PM support mode when the maintenance is finished.

The reset condition of each counter is as follows:

- FS-08-6194: Current value of PM counter [process unit (K)]
- FS-08-6195: Current value of PM time counter [process unit (K)]  
When the current value of “CLEANER/DRUM/CHARGER (K)” on the main screen or “DRUM (K)” on the sub-screen in the 20 PM support mode is cleared, the counter is reset.  
In addition, when the cleaner unit is recognized as a new one by the old/new detection switch of “CLEANER/DRUM/CHARGER (K)”, the counter is also reset.
- FS-08-6196: Current value of PM counter [process unit (Y)]
- FS-08-6197: Current value of PM time counter [process unit (Y)]  
When the current value of “CLEANER/DRUM/CHARGER (Y)” on the main screen or “DRUM (Y)” on the sub-screen in the 20 PM support mode is cleared, the counter is reset.  
In addition, when the cleaner unit is recognized as a new one by the old/new detection switch of “CLEANER/DRUM/CHARGER (Y)”, the counter is also reset.
- FS-08-5564: Current value of PM counter [process unit (M)]
- FS-08-5565: Current value of PM time counter [process unit (M)]  
When the current value of “CLEANER/DRUM/CHARGER (M)” on the main screen or “DRUM (M)” on the sub-screen in the 20 PM support mode is cleared, the counter is reset.  
In addition, when the cleaner unit is recognized as a new one by the old/new detection switch of “CLEANER/DRUM/CHARGER (M)”, the counter is also reset.
- FS-08-5566: Current value of PM counter [process unit (C)]
- FS-08-5567: Current value of PM time counter [process unit (C)]  
When the current value of “CLEANER/DRUM/CHARGER (C)” on the main screen or “DRUM (C)” on the sub-screen in the 20 PM support mode is cleared, the counter is reset.  
In addition, when the cleaner unit is recognized as a new one by the old/new detection switch of “CLEANER/DRUM/CHARGER (C)”, the counter is also reset.
- FS-08-5568: Current value of PM counter [developer material (K)]
- FS-08-5569: Current value of PM time counter [developer material (K)]  
When the current value of “DEVELOPMENT UNIT” on the main screen or “BLACK DEVELOPER (K)” on the sub-screen in the 20 PM support mode is cleared, the counter is reset.  
In addition, when the developer unit is recognized as a new one by the K developer unit old/new detection switch, or the auto-toner sensor adjustment is performed, the counter is also reset.
- FS-08-5570: Current value of PM counter [developer material (Y)]
- FS-08-5571: Current value of PM time counter [developer material (Y)]  
When the current value of “DEVELOPMENT UNIT” on the main screen or “YELLOW DEVELOPER (Y)” on the sub-screen in the 20 PM support mode is cleared, the counter is reset.  
In addition, when the developer unit is recognized as a new one by the Y developer unit old/new detection switch, or the auto-toner sensor adjustment is performed, the counter is also reset.
- FS-08-5572: Current value of PM counter [developer material (M)]
- FS-08-5573: Current value of PM time counter [developer material (M)]  
When the current value of “DEVELOPMENT UNIT (M)” on the main screen or “MAGENTA DEVELOPER (M)” on the sub-screen in the 20 PM support mode is cleared, the counter is reset.

In addition, when the developer unit is recognized as a new one by the M developer unit old/new detection switch, or the auto-toner sensor adjustment is performed, the counter is also reset.

- FS-08-5574: Current value of PM counter [developer material (C)]
- FS-08-5575: Current value of PM time counter [developer material (C)]  
When the current value of “DEVELOPMENT UNIT” on the main screen or “CYAN DEVELOPER (C)” on the sub-screen in the 20 PM support mode is cleared, the counter is reset.  
In addition, when the developer unit is recognized as a new one by the C developer unit old/new detection switch, or the auto-toner sensor adjustment is performed, the counter is also reset.
- FS-08-5576: Current value of PM counter [parts other than the PM parts of the process unit]
- FS-08-5577: Current value of PM time counter [parts other than the PM parts of the process unit]  
When the current value of “2nd TRANSFER” on the main screen or “2nd TRANSFER ROLLER” on the sub screen in the 20 PM support mode is cleared, the counter is reset.

### 7.3 General Descriptions for PM Procedure

(1) Preparation

- Ask the user about the current conditions of the equipment and note them down.
- Before starting maintenance, make some sample copies and store them.
- See the replacement record and check the parts to be replaced in the 20 PM SUPPORT MODE or 30 LIST PRINT MODE.
  - 20 PM SUPPORT MODE (FS-20)
  - 30 LIST PRINT MODE (FS-30-103)

UNIT	OUTPUT PAGES DEVELOP COUNTS	PM OUTPUT PAGES DEVELOP COUNTS	DRIVE COUNTS	PM DRIVE COUNTS
DRUM(K)	1957	1957	3940	170000
DRUM BLADE(K)	1957	1957	10870	170000
GRID(K)	1957	1957	10870	170000
MAIN CHARGER NEEDLE(K)	1957	1957	10870	170000
CHARGER CLEANING PAD(K)	1957	1957	10870	170000
DRUM(Y)	1077	1077	3766	170000
DRUM BLADE(Y)	1077	1077	3766	170000
GRID(Y)	1077	1077	3766	170000
MAIN CHARGER NEEDLE(Y)	1077	1077	3766	170000
CHARGER CLEANING PAD(Y)	1077	1077	3766	170000
DRUM(M)	1077	1077	9547	170000
DRUM BLADE(M)	1077	1077	9547	170000
GRID(M)	1077	1077	9547	170000
MAIN CHARGER NEEDLE(M)	1077	1077	9547	170000
CHARGER CLEANING PAD(M)	1077	1077	9547	170000
DRUM(C)	1077	1077	9547	170000
DRUM BLADE(C)	1077	1077	9547	170000
GRID(C)	1077	1077	9547	170000
MAIN CHARGER	1077	1077	9547	170000
			9547	170000

Fig. 7-1

- Turn OFF the power and make sure to unplug the equipment.
- (2) Perform a preventive maintenance using the following checklist and illustrations.
- (3) Plug in the equipment after the maintenance has been finished. Then turn ON the power and make some copies to confirm that the equipment is working properly.

## 7.4 PM Support Mode

### 7.4.1 General Description

This equipment has a 20 PM support mode which enables you to confirm the use status of each part (the number of output pages or developed pages, and drive counts) requiring periodic replacement and also the replacement record, as well as resetting counter values efficiently. This record can be printed out in the list print mode.

### 7.4.2 Operational flow

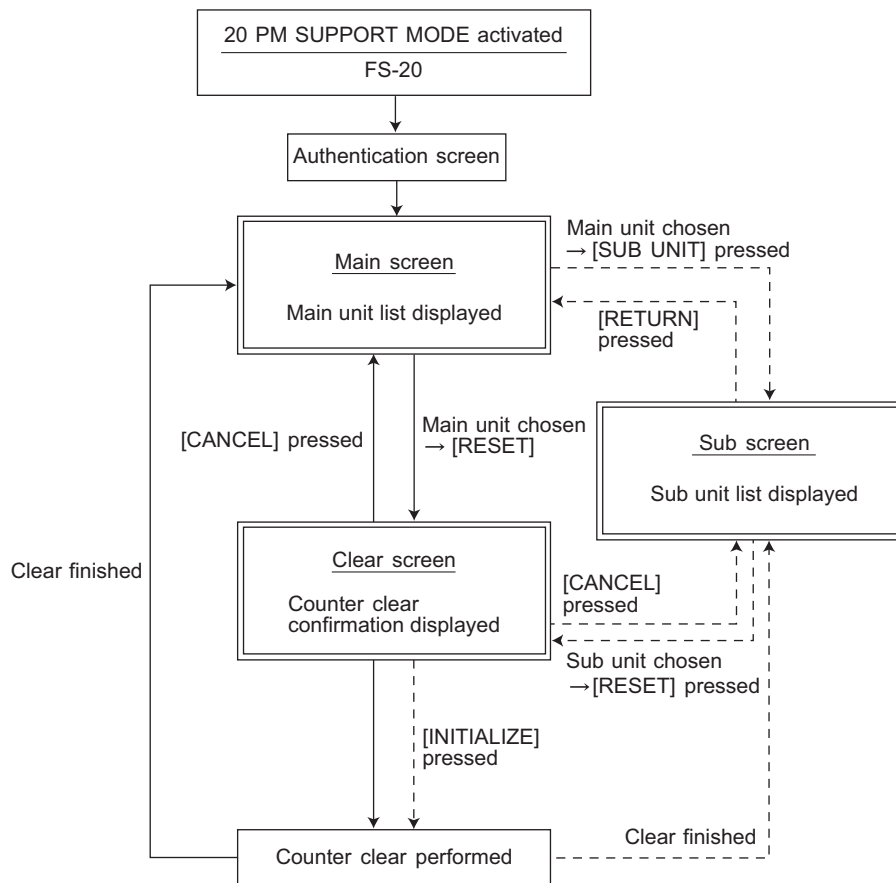


Fig. 7-2

- \* When the authentication screen appears, press [OK]. (Enter the password, if one has been set.)
- \* The screen goes back to the main screen when the counter clear is performed or the [CANCEL] button is pressed after moving from the main screen, while it goes back to the sub screen after moving from the sub screen.



## 7.4.3 Operational screen

The description of the display (including the function of each button) on the LCD screen is shown below.

### 1. Main screen

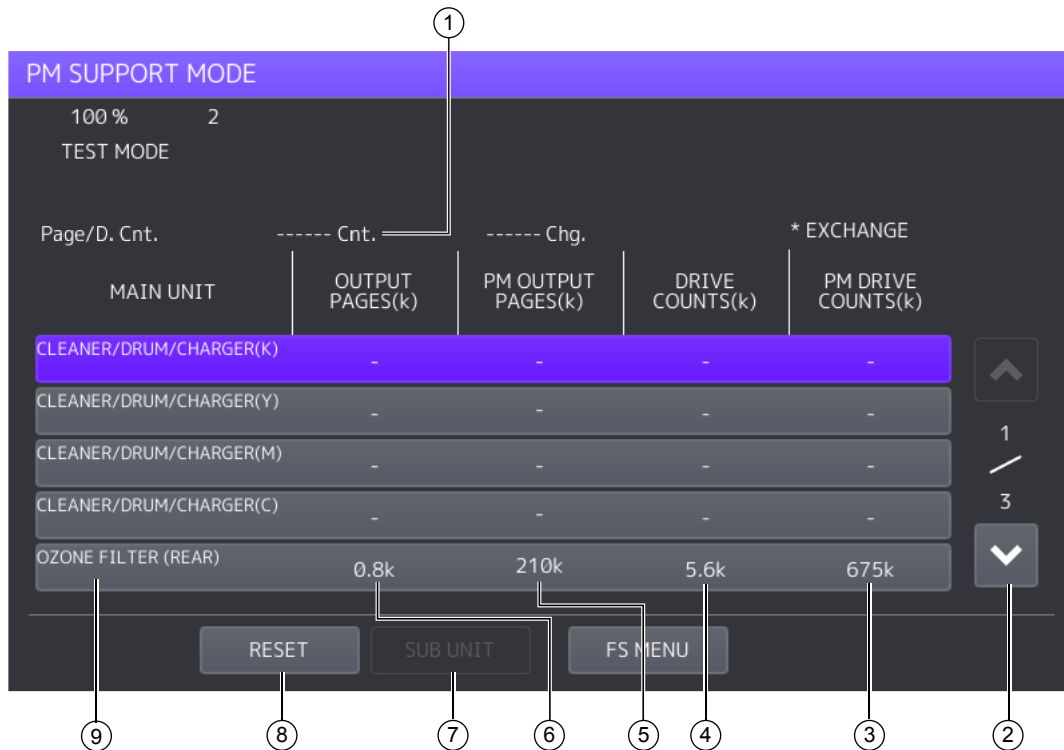


Fig. 7-3

- ① Displaying of the number of print / develop pages (Page/D. cnt), drive counts (Cnt.) and previous replacement date (Chg.) for a chosen unit  
When the replacement date for the sub unit is different, press the [SUB UNIT] button to move to the sub screen and see each information, otherwise information is not displayed
- ② Moving to the next/previous page
- ③ Displaying of the standard number of drive counts to replace the unit parts
- ④ Displaying of the present drive counts  
“\*” is displayed next to the present number when the number of drive counts has exceeded its PM standard number.
- ⑤ Displaying of the present number of print / develop pages  
When there are differences among the sub units (parts), “\_” is displayed and “CHECK SUBUNIT” is displayed at the top  
“\*” is displayed next to the present number when the number of print / develop pages has exceeded its PM standard number.
- ⑥ Displaying of the standard number of print / develop pages to replace the unit parts
- ⑦ Moving to the sub screen of the selected unit
- ⑧ Moving to the clear screen to clear the selected unit counters ④ and ⑥, including all sub unit (parts) counters belonging to that unit When the unit is not selected, all counters are cleared.
- ⑨ Displaying of the main unit name

## Notes:

- “—” is always displayed at the drive counts section for the reversing automatic document feeder (RADF) and feed unit.
- “—” is displayed at the numeric section for the paper source which is not installed since the paper source is different depending on the structure of options.

## 2. Sub screen

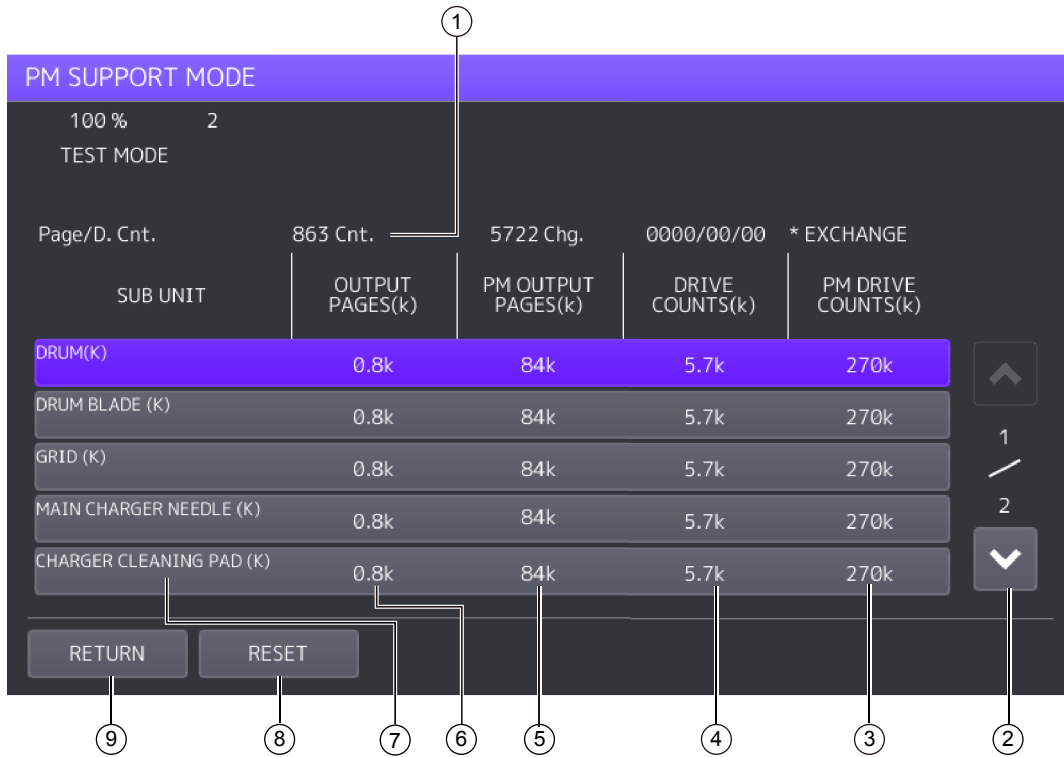


Fig. 7-4

- ① Displaying of the number of print / develop pages and drive counts and previous replacement date for a chosen sub unit
- ② Moving to the next/previous page
- ③ Displaying of the standard number of drive counts to replace the sub unit (parts)
- ④ Displaying of the present drive counts  
“\*” is displayed next to the present number when the number of drive counts has exceeded its PM standard number.
- ⑤ Displaying of the standard number of print / develop pages to replace the sub unit (parts)
- ⑥ Displaying of the present number of print / develop pages  
“\*” is displayed next to the present number when the number of print / develop pages has exceeded its PM standard number.
- ⑦ Displaying of the sub unit (parts) name
- ⑧ Moving to the clear screen to clear the selected unit (parts) counters
- ⑨ Back to the main screen

### 3. Clear screen

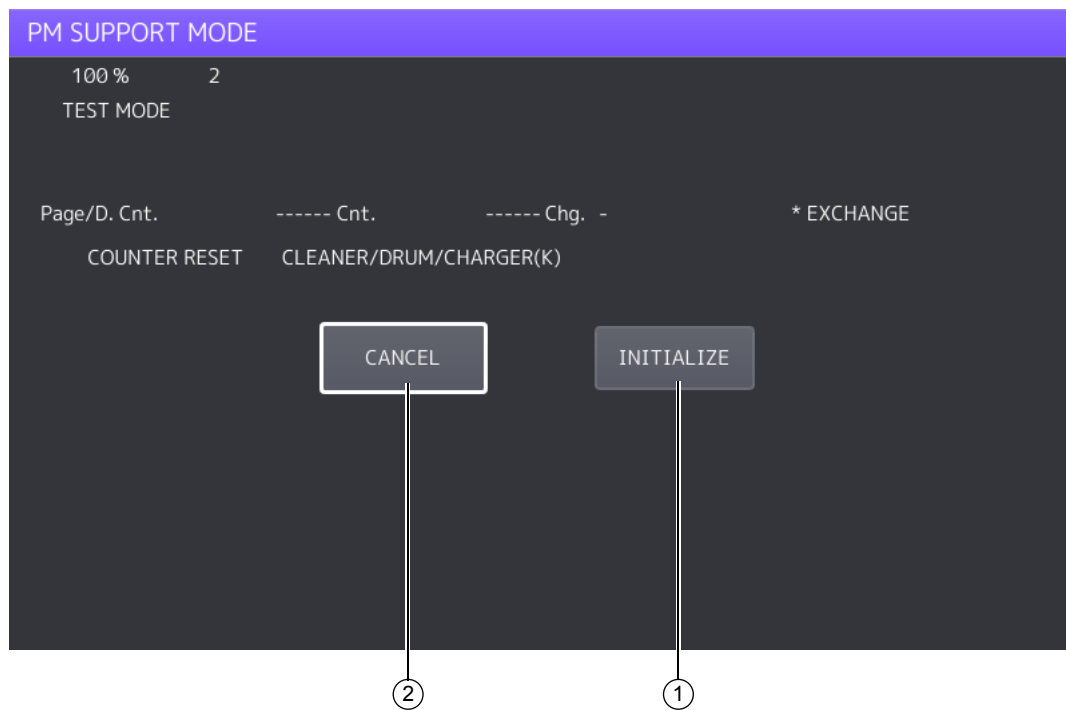


Fig. 7-5

- ① When the [INITIALIZE] button is pressed, "Present number of print / develop pages" and Present driving counts" are cleared and "Previous replacement date" is updated.
- ② When the [CANCEL] button is pressed, the counter is not cleared and the display returns to the main or sub screen.

## 7.4.4 Access tree

The relation between the main unit and the sub unit is shown below.

### Notes:

Some parts in this manual are described with different names on the LCD screen. In this case, the name in this manual is indicated in square brackets [ ].

Main screen	Sub-screen
CLEANER/DRUM/CHARGER (K) [Process unit (K)]	DRUM (K) DRUM BLADE (K) [Drum cleaning blade] GRID (K) [Main charger grid] MAIN CHARGER NEEDLE (K) [Needle electrode] CHARGER CLEANING PAD (K) [Main charger cleaner] LED GAP SPACER (K)
CLEANER/DRUM/CHARGER (Y) [Process unit (Y)]	DRUM (Y) DRUM BLADE (Y) [Drum cleaning blade] GRID (Y) [Main charger grid] MAIN CHARGER NEEDLE (Y) [Needle electrode] CHARGER CLEANING PAD (Y) [Main charger cleaner] LED GAP SPACER (Y)
CLEANER/DRUM/CHARGER (M) [Process unit (M)]	DRUM (M) DRUM BLADE (M) [Drum cleaning blade] GRID (M) [Main charger grid] MAIN CHARGER NEEDLE (M) [Needle electrode] CHARGER CLEANING PAD (M) [Main charger cleaner] LED GAP SPACER (M)
CLEANER/DRUM/CHARGER (C) [Process unit (C)]	DRUM (C) DRUM BLADE (C) [Drum cleaning blade] GRID (C) [Main charger grid] MAIN CHARGER NEEDLE (C) [Needle electrode] CHARGER CLEANING PAD (C) [Main charger cleaner] LED GAP SPACER (C)
OZONE FILTER [Ozone filter-1]	OZONE FILTER [Ozone filter-1]
DEVELOPMENT UNIT	BLACK DEVELOPER [Developer material K] YELLOW DEVELOPER [Developer material Y] MAGENTA DEVELOPER [Developer material M] CYAN DEVELOPER [Developer material C]
2nd TRANSFER	2nd TRANSFER ROLLER
1st CST. [1st drawer]	FEED ROLLER SEP PAD (1st CST.) [Separation pad]
2nd CST. [2nd drawer]	PICK UP ROLLER (2nd CST.) FEED ROLLER (2nd CST.) SEP ROLLER (2nd CST.) [Separation roller]
SFB [Bypass unit]	FEED ROLLER (SFB) SEP PAD (SFB) [Separation pad]
RADF	PICK UP ROLLER (RADF) FEED ROLLER (RADF) SEP ROLLER (RADF) [Separation roller]
LCF	PICK UP ROLLER (LCF) FEED ROLLER (LCF) SEP ROLLER (LCF) [Separation roller]
3rd CST. [PFP upper drawer]	PICK UP ROLLER (3rd CST.) FEED ROLLER (3rd CST.) SEP ROLLER (3rd CST.) [Separation roller]

Main screen	Sub-screen
4th CST. [PFP lower drawer]	PICK UP ROLLER (4th CST.) FEED ROLLER (4th CST.) SEP ROLLER (4th CST.) [Separation roller]

**Notes:**

When the counter value of any of the pick-up roller, feed roller and separation roller in each unit is reset, the value of the feeding retry counter is also reset simultaneously. When the [RESET] button is pressed after selecting the feed unit in the Main Screen, the value of the feeding retry counter is also reset simultaneously.

The feeding retry counter:

- 1st drawer           Reset the feeding retry counter (FS-08-6230)
- 2nd drawer         Reset the feeding retry counter (FS-08-6231)
- PFP upper drawer Reset the feeding retry counter (FS-08-6232)
- PFP lower drawer Reset the feeding retry counter (FS-08-6233)
- Bypass unit        Reset the feeding retry counter (FS-08-6234)
- LCF                 Reset the feeding retry counter (FS-08-6235)

## 7.5 Work flow of parts replacement

The life span of the parts changes depending on their general use, such as the ratio of the color/black printing or the adjustment for keeping the printing quality. Therefore, it is necessary to consider not only the number of printed/developed pages but also the drive counts when deciding the timing for parts replacement. Even if the number of print / develop pages has reached the level of replacement, for instance, the part may still be usable with its drive counts not reaching the specified drive counts. On the other hand, the part may need replacement even if the number of print / develop pages has not reached the level of replacement with its driving time exceeding the specified drive counts. The life span of some parts such as feed roller is heavily dependent on the number of output pages rather than the drive counts.

The following work flow diagram shows how to judge the timing of replacement with the number of print / develop pages.

### **Example 1:**

#### **When the number of print / develop pages has reached the specified level**

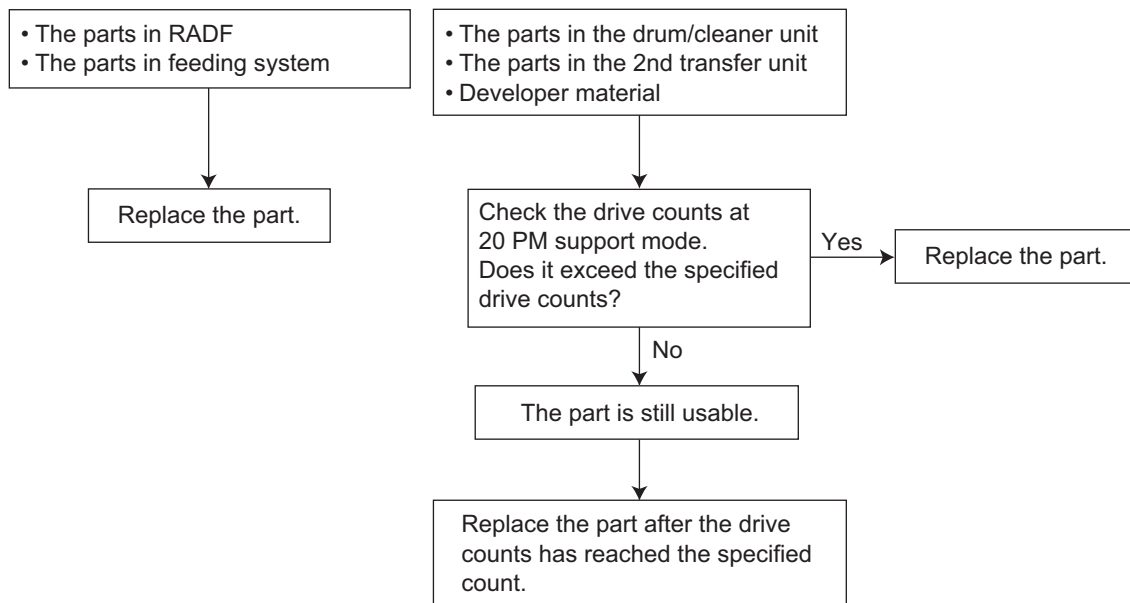


Fig. 7-6

### **Example 2:**

#### **When the image failure occurred before the number of print / develop pages has reached the specified level**

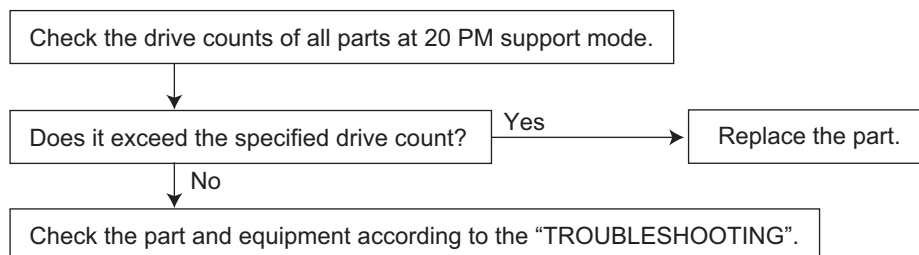


Fig. 7-7

## 7.6 Preventive Maintenance Checklist

Symbols/value used in the checklist

Item	Description
Cleaning	<b>A:</b> Clean with alcohol <b>B:</b> Clean with soft pad, cloth or vacuum cleaner
Lubrication/ Coating	<b>L:</b> Launa 40 <b>SI:</b> Silicon oil <b>W1:</b> White grease (Molykote EM-30L) <b>W2:</b> White grease (Molykote HP-300) <b>AV:</b> Alvania No.2 <b>FL:</b> Floil (GE-334C) <b>C:</b> Coating material (SANKOL CFD-409M)
Replacement	<b>Value:</b> Replacement cycle <b>R1:</b> Replacement <b>R3:</b> Replace if deformed or damaged
Operation check	<b>O:</b> After cleaning or replacement, confirm there is no problem.

### Notes:

- Perform cleaning and lubricating in the following timing. Lubricate the replacement parts according to the replacement cycle.

Model	Color	Black/white
20ppm	Every 67,200 sheets	Every 67,200 sheets
25ppm	Every 84,000 sheets	Every 84,000 sheets

- The value in the "Replacement" field of the table below indicates the replacement number of output pages in either the black or the full color mode. If they differ according to the model, they are indicated in the order of the 20ppm, 25ppm.
- The replacement cycle of the parts in the feeding section equals to the number of sheets fed from each paper source.
- Be careful not to put oil on the rollers, belts and belt pulleys when lubricating.
- Parts list <P-I> represents the page item in "e-STUDIO2000AC/2500AC Service Parts List".

## 7.6.1 Feed unit

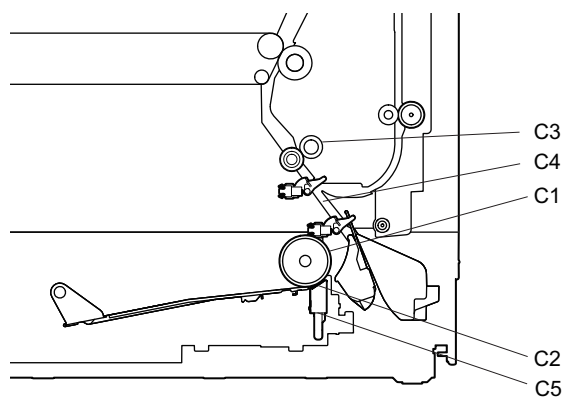


Fig. 7-8

20ppm

Items to check		Preventive maintenance				Operation check	P-I
		67.2					
		Cleaning	Lubrication/Coating	Replacement			
(x 1,000 sheets)	(x 1,000 drive counts)						
C1	Drawer feed roller	B		80	-		43-12
C2	Drawer separation pad			80	-		43-7
C3	Registration roller (rubber)						22-11
C4	Paper guide						13-9
C5	Drawer separation pad holder						43-7

25ppm

Items to check		Preventive maintenance				Operation check	P-I
		84					
		Cleaning	Lubrication/Coating	Replacement			
(x 1,000 sheets)	(x 1,000 drive counts)						
C1	Drawer feed roller	B		80	-		43-12
C2	Drawer separation pad			80	-		43-7
C3	Registration roller (rubber)						22-11
C4	Paper guide						13-9
C5	Drawer separation pad holder						43-7

\* C1:  
Clean the inner diameter of the bushing when replacing the drawer feed roller.



## 7.6.2 Bypass feed unit

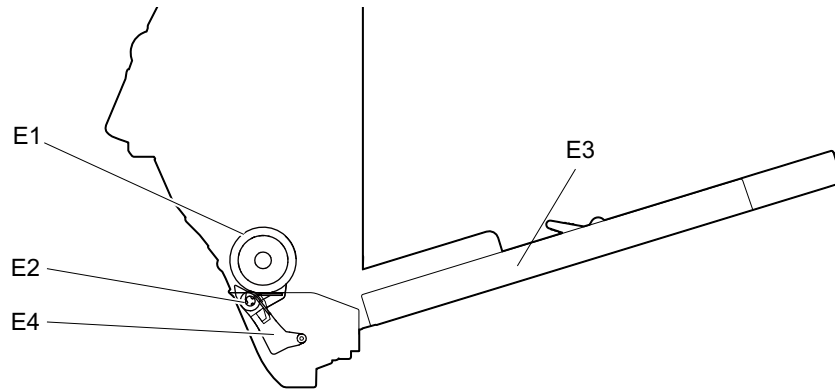


Fig. 7-9

20ppm

Items to check		Preventive maintenance				Operation check	P-I
		67.2					
		Cleaning	Lubrication/Coating	Replacement			
(x 1,000 sheets)	(x 1,000 drive counts)						
E1	Bypass feed roller			80	-		21-19
E2	Bypass separation roller			80	-		21-7
E3	Bypass tray						20-13
E4	Bypass separation roller holder		W2				21-9

25ppm

Items to check		Preventive maintenance				Operation check	P-I
		84					
		Cleaning	Lubrication/Coating	Replacement			
(x 1,000 sheets)	(x 1,000 drive counts)						
E1	Bypass feed roller			80	-		21-19
E2	Bypass separation roller			80	-		21-7
E3	Bypass tray						20-13
E4	Bypass separation roller holder		W2				21-9

### 7.6.3 Main charger

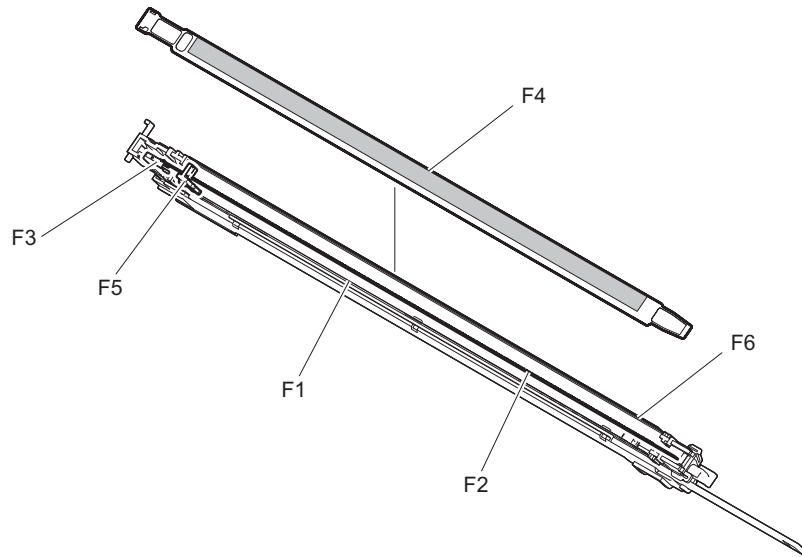


Fig. 7-10

20ppm

Items to check		Preventive maintenance				Operation check	P-I
		67.2 (270*)					
		Cleaning	Lubrication/Coating	Replacement			
(x 1,000 sheets)	(x 1,000 drive counts)						
F1	Main charger case	B					35-12
F2	Needle electrode			R1	R1	O	35-8
F3	Contact point of terminals	B					35-2, 35-4
F4	Main charger grid			R1	R1		35-6
F5	Main charger cleaner			R1	R1		35-7
F6	Main charger duct seal	B				O	35-15

\*: Drive counts

25ppm

Items to check		Preventive maintenance				Operation check	P-I
		84 (270*)					
		Cleaning	Lubrication/Coating	Replacement			
(x 1,000 sheets)	(x 1,000 drive counts)						
F1	Main charger case	B					35-12
F2	Needle electrode			R1	R1	O	35-8
F3	Contact point of terminals	B					35-2, 35-4
F4	Main charger grid			R1	R1		35-6

Items to check		Preventive maintenance				Operation check	P-I
		84 (270*)					
		Cleaning	Lubrication/Coating	Replacement			
(x 1,000 sheets)	(x 1,000 drive counts)						
F5	Main charger cleaner			R1	R1		35-7
F6	Main charger duct seal	B				O	35-15

\*: Drive counts

\* F1: Main charger case

Clean the main charger case with a cloth soaked in water and squeezed tightly, and then wipe them with a dry cloth.

When cleaning the main charger, do so with the duct seal joint sections (at both the main charger and the equipment sides) at the front.

## 7.6.4 Drum unit, Cleaner related section

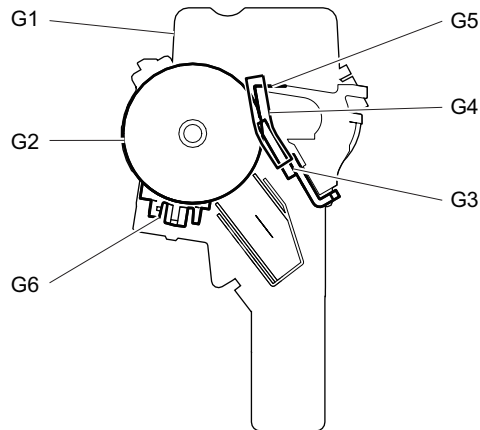


Fig. 7-11

20ppm

Items to check		Preventive maintenance				Operation check	P-I
		67.2 (270*)					
		Cleaning	Lubrication/Coating	Replacement			
(x 1,000 sheets)	(x 1,000 drive counts)						
G1	Whole cleaner unit	B					-
G2	Drum			R1	R1		34-28
G3	Drum cleaning blade			R1	R1		34-35
G4	Side seal	B		R3	R3		34-6 / 34-7
G5	Recovery blade	B					34-9
G6	LED gap spacer	B		R1	R1		34-10
G7	Drum TBU drive unit						-

\*: Drive counts

25ppm

Items to check		Preventive maintenance				Operation check	P-I
		84 (270*)					
		Cleaning	Lubrication/Coating	Replacement			
(x 1,000 sheets)	(x 1,000 drive counts)						
G1	Whole cleaner unit	B					-
G2	Drum			R1	R1		34-28
G3	Drum cleaning blade			R1	R1		34-35
G4	Side seal	B		R3	R3		34-6 / 34-7
G5	Recovery blade	B					34-9
G6	LED gap spacer	B		R1	R1		34-10
G7	Drum TBU drive unit						-

\*: Drive counts

\* G2: Drum

- Handling precautions

If fingerprints or oil adhere to the surface of the drum, its properties may degrade, affecting the quality of the copy image. So, wear gloves to avoid touching the drum surface with your bare hands. Be sure to handle the drum carefully when installing and removing it so as not to damage its surface.

- Do not use “patting powder” (lubricant)

Since “patting powder” may affect the initial image if it adheres to the OPC surface, do not apply it. The friction between the drum and cleaning blade is sufficiently small without it and no problem would occur even if it is not applied.

- Clearing the drum counter

When the drum has been replaced with a new one, the drum counter for the new drum (K, Y, M, C) must be cleared to 0 (zero). This clearing can be performed in PM support mode.

- Drum counter

- Drum (K): FS-08-6250-0, 3, 6, 7

- Drum (Y): FS-08-6252-0, 3, 6, 7

- Drum (M): FS-08-6254-0, 3, 6, 7

- Drum (C): FS-08-6256-0, 3, 6, 7

- Storage location of photoconductive drums

The drum should be stored in a dark place where the ambient temperature is between 10°C to 35°C (no condensation). Be sure to avoid places where drums may be subjected to high humidity, chemicals and/or their fumes.

Do not place the drum in a location where it is exposed to direct sunlight or high intensity light such as near a window. Otherwise the drum will fatigue, and will not produce sufficient image density immediately after being installed in the equipment.

- Cleaning the drum

At periodic maintenance calls, wipe the entire surface of the drum clean using the designated cleaning cotton. Note that there is no need to clean the surface of the new drum unless there is a problem. Use sufficiently thick cleaning cotton (dry soft pad) so as not to scratch the drum surface inadvertently with your fingertips or nails. Also, remove your rings and wristwatch before starting cleaning work to prevent accidental damage to the drum.

Do not use alcohol, selenium refresher and other organic solvents or silicon oil as they will have an adverse effect on the drum.

- Scratches on drum surface

If the surface is scratched in such a way that the aluminum substrate is exposed, no copy image will be produced on this area. In addition, the cleaning blade will be damaged so replacement with a new drum will be necessary.

- Collecting used drums

Regarding the recovery and disposal of used drums, we recommend following the relevant local regulations or rules.

\* G3: Drum cleaning blade

- Handling precautions

Pay attention to the following points as the cleaning blade life is determined by the condition of its edge. Since the edge of the blade is vulnerable and can be easily damaged by factors such as the adherence of paper dust.

- Do not allow hard objects to hit or rub against blade edge.
- Do not rub the edge with a cloth or soft pad.
- Do not leave oil (or fingerprints, etc.) on the edge.
- Do not apply solvents such as paint thinner to the blade.
- Do not allow paper fibers or dirt to contact the blade edge.
- Do not place the blade near a heat source.

- Cleaning procedure

Clean the blade edge with a cloth moistened with water and squeezed lightly.

Replace the cleaning blade with new ones if poor images are copied due to the damaged blade regardless of the number of output pages which have been made

- \* G4: Side seal

When replacing the drum cleaning unit, check that there is no gap between the blade and side seal on both ends. If there is, or when the side seals put pressure to the cleaning blade, reattach the felts on the position shown in the figure (by slightly pushing them to the direction of the arrows).



Fig. 7-12

- \* G5: Recovery blade

Clean the surface of the recovery blade with a soft pad or cloth, if dirt cannot be removed with a vacuum cleaner. If the edge of recovery blade is damaged, replace the blade regardless of the number of output pages.

**Notes:**

Never use water or alcohol for cleaning the transfer belt recovery blade.

## 7.6.5 Developer unit (K, Y, M, and C)

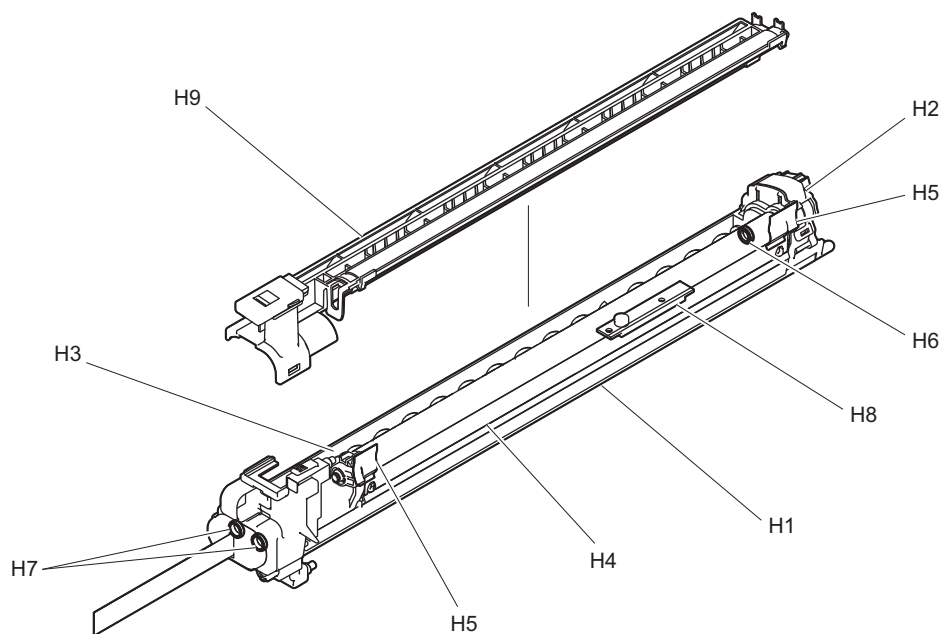


Fig. 7-13

20ppm

Items to check		Preventive maintenance				Operation check	P-I
		67.2 (174*)					
		Cleaning	Lubrication/Coating	Replacement			
(x 1,000 sheets)	(x 1,000 drive counts)						
H1	Whole developer unit	B					-
H2	Paper feeding/developer drive unit		W1				-
H3	Developer material			R1	R1		-
H4	Front seal (unified with the doctor blade)	B		R3	R3		33-34
H5	Side seal (front, rear)	B		R3	R3		33-6, 33-7
H6	Oil seal (Rear side)			R3	R3		33-25
H7	Oil seal (Front side)			R3	R3		33-25
H8	Auto-toner sensor	B					33-4
H9	Developer unit upper cover	B					32-9

\*: Drive counts

25ppm

Items to check		Preventive maintenance				Operation check	P-I
		84 (174*)					
		Cleaning	Lubrication/Coating	Replacement			
(x 1,000 sheets)	(x 1,000 drive counts)						
H1	Whole developer unit	B					-
H2	Paper feeding/ developer drive unit		W1				-
H3	Developer material			R1	R1		-
H4	Front seal (unified with the doctor blade)	B		R3	R3		33-34
H5	Side seal (front, rear)	B		R3	R3		33-6, 33-7
H6	Oil seal (Rear side)			R3	R3		33-25
H7	Oil seal (Front side)			R3	R3		33-25
H8	Auto-toner sensor	B					33-4
H9	Developer unit upper cover	B					32-9

\*: Drive counts



\* H1: Developer unit, H4: Front seal (unified with the doctor blade)

1. Cleaning

Clean the doctor blade so as to prevent developer material from adhering to it when the drum is being replaced.

Space the front seal from the developer sleeve and then insert a doctor blade cleaning jig into the doctor sleeve gap. Then clean the doctor blade by running the jig for 3 times to and fro along with the edge of the blade.

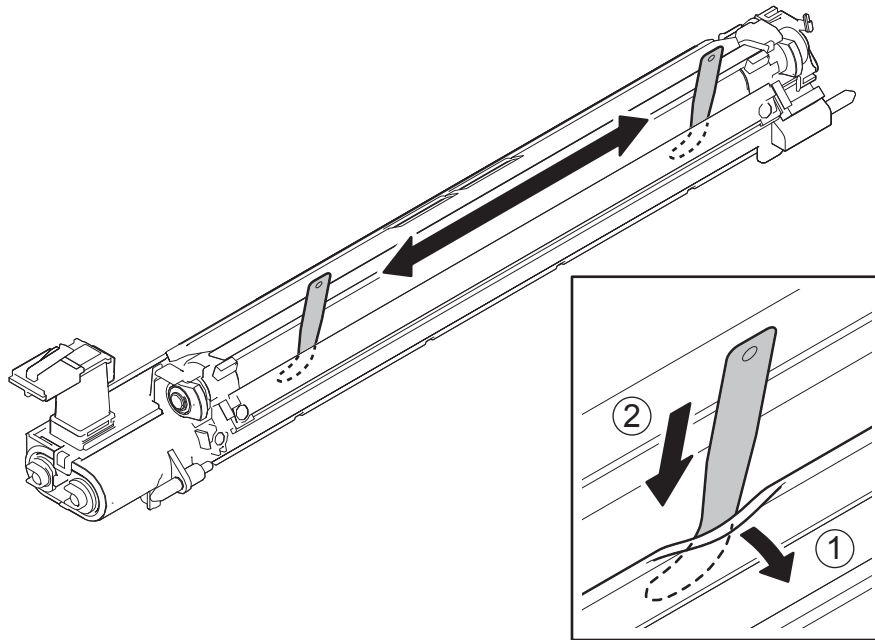


Fig. 7-14

2. Removal of foreign matter in the developer unit

(1) Take off the developer unit.

(2) Space the front seal.

(3) Insert the cleaning jig all the way in the developer unit at a position approx. 30 mm away from the white streak.

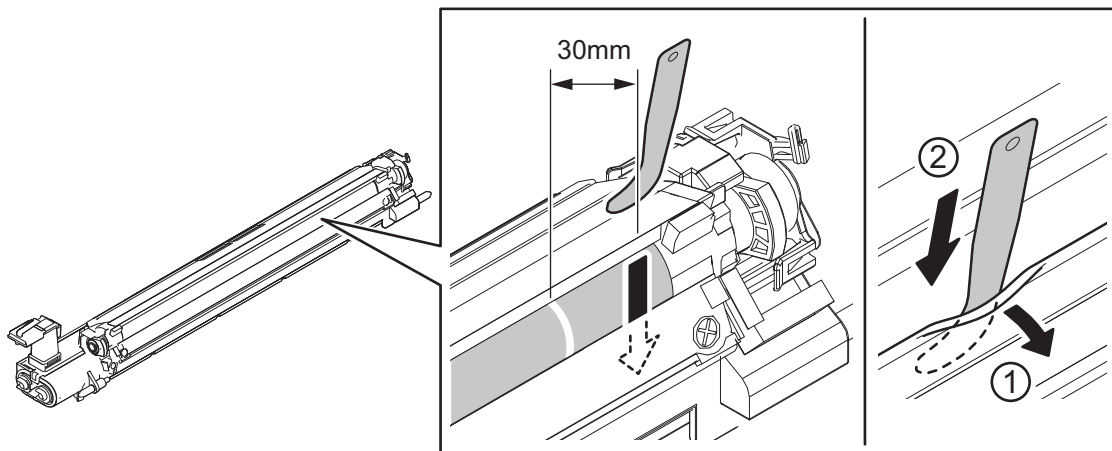


Fig. 7-15

(4) Slide the cleaning jig to where the white streak appears.

(5) Pull out the cleaning jig while manually turning the gear to rotate the developer sleeve.

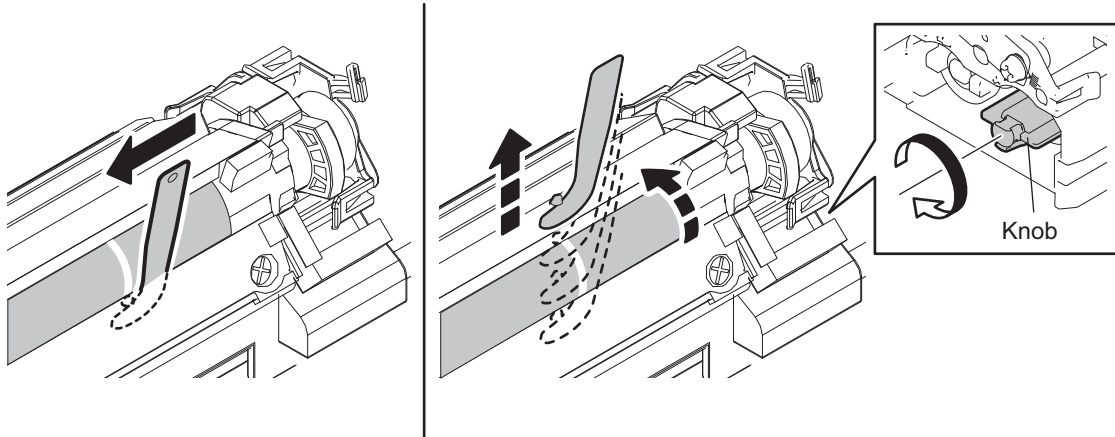


Fig. 7-16

**Tip:**

If foreign matter is not removed by the above procedure, take off the developer unit, discharge the developer material on to a sheet of clean paper and then remove any foreign matter found. If you cannot find any foreign matter, exchange the developer material.

3. Removal of foreign matter on the developer sleeve

(1) Apply a sheet of paper to the developer sleeve.

(2) Scrape off foreign matter and developer material on the developer sleeve using the jig.

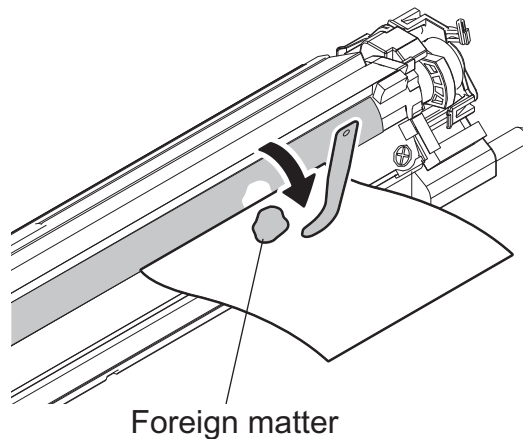


Fig. 7-17

\* H3: Developer material

After replacing the developer material, be sure to perform the auto-toner adjustment and then image quality control initialization.

📖 P. 6-2 "6.1.2 Adjustment of the Auto-Toner Sensor"

📖 P. 6-4 "6.1.3 Performing Image Quality Control"

\* H8: Auto-toner sensor

Clean the surface of the auto-toner sensor with a cotton swab or soft cloth with sufficient alcohol filled in.

## 7.6.6 Transfer belt unit / Transfer belt cleaning unit

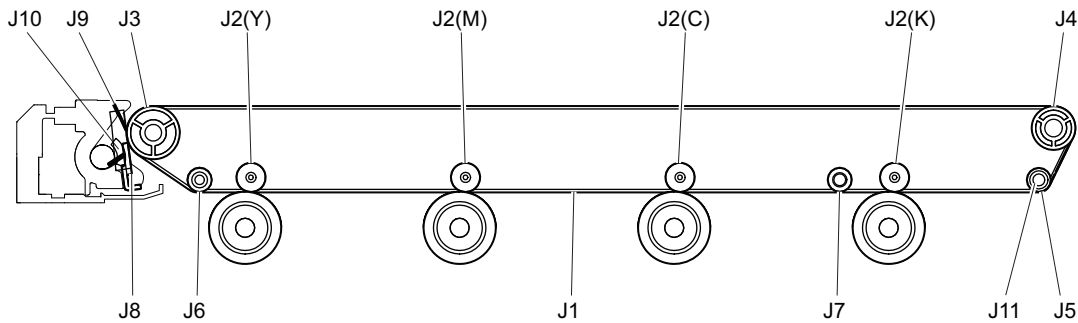


Fig. 7-18

- \* J1: Transfer belt
  - Handling precautions
    - Do not touch the front and rear surfaces of the transfer belt surface with bare hands.
    - Prevent oil or other foreign matter from adhering to both surfaces of the transfer belt.
    - Do not apply external pressure that might scratch the transfer belt.
    - When replacing the belt and transfer belt cleaning unit, apply patting powder sufficiently and evenly. Otherwise, it may reduce the cleaning efficiency.
    - When replacing the transfer belt, clean J3, J5, J6, and J7 with a solvent such as alcohol, and then clean J4 with a dry cloth, and then attach the transfer belt.
  - Cleaning procedure

Fully clean up the toner and such adhering to the roller with alcohol, and then wipe it with a dry cloth until no trace remains. Take care not to have the transfer belt surface being damaged or dented. Replace the transfer belt with a new one regardless of the number of output pages, if any crack or major scar is found.
- \* J2: 1st transfer roller

Since the sponge may be damaged, do not clean the surface of the roller. Clean the toner adhering to the power supplying part including springs with a solvent such as alcohol. When cleaning the spring, be careful not to deform it.
- \* J3: Cleaning unit facing roller, J5: Belt clinging roller before 2nd transfer, J6: Lift roller, J7: Winding roller (K)

Fully clean up the toner and such adhering to the roller with alcohol since an image failure may occur if there is any dirt remaining on the roller. Also, remove dust and toner scattering adhering to the inside of the transfer belt unit in order to keep rollers clean.
- \* J4: TBU drive roller

Clean up the toner adhering to the roller with alcohol.

\* J8: Transfer belt cleaning blade

- Handling precautions

Pay attention to the following points as the cleaning blade life is determined by the condition of its edge.

- Do not allow hard objects to hit or rub against blade edge.
- Do not rub the edge with a cloth or soft pad.
- Do not leave oil (or fingerprints, etc.) on the edge.
- Do not apply solvents such as paint thinner to the blade.
- Do not allow paper fibers or dirt to contact the blade edge.
- Do not place the blade near a heat source.

- Cleaning procedure

Clean the blade edge with a cloth moistened with water and squeezed lightly.

## 7.6.7 Image quality control unit

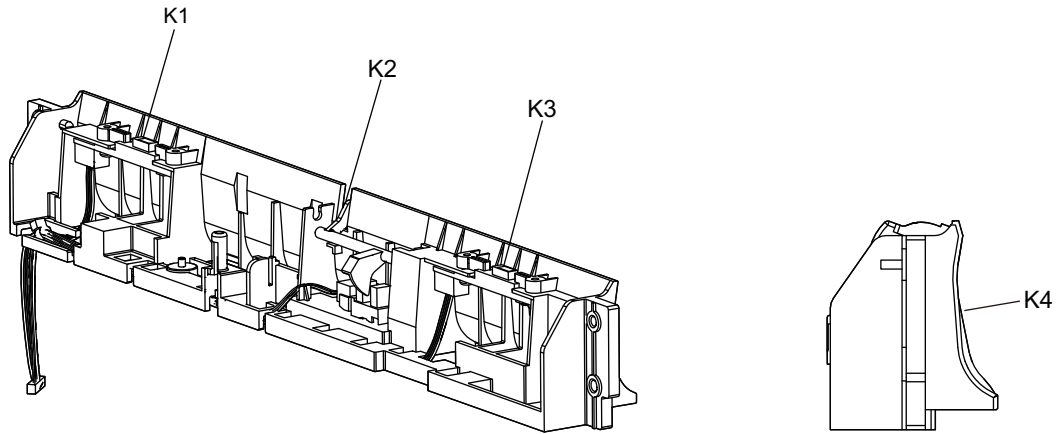


Fig. 7-19

\* K2: Actuator

If toner adheres to the actuator (paper contact section), clean it with a soft pad, cloth or electric vacuum cleaner.

## 7.6.8 2nd transfer roller unit

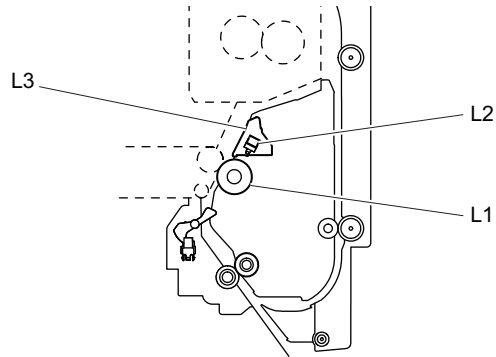


Fig. 7-20

- \* L2: Paper clinging detection sensor  
Open the 2nd transfer unit and clean the paper clinging detection sensor with a cotton swab.

**Notes:**

Be sure to clean the entire surface of the sensor.

- \* L3: 2nd transfer roller paper guide  
If toner adheres to the ribs of the 2nd transfer roller paper guide, clean it with a soft pad, cloth or electric vacuum cleaner.

## 7.6.9 Fuser unit

### 1. Handling precautions

#### \* M2: Pressure roller

- Do not leave any oil (fingerprints, etc.) on the pressure roller.
- Do not deform or damage the pressure roller.
- Be careful not to allow any hard object to hit or rub against the pressure roller, or it may be damaged, possibly resulting in poor cleaning.

#### \* M6: Thermistor

Clean the thermistor with alcohol if the toner or dirt is sticking to it when the fuser belt is replaced. Do not deform or damage the thermistor during the cleaning. Replace the thermistor with a new one if it is damaged or deformed regardless of degree.

## 7.6.10 RADF

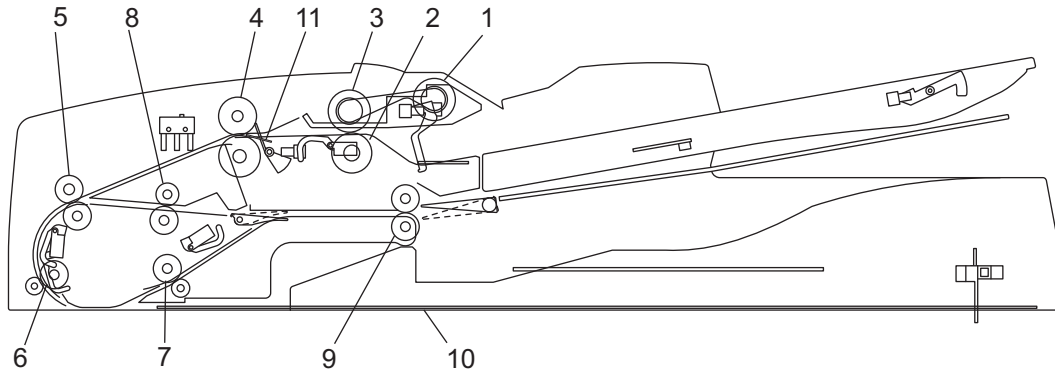


Fig. 7-21

Items to check	Cleaning	Lubrication/ Coating	Replacement		Operation check	Parts list <P-I>	
			(x 1,000 sheets)	(x 1,000 drive counts)			
1	Pick-up roller	A		R1 120	-		5-27
2	Separation roller	A		R1 120	-		4-10
3	Feed roller	A		R1 120	-		5-27
4	Registration roller	A					4-30
5	Intermediate transfer roller	A					3-13
6	Front read roller	A					3-14
7	Rear read roller	A					3-1
8	Reverse registration roller	A					3-10
9	Exit/reverse roller	A					4-25
10	Platen sheet	B or A					1-25
11	Registration roller front sheet*			R1 120			1-25

\* Registration roller front sheet: Attached on the feeder lower guide.



## 7.6.11 PFP

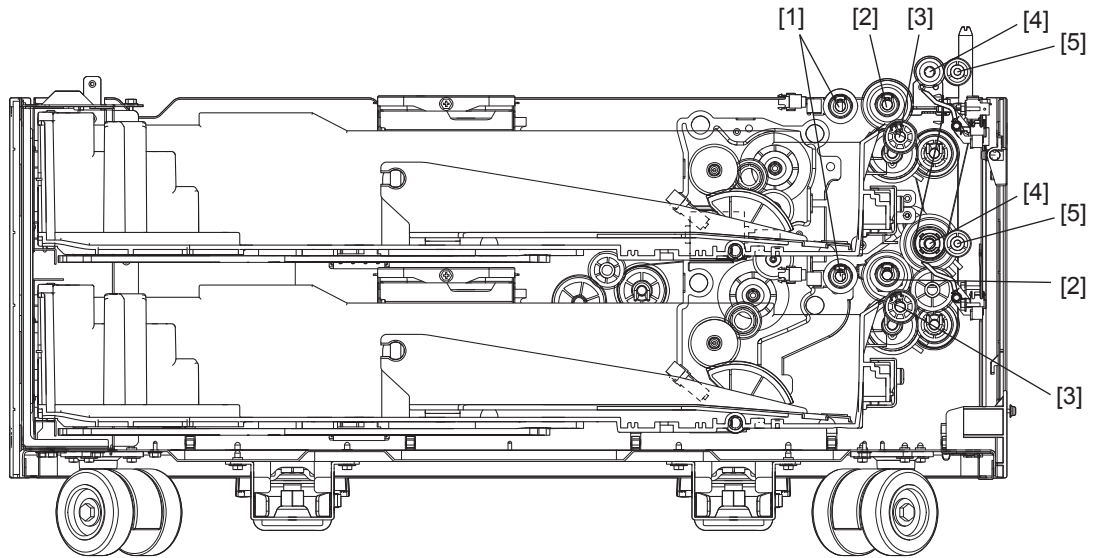


Fig. 7-22

Items to check		Cleaning	Lubrication/ Coating	Replacement		Operation check	Parts list <P-I>
				(x 1,000 sheets)	(x 1,000 drive counts)		
1	Pick-up roller (upper/lower)	A		80 or every 2.5 years, whichever comes first			5-26
2	Feed roller (upper/lower)	A		80 or every 2.5 years, whichever comes first			5-36
3	Separation roller (upper/lower)	A		80 or every 2.5 years, whichever comes first			5-30
4	Transport roller (tooth face)	A		R3			2-35 2-40
5	Idling roller (upper/ lower) Clean the inner diameter of the idle roller and the shaft.	A	W1				4-2
6	Paper guide	B					4-1 4-11

## 7.6.12 LCF

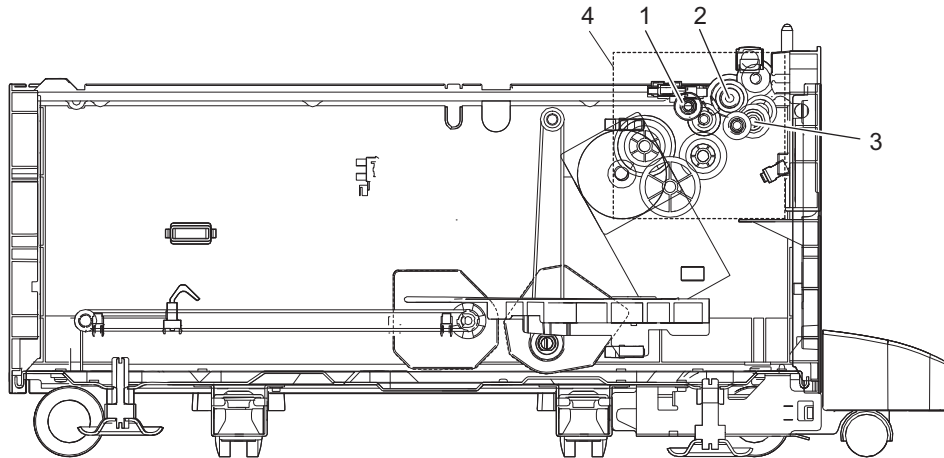


Fig. 7-23

	Items to check	Cleaning	Lubrication/ Coating	Replacement		Operation check	Parts list <P-I>
				(x 1,000 sheets)	(x 1,000 drive counts)		
1	Pick-up roller	A		160			4-4
2	Feed roller	A		160			4-3
3	Separation roller	A		160			5-8
4	Drive gear (tooth face)		W1				-

## 7.6.13 PFU

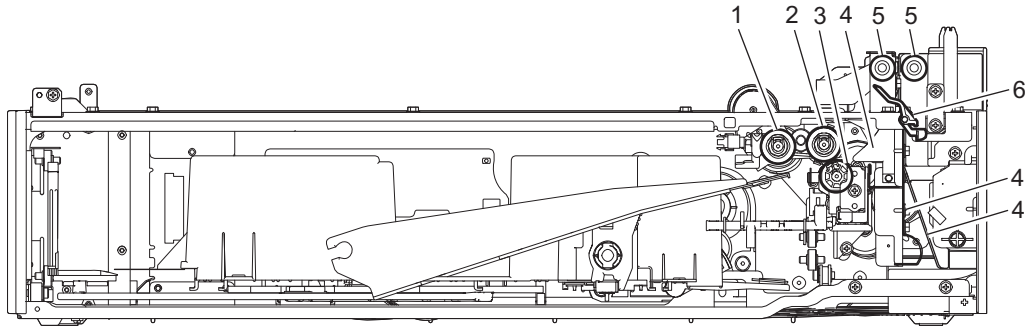


Fig. 7-24

Items to check		Cleaning	Lubrication/ Coating	Replacement		Operation check	Parts list <P-I>
				(x 1,000 sheets)	(x 1,000 drive counts)		
1	Pick-up roller	A		80			5-26
2	Feed roller	A		80			5-26
3	Separation roller	A		80			5-30
4	Guide	A					4-3
5	Transport roller	A					4-23
6	Paper feed roller	A					4-1 4-11

## 7.6.14 JSP

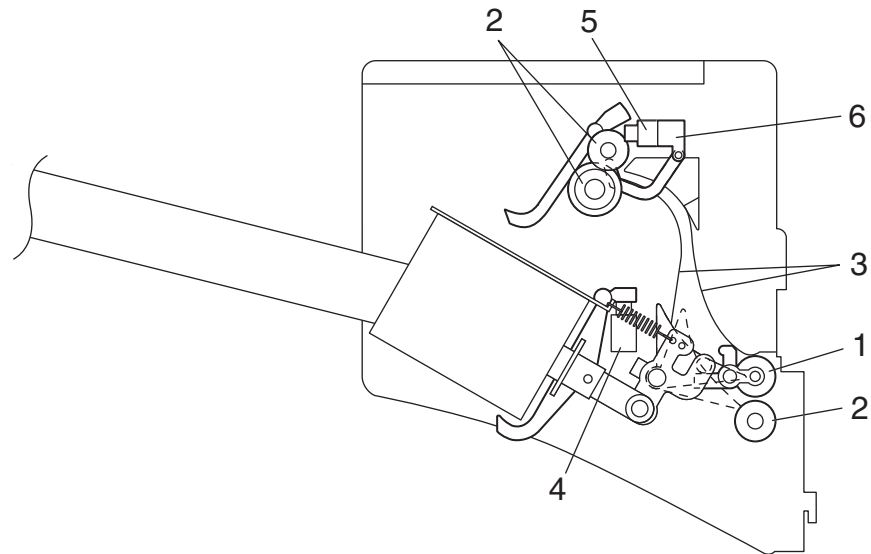


Fig. 7-25

	Items to check	Cleaning	Lubrication/ Coating	Replacement		Operation check	Parts list <P-I>
				(x 1,000 sheets)	(x 1,000 drive counts)		
1	Idling roller	A or B	W1				1-25 1-26 1-27 1-28 1-30
2	Other rollers	A or B					1-40 1-42 1-14
3	Paper guide	A or B					1-5 1-7
4	JSP upper stuck sensor	B				O	1-11
5	SP lower stuck sensor	B				O	1-11
6	JSP feed sensor	B				O	1-16

\* 1: Idling roller

Apply each one-rice-grain amount of the white grease (Molykote EM-30L) at the point A (2 points) in Figure 7-36

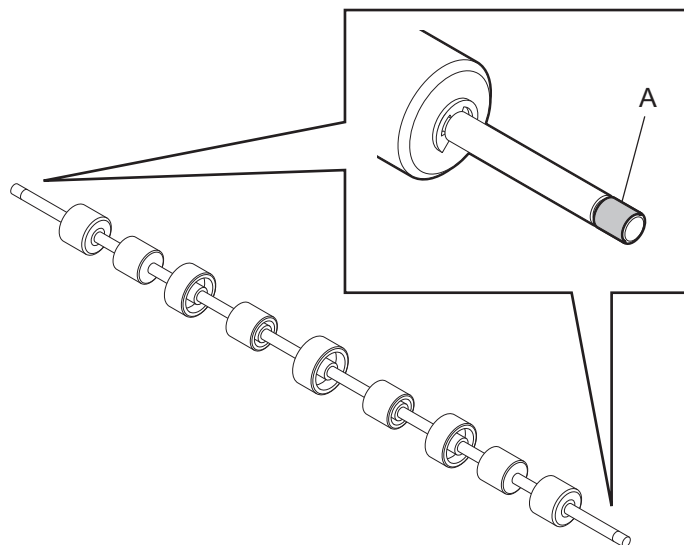


Fig. 7-26

### 7.6.15 Inner Finisher

Item	Interval	Description	Remarks
Transport roller	Every 30,000 of paper feeding times	Cleaning	Wipe with a cloth soaked in water and then tightly squeezed.
Small roller in the paper transport section			
Transport path and guides			Wipe with a dry cloth.
Transport path sensor			
Grease application to drive unit	As needed	Applying grease	EM-50L
Paper detection sensor	Minimum maintenance interval set for the equipment	Cleaning	Wipe with a dry cloth or alcohol

### 7.6.16 Saddle stitch finisher / Finisher

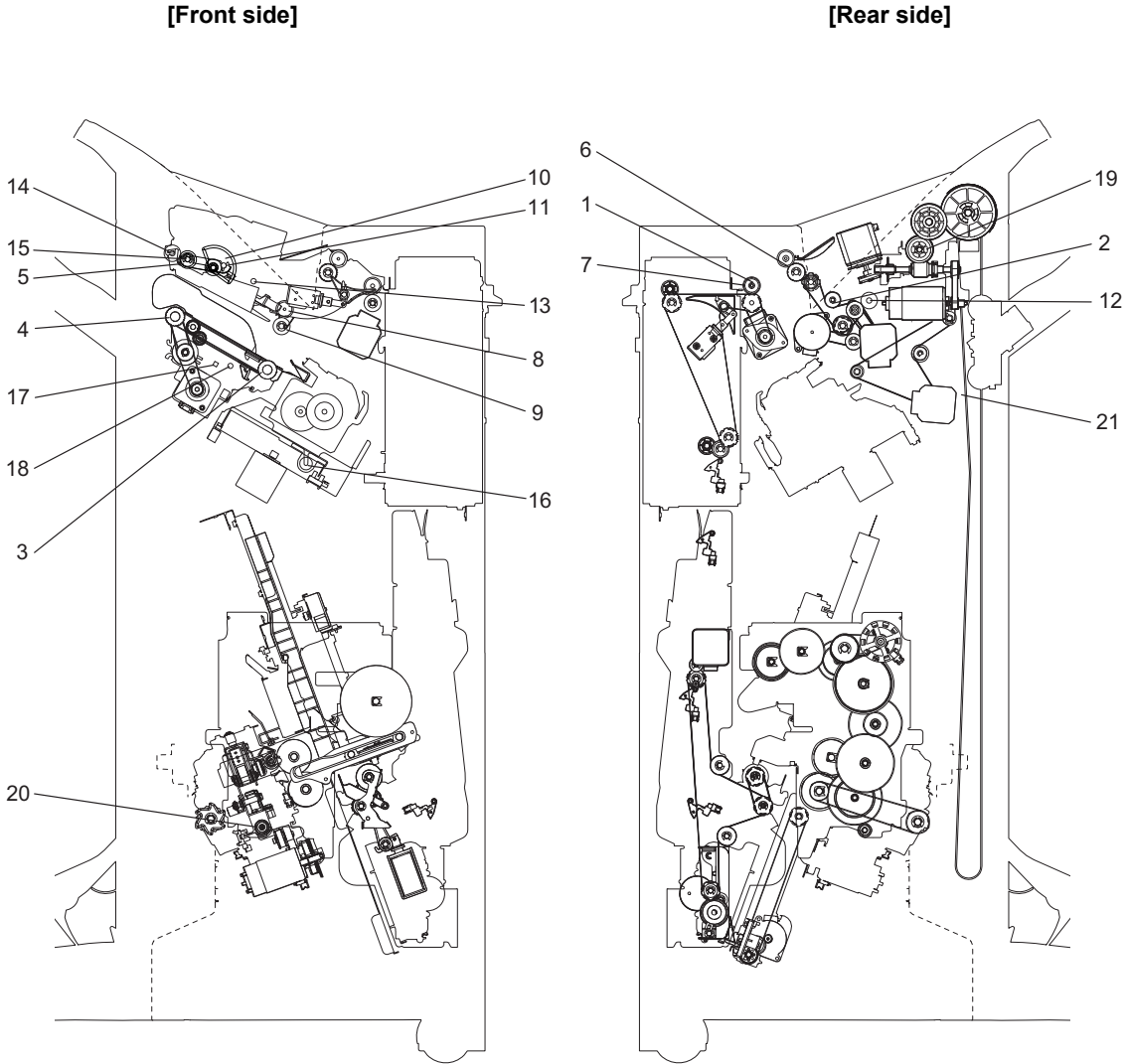


Fig. 7-27

Items to check		Cleaning	Lubrication	Replacement (x1,000)	Operation check	Parts list (P-I)	Remarks
1	Entrance sensor (S1)	A					
2	Transport sensor (S2)	A					
3	Stack transport roller-1	A					
4	Stack transport roller-2	A					
5	Buffer roller	A					
6	Exit roller	A					
7	Entrance roller	A					
8	Transport roller	A					
9	Paddle			1,000			
10	Front assist guide cam/Rear assist guide cam		C				*a

Items to check		Cleaning	Lubrication	Replacement (x1,000)	Operation check	Parts list (P-I)	Remarks
11	Buffer roller link		W3				*b
12	Shaft		W3				*c
13	Buffer tray shaft		W3				*d
14	Pinch roller shaft		W3				*e
15	Buffer roller shaft		W3				*f
16	Stapler carrier shaft		W3				*g
17	Rack gear (Aligning plate)		W3				*h
18	Finishing tray shaft		W3				*i
19	Movable tray drive gear		W2				*j
20	Additional folding unit carrier shaft		W3				*k
21	Grate-shaped guide	A	C				*l

- \*a Front assist guide cam/Rear assist guide cam  
Apply coating material (SANKOL CFD-409M) by using a cleaning brush to the portion on the guide with which the all around the assist guide cam [1].
  - \* Use a cleaning brush (4407915710 BRUSH-33) because cloth contaminated with the coating material shall be treated as industrial waste.
  - \* Do not apply coating material (Molykote PD-910) to the rubber section of the grate-shaped tray.
  - \* When coating material adheres to the skin, rinse it well with water.
  - \* The brush with which the coating agent (SANKOL CFD-409M) was applied must be exclusive for coating. Do not use it to clean other areas.

- \*b. Buffer roller link  
Apply an adequate amount of white grease (Molykote EM-30L) to the entire buffer roller link [2].

- \*c. Shaft  
Apply an adequate amount of white grease (Molykote EM-30L) to the entire shaft [3].

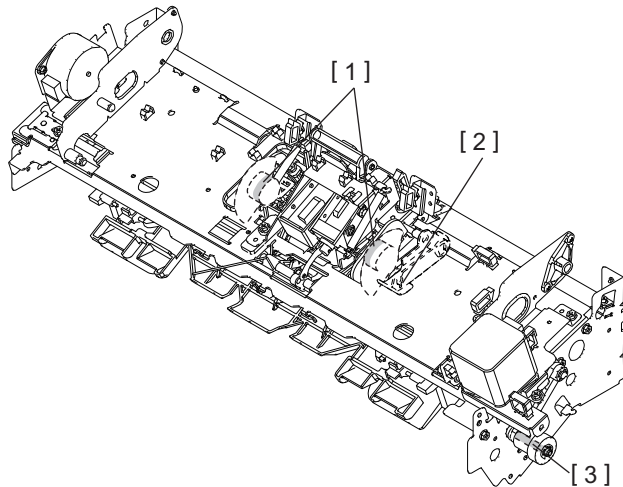


Fig. 7-28

- \*d. Buffer tray shaft  
Apply an adequate amount of white grease (Molykote EM-30L) to the entire buffer tray shaft [1].

\*e. Pinch roller shaft

Apply an adequate amount of white grease (Molykote EM-30L) to the entire pinch roller shaft [2].

\*f. Buffer roller shaft

Apply an adequate amount of white grease (Molykote EM-30L) to the entire buffer roller shaft [3].

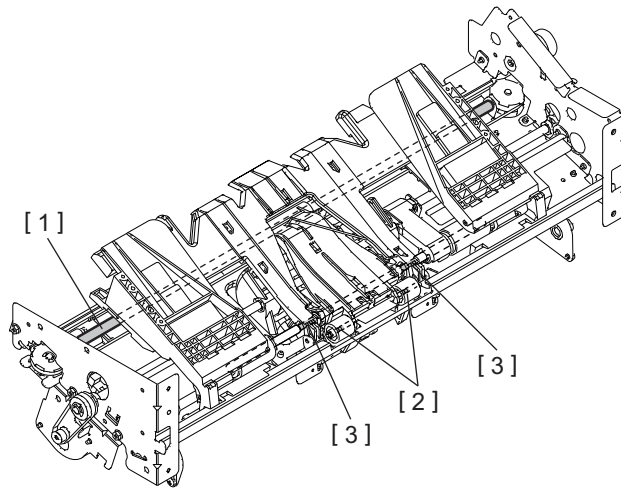


Fig. 7-29

\*g. Stapler carrier shaft

Apply an adequate amount of white grease (Molykote EM-30L) to the entire stapler carrier shaft [1].

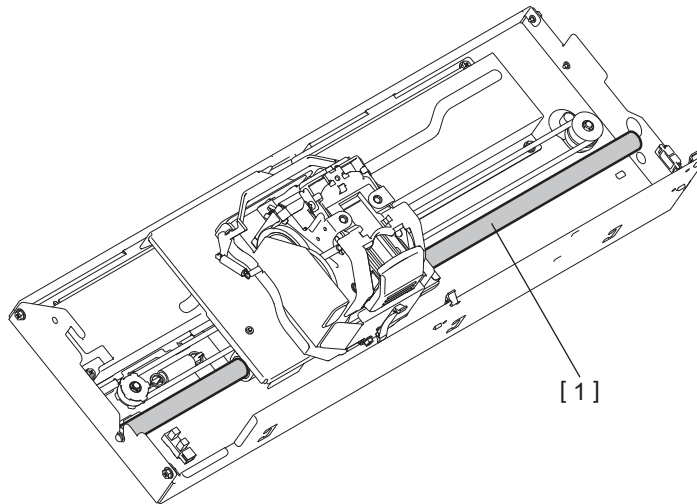


Fig. 7-30



\*h. Rack gear (Aligning plate)

\*i. Finishing tray shaft

1. Take off the junction box unit.

\* If the hole punch unit is installed, take it off beforehand.

2. Apply oil as follows through the opening which shows up when the junction box unit has been removed.

Apply an adequate amount of white grease (Molykote EM-30L) to the gear teeth of the rack gear [1] which drive the aligning plate, and the entire finishing tray shaft [2].

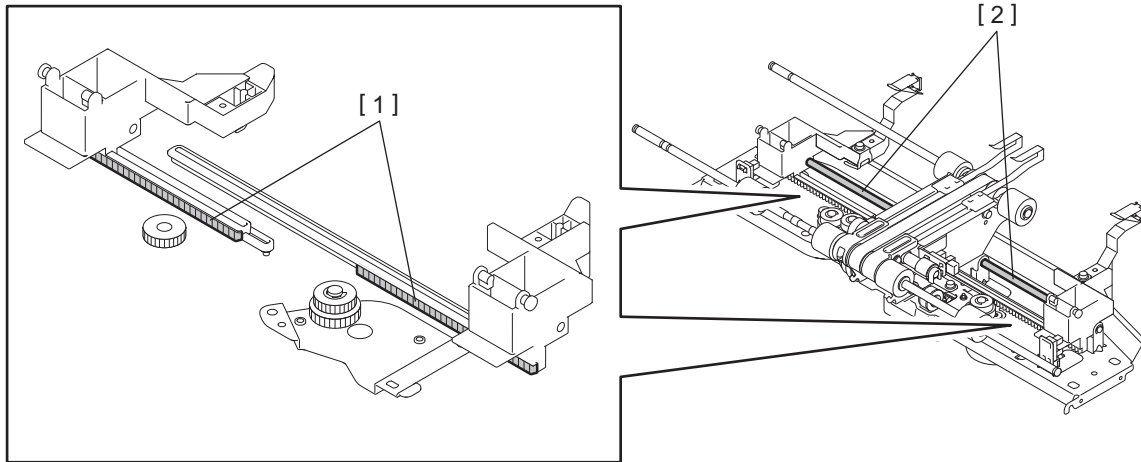


Fig. 7-31

\*j. Movable tray drive gear

Apply an adequate amount of white grease (Molykote HP-300) to the gear teeth of the movable tray drive gear [1].

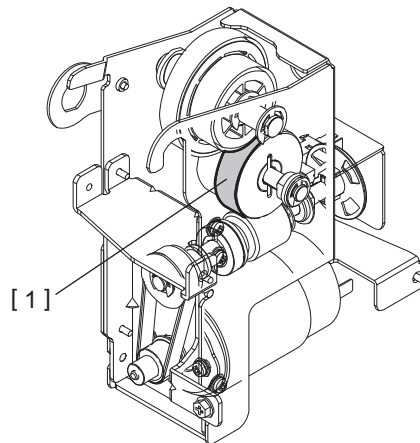


Fig. 7-32

\*k Additional folding unit carrier shaft

Apply an adequate amount of white grease (Molykote EM-30L) to the entire Additional folding unit carrier shaft [1].

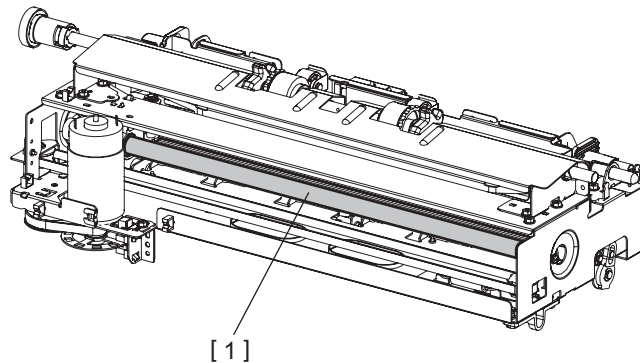


Fig. 7-33

\*l Grate-shaped guide

When an abnormal noise occurs in the grate-shaped guide or the trailing edge of the paper stacked on the tray is dirty, apply coating material (SANKOL CFD-409M) by using a cleaning brush to the portion on the guide with which the paper edge is in contact.

- \* Use a cleaning brush (4407915710 BRUSH-33) because cloth contaminated with the coating material shall be treated as industrial waste.
- \* Do not apply coating material (Molykote PD-910) to the rubber section of the grate-shaped tray.
- \* When coating material adheres to the skin, rinse it well with water.
- \* The brush with which the coating agent (SANKOL CFD-409M) was applied must be exclusive for coating. Do not use it to clean other areas.

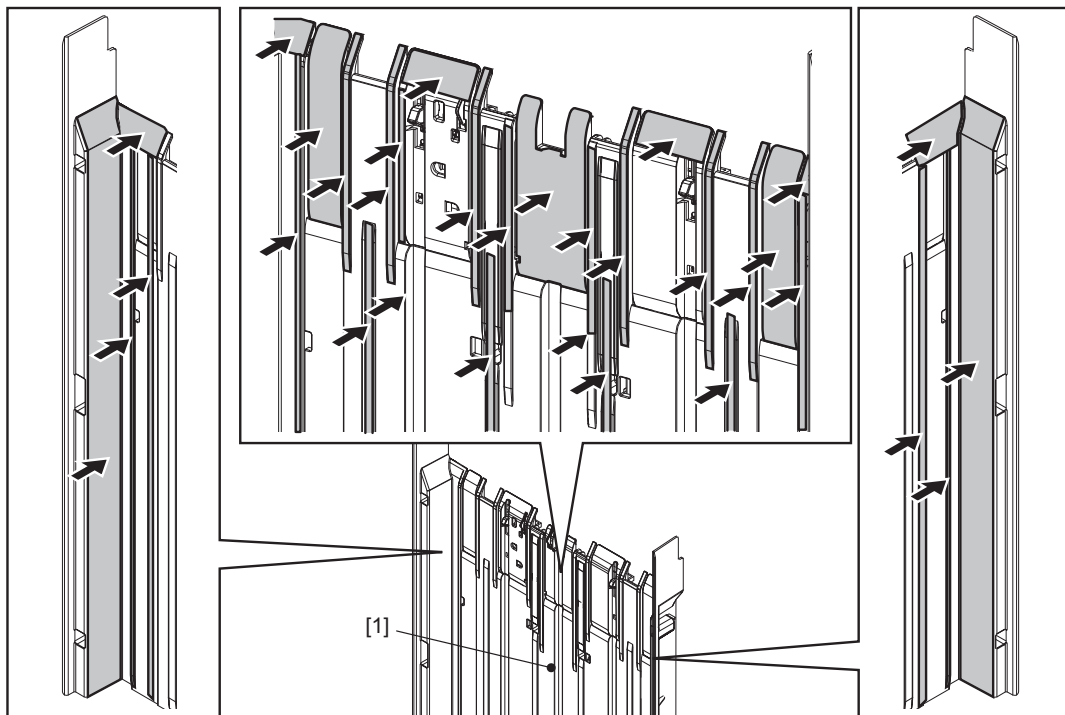


Fig. 7-34

## 7.6.17 Hole punch unit (MJ-6105)

Items to check*1		Cleaning	Lubrication *2	Replacement (x1,000)	Operation check	Parts list (P-I) *3
1	Transport roller	A			O	
2	Sensors	B				
3	Drive gears		W1		O	
4	Punched scrap container	Dispose of the punched paper bits.				
5	Punching unit *4			R1 1000		

\*1: Perform maintenance in the timing of preventive maintenance of the equipment.

\*2: Be careful not to put oil on the rollers, belts and belt pulleys when lubricating.

\*3: Page-Item (P-I) is described in the column of the Parts list.

\*4: This unit may require replacement once or more over the period of machine warranty because of deterioration or damage. Replace them as needed.

## 7.7 Machine Refreshing Checklist

Symbols/value used in the checklist

Item	Description
Cleaning	<b>A:</b> Clean with alcohol <b>B:</b> Clean with soft pad, cloth or vacuum cleaner
Lubrication/ Coating	<b>W1:</b> White grease (Molykote EM-30L) <b>W2:</b> White grease (Molykote HP-300)
Replacement	<b>Value:</b> Replacement cycle <b>R1:</b> Replacement <b>R2:</b> For preventive maintenance, check if the parts are damaged and replace them as required. If the parts are not replaced at the machine refreshing interval, inspect them at the subsequent PM. <b>R3:</b> Replace if deformed or damaged. If the parts are not replaced at the machine refreshing interval, inspect them at the subsequent PM. <b>R4:</b> Lubrication recommended: If the parts are not lubricated at the machine refreshing interval, inspect their lubrication status at the subsequent PM.
Operation check	<b>O:</b> After cleaning or replacement, confirm there is no problem.

### [Machine Refreshing Checklist]

#### Notes:

- When performing machine refreshment, check the items in the preventive maintenance checklist in addition to the items in the machine refreshing checklist.
- Perform cleaning and lubricating in the following timing. Lubricate the replacement parts according to the replacement cycle.

Model	Replacement cycle
20ppm	168,000 sheets
25ppm	210,000 sheets

- The value in the “Replacement” field of the table below indicates the replacement number of output pages in either the black or the full color mode. If they differ according to the model, they are indicated in the order of the 20ppm, 25ppm.
- The replacement cycle of the parts in the feeding section equals to the number of sheets fed from each paper source.
- Be careful not to put oil on the rollers, belts and belt pulleys when lubricating.
- Parts list <P-I> represents the page item in “e-STUDIO2000AC/2500AC Service Parts List”.

Items to check	Cleaning	Lubrication/ Coating	Replacement		Operation check	P-I
			20ppm: 168,000 sheets	20ppm: 675,000 drive counts		
			25ppm: 210,000 sheets	25ppm: 675,000 drive counts		
A1	Original glass	B or A				25-2
A2	ADF original glass	B				25-3
A3	Mirror-1	B				-
A4	Mirror-2	B				-
A5	Mirror-3	B				-
A6	Reflector	B				-
A7	Lens	B				10-9

Items to check		Cleaning	Lubrication/Coating	Replacement		Operation check	P-I
				20ppm: 168,000 sheets	20ppm: 675,000 drive counts		
				25ppm: 210,000 sheets	25ppm: 675,000 drive counts		
A9	Automatic original detection sensor	B				O	10-12
A10	Slide sheet (front and rear)	B		R3	R3		-
B1	LED printer head	B or A					31-21
B2	Discharge LED	B or A					31-15
C3	Registration roller (rubber)	A		R3	R3		22-11
C4	Paper guide	B					13-9
C5	Drawer separation pad holder		W2	R4	R4		43-7
D1	Transport roller	A		R3	R3		41-10
D2	Paper guide	B					41-20
E3	Bypass tray	B					20-13
E4	Bypass separation roller holder		W2		R4		21-9
G7	Drum TBU drive unit		W1	R4	R4		-
G8	Ozone filter			R1	R1		7-10
H2	Paper feeding/ developer drive unit		W1	R4	R4		-
J1	Transfer belt	A		R2	R2		26-14
J2	1st transfer roller			R2	R2		27-9
J3	Cleaning unit facing roller	A		R1	R1		26-10
J4	TBU drive roller	B		R2	R2		26-27
J5	Belt clinging roller before 2nd transfer	A		R3	R3		27-2
J6	Lift roller	A		R3	R3		26-8
J7	Winding roller (K)	A		R3	R3		27-4
J8	Transfer belt cleaning blade			R1	R1		30-19
J9	Recovery blade	B		R1	R1		30-22
J10	Blade seal			R1	R1		30-20, 30-21
J11	Cleaning unit facing roller bushing			R1	R1		26-11
J12	Belt clinging roller bushing before 2nd transfer			R2	R2		27-1
K1	Image position aligning sensor (Rear)/Image quality sensor	A					14-6
K2	Actuator	B					14-9

Items to check		Cleaning	Lubrication/Coating	Replacement		Operation check	P-I
				20ppm: 168,000 sheets	20ppm: 675,000 drive counts		
				25ppm: 210,000 sheets	25ppm: 675,000 drive counts		
K3	Image position aligning sensor (Front)	A					14-6
L2	Paper clinging detection sensor	B					14-19
L3	2nd transfer roller paper guide	B					14-22
M1	Heat roller			R1	R1		38-15
M2	Pressure roller			R1	R1		38-20
M3	Fuser roller separation finger			R1	R1		38-26
M5	Fuser unit entrance guide	A		R3	R3		37-11
M6	Thermistor	A		R3	R3		38-4
M7	Drive gear (tooth face and shaft)		W1	R4	R4		38-17
M8	Heat roller gear	A		R3	R3		40-10
M9	Exit sensor actuator	A		R3	R3		39-24
N1	Exit roller (rubber)			R3	R3		40-17
N2	Idling roller (plastic: lower side of the exit roller)		W1	R4	R4		40-5
N3	Paper exit unit lib (guide rib)	B					-
N4	Exit unit drive section		W1	R4	R4		-

## Scanner

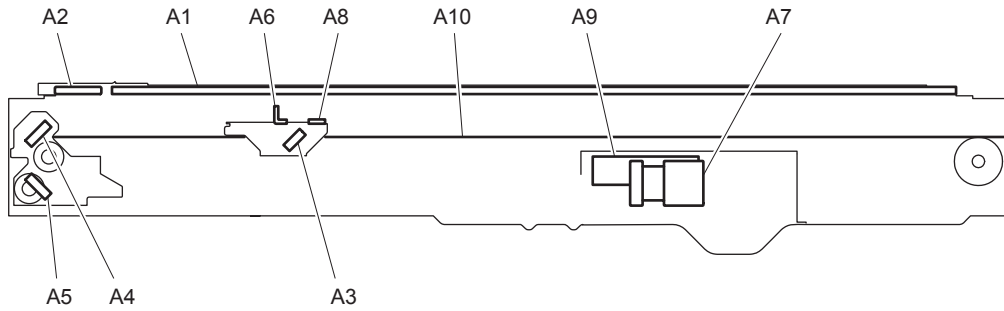


Fig. 7-35

- \* A1: Original glass, A2: ADF original glass

Clean both sides of the original glass and ADF original. Make sure that there is no dust on the mirrors-1, -2, -3 and lens after cleaning. Then install the original glass and ADF original glass. Also clean the film attached to the DF original glass in order to wipe off any dirt or paper dust.

### Notes:

Make sure that there is no fingerprints or oil staining on part of the original glass on where the original scale is mounted since the shading correction plate is located below the scale to be scanned.

Do not use such solvents as alcohol when cleaning the surface of the ADF original glass, because it is coated so as not to be scratched by originals.

When cleaning the original glass with alcohol, do so only for the stained areas because fog may appear.

## LED unit

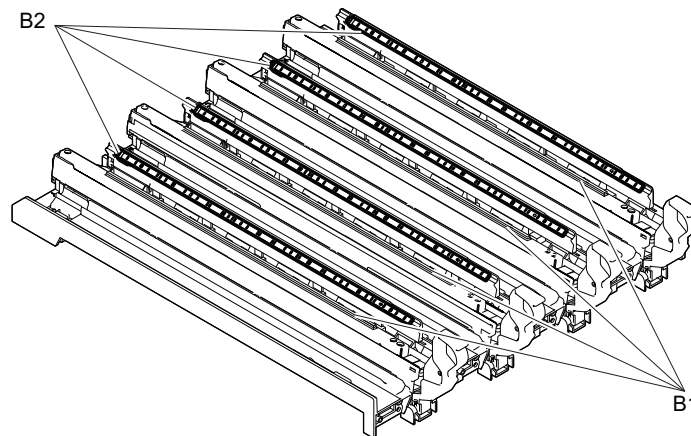


Fig. 7-36

## Automatic duplexing unit

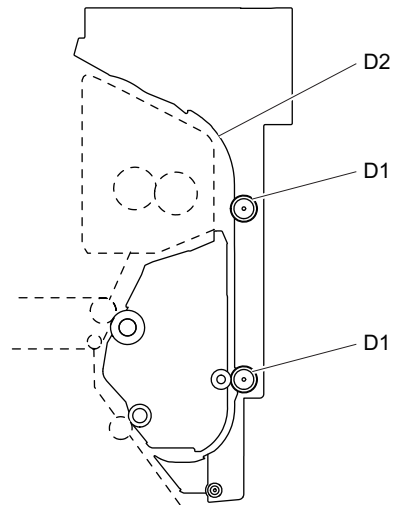




Fig. 7-37

### Drum unit, Cleaner related section

\* G7: Drum TBU drive unit

Refer to chapter  P. 4-130 "4.7.14 Drum TBU drive unit"

\* G8: Ozone filter

Refer to chapter  P. 4-106 "4.6.31 Ozone filter"



## Transfer belt unit / Transfer belt cleaning unit

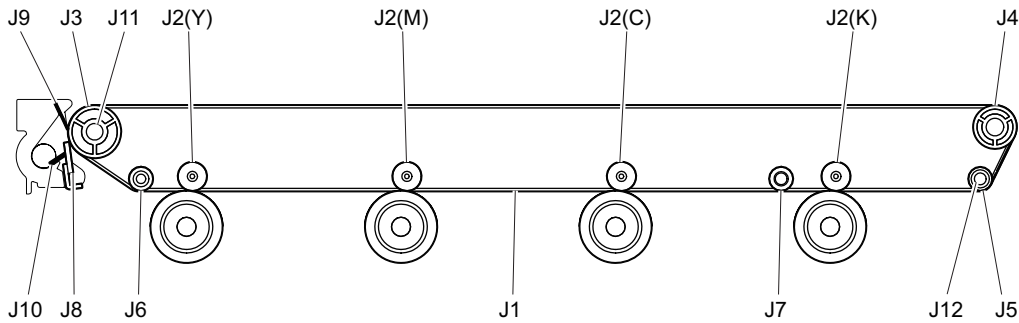


Fig. 7-38

### \* J1: Transfer belt

#### • Handling precautions

- Do not touch the front and rear surfaces of the transfer belt surface with bare hands.
- Prevent oil or other foreign matter from adhering to both surfaces of the transfer belt.
- Do not apply external pressure that might scratch the transfer belt.
- When replacing the belt and transfer belt cleaning unit, apply patting powder sufficiently and evenly. Otherwise, it may reduce the cleaning efficiency.
- When replacing the transfer belt, clean J3, J5, J6, and J7 with a solvent such as alcohol, and then clean J4 with a dry cloth, and then attach the transfer belt.

#### • Cleaning procedure

Fully clean up the toner and such adhering to the roller with alcohol, and then wipe it with a dry cloth until no trace remains. Take care not to have the transfer belt surface being damaged or dented. Replace the transfer belt with a new one regardless of the number of output pages, if any crack or major scar is found.

### \* J3:Cleaning unit facing roller, J5: Belt clinging roller before 2nd transfer, J6: Lift roller

Fully clean up the toner and such adhering to the roller with alcohol when the transfer belt cleaning blade is replaced, since an image failure may occur if there is any dirt remaining on the roller. Also, remove dust and toner scattering adhering to the inside of the transfer belt unit in order to keep rollers clean.

### \* J8: Transfer belt cleaning blade

#### • Handling precautions

Pay attention to the following points as the cleaning blade life is determined by the condition of its edge.

- Do not allow hard objects to hit or rub against blade edge.
- Do not rub the edge with a cloth or soft pad.
- Do not leave oil (or fingerprints, etc.) on the edge.
- Do not apply solvents such as paint thinner to the blade.
- Do not allow paper fibers or dirt to contact the blade edge.
- Do not place the blade near a heat source.

#### • Cleaning procedure

Clean the blade edge with a cloth moistened with water and squeezed lightly.

## Image quality control unit

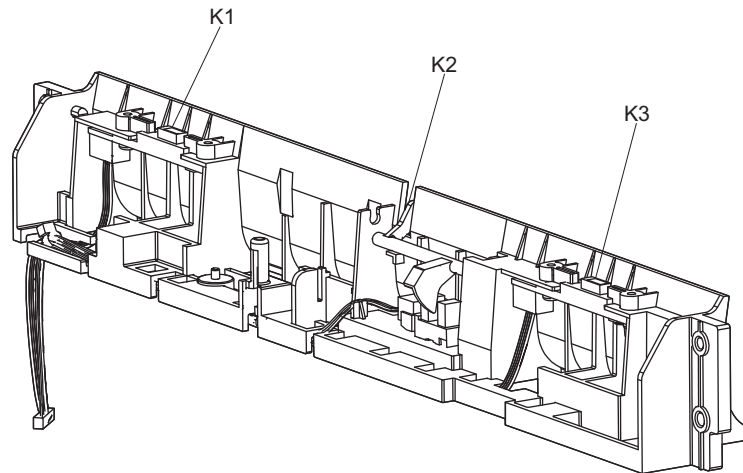


Fig. 7-39

\* K2: Actuator

If toner adheres to the actuator (paper contact section), clean it with a soft pad, cloth or electric vacuum cleaner.

## 2nd transfer roller unit

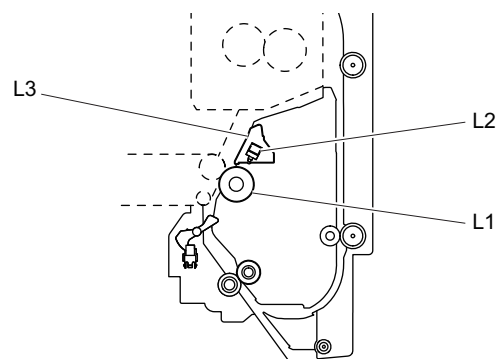


Fig. 7-40

\* L2: Paper clinging detection sensor

Open the 2nd transfer unit and clean the paper clinging detection sensor with a cotton swab.

**Notes:**

Be sure to clean the entire surface of the sensor.

\* L3: 2nd transfer roller paper guide

If toner adheres to the ribs of the 2nd transfer roller paper guide, clean it with a soft pad, cloth or electric vacuum cleaner.

## Fuser unit

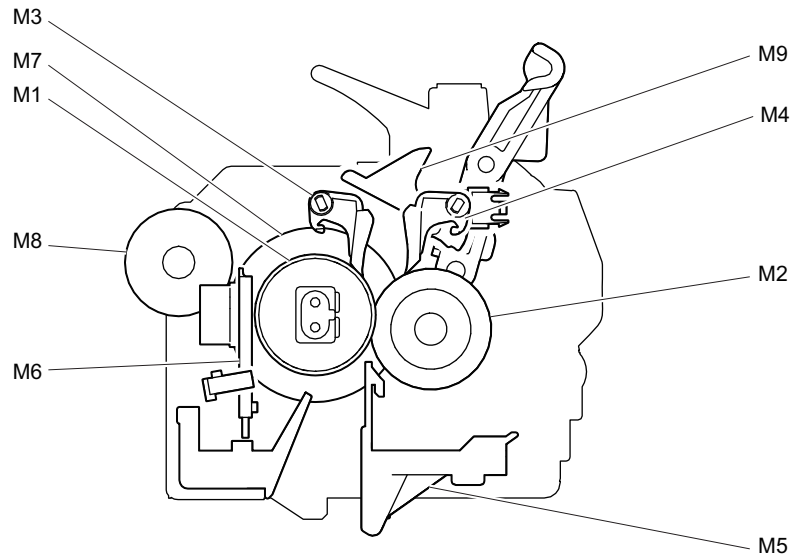
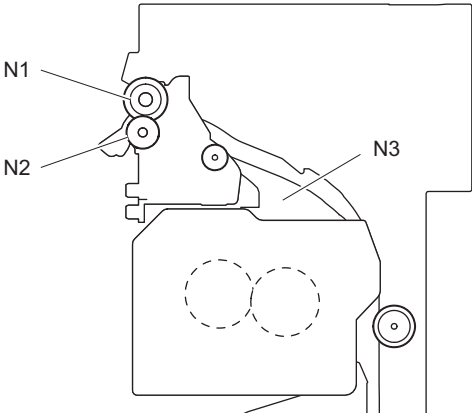


Fig. 7-41

- \* M1: Heat roller  
When replacing the Heat roller, apply small amount of grease on the inside of Heat roller bearings.
- \* M3, M4: Separation finger  
The paper jam may be caused if the tip of the finger is damaged or deformed, or a dirt image caused by the finger occurs. If there is any problem with it, replace the finger with a new one regardless of the number of output pages which have been made. Do not damage the tip of the finger during the cleaning. The finger may be damaged if the toner adhering to the tip of it is scraped off forcibly. Replace the finger if the toner is sticking to it heavily.
- \* M6: Thermistor  
Clean the thermistor with alcohol if the toner or dirt is sticking to it when the Heat roller is replaced.  
Do not deform or damage the thermistor during the cleaning. Replace the thermistor with a new one if it is damaged or deformed regardless of degree.  
Be sure to perform the fuser thermistor correction when it is removed or replaced.
- \* M9: Exit sensor actuator  
If toner has adhered, wipe it off with alcohol.

**Exit unit**



**Fig. 7-42**

- \* N2: Idling roller  
Wipe off any old grease, and then apply 0.5 to 1 rice-sized grains of white grease (Molykote HP-300) onto the inside of the roller and both end faces of the shaft hole.

## 7.8 Storage of Supplies and Replacement Parts

Precautions for storing supplies and replacement parts are shown below.

1. Toner/Developer  
Toner and developer should be stored in a place where the ambient temperature is between 10°C to 35°C (no condensation), and should also be protected against direct sunlight during transportation.
2. Photoconductive drum  
Like the toner and developer, photoconductive drum should be stored in a dark place where the ambient temperature is between 10°C to 35°C (no condensation). Be sure to avoid places where drums may be subjected to high humidity, chemicals and/or their fumes.
3. Drum cleaning blade / Transfer belt cleaning blade  
This item should be stored in a flat place where the ambient temperature is between 10°C to 35°C, and should also be protected against high humidity, chemicals and/or their fumes.
4. Transfer belt / Transfer roller / Fuser roller / Pressure roller  
Avoid places where the rollers may be subjected to high humidity, chemicals and/or their fumes.
5. Paper  
Avoid storing copy paper in places where it may be subjected to high humidity.  
After a package is opened, be sure to place and store it in a storage bag.

## 7.9 PM KIT

A PM kit is a package for each unit of replacement parts requiring PM.

KIT name	Component	P - I	Qty.
DEV-KIT-FC200K	Developer material (K)	-	1
	Drum cleaning blade	34-37	1
	Needle electrode	35-8	1
	Main charger grid	35-6	1
	Main charger cleaner	35-13	2
	LED gap spacer (F)	34-11	1
	LED gap spacer (R)	34-10	1
DEV-KIT-FC200CLR	Developer material (Y)	-	1
	Developer material (M)	-	1
	Developer material (C)	-	1
	Drum cleaning blade	34-37	3
	Needle electrode	35-8	3
	Main charger grid	35-6	3
	Main charger cleaner	35-13	6
	LED gap spacer (F)	34-11	3
	LED gap spacer (R)	34-10	3
ROL-KIT-FC30-U (PFU/PFP)	Pick up roller	5-26 (PFU) 5-26 (PFP)	1
	Feed roller	5-26 (PFU) 5-26 (PFP)	1
	Separation roller	5-30 (PFU) 5-30 (PFP)	1
ROL-KIT-1026 (LCF)	Pick up roller	4-4	1
	Feed roller	4-3	1
	Separation roller	5-8	1
DF-KIT-3031 (RADF)	Pick up roller	5-13	1
	Feed roller	5-13	1
	Separation roller	4-10	1
	Registration roller front sheet	4-38 4-39	3

## 7.10 Machine Refreshing Kit

A Machine Refreshing Kit is a package of replacement parts for each unit required at machine refreshment.

KIT name	Component	P-I	Qty.
FR_R-KIT-FC200	Fuser roller	38-15	1
	Pressure roller	38-20	1
	Fuser roller separation finger	38-26	5
	Pressure roller separation finger (Not use)	-	2
TBU_R-KIT-FC200	Ozone filter	7-10	1
	Cleaning unit facing roller	26-10	1
	Cleaning unit facing roller bearing	26-11	2
	Blade seal (front)	30-20	1
	Blade seal (rear)	30-21	1
	Blade seal (back)	30-17	2
	Transfer belt cleaning blade	30-19	1

## 7.11 Maintenance Part List

The parts used for the maintenance of this equipment are as follows.

No.	Item	Purpose	P-I
1	Cleaning brush	Cleaning inside of the equipment	101-2
2	Doctor blade cleaning jig	Cleaning the doctor blade	101-3
3	Wire holder jig	Fixing the wire at the assembly of the carriage wire	101-4
4	Doctor-sleeve gap jig	Measuring the gap between the developer sleeve and the doctor blade (gauge 0.50, 0.55, 0.60)	101-6
5	Belt tension jig	Adjusting the belt tension at the installation of the scan motor	101-7
6	Drum bag	Storing the drum	101-9
7	Patting powder	For transfer belt	101-25
8	Door-switch jig	Lock of door switch	101-1
9	Color test chart	For test print (A4/LT)	101-10
10	Color test chart	For test print (A3/LD)	101-11
11	Thermistor gap jig	Measuring the gap between the thermistor and the pressure roller	101-8
12	Thermostat gap jig	Measuring the gap between the thermostat and the fuser roller and measuring the gap between the thermostat and the pressure roller	101-8
13	Harness holding jig	For installing/removing the LED unit.	101-12
14	Doctor-sleeve gap jig	Measuring the gap between the developer sleeve and the doctor blade (gauge 0.60, 0.65, 0.70)	101-27



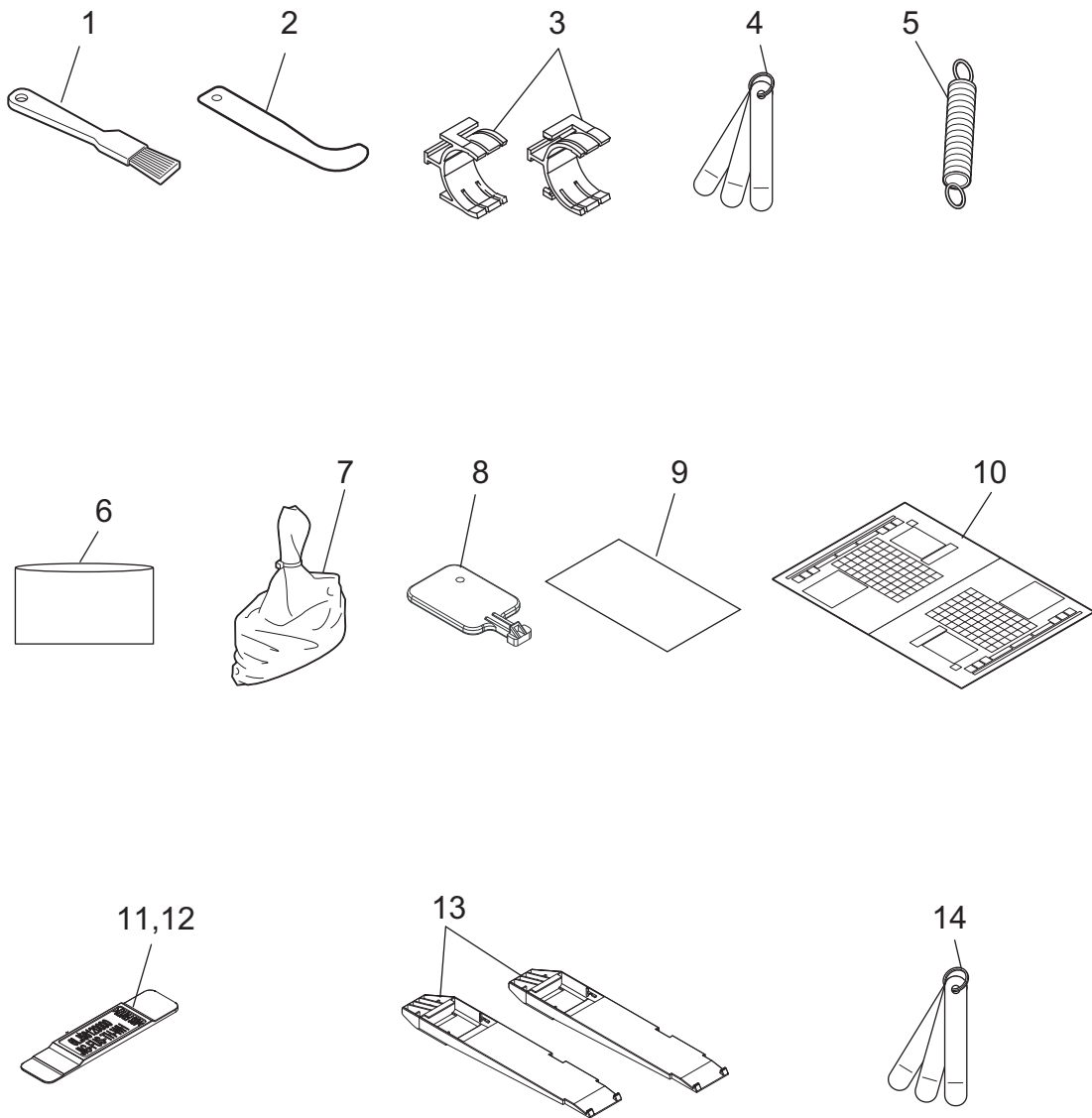


Fig. 7-43

## 7.12 Grease List

The parts used for the maintenance of this equipment are as follows.

Symbol	Grease name	Type	Color	Volume	Container	Parts list <P-I>*
L	Launa 40	Lubricating oil	Yellow or transparent	100 cc	Oiler	101-21
W1	White grease (Molykote EM-30L)	Grease	White	100 g	Bottle	101-24
W2	White grease (Molykote HP-300)	Heat-resisting grease	White	10 g	Bottle	101-22
AV	Alvania No.2	Grease	Amber	100 g	Tube	101-23
FL	FLOIL (GE-334C)	Conductive grease	Black	20 g	Bottle	101-26
SI	Silicon oil	Lubricating oil	Transparent	100 cc	Bottle	-

\* : Part list <P-I> represents the page item in “e-STUDIO2000AC/2500AC Service Parts List”.

## 8. ERROR CODE AND TROUBLESHOOTING

### 8.1 General Descriptions

This chapter explains the procedures for solving trouble occurring in the equipment. When trouble occurs, check if an error code is displayed on the LCD screen of the control panel first. If displayed, refer to "8.2 Error Code List" to figure out the classification and contents of the error, and then refer to "8.3 Diagnosis and Prescription for Each Error Code" to remove its cause. When no error is displayed but the equipment does not operate properly or images are not printed properly, refer to "8.4 Other errors" or "8.5 Troubleshooting for the Image" to remove its cause.

When trouble has occurred in the equipment, various causes can be considered. Check the items below first.

1. Is there any problem with the power cable?
  - \* Check if the power cable is inserted securely. When it is almost removed or not inserted securely, power voltage may become unstable, causing a trouble in the equipment.
2. Are the connectors connected securely?
  - \* Reconnect them securely. Even if they are apparently inserted, there may be a contact failure. Carefully check if the connection is secured especially after the disassembly or replacement of parts.
3. Are there any abnormalities in the setting value of the self-diagnostic code?
  - \* If an abnormal value has been entered in the self-diagnostic code related to the problem, an operation failure adjustment, defective images may occur. Therefore, check that the proper value has been entered in the self-diagnostic code.
4. Are there any similar cases?
  - \* Check if there have been any similar problems in the troubleshooting in the Service Manual. If there are similar cases, refer to their troubleshooting.

#### Notes:

If unusual odor is detected or if smoke or fire comes out of the equipment, immediately turn the power OFF. Even in the cases other than the above, fully observe safety precautions.  
If any PC board or HDD shall be replaced, refer to "9.2 Precautions, Procedures and Settings for Replacing PC Boards and HDD".

### 8.1.1 If a problem continues even after performing all troubleshooting

If a problem continues even after performing all troubleshooting and technical tips, report the problem to the appropriate Toshiba service center along with the following information. This information will help the service center understand your problem and take quick action to find the solution.

1. Serial Number

2. List Print

Refer to the appropriate Service Manual for the detailed procedure to obtain a List Print.

A. Enter the value given below to obtain a List Print by CSV file.

FS-30-300: All CSV files

B. Enter the value given below to obtain a List Print by printing it out.

FS-30-101: 05 code

FS-30-102: 08 code

FS-30-104: Pixel counter data (Toner cartridge standard)

FS-30-106: Error history (1000 cases max)

FS-30-108: Firmware update log (200 cases max)

FS-30-110: Power on/off log (100 cases max)

3. For an image-related problem, refer to "8.5.36 If an image-related problem continues after performing all troubleshooting". If a problem nevertheless continues to persist, collect image samples with the problem areas and the feeding direction marked first. Then provide information about the type, size, and weight of the paper along with a copy of the print data / spool file causing the problem.
  4. For abnormal acoustic noise, describe the situation in as much detail as possible.
  5. For hardware-related problems, provide photos of any broken parts, paper jams, etc. In case of paper jams, include the type of paper and its manufacturer.
  6. For software-related problems, provide list prints, TopAccess Logs and the detailed procedure needed to duplicate the problem.
- \* This is the minimum information required to report a complaint. It would be appreciated if you could obtain additional information.
- \* Follow the directions of the service center if they request additional information as each issue is unique to some degree.

## 8.1.2 Collection of debug logs with a USB device

### [ 1 ] General description

The purpose of collecting the debug logs is to acquire the information for analyzing problems which occurred during the MFP's operation. In such a case, you can collect the debug logs by inserting a USB device into the MFP. Even if the power has to be turned OFF with the main power switch after a problem occurs, the debug logs will be saved in the MFP (up to 3 logs). If the debug logs have already been saved in the MFP, they also can be collected.

The following information is included in the USB debug logs.

Internal operation, Job history, HDD/memory usage status, etc. (Personal/Corporate information (address book) not included)

When the debug logs are collected, also do so for the following information since it may be difficult to investigate only using the debug log.

- List print mode [FS-30-300: All CSV files]
- Job logs below in TopAccess -> [Logs] -> [Export Logs]
  - Print Job Log Export
  - Fax Transmission Journal Export
  - Fax Reception Journal Export
  - Scan Log Export
  - Messages Log Export
- Problem occurrence time  
Or the time when the customer called if it is difficult to work out when it occurred.
- Status of when you collected the debug log  
As in the example below, check the status to know if the problem occurred at the debug log collection or how the customer recovered it.  
E.g.
  - You checked the problem and connected a USB device to the equipment.
  - No problem occurred when an attempt to collect the debug log was made; however the customer did turn the main power switch OFF when the problem occurred, so the log can be collected.

### [ 2 ] Collection procedure

1. Note  
When collecting a log, be sure to obtain consent from the user in advance and get the dedicated script file from the service center.
2. About USB devices  
Be sure to format the USB device with FAT16/32 beforehand. (Recommend size: 2GB or more)
3. Advance preparation of collection  
Store the dedicated script file to the root directory of the USB device.
4. Procedure for collecting debug logs
  - (1) Insert the USB device, in which the dedicated script file is stored, into the MFP while the power is ON.
    - After the USB device is inserted into the MFP, the screen will change.
  - (2) Select [Basic Debug Logs], [All Debug Logs] or [9S-300CSV Print Job List] and then press the [START] button.
    - [9S-300CSV Print Job List] can be selected together with [Basic Debug Logs] or [All Debug Logs].
    - The log collection of [All Debug Logs] will start automatically if no operation is made for 30 seconds after the screen has been changed.
    - The LED of the MFP starts blinking when the log collection has begun.
    - The panel display will be changed during the log collection depending on the conditions of the MFP. However, the log collection will continue as long as the LED is blinking.
  - (3) When the log collection is finished, the beeping is heard. After the beeping has stopped, remove the USB device.
    - The MFP will reboot automatically in 10 seconds after a beeping sound.

- If this has not been done automatically after 30 seconds have passed, reboot the MFP manually.

**Notes:**

- Do not remove the USB device while the LED in the MFP is blinking.
- If the LED does not start blinking after the USB device is inserted and a few minutes have passed, try the procedure from step (1) again.
- If there is no beeping after the LED starts blinking (about 20 minutes), try procedure from step (1) again.
- If the USB device is inserted when the MFP is not ready, the debug logs cannot be collected.

5. Collected debug logs

- When the collection of the debug logs is completed, the compressed file of the collected logs is stored in the root directory of the USB device.  
File name:

XXXX.YYYYMMDDHHmmSS	(for basic version and all version)
XXXX.YYYYMMDDHHmmSS.Defunct	(for all version)
XXXX.YYYYMMDDHHmmSS.PowerOff	(for all version)
XXXX.YYYYMMDDHHmmSS_9S300	(for "3. 9S300 csv files, Print job list")
XXXX.YYYYMMDDHHmmSS_JobLis	(for "3. 9S300 csv files, Print job list")
XXXX.YYYYMMDDHHmmSS.USBLog	(for basic version, all version and "3. 9S300 csv files, Print job list")
md5sum.txt	(for basic version, all version and "3. 9S300 csv files, Print job list")

(XXXX= Serial number of the equipment, YYYY= year, MM= month, DD= day, HH= hour, mm= minute, SS= second)

- After the debug logs have been collected, be sure to send them to the service center together with a report.

### 8.1.3 Traceability label

A traceability label on which a management No. at the manufacturing has been printed is attached to some units. If a problem occurs in a unit, report it to the appropriate Toshiba service center along with the traceability label information to help them to understand it.

#### [ 1 ] Management No.

A management No. consists of 13 digits with letters of the alphabet and numbers. The following shows the meaning of each block.

From the 1st to 4th digits: Classification

From the 5th to 10th digits: Production date

From the 11th to 13th digits: Sequential numbers

Classification				Production date						Sequential numbers			
1	2	3	4	5	6	7	8	9	10	11	12	13	(digits)
1	2	2	4	1	2	3	4	5	6	1	2	3	

## [ 2 ] Applicable units

A traceability label is attached to the following units.

No.	Unit	Remarks
1	-	
2	-	
3	-	
4	Automatic duplexing unit (ADU)	
5	Fuser unit	
6	Transfer belt unit (TBU)	
7	Cleaner unit	
8	Developer unit	
9	LED tray	
10	Switching regulator	

## [ 3 ] Label attachment position

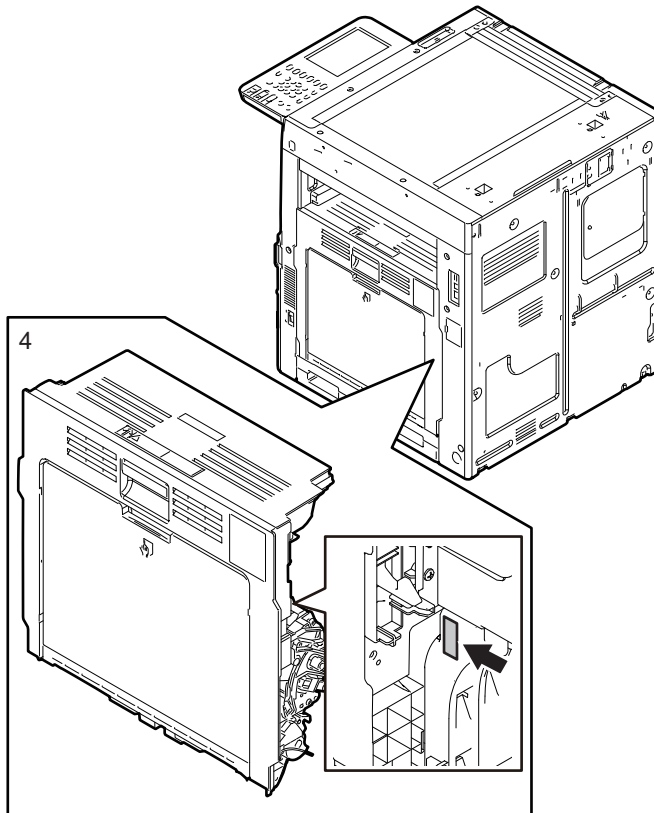


Fig.8-1

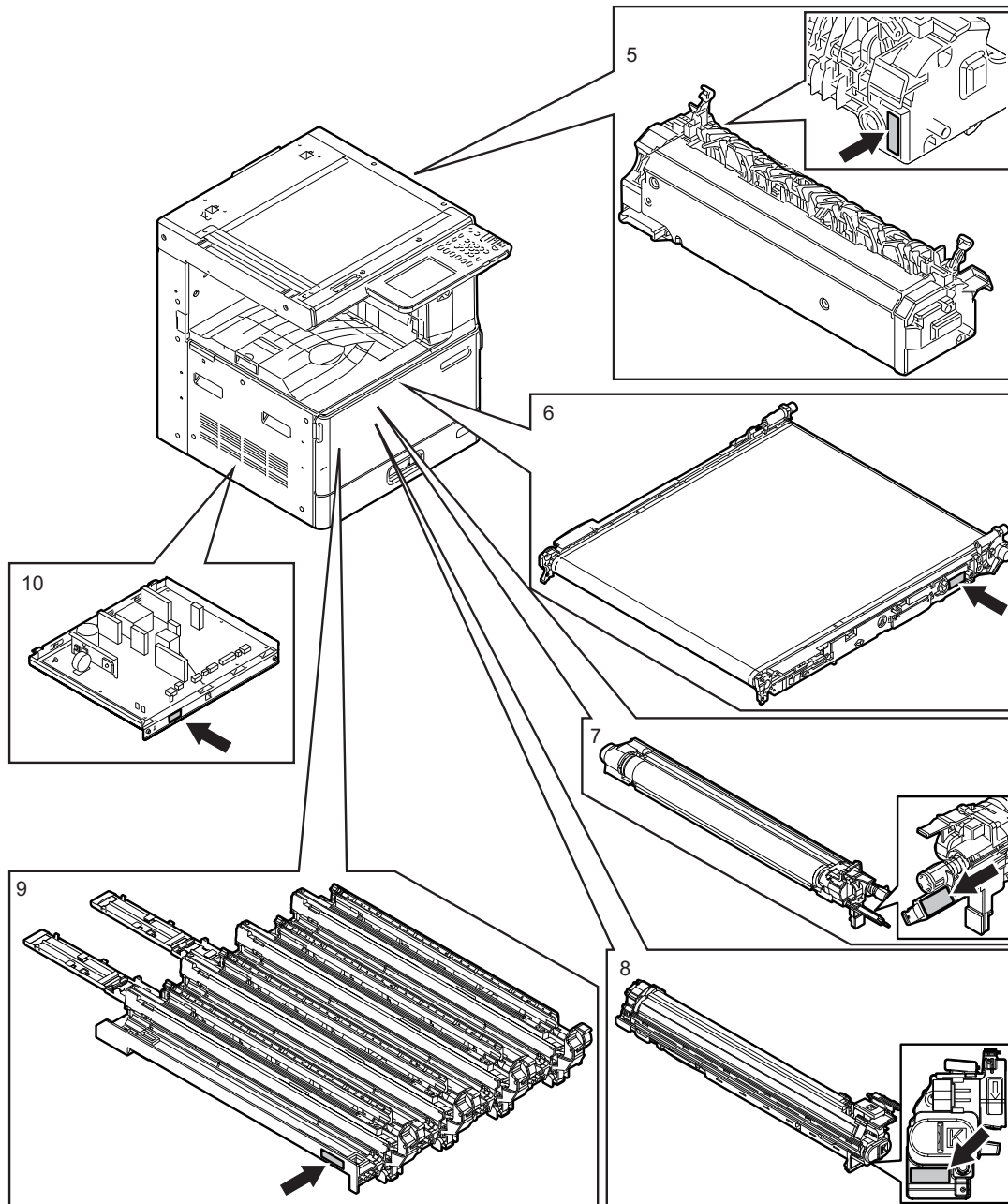


Fig.8-2



## 8.2 Error Code List

The following error codes is displayed at the upper right of the screen when the “CLEAR PAPER” or “CALL SERVICE” symbol is blinking.

### Remarks:

Elision character of the “Error code display media”

Panl: Control panel

JLog: JobLog (TopAccess Print Log - Scan Log)

ML: Message Log (TopAccess Message Log)

Noti: Notification

CSV: CSV output (List print)

Y: Yes

2nd: An error status has been detected twice (= error code has been determined)

### 8.2.1 Jam

Error code	Classification	Message	Contents	Error code display media					Troubles hooting
				Panl	JL	ML	Noti	CSV	
E010	Paper exit jam	Paper Ejection Jam - Please Clear Paper Path.	Paper not reaching the exit sensor jam	-	-	Y	Y	-	P. 8-100
E011	Other paper jam	Paper Jam in Printer - Please Clear Paper Path.	Transfer belt paper-clinging jam	-	-	Y	Y	-	P. 8-117
E013	Other paper jam		Paper not reaching the transport sensor after a registration jam	Y	-	-	-	-	P. 8-119
E020	Paper exit jam	Paper Ejection Jam - Please Clear Paper Path.	Paper stopping at the exit sensor jam	-	-	Y	Y	-	P. 8-102
E030	Other paper jam	Paper Jam in Printer - Please Clear Paper Path.	Power-ON jam	-	-	Y	Y	-	P. 8-120
E061	Other paper jam	Paper Jam in Printer - Please Clear Paper Path.	Incorrect paper size setting for the 1st drawer jam	-	-	Y	Y	-	P. 8-121
E062	Other paper jam	Paper Jam in Printer - Please Clear Paper Path.	Incorrect paper size setting for the 2nd drawer jam	-	-	Y	Y	-	P. 8-121
E063	Other paper jam	Paper Jam in Printer - Please Clear Paper Path.	Incorrect paper size setting for the PFP upper drawer jam	-	-	Y	Y	-	P. 8-121

Error code	Classification	Message	Contents	Error code display media					Troubleshooting
				PanI	JL	ML	Noti	CSV	
E064	Other paper jam	Paper Jam in Printer - Please Clear Paper Path.	Incorrect paper size setting for the PFP lower drawer.	-	-	Y	Y	-	P. 8-121
E065	Other paper jam	Paper Jam in Printer - Please Clear Paper Path.	Incorrect paper size setting for the bypass tray jam	-	-	Y	Y	-	P. 8-121
E090	Other paper jam	Paper Jam in Printer - Please Clear Paper Path.	Image data delay jam	-	-	Y	Y	-	P. 8-121
E091	Other paper jam	Paper Jam in Printer - Please Clear Paper Path.	Motor-ON time-out jam	-	-	Y	Y	-	P. 8-122
E0A0	Other paper jam	Paper Jam in Printer - Please Clear Paper Path.	Image transport ready time-out jam	-	-	Y	Y	-	P. 8-122
E110	Paper misfeeding	Paper Insertion Jam - Please Clear Paper Path.	Paper misfeeding in the ADU (paper not reaching the registration sensor)	-	-	Y	Y	-	P. 8-103
E120	Paper misfeeding	Paper Insertion Jam - Please Clear Paper Path.	Paper misfeeding in the bypass tray (paper not reaching the bypass feed sensor)	-	-	Y	Y	-	P. 8-103
E130	Paper misfeeding	Paper Insertion Jam - Please Clear Paper Path.	Paper misfeeding in the 1st drawer (paper not reaching the 1st drawer feed sensor):	-	-	Y	Y	-	P. 8-104
E140	Paper misfeeding	Paper Insertion Jam - Please Clear Paper Path.	Paper misfeeding in the 2nd drawer (paper not reaching the 2nd drawer feed sensor)	-	-	Y	Y	-	P. 8-104

Error code	Classification	Message	Contents	Error code display media					Troubleshooting
				Panl	JL	ML	Noti	CSV	
E150	Paper misfeeding	Paper Insertion Jam - Please Clear Paper Path.	Paper misfeeding in the PFP upper drawer (paper not reaching the PFP upper drawer feed sensor)	-	-	Y	Y	-	P. 8-105
E160	Paper misfeeding	Paper Insertion Jam - Please Clear Paper Path.	Paper misfeeding in the PFP lower drawer (paper not reaching the PFP lower drawer feed sensor)	-	-	Y	Y	-	P. 8-106
E190	Paper misfeeding	Paper Insertion Jam - Please Clear Paper Path.	Paper misfeeding in the LCF (paper not reaching the LCF feed sensor)	-	-	Y	Y	-	P. 8-106
E200	Paper transport jam	Paper Jam in Printer - Please Clear Paper Path.	Paper transport jam in the 1st drawer (paper not reaching the registration sensor)	-	-	Y	Y	-	P. 8-108
E210	Paper transport jam	Paper Jam in Printer - Please Clear Paper Path.	Paper transport jam in the 2nd drawer (paper not reaching the registration sensor)	-	-	Y	Y	-	P. 8-108
E220	Paper transport jam	Paper Jam in Printer - Please Clear Paper Path.	Paper transport jam in the 2nd drawer (paper not reaching the 1st drawer feed sensor)	-	-	Y	Y	-	P. 8-109
E270	Paper transport jam	Paper Insertion Jam - Please Clear Paper Path.	Paper transport jam in the bypass tray (paper not reaching the registration sensor)	-	-	Y	Y	-	P. 8-108
E300	Paper transport jam	Paper Jam in Printer - Please Clear Paper Path.	Paper transport jam in the PFP upper drawer (paper not reaching the registration sensor)	-	-	Y	Y	-	P. 8-108

Error code	Classification	Message	Contents	Error code display media					Troubles shooting
				PanI	JL	ML	Noti	CSV	
E310	Paper transport jam	Paper Jam in Printer - Please Clear Paper Path.	Paper transport jam in the PFP upper drawer (paper not reaching the 1st drawer feed sensor)	-	-	Y	Y	-	P. 8-109
E320	Paper transport jam	Paper Jam in Printer - Please Clear Paper Path.	Paper transport jam in the PFP upper drawer (paper not reaching the 2nd drawer feed sensor)	-	-	Y	Y	-	P. 8-110
E330	Paper transport jam	Paper Jam in Printer - Please Clear Paper Path.	Paper transport jam in the PFP lower drawer (paper not reaching the registration sensor)	-	-	Y	Y	-	P. 8-108
E340	Paper transport jam	Paper Jam in Printer - Please Clear Paper Path.	Paper transport jam in the PFP lower drawer (paper not reaching the 1st drawer feed sensor)	-	-	Y	Y	-	P. 8-109
E350	Paper transport jam	Paper Jam in Printer - Please Clear Paper Path.	Paper transport jam in the PFP lower drawer (paper not reaching the 2nd drawer feed sensor)	-	-	Y	Y	-	P. 8-110
E360	Paper transport jam	Paper Jam in Printer - Please Clear Paper Path.	Paper transport jam in the PFP lower drawer (paper not reaching the PFP upper drawer feed sensor)	-	-	Y	Y	-	P. 8-111
E3C0	Paper transport jam	Paper Jam in Printer - Please Clear Paper Path.	Paper transport jam in the LCF (paper not reaching the registration sensor)	-	-	Y	Y	-	P. 8-108
E3D0	Paper transport jam	Paper Jam in Printer - Please Clear Paper Path.	Paper transport jam in the LCF (paper not reaching the 1st drawer feed sensor)	-	-	Y	Y	-	P. 8-109

Error code	Classification	Message	Contents	Error code display media					Troubleshooting
				Panl	JL	ML	Noti	CSV	
E3E0	Paper transport jam	Paper Jam in Printer - Please Clear Paper Path.	Paper transport jam in the LCF (paper not reaching the 2nd drawer feed sensor)	-	-	Y	Y	-	P. 8-110
E410	Cover open jam	Paper Jam in Printer - Please Clear Paper Path.	Front cover open jam	-	-	Y	Y	-	P. 8-125
E420	Cover open jam	Paper Jam in Printer - Please Clear Paper Path.	PFP side cover open jam	-	-	Y	Y	-	P. 8-126
E430	Cover open jam	Paper Jam in Printer - Please Clear Paper Path.	ADU open jam	-	-	Y	Y	-	P. 8-126
E440	Cover open jam	Paper Jam in Printer - Please Clear Paper Path.	Jam access cover open jam	-	-	Y	Y	-	P. 8-127
E450	Cover open jam	Paper Jam in Printer - Please Clear Paper Path.	LCF side cover open jam	-	-	Y	Y	-	P. 8-127
E480	Cover open jam	Paper Jam in Printer - Please Clear Paper Path.	Bridge unit front cover open jam	-	-	Y	Y	-	P. 8-128
E490	Cover open jam	Paper Jam in Printer - Please Clear Paper Path.	Job separator cover open jam	Y	-	Y	Y	-	P. 8-128
E510	Paper transport jam (ADU section)	Paper Jam in Automatic Duplexing Unit - Please Clear Paper Path.	Paper not reaching the ADU entrance sensor jam	-	-	Y	Y	-	P. 8-123
E520	Paper transport jam (ADU section)	Paper Jam in Automatic Duplexing Unit - Please Clear Paper Path.	Paper stopping in the ADU jam	-	-	Y	Y	-	P. 8-113
E550	Other paper jam	Paper Jam in the engine. Please clear paper path	Paper remaining jam on the transport path	-	-	Y	Y	-	P. 8-123
E551	Other paper jam	Paper Jam in the engine. Please clear paper path	Paper remaining jam on the transport path (when a service call occurs)	-	-	Y	Y	-	P. 8-124

Error code	Classification	Message	Contents	Error code display media					Troubleshooting
				Panl	JL	ML	Noti	CSV	
E552	Other paper jam	Paper Jam in the engine. Please clear paper path	Paper remaining jam on the transport path (when the cover is closed)	-	-	Y	Y	-	P. 8-124
E712	RADF jam	Paper Jam in Automatic Document Feeder - Please Clear Paper Path.	Original not reaching the original registration sensor jam	-	-	Y	Y	-	P. 8-129
E714	RADF jam	Paper Jam in Automatic Document Feeder - Please Clear Paper Path.	Feed signal reception jam	-	-	Y	Y	-	P. 8-129
E721	RADF jam	Paper Jam in Automatic Document Feeder - Please Clear Paper Path.	Original not reaching the read sensor jam	-	-	Y	Y	-	P. 8-130
E722	RADF jam	Paper Jam in Automatic Document Feeder - Please Clear Paper Path.	Original not reaching the original exit/ reverse sensor jam (during scanning)	-	-	Y	Y	-	P. 8-130
E724	RADF jam	Paper Jam in Automatic Document Feeder - Please Clear Paper Path.		-	-	Y	Y	-	P. 8-131
E725	RADF jam	Paper Jam in Automatic Document Feeder - Please Clear Paper Path.	Original stopping at the read sensor jam	-	-	Y	Y	-	P. 8-131
E726	RADF jam	Paper Jam in Automatic Document Feeder - Please Clear Paper Path.	Transport/exit signal reception jam	-	-	Y	Y	-	P. 8-132
E731	RADF jam	Paper Jam in Automatic Document Feeder - Please Clear Paper Path.	Original stopping at the original exit/reverse sensor jam	-	-	Y	Y	-	P. 8-132

Error code	Classification	Message	Contents	Error code display media					Troubleshooting
				PanI	JL	ML	Noti	CSV	
E860	RADF jam	Paper Jam in Automatic Document Feeder - Please Clear Paper Path.	RADF jam access cover open jam	-	-	Y	Y	-	P. 8-133
E870	RADF jam	Paper Jam in Automatic Document Feeder - Please Clear Paper Path.	RADF open jam	-	-	Y	Y	-	P. 8-133
E910	Finisher jam (Bridge unit section)	Paper Jam in Printer - Please Clear Paper Path.	Paper not reaching the bridge unit transport sensor-1 jam	Y	-	Y	Y	-	P. 8-134
E920	Finisher jam (Bridge unit section)	Paper Jam in Printer - Please Clear Paper Path.	Paper stopping at the bridge unit transport sensor-1 jam	Y	-	Y	Y	-	P. 8-134
E930	Finisher jam (Bridge unit section)	Paper Jam in Printer - Please Clear Paper Path.	Paper not reaching the bridge unit transport sensor-2 jam	Y	-	Y	Y	-	P. 8-135
E940	Finisher jam (Bridge unit section)	Paper Jam in Printer - Please Clear Paper Path.	Paper stopping at the bridge unit transport sensor-2 jam	Y	-	Y	Y	-	P. 8-135
E950	Job separator jam	Paper Jam in Printer - Please Clear Paper Path.	Paper not reaching the job separator transport sensor jam	Y	-	Y	Y	-	P. 8-136
E951	Job separator jam	Paper Jam in Printer - Please Clear Paper Path.	Paper stopping at the job separator transport sensor jam	Y	-	Y	Y	-	P. 8-136
E9F0	Finisher jam (Puncher unit)	Hole Punch Unit Jam in Finisher - Please Clear Hole Punch.	[MJ-1042] Paper jam at the hole punch unit [MJ-6105] Paper jam at the hole punch unit	Y	-	Y	Y	-	P. 8-158
EA10	Finisher jam (Finisher section)	Paper Jam in Finisher - Please Clear Paper Path.	[MJ-1042] 1st transport motor (M8) fault / 2nd transport motor (M4) fault [MJ-1110] Paper transport delay non-inserting jam	Y	-	Y	Y	-	P. 8-137  P. 8-137

Error code	Classification	Message	Contents	Error code display media					Troubleshooting
				PanI	JL	ML	Noti	CSV	
EA20	Finisher jam (Finisher section)	Paper Jam in Finisher - Please Clear Paper Path.	[MJ-1042] 1st transport motor (M8) fault / 2nd transport motor (M4) fault [MJ-1110] Paper stopping jam	Y	-	Y	Y	-	P. 8-138  P. 8-138
EA21	Finisher jam (Finisher section)	Paper Jam in Finisher - Please Clear Paper Path.	[MJ-1110] Paper size error jam:	Y	-	Y	Y	-	P. 8-139
EA22	Finisher jam (Finisher section)	Paper Jam in Finisher - Please Clear Paper Path.	[MJ-6105] Paper size error jam (paper position sensor)	-	-	Y	Y	-	P. 8-139
EA23	Finisher jam (Finisher section)	Paper Jam in Finisher - Please Clear Paper Path.	[MJ-1110] Paper stopping jam (transport sensor):	-	-	Y	Y	-	P. 8-140
EA24	Finisher jam (Finisher section)	Paper Jam in Finisher - Please Clear Paper Path.	[MJ-1110] Paper stopping jam (between the entrance and transport sensors):	-	-	Y	Y	-	P. 8-140
EA25	Finisher jam (Finisher section)	Paper Jam in Finisher - Please Clear Paper Path.	[MJ-1042] Paper transport jam in the finisher (after the exiting of a stack of paper is completed) [MJ-1110] Paper stopping jam (after the exiting of a stack of the paper is completed)	-	-	Y	Y	-	P. 8-141  P. 8-142
EA26	Finisher jam (Finisher section)	Paper Jam in Finisher - Please Clear Paper Path.	[MJ-1110] Paper transport stop jam (stop command request)	-	-	Y	Y	-	P. 8-142  P. 8-143
EA27	Finisher jam (Finisher section)	Paper Jam in Finisher - Please Clear Paper Path.	[MJ-1110] Paper transport stop jam (entrance sensor ON at the slower timing than the specified one)	-	-	Y	Y	-	P. 8-143
EA28	Finisher jam (Finisher section)	Paper Jam in Finisher - Please Clear Paper Path.	[MJ-1110] Paper stopping jam (paper holder plate operation delay)	-	-	Y	Y	-	P. 8-143



Error code	Classification	Message	Contents	Error code display media					Troubleshooting
				PanI	JL	ML	Noti	CSV	
EA29	Finisher jam (Finisher section)	Paper Jam in Finisher - Please Clear Paper Path.	[MJ-1110] Paper stopping jam (stack transport operation delay)	-	-	Y	Y	-	P. 8-144
EA2A	Finisher jam (Finisher section)	Paper Jam in Finisher - Please Clear Paper Path.	[MJ-1042] Paper transport jam in the finisher (between the entrance path and the middle path sensors)	-	-	Y	Y	-	P. 8-144
EA2B	Finisher jam (Finisher section)	Paper Jam in Finisher - Please Clear Paper Path.	[MJ-1042] Paper transport jam in the finisher (middle path sensor)	-	-	Y	Y	-	P. 8-145
EA2C	Finisher jam (Finisher section)	Paper Jam in Finisher - Please Clear Paper Path.	[MJ-1042] Paper transport jam in the finisher (between the entrance path and the sub-path sensors)	-	-	Y	Y	-	P. 8-145
EA2D	Finisher jam (Finisher section)	Paper Jam in Finisher - Please Clear Paper Path.	[MJ-1042] Paper transport jam in the finisher (sub-path sensor)	-	-	Y	Y	-	P. 8-146
EA2E	Finisher jam (Finisher section)	Paper Jam in Finisher - Please Clear Paper Path.	[MJ-1042] Paper remaining jam in the transport path of the finisher (sub-path sensor)	-	-	Y	Y	-	P. 8-147
EA31	Finisher jam (Finisher section)	Paper Jam in Finisher - Please Clear Paper Path.	[MJ-1042] Paper remaining jam in the transport path of the finisher [MJ-1110] Paper remaining jam in the transport path	Y	-	Y	Y	-	P. 8-147 P. 8-147
EA32	Finisher jam (Finisher section)	Paper Jam in Finisher - Please Clear Paper Path.	[MJ-1042] Paper remaining jam at the paper exit in the finisher [MJ-1110] Paper remaining jam at the paper exit	Y	-	Y	Y	-	P. 8-148 P. 8-148

Error code	Classification	Message	Contents	Error code display media					Troubles hooting
				Panl	JL	ML	Noti	CSV	
EA40	Finisher jam (Finisher section)	Paper Jam in Finisher - Please Clear Paper Path.	[MJ-1042] Finisher cover open jam [MJ-1110] Finisher cover open jam	Y	-	Y	Y	-	P. 8-149 P. 8-149
EA50	Finisher jam (Finisher section)	Staple Jam in Finisher - Please Clear Staple.	[MJ-1042] Stapling jam [MJ-1110] Stapling jam	Y	-	Y	Y	-	P. 8-150 P. 8-150
EA60	Finisher jam (Finisher section)	Paper Jam in Finisher - Please Clear Paper Path.	[MJ-1042] Early arrival jam [MJ-1110] Early arrival jam	Y	-	Y	Y	-	P. 8-151 P. 8-151
EA70	Finisher jam (Finisher section)	Paper Jam in Finisher - Please Clear Paper Path.	[MJ-1110] Stack exit belt home position error	Y	-	Y	Y	-	P. 8-152
EA90	Finisher jam (Saddle Stitch section)	Paper Jam in Finisher - Please Clear Paper Path.	[MJ-1110] Door open jam	Y	-	Y	Y	-	P. 8-154
EAA0	Finisher jam (Saddle Stitch section)	Paper Jam in Finisher - Please Clear Paper Path.	[MJ-1110] Paper remaining jam in the saddle stitch unit	Y	-	Y	Y	-	P. 8-154
EAB0	Finisher jam (Saddle Stitch section)	Paper Jam in Finisher - Please Clear Paper Path.	[MJ-1110] Paper transport jam in the saddle stitch unit	Y	-	Y	Y	-	P. 8-155
EAB1	Finisher jam (Saddle Stitch section)	Paper Jam in Finisher - Please Clear Paper Path.	[MJ-1110] Short paper jam in the saddle stitch unit	Y	-	Y	Y	-	P. 8-157
EAD0	Other paper jams	Paper Jam in Printer - Please Clear Paper Path.	Print end command time-out jam	-	-	Y	Y	-	P. 8-160
EAE0	Other paper jams	Paper Jam in Printer - Please Clear Paper Path.	Receiving time-out jam	-	-	Y	Y	-	P. 8-160
EAf1	Finisher jam	Paper Jam in Finisher - Please Clear Paper Path.	[MJ-1042] Stack exit roller nip home position detection error	Y	-	Y	Y	-	P. 8-152
EAf2	Finisher jam	Paper Jam in Finisher - Please Clear Paper Path.	[MJ-1042] Stapler unit sliding motor home position detection error	Y	-	Y	Y	-	P. 8-153

Error code	Classification	Message	Contents	Error code display media					Troubleshooting
				Panl	JL	ML	Noti	CSV	
EAFA	Finisher jam	Paper Jam in Finisher - Please Clear Paper Path.	Catching motor home position detection error (paper jam)	Y	-	Y	Y	-	-
EAFB	Finisher jam	Paper Jam in Finisher - Please Clear Paper Path.	Stapler movement error (paper jam)	Y	-	Y	Y	-	P. 8-217 P. 8-218
E AFC	Finisher jam	Paper Jam in Finisher - Please Clear Paper Path.	Movable tray height error (paper jam)	Y	-	Y	Y	-	P. 8-213
EAFD	Finisher jam	Paper Jam in Finisher - Please Clear Paper Path.	Movable tray movement error (paper jam)	Y	-	Y	Y	-	P. 8-213
EAFE	Finisher jam	Paper Jam in Finisher - Please Clear Paper Path.	Paper holder cam position error (paper jam)	Y	-	Y	Y	-	P. 8-211
EB30	Other paper jams	Paper Jam in Printer - Please Clear Paper Path.	Ready time-out jam	-	-	Y	Y	-	P. 8-161
EB50	Paper transport jam	Paper Jam in Printer - Please Clear Paper Path.	Paper remaining jam on the transport path	-	-	Y	Y	-	P. 8-114
EB60	Paper transport jam	Paper Jam in Printer - Please Clear Paper Path.	Paper remaining jam on the transport path	-	-	Y	Y	-	P. 8-116
ED10	Finisher jam	Paper Jam in Finisher - Please Clear Paper Path.	[MJ-6105] Skew adjustment motor (M1) home position detection error	Y	-	Y	Y	-	P. 8-161
ED11	Finisher jam	Paper Jam in Finisher - Please Clear Paper Path.	[MJ-6105] Sideways adjustment motor (M2) home position detection error	Y	-	Y	Y	-	P. 8-162
ED13	Finisher jam	Paper Jam in Finisher - Please Clear Paper Path.	[MJ-1110] Front alignment plate home position error	Y	-	Y	Y	-	P. 8-162
ED14	Finisher jam	Paper Jam in Finisher - Please Clear Paper Path.	[MJ-1110] Rear alignment plate home position error	Y	-	Y	Y	-	P. 8-163

Error code	Classification	Message	Contents	Error code display media					Troubles hooting
				Panl	JL	ML	Noti	CSV	
ED15	Finisher jam	Paper Jam in Finisher - Please Clear Paper Path.	[MJ-1110] Paddle home position error	Y	-	Y	Y	-	P. 8-163
ED16	Finisher jam	Paper Jam in Finisher - Please Clear Paper Path.	[MJ-1110] Buffer tray home position error	Y	-	Y	Y	-	P. 8-164
EF10	Finisher jam (Saddle Stitcher section)	Paper Jam in Finisher - Please Clear Paper Path.	[MJ-1110] Selection of unsupported paper for the saddle stitch unit	Y	-	Y	Y	-	P. 8-164
EF11	Finisher jam (Saddle Stitcher section)	Paper Jam in Finisher - Please Clear Paper Path.	[MJ-1110] Stapling error (front) in the saddle stitch unit	Y	-	Y	Y	-	P. 8-165
EF12	Finisher jam (Saddle Stitcher section)	Paper Jam in Finisher - Please Clear Paper Path.	[MJ-1110] Stapling error (rear) in the saddle stitch unit	Y	-	Y	Y	-	P. 8-165
EF13	Finisher jam (Saddle Stitcher section)	Paper Jam in Finisher - Please Clear Paper Path.	[MJ-1110] Paper holder home position detection error in the saddle stitch unit	Y	-	Y	Y	-	P. 8-166
EF14	Finisher jam (Saddle Stitcher section)	Paper Jam in Finisher - Please Clear Paper Path.	[MJ-1110] Paper exit jam in the saddle stitch unit	Y	-	Y	Y	-	P. 8-167
EF15	Finisher jam (Saddle Stitcher section)	Paper Jam in Finisher - Please Clear Paper Path.	[MJ-1110] Side alignment motor home position detection error in the saddle stitch unit	Y	-	Y	Y	-	P. 8-172
EF16	Finisher jam (Saddle Stitcher section)	Paper Jam in Finisher - Please Clear Paper Path.	[MJ-1110] Stacker motor home position detection error in the saddle stitch unit	Y	-	Y	Y	-	P. 8-173
EF17	Finisher jam (Saddle Stitcher section)	Paper Jam in Finisher - Please Clear Paper Path.	[MJ-1110] Folding blade home position detection error in the saddle stitch unit	Y	-	Y	Y	-	P. 8-173

Error code	Classification	Message	Contents	Error code display media					Troubleshooting
				PanI	JL	ML	Noti	CSV	
EF18	Finisher jam (Saddle Stitcher section)	Paper Jam in Finisher - Please Clear Paper Path.	[MJ-1110] Additional folding roller home position detection error in the saddle stitch unit	Y	-	Y	Y	-	P. 8-174
EF19	Finisher jam (Saddle Stitcher section)	Paper Jam in Finisher - Please Clear Paper Path.	[MJ-1110] Paper folding jam in the saddle stitch unit	Y	-	Y	Y	-	P. 8-175
EF20	Finisher jam (Saddle Stitcher section)	Paper Jam in Finisher - Please Clear Paper Path.	[MJ-1110] Stacker jam in the saddle stitch unit	-	-	Y	Y	-	-

## 8.2.2 Service call

Error code	Classification	Message	Contents	Error code display media					Troubleshooting
				Panl	JL	ML	Noti	CSV	
C020	Drive system related service call	Fatal Error - Please Contact Service Technician.	Developer drive motor abnormality	2nd	-	Y	Y	-	P. 8-176
C040	Paper feeding system related service call	Printer Input Error.	PFP motor abnormality	Y	-	Y	Y	-	P. 8-178
C130	Paper feeding system related service call	Printer Input Error.	1st drawer tray abnormality	Y	-	Y	Y	-	-
C140	Paper feeding system related service call	Printer Input Error.	2nd drawer tray abnormality	Y	-	Y	Y	-	P. 8-179
C150	Paper feeding system related service call	Printer Input Error.	PFP upper drawer tray abnormality	Y	-	Y	Y	-	P. 8-180
C160	Paper feeding system related service call	Printer Input Error.	PFP lower drawer tray abnormality	Y	-	Y	Y	-	P. 8-180
C180	Paper feeding system related service call	Printer Input Error.	LCF tray-up motor abnormality	Y	-	Y	Y	-	P. 8-181
C1A0	Paper feeding system related service call	Printer Input Error.	LCF end fence motor abnormality	Y	-	Y	Y	-	P. 8-182
C1B0	Paper feeding system related service call	Printer Input Error.	LCF transport motor abnormality	Y	-	Y	Y	-	P. 8-183
C260	Scanning system related service call	Fatal Error - Please Contact Service Technician.	Peak detection error	2nd	-	Y	Y	-	P. 8-184
C262	Scanning system related service call	Fatal Error - Please Contact Service Technician.	Communication error	2nd	-	Y	Y	-	P. 8-186
C270	Scanning system related service call	Fatal Error - Please Contact Service Technician.	Carriage home position sensor not turned OFF within a specified time	Y	-	Y	Y	-	P. 8-186

Error code	Classification	Message	Contents	Error code display media					Troubleshooting
				Panl	JL	ML	Noti	CSV	
C280	Scanning system related service call	Fatal Error - Please Contact Service Technician.	Carriage home position sensor not turned ON within a specified time	Y	-	Y	Y	-	P. 8-188
C290	Scanning system related service call	Fatal Error - Please Contact Service Technician.	Scanner fuse blowout	2nd	-	Y	Y	-	P. 8-189
C370	Copy process related service call	Fatal Error - Please Contact Service Technician.	Transfer belt unit abnormality	2nd	-	Y	Y	-	P. 8-254
C380	Copy process related service call	Fatal Error - Please Contact Service Technician.	Auto-toner sensor-K abnormality (upper limit)	2nd	-	Y	Y	-	P. 8-255
C381	Copy process related service call	Fatal Error - Please Contact Service Technician.	Auto-toner sensor-K abnormality (lower limit)	2nd	-	Y	Y	-	P. 8-256
C390	Copy process related service call	Fatal Error - Please Contact Service Technician.	Auto-toner sensor-C abnormality (upper limit)	2nd	-	Y	Y	-	P. 8-257
C391	Copy process related service call	Fatal Error - Please Contact Service Technician.	Auto-toner sensor-C abnormality (lower limit)	2nd	-	Y	Y	-	P. 8-258
C3A0	Copy process related service call	Fatal Error - Please Contact Service Technician.	Auto-toner sensor-M abnormality (upper limit)	2nd	-	Y	Y	-	P. 8-259
C3A1	Copy process related service call	Fatal Error - Please Contact Service Technician.	Auto-toner sensor-M abnormality (lower limit)	2nd	-	Y	Y	-	P. 8-260
C3B0	Copy process related service call	Fatal Error - Please Contact Service Technician.	Auto-toner sensor-Y abnormality (upper limit)	2nd	-	Y	Y	-	P. 8-261
C3B1	Copy process related service call	Fatal Error - Please Contact Service Technician.	Auto-toner sensor-Y abnormality (lower limit)	2nd	-	Y	Y	-	P. 8-262
C3E0	Copy process related service call	Fatal Error - Please Contact Service Technician.	Developer unit replacement (old-new) detection abnormality	2nd	-	Y	Y	-	P. 8-263

Error code	Classification	Message	Contents	Error code display media					Troubles hooting
				Panl	JL	ML	Noti	CSV	
C3E1	Copy process related service call	Fatal Error - Please Contact Service Technician.	Drum/cleaner/ charger unit replacement (old-new) detection abnormality	2nd	-	Y	Y	-	P. 8-265
C411	Fuser unit related service call	Fatal Error - Please Contact Service Technician.	Thermistor or heater lamp abnormality at power-ON	Y	-	Y	Y	-	P. 8-190
C412	Fuser unit related service call	Fatal Error - Please Contact Service Technician.	Thermistor/ heater lamp abnormality at power-ON	Y	-	Y	Y	-	P. 8-190
C445	Fuser unit related service call	Fatal Error - Please Contact Service Technician.	Heater lamp abnormality after abnormality judgment (pre-running end temperature abnormality)	Y	-	Y	Y	-	P. 8-191
C446	Fuser unit related service call	Fatal Error - Please Contact Service Technician.	Heater lamp abnormality after abnormality judgment (pre-running end temperature abnormality)	Y	-	Y	Y	-	P. 8-191
C447	Fuser unit related service call	Fatal Error - Please Contact Service Technician.	Heater lamp abnormality after abnormality judgment (temperature abnormality at ready status)	Y	-	Y	Y	-	P. 8-191
C449	Fuser unit related service call	Fatal Error - Please Contact Service Technician.	Heater lamp abnormality after abnormality judgment (temperature abnormality at the ready status)	Y	-	Y	Y	-	P. 8-191
C450	Fuser unit related service call	Fatal Error - Please Contact Service Technician.	Heater lamp abnormality after abnormality judgment	Y	-	Y	Y	-	P. 8-191
C451	Fuser unit related service call	Fatal Error - Please Contact Service Technician.	Heater lamp abnormality after abnormality judgment	Y	-	Y	Y	-	P. 8-191
C452	Fuser unit related service call	Fatal Error - Please Contact Service Technician.	Heater lamp abnormality after abnormality judgment	Y	-	Y	Y	-	P. 8-191



Error code	Classification	Message	Contents	Error code display media					Troubleshooting
				Panl	JL	ML	Noti	CSV	
C4F0	Fuser unit related service call	Fatal Error - Please Contact Service Technician.	Center thermistor error correction	Y	-	Y	Y	-	P. 8-192
C4F1	Fuser unit related service call	Fatal Error - Please Contact Service Technician.	Side thermistor error correction	Y	-	Y	Y	-	P. 8-192
C550	Optional communication related service call	Fatal Error - Please Contact Service Technician.	RADF I/F error	2nd	-	Y	Y	-	P. 8-194
C551	Optional communication related service call	Fatal Error - Please Contact Service Technician.	RADF model detection error	Y	-	Y	Y	-	P. 8-198
C560	Optional communication related service call	Fatal Error - Please Contact Service Technician.	Communication error between the engine CPUs	2nd	-	Y	Y	-	P. 8-194
C580	Optional communication related service call	Fatal Error - Please Contact Service Technician.	Communication error between the LGC board and the finisher	2nd	-	Y	Y	-	P. 8-194
C5A0	Circuit related service call	Fatal Error - Please Contact Service Technician.	EEPROM not connected (LGC board)	Y	-	Y	Y	-	P. 8-200
C5A1	Circuit related service call	Fatal Error - Please Contact Service Technician.	EEPROM data abnormality (LGC board)	Y	-	Y	Y	-	P. 8-200
C8E0	RADF related service call	Automatic Document Feeder Error - Please Contact Service Technician.	RADF communication protocol abnormality	2nd	-	Y	Y	-	P. 8-198
F115	Time-out error	Fatal Error - Please Contact Service Technician.	S-VDEN ON signal time-out error	2nd	-	Y	Y	-	P. 8-198
F116	Time-out error	Fatal Error - Please Contact Service Technician.	S-VDEN OFF signal time-out error	2nd	-	Y	Y	-	P. 8-198
C900	Circuit related service call	Fatal Error - Please Contact Service Technician.	Connection error between the SYS board and the LGC board	2nd	-	Y	Y	-	P. 8-200
C911	Circuit related service call	Failed to access to the toner IC chip	Toner cartridge PC board access abnormality	-	-	Y	Y	-	P. 8-201

Error code	Classification	Message	Contents	Error code display media					Troubleshooting
				Panl	JL	ML	Noti	CSV	
C940	Circuit related service call	Fatal Error - Please Contact Service Technician.	Engine-CPU abnormality	2nd	-	Y	Y	-	P. 8-202
C962	Circuit related service call	Fatal Error - Please Contact Service Technician.	LGC board ID abnormality	Y	-	Y	Y	-	P. 8-202
C963	Circuit related service call	[Error] Printer Needs Attention: Call for service	Detection of the connection between the SYS board and LGC board	2nd	-	Y	Y	-	P. 8-203
C964	Circuit related service call	[Error] Printer Needs Attention: Call for service	LGC board boot process abnormality	Y	-	Y	Y	-	P. 8-203
C970	Process related service call	Fatal Error - Please Contact Service Technician.	High-voltage transformer abnormality	Y	-	Y	Y	-	P. 8-266
C9E0	Circuit related service call	Scanner Error - Please Contact Service Technician.	Connection error between the scanner CPU and the system CPU	Y	-	Y	Y	-	P. 8-203
CA00	Image control related service call	Fatal Error - Please Contact Service Technician.	Color registration abnormality	2nd	-	Y	Y	-	P. 8-236
CB00	Finisher related service call	Fatal Error - Please Contact Service Technician.	[MJ-1110] Finisher detection error	2nd	-	Y	Y	-	P. 8-209
CB10	Finisher related service call	Fatal Error - Please Contact Service Technician.	[MJ-1110] Entrance motor abnormality	2nd	-	Y	Y	-	P. 8-209
CB11	Finisher related service call	Fatal Error - Please Contact Service Technician.	[MJ-1110] Buffer tray guide motor abnormality	2nd	-	Y	Y	-	P. 8-210
CB13	Finisher related service call	Fatal Error - Please Contact Service Technician.	[MJ-1110] Finisher exit motor abnormality	2nd	-	Y	Y	-	P. 8-210
CB14	Finisher related service call	Fatal Error - Please Contact Service Technician.	[MJ-1110] Paper holding arm motor abnormality	2nd	-	Y	Y	-	P. 8-211
CB15	Finisher related service call	Fatal Error - Please Contact Service Technician.	Catching motor abnormality	2nd	-	Y	Y	-	-

Error code	Classification	Message	Contents	Error code display media					Troubleshooting
				Panl	JL	ML	Noti	CSV	
CB30	Finisher related service call	Printer Output Error.	[MJ-1042] Movable tray shift motor abnormality [MJ-1110] Movable tray shift motor abnormality	2nd	-	Y	Y	-	P. 8-211  P. 8-213
CB31	Finisher related service call	Fatal Error - Please Contact Service Technician.	[MJ-1110] Movable tray paper-full detection error.	2nd	-	Y	Y	-	P. 8-213
CB40	Finisher related service call	Printer Output Error.	[MJ-1042] Front alignment plate home position detection error [MJ-1110] Front alignment motor abnormality	2nd	-	Y	Y	-	P. 8-214  P. 8-215
CB50	Finisher related service call	Printer Output Error.	[MJ-1042] Stapler unit home position detection error [MJ-1110] Stapler home position error	2nd	-	Y	Y	-	P. 8-215 P. 8-215 P. 8-216
CB51	Finisher related service call	Fatal Error - Please Contact Service Technician.	[MJ-1042] Stapler unit sliding home position detection error [MJ-1110] Stapler shift home position error	2nd	-	Y	Y	-	P. 8-217  P. 8-218
CB60	Finisher related service call	Printer Output Error.	[MJ-1110] Stapler shift motor abnormality	2nd	-	Y	Y	-	P. 8-218
CB80	Finisher related service call	Printer Output Error.	[MJ-1042] Finisher control PC board (FIN) backup RAM error [MJ-1110] Backup RAM data abnormality	2nd	-	Y	Y	-	P. 8-219  P. 8-219
CB81	Finisher related service call	Fatal Error - Please Contact Service Technician.	[MJ-1110] Flash ROM abnormality	2nd	-	Y	Y	-	P. 8-219
CB82	Finisher related service call	Fatal Error - Please Contact Service Technician.	[MJ-1110] Finisher - Main CPU program error	2nd	-	Y	Y	-	P. 8-220

Error code	Classification	Message	Contents	Error code display media					Troubles shooting
				Panl	JL	ML	Noti	CSV	
CB83	Finisher related service call	Fatal Error - Please Contact Service Technician.	[MJ-1110] Saddle stitch finisher - Main CPU program error	2nd	-	Y	Y	-	P. 8-220
CB84	Finisher related service call	Fatal Error - Please Contact Service Technician.	[MJ-6105] Hole punch unit - Main CPU program error	2nd	-	Y	Y	-	P. 8-220
CB92	Finisher related service call	Fatal Error - Please Contact Service Technician.	[MJ-1110] Saddle stitch finisher - RAM abnormality	2nd	-	Y	Y	-	P. 8-221
CB93	Finisher related service call	Fatal Error - Please Contact Service Technician.	[MJ-1110] Saddle stitch finisher - Additional folding motor abnormality	2nd	-	Y	Y	-	P. 8-221
CB94	Finisher related service call	Fatal Error - Please Contact Service Technician.	[MJ-1110] Saddle stitch finisher - Transport motor abnormality	2nd	-	Y	Y	-	P. 8-222
CB95	Finisher related service call	Fatal Error - Please Contact Service Technician.	[MJ-1110] Saddle stitch finisher - Stacker motor abnormality	2nd	-	Y	Y	-	P. 8-222
CBA0	Finisher related service call	Fatal Error - Please Contact Service Technician.	[MJ-1110] Front saddle stapler home position error	2nd	-	Y	Y	-	P. 8-223
CBB0	Finisher related service call	Fatal Error - Please Contact Service Technician.	[MJ-1110] Rear saddle stapler home position error	2nd	-	Y	Y	-	P. 8-223
CBC0	Finisher related service call	Fatal Error - Please Contact Service Technician.	Saddle stitch alignment motor abnormality	2nd	-	Y	Y	-	P. 8-223
CBE0	Finisher related service call	Fatal Error - Please Contact Service Technician.	[MJ-1110] Saddle stitch finisher folding motor (M17) abnormality	2nd	-	Y	Y	-	P. 8-224
CC02	Finisher related service call	Fatal Error - Please Contact Service Technician.	[MJ-1042] Stack exit roller nip home position detection error	2nd	-	Y	Y	-	P. 8-224
CC20	Finisher related service call	Fatal Error - Please Contact Service Technician.	[MJ-1110] Saddle stitch communication error	2nd	-	Y	Y	-	P. 8-225

Error code	Classification	Message	Contents	Error code display media					Troubleshooting
				Panl	JL	ML	Noti	CSV	
CC30	Finisher related service call	Fatal Error - Please Contact Service Technician.	[MJ-1110] Stack transport motor abnormality	2nd	-	Y	Y	-	P. 8-225
CC31	Finisher related service call	Fatal Error - Please Contact Service Technician.	[MJ-1110] Transport motor abnormality	2nd	-	Y	Y	-	P. 8-226
CC41	Finisher related service call	Fatal Error - Please Contact Service Technician.	[MJ-1110] Paper holder cam home position abnormality	2nd	-	Y	Y	-	P. 8-226
CC51	Finisher related service call	Fatal Error - Please Contact Service Technician.	[MJ-1042] Punch unit sliding motor (M12) abnormality [MJ-6105] Sideways adjustment motor (M2) abnormality	2nd	-	Y	Y	-	P. 8-227 P. 8-227
CC52	Finisher related service call	Fatal Error - Please Contact Service Technician.	[MJ-6105] Skew adjustment motor (M1) abnormality	2nd	-	Y	Y	-	P. 8-228
CC54	Finisher related service call	Fatal Error - Please Contact Service Technician.	[MJ-1042] Paper detection sensors abnormality (S24 and S25)	2nd	-	Y	Y	-	P. 8-229
CC60	Finisher related service call	Fatal Error - Please Contact Service Technician.	[MJ-1042] Punch motor (M11) abnormality	2nd	-	Y	Y	-	P. 8-229
CC61	Finisher related service call	Fatal Error - Please Contact Service Technician.	[MJ-1042] Punch motor (M11) abnormality [MJ-6105] Punch motor (M3) home position detection error	2nd	-	Y	Y	-	P. 8-229 P. 8-230
CC71	Finisher related service call	Fatal Error - Please Contact Service Technician.	[MJ-6105] Punch ROM checksum error	Y	-	Y	Y	-	P. 8-231
CC72	Finisher related service call	Fatal Error - Please Contact Service Technician.	[MJ-6105] Punch RAM read/write error	Y	-	Y	Y	-	P. 8-231

Error code	Classification	Message	Contents	Error code display media					Troubleshooting
				Panl	JL	ML	Noti	CSV	
CC80	Finisher related service call	Fatal Error - Please Contact Service Technician.	[MJ-1042] Front alignment motor (M2) abnormality [MJ-1110] Rear alignment motor abnormality	2nd	-	Y	Y	-	P. 8-231  P. 8-232
CC93	Finisher related service call	Fatal Error - Please Contact Service Technician.	Knurled roller shift solenoid abnormality [MJ-1042]	2nd	-	Y	Y	-	P. 8-232
CC94	Finisher related service call	Fatal Error - Please Contact Service Technician.	[MJ-1042] Fan motor abnormality	2nd	-	Y	Y	-	P. 8-233
CD40	Copy process related service call	Fatal Error - Please Contact Service Technician.	Waste toner box full error	-	-	Y	Y	-	P. 8-266
CDE0	Finisher related service call	Printer Output Error.	[MJ-1110] Paddle motor abnormality	2nd	-	Y	Y	-	P. 8-233
CE00	Finisher related service call	Fatal Error - Please Contact Service Technician.	[MJ-6105] Communication error between the finisher and the punch unit	2nd	-	Y	Y	-	P. 8-195  P. 8-234
CE10	Image control related service call	Fatal Error - Please Contact Service Technician.	Image quality sensor abnormality (OFF level)	2nd	-	Y	Y	-	P. 8-243
CE20	Image control related service call	Fatal Error - Please Contact Service Technician.	Image quality sensor abnormality (no pattern level)	2nd	-	Y	Y	-	P. 8-243
CE40	Image control related service call	Fatal Error - Please Contact Service Technician.	Image quality control test pattern abnormality	2nd	-	Y	Y	-	P. 8-246
CE41	Image control related service call	Fatal Error - Please Contact Service Technician.	Image quality TRC control test pattern abnormality	2nd	-	Y	Y	-	P. 8-249
CE50	Image control related service call	Fatal Error - Please Contact Service Technician.	Temperature/ humidity sensor abnormality	2nd	-	Y	Y	-	P. 8-250
CE70	Image control related service call	Fatal Error - Please Contact Service Technician.	Drum drive switching abnormality	2nd	-	Y	Y	-	P. 8-251

Error code	Classification	Message	Contents	Error code display media					Troubleshooting
				Panl	JL	ML	Noti	CSV	
CE80	LED printer head related service call	Fatal Error - Please Contact Service Technician.	LED printer head communication error	2nd	-	Y	Y	-	P. 8-205
CE81	LED printer head related service call	Fatal Error - Please Contact Service Technician.	Interface initialization error between the LED printer head and the LGC board	Y	-	Y	Y	-	P. 8-207
CE90	Image control related service call	Fatal Error - Please Contact Service Technician.	Drum thermistor 1 abnormality	2nd	-	Y	Y	-	P. 8-253
CF10	Finisher related service call	Printer Output Error.	[MJ-1110] Communication module writing failure	2nd	-	Y	Y	-	P. 8-234
F070	Communication related service call	Fatal Error - Please Contact Service Technician.	Communication error between the system-CPU and the engine-CPU	2nd	-	Y	Y	-	P. 8-195
F071	Communication related service call		Communication initialization error between the system-CPU and the engine-CPU	2nd	-	Y	Y	-	P. 8-196
F074	Communication related service call	Fatal Error - Please Contact Service Technician.	Communication error between the system-CPU and the engine-CPU	2nd	-	Y	Y	-	P. 8-196
F090	Circuit related service call	Fatal Error - Please Contact Service Technician.	EEPROM abnormality on the SYS board	Y	-	Y	Y	-	P. 8-204
F100_0	Other service call	Fatal Error - Please Contact Service Technician.	HDD format error	Y	-	Y	Y	-	P. 8-267
F100_1	Other service call	Fatal Error - Please Contact Service Technician.	HDD format error	Y	-	Y	Y	-	P. 8-267
F100_2	Other service call	Fatal Error - Please Contact Service Technician.	HDD format error	Y	-	Y	Y	-	P. 8-268
F100_3	Other service call	Fatal Error - Please Contact Service Technician.	HDD format error	Y	-	Y	Y	-	P. 8-269

Error code	Classification	Message	Contents	Error code display media					Troubleshooting
				Panl	JL	ML	Noti	CSV	
F101_0	Other service call	Fatal Error - Please Contact Service Technician.	HDD connection error	Y	-	Y	Y	-	P. 8-270
F101_1	Other service call	Fatal Error - Please Contact Service Technician.	Root partition mount error (HDD formatting failure)	Y	-	Y	Y	-	P. 8-270
F101_2	Other service call	Fatal Error - Please Contact Service Technician.	Partition mount error	Y	-	Y	Y	-	P. 8-270
F101_3	Other service call	Fatal Error - Please Contact Service Technician.	Partition mount error:	Y	-	Y	Y	-	P. 8-270
F101_4	Other service call	Fatal Error - Please Contact Service Technician.	Partition mount error:	-	-	-	-	-	P. 8-271
F101_5	Other service call	Fatal Error - Please Contact Service Technician.	Partition mount error:	-	-	-	-	-	P. 8-272
F101_6	Other service call	Fatal Error - Please Contact Service Technician.	Partition mount error:	-	-	-	-	-	P. 8-273
F101_7	Other service call	Fatal Error - Please Contact Service Technician.	Partition mount error:	-	-	-	-	-	P. 8-274
F101_8	Other service call	Fatal Error - Please Contact Service Technician.	Partition mount error:	-	-	-	-	-	P. 8-275
F101_9	Other service call	Fatal Error - Please Contact Service Technician.	Partition mount error:	-	-	-	-	-	P. 8-276
F101_10	Other service call	Fatal Error - Please Contact Service Technician.	Partition mount error:	-	-	-	-	-	P. 8-277
F101_11	Other service call	Fatal Error - Please Contact Service Technician.	Partition mount error:	-	-	-	-	-	P. 8-278
F101_12	Other service call	Fatal Error - Please Contact Service Technician.	Partition mount error:	-	-	-	-	-	P. 8-271



Error code	Classification	Message	Contents	Error code display media					Troubleshooting
				Panl	JL	ML	Noti	CSV	
F101_13	Other service call	Fatal Error - Please Contact Service Technician.	Error due to damage to file	-	-	-	-	-	P. 8-279
F101_14	Other service call	Fatal Error	Partition mount error	-	-	-	-	-	P. 8-279a
F102	Other service call	Fatal Error - Please Contact Service Technician.	HDD start error	2nd	-	Y	Y	-	P. 8-280
F103	Other service call	Fatal Error - Please Contact Service Technician.	HDD transfer time-out	2nd	-	Y	Y	-	P. 8-280
F104	Other service call	Fatal Error - Please Contact Service Technician.	HDD data error	2nd	-	Y	Y	-	P. 8-280
F105	Other service call	Fatal Error - Please Contact Service Technician.	HDD other error	2nd	-	Y	Y	-	P. 8-280
F106_0	Other service call		Secure HDD error	2nd	-	-	-	-	P. 8-280
F106_1	Other service call		Secure HDD error	2nd	-	-	-	-	P. 8-281
F106_2	Other service call		Secure HDD error	2nd	-	-	-	-	P. 8-282
F106_3	Other service call		Secure HDD error	2nd	-	-	-	-	P. 8-282
F106_4	Other service call		Secure HDD error	2nd	-	-	-	-	P. 8-283
F106_5	Other service call		Secure HDD error	2nd	-	-	-	-	P. 8-284
F106_6	Other service call		Secure HDD error	2nd	-	-	-	-	P. 8-285
F106_7	Other service call		Secure HDD error	2nd	-	-	-	-	P. 8-285
F106_8	Other service call		Secure HDD error	2nd	-	-	-	-	P. 8-285
F106_10	Other service call		Secure HDD error	2nd	-	-	-	-	P. 8-285
F106_11	License management		License damaged (HDD and SRAM)	2nd	-	-	-	-	P. 8-285
F106_12	License management		License damaged (SRAM)	2nd	-	-	-	-	P. 8-286
F107	Other service call		File system error	2nd	-	-	-	-	P. 8-286
F109_0	Other service call		Key consistency error	Y	-	-	-	-	P. 8-286a

Error code	Classification	Message	Contents	Error code display media					Troubleshooting
				Panl	JL	ML	Noti	CSV	
F109_1	Other service call		Key consistency error	Y	-	-	-	-	P. 8-286a
F109_2	Other service call		Key consistency error	Y	-	-	-	-	P. 8-287
F109_3	Other service call		Key consistency error	Y	-	-	-	-	P. 8-287
F109_4	Other service call		Key consistency error	Y	-	-	-	-	P. 8-289
F109_5	Other service call		Key consistency error	Y	-	-	-	-	P. 8-290
F109_6	Other service call		Key consistency error	Y	-	-	-	-	P. 8-292
F110	Communication related service call	Fatal Error - Please Contact Service Technician.	Communication error between the system-CPU and the scanner-CPU	2nd	-	Y	Y	-	P. 8-294
F111	Communication related service call	Fatal Error - Please Contact Service Technician.	Scanner response abnormality	2nd	-	Y	Y	-	P. 8-294
F11A	Time-out error	Fatal Error - Please Contact Service Technician.	Communication error between the SYS board and the CCD board	2nd	Y	Y	Y	-	P. 8-294
F120	Other service call	Fatal Error - Please Contact Service Technician.	Database abnormality	Y	-	Y	Y	-	P. 8-295
F121	Other service call	User Management DB corrupted.	Database abnormality (user information management database error)	Y	-	Y	Y	-	P. 8-295
F122	Other service call	User Management DB corrupted.	Database abnormality (message/job log management database error)	Y	-	Y	Y	-	P. 8-296
F124	Other service call	AppManagement DB corrupted.	Database abnormality (application management database damage error)	Y	-	Y	Y	-	P. 8-296
F125	Other service call	HomeScreen DB corrupted.	Database abnormality (Home screen database damage error)	Y	-	Y	Y	-	P. 8-296

Error code	Classification	Message	Contents	Error code display media					Troubleshooting
				PanI	JL	ML	Noti	CSV	
F126	Other service call	JobHistory DB corrupted.	Database abnormality (Job history database damage error)	Y	-	Y	Y	-	P. 8-297
F127	Other service call	AppLicense DB corrupted.	Database abnormality (application license management database damage error)	Y	-	Y	Y	-	P. 8-297
F128	License Management	LMDB ERROR	License management database damage	Y	-	Y	Y	-	P. 8-297
F130	Other service call		Invalid MAC address	Y	-	-	-	-	P. 8-298
F131	Other service call	Fatal Error - Please Contact Service Technician.	Filtering setting file damage error	Y	-	Y	Y	-	P. 8-298
F140	Other service call	Fatal Error - Please Contact Service Technician.	ASIC format error	Y	-	Y	Y	-	P. 8-298
F150	Other service call	-	Power failure during the manufacturing mode	Y	-	Y	Y	-	P. 8-299
F200	Other service call	Fatal Error - Please Contact Service Technician.	Data Overwrite option (GP-1070) is disabled	Y	-	Y	Y	-	P. 8-299
F350	Circuit related service call	Fatal Error - Please Contact Service Technician.	SYS board abnormality	Y	-	Y	Y	-	P. 8-204
F400	Circuit related service call	Fatal Error - Please Contact Service Technician.	SYS cooling fan abnormality	Y	-	Y	Y	-	P. 8-299
F410	Circuit related service call	Fatal Error - Please Contact Service Technician.	Power abnormality	Y	-	Y	Y	-	P. 8-300
F510	Other service call		Application start error	Y	-	-	-	-	P. 8-300
F520	Other service call		Operating system start error	Y	-	-	-	-	P. 8-301
F521	Other service call		Integrity check error	Y	-	-	-	-	P. 8-301
F550	Other service call	Fatal Error - Please Contact Service Technician.	Encryption partition error	-	-	Y	Y	-	P. 8-301

Error code	Classification	Message	Contents	Error code display media					Troubleshooting
				PanI	JL	ML	Noti	CSV	
F600	Other service call	Fatal Error - Please Contact Service Technician.	Software update error	Y	-			-	P. 8-301
F700	Other service call	Fatal Error - Please Contact Service Technician.	Overwrite error	-	-	Y	Y	-	P. 8-302
F800	Other service call	Fatal Error - Please Contact Service Technician.	Date error	Y	-	-	-	-	P. 8-302
F900	Other service call		Machine information consistency error	Y	-	-	-	-	P. 8-302
F902_1	Other service call		System firmware / system software model information consistency error	Y	-	-	-	-	P. 8-303
F902_2	Other service call		A model-unmatched SYS board is installed or the SRAM is cleared.	Y	-	-	-	-	P. 8-303
F902_3	Other service call		SRAM abnormality on the SYS board	Y	-	-	-	-	P. 8-304
F902_4	Other service call		SYS board model information consistency error	Y	-	-	-	-	P. 8-304

## 8.2.3 Error in Internet FAX / Scanning Function

### 1. Internet FAX related error

Error code	Classification	Message	Contents	Error code display media					Troubleshooting
				Panl	JL	ML	Noti	CSV	
1C10	Internet fax related error		System access abnormality	-	Y	-	Y	-	P. 8-305
1C11	Internet fax related error		Insufficient memory	-	Y	-	Y	-	P. 8-305
1C12	Internet fax related error		Message reception error	-	Y	-	Y	-	P. 8-305
1C13	Internet fax related error		Message transmission error	-	Y	-	Y	-	P. 8-305
1C14	Internet fax related error		Invalid parameter	-	Y	-	Y	-	P. 8-305
1C15	Internet fax related error		Exceeding file capacity	-	Y	-	Y	-	P. 8-305
1C30	Internet fax related error		Directory creation failure	-	Y	-	Y	-	P. 8-305
1C31	Internet fax related error		File creation failure	-	Y	-	Y	-	P. 8-305
1C32	Internet fax related error		File deletion failure	-	Y	-	Y	-	P. 8-305
1C33	Internet fax related error		File access failure	-	Y	-	Y	-	P. 8-305
1C40	Internet fax related error		Image conversion abnormality	-	Y	-	Y	-	P. 8-305
1C60	Internet fax related error	Syntax error, command unrecognized	HDD full failure during processing	-	Y	-	Y	-	P. 8-305
1C61	Internet fax related error		Address book reading failure	-	Y	-	Y	-	P. 8-305
1C63	Internet fax related error		Terminal IP address unset	-	Y	-	Y	-	P. 8-305
1C64	Internet fax related error		Terminal mail address unset	-	Y	-	Y	-	P. 8-305
1C65	Internet fax related error		SMTP address unset	-	Y	-	Y	-	P. 8-306
1C66	Internet fax related error		Server time-out error	-	Y	-	Y	-	P. 8-306
1C69	Internet fax related error		SMTP server connection error	-	Y	-	Y	-	P. 8-306
1C6B	Internet fax related error		Terminal mail address error	-	Y	-	Y	-	P. 8-306
1C6C	Internet fax related error		Destination mail address error	-	Y	-	Y	-	P. 8-306
1C6D	Internet fax related error		System error	-	Y	-	Y	-	P. 8-306
1C70	Internet fax related error		SMTP client OFF	-	Y	-	Y	-	P. 8-306

Error code	Classification	Message	Contents	Error code display media					Troubleshooting
				Panl	JL	ML	Noti	CSV	
1C71	Internet fax related error		SMTP authentication error	-	Y	-	Y	-	P. 8-306
1C72	Internet fax related error		POP before SMTP error	-	Y	-	Y	-	P. 8-306
1CC0	Internet fax related error		Job canceling	-	Y	-	Y	-	-
1CC1	Internet fax related error		Power failure	-	Y	-	Y	-	P. 8-306

## 2. RFC related error

Error code	Classification	Message	Contents	Error code display media					Troubleshooting
				Panl	JL	ML	Noti	CSV	
2500	RFC related error	Syntax error, command unrecognized	HOST NAME error (RFC: 500) Destination mail address error (RFC: 500) Terminal mail address error (RFC: 500)	-	Y	-	Y	-	P. 8-306
2501	RFC related error	Syntax error in parameters or arguments	HOST NAME error (RFC: 501) Destination mail address error (RFC: 501) Terminal mail address error (RFC: 501)	-	Y	-	Y	-	P. 8-306
2503	RFC related error	Bad sequence of commands	Destination mail address error (RFC: 503)	-	Y	-	Y	-	P. 8-306
2504	RFC related error	Command parameter not implemented	HOST NAME error (RFC: 504)	-	Y	-	Y	-	P. 8-306
2550	RFC related error	Mailbox unavailable	Destination mail address error (RFC: 550)	-	Y	-	Y	-	P. 8-307
2551	RFC related error	User not local	Destination mail address error (RFC: 551)	-	Y	-	Y	-	P. 8-306
2552	RFC related error	Insufficient system storage	Terminal/ Destination address error (RFC: 552)	-	Y	-	Y	-	P. 8-307
2553	RFC related error	Mailbox name not allowed	Destination mail address error (RFC: 553)	-	Y	-	Y	-	P. 8-307

### 3. Remote scanning related error

Error code	Classification	Message	Contents	Error code display media					Troubleshooting
				Panl	JL	ML	Noti	CSV	
2A00	Remote scanning related error		Successful completion (BoxInTA)						-
2A20	Remote scanning related error	Failed to acquire resource	System management module resource acquiring failure	-	Y	-	-	-	P. 8-307
2A31	Remote scanning related error	WS Scan function is not available	WS Scan disabled	-	Y	-	-	-	P. 8-307
2A40	Remote scanning related error	System fatal error	System error	-	Y	-	-	-	P. 8-307
2A50	Remote scanning related error	Job canceling	Job canceling	-	Y	-	-	-	-
2A51	Remote scanning related error	Power failure	Power failure	-	Y	-	-	-	P. 8-307
2A60	Remote scanning related error	Authentication for WS Scan failed	WS Scan user authentication failure	-	Y	-	-	-	P. 8-307
2A70	Remote scanning related error	Insufficient permission to execute RemoteScan	Remote Scan privilege check error	-	-	Y	-	-	P. 8-307
2A71	Remote scanning related error	Insufficient permission to execute WS Scan	WS Scan privilege check error	-	Y	-	-	-	P. 8-307
2A72	Remote scanning related error	Insufficient permission to access e-Filing box using scan utility	e-Filing data access privilege check error (Scan Utility)	-	-	Y	-	-	P. 8-307
2A73	Remote scanning related error	Insufficient permission to execute Addressbook Export/Import operation	Error in the address book operation privilege check	-	-	-	-	-	P. 8-307
2AD0	Remote scanning related error	Backup operation of e-Filing data from Backup/Restore Utility is done	e-Filing data backing up	-	-	-	-	-	-



Error code	Classification	Message	Contents	Error code display media					Troubleshooting
				PanI	JL	ML	Noti	CSV	
2AD1	Remote scanning related error	Restore operation of e-Filing data from Backup/ Restore Utility is done	e-Filing data restoring	-	-	-	-	-	-
2AD2	Remote scanning related error	Archive operation of e-Filing data is done	e-Filing data archiving	-	-	-	-	-	-
2AD3	Remote scanning related error	Restore operation of e-Filing data is done	Archived e-Filing data restoring	-	-	-	-	-	-
2AD4	Remote scanning related error	e-Filing data was downloaded by scan utility	e-Filing data downloading (Scan Utility)	-	-	-	-	-	-

#### 4. Electronic Filing related error

Error code	Classification	Message	Contents	Error code display media					Troubleshooting
				PanI	JL	ML	Noti	CSV	
2B00	e-Filing box related error		Doc saving successful	-	Y	-	Y	-	-
2B01	e-Filing box related error		Successful completion (BoxPrnTA)	-	-	-	-	-	-
2B02	e-Filing box related error		Successful completion (BoxEmailTA)	-	-	-	-	-	-
2B11	e-Filing box related error	Job status failed	Job status abnormality	-	Y	-	Y	-	P. 8-308
2B20	e-Filing box related error	Failed to access file	File library function error	-	Y	-	Y	-	P. 8-308
2B30	e-Filing box related error	Insufficient disk space	Insufficient disk space in /BOX partition	-	Y	-	Y	-	P. 8-308
2B31	e-Filing box related error	Failed to access Electronic Filing	Status of the specified e-Filing box or folder is undefined or being created/ deleted	-	Y	-	Y	-	P. 8-308
2B50	e-Filing box related error	Failed to process image	Image library error	-	Y	-	Y	-	P. 8-308
2B51	e-Filing box related error	Failed to print images from the document box	List library error	-	Y	-	Y	-	P. 8-308
2B71	e-Filing box related error	Document(s) expire(s) in a few days	There are documents which will expire in a few days	-	-	Y	Y	-	-
2B80	e-Filing box related error	Hard Disk space for Electronic Filing nearly full	Hard disk space in /BOX partition is nearly full (90%)	-	-	Y	Y	-	-
2B90	e-Filing box related error	Insufficient Memory	Insufficient memory capacity	-	Y	-	Y	-	P. 8-308
2BA0	e-Filing box related error	Invalid Box password specified	Invalid Box password	-	Y	-	Y	-	P. 8-308
2BA1	e-Filing box related error	Incorrect paper size / invalid color mode / invalid resolution	The specified paper size, color mode or resolution is not available	-	-	-	Y	-	P. 8-308
2BB0	e-Filing box related error	Job canceled	Job canceling	-	Y	-	Y	-	-
2BB1	e-Filing box related error	Power failure occurred	Power failure	-	Y	-	Y	-	P. 8-308
2BC0	e-Filing box related error	System fatal error	Fatal failure occurred	-	Y	-	Y	-	P. 8-308

Error code	Classification	Message	Contents	Error code display media					Troubleshooting
				PanI	JL	ML	Noti	CSV	
2BD0	e-Filing box related error	Power failure occurred during e-Filing restoring	Power failure during restoring of e-Filing	-	-	Y	Y	-	P. 8-308
2BD1	e-Filing box related error	e-Filing Box Storage is initialized.	e-Filing box is initialized.	-	-	Y	Y	-	-
2BE0	e-Filing box related error	Failed to get machine parameter	Machine parameter reading error	-	Y	-	Y	-	P. 8-308
2BF0	e-Filing box related error	Maximum number of page range is reached	Exceeding the maximum number of pages	-	Y	-	Y	-	P. 8-308
2BF1	e-Filing box related error	Maximum number of document range is reached	Exceeding the maximum number of documents	-	Y	-	Y	-	P. 8-308
2BF2	e-Filing box related error	Maximum number of folder range is reached	Exceeding the maximum number of folders	-	Y	-	Y	-	P. 8-308

## 5. E-mail related error

Error code	Classification	Message	Contents	Error code display media					Troubleshooting
				Panl	JL	ML	Noti	CSV	
2C00	E-mail related error		Communication successful completion	-	Y	-	Y	-	-
2C01	E-mail related error		Transferring completion (fax reception)	-	Y	-	Y	-	-
2C02	E-mail related error		Transferring completion (Email reception)	-	Y	-	Y	-	-
2C04	E-mail related error		Notification transmission successful completion	-	Y	-	Y	-	-
2C10	E-mail related error	Illegal Job status	System access abnormality	-	Y	-	Y	-	P. 8-309
2C11	E-mail related error	Not enough memory	Insufficient memory	-	Y	-	Y	-	P. 8-309
2C12	E-mail related error	Illegal Job status	Message reception error	-	Y	-	Y	-	P. 8-309
2C13	E-mail related error	Illegal Job status	Message transmission error	-	Y	-	Y	-	P. 8-309
2C14	E-mail related error	Invalid parameter specified	Invalid parameter	-	Y	-	Y	-	P. 8-309
2C15	E-mail related error	Email size exceeded limit or maximum size	Exceeding file capacity	-	Y	-	Y	-	P. 8-309
2C20	E-mail related error	Illegal Job status	System management module access abnormality	-	Y	-	Y	-	P. 8-309
2C21	E-mail related error	Illegal Job status	Job control module access abnormality	-	Y	-	Y	-	P. 8-309
2C22	E-mail related error	Illegal Job status	Job control module access abnormality	-	Y	-	Y	-	P. 8-309
2C30	E-mail related error	Failed to create directory	Directory creation failure	-	Y	-	Y	-	P. 8-309
2C31	E-mail related error	Failed to create file	File creation failure	-	Y	-	Y	-	P. 8-309
2C32	E-mail related error	Failed to delete file	File deletion failure	-	Y	-	Y	-	P. 8-309
2C33	E-mail related error	Failed to create file	File access failure	-	Y	-	Y	-	P. 8-309
2C40	E-mail related error	Failed to convert image file format	Image conversion abnormality	-	Y	-	Y	-	P. 8-309

Error code	Classification	Message	Contents	Error code display media					Troubleshooting
				PanI	JL	ML	Noti	CSV	
2C43	E-mail related error	Encryption error. Failed to create file	Encryption error	-	Y	-	Y	-	P. 8-309
2C44	E-mail related error	Creating the image file was not permitted	Encryption PDF enforced mode error	-	Y	-	Y	-	P. 8-309
2C45	E-mail related error	Failed in making meta data	Meta data creation error (Scan to Email)	-	Y	-	Y	-	P. 8-309
2C50	E-mail related error	Insufficient permission to execute Scan job	Authentication failure at job execution	-	Y	-	Y	-	P. 8-309
2C60	E-mail related error	Failed to process your Job. Insufficient disk space.	HDD full failure during processing	-	Y	-	Y	-	P. 8-310
2C61	E-mail related error	Failed to read AddressBook	Address book reading failure	-	Y	-	Y	-	P. 8-310
2C62	E-mail related error	Not enough memory	Memory acquiring failure	-	Y	-	Y	-	P. 8-309
2C63	E-mail related error	Invalid Domain Address	Terminal IP address unset	-	Y	-	Y	-	P. 8-310
2C64	E-mail related error	Invalid Domain Address	Terminal mail address unset	-	Y	-	Y	-	P. 8-310
2C65	E-mail related error	Failed to connect to SMTP server	SMTP address unset	-	Y	-	Y	-	P. 8-310
2C66	E-mail related error	Failed to connect to SMTP server	Server time-out error	-	Y	-	Y	-	P. 8-310
2C69	E-mail related error	Failed to connect to SMTP server	SMTP server connection error	-	Y	-	Y	-	P. 8-310
2C6A	E-mail related error	Failed to send E-Mail message	HOST NAME error (No RFC error)	-	Y	-	Y	-	P. 8-310
2C6B	E-mail related error	Invalid address specified in From: field	Terminal mail address error	-	Y	-	Y	-	P. 8-310
2C6C	E-mail related error	Invalid address specified in To: field	Destination mail address error (No RFC error)	-	Y	-	Y	-	P. 8-310
2C70	E-mail related error	SMTP service is not available	SMTP client OFF	-	Y	-	Y	-	P. 8-310
2C71	E-mail related error	Failed SMTP Authentication	SMTP authentication error	-	Y	-	Y	-	P. 8-311
2C72	E-mail related error	POP Before SMTP Authentication Failed	POP before SMTP error	-	Y	-	Y	-	P. 8-310
2CC0	E-mail related error	Job canceled	Job canceling	-	Y	-	Y	-	-

Error code	Classification	Message	Contents	Error code display media					Troubleshooting
				Panl	JL	ML	Noti	CSV	
2CC1	E-mail related error	Power failure occurred	Power failure	-	Y	-	Y	-	P. 8-311

## 6. File sharing related error

Error code	Classification	Message	Contents	Error code display media					Troubleshooting
				PanI	JL	ML	Noti	CSV	
2D00	File sharing related error		Successful completion (saving in a local directory)	-	Y	-	Y	-	-
2D01	File sharing related error		Successful completion (saving in REMOTE)	-	Y	-	Y	-	-
2D02	File sharing related error		Successful completion (saving of a received FaxtoFile/&File in a local directory)	-	Y	-	Y	-	-
2D03	File sharing related error		Successful completion (saving of a received FaxtoFile/&File in REMOTE)	-	Y	-	Y	-	-
2D04	File sharing related error		Successful completion (saving of a received EmailtoFile/&File in a local directory)	-	Y	-	Y	-	-
2D05	File sharing related error		Successful completion (saving of a received EmailtoFile/&File in REMOTE)	-	Y	-	Y	-	-
2D10	File sharing related error	Illegal Job status	System access abnormality	-	Y	-	Y	-	P. 8-311
2D11	File sharing related error	Not enough memory	Insufficient memory	-	Y	-	Y	-	P. 8-311
2D12	File sharing related error	Illegal Job status	Message reception error	-	Y	-	Y	-	P. 8-311
2D13	File sharing related error	Illegal Job status	Message transmission error	-	Y	-	Y	-	P. 8-311
2D14	File sharing related error	Invalid parameter specified	Invalid parameter	-	Y	-	Y	-	P. 8-311
2D15	File sharing related error	Document size exceeded limit or maximum size	Exceeding the maximum size for file sharing	-	Y	-	Y	-	P. 8-311
2D30	File sharing related error	Failed to create directory	Directory creation failure	-	Y	-	Y	-	P. 8-311
2D31	File sharing related error	Failed to create file	File creation failure	-	Y	-	Y	-	P. 8-311

Error code	Classification	Message	Contents	Error code display media					Troubleshooting
				PanI	JL	ML	Noti	CSV	
2D32	File sharing related error	Failed to delete file	File deletion failure	-	Y	-	Y	-	P. 8-311
2D33	File sharing related error	Failed to create file	File access failure	-	Y	-	Y	-	P. 8-311
2D40	File sharing related error	Failed to convert image file format	Image conversion abnormality	-	Y	-	Y	-	P. 8-311
2D43	File sharing related error	Encryption error. Failed to create file	Encryption error	-	Y	-	Y	-	P. 8-311
2D44	File sharing related error	Creating the image file was not permitted	Encryption PDF enforced mode error	-	Y	-	Y	-	P. 8-311
2D45	File sharing related error	Failed in making meta data	Meta data creation error (Scan to File)	-	Y	-	Y	-	P. 8-311
2D50	File sharing related error	Insufficient permission to execute Scan job	Authentication failure at job execution	-	Y	-	Y	-	P. 8-311
2D62	File sharing related error	Failed to connect to network destination. Check destination path	File server connection failure	-	Y	-	Y	-	P. 8-312
2D63	File sharing related error	Specified network path is invalid. Check destination path	Invalid network path	-	Y	-	Y	-	P. 8-312
2D64	File sharing related error	Logon to file server failed. Check username and password	Login failure	-	Y	-	Y	-	P. 8-312
2D65	File sharing related error	There are too many documents in the folder. Failed in creating new document.	New document creation failure caused by an excess of documents in a folder	-	Y	-	Y	-	P. 8-312
2D66	File sharing related error	Failed To Process your Job. Insufficient Storage space.	Storage capacity full failure during processing	-	Y	-	Y	-	P. 8-312
2D67	File sharing related error	FTP service is not available	FTP service not available	-	Y	-	Y	-	P. 8-312
2D68	File sharing related error	File Sharing service is not available	File sharing service not available	-	Y	-	Y	-	P. 8-312
2D69	File sharing related error	NetWare service is not available	NetWare service not available	-	Y	-	Y	-	P. 8-312



Error code	Classification	Message	Contents	Error code display media					Troubleshooting
				PanI	JL	ML	Noti	CSV	
2DA0	File sharing related error	Expired scan documents deleted from share folder	Periodical deletion of scanned documents has been completed properly.	-	-	Y	Y	-	-
2DA1	File sharing related error	Expired Sent Fax documents deleted from shared folder	Periodical deletion of transmitted fax documents has been completed properly.	-	-	Y	Y	-	-
2DA2	File sharing related error	Expired Received Fax documents deleted from shared folder	Periodical deletion of received fax documents has been completed properly.	-	-	Y	Y	-	-
2DA3	File sharing related error	Scanned documents in shared folder deleted upon user's request	Manual deletion of scanned documents has been completed properly.	-	-	Y	Y	-	-
2DA4	File sharing related error	Sent Fax Documents in shared folder deleted upon user's request.	Manual deletion of transmitted fax documents has been completed properly.	-	-	Y	Y	-	-
2DA5	File sharing related error	Received Fax Documents in shared folder deleted upon user's request.	Manual deletion of received fax documents has been completed properly.	-	-	Y	Y	-	-
2DA6	File sharing related error	Failed to delete file	File deletion failure	-	-	Y	Y	-	P. 8-311
2DA7	File sharing related error	Failed to acquire resource.	Resource acquiring failure	-	-	Y	Y	-	P. 8-311
2DC0	File sharing related error	Job canceled	Job canceling	-	Y	-	Y	-	-
2DC1	File sharing related error	Power failure occurred	Power failure	-	Y	-	Y	-	P. 8-312
2E00	File sharing related error		Successful completion (saving in a USB storage)	-	Y	-	Y	-	-
2E01	File sharing related error		Successful completion (saving of a received FaxtoFile/&File in a USB storage)	-	Y	-	Y	-	-

Error code	Classification	Message	Contents	Error code display media					Troubleshooting
				PanI	JL	ML	Noti	CSV	
2E02	File sharing related error		Successful completion (saving of a received EmailtoFile/&File in a USB storage)	-	Y	-	Y	-	-
2E10	File sharing related error	Failed to store document(s) in USB folder.	System access abnormality in USB storage	-	Y	-	Y	-	P. 8-312
2E11	File sharing related error	Failed to store document(s) in USB folder.	Insufficient memory capacity for USB storage	-	Y	-	Y	-	P. 8-312
2E12	File sharing related error	Failed to store document(s) in USB folder.	Message reception error in USB storage	-	Y	-	Y	-	P. 8-312
2E13	File sharing related error	Failed to store document(s) in USB folder.	Message transmission error in USB storage	-	Y	-	Y	-	P. 8-312
2E14	File sharing related error	Failed to store document(s) in USB folder.	Invalid parameter for USB storage	-	Y	-	Y	-	P. 8-312
2E15	File sharing related error	Document size exceeded limit or maximum size	Exceeding the maximum size for file sharing	-	Y	-	Y	-	P. 8-312
2E30	File sharing related error	Failed to store document(s) in USB folder	Directory creation failure in USB storage	-	Y	-	Y	-	P. 8-312
2E31	File sharing related error	Failed to store document(s) in USB folder	File creation failure in USB storage	-	Y	-	Y	-	P. 8-312
2E32	File sharing related error	Failed to store document(s) in USB folder	File deletion failure in USB storage	-	Y	-	Y	-	P. 8-313
2E33	File sharing related error	Failed to store document(s) in USB folder	File access failure in USB storage	-	Y	-	Y	-	P. 8-313
2E40	File sharing related error	Failed to convert image file format	Image conversion abnormality in USB storage	-	Y	-	Y	-	P. 8-313
2E43	File sharing related error	Encryption error. Failed to create file.	Encryption failure in USB storage	-	Y	-	Y	-	P. 8-313
2E44	File sharing related error	Creating the image file was not permitted	Encryption PDF enforced mode error in USB storage	-	-	-	Y	-	P. 8-313

Error code	Classification	Message	Contents	Error code display media					Troubleshooting
				PanI	JL	ML	Noti	CSV	
2E45	File sharing related error	Failed in making meta data	Meta data creation error in USB storage (Scan to File)	-	Y	-	Y	-	P. 8-313
2E50	File sharing related error	Insufficient permission to execute Scan job	Authentication failure at job execution	-	Y	-	Y	-	P. 8-313
2E65	File sharing related error	There are too many documents in folders. Failed in creating new document.	File creation error due to insufficient USB folder capacity	-	Y	-	Y	-	P. 8-313
2E66	File sharing related error	Failed To Process your Job. Insufficient Storage space.	HDD full failure during USB storage process	-	Y	-	Y	-	P. 8-313
2EC0	File sharing related error	Job canceled	Job canceling	-	Y	-	Y	-	-
2EC1	File sharing related error	Power Failure Job Aborted	Power failure in USB storage	-	Y	-	Y	-	P. 8-313

## 7. E-mail reception related error

Error code	Classification	Message	Contents	Error code display media					Troubleshooting
				PanI	JL	ML	Noti	CSV	
3000	E-mail reception related error		E-mail reception is completed properly.	-	Y	-	Y	-	-
3A10	E-mail reception related error	MIME Error has been detected in the received mail.	E-mail MIME error	-	Y	-	Y	-	P. 8-313
3A20	E-mail reception related error	Analyze Error has been detected in the received mail.	E-mail analysis error	-	Y	-	Y	-	P. 8-313
3A30	E-mail reception related error	Whole partial mails were not reached by timeout.	Partial mail time-out error	-	Y	-	Y	-	P. 8-314
3A40	E-mail reception related error	Partial Mail Error has been detected in the received mail.	Partial mail related error	-	Y	-	Y	-	P. 8-314
3A50	E-mail reception related error	HDD Full Error has been occurred in this mail.	Insufficient HDD capacity error	-	Y	-	Y	-	P. 8-314
3A70	E-mail reception related error	Receiving partial mail was aborted since the partial mail setting has been changed to Disable.	Error of partial mail interruption	-	Y	-	Y	-	P. 8-314
3A80	E-mail reception related error	Partial mail was received during the partial mail setting is disabled.	Partial mail reception setting OFF	-	Y	-	Y	-	P. 8-314
3B10	E-mail reception related error	Format Error has been detected in the received mail.	E-mail format error	-	Y	-	Y	-	P. 8-313
3B20	E-mail reception related error	Content-Type Error has been detected in the received mail.	Content-Type error	-	Y	-	Y	-	P. 8-313
3B40	E-mail reception related error	Decode Error has been detected in the received mail.	E-mail decode error	-	Y	-	Y	-	P. 8-313
3B50	E-mail reception related error	Received Email data was broken. It was deleted from mail server.	Received mail data deletion						P. 8-314

Error code	Classification	Message	Contents	Error code display media					Troubleshooting
				Panl	JL	ML	Noti	CSV	
3C10	E-mail reception related error	Tiff Analyze Error has been detected in the received mail.	TIFF analysis error	-	Y	-	Y	-	P. 8-314
3C13	E-mail reception related error	Tiff Analyze Error has been detected in the received mail.	TIFF analysis error	-	Y	-	Y	-	P. 8-314
3C20	E-mail reception related error	Tiff Compression Error has been detected in the received mail.	TIFF compression error	-	Y	-	Y	-	P. 8-314
3C30	E-mail reception related error	Tiff Resolution Error has been detected in the received mail.	TIFF resolution error	-	Y	-	Y	-	P. 8-314
3C40	E-mail reception related error	Tiff Paper Size Error has been detected in the received mail.	TIFF paper size error	-	Y	-	Y	-	P. 8-314
3C50	E-mail reception related error	Offramp Destination Error has been detected in the received mail.	Offramp destination error	-	Y	-	Y	-	P. 8-315
3C60	E-mail reception related error	Offramp Security Error has been detected in the received mail.	Offramp security error	-	Y	-	Y	-	P. 8-315
3C70	E-mail reception related error	Power Failure has been occurred in Email receiving.	Power failure	-	Y	-	Y	-	P. 8-315
3C90	E-mail reception related error	OffRamp Fax transmission disable error has been detected in the received mail.	OffRamp fax transmission disable error	-	Y	-	Y	-	P. 8-315
3D10	E-mail reception related error	SMTP Destination Error has been detected in the received mail. This mail was deleted.	Destination address error	-	-	Y	Y	-	P. 8-315
3D20	E-mail reception related error	Offramp Destination limitation Error has been detected in the received mail.	Maximum number of offramp destination error	-	-	Y	Y	-	P. 8-315

Error code	Classification	Message	Contents	Error code display media					Troubleshooting
				Panl	JL	ML	Noti	CSV	
3D30	E-mail reception related error	Fax Board Error has been occurred in the received mail.	No fax board error	-	-	Y	Y	-	P. 8-315
3E10	E-mail reception related error	POP3 Connection Error has been occurred in the received mail.	POP3 server connection error	-	-	Y	Y	-	P. 8-315
3E20	E-mail reception related error	POP3 Connection Timeout Error has been occurred in the received mail.	POP3 server connection time-out error	-	-	Y	Y	-	P. 8-315
3E30	E-mail reception related error	POP3 Login Error has been occurred in the received mail.	POP3 login error	-	-	Y	Y	-	P. 8-315
3E40	E-mail reception related error	POP3 Login Error occurred in the received mail.	POP3 login method error	-	-	Y	Y	-	P. 8-315
3F10	E-mail reception related error	File I/O Error has been occurred in this mail. The mail could not be received until File I/O is recovered.	File I/O error	-	-	Y	Y	-	P. 8-315
3F20	E-mail reception related error	File I/O Error has been occurred in this mail. The mail could not be received until File I/O is recovered.	File I/O error	-	Y	-	Y	-	P. 8-315

## 8.2.4 Printer function error

Following codes are displayed at the end of the user name on the print job log screen.

Error code	Classification	Message	Contents	Error code display media					Troubleshooting
				PanI	JL	ML	Noti	CSV	
4000	Printer error	-	Successful completion	-	Y	-	-	-	-
4011	Printer error	-	Print job cancellation: A print job (copy, list print, network print) is deleted from the print job screen.	-	Y	-	-	-	P. 8-316
4021	Printer error	-	Power failure at print job processing: The power of the equipment is turned OFF during a print job (copy, list print, network print) process.	-	Y	-	-	-	P. 8-316
4031	Printer error	-	HDD full during print: A large amount of image data is saved in an HDD at private print or invalid network print.	-	Y	-	-	-	P. 8-316
4032	Printer error	-	Exceeding the upper limit of the registration number for the sharing jobs: No more sharing jobs can be registered because its registration number as a personal or functional has reached the upper limit. (A specific error for the Serverless Location Free Print function)	-	Y	-	-	-	P. 8-316

Error code	Classification	Message	Contents	Error code display media					Troubleshooting
				Panl	JL	ML	Noti	CSV	
4033	Printer error	-	A sharing job cannot be registered since the applicable address has not been found from the list used for the Serverless Location Free Print function. (A specific error for the Serverless Location Free Print function)	-	Y	-	-	-	P. 8-316
4041	Printer error	-	User authentication error: The user who intended to print a document is not registered as a user.	-	Y	-	-	-	P. 8-316
4042	Printer error	-	Department authentication error: The department whose code is specified for a print job is not registered.	-	Y	-	-	-	P. 8-316
4043	Printer error	-	Project authentication error: The project whose code is specified for a print job is not registered.	-	Y	-	-	-	P. 8-316
4045	Printer error	-	Problem in LDAP server connection or LDAP server authorization settings.	-	Y	-	-	-	P. 8-316
4111	Printer error	-	Quota over error (no quota in a department and user): The number of the assigned pages set by the department and user management has reached 0.	-	Y	-	-	-	P. 8-316



Error code	Classification	Message	Contents	Error code display media					Troubleshooting
				PanI	JL	ML	Noti	CSV	
4112	Printer error	-	Quota over error (no quota in a user): The number of the assigned pages set by the user management has reached 0.	-	Y	-	-	-	P. 8-316
4113	Printer error	-	Quota over error (no quota in a department): The number of the assigned pages set by the department management has reached 0.	-	Y	-	-	-	P. 8-316
4121	Printer error	-	Job canceling due to external counter error.	-	Y	-	-	-	P. 8-316
4211	Printer error	-	Printing data storing limitation error: Printing with its data being stored to the HDD temporarily (Proof print, Private print, Scheduled print, etc.) has been performed.	-	Y	-	-	-	P. 8-316
4212	Printer error	-	e-Filing storing limitation error: Printing with its data being stored to the HDD (print and e-Filing, print to e-Filing, etc.) has been performed.	-	Y	-	-	-	P. 8-317
4213	Printer error	-	File storing limitation error: The file storing function is set to "disabled".	-	Y	-	-	-	P. 8-317

Error code	Classification	Message	Contents	Error code display media					Troubleshooting
				Panl	JL	ML	Noti	CSV	
4214	Printer error	-	Fax / internet fax transmission limitation error: The fax / internet fax transmission function or the network fax / internet fax function is set to "disabled".	-	Y	-	-	-	P. 8-317
4221	Printer error	-	Private-print-only error: Jobs other than Private print ones have been performed.	-	Y	-	-	-	P. 8-317
4222	Printer error	-	Hold-print-only error	-	Y	-	-	-	P. 8-317
4223	Printer error	-	Private-print-only/Hold-print-only error	-	Y	-	-	-	P. 8-317
4231	Printer error	-	Hardcopy security printing error: A hardcopy security printing job has been performed when the function is restricted.	-	Y	-	-	-	P. 8-317
4243	Printer error	-	Sharing job - An error caused by not having a license	-	Y	-	-	-	P. 8-317
4244	Printer error	-	Sharing job - An error caused by function disabled	-	Y	-	-	-	P. 8-317
4245	Printer error	-	OCR functions not available	-	Y	-	-	-	P. 8-317
4311	Printer error	-	No privilege to perform a job	-	Y	-	-	-	P. 8-317
4312	Printer error	-	No privilege to store a file	-	Y	-	-	-	P. 8-317
4313	Printer error	-	No privilege for e-Filing storage: No privilege to store e-Filing data is given. (e-Filing storage permission)	-	Y	-	-	-	P. 8-317

Error code	Classification	Message	Contents	Error code display media					Troubleshooting
				Panl	JL	ML	Noti	CSV	
4314	Printer error	-	No privilege for fax / internet fax transmission: No privilege to send a fax or internet fax jobs is given. (Fax / internet fax transmission permission)	-	Y	-	-	-	P. 8-317
4321	Printer error	-	No privilege for the print settings: No privilege to print with the specified settings is given. (Print setting permission)	-	Y	-	-	-	P. 8-317
4411	Printer error	-	Image data creation failure: Data or a file whose printing is attempted may be corrupted. <ul style="list-style-type: none"> <li>• Network print: Data are corrupted or invalid.</li> <li>• Direct print: A file is corrupted or not in a supported format.</li> </ul>	-	Y	-	-	-	P. 8-317
4412	Printer error	-	Double-sign encoding error: A double-sign encoding error has occurred because the PDF file is encrypted in a forbidden language or in a language not supported.	-	Y	-	-	-	P. 8-317
4511	Printer error	Print failure due to connection timeout	In the case the print data is not sent from the client PC during printing and print ends in error, or connection is not disconnected from the PC, timeout error is detected.	-	-	Y	-	-	P. 8-318

Error code	Classification	Message	Contents	Error code display media					Troubleshooting
				Panl	JL	ML	Noti	CSV	
4521	Printer error	Cannot print due to connection limit	In the case the MFP reaches the max. number of connections and cannot receive a job	-	-	Y	-	-	P. 8-318
4522	Printer error	Registered print job number reached to limit during printing	Since the MFP nears the Workflow Full, reception of the jobs is limited.	-	-	Y	-	-	P. 8-318
4523	Printer error	Storage full occurred during printing	Since the MFP nears the HDD Full, reception of the jobs is limited.	-	-	Y	-	-	P. 8-318
4611	Printer error	-	Font download failure (exceeding the maximum number of registrations): A new font cannot be registered because the number of fonts registered in this equipment has already reached the limit.	-	Y	-	-	-	P. 8-318
4612	Printer error	-	Font download failure (HDD full): A new font cannot be registered because there is insufficient space in the font storage area of this equipment.	-	Y	-	-	-	P. 8-318
4613	Printer error	-	Font download failure (others): A new font cannot be registered due to other abnormalities.	-	Y	-	-	-	P. 8-318
4621	Printer error	-	Downloaded font deletion failure: The specified font cannot be deleted because it does not exist, it is undeletable or any another abnormality has occurred.	-	Y	-	-	-	P. 8-318

Error code	Classification	Message	Contents	Error code display media					Troubleshooting
				Panl	JL	ML	Noti	CSV	
4721	Printer error	-	Connection failure of Multi Station Print because of an unexpected ROM version combination.	-	-	Y	-	-	P. 8-318
4F10	Printer error	-	Printing has not been performed successfully due to other abnormalities.	-	Y	-	-	-	P. 8-318

## 8.2.5 TopAccess related error/Communication error with external application

Error code	Classification	Message	Contents	Error code display media					Troubleshooting
				Panl	JL	ML	Noti	CSV	
5012	Communication error	TOSHIBA Global remote monitoring system error	Authentication error: A temporary password entered in this equipment by downloading from e-Bridge is invalid, or the permanent password set in e-Bridge is invalid.	-	-	Y	Y	-	P. 8-319
5013	Communication error	TOSHIBA Global remote monitoring system error	Communication error between e-Bridge: Communication is attempted while e-Bridge is enabled for some reason such as a version upgrade.	-	-	Y	-	-	P. 8-319
5014	Communication error	TOSHIBA Global remote monitoring system error	No SSL certificate: There is no SSL certificate or the certificate is not in a correct file format.	-	-	Y	-	-	P. 8-319
5015	Communication error	TOSHIBA Global remote monitoring system error	Invalid SSL certificate error: The SSL certificate is incorrect	-	-	Y	-	-	P. 8-319
5016	Communication error	TOSHIBA Global remote monitoring system error	Expired SSL certificate error: The SSL certificate is expired.	-	-	Y	-	-	P. 8-319
5017	Communication error	TOSHIBA Global remote monitoring system error	Other SSL certificate related error: The SSL certificate is invalid.	-	-	Y	-	-	P. 8-320
5018	Communication error	TOSHIBA Global remote monitoring system error	Invalid DNS error: The DNS address is incorrect.	-	-	Y	-	-	P. 8-320

Error code	Classification	Message	Contents	Error code display media					Troubleshooting
				PanI	JL	ML	Noti	CSV	
5019	Communication error	TOSHIBA Global remote monitoring system error	Connection error: Settings for the initial URL and proxy are incorrect.	-	-	Y	-	-	P. 8-320
501A	Communication error	TOSHIBA Global remote monitoring system error	Proxy error: Settings for the IP address or port are incorrect.	-	-	Y	-	-	P. 8-320
501B	Communication error	TOSHIBA Global remote monitoring system error	No URL (host/port) or invalid path: The initial URL is incorrect.	-	-	Y	-	-	P. 8-320
501C	Communication error		Toner-K remaining amount notification						-
501D	Communication error		Toner-C remaining amount notification						-
501E	Communication error		Toner-M remaining amount notification						-
501F	Communication error		Toner-Y remaining amount notification						-
5020	Communication error	The first registration was completed.	Initial registration completion	-	-	Y	-	-	-
5021	Communication error	Communication with TOSHIBA Remote monitoring system succeeded	Successful communication with an eBR2 server	-	-	Y	-	-	-
5030	Communication error		An error has occurred in the HTTP communication	-	-	Y	-	-	P. 8-321
50FF	Communication error		A fatal error has occurred in the MFP.	-	-	Y	-	-	P. 8-321
5110	Communication error		Toner cartridge detection error	-	-	-	-	-	P. 8-321
5211	Communication error		PM counter excess						-

Error code	Classification	Message	Contents	Error code display media					Troubleshooting
				Panl	JL	ML	Noti	CSV	
5212	Communication error		Appears when the time for main charger cleaning comes (at the output of approx. every 10,000 sheets)	-	-	Y	Y	-	P. 8-321
5213	Communication error		LED head cleaning period						P. 8-321
5310	Communication error		Toner-K empty						P. 8-322
5311	Communication error		Toner-Y empty						P. 8-322
5312	Communication error		Toner-M empty						P. 8-322
5313	Communication error		Toner-C empty						P. 8-322
5400	Communication error	Succeeded in MFP registration	MFP registration success	-	-	Y	Y	-	-
5410	Communication error	TOSHIBA Global remote monitoring system error	MFP registration error	-	-	Y	Y	-	P. 8-322
5411	Communication error	TOSHIBA Global remote monitoring system error	MFP registration lock error	-	-	Y	Y	-	P. 8-322
5412	Communication error	TOSHIBA Global remote monitoring system error	Server busy error	-	-	Y	Y	-	P. 8-322
5413	Communication error	TOSHIBA Global remote monitoring system error	Server error	-	-	Y	Y	-	P. 8-323
5414	Communication error	TOSHIBA Global remote monitoring system error	Invalid device file error	-	-	Y	Y	-	P. 8-323
5415	Communication error	TOSHIBA Global remote monitoring system error	Communication error	-	-	Y	Y	-	P. 8-323
5416	Communication error	TOSHIBA Global remote monitoring system error	Setting files / system software update error	-	-	Y	Y	-	P. 8-323
5417	Communication error	TOSHIBA Global remote monitoring system error	System software error	-	-	Y	Y	-	P. 8-324



Error code	Classification	Message	Contents	Error code display media					Troubleshooting
				PanI	JL	ML	Noti	CSV	
5BD0	Communication error	Power failure occurred during restore	Power supply has been cut off during the restoration of the database sent from TopAccess.	-	-	Y	Y	-	P. 8-324
5C10	Communication error	FAX Unit is not attached.	Network fax is disabled because no fax unit is installed.	-	-	Y	Y	-	P. 8-324
5C11	Communication error	Security error on Address Book.	A network fax job has failed because the specified address is not registered in the address book.	-	-	Y	Y	-	P. 8-324

## 8.2.6 MFP access error

Error code	Classification	Message	Contents	Error code display media					Troubleshooting
				Panl	JL	ML	Noti	CSV	
6000	MFP access error	Successful user login	User login success to an MFP	-	-	Y	Y	-	-
6001	MFP access error	Failed user login	User login failure to an MFP	-	-	Y	Y	-	-
6002	MFP access error	Successful user logout	User logout success from an MFP: Manual logout	-	-	Y	Y	-	-
6003	MFP access error	Successful user logout (Session Time Out)	User logout success from an MFP: Automatic logout	-	-	Y	Y	-	-
6004	MFP access error	Successful User Box Authentication	Authentication success of a user box password	-	-	Y	Y	-	-
6005	MFP access error	Failed User Box Authentication	Authentication failure of a user box password	-	-	Y	Y	-	-
6006	MFP access error	User login information was broken	UserToken binding failure	-	-	Y	Y	-	-
6007	MFP access error	Failed user login	User login to MFP failure	-	-	Y	Y	-	P. 8-325
6008	MFP access error	Failed to connect on External LDAP server for Role Base Access Control	Connection failure to an external Role Base Access Control (LDAP) server	-	-	Y	Y	-	P. 8-325
6009	MFP access error	Failed user login(Authentication on server connection error)	User login failure to an MFP (during NIC initialization)	-	-	Y	Y	-	P. 8-325
600A	MFP access error	Department code has not been assigned to the user	Department code not assigned to a user	-	-	Y	Y	-	P. 8-325
6010	MFP access error	Cannot find the Home Directory.	Home directory not found	-	-	Y	Y	-	-
6011	MFP access error	Failed to register the user by automatically(Maximum number of registered users)	User automatic registration failure (due to an upper limit of the user registration number)	-	-	Y	Y	-	P. 8-325
6012	MFP access error	Successful user login by cache information	User login success with cache information	-	-	Y	Y	-	-

Error code	Classification	Message	Contents	Error code display media					Troubles hooting
				PanI	JL	ML	Noti	CSV	
6013	MFP access error	Failed to connect on the authentication server	Connection failure to an authentication server	-	-	Y	Y	-	P. 8-326
6014	MFP access error	Detected the authentication server that can not be connected	Inaccessible authentication server detection	-	-	Y	Y	-	P. 8-326
6031	MFP access error	Illegal CL code	Invalid setting: Invalid CL code	-	-	Y	Y	-	P. 8-326
6032	MFP access error	Illegal period	Card related error	-	-	Y	Y	-	P. 8-326
6033	MFP access error	No entering record	Card related error	-	-	Y	Y	-	P. 8-326
6034	MFP access error	Illegal entering record	Card related error	-	-	Y	Y	-	P. 8-327
6035	MFP access error	Illegal SSFC settings of MFP.	Invalid setting: Invalid flag information (not set in an MFP)	-	-	Y	Y	-	P. 8-327
6036	MFP access error	Unmatch settings and card info.	Invalid setting: Invalid flag information (Information between an MFP and card does not match)	-	-	Y	Y	-	P. 8-327
6037	MFP access error	You cannot be used.	Permission flag for use not available	-	-	Y	Y	-	P. 8-327
6040	MFP access error	Failed to read the card	Card authentication: Read error	-	-	Y	Y	-	P. 8-328
6041	MFP access error	Card Authentication Failed because of Card Reading Error	Card authentication	-	-	Y	Y	-	P. 8-328
6042	MFP access error	Card Authentication Failed because of setting Error	Card authentication	-	-	Y	Y	-	P. 8-328
6043	MFP access error	Card Authentication Failed because the card information was duplicated on the card server.	Card authentication failure (duplication of card information)	-	-	Y	Y	-	-
6044	MFP access error	Communication Error of CardNotificcation	Card notification failure (Stage2)	-	-	Y	Y	-	-

Error code	Classification	Message	Contents	Error code display media					Troubleshooting
				PanI	JL	ML	Noti	CSV	
6050	MFP access error	Successful print authentication	Print job authentication success	-	-	Y	Y	-	-
6051	MFP access error	Failed print authentication	Print job authentication failure	-	-	Y	Y	-	-
6052	MFP access error	Failed to connect on External LDAP server for Role Base Access Control	Connection failure to an external Role Base Access Control (LDAP) server	-	-	Y	Y	-	P. 8-328
6053	MFP access error	Failed print authentication(Network Initializing)	Print job authentication failure due to NIC initialization	-	-	Y	Y	-	-
6054	MFP access error	Failed to register the user by automatically(Maximum number of registered users)	Print job authentication failure due to upper limit excess of user automatic registration	-	-	Y	Y	-	-
6055	MFP access error	Successful print authentication by cache information	Print job authentication success with cache information	-	-	Y	Y	-	-
6060	MFP access error	Successful user login	(PIN authentication) User login success to an MFP	-	-	Y	Y	-	-
6061	MFP access error	Successful user logout	(PIN authentication) User logout success from an MFP: Manual logout	-	-	Y	Y	-	-
6062	MFP access error	Successful user logout (Session Time Out)	(PIN authentication) User logout success from an MFP: Automatic logout	-	-	Y	Y	-	-
6063	MFP access error	Department code has not been assigned to the user	(PIN authentication) Department code not assigned to a user	-	-	Y	Y	-	-

Error code	Classification	Message	Contents	Error code display media					Troubleshooting
				Panl	JL	ML	Noti	CSV	
6064	MFP access error	Cannot find the Home Directory.	(PIN authentication) Home directory not found	-	-	Y	Y	-	-
6065	MFP access error	Failed to register the user by automatically(Maximum number of registered users)	(PIN authentication) User automatic registration failure (due to a upper limit of the user registration number)	-	-	Y	Y	-	-
6066	MFP access error	PIN Authentication Failed because the PIN code was duplicated on the PIN server.	PIN authentication failure (duplication of a PIN code)	-	-	Y	Y	-	-
6067	MFP access error	Successful user login by cache information	(PIN authentication) User login success to an MFP with cache information	-	-	Y	Y	-	-
6100	MFP access error	User account is locked	User account locking out	-	-	Y	Y	-	-
6101	MFP access error	Box is locked	e-Filing box locking out	-	-	Y	Y	-	P. 8-329
6102	MFP access error	Failed to login because the user account had been locked out.	User account is being locked out.	-	-	Y	Y	-	-
6103	MFP access error	Failed to access Box because the Box had been locked out.	e-Filing box is being locked out.	-	-	Y	Y	-	-
6121	MFP access error	SecureErase fails	Automatic secure erase failure	-	-	Y	Y	-	P. 8-329
6130	MFP access error	Successfully verified clock with Time Server	Synchronization success to a time server	-	-	Y	Y	-	-
6131	MFP access error	SNTP server synchronization failure	Synchronization with an SNTP server has failed.	-	-	Y	Y	-	P. 8-329
6150	MFP access error	Print Log full (100% Used) Log OverWrite will be start	Print log database full	-	-	Y	Y	-	-
6151	MFP access error	Print Log near full (95% Used)	Print log database nearly full (95%)	-	-	Y	Y	-	-

Error code	Classification	Message	Contents	Error code display media					Troubles hooting
				PanI	JL	ML	Noti	CSV	
6152	MFP access error	Print Log near full (90% Used)	Print log database nearly full (90%)	-	-	Y	Y	-	-
6153	MFP access error	Print Log near full (80% Used)	Print log database nearly full (80%)	-	-	Y	Y	-	-
6154	MFP access error	Print Log near full (70% Used)	Print log database nearly full (70%)	-	-	Y	Y	-	-
6160	MFP access error	Scan Log full (100% Used) Log OverWrite will be start	Scan log database full	-	-	Y	Y	-	-
6161	MFP access error	Scan Log near full (95% Used)	Scan log database nearly full (95%)	-	-	Y	Y	-	-
6162	MFP access error	Scan Log near full (90% Used)	Scan log database nearly full (90%)	-	-	Y	Y	-	-
6163	MFP access error	Scan Log near full (80% Used)	Scan log database nearly full (80%)	-	-	Y	Y	-	-
6164	MFP access error	Scan Log near full (70% Used)	Scan log database nearly full (70%)	-	-	Y	Y	-	-
6170	MFP access error	FAX_Transmission Log full (100% Used) Log OverWrite will be started	Fax transmission database full	-	-	Y	Y	-	-
6171	MFP access error	FAX_Transmission Log near full (95% Used)	Fax transmission database nearly full (95%)	-	-	Y	Y	-	-
6172	MFP access error	FAX_Transmission Log near full (90% Used)	Fax transmission database nearly full (90%)	-	-	Y	Y	-	-
6173	MFP access error	FAX_Transmission Log near full (80% Used)	Fax transmission database nearly full (80%)	-	-	Y	Y	-	-
6174	MFP access error	FAX_Transmission Log near full (70% Used)	Fax transmission database nearly full (70%)	-	-	Y	Y	-	-
6180	MFP access error	FAX_Receive Log full (100% Used) Log OverWrite will be start	Fax reception database full	-	-	Y	Y	-	-
6181	MFP access error	FAX_Receive Log near full (95% Used)	Fax reception database nearly full (95%)	-	-	Y	Y	-	-

Error code	Classification	Message	Contents	Error code display media					Troubles shooting
				Panl	JL	ML	Noti	CSV	
6182	MFP access error	FAX_Receive Log near full (90% Used)	Fax reception database nearly full (90%)	-	-	Y	Y	-	-
6183	MFP access error	FAX_Receive Log near full (80% Used)	Fax reception database nearly full (80%)	-	-	Y	Y	-	-
6184	MFP access error	FAX_Receive Log near full (70% Used)	Fax reception database nearly full (70%)	-	-	Y	Y	-	-
6190	MFP access error	Message Log full (100% Used) Log OverWrite will be start	Message log database full	-	-	Y	Y	-	-
6191	MFP access error	Message Log near full (95% Used)	Message log database nearly full (95%)	-	-	Y	Y	-	-
6192	MFP access error	Message Log near full (90% Used)	Message log database nearly full (90%)	-	-	Y	Y	-	-
6193	MFP access error	Message Log near full (80% Used)	Message log database nearly full (80%)	-	-	Y	Y	-	-
6194	MFP access error	Message Log near full (70% Used)	Message log database nearly full (70%)	-	-	Y	Y	-	-
61B0	MFP access error	Failed to save Image Log data	Image log saving failure to an MFP local storage	-	-	Y	Y	-	P. 8-329
61C0	MFP access error	Application Log full (100% Used) Log OverWrite will be start	Application log database full	-	-	Y	Y	-	-
61C1	MFP access error	Application Log near full (95% Used)	Application log database nearly full (95%)	-	-	Y	Y	-	-
61C2	MFP access error	Application Log near full (90% Used)	Application log database nearly full (90%)	-	-	Y	Y	-	-
61C3	MFP access error	Application Log near full (80% Used)	Application log database nearly full (80%)	-	-	Y	Y	-	-
61C4	MFP access error	Application Log near full (70% Used)	Application log database nearly full (70%)	-	-	Y	Y	-	-
6200	MFP access error	Service Technician changed Security Level	Security level change of an MFP by a service technician	-	-	Y	Y	-	-
6220	MFP access error	Administrator's setting wizard is finished	Execution of the administrator setting wizard	-	-	-	-	-	-

Error code	Classification	Message	Contents	Error code display media					Troubleshooting
				Panl	JL	ML	Noti	CSV	
6221	MFP access error	Security settings are changed by Administrator	Security setting items change by an administrator	-	-	-	-	-	-
6240	MFP access error	User account password is not pursuant to Security Policy	A user password is outside the security policy.	-	-	-	-	-	-
6241	MFP access error	e-Filing Box password is not pursuant to Security Policy	An e-Filing box password is outside the security policy.	-	-	-	-	-	-
6260	MFP access error	User Information updated	User information change	-	-	-	-	-	-
6261	MFP access error	Role Information updated	Role information change	-	-	-	-	-	-
6262	MFP access error	Role in Group is edited	Group role information change	-	-	-	-	-	-
6263	MFP access error	Failed to add the new build-in user or role	New build-in user and role update failure	-	-	-	-	-	P. 8-330
6280	MFP access error	Selfsigned Certificate generated	Self-signed certification generation	-	-	-	-	-	-
6281	MFP access error	ServerCertificate generated	Server certification generation	-	-	-	-	-	-
6282	MFP access error	Failed to add certificate	Certification addition failure	-	-	-	-	-	-
6283	MFP access error	Cryptographic key generated	Encryption key generation	-	-	-	-	-	-



## 8.2.7 Maintenance error

Error code	Classification	Message	Contents	Error code display media					Troubleshooting
				Panl	JL	ML	Noti	CSV	
711A	Maintenance error	Cleared License Key	Electronic key clear	-	-	Y	Y	-	-
711C	Maintenance error	Successfully removed License Key	Electronic key returning success	-	-	Y	Y	-	-
711D	Maintenance error	Failed to remove License Key	License key returning failure	-	-	Y	Y	-	P. 8-331
711E	Maintenance error	Successfully installed License Key	Electronic key installation success	-	-	Y	Y	-	-
711F	Maintenance error	Failed to install License Key	License key installation failure	-	-	Y	Y	-	P. 8-331
7136	Maintenance error	Successfully imported EWB error screen file	EWB error screen file importing success	-	-	Y	Y	-	-
7137	Maintenance error	Failed to imported EWB error screen file	EWB error screen file importing failure	-	-	Y	Y	-	-
7154	Maintenance error	Rebuilt the Log DB by Log DB corruption	LogDB rebuilding caused by damage on it	-	-	Y	Y	-	-
7155	Maintenance error	Rebuilt the Image Log DB by Image Log DB corruption	Image log DB rebuilding caused by damage on it	-	-	Y	Y	-	-
71B0	Maintenance error	Failed to decrypt Software Package	Software package file decryption failure	-	-	Y	Y	-	P. 8-331
71B2	Maintenance error	Successfully updated Laser ROM	Laser firmware installation success	-	-	Y	Y	-	-
71B3	Maintenance error	Failed to update Laser ROM	Laser firmware installation failure	-	-	Y	Y	-	-
71B4	Maintenance error	Successfully updated Finisher ROM	Finisher firmware installation success	-	-	Y	Y	-	-
71B5	Maintenance error	Failed to update Finisher ROM	Finisher firmware installation failure	-	-	Y	Y	-	P. 8-331
71B6	Maintenance error	Successfully updated Saddle ROM	Saddle firmware installation failure	-	-	Y	Y	-	-
71B7	Maintenance error	Failed to update Saddle ROM	Saddle firmware installation failure	-	-	Y	Y	-	P. 8-332
71B8	Maintenance error	Successfully updated Punch ROM	Punch firmware installation success	-	-	Y	Y	-	-
71B9	Maintenance error	Failed to update Punch ROM	Punch firmware installation failure	-	-	Y	Y	-	P. 8-332

Error code	Classification	Message	Contents	Error code display media					Troubles hooting
				PanI	JL	ML	Noti	CSV	
71BA	Maintenance error	Successfully updated UI Data	UI data installation success	-	-	Y	Y	-	-
71BB	Maintenance error	Failed to update UI Data	UI data installation failure	-	-	Y	Y	-	-
71BC	Maintenance error	Successfully rollback UI Data	UI data recovery success	-	-	Y	Y	-	-
71BD	Maintenance error	Failed to rollback UI Data	UI data recovery failure	-	-	Y	Y	-	-
71BE	Maintenance error	Failed to update UI Data (nonpermitted machine)	UI data installation failure	-	-	Y	-	-	-
71BF	Maintenance error	Failed to update UI Data (nonpermitted model)	UI data installation failure	-	-	Y	-	-	-
71E0	License Management	LMDB Recovery.	License abnormality due to damage on the license manager database	-	-	Y	Y	-	P. 8-332
7200	Maintenance error	Successful transfer of Image Log to the external server	Image log saving success to an external server	-	-	Y	Y	-	-
7201	Maintenance error	Failed to transfer of Image Log to the external server	Image log saving failure to an external server	-	-	Y	Y	-	-
7202	Maintenance error	Image Log was deleted	Image log deletion	-	-	Y	Y	-	-
7203	Maintenance error	Image Log was deleted automatically	Image log automatic deletion	-	-	Y	Y	-	-
7204	Maintenance error	Image log was downloaded	Image log downloading	-	-	Y	Y	-	-
7210	Maintenance error	Successful synchronization of User Management information	User management information synchronization success	-	-	Y	Y	-	-
7211	Maintenance error	Failed to synchronize User Management information	User management information synchronization failure	-	-	Y	Y	-	-

Error code	Classification	Message	Contents	Error code display media					Troubleshooting
				Panl	JL	ML	Noti	CSV	
7212	Maintenance error	Failed to synchronize User Management information (setting mistake)	User management information synchronization failure (incorrect setting)	-	-	Y	Y	-	-
7213	Maintenance error	Failed to synchronize User Management information for some Secondary MFP	Some user management information synchronization failure	-	-	Y	Y	-	-
7220	Maintenance error	Successful synchronization of AddressBook	Address book delivery success	-	-	Y	Y	-	-
7221	Maintenance error	Failed to synchronize AddressBook	Address book delivery failure	-	-	Y	Y	-	-
7222	Maintenance error	Failed to synchronize AddressBook for some Secondary MFP	Some address book delivery failure	-	-	Y	Y	-	-
7230	Maintenance error	Added new Project Code	Project creation	-	-	Y	Y	-	-
7231	Maintenance error	Edited Project Code	Project edition	-	-	Y	Y	-	-
7232	Maintenance error	Removed a Project Code	Project deletion	-	-	Y	Y	-	-
7233	Maintenance error	Successfully exported Project Code	Project export success	-	-	Y	Y	-	-
7234	Maintenance error	Failed to export Project Code	Project export failure	-	-	Y	Y	-	-
7235	Maintenance error	Download Project Code.	Exported project downloading	-	-	Y	Y	-	-
7236	Maintenance error	Successfully imported Project Code	Project import success	-	-	Y	Y	-	-
7237	Maintenance error	Failed to import Project Code	Project import failure	-	-	Y	Y	-	-
7238	Maintenance error	Failed to import some Project Code	Some project import failure	-	-	Y	Y	-	-
7272	Maintenance error	Successfully updated FAX FIRMWARE1	Fax firmware1 installation success	-	-	Y	Y	-	-
7273	Maintenance error	Failed to update FAX FIRMWARE1	Fax firmware1 installation failure	-	-	Y	Y	-	-

Error code	Classification	Message	Contents	Error code display media					Troubles hooting
				PanI	JL	ML	Noti	CSV	
7274	Maintenance error	Successfully updated FAX FIRMWARE2	Fax firmware2 installation success	-	-	Y	Y	-	-
7275	Maintenance error	Failed to update FAX FIRMWARE2	Fax firmware2 installation failure	-	-	Y	Y	-	-
7276	Maintenance error	Successfully updated NIC FIRMWARE	NIC firmware installation success	-	-	Y	Y	-	-
7277	Maintenance error	Failed to update NIC FIRMWARE	NIC firmware installation failure	-	-	Y	Y	-	-
72A0	Maintenance error	Notification events that were registered from an application were deleted	Deletion of event notification destination information registered from an application	-	-	Y	Y	-	-
72D0	Maintenance error	Failed to update UI Data (compatibility check error)	UI data installation failure	-	-	Y	-	-	-
72D1	Maintenance error	Failed to update Copier Firmware (compatibility check error)	System firmware installation failure	-	-	Y	-	-	-
72D2	Maintenance error	Successfully updated plugin of printer driver.	Upgrading of the plug-in for printer drivers has succeeded.	-	-	Y	Y	-	-
72D3	Maintenance error	Failed to update plugin of printer driver.	Upgrading of the plug-in for printer drivers has failed.	-	-	Y	Y	-	-
72D4	Maintenance error	Successfully deleted plugin of printer driver.	Deletion of the plug-in for printer drivers has succeeded.	-	-	Y	Y	-	-
72D5	Maintenance error	Failed to delete plugin of printer driver.	Deletion of the plug-in for printer drivers has failed.	-	-	Y	Y	-	-
72D6	Maintenance error	Failed to update UI Data (License check error)	UI data installation failure	-	-	Y	-	-	-
7300	Maintenance error	Successfully installed Application	An application is installed.	-	-	Y	Y	-	-
7301	Maintenance error	Failed to install Application	Installation of an application fails.	-	-	Y	Y	-	-
7302	Maintenance error	Successfully uninstalled Application	An application is uninstalled.	-	-	Y	Y	-	-

Error code	Classification	Message	Contents	Error code display media					Troubles hooting
				PanI	JL	ML	Noti	CSV	
7303	Maintenance error	Failed to uninstall Application	Uninstallation of an application fails.	-	-	Y	Y	-	-
7304	Maintenance error	Successfully updated Application	An application is updated.	-	-	Y	Y	-	-
7305	Maintenance error	Failed to update Application	Updating of an application fails.	-	-	Y	Y	-	-
7311	Maintenance error	Failed to start Application	Start of an application fails.	-	-	Y	Y	-	-
7313	Maintenance error	Application was terminated abnormally	An application ends abnormally.	-	-	Y	Y	-	-
7320	Maintenance error	Application license was activated.	The license of an application is enabled.	-	-	Y	Y	-	-
7321	Maintenance error	Failed to activation of application license	Enabling of the license for an application fails.	-	-	Y	Y	-	-
7322	Maintenance error	Application license was inactivated.	The license of an application is disabled.	-	-	Y	Y	-	-
7323	Maintenance error	Failed to inactivation of application license	Disabling of the license for an application fails.	-	-	Y	Y	-	-
7330	Maintenance error	The expiration date of the license of the application approaches.	The validated date of the license for an application will nearly have expired.	-	-	Y	Y	-	-
7331	Maintenance error	The time limit of the application license expired.	The validity date of the license for an application has expired.	-	-	Y	Y	-	-
7332	Maintenance error	Application install error. Please update the application.	Application installation error	-	-	Y	Y	-	P. 8-332
7333	Maintenance error	Application start error. Please update the application.	Application start error	-	-	Y	Y	-	P. 8-333
7334	Maintenance error	Application start error. Please update the application.	Application start error	-	-	Y	Y	-	-

Error code	Classification	Message	Contents	Error code display media					Troubleshooting
				PanI	JL	ML	Noti	CSV	
7335	Maintenance error	Successfully installed Application Localization.	Successfully installed Application Localization.	-	-	Y	Y	-	-
7336	Maintenance error	Failed to install Application Localization.	Failed to install Application Localization.	-	-	Y	Y	-	-
7400	License Management	License Activation Success (Online)	License activation success (Online)	-	-	Y	Y	-	-
7401	License Management	License Activation Success (Offline)	License activation success (Off line)	-	-	Y	Y	-	-
7402	License Management	License Activation failed	License activation failure (Online)	-	-	Y	Y	-	P. 8-333
7403	License Management	License Activation failed, NW timeout	License activation failure (network timeout)	-	-	Y	Y	-	P. 8-333
7404	License Management	License Activation failed, NW error	License activation failure (network error)	-	-	Y	Y	-	P. 8-333
7410	License Management	License Deactivate Success (Online)	License deactivation success (Online)	-	-	Y	Y	-	-
7411	License Management	License Deactivate Success (Offline)	License deactivation success (Off line)	-	-	Y	Y	-	-
7412	License Management	License Deactivation failed	License deactivation failure (Online)	-	-	Y	Y	-	P. 8-333
7423	License Management	License Deactivation failed, NW timeout	License deactivation failure (network timeout)	-	-	Y	Y	-	P. 8-334
7424	License Management	License Deactivation failed, NW error	License deactivation failure (network error)	-	-	Y	Y	-	P. 8-334
7430	License Management	License Activation failed, Invalid serial number	Serial number mismatching	-	-	Y	Y	-	P. 8-334
7431	License Management	License Activation failed, Invalid subnet	Subnet mismatching	-	-	Y	Y	-	P. 8-334
7432	License Management	License Activation failed, Invalid Domain	Domain mismatching	-	-	Y	Y	-	P. 8-335
7440	License Management	License file Signature mismatch error	Signature mismatching	-	-	Y	Y	-	P. 8-335

Error code	Classification	Message	Contents	Error code display media					Troubleshooting
				PanI	JL	ML	Noti	CSV	
7441	License Management	Trial License expired	End of the trial period	-	-	Y	Y	-	-
7442	License Management	License period expired	End of the valid	-	-	Y	Y	-	-
7443	License Management	License Expired	License use period expired	-	-	Y	Y	-	P. 8-335
7444	License Management	License Not Found	No license exists	-	-	Y	Y	-	P. 8-335
7445	License Management	License Full	Full of the license	-	-	Y	Y	-	P. 8-336

## 8.2.8 Network error

Error code	Classification	Message	Contents	Error code display media					Troubleshooting
				Panl	JL	ML	Noti	CSV	
8000	Network error	Static IPv4 duplicated address detected	IPv4 address conflict	-	-	Y	Y	-	P. 8-337
8011	Network error	Link Local address of IPv6 was duplicated.	IPv6 link local address conflict	-	-	Y	Y	-	P. 8-337
8012	Network error	Manual address of IPv6 was duplicated.	IPv6 manual address conflict	-	-	Y	Y	-	P. 8-337
8013	Network error	Stateless address of IPv6 was duplicated.	IPv6 stateless address conflict	-	-	Y	Y	-	P. 8-337
8014	Network error	Stateful address of IPv6 was duplicated.	IPv6 stateful address conflict	-	-	Y	Y	-	P. 8-337
8021	Network error	N/A		-	-	Y	Y	-	-
8022	Network error	Authentication Failure	802.1X authentication failure	-	-	Y	Y	-	P. 8-337
8023	Network error	Can not contact Authentication Server/Switch	Connection failure to an authentication server and a switch	-	-	Y	Y	-	P. 8-338
8024	Network error	Certificate verification Failure	Failure in verification of certification	-	-	Y	Y	-	P. 8-338
8031	Network error	No IKE proposal chosen	Ipsec error for IKEv1 certification failure	-	-	Y	Y	-	P. 8-338
8032	Network error	IKE Certificate Authentication failed	Ipsec error for wrong proposal selection	-	-	Y	Y	-	P. 8-338
8033	Network error	IKE Pre-shared key Authentication failed	Ipsec error for shared key authentication failure	-	-	Y	Y	-	P. 8-338
8034	Network error	Invalid Certificate	Ipsec error for invalid certificate upload	-	-	Y	Y	-	P. 8-339
8035	Network error	Certificate Type unsupported	Ipsec error for non-supported certification	-	-	Y	Y	-	P. 8-339
8036	Network error	Invalid certificate authority	Ipsec error for invalid certification of authentication	-	-	Y	Y	-	P. 8-339



Error code	Classification	Message	Contents	Error code display media					Troubleshooting
				PanI	JL	ML	Noti	CSV	
8037	Network error	Certificate unavailable	Ipssec error for certification disable	-	-	Y	Y	-	P. 8-339
8038	Network error	No ISAKMP SA established	Ipssec error for SA non-existing	-	-	Y	Y	-	P. 8-339
8039	Network error	Invalid Signature	Ipssec error for invalid signature for certification	-	-	Y	Y	-	P. 8-340
803A	Network error	No IKEv2 proposal chosen	Ipssec error for wrong selection of proposal	-	-	Y	Y	-	P. 8-340
803B	Network error	IKEv2 Certificate Authentication failed	Ipssec error for IKEv2 certification failure	-	-	Y	Y	-	P. 8-340
803C	Network error	IKEv2 Secret key Authentication failed	Ikev2 error for IKEv2 if secret key authentication failed	-	-	Y	Y	-	P. 8-340
803D	Network error	Falling Back to IKEv1	Ipssec error if peer does not support IKEv2 and falling back to IKEv1	-	-	Y	Y	-	P. 8-341
803E	Network error	ISAKMP SA unusable (deleted)	Ipssec error if ISAKMP SA is uncreated or destroyed due to some uncertain conditions	-	-	Y	Y	-	P. 8-341
803F	Network error	Crypto operation failed	Ipssec error for IKEv2 if crypto operation failed	-	-	Y	Y	-	P. 8-341
8040	Network error	Invalid key information	Ipssec error for IKEv2 if key info is invalid	-	-	Y	Y	-	P. 8-341
8041	Network error	CA not trusted	Ipssec error for IKEv2 if CA is not trusted	-	-	Y	Y	-	P. 8-341
8042	Network error	Authentication Method mismatch	Ipssec error for authentication method inconsistency	-	-	Y	Y	-	P. 8-342
8043	Network error	IKE Version mismatch	Ipssec error for version inconsistency	-	-	Y	Y	-	P. 8-342
8044	Network error	Encapsulation mode mismatch	Ipssec error for encapsulation inconsistency	-	-	Y	Y	-	P. 8-342

Error code	Classification	Message	Contents	Error code display media					Troubleshooting
				PanI	JL	ML	Noti	CSV	
8045	Network error	Peer IP Address mismatch	Ipsec error for peer ip inconsistency	-	-	Y	Y	-	P. 8-342
8046	Network error	Local IP Address mismatch	Ipsec error for local ip inconsistency	-	-	Y	Y	-	P. 8-342
8047	Network error	Local ID mismatch	Ipsec error for local id inconsistency	-	-	Y	Y	-	P. 8-343
8048	Network error	Remote ID mismatch	Ipsec error for remote id inconsistency	-	-	Y	Y	-	P. 8-343
8049	Network error	IPsec Remote IP mismatch	Ipsec error for remote ip inconsistency	-	-	Y	Y	-	P. 8-343
804A	Network error	IKEv1/IKEv2 Timed out	Ipsec error for IKEv2 timeout	-	-	Y	Y	-	P. 8-343
804B	Network error	Invalid manual key data	Ipsec error for invalid of id manual key	-	-	Y	Y	-	P. 8-343
8061	Network error	Secure Update to Primary IPv4 DDNS failed.	Update error for secure primary DDNS	-	-	Y	Y	-	P. 8-344
8062	Network error	Secure Update to Secondary IPv4 DDNS failed	Update error for secure secondary DDNS	-	-	Y	Y	-	P. 8-344
8063	Network error	Secure Update to Primary IPv6 DDNS failed.	Update error for IPv6 secure primary DDNS	-	-	Y	Y	-	P. 8-344
8064	Network error	Secure Update to Secondary IPv6 DDNS failed	Update error for IPv6 secure secondary DDNS	-	-	Y	Y	-	P. 8-344
8065	Network error	IPv6 Update to Primary DDNS failed.	Update error for IPv6 primary DDNS	-	-	Y	Y	-	P. 8-344
8066	Network error	IPv6 Update to Secondary DDNS failed.	Update error for IPv6 secondary DDNS	-	-	Y	Y	-	P. 8-344
8067	Network error	IPv4 Update to Primary DDNS failed.	Update error for IPv4 primary DDNS	-	-	Y	Y	-	P. 8-344
8068	Network error	IPv4 Update to Secondary DDNS failed.	Update error for IPv4 secondary DDNS	-	-	Y	Y	-	P. 8-344
8069	Network error	Invalid TSIG/SIG(0) Key file uploaded	This message is displayed when the key file for SIG(0) or TSIG is invalid.	-	-	Y	Y	-	P. 8-344

Error code	Classification	Message	Contents	Error code display media					Troubleshooting
				Panl	JL	ML	Noti	CSV	
80B1	Network error	Bluetooth Disconnected	Bluetooth connection failure	-	-	Y	Y	-	P. 8-344
80B2	Network error	Bluetooth Print error	Bluetooth print error	-	-	Y	Y	-	P. 8-344
80B3	Network error	Bluetooth Fatal error	Bluetooth fatal error	-	-	Y	Y	-	P. 8-345
80B4	Network error	Bluetooth Storage Near Full	Bluetooth storage near full	-	-	Y	Y	-	P. 8-345
80B5	Network error	Bluetooth Storage Full	Bluetooth storage full	-	-	Y	Y	-	P. 8-345
8101	Network error	Wireless association with Access point failure	Wireless connection in the Access point failure	-	-	Y	Y	-	P. 8-345
8102	Network error	Unable to contact Access point	Connection of MFP to the Access point with a specified SSID failure	-	-	Y	Y	-	P. 8-345
8103	Network error	Certificate verification Failure	Wireless certificate verification failure	-	-	Y	Y	-	P. 8-345
8104	Network error	Cannot connect to the access point due to H/W abnormality of wireless LAN	Wireless certificate verification failure	-	-	Y	Y	-	P. 8-346
8121	Network error	Domain - General Failure during Authentication	Domain: Authentication failure	-	-	Y	Y	-	P. 8-346
8122	Network error	Domain - Invalid Username or Password	Domain: Invalid user name or password	-	-	Y	Y	-	P. 8-346
8123	Network error	Domain - Server not present in Network	Domain: Invalid server	-	-	Y	Y	-	P. 8-347
8124	Network error	Domain - User account is disabled on Server	Domain: Invalid user account	-	-	Y	Y	-	P. 8-347
8125	Network error	Domain - User account has expired and cannot be used for logon	Domain: Expired user account (cannot be used for logon)	-	-	Y	Y	-	P. 8-347

Error code	Classification	Message	Contents	Error code display media					Troubleshooting
				Panl	JL	ML	Noti	CSV	
8126	Network error	Domain - User account is locked and cannot be used for logon	Domain: Locked user account (cannot be used for logon)	-	-	Y	Y	-	P. 8-347
8127	Network error	Domain - Invalid logon hours for the User	Domain: Invalid logon hours	-	-	Y	Y	-	P. 8-347
8128	Network error	Active Directory Domain - Clock Skew error due to difference in Time between Server and MFP	Active directory domain: Clock skew error (due to difference in time between the server and the MFP)	-	-	Y	Y	-	P. 8-348
8129	Network error	Active Directory Domain - Kerberos Ticket has expired and cannot be used for Authentication	Active directory domain: Expired Kerberos ticket (cannot be used for authentication)	-	-	Y	Y	-	P. 8-348
812A	Network error	Active Directory Domain - Verification of the Ticket has failed	Active directory domain: Kerberos ticket authentication failure	-	-	Y	Y	-	P. 8-348
812B	Network error	Active Directory Domain - The Domain specified could not be found	Active directory domain: Invalid realm name	-	-	Y	Y	-	P. 8-348

## 8.2.9 Notification

Error code	Classification	Message	Contents	Error code display media					Troubleshooting
				Panl	JL	ML	Noti	CSV	
D101	Information		Paper presence/absence in the LCF	-	-	-	Y	Y	-
D102	Information		Paper presence/absence in the SFB	-	-	-	Y	Y	-
D103	Information	Paper Empty in Drawer 1 - Please Add Paper.	Paper presence/absence in the CST1	-	-	Y	Y	Y	-
D104	Information		Paper presence/absence in the CST2	-	-	-	Y	Y	-
D105	Information		Paper presence/absence in the PFP1	-	-	-	Y	Y	-
D106	Information		Paper presence/absence in the PFP2	-	-	-	Y	Y	-
D201	Information	Front Cover Open - Please Close Cover.	Front cover	-	-	Y	Y	Y	-
D202	Information	Paper Feeding Cover Open - Please Close Cover.	Paper feed cover of the equipment	-	-	Y	Y	Y	-
D204	Information	Lower Side Cover Open - Please Close Cover.	Tandem LCF cover (taking off of the LCF (large capacitor feeder))	-	-	Y	Y	Y	-
D205	Information	Lower Side Cover Open - Please Close Cover.	Paper feed cover of the PFP (side cover)	-	-	Y	Y	Y	-
D206	Information	Automatic Duplexing Unit Cover Open - Please Close Cover.	ADU cover / unit	-	-	Y	Y	Y	-
D207	Information	Relay Unit Cover Open - Please Close Cover.	Bridge unit transport cover	-	-	Y	Y	Y	-
D209	Information	Finisher Joint Cover Open - Please Close Cover.	Finisher joint (when a hanging finisher is taken off)	-	-	Y	Y	Y	-
D20A	Information	Finisher Door Open - Please Close Door.	Finisher door	-	-	Y	Y	Y	-

Error code	Classification	Message	Contents	Error code display media					Troubles shooting
				Panl	JL	ML	Noti	CSV	
D20E	Information	Lower Tray Delivery Cover Open - Please Close Cover	Saddle stitch stapler connection	-	-	Y	Y	Y	-
D20F	Information	Punch Unit Front Cover Open - Please Close Cover.	Front cover of the punch unit	-	-	Y	Y	Y	-
D211	Information	Job Separator Cover Open - Please Close Cover.	Job separator cover	-	-	Y	Y	Y	-
D217	Information	Finisher Door Open - Please Close Door.	Upper cover of the finisher (OPEN: eB2)	-	-	Y	Y	Y	-
D301	Information	Black Toner Empty - Please Refill.	Toner-K empty	-	-	Y	Y	Y	-
D302	Information	Cyan Toner Empty - Please Refill.	Toner-C empty	-	-	Y	Y	Y	-
D303	Information	Magenta Toner Empty - Please Refill.	Toner-M empty	-	-	Y	Y	Y	-
D304	Information	Yellow Toner Empty - Please Refill.	Toner-Y empty	-	-	Y	Y	Y	-
D30F	Information	Used Toner Container Full - Please Replace.	Waste toner box full	-	-	Y	Y	Y	-
D311	Information		Non-genuine toner-K	-	-	-	Y	Y	-
D312	Information		Non-genuine toner-C	-	-	-	Y	Y	-
D313	Information		Non-genuine toner-M	-	-	-	Y	Y	-
D314	Information		Non-genuine toner-Y	-	-	-	Y	Y	-
D321	Information		Toner-K nearly empty	-	-	-	Y	-	-
D322	Information		Toner-C nearly empty	-	-	-	Y	-	-
D323	Information		Toner-M nearly empty	-	-	-	Y	-	-
D324	Information		Toner-Y nearly empty	-	-	-	Y	-	-
D32E	Information		Waste toner box nearly full	-	-	-	Y	Y	-
D341	Information	Black Toner Empty - Please Refill.	Cartridge-K empty	-	-	Y	-	-	-

Error code	Classification	Message	Contents	Error code display media					Troubles hooting
				Panl	JL	ML	Noti	CSV	
D342	Information	Cyan Toner Empty - Please Refill.	Cartridge-C empty	-	-	Y	-	-	-
D343	Information	Magenta Toner Empty - Please Refill.	Cartridge-M empty	-	-	Y	-	-	-
D344	Information	Yellow Toner Empty - Please Refill.	Cartridge-Y empty	-	-	Y	-	-	-
D362	Information	New unit was installed.	EPU-K replacement completion	-	-	Y	-	Y	-
D363	Information	New unit was installed.	EPU-C replacement completion	-	-	Y	-	Y	-
D364	Information	New unit was installed.	EPU-M replacement completion	-	-	Y	-	Y	-
D365	Information	New unit was installed.	EPU-Y replacement completion	-	-	Y	-	Y	-
D366	Information	New unit was installed.	EPU2-K replacement completion	-	-	Y	-	Y	-
D367	Information	New unit was installed.	EPU2-C replacement completion	-	-	Y	-	Y	-
D368	Information	New unit was installed.	EPU2-M replacement completion	-	-	Y	-	Y	-
D369	Information	New unit was installed.	EPU2-Y replacement completion	-	-	Y	-	Y	-
D401	Information	Close Drawer 1	Drawer 1 (upper drawer open: eB2)	-	-	Y	Y	Y	-
D402	Information	Close Drawer 2	Drawer 2 (lower drawer open: eB2)	-	-	Y	Y	Y	-
D403	Information	Close Drawer 3	Drawer 3 (PFP upper drawer open: eB2)	-	-	Y	Y	Y	-
D404	Information	Close Drawer 4	Drawer 4 (PFP lower drawer open: eB2)	-	-	Y	Y	Y	-
D405	Information	Close large capacity feeder (LCF)	Paper supply door of the tandem LCF (LCF open: eB2)	-	-	Y	Y	Y	-

Error code	Classification	Message	Contents	Error code display media					Troubles shooting
				Panl	JL	ML	Noti	CSV	
D407	Information	Close large capacity feeder (LCF)	Paper supply door of the tandem LCF (left side)	-	-	Y	Y	Y	-
D711	Information	Add/Remove Drawer 2	Drawer 2 installation/removal	-	-	Y	Y	Y	-
D712	Information	Add/Remove Drawer 3	Drawer 3 installation/removal	-	-	Y	Y	Y	-
D713	Information	Add/Remove Drawer 4	Drawer 4 installation/removal	-	-	Y	Y	Y	-
D718	Information	Add/Remove Large Capacity Feeder	LCF installation/removal	-	-	Y	Y	Y	-
D730	Information	Add/Remove Finisher	Finisher installation/removal	-	-	Y	Y	Y	-
D731	Information	Add/Remove Saddle Finisher	Saddle stitch unit installation/removal	-	-	Y	Y	Y	-
D732	Information	Add/Remove Hole Punch Unit	Hole punch unit installation/removal	-	-	Y	Y	Y	-
D750	Information	Add/Remove Automatic Duplexing Unit	ADU installation/removal	-	-	Y	Y	Y	-
D751	Information	Add/Remove Relay Unit	Bridge unit installation/removal	-	-	Y	Y	Y	-
D770	Information	Add/Remove Automatic Document Feeder	ADF installation/removal	-	-	Y	Y	Y	-
D7B0	Information	Add/Remove Fax Unit(Line1)	Fax (line1) installation/removal	-	-	Y	Y	Y	-
D7B1	Information	Add/Remove Fax Unit(Line2)	Fax (line2) installation/removal	-	-	Y	Y	Y	-
D7E0	Information	Add/Remove Coin Controller	Coin controller installation/removal	-	-	Y	Y	Y	-
D7E1	Information	Add/Remove Key Copy Counter	Key counter installation/removal	-	-	Y	Y	Y	-
D800	Information	The machine was shut down		-	-	Y	Y	Y	-
D801	Information	Turned on the power		-	-	Y	Y	Y	-



Error code	Classification	Message	Contents	Error code display media					Troubles hooting
				PanI	JL	ML	Noti	CSV	
D802	Information	Gone into the energy save mode		-	-	Y	Y	Y	-
D803	Information	Gone into the sleep mode		-	-	Y	-	Y	-
D804	Information	The machine was rebooted		-	-	Y	Y	Y	-
D805	Information			-	-	Y	-	Y	-

## 8.2.10 FAX error

Error code	Classification	Message	Contents	Error code display media					Troubleshooting
				Panl	JL	ML	Noti	CSV	
0000	Fax error	-	Information: The fax transmission has succeeded.	-	Y	-	Y	-	-
	Fax error	-	Information: The fax reception has succeeded.	-	Y	-	Y	-	-
0012	Fax error	-	Original jam: The fax transmission has failed since an original was misfed in the DF while a fax job was being sent.	-	Y	-	Y	-	P. 8-349
0013	Fax error	-	Cover is open: The fax transmission has failed since the cover of the equipment or options that process paper was opened.	-	Y	-	Y	-	P. 8-349
0020	Fax error	-	Power failure: The fax transmission has failed due to a power failure.	-	Y	-	Y	-	P. 8-349
	Fax error	-	Power failure: The fax reception has failed due to a power failure.	-	Y	-	Y	-	
0030	Fax error	-	Recording paper jam: The fax transmission has been stopped due to the following reason. <ul style="list-style-type: none"> <li>• Paper misfeeding occurred with another job.</li> <li>• A fax job was canceled.</li> </ul>	-	Y	-	Y	-	P. 8-349

Error code	Classification	Message	Contents	Error code display media					Troubles shooting
				Panl	JL	ML	Noti	CSV	
0033	Fax error	-	Polling error: The polling reception has failed due to the following reason. <ul style="list-style-type: none"> <li>• A polling original was not set on the other side's device.</li> <li>• The security setting between this equipment and the other side's device did not match.</li> </ul>	-	Y	-	Y	-	P. 8-350
0040	Fax error	-	Modem communication error: The fax transmission has failed since the modem could not send the signal properly.	-	Y	-	Y	-	P. 8-350
	Fax error	-	Modem communication error: The fax reception has failed since the modem could not receive the signal properly.	-	Y	-	Y	-	
0042	Fax error	-	Memory full: The fax reception has been canceled since the capacity shortage or an abnormality occurred in the storage while a fax job was being received. (Pages which are received successfully will be printed out.)	-	Y	-	Y	-	P. 8-350

Error code	Classification	Message	Contents	Error code display media					Troubles hooting
				Panl	JL	ML	Noti	CSV	
0050	Fax error	-	Line is busy: Since the line of the other side's device was busy, the fax transmission has failed even though the redialing was carried out by the maximum number of specified times.	-	Y	-	Y	-	P. 8-351
0051	Fax error	Please confirm the cable or connection equipment for Line1. Please confirm the cable or connection equipment for Line2.	No cable connected for fax line: The fax transmission has failed since no cable for the fax line was connected.	Y	Y	-	Y	-	P. 8-351
0052	Fax error	-	T1 Time-out: The fax transmission has failed since NSF/DIS could not be detected. (Memory transmission)	-	Y	-	Y	-	P. 8-351
00B0	Fax error	-	Initial signal not detected: The fax transmission has failed since NSF/DIS could not be detected. (Direct transmission)	-	Y	-	Y	-	P. 8-351

Error code	Classification	Message	Contents	Error code display media					Troubleshooting
				PanI	JL	ML	Noti	CSV	
00B1	Fax error	-	Terminal constants not compatible: The fax transmission has failed since the other side's device did not have the capability which was transferred by NSF/DIS on this equipment.	-	Y	-	Y	-	P. 8-351
	Fax error	-	Terminal constants not compatible: The fax reception has failed since NSS/DCS, which was a capability other than the ones transferred by NSF/DIS on this equipment, was received.	-	Y	-	Y	-	
00B2	Fax error	-	Reception of DCN (Phase B): The fax transmission has failed since DCN was sent in Phase B.	-	Y	-	Y	-	P. 8-352
	Fax error	-	Reception of DCN (Phase B): The fax reception has failed since DCN was received in Phase B.	-	Y	-	Y	-	
00B3	Fax error	-	DCS/DTC not detected: The fax reception has failed since DCS/DTC could not be detected.	-	Y	-	Y	-	P. 8-352

Error code	Classification	Message	Contents	Error code display media					Troubles hooting
				Panl	JL	ML	Noti	CSV	
00B4	Fax error	-	Training error: This equipment has performed fall-back but the fax transmission has failed.	-	Y	-	Y	-	P. 8-352
	Fax error	-	Training error: The fax reception has failed since after receiving FTT, the receiver has received a timeout or DCN.	-	Y	-	Y	-	
00B5	Fax error	-	CFR not detected: The fax transmission has failed since a training signal has been sent out but CFR could not be detected.	-	Y	-	Y	-	P. 8-353
00B6	Fax error	-	No response made to CTC: The fax transmission has failed since no response was made to CTC.	-	Y	-	Y	-	P. 8-353
00B7	Fax error	-	Phase B cannot be completed: The fax transmission has failed since a modem error or a sequence error in the fax board occurred.	-	Y	-	Y	-	P. 8-353
	Fax error	-	Phase B cannot be completed: The fax reception has failed since a modem error or a sequence error in the fax board occurred.	-	Y	-	Y	-	

Error code	Classification	Message	Contents	Error code display media					Troubleshooting
				PanI	JL	ML	Noti	CSV	
00C0	Fax error	-	Image signal carrier not detected: The fax reception has failed since this equipment has failed to detect a carrier.	-	Y	-	Y	-	P. 8-353
00C1	Fax error	-	High-speed signal not detected: The fax reception has failed since this equipment has failed to detect a high-speed signal.	-	Y	-	Y	-	P. 8-354
00C2	Fax error	-	Image signal carrier disconnected: The fax transmission has failed since a carrier disconnection was detected after the image signal was picked up by the other side's device.	-	Y	-	Y	-	P. 8-354
	Fax error	-	Image signal carrier disconnected: The fax reception has failed since a carrier disconnection was detected after the image signal was picked up by this equipment.	-	Y	-	Y	-	
00C4	Fax error	-	EOL time-out: The fax reception has failed since this equipment could not detect EOL or not decode with MMR.	-	Y	-	Y	-	P. 8-354

Error code	Classification	Message	Contents	Error code display media					Troubleshooting
				PanI	JL	ML	Noti	CSV	
00C5	Fax error	-	Excess length of data received: The fax reception has failed due to the disconnection of the communication since the length of the received original exceeded 2 m.	-	Y	-	Y	-	P. 8-354
00C6	Fax error	-	Image code conversion error: The fax reception has failed since the conversion of the received image went wrong.	-	Y	-	Y	-	P. 8-355
00C7	Fax error	-	Phase C cannot be completed: The fax transmission has failed since a modem error or a sequence error in the fax board occurred.	-	Y	-	Y	-	P. 8-355
	Fax error	-	Phase C cannot be completed: The fax reception has failed since a modem error or a sequence error in the fax board occurred.	-	Y	-	Y	-	



Error code	Classification	Message	Contents	Error code display media					Troubleshooting
				Panl	JL	ML	Noti	CSV	
00D0	Fax error	-	Post message not detected: The fax transmission has failed since this equipment could not detect an MCF, RTP, RTN, PIN or PIP fax or the other side's device could not detect MPS, EOM or EOP.	-	Y	-	Y	-	P. 8-355
	Fax error	-	Post message not detected: The fax reception has failed since the other side's device could not detect an MCF, RTP, RTN, PIN or PIP fax or this equipment could not detect MPS, EOM or EOP.	-	Y	-	Y	-	
00D1	Fax error	-	Reception of DCN: The fax reception has failed since DCN was received.	-	Y	-	Y	-	P. 8-356
00D2	Fax error	-	Poor image quality: The fax transmission has failed since the quality of the received image was poor in the other side's device.	-	Y	-	Y	-	P. 8-356
	Fax error	-	Poor image quality: The fax reception has failed since the quality of the received image was poor.	-	Y	-	Y	-	

Error code	Classification	Message	Contents	Error code display media					Troubleshooting
				Panl	JL	ML	Noti	CSV	
00D3	Fax error	-	No response made to EOR: The fax transmission has failed since no response was made to EOR or DCN was received during ECM transmission.	-	Y	-	Y	-	P. 8-356
00D4	Fax error	-	No response made to RR: The fax transmission has failed since no response was made to RR or DCN was received during ECM transmission.	-	Y	-	Y	-	P. 8-356
00D5	Fax error	-	T5 Time-out: The fax transmission has failed since RNR-RR was repeated and the line was disconnected due to timeout during ECM transmission.	-	Y	-	Y	-	P. 8-357
00D6	Fax error	-	ERR returned to EOR: The fax reception has failed due to the bad condition of the communication.	-	Y	-	Y	-	P. 8-357
00D7	Fax error	-	Line disconnected by transmission of EOR: The fax transmission has failed since the line was disconnected after EOR was sent by this equipment during ECM transmission.	-	Y	-	Y	-	P. 8-357

Error code	Classification	Message	Contents	Error code display media					Troubleshooting
				Panl	JL	ML	Noti	CSV	
00D8	Fax error	-	Time-out between FCD frames: The fax reception has failed since a time-out occurred between the FCD frames.	-	Y	-	Y	-	P. 8-357
00DA	Fax error	-	MCF not returned: The fax reception has failed since MCF could not be returned from this equipment.	-	Y	-	Y	-	P. 8-357
00E8	Fax error	-	HDD error: The fax transmission has failed due to a defective HDD.	-	Y	-	Y	-	P. 8-358
	Fax error	-	HDD error: The fax reception has failed due to a defective HDD.	-	Y	-	Y	-	
00F0	Fax error	-	Software trouble: The fax transmission has failed due to defective software.	-	Y	-	Y	-	P. 8-358
	Fax error	-	Software trouble: The fax reception has failed due to defective software.	-	Y	-	Y	-	
00F1	Fax error	-	Hardware noise: The fax transmission has failed due to defective hardware.	-	Y	-	Y	-	P. 8-358
	Fax error	-	Hardware noise: The fax reception has failed due to defective hardware.	-	Y	-	Y	-	

Error code	Classification	Message	Contents	Error code display media					Troubles hooting
				Panl	JL	ML	Noti	CSV	
00F4	Fax error	-	Software trouble (fax board): The fax transmission has failed due to defective software.	-	Y	-	Y	-	P. 8-360
	Fax error	-	Software trouble (fax board): The fax reception has failed due to defective software.	-	Y	-	Y	-	
DA01	Fax error	(Panl)Fax line1 is out of order. Reboot the machine. (ML)FAX Unit Line1 is broken. Please Contact Service Technician.	The fax board of line 1 has been damaged: The fax board of line 1 has been damaged or an abnormality has occurred in the interface between the systems.	Y	-	Y	-	-	P. 8-360
DA02	Fax error	(Panl)Fax line2 is out of order. Reboot the machine. (ML)FAX Unit Line2 is broken. Please Contact Service Technician.	The fax board of line 2 has been damaged: The fax board of line 2 has been damaged or an abnormality has occurred in the interface between the systems.	Y	-	Y	-	-	P. 8-360

## 8.2.11 Error history

In the setting mode (08-9703), the latest twenty groups of error data will be displayed.

Display example

EA10	99999999	2013-07-11 17:05:32	064	064	2362_1000_0000_0_X XXXXXXXXXX
Error code	Total counter	YYYY-MM-DD HH:MM:SS	MMM	NNN	ABCD_EFHI_JLOP_Q _R
4 digits	8 digits	14 digits	3 digits	3 digits	23 digits

A	Paper source
	0: Not selected 1: Bypass feed 2: LCF 3: 1st drawer 4: 2nd drawer 5: PFP upper drawer 6: PFP lower drawer 7: Unused 8: Unused
B	Paper size code
	0: A5/ST 1: A5-R 2: ST-R 3: LT 4: A4 5: B5-R 6: LT-R 7: A4-R 8: OTHER/UNIV 9: B5 A: FOLIO/COMP B: LG C: B4 D: LD E: A3 F: 13"LG G: Unused H: A6-R I: Post card J: 8.5"SQ K: A3-wide / LD wide L: Unused M: 8K N: 16K-R O: 16K P: COM10 Q: DL R: Monarch S: CHO-3 T: YOU-4 U: SRA3(320x450) V: SRA3(320x460) Z: Not selected a: Envelope Kaku-2
C	Sort mode/staple mode
	0: Non-sort/Non-staple 1: Group 2: Sort 7: Front staple 8: Double staple 9: Rear staple A: Saddle stitch B: center fold C: Top Left D: Top Right E: Top Center F: Left Center
D	ADF mode
	0: Unused 1: AUTO FEED (SADF) 2: STACK FEED
E	APS/AMS mode
	0: Not selected 1: APS 2: AMS
F	Duplex mode
	Copy: 0: Single-sided/Single-sided 1: Book 2: Double-sided/Single-sided 4: Double-sided/Duplex copying 8: Single-sided/Duplex copying Printer: 0: Single-sided 8: Double-sided FAX: 0: Single-sided 8: Double-sided e-Filing: 0: Single-sided 8: Double-sided List printing: 0: Single-sided -
G	Unused
H	Image shift
	0: Unused 1: Book 2: Left 3: Right 4: Top 5: Bottom 6: Book+Top 7: Book+Bottom 8: Left+Top 9: Left+Bottom A: Right+Top B: Right+Bottom
I	Editing
	0: Unused 1: Masking 2: Trimming 3: Mirror image 4: Unused 5: NEG/POS
J	Edge erase/Dual-page
	0: Unused 1: Edge erase 2: Dual-page 3: Edge erase & Dual-page
K	Unused
L	Function
	0: Unused 1: Copying 2: FAX/Internet FAX transmission 3: FAX/Internet FAX/E-mail reception printing 4: Unused 5: Printing/List print 6: Scan/E-mail transmission

MMM	Primary scanning reproduction ratio (Display in hexadecimal)
	(Mx256)+(Mx16)+M
NNN	Secondary scanning reproduction ratio (Display in hexadecimal)
	(Nx256)+(Nx16)+N
O	Color mode
	0: Auto color 1: Full color 2: Black 3: Unused 4: Twin color copy 5: Gray scale 6: Unused 7: Image smoothing
P	Media type
	0: Plain paper 1: Thick 1 2: Thick 2 3: Thick 3 4: Thick 4 5: Special paper 1 6: Special paper 2 7: Recycled paper 8: Plain paper 1 9: Unused A: Thin paper B: OHP film C: Thick 1/ reverse D: Thick 2/ reverse E: Thick 3/ reverse F: Thick 4/ reverse G: Special paper 1/ reverse H: Special paper 2/ reverse I: Envelope J: Tab paper K: Plain paper/ reverse L: Recycled paper/ reverse M: Thin paper/ reverse N: Special paper 3/ reverse O: Special paper 3/ reverse P: Envelope/ reverse Q: Thick R: Thick/reverse S to Z: Unused a: User type 1 b: User type 2 c: User type 3 d: User type 4 e: User type 5 f: User type 6 g: User type 7 h: User type 8 i: User type 9 j: User type 10
Q	RADF size mixed
	0: Unused 1: Size mixed 2: Single-size document
R	Workflow ID: 10-digit ID

## 8.3 Diagnosis and Prescription for Each Error Code



### 8.3.1 Check item

Check item	Contents
Sensor check	<ul style="list-style-type: none"> <li>• Check the sensor in the test mode.</li> <li>• Check that there is no dust on the sensor.</li> <li>• Check that the actuator is correctly operated.</li> </ul>
Connector check	<ul style="list-style-type: none"> <li>• Check that the connector is not disconnected.</li> <li>• Check that the pins are not deformed and do not come off.</li> <li>• Disconnect and reconnect the connector.</li> </ul>
Harness check	<ul style="list-style-type: none"> <li>• Check if the harnesses are open circuited.</li> </ul>
Motor check	<ul style="list-style-type: none"> <li>• Check the motor in the test mode.</li> <li>• Check that there is no abnormality in the driving section.</li> <li>• Check that there is no abnormality in the roller.</li> </ul>
Board check	<ul style="list-style-type: none"> <li>• Check if the board is short circuited or open circuited.</li> </ul>

### 8.3.2 Paper transport jam (paper exit section)

#### [E010] Jam not reaching the exit sensor

Classification	Error content
Paper transport jam	Jam not reaching the exit sensor

Phenomenon of paper jamming	Check item	Measures
Paper jamming immediately after the removal and installation of the transfer belt unit.	Transfer belt unit	Check if the transfer belt unit is installed properly.  P. 4-117 "4.7.3 Transfer belt unit (TBU)"
Paper jamming at separation finger in the Fuser Unit.	Fuser unit	Clean the separation finger. Check if the fingers or springs of the separation finger are securely attached. Replace the separation finger.
Paper separation failure at separation finger in the Fuser Unit	Fuser unit	<ul style="list-style-type: none"> <li>• Paper transport check</li> </ul>
	Drawer	Check that paper is not skewed in the side guides of the drawer.
	Leading edge margin	Adjust the margin with FS-05-4402 (Leading edge position adjustment) to "Color: 5.5 mm". Widen the margin if needed. (Specification Black: 4.2 mm / Color: 5 mm) <ul style="list-style-type: none"> <li>• Use A3/LD paper</li> <li>• It is easy to check skew with a copy of a solid image (about 10 mm on its leading edge).</li> </ul> Refer to  P. 6-15 "[C] Secondary scanning data writing start position".
Paper jamming at separation finger in the Fuser Unit.	Fuser unit	Clean the separation finger. Check if the fingers or springs of the separation finger are securely attached. Replace the separation finger.


Phenomenon of paper jamming	Check item	Measures
The leading edge of paper has no scratches and the paper stops before being fused.	Fuser unit	Check that the pressure release screw of the pressure roller is securely tightened and pressure is properly applied.
	Transfer belt	Replace the transfer belt. Replace the transfer belt unit.
Paper folded in one side and fused during duplex printing		Check if toner adheres to the fuser entry guide. Clean it if needed.
All	Exit sensor	<ul style="list-style-type: none"> <li>• Sensor check (Perform the input check: FS-03-[ALL]OFF/[9]/[C])</li> <li>• Connector check</li> <li>• Harness check</li> </ul>
	LGC board	<ul style="list-style-type: none"> <li>• Board check</li> <li>• Connector check (CN342)</li> <li>• Harness check</li> </ul>

Parts to be replaced	Remark
Separation finger of the fuser unit	
Transfer belt	
Transfer belt unit	
Exit sensor	
LGC board	



**[E020] Stop jam at the exit sensor**

Classification	Error content
Paper transport jam	Stop jam at the exit sensor

Phenomenon of paper jamming	Check item	Measures
Paper jamming at separation finger in the Fuser Unit.	Fuser unit	Clean the separation finger. Check if the fingers or springs of the separation finger are securely attached. Replace the separation finger.
Paper separation failure at separation finger in the fuser unit	Fuser unit	<ul style="list-style-type: none"> <li>Paper transport check</li> </ul>
	Drawer	Check that paper is not skewed in the side guides of the drawer.
	Leading edge margin	Adjust the margin with FS-05-4402 (Leading edge position adjustment) to "Color: 5.5 mm". (Specification Black: 4.2 mm / Color: 5 mm) <ul style="list-style-type: none"> <li>Use A3/LD paper</li> <li>It is easy to check skew with a copy of a solid image (about 10 mm on its leading edge).</li> </ul> Refer to  P. 6-15 "[C] Secondary scanning data writing start position".
Scratches on the leading edge of paper		Check if toner adheres to the exit gate. Clean it if needed.
All	Self-diagnosis code	Change the setting value of FS-08-4542 (Switching for incorrect size jam detection) from "1" (Disabled) to "0"(Enabled).
	Exit sensor	<ul style="list-style-type: none"> <li>Sensor check (Perform the input check: FS-03-[ALL]OFF/[9]/[C])</li> <li>Actuator check</li> <li>Connector check</li> <li>Harness check</li> </ul>
	LGC board	<ul style="list-style-type: none"> <li>Board check</li> <li>Connector check (CN342)</li> <li>Harness check</li> </ul>

Parts to be replaced	Remark
Separation finger of the fuser unit	
Exit sensor	
LGC board	

### 8.3.3 Paper misfeeding

#### [E110] ADU misfeeding (paper not reaching the registration sensor)

Classification	Error content
Paper transport jam	ADU misfeeding (paper not reaching the registration sensor)

Phenomenon of paper jamming	Check item	Measures
Paper stop jam at the registration roller position	Registration guide	Check the registration guide. Replace it if needed.
All	Registration sensor	<ul style="list-style-type: none"> <li>• Sensor check (Perform the input check: FS-03-[ALL]OFF/[9]/[A])</li> <li>• Connector check (CN404)</li> <li>• Harness check</li> </ul>
	CFD board	<ul style="list-style-type: none"> <li>• Board check</li> <li>• Connector check (CN404, CN408)</li> <li>• Harness check</li> </ul>
	LGC board	<ul style="list-style-type: none"> <li>• Board check</li> <li>• Connector check (CN369)</li> <li>• Harness check</li> </ul>
	ADU	Check if the connector between the ADU and equipment is connected.

Parts to be replaced	Remark
Registration sensor	
CFD board	
LGC board	
Rollers in the ADU	Clean or replace it.

#### [E120] Bypass misfeeding (paper not reaching the bypass feed sensor)

Classification	Error content
Paper transport jam	Bypass misfeeding (paper not reaching the feed sensor)

Check item	Measures
Bypass feed clutch	<ul style="list-style-type: none"> <li>• Clutch check (Perform the output check: FS-03-204)</li> <li>• Connector check (J819, CN403)</li> <li>• Harness check</li> </ul>
Feed sensor	<ul style="list-style-type: none"> <li>• Sensor check (Perform the input check: FS-03-[ALL]OFF/[9]/[B])</li> <li>• Connector check (J820, CN403)</li> <li>• Harness check</li> </ul>
CFD board	<ul style="list-style-type: none"> <li>• Board check</li> <li>• Connector check (CN403, CN408)</li> <li>• Harness check</li> </ul>
LGC board	<ul style="list-style-type: none"> <li>• Board check</li> <li>• Connector check (CN369)</li> <li>• Harness check</li> </ul>

Parts to be replaced	Remark
Bypass feed clutch	
Feed sensor	
CFD board	

Parts to be replaced	Remark
LGC board	
Bypass feed roller	Replace it if it is worn out.
Bypass separation pad	Replace it if it is worn out.

### [E130] 1st drawer misfeeding (paper not reaching the 1st drawer feed sensor)

Classification	Error content
Paper transport jam	1st drawer misfeeding (paper not reaching the feed sensor)

Check item	Measures
1st drawer (loaded paper amount)	When thick paper is used and if it is overloaded, reduce the amount as specified (Stack height 14 mm).
Feed clutch	<ul style="list-style-type: none"> <li>Clutch check (Perform the output check: FS-03-201)</li> <li>Connector check (J802, CN367)</li> <li>Harness check</li> </ul>
Feed sensor	<ul style="list-style-type: none"> <li>Sensor check (Perform the input check: FS-03-[ALL]OFF/[9]/[B])</li> <li>Connector check (CN404, J790)</li> <li>Harness check</li> </ul>
CFD board	<ul style="list-style-type: none"> <li>Board check</li> <li>Connector check (CN404, CN408)</li> <li>Harness check</li> </ul>
LGC board	<ul style="list-style-type: none"> <li>Board check</li> <li>Connector check (CN369, CN367)</li> <li>Harness check</li> </ul>

Parts to be replaced	Remark
Feed sensor	
Feed clutch	
CFD board	
LGC board	
1st drawer feed roller	Replace it if it is worn out.
1st drawer separation pad	Replace it if it is worn out.
1st drawer pick-up roller	Replace it if it is worn out.

### [E140] 2nd drawer misfeeding (paper not reaching the 2nd drawer feed sensor)

Classification	Error content
Paper transport jam	2nd drawer misfeeding (paper not reaching the 2nd drawer feed sensor)

Check item	Measures
2nd drawer feed sensor	<ul style="list-style-type: none"> <li>Sensor check (Perform the input check: FS-03-[F2]ON/[4]/[D])</li> <li>Connector check (CN368, J805, CN920, CN923, CN925, J934, J936)</li> <li>Harness check</li> </ul>
2nd drawer feed clutch	<ul style="list-style-type: none"> <li>Clutch check (Perform the output check: FS-03-202)</li> <li>Harness check</li> <li>Connector check (CN368, J805, CN920, CN923, CN927, J941)</li> </ul>

Check item	Measures
PFU board	<ul style="list-style-type: none"> <li>• Board check</li> <li>• Connector check (CN925, CN927)</li> <li>• Harness check</li> </ul>

Parts to be replaced	Remark
2nd drawer feed sensor	
2nd drawer feed clutch	
PFU board	
2nd drawer feed roller	Replace it if it is worn out.
2nd drawer separation roller	Replace it if it is worn out.
2nd drawer pick-up roller	Replace it if it is worn out.

**[E150] PFP upper drawer misfeeding (paper not reaching the PFP upper drawer feed sensor)**

Classification	Error content
Paper transport jam	PFP upper drawer misfeeding (paper not reaching the PFP upper drawer feed sensor)

Check item	Measures
PFP upper drawer feed sensor	<ul style="list-style-type: none"> <li>• Sensor check (Perform the input check: FS-03-[F2]ON/[0]/[C])</li> <li>• Connector check (CN247, J959, J975)</li> <li>• Harness check</li> </ul>
PFP upper drawer feed clutch	<ul style="list-style-type: none"> <li>• Clutch check (Perform the output check: FS-03-226)</li> <li>• Connector check (CN246, J960, J963)</li> <li>• Harness check</li> </ul>
PFU board	<ul style="list-style-type: none"> <li>• Board check</li> <li>• Connector check (CN920, CN923, J805)</li> <li>• Harness check</li> </ul>
PFP board	<ul style="list-style-type: none"> <li>• Board check</li> <li>• Connector check (J959, CN241, CN246, CN247)</li> <li>• Harness check</li> </ul>
LGC board	<ul style="list-style-type: none"> <li>• Board check</li> <li>• Connector check (CN368)</li> <li>• Harness check</li> </ul>

Parts to be replaced	Remark
PFP upper drawer feed sensor	
PFP upper drawer feed clutch	
PFC board	
PFP board	
LGC board	
PFP upper drawer feed roller	Replace it if it is worn out.
Separation roller	Replace it if it is worn out.
Pick-up roller	Replace it if it is worn out.

**[E160] PFP lower drawer misfeeding (paper not reaching the PFP lower drawer feed sensor)**

Classification	Error content
Paper transport jam	PFP lower drawer misfeeding (paper not reaching the PFP lower drawer feed sensor)

Check item	Measures
PFP lower drawer feed sensor	<ul style="list-style-type: none"> <li>• Sensor check (Perform the input check: FS-03-[F2]ON/[0]/[D])</li> <li>• Connector check (CN247, J959, J976)</li> <li>• Harness check</li> </ul>
PFP lower drawer feed clutch	<ul style="list-style-type: none"> <li>• Clutch check (Perform the output check: FS-03-228)</li> <li>• Connector check (CN246, J960, J962)</li> <li>• Harness check</li> </ul>
PFU board	<ul style="list-style-type: none"> <li>• Board check</li> <li>• Connector check (CN920, CN923, J805)</li> <li>• Harness check</li> </ul>
PFP board	<ul style="list-style-type: none"> <li>• Board check</li> <li>• Connector check (J959, CN241, CN246, CN247)</li> <li>• Harness check</li> </ul>
LGC board	<ul style="list-style-type: none"> <li>• Board check</li> <li>• Connector check (CN368)</li> <li>• Harness check</li> </ul>

Parts to be replaced	Remark
PFP lower drawer feed sensor	
PFP lower drawer feed clutch	
PFU board	
PFP board	
LGC board	
PFP lower drawer feed roller	Replace it if it is worn out.
Separation roller	Replace it if it is worn out.
Pick-up roller	Replace it if it is worn out.

**[E190] LCF misfeeding (paper not reaching the LCF feed sensor)**

Classification	Error content
Paper transport jam	LCF misfeeding (paper not reaching the LCF feed sensor)

Check item	Measures
LCF feed sensor	<ul style="list-style-type: none"> <li>• Sensor check (Perform the input check: FS-03-[F1]ON/[9]/[F])</li> <li>• Connector check (CN1, CN6, CN349)</li> <li>• Harness check</li> </ul>
LCF feed clutch	<ul style="list-style-type: none"> <li>• Clutch check (Perform the output check: FS-03-209)</li> <li>• Connector check (CN1, CN5, CN349)</li> <li>• Harness check</li> </ul>
PFU board	<ul style="list-style-type: none"> <li>• Board check</li> <li>• Connector check (CN920, CN923, J805)</li> <li>• Harness check</li> </ul>
LGC board	<ul style="list-style-type: none"> <li>• Board check</li> <li>• Connector check (CN368)</li> <li>• Harness check</li> </ul>

Check item	Measures
LCF board	<ul style="list-style-type: none"> <li>• Board check</li> <li>• Connector check (CN1, CN6)</li> <li>• Harness check</li> </ul>

Parts to be replaced	Remark
LCF feed sensor	
LCF feed clutch	
PFU board	
LGC board	
LCF board	
LCF feed roller	Replace it if it is worn out.
Separation roller	Replace it if it is worn out.
Pick-up roller	Replace it if it is worn out.

### 8.3.4 Paper transport jam

[E200] 1st drawer transport jam (not reaching the registration sensor)

[E210] 2nd drawer transport jam (not reaching the registration sensor)

[E270] Bypass transport jam (not reaching the registration sensor)

[E300] PFP upper drawer transport jam (not reaching the registration sensor)

[E330] PFP lower drawer transport jam (not reaching the registration sensor)

[E3C0] LCF transport jam (not reaching the registration sensor)

Classification	Error content
Paper transport jam	1st drawer transport jam (not reaching the registration sensor) 2nd drawer transport jam (not reaching the registration sensor) Bypass transport jam (not reaching the registration sensor) PFP upper drawer transport jam (not reaching the registration sensor) PFP lower drawer transport jam (not reaching the registration sensor) LCF transport jam (not reaching the registration sensor)

Check item	Measures
Registration sensor	<ul style="list-style-type: none"> <li>• Sensor check (Perform the input check: FS-03-[ALL]OFF/[9]/[A])</li> <li>• Connector check (CN404, J791)</li> <li>• Harness check</li> </ul>
Feed clutch	<ul style="list-style-type: none"> <li>• Clutch check (Perform the output check: FS-03-201)</li> <li>• Connector check (CN367, J802)</li> <li>• Harness check</li> </ul>
CFD board	<ul style="list-style-type: none"> <li>• Board check</li> <li>• Connector check (CN404, CN408)</li> <li>• Harness check</li> </ul>
LGC board	<ul style="list-style-type: none"> <li>• Board check</li> <li>• Connector check (CN369)</li> <li>• Harness check</li> </ul>

Parts to be replaced	Remark
Registration sensor	
Feed clutch	
CFD board	
LGC board	
Feed roller	Replace it if it is worn out.
Separation roller, Separation pad	Replace it if it is worn out.
Pick-up roller	Replace it if it is worn out.
Transport roller	Replace it if it is worn out.

**[E220] 2nd drawer transport jam (not reaching the feed sensor)**  
**[E310] PFP upper drawer transport jam (not reaching the feed sensor)**  
**[E340] PFP lower drawer transport jam (not reaching the feed sensor)**  
**[E3D0] LCF transport jam (not reaching the feed sensor)**

Classification	Error content
Paper transport jam	2nd drawer transport jam (not reaching the feed sensor) PFP upper drawer transport jam (not reaching the feed sensor) PFP lower drawer transport jam (not reaching the feed sensor) LCF transport jam (not reaching the feed sensor)

Check item	Measures
Feed sensor	<ul style="list-style-type: none"> <li>• Sensor check (Perform the input check: FS-03-[ALL]OFF/[9]/[B])</li> <li>• Connector check (CN404, J790)</li> <li>• Harness check</li> </ul>
Transport clutches (high speed)	<ul style="list-style-type: none"> <li>• Clutch check (Perform the output check: FS-03-230)</li> <li>• Connector check (CN927, J942)</li> <li>• Harness check</li> </ul>
Transport clutches (low speed)	<ul style="list-style-type: none"> <li>• Clutch check (Perform the output check: FS-03-233)</li> <li>• Connector check (CN927, J943)</li> <li>• Harness check</li> </ul>
CFD board	<ul style="list-style-type: none"> <li>• Board check</li> <li>• Connector check (CN404, CN408)</li> <li>• Harness check</li> </ul>
LGC board	<ul style="list-style-type: none"> <li>• Board check</li> <li>• Connector check (CN368, CN369)</li> <li>• Harness check</li> </ul>
PFU board	<ul style="list-style-type: none"> <li>• Board check</li> <li>• Connector check (CN920, CN923, CN927)</li> <li>• Harness check</li> </ul>

Parts to be replaced	Remark
Feed sensor	
Transport clutches (high speed)	
Transport clutches (low speed)	
CFD board	
LGC board	
PFU board	
Feed roller	Replace it if it is worn out.
Separation roller	Replace it if it is worn out.
Pick-up roller	Replace it if it is worn out.
Transport roller	Replace it if it is worn out.



**[E320] PFP upper drawer transport jam (not reaching the 2nd drawer feed sensor)**

**[E350] PFP lower drawer transport jam (not reaching the 2nd drawer feed sensor)**

**[E3E0] LCF transport jam (not reaching the 2nd drawer feed sensor)**

<b>Classification</b>	<b>Error content</b>
Paper transport jam	PFP upper drawer transport jam (not reaching the 2nd drawer feed sensor) PFP lower drawer transport jam (not reaching the 2nd drawer feed sensor) LCF transport jam (not reaching the 2nd drawer feed sensor)

<b>Check item</b>	<b>Measures</b>
2nd drawer feed sensor	<ul style="list-style-type: none"><li>• Sensor check (Perform the input check: FS-03-[F2]ON/[1]/[F])</li><li>• Connector check (CN925, J934, J936)</li><li>• Harness check</li></ul>
PFU board	<ul style="list-style-type: none"><li>• Board check</li><li>• Connector check (CN920, CN925, CN923)</li><li>• Harness check</li></ul>
LGC board	<ul style="list-style-type: none"><li>• Board check</li><li>• Connector check (CN368)</li><li>• Harness check</li></ul>

<b>Parts to be replaced</b>	<b>Remark</b>
2nd drawer feed sensor	
LGC board	
PFC board	
Feed roller	Replace it if it is worn out.
Separation roller	Replace it if it is worn out.
Pick-up roller	Replace it if it is worn out.
Transport roller	Replace it if it is worn out.

**[E360] PFP lower drawer transport jam (not reaching the PFP upper drawer feed sensor)**

Classification	Error content
Paper transport jam	PFP lower drawer transport jam (not reaching the PFP upper drawer feed sensor)

Check item	Measures
PFP upper drawer feed sensor	<ul style="list-style-type: none"> <li>• Sensor check (Perform the input check: FS-03-[F2]ON/[0]/[C])</li> <li>• Connector check (J959, J975)</li> <li>• Harness check</li> </ul>
PFP transport clutch	<ul style="list-style-type: none"> <li>• Clutch check (Perform the output check: FS-03-225)</li> <li>• Connector check (CN241, CN244, CN349)</li> <li>• Harness check</li> </ul>
PFU board	<ul style="list-style-type: none"> <li>• Board check</li> <li>• Connector check (CN920, CN923)</li> <li>• Harness check</li> </ul>
LGC board	<ul style="list-style-type: none"> <li>• Board check</li> <li>• Connector check (CN368)</li> <li>• Harness check</li> </ul>
PFP board	<ul style="list-style-type: none"> <li>• Board check</li> <li>• Connector check (CN241, CN244)</li> <li>• Harness check</li> </ul>

Parts to be replaced	Remark
PFP lower drawer feed sensor	
PFP transport clutches	
PFU board	
LGC board	
PFP board	
Feed roller	Replace it if it is worn out.
Separation roller	Replace it if it is worn out.
Pick-up roller	Replace it if it is worn out.
PFP transport roller	Replace it if it is worn out.

## [E510] ADU transport stop jam

Classification	Error content
Paper transport jam	ADU transport stop jam

Phenomenon of paper jamming	Check item	Measures
Paper falling on the inner tray	ADU	Check if the connector between the ADU and equipment is connected.
Paper jamming at the exit gate section	Drawer	Check that paper is not skewed in the side guides of the drawer. Check the setting size and paper size. Example: Check if the paper size is A4 though A3 is set.
	Fuser Unit	Check that springs are securely attached to the separation finger.
	Exit unit	Check if the toner is adhered to the exit gate, and wipe it off if necessary.
Stop in the fuser unit / scratches on the leading edge of paper	Fuser Unit	Check if the bracket or jam releasing guide of the fuser unit is deformed. Replace it if needed.
All	ADU entrance sensor	<ul style="list-style-type: none"> <li>• Sensor check (Perform the input check: FS-03-[ALL]OFF/[9]/[G])</li> <li>• Connector check (J826, CN421)</li> <li>• Harness check</li> </ul>
	Exit motor	<ul style="list-style-type: none"> <li>• Motor check (Perform the output check: FS-03-121/171)</li> <li>• Connector check (J751, CN341)</li> <li>• Harness check</li> </ul>
	ADU motor	<ul style="list-style-type: none"> <li>• Motor check (Perform the output check: FS-03-110/160)</li> <li>• Connector check (J811, CN422)</li> <li>• Harness check</li> </ul>
	LGC board	<ul style="list-style-type: none"> <li>• Board check</li> <li>• Connector check (CN369)</li> <li>• Harness check</li> </ul>
	ADU board	<ul style="list-style-type: none"> <li>• Board check</li> <li>• Connector check (CN420, CN421, CN422, J810)</li> <li>• Harness check</li> </ul>

Parts to be replaced	Remark
ADU entrance sensor	
Exit motor	
ADU motor	
LGC board	
ADU board	
Rollers in the ADU	Replace it if it is worn out.
Exit roller	Replace it if it is worn out.
Pressure spring	

**[E520] Stop jam in the ADU**

Classification	Error content
Paper transport jam	Stop jam in the ADU

Check item	Measures
ADU entrance sensor	<ul style="list-style-type: none"><li>• Sensor check (Perform the input check: FS-03-[ALL]OFF/[9]/[H])</li><li>• Connector check (J825, CN421)</li><li>• Harness check</li></ul>
LGC board	<ul style="list-style-type: none"><li>• Board check</li><li>• Connector check (CN369)</li><li>• Harness check</li></ul>
ADU board	<ul style="list-style-type: none"><li>• Board check</li><li>• Connector check (J810, CN420, CN421)</li><li>• Harness check</li></ul>
ADU motor	<ul style="list-style-type: none"><li>• Motor check (Perform the output check: FS-03-110/160)</li><li>• Connector check (J811, CN422)</li><li>• Harness check</li><li>• Bracket check</li></ul>

Parts to be replaced	Remark
ADU entrance sensor	
ADU clutch	
LGC board	
ADU board	
Rollers in the ADU	Replace it if it is worn out.
Pressure spring	

**[EB50] Paper remaining on the transport path due to multiple feeding**

Classification	Error content
Paper transport jam	Paper remaining on the transport path due to multiple feeding

When the paper is fed from any of the 1st drawer, bypass feed unit or ADU:  
(When the paper is fed from the 1st drawer:)

Check item	Measures
Feed sensor	<ul style="list-style-type: none"> <li>• Sensor check (Perform the input check: FS-03-[ALL]OFF/[9]/[B])</li> <li>• Connector check (J790, CN404)</li> <li>• Harness check</li> </ul>
CFD board	<ul style="list-style-type: none"> <li>• Board check</li> <li>• Connector check (CN404, CN408)</li> <li>• Harness check</li> </ul>
LGC board	<ul style="list-style-type: none"> <li>• Board check</li> <li>• Connector check (CN369)</li> <li>• Harness check</li> </ul>

Parts to be replaced	Remark
Feed sensor	
CFD board	
LGC board	
Separation roller, Separation pad	Replace it if it is worn out.

(When the paper is fed from the bypass feed unit:)

Check item	Measures
Bypass feed sensor	<ul style="list-style-type: none"> <li>• Sensor check (Perform the input check: FS-03-[ALL]OFF/[2][E])</li> <li>• Connector check (J820, CN403)</li> <li>• Harness check</li> </ul>
CFD board	<ul style="list-style-type: none"> <li>• Board check</li> <li>• Connector check (CN408, CN403)</li> <li>• Harness check</li> </ul>
LGC board	<ul style="list-style-type: none"> <li>• Board check</li> <li>• Connector check (CN369)</li> <li>• Harness check</li> </ul>

Parts to be replaced	Remark
Bypass feed sensor	
CFD board	
LGC board	
Separation roller, Separation pad	Replace it if it is worn out.

(When the paper is fed from the ADU:)

Check item	Measures
ADU exit sensor	<ul style="list-style-type: none"> <li>• Sensor check (Perform the input check: FS-03-[ALL]OFF/[9]/[H])</li> <li>• Connector check (J825, CN421)</li> <li>• Harness check</li> </ul>
LGC board	<ul style="list-style-type: none"> <li>• Board check</li> <li>• Connector check (CN369)</li> <li>• Harness check</li> </ul>
ADU board	<ul style="list-style-type: none"> <li>• Board check</li> <li>• Connector check (J810, CN420, CN421)</li> <li>• Harness check</li> </ul>
Registration sensor	<ul style="list-style-type: none"> <li>• Sensor check (Perform the input check: FS-03-[ALL]OFF/[9]/[A])</li> <li>• Connector check (CN404)</li> <li>• Harness check</li> </ul>
CFD board	<ul style="list-style-type: none"> <li>• Board check</li> <li>• Connector check (CN404, CN408)</li> <li>• Harness check</li> </ul>

Parts to be replaced	Remark
ADU exit sensor	
LGC board	
ADU board	
CFD board	
Registration sensor	
Roller	Replace it if it is worn out.

When the paper is fed from any of the PFU, PFP or LCF:

Check item	Measures
PFU, PFP or LCF	<ul style="list-style-type: none"> <li>• Sensor check (Perform the input check: FS-03-[F2]ON/[4]/[D])</li> <li>• Connector check (CN923, J944)</li> <li>• Harness check</li> </ul>
PFU board	<ul style="list-style-type: none"> <li>• Board check</li> <li>• Connector check (CN368, CN920, CN923, CN944)</li> <li>• Harness check</li> </ul>
LGC board	<ul style="list-style-type: none"> <li>• Board check</li> <li>• Connector check (CN368)</li> <li>• Harness check</li> </ul>

Parts to be replaced	Remark
1st/2nd drawer feed sensor	
LGC board	
PFC board	
Roller	Replace it if it is worn out.

**[EB60] Paper remaining on the transport path due to multiple feeding**

<b>Classification</b>	<b>Error content</b>
Paper transport jam	

<b>Check item</b>	<b>Measures</b>
Registration sensor	<ul style="list-style-type: none"><li>• Sensor check (Perform the input check: FS-03-[ALL]OFF/[9]/[A])</li><li>• Connector check (CN404, J791)</li><li>• Harness check</li></ul>
Registration clutch	<ul style="list-style-type: none"><li>• Connector check (CN367, J801)</li><li>• Harness check</li></ul>
CFD board	<ul style="list-style-type: none"><li>• Board check</li><li>• Connector check (CN404, CN408)</li><li>• Harness check</li></ul>
LGC board	<ul style="list-style-type: none"><li>• Connector check (CN369, CN367)</li><li>• Board check</li></ul>
Drive unit, Rollers	<ul style="list-style-type: none"><li>• Gear check</li><li>• Roller check</li></ul>

<b>Parts to be replaced</b>	<b>Remark</b>
Registration sensor	
Registration clutch	
CFD board	
LGC board	
Rollers	Replace it if it is worn out.

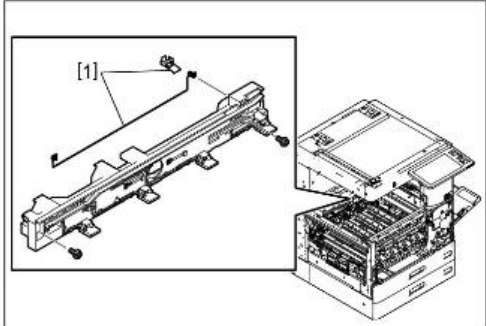
### 8.3.5 Other paper jam

[E011] Paper jam caused by clinging to the transfer belt (Paper not reached the paper clinging detection sensor)

Classification	Error content
Other paper jam	Paper jam caused by clinging to the transfer belt (Paper not reached the paper clinging detection sensor)

Phenomenon of paper jamming	Check item	Measures
Paper jamming immediately after the removal and installation of the transfer belt unit.	Transfer belt unit	Check if the transfer belt unit is installed properly. 📖 P. 4-117 "4.7.3 Transfer belt unit (TBU)"
Paper stop jam at transfer belt	Drawer	Check if paper is folded at the leading edge.
No scratches on the paper leading edge	Drawer	Check if paper is folded at the leading edge. Check that paper is not skewed in the side guides of the drawer.
	Process unit	Clean the process unit or replace it.
	Paper clinging detection sensor	Clean the sensor
All	CFD board	<ul style="list-style-type: none"> <li>• Board check</li> <li>• Connector check (CN405, CN408)</li> <li>• Harness check</li> </ul>
	LGC board	<ul style="list-style-type: none"> <li>• Board check</li> <li>• Connector check (CN369)</li> <li>• Harness check</li> </ul>
	Paper clinging detection sensor	<ul style="list-style-type: none"> <li>• Sensor check (Perform the input check: FS-03-[ALL]OFF/[9]/[E])</li> <li>• Connector check (J824, J823, CN405)</li> <li>• Harness check</li> </ul>
	Paper clinging detection sensor	<ul style="list-style-type: none"> <li>• Sensor check (Perform the input check: FS-03-[ALL]OFF/[9]/[E])</li> <li>• Connector check (J824, J823, CN405)</li> <li>• Harness check</li> </ul>
	Check of the 2nd transfer roller connection	<p>Check that the 2nd transfer roller shaft is securely grounded via the ADU rear frame (metal plate).</p> <ul style="list-style-type: none"> <li>• Check if the spring is deformed.</li> <li>• Check if the bearing and the spring contact properly.</li> </ul>
Aligning amount	<p>If the aligning amount is too small, a skew, an image dislocation in the feeding direction, E011 (a paper jam occurring between the registration pass sensor and the paper clinging detection sensor) may happen. If the aligning amount is too large, on the other hand, an abnormal noise (paper-folding noise) or actual paper folding may occur. Confirm that the value of the aligning amount is appropriate.</p>	

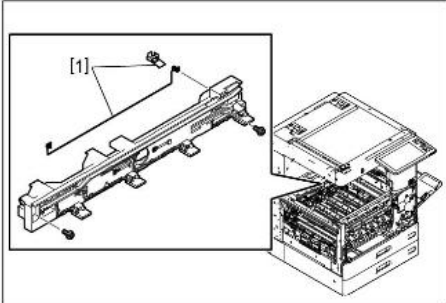


Phenomenon of paper jamming	Check item	Measures
All	Paper clinging detection sensor  Check of the 2nd transfer roller connection  Change of the 2nd transfer bias	<ul style="list-style-type: none"> <li>• Sensor check (Perform the input check: FS-03-[ALL]OFF/[9]/[E])</li> <li>• Connector check (J824, J823, CN405)</li> <li>• Harness check</li> </ul> Check that the 2nd transfer roller shaft is securely grounded via the ADU rear frame (metal plate). <ul style="list-style-type: none"> <li>• Check if the spring is deformed.</li> <li>• Check if the bearing and the spring contact properly.</li> </ul> If the leading edge of paper clings to the 2nd transfer roller and causes paper jamming, change the 2nd transfer roller bias correction factor of the leading/trailing edge of the paper. (The larger the value, the smaller the transfer voltage of the leading/trailing edge of the paper.) <p>Codes to be changed (Initial value of the transfer bias of the leading edge of the paper: 0)</p> <ul style="list-style-type: none"> <li>• Color mode print (front side): FS-05-2938-*</li> <li>• Color mode print (back side): FS-05-2939-*</li> <li>• Black mode print (front side): FS-05-2940-*</li> <li>• Black mode print (back side): FS-05-2941-*</li> </ul> Sub codes:* -> Plain paper: 0, Thick paper 1: 1, Thick paper 2: 2, OHP: 4 (front side only), Special paper 1: 5, Special paper 2: 6, Recycled paper: 7, Envelope: 10 <p><b>Notes:</b> After these codes are changed, perform solid duplex-printing and check that there is no faint or void image on the leading/trailing edge of the paper.</p>
	Spring of the high-voltage supply contact point	<ul style="list-style-type: none"> <li>• Check if the spring of the high-voltage supply contact point [1] is deformed. If yes, replace it.</li> <li>• Check if foreign matter adheres to the spring of the high-voltage supply contact point [1]. If yes, clean it.</li> </ul> 

Parts to be replaced	Remark
Process unit	
CFD board	
LGC board	
Paper clinging detection sensor	
Registration roller	Replace it if it is worn out.
Spring of the high-voltage supply contact point	

**[E013] Jam not reaching transport sensor after paper alignment at the registration roller**

Classification	Error content
Other paper jam	Jam not reaching transport sensor after paper alignment at the registration roller

Phenomenon of paper jamming	Check item	Measures
Paper stop jam at Registration roller	Drawer	Check if any damage is at the leading edge. Check if paper is folded at the leading edge.
	Drive unit, Rollers	<ul style="list-style-type: none"> <li>• Drive unit check</li> <li>• Gear check</li> <li>• Roller check</li> </ul>
	Developer unit	Replace the Developer unit.
	CFD board	<ul style="list-style-type: none"> <li>• Board check</li> <li>• Connector check (CN404)</li> <li>• Harness check</li> </ul>
	LGC board	<ul style="list-style-type: none"> <li>• Board check</li> <li>• Connector check (CN367, CN351)</li> <li>• Harness check</li> </ul>
	Registration sensor	<ul style="list-style-type: none"> <li>• Sensor check (Perform the input check: FS-03-[ALL]OFF/[9]/[A])</li> <li>• Connector check (CN404, J791)</li> <li>• Harness check</li> </ul>
	Registration pass sensor	<ul style="list-style-type: none"> <li>• Sensor check (Perform the input check: FS-03-[ALL]OFF/[9]/[F])</li> <li>• Connector check (CN351)</li> <li>• Harness check</li> </ul>
	Spring of the high-voltage supply contact point	<ul style="list-style-type: none"> <li>• Check if the spring of the high-voltage supply contact point [1] is deformed. If yes, replace it.</li> <li>• Check if foreign matter adheres to the spring of the high-voltage supply contact point [1]. If yes, clean it.</li> </ul> 

Parts to be replaced	Remark
Rollers	
Developer unit	
CFD board	
LGC board	
Registration clutch	
Registration roller	Replace it if it is worn out.
Registration sensor	
Registration pass sensor	
Spring of the high-voltage supply contact point	

## [E030] Power-ON jam

Classification	Error content
Other paper jam	The paper is remaining on the paper transport path when power is turned ON.

Check item	Measures
Sensor in the jamming area	- Sensor check (Refer to the table below) - Connector check - Harness check
LGC board	- Board check - Connector check - Harness check
PFC board	- Board check - Connector check - Harness check

Parts to be replaced	Remark
Sensor in the jamming area	Refer to the table below.
LGC board	
PFC board	

Relation between the jamming area and the corresponding sensors/covers.

(If a jam is occurring in the ADU, PFC, PFU, CFD, LCF or PFP, check the board in each unit.)

Jamming area	Cover	Sensor	Test Mode/Input check
Registration area	Jam access cover	Registration sensor	FS-03-[ALL]OFF/[9]/[A]
		Paper clinging detection sensor	FS-03-[ALL]OFF/[9]/[E]
		Registration pass sensor	FS-03-[ALL]OFF/[9]/[F]
		Feed sensor	FS-03-[ALL]OFF/[9]/[B]
Exit area	Fuser cover	Exit sensor	FS-03-[ALL]OFF/[9]/[C]
ADU	ADU	ADU entrance sensor	FS-03-[ALL]OFF/[9]/[G]
		ADU exit sensor	FS-03-[ALL]OFF/[9]/[H]
PFU	Side cover	2nd drawer feed sensor	FS-03-[F2]ON/[1]/[F]
LCF	LCF side cover	LCF transport sensor	FS-03-[F1]ON/[9]/[F]
PFP	PFP side cover	PFP upper drawer feed sensor	FS-03-[F2]ON/[0]/[C]
		PFP lower drawer feed sensor	FS-03-[F2]ON/[0]/[D]
Bridge unit	Bridge unit	Bridge unit transport sensor-1 (Entrance sensor)	FS-03-[ALL]OFF/[0]/[A]
		Bridge unit transport sensor-2 (Exit sensor)	FS-03-[ALL]OFF/[0]/[B]
Finisher	Finisher door	Sensors in the finisher	-

- [E061]Incorrect paper size setting for 1st drawer**
- [E062]Incorrect paper size setting for 2nd drawer**
- [E063]Incorrect paper size setting for PFP upper drawer**
- [E064]Incorrect paper size setting for PFP lower drawer**
- [E065]Incorrect paper size setting for bypass tray**

If any paper remains in the equipment or drawer, remove it. Match the paper size of the drawer setting and the one in the drawer.

- \* Paper size detection is performed at the first sheet of paper when the drawer is opened or closed, or when the power of the equipment is turned ON.

**[E090]Image data delay jam**

Classification	Error item
Other paper jam	Image data to be printed cannot be prepared.

Check item	Measures
Paper path	<ul style="list-style-type: none"> <li>• Remove the paper remained in front of the registration sensor)</li> </ul>
Power	<ul style="list-style-type: none"> <li>• Check if the error is cleared by turning the power OFF and then back ON.</li> </ul>
SYS board	<ul style="list-style-type: none"> <li>• Connector check (SYS board - LGC board)</li> <li>• Board check</li> </ul>
HDD	<ul style="list-style-type: none"> <li>• Connector check</li> <li>• HDD check</li> </ul>
Page memory	<ul style="list-style-type: none"> <li>• Check if the page memory is correctly connected to the connector on the SYS board.</li> </ul>

Replace parts	Remarks
SYS board	
LGC board	
HDD	
Page memory	

**[E091] Motor on time-out jam**

Classification	Error item
Other paper jam	The equipment does not operate normally because abnormality occurred on an interface between the SYS board and engine firmware.

Check item	Measures
Paper path	<ul style="list-style-type: none"> <li>• Check if there is any paper in the equipment. Remove it if there is.</li> <li>• If the error still occurs, check the following.</li> </ul>
Power	Check if the error is cleared by turning the power OFF and then back ON.
SYS board	<ul style="list-style-type: none"> <li>• Connector check (SYS board - LGC board)</li> <li>• Board check</li> </ul>
LGC board	<ul style="list-style-type: none"> <li>• Connector check</li> <li>• Board check</li> </ul>
HDD	<ul style="list-style-type: none"> <li>• Connector check</li> <li>• HDD check</li> </ul>

Replace parts	Remarks
SYS board	
LGC board	
HDD	

**[E0A0] Image transport ready time-out jam**

Classification	Error content
Other paper jam	Image transport ready time-out jam

Check item	Measures
LGC board	<ul style="list-style-type: none"> <li>• Flat cable check (SYS board - LGC board)</li> <li>• Connector check (CN371)</li> <li>• Board check</li> </ul>
SYS board	<ul style="list-style-type: none"> <li>• Flat cable check (SYS board - LGC board)</li> <li>• Connector check (CN133)</li> <li>• Board check</li> </ul>

Parts to be replaced	Remark
LGC board	
SYS board	
Flat cable	

## [E550] Paper remaining jam on the transport path

Classification	Error content
Other paper jam	Paper remaining on the transport path when printing is finished (caused by a multiple paper feeding)

Step	Check Item	Result	Measure	Next Step
1	Jamming transport path		Open the cover of the unit/area whose picture is flashing on the control panel and remove any paper on the transport path.	
2	Feed or transport roller possibly causing multiple feeding		Check the feed roller.	
3	Sensor in the jamming area		<ul style="list-style-type: none"> <li>• Sensor check (Refer to the table below)</li> <li>• Harness check</li> <li>• Connector check</li> </ul>	
4	LGC board		<ul style="list-style-type: none"> <li>• Harness check</li> <li>• Connector check</li> <li>• Board check</li> </ul>	
	<b>Notes:</b> If the jam is occurring in the ADU, PFC, PFU, CFD, LCF or PFP, check the board in each unit.			

Parts to be replaced	Remark
Feed or transport roller possibly causing multiple feeding	
Sensor in the jamming area	Refer to the table below.
LGC board	

Relation between the jamming area and the corresponding sensors/covers.

Jamming area	Cover	Sensor	Test Mode/Input check
Registration area	Jam access cover	Registration sensor	FS-03-[ALL]OFF/[9]/[A]
		Paper clinging detection sensor	FS-03-[ALL]OFF/[9]/[E]
		Registration pass sensor	FS-03-[ALL]OFF/[9]/[F]
		Feed sensor	FS-03-[ALL]OFF/[9]/[B]
Exit area	Fuser cover	Exit sensor	FS-03-[ALL]OFF/[9]/[C]
ADU	ADU	ADU entrance sensor	FS-03-[ALL]OFF/[9]/[G]
		ADU exit sensor	FS-03-[ALL]OFF/[9]/[H]
PFU	Side cover	2nd drawer feed sensor	FS-03-[F2]ON/[1]/[F]
LCF	LCF side cover	LCF feed sensor	FS-03-[F1]ON/[9]/[F]
PFP	PFP side cover	PFP upper drawer feed sensor	FS-03-[F2]ON/[0]/[C]
		PFP lower drawer feed sensor	FS-03-[F2]ON/[0]/[D]
Bridge unit	Bridge unit	Bridge unit transport sensor-1 (Entrance sensor)	FS-03-[ALL]OFF/[0]/[A]
		Bridge unit transport sensor-2 (Exit sensor)	FS-03-[ALL]OFF/[0]/[B]
Finisher	Finisher door	Sensors in the finisher	-

**[E551] Paper remaining jam on the transport path (when a service call occurs)**

**[E552] Paper remaining jam on the transport path (when the cover is closed)**

Classification	Error content
Other paper jam	Paper remaining on the transport path when printing is finished (when a service call occurs) (E551) Paper remaining on the transport path when printing is finished (when the cover is closed) (E552)

Step	Check Item	Result	Measure	Next Step
1	Jamming transport path		Open the cover of the unit/area whose picture is flashing on the control panel and remove any paper on the transport path.	
2	Sensor in the jamming area		<ul style="list-style-type: none"> <li>• Sensor check (Refer to the table below)</li> <li>• Harness check</li> <li>• Connector check</li> </ul>	
3	LGC board		<ul style="list-style-type: none"> <li>• Harness check</li> <li>• Connector check</li> <li>• Board check</li> </ul>	
	<b>Notes:</b> If the jam is occurring in the ADU, PFC, PFU, CFD, LCF or PFP, check the board in each unit.			

Parts to be replaced	Remark
Feed or transport roller possibly causing multiple feeding	
Sensor in the jamming area	Refer to the table below.
LGC board	

Relation between the jamming area and the corresponding sensors/covers.

Jamming area	Cover	Sensor	Test Mode/Input check
Registration area	Jam access cover	Registration sensor	FS-03-[ALL]OFF/[9]/[A]
		Paper clinging detection sensor	FS-03-[ALL]OFF/[9]/[E]
		Registration pass sensor	FS-03-[ALL]OFF/[9]/[F]
		Feed sensor	FS-03-[ALL]OFF/[9]/[B]
Exit area	Fuser cover	Exit sensor	FS-03-[ALL]OFF/[9]/[C]
ADU	ADU	ADU entrance sensor	FS-03-[ALL]OFF/[9]/[G]
		ADU exit sensor	FS-03-[ALL]OFF/[9]/[H]
PFU	Side cover	2nd drawer feed sensor	FS-03-[F2]ON/[1]/[F]
LCF	LCF side cover	LCF feed sensor	FS-03-[F1]ON/[9]/[F]
PFP	PFP side cover	PFP upper drawer feed sensor	FS-03-[F2]ON/[0]/[C]
		PFP lower drawer feed sensor	FS-03-[F2]ON/[0]/[D]
Bridge unit	Bridge unit	Bridge unit transport sensor-1 (Entrance sensor)	FS-03-[ALL]OFF/[0]/[A]
		Bridge unit transport sensor-2 (Exit sensor)	FS-03-[ALL]OFF/[0]/[B]
Finisher	Finisher door	Sensors in the finisher	-

### 8.3.6 Cover open jam

#### [E410] Front cover open jam

Classification	Error content
Cover open jam	Front cover open jam

Check item	Measures
Switching regulator	<ul style="list-style-type: none"><li>• Is the voltage of 24V being supplied from the power supply unit? (Perform the input check: FS-03-[ALL]OFF/[7]/[D])</li><li>• Connector check (CN512, CN513, CN514, CN516)</li><li>• Fuse check (F201, F202, F203, F204)</li></ul>
LGC board	<ul style="list-style-type: none"><li>• Board check</li><li>• Connector check (CN350, CN353)</li><li>• Harness check</li></ul>
Front cover switch	<ul style="list-style-type: none"><li>• Switch check (Perform the input check: FS-03-[ALL]OFF/[7]/[C])</li><li>• Connector check (CN350, J778)</li><li>• Harness check</li></ul>

Parts to be replaced	Remark
Switching regulator	
LGC board	
Front cover switch	



**[E420] PFP side cover open jam**

Classification	Error content
Cover open jam	PFP side cover open jam

Check item	Measures
PFP side cover opening/ closing switch	<ul style="list-style-type: none"> <li>Is the PFP side cover opening/closing switch working? (Perform the input check: FS-03-[F2]ON/[0]/[A])</li> <li>Connector check (CN247, J959, J974)</li> <li>Harness check</li> </ul>
PFP board	<ul style="list-style-type: none"> <li>Board check</li> <li>Connector check (CN241, CN247, J944)</li> <li>Harness check</li> </ul>
PFU board	<ul style="list-style-type: none"> <li>Board check</li> <li>Connector check (CN923, J805)</li> <li>Harness check</li> </ul>
LGC board	<ul style="list-style-type: none"> <li>Board check</li> <li>Connector check (CN368)</li> <li>Harness check</li> </ul>

Parts to be replaced	Remark
PFP side cover opening/ closing switch	
PFP board	
PFU board	
LGC board	

**[E430] ADU opened during printing**

Classification	Error content
Cover open jam	ADU open jam

Check item	Measures
Side cover switch	<ul style="list-style-type: none"> <li>Is the switch working? (Perform the input check: FS-03-[ALL]OFF[7]/[A])</li> <li>Connector check (CN342, J735, J754)</li> <li>Harness check</li> </ul>
LGC board	<ul style="list-style-type: none"> <li>Board check</li> <li>Connector check (CN342)</li> <li>Harness check</li> </ul>
Switching regulator	Replace the switching regulator.

Parts to be replaced	Remark
Side cover switch	
LGC board	
Switching regulator	

### [E440] Jam access cover open jam

Classification	Error content
Cover open jam	Jam access cover open jam

Check item	Measures
Jam access cover opening/ closing switch	<ul style="list-style-type: none"> <li>Is the switch working? (Perform the input check: FS-03-[F2]ON[4]/[A])</li> <li>Connector check (CN925, J934, J935)</li> <li>Harness check</li> </ul>
PFU board	<ul style="list-style-type: none"> <li>Board check</li> <li>Connector check (CN920, J805)</li> <li>Harness check</li> </ul>
LGC board	<ul style="list-style-type: none"> <li>Board check</li> <li>Connector check (CN368)</li> <li>Harness check</li> </ul>

Parts to be replaced	Remark
Jam access cover opening/ closing switch	
PFU board	
LGC board	

### [E450] LCF side cover open jam

Classification	Error content
Cover open jam	LCF side cover open jam

Check item	Measures
LCF side cover opening/ closing switch	<ul style="list-style-type: none"> <li>Is the switch working? (Perform the input check: FS-03-[F1]ON[9]/[A])</li> <li>Connector check (CN7, CN70)</li> <li>Harness check</li> </ul>
LCF board	<ul style="list-style-type: none"> <li>Board check</li> <li>Connector check (CN1, CN7)</li> <li>Harness check</li> </ul>
PFU board	<ul style="list-style-type: none"> <li>Board check</li> <li>Connector check (CN923, CN920)</li> <li>Harness check</li> </ul>
LGC board	<ul style="list-style-type: none"> <li>Board check</li> <li>Connector check (CN368)</li> <li>Harness check</li> </ul>

Parts to be replaced	Remark
LCF side cover opening/ closing switch	
LCF board	
PFC board	
LGC board	

**[E480] Bridge unit open jam**

Classification	Error content
Cover open jam	Bridge unit open jam

Check item	Measures
Bridge unit cover opening/ closing detection sensor	<ul style="list-style-type: none"> <li>Is the sensor working? (Perform the input check: FS-03-[ALL]OFF/[7]/[B])</li> <li>Connector check (J805)</li> <li>Harness check</li> </ul>
LGC board	<ul style="list-style-type: none"> <li>Board check</li> <li>Connector check (CN343)</li> <li>Harness check</li> </ul>

Parts to be replaced	Remark
Bridge unit cover opening/ closing detection sensor	
LGC board	

**[E490] Job separator cover has opened during printing**

Classification	Error content
Cover open jam	Job separator cover open jam

Check item	Measures
Job separator cover switch	<ul style="list-style-type: none"> <li>Is the Job separator cover switch working? (Perform the input check: FS-03-[ALL]OFF/[7]/[B])</li> <li>Connector check (CN260, CN261)</li> <li>Harness check</li> </ul>
LGC board	<ul style="list-style-type: none"> <li>Board check</li> <li>Connector check (CN343)</li> <li>Harness check</li> </ul>

Parts to be replaced	Remark
Job separator cover switch	
LGC board	

### 8.3.7 RADF jam

#### [E712] Jam not reaching the original registration sensor

Classification	Error content
RADF jam	Jam not reaching the original registration sensor

Check item	Measures
Pick-up roller Feed roller Separation roller	Clean them if they are stained.
Original registration sensor	<ul style="list-style-type: none"> <li>• Sensor check (Perform the input check: FS-03-[F2] ON[7]/[H])</li> <li>• Connector check (CN74, J88, J86)</li> <li>• Harness check</li> </ul>
RADF board	<ul style="list-style-type: none"> <li>• Board check</li> <li>• Connector check (CN74)</li> <li>• Harness check</li> </ul>

Parts to be replaced	Remark
Original registration sensor	
RADF board	
Pick-up roller	Replace it if it is worn out
Feed roller	Replace it if it is worn out.
Separation roller	Replace it if it is worn out.

#### [E714] Feed signal reception jam

Classification	Error content
RADF jam	Feed signal reception jam

Check item	Measures
Empty sensor	<ul style="list-style-type: none"> <li>• Sensor check (Perform the input check: FS-03-[F2] ON[7]/[B])</li> <li>• Lever check</li> <li>• Connector check (CN75, J92, J96)</li> <li>• Harness check</li> </ul>
RADF board	<ul style="list-style-type: none"> <li>• Board check</li> <li>• Connector check (CN75)</li> <li>• Harness check</li> </ul>

Parts to be replaced	Remark
Empty sensor	
RADF board	

**[E721] Jam not reaching the read sensor**

Classification	Error content
RADF jam	Jam not reaching the read sensor

Phenomenon of paper jamming	Check item	Measures
All	Registration sensor Read roller	Clean the registration roller and the read roller if they are stained.
	Read sensor	<ul style="list-style-type: none"> <li>• Sensor check (Perform the input check: FS-03-[F2] ON[7]/[G])</li> <li>• Connector check (J75, J94)</li> <li>• Harness check</li> </ul>
	RADF board	<ul style="list-style-type: none"> <li>• Board check</li> <li>• Connector check (CN75)</li> <li>• Harness check</li> </ul>

Parts to be replaced	Remark
Reading start guide of the RADF	
Paper guide of the RADF	
Read sensor	
RADF board	
Registration roller	Replace it if it is worn out.
Read roller	Replace it if it is worn out.

**[E722] Jam not reaching the original exit/reverse sensor (during scanning)**

Classification	Error content
RADF jam	Jam not reaching the original exit/reverse sensor (during scanning)

Check item	Measures
Read roller	Clean the read roller if it is stained.
Original exit/reverse sensor	<ul style="list-style-type: none"> <li>• Sensor check (Perform the input check: FS-03-[F2] ON[7]/[E])</li> <li>• Connector check (CN75, J93)</li> <li>• Harness check</li> </ul>
RADF board	<ul style="list-style-type: none"> <li>• Board check</li> <li>• Connector check (CN75)</li> <li>• Harness check</li> </ul>

Parts to be replaced	Remark
Original exit/reverse sensor	
RADF board	
Read roller	Replace it if it is worn out.

### [E724] Stop jam at the registration sensor

Classification	Error content
RADF jam	Stop jam at the registration sensor

Check item	Measures
Registration roller	Clean the registration roller if it is stained.
Registration sensor	<ul style="list-style-type: none"> <li>• Sensor check (Perform the input check: FS-03-[F2] ON[7]/[H])</li> <li>• Connector check (CN74, J88, J86)</li> <li>• Harness check</li> </ul>
RADF board	<ul style="list-style-type: none"> <li>• Board check</li> <li>• Connector check (CN74)</li> <li>• Harness check</li> </ul>
Original width detection sensor-1	<ul style="list-style-type: none"> <li>• Sensor check (Perform the input check: FS-03-[F2] ON[8]/[F])</li> <li>• Connector check (CN74, J86, J89)</li> <li>• Harness check</li> </ul>
Original width detection sensor-2	<ul style="list-style-type: none"> <li>• Sensor check (Perform the input check: FS-03-[F2] ON[8]/[G])</li> <li>• Connector check (CN74, J86, J90)</li> <li>• Harness check</li> </ul>

Parts to be replaced	Remark
Registration sensor	
RADF board	
Registration roller	Replace it if it is worn out.
Original width detection sensor-1	
Original width detection sensor-2	

### [E725] Stop jam at the read sensor

Classification	Error content
RADF jam	Stop jam at the read sensor

Check item	Measures
Read roller	Clean the read roller if it is stained.
Read sensor	<ul style="list-style-type: none"> <li>• Sensor check (Perform the input check: FS-03-[F2] ON[7]/[G])</li> <li>• Connector check (CN75, J94)</li> <li>• Harness check</li> </ul>
Original intermediate transport sensor	<ul style="list-style-type: none"> <li>• Sensor check (Perform the input check: FS-03-[F2] ON[7]/[F])</li> <li>• Connector check (CN75, J95)</li> <li>• Harness check</li> </ul>
RADF board	<ul style="list-style-type: none"> <li>• Board check</li> <li>• Connector check (CN75)</li> <li>• Harness check</li> </ul>

Parts to be replaced	Remark
Read sensor	
RADF board	
Read roller	Replace it if it is worn out.

**[E726] Transport/exit signal reception jam**

Classification	Error content
RADF jam	Transport/exit signal reception jam

Check item	Measures
RADF board	<ul style="list-style-type: none"> <li>• Board check</li> <li>• Connector check</li> <li>• Harness check</li> </ul>
SYS board	<ul style="list-style-type: none"> <li>• Board check</li> <li>• Connector check</li> <li>• Harness check</li> </ul>
Switching power supply	<ul style="list-style-type: none"> <li>• Check if the 24V and 5V outputs of the switching power supply are normal.</li> <li>• Board check</li> <li>• Connector check</li> <li>• Harness check</li> </ul>

Parts to be replaced	Remark
RADF board	
SYS board	
Switching power supply	

**[E731] Stop jam at the original exit/reverse sensor**

Classification	Error content
RADF jam	Stop jam at the original exit/reverse sensor

Check item	Measures
Exit roller	Clean the exit roller if it is stained.
Original exit/reverse sensor	<ul style="list-style-type: none"> <li>• Sensor check (Perform the input check: FS-03-[F2] ON[7]/[E])</li> <li>• Connector check (J93, CN75)</li> <li>• Harness check</li> </ul>
RADF board	<ul style="list-style-type: none"> <li>• Board check</li> <li>• Connector check (CN75)</li> <li>• Harness check</li> </ul>

Parts to be replaced	Remark
Original exit/reverse sensor	
RADF board	
Exit roller	Replace it if it is worn out.

**[E860] RADF jam access cover open**

Classification	Error content
RADF jam	RADF jam access cover open

Check item	Measures
RADF jam access cover sensor	<ul style="list-style-type: none"> <li>• Switch check (Perform the input check: FS-03-[F2] ON[7]/[C])</li> <li>• Connector check (CN75, J92, J97)</li> <li>• Harness check</li> </ul>
RADF board	<ul style="list-style-type: none"> <li>• Board check</li> <li>• Connector check (CN75)</li> <li>• Harness check</li> </ul>

Parts to be replaced	Remark
RADF jam access cover sensor	
RADF board	

**[E870] RADF open jam**

Classification	Error content
RADF jam	RADF open jam

Check item	Measures
Platen sensor	<ul style="list-style-type: none"> <li>• Sensor check (Perform the input check: Platen sensor-1: FS-03-[F2]ON[5]/[C], Platen sensor-2: FS-03-[F2]ON[5]/[G])</li> <li>• Connector check (CN121, J1003, J1004)</li> <li>• Harness check</li> </ul>
SYS board	<ul style="list-style-type: none"> <li>• Board check</li> <li>• Connector check</li> <li>• Harness check</li> </ul>

Parts to be replaced	Remark
Platen sensor	
SYS board	



### 8.3.8 Paper jam in bridge unit

[E910] Paper not reaching the bridge unit transport sensor-1

[E920] Paper stopping at the bridge unit transport sensor-1

Classification	Error content
Jam in bridge unit	Paper not reaching the bridge unit transport sensor-1 Paper stopping at the bridge unit transport sensor-1

Phenomenon of paper jamming	Check item	Measures
Paper separation failure at separation guide in the fuser unit	Drawer	Check that paper is not skewed in the side guides of the drawer.
	Leading edge margin	Adjust the margin with FS-05-4402 (Leading edge position adjustment) to "Color: 5.5 mm". Widen the margin if needed. (Specification Black: 4.2 mm / Color: 5 mm) <ul style="list-style-type: none"> <li>Use A3/LD paper</li> <li>It is easy to check skew with a copy of a solid image (about 10 mm on its leading edge).</li> </ul> Refer to "☞ P. 6-1 "6.1.1 Adjustment Order".
There are scratches on the leading paper edge		Replace it if needed. Check if the guide is not deformed. Replace it if needed.
All	Bridge unit exit	Check that Mylar on the bridge unit exit is not deformed. Replace it if needed. (E920)
	Finisher	Check if paper jamming occurs in the finisher.
	Bridge unit transport sensor-1 (entrance sensor)	<ul style="list-style-type: none"> <li>Sensor check (Perform the input check: FS-03-[ALL]OFF[0]/[A])</li> <li>Connector check (CN343, J607, J801)</li> <li>Harness check</li> </ul>
	Bridge unit gate solenoid	<ul style="list-style-type: none"> <li>Solenoid check (Perform the output check: FS-03-232)</li> <li>Connector check (CN343, J607, J804)</li> <li>Harness check</li> </ul>
	LGC board	<ul style="list-style-type: none"> <li>Board check</li> <li>Connector check (CN343)</li> <li>Harness check</li> </ul>
	Bridge unit	<ul style="list-style-type: none"> <li>Does the transport roller of the bridge unit work when the fuser motor is rotated? (Perform the output check: FS-03-113/163)</li> <li>Check the drive system of the equipment and bridge unit.</li> <li>Check if the rollers in the exit roller, the pressure spring and the bridge unit are worn out.</li> </ul>

Parts to be replaced	Remark
Bridge unit transport sensor-1 (entrance sensor)	
LGC board	
Bridge unit gate solenoid	

**[E930] Paper not reaching the bridge unit transport sensor-2****[E940] Paper stopping at the bridge unit transport sensor-2**

Classification	Error content
Jam in bridge unit	Paper not reaching the bridge unit transport sensor-2 Paper stopping at the bridge unit transport sensor-2

Check item	Measures
Bridge unit transport sensor-2 (exit sensor)	<ul style="list-style-type: none"> <li>• Sensor check (Perform the input check: FS-03-[ALL]OFF[0]/[B])</li> <li>• Connector check (CN343, J607, J802)</li> <li>• Harness check</li> </ul>
LGC board	<ul style="list-style-type: none"> <li>• Board check</li> <li>• Connector check (CN343)</li> <li>• Harness check</li> </ul>
Bridge unit	<ul style="list-style-type: none"> <li>• Does the transport roller of the bridge unit work when the fuser motor is rotated? (Perform the output check: FS-03-113/163)</li> <li>• Check the drive system of the equipment and bridge unit.</li> <li>• Check if the rollers in the exit roller, the pressure spring and the bridge unit are worn out.</li> </ul>

Parts to be replaced	Remark
Bridge unit transport sensor-2 (exit sensor)	
LGC board	

### 8.3.9 Paper jam in job separator

[E950] Jam not reaching the JSP feed sensor

[E951] Stop jam at the JSP feed sensor

Classification	Error content
Job separator jam	Jam not reaching the job separator transport sensor Stop jam at the job separator transport sensor

Procedure	Check item	Result	Measure	Next Step
1	Open the JSP cover. Is there any paper on the transport path?	Yes	Remove the paper.	
		No		2
2	Is the JSP feed sensor working? (Perform the input check in the test mode: FS-03-[ALL]OFF/[0]/[A])	Yes		3
		No	<ul style="list-style-type: none"> <li>• Check if the connector of the JSP feed sensor is disconnected.</li> <li>• Check if either of the connectors CN260 or CN262 on the JSP board is disconnected.</li> <li>• Check if the connector CN343 on the LGC board is disconnected.</li> <li>• Check if the relay connector J756 is disconnected.</li> <li>• Check if the connector pins are disconnected and the harnesses are open circuited.</li> <li>• Check if the conductor patterns on the JSP board and LGC board are short circuited or open circuited.</li> <li>• Replace the JSP feed sensor.</li> <li>• Replace the JSP board.</li> <li>• Replace the LGC board.</li> </ul>	
3	Replacing board		<ul style="list-style-type: none"> <li>• Replace the JSP board.</li> <li>• Replace the LGC board.</li> </ul>	

Parts to be replaced	Remark
JSP feed sensor	
JSP board	
LGC board	

### 8.3.10 Paper jam in finisher section

[EA10, EA20] 1st transport motor (M8) fault/ 2nd transport motor (M4) fault

Classification	Error content
Finisher jam (Finisher section)	Paper transport delay jam

#### MJ-1042

Probable cause	Checking and measures
1st transport motor (M8) abnormality	Check if the electrical continuity of the coil is normal. If electricity is not conducted, replace the motor.
Faulty cables and connectors	Check if the electrical continuity between the connector terminals is normal. If electricity is not conducted, replace the connector. (Finisher control PC board (FIN): CN22)
2nd transport motor (M4) abnormality	Check if the electrical continuity of the coil is normal. If electricity is not conducted, replace the motor.
Faulty cables and connectors	Check if the electrical continuity between the connector terminals is normal. If electricity is not conducted, replace the connector. (Finisher control PC board (FIN): CN14)
Finisher control PC board (FIN) abnormality	If the error still occurs after replacing the motor and the connector, exchange the finisher control PC board (FIN).

#### [EA10] Transport delay jam (paper not inserted)

MJ-1110

Classification	Error content
Paper jam in finisher section	Transport delay jam (paper not inserted)

Check item	Measures
Paper	Check if there is any paper in the finisher or on the transport path of the equipment and remove it if there is.
Feeding sensor (S22)	Check if there is a disconnection of the connector, incorrect installation or breakage of the feeding sensor (S22). If there is, reinstall the sensor correctly or replace it.
Transport path switching solenoid (SOL5)	Check that the gap between the transfer guide surface and the upper surface of the flapper tip is in the acceptable range according to the status of the transport path switching solenoid (SOL5) (solenoid OFF: 1.5 to 2.1 mm, solenoid ON: 2.3 to 2.9 mm). If it is not, adjust it. Check the harness between the transport path switching solenoid (SOL5) and the finisher controller board (CN1). If there is any abnormality, correct it.
Entrance motor (M1)	Check the harness between the entrance motor (M1) and the finisher controller board (CN17). If there is any abnormality, correct it.
Finisher control PC board (FIN)	<ul style="list-style-type: none"> <li>• Board check</li> <li>• Connector check (CN1, CN17)</li> <li>• Harness check</li> </ul>

Parts to be replaced	Remark
Feeding sensor (S22)	
Transport path switching solenoid (SOL5)	
Entrance motor (M1)	
Finisher control PC board (FIN)	

#### [EA20] 1st transport motor (M8) fault/ 2nd transport motor (M4) fault

Classification	Error content
Finisher jam (Finisher section)	Paper transport delay jam

MJ-1042

Probable cause	Checking and measures
1st transport motor (M8) abnormality	Check if the electrical continuity of the coil is normal. If electricity is not conducted, replace the motor.
Faulty cables and connectors	Check if the electrical continuity between the connector terminals is normal. If electricity is not conducted, replace the connector. (Finisher control PC board (FIN): CN22)
2nd transport motor (M4) abnormality	Check if the electrical continuity of the coil is normal. If electricity is not conducted, replace the motor.
Faulty cables and connectors	Check if the electrical continuity between the connector terminals is normal. If electricity is not conducted, replace the connector. (Finisher control PC board (FIN): CN14)
Finisher control PC board (FIN) abnormality	If the error still occurs after replacing the motor and the connector, exchange the finisher control PC board (FIN).

#### [EA20] Paper transport stop jam (entrance sensor)

Classification	Error content
Paper jam in finisher section	Paper transport stop jam (entrance sensor)

MJ-1110

Check item	Measures
Paper	Check if there is any paper in the finisher or on the transport path of the equipment and remove it if there is.
Entrance sensor (S1)	<ul style="list-style-type: none"> <li>• Sensor check</li> <li>• Connector check</li> <li>• Harness check</li> </ul>
Finisher control PC board (FIN)	<ul style="list-style-type: none"> <li>• Board check</li> <li>• Connector check (CN8)</li> <li>• Harness check</li> </ul>
Assist guide	Check that there is no abnormality in the adjustment for its height.

Parts to be replaced	Remark
Entrance sensor (S1)	
Finisher control PC board (FIN)	
Assist guide	

#### [EA21] Paper size error jam (transport sensor)

Classification	Error content
Paper jam in finisher section	Paper size error jam (transport sensor) Paper size error jam (punch paper edge sensor)

MJ-1110

Check item	Measures
Paper	<ul style="list-style-type: none"> <li>Check if there is any paper in the finisher or on the transport path of the equipment and remove it if there is.</li> <li>Use paper accepted in the specifications.</li> </ul>
Entrance sensor (S1)	<ul style="list-style-type: none"> <li>Sensor check</li> <li>Connector check</li> <li>Harness check</li> </ul>
Transport sensor (S2)	<ul style="list-style-type: none"> <li>Sensor check</li> <li>Connector check</li> <li>Harness check</li> </ul>
Finisher control PC board (FIN)	<ul style="list-style-type: none"> <li>Board check</li> <li>Connector check (CN8)</li> <li>Harness check</li> </ul>

Parts to be replaced	Remark
Entrance sensor (S1)	
Transport sensor (S2)	
Finisher control PC board (FIN)	

#### [EA22] Paper size error jam (punch paper edge sensor)

Classification	Error content
Paper jam in finisher section	Paper size error jam (transport sensor) Paper size error jam (punch paper edge sensor)

MJ-1110

Check item	Measures
Paper	Check if there is any paper in the finisher or on the transport path of the equipment and remove it if there is.
Entrance sensor (S1)	<ul style="list-style-type: none"> <li>Sensor check</li> <li>Connector check</li> <li>Harness check</li> </ul>

Check item	Measures
Transport sensor (S2)	<ul style="list-style-type: none"> <li>• Sensor check</li> <li>• Connector check</li> <li>• Harness check</li> </ul>
Paper position sensor (Hole punch unit)	<ul style="list-style-type: none"> <li>• Sensor check (S6-1, S6-2)</li> <li>• Connector check (CN1, CN4, CN5)</li> <li>• Harness check</li> </ul>
Finisher control PC board (FIN)	<ul style="list-style-type: none"> <li>• Board check</li> <li>• Connector check (CN8)</li> <li>• Harness check</li> </ul>

Parts to be replaced	Remark
Entrance sensor (S1)	
Transport sensor (S2)	
Paper position sensor (S6-1, S6-2)	Hole punch unit
Finisher control PC board (FIN)	

### [EA23] Paper transport stop jam (transport sensor)

MJ-1110

Classification	Error content
Paper jam in finisher section	Paper stop jam at the transport sensor located on the transport path of the finisher (transport sensor)

Check item	Measures
Paper	Check if there is any paper in the finisher or on the transport path of the equipment and remove it if there is.
Transport sensor (S2)	<ul style="list-style-type: none"> <li>• Sensor check</li> <li>• Connector check</li> <li>• Harness check</li> </ul>
Finisher control PC board (FIN)	<ul style="list-style-type: none"> <li>• Board check</li> <li>• Connector check (CN8)</li> <li>• Harness check</li> </ul>

Parts to be replaced	Remark
Transport sensor (S2)	
Finisher control PC board (FIN)	

### [EA24] Paper transport stop jam (between entrance & transport sensor)

MJ-1110

Classification	Error content
Paper jam in finisher section	Paper transport stop jam (between entrance and transport sensor)

Check item	Measures
Paper	Check if there is any paper in the finisher or on the transport path of the equipment and remove it if there is.
Pinch roller arm	Check the position of pinch roller arm. If it is down, fix its mechanism.
Transport path switching solenoid (SOL5)	<ul style="list-style-type: none"> <li>Check that the gap between the transfer guide surface and the upper surface of the flapper tip is in the acceptable range according to the status of the transport path switching solenoid (SOL5) (solenoid OFF: 1.5 to 2.1 mm, solenoid ON: 2.3 to 2.9 mm). If it is not, adjust it.</li> <li>Check the harness between the transport path switching solenoid (SOL5) and the finisher controller board (CN1). If there is any abnormality, correct it.</li> </ul>
Entrance sensor (S1)	<ul style="list-style-type: none"> <li>Sensor check</li> <li>Connector check</li> <li>Harness check</li> </ul>
Transport sensor (S2)	<ul style="list-style-type: none"> <li>Sensor check</li> <li>Connector check</li> <li>Harness check</li> </ul>
Entrance motor (M1)	<ul style="list-style-type: none"> <li>Motor check</li> <li>Connector check</li> <li>Harness check</li> </ul>
Finisher control PC board (FIN)	<ul style="list-style-type: none"> <li>Board check</li> <li>Connector check (CN8, CN17)</li> <li>Harness check</li> </ul>

Parts to be replaced	Remark
Transport path switching solenoid (SOL5)	
Entrance sensor (S1)	
Transport sensor (S2)	
Entrance motor (M1)	
Finisher control PC board (FIN)	

### [EA25] Stack exit motor (M5) abnormality

Classification	Error content
Paper jam in finisher section	Paper transport jam in the Finisher

MJ-1042

Probable cause	Checking and measures
Stack exit motor (M5) abnormality	Check if the electrical continuity of the coil is normal. If electricity is not conducted, replace the motor.
Faulty cables and connectors	Check if the electrical continuity between the connector terminals is normal. If electricity is not conducted, replace the connectors. (Finisher control PC board (FIN): CN14)
Finisher control PC board (FIN) abnormality	If the error still occurs after replacing the motor, sensor and connectors, exchange the finisher control PC board (FIN).



**[EA25] Paper transport stop jam (after paper stack exit)**

MJ-1110

Classification	Error content
Paper jam in finisher section	Paper transport stop jam (after paper stack exit)

Check item	Measures
Paper	Check if there is any paper in the finisher or on the transport path of the equipment and remove it if there is.
Finishing tray paper detection sensor (S12)	<ul style="list-style-type: none"> <li>• Sensor check</li> <li>• Connector check (CN25)</li> <li>• Harness check</li> </ul>
Finisher control PC board (FIN)	<ul style="list-style-type: none"> <li>• Board check</li> <li>• Connector check (CN25)</li> <li>• Harness check</li> </ul>

Parts to be replaced	Remark
Finishing tray paper detection sensor (S12)	
Finisher control PC board (FIN)	

**[EA26] Paper transport stop jam (stop command request)**

MJ-1042

Classification	Error content
Paper jam in finisher section	The equipment sends a stop signal during feeding.

Check item	Measures
Finisher	<ul style="list-style-type: none"> <li>• Check if the harness connecting the equipment and the finisher control PC board is disconnected or open circuited.</li> <li>• Check if the conductor pattern on the finisher controller PC board is open circuited or short circuited.</li> <li>• Update the finisher firmware.</li> <li>• Replace the finisher control PC board.</li> </ul>
LGC board	<ul style="list-style-type: none"> <li>• Check if the harness connecting the finisher and the LGC board on the equipment is disconnected or open circuited.</li> <li>• Connector check</li> <li>• Check if the conductor pattern on the LGC board is open circuited or short circuited.</li> <li>• Replace the LGC board.</li> </ul>

Parts to be replaced	Remark
Finisher control PC board (FIN)	
LGC board (LGC)	

**[EA26] Paper transport stop jam (stop command request)****[EA27] Paper transport stop jam (entrance sensor ON at the slower timing than the specified one)**

MJ-1110

Classification	Error content
Paper jam in finisher section	[EA26] Paper transport stop jam (stop command request) [EA27] Paper transport stop jam (entrance sensor ON at the slower timing than the specified one)

Check item	Measures
Paper	Check if there is any paper in the finisher or on the transport path of the equipment and remove it if there is.
Entrance sensor (S1)	<ul style="list-style-type: none"> <li>• Sensor check</li> <li>• Connector check (CN8)</li> <li>• Harness check</li> </ul>
Finisher control PC board (FIN)	<ul style="list-style-type: none"> <li>• Board check</li> <li>• Connector check (CN8)</li> <li>• Harness check</li> </ul>

Parts to be replaced	Remark
Entrance sensor (S1)	
Finisher control PC board (FIN)	

**[EA28] Paper transport stop jam (paper holder plate operation delay)**

MJ-1110

Classification	Error content
Paper jam in finisher section	Paper transport stop jam (paper holder plate operation delay)

Check item	Measures
Paper	Check if there is any paper in the finisher or on the transport path of the equipment and remove it if there is.
Assist guide	Is there any mechanical problem when the assist guide is rotated? If there is any mechanical problem, fix its mechanism.
Assist guide motor (M10)	<ul style="list-style-type: none"> <li>• Motor check</li> <li>• Connector check (CN10)</li> <li>• Harness check</li> </ul>
Finisher control PC board (FIN)	<ul style="list-style-type: none"> <li>• Board check</li> <li>• Connector check (CN10)</li> <li>• Harness check</li> </ul>

Parts to be replaced	Remark
Assist guide motor (M10)	
Finisher control PC board (FIN)	

**[EA29] Paper transport stop jam (stack transport delay)**

MJ-1110

Classification	Error content
Paper jam in finisher section	Paper transport stop jam (stack transport delay)

Check item	Measures
Paper	Check if there is any paper in the finisher or on the transport path of the equipment and remove it if there is.
Buffer tray guide	Is there any mechanical problem when the buffer tray guide is opened and closed while the buffer roller is kept raised? If there is any mechanical problem, fix its mechanism.
Buffer tray guide motor (M2)	<ul style="list-style-type: none"> <li>• Motor check</li> <li>• Connector check (CN10)</li> <li>• Harness check</li> </ul>
Finisher control PC board (FIN)	<ul style="list-style-type: none"> <li>• Board check</li> <li>• Connector check (CN8)</li> <li>• Harness check</li> </ul>

Parts to be replaced	Remark
Buffer tray guide motor (M2)	
Finisher control PC board (FIN)	

**[EA2A] Paper transport jam in the Finisher (Entrance path - middle path sensor)**

Classification	Error content
Paper jam in finisher section	Paper transport jam in the Finisher (Entrance path - middle path sensor)

MJ-1042

Probable cause	Checking and measures
1st transport motor (M8) abnormality	Check if the electrical continuity of the coil is normal. If electricity is not conducted, replace the motor.
2nd transport motor (M4) abnormality	Check if the electrical continuity of the coil is normal. If electricity is not conducted, replace the motor.
Entrance path sensor (S19) abnormality	Measure the voltage on TP86 on the finisher control PC board (FIN). Then check that the measured voltage is 1V or lower when not shielded and within the range of $3.3V \pm 5\%$ when shielded. If the voltage does not fall within the range mentioned, replace the sensor.
Middle path sensor (S7) abnormality	Measure the voltage on TP84 on the finisher control PC board (FIN). Then check that the measured voltage is 1V or lower when not shielded and within the range of $3.3V \pm 5\%$ when shielded. If the voltage does not fall within the range mentioned, replace the sensor.
Faulty cables and connectors	Check if the electrical continuity between the connector terminals is normal. If electricity is not conducted, replace the connector. (Finisher control PC board (FIN): CN6, CN14, CN22)

Probable cause	Checking and measures
Finisher control PC board (FIN) abnormality	If the error still occurs after replacing the sensor and the connector, replace the finisher control PC board (FIN).

### [EA2B] Paper transport jam in the Finisher (Middle path sensor)

Classification	Error content
Paper jam in finisher section	Paper transport jam in the Finisher (Middle path sensor)

MJ-1042

Probable cause	Checking and measures
2nd transport motor (M4) abnormality	Check if the electrical continuity of the coil is normal. If electricity is not conducted, replace the motor.
Entrance path sensor (S19) abnormality	Measure the voltage on TP86 on the finisher control PC board (FIN). Then check that the measured voltage is 1V or lower when not shielded and within the range of $3.3V \pm 5\%$ when shielded. If the voltage does not fall within the range mentioned, replace the sensor.
Middle path sensor (S7) abnormality	Measure the voltage on TP84 on the finisher control PC board (FIN). Then check that the measured voltage is 1V or lower when not shielded and within the range of $3.3V \pm 5\%$ when shielded. If the voltage does not fall within the range mentioned, replace the sensor.
Faulty cables and connectors	Check if the electrical continuity between the connector terminals is normal. If electricity is not conducted, replace the connector. (Finisher control PC board (FIN): CN6, CN14, CN22)
Finisher control PC board (FIN) abnormality	If the error still occurs after replacing the sensor and the connector, replace the finisher control PC board (FIN).

### [EA2C] Paper transport jam in the Finisher (Entrance path - sub-path sensor)

Classification	Error content
Paper jam in finisher section	Paper transport jam in the Finisher (Entrance path - sub-path sensor)

MJ-1042

Probable cause	Checking and measures
1st transport motor (M8) abnormality	Check if the electrical continuity of the coil is normal. If electricity is not conducted, replace the motor.
2nd transport motor (M4) abnormality	Check if the electrical continuity of the coil is normal. If electricity is not conducted, replace the motor.
Entrance path sensor (S19) abnormality	Measure the voltage on TP86 on the finisher control PC board (FIN). Then check that the measured voltage is 1V or lower when not shielded and within the range of $3.3V \pm 5\%$ when shielded. If the voltage does not fall within the range mentioned, replace the sensor.

Probable cause	Checking and measures
Sub-path sensor (S8) abnormality	Measure the voltage on TP85 on the finisher control PC board (FIN). Then check that the measured voltage is 1V or lower when not shielded and within the range of 3.3V±5% when shielded. If the voltage does not fall within the range mentioned, replace the sensor.
Stationary tray full detection sensor (S11) abnormality	Measure the voltage on TP26 on the finisher control PC board (FIN). Then check that the measured voltage is 1V or lower when not shielded and within the range of 3.3V±5% when shielded. If the voltage does not fall within the range mentioned, replace the sensor.
Faulty cables and connectors	Check if the electrical continuity between the connector terminals is normal. If electricity is not conducted, replace the connector. (Finisher control PC board (FIN): CN6, CN10, CN14, CN22)
Finisher control PC board (FIN) abnormality	If the error still occurs after replacing the sensor and the connector, replace the finisher control PC board (FIN).

### [EA2D] Paper transport jam in the Finisher (Sub-path sensor)

Classification	Error content
Paper jam in finisher section	Paper transport jam in the Finisher (Sub-path sensor)

MJ-1042

Probable cause	Checking and measures
2nd transport motor (M4) abnormality	Check if the electrical continuity of the coil is normal. If electricity is not conducted, replace the motor.
Entrance path sensor (S19) abnormality	Measure the voltage on TP86 on the finisher control PC board (FIN). Then check that the measured voltage is 1V or lower when not shielded and within the range of 3.3V±5% when shielded. If the voltage does not fall within the range mentioned, replace the sensor.
Sub-path sensor (S8) abnormality	Measure the voltage on TP85 on the finisher control PC board (FIN). Then check that the measured voltage is 1V or lower when not shielded and within the range of 3.3V±5% when shielded. If the voltage does not fall within the range mentioned, replace the sensor.
Stationary tray full detection sensor (S11) abnormality	Measure the voltage on TP26 on the finisher control PC board (FIN). Then check that the measured voltage is 1V or lower when not shielded and within the range of 3.3V±5% when shielded. If the voltage does not fall within the range mentioned, replace the sensor.
Faulty cables and connectors	Check if the electrical continuity between the connector terminals is normal. If electricity is not conducted, replace the connector. (Finisher control PC board (FIN): CN6, CN10, CN14, CN22)
Finisher control PC board (FIN) abnormality	If the error still occurs after replacing the sensor and the connector, replace the finisher control PC board (FIN).

## [EA2E, EA31] Transport jam in Finisher

Classification	Error content
Paper jam in finisher section	Paper transport remaining jam in the Finisher

MJ-1042

Probable cause	Checking and measures
Entrance path sensor (S19) abnormality	Measure the voltage on TP86 on the finisher control PC board (FIN). Then check that the measured voltage is 1V or lower when not shielded and within the range of $3.3V \pm 5\%$ when shielded. If the voltage does not fall within the range mentioned, replace the sensor.
Middle path sensor (S7) abnormality	Measure the voltage on TP84 on the finisher control PC board (FIN). Then check that the measured voltage is 1V or lower when not shielded and within the range of $3.3V \pm 5\%$ when shielded. If the voltage does not fall within the range mentioned, replace the sensor.
Sub-path sensor (S8) abnormality	Measure the voltage on TP85 on the finisher control PC board (FIN). Then check that the measured voltage is 1V or lower when not shielded and within the range of $3.3V \pm 5\%$ when shielded. If the voltage does not fall within the range mentioned, replace the sensor.
Faulty cables and connectors	Check if the electrical continuity between the connector terminals is normal. If electricity is not conducted, replace the connector. (Finisher control PC board (FIN): CN6, CN22)
Finisher control PC board (FIN) abnormality	If the error still occurs after replacing the sensor and the connector, exchange the finisher control PC board (FIN).

## [EA31] Transport path paper remaining jam

Classification	Error content
Paper jam in finisher section	Transport path paper remaining jam

MJ-1110

Check item	Measures
Paper	Check if there is any paper in the finisher or on the transport path of the equipment and remove it if there is.
Entrance sensor (S1)	<ul style="list-style-type: none"> <li>• Sensor check</li> <li>• Connector check (CN8)</li> <li>• Harness check</li> </ul>
Feeding sensor (S22)	<ul style="list-style-type: none"> <li>• Sensor check (S22)</li> <li>• Connector check (CN1)</li> <li>• Harness check</li> </ul>
Paper position sensor (Hole punch unit: S6-1, S6-2)	<ul style="list-style-type: none"> <li>• Remove any paper dust in and around the sensors (S6-1 and S6-2) and clean them.</li> </ul>
	<ul style="list-style-type: none"> <li>• Sensor check (S6-1, S6-2)</li> <li>• Connector check (CN1, CN4, CN5)</li> <li>• Harness check</li> </ul>

Check item	Measures
Transport sensor (S2)	<ul style="list-style-type: none"> <li>• Sensor check</li> <li>• Connector check (CN8)</li> <li>• Harness check</li> </ul>
Finisher control PC board (FIN)	<ul style="list-style-type: none"> <li>• Board check</li> <li>• Connector check (CN1, CN8)</li> <li>• Harness check</li> </ul>

Parts to be replaced	Remark
Entrance sensor (S1)	
Feeding sensor (S22)	
Paper position sensor (S6-1, S6-2)	Hole punch unit
Transport sensor (S2)	
Finisher control PC board (FIN)	

### [EA32] Finishing tray paper detection error

Classification	Error content
Paper jam in finisher section	Exit paper remaining jam

MJ-1042

Probable cause	Checking and measures
Finishing tray sensor (S4) abnormality	Measure the voltage on TP14 on the finisher control PC board (FIN). Then check that the measured voltage is 1V or lower when not shielded and within the range of $3.3V \pm 5\%$ when shielded. If the voltage does not fall within the range mentioned, replace the sensor.
Faulty cables and connectors	Check if the electrical continuity between the connector terminals is normal. If electricity is not conducted, replace the connector. (Finisher control PC board (FIN): CN5)
Finisher control PC board (FIN) abnormality	If the error still occurs after replacing the sensor and the connector, exchange the finisher control PC board (FIN).

### [EA32] Exit paper remaining jam

Classification	Error content
Paper jam in finisher section	Exit paper remaining jam

MJ-1110

Check item	Measures
Paper	Check if there is any paper in the finisher or on the transport path of the equipment and remove it if there is.
Finishing tray paper detection sensor (S12)	<ul style="list-style-type: none"> <li>• Sensor check</li> <li>• Connector check</li> <li>• Harness check</li> </ul>

Check item	Measures
Finisher control PC board (FIN)	<ul style="list-style-type: none"> <li>• Board check</li> <li>• Connector check (CN25)</li> <li>• Harness check</li> </ul>

Parts to be replaced	Remark
Finishing tray paper detection sensor (S12)	
Finisher control PC board (FIN)	

#### [EA40] Cover open detection error

Classification	Error content
Paper jam in finisher section	Cover open error

MJ-1042

Probable cause	Checking and measures
Sub-path opening/closing sensor (S12) abnormality	Measure the voltage on TP12 on the finisher control PC board (FIN). Then check that the measured voltage is 1V or lower when not shielded and within the range of $3.3V \pm 5\%$ when shielded. If the voltage does not fall within the range mentioned, replace the sensor.
Front cover switch (SW1) abnormality	Measure the voltage on TP77 on the finisher control PC board (FIN). Then check that the measured voltage is 1V or lower when the switch is ON and within the range of $3.3V \pm 5\%$ when OFF. If the voltage does not fall within the range mentioned, replace the switch.
Faulty cables and connectors	Check if the electrical continuity between the connector terminals is normal. If electricity is not conducted, replace the connector. (Finisher control PC board (FIN): CN10, CN13)
Finisher control PC board (FIN) abnormality	If the error still occurs after replacing the switches, sensor and connector, exchange the finisher control PC board (FIN).

#### [EA40] Cover open error

Classification	Error content
Paper jam in finisher section	Cover open error

MJ-1110

Check item	Measures
Cover	<ul style="list-style-type: none"> <li>• Close the front cover or the stationary tray if they are opened.</li> </ul>
Front cover switch (SW1)	<ul style="list-style-type: none"> <li>• Sensor check</li> <li>• Connector check</li> <li>• Harness check</li> </ul>
Stationary tray opening/closing switch (SW2)	<ul style="list-style-type: none"> <li>• Sensor check</li> <li>• Connector check</li> <li>• Harness check</li> </ul>
Finisher controller board	<ul style="list-style-type: none"> <li>• Connector check (CN14)</li> <li>• Board check</li> </ul>



Parts to be replaced	Remark
Cover locking bracket	If it is broken.
Front cover switch (SW1)	
Stationary tray opening/closing switch (SW2)	
Finisher controller board (FIN)	

### [EA50] Stapling jam

Classification	Error content
Paper jam in finisher section	Stapling jam

MJ-1042

Probable cause	Checking and measures
Staple unit stapling start position sensor (S17) abnormality	Measure the voltage on TP23 on the finisher control PC board (FIN). Then check that the measured voltage is 1V or lower when the sensor is ON and within the range of 3.3V $\pm$ 5% when OFF. If the voltage does not fall within the range mentioned, replace the staple unit.
Staple unit staple empty sensor (S18) abnormality	Measure the voltage on TP24 on the finisher control PC board (FIN). Then check that the measured voltage is 1V or lower when the sensor is ON and within the range of 3.3V $\pm$ 5% when OFF. If the voltage does not fall within the range mentioned, replace the staple unit.
Faulty cables and connectors	Check if the electrical continuity between the connector terminals is normal. If electricity is not conducted, replace the connectors. (Finisher control PC board (FIN): CN17)
Finisher control PC board (FIN) abnormality	If the error still occurs after replacing the staple unit and the connectors, exchange the finisher control PC board (FIN).

### [EA50] Stapling jam

Classification	Error content
Paper jam in finisher section	Stapling jam

MJ-1110

Check item	Measures
Stapler	<ul style="list-style-type: none"> <li>• Check if there is any paper in the finisher or on the transport path of the equipment or on the finishing tray. Remove it if there is</li> <li>• Is the jam cleared by taking off the staple cartridge from the finisher and removing the staple sheet slid from the staple case?</li> <li>• If the actuator of the stapler safety sensor (S11) does not move smoothly, remove its clip from the side and then reattach it.</li> <li>• Connector check</li> <li>• Harness check</li> </ul>

Check item	Measures
Finisher controller PC board (FIN)	<ul style="list-style-type: none"> <li>• Board check</li> <li>• Connector check (CN19)</li> <li>• Harness check</li> </ul>

Parts to be replaced	Remark
Stapler	
Finisher controller PC board (FIN)	

### [EA60] Early arrival jam

Classification	Error content
Paper jam in finisher section	Early arrival jam

MJ-1042

Probable cause	Checking and measures
Entrance path sensor (S19) abnormality	Measure the voltage on TP86 on the finisher control PC board (FIN). Then check that the measured voltage is 1V or lower when not shielded and within the range of $3.3V \pm 5\%$ when shielded. If the voltage does not fall within the range mentioned, replace the sensor.
Faulty cables and connectors	Check if the electrical continuity between the connector terminals is normal. If electricity is not conducted, replace the connector. (Finisher control PC board (FIN): CN22)
Finisher control PC board (FIN) abnormality	If the error still occurs after replacing the sensor and the connector, exchange the finisher control PC board (FIN).

### [EA60] Early arrival jam

Classification	Error content
Paper jam in finisher section	Early arrival jam

MJ-1110

Check item	Measures
Paper	Check if there is any paper in the finisher or on the transport path of the equipment and remove it if there is.
Feeding sensor (S22)	<ul style="list-style-type: none"> <li>• Sensor check(S22)</li> <li>• Connector check (CN1)</li> <li>• Harness check</li> </ul>
Finisher controller PC board (FIN)	<ul style="list-style-type: none"> <li>• Board check</li> <li>• Connector check (CN1)</li> <li>• Harness check</li> </ul>

Parts to be replaced	Remark
Feeding sensor (S22)	
Finisher controller PC board (FIN)	

**[EA70] Stack exit belt home position error**

Classification	Error content
Paper jam in finisher section	Stack exit belt home position error

MJ-1110

Check item	Measures
Stack belt exit home position sensor (S9)	Check if there is a disconnection of the connector, incorrect installation or breakage of the stack belt exit home position sensor (S9). If there is, reinstall the sensor correctly or replace it.
	Check if the connector (CN25) on the finisher controller PC board is disconnected from the stack belt exit home position sensor (S9) and the harnesses are open circuited. Correct if any.
Stack transport motor (M8)	Check if the connector (CN18) on the finisher controller PC board is disconnected from the stack transport motor (M8) and the harnesses are open circuited. Correct if any.

Parts to be replaced	Remark
Stack belt exit home position sensor (S9)	
Stack transport motor (M8)	
Finisher controller PC board (FIN)	

**[EAF1] Stack exit roller nip home position detection error**

MJ-1042

Classification	Error content
Finisher jam	The detection of the home position of the stack exit roller nip motor ends abnormally. This error may occur if paper is jammed while being transported, so it is treated as a paper jam.

Replacement part	Measure
Stack exit roller shift motor (M6) Stack exit roller home position sensor (S13)	The stack exit roller home position sensor (S13) does not detect that the exit roller is not at the upper position after the stack exit roller motor (M6) has been driven in the specified time when the exit roller is moved down.
	The stack exit roller home position sensor (S13) does not detect that the exit roller is at the upper position after the stack exit roller shift motor (M6) has been driven in the specified time when the exit roller is moved up.

**[EAF2] Stapler unit sliding motor home position detection error**  
MJ-1042

Classification	Error content
Paper jam in finisher section	The detection of the home position of the stapler unit sliding motor ends abnormally.

Error	Timing of detection
Staple unit sliding motor (M7) Staple unit sliding home position sensor (S3)	The turning OFF of the staple unit sliding home position sensor (S3) is not detected when the staple unit is moved from a point where this sensor is turned ON to one point where this sensor is turned OFF after the staple unit sliding motor (M7) has been driven at the specified number of pulse.
	The turning ON of the staple unit sliding home position sensor (S3) is not detected when the staple unit is moved from a point where this sensor is turned OFF to one point where this sensor is turned ON after the staple unit sliding motor (M7) has been driven at the specified number of pulse.

Probable cause	Checking and measures
Staple unit sliding motor (M7) abnormality	Check if the electrical continuity of the coil is normal. If electricity is not conducted, replace the staple unit.
Staple unit sliding home position sensor (S3) abnormality	Measure the voltage on TP18 on the finisher control PC board (FIN). Then check that the measured voltage is 1V or lower when not shielded and within the range of $3.3V \pm 5\%$ when shielded. If the voltage does not fall within the range mentioned, replace the sensor.
Faulty cables and connectors	Check if the electrical continuity between the connector terminals is normal. If electricity is not conducted, replace the connectors. (Finisher control PC board (FIN): CN3, CN18)
Finisher control PC board (FIN) abnormality	If the error still occurs after replacing the staple unit, sensors and connectors, exchange the finisher control PC board (FIN).

### 8.3.11 Paper jam in saddle stitcher section

#### [EA90] Saddle stitch unit open error

MJ-1110

Classification	Error item
Paper jam in saddle stitch section	Door open jam

Check item	Measures
Saddle stitch unit	Close the saddle stitch unit if it is open.
Paper	Remove any paper on the stacker.
Saddle stitch unit opening/closing switch (SW5)	<p>Check if there is a disconnection of the connector, incorrect installation or breakage of the saddle stitch unit opening/closing switch (SW5). If there is, reinstall the sensor correctly or replace it.</p> <p>Check if the harness between the saddle stitch unit opening/closing switch (SW5) and the CN26 of the finisher controller PC board (FIN) is disconnected or open circuited. Correct if so.</p>

Replace parts	Remarks
Saddle stitch unit opening/closing switch (SW5)	
Finisher controller PC board (FIN)	

#### [EAA0] Paper remaining in Saddle Stitch Unit

Classification	Error item
Finisher jam (Saddle stitcher section)	Paper remaining in saddle stitch unit

MJ-1110

Check item	Measures
Paper	<ul style="list-style-type: none"> <li>Check if there is any paper in the finisher, saddle stitcher or the on the transport path of the equipment. Remove it if there is.</li> <li>Use paper accepted in the specifications.</li> </ul> <p>Do not use the paper shorter than the specification.</p>
Junction box paper detection sensor (S26)	<ul style="list-style-type: none"> <li>Sensor check(S26)</li> <li>Connector check(CN1)</li> <li>Harness check</li> </ul>
Transport path-2 sensor (S27)	<ul style="list-style-type: none"> <li>Sensor check(S27)</li> <li>Connector check(CN3)</li> <li>Harness check</li> </ul>
Transport path-3 sensor (S28)	<ul style="list-style-type: none"> <li>Sensor check(S28)</li> <li>Connector check(CN3)</li> <li>Harness check</li> </ul>
Ejecting roller sensor(S29)	<ul style="list-style-type: none"> <li>Sensor check(S29)</li> <li>Connector check(CN3)</li> <li>Harness check</li> </ul>

Check item	Measures
Harness	Check if the flat cable between the finisher control PC board (FIN) and the saddle control PC board (SDL) is disconnected or open circuited. Correct if so. (Replace the harness if open circuited. Reconnect the connector securely if there is any disconnection.)
Finisher control PC board (FIN)	<ul style="list-style-type: none"> <li>• Board check</li> <li>• Connector check(CN21)</li> <li>• Harness check</li> </ul>
Saddle control PC board (SDL)	<ul style="list-style-type: none"> <li>• Board check</li> <li>• Connector check(CN3, CN6)</li> <li>• Harness check</li> </ul>

Replace parts	Remarks
Junction box paper detection sensor (S26)	
Transport path-2 sensor (S27)	
Transport path-3 sensor (S28)	
Ejecting roller sensor (S29)	
Finisher control PC board (FIN)	
Saddle control PC board (SDL)	

### [EAB0] Paper transport jam in Saddle Stitch Unit

Classification	Error item
Finisher jam (Saddle stitcher section)	Paper transport jam in saddle stitch unit

MJ-1110

Check item	Measures
Paper	<ul style="list-style-type: none"> <li>• Check if there is any paper in the finisher, saddle stitcher or the on the transport path of the equipment. Remove it if there is.</li> <li>• Use paper accepted in the specifications.</li> </ul>
	Do not use the paper longer than the specification.
Transport roller	Fix any mechanical problem occurring when the transfer roller is rotated.
Feeding sensor (S22)	<ul style="list-style-type: none"> <li>• Sensor check(S22)</li> <li>• Connector check (CN1)</li> <li>• Harness check</li> </ul>
Junction box paper detection sensor (S26)	<ul style="list-style-type: none"> <li>• Sensor check(S26)</li> <li>• Connector check(CN1)</li> <li>• Harness check</li> </ul>
Transport path-2 (S27)	<ul style="list-style-type: none"> <li>• Sensor check(S27)</li> <li>• Connector check(CN3)</li> <li>• Harness check</li> </ul>
Transport path-3 (S28)	<ul style="list-style-type: none"> <li>• Sensor check(S28)</li> <li>• Connector check(CN3)</li> <li>• Harness check</li> </ul>

Check item	Measures
Ejecting roller sensor(S29)	<ul style="list-style-type: none"> <li>• Sensor check(S29)</li> <li>• Connector check(CN3)</li> <li>• Harness check</li> </ul>
Saddle transport motor (M16)	<ul style="list-style-type: none"> <li>• Motor check(M16)</li> <li>• Connector check(CN5)</li> <li>• Harness check</li> </ul>
Transport path switching solenoid (SOL5)	<p>Check that the gap between the transfer guide surface and the upper surface of the flapper tip is in the acceptable range according to the status of the transport path switching solenoid (SOL5) (solenoid OFF: 1.5 to 2.1 mm, solenoid ON: 2.3 to 2.9 mm). If it is not, adjust it.</p> <p>Check if the harness between the transport path switching solenoid (SOL5) and the CN1 of the finisher controller PC board (FIN) is disconnected or open circuited. Correct if so.</p>
Entrance motor (M1)	<ul style="list-style-type: none"> <li>• Motor check(M1)</li> <li>• Connector check(CN17)</li> <li>• Harness check</li> </ul>
Harness	<p>Check if the flat cable between the finisher control PC board (FIN) and the saddle control PC board (SDL) is disconnected or open circuited. Correct if so. (Replace the harness if open circuited. Reconnect the connector securely if there is any disconnection.)</p>
Finisher control PC board (FIN)	<ul style="list-style-type: none"> <li>• Board check</li> <li>• Connector check(CN21)</li> <li>• Harness check</li> </ul>
Saddle control PC board (SDL)	<ul style="list-style-type: none"> <li>• Board check</li> <li>• Connector check(CN3, CN6)</li> <li>• Harness check</li> </ul>

Replace parts	Remarks
Junction box paper detection sensor (S26)	
Feeding sensor (S22)	
Transport path-2 (S27)	
Transport path-3 (S28)	
Ejecting roller sensor (S29)	
Saddle transport motor (M16)	
Entrance motor (M1)	
Transport path switching solenoid (SOL5)	
Saddle control PC board (SDL)	
Finisher controller board (FIN)	

## [EAB1] Short paper jam in Saddle Stitch Unit

Classification	Error item
Finisher jam (Saddle stitcher section)	Short paper jam in saddle stitch unit

MJ-1110

Check item	Measures
Paper	<ul style="list-style-type: none"> <li>• Check if there is any paper in the finisher, saddle stitcher or the on the transport path of the equipment. Remove it if there is.</li> <li>• Use paper accepted in the specifications.</li> </ul>
Feeding sensor (S22)	<ul style="list-style-type: none"> <li>• Sensor check (S22)</li> <li>• Connector check (CN1)</li> <li>• Harness check</li> </ul>
Junction box paper detection sensor (S26)	<ul style="list-style-type: none"> <li>• Sensor check (S26)</li> <li>• Connector check (CN1)</li> <li>• Harness check</li> </ul>
Transport path-2 sensor (S27)	<ul style="list-style-type: none"> <li>• Sensor check (S27)</li> <li>• Connector check (CN3)</li> <li>• Harness check</li> </ul>
Transport path-3 sensor (S28)	<ul style="list-style-type: none"> <li>• Sensor check (S28)</li> <li>• Connector check (CN3)</li> <li>• Harness check</li> </ul>
Ejecting roller sensor (S29)	<ul style="list-style-type: none"> <li>• Sensor check (S29)</li> <li>• Connector check (CN3)</li> <li>• Harness check</li> </ul>
Harness	Check if the flat cable between the finisher control PC board (FIN) and the saddle control PC board (SDL) is disconnected or open circuited. Correct if so. (Replace the harness if open circuited. Reconnect the connector securely if there is any disconnection.)
Finisher control PC board (FIN)	<ul style="list-style-type: none"> <li>• Board check</li> <li>• Connector check (CN1, CN21)</li> <li>• Harness check</li> </ul>
Saddle control PC board (SDL)	<ul style="list-style-type: none"> <li>• Connector check (CN3, CN6)</li> <li>• Board check</li> </ul>

Replace parts	Remarks
Feeding sensor (S22)	
Junction box paper detection sensor (S26)	
Transport path-2 sensor (S27)	
Transport path-3 sensor (S28)	
Ejecting roller sensor (S29)	
Finisher control PC board (FIN)	
Saddle control PC board (SDL)	



## 8.3.12 Paper jam in puncher unit

### [E9F0] Punching jam

Classification	Error content
Finisher jam (Punch section)	Punching jam

MJ-1042 (When MJ-6011 is installed)

Probable cause	Checking and measures
Punch unit sliding motor abnormality	Check if the electrical continuity of the coil is normal. If electricity is not conducted, replace the motor.
Punch sliding unit home position sensor abnormality	Measure the voltage on TP26 on the hole punch control PC board. Then check that the measured voltage is 1V or lower when not shielded and within the range of $5V \pm 5\%$ when shielded. If the voltage does not fall within the range mentioned, replace the sensor.
Paper detection sensor (light-receiving/light-emitting) (S24/S25)	Measure the voltage on 8 pin of CN6 on the hole punch control PC board. Then check that the measured voltage is 3.0V or higher when not shielded and 1.2 or lower when shielded. If the voltage does not fall within the range mentioned, replace the sensor.
Faulty cables and connectors	Check if the electrical continuity between the connector terminals is normal. If electricity is not conducted, replace the connector. (Hole punch control PC board: CN3, CN4, CN5, CN6, CN7)
Hole punch control PC board abnormality	If the error still occurs after replacing the sensor and the connector, replace the hole punch control PC board.
Finisher control PC board (FIN) abnormality	Replace the finisher control PC board (FIN).

MJ-1110 (When MJ-6105 is installed)

Check item	Measures
Paper	Check if there is any paper on the transport path of the equipment and remove it if there is.
Punch motor (M3)	<ul style="list-style-type: none"> <li>• Motor check</li> <li>• Connector check</li> <li>• Harness check</li> </ul>
Punch HP sensor (S4)	<ul style="list-style-type: none"> <li>• Sensor check</li> <li>• Connector check</li> <li>• Harness check</li> </ul>
Punch sensor (S5)	<ul style="list-style-type: none"> <li>• Sensor check</li> <li>• Connector check</li> <li>• Harness check</li> </ul>
Hole punch control PC board (HP)	<ul style="list-style-type: none"> <li>• Board check</li> <li>• Connector check</li> <li>• Harness check</li> </ul>

Parts to be replaced	Remark
Punch HP sensor (S4)	
Punch sensor (S5)	
Punch motor (M3)	

Parts to be replaced	Remark
Hole punch control PC board (HP)	

## 8.3.12a Scanning of an original from the DF is stopped

### [ 1 ] Original size misdetection

DSDF

Classification	Error item
DSDF	<ul style="list-style-type: none"> <li>After the first page of the original has exited, the job is finished and "Change drawer to correct paper size. Place last original." is displayed.</li> <li>After the first page of the original has exited, the job is finished and "Change direction of original" is displayed.</li> </ul> <p>If the size of paper placed in the drawer has been recognized correctly, perform the following steps.</p>

Step	Check item	Measures
1	Connector	Check if the connectors (CN73, CN76) of the DSDF control PC board are connected or the harnesses are open circuited.
2	DSDF tray original length sensor-1	<ul style="list-style-type: none"> <li>Check if the DSDF tray original length sensor-1 is working properly. (Input check: FS-03-[F2]ON/[7]/[A])</li> <li>Replace the DSDF tray original length sensor-1.</li> </ul>
3	DSDF tray original length sensor-2	<ul style="list-style-type: none"> <li>Check if the DSDF tray original length sensor-2 is working properly. (Input check: FS-03-[F2]ON/[8]/[D])</li> <li>Replace the DSDF tray original length sensor-2.</li> </ul>
4	DSDF tray original width sensor	<ul style="list-style-type: none"> <li>Check if the DSDF tray original width sensor is working properly. (Input check: FS-03-[F2]ON/[8]/[C], FS-03-[F2]ON/[8]/[B], FS-03-[F2]ON/[8]/[A])</li> <li>Replace the DSDF tray original width sensor.</li> </ul>
5	DSDF control PC board	Replace the DSDF control PC board.

Replacement part	Remark
DSDF tray original length sensor-1	
DSDF tray original length sensor-2	
DSDF tray original width sensor	
DSDF control PC board	

RADF

Classification	Error item
RADF	<ul style="list-style-type: none"> <li>After the first page of the original has exited, the job is finished and "Change drawer to correct paper size. Place last original." is displayed.</li> <li>After the first page of the original has exited, the job is finished and "Change direction of original" is displayed.</li> </ul> <p>If the size of paper placed in the drawer has been recognized correctly, perform the following steps.</p>

Step	Check item	Measures
1	Connector	Check if the connector (CN73) of the RADF control PC board is connected or the harnesses are open circuited.

Step	Check item	Measures
2	Original width detection sensor-1	<ul style="list-style-type: none"> <li>Check if the original width detection sensor-1 is working properly. (Input check: FS-03-[F2]ON/[8]/[F])</li> <li>Replace the original width detection sensor-1.</li> </ul>
3	Original width detection sensor-2	<ul style="list-style-type: none"> <li>Check if the original width detection sensor-2 is working properly. (Input check: FS-03-[F2]ON/[8]/[G])</li> <li>Replace the original width detection sensor-2.</li> </ul>
4	Original tray sensor	<ul style="list-style-type: none"> <li>Check if the original tray sensor is working properly. (Input check: FS-03-[F2]ON/[8]/[E])</li> <li>Replace the original tray sensor.</li> </ul>
5	RADF control PC board	Replace the RADF control PC board.

Replacement part	Remark
Original width detection sensor-1	
Original width detection sensor-2	
Original tray sensor	
RADF control PC board	

## [ 2 ] HDD full

DSDf, RADF

Classification	Error item
DSDf, RADF	Continuous scanning of originals is stopped in the middle and "Not enough memory to store original(s) Will you print out stored originals?" is displayed.

Step	Check item	Measures
1	HDD	<ul style="list-style-type: none"> <li>Delete unnecessary data stored in the HDD.</li> <li>Check if there is any abnormality in the HDD and replace it if necessary.</li> </ul>

Replacement part	Remark
HDD	

## [ 3 ] Scanning abnormality

DSDf

Classification	Error item
DSDf	After the first or several pages of an original have exited, the job is finished.

### Remarks:

If this problem has occurred during simplex scanning, perform step 6 and later.

Step	Check item	Measures
1	DSDF-I/F board	<ul style="list-style-type: none"> <li>Check if the HDMI cable is properly connected to the connector (CN90) of the DSDF-I/F board.</li> <li>Check if the connector (CN89) is properly connected to the SYS board.</li> <li>Replace the DSDF-I/F board.</li> </ul>
2	DSDF control PC board, DSDF relay board	<ul style="list-style-type: none"> <li>Check if the HDMI cable is properly connected to the connector (CN78) of the DSDF control PC board or the DSDF relay board.</li> <li>Replace the DSDF control PC board or the DSDF relay board.</li> </ul>
3	HDMI cable (DSDF)	<ul style="list-style-type: none"> <li>Check if the HDMI cable is open circuited.</li> <li>Replace the HDMI cable.</li> </ul>
4	Flat cable	<ul style="list-style-type: none"> <li>Check if the connectors (CN88, CN91) of the DSDF-CCD module and the DSDF control PC board are connected properly.</li> <li>Check if the flat cable is open circuited.</li> <li>Replace the flat cable.</li> </ul>
5	DSDF-CCD module	Replace the DSDF-CCD module.
6	HDMI cable (scanner)	<ul style="list-style-type: none"> <li>Check if the connectors (CN120, CN001) of the SYS board and the CCD driving PC board are connected properly.</li> <li>Check if the HDMI cable is open circuited.</li> <li>Replace the HDMI cable.</li> </ul>
7	CCD driving PC board of the lens unit	<ul style="list-style-type: none"> <li>Check if there is any abnormality in the appearance of the parts mounted on the CCD driving PC board.</li> <li>Replace the lens unit.</li> </ul>
8	SYS board	<ul style="list-style-type: none"> <li>Check if there is any abnormality in the appearance of the parts mounted on the SYS board.</li> <li>Replace the SYS board.</li> </ul>

Replacement part	Remark
DSDF-I/F board	
DSDF control PC board	
DSDF relay board	
HDMI cable (DSDF)	HDMI cable between the DSDF control PC board and the DSDF-I/F board or between the DSDF relay board and the DSDF-I/F board (CN78, CN90)
Flat cable	
DSDF-CCD module	
HDMI cable (scanner)	HDMI cable between the SYS board and the lens unit (CN120, CN001)
Lens unit	Since the lens unit and the CCD driving PC board are integrated, they cannot be replaced individually. Therefore, replace the lens unit if there is any abnormality in the CCD driving PC board.
SYS board	

RADF

Classification	Error item
RADF	After the first or several pages of an original have exited, the job is finished.

Step	Check item	Measures
1	HDMI cable (scanner)	<ul style="list-style-type: none"> <li>• Check if the connectors (CN120, CN001) of the SYS board and the CCD driving PC board are connected properly.</li> <li>• Check if the HDMI cable is open circuited.</li> <li>• Replace the HDMI cable.</li> </ul>
2	CCD driving PC board of the lens unit	<ul style="list-style-type: none"> <li>• Check if there is any abnormality in the appearance of the parts mounted on the CCD driving PC board.</li> <li>• Replace the lens unit.</li> </ul>
3	SYS board	<ul style="list-style-type: none"> <li>• Check if there is any abnormality in the appearance of the parts mounted on the SYS board.</li> <li>• Replace the SYS board.</li> </ul>

Replacement part	Remark
HDMI cable (scanner)	HDMI cable between the SYS board and the lens unit (CN120, CN001)
Lens unit	Since the lens unit and the CCD driving PC board are integrated, they cannot be replaced individually. Therefore, replace the lens unit if there is any abnormality in the CCD driving PC board.
SYS board	

### 8.3.13 Other paper jam

#### [EAD0] Print end command time-out jam

Classification	Error content
Other paper jam	The printing has not finished normally because of an error occurring on the interface between the SYS board and the engine firmware at the end of printing.

Check item	Measures
Power	<ul style="list-style-type: none"> <li>• Check if the error is cleared by turning the power OFF and then back ON.</li> </ul>
SYS board	<ul style="list-style-type: none"> <li>• Connector check</li> <li>• Board check</li> </ul>
LGC board	<ul style="list-style-type: none"> <li>• Connector check</li> <li>• Board check</li> </ul>

Parts to be replaced	Remark
SYS board	
LGC board	

#### [EAE0] Receiving time-out jam

Classification	Error content
Other paper jam	Receiving time-out jam

Check item	Measures
Finisher	<ul style="list-style-type: none"> <li>• Is the finisher working?</li> <li>• Check if the voltage (24V) is being supplied to the finisher.</li> <li>• Check if the harness connecting the I/F connector of the finisher side and PFC board is open circuited.</li> <li>• Connector check</li> </ul>
LGC board	<ul style="list-style-type: none"> <li>• Connector check (CN346)</li> <li>• Check if the harness connecting the FIN board and LGC board is open circuited.</li> <li>• Check if the conductor pattern on the LGC board is short circuited or open circuited.</li> </ul>

Parts to be replaced	Remark
LGC board	
Harness	

**[EB30] Ready time-out jam**

Classification	Error content
Other paper jam	Ready time-out jam

Check item	Measures
Finisher	<ul style="list-style-type: none"> <li>• Check if the connector on the equipment is disconnected from the finisher or the harnesses are open circuited. Correct if any.</li> <li>• Check the finisher firmware version.</li> <li>• Update the finisher firmware to the latest one.</li> </ul>

Parts to be replaced	Remark
LGC board	

**[ED10] Skew adjustment motor (M1) home position detection abnormality**

MJ-1110 (when MJ-6105 is installed)

Classification	Error content
Other paper jam	Skew adjustment motor (M1) home position detection abnormality

Check item	Measures
Paper	<ul style="list-style-type: none"> <li>• Check if there is any paper in the hole punch unit, finisher or the on the transport path of the equipment. Remove it if there is.</li> <li>• Use paper accepted in the specifications.</li> </ul>
Skew adjustment motor (M1)	Rotate skew adjustment motor and fix its mechanism if it does not rotate smoothly.
Skew HP sensor (S2) Skew adjustment motor (M1) Hole punch control PC board	Check if the connectors on the hole punch controller PC board (HP board) are disconnected from the skew HP sensor (S2) and the skew adjustment motor, or the harnesses are open circuited. Correct if any.

Parts to be replaced	Remark
Skew adjustment motor (M1)	
Skew HP sensor (S2)	
Hole punch control PC board (HP)	



**[ED11] Sideways adjustment motor (M2) home position detection error**

MJ-1110 (when MJ-6105 is installed)

Classification	Error content
Other paper jam	Sideways adjustment motor (M2) home position detection error

Check item	Measures
Paper	<ul style="list-style-type: none"> <li>Check if there is any paper in the hole punch unit, finisher or the on the transport path of the equipment. Remove it if there is.</li> <li>Use paper accepted in the specifications.</li> </ul>
Sideways adjustment motor (M2)	Rotate sideways adjustment motor and fix its mechanism if it does not rotate smoothly.
Sideways deviation HP sensor (S3) Sideways adjustment motor (M2) Hole punch control PC board (HP)	Check if the connectors on the hole punch controller PC board (HP board) are disconnected from the sideways deviation HP sensor (S3) and the sideways adjustment motor, or the harnesses are open circuited. Correct if any.

Parts to be replaced	Remark
Sideways adjustment motor (M2)	
Sideways deviation HP sensor (S3)	
Hole punch control PC board (HP)	

**[ED13] Front alignment plate home position error**

Classification	Error content
Other paper jam	Front alignment plate home position error

MJ-1110

Check item	Measures
Front alignment plate	Move the front alignment plate. Fix any mechanical problem.
Front alignment plate home position sensor (S7)	<p>Check if there is a disconnection of the connector, incorrect installation or breakage of the front alignment plate home position sensor (S7). If there is, reinstall the sensor correctly or replace it.</p> <p>Check if the connector (CN25) on the finisher controller PC board is disconnected from the front alignment plate home position sensor (S7) and the harnesses are open circuited. Correct if so.</p>
Front alignment motor (M5)	Check if the connector (CN18) on the finisher controller PC board is disconnected from the front alignment motor (M5) and the harnesses are open circuited. Correct if so.

Parts to be replaced	Remark
Front alignment plate home position sensor (S7)	

Parts to be replaced	Remark
Front alignment motor (M5)	
Finisher controller PC board (FIN)	

#### [ED14] Rear alignment plate home position error

Classification	Error content
Other paper jam	Rear alignment plate home position error

MJ-1110

Check item	Measures
Rear alignment plate	Move the rear alignment plate. Fix any mechanical problem.
Rear alignment plate home position sensor (S8)	Check if there is a disconnection of the connector, incorrect installation or breakage of the rear alignment plate home position sensor (S8). If there is, reinstall the sensor correctly or replace it. Check if the connector (CN25) on the finisher controller PC board is disconnected from the rear alignment plate home position sensor (S8) and the harnesses are open circuited. Correct if so.
Rear alignment motor (M6)	Check if the connector (CN18) on the finisher controller PC board is disconnected from the rear alignment motor (M6) and the harnesses are open circuited. Correct if so.

Parts to be replaced	Remark
Rear alignment plate home position sensor (S8)	
Rear alignment motor (M6)	
Finisher controller PC board (FIN)	

#### [ED15] Paddle home position error

Classification	Error content
Other paper jam	Paddle home position error

MJ-1110

Check item	Measures
Paddle	Rotate the paddle. If there is any mechanical problem, fix its mechanism.
Paddle home position sensor Paddle motor Finisher controller PC board	Check if the connectors (CN15, CN16) on the finisher control PC board are disconnected from the paddle home position sensor (S3) and the paddle motor (M3), or the harnesses are open circuited. Correct if any.

Parts to be replaced	Remark
Paddle motor (M3)	

Parts to be replaced	Remark
Paddle home position sensor (S3)	
Finisher control PC board (FIN)	

### [ED16] Buffer tray home position error

Classification	Error content
Other paper jam	Buffer tray home position error

MJ-1110

Check item	Measures
Buffer tray guide	Open and close the buffer tray guide. Fix any mechanical problem.
Buffer tray home position sensor (S5)	Check if there is a disconnection of the connector, incorrect installation or breakage of the buffer tray home position sensor (S5). If there is, reinstall the sensor correctly or replace it. Check if the connector (CN11) on the finisher controller PC board is disconnected from the buffer tray home position sensor (S5) and the harnesses are open circuited. Correct if so.
Assist arm motor (M10)	Check if the connector (CN10) on the finisher controller PC board is disconnected from the assist arm motor (M10) and the harnesses are open circuited. Correct if so.
Buffer tray guide motor (M2)	Check if the connector (CN10) on the finisher controller PC board is disconnected from the buffer tray guide motor (M2) and the harnesses are open circuited. Correct if so.

Parts to be replaced	Remark
Buffer tray home position sensor (S5)	
Assist arm motor (M10)	
Buffer tray guide motor (M2)	
Finisher controller PC board (FIN)	

### [EF10] Paper not supported for Saddle Stitch Unit

MJ-1110

Check the paper size, paper type, or number of pages for stapling. Change them if they are unsupported.

**[EF11] Saddle Stitch Finisher stapling error (front)**

MJ-1110

Classification	Error item
Finisher jam (Saddle stitch section)	Front stapling is not correctly done.

Check item	Measures
Paper	<ul style="list-style-type: none"> <li>• Check if there is any paper in the hole punch unit, finisher or the on the transport path of the equipment. Remove it if there is.</li> <li>• Use paper accepted in the specifications.</li> </ul>
Staple cartridge (front side)	<ul style="list-style-type: none"> <li>• Is the jam released by taking off the front staple cartridge from the Finisher and removing the staple sheet slid from the staple case?</li> </ul>
Front saddle stapler drive unit	<ul style="list-style-type: none"> <li>• Unit check</li> <li>• Connector check</li> <li>• Harness check</li> </ul>
Saddle control PC board (SDL)	<ul style="list-style-type: none"> <li>• Connector check (CN2)</li> <li>• Board check</li> </ul>

Replace parts	Remarks
Front saddle stapler drive unit	
Saddle control PC board (SDL)	

**[EF12] Saddle Stitch Finisher stapling error (rear)**

MJ-1110

Classification	Error item
Finisher jam (Saddle stitch section)	Rear stapling is not correctly done.

Check item	Measures
Paper	<ul style="list-style-type: none"> <li>• Check if there is any paper in the hole punch unit, finisher or the on the transport path of the equipment. Remove it if there is.</li> <li>• Use paper accepted in the specifications.</li> </ul>
Staple cartridge (rear side)	<ul style="list-style-type: none"> <li>• Is the jam released by taking off the rear staple cartridge from the Finisher and removing the staple sheet slid from the staple case?</li> </ul>
Rear saddle stapler drive unit	<ul style="list-style-type: none"> <li>• Unit check</li> <li>• Connector check</li> <li>• Harness check</li> </ul>
Saddle control PC board (SDL)	<ul style="list-style-type: none"> <li>• Connector check (CN1)</li> <li>• Board check</li> </ul>

Replace parts	Remarks
Rear saddle stapler drive unit	
Saddle control PC board (SDL)	

**[EF13] Saddle stitch unit paper holding home position detection error**

MJ-1110

Classification	Error item
Finisher jam (Saddle stitch section)	The paper holder home position cannot be detected.

Check item	Measures
Paper holding cam	<ul style="list-style-type: none"> <li>Is there any mechanical problem when the paper holding cam is rotated? Correct if so.</li> </ul>
Paper holding home position sensor (S38)	<ul style="list-style-type: none"> <li>Sensor check</li> <li>Connector check</li> <li>Harness check</li> </ul>
Paper holding clutch (CLT4)	Check if the harness between the saddle control PC board (SDL) and the paper holding clutch (CLT4) is disconnected or open circuited. Correct if so. (Replace the harness if open circuited. Reconnect the connector securely if there is any disconnection.)
Saddle transport motor (M16)	Check if the harness between the saddle control PC board (SDL) and the saddle transport motor (M16) is disconnected or open circuited. Correct if so. (Replace the harness if open circuited. Reconnect the connector securely if there is any disconnection.)
Saddle control PC board (SDL)	<ul style="list-style-type: none"> <li>Connector check (CN5)</li> <li>Board check</li> </ul>

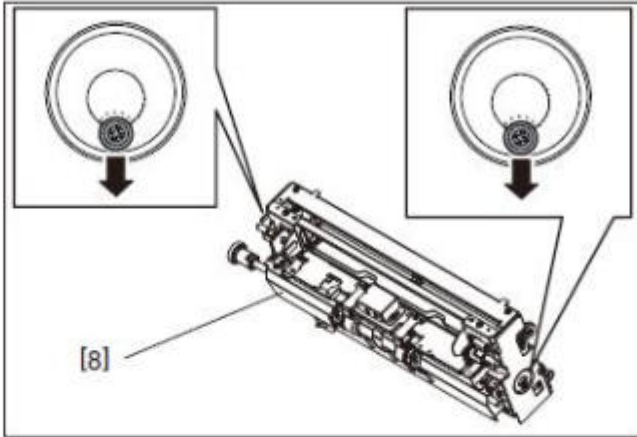
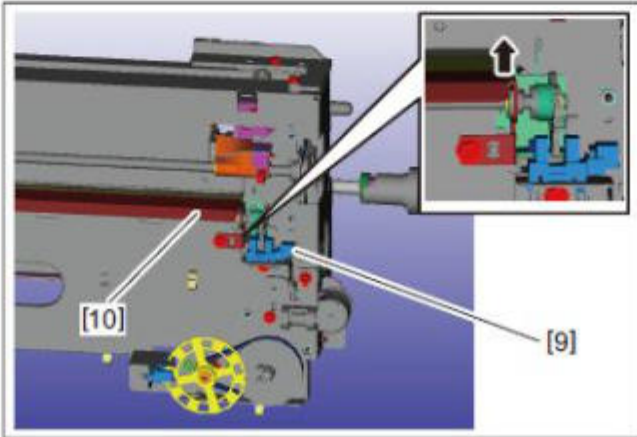
Replace parts	Remarks
Paper holding home position sensor (S38)	
Paper holding clutch (CLT4)	
Saddle transport motor (M16)	
Saddle control PC board (SDL)	

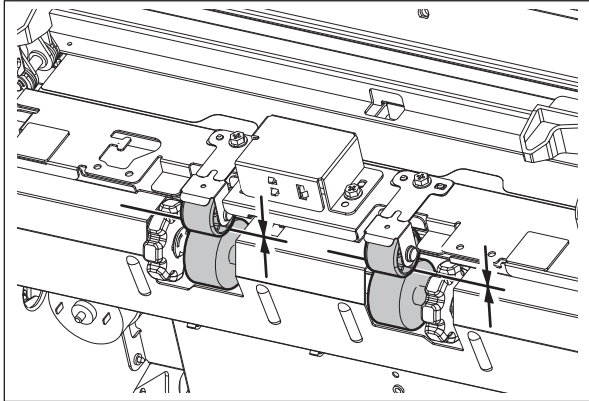
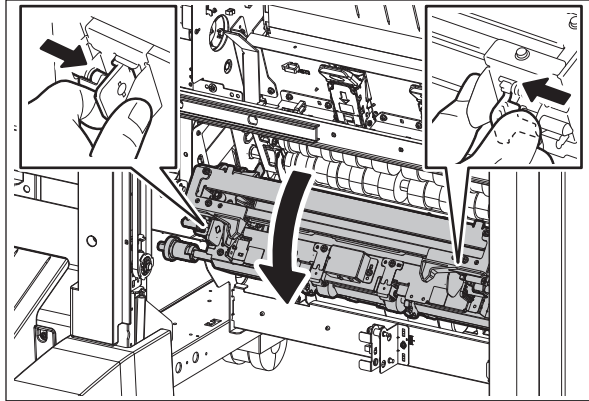
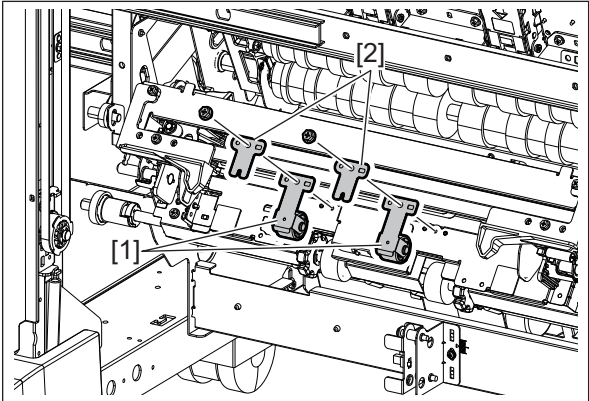
**[EF14] Saddle paper exit jam**

MJ-1110

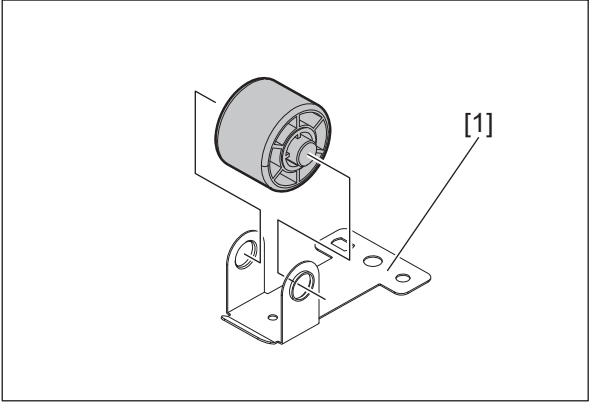
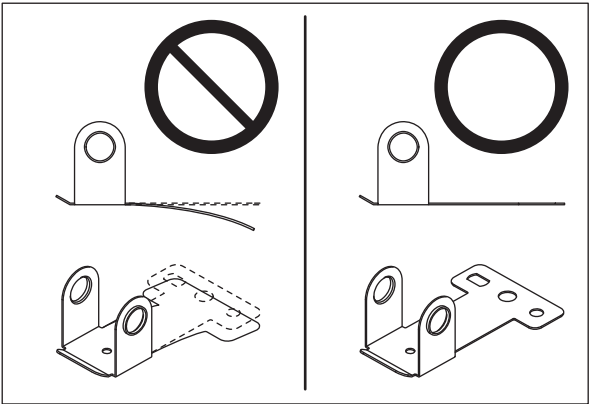
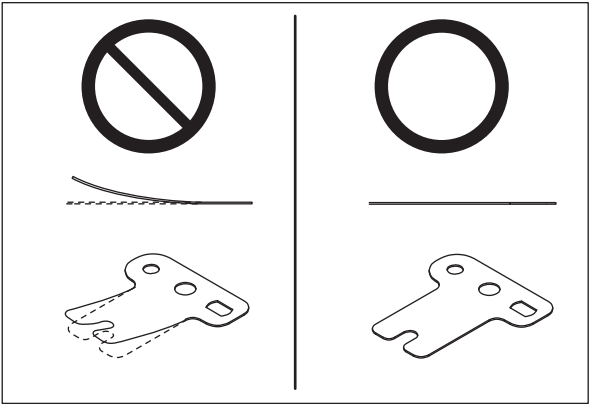
Classification	Error item
Finisher jam (Saddle stitch section)	Outputting paper is not completed within a fixed time.

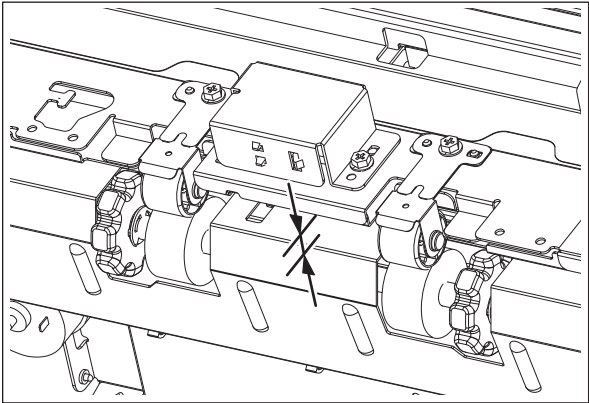
Check item	Measures
Paper	<ul style="list-style-type: none"><li>• Is there any paper remaining in the paper transport path of the equipment or the saddle stitch section of the Finisher?</li></ul>
Exit sensor (S31)	<ul style="list-style-type: none"><li>• Sensor check</li><li>• Connector check (CN7)</li><li>• Harness check</li></ul>
Harness	Check if the harness between the finisher controller PC board (FIN) and the saddle control PC board (SDL) is disconnected or open circuited. Correct if so. (Replace the harness if open circuited. Reconnect the connector securely if there is any disconnection.)
Finisher control PC board (FIN)	<ul style="list-style-type: none"><li>• Board check</li><li>• Connector check (CN21)</li><li>• Harness check</li></ul>
Saddle control PC board (SDL)	<ul style="list-style-type: none"><li>• Connector check (CN6, CN7)</li><li>• Board check</li></ul>

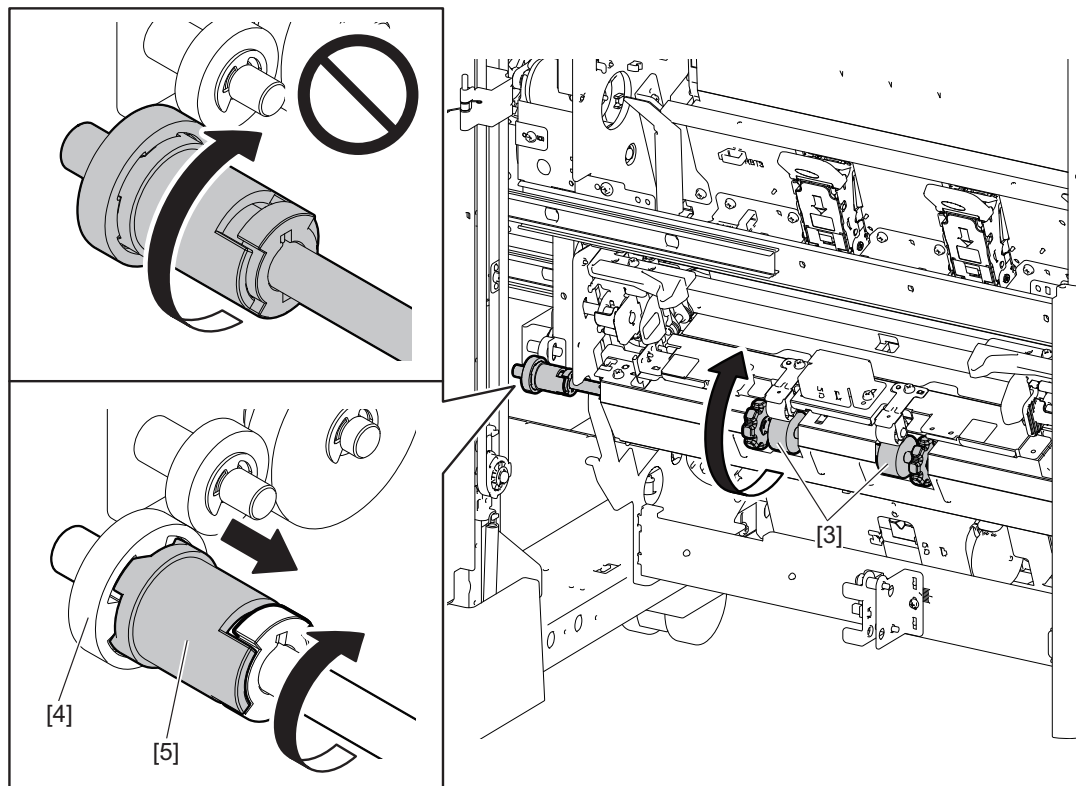
Check item	Measures
EFS unit	<ul style="list-style-type: none"> <li> <p data-bbox="579 237 1310 322">Correct the misalignment of the shaft of the EFS unit [8]. Move the screws in the direction of the arrow and secure them. (both the front and rear)</p>  </li> <li> <p data-bbox="579 882 1070 1025">Replace the following parts.</p> <ul style="list-style-type: none"> <li>- BRIR-ROD-EX-F-SDL-F5330 (P-I:24-23)</li> <li>- PLT-BURR-ROD-EX-F-SDL (P-I:24-24)</li> <li>- ASYS-PLT3-FILM3-EFS (P-I:25-16)</li> <li>- FILM4-EFS (P-I:25-51)</li> </ul> </li> <li> <p data-bbox="579 1055 1406 1198">Check if there is a disconnection of the connector, incorrect installation or breakage of the exit transport sensor (S41) [9]. If there is, reinstall the sensor correctly or replace it. Move the bracket [10] in the direction of the arrow and secure it with the screw.</p>  </li> </ul>

Check item	Measures
<p>Leaf springs and assist leaf springs of the transport pinch roller (for the saddle)</p>	<ul style="list-style-type: none"> <li> <p>Check if there is any gap between the exit roller (for the saddle) and the transport pinch roller (for the saddle). If there is, replace the leaf springs [1] and the assist leaf springs [2] of the transport pinch roller (for the saddle).</p>  <p>Fig.8-3</p> </li> <li> <p>Check if the leaf springs [1] and the assist leaf springs [2] of the transport pinch roller (for the saddle) are misshapen. If they are warped or deformed, replace them. For the removal procedure of the leaf springs [1] and the assist leaf springs [2], refer to the following figures.</p>  <p>Fig.8-4</p> </li> <li>  <p>Fig.8-5</p> </li> </ul>

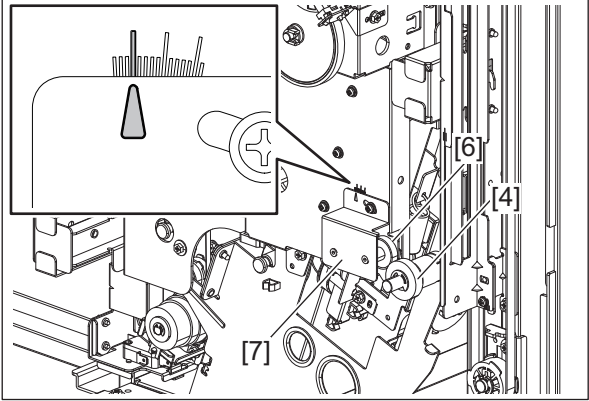
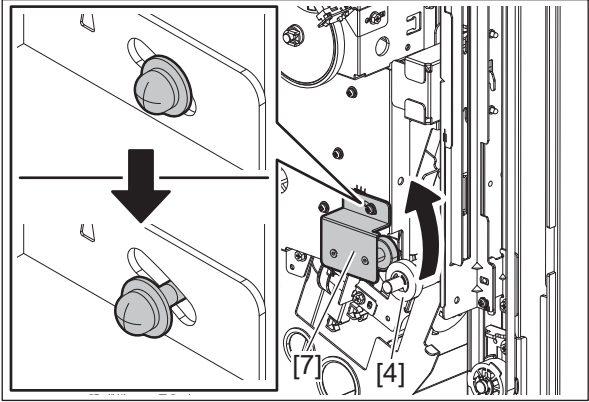
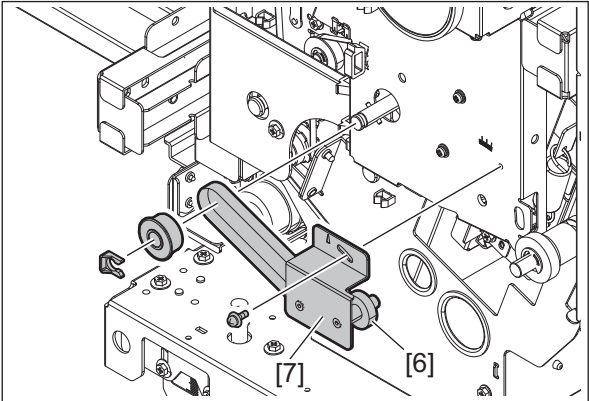


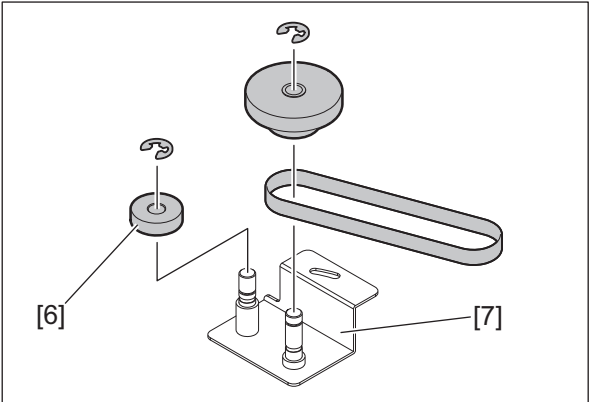
Check item	Measures
<p>Leaf springs and assist leaf springs of the transport pinch roller (for the saddle)</p>	<ul style="list-style-type: none"> <li>Take off the leaf springs [1].</li> </ul> <div data-bbox="730 202 1321 606" style="text-align: center;">  </div> <p style="text-align: center;">Fig.8-6</p> <p><b>Notes:</b>  In order to confirm that there is no warpage or deformation on the leaf springs [1] and the assist leaf springs [2] of the transport pinch roller (for the saddle), remove them and put them on a flat place.</p> <div data-bbox="730 876 1321 1281" style="text-align: center;">  </div> <p style="text-align: center;">Fig.8-7</p> <div data-bbox="730 1391 1321 1796" style="text-align: center;">  </div> <p style="text-align: center;">Fig.8-8</p>

Check item	Measures
Lower transport guide	<p>Check that the gap of the lower transport guide is 15 mm or below.</p> <p>15 mm or below: OK Larger than 15 mm: Not good</p>  <p style="text-align: center;"><b>Fig.8-9</b></p> <p>If the gap is larger than 15 mm, check the attachment condition or replace the lower transport guide.</p>
Exit roller (for the saddle)	<ul style="list-style-type: none"> <li>• Check the engagement status of the gear [4] by rotating the exit roller [3] (for the saddle) in the direction of the arrow (opposite direction of the exiting). <ul style="list-style-type: none"> <li>- When not good: The gear [4] rotates without having been engaged. (The ratchet [5] does not rotate.)</li> <li>- When OK: The ratchet [5] rotates while sliding, but the gear [4] is stopped. (The gear [4] is engaged.)</li> </ul> </li> </ul>



**Fig.8-10**

Check item	Measures
Exit roller (for the saddle)	<ul style="list-style-type: none"> <li>In the case of "not good", replace the bracket [7] at the idle gear [6] side.</li> </ul> <p><b>Notes:</b> When replacing, check the position where the pre-change bracket [7] is attached and add its marking in order to install the post-change one in the same place.</p>  <p style="text-align: center;"><b>Fig.8-11</b></p> <ul style="list-style-type: none"> <li>For the removal procedure of the bracket [7], refer to the following figures.</li> </ul>  <p style="text-align: center;"><b>Fig.8-12</b></p>  <p style="text-align: center;"><b>Fig.8-13</b></p>

Check item	Measures
Exit roller (for the saddle)	 <p style="text-align: center;"><b>Fig.8-14</b></p>

Replace parts	Remarks
Exit sensor (S31)	
Saddle control PC board (SDL)	
Finisher controller PC board (FIN)	
Leaf springs for the transport pinch roller (for the saddle)	Even if no abnormalities have been confirmed by the check items for the lower transport guide (for the saddle) and the transport pinch roller (for the saddle), replace the leaf springs and the assist leaf springs of the transport pinch roller (for the saddle) if an EF14 error has occurred.
Assist leaf springs for the transport pinch roller (for the saddle)	
Bracket at the idle gear side	
Lower transport guide (for the saddle)	
Exit roller (for the saddle)	

### [EF15] Saddle Stitch Finisher side alignment motor home position detection abnormality

MJ-1110

Classification	Error item
Finisher jam (Saddle stitch section)	The side alignment motor home position cannot be detected.

Check item	Measures
Jog	<ul style="list-style-type: none"> <li>Is there any mechanical problem when the jog is moved? Correct if so.</li> </ul>
Side alignment home position sensor (S36)	<ul style="list-style-type: none"> <li>Sensor check</li> <li>Connector check</li> <li>Harness check</li> </ul>
Side alignment motor (M15)	<ul style="list-style-type: none"> <li>Motor check</li> <li>Connector check</li> <li>Harness check</li> </ul>
Saddle control PC board (SDL)	<ul style="list-style-type: none"> <li>Connector check (CN4)</li> <li>Board check</li> </ul>

Replace parts	Remarks
Side alignment home position sensor (S36)	
Side alignment motor (M15)	
Saddle control PC board (SDL)	

#### [EF16] Saddle Stitch Finisher stacker motor home position detection abnormality

MJ-1110

Classification	Error item
Finisher jam (Saddle stitch section)	The stacker motor home position cannot be detected.

Check item	Measures
Stacker carrier	<ul style="list-style-type: none"> <li>Is there any mechanical problem when the stacker carrier is moved? Correct if so.</li> </ul>
Stacker home position sensor (S33)	<ul style="list-style-type: none"> <li>Sensor check</li> <li>Connector check</li> <li>Harness check</li> </ul>
Stacker motor (M14)	<ul style="list-style-type: none"> <li>Motor check</li> <li>Connector check</li> <li>Harness check</li> </ul>
Saddle control PC board (SDL)	<ul style="list-style-type: none"> <li>Connector check (CN8)</li> <li>Board check</li> </ul>

Replace parts	Remarks
Stacker home position sensor (S33)	
Stacker motor (M14)	
Saddle control PC board (SDL)	

#### [EF17] Saddle Stitch Finisher folding blade home position detection abnormality

MJ-1110

Classification	Error item
Finisher jam (Saddle stitch section)	The folding blade home position cannot be detected.

Check item	Measures
Folding blade cam	<ul style="list-style-type: none"> <li>Is there any mechanical problem when the folding blade cam is rotated? Correct if so.</li> </ul>
Folding blade home position sensor (S35)	<ul style="list-style-type: none"> <li>Sensor check</li> <li>Connector check (CN12)</li> <li>Harness check</li> </ul>
Folding blade clutch (CLT3)	<ul style="list-style-type: none"> <li>Clutch check</li> <li>Connector check (CN13)</li> <li>Harness check</li> </ul>
Saddle control PC board (SDL)	<ul style="list-style-type: none"> <li>Connector check (CN12, CN13)</li> <li>Board check</li> </ul>

Replace parts	Remarks
Folding blade home position sensor (S35)	
Folding blade clutch (CLT3)	
Saddle control PC board (SDL)	

**[EF18] Saddle Stitch Finisher additional folding roller home position detection abnormality**

MJ-1110

Classification	Error item
Finisher jam (Saddle stitch section)	The additional folding roller home position cannot be detected.

Check item	Measures
Additional folding carrier	<ul style="list-style-type: none"> <li>Is there any mechanical problem when the additional folding carrier is moved? Correct if so.</li> </ul>
Additional folding home position sensor (S39) Additional folding motor encoder sensor (S42)	<ul style="list-style-type: none"> <li>Sensor check</li> <li>Connector check (CN7)</li> <li>Harness check</li> </ul>
Additional folding motor (M20)	<ul style="list-style-type: none"> <li>Motor check. Check if the motor and timing belt is installed properly.</li> <li>Connector check (CN10)</li> <li>Harness check</li> </ul>
Saddle control PC board (SDL)	<ul style="list-style-type: none"> <li>Connector check (CN7, CN10)</li> <li>Board check</li> </ul>

Replace parts	Remarks
Additional folding home position sensor (S39)	
Additional folding motor encoder sensor (S42)	
Additional folding motor (M20)	
Saddle control PC board (SDL)	

**[EF19] Saddle paper folding jam**

MJ-1110

<b>Classification</b>	<b>Error item</b>
Finisher jam (Saddle stitch section)	Fold processed paper cannot be transported to the additional folding roller.

<b>Check item</b>	<b>Measures</b>
Paper	<ul style="list-style-type: none"><li>• Is there any paper remaining in the paper transport path in the equipment or the saddle stitch section of the Finisher?</li></ul>
Exit transport sensor (S41)	<ul style="list-style-type: none"><li>• Sensor check</li><li>• Connector check (CN7)</li><li>• Harness check</li></ul>
Saddle control PC board (SDL)	<ul style="list-style-type: none"><li>• Connector check (CN7)</li><li>• Board check</li></ul>

<b>Replace parts</b>	<b>Remarks</b>
Exit transport sensor (S41)	
Saddle control PC board (SDL)	

### 8.3.14 Drive system related service call

#### [C020] Developer drive motor abnormality

Classification	Error content
Drive system related service call	Developer drive motor abnormality: The developer drive motor is not rotating normally.

Check item	Measures
Developer unit	<ul style="list-style-type: none"> <li>• Check if the developer material is caked.</li> <li>• Check if there is any abnormality in the row of gears on the rear side of the developer unit.</li> <li>• Check if the amount of developer material is proper.</li> </ul>
Feeding/developing drive unit	<ul style="list-style-type: none"> <li>• Check if there is any foreign matter between the gears.</li> <li>• Check if there is any damage on the gear tooth surface.</li> <li>• Check if there is any scratch on the caliber or the shaft of each gear.</li> <li>• Check if the proper amount of grease is applied to the caliber or the shaft of each gear.</li> <li>• Check if there is any damage to the developer drive output coupling.</li> </ul>
Paper feeding/developer unit drive motor	<ul style="list-style-type: none"> <li>• Check that the motor is rotated normally. (FS-03-112/162)</li> <li>• Connector check</li> <li>• Harness check</li> </ul>
Drum TBU drive unit	<ul style="list-style-type: none"> <li>• Check if there is any foreign matter in the row of the color developer drive gears.</li> <li>• Check if there is any damage on the tooth surface of the color developer drive gears.</li> <li>• Check if there is any scratch on the caliber or the shaft of each color developer drive gear.</li> <li>• Check if the proper amount of grease is applied to the caliber or the shaft of each color developer drive gear.</li> <li>• Check if there is any damage to the developer drive output coupling.</li> </ul>
LGC board	<ul style="list-style-type: none"> <li>• Board check</li> <li>• Connector check (CN367)</li> <li>• Harness check</li> </ul>
Registration roller	<ul style="list-style-type: none"> <li>• Check if the registration rollers on both the equipment and the ADU are rotated normally.</li> <li>• Check if there is any damage to the roller bushing.</li> </ul>
1st drawer feed roller	<ul style="list-style-type: none"> <li>• Check if the 1st drawer feed roller is overloaded.</li> <li>• Check if there is any damage to the roller coupling.</li> </ul>
Bypass unit	<ul style="list-style-type: none"> <li>• Check if the bypass feed roller is overloaded.</li> <li>• Check if there is any damage to the row of the bypass unit gears.</li> </ul>
PFU drive section	<ul style="list-style-type: none"> <li>• Check if there is any foreign matter between the gears.</li> <li>• Check if there is any damage on the gear tooth surface.</li> <li>• Check if there is any scratch on the caliber or the shaft of each gear.</li> </ul>
PFU transport roller	<ul style="list-style-type: none"> <li>• Check if the PFU transport roller is overloaded.</li> </ul>
PFU feed roller	<ul style="list-style-type: none"> <li>• Check if the PFU feed roller is overloaded.</li> </ul>



Parts to be replaced	Remark
Developer unit	
Feeding/developing drive unit	
Paper feeding/developer unit drive motor	
Drum TBU drive unit	
LGC board	
Registration roller	
1st drawer feed roller	
Bypass unit	
PFU drive section	
PFU transport roller	
PFU feed roller	

## 8.3.15 Paper feeding system related service call

### [C040] PFP motor abnormality

Classification	Error content
Paper feeding system related service call	PFP motor abnormality

Procedure	Check item	Result	Measure	Next Step
1	Is the PFP motor working? (Perform the output check: FS-03-109/159)	Yes		2
		No	<ul style="list-style-type: none"> <li>• Check if the connector J952 of the PFP motor is disconnected.</li> <li>• Check if the connector CN245 on the PFP board is disconnected.</li> <li>• Check if the connector CN241 on the PFP board is</li> <li>• Check if the connector CN368 on the LGC board is disconnected.</li> <li>• Check if the connector pins are disconnected or the harnesses are open circuited.</li> <li>• Check if the conductor patterns on the PFP motor board, PFP board and LGC board are short circuited or open circuited.</li> </ul>	
2	Is the LED on the PFP motor board lit without flashing?	Yes		3
		No	<ul style="list-style-type: none"> <li>• Check if the connector pins are disconnected or the harnesses are open circuited.</li> <li>• Check if the conductor patterns on the PFP motor board, PFP board and LGC board are short circuited or open circuited.</li> </ul>	
3	PFP board		<ul style="list-style-type: none"> <li>• Board check</li> <li>• Connector check</li> <li>• Harness check</li> <li>• Replace the PFP board.</li> </ul>	

Parts to be replaced	Remark
PFP motor	
PFP board	
LGC board	

## [C140] 2nd drawer tray abnormality

Classification	Error content
Paper feeding system related service call	2nd drawer tray abnormality

Procedure	Check item	Result	Measure	Next Step
1	Does the tray go up? (Perform the output check: FS-03-243)	Yes		2
		No	<ul style="list-style-type: none"> <li>• Check if the connector of the tray-up motor is disconnected (CN922, J936).</li> <li>• Check if the connector on the PFU board is disconnected. (CN920, CN913)</li> <li>• Check if the connector on the LGC board is disconnected (CN368).</li> <li>• Check if the connector pins are disconnected or the harnesses are open circuited.</li> <li>• Check if the conductor pattern on the LGC board is short circuited or open circuited.</li> </ul>	
2	Is the tray-up sensor working? (Perform the input check: FS-03-[F2]ON/[4]/[E])	Yes		3
		No	<ul style="list-style-type: none"> <li>• Check if the connector of the sensor is disconnected (CN926, J933, J931).</li> <li>• Check if the connector on the PFU board is disconnected. (CN920, CN926)</li> <li>• Check if the connector on the LGC board is disconnected (CN368).</li> <li>• Check if the slit reaches the sensor.</li> <li>• Check if the connector pins are disconnected or the harnesses are open circuited.</li> <li>• Check if the conductor pattern on the LGC board is short circuited or open circuited.</li> </ul>	
3	PFU board		<ul style="list-style-type: none"> <li>• Check if the conductor pattern on the PFU board is short circuited or open circuited.</li> </ul>	
4	LGC board		<ul style="list-style-type: none"> <li>• Check if the conductor pattern on the LGC board is short circuited or open circuited.</li> </ul>	

Parts to be replaced	Remark
Tray-up motor	
PFU board	
LGC board	
Tray-up sensor	

**[C150] PFP upper drawer tray abnormality**  
**[C160] PFP lower drawer tray abnormality**

Classification	Error content
Paper feeding system related service call	PFP upper drawer tray abnormality PFP lower drawer tray abnormality

Procedure	Check item	Result	Measure	Next Step
1	Does the tray go up? (Perform the output check: FS-03-278, 280)	Yes		2
		No	<ul style="list-style-type: none"> <li>• Check if the connector of the tray-up motor is disconnected. (J967, J961, CN244)</li> <li>• Check if any of the connectors CN241 and CN244 on the PFP board is disconnected.</li> <li>• Check if the connector CN923 on the PFU board is disconnected.</li> <li>• Check if the connector pins are disconnected or the harnesses are open circuited.</li> <li>• Check if the conductor patterns on the PFP board and PFU board are short circuited or open circuited.</li> </ul>	
2	Is the tray-up sensor working? (Perform the input check: FS-03-[F1]ON/[5]/[A], FS-03-[F1]ON/[5]/[E])	Yes		3
		No	<ul style="list-style-type: none"> <li>• Check if the connector of the sensor is disconnected. (CN246, J960, J965, J966, J970, J972)</li> <li>• Check if any of the connectors CN241, CN244 and CN246 on the PFP board is disconnected.</li> <li>• Check if the connector CN913 on the PFU board is disconnected.</li> <li>• Check if the slit reaches the sensor.</li> <li>• Check if the connector pins are disconnected or the harnesses are open circuited.</li> <li>• Check if the conductor patterns on the PFP board and PFU board are short circuited or open circuited.</li> </ul>	
3	PFU board		<ul style="list-style-type: none"> <li>• Check if the conductor pattern on the PFU board is short circuited or open circuited.</li> </ul>	

Parts to be replaced	Remark
Tray-up motor	
PFP board	
PFU board	
Tray-up sensor	

**[C180] LCF tray-up motor abnormality**

Classification	Error content
Paper feeding system related service call	LCF tray-up motor abnormality

Procedure	Check item	Result	Measure	Next Step
1	Does the tray move? (Perform the output check: FS-03-271)	Yes		2
		No	<ul style="list-style-type: none"> <li>• Check if the connector of the LCF tray-up motor is disconnected. (CN5, CN50)</li> <li>• Check if any of the connectors CN100 and CN101 on the LCF board is disconnected.</li> <li>• Check if the connector CN923 on the PFU board is disconnected.</li> <li>• Check if the connector pins are disconnected or the harnesses are open circuited.</li> <li>• Check if the conductor patterns on the LCF board and PFU board are short circuited or open circuited.</li> </ul>	
2	Are the LCF tray-up sensor and LCF tray bottom sensor working? (Perform the input check: FS-03-[F1]ON/[8]/[A], FS-03-[F1]ON/[8]/[E])	Yes		3
		No	<ul style="list-style-type: none"> <li>• Check if the connectors of the sensors are disconnected.</li> <li>• Check if any of the connectors CN100 and CN101 on the LCF board is disconnected.</li> <li>• Check if the connector CN923 on the PFU board is disconnected.</li> <li>• Check if the slit reaches the sensors.</li> <li>• Check if the connector pins are disconnected or the harnesses are open circuited.</li> <li>• Check if the conductor patterns on the LCF board and PFU board are short circuited or open circuited.</li> </ul>	
3	PFU board		<ul style="list-style-type: none"> <li>• Check if the conductor pattern on the PFU board is short circuited or open circuited.</li> </ul>	

Parts to be replaced	Remark
LCF tray-up motor	
LCF board	
PFU board	
LCF tray-up sensor	
LCF tray bottom sensor	

## [C1A0] LCF end fence motor abnormality

Classification	Error content
Paper feeding system related service call	LCF end fence motor abnormality

Procedure	Check item	Result	Measure	Next Step
1	Is the LCF end fence motor working? (Perform the output check: FS-03-207)	Yes		2
		No	<ul style="list-style-type: none"> <li>• Check if the connector of the LCF end fence motor is disconnected. (CN5, CN51)</li> <li>• Check if any of the connectors CN100 and CN101 on the LCF board is disconnected.</li> <li>• Check if the connector CN923 on the PFU board is disconnected.</li> <li>• Check if the connector pins are disconnected or the harnesses are open circuited.</li> <li>• Check if the conductor patterns on the LCF board and PFU board are short circuited or open circuited.</li> </ul>	
2	Are the LCF end fence home/stop position sensors working? (Perform the input check: FS-03-[F1]ON/[8]/[H], FS-03-[F1]ON/[8]/[G])	Yes		3
		No	<ul style="list-style-type: none"> <li>• Check if the connectors of the sensors are disconnected. (CN4, CN40, CN400, CN402, CN403)</li> <li>• Check if either of the connectors CN100 or CN107 on the LCF board is disconnected.</li> <li>• Check if the connector CN923 on the PFU board is disconnected.</li> <li>• Check if the slit reaches the sensors.</li> <li>• Check if the connector pins are disconnected or the harnesses are open circuited.</li> <li>• Check if the conductor patterns on the LCF board and PFU board are short circuited or open circuited.</li> </ul>	
3	PFU board		<ul style="list-style-type: none"> <li>• Check if the conductor pattern on the PFU board is short circuited or open circuited.</li> </ul>	

Parts to be replaced	Remark
LCF end fence motor	
LCF board	
PFU board	
LCF end fence home position sensor	
LCF end fence stop position sensor	

**[C1B0] LCF transport motor abnormality**

Classification	Error content
Paper feeding system related service call	The LCF transport motor is not rotating normally (when paper can be fed from any drawer except the LCF).

Procedure	Check item	Result	Measure	Next Step
1	Is the LCF transport motor working? (Perform the output check: FS-03-122/172)	Yes		2
		No	<ul style="list-style-type: none"> <li>• Check if the connector CN3, CN30 of the LCF transport motor is disconnected.</li> <li>• Check if the signal line connector CN100 on the LCF board is disconnected.</li> <li>• Check if the power line connector CN101 on the LCF board is disconnected.</li> <li>• Check if the connector CN923 on the PFU board is disconnected.</li> <li>• Check if the connector pins are disconnected or the harnesses are open circuited.</li> <li>• Check if the connector pins are disconnected or the harnesses are open circuited.</li> </ul>	
2	LCF transport motor PFU board		<ul style="list-style-type: none"> <li>• Check if the connector pins are disconnected or the harnesses are open circuited.</li> <li>• Check if the conductor patterns on the LCF transport motor board, LCF board and PFU board are short circuited or open circuited.</li> <li>• Check if the PLL lock signal CN102-3 pin output from the LCF board is always "L" level.</li> <li>• Check if the voltage supplied to the microcomputer input terminal IC4 - 59pin of PFU board is always "L" level.</li> </ul>	

Parts to be replaced	Remark
LCF transport motor	
LCF board	
PFU board	

## 8.3.16 Scanning system related service call

### [C260] Peak detection error

Classification	Error content
Scanning system related service call	Peak detection error

Procedure	Check item	Result	Measure	Next Step
1	Does the exposure lamp lit? (Perform the output check: FS-03-267)	Yes	It is lit.	2
		No	It is not lit.	3
2	Shading correction plate		Check if there is any scratch or stain on the shading correction plate.	
	Mirror		Check if the mirror is tilted. 1. Check that the lens is reflected in the mirror looking at carriage-1 from the upper position. 2. Check that the mirror is secured at the leaf spring.	
	Carriage		1. Check if the carriage is tilted by moving it to the left stopping point. 2. Check if the wire fixing screw is loosened. 3. Check if the movement of the carriage is unstable due to disengagement of the carriage roller.	
	LED		1. Check if the LED lamp is correctly lit. 2. Check if the harness is connected properly to the LED lamp connector. 3. When the carriage is driven, check if the harness interferes with it or parts are caught in it.	
	CCD board / Lens unit		1. Check if the connector of the CCD board is connected properly. 2. Check if the CCD board is installed properly. (Check that the lens unit is not tilted or the screw is securely tighten.)	
	SYS board		1. Check if the connector of the SYS board (CN120, CN123) is connected properly. 2. Check if the mounted parts on the SYS board are damaged or abnormal. 3. Check if the power is output from the SYS board for CCD.	



Procedure	Check item	Result	Measure	Next Step
3	SYS board		<ol style="list-style-type: none"> <li>1. Check if the supply cable is connected properly to the connector (CN125).</li> <li>2. Check if the mounted parts on the SYS board are damaged or abnormal.</li> </ol>	
	LED		<ol style="list-style-type: none"> <li>1. Check if the harness of the lamp is connected to the LED light source properly.</li> <li>2. Check if the lamp is scratched or damaged.</li> <li>3. Check if the LED harness comes off the board.</li> </ol>	
	Supply harness		<ol style="list-style-type: none"> <li>1. Check if wiring of the supply harness (CN125) is abnormal.</li> <li>2. Check if the harness is scratched or open circuited.</li> </ol>	

Parts to be replaced	Remark
Lens unit	
SYS board	
LED	
Supply harness	

**[C262] Communication error**


Classification	Error content
Scanning system related service call	Communication error

Procedure	Check item	Measure
1	Lens unit	<ol style="list-style-type: none"> <li>1. Check if the connector is properly connected all the way in the CCD board. (CN001)</li> <li>2. Check if there is any abnormality in the appearance of parts mounted on the CCD board.</li> <li>3. Replace the Lens unit.</li> </ol>
2	SYS board	<ol style="list-style-type: none"> <li>1. Check if the connector is properly connected all the way in the SYS board. (CN120)</li> <li>2. Check if there is any abnormality in the appearance of parts mounted on the SYS board.</li> <li>3. Check if +5V is output to the SYS board by measuring the voltage of both edges of the capacitor C283 or C284. (For both C283 and C284, the upper side is GND and the lower side is +5V.)</li> <li>4. Replace the SYS board.</li> </ol>
3	Harnesses	<ol style="list-style-type: none"> <li>1. Check if the harness has any scratch on it or is open circuited or caught anywhere.</li> <li>2. Check if there is any abnormality in the connector terminal or the contacting surface of the flat cable.</li> <li>3. Replace the harness between the SYS board and the CCD board.</li> </ol>
4	RADF	<ol style="list-style-type: none"> <li>1. Turn the power OFF, disconnect the communication cable of the RADF from the equipment and turn the power ON again. Then check if the error is reproduced.</li> <li>2. If the error is reproduced, check if there is any abnormality in the communication cable and the connector between the RADF and the equipment.</li> <li>3. Replace the communication cable between the RADF and the equipment.</li> <li>4. Replace the RADF.</li> </ol>

Parts to be replaced	Remark
Lens unit	
SYS board	
Harnesses	
RADF	

**[C270] Carriage home position sensor not going OFF within a specified time / Downloading firmware with an incorrect model**

Classification	Error content
Scanning system related service call	Carriage home position sensor not going OFF within a specified time / Downloading firmware with an incorrect model

Procedure	Check item	Result	Measure	Next Step
1	Carriage locking		Check if the carriage locking screw for packaging is attached.	
2	Are the carriages slightly moved to the feeding direction?/Are the carriages staying at a position other than home position?	Yes	Check if the circuits of the CCD board are abnormal.	
		No		3
3	CCD board		<ul style="list-style-type: none"> <li>• Check if the connector pin is disconnected or the harness is short circuited or open circuited.</li> <li>• Check if the conductor pattern on the CCD board is short circuited or open circuited.</li> <li>• If the model of the firmware downloaded is incorrect, a C270 error (exposure lamp blinks twice) occurs. If the exposure lamp blinks twice, download the correct firmware.</li> </ul>	
4	Carriage home position sensor		<ol style="list-style-type: none"> <li>1. Check if the harness of the carriage home position sensor is connected properly.</li> <li>2. Check if the harness is caught or open circuited.</li> </ol>	
5	SYS board		<ol style="list-style-type: none"> <li>1. Check if the connector of the SYS board (CN120, CN121, CN124, CN125) is connected properly.</li> <li>2. Check if the mounted parts on the SYS board are damaged or abnormal.</li> <li>3. Check if 24 V (CN125) on the SYS board is short circuited.</li> <li>4. Check if 24 V is supplied to the SYS board (CN125).</li> </ol>	
6	Scan motor		<ol style="list-style-type: none"> <li>1. Check if the belt tension is loosened.</li> <li>2. Check if the motor fixing screw is loosened.</li> <li>3. Check if the carriage wire and the timing belt come off.</li> <li>4. Check if the connector (CN124) is connected to the motor properly.</li> <li>5. Check if the harness of the motor is caught or open circuited.</li> </ol>	
7	Setting		Clear the SRAM data and initialize them. Refer to  P. 9-25 "9.2.5 Precautions and procedure when replacing the SRAM".	

Parts to be replaced	Remark
CCD board	
Carriage home position sensor	
Carriage home position sensor harness	
SYS board	
Scan motor	
Scan motor harness	

**[C280] Carriage home position sensor not going ON within a specified time**

Classification	Error content
Scanning system related service call	Carriage home position sensor not going ON within a specified time

Procedure	Check item	Result	Measure	Next Step
1	Carriage lock		Check if the carriage locking screw for packaging is attached.	2
2	Carriage home position sensor		<ol style="list-style-type: none"> <li>1. Check if the harness is properly connected to the sensor.</li> <li>2. Check if the harness is caught or open circuited.</li> </ol>	3
3	SYS board		<ol style="list-style-type: none"> <li>1. Check if the harness (CN121) of the carriage home position sensor is connected properly.</li> <li>2. Check if the mounted parts on the SYS board are damaged or abnormal.</li> <li>3. Check if 24 V (CN125) on the SYS board is short circuited.</li> <li>4. Check if 24 V is supplied to the SYS board (CN125).</li> </ol>	4
4	Scan motor		<ul style="list-style-type: none"> <li>• Check if the belt tension is loosened (if the motor screw is loosened).</li> <li>• Check if the wire and the belt come off.</li> <li>• Check if the connector (CN124) is connected to the motor properly.</li> <li>• Check if the harness of the motor is caught or open circuited.</li> </ul>	

Parts to be replaced	Remark
Carriage home position sensor	
Carriage home position sensor harness	
SYS board	
Scan motor	
Scan motor harness	

## [C290] Scanner fuse blowout

Classification	Error content
Scanning system related service call	The scanning system does not operate due to a blowout of the fuse in the scanning system.

Procedure	Check item	Result	Measure	Next Step
1	Is 24V supplied to the SYS board?	Yes	Check the following because the signal for checking 24V on the SYS board is abnormal. 1. Check if the scanner CPU (IC26) is damaged or abnormal. 2. Check if the mounted parts on the SYS board are damaged or abnormal. 3. Check if 24V on the SYS board is short circuited. 4. Check if 24V is supplied to the SYS board (CN125).	
		No	1. Check if the 24V supply harness is properly connected to the connector (CN125). 2. Check if 24V and SG on the SYS board are short circuited. 3. Check if the power supply is short circuited by pulling out the supply harness on the SYS board (CN125). 4. Check if the fuse on the LVPS (F203) is open circuited. 5. Check if there is no abnormality on the LVPS.	

Parts to be replaced	Remark
SYS board	
Fuse (F203)	
Supply harness	
LVPS	

### 8.3.17 Fuser unit related service call

**Notes:**

Be sure to turn OFF the power and unplug the power cable beforehand when checking the power supply unit and fuser unit.  
The fuser unit itself or the part of the unit remains heated and the capacitors are still charged after a while the power cable is unplugged. So make sure the unit is cooled down enough before checking.

**[C411/C412] Thermistor / heater lamp abnormality at power-ON**

Classification	Error content
Fuser unit related service call	Thermistor / heater lamp abnormality at power-ON

Procedure	Check item	Measures
1	Power voltage	Check if the power voltage is normal.(Is the voltage during the operation $\pm 10\%$ of the rated voltage?)
2	Thermistor	<ul style="list-style-type: none"> <li>• Check if the center, side and front thermistor are installed properly.</li> <li>• Check if the harnesses of the center, side and front thermistor are open circuited.</li> <li>• Check if the connectors of the center, side and front thermistor are disconnected (J752).</li> </ul>
3	Power supply unit and fuser unit	<ul style="list-style-type: none"> <li>• Is the fuser unit installed correctly?</li> <li>• Check if the heater lamp is broken.</li> <li>• Check if the terminal of the heater lamp is attached securely.</li> <li>• Check if the center and side thermostat are blown</li> <li>• Check if the drawer connector is damaged or its connection is detected.</li> <li>• Check if the connectors of the power supply unit are disconnected (CN504, CN508).</li> <li>• Check if the power supply unit is abnormal.</li> </ul>
4	LGC board	<ul style="list-style-type: none"> <li>• Check if the connectors CN342 and CN353 are disconnected.</li> <li>• Check if the conductor pattern on the LGC board is short circuited or open circuited.</li> </ul>
5	Status counter	<p>After repairing the matter which caused the error [C411/C412], perform the following:</p> <ul style="list-style-type: none"> <li>• Performs FS-08-2002.</li> <li>• Change the current status counter value "1", "2" or "4" to "0".</li> <li>• Turn the power OFF and then back ON. Make sure that the equipment enters the normal ready state.</li> </ul>

Parts to be replaced	Remark
Power supply unit.	
Thermistor	
LGC board	

**[C445/C446/C447/C449/C450/C451/C452] Heater lamp abnormality after abnormality judgment**

Classification	Error content
Fuser unit related service call	Heater lamp abnormality after abnormality judgment

**1.2.3.4. Check the thermopiles, Heater and LGC board**

Check the above components following the procedures 1, 2,3 and 4 for [C411/C412].

Procedure	Check item	Measures
5	Clear the status counter	<p>Change the current status counter value (08-2002) “5”, “6”, “7”, “9”, “19”, “21”, “22”, “23”, “24”, “25”, “27”, “29”, “38”, “41”, “48” or “50” to “0” for [C44X], taking the same procedure as that for [C41X].</p> <p>* The status counter value is as follows in the following cases.</p> <ul style="list-style-type: none"> <li>- The error occurred during warming-up: “5” or “6” The error occurred after the equipment has become ready: “7”.</li> <li>- The temperature detected by the center thermistor is 200°C or higher, the temperature detected by the side thermistor is 200°C or higher or the temperature detected by the front thermistor is 230°C or higher: “9”, “19”, “22”, “23”, “25”, “27” or “29”</li> <li>- The error occurred during printing: “24” or “25”.</li> <li>- The error occurred during energy saving: “27”.</li> <li>- A paper jam occurred: “29”.</li> </ul>

8

**[C4B0] IGBT overheating abnormality**


Classification	Error content
Fuser unit related service call	IGBT overheating abnormality

Check item	Measure
LGC board	<ul style="list-style-type: none"> <li>• Check if the conductor pattern on the board is short circuited or open circuited.</li> <li>• Check if EEPROM is mounted.</li> </ul>
Status counter	<ol style="list-style-type: none"> <li>1. Performs FS-08-2002.</li> <li>2. Reset the displayed current status counter value “3”, “8”, “10”, “11”, “12”, “13”, “14”, “15”, “16”, “17”, “18”, “20”, “21”, “26”, “28”, “30”, “31”, “32”, “33”, “34”, “35”, “36”, “37”, “39”, “40”, “42”, “43”, “44”, “45”, “46”, “47”, “49”, “51”, “52”, “53”, “54”, “55”, “56”, “57”, “58”, “59”, “60”, “61”, “62” or “63” to “0”.</li> <li>3. Turn the power OFF and then back ON. Make sure that the equipment enters the normal status.</li> </ol>

Parts to be replaced	Remark
LGC board	

## [C4F0] Center thermistor error correction


Classification	Error content
Fuser unit related service call	Center thermistor error correction

Check item	Measure
Thermistor	<ul style="list-style-type: none"> <li>Check the gap between the center thermistor and the fuser roller.   P. 6-85 "6.12.1 Adjustment of the non-contact thermistor Gap"</li> <li>Check that the front thermistor is installed properly.</li> <li>Connector check (J752)</li> <li>Check if the harnesses of the center, side and front thermistor are open circuited.</li> </ul>
LGC board	<ul style="list-style-type: none"> <li>Connector check (CN342, CN372)</li> <li>Check if the conductor pattern on the LGC board is open circuited or short circuited.</li> </ul>
Power supply unit and fuser unit	<ul style="list-style-type: none"> <li>Is the fuser unit installed correctly?</li> <li>Check if the heater lamp is broken.</li> <li>Check if the terminal of the heater lamp is attached securely.</li> <li>Check if the center and side thermostat are blown</li> <li>Check if the drawer connector is damaged or its connection is detected.</li> <li>Check if the connectors of the power supply unit are disconnected (CN504, CN508).</li> <li>Check if the power supply unit is abnormal.</li> </ul>

Parts to be replaced	Remark
Center thermistor	
front thermistor	
LGC board	
Heater lamp	
Power supply unit	

## [C4F1] Side thermistor error correction

Classification	Error content
Fuser unit related service call	Side thermistor error correction

Check item	Measure
Thermistor	<ul style="list-style-type: none"> <li>Check the gap between the side thermistor and the fuser roller.   P. 6-85 "6.12.1 Adjustment of the non-contact thermistor Gap"</li> <li>Check that the front thermistor is installed properly.</li> <li>Connector check</li> <li>Check if the harnesses of the center, side and front thermistor are open circuited.</li> </ul>
LGC board	<ul style="list-style-type: none"> <li>Connector check (CN342, J752)</li> <li>Check if the conductor pattern on the LGC board is open circuited or short circuited.</li> </ul>



Check item	Measure
Power supply unit and fuser unit	<ul style="list-style-type: none"> <li>• Is the fuser unit installed correctly?</li> <li>• Check if the heater lamp is broken.</li> <li>• Check if the terminal of the heater lamp is attached securely.</li> <li>• Check if the center and side thermostat are blown</li> <li>• Check if the drawer connector is damaged or its connection is detected.</li> <li>• Check if the connectors of the power supply unit are disconnected (CN504, CN508).</li> <li>• Check if the power supply unit is abnormal.</li> </ul>

Parts to be replaced	Remark
Side thermistor	
front thermistor	
LGC board	
Heater lamp	
Power supply unit	

### 8.3.18 Communication related service call

#### [C550] RADF I/F error

Classification	Error content
Communication related service call	RADF I/F error

Check item	Measure
RADF board	<ul style="list-style-type: none"> <li>Check if the harness connecting the RADF board and SYS board is disconnected or open circuited.</li> <li>Check if the conductor pattern on the RADF board is short circuited or open circuited.</li> </ul>
SYS board	<ul style="list-style-type: none"> <li>Check if the conductor pattern on the SYS board is short circuited or open circuited.</li> <li>Check the connector (CN122) of the SYS board.</li> <li>Check if the connectors on the SYS board are disconnected from the RADF board / the DSDF control PC board or the harnesses are open circuited. Correct if any.</li> <li>Check the SYS board (IC25, IC28).</li> <li>Replace the SYS board.</li> </ul>

Parts to be replaced	Remark
RADF board	
SYS board	

#### [C560] Communication error between Engine-CPUs

Classification	Error item
Optional communication related service call	<ul style="list-style-type: none"> <li>Communication error between Engine-CPUs</li> <li>Communication error between LGC-PFC</li> </ul>

Check item	Measures
Harness	<ul style="list-style-type: none"> <li>Connector check</li> <li>Harness check</li> </ul>
LGC board	<ul style="list-style-type: none"> <li>Connector check (CN368)</li> <li>Board check</li> </ul>
PFU board	<ul style="list-style-type: none"> <li>Connector check (CN920)</li> <li>Board check</li> </ul>

Replace parts	Remarks
LGC board	
PFU board	

#### [C580] Communication error between LGC board and finisher

Classification	Error content
Communication related service call	Communication error between LGC board and finisher

Check item	Measure
Finisher	Check if the specified finisher is attached.

## [CE00] Punch communication error

Classification	Contents
Finisher related service call	Communication error between finisher and punch unit: Communication error between finisher controller PC board and punch controller PC board

MJ-1110 (When MJ-6105 is installed)

Check item	Measures
Hole punch control PC board (HP)	<ul style="list-style-type: none"> <li>• Check the connectors and harnesses between the hole punch control PC board (HP) and the finisher control PC board.</li> <li>• Board check</li> </ul>

Parts to be replaced	Remark
Hole punch control PC board (HP)	
Finisher control PC board (FIN)	

## [F070] Communication error between System-CPU and Engine-CPU

Classification	Error content
Communication related service call	Communication error between System-CPU and Engine-CPU

Check item	Measure
Error code	<ul style="list-style-type: none"> <li>• Turn the power OFF and then back ON using the main power switch, and then check if the error code changes to another one.</li> <li>• If it changes to another one, follow the procedure for the changed error code.</li> </ul>
Check firmware version	<ul style="list-style-type: none"> <li>• Check the version of the system firmware on the SYS board.</li> <li>• Check the version of the engine firmware on the LGC board.</li> </ul>
Board check	<ul style="list-style-type: none"> <li>• Check if the connector CN131, CN132 on the SYS board and the connector CN371, CN370 on the LGC board are completely inserted, and the harness is disconnected or open circuited.</li> <li>• Check if the connector pin between the SYS board (connector CN131, CN132) and the LGC board (connector CN371, CN370) is disconnected.</li> <li>• Check if the connectors CN329, CN330, CN331, CN332, CN356, CN357, CN358 and CN359 of the LED printer head are completely inserted, and the harness is disconnected or open circuited.</li> <li>• Check if the conductor patterns on the LGC board and SYS board are short circuited or open circuited</li> </ul>
Harness	<ul style="list-style-type: none"> <li>• Connector check</li> <li>• Harness check</li> </ul>

Parts to be replaced	Remark
Harness	Be sure to exchange the parts in the order of the harness, LGC board, SYS board and LED printer head.
LGC board	Be sure to exchange the parts in the order of the harness, LGC board, SYS board and LED printer head.
SYS board	Be sure to exchange the parts in the order of the harness, LGC board, SYS board and LED printer head.
LED printer head	Be sure to exchange the parts in the order of the harness, LGC board, SYS board and LED printer head.

**[F071] Communication initialization error between System-CPU and Engine-CPU**  
**[F074] Communication error between System-CPU and Engine-CPU (Engine-CPU response abnormality)**

Classification	Error content
Communication related service call	Communication initialization error between System-CPU and Engine-CPU

Procedure	Check item	Measures
1	LED printer head, harness	<p>1-1. Disconnect all the harnesses (flat cable and power supply) of the LED printer heads, and then turn the power ON. Check if the error changes to another service call (CE80 etc.). (CN329, CN330, CN331, CN332, CN356, CN357, CN358, CN359)</p> <p>1-2. If the error does not change to another service call such as CE80 in step 1-1, go to step 2. If the error changes to another service call, follow the steps below.</p> <p>1-3. Connect the harnesses of the LED printer head to the LGC board single color at a time, and then turn the power ON to identify the LED printer head in error. Check if F071 occurs. Place the parts causing the error.</p> <p>Check the connectors and harnesses of the color in error.</p> <p>&lt;Harness (flat cable) - LGC board&gt;  Y color: CN357  M color: CN358  C color: CN331  K color: CN329</p> <p>&lt;Harness (power supply) - LGC board&gt;  Y color: CN359  M color: CN358  C color: CN332  K color: CN330</p> <p>&lt;Harness (flat cable) - LED printer head&gt;  Y color: CN788  M color: CN790  C color: CN792  K color: CN794</p> <p>&lt;Harness (power supply) - LED printer head&gt;  Y color: CN787  M color: CN789  C color: CN791  K color: CN793</p>
2	Check firmware version	<ul style="list-style-type: none"> <li>• Check the version of the system firmware on the SYS board.</li> <li>• Check the version of the engine firmware on the LGC board.</li> </ul>

Procedure	Check item	Measures
3	Board check	<ul style="list-style-type: none"> <li>• Check if the connector CN131, CN132 on the SYS board and the connector CN371, CN370 on the LGC board are completely inserted, and the harness is disconnected or open circuited.</li> <li>• Check if the connector pin between the SYS board (connector CN131, CN132) and the LGC board (connector CN371, CN370) is disconnected.</li> <li>• Check if the connectors CN329, CN330, CN331, CN332, CN356, CN357, CN358 and CN359 of the LED printer head are completely inserted, and the harness is disconnected or open circuited.</li> <li>• Check if the conductor patterns on the LGC board and SYS board are short circuited or open circuited.</li> </ul>
4	Harness	<ul style="list-style-type: none"> <li>• Connector check</li> <li>• Harness check</li> </ul>

Parts to be replaced	Remark
Harness	Be sure to exchange the parts in the order of the harness, LGC board, SYS board and LED printer head.
LGC board	Be sure to exchange the parts in the order of the harness, LGC board, SYS board and LED printer head.
SYS board	Be sure to exchange the parts in the order of the harness, LGC board, SYS board and LED printer head.
LED printer head	Be sure to exchange the parts in the order of the harness, LGC board, SYS board and LED printer head.

### 8.3.19 RADF related service call

#### [C551] RADF model detection error

Classification	Error content
RADF related service call	Incorrect RADF installed to the equipment

Check item	Measure
RADF	<ul style="list-style-type: none"><li>• Check if the installed RADF is an option exclusively set for the model.</li><li>• Replace the RADF with the one exclusively set for the model.</li></ul>
SYS board	<ul style="list-style-type: none"><li>• Check the connector (CN129) of the SYS board.</li><li>• Replace the SYS board.</li></ul>

Parts to be replaced	Remark
RADF	
RADF board	
SYS board	

#### [C8E0] RADF communication protocol abnormality

Classification	Error content
Optional communication related service call	The system has to be stopped because the control abnormality occurred.

Check item	Measure
Power	<ul style="list-style-type: none"><li>• Turn the power OFF and then back ON to check if the equipment operates normally.</li></ul>
RADF board	<ul style="list-style-type: none"><li>• Connector check</li><li>Board check</li></ul>

Parts to be replaced	Remark
RADF board	

#### [F115] S-VDEN ON signal time-out error

#### [F116] S-VDEN OFF signal time-out error

Classification	Error content
RADF service call	The scanning job has not finished normally.

Check item	Measure
Reproducing ability	Turn the power OFF and then back ON to check the occurrence.

Check item	Measure
Connector / Harness	<ul style="list-style-type: none"> <li>• Check if the relay connector (J12) between the RADF and the equipment is disconnected or its pin is deformed.</li> <li>• Check if the SYS board connector (CN122) and the RADF control PC board connector (CN71) are disconnected.</li> <li>• Check if the harnesses between the SYS board and the relay connector and between the relay connector and the RADF control PC board are normal. If the harnesses have any scratches on them, are open circuited, caught anywhere or their pin is deformed, replace them.</li> </ul>
SYS board	Replace the board.
RADF control PC board	Replace the board.

Parts to be replaced	Remark
Harness	Be sure to exchange the parts in the order of the harness, RADF control PC board and SYS board.
RADF control PC board	Be sure to exchange the parts in the order of the harness, RADF control PC board and SYS board.
SYS board	Be sure to exchange the parts in the order of the harness, RADF control PC board and SYS board.



### 8.3.20 Circuit related service call

#### [C5A0] EEPROM not connected (LGC board)

Classification	Contents
Circuit related service call	EEPROM abnormality (LGC board)

Check item	Measure
EEPROM	EEPROM check
LGC board	<ul style="list-style-type: none"><li>• IC socket check (IC26)</li><li>• Board check</li></ul>

Replacement part	Remark
EEPROM	
LGC board	

#### [C5A1] EEPROM data abnormality (LGC board)

Classification	Contents
Circuit related service call	EEPROM data abnormality (LGC board)

Check item	Measure
EEPROM	EEPROM check
LGC board	<ul style="list-style-type: none"><li>• IC socket check (IC26)</li><li>• Board check</li></ul>

Replacement part	Remark
EEPROM	
LGC board	

#### [C900] Connection error between the SYS board and the LGC board

Classification	Contents
Circuit related service call	Connection error between SYS board and LGC board

Check item	Measure
LGC board	<ul style="list-style-type: none"><li>• Connector check (CN370)</li><li>• Board check</li></ul>
SYS board	<ul style="list-style-type: none"><li>• Connector check (CN132)</li><li>• Board check</li></ul>
Harness	<ul style="list-style-type: none"><li>• Connector check</li><li>• Harness check</li></ul>

Replacement part	Remark
LGC board	If the problem is not corrected with the replacement of the LGC board, reinstall the removed LGC board and replace the SYS board.
SYS board	
Harness (Flat cable)	

## [C911] Toner cartridge PC board access abnormality

Classification	Contents
Toner cartridge related service call	Abnormal access between the CTRG board and LGC board (High possibility of failure except the LGC board)

Procedure	Check item	Result	Measure	Next Step
1	Does non-genuine toner cartridge display appear when the front cover is opened and closed?	Yes	Use the genuine toner cartridge.	
		No		2
2	Toner cartridge		<ul style="list-style-type: none"> <li>Check the phenomenon by removing the toner cartridges (Y, M, C and K) and reinserting them.</li> <li>Check that the CTRG board of each cartridge (Y, M, C and K) is installed properly.</li> <li>Avoid touching the contact point.</li> <li>Wipe the contact point with a soft cloth if it's stained.</li> </ul>	
3	Contact point on the equipment side		Check that the spring of the contact point for each color (Y, M, C and K) is not deformed.	
4	Is the spring of the contact point returned when it is pushed lightly?	Yes		
		No	<ul style="list-style-type: none"> <li>Check that the CTIF board is installed properly.</li> <li>Board check</li> </ul>	7
<p><b>Notes:</b> The spring of the contact point may be released if you push the toner cartridge all the way in when an abnormality occurs.</p>				
5	LGC board		<ul style="list-style-type: none"> <li>Connector check (CN354)</li> <li>Board check</li> </ul>	
6	Harness		<ul style="list-style-type: none"> <li>Connector check (CN354, CN440)</li> <li>Harness check</li> </ul>	
7	CTIF board for each color (Y, M, C and K)		<ul style="list-style-type: none"> <li>Check that the board is installed properly.</li> <li>Board check</li> </ul>	
8	Perform the above troubleshooting and if the C911 error is cleared, set the following self-diagnostic codes to "0" (normal). <ul style="list-style-type: none"> <li>FS-08-4689-0: Board information of toner cartridge (Y)</li> <li>FS-08-4689-1: Board information of toner cartridge (M)</li> <li>FS-08-4689-2: Board information of toner cartridge (C)</li> <li>FS-08-4689-3: Board information of toner cartridge (K)</li> </ul>			

Replacement part	Remark
Toner cartridge	
LGC board	
Harness	
CTIF board	

### [C940] Engine-CPU abnormality


Classification	Contents
Circuit related service call	Engine-CPU abnormality

Check item	Measure
Main power switch	Turn OFF the main power switch, then back ON.
Engine-CPU, FROM, and SDRAM	Check if the conductor pattern between the Engine-CPU, FROM is short circuited or open circuited. Check if the conductor pattern between the Engine-CPU, SDRAM is short circuited or open circuited.
LGC board	Board check

Replacement part	Remark
LGC board	

### [C962] LGC board ID abnormality

Classification	Contents
Circuit related service call	LGC board ID abnormality

Check item	Measure
Error code	<ul style="list-style-type: none"><li>Turn the power OFF and then back ON using the main power switch, and then check if the error code changes to another one.</li><li>If it changes to another one, follow the procedure for the changed error code</li></ul>
LGC board	<ul style="list-style-type: none"><li>Connector check (CN370)</li><li>Board check</li><li>Check if the model of the equipment matches the color of the label on the LGC board.  P. 9-5 "9.1.5 LGC board"</li></ul>
SYS board	<ul style="list-style-type: none"><li>Connector check (CN132)</li><li>Board check</li></ul>
Harness	<ul style="list-style-type: none"><li>Connector check</li><li>Harness check</li></ul>

Replacement part	Remark
LGC board	If the problem is still not corrected with the replacement of the LGC board, reinstall it and ask a specialist to repair it. (Abnormal ID)

**[C963] Connection detection error between the SYS board and the LGC board**

Classification	Contents
Circuit related service call	3.3V output from the SYS board not detected on the LGC board

Check Item	Measure
LGC board	Connector check (CN370, CN371)
SYS board	Connector check (CN132, CN133)
Harness between the SYS board and the LGC board	Harness check
Harness between the SYS board and the low-voltage power supply	Harness check

Replacement part	Remark
Harness between the SYS board and the LGC board	
LGC board	If the problem is not corrected by the replacement of the LGC board, reinstall the removed LGC board and replace the SYS board.
SYS board	
Harness between the SYS board and the low-voltage power supply	

**[C964] LGC board boot process abnormality**

Classification	Contents
Circuit related service call	LGC board boot process abnormality

Check item	Measure
LGC board	Turn the power OFF and then back ON using the main power switch. If the same error occurs again, replace the LGC board.

Replacement part	Remark
LGC board	

**[C9E0] Connection error between the scanner CPU and system CPU**

Classification	Contents
Circuit related service call	Connection error between the scanner CPU and system CPU

Check item	Measure
SYS board	Board check

Replacement part	Remark
SYS board	

## [F090] SRAM abnormality on the SYS board

Classification	Contents
Circuit related service call	SRAM abnormality on the SYS board

Check Item	Measure
SRAM	<ol style="list-style-type: none"> <li>1. Check that the SRAM is installed properly.</li> <li>2. Shut down the equipment.</li> <li>3. Perform [FS-08].</li> <li>4. Press [CLASSIC].</li> <li>5. When "SRAM REQUIRES INITIALIZATION" appears on the LCD screen, confirm the destination and press the [START] button. If the destination is incorrect, enter the number for the correct one and press the [START] button.</li> <li>6. When the confirmation message appears on the LCD screen, press [INITIALIZE]. (SRAM initialization starts.)</li> <li>7. Enter the serial number of the equipment correctly. (FS-08-9601)</li> <li>8. Initialize the NIC information. (FS-08-9083)</li> <li>9. Shut down the equipment.</li> <li>10. Perform [FS-05].</li> <li>11. Press [CLASSIC].</li> <li>12. Perform "Data transfer of characteristic value of scanner". (FS-05-3203)</li> <li>13. By using the [4] [TEST PRINT] test pattern, perform "Automatic gamma adjustment" &lt;PPC&gt;. (FS-05-7869)</li> <li>14. By using the [70] [TEST PRINT] test pattern, perform "Automatic gamma adjustment" &lt;PRT&gt;. (FS-05-8008 / FS-05-8009)</li> <li>15. Reboot the equipment.</li> <li>16. If the error still occurs, replace the SRAM.</li> </ol>
SYS board	Board check

Replacement part	Remark
SRAM	Be sure to exchange the parts in the order of the SRAM and SYS board.
SYS board	Be sure to exchange the parts in the order of the SRAM and SYS board.

## [F350] CCD board abnormality

Classification	Contents
Circuit related service call	CCD board abnormality

Check item	Measure
CCD board	Board check
Combination of the firmware version	<ul style="list-style-type: none"> <li>• Check the combination of the firmware version of the system firmware, system software, engine firmware, and scanner firmware.</li> <li>• Reinstall the firmware of correct combination.</li> </ul>

Replacement part	Remark
CCD board	

## 8.3.21 LED printer head related service call

### [CE80] LED printer head communication error

Classification	Contents
LED printer head related service call	Communication error between the LGC board and the LED printer head

Step	Check Item	Result	Measure	Next Step
1	Check the value of the self-diagnosis code (FS-08-4706) in which is displayed in the details of the LED printer head communication error. <ul style="list-style-type: none"> <li>Check each color with its corresponding self-diagnosis mode.</li> </ul> Y: FS-08-4706-0 M: FS-08-4706-1 C: FS-08-4706-2 K: FS-08-4706-3 <b>Remarks:</b> The self-diagnosis value other than "0" (Normal) indicates that an error has occurred.		Self-diagnosis values 1, 5, 9 and 13: LED printer head unconnected error	2
			Self-diagnosis values 2, 6, 10 and 14: LED printer head mix error	4
			Self-diagnosis values 4, 8 and 12: Checksum mismatch / Gradation module error	2
			Self-diagnosis values other than the above	2
2	Is the LGC board normal? <ul style="list-style-type: none"> <li>Check the connectors used for the colors in which errors have occurred.</li> </ul> Y: CN357 and CN359 M: CN356 and CN358 C: CN331 and CN332 K: CN329 and CN330 <ul style="list-style-type: none"> <li>Check the LGC board.</li> </ul>	Yes		3
		No	Repair or replace it.	5

Step	Check Item	Result	Measure	Next Step
3	Check if the harnesses between the LGC board and the LED printer head are disconnected or open circuited. <ul style="list-style-type: none"> <li>Check the connectors and the harnesses used for the colors in which errors have occurred.</li> </ul> <Flat cable at the LGC board side> Y: CN357 M: CN358 C: CN331 K: CN329  <Harness (power supply) at the LGC board side> Y: CN359 M: CN358 C: CN332 K: CN330  <Flat cable at the LED printer head side> Y: CN788 M: CN790 C: CN792 K: CN794  <Harness (power supply) at the LED printer head side> Y: CN787 M: CN789 C: CN791 K: CN793	Yes		4
		No	Repair it.	5
4	The LED printer head used for the colors in which errors have occurred.		Repair it.	5
5	Reset the self-diagnosis value.		Change the setting value of the LED printer head communication error details to "0" (Normal) to reset the self-diagnosis value. Y: FS-08-4706-0 M: FS-08-4706-1 C: FS-08-4706-2 K: FS-08-4706-3	

Replacement part	Remark
LGC board	
Flat cable	
Harness (power supply)	
LED printer head	

**[CE81] Interface initialization error between LED printer head and LGC board**

Classification	Contents
LED printer head related service call	Interface initialization error between LED printer head and LGC board

Procedure	Check item	Result	Measure	Next Step
1	<p>Perform FS-08-4723 to identify the color of the LED printer head in error. The relationship between the values to be displayed and the colors indicating errors is as below.</p> <p>0: No error occurred                      1: Y                      2: M                      4: C                      8: K</p> <p>If errors have occurred in the multiple colors, the total value of that for each color will be displayed.                      E.g.:                      6: Errors occurred in M and C                      9: Errors occurred in Y and K</p>			2
2	<p>Is the LGC board normal?</p> <p>- Check the connectors of the LED printer head identified in step 1.                      Y color: CN356 and CN358                      M color: CN356 and CN358                      C color: CN331 and CN332                      K color: CN329 and CN330</p> <p>- Check the LGC board.</p>	Yes		3
		No	Repair or replace it.	



Procedure	Check item	Result	Measure	Next Step
3	Check the harnesses between the LGC board and the LED printer heads.  Check the connectors and harnesses of the color in error. <Harness (flat cable) - LGC board> Y color: CN357 M color: CN358 C color: CN331 K color: CN329 <Harness (power supply) - LGC board> Y color: CN359 M color: CN358 C color: CN332 K color: CN330 <Harness (flat cable) - LED printer head> Y color: CN788 M color: CN790 C color: CN792 K color: CN794 <Harness (power supply) - LED printer head> Y color: CN787 M color: CN789 C color: CN791 K color: CN793	Yes		4
		No	Replace it.	
4	LED printer head in error		Replace it.	

Replacement part	Remark
LGC board	
Harness of LED printer head (flat cable)	
Harness of LED printer head (power supply)	
LED printer head	

### 8.3.22 Finisher related service call

#### [CB00] Finisher detection error

Classification	Error content
Finisher related service call	Finisher not connected Finisher communication error

Check item	Measure
Finisher	<ul style="list-style-type: none"> <li>• Check if the harness connecting the equipment and the finisher controller PC board is disconnected or open circuited.</li> <li>• Check if the conductor pattern on the finisher controller PC board is open circuited or short circuited.</li> <li>• Update the finisher firmware.</li> </ul>
LGC board	<ul style="list-style-type: none"> <li>• Check if the harness connecting the FIN board and the LGC board on the equipment is disconnected or open circuited.</li> <li>• Connector check (CN346)</li> <li>• Check if the conductor pattern on the LGC board is open circuited or short circuited.</li> </ul>

Parts to be replaced	Remark
Finisher control PC board	
LGC board	

#### [CB10] Entrance motor abnormality

Classification	Contents
Finisher related service call	Entrance motor abnormality: The entrance motor is not rotating normally.

MJ-1110

Check Item	Measure
Feeding roller	Rotate the feeding roller. Fix any mechanical problem.
Entrance motor (M1)	Check if the connector (CN17) on the finisher controller PC board is disconnected from the entrance motor (M1) and the harnesses are open circuited. Correct if so.

Replacement part	Remark
Entrance motor (M1)	
Finisher control PC board (FIN)	

**[CB11] Buffer tray guide motor abnormality**

\* A [CB11] error occurs if the [ED16] error occurs three times in succession or the [ED16] error occurs during the initialization.

Classification	Contents
Finisher related service call	Buffer tray guide motor abnormality: The buffer tray guide motor is not rotating or the buffer tray guide is not moving normally.

MJ-1110

Check Item	Measure
Buffer tray guide	Raise the buffer roller and open/close the buffer tray guide. Fix any mechanical problem.
Buffer tray guide motor (M2)	Check if the connector (CN10) on the finisher control PC board is disconnected from the buffer tray guide motor (M2) and the harnesses are open circuited. Correct if so.

Replacement part	Remark
Buffer tray guide motor (M2)	
Finisher control PC board (FIN)	

**[CB13] Finisher exit motor (M11) abnormality**

MJ-1110

Classification	Error item
Finisher related service call	The exit motor is not rotating or the exit roller is not moving normally.

Check item	Measures
Exit roller	<ul style="list-style-type: none"> <li>Is there any mechanical problem when the exit roller is rotated? Correct if so.</li> </ul>
Exit motor (M11).	<ul style="list-style-type: none"> <li>Motor check</li> <li>Connector check (CN15)</li> <li>Harness check</li> </ul>
Finisher control PC board (FIN)	<ul style="list-style-type: none"> <li>Connector check (CN15)</li> <li>Board check</li> </ul>

Replace parts	Remarks
Exit motor (M11)	
Finisher control PC board (FIN)	

**[CB14] Assist arm motor (M10) abnormality**  
**[EAFE] Paper holding cam position error (paper jam)**  
 MJ-1110

Classification	Error item
Finisher related service call	The assist arm motor is not rotating or the paper pusher cam is not moving normally.

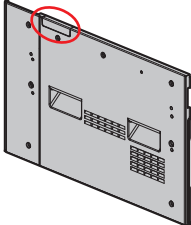
Check item	Measures
Paper pusher cam	<ul style="list-style-type: none"> <li>Is there any mechanical problem when the paper pusher cam is rotated?</li> </ul>
Assist arm motor (M10)	<ul style="list-style-type: none"> <li>Motor check</li> <li>Connector check (CN10)</li> <li>Harness check</li> </ul>
Finisher control PC board (FIN)	<ul style="list-style-type: none"> <li>Connector check (CN10)</li> <li>Board check</li> </ul>

Replace parts	Remarks
Assist arm motor (M10)	
Finisher control PC board (FIN)	

**[CB30] Movable tray shift motor (M1) abnormality, Movable tray paper top detection error**  
 MJ-1042

Classification	Contents
Finisher related service call	Movable tray shift motor abnormality: The movable tray shift motor is not rotating or the movable tray is not moving normally.

Error	Timing of detection
Movable tray shift motor (M1) Stack top detection solenoid (SOL1) Stack top detection sensor-1 (S1) Stack top detection sensor-2 (S2) Movable tray lower limit sensor (S14)	A locking signal is detected after the specified time *while the movable tray is moving. * A locking signal is not monitored from the start driving the motor until the specified time has passed.
	The stack top position of paper is not detected after the movable tray shift motor (M1) is driven in the specified time when the movable tray is moved up.
	The lower limit position of the stack top of paper is not detected after the movable tray shift motor (M1) has been driven in the specified time during the initial movement of the movable tray.
	The turning OFF of the movable tray lower limit sensor (S14) is not detected when the movable tray is moved from a point where this sensor is turned ON to one point where this sensor is turned OFF after the movable tray shift motor (M1) has been driven in the specified time.

Probable cause	Checking and measures
Movable tray	<p>If there is mechanical problem when the movable tray is moved, fix the mechanism.</p> <ul style="list-style-type: none"> <li>When installing the finisher, exercise care not to forget to remove the small left cover.</li> </ul>  <ul style="list-style-type: none"> <li>Check there is any obstacle which obstructs of operation under a movable tray. Remove any obstacles from the area of the movable tray operation.</li> </ul>
Movable tray shift motor (M1) abnormality	Check if the electrical continuity of the coil is normal. If electricity is not conducted, replace the motor.
Movable tray lower limit sensor (S14) abnormality	Measure the voltage on TP17 on the finisher control PC board (FIN). Then check that the measured voltage is 1V or lower when not shielded and within the range of 3.3V $\pm$ 5% when shielded. If the voltage does not fall within the range mentioned, replace the sensor.
Faulty cables and connectors	Check if the electrical continuity among the connector terminals is normal. If electricity is not conducted, replace the connectors. (Finisher control PC board (FIN): CN4, CN10)
Finisher control PC board (FIN) abnormality	If the error still occurs after replacing the motor, sensors and connectors, exchange the finisher control PC board (FIN).
Stack top detection solenoid (SOL1) abnormality	Check if the electrical continuity of the coil is normal. If electricity is not conducted, replace the solenoid.
Stack top detection sensor-1 (S1) abnormality	Measure the voltage on TP11 on the finisher control PC board (FIN). Then check that the measured voltage is 1V or lower when not shielded and within the range of 3.3V $\pm$ 5% when shielded. If the voltage does not fall within the range mentioned, replace the sensor.
Stack top detection sensor-2 (S2) abnormality	Measure the voltage on TP20 on the finisher control PC board (FIN). Then check that the measured voltage is 1V or lower when not shielded and within the range of 3.3V $\pm$ 5% when shielded. If the voltage does not fall within the range mentioned, replace the sensor.
Faulty cables and connectors	Check if the electrical continuity between the connector terminals is normal. If electricity is not conducted, replace the connector. (Finisher control PC board (FIN): CN3)
Finisher control PC board (FIN) abnormality	If the error still occurs after replacing the solenoid, sensors and connector, exchange the finisher control PC board (FIN).

**[CB30] Movable tray shift motor abnormality**  
**[EAFC] Movable tray height error (paper jam)**

Classification	Contents
Finisher related service call	Movable tray shift motor abnormality: The movable tray shift motor is not rotating or the movable tray is not moving normally.

MJ-1110

Check item	Measures
Movable tray	If there is mechanical problem when the movable tray is moved, fix the mechanism.
Movable tray shift motor (M12)	Check the connectors and harnesses between the movable tray shift motor (M12) and the finisher control PC board (CN19).
Movable tray position A, B, and C sensors (S13, S14 and S15)	<ul style="list-style-type: none"> <li>• Connector check (CN20)</li> <li>• Sensor check</li> <li>• Harness check</li> </ul>

Parts to be replaced	Remark
Movable tray shift motor (M12)	
Movable tray position A, B, and C sensors (S13, S14 and S15)	
Finisher control PC board (FIN)	

**[CB31] Movable tray paper-full detection error**  
**[EAFD] Movable tray movement error (paper jam)**

Classification	Contents
Finisher related service call	Movable tray paper-full detection error: The actuator of the movable tray paper-full detection sensor does not move smoothly.

MJ-1110

Check item	Measures
Movable tray paper-full sensor (S16)	Fix any mechanical problem occurring when the actuator is moved.
	Check if there is a disconnection of the connector, incorrect installation or breakage of the movable tray paper-full sensor (S16). If there is, reinstall the sensor correctly or replace it.
	Check if the connector (CN22) on the finisher controller PC board is disconnected from the movable tray paper-full sensor (S16) and the harnesses are open circuited. Correct if so.
Movable tray position A, B, and C sensors (S13, S14 and S15)	<ul style="list-style-type: none"> <li>• Connector check (CN20)</li> <li>• Sensor check</li> <li>• Harness check</li> </ul>

Parts to be replaced	Remark
Movable tray paper-full sensor (S16)	

Parts to be replaced	Remark
Movable tray position A, B, and C sensors (S13, S14 and S15)	
Finisher control PC board (FIN)	

#### [CB40] Front alignment motor abnormality

\* You receive a [CB40] error when the [ED13] error occurs three times in succession.

MJ-1042

Classification	Contents
Finisher related service call	Front alignment motor abnormality: The front alignment motor is not rotating or the front alignment plate is not moving normally.

Error	Timing of detection
Rear alignment motor (M3) Rear alignment plate home position sensor (S6)	The turning OFF of the rear alignment plate home position sensor (S6) is not detected when the rear alignment plate is moved from a point where this sensor is turned ON to one point where this sensor is turned OFF after the rear alignment motor (M3) has been driven at the specified number of pulse.
	The turning ON of the rear alignment plate home position sensor (S6) is not detected when the rear alignment plate is moved from a point where this sensor is turned OFF to one point where this sensor is turned ON after the rear alignment motor (M3) has been driven at the specified number of pulse.

Probable cause	Checking and measures
Rear alignment motor (M3) abnormality	Check if the electrical continuity of the coil is normal. If electricity is not conducted, replace the motor.
Rear alignment plate home position sensor (S6) abnormality	Measure the voltage on TP16 on the finisher control PC board (FIN). Then check that the measured voltage is 1V or lower when not shielded and within the range of $3.3V \pm 5\%$ when shielded. If the voltage does not fall within the range mentioned, replace the sensor.
Faulty cables and connectors	Check if the electrical continuity between the connector terminals is normal. If electricity is not conducted, replace the connectors. (Finisher control PC board (FIN): CN5, CN12)
Finisher control PC board (FIN) abnormality	If the error still occurs after replacing the motor, sensor and connectors, exchange the finisher control PC board (FIN).

**[CB40] Front alignment motor abnormality**

\* You receive a [CB40] error when the [ED13] error occurs three times in succession.

Classification	Contents
Finisher related service call	Front alignment motor abnormality: The front alignment motor is not rotating or the front alignment plate is not moving normally.

MJ-1110

Check item	Measures
Front alignment plate	If there is mechanical problem when the front alignment plate is moved, fix the mechanism.
Front alignment motor (M5)	Check the connectors and harnesses between the front alignment motor (M5) and the finisher control PC board (CN18).

Parts to be replaced	Remark
Front alignment motor (M5)	
Finisher control PC board (FIN)	

**[CB50] Stapler home position error**

\* You receive a [CB50] error when the [EA50] error occurs three times in succession.

Classification	Contents
Finisher related service call	Stapler home position error: The stapler home position sensor does not work.

**[CB50] Staple motor (M10) abnormality**

MJ-1042

Error	Timing of detection
Stapler motor (M10) Staple unit clinching home position sensor (S16)	The staple unit clinching home position sensor (S16) does not detect the opening of the staple unit after the stapler motor (M10) has been driven reversely in the specified time from the closing during the initial movement of the staple unit.
	The staple unit clinching home position sensor (S16) does not detect the opening of the staple unit in the specified time from the closing during the clinching movement of the staple unit, and also this sensor does not detect the opening by the reverse rotation of the motor after the stapler is stopped.
	The staple unit clinching home position sensor (S16) does not detect the closing of the staple unit after the specified time during the clinching movement of the staple unit.
	The staple unit clinching home position sensor (S16) does not detect the opening of the staple unit at the start of the clinching.

Probable cause	Checking and measures
Staple motor (M10) abnormality	Check if the electrical continuity of the coil is normal. If electricity is not conducted, replace the staple unit.



Probable cause	Checking and measures
Staple unit clinching home position sensor (S16) abnormality	Measure the voltage on CN16 on the finisher control PC board (FIN). Then check that the measured voltage is 1V or lower when the sensor is ON and within the range of 3.3V $\pm$ 5% when OFF. If the voltage does not fall within the range mentioned, replace the staple unit.
Staple unit improper clinching prevention sensor (S15) abnormality	Measure the voltage on TP25 on the finisher control PC board (FIN). Then check that the measured voltage is 1V or lower when not shielded and within the range of 3.3V $\pm$ 5% when shielded. If the voltage does not fall within the range mentioned, replace the sensor.
Faulty cables and connectors	Check if the electrical continuity between the connector terminals is normal. If electricity is not conducted, replace the connectors. (Finisher control PC board (FIN): CN16, CN17)
Finisher control PC board (FIN) abnormality	If the error still occurs after replacing the motor, sensors, switch and connectors, exchange the finisher control PC board (FIN).

### [CB50] Stapler home position error

\* You receive a [CB50] error when the [EA50] error occurs three times in succession.

Classification	Contents
Finisher related service call	Stapler home position error: The stapler home position sensor does not work.

MJ-1110

Check item	Measures
Stapler	<ul style="list-style-type: none"> <li>Check the connectors and harnesses between the stapler and finisher controller PC board (CN2).</li> <li>Check the harnesses in the stapler.</li> </ul>

Parts to be replaced	Remark
Stapler	
Finisher control PC board (FIN)	

**[CB51] Stapler shift home position error**  
**[EAFB] Stapler movement error (paper jam)**

Classification	Contents
Finisher related service call	Stapler shift home position error: The stapler is not at the home position.

MJ-1042

Error	Timing of detection
Staple unit sliding motor (M7) Staple unit sliding home position sensor (S3)	The turning OFF of the staple unit sliding home position sensor (S3) is not detected when the staple unit is moved from a point where this sensor is turned ON to one point where this sensor is turned OFF after the staple unit sliding motor (M7) has been driven at the specified number of pulse.
	The turning ON of the staple unit sliding home position sensor (S3) is not detected when the staple unit is moved from a point where this sensor is turned OFF to one point where this sensor is turned ON after the staple unit sliding motor (M7) has been driven at the specified number of pulse.

Probable cause	Checking and measures
Staple unit sliding motor (M7) abnormality	Check if the electrical continuity of the coil is normal. If electricity is not conducted, replace the staple unit.
Staple unit sliding home position sensor (S3) abnormality	Measure the voltage on TP18 on the finisher control PC board (FIN). Then check that the measured voltage is 1V or lower when not shielded and within the range of $3.3V \pm 5\%$ when shielded. If the voltage does not fall within the range mentioned, replace the sensor.
Faulty cables and connectors	Check if the electrical continuity between the connector terminals is normal. If electricity is not conducted, replace the connectors. (Finisher control PC board (FIN): CN3, CN18)
Finisher control PC board (FIN) abnormality	If the error still occurs after replacing the staple unit, sensors and connectors, exchange the finisher control PC board (FIN).

**[CB51] Stapler shift home position error**  
**[EAFB] Stapler movement error (paper jam)**

Classification	Contents
Finisher related service call	Stapler shift home position error: The stapler is not at the home position.

MJ-1110

Check item	Measures
Stapler	Move the stapler. Fix any mechanical problem.
Stapler unit home position sensor (S10)	Check if there is a disconnection of the connector, incorrect installation or breakage of the stapler unit home position sensor (S10). If there is, reinstall the sensor correctly or replace it. Check if the connector (CN27) on the finisher controller PC board is disconnected from the stapler unit home position sensor (S10) and the harnesses are open circuited. Correct if so.
Stapler unit shift motor (M9)	Check if the connector (CN15) on the finisher control PC board is disconnected from the stapler unit shift motor (M9) and the harnesses are open circuited. Correct if so.

Parts to be replaced	Remark
Stapler unit home position sensor (S10)	
Stapler unit shift motor (M9)	
Finisher control PC board (FIN)	

**[CB60] Stapler unit shift motor abnormality**

Classification	Contents
Finisher related service call	Stapler shift motor abnormality: Stapler shift motor is not rotating or staple unit is not moving normally.

MJ-1110

Check Item	Measure
Stapler	If there is mechanical problem when the stapler is moved, fix the mechanism.
Stapler unit shift motor (M9)	Check the connectors and harnesses between the stapler unit shift motor (M9) and the finisher control PC board (CN15).

Replacement part	Remark
Stapler unit shift motor (M9)	
Finisher control PC board (FIN)	

**[CB80] Finisher control PC board (FIN) backup RAM error**

Classification	Contents
Finisher related service call	Backup RAM data abnormality: Abnormality of checksum value on finisher controller PC board is detected when the power is turned ON.

MJ-1042

Error	Timing of detection
EEPROM	Data readout check is performed after data writing and the result of the data readout check does not conform to the written data.
	The equipment does not enter the ready status after the specified time has passed from data writing.

Probable cause	Checking and measures
Finisher control PC board (FIN) abnormal it	Replace the finisher control PC board (FIN) as the cause is a fault in the IC of the backup RAM.

**[CB80] Backup RAM data abnormality**

MJ-1110

Classification	Contents
Finisher related service call	Backup RAM data abnormality: Abnormality of checksum value on finisher controller PC board is detected when the power is turned ON.

Check Item	Measure
Main power switch	Turn OFF the main power switch, then back ON.

Replacement part	Remark
Finisher control PC board (FIN)	

**[CB81] Flash ROM abnormality**

MJ-1110

Classification	Contents
Finisher related service call	Flash ROM abnormality: Abnormality of checksum value on finisher control PC board is detected when the power is turned ON.

Check Item	Measure
Main power switch	Turn OFF the main power switch, then back ON.
Finisher control PC board (FIN)	Board check

Replacement part	Remark
Finisher control PC board (FIN)	

**[CB82] Finisher main program error**  
MJ-1110

Classification	Error item
Finisher related service call	Finisher main program error

Check item	Measures
Finisher control PC board (FIN)	<ul style="list-style-type: none"> <li>• Update the firmware version of the finisher control PC board (FIN).</li> <li>• Board check</li> </ul>

Replace parts	Remarks
Finisher control PC board (FIN)	

**[CB83] Saddle main program error**  
MJ-1110

Classification	Error item
Finisher related service call	Saddle main program error

Check item	Measures
Saddle control PC board (SDL)	<ul style="list-style-type: none"> <li>• Update the firmware version of the saddle control PC board (SDL).</li> <li>• Board check</li> </ul>

Replace parts	Remarks
Saddle control PC board (SDL)	

**[CB84] Punch unit main program error**  
MJ-1110 (When MJ-6105 is installed)

Classification	Error item
Finisher related service call	Hole Punch Unit - Main CPU program error

Check item	Measures
Hole punch control PC board (HP)	<ul style="list-style-type: none"> <li>• Update the firmware version of the hole punch control PC board (HP).</li> <li>• Board check</li> </ul>

Replace parts	Remarks
Hole punch control PC board (HP)	

**[CB92] Saddle Stitch Finisher RAM abnormality**

MJ-1110

Classification	Error item
Finisher related service call	Saddle Stitch Finisher RAM abnormality

Check item	Measures
Reproducibility	Turn the power OFF and then back ON.
Saddle control PC board (SDL)	<ul style="list-style-type: none"> <li>• Check if the conductor pattern on the saddle control PC board (SDL) is open circuited or short circuited.</li> <li>• Board check</li> </ul>

Replace parts	Remarks
Saddle control PC board (SDL)	

**[CB93] Saddle Stitch Finisher additional folding motor abnormality**

MJ-1110

Classification	Error item
Finisher related service call	An abnormal interruption of the encoder pulse of the additional folding motor occurs. The [CB93] error also occurs when the error [EF18] has occurred consecutively for 3 times.

Check item	Measures
Additional folding carrier	<ul style="list-style-type: none"> <li>• Is there any mechanical problem when the additional folding carrier is moved? Correct if so.</li> </ul>
Additional folding motor (M20)	<ul style="list-style-type: none"> <li>• Motor check</li> <li>• Connector check (CN10)</li> <li>• Harness check</li> </ul>
Saddle control PC board (SDL)	<ul style="list-style-type: none"> <li>• Connector check (CN10)</li> <li>• Board check</li> </ul>

Replace parts	Remarks
Additional folding motor (M20)	
Saddle control PC board (SDL)	

**[CB94] Saddle transport motor abnormality**

MJ-1110

Classification	Error item
Finisher related service call	Saddle transport motor abnormality or the motor is not moving normally. Paper holding mechanism or transport path switching solenoid abnormality. The [CB94] error also occurs when the error [EAB0] or [EF13] has occurred consecutively for 3 times.

Check item	Measures
Transport roller	<ul style="list-style-type: none"> <li>Is there any mechanical problem when the transport rollers are rotated?</li> </ul>
Saddle transport motor (M16)	<ul style="list-style-type: none"> <li>Motor check</li> <li>Connector check (CN5)</li> <li>Harness check</li> </ul>
Saddle control PC board (SDL)	<ul style="list-style-type: none"> <li>Connector check (CN5)</li> <li>Board check</li> </ul>

Replace parts	Remarks
Saddle transport motor (M16)	
Saddle control PC board (SDL)	

**[CB95] Saddle Stitch Finisher stacker motor abnormality**

MJ-1110

Classification	Error item
Finisher related service call	The [CB95] error also occurs when the error [EF16] has occurred consecutively for 3 times.

Check item	Measures
Stacker carrier	<ul style="list-style-type: none"> <li>Is there any mechanical problem when the stacker carrier is moved?</li> </ul>
Stacker motor (M14)	<ul style="list-style-type: none"> <li>Motor check</li> <li>Connector check (CN8)</li> <li>Harness check</li> </ul>
Saddle control PC board (SDL)	<ul style="list-style-type: none"> <li>Connector check (CN8)</li> <li>Board check</li> </ul>

Replace parts	Remarks
Stacker motor	
Saddle control PC board	

**[CBA0] Front saddle stapler home position error**  
MJ-1110

Classification	Error item
Finisher related service call	The detection of the home position of the stapler unit ends abnormally.

Check item	Measures
Front saddle stapler clinch unit	<ul style="list-style-type: none"> <li>• Harness check</li> <li>• Connector check</li> </ul>
Saddle control PC board (SDL)	<ul style="list-style-type: none"> <li>• Connector check (CN2)</li> <li>• Board check</li> </ul>

Replace parts	Remarks
Front saddle stapler clinch unit	
Saddle control PC board (SDL)	

**[CBB0] Rear saddle stapler home position error**  
MJ-1110

Classification	Error item
Finisher related service call	The detection of the home position of the stapler unit ends abnormally.

Check item	Measures
Rear saddle stapler clinch unit	Harness check
Saddle control PC board (SDL)	<ul style="list-style-type: none"> <li>• Connector check (CN1)</li> <li>• Board check</li> </ul>

Replace parts	Remarks
Rear saddle stapler clinch unit	
Saddle control PC board (SDL)	

**[CBC0] Saddle Stitch Finisher side alignment motor (M15) abnormality**  
MJ-1110

Classification	Error item
Finisher related service call	<ul style="list-style-type: none"> <li>• The side alignment motor (M15) is not rotating or the jog is not moving normally.</li> <li>• The [CBC0] error also occurs when the error [EF15] has occurred consecutively for 3 times.</li> </ul>

Check item	Measures
Saddle stitch unit	Is there any mechanical problem when the jog is moved? Correct if so.
Side alignment motor (M15)	<ul style="list-style-type: none"> <li>• Harness check</li> <li>• Connector check (CN4)</li> </ul>



Check item	Measures
Saddle control PC board (SDL)	<ul style="list-style-type: none"> <li>• Connector check (CN4)</li> <li>• Board check</li> </ul>

Replace parts	Remarks
Side alignment motor (M15)	
Saddle control PC board (SDL)	

### [CBE0] Saddle Stitch Finisher folding motor (M17) abnormality

MJ-1110

\* You receive a [CBE0] error when the [EF17] error occurs three times in succession.

Classification	Contents
Finisher related service call	An encoder pulse interruption error or rotation abnormality occurs in the saddle stitch finisher folding motor.

Check Item	Measure
Folding motor encoder sensor (S34)	<ul style="list-style-type: none"> <li>• Sensor check (S34)</li> <li>• Connector check (CN13)</li> <li>• Harness check</li> </ul>
Folding motor (M17)	<ul style="list-style-type: none"> <li>• Harness check</li> <li>• Connector check (CN19)</li> </ul>
Saddle control PC board (SDL)	<ul style="list-style-type: none"> <li>• Connector check (CN13, CN19)</li> <li>• Board check</li> </ul>

Replacement part	Measure
Folding motor encoder sensor (S34)	
Folding motor (M17)	
Saddle control PC board (SDL)	

### [CC02] Stack exit roller nip home position detection error

MJ-1042

Replacement part	Measure
Stack exit roller shift motor (M6) Stack exit roller home position sensor (S13)	<p>The stack exit roller home position sensor (S13) does not detect that the exit roller is not at the upper position after the stack exit roller motor (M6) has been driven in the specified time when the exit roller is moved down.</p> <p>The stack exit roller home position sensor (S13) does not detect that the exit roller is at the upper position after the stack exit roller shift motor (M6) has been driven in the specified time when the exit roller is moved up.</p>

**[CC20] Saddle communication error**

MJ-1110

Classification	Contents
Finisher related service call	Saddle communication error: Communication error between finisher control PC board and saddle control PC board

Check Item	Measure
Finisher control PC board (FIN)	<ul style="list-style-type: none"> <li>• Connector check</li> <li>• Harness check</li> <li>• Board check</li> </ul>
Saddle control PC board (SDL)	<ul style="list-style-type: none"> <li>• Connector check</li> <li>• Harness check</li> <li>• Board check</li> </ul>
Finisher control PC board (FIN)	Update the firmware version of the finisher control PC board (FIN).
Saddle control PC board (SDL)	Update the firmware version of the saddle control PC board (SDL).

Replacement part	Remark
Finisher control PC board (FIN)	
Saddle control PC board (SDL)	

**[CC30] Stack transport motor abnormality**

\* You receive a [CC30] error when the [EA70] error occurs three times in succession.

Classification	Contents
Finisher related service call	Stack transport motor abnormality: The stack transport motor is not rotating or the stack transport belt is not moving normally.

MJ-1110

Check item	Measures
Stack transport belt	Move the stack transport belt. Fix any mechanical problem.
Stack transport motor (M8)	Check if the connector (CN18) on the finisher control PC board is disconnected from the stack transport motor (M8) and the harnesses are open circuited. Correct if so.

Parts to be replaced	Remark
Stack transport motor (M8)	
Finisher control PC board (FIN)	

**[CC31] Transport motor abnormality**

\* You receive a [CC31] error when the [ED12] error occurs three times in succession.

Classification	Contents
Finisher related service call	Transport motor abnormality: The transport motor is not rotating or the stack transport roller -1 and -2 is not rotating normally.

MJ-1110

Check item	Measures
Stack transport roller -1 Stack transport roller -2	Rotate the stack transport roller -1 and -2. Fix any mechanical problem.
Transport motor	Check if the connector (CN15) on the finisher control PC board is disconnected from the transport motor (M7) and the harnesses are open circuited. Correct if so.

Parts to be replaced	Remark
Transport motor (M7)	
Finisher control PC board (FIN)	

**[CC41] Paper holder cam home position abnormality**

Classification	Contents
Finisher related service call	Paper holder cam home position abnormality: The paper holder cam is not at the home position.

MJ-1110

Check item	Measures
Paper pusher cam	Rotate the paper pusher cam. Fix any mechanical problem.
Paper holder home position sensor (S6)	Check if the connector (CN11) on the finisher control PC board is disconnected from the paper holder home position sensor (S6) and the harnesses are open circuited. Correct if so.

Parts to be replaced	Remark
Paper holder home position sensor (S6)	
Finisher control PC board (FIN)	

**[CC51] Punch unit sliding motor (M12) abnormality**

\* You receive a [CC51] error when the [ED11] error occurs three times in succession or occurs during the initialization.

MJ-1042

Error	Timing of detection
Punch unit sliding motor (M12) Punch sliding unit home position sensor (S23)	The punch sliding unit is not slid after sliding request is sent.
	The punch sliding unit home position sensor (S23) does not detect that the unit is at its home position after the specified time when the unit is returned to the home position, or this sensor does not detect that the unit is out of its home position after the specified time when the unit is released.
	The punch sliding unit home position sensor (S23) does not detect that the unit is at its home position after the specified time when the unit is moved, or this sensor does not detect that the unit is at its home position when the unit is released.

Probable cause	Checking and measures
Punch unit sliding motor (M12) abnormality	Check if the electrical continuity of the coil is normal. If electricity is not conducted, replace the motor.
Punch sliding unit home position sensor (S23) abnormality	Measure the voltage on TP26 on the hole punch control PC board (HP). Then check that the measured voltage is 1V or lower when not shielded and within the range of 5V ± 5% when shielded. If the voltage does not fall within the range mentioned, replace the sensor.
Faulty cables and connectors	Check if the electrical continuity between the connector terminals is normal. If electricity is not conducted, replace the connector. (Hole punch control PC board (HP): CN3, CN4, CN5, CN6, CN7)
Hole punch control PC board (HP) abnormality	If the error still occurs after replacing the motor, sensor and connectors, exchange the hole punch control PC board (HP).

**[CC51] Sideways adjustment motor (M2) abnormality**

MJ-1110 (When MJ-6105 is installed)

\* You receive a [CC51] error when the [ED11] error occurs three times in succession or occurs during the initialization.

Classification	Contents
Finisher related service call	Sideways adjustment motor (M2) abnormality: Sideways adjustment motor is not rotating or puncher is not shifting normally.

Check Item	Measure
Paper	If there is any paper remaining on the transport path, remove the paper.
Sideways adjustment motor (M2)	<ul style="list-style-type: none"> <li>If there is mechanical problem when the sideways adjustment motor (M2) is rotated, fix the mechanism.</li> <li>Check the connector (CN10) and harnesses between the hole punch control PC board (HP) and sideways adjustment motor (M2).</li> </ul>

Check Item	Measure
Sideways deviation home position sensor (S3)	<ul style="list-style-type: none"> <li>• Sensor check</li> <li>• Harness check</li> <li>• Connector check (CN8)</li> </ul>

Replacement part	Remark
Sideways adjustment motor (M2)	
Sideways deviation home position sensor (S3)	
Hole punch control PC board (HP)	

### [CC52] Skew adjustment motor (M1) abnormality

MJ-1110 (When MJ-6105 is installed)

\* The [CC52] error occurs when the [ED10] error occurs three times in succession or during the initial operation.

Classification	Contents
Finisher related service call	Skew adjustment motor (M1) abnormality: Skew adjustment motor is not rotating or puncher is not shifting normally.

Check Item	Measure
Paper	If there is any paper remaining on the transport path, remove the paper.
Skew adjustment motor (M1)	<ul style="list-style-type: none"> <li>• If there is mechanical problem when the skew adjustment motor (M1) is rotated, fix the mechanism.</li> <li>• Check the connector (CN10) and harnesses between the hole punch control PC board (HP) and skew adjustment motor (M1).</li> </ul>
Skew home position sensor (S2)	<ul style="list-style-type: none"> <li>• Sensor check</li> <li>• Harness check</li> <li>• Connector check (CN10)</li> </ul>

Replacement part	Remark
Skew home position sensor (S2)	
Skew adjustment motor (M1)	
Hole punch control PC board (HP)	

**[CC54] Abnormality of paper detection sensors (S24 and S25)**

MJ-1042

Error	Timing of detection
Paper detection sensor (S24/S25) adjustment error	The adjustment of the paper detection sensors (S24 and S25) has been failed.ÅB

Probable cause	Checking and measures
Paper detection sensors (S24 and S25) abnormality	Measure the voltage on pin CN6.8 on the hole punch control PC board (HP). Then check that the measured voltage is 3.0V or higher when not shielded and 1.2V or lower when shielded. If the voltage does not fall within the range mentioned, replace a couple of PC boards on either the light-receiving side or the light-emitting side.
Faulty cables and connectors	Check if the electrical continuity between the connector terminals is normal. If electricity is not conducted, replace the connector. (Hole punch control PC board (HP): CN4, CN5, CN6)
Hole punch control PC board (HP) abnormality	If the error still occurs after replacing the sensors and the connectors, exchange the hole punch control PC board (HP).

**[CC60, CC61] Punch motor abnormality**

MJ-1042

Error	Timing of detection
Punch motor (M11) Paper detection sensor (S24/S25) Punch shaft home position sensor (S26) Rear punch shaft home position sensor (S22)	The paper detection sensors (S24 and S25) do not emit light after specified time when they are selected
	The level of the light-receiving amount is not lowered after the light-emitting amount of the paper detection sensors (S24 and S25) is adjusted to the lower limit.
	Punching is not performed after punching request is sent, or the punching request is sent during the punching.
	The status of the punch shaft home position sensor (S26) or the rear punch shaft home position sensor (S22) is not changed after punching request is sent.
	A punching locking signal is detected consistently over the specified time.
	The punch shaft home position sensor (S26) or the rear punch shaft home position sensor (S22) does not detect that the shaft is not at its home position at the start of punching or punch waste full detection.

Probable cause	Checking and measures
Punch motor (M11) abnormality	Check if the electrical continuity of the coil is normal. If electricity is not conducted, replace the motor.
Rear punch shaft home position sensor (S22) abnormality	Measure the voltage on TP25 on the hole punch control PC board (HP). Then check that the measured voltage is 1V or lower when not shielded and within the range of $5V \pm 5\%$ when shielded. If the voltage does not fall within the range mentioned, replace the sensor.

Probable cause	Checking and measures
Punch shaft home position sensor (S26) abnormality	Measure the voltage on TP24 on the hole punch control PC board (HP). Then check that the measured voltage is 1V or lower when not shielded and within the range of 5V±5% when shielded. If the voltage does not fall within the range mentioned, replace the sensor.
Punch motor clock sensor (S20) abnormality	Measure the voltage on TP27 on the hole punch control PC board (HP). Then check that the measured voltage is 1V or lower when not shielded and within the range of 5V±5% when shielded. If the voltage does not fall within the range mentioned, replace the sensor.
Faulty cables and connectors	Check if the electrical continuity between the connector terminals is normal. If electricity is not conducted, replace the connector. (Hole punch control PC board (HP): CN2, CN5, CN6, CN7, CN8)
Hole punch control PC board (HP) abnormality	If the error still occurs after replacing the motor, sensors and connectors, exchange the hole punch control PC board (HP).

### [CC61] Punch motor (M3) home position detection error

MJ-1110 (When MJ-6105 is installed)

\* The [CC61] error occurs when the [E9F0] error occurs three times in succession or during the initial operation.

Classification	Contents
Finisher related service call	Punch motor (M3) home position detection error: Punch motor is not rotating or puncher is not shifting normally.

Check Item	Measure
Paper	If there is any paper remaining on the transport path, remove the paper.
Punch motor (M3)	<ul style="list-style-type: none"> <li>If there is mechanical problem when the punch motor (M3) is rotated, fix the mechanism.</li> <li>Check the connector (CN2) and harnesses between the hole punch control PC board (HP) and punch motor (M3).</li> </ul>
Punch home position sensor (S4)	<ul style="list-style-type: none"> <li>Sensor check</li> <li>Harness check</li> <li>Connector check (CN3)</li> </ul>

Replacement part	Remark
Punch home position sensor (S4)	
Punch motor (M3)	
Hole punch control PC board (HP)	

**[CC71] Punch ROM checksum error**

MJ-1110 (When MJ-6105 is installed)

Classification	Contents
Finisher related service call	Punch ROM checksum error: Abnormality of checksum value on Hole punch controller PC board is detected when the power is turned on.

Check Item	Measure
Hole punch control PC board (HP)	Board check

Replacement part	Remark
Hole punch control PC board (HP)	

**[CC72] Punch RAM read/write error**

MJ-1110 (When MJ-6105 is installed)

Classification	Contents
Finisher related service call	Punch RAM read/write error: Abnormality of checksum value on Hole punch controller PC board is detected when the power is turned on.

Check Item	Measure
Hole punch control PC board (HP)	Board check

Replacement part	Remark
Hole punch control PC board (HP)	

**[CC80] Front alignment motor (M2) abnormality**

MJ-1042

Error	Timing of detection
Front alignment motor (M2) Front alignment plate home position sensor (S5)	The turning OFF of the front alignment plate home position sensor (S5) is not detected when the front alignment plate is moved from a point where this sensor is turned ON to one point where this sensor is turned OFF after the front alignment motor (M2) has been driven at the specified number of pulse.
	The turning ON of the front alignment plate home position sensor (S5) is not detected when the front alignment plate is moved from a point where this sensor is turned OFF to one point where this sensor is turned ON after the front alignment motor (M2) has been driven at the specified number of pulse.

Probable cause	Checking and measures
Front alignment motor (M2) abnormality	Check if the electrical continuity of the coil is normal. If electricity is not conducted, replace the motor.



Probable cause	Checking and measures
Front alignment plate home position sensor (S5) abnormality	Measure the voltage on TP15 on the finisher control PC board (FIN). Then check that the measured voltage is 1V or lower when not shielded and within the range of 3.3V ± 5% when shielded. If the voltage does not fall within the range mentioned, replace the sensor.
Faulty cables and connectors	Check if the electrical continuity between the connector terminals is normal. If electricity is not conducted, replace the connectors. (Finisher control PC board (FIN): CN5, CN12)
Finisher control PC board (FIN) abnormality	If the error still occurs after replacing the motor, sensor and connectors, exchange the finisher control PC board (FIN).

### [CC80] Rear alignment motor abnormality

\* You receive a [CC80] error when the [ED14] error occurs three times in succession.

Classification	Contents
Finisher related service call	Rear alignment motor abnormality: The rear alignment motor is not rotating or the rear alignment plate is not moving normally.

MJ-1110

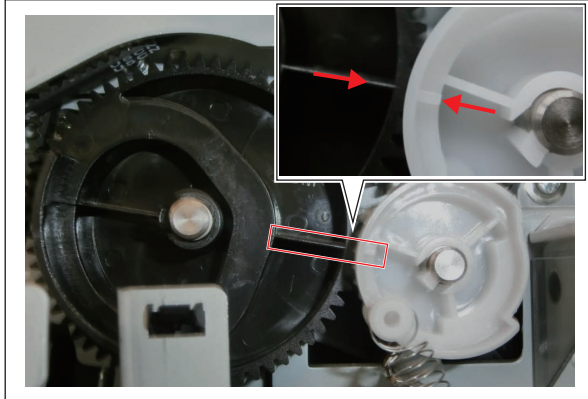
Check Item	Measure
Rear alignment plate	If there is mechanical problem when the rear alignment plate is moved, fix the mechanism.
Rear alignment motor (M6)	Check the connectors and harnesses between the rear alignment motor (M6) and the finisher control PC board (CN18).

Replacement part	Remark
Rear alignment motor (M6)	
Finisher control PC board (FIN)	

### [CC93] Knurled roller shift solenoid abnormality

MJ-1042

Error	Timing of detection
Knurled roller shift solenoid (SOL3) 2nd transport motor (M4) Knurled roller home position sensor (S10)	The knurled roller home position sensor (S10) does not detect that the knurled roller is at the upper position after the 2nd transport motor (M4) has been driven at the specified number of pulses during the initial rising movement of the knurled roller.
	The knurled roller home position sensor (S10) does not detect that the knurled roller is not at the upper position after the 2nd transport motor (M4) has been driven at the specified number of pulses during the initial lowering movement of the knurled roller.
	The knurled roller home position sensor (S10) does not detect that the knurled roller is at the upper position when the pressurization of stack exit movement is finished.

Error	Timing of detection
Gear	<p>Check the gear of transport unit in finishing section. When assembling the gear, align its rib to the protrusion as shown in the figure.</p>  <p style="text-align: center;"><b>Fig.8-15</b></p>

**[CC94] Fan motor abnormality**  
MJ-1042

Error	Timing of detection
Fan motor (M9)	<p>The turning ON of the fan locking signal is detected consistently after the specified time*.</p> <p>* A locking signal is not monitored from the start driving the motor until the specified time has passed.</p>

**[CDE0] Paddle motor abnormality**

\* You receive a [CDE0] error when the [ED15] error occurs three times in succession or during the initial operation.

Classification	Contents
Finisher related service call	Paddle motor abnormality: The paddle motor is not rotating or the paddle is not rotating normally.

MJ-1110

Check Item	Measure
Paddle	IRotate the paddle. Fix any mechanical problem.
Paddle motor (M3)	Check the connectors and harnesses between the paddle motor (M3) and the finisher control PC board (CN16).

Replacement part	Remark
Paddle motor (M3)	
Finisher control PC board (FIN)	

**[CE00] Punch communication error**

Classification	Contents
Finisher related service call	Communication error between finisher and punch unit: Communication error between finisher controller PC board and punch controller PC board

MJ-1110 (When MJ-6105 is installed)

Check item	Measures
Hole punch control PC board (HP)	<ul style="list-style-type: none"> <li>Check the connectors and harnesses between the hole punch control PC board (HP) and the finisher control PC board.</li> <li>Board check</li> </ul>

Parts to be replaced	Remark
Hole punch control PC board (HP)	
Finisher control PC board (FIN)	

**[CF10] Communication module writing failure**

Classification	Contents
Finisher related service call	Communication module writing failure.

Check item	Measure
Finisher	<ul style="list-style-type: none"> <li>Check if the harness connecting the equipment and the finisher control PC board is disconnected or open circuited.</li> <li>Check if the conductor pattern on the finisher controller PC board is open circuited or short circuited.</li> <li>Update the finisher firmware.</li> </ul>
LGC board	<ul style="list-style-type: none"> <li>Check if the harness connecting the finisher and the LGC board on the equipment is disconnected or open circuited.</li> <li>Connector check</li> <li>Check if the conductor pattern on the LGC board is open circuited or short circuited.</li> </ul>

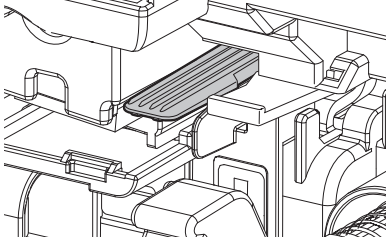
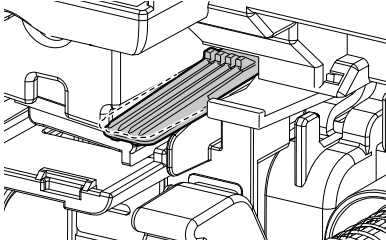
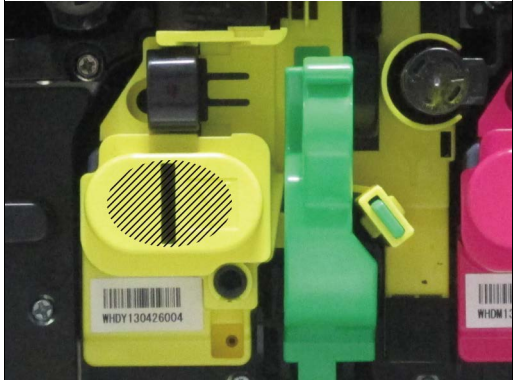
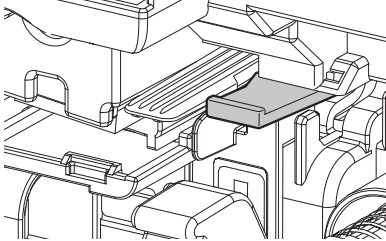
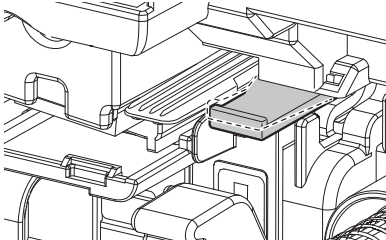
Parts to be replaced	Remark
Finisher control PC board (FIN)	
LGC board	

### 8.3.23 Image control related service call

- (1) Based on the procedure of [CE10], [] and [CE40] described below, check the status and take appropriate actions. And then perform the forced performing of image quality closed-loop control according to the following procedure.
  1. Perform FS-05-2742.
  2. Confirm that the image quality control has finished normally.
- (2) After confirming the items in (1), clear the abnormal detection counter of image quality control.
  1. Perform FS-08-2528.
  2. Rewrite the displayed status counter from “1” - “16” to “0”.
  3. Perform FS-08-2529.
  4. Rewrite the displayed status counter from “1” - “16” to “0”.
  5. Perform FS-08-2530.
  6. Rewrite the displayed status counter from “1” - “16” to “0”.
  7. Perform FS-08-2531.
  8. Rewrite the displayed status counter from “1” - “16” to “0”.
  9. Turn the power OFF and then back ON. Make sure that the equipment enters the normal ready state.

**[CA00] Color registration abnormality**

Classification	Contents
Image control related service call	Color registration abnormality

Step	Check Item	Result	Measure	Next Step
1	<p>Has the developer unit been installed securely?</p> <p>- Installed securely</p>  <p>- Not installed securely</p> 	No	<p>Press the slanted line portion of the developer unit until a click sound is heard.</p> 	
	<p>Has the cleaner unit been installed securely?</p> <p>- Installed securely</p>  <p>- Not installed securely</p> 			

Step	Check Item	Result	Measure	Next Step
2	Remove the transfer belt unit. 📖 P. 4-117 "4.7.3 Transfer belt unit (TBU)"			
3	Is an image created on the transfer belt?	Yes		7
		No		4
4	Check if there is any abnormality on the hand grips and rods of the main charger cleaner. Correct if there is.			
5	Check if the drum is rotated properly by turning the coupling of the developer unit. Correct the auger and the surrounding hardware if not.			
6	LED printer head		<ul style="list-style-type: none"> <li>• Check the connectors and harnesses between the LGC board (CN357, CN359, CN356, CN358, CN331, CN332, CN329, CN330, CN788, CN787, CN790, CN789, CN792, CN791, CN794 and CN793) and the LED printer head.</li> <li>• Check if there is any stain or scratch on the LED printer head. Clean or correct if there is.</li> </ul>	
7	Check if there is any stain on the image quality sensor (Front) and image quality sensor (Rear).			
8	Check if the sensor shutter is working properly.			
9	< Invalidating color registration control >		<ul style="list-style-type: none"> <li>• Perform FS-08-4546.</li> <li>• Set the value to "0" (not performed automatically).</li> <li>• Turn the power OFF.</li> </ul>	
10	< Checking the abnormal status on color registration >		<ul style="list-style-type: none"> <li>• Perform FS-05-4720.</li> </ul>	

Step	Check Item	Result	Measure	Next Step
11	Check the displayed value. When the error [CA00] occurs, the value between 1 and 255 is displayed. (0: Normal completion) (The statuses of total 8 sections (4 colors on the front and rear sides) are displayed.)		1: Y on the rear side detection abnormality (*1)	17
			2: Y on the front side detection abnormality (*1)	17
			3: Y on the front and rear sides detection abnormality	17
			4: M on the rear side detection abnormality (*1)	17
			8: M on the front side detection abnormality (*1)	17
			12: M on the front and rear sides detection abnormality	17
			16: C on the rear side detection abnormality (*1)	17
			32: C on the front side detection abnormality (*1)	17
			48: C on the front and rear sides detection abnormality	17
			64: K on the rear side detection abnormality (*1)	17
			85: All colors on the rear side detection abnormality	12
			128: K on the front side detection abnormality (*1)	17
			170: All colors on the front side detection abnormality	12
			192: K on the front and rear sides detection abnormality	17
			255: All colors on the front and rear sides detection abnormality	12
Other than the above: Multiple colors detection abnormality	17			
			<p><b>Remarks:</b> The adjustment value is the sum of (*1), which, as in the example below, specifies the cause of the detection abnormality. (E.g. 1) FS-05-4720 --- in case of 72 <math>72 = 64 + 8</math> → K on the rear side / M on the front side detection abnormality (E.g. 2) FS-05-4720 --- in case of 146 <math>146 = 128 + 18 = 128 + 16 + 2</math> → K on the front side / C on the rear side / Y on the front side detection abnormality</p>	

Step	Check Item	Result	Measure	Next Step
12	< Checking the status of the image position aligning sensor >		<p>Check if the light emitting area of the image position aligning sensor emits LEDs and if the reflected lights on the transfer belt surface are detected by the light receiving area of the image position aligning sensor.</p> <ol style="list-style-type: none"> <li>1. FS-03-[F2]ON/[1]/[B]: Check the image position aligning sensor (Front).</li> <li>2. FS-03-[F2]ON/[1]/[A]: Check the image position aligning sensor (Rear) / Image quality sensor.</li> <li>3. FS-03-125: Sensor shutter is opened.</li> <li>4. FS-03-126: Image position aligning sensor / LED ON</li> <li>5. FS-03-[F2]ON/[1]/[B]: Check the image position aligning sensor (Front).</li> <li>6. FS-03-[F2]ON/[1]/[A]: Check the image position aligning sensor (Rear) / Image quality sensor.</li> <li>7. Compare them (step 5 and 6) with the statues of [A] and [B] displayed in step 1 and 2.               <ul style="list-style-type: none"> <li>- Both [A] and [B] are changed - The image position aligning sensors on both sides are operating normally.</li> <li>- [A] remains same - The image position aligning sensor on the rear side is not operating normally.</li> <li>- [B] remains same - The image position aligning sensor on the front side is not operating normally.</li> <li>- Both [A] and [B] remain same - The image position aligning sensors on both sides are not operating normally.</li> </ul> </li> <li>8. FS-03-176: Image position aligning sensor / LED OFF</li> <li>9. FS-03-175: Sensor shutter is closed.</li> <li>10. Turn the power OFF.</li> <li>11. If the image position aligning sensors on both sides are operating normally, proceed to step (15). In other cases, proceed to step (13).</li> </ol>	
13	Image position aligning sensor		<ul style="list-style-type: none"> <li>• Check the connectors and harnesses between the image position aligning sensor and the LGC board (CN351).</li> <li>• Check if the light emitting or receiving area of the image position aligning sensor stained with toner.</li> </ul>	



Step	Check Item	Result	Measure	Next Step
14	Are the sensor shutters of the image position aligning sensor opening or closing normally? Are they normal without any damage? 1. Take off the transfer belt unit so that the sensor unit can be seen. 2. Perform FS-03-125/175.	Yes		15
		No		16
15	Is the light emitting area of the image position aligning sensor emitting LEDs? 1. Perform FS-03-125. (Open the sensor shutter) 2. Perform FS-03-126. (The light emitting area of the sensor should emit LEDs)	Yes		17
		No		16
16	Image position aligning sensor		<ul style="list-style-type: none"> <li>• Connector and harness check</li> <li>• Clean the light emitting and receiving areas of the image position aligning sensor.</li> <li>• If the sensor shutter is damaged, replace it.</li> <li>• If the sensor shutter solenoid is not operating normally, replace the solenoid.</li> </ul>	12
17	< Checking with test pattern >		<ul style="list-style-type: none"> <li>• Perform FS-04-286.</li> <li>• Check if the printed image of the test pattern in each color contains difference in density on its front, center and rear sides, or if there is any image trouble in a whole image.</li> </ul>	
18	Is the image of the test pattern printed normally without any difference in density on its front and rear sides?	Yes		21
		No		19
19	Transfer belt and the photoconductive drum		Check the contacting status of the transfer belt and the photoconductive drum.	20
20	Developer material		Check the amount of the developer material. (Check if the developer material is supplied on the developer sleeve.)	21
21	Is the image printed normally without yellow, magenta, cyan or black streaks in the secondary scanning direction?	Yes		23
		No		22
22	Check if the main charger wire corresponding to the color of the streaks is stained.			23
23	Is the image printed normally without white streaks in the secondary scanning direction?	Yes		25
		No		24
24	Check if the LED printer head is stained.			25

Step	Check Item	Result	Measure	Next Step
25	Is a certain color in the printed image turned to black solid?	Yes		27
		No		26
26			<ul style="list-style-type: none"> <li>Abnormality in the main high-voltage transformer corresponding to the color or abnormality in the LED printer head.</li> <li>Switch one of 4 main high-voltage transformers which possibly contains abnormality with the one possibly normal. Then print the same test pattern.</li> <li>If the color which turned into black solid changes along with the replacement of the main high-voltage transformer, this main high-voltage transformer is defined as abnormal.</li> <li>If the color which turned into black solid does not change, check if the harness between the LGC board and the main high-voltage transformer is broken or if the power is sufficiently supplied to the main charger (breaking of the high-voltage harness or connection defect). If no problem is found, check the LED printer head.</li> </ul>	27
27	If the density level is low on both front and rear sides, is the image printed normally in cases other than noted above?	Yes		29
		No		28

Step	Check Item	Result	Measure	Next Step
28			<ul style="list-style-type: none"> <li>• Check if the photoconductive drum and the transfer belt are rotating. If not, correct their mechanism.</li> <li>• Check if there are abnormal stain, large breaking or scratches on the transfer belt surface.</li> <li>• Check if the connector of the transfer transformer is disconnected.</li> <li>• Check if the high-voltage harnesses of the main high-voltage transformer and the transfer transformer are disconnected.</li> <li>• Check if the harness between the LGC board and the transfer transformer is broken.</li> <li>• Check if the high-voltage joints of the transfer belt unit are securely contacted or if they are not stained.</li> <li>• Check if the high-voltage harness is broken.</li> <li>• Check if the connector of the main high-voltage transformer is disconnected.</li> <li>• Check if the harness between the LGC board and the main high-voltage transformer is broken.</li> <li>• Replace the transfer transformer.</li> <li>• Replace the main high-voltage transformer.</li> </ul>	17
29	<p>&lt; Checking with the enforced image position adjustment &gt;  Does the error [CA00] occur during the position adjustment control?  1. Perform FS-05-4719. (Enforced position adjustment)</p>	Yes		30
		No		10
30	< Validating the color registration control >		<p>Check the operation and correct if necessary. Then be sure to perform the following:</p> <ol style="list-style-type: none"> <li>1. Perform FS-08-4546. (Position adjustment control / Mode setting)</li> <li>2. Set the value to "3" (default value).</li> <li>3. Turn the power OFF.</li> </ol>	
31	<Checking the image position aligning sensor>		Clean the image position aligning sensor (S7, S8).	
32	<Checking the power supply>		Check if any of the springs for supplying power to the transfer belt unit is deformed. Replace the spring if it is deformed.	

**[CE10] Image quality sensor abnormality (OFF level)**

Classification	Contents
Image control related service call	Image quality sensor abnormality (OFF level): The output value of this sensor is out of a specified range when sensor light source is OFF.

Check Item	Measure
Image quality sensor	Connector check
LGC board	<ul style="list-style-type: none"> <li>Connector check (CN351)</li> <li>Check the harnesses between the LGC board and the image quality sensor.</li> <li>Check the harnesses between the LGC board and the switching power supply.</li> </ul>

Replacement part	Remark
Switching power supply	
Image quality sensor	
LGC board	
High-voltage transformer	

**[CE20] Image quality sensor abnormality**

Classification	Contents
Image control related service call	Image quality sensor abnormality (no pattern level): The output value of this sensor is out of a specified range when the image quality control test pattern is not formed.

Step	Check Item	Result	Measure	Next Step
1	<ul style="list-style-type: none"> <li>Check the image quality sensor detection value (FS-05-2757).</li> <li>Is the value of FS-05-2757-0 "0", and is the value of FS-05-2757-1 "255"?</li> </ul>	Yes		9
		No		2
2	<ul style="list-style-type: none"> <li>Is the transfer belt or the transfer belt unit securely installed?</li> <li>Are there any abnormal stains (cleaning defects), large scratches or breaking on the transfer belt surface?</li> <li>Are the drum and the transfer belt rotating smoothly?</li> <li>Is the transfer belt tight?</li> </ul>	Yes		6
		No		3
3	Transfer belt unit		Check if the transfer belt unit is securely installed. Correct it if not.	4

Step	Check Item	Result	Measure	Next Step
4	Transfer belt		Check if any toner image remains on the transfer belt surface. If any, check the installation status of the TBU cleaner unit. If there is any abnormality, correct it, and clean the transfer belt.	5
5	Drum and transfer belt		Check if the drum and the transfer belt are properly operated. (ON: FS-03-101 / OFF: FS-03-151) If the transfer belt rotates normally, check if any abnormal stains (cleaning defects), large scratches or breaking are on the surface of transfer belt by making full rotation of transfer belt. Replace the transfer belt if any. Check if the transfer belt is loose or heaving, and correct it if needed. If they are not rotating normally, check if their drive gears are damaged or if they contact the equipment. Correct it if needed.	19*
6	<ul style="list-style-type: none"> <li>Is the sensor shutter of the image quality sensor opening or closing normally? Or is it normal without any damage?</li> <li>Is the sensor surface of the image quality sensor clean?</li> </ul>	Yes		9
		No		7
7	Sensor unit		Take off the transfer belt unit so that you can see the sensor unit.	
8	Sensor shutter		<ul style="list-style-type: none"> <li>Check if the sensor shutter is opening or closing normally. (Opening: FS-03-125 / Closing: FS-03-175) If the sensor shutter is not opening or closing, check if it is damaged or there is any abnormality in the sensor shutter solenoid. * If the shutter is opened (FS-03-125), close the shutter (FS-03-175).</li> <li>Check the connector and the harness between the sensor shutter solenoid and the LGC board. (CN351 - 9pin, 10pin)</li> <li>Slide the sensor shutter so that the sensor surface can be seen. Clean the sensor surface with a cotton swab or a soft cloth. Clean the area around the sensor (e.g.: sensor shutter) if it is stained, so that the sensor surface does not become dirty.</li> </ul>	19*
9	Image quality sensor		Check the connectors and harnesses between the LGC board (CN351) and the image quality sensor.	*

Step	Check Item	Result	Measure	Next Step
10	<ul style="list-style-type: none"> <li>Is +12V power supply voltage normally supplied to the image quality sensor?</li> <li>Is 5V voltage normally output by the CN315 - 5pin on the LGC board?</li> </ul>	Yes		13
		No		11
11	Switching power supply		Check if 5V voltage is output by the switching power supply (CN512 - 5pin, 6pin).	
12	LGC board		<ul style="list-style-type: none"> <li>Check if 5V voltage is output by the TP13 terminal on the LGC board.</li> <li>Check if the supply harness between the switching power supply and the LGC board is open circuited, damaged or disconnected.</li> </ul>	19*
13	Set the values of "Image quality closed-loop control / Contrast voltage (FS-08-2486)" to "0" (Invalid).			
14	Perform "Enforced performing of image quality open-loop control (FS-05-2740)".			
15	Output the image quality control test pattern (FS-04-270) more than one time and the list print. Is the image normal?	Yes		17
		No		16
16	Abnormal image Correct the abnormal image.		Blank print, Solid print, White banding, Color banding, White spots, Poor transfer, Uneven image density, Faded image (low density), Uneven light distribution, Blotched image. * Blank print: including when one of the YMCK colors is not printed.	18
17	Replace the image quality sensor or the LGC board.			
18	Set the values of "Image quality closed-loop control / Contrast voltage (FS-08-2486)" to "1" (Valid).			
19	Perform "Forced performing of image quality closed-loop control (FS-05-2742)" and make sure it is completed normally. (Error [CE10], [CE20] and [CE40] do not appear.)	Yes		21
		No		20
20	Check and correct it accordingly.			
21	Perform "Automatic gamma adjustment".			
22	Reset all of the values in the codes "Abnormality detection count (Y/M/C/K) Display/0 clearing (FS-08-2528 to FS-08-2531)".			

Step	Check Item	Result	Measure	Next Step
23	High-voltage transformer		Check if the high-voltage transformer is damaged or abnormal.	

\* Go to step 13 for the second time.

#### [CE40] Image quality control test pattern abnormality

Classification	Contents
Image control related service call	Image quality control test pattern abnormality: The test pattern is not formed normally.

Step	Check Item	Result	Measure	Next Step
1	Check if there is any abnormality on the hand grips and rods of the main charger cleaner. Correct if there is.			
2	Check if the drum is rotated properly by turning the coupling of the cleaner unit. Correct the auger and the surrounding hardware if not.			
3	LED printer head		<ul style="list-style-type: none"> <li>Check the connectors and harnesses between the LGC board (CN357, CN359, CN356, CN358, CN331, CN332, CN329, CN330, CN788, CN787, CN790, CN789, CN792, CN791, CN794 and CN793) and the LED printer head.</li> <li>Check if there is any stain or scratch on the LED printer head. Clean or correct if there is.</li> </ul>	
4	Check if there is any stain on the image quality sensor (Rear).			
5	Check if the sensor shutter is working properly.			

Step	Check Item	Result	Measure	Next Step
6	Transfer belt		<p>Check if the transfer belt is installed in the transfer belt unit properly. Check if the transfer belt is loose or heaving, and correct it if needed.</p> <p>Check if the transfer belt unit is installed in the equipment properly.</p> <p>Check if the transfer belt is properly operated. (ON: FS-03-101 / OFF: FS-03-151)</p> <p>If the transfer belt rotates normally, check if any abnormal stains (cleaning defects), large scratches or breaking are on the surface of transfer belt by making full rotation of transfer belt.</p> <p>Replace the transfer belt if any.</p> <p>If the transfer belt is not rotating normally, check if the drive gears are damaged or if it contacts the equipment or if the transfer belt cleaning unit is normal. Correct it if needed.</p>	17*
7	Check if any of the springs for supplying power to the transfer belt unit is deformed. Replace the spring if it is deformed.			
8	Use "Image quality control abnormal detection counter Y to K display/0 clearing (FS-08-2528 to 2531)" to check the abnormal occurring condition for each color.			
9	Check the first pattern detection value for each color of image quality sensor detection value (FS-05-2758-2 to 5), and identify the color of unit which causing test pattern abnormality. Identify the color of unit by check the value which exceeds "600". (Sub-code 2: Y, 3: M, 4: C, 5: K)		<p>If the detected value of K is normal but that for only Y, those for Y and M, or those for Y, M and C is abnormal, perform the following procedure.</p> <p>-&gt; Check that the phenomenon can be recovered by replacing the 1st transfer contact/release clutch or the 1st transfer roller status detection sensor.</p>	
10	Check if the developer unit identified in step 9 has been installed properly.		Visually check the installation and assembly status of the developer unit, and correct it if there is any abnormality.	17*
11	Set the values of "Image quality closed-loop control / Contrast voltage (FS-08-2486)" to "0" (Invalid).			
12	Perform "Enforced performing of image quality open-loop control (FS-05-2740)".			




Step	Check Item	Result	Measure	Next Step
13	Output several number of sheets of the image quality control test pattern (FS-04-270) and the list print (FS-30-101), and check the pattern of the color identified in step 9. Is the image normal?	Yes		15
		No		14
14	Abnormal image Correct the abnormal image.		Blank print, Solid print, White banding, Color banding, White spots, Poor transfer, Uneven image density, Faded image (low density), Uneven light distribution, Blotched image.  <b>Notes:</b> <ul style="list-style-type: none"> <li>Refer to the each troubleshooting for the image.</li> <li>Blank print: including when one of the YMCK colors is not printed.</li> </ul>	16
15	Replace the image quality sensor or LGC board.			
16	Set the values of "Image quality closed-loop control / Contrast voltage (FS-08-2486)" to "1" (Valid).			
17	Perform "Forced performing of image quality closed-loop control (FS-05-2742)." Is it completed normally?	Yes		19
		No		18
18	Check and correct it accordingly.			
19	Perform "Automatic gamma adjustment".			
20	Clear all "Image quality control abnormal detection counter Y to K display/0 clearing (FS-08-2528 to 2531)".			

\* If you have already performed this checking cycle once, proceed to step (11).

Replace parts	Remarks
Main charger cleaner	
Drum cleaner unit	
LED printer head	
Image quality sensor (Rear)	
Transfer belt	
Spring	
1st transfer contact/release clutch	
1st transfer roller status detection sensor	
Image quality sensor	
LGC board	
High-voltage transformer (HVT)	

**[CE41] Image quality TRC control test pattern abnormality**

Classification	Error item
Image control related service call	The image quality TRC control test pattern is not printed normally.

Step	Check item	Result	Measures	Next step
1	Change the setting of the image quality TRC control to "Disabled". Set the values of FS-08-2600 and FS-08-8103 to "0".			2
2	Output several number of sheets of the image quality control test pattern (FS-04-270) and the list print (FS-30-101), and check the pattern of each color. Is the image normal?	YES NO	<ul style="list-style-type: none"> <li>• Check if process units and developer units are properly installed.</li> <li>• Check if there is any scattered toner or developer material around the LED printer head, clean it if there is any.</li> <li>• Correct the problem by referring to "Troubleshooting for the Image".   P. 8-372 "8.5 Troubleshooting for the Image"</li> </ul>	3
3	Change the setting of the image quality TRC control to "Enabled". Set the values of FS-08-2600 and FS-08-8103 to "1".			4
4	Perform the automatic gamma adjustment. If the adjustment is normally finished, this is the end of the procedure. If the error CE41 still occurs, proceed to step 5.			
5	4.Check if the harness between the connector CN131 on the SYS board and the connector CN371 on the LGC board is disconnected or open circuited. Correct if so.			6
6	6.Check if the conductor patterns on the SYS board and the LGC board are short circuited or open circuited.			7
7	7.If no abnormality is found in steps 5 to 6 above, replace the SYS board.			8

Step	Check item	Result	Measures	Next step
8	8.Perform automatic gamma adjustment. If the adjustment is normally finished, this is the end of the procedure. If the error CE41 still occurs, proceed to step 9.			
9	Reinstall the removed SYS board and then replace the LGC board. Perform automatic gamma adjustment after the board is replaced.			

Replace parts	Remarks
LGC board	
SYS board	
High-voltage transformer	

#### [CE50] Temperature/humidity sensor abnormality

Classification	Contents
Image control related service call	Temperature/humidity sensor abnormality: The output value of this sensor is out of a specified range.

Check Item	Measure
Temperature/humidity sensor	Check the connectors and harnesses between the temperature/humidity sensor and LGC board (CN350).

Replacement part	Remark
Temperature/humidity sensor	
LGC board	

## [CE70] Drum drive switching abnormality

Classification	Contents
Image control related service call	Drum drive switching abnormality: The drum switching detection sensor (S11) is not turned ON after the drum motor was rotated for a specified period of time.

Step	Check Item	Result	Measure	Next Step
1	Is the drum switching motor (M3) operating properly? (Perform the output check: FS-03-240)	Yes		7
		No		2
2	Drum switching motor (M3)		Check the connector (J803) of the motor.	
3	Drum switching detection sensor (S11)		Sensor check	
4	LGC board		<ul style="list-style-type: none"> <li>Connector check (CN367)</li> <li>Board check</li> </ul>	
5	Is the drum TBU drive unit [1] installed properly? P. 8-252 "Fig.8-16"		Install the drum TBU drive unit [1] properly. P. 8-252 "Fig.8-16"	
6	Check that there is no friction or abnormality by pushing the protrusion [2] of the drive switching cam and the one [3] for the developer/paper feeding drive switching cam while the drum TBU drive unit [1] is removed. P. 8-252 "Fig.8-16"		<ul style="list-style-type: none"> <li>If there is any foreign matter in the unit, remove it.</li> <li>If the slide area spring [4] in the unit is deformed or is not attached properly, correct it.</li> <li>Apply grease (Molykote EM-30L) to the slide area of the switching cam [5]. P. 8-252 "Fig.8-17" P. 8-252 "Fig.8-17"</li> </ul>	
7	Is the drum switching detection sensor (S11) working? (Perform the input check: FS-03-[ALL]OFF/[8]/[G] (Highlighted in the black mode))	Yes		10
		No		8
8	Drum switching detection sensor (S11)		<ul style="list-style-type: none"> <li>Sensor, connector, relay connector check</li> <li>Check if there is any foreign matter such as grease in the detection area of the drum switching detection sensor.</li> </ul>	
9	LGC board		<ul style="list-style-type: none"> <li>Connector check (CN367)</li> <li>Board check</li> </ul>	
10	Is the drum switching motor assembled in the drum drive unit able to be rotated smoothly by hand?	Yes		12
		No		11
11	Drum switching motor (M3)		<ul style="list-style-type: none"> <li>While reinstalling the drum switching motor, push it so that its gear will slightly move away from the engaging gear.</li> <li>Check the bracket in which the drum switching motor is installed. If it is deformed, replace it.</li> </ul>	

Step	Check Item	Result	Measure	Next Step
12	Is the drum switching guide able to be moved smoothly by hand after the drum switching motor has been removed?	Yes		14
		No		13
13	Drum switching motor (M3)		Check if the slide area (guide, plate) of the drum switching guide is deformed or any foreign matter is attached to it. (Replace it if there is.)	
14	LGC board		Board check	

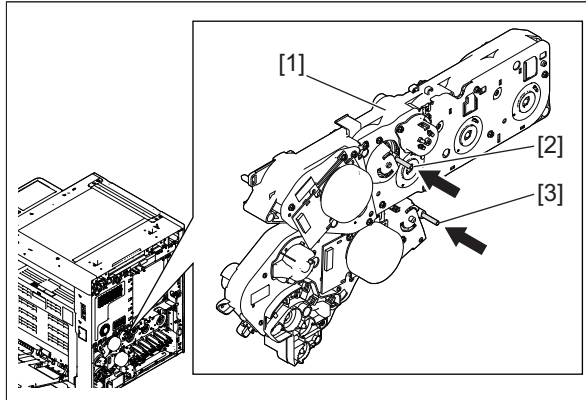


Fig.8-16

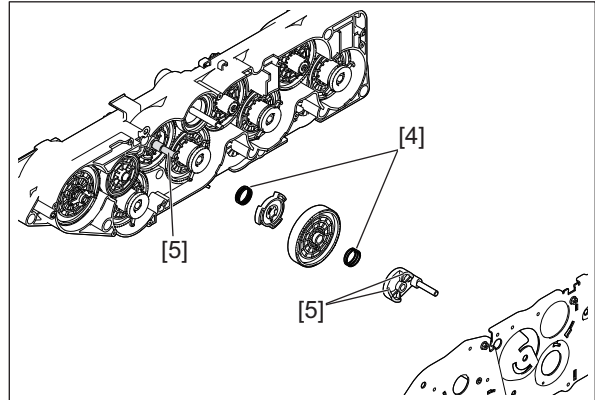


Fig.8-17

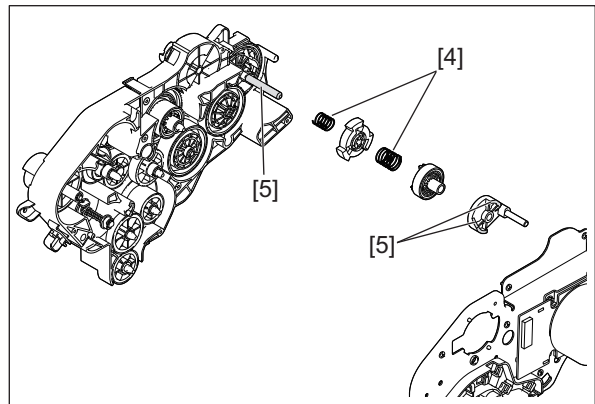


Fig.8-18

Replacement part	Remark
Drum switching motor (M3)	
Drum switching detection sensor (S11)	
LGC board	

**[CE90] Drum thermistor abnormal**

<b>Classification</b>	<b>Contents</b>
Image control related service call	Drum thermistor abnormality: The output value of the drum thermistor is out of a specified range.

<b>Check Item</b>	<b>Measure</b>
Drum thermistor	Connector and harness check of drum thermistor
LGC board	<ul style="list-style-type: none"><li>• Check the harnesses between the LGC board and the drawer connector for developer unit.</li><li>• Connector check (CN360)</li></ul>

<b>Replacement part</b>	<b>Remark</b>
Drum thermistor	
LGC board	

## 8.3.24 Copy process related service call

### [C370] Transfer belt unit abnormality

Classification	Contents
Copy process related service call	Transfer belt abnormality

Check Item	Measure
Transfer belt unit	Check if the transport belt unit is working normally.
Drum TBU drive unit	Connector check (CN368, J808, J809)
Drum TBU motor	Connector check
Drum cleaner unit	Check if the drum is overloaded.
Transfer belt cleaning unit	Check that there is no abnormality in the cleaning blade. Check if the waste toner auger is overloaded.
LGC board	Connector check (CN368)
Transfer belt	Check if it's normal
1st transfer roller status detection sensor (S12)	Sensor check
1st transfer contact/release clutch (CLT3)	Clutch check

Replacement part	Remark
Drum TBU motor	
LGC board	
1st transfer roller status detection sensor (S12)	
1st transfer contact/release clutch (CLT3)	

**[C380] Auto-toner sensor-K abnormality (upper limit)**

Classification	Contents
Copy process related service call	Auto-toner sensor-K abnormality (upper limit)

Step	Check Item	Result	Measure	Next Step
1	Developer unit		<ul style="list-style-type: none"> <li>• Check if the developer unit is installed properly.</li> <li>• Check that the developer unit and coupling on the equipment side are properly engaged.</li> <li>• Check that the mixer of the developer unit is rotated.</li> <li>• Check if the developer material is too light visually.</li> <li>• Check if the amount of the developer material is too large or too small.</li> <li>• Remove any toner or dust on the auto-toner sensor connector and the drawer connector of the process cover.</li> <li>• Remove any toner or dust on the EPU sensor connector and the drawer connector on the equipment side.</li> </ul>	
2	Auto toner sensor - Equipment Harness - LGC board		<ul style="list-style-type: none"> <li>• Check the connectors and harnesses between the auto toner sensor and LGC board (CN347).</li> <li>• Remove any foreign matter such as toner in the connector of the auto toner sensor.</li> </ul>	

Replacement part	Remark
Auto toner sensor	
Harness	
LGC board	
Developer material	
High-voltage transformer	



**[C381] Auto-toner sensor-K abnormality (lower limit)**

Classification	Contents
Copy process related service call	Auto-toner sensor-K abnormality (lower limit)

Step	Check Item	Result	Measure	Next Step
1	Developer unit		<ul style="list-style-type: none"> <li>• Check if the developer unit is installed properly.</li> <li>• Check that the developer unit and coupling on the equipment side are properly engaged.</li> <li>• Check that the mixer of the developer unit is rotated.</li> <li>• Check if the amount of the developer material is too large or too small.</li> <li>• Remove any toner or dust on the auto-toner sensor connector and the drawer connector of the process cover.</li> <li>• Remove any toner or dust on the EPU sensor connector and the drawer connector on the equipment side.</li> </ul>	
2	Auto toner sensor Harness LGC board		<ul style="list-style-type: none"> <li>• Check the connectors and harnesses between the auto toner sensor and LGC board (CN347).</li> <li>• Check if there is any foreign matter such as toner in the connector of the auto toner sensor. Remove if there is and reconnect it.</li> </ul>	

Replacement part	Remark
Auto toner sensor	
Harness	
LGC board	
Developer material	

**[C390] Auto-toner sensor-C abnormality (upper limit)**

Classification	Contents
Copy process related service call	Auto-toner sensor-C abnormality (upper limit)

Step	Check Item	Result	Measure	Next Step
1	Developer unit		<ul style="list-style-type: none"> <li>• Check if the developer unit is installed properly.</li> <li>• Check that the developer unit and coupling on the equipment side are properly engaged.</li> <li>• Check that the mixer of the developer unit is rotated.</li> <li>• Check if the developer material is too light visually.</li> <li>• Check if the amount of the developer material is too large or too small.</li> <li>• Remove any toner or dust on the auto-toner sensor connector and the drawer connector of the process cover.</li> <li>• Remove any toner or dust on the EPU sensor connector and the drawer connector on the equipment side.</li> </ul>	
2	Auto toner sensor Harness LGC board		<ul style="list-style-type: none"> <li>• Check the connectors and harnesses between the auto toner sensor and LGC board (CN347).</li> <li>• Check if there is any foreign matter such as toner in the connector of the auto toner sensor. Remove if there is and reconnect it.</li> </ul>	

Replacement part	Remark
Auto toner sensor	
Harness	
LGC board	
Developer material	
High-voltage transformer	

**[C391] Auto-toner sensor-C abnormality (lower limit)**

Classification	Contents
Copy process related service call	Auto-toner sensor-C abnormality (lower limit)

Step	Check Item	Result	Measure	Next Step
1	Developer unit		<ul style="list-style-type: none"> <li>• Check if the developer unit is installed properly.</li> <li>• Check that the developer unit and coupling on the equipment side are properly engaged.</li> <li>• Check that the mixer of the developer unit is rotated.</li> <li>• Check if the amount of the developer material is too large or too small.</li> <li>• Remove any toner or dust on the auto-toner sensor connector and the drawer connector of the process cover.</li> <li>• Remove any toner or dust on the EPU sensor connector and the drawer connector on the equipment side.</li> </ul>	
2	Auto toner sensor Harness LGC board		<ul style="list-style-type: none"> <li>• Check the connectors and harnesses between the auto toner sensor and LGC board (CN347).</li> <li>• Check if there is any foreign matter such as toner in the connector of the auto toner sensor. Remove if there is and reconnect it.</li> </ul>	

Replacement part	Remark
Auto toner sensor	
Harness	
LGC board	
Developer material	

**[C3A0] Auto-toner sensor-M abnormality (upper limit)**

Classification	Contents
Copy process related service call	Auto-toner sensor-M abnormality (upper limit)

Step	Check Item	Result	Measure	Next Step
1	Developer unit		<ul style="list-style-type: none"> <li>• Check if the developer unit is installed properly.</li> <li>• Check that the developer unit and coupling on the equipment side are properly engaged.</li> <li>• Check that the mixer of the developer unit is rotated.</li> <li>• Check if the developer material is too light visually.</li> <li>• Check if the amount of the developer material is too large or too small.</li> <li>• Remove any toner or dust on the auto-toner sensor connector and the drawer connector of the process cover.</li> <li>• Remove any toner or dust on the EPU sensor connector and the drawer connector on the equipment side.</li> </ul>	
2	Auto toner sensor Harness LGC board		<ul style="list-style-type: none"> <li>• Check the connectors and harnesses between the auto toner sensor and LGC board (CN347).</li> <li>• Check if there is any foreign matter such as toner in the connector of the auto toner sensor. Remove if there is and reconnect it.</li> </ul>	

Replacement part	Remark
Auto toner sensor	
Harness	
LGC board	
Developer material	
High-voltage transformer	

**[C3A1] Auto-toner sensor-M abnormality (lower limit)**

Classification	Contents
Copy process related service call	Auto-toner sensor-M abnormality (lower limit)

Step	Check Item	Result	Measure	Next Step
1	Developer unit		<ul style="list-style-type: none"> <li>• Check if the developer unit is installed properly.</li> <li>• Check that the developer unit and coupling on the equipment side are properly engaged.</li> <li>• Check that the mixer of the developer unit is rotated.</li> <li>• Check if the amount of the developer material is too large or too small.</li> <li>• Remove any toner or dust on the auto-toner sensor connector and the drawer connector of the process cover.</li> <li>• Remove any toner or dust on the EPU sensor connector and the drawer connector on the equipment side.</li> </ul>	
2	Auto toner sensor Harness LGC board		<ul style="list-style-type: none"> <li>• Check the connectors and harnesses between the auto toner sensor and LGC board (CN347).</li> <li>• Check if there is any foreign matter such as toner in the connector of the auto toner sensor. Remove if there is and reconnect it.</li> </ul>	

Replacement part	Remark
Auto toner sensor	
Harness	
LGC board	
Developer material	

**[C3B0] Auto-toner sensor-Y abnormality (upper limit)**

Classification	Contents
Copy process related service call	Auto-toner sensor-Y abnormality (upper limit)

Step	Check Item	Result	Measure	Next Step
1	Developer unit		<ul style="list-style-type: none"> <li>• Check if the developer unit is installed properly.</li> <li>• Check that the developer unit and coupling on the equipment side are properly engaged.</li> <li>• Check that the mixer of the developer unit is rotated.</li> <li>• Check if the developer material is too light visually.</li> <li>• Check if the amount of the developer material is too large or too small.</li> <li>• Remove any toner or dust on the auto-toner sensor connector and the drawer connector of the process cover.</li> <li>• Remove any toner or dust on the EPU sensor connector and the drawer connector on the equipment side.</li> </ul>	
2	Auto toner sensor Harness LGC board		<ul style="list-style-type: none"> <li>• Check the connectors and harnesses between the auto toner sensor and LGC board (CN347).</li> <li>• Check if there is any foreign matter such as toner in the connector of the auto toner sensor. Remove if there is and reconnect it.</li> </ul>	

Replacement part	Remark
Auto toner sensor	
Harness	
LGC board	
Developer material	
High-voltage transformer	

**[C3B1] Auto-toner sensor-Y abnormality (lower limit)**

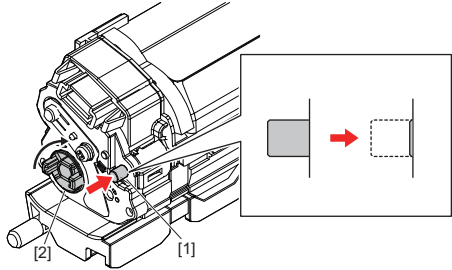
Classification	Contents
Copy process related service call	Auto-toner sensor-Y abnormality (lower limit)

Step	Check Item	Result	Measure	Next Step
1	Developer unit		<ul style="list-style-type: none"> <li>• Check if the developer unit is installed properly.</li> <li>• Check that the developer unit and coupling on the equipment side are properly engaged.</li> <li>• Check that the mixer of the developer unit is rotated.</li> <li>• Check if the amount of the developer material is too large or too small.</li> <li>• Remove any toner or dust on the auto-toner sensor connector and the drawer connector of the process cover.</li> <li>• Remove any toner or dust on the EPU sensor connector and the drawer connector on the equipment side.</li> </ul>	
2	Auto toner sensor Harness LGC board		<ul style="list-style-type: none"> <li>• Check the connectors and harnesses between the auto toner sensor and LGC board (CN347).</li> <li>• Check if there is any foreign matter such as toner in the connector of the auto toner sensor. Remove if there is and reconnect it.</li> </ul>	

Replacement part	Remark
Auto toner sensor	
Harness	
LGC board	
Developer material	

**[C3E0] Developer unit replacement (old-new) detection abnormality**

Classification	Contents
Copy process related service call	Developer unit replacement (old-new) detection abnormality

Step	Check Item	Result	Measure	Next Step
1	Check if the old/new detection pusher of the developer unit is being ejected.	Yes		4
		No		2
2	Check if the harness of the old/new detection switch in the developer unit is open circuited.	Yes		3
		No	Replace the harness.	
3	Is the old/new detection switch of the developer unit normal?	Yes		4
		No	Replace the old/new detection switch.	
4	Check if the old/new detection pusher is moved to the escape position while the coupling of the developer unit is rotated by hand. (Is the driving in the old/new detection pusher section transmitted?)	Yes		3
		No	<p>Correct the old/new detection pusher so that it is moved to the escape position.</p>  <p><b>Fig.8-19</b></p> <p>Temporarily take off the developer unit, and then rotate the developer sleeve clockwise (in the direction of the black arrow) while pushing the old/new detection pusher (shown with the red arrow). Rotate it until the pusher is fully stored.</p>	
5	Check that the coupling of the paper feed developer drive unit is driven properly.	Yes	Correct the engagement of the couplings in the paper feed developer drive unit and the developer unit.	9
		No		6
6	Check that the paper feeding/developer unit drive motor rotates properly. (Output check: FS-03-112/162)	Yes		9
		No		7
7	Check that the connector of the paper feeding/developer unit drive motor is connected properly.	Yes		9
		No		8
8	Check if the harness of the paper feeding/developer unit drive motor is open circuited.	Yes		9
		No	Replace the paper feeding/developer unit drive motor.	



Step	Check Item	Result	Measure	Next Step
9	Check that the coupling of the drum TBU drive unit is driven properly.	Yes	Correct the engagement of the couplings in the drum TBU drive unit and the developer unit.	
		No		10
10	Check that the connector of the LGC board (CN347, CN367) is connected properly.	Yes		11
		No	Reconnect the connector.	
11	Is the harness of the LGC board normal?	Yes		12
		No	Replace the harness.	
12	Is the LGC board normal?		Replace the LGC board.	

Replacement part	Remark
Developer unit old/new detection switches	
Paper feeding/developer unit drive motor	
LGC board	
Harness	

### [C3E1] Drum/cleaner/charger unit replacement (old-new) detection abnormality

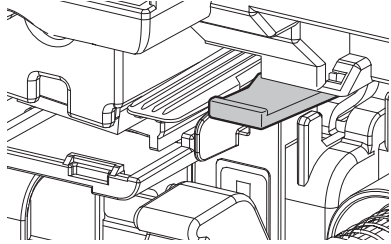
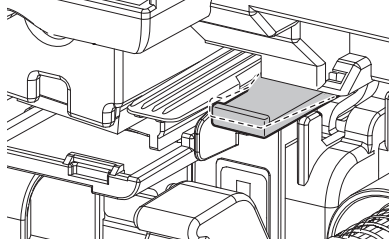
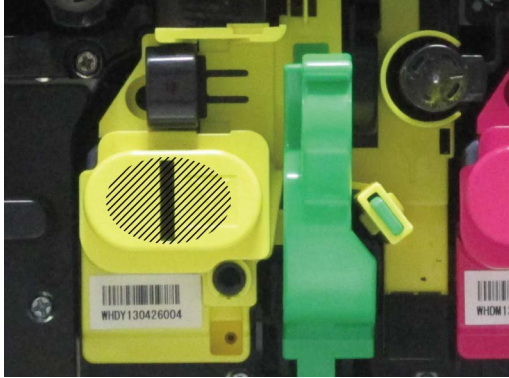
Classification	Contents
Copy process related service call	Drum/cleaner/charger unit replacement (old-new) detection abnormality

Step	Check Item	Result	Measure	Next Step
1	Check if the old/new detection pusher of the drum cleaner unit is being ejected.	Yes		4
		No		2
2	Check if the harness of the drum old/new detection switch in the drum cleaner unit is open circuited.	Yes		3
		No	Replace the harness.	
3	Is the drum old/new detection switch of the drum cleaner unit normal?	Yes		4
		No	Replace the drum old/new detection switch.	
4	Check if the drum old/new detection pusher is moved to the escape position while the coupling of the drum cleaner unit is rotated by hand. (Is a driving in the old/new detection pusher section transmitted?)	Yes		3
		No	Correct the drum old/new detection pusher so that it is moved to the escape position.	
5	Check that the coupling of the drum TBU drive unit is driven properly.	Yes	Correct the engagement of the couplings in the drum TBU drive unit and the drum cleaner unit.	9
		No		6
6	Check that the drum TBU drive motor rotates properly. (Output check: FS-03-101/151)	Yes		9
		No		7
7	Check that the connector of the drum TBU drive motor is connected properly.	Yes		9
		No		8
8	Check if the harness of the drum TBU drive motor is open circuited.	Yes		9
		No	Replace the drum TBU drive motor.	
9	Check that the connector of the LGC board (CN347, CN367) is connected properly.	Yes		11
		No	Reconnect the connector.	
10	Is the harness of the LGC board normal?	Yes		12
		No	Replace the harness.	
11	Is the LGC board normal?		Replace the LGC board.	

Replacement part	Remark
Drum old/new detection switches	
Drum TBU motor	
LGC board	
Harness	

### [C970] High-voltage transformer abnormality

Classification	Contents
Copy Process related service call	High-voltage transformer abnormality: Leakage of the main charger is detected.

Check Item	Measure
<p>Has the cleaner unit been installed securely?</p> <p>- Installed securely</p>  <p>- Not installed securely</p> 	<p>Press the slanted line portion of the developer unit until a click sound is heard.</p> 
Main charger	Check if the main charger is installed securely.
Spring of high-voltage supply contact point	Check if the spring of high-voltage supply contact point is deformed.
Needle electrode	<ul style="list-style-type: none"> <li>• Check if the needle electrode is broken or the main charger grid is deformed.</li> <li>• Check if any foreign matter is on the needle electrode or main charger grid.</li> </ul>

### [CD40] Waste toner box full error

Classification	Contents
Copy Process related service call	Waste toner box full is detected.

Check Item	Measure
Waste toner box	<ol style="list-style-type: none"> <li>1. Replace the waste toner box with a new one.</li> <li>2. Turn the power OFF and then back ON.</li> </ol>
Clear the counter	<ol style="list-style-type: none"> <li>1. Set the value of FS-08-4541 to "0".</li> <li>2. Turn the power OFF and then back ON.</li> </ol>

Replacement part	Remark
Waste toner box	

### 8.3.25 Other service call

#### [F100\_0] HDD format error (Operation failure of key data)

Classification	Contents
Other service call	HDD format error: Operation of HDD key data fails.

Check item	Measures
Setting	Reboot the equipment. If it cannot be recovered, reinstall the software in the following procedure. 1. Install the system firmware. 📖 P. 11-2 "11.2 Firmware Updating with USB Device"
SRAM	Replace the SRAM.
SYS board	Replace the SYS board.

Replacement part	Remark
SRAM	Be sure to exchange the parts in the order of the SRAM and SYS board.
SYS board	Be sure to exchange the parts in the order of the SRAM and SYS board.

#### [F100\_1] HDD format error (HDD encryption key data damaged - one board)

Classification	Contents
Other service call	HDD format error: Encryption key data of either the SYS board or the SRAM are damaged.

Check item	Measures
Encryption key status	Check the displayed message. (HS-73 Firmware Assist mode - > Key Backup/Restore)




Take appropriate countermeasures shown in the table below according to the messages displayed in "SRAM" and "FROM".

**Remarks:**

If the error is not cleared, reinstallation of the system firmware, system software and application is needed. (HS-49 Firmware Update mode)

📖 P. 11-2 "11.2 Firmware Updating with USB Device"

SRAM	FROM	Measure
OK	AccessFailed	Replace the SYS board. 📖 P. 9-21 "9.2.4 Precautions and procedures when replacing the SYS board" (all steps)
OK	KeyNull KeyBroken	Recover the encryption key on the SYS board. 📖 P. 9-21 "9.2.4 Precautions and procedures when replacing the SYS board" ([D]Restore encryption key)
AccessFailed	OK	Replace the SRAM. (USB backup data are not used) 📖 P. 9-21 "9.2.4 Precautions and procedures when replacing the SYS board" (all steps)

SRAM	FROM	Measure
KeyNull	OK	Recover the encryption key on the SRAM.  P. 9-25 "9.2.5 Precautions and procedure when replacing the SRAM" ([H] Backup encryption key (FROM -> SRAM))
KeyBroken		
Keymismatch	Keymismatch	<The error occurs when the SYS board is replaced> Recover the encryption key on the SYS board.  P. 9-21 "9.2.4 Precautions and procedures when replacing the SYS board" ([D]Restore encryption key) <The error occurs except when the SYS board is replaced> Replace the SRAM.  P. 9-25 "9.2.5 Precautions and procedure when replacing the SRAM" (all steps)

Replacement part	Remark
SRAM	Be sure to exchange the parts in the order of the SRAM and SYS board.
SYS board	Be sure to exchange the parts in the order of the SRAM and SYS board.

**[F100\_2] HDD format error (HDD encryption key data damaged - both boards)**

Classification	Contents
Other service call	HDD format error: Encryption key data of both the SYS board and the SRAM are damaged.

Check item	Measures
Encryption key status	Check the displayed message. (HS-73 Firmware Assist mode - > Key Backup/Restore)

Take appropriate countermeasures shown in the table below according to the messages displayed in "SRAM" and "FROM".

**Remarks:**

If the error is not cleared, reinstallation of the system firmware / system software and application is needed. (HS-49 Firmware Update mode)

SRAM	FROM	Measure
*	AccessFailed	Replace the SYS board. ☞ P. 9-21 "9.2.4 Precautions and procedures when replacing the SYS board" (all steps) <With USB backup data: All key data recovery> 1. Recover all the data on the SRAM. HS-59 SRAM Data Cloning mode -> Restore SRAM Data from USB (For details, see "☞ P. 12-2 "12.1.4 Cloning procedure" [B] Restore procedure") 2. Recover the encryption key/license on the SYS board. Follow the procedures below noted in ☞ P. 9-21 "9.2.4 Precautions and procedures when replacing the SYS board". [C] Restore ADI key (only when Secure HDD is installed) [D] Restore encryption key [E] Restore license
AccessFailed	*	Replace the SRAM. ☞ P. 9-25 "9.2.5 Precautions and procedure when replacing the SRAM" (all steps)
KeyNull/ KeyBroken	KeyNull/ KeyBroken	<No USB backup data> 1. Reinstall the system software. ☞ P. 11-2 "11.2 Firmware Updating with USB Device" <With USB backup data: All key data recovery> 1. Recover all the data on the SRAM. HS-59 SRAM Data Cloning mode -> Restore SRAM Data from USB (For details, see "☞ P. 12-2 "12.1.4 Cloning procedure" [B] Restore procedure") 2. Recover the encryption key/license on the SYS board. Follow the procedures below noted in ☞ P. 9-21 "9.2.4 Precautions and procedures when replacing the SYS board". [C] Restore ADI key (only when Secure HDD is installed) [D] Restore encryption key [E] Restore license

\* AccessFailed, KeyNull or KeyBroken

Replacement part	Remark
SRAM	Be sure to exchange the parts in the order of the SRAM and SYS board.
SYS board	Be sure to exchange the parts in the order of the SRAM and SYS board.

**[F100\_3] Serial number value error**

Classification	Contents
Other service call	Only the first two characters of the serial number are entered. (The serial number is not completely entered.)

Check item	Measures
Serial number	Enter the serial number with [FS-08-9601]. If an F100_3 error occurs at the FS Menu startup, select HS-76 SRAM clear mode -> Set Serial Number and enter the serial number.

### [F100\_3] Serial number value error

Classification	Contents
Other service call	Only the first two characters of the serial number are entered. (The serial number is not completely entered.)

Check item	Measures
Serial number	Enter the serial number with [FS-08-9601]. If an F100_3 error occurs at the FS Menu startup, select HS-76 SRAM clear mode -> Set Serial Number and enter the serial number.



[F101\_0] HDD connection error (HDD connection cannot be detected.)

[F101\_1] Root partition mount error (HDD formatting fails.)

[F101\_2][F101\_3] Partition mount error (The HDD cannot be connected (mounted) caused by damage to areas other than those described in the F101\_1 and F101\_4 to F101\_10 errors.)

Classification	Contents
Other service call	HDD unmounted: Connection of HDD cannot be detected. Sub-code 0: HDD connection error (HDD connection cannot be detected.) Sub-code 1: Root partition mount error (HDD formatting fails.) Sub-code 2, 3: Partition mount error (The areas other than those described in the F101_1 and F101_4 to F101_10 errors are damaged.)

Check item	Measures
HDD, SYS board, Setting	<ol style="list-style-type: none"> <li>1. Turn the power of the equipment OFF and check the connection of the HDD. <ul style="list-style-type: none"> <li>- Connector and harness check</li> <li>- Check if the connector pins of the HDD are bent.</li> <li>- Check if HDD for other equipment is not installed.</li> <li>- Check if SRAM for other equipment is not installed.</li> </ul> </li> <li>2. If the error still occurs after step 1, perform the following. <ul style="list-style-type: none"> <li>- Perform HS-73 Firmware Assist mode -&gt; Key Backup/Restore and check that each Key Status is "OK".</li> <li>- If not, recover the key (press [Key] and select the menu, and then press [Execute]).</li> </ul> </li> <li>3. If the error still persists after step 2, perform the following. <ul style="list-style-type: none"> <li>- Perform HS-73 Firmware Assist mode -&gt; Format HDD, and then install "System software" (HS-49 Firmware Update mode -&gt; SYSTEM SOFTWARE (HD Data)).</li> </ul> <p><b>Notes:</b> The following items will be deleted by HS-73 Firmware Assist mode -&gt; Format HDD.</p> <ul style="list-style-type: none"> <li>• Message Log</li> <li>• Job Log</li> <li>• Spool Data (Print, Email reception)</li> <li>• Template</li> </ul> <p>If F101_1 occurs with secure HDD or the error persists after performing step 3, perform step 3 after performing HS-74 HDD Assist mode -&gt; Revert Factory Initial Status HDD.</p> </li> <li>4. If the error persists even after step 3, replace the HDD.</li> <li>5. If the error persists even after step 4, replace the HDD harness.</li> <li>6. If the error persists even after step 5, replace the SYS board.</li> </ol>

Replacement part	Remark
HDD harness	Be sure to exchange the parts in the order of the HDD harness, HDD and SYS board.
HDD	Be sure to exchange the parts in the order of the HDD harness, HDD and SYS board.

<b>Replacement part</b>	<b>Remark</b>
SYS board	Be sure to exchange the parts in the order of the HDD harness, HDD and SYS board.

**[F101\_4] Partition mount error (The HDD cannot be connected (mounted) caused by damage to the "/work" partition.)**

**[F101\_12] Partition mount error (File link error in the "/work" partition)**

Classification	Contents
Other service call	HDD unmounted: Connection of HDD cannot be detected. Sub-code 4: Partition mount error (The "/work" partition is damaged.) Sub-code 12: Partition mount error (File link error in the "/work" partition)

Check item	Measures
HDD, SYS board, Setting	<ol style="list-style-type: none"> <li>1. Turn the power of the equipment OFF and check the connection of the HDD. <ul style="list-style-type: none"> <li>- Connector and harness check</li> <li>- Check if the connector pins of the HDD are bent.</li> <li>- Check if HDD for other equipment is not installed.</li> <li>- Check if SRAM for other equipment is not installed.</li> </ul> </li> <li>2. If the error still occurs after step 1, perform the following. <ul style="list-style-type: none"> <li>- Perform HS-73 Firmware Assist mode -&gt; Key Backup/Restore and check that each Key Status is "OK".</li> <li>- If not, recover the key (press [Key] and select the menu, and then press [Execute]).</li> </ul> </li> <li>3. If the error persists after step 2, perform HS-75 File System Recovery mode→Recovery F/S→/work, and then restart the equipment.</li> <li>4. If the error persists after step 3, perform HS-75 File System Recovery mode→Initialize HDD→/work, and then restart the equipment.</li> <li>5. If the error still persists after step 4, perform the following. <ul style="list-style-type: none"> <li>- Perform HS-73 Firmware Assist mode -&gt; Format HDD, and then install "System Software (HD data)" with HS-49 Firmware Update mode.</li> </ul> <p><b>Notes:</b> The following items will be deleted by performing HS-73 Firmware Assist mode -&gt; Format HDD.</p> <ul style="list-style-type: none"> <li>• Message Log</li> <li>• Job Log</li> <li>• Spool Data (Print, Email reception)</li> <li>• Template</li> </ul> <p>If the error persists after performing step 5, perform step 5 after performing HS-74 HDD Assist mode -&gt; Revert Factory Initial Status HDD.</p> </li> <li>6. If the error persists even after step 5, replace the HDD.</li> <li>7. If the error persists even after step 6, replace the HDD harness.</li> <li>8. If the error persists even after step 7, replace the SYS board.</li> </ol>

Replacement part	Remark
HDD harness	Be sure to exchange the parts in the order of the HDD harness, HDD and SYS board.

Replacement part	Remark
HDD	Be sure to exchange the parts in the order of the HDD harness, HDD and SYS board.
SYS board	Be sure to exchange the parts in the order of the HDD harness, HDD and SYS board.

**[F101\_5] Partition mount error (The HDD cannot be connected (mounted) caused by damage to the "/registration" partition.)**

Classification	Contents
Other service call	HDD unmounted: Connection of HDD cannot be detected. Sub-code 5: Partition mount error (The "/registration" partition is damaged.)

Check item	Measures
HDD, SYS board, Setting	<ol style="list-style-type: none"> <li>1. Turn the power of the equipment OFF and check the connection of the HDD. <ul style="list-style-type: none"> <li>- Connector and harness check</li> <li>- Check if the connector pins of the HDD are bent.</li> <li>- Check if HDD for other equipment is not installed.</li> <li>- Check if SRAM for other equipment is not installed.</li> </ul> </li> <li>2. If the error still occurs after step 1, perform the following. <ul style="list-style-type: none"> <li>- Perform HS-73 Firmware Assist mode -&gt; Key Backup/Restore and check that each Key Status is "OK".</li> <li>- If not, recover the key (press [Key] and select the menu, and then press [Execute]).</li> </ul> </li> <li>3. If the error persists after step 2, perform HS-75 File System Recovery mode→Recovery F/S→/registration, and then restart the equipment.</li> <li>4. If the error persists after step 3, perform HS-75 File System Recovery mode→Initialize HDD→/registration, and then restart the equipment.</li> <li>5. If the error still persists after step 4, perform the following. <ul style="list-style-type: none"> <li>- Perform HS-73 Firmware Assist mode -&gt; Format HDD, and then install "System Software (HD data)" with HS-49 Firmware Update mode.</li> </ul> <p><b>Notes:</b> The following items will be deleted by performing HS-73 Firmware Assist mode -&gt; Format HDD.</p> <ul style="list-style-type: none"> <li>• Message Log</li> <li>• Job Log</li> <li>• Spool Data (Print, Email reception)</li> <li>• Template</li> </ul> <p>If the error persists after performing step 5, perform step 5 after performing HS-74 HDD Assist mode -&gt; Revert Factory Initial Status HDD.</p> </li> <li>6. If the error persists even after step 5, replace the HDD.</li> <li>7. If the error persists even after step 6, replace the HDD harness.</li> <li>8. If the error persists even after step 7, replace the SYS board.</li> </ol>

Replacement part	Remark
HDD harness	Be sure to exchange the parts in the order of the HDD harness, HDD and SYS board.
HDD	Be sure to exchange the parts in the order of the HDD harness, HDD and SYS board.
SYS board	Be sure to exchange the parts in the order of the HDD harness, HDD and SYS board.

**[F101\_6] Partition mount error (The HDD cannot be connected (mounted) caused by damage to the "/backup" partition.)**

Classification	Contents
Other service call	HDD unmounted: Connection of HDD cannot be detected. Sub-code 6: Partition mount error (The "/backup" partition is damaged.)

Check item	Measures
HDD, SYS board, Setting	<ol style="list-style-type: none"> <li>1. Turn the power of the equipment OFF and check the connection of the HDD. <ul style="list-style-type: none"> <li>- Connector and harness check</li> <li>- Check if the connector pins of the HDD are bent.</li> <li>- Check if HDD for other equipment is not installed.</li> <li>- Check if SRAM for other equipment is not installed.</li> </ul> </li> <li>2. If the error still occurs after step 1, perform the following. <ul style="list-style-type: none"> <li>- Perform HS-73 Firmware Assist mode -&gt; Key Backup / Restore and check that each Key Status is "OK".</li> <li>- If not, recover the key (press [Key] and select the menu, and then press [Execute]).</li> </ul> </li> <li>3. If the error persists after step 2, perform HS-75 File System Recovery mode→Recovery F/S→/backup, and then restart the equipment.</li> <li>4. If the error persists after step 3, perform HS-75 File System Recovery mode→Initialize HDD→/backup, and then restart the equipment.</li> <li>5. If the error still persists after step 4, perform the following. <ul style="list-style-type: none"> <li>- Perform HS-73 Firmware Assist mode -&gt; Format HDD, and then install "System Software (HD data)" with HS-49 Firmware Update mode.</li> </ul> <p><b>Notes:</b> The following items will be deleted by performing HS-73 Firmware Assist mode -&gt; Format HDD.</p> <ul style="list-style-type: none"> <li>• Message Log</li> <li>• Job Log</li> <li>• Spool Data (Print, Email reception)</li> <li>• Template</li> </ul> <p>If the error persists after performing step 5, perform step 5 after performing HS-74 HDD Assist mode -&gt; Revert Factory Initial Status HDD.</p> </li> <li>6. If the error persists even after step 5, replace the HDD.</li> <li>7. If the error persists even after step 6, replace the HDD harness.</li> <li>8. If the error persists even after step 7, replace the SYS board.</li> </ol>

Replacement part	Remark
HDD harness	Be sure to exchange the parts in the order of the HDD harness, HDD and SYS board.
HDD	Be sure to exchange the parts in the order of the HDD harness, HDD and SYS board.
SYS board	Be sure to exchange the parts in the order of the HDD harness, HDD and SYS board.

**[F101\_7] Partition mount error (The HDD cannot be connected (mounted) caused by damage to the "/imagedata" partition.)**

Classification	Contents
Other service call	HDD unmounted: Connection of HDD cannot be detected. Sub-code 7: Partition mount error (The "/imagedata" partition is damaged.)

Check item	Measures
HDD, SYS board, Setting	<ol style="list-style-type: none"> <li>1. Turn the power of the equipment OFF and check the connection of the HDD. <ul style="list-style-type: none"> <li>- Connector and harness check</li> <li>- Check if the connector pins of the HDD are bent.</li> <li>- Check if HDD for other equipment is not installed.</li> <li>- Check if SRAM for other equipment is not installed.</li> </ul> </li> <li>2. If the error still occurs after step 1, perform the following. <ul style="list-style-type: none"> <li>- Perform HS-73 Firmware Assist mode -&gt; Key Backup/Restore and check that each Key Status is "OK".</li> <li>- If not, recover the key (press [Key] and select the menu, and then press [Execute]).</li> </ul> </li> <li>3. If the error persists after step 2, perform HS-75 File System Recovery mode→Recovery F/S→/imagedata, and then restart the equipment.</li> <li>4. If the error persists after step 3, perform HS-75 File System Recovery mode→Initialize HDD→/imagedata, and then restart the equipment.</li> <li>5. If the error still persists after step 4, perform the following. <ul style="list-style-type: none"> <li>- Perform HS-73 Firmware Assist mode -&gt; Format HDD, and then install "System Software (HD data)" with HS-49 Firmware Update mode.</li> </ul> <p><b>Notes:</b> The following items will be deleted by performing HS-73 Firmware Assist mode -&gt; Format HDD.</p> <ul style="list-style-type: none"> <li>• Message Log</li> <li>• Job Log</li> <li>• Spool Data (Print, Email reception)</li> <li>• Template</li> </ul> <p>If the error persists after performing step 5, perform step 5 after performing HS-74 HDD Assist mode -&gt; Revert Factory Initial Status HDD.</p> </li> <li>6. If the error persists even after step 5, replace the HDD.</li> <li>7. If the error persists even after step 6, replace the HDD harness.</li> <li>8. If the error persists even after step 7, replace the SYS board.</li> </ol>

Replacement part	Remark
HDD harness	Be sure to exchange the parts in the order of the HDD harness, HDD and SYS board.
HDD	Be sure to exchange the parts in the order of the HDD harness, HDD and SYS board.
SYS board	Be sure to exchange the parts in the order of the HDD harness, HDD and SYS board.

**[F101\_8] Partition mount error (The HDD cannot be connected (mounted) caused by damage to the "/storage" partition.)**

Classification	Contents
Other service call	HDD unmounted: Connection of HDD cannot be detected. Sub-code 8: Partition mount error (The "/storage" partition is damaged.)

Check item	Measures
HDD, SYS board, Setting	<ol style="list-style-type: none"> <li>1. Turn the power of the equipment OFF and check the connection of the HDD. <ul style="list-style-type: none"> <li>- Connector and harness check</li> <li>- Check if the connector pins of the HDD are bent.</li> <li>- Check if HDD for other equipment is not installed.</li> <li>- Check if SRAM for other equipment is not installed.</li> </ul> </li> <li>2. If the error still occurs after step 1, perform the following. <ul style="list-style-type: none"> <li>- Perform HS-73 Firmware Assist mode -&gt; Key Backup/Restore and check that each Key Status is "OK".</li> <li>- If not, recover the key (press [Key] and select the menu, and then press [Execute]).</li> </ul> </li> <li>3. If the error persists after step 2, perform HS-75 File System Recovery mode→Recovery F/S→/storage, and then restart the equipment.</li> <li>4. If the error persists after step 3, perform HS-75 File System Recovery mode→Initialize HDD→/storage, and then restart the equipment.</li> <li>5. If the error still persists after step 4, perform the following. <ul style="list-style-type: none"> <li>- Perform HS-73 Firmware Assist mode -&gt; Format HDD, and then install "System Software (HD data)" with HS-49 Firmware Update mode.</li> </ul> <p><b>Notes:</b> The following items will be deleted by performing HS-73 Firmware Assist mode -&gt; Format HDD.</p> <ul style="list-style-type: none"> <li>• Message Log</li> <li>• Job Log</li> <li>• Spool Data (Print, Email reception)</li> <li>• Template</li> </ul> <p>If the error persists after performing step 5, perform step 5 after performing HS-74 HDD Assist mode -&gt; Revert Factory Initial Status HDD.</p> </li> <li>6. If the error persists even after step 5, replace the HDD.</li> <li>7. If the error persists even after step 6, replace the HDD harness.</li> <li>8. If the error persists even after step 7, replace the SYS board.</li> </ol>

Replacement part	Remark
HDD harness	Be sure to exchange the parts in the order of the HDD harness, HDD and SYS board.
HDD	Be sure to exchange the parts in the order of the HDD harness, HDD and SYS board.
SYS board	Be sure to exchange the parts in the order of the HDD harness, HDD and SYS board.



**[F101\_9] Partition mount error (The HDD cannot be connected (mounted) caused by damage to the "/encryption" partition.)**

Classification	Contents
Other service call	HDD unmounted: Connection of HDD cannot be detected. Sub-code 9: Partition mount error (The "/encryption" partition is damaged.)

Check item	Measures
HDD, SYS board, Setting	<ol style="list-style-type: none"> <li>1. Turn the power of the equipment OFF and check the connection of the HDD. <ul style="list-style-type: none"> <li>- Connector and harness check</li> <li>- Check if the connector pins of the HDD are bent.</li> <li>- Check if HDD for other equipment is not installed.</li> <li>- Check if SRAM for other equipment is not installed.</li> </ul> </li> <li>2. If the error still occurs after step 1, perform the following. <ul style="list-style-type: none"> <li>- Perform HS-73 Firmware Assist mode -&gt; Key Backup/Restore and check that each Key Status is "OK".</li> <li>- If not, recover the key (press [Key] and select the menu, and then press [Execute]).</li> </ul> </li> <li>3. If the error persists after step 2, perform HS-75 File System Recovery mode→Recovery F/S→/encryption, and then restart the equipment.</li> <li>4. If the error persists after step 3, perform HS-75 File System Recovery mode→Initialize HDD→/encryption, and then restart the equipment.</li> <li>5. If the error still persists after step 4, perform the following. <ul style="list-style-type: none"> <li>- Perform HS-73 Firmware Assist mode -&gt; Format HDD, and then install "System Software (HD data)" with HS-49 Firmware Update mode.</li> </ul> <p><b>Notes:</b> The following items will be deleted by performing HS-73 Firmware Assist mode -&gt; Format HDD.</p> <ul style="list-style-type: none"> <li>• Message Log</li> <li>• Job Log</li> <li>• Spool Data (Print, Email reception)</li> <li>• Template</li> </ul> <p>If the error persists after performing step 5, perform step 5 after performing HS-74 HDD Assist mode -&gt; Revert Factory Initial Status HDD.</p> </li> <li>6. If the error persists even after step 5, replace the HDD.</li> <li>7. If the error persists even after step 6, replace the HDD harness.</li> <li>8. If the error persists even after step 7, replace the SYS board.</li> </ol>

Replacement part	Remark
HDD harness	Be sure to exchange the parts in the order of the HDD harness, HDD and SYS board.
HDD	Be sure to exchange the parts in the order of the HDD harness, HDD and SYS board.
SYS board	Be sure to exchange the parts in the order of the HDD harness, HDD and SYS board.

**[F101\_10] Partition mount error (The HDD cannot be connected (mounted) caused by damage to the "/application" partition.)**

Classification	Contents
Other service call	HDD unmounted: Connection of HDD cannot be detected. Sub-code 10: Partition mount error (The "/application" partition is damaged.)

Check item	Measures
HDD, SYS board, Setting	<ol style="list-style-type: none"> <li>Turn the power of the equipment OFF and check the connection of the HDD. <ul style="list-style-type: none"> <li>Connector and harness check</li> <li>Check if the connector pins of the HDD are bent.</li> <li>Check if HDD for other equipment is not installed.</li> <li>Check if SRAM for other equipment is not installed.</li> </ul> </li> <li>If the error still occurs after step 1, perform the following. <ul style="list-style-type: none"> <li>Perform HS-73 Firmware Assist mode -&gt; Key Backup/Restore and check that each Key Status is "OK".</li> <li>If not, recover the key (press [Key] and select the menu, and then press [Execute]).</li> </ul> </li> <li>If the error persists after step 2, perform HS-75 File System Recovery mode→Recovery F/S→/application, and then restart the equipment.</li> <li>If the error persists after step 3, perform HS-75 File System Recovery mode→Initialize HDD→/application, and then restart the equipment.</li> <li>If the error still persists after step 4, perform the following. <ul style="list-style-type: none"> <li>Perform HS-73 Firmware Assist mode -&gt; Format HDD, and then install "System Software (HD data)" with HS-49 Firmware Update mode.</li> </ul> <p><b>Notes:</b> The following items will be deleted by performing HS-73 Firmware Assist mode -&gt; Format HDD.</p> <ul style="list-style-type: none"> <li>Message Log</li> <li>Job Log</li> <li>Spool Data (Print, Email reception)</li> <li>Template</li> </ul> <p>If the error persists after performing step 5, perform step 5 after performing HS-74 HDD Assist mode -&gt; Revert Factory Initial Status HDD.</p> </li> <li>If the error persists even after step 5, replace the HDD.</li> <li>If the error persists even after step 6, replace the HDD harness.</li> <li>If the error persists even after step 7, replace the SYS board.</li> </ol>

Replacement part	Remark
HDD harness	Be sure to exchange the parts in the order of the HDD harness, HDD and SYS board.
HDD	Be sure to exchange the parts in the order of the HDD harness, HDD and SYS board.
SYS board	Be sure to exchange the parts in the order of the HDD harness, HDD and SYS board.

**[F101\_11] Partition mount error (The HDD cannot be connected (mounted) caused by damage to the "/platform" partition.)**

Classification	Contents
Other service call	HDD unmounted: Connection of HDD cannot be detected. Sub-code 11: A file in the "/platform" partition is damaged.

Check item	Measures
HDD, SYS board, Setting	<ol style="list-style-type: none"> <li>1. Turn the power of the equipment OFF and check the connection of the HDD. <ul style="list-style-type: none"> <li>- Connector and harness check</li> <li>- Check if the connector pins of the HDD are bent.</li> <li>- Check if HDD for other equipment is not installed.</li> <li>- Check if SRAM for other equipment is not installed.</li> </ul> </li> <li>2. If the error persists after step 1, perform the following. <ul style="list-style-type: none"> <li>- Perform HS-73 Firmware Assist mode → Format HDD, and then install "System Software (HD data)" with HS-49 Firmware Update mode.</li> </ul> <p><b>Notes:</b> The following items will be deleted by performing HS-73 Firmware Assist mode → Format HDD.</p> <ul style="list-style-type: none"> <li>• Message Log</li> <li>• Job Log</li> <li>• Spool Data (Print, Email reception)</li> <li>• Template</li> </ul> </li> <li>3. If the error persists even after step 2, perform the following and then reattempt step 2. <ul style="list-style-type: none"> <li>- HS-74 HDD Assist mode → Revert Factory Initial Status HDD.</li> </ul> </li> <li>4. If the error persists even after step 3, replace the HDD.</li> <li>5. If the error persists even after step 4, replace the HDD harness.</li> <li>6. If the error persists even after step 5, replace the SYS board.</li> </ol>

Replacement part	Remark
HDD harness	Be sure to exchange the parts in the order of the HDD harness, HDD and SYS board.
HDD	Be sure to exchange the parts in the order of the HDD harness, HDD and SYS board.
SYS board	Be sure to exchange the parts in the order of the HDD harness, HDD and SYS board.

**[F101\_13] Error due to damage to file (Damage to the file in the "/imagedata" partition)**

Classification	Contents
Other service call	HDD unmounted: Connection of HDD cannot be detected. Sub-code 13: A file in the "/imagedata" partition is damaged.

Check item	Measures
HDD, SYS board, Setting	<ol style="list-style-type: none"> <li>1. Turn the power of the equipment OFF and check the connection of the HDD. <ul style="list-style-type: none"> <li>- Connector and harness check</li> <li>- Check if the connector pins of the HDD are bent.</li> <li>- Check if HDD for other equipment is not installed.</li> <li>- Check if SRAM for other equipment is not installed.</li> </ul> </li> <li>2. If the error still occurs after step 1, perform the following. <ul style="list-style-type: none"> <li>- HS-75 File System Recovery mode → Recovery F/S → /imagedata, and then restart the equipment.</li> </ul> </li> <li>3. If the error persists after step 2, perform the following. <ul style="list-style-type: none"> <li>- Perform HS-73 Firmware Assist mode → Format HDD, and then install "System Software (HD data)" with HS-49 Firmware Update mode.</li> </ul> <p><b>Notes:</b> The following items will be deleted by performing HS-73 Firmware Assist mode → Format HDD.</p> <ul style="list-style-type: none"> <li>• Message Log</li> <li>• Job Log</li> <li>• Spool Data (Print, Email reception)</li> <li>• Template</li> </ul> </li> <li>4. If the error persists even after step 3, perform the following and then reattempt step 3. <ul style="list-style-type: none"> <li>- HS-74 HDD Assist mode → Revert Factory Initial Status HDD.</li> </ul> </li> <li>5. If the error persists even after step 4, replace the HDD.</li> <li>6. If the error persists even after step 6, replace the SYS board.</li> <li>7. If the error still persists even after step 6, replace the SYS board.</li> </ol>

Replacement part	Remark
HDD harness	Be sure to exchange the parts in the order of the HDD harness, HDD and SYS board.
HDD	Be sure to exchange the parts in the order of the HDD harness, HDD and SYS board.
SYS board	Be sure to exchange the parts in the order of the HDD harness, HDD and SYS board.

**[F101\_14] Partition mount error**

Classification	Error content
Other service call	The HDD cannot be connected (mounted) due to the damage to sub-code 14: "//roolbacl" partition.

Check item	Measures
HDD, SYS board, Setting	<p>1. Reboot the equipment. If the error still persists, perform the following steps.</p> <p>2. Turn the power of the equipment OFF and check the connection of the HDD.</p> <p>Connector and harness check</p> <p>Check if the connector pins of the HDD are bent.</p> <p>Check if an HDD for other equipment is installed.</p> <p>Check if a SRAM for other equipment is installed.</p> <p>If the error still persists after step 2, perform the following items.</p> <p>Perform HS-73 Firmware Assist mode -&gt; [Format HDD], and then install "System Software (HD data)" with HS-49 Firmware Update mode.</p> <p>Note:</p> <p>The following items will be deleted by performing HS-73 Firmware Assist mode -&gt; [Format HDD].</p> <ul style="list-style-type: none"> <li>- Message Log</li> <li>- Job Log</li> <li>- Spool Data (Print, Email reception)</li> <li>- Template</li> </ul> <p>4. If the error still persists even after step 3, replace the HDD.</p> <p>5. If the error still persists even after step 4, replace the HDD harness.</p> <p>If the error still persists even after step 5, replace the SYS board.</p>

Parts to be replaced	Remarks
HDD	
HDD harness	
SYS board	

- [F102] HDD start error
- [F103] HDD transfer time-out
- [F104] HDD data error
- [F105] HDD other error

Classification	Contents
Other service call	HDD start error: HDD cannot become "Ready" state. HDD transfer time-out: Reading/writing cannot be performed in the specified period of time. HDD data error: Abnormality is detected in the data of HDD. HDD other error

Check item	Measures
HDD	<ul style="list-style-type: none"> <li>Connector and harness check</li> <li>Check if the connector pins of the HDD are bent.</li> <li>Perform the bad sector check (FS-08-9072). If the check result is OK, recover the data in the HDD. If the check result is failed, replace the HDD.</li> </ul>

Replacement part	Remark
HDD harness	Be sure to exchange the parts in the order of the HDD harness, HDD and SYS board.
HDD	Be sure to exchange the parts in the order of the HDD harness, HDD and SYS board.
SYS board	Be sure to exchange the parts in the order of the HDD harness, HDD and SYS board.

**[F106\_0] Secure HDD error: Illegal disk replacement detected (Secure HDD Exchange to Normal HDD)**

Classification	Error item
Other service call	Secure HDD error: The Secure HDD has been replaced illegally to Normal HDD.

Check item	Measures
Setting	<p>Check if the HDD has been replaced with a Normal HDD.</p> <ol style="list-style-type: none"> <li>1. Perform HS-74 HDD assist mode.</li> <li>2. Check the type of the HDD shown on the top left of the control panel display "Current HDD type".               <ol style="list-style-type: none"> <li>1. In case of Normal HDD, replace it with the original Secure HDD or a new Secure HDD.</li> </ol> </li> </ol> <p><b>Notes:</b></p> <ul style="list-style-type: none"> <li>To replace with the original Secure HDD, start the equipment in the normal mode and then reinstall system software only if any abnormality occurs.</li> <li>2. In case of "Secure HDD"               <ul style="list-style-type: none"> <li>Check each item in the Measures field for the HDD below.</li> <li>If the error still occurs, reinstall the system software.</li> </ul> </li> </ul>

Check item	Measures
HDD	<ul style="list-style-type: none"> <li>• Connector check</li> <li>• Harness check</li> </ul> <p>Follow the procedure below if no abnormality is found in the check items above.</p> <ol style="list-style-type: none"> <li>1. Perform HS-74 HDD assist mode. -&gt; Revert Factory Initial Status HDD</li> <li>2. Reinstall the system software.</li> </ol> <p>If the error persists even after above step, replace the HDD. If the equipment operation disabled after above step, replace the HDD.</p>

Replacement part	Remark
HDD harness	Be sure to exchange the parts in the order of the HDD harness, HDD and SYS board.
HDD	Be sure to exchange the parts in the order of the HDD harness, HDD and SYS board.
SYS board	Be sure to exchange the parts in the order of the HDD harness, HDD and SYS board.

#### [F106\_1] Secure HDD error: HDD type detection error

Classification	Error item
Other service call	Secure HDD error: HDD type detection fails.

Check item	Measures
Setting	If the error is not recovered after rebooting the equipment or no abnormality is found on any check items for the HDD, reinstall the system software.
HDD	<ul style="list-style-type: none"> <li>• Connector check</li> <li>• Harness check</li> <li>• Perform HS-75 File system recovery mode. Check the file system and recover it if necessary. If the recovery fails, replace the HDD. If the equipment does not start in the HS-75 File system recovery mode, also replace the HDD.</li> <li>• Check that either the Secure HDD or Normal HDD is mounted.</li> </ul> <ol style="list-style-type: none"> <li>1. Perform HS-74 HDD assist mode.</li> <li>2. Check the type of the HDD shown on the control panel display "Current HDD type". Normal status: Secure HDD or Normal HDD Abnormal status: Unknown HDD</li> </ol> <p>If "Unknown HDD" is displayed, reinstall the system software. If the error persists even after above step, replace the HDD. If the equipment operation disabled after above step, replace the HDD.</p>

Replacement part	Remark
HDD harness	Be sure to exchange the parts in the order of the HDD harness, HDD and SYS board.
HDD	Be sure to exchange the parts in the order of the HDD harness, HDD and SYS board.

Replacement part	Remark
SYS board	Be sure to exchange the parts in the order of the HDD harness, HDD and SYS board.

### [F106\_2] Secure HDD error: Secure HDD encryption key download operation error

Classification	Error item
Other service call	Secure HDD error: Downloading of or consistency check for Secure HDD encryption key fails.

Check item	Measures
Setting	<p>Checking of Secure HDD encryption key status</p> <ol style="list-style-type: none"> <li>1. Perform HS-73 Assist mode.</li> <li>2. Perform "Key Backup / Restore".</li> <li>3. Check the status of the Secure HDD encryption key on the Key Backup / Restore menu.</li> <li>4. After the operation is completed, shut down the equipment. <ul style="list-style-type: none"> <li>• In case both the ADIKey SRAM/FROM status are OK Reinstall the system firmware.</li> <li>• In case either the ADIKey SRAM/FROM status is other than OK Restore the Secure HDD encryption key.</li> <li>• In case both of the ADIKey SRAM/FROM status are other than OK Reinstall the system software.</li> </ul> </li> </ol>
HDD	<p>If the error persists even after above step, replace the HDD. If the equipment operation disabled after above step, replace the HDD.</p>

Replacement part	Remark
HDD harness	Be sure to exchange the parts in the order of the HDD harness, HDD and SYS board.
HDD	Be sure to exchange the parts in the order of the HDD harness, HDD and SYS board.
SYS board	Be sure to exchange the parts in the order of the HDD harness, HDD and SYS board.

### [F106\_3] Secure HDD error: Secure HDD authentication Admin Password generation error

Classification	Error item
Other service call	Secure HDD error: The generation of Secure HDD authentication Admin Password fails.



Check item	Measures
Setting	Perform HS-73 Assist mode -> Format HDD, and then install the system software by performing HS-49 Firmware update mode -> SYSTEM SOFTWARE (HD Data).  <b>Notes:</b> The following items will be deleted by performing HS-73 Assist mode -> Format HDD. <ul style="list-style-type: none"> <li>• Message Log</li> <li>• Job Log</li> <li>• Spool Data (Print, Email reception)</li> <li>• Template</li> </ul>
HDD	If the error persists even after above step, replace the HDD. If the equipment operation disabled after above step, replace the HDD.

Replacement part	Remark
HDD harness	Be sure to exchange the parts in the order of the HDD harness, HDD and SYS board.
HDD	Be sure to exchange the parts in the order of the HDD harness, HDD and SYS board.
SYS board	Be sure to exchange the parts in the order of the HDD harness, HDD and SYS board.

**[F106\_4] Secure HDD error: Authentication random number generation error**

Classification	Error item
Other service call	Secure HDD error: The generation of a random number for authentication data fails.

Check item	Measures
Setting	<p>Perform HS-73 Assist mode -&gt; Format HDD, and then install the system software by performing HS-49 Firmware update mode -&gt; SYSTEM SOFTWARE (HD Data).</p> <p><b>Notes:</b> The following items will be deleted by performing HS-73 Assist mode -&gt; Format HDD.</p> <ul style="list-style-type: none"> <li>• Message Log</li> <li>• Job Log</li> <li>• Spool Data (Print, Email reception)</li> <li>• Template</li> </ul>
HDD	If the error persists even after above step, replace the HDD. If the equipment operation disabled after above step, replace the HDD.

Replacement part	Remark
HDD harness	Be sure to exchange the parts in the order of the HDD harness, HDD and SYS board.
HDD	Be sure to exchange the parts in the order of the HDD harness, HDD and SYS board.
SYS board	Be sure to exchange the parts in the order of the HDD harness, HDD and SYS board.

**[F106\_5] Secure HDD error: Authentication data transmission error**

Classification	Error item
Other service call	Secure HDD error: The transmission of authentication data fails.

Check item	Measures
Setting	<p>Perform HS-73 Assist mode -&gt; Format HDD, and then install the system software by performing HS-49 Firmware update mode -&gt; SYSTEM SOFTWARE (HD Data).</p> <p><b>Notes:</b> The following items will be deleted by performing HS-73 Assist mode -&gt; Format HDD.</p> <ul style="list-style-type: none"> <li>• Message Log</li> <li>• Job Log</li> <li>• Spool Data (Print, Email reception)</li> <li>• Template</li> </ul> <ul style="list-style-type: none"> <li>• In case this error occurred after returning SRAM data for SRAM cloning: Copy the Secure HDD key from FROM to SRAM.               <ol style="list-style-type: none"> <li>1. Perform HS-73 Assist mode.</li> <li>2. Select "Key Backup / Restore".</li> <li>3. Check the status of the Secure HDD key on the Key/ Backup Restore menu.</li> <li>4. Select [ADikey] twice.</li> <li>5. Check that copying of the Secure HDD key from the FROM to SRAM is selected.</li> <li>6. Press [Execute].</li> <li>7. When the restoring of the encryption key is completed, "Success" appears to the right-hand side of [ADiKey] FROM.</li> <li>8. After the operation has been completed, shut down the equipment.</li> </ol> </li> </ul>
HDD	If the error persists even after above step, replace the HDD. If the equipment operation disabled after above step, replace the HDD.

Replacement part	Remark
HDD harness	Be sure to exchange the parts in the order of the HDD harness, HDD and SYS board.
HDD	Be sure to exchange the parts in the order of the HDD harness, HDD and SYS board.
SYS board	Be sure to exchange the parts in the order of the HDD harness, HDD and SYS board.

**[F106\_6]/[F106\_7]/[F106\_8]/[F106\_10]/[F106\_UNDEF] Secure HDD error: Error caused by reason other than F106\_0 to 5 errors**

Classification	Error item
Other service call	Secure HDD error: Error caused by reason other than F106_0 to 5 errors

Check item	Measures
Setting	<p>Perform HS-73 Assist mode -&gt; Format HDD, and then install the system software by performing HS-49 Firmware update mode -&gt; SYSTEM SOFTWARE (HD Data).</p> <p><b>Notes:</b> The following items will be deleted by performing HS-73 Assist mode -&gt; Format HDD.</p> <ul style="list-style-type: none"> <li>• Message Log</li> <li>• Job Log</li> <li>• Spool Data (Print, Email reception)</li> <li>• Template</li> </ul>
HDD	If the error persists even after above step, replace the HDD. If the equipment operation disabled after above step, replace the HDD.

Replacement part	Remark
HDD harness	Be sure to exchange the parts in the order of the HDD harness, HDD and SYS board.
HDD	Be sure to exchange the parts in the order of the HDD harness, HDD and SYS board.
SYS board	Be sure to exchange the parts in the order of the HDD harness, HDD and SYS board.

**[F106\_11] License damaged (HDD and SRAM)**

Classification	Error item
License management	Both licenses registered in the HDD and SRAM are damaged.

Check item	Measures
Backup data	<p>Restore the backup data in which all the activated licenses with the latest status are stored.</p> <p><b>Remarks:</b> Applications with the trial license cannot be recovered from the backup data. If necessary, reinstall the applications.</p>
License	<ul style="list-style-type: none"> <li>• If there are no backup data as above, reactivate all the licenses which have been activated in this equipment.</li> <li>• If the functions have been activated by the export license file, import the license exported from the host unit of the equipment.</li> </ul>

Replacement part	Remark
HDD harness	Be sure to exchange the parts in the order of the HDD harness, HDD, SRAM and SYS board.

Replacement part	Remark
HDD	Be sure to exchange the parts in the order of the HDD harness, HDD, SRAM and SYS board.
SRAM	Be sure to exchange the parts in the order of the HDD harness, HDD, SRAM and SYS board.
SYS board	Be sure to exchange the parts in the order of the HDD harness, HDD, SRAM and SYS board.

#### [F106\_12] License damaged (SRAM)

Classification	Error item
License management	The license registered in the SRAM is damaged.

Check item	Measures
-	<ol style="list-style-type: none"> <li>1. Reboot the equipment.</li> <li>2. If the problem still persists, perform FS-08-9053 and reboot the equipment again.</li> <li>3. If the problem still occurs after performing step 2, replace the SRAM.</li> </ol>

Replacement part	Remark
SRAM	Be sure to exchange the parts in the order of the SRAM and SYS board.
SYS board	Be sure to exchange the parts in the order of the SRAM and SYS board.




#### [F107] File system error

Classification	Error content
System related service call	File system error
Setting	<p>Perform HS-73 Firmware Assist &gt; Format HDD and then install "System Software (HD data)" with the HS-49 Firmware update mode.</p> <p>Note: The following contents will be removed by performing HS-73 Firmware Assist &gt; Format HDD.</p> <ul style="list-style-type: none"> <li>• Message Log</li> <li>• Job Log</li> <li>• Spool Data (Print, Email reception)</li> <li>• Template</li> </ul>
HDD	If the error still persists even after the above step is performed, replace the HDD. Moreover, if the above step is cannot be performed, replace the HDD.

Parts to be replaced	Remarks
HDD	
SYS board	

**[F109\_0] Key consistency error (Consistency check operation error)**


Classification	Contents
Other service call	Key consistency error - Key consistency check on each key data fails.

Check item	Measures
Setting	<p>Reboot the equipment. If it cannot be recovered, reinstall the software in the following procedure.</p> <ol style="list-style-type: none"> <li>1. Install the system firmware.</li> <li>2. If the error cannot be solved after installing the system firmware, reinstall the system software and application program.</li> </ol> <p> P. 11-2 "11.2 Firmware Updating with USB Device"</p>
SRAM	<p>If the error is not cleared after the software reinstallation, replace the SRAM.</p> <p> P. 9-25 "9.2.5 Precautions and procedure when replacing the SRAM"</p>
SYS board	<p>If the error is not cleared after this (see above), replace the SYS board.</p> <p> P. 9-21 "9.2.4 Precautions and procedures when replacing the SYS board"</p>

Replacement part	Remark
SRAM	Be sure to exchange the parts in the order of the SRAM and SYS board.
SYS board	Be sure to exchange the parts in the order of the SRAM and SYS board.

**[F109\_1] Key consistency error (SRAM encryption AES key data damage)**


Classification	Contents
Other service call	Key consistency error - AES key data used for SRAM encryption are damaged.

Check item	Measures
Setting	<p>Reboot the equipment. If it cannot be recovered, reinstall the software in the following procedure.</p> <ol style="list-style-type: none"> <li>1. Install the system firmware.</li> <li>2. If the error cannot be solved after installing the system firmware, reinstall the system software and application program.</li> </ol> <p> P. 11-2 "11.2 Firmware Updating with USB Device"</p>

Replacement part	Remark
SRAM	Be sure to exchange the parts in the order of the SRAM and SYS board.
SYS board	Be sure to exchange the parts in the order of the SRAM and SYS board.

### [F109\_2] Key consistency error (Signature Check public key damage)

Classification	Contents
Other service call	Key consistency error - Public key data used for Integrity Check are damaged.

Check item	Measures
Setting	Reboot the equipment. If it cannot be recovered, reinstall the software in the following procedure. 1. Install the system firmware. 2. If the error cannot be solved after installing the system firmware, reinstall the system software and application program.  P. 11-2 "11.2 Firmware Updating with USB Device"

Replacement part	Remark
SRAM	Be sure to exchange the parts in the order of the SRAM and SYS board.
SYS board	Be sure to exchange the parts in the order of the SRAM and SYS board.

### [F109\_3] Key consistency error (HDD encryption parameter damage)

Classification	Contents
Other service call	Key consistency error - Parameter used for HDD partition encryption are damaged.

Check item	Measures
Encryption key status confirmation	Check the message displayed by HS-73 Assist mode → Key Backup / Restore.

Take measures given in the following table according to the messages displayed in the SRAM and FROM fields.

**Remarks:**

If the error is not cleared, reinstallation of the system firmware, system software and application is needed. (HS-49 Firmware update mode)

SRAM	FROM	Measure
*	AccessFailed	<p>Replace the SYS board.</p> <p>📖 P. 9-21 "9.2.4 Precautions and procedures when replacing the SYS board" (all steps)</p> <p>&lt;With USB backup data: All key data recovery&gt;</p> <ol style="list-style-type: none"> <li>1. Recover all the data on the SRAM. HS-59 SRAM data cloning mode → Restore SRAM Data from USB (For details, see "📖 P. 12-2 "12.1.4 Cloning procedure" [B] Restore procedure")</li> <li>2. Recover the encryption key/license on the SYS board. Follow the procedures below noted in 📖 P. 9-21 "9.2.4 Precautions and procedures when replacing the SYS board". [C] Restore ADI key (only when Secure HDD is installed) [D] Restore encryption key [D] Restore encryption key</li> </ol>
AccessFailed	*	<p>Replace the SYS board.</p> <p>📖 P. 9-25 "9.2.5 Precautions and procedure when replacing the SRAM" (for the SYS board, all steps)</p>
OK	KeyNull/ KeyBroken	<p>Recover the encryption key on the SYS board.</p> <p>📖 P. 9-21 "9.2.4 Precautions and procedures when replacing the SYS board" ([D]Restore encryption key)</p>
AccessFailed	OK	<p>Replace the SRAM.</p> <p>📖 P. 9-25 "9.2.5 Precautions and procedure when replacing the SRAM" (all steps)</p>
KeyNull/ KeyBroken	OK	<p>Recover the encryption key on the SRAM.</p> <p>📖 P. 9-25 "9.2.5 Precautions and procedure when replacing the SRAM" ([H] Backup encryption key (FROM -&gt; SRAM))</p>
KeyNull/ KeyBroken	KeyNull/ KeyBroken	<p>&lt;No USB backup data&gt;</p> <ol style="list-style-type: none"> <li>1. Reinstall the system software. 📖 P. 11-2 "11.2 Firmware Updating with USB Device"</li> </ol> <p>&lt;With USB backup data: All key data recovery&gt;</p> <ol style="list-style-type: none"> <li>1. Recover all the data on the SRAM. HS-59 SRAM data cloning mode → Restore SRAM Data from USB (For details, see "📖 P. 12-2 "12.1.4 Cloning procedure" [B] Restore procedure")</li> <li>2. Recover the encryption key/license on the SYS board. Follow the procedures below noted in 📖 P. 9-21 "9.2.4 Precautions and procedures when replacing the SYS board". [C] Restore ADI key (only when Secure HDD is installed) [D] Restore encryption key [E] Restore license</li> </ol>

\* AccessFailed, KeyNull or KeyBroken

Replacement part	Remark
SRAM	Be sure to exchange the parts in the order of the SRAM and SYS board.
SYS board	Be sure to exchange the parts in the order of the SRAM and SYS board.



**[F109\_4] Key consistency error (license data damage)**

Classification	Contents
Other service call	Key consistency error - The license data are damaged.

Check item	Measures
Encryption key status confirmation	Check the message displayed by HS-73 Assist mode → Key Backup / Restore.

Take appropriate countermeasures shown in the table below according to the messages displayed in the SRAM and FROM fields of LICENCE [F109\_4].

**Remarks:**

If the error is not cleared, reinstallation of the system firmware, system software and application is needed. (HS-49 Firmware update mode)

SRAM Licence Status	FROM Licence Status	Measure
*	AccessFailed	Replace the SYS board. 📖 P. 9-21 "9.2.4 Precautions and procedures when replacing the SYS board" (all steps) <With USB backup data: All key data recovery> 1. Recover all the data on the board. HS-59 SRAM data cloning mode → Restore SRAM Data from USB (For details, see "📖 P. 12-2 "12.1.4 Cloning procedure" [B] Restore procedure") 2. Recover the encryption key/license on the SYS board. Follow the procedures below noted in 📖 P. 9-21 "9.2.4 Precautions and procedures when replacing the SYS board". [C] Restore ADI key (only when Secure HDD is installed) [D] Restore encryption key [E] Restore license
AccessFailed	*	Replace the SRAM. 📖 P. 9-25 "9.2.5 Precautions and procedure when replacing the SRAM" (all steps)
KeyMismatch	KeyMismatch	<The error occurs when the SYS board is replaced> Recover the license on the SYS board. (Transfer the license from SRAM to FROM.) 📖 P. 9-21 "9.2.4 Precautions and procedures when replacing the SYS board"([E]Restore license) <The error occurs except when the SYS board is replaced> Recover the license on the SRAM. (Transfer the license from FROM to SRAM.) 📖 P. 9-25 "9.2.5 Precautions and procedure when replacing the SRAM"([I]Backup license (FROM -> SRAM))

\* AccessFailed or KeyMismatch

Replacement part	Remark
SRAM	Be sure to exchange the parts in the order of the SRAM and SYS board.
SYS board	Be sure to exchange the parts in the order of the SRAM and SYS board.

**[F109\_5] Key consistency error (encryption key for Secure HDD is damaged)**

Classification	Contents
Other service call	Key consistency error - Encryption key for Secure HDD is damaged.

Check item	Measures
Encryption key status confirmation	Check the message displayed by HS-73 Assist mode → Key Backup Restore.

Take appropriate countermeasures shown in the table below according to the messages displayed in the SRAM and FROM fields of AGLNCKEY [F109\_5] / AGLDECKEY [F109\_5].

**Remarks:**

If the error is not cleared, reinstallation of the system firmware, system software and application is needed. (HS-49 Firmware update mode)

SRAM	FROM	Measure
*	AccessFailed	Replace the SYS board. ☞ P. 9-21 "9.2.4 Precautions and procedures when replacing the SYS board" (all steps) <With USB backup data: All key data recovery> 1. Recover all the data on the SRAM. HS-59 SRAM data cloning mode → Restore SRAM Data from USB (For details, see "☞ P. 12-2 "12.1.4 Cloning procedure" [B] Restore procedure") 2. Recover the encryption key/license on the SYS board. Follow the procedures below noted in ☞ P. 9-21 "9.2.4 Precautions and procedures when replacing the SYS board". [C] Restore ADI key (only when Secure HDD is installed) [D] Restore encryption key [E] Restore license
AccessFailed	*	Replace the SRAM. ☞ P. 9-25 "9.2.5 Precautions and procedure when replacing the SRAM" (all steps)
OK	KeyNull/ KeyBroken	Recover the ADI key on the SYS board. ☞ P. 9-21 "9.2.4 Precautions and procedures when replacing the SYS board" ([C]Restore ADI key)
KeyNull/ KeyBroken	OK	Recover the ADI key on the SRAM. ☞ P. 9-25 "9.2.5 Precautions and procedure when replacing the SRAM" ([G]Backup ADI key (FROM -> SRAM))

SRAM	FROM	Measure
KeyNull/ KeyBroken	KeyNull/ KeyBroken	<p>&lt;No USB backup data&gt;</p> <ol style="list-style-type: none"> <li>1. Create the partition in the HDD, and reinstall the system software.  <small>☞ P. 9-17 "9.2.3 Precautions and procedures when replacing the HDD" (Perform step 3 or later in "")</small></li> </ol> <p>&lt;With USB backup data: All key data recovery&gt;</p> <ol style="list-style-type: none"> <li>1. Recover all the data on the SRAM.                      HS-59 SRAM data cloning mode → Restore SRAM Data from USB  <small>(For details, see "☞ P. 12-2 "12.1.4 Cloning procedure" [B] Restore procedure")</small></li> <li>2. Recover the encryption key/license on the SYS board.                      Follow the procedures below noted in <small>☞ P. 9-21 "9.2.4 Precautions and procedures when replacing the SYS board"</small>.                      [C] Restore ADI key (only when Secure HDD is installed)                      [D] Restore encryption key                      [E] Restore license</li> </ol>
KeyMismatch	KeyMismatch	<p>&lt;The error occurs when the SYS board is replaced&gt;                      Recover the ADI key on the SYS board. (Transfer the ADI key from SRAM to FROM.)  <small>☞ P. 9-21 "9.2.4 Precautions and procedures when replacing the SYS board"()</small></p> <p>&lt;The error occurs except when the SYS board is replaced&gt;                      Recover the ADI key on the SRAM. (Transfer the ADI key from FROM to SRAM.)  <small>☞ P. 9-25 "9.2.5 Precautions and procedure when replacing the SRAM"([G]Backup ADI key (FROM -&gt; SRAM))</small></p>

\* AccessFailed or KeyMismatch

Replacement part	Remark
SRAM	Be sure to exchange the parts in the order of the SRAM and SYS board.
SYS board	Be sure to exchange the parts in the order of the SRAM and SYS board.

**[F109\_6] Key consistency error (administrator password error for Secure HDD authentication)**







Classification	Contents
Other service call	Key consistency error - Administrator password error for Secure HDD authentication.






Check item	Measures
Encryption key status confirmation	Check the message displayed by HS-73 Assist mode → Key Backup Restore.

Take appropriate countermeasures shown in the table below according to the messages displayed in the SRAM and FROM fields of AdminPassword [F109\_6].

**Remarks:**

If the error is not cleared, reinstallation of the system firmware, system software and application is needed. (HS-49 Firmware update mode)

SRAM	FROM	Measure
*	AccessFailed	<p>Replace the SYS board.   P. 9-21 "9.2.4 Precautions and procedures when replacing the SYS board" (all steps)                      &lt;With USB backup data: All key data recovery&gt;                      1. Recover all the data on the SRAM.                      HS-59 SRAM data cloning mode → Restore SRAM Data from USB                      (For details, see " P. 12-2 "12.1.4 Cloning procedure" [B] Restore procedure")                      2. Recover the encryption key/license on the SYS board.                      Follow the procedures below noted in  P. 9-21 "9.2.4 Precautions and procedures when replacing the SYS board".                      [C] Restore ADI key (only when Secure HDD is installed)                      [D] Restore encryption key                      [E] Restore license</p>
AccessFailed	*	<p>Replace the SRAM.   P. 9-25 "9.2.5 Precautions and procedure when replacing the SRAM" (all steps)</p>
OK	KeyNull/ KeyBroken	<p>Recover the ADI key on the SYS board.   P. 9-21 "9.2.4 Precautions and procedures when replacing the SYS board" ([C]Restore ADI key)</p>
KeyNull/ KeyBroken	OK	<p>Recover the ADI key on the SRAM.   P. 9-25 "9.2.5 Precautions and procedure when replacing the SRAM" ([G]Backup ADI key (FROM -&gt; SRAM))</p>

SRAM	FROM	Measure
KeyNull/ KeyBroken	KeyNull/ KeyBroken	<p>&lt;No USB backup data&gt;</p> <ol style="list-style-type: none"> <li>1. Create the partition in the HDD, and reinstall the system software.   P. 9-17 "9.2.3 Precautions and procedures when replacing the HDD" (Perform step 3 or later in "[E]Replace / Format HDD")</li> </ol> <p>&lt;With USB backup data: All key data recovery&gt;</p> <ol style="list-style-type: none"> <li>1. Recover all the data on the SRAM.            HS-59 SRAM data cloning mode → Restore SRAM Data from USB            (For details, see " P. 12-2 "12.1.4 Cloning procedure" [B] Restore procedure")</li> <li>2. Recover the encryption key/license on the SYS board.            Follow the procedures below noted in  P. 9-21 "9.2.4 Precautions and procedures when replacing the SYS board".            [C] Restore ADI key (only when Secure HDD is installed)            [D] Restore encryption key            [E] Restore license</li> </ol>
KeyMismatch	KeyMismatch	<p>&lt;The error occurs when the SYS board is replaced&gt;            Recover the ADI key on the SYS board. (Transfer the ADI key from SRAM to FROM.)   P. 9-21 "9.2.4 Precautions and procedures when replacing the SYS board"([C]Restore ADI key)</p> <p>&lt;The error occurs except when the SYS board is replaced&gt;            Recover the ADI key on the SRAM. (Transfer the ADI key from FROM to SRAM.)   P. 9-25 "9.2.5 Precautions and procedure when replacing the SRAM"([G]Backup ADI key (FROM -&gt; SRAM))</p>



\* AccessFailed or KeyMismatch

Replacement part	Remark
SRAM	Be sure to exchange the parts in the order of the SRAM and SYS board.
SYS board	Be sure to exchange the parts in the order of the SRAM and SYS board.

**[F110] Communication error between System-CPU and Scanner-CPU****[F111] Scanner response abnormality**

Classification	Error content
Communication related service call	Communication error between System-CPU and Scanner-CPU Scanner response abnormality.

Check item	Measures
Reproducibility	<ul style="list-style-type: none"> <li>Turn the power OFF and then back ON using the main power switch.</li> </ul>
Setting	Check if the value of 08-9000 (Destination setting of the equipment) is set correctly.
SYS board	<ul style="list-style-type: none"> <li>Check if the conductor pattern on the SYS board is short circuited or open circuited.</li> <li>Check if the connector (CN120) on the SYS board is abnormally.</li> <li>Check if the harness (CN120) on the SYS board is abnormally.</li> </ul>

Parts to be replaced	Remarks
SYS board	Refer to the following sections:  P. 9-3 "9.1.4 SYS board"  P. 9-21 "9.2.4 Precautions and procedures when replacing the SYS board"

**[F11A] Communication error between the SYS board and the CCD board**

Classification	Error content
Communication error	Communication error between the SYS board and the CCD board

Check item	Measures
Reproducing ability	Turn the power OFF and then back ON to check the occurrence.
SYS board	<ul style="list-style-type: none"> <li>Check if the connectors of the CCD board and SYS board are disconnected or the harnesses are open circuited. (CN120, CN001)</li> <li>Check if there is no abnormality in the SYS board.</li> </ul>

Parts to be replaced	Remark
Harness	Be sure to exchange the parts in the order of the harness, CCD board and SYS board.
CCD board	Be sure to exchange the parts in the order of the harness, CCD board and SYS board.
SYS board	Be sure to exchange the parts in the order of the harness, CCD board and SYS board.

## [F120] Database abnormality

Classification	Error item
Other service call	Database abnormality: Database is not operating normally.

Check item	Measures
Setting	<ol style="list-style-type: none"> <li>1. Check that no jobs remain and rebuild the databases. (HS-75 File system recovery mode -&gt; Initialize database -&gt; LDAP DB and Log DB (Job,Msg).</li> <li>2. If the error is not recovered, reinstall the system software. (HS-49 Firmware update mode -&gt; System Software(HD data))</li> </ol> <p><b>Notes:</b></p> <ul style="list-style-type: none"> <li>• If you rebuild the databases with a job remaining, delete it after finishing.</li> <li>• When "Rebuilding all databases" is performed, all data including log/user/role/group/department information and address book data are deleted. If you back up the data in advance, they will be recovered by restoring them after rebuilding the database.</li> </ul>

Parts to be replaced	Remark
HDD	

## [F121] Database abnormality (user information management database)

Classification	Error item
Other service call	Login after the startup fails in any starting mode because user management database is corrupted.

Check item	Measures
Setting	<ol style="list-style-type: none"> <li>1. Check that no jobs remain and rebuild the databases.</li> <li>2. Delete the data in the following procedure: HS-75 File system recovery mode → Initialize database → LDAP database (Note that all user, role, group and accounting data will be deleted.)</li> <li>3. If the error is not recovered, reinstall the system software. (HS-49 Firmware update mode -&gt; System Software(HD data))</li> </ol> <p><b>Notes:</b></p> <ul style="list-style-type: none"> <li>• If you rebuild the databases with a job remaining, delete it after finishing.</li> <li>• When "Rebuilding all databases" is performed, all data including log/user/role/group/department information and address book data are deleted. If you back up the data in advance, they will be recovered by restoring them after rebuilding the database.</li> </ul>

Parts to be replaced	Remark
HDD	

**[F122] Database abnormality (message/job log management database)**

Classification	Error item
Other service call	Login after the startup fails in any starting mode because log management database is corrupted.

Check item	Measures
Setting	<ol style="list-style-type: none"> <li>1. Check that no jobs remain and rebuild the databases.</li> <li>2. Delete the data in the following procedure: HS-75 File system recovery mode → Initialize database → Log database (jobs and messages) (Note that all job and message logs will be deleted.)</li> <li>3. If the error is not recovered, reinstall the system software. (HS-49 Firmware update mode → System Software(HD data))</li> </ol> <p><b>Notes:</b></p> <ul style="list-style-type: none"> <li>• If you rebuild the databases with a job remaining, delete it after finishing.</li> <li>• When "Rebuilding all databases" is performed, all data including log/user/role/group/department information and address book data are deleted. If you back up the data in advance, they will be recovered by restoring them after rebuilding the database.</li> </ul>

Parts to be replaced	Remark
HDD	

**[F124] Database abnormality (application management database damage error)**

Classification	Error item
Other service call	Application management database is damaged.

Check item	Measures
Setting	<ol style="list-style-type: none"> <li>1. Perform HS-75 File System recovery mode &gt; Initialize DB → AppMgmt DB and then delete the journal file.</li> </ol> <p><b>Notes:</b></p> <p>All of the application information will be deleted.</p> <ol style="list-style-type: none"> <li>2. If the error is not recovered, reinstall the system software. (HS-49 Firmware update mode &gt; System Software(HD data))</li> </ol>

Parts to be replaced	Remark
HDD	



**[F125] Database abnormality (Home screen database damage error)**

Classification	Error item
Other service call	Home screen database is damaged.

Check item	Measures
Setting	<ol style="list-style-type: none"> <li>1. Perform HS-75 File System recovery mode &gt; Initialize DB → HomeScreen DB and then delete the journal file.</li> <li>2. If the error is not recovered, reinstall the system software. (HS-49 Firmware update mode &gt; System Software(HD data))</li> </ol>

Parts to be replaced	Remark
HDD	

**[F126] Database abnormality (Job history database damage error)**

Classification	Error item
Other service call	Job history database is damaged.

Check item	Measures
Setting	<ol style="list-style-type: none"> <li>1. Perform HS-75 File System recovery mode &gt; Initialize DB → JobHistory DB and then delete the journal file.</li> <li>2. If the error is not recovered, reinstall the system software. (HS-49 Firmware update mode &gt; System Software(HD data))</li> </ol>

Parts to be replaced	Remark
HDD	

**[F127] Database abnormality (application license management database damage error)**

Classification	Error item
Other service call	Application license management database is damaged.

Check item	Measures
Setting	<ol style="list-style-type: none"> <li>1. Perform HS-75 File System recovery mode &gt; Initialize DB → AppLicense DB and then delete the journal file.</li> <li>2. If the error is not recovered, reinstall the system software. (HS-49 Firmware update mode &gt; System Software(HD data))</li> </ol>

Parts to be replaced	Remark
HDD	

**[F128] License management database damage**

Classification	Error item
License management	The license management database stored in the HDD has been damaged.

Check item	Measures
Setting	<p>Reboot the equipment.</p> <p>When a 71E0 error has appeared, perform its troubleshooting.</p> <p>If an F128 error has appeared again, perform the following procedure.</p> <ol style="list-style-type: none"> <li>1. Open HS-[75 File System Recovery]-[Initialize DB].</li> <li>2. Select [ULM DB] only and press [OK].</li> <li>3. Reboot the equipment. When a 71E0 error has appeared, perform its troubleshooting.</li> </ol>

Parts to be replaced	Remark
HDD	Be sure to exchange the parts in the order of the HDD and SRAM.
SRAM	Be sure to exchange the parts in the order of the HDD and SRAM.

**[F130] Invalid MAC address**

Classification	Contents
Other service call	Invalid MAC address

Check item	Measures
Setting	This error occurs when the top 3 bytes of the MAC address is not "00" "80" "91".
SYS board	Replace the SYS board.

Parts to be replaced	Remark
SYS board	

**[F131] Error due to damage to filtering setting file**

Classification	Contents
Other service call	The filtering function is not working properly due to the damage to the file for the filtering setting.

Check item	Measures
Setting	<ol style="list-style-type: none"> <li>1. Check the bad sector of the HDD (FS-08-9072). If the result is "NG", replace the HDD.  <b>Notes:</b>                      It may take more than 30 minutes to finish the checking.</li> <li>2. Perform HS-73 Assist mode -&gt; Format HDD, and then reinstall the HDD software.  <b>Notes:</b>                      User data will be deleted when HS-73 Assist mode -&gt; Format HDD is performed.</li> </ol>

Parts to be replaced	Remarks
HDD	

**[F140] ASIC initialization error**

Classification	Contents
Other service call	ASIC initialization fails or memory accessing fails when software startup.

Check item	Measures
SYS board	<ul style="list-style-type: none"> <li>• Connector check</li> <li>• Board check</li> </ul>
Main memory	<ul style="list-style-type: none"> <li>• Check the installation</li> <li>• Main memory check</li> </ul>

Parts to be replaced	Remarks
SYS board	
Main memory	

**[F150] Power failure during the manufacturing mode**

Classification	Contents
Other service call	When a power failure occurred during the manufacturing mode, this error code appears at the next startup.

Check item	Measures
Power supply	<ul style="list-style-type: none"> <li>• Turn the power OFF and then back ON.</li> <li>• Set the value of FS-08-9010 to "0".</li> <li>• If it changes to another error code, follow the procedure for the changed error code.</li> </ul>

**[F200] Data Overwrite option (GP-1070) disabled**

Classification	Contents
Other service call	Data Overwrite option (GP-1070) disabled Remarks: An F200 error will not occur in an MFP in which a data overwrite option is installed as the standard.

Check item	Measures
Setting	Perform FS-08-3840 to install the Data Overwrite Enabler (GP-1070).

**[F400] SYS board cooling fan abnormality**

Classification	Contents
Circuit related service call	SYS board cooling fan abnormality

Check item	Measures
SYS board cooling fan	Check if the fan is rotating properly. If not, check if any foreign object is adhered.
SYS board	Check the connector (CN117) and relay connector.

Replacement part	Remark
SYS board	
SYS board cooling fan	

**[F410] Power abnormality**

Classification	Contents
Circuit related service call	This error occurs when the status of the LSI mounted on the SYS board has become an error due to a power abnormality. The equipment will be automatically rebooted at the first-time occurrence; however, the error history will not remain when rebooting is done automatically. This error code appears if an error has occurred continuously.

Check item	Measures
Power cable	Check that the power cable is inserted securely or it is not damaged.
User's site	<ul style="list-style-type: none"> <li>• Do not plug any cables for other devices in the outlet to which that for the equipment is connected.</li> <li>• The power cable co-packed with the equipment must be used without employing any extension cables.</li> <li>• Be sure to use an outlet which is far from the one to which a device, such as an air conditioner or a printer, which uses a large amount of power is connected.</li> </ul>
Board	<ol style="list-style-type: none"> <li>1. Power supply unit</li> <li>2. SYS board</li> </ol>

Replacement part	Remark
1. Power supply unit	Be sure to exchange the power supply unit and the SYS board in the order described on the left-hand side.
2. SYS board	

### [F510] Application start error

Classification	Error item
Other service call	The application fails to start.

Check item	Measures
Setting	<ol style="list-style-type: none"> <li>1. Reboot.</li> <li>2. If it has still not recovered, reinstall the system software.</li> <li>3. If it still persists after step 2, perform [HS-73 Assist mode -&gt; Format HDD, and then reinstall the system software.</li> </ol> <p>User data will be deleted when HS-73 Assist mode -&gt; Format HDD is performed.</p>


### [F520] Operating system start error

Classification	Error item
Other service call	The operating system fails to start.

Check item	Measures
Setting	<ol style="list-style-type: none"> <li>1. Reboot.</li> <li>2. If it has still not recovered, reinstall the system software.</li> <li>3. If it still persists after step 2, perform HS-73 Assist mode -&gt; Format HDD, and then reinstall the system software.</li> </ol> <p>User data will be deleted when HS-73 Assist mode -&gt; Format HDD is performed.</p>

### [F521] Integrity check error

Classification	Error item
Other service call	The program data fails to be authenticated.

Check item	Measures
Setting	<p>Restart the equipment.</p> <p>If the error is not recovered after restarting the equipment, reinstall software following the procedure below.</p> <ol style="list-style-type: none"> <li>1. Reinstall the system software and application program.   P. 9-17 "9.2.3 Precautions and procedures when replacing the HDD"</li> </ol>

**[F550] Encryption partition error**

Classification	Error item
Other service call	The encryption partition fails to be read and written.

Check item	Measures
Setting	<ul style="list-style-type: none"> <li>Recover the encryption key with HS-73 Assist mode -&gt; Key Backup/Restore.</li> </ul>

**[F600] F/W update error**

Classification	Error item
Other service call	The firmware fails to be updated.

Check item	Measures
Setting	<ol style="list-style-type: none"> <li>Perform HS-73 Assist mode -&gt; Clear Error Flag in Software Installation.</li> <li>Reinstall the firmware in error displayed on the F600 error screen.</li> </ol>

**[F700] Overwrite error**

Classification	Error item
Other service call	Overwriting fails.

Check item	Measures
Setting	<ul style="list-style-type: none"> <li>If a service call occurs again after the reboot, replace the HDD.</li> </ul>

Parts to be replaced	Remarks
HDD	

**[F800] Date error**

Classification	Error item
Other service call	The year 2038 problem

Check item	Measures
Setting	Reset the date, and request the administrator to set the date and time. <ol style="list-style-type: none"> <li>Perform HS-76 SRAM clear mode -&gt; Reset Date and Time.</li> <li>Request the administrator to set the date and time.</li> </ol>

Parts to be replaced	Remarks
SYS board	


### [F900] Model information error

Classification	Error item
Other service call	Machine information alignment error. The machine information is damaged.

Check item	Measures
Setting	<p>Recover the machine information by means of the following procedure.</p> <p>&lt;Machine information recovery&gt;</p> <ol style="list-style-type: none"> <li>1. Perform HS-76 SRAM clear mode -&gt; SRAM Re-Initialize.</li> <li>2. After the operation is completed, shut down the equipment. * If it is not recovered, perform the following procedure.</li> <li>3. Perform HS-73 Assist mode -&gt; Key Backup/Restore.</li> <li>4. Press [Key] twice.</li> <li>5. Check that copying of the key from the FROM to SRAM is selected.</li> <li>6. Press [Execute].</li> <li>7. When the restoring of the key is completed, "Success" appears to the right-hand side of [Key] FROM.</li> <li>8. After the operation is completed, shut down the equipment.</li> </ol>

### [F902\_1] System firmware / System software model information error

Classification	Error item
Other service call	Invalid system firmware/software is installed.

Check item	Measures
Setting	<ol style="list-style-type: none"> <li>1. Confirm the model of the equipment.</li> <li>2. Install the system firmware corresponding to the model.</li> <li>3. Install the system software corresponding to the model.   P. 11-2 "11.2 Firmware Updating with USB Device"</li> </ol>
SYS board	Replace the SYS board.

Parts to be replaced	Remark
SYS board	

### [F902\_2] A model-unmatched SYS board is installed or the SRAM is cleared

Classification	Error item
Other service call	<ul style="list-style-type: none"> <li>• The SYS board for 20ppm/25ppm is installed in e-STUDIO2505AC/3005AC/3505AC/4505AC/5005AC. Or the opposite combination.</li> <li>• The SRAM is cleared.</li> </ul>

Check item	Measures
SYS board	Check if the model of the equipment matches the part number of the SYS board.

Check item	Measures
Setting	<p>Perform the following procedure if an error occurs when the SRAM is cleared.</p> <ol style="list-style-type: none"> <li>1. Perform FS-08 SETTING MODE.</li> <li>2. When "SRAM REQUIRES INITIALIZATION" is displayed on the display, check the destination and then press the [START] button. If the destination is not correct, key in the correct one and then press the [START] button.</li> <li>3. After the confirmation message is displayed, press the [Initialize] button. (SRAM is initialized.)</li> <li>4. Enter the serial number (FS-08-9601). Match it with the serial number on the label attached to the rear cover of the equipment.</li> <li>5. Initialize the NIC information (FS-08-9083).</li> <li>6. Perform 05 ADJUSTMENT MODE.</li> <li>7. Perform "Data transfer of characteristic value of scanner" (FS-05-3203).</li> <li>8. Perform "Automatic gamma adjustment" &lt;PPC&gt; (FS-05-7869).</li> <li>9. Perform "Automatic gamma adjustment" &lt;PRT&gt; (FS-05-8008 / FS-05-8009).</li> <li>10. Turn the power OFF and then back ON.</li> </ol>

Parts to be replaced	Remark
SYS board	



### [F902\_3] SRAM abnormality on the SYS board



Classification	Contents
Circuit related service call	SRAM abnormality on the SYS board

Check Item	Measure
SRAM	<ol style="list-style-type: none"> <li>1. Check that the SRAM is installed properly.</li> <li>2. Shut down the equipment.</li> <li>3. Perform [FS-08].</li> <li>4. Press [CLASSIC].</li> <li>5. When "SRAM REQUIRES INITIALIZATION" appears on the LCD screen, confirm the destination and press the [START] button. If the destination is incorrect, enter the number for the correct one and press the [START] button.</li> <li>6. When the confirmation message appears on the LCD screen, press [INITIALIZE]. (SRAM initialization starts.)</li> <li>7. Enter the serial number of the equipment correctly. (FS-08-9601)</li> <li>8. Initialize the NIC information. (FS-08-9083)</li> <li>9. Shut down the equipment.</li> <li>10. Perform [FS-05].</li> <li>11. Press [CLASSIC].</li> <li>12. Perform "Data transfer of characteristic value of scanner". (FS-05-3203)</li> <li>13. By using the [4] [TEST PRINT] test pattern, perform "Automatic gamma adjustment" &lt;PPC&gt;. (FS-05-7869)</li> <li>14. By using the [70] [TEST PRINT] test pattern, perform "Automatic gamma adjustment" &lt;PRT&gt;. (FS-05-8008 / FS-05-8009)</li> <li>15. Reboot the equipment.</li> <li>16. If the error still occurs, replace the SRAM.</li> </ol>
SYS board	Board check

Replacement part	Remark
SRAM	Be sure to exchange the parts in the order of the SRAM and SYS board.
SYS board	Be sure to exchange the parts in the order of the SRAM and SYS board.

### [F902\_4] SYS board model information error


Classification	Error item
Other service call	Invalid SYS board is installed to the equipment.

Check item	Measures
SYS board	<p>Check if the model of the equipment matches the color of the label on the SYS board.</p> <p> P. 9-3 "9.1.4 SYS board"</p>
Setting	<ol style="list-style-type: none"> <li>1. Install the system firmware.</li> <li>2. If the error cannot be solved after installing the system firmware, reinstall the system software and application program.</li> </ol> <p> P. 11-2 "11.2 Firmware Updating with USB Device"</p>

Parts to be replaced	Remark
SYS board	

## 8.3.26 Error in Internet FAX / Scanning Function

### Notes:

- When formatting the HDD (HS-75 -> Initialize HDD -> Clear Error Flag in Software Installation), all data in the shared folder, Electronic Filing, Address Book, template, etc. are erased. Back up these data before the initialization. Note that some of data cannot be backed up  
 P. 9-17 "9.2.3 Precautions and procedures when replacing the HDD"

### [ 1 ] Internet FAX related error

#### [1C10] System access abnormality

#### [1C32] File deletion failure

Turn the power OFF and then back ON. Perform the job in error again.

If the error still occurs, first, check if there are no jobs existing and then perform the HDD formatting (HS-75 -> Initialize HDD -> Clear Error Flag in Software Installation).

#### [1C11] Insufficient memory

When there are running jobs, perform the job in error again after the completion of the running jobs. If the error still occurs, turn the power OFF and then back ON, and perform the job again.

#### [1C12] Message reception error

#### [1C13] Message transmission error

Turn the power OFF and then back ON. Perform the job in error again.

#### [1C14] Invalid parameter

When a template is used, form the template again.

If the error still occurs, turn the power OFF and then back ON, and perform the job again.

#### [1C15] Exceeding file capacity

Reset and extend the "Maximum send to E-mail/iFAX size" or reduce the number of pages and perform the job again.

#### [1C30] Directory creation failure

#### [1C31] File creation failure

#### [1C33] File access failure

Check if the access privilege to the storage directory is writable.

Check if the server or local disk has a sufficient space in disk capacity.

#### [1C40] Image conversion abnormality

Turn the power OFF and then back ON. Perform the job in error again.

Replace the main memory and perform the job again.

#### [1C60] HDD full failure during processing

Delete the job in progress or being set or in the HOLD/PRIVATE/PROOF/INVALID, and perform it again.

Decrease the number of pages of the job in error and then reattempt it.

Check if the server or local disk has a sufficient space in disk capacity.

#### [1C61] Address Book reading failure

Turn the power OFF and then back ON. Perform the job in error again.

Reset the data in the Address Book and perform the job again.

#### [1C63] Terminal IP address unset

Reset the Terminal IP address.

Turn the power OFF and then back ON. Perform the job in error again.

#### [1C64] Terminal mail address unset

Reset the Terminal mail address.

Turn the power OFF and then back ON. Perform the job in error again.

**[1C65] SMTP address unset**

Reset the SMTP address and perform the job.  
Turn the power OFF and then back ON. Perform the job in error again.

**[1C66] Server time-out error**

Check if the SMTP server is operating properly.

**[1C69] SMTP server connection error**

Reset the login name or password of SMTP server and perform the job again.  
Check if the SMTP server is operating properly.

**[1C6B] Terminal mail address error**

Check the SMTP Authentication method.  
Check if there is an illegal character in the Terminal mail address.  
Set the correct SMTP Authentication method or delete the illegal character and reset the appropriate Terminal mail address, then perform the job again.

**[1C6C] Destination mail address error**

Check if there is an illegal character in the Destination mail address.  
Delete the illegal character and reset the appropriate Destination mail address, then perform the job again.

**[1C6D] System error**

Turn the power OFF and then back ON. Perform the job in error again.  
If the error still occurs, replace the SYS board.

**[1C70] SMTP client OFF**

Set the SMTP valid and perform the job again.

**[1C71] SMTP authentication error**

Check that SMTP authentication method, login name and password are correct, then perform authentication again.

**[1C72] POP Before SMTP error**

Check that both the POP Before SMTP setting and POP3 setting are correct, then perform authentication again.

**[1CC1] Power failure**

Check if the power cable is connected properly and it is inserted securely.  
Check if the power voltage is unstable.

**[ 2 ] RFC related error**

**[2500] HOST NAME error (RFC: 500) / Destination mail address error (RFC: 500) / Terminal mail address error (RFC: 500)**

**[2501] HOST NAME error (RFC: 501) / Destination mail address error (RFC: 501) / Terminal mail address error (RFC: 501)**

Check if the Terminal mail address and Destination mail address are correct.  
Check if the mail server is operating properly.  
Turn the power OFF and then back ON. Perform the job in error again.

**[2503] Destination mail address error (RFC: 503)**

**[2504] HOST NAME error (RFC: 504)**

**[2551] Destination mail address error (RFC: 551)**

Check if the mail server is operating properly.  
Turn the power OFF and then back ON. Perform the job in error again.  
If the error still occurs, replace the SYS board.

**[2550] Destination mail address error (RFC: 550)**

Check the state of the mail box in the mail server.

**[2552] Terminal/Destination mail address error (RFC: 552)**

Confirm the size on the mail server.

Transmit again in text mode or with lower resolution or divide the document and transmit again.

If the error still occurs, turn the power OFF and then back ON. Perform the job in error again.

**[2553] Destination mail address error (RFC: 553)**

Check if there is an illegal character in the mail box in the mail server.

**[ 3 ] Remote scanning related error****[2A20] System management module resource acquiring failure**

Retry the job in error.

If the error still occurs, turn the power OFF and then back ON, then retry the job in error.

**[2A31] Disabled WS Scan**

Check if the WS Scan function is disabled.

Or, check if the forcible encryption setting of the secure PDF is enabled.

**[2A40] System error**

Turn the power OFF and then back ON, then retry the job in error.

**[2A51] Power failure**

Check if the power cable is properly connected.

Check if the power supply voltage is inconstant.

**[2A60] WS Scan user authentication failure**

- When "1" (TTEC's WIA driver) is set for 08-9749 and also Windows Fax&Scan is used Check if the user name that you used to log in Windows is a name registered as a user.
- When MFP panel or EWB Scan is used Check if the login user name is a name registered as a user.

**[2A70] Remote Scan privilege check error**

Check if correct privilege is given to the user.

**[2A71] WS Scan privilege check error**

Check if correct privilege is given to the user.

**[2A72] e-Filing data access privilege check error (Scan Utility)**

Check if correct privilege is given to the user.

**[2A73] Error in the address book operation privilege check**

A user, who does not have the AddressbookRemoteAccess privilege, has performed export/import of the address book.

Check if the correct privilege is given to a user.

#### **[ 4 ] Electronic Filing related error**

##### **[2B11] JOB status abnormality**

##### **[2B20] File library function error**

##### **[2B30] Insufficient disk space in BOX partition**

##### **[2BC0] Fatal failure occurred**

Erase some data in the Electronic Filing or the shared folder and perform the job in error again (in case of [2B30]).

Ask the administrator if e-Filing has been disabled.

Turn the power OFF and then back ON. Perform the job in error again.

Check if there are no other running jobs and perform the HDD formatting (HS-75 -> Initialize HDD -> Clear Error Flag in Software Installation).

If the recovery is still not completed, replace the SYS board.

##### **[2B31] Status of specified Electronic Filing or folder is undefined or being created/deleted**

Check if the specified Electronic Filing or folder exists.

Delete the specified Electronic Filing or folder.

Change the name of folder to be created.

Perform the job in error again.

##### **[2B50] Image library error**

##### **[2B90] Insufficient memory capacity**

Turn the power OFF and then back ON. Perform the job in error again.

If the error still occurs, replace the main memory.

Delete the job in progress or being set or in the HOLD/PRIVATE/PROOF/INVALID, and retry the job in error.

##### **[2B51] List library error**

Check if the Function list can be printed.

If it can be printed, retry the job in error.

If it cannot, replace the main memory.

If it still cannot be printed, initialize the HDD (HS-75 -> Initialize HDD -> Clear Error Flag in Software Installation).

##### **[2BA0] Invalid Box password**

Check if the password is correct.

Reset the password.

When this error occurs when printing the data in the Electronic Filing, perform the printing with the administrator's password.

##### **[2BA1]Invalid paper size/color mode/resolution.**

The specified paper size, color mode or resolution cannot be used. Check the setting.

##### **[2BB1] Power failure**

##### **[2BD0] Power failure occurred during restoring of Electronic Filing**

Check if the power cable is connected properly and it is inserted securely.

Check if the power voltage is unstable.

##### **[2BE0] Machine parameter reading error**

Turn the power OFF and then back ON. Perform the job in error again.

##### **[2BF0] Exceeding maximum number of pages**

Reduce the number of the pages of the job in error, and retry the job.

##### **[2BF1] Exceeding maximum number of documents**

Backup the documents in the box or folder to PC or delete them.

##### **[2BF2] Exceeding maximum number of folders**

Backup the folders in the box or folder to PC or delete them.

## **[ 5 ] E-mail related error**

### **[2C10] System access abnormality**

#### **[2C32] File deletion failure**

Turn the power OFF and then back ON. Perform the job in error again.

If the error still occurs, first, check if there are no jobs existing and then perform the HDD formatting (HS-75 -> Initialize HDD -> Clear Error Flag in Software Installation).

### **[2C11] Insufficient memory**

When there are running jobs, perform the job in error again after the completion of the running jobs.

If the error still occurs, turn the power OFF and then back ON, and perform the job again.

### **[2C12] Message reception error**

### **[2C13] Message transmission error**

Turn the power OFF and then back ON. Perform the job in error again.

### **[2C14] Invalid parameter**

When a template is used, form the template again.

If the error still occurs, turn the power OFF and then back ON, and perform the job again.

### **[2C15] Exceeding file capacity**

Reset and extend the "Maximum send to E-mail/iFAX size" or reduce the number of pages and perform the job again.

### **[2C20] System management module access abnormality**

### **[2C21] Job control module access abnormality**

### **[2C22] Job control module access abnormality**

Turn the power OFF and then back ON. Perform the job in error again.

Check if there are no other running jobs and perform the HDD formatting (HS-75 -> Initialize HDD -> Clear Error Flag in Software Installation).

If the recovery is still not completed, replace the SYS board.

### **[2C30] Directory creation failure**

### **[2C31] File creation failure**

### **[2C33] File access failure**

Check if the access privilege to the storage directory is writable.

Check if the server or local disk has a sufficient space in disk capacity.

### **[2C40] Image conversion abnormality**

### **[2C62] Memory acquiring failure**

Turn the power OFF and then back ON. Perform the job in error again.

Replace the main memory and perform the job again.

### **[2C43] Encryption error**

Turn the power OFF and then back ON. Perform the job in error again.

### **[2C44] Encryption PDF enforced mode error**

Reset the encryption and perform the job in error again.

If an image file not encrypted is created, consult your administrators.

### **[2C45] Meta data creation error (Scan to Email)**

Check the template settings. Perform the job in error again. If the error still occurs, turn the power OFF and then back ON, and then perform the job in error again.

### **[2C50] Authentication failure at job execution (A Scan To Email job has been executed without user or department authentication.)**

- A Scan To Email job is carried out while user authentication or department authentication has not been done.
- Retry the job after user authentication or department authentication has been done.

**[2C60] HDD full failure during processing**

Delete the job in progress or being set or in the HOLD/PRIVATE/PROOF/INVALID, and perform it again.

Check if the server or local disk has a sufficient space in disk capacity.

Check that there is enough space in the server or local disk.

**[2C61] Address Book reading failure**

Turn the power OFF and then back ON. Perform the job in error again.

Reset the data in the Address Book and perform the job again.

**[2C63] Terminal IP address unset**

Reset the Terminal IP address.

Turn the power OFF and then back ON. Perform the job in error again.

**[2C64] Terminal mail address unset**

Reset the Terminal mail address.

Turn the power OFF and then back ON. Perform the job in error again.

**[2C65] SMTP address unset**

Reset the SMTP address and perform the job.

Turn the power OFF and then back ON. Perform the job in error again.

**[2C66] Server time-out error**

Check if the SMTP server is operating properly.

**[2C69] SMTP server connection error**

Reset the login name and password of SMTP server and perform the job again.

Check if the SMTP server is operating properly.

**[2C6A] HOST NAME error (No RFC error)**

Check if there is an illegal character in the device name.

Delete the illegal character and reset the appropriate device name.

**[2C6B] Terminal mail address error**

Check the SMTP Authentication method.

Check if there is an illegal character in the Terminal mail address.

Set the correct SMTP Authentication method or delete the illegal character and reset the appropriate Terminal mail address, then perform the job again.

**[2C6C] Destination mail address error (No RFC error)**

Check if there is an illegal character in the Destination mail address.

Delete the illegal character and reset the appropriate Destination mail address, then perform the job again.

**[2C70] SMTP client OFF**

Set the SMTP valid and perform the job again.

**[2C71] SMTP authentication error**

Check that SMTP authentication method, login name and password are correct, then perform authentication again.

**[2C72] POP Before SMTP error**

Check that both the POP Before SMTP setting and POP3 setting are correct, then perform authentication again.



**[2CC1] Power failure**

Check if the power cable is connected properly and it is inserted securely.  
Check if the power voltage is unstable.

**[ 6 ] File sharing related error****[2D10] System access abnormality****[2D32] File deletion failure****[2DA6] File deletion failure****[2DA7] Resource acquiring failure**

Delete some files in the shared folder by using Explorer because of automatic/manual file deletion failure (in case of [2DA6])

Turn the power OFF and then back ON. Perform the job in error again.

If the error still occurs, first, check if there are no jobs existing and then perform the HDD formatting (HS-75 -> Initialize HDD -> Clear Error Flag in Software Installation).

**[2D11] Insufficient memory**

When there are running jobs, perform the job in error again after the completion of the running jobs.  
If the error still occurs, turn the power OFF and then back ON, and perform the job again.

**[2D12] Message reception error****[2D13] Message transmission error**

Turn the power OFF and then back ON. Perform the job in error again.

**[2D14] Invalid parameter**

When a template is used, form the template again.

If the error still occurs, turn the power OFF and then back ON, and perform the job again.

**[2D15] Exceeding the maximum size for file sharing**

Delete the documents in the folder, and reattempt the job in error.

**[2D30] Directory creation failure****[2D31] File creation failure****[2D33] File access failure**

Check if the access privilege to the storage directory is writable.

Check if the server or local disk has a sufficient space in disk capacity.

**[2D40] Image conversion abnormality**

Turn the power OFF and then back ON. Perform the job in error again.

Replace the main memory and perform the job again.

**[2D43] Encryption error**

Turn the power OFF and then back ON. Perform the job in error again.

**[2D44] Encryption PDF enforced mode error**

Reset the encryption and perform the job in error again.

If an image file not encrypted is created, consult your administrators.

**[2D45] Meta data creation error (Scan to File)**

Check the template settings. Perform the job in error again. If the error still occurs, turn the power OFF and then back ON, and then perform the job in error again.

**[2D50] Authentication failure at job execution (A Scan To File job has been executed without user or department authentication.)**

- A Scan To File job is carried out while user authentication or department authentication has not been done.
- Retry the job after user authentication or department authentication has been done.

**[2D62] File server connection error**

Check the IP address or path of the server.  
Check if the server is operating properly.

**[2D63] Invalid network path**

Check the network path.  
If the path is correct, turn the power OFF and then back ON, and perform the job again.

**[2D64] Login failure**

Reset the login name and password. Perform the job.  
Check if the account of the server is properly set up.

**[2D65] Exceeding documents in folder: Creating new document is failed**

Delete some documents in the folder.

**[2D66] Storage capacity full failure during processing**

Delete the job in progress or being set or in the HOLD/PRIVATE/PROOF/INVALID, and perform it again.  
Check if the server or local disk has a sufficient space in disk capacity.  
Check that there is enough space in the server or local disk.

**[2D67] FTP service not available**

Check if the setting of FTP service is valid.

**[2D68] File sharing service not available**

Check if the setting of SMB is valid.

**[2D69] NetWare service not available**

Check if the Netware setting is enabled.

**[2DC1] Power failure**

Check if the power cable is connected properly and it is inserted securely.  
Check if the power voltage is unstable.

**[2E10] USB storage system access abnormality**

Turn the power OFF and then back ON. Perform the job in error again. If the error still occurs, first, check if there are no jobs existing and then perform HDD formatting (HS-75 -> Initialize HDD -> Clear Error Flag in Software Installation).

**[2E11] Insufficient memory capacity for USB storage**

If there is a job in progress, perform the job in error again after the job in progress is finished. If the error still occurs, turn the power OFF and then back ON, and then perform the job in error again.

**[2E12] Message reception error in USB storage****[2E13] Message transmission error in USB storage**

Turn the power OFF and then back ON. Perform the job in error again.

**[2E14] Invalid parameter for USB storage**

If a template is being used, recreate the template. If the error still occurs, turn the power OFF and then back ON. Perform the job in error again.

**[2E15] Exceeding maximum file capacity**

Delete some files in the folder. Perform the job in error again.

**[2E30] Directory creation failure in USB storage****[2E31] File creation failure in USB storage**

Check if access privilege to the storage directory is writable. Check if the server or local disk has sufficient space in its disk capacity.

**[2E32] File deletion failure in USB storage**

Turn the power OFF and then back ON. Perform the job in error again. If the error still occurs, first, check if there are no jobs existing and then perform HDD formatting (HS-75 -> Initialize HDD -> Clear Error Flag in Software Installation).

**[2E33] File access failure in USB storage**

Check if access privilege to the storage directory is writable. Check if the server or local disk has sufficient space in its disk capacity.

**[2E40] Image conversion abnormality in USB storage**

Turn the power OFF and then back ON. Perform the job in error again. Replace the main memory and then perform the job in error again.

**[2E43] Encryption failure in USB storage**

Turn the power OFF and then back ON. Perform the job in error again.

**[2E44] Encryption PDF enforced mode error in USB storage**

Reset the encryption and perform the job in error again. To create an image file not encrypted, consult your administrator.

**[2E45] Meta data creation error in USB storage (Scan to File)**

Check the template settings. Perform the job in error again. If the error still occurs, turn the power OFF and then back ON, and then perform the job in error again.

**[2E50] Authentication failure at job execution (A Scan To USB job has been executed without user or department authentication.)**

- A Scan To USB job is carried out while user authentication or department authentication has not been done.
- Retry the job after user authentication or department authentication has been done.

**[2E65] File creation error due to insufficient USB folder capacity**

Delete unnecessary files in the folder.

**[2E66] HDD full failure in USB storage**

Delete the job in progress or being set or in the HOLD/PRIVATE/PROOF/INVALID, and perform it again.

Check if the server or local disk has a sufficient space in disk capacity.

Check that there is enough space in the USB memory.

**[2EC1] Power failure in USB storage**

Check if the power cable is connected properly and inserted securely. Check if the power voltage is unstable.

**[ 7 ] E-mail reception related error****[3A10] E-mail MIME error**

The format of the mail is not corresponding to MIME 1.0.

Request the sender to retransmit the mail in the format corresponding to MIME 1.0.

**[3A20] E-mail analysis error****[3B10] E-mail format error****[3B40] E-mail decode error**

These errors occur when the mail data is damaged from the transmission to the reception of the mail.

Request the sender to retransmit the mail.

**[3A30] Partial mail time-out error**

The partial mail is not received in a specified period of time.

Request the sender to retransmit the partial mail, or set the time-out period of the partial mail longer.

**[3A40] Partial mail related error**

The format of the partial mail is not corresponding to this equipment.

Request the sender to remake and retransmit the partial mail in RFC2046 format.

**[3A50] Insufficient HDD capacity error**

These errors occur when the HDD capacity is not sufficient for a temporary concentration of the jobs, etc.

Request the sender to retransmit after a certain period of time, or divide the mail into more than one.

Insufficient HDD capacity error also occurs when printing is disabled for no printing paper.

In this case, supply the printing paper.

**[3A70] Error of partial mail interruption**

This error occurs when the partial mail reception setting becomes OFF during the partial mail reception.

Reset the partial mail reception setting ON and then request the sender to retransmit the mail.

**[3A80] Partial mail reception setting OFF**

Reset the partial mail reception setting ON and then request the sender to retransmit the mail.

**[3B20] Content-Type error**

The file format attached to the e-mail is not supported by this equipment (TIFF-FX/PDF/JPEG/XPS). Or the combination of the file formats attached to the e-mail is not available to be received together by this equipment. (The file format TIFF-FX cannot be received together PDF, JPEG and XPS ones.)

Request the sender to retransmit the file by modifying the file format which is supported by this equipment. Or request the sender to retransmit the e-mail by attaching only TIFF-FX format files or by attaching PDF, JPEG and XPS format files (a mixture of the formats is available).

**[3B50] Received mail data deletion**

Mail data received have been deleted from a server as their reception process could not be carried out since they were broken.

Check that the address of the mail sent immediately before the error was correct.

Request the transmitter of the deleted mail to reattempt the transmission.

**[3C10] TIFF analysis error****[3C13] TIFF analysis error**

These errors occur when the mail data is damaged from the transmission to the reception of the mail, or when the format of the attached file is not supported by this equipment (TIFF-FX).

Request the sender to retransmit the mail.

**[3C20] TIFF compression error**

The compression method of the TIFF file is not acceptable for this equipment. (Acceptable: MH/MR/MMR/JBIG)

Request the sender to retransmit the file in the acceptable compression method.

**[3C30] TIFF resolution error**

The resolution of the TIFF file is not acceptable for this equipment. (Acceptable: 200 x 100, 200 x 200, 200 x 400, 400 x 400, 300 x 300 or equivalent)

Request the sender to retransmit the file in the acceptable resolution.

**[3C40] TIFF paper size error**

The paper size of the TIFF file is not acceptable for this equipment. (Acceptable: A4, B4, A3, B5, LT, LG, LD or ST)

Request the sender to retransmit the file in the acceptable paper size.

**[3C50] Offramp destination error**

These errors occur when the FAX number of the offramp destination is incorrect.  
Request the sender to correct the FAX number of offramp destination and then retransmit the mail.

**[3C60] Offramp security error**

These errors occur when the FAX number of the offramp destination is not on the Address Book.  
Check if the FAX number of the offramp destination is correctly entered or the number has not been changed.

**[3C70] Power failure error**

Check if the mail is recovered after turning ON the power again.  
Request the sender to retransmit the mail if it is not recovered.

**[3C90] OffRamp Fax transmission disable error**

OffRamp Fax transmission disable error has been detected in the received mail.  
Confirm if the Fax Send Function of MFP setting is disable or not.

**[3D10] Destination address error**

Check if the setting of the server or DNS is correct. Correct if any of the setting is incorrect.  
When the content of the setting is correct, confirm the sender if the destination is correct.

**[3D20] Offramp destination limitation error**

Inform the sender that the transfer of the FAX data over 40 is not supported.

**[3D30] FAX board error**

This error occurs when the FAX board is not installed or the FAX board has an abnormality.  
Check if the FAX board is correctly connected.

**[3E10] POP3 server connection error**

Check if the IP address or domain name of the POP3 server set for this equipment is correct, or check if POP3 server to be connected is operating properly.

**[3E20] POP3 server connection time-out error**

Check if POP3 server to be connected is operating properly.  
Check if the LAN cable is correctly connected.

**[3E30] POP3 login error**

Check if the POP3 server login name and password set for this equipment are correct.

**[3E40] POP3 Login Type error**

Check that the login type (Auto, POP3 or APOP) to the POP3 server is correct.

**[3F10] File I/O error****[3F20] File I/O error**

These errors occur when the mail data is not transferred properly to the HDD.  
Request the sender to retransmit the mail.  
Replace the HDD if the error still occurs after retransmission.

## 8.3.27 Printer function error

### [4011] Print job cancellation

This message appears when deleting the job on the screen.

### [4021] Print job power failure

When there are running jobs, perform the job in error again after the completion of the running jobs. If the error still occurs, turn the power OFF and then back ON, and perform the job again.

### [4031] HDD full error

Delete unnecessary private print jobs and invalid department print jobs.  
Check if the server or local disk has sufficient space in its disk capacity.

### [4032] Exceeding the upper limit of the registration number for the sharing jobs

Check that no unnecessary shared jobs yet to be printed are remaining. If there are such jobs, delete them.

### [4033] Network setting error

The address applicable to this equipment has not been registered in the cooperating machine list.  
Add the address applicable to this equipment.

### [4041] User authentication error (The user who intended to print a document is not registered as a user.)

Perform the authentication or register as a user, and then perform the printing again.

### [4042] Department authentication error (The department whose code is specified for a print job is not registered.)

Check department information registered in this equipment.

### [4043] Project authentication error

Check project information registered in this equipment.

### [4045] Problem in LDAP server connection or LDAP server authorization settings

Confirm the administrator for the LDAP server connection or LDAP server authorization settings.

### [4111] Quota over error (The number of the assigned pages set by department and user management has reached 0.)

The number of the assigned pages set by the department and the number of those assigned by user management have both reached 0. Assign the number of the pages again or perform initialization.

### [4112] Quota over error (The number of the assigned pages set by user management has reached 0.)

The number of the assigned pages set by the user management has reached 0. Assign the number of the pages again or perform initialization.

### [4113] Quota over error (The number of the assigned pages set by department management has reached 0.)

The number of the assigned pages set by the department management has reached 0. Assign the number of the pages again or perform initialization.

### [4121] Job canceling due to external counter error

1. Drop a coin in. Perform the print job in error again.
2. Insert a key card and then perform the print job in error again, or consult your administrator.
3. Insert a key copy counter and then perform the print job in error again.
4. Reset the scheduled print job and then perform the print job in error again.

### [4211] Printing data storing limitation error

Select "Normal Print", and then perform the printing again.

**[4212] e-Filing storing limitation error**

Select "Normal Print", and then perform the printing again.

**[4213] File storing limitation error**

The file storing function is set to "disabled". Check the settings of the equipment.

**[4214] Fax/Internet Fax transmission limitation error**

Check the settings of this equipment.

**[4221] Private-print-only error**

Email direct printing cannot be performed since Private printing is not selectable for it. Select "Private print" and then perform the printing again.

**[4222] Hold-print-only error**

Email direct printing cannot be performed since Hold printing is not selectable for it.

**[4223] Private-print-only/Hold-print-only error**

Email direct printing cannot be performed since Private printing and Hold printing are not selectable for it.

**[4231] Hardcopy security printing error**

Hardcopy security printing cannot be performed because the function is restricted in the self-diagnosis mode.

**[4243] Sharing job - An error caused by not having a license**

Check that the license of the multi station print option is installed. If it is not, install it.

**[4244] Sharing job - An error caused by function disabled**

Check from TopAccess whether the function of the multi station print option is disabled. If it is disabled, enable it.

**[4245] OCR functions not available**

Check whether the OCR license or an extended memory is installed.

**[4311] Printing not permitted**

Confirm the administrator for the JOB authorization.

**[4312] Not authorized to store a file**

The user has not been authorized to perform this operation. Ask your administrator.

**[4313] No privilege for e-Filing storage****[4314] No privilege for Fax / Internet Fax transmission****[4321] No privilege for print settings**

Check the privilege given, or request the administrator to add the necessary privilege.

**[4411] Image data creation failure**

Check if the file to be printed is broken. Perform printing again or use another printer driver.

- Network print: Perform the print job in error again, or use another printer driver (e.g.; PS3, Universal).
- Direct print: Check if the file is corrupted (e.g. checking if the file is displayed on your PC monitor), or check if the file format is supported by this equipment.

**[4412] Double-sign encoding error**

Printing using this function cannot be performed due to a decoding process error which occurs because the PDF file is encrypted incorrectly or encrypted in a language not supported.

**[4511] Connection timeout**

- Check that the Ethernet setting of the MFP is the same as that for the hub to which the MFP is being connected.
- Check that the Ethernet cable is connected properly.

**[4521] Reaching the maximum number of connections**

- Perform printing again after a certain period of time.
- If this frequently occurs due to the network environment or the number of the client PCs, change the setting of the following self-diagnostic codes.  
08-3727, 08-3731, 08-3732, 08-3765, 08-9561

**[4522] Exceeding the upper limit of the registration number of jobs during data reception**

- Wait until the printing of the jobs which are being processed or are waiting is completed and then perform printing again.
- Delete unnecessary private print jobs and invalid department print jobs and then perform printing again.

**[4523] HDD full during data reception**

- Delete unnecessary private print jobs and invalid department print jobs and then perform printing again.
- Check if the server or local disk has sufficient space in its disk capacity.

**[4611] Font download failure (reached the registration limit)****[4612] Font download failure (HDD full)**

Delete one or more font already registered.

**[4613] Font download failure (others)**

Reattempt the downloading. Recreate font data and reattempt the downloading.


**[4621] Font deletion failure**

Check if the font to be deleted is registered (or pre-registered) in this equipment.

**[4721] Connection Error of Multi Station Print (Unexpected combination of ROM version)**

Connection failure of Multi Station Print because of an unexpected ROM version combination. Then update the version of the unconnectable equipment to become the same as that for the connected one.

**[4F10] System abnormality**

- (1) Perform the job in error again. If the error still occurs, turn the power OFF and then back ON, and perform the job again.
- (2) Collect the debug log with USB device.  
 P. 8-2 "8.1.2 Collection of debug logs with a USB device"
- (3) Initialize HDD.  
Refer to step 3 and later in "[E]Replace / Format HDD" in "9.2.3Precautions and procedures when replacing the HDD".



## 8.3.28 TopAccess related error/Communication error with external application

### [5012] Authentication error

Classification	Error item
Communication error with external application	A temporary password downloaded from e-Bridge and entered in this equipment is not valid, or the permanent password set in the e-Bridge is not valid.

Check item	Measures
Setting	Confirm the user name and tentative password.

### [5013] e-Bridge communication error

Classification	Error item
Communication error with external application	Communication is attempted while the e-Bridge is enabled for some reason such as version upgrade.

Check item	Measures
Setting	Check if the MFP is connected to the eBR2 server.

### [5014] No SSL certificate

Classification	Error item
Communication error with external application	There is no SSL certificate or the certificate is not in a correct file format.

Check item	Measures
Setting	Install the correct SSL certificate.

### [5015] Invalid SSL certificate

Classification	Error item
Communication error with external application	SSL certificate is not valid.

Check item	Measures
Setting	Install the correct SSL certificate.

### [5016] Expired SSL certificate

Classification	Error item
Communication error with external application	SSL certificate is expired.

Check item	Measures
Setting	Set the correct time.

**[5017] Other SSL certificate related error**

Classification	Error item
Communication error with external application	SSL certificate is invalid.

Check item	Measures
Setting	Install the correct SSL certificate.

**[5018] Invalid DNS error**

Classification	Error item
Communication error with external application	DNS address is invalid.

Check item	Measures
Setting	Set the correct DNS address. If any setting is needed in DNS, consult your administrators.

**[5019] Connection error**

Classification	Error item
Communication error with external application	Settings for initial URL and proxy are incorrect.

Check item	Measures
Setting	Perform the correct settings for initial URL and proxy.

**[501A] Proxy error**

Classification	Error item
Communication error with external application	IP address or port for proxy setting is invalid.

Check item	Measures
Setting	Set the correct IP address or port for the proxy setting. If any setting is needed in proxy, consult your administrators.

**[501B] No URL (host/port) or invalid path**

Classification	Error item
Communication error with external application	Initial URL is invalid.

Check item	Measures
Setting	Set the correct initial URL.

**[5030] HTTP communication error**

Classification	Error item
Communication error with external application	An error in the HTTP communication

Check item	Measures
Setting	Check the URL for communication. Check that the valid IP address is assigned to connect to the server.


**[50FF] eBR2 internal error**

Classification	Error item
MFP internal error	A fatal error occurred in the MFP

Check item	Measures
Setting	Restart the MFP, and then try again.

**[5110] Toner cartridge detection error**

Classification	Error item
TopAccess related error	Toner cartridge PC board access abnormality

Check item	Measures
Toner cartridge	Refer to the troubleshooting for C911 error.  P. 8-201 " [C911] Toner cartridge PC board access abnormality"

**[5212] Time for cleaning of the main charger**

Classification	Error item
TopAccess related error	

Check item	Measures
Setting	<ul style="list-style-type: none"> <li>Clean the LED printer head and main charger.</li> </ul>

**[5213] Time for cleaning of the LED printer head**

Classification	Error item
TopAccess related error	

Check item	Measures
LED printer head	Clean the LED printer head.

- [5310] Toner-K empty
- [5311] Toner-Y empty
- [5312] Toner-M empty
- [5313] Toner-C empty

Classification	Error item
TopAccess related error	The toner cartridge has become empty.

Check item	Measures
Toner cartridge	Replace the toner cartridges corresponding to the errors. If the errors still persist after replacement, check that the toner cartridge interface board (CTIF board) or the toner cartridge board (CTRG board) is connected properly.

**[5410] MFP registration error**

Classification	Error item
MFP registration error	An invalid registration by accessing a cloud server using a valid serial No. of the equipment has been performed. Or database in the cloud server has been damaged.

Check item	Measures
Setting of a cloud server	Retry the registration. Contact the administrator of the cloud server.

**[5411] MFP registration lock error**

Classification	Error item
MFP registration error	Data to be sent to a cloud server from the equipment has been damaged or incorrect authentication data have been sent. Or Toshiba equipment which has not been supported by the cloud server has been tried to be registered.

Check item	Measures
None	Contact the administrator of the cloud server.

**[5412] Server busy error**

Classification	Error item
Server busy error	The server cannot handle periodic communication from the equipment due to overloading. This phenomenon occurs when a busy signal is sent from the server at the start of the periodic communication of the equipment.

Check item	Measures
None	Not required

**[5413] Server error**

Classification	Error item
Server error	A fatal error has occurred on the cloud server.

Check item	Measures
Setting of a cloud server	Contact the administrator of the cloud server.

**[5414] Invalid device file error**

Classification	Error item
Invalid device file	A device file to be sent to a cloud server from the equipment has been damaged.

Check item	Measures
Communication environment	Check the connection of network devices. If there is no problem with the network environment, reinstall the system software.

**[5415] Communication error**

Classification	Error item
Communication error	Communication with a cloud server has failed.

Check item	Measures
Setting	Check the connection and the settings of network devices and the cloud server.

**[5416] Setting files / system software update error**

Classification	Error item
Update failure of system software / setting files of the equipment	The system software and the setting files of the equipment cannot be updated because there is an ongoing job.

Check item	Measures
Communication environment	Retry the update of the setting files and the system software. If the same error occurs more than one time, contact the administrator of the cloud server.

**[5417] System software error**

Classification	Error item
Invalid system software / setting files of the equipment	The system software and the setting files of the equipment that have been downloaded from a cloud server have been damaged.

Check item	Measures
Communication environment	Retry the downloading of the setting files and the system software. Check if the network cable is disconnected. Check the connection of network devices. If there is no problem with the network environment, contact the administrator of the cloud server.

**[5BD0] Power failure during restoration**

Classification	Error item
TopAccess related error	

Check item	Measures
Setting	<ul style="list-style-type: none"> <li>• Check if the power cable is connected properly and is inserted securely.</li> <li>• Check if the power voltage is unstable.</li> <li>• Reattempt the restoration of the database (Address Book, templates, F-code (Mailbox) or user information).</li> </ul>

**[5C10] FAX Unit attachment error**

Classification	Error item
TopAccess related error	

Check item	Measures
Setting	<ul style="list-style-type: none"> <li>• Check if the FAX Unit is attached.</li> <li>• Check if there is any damage or abnormality on the FAX board.</li> <li>• Check if the connector on the FAX board is connected properly.</li> </ul>

**[5C11] Network FAX transmission error**

Classification	Error item
TopAccess related error	

Check item	Measures
Setting	The address specified for the network FAX is not registered on the Address Book. Register it.

### 8.3.29 MFP access error

#### [6007] Unsuccessful User Login to MFP

Classification	Error item
MFP access error	User authentication cannot be done because connection to the authentication server has failed.

Check item	Measures
Setting	Check if the operating status of the server and connection from an MFP have been confirmed.

#### [6008] Failed to connect on External Role Base Access Control (LDAP) Server

Classification	Error item
MFP access error	User authentication cannot be done because connection to an external RBAC server has failed.

Check item	Measures
Setting	Check if the operating status of the server and connection from the MFP have been confirmed.

#### [6009] User login failure to an MFP (during NIC initialization)

Classification	Error item
MFP access error	Connection to an authentication server failed since NIC initialization is being performed.

Check item	Measures
Setting	Perform the user log-in after NIC initialization has been completed.

#### [600A] Department code not assigned to a user

Classification	Error item
MFP access error	Authentication failed since the department code has not been assigned to the user.

Check item	Measures
Setting	Assign the department code to the user.

#### [6011] User automatic registration failure (due to an upper limit of the user registration number)

Classification	Error item
MFP access error	User automatic registration failed since the user registration number has reached the upper limit.

Check item	Measures
Setting	Delete unnecessary registered users.

**[6013] Connection failure to the authentication server**

Classification	Error item
MFP access error	Failed to connect to the authentication server

Check item	Measures
Setting	Check that the server setting is proper by accessing [TopAccess] -> [Administration] -> [Maintenance] -> [Directory Service]. When "Auto" is selected as the authentication method, this error may output to the log depending on the environment.

**[6014] The authentication server that cannot be accessed is detected**

Classification	Error item
MFP access error	The authentication server that cannot be accessed is detected

Check item	Measures
Setting	Check if the authentication server is down since the access to the authentication server is not available. The unavailable authentication server is accessed again if the time set in FS-08-8788 passes or the power of the equipment is turned OFF and back ON.

**[6031] Invalid setting: Invalid CL code**

Classification	Error item
MFP access error	A card is not usable as its CL code does not match.

Check item	Measures
Setting	Use an available card.

**[6032] Card related error: Expired card**

Classification	Error item
MFP access error	The card cannot be used because it has expired.

Check item	Measures
Setting	Use a card with a valid expiration.

**[6033] Card related error: Invalid flag data (no room-entry data)**

Classification	Error item
MFP access error	The card cannot be used because no room-entry data are recorded in it.

Check item	Measures
Setting	Use a correct card that has been used for entering the room.



**[6034] Card related error: Invalid flag data (invalid card data)**

Classification	Error item
MFP access error	The card cannot be used because the data required for the use of the card are not correctly set.

Check item	Measures
Setting	Use a valid card.

**[6035] Invalid setting: Invalid flag information (not set in an MFP)**

Classification	Error item
MFP access error	The necessary information in order to use a card is not set in the equipment.

Check item	Measures
Setting	Use an available card or ask the administrator to register the information.

**[6036] Invalid setting: Invalid flag information (Information between an MFP and card does not match)**

Classification	Error item
MFP access error	A card is not usable since its information and the value set in the equipment do not match.

Check item	Measures
Setting	Use an available card or ask the administrator to register the information.

**[6037] Permission flag for use not available**

Classification	Error item
MFP access error	A card is not usable since the privilege to use the device or equipment is not applied.

Check item	Measures
Setting	Use an available card or request the administrator to apply the privilege.

**[6040] Card authentication: Read error**

Classification	Error item
MFP access error	Card information could not be obtained correctly.

Check item	Measures
Setting	Reattempt card scanning. If the error persists even though the card scanning is attempted several times, the card information may be broken or the card reader may be damaged.

**[6041] Card authentication: Card related error**

Classification	Error item
MFP access error	Card data cannot be obtained correctly.

Check item	Measures
Setting	Reattempt scanning. If the error still occurs after reattempting scanning for several times, card data may be corrupted or the card reader may be out of order.

**[6042] Card authentication: Card setting error**

Classification	Error item
MFP access error	The self-diagnostic code required for card authentication is not set in this equipment correctly.

Check item	Measures
Setting	Set the correct self-diagnostic code.

**[6052] User authentication for print job failed because connection to an external RBAC server has failed.**

Classification	Error item
MFP access error	User authentication for print job cannot be done because connection to an external RBAC server has failed.

Check item	Measures
Setting	Check if the operating status of the server and connection from the MFP have been confirmed.

**[6101] e-Filing box locking out**

Classification	Error item
MFP access error	An e-Filing box becomes unusable since the entry of a password has failed for a specified number of times.

Check item	Measures
Setting	Reattempt to access the e-Filing box after a while. Contact the administrator to check this.

**[6121] Automatic Secure Erase failure**

Classification	Error item
MFP access error	The automatic secure erase fails.

Check item	Measures
Setting	Data overwriting failed for some reason. If the error still occurs after rebooting the equipment, start up using the following procedure: HS-73 Assist mode → Format HDD → Reinstallation of software or HDD replacement

**[6131] MFP fail to verify clock with Time Server**

Classification	Error item
MFP access error	The MFP is not synchronized with the SNTP server.

Check item	Measures
Setting	Check that the SNTP server is operating correctly. Check that the path to the SNTP server is operating correctly. Check that the settings are correct in TopAccess -> [Administrator] -> [Setup] -> [General] -> [SNTP Service].

**[61B0] Image log saving failure to an MFP local storage**

Classification	Error item
MFP access error	Saving of an image log failed.

Check item	Measures
Setting	Confirm that a local folder has a sufficient space in the disk capacity. If not, delete image logs, data in the e-Filing box and shared files.

**[6263] New build-in user and role update failure**

<b>Classification</b>	<b>Error item</b>
MFP access error	Updating of new built-in user and role failed.

<b>Check item</b>	<b>Measures</b>
Setting	When updating is performed, Remote-access-service and Remote-service-technician are added. However, updating failed since a user or role with the same names already existed. Change the name of the user or the role and reboot the equipment.

### 8.3.30 Maintenance error

#### [711D] License key returning failure

Classification	Error item
Maintenance error	The one-time dongle license fails to be returned to USB device.

Check item	Measures
Setting	Return the license to the USB device used for installing the license. Check that the USB device is correctly installed. <b>Notes:</b> The GP-1080 IPsec Enabler cannot return to the USB device due to license problem. The GP-1070 Overwrite Enabler cannot return to the USB device in the high security (08-8911: 3).

#### [711F] License key installation failure

Classification	Error item
Maintenance error	The one-time dongle license fails to be installed.

Check item	Measures
Setting	Check that the USB device is correctly installed.

#### [71B0] Software package file decryption failure

Classification	Error item
Maintenance error	Software package file decryption failed.

Check item	Measures
Setting	Software package file may have a problem or may be corrupted. Check the software package file and then reattempt the installation.

#### [71B5] Finisher firmware installation failure

Classification	Error item
Maintenance error	Finisher firmware installation failure

Check item	Measures
Setting	Finisher firmware installation failed. Reinstall the firmware.

**[71B7] Saddle firmware installation failure**

Classification	Error item
Maintenance error	Saddle firmware installation failure

Check item	Measures
Setting	Saddle firmware installation failed. Reinstall the firmware.

**[71B9] Punch firmware installation failure**

Classification	Error item
Maintenance error	Punch firmware installation failure

Check item	Measures
Setting	Punch firmware installation failed. Reinstall the firmware.

**[71E0] License abnormality due to damage on the license manager database**

Classification	Error item
License management	A message which notifies that the license manager database is has been restored and the recovery of the license has become possible.

Check item	Measures
Backup data	Restore the backup data with the latest status, including all the activated licenses, are stored.  <b>Notes:</b> Applications with the trial license cannot be recovered from the backup data. If necessary, reinstall the applications.
License	<ul style="list-style-type: none"> <li>• If there are no backup data as above, reactivate all the licenses which have been activated in this equipment.</li> <li>• If the functions have been activated by the export license file, import the license exported from the host unit of the equipment.</li> </ul>

**[7332] Application installation error**

Classification	Error item
Maintenance error	Application installation error

Check item	Measures
Setting	Installation of the application has failed. Update the application.

**[7333] Application start error**

Classification	Error item
Maintenance error	Application start error

Check item	Measures
Setting	Start of the installation has failed. Update the application.

**[7402] License activation failure (Online)**

Classification	Error item
License management	License activation by means of [Online] has failed.

Check item	Measures
License	Ask the license provider whether the license is correct or not. If the license is not correct, ask the license provider to issue the correct license authentication ID.

**[7403] License activation failure (network timeout)****[7404] License activation failure (network error)**

Classification	Error item
License management	License activation by means of [Online] has failed due to a network problem.

Check item	Measures
Network setting	<ul style="list-style-type: none"> <li>Check that the URL for the license server has not been changed. If the URL for the license server has been changed, enter the post change URL into FS-08-3634 and then reattempt the activation.</li> <li>Ask a user (a network administrator) to check that the value entered in the following code is correct. FS-08-8693~8696</li> </ul>
Network environment	Ask a user (a network administrator) to check whether the following settings are correct. <ul style="list-style-type: none"> <li>The proxy is not filtered.</li> <li>The firewall is set properly.</li> </ul>
License server	Ask the license provider that both servers are working. If they are not working, reattempt the activation after recovering.

**[7412] License deactivation failure (Online)**

Classification	Error item
License management	License deactivation by means of [Online] has failed.

Check item	Measures
License server	Ask the license provider whether the license information exists in the server.

**[7423] License deactivation failure (network timeout)****[7424] License deactivation failure (network error)**

Classification	Error item
License management	License activation by means of [Online] has failed due to a network problem.

Check item	Measures
Network setting	<ul style="list-style-type: none"> <li>Check that the URL for the license server has not been changed. If the URL for the license server has been changed, enter the post change URL into FS-08-3634 and then reattempt the activation.</li> <li>Ask a user (a network administrator) to check that the value entered in the following code is correct. FS-08-8693~8696</li> </ul>
Network environment	<p>Ask a user (a network administrator) to check whether the following settings are correct.</p> <ul style="list-style-type: none"> <li>The proxy is not filtered.</li> <li>The firewall is set properly.</li> </ul>
License server	<p>Ask the license provider that both servers are working. If they are not working, reattempt the activation after recovering.</p>

**[7430] Serial number mismatching**

Classification	Error item
License management	The serial number registered in the license does not match that for the activated equipment while the license has been activated by means of [Offline].

Check item	Measures
Serial number	<p>Check whether the serial number for the equipment matches the one included in the file name of the license file.</p> <p>If the serial number does not match, perform the activation in the equipment which has a serial number which is included in the file name of the license file.</p>

**[7431] Subnet mismatching**

Classification	Error item
License management	The values of the 1st to 3rd octet registered in the license do not match those for the IP address of the equipment in which activation is being performed while the license has been activated by means of [Offline].

Check item	Measures
IP address	<p>If this error has occurred during the activation in the host unit of the equipment, ask the license provider to release the license with the correct information.</p> <p>If this error has occurred during the activation by means of the export license file, check that the values of the 1st to 3rd octet for the IP address of the equipment in which activation is being performed match those for the host unit.</p>



**[7432] Domain mismatching**

Classification	Error item
License management	The domain registered in the license does not match that for the equipment while the license has been activated by means of [Offline].

Check item	Measures
IP address	If this error has occurred during the activation in the host unit of the equipment, ask the license provider to release the license with the correct domain. If this error has occurred during the activation by means of the export license file, check that the domain of the equipment in which activation is being performed matches that for the host unit.

**[7440] Signature mismatching**

Classification	Error item
License management	The license file is broken.

Check item	Measures
License server	Ask the license provider to release the license.

**[7443] License use period expired**

Classification	Error item
License management	More than 30 days have passed after the license file or the export license file was created.

Check item	Measures
License created date	If this error has occurred in the host unit of the equipment of the node license or the subnet/domain license, ask the license provider to release the reusable license. If this error has occurred in the export license file, export the license from the host unit again. * The license created date can be checked by the time stamp on the license file.

**[7444] No license exists**

Classification	Error item
License management	License Not Found

Check item	Measures
License status	Wait for a while and then reattempt the same operation. If this error has occurred repeatedly and the license is used continuously, deactivate or delete the license and then perform reactivation with the reusable license.

**[7445] Full of the license**

<b>Classification</b>	<b>Error item</b>
License management	Since the number of the licenses registered in this equipment has reached the maximum, new ones cannot be activated.

<b>Check item</b>	<b>Measures</b>
License	Deactivate or delete the licenses which are not being used.

### 8.3.31 Network error

#### [8000] Static IPv4 address conflict

Classification	Error item
Network error	IPv4 address overlaps.

Check item	Measures
Setting	Check if the same IP address is not used by other machine.

#### [8011] Linklocal Address Conflict

Classification	Error item
Network error	Linklocal Address Conflict

Check item	Measures
Setting	Check if the same IP address is not used by other machine.

#### [8012] Manual Address Conflict

Classification	Error item
Network error	Manual IPv6 Address Conflict

Check item	Measures
Setting	Check if the same IP address is not used by other machine.

#### [8013] Stateless Address Conflict

Classification	Error item
Network error	Stateless Address Conflict

Check item	Measures
Setting	Check if the same IP address is not used by other machine.

#### [8014] Stateful Address Conflict

Classification	Error item
Network error	Stateful Address Conflict

Check item	Measures
Setting	Check if the same IP address is not used by other machine.

#### [8022] Authentication Failure

Classification	Error item
Network error	Failed in 802.1X authentication.

Check item	Measures
Setting	Check the user credential.

**[8023] Can not contact Authentication Server/Switch**

Classification	Error item
Network error	Failed in connection to authentication server and switch.

Check item	Measures
Setting	Check connectivity to switch or server.

**[8024] Certificate verification Failure**

Classification	Error item
Network error	Failed in verification of certificate.

Check item	Measures
Setting	Check if a valid certificate is installed.

**[8031] IKEv1 certification failed**

Classification	Error item
Network error	Ipsec error for ikev1 certification failed

Check item	Measures
Setting	Check <ol style="list-style-type: none"> <li>1. CA and user certificate in both MFP and remote peer - certificate timestamp and IPsec Certificate template should be valid.</li> <li>2. CRL DP server name is mapped in MFP's host table or DNS entry.</li> <li>3. Certificate against CRL.</li> </ol>

**[8032] IKEv1 wrong proposal chosen**

Classification	Error item
Network error	Ipsec error for wrong proposal chosen

Check item	Measures
Setting	Check the IKEv1 IPsec proposal parameters (like encryption/ authentication algorithms, DH group, authentication methods) in MFP and peer machine.

**[8033] IKEv1 shared key authentication failed**

Classification	Error item
Network error	Ipsec error if auth for shared key failed

Check item	Measures
Setting	Mismatch in IKEv1 Pre Shared Key. Check the PSK in MFP and remote machine.

**[8034] IKEv1 invalid certificate**

Classification	Error item
Network error	Ipsec error if invalid certificate uploaded

Check item	Measures
Setting	Check the CA and User certificate in MFP and peer machine.

**[8035] IKEv1 certificate not supported**

Classification	Error item
Network error	Ipsec error if certificate not supported

Check item	Measures
Setting	Check the User certificate type.

**[8036] IKEv1 invalid certificate authentication**

Classification	Error item
Network error	Ipsec error if invalid certificate authentication

Check item	Measures
Setting	Check the CA certificate in MFP and Peer machine.

**[8037] IKEv1 certificate unavialable**

Classification	Error item
Network error	Ipsec error if certificate are not avialable

Check item	Measures
Setting	Certificate has been deleted from Certificate store. Re-upload the corresponding certificates.

**[8038] IKEv1 no SA established**

Classification	Error item
Network error	Ipsec error for SA is not present

Check item	Measures
Setting	Check the IKEv1/IPsec proposal parameters (like encryption/ authentication algorithms, DH group, authentication methods) in MFP and peer machine. Check <ol style="list-style-type: none"> <li>1. CA and user certificate in both MFP and remote peer - certificate timestamp and IPsec Certificate template should be valid.</li> <li>2. CRL DP server name is mapped in MFP's host table or DNS entry.</li> <li>3. Certificate against CRL.</li> </ol>

**[8039] IKEv1 invalid signature**

Classification	Error item
Network error	Ipsec error for invalid signaturer for certificate

Check item	Measures
Setting	Mismatch in Signature payload (MAC or IV). Check the CA and user certificate in MFP and peer machine.

**[803A] IKEv2 wrong proposal choosen**

Classification	Error item
Network error	Ipsec error is proposal choosen is wrong

Check item	Measures
Setting	Check the IKEv2/IPsec proposal parameters (encryption/ authentication algorithms, DH group, authentication methods) in MFP and peer machine.

**[803B] IKEv2 Certificate failed**

Classification	Error item
Network error	Ipsec error for ikev2 certification failed

Check item	Measures
Setting	Check <ol style="list-style-type: none"> <li>1. CA and user certificate in both MFP and remote peer - certificate timestamp and IPsec Certificate template should be valid.</li> <li>2. CRL DP server name is mapped in MFP's host table or DNS entry.</li> <li>3. Certificate against CRL.</li> </ol>

**[803C] IKEv2 secret key authentication failed**

Classification	Error item
Network error	Ipsec error for ikev2 if secret key auth failed

Check item	Measures
Setting	Mismatch in IKEv2 Pre Shared Key. Check the PSK in MFP and peer machine.

**[803D] IKEv2 falling back to IKEv1**

Classification	Error item
Network error	Ipsec error if peer dosent support IKEv2 and falling back to IKEv1

Check item	Measures
Setting	Remote machine is not supporting IKEv2. Going back to use IKEv1.

**[803E] IKEv2 ISAKMP SA unavailalbe**

Classification	Error item
Network error	Ipsec error if ISAKMP SA is not created of destroyed due to some uncertain condition

Check item	Measures
Setting	Restart IPsec service on Peer and retry.

**[803F] IKEv2 cryptographic operation failed**

Classification	Error item
Network error	Ipsec error for ikev2 if crypto operation failed

Check item	Measures
Setting	If Certificates are being used, re-upload the corresponding certificates using Security Services. Restart IPsec Service on MFP.

**[8040] IKEv2 invalid key information**

Classification	Error item
Network error	Ipsec error for ikev2 if key info is invalid

Check item	Measures
Setting	Check IKE settings in MFP and peer.

**[8041] IKEv2 CA not trusted**

Classification	Error item
Network error	Ipsec error for ikev2 if CA is not trusted

Check item	Measures
Setting	Check the CA certificate in MFP and peer machine. Check the CA certificate timestamp.

**[8042] IKEv2 Authentication method mismatch**

Classification	Error item
Network error	Ipsec error if auth method is not matching

Check item	Measures
Setting	Mismatch in IKE authentication type. Check the Authentication type in MFP and peer.

**[8043] IPsec IKE version mismatch**

Classification	Error item
Network error	Ipsec error if ike version is not matching

Check item	Measures
Setting	Mismatch in IKE version. Check the IKE version in MFP and peer.

**[8044] IPsec encapsulation mismatch**

Classification	Error item
Network error	Ipsec error for encapsulation is not matching

Check item	Measures
Setting	Check the IPsec mode (Transport/Tunnel) in MFP and peer.

**[8045] IPsec Peer IP mismatch**

Classification	Error item
Network error	Ipsec error for peer ip mismatch

Check item	Measures
Setting	Remote Traffic selector mismatch. Check the destination address/port in IPsec filter.

**[8046] IPsec local IP mismatch**

Classification	Error item
Network error	Ipsec error for local ip mismatch

Check item	Measures
Setting	Local traffic selector mismatch. Check the source address/port in IPsec filter.



**[8047] IPsec local ID mismatch**

Classification	Error item
Network error	Ipsec error for local id mismatch

Check item	Measures
Setting	Check the user certificate in MFP

**[8048] IPsec Remote ID mismatch**

Classification	Error item
Network error	Ipsec error for remote id mismatch

Check item	Measures
Setting	Check the user certificate in peer machine.

**[8049] IPsec Remote IP mismatch**

Classification	Error item
Network error	Ipsec error for remote ip mismatch

Check item	Measures
Setting	Remote traffic selector mismatch. Check the source address/port in IPsec filter.

**[804A] IPsec IKE timeout**

Classification	Error item
Network error	Ipsec error for ike timeout

Check item	Measures
Setting	Check the network connectivity between MFP and peer machine. Select the Flush Connections Option and retry.

**[804B] IPsec invalid manual key**

Classification	Error item
Network error	Ipsec error id manual key is not valid

Check item	Measures
Setting	Check the Inbound and Outbound (ESP Encryption/ Authentication and AH Authentication) keys in MFP and Remote PC.

- [8061] Secure update to primary IPv4 server failed**
- [8062] Secure update to secondary IPv4 server failed**
- [8063] Secure update to primary IPv6 server failed**
- [8064] Secure update to secondary IPv6 server failed**
- [8065] IPv6 primary DDNS update error**
- [8066] IPv6 secondary DDNS update error**
- [8067] IPv4 primary DDNS update error**
- [8068] IPv4 secondary DDNS update error**

Classification	Error item
Network error	Secure update to primary IPv4 server failed. ([8061]) Secure update to secondary IPv4 server failed. ([8062]) Secure update to primary IPv6 server failed. ([8063]) Secure update to secondary IPv6 server failed. ([8064]) IPv6 primary DDNS update error. ([8065]) IPv6 secondary DDNS update error. ([8066]) IPv4 primary DDNS update error. ([8067]) IPv4 secondary DDNS update error. ([8068])

Check item	Measures
Setting	Check if there is any problem with DNS or DDNS settings.

**[8069] Invalid TSIG/SIG(0) Key file**

Classification	Error item
Network error	This message is displayed when the key file for SIG(0) or TSIG is invalid.

Check item	Measures
Setting	Verify the TSIG/SIG(0) key files used.

**[80B1] Bluetooth connection failure**

Classification	Error item
Network error	Bluetooth connection failure

Check item	Measures
Wireless LAN / Bluetooth module connection status	Check the connection of the wireless LAN / Bluetooth module.

**[80B2] Bluetooth print error**

Classification	Error item
Network error	Print data could not be received completely.

Check item	Measures
Radio wave condition	Wait for a while and then reattempt the printing.

**[80B3] Bluetooth fatal error**

Classification	Error item
Network error	The Bluetooth software has detected a fatal failure.

Check item	Measures
Bluetooth module	1. Turn the power OFF and then back ON. 2. Replace the Bluetooth module.

**[80B4] Bluetooth storage near full**

Classification	Error item
Network error	The capacity of the Bluetooth storage has become nearly full.

Check item	Measures
Data size	Wait for a while and then reattempt the printing.

**[80B5] Bluetooth storage full**

Classification	Error item
Network error	The capacity of the Bluetooth storage has become full.

Check item	Measures
Data size	Wait for a while and then reattempt the printing.

**[8101] Wireless association with Access point failure**

Classification	Error item
Network error	Wireless association with Access point failure

Check item	Measures
Setting	Verify the credentials used for association with Access point.

**[8102] MFP not able to contact the Access point with the specified SSID**

Classification	Error item
Network error	MFP not able to contact the Access point with the specified SSID

Check item	Measures
Setting	Verify the access point name setting and mechanism used for association same as Access Point setting.

**[8103] Wireless Certificate verification failure**

Classification	Error item
Network error	Wireless Certificate verification failure

Check item	Measures
Setting	Verify the certificate settings used for association.

#### [8104] Wireless certificate verification failure

Classification	Error item
Network error	Wireless LAN / Bluetooth module hardware error

Check item	Measures
Wireless LAN/Bluetooth module	<ul style="list-style-type: none"> <li>• Check the connection of the wireless LAN/Bluetooth</li> <li>• Replace the wireless LAN/Bluetooth module.</li> </ul>

#### [8121] Domain - General Failure during Authentication

Classification	Error item
Network error	An unknown domain authentication error occurs when connecting to the domain controller.

Check item	Measures
Setting	Check the network settings of the equipment, and retry connecting to the domain controller.

#### [8122] Domain - Invalid Username or Password

Classification	Error item
Network error	The user name or password of the domain authentication is not valid and the user cannot log on.

Check item	Measures
Setting	Check if the user name or password is correctly entered. Enter them by specifying the upper and lower case letters correctly.

**[8123] Domain - Server not present in Network**

Classification	Error item
Network error	The server cannot be detected at domain authentication.

Check item	Measures
Setting	Check if the server fails. Check the network settings of the equipment. If name resolution is used, check the settings of the DNS and DDNS.

**[8124] Domain - User account is disabled on Server**

Classification	Error item
Network error	The user account is invalid at domain authentication and it cannot be used to log on.

Check item	Measures
Setting	Check if the setting of the user account in "Active Directory User and Computer" is disabled.

**[8125] Domain - User account has expired and cannot be used for logon**

Classification	Error item
Network error	The user account has expired at domain authentication and it cannot be used to log on.

Check item	Measures
Setting	Check if the setting of the user account in "Active Directory User and Computer" has expired.

**[8126] Domain - User account is locked and cannot be used for logon**

Classification	Error item
Network error	The user account is locked at domain authentication and it cannot be used to log on.

Check item	Measures
Setting	Check the setting of the account lock-out on the server.

**[8127] Domain - Invalid logon hours for the User**

Classification	Error item
Network error	The user log-on time is invalid at domain authentication and the user cannot log-on.

Check item	Measures
Setting	Check the log-on time setting of the user account in "Active Directory User and Computer".

**[8128] Active Directory Domain - Clock Skew error due to difference in Time between Server and MFP**

<b>Classification</b>	<b>Error item</b>
Network error	The difference between the time set in the equipment and that set in the server is more than five minutes at domain authentication of the Active Directory and the user cannot log on.

<b>Check item</b>	<b>Measures</b>
Setting	Match the time of the equipment and domain controller, or if an SNTP server is in the network, recommend the use of SNTP.

**[8129] Active Directory Domain - Kerberos Ticket has expired and cannot be used for Authentication**

<b>Classification</b>	<b>Error item</b>
Network error	A Kerberos ticket has expired at the domain authentication of the Active Directory and the user cannot log on.

<b>Check item</b>	<b>Measures</b>
Setting	Check if the Kerberos ticket on the Kerberos server has expired.

**[812A] Active Directory Domain - Verification of the Ticket has failed**

<b>Classification</b>	<b>Error item</b>
Network error	A Kerberos ticket authentication error of the Active Directory domain authentication occurs and the user cannot log on.

<b>Check item</b>	<b>Measures</b>
Setting	Check if the user name or password is correctly entered. If this problem still persists, contact your Window server administrator.

**[812B] Active Directory Domain-The Domain specified could not be found**

<b>Classification</b>	<b>Error item</b>
Network error	The Realm name for the domain authentication of the Active Directory is invalid and the user cannot log on.

<b>Check item</b>	<b>Measures</b>
Setting	Check if the Realm name of the Active Directory server of the equipment is wrong. If this problem still persists, contact your Window server administrator.

### 8.3.32 FAX error

#### [0012] Original jam

Classification	Error item
Fax error	The fax transmission has failed since an original was misfed in the DF while a fax job was being sent.

Check item	Measures
Setting	Remove the misfed original and reattempt the fax transmission.

#### [0013] Cover is open

Classification	Error item
Fax error	The fax transmission has failed since the cover of the equipment or options that process paper was opened.

Check item	Measures
Setting	Close the cover and reattempt the fax transmission.

#### [0020] Power failure Transmission

Classification	Error item
Fax error	The fax transmission has failed due to a power failure.

Check item	Measures
Setting	Reattempt the fax transmission.

#### Reception

Classification	Error item
Fax error	The fax reception has failed due to a power failure.

Check item	Measures
Setting	Reattempt the fax reception.

#### [0030] Recording paper jam

Classification	Error item
Fax error	The fax transmission has been stopped due to the following reason. <ul style="list-style-type: none"><li>• Paper misfeeding occurred with another job.</li><li>• A fax job was canceled.</li></ul>

Check item	Measures
Setting	In the case of paper misfeeding, remove it and reattempt the fax transmission.

**[0033] Polling error**

Classification	Error item
Fax error	The polling reception has failed due to the following reason. <ul style="list-style-type: none"> <li>• A polling original was not set on the other side's device.</li> <li>• The security setting between this equipment and the other side's device did not match.</li> </ul>

Check item	Measures
Setting	Take the following action and reattempt the polling reception. <ul style="list-style-type: none"> <li>• Ask to set the polling original on the other side's device.</li> <li>• Make the security setting matched between this equipment and the other side's device.</li> </ul>

**[0040] Modem communication error  
Transmission**

Classification	Error item
Fax error	The fax transmission has failed since the modem could not send the signal properly.

Check item	Measures
Setting	Reattempt the fax transmission.

**Reception**

Classification	Error item
Fax error	The fax reception has failed since the modem could not receive the signal properly.

Check item	Measures
Setting	Reattempt the fax reception.

**[0042] Memory full**

Classification	Error item
Fax error	The fax reception has been canceled since the capacity shortage or an abnormality occurred in the storage while a fax job was being received. (Pages which are received successfully will be printed out.)

Check item	Measures
Setting	Take the following action and reattempt the fax reception. <ul style="list-style-type: none"> <li>• In the case of a capacity shortage, free up the memory space.</li> <li>• In the case of an abnormality, replace the storage.</li> </ul>



**[0050] Line is busy**

Classification	Error item
Fax error	Since the line of the other side's device was busy, the fax transmission has failed even though the redialing was carried out by the maximum number of specified times.

Check item	Measures
Setting	Reattempt the fax transmission. Increase the number of redialing times if required.

**[0051] No cable connected for fax line**

Classification	Error item
Fax error	The fax transmission has failed since no cable for the fax line was connected.

Check item	Measures
Setting	Connect a cable for the fax line and reattempt the fax transmission.

**[0052] T1 Time-out**

Classification	Error item
Fax error	The fax transmission has failed since NSF/DIS could not be detected. (Memory transmission)

Check item	Measures
Setting	Check that the other side's device is answering in the fax mode and reattempt the fax transmission.

**[00B0] Initial signal not detected**

Classification	Error item
Fax error	The fax transmission has failed since NSF/DIS could not be detected. (Direct transmission)

Check item	Measures
Setting	Check that the other side's device is answering in the fax mode and reattempt the fax transmission.

**[00B1] Terminal constants not compatible  
Transmission**

Classification	Error item
Fax error	The fax transmission has failed since the other side's device did not have the capability which was transferred by NSF/DIS on this equipment.

Check item	Measures
Setting	Check the capability of the other side's device and reattempt the fax transmission by using a receivable mode for it.

**Reception**

Classification	Error item
Fax error	The fax reception has failed since NSS/DCS, which was a capability other than the ones transferred by NSF/DIS on this equipment, was received.

Check item	Measures
Setting	Check the capability of this equipment and reattempt the fax reception by using a receivable mode for it.

**[00B2] Reception of DCN (Phase B)****Transmission**

Classification	Error item
Fax error	The fax transmission has failed since DCN was sent in Phase B.

Check item	Measures
Setting	Reattempt the fax transmission.

**Reception**

Classification	Error item
Fax error	The fax reception has failed since DCN was received in Phase B.

Check item	Measures
Setting	Reattempt the fax reception.

**[00B3] DCS/DTC not detected**

Classification	Error item
Fax error	The fax reception has failed since DCS/DTC could not be detected.

Check item	Measures
Setting	Reattempt the fax reception.

**[00B4] Training error****Transmission**

Classification	Error item
Fax error	This equipment has performed fall-back but the fax transmission has failed.

Check item	Measures
Setting	Adjust the attenuator and link equalizer of this equipment and the other side's device and reattempt the fax transmission.

**Reception**

Classification	Error item
Fax error	The fax reception has failed since after receiving FTT, the receiver has received a timeout or DCN.

Check item	Measures
Setting	Adjust the attenuator and link equalizer of this equipment and the other side's device and reattempt the fax reception.

**[00B5] CFR not detected**

Classification	Error item
Fax error	The fax transmission has failed since a training signal has been sent out but CFR could not be detected.

Check item	Measures
Setting	Adjust the attenuator and link equalizer of this equipment and the other side's device and reattempt the fax transmission.

**[00B6] No response made to CTC**

Classification	Error item
Fax error	The fax transmission has failed since no response was made to CTC.

Check item	Measures
Setting	Adjust the attenuator and link equalizer of this equipment and the other side's device and reattempt the fax transmission.

**[00B7] Phase B cannot be completed  
Transmission**

Classification	Error item
Fax error	The fax transmission has failed since a modem error or a sequence error in the fax board occurred.

Check item	Measures
Setting	Reattempt the fax transmission. If the error persists, replace the fax board.

**Reception**

Classification	Error item
Fax error	The fax reception has failed since a modem error or a sequence error in the fax board occurred.

Check item	Measures
Setting	Reattempt the fax reception. If the error persists, replace the fax board.

**[00C0] Image signal carrier not detected**

Classification	Error item
Fax error	The fax reception has failed since this equipment has failed to detect a carrier.

Check item	Measures
Setting	Adjust the attenuator and link equalizer of this equipment and the other side's device and reattempt the fax reception.

#### [00C1] High-speed signal not detected

Classification	Error item
Fax error	The fax reception has failed since this equipment has failed to detect a high-speed signal.

Check item	Measures
Setting	Adjust the attenuator and link equalizer of this equipment and the other side's device and reattempt the fax reception.

#### [00C2] Image signal carrier disconnected Transmission

Classification	Error item
Fax error	The fax transmission has failed since a carrier disconnection was detected after the image signal was picked up by the other side's device.

Check item	Measures
Setting	Reattempt the fax transmission.

#### Reception

Classification	Error item
Fax error	The fax reception has failed since a carrier disconnection was detected after the image signal was picked up by this equipment.

Check item	Measures
Setting	Reattempt the fax reception.

#### [00C4] EOL time-out

Classification	Error item
Fax error	The fax reception has failed since this equipment could not detect EOL or not decode with MMR.

Check item	Measures
Setting	Reattempt the fax reception.

#### [00C5] Excess length of data received

Classification	Error item
Fax error	The fax reception has failed due to the disconnection of the communication since the length of the received original exceeded 2 m.

Check item	Measures
Setting	Ask to make the length of the original 2 m or less and reattempt the fax reception.

#### [00C6] Image code conversion error

Classification	Error item
Fax error	The fax reception has failed since the conversion of the received image went wrong.

Check item	Measures
Setting	Reattempt the fax reception.

#### [00C7] Phase C cannot be completed Transmission

Classification	Error item
Fax error	The fax transmission has failed since a modem error or a sequence error in the fax board occurred.

Check item	Measures
Setting	Reattempt the fax transmission. If the error persists, replace the fax board.

#### Reception

Classification	Error item
Fax error	The fax reception has failed since a modem error or a sequence error in the fax board occurred.

Check item	Measures
Setting	Reattempt the fax reception. If the error persists, replace the fax board.

#### [00D0] Post message not detected Transmission

Classification	Error item
Fax error	The fax transmission has failed since this equipment could not detect an MCF, RTP, RTN, PIN or PIP fax or the other side's device could not detect MPS, EOM or EOP.

Check item	Measures
Setting	Reattempt the fax transmission.

#### Reception

Classification	Error item
Fax error	The fax reception has failed since the other side's device could not detect an MCF, RTP, RTN, PIN or PIP fax or this equipment could not detect MPS, EOM or EOP.

Check item	Measures
Setting	Reattempt the fax reception.

**[00D1] Reception of DCN**

Classification	Error item
Fax error	The fax reception has failed since DCN was received.

Check item	Measures
Setting	Reattempt the fax reception.

**[00D2] Poor image quality  
Transmission**

Classification	Error item
Fax error	The fax transmission has failed since the quality of the received image was poor in the other side's device.

Check item	Measures
Setting	Reattempt the fax transmission.

**Reception**

Classification	Error item
Fax error	The fax reception has failed since the quality of the received image was poor.

Check item	Measures
Setting	Reattempt the fax reception.

**[00D3] No response made to EOR**

Classification	Error item
Fax error	The fax transmission has failed since no response was made to EOR or DCN was received during ECM transmission.

Check item	Measures
Setting	Ask to adjust the attenuator and link equalizer of the other side's device and reattempt the fax transmission.

**[00D4] No response made to RR**

Classification	Error item
Fax error	The fax transmission has failed since no response was made to RR or DCN was received during ECM transmission.

Check item	Measures
Setting	Ask to adjust the attenuator and link equalizer of the other side's device and reattempt the fax transmission.

**[00D5] T5 Time-out**

Classification	Error item
Fax error	The fax transmission has failed since RNR-RR was repeated and the line was disconnected due to timeout during ECM transmission.

Check item	Measures
Setting	Reattempt the fax transmission. If the error persists, check whether the other side's device can output MCF or not.

**[00D6] ERR returned to EOR**

Classification	Error item
Fax error	The fax reception has failed due to the bad condition of the communication.

Check item	Measures
Setting	Reattempt the fax reception.

**[00D7] Line disconnected by transmission of EOR**

Classification	Error item
Fax error	The fax transmission has failed since the line was disconnected after EOR was sent by this equipment during ECM transmission.

Check item	Measures
Setting	Adjust the attenuator and link equalizer of this equipment and reattempt the fax transmission.

**[00D8] Time-out between FCD frames**

Classification	Error item
Fax error	The fax reception has failed since a time-out occurred between the FCD frames.

Check item	Measures
Setting	Reattempt the fax reception.

**[00DA] MCF not returned**

Classification	Error item
Fax error	The fax reception has failed since MCF could not be returned from this equipment.

Check item	Measures
Setting	Reattempt the fax reception.

**[00E8] HDD error  
Transmission**

Classification	Error item
Fax error	The fax transmission has failed due to a defective HDD.

Check item	Measures
Setting	Reattempt the fax transmission. If the error persists, replace the HDD.

**Reception**

Classification	Error item
Fax error	The fax reception has failed due to a defective HDD.

Check item	Measures
Setting	Reattempt the fax reception. If the error persists, replace the HDD.

**[00F0] Software trouble  
Transmission**

Classification	Error item
Fax error	The fax transmission has failed due to defective software.

Check item	Measures
Setting	Reinstall the fax firmware. If the error persists, replace the fax board.

**Reception**

Classification	Error item
Fax error	The fax reception has failed due to defective software.

Check item	Measures
Setting	Reinstall the fax firmware. If the error persists, replace the fax board.

**[00F1] Hardware noise  
Transmission**

Classification	Error item
Fax error	The fax transmission has failed due to defective hardware.

Check item	Measures
Setting	<ul style="list-style-type: none"> <li>• Reboot this equipment and reattempt the fax transmission.</li> <li>• Reinstall the fax firmware.</li> <li>• If the error persists, replace the fax board.</li> </ul>

**Reception**

Classification	Error item
Fax error	The fax reception has failed due to defective hardware.



Check item	Measures
Setting	<ul style="list-style-type: none"><li>• Reboot this equipment and reattempt the fax reception.</li><li>• Reinstall the fax firmware.</li><li>• If the error persists, replace the fax board.</li></ul>

**[00F4] Software trouble (fax board)****Transmission**

Classification	Error item
Fax error	The fax transmission has failed due to defective software.

Check item	Measures
Setting	<ul style="list-style-type: none"> <li>• Reboot this equipment and reattempt the fax transmission.</li> <li>• Reinstall the fax firmware.</li> <li>• If the error persists, replace the fax board.</li> </ul>

**Reception**

Classification	Error item
Fax error	The fax reception has failed due to defective software.

Check item	Measures
Setting	<ul style="list-style-type: none"> <li>• Reboot this equipment and reattempt the fax reception.</li> <li>• Reinstall the fax firmware.</li> <li>• If the error persists, replace the fax board.</li> </ul>

**[DA01] The fax board of line 1 has been damaged**

Classification	Error item
Fax error	The fax board of line 1 has been damaged or an abnormality has occurred in the interface between the systems.

Check item	Measures
Setting	Reboot the equipment. If the error still persists, replace the fax board of line 1.

**[DA02] The fax board of line 2 has been damaged**

Classification	Error item
Fax error	The fax board of line 2 has been damaged or an abnormality has occurred in the interface between the systems.

Check item	Measures
Setting	Reboot the equipment. If the error still persists, replace the fax board of line 2.

## 8.4 Other errors

### 8.4.1 Equipment operation disabled after the installation of option(s)

Check if the optional board is installed properly.

### 8.4.2 Wireless LAN connection disabled

The connection state and settings of the Wireless LAN can be checked with [USER FUNCTIONS] → [ADMIN] → [WIRELESS LAN] → [SETTING CHECK].

Confirm the settings with the administrator.

- "NIC INITIALIZING" does not disappear at the time of the power being turned ON and it disappears after 6 minutes with the NIC initializing time-out. In this case, the connection to the Wireless LAN did not succeed even though "NIC INITIALIZING" disappears.
- The connection to the Wireless LAN cannot be made if the Access Point to be connected is not found or security settings are not correct.

### 8.4.3 "Invalid Department Code" is displayed

Log in to TopAccess as an administrator, select [Authentication] on the [User Management] tab, and then check whether Department Setting is enabled or disabled.

Department Setting is enabled:

- Log in to TopAccess as an administrator, select [Authentication] on the [User Management] tab, and then check User Management Setting.
- Confirm the settings of 08-3805 in the setting mode.

Department Setting is disabled:

- Log in to TopAccess as an administrator, select [Authentication] on the [User Management] tab, and then check User Management Setting.

### 8.4.4 Paper folded on the leading edge

If the leading edge of B4, B5 or B5-R paper is folded when it exits, check the following items.

- Check if the rear and side guides of the drawer or the side guide of the bypass tray correspond to the paper size.

### 8.4.5 Toner cartridge unrecognized

If the toner cartridge is not recognized, check the following.

- Check that there is no access abnormality to the toner cartridge IC chip.
- Check the setting of FS-08-4689 in the setting mode. If the value is "1" to "5", perform the C911 troubleshooting.

 P. 8-201 " [C911] Toner cartridge PC board access abnormality"

### 8.4.6 Ethernet disabled in half-duplex communication

The Ethernet of this equipment does not support half-duplex communication.

When the port setting of the switch is fixed at half-duplex communication, use any of 10/100/1000 Mbps, full-duplex fixed communication mode or auto-negotiation function.

In addition, select the setting of the equipment corresponding to that of the switch.

([ADMIN] > [NETWORK] > [ETHERNET])

Check the set communication speed as follows if required:

[ADMIN] > [NETWORK] > [ETHERNET]

## 8.4.7 The equipment does not start after the power has been turned ON.

### [ 1 ] The LCD screen does not display after the power has been turned ON.

#### 1. General description

When the lamps on the control panel do not light or error codes are not displayed on the LCD screen after the power has been turned ON, perform this troubleshooting.

#### 2. Status LED / Power LED

After the power is turned ON, the status of the equipment from the startup until the end of system device initialization (the LCD screen works) is displayed by the status LED (8-bit) on the SYS board. When the equipment does not start or the LCD screen does not display after the power is turned ON, check this status LED on the SYS board in order to judge the corresponding troubleshooting. In addition to this, the power LED is lit when 12 VA power is being supplied to the SYS board.

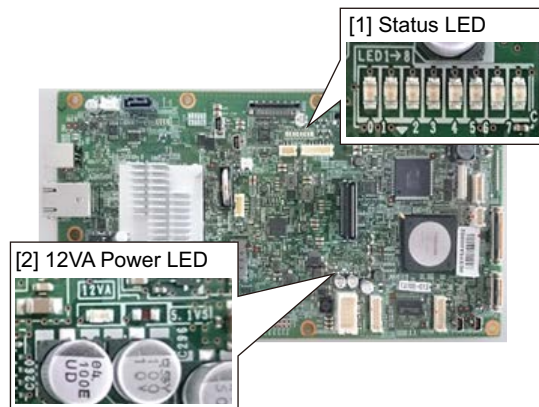


Fig.8-20

#### 3. Measures

When an error code is displayed, perform its troubleshooting.


If the LCD screen is turned OFF and an error code cannot be confirmed as a result, check the lighting condition of each LED and perform the troubleshooting by following the status below.

Main Power LED / Energy Saver LED (on Control panel)

LED	Lighting condition	SYS power LED	Troubleshooting
Main Power LED	ON	-	-
	OFF	ON	The 5 VS power is not supplied to the control panel. <ul style="list-style-type: none"> <li>• Check the connection of the harness of the control panel.</li> <li>• Check if there is no abnormality in the parts of the control panel.</li> </ul>
		OFF	OFF

LED	Lighting condition	SYS power LED	Troubleshooting
Energy Saver LED	ON	-	-
	Blinking	-	When the Energy Saver LED is turned OFF after some times have passed: Initialization between the control panel and the SYS board is not completed. <ul style="list-style-type: none"> <li>• Check the connection of the harness of the control panel.</li> <li>• SYS board abnormality (Check the lighting condition of the SYS power LED and the SYS status LED, and perform the measures described in the next table.)</li> </ul>
		-	When the Energy Saver LED blinks even if some times have passed: The LCD is not turned ON after initialization between the control panel and the SYS board is completed. <ul style="list-style-type: none"> <li>• Check the connection of the harness of the control panel.</li> <li>• Check if there is no abnormality in the parts of the control panel.</li> <li>• SYS board abnormality (Check the lighting condition of the SYS power LED and the SYS status LED, and perform the measures described in the next table.)</li> </ul>
	OFF	ON	The 12 VA power is not supplied to the control panel. <ul style="list-style-type: none"> <li>• Check the connection of the harness of the control panel.</li> <li>• Check if there is no abnormality in the parts of the control panel.</li> </ul>
		OFF	The power is not supplied to the SYS board <ul style="list-style-type: none"> <li>• Check the connection of the power harness of the SYS board</li> <li>• Check if there is no abnormality in the switching regulator.</li> <li>• Check if there is no abnormality in the SYS board.</li> </ul>

Power LED / Status LED (on SYS board)

LED	Lighting condition	SYS board status	Troubleshooting
Power LED	OFF	Waiting for the power supply	Check the connection of the switching regulator harness and the power supply harness.  P. 8-365 "[ 2 ] The equipment does not start after the power has been turned ON."

LED		Lighting condition	SYS board status	Troubleshooting
Status LED	Bit7	ON	Main memory abnormality	<ul style="list-style-type: none"> <li>Check the installation status of the main memory, and reinstall it if necessary.</li> <li>Perform calibration of the main memory at the startup.</li> <li>Replace the main memory or the SYS board.</li> </ul>
	Bit4	ON	Network IC communication error	Replace the SYS board.
	Bit3	ON	ASIC detection error	Replace the SYS board.
	Bit2	ON	HDD/SSD detection error	<ul style="list-style-type: none"> <li>When the error code is from F100 to F109, perform the HDD/SSD fault diagnosis by following each troubleshooting.</li> <li>If the LCD screen does not display, check the connection of the HDD harness.</li> </ul>
	Bit1	ON	Control panel communication error	<ul style="list-style-type: none"> <li>Check the connection of the harness of the control panel.</li> <li>Check if there is no abnormality in the parts of the control panel.</li> </ul>
	Bit0	ON	Errors other than the above	Replace the SYS board.

**Remarks:**

- When Bit1 or Bit7 of the status LED is ON and an error code is displayed on the LCD screen, perform the troubleshooting for each error code.
- The lighting condition of the status LED is determined while Bit0 is turned OFF. Due to this, be sure to check the condition from Bit1 to Bit7 while Bit0 is turned OFF.

**[ 2 ] The equipment does not start after the power has been turned ON.**

Check the following items when the equipment does not start due to an abnormality in the power supply side even if the power has been turned ON.

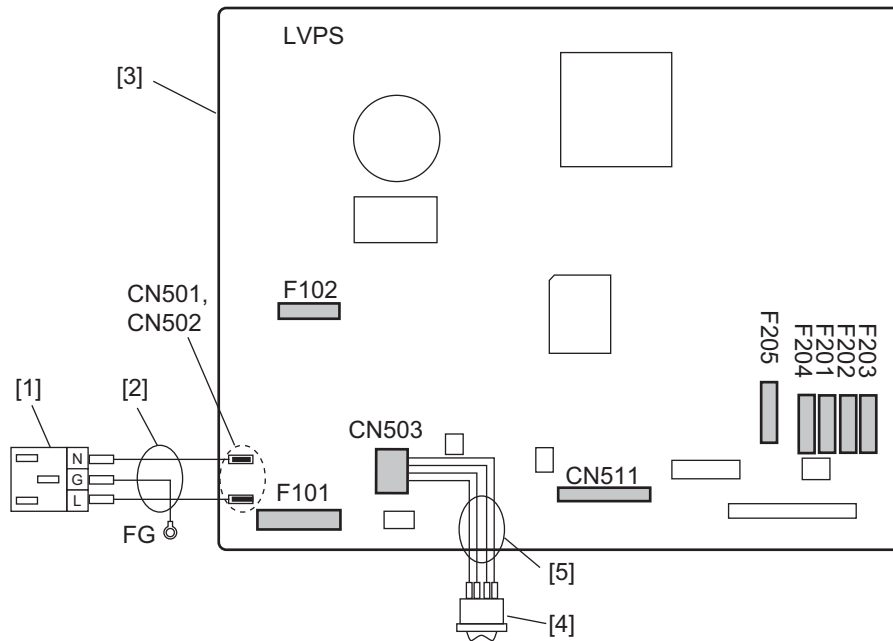


Fig.8-21

1. When the [Power] LED on the control panel does not light. / When the fan on the SYS board does not work. / The LCD screen does not display.

Check item	Measures
Power voltage	Is the power voltage within +/- 10% of the rated voltage?
Power cable	Check if the harnesses are open circuited or if contact failure occurs in the connector.
Inlet [1][2]	Check if the inlet [1] and its harness [2] are open circuited or disconnected.
Main power switch [4]	Check if the main power switch [4] and its harness [5] are open circuited or disconnected.

Check item	Measures
Switching regulator (LVPS) [3]	Check if the harness [2] is inserted into the connectors (CN501, CN502) of the switching regulator [3] properly. Check if the harness [5] is inserted into the connector (CN503) of the switching regulator [3] properly.
	Check if the fuse (F101) has melted. <ul style="list-style-type: none"> <li>If the fuse (F101) cannot be blown out even when it has been replaced and the damp heater switch has been turned OFF (in the equipment with the damp heater installed) and then the main power switch is turned ON, exchange the damp heater in question.</li> </ul> <p><b>Remarks: If the resistance value of the damp heater is as below, there will be an abnormality in the damp heater in question.</b></p> <ul style="list-style-type: none"> <li>Scanner damp heater: 714Ω -10% or below</li> <li>Drum damp heater (right): 830Ω -10% or below</li> <li>Drum damp heater (left): 830Ω -10% or below</li> <li>Drawer damp heater: 2KΩ -10% or below</li> </ul> <ul style="list-style-type: none"> <li>If the fuse (F101) cannot be blown out even when it has been replaced and the fuser unit has been taken off and then the main power switch is turned ON, exchange the fuser unit.</li> <li>If the problem still persists even though the above steps have been carried out, replace the switching regulator [3].</li> </ul>
	Check if the fuse (F102) has melted. <ul style="list-style-type: none"> <li>Replace the switching regulator [3].</li> </ul>
	Check if the CN511 5-pin and 6-pin of the switching regulator output 5V +/- 5%. <ul style="list-style-type: none"> <li>Output when the connectors of the control panel are disconnected: Replace the control panel.</li> <li>Output when all of the connectors of the SYS board are disconnected: Replace the SYS board.</li> <li>Output when all of the connectors of the LGC board are disconnected: Replace the LGC board.</li> <li>If the problem still persists even though the above steps have been carried out, replace the switching regulator [3].</li> </ul>

2. When the [Power] LED on the control panel lights. / When the fan on the SYS board does not work.  
/ The LCD screen does not display.

Check item	Measures
Options	Check if this problem can be resolved when the connectors of the paper handling options are disconnected and then the power is turned OFF and then back ON. (Does the LCD screen display?) <ul style="list-style-type: none"> <li>Check if there is abnormality such as catching in the harnesses of the applicable options.</li> </ul>



Check item	Measures
LGC board	<p>Check if this problem can be resolved when the ADU is opened. (Does the LCD screen display?)</p> <p>If the problem is resolved (the LCD screen displays), close all covers and check the following items.</p> <ul style="list-style-type: none"> <li>• The LCD screen displays when CN342 is disconnected: Check or replace the fuser motor and the harness.</li> <li>• The LCD screen displays when CN366 is disconnected: Check or replace the ozone exhaust fan and the harness.</li> <li>• The LCD screen displays when CN349 is disconnected: Check or replace the suctioning fan and the harness.</li> <li>• The LCD screen displays when CN351 is disconnected: Check or replace the sensor shutter solenoid and the harness.</li> <li>• The LCD screen displays when CN352 is disconnected: Check or replace the high-voltage transformer and the harness.</li> <li>• The LCD screen displays when CN360 is disconnected: Check or replace the discharge LED (Y, M, C and K) and the harness.</li> <li>• The LCD screen displays when CN367 is disconnected: Check or replace the paper feeding/developer unit drive motor and the harness. Check or replace the registration clutch and the harness. Check or replace the feed clutch and the harness.</li> <li>• The LCD screen displays when CN368 is disconnected: Check or replace the mono/color switching motor and the harness. Check or replace the 1st transfer contact/release clutch and the harness.</li> <li>• The LCD screen displays when CN369 is disconnected: Replace the ADU board. Check or replace the CFD board and the harness.</li> <li>• If the problem still persists even though the above items have been done, replace the LGC board.</li> </ul>
CFD board	<ul style="list-style-type: none"> <li>• The LCD screen displays when CN409 is disconnected: Check or replace the bypass feed clutch and the harness.</li> <li>• If the problem still persists even though the above items have been done, replace the CFD board.</li> </ul>
SYS board	The LCD screen displays when CN125 is disconnected: Replace the SYS board.
Switching regulator (LVPS) [3]	When the problem is not resolved (the LCD screen does not display) even if the front cover or the side cover is opened, replace the switching regulator.

## 8.4.8 Countermeasure to Sudden Power Failure



	Phenomenon	Check item	Measures
1	The [ENERGY SAVER] button is lit. The power supply is recovered by pressing the [ENERGY SAVER] button.	The mode is at the Sleep mode.	Turn off the Sleep mode setting. Or change the setting.
2	The power supply is recovered by pressing the [POWER] button.	The weekly timer has run.	<ul style="list-style-type: none"> <li>• Turn off the setting of the weekly timer. Or change the setting.</li> <li>• Check if the time is set correctly.</li> </ul>
3	The power supply is not recovered even if the [POWER] button is pressed.	The harnesses of 12V or 24V are short circuited. <ul style="list-style-type: none"> <li>• Check if there is any abnormality, such as scratches or being caught on the harnesses of each board, and damage on the connector pins.</li> </ul>	<ul style="list-style-type: none"> <li>• Replace the harness.</li> <li>• Replace the switching regulator.</li> </ul>
4	The LED of the main power is not lit.	<ul style="list-style-type: none"> <li>• Check if there is any abnormality in the power cable.</li> <li>• Check if there is any abnormality such as scratches or being caught on the harnesses for the inlet or the main power switch.</li> <li>• Check if the fuses (F101/102) for the main power switch are cut.</li> <li>• Check if the harness for the switching regulator is properly connected.</li> </ul>	<ul style="list-style-type: none"> <li>• Replace the power cable.</li> <li>• Replace the harnesses for the inlet, the main power switch and the switching regulator.</li> <li>• Replace the switching regulator.</li> </ul>
5	The LED of the main power is lit.	Check the voltage of the power connector (CN105) on the SYS board. <ul style="list-style-type: none"> <li>• The voltage of 5pin is lower than 4.8V.</li> <li>• The voltage of 9pin is lower than 10.8V.</li> <li>• The voltage of 5pin is 4.8V or more, that for 9pin is 0V and that for 1pin is 0V.</li> </ul>	Replace the switching regulator.
		Check the voltage of the power connector (CN105) on the SYS board. <ul style="list-style-type: none"> <li>• The voltage of 5pin is 4.8V or more, that for 9pin is 0V and that for 1pin is 4.8V or more.</li> </ul>	Replace the SYS board.

	Phenomenon	Check item	Measures
6	Power supply failed at warming up. (The LED of the main power is lit.)	Check if there is any abnormality in the fuser unit. <ul style="list-style-type: none"> <li>Check if there is any abnormality in the terminal of the connector.</li> <li>Check if there is any abnormality in the installation of the thermistor and no dust on it.</li> </ul>	<ul style="list-style-type: none"> <li>Repair the defective portions of the fuser unit.</li> <li>Replace the fuser unit.</li> </ul>
		Check if there is any abnormality in the LGC board. <ul style="list-style-type: none"> <li>Check if the connectors of LGC board are disconnected, installed properly or their pins are damaged.</li> </ul>	<ul style="list-style-type: none"> <li>Replace the harness.</li> <li>Replace the LGC board.</li> </ul>
		Check if there is any abnormality in the switching regulator.	Replace the switching regulator.
7	Power supply failed when the motor rotates. Power supply failed when the cover is closed.	Check if there is any abnormality in the motor. <ul style="list-style-type: none"> <li>Check if there is any abnormality which makes the motor disable to rotate.</li> <li>Check if there is any abnormality such as scratches or being caught on the harness of the motor.</li> </ul>	Release the problems or replace the motor and harness.
		Check if there is any abnormality in the options. <ul style="list-style-type: none"> <li>Check if the problem is released when disconnecting the option.</li> </ul>	Check if there is any abnormality in the disconnected option and release the problems.
8	Power supply failed when the ADU is opened and closed.	Check if there is any abnormality such as scratches or being caught on the harness for the ADU hinge.	Replace the harness.
9	Power supply failed when the DF is opened and closed.	<ul style="list-style-type: none"> <li>Check if there is any abnormality such as scratches or being caught on the harness for the DF and the scanner.</li> <li>Check if there is any abnormality such as scratches or being caught on the harness between the SYS board and the scanner.</li> </ul> Check if there is any abnormality on the connector pins.	Replace the harness.
10	The equipment is rebooted.	An error occurred. (Depending on the error, the equipment will reboot at its first time and then a service call will happen at its second time.)	<ul style="list-style-type: none"> <li>Check the error code and release it.</li> <li>Check the installation status of the main memory, and reinstall it if necessary.</li> <li>Replace the main memory.</li> </ul>

Replace parts	Remarks
Power cable	
Switching regulator	
Fuser unit	
SYS board	
LGC board	

Replace parts	Remarks
Harnesses in question	
Main memory	

### 8.4.9 “Authentication Failed” is displayed

- Reset the service password  
Reset the service password by accessing [USER FUNCTIONS] -> [ADMIN] -> [GENERAL] -> [PASSWORD SETUP] -> [RESET SERVICE PASSWORD].
- Initialize the SRAM  
Refer to  P. 9-25 "9.2.5 Precautions and procedure when replacing the SRAM", and perform “[D] Initialize SRAM system storage area” and following steps.
- Replace the SRAM  
Refer to  P. 9-25 "9.2.5 Precautions and procedure when replacing the SRAM", and replace the SRAM.

### 8.4.10 Error code “M00” is displayed while updating firmware

Check item	Measures
SYS board	<ul style="list-style-type: none"> <li>• Connector check (CN131, CN132)</li> <li>• Harness check</li> <li>• Short circuited or open circuited check</li> </ul>
LGC board	<ul style="list-style-type: none"> <li>• Connector check (CN353, CN370, CN371)</li> <li>• Harness check</li> <li>• Short circuited or open circuited check</li> </ul>
LVPS board	<ul style="list-style-type: none"> <li>• Connector check (CN512)</li> </ul>
LED printer head	<ul style="list-style-type: none"> <li>• Connector check (CN359, CN357, CN358, CN356, CN332, CN331, CN330, CN329)</li> <li>• Harness check</li> <li>• Short circuited or open circuited check</li> </ul>

Replace parts	Remarks
SYS board	
LGC board	
LED printer head	
Harness	

### 8.4.11 “Fax line1 is out of order.” or “Fax line2 is out of order.” is displayed

1. Turn the power OFF and then back ON.
2. Replace the fax board.

## 8.4.12 “Latch the developer unit (Yellow, Magenta, Cyan, Black)” remains displayed

After the power is turned ON, “Latch the developer unit (Yellow, Magenta, Cyan, Black)” is displayed on the panel. This display is not changed even if the developer unit is removed and then installed.

Step	Check item	Measures
1	Installation state of the developer unit (Y, M, C, K)	<ul style="list-style-type: none"> <li>Remove and install the developer unit. Close the front cover.</li> <li>Check if the drawer connector is not connected sufficiently or its pin is not deformed.</li> </ul> <p>If the display for all colors is not changed even if step 1 has been carried out, perform steps 2 to 5. If the display for any of the colors is changed, perform steps 6 and 7.</p>
2	Change in the display	Check if the display is changed when the power is turned OFF and then back ON. If an error indication is displayed, perform its troubleshooting in accordance with its procedure.
3	SYS board	<ul style="list-style-type: none"> <li>Connector check (CN132)</li> <li>Harness check</li> <li>Short circuited or open circuited check</li> </ul>
4	LGC board	<ul style="list-style-type: none"> <li>Connector check (CN370)</li> <li>Harness check</li> <li>Short circuited or open circuited check</li> </ul>
5	Flat cable	Check if there is any abnormality in the terminal of the flat cable between the SYS and LGC boards. Check if the flat cable is open circuited.
6	Harness	Check if there is a short circuit or open circuit in the harness (CN347) for connecting the LGC board and the developer unit whose display is not changed.
7	LGC board	<ul style="list-style-type: none"> <li>Connector check (CN347)</li> <li>Harness check</li> <li>Short circuited or open circuited check</li> </ul>




Replacement part	Remark
Flat cable	
SYS board	
LGC board	
Developer unit	

## 8.5 Troubleshooting for the Image

### 8.5.1 Color deviation

1) Color deviation

<Symptoms>

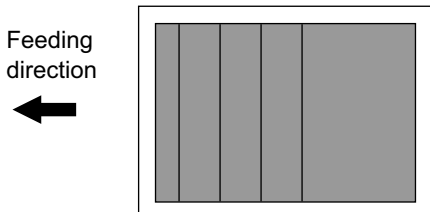
Original mode	Location	Phenomena	
All modes	Color blurred in outline of white text or illustration on a colored background	Color deviation→	 <p>Fig.8-22</p>
Text Mode Text/Photo Mode	Outline in black text on a colored background	White void→	 <p>Fig.8-23</p>
Photo Mode Map Mode	Color blurred in outline of line or text	Color deviation→	 <p>Fig.8-24</p>

Cause/Section	Step	Check Item	Measure	Remark
	1	Perform the Forced performing of color registration control adjustment (FS-05-4719).	Has it ended normally?  When CA00 occurs: → Proceed to [CA00] troubleshooting.	
	2	Test printing (A3/LD)	Output the built-in grid pattern	For the following checks
Drum rotation abnormality	3	Check the drum rotation to see if there is any rotation abnormality of the drum.	Replace the drum TBU motor.	
	4	Check the drum TBU motor operation in the test mode (FS-03) to see if there is any rotation abnormality of the drum.	Reconnect the connectors. Replace the harnesses. Replace the LGC board.	
Inadequate drum TBU motor rotation speed	5	Check the value set for drum TBU motor rotation speed. (Is the value significantly different from the default value?)	Reset drum TBU motor speed to 128.	
Drum coupling and coupling on the equipment side	6	Loose coupling, damage, deformation	Check if they are installed properly or replace the couplings.	

Cause/Section	Step	Check Item	Measure	Remark
Transfer belt	7	Deformation or damage of the transfer belt or stains on the transfer belt.	Clean or replace the transfer belt.	
	8	Are the gears on the transfer belt side loosen, damaged or deformed?	Tighten the screws if they loosen, or replace the gears.	
	9	Stain or damage of the drive roller	Clean or replace the drive roller.	
	10	Does the rib of the transfer belt overlap the collar on both edge of the drive roller?	Adjust the position of the transfer belt.	
	11	Is the belt edge damaged or stained?	Clean or replace the transfer belt.	
	12	Peeling of the cleaning blade (Large driving load)	Replace the cleaning blade.	
	13	Is the transfer belt unit installed normally? (Is the unit properly grounded?)	Check and correct the installing.	
High-voltage transformer	14	Check the connection of the high-voltage supply terminal of the 1st or 2nd transfer rollers.	Correct or replace the terminal if it is loosened or damaged.	
Electrical component	15	Check if the flat cable between the LGC board and the LED printer head is short circuited or open circuited.	Replace the flat cable.	
	16	Is there any abnormalities in the LED printer head.	Replace the LED printer head.	

## 8.5.2 Uneven pitch and jitter image

<Symptoms>

Original mode	Location	Phenomena	
All modes	Occurs cyclically at right angles to paper feeding direction	Uneven pitch	 <p>Feeding direction</p> <p>←</p> <p>Fig.8-25</p>

Cause/Section	Step	Check Item	Measure	Remark
	1	Test printing (A3/LD)	Output the built-in halftone and grid patterns.	For the following checks
Drum	2	Are there uneven pitches of approx. 94 mm?	Replace the drum.	
	3	Is there any damage on the drum surface?	Clean or replace the drum.	
Drum drive	4	Is there any dent, damage or deformation on the gears of the drum drive unit?	Replace the gears of the drum drive unit.	
Drum rotation abnormality	5	Check the drum TBU motor operation in the test mode (FS-03 TEST MODE) to see if there is any rotation abnormality of the drum.	Reconnect the connectors. Replace the harnesses. Replace the LGC board. Replace the drum TBU motor.	
Developer sleeve	6	Are there uneven pitches of approx. 28 mm?	Replace the developer sleeve.	
Inadequate drum TBU motor rotation speed	7	Check the value set for drum TBU motor rotation speed. (Is the value significantly different from the default value?)	Reset drum TBU motor speed to 128.	
Drum coupling	8	Loose coupling, damage, deformation	Replace the couplings.	
Transfer belt	9	Deformation or damage of the transfer belt	Replace the transfer belt.	Check the halftone pattern. (Uneven pitch: approx. 56 mm)
	10	Stain or damage of the drive roller	Clean or replace the drive roller.	Check the halftone pattern. (Uneven pitch: approx. 56 mm)
	11	Large driving load due to the peeling of the cleaning blade	Replace the cleaning blade.	
Transfer belt drive	12	Are there uneven pitches of 0.5 mm or 0.71 mm?	Replace the TBU gears.	



Cause/Section	Step	Check Item	Measure	Remark
Feeding drive	13	Are there uneven pitches of approx 2.0 mm or 0.79 mm, 1.25 mm?	Replace the gears of the feed/transport gear unit and the first drawer transport clutches.	
	14	Is there any dent, damage or deformation on the gear of the feed/transport gear unit and the first drawer transport clutch (CLT1 or CLT2)?		
Fusing drive	15	Are there uneven pitches of approx. 94 mm?	Perform "Fine adjustment of fuser roller rotational speed" (FS-05-4529-0, 3, 4, 7).	
	16	Is the fuser unit properly installed in the equipment?	Check if the fuser unit is installed correctly.	
	17	Is there any dent, damage or deformation on the drive gears of the pressure roller?	Replace the drive gear of the pressure roller.	
EPU drive	18	Are there uneven pitches of approx. 0.78 mm?	Replace the developer drive unit, developer sleeve and drive gears of the mixer.	
	19	Is there any dent, damage or deformation on the developer drive unit, developer sleeve and drive gears of the mixer?		
2nd transfer roller	20	Are there uneven pitches of approx. 75 mm? Is there any deformation to the 2nd transfer roller? Since the 2nd transfer roller is always in contact with the transfer belt, the roller may creep if the power has not been turned on and the equipment left unused for a long time (1 month or more), causing an uneven pitch.	Replace the 2nd transfer roller.	This problem may occur on thick paper or the image on the back side of the paper in duplex printing.

### 8.5.3 Poor image density, color reproduction and gray balance

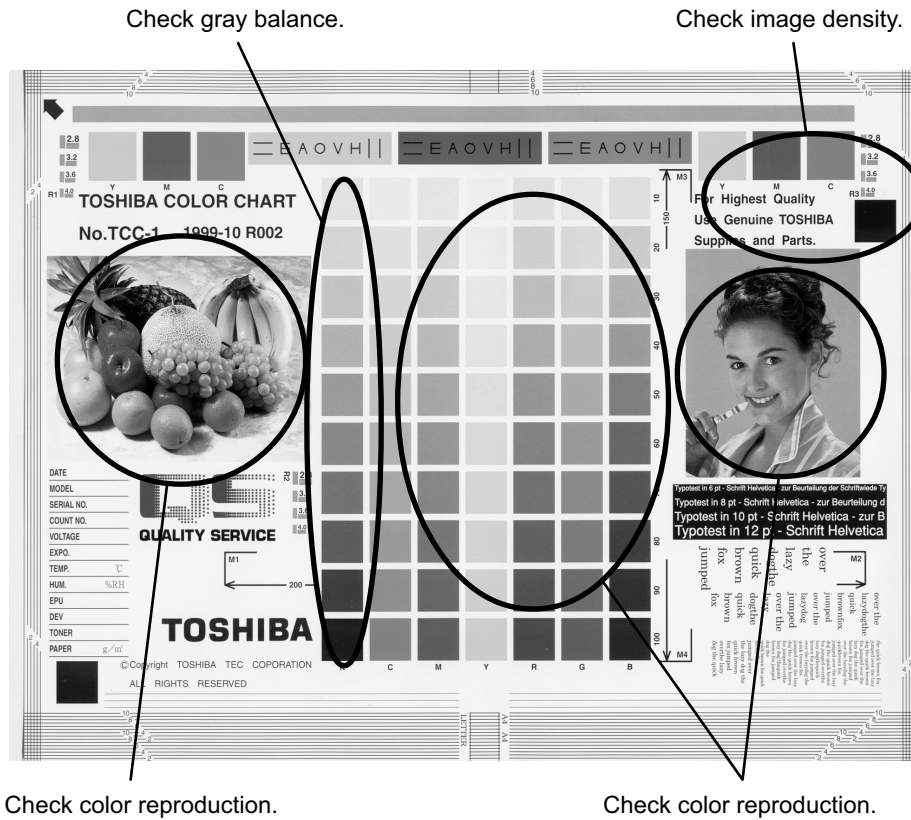


Fig.8-26

Cause/Section	Step	Check item	Measures	Remarks
Scanner	1	Check if the original glass, mirrors or lens is dirty.	Clean it.	
Density / Color reproduction / Gray balance	2	Check the image density / color reproduction / gray balance.	Perform the enforced performing of image quality closed-loop control (FS-05-2742) and then automatic gamma adjustment.	
Printer density	3	Check the density of printer output image.	Output the test patterns and check them. Using FS-04-36 for each color	See step 5 if defect occurs.
Parameter adjustment value	4	Check the image processing parameters.	Adjust the color balance (color). Adjust the image density.	

Cause/Section	Step	Check item	Measures	Remarks
Printer output image abnormal	5	Is there any faded image (low density)?	Perform the troubleshooting procedures against the faded image.	
		Is there any fog in the background?	Perform the troubleshooting procedures against the background fogging.	
		Is there any blotch image?	Perform the troubleshooting procedures against the blotch image.	
		Is there any poor transfer?	Perform the troubleshooting procedures against the poor transfer.	
		Is there any poor cleaning of the transfer belt? (Check inside the equipment.)	Correct the transfer belt area.	
Drum cleaner unit	6	Is there any abnormalities or deformation in the LED gap spacer.	Replace the LED gap spacer.	
	7	Check if the LED printer head lifting mechanism works properly.	If not, correct the LED printer head lifting mechanism. (📖 P. 3-47 "3.9.3 LED printer head lifting mechanism")	

\* If the trouble is not solved at the step 1 and the step 2 or followings (excluding the parameter adjustment) are performed, make sure to perform "Enforced performing of image quality closed-loop control" and then "Automatic gamma adjustment" after taking a measure.

## 8.5.4 Background fogging 1

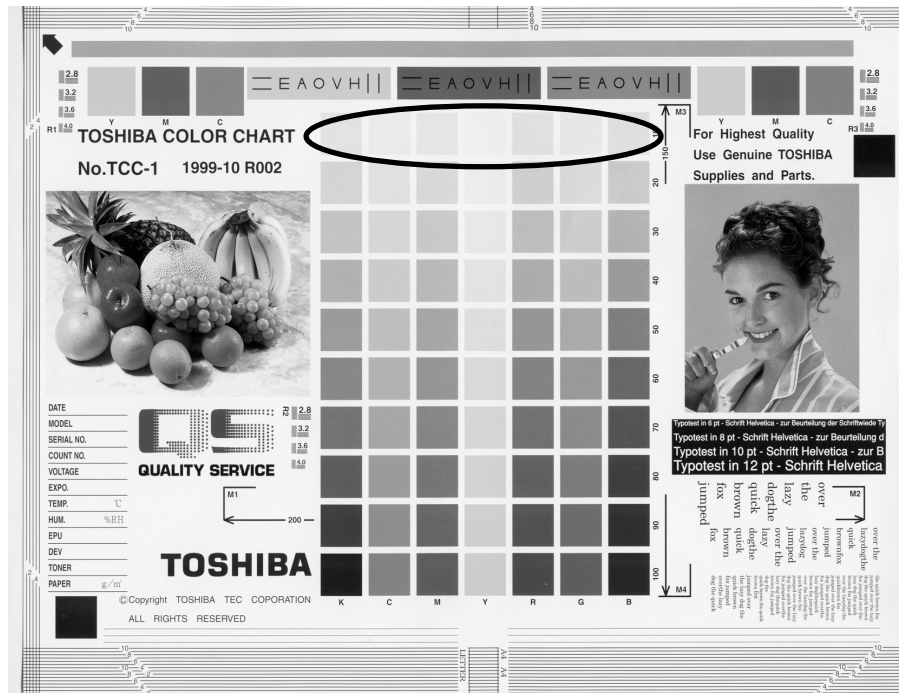


Fig.8-27

Cause/Section	Step	Check item	Measures	Remarks
Adjustment	1	Perform the shading correction.	Perform FS-05-3218. If an error occurs, retry it. If the error still persists, clean the original glass.	
Density reproduction	2	Check the gradation reproduction.	Perform the forced performing of image quality closed-loop control (FS-05-2742) and then automatic gamma adjustment.	
Printer section	3	Check the printer output image.	Output the test patterns and check them. Using FS-04-36 for each color	See step 6 if defects occur.
Scanner	4	Check if the original glass, mirrors or lens is dirty.	Clean it.	
Parameter adjustment value	5	Check the image processing parameters.	Check the value of offsetting adjustment for background adjustment.	
	6	Adjust the image processing parameters.	While checking the above encircled image, adjust the reproduction level by the offsetting adjustment for background adjustment.	
Cover	7	Is the cover installed properly? (Is the drum exposed to the external light?)	Correct it.	

Cause/Section	Step	Check item	Measures	Remarks
Auto-toner	8	Is the auto-toner sensor normal?	Check the operation of auto-toner sensor and readjust.	
	9	Is the toner supply operating constantly?	Check the motor and circuits.	
Main charger output	10	Is the main charger output normal?	Check the circuits.	
Developer bias	11	Is the developer bias proper?	Check the circuits.	
Developer unit	12	Is the contact between the drum and developer material proper?	Check the doctor-to-sleeve gap and pole position.	
Developer material/ Toner/Drum	13	Using the specified developer material, toner and drum?	Use the specified developer material, toner and drum.	
	14	Have the developer material and drum reached their PM life?	Replace the developer material and drum.	
	15	Is the storage environment of the toner cartridge 35°C or less without dew?	Use the toner cartridge stored in the environment within specification.	
Drum cleaning blade	16	Is the drum cleaned properly?	Check the drum cleaning blade pressure.	
Transfer belt cleaning blade	17	Is the transfer belt cleaning blade in proper contact with the transfer belt?	Take off the transfer belt and check if the transfer belt cleaning blade pressure spring and pressure hook are installed properly.	
Toner dusting	18	Is the toner accumulated on the seals of the developer unit?	Remove the toner and clean the seals.	

\* If the trouble is not solved at the step 1 and the step 2 or followings (excluding the parameter adjustment) are performed, make sure to perform “Enforced performing of image quality closed-loop control” and then “Automatic gamma adjustment” after taking a measure.

## 8.5.5 Background fogging 2 (1200 dpi printing)

<Symptoms>

The stripe pattern is printed on the whole area of paper at 1200 dpi printing, it looks like background fogging.



Fig.8-28

Cause/Section	Step	Check item	Measures	Remarks
Connectors which connect the LGC board and SYS board	1	Check if there is foreign matter or dust on the terminals of connectors (CN131, CN132, CN370 and CN371).	Remove the foreign matter or clean the connectors if there is dust.	
	2	Check if the harnesses (CN131, CN132, CN370 and CN371) are inserted at an angle.	Insert the harnesses properly.	
LGC board and SYS board	3	Check if the board is short circuited or open circuited.	Replace the LGC board or SYS board.	

## 8.5.6 Moire /lack of sharpness

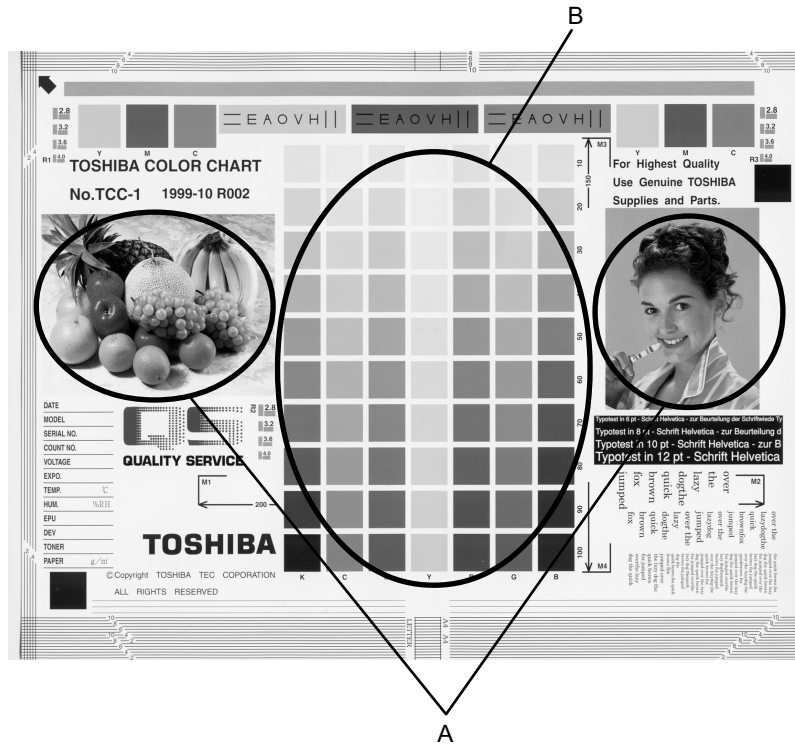


Fig.8-29

### Moire

Cause/Section	Step	Check item	Measures	Remarks
Density reproduction	1	Check the gradation reproduction.	Perform the forced performing of image quality closed-loop control (FS-05-2742) and then automatic gamma adjustment.	
Parameter adjustment value	2	Check the image processing parameters.	Check the sharpness adjustment value.	
	3	Adjust the image processing parameters.	While checking the above encircled images A and B, decrease moire by sharpness adjustment.	
Printer section	4	Check the printer output image.	Output the test patterns and check them. Using FS-04-36 for each color	When defects occur, perform the corresponding troubleshooting procedures.

### Lack of sharpness

Cause/Section	Step	Check item	Measures	Remarks
Density reproduction	1	Check the gradation reproduction.	Perform the forced performing of image quality closed-loop control (FS-05-2742) and then automatic gamma adjustment.	

Cause/Section	Step	Check item	Measures	Remarks
Parameter adjustment value	2	Check the image processing parameters.	Check the sharpness adjustment value.	
	3	Adjust the image processing parameters.	While checking the above encircled image A, increase sharpness by sharpness adjustment.	

\* If the trouble is not solved at the step 1 and the step 2 or followings (excluding the parameter adjustment) are performed, make sure to perform “Enforced performing of image quality closed-loop control” and then “Automatic gamma adjustment” after taking a measure.



## 8.5.7 Toner offset

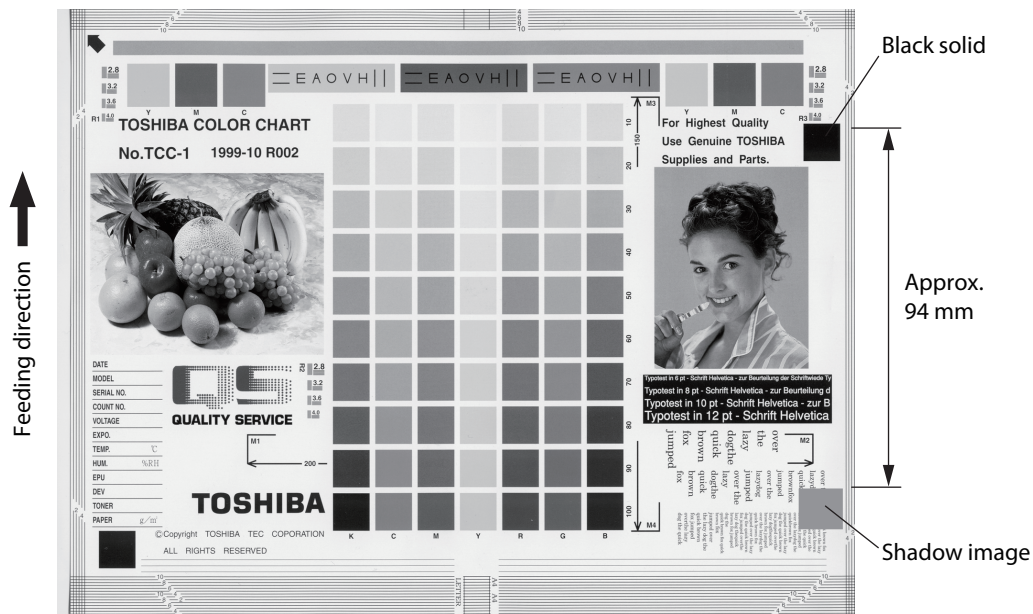


Fig.8-30

Toner offset (Shadow image appears approx. 94 mm behind the high density image.)

Cause/Section	Step	Check item	Measures	Remarks
Fuser unit	1	Is the pressure between the fuser roller and pressure roller proper?	Check the pressure removal parts and pressure mechanism.	
	2	Is there scratch on the fuser roller or pressure roller surface?	Replace the fuser roller or the pressure roller.	
	3	Has the fuser roller or pressure roller reached its PM life?	Replace the fuser roller or the pressure roller.	
	4	Is the fuser roller temperature proper?	Check and correct the control circuit.	
	5	<ul style="list-style-type: none"> <li>Is the gap of the non-contact thermistor proper?</li> <li>Is there any deformation to the front thermistor?</li> <li>Is the front thermistor contacted with the fuser roller?</li> </ul>	<ul style="list-style-type: none"> <li>Adjust the gap and then perform non-contact thermistor correction.</li> <li>Replace the thermistor and then perform non-contact thermistor correction.</li> <li>Replace the thermistor and then perform non-contact thermistor correction.</li> </ul>	
	6	Has non-contact thermistor correction been performed after the fuser unit or any part is replaced?	Perform non-contact thermistor correction.	
	7	Is the thermistor dirty?	Clean or replace the thermistor and then perform non-contact thermistor correction.	

Cause/Section	Step	Check item	Measures	Remarks
Paper	8	Is the paper type corresponding to its mode?	Use the proper type of paper or select the proper mode.	
	9	Using recommended paper?	Use the recommended paper.	
Developer material	10	Is the specified developer used?	Use the specified developer and toner.	
Scanner	11	Are the mirrors, original glass or lens dirty?	Clean them.	
Image quality control	12	Is the control activated?	Check the image quality control related codes.	
Density	13	Is the density too high?	Perform the forced performing of image quality closed-loop control (FS-05-2742) and then automatic gamma adjustment.	
Printer density	11	Check the density of printer output image.	Output the test patterns and check them. using FS-04-36 for each color	When defects occur, perform the corresponding troubleshooting procedures.

## 8.5.8 Blurred image

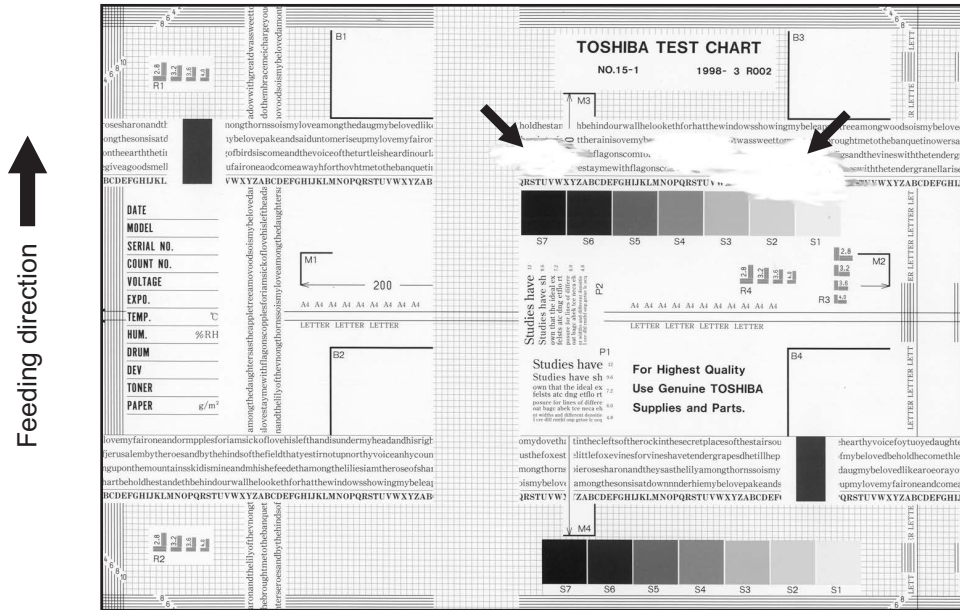


Fig.8-31

Cause/Section	Step	Check item	Measures
Scanner	1	Is the scanner bedewed?	Clean it.
Drum	2	Is the drum bedewed or dirty?	Wipe the drum with dry cloth. * Be sure never use alcohol or other organic solvents because they have bad effect on the drum.
Ozone exhaust	3	Is the ozone exhaust fan operating properly?	Check the connection of the connector.
	4	Is the ozone filter stained or damaged?	Replace it.
LED printer head	5	Is there foreign matter or dust on the LED printer head?	Clean the LED printer head.
Main charger	6	Is the charger grid dirty or deformed?	Clean or replace the charger grid.
Main charger	7	Is there foreign matter on the charger grid?	Remove foreign matter. Clean or replace the charger grid.
Drum cleaner unit	8	Is there any abnormalities or deformation on the gap spacer?	Replace the gap spacer.
	9	Check if the LED printer head lifting mechanism works properly.	If not, correct the LED printer head lifting mechanism. ( P. 3-47 "3.9.3 LED printer head lifting mechanism")

## 8.5.9 Poor fusing

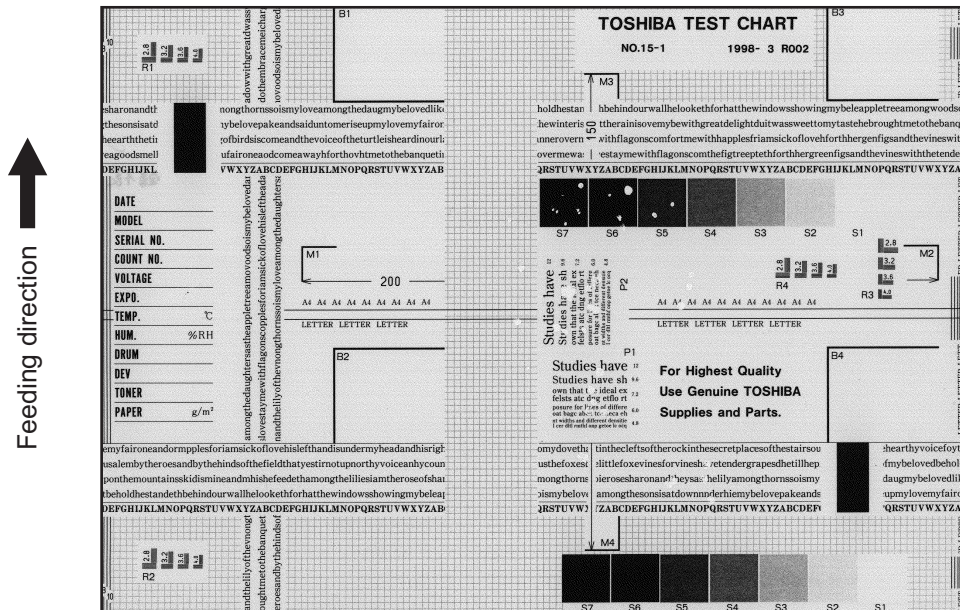


Fig.8-32

Cause/Section	Step	Check item	Measures
Electric power/control abnormal	1	Is the connector in proper contact with the equipment?	Correct it.
	2	Is the heater lamp control circuit (switching power supply) working properly?	Replace the switching power supply.
	3	Are the connectors on the LGC board and relay connectors connected properly?	Reconnect them.
	4	Is the LGC board normal?	Replace the LGC board.
	5	Is the harness connected with the LGC board short circuited or open circuited?	Replace the harness.
	6	<ul style="list-style-type: none"> <li>Is the gap of the non-contact thermistor proper?</li> <li>Is there any deformation to the front thermistor?</li> <li>Is the front thermistor contacted with the fuser roller?</li> </ul>	<ul style="list-style-type: none"> <li>Adjust the gap and then perform non-contact thermistor correction.</li> <li>Replace the thermistor and then perform non-contact thermistor correction.</li> <li>Replace the thermistor and then perform non-contact thermistor correction.</li> </ul>
	7	Has non-contact thermistor correction been performed after the fuser unit or any part is replaced?	Perform non-contact thermistor correction.
Pressure between fuser roller and pressure roller improper	8	Are the pressure springs working properly?	Check/adjust the pressure springs.

<b>Cause/Section</b>	<b>Step</b>	<b>Check item</b>	<b>Measures</b>
Fuser roller temperature	9	Is the temperature of fuser roller too low?	Check/correct the setting value of fuser roller temperature. Perform non-contact thermistor correction. Check/correct the related circuit.
Developer material and toner	10	Using the specified developer material and toner?	Use the specified developer material and toner.
Paper	11	Is the paper damp?	Change the paper.
	12	Is the paper type corresponding to its mode?	Use the proper type of paper or select the proper mode.
	13	Using the recommended paper?	Use the recommended paper.

## 8.5.10 Blank print



Fig.8-33

Cause/Section	Step	Check item	Measures
High-voltage transformer (1st/2nd transfer roller and developer bias)	1	Is the high-voltage transformer output defective?	Adjust the output and correct the circuit, or replace the transformer.
	2	Are the connector of the high-voltage harness securely connected? Is the harness open circuited?	Reconnect the harness securely. Replace the high-voltage harness.
Developer unit	3	Is the developer unit installed securely?	Check/correct the developer sleeve coupling engaging.
	4	Do the developer sleeve and mixer rotate?	Check/correct the developer drive system.
	5	Is the developer unit filled up with the developer material?	Check that the charger grid is not dirty. (The developer material may be reduced due to the carrier offset.)
	6	Is the developer material properly transported?	Remove foreign matter from the developer material, if any.
	7	Is there any magnetic brush phase error?	Check the developer pole position.
	8	Is the doctor sleeve gap incorrect?	Adjust the gap with the doctor-sleeve jig.
Drum	9	Is the drum rotating?	Check/correct the drum coupling engaging. Check the drum drive system.
	10	Is the drum grounded?	Check the contact of the grounding plate.

<b>Cause/Section</b>	<b>Step</b>	<b>Check item</b>	<b>Measures</b>
Transfer unit	11	Is the transfer belt in proper contact with the drum?	Check if the contact releasing lever is at releasing position. Check the installation of the transfer belt.
	12	Is the transport of the transfer belt normal?	Check the installation of the transfer belt or transport mechanism.
Harnesses for CCD, SYS and LGC boards	13	Are the connectors securely connected? Is any harness between the boards open circuited?	Reconnect the connectors securely. Replace the harness.

## 8.5.11 Solid print

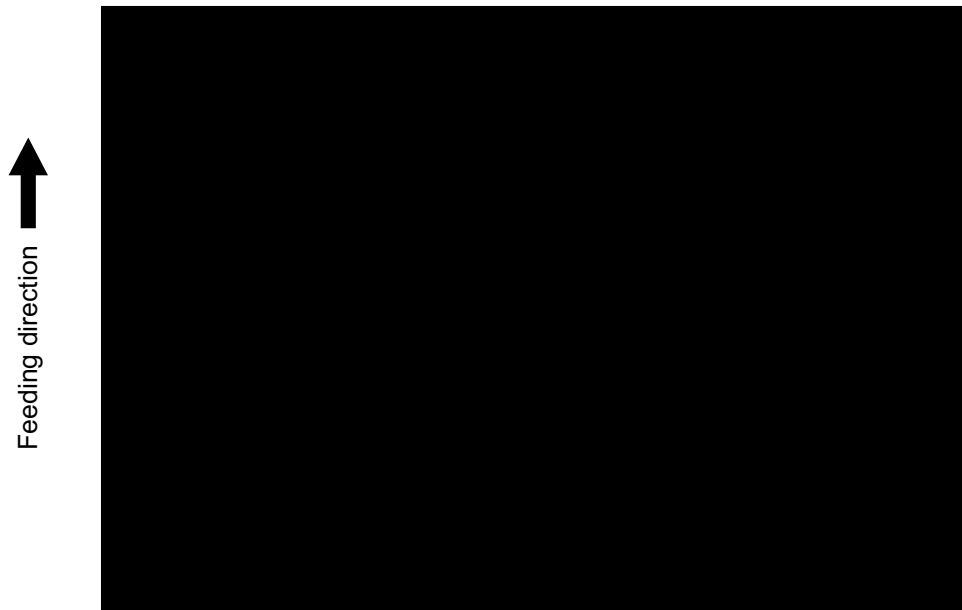


Fig.8-34

When there is a void on the solid image

Cause/Section	Step	Check item	Measures
Exposure lamp	1	Does the exposure lamp light?	If the lamp does not work, replace it.
Harnesses for CCD, SYS and LGC boards	2	Are the connectors securely connected? Is any harness between the boards open circuited? Is the harness between the SYS and LGC boards not disconnected?	Reconnect the connectors securely. Replace the harness.
Scanner	3	Is there foreign matter in the optical path?	Remove it.
Bedewing of scanner	4	Is the scanner bedewed?	Clean the mirrors and lens. Keep the power cord plugged so that the damp heater can work.

When there is no void on the solid image

Cause/Section	Step	Check item	Measures
Main charger	1	Is the main charger securely installed?	Reinstall it securely.
	2	Does the needle electrode not come off?	Reinstall it securely.
High-voltage transformer (main charger needle electrode/grid bias)	3	Is the high-voltage transformer output defective?	Adjust the output and correct the circuit, or replace the high-voltage transformer.
	4	Are the connector of the high-voltage harness securely connected? Is the harness open circuited?	Reconnect the harness securely. Replace the high-voltage harness.



<b>Cause/Section</b>	<b>Step</b>	<b>Check item</b>	<b>Measures</b>
Bedewing of drum	5	Is the drum bedewed?	Clean the drum. Keep the power cord plugged so that the damp heater can work.

## 8.5.12 White banding (in feeding direction)

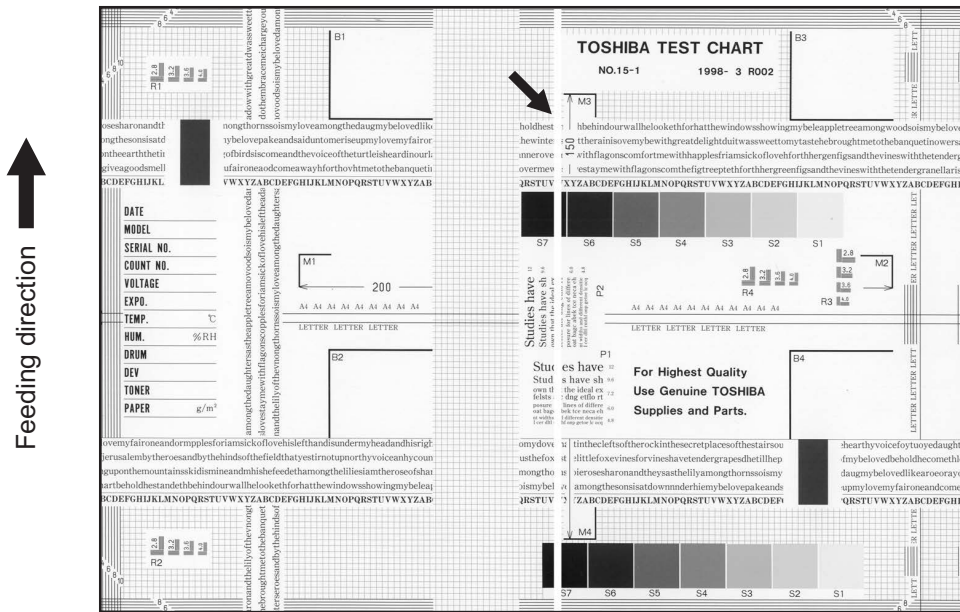


Fig.8-35

Cause/Section	Step	Check item	Measures	Phenomenon	
-	0	Check whether this phenomenon occurs in the same place of the paper in all four colors (Y, M, C and K) or a particular one.	Perform the measures by referring to "Y" described in the Phenomenon column, depending on the occurrence state of each color.	One color	Four colors
LED printer head	1	Is there foreign matter or dust on the LED printer head?	Clean the LED printer head.	Y	-
	2	Check if the width of the white banding is 8 mm. (Including the multiple number width of 8 mm)	Replace the LED printer head.	Y	-
Main charger grid	3	Is there foreign matter on the charger grid?	Remove foreign matter.	Y	-
Developer unit	4	Is there foreign matter inside the doctor blade?	Remove foreign matter.	Y	-
	5	Is there foreign matter on the drum seal?	Remove foreign matter.	Y	-
	6	Do any paper fibers or dirt adhere to the developer unit and contact with the drum?	Remove the paper fibers or dirt.	Y	-
Drum	7	Is there scratch or foreign matter on the drum surface?	Replace the drum.	Y	-

Transfer unit	8	Is there scratch or foreign matter on the transfer belt surface?	Replace the transfer belt.	-	Y
	9	Are the harness or foreign matters in contact with the transfer belt surface?	Correct or remove them.	-	Y
	10	Is there any scratch or hole on the 1st transfer roller?	Replace the 1st transfer roller.	Y	-
	11	Is there any scratch or hole on the 2nd transfer roller?	Replace the 2nd transfer roller.	-	Y
	12	Is there any foreign matter on the TBU drive roller?	Remove foreign matter or clean the roller.	-	Y
Transport path	13	Does the toner image touch foreign matter after transfer, before entering the fuser unit?	Remove foreign matter.	-	Y
Discharge LED	14	Has any LED of discharge LED gone out?	Replace the discharge LED.	Y	-
Scanner	15	Is there foreign matter or dust in the optical path?	Clean the lens and mirrors.	-	Y
LED printer head	16	Check if the width of the white banding is other than 8 mm.	Replace the flat cable. Replace the LED printer head.	Y	-

## 8.5.13 White banding (at right angles to feeding direction)

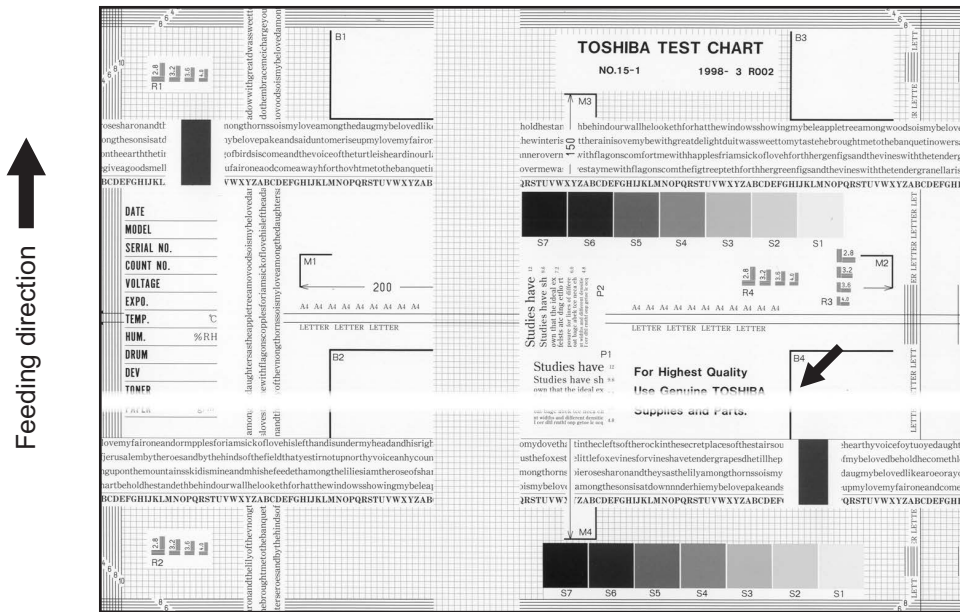


Fig.8-36

Cause/Section	Step	Check item	Measures
Main charger	1	Is the terminal contact poor?	Clean or adjust the terminals.
Drum	2	Is there any abnormalities on the drum surface?	Replace the drum.
	3	Is the drum grounded?	Check the contact of the grounding plate.
Discharge LED	4	Is the discharge LED lighting properly?	Replace the discharge LED or clean terminals.
Developer unit	5	Is the developer sleeve rotating correctly? Is there any abnormalities on the sleeve surface?	Check the developer drive system, or clean the sleeve surface.
	6	Is the connection of developer bias supply terminal normal?	Correct it.
Drive systems	7	Is the drum, scanner or transfer belt jittery?	Check each drive system.
High-voltage transformer (main charger needle electrode/grid, 1st/2nd transfer roller and developer bias)	8	Is the high-voltage transformer output defective?	Check/correct any electric leakage and related circuits. If the high-voltage transformer does not work, replace it.
Main charger	9	Is the charger grid dirty or deformed?	Clean or replace the charger grid.
Main charger	10	Is there foreign matter on the charger grid?	Remove foreign matter. Clean or replace the charger grid.

## 8.5.14 Skew (slantwise copying)

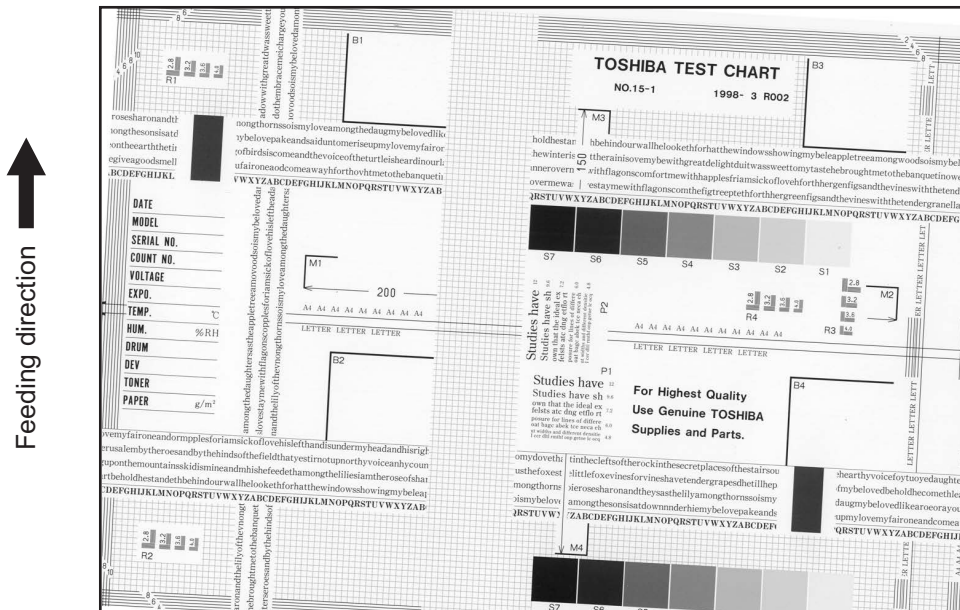


Fig.8-37

Cause/Section	Step	Check item	Measures
Drawer/LCF	1	Is the drawer or LCF properly installed?	Reinstall the drawer or LCF properly.
	2	Is too much paper loaded in the drawer or LCF?	Reload paper within the acceptable range of paper weight. <Acceptable paper weight> 1st drawer: Plain paper - 28 mm Thick paper - 14 mm 2nd, 3rd and 4th drawers: 60.5 mm LCF: 137.8 mm x 2 places
	3	Is the paper corner folded?	Change the paper direction and reinsert it.
	4	Are the drawer or LCF side guides properly set?	Adjust the side guides.
Paper feed roller	5	Is the surface of paper feed roller dirty?	Clean the roller surface with alcohol, or replace the roller.
Rollers	6	Is each roller improperly fixed to the shaft?	Check E-rings, pins and clips.
2nd transfer roller	7	Install the roller by reversing its back and front sides.	Output and check the printed image.
Aligning amount	8	Is the aligning amount proper?	Increase the aligning amount.
Registration roller	9	Is the registration roller spring removed?	Mount the spring correctly. Clean the roller if it is dirty.
Registration guide	10	Is the registration guide improperly installed?	Correct it.
2nd transfer front guide	11	Is the 2nd transfer front guide installed properly?	Correct it.

<b>Cause/Section</b>	<b>Step</b>	<b>Check item</b>	<b>Measures</b>
RADF	12	Is the RADF installed and adjusted properly?	Reinstall and readjust it.
Transfer unit	13	Is the transfer belt unit installed properly?	Correct it.

## 8.5.15 Color banding (in feeding direction)

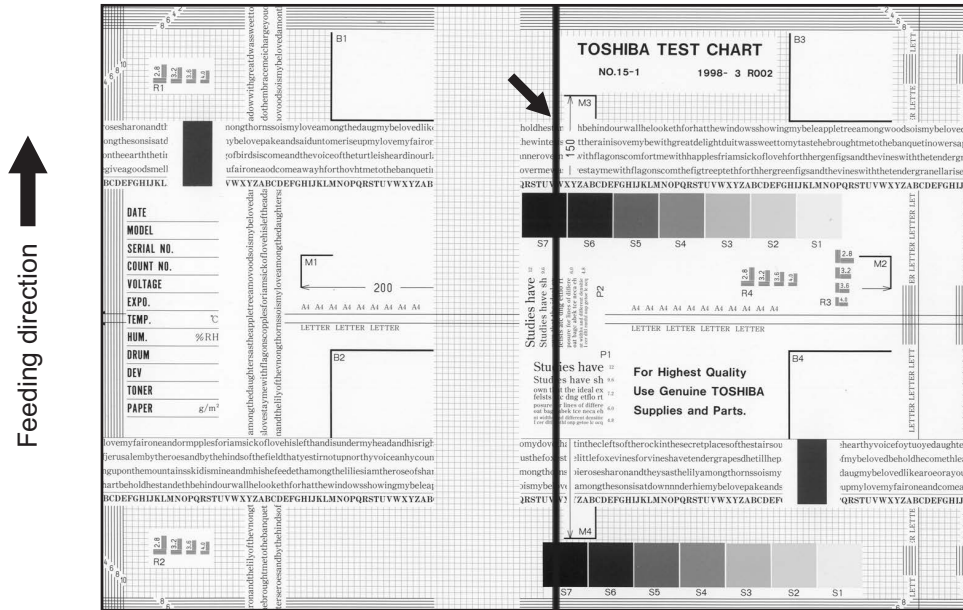


Fig.8-38

Cause/Section	Step	Check item	Measures
Scanner	1	Is there foreign matter in the optical path?	Clean the slit, lens and mirrors.
	2	Is there dust or stain on the shading correction plate or ADF original glass?	Clean it.
	3	Disconnect the harness from the connector at the CCD board to confirm that no foreign matter is adhering to the connector and the terminal of the harness.	Clean the terminals of the connector and the harness with an air blower or brush.
Main charger	4	Is there foreign matter on the charger grid?	Remove foreign matter.
	5	Is the charger grid dirty or deformed?	Clean or replace the charger grid.
	6	Is there foreign matter on the main charger?	Remove foreign matter.
	7	Is the needle electrode dirty or deformed?	Clean or replace the needle electrode.
	8	Is there foreign matter inside the charger case?	Remove foreign matter.
	9	Is the inner surface of charger case dirty?	Clean inside.

Cause/Section	Step	Check item	Measures
Drum cleaner	10	Is there any foreign matter on the edge of the drum cleaning blade?	Clean the drum cleaning blade.
	11	Are there any scratches on the edge of the drum cleaning blade?	Replace the drum cleaning blade.
	12	Is there any foreign matter on the drum?	Clean or replace the drum.
	13	Are there any scratches on the drum?	Replace the drum.
	14	Is toner recovery defective?	Clean the toner recovery auger section.
Transfer unit	15	Are the harness or foreign matters in contact with the transfer belt surface?	Correct or remove them.
	16	Is there any foreign matter (such as paper dust or the adhesive paste of a sticker label) on the edge of the transfer belt cleaning blade?	Clean or replace the transfer belt cleaning blade.
	17	Are there any scratches on the edge of the transfer belt cleaning blade?	Replace the transfer belt cleaning blade.
	18	Is there any foreign matter (such as the adhesive paste of a sticker label) on the transfer belt?	Clean or replace the transfer belt.
	19	Are there any scratches on the transfer belt?	Replace the transfer belt.
Fuser unit	20	a. Is there dirt or scratches on the fuser roller and pressure roller surface? b. Is the thermistor dirty?	a. Clean or replace them. b. Clean the thermistor.
LED printer head	21	Is there foreign matter or dust on the LED printer head?	Clean or replace them.
SYS board	22	Disconnect the harness (between the CCD and the SYS board) from the connector at the SYS board to confirm that no foreign matter is adhering to the connector and the terminal of the harness.	Clean the terminals of the connector and the harness with an air blower or brush.



## 8.5.16 Color banding (at right angles to feeding direction)

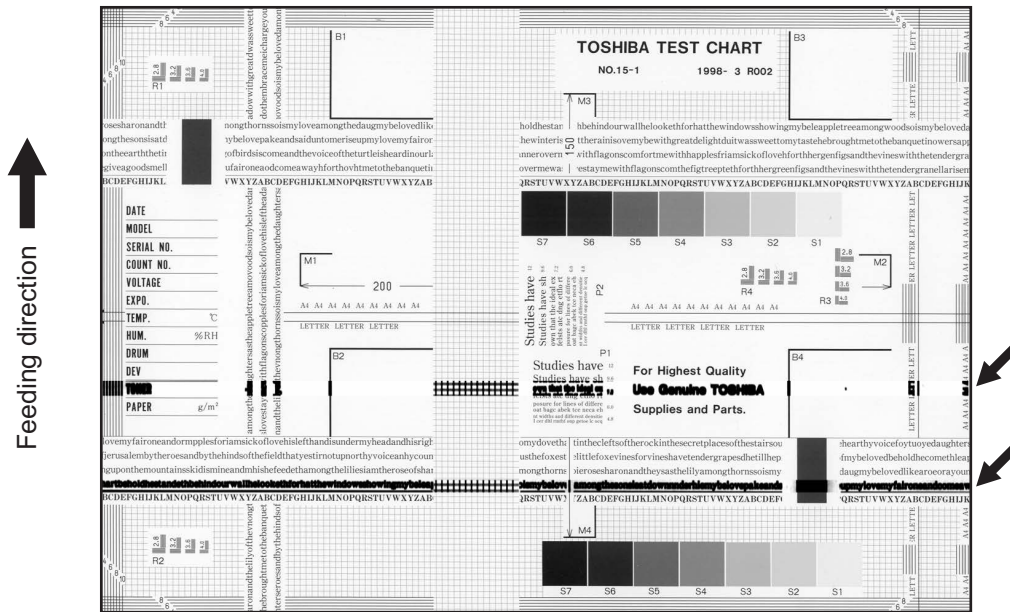


Fig.8-39

Cause/Section	Step	Check item	Measures
Main charger	1	Is the needle electrode dirty or deformed?	Clean or replace the needle electrode.
Fuser unit	2	Is the fuser roller or pressure roller dirty?	Clean them.
High-voltage transformer (main charger needle electrode/grid and transfer roller bias)	3	Is the high-voltage transformer output defective?	Check the circuit and replace the high-voltage transformer if not working.
	4	Is each joint of high-voltage output loosened? (Check if any electric leakage is causing noise.)	Reconnect each joint.
Drum	5	Is there deep scratch on the drum surface?	Replace the drum, especially if the scratch has reached the aluminum base.
	6	Are there fine scratches on the drum surface (drum pitting)?	Check and correct the contact of cleaning blade and recovery blade.
	7	Is the drum grounded?	Check the contact of the grounding plate.
2nd transfer roller	8	Is the 2nd transfer roller rotating normally?	Clean the roller area or replace the roller.
Scanner	9	Is there foreign matter on the carriage rail?	Remove foreign matter.
Main charger	10	Is the charger grid dirty or deformed?	Clean or replace the charger grid.
Main charger	11	Is there foreign matter on the charger grid?	Remove foreign matter. Clean or replace the charger grid.

## 8.5.17 White spots

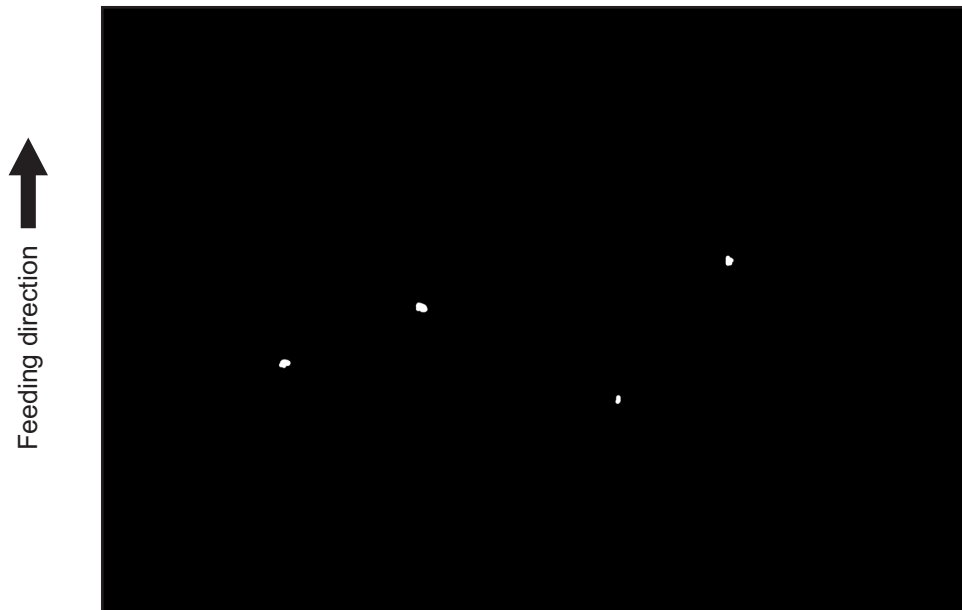


Fig.8-40

Cause/Section	Step	Check item	Measures
Developer unit/Toner cartridge	1	Is the toner density of developer material proper?	Check and correct the auto-toner sensor and toner supply operation. Check if the amount of toner is sufficient in the toner cartridge.
	2	Is the doctor-sleeve gap proper?	Adjust the gap.
Developer material/ Toner/Drum	3	Using the specified developer material, toner and drum?	Use the specified developer material, toner and drum.
	4	Have the developer material and drum reached their PM life?	Replace the developer material and drum.
	5	Is the storage environment of the toner cartridge 35°C or less without dew?	Use the toner cartridge stored in the environment within specification.
	6	Is there any dent on the surface of the drum?	Replace the drum.
	7	Is there any film forming on the drum?	Clean or replace the drum.
	8	Is the drum bedewed?	Wipe the drum surface with a piece of dry cloth.
Transfer unit	9	Is there foreign matter on the transfer belt surface?	Remove foreign matter.
	10	Is there foreign matter on the transfer belt TBU drive roller?	Clean the transfer belt unit.
Main charger	11	Is there foreign matter on the charger?	Remove it.
	12	Is the needle electrode dirty or deformed?	Clean or replace the needle electrode.

Cause/Section	Step	Check item	Measures
High-voltage transformer (main charger needle electrode/grid, developer 1st/ 2nd transfer roller bias)	13	Is the high-voltage transformer output defective?	Adjust the output.
Paper	14	Is the paper type corresponding to its mode?	Use the proper type of paper or select the proper mode.

## 8.5.18 Poor transfer

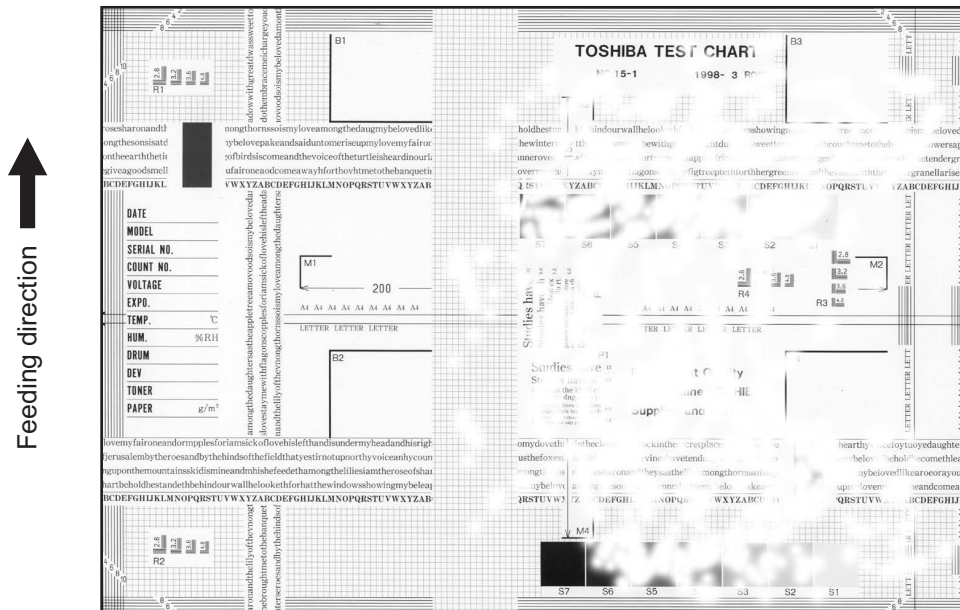


Fig.8-41

Cause/Section	Step	Check item	Measures
Transfer unit	1	Is the transfer belt or 1st/2nd transfer rollers dirty?	Clean it.
	2	Is the transfer belt in proper contact with the drum?	Correct it.
	3	Is the 2nd transfer roller in proper contact with the transfer belt?	Correct it.
	4	Is there any deformation or abnormalities on the transfer belt?	Replace the belt.
	5	Is the TBU drive roller dirty?	Clean the roller and replace the cleaning pad.
Paper	6	Is the high-voltage fed to the 2nd transfer roller correctly?	If any contact failure occurs in the feeding area (e.g. the conductive bushing and spring come off), correct it.
	7	Is paper in the drawer or LCF curled?	Reinsert paper with reverse side up or change paper.
	8	Is paper in the drawer or LCF damp?	Change paper. * Avoid storing paper in damp place.
Registration roller	9	Is the registration roller malfunctioning?	Clean the roller, remount the spring, or replace defective motor-related parts.
Aligning amount	10	Is the aligning amount proper?	Decrease the aligning amount

<b>Cause/Section</b>	<b>Step</b>	<b>Check item</b>	<b>Measures</b>
High-voltage transformer (1st/2nd transfer roller bias)	11	Is the high-voltage transformer output defective?	Check the circuit and adjust the transformer output.
	12	Are the high-voltage harness and terminals in proper contact?	Correct them if loosened.

## 8.5.19 Uneven image density 1 (in feeding direction)

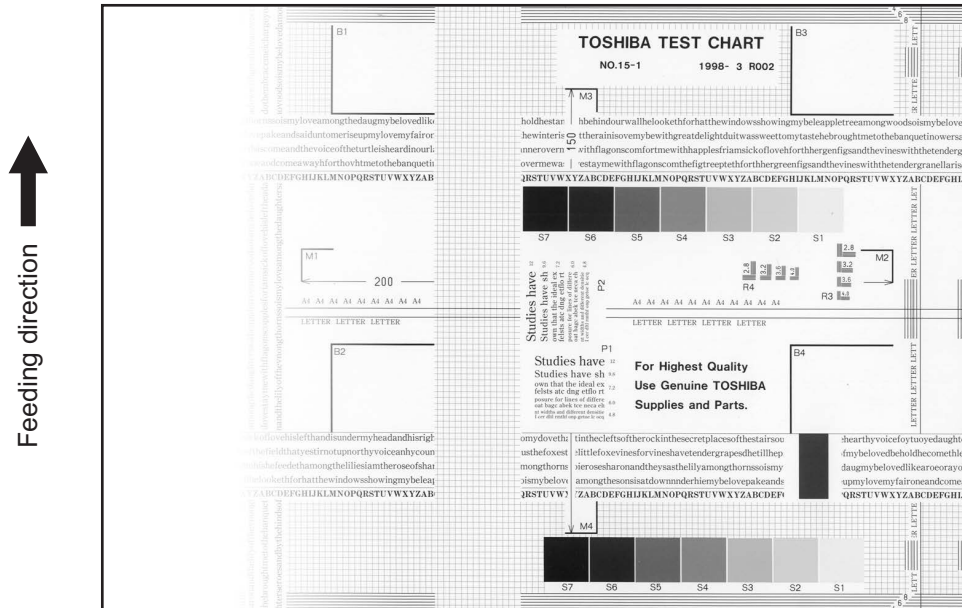


Fig.8-42

Cause/Section	Step	Check item	Measures
Main charger	1	Is the main charger dirty?	Clean it or replace the needle electrode.
	2	Is the main charger grid color tarnish (black, red or green etc.)?	Replace the main charger grid.
Transfer unit	3	Is the transfer belt or 1st/2nd transfer rollers dirty?	Clean the belt.
	4	Is the transfer belt in proper contact with the drum?	Correct it.
	5	Is 2nd transfer roller in proper contact with the transfer belt? (Is the roller tilted?)	Open and close the jam access cover. Check if there is any abnormality in the movement of the 2nd transfer roller pressure mechanism.
	6	Is there any abnormalities or deformation on the transfer belt?	Replace the transfer belt.
LED printer head	7	Is there foreign matter or dust on the LED printer head?	Clean the LED printer head
Discharge LED	8	Is the discharge LED dirty?	Clean it.
	9	Has any LED of discharge LED gone out?	Replace it.
Developer unit	10	Is the magnetic brush in proper contact with the drum?	Adjust the doctor-sleeve gap.
	11	Is the developer unit pressure spring applying properly?	Check the pressure spring.
	12	Is the transport of developer material poor?	Remove foreign matter if any.

Cause/Section	Step	Check item	Measures
Scanner section	13	a. Is the platen cover or RADF open? b. Is the original glass, mirrors, or lens dirty?	a. Close the platen cover or RADF. b. Clean them.
Drum cleaner unit	14	Is there any abnormalities or deformation on the gap spacer?	Replace the gap spacer.
	15	Check if the LED printer head lifting mechanism works properly.v	If not, correct the LED printer head lifting mechanism. (📖 P. 3-47 "3.9.3 LED printer head lifting mechanism")

**8.5.20 Uneven image density 1 (at right angles to feeding direction)**

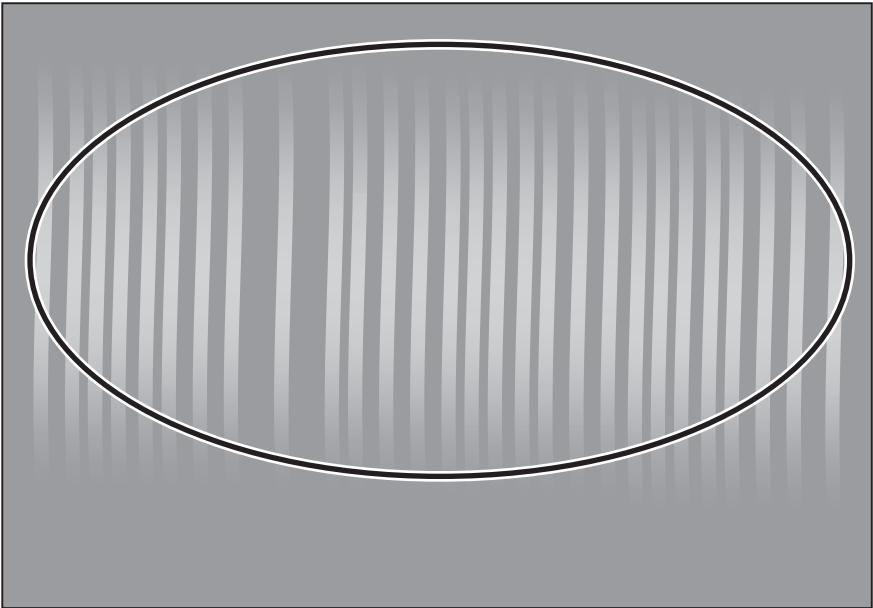


Fig.8-43

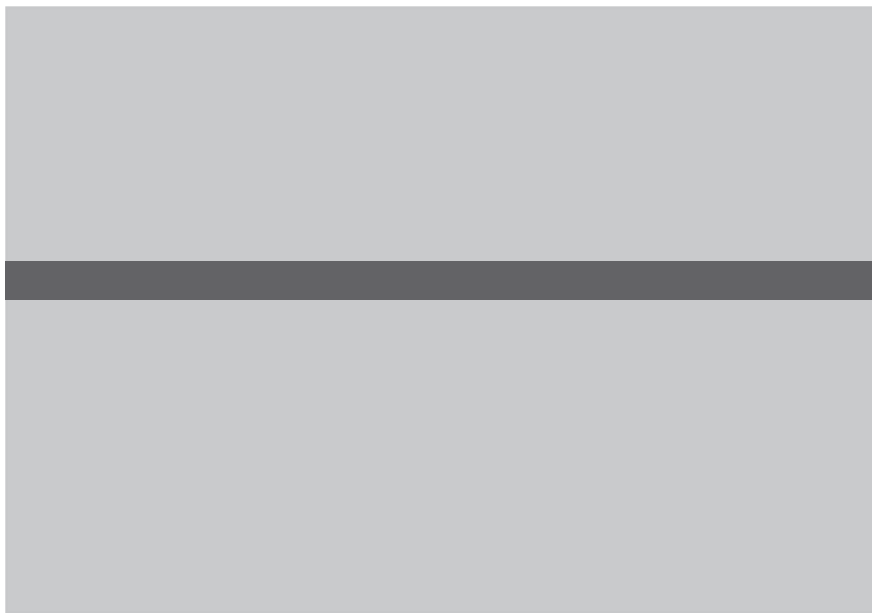
Cause/Section	Step	Check item	Measures
Developer unit	1	Is the magnetic brush in proper contact with the drum?	Adjust the doctor sleeve gap.






## 8.5.21 Uneven image density 2



← Feeding direction  
Fig.8-44



← Feeding direction  
Fig.8-45

Cause/Section	Step	Check item	Measures
Developer unit	1	Is the layer of the developer material on the developer sleeve where the density is uneven thin or lacking?	<ul style="list-style-type: none"> <li>Remove the foreign matter in the developer unit. See "2. Removal of foreign matter in the developer unit" in  P. 7-21 "7.6.5 Developer unit (K, Y, M, and C)".</li> <li>Clean the developer unit. See "1. Cleaning" in  P. 7-21 "7.6.5 Developer unit (K, Y, M, and C)".</li> </ul>
	2	Does uneven image density occur again?	See work flow diagram in  P. 7-12 "7.5 Work flow of parts replacement".
LED printer head	3	Is there any abnormalities in the LED printer head.	Replace the LED printer head.

## 8.5.22 Faded image (low density, roughness)

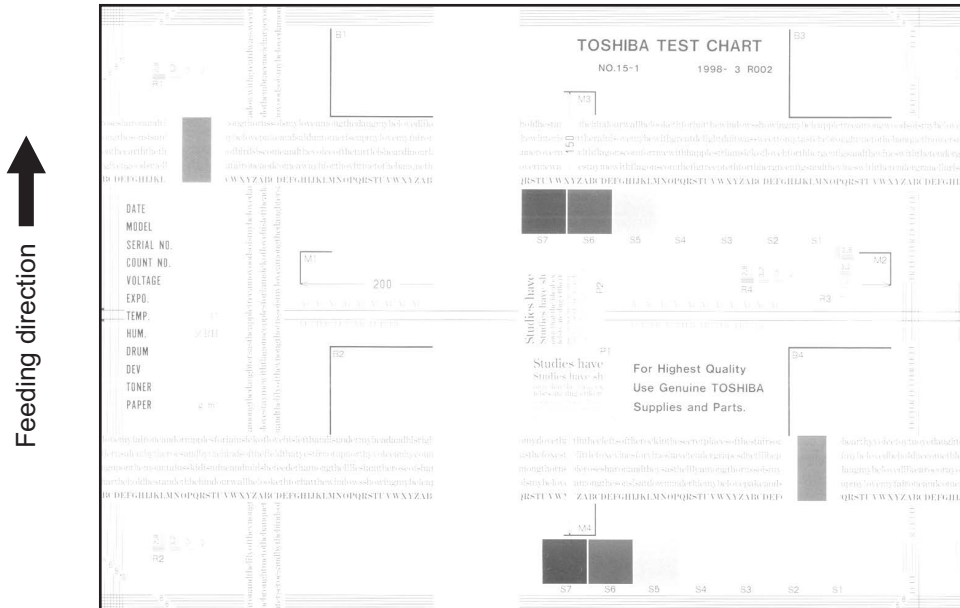


Fig.8-46

Cause/Section	Step	Check item	Measures
Toner empty Auto-toner circuit	1	Is the "ADD TONER" symbol blinking?	Replace the toner cartridge.
	2	Is there enough toner in the cartridge?	Check the auto-toner circuit function.
	3	Is the toner density of developer material too low?	
Toner motor	4	Is the toner motor malfunctioning?	Check the motor drive circuit.
Toner cartridge	5	Are there any abnormalities in the toner cartridge?	Replace the toner cartridge.
Developer material	6	Has the developer material reached its PM life?	Replace developer material.
Developer unit	7	Is the magnetic brush in proper contact with the drum?	Check the developer unit installation. Check the doctor-sleeve gap and pole position.
Main charger	8	Is the main charger dirty?	Clean it or replace the needle electrode.
Drum	9	Is there film forming on the drum surface?	Clean or replace the drum.
	10	Has the drum reached its PM life?	Replace the drum.
Transfer unit	11	Has the transfer belt, 1st or 2nd transfer roller reached its PM life?	Replace the transfer belt, 1st or 2nd transfer roller.
High-voltage transformer (developer bias)	12	Is the high-voltage transformer output settings improper?	Adjust the high-voltage transformer output.
	13	Are the connector of the high-voltage harness securely connected? Is the harness open circuited?	Reconnect the harness securely. Replace the high-voltage harness.

Cause/Section	Step	Check item	Measures
Drum cleaner unit	14	Is there any abnormalities or deformation on the gap spacer?	Replace the gap spacer.
	15	Check if the LED printer head lifting mechanism works properly.	If not, correct the LED printer head lifting mechanism. ( P. 3-47 "3.9.3 LED printer head lifting mechanism")
2nd transfer	16	Is the recommended paper used?	<p>If not, change the values of FS-05-2934 to FS-05-2937 to adjust the 2nd transfer bias offset. Check the mode (color or monochrome) and the side (front or back). Set the value for each paper type so that the density of the image quality becomes the darkest.</p> <p><b>Notes:</b></p> <ul style="list-style-type: none"> <li>• After the setting has been changed, perform automatic gamma adjustment.</li> <li>• When the value is increased close to 10, white spots may occur. To avoid, this, perform the adjustment while checking the image.</li> <li>• When the value is reduced close to 0, poor transfer may occur. To avoid, this, perform the adjustment while checking the image.</li> </ul>

## 8.5.23 Image dislocation in feeding direction

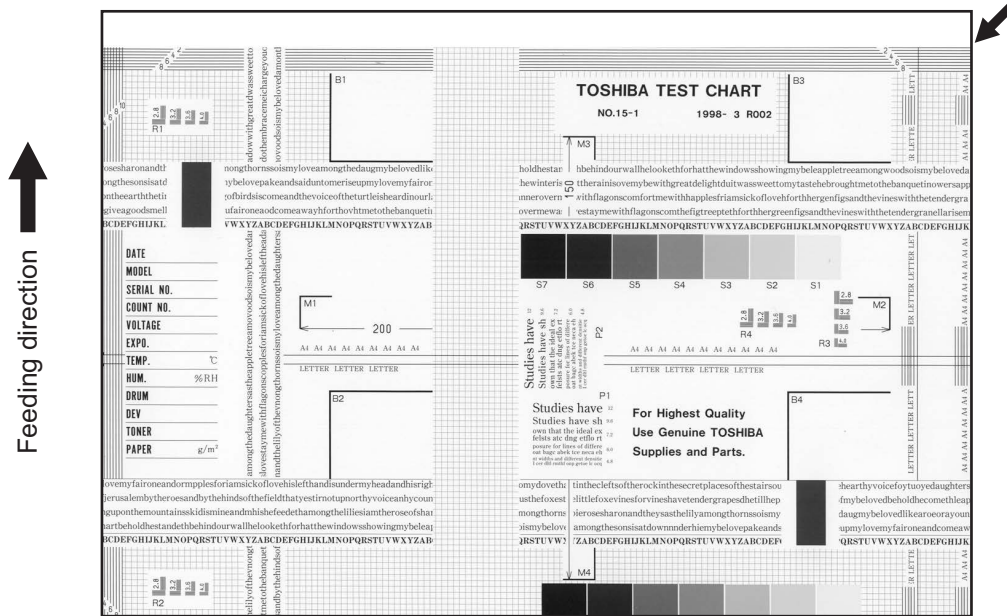


Fig.8-47

Cause/Section	Step	Check item	Measures
Adjustment error of scanner or printer section	1	Is same dislocation on every copy?	Adjust the scanner/printer using the Adjustment Mode.
Registration roller	2	Is the registration roller dirty, or is the spring removed?	Clean the roller with alcohol. Reinstall the spring.
	3	Is the registration motor malfunctioning?	Adjust or replace the gears, etc. if they are not engaged properly.
	4	Is the registration clutch operating normally? (Is the timing of operation delaying?)	Replace the registration clutch.
Paper feed clutch	5	Is the paper feed clutch malfunctioning?	Check the circuit or the clutch and replace them if necessary.
Aligning amount	6	Is the aligning amount proper?	Decrease the aligning amount.
Paper pushing amount	7	Is the paper pushing amount proper?	Decrease the paper pushing amount.
Each roller	8	Are the roller and shaft not fixed securely?	Check the E-ring, pin and clip.
	9	Is the roller surface dirty?	Clean the roller surface with alcohol or replace it.
Registration guide	10	Is the registration guide improperly installed?	Reinstall the guide.

## 8.5.24 Image jittering

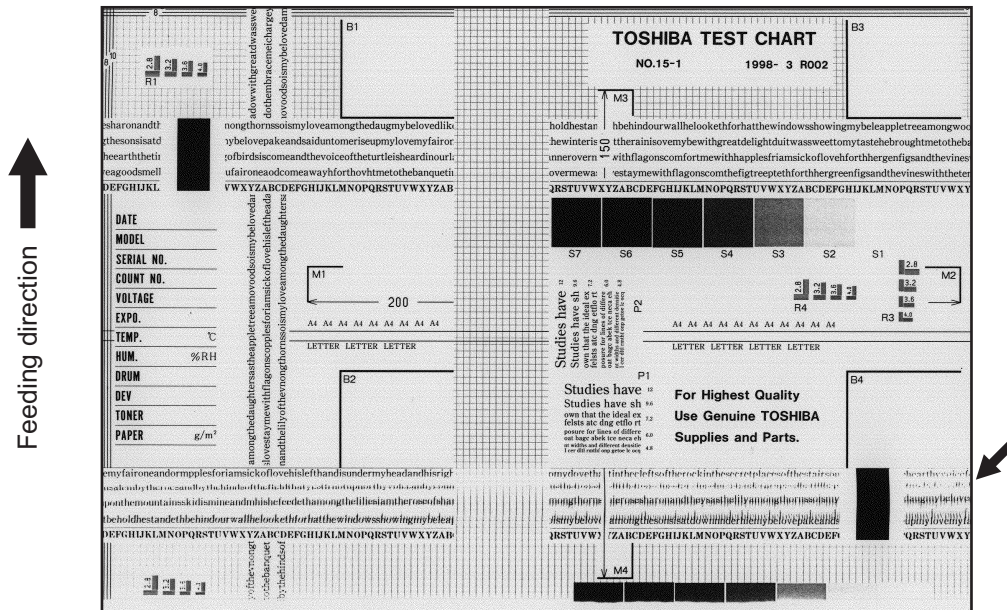


Fig.8-48

Cause/Section	Step	Check item	Measures
-	1	Is the toner image on the drum proper?	If proper, perform step 2 to 3; otherwise perform step 4 and after.
Registration roller	2	Is the registration roller rotating normally?	Check the registration roller section and its springs.
Transfer unit	3	Is the transfer belt or 2nd transfer roller operating normally?	Check the drive system and replace the transfer belt or 2nd transfer roller if necessary.
Fuser unit	4	Are the fuser roller and pressure roller rotation proper? Is the fuser belt transportation proper?	Check the drive system. Replace the fuser roller and pressure roller if necessary.
Drum	5	Is there large scratch on the drum?	Replace the drum.
Scanner	6	Is the slide sheet defective?	Replace it.
	7	Are there any abnormalities on the carriage feet?	Replace the feet.
	8	Is the tension of timing belt inappropriate?	Correct the tension.
	9	Is the carriage drive system malfunctioning?	Check the carriage drive system.
	10	Are any mirrors loosely installed?	Install them properly.
Drum drive system	11	Is the drum drive system malfunctioning?	Check the drum drive system. Clean or replace the belts, pulleys, bushings if they have dirt or scratches.

## 8.5.25 Poor cleaning

### Notes:

Poor cleaning may occur in feeding direction.

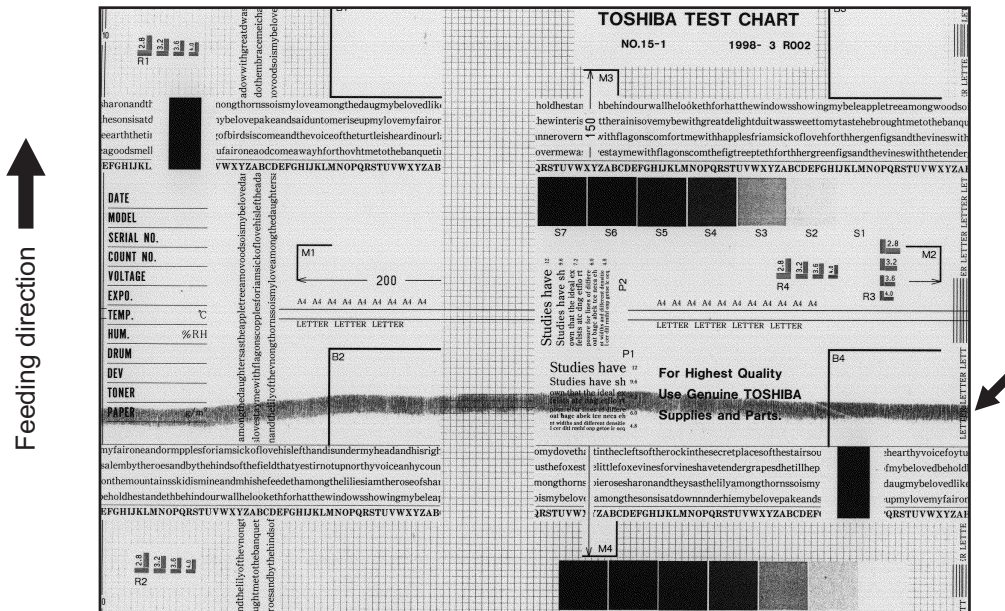


Fig.8-49

Cause/Section	Step	Check item	Measures
Developer material	1	Is the specified developer material used?	Use the specified developer material and toner.
Drum cleaner	2	Is there dust on the drum cleaning blade edge?	Clean or replace it.
	3	Is the drum cleaning blade peeled?	Replace the blade.
Transfer belt cleaner	4	Is there paper dust on the edge of transfer belt cleaning blade?	Clean or replace it.
	5	Is the transfer belt cleaning blade peeled?	Replace the blade.
	6	Is the transfer belt cleaning blade in proper contact with the transfer belt?	<ul style="list-style-type: none"> <li>Check if the transfer belt cleaning blade is installed in the transfer belt cleaning unit properly.</li> <li>Check if the transfer belt cleaning unit is installed in the transfer belt unit properly.</li> </ul>
Toner recovery auger	7	Is the toner recovery defective?	Clean the toner recovery auger. Check the cleaning blade pressure.

Cause/Section	Step	Check item	Measures
Fuser unit	8	Is there any bubble-like defect on the fuser roller (approx. 94 mm pitch on the image)?	Replace the fuser roller. Check and modify the heater lamp control circuit. Perform non-contact thermistor correction.
	9	Have the fuser roller and pressure roller reached their PM life?	Replace them. Perform non-contact thermistor correction.
	10	Is the pressure between the fuser roller and pressure roller proper?	Check and adjust the pressure mechanism.
	11	Is the temperature of fuser roller proper?	Check/correct the setting value of fuser roller temperature. Clean or replace the thermistors. Perform non-contact thermistor correction. Check and correct the circuit.

**Remarks:**

Depending on the paper to be used, image staining tends to occur due to the poor cleaning of the transfer belt.

Conditions in which poor cleaning of the transfer belt caused by the paper easily occurs:

- Paper generating a lot of paper dust is used.
- Labels, coating paper or ink-jet paper is frequently used.
- The number of the continuous paper feeding times is large.
- Paper whose width is narrow, such as A4-R, LT-R or B5, is frequently used.

Sample of image staining due to poor cleaning caused by the paper:

- Streak-like image staining, which is parallel to the paper feeding direction, occurs in the both areas approx. 90 mm or more outside from the center of the paper.
- If the width of the paper is 180 mm or less, streak-like image staining may occur around both its edges.

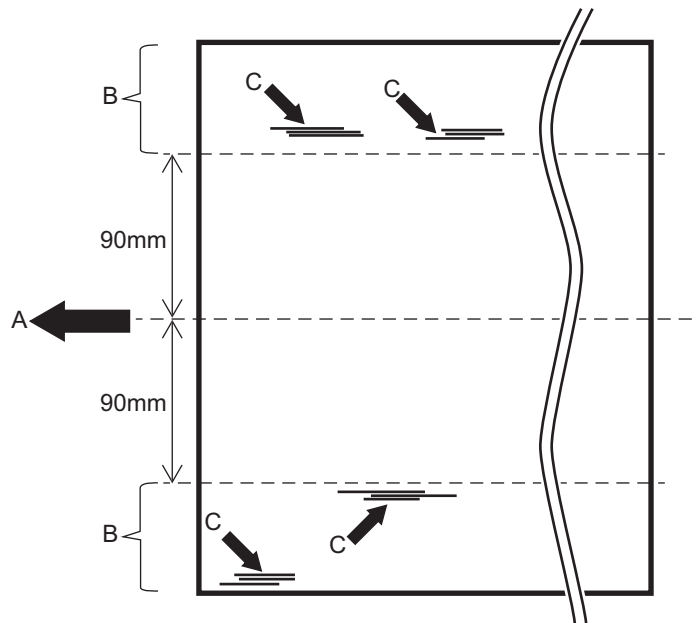


Fig.8-50



- A: Paper feeding direction
- B: Areas where the poor cleaning (image staining) frequently occurs
- C: Image staining

Countermeasure:

1. Change the setting of FS-08-9199 (Automatic interruption page number setting for printing). (Recommended value: 80)
2. Recommend the users to feed the paper in the A4 or LT direction if they frequently use paper of a narrow width, such as A4-R, LT-R or B5

**Notes:**

When a smaller value is set in FS-08-9199 (Automatic interruption page number setting for printing), a better cleaning effect can be obtained. However, the performance ability will be reduced since the number of the printing interruption times is increased. The interruption time of the printing is approx. 3 to 4 seconds per one time. However, this will vary depending on the models, environment and use status.

## 8.5.26 Uneven light distribution

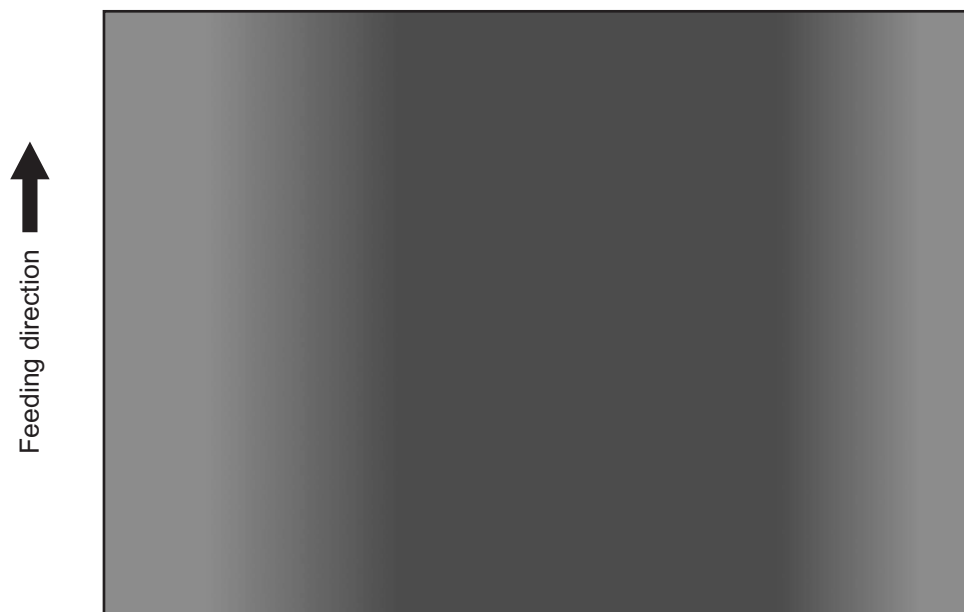


Fig.8-51

Cause/Section	Step	Check item	Measures
Original glass	1	Is the original glass dirty?	Clean the glass.
Main charger	2	Are the needle electrode, grid and case dirty?	Clean or replace them.
Discharge LED	3	Is the discharge LED dirty?	Clean it.
Scanner exposure lamp	4	Are the reflector, exposure lamp, mirrors, lens, etc. dirty?	Clean them.
	5	Is the exposure lamp tilted?	Adjust the installed position of the lamp.
	6	Is the lamp discolored or degraded?	Replace it.

## 8.5.27 Blotched image

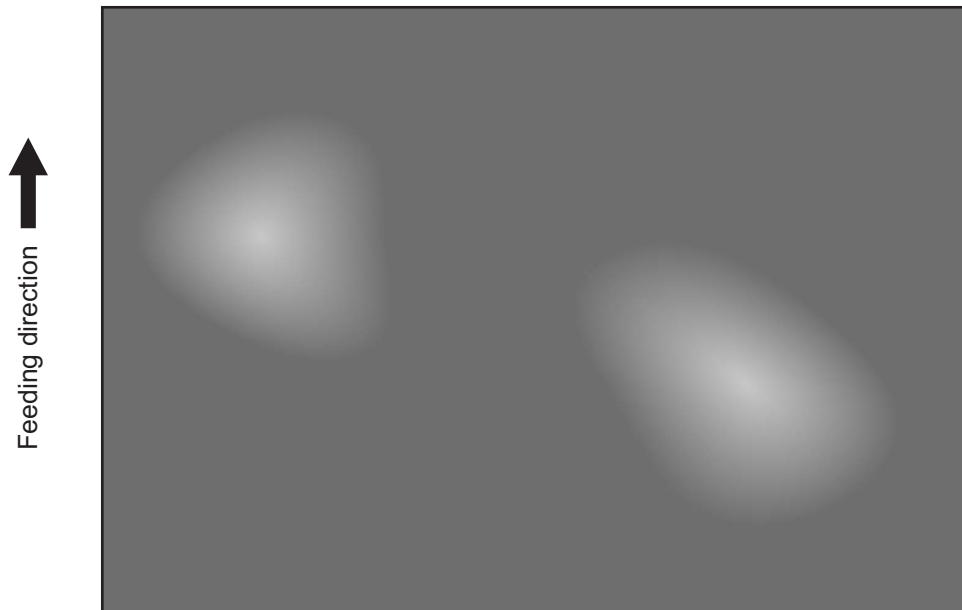


Fig.8-52

Cause/Section	Step	Check item	Measures
Paper	1	Is the paper type corresponding to its mode?	Check the paper type and mode.
	2	Is paper too dry?	Change paper.
Transfer unit	3	Is the transfer belt in proper contact with the drum?	Contact and release the transfer belt unit several times with the TBU lifting lever. Check that the 1st transfer roller is rotated smoothly upward and downward.
	4	Is the 2nd transfer roller in proper contact with the transfer belt?	Open and close the jam access cover. Check if there is any abnormality in the movement of the 2nd transfer roller pressure mechanism.
	5	Are there any abnormalities on the transfer belt?	Clean or replace the transfer belt.
High-voltage transformer (1st/2nd transfer roller bias)	6	Is the high-voltage transformer output abnormal?	Adjust the output. Replace the transformer, if necessary.

### 8.5.28 Stain on the paper back side

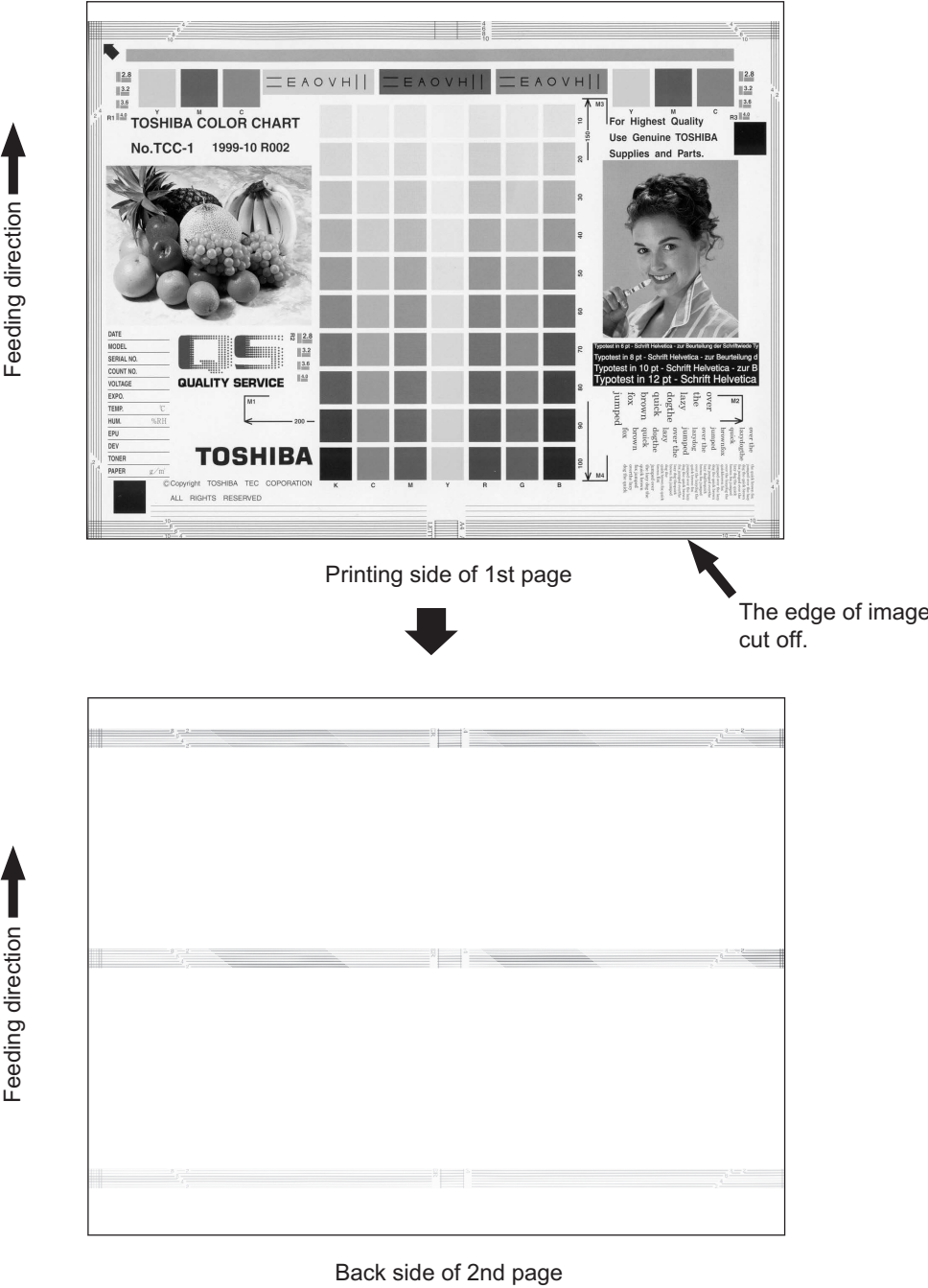
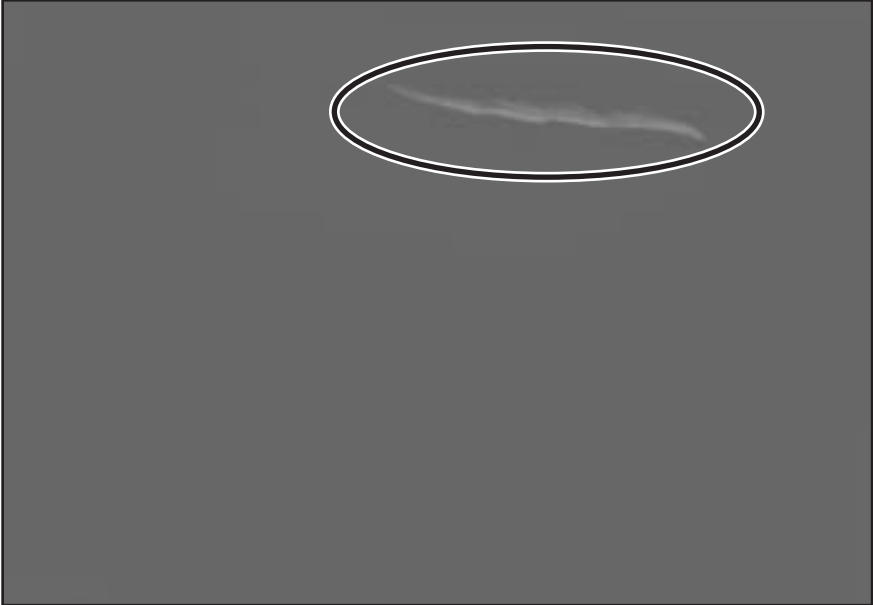


Fig.8-53

Cause/Section	Step	Check item	Measures
Image adjustment/ setting	1	Is the margin adjustment of image correct?	Adjust the margin.
	2	Is the margin adjustment of image correct when the paper size is not selected in bypass feeding?	Adjust the margin.
	3	Is the margin adjustment of image at duplexing correct?	Adjust the margin. (FS-05-4064-0 to 5)
	4	Is the image location in primary/ secondary scanning direction correct?	Adjust the location.
	5	Is the reproduction ratio of image in primary/secondary scanning direction correct?	Adjust the reproduction ratio.
	6	Is the tab setting correct?	Correct the setting.
Paper feeding /Transport area	7	Does the size of paper in the drawer or LCF correspond to the setting?	Use the appropriate paper size or correct the size setting.
	8	Is the width between the slides in the drawer correct (too wide)?	Correct the position of the slides.
	9	Is the width between the slides of the bypass tray correct (too wide)?	Correct the width.
	10	Is the paper aligning amount sufficient?	Adjust the aligning amount.
	11	Are the feed roller and transport roller dirty or worn out?	Clean or replace the rollers.
	12	Does the paper mode correspond to the paper type?	Use the appropriate paper type or paper mode.
	13	Using the recommended paper?	Use the recommended paper.
Transfer unit	14	Is there any stain caused by a poor cleaning, etc. on the transfer belt?	Clean the transfer belt.
	15	Is the transfer belt cleaning blade in proper contact with the transfer belt?	Take off the transfer belt and check if the transfer belt cleaning blade pressure spring and the pressure hook are installed properly.
	16	Is the 2nd transfer roller rotating properly?	Clean the area around the roller. Otherwise replace the roller.
	17	Is there any foreign matter or stain on the 2nd transfer roller?	Clean or replace the roller.
	18	Has the 2nd transfer roller reached to its PM life?	Replace the 2nd transfer roller.
Fuser unit	19	Are the fuser belt and pressure roller dirty? Is the back side of the paper stained?	Clean the fuser belt and pressure roller.
	20	Is the separation finger dirty?	Clean the separation finger.
	21	Is the rib of transport guide dirty?	Clean the rib.

**8.5.29 White void in the halftone**



← Feeding direction

Fig.8-54

Cause/Section	Step	Check item	Measures
Fuser unit	1	Installed position of the fuser unit	Loosen the 2 screws [2] on the fuser unit guide rail (front) [1]. Remove 1 screw [3]. Change its position to the adjustment hole [4] and move the fuser unit guide rail (front) [2] up or down. (Fig.8-55)
	2	The installation position of the fuser unit paper entrance guide	<p>Following are the adjustment procedure of the fuser unit paper entrance guide.(Fig.8-36)</p> <ol style="list-style-type: none"> <li>(1) Take off the fuser unit and remove its front and rear side covers from it.</li> <li>(2) Remove the 2 screws of the paper entrance guide [1], and then secure them to the holes next to the original ones.</li> <li>(3) Vertically move the paper entrance guide to the upper direction of the figure so that it is separated by approx. 0.5 mm from the fuser roller.</li> <li>(4) In the condition of step (3), check whether white void occurs or not.</li> <li>(5) If white void still persists, move the paper entrance guide by 0.1 to 0.2 mm to upward or downward.</li> </ol> <p><b>Notes:</b></p> <ol style="list-style-type: none"> <li>1. Be careful not to move the paper entrance guide too much, for this could cause paper wrinkling.</li> <li>2. If paper wrinkling does occur, return the position of the paper entrance guide to the condition of step (3).</li> </ol>

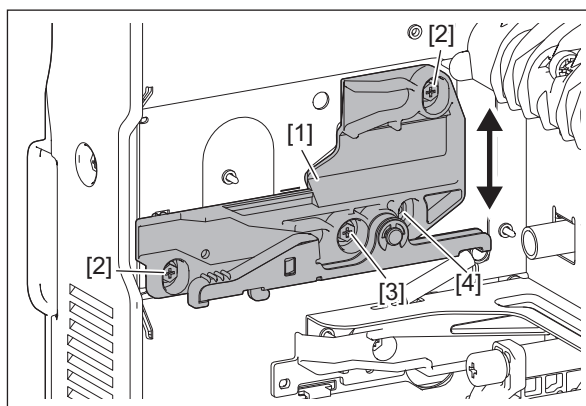


Fig.8-55



**Fig.8-56**



### 8.5.30 Paper wrinkle

There are 2 locations where the paper wrinkle occurs: before the fusing stage and in the fuser unit  
See below to determine the case.

Smooth out the wrinkled paper. When there is no image in the wrinkled area

→See (1) "Paper wrinkle before fusing".

Smooth out the wrinkled paper. When there is a copied image in the wrinkled area

→See (2) "Paper wrinkle in the fuser unit".

#### (1) Paper wrinkle before fusing

Is paper properly set?

| NO → Set paper properly.

↓

YES

Is there any abnormality such as scratch or wear on the transport roller?

| YES Replace the transport roller.

↓ →

NO


Is flexible paper such as recycled paper used?

| YES Switch to the recycled paper mode.

| → (Select "RECYCLED PAPER" in MEDIA TYPE.)

↓ If the paper wrinkle still appears, proceed to NO.

NO

1. Increase the adjustment value for the paper alignment.  
( P. 6-8 "6.1.6 Paper alignment at the registration roller")
2. Increase the transport motor speed. (Adjust it at the code FS-05-4532-0, 3, 4, 7.)

(2) Paper wrinkle in the fuser unit

Is the paper properly set?

| NO → Set the paper properly.

↓

YES

Has the paper absorbed moisture?

| YES → Use paper that has not absorbed moisture.

↓

NO

Is flexible paper such as recycled paper used?

| YES → Switch to the recycled paper mode.

|

(Select "RECYCLED PAPER" in MEDIA TYPE.)

↓

If the paper wrinkle still appears, proceed to NO.

NO

1. Adjust the installed position of the fuser unit up or down and check if the paper wrinkle disappears. (P. 8-420 "8.5.29 White void in the halftone")
2. Adjust the inlet guide[1] of the fuser unit and check if the paper wrinkle disappears. (Fig.8-57)



Fig.8-57

### 8.5.31 Staining at the leading/trailing edge

Staining may occur at the leading/trailing edge of the paper.

If a large amount of printing is carried out, staining may be seen as streaks as shown below.

Example: Leading edge of paper

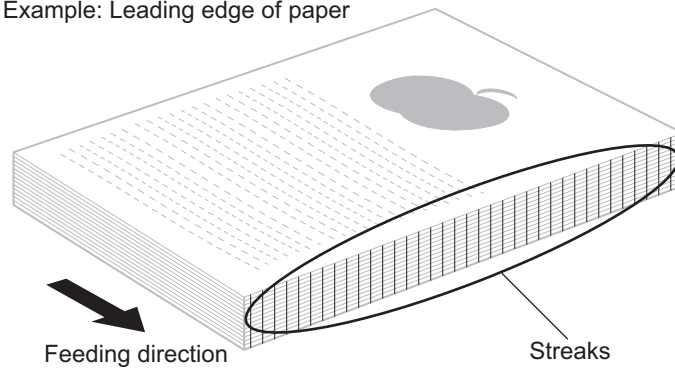


Fig.8-58

Cause/Section	Step	Check item	Measures
2nd transfer unit	1	Is there any toner adhering to the ribs of the transfer guide?	Clean the ribs of the transfer guide.
Image quality control unit	2	Is there any toner adhering to the ribs of the transfer guide?	Clean the ribs of the transfer guide.
Finisher	3	The coating material is applied to the grate-shaped guide?	Apply an adequate amount of coating material (SANKOL CFD-409M) to the grate-shaped guide.

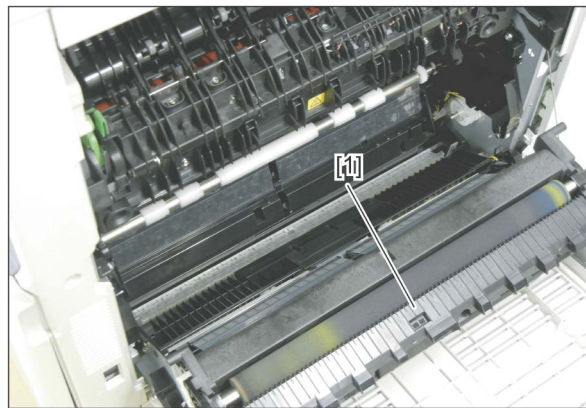


Fig.8-59

**Notes:**

Clean them with a soft pad, cloth or electric vacuum cleaner.

## 8.5.32 Faint image

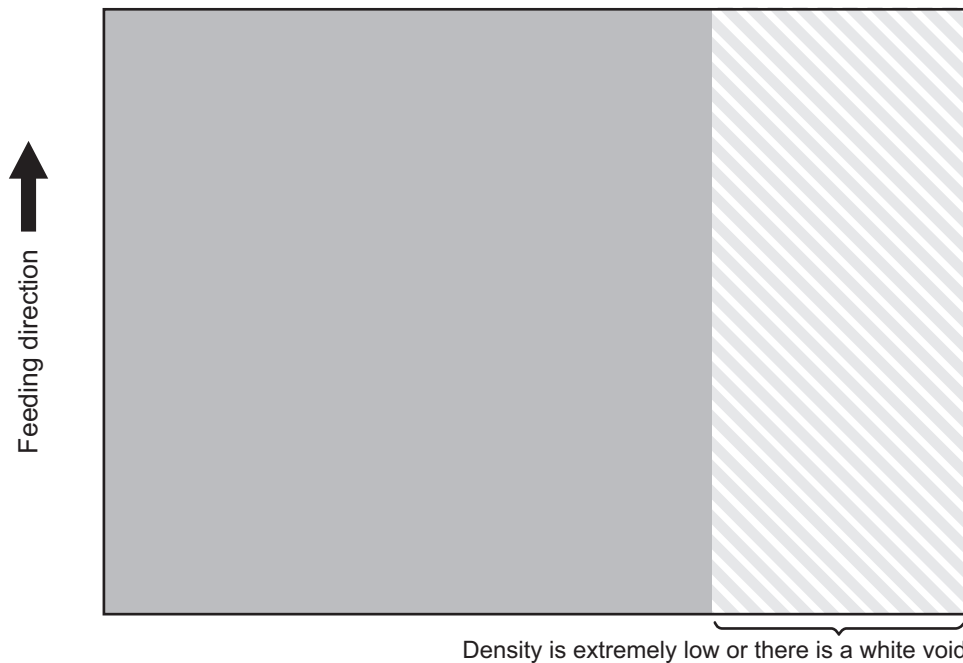


Fig.8-60

\* Checking is easier with a halftone (Y) test chart.

Cause/Section	Step	Check item	Measures
Transfer belt unit (TBU)	1	Are the drum and the transfer belt contacted?	Contact and release the transfer belt unit several times with the TBU lifting lever. Check that the 1st transfer roller is rotated smoothly upward and downward.
Process unit (EPU)	3	Is the contact between the drum and developer material proper?	Check the doctor-to-sleeve gap and pole position.
LED printer head	4	Is there foreign matter or dust on the LED printer head?	Clean the LED printer head.
	5	Is the problem resolved if you replace the LED printer head?	Replace the LED printer head.
Transfer unit (TRU)	6	Is 2nd transfer roller in proper contact with the transfer belt? (Is the roller tilted?)	Open and close the jam access cover. Check if there is any abnormality in the movement of the 2nd transfer roller pressure mechanism.
Electrical component	7	Check if the flat cable is short circuited or open circuited.	Replace the flat cable.

### 8.5.33 Toner scattering

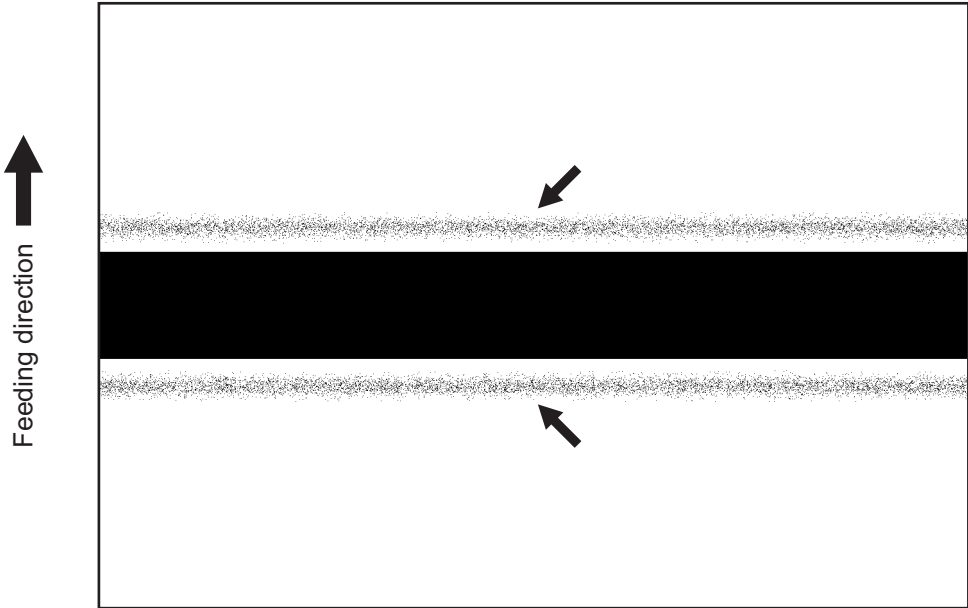
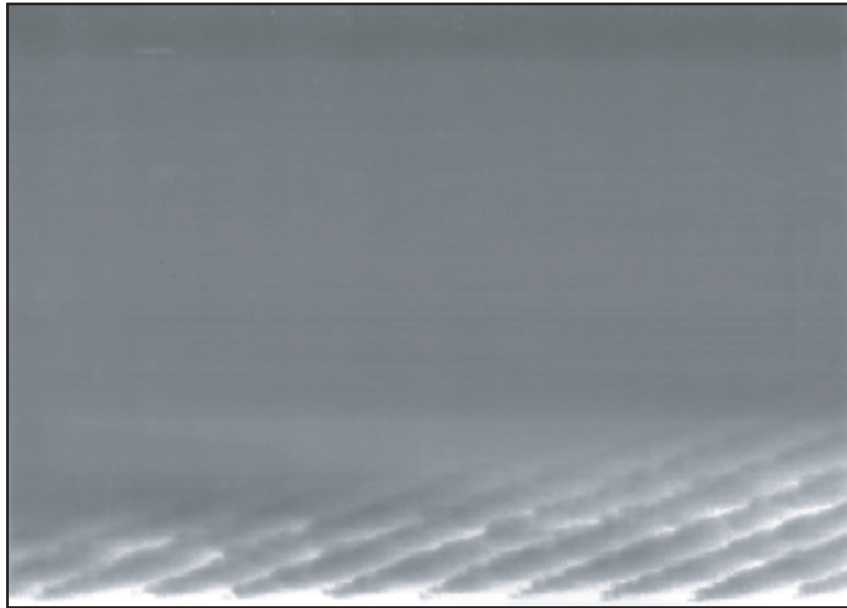


Fig.8-61

Cause/Section	Step	Check Item	Measure
Paper	1	Check if the paper type is set properly.	Set the paper type to be used properly.
Drawer / bypass tray	2	Is toner scattered when printing is performed on the back side of which front side has been printed?	When printing on the back side is performed, place the paper on the bypass tray and select the paper type and [Printed] in "Back Printed".

Cause/Section	Step	Check Item	Measure
2nd transfer	3	Is the recommended paper used?	<p>If not, change the values of FS-05-2934 to FS-05-2937 to adjust the 2nd transfer bias offset.</p> <p>Check the mode (color or monochrome) and the side (front or back). Set the value for each paper type so that the density of the image quality becomes the darkest.</p> <p><b>Notes:</b></p> <ul style="list-style-type: none"> <li>• After the setting has been changed, perform automatic gamma adjustment.</li> <li>• When the value is increased close to 10, white spots may occur. To avoid, this, perform the adjustment while checking the image.</li> <li>• When the value is reduced close to 0, poor transfer may occur. To avoid, this, perform the adjustment while checking the image.</li> </ul>

### 8.5.34 Feathered image



← Feeding direction

Fig.8-62

Cause/Section	Step	Check Item	Measure
Developer unit	1	Pole position adjustment plate	<p>Adjust the pole position adjustment plate. (Fig.8-63)</p> <ol style="list-style-type: none"> <li>1. Record or mark the scale position [2] indicated by the pole position adjustment plate [1].</li> <li>2. Remove 1 screw [3] and take off the pole position adjustment plate [1].</li> <li>3. Cut out the pin [4] fixing the pole position adjustment plate.</li> <li>4. Turn the pole position adjustment plate [1] counterclockwise (in the direction of the black arrow) by 3 scales.</li> </ol>

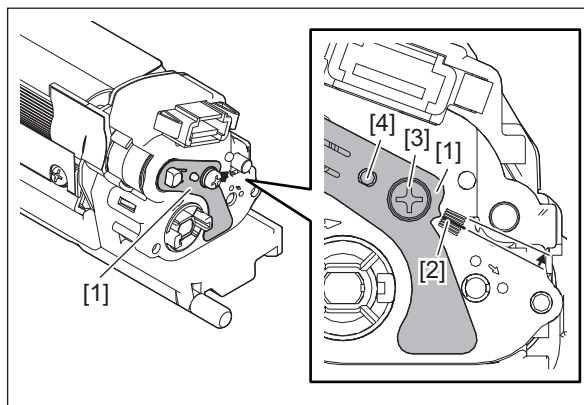


Fig.8-63

**Notes:**

- Check the image after the pole position is adjusted.

### 8.5.35 Image Skewing on Paper Trailing Edge

When a grid pattern is output, follow the procedure below if the image on the paper trailing edge is skewed by 1.0 mm or more.

[A] The rear side in the secondary scanning direction is longer than the front side. (Front < Rear)

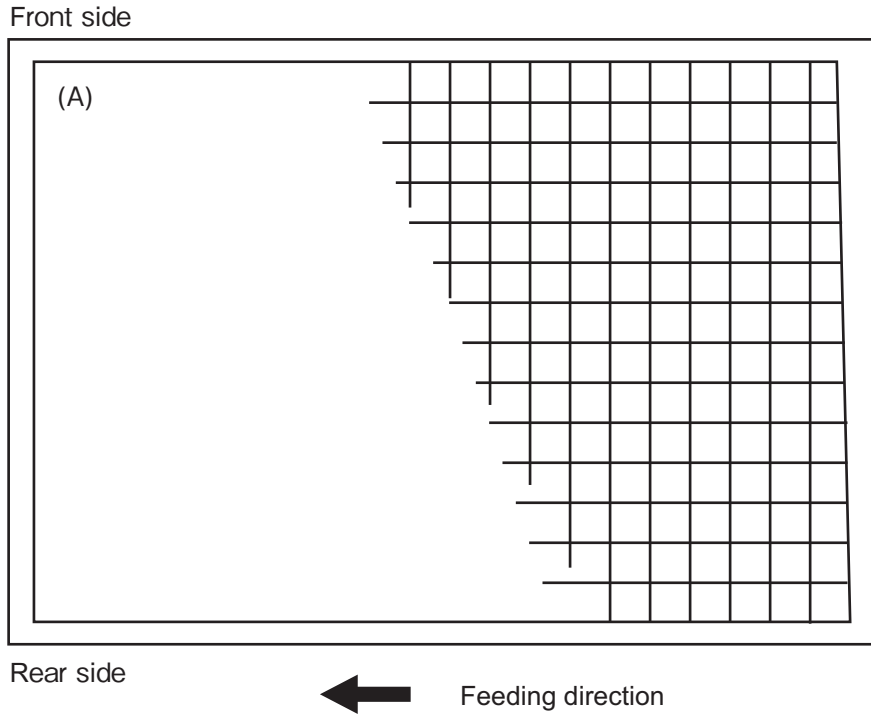


Fig.8-64

Cause/Section	Step	Check Item	Measure
Fuser unit	1	Fuser unit guide rail	Adjust the fuser unit guide rail(Fig.8-65 ) 1. Take off the fuser unit. 2. Loosen the 2 fixing screws [2] of the front guide rail [1] in the fuser unit. 3. Remove 1 screw [3] and attach it to the screw hole for adjustment [4]. 4. Move the guide rail upward by 1 mm. * Moving it by 1 mm changes the screw in the trailing edge by 0.65 mm. * There is a 1-mm scale [5]. 5. Tighten the 2 fixing screws [2] of the front guide rail [1] in the fuser unit. 6. Install the fuser unit. * Check that the image on the paper trailing edge is skewed by 1 mm or less after the adjustment.



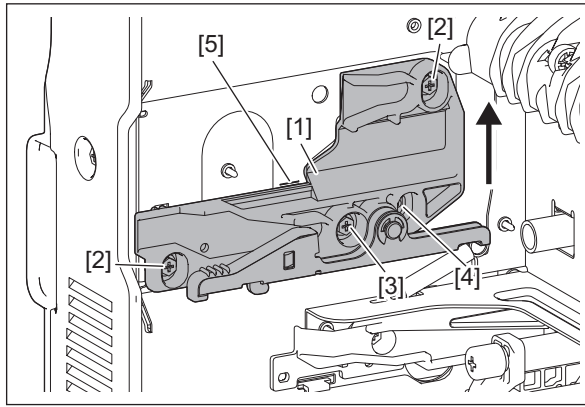


Fig.8-65

[B] The front side in the secondary scanning direction is longer than the rear side. (Front > Rear)

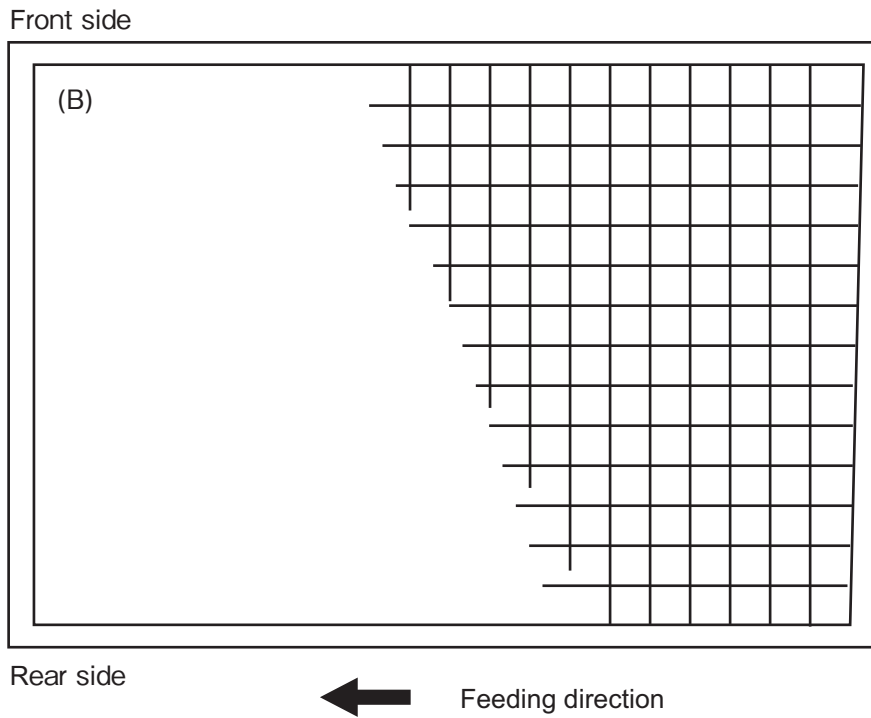


Fig.8-66

Cause/Section	Step	Check Item	Measure
Fuser unit	1	Fuser unit guide rail	<p>Adjust the fuser unit guide rail(Fig.8-67 )</p> <ol style="list-style-type: none"> <li>1. Take off the fuser unit.</li> <li>2. Loosen the 2 fixing screws [2] of the front guide rail [1] in the fuser unit.</li> <li>3. Remove 1 screw [3] and attach it to the screw hole for adjustment [4].</li> <li>4. Move the guide rail downward by 1 mm. <ul style="list-style-type: none"> <li>* Moving it by 1 mm changes the screw in the trailing edge by 0.65 mm.</li> <li>* There is a 1-mm scale [5].</li> </ul> </li> <li>5. Tighten the 2 fixing screws [2] of the front guide rail [1] in the fuser unit.</li> <li>6. Install the fuser unit.</li> </ol> <p>* Check that the image on the paper trailing edge is skewed by 1 mm or less after the adjustment.</p>

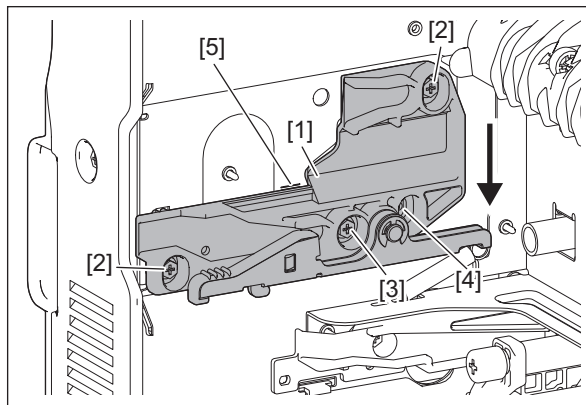


Fig.8-67

## 8.5.36 If an image-related problem continues after performing all troubleshooting

If an image-related problem continues even after performing all the troubleshooting, an abnormal value may have been entered in the self-diagnostic code. In such a case, attempt the initialization of the self-diagnostic code in accordance with the table below.

Notes:


- Perform the list print before the initialization.
- Initialization should be performed only for the function in which the image-related problem has occurred.
- The self-diagnostic code which will be initialized is related to the image adjustment. Therefore, only problems which have occurred during the image processing can be solved. If a cause of the problem is related to the hardware or other system issues, it will not be able to be solved even if the initialization of the self-diagnostic code is performed.

Function	Self-diagnostic code to be initialized	Precautions
Copying	FS-08-7000	After the initialization has been carried out, perform automatic gamma adjustment.
Printing	FS-08-7300	After the initialization has been carried out, perform automatic gamma adjustment (600 dpi and 1200 dpi).
Scanning	FS-08-7400	None
Scanning	FS-08-7500	None



## 9. REPLACEMENT OF PC BOARDS/HDD

### 9.1 Removal and Installation of PC Boards/HDD

#### Notes:

When the PC board/HDD is replaced, refer to the respective Notes and Cautions of "Replacement of PC boards and HDD" in  P. 9-14 "9.2 Precautions, Procedures and Settings for Replacing PC Boards and HDD".

#### 9.1.1 SYS board cover

- (1) Take off the rear cover.  
 P. 4-6 "4.1.15 Rear cover"
- (2) Take off the right rear cover.  
 P. 4-5 "4.1.11 Right rear cover"
- (3) Remove 1 screw and take off the SYS board cover [1] by sliding it toward the right side.

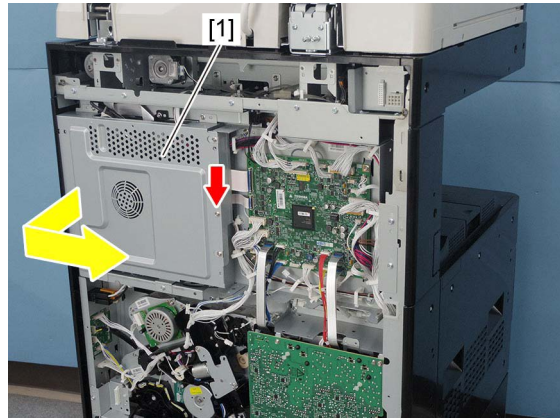



Fig. 9-1

#### 9.1.2 SYS board cooling fan (F1)

- (1) Remove the SYS board cover.  
 P. 9-1 "9.1.1 SYS board cover"
- (2) Disconnect 1 connector and lift up 2 latches. Then, remove the SYS board cooling fan [1] by sliding it out toward the rear side.

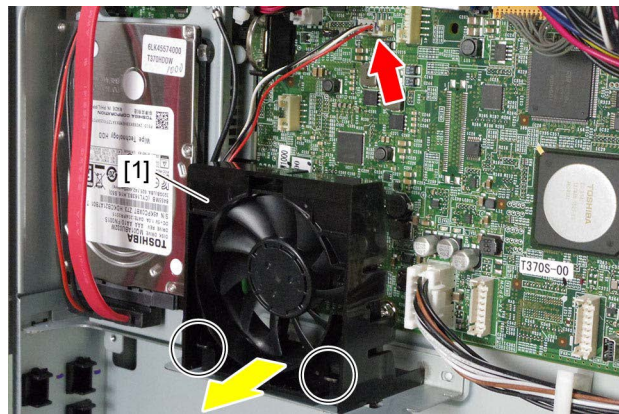



Fig. 9-2

### 9.1.3 Hard disk (HDD)

- (1) Take off the SYS board cover.  
 P. 9-1 "9.1.1 SYS board cover"
- (2) Remove 4 screws and disconnect 2 connectors [1], and then take off the HDD unit [2].

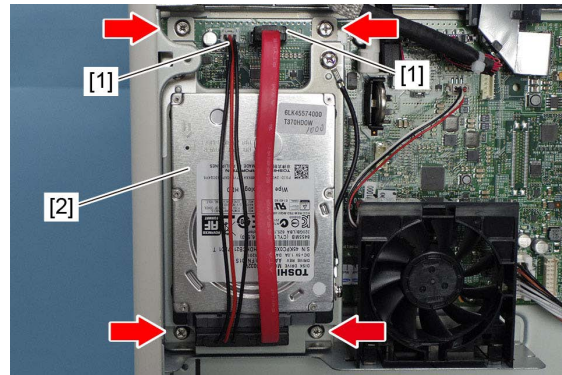


Fig. 9-3

- (3) Loosen 4 screws.

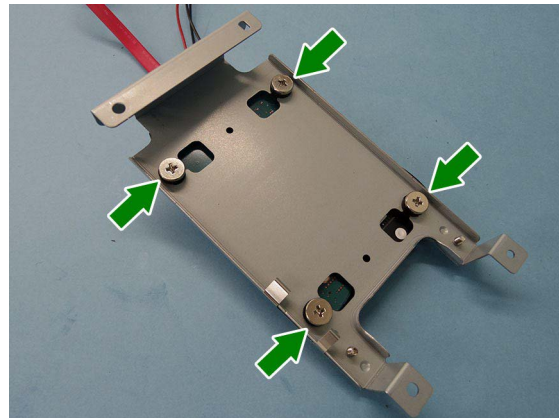


Fig. 9-4

- (4) Remove 2 screws and disconnect the ground cable [3]. Take off the hard disk [4] from the bracket.

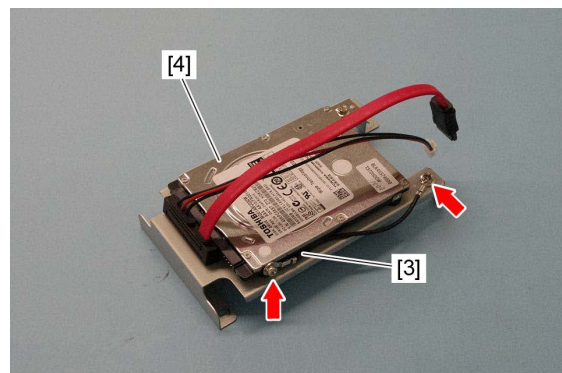


Fig. 9-5

## 9.1.4 SYS board

### Notes:

- When the SYS board or main memory has been replaced, be sure to perform the calibration of memory.
- When performing the calibration of memory, turn the power ON while pressing the [ENERGY SAVER] button.
- When the equipment is started up normally, the calibration has been completed.
- If the calibration is not performed, the equipment may be not started up normally.

- (1) Take off the SYS board cover.  
📖 P. 9-1 "9.1.1 SYS board cover"
- (2) Remove the HDD unit.  
📖 P. 9-2 "9.1.3 Hard disk (HDD)"
- (3) Remove the SYS board cooling fan.  
📖 P. 9-1 "9.1.2 SYS board cooling fan (F1)"
- (4) Remove 1 screw and take off the harness holder [1].

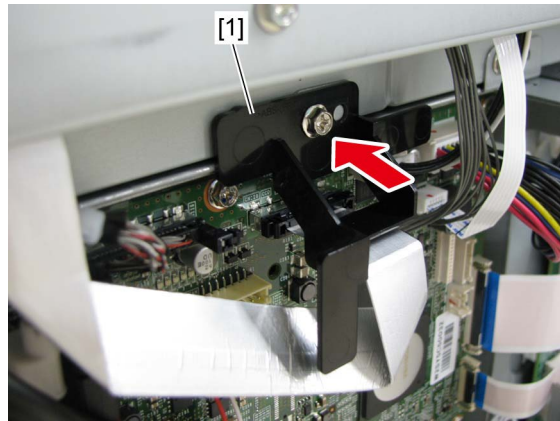


Fig. 9-6

- (5) Release the lock by pushing the both sides of the connector, remove the flat cable [2].

### Notes:

- When installing the flat cable [2], be careful not to insert it at an angle.
- Do not apply pressure to or damage the edge of the flat cable [2].

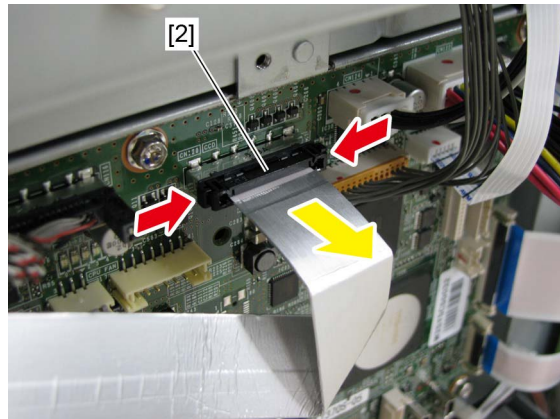


Fig. 9-7

- (6) Disconnect 10 connectors from the SYS board. Release the lock by pushing the actuator and remove 2 flat cables [3].

**Notes:**

- When installing the harnesses, be careful not to connect each different USB harness.

CN112: White USB harness

(The harness of the control panel)

CN113: Black USB harness

(The harness of the USB Hub board)

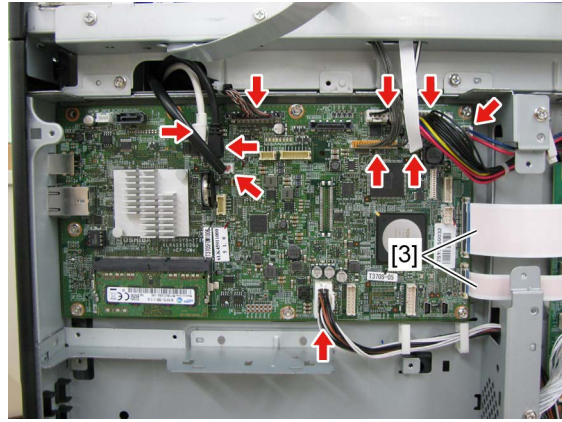


Fig. 9-8

- When removing the flat cable [3], pull out the actuator [4] while pushing it.
- When connecting the flat cable [3] to the actuator [4], connect it until a click sound is heard.

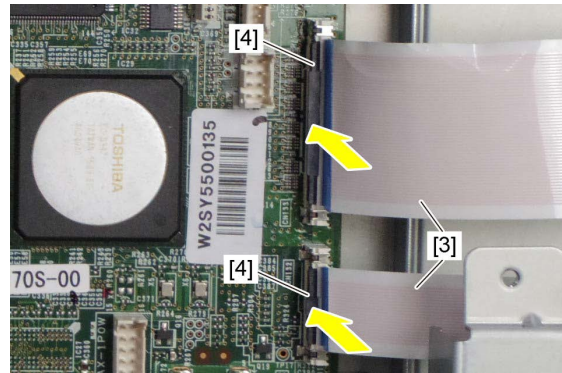


Fig. 9-9

- When installing the flat cable [3], do not push it in strongly.
- When installing the flat cable [3], be careful not to insert it at an angle.
- Do not apply pressure to or damage the edge of the flat cable [3].

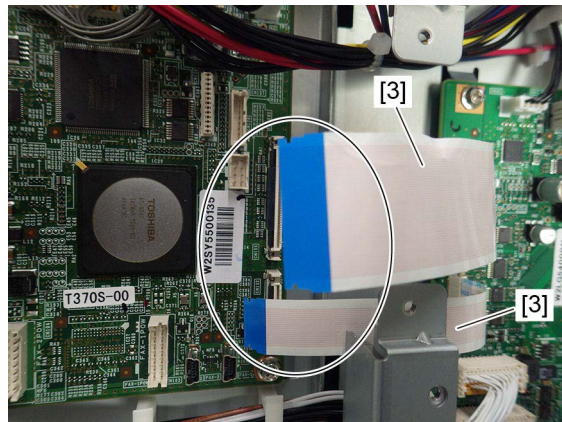


Fig. 9-10

- (7) Remove 6 screws and take off the SYS board [5].

**Notes:**

When attaching the SYS board, tighten the screw [6] first.

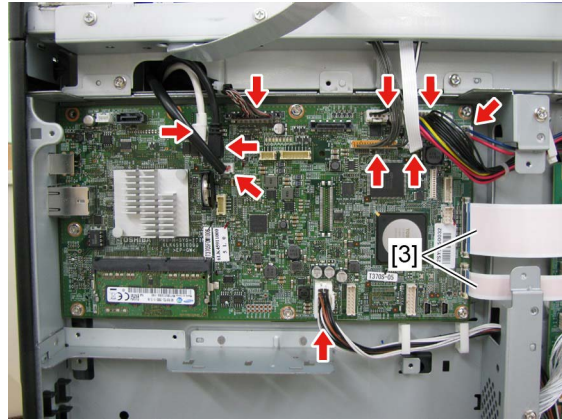


Fig. 9-11

**Notes:**

The SYS board to be installed differs depending on the models. Due to this, before replacing, be sure to check the color of the identification label on the SYS board to install the corresponding one in the equipment.

- White

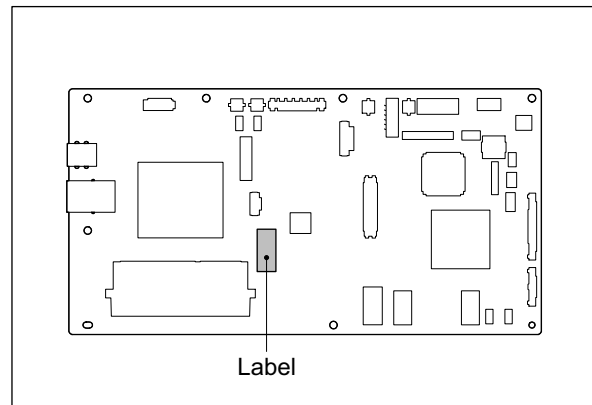



Fig. 9-12

### 9.1.5 LGC board

- (1) Take off the rear cover.  
 P. 4-6 "4.1.15 Rear cover"
- (2) Disconnect 21 connectors from the LGC board.

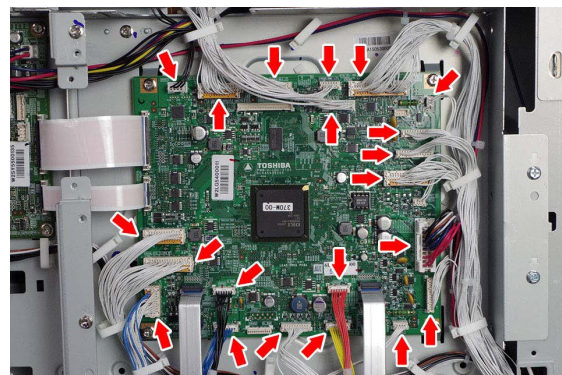


Fig. 9-13



- (3) Release the lock by pushing the actuator and remove 2 flat cables [1].

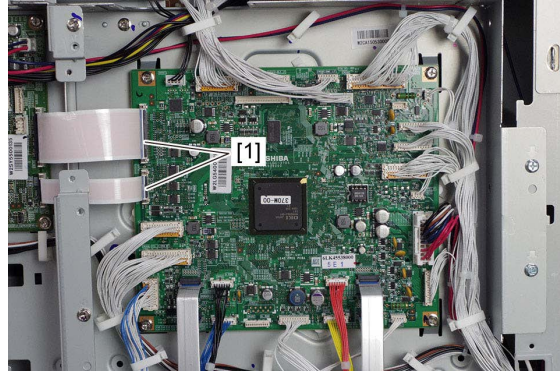


Fig. 9-14

**Notes:**

- When removing the flat cable [1], pull out the actuator [2] while pushing it.
- When connecting the flat cable [1] to the actuator [2], connect it until a click sound is heard.

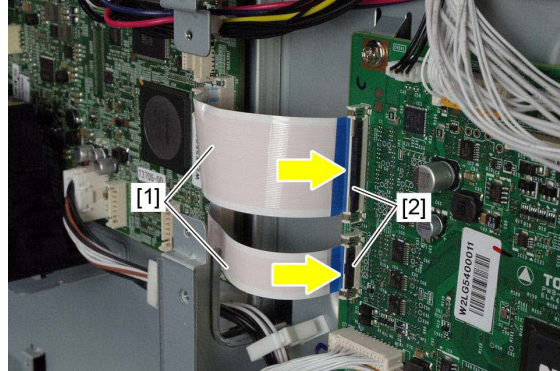


Fig. 9-15

**Notes:**

- When installing the flat cable [1], do not push it in strongly.
- When installing the flat cable [1], be careful not to insert it at an angle.
- Do not apply pressure to or damage the edge of the flat cable [1].

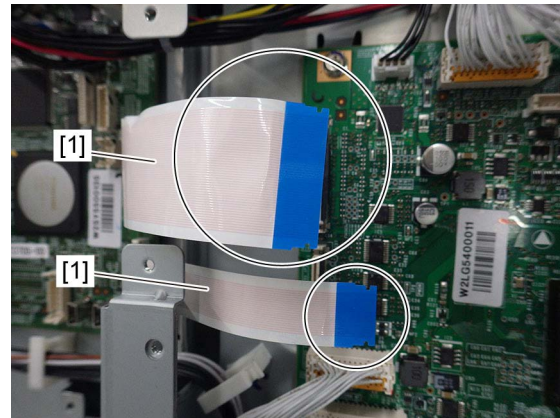


Fig. 9-16

- (4) Release the lock by tilting the flap and remove 4 flat cables [3].

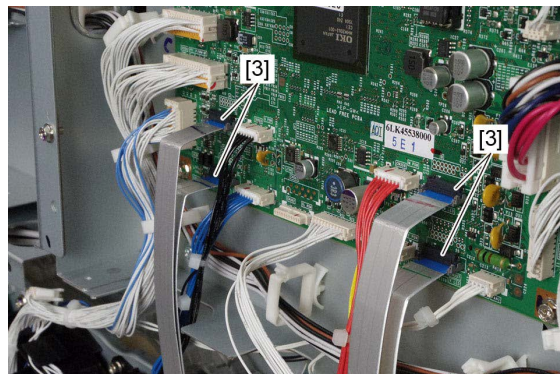
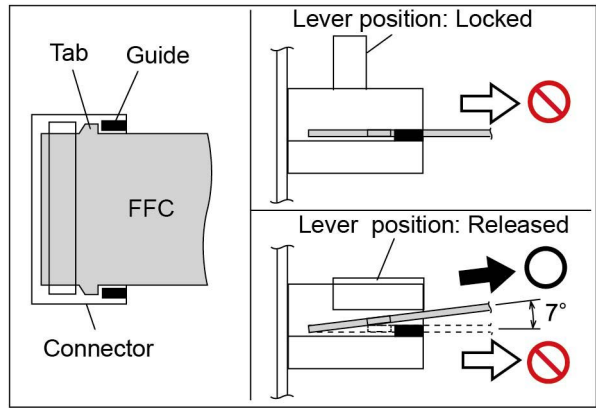


Fig. 9-17

**Notes:**

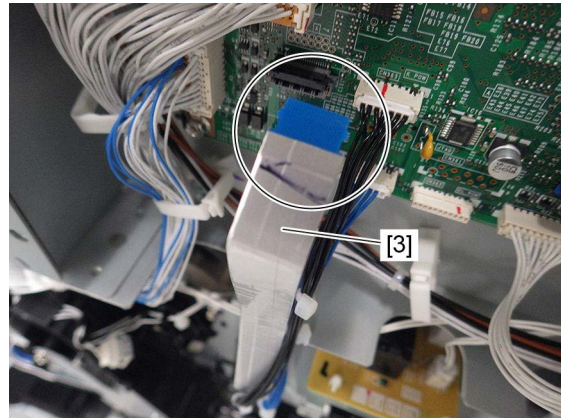
- When removing the flat cable [3], change the lever position so that the connector is released, and remove the flat cable by lifting it up slightly (approx. 7 degrees) as shown in the right figure.
- When connecting the flat cable [3] to the connector, insert the flat cable straightly and lock it securely. Confirm that the tabs are in the positions shown in the right figure.



**Fig. 9-18**

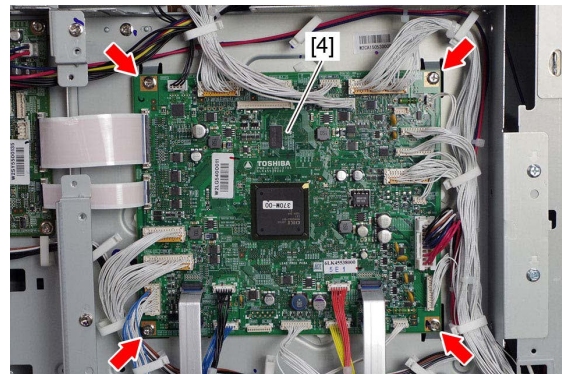
**Notes:**

- When installing the flat cable [3], do not push it in strongly.
- When installing the flat cable [3], be careful not to insert it at an angle.
- Do not apply pressure to or damage the edge of the flat cable [3].



**Fig. 9-19**

- (5) Remove 4 screws and take off the LGC board [4].



**Fig. 9-20**

**Notes:**

Check if the model of the equipment matches the color of the label on the LGC board.

<Color of label>

- 20 ppm: White
- 25 ppm: Yellow

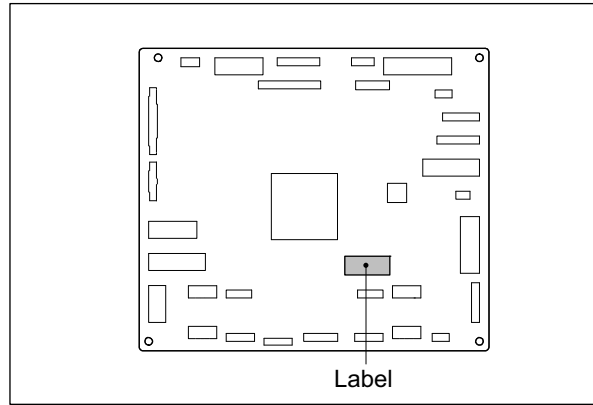


Fig. 9-21

### 9.1.6 Switching regulator

**Notes:**

- Be sure to unplug the power cable before starting this work.
- Static electricity may remain in the capacitors on the switching regulator even if the main power is turned off and the plug is disconnected.
- Since there is a risk of an electric shock, pay full attention not to touch the board and mounted parts while handling the switching regulator.

- (1) Take off the left cover.  
 P. 4-1 "4.1.2 Left cover"
- (2) Remove 2 screws and slide the switching regulator [1] slightly toward you.

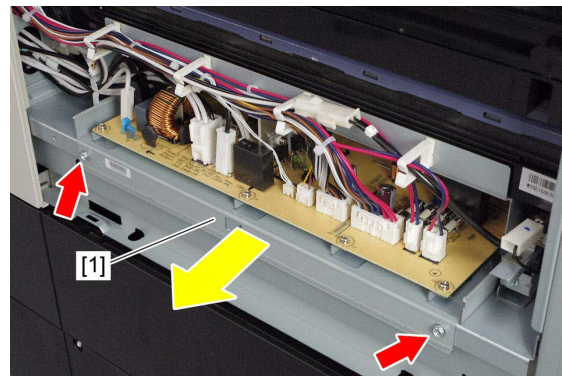


Fig. 9-22

- (3) Disconnect 11 connectors, and slide the switching regulator [1] to the front side and take it off.

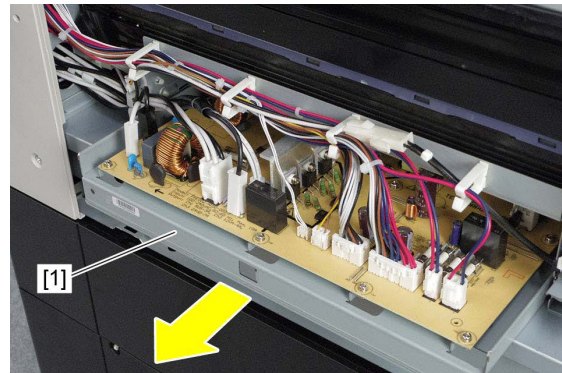



Fig. 9-23

## 9.1.7 High-voltage transformer (HVT)

### Notes:

- Be sure to unplug the power cable before starting this work.

- (1) Take off the rear cover.  
 P. 4-6 "4.1.15 Rear cover"
- (2) Remove 5 screws and release 4 locking supports [1].

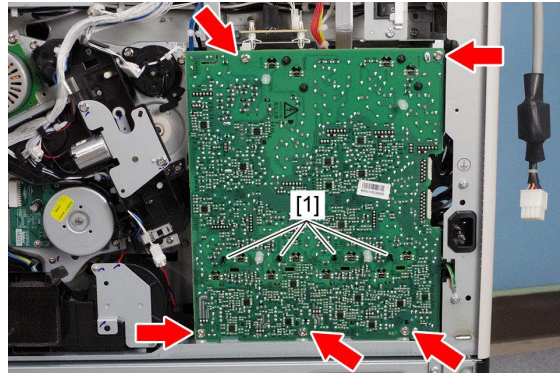


Fig. 9-24

- (3) Disconnect 2 connectors and take off the high-voltage transformer [2].

### Notes:

When installing, match the frame with the concave portion of the high-voltage transformer, and then push it until the supports are locked.

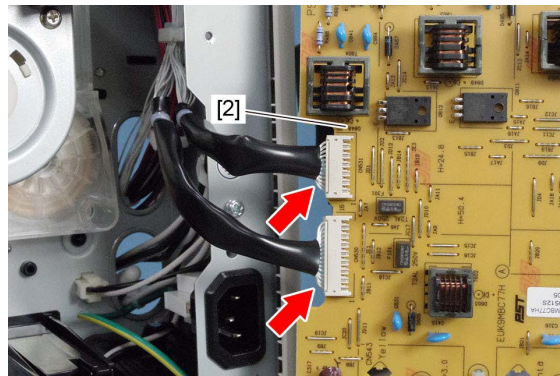


Fig. 9-25

### Notes:

When installing the high-voltage transformer, make sure the feed springs contact the plastic (locator) pins as shown in the figure.

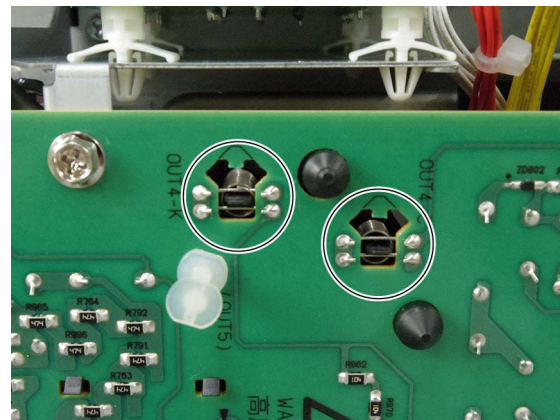



Fig. 9-26

## 9.1.8 SRAM

- (1) Take off the HDD unit.  
 P. 9-2 "9.1.3 Hard disk (HDD)"
- (2) Remove the SRAM [1] from the SYS board.

### Notes:

- Be careful not to damage the SRAM when removing the SRAM from the SYS board.
- When installing the SRAM, pay attention to the orientation. Install the SRAM with its concave portion up.

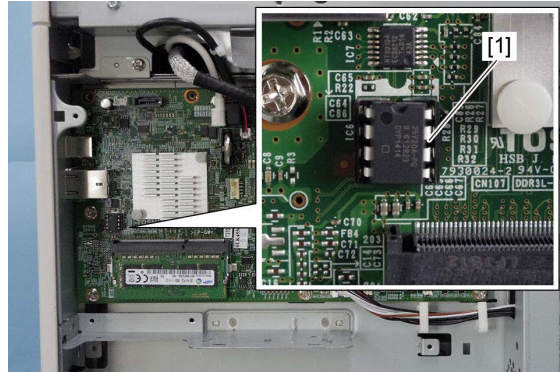




Fig. 9-27

## 9.1.9 Main memory (DIMM)

### Notes:

- When the SYS board or main memory has been replaced, be sure to perform the calibration of memory.
- When performing the calibration of memory, turn the power ON while pressing the [ENERGY SAVER] button.
- When the equipment is started up normally, the calibration has been completed.
- If the calibration is not performed, the equipment may be not started up normally.

- (1) Remove the SYS board cooling fan.  
 P. 9-1 "9.1.2 SYS board cooling fan (F1)"
- (2) Take off the HDD unit.  
 P. 9-2 "9.1.3 Hard disk (HDD)"
- (3) Release 2 latches and remove the main memory [1].

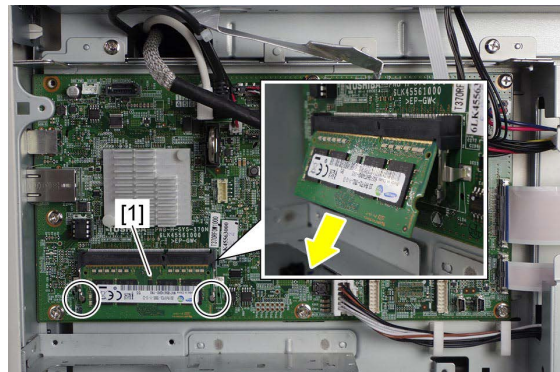



Fig. 9-28

## 9.1.10 EEPROM

- (1) Take off the rear cover.  
 P. 4-6 "4.1.15 Rear cover"
- (2) Remove the EEPROM [1] from the LGC board.

### Notes:

- Be careful not to damage the EEPROM when replacing the EEPROM.
- When installing the EEPROM, pay attention to the orientation. Install the EEPROM with its concave portion left.

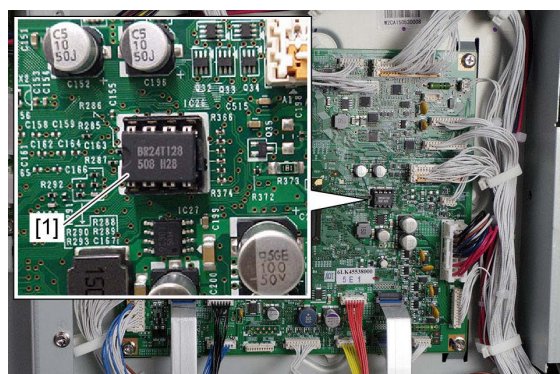


Fig. 9-29

### 9.1.11 CFD board

- (1) Take off the rear cover.  
📖 P. 4-6 "4.1.15 Rear cover"
- (2) Take off the right rear cover.  
📖 P. 4-5 "4.1.11 Right rear cover"
- (3) Disconnect 4 connectors from the CFD board.

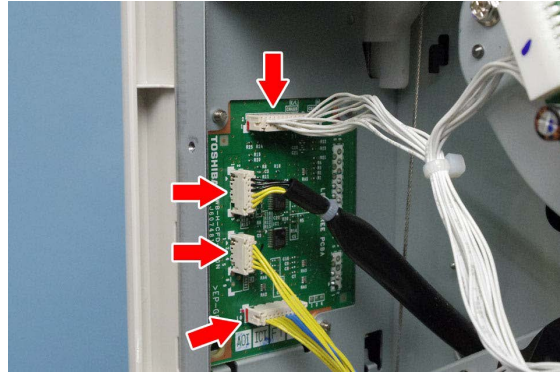


Fig. 9-30

- (4) Disconnect 2 connectors [1], remove 3 screws and take off the CFD board [2].

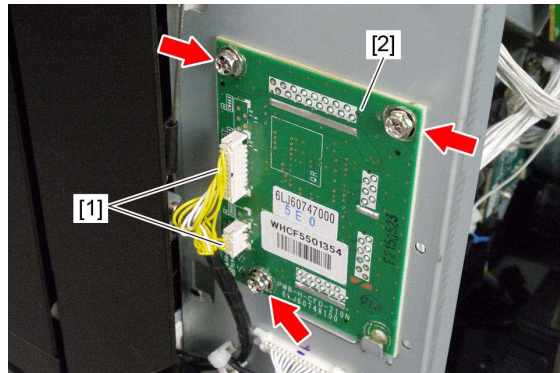


Fig. 9-31

### 9.1.12 CTIF board

- (1) Remove the toner motor assembly.  
📖 P. 4-103 "4.6.29 Toner motor assembly"
- (2) Disconnect 4 connectors, release 4 latches, and take off the CTIF board [1].

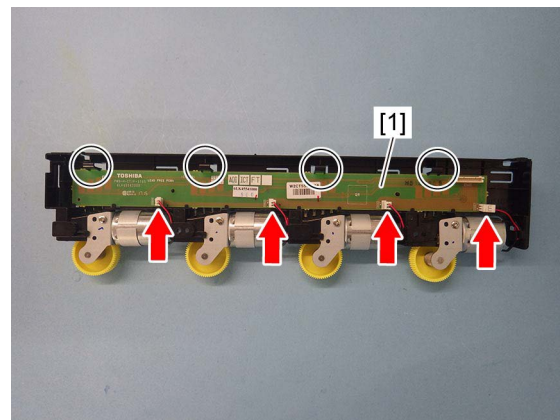




Fig. 9-32

### 9.1.13 DAMP board

#### Notes:

- Be sure to unplug the power cable before starting this work.
- If the DAMP board is not installed appropriately, a serious accident such as an electric shock may occur. Therefore, to avoid this, be sure to perform correct handling and installation.

- (1) Remove the rear cover.  
 P. 4-6 "4.1.15 Rear cover"
- (2) Remove the high-voltage transformer.  
 P. 9-9 "9.1.7 High-voltage transformer (HVT)"
- (3) Disconnect 3 connectors [1] from the LGC board. Remove 2 flat cables [2].

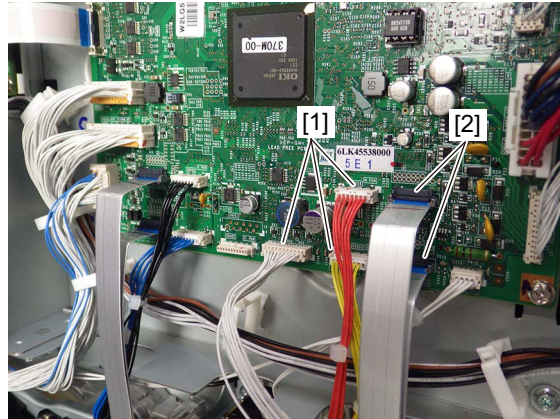


Fig. 9-33

- (4) Move the harness guide [3] downward toward you.

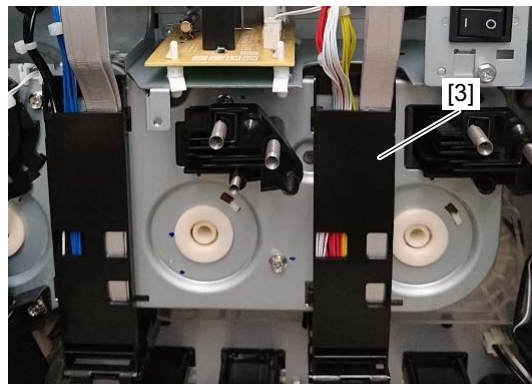


Fig. 9-34

- (5) Remove 2 screws of the bracket fixing the DAMP board and pull out the bracket toward you.

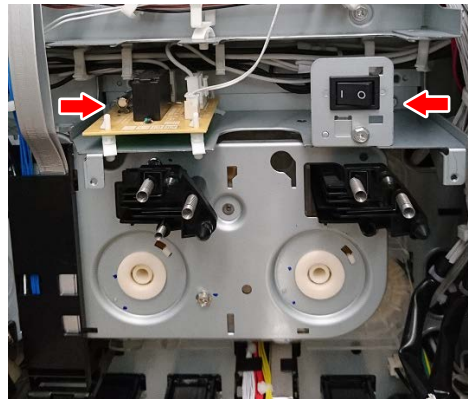


Fig. 9-35

- (6) Disconnect 3 connectors from the DAMP board [4]. Release 4 locking supports and remove the DAMP board [4].

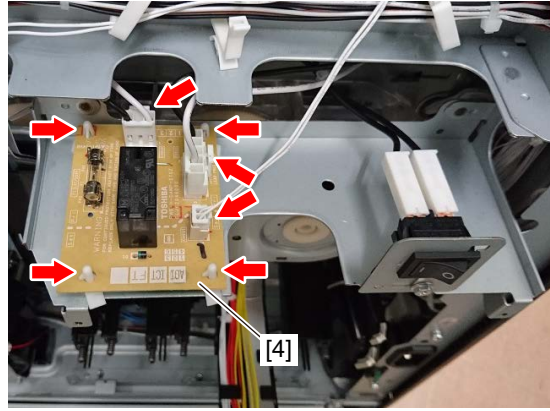






Fig. 9-36



## 9.2 Precautions, Procedures and Settings for Replacing PC Boards and HDD

### 9.2.1 Precautions when replacing PC boards

- The ID for each equipment is registered on the LGC board, the SYS board and Lens unit. So, if their replacement is required, be sure to replace only one board at a time. Do not replace the SYS board and the SRAM together.
- If both the LGC board and SYS board require replacement, replace them in the following procedure.
  1. First, replace one of the board to be replaced.
  2. Turn the power ON and confirm that "READY" is displayed.
  3. Turn the power OFF.
  4. Replace another board that requires replacement.
- When replacing the LGC board, remove the EEPROM on the old board, and then attach it to the new board.
- When the HDD requires replacement, see  P. 9-17 "9.2.3 Precautions and procedures when replacing the HDD".
- When the SYS board requires replacement, see  P. 9-21 "9.2.4 Precautions and procedures when replacing the SYS board".
- When the Lens unit requires replacement, see  P. 9-33 "9.2.8 Procedures and settings when replacing the Lens unit".
- When SRAM requires replacement, see  P. 9-25 "9.2.5 Precautions and procedure when replacing the SRAM".

## 9.2.2 HDD fault diagnosis

This code displays the HDD operation history, which is recorded in the HDD, on the control panel. HDD failure can be diagnosed or predicted with the information displayed.

### 1. Display

The following screen is displayed with setting code FS-08-9065. You can also refer to the same information by perform HS-75 → [SMART Info]

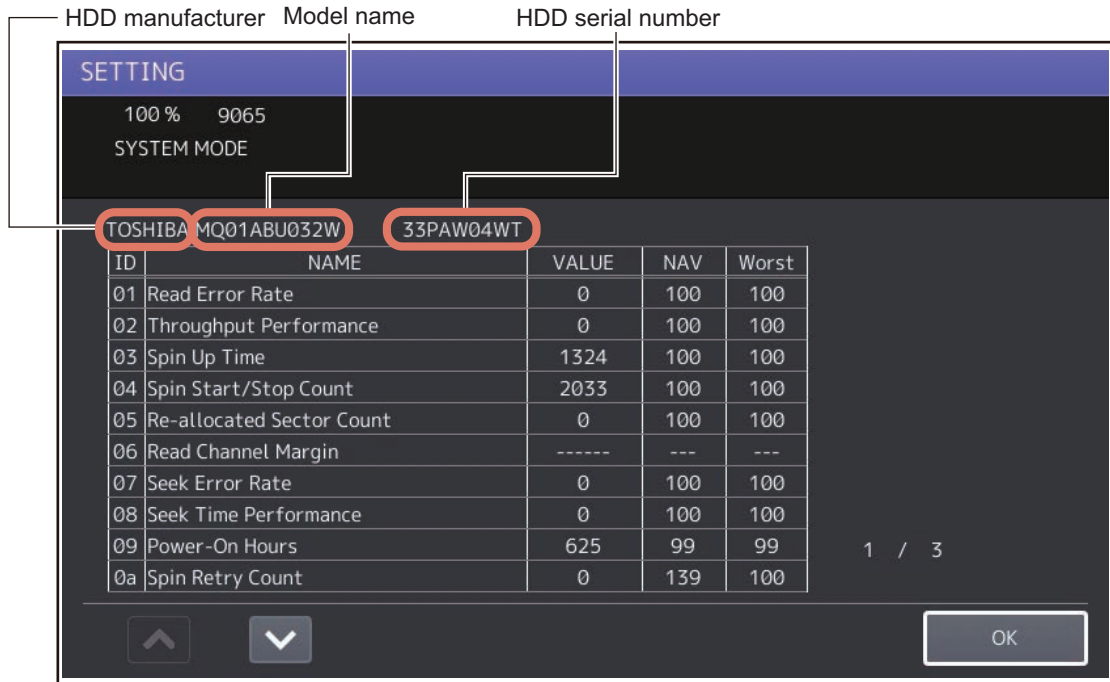


Fig. 9-37

- Items supported differ depending on the HDD manufacturer.
- “---” is displayed on the VALUE, NAV and Worst columns if items are not supported.

### 2. Usage

The combination of the values of ID=05 and c5 is used to diagnose whether or not the HDD has a physical failure when HDD failure is suspected (service call F100 - F109 or F120 or F124 occurred).

Result		Description	Diagnosis
ID	VALUE		
05	0	Low possibility of physical failure	HDD replacement is not required.
c5	0		
05	From 1 to 999	Defective sector has been reassigned and HDD is recovered.	HDD replacement is not required.
c5	0		
05	Any value	High possibility of defective sector existence. (There will be a possibility of physical failure depending on the use of HDD.)	HDD replacement is recommended.
c5	1 or more		
05	Either one is at least 1000.	High possibility of physical failure	HDD replacement is recommended.
c5			
05	All values are displayed as “-----”.	High possibility of physical failure (A HDD connector, harness or SYS board may be one of the causes.)	HDD replacement is recommended.
c5			

3. ID=05 and c5

ID	Name	Description	Remarks
05	Re-allocated Sector Count	The number of sectors reassigned	This value tends to increase at HDD failure.
c5	Current Pending Sector Count	The number of candidate sectors to be reassigned	This value tends to increase at HDD failure.

4. Description of each ID

ID	Name	Meaning
01	Read Error Rate	This attribute is a measure of the read error rate.
02	Throughput Performance	This attribute is a measure of the throughput performance.
03	Spin Up Time	This attribute is a measure of how quickly the drive is able to spin up from a spun down condition.
04	Spin Start/Stop Count	This attribute is a measure of the total number of spin ups from a spun down condition.
05	Re-allocated Sector Count	This attribute is a measure of the total number of reallocated sectors.
07	Seek Error Rate	This is a measure of the seek error rate.
08	Seek Time Performance	This attribute is a measure of a drive's seek performance during normal online operations.
09	Power-On Hours	This attribute is a measure of the total time (hours or minutes depending on disk manufacturer) the drive has been on.
0a	Spin Retry Count	This attribute is a measure of the total number of spin retries.
0c	Power Cycle Count	This attribute is a measure of the number of times the drive has been turned on.
c0	Power off Retract Count	This attribute is a measure of the total number of emergency unloads.
c1	Load Cycle Count	This attribute is a measure of the total number of load/unloads.
c2	Temperature	This attribute is a measure of the temperature in the HDD.
c3	ECC On the Fly Count	This attribute is a measure of the total number of the ECC On the Fly.
c4	Reallocation Event Count	This attribute is a measure of the total number of the reallocation events.
c5	Current Pending Sector Count	This attribute is a measure of the total number of candidate sectors to be reallocated.
c6	Off-Line Scan Uncorrectable Sector Count	This attribute is a measure of the total number of uncorrectable sectors found during the off-line scan.
c7	Ultra DMA CRC Error Count (Rate)	This attribute is a measure of the total number of errors found in data transfer in the Ultra-DMA mode.
c8	Write Error Rate	This attribute is a measure of the write error rate.

**Notes:**

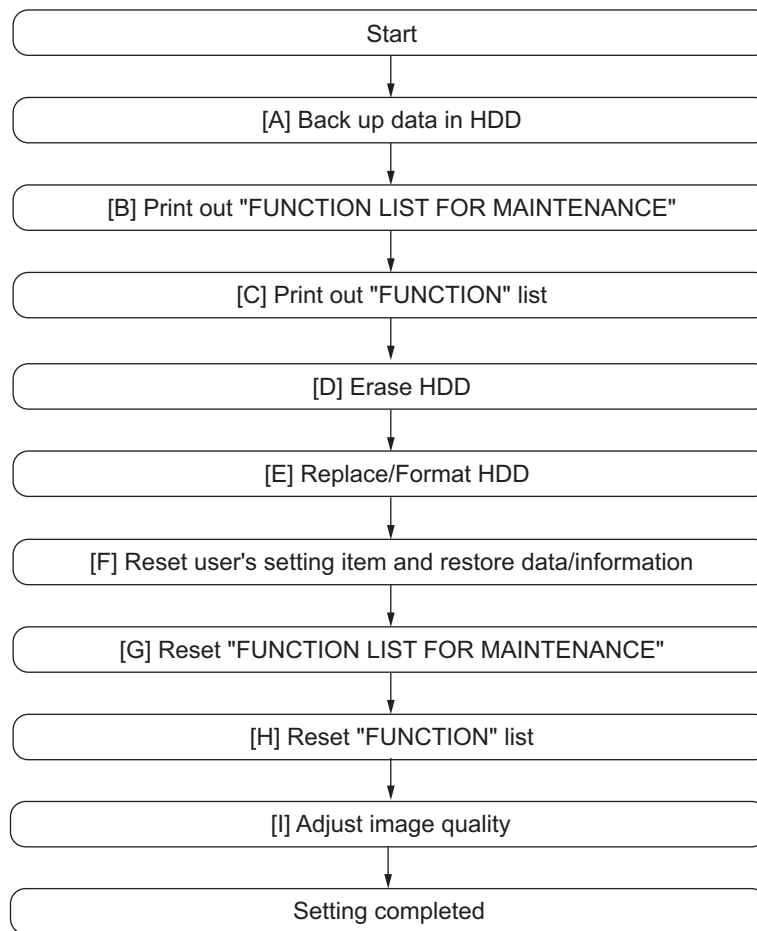
"Over-range" is displayed if the number of digits acquired from the HDD exceeds the maximum digits which can be displayed on the control panel; however, this does not indicate an error.

### 9.2.3 Precautions and procedures when replacing the HDD

**Notes:**

- When the HDD is replaced, it is necessary to back up the data in the HDD before replacing and to recover them after replacing.
- To maintain the security, ask users to perform the backup/restore for users' data/information in the HDD. The service technician can perform them only when users permit it.
- Some data in the HDD cannot be backed up and can be kept only on the paper.
- Do not replace the HDD and the SRAM together.
- When the HDD is replaced, do not perform SRAM data formatting (Clear SRAM) before the normal start-up.
- When the HDD is replaced, do not restore the back-up file before the normal start-up.

A procedure for replacing the HDD is shown below.



**Fig. 9-38**

**[A] Back up in HDD**

Ask the user (machine administrator) to back up the data in the HDD. Refer to the table below for the type of data, availability and method of backup.

Type of data in HDD	Availability	Backup method
Image data in the e-Filing	Available	Archive them in the “e-Filing” of TopAccess. As for the backup in Box data, all data (selectable by the box) can be backed up / restored in one go by using “e-Filing Backup/Restore Utility”.
F-code information, Template registration information, Address book data	Available	Back them up in the “Administrator” menu of TopAccess.
Department management data	Available	Export them in “Administrator” menu of TopAccess.
Log data (Print, Scan, FAX (Transmission/Reception))	Available	Export them in the “Administrator” menu of TopAccess. (Import cannot be performed.)
Data in the shared folder (Scanned data, Saved data of copy / FAX transmission)	Available	Copy them to the client computer via the network. (The data which have been copied to the client computer cannot be copied to the shared folder.)
Print waiting data (Copying data and FAX reception data that are waiting to be printed due to the paper run-out and jam, etc.)	Not available	Finish printing them after supplying paper or releasing the jam, etc. (The data cannot be left.)
Print job (Private print data, Schedule print data)	Not available	If any jobs are left, print them. (The data cannot be backed up.)
FAX saved data (Confidential / Bulletin board data)	Not available	Print them. (The data cannot be backed up.)
Registration data for FAX transmission (Delayed transmission / Recovery transmission)	Not available	Print them. (The data cannot be backed up.)

**[B] Print out “FUNCTION LIST FOR MAINTENANCE”**

- (1) Perform FS-12 (12 FAX LIST PRINT MODE).
- (2) Select "Function list for Maintenance" and then press [PRINT].

### [C] Print out "FUNCTION" list

- (1) Press [USER FUNCTIONS] on the [HOME] screen.
- (2) Enter the password in [Administrator] tab and press [OK].

#### Notes:

Explain the procedure to the user (machine administrator) and ask him/her to enter his/her password.

- (3) Press [LIST/REPORT] and then [LIST].
- (4) Press [FUNCTION]. The "FUNCTION LIST FOR MAINTENANCE" is printed out.

### [D] Erase HDD



In case of the Secure HDD:

- (1) Perform HS-74 → [Revert Factory Initial Status HDD] and then press [OK].
- (2) Turn the power OFF.

In case of Normal HDD:

- (1) Perform HS-73 → [Erase HDD Security] and then press [OK].
- (2) Select any of "LOW", "MEDIUM", "HIGH" or "SIMPLE" and then press [OK].
- (3) Turn the power OFF.

### [E] Replace / Format HDD

- (1) Confirm that the power is turned OFF.
- (2) Replace the HDD.  
(Refer to  P. 9-2 "9.1.3 Hard disk (HDD)".)
- (3) Create the partitions on the HDD.
  1. Perform HS-73 → [Format HDD] and then press [OK].
  2. When "Operation Complete" is displayed on the LCD, creating of the partitions is completed.
- (4) Turn the power OFF.
- (5) Format the service password.
  1. Perform HS-73 → [Clear Service Tech Password] and then press [OK].
  2. When "Reset Complete" is displayed on the LCD, formatting of the service tech password is completed.
- (6) Turn the power OFF.
- (7) Update the system software using the USB device.  
See " P. 11-2 "11.2 Firmware Updating with USB Device"" for details.
- (8) Turn the power OFF.
- (9) When the Fax Board (GD-1370) is installed, perform [CUSTOM INITIALIZE] → [INIT MEMORY] and [CLEAR DATA] in the FS-11 FAX CLEAR MODE. Then turn the power OFF.
- (10) Check the system software version (08-8952).  
Confirm the version displayed on the LCD, and then press [OK].
- (11) Initialization of NIC information (08-9083).

(12) Turn the power OFF.

### [F] Reset user's setting items and restore data/information

Ask the user (machine administrator) to reset the user's setting items and to restore data or information. Refer to the following for the reset and restore:

Items to reset/restore	Method
Printer driver	Upload them in the "Administrator" menu of TopAccess.
F-code information, Template registering information, Address book data	Restore them in the "Administrator" menu of TopAccess
Department management data	Import them in the "Administrator" menu of TopAccess.
Image data in the Electronic Filing	Upload them in the "e-Filing" of TopAccess.

- When the SSL is enabled, perform the setting of the following items again with "Self-signed certificate" of TopAccess.
  - Country/Region Name
  - State or Province Name
  - Locality Name
  - Organization Name
  - Organizational Unit Name
  - Common Name
  - Email Address
- When the wireless LAN is used, recreate its setting. (only when security with a certificate is used) Also, upload the following certificate file with "Install Certificate for Wireless LAN" of TopAccess.
  - CA certificate
  - User certificate

### [G] Reset "FUNCTION LIST FOR MAINTENANCE"

- (1) Print out the "FUNCTION LIST FOR MAINTENANCE" list after the formatting. For how to print it out, refer to [B] Print out "FUNCTION LIST FOR MAINTENANCE".
- (2) Perform FS-13 (13 FAX FUNCTION MODE).
- (3) Compare the lists which were printed before and after the formatting to check the setting items having the different setting values. Set the value which was set before the formatting.
- (4) Turn the power OFF.

### [H] Reset "FUNCTION" list

Reset the fax function by referring to the "function list" that was printed out in [C] Print out "FUNCTION" list.

- (1) Press [USER FUNCTIONS] on the [HOME] screen.
- (2) Press [ADMIN], enter the password, and then press [OK].

#### Notes:

Explain the user (machine administrator) about the next operation and ask him/her to enter his/her password.

- (3) Press [FAX] and then [TERMINAL ID] to set each item.
- (4) Press [INITIAL SETUP] to set each item.

## [I] Adjust image quality

- (1) Perform "Automatic gamma adjustment (PPC)" (FS-05-7869).  
📖 P. 6-27 "6.2.1 Automatic gamma adjustment"
- (2) Perform "Automatic gamma adjustment (PRT)" (FS-05-8008, 8009).  
📖 P. 6-49 "6.3.1 Automatic gamma adjustment"
- (3) Turn the power OFF.

## 9.2.4 Precautions and procedures when replacing the SYS board

A procedure for SYS board replacement is shown below.

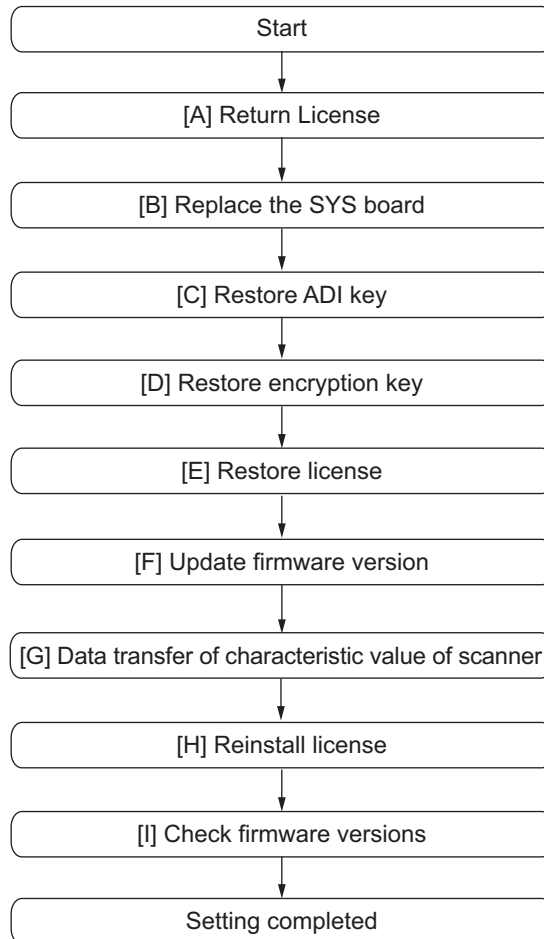


Fig. 9-39

### Notes:

\*1 If the combination of the main memory and the SYS board has been changed in [B], be sure to perform the calibration of the main memory at the next startup.

\*2 [C] is required only for the equipment in which the Secure HDD has been installed.



## [A] Return License

### Notes:

- If the 08 Setting Mode is not started up, "[A]Return License" can be omitted. In that case, reinstall the license with "[ 1 ]Re-registration when the board is replaced" if it is cleared since "[H] Reinstallation of License" cannot be performed.
- When installing the Data Overwrite Enabler (GP-1070) and security mode is setting High Security, set the security mode level to "1" (Low level). Then restart the equipment.

- (1) Perform FS-08-3840.
- (2) Select the license to be returned, and then press [REMOVE].
- (3) Install the one-time dongle, which you used for uploading the selected license, in the equipment, and then press [OK].
- (4) The Remove screen is displayed, then press [YES]. If this screen is not displayed, check whether the one-time dongle is installed in the equipment properly.
- (5) After 10 to 40 seconds passes, the screen for notifying the success of performance is displayed. Then press [OK]. If this screen is not displayed or the screen for notifying the failure of performance is displayed, quit this operation by pressing [NO]/[CLOSE]. Then, check whether the one-time dongle, which you used for uploading the selected license, is installed in the equipment.
- (6) Check that the returned license is not displayed on the screen.

### Tips

- If there are any other licenses to be returned, repeat from step (2).
- If there is no more licenses to be returned, press [CLOSE], and then turn the power OFF.

## [B] Replace the SYS board

### Notes:

Before replacing the SYS board, perform the following procedure.

 P. 9-14 "9.2.1 Precautions when replacing PC boards"

- (1) Confirm that the power is turned OFF.
- (2) Replace the SYS board.
- (3) Install main memory (DIMM) to the new SYS board (from the old SYS board).
- (4) Install SRAM to the new SYS board (from the old SYS board).

### Notes:

When the combination of the main memory and the SYS board has been changed by replacing either of them, it is necessary to perform the calibration of the main memory at the next startup. To perform the calibration of the main memory, start up the equipment while pressing the [ENERGY SAVER] button.

E.g.:

To start up HS Menu, turn the power ON by pressing the [POWER] button while pushing the [HOME], [START] and [ENERGY SAVER] buttons simultaneously.

### **[C] Restore ADI key**

If the Secure HDD is installed, follow the steps below. To confirm the type of device, start up the equipment in the HS-74.

- (1) Perform HS-73.
- (2) Press [Key Backup/Restore].
- (3) Press [ADIKKey], and then press [Execute].
- (4) Wait until the restoring of the encryption key is completed. "Success" is displayed.
- (5) Restart the equipment after the restoring is completed. If you want to perform the restoring of the license, do not restart the equipment but perform from (2) in "[D] Restore encryption key".



### **[D] Restore encryption key**

- (1) Perform HS-73.
- (2) Press [Key Backup/Restore].
- (3) Press [Key], and then press [Execute].
- (4) Wait until the restoring of the encryption key is completed. "Success" is displayed.
- (5) Restart the equipment after the restoring is completed. If you want to perform the restoring of the license, do not restart the equipment but perform from (2) in "[E] Restore license".

### **[E] Restore license**

- (1) Perform HS-73.
- (2) Press [Key Backup/Restore].
- (3) Press [License] and then [Execute].
- (4) Wait until the restoring of the license is completed. "Success" is displayed.  
\* Confirm that "OK" is indicated in all of the FROM column and then reboot the equipment.

### **[F] Update firmware version**

- (1) Update the version of system firmware using the USB device.  
 P. 11-2 "11.2 Firmware Updating with USB Device"
- (2) Update the version of scanner firmware with the USB device.  
 P. 11-2 "11.2 Firmware Updating with USB Device"

### **[G] Data transfer of characteristic value of scanner**

- (1) Perform FS-05-3203.
- (2) Turn the power OFF.

## **[H] Reinstall license**

If the license was returned "[A]Return License", reinstall it with the following procedure.

- (1) Perform FS-08-3840.
- (2) Press [INSTALL].
- (3) Install the one-time dongle in the equipment (the one which you used for returning the selected license before replacing the equipment). Then press [OK].
- (4) Select the license to be installed, and then press [INSTALL].
- (5) The screen for notifying that the installation will be started is displayed. Then press [YES].
- (6) After 10 to 40 seconds have passed, the screen for notifying the success of the performance is displayed. Then press [OK]. If the screen for notifying a failure of the performance is displayed, quit this operation by pressing [NO]. Then check that the one-time dongle is installed properly in the equipment.
- (7) Check that the installed license is displayed on the license list.

### **Tips**

If there are any other licenses to be installed, repeat from step (2). If there are no other licenses to be installed, press [CLOSE], and then turn the power OFF.

## **[I] Check firmware versions**

- System firmware version (FS-08-9930)
- Scanner firmware version (FS-08-9902)

### **Notes:**

If the security mode is changed from High Security to Low Security in the step "[A] Return License", set the value of FS-08-8911 to "3" (High Security).

## 9.2.5 Precautions and procedure when replacing the SRAM

### Notes:

- Do not replace the HDD and the SRAM together.
- Be careful not to damage the board when replacing the SRAM.
- When the SRAM is replaced, do not perform HDD partition creation (Format HDD) before the normal start-up.

A procedure for replacing the SRAM is shown below.

When disposing of the SRAM, perform the items in  P. 9-36 "9.3.4 Precautions when disposing of the SRAM".

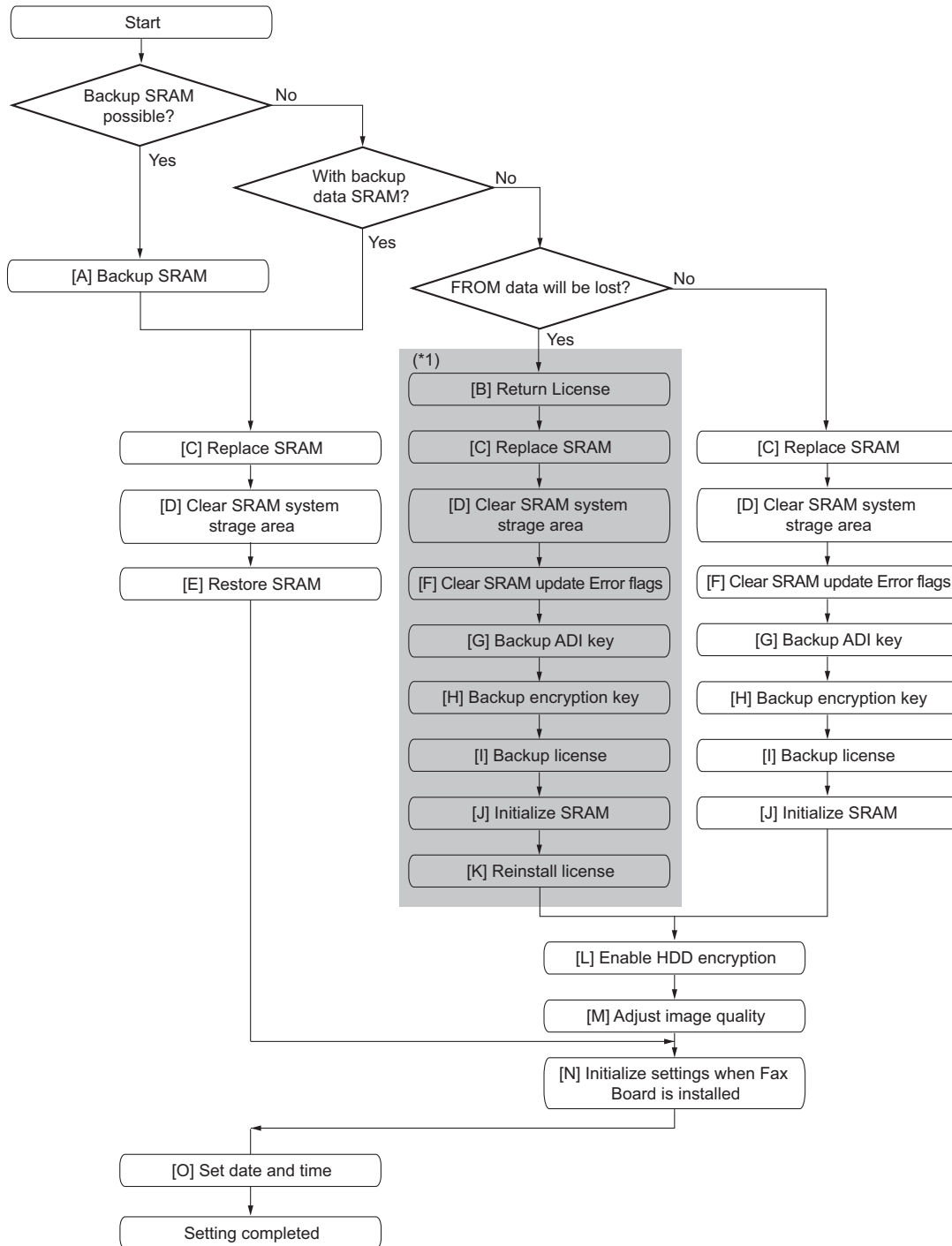



Fig. 9-40

**Notes:**

- [G], [H] and [I] are required only for the equipment in which the Secure HDD has been installed.
- [H] and [I] are required only for the equipment in which a Normal HDD has been installed.
- Use the flow (\*1) when securely returning and reinstalling the license. Returning and reinstalling the license is required when it has been lost. The examples are as below.
  - E.g. 1: When SRAM data are overwritten on the FROM mistakenly due to an incorrect operation during the backup of the license
  - E.g. 2: When the SYS board (SRAM) is damaged or the license data in the FROM are broken

**[A] Backup SRAM**

Perform a backup before replacing the SRAM.

 P. 12-2 "[A] Backup procedure"

**Notes:**

- If "[A]Backup SRAM" fails, proceed to "[B] Return License".
- If "[A]Backup SRAM" succeeds, proceed to "[C] Replace SRAM".

**[B] Return License****Notes:**


When installing the Data Overwrite Enabler (GP-1070) and security mode is setting High Security, set the security mode level to "1" (Low level). Then restart the equipment.

- (1) Perform FS-08-3840.
- (2) Select the license to be returned, and then press [REMOVE].
- (3) Install the one-time dongle, which you used for uploading the selected license, in the equipment, and then press [OK].
- (4) The Remove screen is displayed, then press [YES]. If this screen is not displayed, check whether the one-time dongle is installed in the equipment properly.
- (5) After 10 to 40 seconds passes, the screen for notifying the success of performance is displayed. Then press [OK]. If this screen is not displayed or the screen for notifying the failure of performance is displayed, quit this operation by pressing [NO]/[CLOSE]. Then, check whether the one-time dongle, which you used for uploading the selected license, is installed in the equipment.
- (6) Check that the returned license is not displayed on the screen.

**Tips**

- If there are any other licenses to be returned, repeat from step (2).
- If there is no more licenses to be returned, press [CLOSE], and then turn the power OFF.

**[C] Replace SRAM**


- (1) Confirm that the power is turned OFF.
- (2) Take off the Fax Board (GD-1370) if it is installed.
- (3) Replace the SRAM.  
 P. 9-10 "9.1.8 SRAM"

**[D] Clear SRAM system storage area**


- (1) Performs HS-76.  
The authentication screen appears. Press [OK]. (Entry of a password is unnecessary.)
- (2) When "SRAM Clear Mode" appears on the LCD, press the [Clear SRAM].

- (3) When "SRAM Format Completed" is displayed on the LCD, initializing is completed.
- (4) Turn the power OFF.

#### **[E] Restore SRAM**

- (1) Perform HS-76.
- (2) When "SRAM Clear Mode" appears on the LCD screen, press [Set Serial Number].
- (3) Key in the serial number printed on the label attached to the rear cover of the equipment and then press [OK].
- (4) "Set Serial Number was completed." is displayed.
- (5) Turn the power OFF.
- (6) If there are SRAM backup data, perform restoring.  
 P. 12-3 "[B] Restore procedure"
- (7) Turn the power OFF after the restoring of SRAM is completed.

#### **Tips**


When the restoration is completed successfully, proceed to " P. 9-29 "[N] Initialize settings when FAX Board (GD-1370) is installed".

#### **[F] Clear Software Update Error Flag**

- (1) Perform HS-73.
- (2) Press [Clear Software Update Error Flag].
- (3) When "Operation Complete" is displayed on the LCD, clearing the flag is completed.
- (4) Turn the power OFF.

#### **[G] Backup ADI key (FROM -> SRAM)**

If the Secure HDD is installed, follow the steps below. To confirm the type of device, start up the equipment in HS-74.

- (1) Perform HS-73.
- (2) Press [Key Backup/Restore].
- (3) Press [ADIKKey] twice and then [Execute].
- (4) Wait until the backup of the ADI key is completed. "Success" is displayed.
- (5) Restart the equipment after the backup is completed.  
If you want to perform the backup of the license, do not restart the equipment but perform from (3) in " P. 9-27 "[H] Backup encryption key (FROM -> SRAM)".
- (6) Turn the power OFF.

#### **[H] Backup encryption key (FROM -> SRAM)**

- (1) Perform HS-73.
- (2) Press [Key Backup/Restore].

- (3) Press [Key] twice and then [Execute].
- (4) Wait until the backup of the encryption key is completed. "Success" is displayed.
- (5) Restart the equipment after the backup is completed. If you want to perform the backup of the license, do not restart the equipment but perform from (3) in "📖 P. 9-28 "[I] Backup license (FROM -> SRAM)".
- (6) Turn the power OFF.

#### **[I] Backup license (FROM -> SRAM)**

##### **Notes:**

If "License SRAM to FROM" is performed by mistake, carry out the following procedure.  
 📖 P. 9-34 "[ 1 ] Re-registration when the board is replaced"

- (1) Perform HS-73.
- (2) Press [Key Backup/Restore].
- (3) Press [License] twice and then [Execute].
- (4) Wait until the backup of the license is completed. "Success" is displayed.
- (5) Restart the equipment after the backup is completed.
- (6) Turn the power OFF.  
 \* After the restoring is completed, check that "OK" is indicated in SRAM column. Then, restart the equipment.

#### **[J] Initialize SRAM**

- (1) Perform FS-08.
- (2) Initialize the SRAM error.
  1. When "SRAM REQUIRES INITIALIZATION" is displayed on the LCD, check the destination and then press the [START] button.  
 If the destination is not correct, key in the correct one and then press the [START] button.
  2. After the confirmation message is displayed, press [OK].
- (3) Perform the initialization at the software version upgrade (FS-08-9030).
- (4) Initialize the NIC information (FS-08-9083).
- (5) Enter the serial number (FS-08-9601).  
 Key in the serial number on the label attached to the rear cover of the equipment, and then press [OK].
- (6) Turn the power off.

#### **[K] Reinstall license**

If the license was returned in "[B] Return License", reinstall it with the following procedure.

- (1) Perform FS-08-3840.
- (2) Press [INSTALL].
- (3) Install the one-time dongle in the equipment (the one which you used for returning the selected license before replacing the equipment). Then press [OK].

- (4) Select the license to be installed, and then press [INSTALL].
- (5) The screen for notifying that the installation will be started is displayed. Then press [YES].
- (6) After 10 to 40 seconds have passed, the screen for notifying the success of the performance is displayed. Then press [OK]. If the screen for notifying a failure of the performance is displayed, quit this operation by pressing [NO]. Then check that the one-time dongle is installed properly in the equipment.
- (7) Check that the installed license is displayed on the license list.

**Tips**

- If there are any other licenses to be installed, repeat from step (2).
- If there are no other licenses to be installed, press [CLOSE], and then turn the power OFF.

**[L] Enable HDD encryption**



If the HDD encryption function is used, follow the procedure below.

**Notes:**

When the installation of the license of the Data Overwrite Enabler (GP-1070) is required, be sure to do this before HDD encryption is performed. However, it is not necessary to do so for the models (NAD) in which the Data Overwrite Enabler (GP-1070) is installed as a standard.

- (1) Perform FS-08-8911.
- (2) Enable the encryption function.
  - For enabling HDD encryption only  
Set the value of FS-08-8911 to "1", and then set the value of FS-08-9379 to "1" (Security priority) or "2" (Performance priority).
  - For high security mode  
Set the value of FS-08-8911 to "3".
- (3) Turn the power OFF.

**[M] Adjust image quality**

- (1) Perform "Data transfer of characteristic value of scanner" (FS-05-3203).
- (2) Perform "Automatic gamma adjustment" <PPC> (FS-05-7869).  
 P. 6-27 "6.2.1 Automatic gamma adjustment"
- (3) Perform "Automatic gamma adjustment" <PRT> (FS-05-8008/8009).  
 P. 6-49 "6.3.1 Automatic gamma adjustment"
- (4) Turn the power OFF.

**[N] Initialize settings when FAX Board (GD-1370) is installed**

- (1) Reinstall the FAX Board (GD-1370).
- (2) Set the destination of FAX (FS-08-9001).
- (3) Turn the power OFF.
- (4) Perform FS-13 → CUSTOM INITIALIZE → INIT MEMORY.
- (5) Turn the power OFF and then back ON.



- (6) Set the dial type according to these buttons: [HOME] → [USER FUNCTIONS] → [ADMIN] → [FAX] → [INITIAL SETUP]

### [O] Set date and time

Set the date and time according to these buttons.

[HOME] → [USER FUNCTIONS] → [ADMIN] → [GENERAL] → [CLOCK] → [DATE/TIME]

## 9.2.6 Procedures when replacing the LGC board

Before replacing the LGC board, perform the following procedure.

- (1) Turn the power OFF.
- (2) Remove the LGC board.  
📖 P. 9-5 "9.1.5 LGC board"
- (3) Install the removed LGC board's EEPROM into the new LGC board.
- (4) Attach the new LGC board.

## 9.2.7 Procedures and settings when replacing EEPROM

### Notes:

Be careful not to damage the EEPROM when replacing the EEPROM.

A procedure for replacing the EEPROM is shown below.

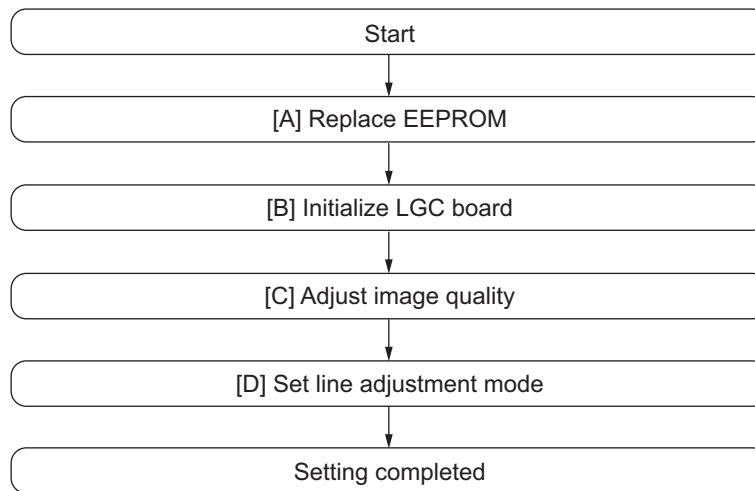


Fig. 9-41

### [A] Replace SRAM

- (1) Confirm that the power is turned OFF.
- (2) Replace the EEPROM.  
📖 P. 9-10 "9.1.10 EEPROM"

### [B] Initialize LGC board

- (1) Open the front cover, and check the destination printed on the white tape stuck on the equipment.
- (2) Perform "Destination display at SRAM initialization" (FS-08-9060).

- (3) Check whether the displayed destination (see the below figure) of the SRAM is the same as the one in step (1).

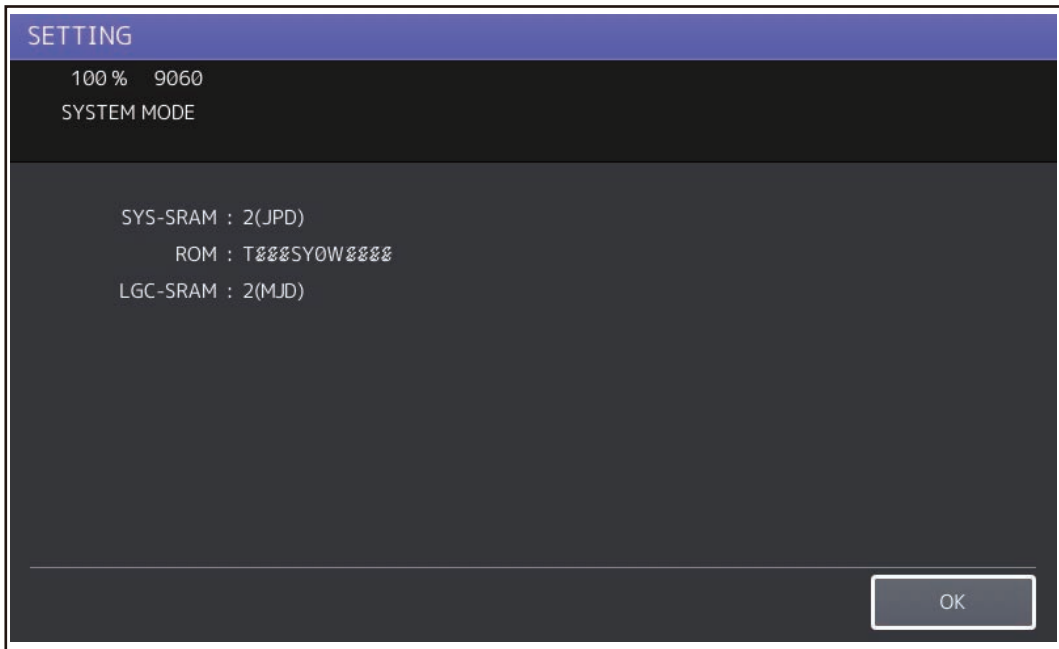


Fig. 9-42

**Tips**

If the destinations are different, initialize the SRAM with reference to the following procedure.  
P. 9-25 "9.2.5 Precautions and procedure when replacing the SRAM"

- (4) Perform "Printer all clear" (FS-08-9090).  
(5) Press [INITIALIZE] to perform the initialization of the EEPROM.

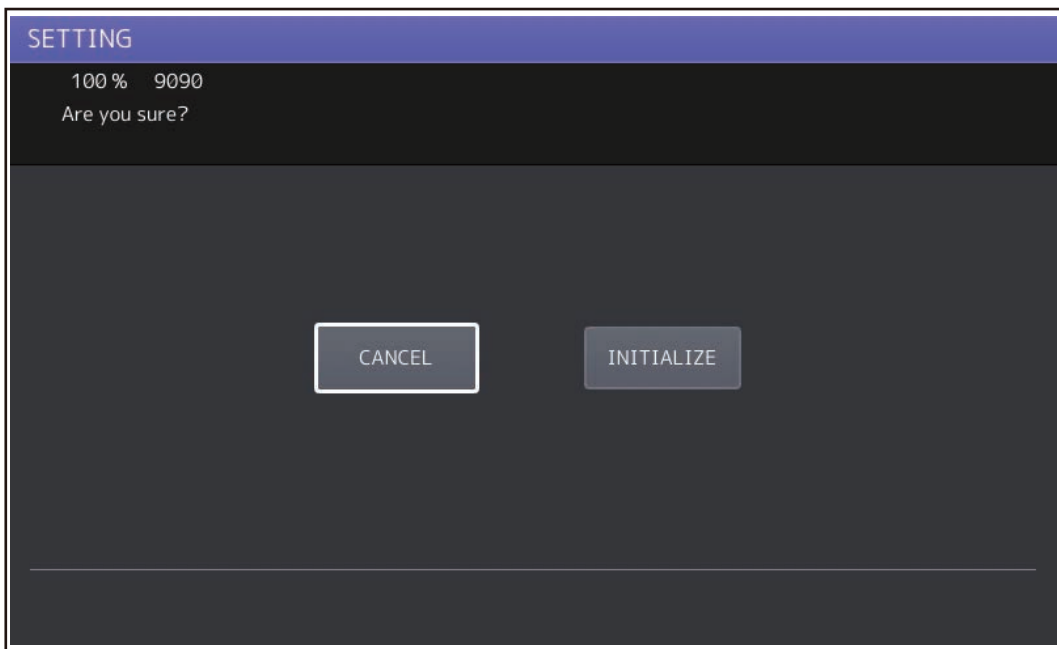


Fig. 9-43

- (6) Perform "Destination display at SRAM initialization" (FS-08-9060), and check whether the same destinations are displayed for the SRAM and the LGC board.



Fig. 9-44

**Remarks:**

If an error occurs during the initialization of the LGC board and the initialization fails, error messages are displayed on the touch panel. The error messages and the corresponding troubleshooting methods are shown below.

Error message	Troubleshooting
UNDEFINED MODEL	Since the LGC board probably has a problem, replace it with a new one by following the procedure below. 📖 P. 9-5 "9.1.5 LGC board"
UNDEFINED VERSION	Recheck the destination of the SRAM. Since the SRAM probably has a problem, replace it with a new one by following the procedure below. 📖 P. 9-10 "9.1.8 SRAM"
VERIFY ERROR	Check whether the EEPROM (for the LGC board) is connected properly.

**[C] Adjust image quality**

- (1) Write down the adjustment values of the following code attached to the rear side of the front cover.





	L (0)	H (1)
FS-05-2627		
FS-05-2628		
FS-05-2629		
FS-05-2630		

- (2) Perform FS-05-2627 ~ 2630 and then enter all the adjustment values written down in step (1).

- (3) Reset the auto toner sensor.
  1. Turn the power OFF.
  2. Replace the developer materials for four colors (YMCK).
  3. Perform automatic adjustment of auto-toner sensor (FS-05-2400).

**Notes:**

- You can reset the auto-toner sensor by directly entering the adjustment values for FS-05-2405-0 to 3 with the Adjustment mode data list, which has been printed during normal operation of equipment such as when it is setup, when preventive maintenance (PM) is performed or when developer material is replaced, etc.
- If you perform automatic adjustment (FS-05-2400) of the auto-toner sensor without replacing the developer materials for four colors (YMCK), image quality is not guaranteed.

- (4) Perform the "Forced performing of image quality closed-loop control (FS-05-2742)".
- (5) Perform the enforced position adjustment (FS-05-4719).
- (6) Perform printer related adjustment and scanner related adjustment.
  -  P. 6-12 "6.1.7 Image dimensional adjustment at the printing section"
  -  P. 6-18 "6.1.8 Image dimensional adjustment at the scanning section"
- (7) Perform "Automatic gamma adjustment" <PPC> (FS-05-7869).
  -  P. 6-27 "6.2.1 Automatic gamma adjustment"
- (8) Perform "Automatic gamma adjustment" <PRT> (FS-05-8008/8009).
  -  P. 6-49 "6.3.1 Automatic gamma adjustment"

**Notes:**

Usually, it is only necessary to perform automatic gamma adjustment for [Plain paper]; however if other paper is used, perform automatic gamma adjustment per paper type.

**[D] Set line adjustment mode**


- (1) Turn the power OFF.
- (2) Perform FS-08-9010.
- (3) Set "Line adjustment mode" to "0: For factory shipment".

**Notes:**

Be sure to change the setting of "Line adjustment mode" (FS-08-9010) to "0: For factory shipment". Since "1: For line" is set for "Line adjustment mode" in [B] Initialize LGC board in EEPROM (for LGC board) supplied as a service part, number of prints is not counted unless it is changed.

## 9.2.8 Procedures and settings when replacing the Lens unit

When replacing the lens unit, follow the procedure below.

- (1) Confirm that the power is turned OFF.
- (2) Replace the lens unit.
  -  P. 4-21 "4.3.5 Lens unit/CCD driving PC board"
- (3) Perform "Data transfer of characteristic value of scanner / SYS board -> Lens unit (FS-05-3209)".
- (4) Perform "Shading correction plate Automatic dust detection adjustment (FS-05-3218)".
- (5) Turn the power OFF.

## 9.2.9 Firmware confirmation after the PC board/HDD replacement

After replacing the PC board/HDD, check the firmware version in the 08 Setting Mode and confirm if the firmware combination is correct.

Firmware	Code
System software	9900
System firmware	9930
Engine firmware	9901
Scanner firmware	9902
NIC firmware	9990
DF firmware	9903
PFC firmware	9940
Finisher firmware	9904
Hole punch firmware	9944
FAX board firmware(Line1)	9905
FAX board firmware(Line2)	9969

The installed ROM versions and the registered optional Electronic License Keys can be confirmed in the list print mode following the procedure below.

- (1) Perform [FS-30-111] to print out VERSION LIST.  
\* It is recommended to keep this list for future reinstallation such as the replacement of the SYS board.
- (2) Keep pressing [ON/OFF] until you hear a sound to shut down the equipment.

## 9.2.10 License re-registration using the one-time dongle

### [ 1 ] Re-registration when the board is replaced

The license registered using the one-time dongle can be re-registered only in the same equipment. When the SYS board or SRAM is replaced, follow the procedures for re-registration given below.

- (1) Perform FS-08-3840.
- (2) Press [INSTALL].
- (3) Install the one-time dongle in the equipment (the one which you used for registering the selected license), and then press [OK].
- (4) Select the license to be installed, and then press [INSTALL].
- (5) The screen for notifying that the installation will be started is displayed. Then press [YES].
- (6) After 10 to 40 seconds have passed, the screen for notifying the success of the performance is displayed. Then press [OK]. If the screen for notifying a failure of the performance is displayed, quit this operation by pressing [CLOSE]. Then check that the one-time dongle, which you used for uploading the selected license, is installed in the equipment.
- (7) Check that the installed license is displayed on the license list.

#### Tips

If there are any other licenses to be returned, repeat from step (2). If there are no other licenses to be returned, press [CLOSE], and then turn the power OFF.

**Notes:**

This procedure is available only with the one-time dongle used for the previous registration, since the model information registered in it is utilized. Use the same one-time dongle and the equipment when registering the license.

**[ 2 ] Re-registration when the equipment is replaced due to malfunction**

When the equipment has to be replaced due to a malfunction, return the license registered in the equipment to the one-time dongle and register it to the new equipment following the procedure below.

**Notes:**

It is not possible to re-register the license for the IPsec Enabler (GP-1080) into other equipment.

- (1) Perform FS-08-3840.
- (2) Select the license to be returned, and then press [REMOVE].
- (3) Install the one-time dongle in the equipment (the one which you used for uploading the selected license), and then press [OK].
- (4) The Remove screen is displayed. Then press [YES].  
If this screen is not displayed, check that the one-time dongle is installed in the equipment properly.
- (5) After 10 to 40 seconds have passed, the screen for notifying the success of the performance is displayed. Then press [OK].  
If the screen for notifying a failure of the performance is displayed, quit this operation by pressing [CLOSE]. Then check that the one-time dongle, which you used for uploading the selected license, is installed in the equipment.
- (6) Check that the returned license is not displayed on the screen.

**Tips**

If there are any other licenses to be returned, repeat from step (2).

If there are no other licenses to be returned, press [CLOSE], and then turn the power OFF.

- (7) Replace the equipment.
- (8) Perform FS-08-3840.
- (9) Press [INSTALL].
- (10) Install the one-time dongle in the equipment (the one which you used for returning the selected license before replacing the equipment). Then press [OK].
- (11) Select the license to be installed, and then press [INSTALL].
- (12) The screen for notifying that the installation will be started is displayed. Then press [YES].
- (13) After 10 to 40 seconds have passed, the screen for notifying the success of the performance is displayed. Then press [OK]. If the screen for notifying a failure of the performance is displayed, quit this operation by pressing [NO]. Then check that the one-time dongle is installed properly in the equipment.
- (14) Check that the installed license is displayed on the license list.

**Tips**

If there are any other licenses to be installed, repeat from step (9). If there are no other licenses to be installed, press [CLOSE], and then turn the power OFF.

## 9.3 Precautions for Installation of GP-1070 and Disposal of HDD/ Board

### 9.3.1 Precautions for Installation of GP-1070

When installing the Data Overwrite Enabler (GP-1070), perform the following setting:

HS-73→[Erase HDD Securely]: HDD securely erasing

This setting is the overwriting method complying with DoD 5220.22-M.

1. LOW: This is the normal overwriting method. (This setting is used normally.)  
"00-FF-Random-Verify" Once
2. MEDIUM: This overwriting method is more secure than LOW. The erasing time is between LOW and HIGH.  
"00-FF-Random" three times repeatedly -Verify
3. HIGH: This is the most secure overwriting method. It takes the longest time to erase data  
"00-FF-Random" five times repeatedly -Verify
4. SIMPLE: This is the simple overwriting method. It takes the shortest time to erase data.  
Overwrite the Random data once

### 9.3.2 Precautions when disposing of HDD

#### [ 1 ] When disposing of Secure HDD

When disposing of Secure HDD, perform the following setting:

HS-74→[Revert factory initial status HDD]

#### [ 2 ] When disposing of Normal HDD

When disposing of Normal HDD, perform the following setting:

HS-73→[Erase HDD Securely]: HDD securely erasing

This setting is the overwriting method complying with DoD 5220.22-M.

1. LOW: This is the normal overwriting method. (This setting is used normally.)  
"00-FF-Random-Verify" Once
2. MEDIUM: This overwriting method is more secure than LOW. The erasing time is between LOW and HIGH.  
"00-FF-Random" three times repeatedly -Verify
3. HIGH: This is the most secure overwriting method. It takes the longest time to erase data  
"00-FF-Random" five times repeatedly -Verify
4. SIMPLE: This is the simple overwriting method. It takes the shortest time to erase data.  
Overwrite the Random data once

### 9.3.3 Precautions when disposing of the SYS board

When disposing of the SYS board, data clearing is not required since important data, such as user information, etc. are stored in the SRAM.

### 9.3.4 Precautions when disposing of the SRAM

When disposing of the SRAM, perform HS-73→Erase SRAM Securely (SRAM securely erasing) for security reasons.

#### Notes:

If this is performed, the equipment cannot be started up.

## 10. REMOTE SERVICE

There are following functions as Remote Service.

1. Auto Supply Order  
Automatically orders the toner and used waste toner box by FAX or E-mail.
2. Service Notification  
Notifies the status of the equipment to the service technician by E-mail or FAX.

### 10.1 Auto Supply Order

#### 10.1.1 Outline

Automatically orders the toner and used waste toner box.

(1) Placing an Order

There are two ways to place an order.

- FAX  
Installation of the FAX board is required.  
If the FAX board has not been installed, it is regarded as OFF setting.
- E-mail (E-mail body + TIFF image)

(2) Order Intervals

The Auto Supply Order is sent as indicated in the following steps.

- Toner cartridge
  1. Toner empty occurs.
  2. The toner cartridge is replaced.
  3. The toner empty counter is incremented when the total number of prints or the pixel counter value exceeds the threshold set in the following self-diagnostic code.

Items	Code	Contents
Toner empty determination counter	FS-08-6506	Selects the counter to determine toner empty. 0: Output pages 1: Pixel counter
Threshold setting for toner empty determination (output pages)	FS-08-6507	Sets the number of output pages to determine toner empty. This setting is valid when "0" is set at FS-08-6506.
Threshold setting for toner empty determination (pixel counter)	FS-08-6508	Sets the number of the pixel counter value to determine toner empty. This setting is valid when "1" is set at FS-08-6506.

e.g.) When "0" is set for FS-08-6506 and "50" is set for FS-08-6507

The toner empty counter is incremented when 50 sheets are printed after the toner cartridge has been replaced.

4. When the accumulated number of toner empty times reaches the set condition, an order is placed automatically.

- Waste toner box  
When the number of the waste toner full detection times reaches the set condition, an order is placed automatically.  
The order condition for the toner cartridge and the waste toner box can be set individually.

(3) If Order Failure Occurs

If some problems occur and the order cannot be placed after registering an order as a job, refer to the standard countermeasure for the FAX/E-mail transmission failure.



## 10.1.2 Setting Item

To enable Auto Supply Order, the following settings are required.

### Notes:

When selecting E-mail to place an order, it is required that sending and receiving E-mails are available. Confirm the details to the administrator.

#### (1) Self-diagnosis (08 Setting Mode)

As the default setting, the Auto Supply Order setting screen is not displayed on the touch panel. To display it, switching the Valid/Invalid setting (FS-08-9783) is required.

0: Valid (FAX/Internet FAX)

1: Valid (FAX/Internet FAX/HTTP)\*

2: Invalid (Default)

When changing the setting value from "2" (default) to "0", the Auto Supply Order setting screen is displayed. (\* HTTP has not been supported yet.)

#### (2) Touch Panel Setting

Each item is set from the Auto Supply Order screen on the touch panel.

Entering the password and customer information is required because the setting is made from the ADMIN screen. Setting it with the administrator is a must.

- Basic setting

[ADMIN] > [SERVICE] > [SUPPLY ORDER SETUP] > [ORDER INFORMATION]

AUTO SUPPLY ORDER	Ordered by: [FAX], [MAIL], [HTTP] (*1)
FAX NUMBER	FAX number of supplier (*2)
E-MAIL	E-mail address of supplier (*3)
CUSTOMER	Customer information
NAME	
TEL NUMBER	
E-MAIL	
ADDRESS	
SUPPLIER	Supplier information
NAME	
ADDRESS	
SERVICE TECNICIAN	Service technician information
NUMBER	
NAME	
TEL NUMBER	
E-MAIL	

\*1 HTTP has not been supported yet.

\*2 The fax number of the supplier must be entered when an order is made by means of a fax.

\*3 The e-mail address of the supplier must be entered when an order is made by means of an e-mail.

- Detailed setting for the order

[ADMIN] > [SERVICE] > [SUPPLY ORDER SETUP] > [TONER ORDERING]

***** TONER ORDER	Order information (TONER /USED TONER CONTAINER)
PART NUMBER	Part number to be ordered
CONDITION	The number of conditions (*)
QUANTITY	The quantity to be ordered

AUTO ORDER	ON/OFF setting of order for each part
------------	---------------------------------------

\* The order is placed when the number of replacement reaches the number specified for the CONDITION.

- FAX number of this equipment (common information)  
[ADMIN] > [FAX] > [TERMINAL ID]

ID NAME	ID name of this equipment
FAX NUMBER	FAX number of this equipment

- E-mail information of this equipment (common information)  
[ADMIN] > [E-MAIL]

FROM ADDRESS	E-mail address of this equipment (*)
FROM NAME	E-mail username of this equipment

\* When sending an E-mail, validity of the address is checked. If the address is invalid, it is not sent.

- (3) Output of setting list of the Auto Supply Order.
1. Perform FS-12 (12 FAX LIST PRINT MODE).
  2. Select "SUPPLY ORDER LIST" and then press [PRINT].

### 10.1.3 Setting procedure

- (1) Perform FS-08-9783 and set the setting value to "0".
- (2) Turn the power OFF and then back ON.
- (3) Press [USER FUNCTIONS] on the HOME screen.
- (4) Press the [ADMIN] tab.  
When the Administrator Password has been set, the ADMINISTRATOR PASSWORD screen is displayed.

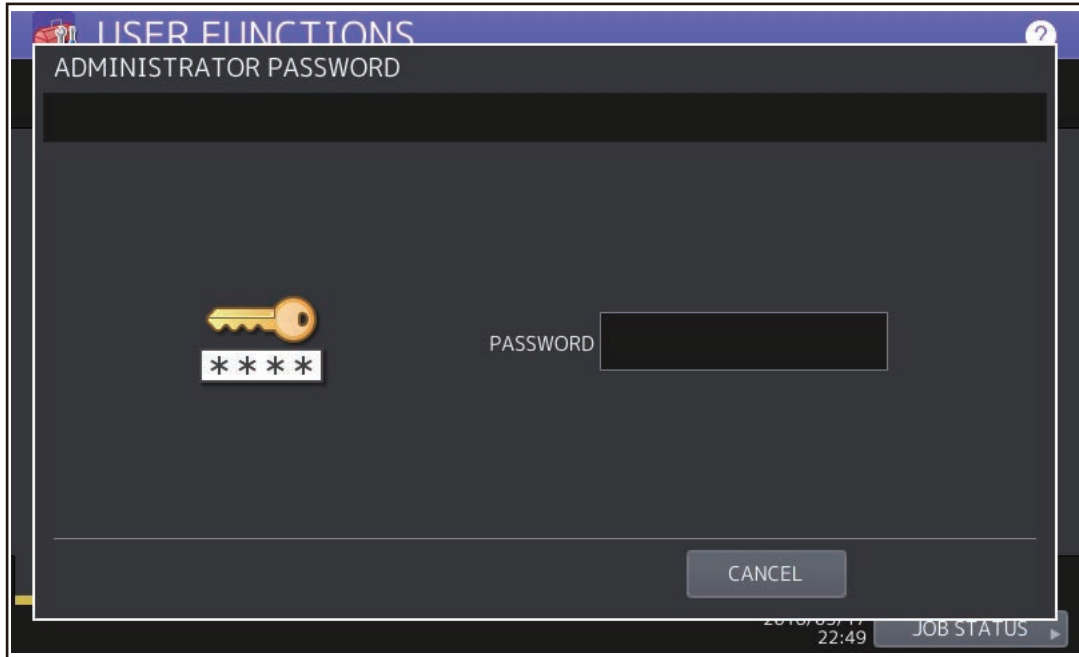


Fig.10-1

- (5) The keyboard appears upon your touching the entry box for a password. Enter the administrator password and then press [OK] or [CLOSE].
  - \* Confirm the password to the administrator.

(6) Press [SERVICE] in the ADMIN screen.



Fig.10-2

(7) The SERVICE screen is displayed.

(8) Press [SUPPLY ORDER SETUP].

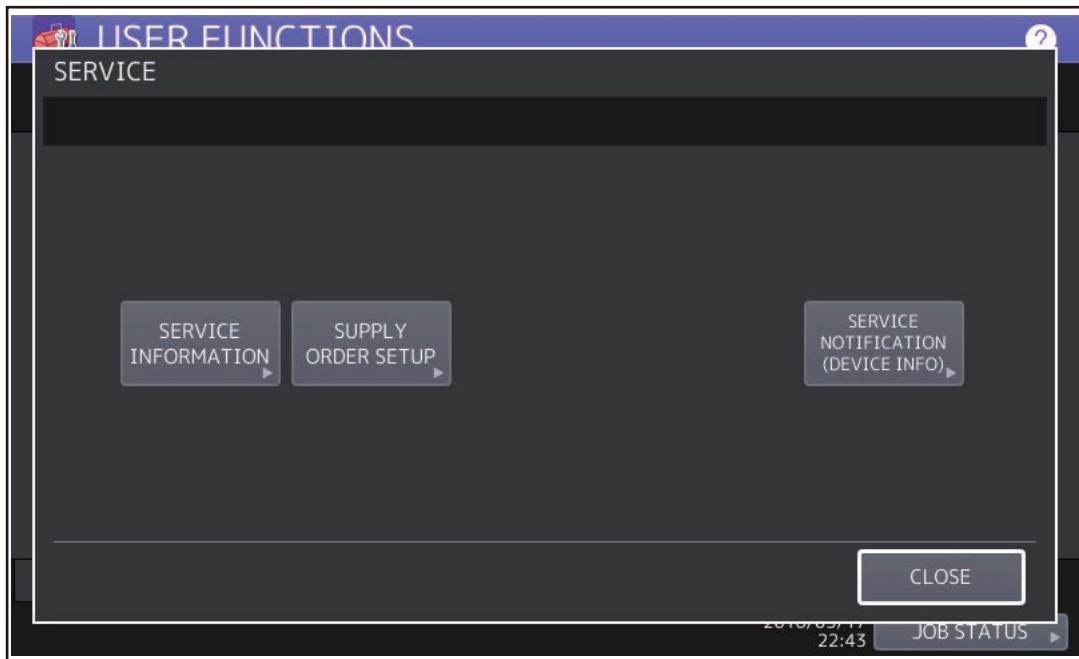


Fig.10-3

(9) Press [ORDER INFORMATION].



Fig.10-4

(10) The ORDER INFORMATION screen is displayed.

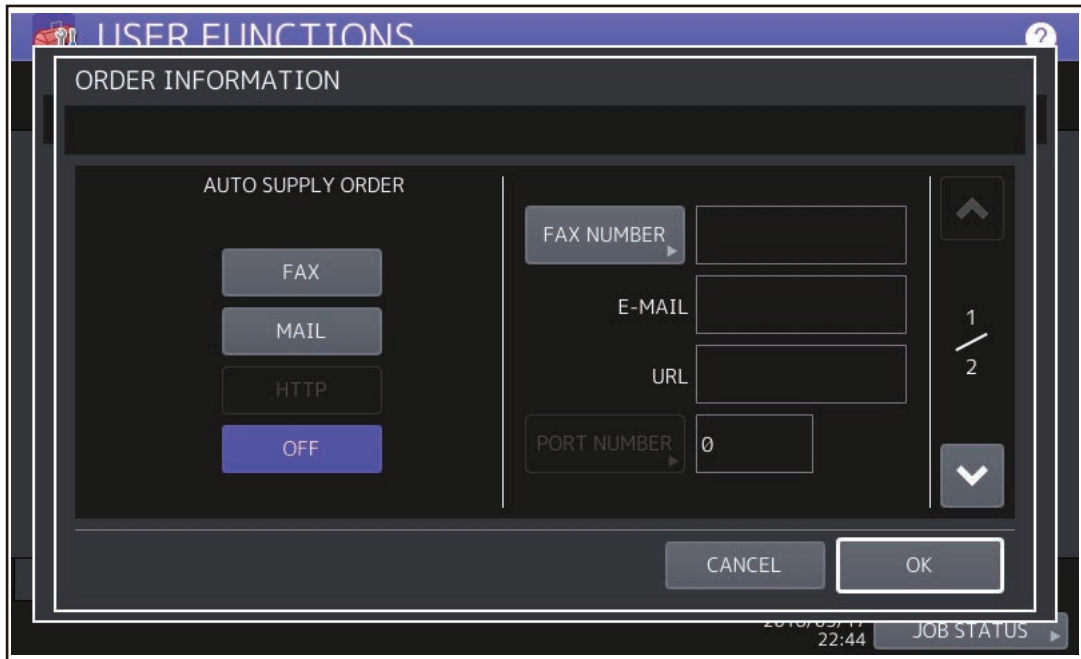


Fig.10-5

(11) Press the buttons on the screen of ORDER INFORMATION to set the required item.

- |                        |  |
|------------------------|--|
| [FAX]/[MAIL]/<br>[OFF] | Select [FAX] or [MAIL] for the transmitting way of order.<br>(HTTP has not been supported yet.)<br>[OFF]: Turn off the AUTO SUPPLY ORDER function. |
| [FAX NUMBER]           | Input the FAX number of supplier.<br>(This must be entered when an order is transmitted by means of a fax.)  |
| [E-MAIL]               | Input the E-mail address of supplier.<br>(This must be entered when an order is transmitted by means of an e-mail.)                                |

(12) Press the scroll button.

(13) The SUPPLIER screen is displayed.

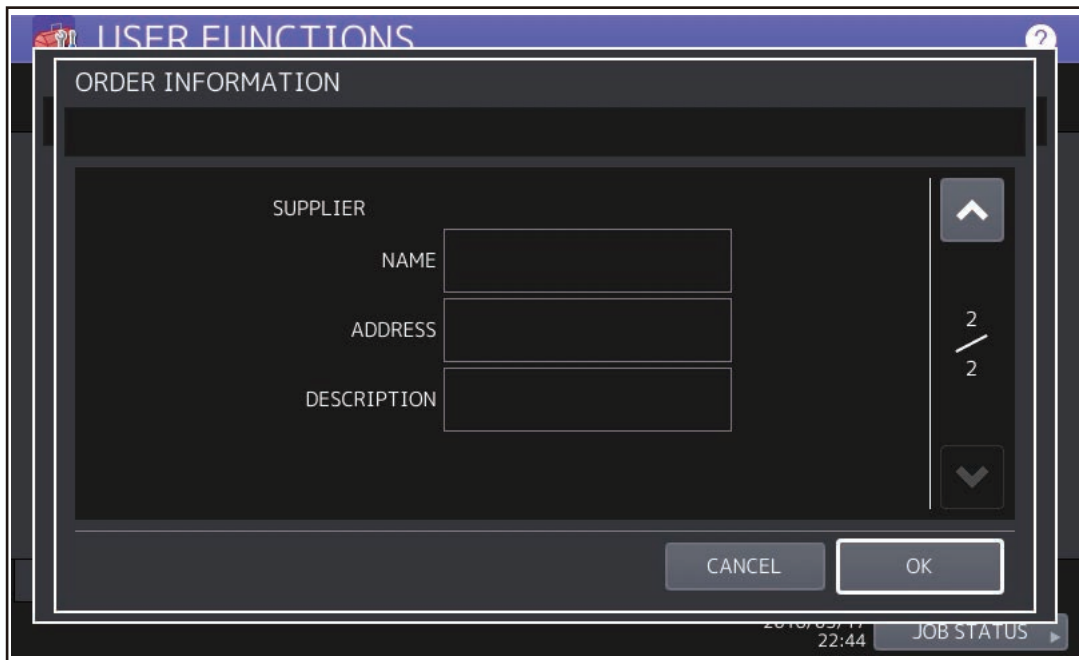


Fig.10-6

(14) Press the buttons of the screen of SUPPLIER to set the required item.

- |           |                                |
|-----------|--------------------------------|
| [NAME]    | Input the name of supplier.    |
| [ADDRESS] | Input the address of supplier. |

(15) Press [OK].

Press [OK] to register the entered information and then the screen returns to the (7) SERVICE screen.

Press [CANCEL] to cancel the entered information and then the screen returns to the (7) SERVICE screen.

(16) The SERVICE screen is displayed.



Fig.10-7

(17) Press [SERVICE INFORMATION].

(18) The CUSTOMER/SERVICE TECHNICIAN screen is displayed.

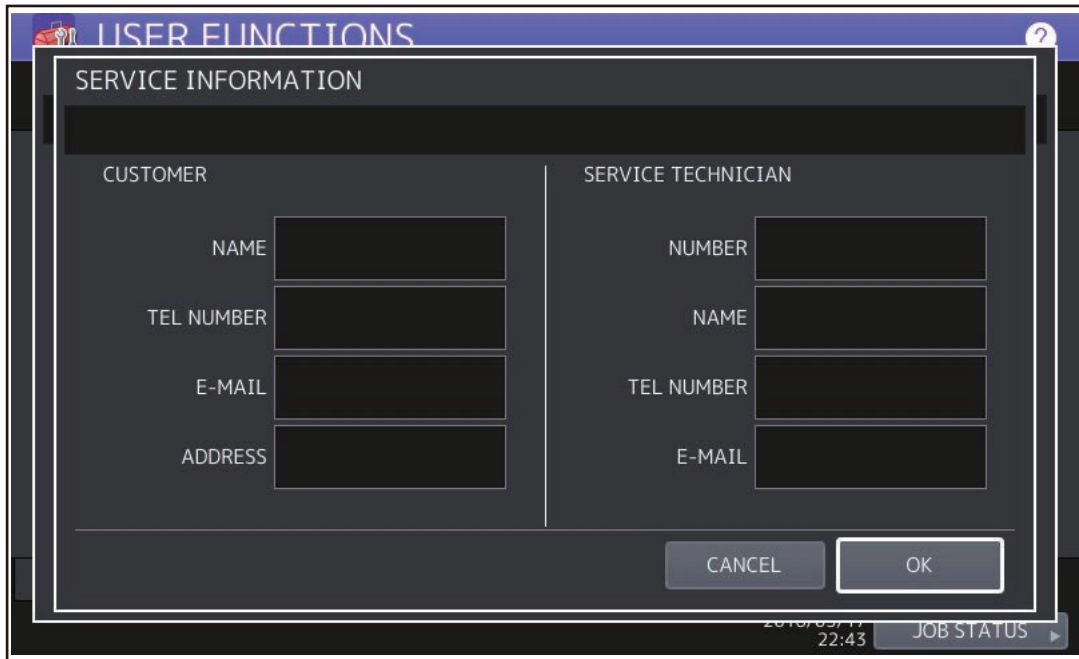


Fig.10-8

(19) Press the buttons of the screen of CUSTOMER/SERVICE TECHNICIAN to set the required item.  
CUSTOMER

[NAME]            Input the name of customer.

[TEL NUMBER]    Input the telephone number of customer.

[E-MAIL] Input the E-mail address of customer.  
[ADDRESS] Input the address of customer.

### SERVICE TECHNICIAN

[NUMBER] Input the number of SERVICE TECHNICIAN.  
[NAME] Input the name of SERVICE TECHNICIAN.  
[TEL NUMBER] Input the telephone number of SERVICE TECHNICIAN.  
[E-MAIL] Input the E-mail address of SERVICE TECHNICIAN.

(20) Press [OK] to register and complete the order information setting.

(21) The SERVICE screen is returned.

(22) Press [SUPPLY ORDER SETUP].



Fig.10-9



(23) Press [TONER ORDERING].



Fig.10-10

(24) The TONER ORDERING screen is displayed.

(25) Select the part to be ordered. (Press [YELLOW])

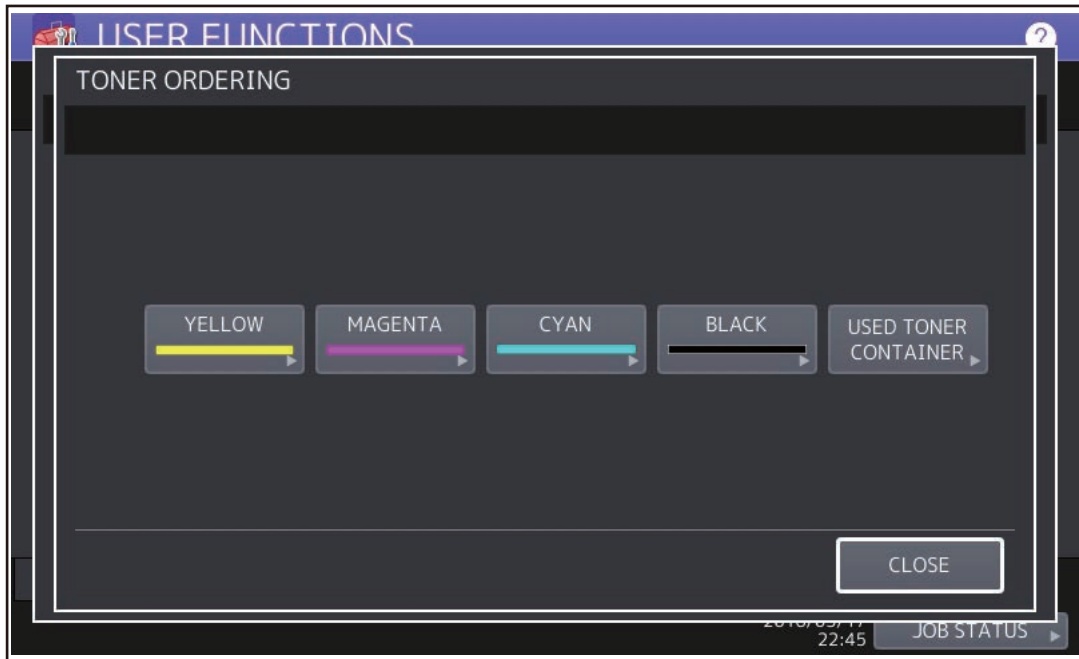


Fig.10-11

(26) Input the order information of TONER.

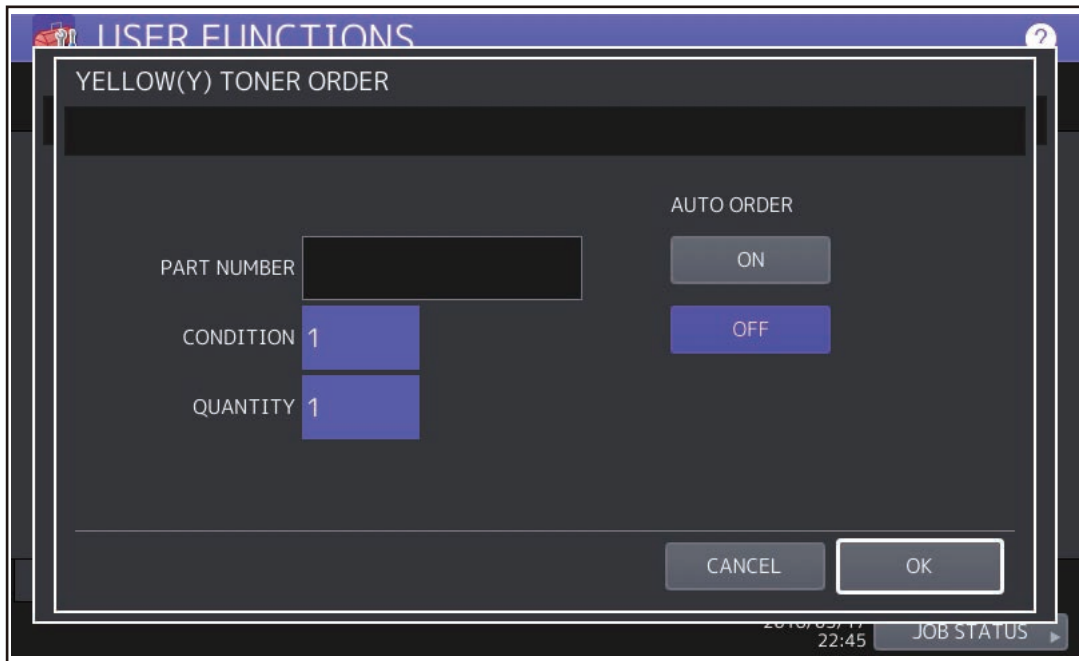


Fig.10-12

- [PART NUMBER] Toner number
- [CONDITION] The order is placed when the accumulated number of toner empty times reaches the value set in here.
- [QUANTITY] Quantity to be ordered
- AUTO ORDER
- [ON]/[OFF] Allows you to select whether each part to be ordered is placed automatically or not.

(27) Press [OK] to register the setting of toner order.

(28) The TONER ORDERING screen is displayed.

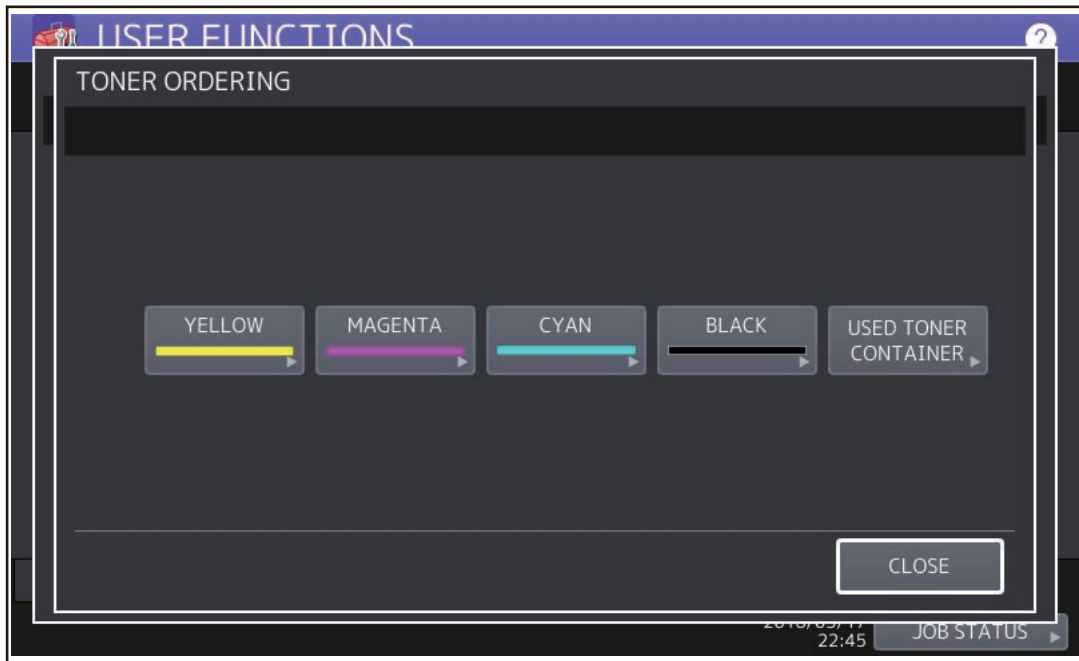


Fig.10-13

(29) Press [MAGENTA] / [CYAN] / [BLACK] / [USED TONER CONTAINER], and then input the order information in the same way.

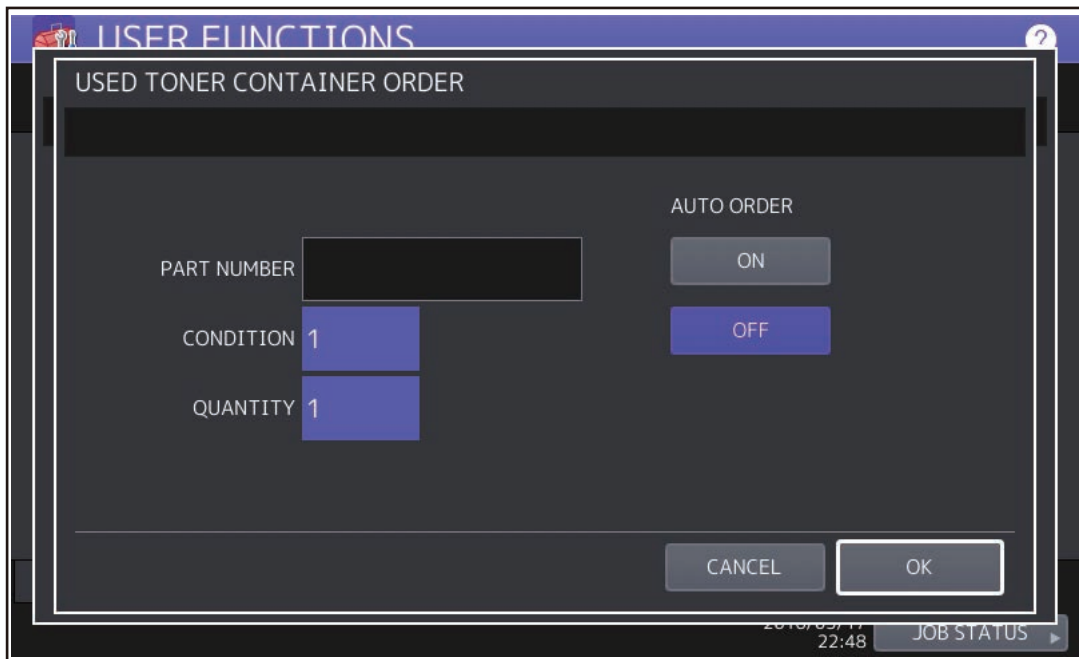


Fig.10-14

(30) Press [OK] to register the order information.

**Notes:**

Auto Supply Order setting is also available from the following 08 Setting Mode.

Items	Code	Contents
The transmitting way of order [FAX]/[MAIL] /[OFF]	FS-08-9750	0: Ordered by FAX 1: Ordered by E-mail 2: Ordered by HTTP 3: OFF
SUPPLIER [FAX NUMBER]	FS-08-9751	Maximum 32 digits
SUPPLIER [E-MAIL]	FS-08-9752	Maximum 192 letters
CUSTOMER [NAME]	FS-08-9756	Maximum 50 letters
CUSTOMER [TEL NUMBER]	FS-08-9757	Maximum 32 digits
CUSTOMER [E-MAIL]	FS-08-9758	Maximum 192 letters
CUSTOMER [ADDRESS]	FS-08-9759	Maximum 100 letters
SUPPLIER [NAME]	FS-08-9764	Maximum 50 letters
SUPPLIER [ADDRESS]	FS-08-9765	Maximum 100 letters
SERVICE TECHNICIAN [NUMBER]	FS-08-9760	Maximum 5 digits
SERVICE TECHNICIAN [NAME]	FS-08-9761	Maximum 50 letters
SERVICE TECHNICIAN [TEL NUMBER]	FS-08-9762	Maximum 32 digits
SERVICE TECHNICIAN [E-MAIL]	FS-08-9763	Maximum 192 letters
Remarks [DESCRIPTION]	FS-08-9766	Maximum 128 letters
YELLOW(Y) TONER [PART NUMBER]	FS-08-9773	Maximum 20 digits
YELLOW(Y) TONER [CONDITION]	FS-08-9775	1-99
YELLOW(Y) TONER [QUANTITY]	FS-08-9774	1-99
MAGENTA(M) TONER [PART NUMBER]	FS-08-9770	Maximum 20 digits
MAGENTA(M) TONER [CONDITION]	FS-08-9772	1-99
MAGENTA(M) TONER [QUANTITY]	FS-08-9771	1-99
CYAN(C) TONER [PART NUMBER]	FS-08-9767	Maximum 20 digits
CYAN(C) TONER [CONDITION]	FS-08-9769	1-99
CYAN(C) TONER [QUANTITY]	FS-08-9768	1-99
BLACK(K) TONER [PART NUMBER]	FS-08-9776	Maximum 20 digits

Items	Code	Contents
BLACK(K) TONER [CONDITION]	FS-08-9778	1-99
BLACK(K) TONER [QUANTITY]	FS-08-9777	1-99
USED TONER CONTAINER [PART NUMBER]	FS-08-9779	Maximum 20 digits
USED TONER CONTAINER [CONDITION]	FS-08-9781	1-99
USED TONER CONTAINER [QUANTITY]	FS-08-9780	1-99

(31) The SERVICE screen is returned.

(32) Press [SERVICE NOTIFICATION (DEVICE INFO)].



Fig.10-15

(33) Press [ON] or [OFF] in SERVICE NOTIFICATION (DEVICE INFO).  
When [OFF] is pressed, all functions related SERVICE NOTIFICATION (DEVICE INFO) become ineffective.

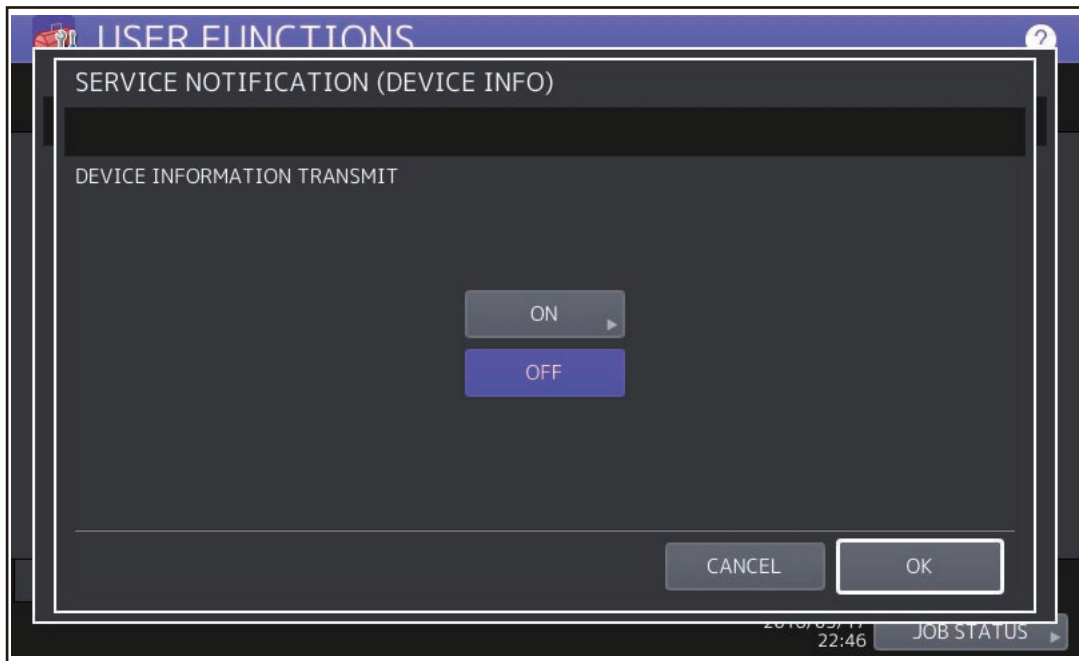


Fig.10-16

- (34) When SERVICE NOTIFICATION (DEVICE INFO) is set to ON, the screen to set the notification date is displayed.  
Then set the notification date with the following procedure.

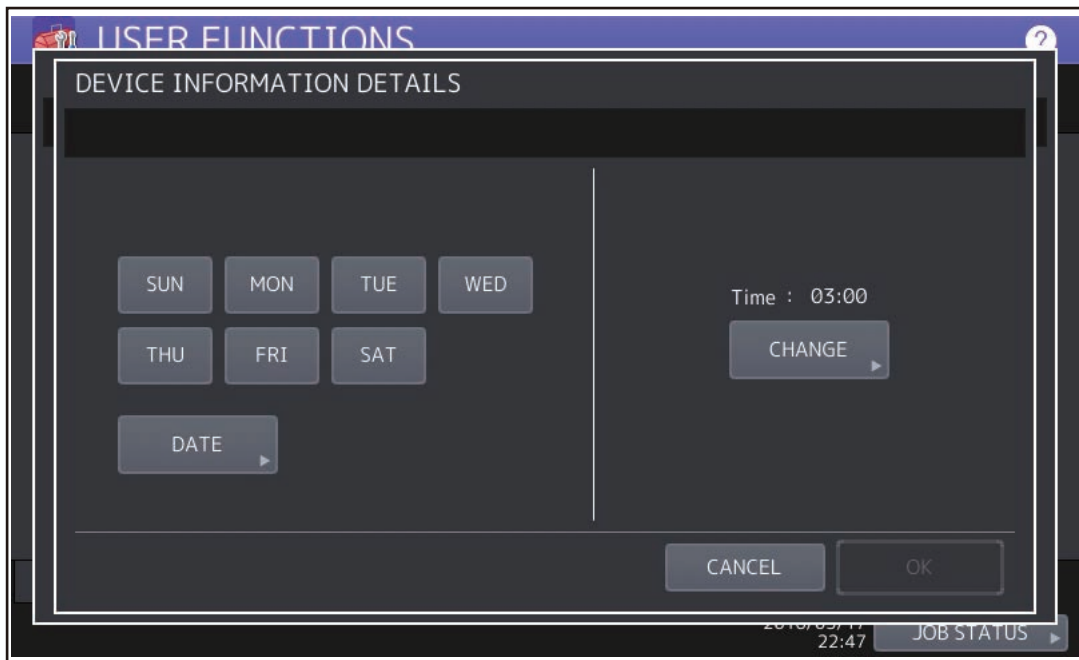


Fig.10-17

Set the date and time of the Total Counter.

The following 3 items can be specified for the date setting, and more than one day of the week also can be selected.

- Day of the week (More than one day can be selected.)
- Notify Date 1
- Notify Date 2

- **Day of the week ([SUN] to [SAT])**  
Pressing [SUN] to [SAT] of the desired day makes transmission on every specified day. More than one day can be selected.
- \* This does not affect the settings of “Notify Date 1” and “Notify Date 2”.
- **Notify Date 1 and Notify Date 2 ([DATE])**  
Pressing [DATE] sets up to 2 dates on which you want to send data.
- \* This is not affected by the specified day of the week.

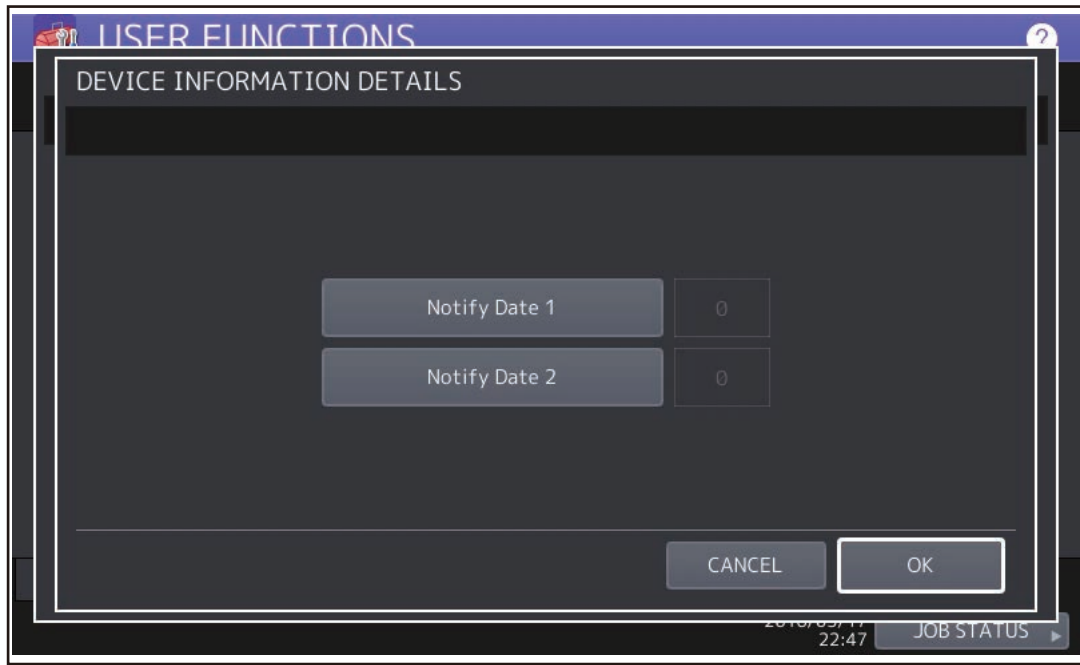


Fig.10-18

Key in the date (acceptable values: 0-31) in “Notify Date 1” or “Notify Date 2” and press [OK].

- **Time setting ([CHANGE])**  
Pressing [CHANGE] sets the time at which you want to send data.  
This is the time when data are sent with “Day of the week”, “Notify Date 1” and “Notify Date 2”.

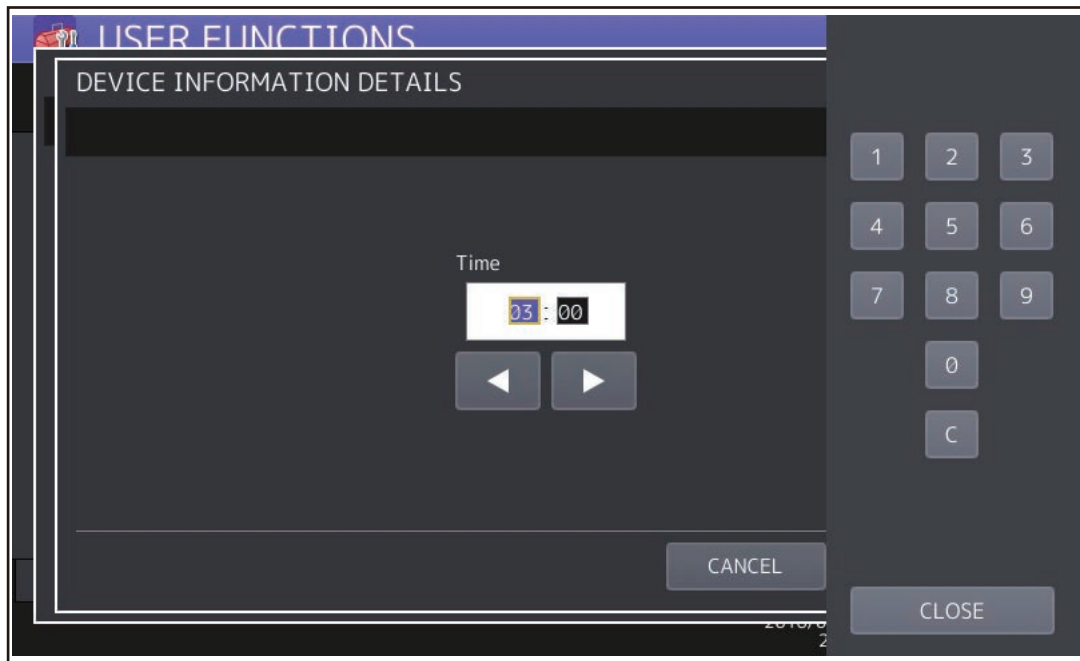


Fig.10-19

Key in the time (acceptable values: 00:00-23:59) in "Time".

Key in the time in the hour column of "Time", press the scroll button, key in the time in the minute column of "Time".

After all the settings are completed, press [OK].

(35) Press [CLOSE]. The setting completes.



## 10.1.4 Order Sheet Format

The sample of order sheet is as follows.

- (1) FAX (This format is the same as that of TIFF image attached E-mail.)  
 \*1 Part not to be ordered is not output. (Less space between the lines)

DATE & TIME	:99-99-'99 99:99			
CUSTOMER NUMBER	:XXX			
CUSTOMER NAME	:XX			
CUSTOMER ADDRESS	:XX			
CUSTOMER TEL NUMBER	:XX			
CUSTOMER E-MAIL ADDRESS	:XX			
SERVICE TECHNICIAN TEL NUMBER	:XX			
SERVICE TECHNICIAN E-MAIL	:XX			
SUPPLIER NAME	:XX			
SUPPLIER ADDRESS	:XX			

---

	PART NUMBER	QUANTITY	
TONER CARTRIDGE			
CYAN	:XXXXXXXXXXXX	99	} (*1)
MAGENTA	:XXXXXXXXXXXX	99	
YELLOW	:XXXXXXXXXXXX	99	
BLACK	:XXXXXXXXXXXX	99	
USED TONER CONTAINER	:XXXXXXXXXXXX	99	

---

DESCRIPTION AREA .....

.....

DEVICE DESCRIPTION	:XXXXXXXXXXXXXXXXXXXXXXXXXXXX			
SERIAL NUMBER	:XXXXXXXXXXXXXXXXXXXXXXXXXXXX			
DEVICE FAX NUMBER	:XXXXXXXXXXXXXXXXXXXXXXXXXXXX			
DEVICE E-MAIL ADDRESS	:XXXXXXXXXXXXXXXXXXXXXXXXXXXX			

	TOTAL	BLACK	TWIN COLOR	FULL COLOR
PRINT COUNTER	999999999	999999999	999999999	999999999
SCAN COUNTER	999999999	999999999	999999999	999999999

TONER INFORMATION

YELLOW REMAINING QUANTITY (%)	: 0000059
MAGENTA REMAINING QUANTITY (%)	: 0000060
CYAN REMAINING QUANTITY (%)	: 0000061
BLACK REMAINING QUANTITY (%)	: 0000062

Fig.10-20

DESCRIPTION AREA:           Remarks  
 DEVICE DESCRIPTION:       Model name  
 SERIAL NUMBER:            Serial number  
 DEVICE FAX NUMBER:        Fax number  
 DEVICE E-MAIL ADDRESS:   E-mail address

(2) E-MAIL (TIFF image attached with the E-mail is the same format with that of the FAX order sheet.)

SUBJECT: SUPPLY ORDER REQUEST

\*1 Part not to be ordered is not output. (Less space between the lines)

```
Date&Time: '12-04-14 00:17
Customer Number: a1 MachineName: TOSHIBA e-STUDIOxxxx
SerialNumber: 1234567890
Device FAX Number: 456
Device Email: aaa@linux.nam1.local
OrderInformation:
CYAN PartNumber: CYAN-01 Quantity: 15
MAGENTA PartNumber: MAGENTA-02 Quantity: 16 } (*1)
BLACK PartNumber: BLACK-04 Quantity: 18
CounterInformation:
PrintCounter(Small) FullColor: 0 TwinColor: 0 Black: 150
PrintCounter(Large) FullColor: 0 TwinColor: 0 Black: 0
ScanCounter FullColor: 0 TwinColor: 0 Black: 7
```

Fig.10-21

Date&Time:	Order date and time
Customer Number:	Customer number
MachineName:	Model name (MFP model name)
SerialNumber:	Serial number
Device FAX Number:	Fax number
Device Email:	E-mail address
OrderInformation:	Order information
CYAN PartNumber:	Cyan toner cartridge part number
MAGENTA PartNumber:	Magenta toner cartridge part number
BLACK PartNumber:	Black toner cartridge part number
Quantity:	Order quantity
CounterInformation:	Counter information
PrintCounter (Small) FullColor: 0 TwinColor: 0 Black:	Print count (Small size) for Full color, Twin color and Black
PrintCounter (Large) FullColor: 0 TwinColor: 0 Black:	Print count (Large size) for Full color, Twin color and Black
ScanCounter FullColor: 0 TwinColor: 0 Black:	Scan count
	Scan count for Full color, Twin color and Black

(3) Result list

\*1 Part not to be ordered is not output. (Less space between the lines)

```
ORDER XXXXXXXXX
DATE & TIME          :99-99-'99 99:99
CUSTOMER NUMBER      :XXX
CUSTOMER NAME        :XXXXXXXXXXXXXXXXXXXXXXXXXXXXXXXXXXXX
CUSTOMER ADDRESS     :XXXXXXXXXXXXXXXXXXXXXXXXXXXXXXXXXXXXXXXXXXXX
CUSTOMER TEL NUMBER  :XXXXXXXXXXXXXXXXXXXXXXXXXXXXXXXXXXXX
CUSTOMER E-MAIL ADDRESS :XXXXXXXXXXXXXXXXXXXXXXXXXXXXXXXXXXXXXXXXXXXX
SERVICE TECHNICIAN
TEL NUMBER           :XXXXXXXXXXXXXXXXXXXXXXXXXXXXXXXXXXXX
SERVICE TECHNICIAN E-MAIL :XXXXXXXXXXXXXXXXXXXXXXXXXXXXXXXXXXXXXXXXXXXX
SUPPLIER NAME        :XXXXXXXXXXXXXXXXXXXXXXXXXXXXXXXXXXXX
SUPPLIER ADDRESS     :XXXXXXXXXXXXXXXXXXXXXXXXXXXXXXXXXXXXXXXXXXXX

-----
TONER CARTRIDGE      PART NUMBER      QUANTITY
CYAN                  :XXXXXXXXXXXXX      99
MAGENTA               :XXXXXXXXXXXXX      99
YELLOW                :XXXXXXXXXXXXX      99  (*1)
BLACK                 :XXXXXXXXXXXXX      99
USED TONER CONTAINER :XXXXXXXXXXXXX      99
-----
DESCRIPTION AREA .....
.....
DEVICE DESCRIPTION   :XXXXXXXXXXXXXXXXXXXXXXXXXXXX
SERIAL NUMBER        :XXXXXXXXXXXXXXXXXXXXXXXXXXXX
DEVICE FAX NUMBER    :XXXXXXXXXXXXXXXXXXXXXXXXXXXX
DEVICE E-MAIL ADDRESS :XXXXXXXXXXXXXXXXXXXXXXXXXXXX

PRINT COUNTER      TOTAL      BLACK      TWIN COLOR      FULL COLOR
999999999          999999999  999999999  999999999      999999999
SCAN COUNTER       999999999  999999999  999999999      999999999

TONER INFORMATION

YELLOW REMAINING QUANTITY (%) : 00000059
MAGENTA REMAINING QUANTITY (%) : 00000059
CYAN REMAINING QUANTITY (%)    : 00000059
BLACK REMAINING QUANTITY (%)   : 00000059
```

Fig.10-22

ORDER SUCCESSFUL/FAILURE:	Automatic supply ordering: transmission success or failure
DATE & TIME:	Order date and time
CUSTOMER NUMBER:	Customer number
CUSTOMER NAME:	Customer name
CUSTOMER ADDRESS:	Customer address
CUSTOMER TEL NUMBER:	Customer telephone number
CUSTOMER E-MAIL ADDRESS:	Customer E-mail address
SERVICE TECHNICIAN TEL NUMBER:	Service technician telephone number
SERVICE TECHNICIAN E-MAIL:	Service technician E-mail address
SUPPLIER NAME:	Supplier name
SUPPLIER ADDRESS:	Supplier address
PART NUMBER:	Order part number

QUANTITY:	Order quantity
TONER CARTRIDGE:	Toner cartridge
	CYAN: Cyan
	MAGENTA: Magenta
	YELLOW: Yellow
	BLACK: Black
USED TONER CONTAINER:	Used toner container (waste toner box)
DESCRIPTION AREA:	Remarks
DEVICE DESCRIPTION:	Model name (MFP model name)
SERIAL NUMBER:	Serial number
DEVICE FAX NUMBER:	Fax number
DEVICE E-MAIL ADDRESS:	E-mail address
PRINT COUNTER:	Print count
SCAN COUNTER:	Scan count
TOTAL:	Total
BLACK:	Black
TWIN COLOR:	Twin color
FULL COLOR:	Full color
YELLOW REMAINING QUANTITY (%)	Toner remaining quantity (Yellow)
MAGENTA REMAINING QUANTITY (%)	Toner remaining quantity (Magenta)
CYAN REMAINING QUANTITY (%)	Toner remaining quantity (Cyan)
BKACKREMAINING QUANTITY (%)	Toner remaining quantity (Black)

## 10.2 Service Notification

### 10.2.1 Outline

This function automatically notifies the status of the equipment to the service technician by E-mail or FAX. The following 6 are the items to be notified.

- Total counter transmit  
When this function is effective, it notifies each counter information periodically (on the set date and time every month).
- Service call transmit (E-mail only)  
When this function is effective, it notifies the corresponding error code and such at a service call error.
- PM counter transmit  
When this function is effective, it notifies that the PM timing has come when the present PM count has reached to its setting value, or the present PM driving count has reached to its setting value.
- Toner near empty transmit  
When this function is effective, it notifies each counter information and toner cartridge information if toner near empty occurs.
- Waste toner near full transmit  
When this function is effective, it notifies each counter information and toner cartridge information if toner near empty occurs.
- HDD alert notification  
When this function is effective, it notifies an alert for backing up or replacing the HDD.

### 10.2.2 Setting

**Notes:**

When using this function, it is required that sending and receiving E-mails or FAXes are available. Confirm the details to the administrator.

#### [ 1 ] Preparation

If the menu display of this function is disabled (not displayed), set it to be enabled (displayed) with the following code.

FS-08-9604	Setting of notification display
	0: Invalid
	1: Valid

## [ 2 ] Setting procedure

- (1) Press [USER FUNCTIONS] on the HOME screen and select the [ADMIN] tab. Then, enter the password and press [OK].  
Confirm the password to the administrator.

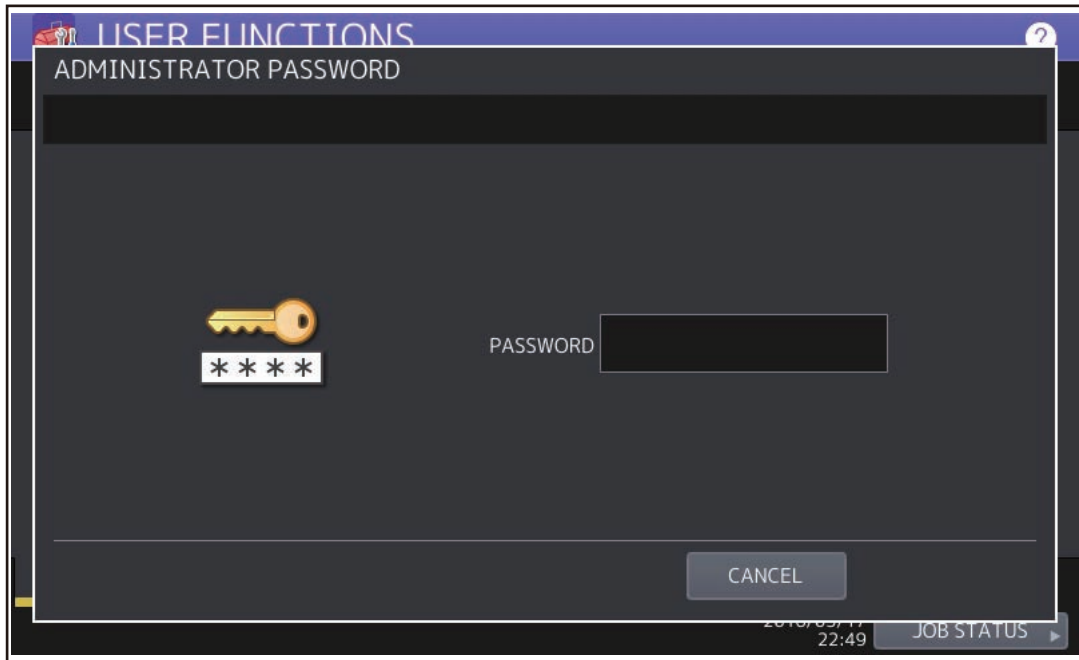


Fig.10-23

- (2) Press [SERVICE].

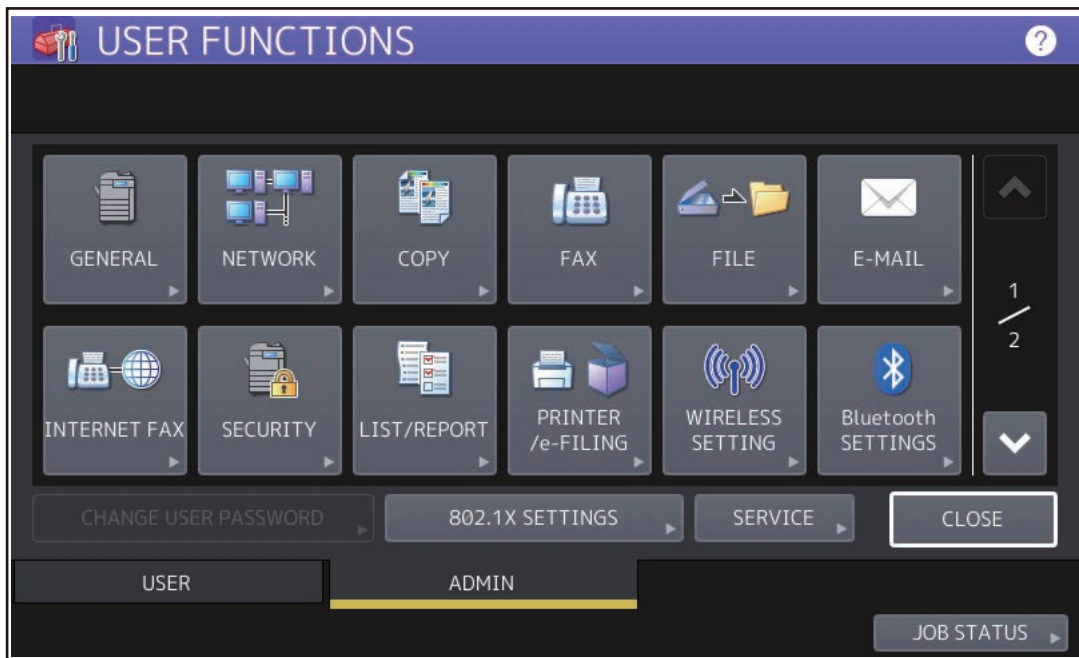


Fig.10-24

(3) Press [SERVICE NOTIFICATION].

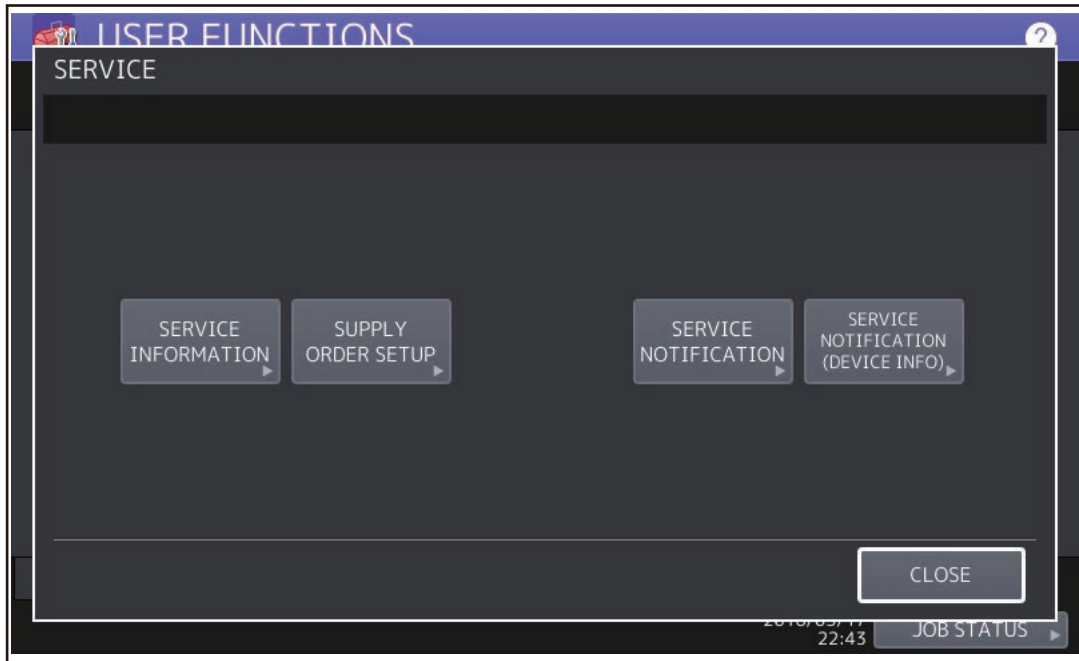


Fig.10-25

(4) Press [E-MAIL] or [FAX].  
When [OFF] is pressed, all functions related Service Notification become ineffective.

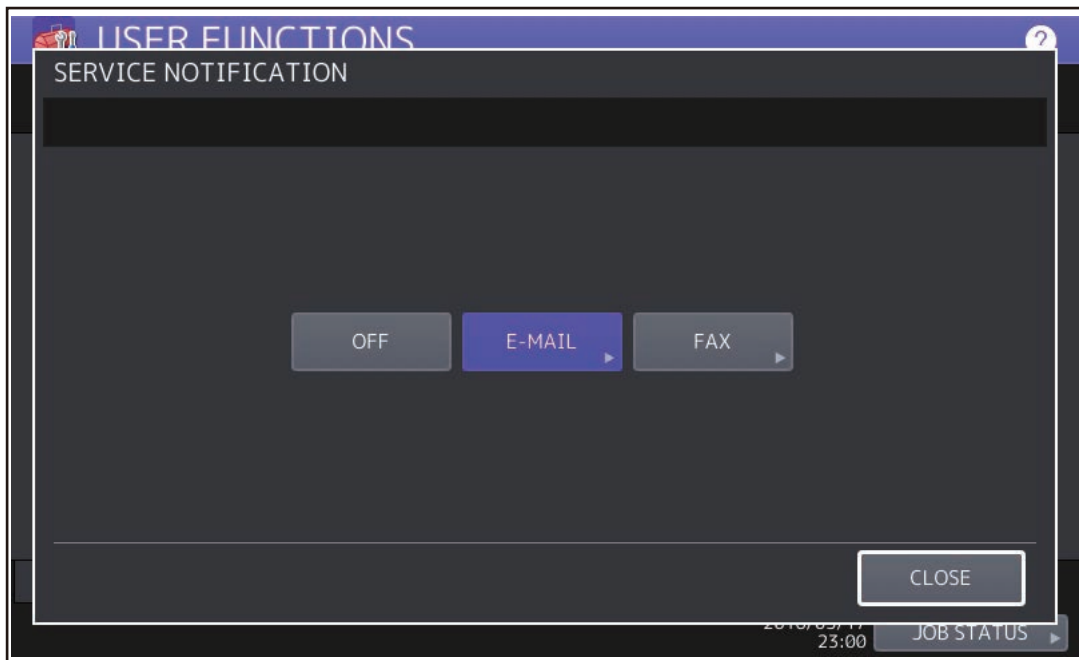


Fig.10-26

- (5) Enter the e-mail address or fax number of the destination and press [OK]. A maximum of 3 addresses can be set. (The keyboard appears upon your touching the entry box for an e-mail address.)

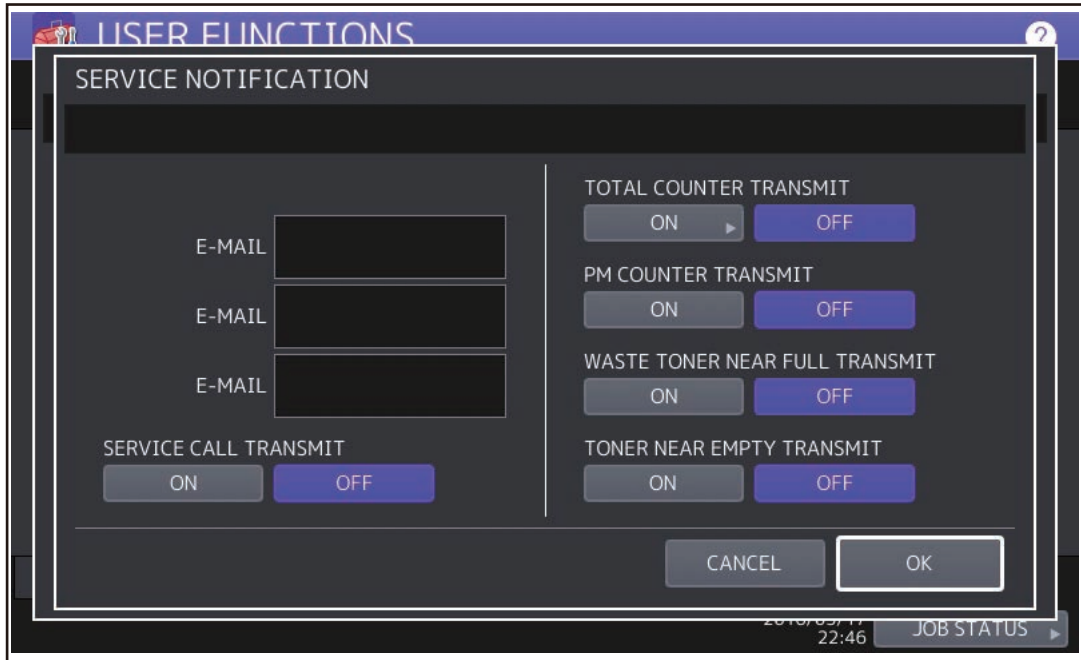


Fig.10-27

Press [FAX NUMBER], key in the FAX number and then press [OK].

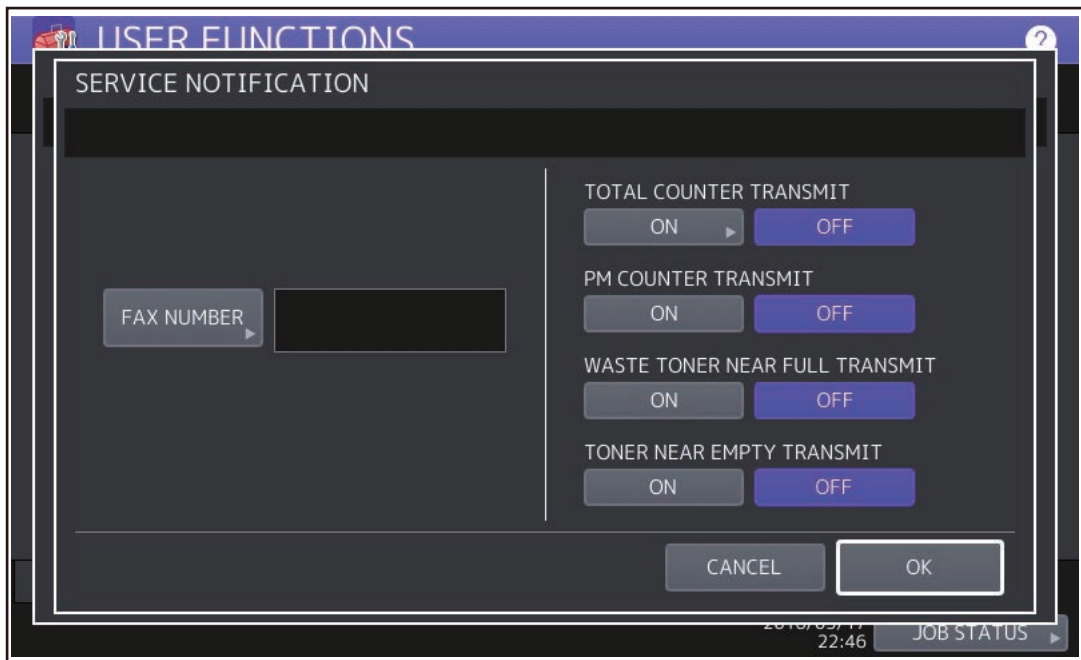


Fig.10-28



- (6) Press [ON] to notify or [OFF] not to notify each item for E-mail and FAX.  
When Total Count Transmit is set to ON, the screen to set the notification date is displayed.  
Then set the notification date with the following procedure.

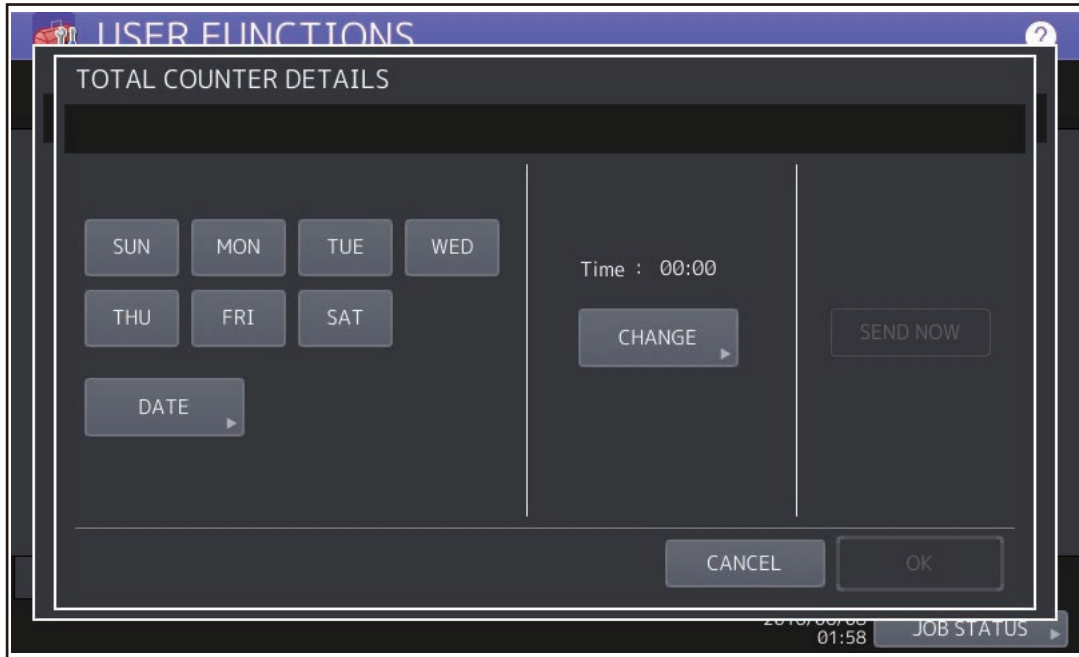


Fig.10-29

Set the date and time of the Total Counter.

The following 3 items can be specified for the date setting, and more than one day of the week also can be selected.

- Day of the week (More than one day can be selected.)
- Notify Date 1
- Notify Date 2

You can send the Total Counter immediately without the above settings by pressing [SEND NOW].

- **Day of the week ([SUN] to [SAT])**  
Pressing [SUN] to [SAT] of the desired day makes transmission on every specified day. More than one day can be selected.
  - \* This does not affect the settings of “Notify Date 1” and “Notify Date 2”.
- **Notify Date 1 and Notify Date 2 ([DATE])**  
Pressing [DATE] sets up to 2 dates on which you want to send data.
  - \* This is not affected by the specified day of the week.

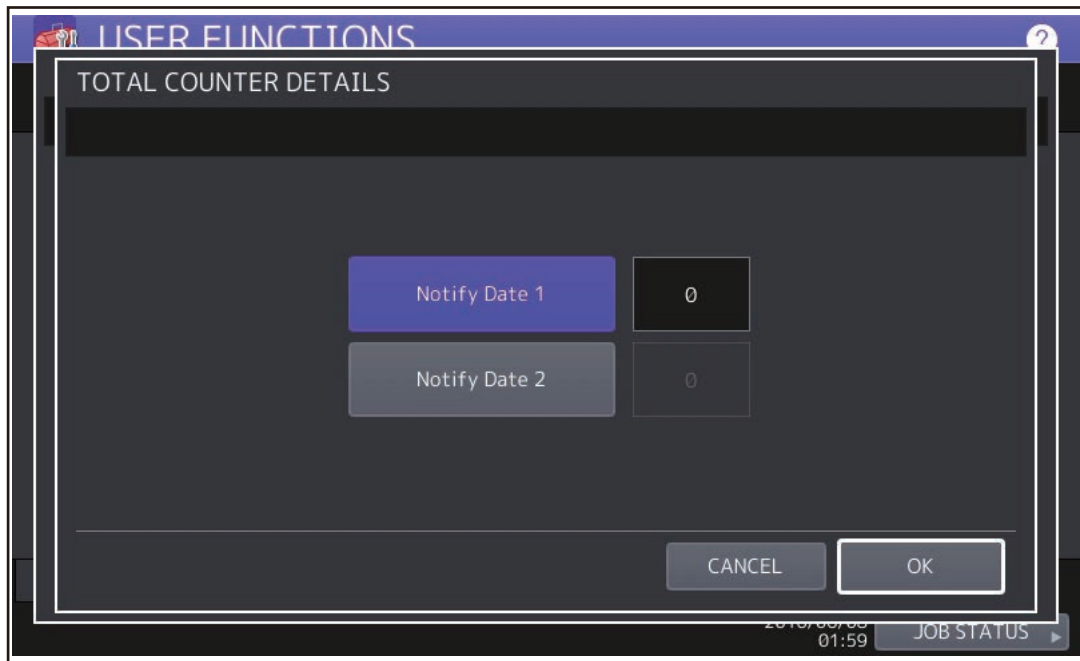


Fig.10-30

Key in the date (acceptable values: 0-31) in “Notify Date 1” or “Notify Date 2” and press [OK].

- **Time setting ([CHANGE])**

Pressing [CHANGE] sets the time at which you want to send data.

This is the time when data are sent with “Day of the week”, “Notify Date 1” and “Notify Date 2”.



Fig.10-31

Key in the time (acceptable values: 00:00-23:59) in "Time".

Key in the time in the hour column of "Time", press the scroll button, key in the time in the minute column of "Time".

After all the settings are completed, press [OK]. The display returns to the screen in step (5).

(7) Press [OK]. The setting completes.

**Notes:**

- Service Notification setting is also available from the following 08 Setting Mode.
- Set the service notification setting (FS-08-9793) to "1" or "2". Then sets the items (self-diagnostic code) which you want to transmit to ON.

Items	Code	Contents
Service Notification setting	FS-08-9793	0: OFF (Invalid) 1: E-mail 2: FAX
E-mail address 1	FS-08-9794	Maximum 192 letters
E-mail address 2	FS-08-9607	Maximum 192 letters
E-mail address 3	FS-08-9608	Maximum 192 letters
FAX number	FS-08-9784	Maximum 32 digits
Total Counter Transmit setting	FS-08-9795	0: OFF (Invalid) 1: ON (Valid)
Total counter transmission date setting	FS-08-9796	0 to 31
Total counter transmission date setting(2)	FS-08-9880	0 to 31
Day of total counter data transmission	FS-08-9881	1 byte 00000000(0)-01111111(127) From the 2nd bit - Sunday, Monday, Tuesday, Wednesday, Thursday, Friday, Saturday
Total counter transmission interval setting (Hour/Minute/Minute)	FS-08-9606	00:00-23:59

<b>Items</b>	<b>Code</b>	<b>Contents</b>
Service Call Transmit setting	FS-08-9605	0: OFF (Invalid) 1: ON (Valid)
PM Counter Transmit setting	FS-08-9797	0: OFF (Invalid) 1: ON (Valid)
Toner near empty Transmit setting	FS-08-8538	0: OFF (Invalid) 1: ON (Valid)
Waste toner near full Transmit setting	FS-08-3699	0: OFF (Invalid) 1: ON (Valid)

### 10.2.3 Items to be notified

The items to be notified are shown below.

#### 1. Total Counter Transmit / PM Counter Transmit by E-mail

Subject: Counter Notification

(In case of the PM Counter Transmit, it is shown as "Periodical Maintenance Notification".)

①	Date	: 04/26/2012 12:34	
②	Machine Model	: TOSHIBA e-STUDIOxxxx	
③	SerialNumber	: 1234567890	
④	Total Counter	: 00004787	
⑤	Supplier:		
	Name	: SUPPLIER_NAME	
	Tel Number	: 1122334455	
	E-Mail	: Supplier_emailaddress@cccc.xxx	
	Address	: SUPPLIER_ADDRESS	
⑥	Customer:		
	Name	: CUSTOMER_NAME	
	Tel Number	: 1234567890	
	E-Mail	: customer_emailaddress@dddd.xxx	
	Address	: CUSTOMER_ADDRESS	
⑦	Service Technician:		
	Number	: svc12	
	Name	: SERVICE_TECHNICIAN_NAME	
	Tel Number	: 0987654321	
	E-Mail	: svc@toshibatec.co.jp	
	ChargeCounterFormat:		
⑧	LargeSizeChargeCount	1	
⑨	LargeSizeChargePaperDefinition	1	
	PMCounterFormat:		
⑩	LargeSizePMCount	1	
⑪	LargeSizePMPaperDefinition	0	
	Charge Counter:	Large	Small
	<Print Counter>		
	Full Color -----		
⑫	Copy	00000000	00000000
⑬	Print	00000000	00000000
	Twin Color -----		
⑭	Copy	00000000	00000000
	Black -----		
⑮	Copy	00000000	00000000
⑯	Print	00000000	00000000
⑰	List	00000000	00000000
⑱	FAX	00000000	00000000
	<Scan Counter>		
	Full Color -----		
⑲	Copy Scan	00000000	00000000
⑳	Net Scan	00000000	00000000
	Twin Color -----		
㉑	Copy Scan	00000000	00000000
	Black -----		
㉒	Copy Scan	00000000	00000000
㉓	FAX Scan	00000000	00000000
㉔	Net Scan	00000000	00000000
	<FAX Counter>		
㉕	Transmit	00000000	00000000
㉖	Receive	00000000	00000000

Fig.10-32

Periodical Maintenance Counter:			
		Pages	Drive Counts
-----			
②7	K-EPU		
	Setting	00000000	00000000
②8	Current	00000000	00000000
Y-EPU			
②9	Setting	00000000	00000000
③0	Current	00000000	00000000
M-EPU			
③1	Setting	00000000	00000000
③2	Current	00000000	00000000
C-EPU			
③3	Setting	00000000	00000000
③4	Current	00000000	00000000
-----			
K-Dev			
③5	Setting	00000000	00000000
③6	Current	00000000	00000000
Y-Dev			
③7	Setting	00000000	00000000
③8	Current	00000000	00000000
M-Dev			
③9	Setting	00000000	00000000
④0	Current	00000000	00000000
C-Dev			
④1	Setting	00000000	00000000
④2	Current	00000000	00000000
-----			
Others			
④3	Setting	00000000	00000000
④4	Current	00000000	00000000
-----			
④5	Printer Error History:		
	Date	Time	ErrorCode Counter
	04/13/2008	16:44	F110 00000000
	04/12/2008	22:28	F110 00000000
	04/12/2008	22:23	F110 00000000
	03/15/2008	22:23	F110 00000000
	02/25/2008	11:12	F110 00000000
	-----		
	Toner Information		
	Toner	Remaining Quantity (%)	
④6	Yellow	00000000	
④7	Magenta	00000000	
④8	Cyan	00000000	
④9	Black	00000000	

Fig.10-33

- ① Date
- ② Machine model name
- ③ Serial number
- ④ Total counter value
- ⑤ Supplier information
- ⑥ Customer information
- ⑦ Service technician information
- ⑧ Count setting of large-sized paper (Fee charging system counter)
- ⑨ Definition setting of large-sized paper (Fee charging system counter)
- ⑩ Count setting of large-sized paper (PM)
- ⑪ Definition setting of large-sized paper (PM)
- ⑫ Number of output pages in the Copier Function (FULL COLOR)
- ⑬ Number of output pages in the Printer Function (FULL COLOR)

- ⑭ Number of output pages in the Copier Function (TWIN COLOR)
- ⑮ Number of output pages in the Copier Function (BLACK)
- ⑯ Number of output pages in the Printer Function (BLACK)
- ⑰ Number of output pages at the List Print Mode (BLACK)
- ⑱ Number of output pages in the FAX Function (BLACK)
- ⑲ Number of scanning pages in the Copier Function (FULL COLOR)
- ⑳ Number of scanning pages in the Network Scanning Function (FULL COLOR)
- ㉑ Number of scanning pages in the Copier Function (TWIN COLOR)
- ㉒ Number of scanning pages in the Copier Function (BLACK)
- ㉓ Number of scanning pages in the FAX Function (BLACK)
- ㉔ Number of scanning pages in the Network Scanning Function (BLACK)
- ㉕ Number of transmitted pages in the FAX Function (BLACK)
- ㉖ Number of received pages in the FAX Function (BLACK)
- ㉗ PM count setting value / PM driving count setting value [EPU (K)]
- ㉘ PM count present value / PM driving count present value [EPU (K)]
- ㉙ PM count setting value / PM driving count setting value [EPU (Y)]
- ㉚ PM count present value / PM driving count present value [EPU (Y)]
- ㉛ PM count setting value / PM driving count setting value [EPU (M)]
- ㉜ PM count present value / PM driving count present value [EPU (M)]
- ㉝ PM count setting value / PM driving count setting value [EPU (C)]
- ㉞ PM count present value / PM driving count present value [EPU (C)]
- ㉟ PM count setting value / PM driving count setting value [Developer material (K)]
- ㊱ PM count present value / PM driving count present value [Developer material (K)]
- ㊲ PM count setting value / PM driving count setting value [Developer material (Y)]
- ㊳ PM count present value / PM driving count present value [Developer material (Y)]
- ㊴ PM count setting value / PM driving count setting value [Developer material (M)]
- ㊵ PM count present value / PM driving count present value [Developer material (M)]
- ㊶ PM count setting value / PM driving count setting value [Developer material (C)]
- ㊷ PM count present value / PM driving count present value [Developer material (C)]
- ㊸ PM count setting value / PM driving count setting value [Other parts]
- ㊹ PM count present value / PM driving count present value [Other parts]
- ㊺ History error

\*1 The latest 20 errors are displayed.

- ④⑥ Toner remaining quantity (Yellow)
- ④⑦ Toner remaining quantity (Magenta)
- ④⑧ Toner remaining quantity (Cyan)
- ④⑨ Toner remaining quantity (Black)



## 2. Total Counter Transmit / PM Counter Transmit by FAX

\*1 In case of the PM Counter Transmit, the title is replaced to "PERIODICAL MAINTENANCE NOTIFICATION".

Sheet 1

COUNTER NOTIFICATION (*1)	
①	DATE : 12/04/14 13:47
②	MACHINE MODEL : TOSHIBA e-STUDIOxxxx
③	SERIAL NUMBER : 1234567890
④	TOTAL COUNTER : 00004787
⑤	CUSTOMER NAME : CUSTOMER_NAME
	CUSTOMER ADDRESS : CUSTOMER_ADDRESS
	CUSTOMER TEL NUMBER : 1234567890
	CUSTOMER E-MAIL ADDRESS : customer_emailaddress@dddd.xxx
⑥	SERVICE TECHNICIAN NUMBER : svc12
	SERVICE TECHNICIAN NAME : SERVICE_TECHNICIAN_NAME
	SERVICE TECHNICIAN TEL NUMBER : 0987654321
	SERVICE TECHNICIAN E-MAIL : svc@toshibatec.co.jp
⑦	SUPPLIER NAME : SUPPLIER_NAME
	SUPPLIER ADDRESS : SUPPLIER_ADDRESS
	SUPPLIER FAX NUMBER : 5544332211
	SUPPLIER E-MAIL : supplier_emailaddress@cccc.xxx

Fig.10-34



COUNTER NOTIFICATION (*1)							
PRINTER ERROR HISTORY							
DATE	TIME	ERROR CODE	COUNTER	DATE	TIME	ERROR CODE	COUNTER
08/04/13	16:44	F110	00000000	08/04/13	16:44	F110	00000000
08/04/12	22:28	F110	00000000	08/04/13	16:44	F110	00000000
08/04/12	22:23	F110	00000000	08/04/13	16:44	F110	00000000
08/03/15	22:23	F110	00000000	08/04/13	16:44	F110	00000000
08/02/25	11:12	F110	00000000	08/04/13	16:44	F110	00000000
TONER INFORMATION							
YELLOW REMAINING QUANTITY (%)				:	00000059		
MAGENTA REMAINING QUANTITY (%)				:	00000059		
CYAN REMAINING QUANTITY (%)				:	00000059		
BLACK REMAINING QUANTITY (%)				:	00000059		

Fig.10-36

- ① Date
- ② Machine model name
- ③ Serial number
- ④ Total counter value
- ⑤ Customer information
- ⑥ Service technician information
- ⑦ Supplier information
- ⑧ Count setting of large-sized paper (Fee charging system counter)
- ⑨ Definition setting of large-sized paper (Fee charging system counter)
- ⑩ Count setting of large-sized paper (PM)
- ⑪ Definition setting of large-sized paper (PM)
- ⑫ Number of output pages in the Copier Function (FULL COLOR)
- ⑬ Number of output pages in the Printer Function (FULL COLOR)
- ⑭ Number of output pages in the Copier Function (TWIN COLOR)
- ⑮ Number of output pages in the Printer Function (TWIN COLOR)
- ⑯ Number of output pages in the Copier Function (BLACK)
- ⑰ Number of output pages in the Printer Function (BLACK)
- ⑱ Number of output pages at the List Print Mode (BLACK)
- ⑲ Number of output pages in the FAX Function (BLACK)

- ②0 Number of scanning pages in the Copier Function (FULL COLOR)
- ②1 Number of scanning pages in the Network Scanning Function (FULL COLOR)
- ②2 Number of scanning pages in the Copier Function (TWIN COLOR)
- ②3 Number of scanning pages in the Copier Function (BLACK)
- ②4 Number of scanning pages in the FAX Function (BLACK)
- ②5 Number of scanning pages in the Network Scanning Function (BLACK)
- ②6 Number of transmitted pages in the FAX Function (BLACK)
- ②7 Number of received pages in the FAX Function (BLACK)
- ②8 PM count setting value [EPU (K)]
- ②9 PM count present value [EPU (K)]
- ③0 PM driving count setting value [EPU (K)]
- ③1 PM driving count present value [EPU (K)]
- ③2 PM count setting value [EPU (Y)]
- ③3 PM count present value [EPU (Y)]
- ③4 PM driving count setting value [EPU (Y)]
- ③5 PM driving count present value [EPU (Y)]
- ③6 PM count setting value [EPU (M)]
- ③7 PM count present value [EPU (M)]
- ③8 PM driving count setting value [EPU (M)]
- ③9 PM driving count present value [EPU (M)]
- ④0 PM count setting value [EPU (C)]
- ④1 PM count present value [EPU (C)]
- ④2 PM driving count setting value [EPU (C)]
- ④3 PM driving count present value [EPU (C)]
- ④4 PM count setting value [Developer material (K)]
- ④5 PM driving count present value [Developer material (K)]
- ④6 PM driving count setting value [Developer material (K)]
- ④7 PM driving count present value [Developer material (K)]
- ④8 PM count setting value [Developer material (Y)]
- ④9 PM driving count present value [Developer material (Y)]
- ⑤0 PM driving count setting value [Developer material (Y)]
- ⑤1 PM driving count present value [Developer material (Y)]
- ⑤2 PM count setting value [Developer material (M)]

- ⑤3 PM driving count present value [Developer material (M)]
- ⑤4 PM driving count setting value [Developer material (M)]
- ⑤5 PM driving count present value [Developer material (M)]
- ⑤6 PM count setting value [Developer material (C)]
- ⑤7 PM driving count present value [Developer material (C)]
- ⑤8 PM driving count setting value [Developer material (C)]
- ⑤9 PM driving count present value [Developer material (C)]
- ⑥0 PM count setting value (Other parts)
- ⑥1 PM driving count present value (Other parts)
- ⑥2 PM driving count setting value (Other parts)
- ⑥3 PM driving count present value (Other parts)
- ⑥4 History of error
  - \*2 The latest 20 errors are displayed.
- ⑥5 Toner remaining quantity (Yellow)
- ⑥6 Toner remaining quantity (Magenta)
- ⑥7 Toner remaining quantity (Cyan)
- ⑥8 Toner remaining quantity (Black)

3. Toner near-empty notification by e-mail  
 Subject: Toner Near-Empty Notification

```

1  Date       : 04/26/2012 12:34
2  Machine Model : TOSHIBA e-STUDIOxxxx
3  SerialNumber : 1234567890
4  Total Counter : 00004787
5  Supplier:
   Name       : SUPPLIER_NAME
   Fax Number : 1122334455
   E-Mail     : Supplier_emailaddress@cccc.xxx
   Address    : SUPPLIER_ADDRESS
6  Customer:
   Name       : CUSTOMER_NAME
   Tel Number : 1234567890
   E-Mail     : customer_emailaddress@dddd.xxx
   Address    : CUSTOMER_ADDRESS
7  Service Technician:
   Number    : svc12
   Name      : SERVICE_TECHNICIAN_NAME
   Tel Number : 0987654321
   E-Mail    : svc@toshibatec.co.jp
   ChargeCounterFormat:
8  LargeSizeChargeCount      1
9  LargeSizeChargePaperDefinition  1
   PMCounterFormat:
10 LargeSizePMCount          1
11 LargeSizePMPaperDefinition  0
   Charge Counter:
   <Print Counter>
   Black -----
12 Copy      00000000  00000000
13 Print     00000000  00000000
14 List      00000000  00000000
15 FAX       00000000  00000000
   <Scan Counter>
   Full Color -----
16 Net Scan  00000000  00000000
   Black -----
17 Copy Scan 00000000  00000000
18 FAX Scan  00000000  00000000
19 Net Scan  00000000  00000000
   <FAX Counter>
20 Transmit 00000000  00000000
21 Receive  00000000  00000000
  
```

Fig.10-37

Periodical Maintenance Counter:			
		Pages	Drive Counts
22	K-EPU		
	Setting	00000000	00000000
23	Current	00000000	00000000
24	K-EPU		
	Setting	00000000	00000000
25	Current	00000000	00000000
26	Others		
	Setting	00000000	00000000
27	Current	00000000	00000000
28	Printer Error History:		
	Date	Time	ErrorCode Counter
	04/13/2008	16:44	F110 00000000
	04/12/2008	22:28	F110 00000000
	04/12/2008	22:23	F110 00000000
	03/15/2008	22:23	F110 00000000
	02/25/2008	11:12	F110 00000000
			(*1)
	Toner Information:		
	Toner		
29	Yellow		00000000
30	Magenta		00000000
31	Cyan		00000000
32	Black		00000000

Fig.10-38

1. Date
2. Machine model name
3. Serial number
4. Total counter value
5. Supplier information
6. Customer information
7. Service technician information
8. Count setting of large-sized paper (Fee charging system counter)
9. Definition setting of large-sized paper (Fee charging system counter)
10. Count setting of large-sized paper (PM)
11. Definition setting of large-sized paper (PM)
12. Number of output pages in the Copier Function (BLACK)
13. Number of output pages in the Printer Function (BLACK)
14. Number of output pages at the List Print Mode (BLACK)
15. Number of output pages in the FAX Function (BLACK)
16. Number of scanning pages in the Network Scanning Function (Full color)
17. Number of scanning pages in the Copier Function (BLACK)
18. Number of scanning pages in the FAX Function (BLACK)
19. Number of scanning pages in the Network Scanning Function (BLACK)
20. Number of transmitted pages in the FAX Function (BLACK)

21. Number of received pages in the FAX Function (BLACK)
22. PM count setting value / PM driving count setting value [EPU (K)]
23. PM count present value / PM driving count present value [EPU (K)]
24. PM count setting value / PM driving count setting value [Developer material (K)]
25. PM count present value / PM driving count present value [Developer material (K)]
26. PM count setting value / PM driving count setting value [Other parts]
27. PM count present value / PM driving count present value [Other parts]
28. History error
29. Toner remaining quantity (Yellow)
30. Toner remaining quantity (Magenta)
31. Toner remaining quantity (Cyan)
32. Toner remaining quantity (Black)



#### 4. Toner near-empty notification by FAX

##### Sheet 1

TONER NEAR-EMPTY NOTIFICATION (*1)		
1	DATE	: 12/04/14 13:47
2	MACHINE MODEL	: TOSHIBA e-STUDIOxxxx
3	SERIAL NUMBER	: 1234567890
4	TOTAL COUNTER	: 00004787
5	CUSTOMER NAME	: CUSTOMER_NAME
	CUSTOMER ADDRESS	: CUSTOMER_ADDRESS
	CUSTOMER TEL NUMBER	: 1234567890
	CUSTOMER E-MAIL ADDRESS	: customer_emailaddress@dddd.xxx
6	SERVICE TECHNICIAN NUMBER	: svc12
	SERVICE TECHNICIAN NAME	: SERVICE_TECHNICIAN_NAME
	SERVICE TECHNICIAN TEL NUMBER	: 0987654321
	SERVICE TECHNICIAN E-MAIL	: svc@toshibatec.co.jp
7	SUPPLIER NAME	: SUPPLIER_NAME
	SUPPLIER ADDRESS	: SUPPLIER_ADDRESS
	SUPPLIER FAX NUMBER	: 5544332211
	SUPPLIER E-MAIL	: supplier_emailaddress@ccccc.xxx

Fig.10-39

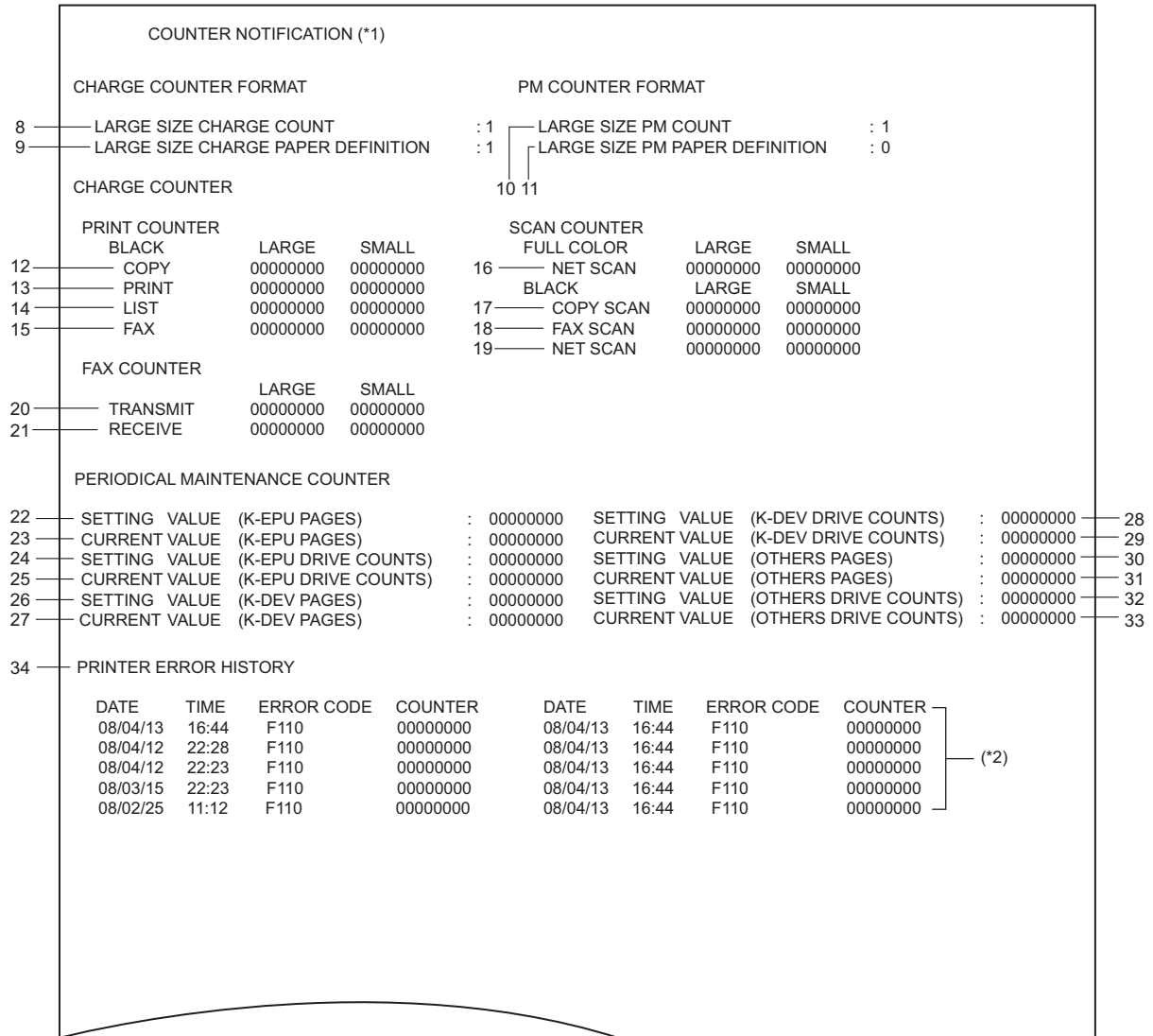


Fig.10-40

COUNTER NOTIFICATION (*1)		
35	Toner Cartridge Information:	
36	Toner Near-Empty Counter	
37	Setting	00000000
38	Current	00000000
39	Color code	1
40	Toner Near-Empty Sensed	1
41	Point Of Destination	0
	Used History	
	Developer Counter	00000056
	Developer Driving Time	00000057
	Drum Driving Time	00000058
	Toner Information	
42	Yellow Remaining Quantity (%)	: 00000059
43	Magenta Remaining Quantity (%)	: 00000060
44	Cyan Remaining Quantity (%)	: 00000061
45	Black Remaining Quantity (%)	: 00000062

Fig.10-41

1. Date
2. Machine model name
3. Serial number
4. Total counter value
5. Customer information
6. Service technician information
7. Supplier information
8. Count setting of large-sized paper (Fee charging system counter)
9. Definition setting of large-sized paper (Fee charging system counter)
10. Count setting of large-sized paper (PM)
11. Definition setting of large-sized paper (PM)
12. Number of output pages in the Copier Function (BLACK)
13. Number of output pages in the Printer Function (BLACK)
14. Number of output pages at the List Print Mode (BLACK)
15. Number of output pages in the FAX Function (BLACK)
16. Number of scanning pages in the Network Scanning Function (Full color)
17. Number of scanning pages in the Copier Function (BLACK)
18. Number of scanning pages in the FAX Function (BLACK)
19. Number of scanning pages in the Network Scanning Function (BLACK)
20. Number of transmitted pages in the FAX Function (BLACK)
21. Number of received pages in the FAX Function (BLACK)
22. PM count setting value [EPU (K)]
23. PM count present value [EPU (K)]
24. PM driving count setting value [EPU (K)]
25. PM driving count present value [EPU (K)]
26. PM count setting value [Developer material (K)]

27. PM driving count present value [Developer material (K)]
28. PM driving count setting value [Developer material (K)]
29. PM driving count present value [Developer material (K)]
30. PM count setting value (Other parts)
31. PM driving count present value (Other parts)
32. PM driving count setting value (Other parts)
33. PM driving count present value (Other parts)
34. History of error
35. Toner cartridge information
36. Toner near-empty counter
37. Setting value of toner cartridge rotation time counter
38. Current value of toner cartridge rotation time counter
39. Color of toner cartridge
  - 1: Black
  - 2: Yellow
  - 3: Magenta
  - 4: Cyan
40. Value of "toner near empty threshold setting (08-5155)"
41. Destination setting of toner cartridge  
\*2 The latest 20 errors are displayed.
42. Toner remaining quantity (Yellow)
43. Toner remaining quantity (Magenta)
44. Toner remaining quantity (Cyan)
45. Toner remaining quantity (Black)

5. Service Call Transmit  
 Subject: Service Call Notification

① Date: 04/14/2012 13:47  
 Machine Name: e-STUDIOxxxx SerialNumber:1234567890  
 ② ③

④ Function: Printer  
 ⑤ Severity: Error  
 ⑥ Error Code: XXXX  
 ⑦ Message:  
 XX

⑧ Supplier:  
 Name : SUPPLIER\_NAME  
 Tel Number : 1122334455  
 E-Mail : supplier\_emailaddress@cccc.xxx  
 Address : SUPPLIER\_ADDRESS

⑨ Customer:  
 Name : CUSTOMER\_NAME  
 Tel Number : 1234567890  
 E-Mail : customer\_emailaddress@dddd.xxx  
 Address : CUSTOMER\_ADDRESS

⑩ Service Technician:  
 Number : svc12  
 Name : SERVICE\_TECHNICIAN\_NAME  
 Tel Number : 0987654321  
 E-Mail : svc@toshibatec.co.jp

⑪ Printer Error History:

Date	Time	Error Code	Counter
04/13/2012	16:44	F110	
04/12/2012	22:28	F110	
04/12/2012	22:23	F110	
03/15/2012	22:23	F110	
02/25/2012	11:12	F110	

(\*1)

Toner Information

Toner	Remaining Quantity(%)
⑫ Yellow	00000000
⑬ Magenta	00000000
⑭ Cyan	00000000
⑮ Black	00000000

Fig.10-42

- ① Date (When an error occurs)
- ② Machine model name
- ③ Serial number
- ④ Function: Fixed at "Printer"
- ⑤ Severity: Fixed at "Error"
- ⑥ Error code
- ⑦ Error message: The content of error is displayed.
- ⑧ Supplier information
- ⑨ Customer information
- ⑩ Service technician information
- ⑪ History of error  
\*1 The latest 20 errors are displayed.
- ⑫ Toner remaining quantity (Yellow)
- ⑬ Toner remaining quantity (Magenta)
- ⑭ Toner remaining quantity (Cyan)
- ⑮ Toner remaining quantity (Black)

6. HDD alert notification by E-mail  
Subject: HDD ALERT NOTIFICATION

```
Date                : 99-99-'99 99:99
Machine Model       : TOSHIBA e-STUDIOxxxx
Serial Number       : 1234567890
F/W Ver.            : XXXXXXXXXXXXXXXX
Total Counter       : 00000000

Supplier:

  Name               : XXXXXXXXXXXXXXXXXXXXXXXXXXXXXXXXXXXX
  Tel Number         : XXXXXXXXXXXXXXXXXXXXXXXXXXXXXXXXXXXX
  E-Mail             : XXXXXXXXXXXXXXXXXXXXXXXXXXXXXXXXXXXX
  Address            : XXXXXXXXXXXXXXXXXXXXXXXXXXXXXXXXXXXX

Customer:

  Name               : XXXXXXXXXXXXXXXXXXXXXXXXXXXXXXXXXXXX
  Tel Number         : XXXXXXXXXXXXXXXXXXXXXXXXXXXXXXXXXXXX
  E-Mail             : XXXXXXXXXXXXXXXXXXXXXXXXXXXXXXXXXXXX
  Address            : XXXXXXXXXXXXXXXXXXXXXXXXXXXXXXXXXXXX

Service Technician:

  Number             : XXXXXXXXXXXXXXXXXXXXXXXXXXXXXXXXXXXX
  Name               : XXXXXXXXXXXXXXXXXXXXXXXXXXXXXXXXXXXX
  Tel Number         : XXXXXXXXXXXXXXXXXXXXXXXXXXXXXXXXXXXX
  E-Mail             : XXXXXXXXXXXXXXXXXXXXXXXXXXXXXXXXXXXX

HDD Model Number    : TOSHIBAXXXXXXXXXXXXXXXXXXXXXX
HDD Serial Number   : XXXXXXXXXXXXXXXXXXXXXXXX

SMART Information
Start/Stop Count    : 0
Reallocated Sector Count : 0
Power-On hours count : 0
Drive Power Cycle Count : 0
Shock Sense Count   : 0
Power-Off Retract Count : 0
Load Cycle Count    : 0
Temperature(Minimum) : 0
Temperature(Maximum) : 0
Reallocated Sector Event : 0
Current Pending Sector Count : 0
CRC Error Count     : 0
Loaded Hours        : 0

HDD Check Result    : Please make a backup of HDD data.
```

Fig.10-43

## 7. HDD alert notification by Fax

### Sheet 1

```
HDD ALERT NOTIFICATION

DATE : 99-99-99 99:99
MACHINE MODEL : TOSHIBA e-STUDIOxxxx
SERIAL NUMBER : 1234567890
TOTAL COUNTER : 00000000
CUSTOMER NAME : XXXXXXXXXXXXXXXXXXXXXXXXXXXXXXXXXXXX
CUSTOMER ADDRESS : XXXXXXXXXXXXXXXXXXXXXXXXXXXXXXXXXXXX
CUSTOMER TEL NUMBER : XXXXXXXXXXXXXXXXXXXXXXXXXXXXXXXXXXXX
CUSTOMER E-MAIL ADDRESS : XXXXXXXXXXXXXXXXXXXXXXXXXXXXXXXXXXXX
SERVICE TECHNICIAN NUMBER : XXXXXXXXXXXXXXXXXXXXXXXXXXXXXXXXXXXX
SERVICE TECHNICIAN NAME : XXXXXXXXXXXXXXXXXXXXXXXXXXXXXXXXXXXX
SERVICE TECHNICIAN TEL NUMBER : XXXXXXXXXXXXXXXXXXXXXXXXXXXXXXXXXXXX
SERVICE TECHNICIAN E-MAIL : XXXXXXXXXXXXXXXXXXXXXXXXXXXXXXXXXXXX
SUPPLIER NAME : XXXXXXXXXXXXXXXXXXXXXXXXXXXXXXXXXXXX
SUPPLIER ADDRESS : XXXXXXXXXXXXXXXXXXXXXXXXXXXXXXXXXXXX
SUPPLIER FAX NUMBER : XXXXXXXXXXXXXXXXXXXXXXXXXXXXXXXXXXXX
SUPPLIER E-MAIL ADDRESS : XXXXXXXXXXXXXXXXXXXXXXXXXXXXXXXXXXXX
```

Fig.10-44

### Sheet 2

```
HDD ALERT NOTIFICATION

HDD MODEL NUMBER : TOSHIBAXXXXXXXXXXXXXXXXXXXXXX
HDD SERIAL NUMBER : XXXXXXXXXXXXXXXXXXXXXXXX

SMART INFORMATION
START/STOP COUNT : 0
REALLOCATED SECTOR COUNT : 0
POWER-ON HOURS COUNT : 0
DRIVE POWER CYCLE COUNT : 0
SHOCK SENSE COUNT : 0
POWER-OFF RETRACT COUNT : 0
LOAD CYCLE COUNT : 0
TEMPERATURE(MINIMUM) : 0
TEMPERATURE(MAXIMUM) : 0
REALLOCATED SECTOR EVENT : 0
CURRENT PENDING SECTOR COUNT : 0
CRC ERROR COUNT : 0
LOADED HOURS : 0

HDD CHECK RESULT : PLEASE MAKE A BACKUP OF HDD DATA.
```

Fig.10-45





# 11. FIRMWARE UPDATING

## 11.1 Overview

When you want to update the firmware to the latest one or the equipment becomes inoperable due to some defect in the firmware, updating can be performed as follows.

### Equipment

Firmware	Updating method
System firmware	USB device
Engine firmware	
Scanner firmware	
System software	
PFC firmware	
NIC firmware	

### Options

Model name	Firmware	Updating method
Reversing Automatic Document Feeder (RADF) (MR-3031)	RADF firmware	USB device
Finisher (MJ-1042)	Finisher firmware	
Finisher (MJ-1110)	Finisher firmware	
Hole Punch Unit (MJ-6105)	Hole punch unit firmware	
FAX Unit (GD-1370)	FAX board firmware (Line1)	
	FAX board firmware (Line2)	

### Notes:

- Written firmware varies depending on the kinds of the boards provided as service parts. For updating, only the minimum firmware is installed on the system control PC board, logic PC board, scanning section control PC board and FAX board. The latest version of the firmware at the time of delivery is written on the RADF control PC board and finisher control PC board. When any of above boards is replaced with a new one in the field, check the other firmware version used and then update with a corresponding suitable version.
- "Can't fetch Ver." is displayed in the Installed Version field when the version of the installed firmware cannot be acquired properly. For example, if [HS-49] is carried out without your performing the normal startup after updating, this message will appear for some firmware.

## 11.2 Firmware Updating with USB Device

The software and firmware can be updated by means of a USB device in which an update package is stored. All necessary files for updating are stored in the package provided, so be sure to save all of them in the model specific folder.

For the data file for each firmware, refer to the following tables.

### Notes:

When performing the update, use the latest program.

### 11.2.1 Updating methods

There are three types of updating methods by means of a USB device. The table below explains the differences.

Method	File	Explanation
Standard update	Standard package	Updating the file of a base version.
Differential items update	Differential items package	Updating the version by means of the package of only the files which have been changed from the base. This method is applied to the system firmware and the system software. Since only the files which have been changed are packaged, the data size is smaller than that for the standard package. This method cannot be used for the equipment whose HDD has been formatted.
Patch update	Patch	Updating can be done in a shorter time than the standard one. This method is applied to the system firmware and the system software only.

### 11.2.2 Firmware type and data file name for updating

#### [A] Standard update Equipment

Firmware	Stored	Data file name	Display
System firmware	System control PC board (SYS board)	T370SF0Wxxxx.tar * xxxx is version.	SYSTEM FIRMWARE (OS Data)
System software	HDD	T370HD0Wxxxx.tar * xxxx is version.	SYSTEM SOFTWARE (HD Data)
Engine firmware	Logic PC board (LGC board)	TH370MWW.xxx * xxx is version.	ENGINE FIRMWARE
PFC firmware	PFU board (MY-1047)	TH370FWW.xxx * xxx is version.	PFC FIRMWARE
Scanner firmware	System control PC board (SYS board)	TH370SLGWW.xxx * xxx is version.	SCANNER FIRMWARE
NIC firmware	System control PC board (SYS board)	T370NIC0Wxxxx.tar * xxxx is version.	NIC FIRMWARE

## Option

Firmware	Stored	Data file name	Display
RADF firmware	DLG board (MR-3031)	H617DFWW.0xxx * xxx is version.	RADF FIRMWARE
Finisher firmware (MJ-1042)	Finisher control PC board	FIN1042T.xxx * xxx is version.	FINISHER FIRMWARE
Finisher firmware (MJ-1110)	Finisher control PC board	FIN1110T.xxx * xxx is version.	FINISHER FIRMWARE
Hole punch unit firmware (MJ- 6105)	Punch control PC board	PUN6105T.xxx * xxx is version.	PUNCH FIRMWARE
FAX firmware (GD-1370)	System control PC board (SYS board)	FAXH625T.xxx * xxx is version.	FAX FIRMWARE1, FAX FIRMWARE2

### [B] Patch update

Firmware	Stored	Data file name	Display
System firmware	System control PC board (SYS board)	T373SFPWxxxx.tar * xxxx is version.	SYSTEM FIRMWARE (OS DATA)
System software	HDD	T373HDPWxxxx.tar * xxxx is version.	SYSTEM SOFTWARE (HDD DATA)

### [C] Differential items update

Firmware	Stored	Data file name	Display
System firmware	System control PC board (SYS board)	T373SFdWxxxx.tar * xxxx is version.	SYSTEM FIRMWARE (OS DATA)
System software	HDD	T373HDdWxxxx.tar * xxxx is version.	SYSTEM SOFTWARE (HDD DATA)

## 11.2.3 Folder configuration of a USB device

### [A] Standard update

Store the data file for updating in the model specific folder. This configuration is an example. The number of files differs depending on the installed option.

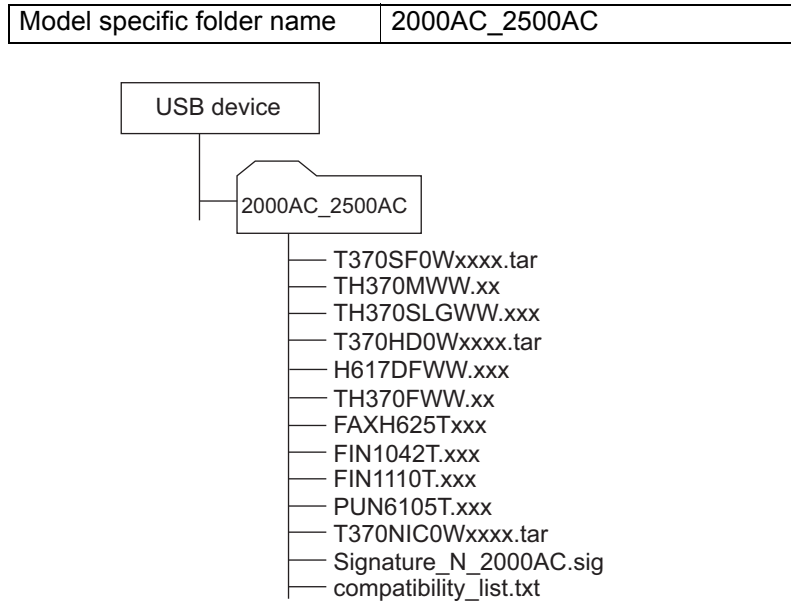


Fig.11-1

### [B] Patch update

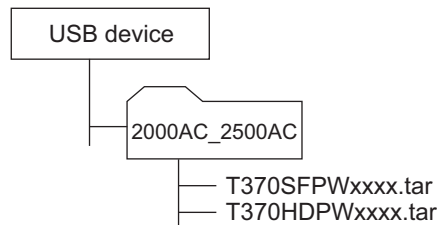


Fig.11-2

### [C] Differential items update

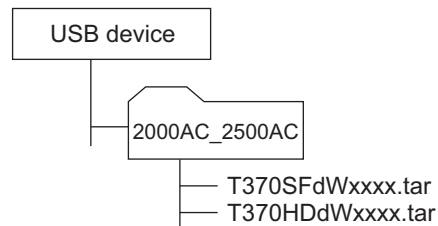


Fig.11-3

**Notes:**

- Since the date and time set in the equipment are recorded in the firmware update log, make sure that they are correct before updating the firmware.
- Never change the model specific folder name, since it is used for identifying the data file when the data files used for updating multiple models are stored in the USB device.

**Important:**

- Only the USB devices which meet the following conditions should be used for updating. Be careful since updating with any device other than the above is never guaranteed.
  - A combination USB device with a flash memory (to be connected directly to the USB port) and its capacity is 2GB or more.
  - Operation of the USB device used for updating has been confirmed at the input check of this equipment (03 Test mode). (P. 5-9 "5.4.2 Input check")
  - USB devices which comply with the following standards regulated by USB-IF (USB Implementers Forum)
    - Class number: 8 (=08h) (Mass-storage class)
    - Sub-class number: 6 (=06h) (SCSI transfer command set)
    - Protocol number: 80 (=50h) (Bulk-Only)
- \* Most common USB devices comply with the specification above and can be used for updating. However, the operation in all the Multi Functional Digital Color Systems and Multi Functional Digital Systems is not necessarily guaranteed since the most of these devices are developed based on use in a PC environment (Windows or Macintosh). Therefore, check thoroughly that the device is operational in the equipment for which the updating will be performed when purchasing it.
- The USB devices complying with USB2.0 can be used for updating.
- Do not update the firmware by any storage device other than a flash memory (such as a USB connection type memory card reader, CD/DVD drive or hard disk), since it is never guaranteed.
- It is possible to store the model specific update program and the data file for updating directly in the root directory when you store the updating data file for one specific model in the USB device. However, if the model specific folder for the same model as that of the data file stored in the root directory already exists, this will have priority.

## 11.2.4 Update procedure

### Important:

- The file system of a USB device should be formatted in the FAT16 or FAT32 format. USB devices formatted in an NTFS or another format will not be able to be operated. The file system of a USB device can be confirmed by opening its property using Windows Explorer or such.
- Never shut down the equipment during the update. Firmware data and the following option data (if installed) could be damaged and may not be able to be operated properly.
  - Data Overwrite Enabler (GP-1070)
  - Meta Scan Enabler (GS-1010)
  - External Interface Enabler (GS-1020)
  - IPsec Enabler (GP-1080)
  - Hardcopy Security kit (GP-1190A)
  - OCR Enabler (GS-1080/1085)
  - Multi Station Print Enabler (GS-1090/1095)

### [A] Updating firmware

- (1) Connect the USB device to the PC and write the model specific folder in which the data file is stored.  
Store the data file for updating in the model specific folder.
- (2) Press the [ON/OFF] button to shut down the equipment.
- (3) Connect the USB device [1] to the USB port [2] on the right upper cover.

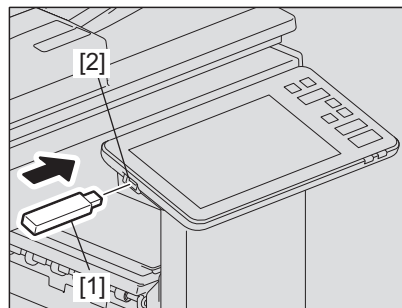


Fig.11-4

- (4) Start the HS Menu.

(5) Press [49 Firmware Update].

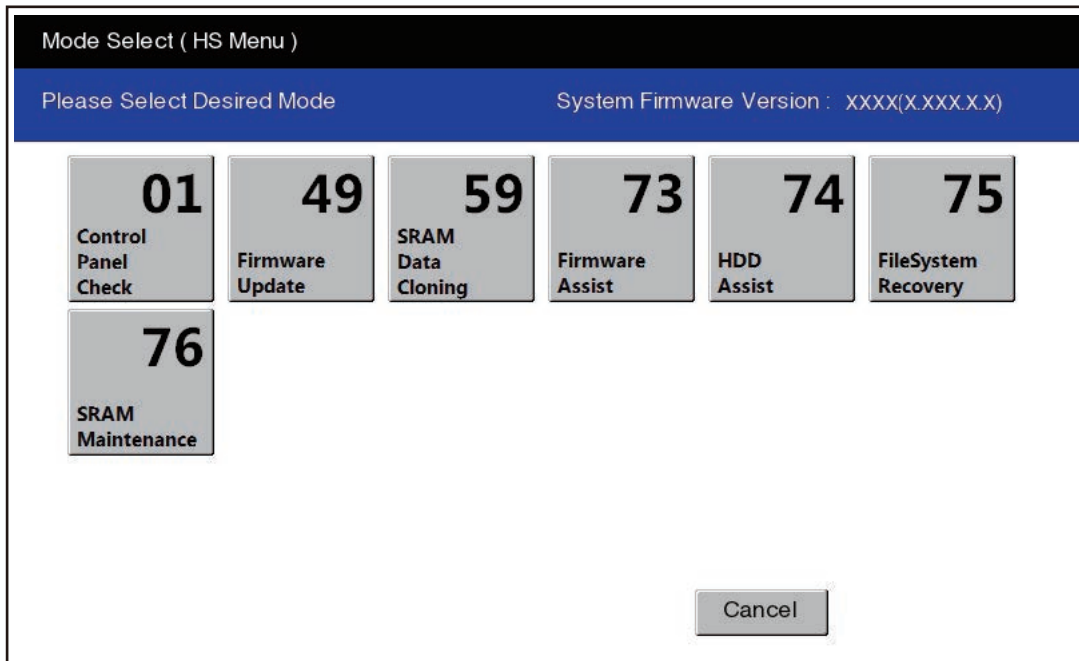


Fig.11-5

(6) Select the update type.  
Normal Update  
Patch Update  
Diff Update

**Note:**

The update file which is selected must be included in the model specific folder. There is no problem if updated files of different types are mixed.

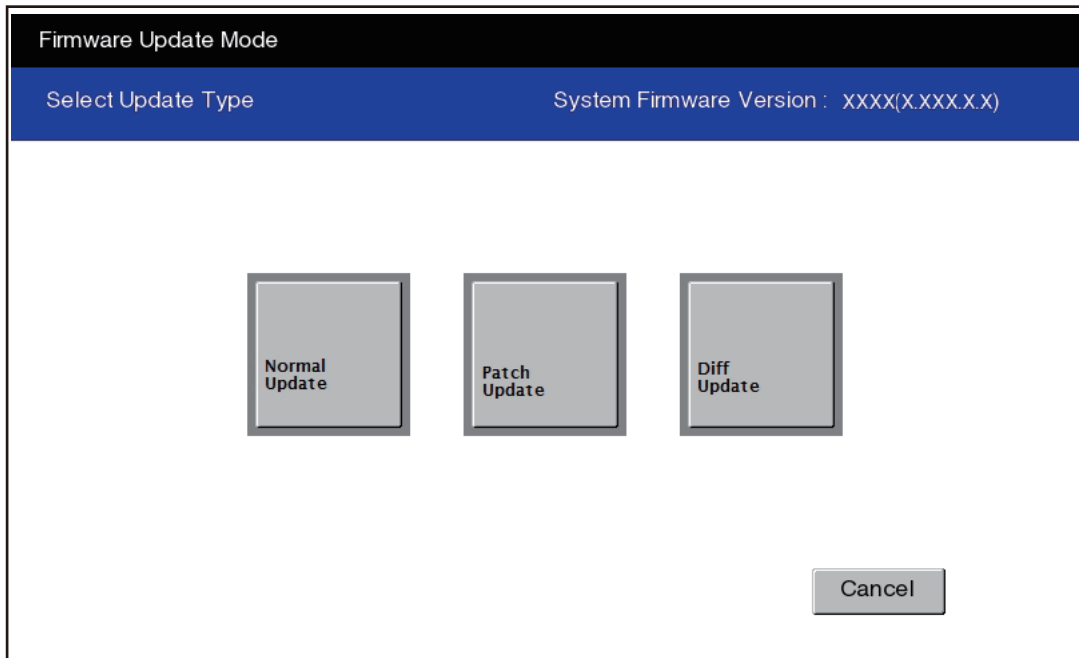


Fig.11-6



The screen for selecting items to be updated is displayed.

- Only the firmware which is included in the update file is displayed.
- The firmware whose version is later than the current one is being selected to be updated if there is such in the update file.

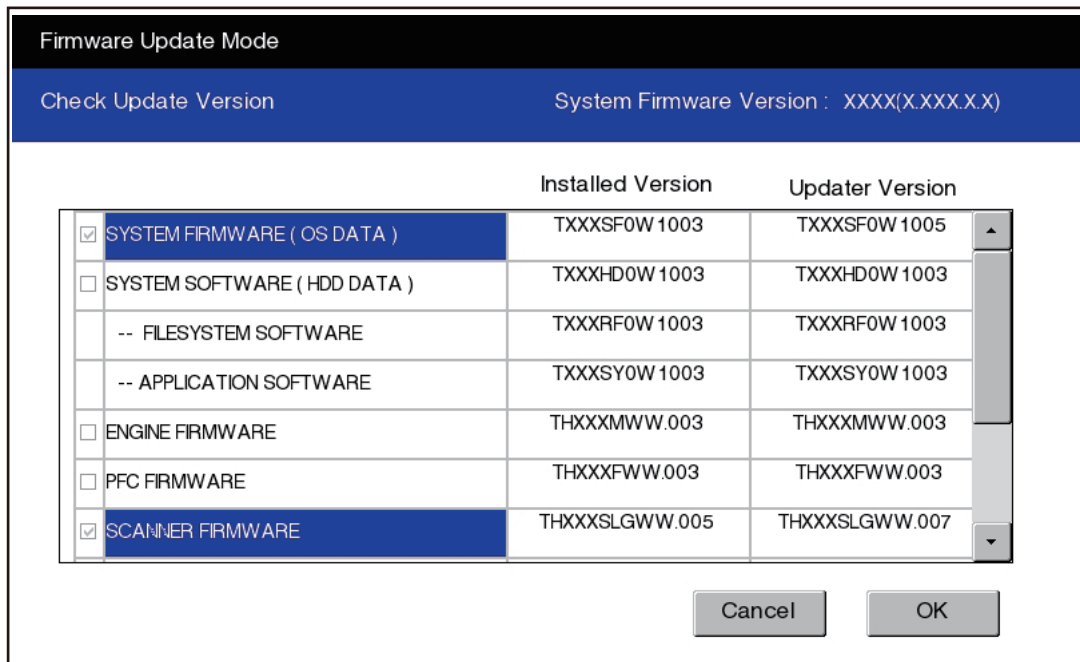


Fig.11-7

**Notes:**

- The display of items on this screen varies depending on the types of data written on the USB device. Each item is displayed only when each data file is written on the USB device in the following conditions.

**[A] Standard update**

Item	Condition (xxx is version)
SYSTEM FIRMWARE (OS Data)	T370SF0Wxxxx.tar is written.
SYSTEM SOFTWARE (HD Data)	T370HD0Wxxxx.tar is written.
ENGINE FIRMWARE	TH370MWW.xxx is written.
SCANNER FIRMWARE	TH370SLGWW.xxx is written.
PFC FIRMWARE	TH370FWW.xxx is written.
RADF FIRMWARE	H617DFWW.0xxx is written. (When MR-3031 is connected)
NIC FIRMWARE	T370NIC0Wxxxx.tar is written.
FAX FIRMWARE	FAXH625Txxx is written. (When GD-1370 is connected.)
FINISHER FIRMWARE	FIN1042T.xxx is written. (When MJ-1042 is connected.) FIN1110T.xxx is written. (When MJ-1110 is connected.)
PUNCH FIRMWARE	PUN6105T.xxx is written. (When MJ-6105 is connected.)

**[B] Patch update**

Item	Condition
SYSTEM FIRMWARE (OS DATA)	T373SFPWxxxx.tar is written. * The version name comes at "xxxx".
SYSTEM SOFTWARE (HDD DATA)	T373HDPWxxxx.tar is written. * The version name comes at "xxxx".

**[C] Differential items update**

Item	Condition
SYSTEM FIRMWARE (OS DATA)	T373SFdWxxxx.tar is written. * The version name comes at "xxxx".
SYSTEM SOFTWARE (HDD DATA)	T373HDdWxxxx.tar is written. * The version name comes at "xxxx".

- If the USB device is not recognized properly, "USB device Not detected" message is displayed. In this case, disconnect the USB device and connect again within 3 minutes, or shut down the equipment and connect the device properly. Then repeat the procedure from (5).
- If any of the error messages below is displayed, confirm if the data file in the USB device is correct. Then repeat the procedure from (5).

Error number	Error message	Cause
01	Model specific update program XXXXXXXXXXXXX is not stored.	No update file of this equipment exists in the USB storage.

- (7) Select the item.  
The item selected is highlighted and a check is marked at its left side. If you press the item once again, its selection is released.

Item	Remarks
SYSTEM FIRMWARE(OS Data)	Updating System firmware
SYSTEM SOFTWARE (HD Data)	Updating System software
ENGINE FIRMWARE	Updating Engine firmware
SCANNER FIRMWARE	Updating Scanner firmware
PFC FIRMWARE	Updating PFC firmware
RADF FIRMWARE	Updating RADF firmware
NIC FIRMWARE	Updating NIC firmware
FAX FIRMWARE	Updating FAX firmware
FINISHER FIRMWARE	Updating Finisher firmware
PUNCH FIRMWARE	Updating Punch firmware

- (8) Press [OK].  
Updating starts and the processing status is displayed on the screen.

Status display during update	Status display when update is completed
SYSTEM FIRMWARE(OS Data) update in progress	SYSTEM FIRMWARE(OS Data) Completed
SYSTEM SOFTWARE (HD Data) update in progress	SYSTEM SOFTWARE (HD Data) Completed
ENGINE FIRMWARE update in progress	ENGINE FIRMWARE Completed
SCANNER FIRMWARE update in progress	SCANNER FIRMWARE Completed
PFC FIRMWARE update in progress	PFC FIRMWARE Completed
RADF FIRMWARE update in progress	RADF FIRMWARE Completed
NIC FIRMWARE update in progress	NIC FIRMWARE Completed
FAX FIRMWARE update in progress	FAX FIRMWARE Completed
FINISHER FIRMWARE update in progress	FINISHER FIRMWARE Completed
PUNCH FIRMWARE update in progress	PUNCH FIRMWARE Completed

- (9) When updating is completed properly, the following message is displayed at the bottom of the LCD screen.

Standard update: Update successfully completed Restart the MFP

Patch update: Patch Update Successfully Restart the MFP

Differential items update: Differential Update Successfully Restart the MFP

**Notes: Troubleshooting when “Customized UI version is not compatible!” is displayed**

In the equipment with the customized UI installed, when its version is not compatible with that for the HDD DATA to be installed, “Customized UI version is not compatible!” is displayed and the updating will fail. To continue the updating, perform FS-08-3512 (Customized UI uninstallation).

**Notes: Troubleshooting**

- Even though an update fails, do not turn the power OFF until other updates are finished.
- “Update Failed.” is displayed at the bottom of the screen when the updating is not completed properly. “Failed” appears next to the failed item on the status display. If “Update Failed” appears at the bottom of the screen, turn OFF the power and then check the following items. After confirming and clearing the problems, restart updating from the beginning.
  - Does the USB device meet the conditions to be used for updating?
  - Is the data file written properly on the USB device?
  - Is the USB device installed properly?
  - Do the USB device and equipment operate properly?
  - When H05 error occurs and it does not clear after a USB media check, replace the main memory (DIMM).
- The integrity check system is automatically operated before firmware updating. During this operation, “Verifying Signature...” and “Progress: \*\*%” are displayed on the control panel. When the check is completed properly, no message for notifying the success will appear and the firmware updating will start. If it fails, “Invalid Signature” and “Copy Data with >valid signature in USB” will be shown. In that case, firmware updating cannot be performed, so turn the power OFF and disconnect the USB device. Check that there is no abnormality in the firmware data, and reperform the update.
- When a system firmware (OS Data) update error or system software (HD Data) update error occurs, “Update Failed” or “Failed” appears on the screen and the error number appears next to the message.

For details of each error, refer to the following tables.

System firmware update Error	
Error number	Error content
O01	FROM writing failed
O02	FROM verification error
O03	File operation error
O04	SRAM flag set error
O05	Electronic key data backup error
O06	Device error
O07	Signature Check Failed error
O08	Signature not present error

System software update Error	
Error number	Error content
H01	File creation error
H02	File decompression error (Out of free disk space on the HDD at file extraction)
H03	Partition mount error
H04	Other errors
H05	Signature Check Failed error
H06	Signature not present error

System software update Error	
Error number	Error content
H07	Hard Disk Full Error

- When an Engine firmware update error, Scanner firmware update error, RADF firmware update error, Punch firmware update error, Finisher firmware update error or FAX firmware update error occurs, "Update Failed" or "Failed" appears on the screen and the error number and error message appear next to the message. For details of each error, refer to the following tables.

Engine firmware update Error		
Error number	Error message	Error content
M01	Time out (When the download is requested)	Communication timeout (When the download is requested)
M02	Time out (When the download is written)	Communication timeout (When the download is written)
M03	Time out (When the download is finished)	Communication timeout (When the download is finished)
M04	Reception failed (When the download is requested)	Downloading request was denied. (When the download is requested)
M05	Deletion error (When the download is written)	Deletion error (When the download is written)
M06	Writing error (When the download is written)	Writing error (When the download is written)
M07	Checksum error (When the download is finished)	Checksum error (When the download is finished)
M08	Reception status code abnormality (When the download is requested)	Reception status code abnormality (When the download is requested)
M09	Reception status code abnormality (When the download is written)	Reception status code abnormality (When the download is written)
M10	Reception status code abnormality (When the download is finished)	Reception status code abnormality (When the download is finished)
M00	Other error	Other error

Scanner firmware update Error		
Error number	Error message	Error content
S01	Time out (When the download is requested)	Communication timeout (When the download is requested)
S02	Time out (When the download is written)	Communication timeout (When the download is written)
S03	Time out (When the download is finished)	Communication timeout (When the download is finished)
S05	Deletion error (When the download is written)	Deletion error (When the download is written)
S06	Writing error (When the download is written)	Writing error (When the download is written)
S08	Reception status code abnormality (When the download is requested)	Reception status code abnormality (When the download is requested)
S09	Reception status code abnormality (When the download is written)	Reception status code abnormality (When the download is written)
S10	Reception status code abnormality (When the download is finished)	Reception status code abnormality (When the download is finished)

<b>Scanner firmware update Error</b>		
<b>Error number</b>	<b>Error message</b>	<b>Error content</b>
S00	Other error	Other error

<b>NIC firmware update Error</b>		
<b>Error number</b>	<b>Error message</b>	<b>Error content</b>
N01	Connection Failure	Communication timeout
N02	No Update Files	No Update Files
N03	Flash Write Error	Writing error
N04	File decompression error	File decompression error
N05	Other Errors	Other error

<b>PFC firmware update Error</b>		
<b>Error number</b>	<b>Error message</b>	<b>Error content</b>
P01	Time out (When the download is requested)	Communication timeout (When the download is requested)
P02	Time out (When the download is written)	Communication timeout (When the download is written)
P03	Time out (When the download is finished)	Communication timeout (When the download is finished)
P04	Downloading request was denied (When the download is requested)	Downloading request was denied. (When the download is requested)
P05	Deletion error (When the download is written)	Deletion error (When the download is written)
P06	Writing error (When the download is written)	Writing error (When the download is written)
P07	Checksum error (When the download is finished)	Checksum error (When the download is finished)
P08	Reception status code abnormality (When the download is requested)	Reception status code abnormality (When the download is requested)
P09	Reception status code abnormality (When the download is written)	Reception status code abnormality (When the download is written)
P10	Reception status code abnormality (When the download is finished)	Reception status code abnormality (When the download is finished)
P00	Other error	Other error

<b>RADF firmware update Error</b>		
<b>Error number</b>	<b>Error message</b>	<b>Error content</b>
R01	Time out (When the download is requested)	Communication timeout (When the download is requested)
R02	Time out (When the download is written)	Communication timeout (When the download is written)
R03	Time out (When the download is finished)	Communication timeout (When the download is finished)
R05	Deletion error (When the download is written)	Deletion error (When the download is written)
R06	Writing error (When the download is written)	Writing error (When the download is written)
R08	Reception status code abnormality (When the download is requested)	Reception status code abnormality (When the download is requested)
R09	Reception status code abnormality (When the download is written)	Reception status code abnormality (When the download is written)

RADF firmware update Error		
Error number	Error message	Error content
R10	Reception status code abnormality (When the download is finished)	Reception status code abnormality (When the download is finished)
R11	ADF not connected	RADF not installed
R12	ADF download error	Firmware for different model data connected
R13	RADF/DADF Mismatch error	Firmware for different model data connected
R00	Other error	Other error

Punch firmware update Error		
Error number	Error message	Error content
U01	Time out (When the download is requested)	Communication timeout (When the download is requested)
U02	Time out (When the download is written)	Communication timeout (When the download is written)
U03	Time out (When the download is finished)	Communication timeout (When the download is finished)
U04	Reception failed (When the download is requested)	Downloading request was denied. (When the download is requested)
U05	Deletion error (When the download is written)	Deletion error (When the download is written)
U06	Writing error (When the download is written)	Writing error (When the download is written)
U07	Checksum error (When the download is finished)	Checksum error (When the download is finished)
U08	Reception status code abnormality (When the download is requested)	Reception status code abnormality (When the download is requested)
U09	Reception status code abnormality (When the download is written)	Reception status code abnormality (When the download is written)
U10	Reception status code abnormality (When the download is finished)	Reception status code abnormality (When the download is finished)
U00	Other error	Other error

Finisher firmware update Error		
Error number	Error message	Error content
F01	Time out (When the download is requested)	Communication timeout (When the download is requested)
F02	Time out (When the download is written)	Communication timeout (When the download is written)
F03	Time out (When the download is finished)	Communication timeout (When the download is finished)
F04	Reception failed (When the download is requested)	Downloading request was denied. (When the download is requested)
F05	Deletion error (When the download is written)	Deletion error (When the download is written)
F06	Writing error (When the download is written)	Writing error (When the download is written)
F07	Checksum error (When the download is finished)	Checksum error (When the download is finished)

Finisher firmware update Error		
Error number	Error message	Error content
F08	Reception status code abnormality (When the download is requested)	Reception status code abnormality (When the download is requested)
F09	Reception status code abnormality (When the download is written)	Reception status code abnormality (When the download is written)
F10	Reception status code abnormality (When the download is finished)	Reception status code abnormality (When the download is finished)
F00	Other error	Other error


FAX firmware update Error		
Error number	Error message	Error content
FX01	Communication Timeout (when download is requested)	Communication timeout (When the download is requested)
FX02	Communication Timeout (when data is downloaded)	Communication timeout (When the download is finished)
FX03	Download request Failed	Downloading request was denied. (When the download is requested)
FX04	Received failure during download request	Reception Error (When the download is requested)
FX05	Received failure during data download	Reception error (During data download)
FX06	File decompression error	File decompression error
FX07	Other Errors	Other error

(10) Check that [Automatic Initialization] is displayed and then remove the USB device.

(11) Press [Automatic Initialization]. The equipment is rebooted and the initialization of the updating data is carried out.






### **[B] Confirmation of the updated data**

After the updating is completed, check each data version in the 08 Setting Mode to confirm that the data were overwritten properly.

 P. 11-15 "11.3 Confirmation of the updated data"

### **[C] Adjustment**

Perform the adjustment of the equipment.

- Performing Image Quality Control (FS-05-2742):  
 P. 6-4 "6.1.3 Performing Image Quality Control"
- Adjustment of Color Registration Control (FS-05-4719):  
 P. 6-5 "6.1.4 Adjustment of Color Registration Control"
- Automatic gamma adjustment <PPC> (FS-05-7869) (using FS-05-4 → [TEST PRINT] test pattern):  
 P. 6-27 "6.2.1 Automatic gamma adjustment"
- Automatic gamma adjustment <PRT> (FS-05-8008) (using FS-05-70 → [TEST PRINT] test pattern):  
 P. 6-49 "6.3.1 Automatic gamma adjustment"
- Automatic gamma adjustment <PRT> (FS-05-8009) (using FS-05-230 → [TEST PRINT] test pattern):  
 P. 6-49 "6.3.1 Automatic gamma adjustment"

### 11.3 Confirmation of the updated data

After the updating is completed, check each data version in 08 Setting Mode to confirm that the data were overwritten properly.

Firmware	Code
System software	9900
System firmware	9930
Engine firmware	9901
Scanner firmware	9902
NIC firmware	9990
DF firmware	9903
PFC firmware	9940
Finisher firmware	9904
Hole punch firmware	9944
FAX board firmware(Line1)	9905
FAX board firmware(Line2)	9969





## 12. BACKUP FUNCTION

### 12.1 Cloning (HS Menu)

#### 12.1.1 General description

Cloning (HS menu) is a function that backs up user data, setting data and SRAM data into a USB storage device and also restores these data into the equipment.

This function backs up or restores the data of the same equipment (same serial number), and is performed when the SRAM is replaced.

**Notes:**

The SYS board and SRAM should never be replaced together.

#### 12.1.2 Precautions

- When the Security HDD is initialized or replaced, back up the SRAM data afterwards.
- It is assumed that data cloning is to be performed when equipment is installed or options are installed. If the address book has been registered, do not perform restore. Registered / set data are lost.
- The USB device for the data cloning must meet the following conditions. A data cloning operation with any devices other than the following will not be guaranteed.
  - A combination USB device with a flash memory (to be connected directly to the USB port) and its capacity is 1GB or more.
  - A device compliant with the following specifications established by USB-IF (USB Implementers Forum)

Class number:	8 (=08h)	(Mass storage class)
Sub-Class number:	6 (=06h)	(SCSI transfer command set)
Protocol number:	80 (=50h)	(Bulk-only)

The USB device should be formatted in the FAT16 or FAT32. (Correct operation cannot be guaranteed if it is formatted in NTFS/exFAT.)
  - Most of the common USB device are compliant with the above specifications and are therefore applicable to this data cloning. However, most of these devices were originally developed to be used in an environment for PCs (e.g. Windows or Macintosh) and thus operations exclusively with this equipment have not been fully guaranteed. Therefore, the user must thoroughly check in advance whether there will be any problem in operating with this equipment when adopting one of these devices.
- The USB device compliant with both USB 1.1 and USB 2.0 can be used for this data cloning.
- Data cloning with any storage devices other than a flash memory (e.g. USB-connectable memory card reader, CD/DVD drive, hard disk) will never be guaranteed. Therefore never use them for this operation.
- Be sure to unplug the LAN cable and Fax line before data are backed up / restored. Also, do not use the RADF and open the cover, drawer, etc. during the data cloning.
- Data can be backed up / restored only for the same model and version. If the version is different, update the firmware and back up / restore data in the same version.
- Restore data to equipment which has the same options as when the data are backed up.
- Delete the backed up data in the USB device after the data cloning.

### 12.1.3 Backup files

The following files are saved in the root directory of the USB device by backing up.

Filename	Remark
Modelname_MFPSerialNo_yyyy-MM-dd_hh-mm	E.g.: When backup was performed at 13:59 on October 1st, 2016. Txxx_CUK911379_2016-10-01_13-59

### 12.1.4 Cloning procedure

#### [A] Backup procedure

- (1) Shut down the equipment.
- (2) Connect the USB device [1] to the USB port [2] on the right upper cover.

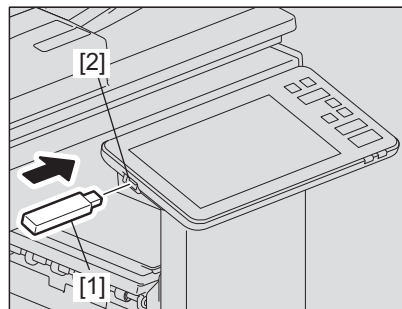


Fig.12-1

- (3) Perform HS-59 → [Backup SRAM Data to USB].

#### **Note:**

When "Operation Failed" is displayed, turn the power OFF and then reattempt the steps from (1).

- (4) Enter the password and press [OK].

#### **[Tips]**

- Maximum 15 characters
- This password will be used when the backed-up clone data are restored in the equipment.

- (5) "Backup successfully done" is displayed on the LCD when the backup has been properly completed.
- (6) Turn the power OFF.

## [B] Restore procedure

- (1) Press the [ON/OFF] button to shut down the equipment.
- (2) Connect the USB device [1] to the USB port [2] on the right upper cover.

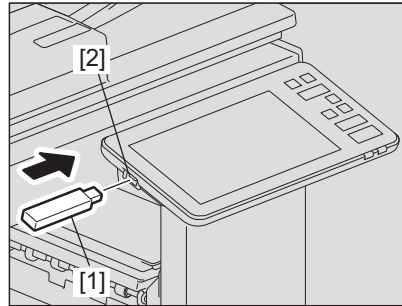


Fig.12-2

- (3) Perform HS-59 → Restore SRAM Data from USB.
- (4) Enter the password which has been set in (4) of "[A] Backup procedure", and press [OK].
- (5) Enter the serial number of the equipment and press [OK].

### Note:

Use the serial number given on the label attached to the rear cover for the entry.

- (6) "Restore successfully done Restart the MFP" is displayed on the LCD when the restoring has been properly completed.
- (7) Then turn the power OFF.

### Notes:

- When the back-up file is restored, do not perform HDD partition creation (Format HDD) before the normal start-up.
- When the backup data, which were created before the HDD has been initialized or replaced, are restored, do so also for ADIKey. (Only for a secure HDD)

**[C] Confirmation of the error**

“Operation Failed” is displayed on the lower left part of the LCD when the data have not been properly backed up or restored.

Moreover, details of an error are displayed under the above message.

(The following is an example screen when "USB Memory not detected" is displayed.)

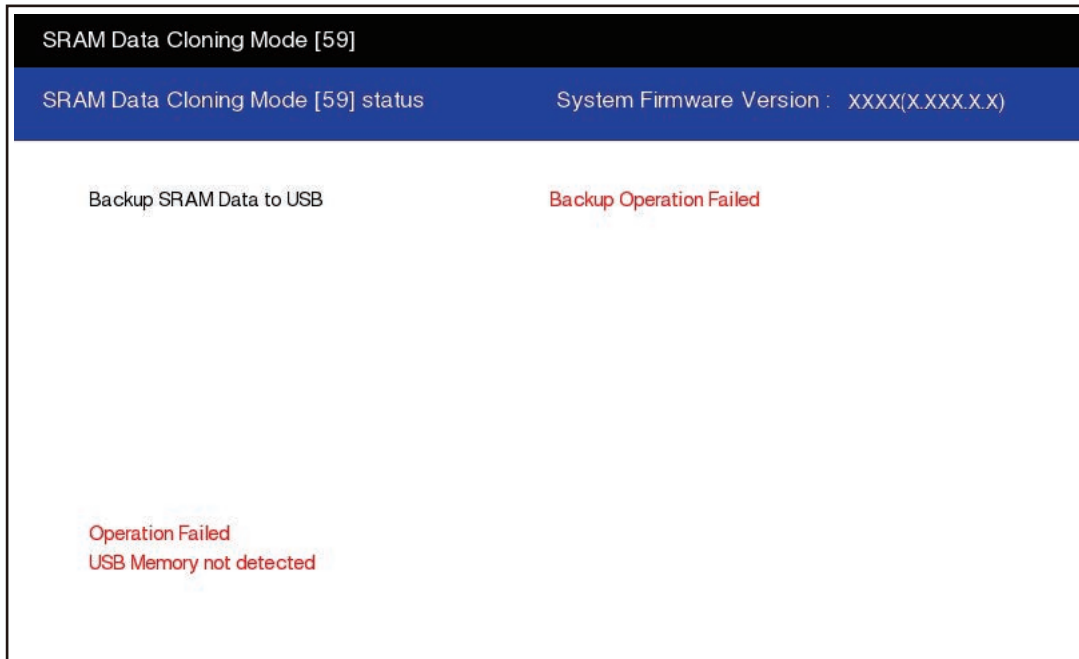


Fig.12-3

In this case, turn the power OFF and then check the following items. After confirming and solving the problem, back up / restore the data again from the beginning.

- Does the USB device meet the conditions being used for this cloning?
- Is the updated program file written on the USB device properly?
- Is the USB device installed properly?
- Is the USB device or the equipment damaged?

Backup	
Display content	Error content
USB device not detected	The USB device has not been installed.
SRAM Device Not Connected	The SRAM has not been installed.
Backup not created	Creation of the Backup file of data of the SRAM has been failed.
Encryption Failed	An encryption of the backup file has been failed.
password Not Appended to Backup	Addition of the encryption password has been failed.
MFP Serial Number Not Set	Acquisition of the MFP Serial No. has been failed.

Restore	
Display content	Error content
USB device not detected	The USB device has not been installed.
SRAM Device Not Connected	The SRAM has not been installed.
Invalid Backup File	The SYS board has not been recognized.
No Backup File Exists	Backup file has not existed in the USB device.
Invalid password	An incorrect password has been entered.
Decryption Failed	Decoding of the backup file has been failed.


<b>Restore</b>	
<b>Display content</b>	<b>Error content</b>
Invalid MFP Serial Number: xxxxxxxx	An incorrect MFP Serial No. has been entered.
MFP Serial Number Not Set	Acquisition of the MFP Serial No. has been failed.
Backup File Corrupted	A backup file has been damaged.

## 12.2 Cloning (FS menu)

### 12.2.1 General description

By means of cloning (FS menu) can store the MFP setting data and user information as a clone file into a USB storage device. In addition, the clone file created by another unit of the equipment can be installed in this one, resulting in making of the same conditions.

### 12.2.2 Precautions

- A clone file created by the following MFPs can be installed in this equipment.
  - e-STUDIO2010AC/2510AC
  - e-STUDIO2515AC/3015AC/3515AC/4515AC/5015AC
  - e-STUDIO5516AC/6516AC/7516AC
  - e-STUDIO2018A/2518A/3018A/3518A/4518A/5018A
  - e-STUDIO5518A/6518A/7518A/8518A
  - e-STUDIO2000AC/2500AC
  - e-STUDIO2505AC/3005AC/3505AC/4505AC/5005AC
  - e-STUDIO5506AC/6506AC/7506AC
  - e-STUDIO2008A/2508A/3008A/3508A/4508A/5008A
  - e-STUDIO5508A/6508A/7508A/8508A
  - e-STUDIO3508LP/4508LP/5008LP
  - e-STUDIO2050C/2550C
  - e-STUDIO2555C/3055C/3555C/4555C/5055C
  - e-STUDIO2555CSE/3055CSE/3555CSE/4555CSE/5055CSE
  - e-STUDIO5560C/6560C/6570C
  - e-STUDIO207L/257/307/357/457/507
  - e-STUDIO557/657/757/857
  - e-STUDIO307LP
  - e-STUDIO287CS/347CS/407CS
  - e-STUDIO287CSL/347CSL
  - e-STUDIO477S/527S
  - e-STUDIO477SL
  - e-STUDIO2040C/2540C/3040C/3540C/4540C
  - e-STUDIO5540C/6540C/6550C
  - e-STUDIO206L/256/306/356/456/506
  - e-STUDIO256SE/306SE/356SE/456SE/506SE
  - e-STUDIO556/656/756/856
  - e-STUDIO556SE/656SE/756SE/856SE
  - e-STUDIO306LP
- When a clone file created by this equipment is installed in another one, confirm the installation ability by referring to the Service Manual for the target model.
- When a clone file created by another unit of the equipment is installed in this one, settings and information about the functions which are not supported by this equipment will be disregarded.
- When cloning of user information is carried out by means of this function, ask your users to change the setting to [Enable] of [User Information Cloning] from [Administration] - [Setup] - [General settings] - [Device Information] via TopAccess.
- When cloning of the administrator password is carried out by means of this function, ask your users to change the setting to [Enable] of [Administrator's Password Cloning] from [Administration] - [Setup] - [General settings] - [Device Information] via TopAccess.
- Be sure to use a USB storage device which satisfies the conditions described in  P. 12-1 "12.1.2 Precautions".
- Delete a clone file stored in the USB storage device after the cloning.

### 12.2.3 Clone file creation procedure

- (1) Press [36 CLONING] in the FS menu.
- (2) Press [Create Clone File].
- (3) Select the categories to be included in the clone file.

**Notes:**

- If the following categories cannot be selected, ask your users to change the setting to [Enable] of [User Information Cloning] from [Administration] - [Setup] - [General settings] - [Device Information] via TopAccess.
  - User Management
  - Address Book
  - Address Book + Template + MailBoxes
- If Administrator's Password cannot be selected, ask your users to change the setting to [Enable] of [Administrator's Password Cloning] from [Administration] - [Setup] - [General settings] - [Device Information] via TopAccess.

- (4) Press [Save].
- (5) Enter a file name. Set a password if necessary.  
Once a password has been set, its entry is required when this clone file is installed in the equipment.
- (6) Press [Save].  
The clone file is stored by a file name with the extension ".enc" applied.

**Notes:**

Be sure to disconnect the USB storage device after the completion screen is displayed.

### 12.2.4 Clone file installation procedure

- (1) Press [36 CLONING] in the FS menu.
- (2) Press [Install Clone File].
- (3) Connect the USB storage device with the store clone file and press [OK].
- (4) Select the clone file to be installed.  
Enter the password if one has been set.
- (5) Press [Install].

**Notes:**

Be sure to disconnect the USB storage device after the completion screen is displayed.



## 12.3 AES Data Encryption Function Setting

### 12.3.1 General description

Data encryption is a function that encrypts data in the HDD to enhance the security. Note that this function may affect the equipment performance.

### 12.3.2 Precautions

When the data encryption function is set to be enabled, the data saved in the HDD before the encryption has been performed cannot be retrieved. Therefore when data encryption function needs to be enabled after the installation of the equipment, it is necessary to back up the data in the HDD before setting this function and then recover them after the setting.

- To ensure security, ask the user (machine administrator) to back up or restore the user's data and information in the HDD. A service technician can back up or restore them only when the user (machine administrator) permits it.
- Some data in the HDD cannot be backed up and can be left only on printouts.

When the data encryption function is enabled, FS-08-9113 (Screen setting for automatic energy saver/automatic power OFF) is automatically set to "0: OFF".

### 12.3.3 Setting procedure

A procedure for setting the data encryption function is shown below.

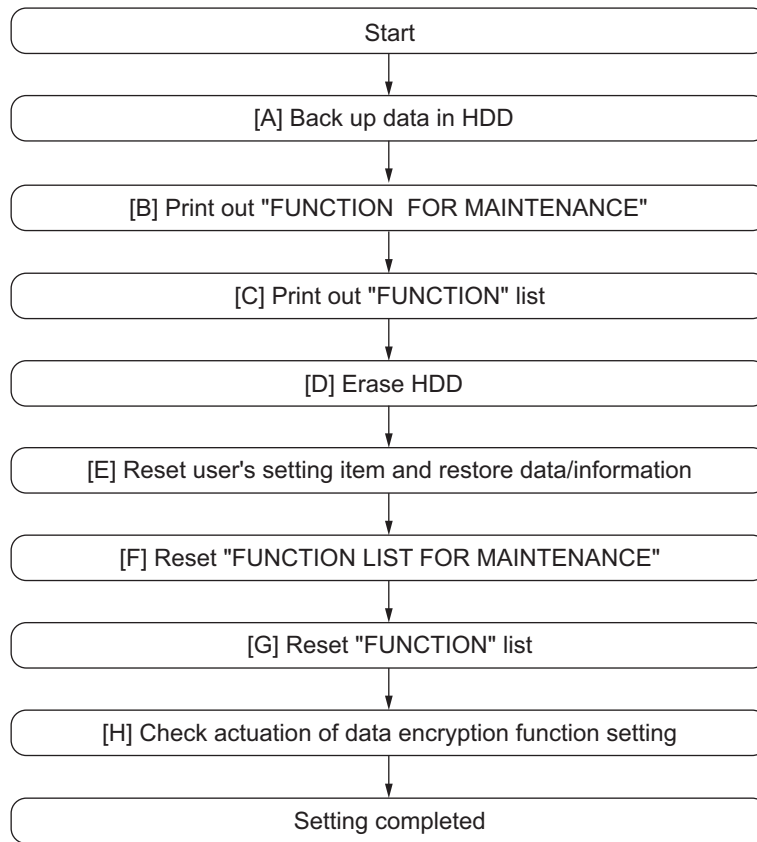


Fig.12-4

## [A] Back up in HDD

Ask the user (machine administrator) to back up the data in the HDD. Refer to the table below for the type of data, availability and method of backup.

Type of data in HDD	Availability	Backup method
Image data in the e-Filing	Available	Archive them in the "e-Filing" of TopAccess. As for the backup in Box data, all data (selectable by the box) can be backed up / restored in one go by using "e-Filing Backup/Restore Utility".
F-code information, Template registration information, Address book data	Available	Export them up in the "Administrator" menu of TopAccess.
Department management data	Available	Export them in "Administrator" menu of TopAccess.
Log data (Print, Scan, FAX (Transmission/Reception) / Message Log	Available	Export them in the "Log" menu of TopAccess. (Import cannot be performed.)
Data in the shared folder (Scanned data, Saved data of copy / FAX transmission)	Available	Copy them to the client computer via the network. (The data which have been copied to the client computer cannot be copied to the shared folder.)
Role information	Available	Export role information on the TopAccess menus. [User Management] tab > [Export]
Print waiting data (Copying data and FAX reception data that are waiting to be printed due to the paper run-out and jam, etc.)	Not available	Finish printing them after the paper supply and the jam release, etc. (The data cannot be kept.)
Print job (Private print data, Schedule print data)	Not available	If any jobs are left, print them. (The data cannot be backed up.)
FAX saved data (Confidential / Bulletin board data)	Not available	Print them. (The data cannot be backed up.)
Registration data for FAX transmission (Delayed transmission / Recovery transmission)	Not available	Print them. (The data cannot be backed up.)

## [B] Print out "FUNCTION LIST FOR MAINTENANCE"

- (1) Select "FAX LIST PRINT MODE" and then press [NEXT].
- (2) Select "Function list for Maintenance" and then press [PRINT].

### [C] Print out “FUNCTION” list

- (1) Press [USER FUNCTIONS] on the HOME screen.
- (2) Press [ADMIN], enter the password, and then press [ENTER].
- (3) Press [LIST/REPORT] and then [LIST].
- (4) Press [FUNCTION]. The “FUNCTION” list is printed out.

#### Notes:

Explain the procedure to the user (machine administrator) and ask him/her to enter his/her password.

### [D] Enable data encryption function

Perform the setting of the data encryption function in the code FS-08-9379. The setting values are shown below.

- 0: Encryption disabled
- 1: Encryption enabled (Security priority)
- 2: Encryption enabled (Performance priority)

Security priority: All user data are encrypted.

Performance priority: Encryption data are generated only in a copying or a printing process temporarily. All user data except files which are deleted in a corresponding process are encrypted.

### [E] Reset user’s setting items and restore data/information

Ask the user (machine administrator) to reset the user’s setting items and to restore data or information. Refer to the following for the reset and restore:

Items to reset/restore	Method
Printer driver	Upload them in the “Administrator” menu of TopAccess.
F-code information, Template registering information, Address book data	Restore them in the “Administrator” menu of TopAccess.
Department management data	Import them in the “Administrator” menu of TopAccess.
Image data in the e-Filing	Restore them in the “e-Filing” of the TopAccess.
Role information	Import role information on the TopAccess menus. [User Management] tab > [User Confirm/Create/Modify] > [Role Information]


#### Notes:

- When the SSL is enabled, perform the setting of the following items again with “Create self-signed certificate” of TopAccess.
  - Country/Region Name
  - State or Province Name
  - Locality Name
  - Organization Name
  - Organizational Unit Name
  - Common Name
  - Email Address
- When the wireless LAN is used, recreate its setting. (only when security with a certificate is used)  
Also, upload the following certificate file with “Security” of TopAccess.
  - CA certificate
  - Device certificate

### [F] Reset "FUNCTION LIST FOR MAINTENANCE"

- (1) Print out the "FUNCTION LIST FOR MAINTENANCE" list after the formatting.  
For how to print it out, refer to [B] Print out "FUNCTION LIST FOR MAINTENANCE".
- (2) Perform FS → 13 FAX FUNCTION MODE.
- (3) Compare the lists which were printed before and after the formatting to check the setting items having the different setting values. Set the value which was set before the formatting.
- (4) Turn the power OFF.

### [G] Reset "FUNCTION" list

Reset the fax function by referring to the "function list" that was printed out in  P. 12-11 "[C] Print out "FUNCTION" list".

- (1) Press [USER FUNCTIONS].
- (2) Press [ADMIN], enter the password, and then press [ENTER].
- (3) Press [FAX] and then [TERMINAL ID] to set each item.
- (4) Press [INITIAL SETUP] to set each item.

#### Notes:

Explain to the user (machine administrator) about the next operation and ask him/her to enter his/her password.

### [H] Check actuation of data encryption function setting

Check if the data encryption function is in operation.

Press [COUNTER] on the control panel. If a key-shaped icon is displayed at the top right of the screen, the data encryption function is in operation.

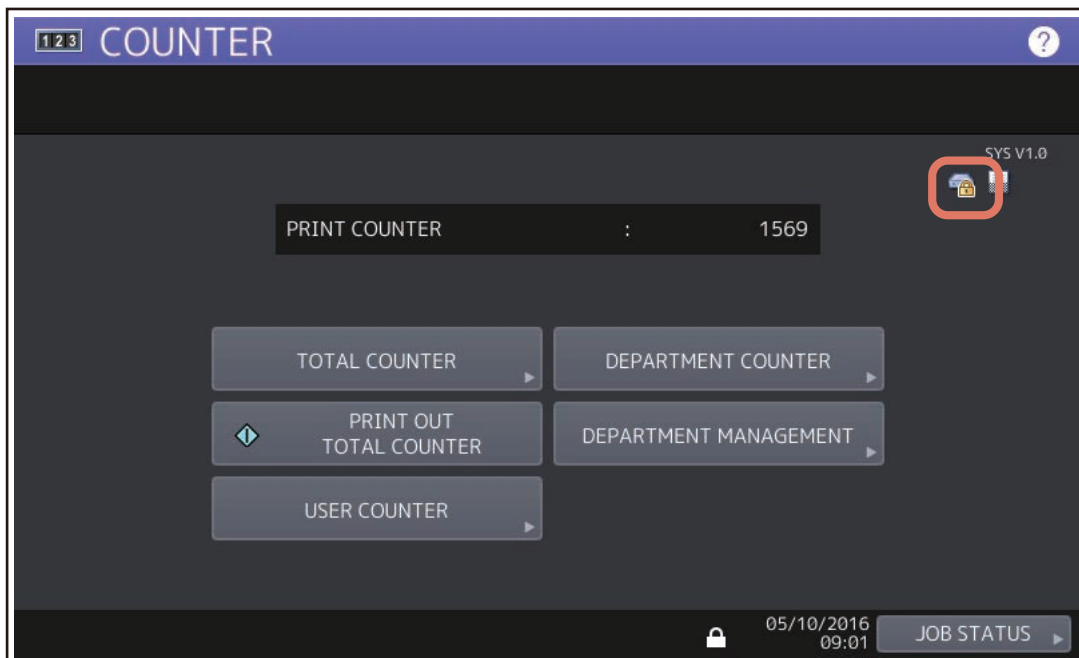




Fig.12-5

### **12.3.4 Procedure for disabling data encryption function**

The basic procedure is the same as the one for enabling this function. To disable it, set "0 (Invalid)" in the code FS-08-9379 at step  P. 12-11 "[D] Enable data encryption function".

### **12.3.5 Procedure for discarding HDD when data encryption function is enabled**


Set the data encryption function disabled following the procedure shown in  P. 12-13 "12.3.4 Procedure for disabling data encryption function". Then perform the code HS-73 → [Erase HDD Securely] to completely erase the data in the HDD.

## 12.4 High Security Mode

### 12.4.1 General description

The High Security Mode is a security mode complying with the IEEE2600.1 Security Standards Requirement. To have the equipment enter this mode, follow the procedure and the precautions below.

### 12.4.2 Prior confirmation

- Confirm that the administrator for the equipment is authorized and ask him/her to observe the installation.
- To have the equipment enter the High Security Mode, the Data Overwrite Enabler GP-1070 (optional) is required. Confirm that this option is installed in advance. Follow the Unpacking Instructions to install it.
- To avoid physical security problems, such as hardware removal or inappropriate disassembly at the installation site, take all necessary measures, such as checking who enters and leaves the site.
- Confirm that no received fax data or print jobs in progress exist. If there are any, be sure to print them all out before entering the High Security Mode.
- The HDD is initialized in the High Security Mode. Be sure first to back up user data such as documents, Address Book, templates or fax settings using the export function or the backup/restore utility of the TopAccess. Refer to items noted in  P. 12-8 "12.3 AES Data Encryption Function Setting".
- Make a note of the settings on the Administration tab page of the TopAccess in advance.
- Compatibility of cloning data is lost between the High Security Mode and the normal mode; therefore, cloning data cannot be imported.

Downloaded from	Downloaded to	Compatibility of cloning data
Normal mode	Normal mode	Yes
Normal mode	High Security Mode	No
High Security Mode	Normal mode	No
High Security Mode	High Security Mode	Yes

### 12.4.3 Procedure for entering the High Security Mode

- (1) Set the value of the code FS-08-8911 (Security mode level setting) to "3" (High). Then restart the equipment.
- (2) A key-shaped icon appears at the bottom of the touch panel, indicating that it is now in the High Security Mode.
- (3) Press [COUNTER] button on the control panel. If a key-shaped icon, indicating that the HDD data are being encrypted, a paper-shaped icon indicating that the Data Overwrite Enabler is operating normally and the version name of the installed system ROM (SYS V1.0) are displayed on the top right of the counter menu, this means the mode is operating normally.
- (4) Reset the user data backed up in advance.

## 12.4.4 Precautions

- In the High Security Mode, an integrity check system is operated at every restart. If F521 (integrity check error) is displayed, take the necessary measures following the troubleshooting procedure.
- When a self-diagnostic mode is started in the High Security Mode, an authentication screen appears. Enter the default user name and password as follows:  
Default user name: service  
Default password: #1048#
- If a password change screen appears, reset the password according to the rules below.
  - It must not include the user name.
  - It must be a combination of letters of the alphabet and numbers.
  - It must be 6 characters or more. (Maximum 64 characters)
  - The same character must not be repeated 4 times within the new password.
  - The old and the new passwords must not be the same.
- When the equipment is shifted to the High Security Mode, the contents for some codes will be changed as below.
  - The default value is changed.
  - The settings cannot be changed.
  - Some setting values cannot be selected.  
For details, refer to the "Self-diagnostic code list" (separate document).
- The HDD is initialized (and the saved user data are deleted) when the equipment returns to the normal mode from the High Security Mode. Be sure to back up user data before having it do so.
- In the above case, the password is not reset. The password setting can be changed with the code FS-08-8919.
- After the equipment enters the High Security Mode, ask the administrator for the equipment to select [FULL] and perform the Integrity check manually.





## 13. EXTERNAL COUNTERS

### 13.1 Outline

This specification describes the interface between external counters, such as Coin Controller and Key copy counter.

### 13.2 Signal

#### 13.2.1 Connector

- Connector on the LGC board: CN303 (JST-made B20B-CZHK-B-1(LF)(SN)(V)) (Coin Controller)
- Connector on the SYS board: CN118 (JST-made B7B-PH-SM4) (Coin Controller)

#### 13.2.2 Coin Controller

##### [ 1 ] Settings

1. Set the value of FS-08-9016 to "1" or "5".
2. Harness kit: GQ-1280

##### [ 2 ] Pin Layout

###### Notes:

- Do not connect inductive loads to CTRON, such as a mechanical counter or a relay coil.

###### 1. LGC Board

Pin No.	I/O	Signal name	Function	Voltage level	Remarks
1 - 4	-	-	-	-	Not connect
5	Power	+24V	24V line	DC24V+10%, -5%	
6	Out	CTRON	Total Counter On Signal	Open Collector	L: ON IO (Max): 500mA
7	In	CTRCNT	Copy permission Signal 1	L=0V, H=DC3.3V	L: Allowed *1
8	Out	MCRUN	Ready to Copy Signal	Open Collector	L: Operating IO (Max): 40mA
9	Out	EXTCTR	Exit Sensor On Signal	Open Collector	L: ON IO (Max): 40mA
10	GND	PG	Power ground	0V	
11 - 18	-	-	-	-	Not connect
19	Power	+5V (Sleep)	5V line	DC5.1V	At the sleep mode: OFF
20	-	-	-	-	Not connect

\*1: When the coin controller outputs the CTRCNT signal, the controller should be driven by means of an open collector or open drain to prevent the inflow of current to the equipment.

## 2. SYS board

Pin No.	I/O	Signal name	Function	Voltage level	Remarks
1	Out	LARGE / SMALL	Paper size Signal	Open Collector	L: Large size IO(Max): 20mA
2	Out	FULL COLOR	Full color mode Signal	Open Collector	L: Full color IO(Max): 20mA
3	Out	TWN/MON COLOR	Twin color / Mono color Mode Signal	Open Collector	L: Twin colors IO(Max): 20mA
4	Out	B/W	Black mode Signal	Open Collector	L: Black IO(Max): 20mA
5	-	-	-	-	Not connect
6	GND	GND	Signal Ground	0V	
7	-	-	-	-	Not connect

### [ 3 ] Details of the signals

#### 1. CTRON signal (output signal)

The CTRON signal is synchronized with an electronic counter of the equipment and it becomes "Low" when one sheet of paper is counted up. This signal is output from the LGC board.



Fig.13-1

#### 2. CTCNT signal (input signal)

The CTCNT signal enables to accept copies when the coin controller is connected, and copies can be accepted with "Low". In case of "High", "Set Key Counter" appears and copies cannot be made.

#### 3. MCRUN signal (output signal)

The MCRUN signal is changed to "Low" during copying. It becomes "Low" at 30 ms or more before the CTRON signal is turned ON, and "High" at 50 ms or more after the EXTCTR signal goes OFF. However, if copying is interrupted due to forced toner supply or similar, this signal is "High" until copying is made possible again.

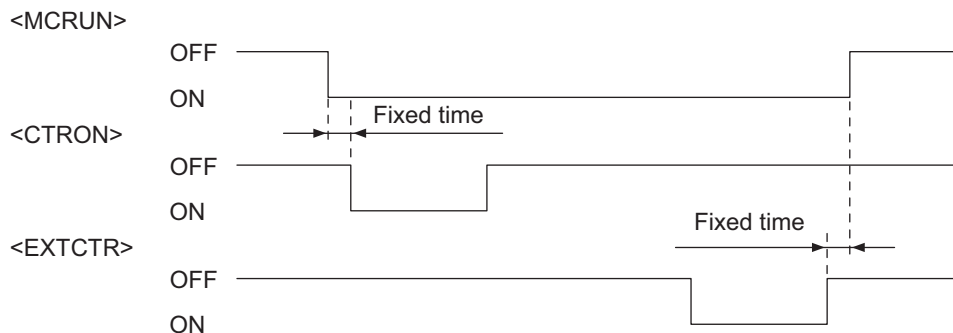


Fig.13-2

4. EXTCTR signal (output signal)

The EXTCTR signal is synchronized with “Exit sensor ON” and becomes “Low” (ON) for 200 ms. The coin controller counts the number of times with this signal. This is the signal only for the coin controller.

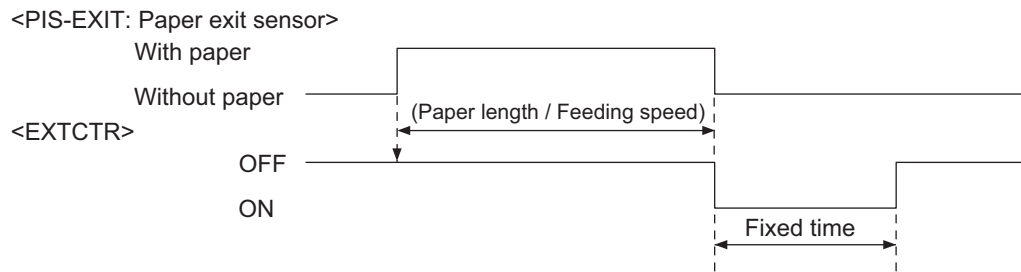


Fig.13-3

5. LARGE/SMALL signal (output signal)

When large size paper (A3 / A3 wide / LD) is selected or paper size is not specified with the manual feeding, it outputs “Low” in real time. In other cases, it outputs “High”. The setting change for large size paper is performed with F/W. This is the signal only for the coin controller.

6. FULL COLOR signal (output signal)

If the full color mode is selected, it outputs “Low” in real time. In other cases, it outputs “High”. By default, it outputs “Low” since it is set as full color mode. This is the signal only for the coin controller.

7. TWN / MON COLOR signal (output signal)

If the twin color or mono color mode is selected, it outputs “Low” in real time. In other cases, it outputs “High”. This is the signal only for the coin controller.

8. B/W signal (output signal)

If the black mode is selected, it outputs “Low” in real time. In other cases, it outputs “High”. This is the signal only for the coin controller.

**[ 4 ] Harness (GQ-1280)**

Board	Connector	Pin No.	Signal name	Pin No.	Connector
SYS board (CN118)	Connector-2	1	LARGE / SMALL	7	Connector-3 (Coin controller)
		2	FULL COLOR	8	
		3	TWN/MON COLOR	9	
		4	B/W	10	
		5	-	-	
		6	SG	12	
		7	-	-	
LGC board (CN303)	Connector-1	1	-	-	
		2	-	-	
		3	-	-	
		4	-	-	
		5	+24V	1	
		6	CTRON	2	
		7	CTRCNT	3	
		8	MCRUN	4	
		9	EXTCTR	5	
		10	PG	6	
		11	-	-	
		12	-	-	
		13	-	-	
		14	-	-	
		15	-	-	
		16	-	-	
		17	-	-	
		18	-	-	
		19	+5VL	11	
		20	-	-	

## 13.2.3 Key copy counter

### [ 1 ] Settings

1. Set the value of FS-08-9016 to "3".
2. Harness kit: -

### [ 2 ] Pin Layout

#### Notes:

- Use 24V supplied from the main equipment as power for the output signals (KCTRON) from the transistor.

1. LGC Board

Pin No.	I/O	Signal name	Function	Voltage level	Remarks
1	GND	SG	Signal Ground	0V	
2	In	CTRCNT	Copy permission Signal 1	L=0V, H=DC3.3V	L: Allowed *1
3	Power	+24V	24V line	DC24V+10%, -5%	
4	Out	KCTRON	Mechanical Counter On Signal	Open Collector	L: ON IO (Max): 500mA
5 - 20	-	-	-	-	Not connect

\*1: When the coin controller outputs the CTRCNT signal, the controller should be driven by means of an open collector or open drain to prevent the inflow of current to the equipment.

2. SYS board

Do not connect to the SYS board.

### [ 3 ] Details of the signals

1. CTRCNT signal (input signal)

The CTRCNT signal enables to accept copies when the coin controller is connected, and copies can be accepted with "Low". In case of "High", "Set Key Counter" appears and copies cannot be made.

2. KCTRON signal (output signal)

These signals are synchronized with the electronic counter of the equipment and they become "Low" when the counter is turned ON. They are the signals for driving a mechanical counter, and output from the LGC board.

They can drive inductive loads, such as a solenoid, using 24V supplied from the equipment. The interval between when they are turned ON and when this happens next must be at least 100 ms. "Single count" or "Double count" can be switched according to the paper size by setting "1" or "2" for FS-08-6010.

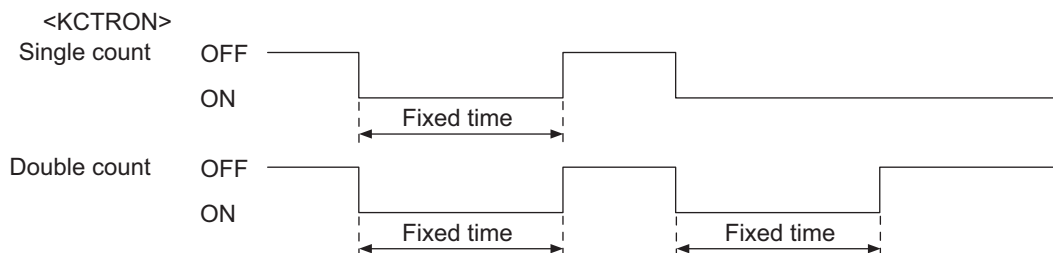


Fig.13-4

## 13.3 Notices

### 13.3.1 Setting code

Each signal will be enabled by configuring the setting code "FS-08-9016" (Externally installed counter).

FS-08-9016

- 0: No external counter (Default)
- 1: Coin controller
- 2: Copy key card (For Japan only)
- 3: Key copy counter
- 5: Coin controller supporting ACS/mixed-size

### 13.3.2 Setting value change and restrictions when using the Card Controller

1. Setting value
  - FS-08-9016 (Externally installed counter): Set to "2" (Copy key card).
  - FS-08-9017 (Setting for counter installed externally): It should be charged precisely according to the usage.  
Example: To charge only when copies are made, set to "1".
  - FS-08-6011 (Definition setting of large sized paper): Set to "0" if only A3 and LD are regarded as large size. Set to "1" if B4, LG, FOLIO and COMP are done so as well.

### 13.3.3 Setting value change and restrictions when using the coin controller

FS-08-9016 (Externally installed counter): Set to "1" (Coin controller) or "5" (Coin controller supporting ACS/mixed-size).

**Notes:**

- A coin controller supporting ACS (Auto Color Selection) can be connected by setting to "5" (Coin controller supporting ACS/mixed-size). However, operation is not guaranteed unless the specification for the ACS timing is met.
- Mixed-size jobs will be supported by setting to "5". The switching process of the size signal is carried out for each page.
- Be sure to make the following charge settings appropriately according to the usage.
  - FS-08-9017 (Setting for counter installed externally): To charge only when copies are made, set to "1".
  - FS-08-6011 (Definition setting of large sized paper): Set to "0" if only A3 and LD are regarded as large size. Set to "1" if B4, LG, FOLIO and COMP are to be so as well.

### 13.3.4 Installation of External Counter

It is not allowed to install more than one external counter (Key copy counter and Coin Controller) at the same time.

### 13.3.5 Setting value

The Key copy counter used for current models is not supported in this equipment, but the circuit for driving the counter has been mounted. The mechanical counter can be used by setting as below, however the harness for connecting it has not been provided as an option.

#### 1. Setting value

- FS-08-9016 (Externally installed counter): Set to "3" (Key copy counter).
- FS-08-9017 (Setting for counter installed externally): It should be charged precisely according to the usage.  
Example: To charge only when copies are made, set to "1".
- FS-08-6011 (Definition setting of large sized paper): Set to "0" if only A3 and LD are regarded as large size. Set to "1" if B4, LG, FOLIO and COMP are done so as well.

### 13.3.6 Restrictions when using the external counter

The Job Skip function will be disabled when an external counter is installed (when a value other than "0" is set for FS-08-9016).

Therefore, if printing is attempted while a counter or a coin controller is used, all jobs stored in the HDD may be printed.





## 14. NOTES FOR THE INSTALLATION OF A CARD READER

- (1) The card reader to use in this equipment needs to satisfy all of the following conditions. However, the operation cannot be guaranteed even if all of these conditions are satisfied.
  1. Complying with the USB HID class and satisfying the following class codes
    - Class code: 0x03
    - Sub Class code: 0x00
    - Protocol code: 0x01
  2. An interface descriptor for the USB HID class needs to be single. (A card reader which consists of multiple HID classes, such as card reader and keyboard functions, cannot be used.)
  3. The USB VID/PID of the card reader has been registered in this equipment. For details about the registration of VID/PID, ask your service contact center.
- (2) When any problems concerning to a card reader have occurred, ask your service contact center to confirm whether the card reader satisfies the above conditions or not.



# 15. WIRE HARNESS CONNECTION

## 15.1 AC Wire Harness

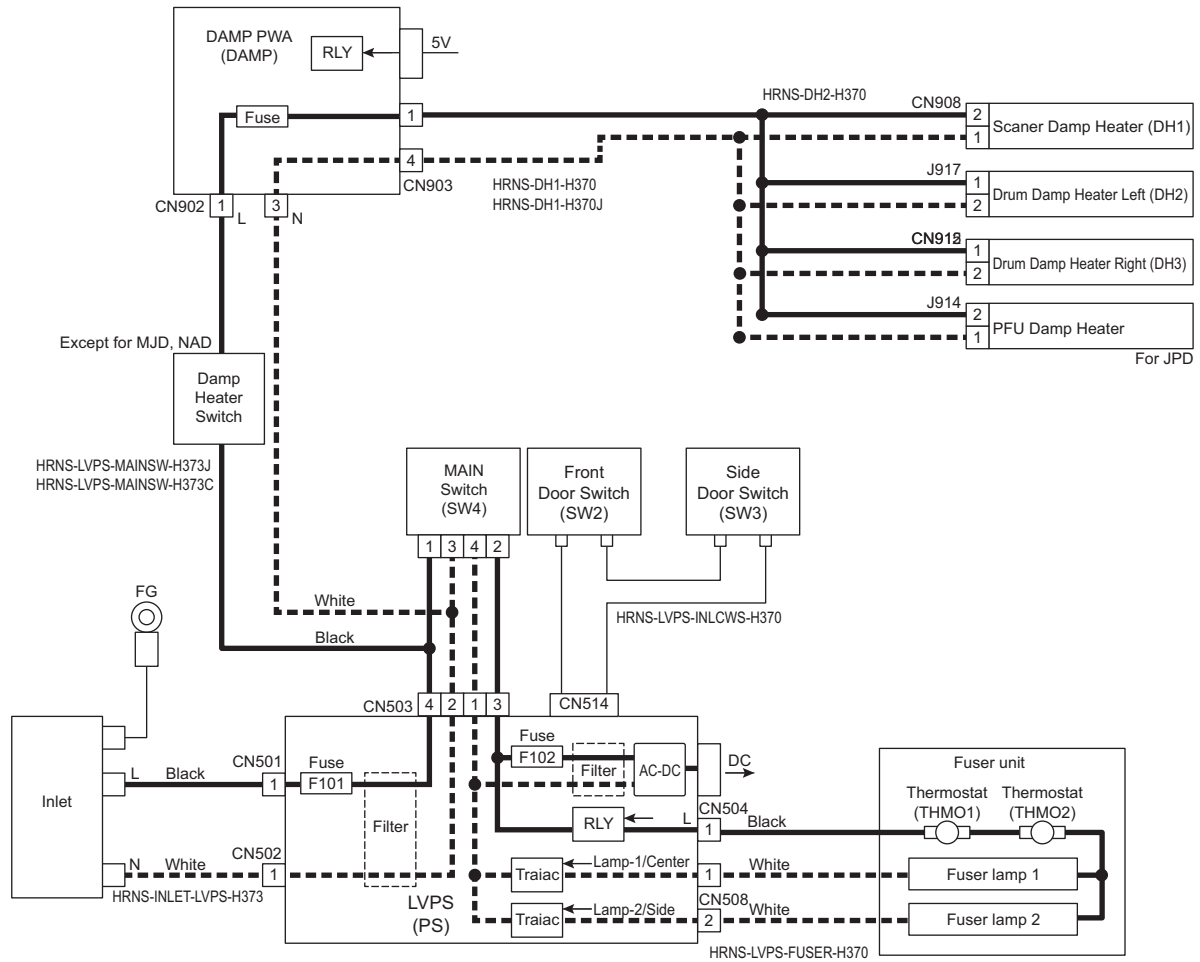
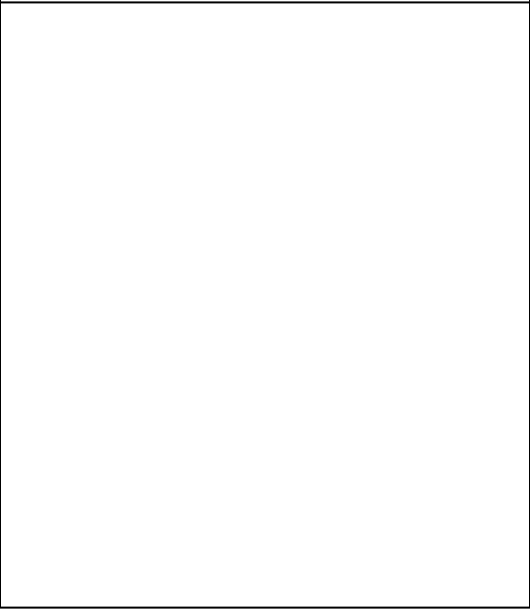
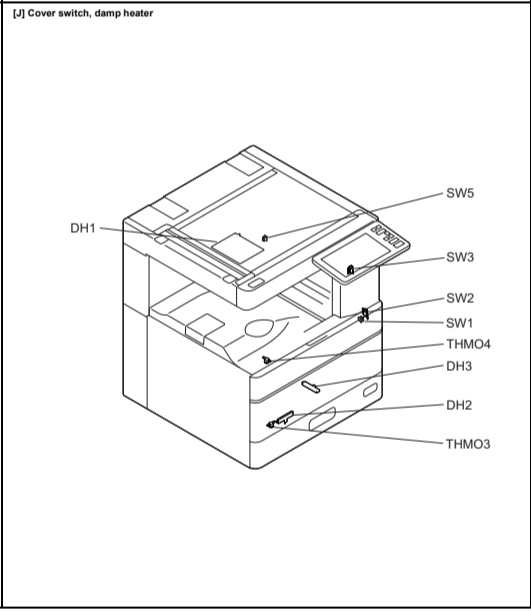
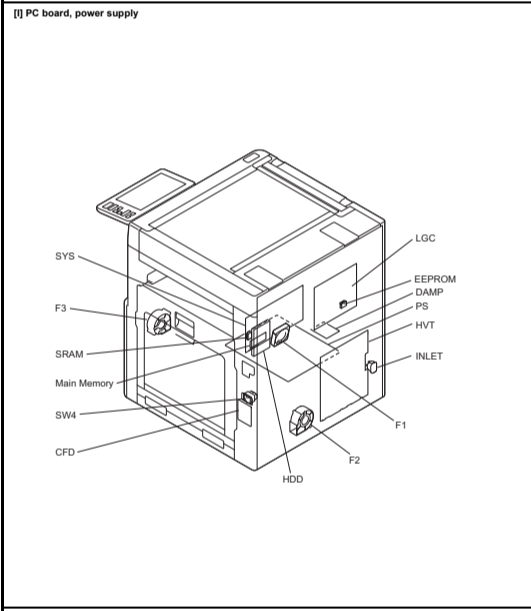
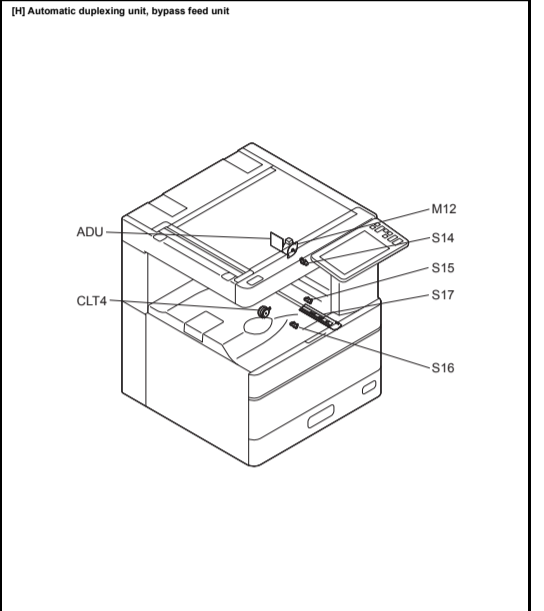
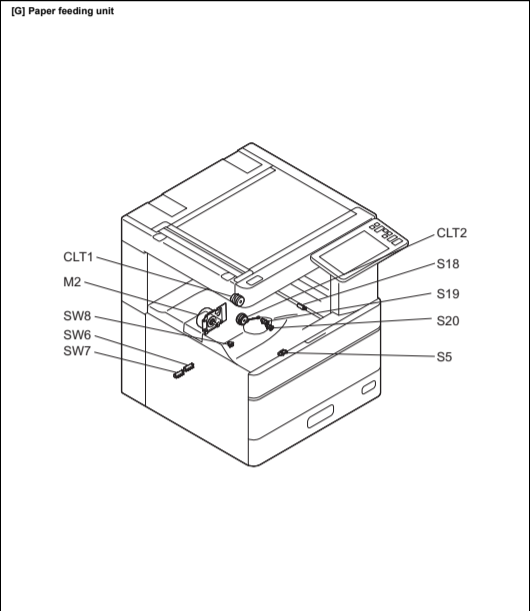
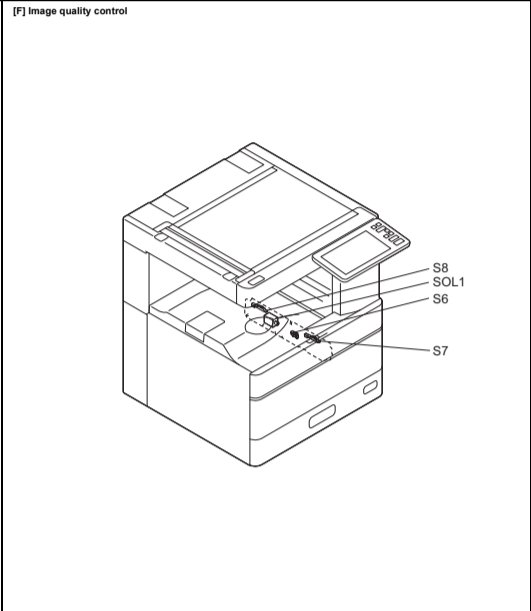
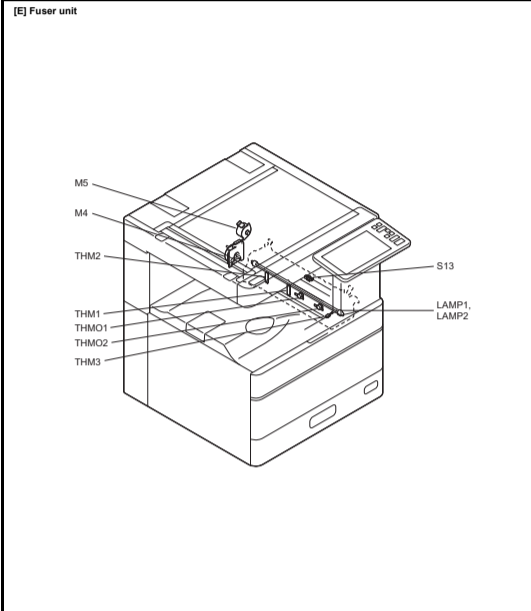
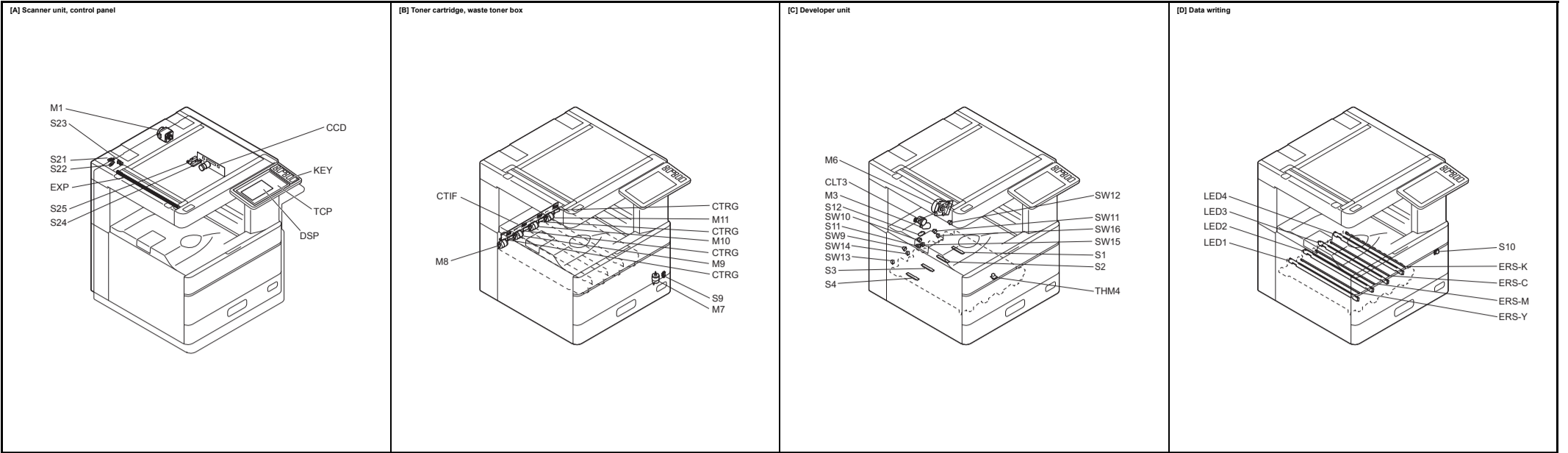


Fig.15-1





## 15.2.2 Electric Parts Layout



Symbol	Name	Figure	Wire harness location
M1	SCAN-MOT Scan motor	[A]	2-B / 3-B
M2	FEEDDEV-MOT Paper feeding/developer unit drive motor	[G]	6-A
M3	DRM-SW-MOT Mono-color switching motor	[C]	6-B
M4	FUS-MOT Fuser motor	[E]	6-C
M5	EXIT-MOT Exit motor	[E]	6-D
M6	DRM/TBU-MOT Drum/TBU motor	[C]	6-E
M7	USD-TNR-MOT Waste toner paddle motor	[B]	8-D
M8	TNR-MOT-Y Toner motor-Y	[B]	8-F
M9	TNR-MOT-M Toner motor-M	[B]	8-F
M10	TNR-MOT-C Toner motor-C	[B]	8-F
M11	TNR-MOT-K Toner motor-K	[B]	8-G
M12	ADU-MOT ADU motor	[H]	5-C
F1	SYS-FAN-MOT SYS/HDD cooling fan	[I]	2-D
F2	OZN-FAN-MOT Ozone exhaust fan	[I]	8-D
F3	PS-FAN-MOT-1 Ozone suctioning fan	[I]	8-E

Symbol	Name	Figure	Wire harness location
S1	ATTNR-SNR-K Auto-toner sensor-K	[C]	8-B
S2	ATTNR-SNR-C Auto-toner sensor-C	[C]	8-B
S3	ATTNR-SNR-M Auto-toner sensor-M	[C]	8-A
S4	ATTNR-SNR-Y Auto-toner sensor-Y	[C]	8-A
S5	CST1-EMP-SNR 1st drawer empty sensor	[G]	5-C
S6	RGST-PASS-SNR Registration pass sensor	[F]	8-D
S7	IMG-POS-SNR-F Image quality sensor (Front)	[F]	8-D
S8	IMG-POS-SNR-R Image quality sensor (Rear) / Image position aligning sensor	[F]	8-D
S9	USD-TNR-LCK-SNR Waste toner paddle rotation detection sensor	[B]	8-D
S10	TEMPHUMI-SNR Temperature/humidity sensor	[D]	8-D
S11	DRM-SW-SNR Drum switching detection sensor	[C]	6-B
S12	1ST-TRNS-SW-SNR 1st transfer roller status detection sensor	[C]	6-E
S13	EXIT-SNR Exit sensor	[E]	6-F
S14	ADU-L-SNR ADU entrance sensor	[H]	5-D
S15	ADU-R-SNR ADU exit sensor	[H]	5-D
S16	SFB-FEED-SNR Bypass feed sensor	[H]	5-B
S17	PWA-F-SFB Paper width detection PC board (SFB board)	[H]	4-B / 5-B
S18	CLNG-SNR Paper clinging detection sensor	[G]	5-A
S19	RGST-SNR Registration sensor	[G]	5-A
S20	TRANS-SNR Feed sensor	[G]	5-A
S21	PLTN1-SNR Platen sensor-1	[A]	2-C / 3-C
S22	PLTN2-SNR Platen sensor-2	[A]	2-B / 3-B
S23	HOME-SNR Carriage home position sensor	[A]	2-B / 3-B
S24	APS1 Automatic original detection sensor-1	[A]	2-B / 3-B
S25	APS2 Automatic original detection sensor-2	[A]	2-B / 3-B
SW1	FRT-COV-SW Front cover switch	[J]	8-D
SW2	F-COV-INTLCK-SW Front cover interlock switch	[J]	4-E
SW3	S-COV-INTLCK-SW Side cover interlock switch	[J]	4-E
SW4	MAIN-SW Main power switch	[I]	AC Wire Harness
SW5	SIDE-COV-SW Side cover switch	[J]	6-F
SW6	CST-SIZE1-SW 1st drawer size detection switch-1	[G]	5-C
SW7	CST-SIZE2-SW 1st drawer size detection switch-2	[G]	5-B
SW8	CST1-SW 1st drawer detection switch	[G]	5-C
SW9	Y-DRUM-SW Y drum old/new detection switch	[C]	8-B
SW10	M-DRUM-SW M drum old/new detection switch	[C]	8-B
SW11	C-DRUM-SW C drum old/new detection switch	[C]	8-B
SW12	K-DRUM-SW K drum old/new detection switch	[C]	8-B

Symbol	Name	Figure	Wire harness location
SW13	Y-DEV-SW Y developer unit old/new detection switch	[C]	8-C
SW14	M-DEV-SW M developer unit old/new detection switch	[C]	8-C
SW15	C-DEV-SW C developer unit old/new detection switch	[C]	8-B
SW16	K-DEV-SW K developer unit old/new detection switch	[C]	8-B

Symbol	Name	Figure	Wire harness location
CLT1	RGST-CLT Registration clutch	[G]	6-B
CLT2	FEED-CLT Feed clutch	[G]	6-B
CLT3	1ST-TRNS-CLT 1st transfer contact/release clutch	[C]	6-E
CLT4	SFB-FEED-CLT Bypass feed clutch	[H]	5-B

Symbol	Name	Figure	Wire harness location
SOL1	SNR-SHUT-SOL Sensor shutter solenoid	[F]	8-D

Symbol	Name	Figure	Wire harness location
CCD	PWA-F-CCD CCD driving PC board (CCD board)	[A]	
DSP	PWA-F-DSP Display PC board (DSP board)	[A]	2-F
KEY	PWA-F-KEY Key PC board (KEY board)	[A]	2-F
CTIF	PWA-F-CTIF Toner cartridge interface PC board (CTIF board)	[B]	8-F
CTRIG	PWA-F-CTRIG Toner cartridge PC board (CTRIG board)	[B]	8-F
ADU	PWA-F-ADU ADU control PC board (ADU board)	[H]	5-C
SFB	PWA-F-SFB Paper width detection PC board (SFB board)		4-B
CFD	PWA-F-CFD Feed control PC board (CFD board)	[I]	5-A
SYS	PWA-F-SYS System control PC board (SYS board)	[I]	2-A
LGC	PWA-F-LGC Logic PC board (LGC board)	[I]	6-D
DAMP	PWA-H-DAMP DAMP heater control PC board	[I]	AC Wire harness

Symbol	Name	Figure	Wire harness location
EXP	LP-EXPO Exposure lamp	[A]	
LED1	LP-LED-Y LED print head-Y	[D]	7-B
LED2	LP-LED-M LED print head-M	[D]	7-C
LED3	LP-LED-K LED print head-K	[D]	7-D
LED4	LP-LED-L LED print head-L	[D]	7-E
ERS-Y	LP-ERS-Y Discharge LED-Y	[D]	7-F
ERS-M	LP-ERS-M Discharge LED-M	[D]	8-C
ERS-C	LP-ERS-C Discharge LED-C	[D]	8-C
ERS-K	LP-ERS-K Discharge LED-K	[D]	8-C
LAMP1	LP-HTR-C Center heater lamp	[E]	AC Wire Harness
LAMP2	LP-HTR-S Side heater lamp	[E]	AC Wire Harness
DH1	SCN-DHL Scanner damp heater	[J]	AC Wire Harness
DH2	DRM-DHL Drum damp heater (Left)	[J]	AC Wire Harness
DH3	DRM-DHR Drum damp heater (Right)	[J]	AC Wire Harness

Symbol	Name	Figure	Wire harness location
THM1	THMS-FR-C Fuser roller center thermostat	[E]	6-F
THM2	THMS-FR-S Fuser roller side thermostat	[E]	6-F
THM3	THMS-FR-E Fuser roller edge thermostat	[E]	6-F
THM4	THMS-DRM Drum thermostat	[C]	8-C
THMO1	THERMO-FR-C Fuser roller center thermostat	[E]	AC Wire harness
THMO2	THERMO-FR-S Fuser roller side thermostat	[E]	AC Wire harness
THMO3	THERMO-SCN-DH Scanner damp heater thermostat		AC Wire harness
THMO4	THERMO-DRM-DH-L Drum damp heater thermostat (Left)		AC Wire harness
THMO5	THERMO-DRM-DH-R Drum damp heater thermostat (Right)		AC Wire harness

Symbol	Name	Figure	Wire harness location
TCP	Touch panel	[A]	2-E
EEPROM	Electrically Erasable Programmable Read Only Memory	[I]	-
SRAM	Static Random Access Memory	[I]	-
HDD	Hard disk	[I]	4-F
Main memory	Main memory	[I]	
PS	PS-ACC Switching regulator	[I]	4-D
HVT	PS-HVT High-voltage transformer	[I]	8-E

MAINTENANCE CHECK LIST /  
 LISTE DE VERIFICATION D'ENTRETIEN /  
 LISTE DER WARTUNGSPRÜFUNG /  
 LISTA DE CONTROL DE MANTENIMIENTO

e-STUDIO2000AC/2500AC

CLEANING UNIT	REPLACEMENT UNIT	COUNTER	TECHNICIAN	DATE
1.DRUM	1.CLEANER/DRUM/CHARGER(K)			
2.CLEANER	2.CLEANER/DRUM/CHARGER(M)			
3.CHARGER	3.CLEANER/DRUM/CHARGER(Y)			
4.DEVELOPER(K)	4.CLEANER/DRUM/CHARGER(C)			
5.DEVELOPER(Y)	5.BLACK DEVELOPER			
6.DEVELOPER(M)	6.YELLOW DEVELOPER			
7.DEVELOPER(C)	7.MAGENTA DEVELOPER			
8.FUSER	8.CYAN DEVELOPER			
9.SCANNER	9.TBU BELT CLEANER UNIT			
10.SLIT GLASS	10.2ND TRANSFER ROLLER UNIT			
11.PAPER FEED SECTION	11.FUSER UNIT			
12.SFB				
13.ADU				
14.RADF				
15.LCF				
16.PFP				
17.PFU				

REPLACEMENT PARTS AND SUPPLIES		COUNTER	TECHNICIAN	DATE
1.DRUM(K)	1.DRUM(K)	2000AC		
2.DRUM BLADE(K)	2.DRUM BLADE(K)	2500AC		
3.GRID(K)	3.GRID(K)	80K		
4.MAIN CHARGER NEEDLE(K)	4.MAIN CHARGER NEEDLE(K)	160K		
5.CHARGER CLEANING PAD(Y)	5.CHARGER CLEANING PAD(Y)	240K		
6.DRUM(Y)	6.DRUM(Y)	320K		
7.DRUM BLADE(Y)	7.DRUM BLADE(Y)	400K		
8.GRID(Y)	8.GRID(Y)	480K		
9.MAIN CHARGER NEEDLE(Y)	9.MAIN CHARGER NEEDLE(Y)	560K		
10.CHARGER CLEANING PAD(Y)	10.CHARGER CLEANING PAD(Y)	640K		
11.DRUM(M)	11.DRUM(M)	720K		
12.DRUM BLADE(M)	12.DRUM BLADE(M)	800K		
13.GRID(M)	13.GRID(M)			
14.MAIN CHARGER NEEDLE(M)	14.MAIN CHARGER NEEDLE(M)			
15.CHARGER CLEANING PAD(M)	15.CHARGER CLEANING PAD(M)			
16.DRUM(C)	16.DRUM(C)			
17.DRUM BLADE(C)	17.DRUM BLADE(C)			
18.GRID(C)	18.GRID(C)			
19.MAIN CHARGER NEEDLE(C)	19.MAIN CHARGER NEEDLE(C)			
20.CHARGER CLEANING PAD(C)	20.CHARGER CLEANING PAD(C)			
21.LED GAP SPACER	21.LED GAP SPACER			
1.FEED ROLLER(1st CST)	1.FEED ROLLER(1st CST)	2000AC		
2.SEP PAD(1st CST)	2.SEP PAD(1st CST)	2500AC		
3.FEED ROLLER(SFB)	3.FEED ROLLER(SFB)	80K		
4.SEP ROLLER(SFB)	4.SEP ROLLER(SFB)	160K		
5.PICK UP ROLLER(2nd CST)	5.PICK UP ROLLER(2nd CST)	240K		
6.FEED ROLLER(2nd CST)	6.FEED ROLLER(2nd CST)	320K		
7.SEP ROLLER(2nd CST)	7.SEP ROLLER(2nd CST)	400K		
8.PICK UP ROLLER(3rd CST)	8.PICK UP ROLLER(3rd CST)	480K		
9.FEED ROLLER(3rd CST)	9.FEED ROLLER(3rd CST)	560K		
10.SEP ROLLER(3rd CST)	10.SEP ROLLER(3rd CST)	640K		
11.PICK UP ROLLER(4th CST)	11.PICK UP ROLLER(4th CST)	720K		
12.FEED ROLLER(4th CST)	12.FEED ROLLER(4th CST)	800K		
13.SEP ROLLER(4th CST)	13.SEP ROLLER(4th CST)			
14.PICK UP ROLLER(LCF)	14.PICK UP ROLLER(LCF)			
15.FEED ROLLER(LCF)	15.FEED ROLLER(LCF)			
16.SEP ROLLER(LCF)	16.SEP ROLLER(LCF)			
1.PICK UP ROLLER(RADF)	1.PICK UP ROLLER(RADF)	2000AC		
2.FEED ROLLER(RADF)	2.FEED ROLLER(RADF)	2500AC		
3.SEP ROLLER(RADF)	3.SEP ROLLER(RADF)	120K		



# REVISION RECORD

## Ver.06h

Ver.06h <2023.06.13>	
Page	Contents
8-299	Added Error content to F200 Error Troubleshooting

## Ver.06g

Ver.06g <2023.05.22>	
Page	Contents
8-120	Added content to E030 error troubleshooting
8-286	Added F107 error Troubleshooting
7-31	Corrected Item #2 (P-I)
4-81	Corrected 4.6.12

## Ver.06f

Ver.06f <2021.10.07>	
Page	Contents
8-120	Added content to E030 error troubleshooting

## Ver.06e

Ver.06e <2021.01.22>	
Page	Contents
8-195	The troubleshooting has been corrected. (F070)
8-196	The troubleshooting has been corrected. (F071,F074)
8-198	The troubleshooting has been corrected. (F115,F116)
8-204	The troubleshooting has been corrected. (F090)
8-267	The troubleshooting has been corrected. (F100_0)
8-267	The troubleshooting has been corrected. (F100_1)
8-268	The troubleshooting has been corrected. (F100_2)
8-270 to 8-273	The troubleshooting has been corrected. (F100_0,F101_1,F101_2,F101_3)
8-271	The troubleshooting has been corrected. (F101_4,F101_12)
8-272	The troubleshooting has been corrected. (F101_5)
8-273	The troubleshooting has been corrected. (F101_6)
8-274	The troubleshooting has been corrected. (F101_7)
8-275	The troubleshooting has been corrected. (F101_8)
8-276	The troubleshooting has been corrected. (F101_9)
8-277	The troubleshooting has been corrected. (F10_10)
8-278	The troubleshooting has been corrected. (F101_11)
8-279	The troubleshooting has been corrected. (F101_13)
8-280	The troubleshooting has been corrected. (F102,F103,F104,F105)
8-281	The troubleshooting has been corrected. (F106_6,F106_1)
8-282	The troubleshooting has been corrected. (F106_2)
8-282a	The troubleshooting has been corrected. (F106_3)
8-283	The troubleshooting has been corrected. (F106_4)
8-284	The troubleshooting has been corrected. (F106_5)
8-285	The troubleshooting has been corrected. (F106_6,F106_7,F106_8,F106_10,F106_UNDEF,F106_11)
8-286	The troubleshooting has been corrected. (F106_11,F106_12)
8-286a	The troubleshooting has been corrected. (F109_0,F109_1)
8-294	The troubleshooting has been corrected. (F109_2)
8-295	The troubleshooting has been corrected. (F109_3)

8-296	The troubleshooting has been corrected. (F109_4)
8-298	The troubleshooting has been corrected. (F109_5)
8-300	The troubleshooting has been corrected. (F109_6)
8-301	The troubleshooting has been corrected. (F110,F111)
8-302	The troubleshooting has been corrected. (F120)
8-303	The troubleshooting has been corrected. (F121,F122,F124)
8-304	The troubleshooting has been corrected. (F125,F126,F127)
8-305	The troubleshooting has been corrected. (F128,F130)
8-307	The troubleshooting has been corrected. (F400)
8-309	The troubleshooting has been corrected. (F700,F800)
8-312	The troubleshooting has been corrected. (F902_3)
313	The troubleshooting has been corrected. (F902_4)
8-159a to 8-159d	Added section 8.3.12a Scanning of an original from the DF is stopped

#### Ver.06d

Ver.06d <2020.07.31>	
Page	Contents
8-1a	Added information to 8.1.1
8-433	Added Section 8.5.36 If an image-related problem continues after performing all troubleshooting

#### Ver.06c

Ver.06c <2020.04.02>	
Page	Contents
8-301 to 8-302	Edited F124,F125,F126 and F127 Measures

#### Ver.06b

Ver.06b <2019.12.10>	
Page	Contents
8-167a	Added page Troubleshooting for EF14 and EF19 Errors
8-83 to 8-84	Modified codes D341,D42,D43,D44

#### Ver.06a

Ver.06a <2019.07.31>	
Page	Contents
8-83 to 8-84	Page 8-90 Corrections "Noti" column
8-118 to 8-119	Added to the troubleshooting procedure for E011 and E013 errors
8-279 to 9-279a	Added F101_13 and F101_14 troubleshooting
9-22	Added "and [ENERGY SAVER]" to Step 4 of Replace the SYS board

#### Ver.06

Ver.06 <2019.04.10>	
Page	Contents
9-8	A note has been corrected

#### Ver05

Ver05 <2019.03.29>	
Page	Contents
2-13	The notes regarding MY-1049, GR1270, GN-4020 and GR-1290 have been added.
3-34	The garbage character has been deleted.
3-58	The mistake has been corrected (Bypass pickup roller → Bypass feed roller).

4-16 to 4-19	The note for the scanner fixing screw has been added.
4-75	The mistake has been corrected (Development sleeve → Developer sleeve).
5-1	“36 CLONING” and “37 LICENSE MANAGEMENT” have been added.
5-2	“36 CLONING” and “37 LICENSE MANAGEMENT” have been added.
5-4	Fig.5-3 has been replaced.
5-5	Fig.5-4 has been replaced.
5-7	Fig.5-6 has been replaced.
5-27	Fig.5-24 has been replaced.
5-28	Fig.5-25 has been replaced.
5-29	Fig.5-26 has been replaced.
5-30	Fig.5-27 has been replaced.
5-31	Fig.5-28 has been replaced.
5-32	“36 CLONING” and “37 LICENSE MANAGEMENT” have been added.
8-4	The illustration of the traceability label has been changed.
8-13	The description for the EA27 error has been changed.
8-22	The descriptions for the F115 and F116 errors have been changed.
8-23	The description for the CB00 error has been changed.
8-29	The F101_11 error has been added.
8-30	The F106_11 and F106_12 errors have been added.
8-32	The F128 error has been added.
8-42	The 2C50 error has been added.
8-45	The 2D50 error has been added.
8-48	The 2E50 error has been added.
8-55	The 4222 and 4223 errors have been added.
8-71	The 71BE, 71BF and 71E0 errors have been added.
8-73	The 72D0 to 72D6 errors have been added.
8-74 to 8-76	The 7332 to 7445 errors have been added.
8-80	The 80B1 to 80B5 errors have been added.
8-83	The D321 to D324 errors have been added.
8-87 to 8-97	“Fax error” has been added.
8-106	The troubleshooting has been corrected. (E160)
8-133	The troubleshooting has been changed. (E870)
8-140	The troubleshooting has been changed. (EA23)
8-143	The troubleshooting has been changed. (EA27)
8-178	The troubleshooting has been changed. (C040)
8-186	The troubleshooting has been changed. (C262)
8-186	The troubleshooting has been changed. (C270)
8-198	The troubleshooting has been changed. (F115/F116)
8-209	The troubleshooting has been changed. (CB00)
8-278	The troubleshooting has been added. (F101_11)
8-285	The troubleshooting has been added. (F106_11, F106_12)
8-294	The troubleshooting has been changed. (F111)
8-297	The troubleshooting has been added. (F128)
8-299	The troubleshooting has been changed. (F150)
8-309	The troubleshooting has been added. (2C50)
8-311	The troubleshooting has been added. (2D50)
8-313	The troubleshooting has been added. (2E50)
8-314	The troubleshooting has been changed. (3B20)
8-316	The troubleshooting has been changed. (4041, 4042)
8-317	The troubleshooting has been added/changed. (4221, 4222, 4223)
8-332 to 8-336	The troubleshooting has been added. (71E0 to 7445)
8-344 to 8-345	The troubleshooting has been added. (80B1 to 80B5)
8-346	The troubleshooting has been added. (8104)

8-349 to 8-360	The troubleshooting has been added. (Fax error)
8-419	The procedure has been corrected.
9-8	The notes have been added.
9-26	Step [D] has been added.
12-1	The description has been changed. (12.1.1 General description)
12-6	The description has been added. (12.2 Cloning (FS menu))
12-7	The description has been added. (12.2.3 Clone file creation procedure)
14-1	"NOTES FOR THE INSTALLATION OF A CARD READER" has been added.

#### Ver04

Ver04 <2018.02.16>	
Page	Contents
2-2	The mistakes have been corrected.
2-6	The mistakes have been corrected.
3-12	The description of DAMP board has been added.
3-18	The description of DAMP board has been added.
3-72 to 3-73	The description has been added.
3-90	The description has been added.
6-102	The mistakes have been corrected.
6-112 to 6-121	The adjust procedure of finisher has been changed.
7-45	The description has been added.
8-2 to 8-3	The procedure has been changed.
8-16	The mistakes have been corrected.
8-22	The mistake has been corrected.
8-23	The mistake has been corrected.
8-28	The F071 error has been added.
8-31	The mistake has been corrected. The F125, F126 and F127 errors have been added.
8-32	The F150 and F410 errors have been added.
8-44	The 2D62 error has been added.
8-56	The 4721 error has been added.
8-71	The 7332 and 7333 errors have been added.
8-136	The description has been added. (EAF1)
8-145	The procedure has been added. (EB30)
8-152 to 8-156	The procedure has been added. (EF14)
8-184	The mistake has been corrected.
8-190	The mistake has been corrected.
8-278 to 8-279	The mistake has been corrected. (F124) The troubleshooting has been added. (F125, F126 and F127)
8-280	The troubleshooting has been added. (F150)
8-281	The troubleshooting has been added. (F410)
8-293	The troubleshooting has been added. (2D62)
8-299 to 8-300	The troubleshooting has been added. (4511, 4521, 4522 and 4523)
8-300	The troubleshooting has been added. (4721)
8-303	The troubleshooting has been changed. (5110)
8-326	The troubleshooting of "Toner cartridge unrecognized" has been changed.
9-12 to 9-13	The replacement procedure of DAMP board has been changed.
11-6	The procedure has been changed.
11-14	The procedure has been changed.
14-1	An AC diagram has been changed.
1093	The mistake has been corrected.
1094	The DAMP board has been added.

#### Ver03

Ver. 03 <2017.04.27>	
Page	Contents
2-7	The description has been added.
3-43	The description has been changed.
4-9 to 4-15	The procedure has been changed.
5-2	The description has been added.
5-9 to 5-10	The operation procedures have been deleted.
5-11 to 5-12	The description has been added.
5-30	The operation procedures have been deleted.
5-31 to 5-33	The description has been changed.
5-41	The description has been changed.
5-45	The description has been changed.
5-48	The mistake has been corrected.
5-51	The mistake has been corrected.
5-62 to 5-64	The description has been changed.
6-105 to 6-106	The description has been added. A note has been added.
6-107 to 6-111	The adjustment procedure has been changed.
7-56	The description has been added.
8-1	The description has been added.
8-3 to 8-4	The description has been added.
8-7	The message of E0A0 has been changed.
8-15	The troubleshooting of EAF2 has been changed.
8-19	The contents of C262 has been changed.
8-28	The F074 error has been added.
8-31	The F11A has been added. The F140 has been added.
8-51	The error code 4043 has been added.
8-53	The error code 4245 has been added.
8-54	The error code 4511 to 4523 have been added.
8-81	The mistake has been corrected.
8-88 to 8-116	The mistake has been corrected.
8-130	The description has been added. (EA31)
8-136	The description has been added. (EAF2)
8-163	The description has been changed. (C262)
8-171	The description has been added. (C550)
8-173	The F074 has been added.
8-175	The description has been added. (C551)
8-188	The description has been added. (CB30)
8-242	The description has been changed. (CD40)
8-269	The F11A has been added.
8-272	The F140 has been added.
8-289	The error code 4043 has been added.
8-325	The description has been added.
8-327	The troubleshooting "Latch the developer unit (Yellow, Magenta, Cyan, Black) remains displayed" has been added.
9-24 to 9-28	The description has been changed.
10-22	The description has been added.
10-48 to 10-49	The description has been added.
11-4	The description has been added.
11-10	A note has been added.
13-1 to 13-6	The description has been changed.

**Ver02**

Ver. 02 <2016.09.30>	
Page	Contents
2-10	The accessories have been corrected.
8-29	F101_10, F101_12 and F101_13 have been added.
8-102	The troubleshooting of E013 has been corrected.
8-105	The troubleshooting of E0A0 has been corrected.
8-179	The troubleshooting of C963 has been added.
8-243	The troubleshooting of CD40 has been added.
8-255	The troubleshooting of F101_13 have been added.
8-326	The troubleshooting of "Countermeasure to Sudden Power Failure" has been Added.
11-10	Descriptions of firmware update error have been added.
Chapter 14.2.1	The mistake has been corrected.

**Ver01**

Ver01 <2016.07.29>	
Page	Contents
2-3	The description has been corrected.
2-7	Scanning speed of DF has been changed.
2-15	The description has been corrected.
3-43	The description has been changed.
4-43	The description has been corrected.
5-56	The description on note has been changed.
7-14	The description has been corrected.
7-52~7-53	The description has been corrected.
8-1	The description has been corrected.
8-43	Errors (2D62, 2D70) have been deleted.
8-47	The description has been corrected.
8-56	5010 has been deleted.
8-67	Errors (7101, 7103, 7105, 7109, 710B, 710F, 7111, 7113, 7115, 7117, 7119, 71A4, 71AA, 71AB, 71AC) have been deleted.
8-78	Errors (D351, D352, D353, D354, D361) have been deleted.
8-109	E400 has been deleted.
8-117	E870 has been deleted.
8-162	C261 has been deleted. The description has been corrected.
8-163	The description has been corrected.
8-168	C4C0 has been deleted.
8-183	The description has been corrected.
8-225	A note has been added. The description has been added.
8-275~8-276	The description has been corrected.
8-285	2D62 has been deleted.
8-288	The description has been corrected.
8-293	5010 has been deleted.
8-304	The description has been corrected.
8-306	Errors (7101, 7103, 7105, 7111, 7113, 7115, 7117, 7119, 7109, 710B, 71A4, 71AA, 71AB, 71AC) have been deleted.
8-328	The procedure has been added.
8-319~8-320	The description has been corrected.
8-328	The procedure has been added.
8-331~8-332	The procedure has been added.
8-340	The procedure has been added.
8-347~8-348	The description has been corrected. The procedure has been added.
8-352~8-353	The description has been corrected. The procedure has been added.
8-359~8-360	The procedure has been added.

8-363	The procedure has been added.
8-364	The description has been corrected. The procedure has been added.
8-380	The procedure has been added.
8-381	The description has been changed.
10-22	The description has been added.
11-2	The description has been corrected.
12-2	The description has been corrected.

## Ver00

<b>Ver00 &lt;2016.03.11&gt;</b>	
<b>Page</b>	<b>Contents</b>
-	Initial release

**TOSHIBA**

**Toshiba Tec Corporation**

1-11-1, OSAKI, SHINAGAWA-KU, TOKYO, 141-8562, JAPAN