

# TOSHIBA

# PC BOARD REPAIR MANUAL

## MULTIFUNCTIONAL DIGITAL SYSTEMS

### e-STUDIO163/165/203/205

### e-STUDIO166/167/206/207/237



## Trademarks

- The company names and product names in this manual are trademarks of their respective companies.

© 2006 TOSHIBA TEC CORPORATION All rights reserved

Under the copyright laws, this manual cannot be reproduced in any form without prior written permission of TOSHIBA TEC CORPORATION. No patent liability is assumed, however, with respect to the use of the information contained herein.

# GENERAL PRECAUTIONS REGARDING THE SERVICE FOR e-STUDIO163/165/166/167/203/205/206/207/237

The installation and service should be done by a qualified service technician.

## 1) Transportation/Installation

- When transporting/installing the equipment, remove the drawer, employ two persons and be sure to hold it in the positions as shown in the figure.  
e-STUDIO163/165/166/167/203/205/206/207/237 weighs approximately 32.5 kg (71.65 lb).  
Because the equipment is very heavy, pay due attention when handling it.

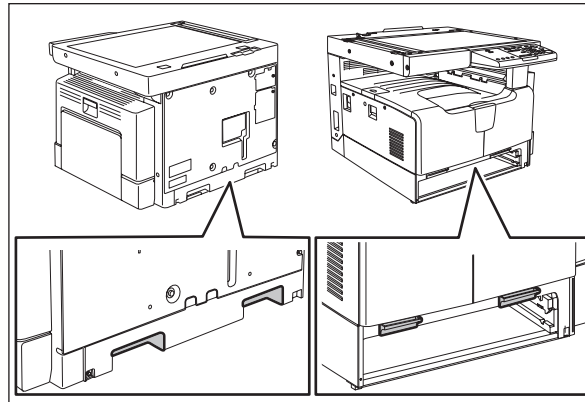

- Be sure not to hold the movable parts or units when transporting the equipment.
- Be sure to use a dedicated outlet with AC 110 V / 13.2 A, 115 V or 127 V / 12 A, 220-240 V or 240 V / 8 A for its power source.
- The equipment must be grounded for safety.
- Select a suitable place for installation. Avoid excessive heat, high humidity, dust, vibration and direct sunlight.
- Provide proper ventilation since the equipment emits a slight amount of ozone.
- To insure adequate working space for the copying operation, keep a minimum clearance of 80 cm (32") on the left, 80 cm (32") on the right and 10 cm (4") on the rear.
- The equipment shall be installed near the socket outlet and shall be easily accessible.
- Be sure to fix and plug in the power cable securely after the installation so that no one trips over it.

## 2) General Precautions at Service

- Be sure to turn the power OFF and unplug the power cable during service (except for the service should be done with the power turned ON).
- Unplug the power cable and clean the area around the prongs of the plug and socket outlet once a year or more. A fire may occur when dust lies on this area.
- When the parts are disassembled, reassembly is the reverse of disassembly unless otherwise noted in this manual or other related documents. Be careful not to install small parts such as screws, washers, pins, E-rings, star washers in the wrong places.
- Basically, the equipment should not be operated with any parts removed or disassembled.
- The PC board must be stored in an anti-electrostatic bag and handled carefully using a wristband since the ICs on it may be damaged due to static electricity.

**Caution:** Before using the wristband, unplug the power cable of the equipment and make sure that there are no charged objects which are not insulated in the vicinity.

- Avoid expose to laser beam during service. This equipment uses a laser diode. Be sure not to expose your eyes to the laser beam. Do not insert reflecting parts or tools such as a screwdriver on the laser beam path. Remove all reflecting metals such as watches, rings, etc. before starting service.
- Be sure not to touch high-temperature sections such as the exposure lamp, fuser unit, damp heater and areas around them.
- Be sure not to touch high-voltage sections such as the chargers, developer, high-voltage transformer and power supply unit. Especially, the board of these components should not be touched since the electric charge may remain in the capacitors, etc. on them even after the power is turned OFF.
- Make sure that the equipment will not operate before touching potentially dangerous places (e.g. rotating/operating sections such as gears, belts pulleys, fans and laser beam exit of the laser optical unit).
- Be careful when removing the covers since there might be the parts with very sharp edges underneath.
- When servicing the equipment with the power turned ON, be sure not to touch live sections and rotating/operating sections. Avoid exposing your eyes to laser beam.
- Use designated jigs and tools.
- Use recommended measuring instruments or equivalents.
- Return the equipment to the original state and check the operation when the service is finished.

### 3) Important Service Parts for Safety

- The breaker, door switch, fuse, thermostat, thermofuse, thermistor, batteries, IC-RAMs including lithium batteries, etc. are particularly important for safety. Be sure to handle/install them properly. If these parts are short-circuited and their functions become ineffective, they may result in fatal accidents such as burnout. Do not allow a short-circuit or do not use the parts not recommended by Toshiba TEC Corporation.

### 4) Cautionary Labels

- During servicing, be sure to check the rating plate and cautionary labels such as "Unplug the power cable during service", "CAUTION. HOT", "CAUTION. HIGH VOLTAGE", "CAUTION. LASER BEAM", etc. to see if there is any dirt on their surface and if they are properly stuck to the equipment.

### 5) Disposal of the Equipment, Supplies, Packing Materials, Used Batteries and IC-RAMs

- Regarding the recovery and disposal of the equipment, supplies, packing materials, used batteries and IC-RAMs including lithium batteries, follow the relevant local regulations or rules.

**Caution:**

Dispose of used batteries and IC-RAMs including lithium batteries according to this manual.

**Attention:**

Se débarrasser de batteries et IC-RAMs usés y compris les batteries en lithium selon ce manuel.

**Vorsicht:**

Entsorgung der gebrauchten Batterien und IC-RAMs (inclusive der Lithium-Batterie) nach diesem Handbuch.

# CONTENTS

<b>1. SYSTEM BLOCK DIAGRAM .....</b>	<b>1-1</b>
1.1 e-STUDIO163/166/203/206 .....	1-1
1.2 e-STUDIO165/205 .....	1-2
1.3 e-STUDIO167/207/237 .....	1-3
<b>2. GENERAL DESCRIPTION OF MAIN IC .....</b>	<b>2-1</b>
2.1 ASIC (EC/N106) .....	2-1
2.1.1 Functions .....	2-1
2.1.2 Pin assignment .....	2-1
2.1.3 Signals .....	2-2
<b>3. ELECTRIC CIRCUIT DIAGRAMS .....</b>	<b>3-1</b>
3.1 Main circuit (MAIN board: e-STUDIO163/165/203/205) .....	3-2
3.2 SRAM circuit (SRAM board: e-STUDIO163/165/203/205) .....	3-36
3.3 Laser drive circuit (LDR board) .....	3-37
3.4 H-sync signal detection circuit (SNS board) .....	3-39
3.5 Fuse circuit (FUS board) .....	3-40
3.6 Control panel circuit (LPNL board: e-STUDIO163/166/203/206) .....	3-41
3.7 Control panel circuit (HPNL board: e-STUDIO165/205) .....	3-45
3.8 Paper feed control circuit (PFC board: GH-1050) .....	3-49
3.9 Facsimile circuit (FAX board: GD-1220) .....	3-53
3.10 Telephone line network control circuit (NCU board: GD-1220NA/TW) .....	3-58
3.11 Telephone line network control circuit (NCU board: GD-1220EU/AU) .....	3-60
3.12 TELBOOK circuit (TELBOOK board: GJ-1040) .....	3-62
3.13 External keyboard circuit (OTK board: GJ-1040) .....	3-63
3.14 Memory circuit (MEM board: GC-1240) .....	3-64
3.15 Main circuit (MAIN board: e-STUDIO166/206) .....	3-65
3.16 Main circuit (MAIN board: e-STUDIO167/207/237) .....	3-99
3.17 SRAM circuit (SRAM board: e-STUDIO166/167/206/207/237) .....	3-134
3.18 Control panel circuit (HPNL board: e-STUDIO167/207/237) .....	3-135
3.19 Paper feed control circuit (PFC board: GH-1060) .....	3-139



# 1. SYSTEM BLOCK DIAGRAM

## 1.1 e-STUDIO163/166/203/206

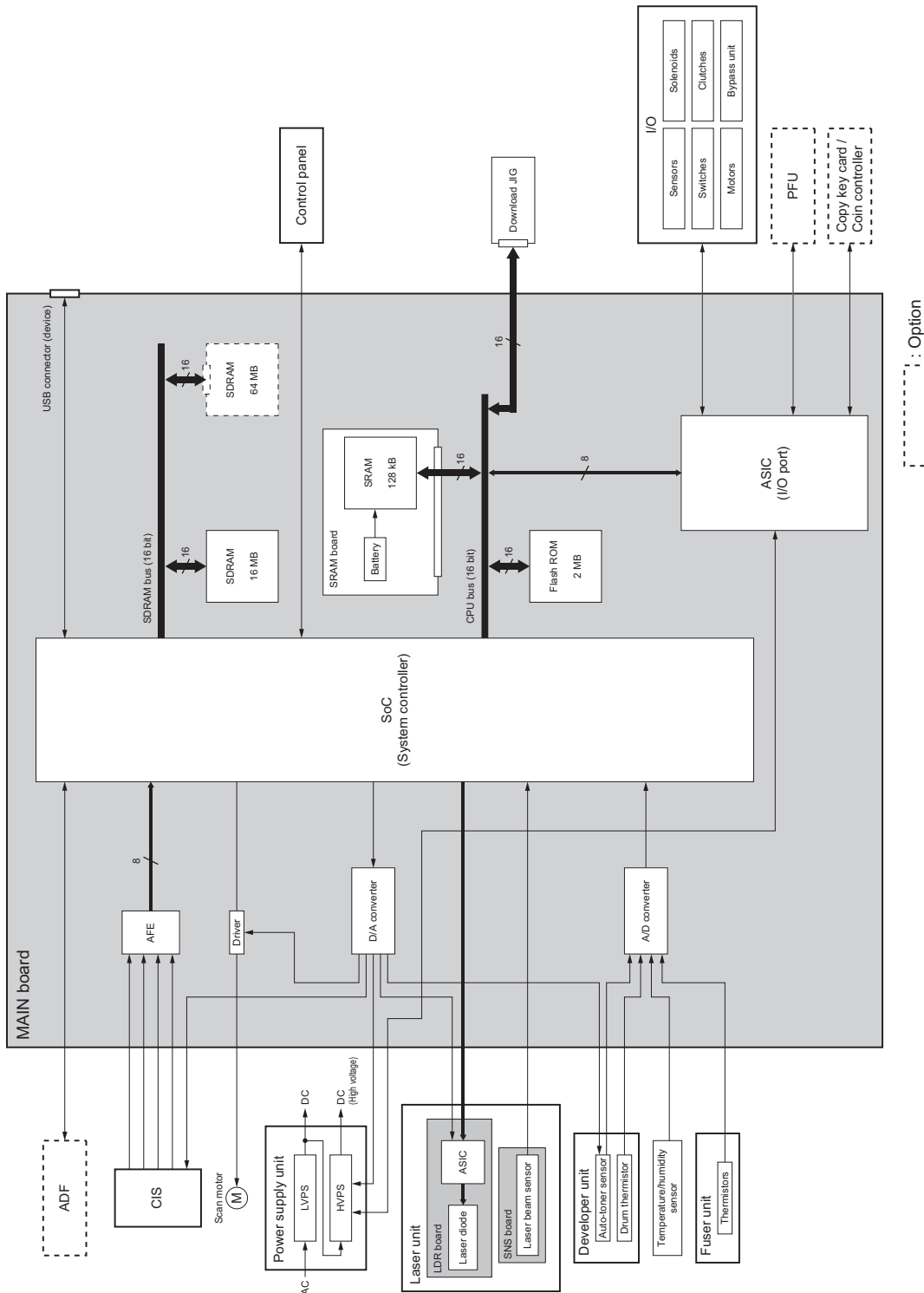

Fig. 1-1

# 1.2 e-STUDIO165/205

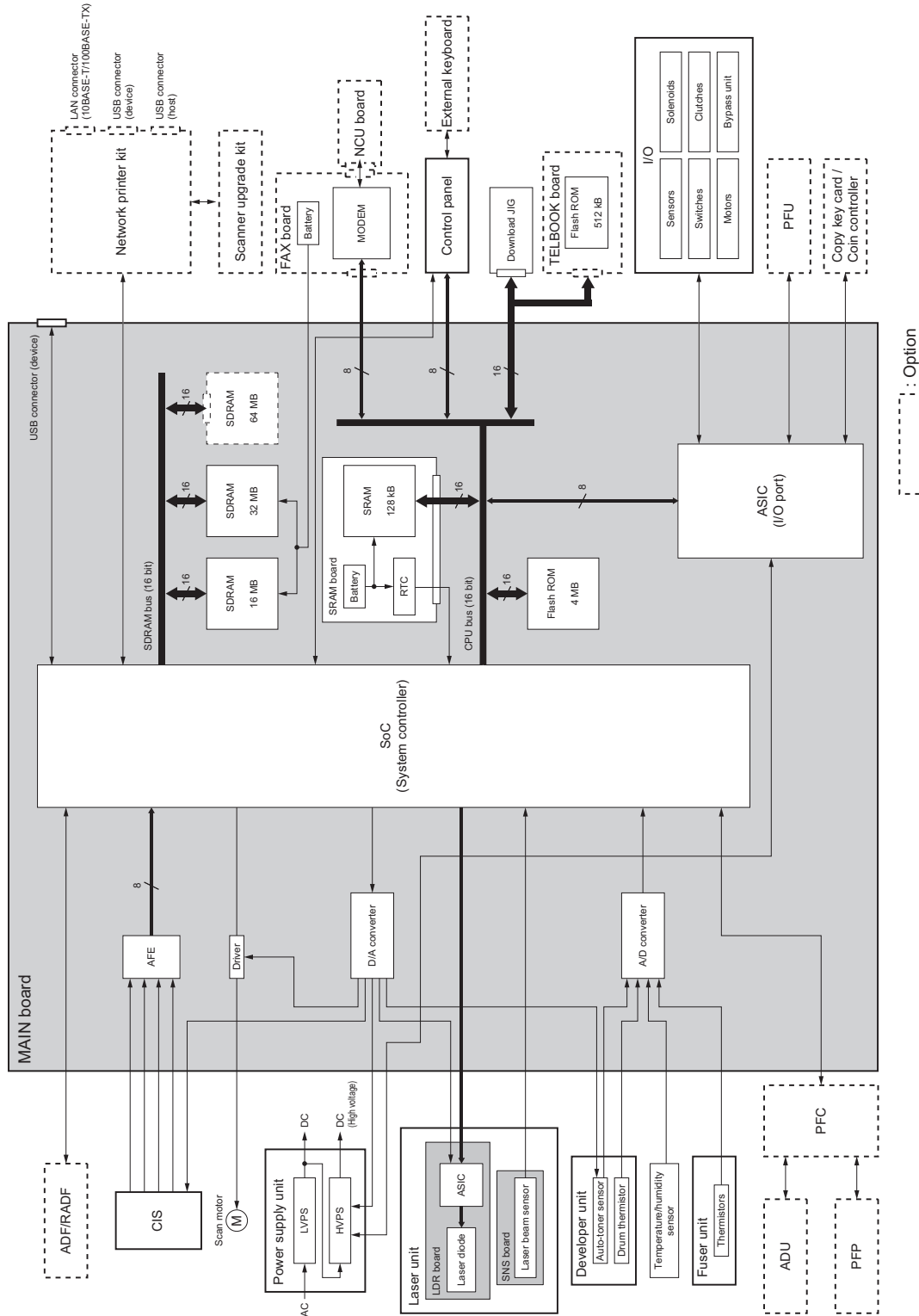

Fig. 1-2



# 1.3 e-STUDIO167/207/237

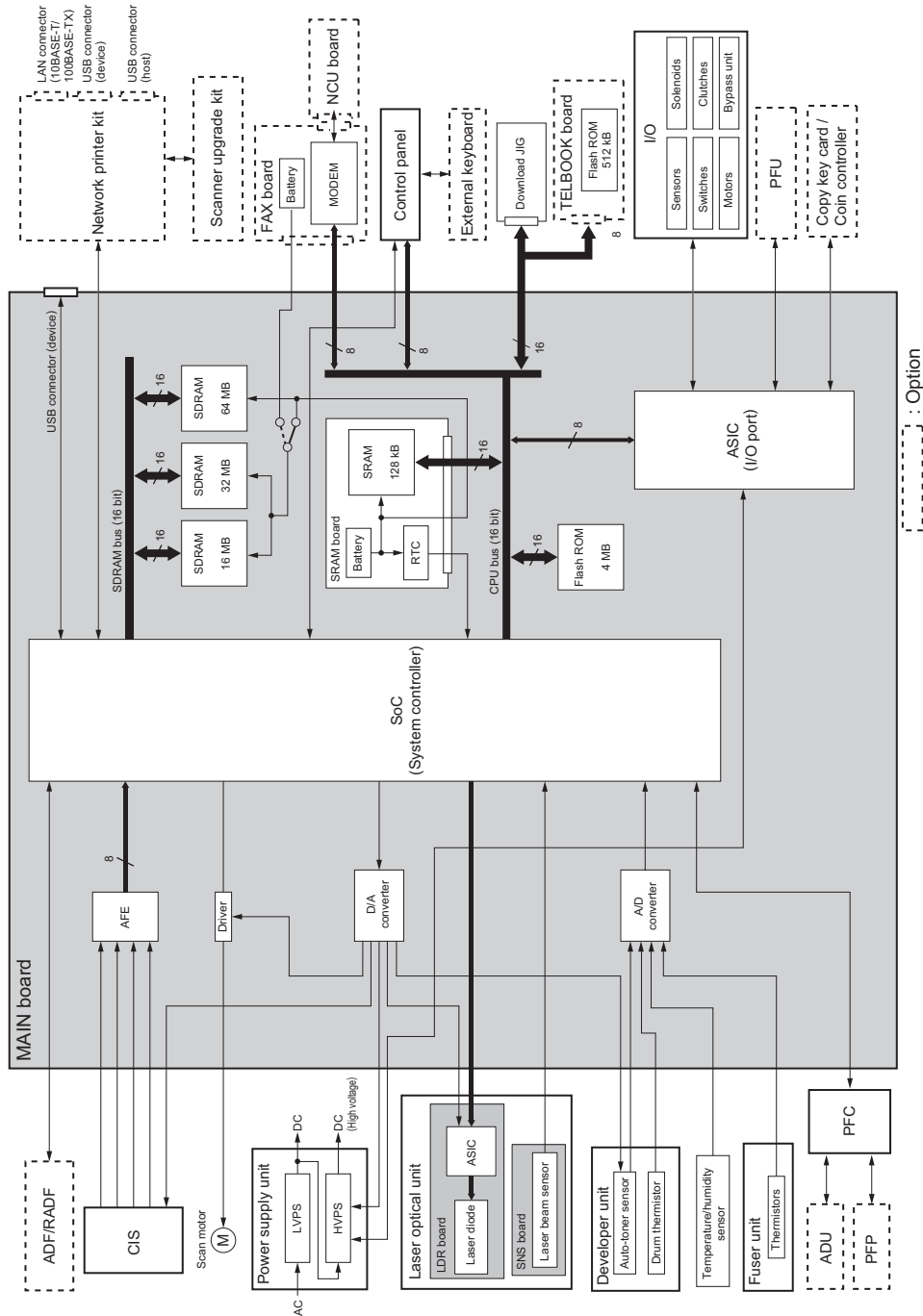

Fig. 1-3



## 2. GENERAL DESCRIPTION OF MAIN IC

### 2.1 ASIC (EC/N106)

#### 2.1.1 Functions

The ASIC is controlled by command from the SoC and the logic circuit inside the gate array. The primary functions of the ASIC are as follows.

- I/O control of each electrical part (motor, sensor, switch, electromagnetic spring clutch, solenoid, etc.)
- Interface to control the high-voltage transformer, bypass unit and PFU

#### 2.1.2 Pin assignment

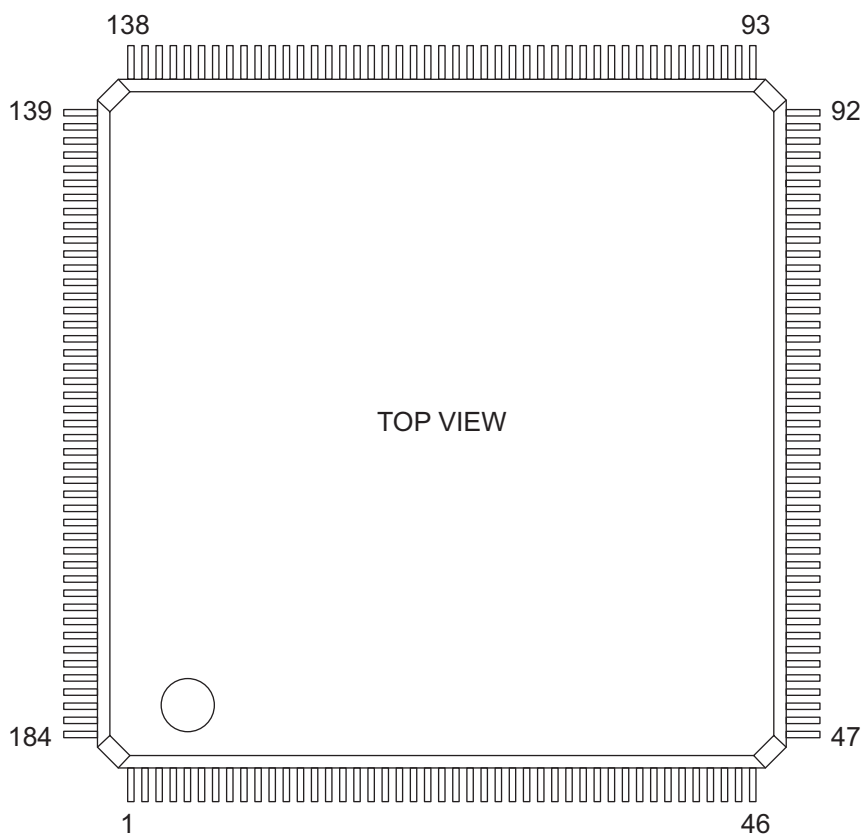

Fig. 2-1

## 2.1.3 Signals

Pin No.	Port name	Signal name	I/O	Function															
1	VSS1	SG	-	Signal ground															
2	D7_1	SD[7]	I/O	Data bus [7]															
3	D6_1	SD[6]	I/O	Data bus [6]															
4	D5_1	SD[5]	I/O	Data bus [5]															
5	D4_1	SD[4]	I/O	Data bus [4]															
6	D3_1	SD[3]	I/O	Data bus [3]															
7	D2_1	SD[2]	I/O	Data bus [2]															
8	D1_1	SD[1]	I/O	Data bus [1]															
9	D0_1	SD[0]	I/O	Data bus [0]															
10	HVDD1-1	+3.3V	-	+3.3V															
11	VSS2	SG	-	Signal ground															
12	PA7_1	-	-	Not used (Open)															
13	PA6_1	APSON	O	APS sensor power supply control signal (H: supply, L: cutoff) * For e-STUDIO165/205															
14	PA5_1	PSFANH	O	Switching regulator cooling fan high speed drive signal															
15	PA4_1	PSFANL	O	Switching regulator cooling fan low speed drive signal <table border="0" style="margin-left: 20px;"> <tr> <td>PSFANL</td> <td>PSFANH</td> <td>Status</td> </tr> <tr> <td>L</td> <td>L</td> <td>High speed drive</td> </tr> <tr> <td>L</td> <td>H</td> <td>High speed drive</td> </tr> <tr> <td>H</td> <td>L</td> <td>Low speed drive</td> </tr> <tr> <td>H</td> <td>H</td> <td>Stop</td> </tr> </table>	PSFANL	PSFANH	Status	L	L	High speed drive	L	H	High speed drive	H	L	Low speed drive	H	H	Stop
PSFANL	PSFANH	Status																	
L	L	High speed drive																	
L	H	High speed drive																	
H	L	Low speed drive																	
H	H	Stop																	
16	PA3_1	PMTR-0	O	Polygonal motor ON/OFF signal (H: OFF, L: ON)															
17	PA2_1	-	-	Not used (Open)															
18	PA1_1	MMTR-0	O	Main motor ON/OFF signal (H: OFF, L: ON)															
19	PA0_1	PWRSWOFF-0	O	Switching regulator relay ON/OFF signal (H: ON, L: OFF)															
20	HVDD2-1	+5V	-	+5V															
21	LVDD1	+3.3V	-	+3.3V															
22	PB7_1	BKUPEEPROMCS-1	O	-															
23	PB6_1	MDM1RST	O	Modem reset signal (H: reset, L: normal) * Reset the modem for the fax kit * For e-STUDIO165/167/205/207/237															
24	PB5_1	PFCRST	O	PFC reset signal (H: normal, L: reset) * Reset the PFC board * For e-STUDIO165/167/205/207/237															
25	PB4_1	SCANRST	O	Scanner reset signal (H: normal, L: reset) * Reset the scan motor and AFE															

Pin No.	Port name	Signal name	I/O	Function
26	PB3_1	PFCBOOT-0	O	PFC-CPU boot mode switching signal (L: boot mode) * For e-STUDIO165/167/205/207/237
27	PB2_1	EEPROMCS-1	O	-
28	PB1_1	EEPROMCK	O	-
29	PB0_1	EEPROMDO	O	-
30	VSS3	SG	-	Signal ground
31	PC7_1	EEPROMDI	I	-
32	PC6_1	APS1-0	I	APS-1 sensor detection signal (Low-active) * For e-STUDIO165/167/205/207/237
33	PC5_1	APS2-0	I	APS-2 sensor detection signal (Low-active) * For e-STUDIO165/167/205/207/237
34	PC4_1	APS3-0	I	APS-3 sensor detection signal (Low-active) * For e-STUDIO165/167/205/207/237
35	PC3_1	APSC-0	I	APS-C sensor detection signal (Low-active) * For e-STUDIO165/167/205/207/237
36	PC2_1	APSR-0	I	APS-R sensor detection signal (Low-active) * For e-STUDIO165/167/205/207/237
37	PC1_1	PLTN-1A	I	Platen sensor detection signal (H: closed, L: open)
38	PC0_1	HOME-1	I	CIS home position sensor detection signal (H: home position)
39	HVDD2-2	+5V	-	+5V
40	PD7_1	CSTEMP-0	I	Paper empty sensor detection signal (H: no paper in the drawer of the equipment, L: paper presence)
41	PD6_1	OTKCNT-0	I	External keyboard connection signal (L: connected) * For e-STUDIO165/167/205/207/237
42	PD5_1	CSTOPEN-1	I	Drawer detection switch detection signal (H: drawer of the equipment is open, L: drawer closed)
43	PD4_1	PFUCNT-0	I	Paper feed unit (PFU) connection signal (L: connected)
44	PD3_1	CH2	I	-
45	PD2_1	CH1	I	-
46	PD1_1	FCOV-1	I	Front cover opening/closing switch detection signal (H: opened, L: closed)
47	PD0_1	HVSDWN-0	I	High voltage transformer leak detection signal (L: error)
48	VSS4	SG	-	Signal ground
49	PE7_1	HVTSP-0	O	Separation charger ON/OFF signal (L: ON)
50	PE6_1	HVTGB-0	O	Transfer guide bias ON/OFF signal (L: ON)
51	PE5_1	HVTT-0	O	Transfer charger ON/OFF signal (L: ON)
52	PE4_1	HVTAC-0	O	Developer AC bias ON/OFF signal (L: ON)

Pin No.	Port name	Signal name	I/O	Function
53	PE3_1	HVTM-0	O	Charge grid ON/OFF signal (L: ON)
54	PE2_1	ERSLP-0	O	Discharger LED drive signal (L: ON)
55	PE1_1	BZON-0	O	Buzzer ON signal (L: ON)
56	PE0_1	SFBSOL-0	O	Bypass pickup solenoid drive signal (H: OFF, L: ON (pickup))
57	HVDD2-3	+5V	-	+5V
58	PF7_1	SRAMCNT-0	I	SRAM board connection signal (L: connected)
59	PF6_1	ADFCNT-0A	I	Automatic document feeder (ADF/RADF) connection signal (L: connected)
60	PF5_1	FAXCNT-0	I	Fax kit connection signal (L: connected) * For e-STUDIO165/167/205/207/237
61	PF4_1	SDRAMCNT-0	I	Expansion memory connection signal (L: connected) * For e-STUDIO163/165/166/203/205/206
62	PF3_1	24VONOFF	I	+24VCOV-OFF supply status detection signal (H: Cutoff (cover open), L: Supply (cover closed)) * +24VCOV-OFF is supplied/cut off by the ADU cover opening/closing interlock switch.
63	PF2_1	EXTSW-1A	I	Exit sensor detection signal (H: paper transport, L: normal)
64	PF1_1	PSTPSW-1A	I	Registration sensor detection signal (H: paper transport, L: normal)
65	PF0_1	ATSCNT-0	I	Developer unit connection signal (L: connected)
66	VSS5	SG	-	Signal ground
67	LVDD2	+3.3V	-	+3.3V
68	PG7_1	-	-	Not used (Open)
69	PG6_1	VCMFANL-0	O	Exhaust fan low speed drive signal
70	PG5_1	VCMFANH-0	O	Exhaust fan high speed drive signal VCMFANL-0 VCMFANH-0 Status L L High speed drive L H High speed drive H L Low speed drive H H Stop
71	PG4_1	SCNLEDASTOFF-1	O	Enforced exposure LED (subsidiary light source) OFF signal (H: exposure LED is forcibly turned OFF)
72	PG3_1	SCNLEDBOFF-1	O	Enforced exposure LED (main light source B) OFF signal (H: exposure LED is forcibly turned OFF)
73	PG2_1	SCNLEDGOFF-1	O	Enforced exposure LED (main light source G) OFF signal (H: exposure LED is forcibly turned OFF)
74	PG1_1	SCNLEDROFF-1	O	Enforced exposure LED (main light source R) OFF signal (H: exposure LED is forcibly turned OFF)
75	PG0_1	CS7AX	O	Download jig chip select signal (Low-active)
76	HVDD2-4	+5V	-	+5V
77	PH7_1	PMTRSTS-0	I	Polygonal motor phase locked loop control signal (H: stop or error, L: uniform speed driving)

Pin No.	Port name	Signal name	I/O	Function
78	PH6_1	TSTMEM-0	I	Not used (for debug)
79	PH5_1	TSTSEL-1	I	Not used (for debug)
80	PH4_1	PGNCNT-0	I	Not used (for debug)
81	PH3_1	PSTPRA	I	ADU paper transport detection signal (H: paper transport) * For e-STUDIO165/167/205/207/237
82	PH2_1	PFCNT-0	I	PFC board connection signal (L: connected) * For e-STUDIO165/167/205/207/237
83	PH1_1	CTLCNT-0	I	Network printer kit connection signal (L: connected) * For e-STUDIO165/167/205/207/237
84	PH0_1	FUSCNT-1	I	Fuser unit connection signal (L: connected)
85	VSS6	SG	-	Signal ground
86	PI7_1	FEDSOL-0	O	Pickup solenoid drive signal (H: OFF, L: ON (pickup))
87	PI6_1	MMTRCCW-1	O	Main motor rotational direction switching signal (H: CCW, L: CW)
88	PI5_1	MMTRBK-0	O	Main motor brake signal (L: brake)
89	PI4_1	TNRMTON-0	O	Toner motor ON/OFF signal (L: ON)
90	PI3_1	DLLED-1	O	Not used
91	PI2_1	PFUFEDCLT-L0	O	PFU transport clutch (L) ON/OFF signal (L: ON)
92	PI1_1	PFUFEDCLT-H0	O	PFU transport clutch (H) ON/OFF signal (L: ON)
93	PI0_1	PFUPSOL-0	O	PFU pickup solenoid drive signal (H: OFF, L: ON (pickup))
94	PJ7_1	CKCTRO-0	I	Not used
95	PJ6_1	CTRON-EN-0	I	Count enable signal for external counter (L: count)
96	PJ5_1	KCTRC-0	I	External counter connection signal (L: connected)
97	PJ4_1	PFUFEDSW-0	I	PFU paper transport detection signal (H: paper transport)
98	PJ3_1	DFSCSTA	I	Automatic document feeder (ADF/RADF) scanning start signal (H: scanning)
99	PJ2_1	PFUSIDECOV-0	I	PFU jam access cover opening/closing switch detection signal (H: opened)
100	PJ1_1	PFUEMP-0	I	PFU paper empty sensor detection signal (H: no paper in the PFU drawer, L: paper presence)
101	PJ0_1	PFUCSTSW-0	I	PFU drawer detection switch detection signal (H: PFU drawer open, L: drawer closed)
102	HVDD2-5	+5V	-	+5V
103	VSS7	SG	-	Signal ground
104	PK7_1	SFBCNT-0	I	Bypass unit connection signal (L: connected)
105	PK6_1	KISYU2	I	Not used
106	PK5_1	SFBSIZE2-0	I	Not used

Pin No.	Port name	Signal name	I/O	Function
107	PK4_1	SFBSIZE1-0	I	Not used
108	PK3_1	SFBSIZE0-0	I	Not used
109	PK2_1	SFBEMP-0	I	Bypass paper sensor detection signal (H: no paper on the bypass tray, L: paper presence)
110	PK1_1	KISYU1	I	-
111	PK0_1	TNRSW	I	-
112	LVDD3	+3.3V	-	+3.3V
113	PL7_1	SZ3	O	Paper size signal [3] for copy key card
114	PL6_1	SZ2	O	Paper size signal [2] for copy key card
115	PL5_1	SZ1	O	Paper size signal [1] for copy key card
116	PL4_1	SZ0	O	Paper size signal [0] for copy key card
117	PL3_1	LEDGLOW-0	O	CIS green LED light emitting level switching signal (H: high level, L: low level)
118	PL2_1	ADUCTR-0	O	Back printing count signal for copy key card
119	PL1_1	CSTCTR-0	O	Front printing count signal for copy key card
120	PL0_1	CTR-ON	O	Total count signal for external counter
121	VSS8	SG	-	Signal ground
122	PM7_1	-	-	Not used (Open)
123	PM6_1	L/S-SIZE	O	Paper size signal for coin controller
124	PM5_1	KCTR-0	O	Not used
125	PM4_1	MCRUN-0	O	Equipment drive signal for external counter
126	PM3_1	EXTCTR-0	O	Paper exit count signal for coin controller
127	PM2_1	-	-	Not used (Open)
128	PM1_1	SCNMD1	O	Scan motor phase mode setting signal [1]
129	PM0_1	SCNMD0	O	Scan motor phase mode setting signal [0]
130	HVDD2-6	+5V	-	+5V
131	PN7_1	-	-	Not used
132	PN6_1	-	-	Not used
133	PN5_1	-	-	Not used
134	PN4_1	-	-	Not used
135	PN3_1	-	-	Not used
136	PN2_1	-	-	Not used
137	PN1_1	-	-	Not used
138	PN0_1	-	-	Not used
139	VSS9	SG	-	Signal ground
140	PO7_1	PLADJ21	O	NCU setting signal [2] for fax kit * For e-STUDIO165/167/205/207/237



Pin No.	Port name	Signal name	I/O	Function
141	PO6_1	PLADJ11	O	NCU setting signal [1] for fax kit * For e-STUDIO165/167/205/207/237
142	PO5_1	ATT3DB1-1	O	Attenuator adjustment signal for fax kit (H: insert 3dB) * For e-STUDIO165/167/205/207/237
143	PO4_1	LD1-1	O	Dial pulse generation signal for fax kit (H: dial make, L: dial break) * For e-STUDIO165/167/205/207/237
144	PO3_1	CML1-1	O	CML relay control signal for fax kit (H: CML relay ON) * For e-STUDIO165/167/205/207/237
145	PO2_1	16HZON-1	O	External ring 16 Hz signal for fax kit * For e-STUDIO165/167/205/207/237
146	PO1_1	EXTRING-1	O	RG relay control signal for fax kit (H: RG relay ON (external TEL line circuit connected)) * For e-STUDIO165/167/205/207/237
147	PO0_1	20KHZON-1	O	External ring 20 kHz signal for fax kit * For e-STUDIO165/167/205/207/237
148	HVDD2-7	+5V	-	+5V
149	PP7_1	SPVOL2	O	Speaker volume control signal [2] for fax kit * For e-STUDIO165/167/205/207/237
150	PP6_1	SPVOL1	O	Speaker volume control signal [1] for fax kit * For e-STUDIO165/167/205/207/237
151	PP5_1	SPVOL0	O	Speaker volume control signal [0] for fax kit * For e-STUDIO165/167/205/207/237
152	PP4_1	TONESEL	O	Line/tone switching signal for fax kit (H: line, L: tone) * For e-STUDIO165/167/205/207/237
153	PP3_1	RING/TONE	O	Ring/tone switching signal for fax kit (H: pseudo ring, L: tone) * For e-STUDIO165/167/205/207/237
154	PP2_1	CHO1	O	Not used
155	PP1_1	BTTBUCHG	O	Backup enable permission signal for fax kit (Up-edge trigger) * For e-STUDIO165/167/205/207/237
156	PP0_1	BTTBUENA	O	Backup enable signal for fax kit (High-active) * For e-STUDIO165/167/205/207/237
157	LVDD4	+3.3V	-	+3.3V
158	TST_1	-	-	Not used (Open)
159	VSS10	SG	-	Signal ground
160	PQ7_1	REVA1-0	I	Line current detection signal [A] for fax kit (L: current detection) * For e-STUDIO165/167/205/207/237
161	PQ6_1	REVB1-0	I	Line current detection signal [B] for fax kit (L: current detection) * For e-STUDIO165/167/205/207/237

Pin No.	Port name	Signal name	I/O	Function
162	PQ5_1	CI1-0	I	Ring detection signal for fax kit (L: ring signal detection) * For e-STUDIO165/167/205/207/237
163	PQ4_1	BTTBUNG-1	I	Backup NG signal for fax kit (H: backup NG) * For e-STUDIO165/167/205/207/237
164	PQ3_1	MMTRPLL-1	I	Main motor phase locked loop control signal (H: stop or error, L: constant speed driving)
165	PQ2_1	HOOK-0	I	Hook detection signal for fax kit (H: on hook) * For e-STUDIO165/167/205/207/237
166	PQ1_1	EXTHOOK-0	I	External TEL hook detection signal for fax kit (L: on hook) * For e-STUDIO165/167/205/207/237
167	PQ0_1	TELBOOKCNT-0	I	TELBOOK board connection signal (L: connected) * For e-STUDIO165/167/205/207/237
168	HVDD2-8	+5V	-	+5V
169	CLK_1	-	I	Pull-down: signal ground
170	RSTSE1	-	I	Pull-up: +3.3V
171	PR1_1	FROMBUSY-0	I	Flash ROM busy signal (L: busy)
172	PR0_1	ROMSEL	I	Download jig connection signal (L: connected)
173	HVDD1-2	+3.3V	-	+3.3V
174	RST_0	RESETX	I	Reset signal (Low-active)
175	VSS11	SG	-	Signal ground
176	A0	SA[1]	I	Address bus [1]
177	A1	SA[2]	I	Address bus [2]
178	A2	SA[3]	I	Address bus [3]
179	A3	SA[4]	I	Address bus [4]
180	A4	SA[5]	I	Address bus [5]
181	CS_0	OPALCS-0	I	ASIC chip select signal (Low-active)
182	RD_0	IORDLX	I	Read signal (Low-active)
183	HVDD1-3	+3.3V	-	+3.3V
184	WR_0	IOWRLX	I	Write signal (Low-active)

### 3. ELECTRIC CIRCUIT DIAGRAMS

3.1	Main circuit (MAIN board: e-STUDIO163/165/203/205) .....	1/34 to 34/34
3.2	SRAM circuit (SRAM board: e-STUDIO163/165/203/205) .....	1/1
3.3	Laser drive circuit (LDR board) .....	1/2 to 2/2
3.4	H-sync signal detection circuit (SNS board) .....	1/1
3.5	Fuse circuit (FUS board) .....	1/1
3.6	Control panel circuit (LPNL board: e-STUDIO163/166/203/206) .....	1/4 to 4/4
3.7	Control panel circuit (HPNL board: e-STUDIO165/205) .....	1/4 to 4/4
3.8	Paper feed control circuit (PFC board: GH-1050) .....	1/4 to 4/4
3.9	Facsimile circuit (FAX board: GD-1220) .....	1/5 to 5/5
3.10	Telephone line network control circuit (NCU board: GD-1220NA/TW) .....	1/2 to 2/2
3.11	Telephone line network control circuit (NCU board: GD-1220EU/AU) .....	1/2 to 2/2
3.12	TELBOOK circuit (TELBOOK board: GJ-1040) .....	1/1
3.13	External keyboard circuit (OTK board: GJ-1040) .....	1/1
3.14	Memory circuit (MEM board: GC-1240) .....	1/1
3.15	Main circuit (MAIN board: e-STUDIO166/206) .....	1/34 to 34/34
3.16	Main circuit (MAIN board: e-STUDIO167/207/237) .....	1/35 to 35/35
3.17	SRAM circuit (SRAM board: e-STUDIO166/167/206/207/237) .....	1/1
3.18	Control panel circuit (HPNL board: e-STUDIO167/207/237) .....	1/4 to 4/4
3.19	Paper feed control circuit (PFC board: GH-1060) .....	1/4 to 4/4

### 3.1 Main circuit (MAIN board: e-STUDIO163/165/203/205)

MAIN board 1/34

F280/281/282/283  
Main Board Circuit Diagram

Sheet No.	Index	018	019	020	021	022	023	024	025	026	027	028	029	030	031	032	033	034	
001																			
002	SOC 1																		
003	SOC 2																		
004	SOC 3																		
005	SOC 4																		
006	SOC 5																		
007	FROM																		
008	SDRAM																		
009	CONTROL PANEL IF&3.3V-5V IF																		
010	3.3V-5V IF&POWER DOWN&POWER SAVE																		
011	RESET																		
012	ASIC																		
013	DAC&ADC																		
014	REGISTER CONTROL																		
015	SCAN-MOTOR DRIVER																		
016	CIS CONTROL SIGNAL IF&WAKE UP&PFC IF																		
017	AFE-SOC IF&APS-PS																		

Fig. 3-1

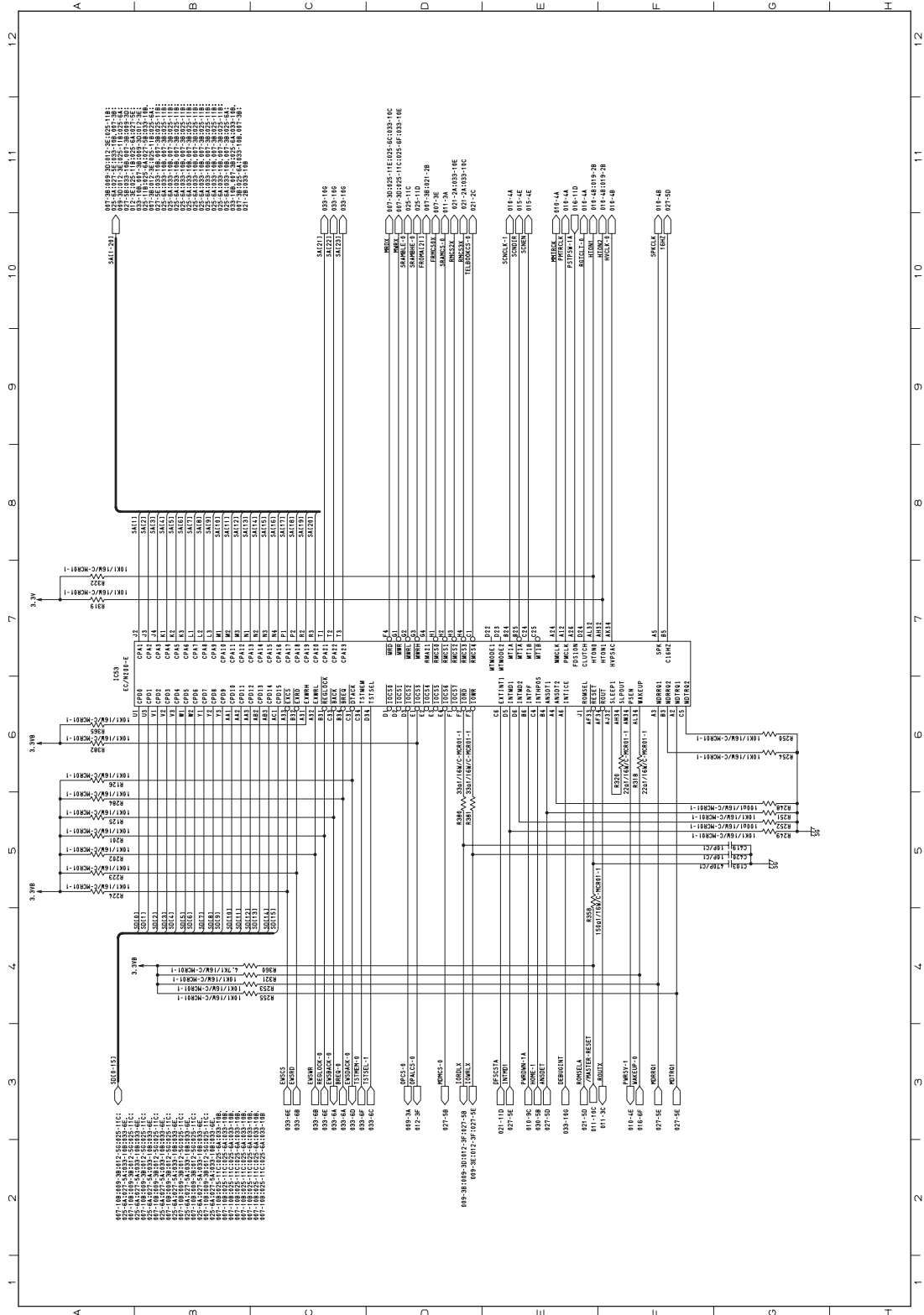

Fig. 3-2



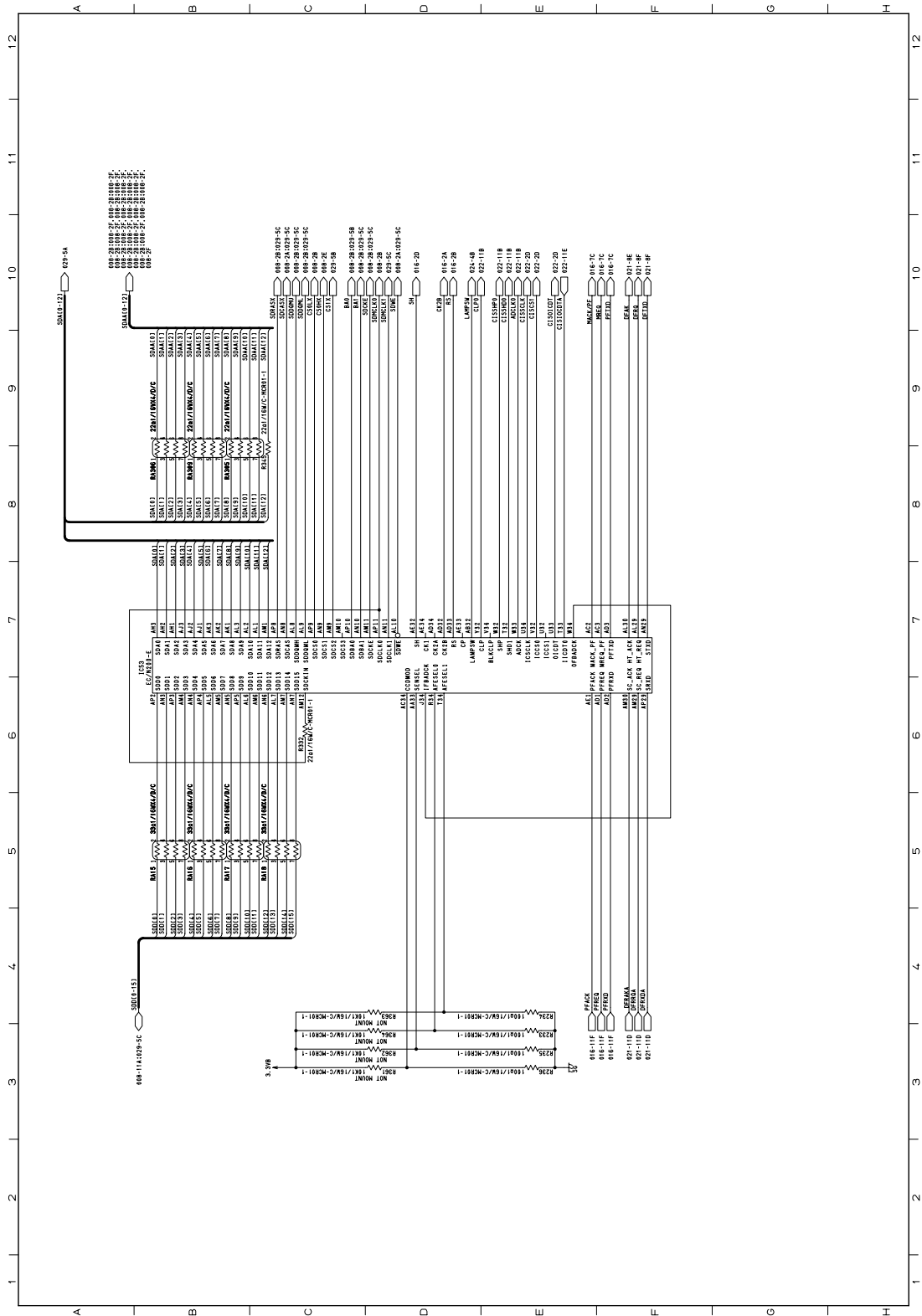

Fig. 3-3

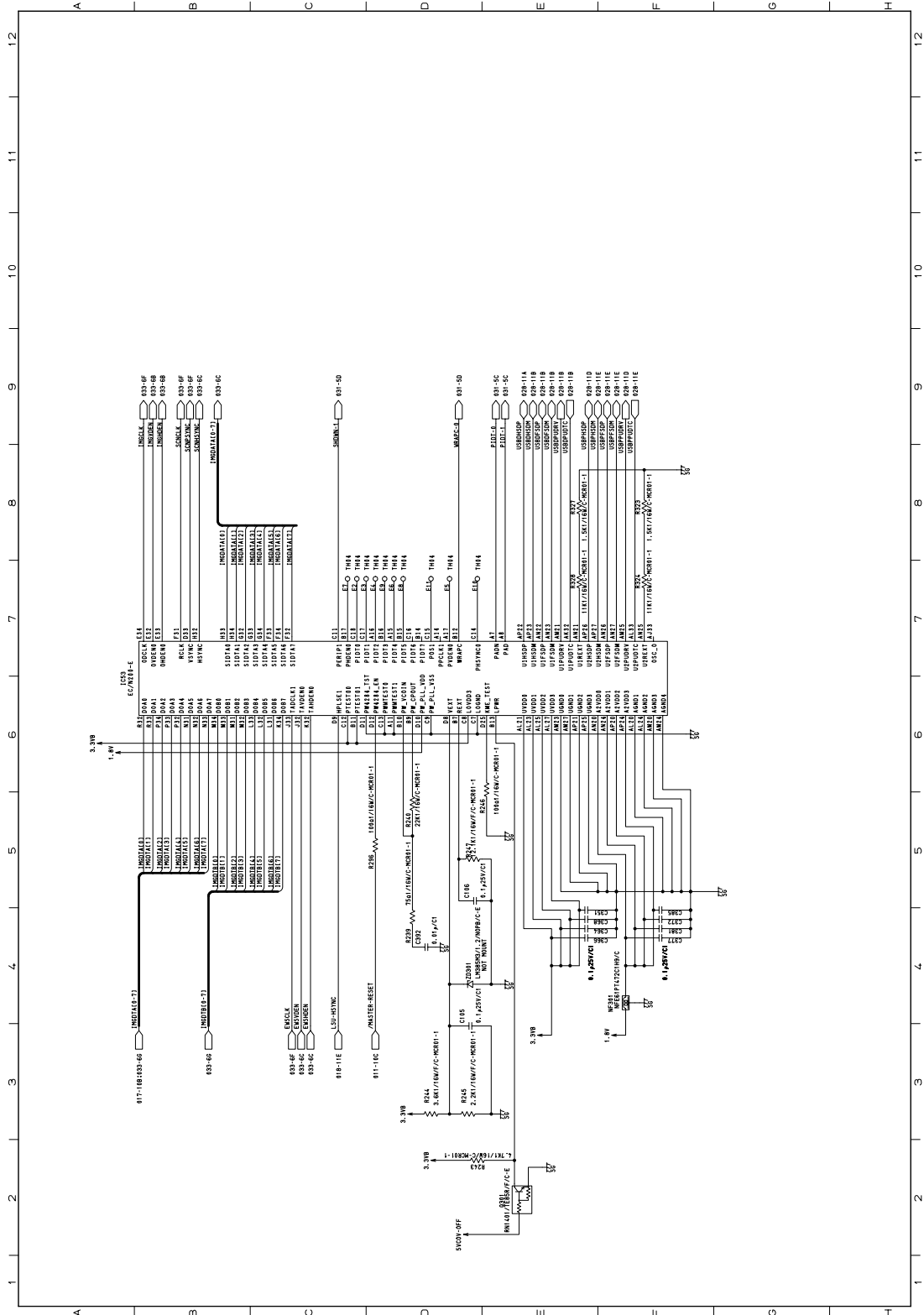

Fig. 3-4







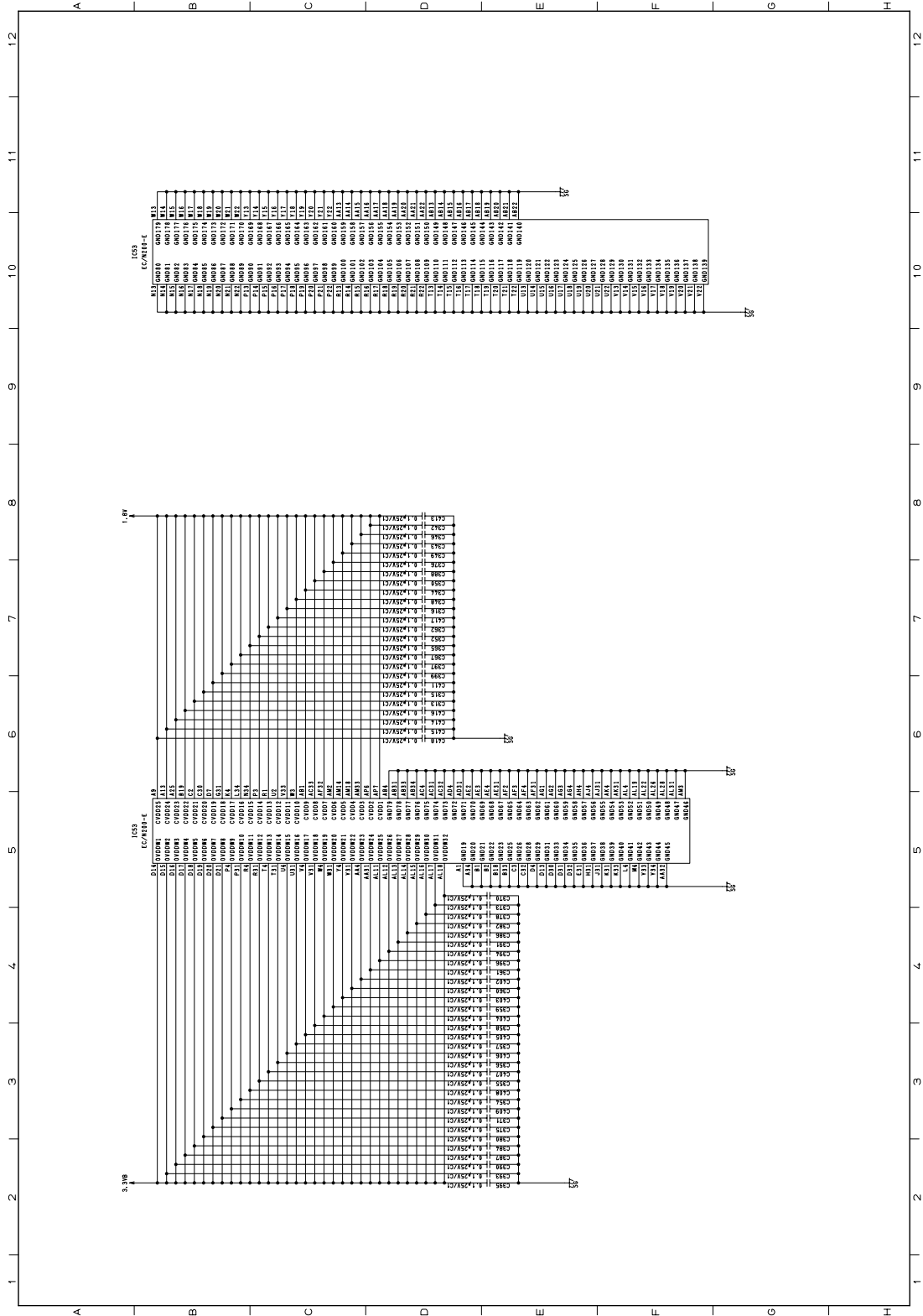

Fig. 3-6





MAIN board 9/34

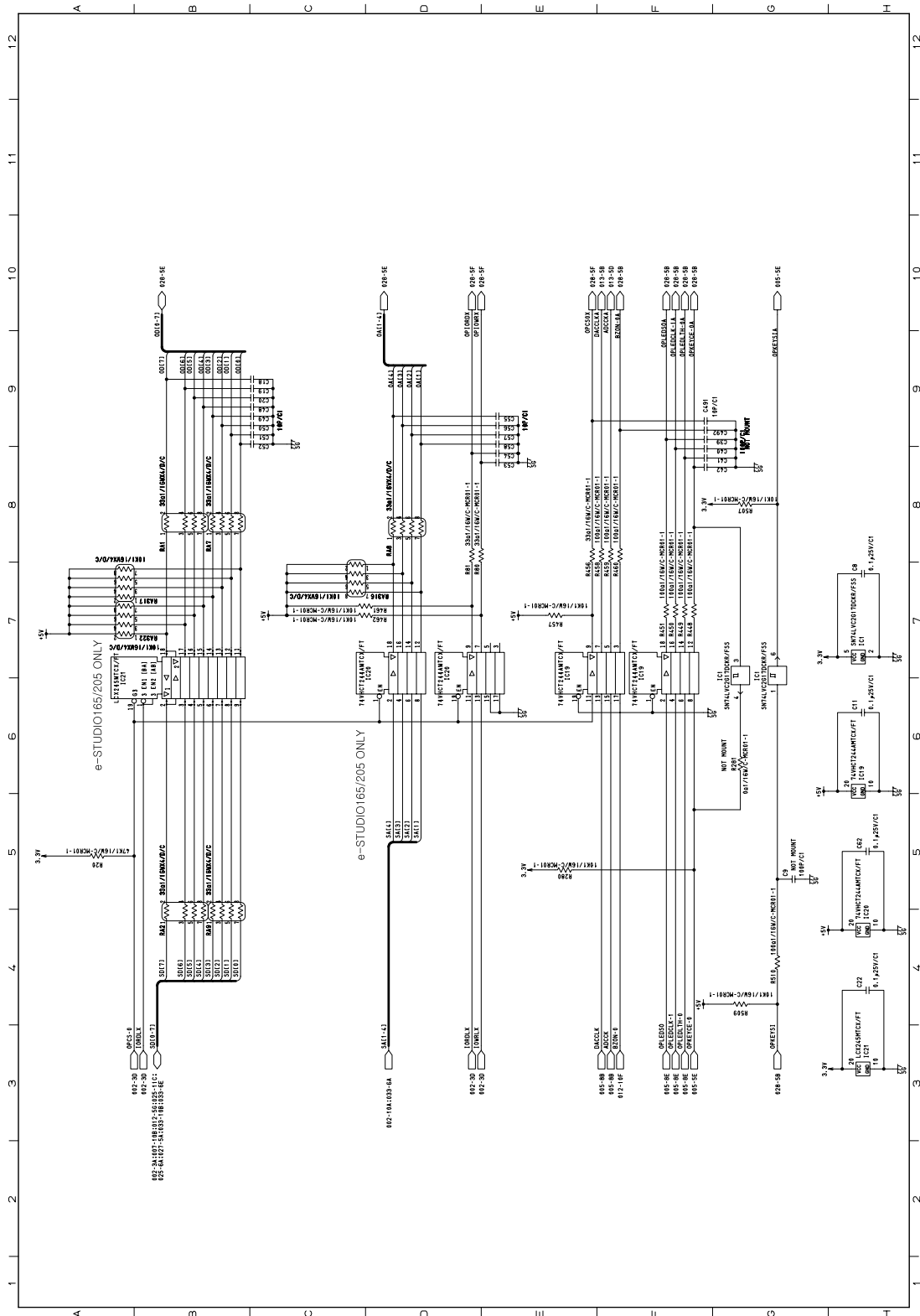

Fig. 3-9

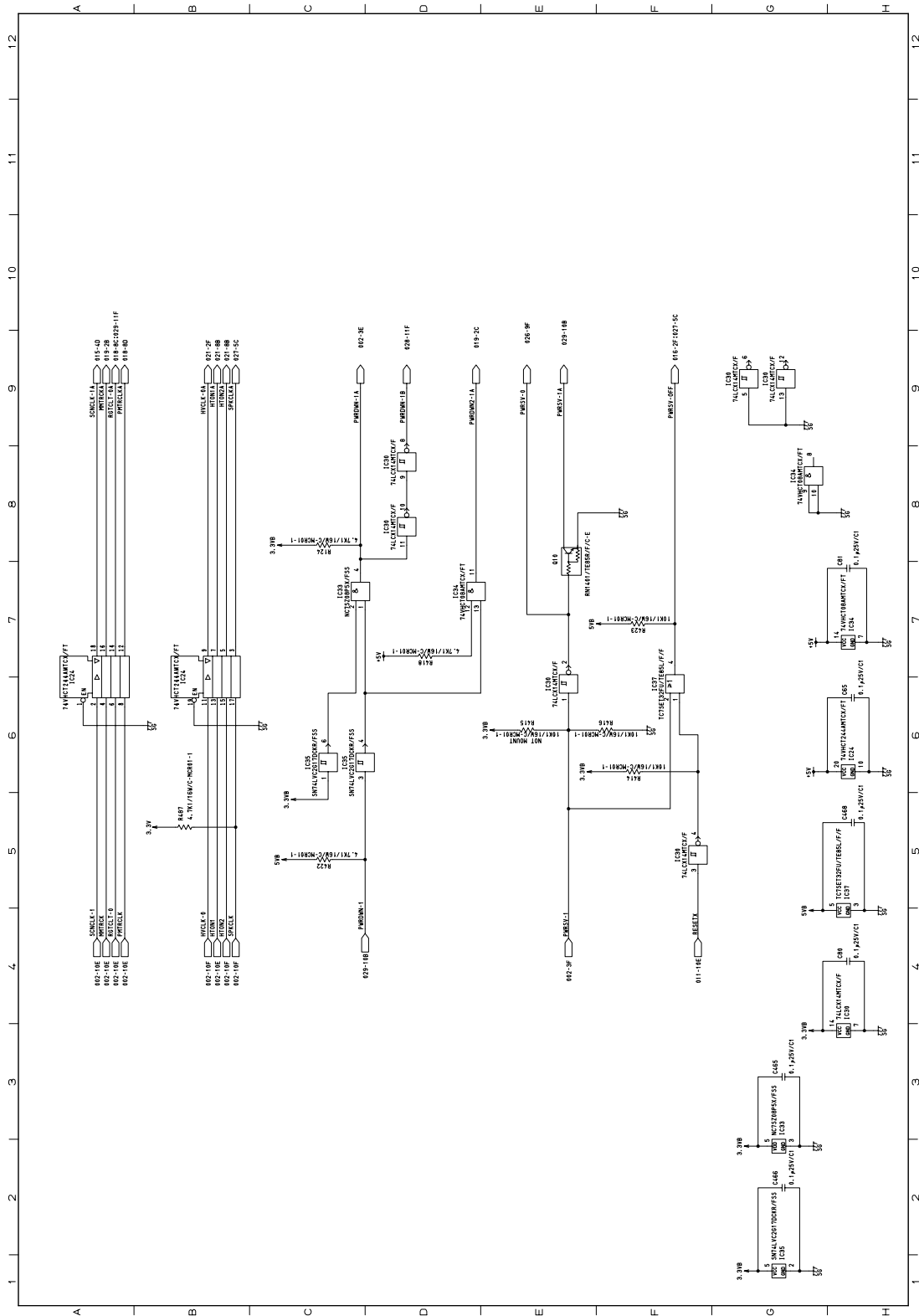

Fig. 3-10

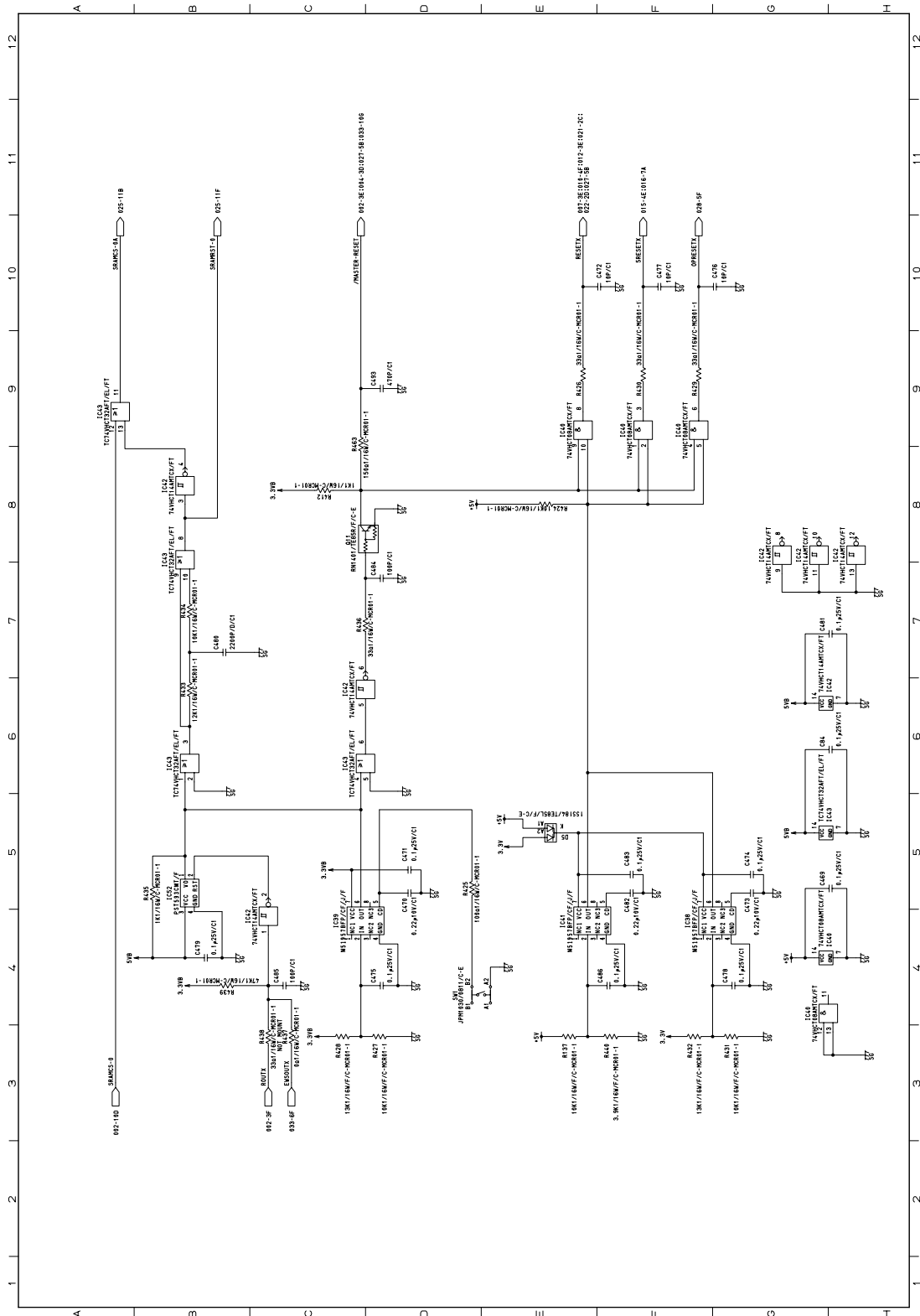

Fig. 3-11

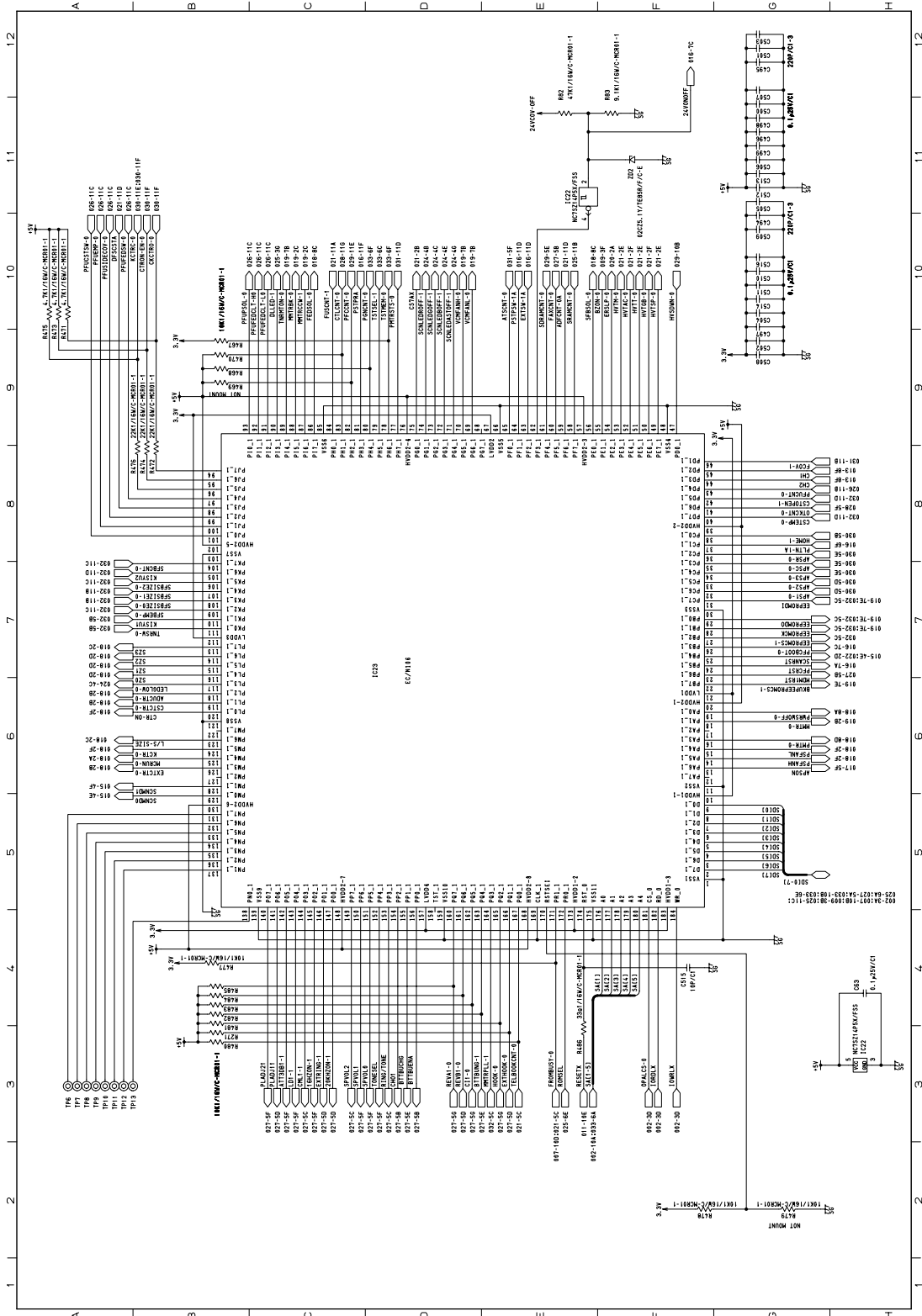

Fig. 3-12

MAIN board 13/34

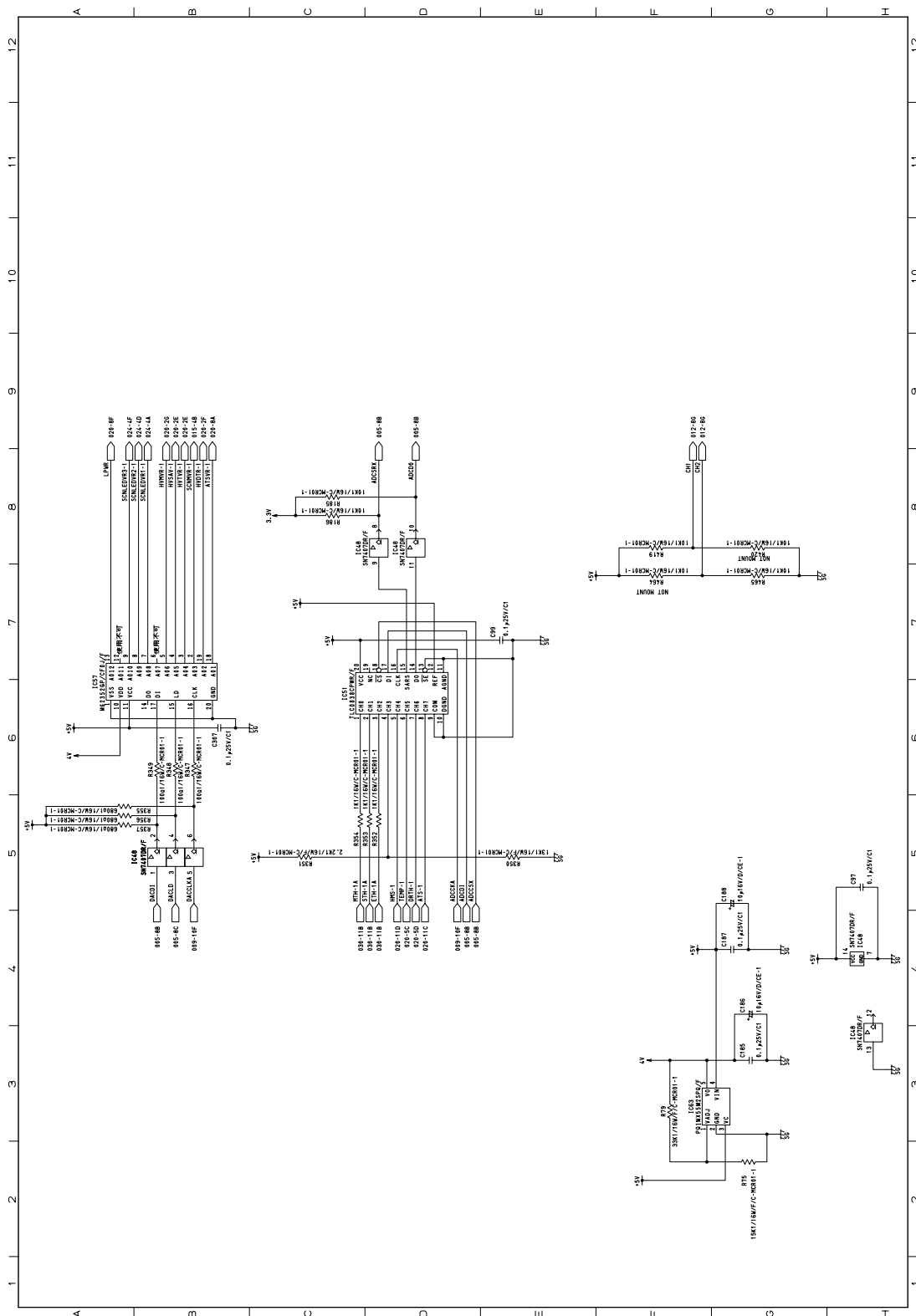

Fig. 3-13



MAIN board 14/34

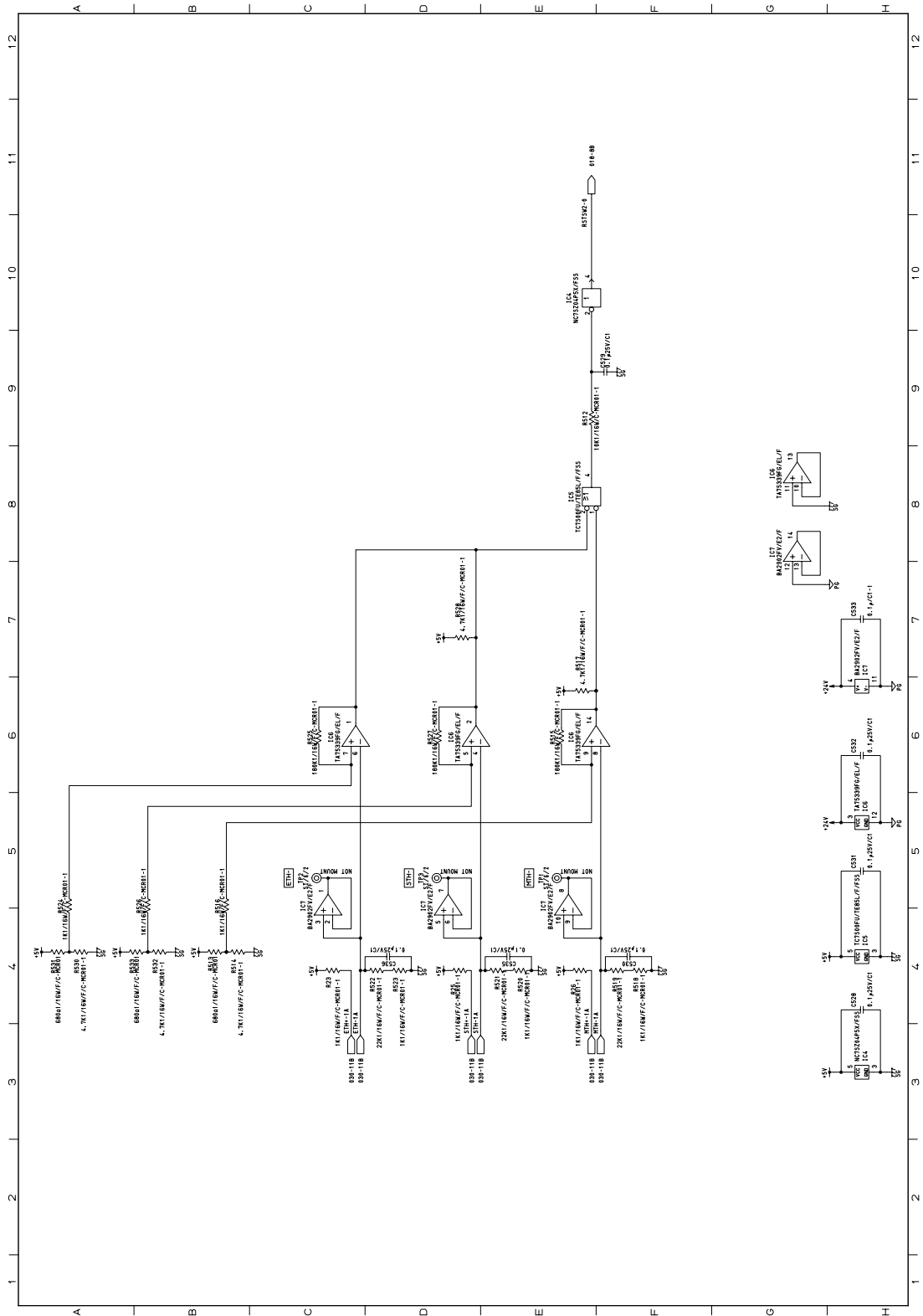

Fig. 3-14

MAIN board 15/34

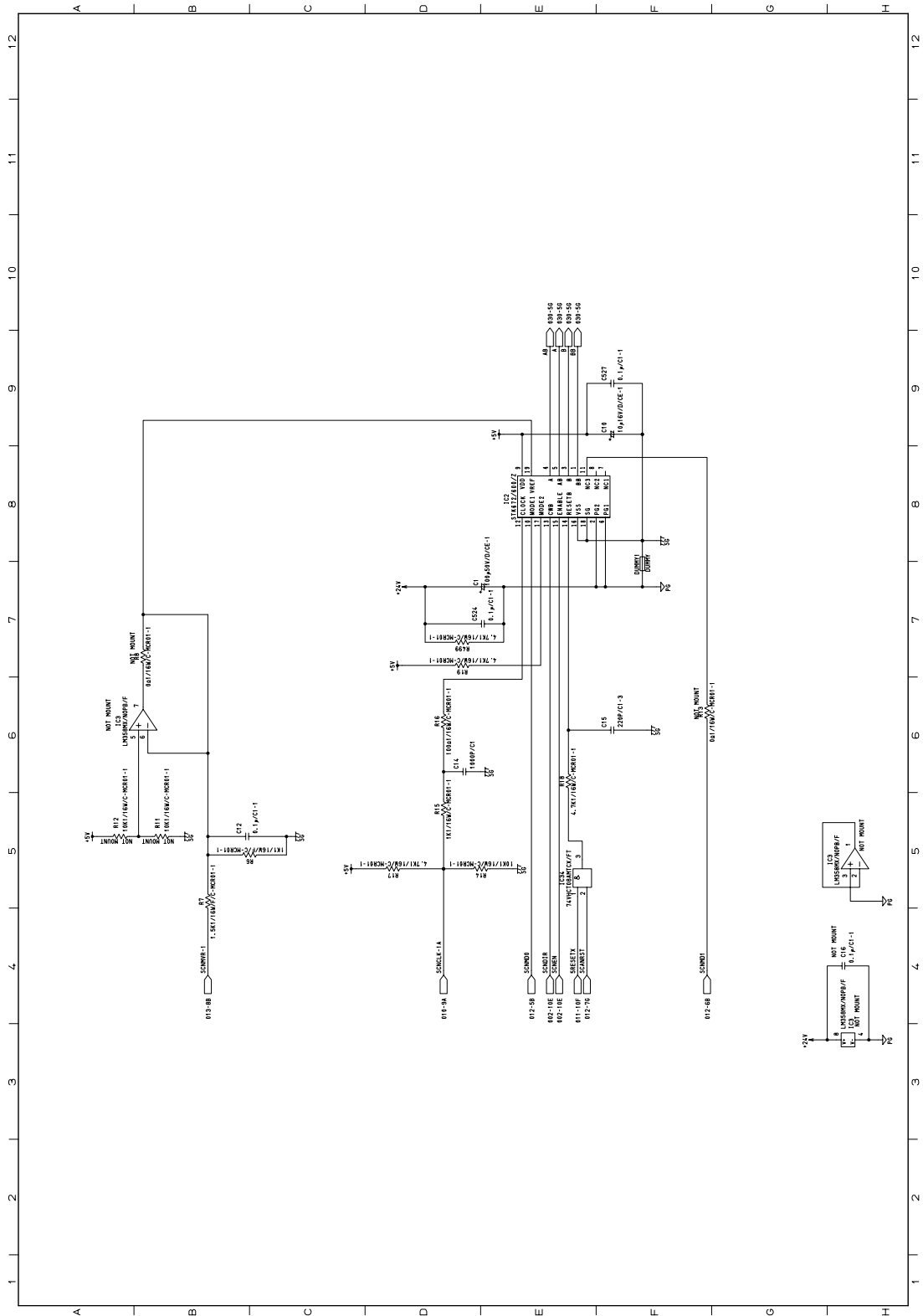

Fig. 3-15

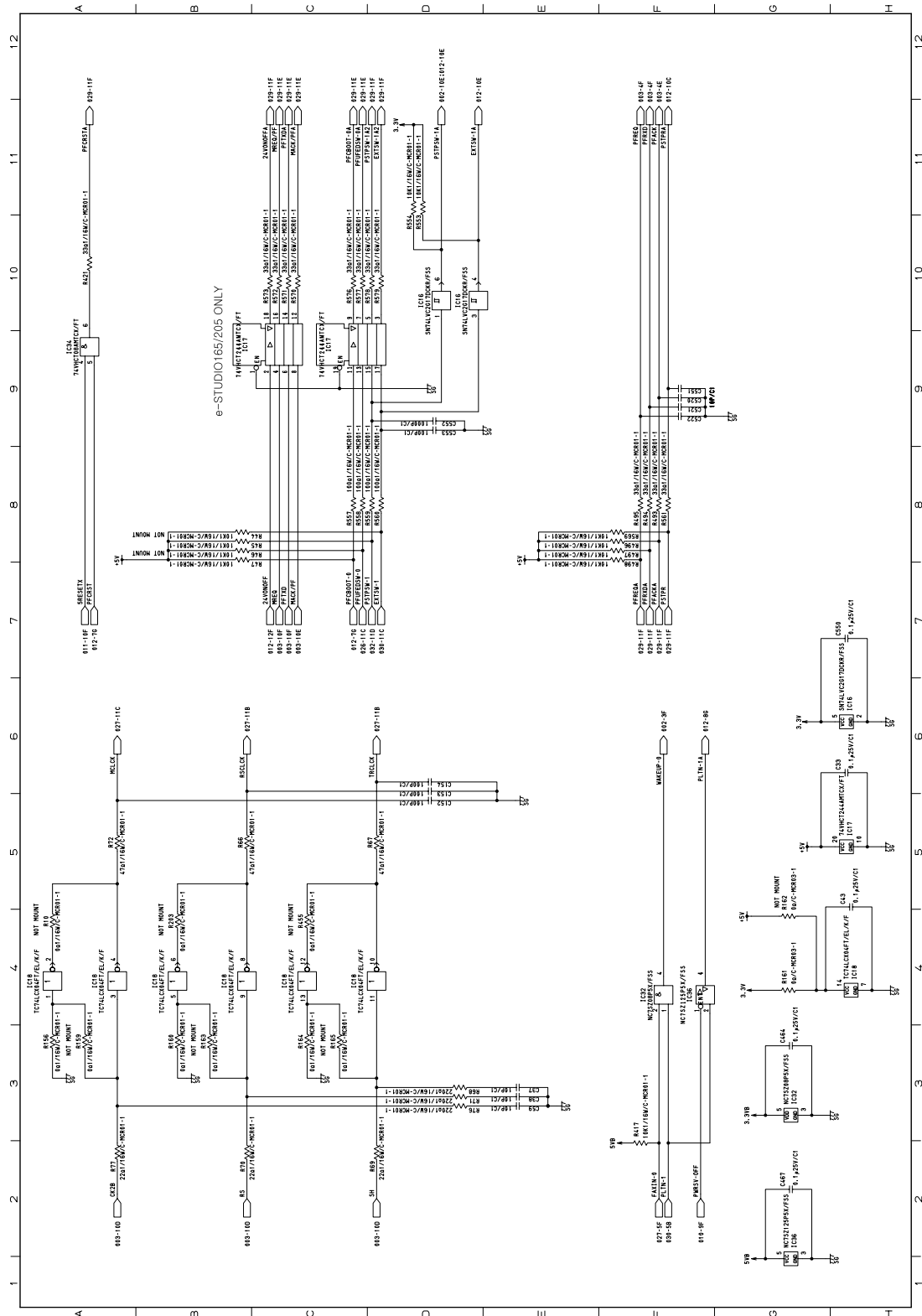
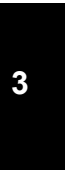

Fig. 3-16



MAIN board 17/34

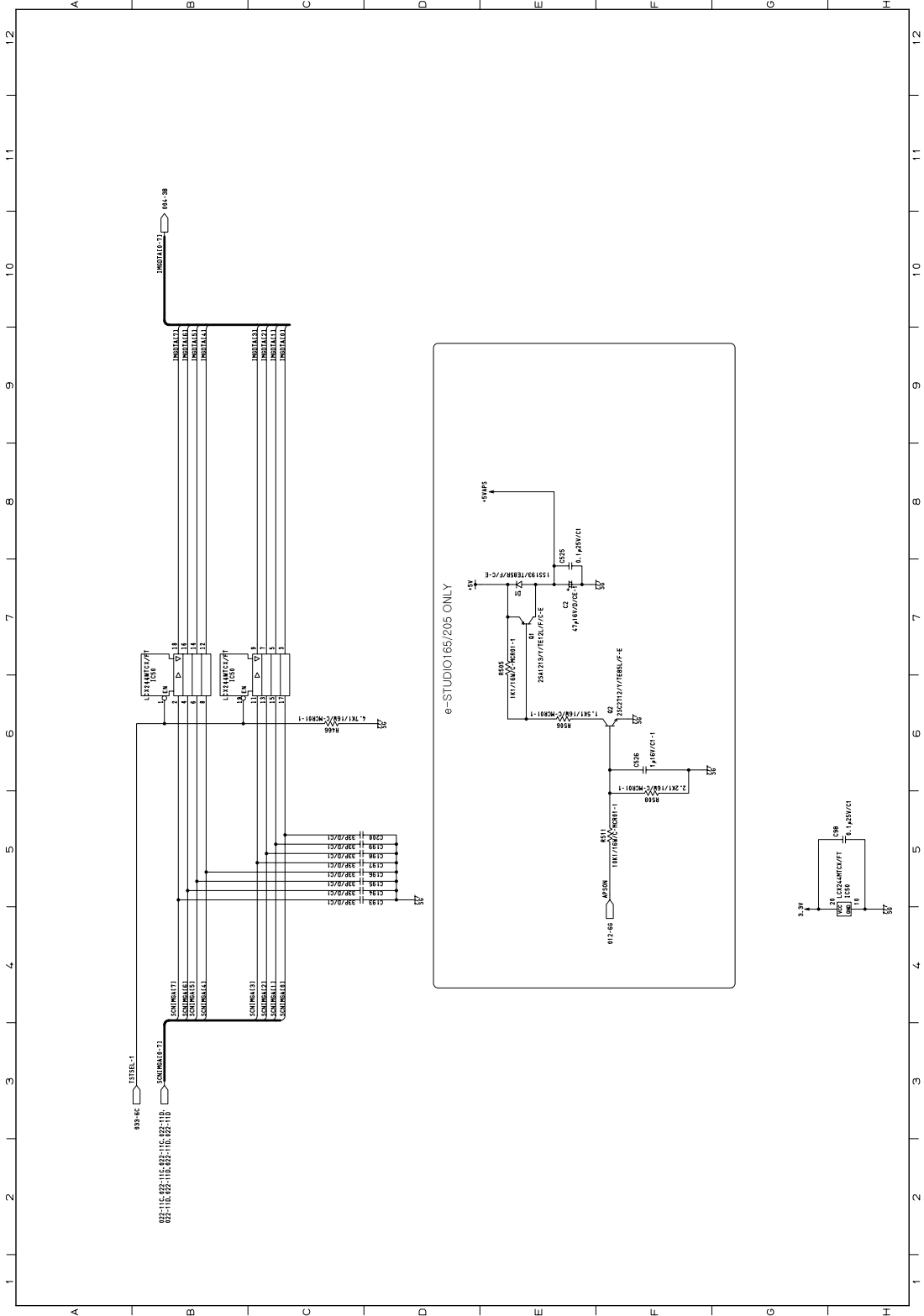

Fig. 3-17

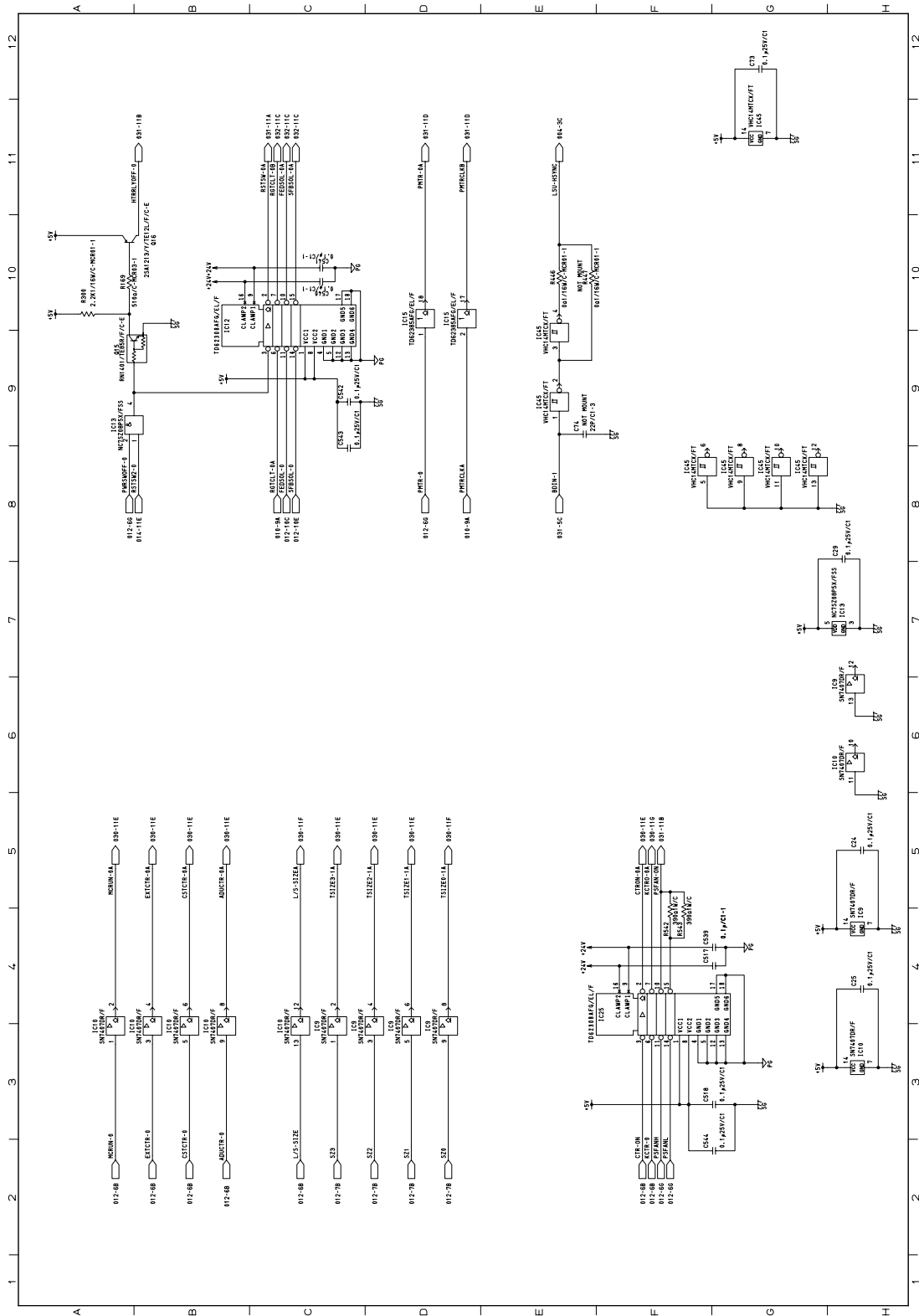

Fig. 3-18



MAIN board 19/34

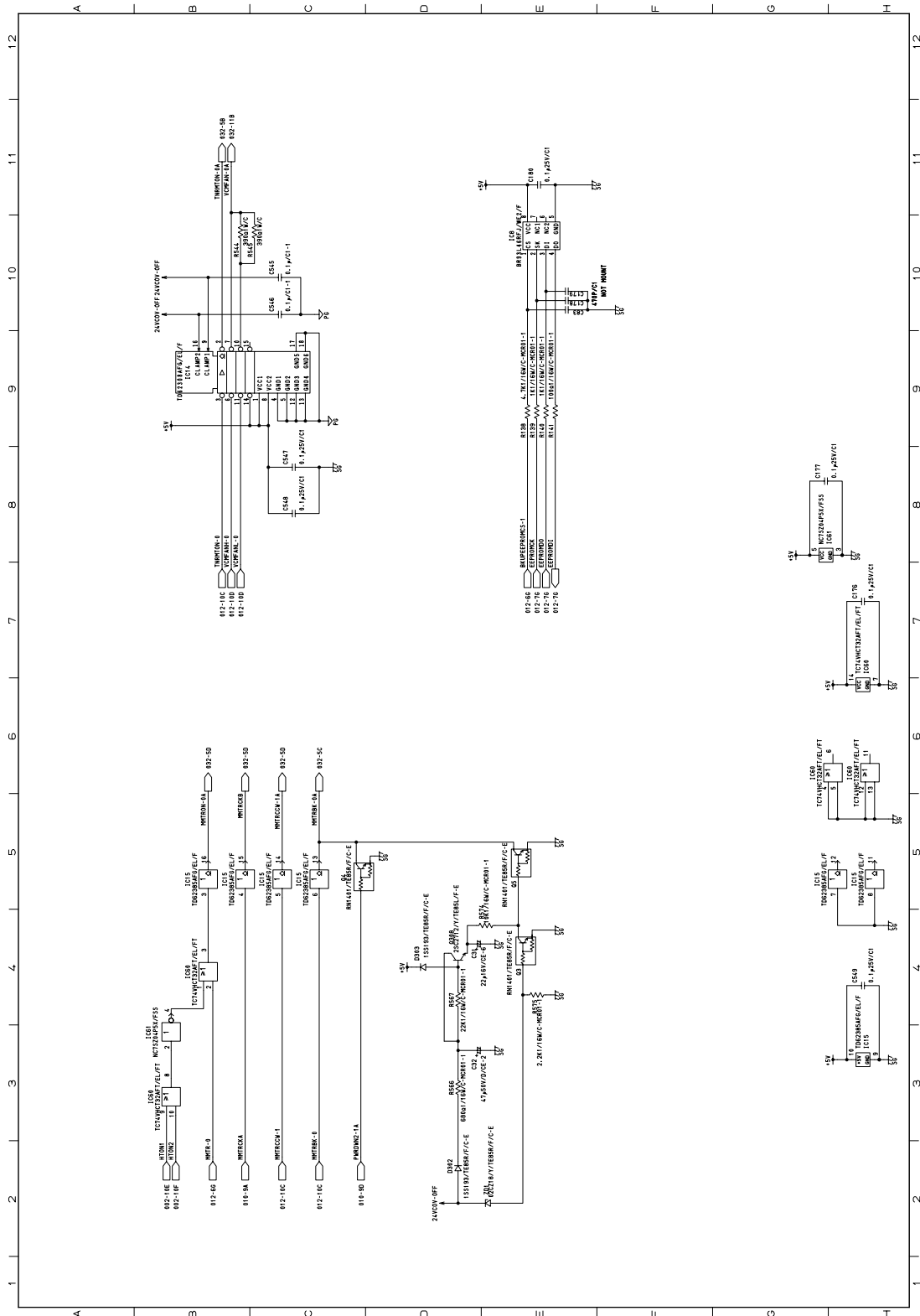

Fig. 3-19



MAIN board 21/34

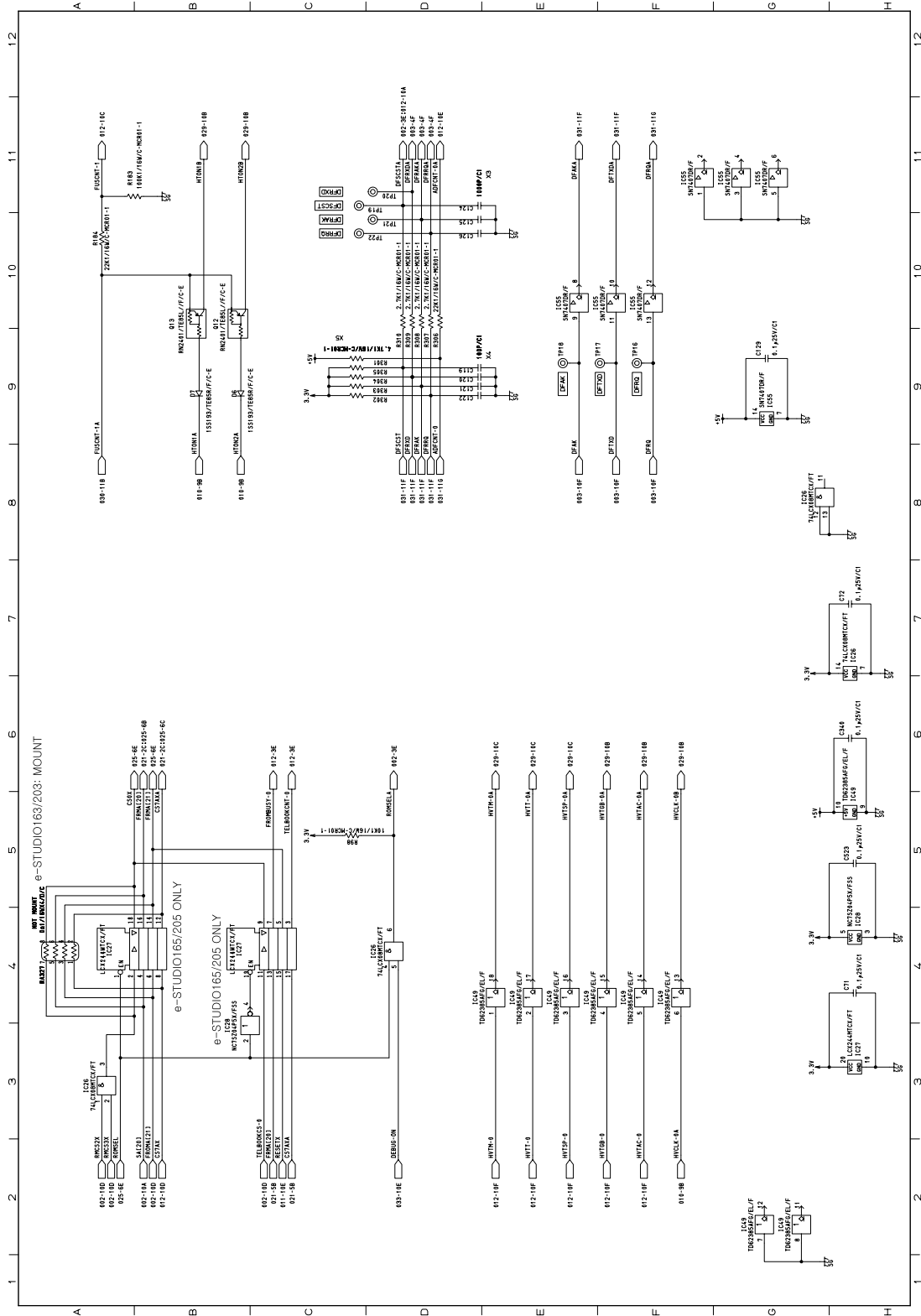

Fig. 3-21



MAIN board 22/34

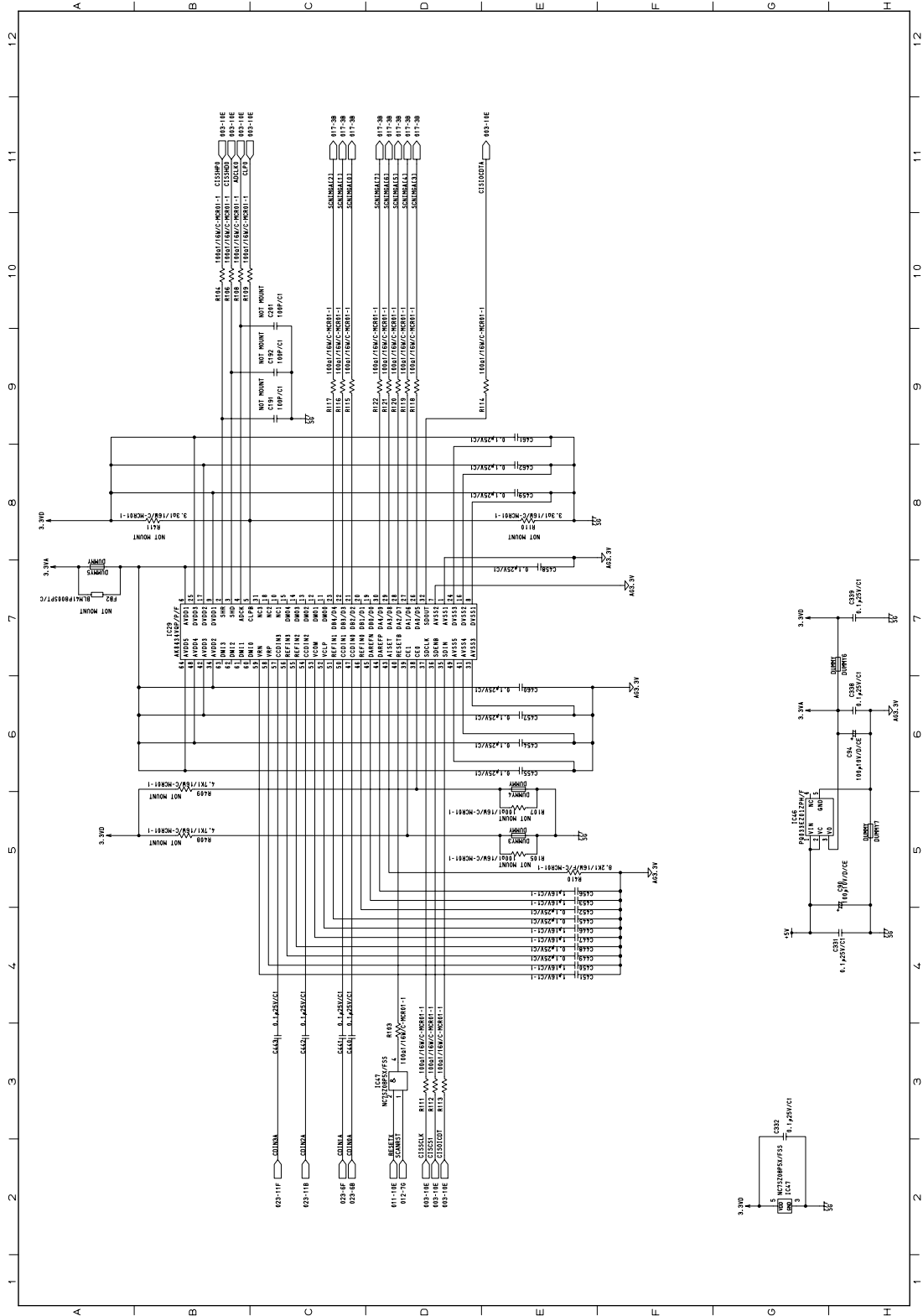

Fig. 3-22



MAIN board 23/34

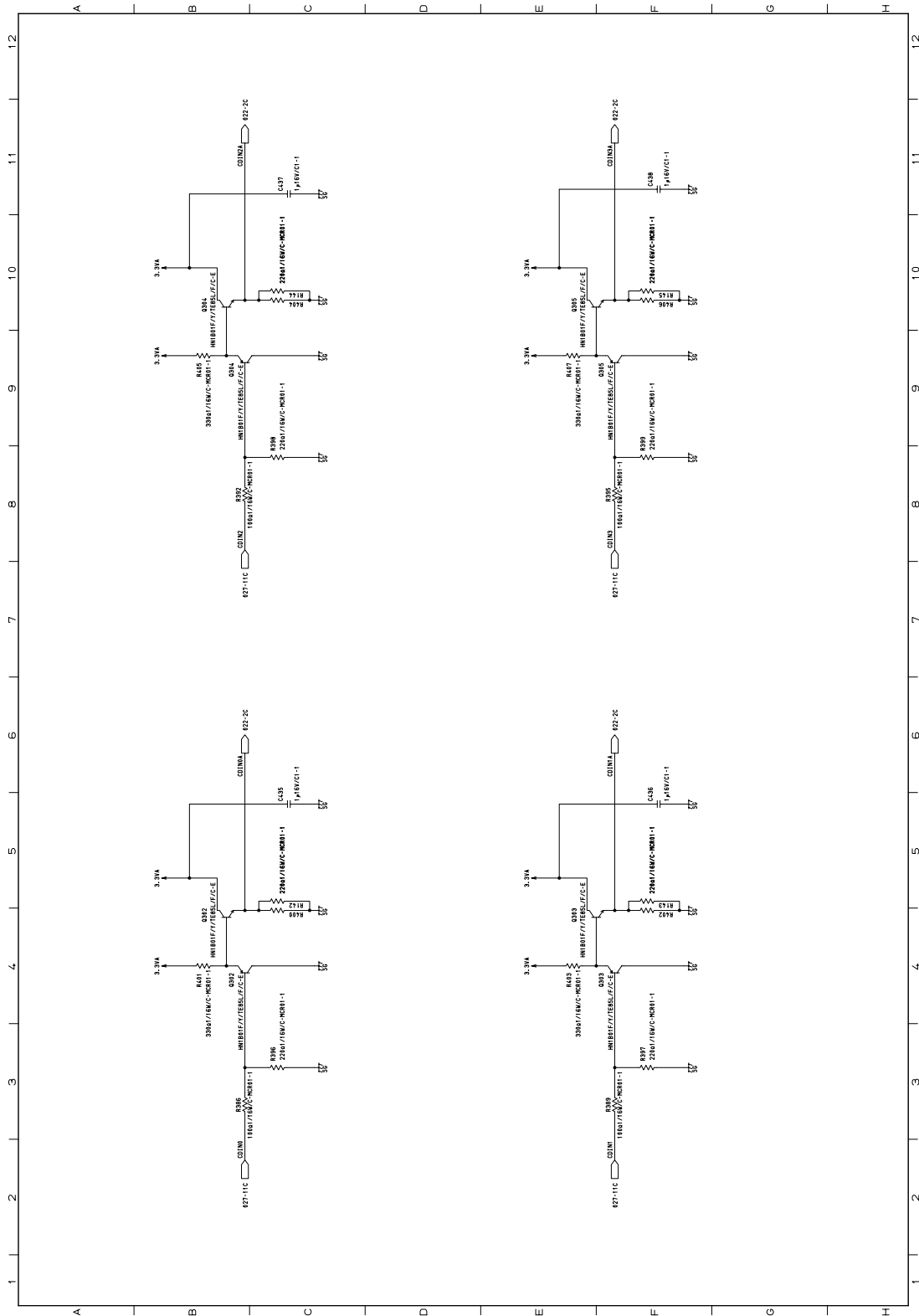

Fig. 3-23

MAIN board 24/34

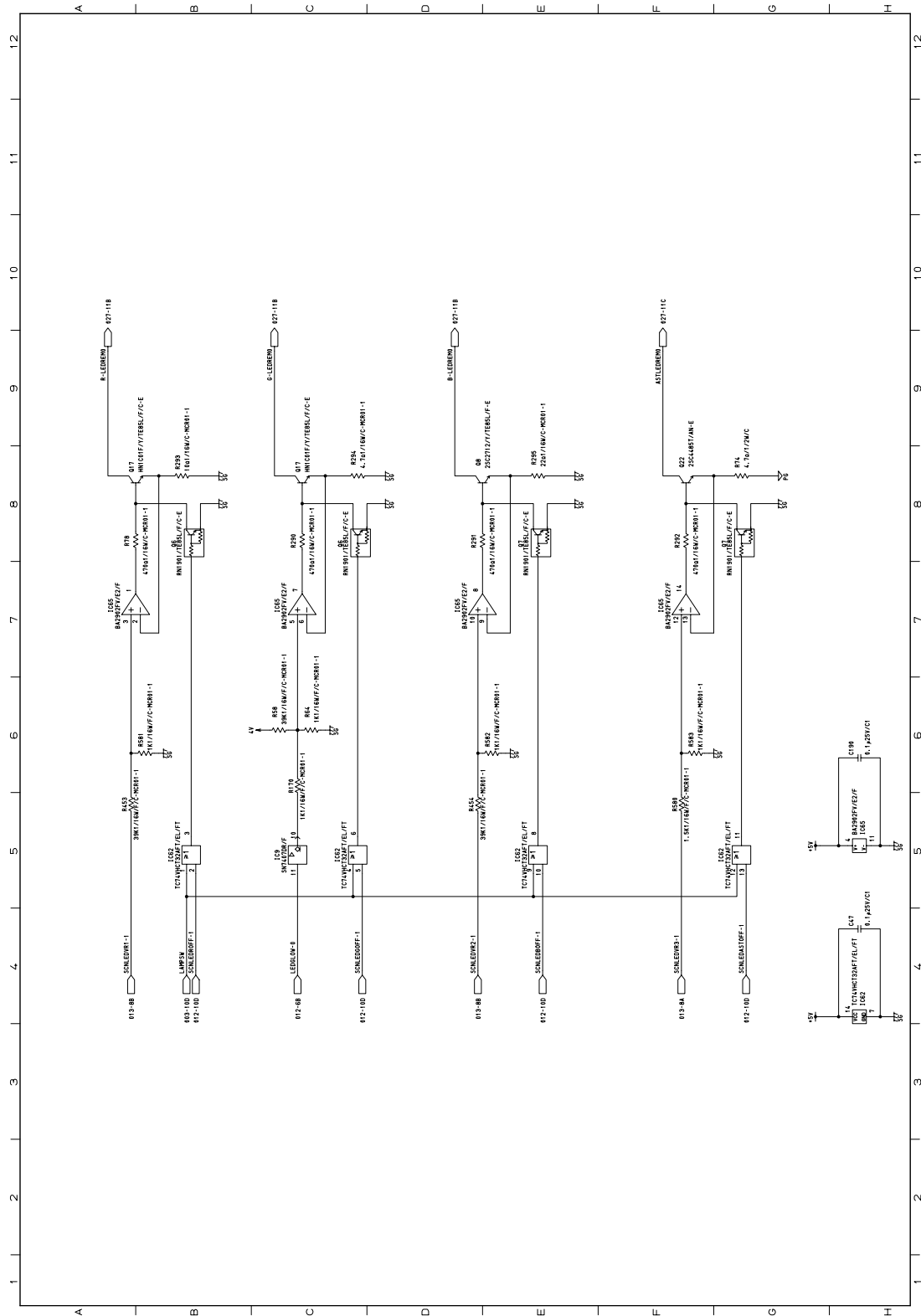

Fig. 3-24



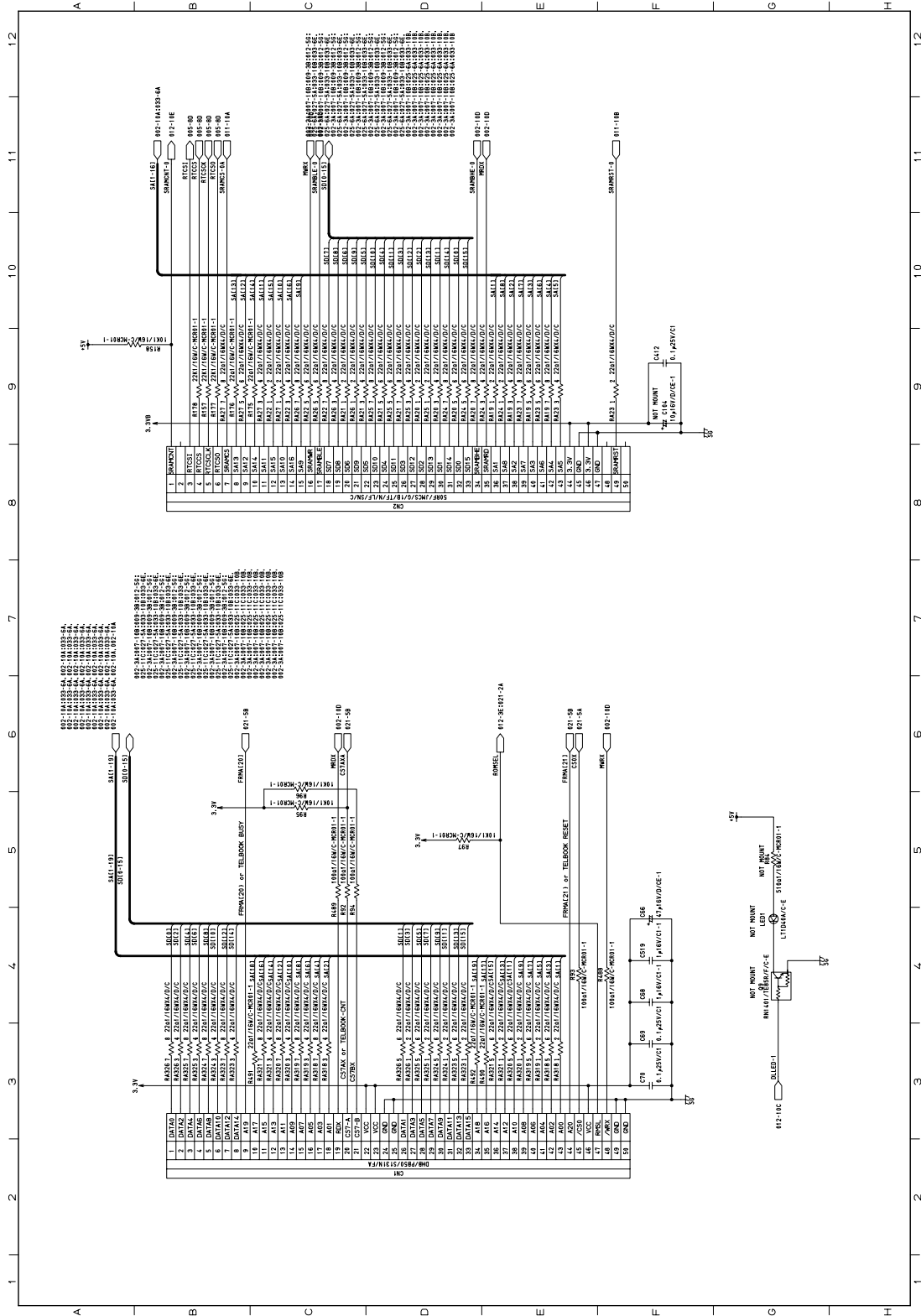

Fig. 3-25

MAIN board 26/34

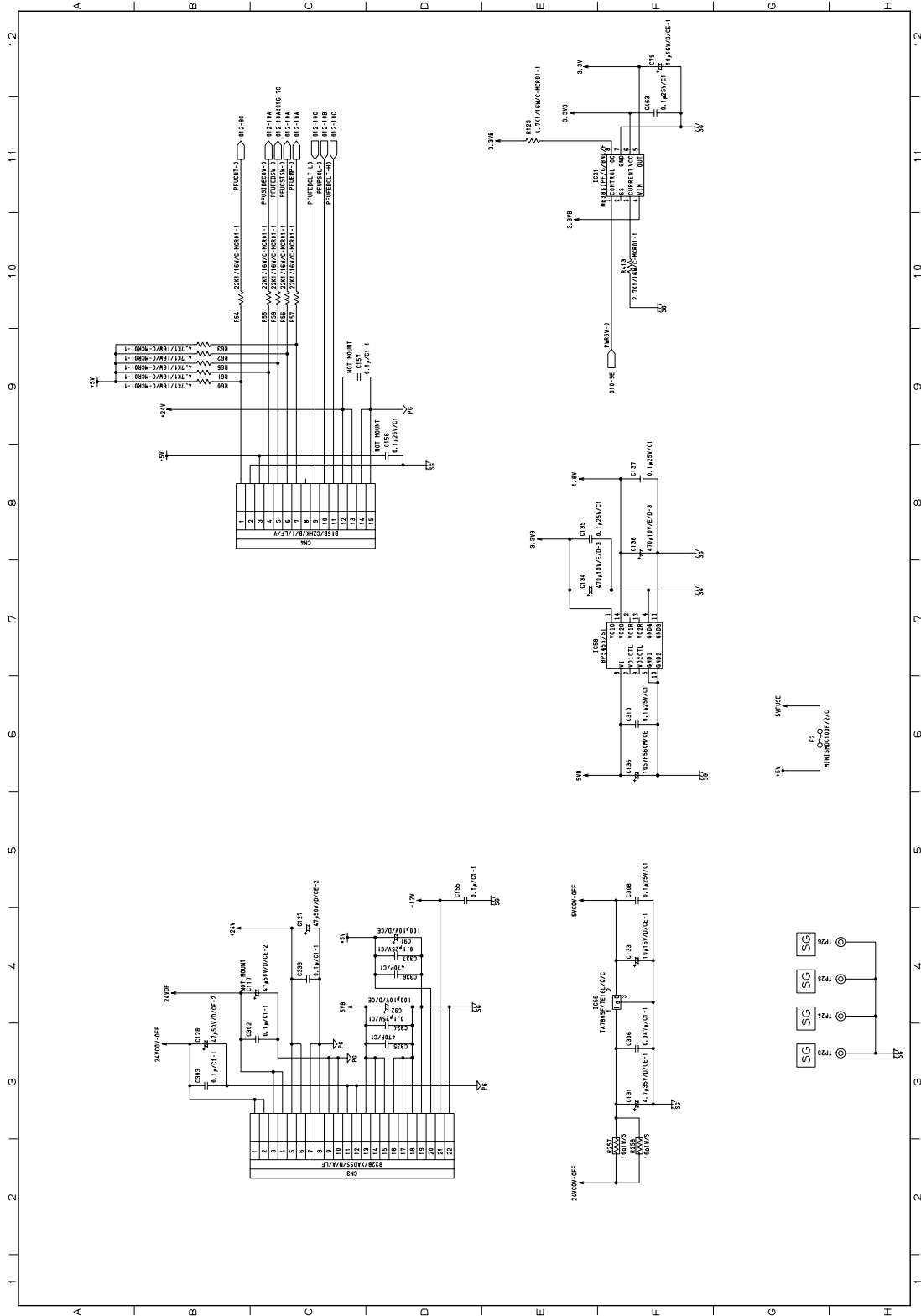

Fig. 3-26



MAIN board 28/34

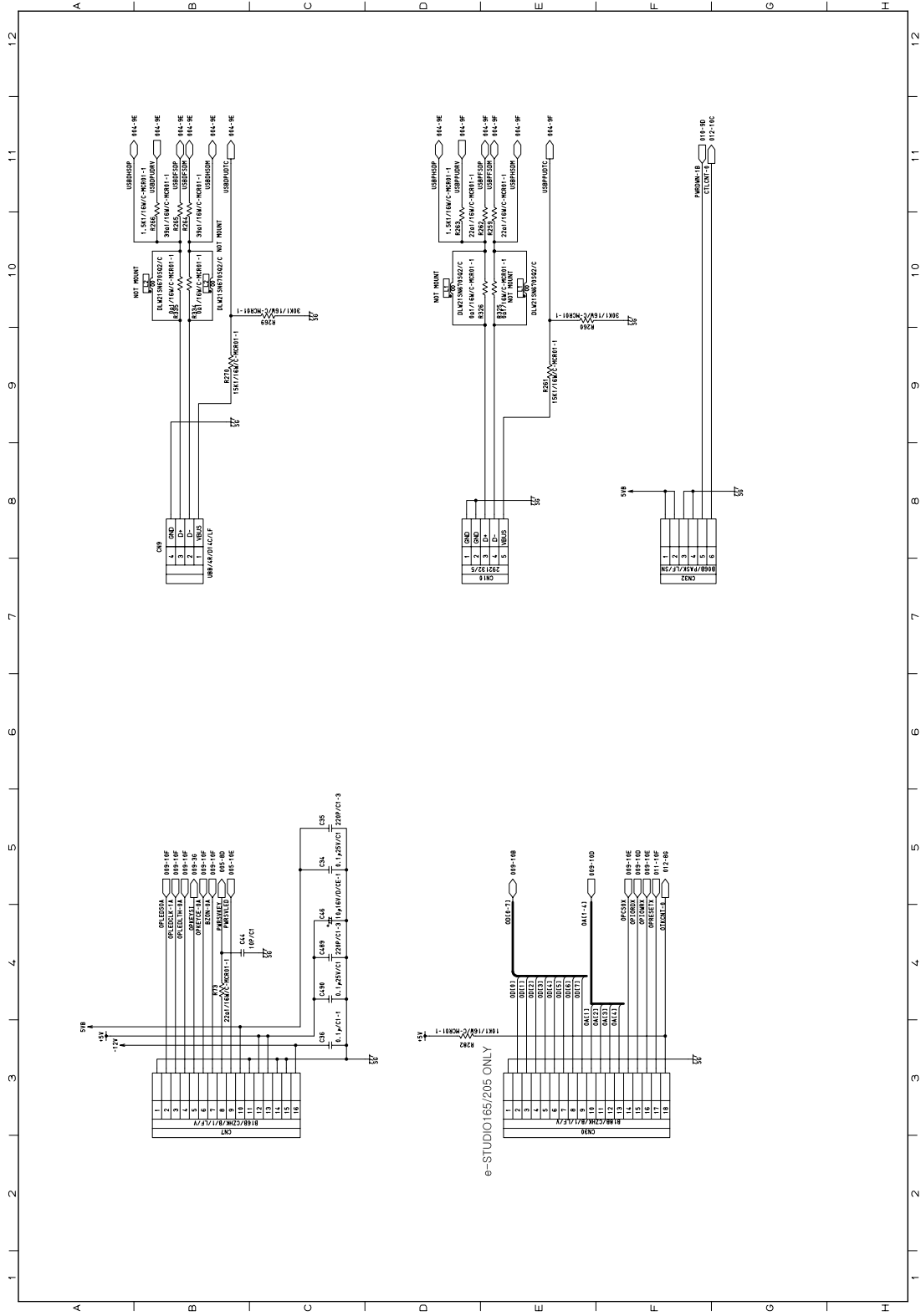

Fig. 3-28

MAIN board 29/34

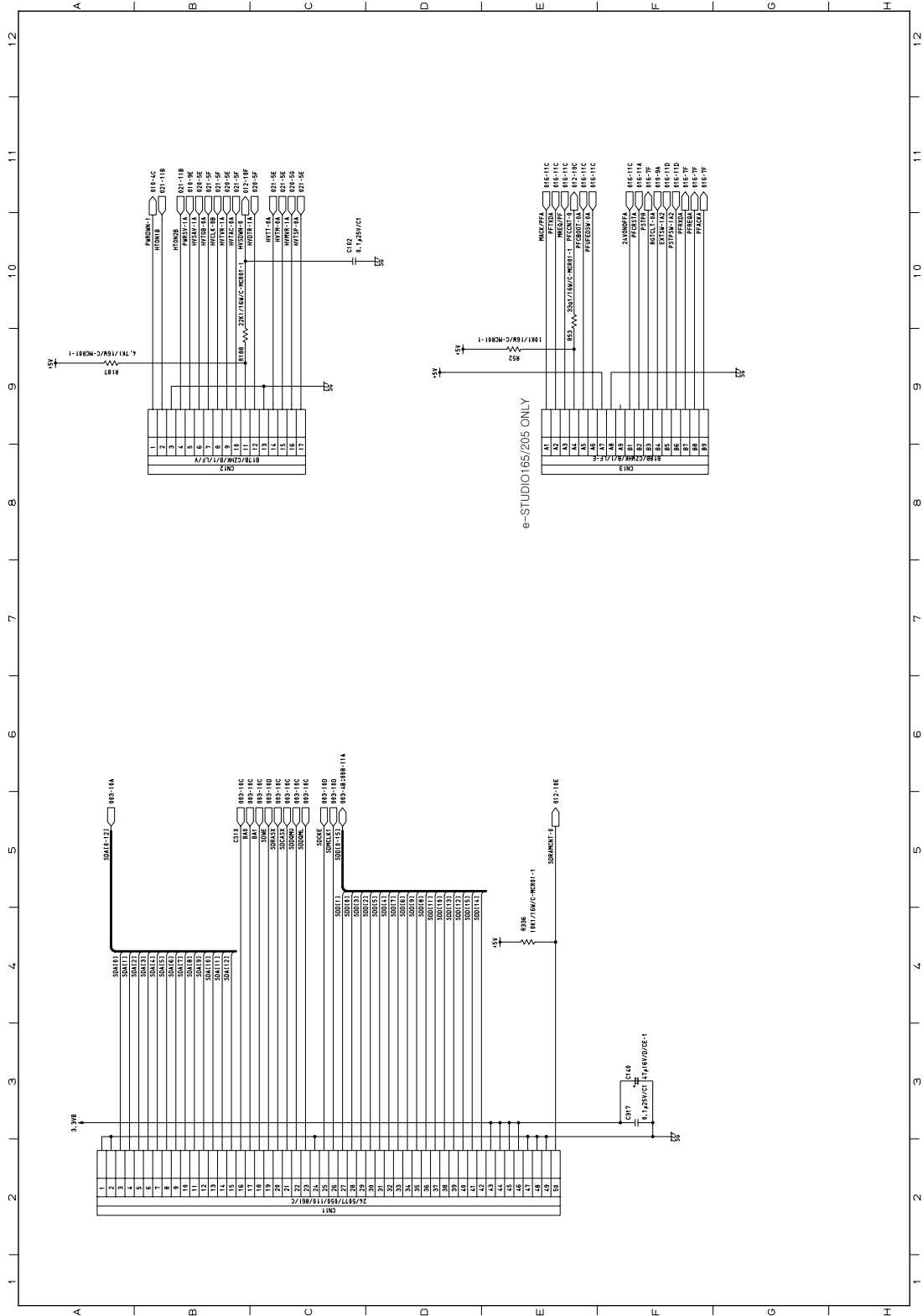

Fig. 3-29



MAIN board 30/34

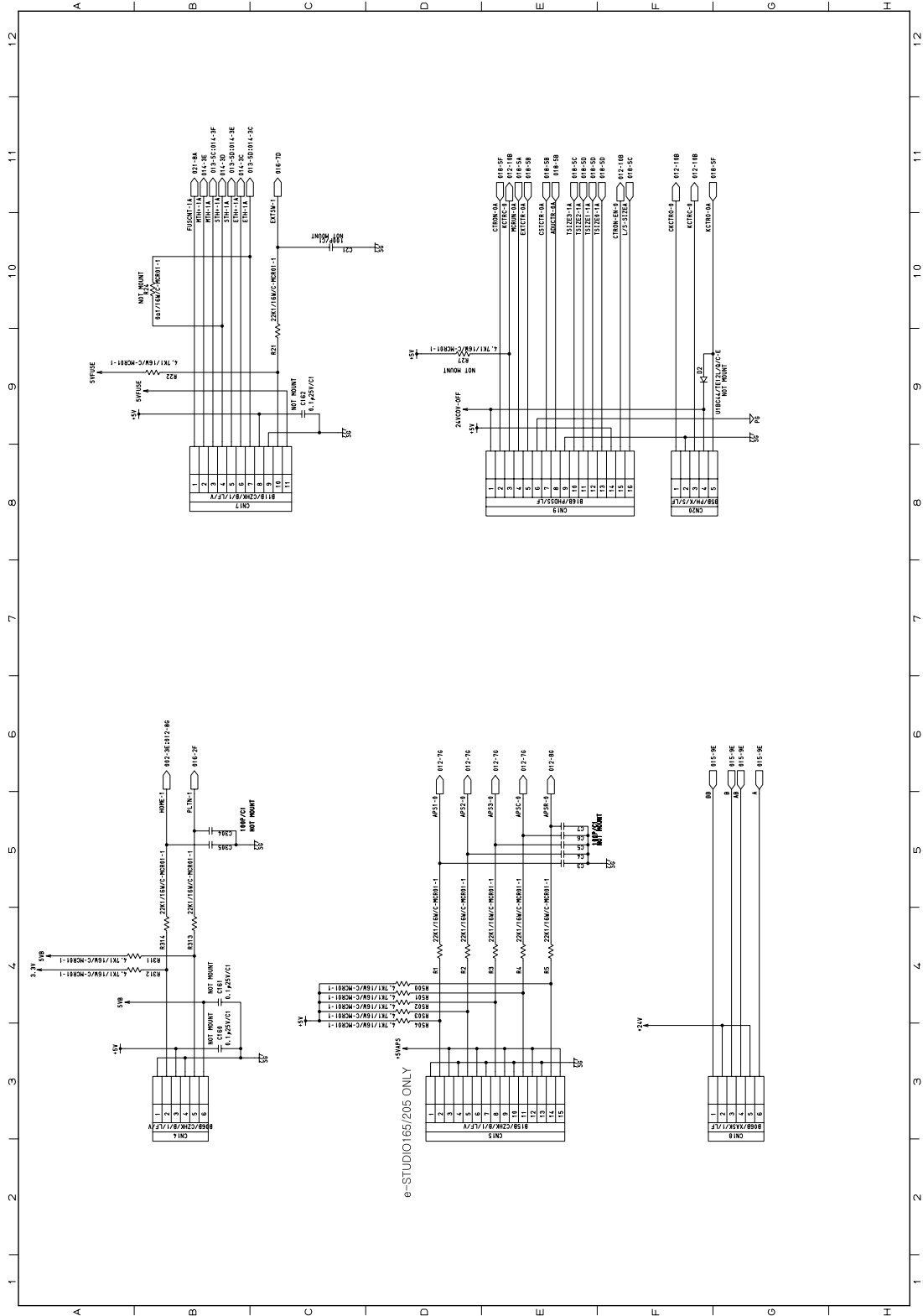

Fig. 3-30



MAIN board 31/34

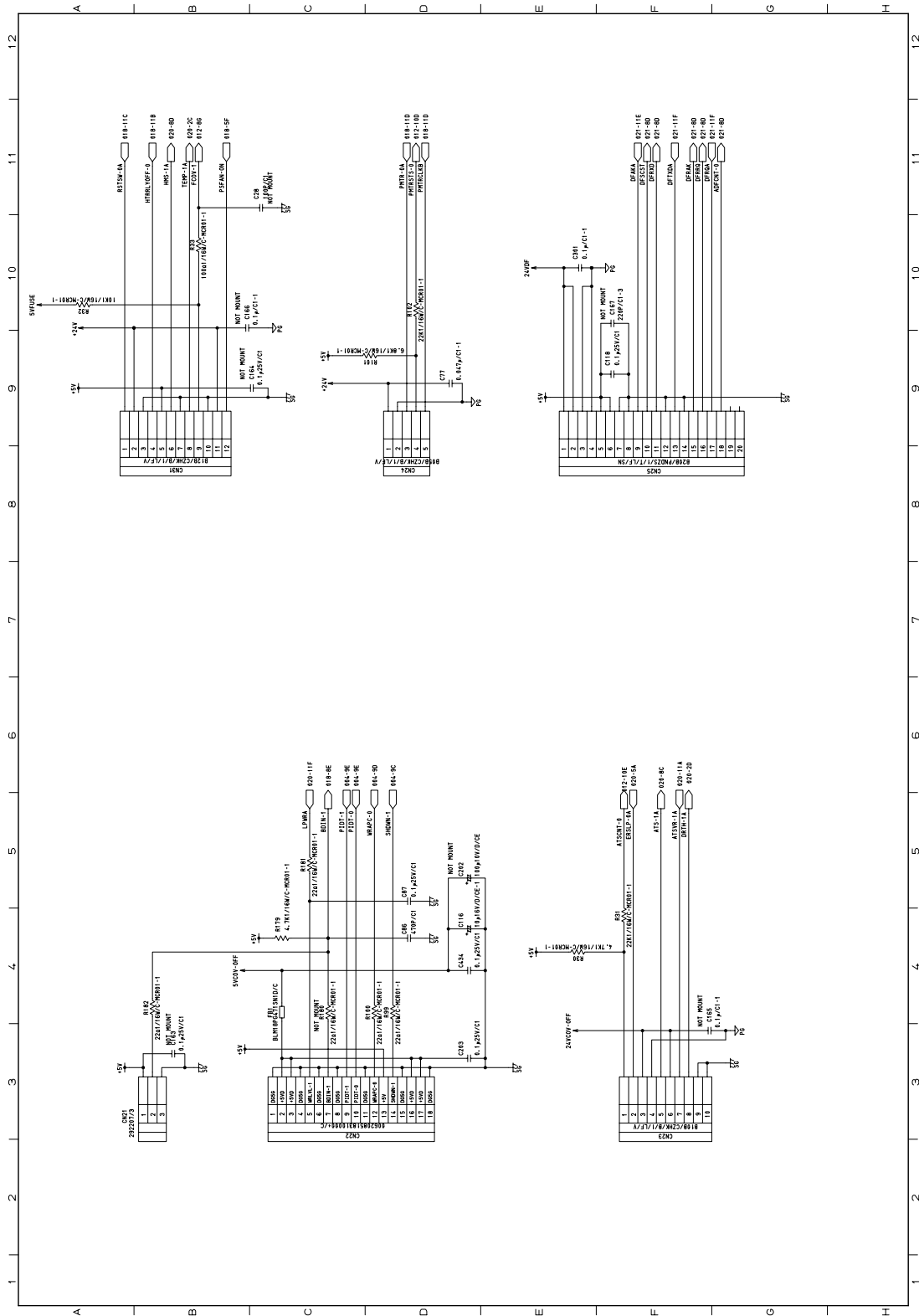

Fig. 3-31

MAIN board 32/34

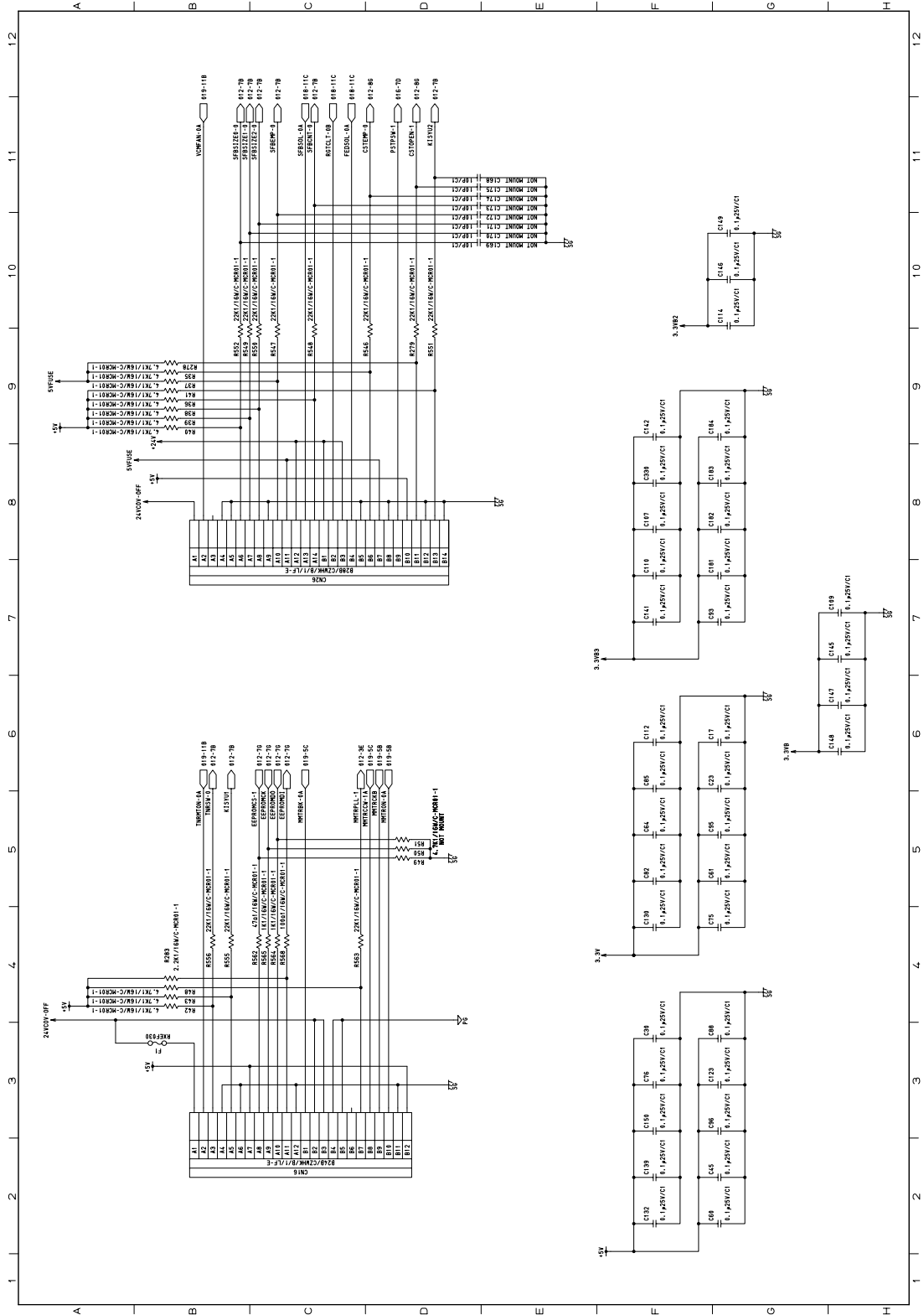

Fig. 3-32



MAIN board 33/34

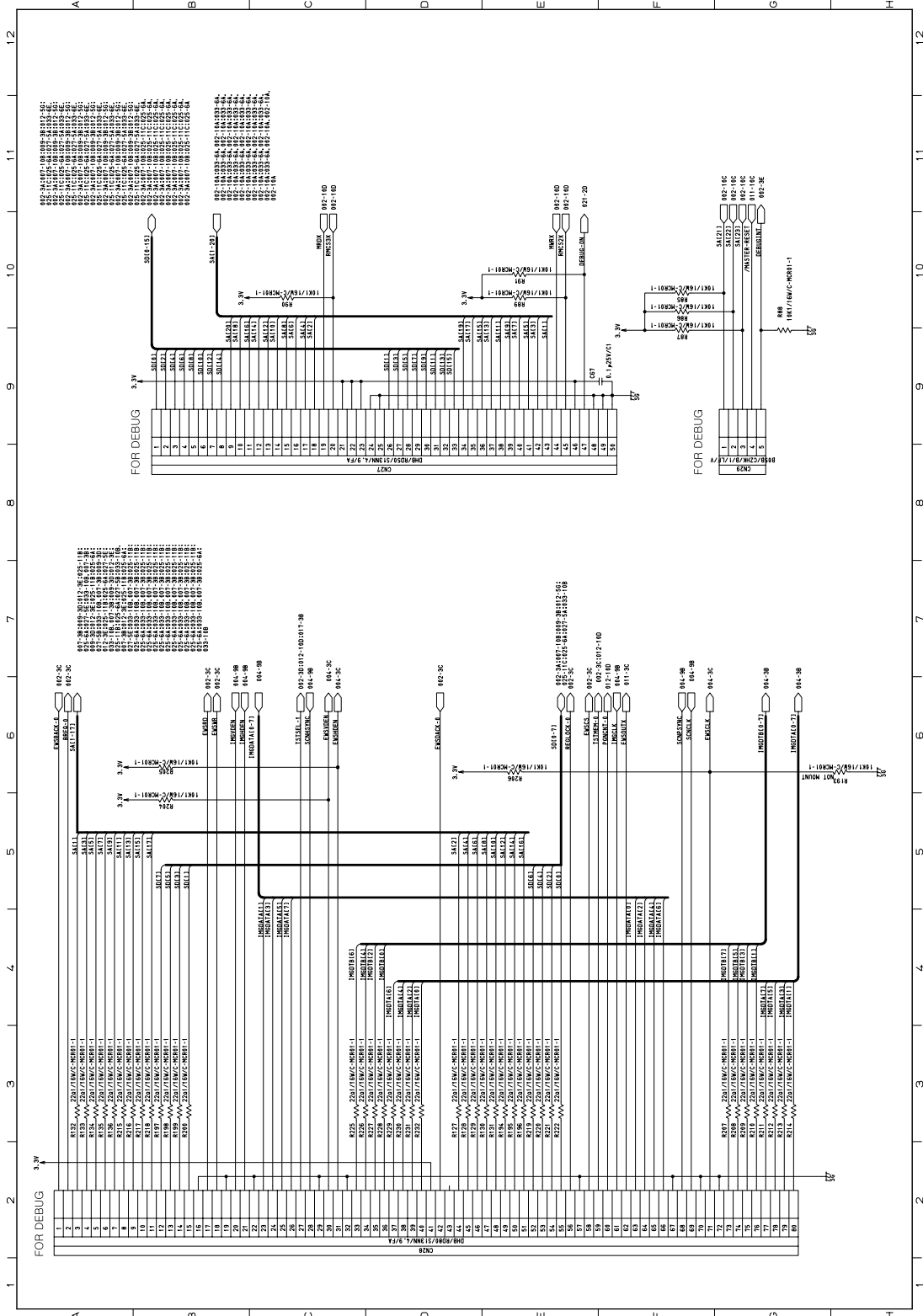

Fig. 3-33

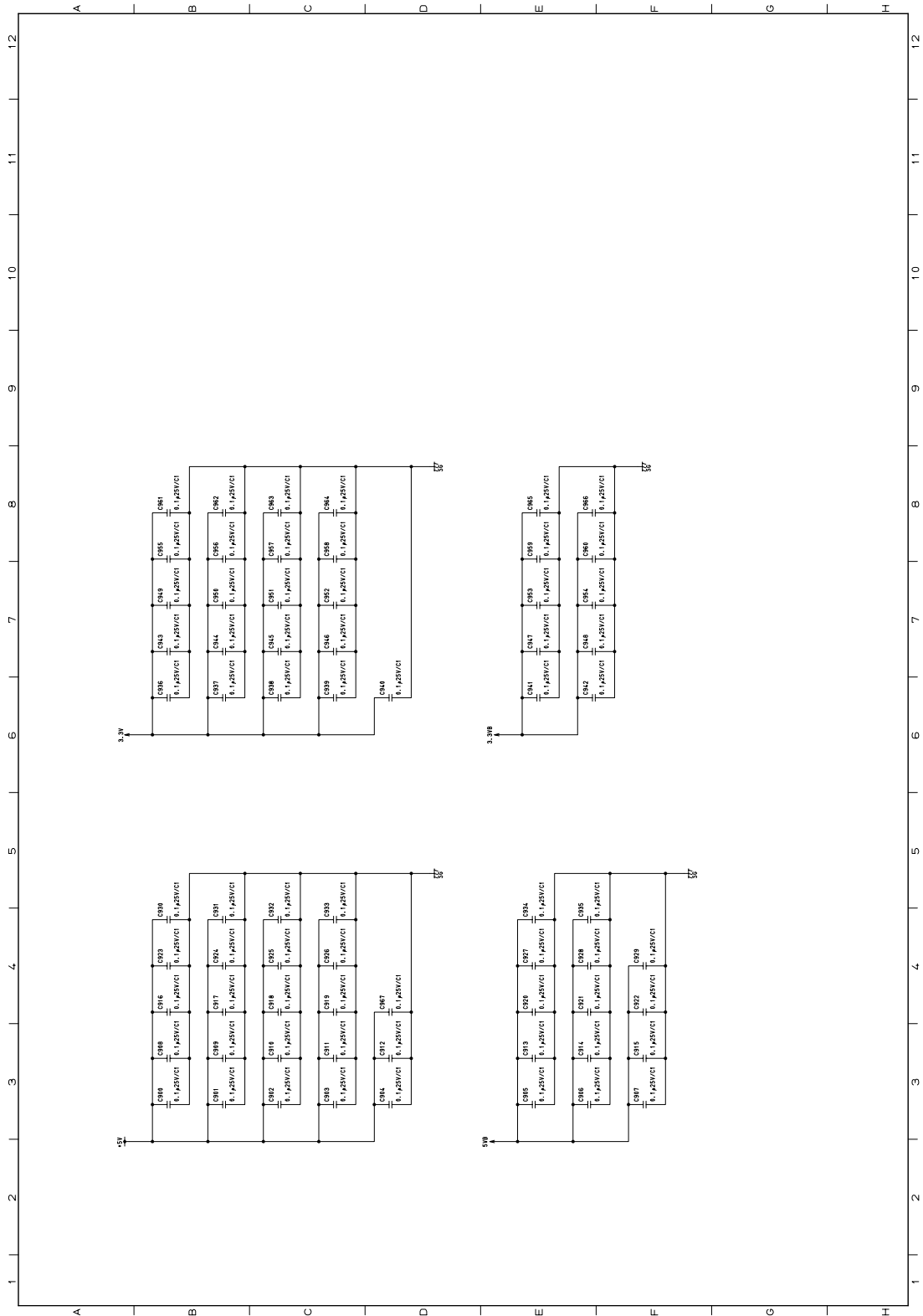

Fig. 3-34

### 3.2 SRAM circuit (SRAM board: e-STUDIO163/165/203/205)

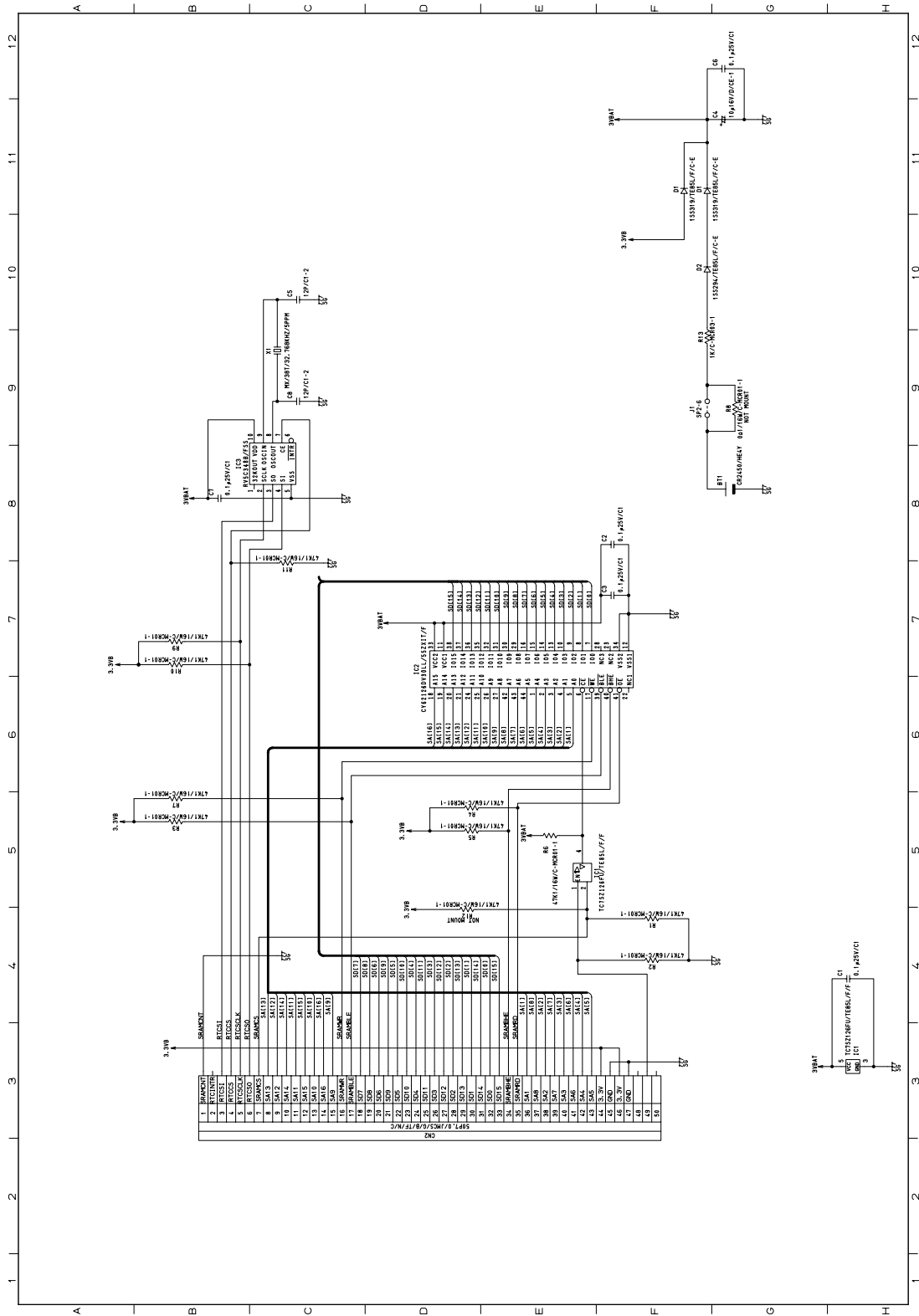

Fig. 3-35

### 3.3 Laser drive circuit (LDR board)

LDR board 1/2

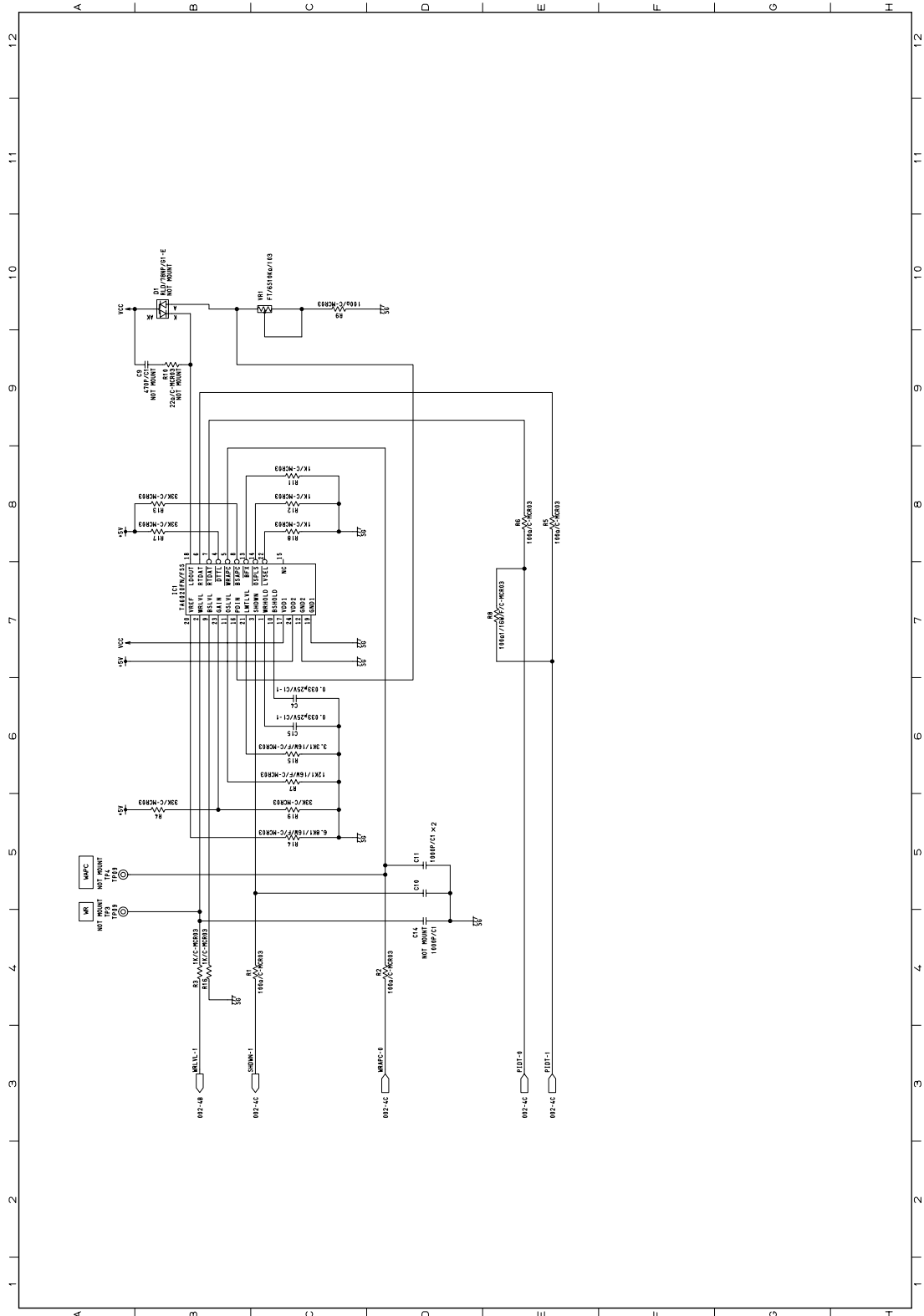

Fig. 3-36

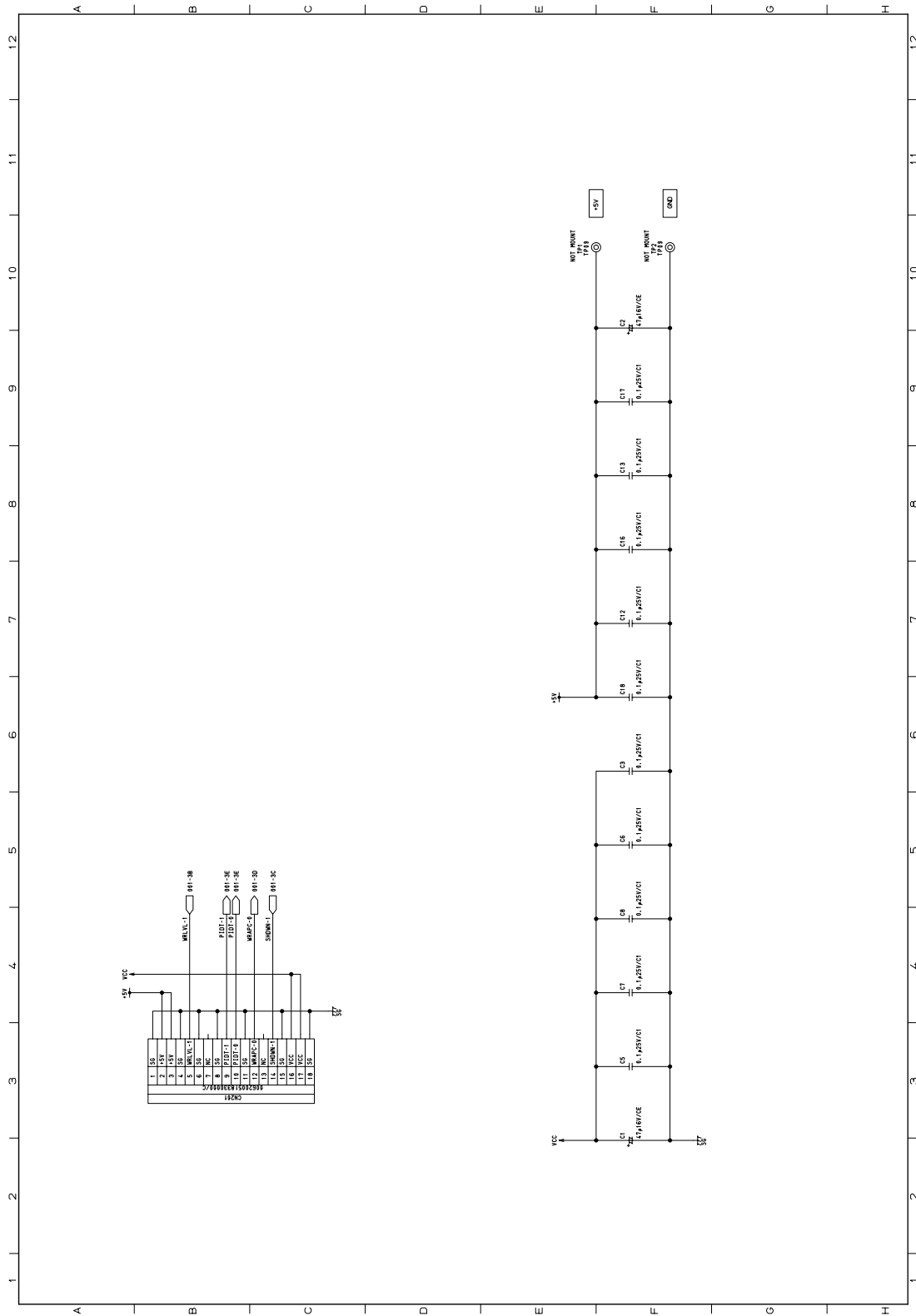

Fig. 3-37



### 3.4 H-sync signal detection circuit (SNS board)

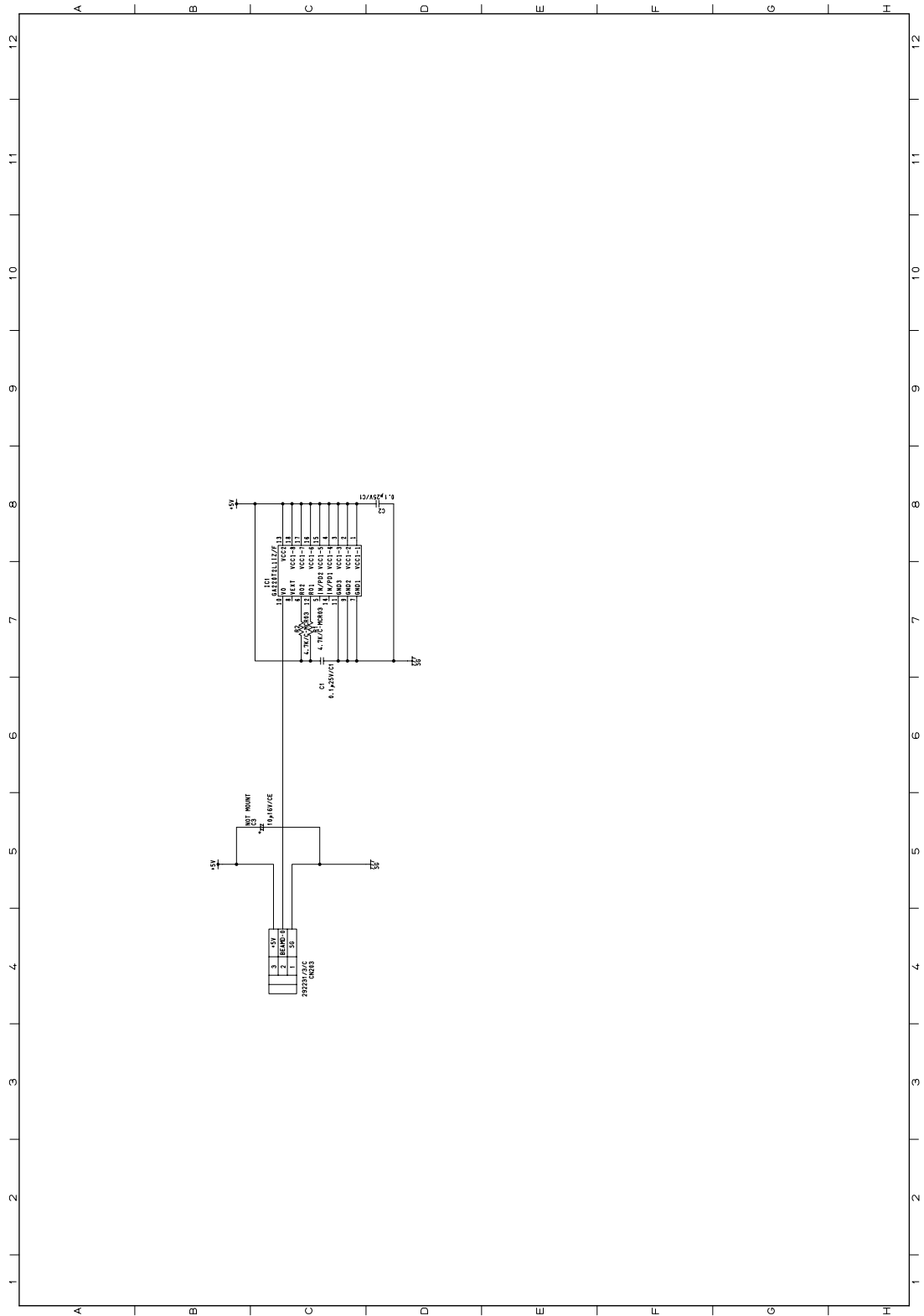

Fig. 3-38

### 3.5 Fuse circuit (FUS board)

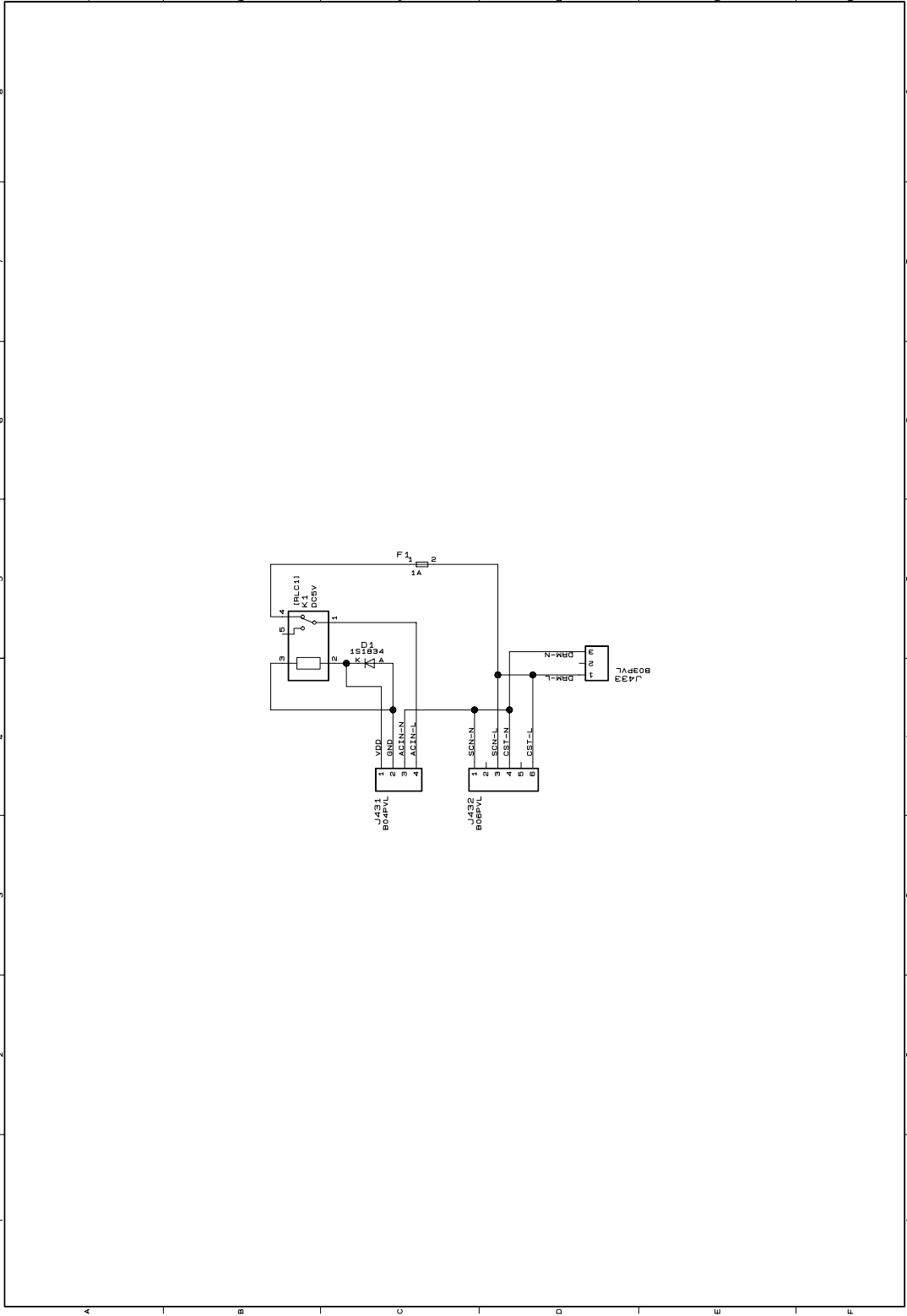

Fig. 3-39

### 3.6 Control panel circuit (LPNL board: e-STUDIO163/166/203/206)

LPNL board 1/4

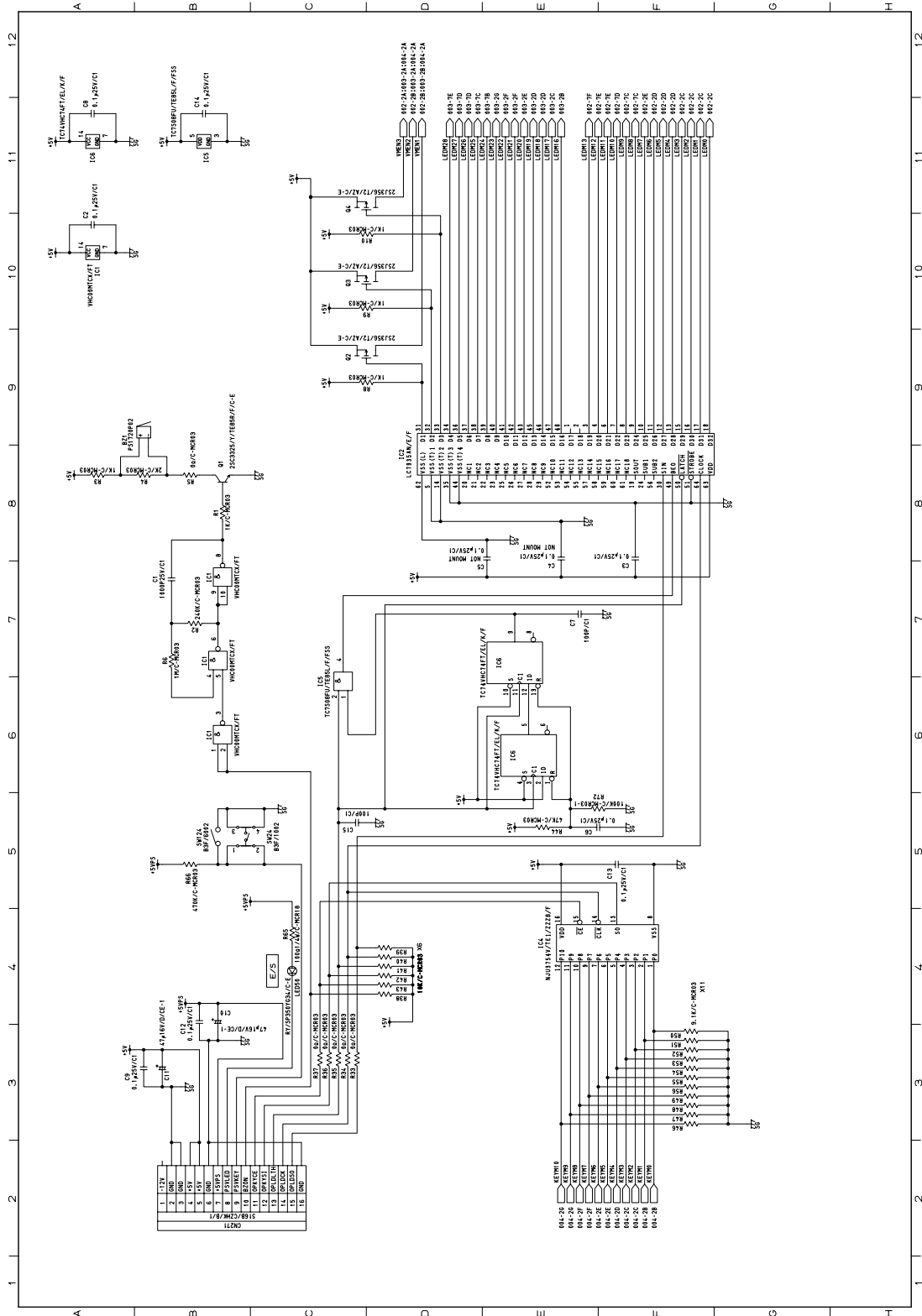

Fig. 3-40



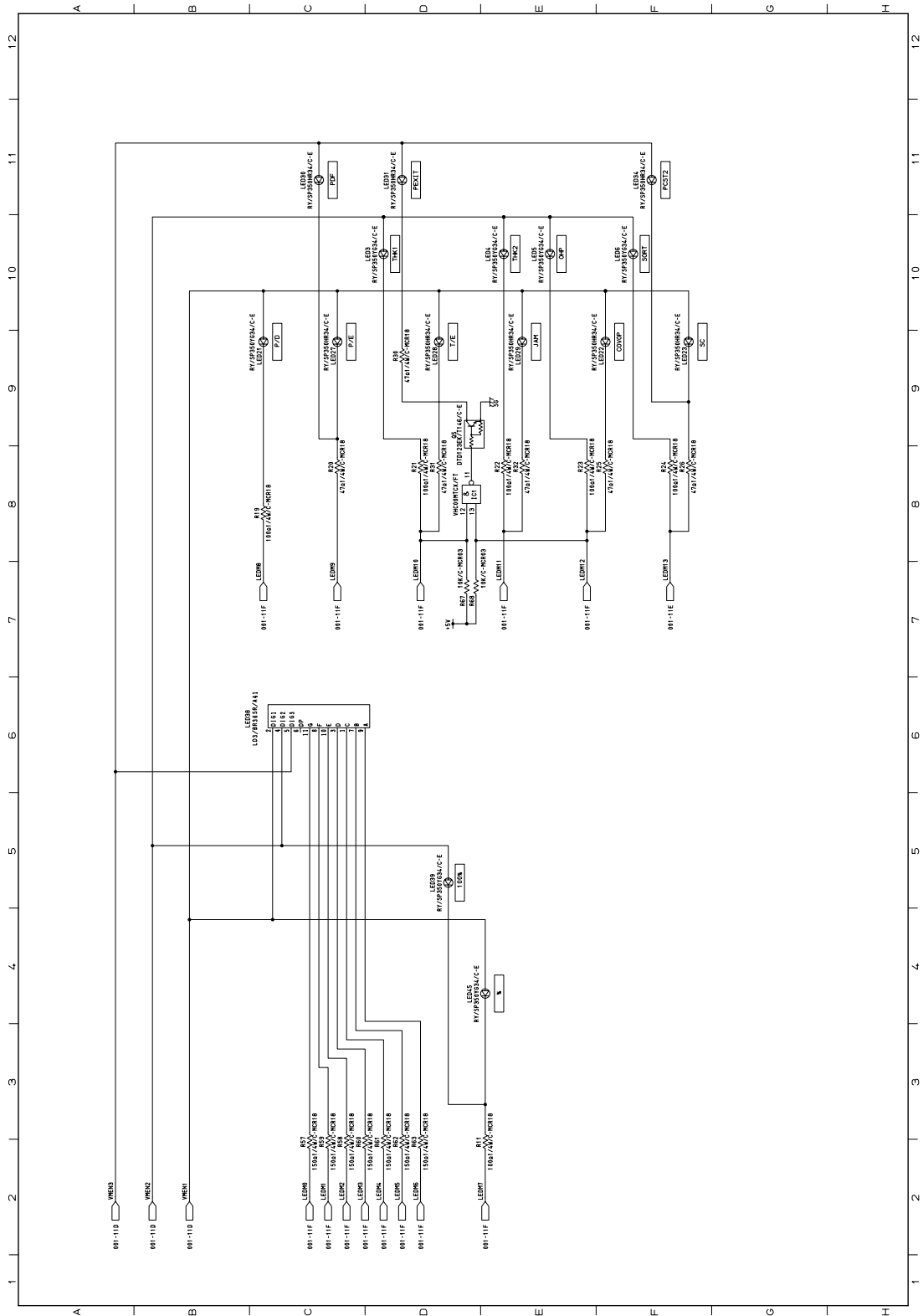

Fig. 3-41

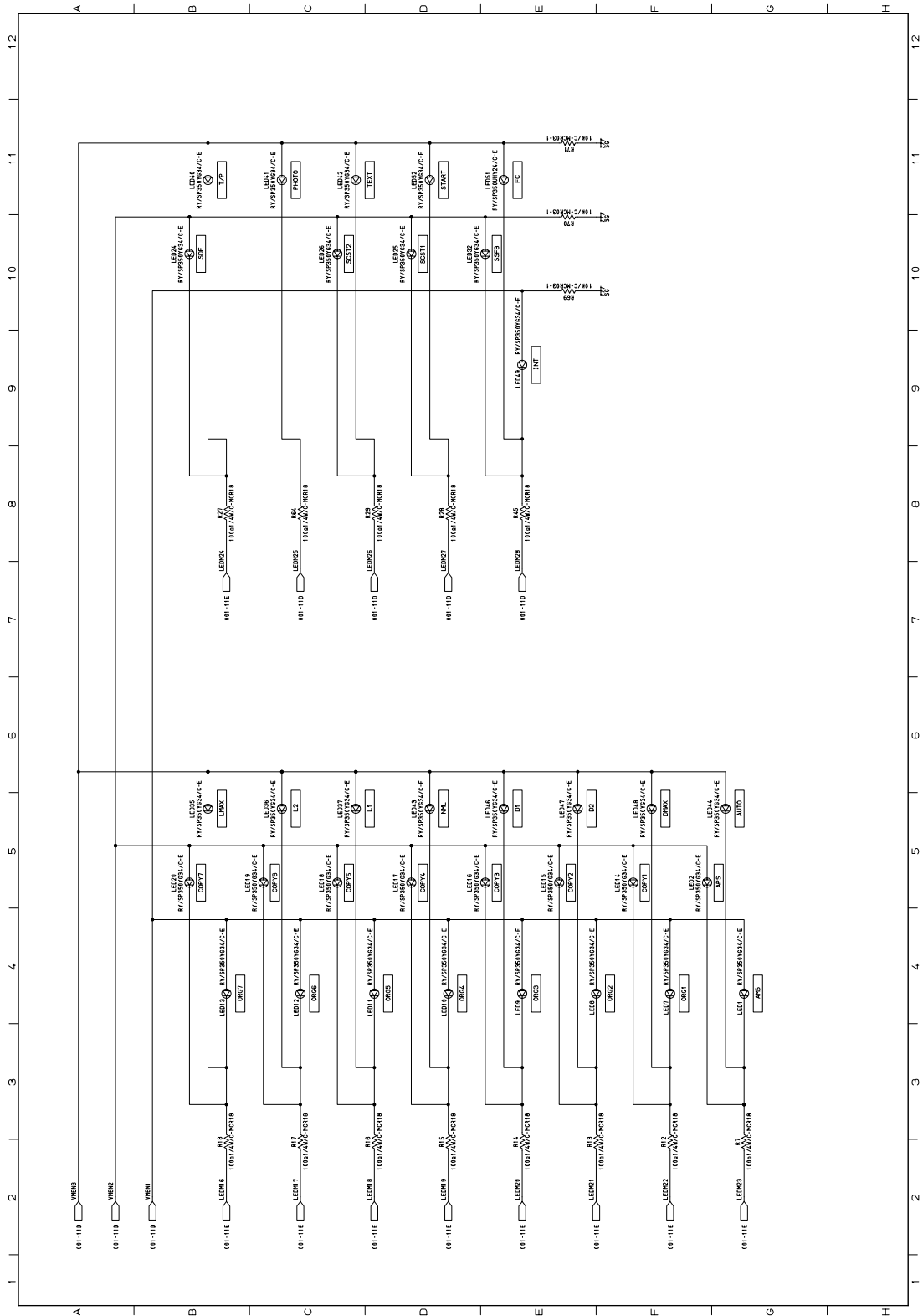

Fig. 3-42



LPNL board 4/4

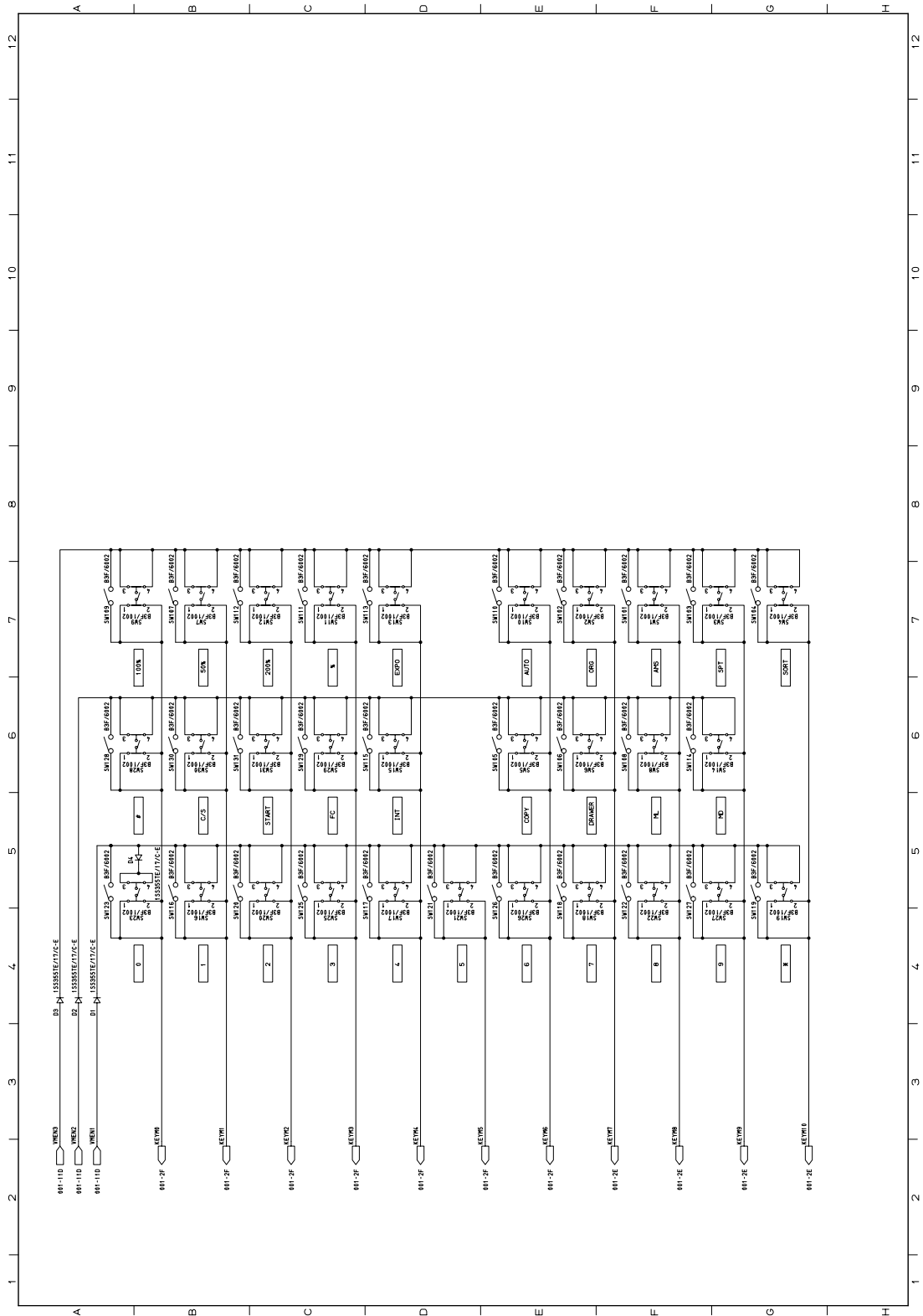

Fig. 3-43

### 3.7 Control panel circuit (HPNL board: e-STUDIO165/205)

HPNL board 1/4

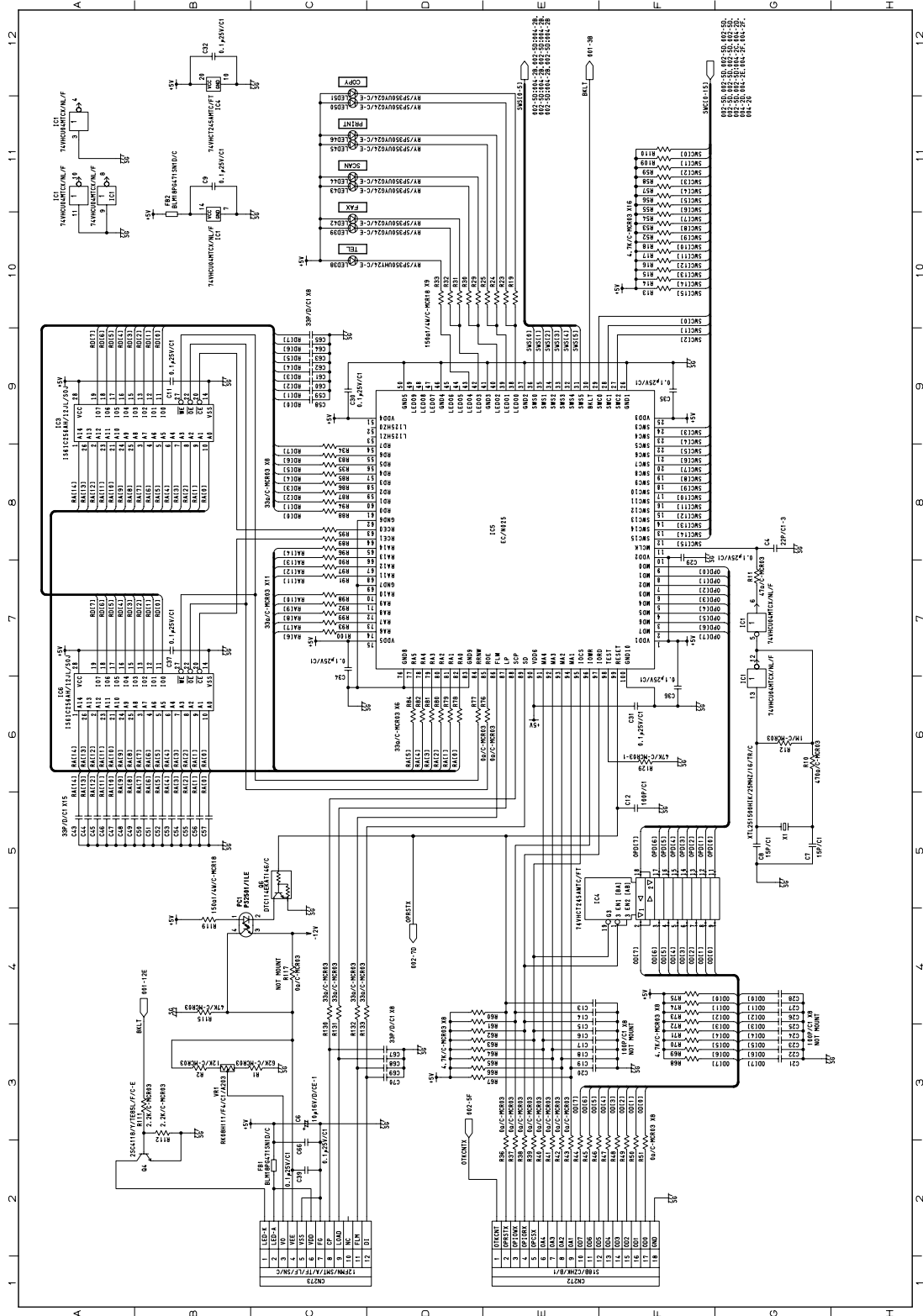

Fig. 3-44

HPNL board 2/4

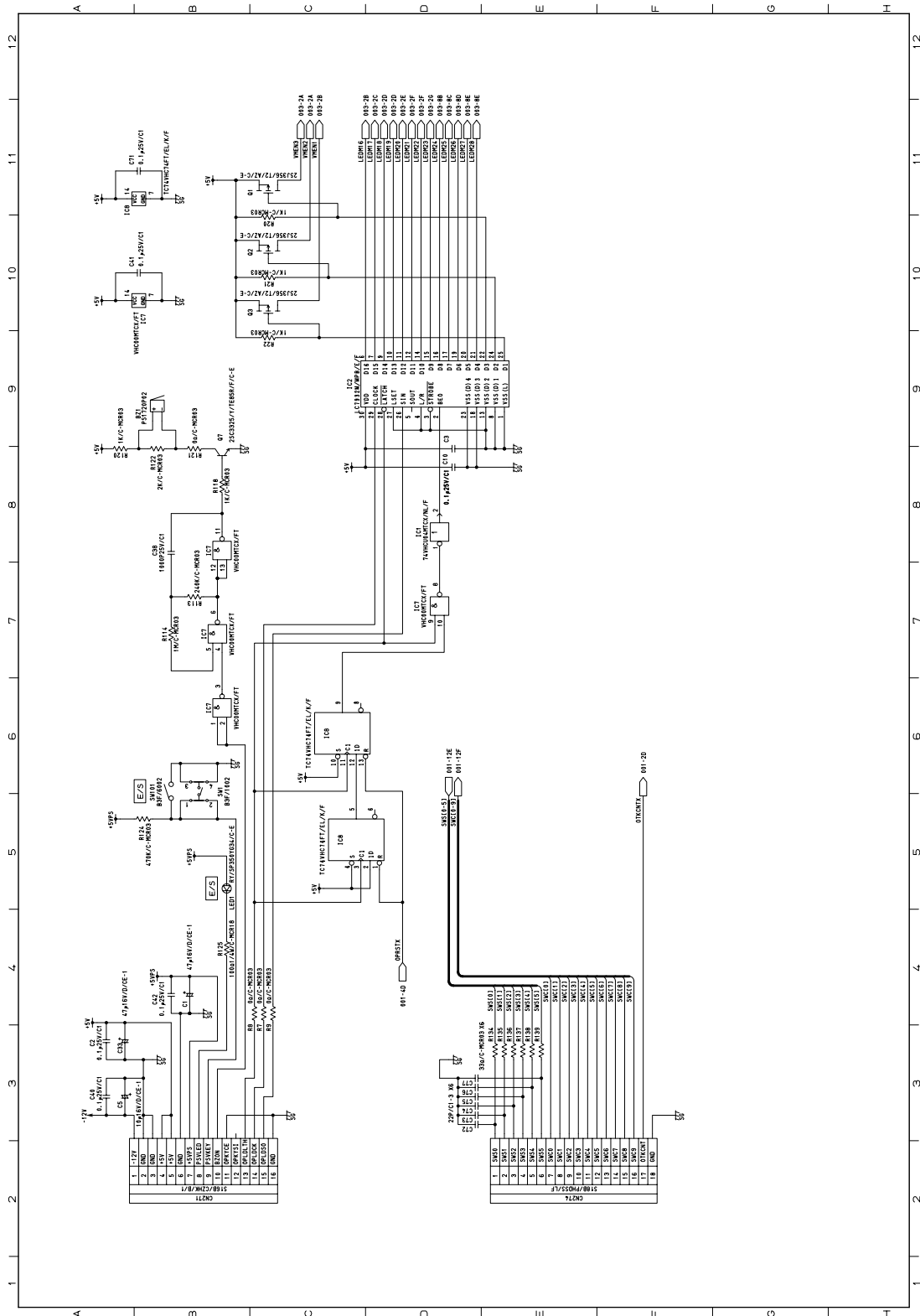

Fig. 3-45



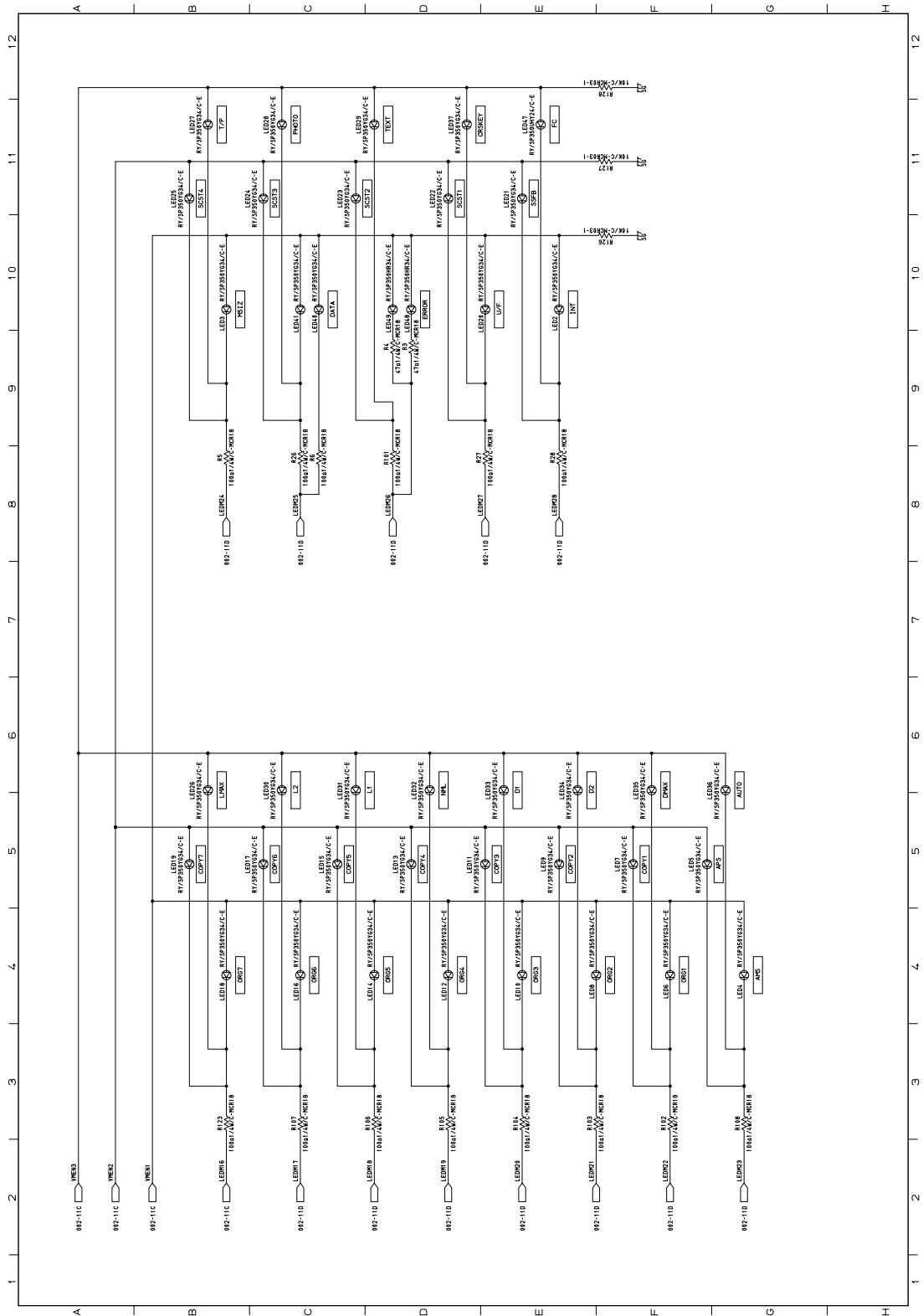

Fig. 3-46



HPNL board 4/4

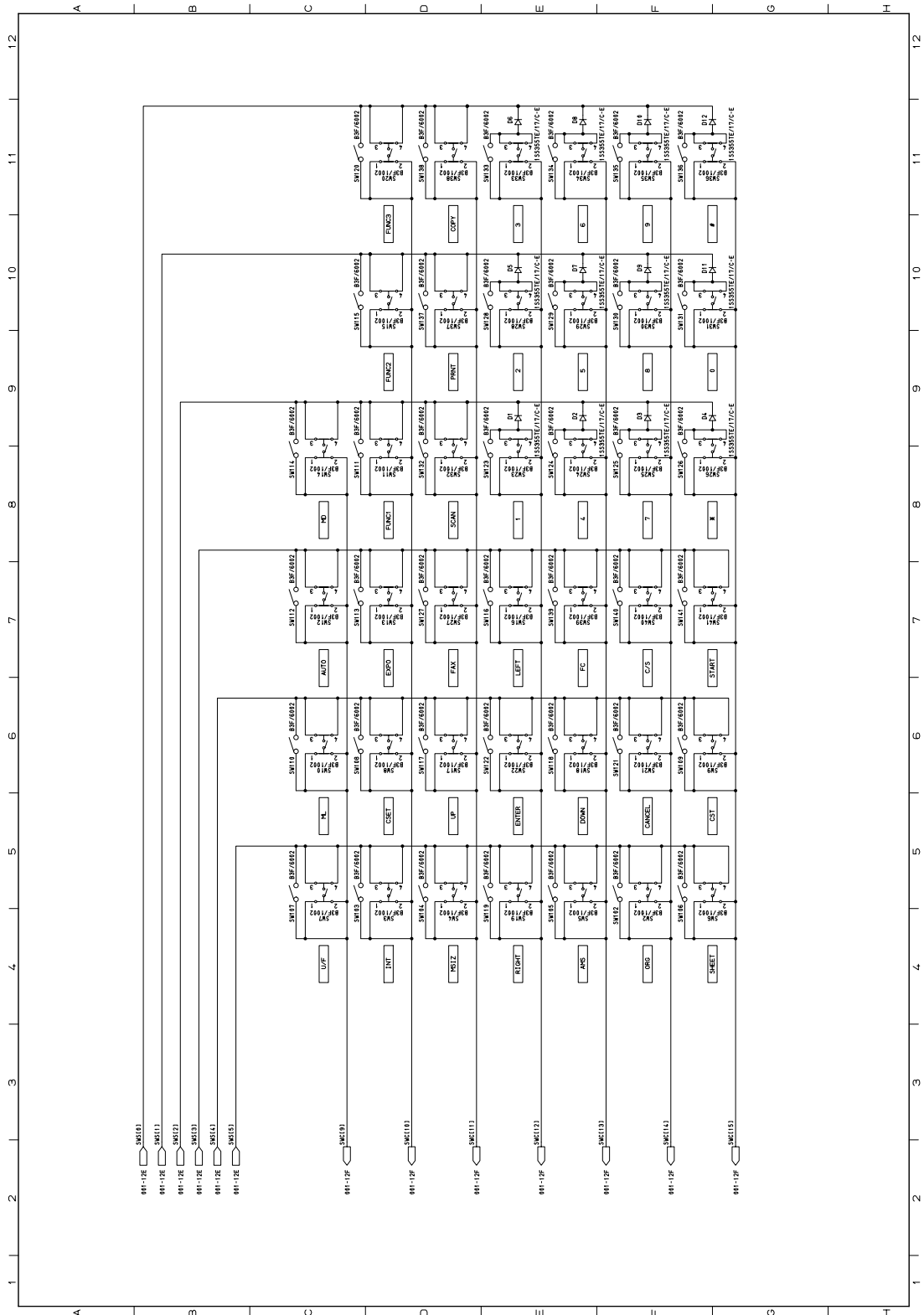

Fig. 3-47

### 3.8 Paper feed control circuit (PFC board: GH-1050)

PFC board 1/4

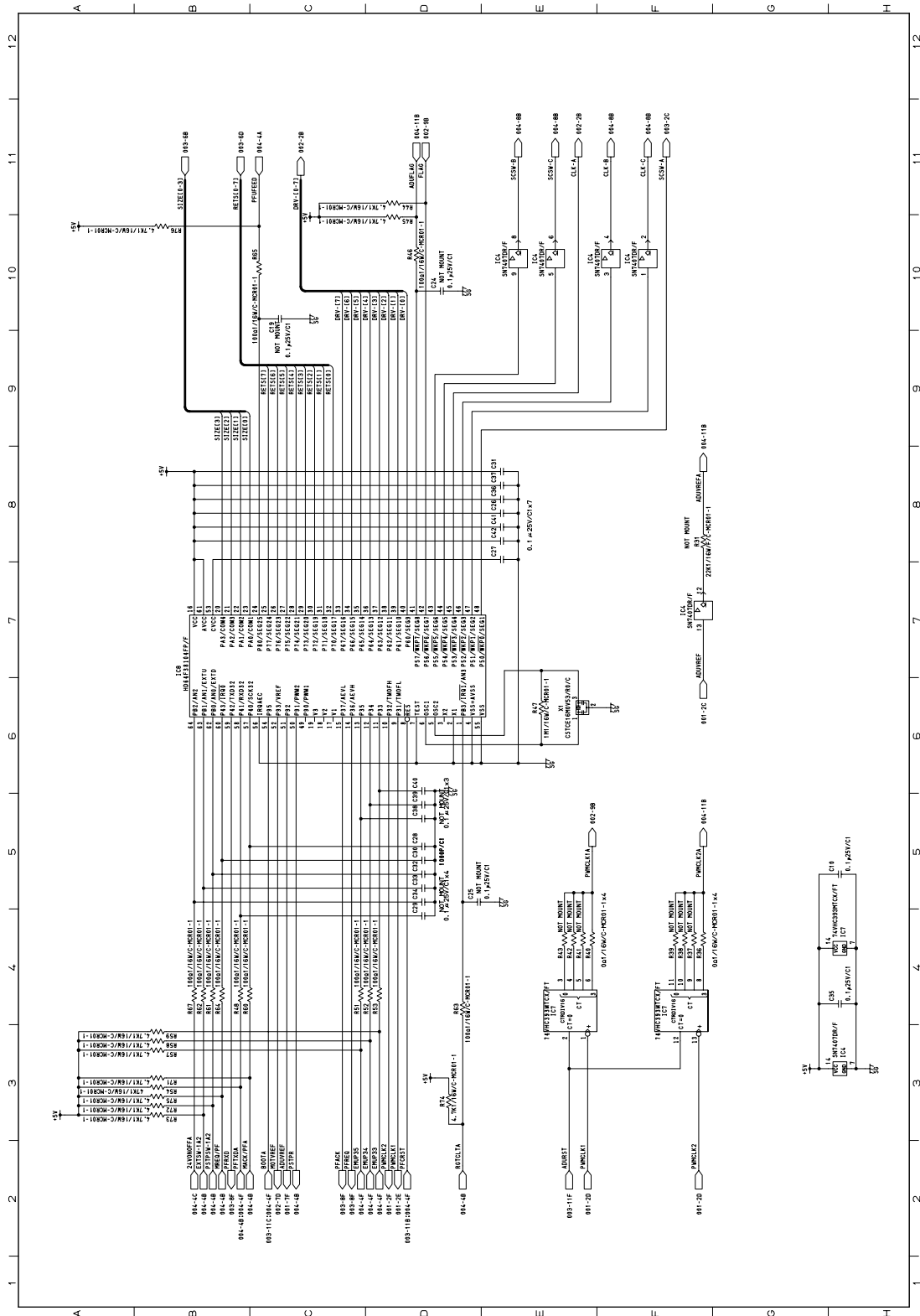

Fig. 3-48



PFC board 2/4

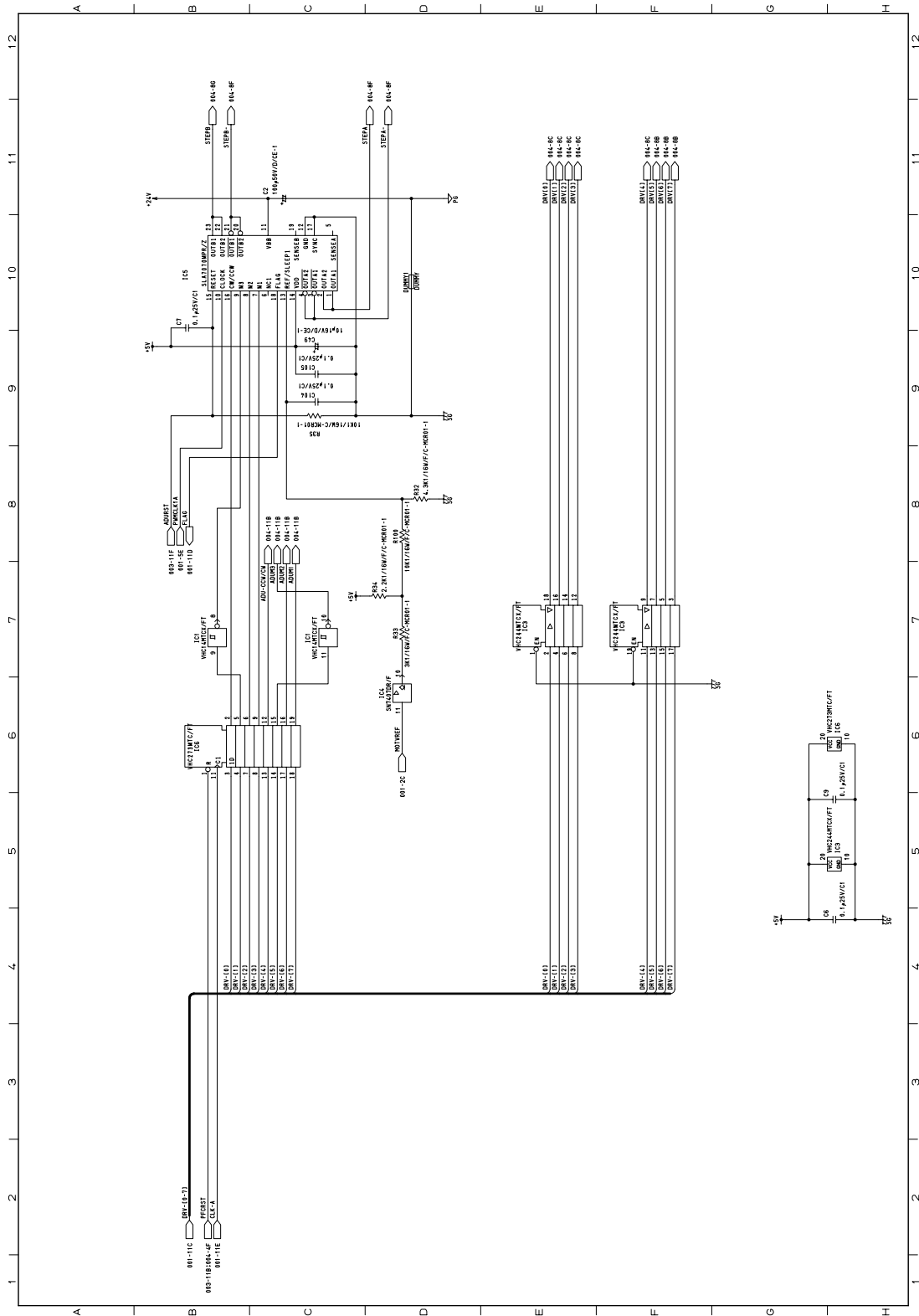

Fig. 3-49

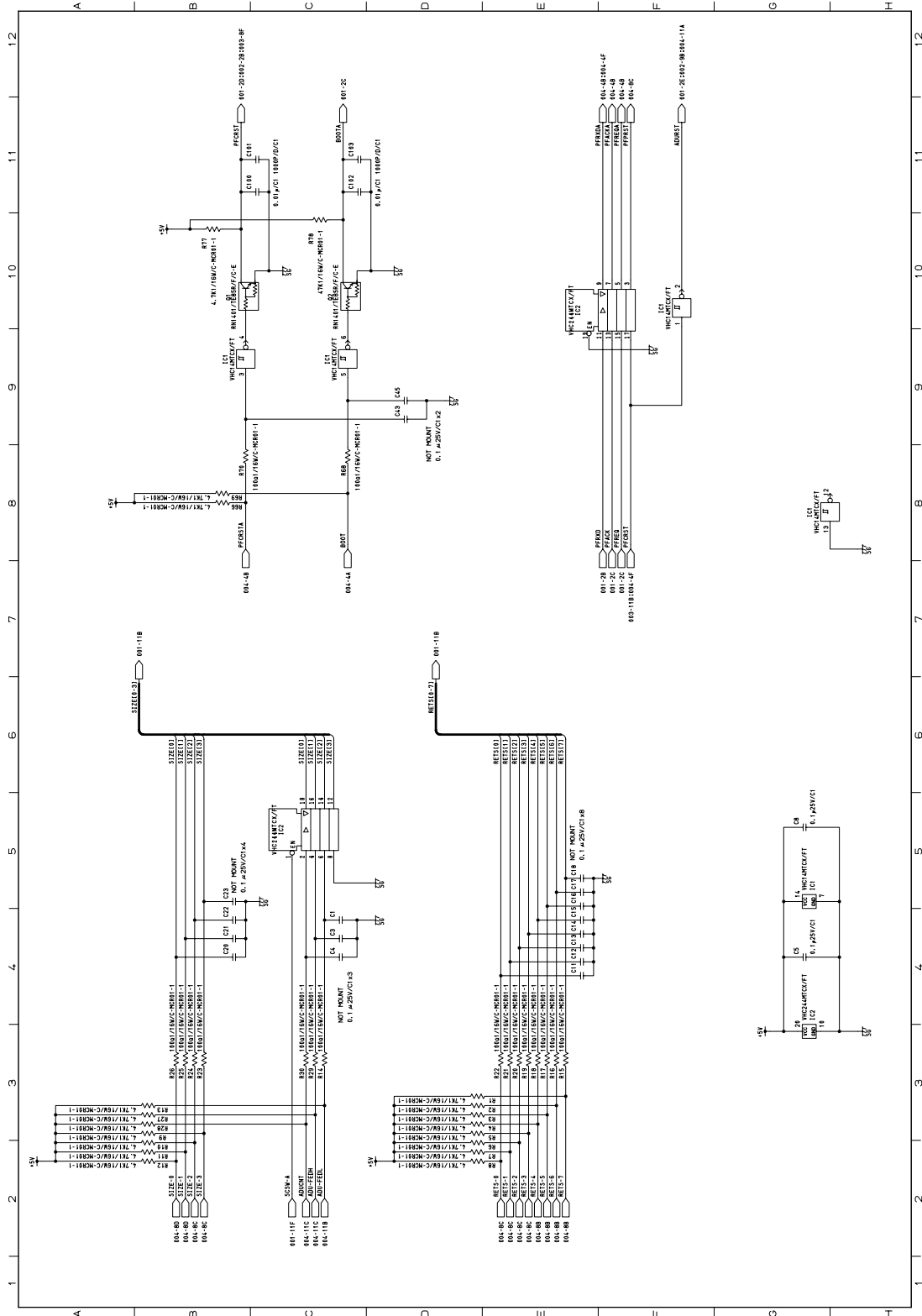

Fig. 3-50



PFC board 4/4

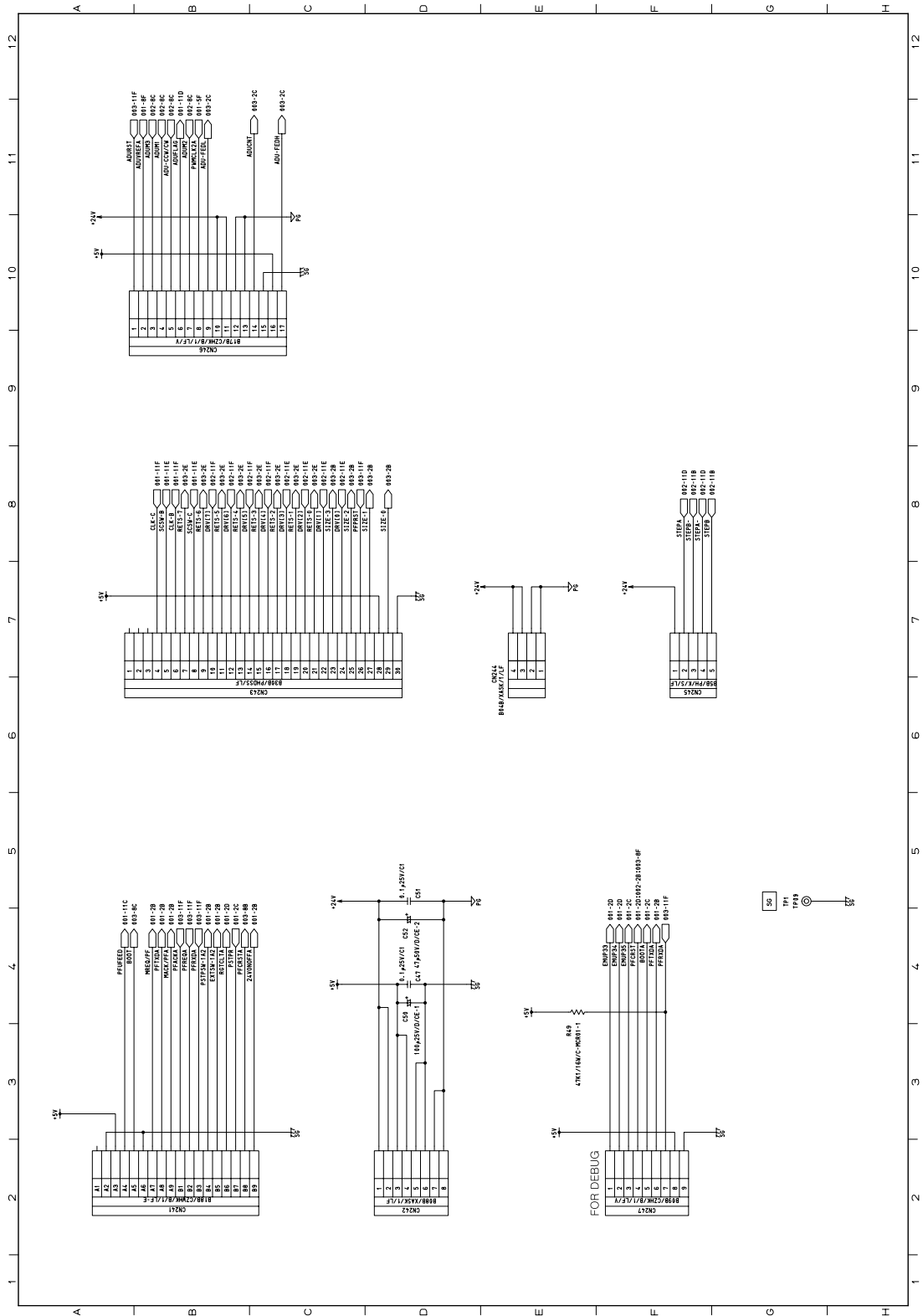

Fig. 3-51

### 3.9 Facsimile circuit (FAX board: GD-1220)

FAX board 1/5

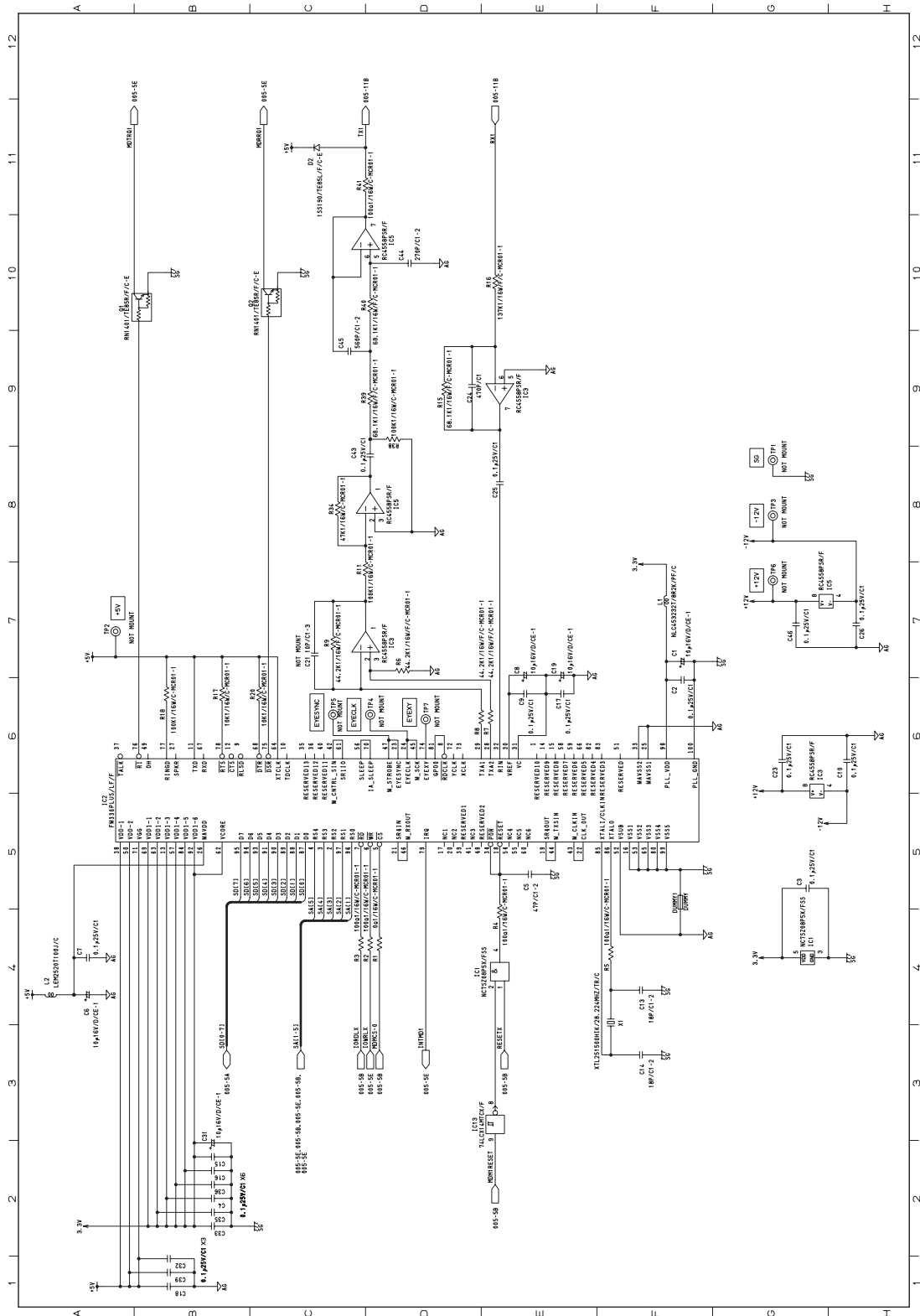

Fig. 3-52

FAX board 2/5

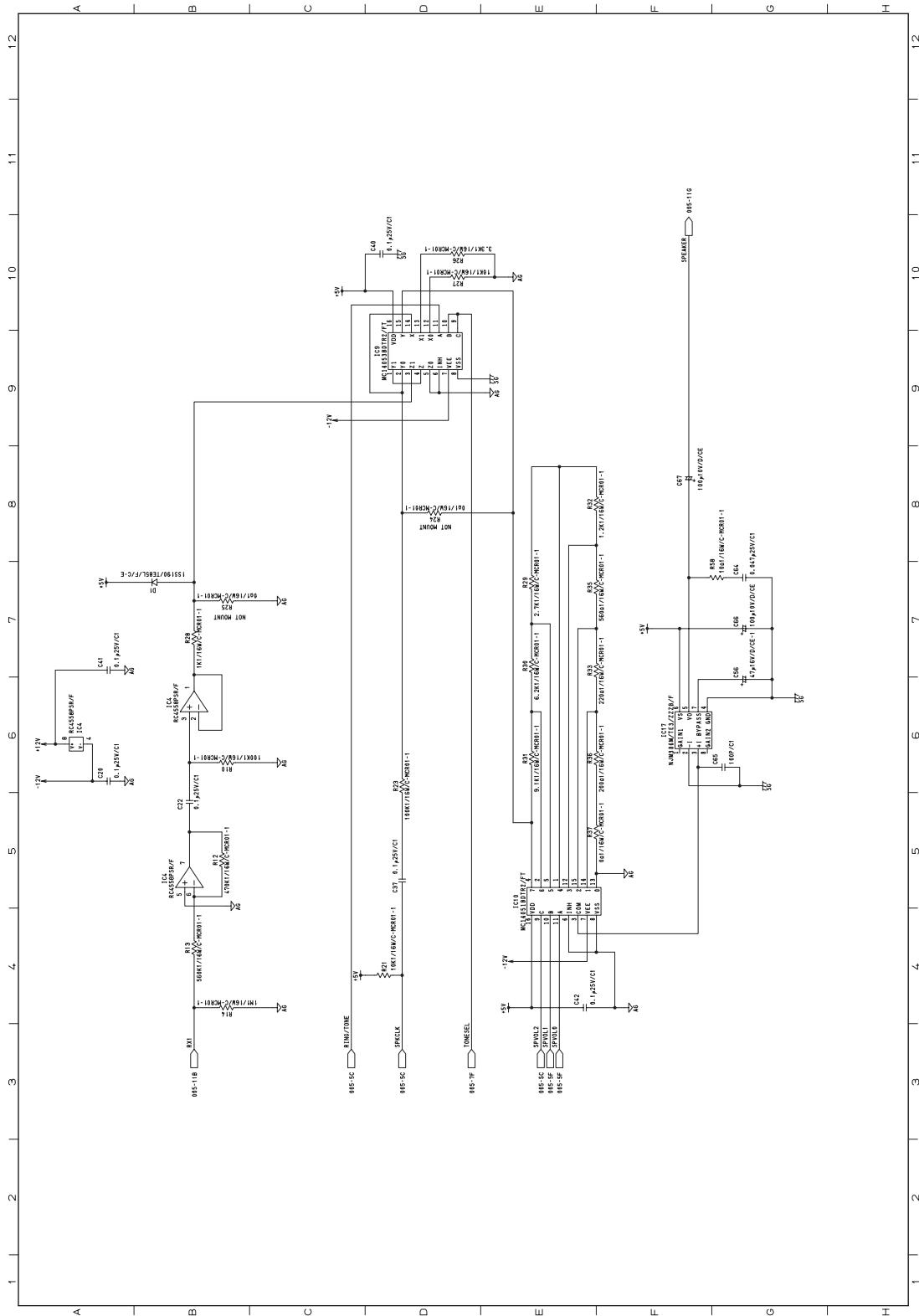

Fig. 3-53



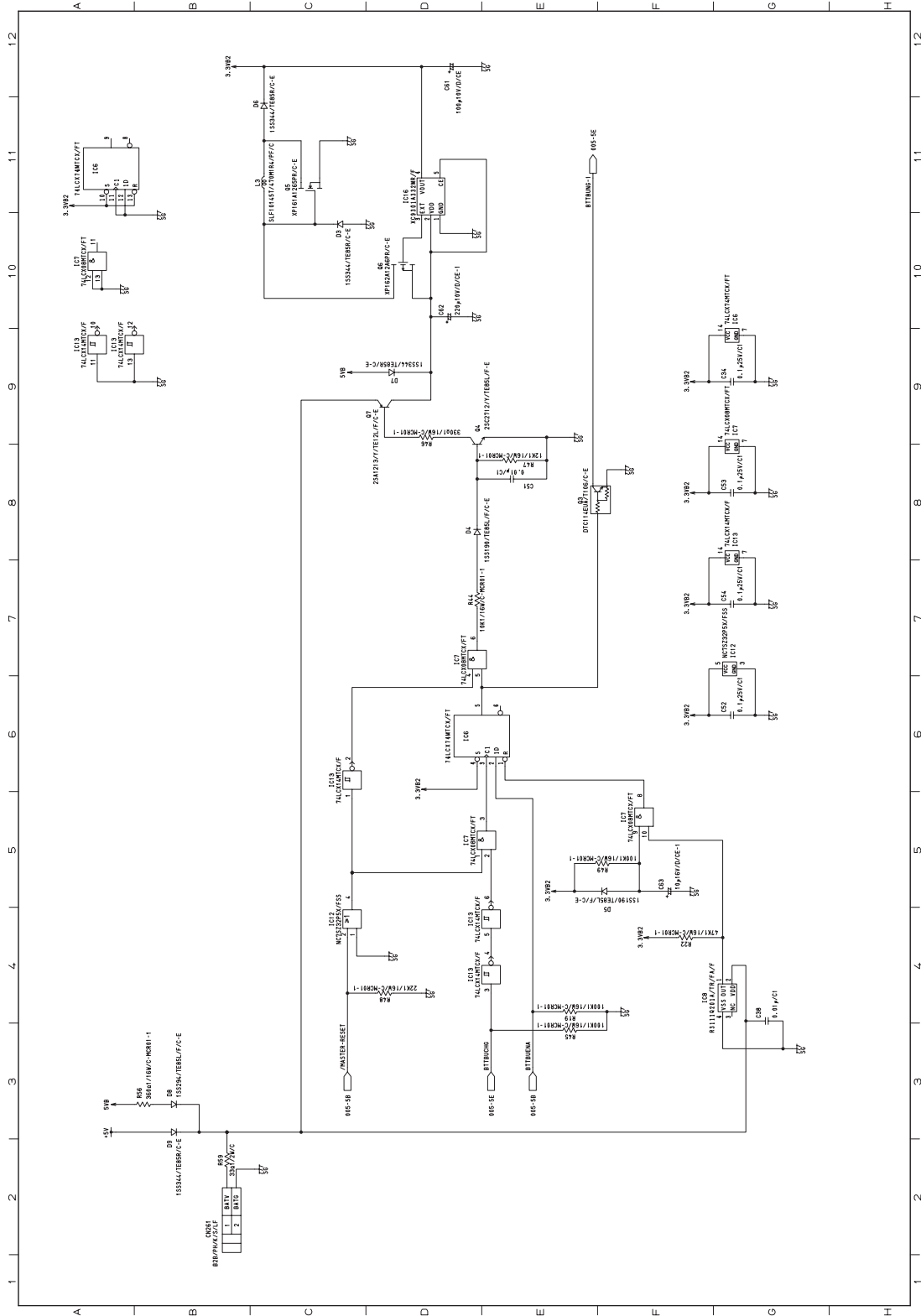

Fig. 3-54



FAX board 4/5

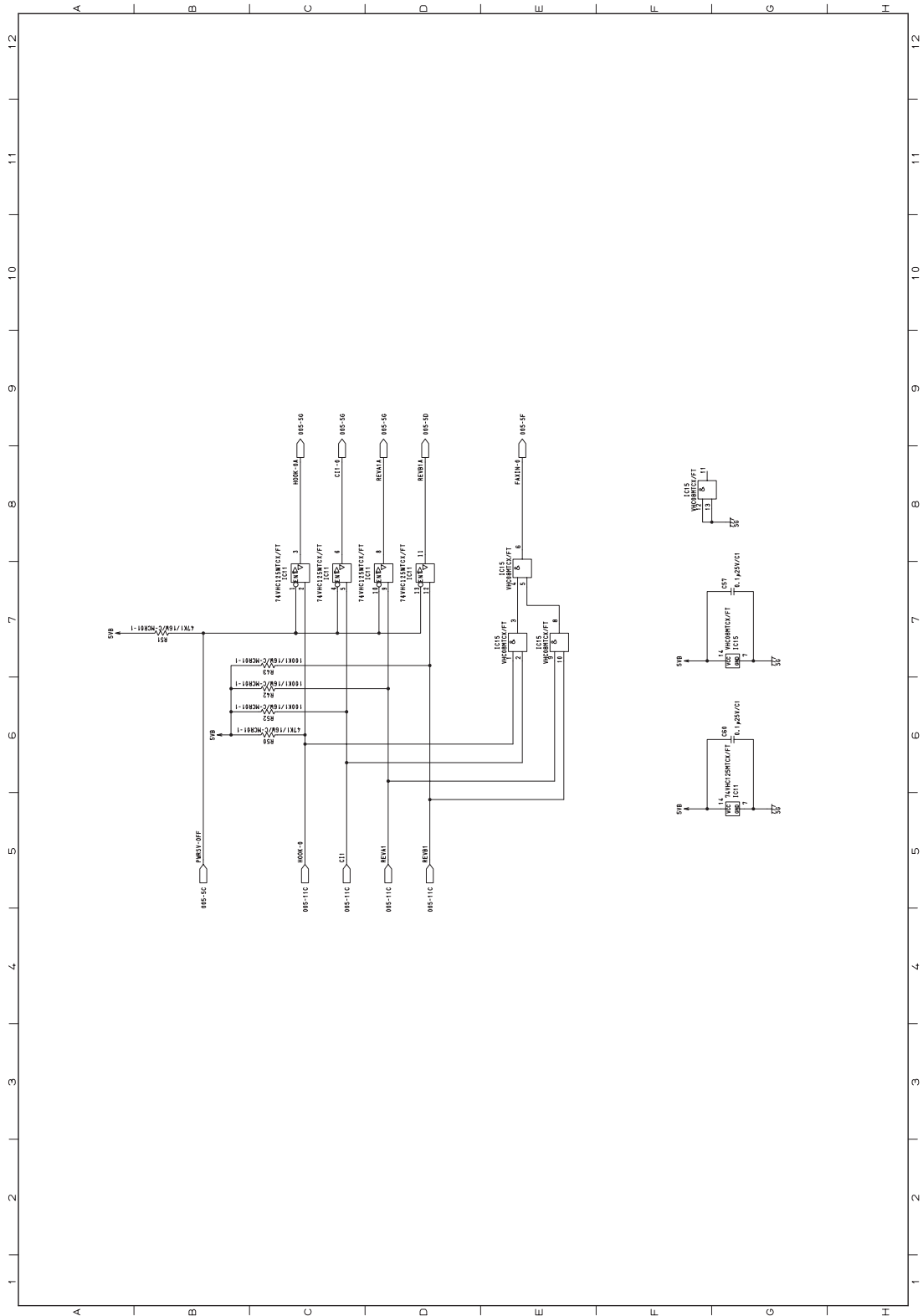

Fig. 3-55

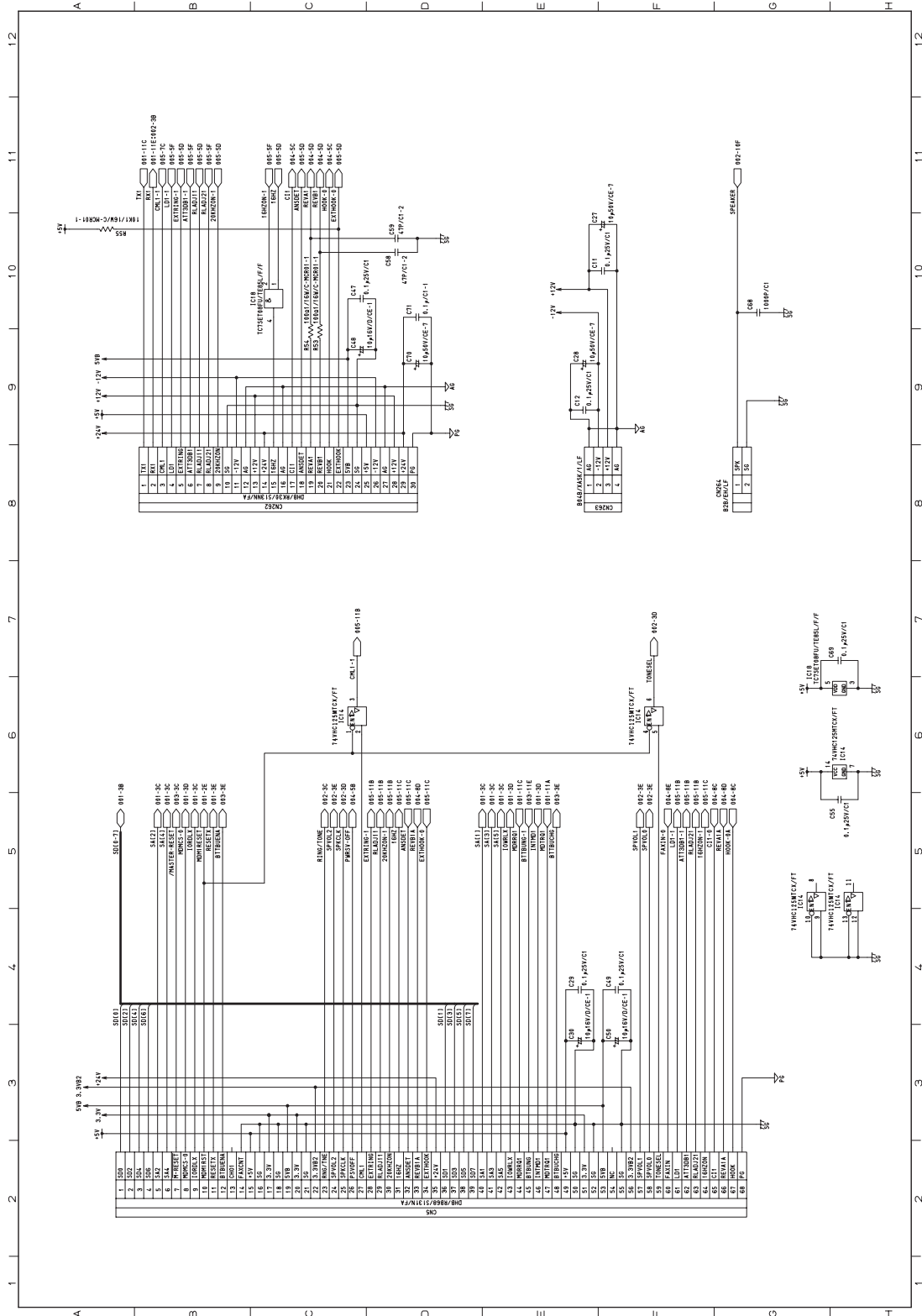

Fig. 3-56



# 3.10 Telephone line network control circuit (NCU board: GD-1220NA/TW)

NCU board 1/2

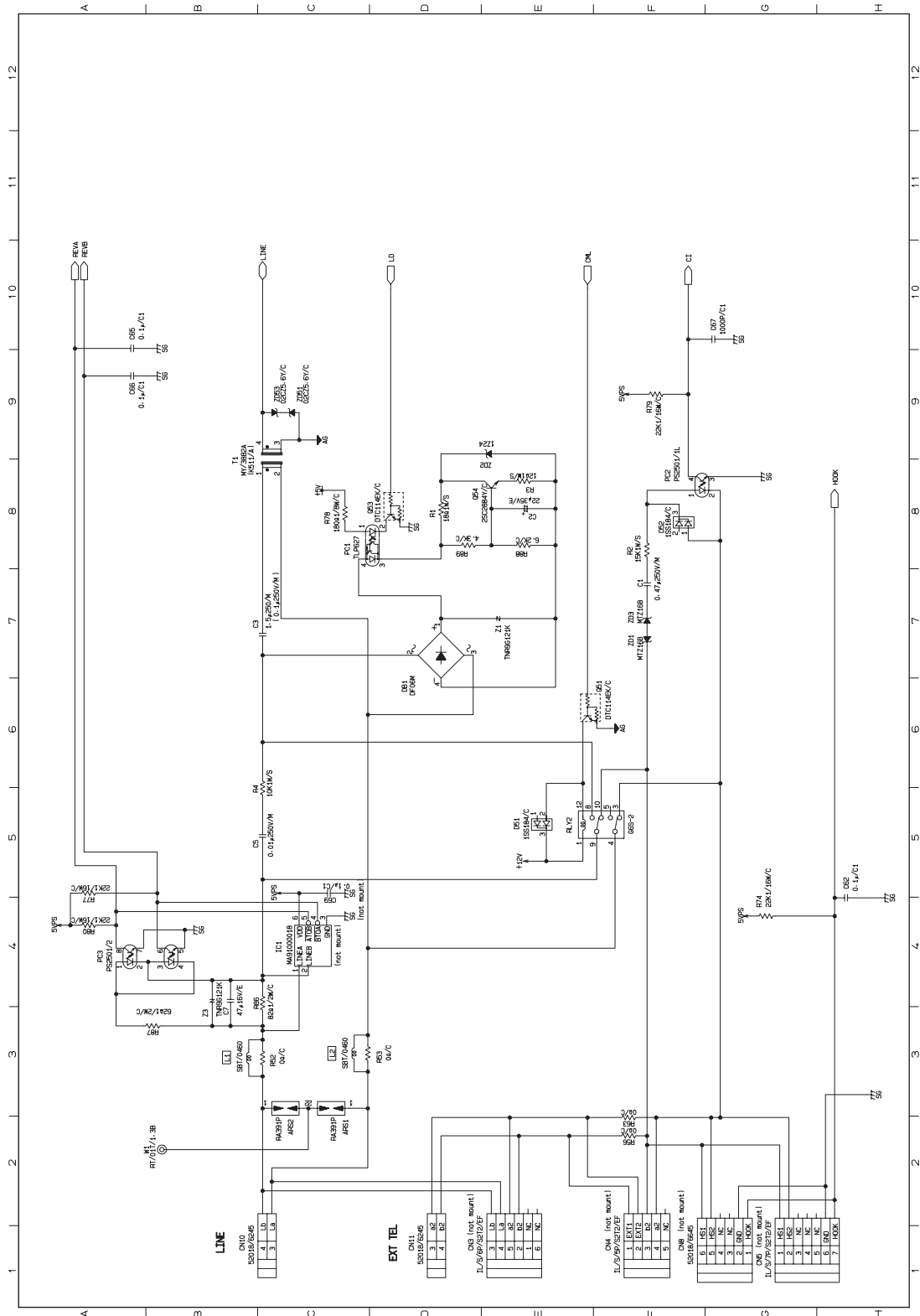

Fig. 3-57

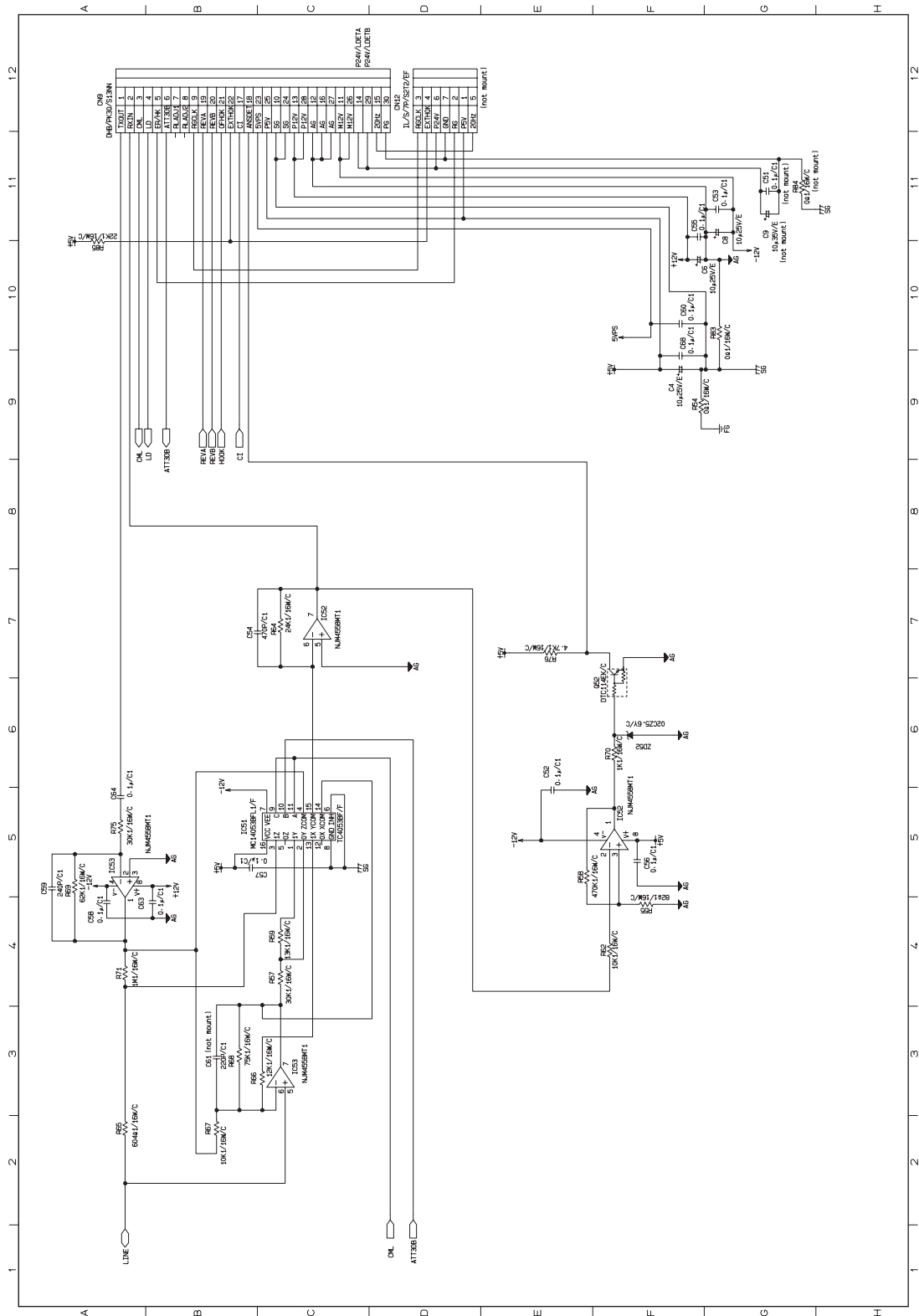

Fig. 3-58



# 3.11 Telephone line network control circuit (NCU board: GD-1220EU/AU)

NCU board 1/2

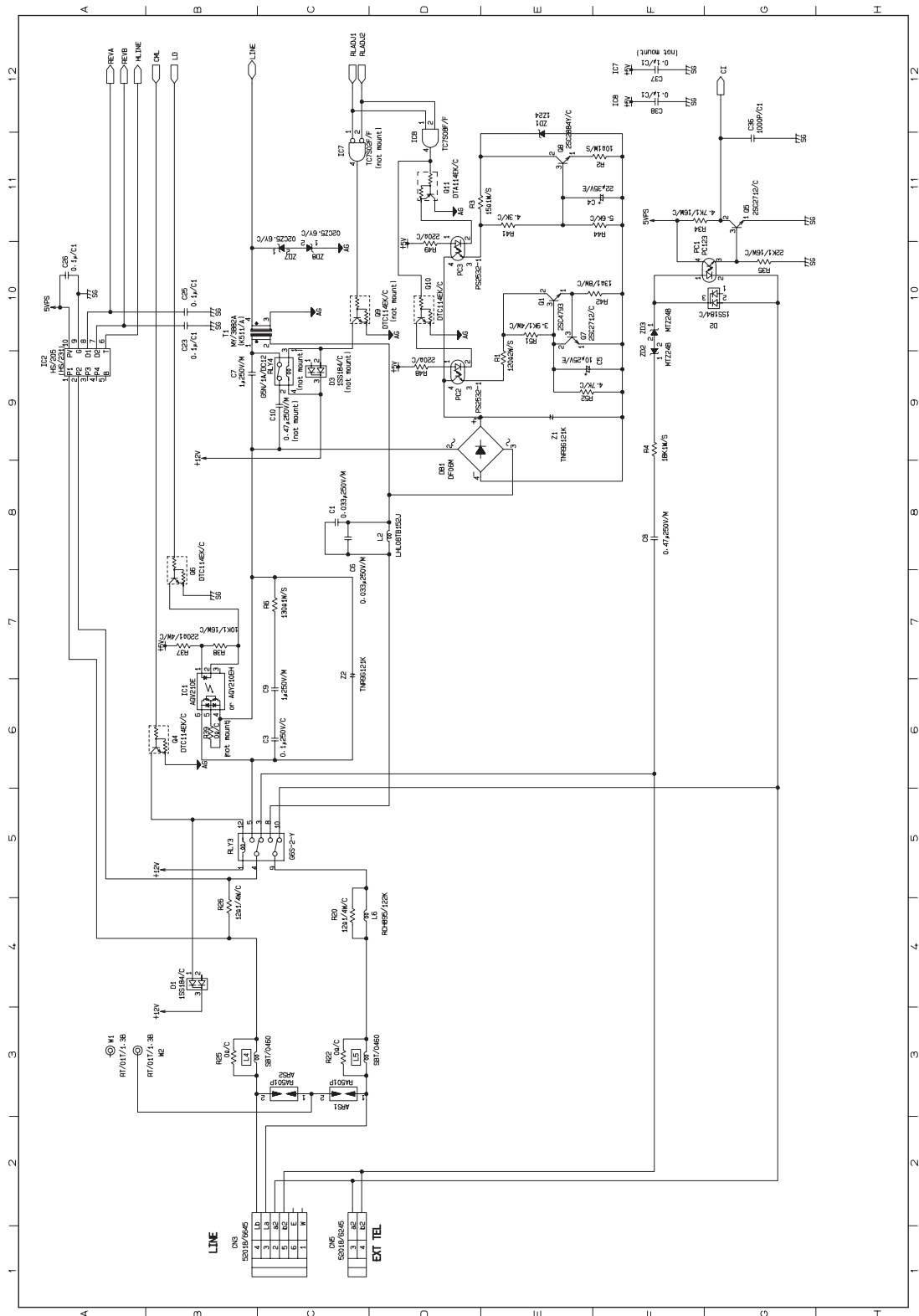

Fig. 3-59

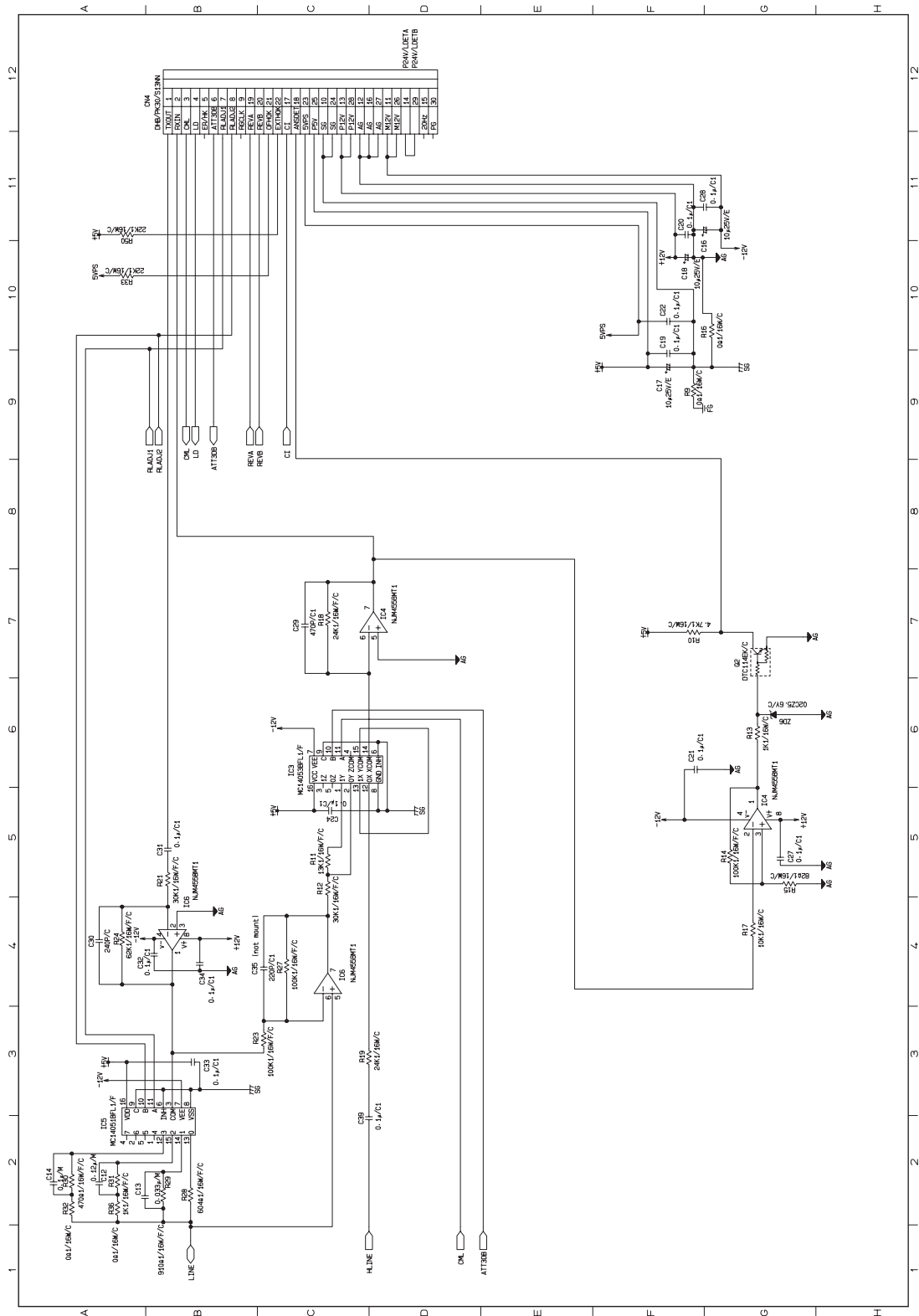

Fig. 3-60



### 3.12 TELBOOK circuit (TELBOOK board: GJ-1040)

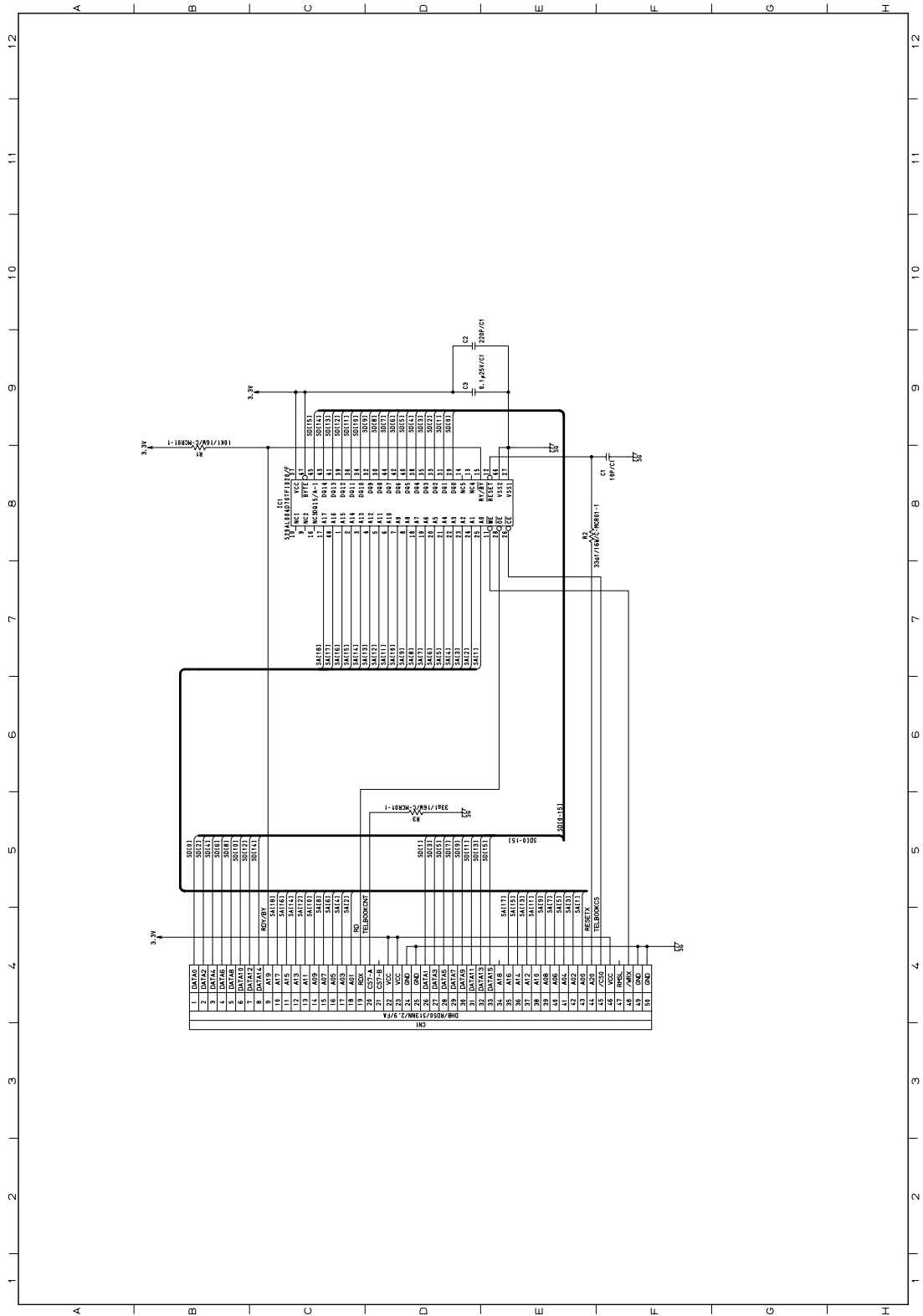

Fig. 3-61



### 3.13 External keyboard circuit (OTK board: GJ-1040)

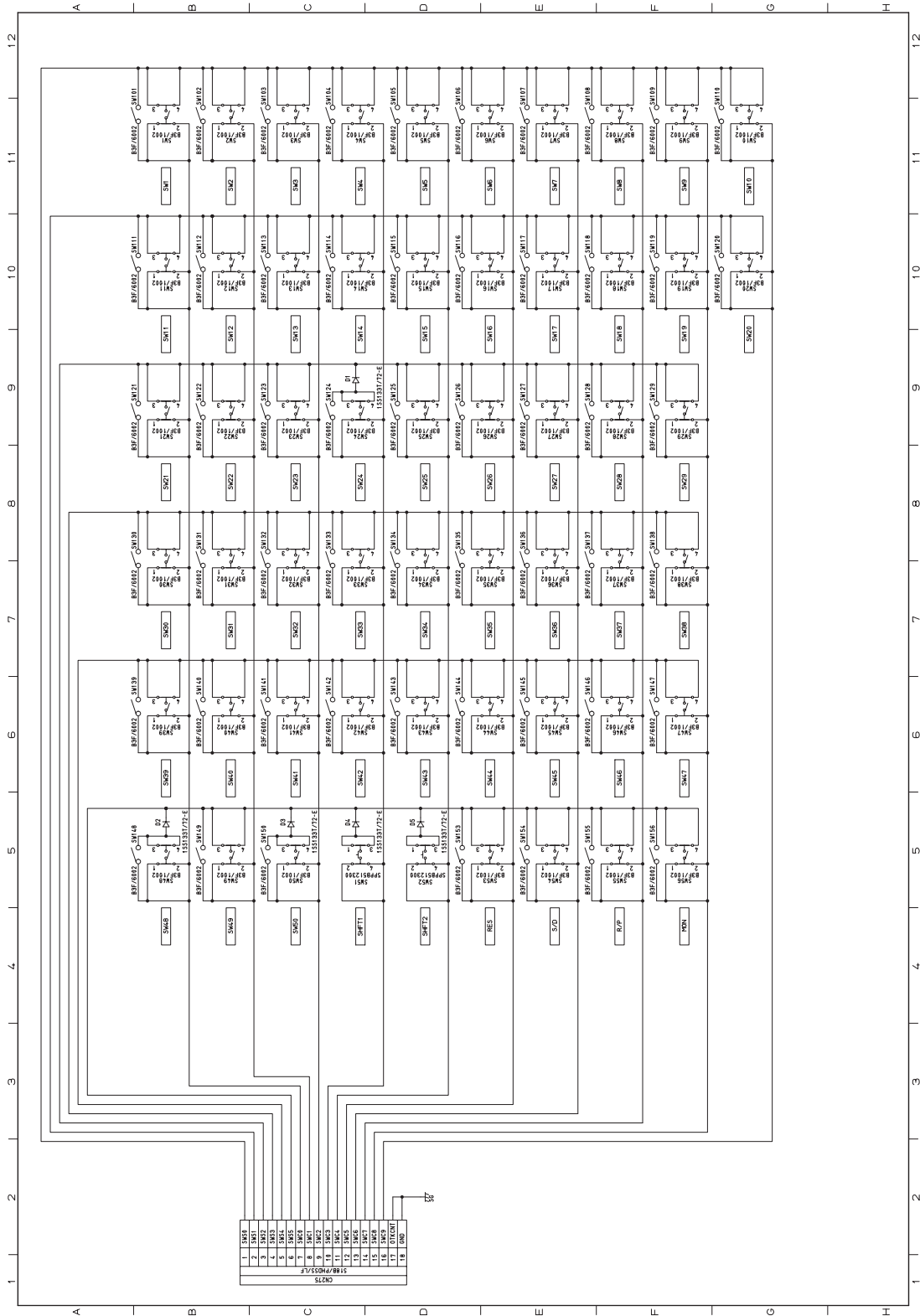

Fig. 3-62



### 3.14 Memory circuit (MEM board: GC-1240)

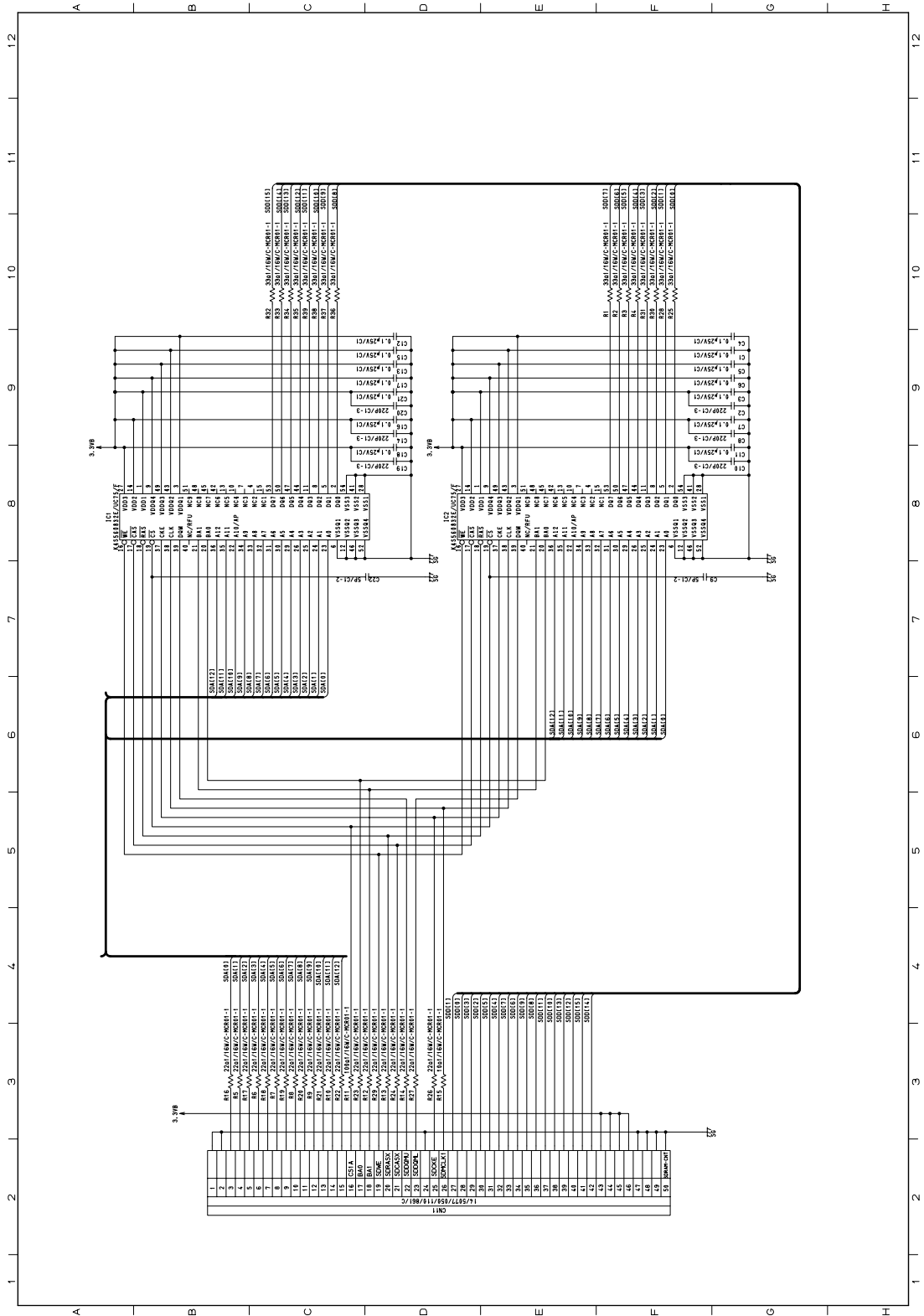

Fig. 3-63

### 3.15 Main circuit (MAIN board: e-STUDIO166/206)

MAIN board 1/34

Sheet No.	Index		
001		018	COUNTER&FAN&RGT-CLT&PS-SW RESET&SOL DRIVER&POL-M DRIVER&BD
002	SOC 1	019	MAIN-M&TNR-M&VCM-FAN DRIVER&BKUPEEPROM
003	SOC 2	020	ERS&HMS&ATS&LPWR&HVTVR
004	SOC 3	021	HVT IF&HTR&ADF IF
005	SOC 4	022	AFE
006	SOC 5	023	CIS IMAGE DATA IF
007	FROM	024	CIS-LED DRIVER
008	SDRAM	025	CONNECTOR (D/L ROM&BACKUP SRAM)
009	CONTROL PANEL IF&3.3V-5V IF	026	CONNECTOR (PS&PFU)&PS-IC
010	3.3V-5V IF&POWER DOWN&POWER SAVE	027	CONNECTOR (FAX&CIS)
011	RESET	028	CONNECTOR (CONTROL PANEL&USB)
012	OPAL (IO ASIC)	029	CONNECTOR (OPTION SDRAM&HVPS)
013	DAC&ADC&MODEL DISCRIMINATION	030	CONNECTOR (HOME, PLTN-SW&APS&SCN-M&THR&COUNTER)
014	THERMISTOR CONTROL	031	CONNECTOR (LSU&DEV/MAIN-SW/FCOV/PS-FAN&POL-M&ADF)
015	SCAN-MOTOR DRIVER	032	CONNECTOR (MAIN-M&TNR-M&TNR-SW&VCM-FAN&et c. )
016	CIS IF&WAKE UP	033	CONNECTOR (EWS&DEBUG)
017	AFE-SOC IF	034	DEMITASNX CAPACITORS

F284/285  
Main Board Circuit Diagram

Fig. 3-64



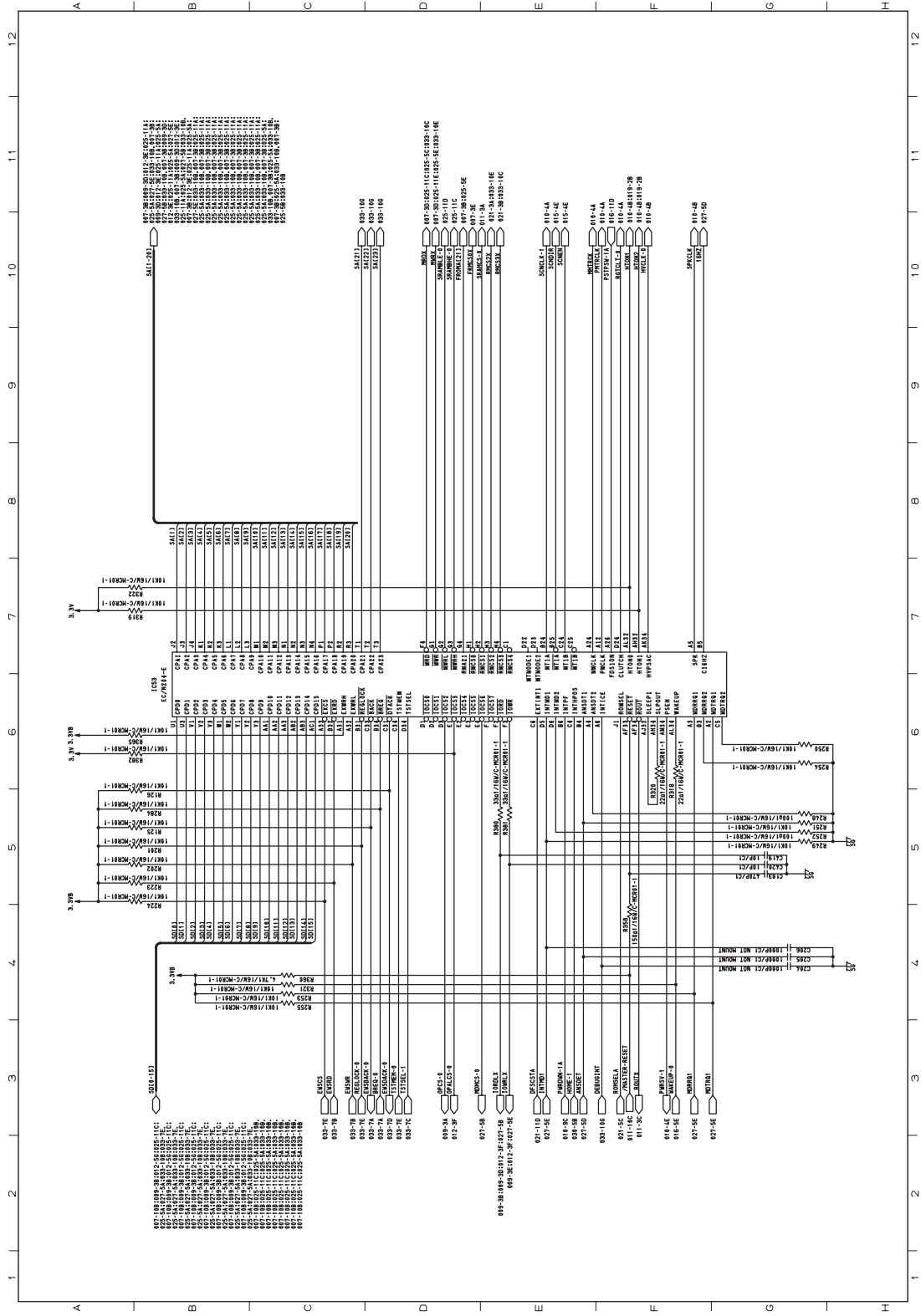

Fig. 3-65

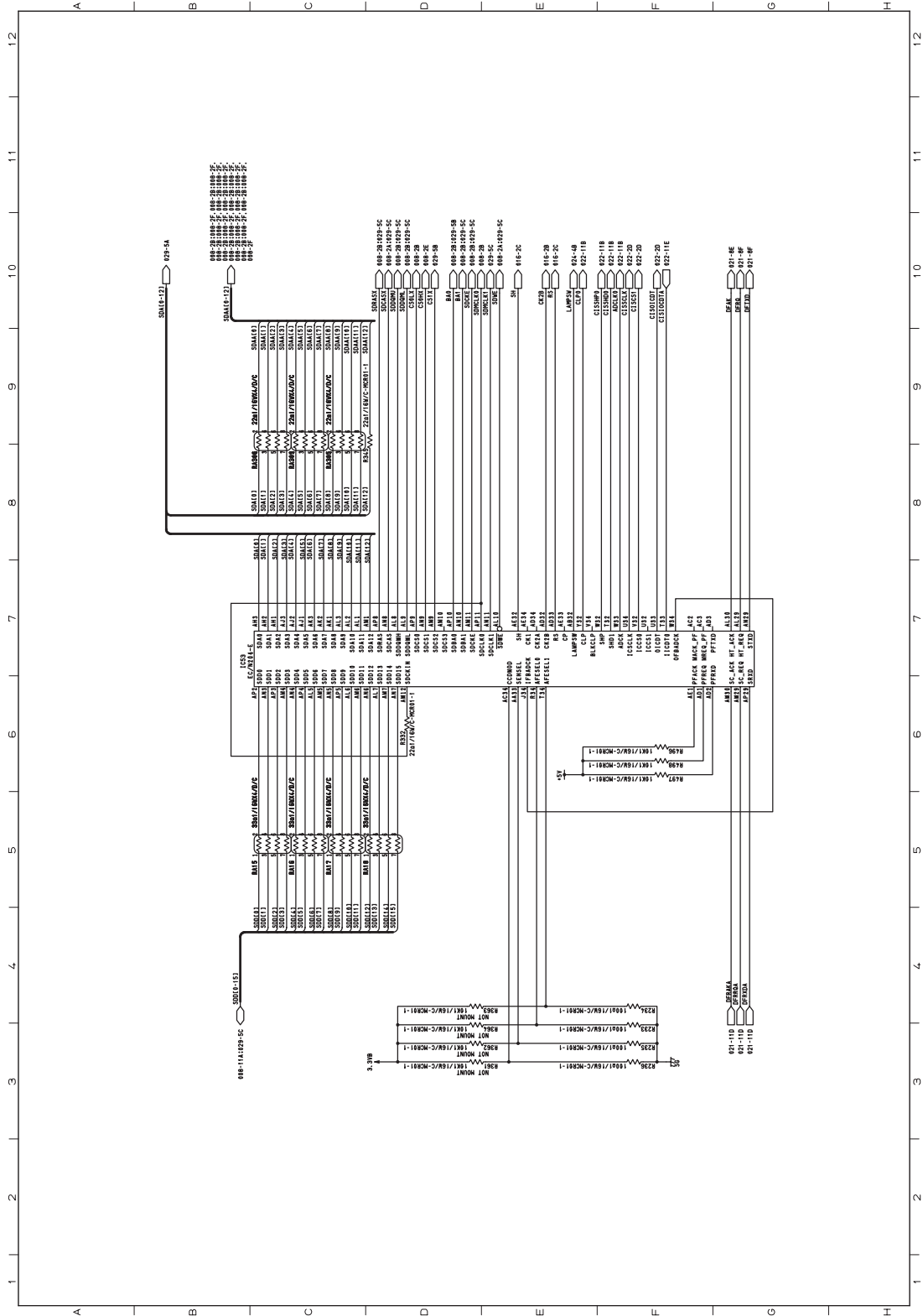

Fig. 3-66

# MAIN board 4/34

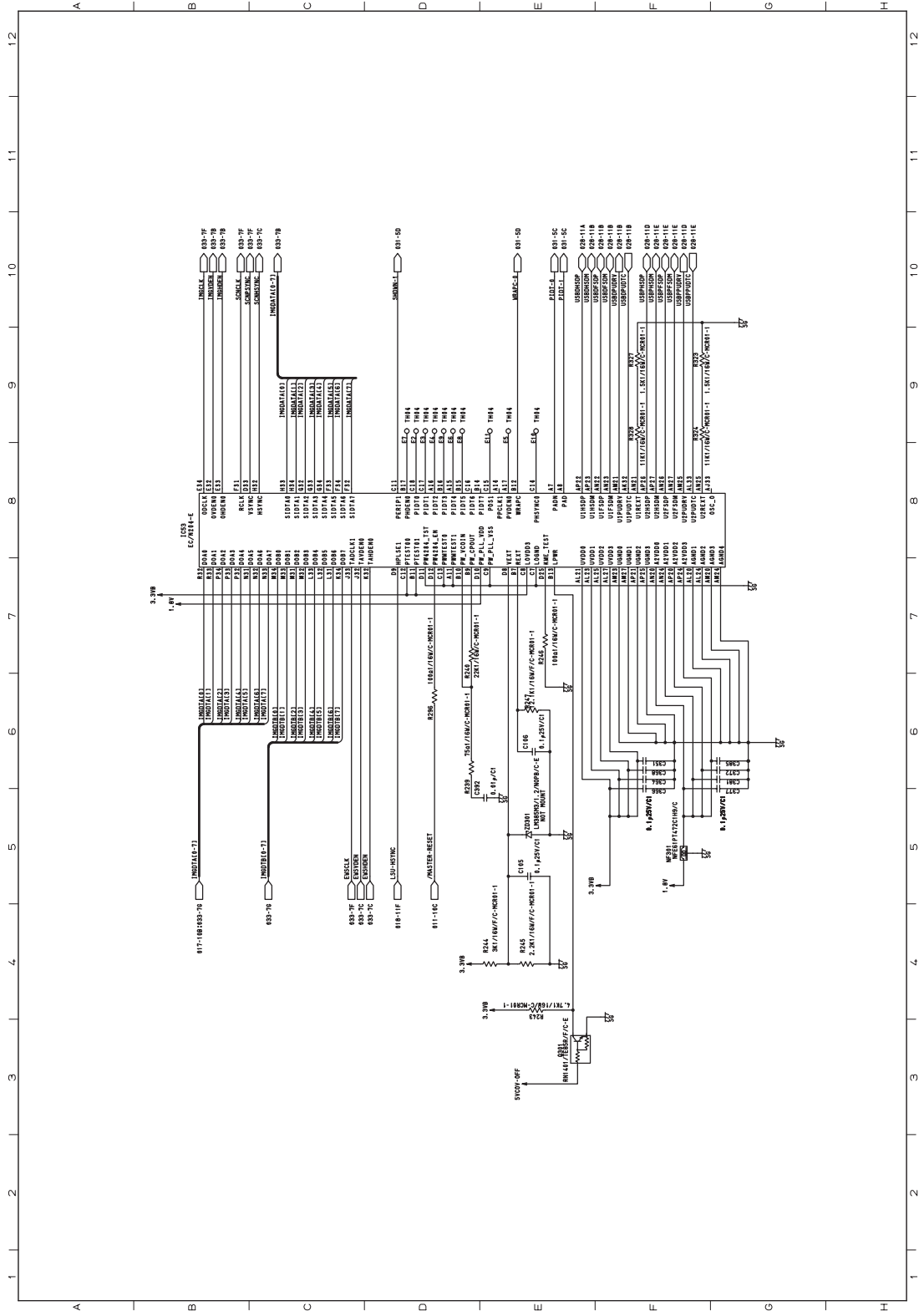

Fig. 3-67

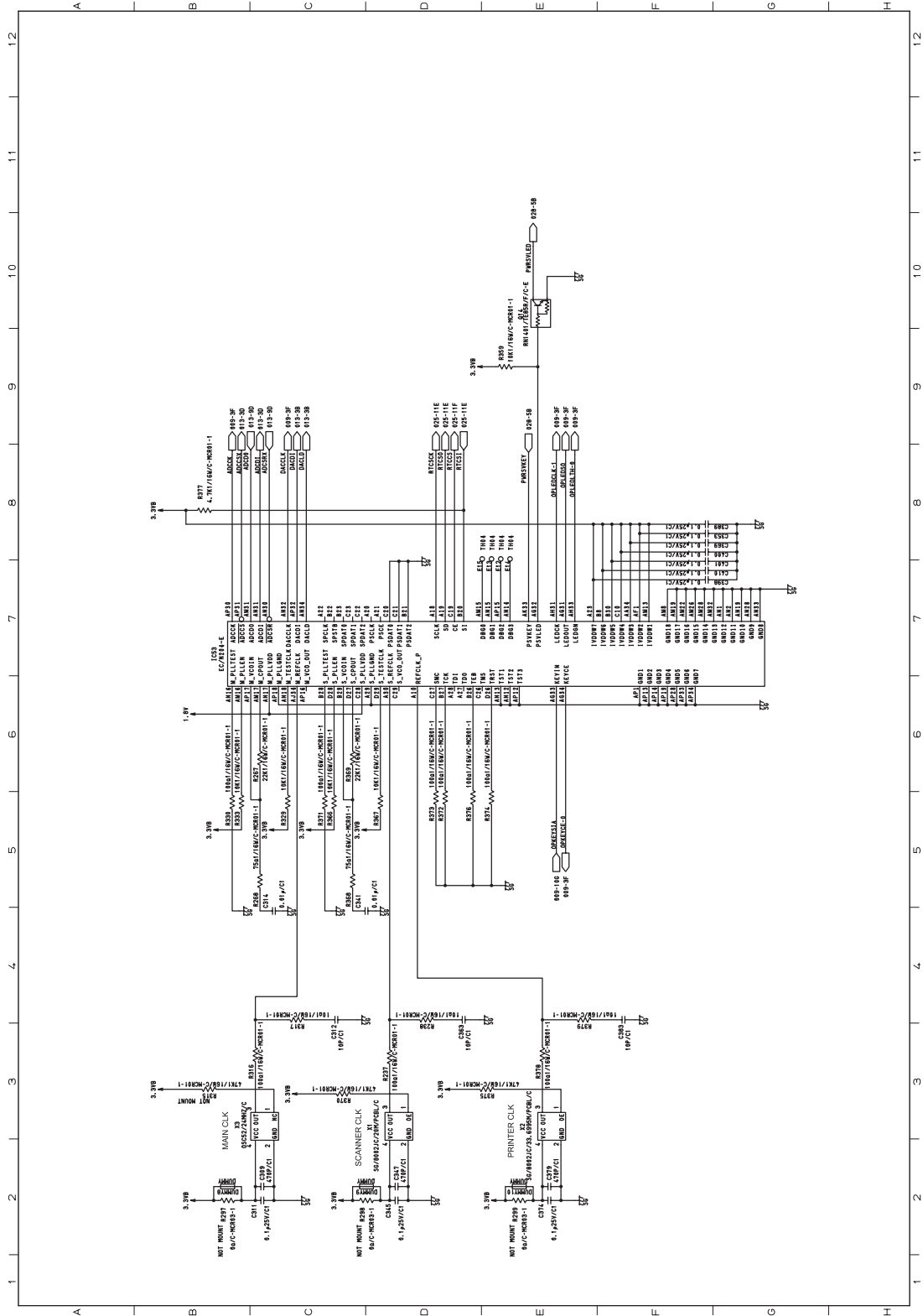

Fig. 3-68







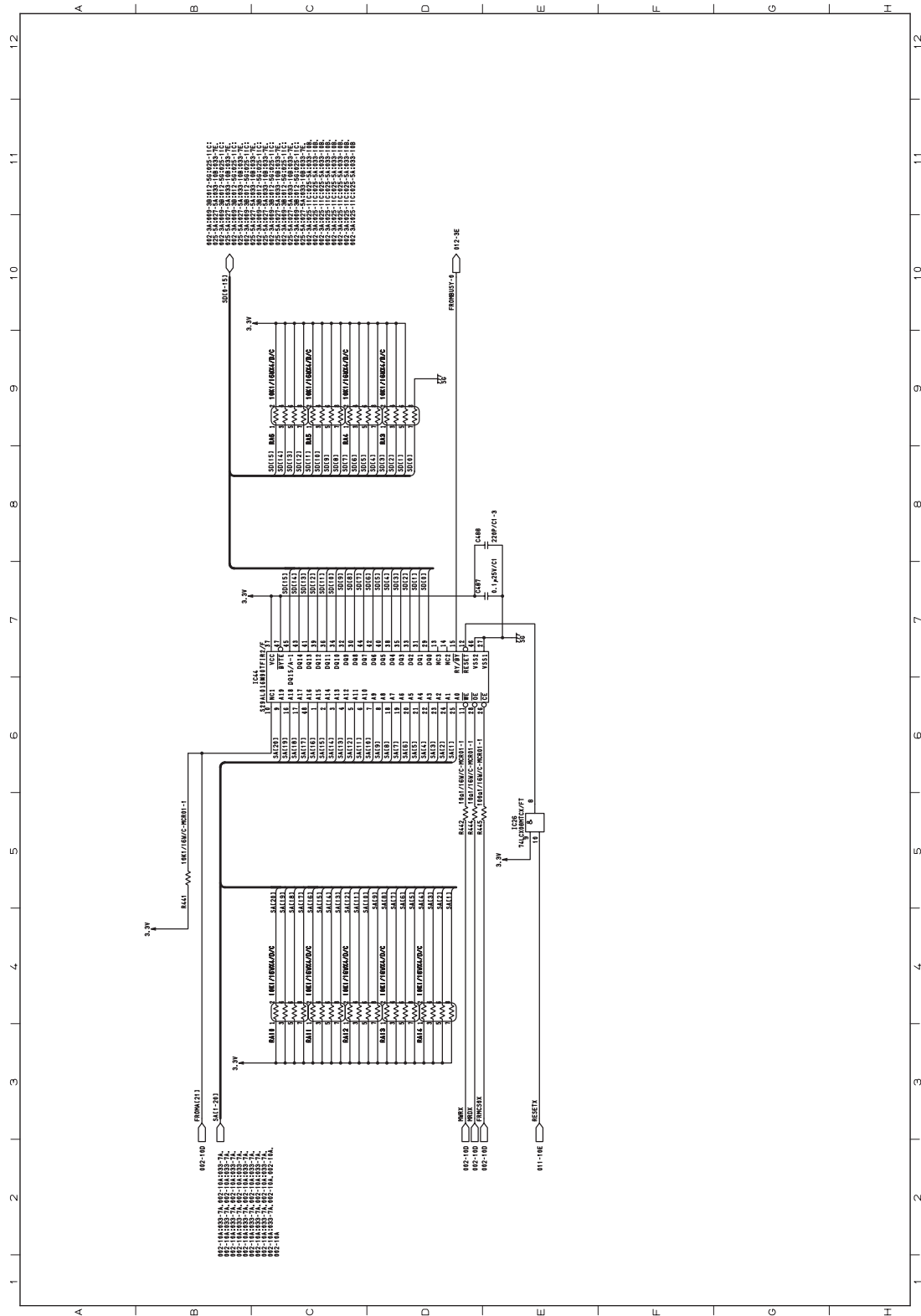

Fig. 3-70

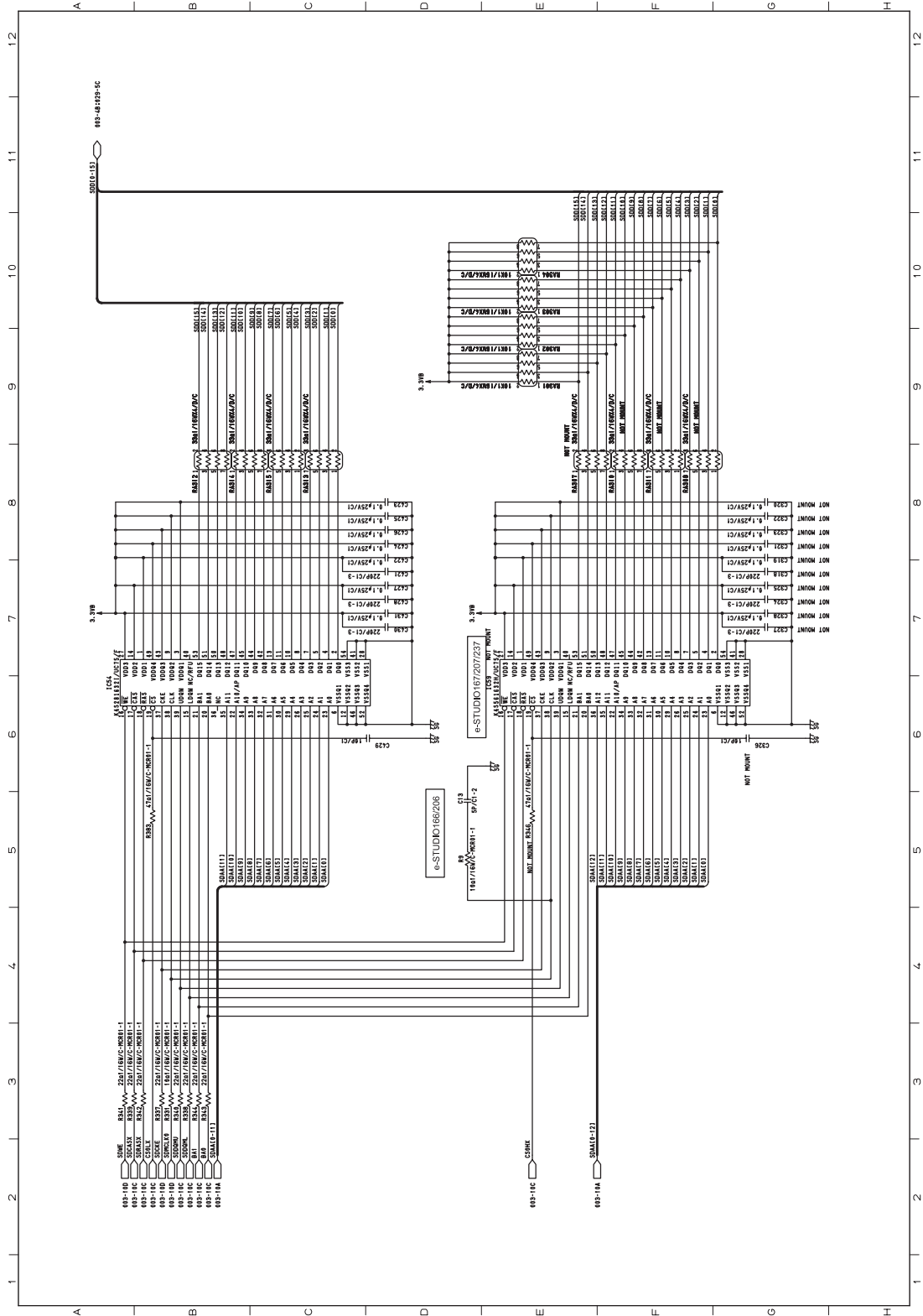

Fig. 3-71

MAIN board 9/34

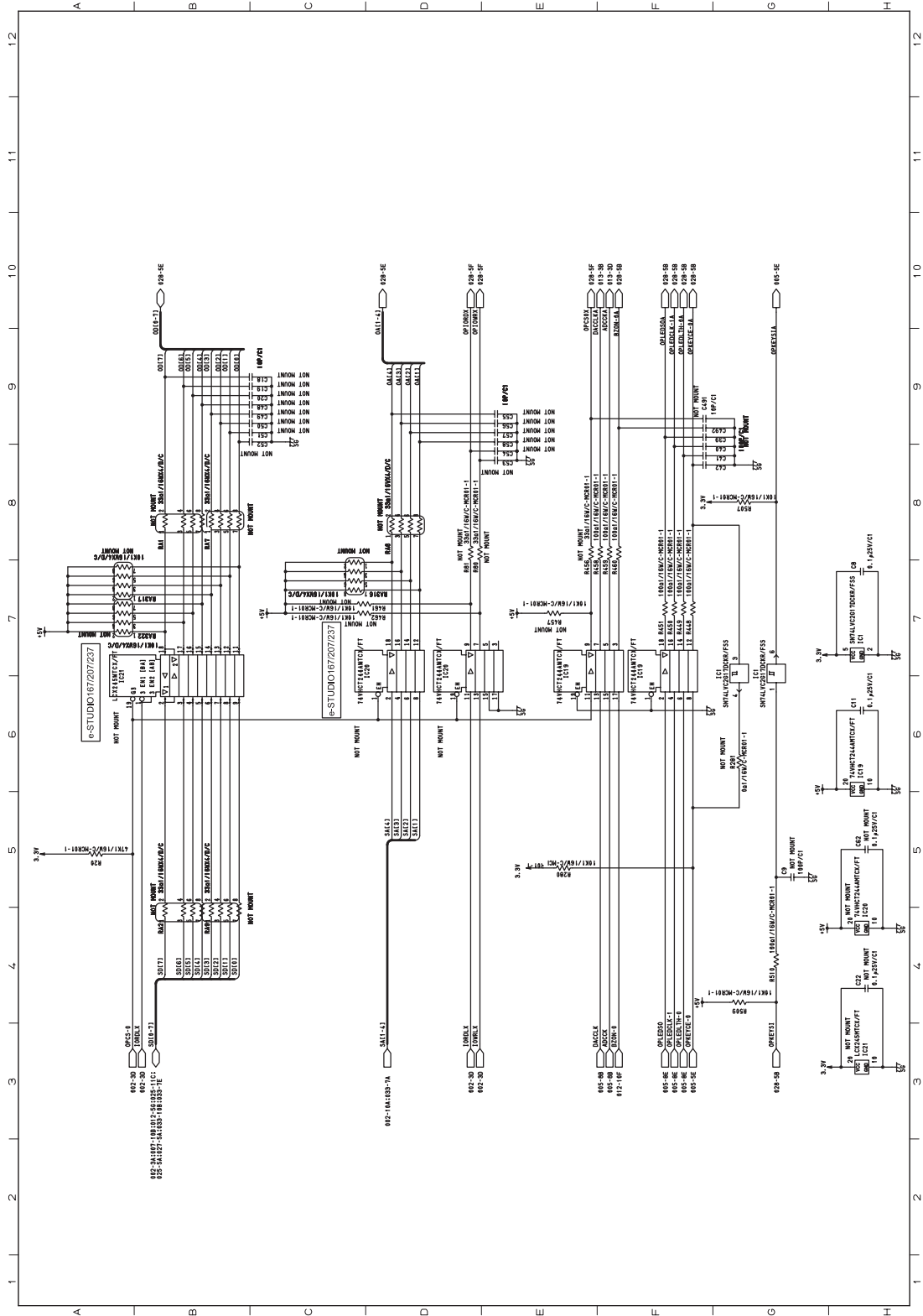

Fig. 3-72

MAIN board 10/34

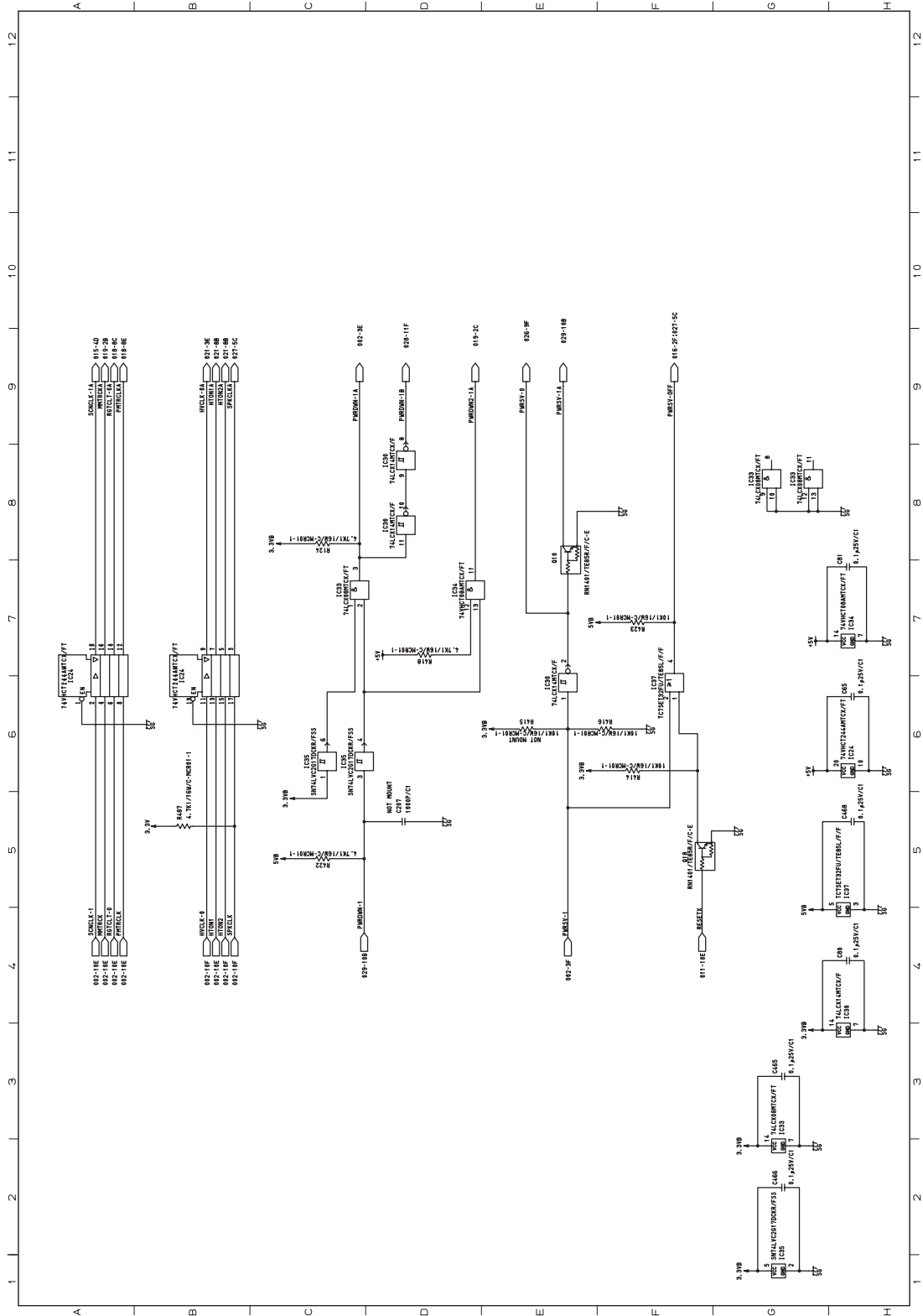

Fig. 3-73



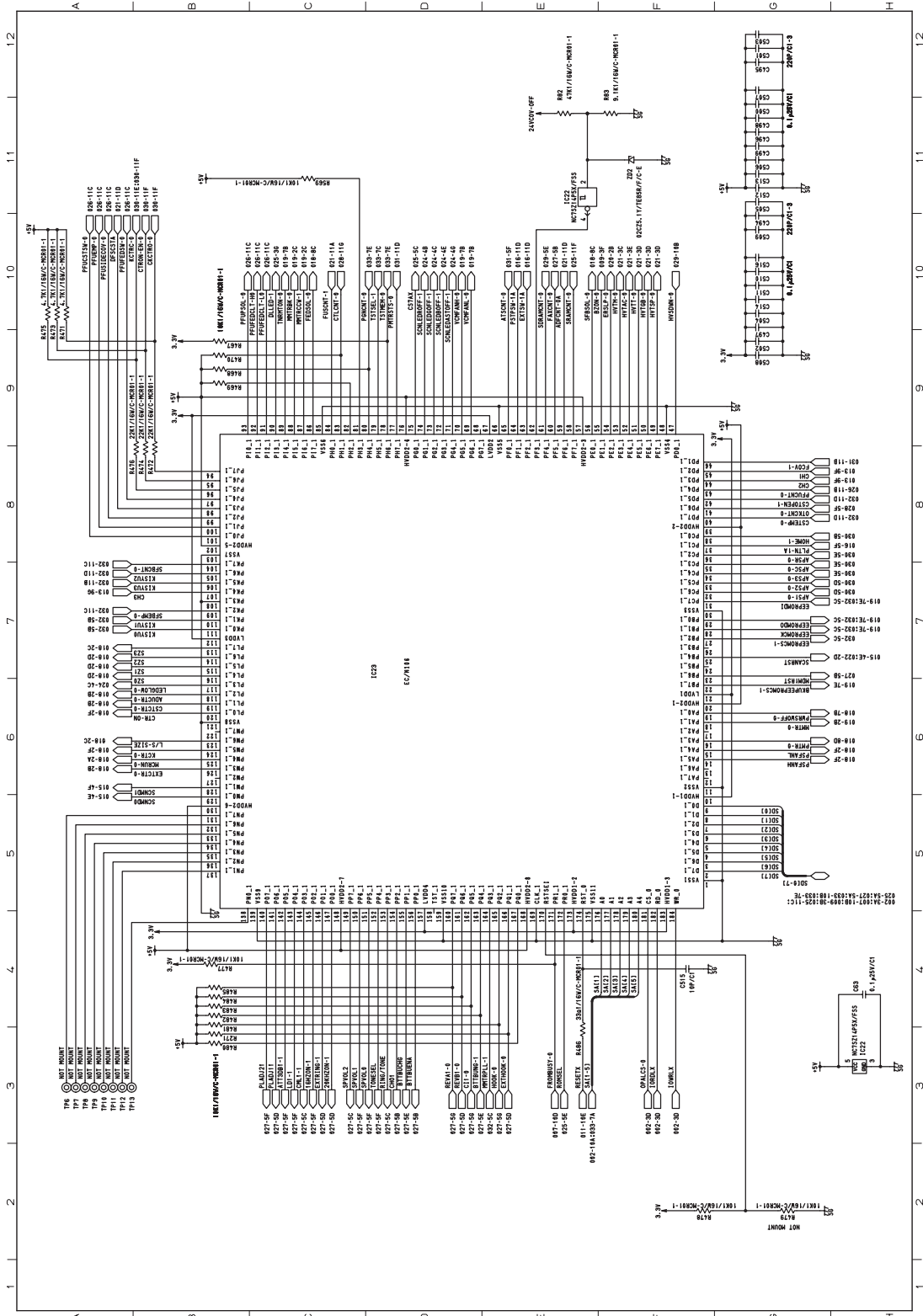

Fig. 3-75

MAIN board 13/34

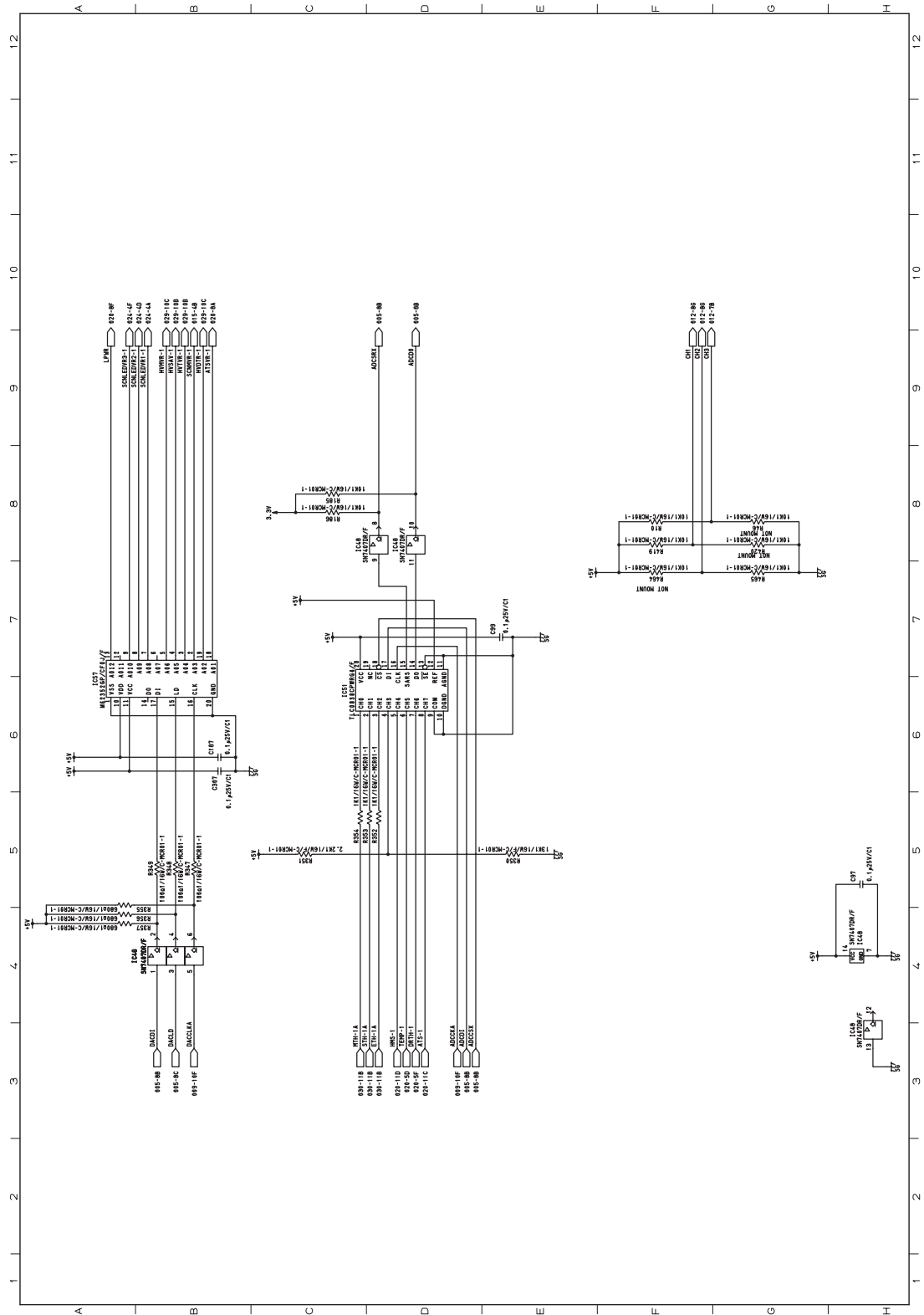

Fig. 3-76

MAIN board 14/34

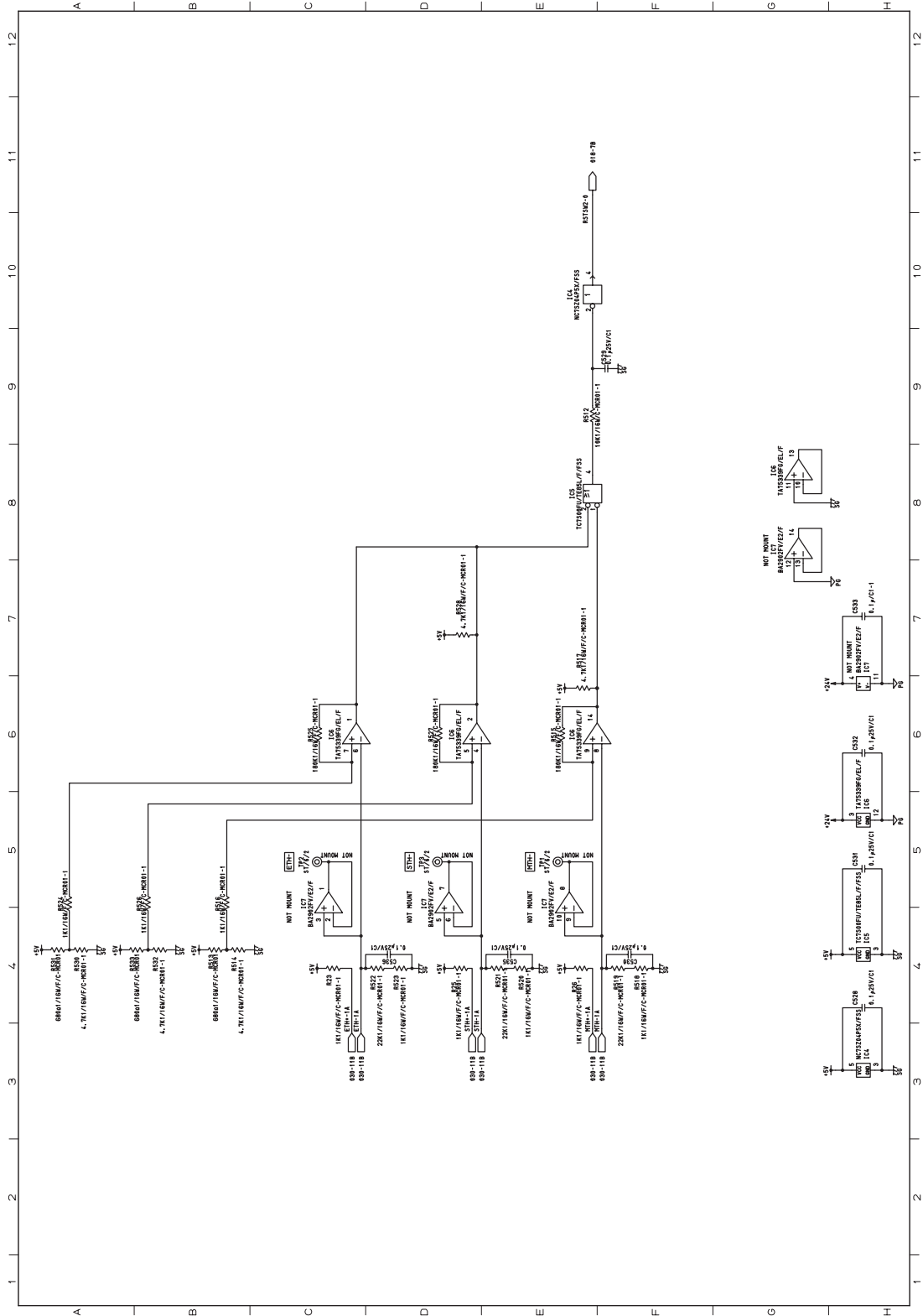

Fig. 3-77



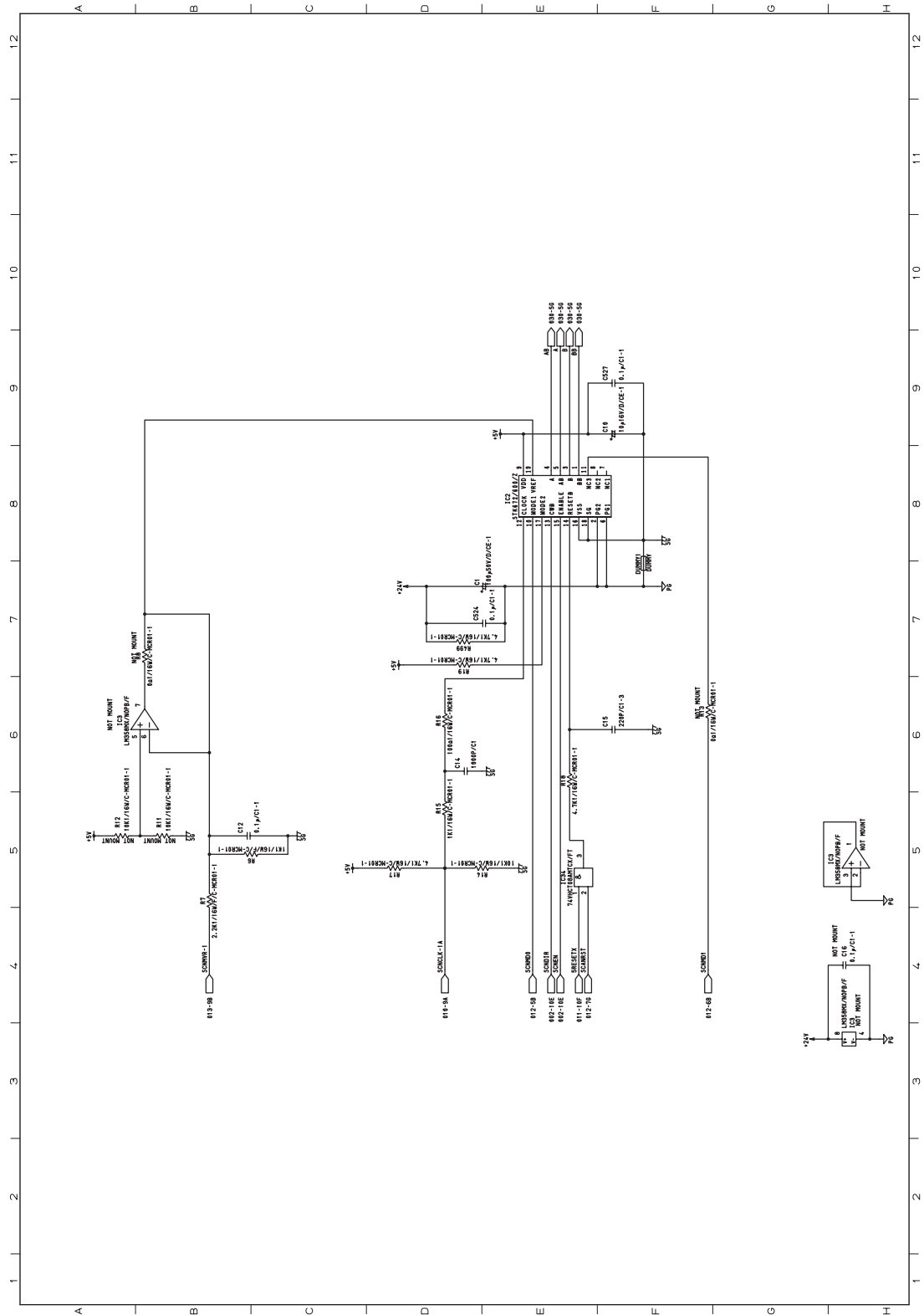

Fig. 3-78



MAIN board 17/34

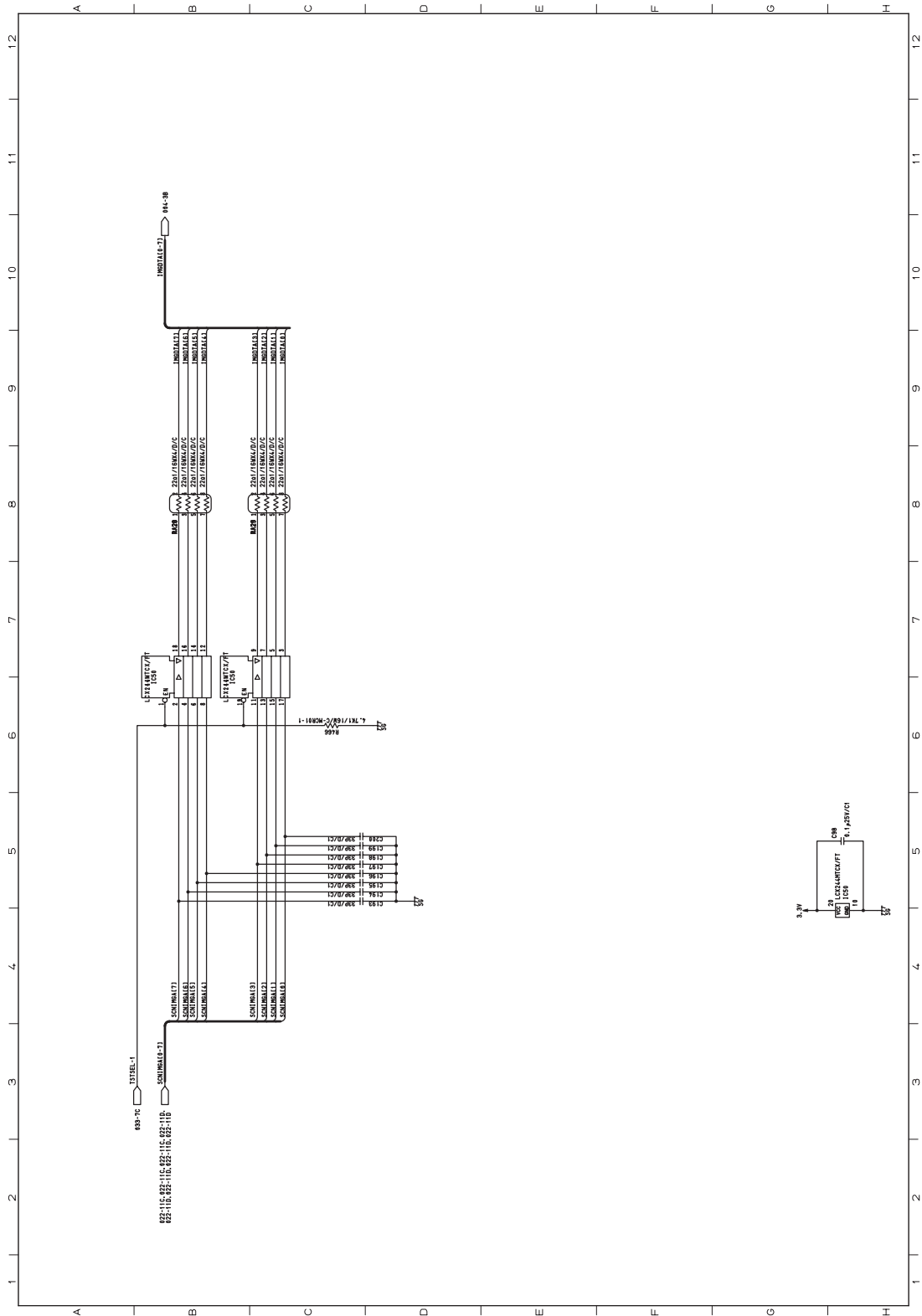

Fig. 3-80









MAIN board 22/34

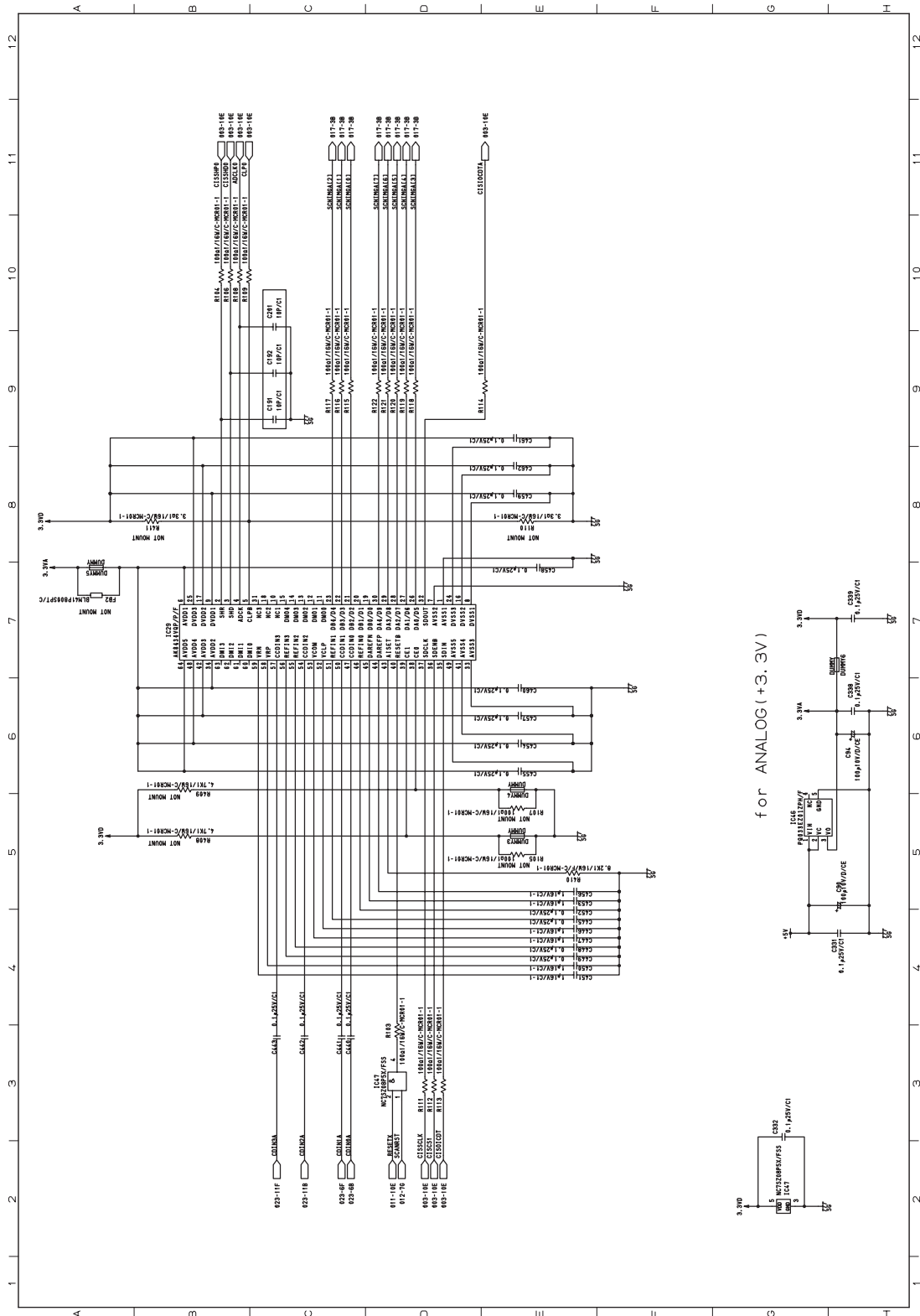

Fig. 3-85



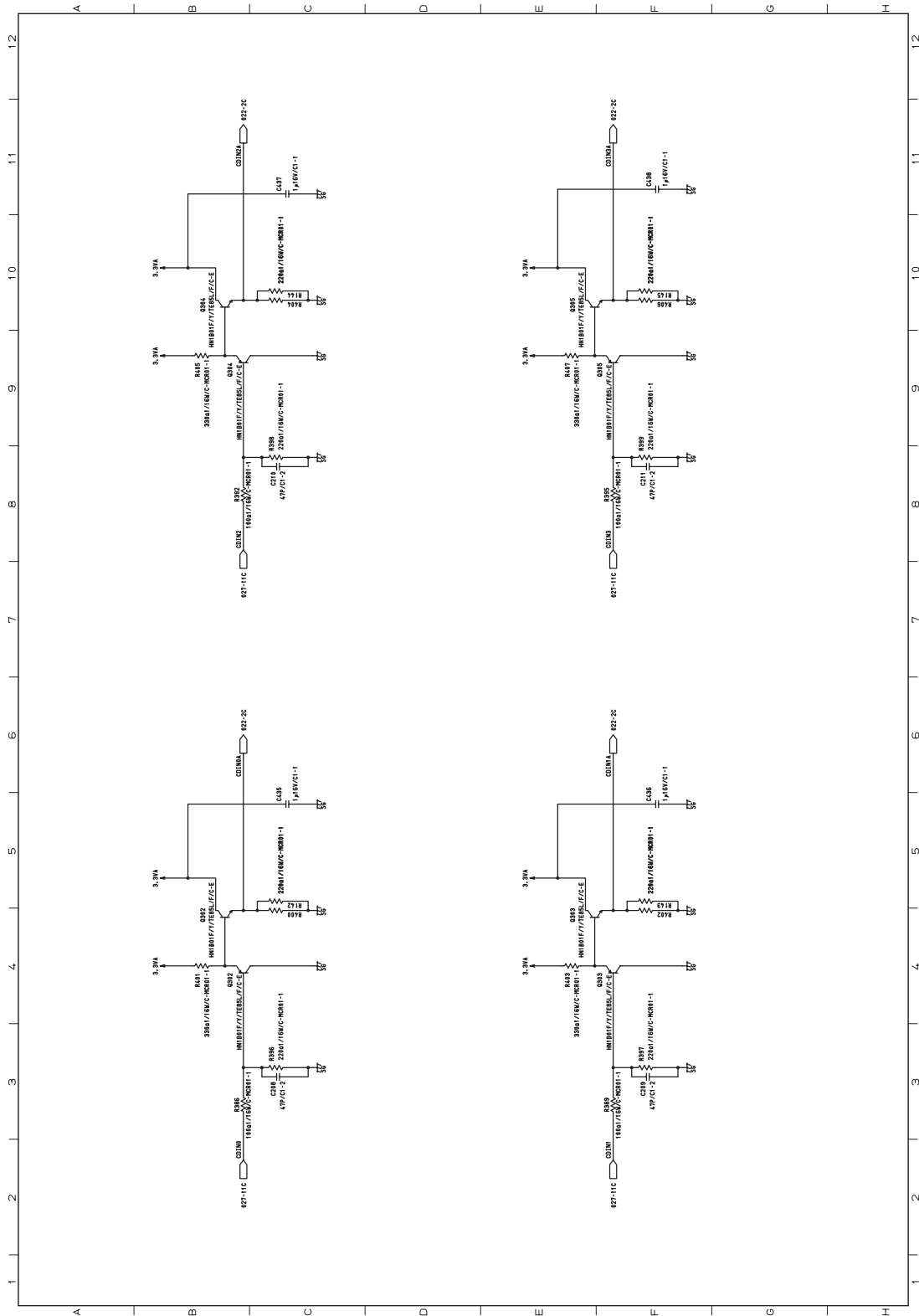

Fig. 3-86



MAIN board 24/34

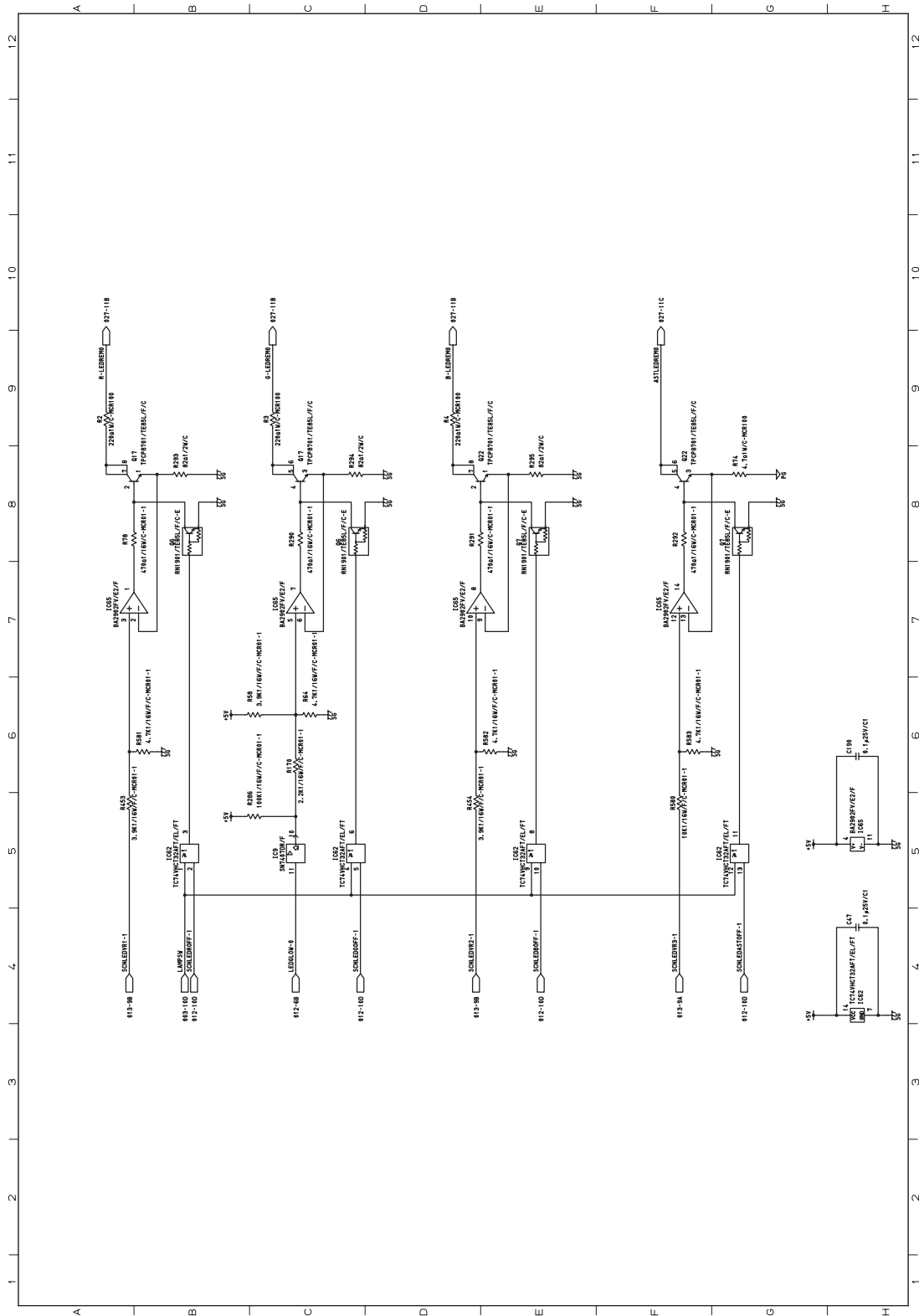

Fig. 3-87

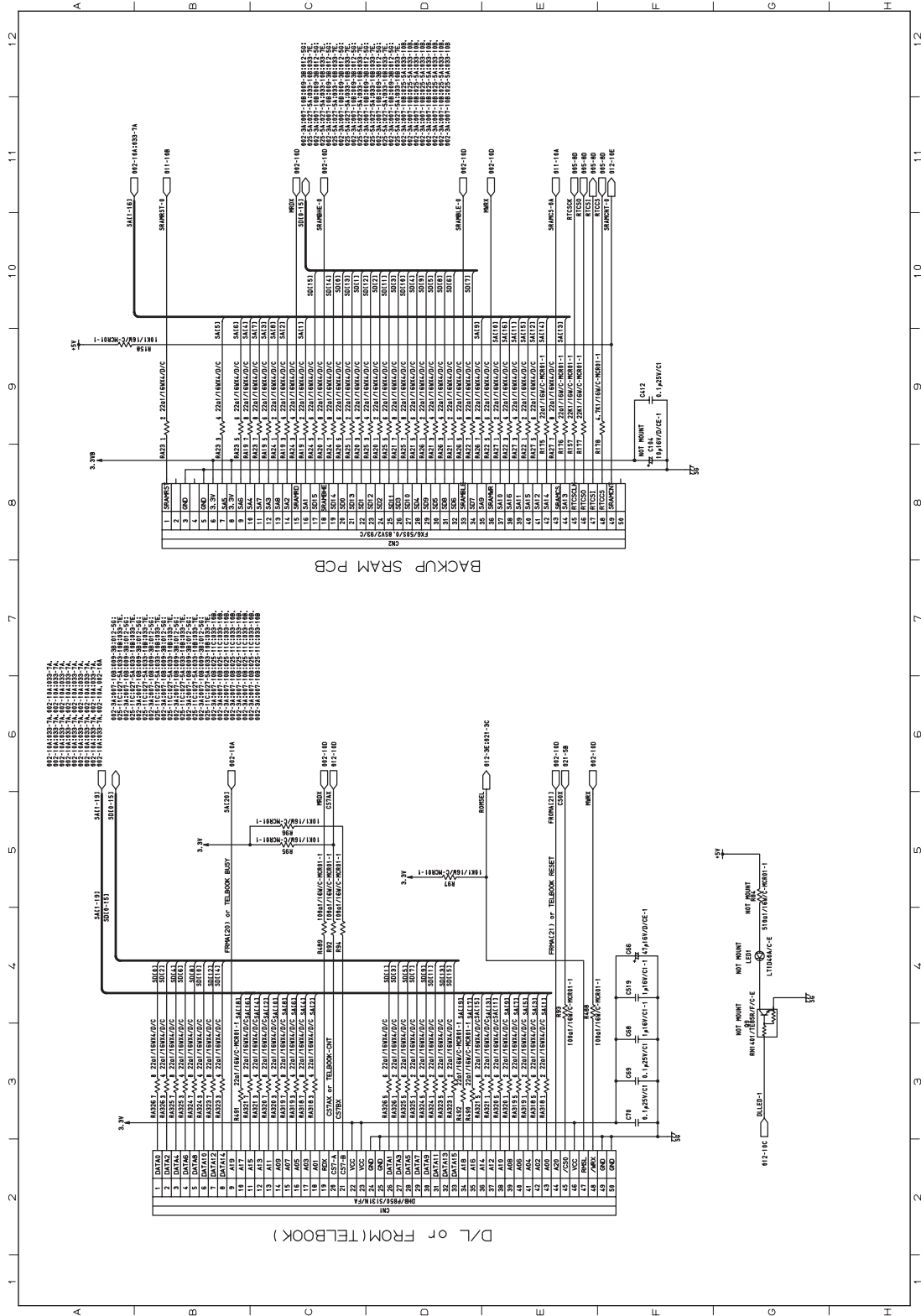

Fig. 3-88

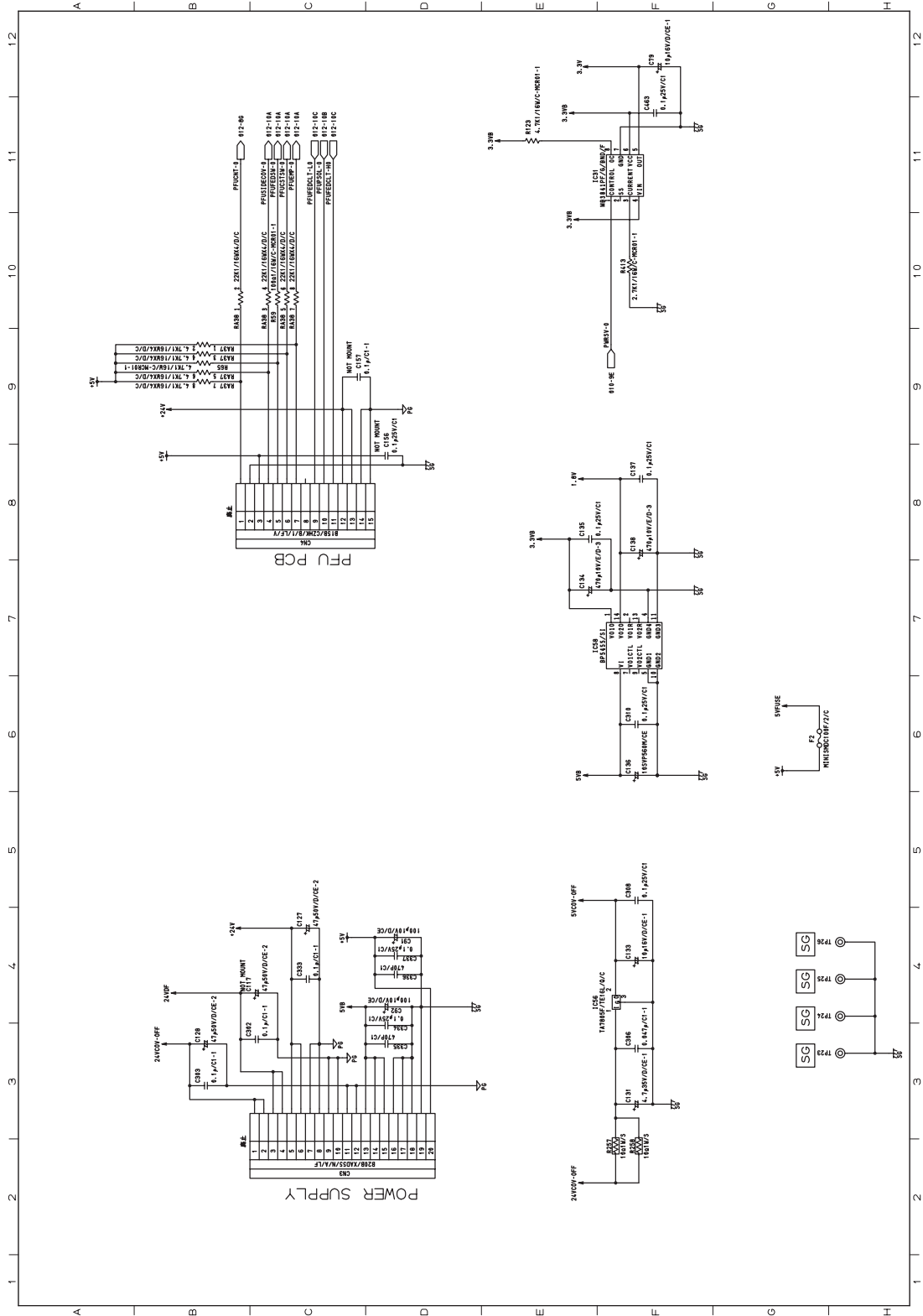

Fig. 3-89

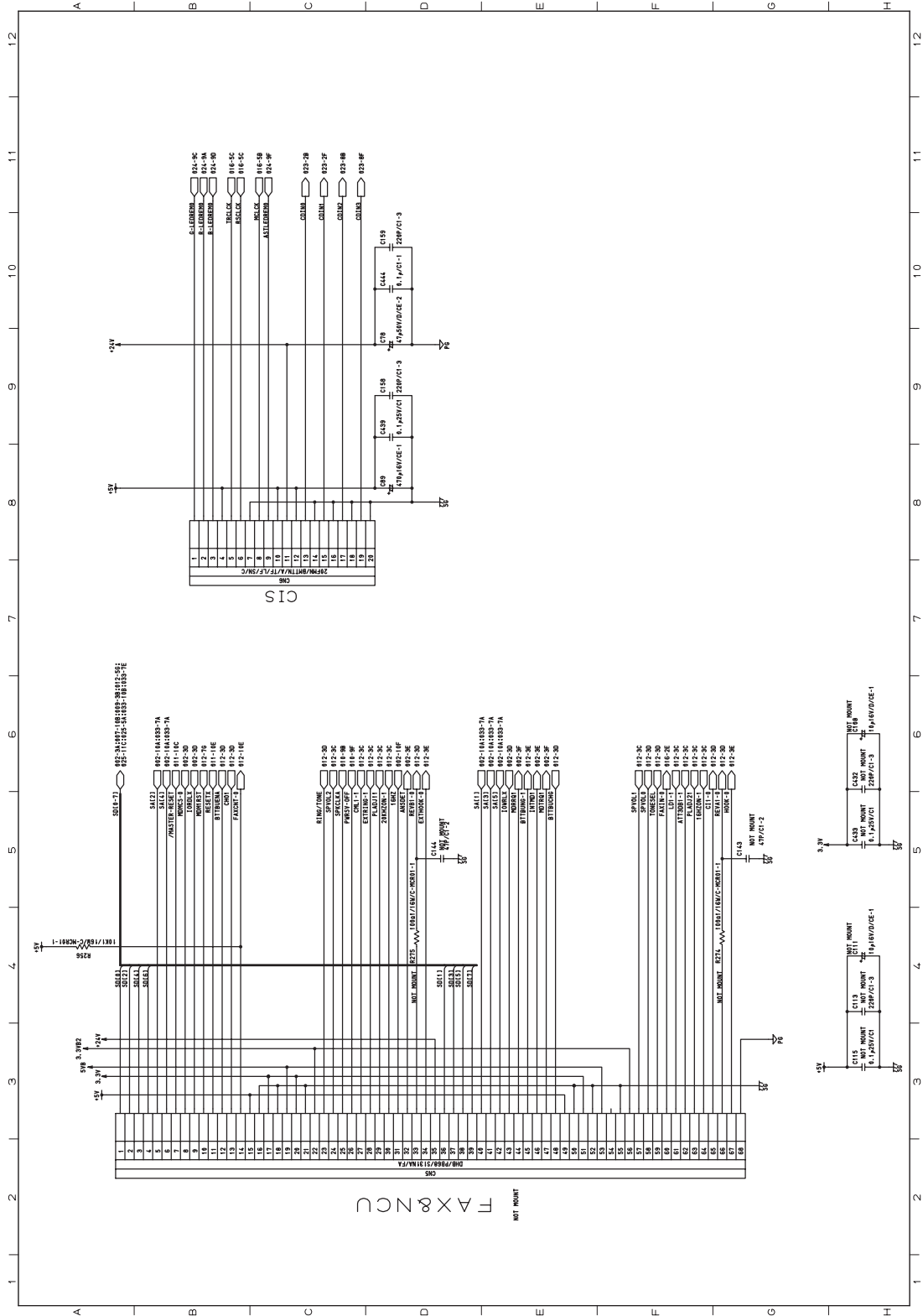

Fig. 3-90





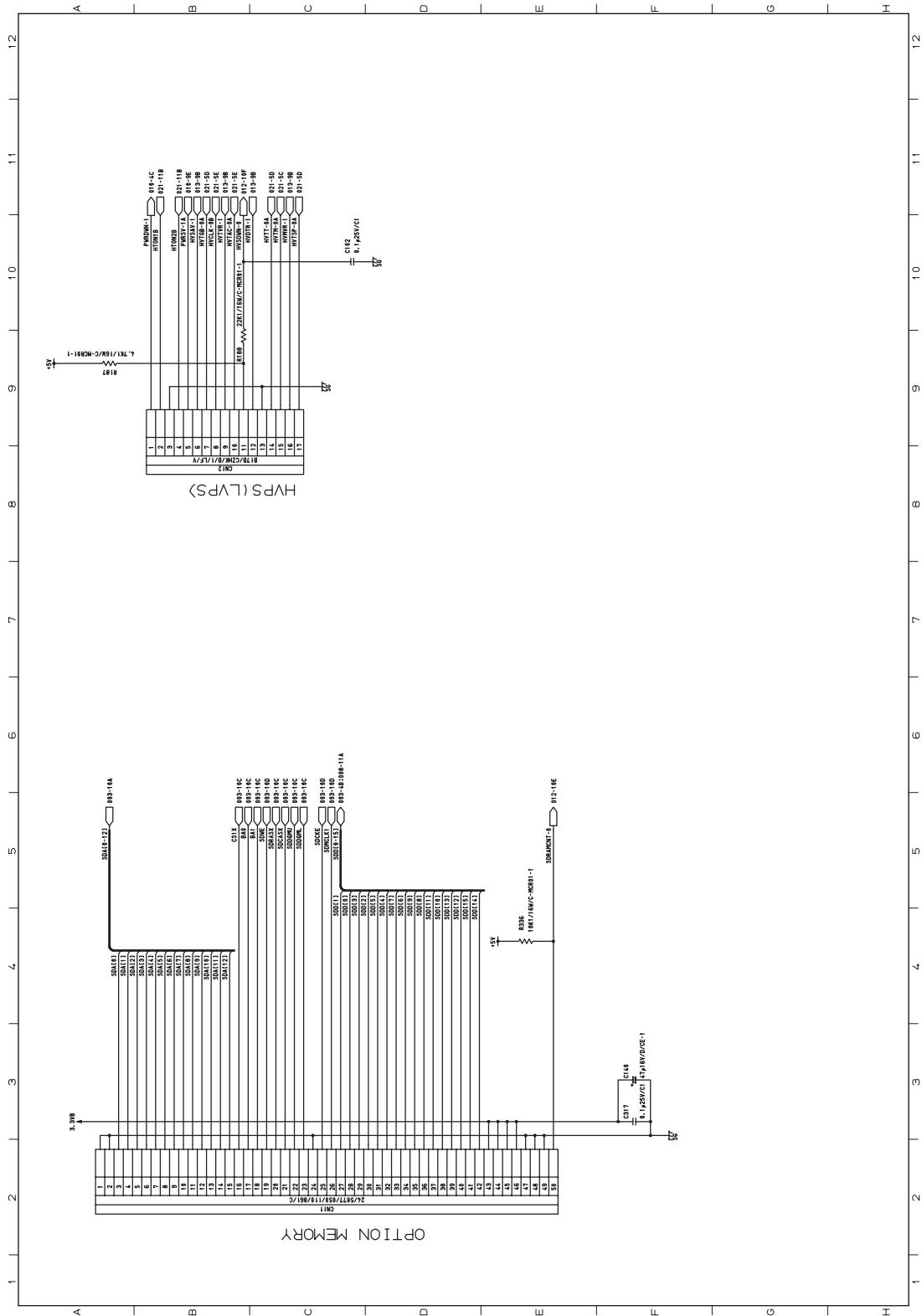

Fig. 3-92

MAIN board 30/34

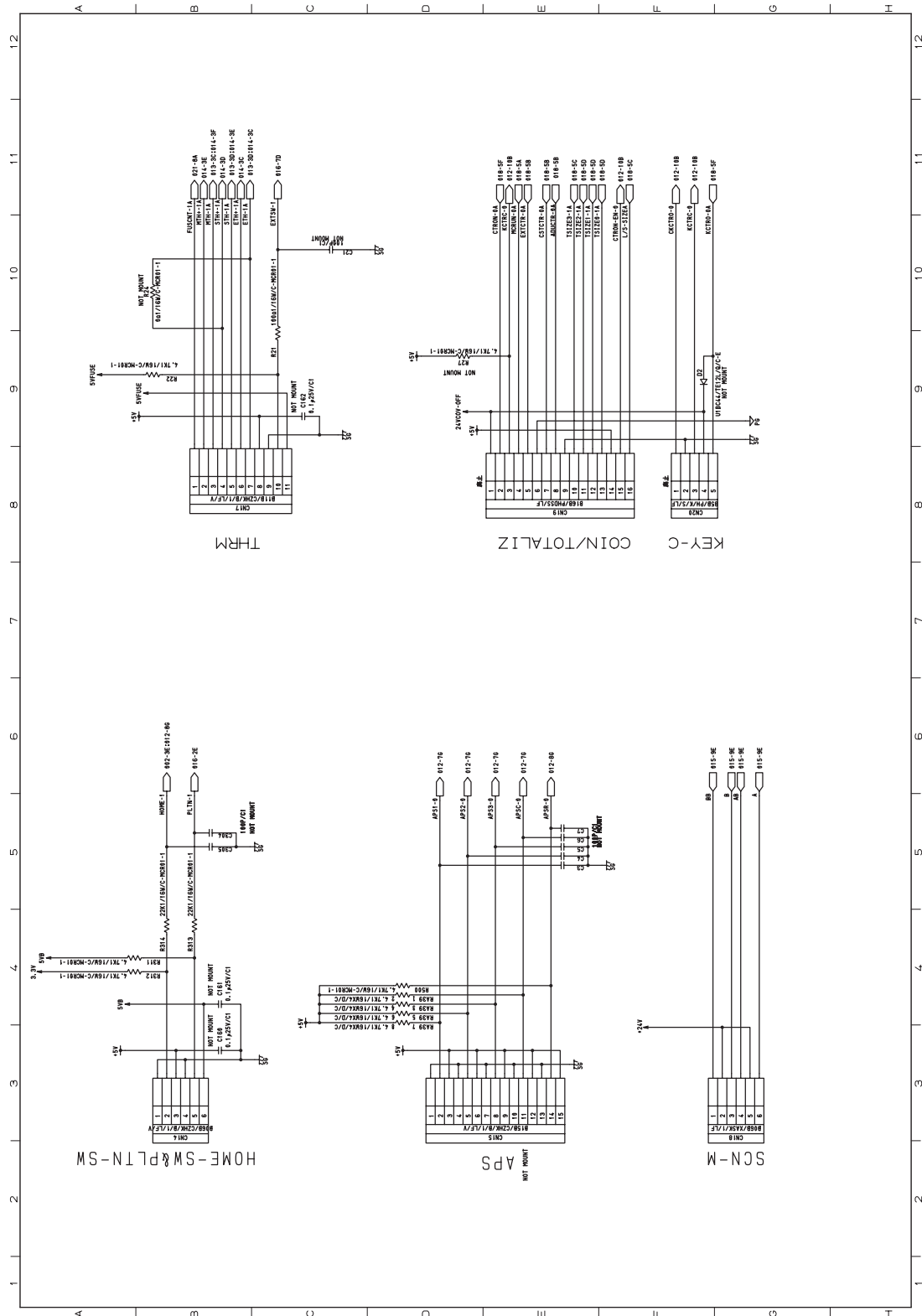

Fig. 3-93



MAIN board 31/34

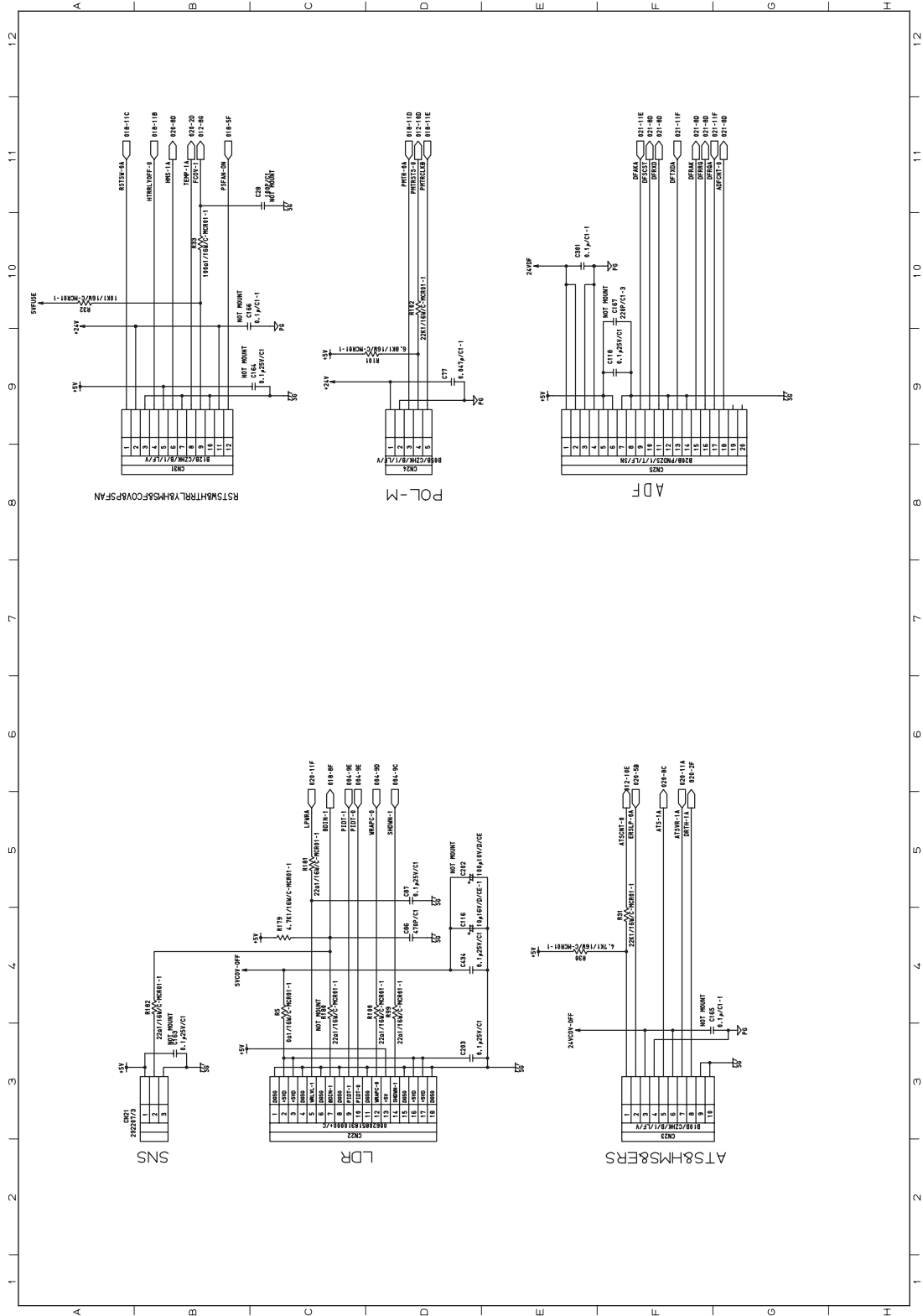

Fig. 3-94



MAIN board 32/34

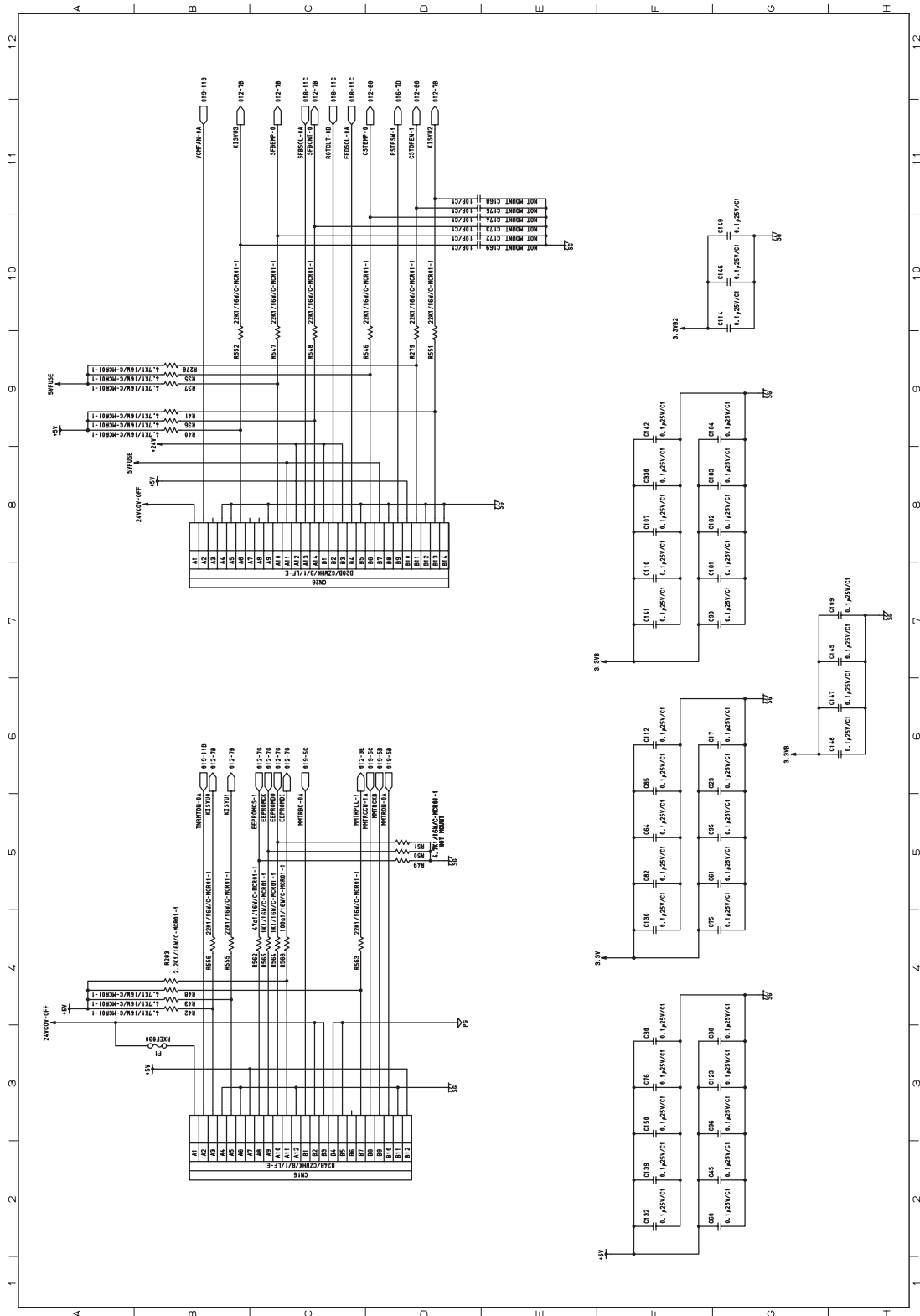

Fig. 3-95

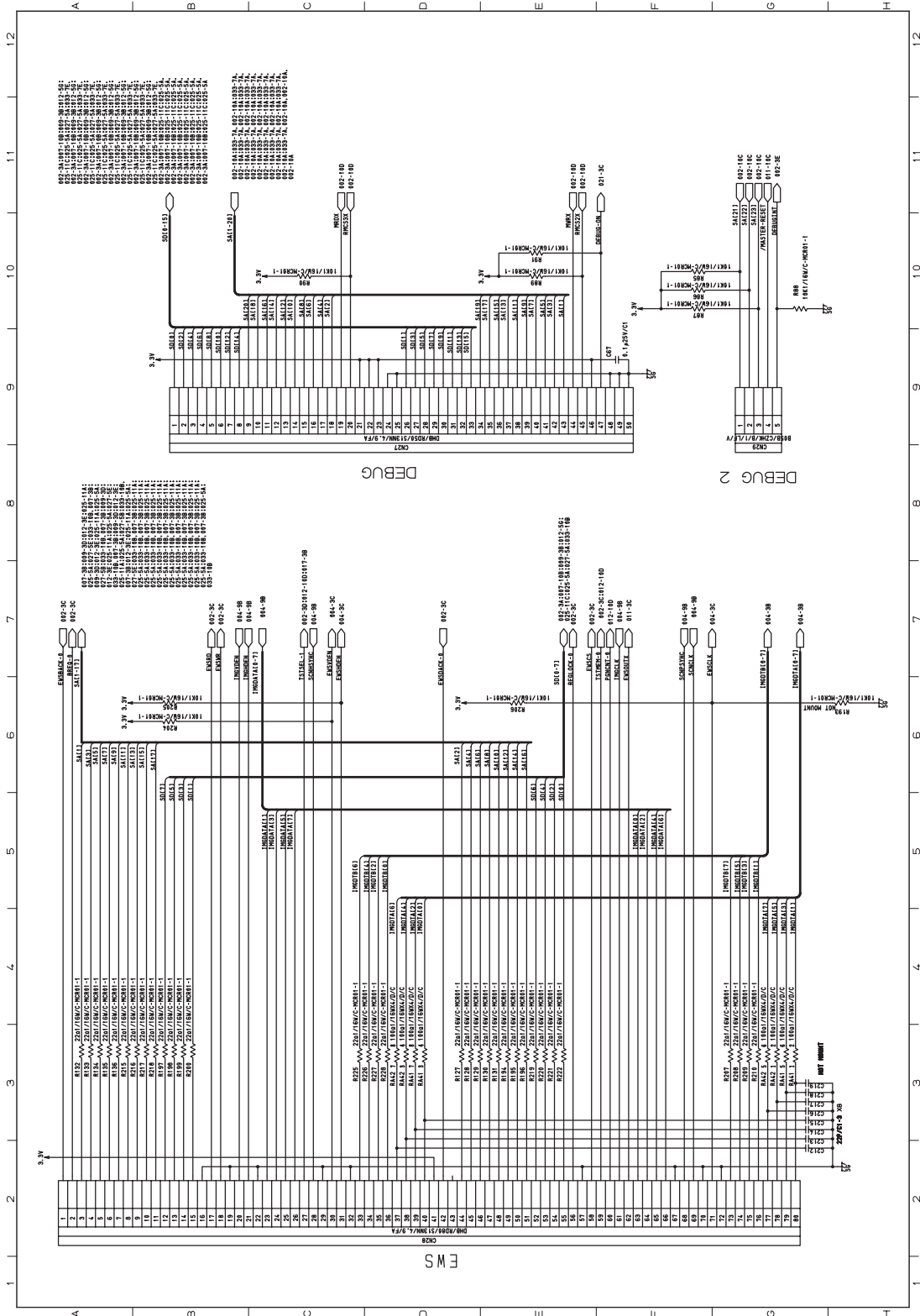

Fig. 3-96

MAIN board 34/34

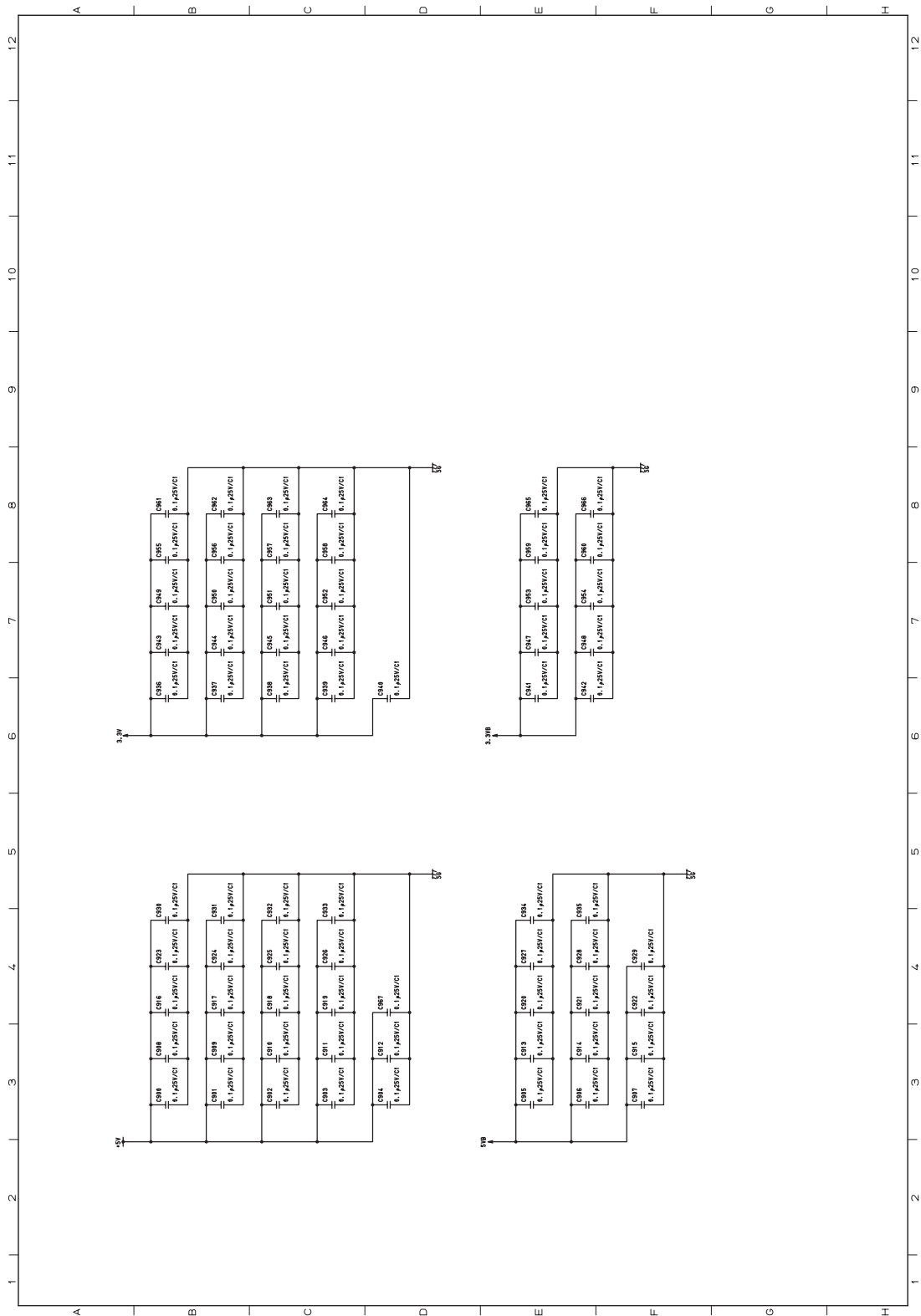

Fig. 3-97

### 3.16 Main circuit (MAIN board: e-STUDIO167/207/237)

MAIN board 1/35

Sheet No.	Index	018	019
001		AFE-SOC IF&APS-PS	COUNTER&FAN&RGT-CLT&PS-SW RESET&SOL DRIVER&POL-M DRIVER&BD
002	SOC 1	MAIN-M&TNR-M&VCM-FAN DRIVER&BKUPEEPROM	
003	SOC 2	ERS&HNS&ATS&LPWR&HVTVR	
004	SOC 3	D/LorTELBOOK&HVT IF&HTR&ADF IF	
005	SOC 4	AFE	
006	SOC 5	CIS IMAGE DATA IF	
007	FROM	CIS-LED DRIVER	
008	SDRAM	CONNECTOR (D/L ROMor TELBOOK&BACKUP_SRAM)	
009	SDRAM2	CONNECTOR (PS&PFU) &PS-IC	
010	CONTROL PANEL IF&3.3V-5V IF	CONNECTOR (FAX&CIS)	
011	3.3V-5V IF&POWER DOWN&POWER SAVE	CONNECTOR (CONTROL PANEL&USB)	
012	RESET	CONNECTOR (OPTION_SDRAM&HVPS&PFC)	
013	OPAL (IO ASIC)	CONNECTOR (HOME_PLTN-SW&APS&SCN-M&THR&COUNTER)	
014	DAC&ADC& MODEL DISCRIMINATION	CONNECTOR (LSUB&DEV/MAIN-SW/FCOV/PS-FAN&POL-M&ADF)	
015	THERMISTOR CONTROL	CONNECTOR (MAIN-M&TNR-M&VCM-FAN&etc.)	
016	SCAN-MOTOR DRIVER	CONNECTOR (EWS&DEBUG)	
017	CIS IF&WAKE UP&PFC IF	DEMITASNX CAPACITORS	

F286/287/288  
Main Board Circuit Diagram

Fig. 3-98



MAIN board 2/35

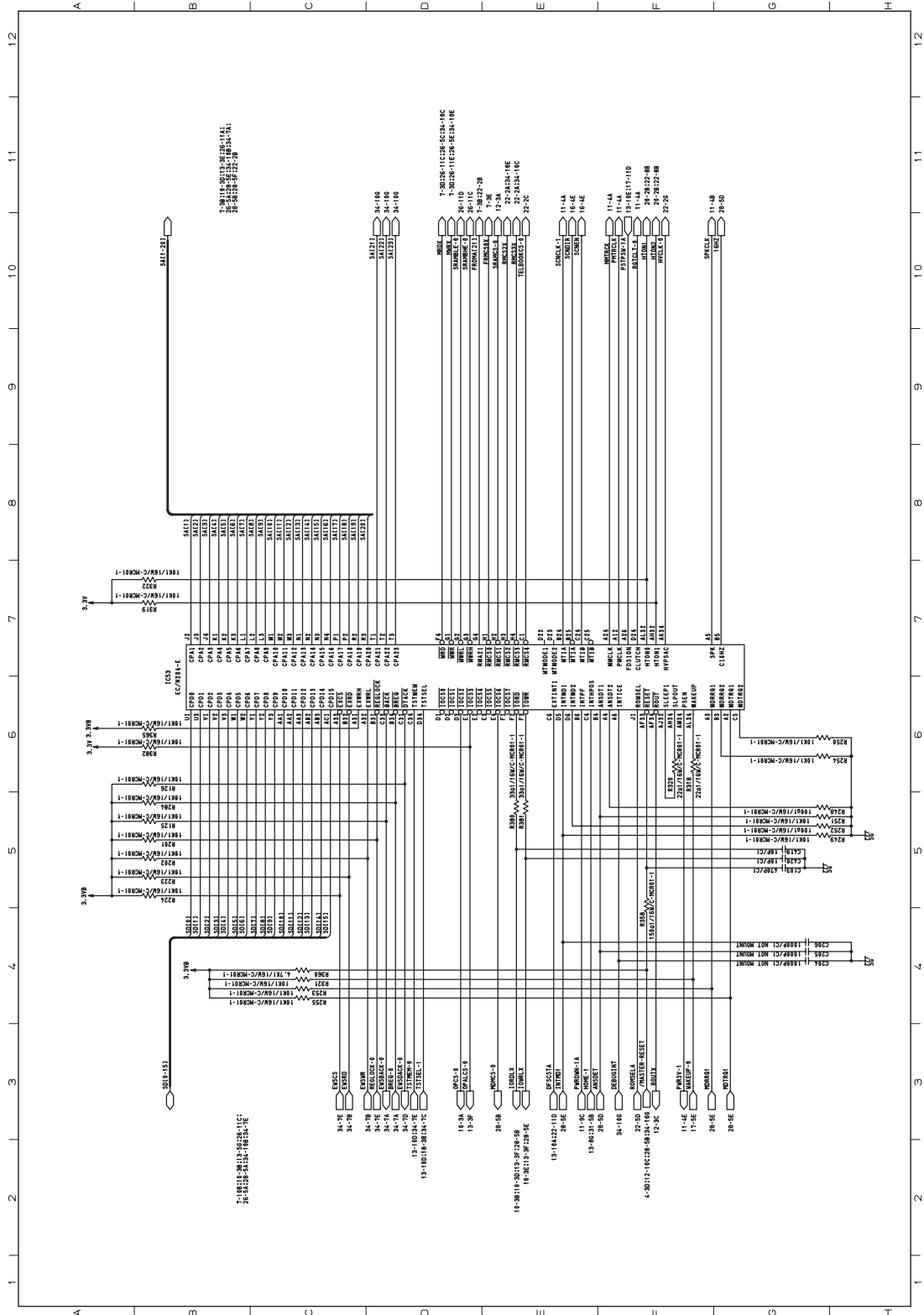

Fig. 3-99







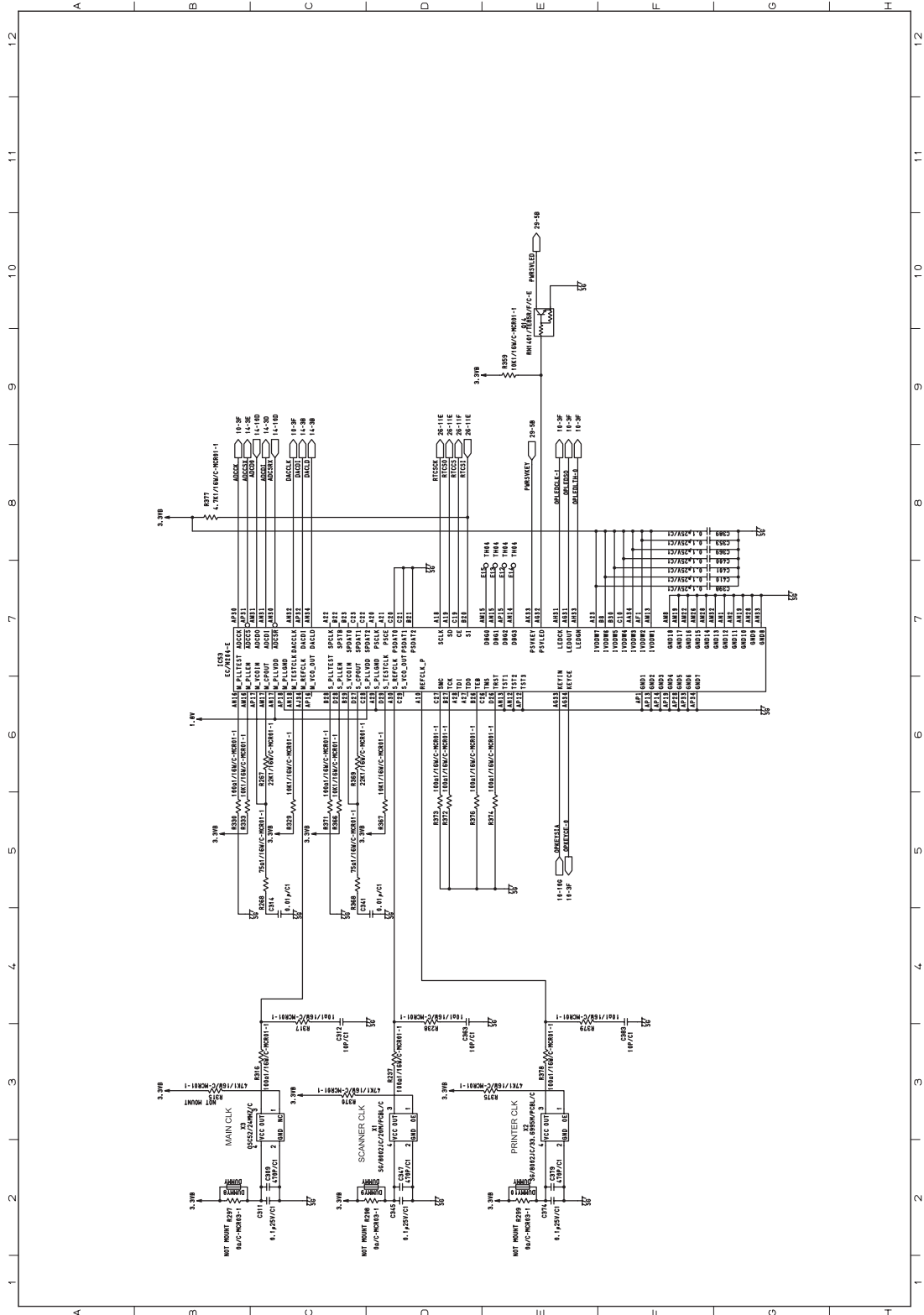
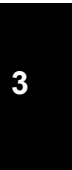

Fig. 3-102



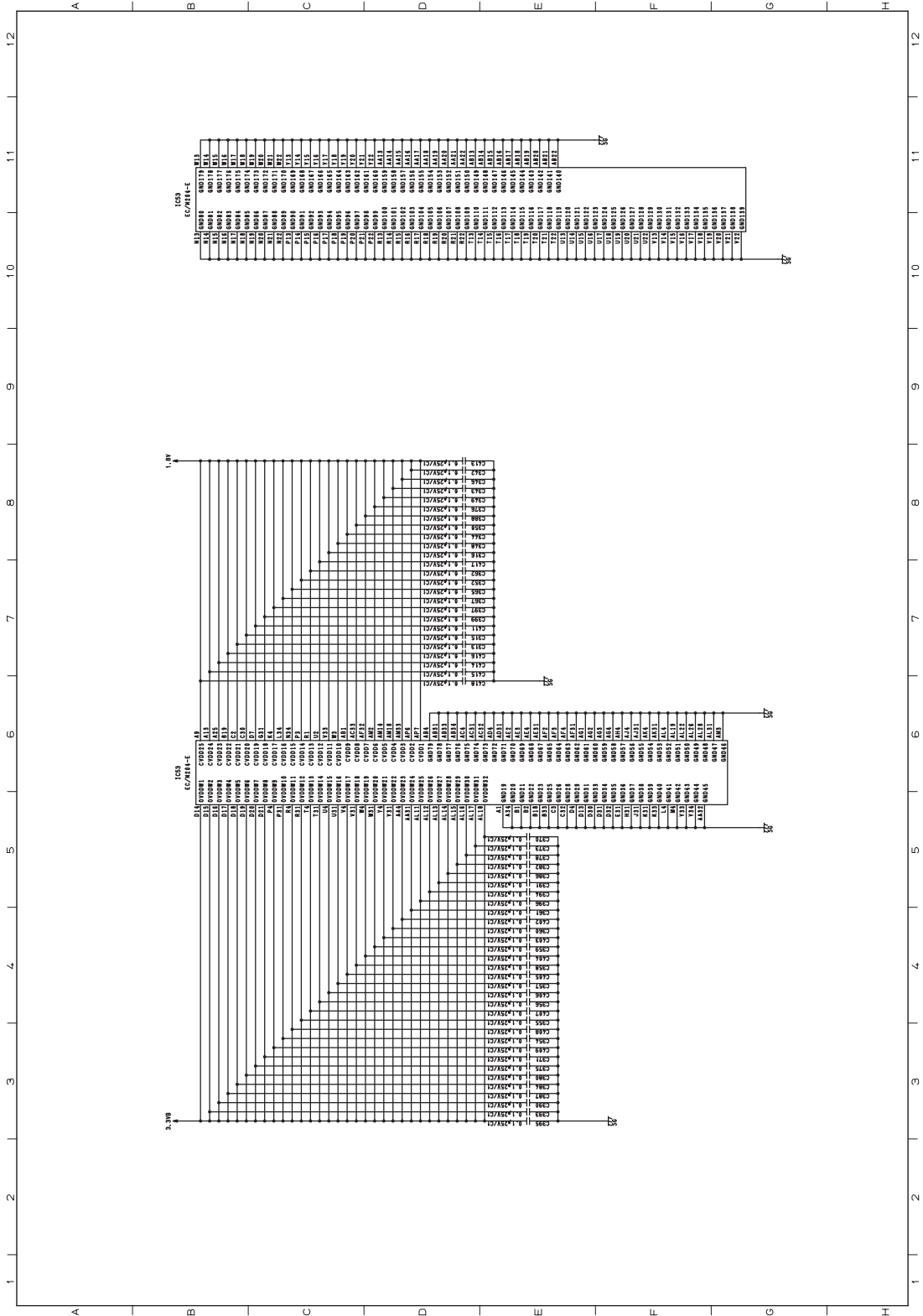

Fig. 3-103

MAIN board 7/35

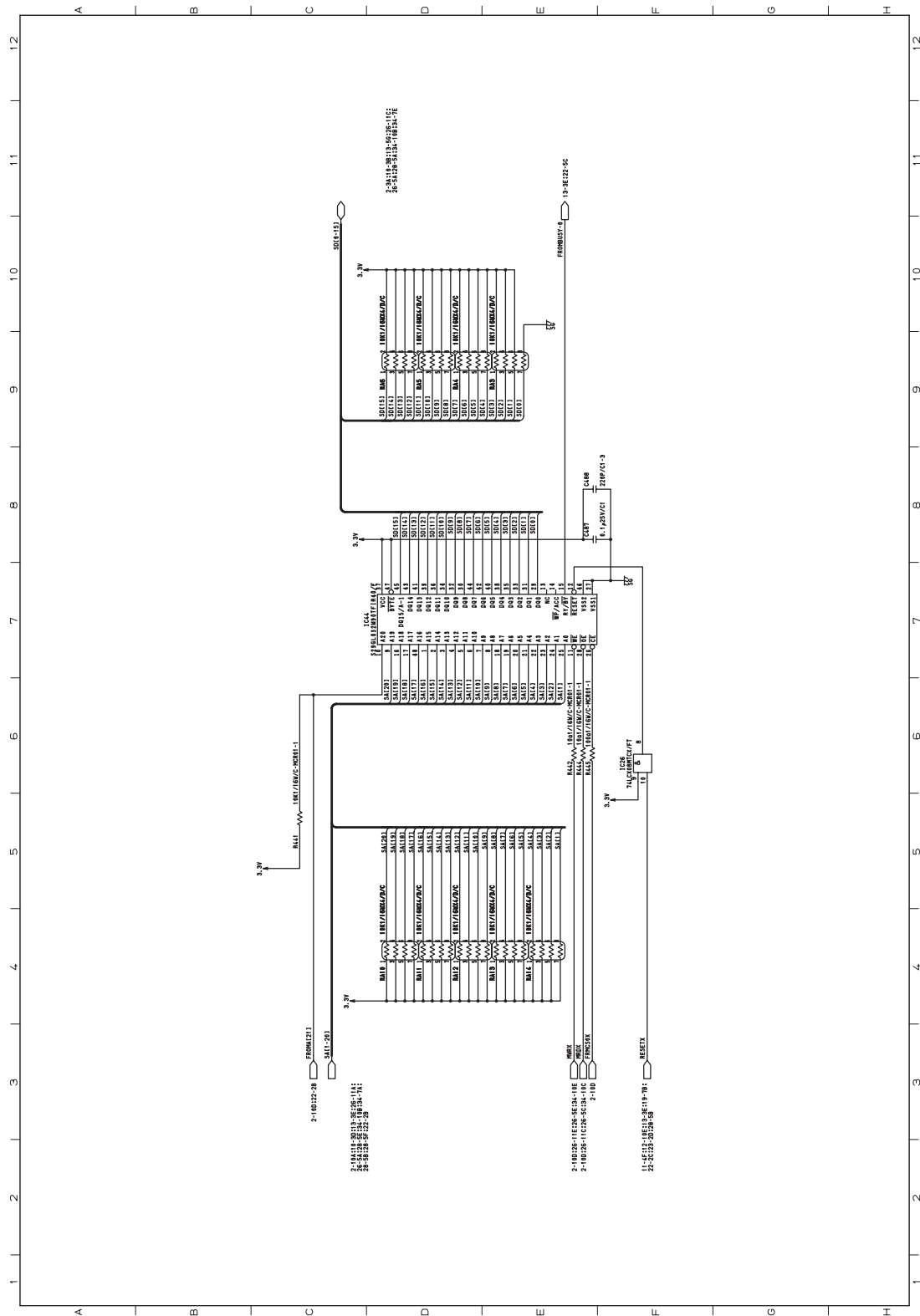

Fig. 3-104

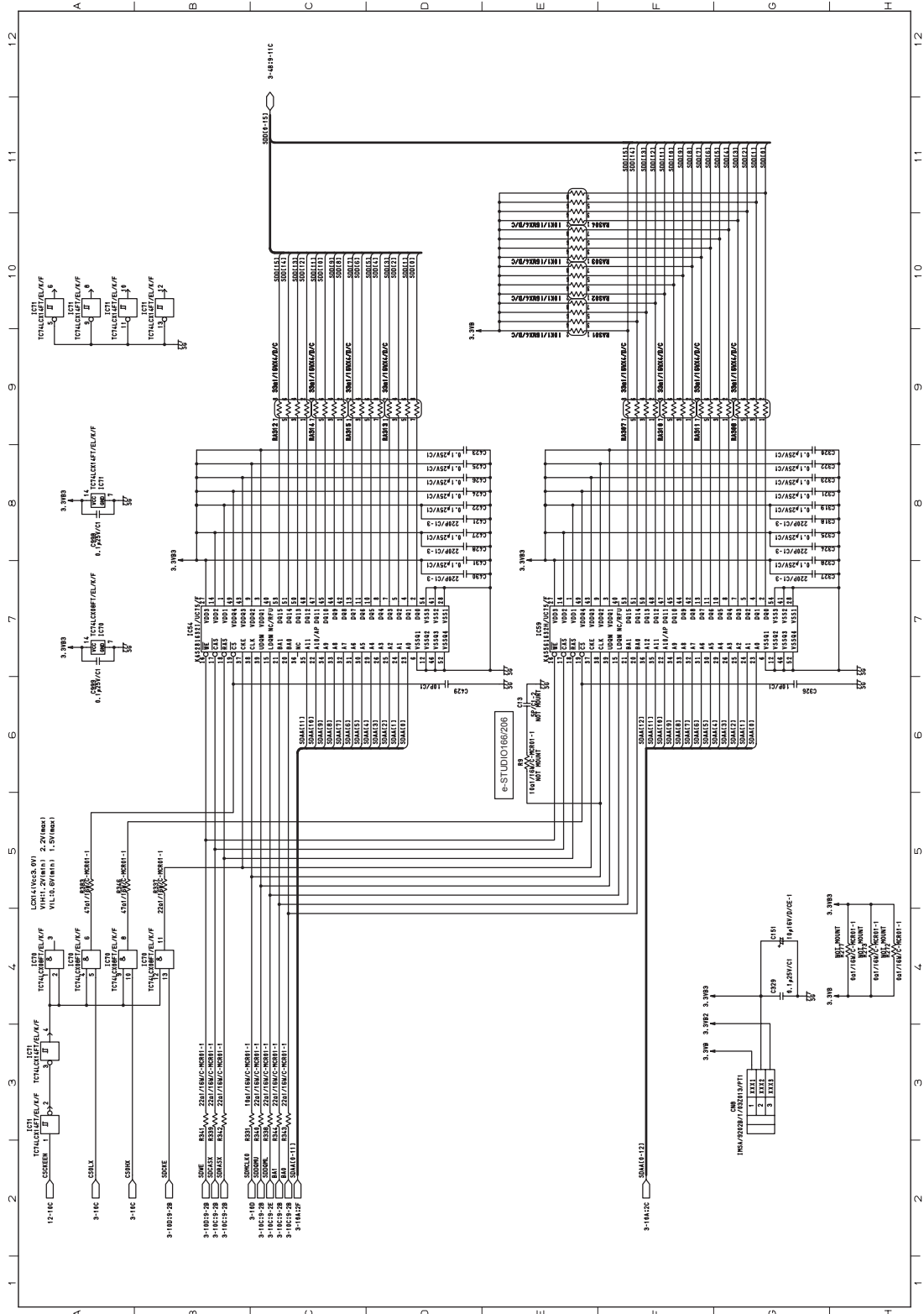

Fig. 3-105



MAIN board 10/35

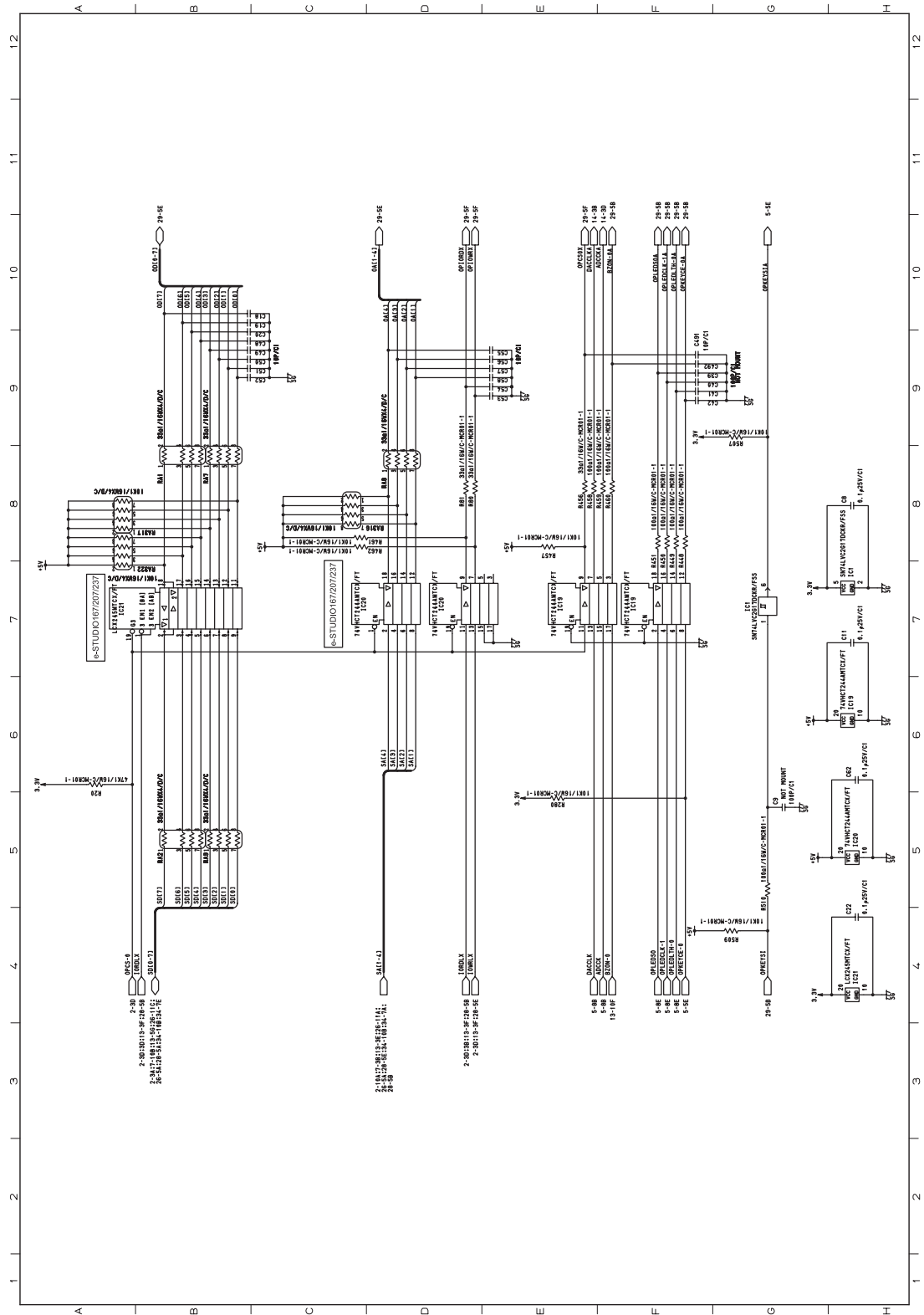

Fig. 3-107

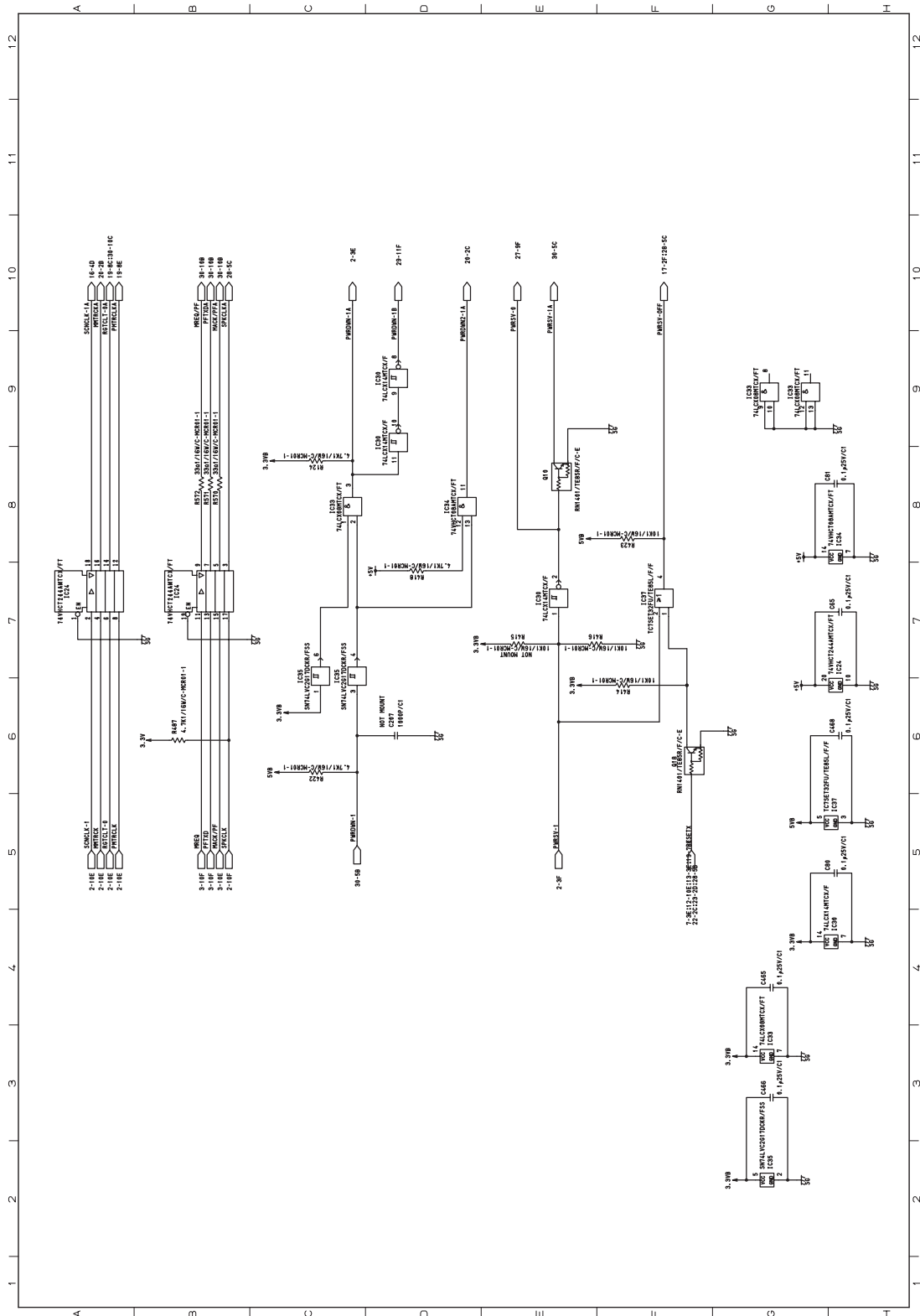

Fig. 3-108



MAIN board 12/35

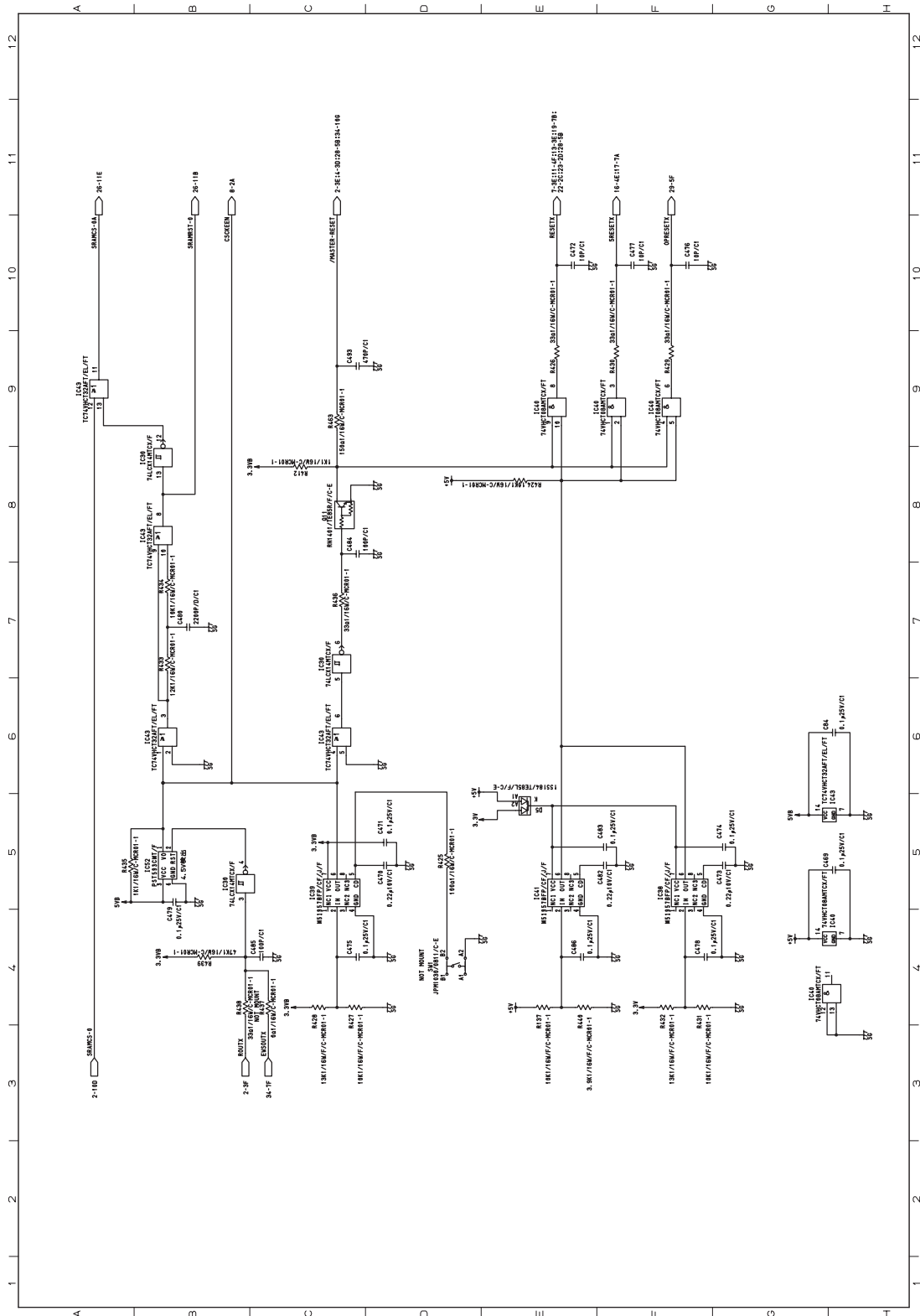

Fig. 3-109



MAIN board 13/35

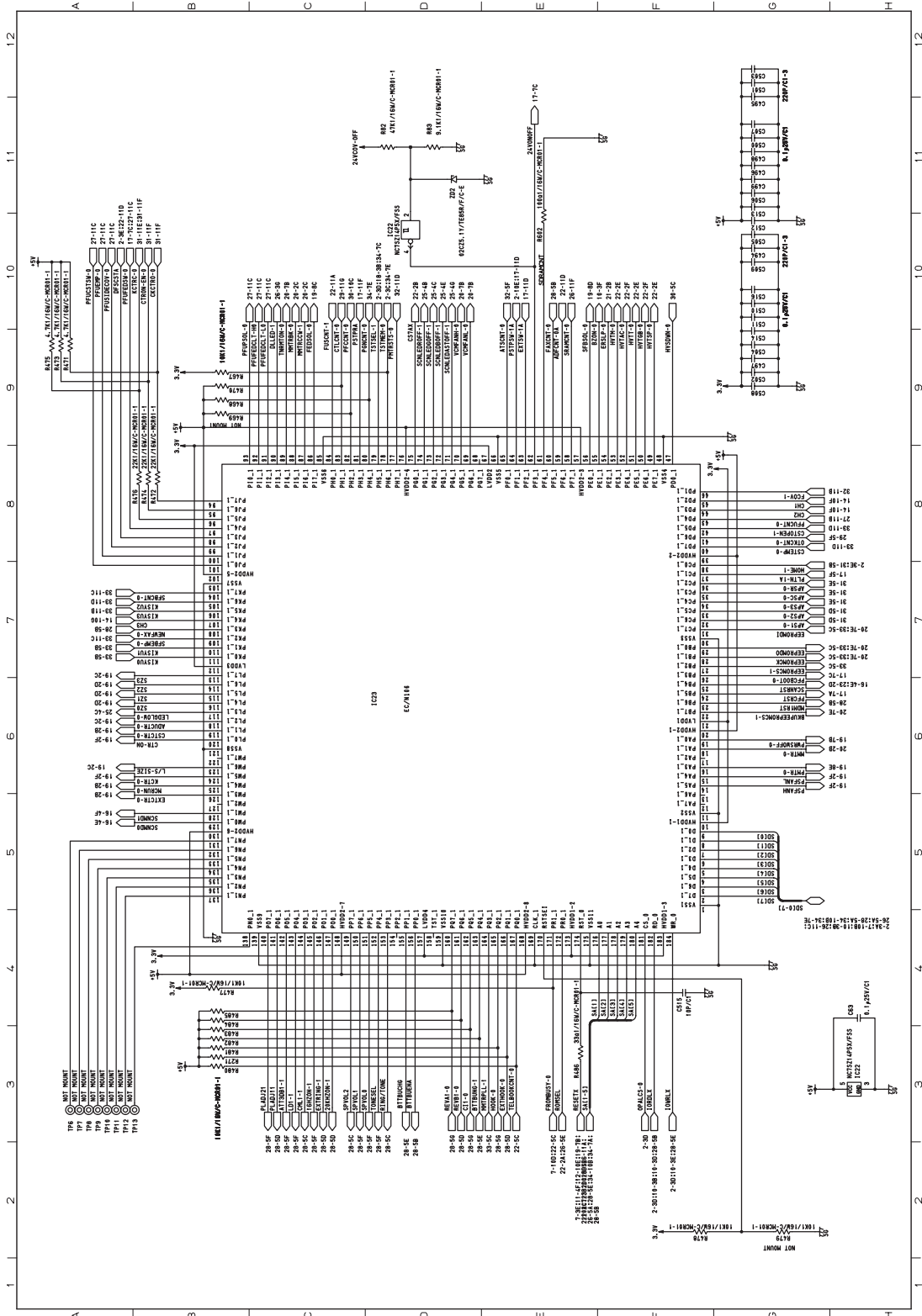

Fig. 3-110



MAIN board 14/35

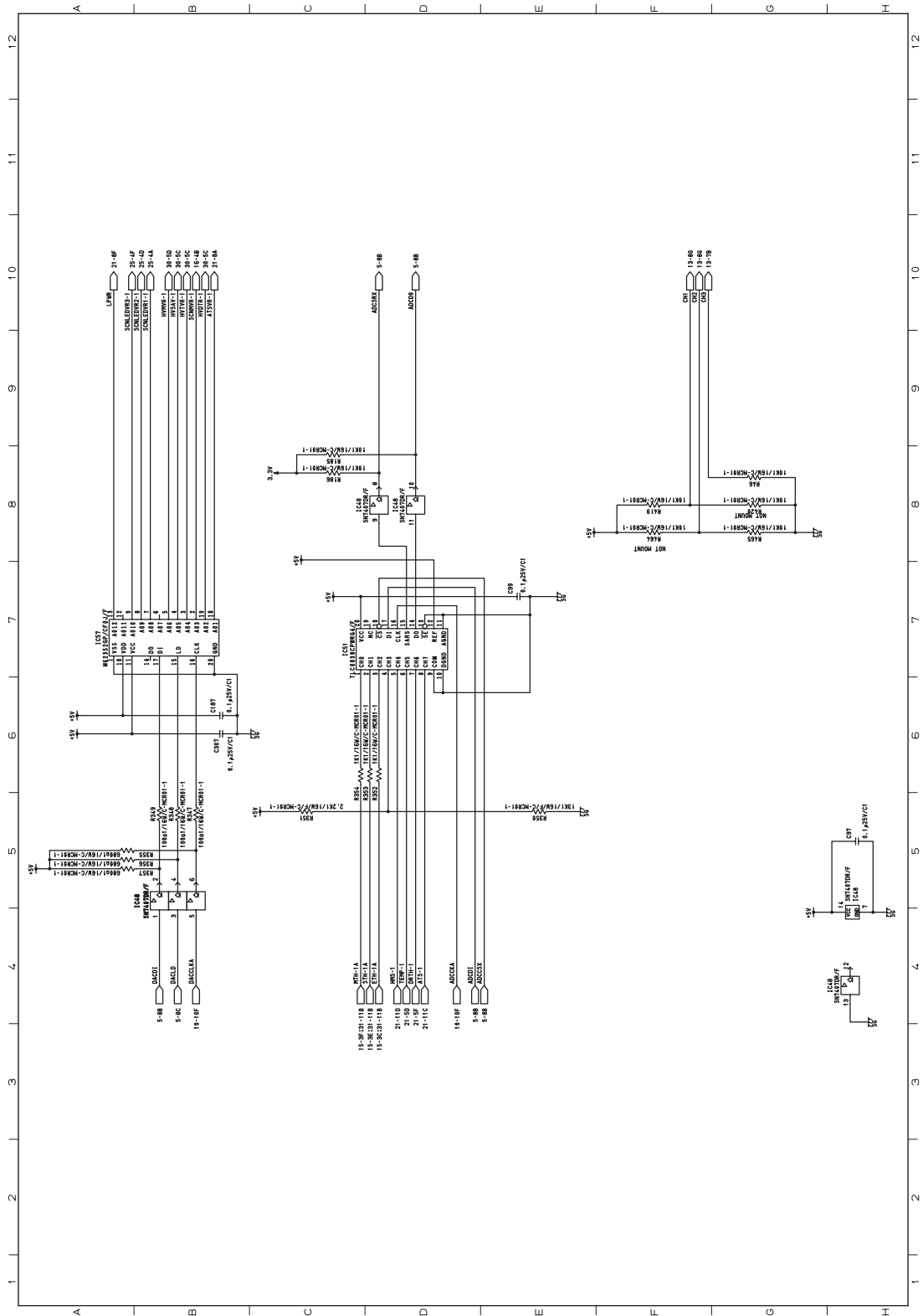

Fig. 3-111

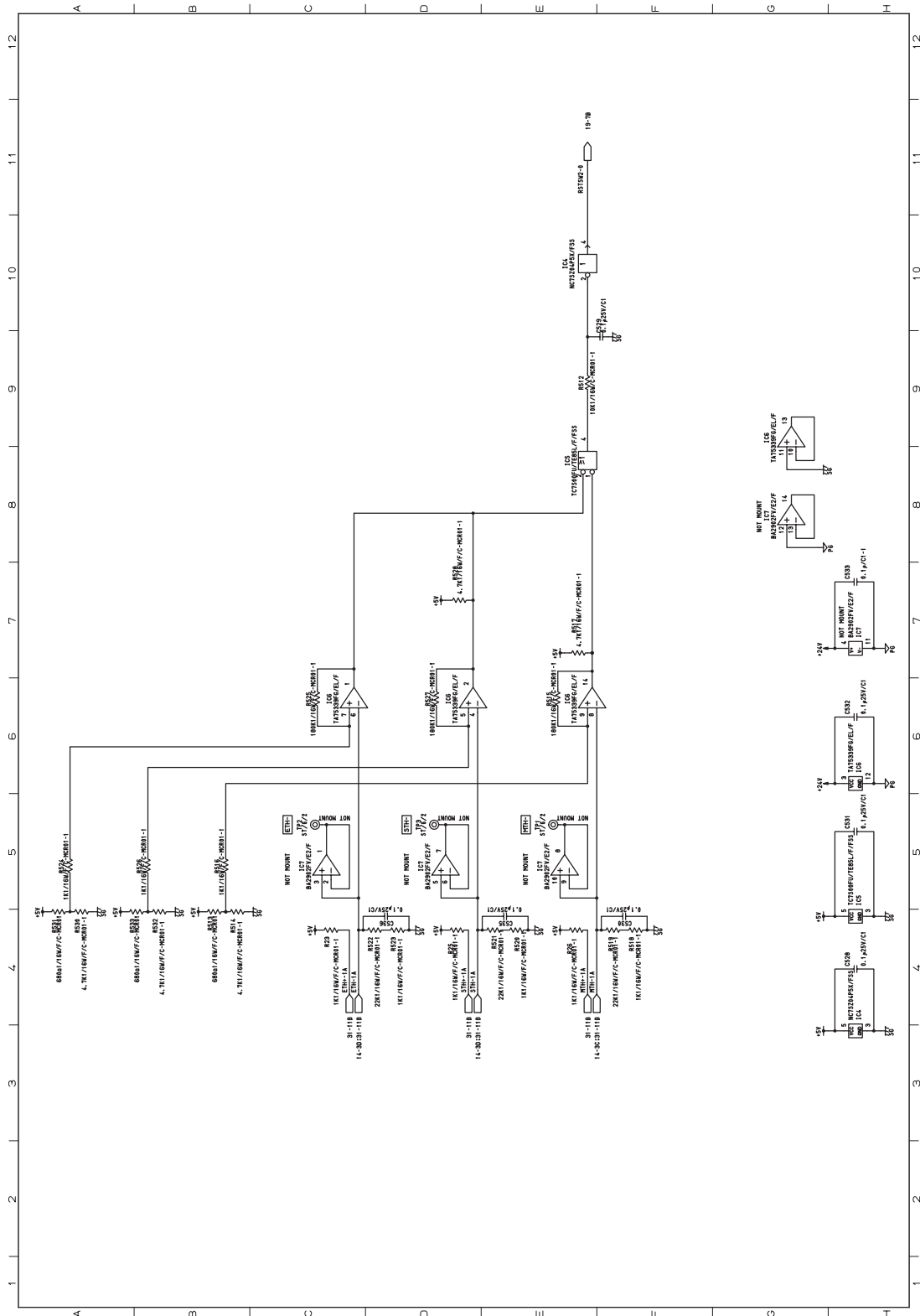

Fig. 3-112

MAIN board 16/35

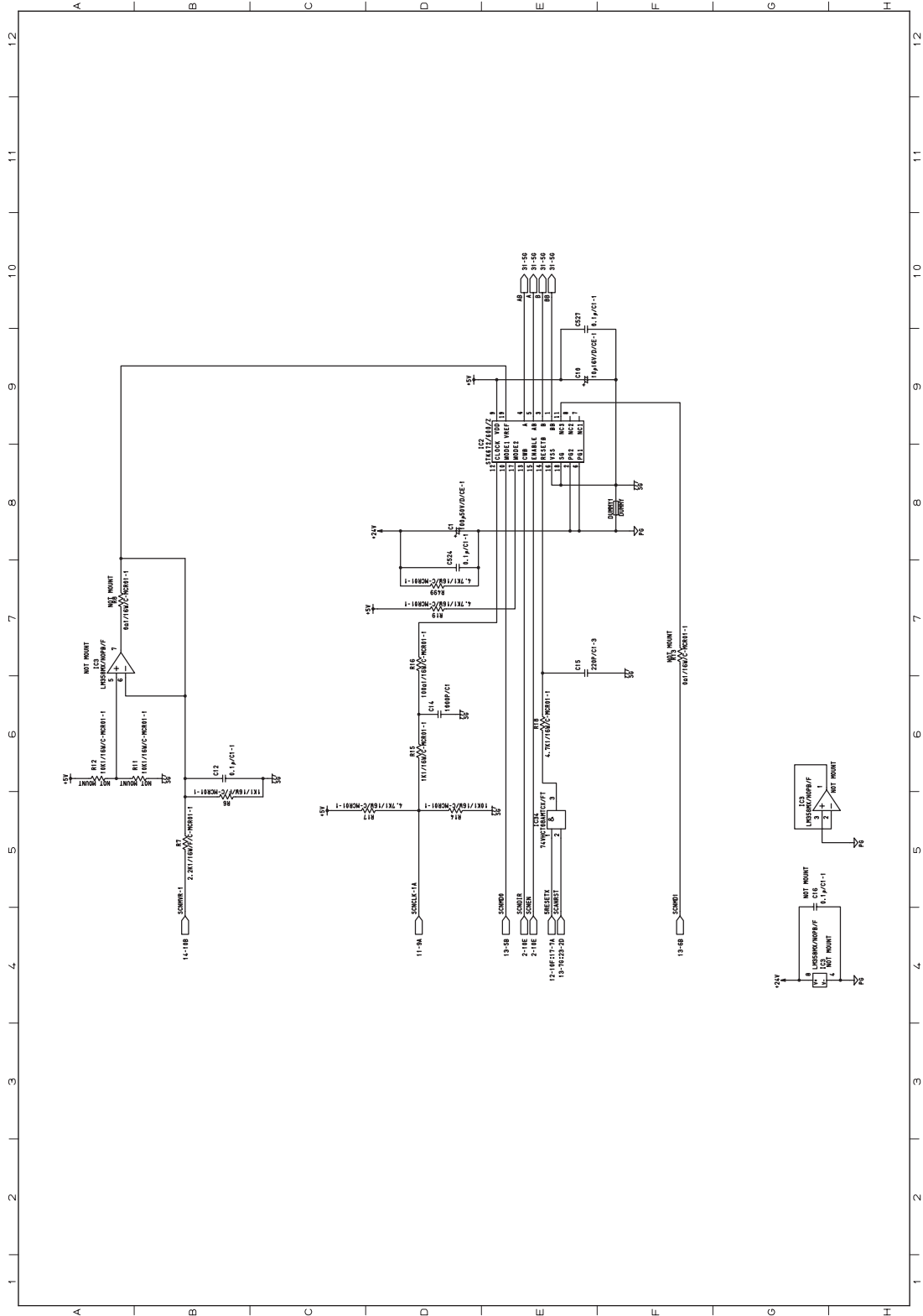

Fig. 3-113



MAIN board 18/35

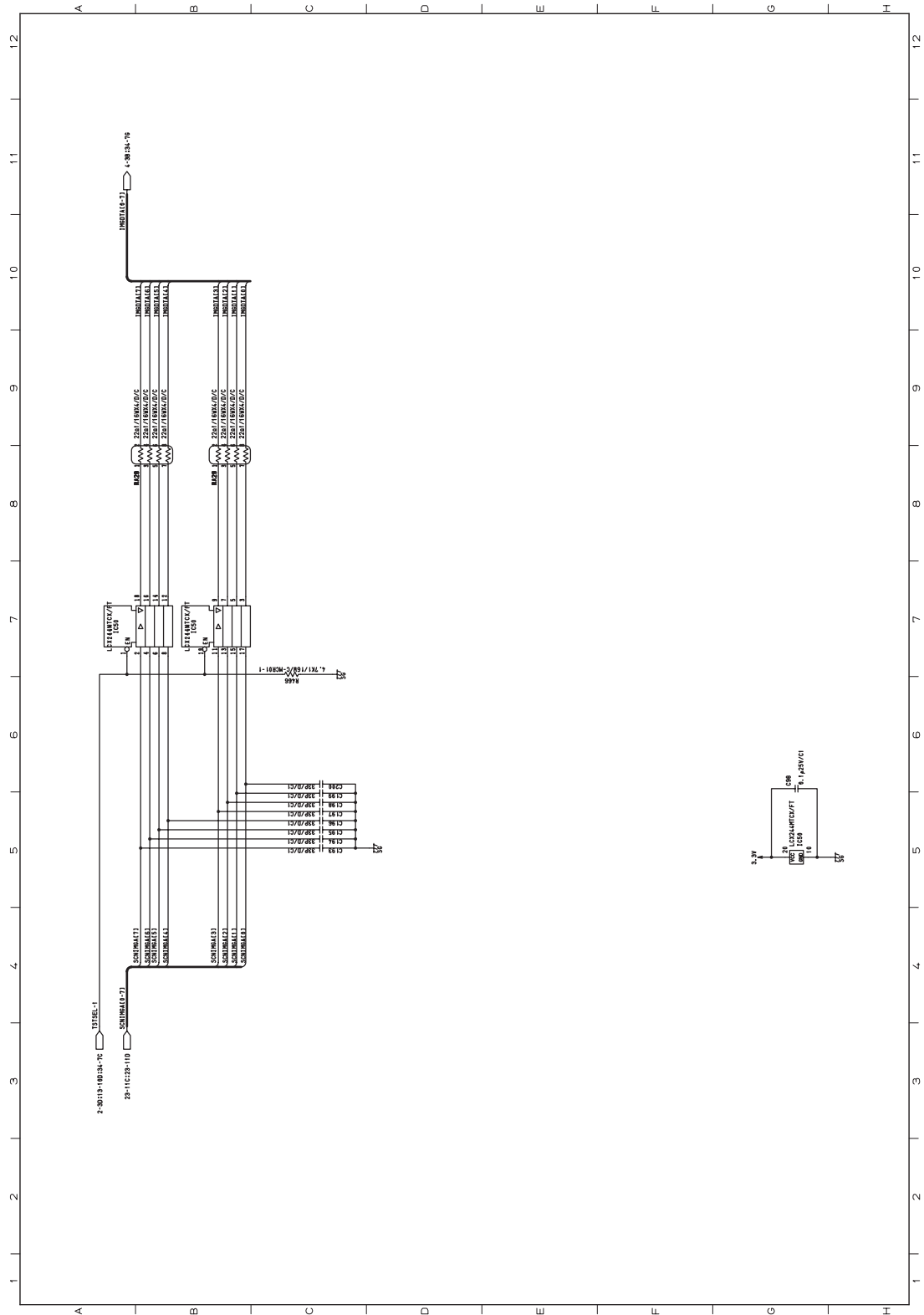

Fig. 3-115

MAIN board 19/35

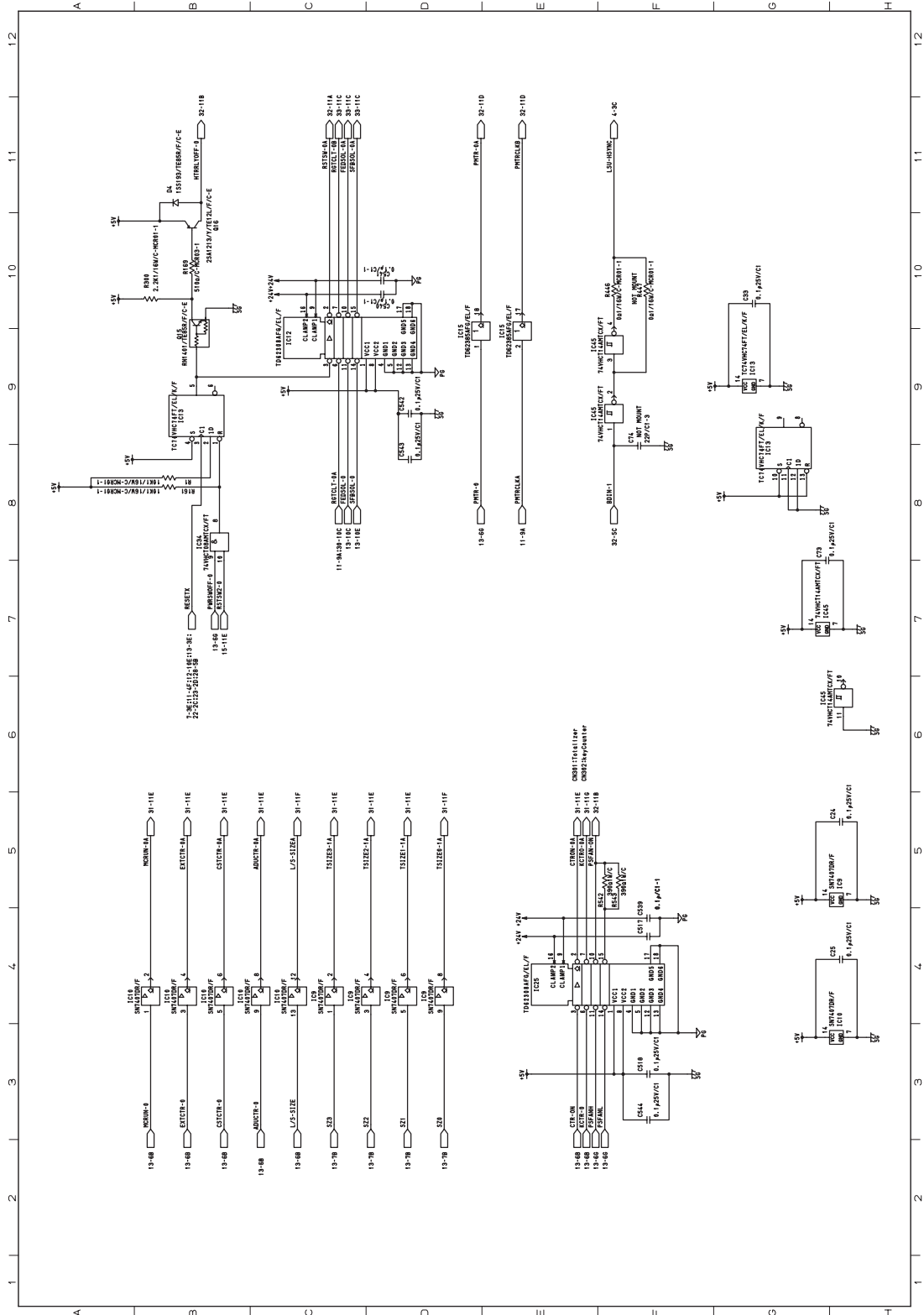

Fig. 3-116







MAIN board 21/35

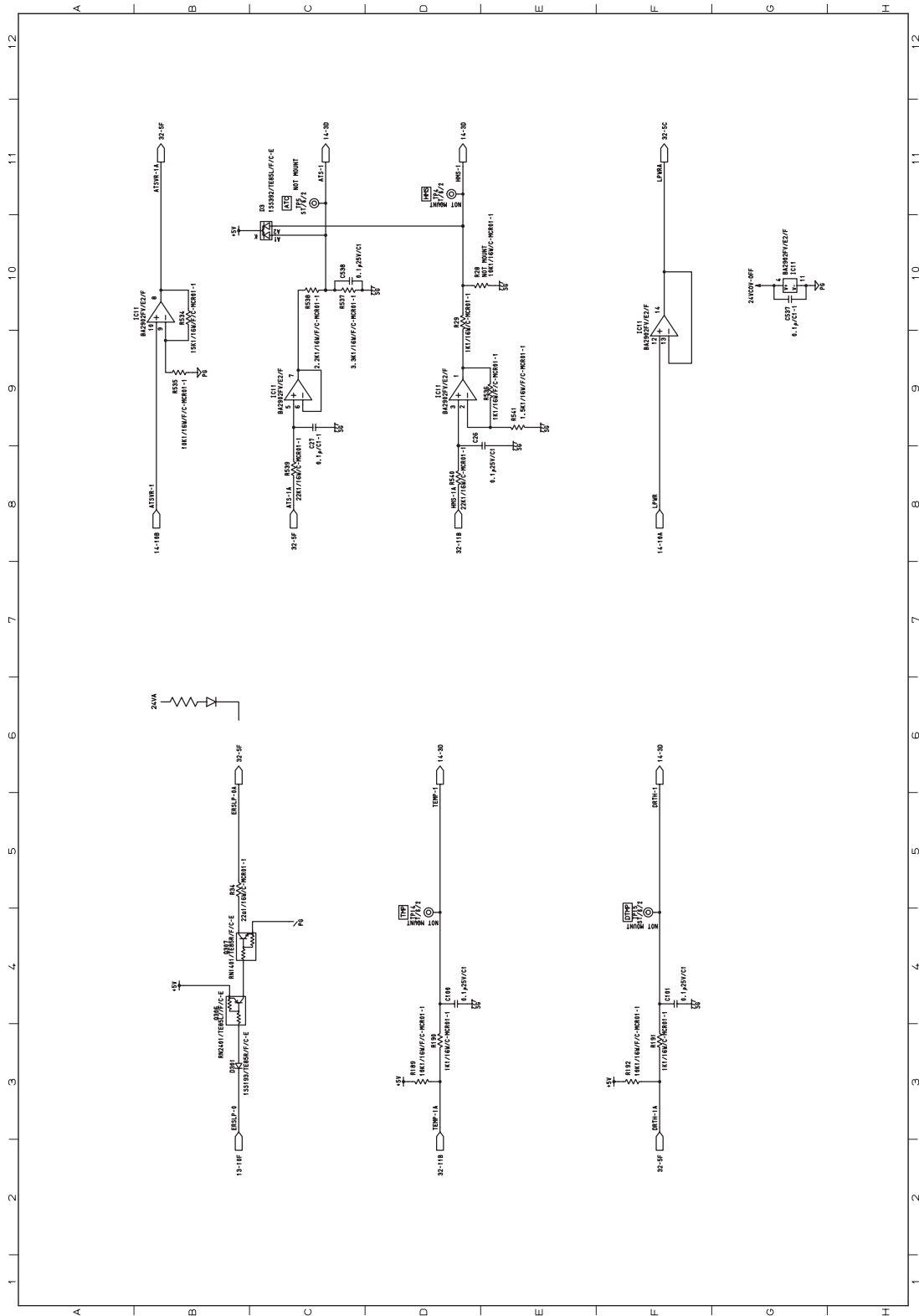

Fig. 3-118

MAIN board 22/35

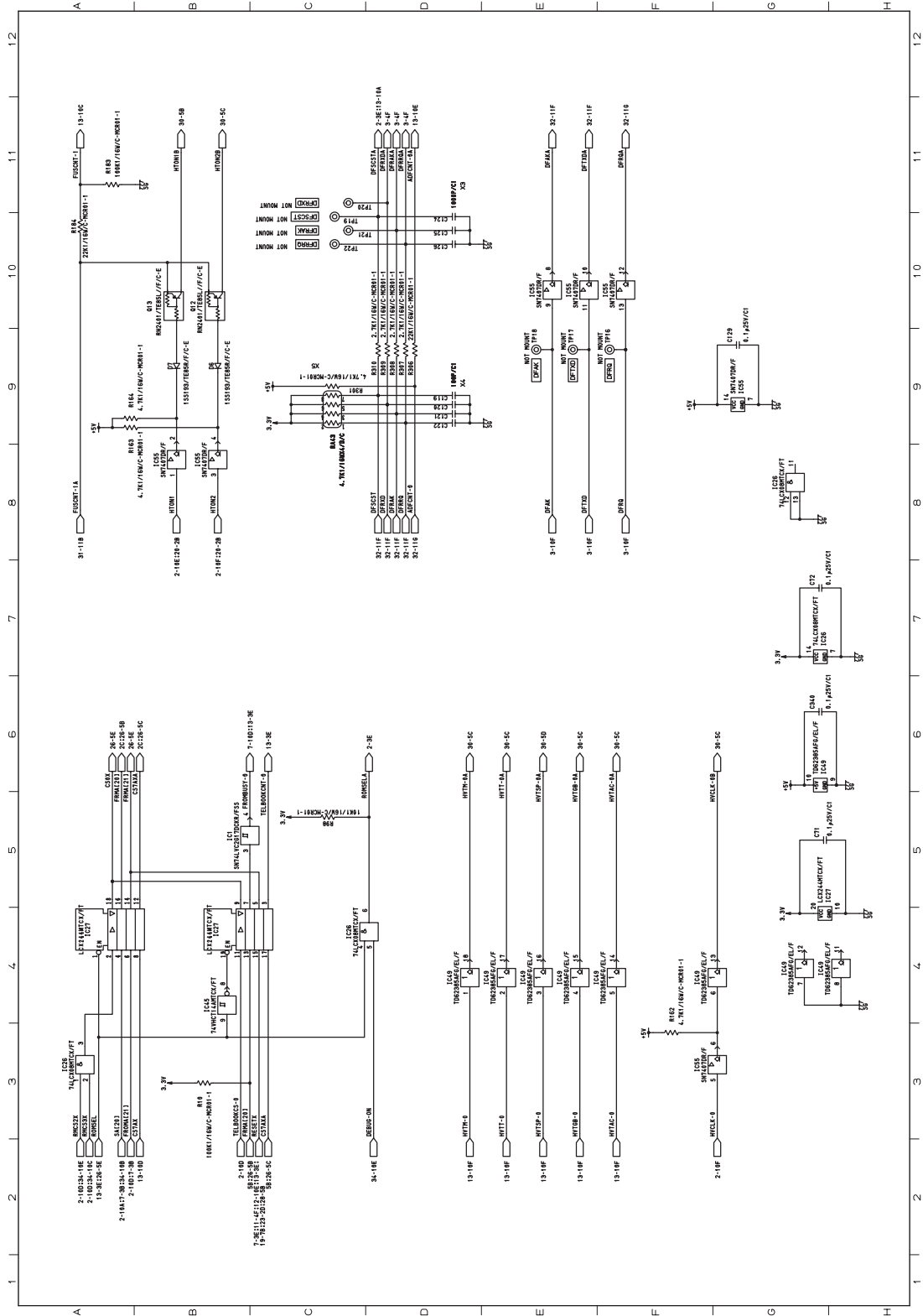

Fig. 3-119



MAIN board 24/35

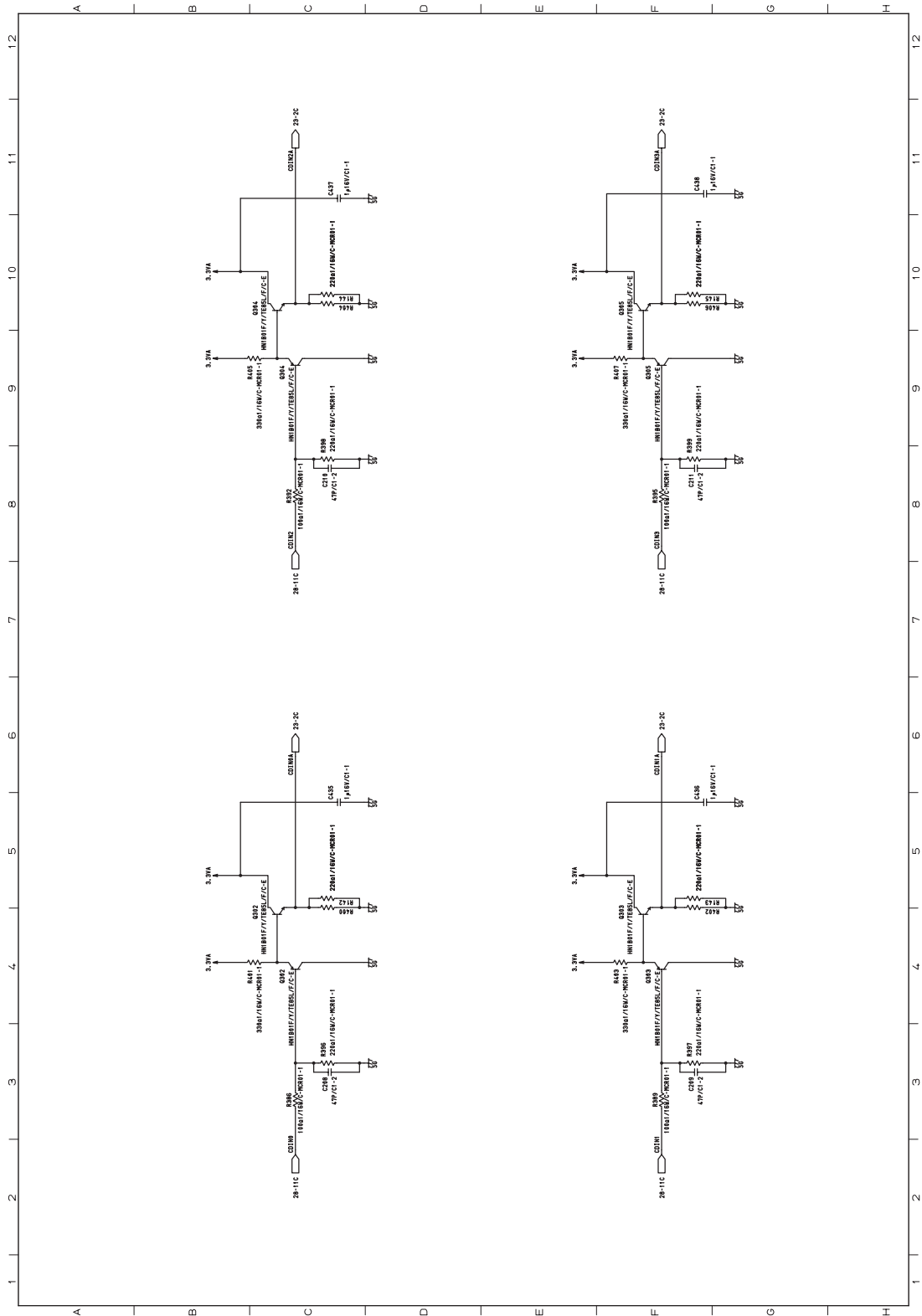

Fig. 3-121

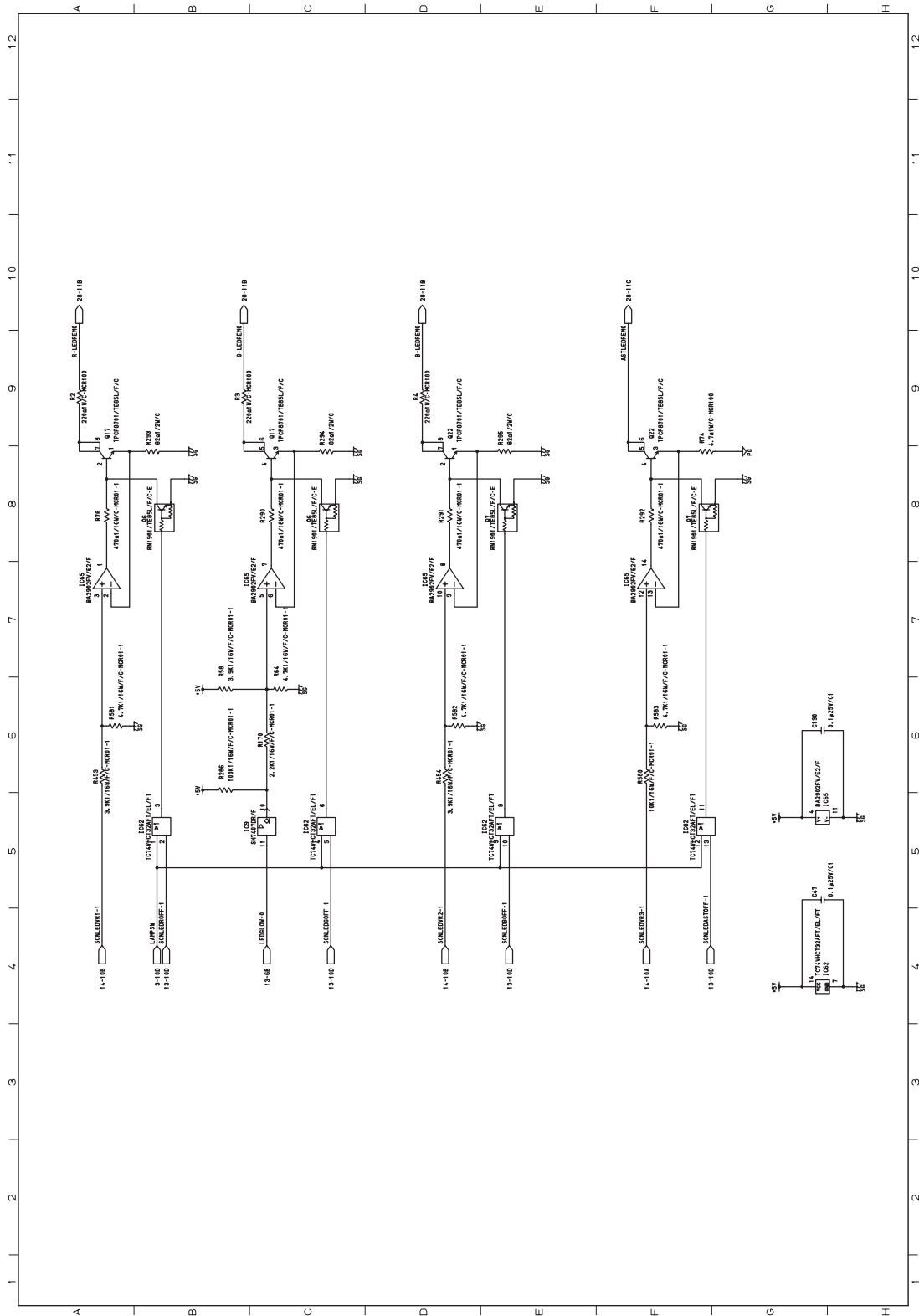

Fig. 3-122

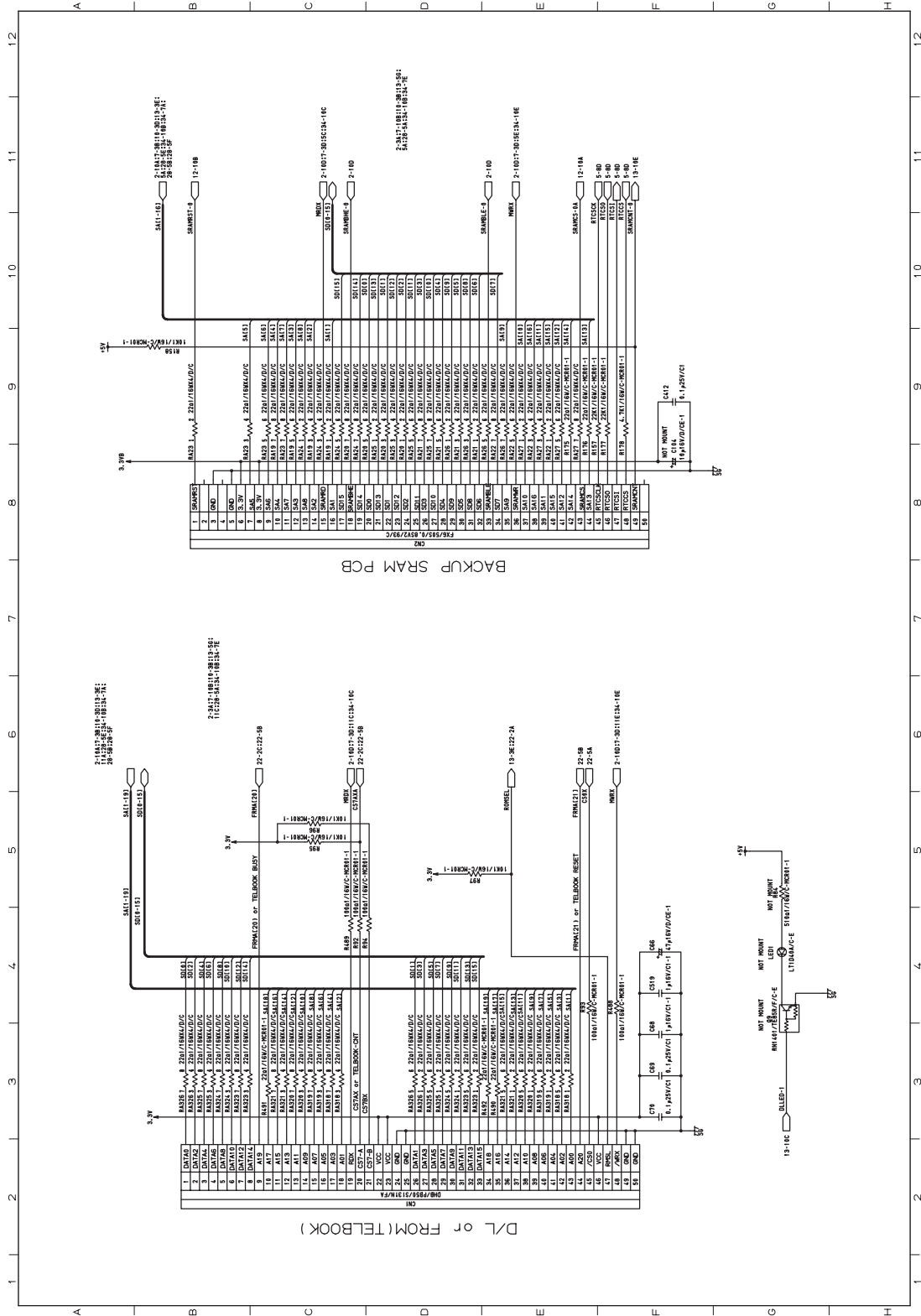

Fig. 3-123



MAIN board 28/35

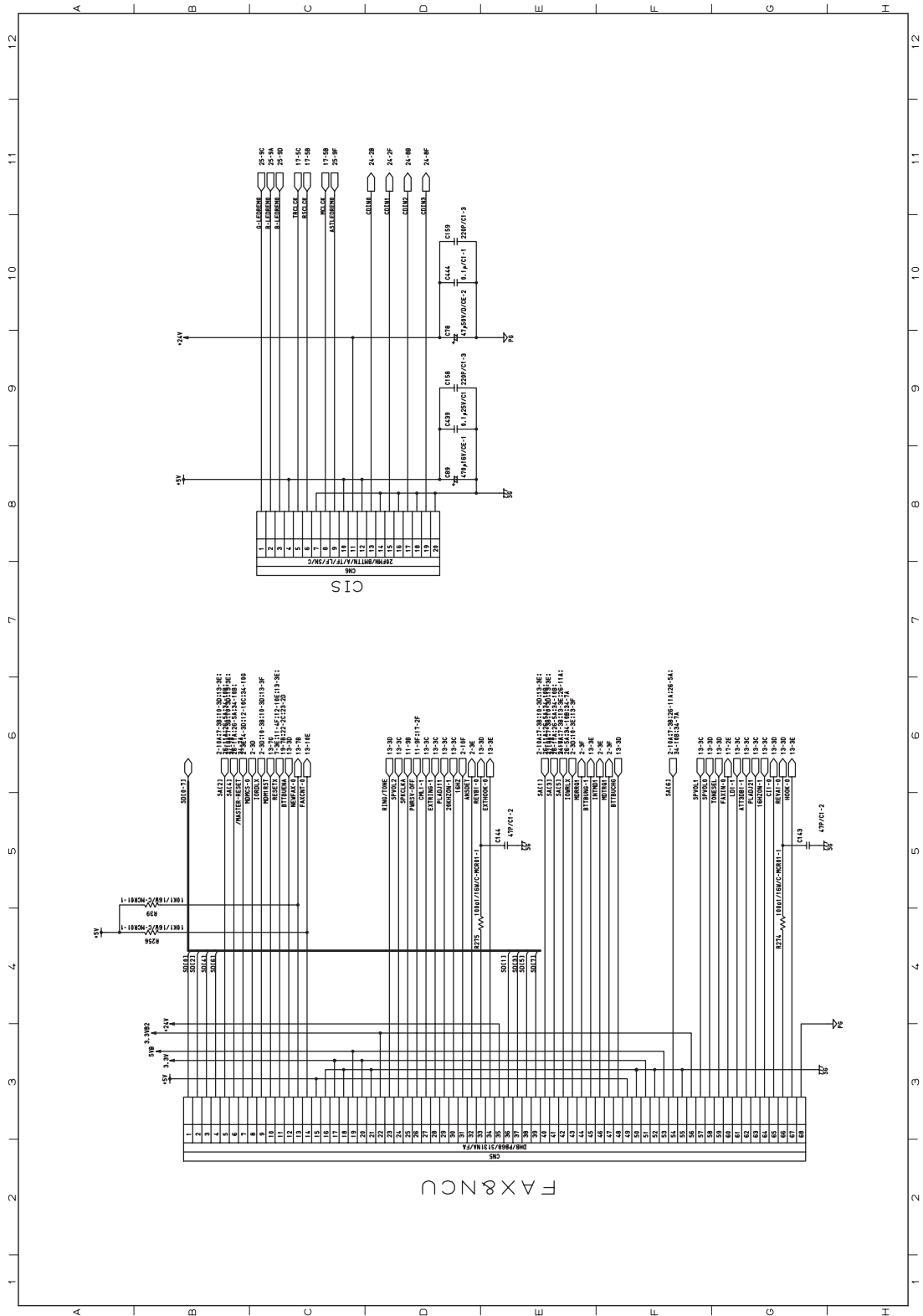

Fig. 3-125



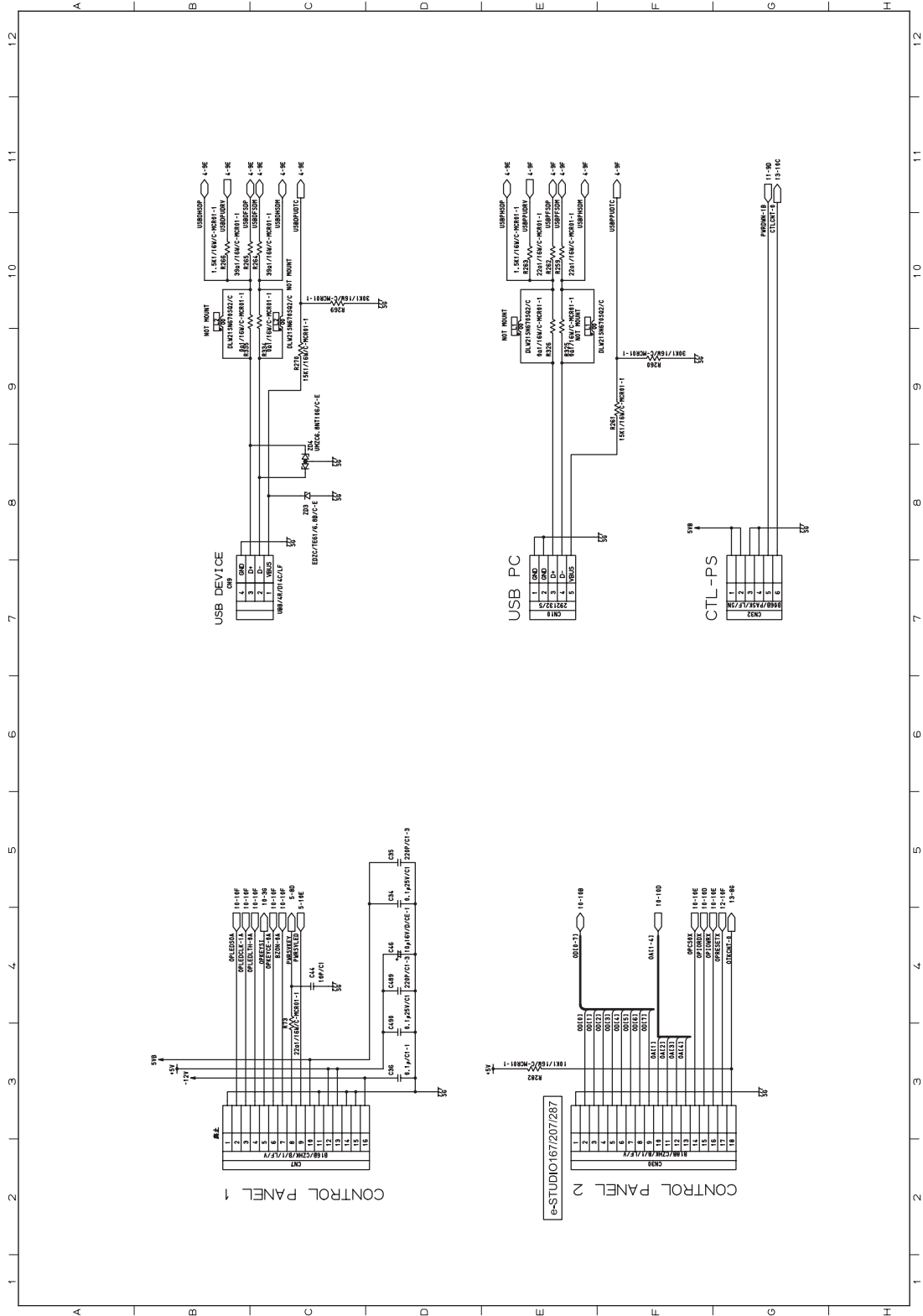

Fig. 3-126

MAIN board 30/35

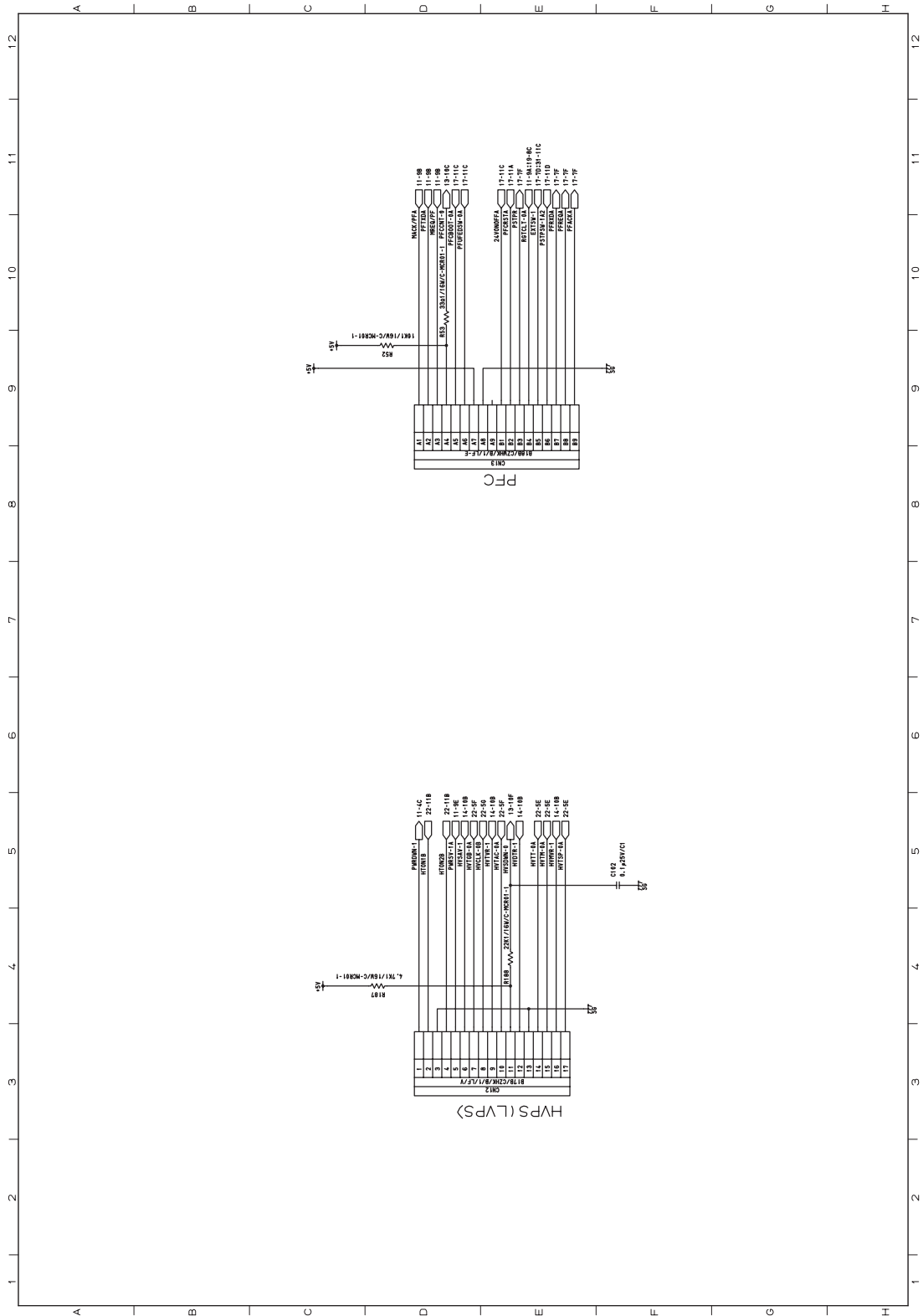

Fig. 3-127

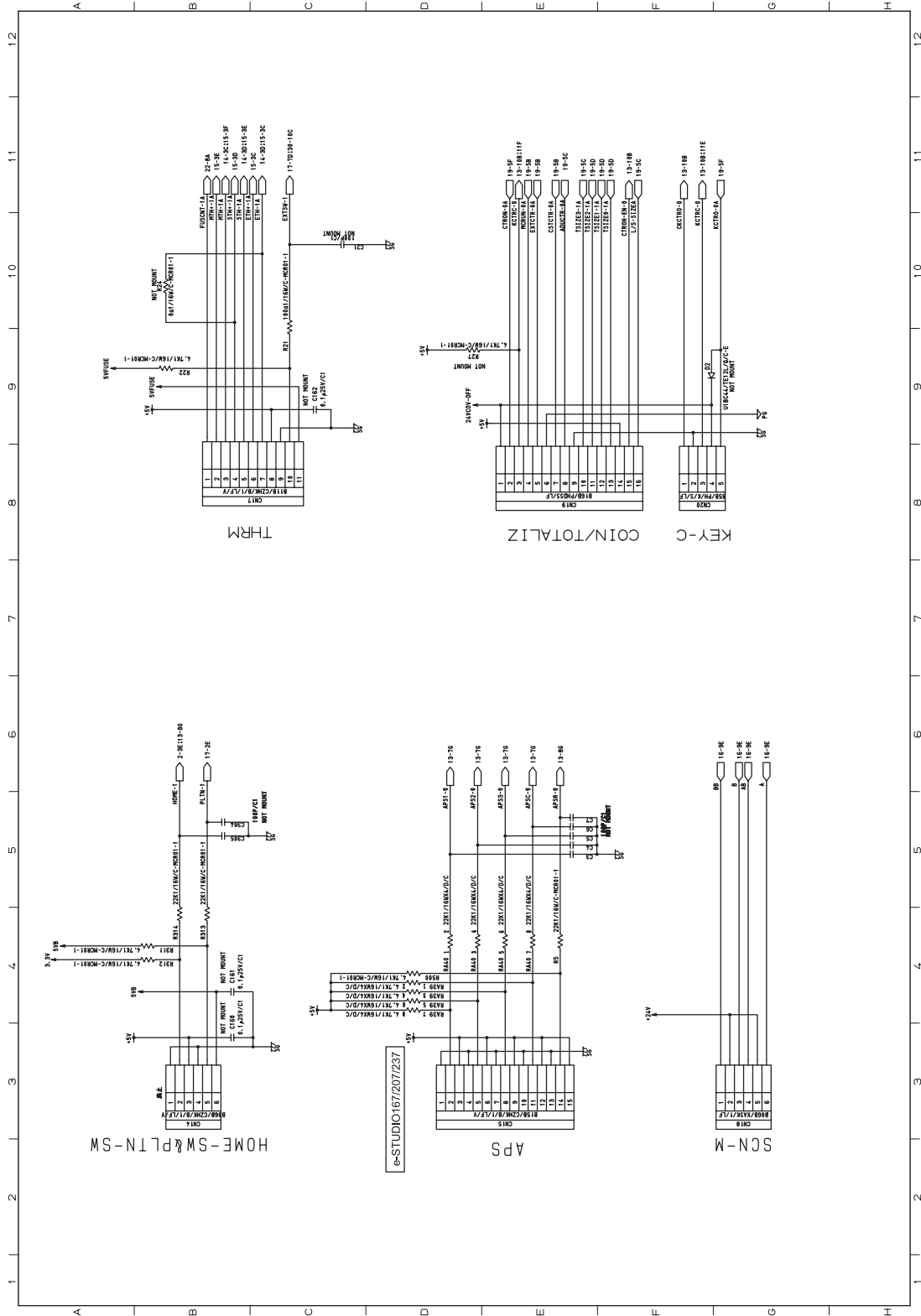

Fig. 3-128

MAIN board 32/35

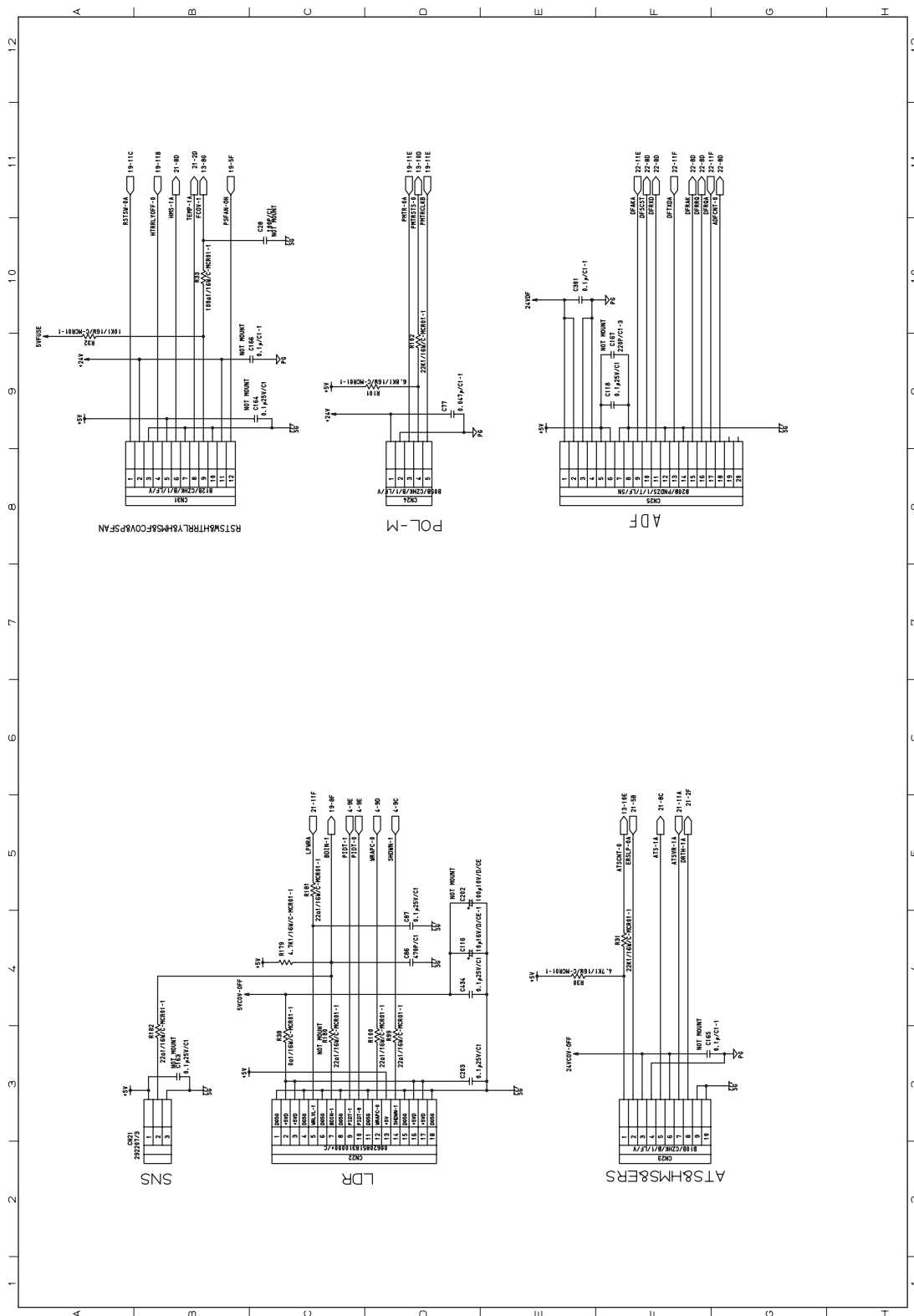

Fig. 3-129

MAIN board 33/35

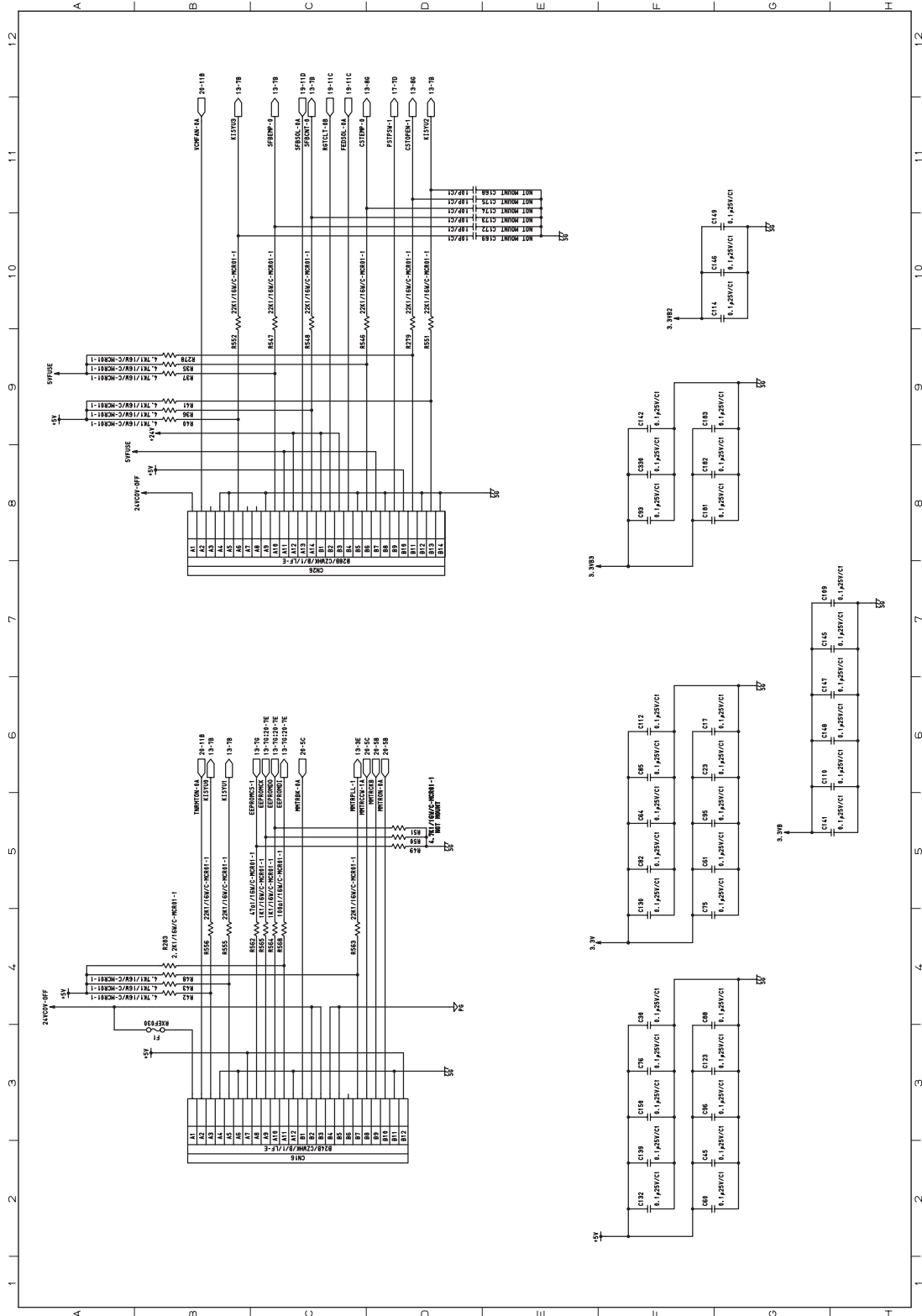

Fig. 3-130

MAIN board 34/35

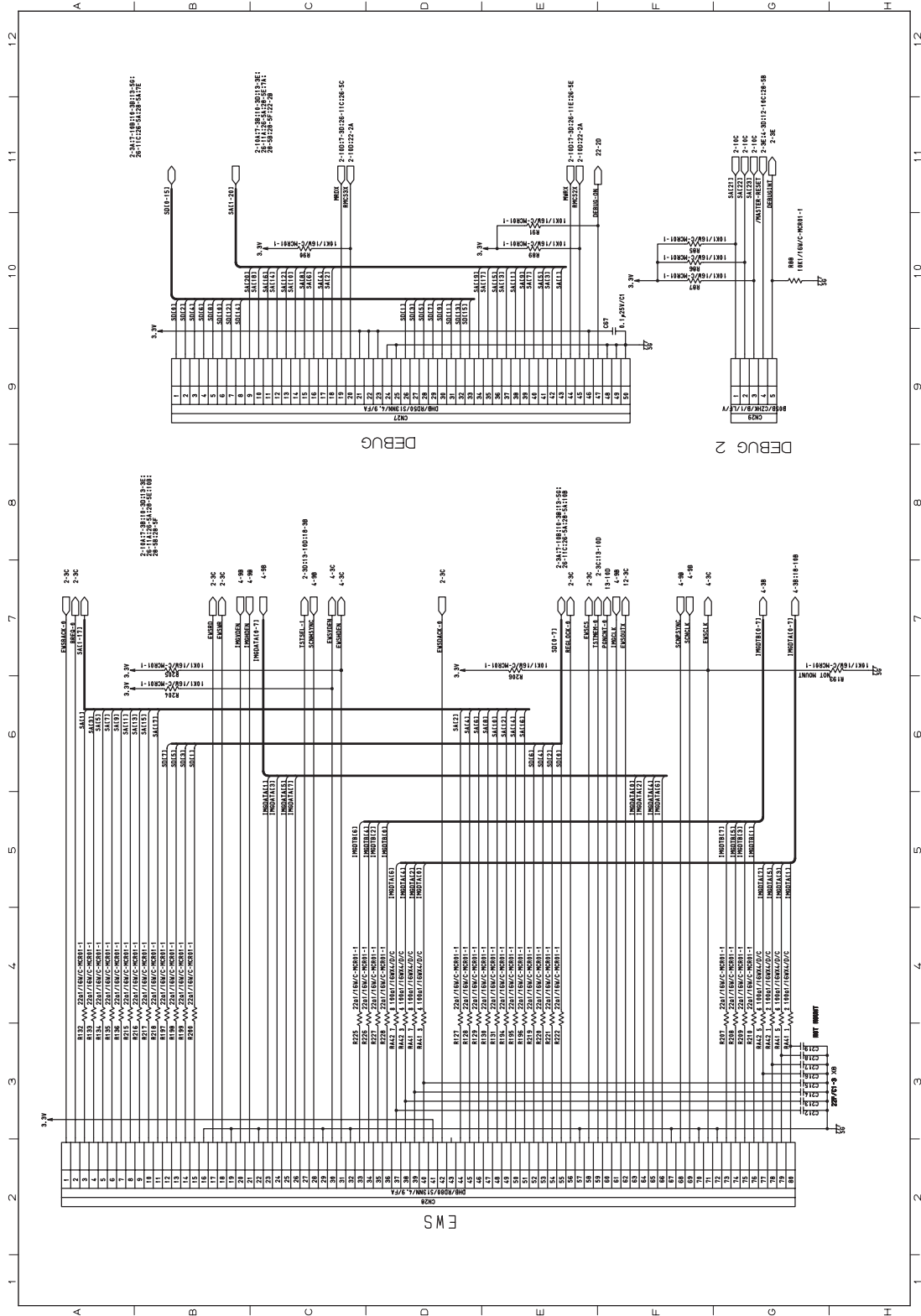

Fig. 3-131

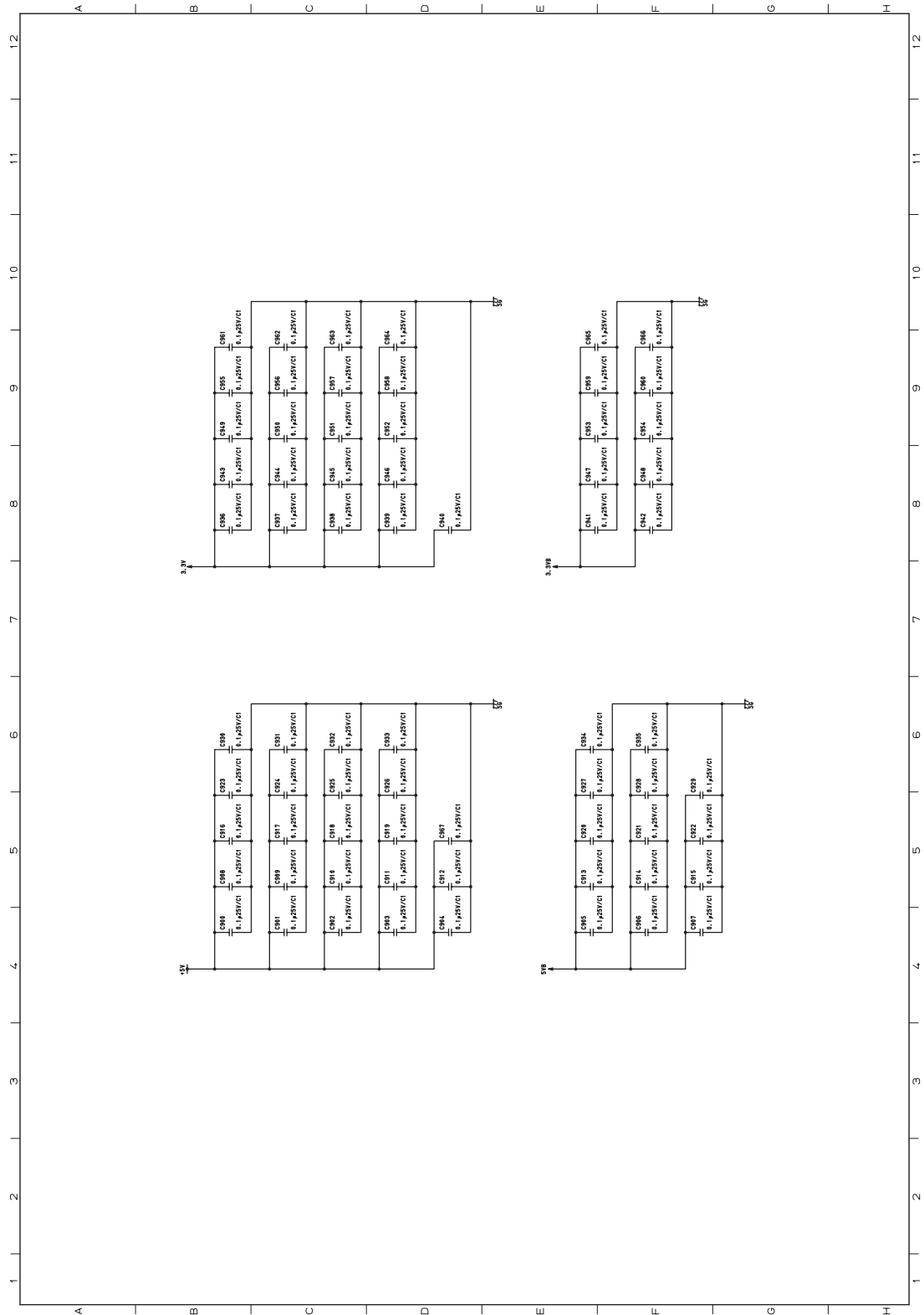

Fig. 3-132

### 3.17 SRAM circuit (SRAM board: e-STUDIO166/167/206/207/237)

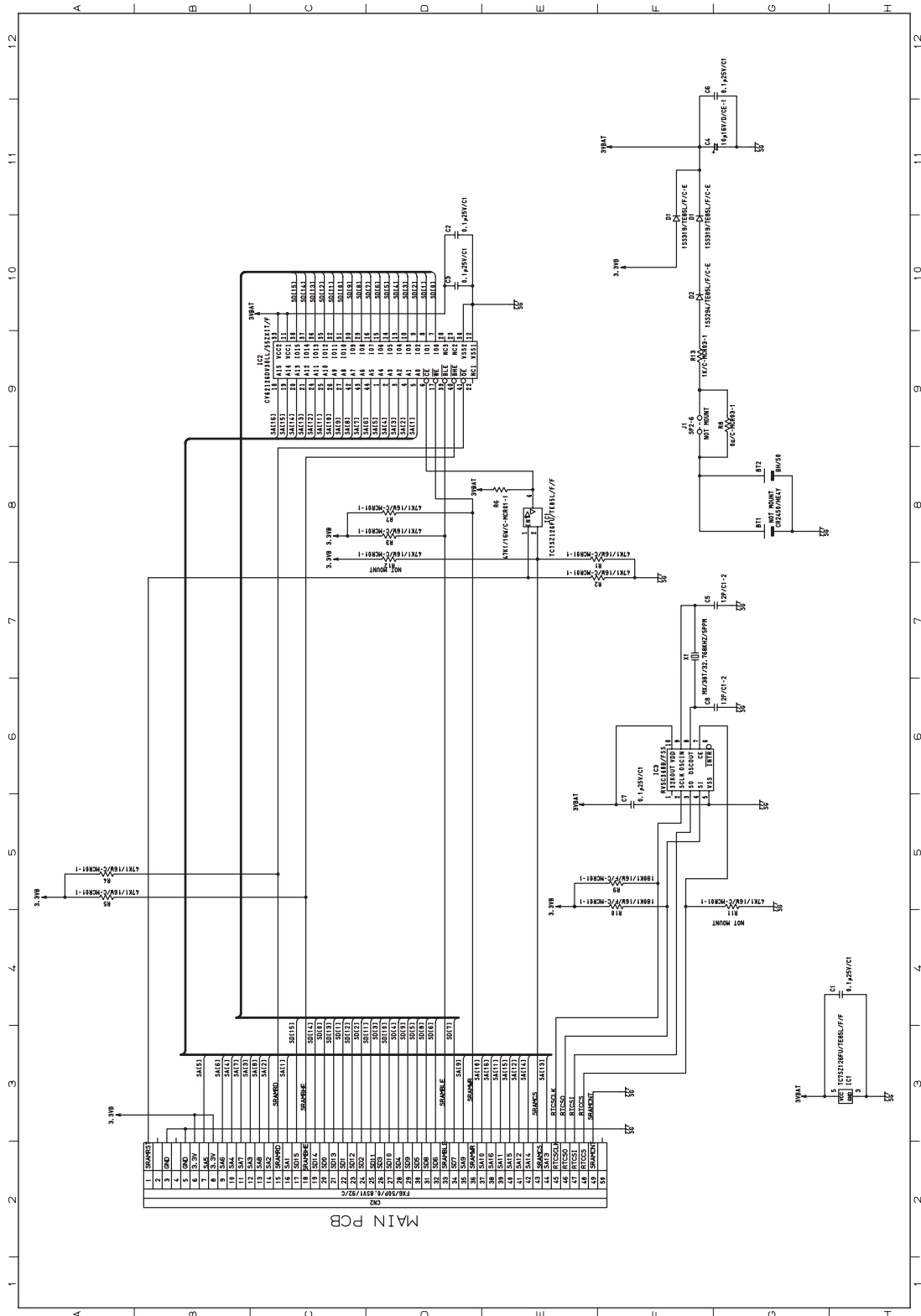

Fig. 3-133



# 3.18 Control panel circuit (HPNL board: e-STUDIO167/207/237)

HPNL board 1/4

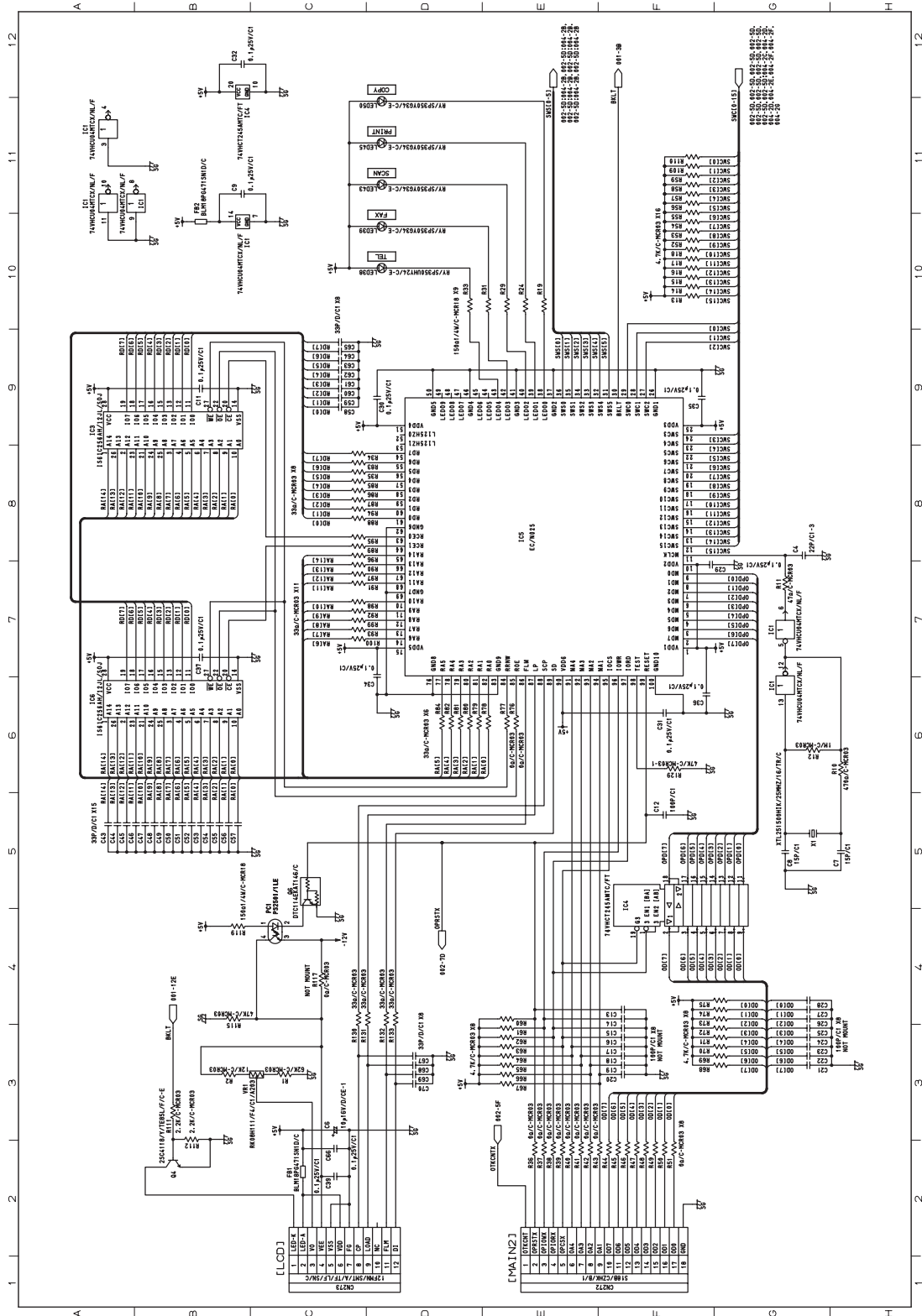

Fig. 3-134

HPNL board 2/4

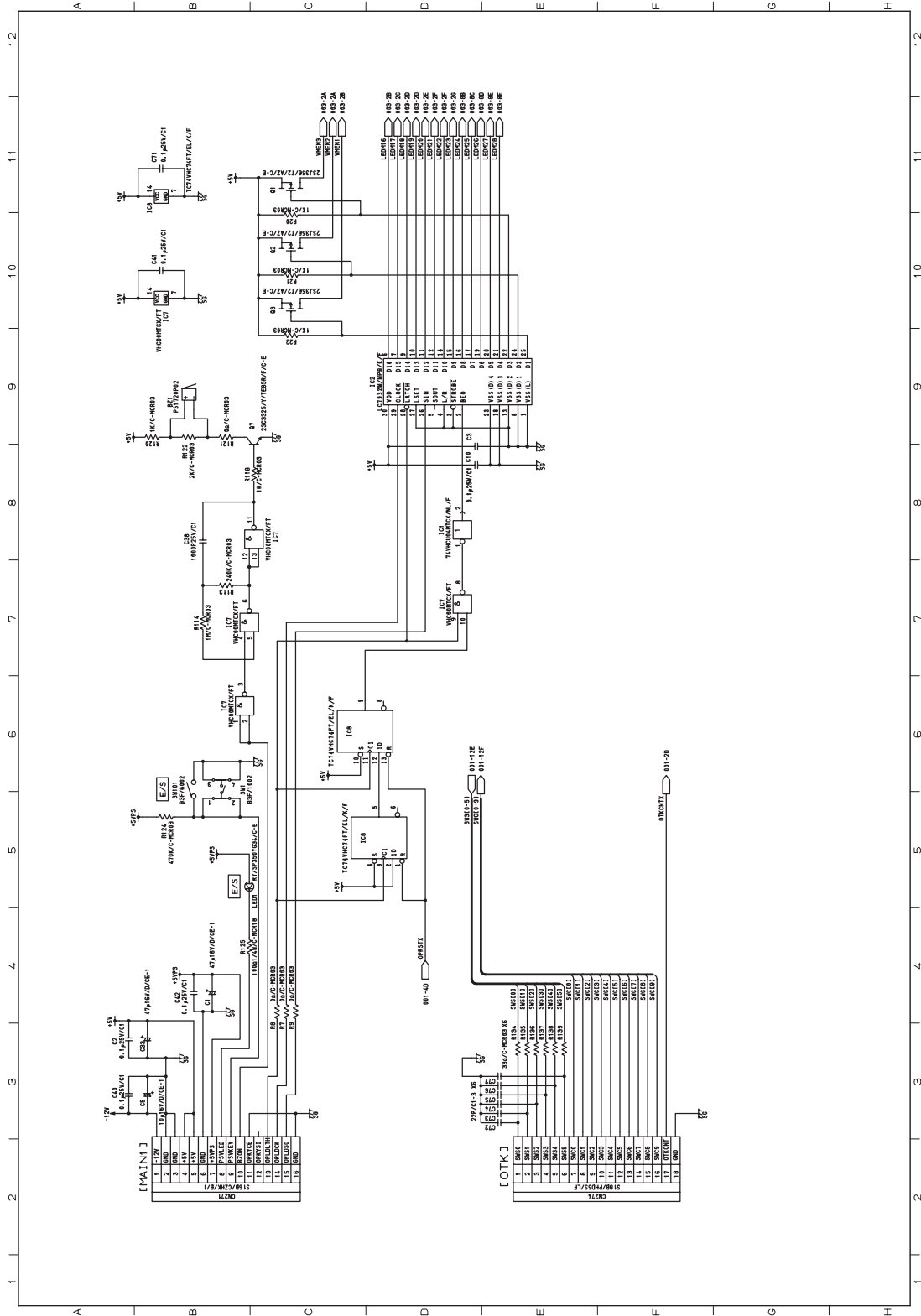

Fig. 3-135

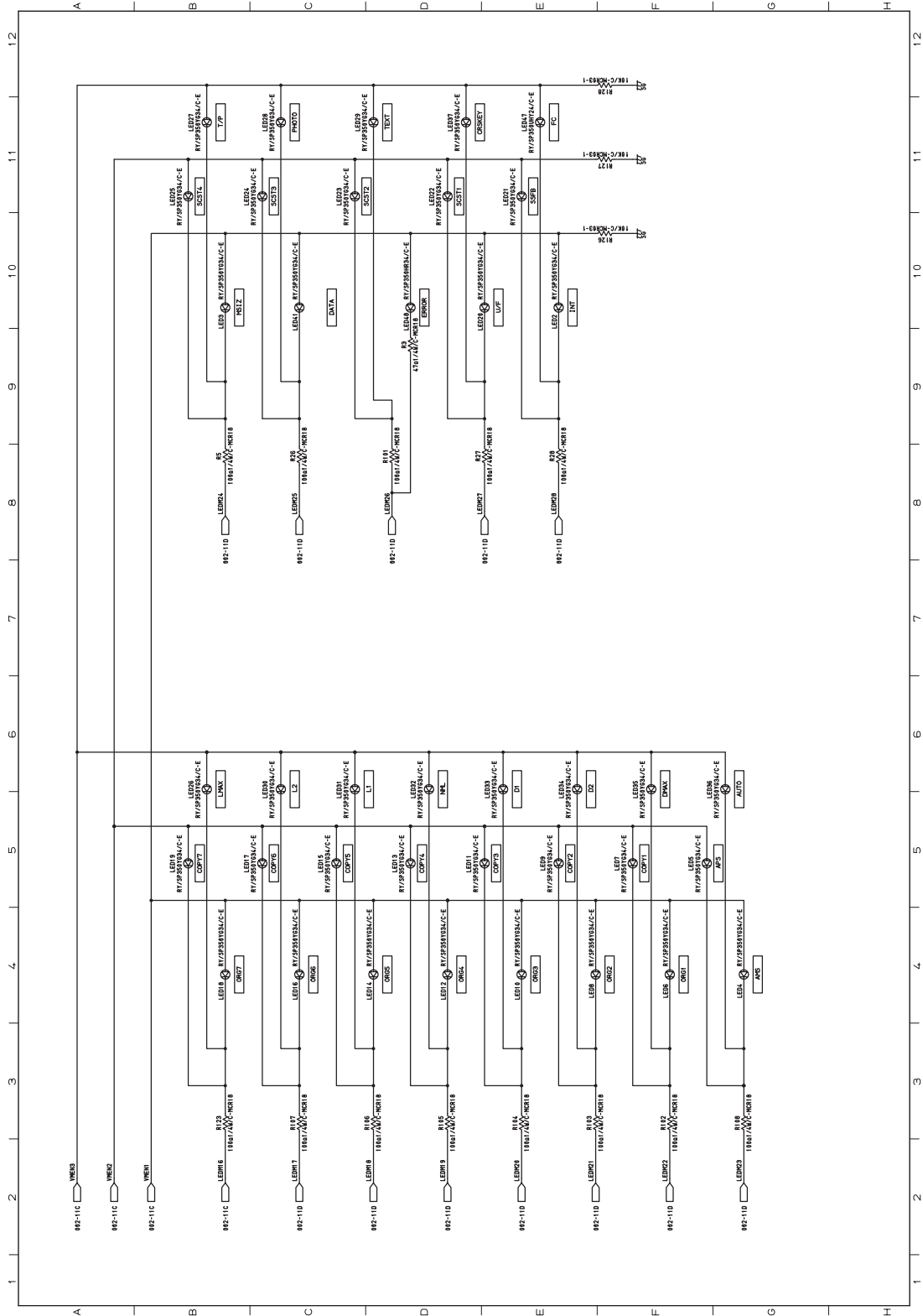

Fig. 3-136

HPNL board 4/4

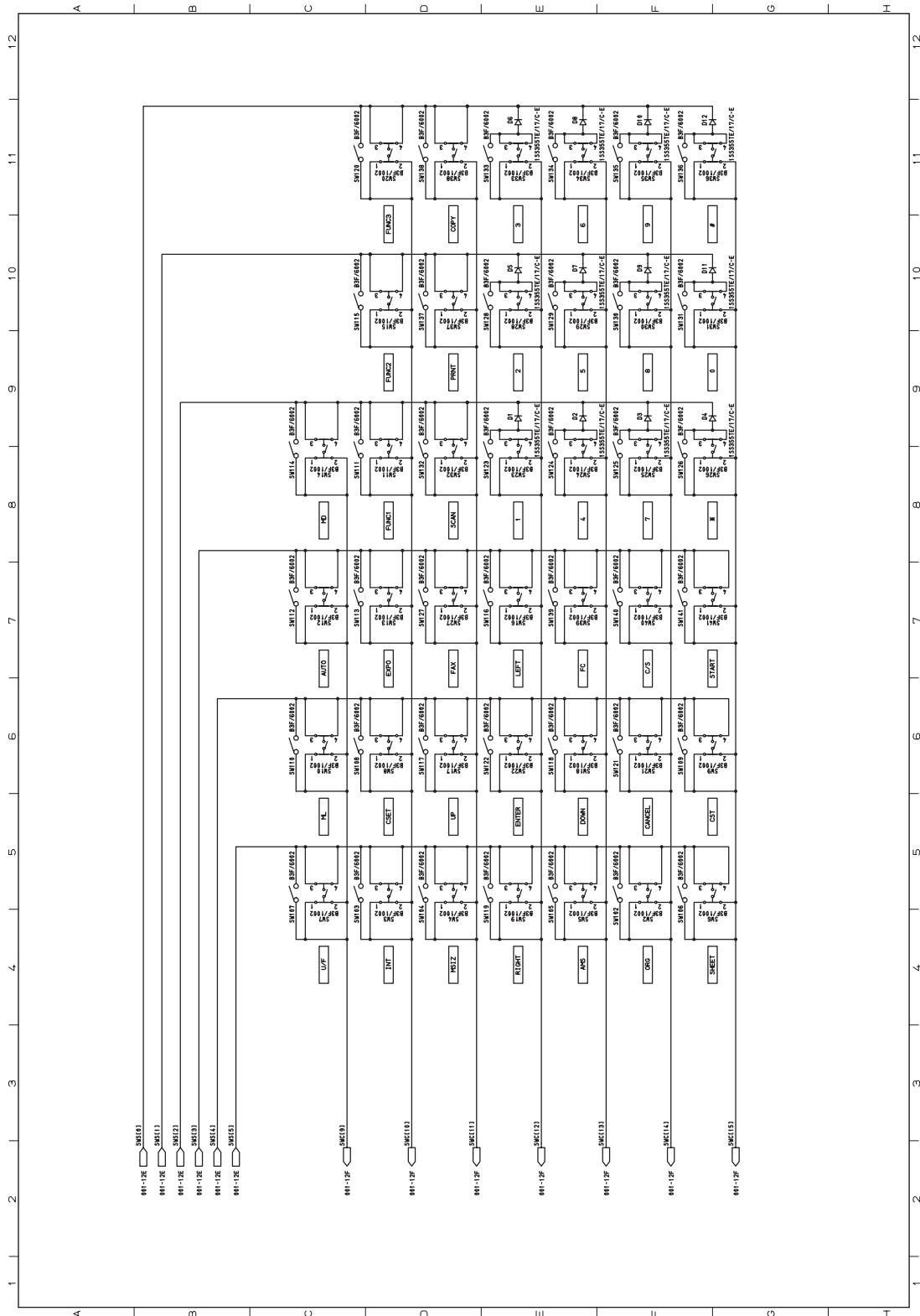

Fig. 3-137

# 3.19 Paper feed control circuit (PFC board: GH-1060)

PFC board 1/4

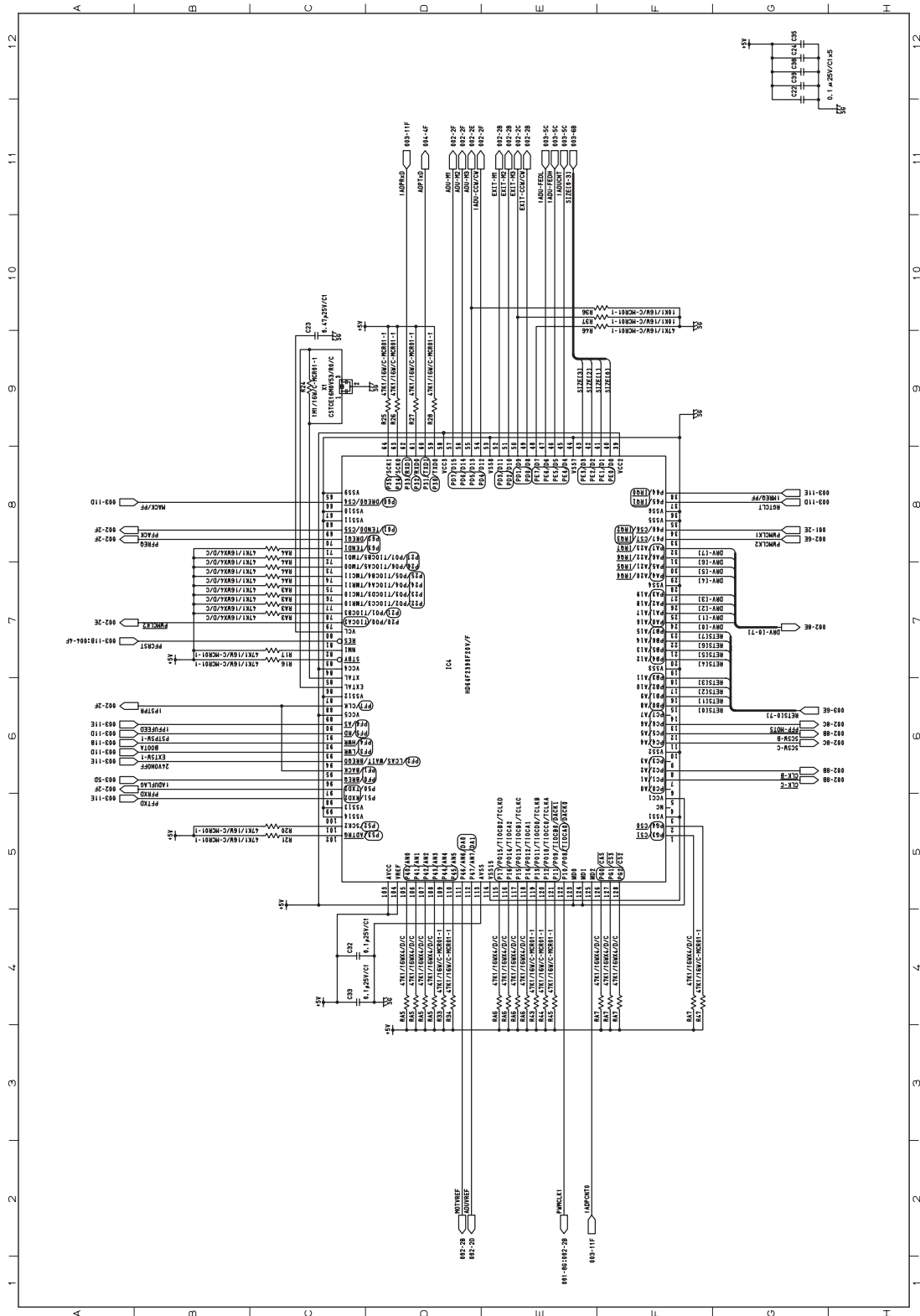

Fig. 3-138



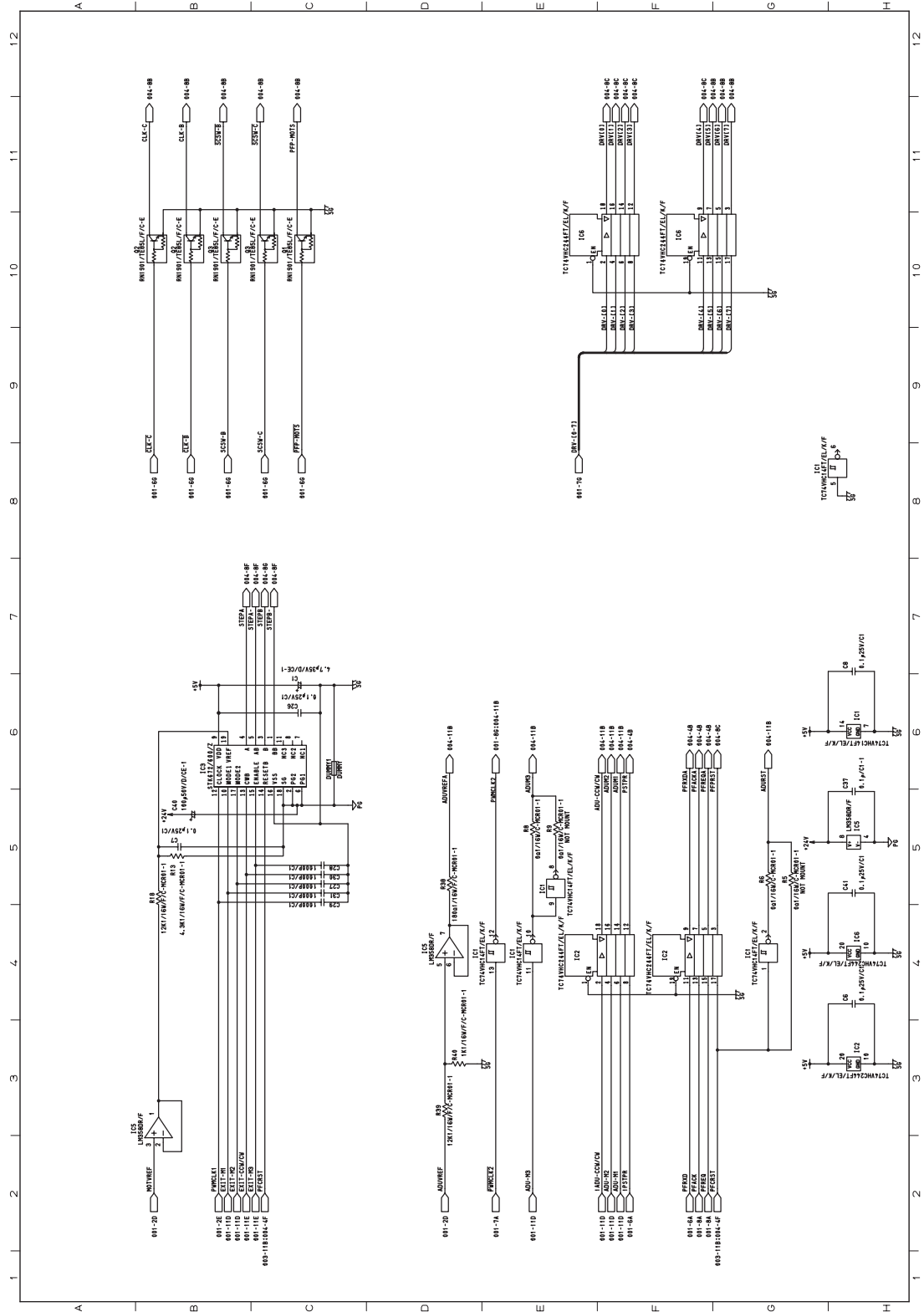

Fig. 3-139



PFC board 4/4

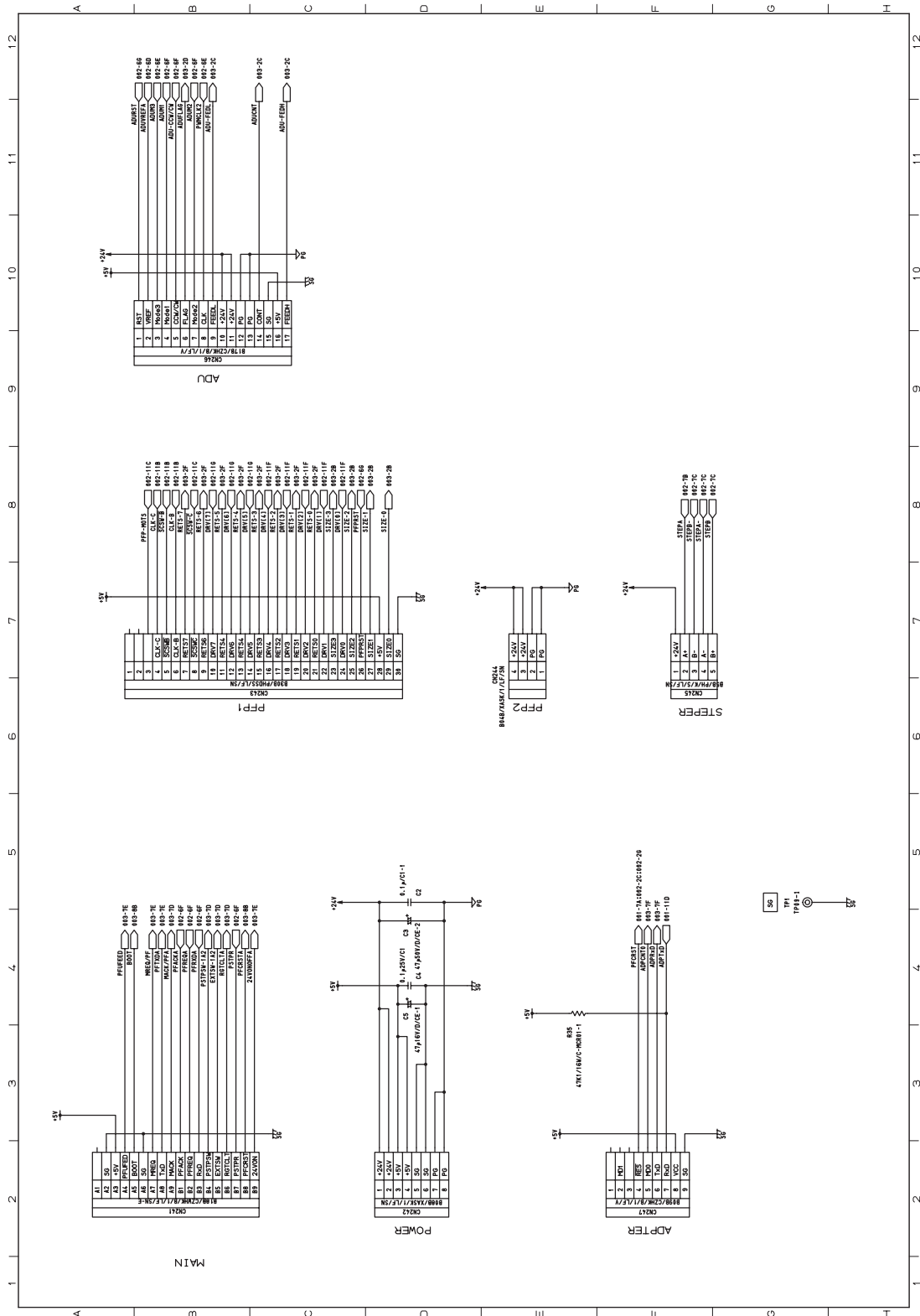

Fig. 3-141





# **TOSHIBA**

**TOSHIBA TEC CORPORATION**

2-17-2, HIGASHIGOTANDA, SHINAGAWA-KU, TOKYO, 141-8664, JAPAN

*WWW.SERVICE-MANUAL.NET*