

TOSHIBA

SERVICE PARTS LIST

Finisher

SR5000

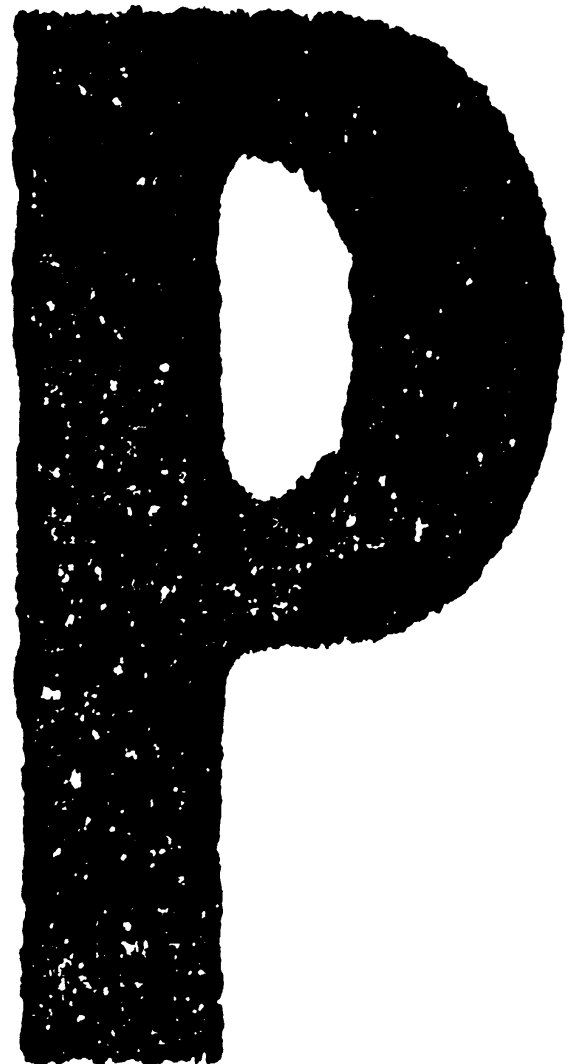

© 2006 TOSHIBA TEC CORPORATION All rights reserved

Under the copyright laws, this manual cannot be reproduced in any form without prior written permission of TOSHIBA TEC CORPORATION. No patent liability is assumed, however, with respect to the use of the information contained herein.

EXPLANATION OF SERVICE-PARTS LIST

1. HOW TO READ THE PARTS LIST

- (1) Number of pieces
The number of pieces in the list denotes total pieces used per unit. But the numbers in the list for PACKING MATERIAL and ACCESSORY denote total pieces used per machine.
- (2) One pack of screws in the list includes 50 pieces.
- (3) ABBREVIATED CODES

QTY/PAC

- QTY.....one piece
- PAC.....one pack
- 1/P.....one piece packed in polyethylene bag
- 1/S.....one piece packed in special pack
- 1/C.....one piece packed in carton box
- 1/PP.....one piece packed in paper and polyethylene bag
- 1/KP.....one piece packed in polyethylene bag with cardboard
- 1/D.....one piece packed in polyethylene-cushion bag
- 1/SB.....one piece packed in shielding bag
- N/A.....not available

P

- P.....PURPOSE
- A.....ADD
- B.....DELETE
- C.....CHANGE
- D.....QTY, CHANGE
- E.....MISENTRY
- F.....OMISSION

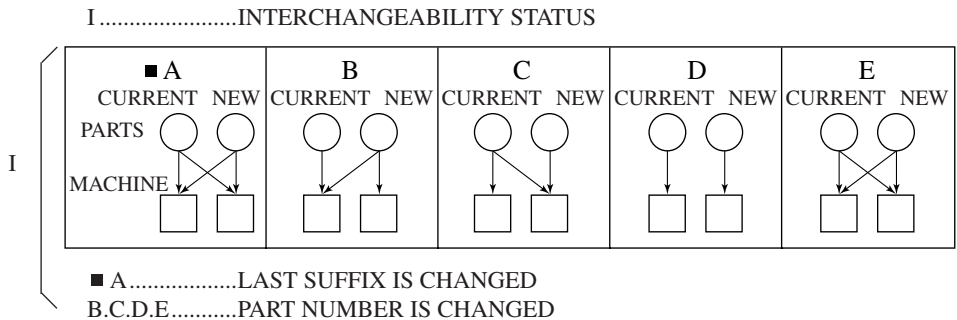

2. HOW TO PLACE ORDER FOR PARTS

- (1) The parts handled as service parts are only those with their "QTY/PACK" column listed with a quantity other than "N/A***" or "SUPPLY".
Those parts with "N/A***" are listed only for the purpose of showing the mechanical construction, those listed with "SUPPLY" are handled only as a sales item, and therefore both types of parts are not supplied as service parts.
- (2) Orders for any parts which form a component of a semi-assembled unit are not acceptable.
Note: All the screws and nuts used are ISO standard.

3. REGION

- NAD.....115V
50/60Hz, NORTH AMERICA, SOUTH AMERICA
- TWD.....110/220V
50/60Hz, TAIWAN
- SAD.....127V/60Hz, SAUDI ARABIA
- ASD.....220-240V
50/60Hz, ASIA, SOUTH AMERICA, etc.
- ASU.....220-240V
50/60Hz, ASIA, etc.
- AUD.....220-240V
50/60Hz, AUSTRALIA
- MJD.....220-240V
50/60Hz, EUROPE
- CND.....220-240V
50/60Hz, CHINA
- KRD.....220-240V
50/60Hz, KOREA

CONTENTS

EXTERIOR	1
STAPLE TRAY 1	2
STAPLE TRAY 2	3
STAPLE TRAY 3	4
STAPLE TRAY 4	5
STAPLE TRAY 5	6
STAPLE TRAY 6	7
STAPLER UNIT 1	8
STAPLER UNIT 2	9
STAPLE TRANSPORT 1	10
STAPLE TRANSPORT 2	11
STAPLE TRANSPORT 3	12
STAPLE TRANSPORT 4	13
STAPLE TRANSPORT 5	14
STAPLE TRANSPORT 6	15
PAPER EXIT SECTION 1	16
PAPER EXIT SECTION 2	17
PAPER EXIT SECTION 3	18
TRAY DRIVE SECTION 1	19
TRAY DRIVE SECTION 2	20
JOGGER UNIT	21
DRIVE SECTION 1	22
DRIVE SECTION 2	23
DRIVE SECTION 3	24
ELECTRICAL SECTION	25
FRAME SECTION 1	26
FRAME SECTION 2	27
DECAL AND DOCUMENT	28

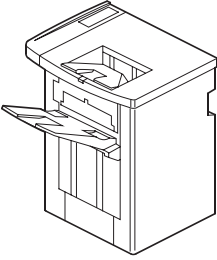
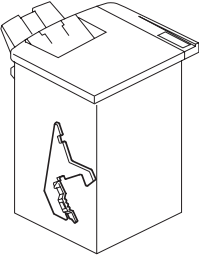
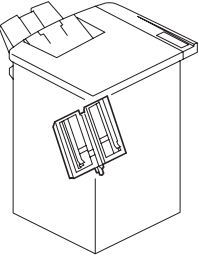
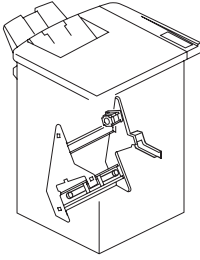
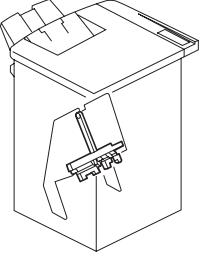
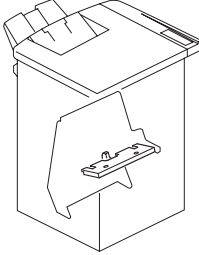
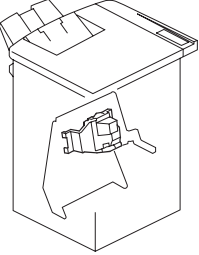
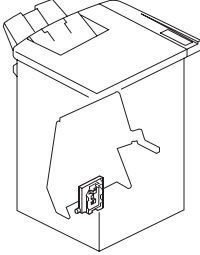
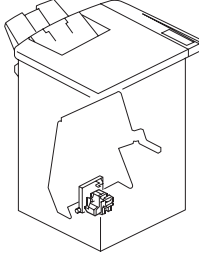
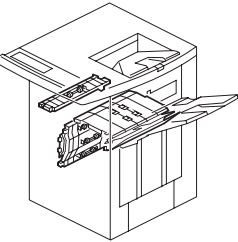
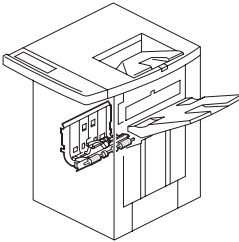
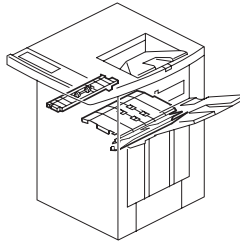
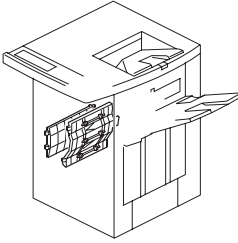
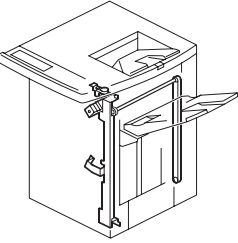
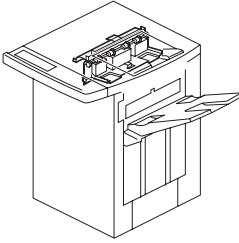
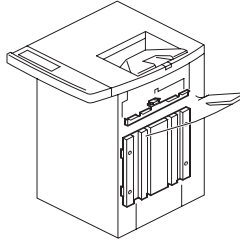
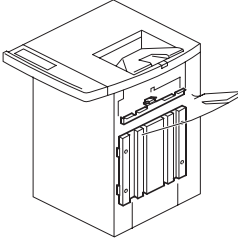
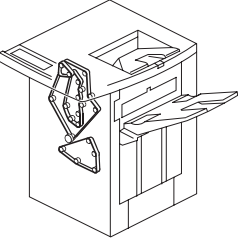
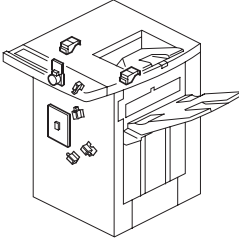
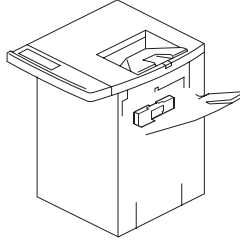
<p>1. EXTERIOR</p> 	<p>2. STAPLE TRAY 1</p> 	<p>3. STAPLE TRAY 2</p> 	<p>4. STAPLE TRAY 3</p> 
<p>5. STAPLE TRAY 4</p> 	<p>6. STAPLE TRAY 5</p> 	<p>7. STAPLE TRAY 6</p> 	<p>8. STAPLER UNIT 1</p> 
<p>9. STAPLER UNIT 2</p> 	<p>10. STAPLE TRANSPORT 1</p> 	<p>11. STAPLE TRANSPORT 2</p> 	<p>12. STAPLE TRANSPORT 3</p> 
<p>13. STAPLE TRANSPORT 4</p> 	<p>14. STAPLE TRANSPORT 5</p> 	<p>15. STAPLE TRANSPORT 6</p> 	<p>16. PAPER EXIT SECTION 1</p> 
<p>17. PAPER EXIT SECTION 2</p> 	<p>18. PAPER EXIT SECTION 3</p> 	<p>19. TRAY DRIVE SECTION 1</p> 	<p>20. TRAY DRIVE SECTION 2</p> 

21. JOGGER UNIT

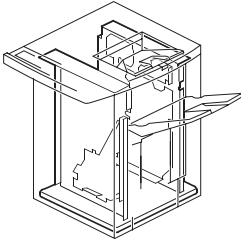

22. DRIVE SECTION 1

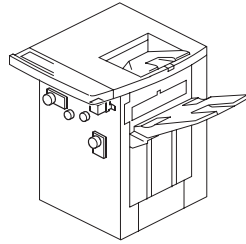

23. DRIVE SECTION 2

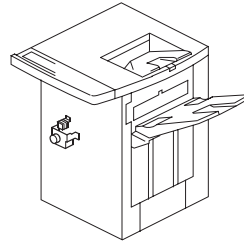

24. DRIVE SECTION 3

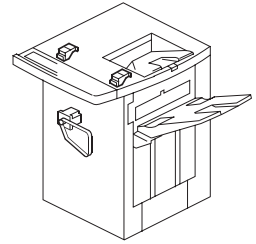

25. ELECTRICAL SECTION

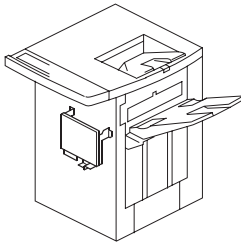

26. FRAME SECTION 1

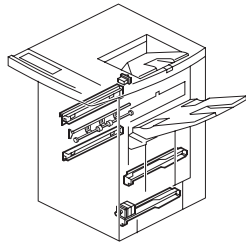

27. FRAME SECTION 2

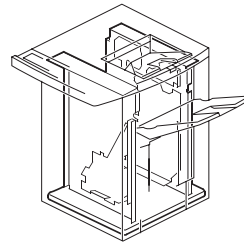

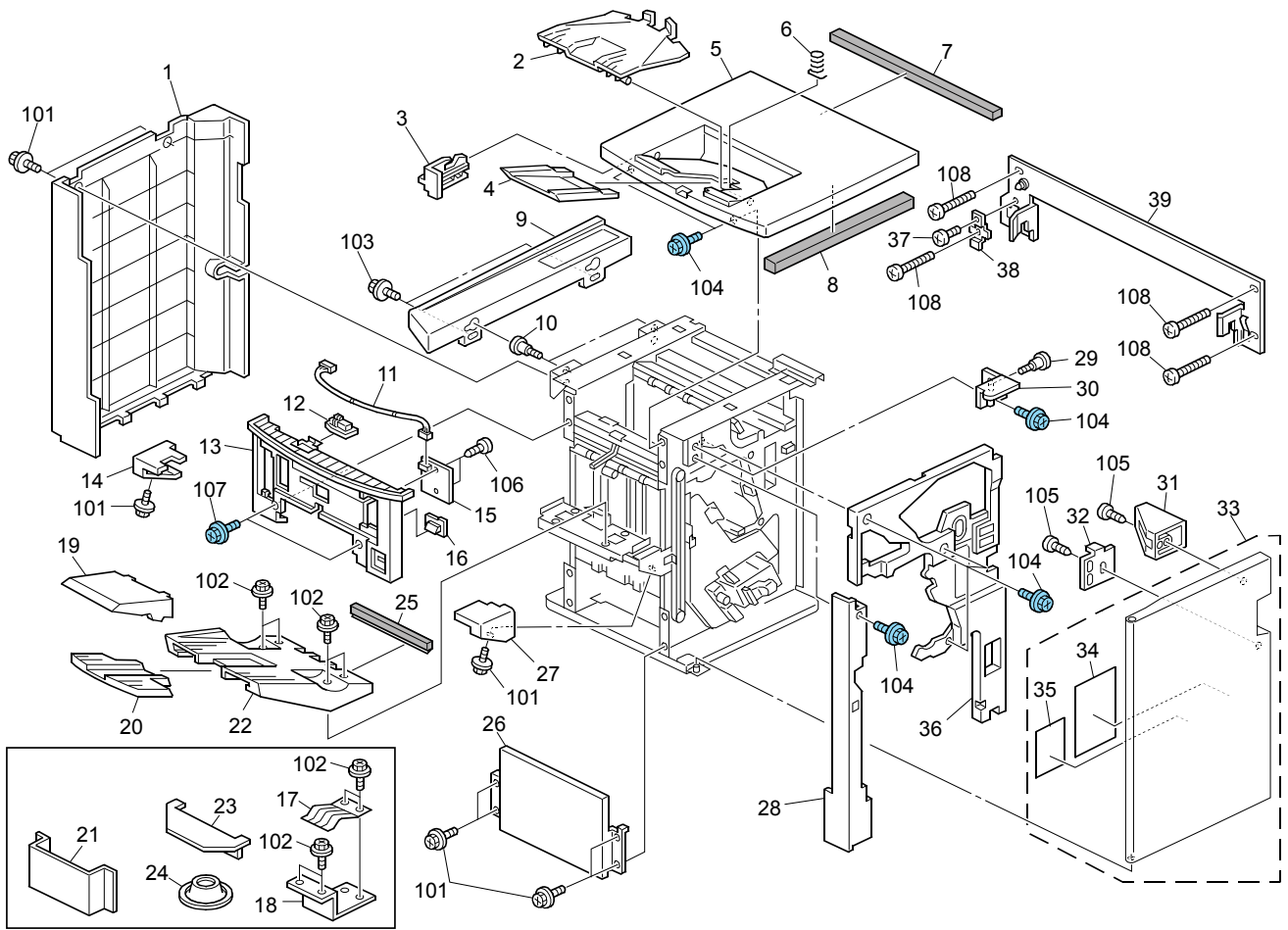

ITEM NO.	PARTS NO.	PARTS NAME	Q'TY / PAGE	Q'TY / PACK	P I R	B S I NO.	T O	T	F R O M	S E R I A L NO.	R E M A R K S	C
1	B4786212	Cover:Rear	1									
2	B8306131	Tray Cover - Upper	1									
3	B3026115	Tray Stopper	1									
4	B4786141	Tray:Slide	1									
5	B8306121	Cover - Upper	1									
6	B3026135	Spring - 23x44mm	1									
7	B3027531	Cushion -10x15x585	1									
8	B7066116	Cushion:Cover:Upper	1									
9	B4786450	Table:Ass'y	1									
10	B7061859	Screw:Slider:LOCK	2									
11	B8305256	Harness - Stop Switch	1									
12	B4786251	Lever:Slide	1									
13	B8306261	Cover - Left Upper	1									
14	B4786721	Cover:Shift Tray:Inner Ba	1									
15	B7065600	PCB:Switch:Stop	1									
16	B4786264	Keytop:Printing	1									
17	B3021163	Grounding Plate	1									
18	B3021164	Grounding Plate Bracket	1									
19	B7067631	Tray:Auxiliary:Shift Tray	1									
20	B8303332	Tray - Slide	1									
21	B0391321	Holder:Operating Instruct	1									
22	B8303331	Shift Tray	1									
23	B7067621	Tray:Auxiliary:Proof Tray	1									
24	B1321226	Holder:Stand	4									
25	B7063035	Guide:Micro Switch:Shift	1									
26	B4786311	Cover:Left Lower	1									
27	B4786711	Cover:Shift Tray:Front:RI	1									
28	B4786351	Inner Cover:Left Sideways	1									
29	AA143807	Screw:A	1									
30	B3026157	Upper Hinge - Front Door	1									
31	A6061595	Small Door Cover	1									
32	B8306161	Magnetic Door Catch	1									
33	B8306170	Cover - Front	1									
34	B8307710	Decal - Misfeed Removal P	1									
35	B8307711	Decal:Misfeed Removal:Sta	1									
36	B8306611	Inner Cover - Front	1									
37	AA143396	Screw - M4X4	1									
38	B8307536	Coupling Bracket - Correc	1									
39	B8307530	Coupling Bracket	1									
101	0451008N	Tapping Screw:4x8										
102	0451006N	Tapping Screw - 3x6										
103	0451008N	Tapping Screw:4x8										
104	0454008Q	Tapping Screw:3x8										
105	0452008N	Tapping Screw:M4x8										
106	0452008N	Tapping Screw:M4x8										
107	0454006Q	Tapping Screw - M3x6										
108	0354140N	Screw M4x14										

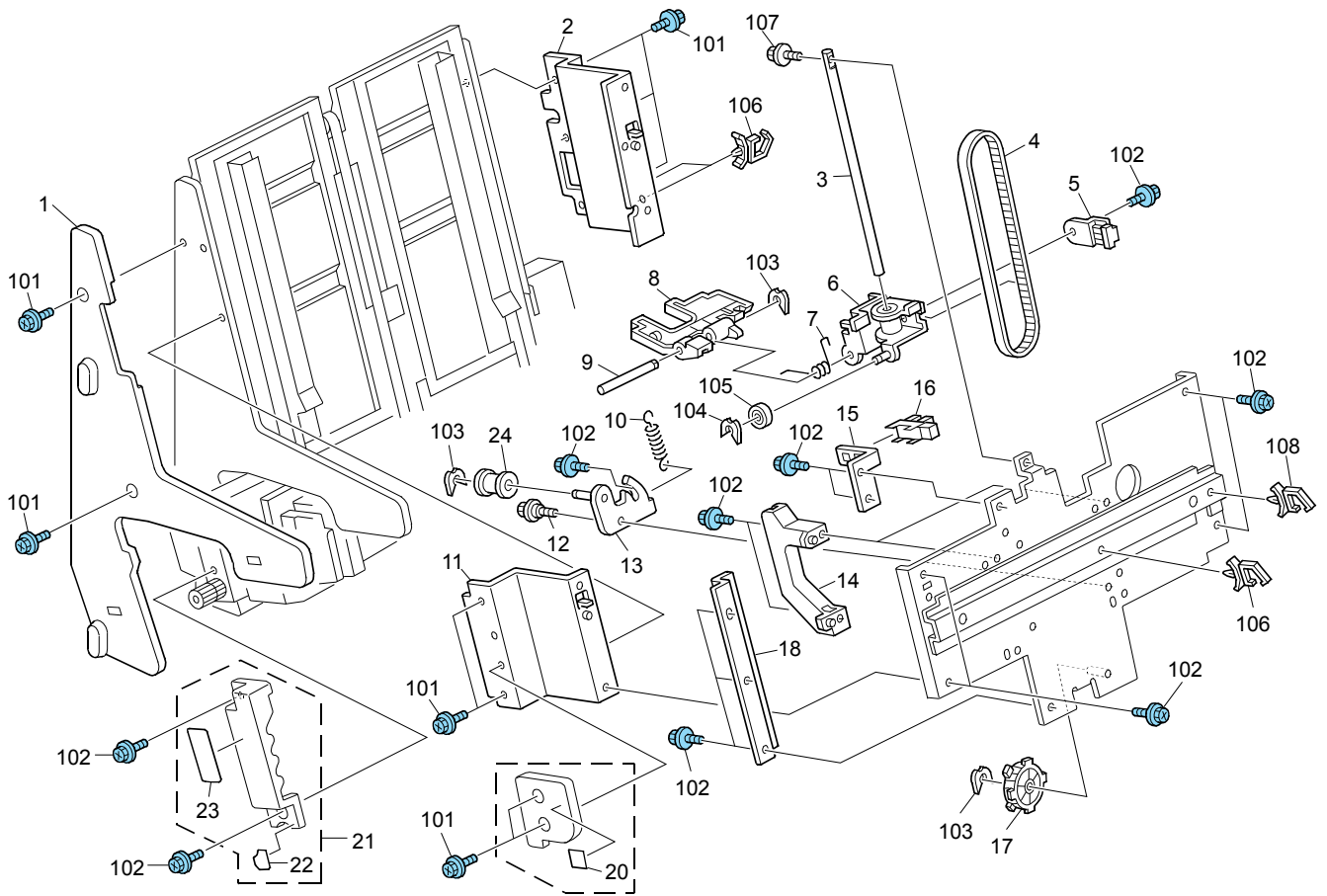

ITEM NO.	PARTS NO.	PARTS NAME	Q'TY / PAGE	Q'TY / PACK	P	I	R	BSI NO.	TO	T	FROM	SERIAL NO.	REMARKS	C
1	B8306651	Inner Cover - Stapler Uni	1											
2	B8304896	Bracket - Rear	1											
3	B8304872	Stopper Slide Shaft	1											
4	B8304889	Timing Belt - 40S2M500	1											
5	B8304871	Stay	1											
6	B8304863	Stopper Pawl Bracket	1											
7	B8304868	Torsion Spring	1											
8	B8304862	Stopper Pawl	1											
9	B8304869	Shaft	1											
10	B8304894	Tension Spring	1											
11	B8304897	Bracket - Front	1											
12	AA143790	Screw:Contact Point	1											
13	B8304891	Tightener	1											
14	B8304856	Guide	1											
15	B8304895	Stopper Sensor Bracket	1											
16	AW020156	PHOTOINTERRUPTOR:EE-SX423	1											
17	B8304888	Pulley - 43T	1											
18	B8304855	Rail	1											
19	B8307007	Stuni Grip	1											
20	B8307706	Decal - Stapler Tray (R8)	1											
21	B8304265	Slider Grip	1											
22	B8307708	Decal - Knob (R10)	1											
23	B8307707	Decal - Stapler Unit (R9)	1											
24	A5482139	Pulley	1											
101	0454008Q	Tapping Screw:3x8												
102	0454006Q	Tapping Screw - M3x6												
103	08050089	Retaining Ring - M4												
104	08050092	Retaining Ring - 3m												
105	07403004	Ball Bearing - 4x12x4												
106	11050516	Clamp												
107	0451010N	Tapping Screw:4x10												
108	11050487	Harness Clamp												

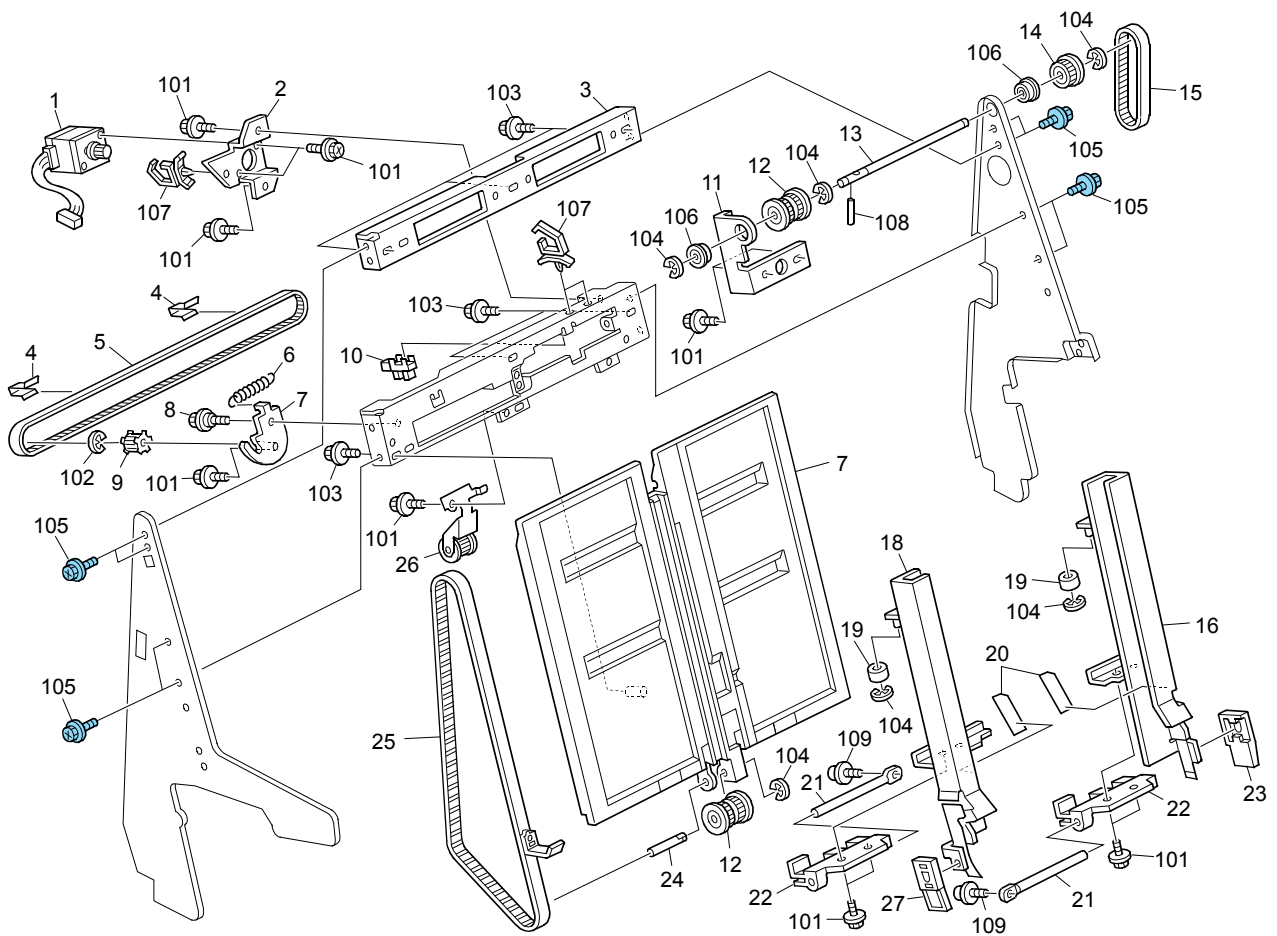

ITEM NO.	PARTS NO.	PARTS NAME	Q'TY / PAGE	Q'TY / PACK	P	I	R	B S I NO.	T O	T	F R O M	S E R I A L NO.	R E M A R K S	C
1	B8305565	Stepper Motor DC6.7V 16W	1											
2	B3024752	Jogger Motor Bracket	1											
3	B4784738	Stay:Stapler:Upper	1											
4	A3003634	Spring Plate - Timing Bel	2											
5	B3024756	Timing Belt - 753P3M6	1											
6	AA062334	Tension Spring:4.9n	1											
7	B4684766	Tightener	1											
8	AA143790	Screw:Contact Point	1											
9	AB030278	Idler - 20z	1											
10	AW020156	PHOTOINTERRUPTOR:EE-SX423	1											
11	B8304782	Bracket	1											
12	A6663180	Timing Pulley - Z32	1											
13	B8304781	Shaft	1											
14	A6972260	Pulley - 17T	1											
15	B3024421	Timing Belt - 293P3M6	1											
16	B8304620	Jogger Fence - Rear	1											
17	B8304711	Guide Plate - Stapler Tra	1											
18	B8304610	Jogger Fence - Front	1											
19	52012722	Bushing - M6x5	2											
20	B3024629	Guide Mylar	2											
21	B4784619	Shaft:Jogger Fence:Slide	2											
22	B3024617	Jogger Fence Slider	2											
23	B8304623	Cover - Rear Jogger Fence	1											
24	B3024731	Lower Exit Shaft	1											
25	B8304770	Exit Belt - 140S2M848	1											
26	B8304761	Tightener	1											
27	B8304613	Cover - Front Jogger Fenc	1											
101	0451006N	Tapping Screw - 3x6												
102	0720060E	Retaining Ring - M6												
103	0450008N	Tapping Screw - M4x8												
104	0720040E	Retaining Ring - M4												
105	0454006Q	Tapping Screw - M3x6												
106	07413506	Ball Bearing - 6x12x4mm												
107	11050516	Clamp												
108	0632100G	Pin - 2x10mm												
109	0951006N	Screw - M3X6												

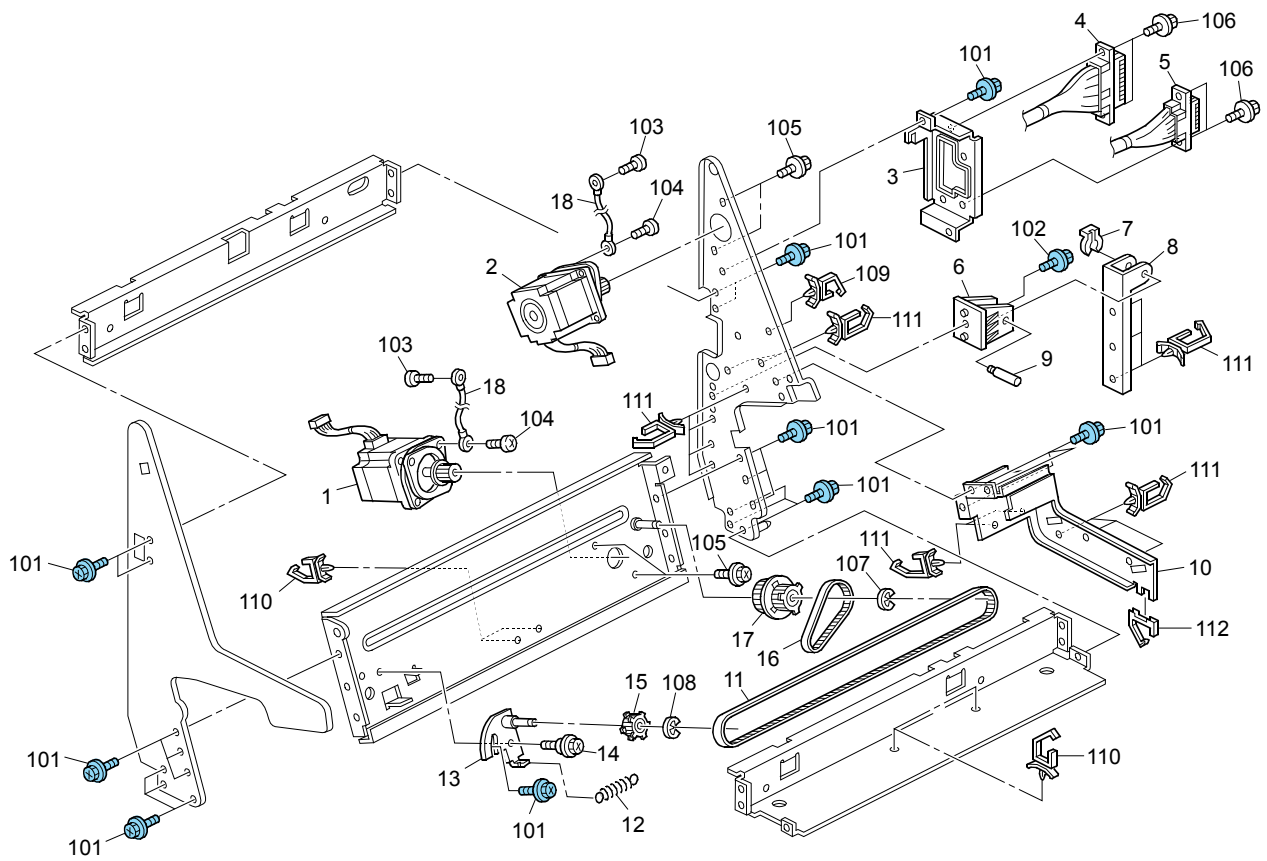

ITEM NO.	PARTS NO.	PARTS NAME	Q'TY / PAGE	Q'TY / PACK	P	I	R	B S I NO.	T O	T	F R O M	S E R I A L NO.	R E M A R K S	C
1	B8305574	Stepper Motor DC2.2V 5.7W	1											
2	B8305564	Stepper Motor DC1.35V 4W	1											
3	B8304431	Connector Bracket	1											
4	B8305286	Harness - Sensor Drawer	1											
5	B8305287	Harness - Motor Drawer	1											
6	B7004521	Holder:Arm:Harness	1											
7	52062686	Snap Ring	1											
8	B7004522	Arm:Harness:Stapler Unit	1											
9	B7004523	Pin:Fix:Arm	1											
10	B4784911	Arm:Swing Unit	1											
11	B3024756	Timing Belt - 753P3M6	1											
12	B4784257	Tension Spring:Tightener	1											
13	B4684766	Tightener	1											
14	AA143790	Screw:Contact Point	1											
15	AB030278	Idler - 20z	1											
16	B4784259	Timing Belt:171P3M6	1											
17	B4784256	Timing Pulley:20T-30T	1											
18	G4175626	Harness:Earth:Motor	2											
101	0454006Q	Tapping Screw - M3x6												
102	0454008Q	Tapping Screw:3x8												
103	0314050N	Pan Head Screw-m4x5												
104	0314080N	Philips Pan Head Screw -												
105	0451006N	Tapping Screw - 3x6												
106	0451010N	Tapping Screw:4x10												
107	0720040E	Retaining Ring - M4												
108	0720060E	Retaining Ring - M6												
109	11050516	Clamp												
110	11050487	Harness Clamp												
111	11050488	Harness Clamp												
112	11050518	Edge Saddle - Les-1010												

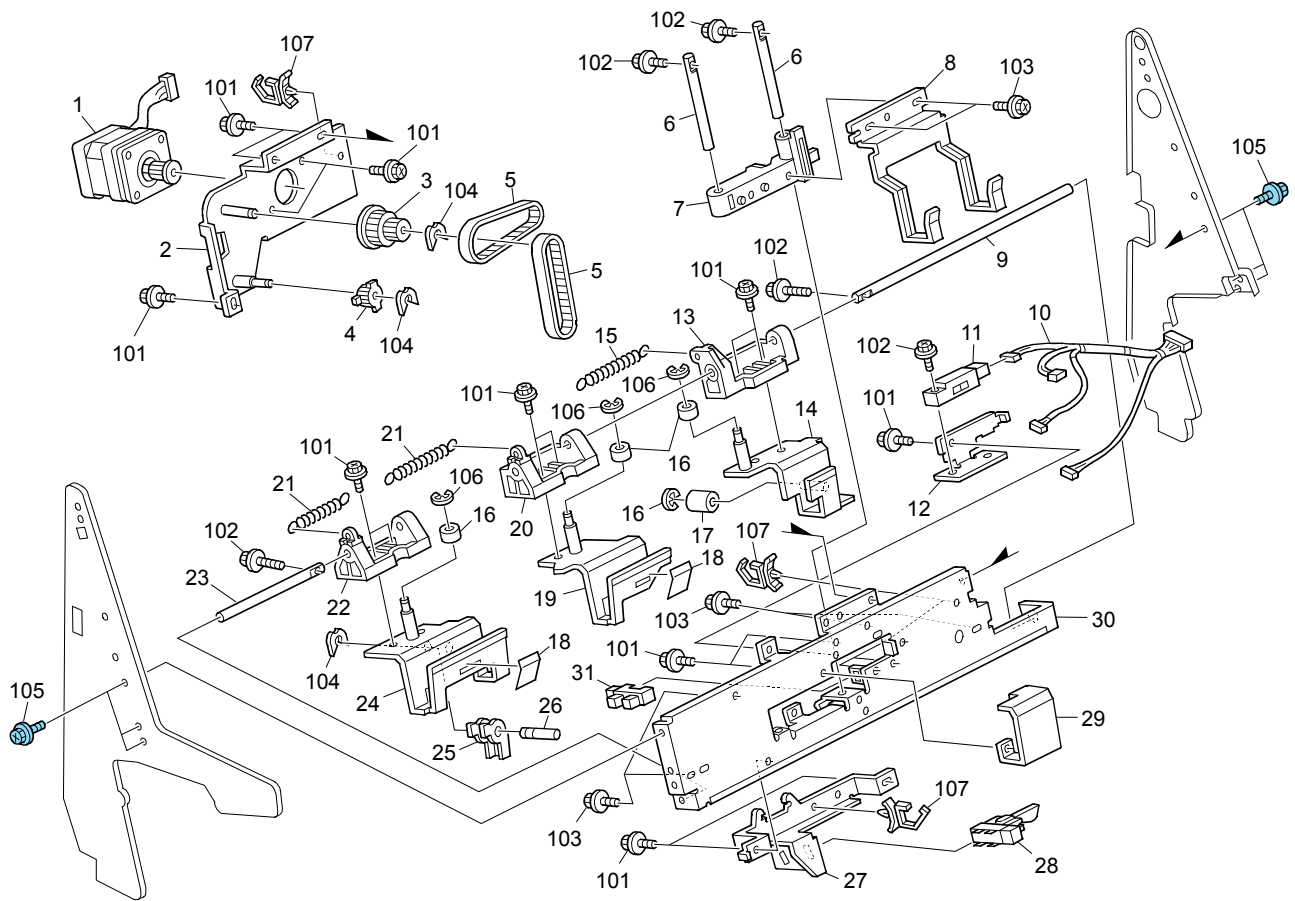

ITEM NO.	PARTS NO.	PARTS NAME	Q'TY / PAGE	Q'TY / PACK	P	I	R	B S I NO.	T O	T	F R O M	S E R I A L NO.	R E M A R K S	C
1	B8305573	Stepper Motor DC2.24V 3.5	1											
2	B8304961	Motor Bracket	1											
3	B8304966	Pulley - 20T/33T	1											
4	B6744334	Pulley - 20T	1											
5	AA043319	Timing Belt - 40S2M156	2											
6	B8304958	Shaft	2											
7	B8304965	Standard Fence Slider	1											
8	B8304957	Standard Fence	1											
9	B3024542	Rear Shaft - Slide Holder	1											
10	B8305262	Harness - Sensor	1											
11	AW010123	Photo Refiection Sensor:P	1											
12	B8304981	Sensor Bracket	1											
13	B8304535	Auxiliary Standard Fence	1											
14	B8304531	Auxiliary Standard Fence	1											
15	B7004107	Spring:Return:Standard Fe	1											
16	B4784538	Bushing:Standard Fence	3											
17	B3024239	Guide Roller	1											
18	B3024517	Mylar Guide	2											
19	B8304521	Standard Fence - Rear	1											
20	B8304525	Standard Fence Slider - R	1											
21	B7004107	Spring:Return:Standard Fe	2											
22	B8304515	Standard Fence Slider - F	1											
23	B3024541	Front Shaft - Slide Holde	1											
24	B8304511	Standard Fence - Front	1											
25	B8304517	Slider Hook Bracket	1											
26	B8304518	Slider Hook Shaft	1											
27	B8304971	Exit Sensor Bracket	1											
28	AW020182	Photointerruptor	1											
29	B8304721	Stapler Tray Guide Plate	1											
30	B8304951	Standard Fence Base	1											
31	AW020156	PHOTOINTERRUPTOR:EE-SX423	1											
101	0451006N	Tapping Screw - 3x6												
102	0451010N	Tapping Screw:4x10												
103	0450008N	Tapping Screw - M4x8												
104	08050089	Retaining Ring - M4												
105	0454006Q	Tapping Screw - M3x6												
106	0720040E	Retaining Ring - M4												
107	11050511	Harness Clamp - LWS-0306Z												

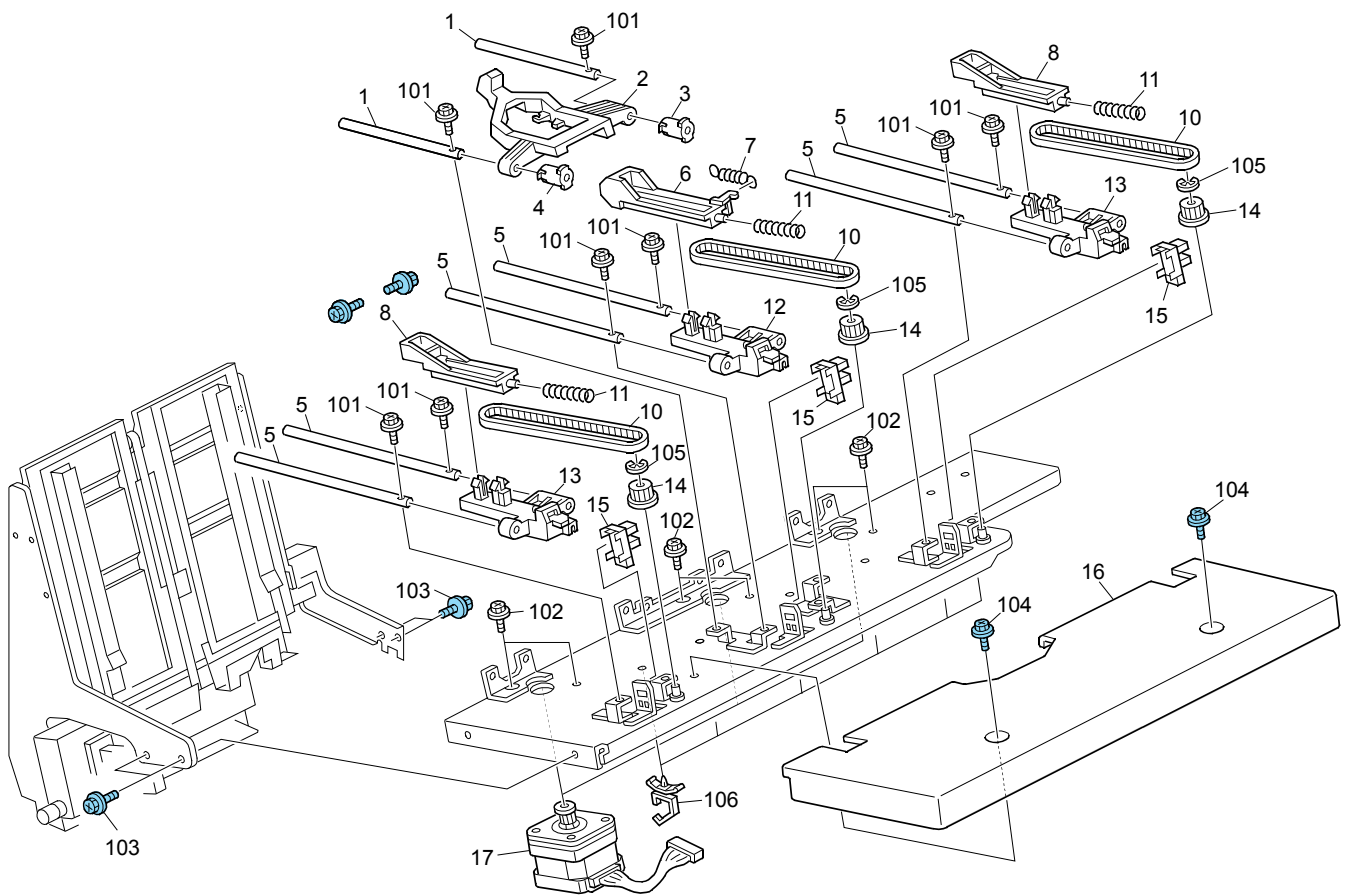

ITEM NO.	PARTS NO.	PARTS NAME	Q'TY / PAGE	Q'TY / PACK	P I R	B S I NO.	T O	T	F R O M	S E R I A L NO.	R E M A R K S	C
1	B8304127	Shaft	2									
2	B8304122	Vibrating Plate - Upper	1									
3	B3024112	Bushing - 6mm	1									
4	B3024113	Bushing - 6x9mm	1									
5	B4784137	Shaft:Vibrating Plate:Bot	6									
6	B8304123	Vibrating Plate - Lower	1									
7	B8304126	Tension Spring	1									
8	B8304131	Paper Vibrating Plate	2									
9	B8304125	Compression Spring	1									
10	B4784136	Timing Belt:B40S2M204	2									
11	B4784134	Compression Spring:Plate:	1									
12	B8304124	Slider	1									
13	B4784132	Slider:Vibrating Plate	1									
14	B4784135	Timing Pulley:18t	2									
15	AW020156	PHOTOINTERRUPTOR:EE-SX423	3									
16	B8304141	Cover - Vibrating Plate	1									
17	B8305573	Stepper Motor DC2.24V 3.5	1									
101	0451008N	Tapping Screw:4x8										
102	0451006N	Tapping Screw - 3x6										
103	0454006Q	Tapping Screw - M3x6										
104	0454008Q	Tapping Screw:3x8										
105	0720040E	Retaining Ring - M4										
106	11050516	Clamp										

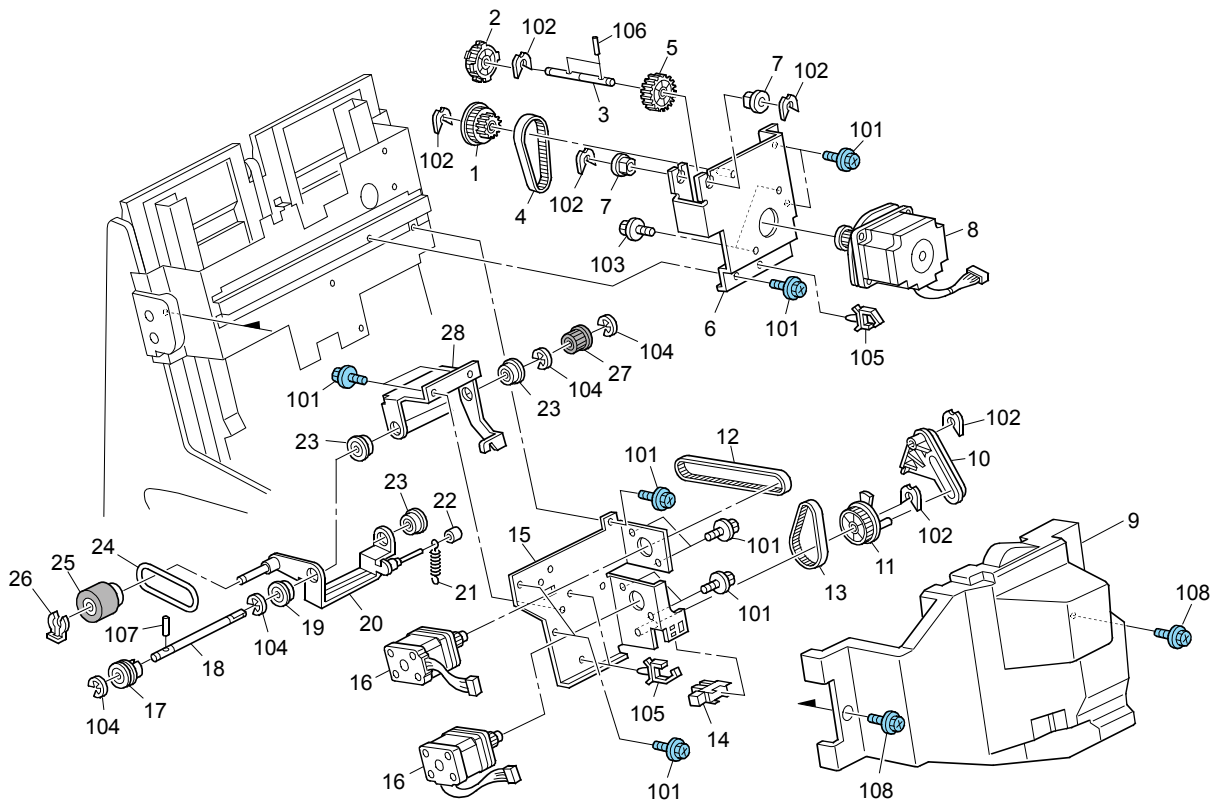

ITEM NO.	PARTS NO.	PARTS NAME	Q'TY / PAGE	Q'TY / PACK	P I R	B S I NO.	T O	T	F R O M	S E R I A L NO.	R E M A R K S	C
1	B8304885	Gear/pulley - 20Z/33T	1									
2	B6744527	Pulley - 48T	1									
3	B8304886	Gear/pulley Shaft	1									
4	B8304884	Timing Belt - 60S3M204	1									
5	B6744531	Gear - 30Z	1									
6	B8304881	Stopper Bracket	1									
7	50530447	Bushing - 6mm	2									
8	B8305562	Stepper Motor DC1.56V 3.7	1									
9	B8304899	Inner Cover	1									
10	B8302131	Gathering Roller Lever	1									
11	B8302132	Cam - Gathering Roller Le	1									
12	B8302141	Timing Belt - 60S3M237	1									
13	B8302142	Timing Belt - 60S3M162	1									
14	AW020156	PHOTOINTERRUPTOR:EE-SX423	1									
15	B8302121	Gathering Roller Bracket	1									
16	B8305567	Stepper Motor DC2.52V 4.5	2									
17	59192127	Positioning Roller Pulley	1									
18	B8302115	Gathering Roller Shaft	1									
19	A8592230	Ball Bearing - 6x13x5	1									
20	B8302111	Gathering Roller Arm	1									
21	B8302116	Tension Spring	1									
22	B8302126	Lever Cushion	1									
23	A8592230	Ball Bearing - 6x13x5	3									
24	59192132	Positioning Roller Belt	1									
25	B4782116	Reverse Roller - Stapler	1									
26	54472681	Snap Ring	1									
27	A6972260	Pulley - 17T	1									
28	B8302125	Gathering Roller Bracket	1									
101	0454006Q	Tapping Screw - M3x6										
102	08050089	Retaining Ring - M4										
103	0451006N	Tapping Screw - 3x6										
104	0720040E	Retaining Ring - M4										
105	11050487	Harness Clamp										
106	0622100E	Spring Pin - 2x10mm										
107	0623120E	Spring Pin - M3x12										
108	0454008Q	Tapping Screw:3x8										

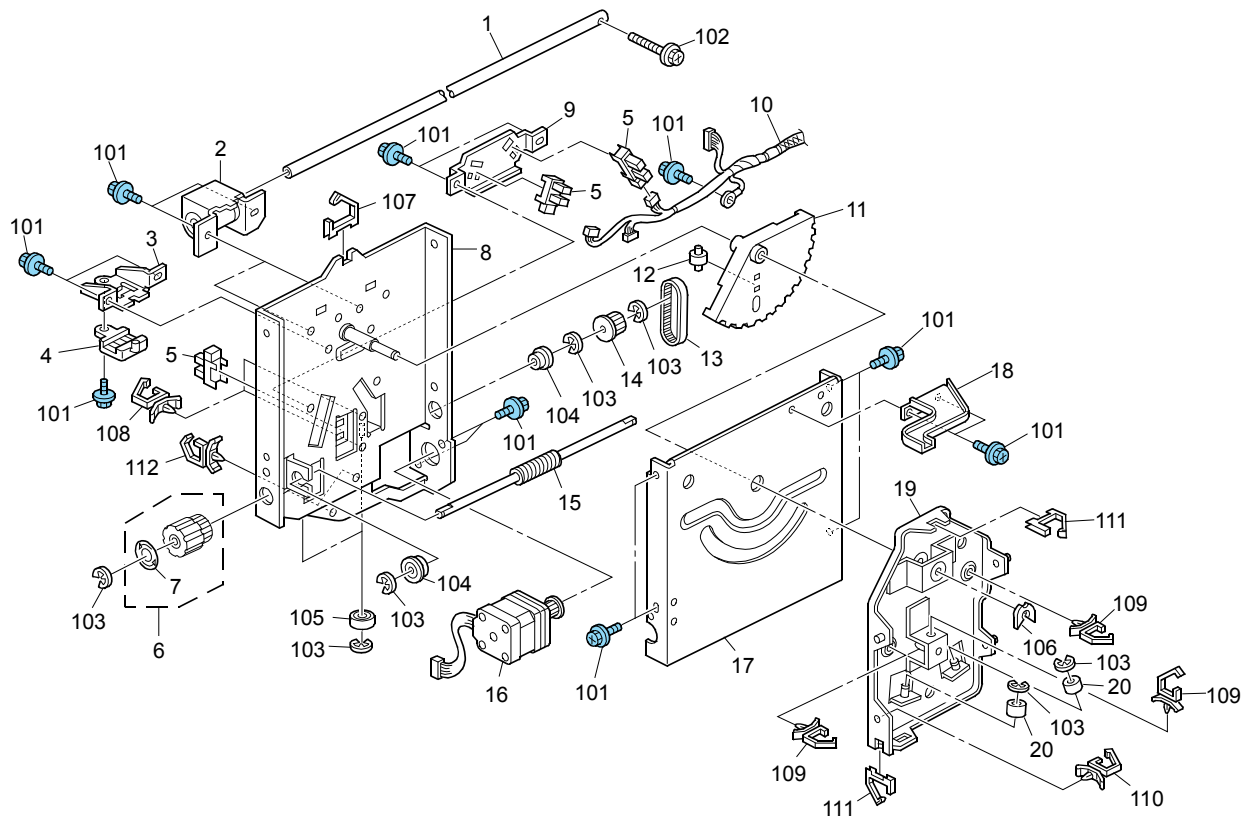

ITEM NO.	PARTS NO.	PARTS NAME	Q'TY / PAGE	Q'TY / PACK	P I R	B S I NO.	T O	T	F R O M	S E R I A L NO.	R E M A R K S	C
1	B4784255	Guide Rod:Stapler	1									
2	B8304245	Ball Bearing	1									
3	B4784291	Bracket:Stay:Timing Belt	1									
4	B3024292	Belt Holder	1									
5	AW020156	PHOTOINTERRUPTOR:EE-SX423	3									
6	B8304275	Knob	1									
7	B8307709	Decal - Stapler Unit (R10	1									
8	B8304235	Slider	1									
9	B8304249	Sensor Bracket	1									
10	B8305264	Harness - Home Position S	1									
11	B8304271	Gear - 166Z	1									
12	A3761343	Original Pressure Roller	1									
13	B8304263	Timing Belt - 60S2M140	1									
14	B8304262	Pulley - 19T	1									
15	B8304261	Worm Gear	1									
16	B7005807	Stepper Motor:MM42:S2M:T1	1									
17	B8304231	Stapler Holder - Middle	1									
18	B8304232	Fence Slider Hook - Rear	1									
19	B8304221	Stapler Holder	1									
20	A3774741	Roller - M14	2									
101	0454006Q	Tapping Screw - M3x6										
102	0451010N	Tapping Screw:4x10										
103	0720040E	Retaining Ring - M4										
104	07413506	Ball Bearing - 6x12x4mm										
105	07403506	Ball Bearing - 6x12x4 mm										
106	08050088	Retaining Ring - M6										
107	11050518	Edge Saddle - Les-1010										
108	11050623	Clamp - LEWS-0206S-V0										
109	11050516	Clamp										
110	11050488	Harness Clamp										
111	11050522	Edge Saddle - Les0510										
112	11050508	Harness Clamp - LWS-0711										

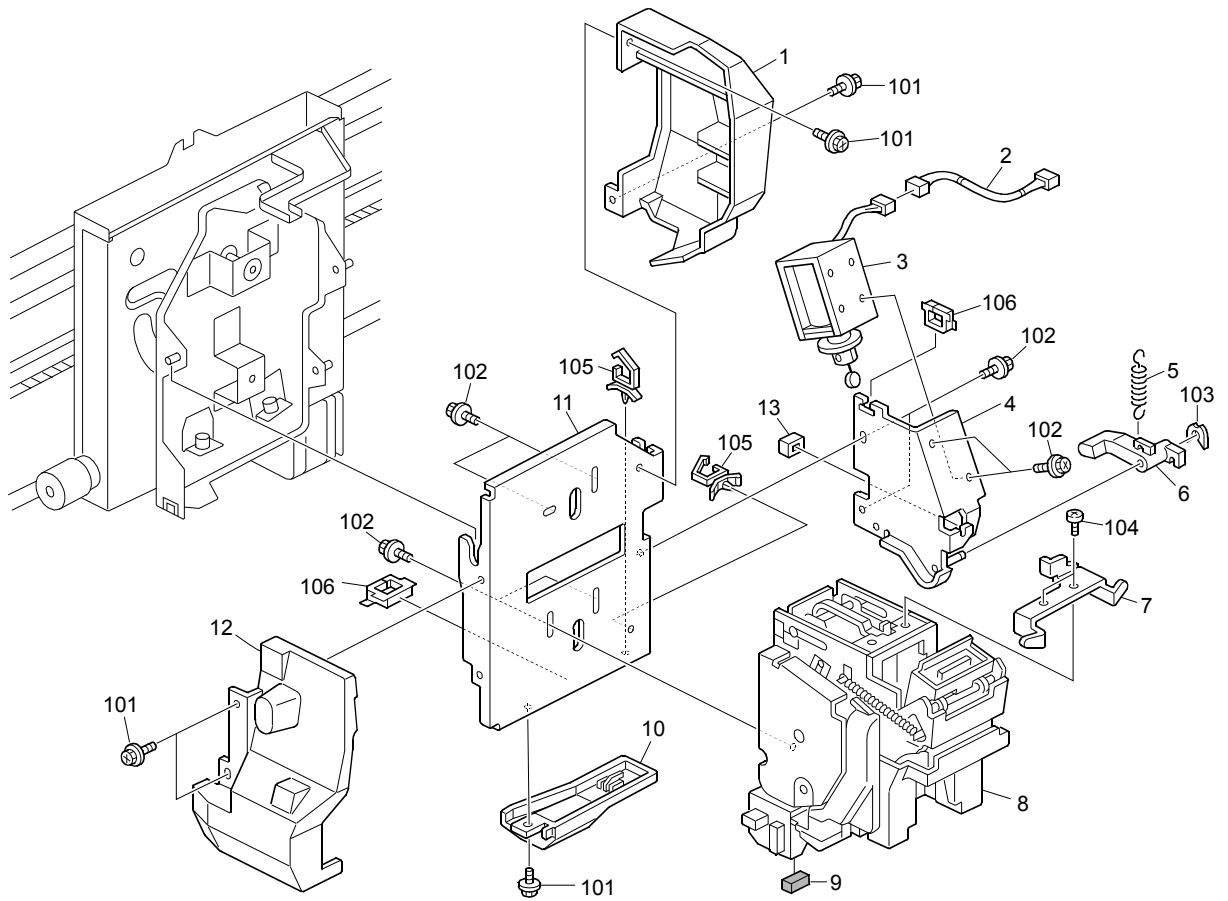

ITEM NO.	PARTS NO.	PARTS NAME	Q'TY / PAGE	Q'TY / PACK	P	I	R	B S I NO.	T O	T	F R O M	S E R I A L NO.	R E M A R K S	C
1	B8304217	Stapler Cover - Rear	1											
2	B8305278	Harness - DC Solenoid	1											
3	B8304286	DC Solenoid 24V	1											
4	B8304281	Lever Bracket	1											
5	B8304285	Tension Spring	1											
6	B8304284	Stapler Lever	1											
7	B8304213	Guide - Standard Fence	1											
8	AJ011023	Stapler:Eh-1200r	1											
9	B7031159	Guard:Frame	1											
10	B8304216	Cover - Stapler Harness	1											
11	B8304214	Stapler Base	1											
12	B8304215	Stapler Cover - Front	1											
13	A6972102	Damper - Junction Gate So	1											
101	0451008N	Tapping Screw:4x8												
102	0451006N	Tapping Screw - 3x6												
103	08050092	Retaining Ring - 3m												
104	0353040N	Screw - M3X4												
105	11050623	Clamp - LBWS-0206S-V0												
106	11050514	Edge Saddle - Eds-06071												

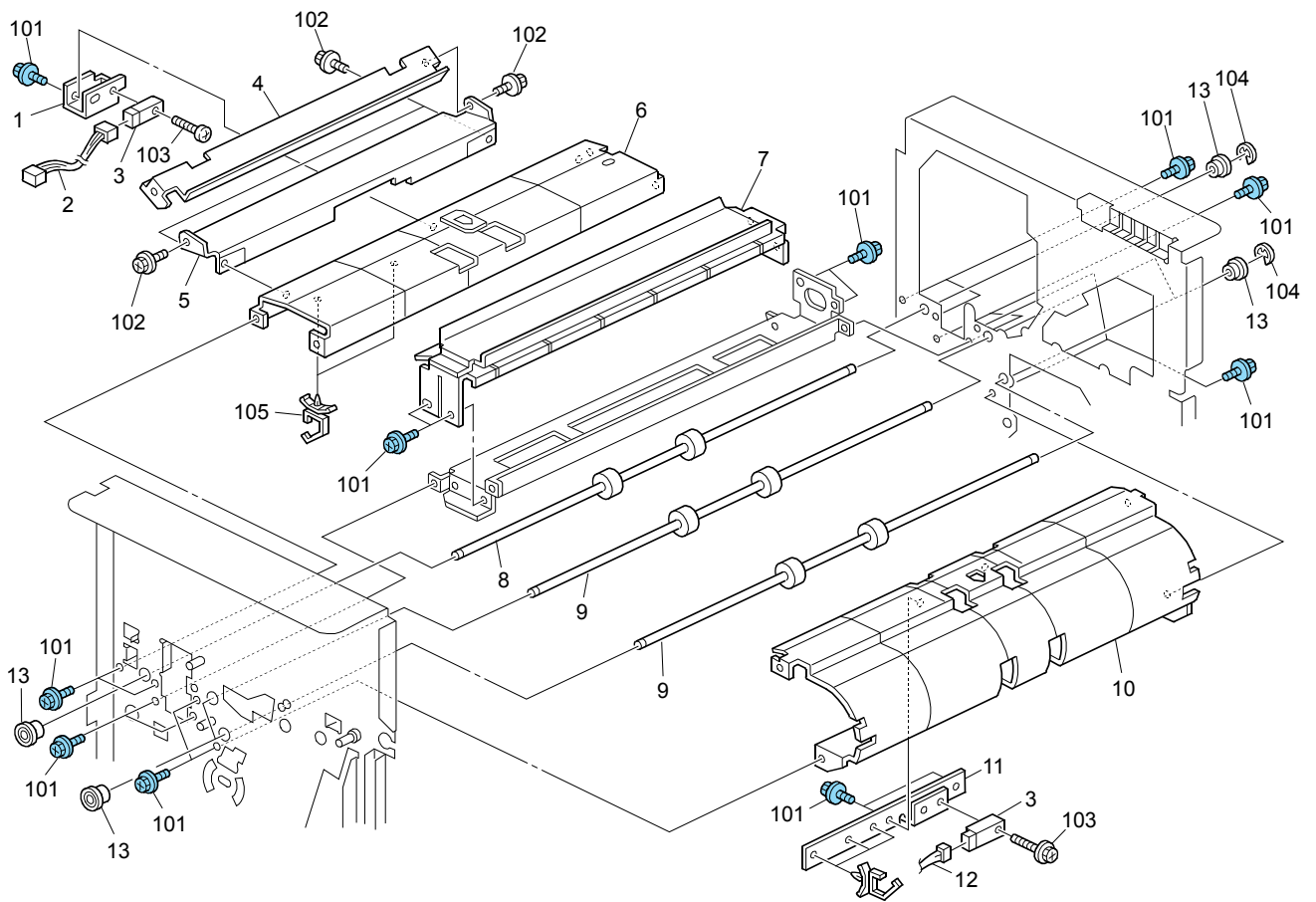

ITEM NO.	PARTS NO.	PARTS NAME	Q'TY / PAGE	Q'TY / PACK	P	I	R	B S I NO.	T O	T	F R O M	S E R I A L NO.	R E M A R K S	C
1	B4782354	Entrance Sensor Bracket	1											
2	B8305250	Harness - Entrance Sensor	1											
3	AW010109	Photo Refiection Sensor:P	2											
4	B8307512	Connecting Guide Plate -	1											
5	B8307511	Connecting Guide Plate -	1											
6	B8302363	Entrance Guide Plate - Lo	1											
7	B8302381	Guide Plate - Punch	1											
8	B8302408	Transport Roller	1											
9	B8302911	Transport Roller	2											
10	B8302347	Turn Guide Plate	1											
11	B8302359	Sensor Bracket	1											
12	B8305233	Harness - Paper Jam Senso	1											
13	A8592230	Ball Bearing - 6x13x5	4											
101	0454006Q	Tapping Screw - M3x6												
102	0451006N	Tapping Screw - 3x6												
103	0451014N	Tapping Screw:3x14												
104	0720040E	Retaining Ring - M4												
105	11050516	Clamp												

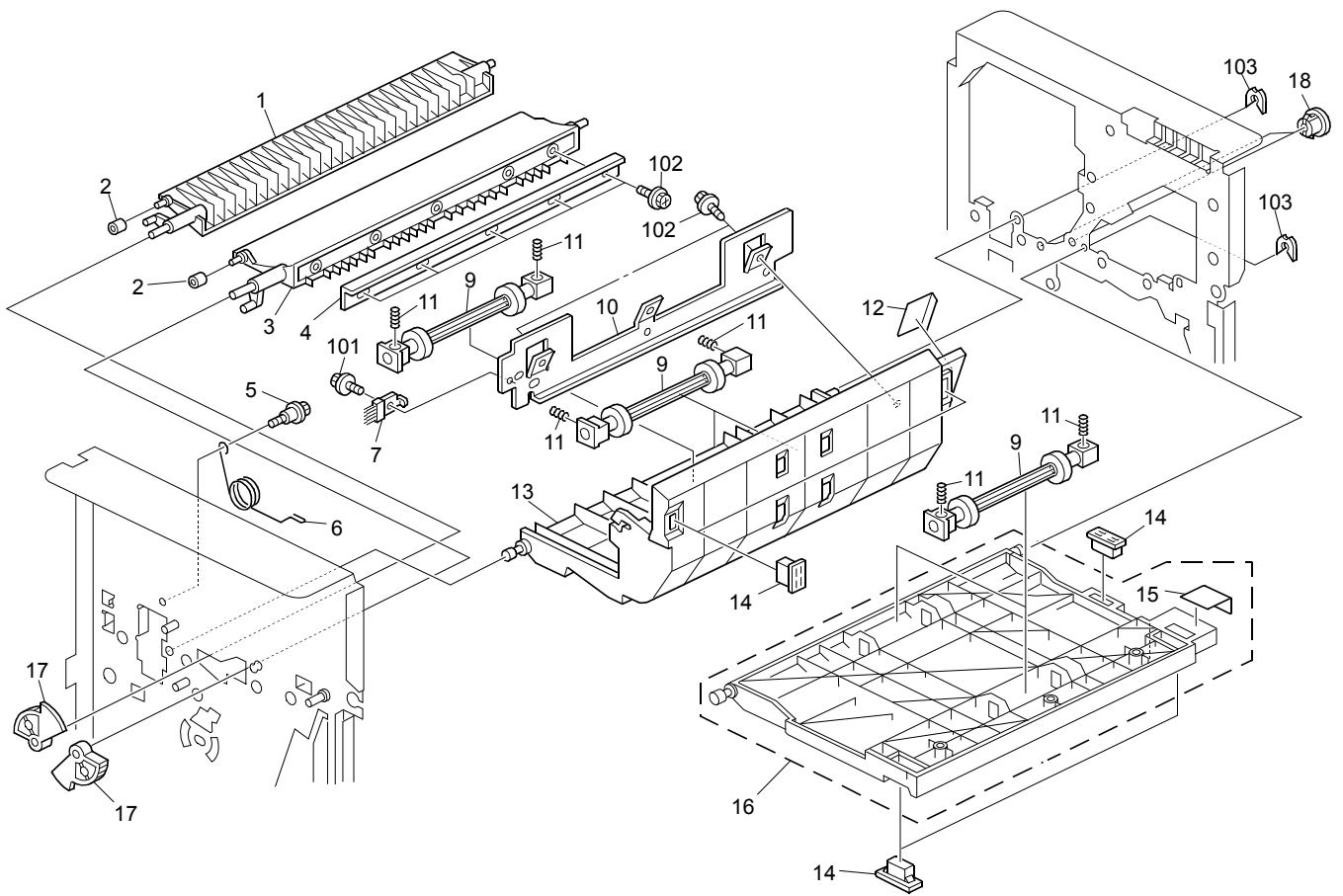

ITEM NO.	PARTS NO.	PARTS NAME	Q'TY / PAGE	Q'TY / PACK	P I R	B S I NO.	T O	T	F R O M	S E R I A L NO.	R E M A R K S	C
1	B8302612	Gate Pawl - Stapler Tray	1									
2	A4582251	Cushion - Bin Solenoid Le	2									
3	B8302514	Gate Pawl - Proof Tray	1									
4	B3022513	Support Plate - Exit Gate	1									
5	AA143702	Screw:Pin:Positioning	1									
6	B8302256	Torsion Spring	1									
7	AA120097	Antistatic Brush	1									
8	B7062224	Compression Spring:Transp	2									
9	AF022147	Driven Roller	3									
10	B8302354	Supporting Plate	1									
11	AA063400	Pressure Spring - 5.5x19.	4									
12	B3027702	Decal - R2	1									
13	B8302221	Guide Plate - Open And Cl	1									
14	AG070513	Magnet Catch	3									
15	B8307703	Decal - Shift Tray (R3)	1									
16	B8302343	Guide Plate - Open And Cl	1									
17	B8302519	Gear - 91Z	2									
18	A2596590	Bushing	2									
101	0451006N	Tapping Screw - 3x6										
102	0450008N	Tapping Screw - M4x8										
103	08050089	Retaining Ring - M4										

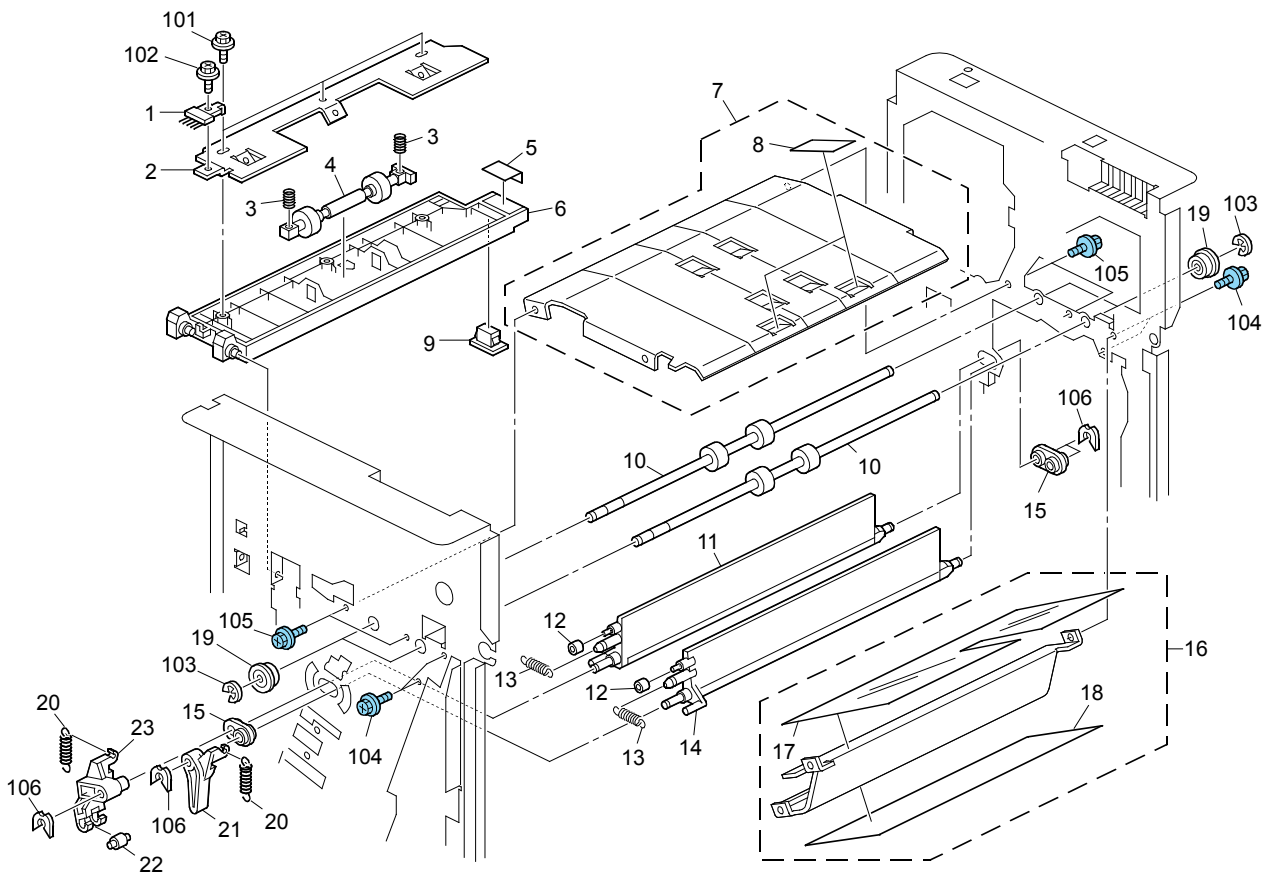

ITEM NO.	PARTS NO.	PARTS NAME	Q'TY / PAGE	Q'TY / PACK	P I R	B S I NO.	T O	T	F R O M	S E R I A L NO.	R E M A R K S	C
1	AA120097	Antistatic Brush	1									
2	B8302354	Supporting Plate	1									
3	AA063400	Pressure Spring - 5.5x19.	2									
4	AF022147	Driven Roller	1									
5	B8307701	Decal - Entrance (R1)	1									
6	B8302353	Guide Plate - Entrance	1									
7	B8302366	Guide Plate - Lower	1									
8	B8302368	Guide - Auxiliary Shift	1									
9	AG070513	Magnet Catch	1									
10	B8302921	Transport Roller	2									
11	B8302726	Lengthwise Gate Pawl - Ri	1									
12	A4582251	Cushion - Bin Solenoid Le	2									
13	AA062333	Tension Spring:2.16n	2									
14	B8302716	Lengthwise Gate Pawl - Le	1									
15	B8302477	Bushing	2									
16	B8302361	Exit Guide Plate	1									
17	B8302362	Guide - Auxiliary Gate	1									
18	B7062361	Guide:Discharge (exit):Le	1									
19	A8592230	Ball Bearing - 6x13x5	2									
20	B8302724	Tension Spring	2									
21	B8302731	Arm - Left	1									
22	B8302729	Roller	1									
23	B8302728	Arm - Right	1									
101	0450008N	Tapping Screw - M4x8										
102	0451006N	Tapping Screw - 3x6										
103	0720040E	Retaining Ring - M4										
104	0454006Q	Tapping Screw - M3x6										
105	0454006Q	Tapping Screw - M3x6										
106	08050089	Retaining Ring - M4										

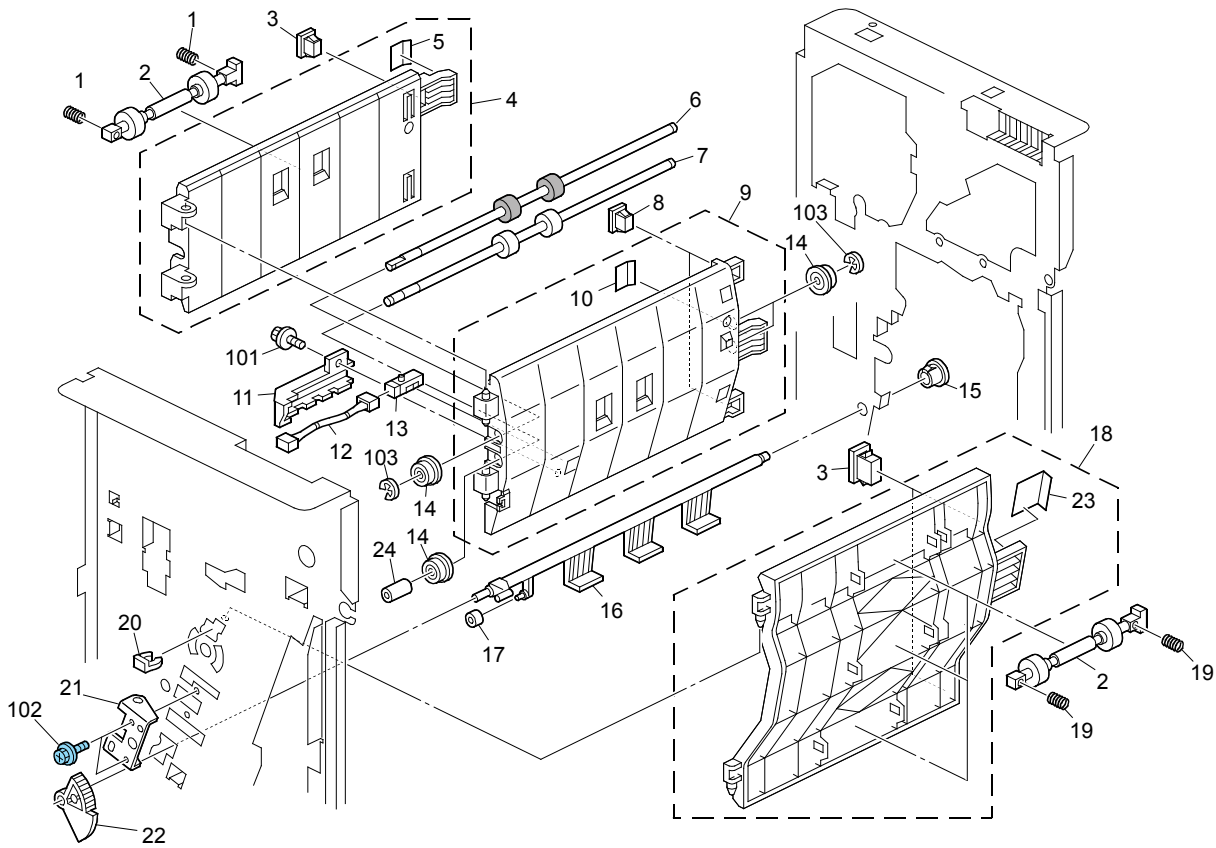

ITEM NO.	PARTS NO.	PARTS NAME	Q'TY / PAGE	Q'TY / PACK	P I R	B S I NO.	T O	T	F R O M	S E R I A L NO.	R E M A R K S	C
1	B8302466	Compression Spring	2									
2	AF022147	Driven Roller	2									
3	AG070513	Magnet Catch	2									
4	B8302465	Lengthwise Guide Plate -	1									
5	B8307704	Decal - Lengthwise Right	1									
6	B8302453	Transport Roller - Duplex	1									
7	B8302445	Transport Roller	1									
8	G0121531	Magnet	2									
9	B8302442	Lengthwise Guide Plate -	1									
10	B3027705	Decal - R5	1									
11	B3022442	Cover - Stack Tray Paper	1									
12	B8305266	Harness - Sensor	1									
13	AW010109	Photo Refiection Sensor:P	1									
14	A8592230	Ball Bearing - 6x13x5	4									
15	A2596590	Bushing	1									
16	B8302816	Stopper Pawl	1									
17	A4582251	Cushion - Bin Solenoid Le	1									
18	B8302434	Lengthwise Guide Plate -	1									
19	AA063400	Pressure Spring - 5.5x19.	2									
20	C1012360	Snap Ring	1									
21	B8302444	Coupling Bracket - Middle	1									
22	B8302519	Gear - 91Z	1									
23	B3027704	Decal - R4	1									
24	B8302443	Spacer:Transport Roller	1									
101	0450008N	Tapping Screw - M4x8										
102	0454006Q	Tapping Screw - M3x6										
103	0720040E	Retaining Ring - M4										

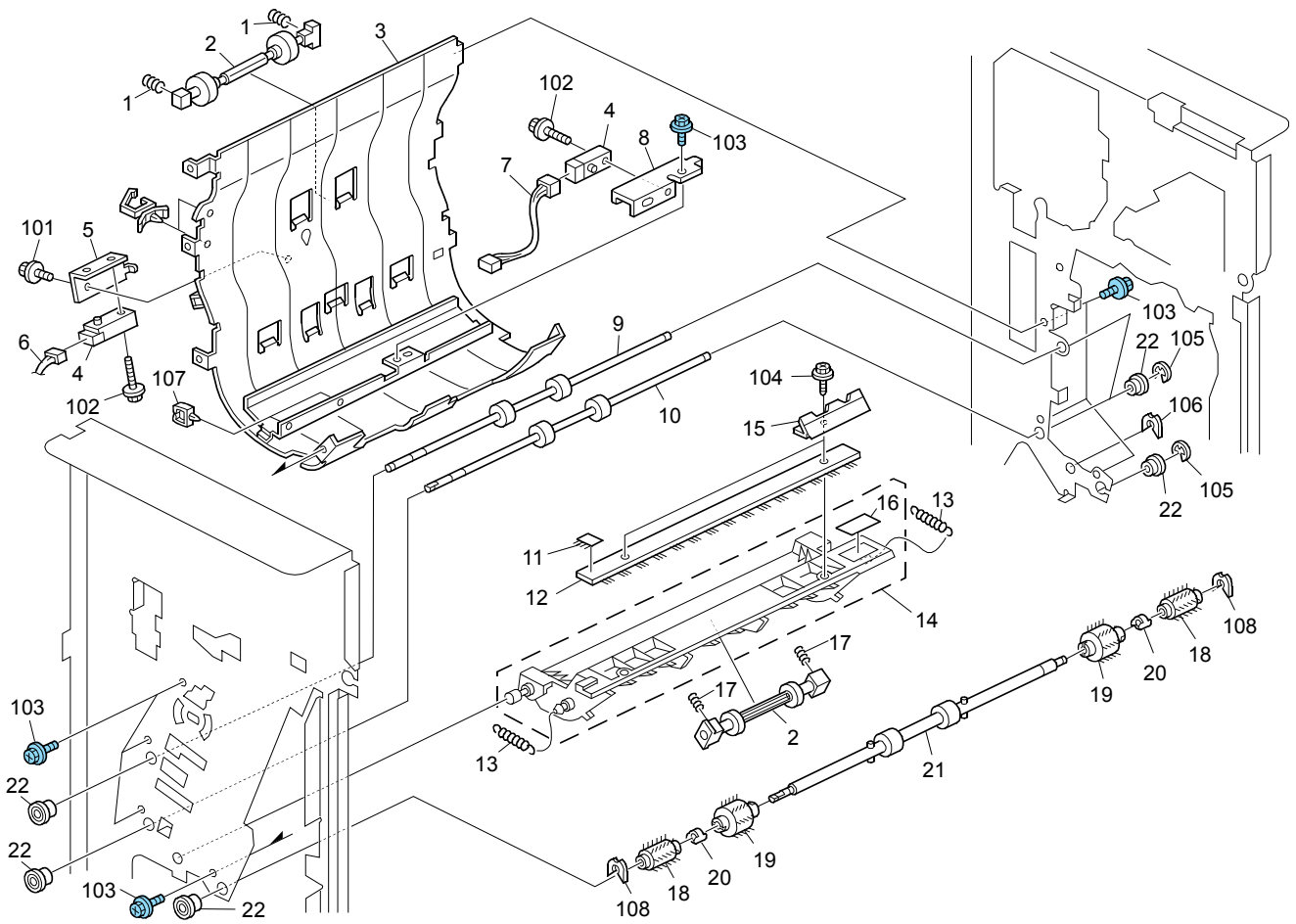

ITEM NO.	PARTS NO.	PARTS NAME	Q'TY / PAGE	Q'TY / PACK	P	I	R	B S I NO.	T O	T	F R O M	S E R I A L NO.	R E M A R K S	C
1	B7062224	Compression Spring:Transp	2											
2	AF022147	Driven Roller	2											
3	B8302435	Guide Plate - Lengthwise	1											
4	AW010109	Photo Refiection Sensor:P	2											
5	B8302422	Positioning Sensor Bracke	1											
6	B8305247	Harness - Sensor	1											
7	B8305261	Harness:Paper Feed Sensor	1											
8	B3022416	Exit Sensor Bracket - Sta	1											
9	B8302921	Transport Roller	1											
10	B8302408	Transport Roller	1											
11	A6972131	Antistatic Brush	1											
12	B7002317	Discharge Brush	1											
13	B3022459	Spring - 5x39mm	2											
14	B8302450	Guide Plate - Lower	1											
15	B4782452	Guide:Open And Close	1											
16	B8307705	Decal - Stapler Tray Exit	1											
17	AA063529	Pressure Spring - 14.5mm	2											
18	B3022413	Brush Roller	2											
19	A6972138	Brush Roller	2											
20	A6972132	Joint - Brush Roller	2											
21	B8302411	Exit Roller - Lower	1											
22	A8592230	Ball Bearing - 6x13x5	6											
101	0451006N	Tapping Screw - 3x6												
102	0451014N	Tapping Screw:3x14												
103	0454006Q	Tapping Screw - M3x6												
104	0450008N	Tapping Screw - M4x8												
105	0720040E	Retaining Ring - M4												
106	08050089	Retaining Ring - M4												
107	11050199	Clamp												
108	08050088	Retaining Ring - M6												

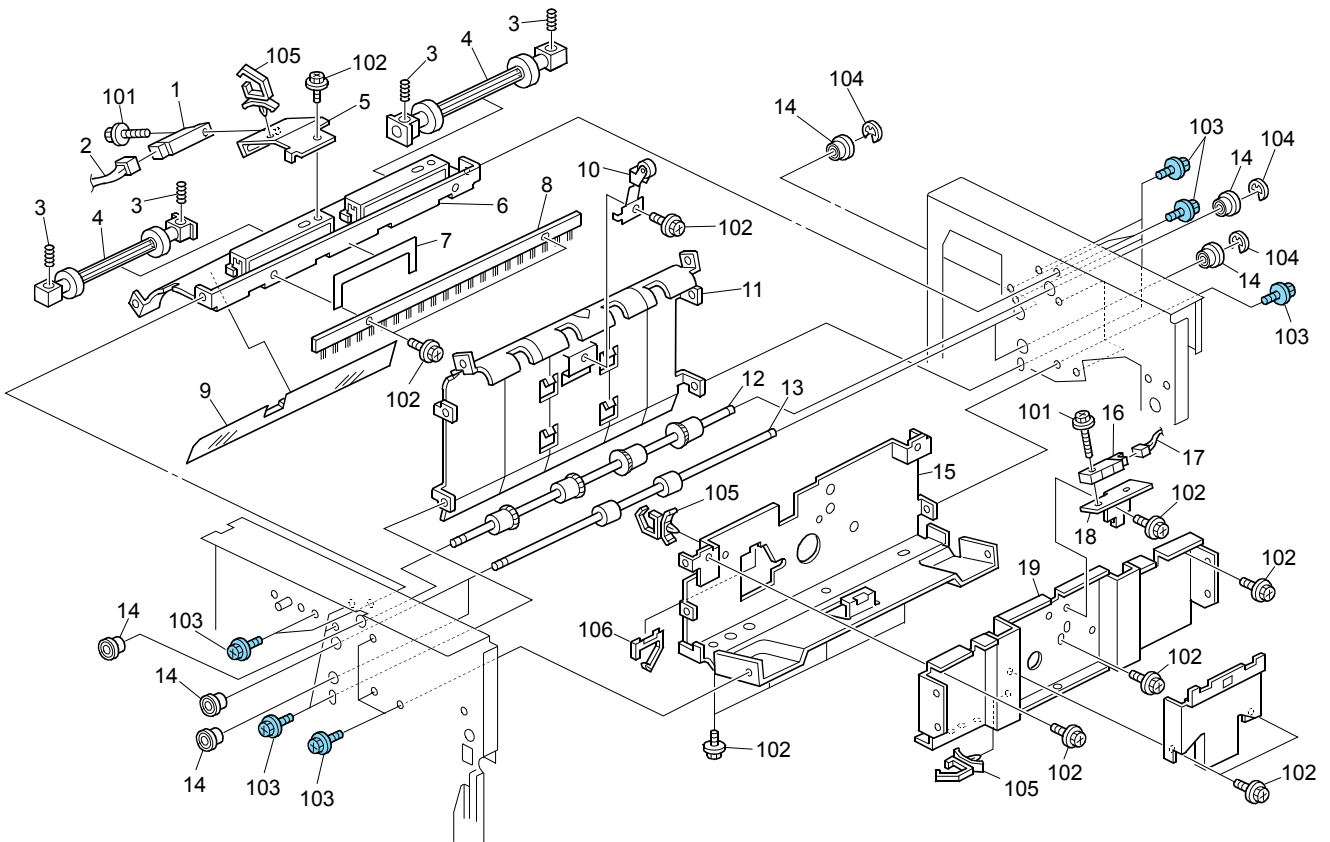

ITEM NO.	PARTS NO.	PARTS NAME	Q'TY / PAGE	Q'TY / PACK	P	I	R	B S I NO.	T O	T	F R O M	S E R I A L NO.	R E M A R K S	C
1	AW010123	Photo Refiection Sensor:P	1											
2	B8305251	Harness - Paper Feed Sens	1											
3	AA063529	Pressure Spring - 14.5mm	4											
4	AF022148	Roller:Driven:L=125	2											
5	B8302217	Exit Sensor Bracket	1											
6	B7062211	Guide Plate:Upper:Fix:Pro	1											
7	B3022216	Exit Guide - Upper Exit G	1											
8	B7062213	Discharge Brush - L=320 M	1											
9	B7062216	Silencer	1											
10	B4782231	Roller:Exit:Auxiliary:Ass	1											
11	B8302225	Proof Tray Guide Plate -	1											
12	B8302202	Exit Roller - Proof Tray	1											
13	B8302921	Transport Roller	1											
14	A8592230	Ball Bearing - 6x13x5	6											
15	B8302246	End Plate - Lower	1											
16	AW010091	Photo Reflection Sensor	1											
17	B8305252	Harness - Proof Tray Sens	1											
18	B7062246	Bracket:Photo Refiection	1											
19	B4782243	End Plate:Upper:Exit:Proo	1											
20	B7062248	Cover - Sensor	1											
101	0451012N	Tapping Screw:4x12												
102	0451006N	Tapping Screw - 3x6												
103	0454006Q	Tapping Screw - M3x6												
104	0720040E	Retaining Ring - M4												
105	11050623	Clamp - LBWS-0206S-V0												
106	11050522	Edge Saddle - Les0510												

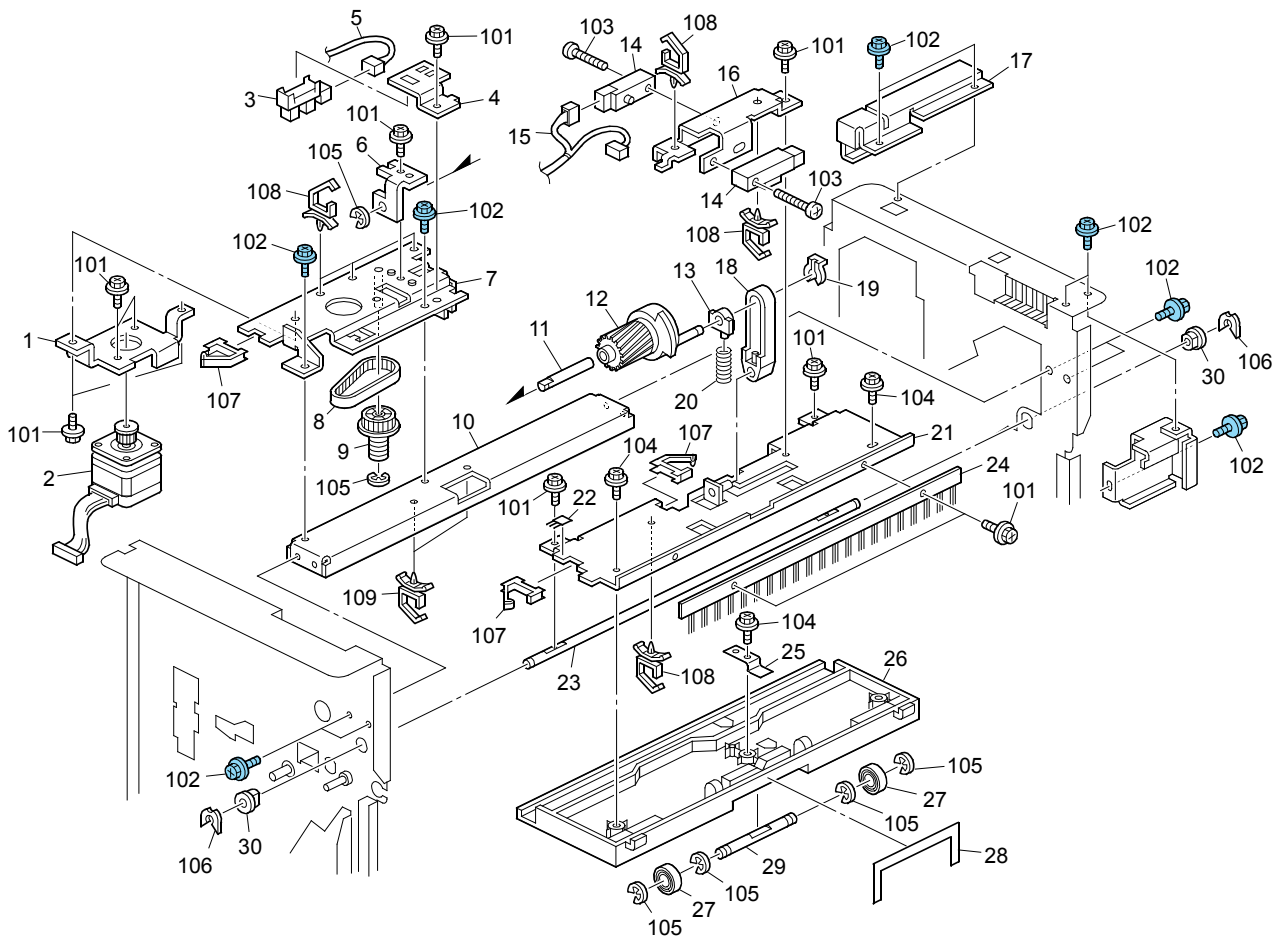

ITEM NO.	PARTS NO.	PARTS NAME	Q'TY / PAGE	Q'TY / PACK	P	I	R	BSI NO.	TO	T	FROM	SERIAL NO.	REMARKS	C
1	B8301448	Bracket:Stepper Motor:Dri	1											
2	B8305568	Stepper Motor DV2.52V 4.5	1											
3	AW020156	PHOTOINTERRUPTOR:EE-SX423	1											
4	B8301455	Bracket - Home Position S	1											
5	B8305253	Harness - Exit Sensor	1											
6	B8301447	Worm Wheel Guide Plate	1											
7	B8301444	Drive Guide Plate - Exit	1											
8	B8301456	Timing Belt - 40S2M190	1											
9	B7003115	Worm Gear:37t	1											
10	B4781133	Upper Exit Stay	1											
11	B8301449	Shaft - Worm Wheel	1											
12	B8301451	Worm Wheel - 16z	1											
13	B4682882	Link Bushing	1											
14	AW010091	Photo Reflection Sensor	2											
15	B8305254	Harness - Exit Shift Sens	1											
16	B8302326	Exit Sensor Bracket	1											
17	B3026414	Upper Cover Stay	1											
18	B8301458	Link - Exit Roller Driven	1											
19	54472681	Snap Ring	1											
20	B8301459	Compression Spring	1											
21	B8302327	Exit Guide Bracket	1											
22	A6972131	Antistatic Brush	1											
23	B8302323	Guide Plate Shaft	1											
24	B7062323	Discharge Brush:L=320:Mm3	1											
25	A3533354	Driven Roller Holder	1											
26	B8302322	Exit Guide Plate	1											
27	B4782328	Exit Roller:Driven	2											
28	A3792215	Exit Mylar	1											
29	B4782324	Exit Roller Shaft	1											
30	50530447	Bushing - 6mm	2											
101	0451006N	Tapping Screw - 3x6												
102	0454006Q	Tapping Screw - M3x6												
103	0353140N	Screw:M3x14												
104	0450008N	Tapping Screw - M4x8												
105	0720040E	Retaining Ring - M4												
106	08050089	Retaining Ring - M4												
107	11050522	Edge Saddle - Les0510												
108	11050623	Clamp - LBWS-0206S-V0												
109	11050487	Harness Clamp												

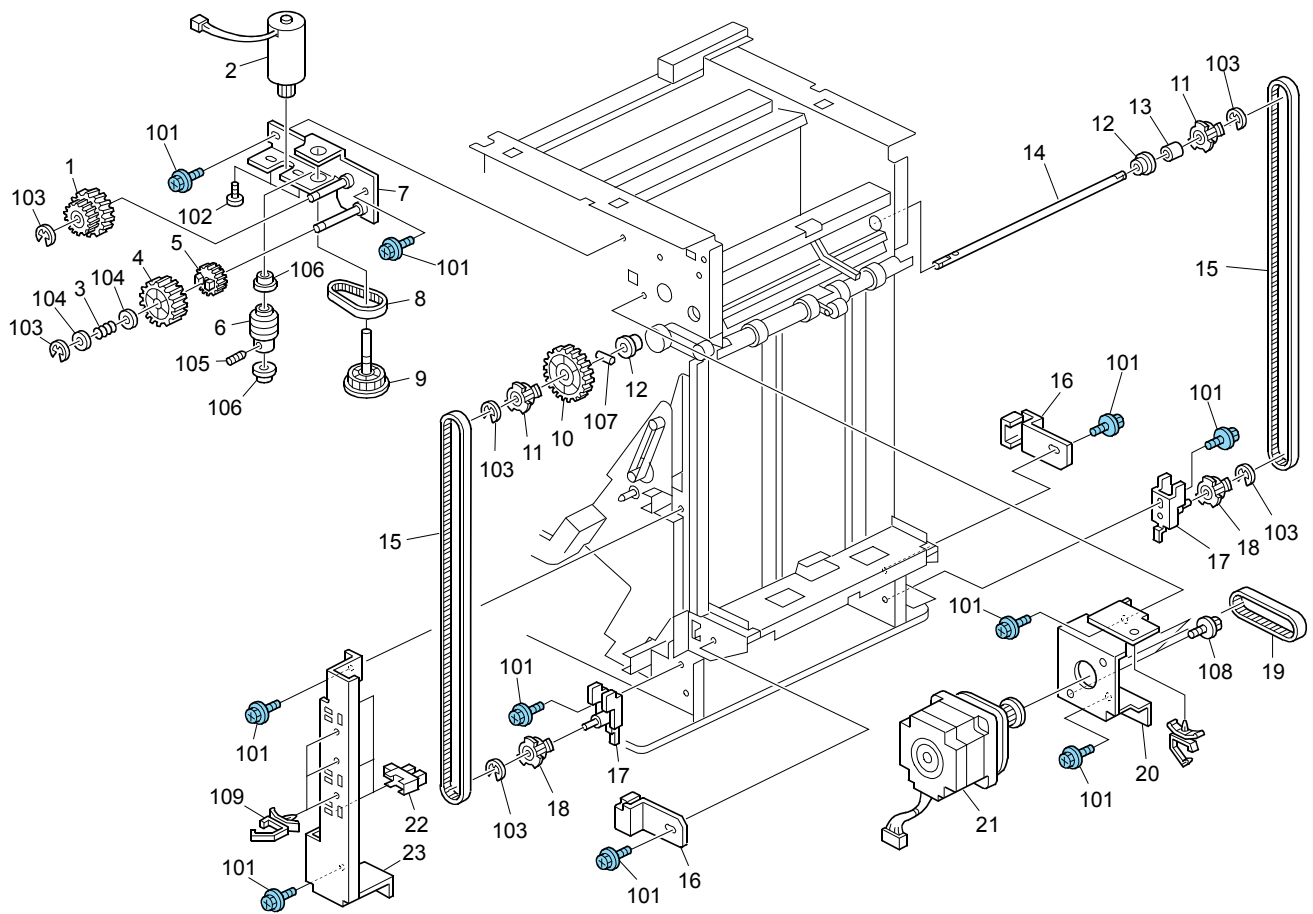

ITEM NO.	PARTS NO.	PARTS NAME	Q'TY / PAGE	Q'TY / PACK	P	I	R	B S I NO.	T O	T	F R O M	S E R I A L NO.	R E M A R K S	C
1	A6973145	Gear - 36Z/18Z	1											
2	AX050277	DC Motor:24V:9.9W	1											
3	B7003322	Compression Spring - 10n	1											
4	A6973140	Gear - 30Z	1											
5	A6973135	Gear - 18Z	1											
6	A3002736	Worm Gear	1											
7	B8303118	Bracket - Upper Lower	1											
8	B8303115	Timing Belt - 40S2M142	1											
9	A6973225	Worm Wheel Shaft	1											
10	A6973170	Gear - 42Z	1											
11	A6973180	Pulley - 18T	2											
12	C2035135	Bushing - 10x14x5.9	2											
13	A6973175	Spacer - 10x14x13.5mm	1											
14	A6973165	Tray Drive Shaft	1											
15	A6973155	Timing Belt - B60S5M1420	2											
16	A6973150	Fixing Plate - Timing Bel	2											
17	B7063190	Tighter Bracket	2											
18	A6973185	Pulley - 18T	2											
19	B8301534	Timing Belt - 60S3M216	1											
20	B8301531	Stepper Motor Bracket	1											
21	B8305562	Stepper Motor DC1.56V 3.7	1											
22	AW020114	Photo Interruptor - Lower	3											
23	B8303163	Paper Volume Sensor Brack	1											
101	0454006Q	Tapping Screw - M3x6												
102	0313050N	Philips Pan Head Screw -												
103	0720060E	Retaining Ring - M6												
104	08075056	Washer - 8.1mm												
105	0574040E	Hexagon Headless Set Scre												
106	07413506	Ball Bearing - 6x12x4mm												
107	0634200G	Parallel Pin - 4x20												
108	0451006N	Tapping Screw - 3x6												
109	11050623	Clamp - LBWS-0206S-V0												

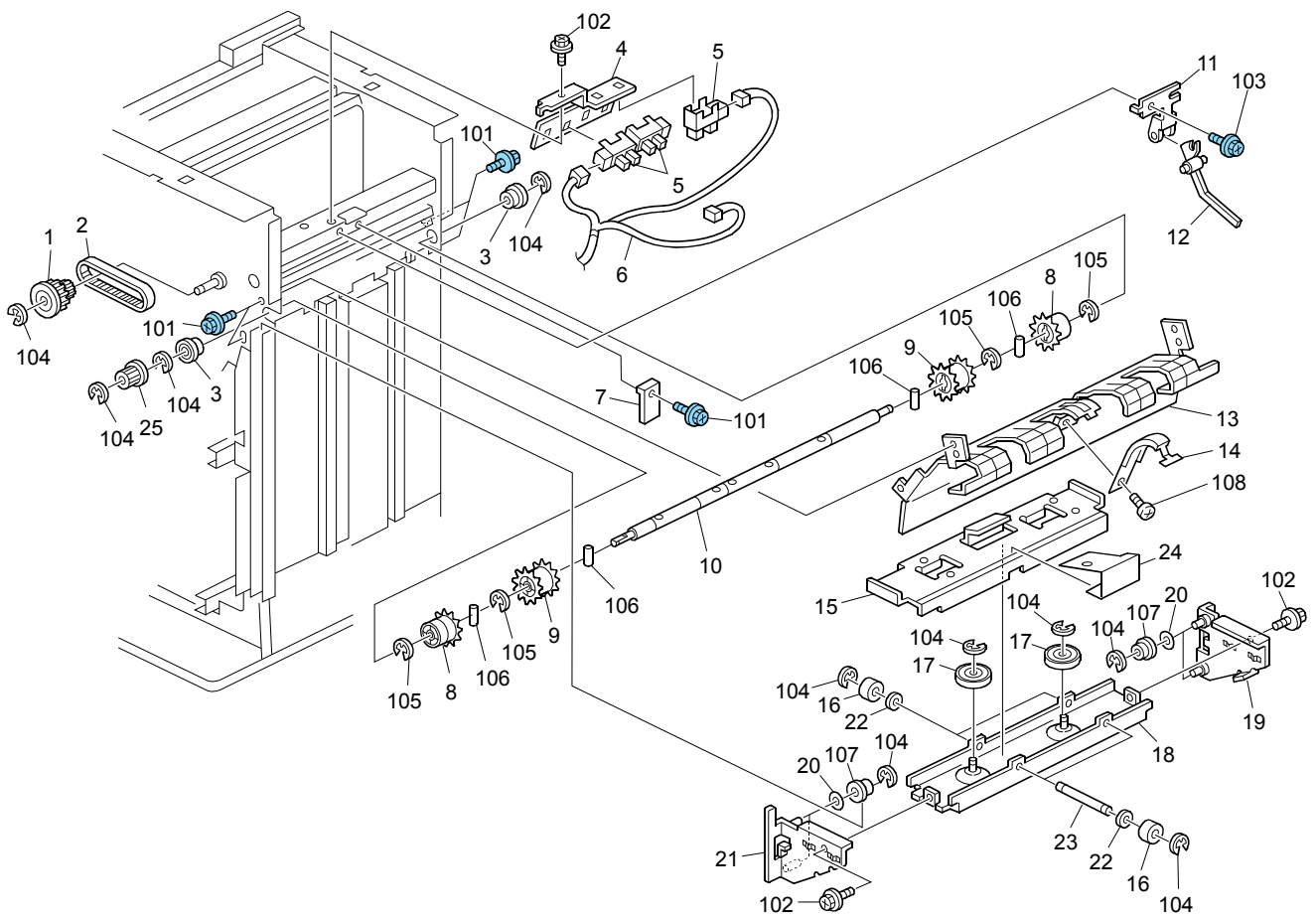

ITEM NO.	PARTS NO.	PARTS NAME	Q'TY / PAGE	Q'TY / PACK	P I R	B S I NO.	T O	T	F R O M	S E R I A L NO.	R E M A R K S	C
1	B8301532	Timing Pulley - 26T/17T	1									
2	B8301533	Timing Belt - 60S3M171	1									
3	A8592230	Ball Bearing - 6x13x5	2									
4	B7061143	Bracket:Sensor:Paper	1									
5	AW020156	PHOTOINTERRUPTOR:EE-SX423	3									
6	B8305255	Harness - Paper Exit Sens	1									
7	B3021134	Lever Stay	1									
8	B3022305	Middle Exit Roller	2									
9	B3022302	Front & Rear Exit Roller	2									
10	B3022311	Exit Roller Shaft	1									
11	B7063172	Actuator Bracket	1									
12	B7061145	Lever:Sensor:Upper	1									
13	B4782336	Guide Plate:Exit:Lower	1									
14	B4782332	Spring Plate:Shift:Exit	1									
15	B7063126	Shift Tray Holder	1									
16	A3533272	Guide Roller	2									
17	B8303315	Roller	2									
18	B8303311	Shift Tray Base	1									
19	B8303320	Side Plate:Shift Tray:Fro	1									
20	B8303322	Guide:Shift Tray:Upper Lo	2									
21	B8303325	Side Plate:Shift Tray:Rea	1									
22	AA132024	Spacer - M6	2									
23	B7063271	Tray Shift Shaft	1									
24	B4783113	Shift Tray Guide Holder	1									
25	A6972260	Pulley - 17T	1									
101	0454006Q	Tapping Screw - M3x6										
102	0451006N	Tapping Screw - 3x6										
103	0454006Q	Tapping Screw - M3x6										
104	0720040E	Retaining Ring - M4										
105	0720060E	Retaining Ring - M6										
106	0633120G	Parallel Pin - 3x12										
107	07403906	Ball Bearing - 6x15x5										
108	0313040N	Screw:M3x4										

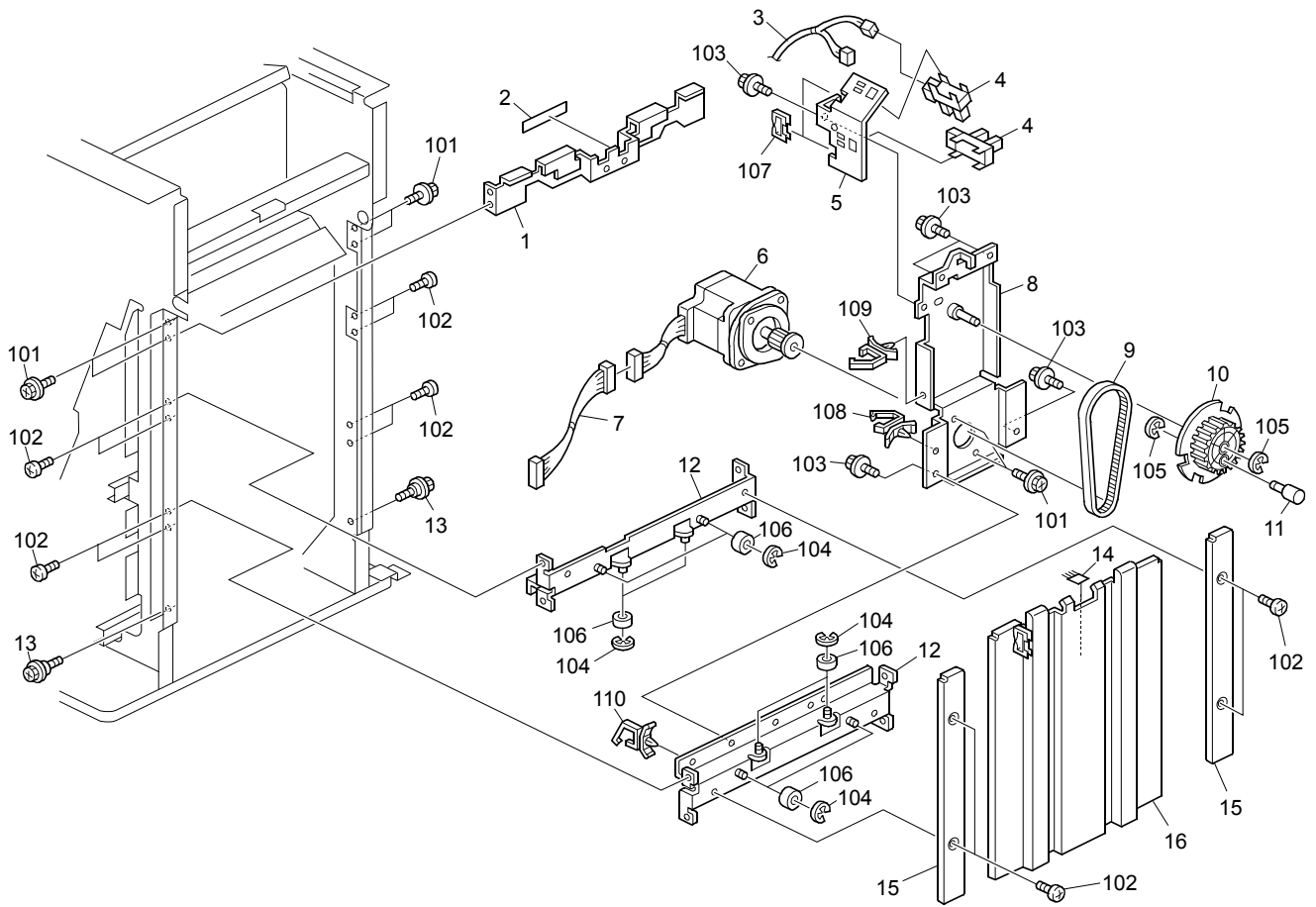

ITEM NO.	PARTS NO.	PARTS NAME	Q'TY / PAGE	Q'TY / PACK	P	I	R	B S I NO.	T O	T	F R O M	S E R I A L NO.	R E M A R K S	C
1	B8303415	Cover - Exit Roller	1											
2	B4783101	Spacer:Gathering Roller:S	1											
3	B8305258	Harness - Shift Sensor	1											
4	AW020156	PHOTOINTERRUPTOR:EE-SX423	2											
5	B8303216	Shift Sensor Bracket	1											
6	B8305563	Stepper Motor DC3.84V 9.2	1											
7	B8305257	Harness - Motor	1											
8	B8303230	Shift Bracket	1											
9	B8303248	Timing Belt - 60S3M342	1											
10	B8303241	Timing Pulley - 43T	1											
11	B8303242	Shift Shaft	1											
12	B8303421	Stay	2											
13	AA143702	Screw:Pin:Positioning	2											
14	A6972131	Antistatic Brush	1											
15	B8303445	Cover - End Fence	2											
16	B8303410	End Fence	1											
101	0451006N	Tapping Screw - 3x6												
102	0453006N	Tapping Screw - M3x6												
103	0451006N	Tapping Screw - 3x6												
104	0720040E	Retaining Ring - M4												
105	0720030E	Retaining Ring - M3												
106	07403906	Ball Bearing - 6x15x5												
107	11050328	Harness Clamp - ES-0505												
108	11050487	Harness Clamp												
109	11050623	Clamp - LBWS-0206S-V0												
110	11050488	Harness Clamp												

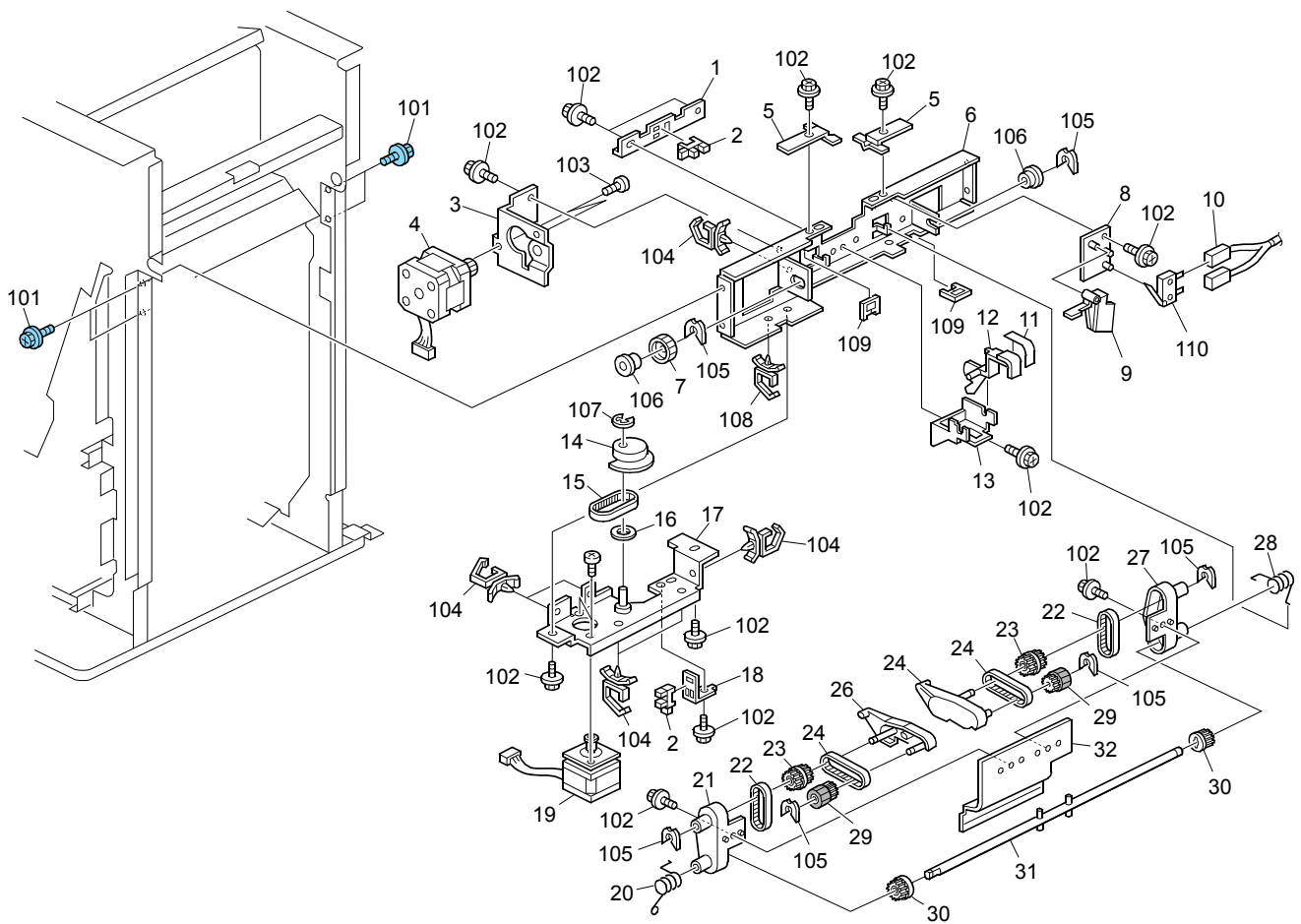

ITEM NO.	PARTS NO.	PARTS NAME	Q'TY / PAGE	Q'TY / PACK	P	I	R	B S I NO.	T O	T	F R O M	S E R I A L NO.	R E M A R K S	C
1	B4783576	Bracket:Sensor:Paper Sens	1											
2	AW020156	PHOTOINTERRUPTOR:EE-SX423	2											
3	B8303587	Stepper Motor Bracket	1											
4	B8305570	Stepper Motor DC3.1V 7.4W	1											
5	B4783511	Cam:Gathering Roller:Driv	2											
6	B8303591	Stay	1											
7	B4783522	Gear:Z35	1											
8	B4783581	Bracket:Micro Switch	1											
9	B4783582	Lever:Micro Switch	1											
10	B8305263	Harness - Tray Switch	1											
11	B4783554	Guide:Feeler:Paper Senser	1											
12	B4783552	Feeler:Paper Senser	1											
13	B4783553	Bracket:Feeler:Paper Sens	1											
14	B8303579	Lever Cam	1											
15	B6522347	Timing Belt:B40S2M158	1											
16	B4783569	Spacer	1											
17	B8303561	Stepper Motor Bracket	1											
18	B4783568	Bracket:Home Position Sen	1											
19	B7005807	Stepper Motor:MM42:S2M:Tl	1											
20	B4783524	Torsion Spring:Plate:Leve	1											
21	B4783507	Lever:Drive:Gathering Rol	1											
22	B8303504	Timing Belt - 40S2M100	2											
23	B4783502	Pulley:Driven:Roller:Spon	2											
24	B8303505	Timing Belt - 40S2M84	2											
25	B4783509	Lever:Driven:Gathering Ro	1											
26	B4783508	Lever:Driven:Gathering Ro	1											
27	B4783506	Lever:Drive:Gathering Rol	1											
28	B4783523	Torsion Spring:Plate:Leve	1											
29	B8303503	Sponge Gathering Roller	2											
30	B4783501	Pulley:Drive:Roller:Spong	2											
31	B8303520	Gathering Roller Shaft	1											
32	B8303510	Coupling Lever Bracket	1											
101	0454006Q	Tapping Screw - M3x6												
102	0451006N	Tapping Screw - 3x6												
103	0353040N	Screw - M3X4												
104	11050623	Clamp - LBWS-0206S-V0												
105	08050089	Retaining Ring - M4												
106	07413706	Ball Bearing - 6x10x3												
107	0720040E	Retaining Ring - M4												
108	11050488	Harness Clamp												
109	11050514	Edge Saddle - Eds-06071												
110	12042544	Switch - DE2L-BJ23												

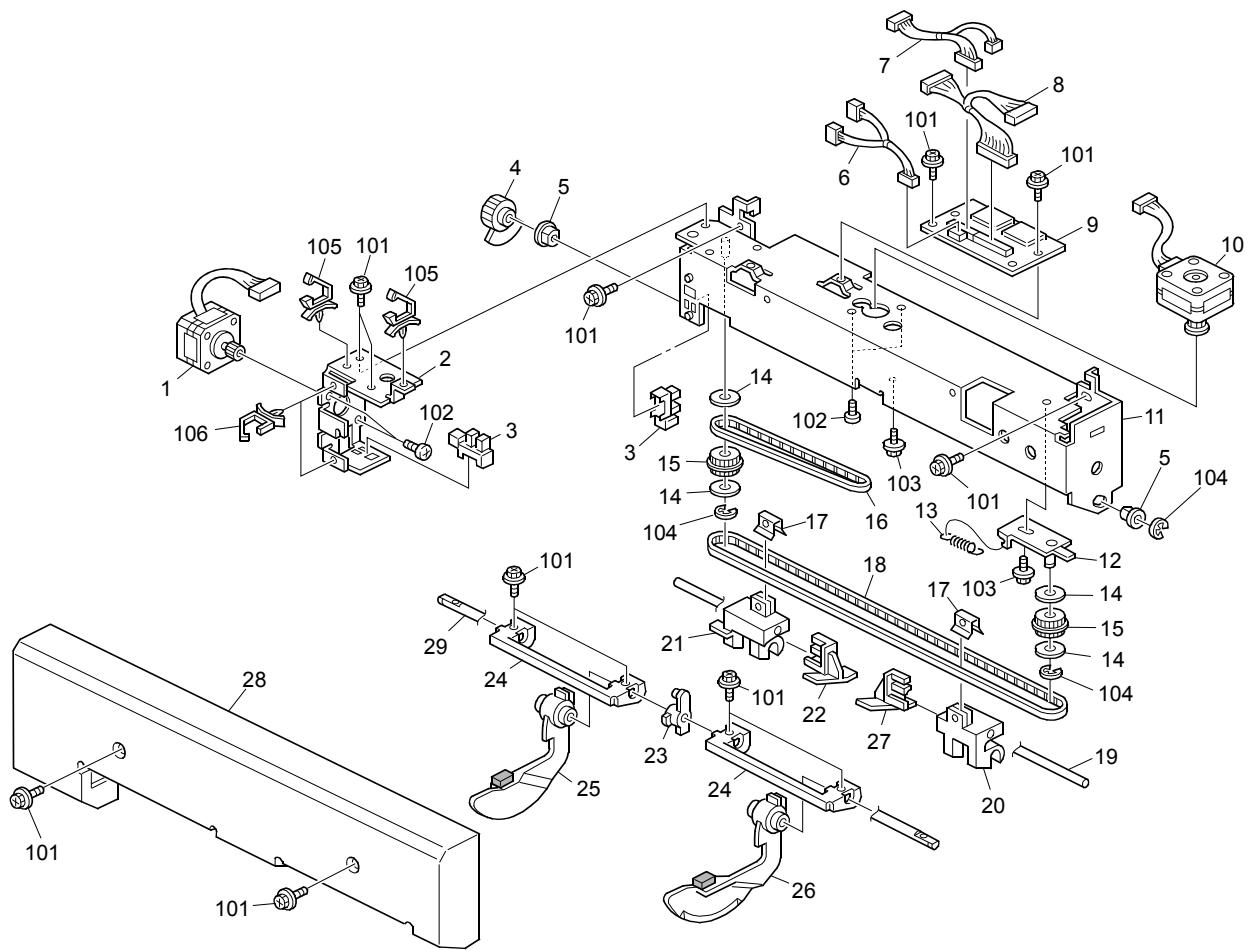

ITEM NO.	PARTS NO.	PARTS NAME	Q'TY / PAGE	Q'TY / PACK	P	I	R	B S I NO.	T O	T	F R O M	S E R I A L NO.	R E M A R K S	C
1	B8305570	Stepper Motor DC3.1V 7.4W	1											
2	B8303697	Stepper Motor Bracket	1											
3	AW020156	PHOTOINTERRUPTOR:EE-SX423	2											
4	B8303651	Gear - 35Z	1											
5	50530447	Bushing - 6mm	2											
6	B8305280	Harness - Sensor	1											
7	B8305281	Harness - Motor Control	1											
8	B8305282	Harness - Motor	1											
9	B8305120	PCB Ogger	1											
10	B8305569	Stepper Motor DC3.3V 3.9W	1											
11	B8303611	Frame - Jogger Uniform	1											
12	B8303711	Tensioner Bracket	1											
13	B8303751	Tension Spring	1											
14	B4783569	Spacer	4											
15	B5131154	Pulley:T30:S2M	2											
16	B7031165	Timing Belt:B40S2M390	1											
17	A3003634	Spring Plate - Timing Bel	2											
18	B8303726	Timing Belt - 40S2M848	1											
19	B8303631	Slide Shaft	1											
20	B8303641	Jogger Fence Holder - Fro	1											
21	B8303646	Jogger Fence Holder - Rea	1											
22	B8303692	Jogger Fence:Exit:Guide:I	1											
23	B3523572	Bushing - 6mm	1											
24	B8303676	Lever - Jogger Fence	2											
25	B8303685	Jogger Fence - Inner Back	1											
26	B8303680	Jogger Fence - Front	1											
27	B8303691	Jogger Fence:Exit:Guide:F	1											
28	B8303731	Cover - Uniform Unit	1											
29	B8303671	Shaft - Jogger Fence Move	1											
101	0451006N	Tapping Screw - 3x6												
102	0313040N	Screw:M3x4												
103	0451008N	Tapping Screw:4x8												
104	0720040E	Retaining Ring - M4												
105	11050516	Clamp												
106	11050623	Clamp - LBWS-0206S-V0												

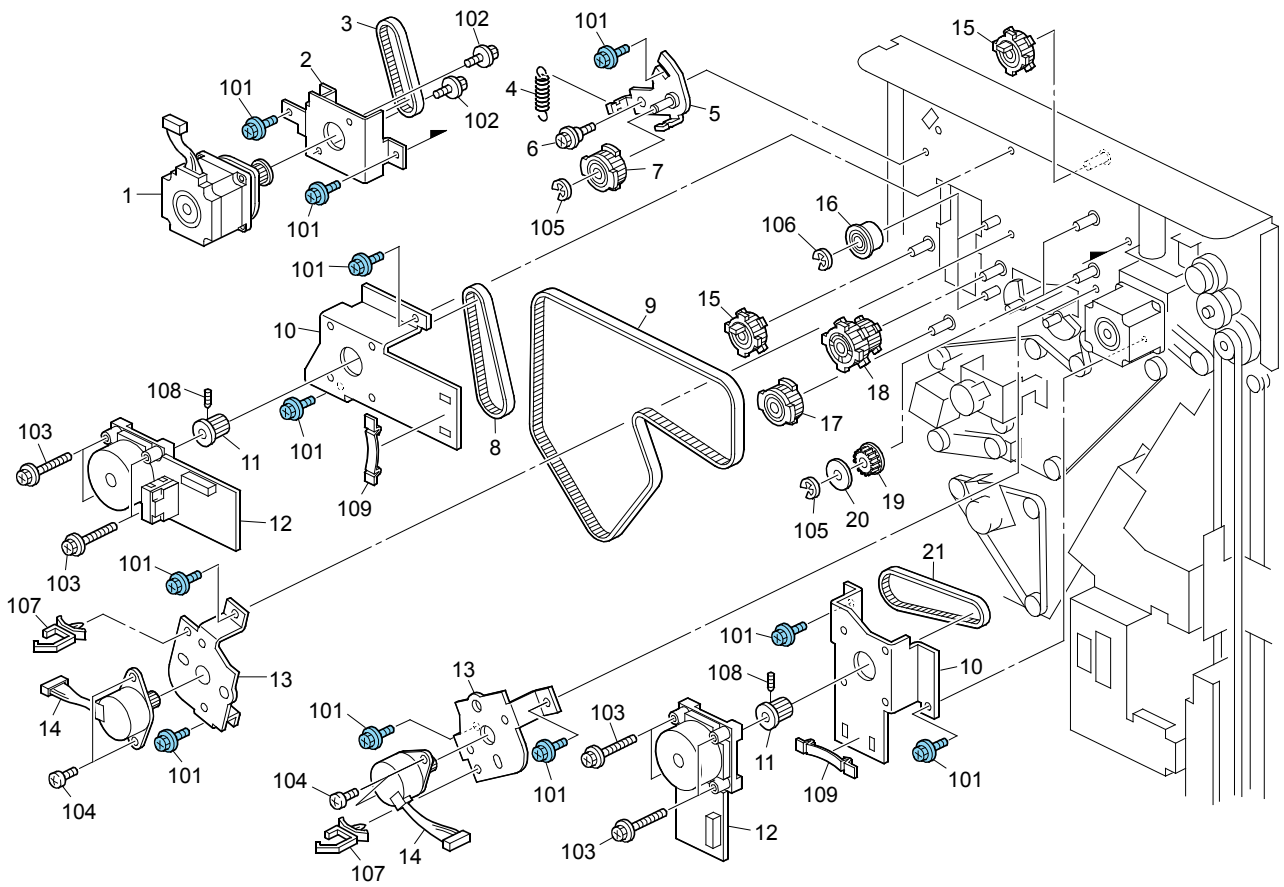

ITEM NO.	PARTS NO.	PARTS NAME	Q'TY / PAGE	Q'TY / PACK	P	I	R	B S I NO.	T O	T	F R O M	S E R I A L NO.	R E M A R K S	C
1	B8305562	Stepper Motor DC1.56V 3.7	1											
2	B8301541	Stepper Motor Bracket	1											
3	B8301534	Timing Belt - 60S3M216	1											
4	AA062334	Tension Spring:4.9n	1											
5	B7061545	Tightener Bracket	1											
6	B8301135	Screw	1											
7	B3021542	Timing Pulley - 20Z	1											
8	B8301516	Timing Belt - 60S3M306	1											
9	B8301517	Timing Belt - 60S3M852	1											
10	B8301512	Brushless Motor Bracket	2											
11	AB030522	Timing Pulley - T14P3M	2											
12	AX050289	Brushless Motor:7W:Dia56	2											
13	B8302525	Motor Bracket	2											
14	B7005804	Stepper Motor:DIA42:Z17:A	2											
15	B3521607	Timing Pulley - T20-S3M	2											
16	A4583281	Idler Roller	2											
17	B3021542	Timing Pulley - 20Z	1											
18	B8301515	Timing Pulley - 29T20T	1											
19	B3021517	Timing Pulley - 20Z	2											
20	B4783569	Spacer	2											
21	B8301534	Timing Belt - 60S3M216	1											
101	0454006Q	Tapping Screw - M3x6												
102	0451006N	Tapping Screw - 3x6												
103	0451014N	Tapping Screw:3x14												
104	0453006N	Tapping Screw - M3x6												
105	0720040E	Retaining Ring - M4												
106	0720060E	Retaining Ring - M6												
107	11050488	Harness Clamp												
108	0573030E	Hexagon Headless Set Scre												
109	11050545	Clamp:Fcr-30												

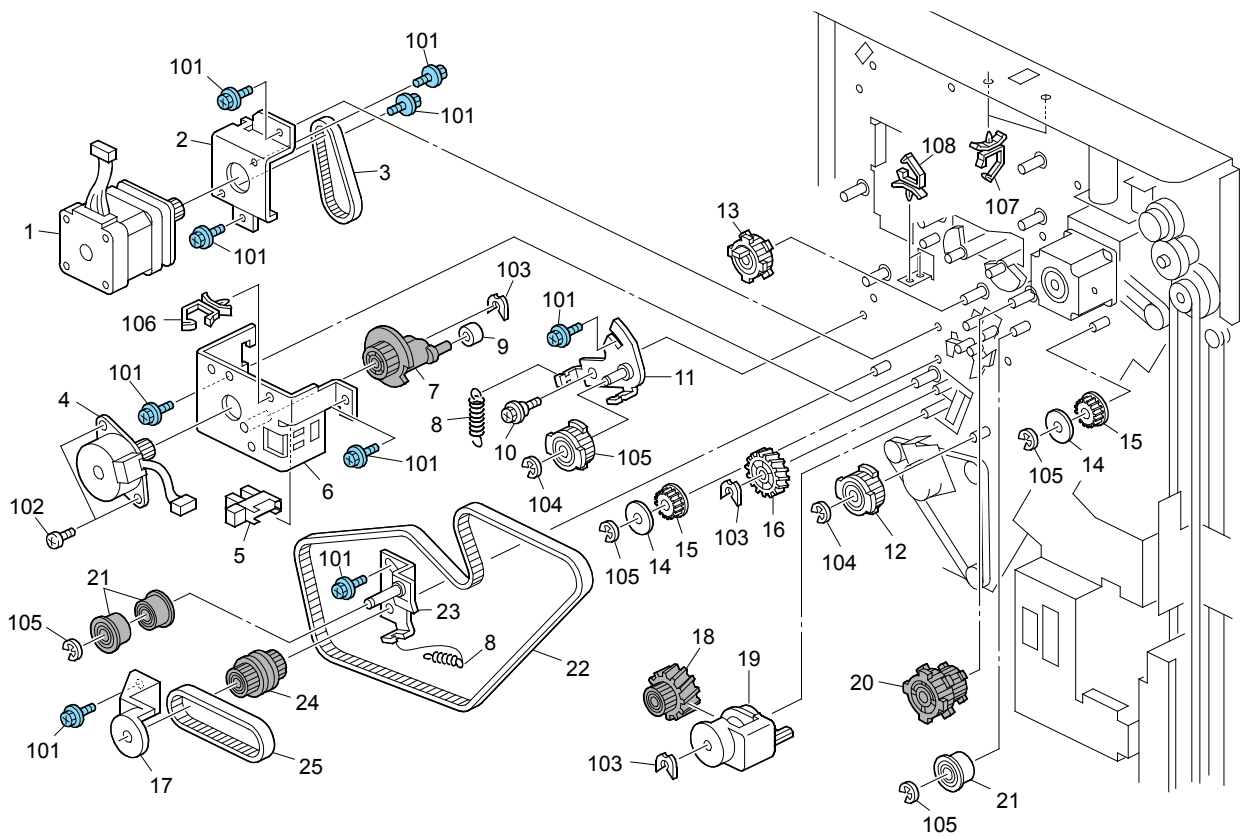

ITEM NO.	PARTS NO.	PARTS NAME	Q'TY / PAGE	Q'TY / PACK	P	I	R	B S I NO.	T O	T	F R O M	S E R I A L NO.	R E M A R K S	C
1	B8305571	Stepper Motor DC2.52V 4.5	1											
2	B8301561	Stepper Motor Bracket	1											
3	B8302142	Timing Belt - 60S3M162	1											
4	B7005804	Stepper Motor:DIA42:Z17:A	1											
5	AW020156	PHOTOINTERRUPTOR:EE-SX423	1											
6	B8302745	Motor Bracket	1											
7	B8302748	Cam	1											
8	AA062334	Tension Spring:4.9n	2											
9	B8302751	Roller	1											
10	B8301135	Screw	1											
11	B7061545	Tightener Bracket	1											
12	B3021542	Timing Pulley - 20Z	2											
13	B3521607	Timing Pulley - T20-S3M	1											
14	B4783569	Spacer	2											
15	B3021517	Timing Pulley - 20Z	2											
16	B3021523	Gear - 33Z	1											
17	B8301555	Timing Belt Guide - FIX	1											
18	B8301554	Gear/pulley - 30Z/20T	1											
19	B8301556	Timing Belt Guide - Movea	1											
20	B8301515	Timing Pulley - 29T20T	1											
21	A4583281	Idler Roller	3											
22	B7004335	Timing Belt:B60S3M954	1											
23	B8301557	Tightener Bracket - Middl	1											
24	B8301552	Timing Pulley - 20T/20T	1											
25	B8302141	Timing Belt - 60S3M237	1											
101	0454006Q	Tapping Screw - M3x6												
102	0453006N	Tapping Screw - M3x6												
103	08050089	Retaining Ring - M4												
104	0720040E	Retaining Ring - M4												
105	0720060E	Retaining Ring - M6												
106	11050623	Clamp - LBWS-0206S-V0												
107	11050488	Harness Clamp												
108	11050511	Harness Clamp - LWS-0306Z												

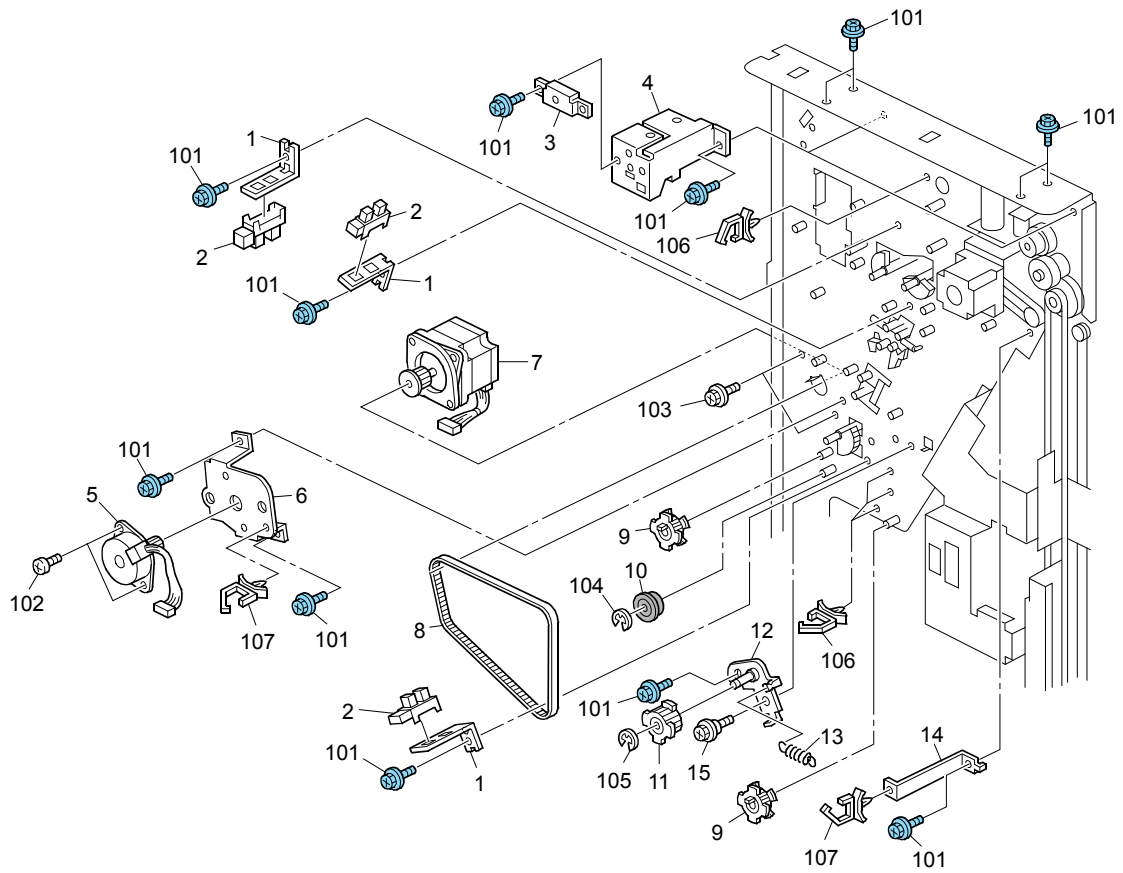

ITEM NO.	PARTS NO.	PARTS NAME	Q'TY / PAGE	Q'TY / PACK	P	I	R	B S I NO.	T O	T	F R O M	S E R I A L NO.	R E M A R K S	C
1	B8302522	Sensor Bracket	3											
2	AW020156	PHOTOINTERRUPTOR:EE-SX423	3											
3	B3026514	Bracket - Rear Upper Stay	1											
4	B8306511	Stay - Rear Upper	1											
5	B7005804	Stepper Motor:DIA42:Z17:A	1											
6	B8302525	Motor Bracket	1											
7	B8305562	Stepper Motor DC1.56V 3.7	1											
8	B8301521	Timing Belt - 60S3M537	1											
9	B3521607	Timing Pulley - T20-S3M	2											
10	A4583281	Idler Roller	1											
11	B3021542	Timing Pulley - 20Z	1											
12	B7061545	Tightener Bracket	1											
13	AA062334	Tension Spring:4.9n	1											
14	B4685991	Harness Bracket	1											
15	B8301135	Screw	1											
101	0454006Q	Tapping Screw - M3x6												
102	0453006N	Tapping Screw - M3x6												
103	0451008N	Tapping Screw:4x8												
104	0720060E	Retaining Ring - M6												
105	0720040E	Retaining Ring - M4												
106	11050511	Harness Clamp - LWS-0306Z												
107	11050488	Harness Clamp												

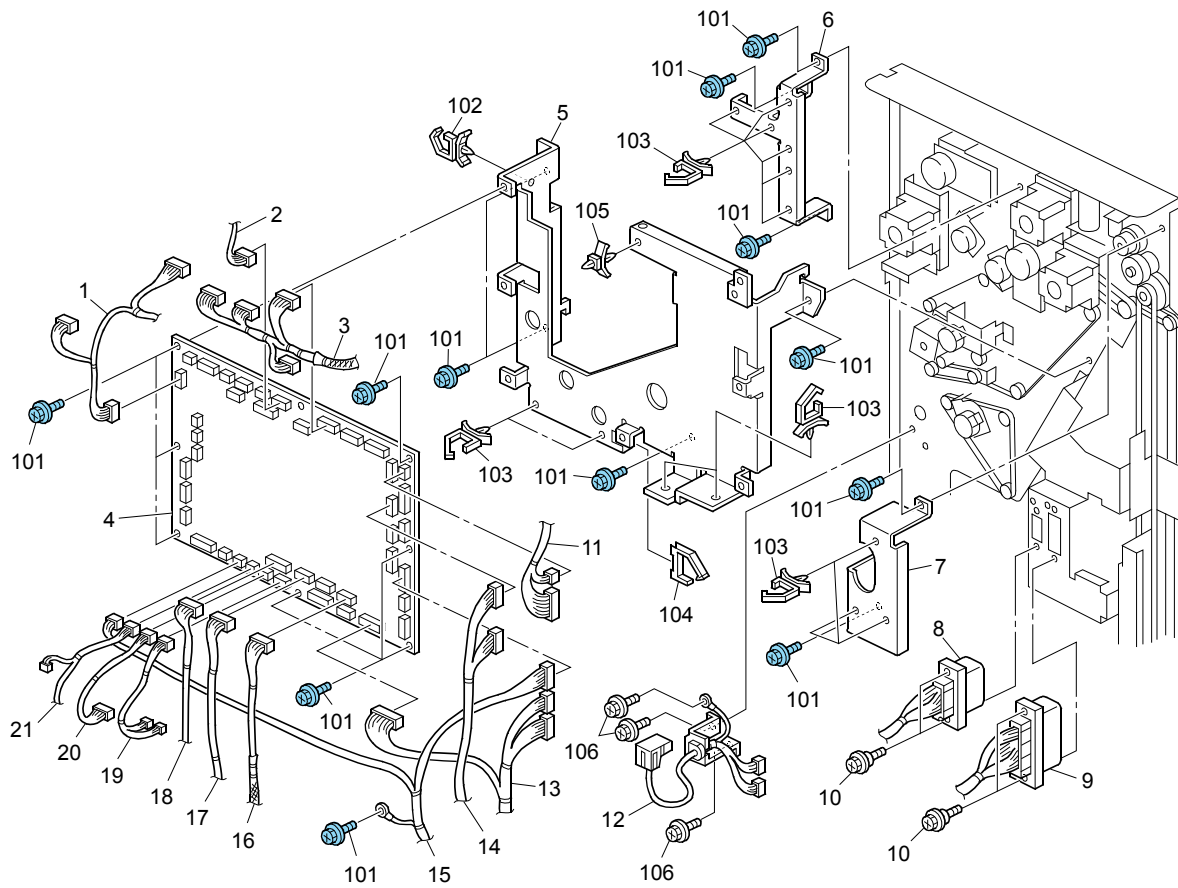



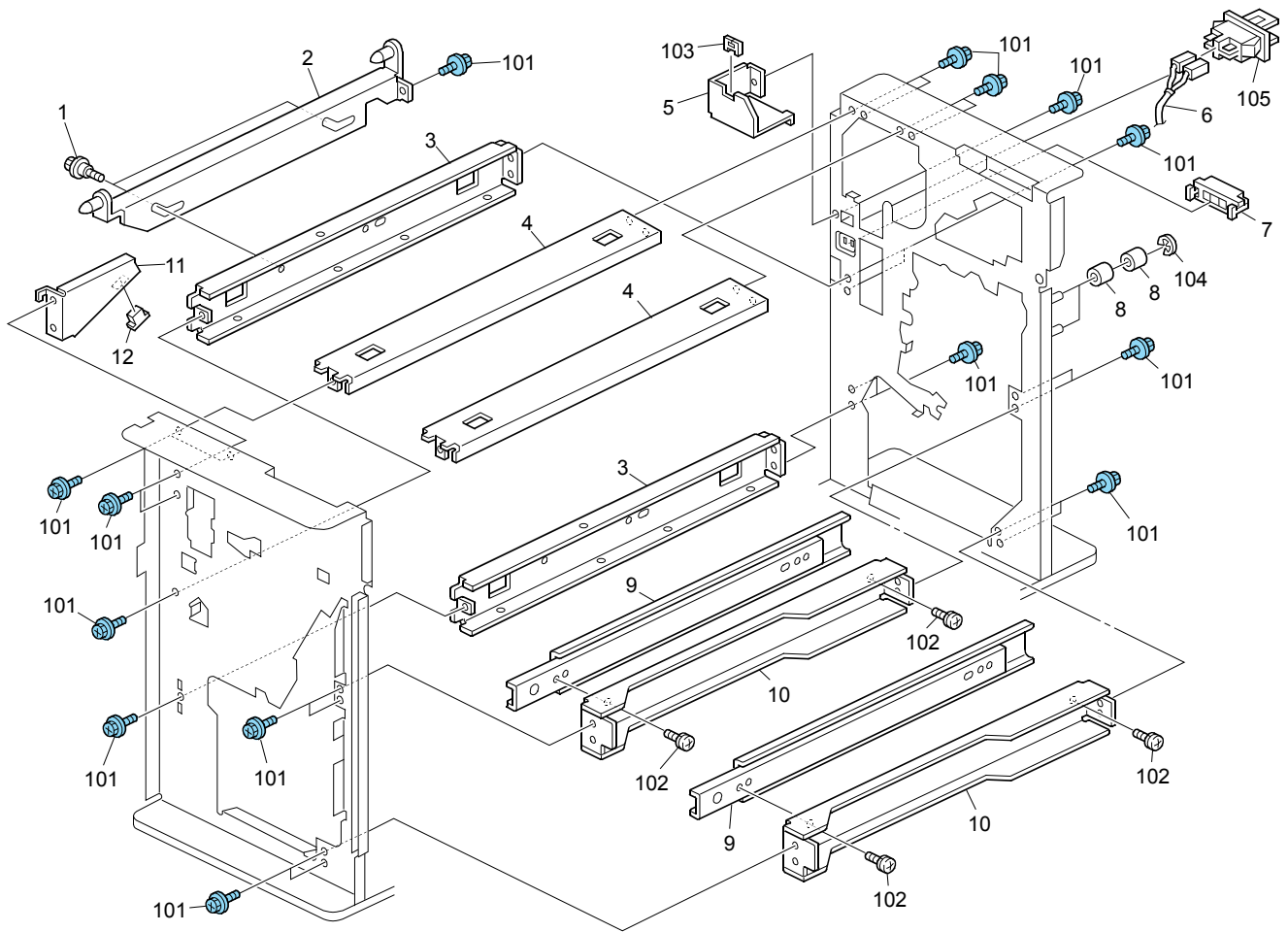



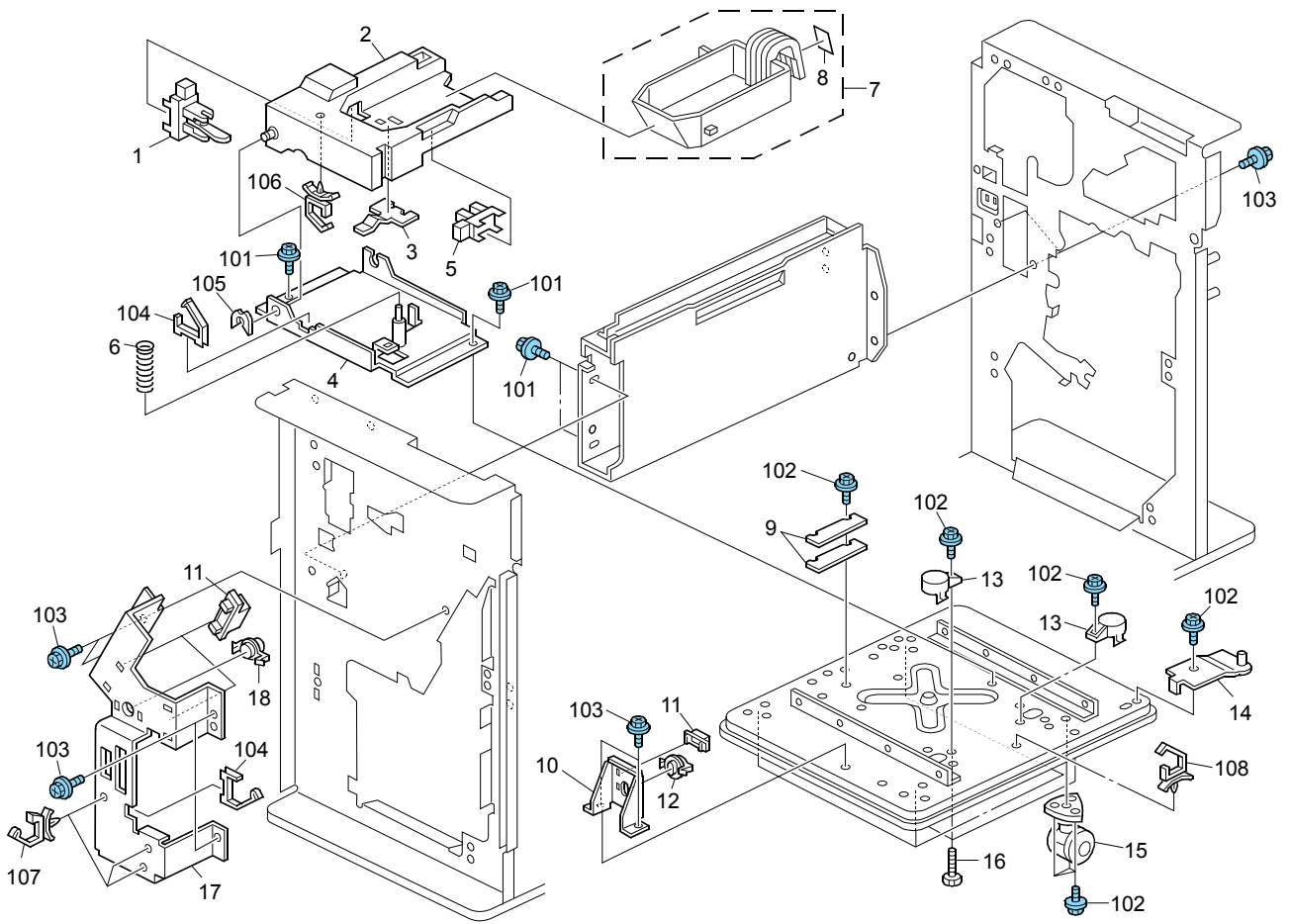

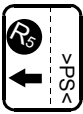
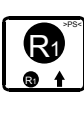

ITEM NO.	PARTS NO.	PARTS NAME	Q'TY / PAGE	Q'TY / PACK	P	I	R	B S I NO.	T O	T	F R O M	S E R I A L NO.	R E M A R K S	C
1	B8305243	Harness - Sensor Main Upp	1											
2	B8305238	Harness - Motor	1											
3	B8305245	Harness - Motor Main Uppe	1											
4	B8305054	PCB Main Control	1											
5	B8305811	PCB Bracket	1											
6	B8305813	Harness Bracket - Upper	1											
7	B8303162	Guard:Tray Bracket - Uppe	1											
8	B8305285	Harness - Motor Drawer	1											
9	B8305284	Harness - Sensor Drawer	1											
10	B7001163	Screw:Connector	4											
11	B8305249	Harness - Sensor Main Shi	1											
12	B8305201	Harness:Interface	1											
13	B8305274	Harness - Motor Stapler S	1											
14	B8305225	Harness - Shift Tray	1											
15	B8305276	Harness:Motor:Stapler Uni	1											
16	B8305240	Harness - Stapler Sensor	1											
17	B8305229	Harness - Sensor	1											
18	B8305239	Harness - Sensor	1											
19	B8305231	Harness - Duplex Stack Se	1											
20	B8305232	Harness - Motor	1											
21	B8305244	Harness - Sensor Staple E	1											
101	0454006Q	Tapping Screw - M3x6												
102	11050623	Clamp - LBWS-0206S-V0												
103	11050488	Harness Clamp												
104	11050522	Edge Saddle - Les0510												
105	11050194	PCB Stud												
106	0451006N	Tapping Screw - 3x6												

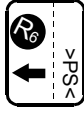

ITEM NO.	PARTS NO.	PARTS NAME	Q'TY / PAGE	Q'TY / PACK	P	I	R	B S I NO.	T O	T	F R O M	S E R I A L NO.	R E M A R K S	C
1	B8301135	Screw	2											
2	B8301130	Lever - Coupling	1											
3	B4081413	Coupling Stay	2											
4	B4786413	Stay:Front Left	2											
5	B4781137	Cover:Safety Switch	1											
6	B8305210	Harness - Door Switch	1											
7	AG071012	Magnet Catch:Ass'y	1											
8	B3024239	Guide Roller	2											
9	B7001161	Slide Rail:Stapler Unit:5	2											
10	B4781154	Stay:Slide Rail:Fix	2											
11	B4781121	Bracket:Stay	1											
12	AG070513	Magnet Catch	1											
101	0454006Q	Tapping Screw - M3x6												
102	0950005N	Screw:Spring Washer:M3x5												
103	11050328	Harness Clamp - ES-0505												
104	0720040E	Retaining Ring - M4												
105	12042752	Interlock Switch												

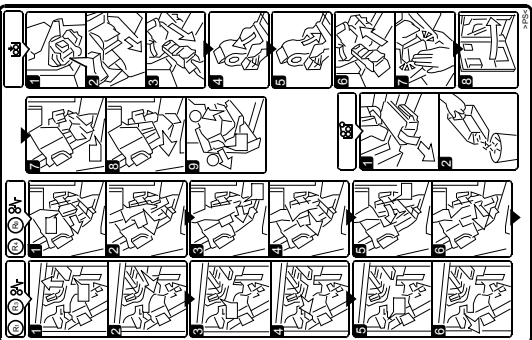
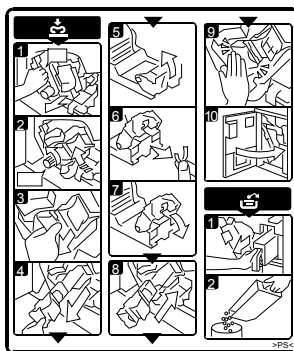

ITEM NO.	PARTS NO.	PARTS NAME	Q'TY / PAGE	Q'TY / PACK	P	I	R	B S I NO.	T O	T	F R O M	S E R I A L NO.	R E M A R K S	C
1	AW020182	Photointerruptor	1											
2	B8301194	Toner Hopper Holder	1											
3	B8301195	Spring Plate	1											
4	B8301191	Toner Hopper Holder Base	1											
5	AW020156	PHOTOINTERRUPTOR:EE-SX423	1											
6	B8301199	Compression Spring	1											
7	B8307010	Toner Hopper	1											
8	B8307712	Decal - Toner Hopper Stap	1											
9	B8307537	Adjusting Plate:Bracket:C	2											
10	B4781172	Bracket:Coupling:Lower	1											
11	AG071012	Magnet Catch:Ass'y	2											
12	B4781175	Holder:Coupling:Lower	1											
13	B8041117	Cap - Base	2											
14	B3026154	Hinge:Door:Lower:Ass'y	1											
15	B5452019	Caster:U50:490n	4											
16	B7061156	Hexagonal Bolt - M12x30	2											
17	B8301181	Coupling Bracket - Upper	1											
18	B4781174	Holder:Coupling:Upper	1											
101	0454008Q	Tapping Screw:3x8												
102	0454008Q	Tapping Screw:3x8												
103	0454006Q	Tapping Screw - M3x6												
104	11050522	Edge Saddle - Les0510												
105	08050089	Retaining Ring - M4												
106	11050623	Clamp - LEWS-0206S-V0												
107	11050489	Harness Clamp - LWS 1316												
108	11050487	Harness Clamp												

1 	2 	3 	4 	5 	
6 	7 	8 	9 	10 	
11 			12 		13 

ITEM NO.	PARTS NO.	PARTS NAME	Q'TY / PAGE	Q'TY / PACK	P I R	B S I NO.	T O	T	F R O M	S E R I A L NO.	R E M A R K S	C
1	B3027702	Decal - R2	1									
2	B3027705	Decal - R5	1									
3	B8307701	Decal - Entrance (R1)	1									
4	B8307703	Decal - Shift Tray (R3)	1									
5	B8307704	Decal - Lengthwise Right	2									
6	B8307705	Decal - Stapler Tray Exit	1									
7	B8307706	Decal - Stapler Tray (R8)	1									
8	B8307707	Decal - Stapler Unit (R9)	1									
9	B8307708	Decal - Knob (R10)	1									
10	B8307709	Decal - Stapler Unit (R10)	1									
11	B8307710	Decal - Misfeed Removal P	1									
12	B8307711	Decal: Misfeed Removal: Sta	1									
13	B8307712	Decal - Toner Hopper Stap	1									

TOSHIBA

TOSHIBA TEC CORPORATION

2-17-2, HIGASHIGOTANDA, SHINAGAWA-KU, TOKYO, 141-8664, JAPAN