

# TOSHIBA

# SERVICE MANUAL

## PAPER FEED UNIT MY-1040/1047

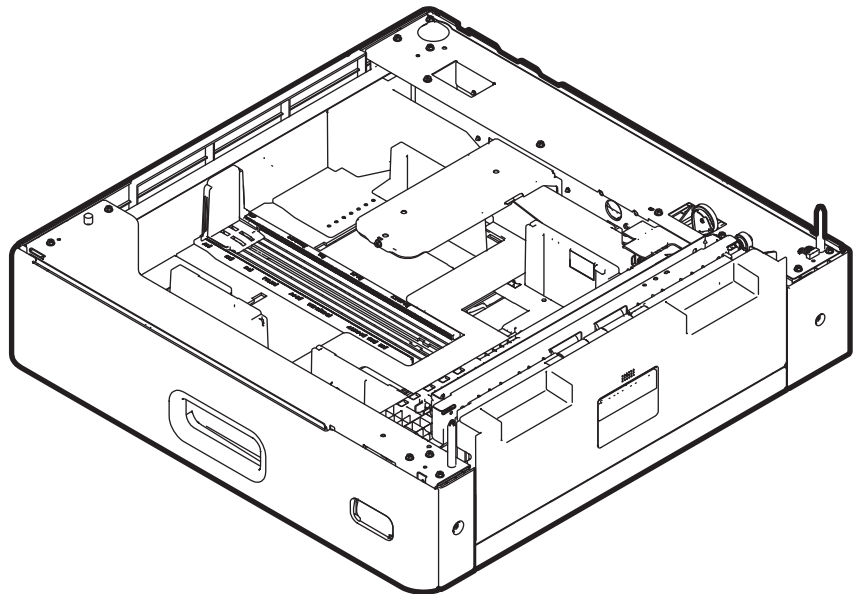

Model: MY-1040/1047  
Publish Date: April 2012  
File No. SME120003B0  
R120121L0802-TTEC  
Ver02 F\_2016-12

## Trademarks

- MOLYKOTE® is a registered trademark of Dow Corning Corporation.
- Other company names and product names in this manual are the trademarks of their respective companies.

© 2012-2016 TOSHIBA TEC CORPORATION All rights reserved

Under the copyright laws, this manual cannot be reproduced in any form without prior written permission of TOSHIBA TEC CORPORATION.

# General Precautions for Installation/Service/Maintenance for this Equipment

The installation and service shall be done by a qualified service technician.

1. When installing this equipment to the MFP, be sure to follow the instructions described in the "Unpacking/Set-Up Procedure for this equipment" booklet which comes with each unit of this equipment.
2. This equipment should be installed by an authorized/qualified person.
3. The equipment must be grounded for safety. Never ground it to a gas pipe, a water pipe, or any other object not suitable for grounding.
4. Before starting installation, servicing or maintenance work, be sure to turn off and unplug the equipment first.
5. The equipment shall be installed near the socket outlet and shall be accessible.
6. Be sure to fix and plug in the power cable securely after the installation so that no one trips over it.
7. Unplug the power cable and clean the area around the prongs of the plug and socket outlet once a year or more. A fire may occur when dust lies on this area.
8. The equipment should be grounded to the specified position on the machine frame.
9. When servicing or maintaining this equipment, be careful about the rotating or operation sections such as gears, pulleys, sprockets, cams, belts, etc.
10. When parts are disassembled, reassembly is basically the reverse of disassembly unless otherwise noted in this manual or other related materials. Be careful not to reassemble small parts such as screws, washers, pins, E-rings, toothed washers to the wrong places.
11. Basically, the machine should not be operated with any parts removed or disassembled.
12. When servicing the equipment with the power turned ON, be sure not to touch live sections and rotating/operating sections.
13. Delicate parts for preventing safety hazard problems (such as breakers, thermofuses, fuses, door switches, sensors, etc. if any) should be handled/installed/adjusted correctly.
14. Be sure not to touch high-temperature sections such as the damp heater and areas around them.
15. Be sure not to touch high-voltage sections such as the damp heater and areas around them.
16. Use suitable measuring instruments and tools.
17. During servicing or maintenance work, be sure to check the serial No. plate and other cautionary labels (if any) to see if they are clean and firmly fixed. If not, take appropriate actions.
18. The PC board must be stored in an anti-electrostatic bag and handled carefully using a wristband, because the ICs on it may be damaged due to static electricity. Before using the wrist band, pull out the power cord plug of the equipment and make sure that there is no uninsulated charged objects in the vicinity.

19. For the recovery and disposal of used equipment, consumable parts and packing materials, follow the relevant local regulations/rules.
20. After completing installation, servicing and maintenance of the equipment, return the equipment to its original state, and check operation.
21. Check the procedures and perform them as described in the Service Manual.
22. Make sure you do not lose your balance.
23. Avoid exposure to your skin and wear protective gloves as needed.
24. Do not leave plastic bags where children can get at them. This may cause an accident such as suffocation if a child puts his/her head into a bag. Plastic bags of options or service parts must be brought back.

# CONTENTS

<b>1. SPECIFICATION .....</b>	<b>1-1</b>
<b>2. GENERAL DESCRIPTION.....</b>	<b>2-1</b>
2.1 Main Components .....	2-1
2.2 Sectional View.....	2-2
2.3 Electric Parts Layout .....	2-3
2.4 Symbols and Functions of Various Components .....	2-4
2.5 Diagram of Signal Blocks .....	2-5
<b>3. DESCRIPTION OF OPERATIONS .....</b>	<b>3-1</b>
3.1 Outline.....	3-1
3.2 Picking up System.....	3-2
3.3 Paper Feed System .....	3-3
<b>4. DISASSEMBLY AND ASSEMBLY .....</b>	<b>4-1</b>
4.1 Rear cover.....	4-1
4.2 Drawer feeding unit.....	4-2
4.3 Feed roller / separation roller / Pickup roller .....	4-2
4.4 Drive unit.....	4-3
4.5 Feed clutch.....	4-5
4.6 Transport clutch (L) / Transport clutch (H) .....	4-6
4.7 Drawer detection switch .....	4-7
4.8 Tray-up motor unit.....	4-8
4.9 Tray-up motor.....	4-10
4.10 Drawer paper stock sensor .....	4-10
4.11 Paper empty sensor / Drawer tray-up sensor .....	4-11
4.12 Paper width detection switch / Paper length detection switch.....	4-13
4.13 Jam access cover .....	4-14
4.14 Jam access cover opening/closing switch .....	4-14
4.15 Paper feed sensor.....	4-15
4.16 PFC board.....	4-16
4.17 Damp heater (Option) .....	4-17
<b>5. ADJUSTMENT .....</b>	<b>5-1</b>
<b>6. TROUBLESHOOTING .....</b>	<b>6-1</b>
<b>7. MAINTENANCE .....</b>	<b>7-1</b>
7.1 Periodic Maintenance.....	7-1
<b>8. HARNESS DIAGRAM .....</b>	<b>8-1</b>
8.1 Harness Diagram .....	8-1



# 1. SPECIFICATION

	MY-1040	MY-1047
Function	Automatic paper feed single cassette front loading	
Paper Size	A5-R, B5, B5-R, A4, A4-R, B4, A3, 320x460mm, SRA3 (320 x 450mm), A3 wide (305 x 357mm / 12" x 18")	A5-R, A4, A4-R, B4, A3, FOLIO, 8K, 16K, 16K-R, ST-R, LT, LT-R, LG, COMP, 13"LG, 8.5" x 8.5"
Paper Thickness	Plain paper 60 to 163 g/m <sup>2</sup> (16 lbs. Bond to 90 lbs. Index)	
Drawer capacity	Paper height 60.5 mm (Approx. 550 sheets)	
Dimensions	575 (W) x 583 (D) x 163 (H) mm (Protrusions excluded)	
Weight	Approx. 9.6 kg	Approx. 9.6 kg
Power supply	5 V DC, 24 V DC (Supplied from MFP) 100 V AC (Damp heater)	
Appearance color	Fair white	Jet black





## 2. GENERAL DESCRIPTION

### 2.1 Main Components

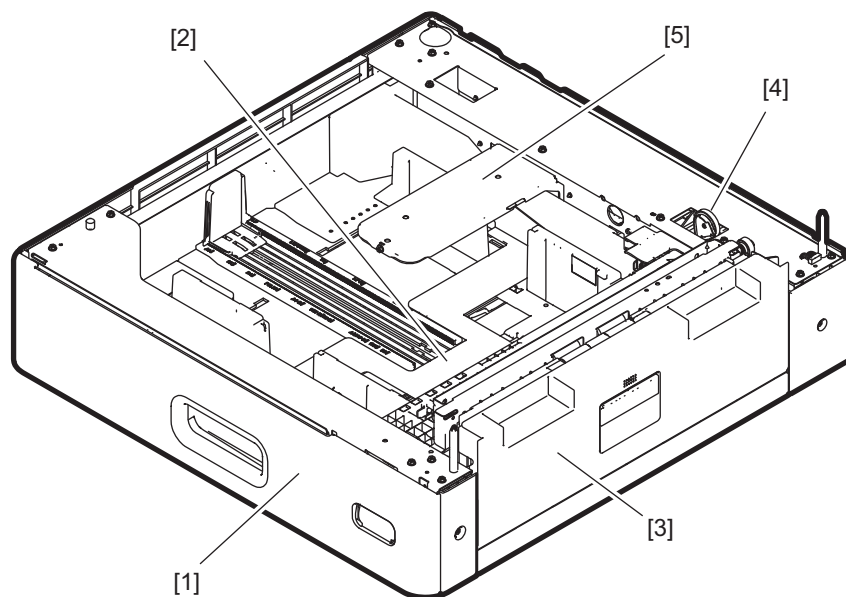

Fig. 2-1

- [1] Drawer
- [2] Drawer tray
- [3] Jam access cover
- [4] Gear
- [5] Damp heater (Option)

## 2.2 Sectional View

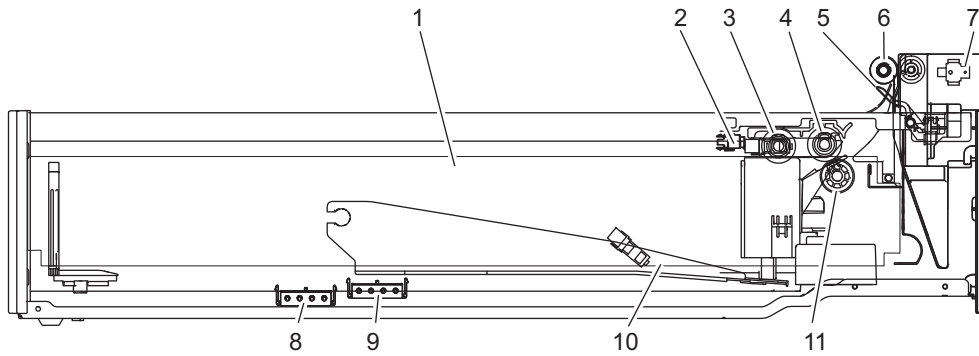

Fig. 2-2

1	Drawer
2	Paper empty sensor
3	Pickup roller
4	Feed roller
5	Paper feed sensor
6	Transport roller
7	Jam access cover opening/closing switch
8	Paper length detection switch
9	Paper width detection switch
10	Drawer paper stock sensor
11	Separation roller

# 2.3 Electric Parts Layout

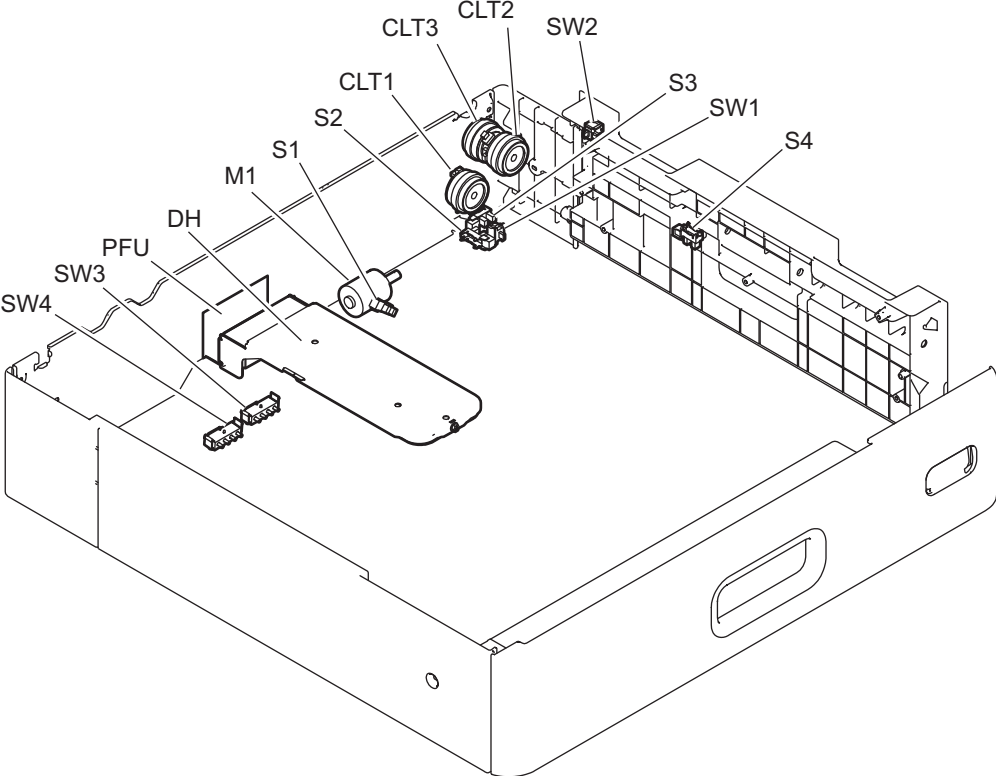

Fig. 2-3

## 2.4 Symbols and Functions of Various Components

The column "P-I" shows the page and item number in the parts list.

Symbol	Name	Function	Remarks	P-I
M1	Tray-up motor	Lifting up the tray in the drawer	P.2-3 "Fig. 2-3"	3-34
S1	Drawer paper stock sensor	Detecting the paper remaining in the drawer	P.2-3 "Fig. 2-3"	3-37
S2	Paper empty sensor	Detecting presence/absence of paper in the drawer	P.2-3 "Fig. 2-3"	2-3
S3	Drawer tray-up sensor	Detecting the lifting status of the tray in the drawer	P.2-3 "Fig. 2-3"	2-3
S4	Paper feed sensor	Detecting paper jamming and paper transport at the feeding section	P.2-3 "Fig. 2-3"	4-23
SW1	Drawer detection switch	Detecting presence/absence of the drawer	P.2-3 "Fig. 2-3"	2-23
SW2	Jam access cover opening/closing switch	Detecting opening/closing of the jam access cover	P.2-3 "Fig. 2-3"	4-25
SW3	Paper width detection switch	Detecting the paper width	P.2-3 "Fig. 2-3"	2-1
SW4	Paper length detection switch	Detecting the paper length	P.2-3 "Fig. 2-3"	2-1
CLT1	Feed clutch	Controlling the driving force transmission of the pickup roller / feed roller	P.2-3 "Fig. 2-3"	3-12
CLT2	Transport clutch (H)	Driving the feed roller (High speed)	P.2-3 "Fig. 2-3"	3-12
CLT3	Transport clutch (L)	Driving the feed roller (Low speed)	P.2-3 "Fig. 2-3"	3-12
DH	Damp heater (Option)	Preventing condensation inside the drawer	P.2-3 "Fig. 2-3"	Option
PFU	PFU board	Controlling the PFU (MY-1047 only)	P.2-3 "Fig. 2-3"	2-34

## 2.5 Diagram of Signal Blocks

MY-1040

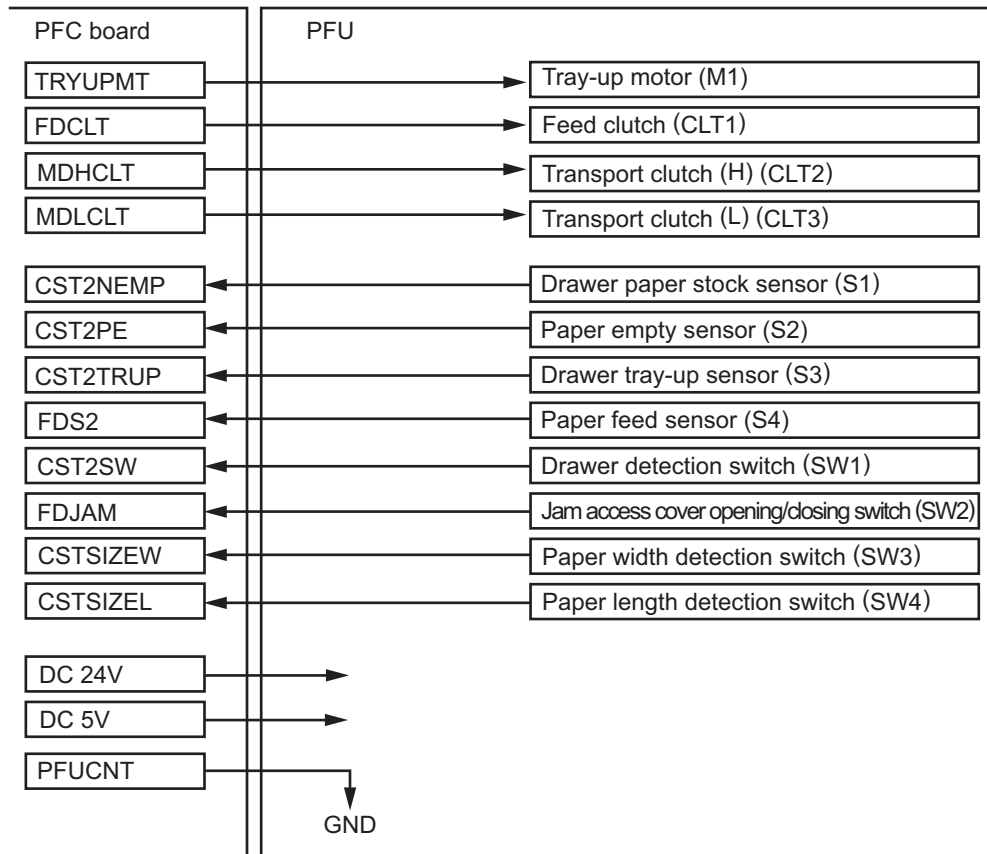

Fig. 2-4

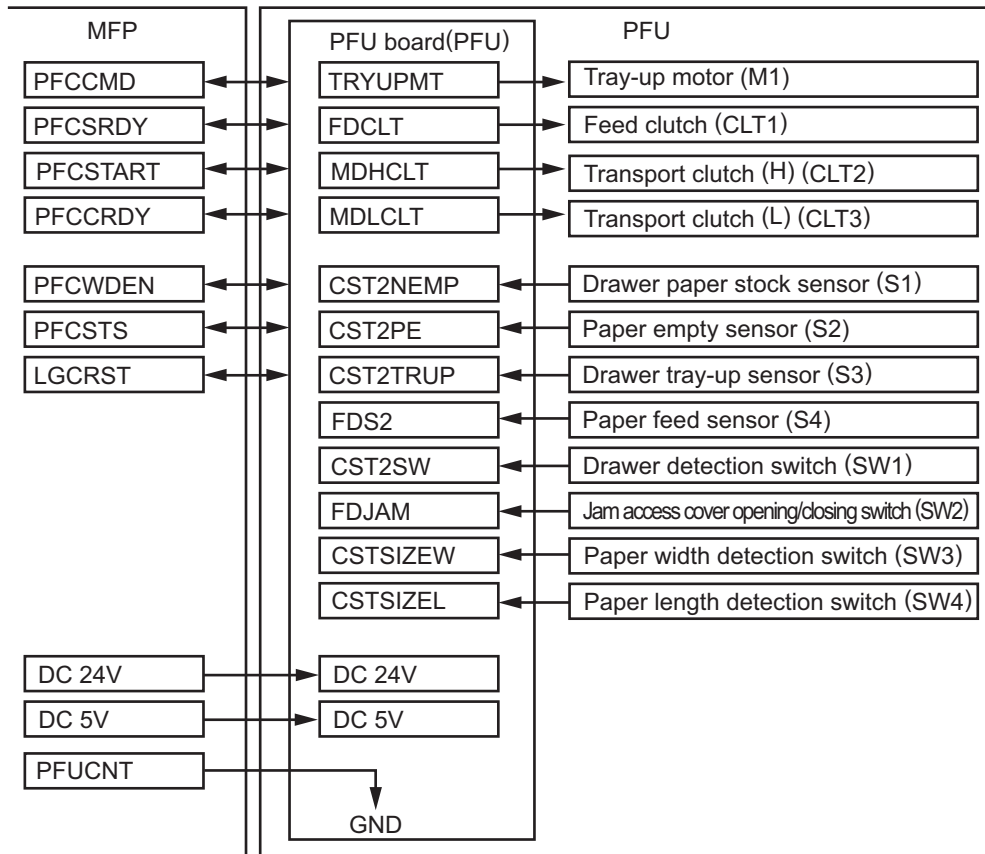

Fig. 2-5

## **3. DESCRIPTION OF OPERATIONS**

### **3.1 Outline**

The PFU is an additional paper feed unit and installed under the standard drawer (in the MFP). The PFU consists of 1 drawer, 4 sensors, 4 switches and 3 magnetic clutches.

## 3.2 Picking up System

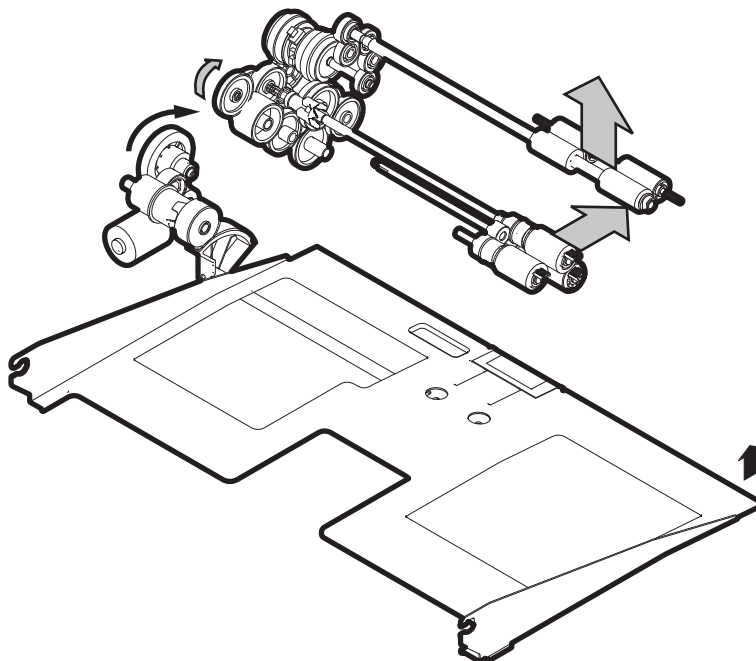

Fig. 3-1

When the drawer is inserted into the PFU, the drawer tray is raised by the tray-up motor and paper can be fed.

The PFU has no motor to operate the feeding and transporting. Paper is fed and transported by transmitting the driving force from the MFP to the gear. This driving force is transmitted to the pickup roller, paper feed roller and transport roller through the gear and clutch.

Paper is picked up by the movement of the feed clutch. When the pickup clutch is turned ON, the pickup roller and feed roller rotate, and the paper is picked up from the drawer. The paper is separated by the separation roller.



### 3.3 Paper Feed System

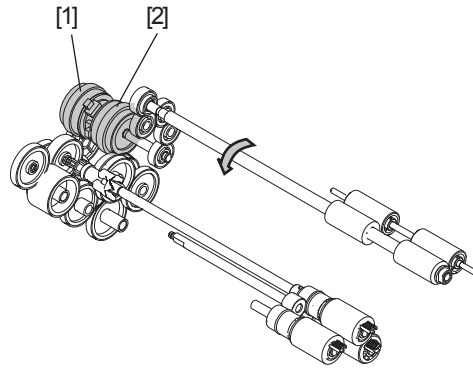

Fig. 3-2

- [1] The transport clutch (L)
- [2] The transport clutch (H)

The transport clutches (L/H) is turned ON when they transport paper and transmit the driving force from the MFP to the transport roller through the gear.  
The transport clutch (Low speed) is turned ON when the paper is picked up from the PFU drawer or when the low speed transportation is performed for printing.  
The transport clutch (High speed) is turned ON when high speed transportation is performed to transport the paper which has passed through the paper feed sensor to the registration position.  
High speed transportation is also performed when the paper is transported from the PFP to the registration position. (When the PFP is connected)



## 4. DISASSEMBLY AND ASSEMBLY

**Note:**

The cover of the actual equipment is different in color from that in the figures below.

### 4.1 Rear cover

- (1) Remove 2 screws and take off the rear cover [1].

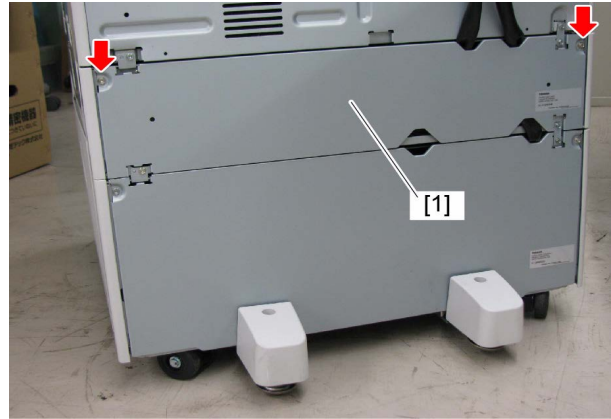

Fig. 4-1

**Note:**

<MY-1047>

When the PFP, LCF, or damp heater is installed, first release the connector of the harness connecting it in the following procedure.

- (1) Remove 1 screw and take off the cover [2].

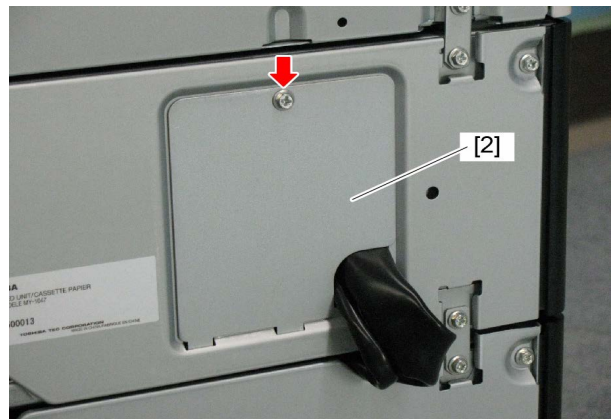

Fig. 4-2

- (2) Disconnect the connector [3], remove 1 screw, and take off the grounding wire [4]. When the damp heater is installed, disconnect its connector [5].

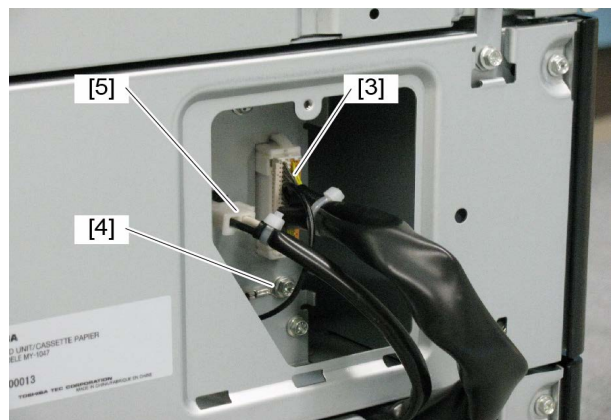

Fig. 4-3

## 4.2 Drawer feeding unit

- (1) Take off the drawer.
- (2) Turn the lock lever [1] clockwise and take off the drawer feeding unit [2].

**Note:**

When installing the drawer feeding unit, align the arrow marked on its upper surface with the guide to insert it.

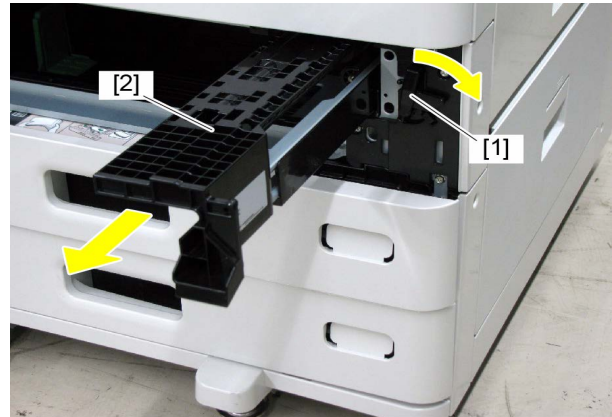

Fig. 4-4

## 4.3 Feed roller / separation roller / Pickup roller

<MY-1040>

- (1) Take off the drawer feeding unit.  
📖 P.4-2 "4.2 Drawer feeding unit"
- (2) Slide the guide [1] to the front side.

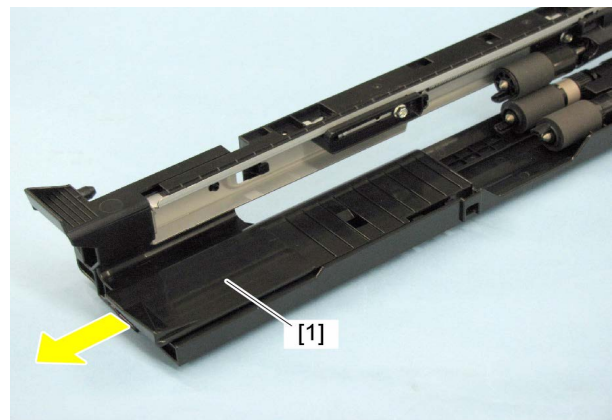

Fig. 4-5

- (3) Take off the separation roller [2], feed roller [3] and pickup roller [4] by pressing each latch.

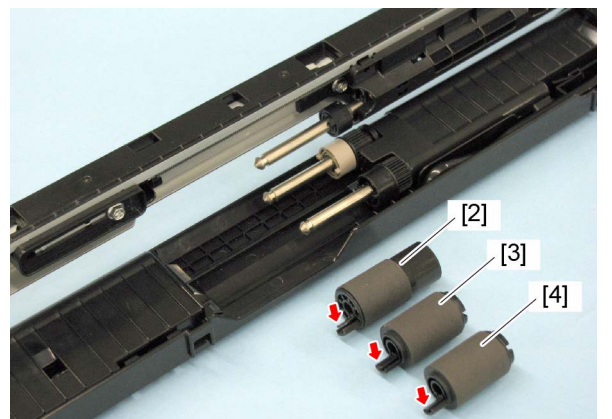

Fig. 4-6

## <MY-1047>

- (1) Take off the drawer feeding unit.  
📖 P.4-2 "4.2 Drawer feeding unit"
- (2) Slide the guide [1] to the front side.

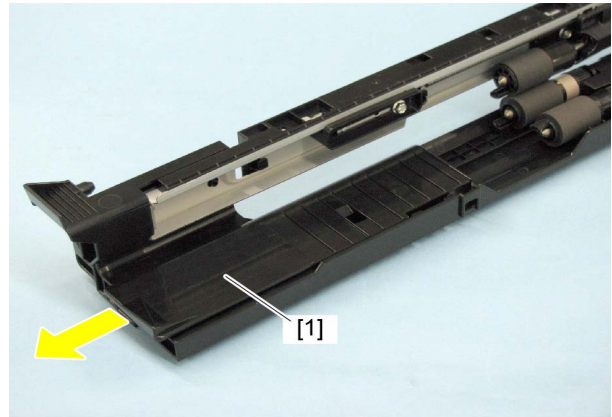

Fig. 4-7

- (3) Remove the clip [1] and take off the separation roller [2].  
Remove the clip [3] and take off the feed roller [4].  
Release the latch and take off the pickup roller [5].

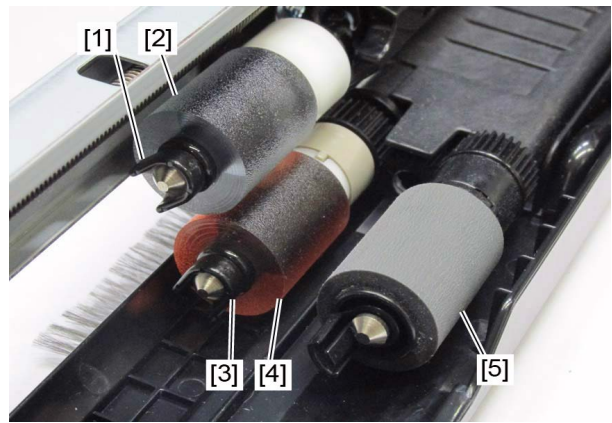

Fig. 4-8

## 4.4 Drive unit

### <MY-1040>

- (1) Remove the rear cover.  
📖 P.4-1 "4.1 Rear cover"
- (2) Disconnect 1 joint connector [1]. Remove 4 screws and take off the drive unit [3] while pressing the gear [2].

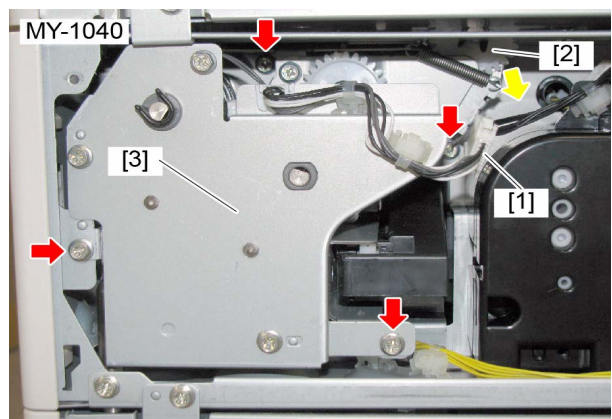
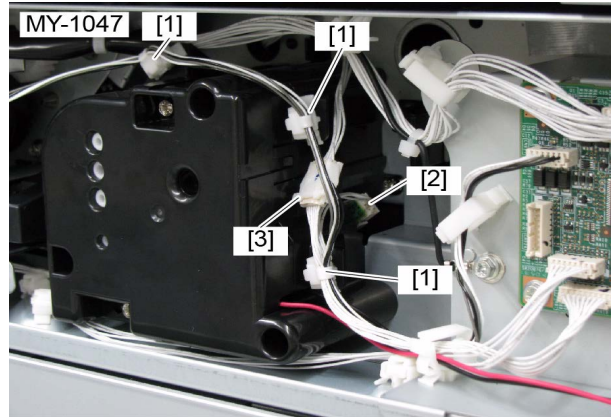

Fig. 4-9

**<MY-1047>**

- (1) Remove the rear cover.  
📖 P.4-1 "4.1 Rear cover"
- (2) Take off 3 harness clamps [1], disconnect 1 connector [2] and 1 joint connector [3].



**Fig. 4-10**

- (3) Release the harnesses from 2 harness clamps [4] and disconnect 2 connectors [5].

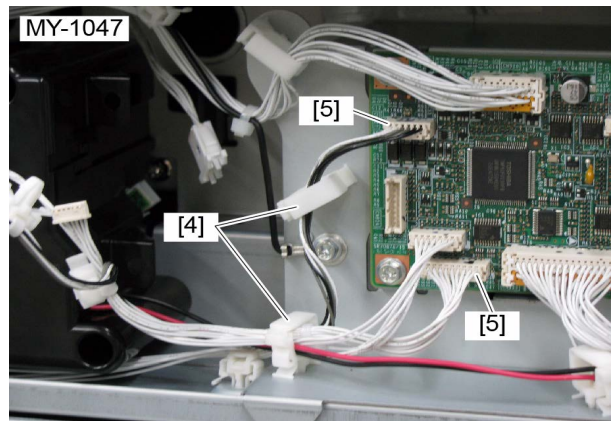

**Fig. 4-11**

- (4) Remove 4 screws and take off the drive unit [3] while pressing the gear [6].

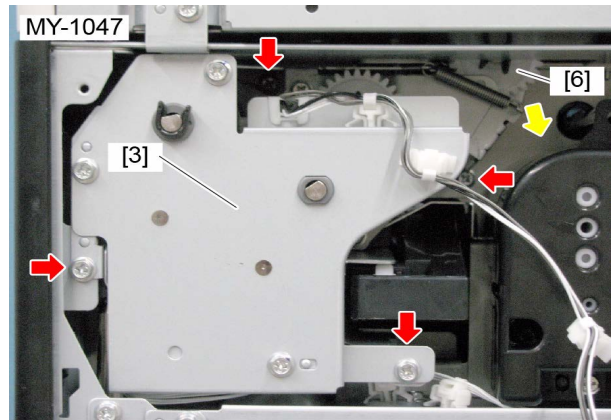

**Fig. 4-12**

## 4.5 Feed clutch

- (1) Remove the drive unit.  
P.4-1 "4.1 Rear cover"
- (2) Remove 3 screws, 1 clip [1], 1 bushing [2], and then take off the cover [3]. Release the harnesses from 1 harness clamp [4] and take off 2 harness clamps [5].

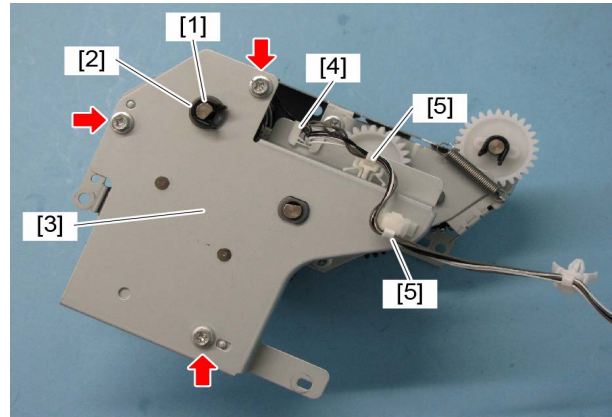

Fig. 4-13

- (3) Remove 1 spring [6], 3 screws, disconnect connector [7], and then take off the bracket [8].

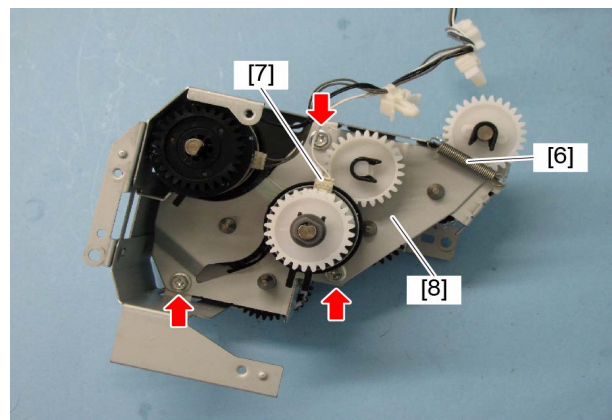

Fig. 4-14

- (4) Remove 1 bushing [9], 2 clips [10], 1 gear [11], 1 pin [12], and then take off the feed clutch [13].

**Note:**

Make sure that the direction of the clips is correct when attaching them.

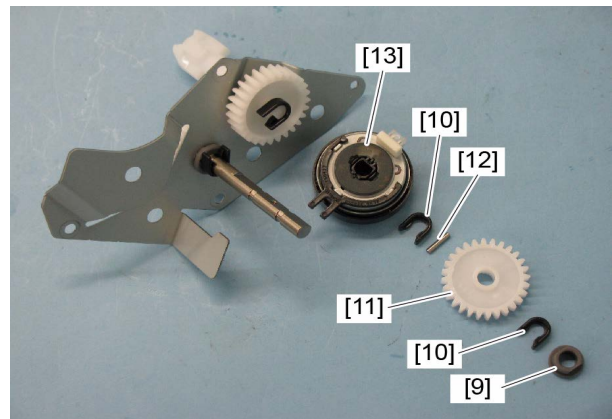

Fig. 4-15

## 4.6 Transport clutch (L) / Transport clutch (H)

- (1) Remove the drive unit.  
📖 P.4-3 "4.4 Drive unit"
- (2) Remove 3 screws, 1 clip [1], 1 bushing [2], and then take off the cover [3].  
Release the harnesses from 1 harness clamp [4] and take off 2 harness clamps [5].

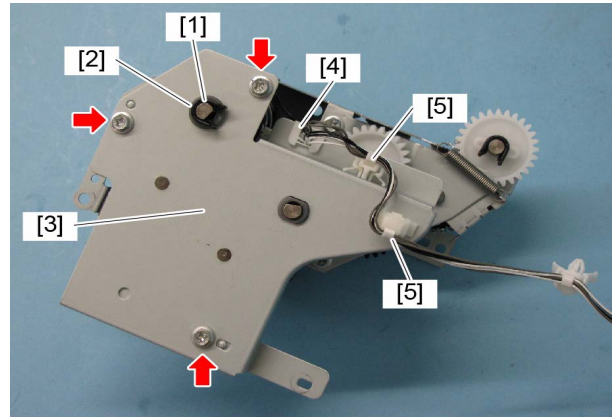

Fig. 4-16

- (3) Disconnect 2 connectors [6].

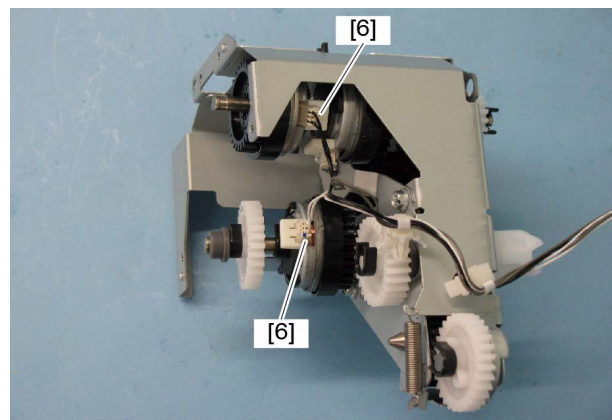

Fig. 4-17

- (4) Remove 1 clip [7], 1 gear [8], 1 pin [9] and 1 bushing [10].

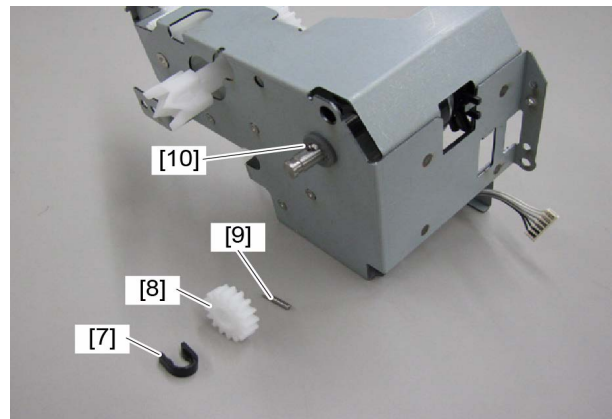

Fig. 4-18



- (5) Take off the transport clutches (low speed [12] / high speed [13]) while taking off the shaft [11].

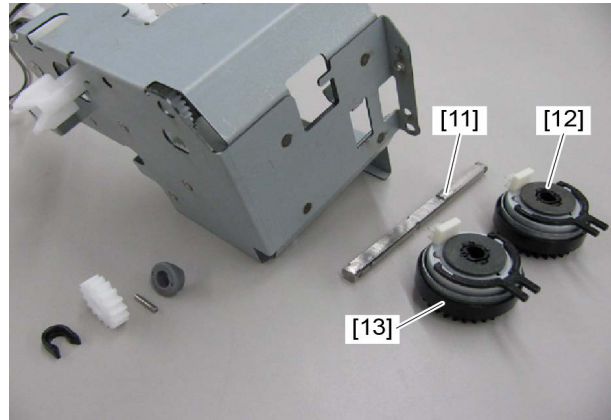



Fig. 4-19

## 4.7 Drawer detection switch

- (1) Pull out the drawer.
- (2) Remove the drive unit.  
 P.4-3 "4.4 Drive unit"
- (3) Release the latches and take off 1 bracket [1].

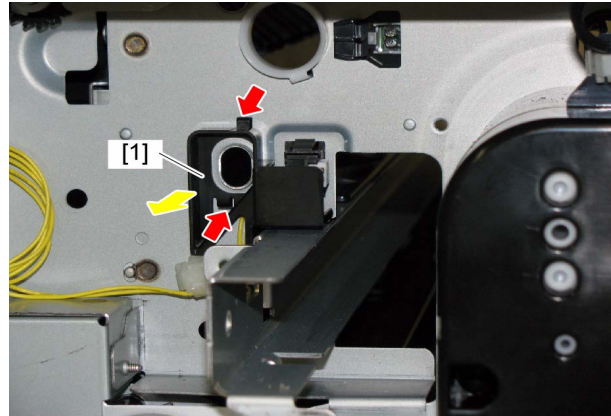

Fig. 4-20

- (4) Disconnect 1 connector [2], release 2 latches, and take off the drawer detection switch [3] to the front side.

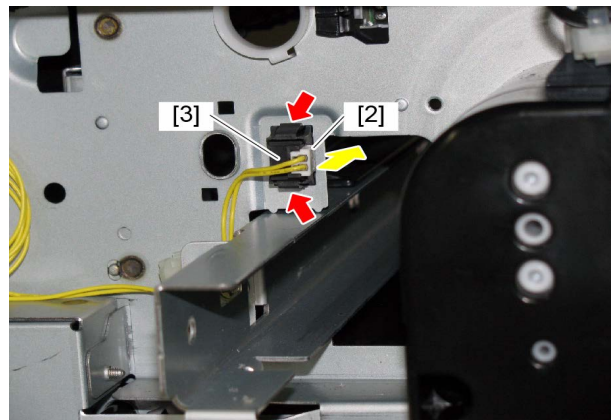

Fig. 4-21

## 4.8 Tray-up motor unit

- (1) Remove the rear cover.  
📖 P.4-1 "4.1 Rear cover"
- (2) Take off 3 harness clamps [1] and disconnect 1 connector [2].

**Note:**

Be sure not to catch the harness when the tray-up motor unit is installed.

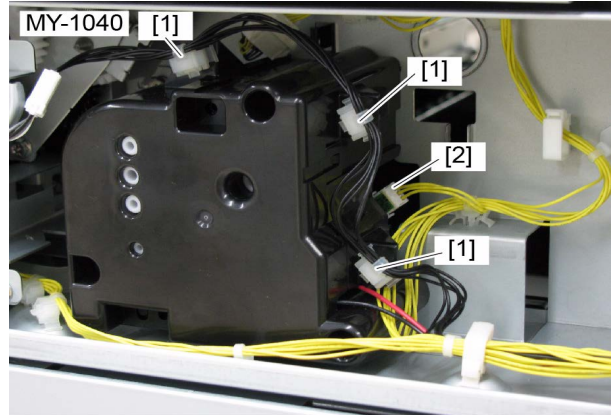

Fig. 4-22

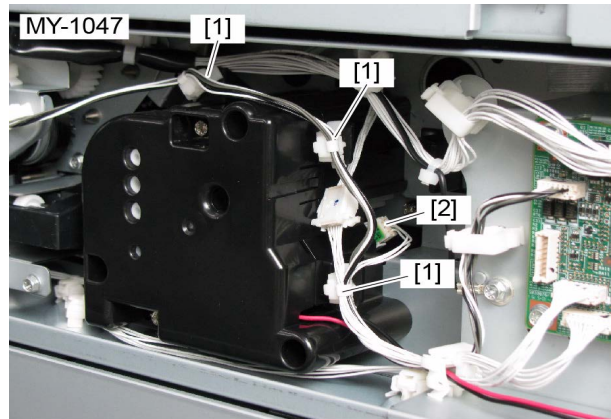

Fig. 4-23

- (3) Release the harnesses from the harness clamp [3] and disconnect 1 joint connector [4].

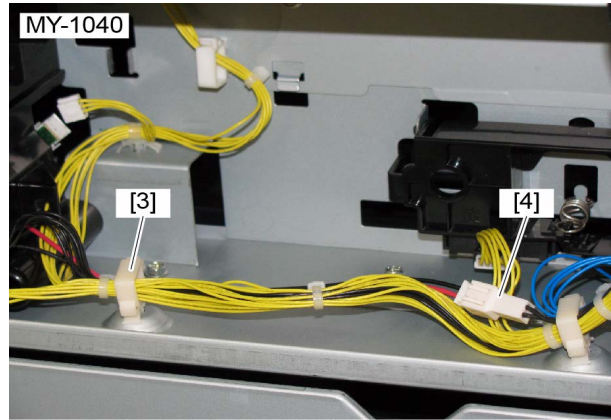

Fig. 4-24

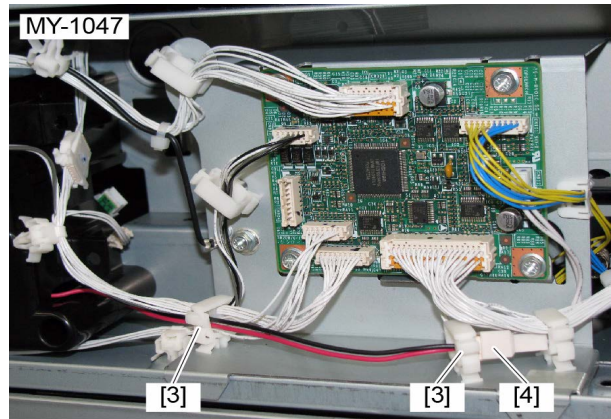

Fig. 4-25

- (4) Remove 3 screws and take off the tray-up motor unit [5].

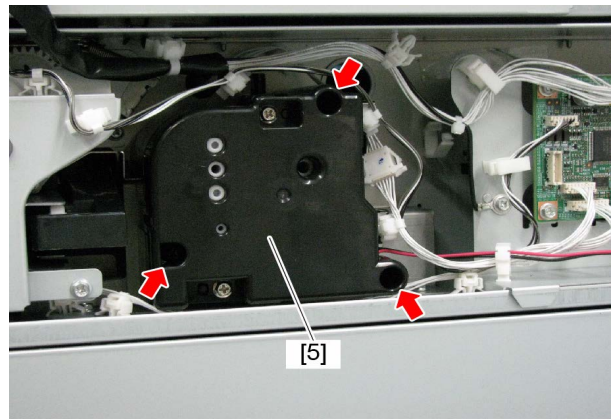

Fig. 4-26

## 4.9 Tray-up motor

- (1) Remove the tray-up motor unit.  
📖 P.4-8 "4.8 Tray-up motor unit"
- (2) Remove 2 screws, release 4 latches [1], and take off the cover [2].

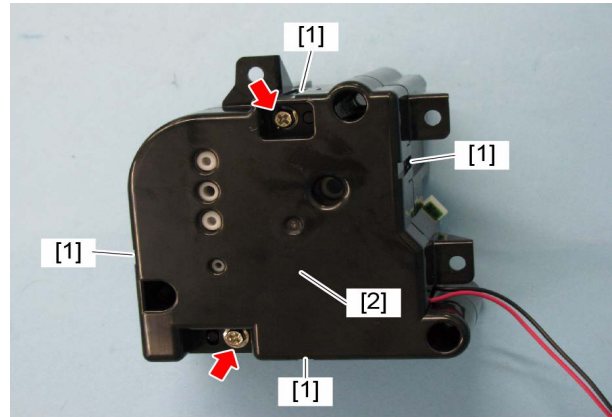

Fig. 4-27

- (3) Take off the tray-up motor [3].

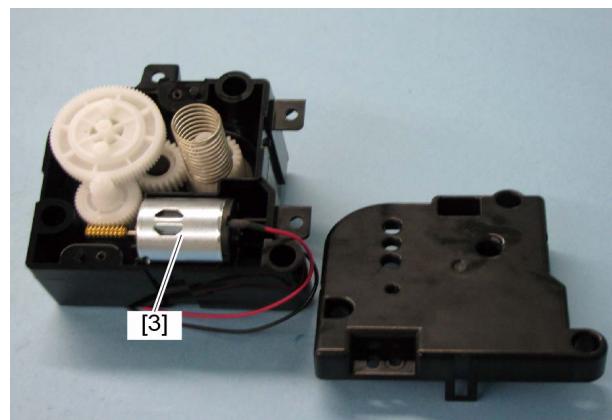

Fig. 4-28

## 4.10 Drawer paper stock sensor

- (1) Remove the tray-up motor unit.  
📖 P.4-8 "4.8 Tray-up motor unit"
- (2) Release the latches and take off the drawer paper stock sensor [1].

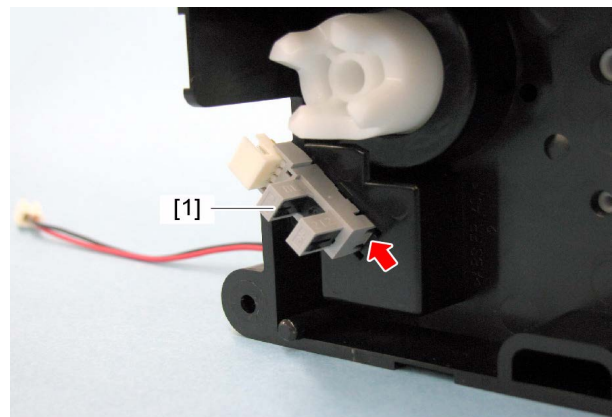

Fig. 4-29

## 4.11 Paper empty sensor / Drawer tray-up sensor

- (1) Take off the drawer feeding unit.  
📖 P.4-2 "4.2 Drawer feeding unit"
- (2) Remove the tray-up motor unit.  
📖 P.4-8 "4.8 Tray-up motor unit"
- (3) <MY-1040>  
Disconnect 1 joint connector [1].

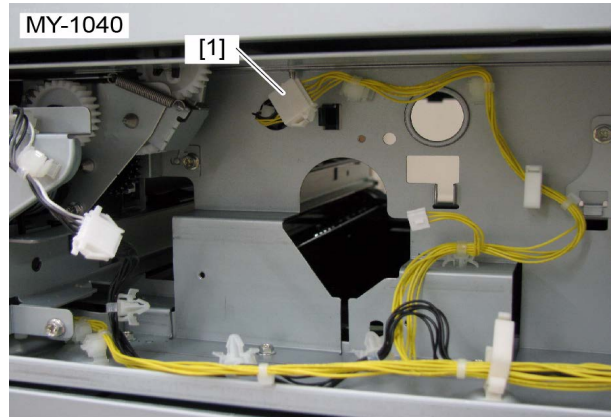

Fig. 4-30

- <MY-1047>  
Disconnect 1 joint connector [1] and take off  
1 harness clamp.

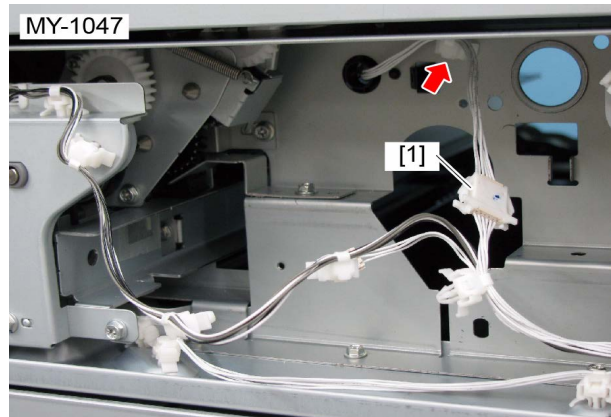

Fig. 4-31

**Note:**

Disconnect the joint connector [1] without  
leaving the joint section on the sensor side.

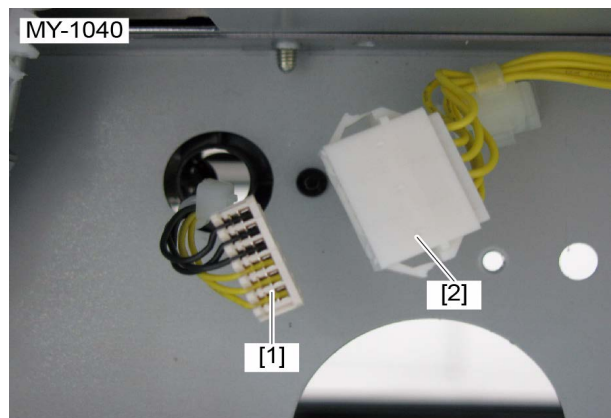

Fig. 4-32

- (4) Release 1 latch on the rear side.



Fig. 4-33

- (5) Take off the sensor holder [3] from the front side.

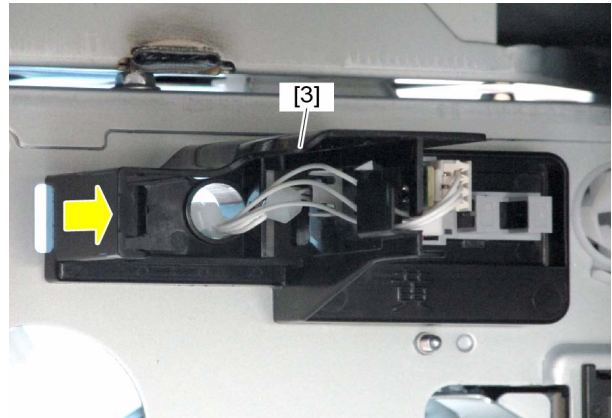

Fig. 4-34

- (6) Disconnect 1 connector [4] and take off the paper empty sensor [5].  
Disconnect 1 connector [6] and take off the drawer tray-up sensor [7].

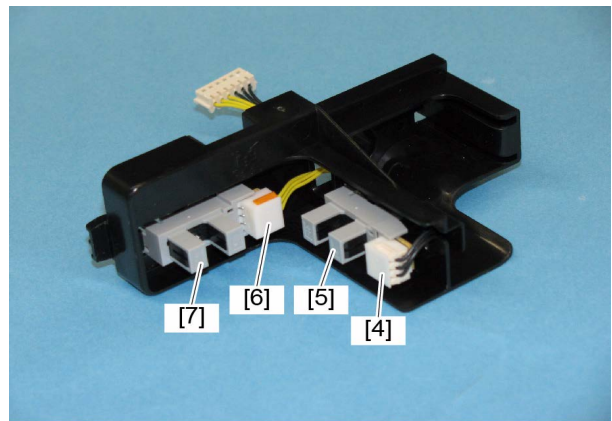

Fig. 4-35

## 4.12 Paper width detection switch / Paper length detection switch

- (1) Remove the rear cover.  
📖 P.4-1 "4.1 Rear cover"
- (2) Remove the PFC board.  
📖 P.4-16 "4.16 PFC board"
- (3) Remove 1 spring [1] and disconnect 2 connectors [2].

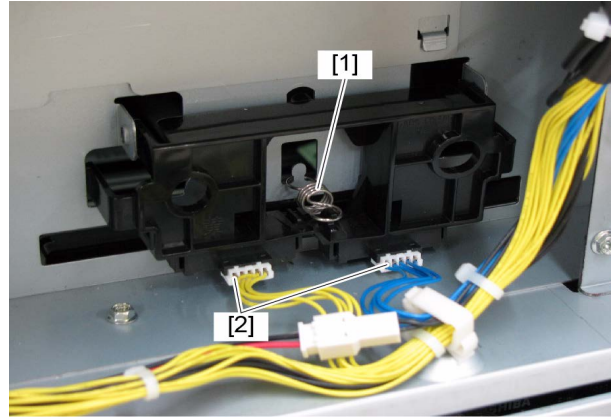

Fig. 4-36

- (4) Release the latch and take off the switch holder [3].

**Note:**

When installing the switch holder, align 3 dowels [3] to the frame holes and fix it with the latches.

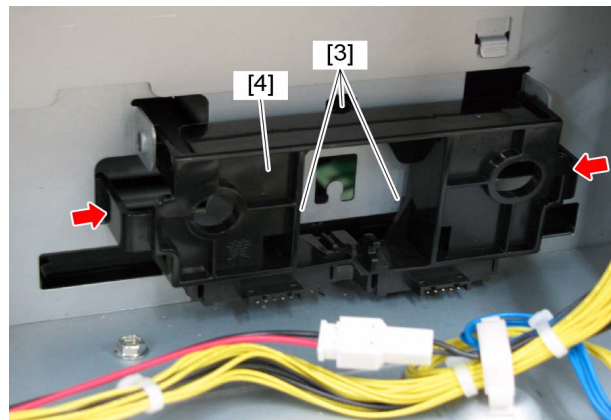

Fig. 4-37

- (5) Release the latches and take off the paper width detection switch [1].  
Release the latches and take off the paper length detection switch [2].

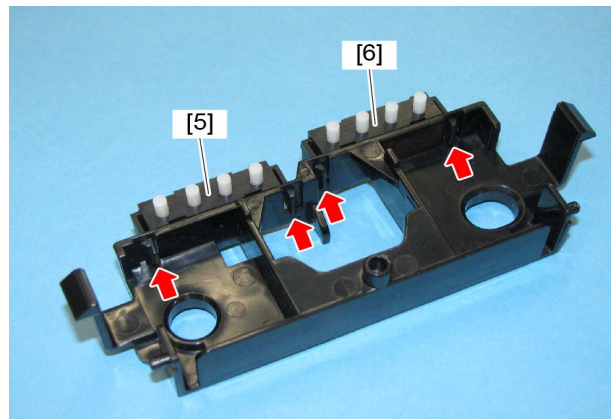

Fig. 4-38

## 4.13 Jam access cover

- (1) Open the jam access cover [1] and disconnect 1 connector [2].
- (2) Remove the block [3].

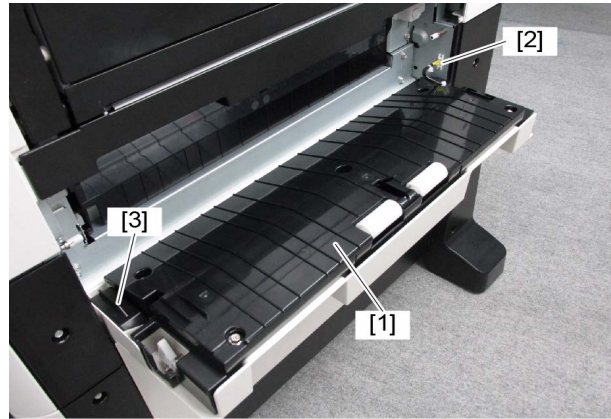

Fig. 4-39

- (3) Take off the jam access cover [1] while pushing its fulcrum [4] to the inside.

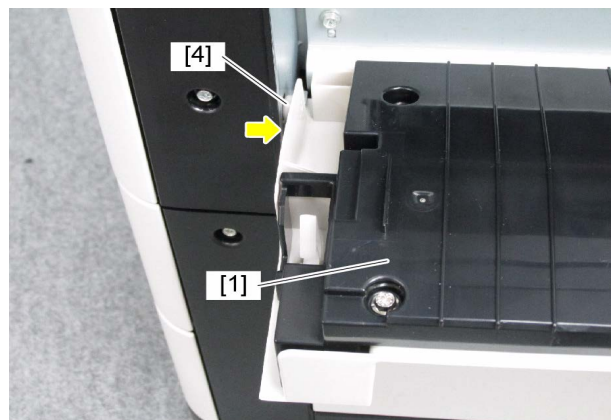

Fig. 4-40

## 4.14 Jam access cover opening/closing switch

- (1) Remove the jam access cover.  
📖 P.4-14 "4.13 Jam access cover"
- (2) Remove 5 screws and take off the guide [1].

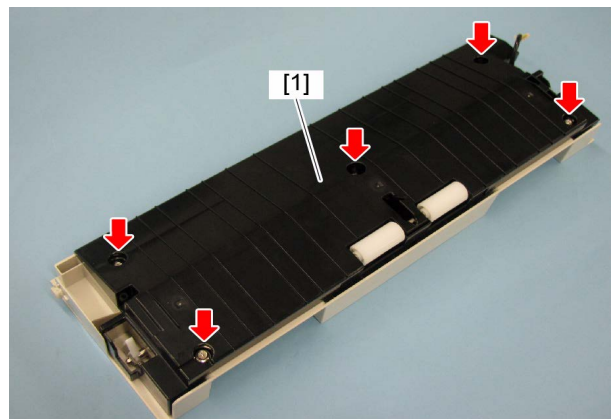

Fig. 4-41



- (3) Disconnect 1 connector [2], release the latches, and take off the jam access cover opening/closing switch [3].

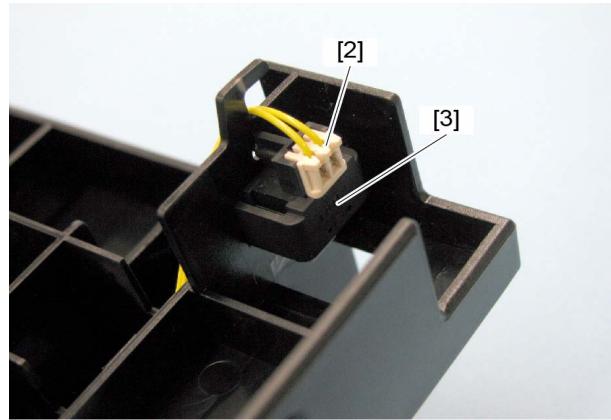



Fig. 4-42

## 4.15 Paper feed sensor

- (1) Remove the jam access cover.  
 P.4-14 "4.13 Jam access cover"
- (2) Remove 5 screws and take off the guide [1].

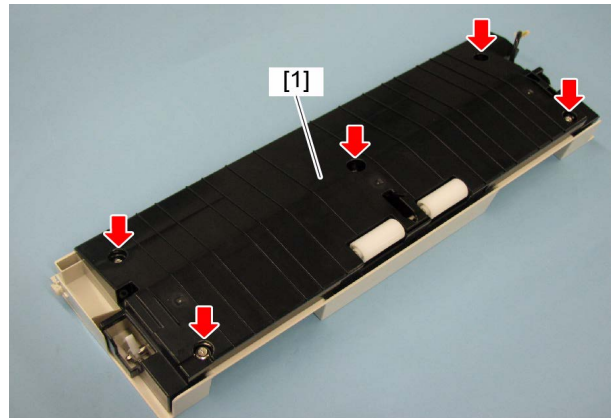

Fig. 4-43

- (3) Remove 3 screws and take off the cover [1].

**Note:**

Be sure to take off the cover carefully, since the internal spring is subject to pressure and will come off with great force.

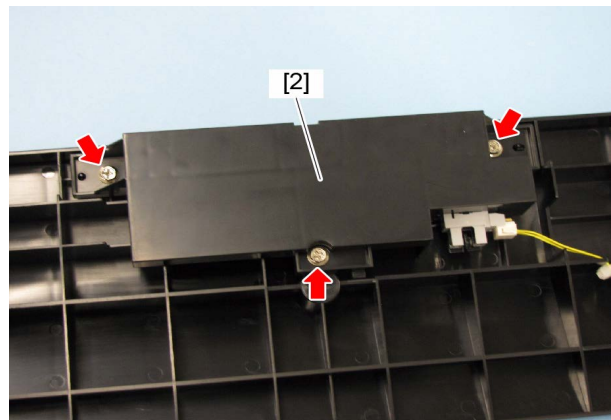

Fig. 4-44

- (4) Disconnect 1 connector [3], release the latches, and take off the paper feed sensor [4].

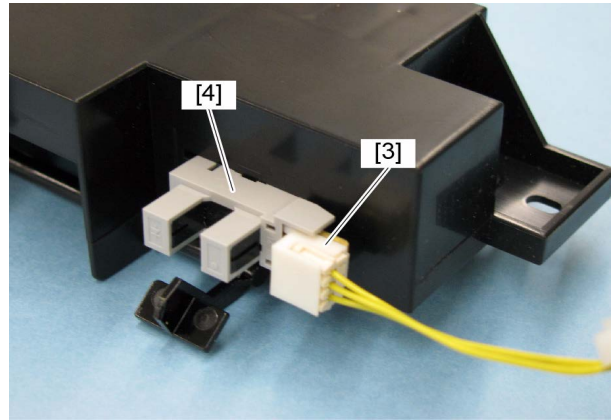



Fig. 4-45

## 4.16 PFC board

- (1) Remove the rear cover.  
 P.4-1 "4.1 Rear cover"
- (2) Disconnect all connectors from the PFC board [4] and take off the grounding wire [2]. Release the harnesses from 6 harness clamps [1], remove 1 screw, and take off the bracket [3].

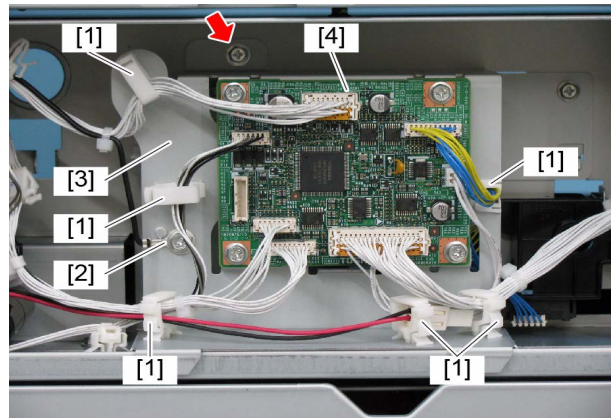

Fig. 4-46

- (3) Remove 4 screws and take off the PFC board [4].

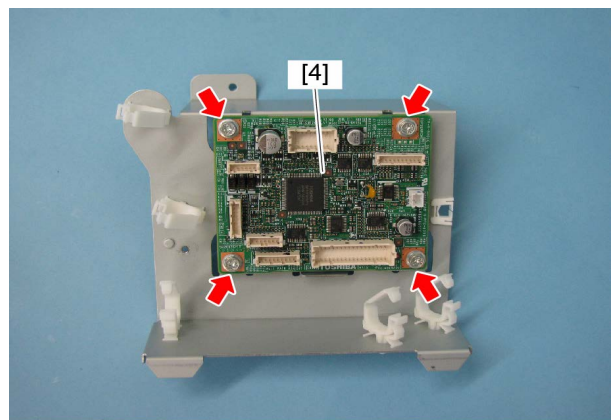

Fig. 4-47

## 4.17 Damp heater (Option)

- (1) Turn the power of the equipment OFF and unplug the power cable before the disassembly.
- (2) Pull out the drawer.
- (3) Remove 2 screws.

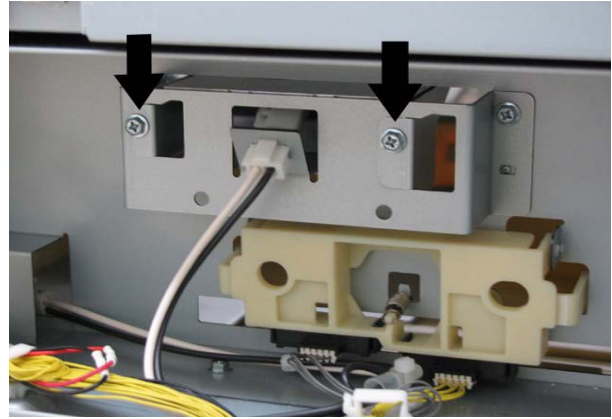

Fig. 4-48

- (4) Slide the damp heater [1] to the feed side.
- (5) Disconnect 1 connector [2] and take off the damp heater.

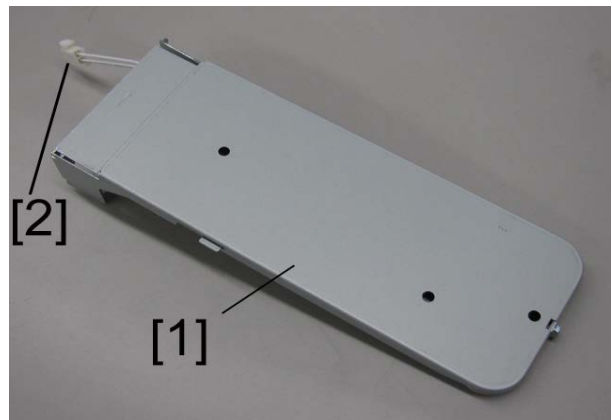

Fig. 4-49



## 5. ADJUSTMENT

The PFU is not adjusted for itself.



## 6. TROUBLESHOOTING

### 1. Paper is not picked up.

Classification	Contents
Paper misfeeding	Paper is not picked up.

Step	Check Item	Result	Measure	Next Step
1	Is there any deformation or wear of the pickup roller?	Yes	Replace the paper pickup roller.	
		No		2
2	Does the pickup roller rotate?	Yes		3
		No	Replace the feed clutch or fix the breakage of the drive system.	
3	Is the lift-up mechanism of the drawer normal?	Yes		4
		No	Fix the lift-up mechanism.	
4	Is the paper empty sensor normal?	Yes		5
		No	Replace the paper empty sensor.	
5			Fan the paper and load it again.	

### 2. Multiple sheets of paper are fed in one go.

Classification	Contents
Paper transport jam	Multiple sheets of paper are fed in one go.

Step	Check Item	Result	Measure	Next Step
1	Is the paper damp?	Yes	Replace the paper.	
		No		2
2	Is the paper separation roller deformed?	Yes	Fix or replace the paper separation roller.	
		No		3
3			Fan the paper and load it again.	

### 3. Paper is picked up, but is not fed to the equipment.

Classification	Contents
Paper transport jam	Paper is picked up, but is not fed to the equipment.

Step	Check Item	Result	Measure	Next Step
1	Does the feed roller rotate?	Yes		2
		No	Replace the drive gear or transport clutch (L).	
2	Is the paper feed sensor normal?	Yes		3
		No	Replace the paper feed sensor.	
3			Check the feed roller and replace it if it is worn or deformed.	

### 4. Paper skews or deviates sideways.

Classification	Contents
Paper transport jam	Paper skews or deviates sideways.

Step	Check Item	Result	Measure	Next Step
1	Is the paper correctly set?	Yes		2
		No	Fan the paper and load it again.	
2	Is the width of the paper guide properly adjusted?	Yes		3
		No	Adjust the width of the guide to that of the paper.	

### 5. The PFU does not operate.

Classification	Contents
Paper feeding system related service call	The PFU does not operate.

Step	Check Item	Result	Measure	Next Step
1	Check if the connection with the equipment is normal.	Yes		2
		No	Connect the connector correctly or replace the harnesses.	



# 7. MAINTENANCE

## 7.1 Periodic Maintenance

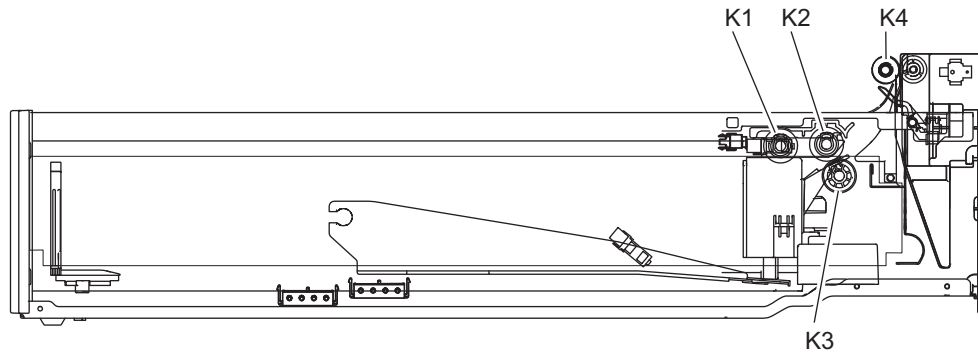

Fig. 7-1

Symbols used in the checklist

Cleaning	Lubrication/Coating	Replacement	Operation check
A: Clean with alcohol	W1: White grease (Molykote EM-30L)	Value: Replacement cycle R: Replace if deformed or damaged	O: After cleaning or replacement, confirm there is no problem.

Preventive Maintenance Checklist

**Note:**

Page-Item (P-I) is described in the column of the Parts list.

Items to check	Cleaning	Lubrication/Coating	Replacement (x 1,000 sheets)	Operation check	Parts list <P-I>	Remarks
K1 Pickup roller	A		80		5-26	
K2 Feed roller	A		80		5-26	
K3 Separation roller	A		80		5-30	
K4 Transport roller	A				4-3	
K5 Guides	A				4-23	
K6 Paper feed sensor	A				4-1, 4-11	



# 8. HARNESS DIAGRAM

## 8.1 Harness Diagram

MY-1040

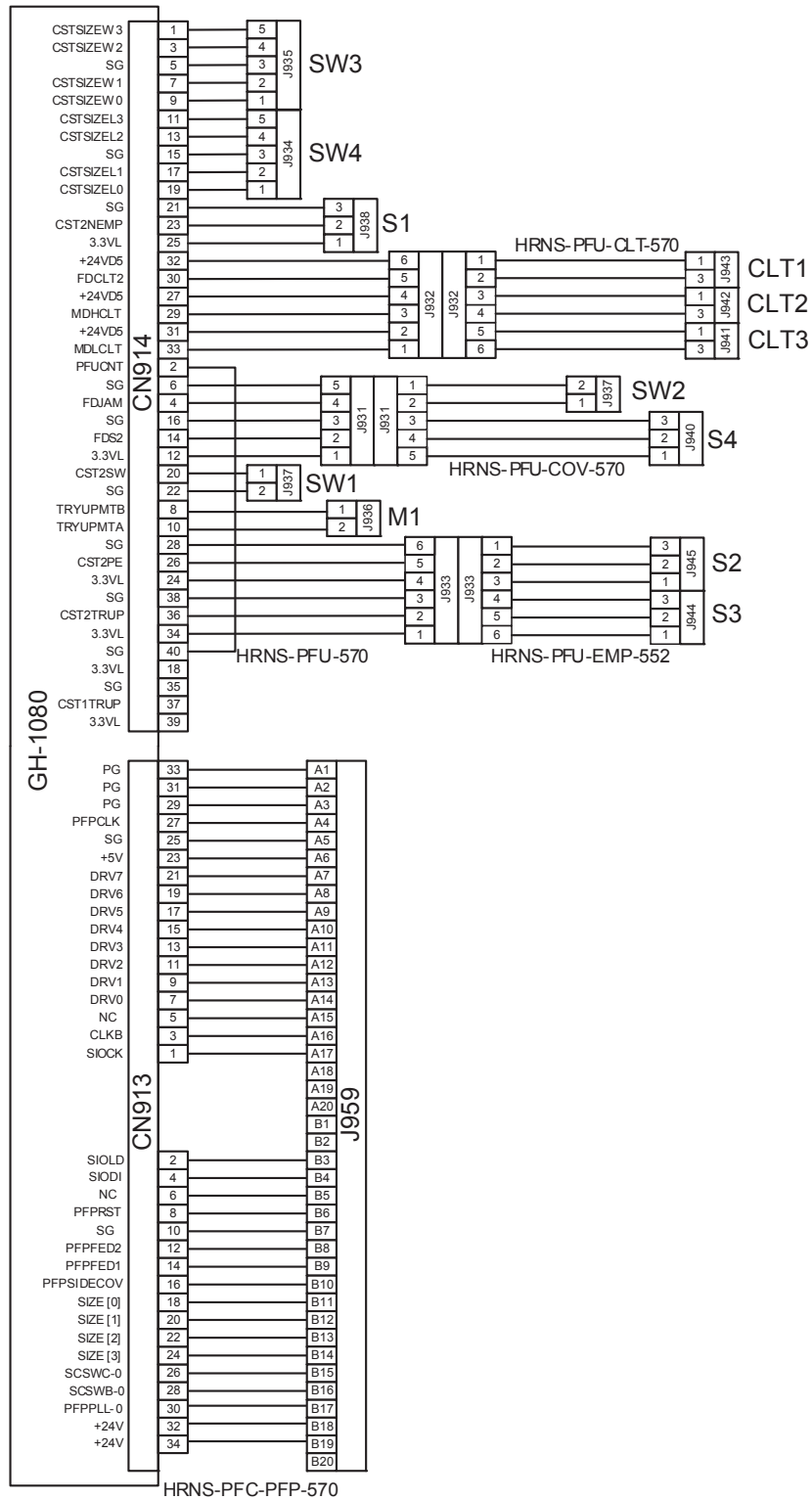

Fig. 8-1

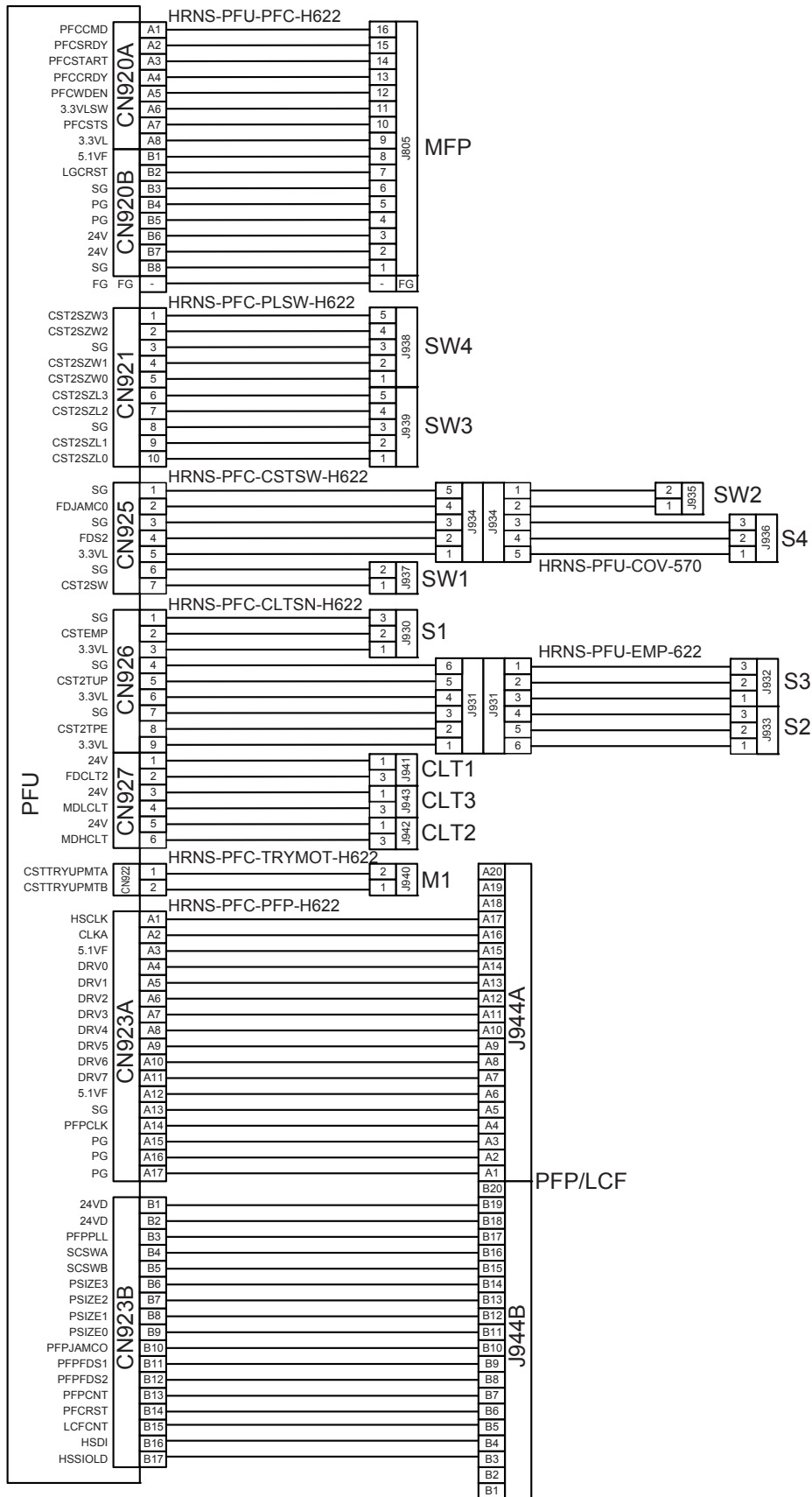

Fig. 8-2

# REVISION RECORD

## Ver.02

Ver02<2016.12.06>	
Page	Contents
2-4	The descriptions for "Remarks" and "P-I" have been added.

## Ver.01

Ver01<2016.03.11>	
Page	Contents
Cover	MY-1047 has been added.
General Precautions	A note has been added.
1-1	MY-1047 has been added.
2-3, 4	The contents of MY-1040 have been changed due to addition of MY-1047.
2-6	MY-1047 has been added.
4-1 to 15	MY-1047 has been added.
8-2	MY-1047 has been added.

## Ver.00

Ver00<2012.04>	
Page	Contents
-	Initial release





**TOSHIBA**

**TOSHIBA TEC CORPORATION**

1-11-1, OSAKI, SHINAGAWA-KU, TOKYO, 141-8562, JAPAN