

TOSHIBA

SERVICE MANUAL

LARGE CAPACITY FEEDER

MP-2501/2502

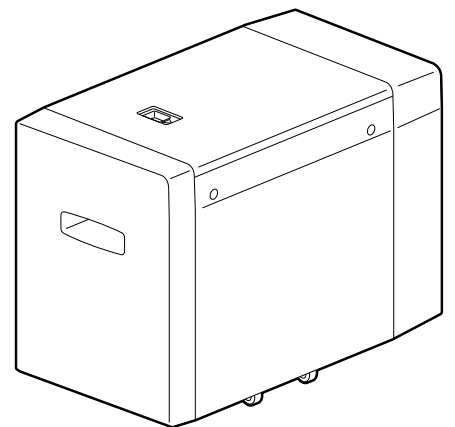

Model: MP-2501/2502
Publish Date: August 2008
File No. SME070018C0
R070921E5102-TTEC
Ver03 F_2018-09

Trademarks

- MOLYKOTE® is a registered trademark of Dow Corning Corporation.
- Other company names and product names in this manual are the trademarks of their respective companies.

© 2008 - 2018 TOSHIBA TEC CORPORATION All rights reserved

Under the copyright laws, this manual cannot be reproduced in any form without prior written permission of TOSHIBA TEC CORPORATION. No patent liability is assumed, however, with respect to the use of the information contained herein.

General Precautions for Installation/Service/Maintenance for this equipment

The installation and service should be done by a qualified service technician.

1. When installing this equipment, be sure to follow the instructions described in the “Unpacking/Set-Up Procedure for this equipment”.
2. This equipment shall be installed by an authorized/qualified person.
3. This equipment is quite heavy and weighs approximately 28.5 kg (62.83 lb), therefore pay full attention when handling it.
4. Before starting installation, servicing or maintenance work, be sure to turn OFF and unplug the equipment first.
5. The equipment shall be installed near the socket outlet and shall be accessible.
6. Be sure to fix and plug in the power cable securely after the installation so that no one trips over it.
7. When selecting the installation site, avoid placing the finisher / hole punch unit and equipment on different levels or inclined floors.
8. When servicing or maintaining the this equipment, be careful about the rotating or operation sections such as gears, pulleys, sprockets, cams, belts, etc.
9. When parts are disassembled, reassembly is basically the reverse of disassembly unless otherwise noted in this manual or other related materials.
Be careful not to reassemble small parts such as screws, washers, pins, E-rings, toothed washers, harnesses to the wrong places.
10. Basically, the machine should not be operated with any parts removed or disassembled.
11. Delicate parts for preventing safety hazard problems (such as switches, sensors, etc. if any) should be handled/installed/adjusted correctly.
12. Use suitable measuring instruments and tools.
13. During servicing or maintenance work, be sure to check the serial No. plate and other cautionary labels (if any) to see if they are clean and firmly fixed.
If not, take appropriate actions.
14. The PC board must be stored in antistatic envelope and handled carefully using a wristband, because the ICs on it may be damaged due to static electricity.
Before using the wrist band, pull out the power cable plug of the equipment and make sure that there is no uninsulated charged objects in the vicinity.
15. For the recovery and disposal of used this equipment, consumable parts and packing materials, follow the relevant local regulations/rules.
16. After completing installation, servicing and maintenance of this equipment, return this equipment to its original state, and check operation.
17. When the equipment is used after the option is removed, be sure to install the parts or the covers which have been taken off so that the inside of the equipment is not exposed.

CONTENTS

1. SPECIFICATIONS	1-1
2. OUTLINE OF THE MACHINE	2-1
2.1 Front Sectional View	2-1
2.2 Electrical Parts Layout	2-2
2.3 Electrical Parts	2-3
3. GENERAL OPERATION	3-1
3.1 Description of Operation	3-1
3.2 Error Detection	3-2
3.3 Flow Chart.....	3-3
4. DISASSEMBLY AND REPLACEMENT	4-1
4.1 Covers.....	4-1
4.2 Feed unit	4-4
4.3 Electric Parts	4-5
4.4 Rollers.....	4-12
4.5 Tray-up drive unit	4-15
4.6 Transport motor drive unit.....	4-18
4.7 Drawer unit.....	4-19
4.8 Setting paper guide	4-25
4.9 Adjustment	4-29
4.9.1 Sheet sideways deviation adjustment.....	4-29
4.9.2 LCF slant adjustment.....	4-31
4.9.3 Separation roller pressure force adjustment.....	4-32
5. ELECTRIC CIRCUIT	5-1
5.1 Harness Diagram	5-1
5.2 Circuit Diagram	5-2
5.3 PC Board.....	5-4
6. PREVENTIVE MAINTENANCE	6-1
REVISION RECORD	1

1. SPECIFICATIONS

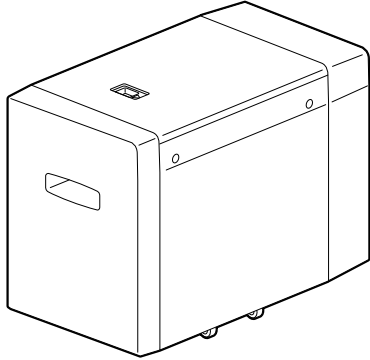
Item	MP-2501	MP-2502
Appearance		
Replenishing method	Front loading method	
Paper	Size: A4, LT Thickness: 64-256 g/m ² (17 lbs. Bond - 140 lbs. Index)	
Capacity of tray	2,500 sheets (Stack height: within 290 mm)	
Dimensions	326 (W) x 610.5 (D) x 464.5 (H) mm (when connected to the equipment)	
Weight	Approx. 28.5 kg (62.83 lbs)	
Power supply	5 V, 24 V (supplied from the equipment)	
Accessory	Unpacking Instructions (1set) Base Unit (1 pc.) Latch Bracket - F (1 pc.) Latch Bracket - R (1 pc.) Harness cover (1 pc.) Screw: TBID M4x8 (10 pcs.) Screw with spring washer: M4x6 (4 pcs.)	
Appearance color	Fair white	Jet black

Comparison of MP-2502A/2502L and MP-2502A/2502L-B

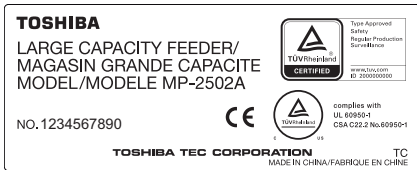
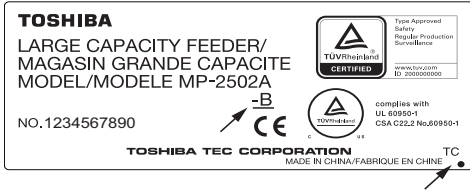
Model Name	MP-2502A / MP-2502L	MJ-2502A-B / MP-2502L-B
European safety standards complied with	Safety standard: EN60950-1 RoHS2: 2011/65/EU	Safety standard: EN60950-1, EN62368-1 RoHS2: 2011/65/EU 2011/65/EU+(EU)2015/863
Applicable models	e-STUDIO5506AC/6506AC/7506AC e-STUDIO5508A/6508A/7508A/8508A	e-STUDIO5506AC/6506AC/7506AC e-STUDIO5516AC/6516AC/7516AC e-STUDIO5508A/6508A/7508A/8508A e-STUDIO5518A/6518A/7518A/8518A
Rating label	 <p>No mark applied</p>	 <p>Black dot mark and "-B" applied</p>
Notes	Purchasing this is not possible after June, 2019.	

2. OUTLINE OF THE MACHINE

2.1 Front Sectional View

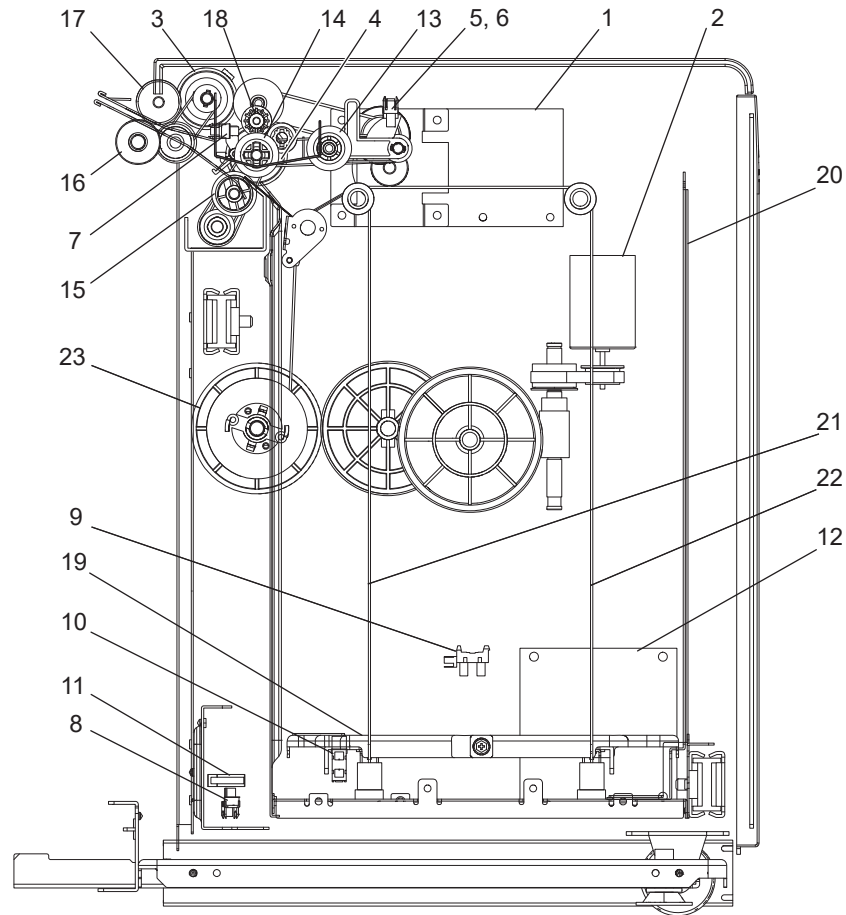

Fig. 2-1

NO.	NAME	NO.	NAME
1	Transport motor (M1)	13	Pickup roller
2	Tray motor (M2)	14	Feed roller
3	Transport clutch (CL1)	15	Separation roller
4	Feed clutch (CL2)	16	Transport roller
5	Empty sensor (S1)	17	Transport idler roller
6	Tray-up sensor (S2)	18	Brush roller (only for MP-2501)
7	Feed sensor (S3)	19	Tray
8	LCF set sensor (S4)	20	End side guide
9	Tray sensor (S5)	21	Short wire
10	Tray bottom sensor (S6)	22	Long wire
11	Door switch (SW1)	23	Brake unit
12	LCF PC board (PWA)		

2.2 Electrical Parts Layout

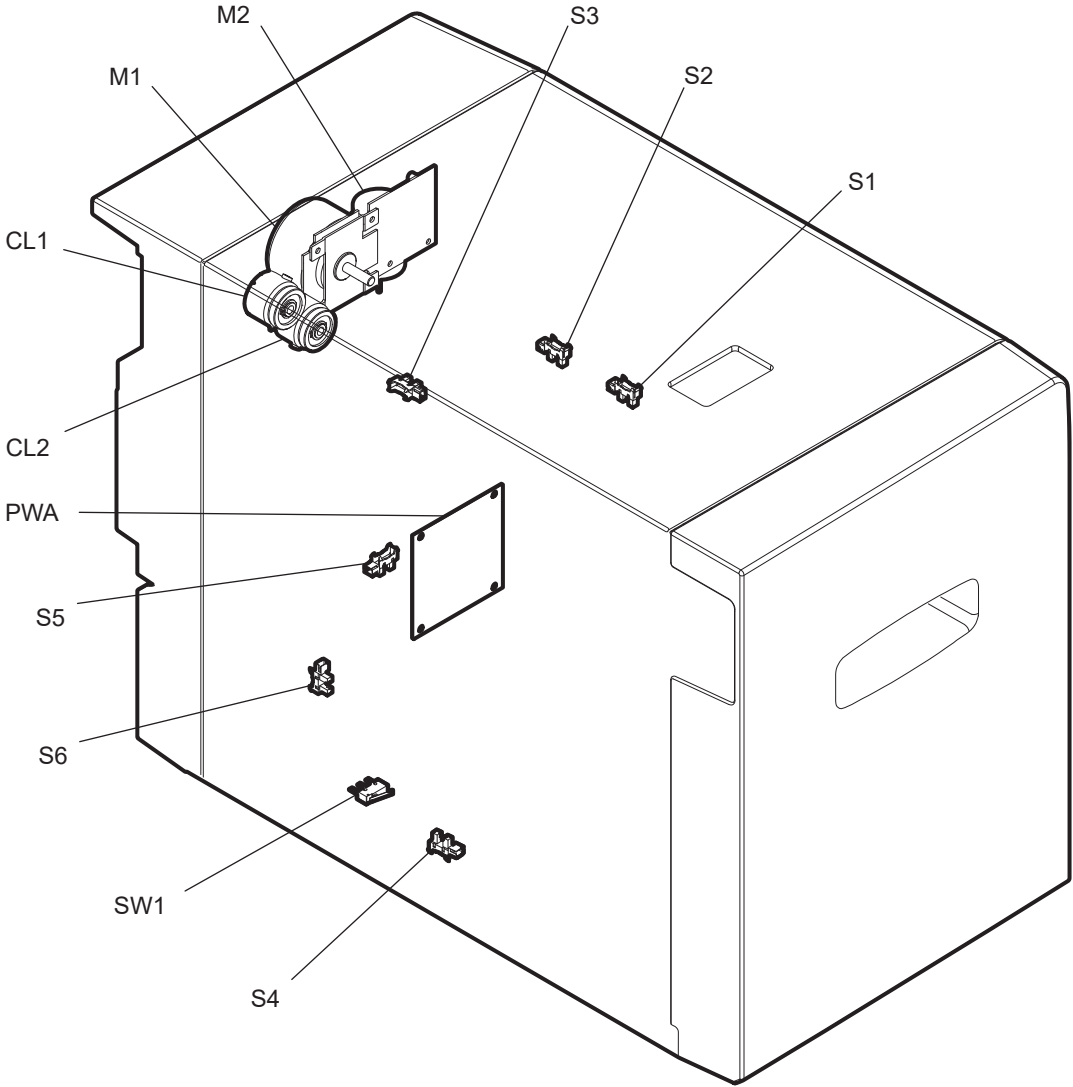

Fig. 2-2

2.3 Electrical Parts

1. Motors

SYMBOL	NAME	FUNCTION	REMARKS
M1	TRNS-MTR Transport motor	Driving of the feeding and transportation	Brushless motor
M2	TRY-MTR Tray motor	Lifting/Lowering of the tray	Brush motor

2. Electromagnetic clutches

SYMBOL	NAME	FUNCTION	REMARKS
CL1	TRNS-CLT Transport clutch	Driving of the transportation	
CL2	FED-CLT Feed clutch	Driving of the feeding	

3. Switches/Sensors

SYMBOL	NAME	FUNCTION	REMARKS
S1	EMP-SNR Empty sensor	Detection of the presence or absence of paper	Photo interrupter
S2	TRY-UP-SNR Tray-up sensor	Detection of the tray upper limit position	Photo interrupter
S3	FED-SNR Feed sensor	Detection of the paper transportation	Photo interrupter
S4	LCF-SET-SNR LCF-set sensor	Detection of the LCF installed to the equipment	Photo interrupter
S5	TRY-SNR Tray sensor	Detection of the drawer installed	Photo interrupter
S6	TRY-BTM-SNR Tray bottom sensor	Detection of the tray lower limit position	Photo interrupter
SW1	DOOR-SW Door switch	Safety switch	Pushing switch

4. PC Board

SYMBOL	NAME	FUNCTION	REMARKS
PWA	PWA-F-LCF LCF PC board	Driving of the feeding Control of the tray driving	

3. GENERAL OPERATION

3.1 Description of Operation

[A] From power ON to standby

1. When the equipment is turned ON, power is also supplied to the feed unit from the equipment to start the pre-running operation. The tray motor (M2) starts to rotate forward to lift the tray. The tray motor (M2) stopped rotating and lifting the tray when the tray has been lifted and the tray-up sensor (S2) has been turned ON (H: Sensor light path blocked by the actuator sensor). Papers are assessed to be present when the empty sensor (S1) is turned ON (L: Passing the sensor light path) while they are assessed to be absent when the empty sensor (S1) is turned OFF (H: Sensor light path blocked).
2. When the LCF is not being installed to the equipment (LCF set sensor (S4): OFF) or when the drawer is being pulled out (Tray sensor (S5): OFF), the tray lifting operation is not carried out. In this case, the tray starts to be lifted and the same operation which is until the detection of the paper presence or absence is carried out when it is installed to the equipment and the drawer is inserted.
3. When the feed sensor (S3) is turned ON (L: Passing the sensor light path), that is, when the paper is remaining at the transport path, the LCF detects it as a paper jam and cannot operate.

[B] Standby state

1. When a paper is detected to be present by the above-described operation, the LCF gets into a standby state.
2. When the tray unit is pulled out, the tray is automatically lowered because of its structure, and when it is inserted once again, it is lifted.

[C] Feeding/Transporting operation from the start to the finish of the printing

1. The [START] key is pressed when the equipment decides that the feeding from the LCF. Then, the transport motor (M1) starts to drive after the feed motor of the equipment has been turned ON.
2. The feed clutch (CL2) is turned ON and pickup and feed rollers start to drive to feed a paper from the tray.
3. After the feeding starts, the transport clutch (CL1) is turned ON and the transport roller starts to drive to transport the paper.
4. When the leading edge of the paper has turned ON the feed sensor (S3), the feed clutch (CL2) is turned OFF and stops the feeding operation. The paper transported by the transport roller is sent to the equipment side, where it is transported by the feed unit.
5. When a specified time has passed after the trailing edge of the paper turned OFF the feed sensor (S3), next paper can be fed.
6. When carrying out a continuous printing, the above steps from (2) to (5) are repeated as many papers as printed.
7. When the printing has been finished, the feed motor of the equipment stops rotating and the transport motor (M1) is turned OFF to finish the feeding/transporting operation.

[D] Tray operation during printing

1. When 10~20 sheet of paper have been fed from the tray, the pickup roller is lowered down to a specified height. The tray-up sensor (S2) detects this and the tray motor (M2) rotates forward to lift the tray.

3.2 Error Detection

[A] Jam detection

In the following cases, the feed jam takes place.

1. When the feed sensor (S3) is not turned ON in a specified time after the feeding has started.
2. When each transport sensor of the equipment does not operate (ON/OFF) in a specified time after the feeding has started at the equipment side.

[B] Call for service

1. When the tray-up sensor (S2) is not turned ON in a specified time after the tray has started to be lifted.

3.3 Flow Chart

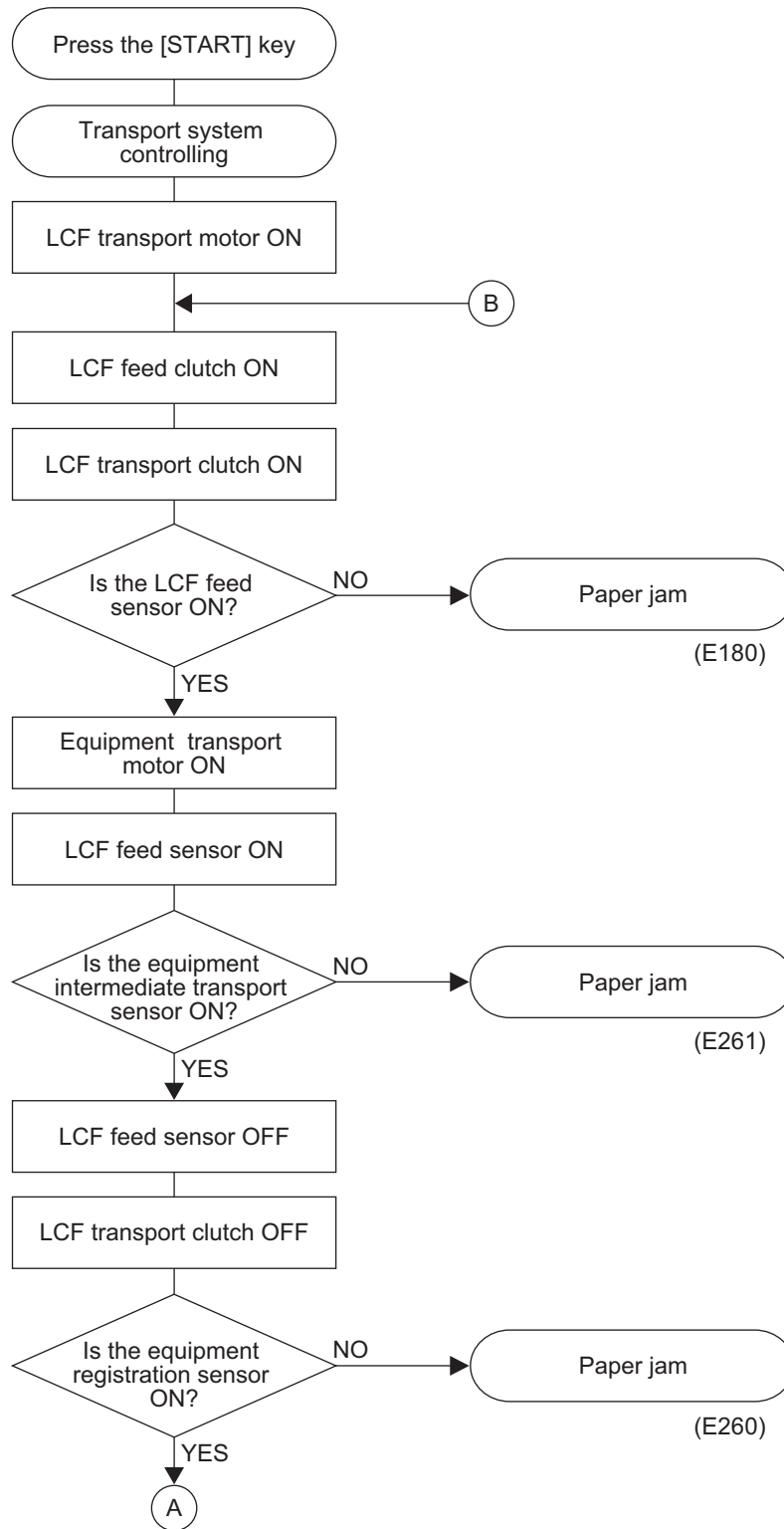

Fig. 3-1

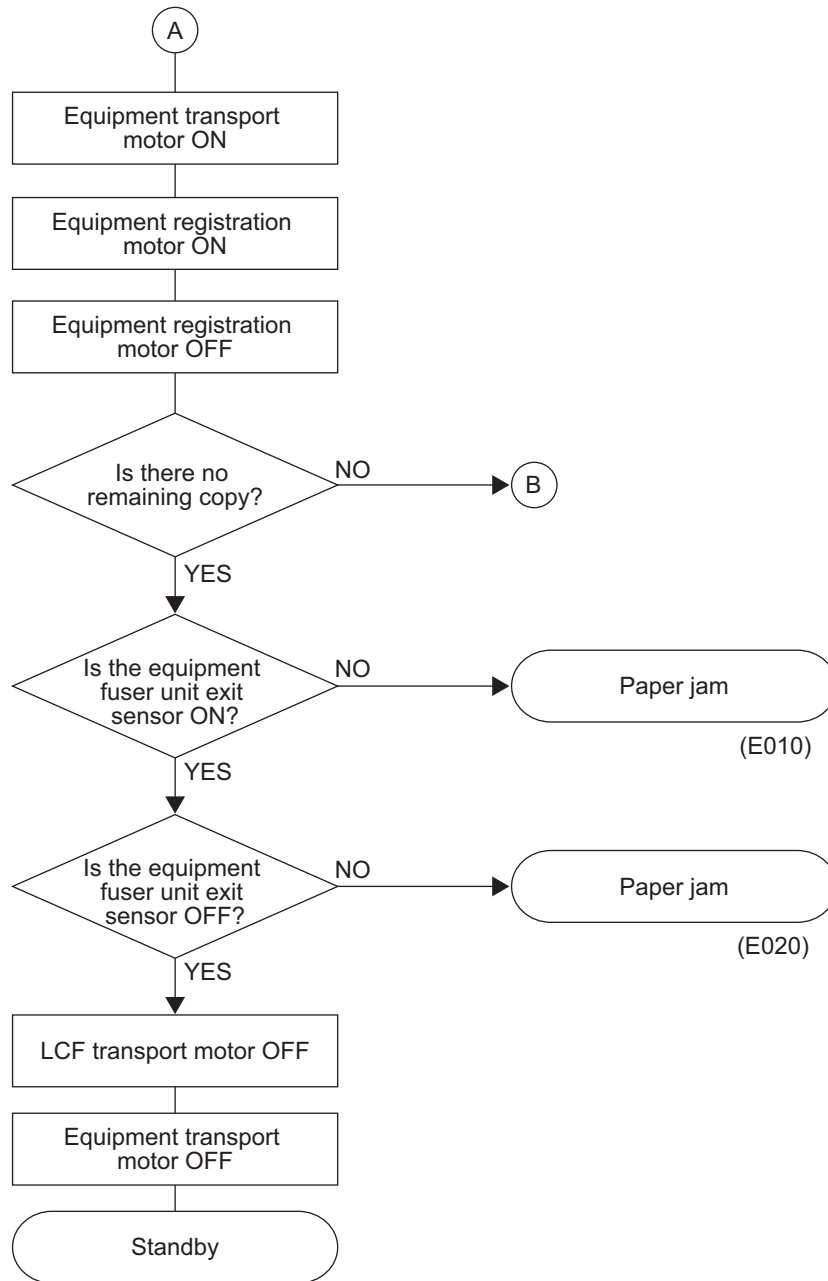

Fig. 3-2

4. DISASSEMBLY AND REPLACEMENT

4.1 Covers

[A] Front cover

- (1) Pull out the drawer.
- (2) Remove 4 screws and take off the front cover.

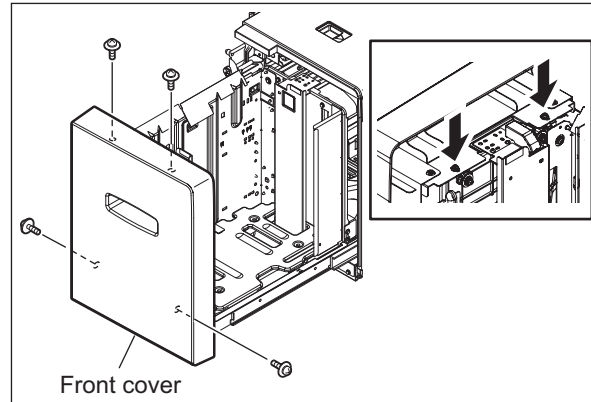

Fig. 4-1

Notes:

- Be sure to hook the arm on the holder when installing the front cover.
- When installing the front cover, adjust the gap between the front and upper cover, and the front and right cover to 3 mm respectively.

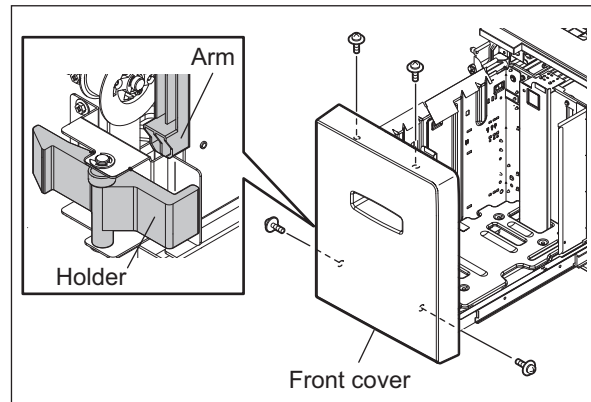

Fig. 4-2

[B] Rear cover

- (1) Remove the spacer and slide the harness to the right side.
- (2) Remove 4 screws and take off the rear cover.

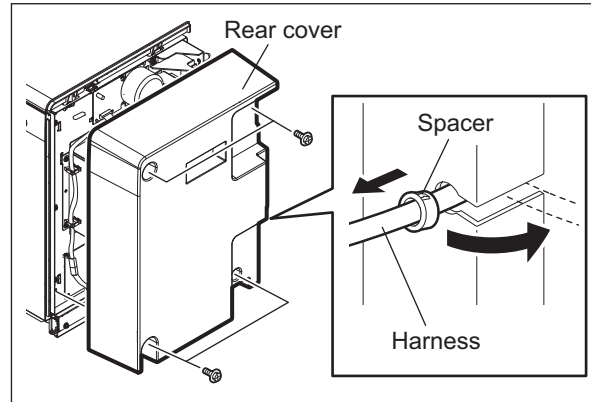



Fig. 4-3

[C] Upper cover

- (1) Remove the rear cover.
( P. 4-2 "[B] Rear cover")
- (2) Pull out the drawer.
- (3) Loosen 5 screws and take off the upper cover.

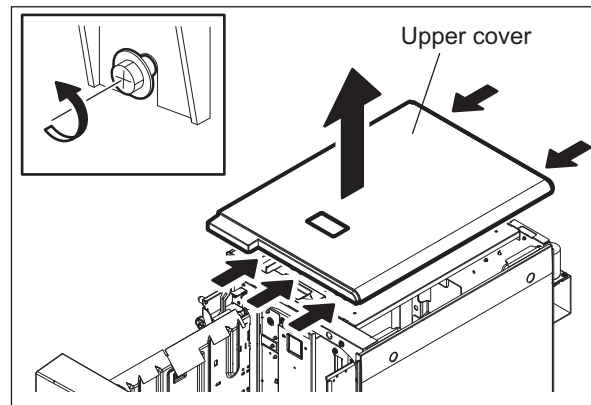

Fig. 4-4

[D] Right cover

- (1) Pull out the drawer.
- (2) Remove 2 screws and take off the right cover sliding it toward the front side.

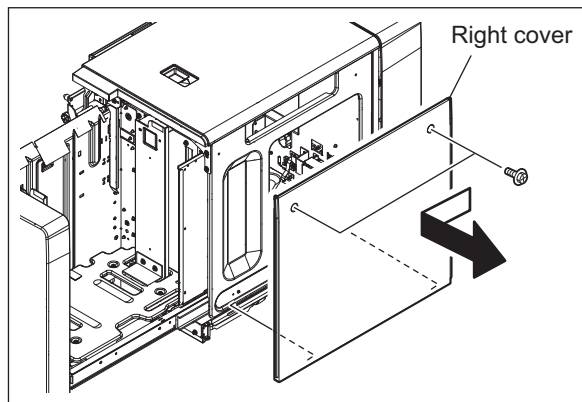



Fig. 4-5

Notes:

When installing the right cover, align 2 latches of the right cover with the holes of the frame.

4.2 Feed unit

- (1) Remove the upper cover.
( P. 4-2 "[C] Upper cover")
- (2) Remove the transport motor.
( P. 4-6 "[C] Transport motor")
- (3) Remove the lever.

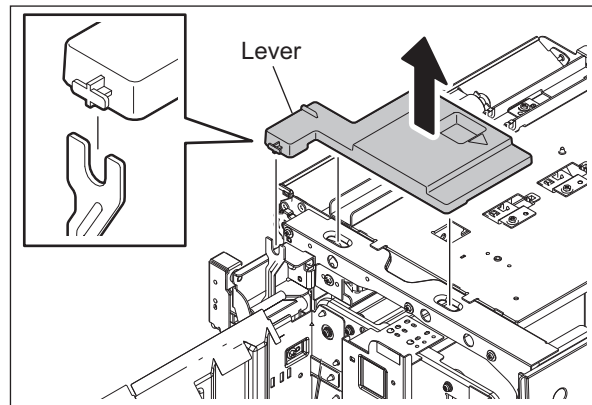

Fig. 4-6

Notes:

- Be careful not to install the lever to the wrong position.
- (4) Disconnect 1 connector from the LCF PC board.
 - (5) Release the harness from the 2 harness clamps.

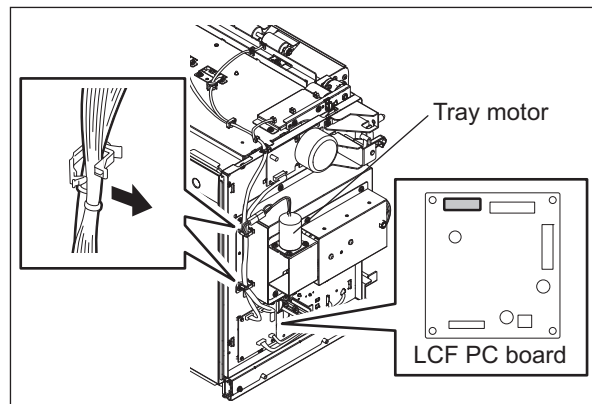



Fig. 4-7

- (6) Remove the transport motor.
( P. 4-6 "[C] Transport motor")
- (7) Remove 5 screws and take off the feed unit upward.

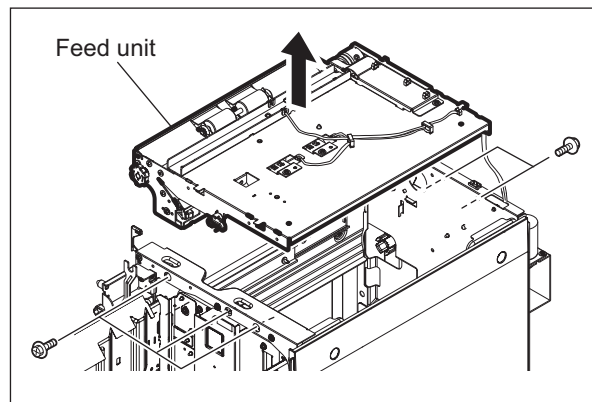



Fig. 4-8

4.3 Electric Parts

[A] LCF PBA

- (1) Remove the rear cover.
( P. 4-2 "[B] Rear cover")
- (2) Disconnect all connectors from the LCF PBA.
- (3) Remove 1 screw. Release 3 locking supports and take off the LCF PC board.

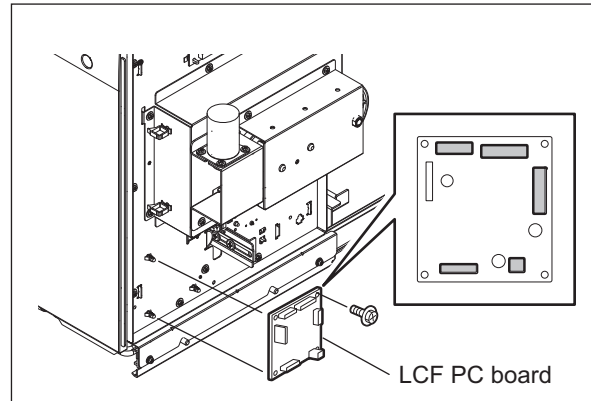



Fig. 4-9

[B] Tray motor

- (1) Remove the rear cover.
( P. 4-2 "[B] Rear cover")
- (2) Disconnect 1 connector from the tray motor.
- (3) Remove 3 screws from the tray motor.
- (4) Release the belt and take off the tray motor.

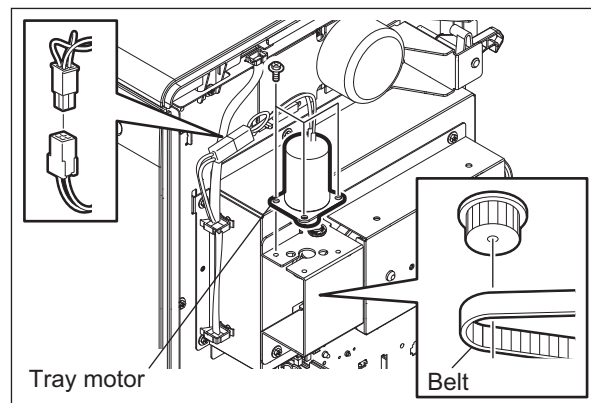



Fig. 4-10

Notes:

Be careful not to let grease adhere to the belt after you have removed the tray motor.

[C] Transport motor

- (1) Remove the rear cover.
( P. 4-2 "[B] Rear cover")
- (2) Disconnect 1 connector from the transport motor PC board
- (3) Remove 2 screws. Release 2 locking supports and take off the transport motor.

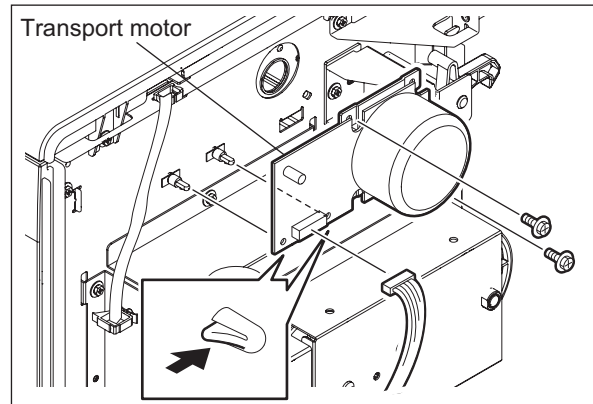



Fig. 4-11

[D] Tray sensor

- (1) Remove the rear cover.
( P. 4-2 "[B] Rear cover")
- (2) Disconnect 1 connector from the tray sensor.
- (3) Release the latches and take off the tray sensor.

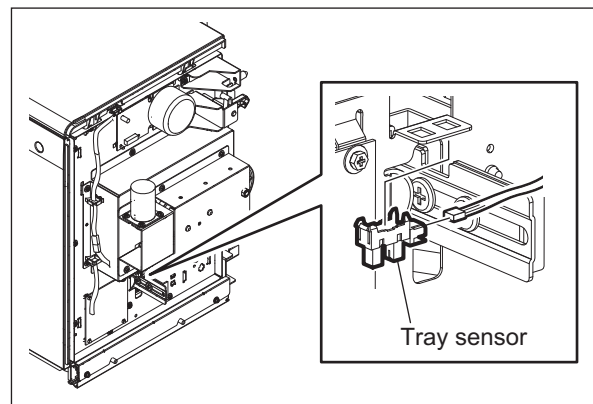



Fig. 4-12

[E] Tray-up sensor, Empty sensor

- (1) Remove the upper cover.
( P. 4-2 "[C] Upper cover")
- (2) Release the harness from the harness clamp.
- (3) Remove 1 screw. Lift up the bracket and disconnect 1 connector from the sensor.

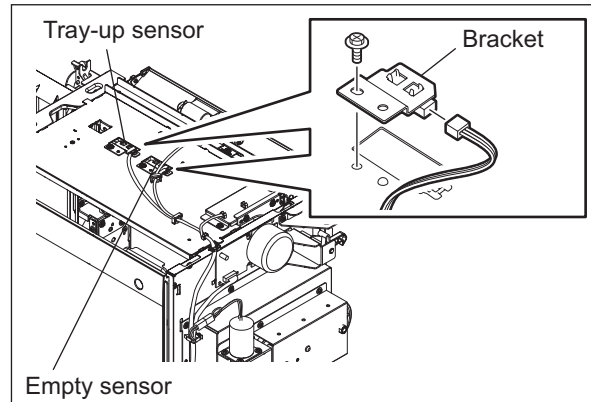

Fig. 4-13

- (4) Release the latches and take off the sensor from the bracket.

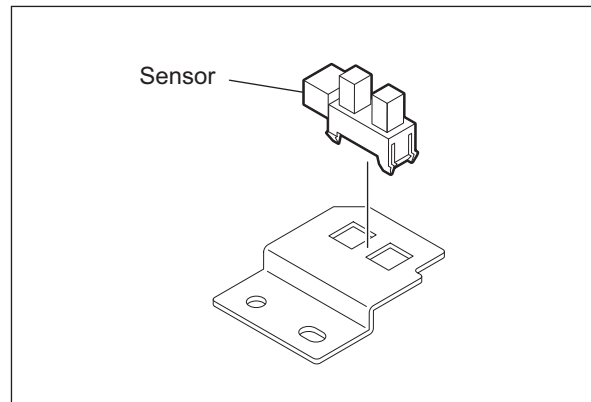



Fig. 4-14

[F] Feed sensor

- (1) Remove the upper cover.
( P. 4-2 "[C] Upper cover")
- (2) Release the harness from 3 harness clamp.
- (3) Remove 1 screw. Lift up the bracket and disconnect 1 connector from the feed sensor.

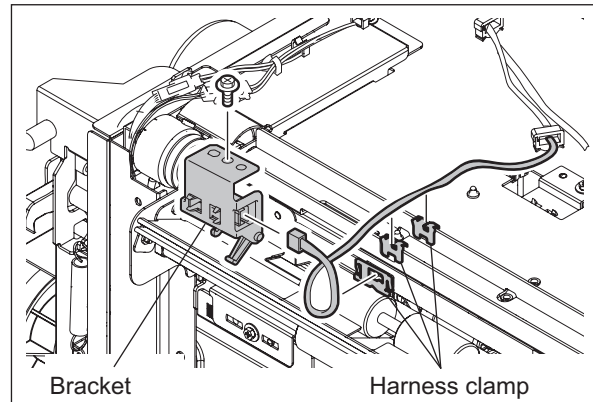

Fig. 4-15

- (4) Release the latches and take off the feed sensor from the bracket.

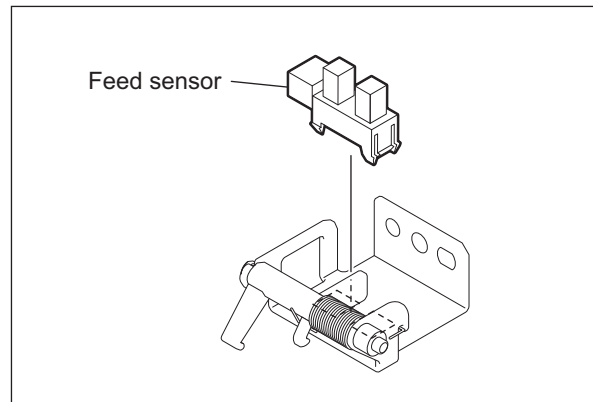



Fig. 4-16

[G] LCF set sensor, Door switch

- (1) Remove the right cover.
( P. 4-3 "[D] Right cover")
- (2) Remove 1 screw and lift up the cover.
- (3) Release the harness from the harness clamp and take off the cover.

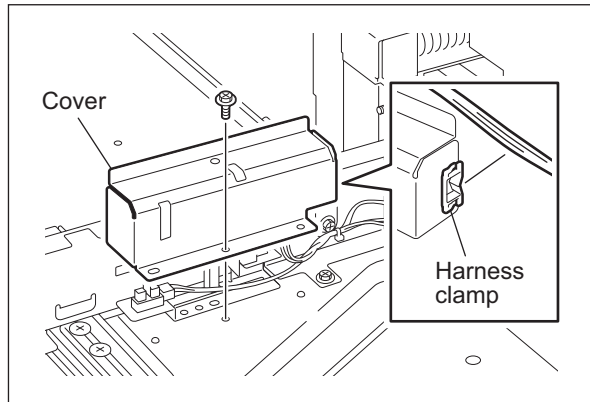

Fig. 4-17

- (4) Remove 1 screw and lift up the bracket.
- (5) Disconnect connectors from the LCF set sensor and door switch.

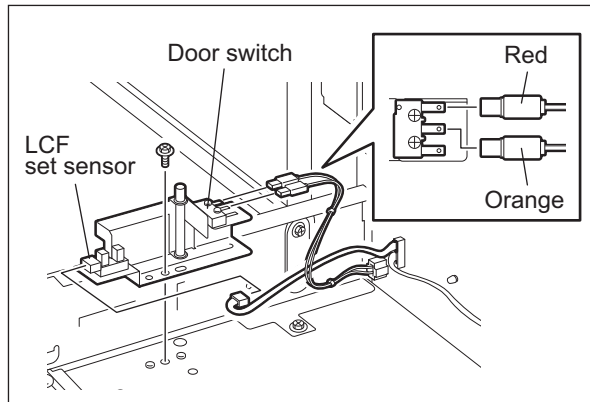

Fig. 4-18

Notes:

Be careful not to connect the door switch connectors to the wrong terminals.

- (6) Release the latches and take off the LCF set sensor from the bracket.
- (7) Remove 2 screws and take off the door switch from the bracket.

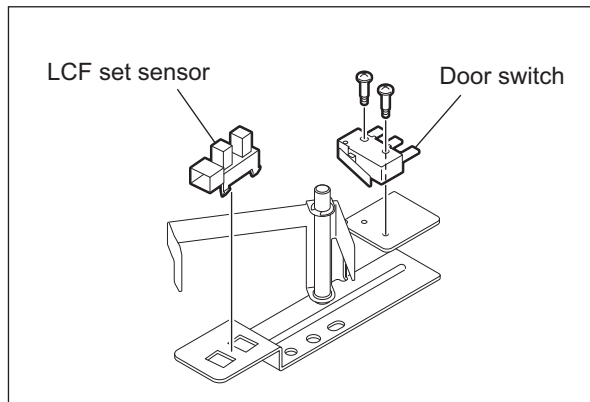



Fig. 4-19

[H] Tray bottom sensor

- (1) Remove the rear cover.
( P. 4-2 "[B] Rear cover")
- (2) Remove the right cover.
( P. 4-3 "[D] Right cover")
- (3) Release 1 clamp and disconnect 1 connector from the tray bottom sensor.
- (4) Release the latches and take off the tray bottom sensor from the frame.

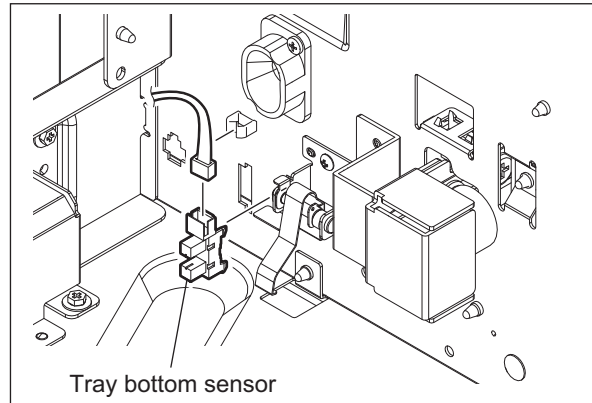



Fig. 4-20

[I] Transport clutch, Feed clutch

- (1) Remove the feed unit.
( P. 4-4 "4.2 Feed unit")
- (2) Remove 2 screws and take off 2 stoppers.

Notes:

When installing 2 stoppers, screw them shut with the hook of the transport clutch and feed clutch caught by the slit of the stopper.

- (3) Release the harnesses from 3 harness clamps.

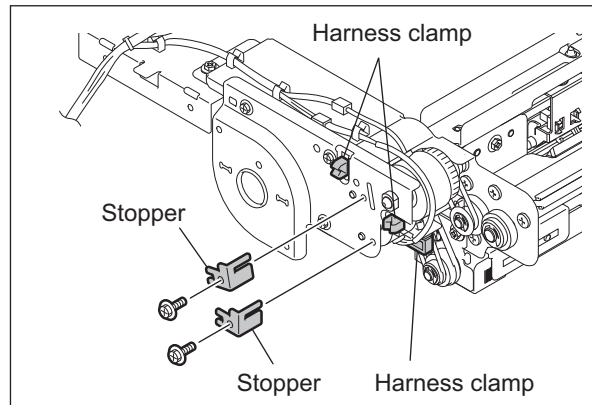

Fig. 4-21

- (4) Remove 4 screws and take off the bracket and bushing.

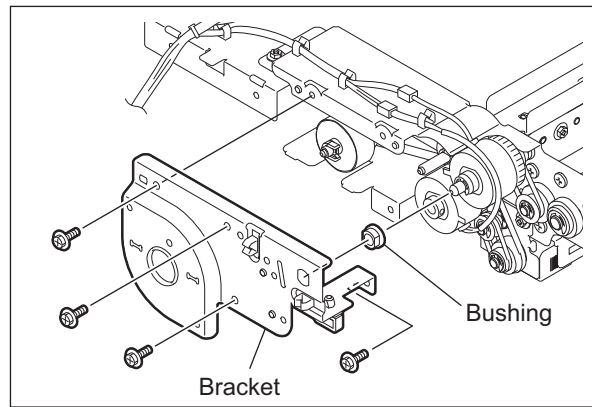

Fig. 4-22

- (5) Disconnect 1 connector, use the hex wrench to loosen 1 set screw, and then take off the feed clutch.

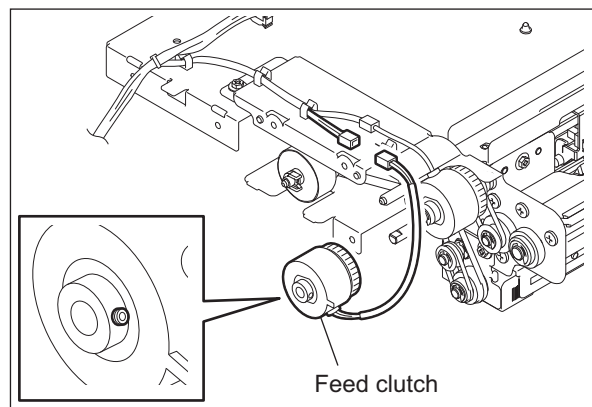

Fig. 4-23

- (6) Disconnect 1 connector and take off the transport clutch and belt.

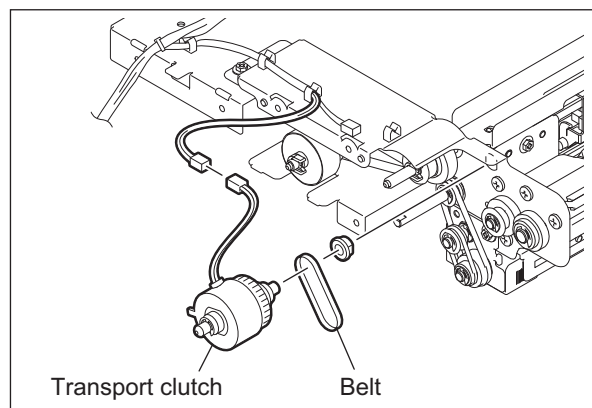

Fig. 4-24

4.4 Rollers

[A] Separation roller

- (1) Pull out the LCF from the equipment.
- (2) Remove 1 clip and take off the separation roller while pushing the shaft down.

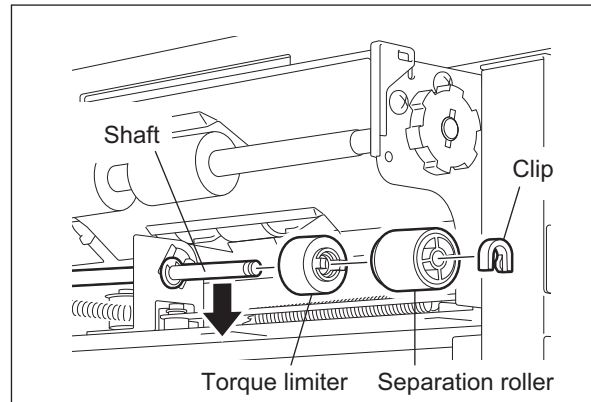



Fig. 4-25

Notes:

Be careful not to have the torque limiter come off of the shaft accidentally, as the torque limiter also becomes removable after the feed roller has been removed.

[B] Pickup roller

- (1) Remove the right cover.
( P. 4-3 "[D] Right cover")
- (2) Close the drawer.
- (3) Remove 2 clips and take off 2 pickup rollers.

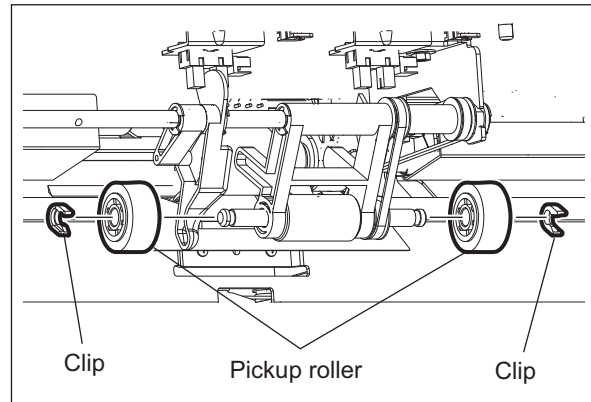



Fig. 4-26

Notes:

Be careful not to install the pickup roller in the wrong direction.

[C] Brush roller (only for MP-2501), Feed roller

- (1) Remove the feed unit.
( P. 4-4 "4.2 Feed unit")
- (2) Remove the brush unit while lifting pickup roller unit.

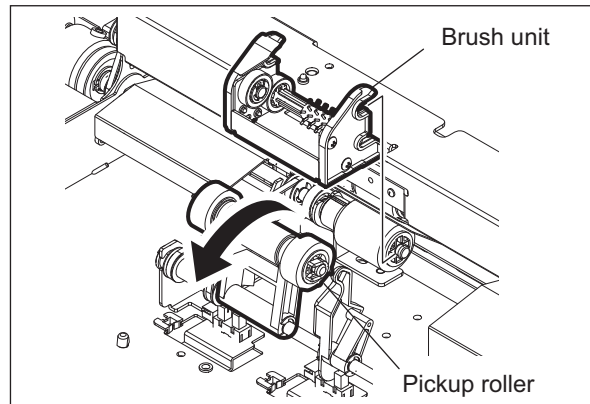

Fig. 4-27

- (3) Remove the brush roller from the brush unit.
- (4) Remove the gear and pin from the brush roller.

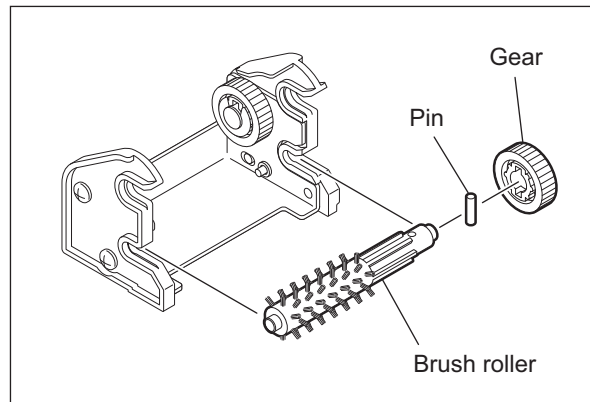

Fig. 4-28

- (5) Remove the separation roller while pushing the separation roller down.

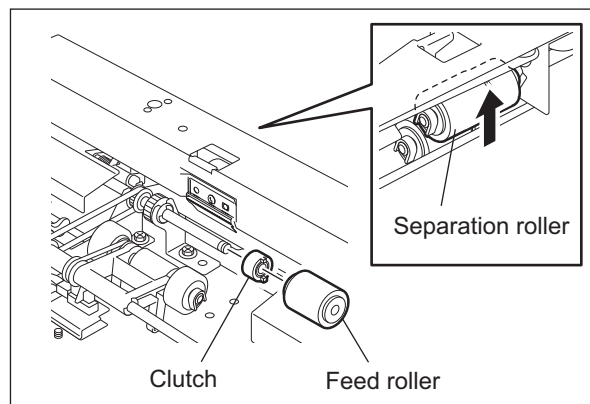

Fig. 4-29

Notes:

- Be careful not to install the feed roller in the wrong direction.
- Be careful not to have the clutch come off of the shaft accidentally, as the clutch also becomes removable after the feed roller has been removed.

[D] Transport idler roller

- (1) Remove the upper cover.
(P. 4-2 "[C] Upper cover")
- (2) Remove 2 springs and take off the transport idler roller.
- (3) Remove 2 E-rings and take off 2 bushings from the transport idler roller.

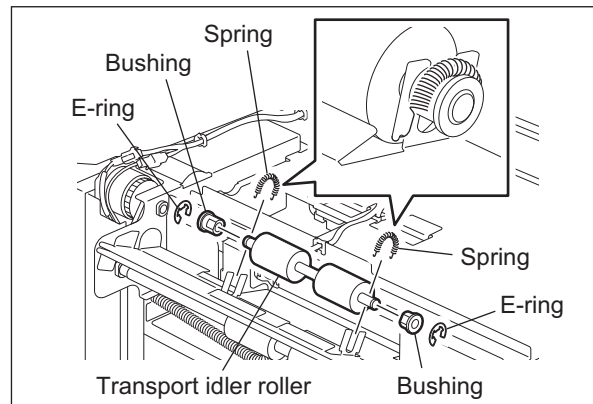

Fig. 4-30

[E] Transport roller

- (1) Remove the transport idler roller.
(P. 4-14 "[D] Transport idler roller")
- (2) Remove 2 E-rings and take off the gear.
- (3) Slide the transport roller to the front side and take off the pin and handle.

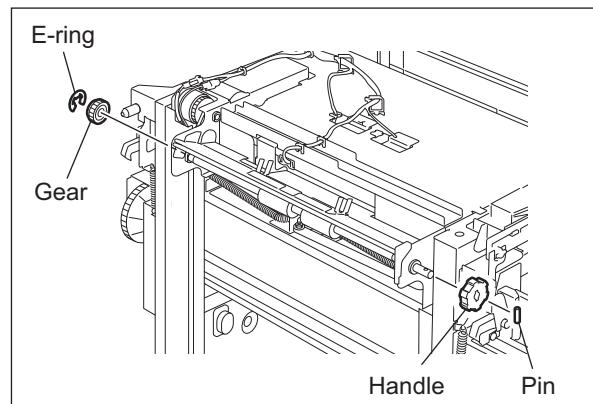

Fig. 4-31

- (4) Remove 2 bushings and take off the transport roller.

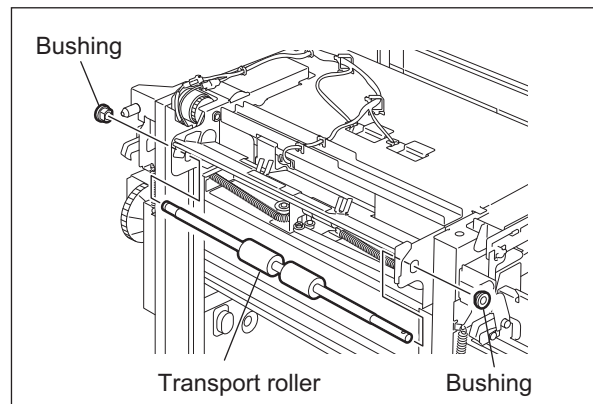



Fig. 4-32

4.5 Tray-up drive unit

[A] Pulley

- (1) Remove the tray motor.
( P. 4-5 "[B] Tray motor")
- (2) Remove 3 screws and take off the bracket.

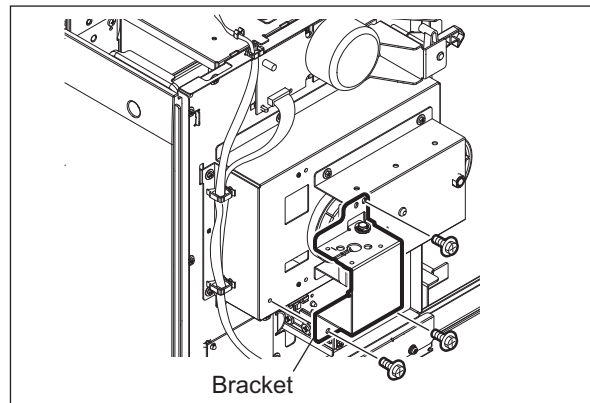

Fig. 4-33

- (3) Remove 1 E-ring and take off the bearing.
- (4) Loosen 2 setscrews and take off the stopper and bearing.
- (5) Remove the relay gear shaft and belt.

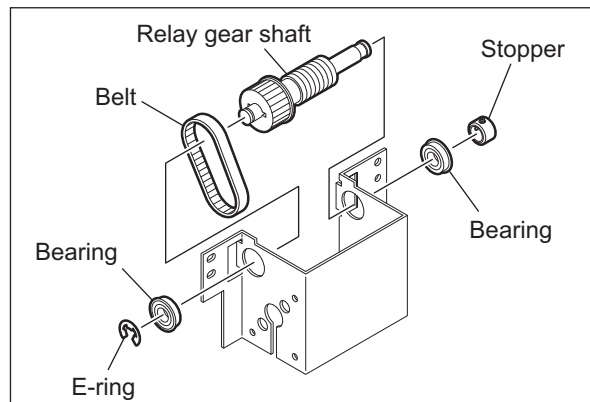

Fig. 4-34

- (6) Remove 1 setscrew and take off the gear from the shaft.
- (7) Remove 1 E-ring and slide the pulley to the left side.
- (8) Remove the pin and pulley from the shaft.

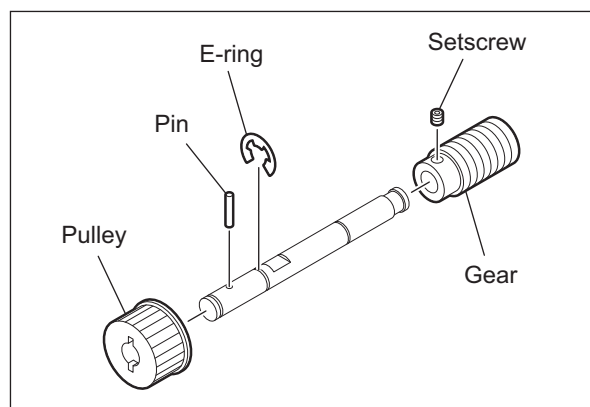



Fig. 4-35

[B] Gear, Coupling

- (1) Remove the tray motor.
( P. 4-5 "[B] Tray motor")
- (2) Remove the tray motor bracket.
( P. 4-15 "[A] Pulley")
- (3) Remove 3 screws and take off the cover and bushing.

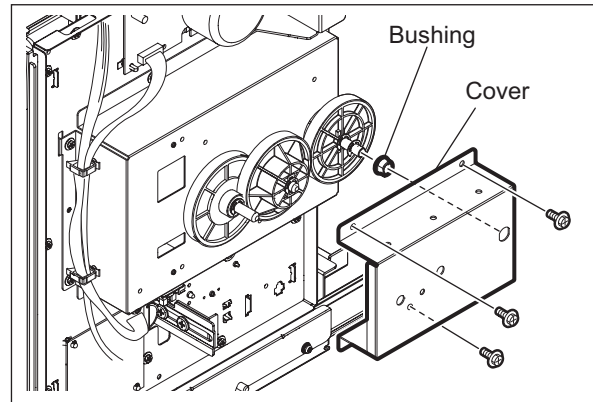

Fig. 4-36

- (4) Remove 2 E-ring and take off the 2 gears.

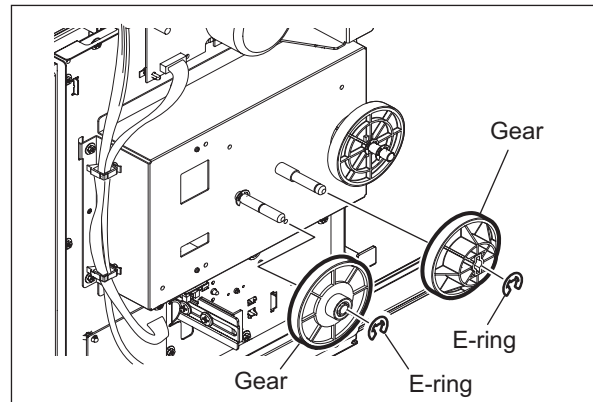

Fig. 4-37

- (5) Remove 2 E-rings and take off the gear and pin.

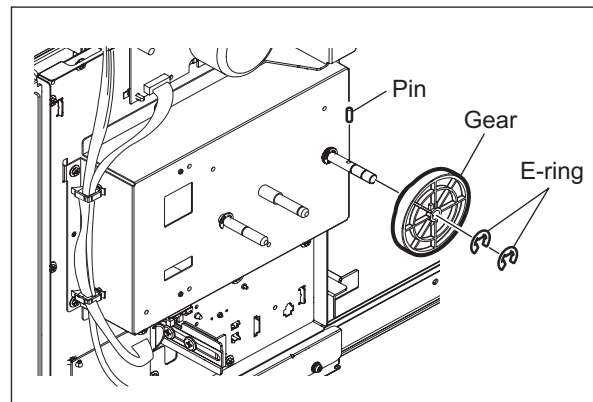

Fig. 4-38

- (6) Remove 1 E-ring and take off the bushing, spring and shaft.
- (7) Remove the coupling and pin from the shaft.

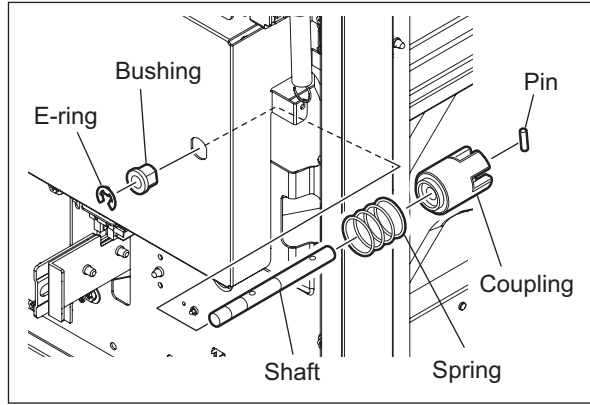



Fig. 4-39

4.6 Transport motor drive unit

[A] Gear, Pulley

- (1) Remove the transport clutch and feed clutch.
( P. 4-10 "[I] Transport clutch, Feed clutch")
- (2) Remove 2 clips and take off the gear, pulley and belt.

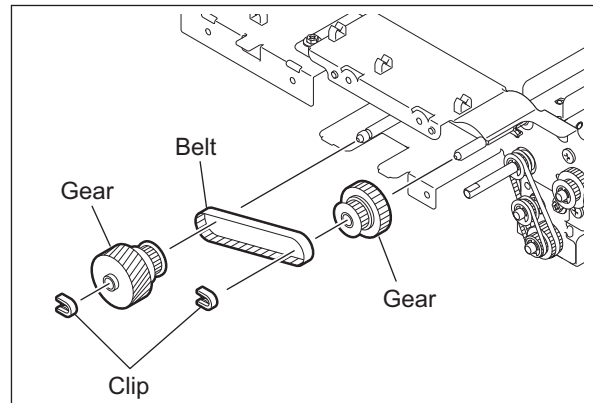

Fig. 4-40

- (3) Remove 1 E-ring and take off the gear.

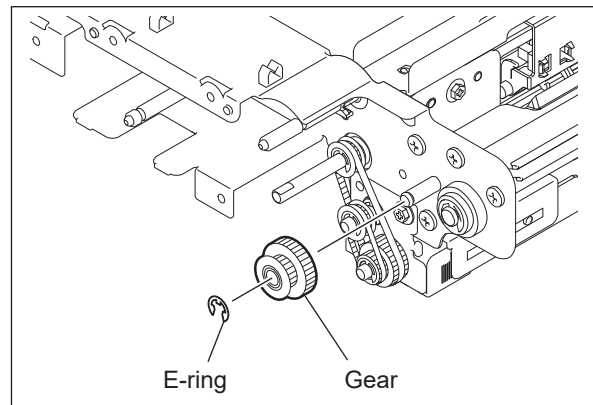

Fig. 4-41

- (4) Remove 3 E-rings and take off the gears, belt and pin.

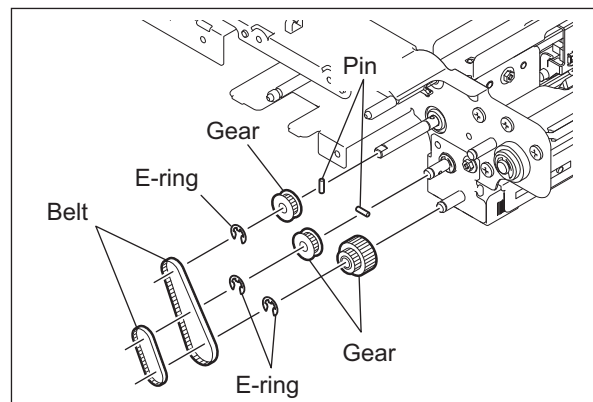

Fig. 4-42

4.7 Drawer unit

[A] Drawer

- (1) Pull out the drawer.
- (2) Remove 2 screws and take off the stopper.

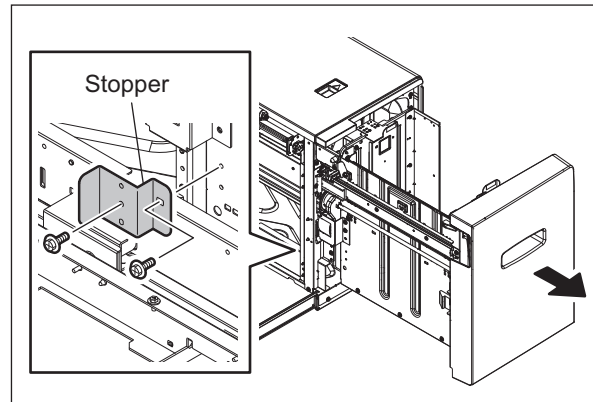

Fig. 4-43

- (3) Remove the right cover.
P. 4-3 "[D] Right cover"
- (4) Remove 1 screw and take off the stopper.

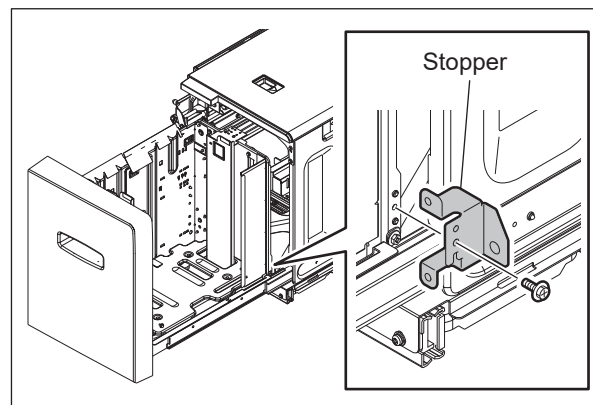

Fig. 4-44

- (5) Pull out the drawer unit completely.
- (6) Remove 4 screws and take off the drawer pulling it upward.

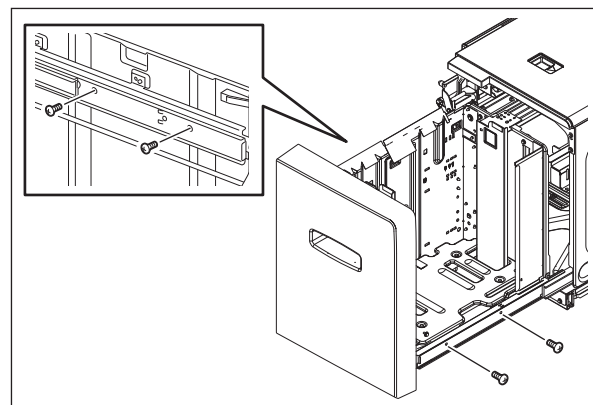

Fig. 4-45

[B] Tray wire

- (1) Remove the drawer.
(📖 P. 4-19 "[A] Drawer")
- (2) Remove the front cover.
(📖 P. 4-1 "[A] Front cover")
- (3) Remove 1 screw and take off the pickup lever guide.
- (4) Remove 2 screws and take off the front side guide.

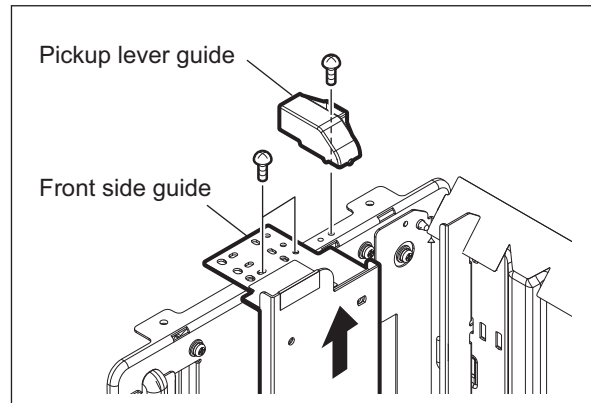

Fig. 4-46

Notes:

When installing the side guide, adapt the groove and screw hole to the paper size.

(📖 P. 4-26 "[B] Front side guide")

- (5) Remove 2 screws and take off the rear side guide.

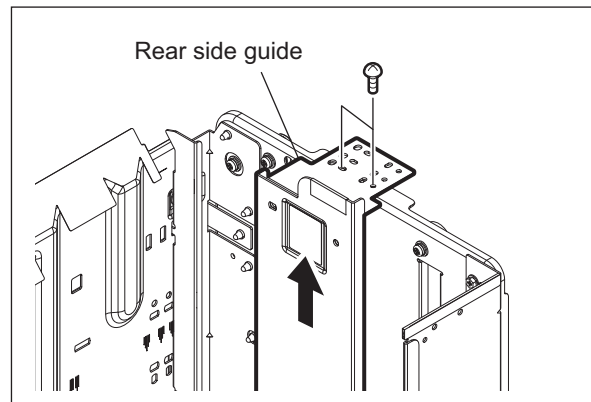

Fig. 4-47

Notes:

When installing the side guide, adapt the groove and screw hole to the paper size.

(📖 P. 4-25 "[A] Rear side guide")

- (6) Remove 1 screw and take off the stopper plate, spring and clip from the front side wire tensioner. (same for the rear side)

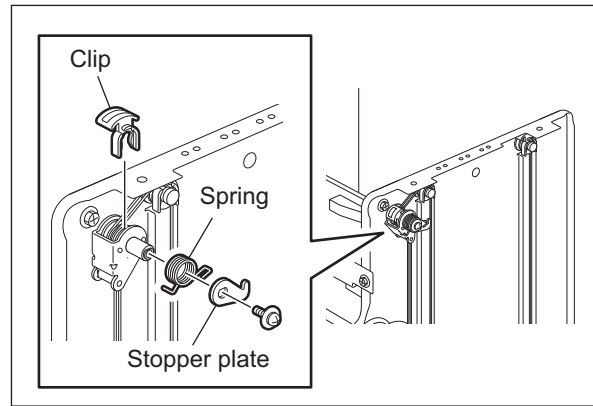

Fig. 4-48

Notes:

When installing the stopper plate, screw it shut after aligning the hole of the stopper plate with the shaft.

- (7) Remove 2 clips and take off the front side wire tensioner and 2 pulleys. (same for the rear side)

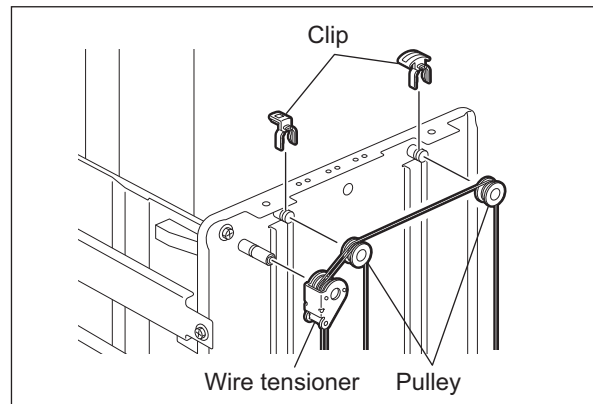

Fig. 4-49

Notes:

When installing the wire tensioner and pulley, be sure that the wire is installed to the wire tensioner and pulley as shown in the figure on the right.

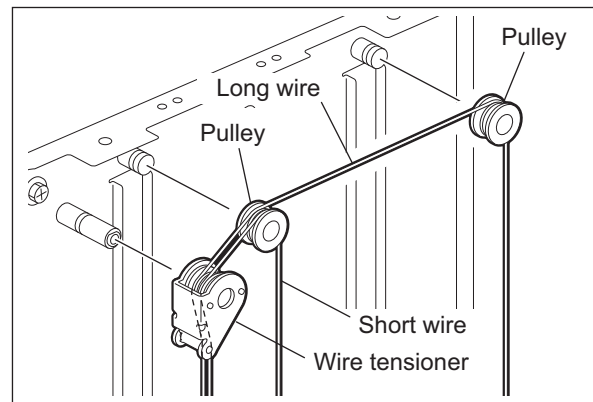

Fig. 4-50

- (8) Pull out the tray.
- (9) Release the latches and take off 4 wire stoppers.

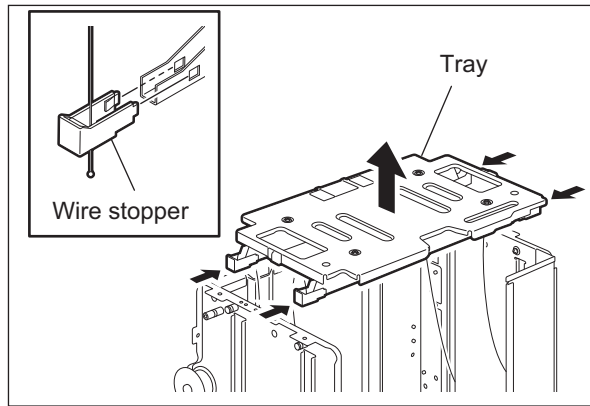

Fig. 4-51

- (10) Release the latches and take off the wire clamps from the front/rear side wire tensioners.

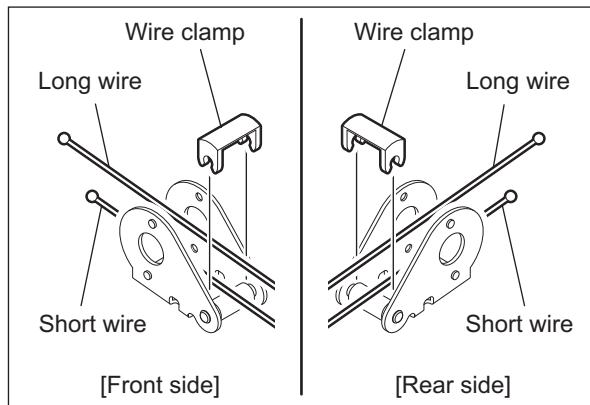

Fig. 4-52

Notes:

Pay attention to the wire position when installing the wire clamp.

- (11) Remove 1 E-ring and take off the front side wire pulley and pin.

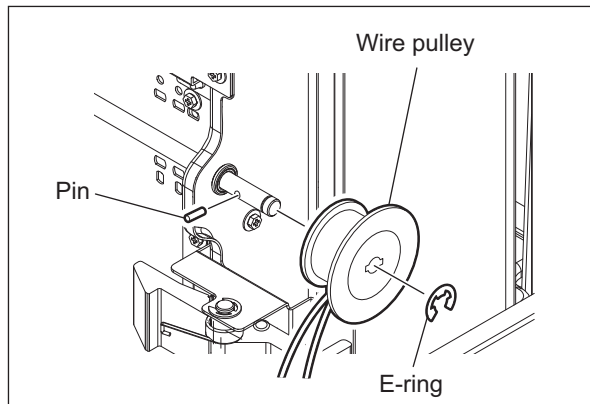

Fig. 4-53

(12) Remove 6 screws and take off the brake unit.

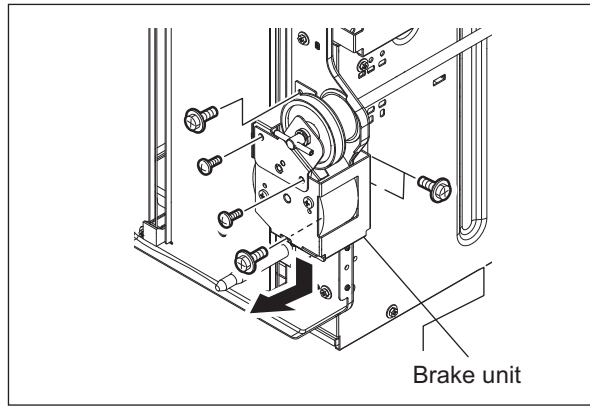

Fig. 4-54

(13) Remove the bush and pull out the rear side pulley with shaft.

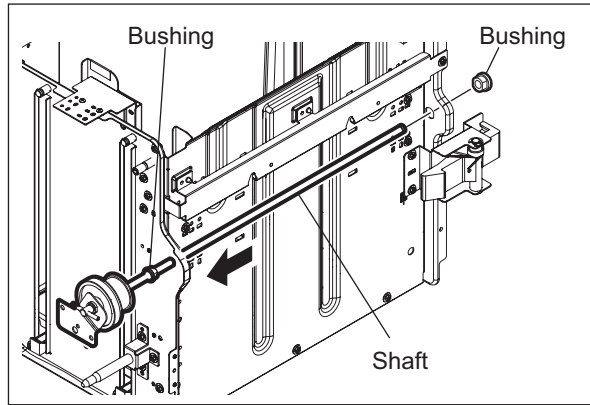

Fig. 4-55

(14) Remove the pulley and pin from the shaft.

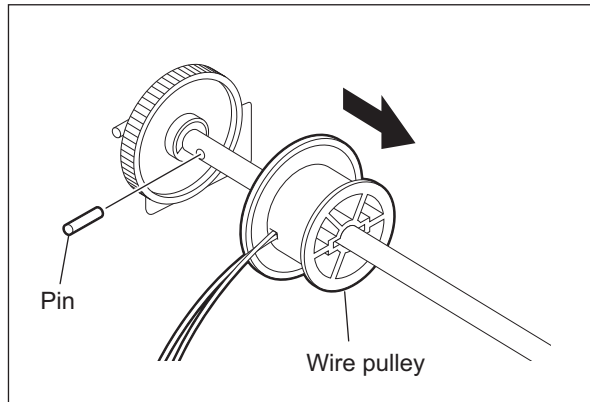

Fig. 4-56

(15) Remove 2 screws. Release the latches and take off the pulley flange.

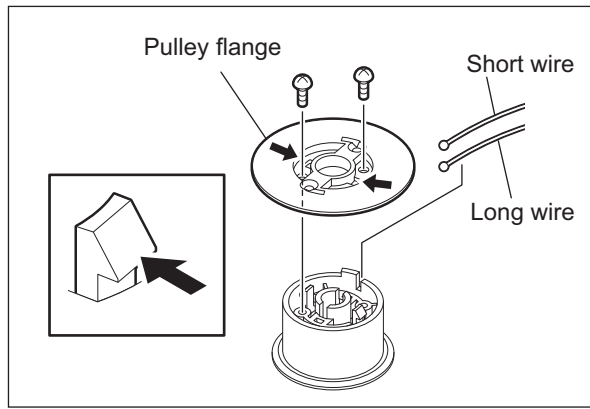

Fig. 4-57

Notes:

Pay attention to the wire installation order when installing the pulley flange.

4.8 Setting paper guide

When changing the paper size, change the position where the side guide (rear/front) and end guide to be installed to.

[A] Rear side guide

- (1) Pull out the drawer.
- (2) Remove 2 screws and take off the stopper.

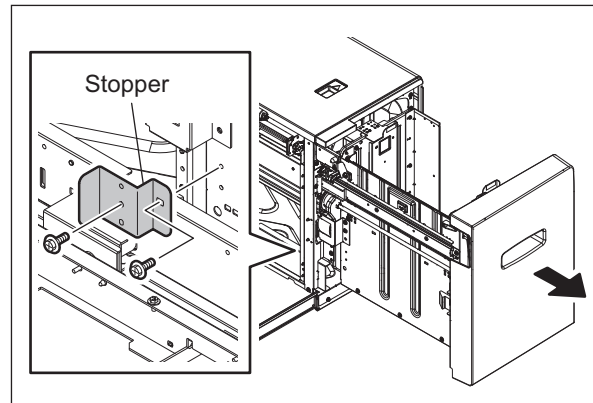

Fig. 4-58

- (3) Remove the right cover.
P. 4-3 "[D] Right cover"
- (4) Remove 1 screw and take off the stopper.

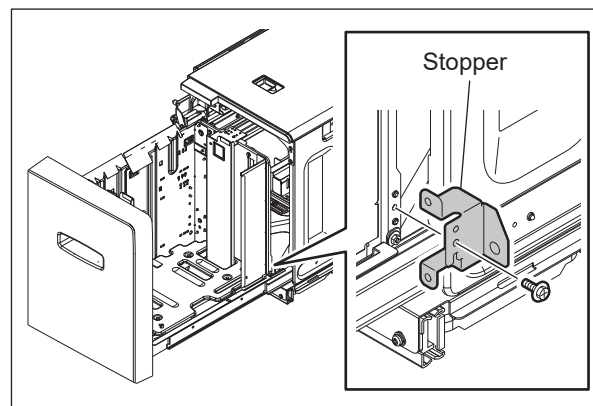

Fig. 4-59

- (5) Remove 2 screws and adapt the groove and screw hole to the paper size. Then screw it shut.

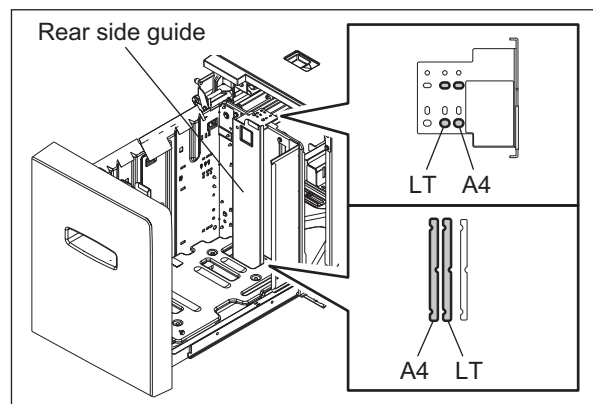

Fig. 4-60

[B] Front side guide

- (1) Pull out the drawer.
- (2) Remove 1 screw and take off the pickup lever guide.

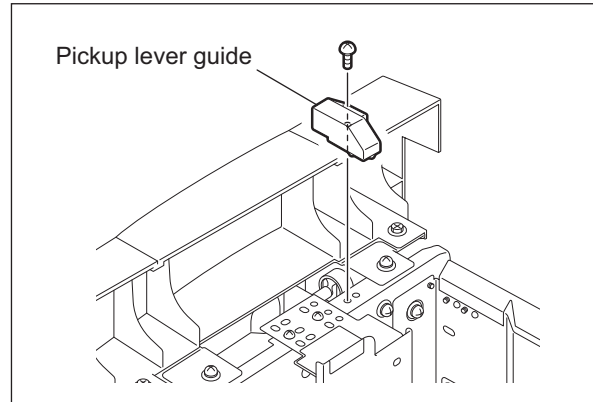

Fig. 4-61

- (3) Remove 2 screws and adapt the groove and screw hole to the paper size. Then screw it shut.

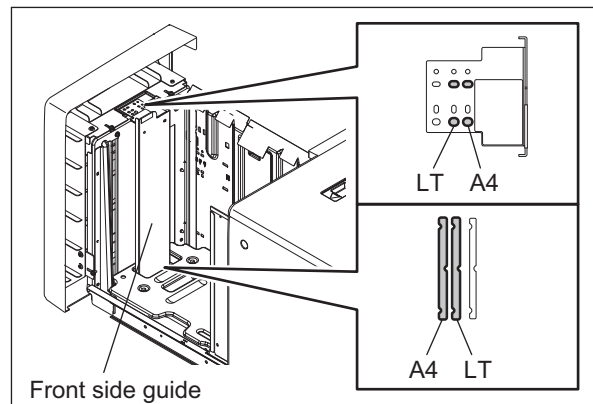

Fig. 4-62

[C] End side guide

- (1) Pull out the drawer.
- (2) Remove 3 screws.

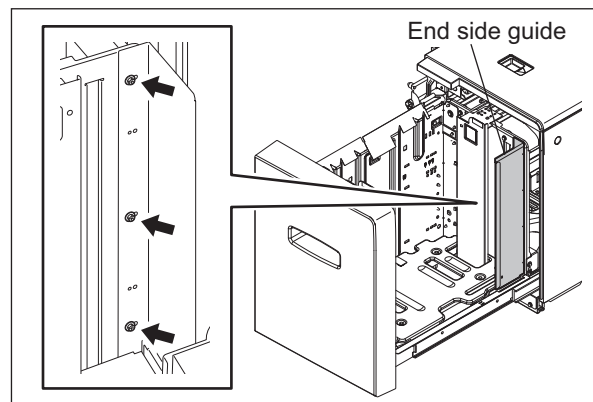

Fig. 4-63

- (3) Remove 2 screws while lifting the tray.

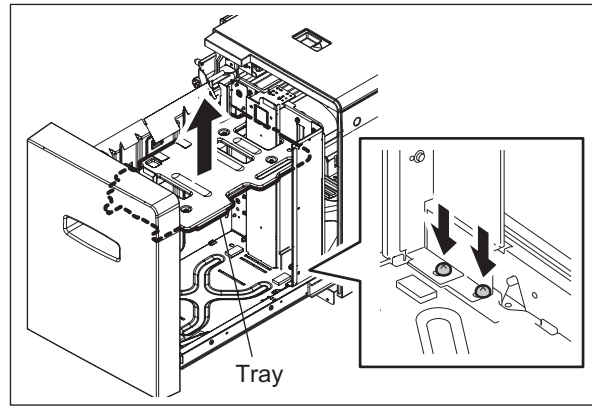

Fig. 4-64

- (4) Adapt the groove and screw hole to the paper size. Then screw it shut.

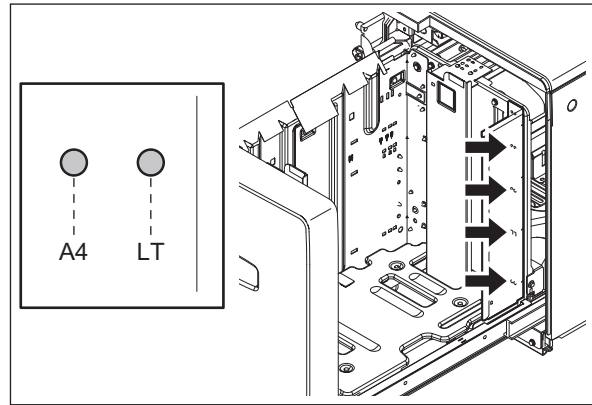

Fig. 4-65

[D] Sub guide

- (1) Remove 2 screws and take off the rear side sub guide.

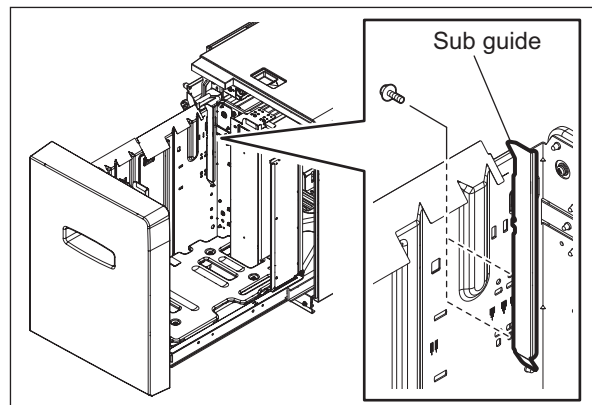

Fig. 4-66

(2) Adapt the screw hole to the paper size. Then screw it shut.

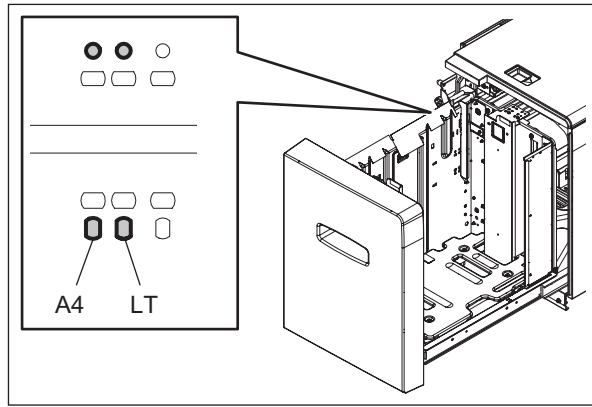

Fig. 4-67

(3) Remove 2 screws and take off the front side sub guide.

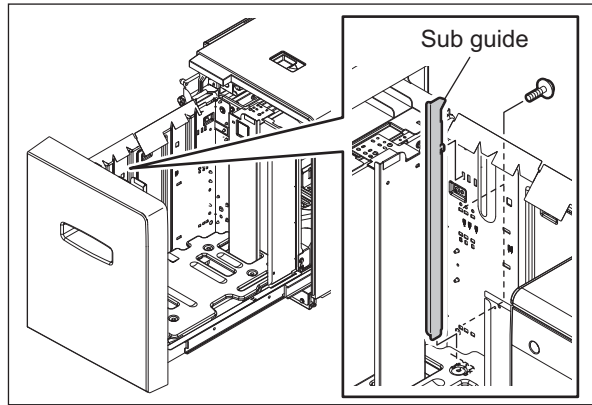

Fig. 4-68

(4) Adapt the screw hole to the paper size. Then screw it shut.

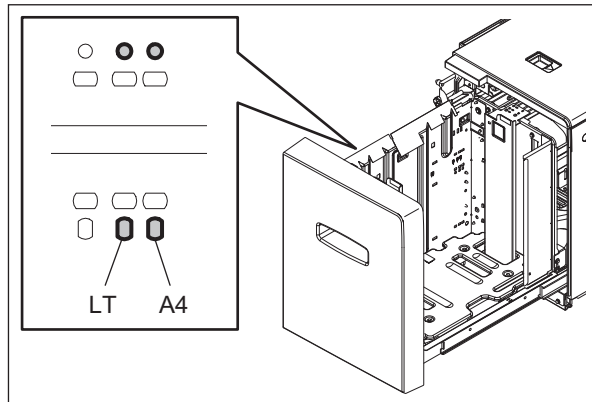

Fig. 4-69

4.9 Adjustment

4.9.1 Sheet sideways deviation adjustment

When the center of the printed image shifts to the front side or rear side, adjust the drawer position taking the following procedure.

<Procedure>

- (1) Pull out the drawer.
- (2) Loosen 3 screws and move the adjustment board to the right position. Then screw it shut.

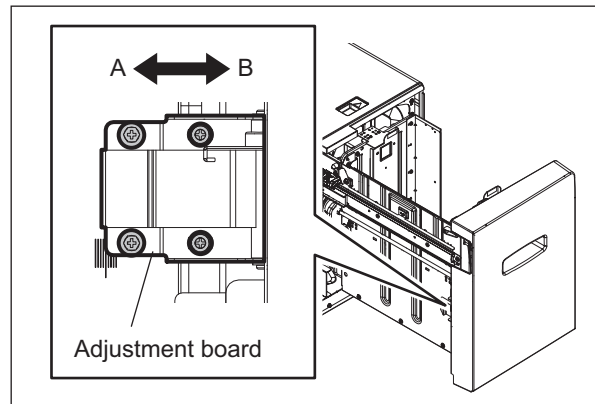

Fig. 4-70

- The center of the printed image shifts to the front side:
Move the adjustment board to the front side (Arrow (B) in the figure).

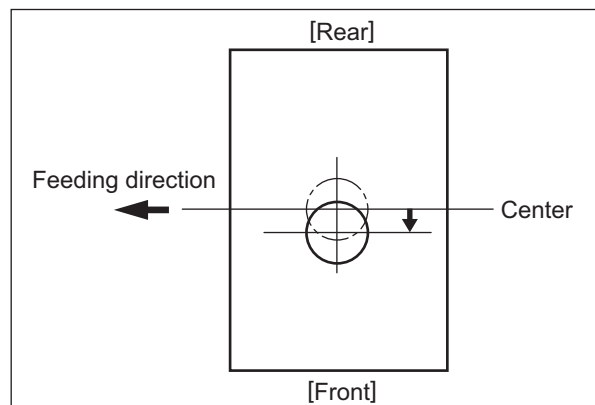

Fig. 4-71

- The center of the printed image shifts to the rear side:
Move the adjustment board to the rear side (Arrow (A) in the figure).

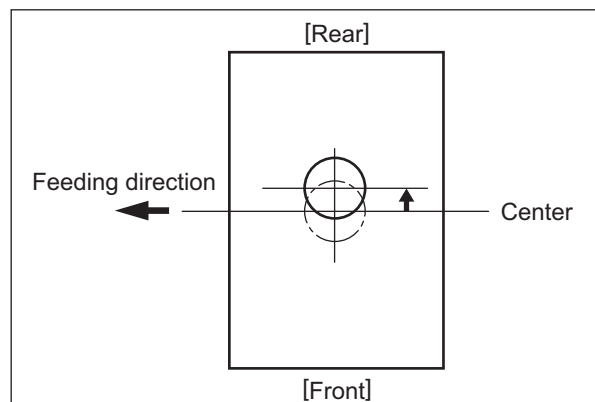

Fig. 4-72

Notes:

After the drawer position adjustment, re-adjust the front cover position. Adjustment: loose 4 screws and slide the front cover to adjust the gap between the front and upper cover, and the front and right cover to 3 mm respectively.

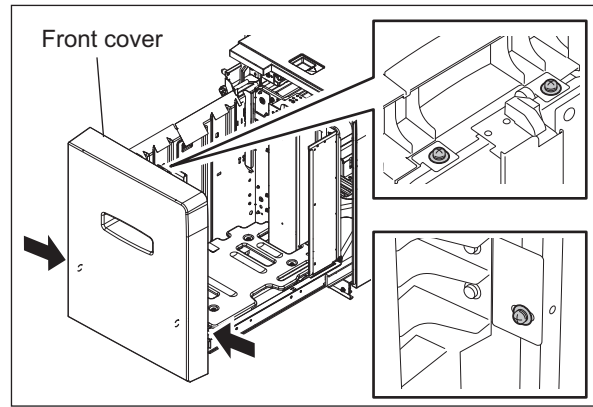

Fig. 4-73

4.9.2 LCF slant adjustment

Compensate the slant of LCF by the adjusting the stoppers.

<Procedure>

- (1) Pull out the LCF from the equipment.
- (2) Turn 2 screws and adjust the stoppers.
Turn to the right: Stopper moves downward.
Turn to the left: Stopper moves upward.

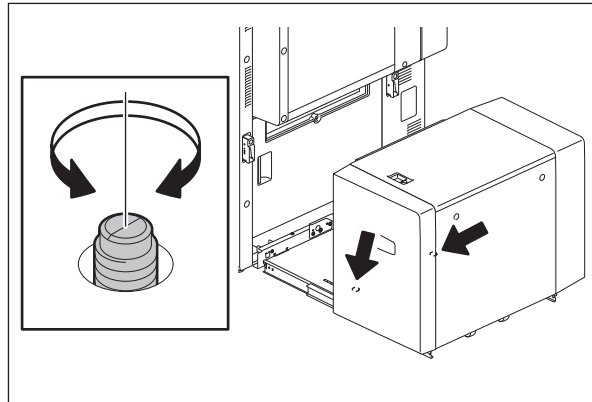

Fig. 4-74

Notes:

When moving the equipment, need to move the stopper upward.

4.9.3 Separation roller pressure force adjustment

In some cases the life of the separation roller may be shortened or paper jams and multiple feeding (EB50) may occur regardless of the operation frequency of the equipment. This comes from the weight or edge status of paper used and the amount of paper dust.

Generally paper jams and multiple feeding often occur as the life end of the roller approaches.

However, if they often occur even though its life has not yet reached its replacement timing, or if the life end comes much earlier than the scheduled replacement timing, the jams and multiple feeding can be suppressed by adjusting the pressure force of the separation roller.

In this method, however, when the roller life becomes longer, jams and multiple feeding may occur frequently, and when the jams and multiple feeding are suppressed, the roller life may become shorter. Therefore, perform this adjustment while checking the status carefully, and if necessary, give a sufficient explanation to users.

<Procedure>

- (1) Check that the screw is tightened in the oblong hole.
- (2) If it is tightened in the round hole, remove and temporarily tighten it in the neighboring oblong hole.

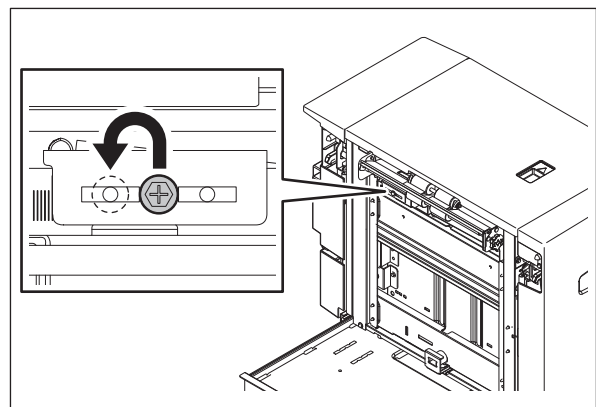

Fig. 4-75

Notes:

Make a mark for the installation position of the bracket in advance.

- (3) Move the bracket.
Move to the direction A: The roller life will become longer (but multiple feeding may occur frequently).
Move to the direction B: Multiple feeding will be suppressed (but the roller life may become shorter).

Notes:

The recommended moving distance of the bracket is within 1 or 2 scale marks.

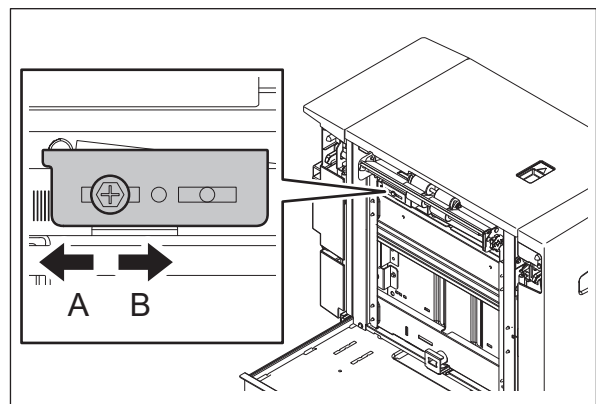

Fig. 4-76

5. ELECTRIC CIRCUIT

5.1 Harness Diagram

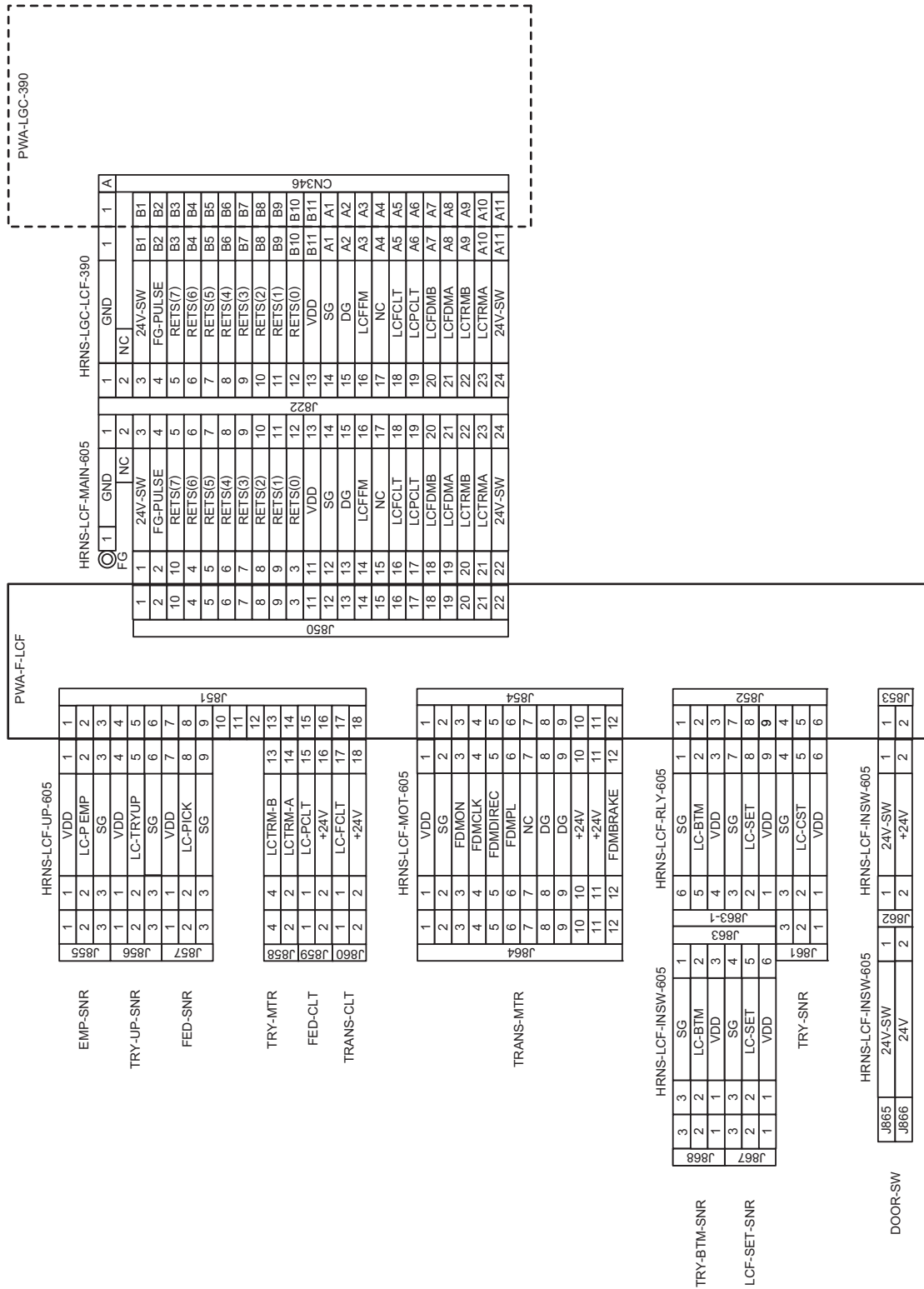

Fig.5-1

5.2 Circuit Diagram

Circuit Diagram (1)

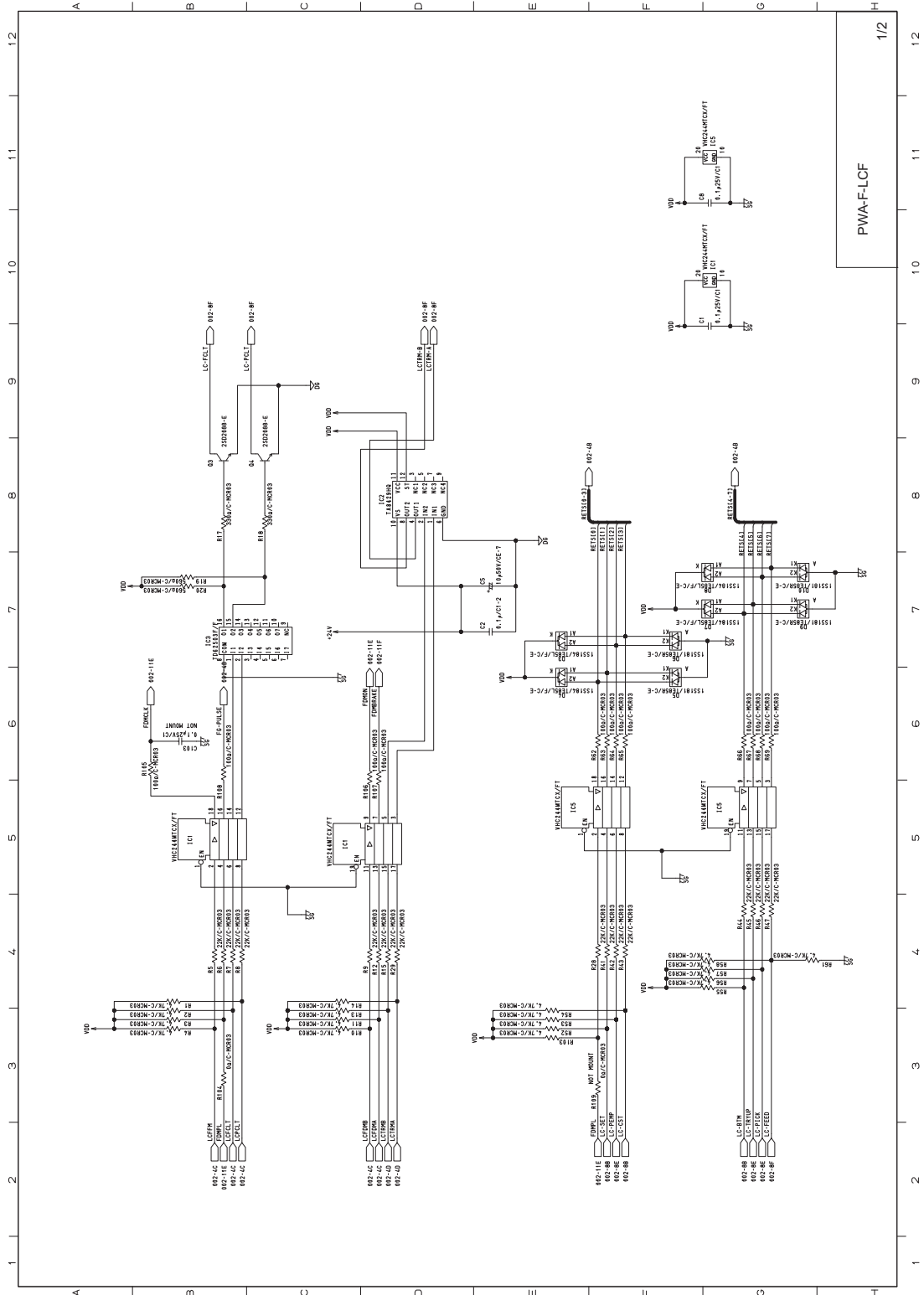

Fig.5-2

5.3 PC Board

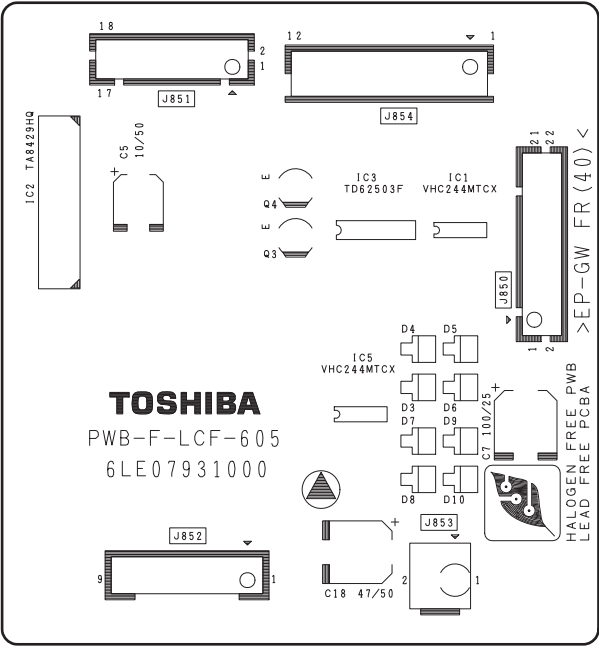

Fig.5-4

6. PREVENTIVE MAINTENANCE

Symbols used in the checklist

Cleaning	Coating	Replacing
A: Cleaning with alcohol B: Cleaning with soft pad, cloth or vacuum cleaner	W: White grease (Molycoat)	The number of sheet consumed before replacement (Value x 1,000) R: Replace if deformed or damaged.

Preventive Maintenance Checklist

Item to check	Cleaning	Coating	Replacing x 1000	Remarks
Pickup roller	A		500	
Feed roller	A		500	
Separation roller	A		500	
Drive gears (tooth face)		W		
Brush unit	B			Note 4 only for MP-2501
Paper path section	B			Note 5
Sensor section	B			

Notes:

- Perform preventive maintenance according to the check list.
- Perform preventive maintenance for this equipment at the same interval as for the main equipment to which this equipment is connected.
- Be careful not to put oil on the rollers, belt and pulleys when lubricating.
- Remove the brush unit, and clean the paper dust of the entire brush unit.

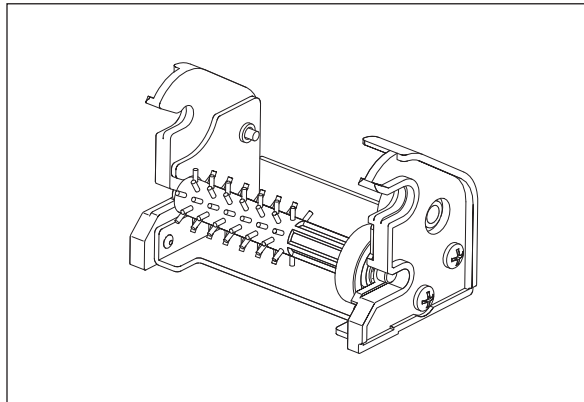

Fig.6-1

- Remove the brush unit (for MP-2501) and feed roller, clean the paper dust of paper path section and the shaded area of figure below.

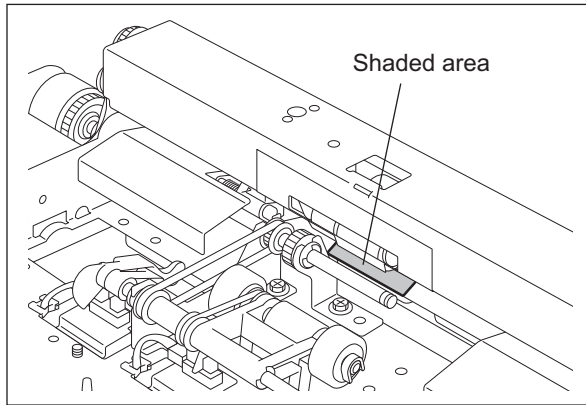

Fig.6-2

REVISION RECORD

Ver.03

Ver.03 <2018.09.13>	
Page	Contents
1-1	The description of rating label has been added.
4-13	The description has been added.
6-1	"Remarks" has been added.

Ver.02

Ver.02 <2016.06.24>	
Page	Contents
Cover	Model names have been added.
Precautions	Model names have been changed.
1-1	The table of specifications has been changed.
6-1	Model names have been changed.

Ver.01

Ver.01 <2008.12.01>	
Page	Contents
-	The weight of MP-2501 has been changed.
1-1	The paper thickness has been changed. The weight of MP-2501 has been changed. The plate (1pc.) has been removed. The product number of the screw has been changed.
2-1	Fig. 2-1 has been changed.
2-2	Fig. 2-2 has been changed.
4-1	Fig. 4-1 has been changed. Fig. 4-2 has been changed.
4-2	Step (3) of "[C] Upper cover" has been changed. Fig. 4-4 has been changed. Fig. 4-5 has been changed. The note in "[D] Right cover" has been changed.
4-3	Fig. 4-6 has been changed.
4-5	Step (3) of "[C] Transfer motor" has been changed. Fig. 4-11 has been changed. Fig. 4-13 has been changed.
4-6	Fig. 4-15 has been changed. Fig. 4-16 has been changed.
4-7	Fig. 4-17 has been changed.
4-8	Step (3) in "[H] Tray bottom sensor" has been changed. Fig. 4-20 has been changed. Fig. 4-21 has been changed. Fig. 4-22 has been changed.
4-9	Fig. 4-23 has been changed. Fig. 4-24 has been changed.
4-11	Fig. 4-29 has been changed.
4-12	Fig. 4-30 has been changed. Fig. 4-31 has been changed. Fig. 4-32 has been changed.
4-15	Fig. 4-39 has been changed.

Ver.01 <2008.12.01>	
Page	Contents
4-16	Fig. 4-40 has been changed. Fig. 4-41 has been changed. Fig. 4-42 has been changed.
4-17	Step (2) of "[A] Drawer" has been changed. Fig. 4-43 has been changed. Steps (3) and (4) have been added to "[A] Drawer". Fig. 4-44 has been added. Fig. 4-45 has been changed.
4-22	Fig. 4-58 has been changed. Steps (3) and (4) have been added to "[A] Rear side guide". Fig. 4-59 has been added. Fig. 4-60 has been changed.
4-23	Fig. 4-62 has been changed. Fig. 4-63 has been changed.
4-24	Fig. 4-65 has been changed.
4-25	Fig. 4-68 has been changed. Fig. 4-69 has been changed.
4-27	Fig. 4-74 has been changed.
4-28	"4.9.3 Separation roller pressure force adjustment" has been added.

TOSHIBA

TOSHIBA TEC CORPORATION

1-11-1, OSAKI, SHINAGAWA-KU, TOKYO, 141-8562, JAPAN