

# TOSHIBA

# SERVICE MANUAL

## LARGE CAPACITY FEEDER

# MP-2002

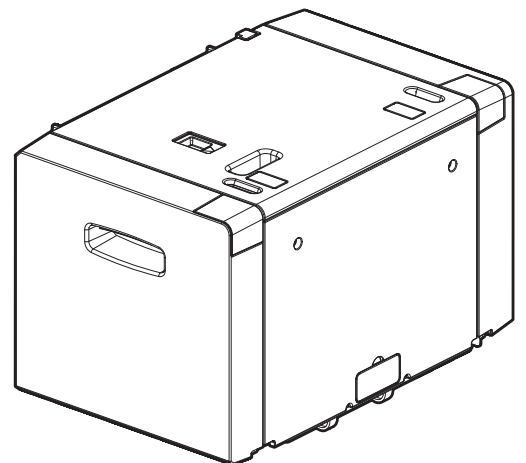

Model: MP-2002  
Publish Date: December 2021  
File No. SME21002500  
R210221X2900-TTEC  
Ver00 F1 2022-03

## Trademarks

- MOLYKOTE® is a trademark of DDP SPECIALTY ELECTRONIC MATERIALS US, INC..
- Other company names and product names in this manual are the trademarks of their respective companies.

© 2021, 2022 Toshiba Tec Corporation All rights reserved

Under the copyright laws, this manual cannot be reproduced in any form without prior written permission of Toshiba Tec Corporation. No patent liability is assumed, however, with respect to the use of the information contained herein.

# General Precautions for Installation, Servicing and Maintenance for this Option

The installation and service shall be done by a qualified service technician.

1. When installing this option to the MFP, be sure to follow the instructions described in the "Unpacking/Set-Up Procedure for the Equipment" booklet which comes with this option.
2. This option shall be installed by an authorized or qualified person.
3. This option weighs approx. 28.5kg, therefore pay full attention when handling it.
4. Before starting installation, servicing or maintenance work, be sure unplug the power cable of the MFP first.
5. The MFP with this option connected shall be installed near the socket outlet and shall be easily accessible.
6. Be sure to fix and plug in the power cable securely after the installation so that no one trips over it.
7. When selecting the installation site, avoid placing this option and the MFP on different levels or inclined floors.
8. When servicing or maintaining the MFP with this option connected, be careful about the rotating or operating sections such as gears, pulleys, sprockets, cams, belts, etc.
9. When the parts of this option are disassembled, reassembly is the reverse of disassembly unless otherwise noted in this manual or other related documents. Be careful not to install small parts such as screws, washers, pins, E-rings, star washers, harnesses in the wrong places.
10. Basically, the MFP with this option connected should not be operated with any parts removed or disassembled.
11. When servicing the MFP with this option connected while the power is turned ON, be sure not to touch live sections and rotating/operating sections.
12. Delicate parts for preventing safety hazard problems (such as fuses, thermofuses, door switches, sensors, etc. if any) should be handled, installed and adjusted correctly.
13. Tools and instruments
  - Use designated jigs and tools.
  - Use recommended measuring instruments or equivalents.
14. During servicing or maintenance work, be sure to check the nameplate and other cautionary labels (if any) to see if they are clean and firmly stuck. If not, take appropriate actions.
15. The ICs on the PC boards tend to be damaged by static electricity. Therefore, the PC boards must be stored in an anti-electrostatic bag and handled carefully using a wristband. Before using the antistatic wrist strap, unplug the power cable of the MFP and make sure that there are no charged objects which are not insulated in the vicinity.
16. Regarding the recovery and disposal of the MFP with this option connected, supplies, packing materials, follow the relevant local regulations or rules.
17. Return the MFP with this option connected to the original state and check the operation when the service is finished.

18. When the MFP is used after this option is removed, be sure to install the parts or the covers which have been taken off so that the inside of the MFP is not exposed.
19. Unplug the power cable and clean the area around the prongs of the plug and socket outlet once a year or more. A fire may occur when dust lies on this area.

# CONTENTS

<b>1. SPECIFICATIONS</b>	<b>1-1</b>
<b>2. OVERVIEW</b>	<b>2-1</b>
2.1 Front Sectional View	2-1
2.2 Electric Parts Layout	2-2
2.3 Electric Parts	2-3
<b>3. GENERAL OPERATION</b>	<b>3-1</b>
3.1 Operation Description	3-1
3.1.1 From power-ON to the ready status	3-1
3.1.2 Ready status	3-1
3.1.3 Paper feeding and transporting operation from the start to the finish of printing	3-1
3.1.4 Tray operation during printing	3-2
3.2 Error Detection	3-2
3.2.1 Paper misfeeding detection	3-2
3.2.2 Call for service	3-2
<b>4. DISASSEMBLY AND REPLACEMENT</b>	<b>4-1</b>
4.1 Cover	4-1
4.1.1 Front cover	4-1
4.1.2 Rear cover	4-2
4.1.3 Top cover	4-2
4.1.4 Right cover	4-3
4.2 Paper Feed Unit	4-4
4.3 Transport Unit	4-5
4.4 Electric Parts	4-6
4.4.1 Ex-LCF board (PWA)	4-6
4.4.2 Ex-LCF tray motor (M2)	4-6
4.4.3 Ex-LCF transport motor (M1)	4-8
4.4.4 Ex-LCF tray sensor (S5)	4-8
4.4.5 Feed bracket	4-9
4.4.6 Ex-LCF paper empty sensor (S1)	4-12
4.4.7 Ex-LCF tray-up sensor (S2)	4-12
4.4.8 Ex-LCF paper feed sensor (S3)	4-13
4.4.9 Ex-LCF set sensor (S4), Ex-LCF door switch (SW1)	4-13
4.4.10 Ex-LCF tray bottom sensor (S6)	4-15
4.4.11 Ex-LCF paper feed clutch (CL2)	4-15
4.4.12 Ex-LCF transport clutch (CL1)	4-16
4.5 Roller	4-18
4.5.1 Ex-LCF separation roller	4-18
4.5.2 Ex-LCF pickup roller	4-18
4.5.3 Ex-LCF paper feed roller	4-19
4.5.4 Ex-LCF transport idling roller	4-19
4.5.5 Ex-LCF transport roller	4-20
4.6 Tray-up Driving Section	4-21
4.6.1 Pulley	4-21
4.6.2 Gear	4-22
4.6.3 Gear, Coupling	4-22
4.7 Ex-LCF Transport Motor Driving Section	4-24
4.7.1 Gear, Pulley	4-24
4.8 Tray Unit Section	4-25
4.8.1 Tray unit	4-25
4.8.2 Tray wire	4-25
4.9 Paper Guide Setting	4-31
4.9.1 Right stopper	4-31

4.9.2	Rear side guide.....	4-31
4.9.3	Front side guide .....	4-32
4.9.4	End guide.....	4-32
4.9.5	Sub guides.....	4-34
<b>5.</b>	<b>ADJUSTMENT .....</b>	<b>5-1</b>
5.1	Sideways adjustment .....	5-1
5.2	Tilted volume adjustment .....	5-3
5.3	Ex-LCF separation roller pressure force adjustment.....	5-4
<b>6.</b>	<b>PERIODIC MAINTENANCE .....</b>	<b>6-1</b>
<b>7.</b>	<b>ELECTRIC CIRCUIT .....</b>	<b>7-1</b>
7.1	Harness Diagram .....	7-1
	<b>REVISION RECORD.....</b>	<b>1</b>

# 1. SPECIFICATIONS

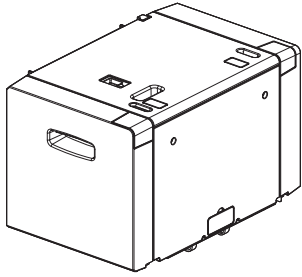
Item	MP-2002
Appearance	
Replenishing method	Front loading method
Paper	Size: A4, LT Thickness: 64 g/m <sup>2</sup> to 300 g/m <sup>2</sup> (17 lbs. Bond - 140 lbs. Index)
Capacity	2,000 sheets (Stacking height: 220 mm or below) (80 g/m <sup>2</sup> or 20 lbs.)
Dimensions	378.2 (W) x 610.5 (D) x 464.5 (H) mm (when installed in an MFP)
Weight	Approx. 28.5 kg
Power supply	5 V, 24 V (supplied from an MFP)
Accessories	Unpacking/Setup Instructions (1 set) Attachment base (1 pc.) Latch bracket (F) (1 pc.) Latch bracket (R) (1 pc.) Latch spacer (F) (1 pc.) Latch spacer (R) (1 pc.) Connector bracket-1 (1 pc.) Connector bracket-2 (1 pc.) Cable-1 (1 pc.) Cable-2 (1 pc.) Screw: M4x8 (8 pcs.) Screw: M4x6 (4 pcs.) Screw: M3x8 (1 pc.) Screw: M3x6 (3 pcs.)
Appearance color	Jet black





## 2. OVERVIEW

### 2.1 Front Sectional View

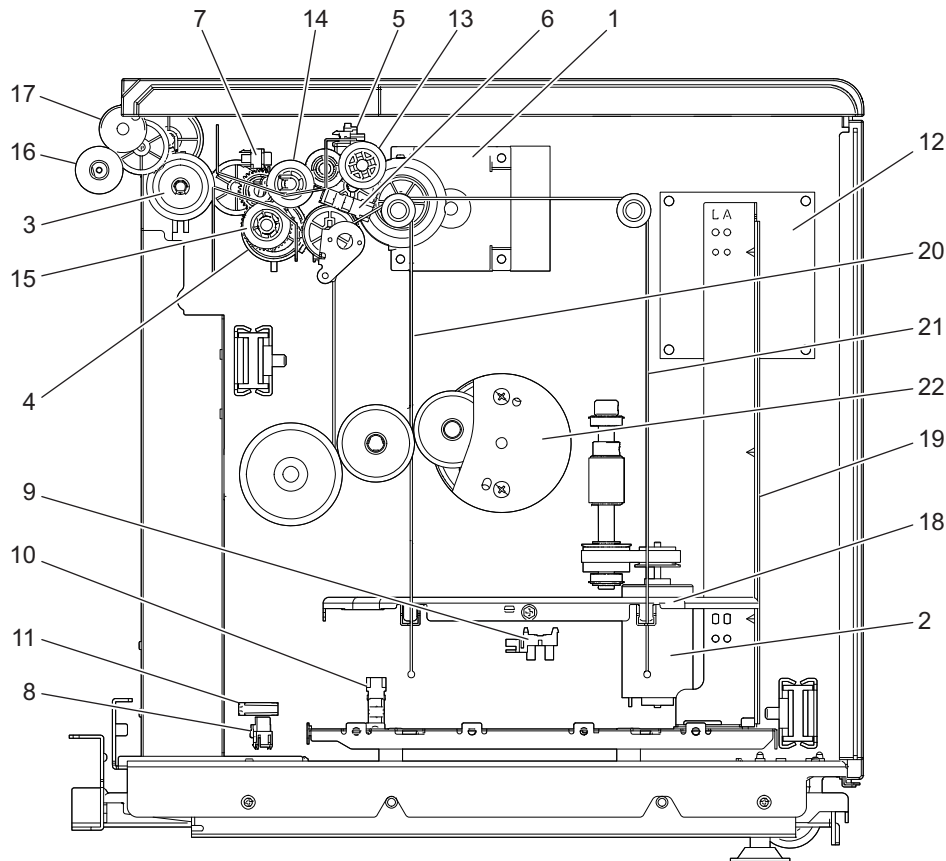

Fig. 2-1

Symbol	Name	Symbol	Name
1	Ex-LCF transport motor (M1)	13	Ex-LCF pickup roller
2	Ex-LCF tray motor (M2)	14	Ex-LCF paper feed roller
3	Ex-LCF transport clutch (CL1)	15	Ex-LCF separation roller
4	Ex-LCF paper feed clutch (CL2)	16	Ex-LCF transport roller
5	Ex-LCF paper empty sensor (S1)	17	Ex-LCF transport idling roller
6	Ex-LCF tray-up sensor (S2)	18	Ex-LCF tray
7	Ex-LCF paper feed sensor (S3)	19	Ex-LCF end guide
8	Ex-LCF set sensor (S4)	20	Short wire
9	Ex-LCF tray sensor (S5)	21	Long wire
10	Ex-LCF tray bottom sensor (S6)	22	Brake unit
11	Ex-LCF door switch (SW1)		
12	Ex-LCF board (PWA)		

# 2.2 Electric Parts Layout

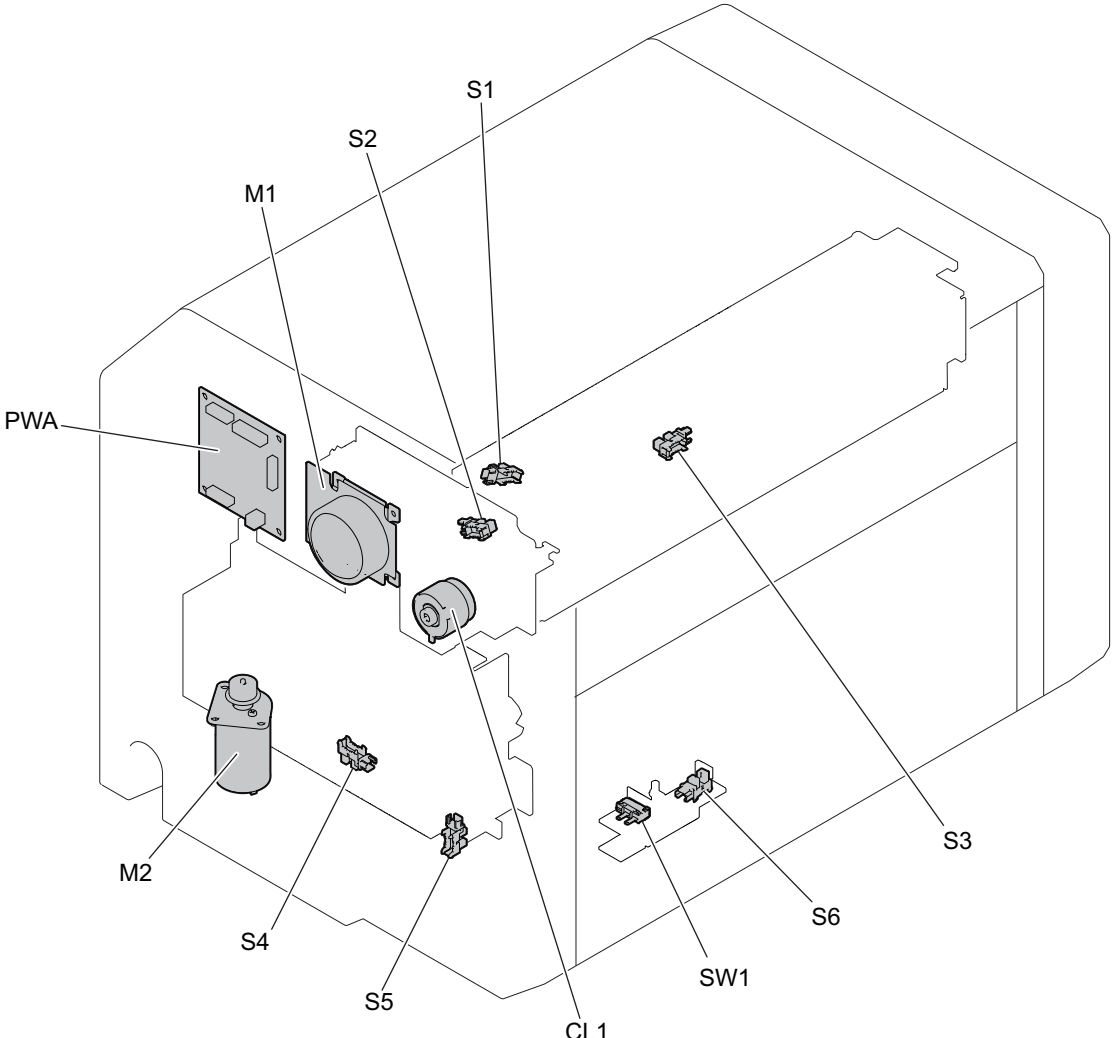

Fig. 2-2

## 2.3 Electric Parts

- Motor

Symbol	Name	Function	P-I
M1	Ex-LCF transport motor	Drives the paper feeding and transport system.	1-17
M2	Ex-LCF tray motor	Shifts the tray.	3-23

- Electromagnetic clutch

Symbol	Name	Function	P-I
CL1	Ex-LCF transport clutch	Drives the transporting system.	5-23
CL2	Ex-LCF paper feed clutch	Drives the paper feeding system.	1-32

- Switch and Sensor

Symbol	Name	Function	P-I
S1	Ex-LCF paper empty sensor	Detects the paper loading level.	4-31
S2	Ex-LCF tray-up sensor	Detects the upper limit position of the tray.	4-31
S3	Ex-LCF paper feed sensor	Detects paper transportation.	4-31
S4	Ex-LCF set sensor	Detects installing in the MFP.	2-11
S5	Ex-LCF tray sensor	Detects the installation of the tray unit.	2-11
S6	Ex-LCF tray bottom sensor	Detects the lower limit position of the tray.	2-11
SW1	Ex-LCF door switch	Safety switch	2-12

- PC board

Symbol	Name	Function	P-I
PWA	Ex-LCF board	Drives the paper feeding system and controls the tray driving.	1-33



## 3. GENERAL OPERATION

### 3.1 Operation Description

#### 3.1.1 From power-ON to the ready status

1. When the MFP is turned ON, the power is also supplied from the MFP to Ex-LCF. The Ex-LCF tray motor (M2) starts to rotate forward to lift the tray.  
When the tray has been lifted and the Ex-LCF the tray-up sensor (S2) has been turned ON (H: Sensor light path blocked by the actuator sensor), the Ex-LCF tray motor (M2) stopped rotating and lifting the tray. When the Ex-LCF paper empty sensor (S1) is turned ON (L: Passing the sensor light path), it is judged that there is paper in this option. On the other hand, when the Ex-LCF paper empty sensor (S1) is turned OFF, it is judged that there is no paper in this option.
2. When the Ex-LCF is not installed in the MFP (Ex-LCF set sensor (S4): OFF) or when the tray unit is being pulled out (Ex-LCF tray sensor (S5): OFF), the tray lifting operation is not carried out. In this case, when the Ex-LCF is installed in the MFP and the tray unit is inserted, the tray starts to be lifted up and the series operation until the detection of the paper loading level is carried out.
3. At the time of power is turned ON, when the Ex-LCF paper feed sensor (S3) is turned ON (L: Passing the sensor light path), that is, when the paper is remaining at the transport path, this option detects it as a paper misfeed and cannot operate.

#### 3.1.2 Ready status

1. When the presence of paper has been detected by means of the above operation, this option gets into a ready state.
2. When the tray unit is pulled out, it is automatically lowered because of its structure. When it is inserted once again, it is lifted.

#### 3.1.3 Paper feeding and transporting operation from the start to the finish of printing

1. When it is judged that paper feeding from the Ex-LCF is possible and the [START] button is pressed, the paper feed motor in the MFP is turned ON and the Ex-LCF transport motor (M1) is driven.
2. The Ex-LCF paper feed clutch (CL2) is turned ON and the Ex-LCF pickup roller and Ex-LCF paper feed roller start to drive to feed the paper from the tray.
3. After the feeding starts, the Ex-LCF transport clutch (CL1) is turned ON and the Ex-LCF transport roller starts to drive to transport the paper.
4. When the leading edge of the paper has turned ON the Ex-LCF paper feed sensor (S3), the Ex-LCF paper feed clutch (CL2) is turned OFF and the paper feeding operation is stopped. The paper transported by the Ex-LCF transport roller is sent to the MFP side and is transported by the paper feed unit.
5. When the trailing edge of the paper has turned OFF the Ex-LCF paper feed sensor (S3), the Ex-LCF transport clutch (CL1) is turned OFF after a specified time has passed and the next sheet can be fed.
6. When continuous printing is performed, the above steps from (2) to (5) are repeated for as many sheets of paper as printed.
7. When printing has been finished, the paper feed motor of the MFP stops rotating and the Ex-LCF transport motor (M1) is turned OFF to finish the feeding and transporting operation.

### **3.1.4 Tray operation during printing**

1. When 10 to 20 sheets of paper have been fed from the tray, the Ex-LCF pickup roller is lowered to a specified height. The Ex-LCF tray-up sensor (S2) detects this and the Ex-LCF tray motor (M2) rotates forward to lift the tray.

## **3.2 Error Detection**

### **3.2.1 Paper misfeeding detection**

Paper misfeeding will occur in the following cases.

- The Ex-LCF paper feed sensor (S3) is not turned ON within a specified period of time after the paper feeding is started.
- Each transport sensor of the MFP does not operate (ON/OFF) within a specified period of time after the feeding has started at the MFP side.

### **3.2.2 Call for service**

- The Ex-LCF paper feed sensor (S2) is not turned ON within a specified period of time after the tray has started to be lifted.

## 4. DISASSEMBLY AND REPLACEMENT

### 4.1 Cover

#### 4.1.1 Front cover

- (1) Pull out the tray unit.
- (2) Remove 4 screws [1] and take off the front cover [2].

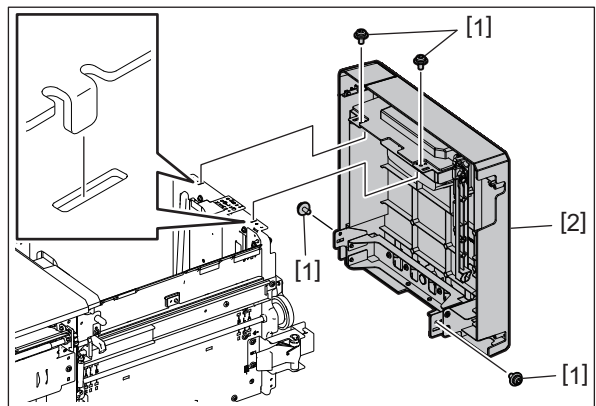

Fig. 4-1

#### Notes:

- When installing the front cover [2], raise the arm [3] until it stops.

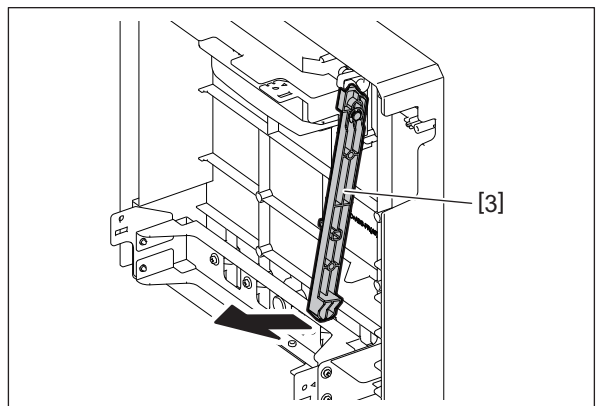

Fig. 4-2

- When installing, be sure to hook the arm [3] to the groove of the holder [2].

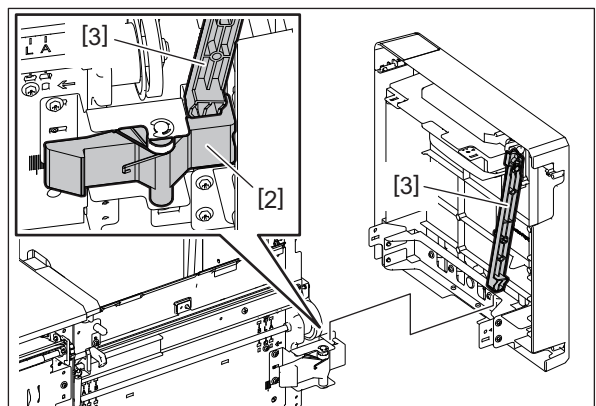

Fig. 4-3

### 4.1.2 Rear cover

- (1) Remove the spacer [2] toward you and slide the harness [3] to the right-hand side.
- (2) Remove 4 screws [4] and take off the rear cover [1].

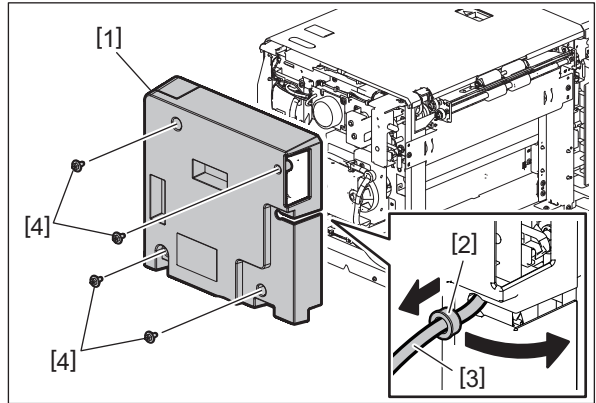

Fig. 4-4

### 4.1.3 Top cover

- (1) Take off the rear cover.  
P. 4-2 "4.1.2 Rear cover"
- (2) Pull out the tray unit.
- (3) Loosen 3 screws [1].

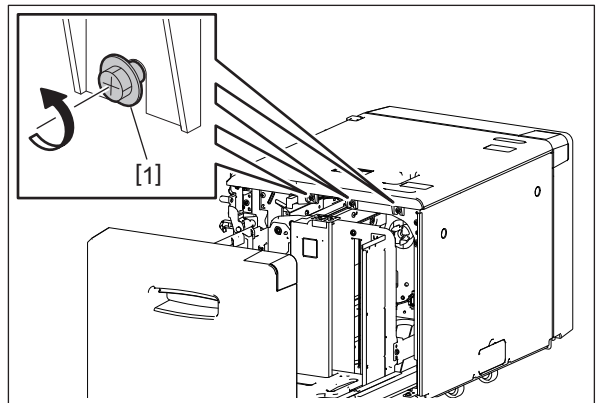

Fig. 4-5

- (4) Release 2 latches [3] of the top cover [2] to remove it.

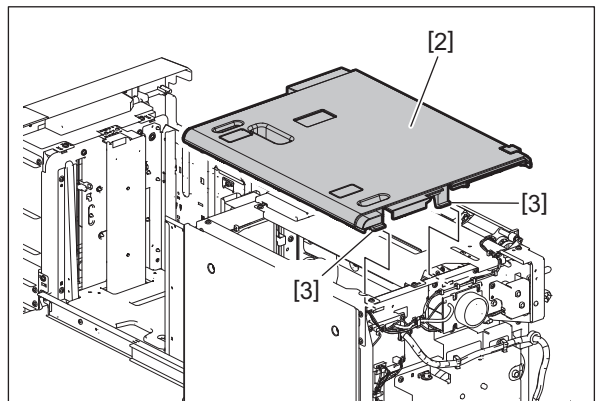

Fig. 4-6



#### 4.1.4 Right cover

- (1) Pull out the tray unit.
- (2) Remove 2 screws [1] and take off the right cover [2] by sliding it to the front side.

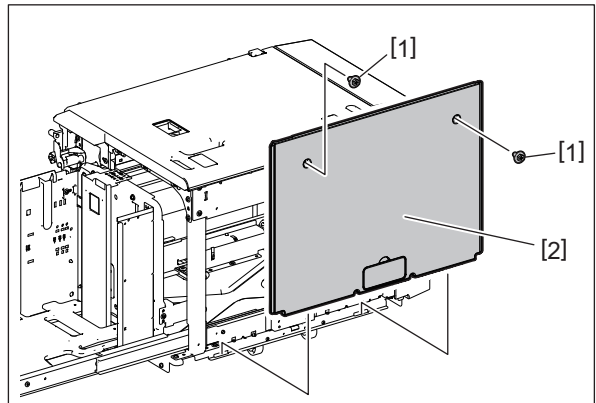



Fig. 4-7

## 4.2 Paper Feed Unit

- (1) Take off the right stopper.  
 P. 4-31 "4.9.1 Right stopper"
- (2) Pull out the tray unit [1] halfway and disconnect the connector [2].

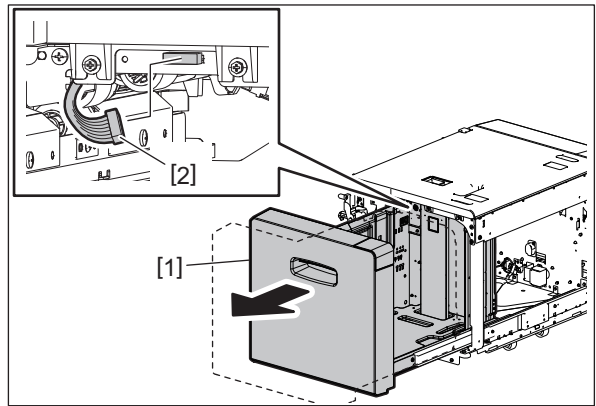

Fig. 4-8

- (3) Pull out the tray unit [1] completely.

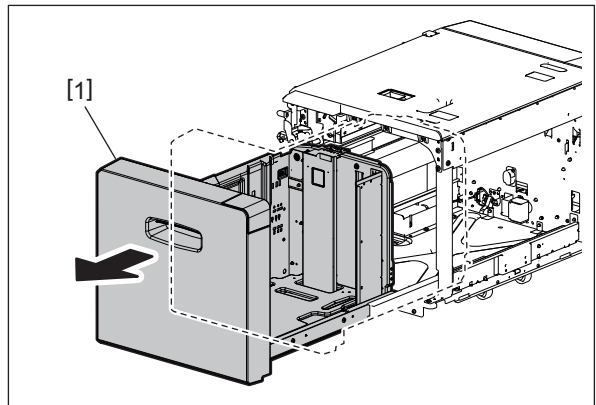

Fig. 4-9

- (4) Remove 1 screw [2] and pull out the paper feed unit [3] to take it out.

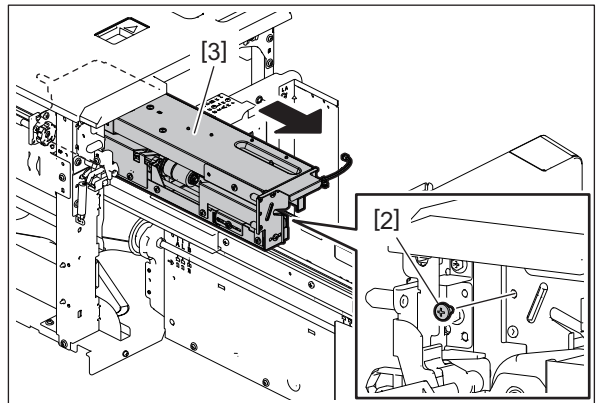



Fig. 4-10

## 4.3 Transport Unit

- (1) Take off the top cover.  
 P. 4-2 "4.1.3 Top cover"
- (2) Remove the lever [1].

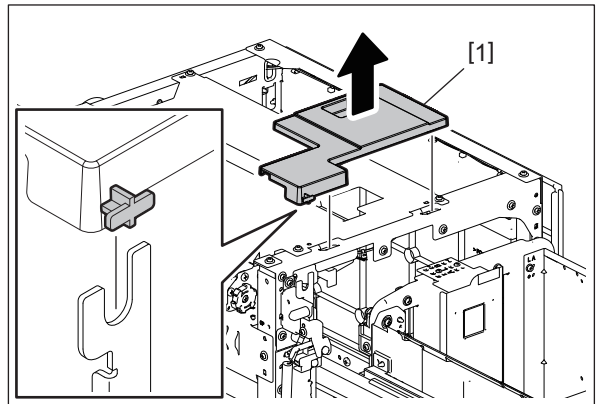

Fig. 4-11

- (3) Disconnect the connector [2] of the Ex-LCF transport clutch.

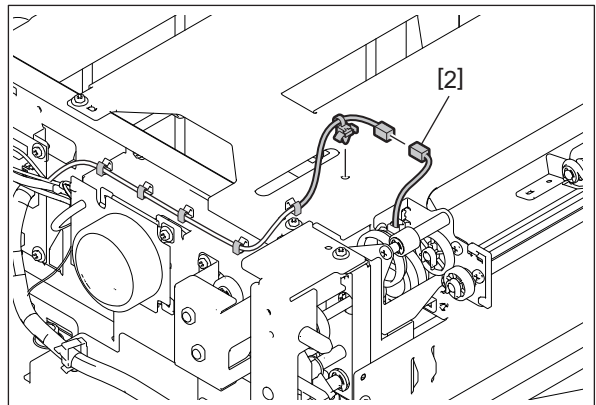

Fig. 4-12

- (4) Remove 4 screws [3] and take off the transport unit [4]. Then remove 1 bushing [5] and 1 gear [6].

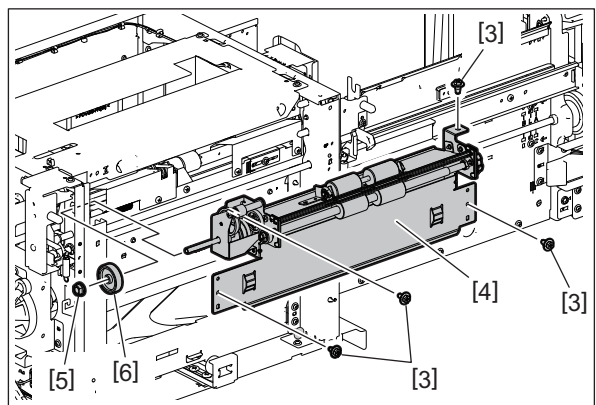

Fig. 4-13

## 4.4 Electric Parts

### 4.4.1 Ex-LCF board (PWA)

- (1) Take off the rear cover.  
📖 P. 4-2 “4.1.2 Rear cover”
- (2) Disconnect all connectors from the Ex-LCF board.
- (3) Remove 4 screws and take off the Ex-LCF board [1].

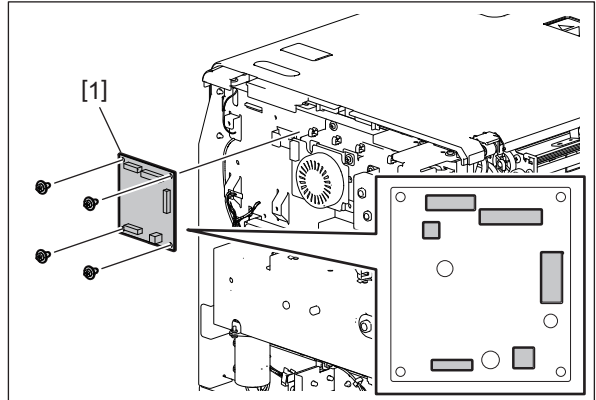

Fig. 4-14

### 4.4.2 Ex-LCF tray motor (M2)

- (1) Take off the rear cover.  
📖 P. 4-2 “4.1.2 Rear cover”
- (2) Disconnect the connector of the Ex-LCF tray motor [1].
- (3) Release the harness from 2 harness clamps [2].

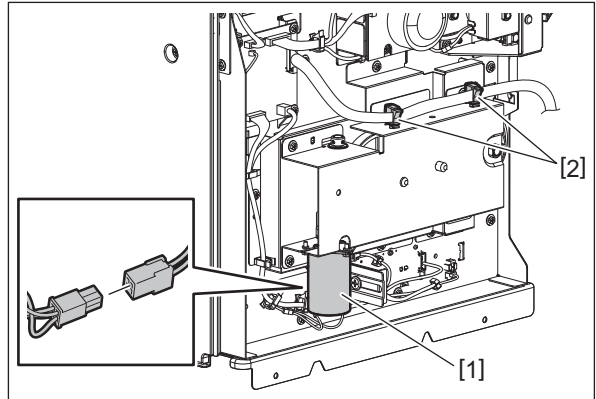

Fig. 4-15

- (4) Remove 4 screws. Take off the Ex-LCF tray motor unit [3] and remove the bushing [4].

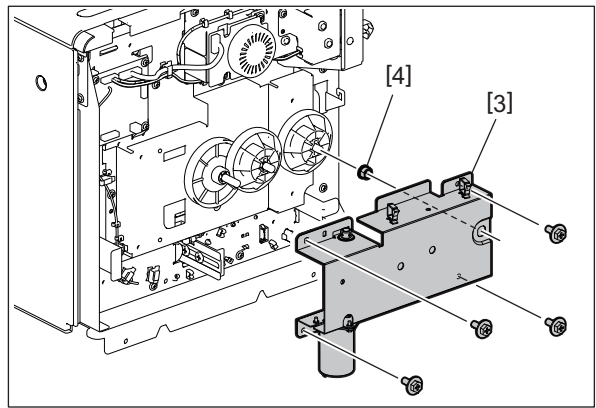

Fig. 4-16

- (5) Remove 3 screws from the Ex-LCF tray motor.  
(6) Remove the belt [5] and take off the Ex-LCF tray motor [1].

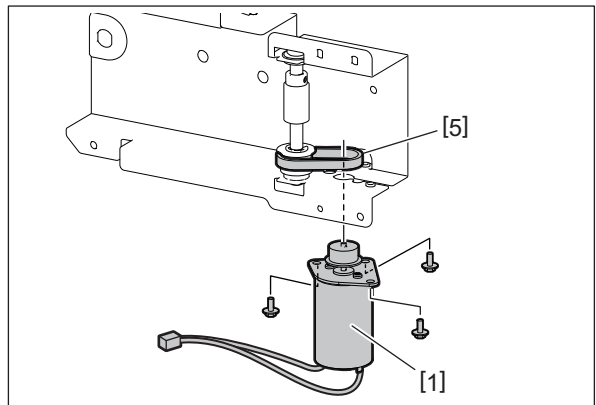

Fig. 4-17

**Notes:**

Be careful not to let grease adhere to the belt after you have removed the Ex-LCF tray motor [1].

### 4.4.3 Ex-LCF transport motor (M1)

- (1) Take off the rear cover.  
📖 P. 4-2 “4.1.2 Rear cover”
- (2) Disconnect the connector [1] from the PC board of the Ex-LCF transport motor.
- (3) Remove 2 screws and take off the Ex-LCF transport motor [2].

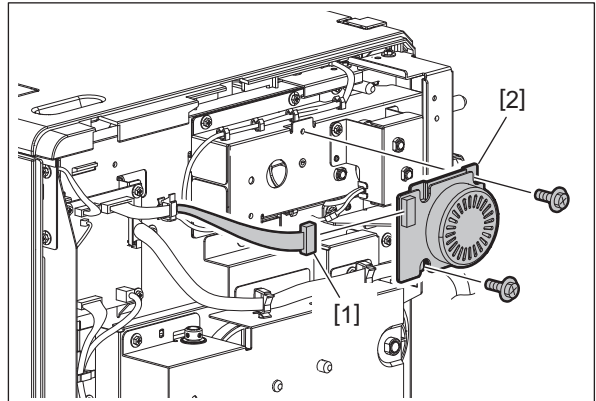

Fig. 4-18

### 4.4.4 Ex-LCF tray sensor (S5)

- (1) Take off the rear cover.  
📖 P. 4-2 “4.1.2 Rear cover”
- (2) Disconnect the connector [1] of the Ex-LCF tray motor and release the harness from 4 harness clamps [2].

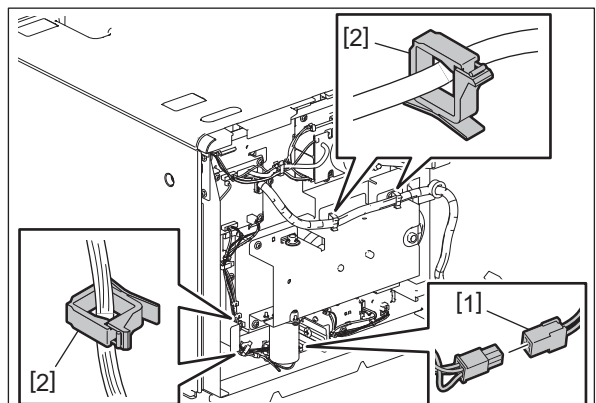

Fig. 4-19

- (3) Remove 6 screws [3] and take off the drive unit [4].

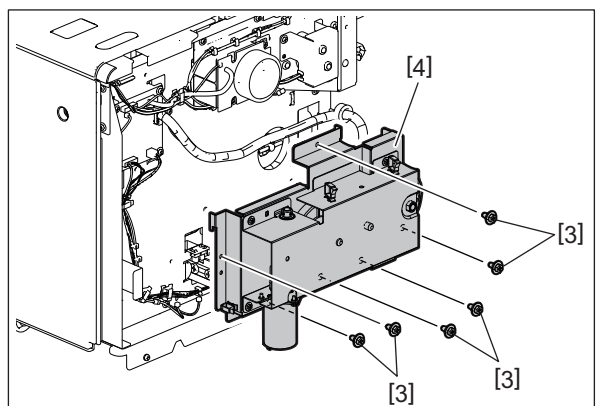

Fig. 4-20

- (4) Disconnect the connector [5] and take off the Ex-LCF tray sensor [6].

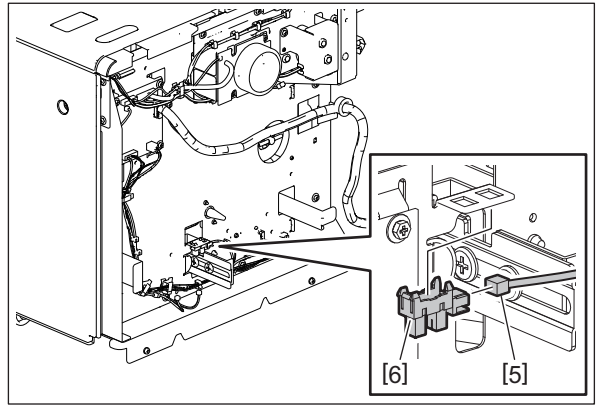

Fig. 4-21

#### 4.4.5 Feed bracket

- (1) Remove the paper feed unit.  
P. 4-4 "4.2 Paper Feed Unit"
- (2) Remove 2 E-rings [1], 1 gear [2], 1 pin [3] and 1 bushing [4].

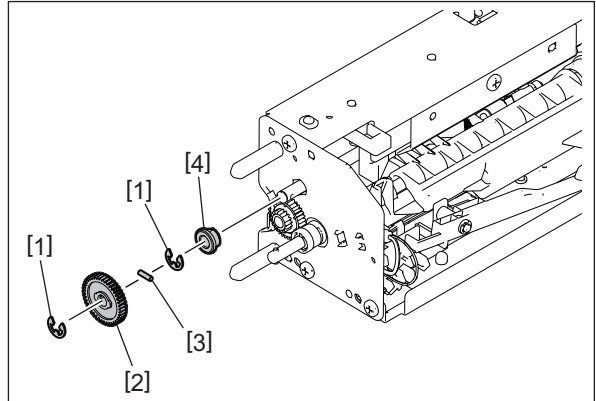

Fig. 4-22

- (3) Remove 2 screws [5] and take off the separation guide unit [6].

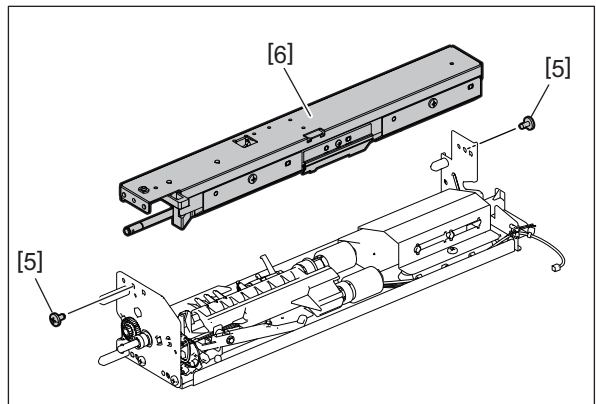

Fig. 4-23

(4) Remove 1 spring [7].

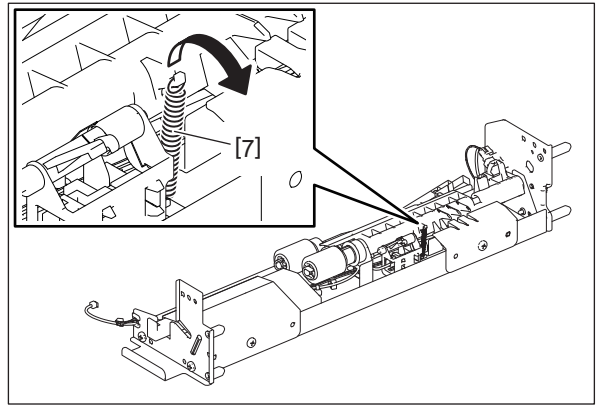

Fig. 4-24

(5) Remove 1 clip [8], 1 roller [9] and 1 clutch [10].

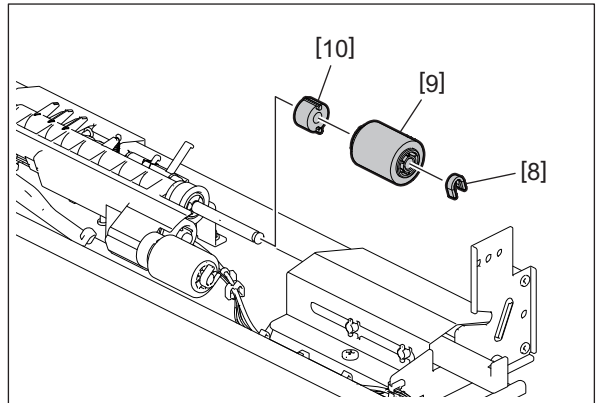

Fig. 4-25

(6) Remove 1 E-ring [11], 1 gear [12] and 1 bushing [13].

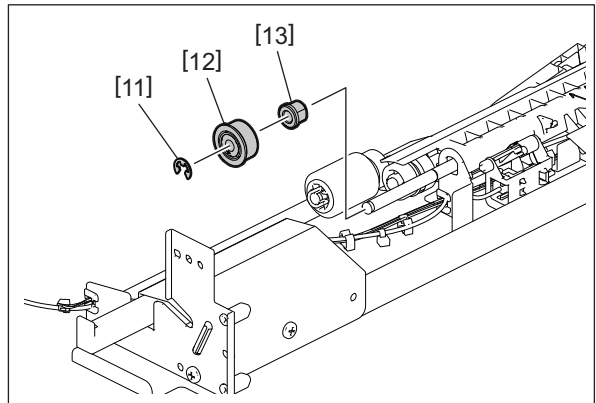

Fig. 4-26



- (7) Remove the shaft [14], 1 bushing [15] and pickup arm [16].

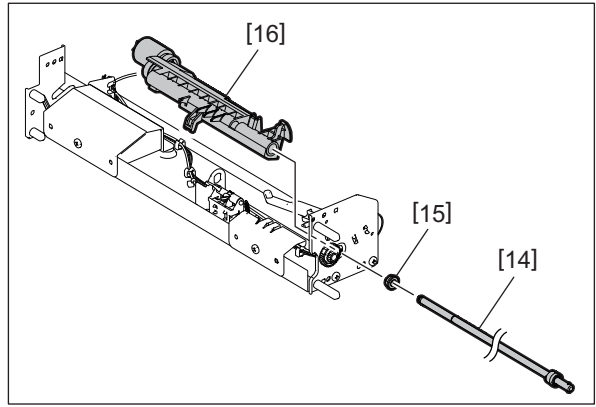

Fig. 4-27

- (8) Disconnect the connector [17] and release the harness from 1 harness clamp [18]. Release the harness from 4 harness clamps [19].

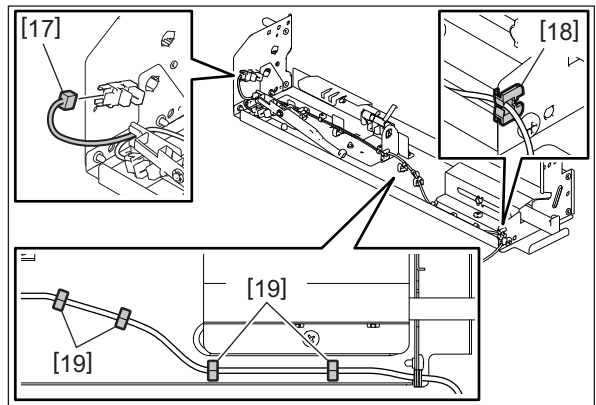

Fig. 4-28

- (9) Remove 3 screws [20] and take off the feed bracket [21].

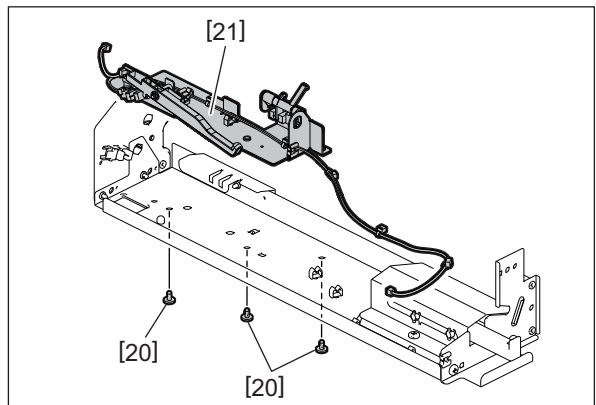

Fig. 4-29

#### 4.4.6 Ex-LCF paper empty sensor (S1)

- (1) Take off the feed bracket.  
📖 P. 4-9 “4.4.5 Feed bracket”
- (2) Disconnect 1 connector [1] and take off the Ex-LCF paper empty sensor [2].

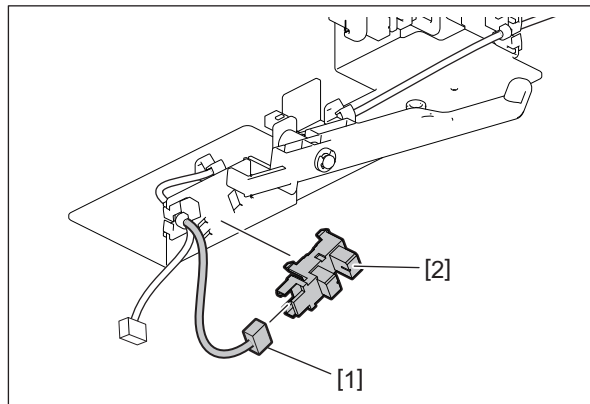

Fig. 4-30

#### 4.4.7 Ex-LCF tray-up sensor (S2)

- (1) Remove the paper feed unit.  
📖 P. 4-4 “4.2 Paper Feed Unit”
- (2) Disconnect 1 connector [1].

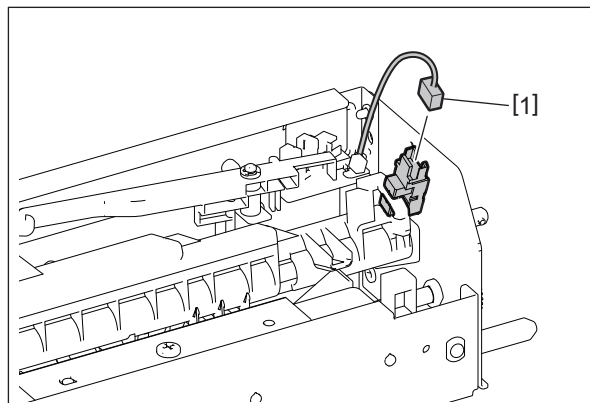

Fig. 4-31

- (3) Slide the lever [2] and take off the Ex-LCF tray-up sensor [3] from the bracket.

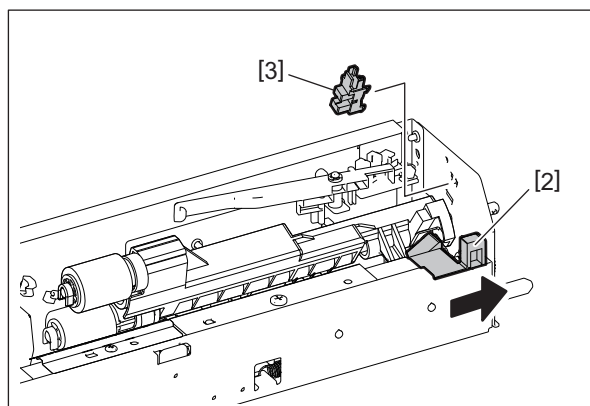

Fig. 4-32

#### 4.4.8 Ex-LCF paper feed sensor (S3)

- (1) Take off the feed bracket.  
📖 P. 4-9 “4.4.5 Feed bracket”
- (2) Remove the stopper [1]. Pull out the shaft [2] and remove the actuator [3] and spring [4].

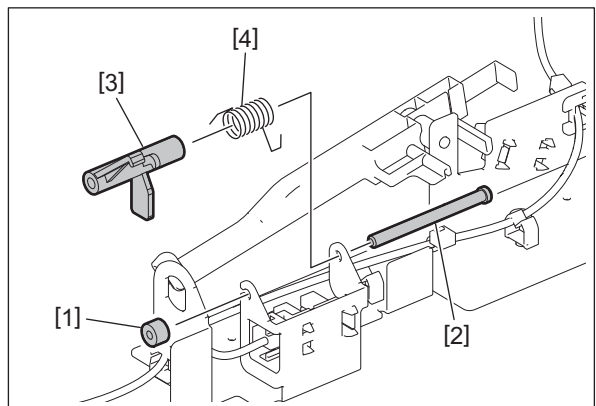

Fig. 4-33

- (3) Disconnect 1 connector [4] and take off the Ex-LCF paper feed sensor [5].

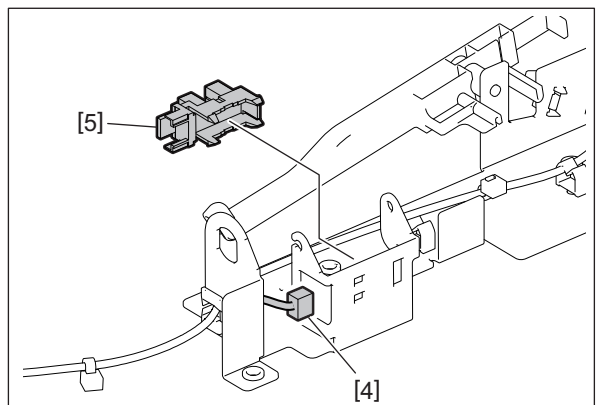

Fig. 4-34

#### 4.4.9 Ex-LCF set sensor (S4), Ex-LCF door switch (SW1)

- (1) Take off the right cover.  
📖 P. 4-3 “4.1.4 Right cover”
- (2) Remove 1 screw [1] and lift up the switch cover [2].
- (3) Release the harness from the harness clamp [3] and take off the switch cover [2].

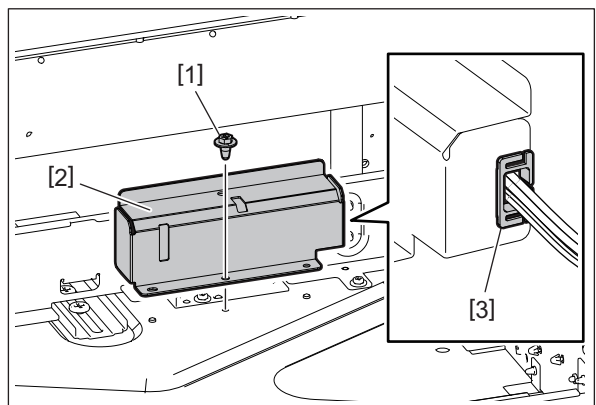

Fig. 4-35

- (4) Remove 1 screw [4] and lift up the switch bracket [5].
- (5) Disconnect 1 connector [6] and release the harness from the harness clamp [7]. Disconnect the connectors [8] (red) and [9] (orange).

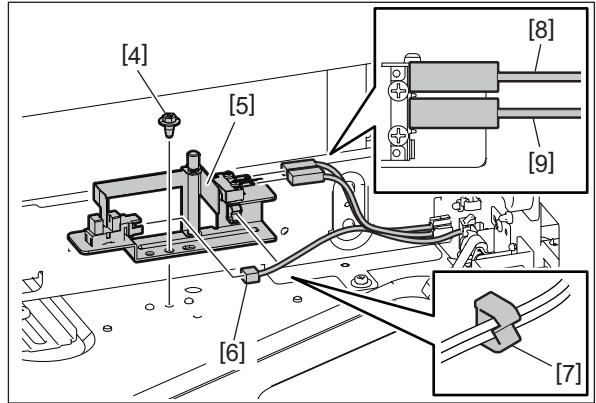

Fig. 4-36

**Notes:**

Be careful not to connect the Ex-LCF door switch connectors to the wrong terminals.

- (6) Take off the Ex-LCF set sensor [10].
- (7) Remove 2 screws [11] and take off the Ex-LCF door switch [12].

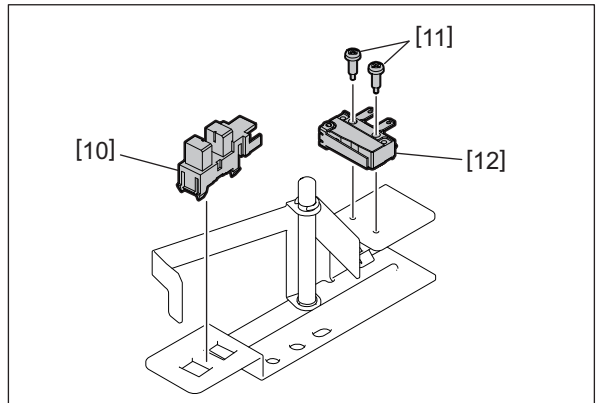

Fig. 4-37

#### 4.4.10 Ex-LCF tray bottom sensor (S6)

- (1) Take off the rear cover.  
📖 P. 4-2 "4.1.2 Rear cover"
- (2) Take off the right cover.  
📖 P. 4-3 "4.1.4 Right cover"
- (3) Disconnect 1 connector [1] from the sensor.
- (4) Release the latch from behind the rear frame and take off the Ex-LCF tray bottom sensor [2].

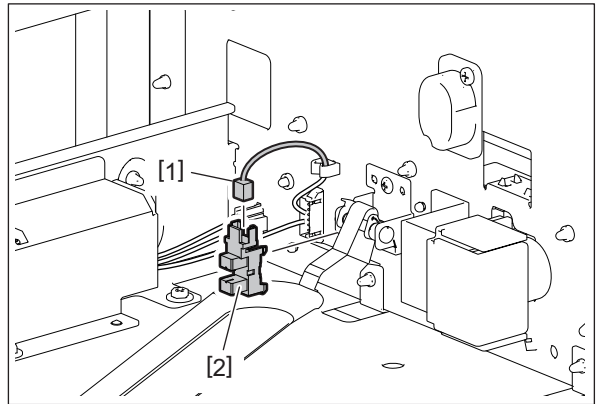

Fig. 4-38

#### 4.4.11 Ex-LCF paper feed clutch (CL2)

- (1) Take off the rear cover.  
📖 P. 4-2 "4.1.2 Rear cover"
- (2) Disconnect the connector [1] and release the harness from the harness clamp [2].

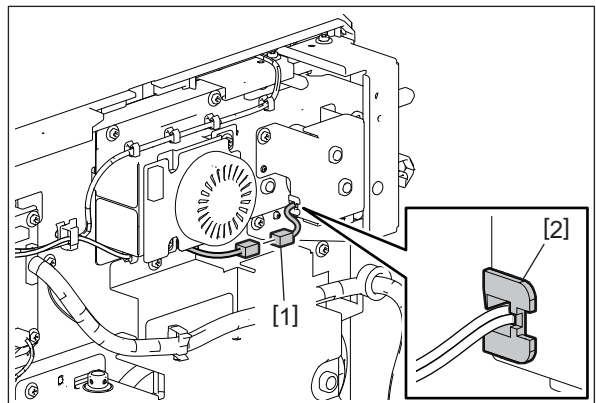

Fig. 4-39

- (3) Remove 2 screws [3]. Take off the bracket [4] and remove 2 bushings [5].

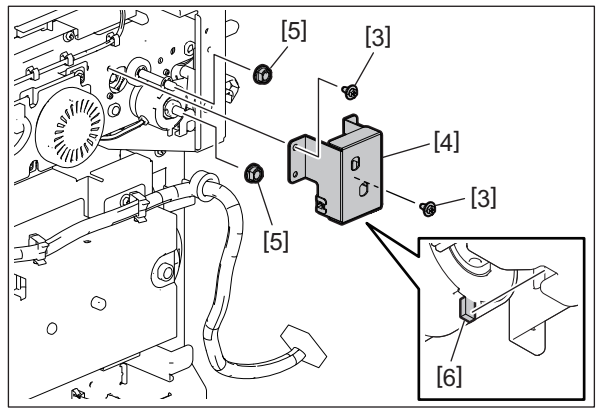

Fig. 4-40

**Notes:**

When installing, align the latch [6] of the clutch to the groove of the bracket.

- (4) Loosen the set screw [7] and take off the Ex-LCF paper feed clutch [8].

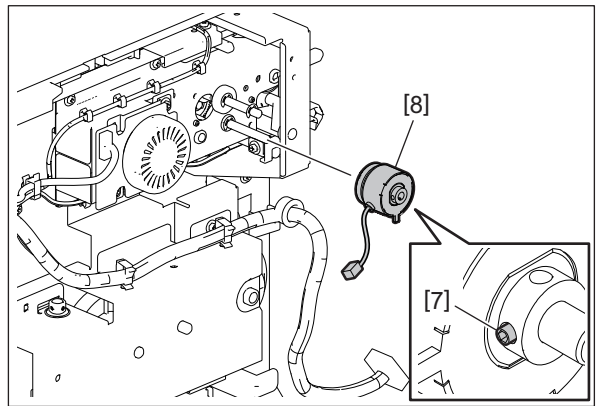

Fig. 4-41

#### 4.4.12 Ex-LCF transport clutch (CL1)

- (1) Take off the transport unit.  
P. 4-5 "4.3 Transport Unit"
- (2) Release the harness from the harness clamp [1].

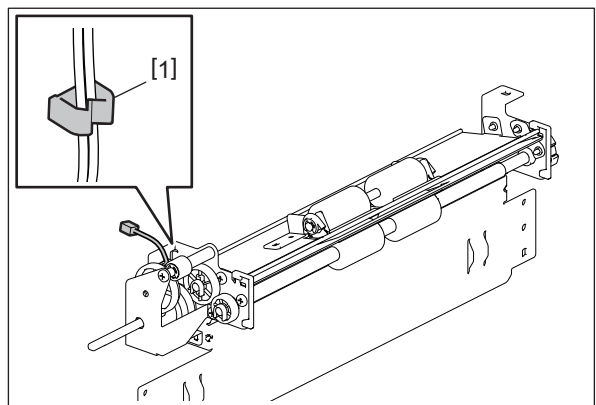

Fig. 4-42

- (3) Remove 3 screws [2] and take off the bracket [3]. Remove 1 bushing [4].

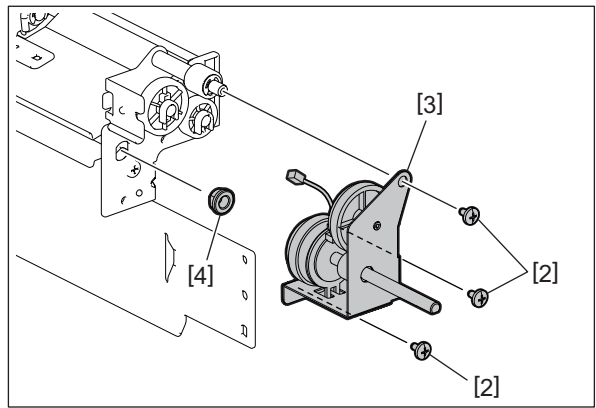

Fig. 4-43

- (4) Remove the clutch unit [5].  
When removing, release the latch.

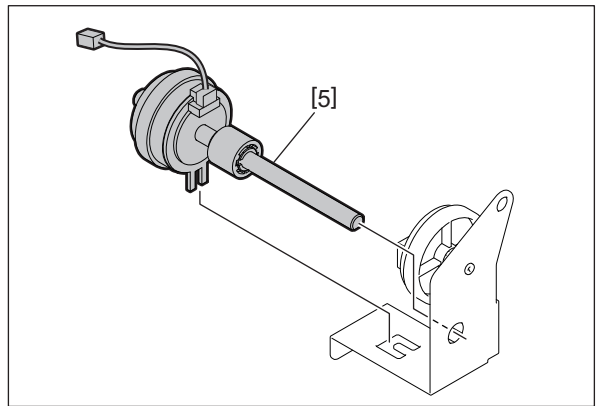

Fig. 4-44

**Notes:**

When installing, align the latch of the clutch to the groove of the bracket.

- (5) Remove the E-ring [6], spacer [7] and clutch [8].  
(6) Remove the harness [9].

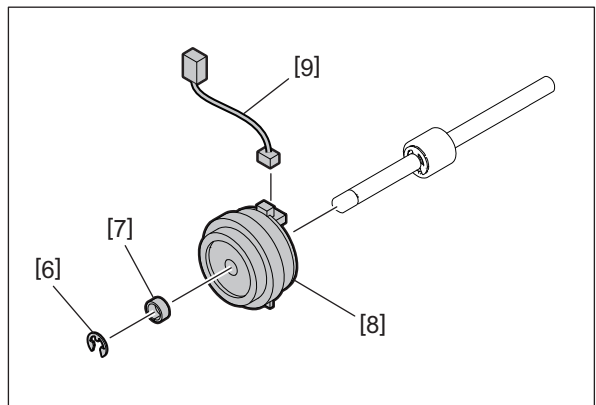

Fig. 4-45

## 4.5 Roller

### 4.5.1 Ex-LCF separation roller **PM**

- (1) Remove the paper feed unit.  
📖 P. 4-4 “4.2 Paper Feed Unit”
- (2) Remove 1 clip [2] and take off the Ex-LCF separation roller [1] while the shaft being pushed down.

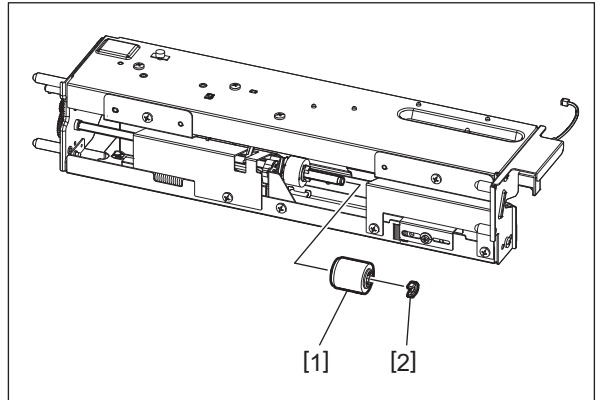

Fig. 4-46

#### Notes:

Be careful not to have the torque limiter come off of the shaft accidentally, as the torque limiter also becomes removable after the Ex-LCF separation roller has been removed.

### 4.5.2 Ex-LCF pickup roller **PM**

- (1) Remove the paper feed unit.  
📖 P. 4-4 “4.2 Paper Feed Unit”
- (2) Remove 1 clip [1] and take off the Ex-LCF pickup roller [2].

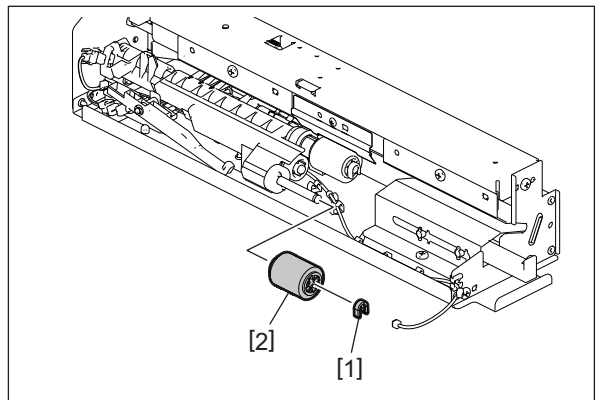

Fig. 4-47

#### Notes:

Be careful not to install the Ex-LCF pickup roller to the wrong position.



### 4.5.3 Ex-LCF paper feed roller **PM**

- (1) Remove the paper feed unit.  
P. 4-4 "4.2 Paper Feed Unit"
- (2) Remove 1 clip [1] and take off the Ex-LCF paper feed roller [2].

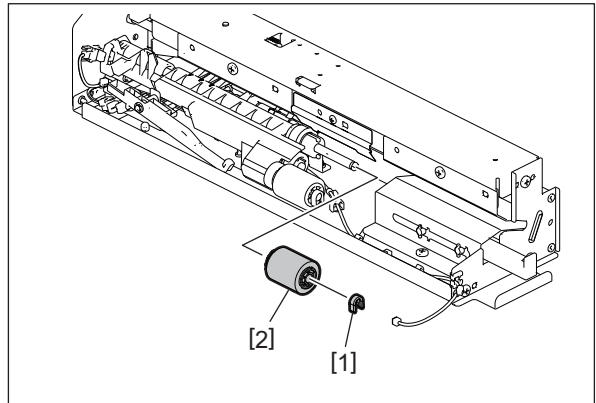

Fig. 4-48

### 4.5.4 Ex-LCF transport idling roller

- (1) Take off the transport unit.  
P. 4-5 "4.3 Transport Unit"
- (2) Remove 2 springs [4] and take off the Ex-LCF transport idling roller [1].
- (3) Remove 2 E-rings [2] and 2 bushings [3] from the Ex-LCF transport idling roller [1].

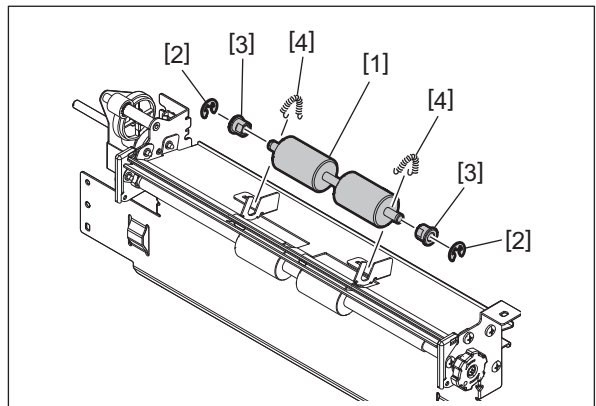

Fig. 4-49

### 4.5.5 Ex-LCF transport roller

- (1) Take off the transport unit.  
P. 4-5 "4.3 Transport Unit"
- (2) Remove 1 screw [1] and take off the handle [2].
- (3) Remove 1 clip [3], 1 gear [4], 1 collar [5], 1 pin [6] and 1 bushing [7].

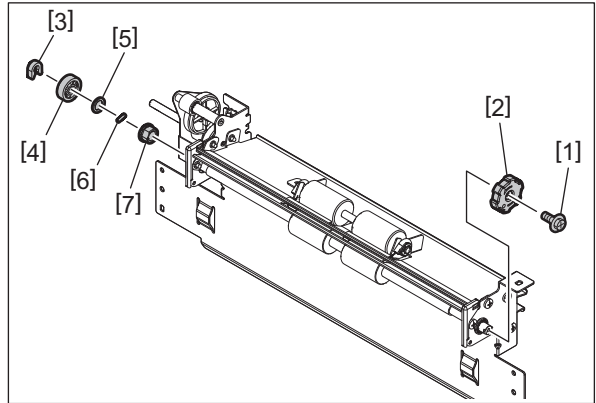

Fig. 4-50

- (4) Remove 1 bushing [8] and take off the Ex-LCF transport roller [9].

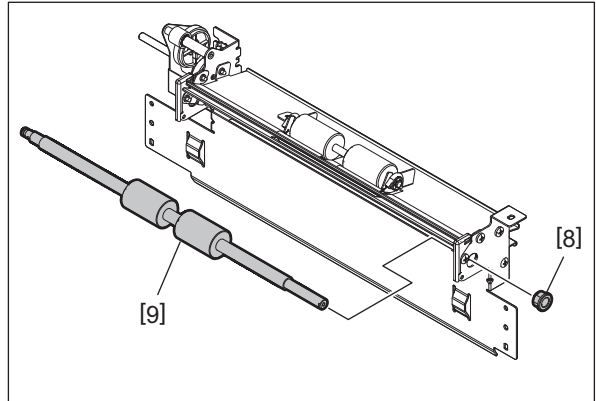

Fig. 4-51

## 4.6 Tray-up Driving Section

### 4.6.1 Pulley

- (1) Take off the Ex-LCF tray-up motor unit.  
☞ P. 4-6 “4.4.2 Ex-LCF tray motor (M2)”
- (2) Loosen 2 set screws [1]. Remove 1 stopper [2] and 1 ball bearing [3].
- (3) Remove 1 E-ring [4] and 1 ball bearing [5].
- (4) Remove the relay gear shaft [6] and belt [7].

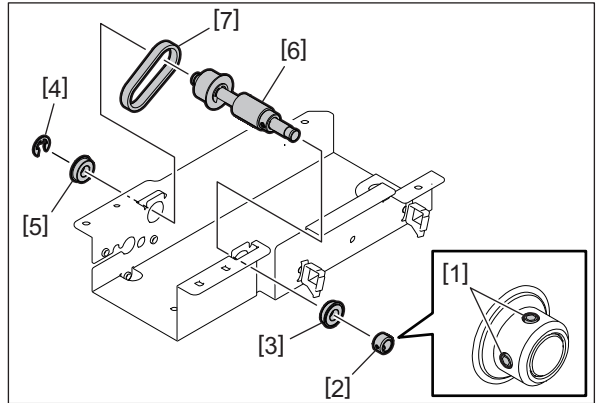

Fig. 4-52

- (5) Loosen the set screw [8] and remove the gear [9].
- (6) Remove 1 E-ring [10] and move the pulley [12] to the inside.
- (7) Remove the pin [11] and pulley [12].

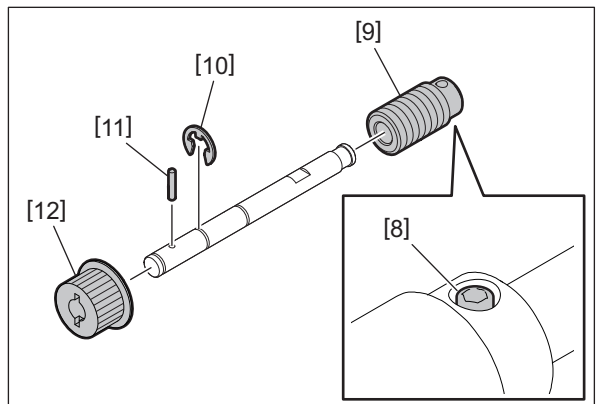

Fig. 4-53

## 4.6.2 Gear

- (1) Take off the Ex-LCF tray-up motor unit.  
📖 P. 4-6 “4.4.2 Ex-LCF tray motor (M2)”
- (2) Remove 2 E-rings [3] and the gears [4], [5].

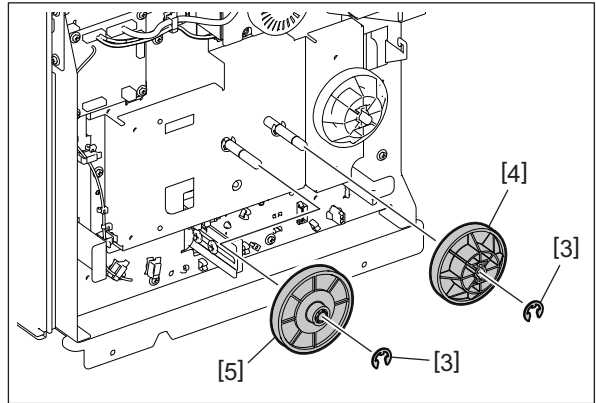

Fig. 4-54

## 4.6.3 Gear, Coupling

- (1) Take off the drive unit.  
📖 P. 4-8 “4.4.4 Ex-LCF tray sensor (S5)”
- (2) Take off the Ex-LCF tray-up motor unit and remove the bushing.  
📖 P. 4-6 “4.4.2 Ex-LCF tray motor (M2)”
- (3) Remove 2 gears.  
📖 P. 4-22 “4.6.2 Gear”
- (4) Push the coupling [1] and spring [2] in the direction of arrow [A]. Pull out the gear [3] in the direction of arrow [B] and remove the E-ring [4].

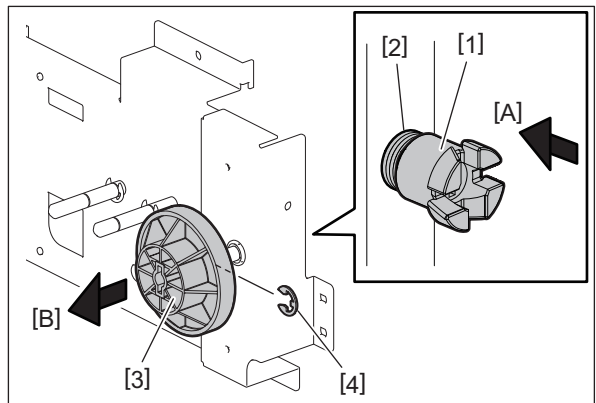

Fig. 4-55

- (5) With the coupling [1] and spring [2] pushed in the direction of arrow [A], push the gear [3] in the direction of arrow [B] and remove the pin [5] and then the gear [3].

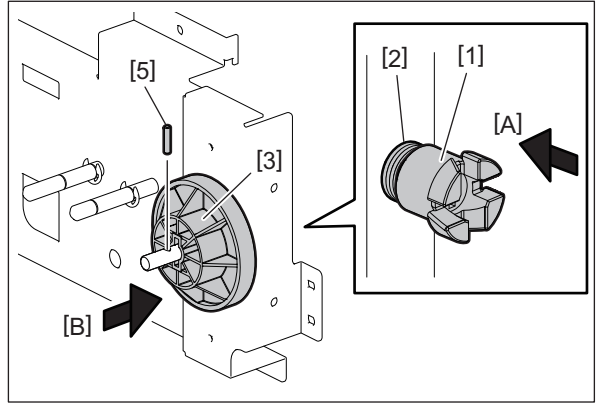

Fig. 4-56

- (6) Remove the shaft [6], pin [7], coupling [1], spring [2] and bushing [8].

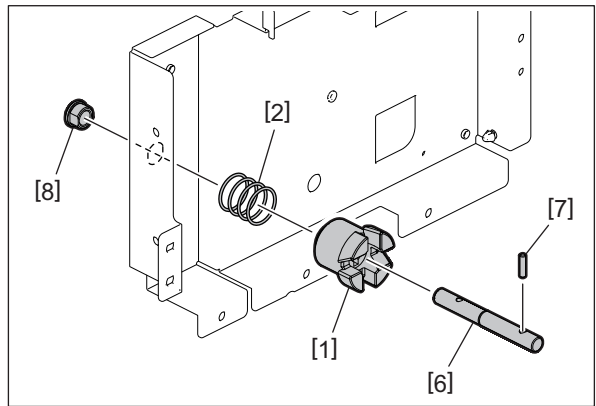

Fig. 4-57

**Notes:**

When installing, pay attention to the orientation of the shaft.

[C] Gear [3] side

[D] Coupling [1] side

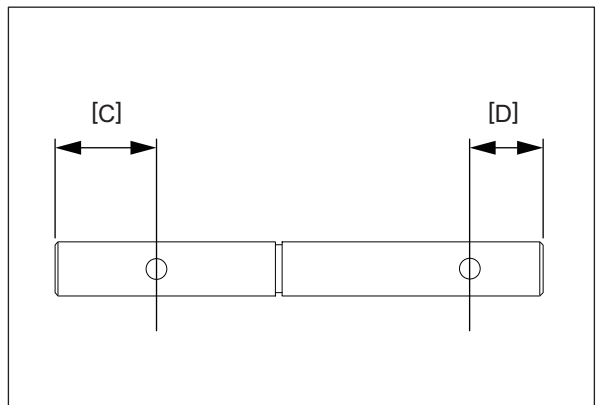

Fig. 4-58

## 4.7 Ex-LCF Transport Motor Driving Section

### 4.7.1 Gear, Pulley

- (1) Remove the Ex-LCF transport clutch.  
P. 4-16 “4.4.12 Ex-LCF transport clutch (CL1)”
- (2) Remove the E-ring [1] and gear [2].

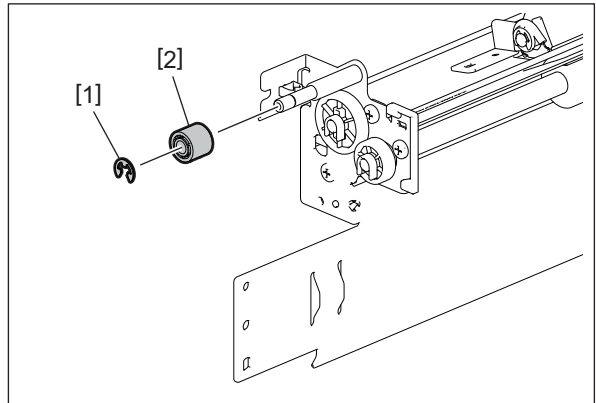

Fig. 4-59

- (3) Remove 1 clip [3] and the gear [4].

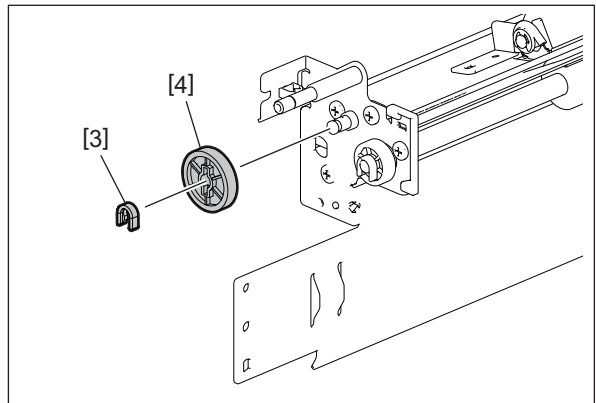

Fig. 4-60

- (4) Remove 1 clip [5], the gear [6] and pin [7].

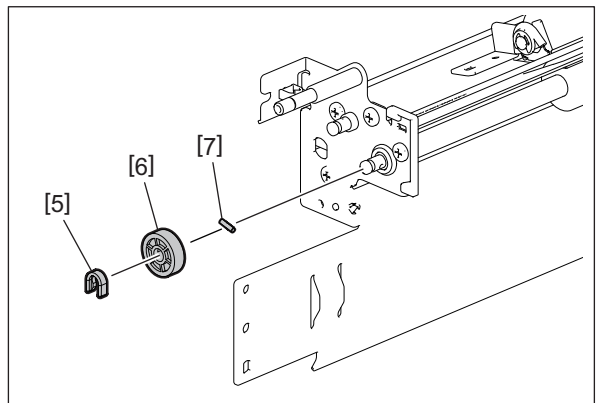

Fig. 4-61

## 4.8 Tray Unit Section

### 4.8.1 Tray unit

- (1) Take off the right stopper.  
📖 P. 4-31 “4.9.1 Right stopper”
- (2) Pull out the tray unit [1] completely.
- (3) Remove 4 screws [2] and take off the tray unit [1] by lifting it up.

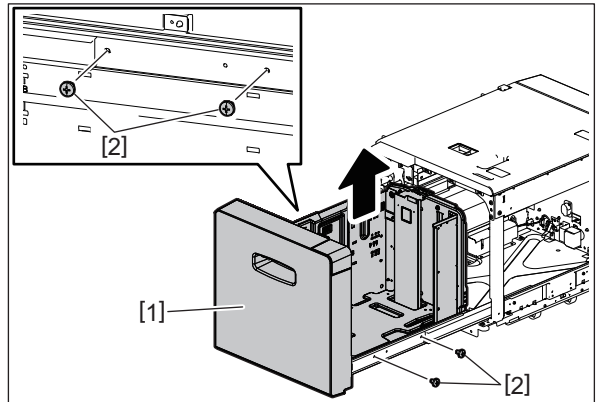

Fig. 4-62

### 4.8.2 Tray wire

- (1) Take off the tray unit.  
📖 P. 4-25 “4.8.1 Tray unit”
- (2) Take off the rear side guide.  
📖 P. 4-31 “4.9.2 Rear side guide”
- (3) Take off the front side guide.  
📖 P. 4-32 “4.9.3 Front side guide”
- (4) Take off the front cover.  
📖 P. 4-1 “4.1.1 Front cover”
- (5) Remove 1 screw. Remove the stopper plate [3], spring [4] and clip [5] from the front wire tensioner. (Same for the rear side)

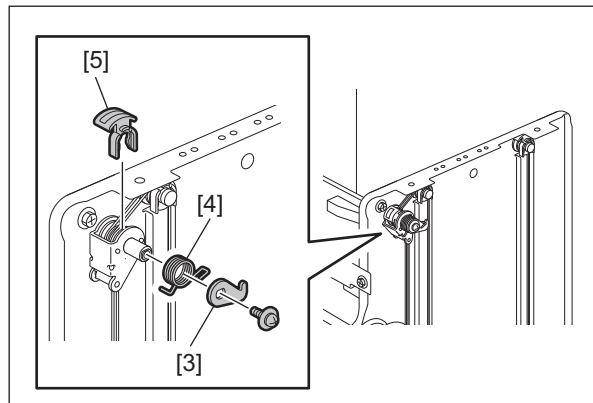

Fig. 4-63

#### Notes:

When installing the stopper plate, screw it shut after aligning the hole of the stopper plate with the shaft.

- (6) Remove 2 clips [5] and [6], 1 wire tensioner [7] and 2 pulleys [8]. (Same for the rear side)

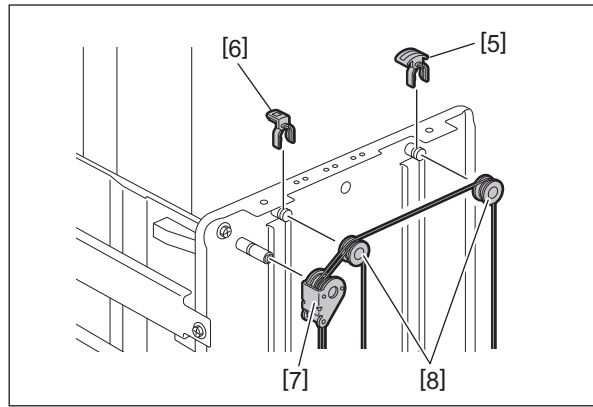

Fig. 4-64

**Notes:**

When installing the wire tensioner [7] and pulley [8], be sure to attach the long wire [a] and short wire [b] to them as shown in the figure.

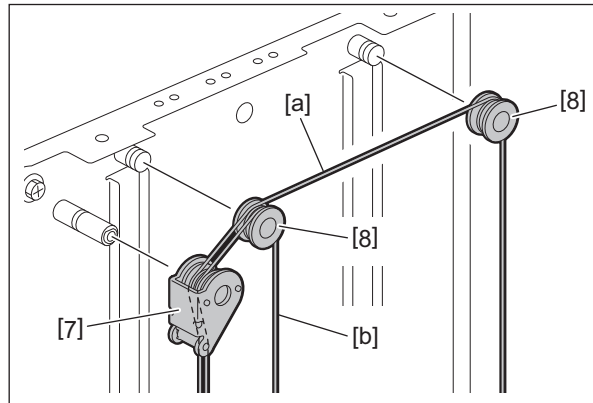

Fig. 4-65

- (7) Take off the tray [9].  
(8) Remove 4 wire stoppers [10] and then the wire [11].

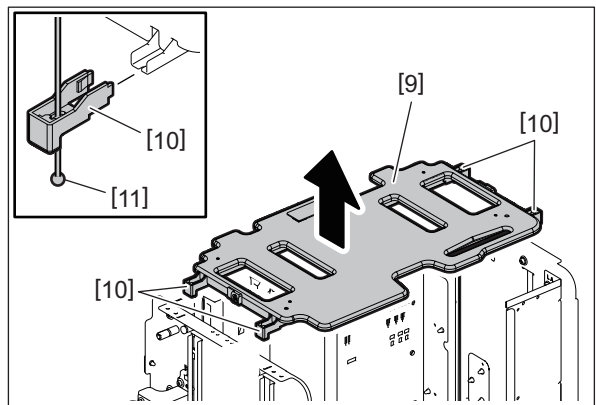

Fig. 4-66



- (9) Remove the wire clamps [12] from the wire tensioners on the front [A] and rear [B] sides.  
Long wire: a, Short wire: b

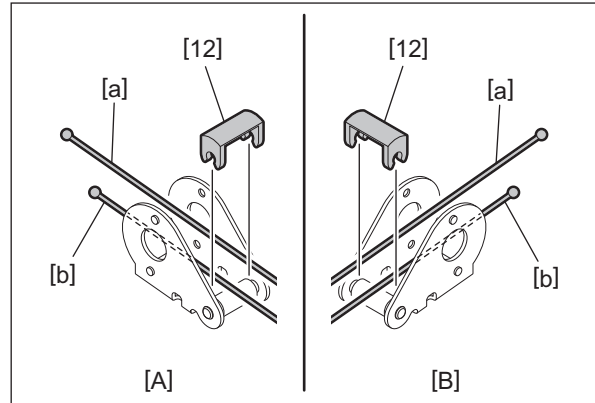

Fig. 4-67

**Notes:**

Pay attention to the wire position when installing the wire clamps.

- (10) Remove 2 screws and take off the bracket [13].

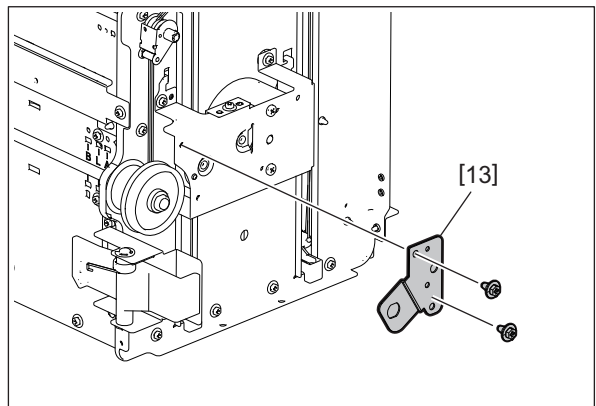

Fig. 4-68

- (11) Remove the bushing [14] and gear [15].

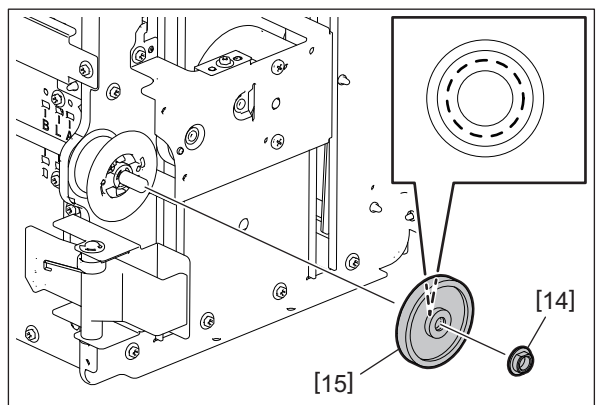

Fig. 4-69

**Notes:**

When the gear [15] is installed, the marking on it should be on the back side.

(12) Remove 5 screws and take off the brake unit [16].

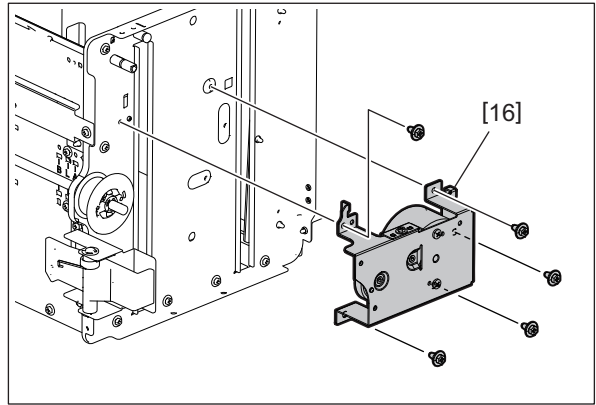

Fig. 4-70

(13) Remove the E-ring [17]. Remove the wire pulley [18], pin [19] and bushing [20] from the shaft.

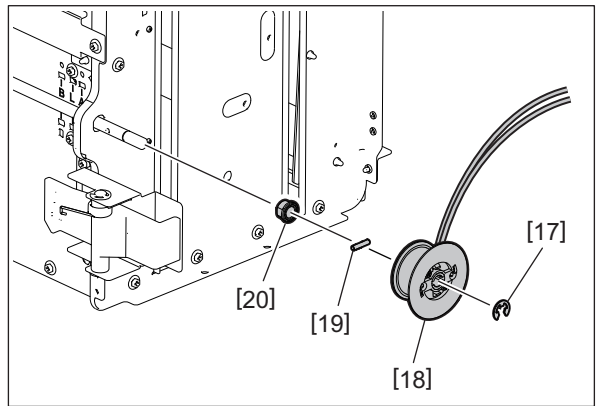

Fig. 4-71

(14) Remove 2 screws. Release 2 latches and remove the pulley flange [21].

(15) Remove the short wire [b] and then the long wire [a].

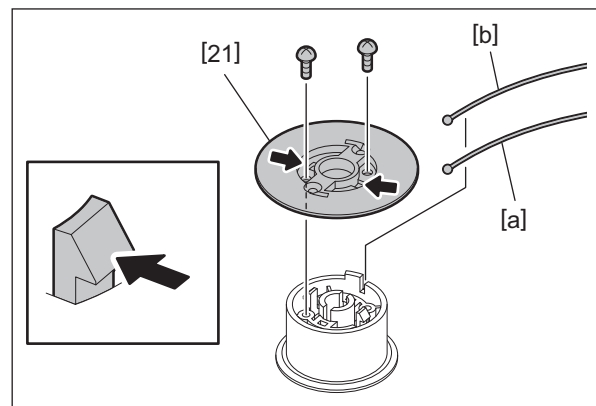

Fig. 4-72

**Notes:**

Pay attention to the wire installation order when installing the pulley flange.

(16) Take off the rear wire unit [22] and remove the bushing [23].

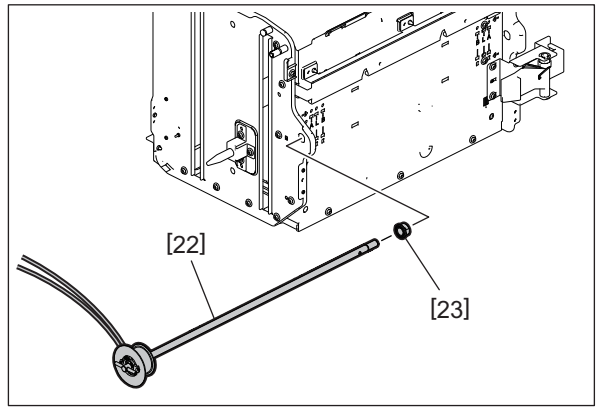

Fig. 4-73

(17) Remove the wire pulley [24] and pin [25] from the shaft.

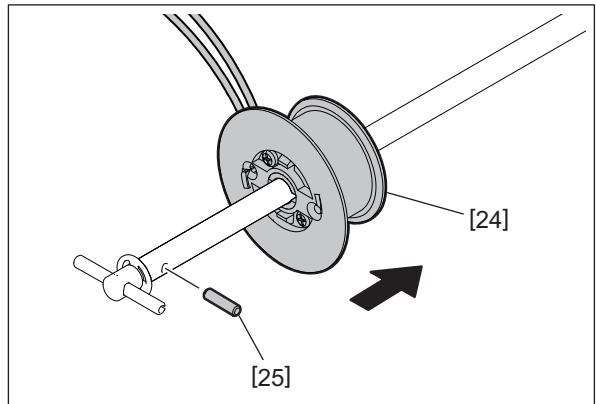

Fig. 4-74

(18) Remove 2 screws. Release 2 latches and remove the pulley flange [26].

(19) Remove the short wire [b] and then long wire [a].

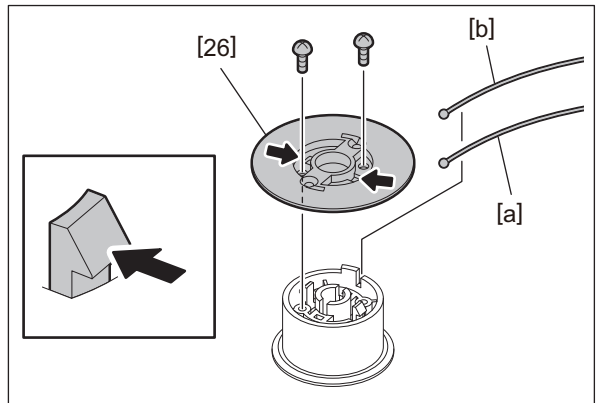
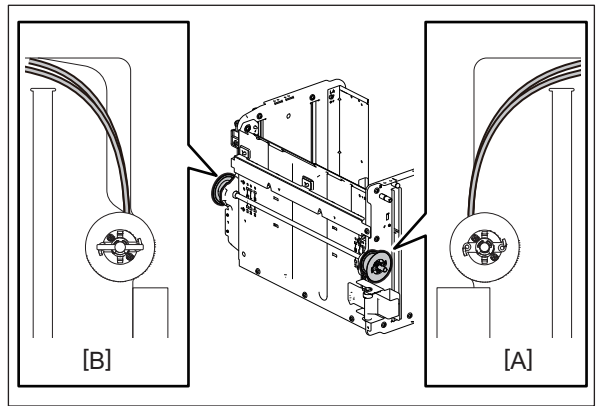

Fig. 4-75

**Notes:**

- Pay attention to the wire installation order when installing the pulley flange.
- When installing the wire unit, align the orientation of the wires on the front [A] and rear [B] sides.



**Fig. 4-76**

## 4.9 Paper Guide Setting

To change the paper size, arrange the installation position of the front and rear side guides and the end guide.

### 4.9.1 Right stopper

- (1) Take off the right cover.  
 P. 4-3 "4.1.4 Right cover"
- (2) Remove 1 screw [1] and the right stopper [2].

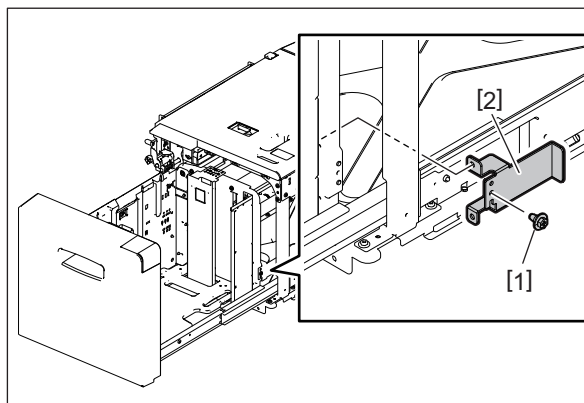

Fig. 4-77

### 4.9.2 Rear side guide

- (1) Pull out the tray unit.
- (2) Remove 2 screws [1]. Arrange the rear side guide [2] and secure it with the screws by adapting the groove and screw holes to the paper size to be matched.

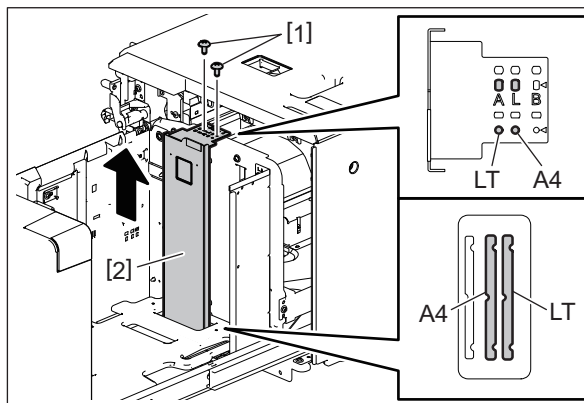

Fig. 4-78

### 4.9.3 Front side guide

- (1) Pull out the tray unit.
- (2) Remove 2 screws [1]. Arrange the front side guide [2] and secure it with the screws by adapting the groove and screw holes to the paper size to be matched.

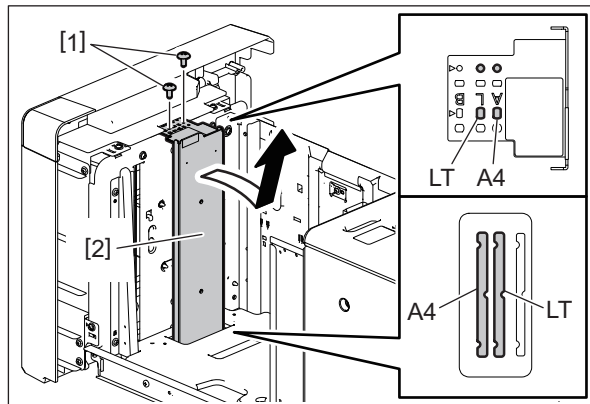

Fig. 4-79

### 4.9.4 End guide

- (1) Pull out the tray unit.
- (2) Remove 2 screws [2] of the end guide [1].

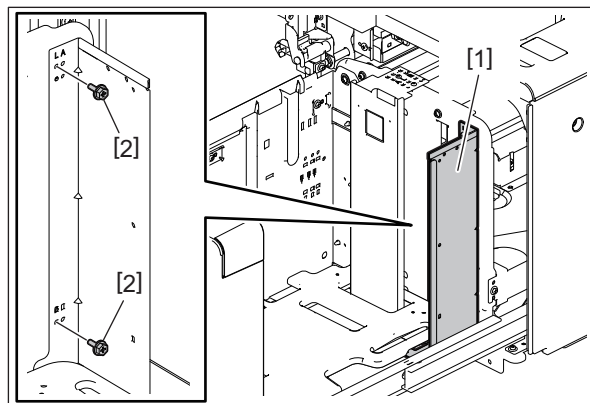

Fig. 4-80

- (3) Remove 2 screws [4] while lifting up the tray [3].

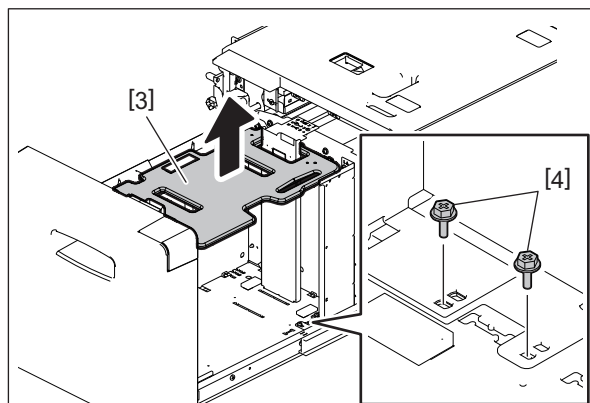

Fig. 4-81

- (4) Arrange the end guide [1] and secure it with screws by adapting the screw holes to the paper size to be matched.

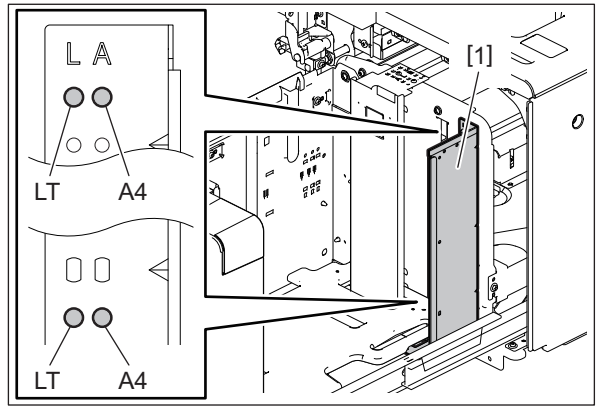

Fig. 4-82

- (5) While lifting up the tray [3], secure the screws to the screw holes matching the paper size.

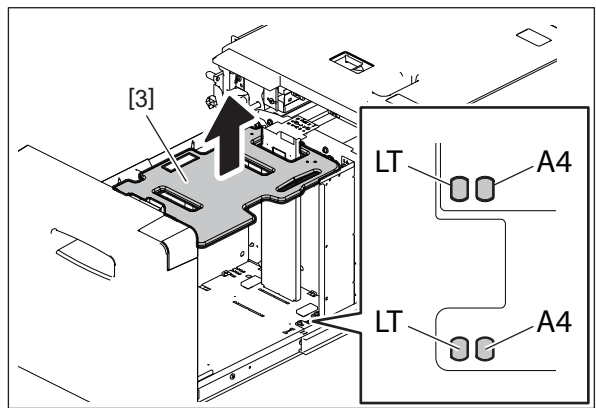

Fig. 4-83

## 4.9.5 Sub guides

- (1) Pull out the tray unit.
- (2) Remove 2 screws [1] and take off the sub guide [2].

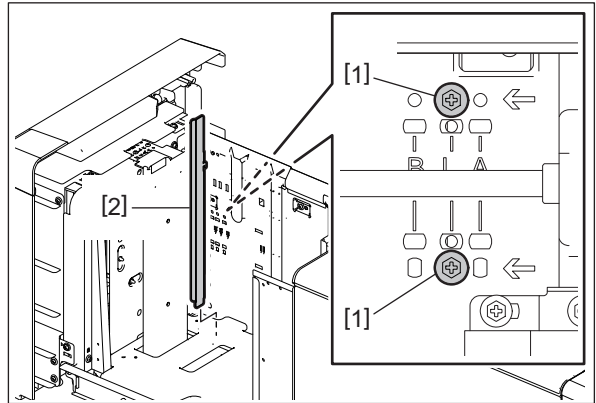

Fig. 4-84

- (3) Arrange the sub guide [2] and secure it with screws by adapting the screw holes to the paper size to be matched.

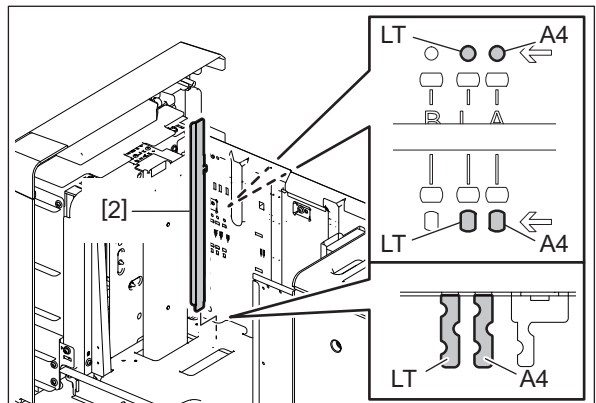

Fig. 4-85



## 5. ADJUSTMENT

### 5.1 Sideways adjustment

When the center of the printed image shifts to the front or rear side, perform the adjustment using the following procedure.

- (1) Pull out the tray unit.
- (2) Loosen 4 screws [1]. Move the adjustment plate [2] to the position to be adjusted and tighten it with the screws.

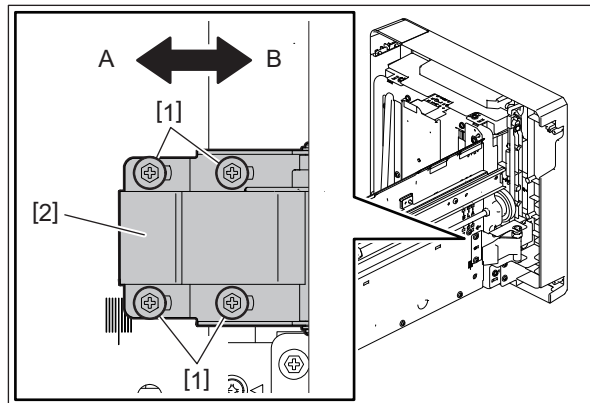

Fig.5-1

- When the center of the printed image shifts to the front side [D], move the adjustment plate [2] to the direction B.

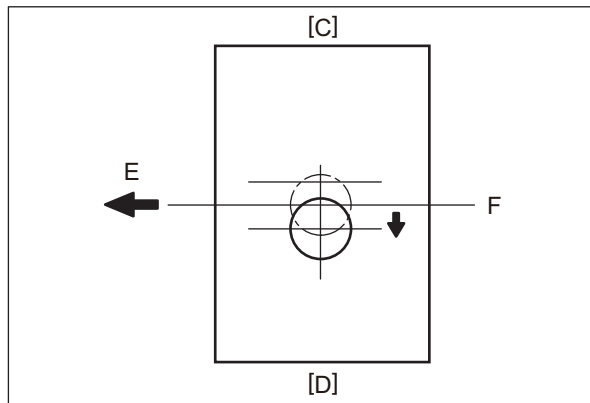

Fig.5-2

- C: Rear side
- D: Front side
- E: Paper feeding direction
- F: Center

- When the center of the printed image shifts to the rear side [C], move the adjustment plate [2] to the direction A.

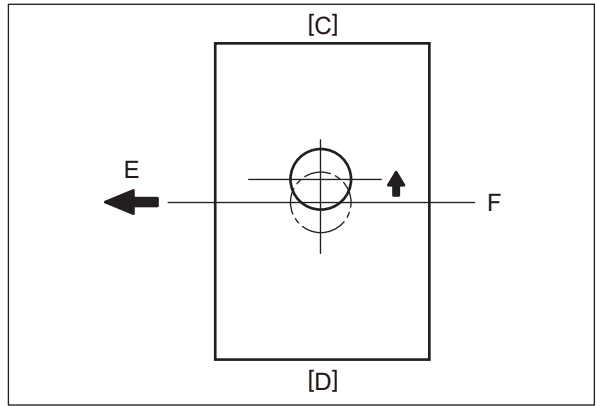

Fig.5-3

C: Rear side  
 D: Front side  
 E: Paper feeding direction  
 F: Center

**Notes:**

- After the tray position adjustment, readjust the front cover [3] position.

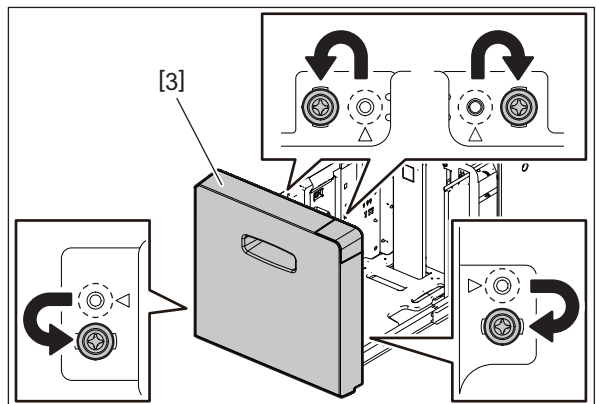

Fig.5-4

- For adjustment, remove the 4 screws of the front cover and attach them to the oblong holes. Then adjust the gap [G] between the front cover [3] and top cover [4], and the front cover [3] and right cover [5] to 3 mm, respectively.

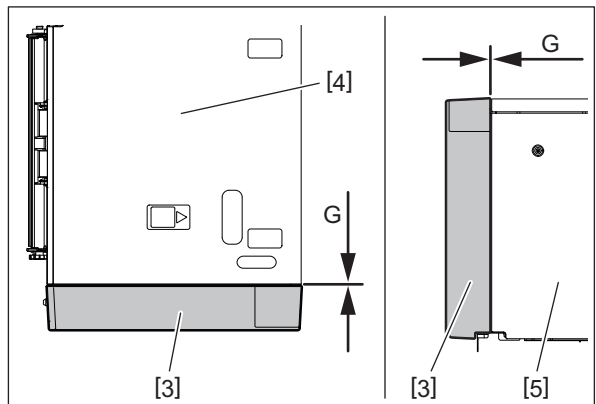

Fig.5-5

## 5.2 Tilted volume adjustment

When the Ex-LCF is tilted, perform the adjustment using the following procedure.

- (1) Separate the Ex-LCF from the MFP.
- (2) Turn the screws to adjust the stoppers.  
Turn to the right: Stoppers move downward.  
Turn to the left: Stoppers move upward.

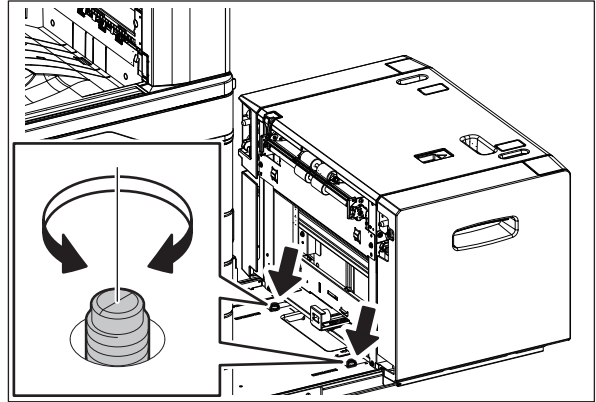

Fig.5-6

### Notes:

When the MPF needs to be moved, be sure to move the stoppers upward.

### 5.3 Ex-LCF separation roller pressure force adjustment

The life of the Ex-LCF separation roller may be shortened or paper misfeeding or multiple feeding (EB50) may occur regardless of the operation frequency of this option. This comes from the weight or edge status of the paper used and the amount of paper dust. Generally, paper misfeeding and multiple feeding often occur as the life end of the Ex-LCF separation roller approaches. However, if they often occur even though its life has not yet reached its replacement timing, or if the life end comes much earlier than the scheduled replacement timing, the paper misfeeding and multiple feeding can be suppressed by adjusting the pressure force of the Ex-LCF separation roller.

In this method, however, when its life becomes longer, paper misfeeding and multiple feeding may occur frequently, and when they are suppressed, its life may become shorter. Therefore, perform this adjustment while checking the status carefully. If necessary, give sufficient explanation to the users.

- (1) Pull out the tray unit.
- (2) Pull out the transport unit.
- (3) Check that the screw is tightened in the oblong hole.
- (4) If it is tightened in the round hole, remove it and temporarily tighten it in the neighboring oblong hole.

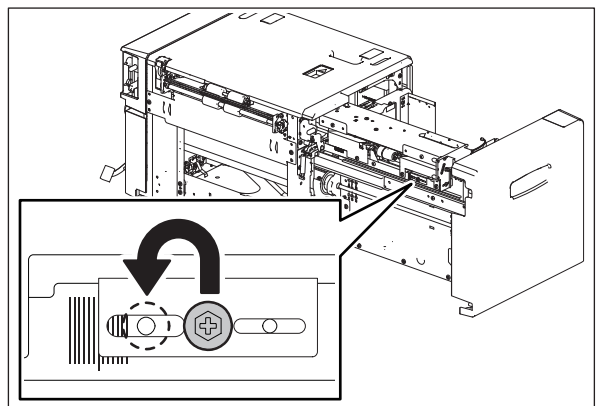

Fig.5-7

**Notes:**

Make a mark for the installation position of the bracket in advance.

- (5) Move the bracket.  
Move to the direction A: The roller life will become longer (but multiple feeding may occur frequently).  
Move to the direction B: Multiple feeding will be suppressed (but the roller life may become shorter).

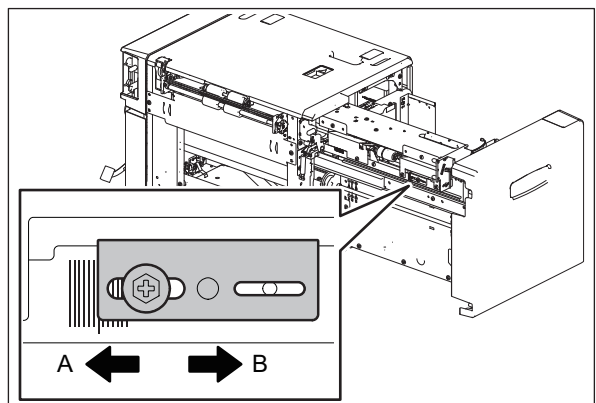

Fig.5-8

**Notes:**

The recommended moving distance of the bracket is within 1 or 2 scale marks.

## 6. PERIODIC MAINTENANCE

Symbols used in the checklist

Cleaning	Coating	Replacement
A: Clean with alcohol B: Clean with a soft pad, cloth or vacuum cleaner	W1: White grease (Molykote)	The number of sheet for the replacement is described in the value. Replacement should be performed by every number of the value x 1,000. R: Replace if deformed or damaged.

Preventive Maintenance Checklist

Item	Cleaning	Coating	Replacement x1,000	P-I
Ex-LCF pickup roller	A		500	4-18
Ex-LCF paper feed roller	A		500	4-9
Ex-LCF separation roller	A		500	4-37
Drive gear (tooth face)		W		
Paper transport section *	B			4-40
Sensor section	B			

### Notes:

- Perform preventive maintenance in accordance with the checklist.
- Perform preventive maintenance at the same intervals as for the MFP to which this option is connected.
- Be careful not to put oil on the rollers, belts and belt pulleys when lubricating.
- Remove the Ex-LCF paper feed roller from the paper feed unit. Remove any paper dust on the film section [A]. \*

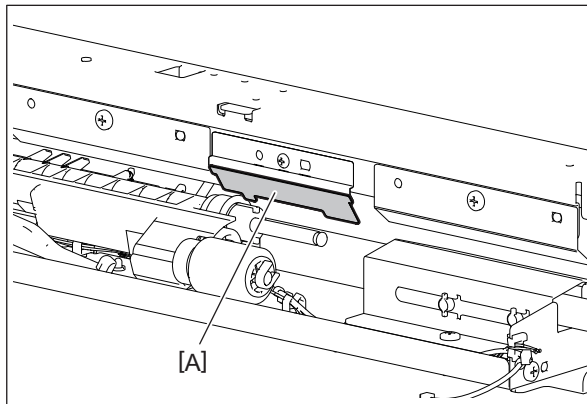
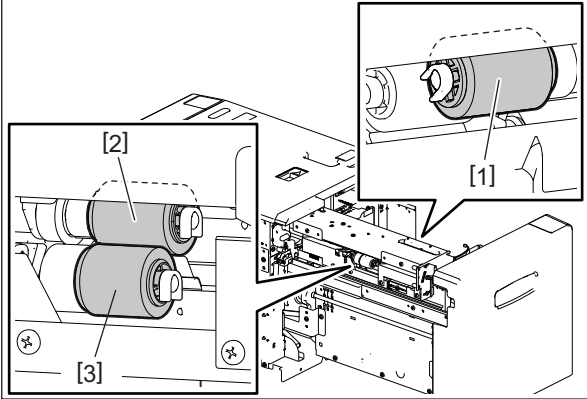

Fig.6-1

**Remarks:**

If there is too much paper dust found during preventive maintenance, clean the EX-LCF pickup roller [1], Ex-LCF paper feed roller [2] and Ex-LCF separation roller [3].



**Fig.6-2**

# 7. ELECTRIC CIRCUIT

## 7.1 Harness Diagram

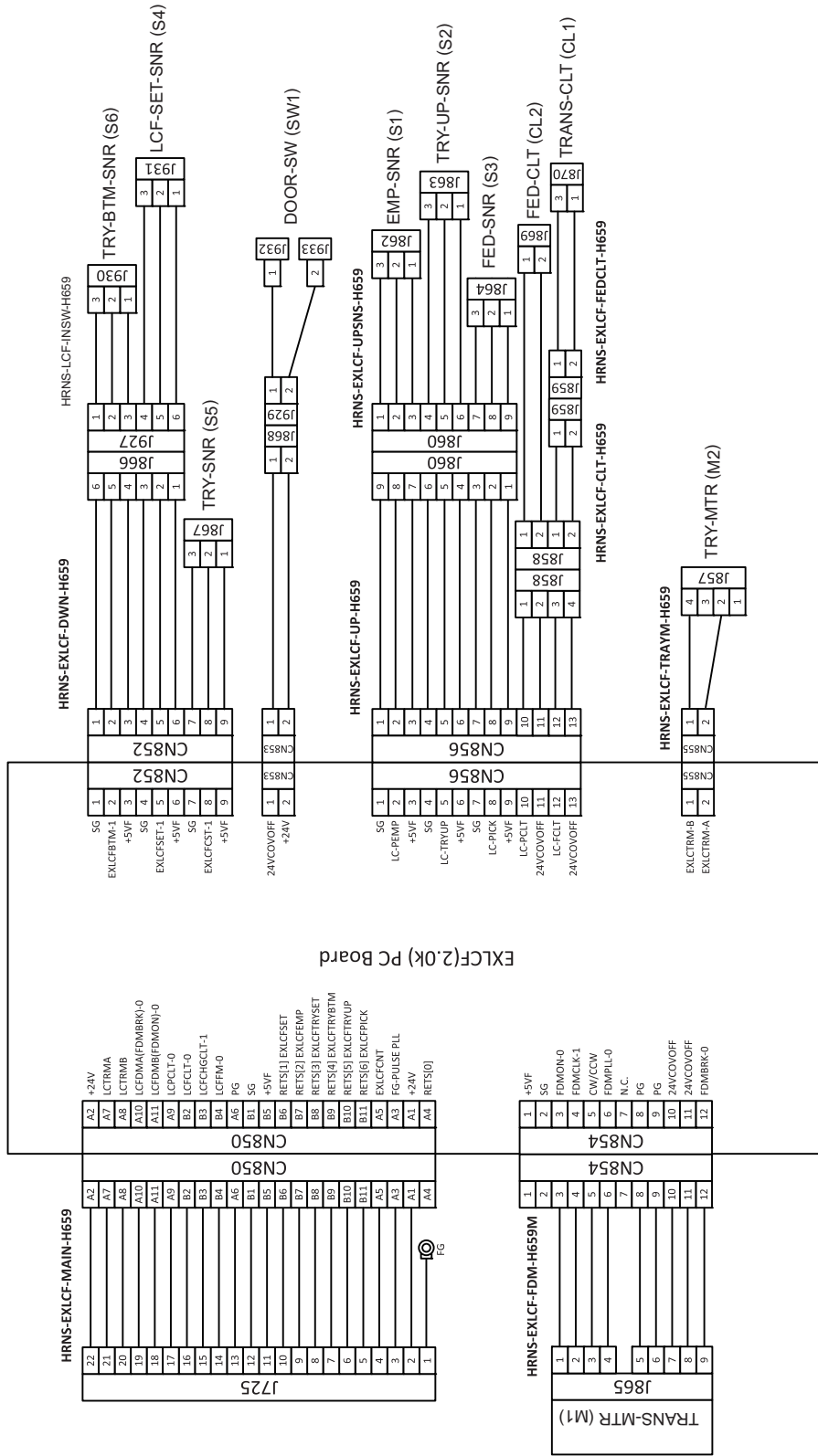

Fig. 7-1





# REVISION RECORD

Ver.00

Ver.00 <2021/12/22>	
Page	Contents
	Initial release





**TOSHIBA**

**Toshiba Tec Corporation**

1-11-1, OSAKI, SHINAGAWA-KU, TOKYO, 141-8562, JAPAN