

# TOSHIBA

# SERVICE MANUAL

## HOLE PUNCH UNIT

# MJ-6107

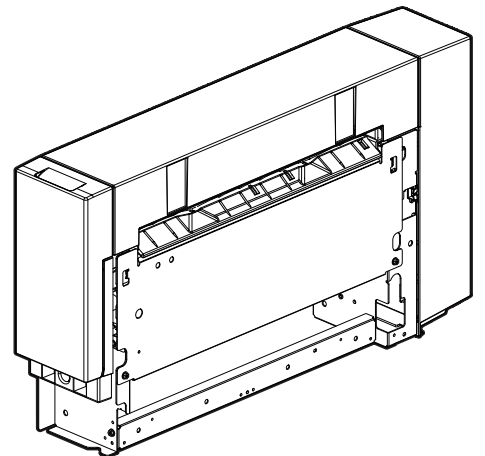

Model: MJ-6107  
Publish Date: December 2021  
File No. SME21003300  
R210221X3700-TTEC  
Ver00 F1 2022-03

## Trademarks

- MOLYKOTE® is a trademark of DDP SPECIALTY ELECTRONIC MATERIALS US, INC..
- Other company names and product names in this manual are the trademarks of their respective companies.

© 2021, 2022 Toshiba Tec Corporation All rights reserved

Under the copyright laws, this manual cannot be reproduced in any form without the prior written permission of Toshiba Tec Corporation.

# General Precautions for Installation, Servicing and Maintenance for this Option

**The installation and service shall be done by a qualified service technician.**

1. When installing this option to the MFP, be sure to follow the instructions described in the "Unpacking/Set-Up Procedure for the Equipment" booklet which comes with this option.
2. This option shall be installed by an authorized or qualified person.
3. This option weighs approx. 7 kg(15.43 lb), therefore pay full attention when handling it.
4. Before starting installation, servicing or maintenance work, be sure unplug the power cable of the MFP first.
5. The MFP with this option connected shall be installed near the socket outlet and shall be easily accessible.
6. Be sure to fix and plug in the power cable securely after the installation so that no one trips over it.
7. When selecting the installation site, avoid placing the Finisher with Hole Punch Unit and MFP on different levels or inclined floors.
8. When servicing or maintaining the MFP with this option connected, be careful about the rotating or operating sections such as gears, pulleys, sprockets, cams, belts, etc.
9. When the parts of this option are disassembled, reassembly is the reverse of disassembly unless otherwise noted in this manual or other related documents.  
Be careful not to install small parts such as screws, washers, pins, E-rings, star washers, harnesses in the wrong places.
10. Basically, the MFP with this option connected should not be operated with any parts removed or disassembled.
11. When servicing the MFP with this option connected while the power is turned ON, be sure not to touch live sections and rotating/operating sections.
12. Delicate parts for preventing safety hazard problems (such as fuses, thermofuses, door switches, sensors, etc. if any) should be handled, installed and adjusted correctly.
13. Tools and instruments
  - Use designated jigs and tools.
  - Use recommended measuring instruments or equivalents.
14. During servicing or maintenance work, be sure to check the nameplate and other cautionary labels (if any) to see if they are clean and firmly stuck. If not, take appropriate actions.
15. The ICs on the PC boards tend to be damaged by static electricity. Therefore, the PC boards must be stored in an anti-electrostatic bag and handled carefully using a wristband.  
Before using the antistatic wrist strap, unplug the power cable of the MFP and make sure that there are no charged objects which are not insulated in the vicinity.
16. Regarding the recovery and disposal of the MFP with this option connected, supplies, packing materials, follow the relevant local regulations or rules.

17. Return the MFP with this option connected to the original state and check the operation when the service is finished.

18. When you move the Finisher, do not move it in the direction of the arrow as shown in the figure below. Otherwise it might topple over.

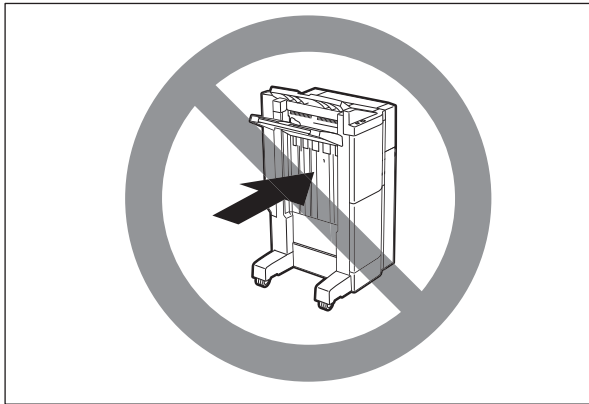

19. Unplug the power cable and clean the area around the prongs of the plug and socket outlet once a year or more. A fire may occur when dust lies on this area.

20. Check the procedures and perform them as described in the Service Manual.

21. Make sure you do not lose your balance.

22. Avoid exposure to your skin and wear protective gloves as needed.

23. Do not leave plastic bags where children can get at them. This may cause an accident such as suffocation if a child puts his/her head into a bag. Plastic bags of options or service parts must be brought back.

# CONTENTS

<b>1. SPECIFICATIONS</b>	<b>1-1</b>
<b>2. OVERVIEW</b>	<b>2-1</b>
2.1 Main Components	2-1
2.2 Sectional View	2-2
2.3 Electric Parts Layout	2-3
2.4 Symbols and Functions of Various Components	2-4
2.4.1 Motor	2-4
2.4.2 Sensor	2-4
2.4.3 PC Board	2-4
2.5 Signal Block Diagram	2-5
2.6 Interface Signals	2-6
<b>3. OPERATION DESCRIPTION</b>	<b>3-1</b>
3.1 Basic Operations	3-1
3.1.1 Overview	3-1
3.1.2 Basic Operations	3-1
3.2 Punching Position Alignment Operation	3-2
3.2.1 Sideways deviation adjustment	3-2
3.2.2 Skew adjustment	3-3
3.3 Punching Operation	3-4
3.4 Transport Operation	3-8
3.5 Punched Wastes Detection	3-9
<b>4. DISASSEMBLY AND REASSEMBLY</b>	<b>4-1</b>
4.1 Cover	4-1
4.1.1 Front bottom cover	4-1
4.1.2 Rear bottom cover	4-1
4.1.3 Rear cover	4-2
4.1.4 Front cover	4-2
4.1.5 Top cover	4-3
4.1.6 Right cover	4-3
4.2 Motor	4-4
4.2.1 Skew adjustment motor (M1)	4-4
4.2.2 Sideways adjustment motor (M2)	4-5
4.2.3 Punch motor (M3)	4-6
4.2.4 Transport motor (M4)	4-6
4.3 Punching unit	4-8
4.4 Sensor and switch	4-10
4.4.1 Front cover sensor (S1)	4-10
4.4.2 Skew home position sensor (S2)	4-10
4.4.3 Sideways deviation home position sensor (S3)	4-11
4.4.4 Punch home position sensor (S4)	4-12
4.4.5 Punching sensor (S5)	4-12
4.4.6 Skew sensor (SEN) (S7-2)	4-13
4.4.7 Skew sensor (LED) (S7-1)	4-13
4.4.8 Paper position sensor (SEN) (S6-2)	4-14
4.4.9 Paper position sensor (LED) (S6-1)	4-15
4.4.10 Punch waste full sensor (SEN) (S8-2)	4-15
4.4.11 Punch waste full sensor (LED) (S8-1)	4-16
4.5 PC board	4-16
4.5.1 Hole punch control PC board (HP)	4-16
4.6 Roller	4-18
4.6.1 Transport roller	4-18
<b>5. ADJUSTMENT</b>	<b>5-1</b>
5.1 Stopping Position Adjustment	5-1

5.1.1	Adjustment with the self-diagnostic code.....	5-1
5.1.2	Adjustment with the DIP-SW .....	5-1
<b>6.</b>	<b>TROUBLESHOOTING .....</b>	<b>6-1</b>
<b>7.</b>	<b>MAINTENANCE .....</b>	<b>7-1</b>
7.1	Maintenance and Inspection Points .....	7-1
7.1.1	Symbols used in the checklist.....	7-1
7.1.2	Preventive Maintenance Checklist.....	7-1
7.2	Firmware Updating.....	7-1
<b>8.</b>	<b>ELECTRIC CIRCUIT .....</b>	<b>8-1</b>
8.1	Harness Diagram .....	8-1
	<b>REVISION RECORD.....</b>	<b>1</b>

# 1. SPECIFICATIONS

Item	Contents		Remarks
1. Destination	E	2 holes	Europe, Japan
	N	2 holes and 3 holes automatically switched	North America
	F	4 holes	France
	S	4 holes	Sweden
2. Punching method	Sequential punching		
3. Hole position correction system	Provided		
4. Paper size	E	A3, A4, A4-R, B4, B5, B5-R, FOLIO, LD, LG, LT, LT-R, COMPUTER, 13"LG, 8.5"SQ, 8K, 16K, 16K-R	Reused paper is not available.
	N	2 holes: A4-R, B4, B5, B5-R, FOLIO, LG, LT-R, COMPUTER, 16K-R	
		3 holes: A3, A4, LD, LT, 8K, 16K	
	F	A3, A4, LD, LT, 8K, 16K	
S	A3, A4, A4-R, B4, B5, B5-R, FOLIO, LD, LG, LT, LT-R, COMPUTER, 13"LG, 8.5"SQ, 8K, 16K, 16K-R		
5. Paper weight	52 g/m <sup>2</sup> to 300 g/m <sup>2</sup> (14 lb. Bond to 110 lb. Cover)		Acceptable paper weight for hole punching: 60 g/m <sup>2</sup> to 256 g/m <sup>2</sup> (16 lb. Bond to 94.5 lb. Cover) * Reused paper is not available.
6. Punched hole diameter	E	φ6.5 mm (φ0.256 in.)	
	N	φ8.0 mm (φ0.315 in.)	
	F	φ6.5 mm (φ0.256 in.)	
	S	φ6.5 mm (φ0.256 in.)	
7. Punch waste container capacity	E	Approx. 5,000 sheets	64 g/m <sup>2</sup> (17 lb. Bond) or equivalent
	N	Approx. 3,000 sheets	75 g/m <sup>2</sup> (20 lb. Bond) or equivalent
	F	Approx. 5,000 sheets	80 g/m <sup>2</sup> (21.3 lb. Bond) or equivalent
	S	Approx. 5,000 sheets	80 g/m <sup>2</sup> (21.3 lb. Bond) or equivalent
8. Dimensions	112 (W) x 573 (D) x 323 (H) mm		Front and rear bottom covers not included
9. Weight	Approx. 7 kg		
10. Power supply	DC 24 V +10/-5 % DC 5.1 V ±4 %		Supplied from the Finisher
11. Accessories	Front bottom cover (1 pc.) Front bottom cover fixing bracket (1 pc.) Rear bottom cover (1 pc.) Rear bottom cover fixing bracket (1 pc.) Screw M4 x 8 (2 pcs.) Unpacking/Setup Instructions (1 set)		

## 12. Hole position

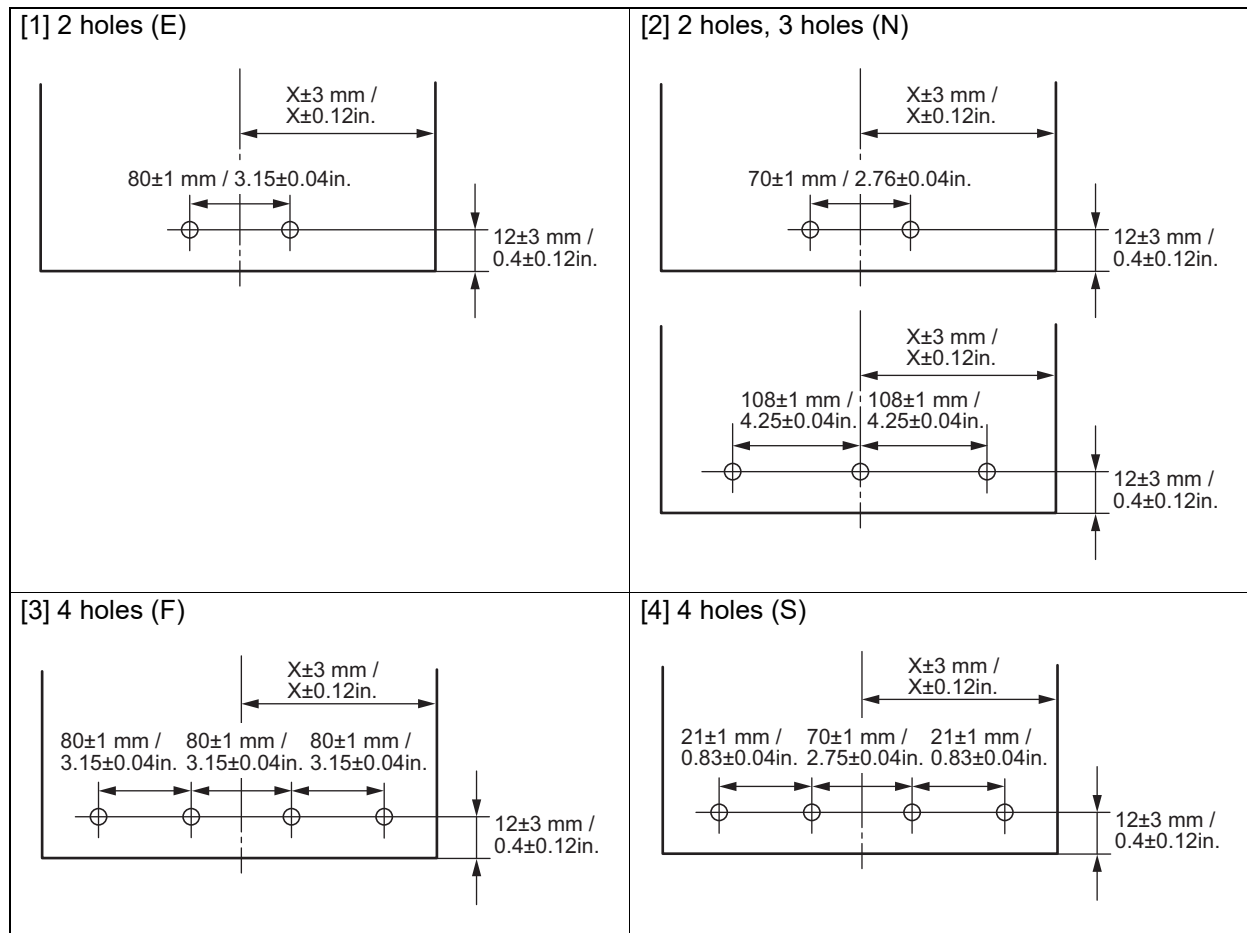

X:

A3, A4	148.5 mm / 5.846 in.
B4, B5	128.5 mm / 5.06 in.
A4-R, FOLIO	105 mm / 4.13 in.
B5-R	91 mm / 3.58 in.
LD, LT	139.5 mm / 5.5 in.
LG, LT-R, 13"LG, 8.5"SQ	108 mm / 4.25 in.
COMPUTER	128.5 mm / 5.06 in.
8K, 16K	135 mm / 5.31 in.
16K-R	97.5 mm / 3.84 in.



## 2. OVERVIEW

### 2.1 Main Components

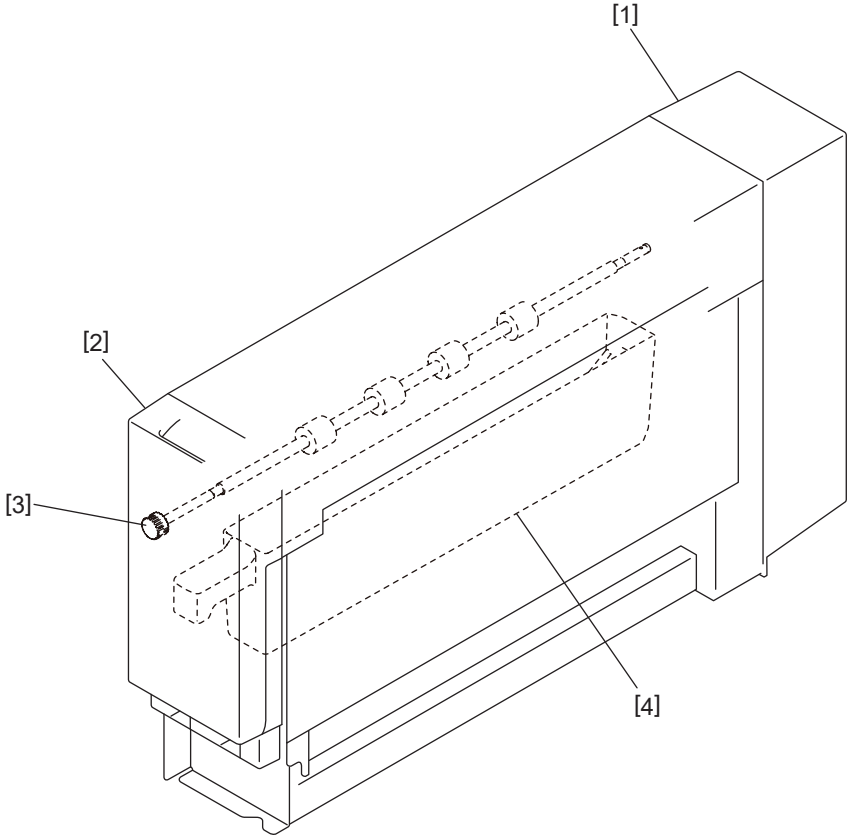
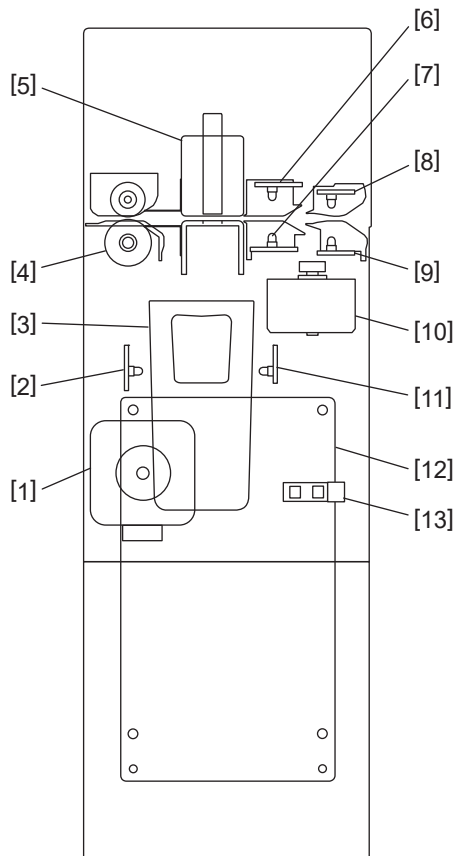

Fig. 2-1

1	Rear cover
2	Front cover
3	Jam access lever
4	Punch waste case

## 2.2 Sectional View



**Fig. 2-2**

1	Transport motor
2	Punch waste full sensor (SEN)
3	Punch waste case
4	Transport roller
5	Punching unit
6	Paper position sensor (SEN)
7	Paper position sensor (LED)
8	Skew sensor (SEN)
9	Skew sensor (LED)
10	Sideways adjustment motor
11	Punch waste full sensor (LED)
12	Hole punch control PC board (PNC board)
13	Front cover sensor

# 2.3 Electric Parts Layout

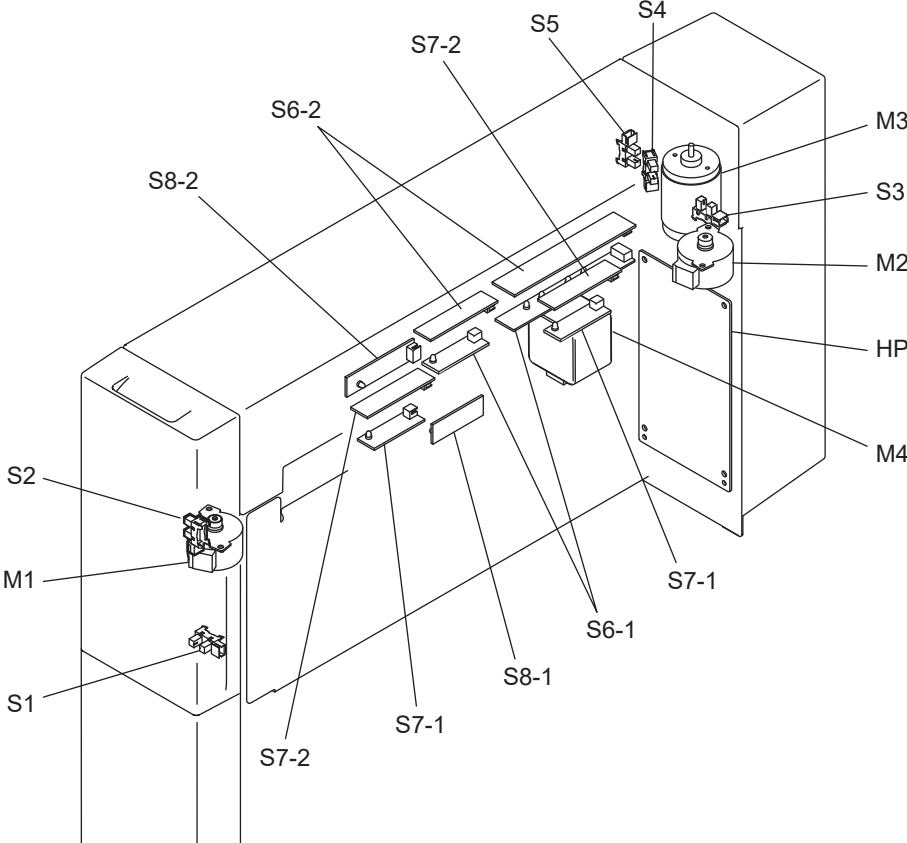

Fig. 2-3

## 2.4 Symbols and Functions of Various Components

The column “P-I” shows the page and item number in the parts list.

### 2.4.1 Motor

Symbol	Name	Function	P-I	Remarks
M1	Skew adjustment motor	Adjusts the punch hole position according to the skew of paper.	1-19	
M2	Sideways adjustment motor	Adjusts the punch hole position according to the sideways deviation of paper.	1-19	
M3	Punch motor	Drives the punch head to punch holes on paper.	3-17	
M4	Transport motor	Transports paper to the Finisher.	1-1	

### 2.4.2 Sensor

Symbol	Name	Function	P-I	Remarks
S1	Front cover sensor	Detects the opening and closing status of the front cover.	1-107	
S2	Skew home position sensor	Detects the home position of the punching unit when skew is adjusted.	1-107	
S3	Sideways deviation home position sensor	Detects the home position of the punching unit when sideways is adjusted.	1-107	
S4	Punch home position sensor	Detects the home position of the punch head.	3-105	
S5	Punching sensor	Detects the timing for braking the punch motor.	3-105	
S6-1	Paper position sensor (LED)	Detects the leading, side and trailing edges of the paper. (Light emitting part)	3-13 3-24	
S6-2	Paper position sensor (SEN)	Detects the leading, side and trailing edges of the paper. (Light sensing part)	3-10 3-23	
S7-1	Skew sensor (LED)	Detects the skew of the paper. (Light emitting part)	1-13	
S7-2	Skew sensor (SEN)	Detects the skew of the paper. (Light sensing part)	1-16	
S8-1	Punch waste full sensor (LED)	Detects the punch waste full state. (Light emitting part)	1-23	
S8-2	Punch waste full sensor (SEN)	Detects the punch waste full state. (Light sensing part)	1-24	

### 2.4.3 PC Board

Symbol	Name	Function	P-I	Remarks
HP	Hole punch control PC board (PNC board)	Controls the Hole Punch Unit.	2-14	

## 2.5 Signal Block Diagram

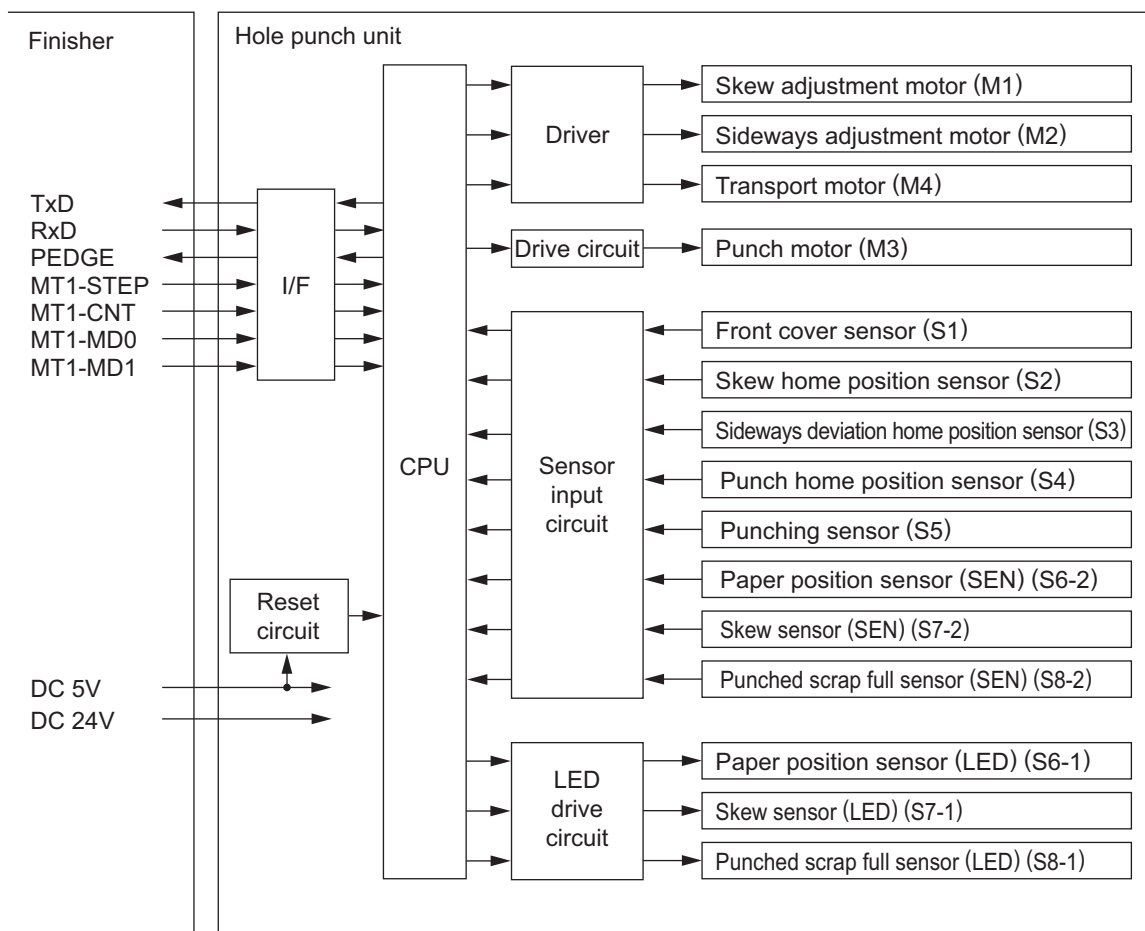

Fig. 2-4

## 2.6 Interface Signals

The Hole Punch Unit operates when a control signal from the Finisher is received. The 2 lines; TxD and RxD are used to transmit and receive signals between the Hole Punch Unit and the Finisher. Also, control signals which are used to drive the motor and detection signals of the Hole Punch Unit are connected.

- TXD: Sent data (transmitted from the Hole Punch Unit to the Finisher)
- RXD: Received data (transmitted from the Finisher to the Hole Punch Unit)
- TRMT-STEP: Transport motor drive pulse signal (from the Finisher to the Hole Punch Unit)
- TRMT-CUR: Transport motor electric current setting signal (from the Finisher to the Hole Punch Unit)
- TRMT-MD0: Transport motor excitation method setting signal (from the Finisher to the Hole Punch Unit)
- TRMT-MD1: Transport motor excitation method setting signal (from the Finisher to the Hole Punch Unit)

Data communication (RXD and TXD) between the Hole Punch Unit and the Finisher has adopted the serial communication system which does not allow checking whether the signals are transmitted and received properly using testing devices in the field.

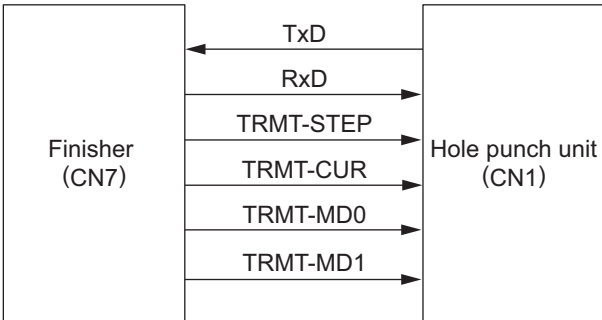

Fig. 2-5

## 3. OPERATION DESCRIPTION

### 3.1 Basic Operations

#### 3.1.1 Overview

The Hole Punch Unit punches holes in paper transported from the MFP and then transports the punched paper to the Finisher.

To make holes at the specified positions, this unit detects the level of skew or sideways deviation of the transported paper and adjusts the position of the punching unit (= punching position alignment operation) to the position of the paper. After the punching position alignment operation, the transport operation pauses when the paper reaches the specified position and then the punching operation starts. When the punching operation is completed, the punched paper is then transported to the Finisher by the transport roller.

Wastes punched out at the punching operation fall into the punch waste case and are accumulate in it.

#### 3.1.2 Basic Operations

The Hole Punch Unit operates by commands from the Finisher and interacts with it by responding to these commands.

When the Hole Punch Unit receives an initialization signal transmitted at the power-ON of the Finisher, it starts detecting the home position of each unit as an initialization operation. This initialization is performed also when the +24 V voltage of the Finisher or the Hole Punch Unit is shut off (in case the front cover of the unit is opened or closed, etc.) and when a job is started.

Upon the start of its operation, the Finisher transmits the Hole Punch Unit the signal including information about the job, such as paper sizes, media type or whether the punching operation is required or not. This unit then operates according to this information. Then this unit continues its operation while the Finisher is operating. (When the Finisher is waiting for a job, the unit does not operate.) When the job is completed and the operation has stopped, this unit deletes the information about this job and prepares for the next job.

This unit does not detect paper misfeeding. Instead, this unit transmits an error signal to the Finisher only when the unit has detected abnormality in its motors or sensors.

## 3.2 Punching Position Alignment Operation

### 3.2.1 Sideways deviation adjustment

The rear, leading and trailing edges of the paper transported to the Hole Punch Unit are detected by the paper position sensors (S6-1, S6-2). The transmissive-type paper position sensors (S6-1, S6-2) are mounted in the punching unit. One pair of them is mounted (at the light emitting part and the light sensing part) on the rear side of the transport guide and the other pair is mounted (at the light emitting part and the light sensing part) on the center of the transport guide in the punching unit.

The paper position sensors (S6-1, S6-2) on the center include 1 LED (light emitting part) and its light sensing part to detect the leading and trailing edges of the paper. The paper position sensors (S6-1, S6-2) on the rear side include 4 LEDs (light emitting part) and their light sensing parts to detect the rear edge of the paper. These 4 LEDs detect the following paper sizes correspondingly.

LED-1	A3, A4, LD, LT
LED-2	B4, B5, COMPUTER, 8K, 16K
LED-3	A4-R, LG, LT-R, FOLIO, 8.5"SQ, 13"LG
LED-4	B5-R, 16K-R

The Hole Punch Unit drives the sideways adjustment motor (M2) to make holes at the specified positions. The driving force of the sideways adjustment motor (M2) is transmitted to the punching unit by a gear and a rack to move the punching unit to the front and rear sides. The sideways adjustment motor (M2) rotates in a normal or reverse direction according to the orientation of the sideways deviation.

When the sideways adjustment motor (M2) starts its rotation, the punching unit also starts moving from its home position. The hole position is calculated from various information such as the leading edge position of the paper, paper sizes and the degree of the skew. Then the punching unit moves to the calculated position.

Then the transport operation pauses and the unit starts the punching.

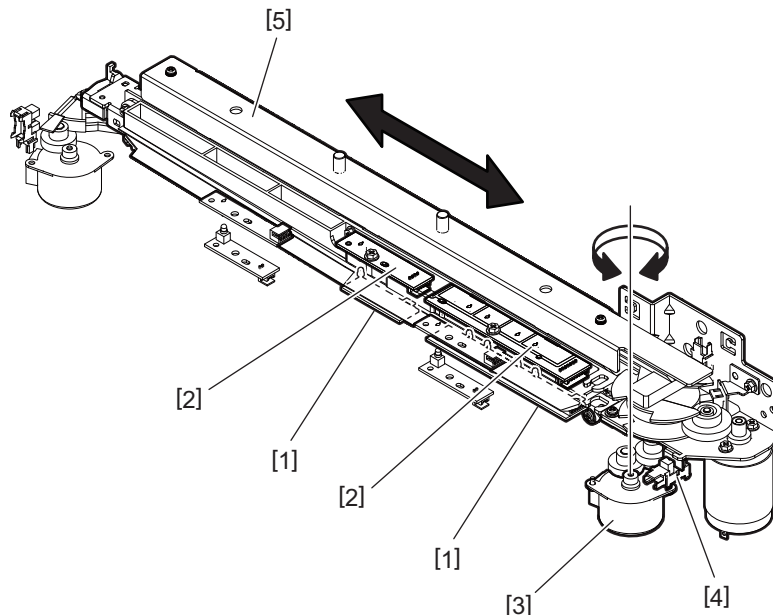

Fig. 3-1

1	Paper position sensor (LED)
2	Paper position sensor (SEN)
3	Sideways adjustment motor
4	Sideways deviation home position sensor
5	Punching unit



### 3.2.2 Skew adjustment

Transmissive-type skew sensors (S7-1, S7-2) are mounted in this Hole Punch Unit. One pair of them is mounted (at the light emitting part and the light sensing part) on the front side and the other pair is mounted (at the light emitting part and the light sensing part) on the rear side of the entrance guide. These skew sensors (S7-1, S7-2) detect the leading edge of paper transported to this unit. The degree of paper skew is calculated by a time lag between the detections of the leading edge of the paper on the front and rear sides measured by the skew sensors (S7-1, S7-2).

When the degree of the skew has been calculated, the unit then drives the skew adjustment motor (M1) to move the punching unit from its home position. The skew adjustment motor (M1) uses a stepping motor, and it rotates in a reverse or normal direction according to the degree of the skew. The rotation of this motor is transmitted to the punching unit by a cam, so the punching unit is skewed at the same degree as that of the paper.

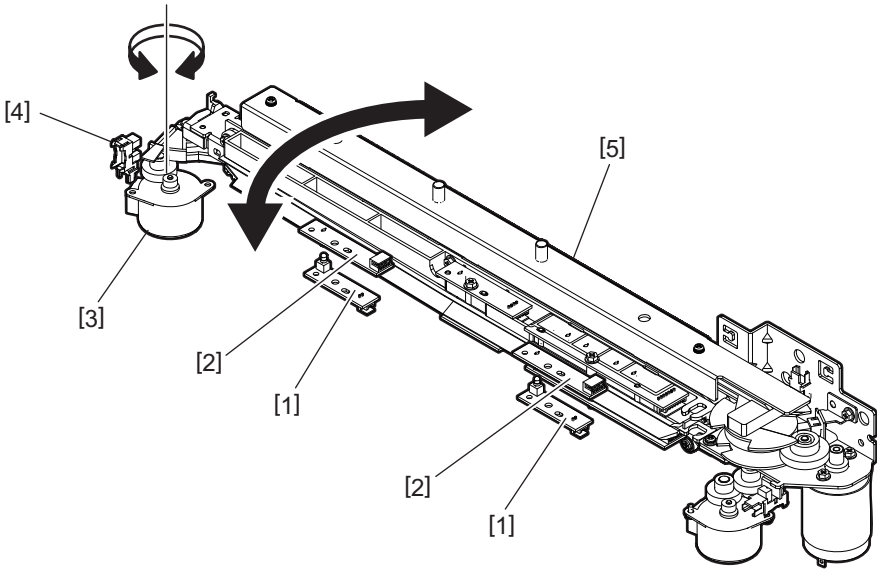

Fig. 3-2

1	Skew sensor (LED)
2	Skew sensor (SEN)
3	Skew adjustment motor
4	Skew home position sensor
5	Punching unit

### 3.3 Punching Operation

The types of punching positions are classified into 4 depending on the destinations; 2 holes, 2 or 3 holes, 4 holes for France and 4 holes for Sweden. Each model for these destinations has its own punching unit and individual punching operation.

The punching unit punches paper. This unit turns the rotation of the punch motor (M3) into the transversal movement, and then the cam turns this transversal movement into the hoisting movement of the punch head. When the punch head is lowered, the paper is punched out.

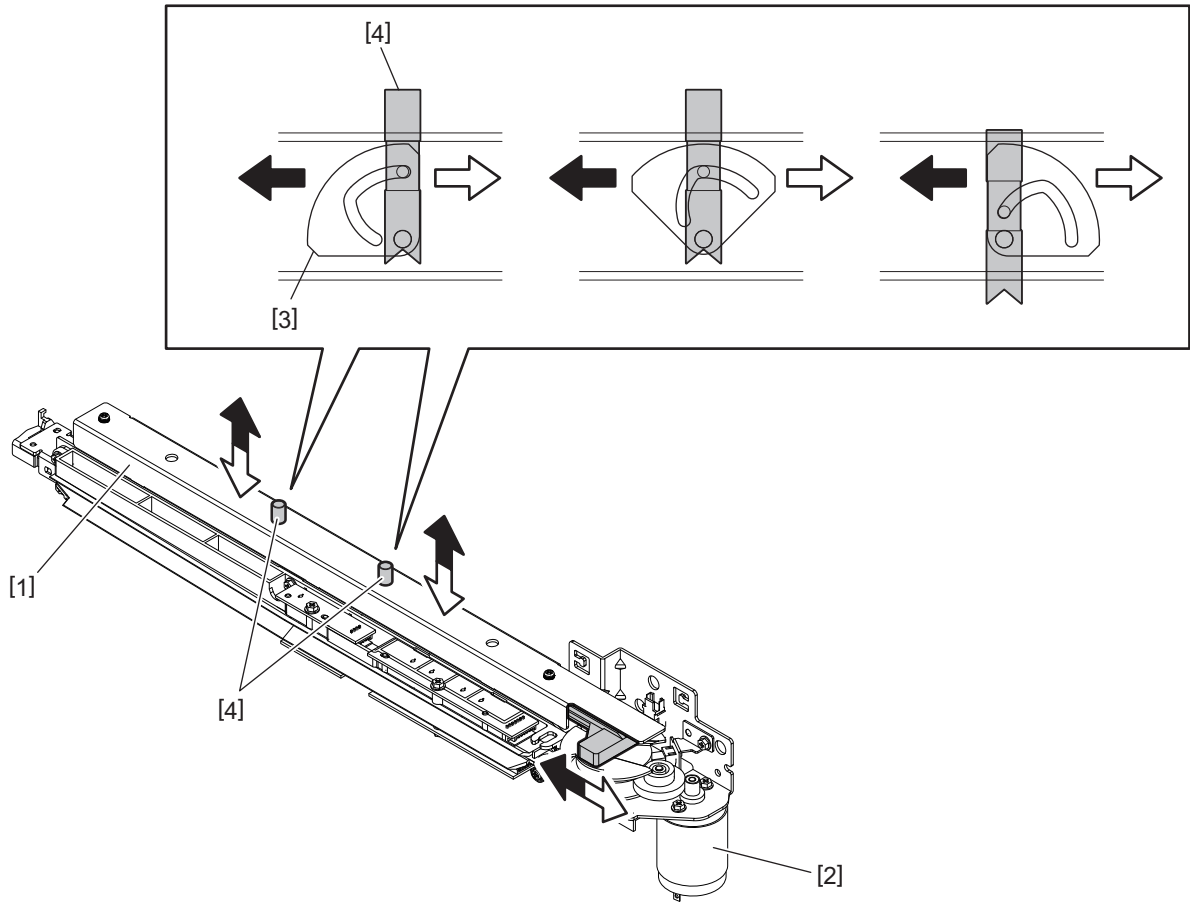

Fig. 3-3

1	Punching unit
2	Punch motor
3	Cam
4	Punch head

The punch motor (M3) uses a DC motor and rotates in a normal or reverse direction. The punch home position sensor (S4) detects the home position of the punching unit. The punching sensor (S5) detects the timing to apply the brake on the punch motor (M3).

The punch home position sensor (S4) and the punching sensor (S5) have an actuator to transmit or shut off the detection light at the specified positions. The combinations of these positions and light status are shown below.

	Punch home position sensor (S4)	Punching sensor (S5)
Position 1	Transmit	Shut off
Position 2	Transmit	Transmit

The combinations of the positions 1 and 2 and the rotational direction of the punch motor (M3) decide the punching operation as shown below.

Destination	Number of holes	Position	Rotational direction of the punch motor (M5)
E	2 holes	Position 1 → Position 2	Reverse rotation
		Position 2 → Position 1	Normal rotation
N	2 holes	Position 1 → Position 2	Normal rotation
		Position 2 → Position 1	Reverse rotation
	3 holes	Position 1 → Position 2	Reverse rotation
		Position 2 → Position 1	Normal rotation
F	4 holes	Position 1 → Position 2	Reverse rotation
		Position 2 → Position 1	Normal rotation
S	4 holes	Position 1 → Position 1	Normal rotation

As for the destinations of E, N and F, the punch motor (M3) rotates in a normal or reverse direction so that their actuators reciprocate between the positions 1 and 2. Paper is thus punched out at the timing along with this reciprocating movement. Namely, one punching operation is performed when the actuator has gone half round.

On the other hand, only the destination of S has a unique punching operation. In this unit, the punch motor (M3) rotates only in a normal direction and paper is punched out when its actuator detects of the position 1. Namely, one punching operation is performed when the actuator has gone one round.

- Destination “E”
  - [1] Normal rotation
  - [2] Reverse rotation

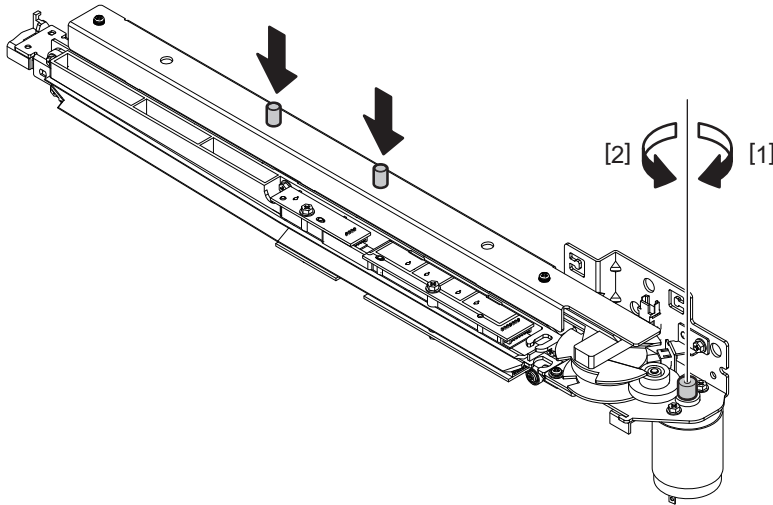

Fig. 3-4

- Destination “N”  
 [1] Normal rotation  
 [2] Reverse rotation

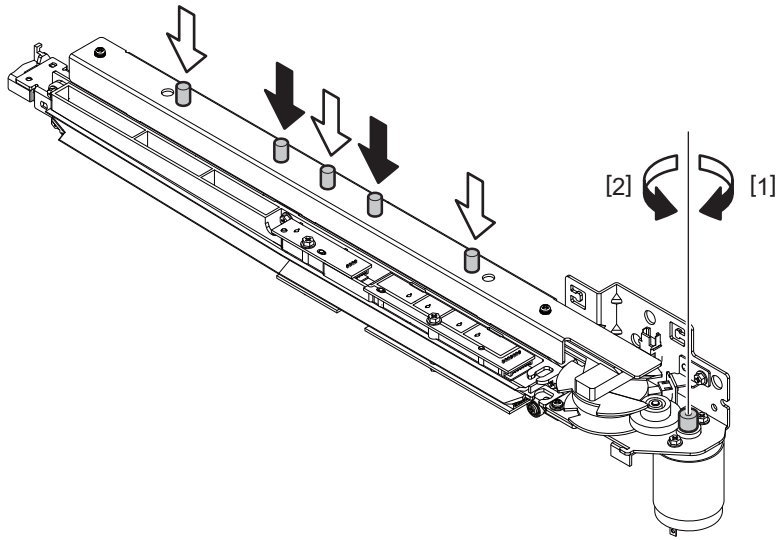

Fig. 3-5

- Destination “F”  
 [1] Normal rotation  
 [2] Reverse rotation

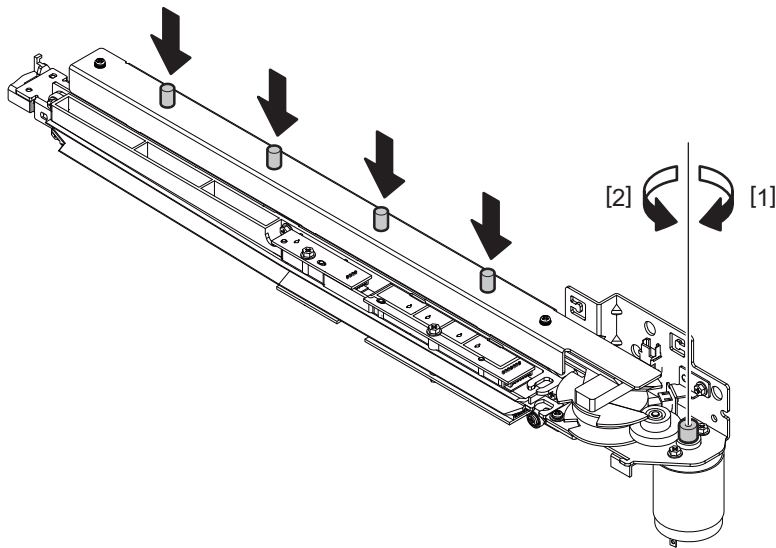

Fig. 3-6

- Destination "S"  
[1] Normal rotation

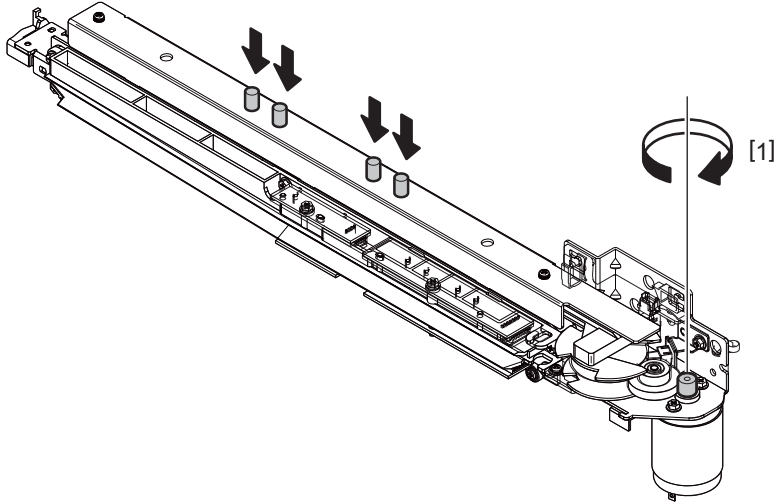

Fig. 3-7

### 3.4 Transport Operation

This Hole Punch Unit has a transport roller to transport paper. The transport roller is rotated by the drive of the transport motor (M4). The transport motor stops its rotation during the punching operation so that the paper is stopped at the specified position for punching. When the punching operation is completed, the transport motor restarts its rotation to transport the punched paper to the Finisher. The transport motor (M4) is controlled by the Finisher.

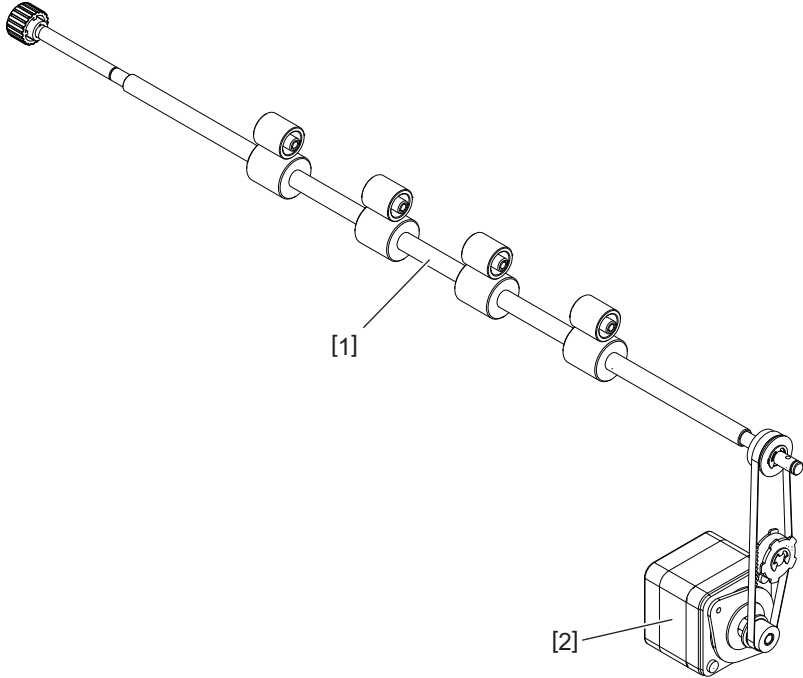

Fig. 3-8

1	Transport roller
2	Transport motor

### 3.5 Punched Wastes Detection

Wastes punched out at the punching operation fall into the punch waste case and accumulate in it. The punch waste full sensors (S8-1, S8-2) detect the presence of the punch waste case and the accumulating status of the punch wastes in the case. There are 2 punch waste full sensors (S8-1, S8-2); one is on the light emitting part (LED) and the other is on the light sensing part (SEN). When the emitted light is shut off by the accumulated wastes and the sensor therefore cannot sense the light, the sensors detect the full status of punch wastes in the case.





## 4. DISASSEMBLY AND REASSEMBLY

### Notes:

It is recommended to take off the punch waste case in case that it is full before performing maintenance on the Hole Punch Unit. Otherwise, the punch wastes may spill out when the Hole Punch Unit is moved.

### 4.1 Cover

#### 4.1.1 Front bottom cover

- (1) Open the front cover. Push 2 latches and take off the front bottom cover [1].

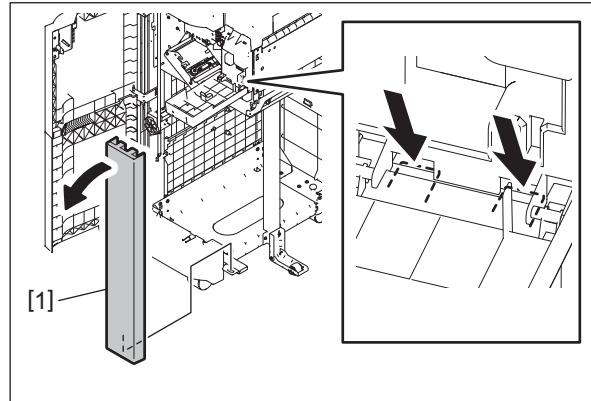

Fig. 4-1

#### 4.1.2 Rear bottom cover

- (1) Push 2 latches and take off the rear bottom cover [2].

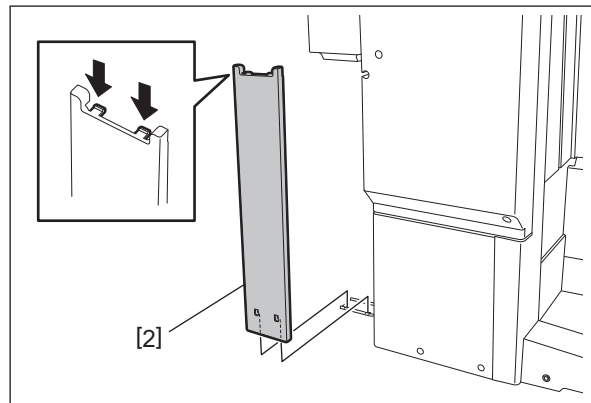

Fig. 4-2

### 4.1.3 Rear cover

- (1) Take off the rear bottom cover.  
📖 P. 4-1 “4.1.2 Rear bottom cover”
- (2) Remove 3 screws and take off the rear cover [3].

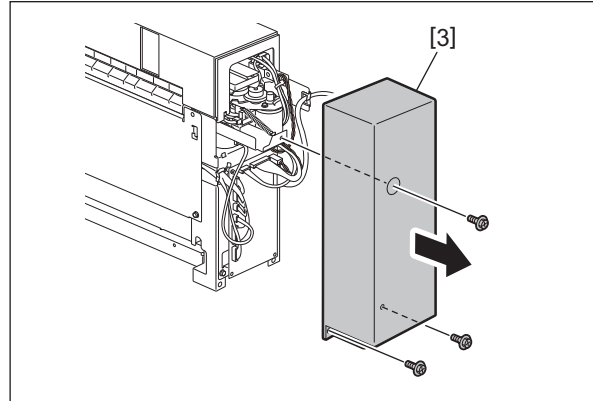

Fig. 4-3

### 4.1.4 Front cover

- (1) Take off the front bottom cover.  
📖 P. 4-1 “4.1.1 Front bottom cover”
- (2) Open the front cover. Pull out the knob [4].

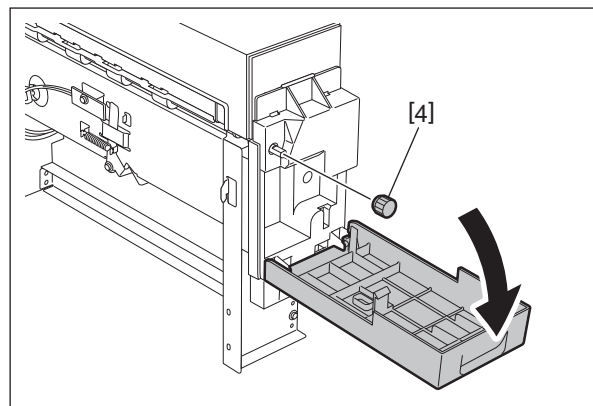

Fig. 4-4

- (3) Remove 3 screws and take off the front cover [5].

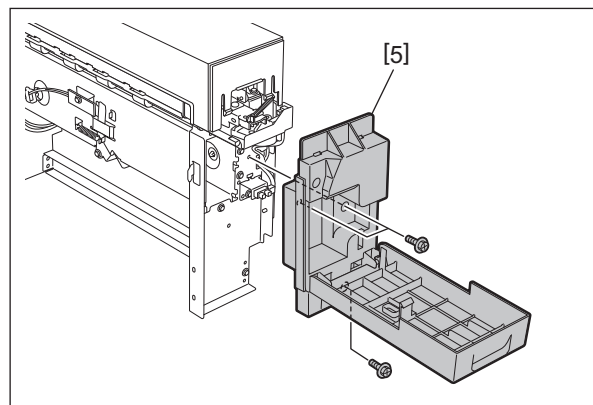

Fig. 4-5

## 4.1.5 Top cover

- (1) Take off the rear cover.  
📖 P. 4-2 "4.1.3 Rear cover"
- (2) Loosen 2 screws and take off the top cover [6].

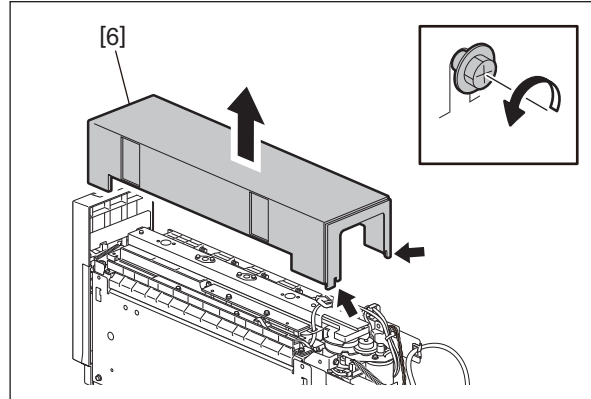

Fig. 4-6

### Notes:

The 2 screws on the upper side of the punching unit must not be loosened as the unit is assembled with high precision.

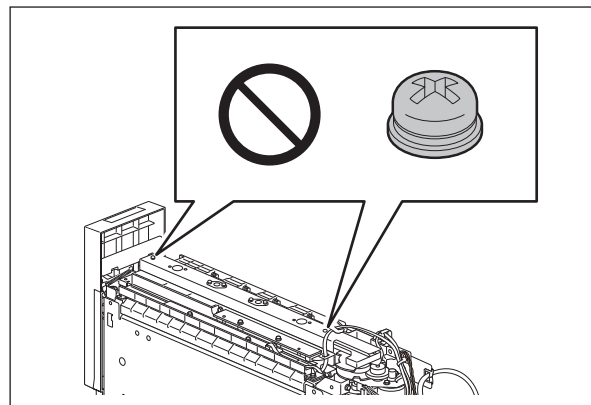

Fig. 4-7

## 4.1.6 Right cover

- (1) Remove 2 screws. Slide the right cover [7] upward and take it off toward the lower right.

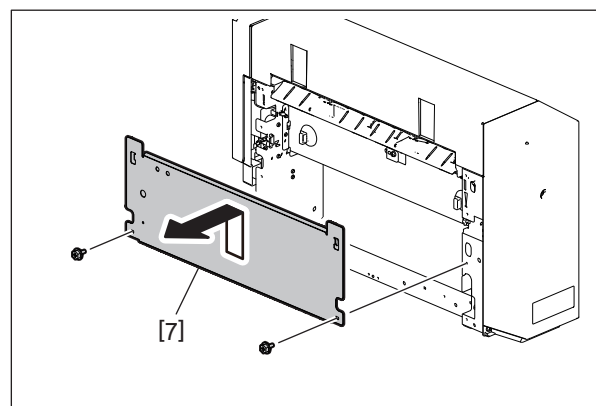

Fig. 4-8

## 4.2 Motor

### 4.2.1 Skew adjustment motor (M1)

- (1) Take off the front cover.  
📖 P. 4-2 “4.1.4 Front cover”
- (2) Take off the right cover.  
📖 P. 4-3 “4.1.6 Right cover”
- (3) Disconnect 1 connector. Release the harness from 3 harness clamps.

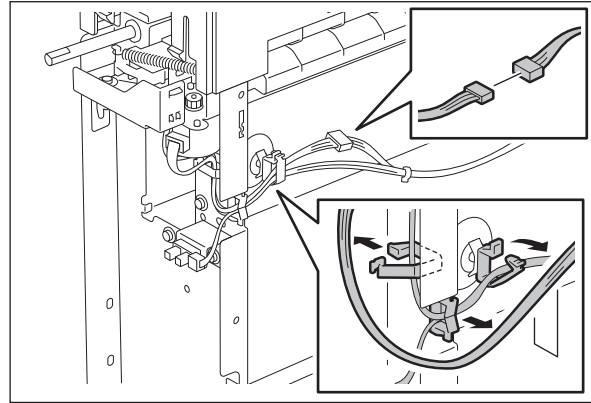

Fig. 4-9

- (4) Remove 2 screws and take off the skew adjustment motor [1].

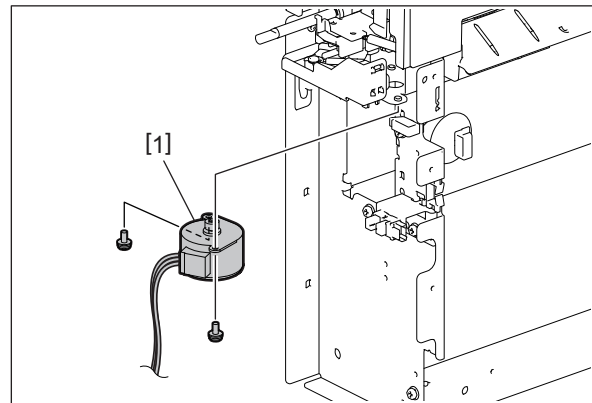

Fig. 4-10

## 4.2.2 Sideways adjustment motor (M2)

- (1) Take off the top cover.  
📖 P. 4-3 "4.1.5 Top cover"
- (2) Disconnect all connectors from the hole punch control PC board.  
📖 P. 4-16 "4.5.1 Hole punch control PC board (HP)"
- (3) Remove 4 screws and slide the PC board bracket upward to take it off.

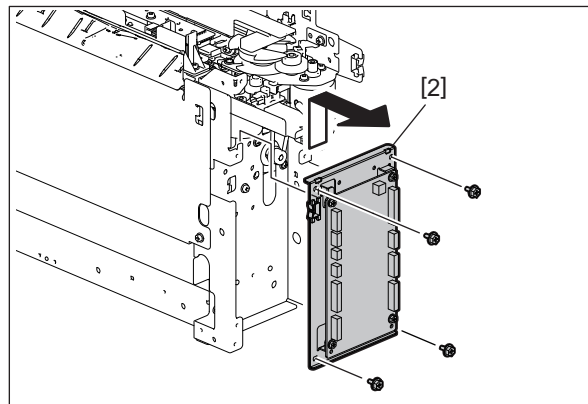

Fig. 4-11

- (4) Remove 2 screws and take off the sideways adjustment motor [3].

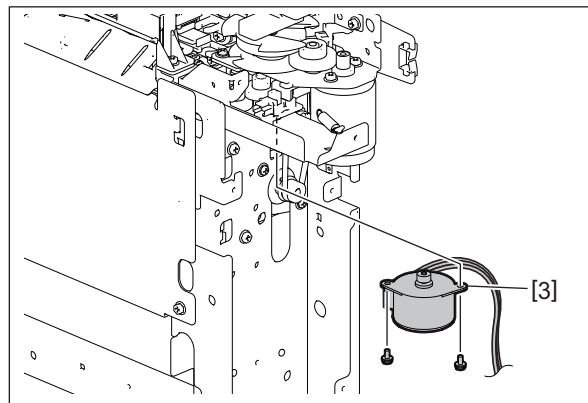

Fig. 4-12

### 4.2.3 Punch motor (M3)

- (1) Take off the rear cover.  
📖 P. 4-2 “4.1.3 Rear cover”
- (2) Remove the harness clamp. Disconnect 1 connector, remove 2 screws and take off the punch motor [4].

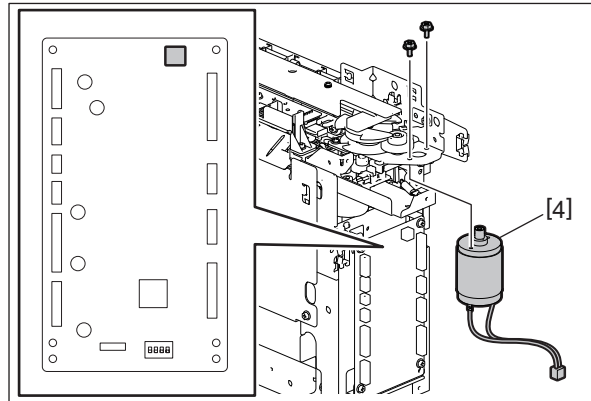

Fig. 4-13

#### Notes:

Pay attention to the size and length of the screws. If you use the wrong ones, the motor could be damaged.

### 4.2.4 Transport motor (M4)

- (1) Take off the rear cover.  
📖 P. 4-2 “4.1.3 Rear cover”
- (2) Disconnect all connectors from the hole punch control PC board.  
📖 P. 4-16 “4.5.1 Hole punch control PC board (HP)”
- (3) Remove 4 screw and take off the PC board bracket [5].

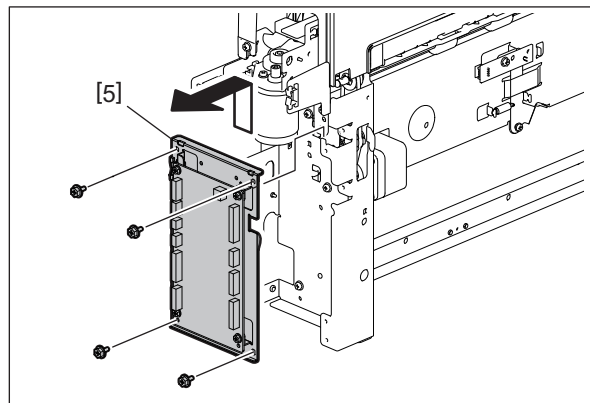

Fig. 4-14

(4) Disconnect 1 connector. Remove 2 screws, release the belt and take off the transport motor [6].

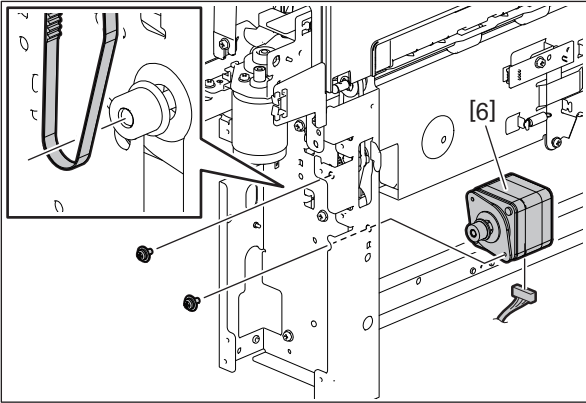

Fig. 4-15

### 4.3 Punching unit

- (1) Take off the front cover.  
📖 P. 4-2 “4.1.4 Front cover”
- (2) Take off the top cover.  
📖 P. 4-3 “4.1.5 Top cover”
- (3) Disconnect 4 connectors from the hole punch control PC board.

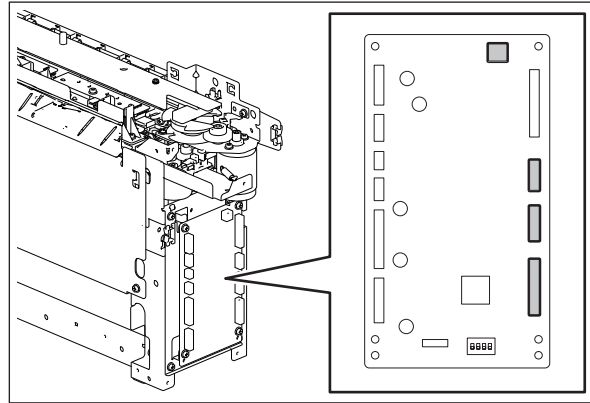

Fig. 4-16

- (4) Remove 2 springs [1].

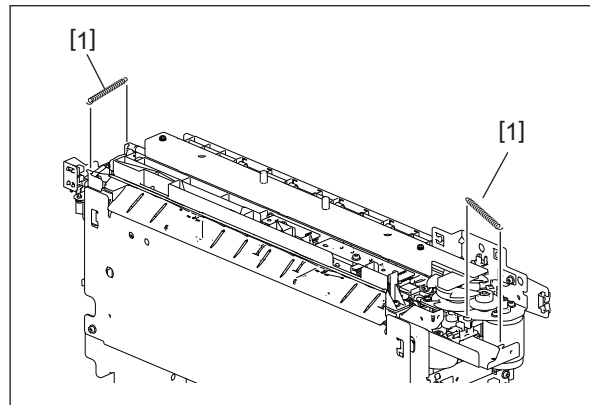

Fig. 4-17

- (5) Remove 2 screws and take off the upper and lower transport guides [2].

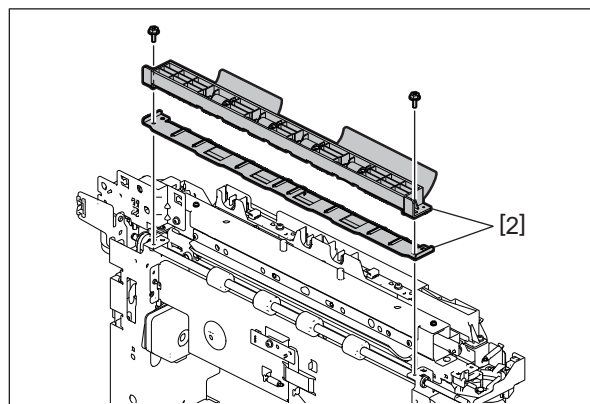

Fig. 4-18



- (6) Remove 2 harness clamps.
- (7) Slide the punching unit [3] to the rear side and then lift it up.

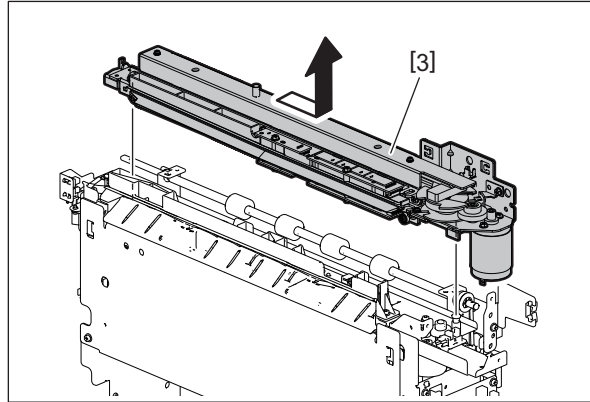

Fig. 4-19

**Notes:**

- Be careful not to damage or deform the film attached to the transport guide and the punching unit during assembling and disassembling it.
- When installing the lower transport guide of the punching unit, push it to the front side until it touches the upper transport guide and then tighten the screws to fit it.

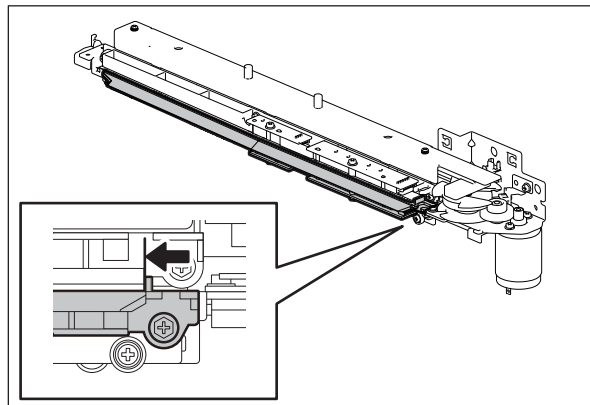

Fig. 4-20

## 4.4 Sensor and switch

### 4.4.1 Front cover sensor (S1)

- (1) Take off the front cover.  
📖 P. 4-2 “4.1.4 Front cover”
- (2) Disconnect 1 connector. Release the latch and remove the front cover sensor [1].

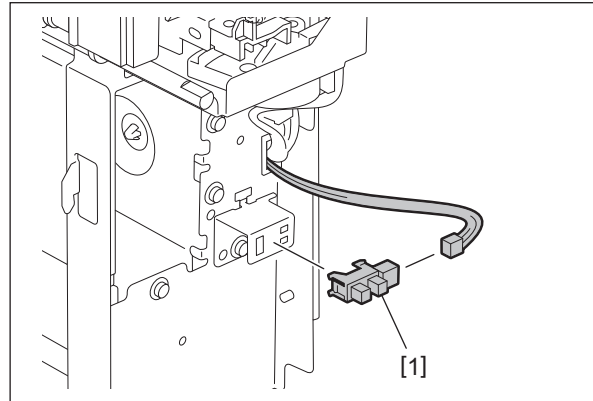

Fig. 4-21

### 4.4.2 Skew home position sensor (S2)

- (1) Take off the front cover.  
📖 P. 4-2 “4.1.4 Front cover”
- (2) Take off the top cover.  
📖 P. 4-3 “4.1.5 Top cover”
- (3) Rotate the actuator.

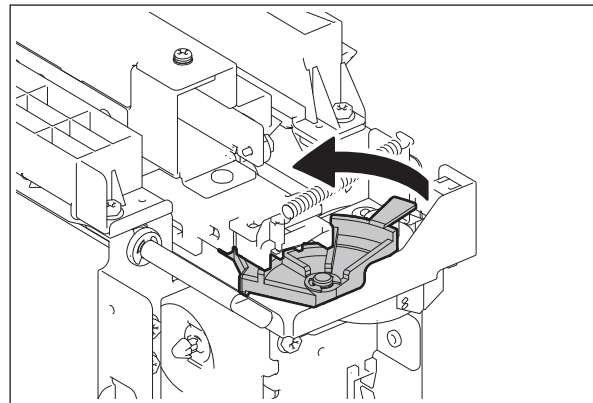

Fig. 4-22

- (4) Disconnect 1 connector. Release the latch and remove the skew home position sensor [2].

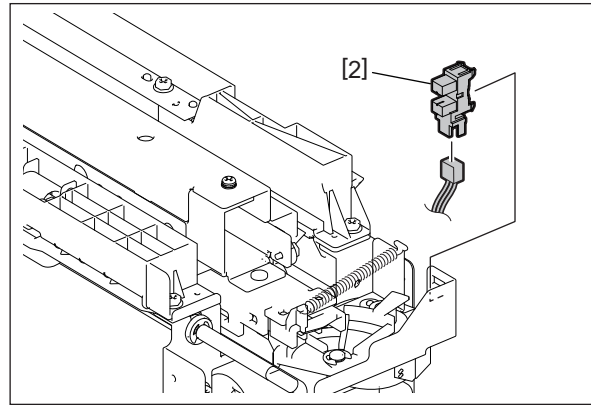

Fig. 4-23

#### 4.4.3 Sideways deviation home position sensor (S3)

- (1) Take off the top cover.  
P. 4-3 "4.1.5 Top cover"
- (2) Remove 2 screws and take off the sensor bracket.
- (3) Release the latch and take off the sideways deviation home position sensor [3] from the sensor bracket.

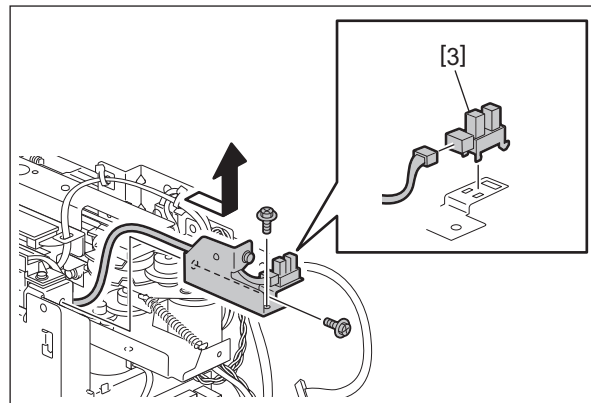

Fig. 4-24

#### 4.4.4 Punch home position sensor (S4)

- (1) Take off the top cover.  
📖 P. 4-3 "4.1.5 Top cover"
- (2) Rotate the actuator so that it does not contact the punch home position sensor.

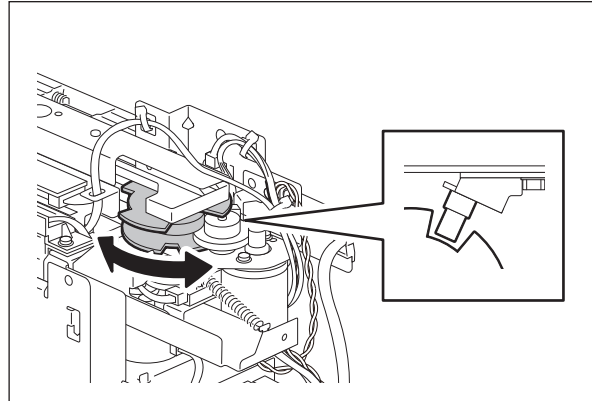

Fig. 4-25

- (3) Disconnect 1 connector, remove 1 screw and take off the sensor bracket.
- (4) Release the latch and take off the punch home position sensor [4] from the sensor bracket.

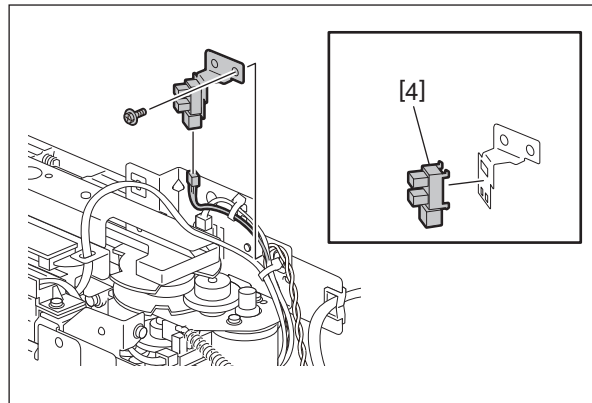

Fig. 4-26

#### 4.4.5 Punching sensor (S5)

- (1) Take off the top cover.  
📖 P. 4-3 "4.1.5 Top cover"
- (2) Rotate the actuator so that it does not contact the punching sensor [5].

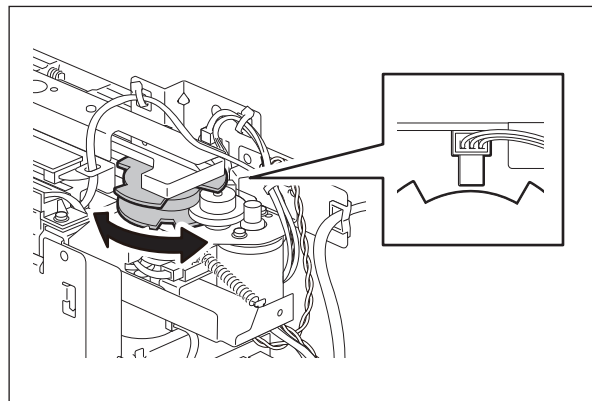

Fig. 4-27

- (3) Disconnect 1 connector. Release the latch and remove the punching sensor [5].

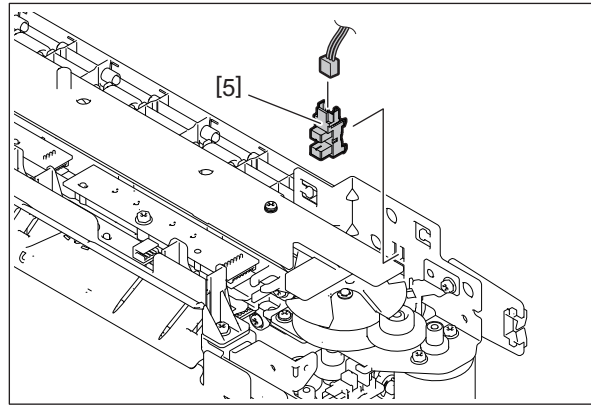

Fig. 4-28

#### 4.4.6 Skew sensor (SEN) (S7-2)

- (1) Take off the top cover.  
P. 4-3 "4.1.5 Top cover"
- (2) Disconnect 1 connector, remove 1 screw and take off each skew sensor (SEN) [6].

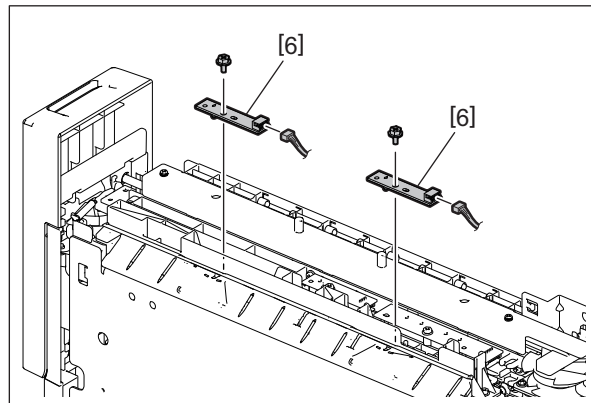

Fig. 4-29

#### 4.4.7 Skew sensor (LED) (S7-1)

- (1) Take off the top cover.  
P. 4-3 "4.1.5 Top cover"
- (2) Remove 2 screws and take off both the upper and lower entrance guides [7][8].

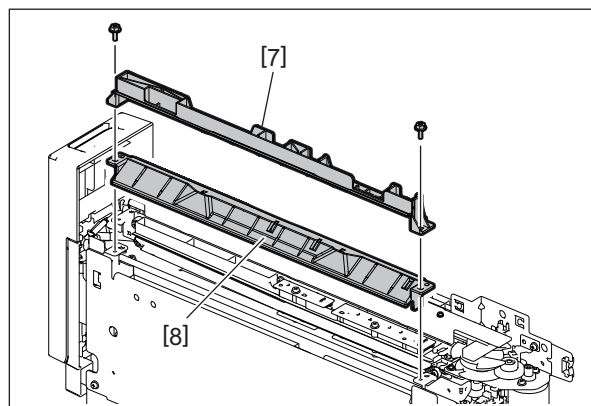

Fig. 4-30

- (3) Remove each 1 connector and each 1 screw from the lower entrance guide [8]. Then take off each skew sensor (LED) [9].

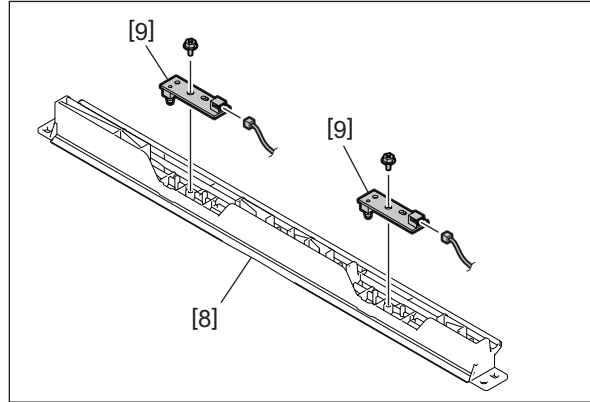



Fig. 4-31

#### 4.4.8 Paper position sensor (SEN) (S6-2)

- (1) Take off the top cover.  
 P. 4-3 "4.1.5 Top cover"
- (2) Disconnect 1 connector, remove 1 screw and take off each paper position sensor (SEN) [10].

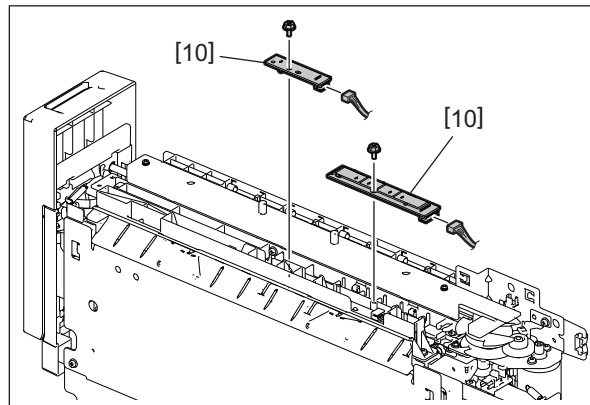

Fig. 4-32

#### 4.4.9 Paper position sensor (LED) (S6-1)

- (1) Take off the punching unit.  
P. 4-8 "4.3 Punching unit"
- (2) Disconnect 1 connector and remove 1 screw from the punching unit. Then take off each paper position sensor (LED) [11].

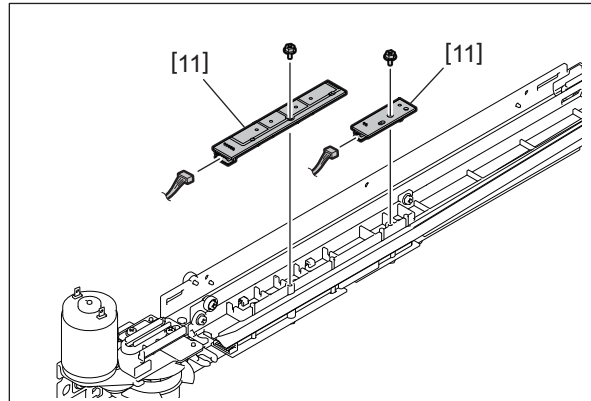

Fig. 4-33

#### 4.4.10 Punch waste full sensor (SEN) (S8-2)

- (1) Disconnect 1 connector. Remove 1 screw and take off the punch waste full sensor (SEN) [12].

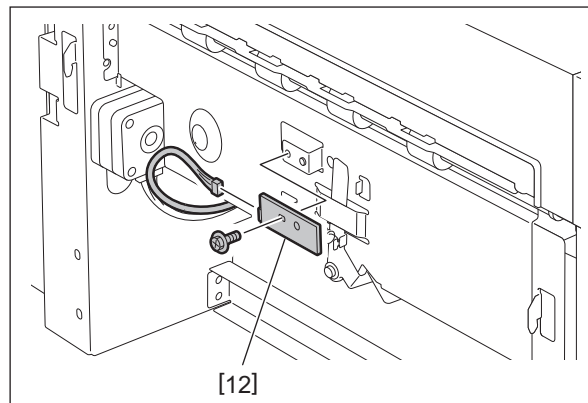

Fig. 4-34

#### 4.4.11 Punch waste full sensor (LED) (S8-1)

- (1) Take off the right cover.  
📖 P. 4-3 "4.1.6 Right cover"
- (2) Disconnect 1 connector. Remove 1 screw and take off the punch waste full sensor (LED) [13].

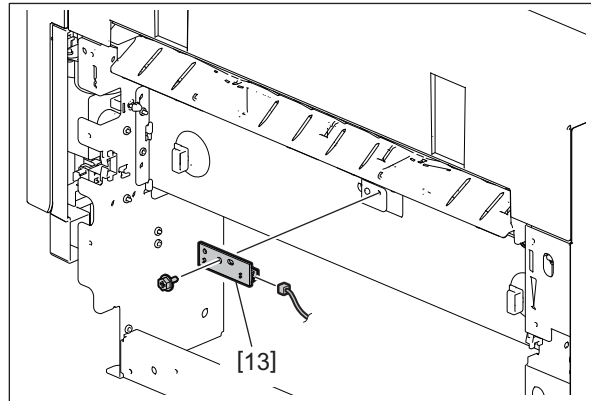

Fig. 4-35

### 4.5 PC board

#### 4.5.1 Hole punch control PC board (HP)

- (1) Take off the rear cover.  
📖 P. 4-2 "4.1.3 Rear cover"
- (2) Disconnect all connectors from the hole punch control PC board.

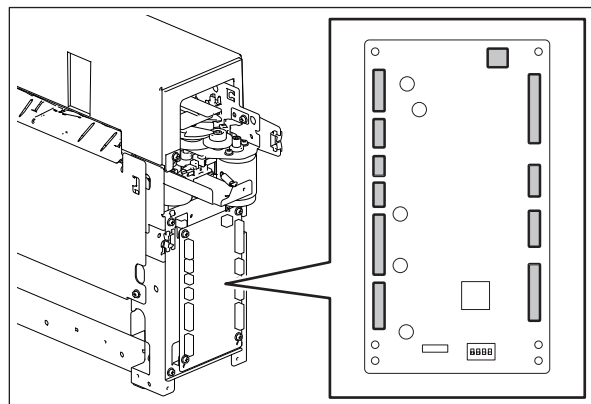

Fig. 4-36



- (3) Remove 4 screws and take off the hole punch control PC board [1].

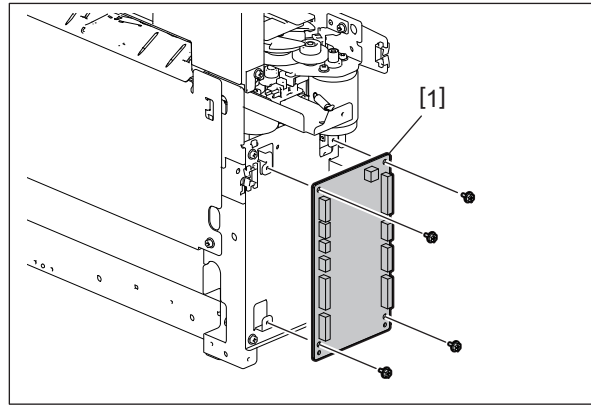

Fig. 4-37

**Notes:**

- After the hole punch control PC board is replaced, set the DIP SW1 and SW2 on it according to the model as shown in the figure.
- After the hole punch control PC board is replaced, check that the firmware is the latest version. If not, upgrade it. If not, update it.

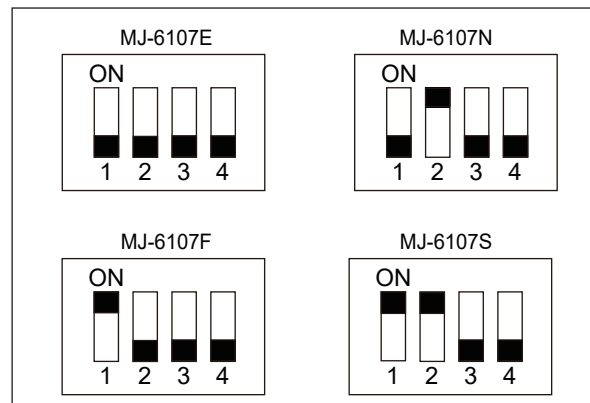

Fig. 4-38

## 4.6 Roller

### 4.6.1 Transport roller

- (1) Take off the punching unit.  
P. 4-8 “4.3 Punching unit”
- (2) Remove 2 E-rings [1], 1 pulley [2], 1 belt [3], 1 pin [4] and 1 bushing [5] from the rear side of the shaft.

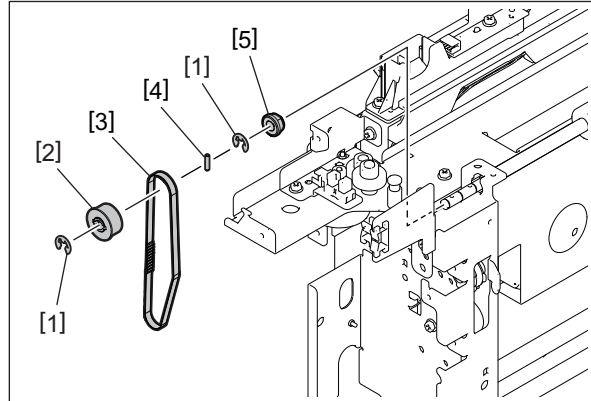

Fig. 4-39

- (3) Remove 1 E-ring [6] and 1 bushing [7] from the front side of the shaft.

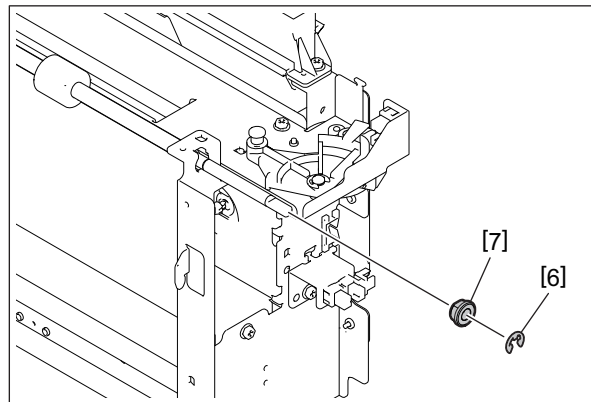

Fig. 4-40

- (4) Remove the transport roller [8].

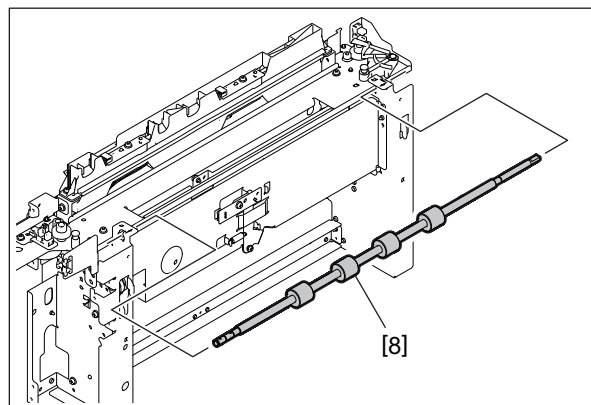

Fig. 4-41

## 5. ADJUSTMENT

### 5.1 Stopping Position Adjustment

This adjustment can change the position where paper transport stops during the punching operation. Perform this adjustment when you adjust the punching position on the paper in the transporting direction.

#### 5.1.1 Adjustment with the self-diagnostic code

If the adjustment values can be confirmed from the pre-change board, check them from the connected MFP and then set them into the post-change board.

Adjustment value check: Perform FS-05-4838-0.

Item to be adjusted	Code	Remarks
Hole punch position	FS-05-4838-0	Adjusts the hole punch position in the paper feeding direction. When a positive value is set, it shifts toward the paper feeding side. When a negative value is set, it shifts toward the paper exit side. 0: Finisher not installed 1: -1.10 mm, 2: -0.88 mm, 3: -0.66 mm, 4: -0.44 mm, 5: -0.22 mm, 6: 0.00 mm, 7: +0.22 mm, 8: +0.44 mm, 9: +0.66 mm, 10: +0.88 mm, 11: +1.10 mm

#### 5.1.2 Adjustment with the DIP-SW

If the adjustment values cannot be confirmed, perform the adjustment in the following procedure.

- (1) Turn the power OFF of the MFP.
- (2) Take off the board access cover [1] of the Finisher. Then set the SW1 (DIP-SW) [2] on the finisher control PC board as shown below.

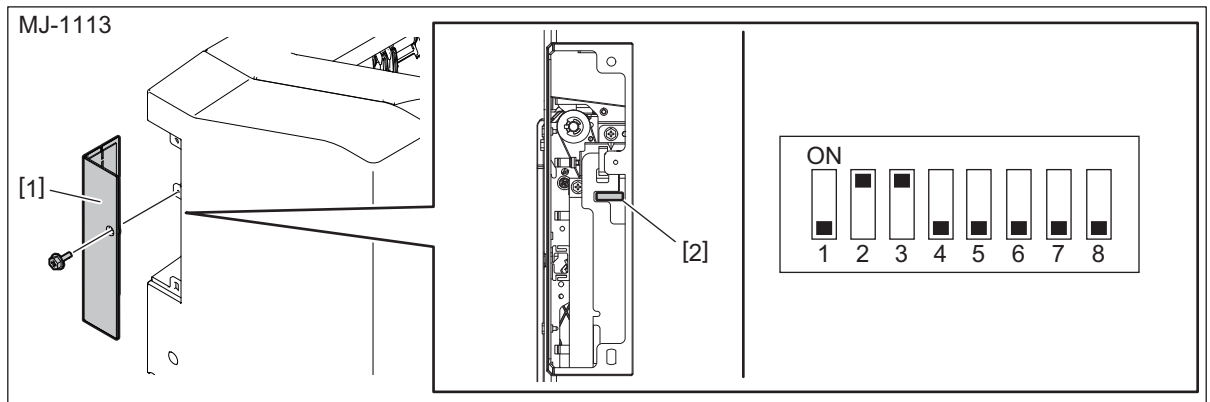

Fig.5-1

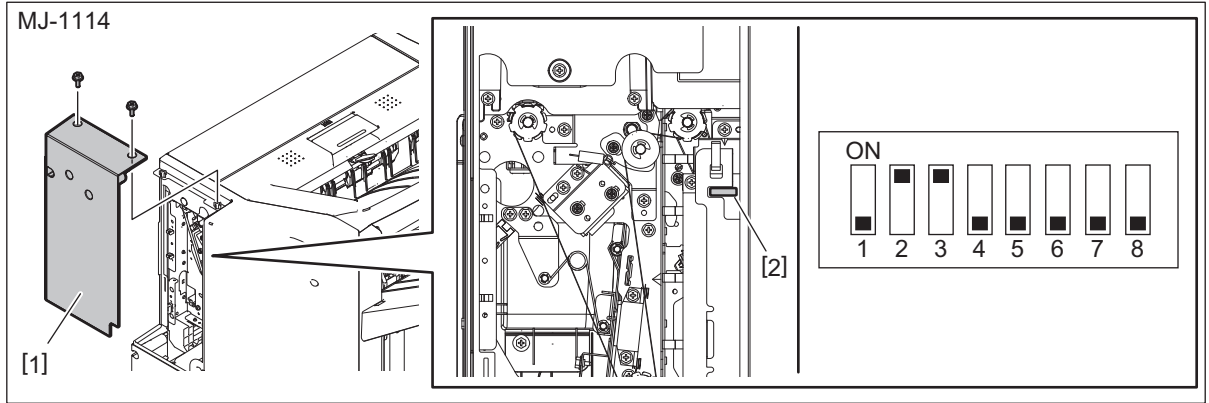

Fig.5-2

- (3) Turn the power ON of the MFP. The Finisher enters into the stopping position adjustment mode.
- (4) LED1 on the finisher control panel blinks. The number of times it blinks indicates the current adjustment value.
- (5) Press [Button1] on the finisher control panel to change the adjustment value. The number of times LED1 blinks changes in ascending order (e.g.: 1, 2, 3... 11) each time you press [Button1].

Number of LED1's blinking	Adjustment Value (Steps from the center value)	Distance from the center value
1	-5	1.10 mm
2	-4	0.88 mm
3	-3	0.66 mm
4	-2	0.44 mm
5	-1	0.22 mm
6	0	0 mm (Center value)
7	+1	0.22 mm
8	+2	0.44 mm
9	+3	0.66 mm
10	+4	0.88 mm
11	+5	1.10 mm

**Notes:**

When the adjustment value goes further in minus numbers in the table above, the distance between the paper edge and the holes becomes wider. When it goes further in plus numbers, this distance becomes narrower.

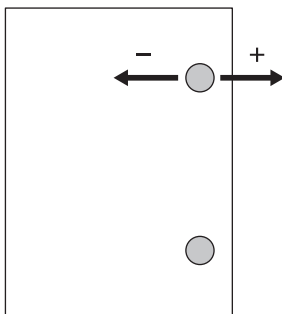

Fig.5-3

- (6) When the value change is completed, press [Button2] on the finisher control panel to determine the adjustment value. (The adjustment value is written into the flash ROM.)

- (7) Turn the power OFF of the MFP.
- (8) Turn OFF all bits of the SW1 (DIP-SW) on the finisher control PC board.
- (9) Install the board access cover of the Finisher.



## 6. TROUBLESHOOTING

For details about the troubleshooting for the option, refer to “ERROR CODE AND TROUBLESHOOTING” in the Service Manual for the MFP.





## 7. MAINTENANCE

### 7.1 Maintenance and Inspection Points

#### 7.1.1 Symbols used in the checklist

Cleaning	Lubrication/Coating	Replacement	Operation check
A: Clean with alcohol B: Clean with a soft pad, cloth or vacuum cleaner	W3: White grease (Molykote EM30L)	Value: Replacement cycle R: Replace if deformed or damaged	O: After cleaning or replacement, confirm there is no problem.

#### 7.1.2 Preventive Maintenance Checklist

Items to check *1		Cleaning	Lubrication/ Coating *2	Replacement (x1,000)	Operation check	Parts list (P-I) *3	Rem arks
1	Transport roller	A			O		
2	Sensor	B					
3	Drive gear		W3		O		
4	Punch waste case	Dispose of the punch wastes.					
5	Punching unit			R 1,000			*4

\*1: Perform the maintenance in the timing of preventive maintenance of the MFP.

\*2: Be careful not to put grease on the rollers, belts and belt pulleys when lubricating.

\*3: The column "Parts List (P-I)" shows the page and item number in the parts list.

\*4: This unit may require replacement once or more over the period of its warranty because of deterioration or damage. Replace it as needed.

## 7.2 Firmware Updating

For updating firmware, refer to "FIRMWARE UPDATING" in the Service Manual for the MFP.



# 8. ELECTRIC CIRCUIT

## 8.1 Harness Diagram

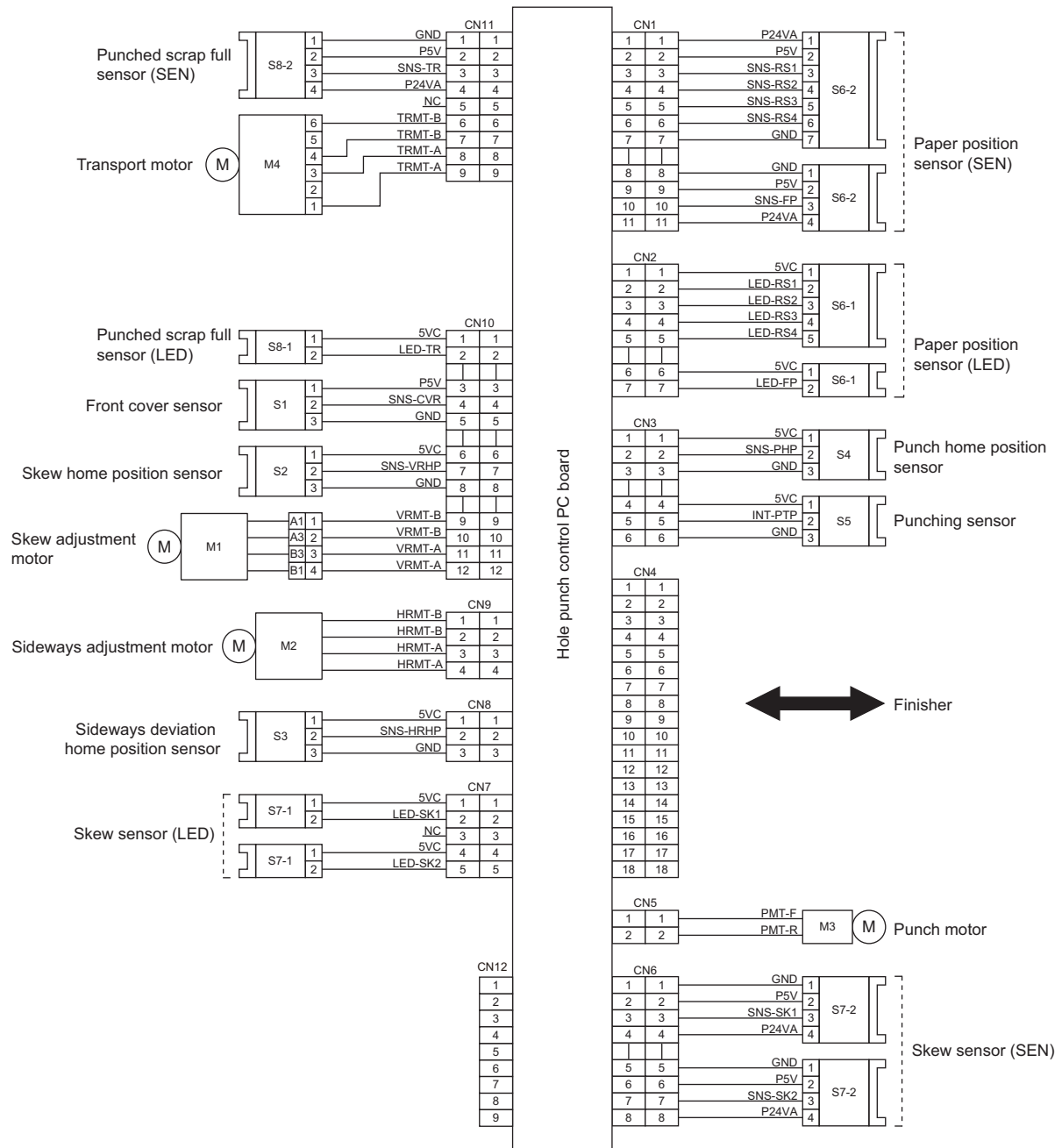

Fig.8-1



# REVISION RECORD

Ver00

Ver00 <2021/12/22>	
Page	Contents
	Initial release





**TOSHIBA**

**Toshiba Tec Corporation**

1-11-1, OSAKI, SHINAGAWA-KU, TOKYO, 141-8562, JAPAN