

TOSHIBA

SERVICE MANUAL

HOLE PUNCH UNIT

MJ-6101/6103/6104/6105/6106



Trademarks

- MOLYKOTE® is a registered trademark of Dow Corning Corporation.
- FLOIL® is a registered trademark of Kanto Kasei CO., Ltd.
- Other company names and product names in this manual are the trademarks of their respective companies.

© 2006 - 2017 TOSHIBA TEC CORPORATION All rights reserved

Under the copyright laws, this manual cannot be reproduced in any form without prior written permission of TOSHIBA TEC CORPORATION.

General Precautions for Installation/Service/Maintenance for this Equipment

The installation and service should be done by a qualified service technician.

- 1) When installing this equipment to the MFP, be sure to follow the instructions described in the “Unpacking/Set-Up Procedure for this equipment” booklet which comes with each unit of this equipment.
- 2) This equipment should be installed by an authorized/qualified person.
- 3) This equipment is quite heavy and weighs approximately 7 kg (15.43 lb), therefore pay full attention when handling it.
- 4) Before starting installation, servicing or maintenance work, be sure to turn OFF and unplug the equipment first.
- 5) The equipment shall be installed near the socket outlet and shall be easily accessible.
- 6) Be sure to fix and plug in the power cable securely after the installation so that no one trips over it.
- 7) When selecting the installation site, avoid placing the finisher / hole punch unit and equipment on different levels or inclined floors.
- 8) When servicing or maintaining the this equipment, be careful about the rotating or operation sections such as gears, pulleys, sprockets, cams, belts, etc.
- 9) When parts are disassembled, reassembly is basically the reverse of disassembly unless otherwise noted in this manual or other related materials.
Be careful not to reassemble small parts such as screws, washers, pins, E-rings, toothed washers, harnesses to the wrong places.
- 10) Basically, the machine should not be operated with any parts removed or disassembled.
- 11) When servicing the equipment with the power turned ON, be sure not to touch live sections and rotating/operating sections.
- 12) Delicate parts for preventing safety hazard problems (such as switches, sensors, etc. if any) should be handled/installed/adjusted correctly.
- 13) Use suitable measuring instruments and tools.
- 14) During servicing or maintenance work, be sure to check the serial No. plate and other cautionary labels (if any) to see if they are clean and firmly fixed.
If not, take appropriate actions.
- 15) The PC board must be stored in antistatic envelope and handled carefully using a wristband, because the ICs on it may be damaged due to static electricity.
Before using the wrist band, pull out the power cord plug of the equipment and make sure that there is no uninsulated charged objects in the vicinity.
- 16) For the recovery and disposal of used MJ-6101/6103/6104, consumable parts and packing materials, follow the relevant local regulations/rules.

17)After completing installation, servicing and maintenance of the MJ-6101/6103, return the MJ-6101/6103/6104 to its original state, and check operation.

18)When you move the finisher, do not move it in the direction of the arrow as shown in the figure below otherwise it might topple over.

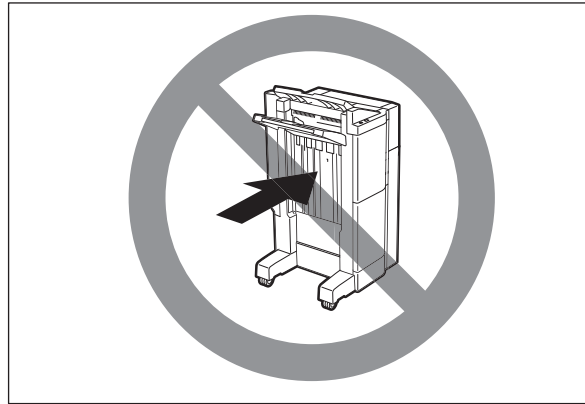

19)Unplug the power cable and clean the area around the prongs of the plug and socket outlet once a year or more. A fire may occur when dust lies on this area.

20)Check the procedures and perform them as described in the Service Manual.

21)Make sure you do not lose your balance.

22)Avoid exposure to your skin and wear protective gloves as needed.

23)Do not leave plastic bags where children can get at them. This may cause an accident such as suffocation if a child puts his/her head into a bag. Plastic bags of options or service parts must be brought back.

CONTENTS

1. SPECIFICATIONS	1-1
2. GENERAL DESCRIPTION	2-1
2.1 Main Components.....	2-1
2.2 Sectional View	2-2
2.3 Electric Parts Layout.....	2-3
2.4 Symbols and Functions of Various Components.....	2-4
2.5 Diagram of Signal Blocks.....	2-5
2.5.1 MJ-6101/6103	2-5
2.5.2 MJ-6104	2-5
2.5.3 MJ-6105/6106	2-6
2.6 Description of Interface Signals.....	2-7
2.6.1 MJ-6101/MJ-6103	2-7
2.6.2 MJ-6104	2-7
2.6.3 MJ-6105/6106	2-8
3. DESCRIPTION OF OPERATIONS	3-1
3.1 General Operation	3-1
3.1.1 Overview	3-1
3.1.2 Basic operation	3-1
3.2 Punching Position Alignment Operation	3-2
3.2.1 Skew adjustment	3-2
3.2.2 Sideways deviation adjustment	3-3
3.3 Punching Operation.....	3-4
3.4 Transport Operation	3-8
3.5 Punched Scrap Detection	3-9
4. DISASSEMBLY AND ASSEMBLY	4-1
4.1 Cover	4-1
4.2 Motor	4-4
4.3 Punching Unit	4-8
4.4 Sensor/Switch.....	4-10
4.5 Board	4-16
4.6 Roller	4-17
5. ADJUSTMENT	5-1
5.1 Stopping Position Adjustment.....	5-1
6. TROUBLESHOOTING	6-1
7. MAINTENANCE	7-1
7.1 Maintenance and Inspection Points.....	7-1
7.2 Firmware Update	7-2
7.2.1 MJ-6101/6103 (Firmware updating with download jig).....	7-2
7.2.2 MJ-6104/6105/6106 (Firmware updating with USB device).....	7-4
8. ELECTRIC CIRCUIT	8-1
8.1 Harness Diagram.....	8-1
8.1.1 MJ-6101/MJ-6103	8-1
8.1.2 MJ-6104	8-2
8.1.3 MJ-6105/6106	8-3
8.2 Circuit Diagram	8-4
8.2.1 MJ-6101/MJ-6103	8-4
8.2.2 MJ-6104	8-10
8.2.3 MJ-6105/6106	8-15

8.3	PC Board	8-21
8.3.1	MJ-6101/MJ-6103	8-21
8.3.2	MJ-6104/6105/6106	8-23

1. SPECIFICATIONS

Item	Specification	Remarks
1.Destination	MJ-6101/6103/6104/6105/6106E: Europe/Japan MJ-6101/6103/6104/6105/6106N: North America MJ-6101/6103/6104/6105/6106F:France MJ-6101/6103/6104/6105/6106S: Sweden	2 holes Automatically switches between 2 and 3 holes 4 holes 4 holes
2.Punching method	Sequential punching	
3.Hole position correction system	Provided	
4.Paper size	MJ-6101/6103/6104/6105/6106E: A3, A4, A4-R, B4, B5, B5-R, FOLIO, LD, LG, LT, LT-R, COMPUTER, 13"LG, 8.5"SQ, 8K, 16K, 16K-R MJ-6101/6103/6104/6105/6106N: 2 holes: A4-R, B4, B5, B5-R, FOLIO, LG, LT-R, COMPUTER, 16K-R 3 holes: A3, A4, LD, LT, 8K, 16K MJ-6101/6103/6104/6105/6106F: A3, A4, LD, LT, 8K, 16K MJ-6101/6103/6104/6105/6106S: A3, A4, A4-R, B4, B5, B5-R, FOLIO, LD, LG, LT, LT-R, COMPUTER, 13"LG, 8.5"SQ, 8K, 16K, 16K-R	Reused paper not available
5.Paper weight	MJ-6101/6103 : 64 to 280g/m ² (17 lb. Bond to 100 lb. Cover) MJ-6104/6105/6106 : 60 to 280g/m ² (16 lb. Bond to 100 lb. Cover)	Paper weight for hole punch: MJ-6101/6103 : 64 to 256g/m ² (17 lb. Bond to 94.5 lb. Cover) MJ-6104/6105/6106 : 60 to 256g/m ² (16 lb. Bond to 94.5 lb. Cover) * Reused paper not available
6.Punched hole diameter	MJ-6101/6103/6104/6105/6106E: φ6.5 mm (φ0.256 in.) MJ-6101/6103/6104/6105/6106N: φ8.0 mm (φ0.315 in.) MJ-6101/6103/6104/6105/6106F: φ6.5 mm (φ0.256 in.) MJ-6101/6103/6104/6105/6106S: φ6.5 mm (φ0.256 in.)	

Item	Specification	Remarks
7.Punched scrap container capacity	MJ-6101/6103/6104/6105/6106E: Approx. 5,000 sheets MJ-6101/6103/6104/6105/6106N: Approx. 3,000 sheets MJ-6101/6103/6104/6105/6106F: Approx. 5,000 sheets MJ-6101/6103/6104/6105/6106S: Approx. 5,000 sheets	64g/m ² (17 lb. Bond) paper or equivalent 75g/m ² (20 lb. Bond) paper or equivalent 80g/m ² (21.3 lb. Bond) paper or equivalent 80g/m ² (21.3 lb. Bond) paper or equivalent
8.Dimensions	W112 x D573 x H323 (mm) W4.41 x D22.56 x H12.72 (inch)	Excluding the front and rear lower cover
9.Weight	Approx. 7kg (Approx. 15.43 lb.)	
10.Power supply	MJ-6101/6103 : DC24V±10%, DC5V±5% MJ-6104/6105/6106 : DC24V +10/-5%, DC5V +5/-4%	Supplied from the Finisher
11.Bundled	Front lower cover: 1pc Front lower cover bracket: 1pc Rear lower cover: 1pc Rear lower cover bracket: 1pc Screws: 2pcs Unpacking instruction: 1set	M4 x 8
12.Color	MJ-6101 : NEW POLITE GRAY MJ-6103 : DEEP VIOLET GRAY MJ-6104 : FAIR WHITE MJ-6105/6106 : JET BLACK	The width of the entrance guide is also different between MJ-6101 and MJ-6103/MJ-6104.

13. Hole position

[1] 2-Hole (MJ-6101/6103/6104/6105/6106E)

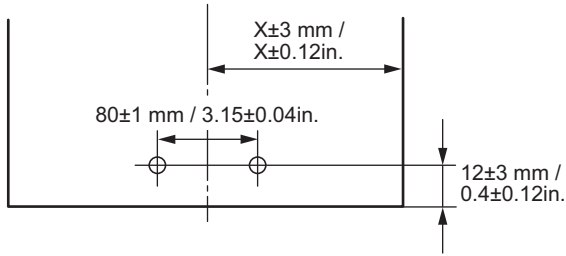

[3] 4-Hole (MJ-6101/6103/6104/6105/6106F)

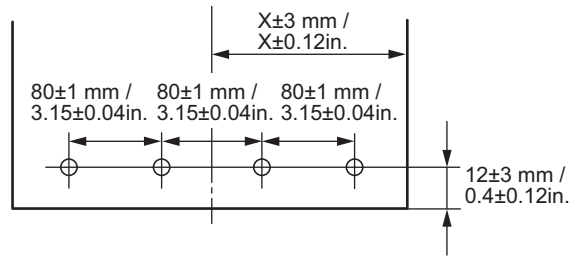

[2] 2-Hole / 3-Hole (MJ-6101/6103/6104/6105/6106N) [4] 4-Hole (MJ-6101/6103/6104/6105/6106S)

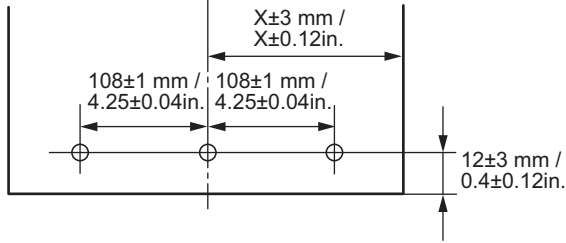
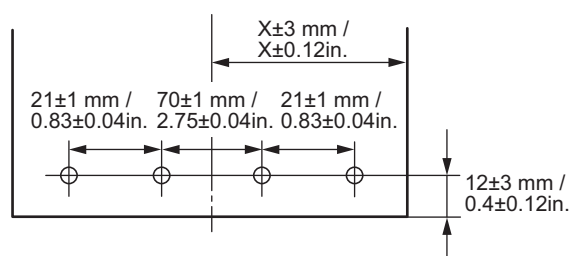
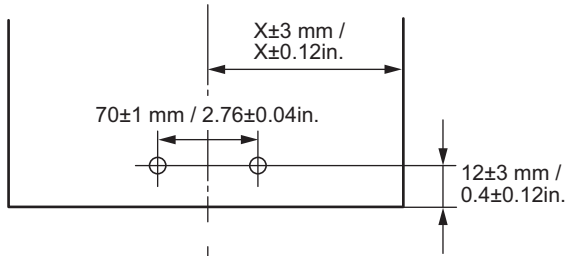

X :

A3/A4	148.5 mm / 58.46 in.
B4/B5	128.5 mm / 5.06 in.
A4-R/FOLIO	105 mm / 4.13 in.
B5-R	91 mm / 3.58 in.
LD/LT	139.5 mm / 5.5 in.
LG/LT-R/13"LG/8.5"SQ	108 mm / 4.25 in.
COMPUTER	128.5 mm / 5.06 in.
8K/16K	135 mm / 5.31 in.
16K-R	97.5 mm / 3.84 in.

2. GENERAL DESCRIPTION

2.1 Main Components

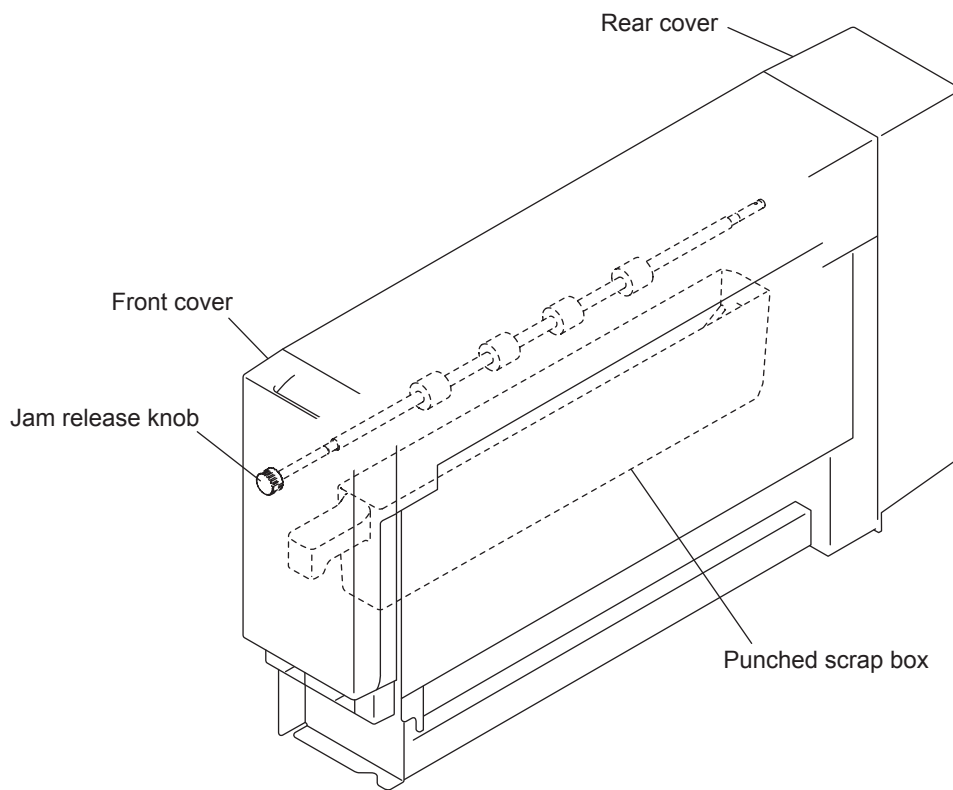

Fig. 2-1

2.2 Sectional View

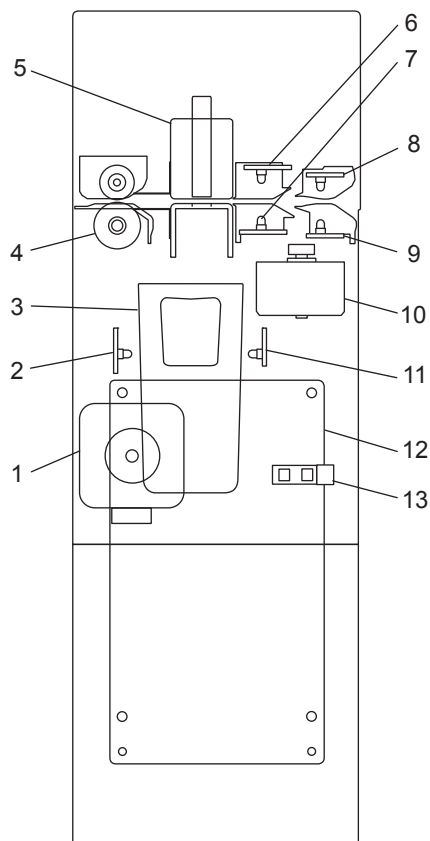

Fig. 2-2

1	Transport motor
2	Punched scrap full sensor (SEN)
3	Punched scrap box
4	Transport roller
5	Punching unit
6	Paper position sensor (SEN)
7	Paper position sensor (LED)
8	Skew sensor (SEN)
9	Skew sensor (LED)
10	Sideways adjustment motor
11	Punched scrap full sensor (LED)
12	Hole punch control PC board (PNC board)
13	Front cover sensor

2.3 Electric Parts Layout

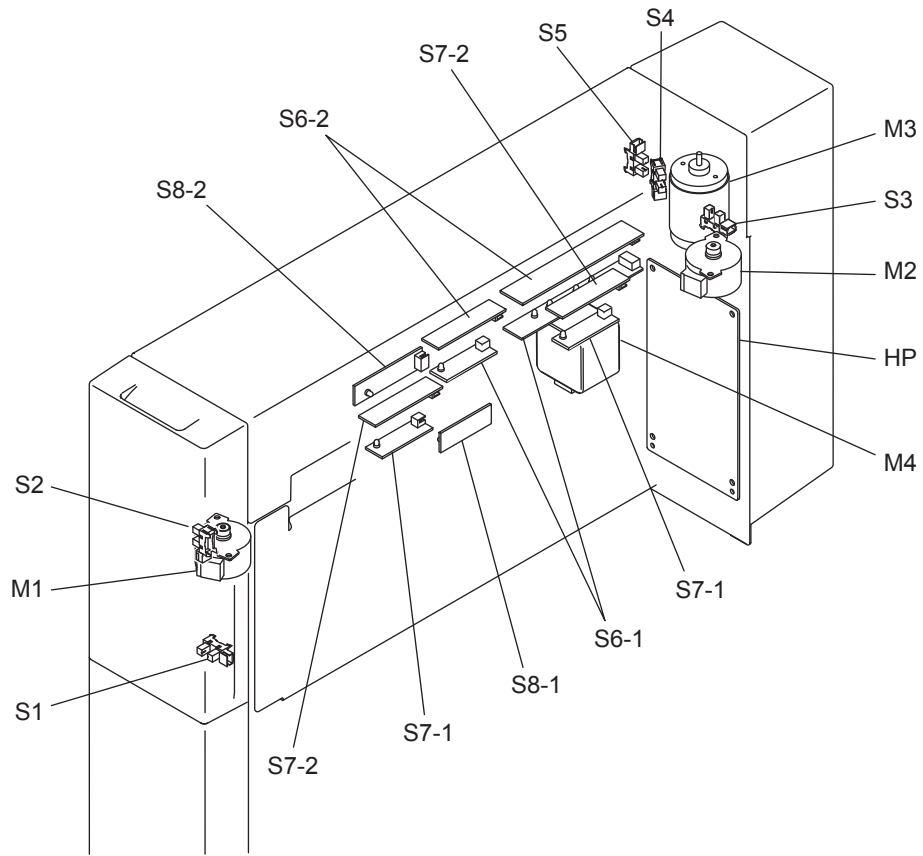

Fig. 2-3

2.4 Symbols and Functions of Various Components

The column <P-I> shows the page and item number in the parts list.

1) Motors

Symbol	Name	Function	P-I	Remarks
M1	Skew adjustment motor	Adjusts the punch hole position according to the skew of paper.		
M2	Sideways adjustment motor	Adjusts the punch hole position according to the sideways deviation of paper.		
M3	Punch motor	Drives the punch head to punch holes on paper.		
M4	Transport motor	Transports paper to the Finisher.		

2) Sensors

Symbol	Name	Function	P-I	Remarks
S1	Front cover sensor	Detects opening/closing of the front cover.		
S2	Skew home position sensor	Detects the home position of the punching unit when skew is adjusted.		
S3	Sideways deviation home position sensor	Detects the home position of the punching unit when sideways is adjusted.		
S4	Punch home position sensor	Detects the home position of the punch head.		
S5	Punching sensor	Detects the timing for braking the punch motor.		
S6-1	Paper position sensor (LED)	Detects the leading/side/trailing edge of the paper (Light emitting part)		
S6-2	Paper position sensor (SEN)	Detects the leading/side/trailing edge of the paper (Light sensing part)		
S7-1	Skew sensor (LED)	Detects the skew of the paper.(Light emitting part)		
S7-2	Skew sensor (SEN)	Detects the skew of the paper.(Light sensing part)		
S8-1	Punched scrap full sensor (LED)	Detects the punched scrap full state.(Light emitting part)		
S8-2	Punched scrap full sensor (SEN)	Detects the punched scrap full state.(Light sensing part)		

3) PC board

Symbol	Name	Function	P-I	Remarks
HP	Hole punch control PC board (PNC board)	Controls the hole punch unit.		

2.5 Diagram of Signal Blocks

2.5.1 MJ-6101/6103

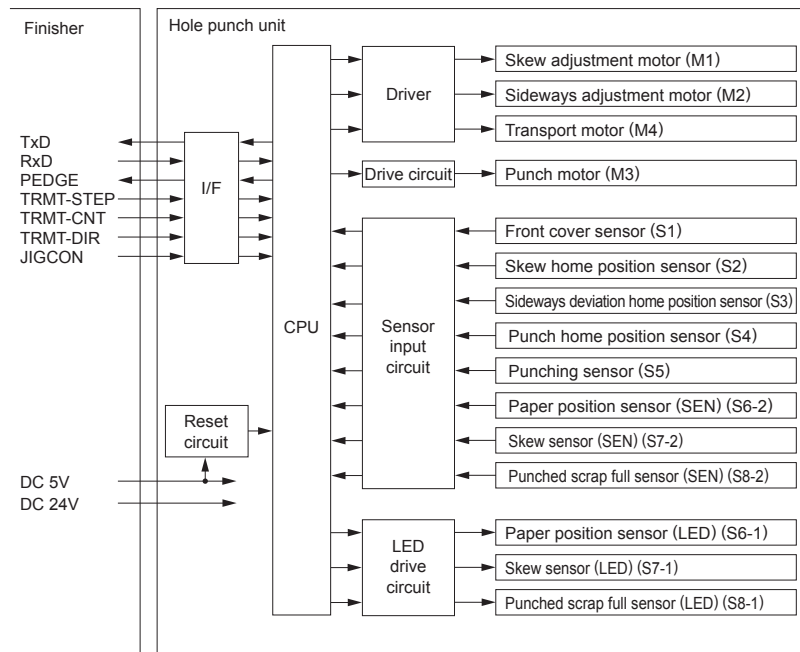

Fig. 2-4

2.5.2 MJ-6104

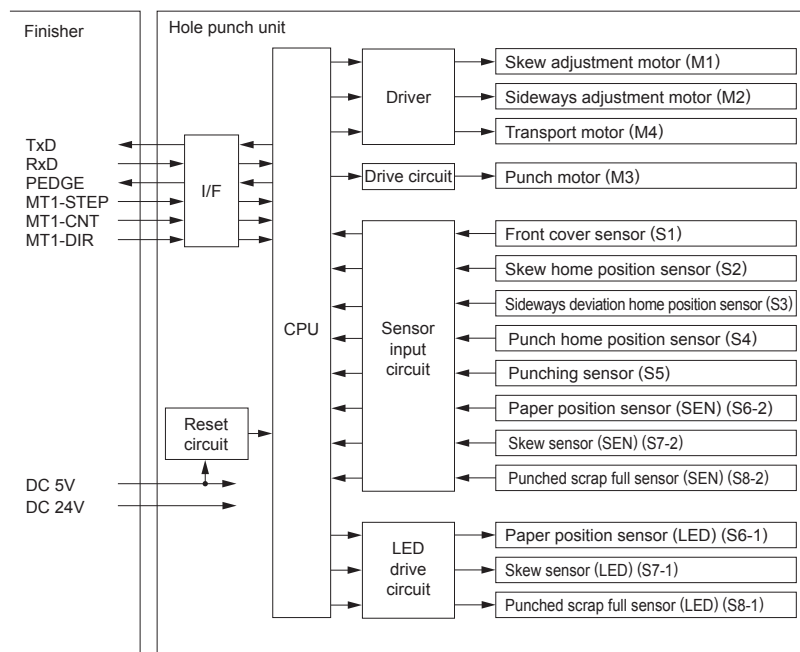

Fig. 2-5

2.5.3 MJ-6105/6106

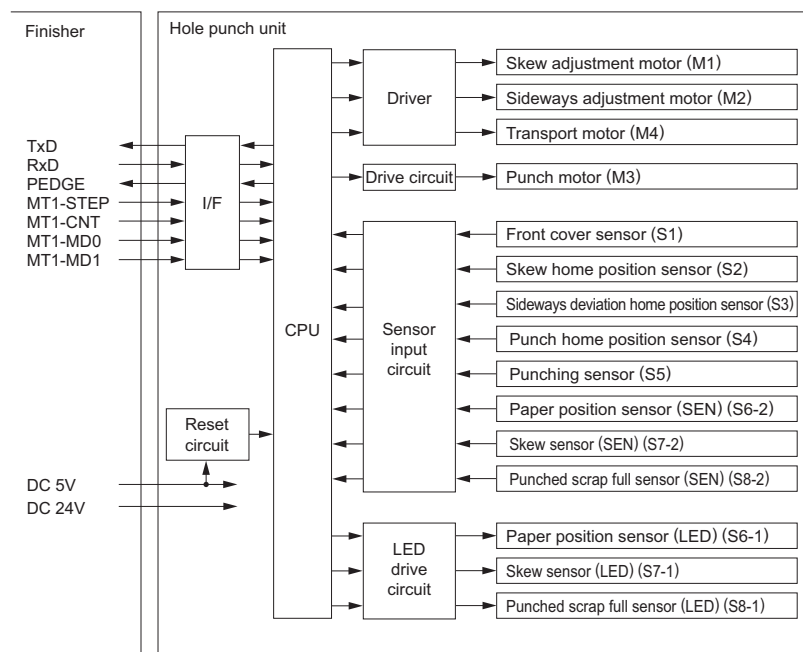

Fig. 2-6

2.6 Description of Interface Signals

The hole punch unit operates when a control signal from the Finisher is received.

The 2 lines; TXD and RXD are used to transmit/receive signals between the hole punch unit and the Finisher. Also, control signals which are used to drive the motor and detection signals of the hole punch unit are connected.

2.6.1 MJ-6101/MJ-6103

- TXD: Sent data (transmitted from the hole punch unit to the Finisher)
- RXD: Received data (transmitted from the Finisher to the hole punch unit)
- TRMT-STEP: Transport motor drive pulse signal (from the Finisher to the hole punch unit)
- TRMT-CNT: Transport motor electric current setting signal (from the Finisher to the hole punch unit)
- TRMT-DIR: Transport motor rotational direction signal (from the Finisher to the hole punch unit)
- PEDGE: Paper end detection signal (from the hole punch unit to the Finisher)
- JIGCON: Hole Punch Unit firmware downloading control signal

Data communication (RXD and TXD) between the hole punch unit and the Finisher has adopted the serial communication system which does not allow checking whether the signals are transmitted/received properly using testing devices in the field.

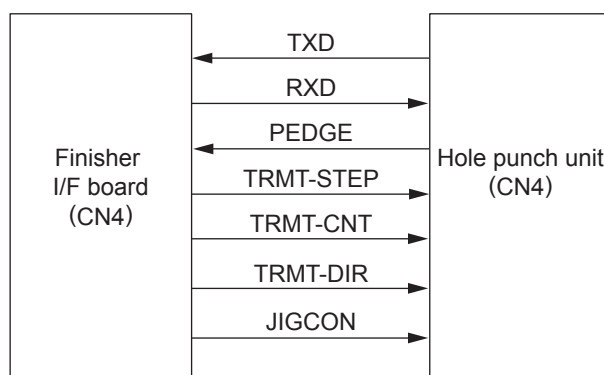

Fig. 2-7

2.6.2 MJ-6104

- TXD: Sent data (transmitted from the hole punch unit to the Finisher)
- RXD: Received data (transmitted from the Finisher to the hole punch unit)
- MT1-STEP: Transport motor drive pulse signal (from the Finisher to the hole punch unit)
- MT1-CNT: Transport motor electric current setting signal (from the Finisher to the hole punch unit)
- MT1-DIR: Transport motor rotational direction signal (from the Finisher to the hole punch unit)
- PEDGE: Paper end detection signal (from the hole punch unit to the Finisher)

Data communication (RXD and TXD) between the hole punch unit and the Finisher has adopted the serial communication system which does not allow checking whether the signals are transmitted/received properly using testing devices in the field.

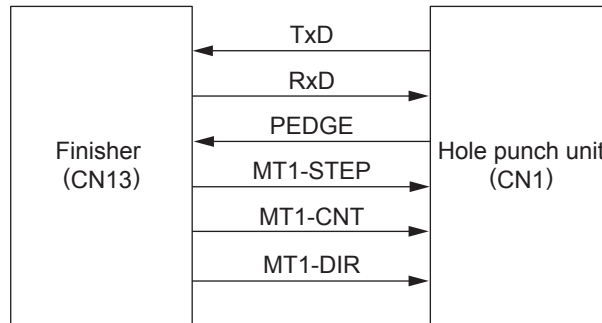

Fig. 2-8

2.6.3 MJ-6105/6106

- TxD: Sent data (transmitted from the hole punch unit to the Finisher)
- RxD: Received data (transmitted from the Finisher to the hole punch unit)
- TRMT-STEP: Transport motor drive pulse signal (from the Finisher to the hole punch unit)
- TRMT-CUR: Transport motor electric current setting signal (from the Finisher to the hole punch unit)
- TRMT-MD0: Transport motor excitation method setting signal (from the Finisher to the hole punch unit)
- TRMT-MD1: Transport motor excitation method setting signal (from the Finisher to the hole punch unit)

Data communication (RxD and TxD) between the hole punch unit and the Finisher has adopted the serial communication system which does not allow checking whether the signals are transmitted/received properly using testing devices in the field.

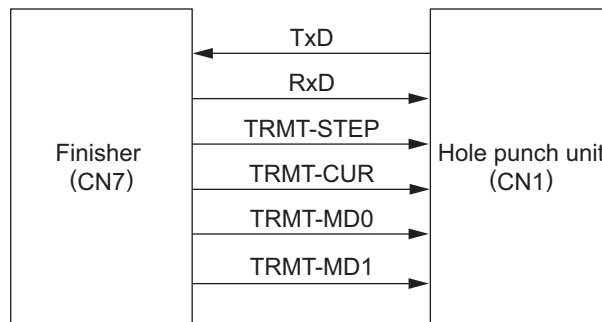

Fig. 2-9

3. DESCRIPTION OF OPERATIONS

3.1 General Operation

3.1.1 Overview

The Hole Punch Unit punches holes in paper transported from the equipment, and then transports the punched paper to the Finisher.

To make holes at the specified positions, this unit detects the level of skew or sideways deviation of the transported paper and adjusts the position of the punching unit (= punching position alignment operation) to the position of the paper. After the punching position alignment operation, the transport operation pauses when the paper reaches the specified position, and then the punching operation starts.

When the punching operation is completed, the punched paper is then transported to the Finisher by the transport roller.

Scraps punched out at the punching operation fall into the punched scrap case and accumulate in it.

3.1.2 Basic operation

The Hole Punch Unit operates by commands from the Finisher and interacts with the Finisher by responding to these commands.

When the unit receives an initialization signal transmitted at the power-ON of the Finisher, it starts detecting the home position of each unit as an initialization operation. This initialization is performed also when the +24V voltage of the Finisher or the Hole Punch Unit is shut off (in case the front cover of the unit is opened or closed, etc.) and when a job is started.

Upon the start of its operation, the Finisher transmits the Hole Punch Unit the signal including information about the job, such as paper sizes, media type or whether the punching operation is required or not. The unit then operates according to this information. The unit continues its operation while the Finisher is operating. (When the Finisher is waiting for a job, the unit does not operate.) When the job is completed and the operation has stopped, the unit deletes the information about this job and prepares for the next job.

The unit does not detect paper jams. Instead, the unit transmits an error signal to the Finisher only when the unit has detected abnormality in its motors or sensors.

3.2 Punching Position Alignment Operation

3.2.1 Skew adjustment

Transmissive-type skew sensors (S7-1/S7-2) are mounted in this Hole Punch Unit. One pair of them is mounted (at the light emitting part and the light sensing part) on the front side of the entrance guide, and the other pair is mounted (at the light emitting part and the light sensing part) on the rear side of the entrance guide. These skew sensors (S7-1/S7-2) detect the leading edge of paper transported to the unit. The degree of paper skew is calculated by a time lag between the detections of the leading edge of the paper on the front and rear sides measured by the skew sensors (S7-1/S7-2).

When the degree of the skew has been calculated, the unit then drives the skew adjustment motor (M1) to move the punching unit from its home position. The skew adjustment motor (M1) uses a stepping motor, and it rotates in a reverse direction or in a normal direction according to the degree of the skew. The rotation of this motor is transmitted to the punching unit by a cam, so the punching unit is skewed at the same degree as that of the paper.

The adjustable range of skew is ± 0.6 degrees. The adjustment requires approx. 0.15 seconds.

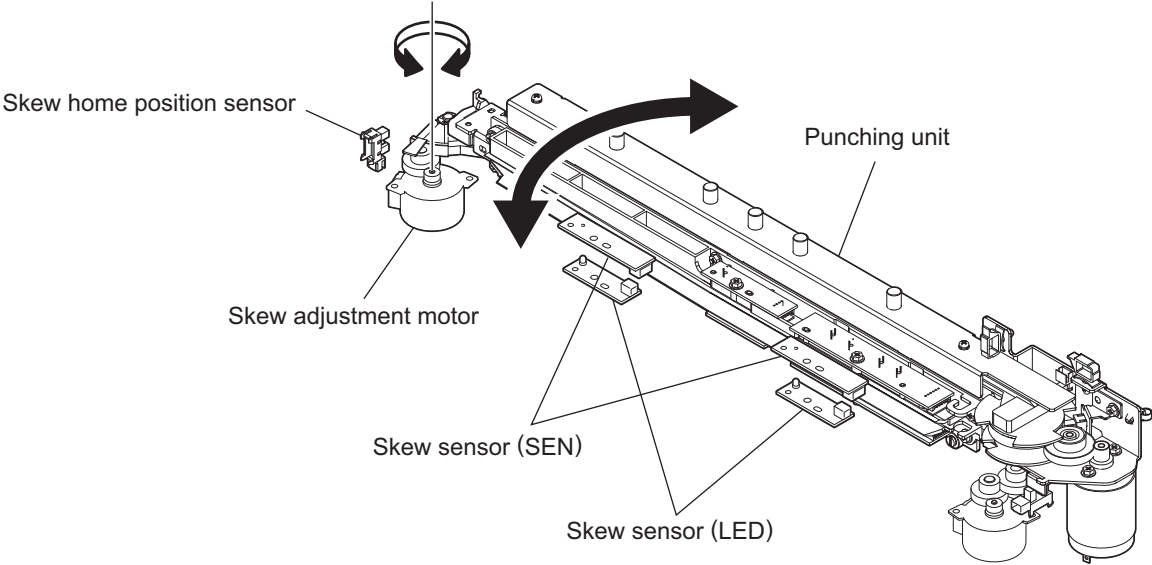

Fig. 3-1

3.2.2 Sideways deviation adjustment

The rear, leading and trailing edges of the paper transported to the Hole Punch Unit are detected by the paper position sensors (S6-1/S6-2). The transmissive-type paper position sensors (S6-1/S6-2) are mounted in the punching unit. One pair of them is mounted (at the light emitting part and the light sensing part) on the rear side of the transport guide and the other pair is mounted (at the light emitting part and the light sensing part) on the center section.

The paper position sensors (S6-1/S6-2) on the center section include 1 LED (light emitting part) and its light sensing part to detect the leading and trailing edges of the paper. The paper position sensors (S6-1/S6-2) on the rear side include 4 LEDs (light emitting part) and their light sensing parts to detect the rear edge of the paper. These 4 LEDs detect the following paper sizes correspondingly:

LED-1	A3, A4, LD, LT
LED-2	B4, B5, COMPUTER, 8K, 16K
LED-3	A4-R, LG, LT-R, FOLIO, 8.5"SQ, 13"LG
LED-4	B5-R, 16K-R

When the skew adjustment is completed, the Hole Punch Unit drives the sideways adjustment motor (M2). The drive of the sideways adjustment motor (M2) is transmitted to the punching unit by a gear and a rack, and this drive makes the punching unit move to the front and the rear. The sideways adjustment motor (M2) uses a stepping motor, and it rotates in a normal direction or in a reverse direction according to the direction of the sideways deviation.

When the sideways adjustment motor (M2) starts its rotation, the punching unit also starts moving from its home position. The hole position is calculated from various information such as the leading edge position of the paper, paper sizes or the degree of the skew. Then the punching unit moves to the calculated position.

When the punching unit has been moved, the unit then checks the trailing edge and front edge positions of the paper, and finely readjusts these positions if required. When the trailing edge of the paper has been detected, the transport operation pauses and the unit starts the next punching.

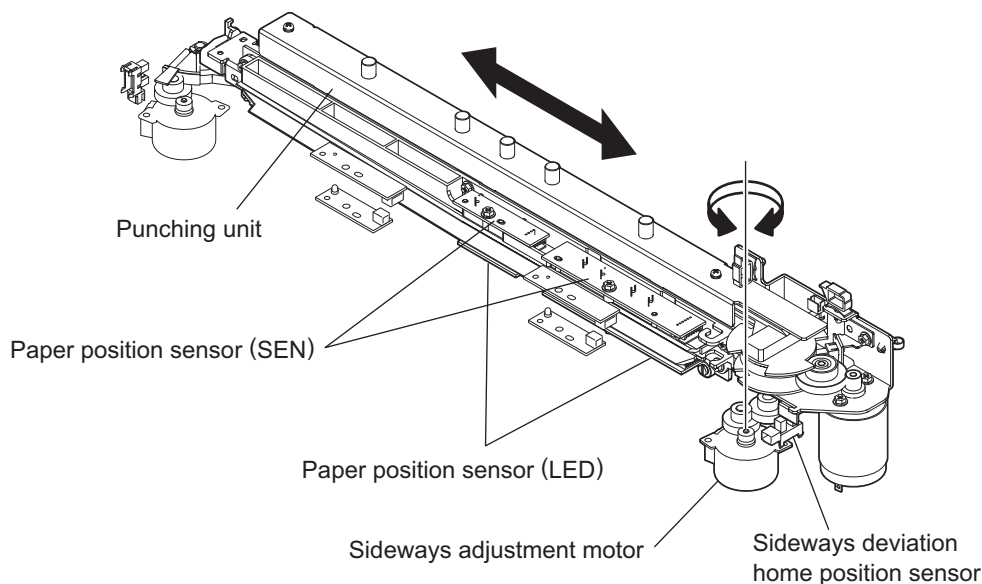

Fig. 3-2

3.3 Punching Operation

The types of punching positions are divided into 4 depending on the destination; 2 holes, 2 or 3 holes, 4 holes for France and 4 holes for Sweden. Each model for these destinations has its own punching unit and individual punching operation.

The punching unit punches paper. This unit turns the rotation of the punch motor (M3) into the transversal movement, and then the cam turns this transversal movement into the hoisting movement of the punch head. When the punch head is lowered, the paper is punched out.

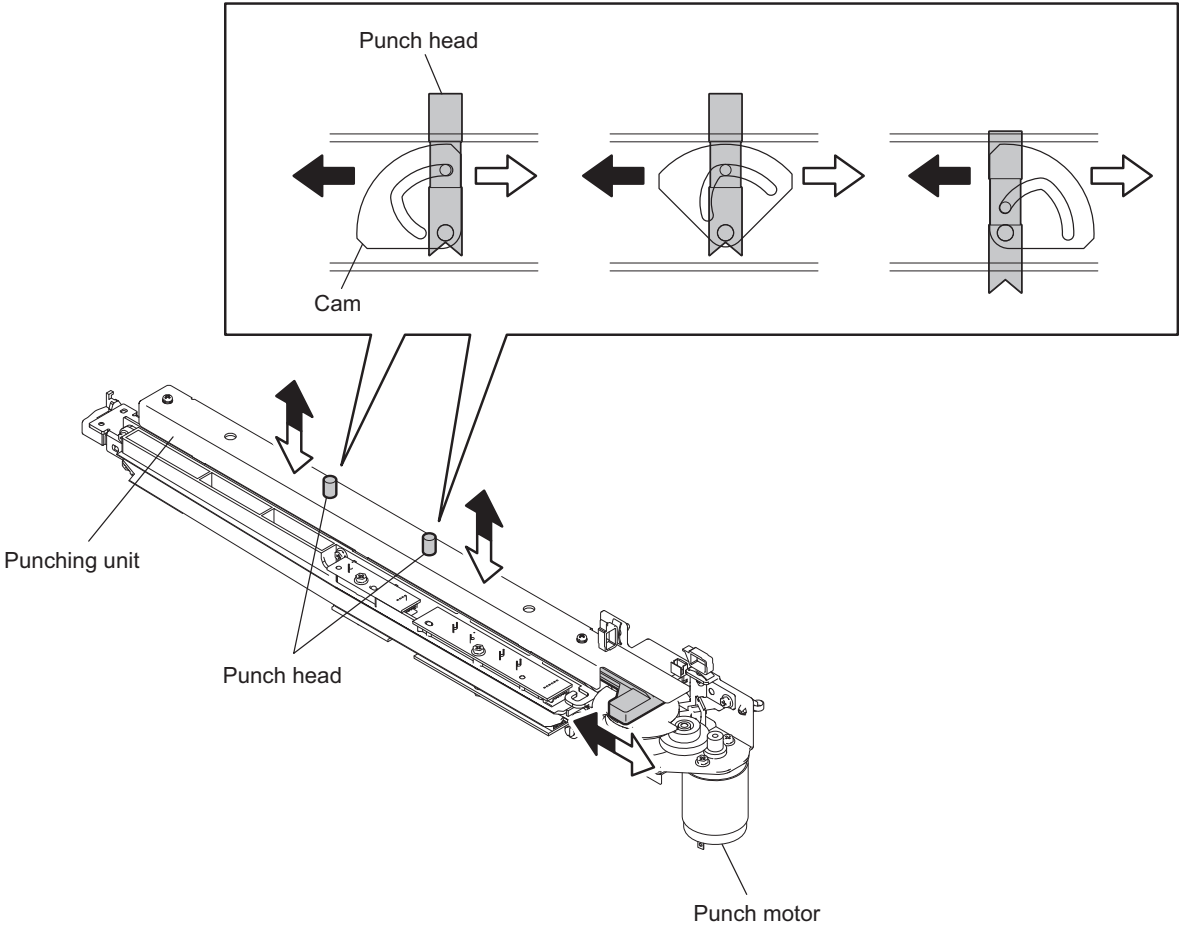

Fig. 3-3

The punch motor (M3) uses a DC motor, and rotates in a normal direction or a reverse direction. The punch home position sensor (S4) detects the home position of the punching unit. The punching sensor (S5) detects the timing to apply the brake on the punch motor (M3).

The punch home position sensor (S4) and the punching sensor (S5) have an actuator to transmit or shut off the detection light at the specified positions. The combinations of these positions and light status are shown below.

	Punch home position sensor (S4)	Punching sensor (S5)
Position 1	Transmit	Shut off
Position 2	Transmit	Transmit

The combinations of the positions 1 and 2, and the rotational direction of the punch motor (M3) decide the punching operation as shown below.

	Number of holes	Position	Rotational direction of punch motor (M5)
MJ-6101/6103/ 6104/6105/6106E 2 holes	2	Position 1 → Position 2	Reverse rotation
		Position 2 → Position 1	Normal rotation
MJ-6101/6103/ 6104/6105/6106N 2 or 3 holes	2	Position 1 → Position 2	Normal rotation
		Position 2 → Position 1	Reverse rotation
	3	Position 1 → Position 2	Reverse rotation
		Position 2 → Position 1	Normal rotation
MJ-6101/6103/ 6104/6105/6106F 4 holes (France)	4	Position 1 → Position 2	Reverse rotation
		Position 2 → Position 1	Normal rotation
MJ-6101/6103/ 6104/6105/6106S 4 holes (Sweden)	4	Position 1 → Position 1	Normal rotation

As for the MJ-6101/6103/6104/6105/6106E/N/F, the punch motor (M3) rotates in a normal direction or in a reverse direction so that their actuators reciprocate between the positions 1 and 2. Paper is thus punched out at the timing along with this reciprocating movement. Namely, 1 punching operation is performed when the actuator has gone half round.

On the other hand, the MJ-6101/6103/6104/6105/6106S has a unique punching operation. In this unit, the punch motor (M3) rotates only in a normal direction and paper is punched out when its actuator detects of the position 1. Namely, 1 punching operation is performed when the actuator has gone one round.

- MJ-6101/6103/6104/6105/6106E

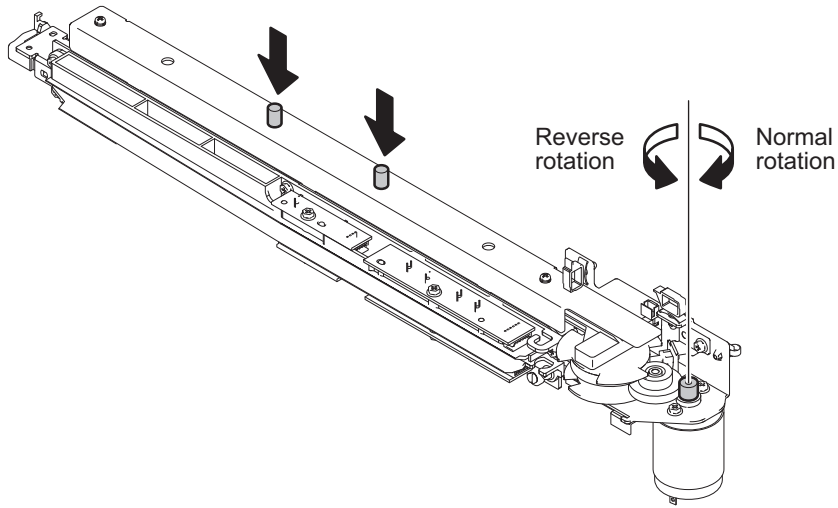

Fig. 3-4

- MJ-6101/6103/6104/6105/6106N

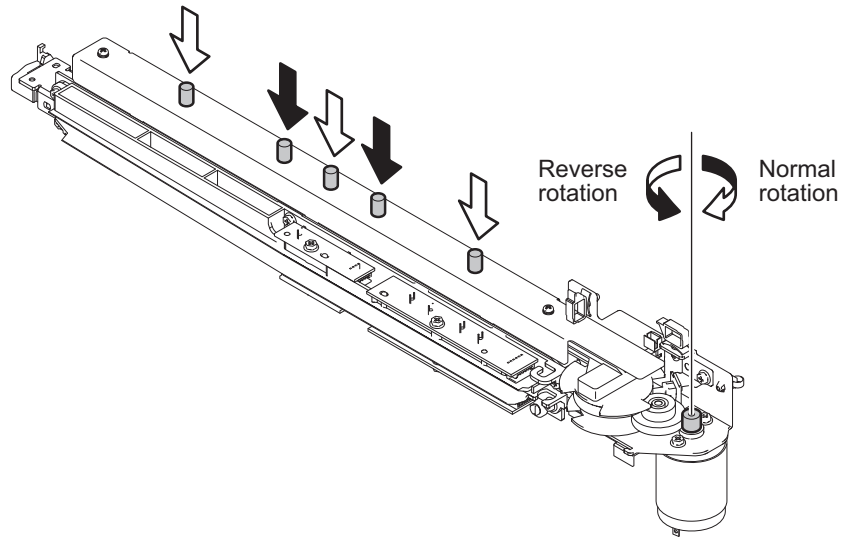

Fig. 3-5

- MJ-6101/6103/6104/6105/6106F

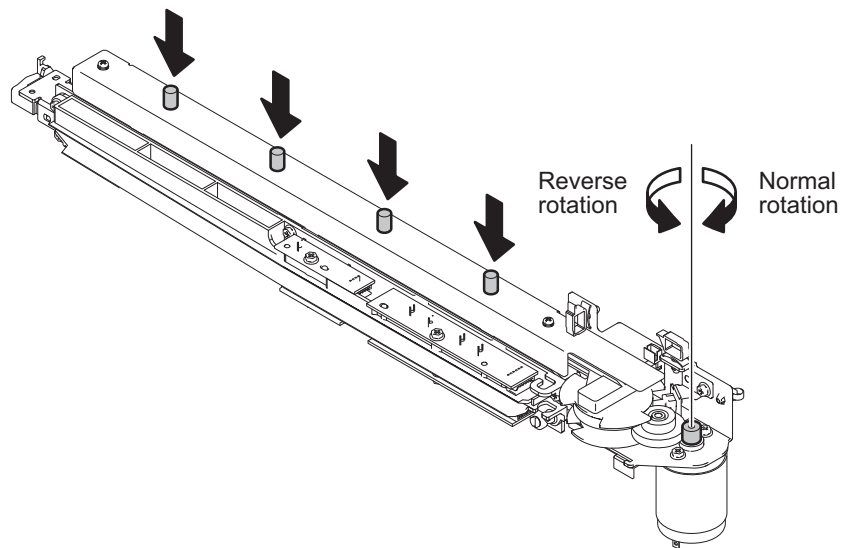

Fig. 3-6

- MJ-6101/6103/6104/6105/6106S

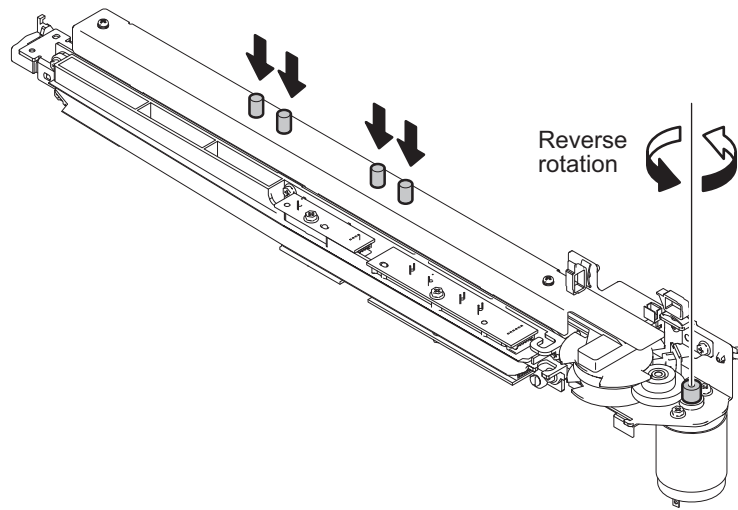

Fig. 3-7

3.4 Transport Operation

This Hole Punch Unit has a transport roller to transport paper. The transport roller is rotated by the drive of the transport motor (M4). The transport motor (M4) uses a stepping motor, and stops its rotation during the punching operation so that the paper is stopped at the specified position for punching. When the punching operation is completed, the motor restarts its rotation to transport the punched paper to the Finisher. The transport motor (M4) is controlled by the finisher.

The rotational speed of the transport roller is divided into 2 types; high speed and low speed. A gear to switch the speed is mounted in this unit. When the transport motor (M4) rotates in a normal direction, the gear moves to the position for high speed, and when the motor rotates in a reverse direction, it moves to the position for low speed, and thus the rotational speed of the transport roller can be switched. Normally the transport roller rotates at high speed. (The motor rotates in a normal direction.) However, it rotates at low speed (the motor rotates in a reverse direction) in the thick paper modes or under certain conditions of the paper transport speed in the connected equipment.

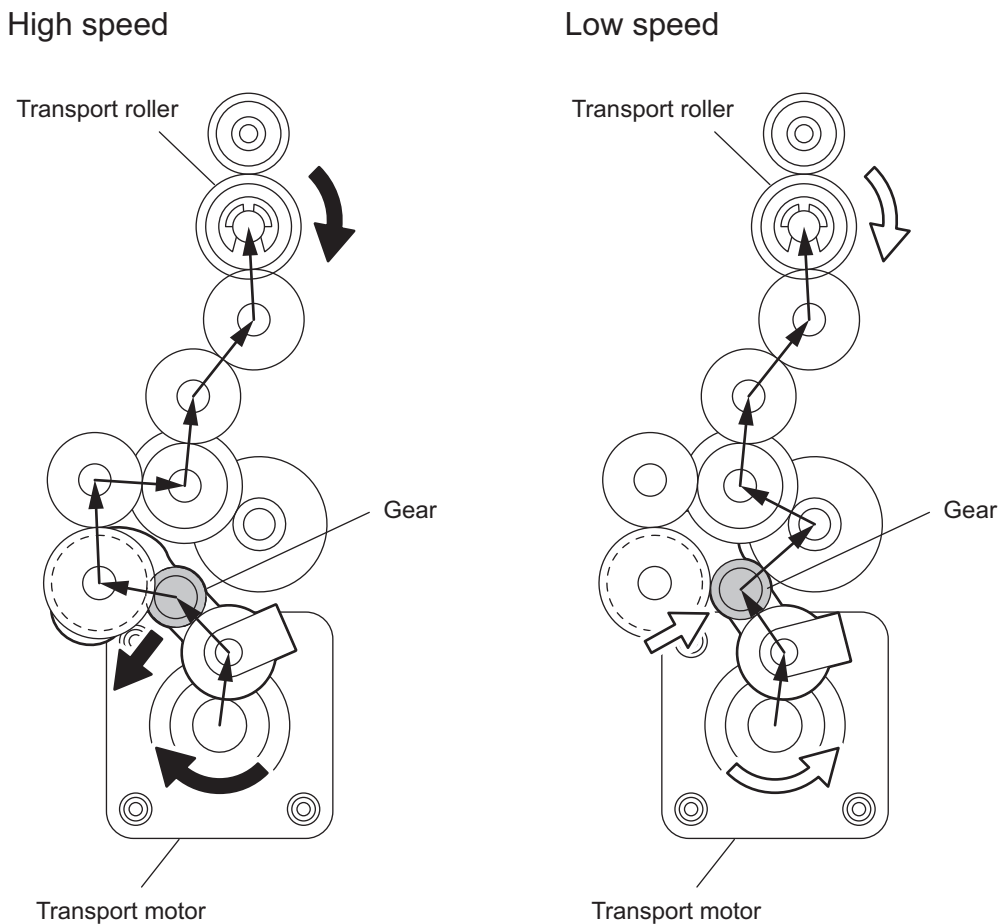

Fig. 3-8

3.5 Punched Scrap Detection

Scraps punched out at the punching operation fall into the punched scrap case and accumulate in it. The punched scrap full sensors (S8-1/S8-2) detect the presence of the punched scrap case and the accumulating status of the punched scraps in the case. There are 2 punched scrap full sensors (S8-1/S8-2); one is on the light emitting part (LED) and the other is on the light sensing part (SEN). When the emitted light is shut off by the accumulated scraps and the sensor therefore cannot sense the light, the sensors detect the full status of punched scraps in the case.

4. DISASSEMBLY AND ASSEMBLY

Note:

It is recommended to take off the punched scrap container before performing maintenance on the hole punch unit in case that the container is full, otherwise the punched scrap may spill out when the unit is moved.

4.1 Cover

[A] Front lower cover

- (1) Open the front cover. Push the 2 latches and take off the front lower cover.

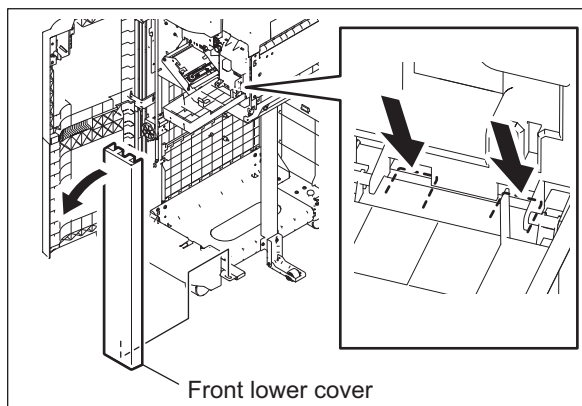

Fig. 4-1

[B] Rear lower cover

- (1) Release 2 latches and take off the rear lower cover.

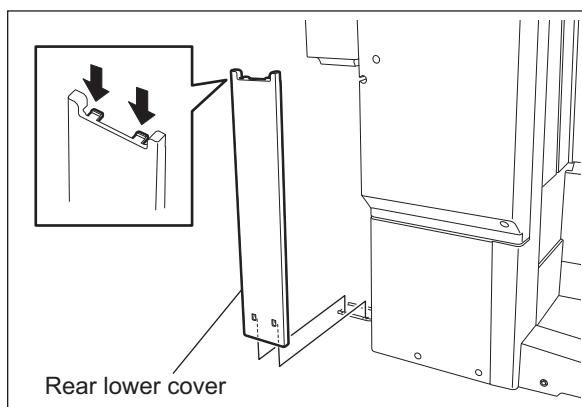

Fig. 4-2

[C] Rear cover

- (1) Take off the rear lower cover.
📖 P. 4-1 "[B] Rear lower cover"
- (2) Remove 3 screws and take off the rear cover.

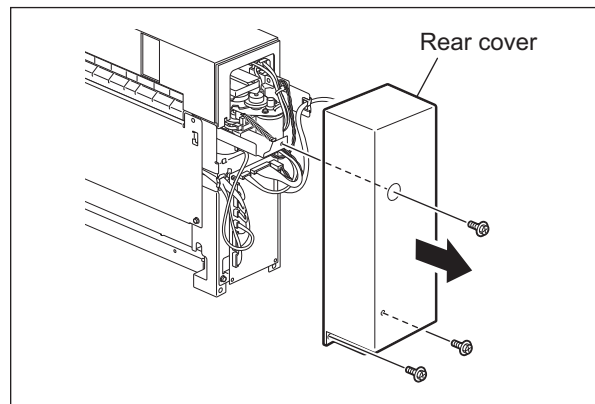

Fig. 4-3

[D] Front cover

- (1) Take off the front lower cover.
📖 P. 4-1 "[A] Front lower cover"
- (2) Open the front cover. Pull out the knob.

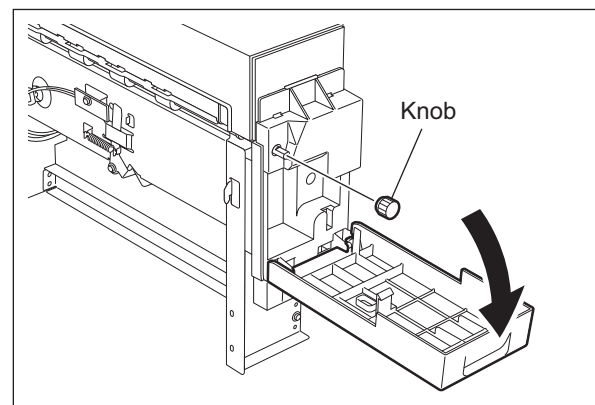

Fig. 4-4

- (3) Remove 3 screws and take off the front cover.

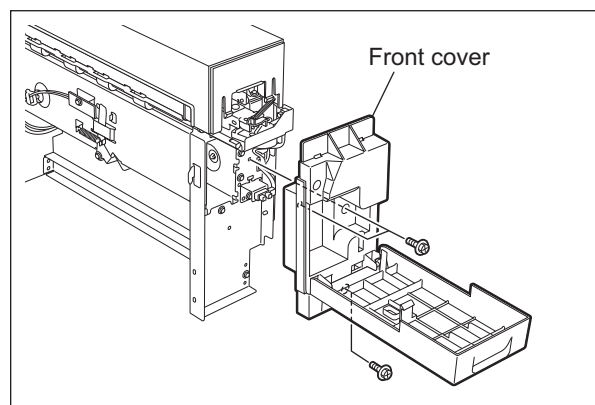

Fig. 4-5

[E] Upper cover

- (1) Take off the rear cover.
📖 P. 4-2 "[C] Rear cover"
- (2) Loosen 2 screws and take off the upper cover.

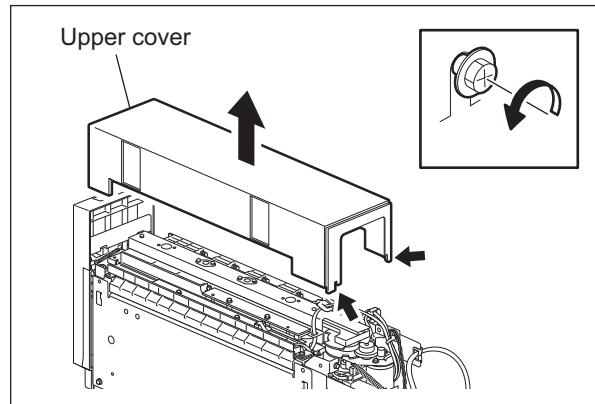

Fig. 4-6

Note:

The screws on the upper side of the punching unit must not be loosened as the unit is assembled with high precision.

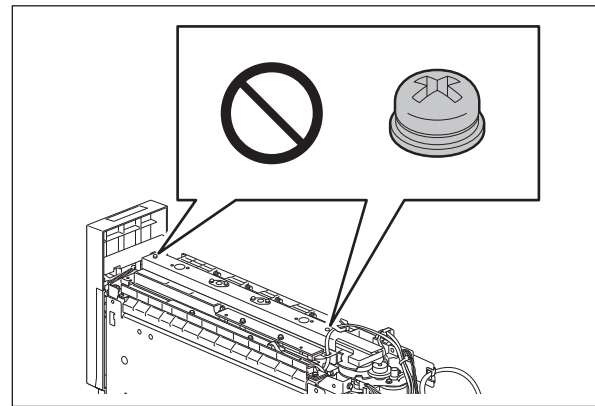

Fig. 4-7

[F] Right cover

- (1) Remove 2 screws. Slide the right cover upward and take it out toward the lower right.

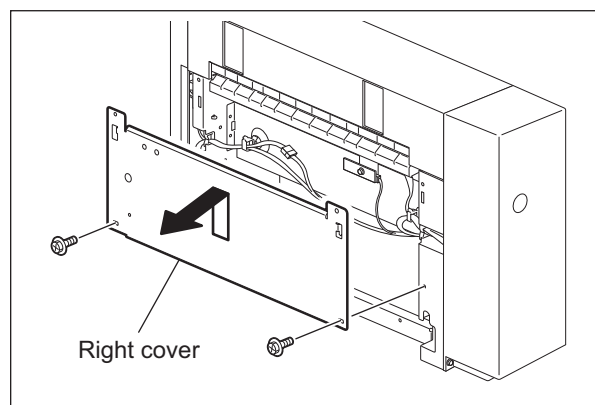

Fig. 4-8

4.2 Motor

[A] Skew adjustment motor (M1)

- (1) Take off the front cover.
📖 P. 4-2 "[D] Front cover"
- (2) Take off the right cover.
📖 P. 4-3 "[F] Right cover"
- (3) Disconnect 1 connector. Release the harnesses from 3 clamps.

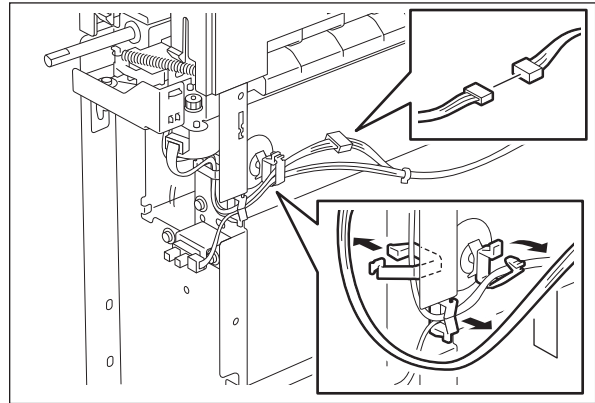

Fig. 4-9

- (4) Remove 2 screws and take off the skew adjustment motor.

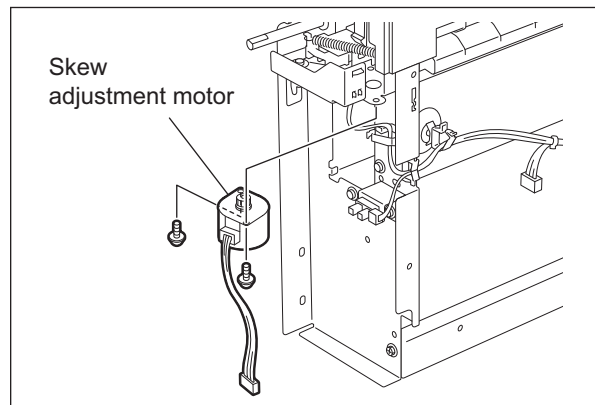

Fig. 4-10

[B] Sideways adjustment motor (M2)

- (1) Take off the upper cover.
P. 4-3 "[E] Upper cover"
- (2) Remove 4 screws and take off the circuit board bracket.

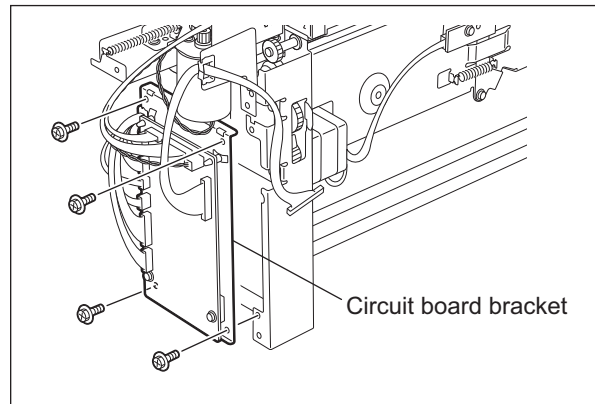

Fig. 4-11

- (3) Disconnect 1 connector. Remove 2 screws and take off the sideways adjustment motor.

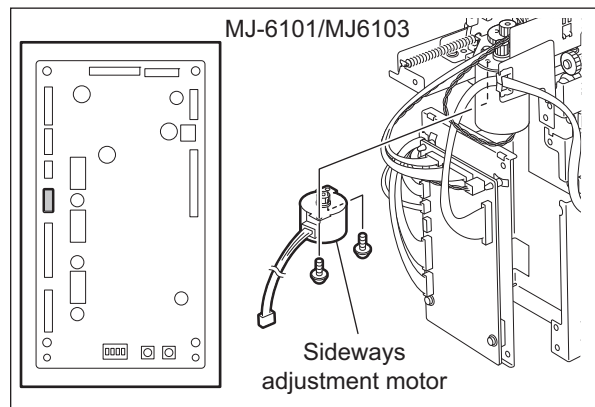

Fig. 4-12

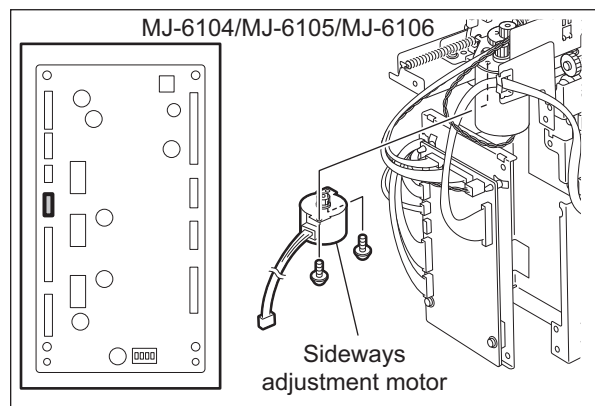

Fig. 4-13

[C] Punch motor (M3)

- (1) Remove the rear cover.
📖 P. 4-2 "[C] Rear cover"
- (2) Release the harness clamp. Disconnect 1 connector, remove 2 screws, and take off the punch motor.

Note:

Pay attention to the size and length of the screws. If you use the wrong ones, the motor could be damaged.

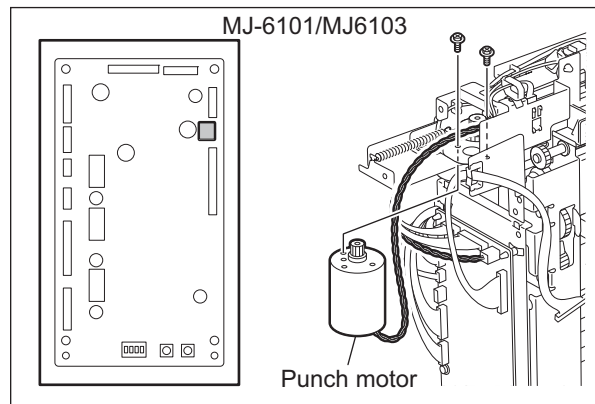

Fig. 4-14

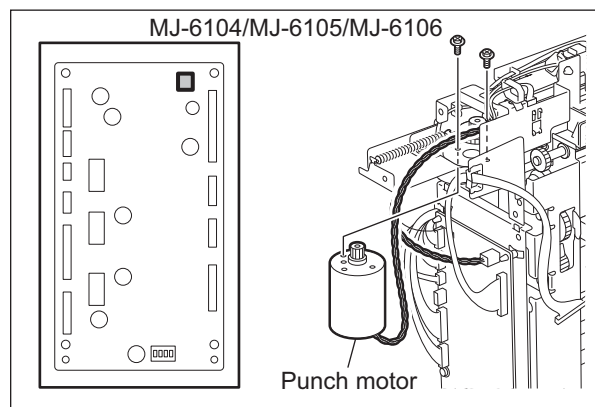

Fig. 4-15

[D] Transport motor (M4)

- (1) Take off the rear cover.
📖 P. 4-2 "[C] Rear cover"
- (2) Remove 4 screws and take off the circuit board bracket.

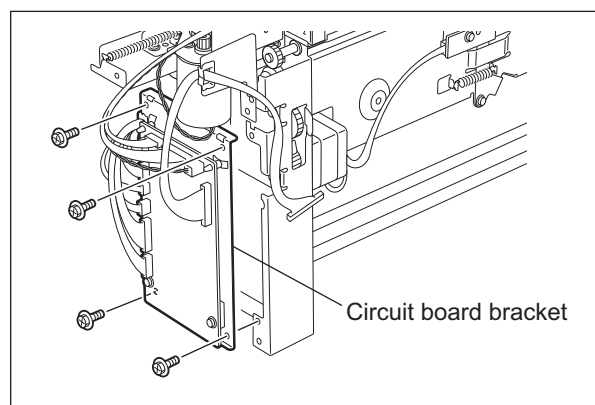

Fig. 4-16

- (3) Remove 3 screws and take off the gear unit.

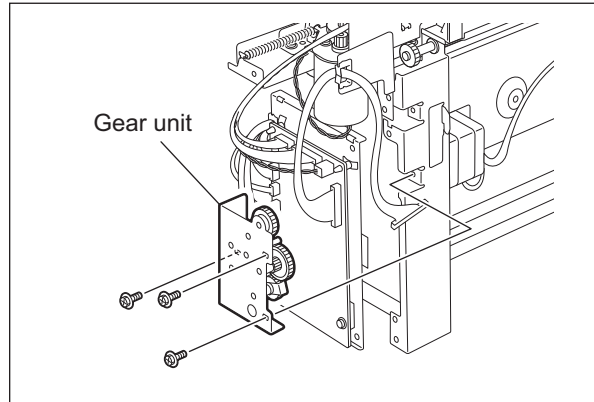

Fig. 4-17

- (4) Disconnect 1 connector. Remove 2 screws, 2 screw dampers, 2 bushings, 1 motor damper and take off the transport motor.

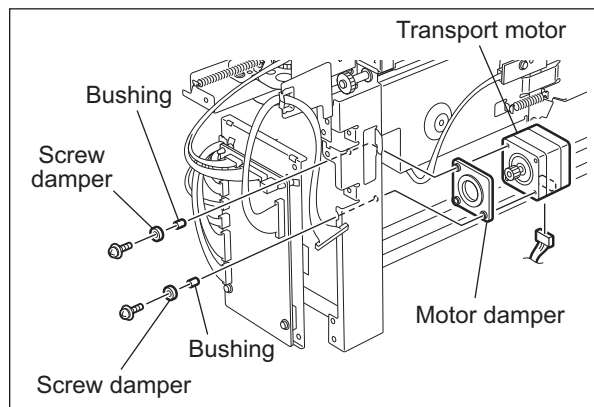

Fig. 4-18

4.3 Punching Unit

[A] Punching unit

- (1) Take off the front cover.
📖 P. 4-2 "[D] Front cover"
- (2) Take off the upper cover.
📖 P. 4-3 "[E] Upper cover"
- (3) Disconnect 4 connectors from the hole punch control PC board.

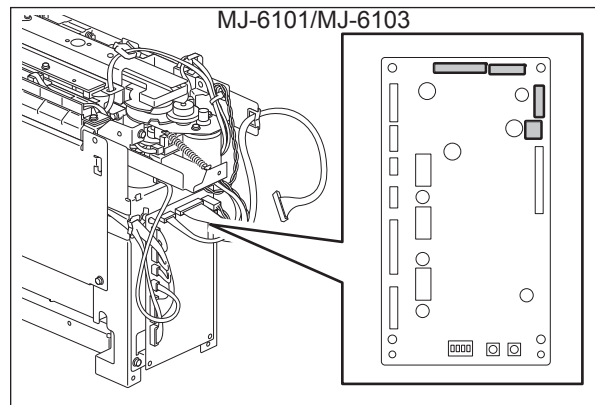

Fig. 4-19

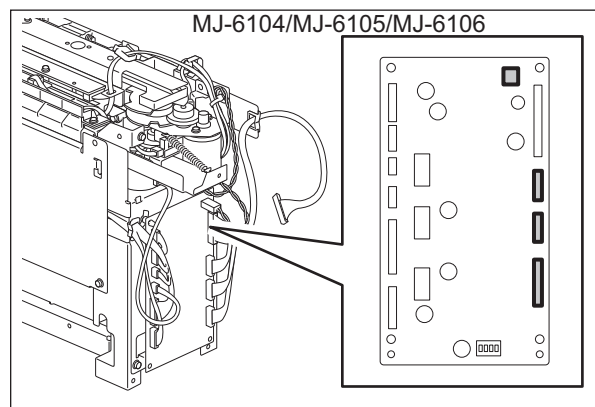

Fig. 4-20

- (4) Remove 2 springs.

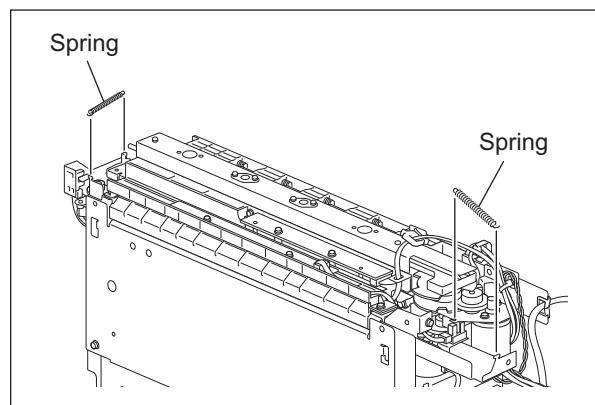

Fig. 4-21

- (5) Remove 2 harness clamps.
- (6) Slide the punching unit toward the rear side and lift it up.

Notes:

- When assembling/disassembling the punching unit, make sure not to damage the Mylar sheet attached to it.

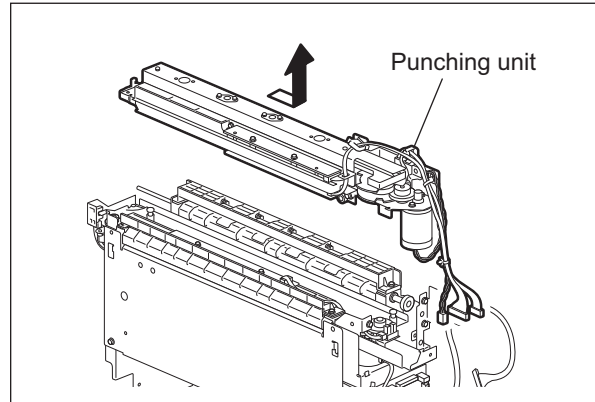

Fig. 4-22

- When installing the lower transport guide of the punching unit, push it to the front side until it touches the upper transport guide, and then tighten the screws to fit it.

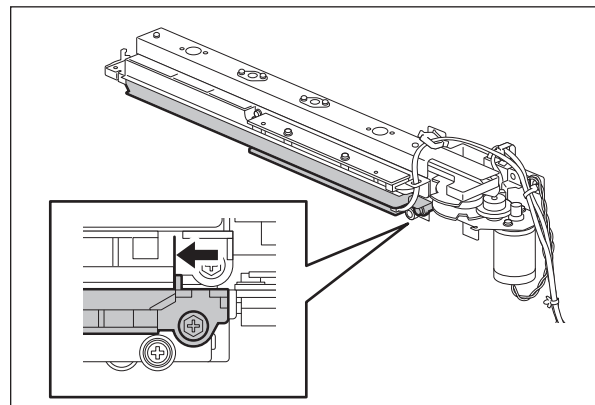

Fig. 4-23

4.4 Sensor/Switch

[A] Front cover sensor (S1)

- (1) Take off the front cover.
📖 P. 4-2 "[D] Front cover"
- (2) Disconnect 1 connector. Release the latches and take off the front cover sensor.

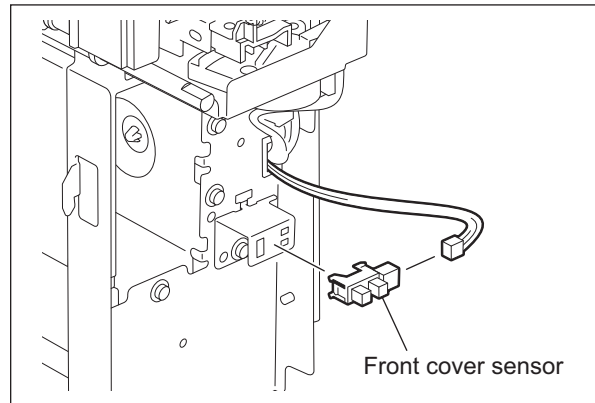

Fig. 4-24

[B] Skew home position sensor (S2)

- (1) Take off the front cover.
📖 P. 4-2 "[D] Front cover"
- (2) Take off the upper cover.
📖 P. 4-3 "[E] Upper cover"
- (3) Rotate the actuator.

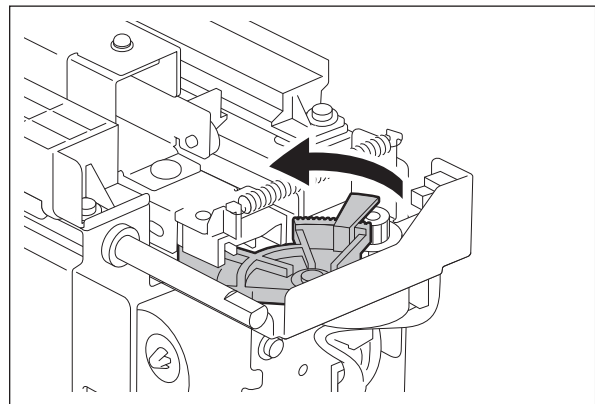

Fig. 4-25

- (4) Disconnect 1 connector. Release the latches and take off the skew home position sensor.

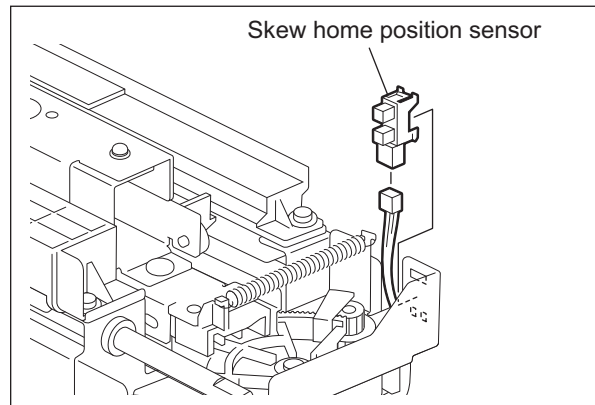

Fig. 4-26

[C] Sideways deviation home position sensor (S3)

- (1) Take off the upper cover.
 📖 P. 4-3 "[E] Upper cover"
- (2) Remove 2 screws and take off the sensor bracket
- (3) Release the latches and take off the sideways deviation home position sensor from the sensor bracket.

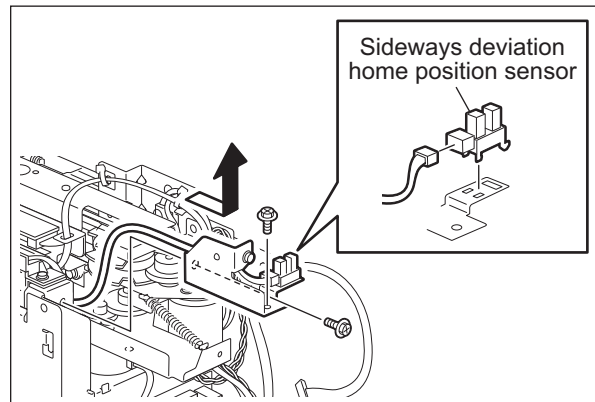

Fig. 4-27

[D] Punch home position sensor (S4)

- (1) Take off the upper cover.
 📖 P. 4-3 "[E] Upper cover"
- (2) Rotate the actuator so that it does not contact the punch home position sensor.

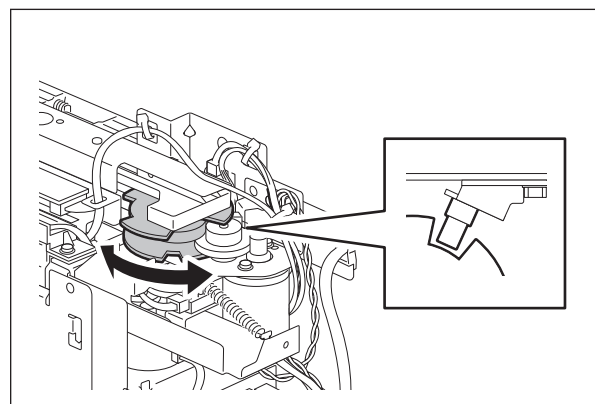

Fig. 4-28

- (3) Disconnect 1 connector, remove 1 screw, and take off the sensor bracket.
- (4) Release the latches and take off the punch home position sensor from the sensor bracket.

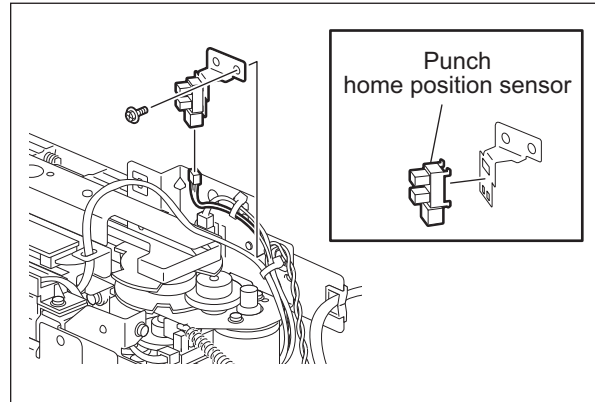

Fig. 4-29

[E] Punch sensor (S5)

- (1) Take off the upper cover.
 P. 4-3 "[E] Upper cover"
- (2) Rotate the actuator so that it does not contact the punch sensor.

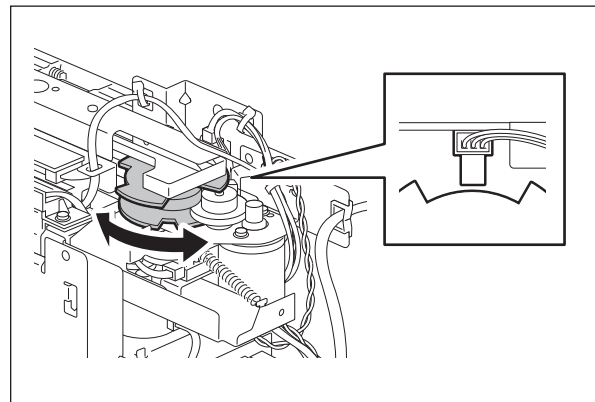

Fig. 4-30

- (3) Disconnect 1 connector. Release the latch and take off the punch sensor.

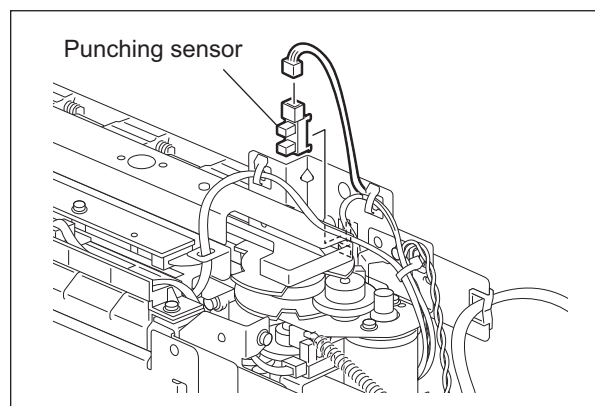

Fig. 4-31

[F] Skew sensor (SEN)(S7-2)

- (1) Take off the upper cover.
📖 P. 4-3 "[E] Upper cover"
- (2) Disconnect 1 connector, remove 1 screw, and take off each skew sensor (SEN).

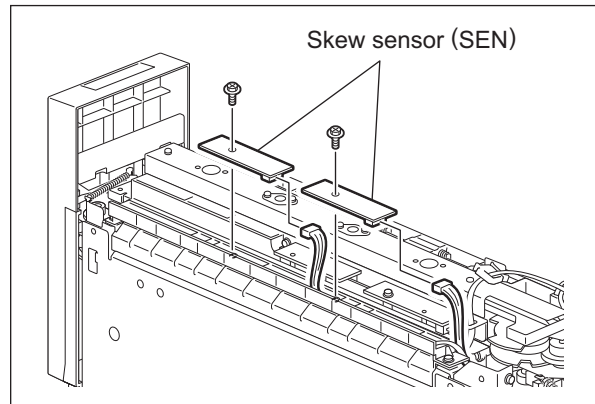

Fig. 4-32

[G] Skew sensor (LED)(S7-1)

- (1) Take off the upper cover.
📖 P. 4-3 "[E] Upper cover"
- (2) Remove 2 screws and take off both the upper and lower entrance guide.

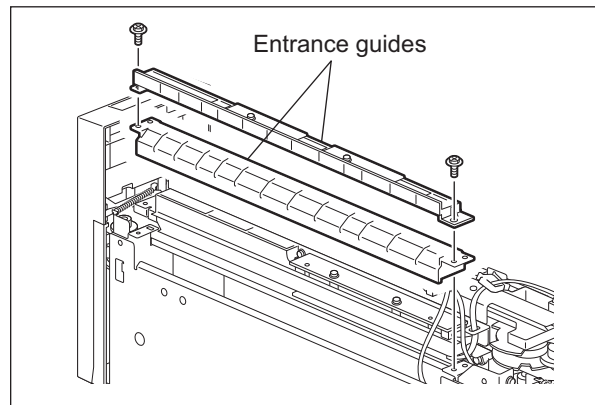

Fig. 4-33

- (3) Disconnect 1 connector and remove 1 screw from the lower entrance guide to take off each skew sensor (LED).

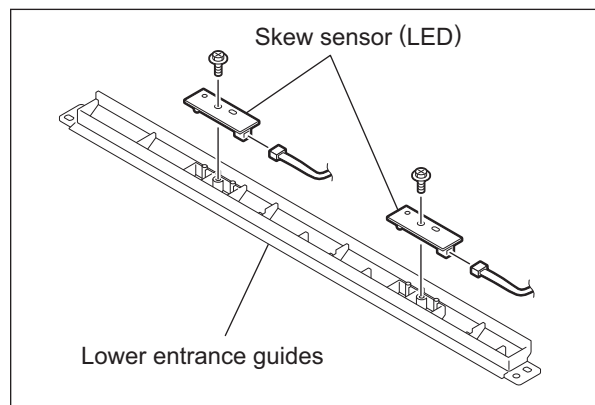

Fig. 4-34

[H] Paper position sensor (SEN)(S6-2)

- (1) Take off the upper cover.
📖 P. 4-3 "[E] Upper cover"
- (2) Disconnect 1 connector, remove 1 screw, and take off each paper position sensor (SEN).

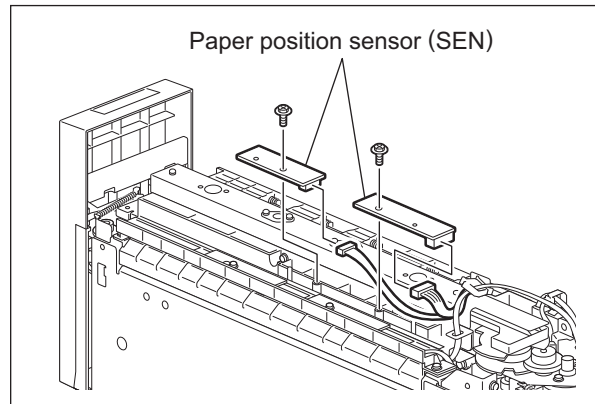

Fig. 4-35

[I] Paper position sensor (LED)(S6-1)

- (1) Take off the punching unit.
📖 P. 4-8 "[A] Punching unit"
- (2) Disconnect 1 connector, remove 1 screw, and take off each paper position sensor (light emitting) from the punching unit.

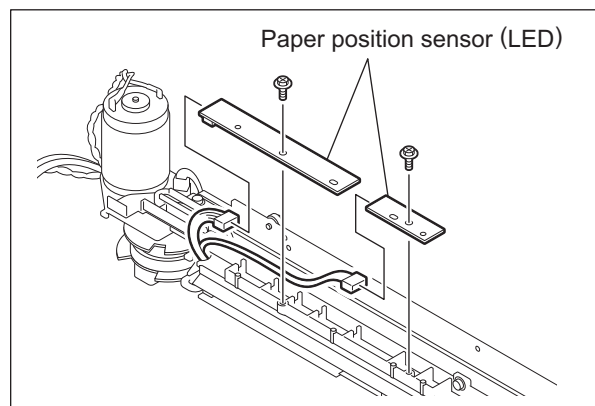

Fig. 4-36

[J] Punched scrap full sensor (SEN)(S8-2)

- (1) Disconnect 1 connector, remove 1 screw, and take off each punched scrap full sensor (SEN).

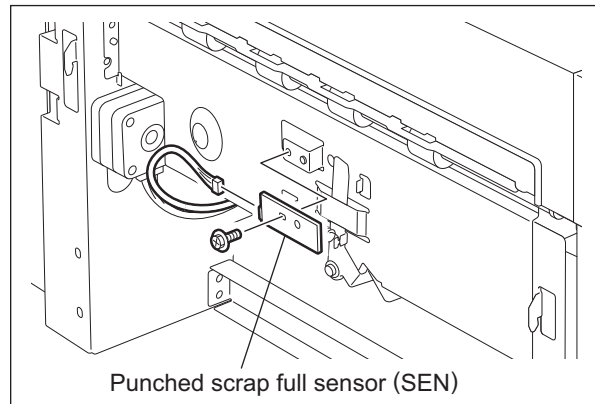

Fig. 4-37

[K] Punched scrap full sensor (LED)(S8-1)

- (1) Take off the right cover.
P. 4-3 "[F] Right cover"
- (2) Disconnect 1 connector, remove 1 screw, and take off each punched scrap full sensor (LED).

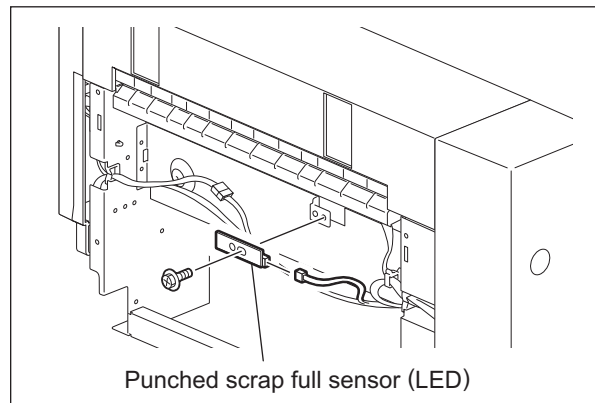



Fig. 4-38

4.5 Board

[A] Hole punch control PC board (HP)

- (1) Take off the rear cover.
 P. 4-2 "[C] Rear cover"
- (2) Disconnect 10 connectors.

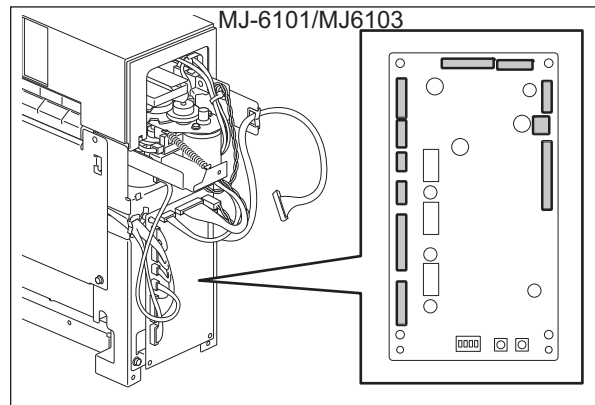

Fig. 4-39

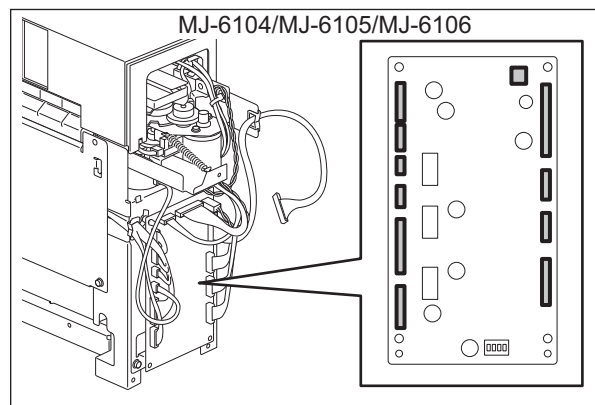

Fig. 4-40

- (3) Remove 4 screws and take off the hole punch control PC board.

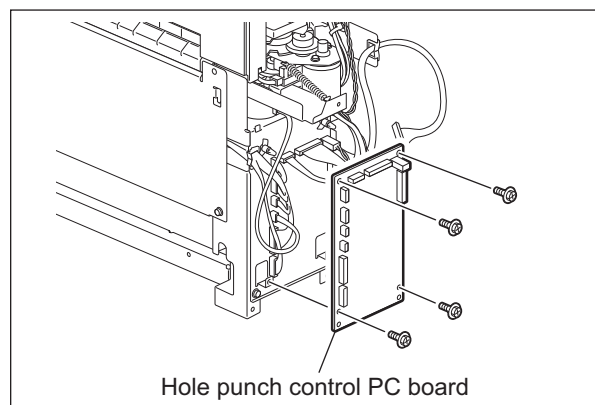

Fig. 4-41

Notes:

- Change the settings of the DIP-SW1 and -SW2 on the hole punch control PC board according to the model as shown in the figure after the hole punch control PC board has been replaced.
- After the hole punch control PC board has been replaced, check that the firmware is the latest version. If not, upgrade it.

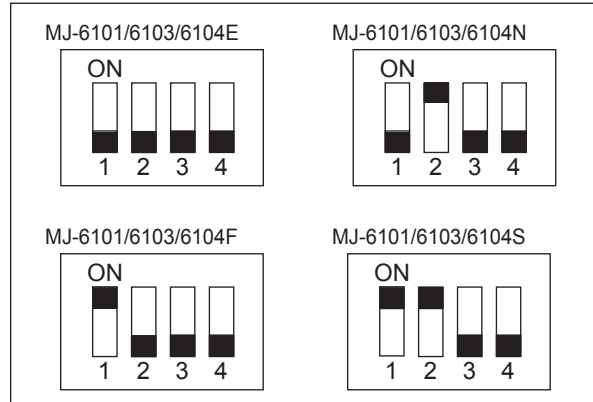

Fig. 4-42

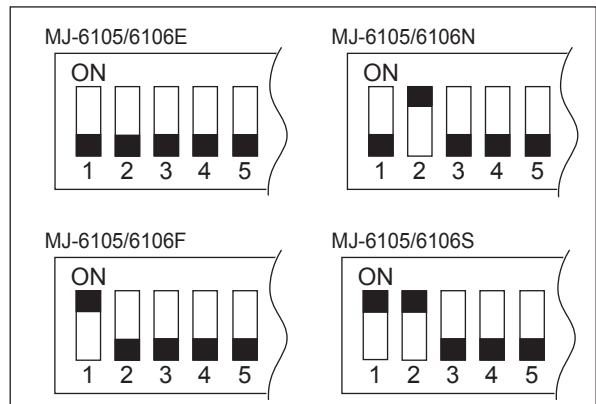

Fig. 4-43

4.6 Roller

[A] Transport roller

- (1) Take off the punching unit.
 P. 4-8 "[A] Punching unit"
- (2) Remove 2 screws and take off both the upper and lower transport guides.

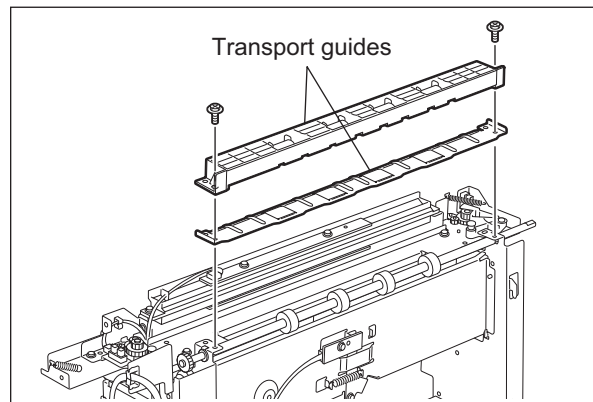

Fig. 4-44

- (3) Remove 2 E-rings, 1 gear, 1 pin and 1 bushing from the rear side of the shaft.

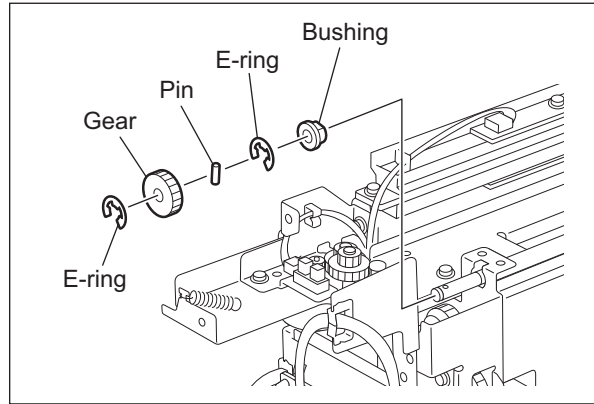

Fig. 4-45

- (4) Remove 1 E-ring and 1 bushing from the front side of the shaft.

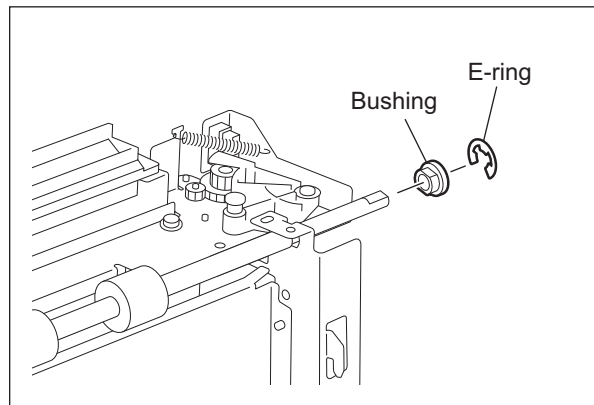

Fig. 4-46

- (5) Take off the transport roller.

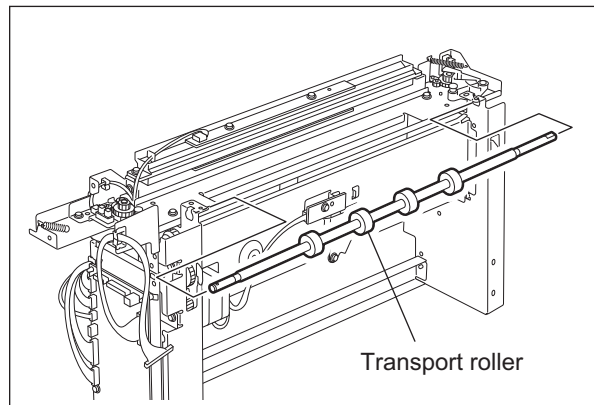

Fig. 4-47

5. ADJUSTMENT

5.1 Stopping Position Adjustment

This adjustment can change the position where paper transport stops during the punching operation. Perform this adjustment when you adjust the punching position on the paper in the transporting direction.

[A] Adjustment with self-diagnostic mode (MJ-6105/6106 only)

Item to be adjusted	Code	Remarks
Hole punch position	FS-05-4838-0	Adjusts the hole punch position in the paper feeding direction. When a positive value is set, it shifts toward the feeding side. When a negative value is set, it shifts toward the exit side. 0: Finisher not installed 1: -1.10mm 2: -0.88mm 3: -0.66mm 4: -0.44mm 5: -0.22mm 6: 0.00mm 7: +0.22mm 8: +0.44mm 9: +0.66mm 10: +0.88mm 11: +1.10mm

If the adjustment values can be confirmed from the pre-change board, check them from the connected equipment and then set them into the post-change board.

[B] Adjustment with DIP-SW

- (1) Turn the power of the equipment OFF.
- (2) Take off the board access cover [1] of the Finisher. Then set SW1 (DIP-SW) [2] on the finisher control PC board as shown below.

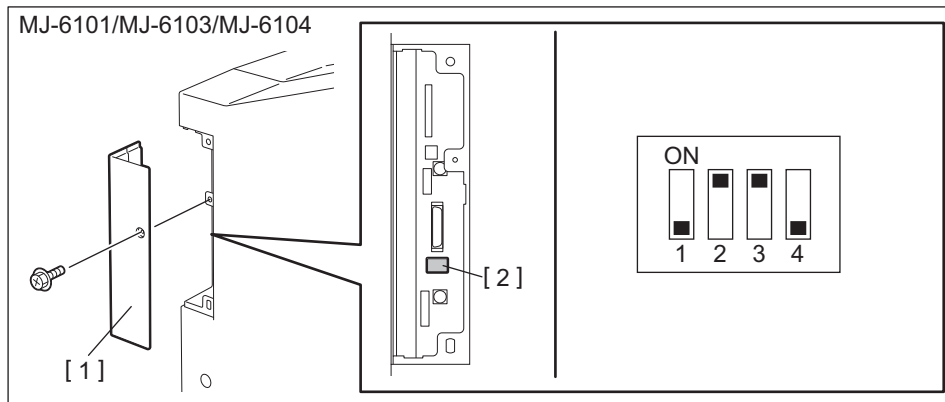

Fig. 5-1w

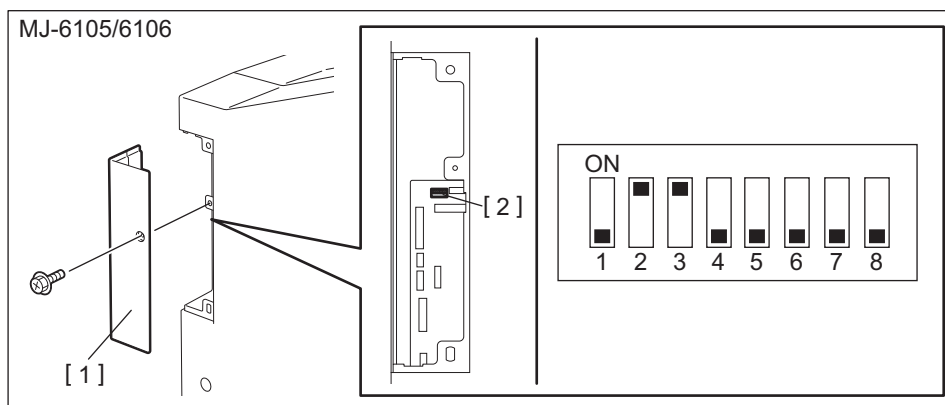

Fig. 5-2

- (3) Turn the power of the equipment ON. The finisher enters into the stopping position adjustment mode.
- (4) LED1 on the finisher control panel blinks. The number of times it blinks indicates the current adjustment value.

- (5) Press Button1 on the finisher control panel to change the adjustment value. The number of times LED1 blinks changes in ascending order (e.g. 1, 2, 3... 11) each time you press Button1

Number of LED1's blinking	Adjustment Value (Steps from the center value)	Distance from the center value
1	-5	1.10 mm
2	-4	0.88 mm
3	-3	0.66 mm
4	-2	0.44 mm
5	-1	0.22 mm
6	0	0 mm (Center value)
7	+1	0.22 mm
8	+2	0.44 mm
9	+3	0.66 mm
10	+4	0.88 mm
11	+5	1.10 mm

Note:

When the adjustment value goes further in minus numbers in the table above, the distance between the paper edge and the holes becomes wider. When it goes further in plus numbers, this distance becomes narrower.

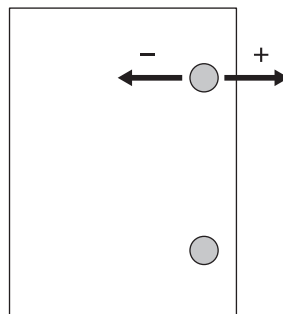

Fig. 5-3

- (6) When the value change is completed, press Button2 on the finisher control panel to determine the adjustment value. (The adjustment value is written into the flash ROM.)
- (7) Turn the power of the equipment OFF.
- (8) Turn all the bits of SW1 (DIP-SW) on the finisher control PC board OFF.
- (9) Install the board access cover of the Finisher.

6. TROUBLESHOOTING

[ED10] Skew adjustment motor (M1) home position detection abnormality

Is there any paper remaining on the transport path?

↓ →YES Remove the paper.

NO

Rotate the sideways adjustment motor (M2). Does it rotate smoothly?

↓ →NO Fix the mechanism.

YES

Are the sideways deviation home position sensor (S3) and its wiring correct?

↓ →NO Replace the sensor. Correct the wiring.

YES

Is the wiring between the hole punch control PC board (HP) and punch sideways adjustment motor (M2) correct?

↓ →NO Correct the wiring.

YES

- 1) Replace the sideways adjustment motor (M2).
- 2) Replace the hole punch control PC board (HP).

[ED11] Sideways adjustment motor (M2) home position detection error

Is there any paper remaining on the transport path?

↓ →YES Remove the paper.

NO

Rotate the skew adjustment motor (M1). Does it rotate smoothly?

↓ →NO Fix the mechanism.

YES

Are the skew home position sensor (S2) and its wiring correct?

↓ →NO Replace the sensor. Correct the wiring.

YES

Is the wiring between the hole punch control PC board (HP) and skew adjustment motor (M1) correct?

↓ →NO Correct the wiring.

YES

- 1) Replace the skew adjustment motor (M1).
- 2) Replace the hole punch control PC board (HP).

[E9F0] Punching jam

Is there any paper remaining on the transport path?

↓ →YES Remove the paper.

NO

Rotate the punch motor (M3). Does it rotate smoothly?

↓ →NO Fix the mechanism.

YES

Are the punch home position sensor (S4) and its wiring correct?

↓ →NO Replace the sensor. Correct the wiring.

YES

Is the wiring between the hole punch control PC board (HP) and punch motor (M3) correct?

↓ →NO Correct the wiring.

YES

- 1) Replace the punch motor (M3).
- 2) Replace the hole punch control PC board (HP).

[CC51] Sideways adjustment motor (M2) abnormality

***The [CC51] error will be displays when the [ED11] error occurs three times in succession or during the initial operation.**

Is there any paper remaining on the transport path?

↓ →YES Remove the paper.

NO

Rotate the sideways adjustment motor (M2). Does it rotate smoothly?

↓ →NO Fix the mechanism.

YES

Are the sideways deviation home position sensor (S3) and its wiring correct?

↓ →NO Replace the sensor. Correct the wiring.

YES

Is the wiring between the hole punch control PC board (HP) and sideways adjustment motor (M2) correct?

↓ →NO Correct the wiring.

YES

- 1) Replace the punch sideways adjustment motor (M2).
- 2) Replace the hole punch control PC board (HP).

[CC52] Skew adjustment motor (M1) abnormality

***The [CC52] error will be displays when the [ED10] error occurs three times in succession or during the initial operation.**

Is there any paper remaining on the transport path?

↓ →YES Remove the paper.

NO

Rotate the skew adjustment motor (M1). Does it rotate smoothly?

↓ →NO Fix the mechanism.

YES

Are the skew home position sensor (S2) and its wiring correct?

↓ →NO Replace the sensor. Correct the wiring.

YES

Is the wiring between the hole punch control PC board (HP) and skew adjustment motor (M1) correct?

↓ →NO Correct the wiring.

YES

- 1) Replace the skew adjustment motor (M1).
- 2) Replace the hole punch control PC board (HP).

[CC61] Punch motor (M3) home position detection error

*The [CC61] error will be displays when the [E9F0] error occurs three times in succession or during the initial operation.

Is there any paper remaining on the transport path?

↓ →YES Remove the paper.

NO

Rotate the punch motor (M3). Does it rotate smoothly?

↓ →NO Fix the mechanism.

YES

Are the punch home position sensor (S4) and its wiring correct?

↓ →NO Replace the sensor. Correct the wiring.

YES

Is the wiring between the hole punch control PC board (HP) and punch motor (M3) correct?

↓ →NO Correct the wiring.

YES

- 1) Replace the punch motor (M3).
- 2) Replace the hole punch control PC board (HP).

[CC71] Punch ROM checksum error

Is the conductor pattern on the hole punch control PC board (HP) open circuited or short circuited?

↓ →YES Replace the hole punch control PC board (HP).

NO

Replace the finisher control PC board.

[CC72] Punch RAM read/write error

Is the conductor pattern on the hole punch control PC board (HP) open circuited or short circuited?

↓ →YES Replace the hole punch control PC board (HP).

NO

Replace the finisher control PC board.

[CE00] Punch communication error

Is the harness between the hole punch control PC board (HP) and the finisher control PC board disconnected or open circuited?

↓ →YES Replace the harness. Correct the wiring.

NO

Is the conductor pattern on the hole punch control PC board (HP) open circuited or short circuited?

↓ →YES Replace the hole punch control PC board (HP).

NO

Replace the finisher control PC board.

7. MAINTENANCE

7.1 Maintenance and Inspection Points

1) Symbols used in the checklist

Cleaning	Lubrication/Coating	Replacement	Operation check
A: Clean with alcohol B: Clean with soft pad, cloth or vacuum cleaner	L: Launa 40 SI: Silicon oil W1:White grease (Molykote X5-6020) W2:White grease (Molykote HP-300) W3:White grease (Molykote EM30L) AV: Alvania No.2 FL: Floil (GE-334C)	Value: Replacement cycle (output pages or develop counts) R: Replace if deformed or damaged	O: After cleaning or replacement, confirm there is no problem.

2) Preventive Maintenance Checklist

Items to check *1	Cleaning	Lubrication/Coating *2	Replacement (x1,000)	Operation check	Parts list <P-I> *3	Remarks
1 Transport roller	A			O		
2 Sensors	B					
3 Drive gears		W3		O		
4 punched scrap container	Dispose of the punched paper bits.					
5 Punching unit			R 1,000			*4

*1: Perform maintenance in the timing of preventive maintenance of the equipment.

*2: Be careful not to put oil on the rollers, belts and belt pulleys when lubricating.

*3: Page-Item (P-I) is described in the column of the Parts list.

*4: This unit may require replacement once or more over the period of machine warranty because of deterioration or damage. Replace them as needed.

7.2 Firmware Update

7.2.1 MJ-6101/6103 (Firmware updating with download jig)

1. Checking the hole punch position

Follow the procedure below to check the stopping position of the paper transport during the punching operation before updating the firmware, as the value for the position is defaulted when the firmware is updated.

- (1) Turn the power of the equipment OFF.
- (2) Remove the finisher board access cover and change the setting of the DIP-SW1 (SW1) on the finisher control PC board as shown in the figure below.

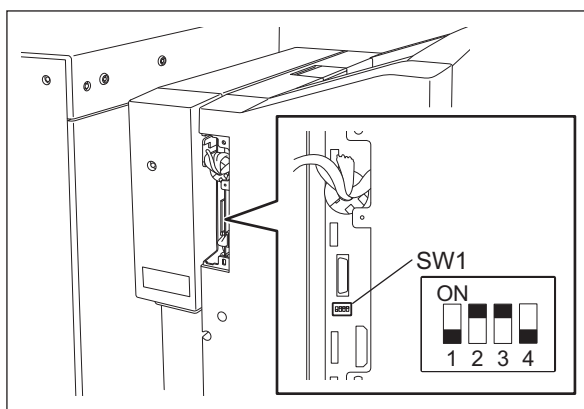

Fig. 7-1

- (3) The LED1 on the finisher control panel starts blinking as you turn the power of the equipment ON. Count the number of times the LED1 blinks. When the number of blinks is “6”, this indicates that the value for the stopping position is defaulted. If the number is other than “6”, record the number of blinks, because it will be needed to reset the value after the firmware is updated.

2. Firmware update

Update the firmware using the download jig (K-PWA-DLM-320).

- (1) Attach the ROM to the download jig. Make sure that the ROM and its direction are correct.

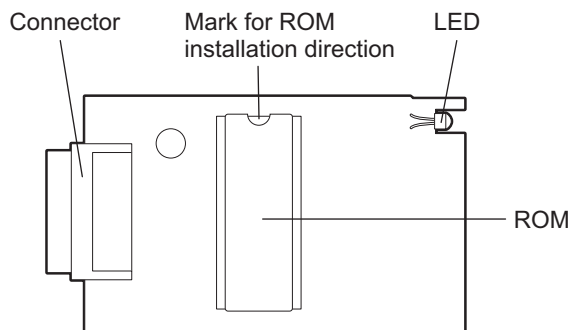

Fig. 7-2

- (2) Turn OFF the power of the equipment.

- (3) Remove 1 screw and take off the finisher board access cover.

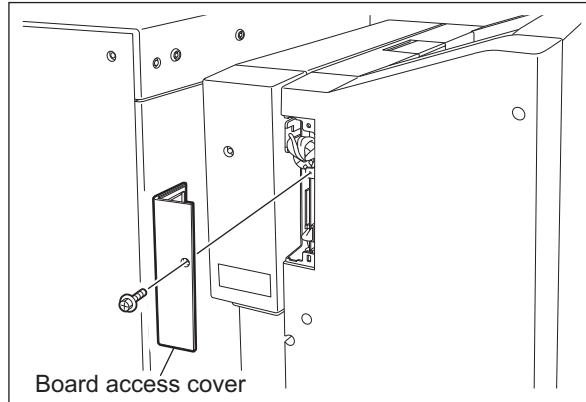

Fig. 7-3

- (4) Release the latches and take off the rear lower cover of the hole punch unit. (Refer to P. 4-1 "[B]").)
- (5) Remove 3 screws and take off the rear cover of the hole punch unit. (Refer to P. 4-2 "[C]").)
- (6) Connect the download jig with the jig connector (CN9) on the finisher control PC board.

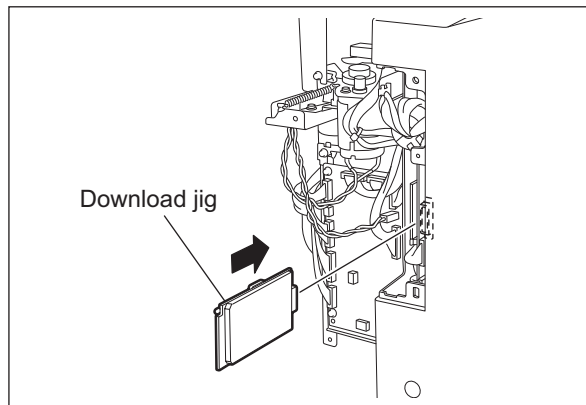

Fig. 7-4

- (7) Set the DIP-SW4 on the hole punch control PC board to ON.

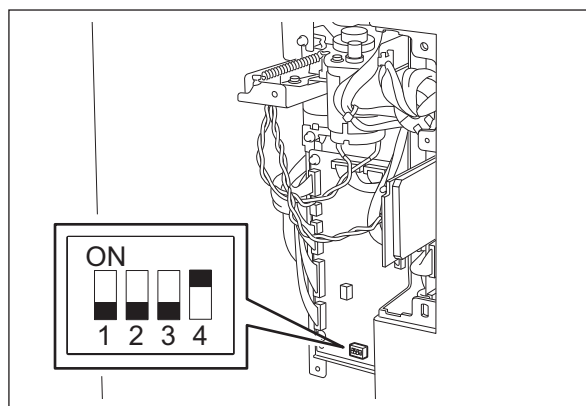



Fig. 7-5

- (8) Turn the power ON while pressing [0] and [8] simultaneously. Updating starts and the LED on the download jig lights.
- (9) When the update is completed normally, the LED on the download jig starts blinking. The LED on the download jig starts blinking in approx. 20 seconds after the update started. It is assumed that the update is failed if the LED does not start blinking even after 30 seconds have elapsed. In this case, turn the power OFF and check the following items. Then, clear the problem and restart updating from the beginning.
- Is the downloading jig connected properly?
 - Is the ROM attached to the downloading jig properly?
 - Is the DIP-SW4 on the hole punch control PC board set properly?
 - Has the update data been written correctly to the ROM on the jig?
 - Is the download jig or the equipment damaged?
 - Is the connector (CN12) on the finisher control PC board connected properly?
 - Are the connector (CN15) on the finisher control PC board and the connector (CN1) on the hole punch control PC board connected properly?
- (10) Turn the power OFF and remove the download jig.
- (11) Set the DIP-SW4 on the hole punch control PC board to OFF.

Note:

When the number of blinks is other than “6” (which indicates that the adjustment value is “0”) at the section “1. Checking the hole punch position”, follow the steps of  P. 5-1 "5.1 Stopping Position Adjustment" to adjust the value to the one that has been set before the update.

- (12) Change the settings of the DIP-SW1 and -SW2 on the hole punch control PC board according to the model as shown in the figure below.

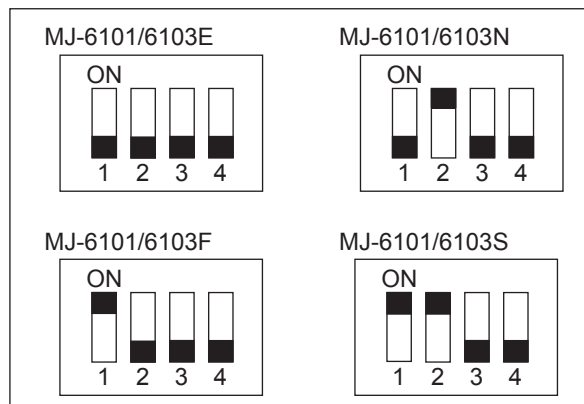

Fig. 7-6

- (13) Install the rear cover of the hole punch unit.
- (14) Install the rear lower cover of the hole punch unit.
- (15) Install the finisher board access cover.

7.2.2 MJ-6104/6105/6106 (Firmware updating with USB device)

Refer to "FIRMWARE UPDATING" in the Service Manual for MFP.

8. ELECTRIC CIRCUIT

8.1 Harness Diagram

8.1.1 MJ-6101/MJ-6103

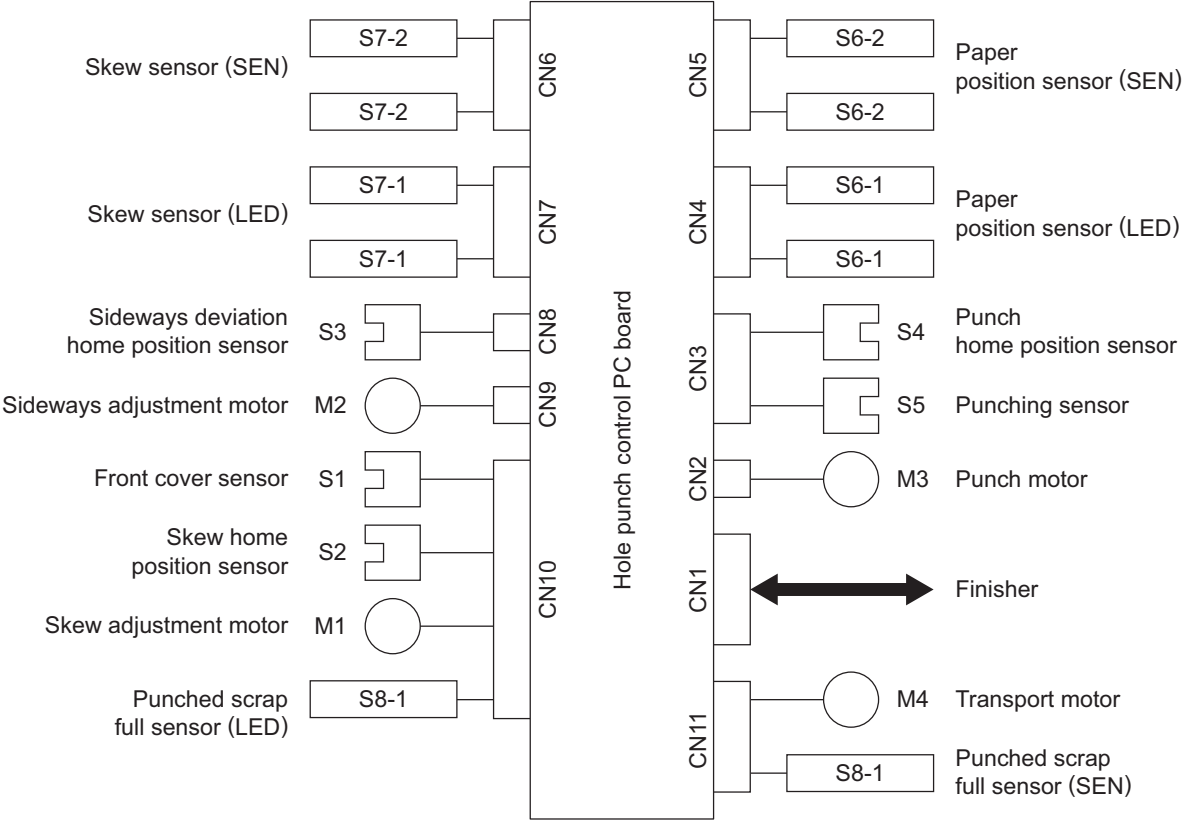

Fig. 8-1

8.1.2 MJ-6104

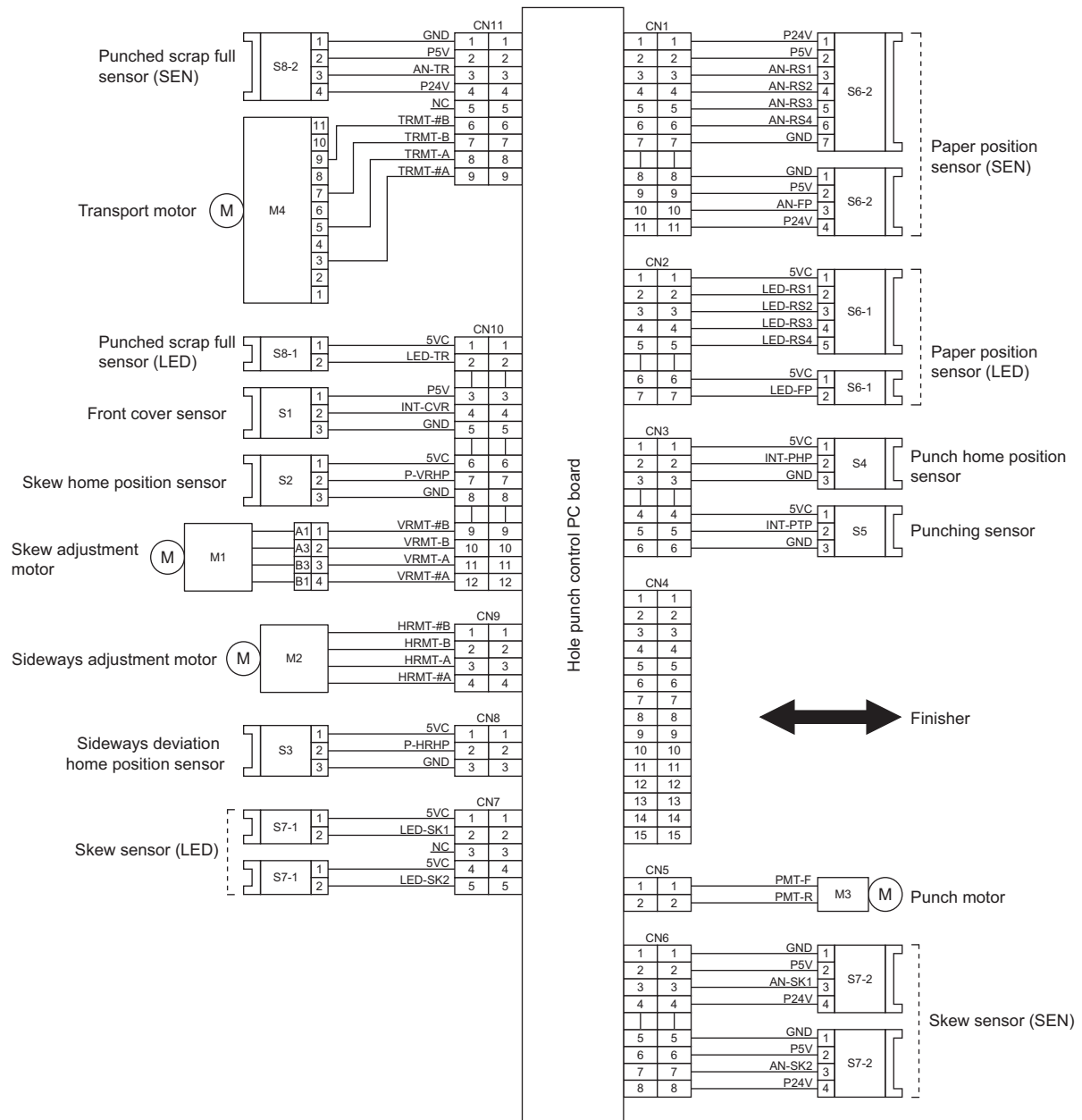

Fig. 8-2

8.1.3 MJ-6105/6106

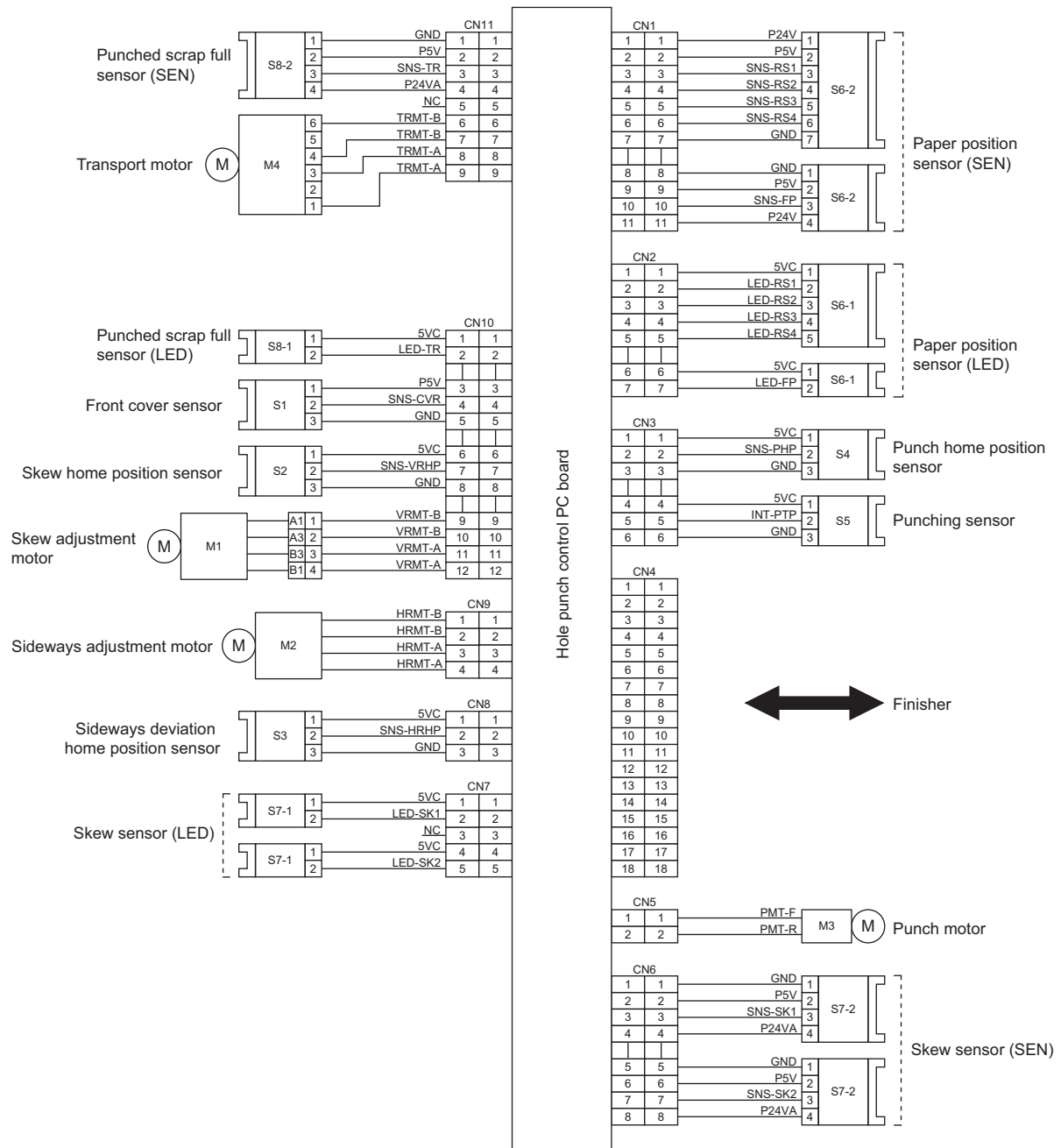

Fig. 8-3

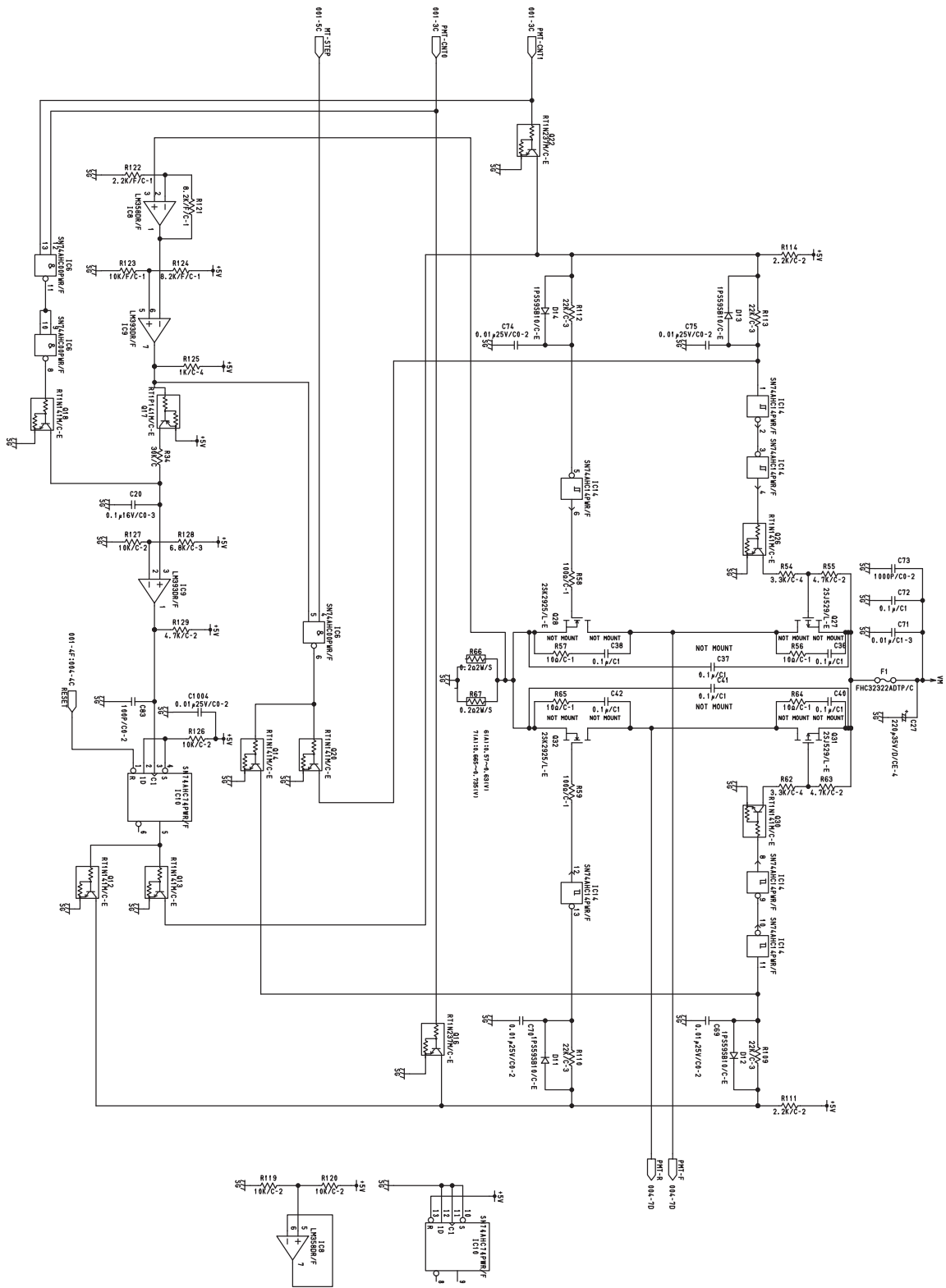

Fig. 8-5

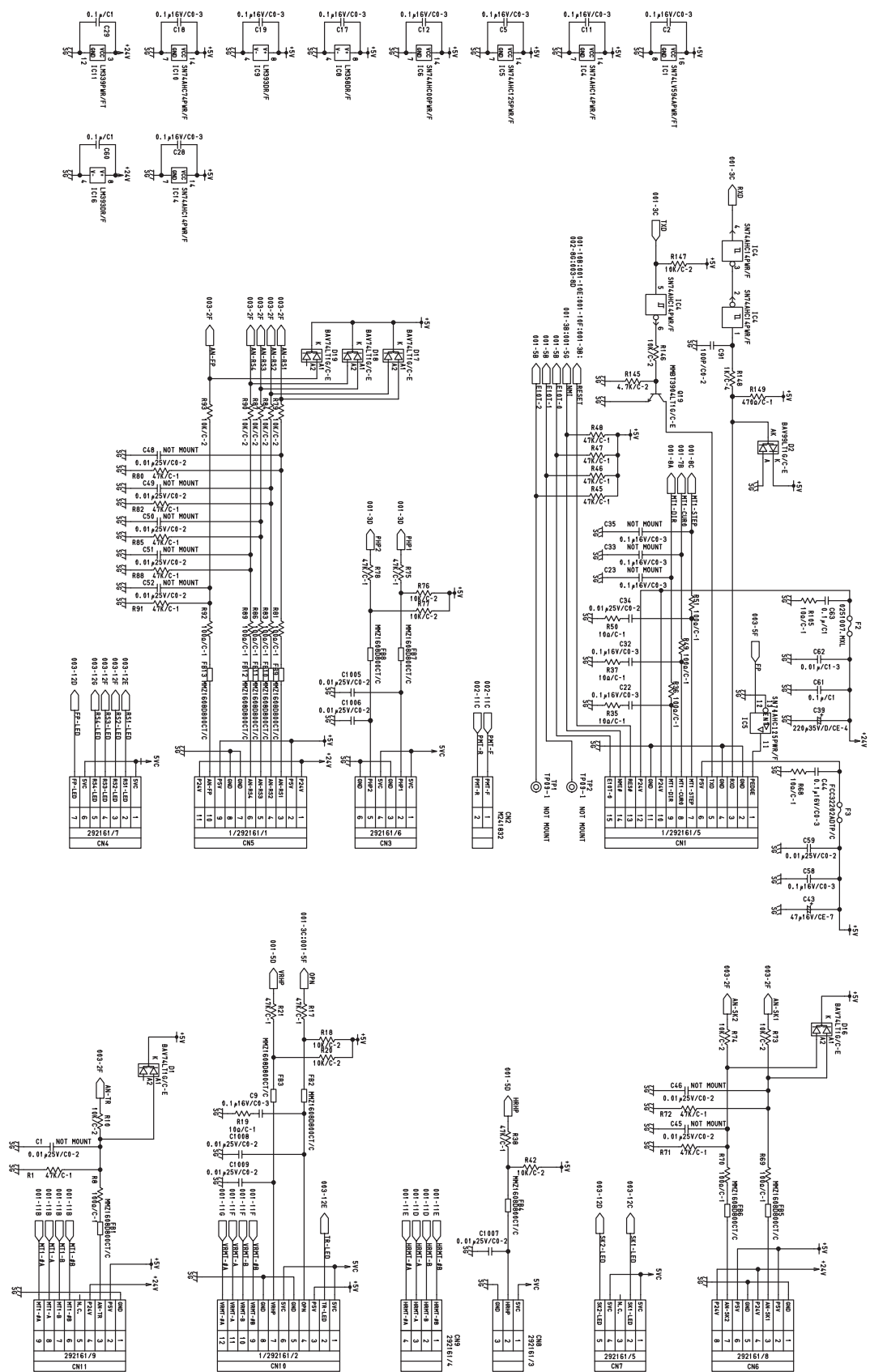

Fig. 8-7

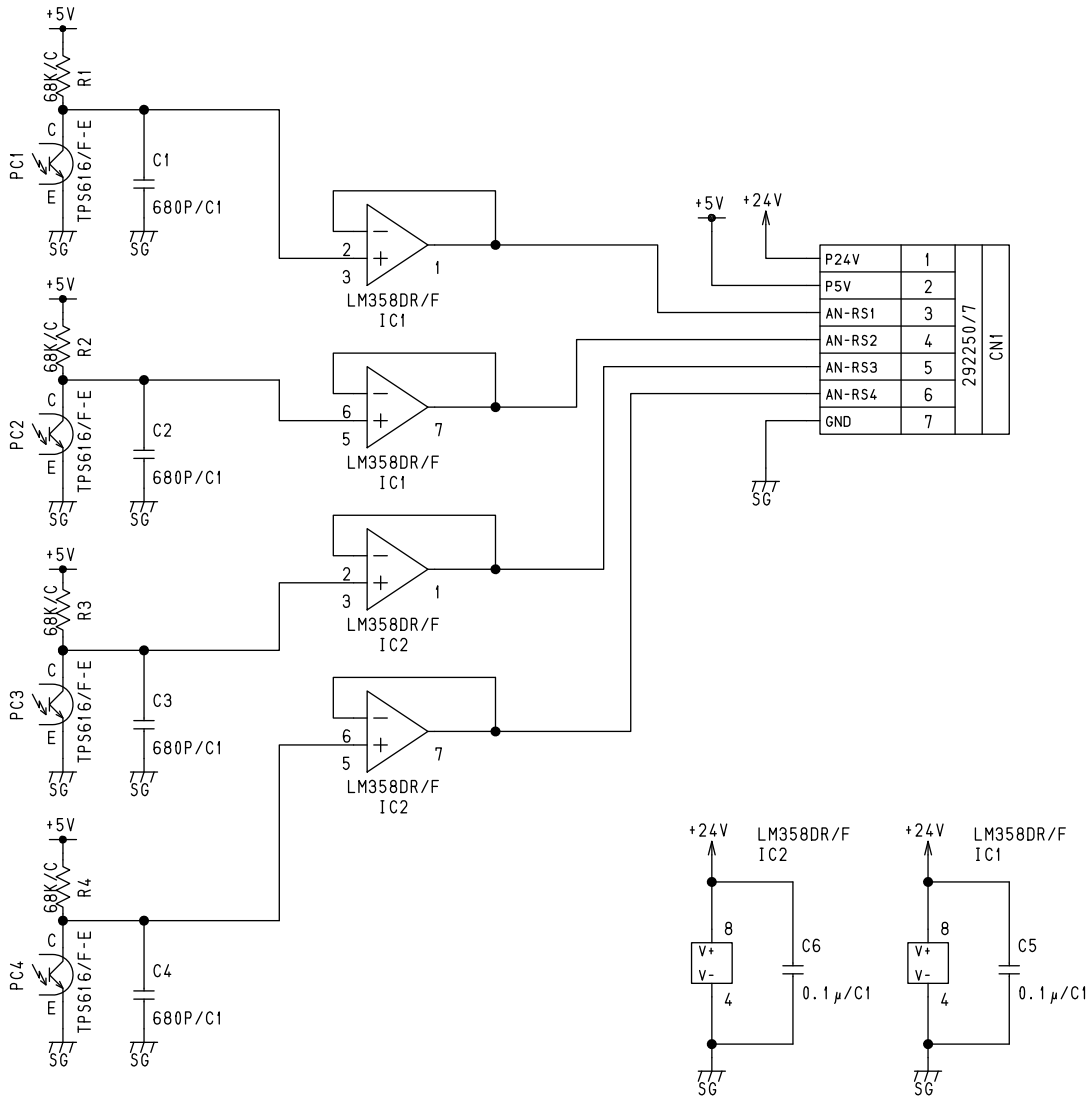
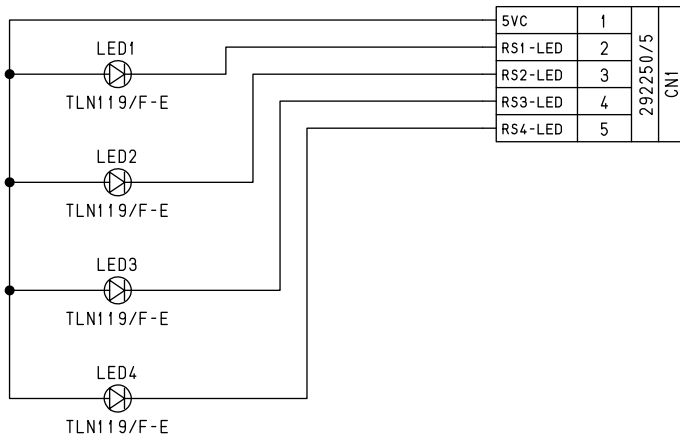

Fig. 8-8

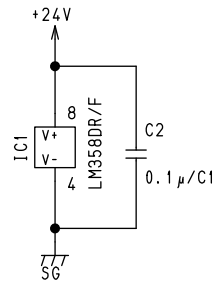
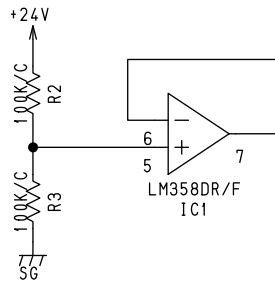
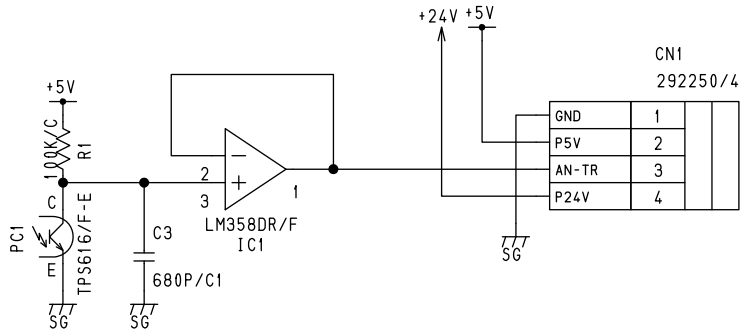
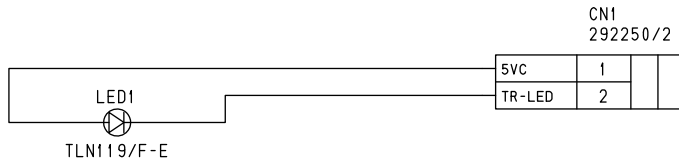

Fig. 8-9

8.2.2 MJ-6104

- Circuit Diagram (1)

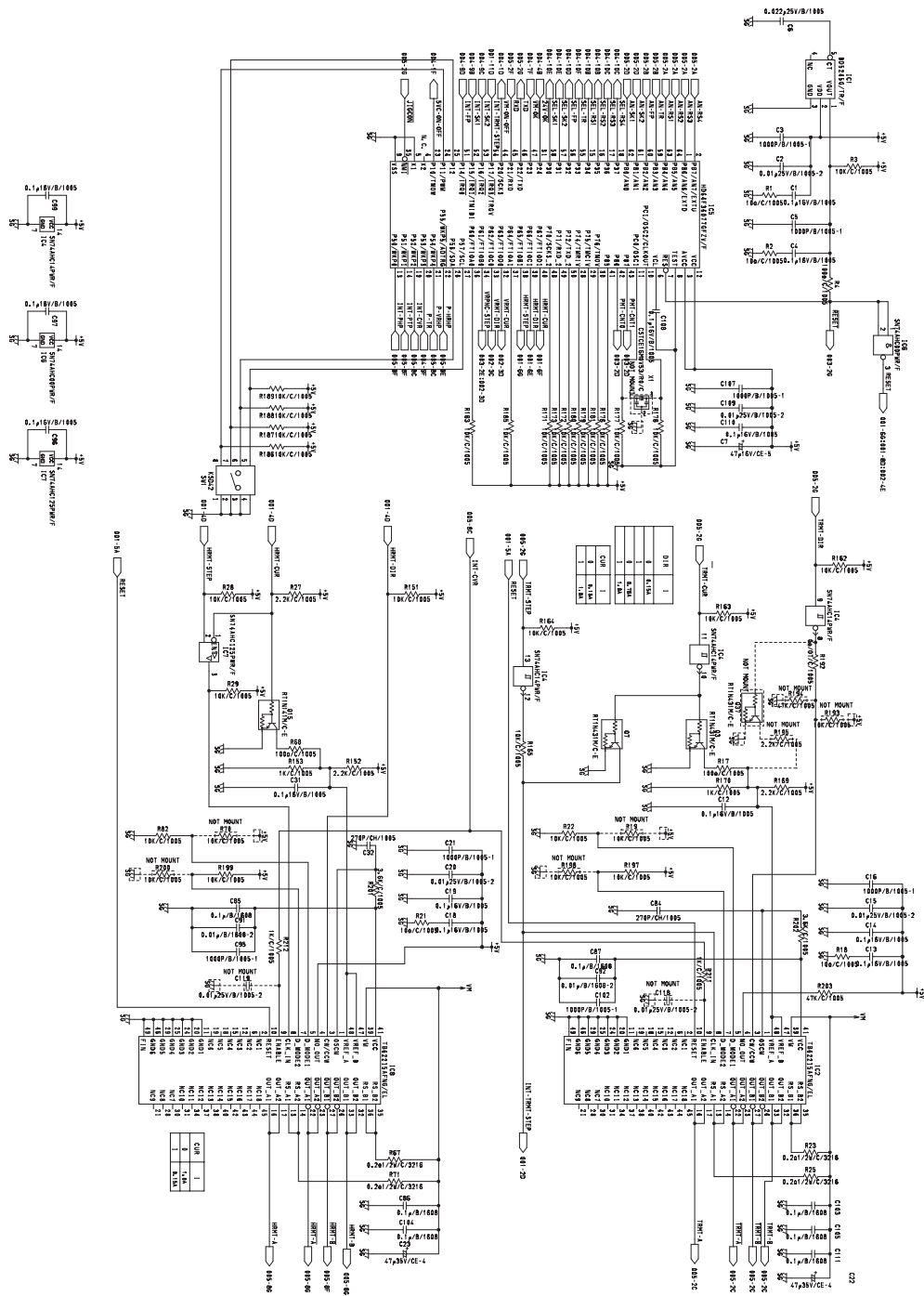

Fig. 8-10

- Circuit Diagram (2)

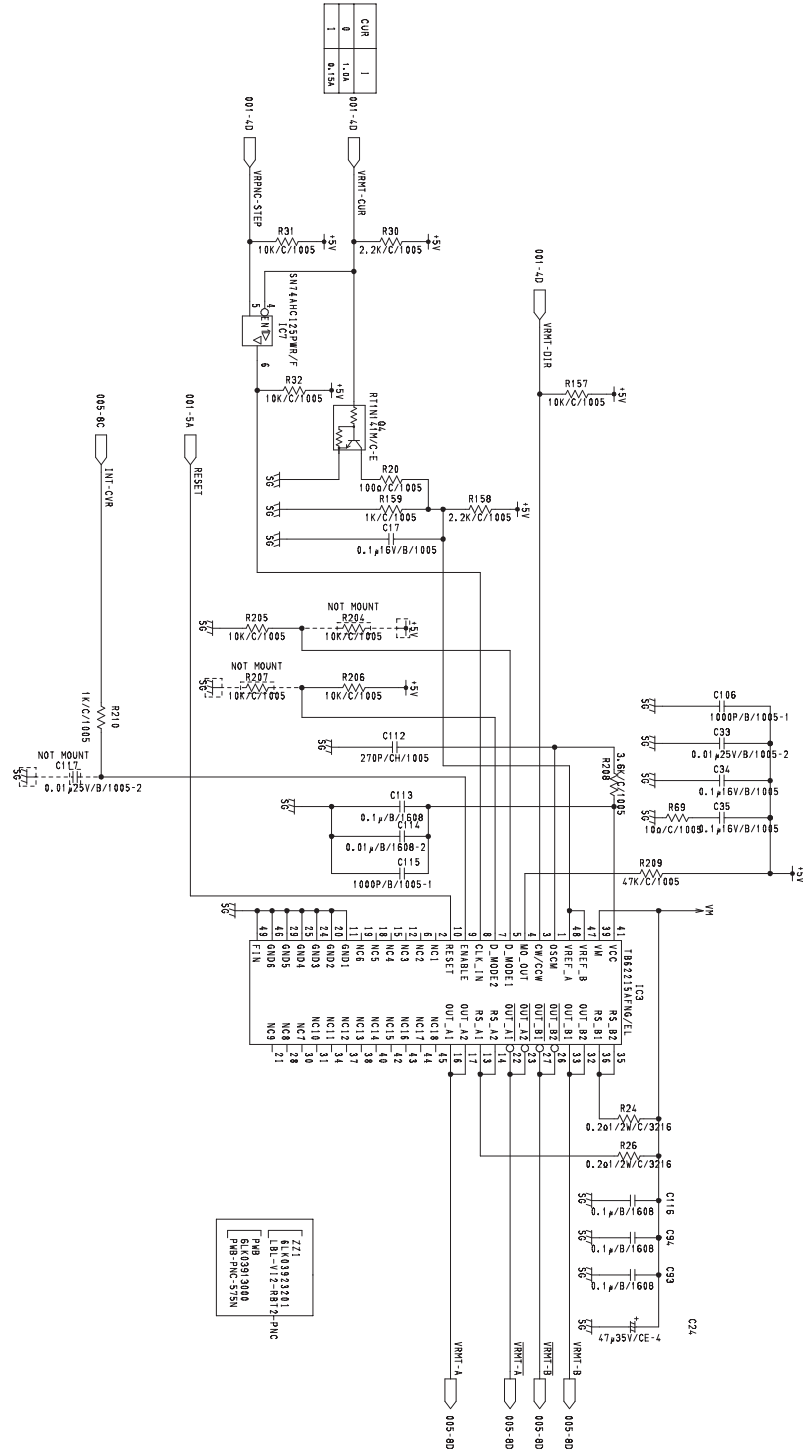

Fig. 8-11

- Circuit Diagram (3)

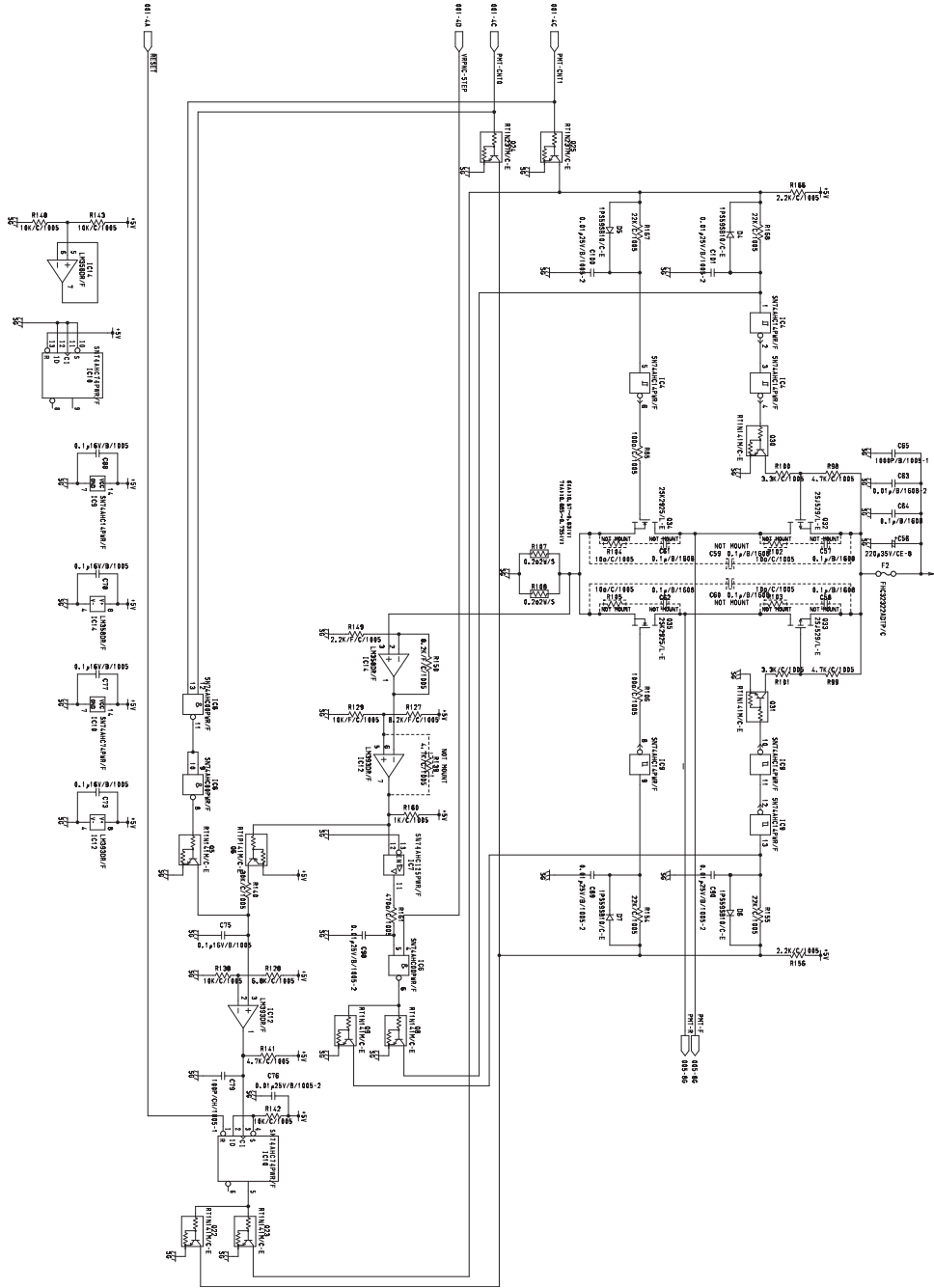

Fig. 8-12

- Circuit Diagram (4)

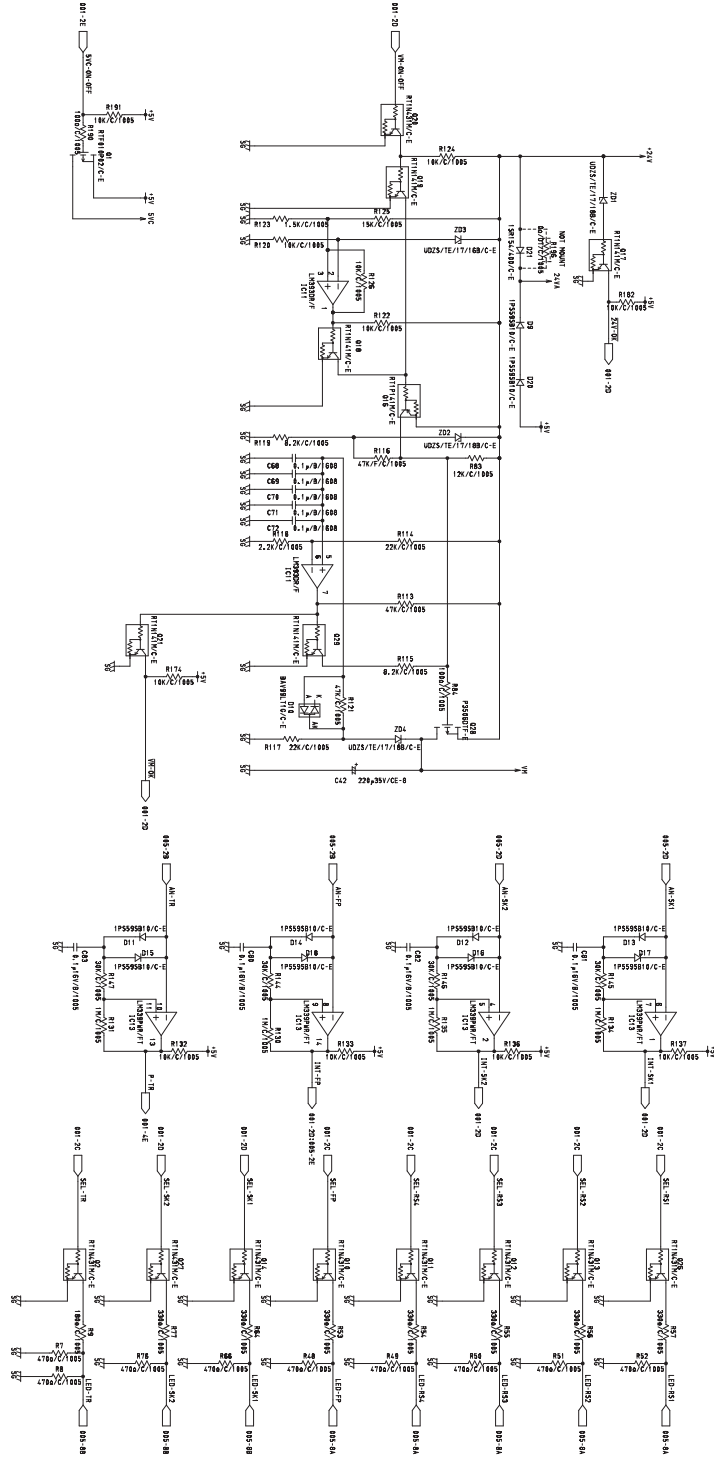

Fig. 8-13

• Circuit Diagram (5)

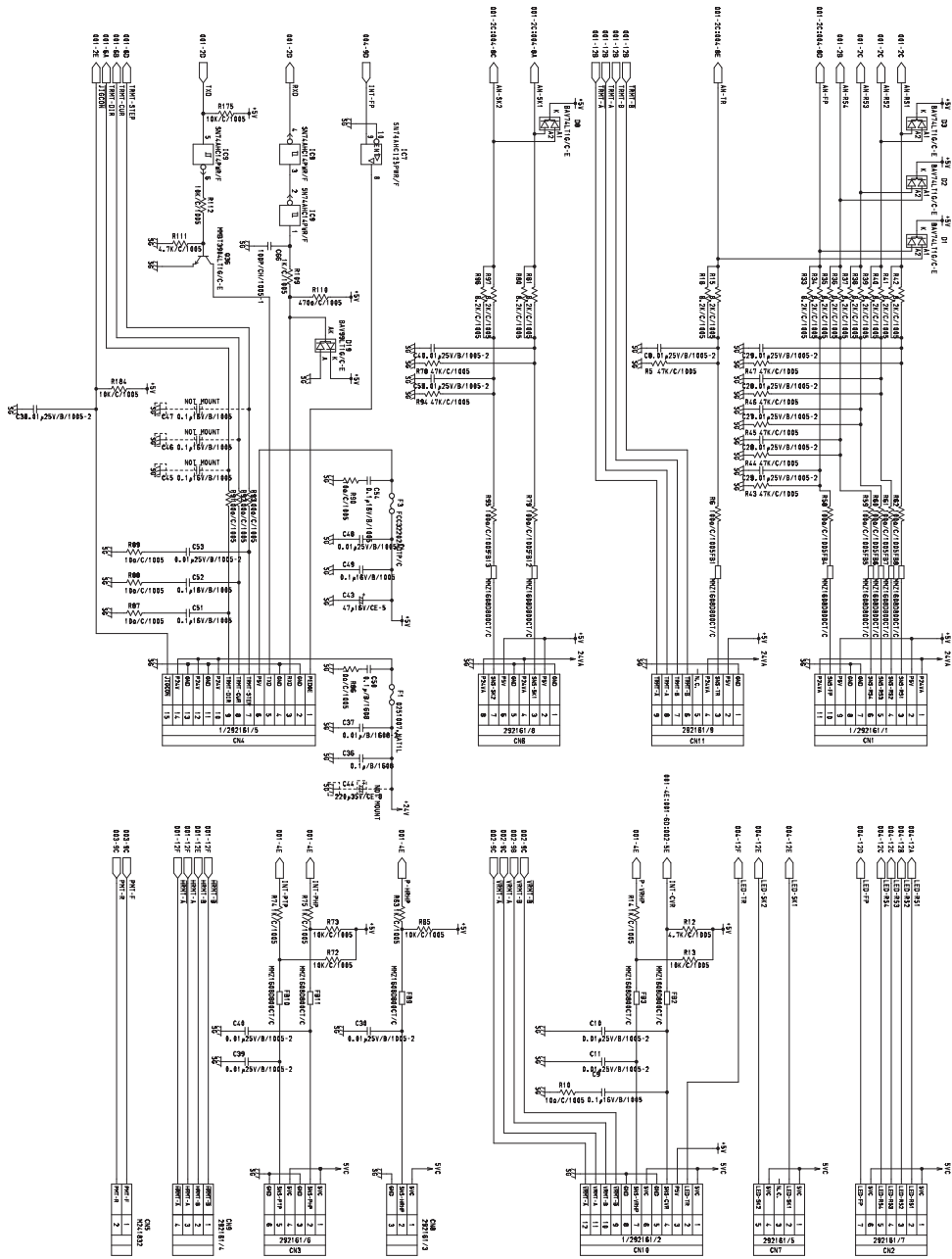

Fig. 8-14

8.2.3 MJ-6105/6106

- Circuit Diagram (1)

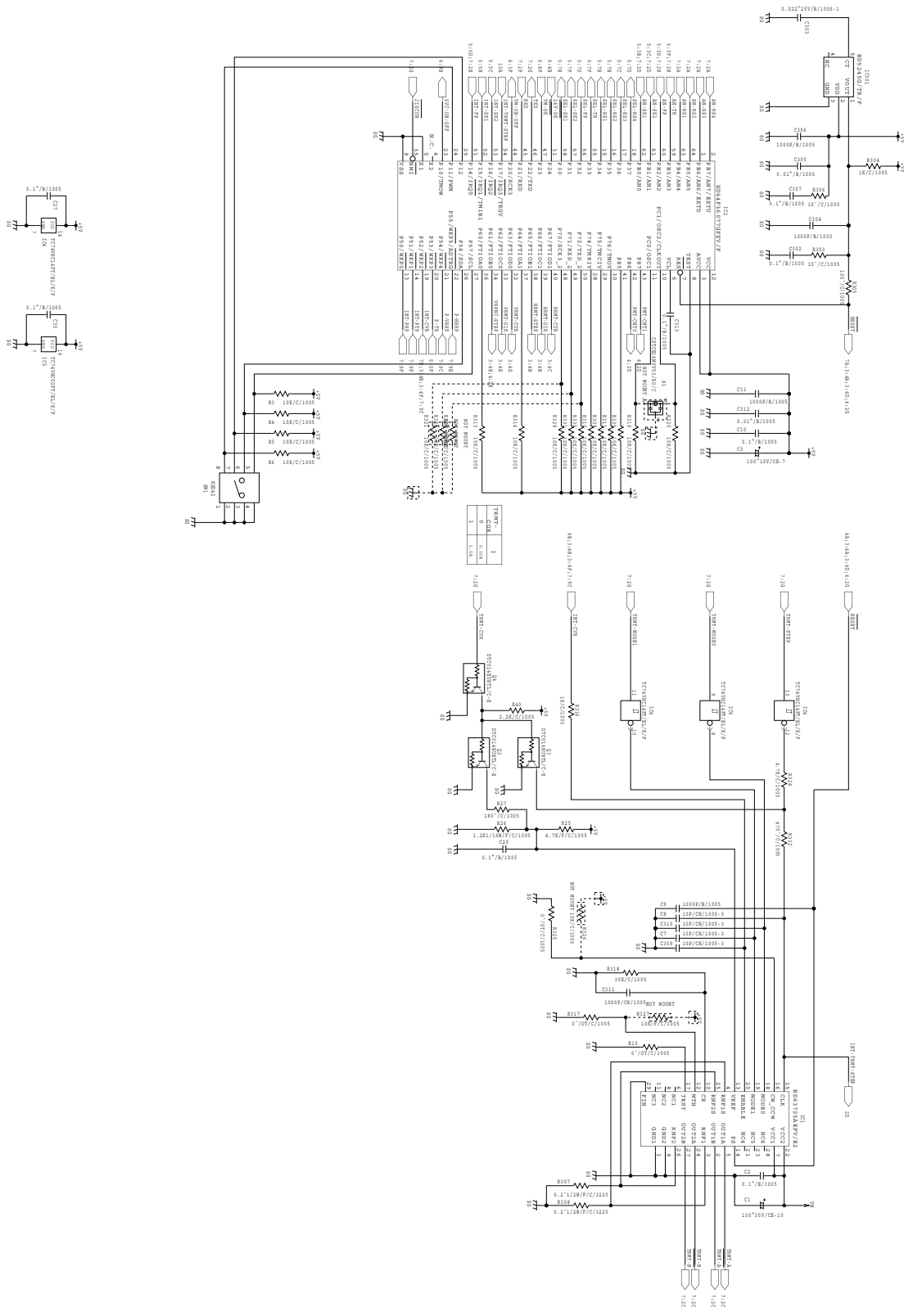

Fig. 8-15

• Circuit Diagram (2)

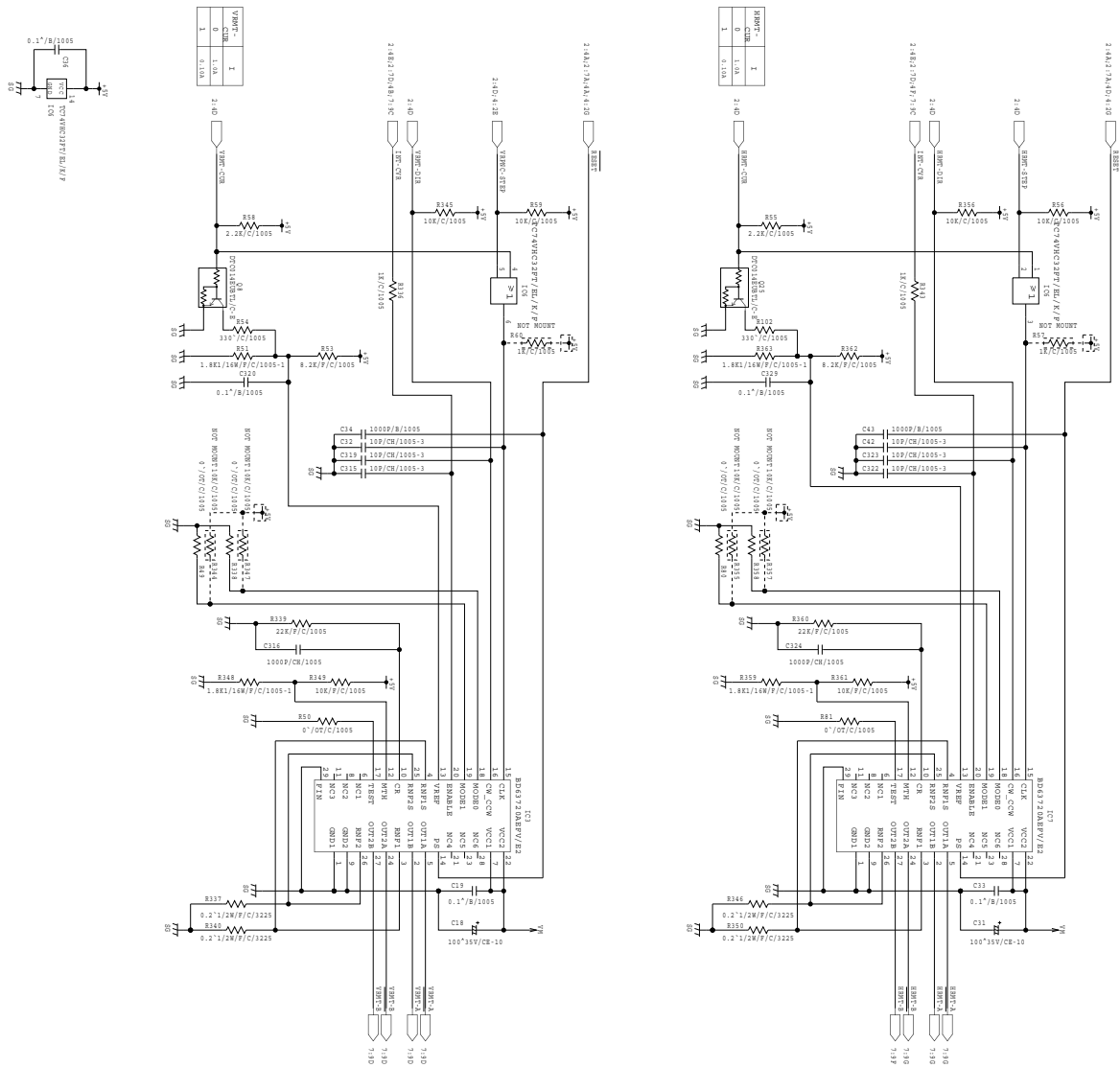

Fig. 8-16

• Circuit Diagram (3)

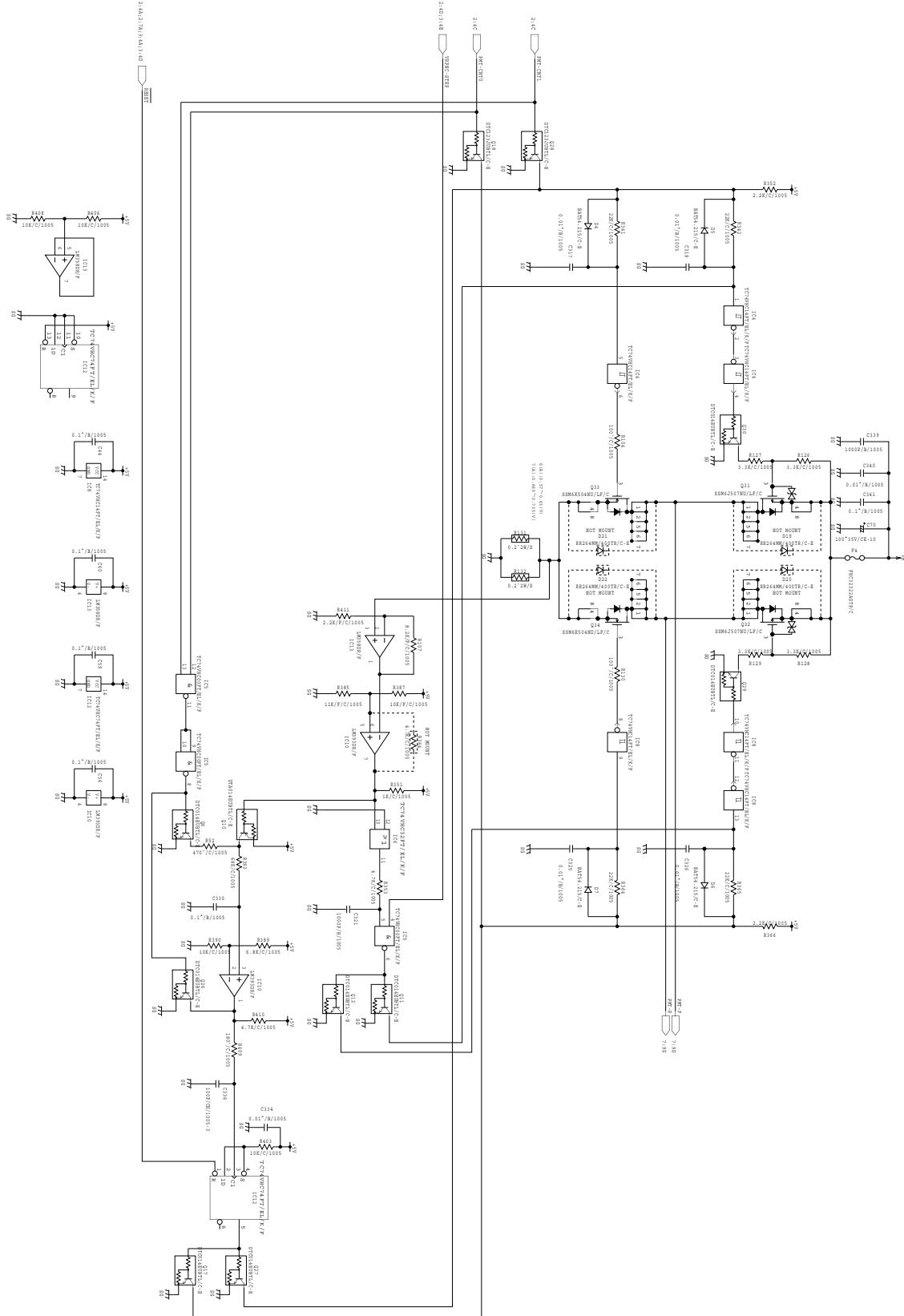

Fig. 8-17

- Circuit Diagram (4)

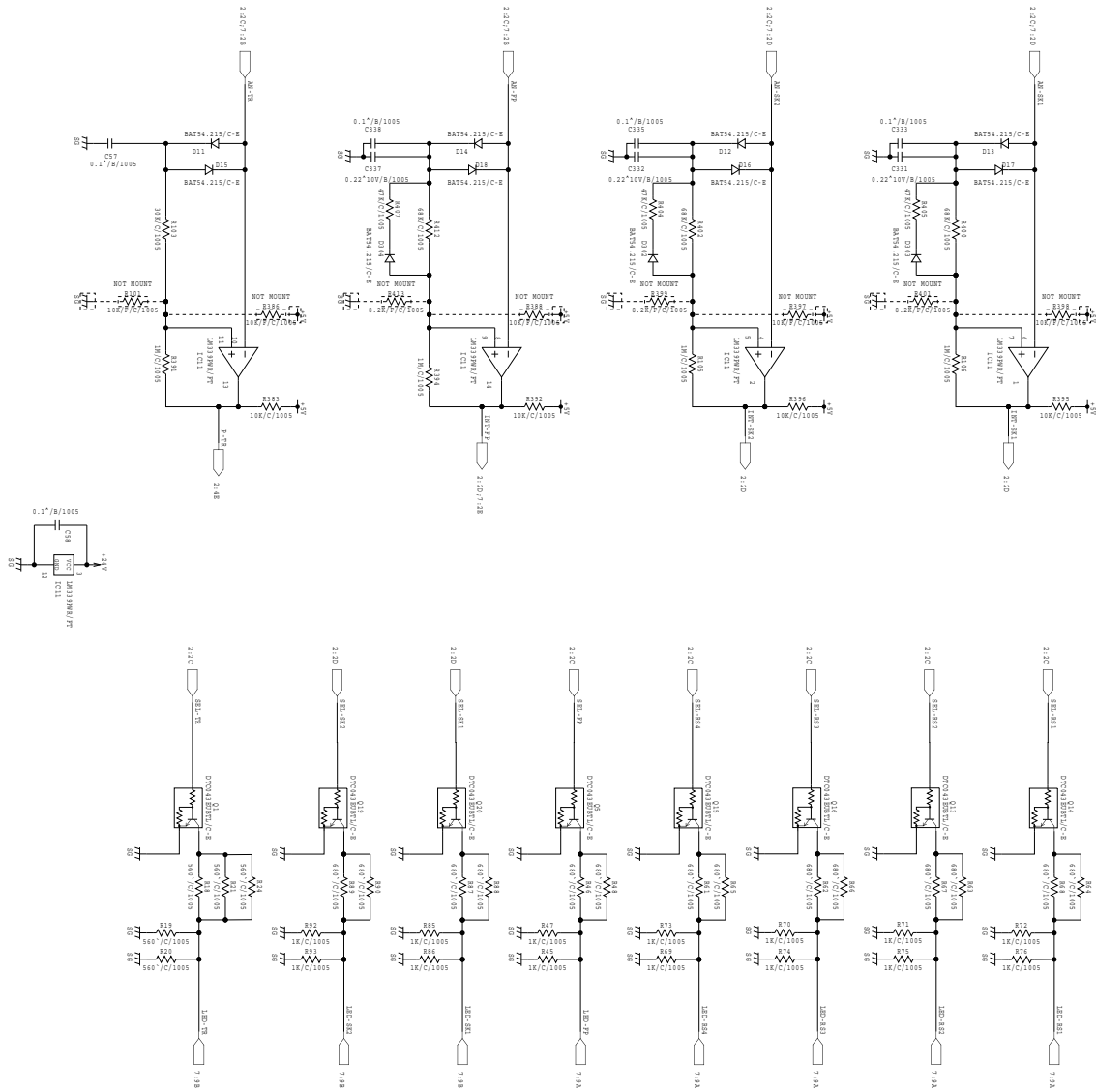

Fig. 8-18

- Circuit Diagram (5)

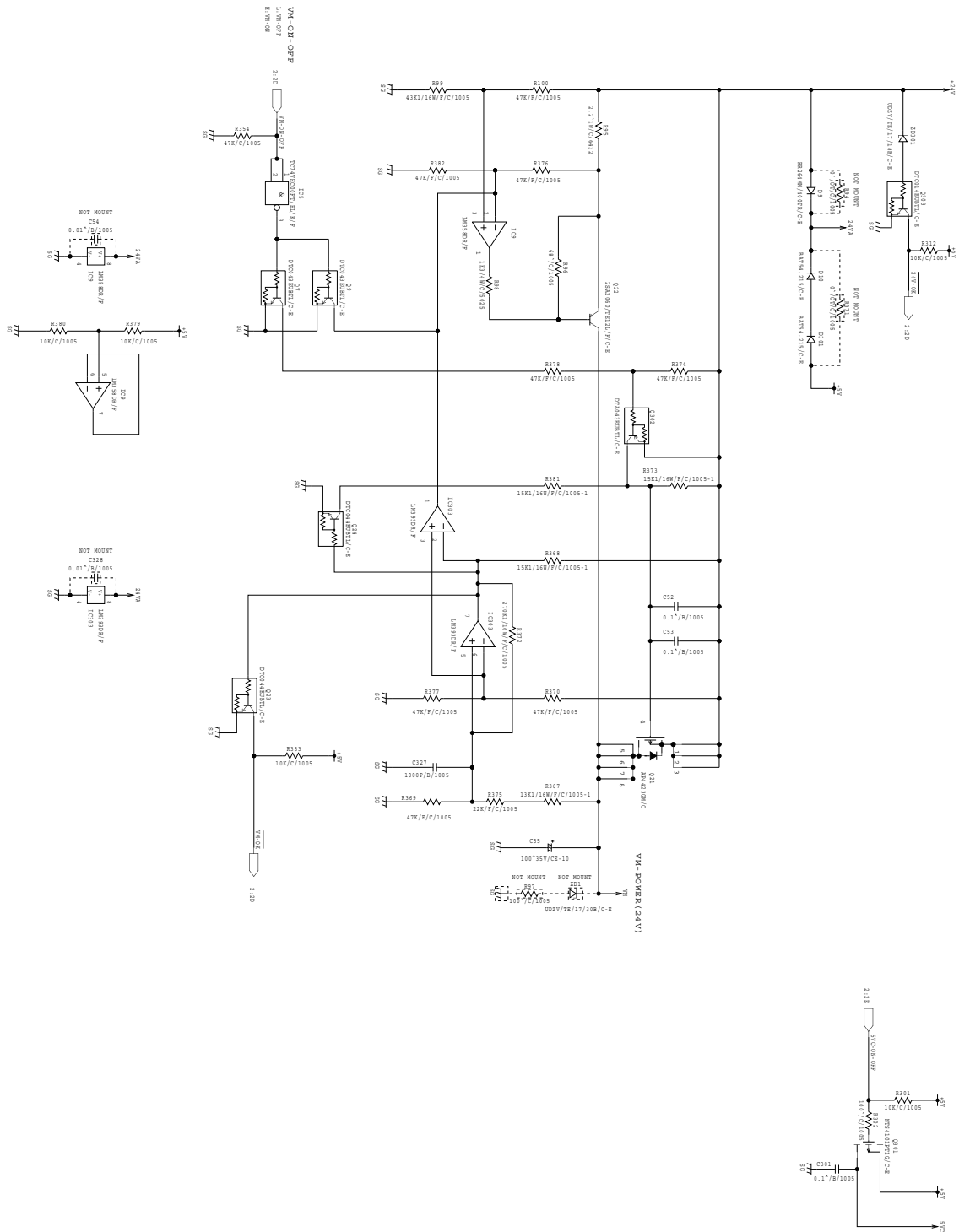

Fig. 8-19

• Circuit Diagram (6)

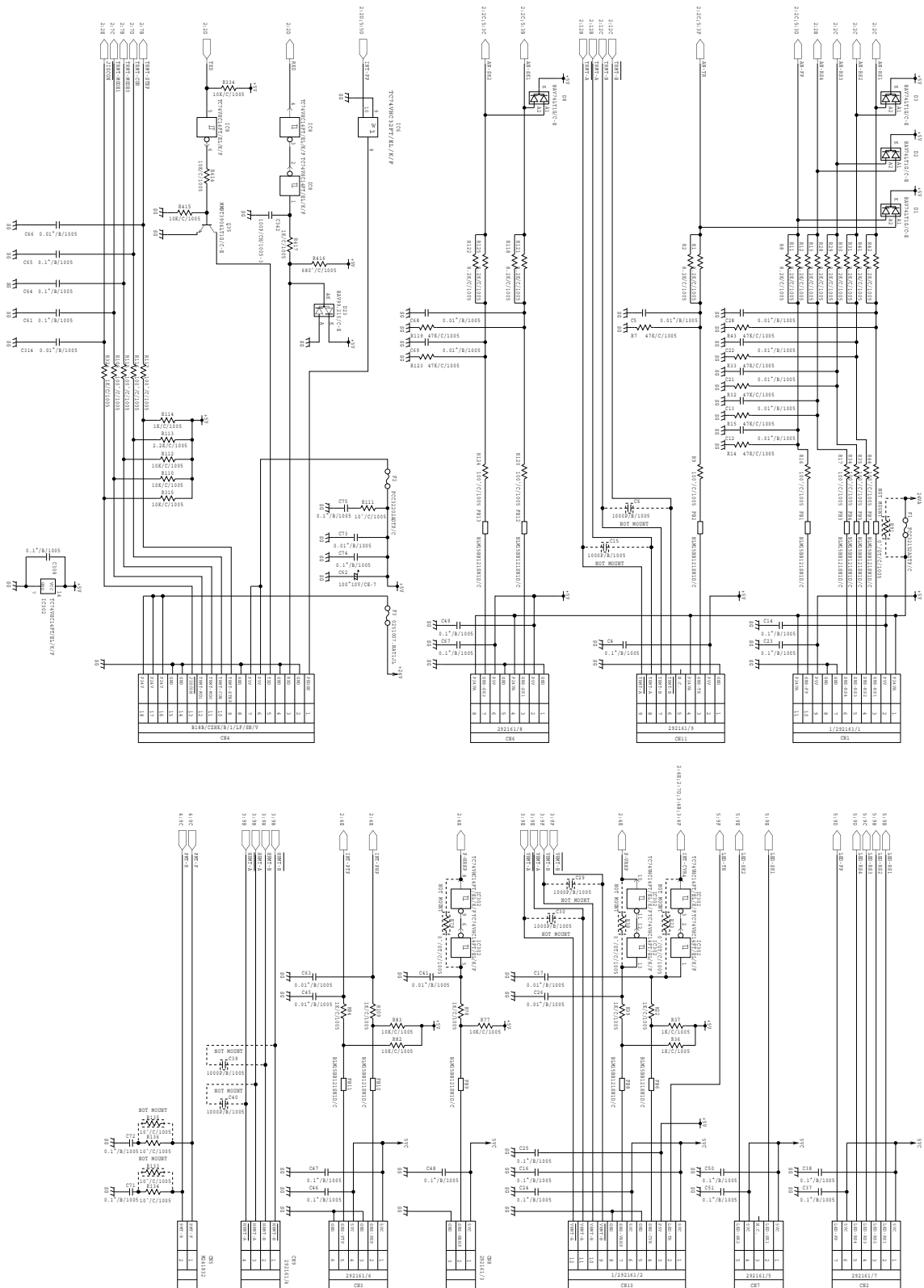

Fig. 8-20

8.3 PC Board

8.3.1 MJ-6101/MJ-6103

1) Hole punch control PC board

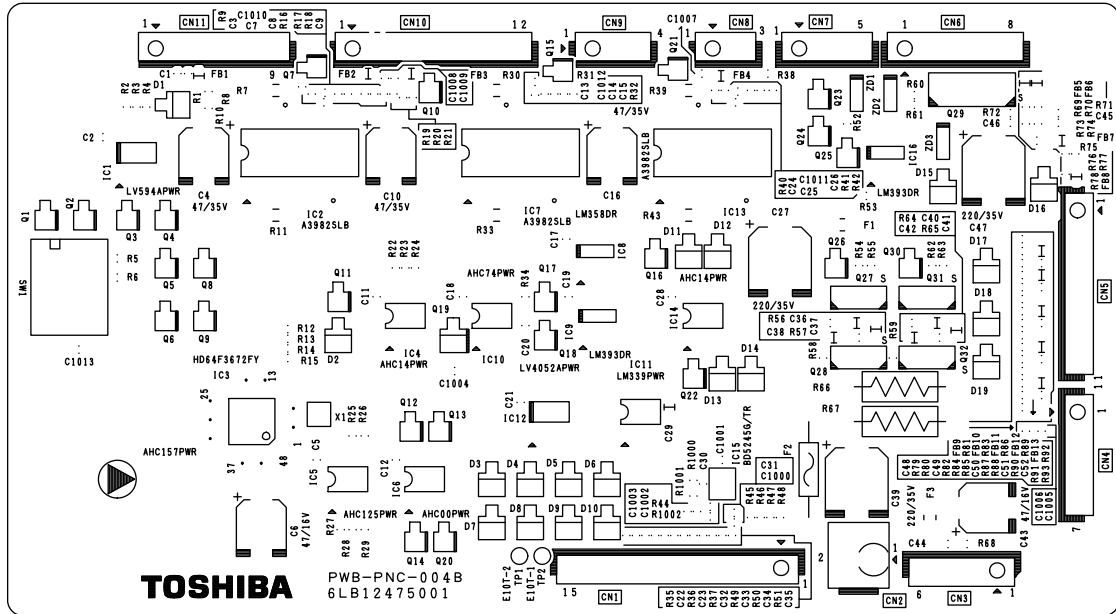

Fig. 8-21

2) Rear side paper position sensor (LED)

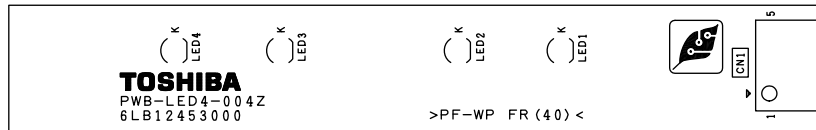

Fig. 8-22

3) Rear side paper position sensor (SEN)



Fig. 8-23

4) Front side paper position sensor (SEN), Skew sensor (SEN), Punched scrap full sensor (SEN)

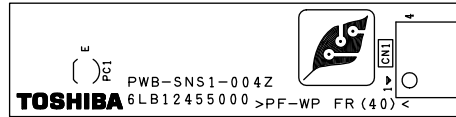

Fig. 8-24

5) Front side paper position sensor (LED), Skew sensor (LED), Punched scrap full sensor (LED)



Fig. 8-25

8.3.2 MJ-6104/6105/6106

[A] Hole punch control PC board

[A-1] MJ-6104

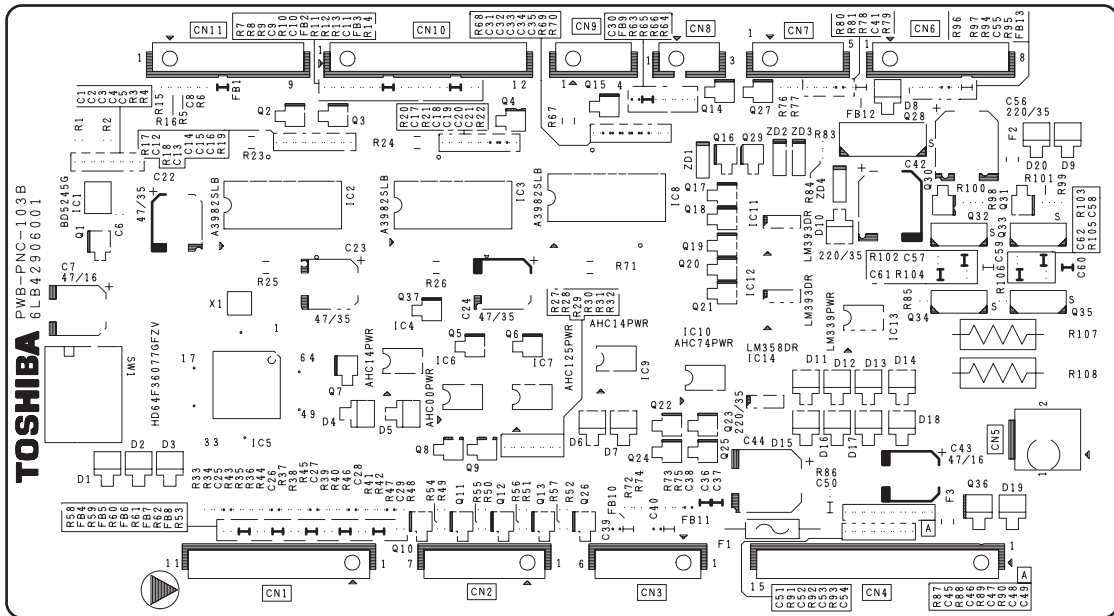

Fig. 8-26

[A-2] MJ-6105/6106

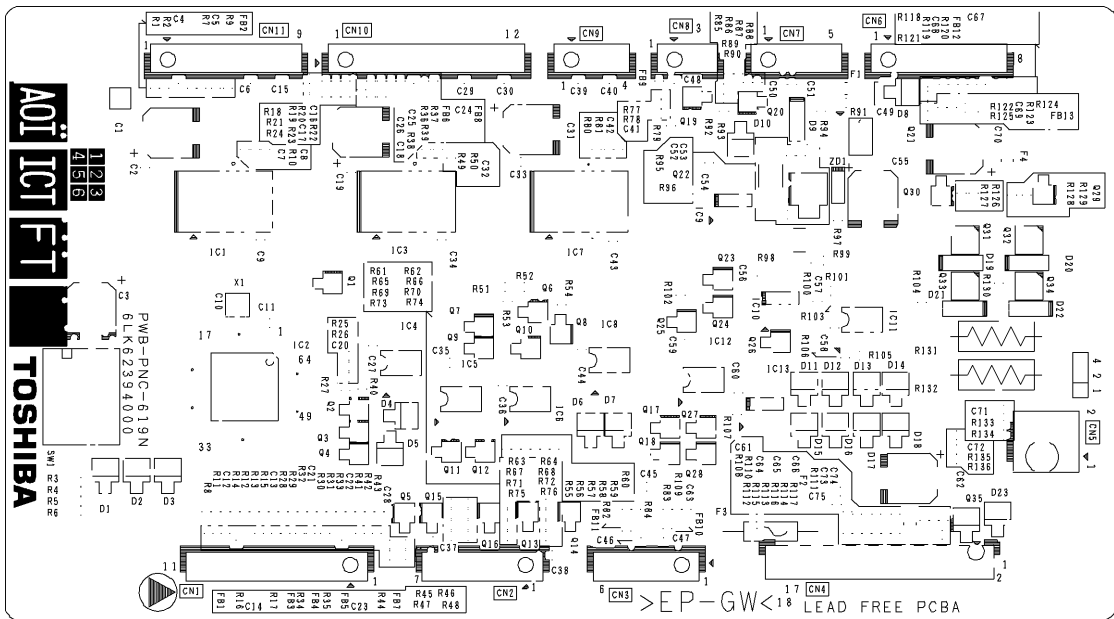

Fig. 8-27

[B] Rear side paper position sensor (LED)

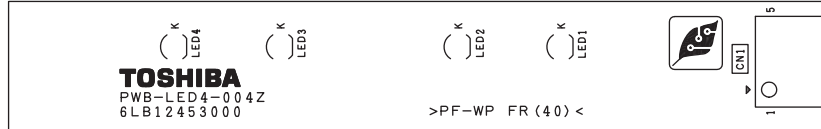

Fig. 8-28

[C] Rear side paper position sensor (SEN)



Fig. 8-29

[D] Front side paper position sensor (SEN), Skew sensor (SEN), Punched scrap full sensor (SEN)

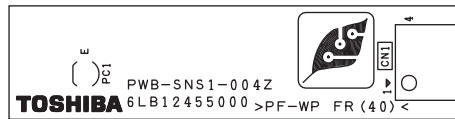

Fig. 8-30

[E] Front side paper position sensor (LED), Skew sensor (LED), Punched scrap full sensor (LED)



Fig. 8-31

REVISION RECORD

Ver.09a

Ver.09a<2023.11.06>	
Page	Contents
6-1	Changed content to ED10 and ED11 errors

Ver.09

Ver.09<2017.3.28>	
Page	Contents
1-1	Information for reused paper has been added.

TOSHIBA

TOSHIBA TEC CORPORATION

1-11-1, OSAKI, SHINAGAWA-KU, TOKYO, 141-8562, JAPAN