

TOSHIBA

SERVICE MANUAL

Finisher

MJ-1115/1116

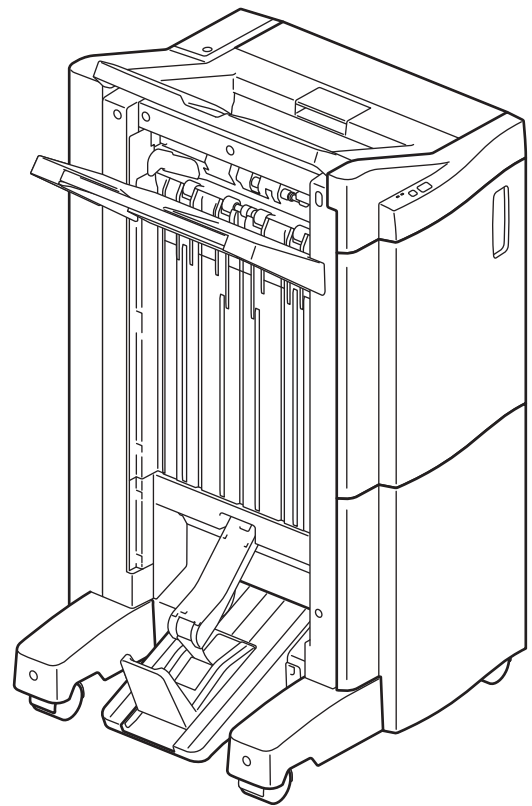

Model: MJ-1115/1116
Publish Date: November, 2022
File No. SME210043A0
R220421Z0900-TTEC
Ver01 F 2023-02

Trademarks

- MOLYKOTE® is a trademark of DDP SPECIALTY ELECTRONIC MATERIALS US, INC.
- SANKOL is a registered trademark of SANKEIKAGAKU Co., Ltd.
- The company and product names described in this manual are trademarks or registered trademarks of their respective companies.

© 2022, 2023 Toshiba Tec Corporation All rights reserved

Under the copyright laws, this manual cannot be reproduced in any form without the prior written permission of Toshiba Tec Corporation.

General Precautions for Installation, Servicing and Maintenance for this Option

The installation and service shall be done by a qualified service technician.

1. When installing this option to the MFP, be sure to follow the instructions described in the “Unpacking/Set-Up Procedure for the Equipment” booklet which comes with this option.
2. This option should be installed by an authorized or qualified service technician.
3. MJ-1115 weighs approx. 40 kg (88.19 lbs.) and MJ-1116 weighs approx. 70 kg (154.32 lbs.), therefore pay full attention when handling it.
4. Before starting installation, servicing or maintenance work, be sure to unplug the power cable of the MFP first.
5. Static electricity may remain in the boards in the MFP even after the power cable is unplugged. Therefore, when disconnecting the connector, wait approx. 1 minute after the power cable is unplugged.
6. Generally, the fuse is embedded so that it would be on the live side. However, it could be on the neutral side depending on the type of the power plug to be used.
7. The MFP with this option connected shall be installed near the socket outlet and shall be easily accessible.
8. Be sure to fix and plug in the power cable securely after the installation so that no one trips over it.
9. When this option is removed from the MFP due to malfunction or other reasons but no substitute one is to be installed, be sure to remove all the installation hardware from the MFP as well.
10. When selecting the installation site, avoid placing this option and the MFP on different levels or inclined floors.
11. When servicing or maintaining the MFP with this option connected, be careful about the rotating or operating sections such as gears, pulleys, sprockets, cams, belts, etc.
12. When the parts of this option are disassembled, reassembly is the reverse of disassembly unless otherwise noted in this manual or other related documents.
Be careful not to install small parts such as screws, washers, pins, E-rings, star washers, harnesses in the wrong places.
13. Basically, the MFP with this option connected should not be operated with any parts removed or disassembled.
14. When servicing the MFP with this option connected while the power is turned ON, be sure not to touch live sections and rotating/operating sections.
15. Delicate parts for preventing safety hazard problems (such as fuses, thermofuses, door switches, sensors, etc. if any) should be handled, installed and adjusted correctly.
16. Tools and instruments
 - Use designated jigs and tools.
 - Use recommended measuring instruments or equivalents.

17. During servicing or maintenance work, be sure to check the nameplate and other cautionary labels (if any) to see if they are clean and firmly stuck. If not, take appropriate actions.

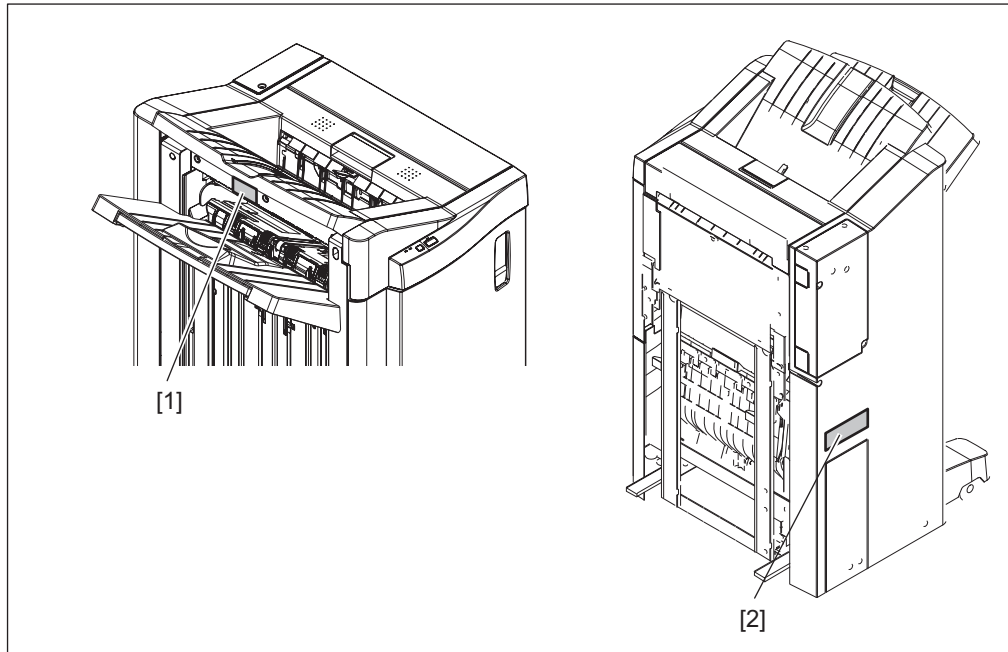

[1] Cautionary label for the paper exit section

[2] Rating label

18. The ICs on the PC boards tend to be damaged by static electricity. Therefore, the PC boards must be stored in an antistatic bag and handled carefully using an antistatic wristband.

Before using the wristband, unplug the power cable of the MFP and make sure that there are no charged objects which are not insulated in the vicinity.

19. Regarding the recovery and disposal of the MFP with this option connected, supplies, packing materials, follow the relevant local regulations or rules.

20. Return the MFP with this option connected to the original state and check the operation when the service is finished.

21. When the MFP is used after this option is removed, be sure to install the parts or the covers which have been taken off so that the inside of the MFP is not exposed.

22. When you move this option, do not move it in the direction of the arrows as shown in the figure below. Otherwise it might topple over.

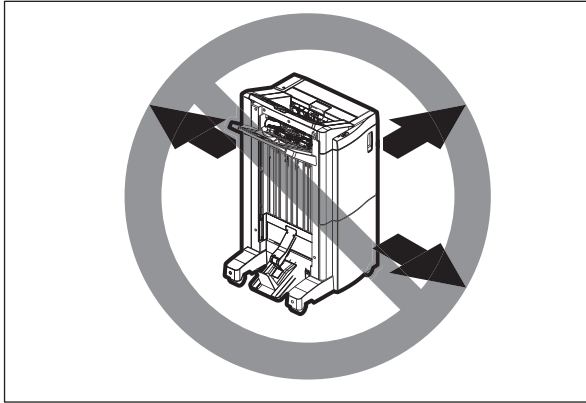

23. Unplug the power cable and clean the area around the prongs of the plug and socket outlet once a year or more. A fire may occur when dust lies on this area.

24. When you remove this option and then lift the MFP, do not hold its studs. This could cause injury since the studs may break off and make the MFP fall.

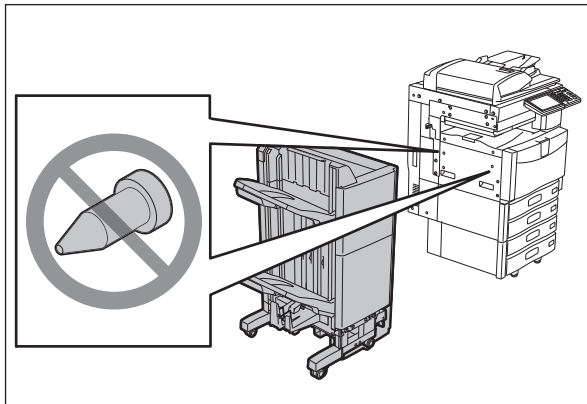

25. Check the procedures and perform them as described in the Service Manual.

26. Make sure you do not lose your balance.

27. Avoid exposure to your skin and wear protective gloves as needed.

28. Do not leave plastic bags where children can get at them. This may cause an accident such as suffocation if a child puts his/her head into a bag. Plastic bags of options or service parts must be brought back.

CONTENTS

1. SPECIFICATIONS, ACCESSORIES AND CONSUMABLES	1-1
1.1 Specifications	1-1
1.1.1 Finisher section (common for MJ-1115 and MJ-1116)	1-2
1.1.2 Saddle stitch section (MJ-1116)	1-6
1.2 Accessories	1-7
1.3 Consumables	1-7
2. OVERVIEW	2-1
2.1 Main Components	2-1
2.2 Sectional View	2-2
2.2.1 Units	2-2
2.2.2 Finisher section	2-3
2.2.3 Saddle stitch section	2-5
2.3 Electric Parts Layout	2-7
2.4 Symbols and Functions of Various Components	2-15
2.4.1 Motor (finisher section: common for MJ-1115 and MJ-1116)	2-15
2.4.2 Motor (saddle stitch section: MJ-1116)	2-16
2.4.3 Electromagnetic spring clutch (finisher section: common for MJ-1115 and MJ-1116)	2-16
2.4.4 Electromagnetic spring clutch (saddle stitch section: MJ-1116)	2-16
2.4.5 Solenoid (finisher section: common for MJ-1115 and MJ-1116)	2-16
2.4.6 Solenoid (saddle stitch section: MJ-1116)	2-16
2.4.7 Sensor (finisher section: common for MJ-1115 and MJ-1116)	2-17
2.4.8 Sensor, Switch (saddle stitch section: MJ-1116)	2-18
2.4.9 PC board (finisher section: common for MJ-1115 and MJ-1116)	2-19
2.4.10 PC board (saddle stitch section: MJ-1116)	2-19
2.5 Signal Block Diagram	2-20
2.6 Interface Signals	2-22
3. OPERATION DESCRIPTION	3-1
3.1 Basic Operations	3-1
3.1.1 Overview	3-1
3.1.2 Junction Box (MJ-1116)	3-5
3.1.3 Paper exiting to the stationary tray	3-6
3.1.4 Paper exiting to the movable tray	3-8
3.1.5 Operation in the saddle stitch section (MJ-1116)	3-17
4. DISASSEMBLY AND REASSEMBLY	4-1
4.1 Cover	4-1
4.1.1 Stationary tray	4-1
4.1.2 Movable tray	4-2
4.1.3 Saddle tray (MJ-1116)	4-3
4.1.4 Control panel unit	4-4
4.1.5 Front cover (MJ-1115)	4-5
4.1.6 Front upper cover, Front lower cover (MJ-1116)	4-6
4.1.7 Handle cover, Cover lock bracket	4-7
4.1.8 Rear cover	4-7
4.1.9 Board access cover	4-8
4.1.10 Saddle access cover	4-8
4.1.11 Right upper cover	4-9
4.1.12 Relay guide, Paper feed discharge brush, Right cover	4-10
4.1.13 Left upper cover	4-11
4.1.14 Front rail cover, Rear rail cover	4-11
4.1.15 Grate-shaped guide	4-12
4.1.16 Left lower cover	4-14
4.1.17 Front foot cover, Rear foot cover	4-15

4.2	Unit (Finisher Section).....	4-16
4.2.1	Junction box unit.....	4-16
4.2.2	Buffer unit	4-18
4.2.3	Buffer unit-1	4-21
4.2.4	Finishing tray unit.....	4-25
4.2.5	Stapler unit.....	4-28
4.2.6	Stapler	4-29
4.2.7	Movable tray shift motor unit.....	4-30
4.3	Unit (Saddle Stitch Section: MJ-1116)	4-33
4.3.1	Saddle stitch unit	4-33
4.3.2	Switchback unit.....	4-36
4.3.3	Paper holding unit.....	4-37
4.3.4	Side alignment unit	4-38
4.3.5	Saddle stapler unit	4-39
4.3.6	Folding drive unit	4-43
4.3.7	Additional folding unit.....	4-45
4.3.8	Stacker unit.....	4-46
4.4	Roller (Finisher Section).....	4-47
4.4.1	Paper feed roller (MJ-1115).....	4-47
4.4.2	Paper feed roller (MJ-1116).....	4-49
4.4.3	Junction roller (MJ-1116).....	4-52
4.4.4	Paddle-1, Paddle-2, Paddle-3, Paddle-4, Paddle-5, Paddle-6	4-53
4.4.5	Transport roller	4-54
4.4.6	Entrance roller	4-59
4.4.7	Stack transport roller-1	4-60
4.4.8	Stack transport roller-2	4-62
4.4.9	Buffer roller	4-64
4.4.10	Upper paper exit roller, Upper paper exit roller guide	4-71
4.5	Roller (Saddle Stitch Section: MJ-1116)	4-74
4.5.1	Switchback transport roller	4-74
4.5.2	Assist roller	4-75
4.5.3	Eject roller.....	4-76
4.5.4	Upper folding roller, Lower folding roller	4-77
4.5.5	Exit roller	4-80
4.6	Motor (Finisher Section).....	4-81
4.6.1	Entrance motor (M1).....	4-81
4.6.2	Buffer tray guide motor (M2).....	4-83
4.6.3	Paddle motor (M3).....	4-83
4.6.4	Front alignment motor (M5)	4-86
4.6.5	Rear alignment motor (M6).....	4-86
4.6.6	Transport motor (M7).....	4-87
4.6.7	Stack transport motor (M8)	4-88
4.6.8	Stapler unit shift motor (M9)	4-88
4.6.9	Assist guide motor (M10).....	4-90
4.6.10	Exit motor (M11)	4-91
4.6.11	Movable tray shift motor (M12)	4-93
4.6.12	Catching motor (M21)	4-95
4.7	Motor (saddle stitch section: MJ-1116)	4-98
4.7.1	Stacker motor (M14).....	4-98
4.7.2	Side alignment motor (M15)	4-100
4.7.3	Saddle transport motor (M16).....	4-101
4.7.4	Folding motor (M17)	4-102
4.7.5	Additional folding motor (M20).....	4-103
4.8	Electromagnetic Spring Clutch, Solenoid.....	4-105
4.8.1	Stack exit guide clutch (CLT2).....	4-105
4.8.2	Folding blade clutch (CLT3) (MJ-1116)	4-107
4.8.3	Paper holding clutch (CLT4) (MJ-1116).....	4-108
4.8.4	Buffer roller lift solenoid (SOL2), Exit roller lift solenoid (SOL8)	4-108

4.8.5	Gate solenoid (SOL4)	4-111
4.8.6	Transport path switching solenoid (SOL5) (MJ-1116)	4-114
4.8.7	Assist roller solenoid (SOL6) (MJ-1116)	4-116
4.9	Sensor, Switch (Finisher Section)	4-117
4.9.1	Entrance sensor (S1)	4-117
4.9.2	Transport sensor (S2)	4-118
4.9.3	Paddle home position sensor (S3)	4-119
4.9.4	Buffer tray home position sensor (S5)	4-121
4.9.5	Assist guide home position sensor (S6)	4-122
4.9.6	Front alignment plate home position sensor (S7)	4-122
4.9.7	Rear alignment plate home position sensor (S8)	4-123
4.9.8	Stack exit belt home position sensor (S9)	4-123
4.9.9	Stapler unit home position sensor (S10)	4-124
4.9.10	Stapler interference sensor (S11), Actuator	4-125
4.9.11	Finishing tray paper sensor (S12)	4-126
4.9.12	Movable tray position-A sensor (S13), Movable tray position-B sensor (S14), Movable tray position-C sensor (S15)	4-128
4.9.13	Movable tray stack height detection sensor (S16)	4-129
4.9.14	Movable tray paper sensor (S17)	4-130
4.9.15	Stationary tray stack height detection sensor (S18)	4-130
4.9.16	Paper feed sensor (S22)	4-131
4.9.17	Movable tray shift motor sensor (S23)	4-132
4.9.18	Connection sensor (S25)	4-132
4.9.19	Catching home position sensor (S52)	4-133
4.9.20	Front cover opening/closing switch (SW1)	4-133
4.9.21	Stationary tray opening/closing switch (SW2)	4-134
4.9.22	Stapler interference switch (SW3)	4-136
4.9.23	Connection switch (SW4)	4-137
4.10	Sensor, Switch (Saddle Stitch Section: MJ-1116)	4-138
4.10.1	Junction box sensor (S26)	4-138
4.10.2	Transport path-2 sensor (S27)	4-139
4.10.3	Transport path-3 sensor (S28)	4-140
4.10.4	Eject roller sensor (S29)	4-141
4.10.5	Stacker paper detection sensor (S30)	4-142
4.10.6	Exit sensor (S31)	4-143
4.10.7	Saddle tray paper detection sensor (S32)	4-144
4.10.8	Stacker home position sensor (S33)	4-145
4.10.9	Folding motor encoder sensor (S34)	4-145
4.10.10	Folding blade home position sensor (S35)	4-146
4.10.11	Side alignment plate home position sensor (S36)	4-146
4.10.12	Paper holding home position sensor (S38)	4-147
4.10.13	Additional folding home position sensor (S39)	4-148
4.10.14	Exit transport sensor (S41)	4-148
4.10.15	Additional folding motor encoder sensor (S42)	4-149
4.10.16	Saddle stitch unit opening/closing switch (SW5)	4-150
4.11	PC Board, Discharge Brush	4-151
4.11.1	Finisher control PC board (FIN)	4-151
4.11.2	Saddle control PC board (SDL) (MJ-1116)	4-152
4.11.3	Saddle flat cable (MJ-1116)	4-153
4.11.4	Stationary tray front discharge brush, Stationary tray rear discharge brush	4-156
4.12	Lowering Procedure of the Movable Tray	4-157
5.	ADJUSTMENT	5-1
5.1	Alignment position adjustment	5-1
5.2	Stapling Position Adjustment	5-4
5.3	Stapling and Folding Position Adjustment	5-6
5.3.1	Folding position adjustment	5-8
5.3.2	Stapling position adjustment	5-8
5.4	Saddle Stitch Section Skew Adjustment	5-9

6. TROUBLESHOOTING	6-1
6.1 Error Code List	6-1
6.2 Analysis from Error Codes	6-1
6.3 Other Errors	6-2
6.3.1 Countermeasure when an exit paper alignment problem occurs	6-2
6.3.2 Paper trailing edge abnormality when it is exiting to the movable tray (dents, folding, tears)	6-3
6.4 Self-Diagnostic Mode	6-7
6.4.1 Overview	6-7
6.4.2 Operation procedure	6-7
6.4.3 Operation status check	6-8
6.4.4 Test list	6-8
6.4.5 Error indications	6-16
7. PREVENTIVE MAINTENANCE (PM) AND FIRMWARE UPDATING	7-1
7.1 Maintenance and Inspection Points	7-1
7.2 Firmware Updating	7-8
8. HARNESS DIAGRAM	8-1
8.1 Finisher Control PC Board	8-1
8.2 Saddle Control PC Board	8-3
REVISION RECORD	1

1. SPECIFICATIONS, ACCESSORIES AND CONSUMABLES

1.1 Specifications

Type	MJ-1115: Console finisher (2 trays) MJ-1116: Console saddle stitch finisher (3 trays)
Paper loading tray	Stationary tray, Movable tray, Saddle tray (MJ-1116 only)
Paper size	A3, A4, A4-R, A5, A5-R, A6-R, B4, B5, B5-R, FOLIO, A3 wide, LD, LG, LT, LT-R, ST-R, COMPUTER, 13"LG, 8.5"SQ, 8K, 16K, 16K-R
Paper weight	52 g/m ² to 300 g/m ² (16 lbs. Bond to 110 lbs. Cover) Remarks: Thin (52 g/m ² to 59 g/m ²) is available when a single sheet is printed out to the stationary tray.
Stacking mode	Simple, Job Offset, Staple, Composite, Center-binding, Center-folding
Dimensions	With the sub tray retracted: 617 mm (W) x 603 mm (D) x 1,085 mm (H) With the sub tray pulled out: 750 mm (W) x 603 mm (D) x 1,085 mm (H)
Weight	MJ-1115: Approx. 40 kg (88.19 lbs.) MJ-1116: Approx. 70 kg (154.32 lbs.)
Power supply	DC 24 V +10/-5 % and DC 5.1 V ± 4 % supplied from the MFP
Power consumption	DC 24 V, 3.9 A or less (Peak: 11.0 A or less) DC 5.1 V, 1.0 A or less

1.1.1 Finisher section (common for MJ-1115 and MJ-1116)

- Stacking direction: Face-down
- Stacking height

<Stationary tray>

Paper size		Stacking height	Number of sheets (reference)		
			60 g/m ² to 80 g/m ²	81 g/m ² to 90 g/m ²	91 g/m ² to 105 g/m ²
Plain, Thick	A4, B5, LT, A5-R, ST-R, 8.5"SQ, 16K, A6-R	36.75 mm	250	225	190
	A3, A4-R, B4, FOLIO, LD, LG, LT-R, COMPUTER, B5-R, 13"LG, 8K, 16K-R, A3 wide, 12" x 18", 320 x 450 mm, 320 x 460 mm, Non-standard	18.4 mm	125	112	95
Envelope		18.4 mm	50	50	50

The maximum height is 18.4 mm for the mixed-size paper stacking.

The "Full" status is defined as when the stationary tray stack height detection sensor (S18) detected the full status of paper in the size available for feeding.

<Movable tray (other than the staple stacking mode)>

Paper size		Stacking height (60 g/m ² to 105 g/m ²)	Number of sheets (reference)			
			60 g/m ² to 80 g/m ²	81 g/m ² to 90 g/m ²	91 g/m ² to 105 g/m ²	106 g/m ² to 256 g/m ²
Plain, Thick	A4, B5, LT, 8.5"SQ, 16K	350 mm	3,000	2,700	2,300	900
	A3, A4-R, B4, FOLIO, LD, LG, LT-R, COMPUTER, 13"LG, 8K, 16K-R, A3 wide, 12" x 18"	175 mm	1,500	1,350	1,150	450
	ST-R, A5-R, B5-R, A6-R, Non-standard	-	500	500	500	450

The maximum height is 175 mm for the mixed-size paper stacking. However, ST-R, A5-R, B5-R, A6-R and non-standard are not acceptable for the mixed-size paper stacking.

The "Full" status is defined as when the number of sheets has reached 3,000 for the paper size whose stacking height is 350 mm and 1,500 for others.

<Movable tray (staple stacking mode)>

Paper size		Stacking height 60 g/m ² to 105 g/m ²	
		Single (Front/Rear)	Double
Plain, Thick	A4, B5, LT	The "Full" status is defined as when the number of sets has reached 100 or the number of sheets has reached 2,000.	The "Full" status is defined as when the number of sets has reached 150 or the number of sheets has reached 2,000.
	A3, A4-R, B4, FOLIO, LD, LG, LT-R, COMPUTER, 13"LG, 8K, 16K, 8.5"SQ	The "Full" status is defined as when the number of sets has reached 50 or the number of sheets has reached 1,000.	The "Full" status is defined as when the number of sets has reached 75 or the number of sheets has reached 1,000.

- Stapling position

Single (Front)

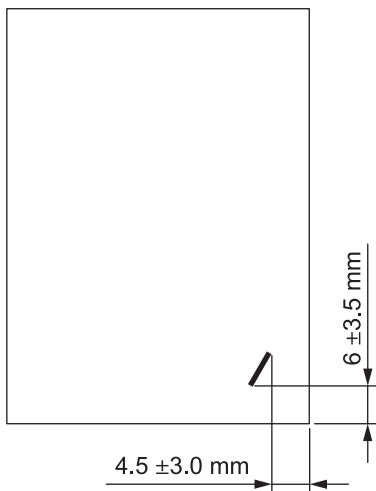

Fig. 1-1

Single (Rear)

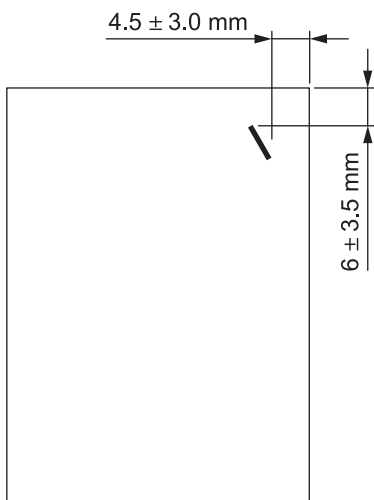

Fig. 1-2

Double

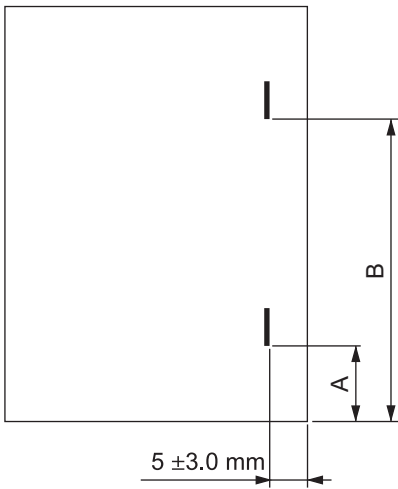

Fig. 1-3

Paper size	A	B
A3, A4	81.0 mm \pm 3.5 mm	205.0 mm \pm 3.5 mm
A4-R, FOLIO	37.5 mm \pm 3.5 mm	161.5 mm \pm 3.5 mm
B4, B5, COMPUTER	61.0 mm \pm 3.5 mm	185.0 mm \pm 3.5 mm
LD, LT	72.0 mm \pm 3.5 mm	196.0 mm \pm 3.5 mm
LT-R, LG	40.5 mm \pm 3.5 mm	164.5 mm \pm 3.5 mm

- Acceptable paper size for stapling

Stapling position	Paper size
Single (Front)	A3, A4, A4-R, B4, B5, FOLIO, LD, LG, LT, LT-R, COMPUTER, 13"LG, 8.5"SQ, 8K, 16K
Single (Rear)	A3, A4, A4-R, B4, B5, FOLIO, LD, LG, LT, LT-R, COMPUTER, 13"LG, 8.5"SQ, 8K, 16K
Double	A3, A4, A4-R, B4, B5, FOLIO, LD, LG, LT, LT-R, COMPUTER, 13"LG, 8.5"SQ, 8K, 16K

Stapling is not available for paper in sizes other than the above.

- Acceptable paper weight for stapling: 60 g/m² to 105 g/m²
- Acceptable number of sheets for stapling (including 2 cover sheets (200 g/m² to 256 g/m²))

Paper size	60 g/m ² to 80 g/m ²	81 g/m ² to 90 g/m ²	91 g/m ² to 105 g/m ²
A4, A4-R, B5, LT, LT-R, 8.5"SQ, 16K	65	50	30
A3, B4, FOLIO, LD, LG, COMPUTER, 13"LG, 8K	30	30	15

Maximum number of sheets acceptable for stapling:

- A4, A4-R, B5, LT, LT-R, 8.5"SQ, 16K: 50 sheets
- A3, B4, FOLIO, LD, LG, COMPUTER, 13"LG, 8K: 30 sheets

- Staple loading: Exclusive cartridge (5,000 staples)
- Manual stapling: Available

1.1.2 Saddle stitch section (MJ-1116)

- Type: Center-binding only
- Paper size: A3, B4, A4-R, LD, LG, LT-R, 8K
- Acceptable number of sheets for saddle stitching (including 1 cover sheet (200 g/m² to 256 g/m²))

60 g/m ² to 80 g/m ²	81 g/m ² to 90 g/m ²	91 g/m ² to 105 g/m ²
15	15	10

- Acceptable paper weight for stapling: 60 g/m² to 105 g/m²
- Staple loading: Exclusive cartridge (2,000 staples)
- Exiting paper without folding: Not available
- Exiting paper without stapling: At the exiting with center-folding
- Stapling interval: 120 mm
- Number of sets for stacking (for center-binding)

No thick cover page included

Number of sheets	60 g/m ² to 90 g/m ²	91 g/m ² to 105 g/m ²
5 or less (per set)	50	40
10 or less (per set)	30	25
15 or less (per set)	25	-

Thick cover page included

Number of sheets	60 g/m ² to 90 g/m ²	91 g/m ² to 105 g/m ²
5 or less (per set)	50	30
10 or less (per set)	15	15
15 or less (per set)	10	-

- Number of sets for stacking (for center-folding)

No thick cover page included

Number of sheets	60 g/m ² to 105 g/m ²
2 to 5 (per stack)	25

Thick cover page included

Number of sheets	60 g/m ² to 90 g/m ²	91 g/m ² to 105 g/m ²
2 to 5 (per stack)	25	15

1.2 Accessories

	MJ-1115	MJ-1116
Unpacking/Setup Instructions	1	1
Movable tray	1 pc.	1 pc.
Connect rail plate	1 pc.	1 pc.
Connect rail	1 pc.	1 pc.
Connect plate	1 pc.	1 pc.
Joint plate	1 pc.	1 pc.
Saddle tray	-	1 pc.
Slide tray	-	1 pc.
Leveling arm	-	1 pc.
Screw: TBID M4 x 8	6 pcs.	6 pcs.
Screw: TBID M4 x 12	5 pcs.	5 pcs.
Screw: M3 x 8	5 pcs.	7 pcs.
Screw: M3 x 8 (black)	-	2 pcs.

1.3 Consumables

- Staple cartridge for the finisher section
Exclusive cartridge (STAPLE-3900: 5,000 staples x 3 cartridges per 1 box)
- Staple cartridge for the saddle section (MJ-1116)
Exclusive cartridge (STAPLE-3100: 2,000 staples x 4 cartridges per 1 box)

2. OVERVIEW

2.1 Main Components

MJ-1115/1116

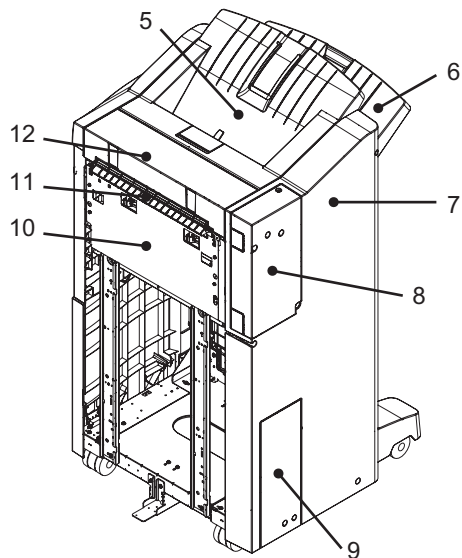
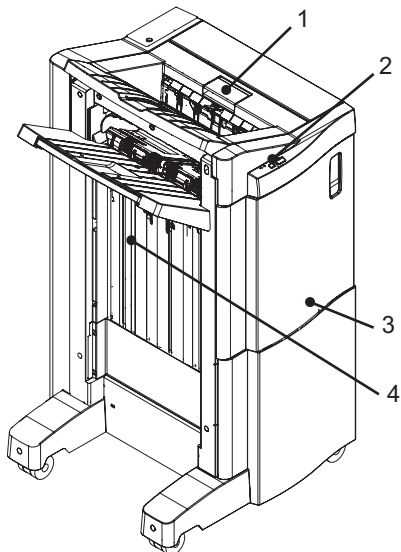

MJ-1116

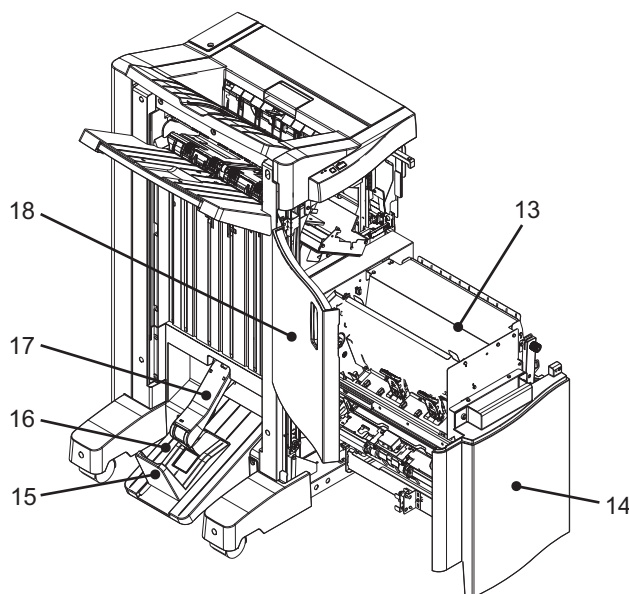

Fig. 2-1

1	Jam access lever	10	Right cover
2	Control panel	11	Relay guide
3	Front cover	12	Right upper cover
4	Grate-shaped guide	13	Saddle stitch unit
5	Stationary tray	14	Front lower cover
6	Movable tray	15	Slide tray
7	Rear cover	16	Saddle tray
8	Board access cover	17	Leveling arm
9	Saddle access cover	18	Front upper cover

2.2 Sectional View

2.2.1 Units

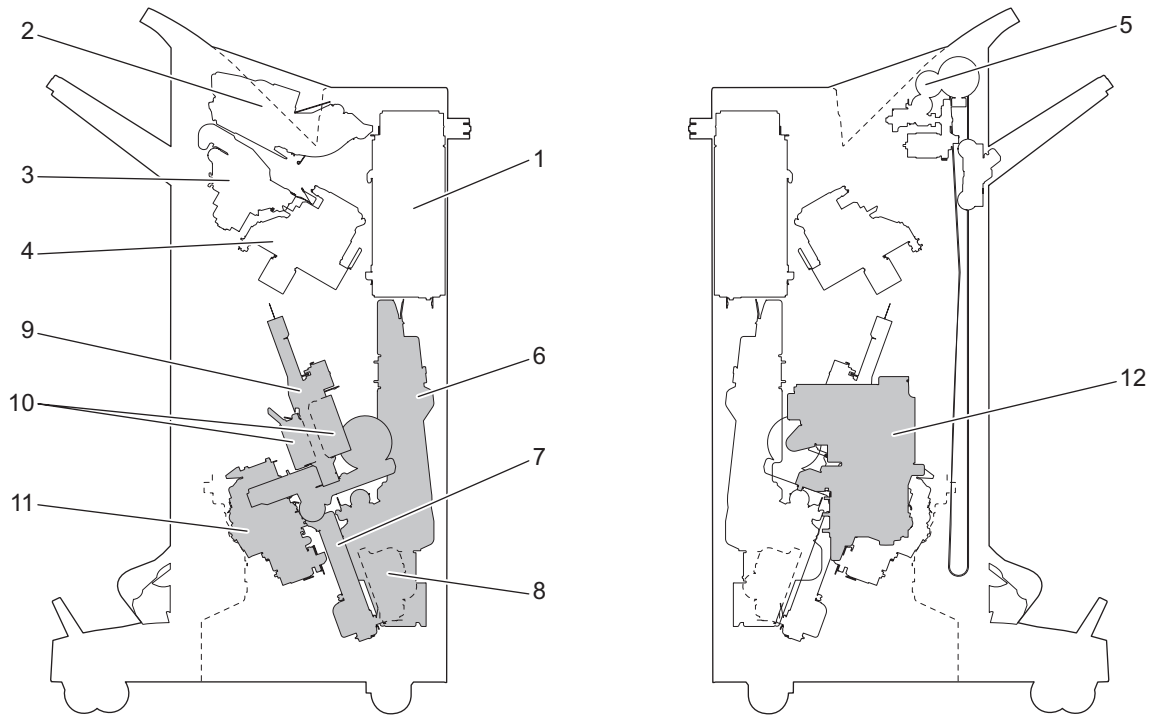

Fig. 2-2

1	Junction box unit
2	Buffer unit
3	Finishing tray unit
4	Stapler
5	Movable tray shift motor unit
6	Switchback unit (MJ-1116)
7	Stacker unit (MJ-1116)
8	Paper holding unit (MJ-1116)
9	Side alignment unit (MJ-1116)
10	Saddle stapler unit (MJ-1116)
11	Additional folding unit (MJ-1116)
12	Folding drive unit (MJ-1116)

2.2.2 Finisher section

[A] Front side view

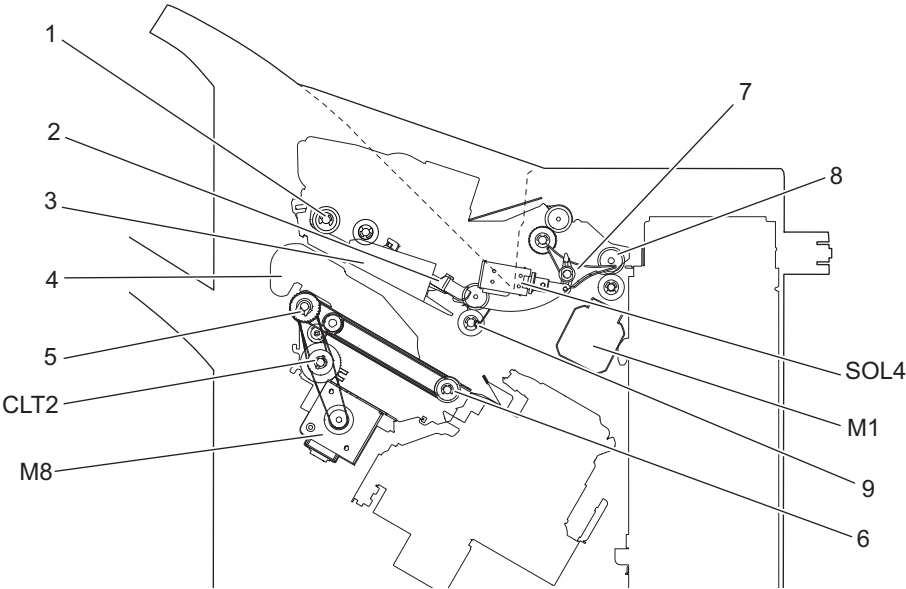

Fig. 2-3

1	Buffer roller
2	Assist guide
3	Buffer tray
4	Alignment plate
5	Stack transport roller-2
6	Stack transport roller-1
7	Gate flap
8	Entrance roller
9	Exit roller
M1	Entrance motor
M8	Stack transport motor
CLT2	Stack exit guide clutch
SOL4	Gate solenoid

[B] Rear side view

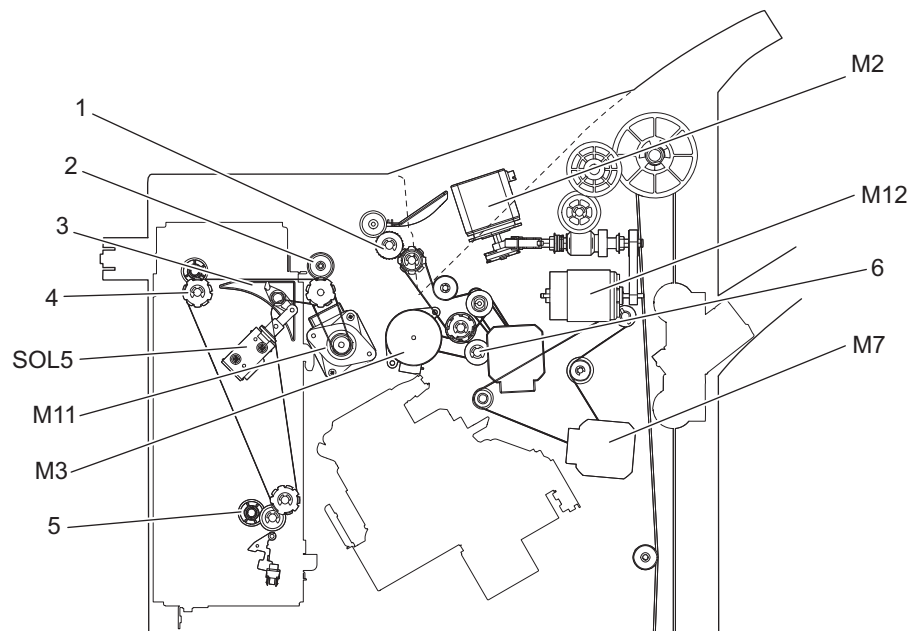

Fig. 2-4

1	Stationary tray roller
2	Entrance roller
3	Flapper
4	Paper feed roller
5	Junction roller
6	Paddle
M2	Buffer tray guide motor
M3	Paddle motor
M7	Transport motor
M11	Exit motor
M12	Movable tray shift motor
SOL5	Transport path switching solenoid (MJ-1116)

2.2.3 Saddle stitch section

[A] Front side view

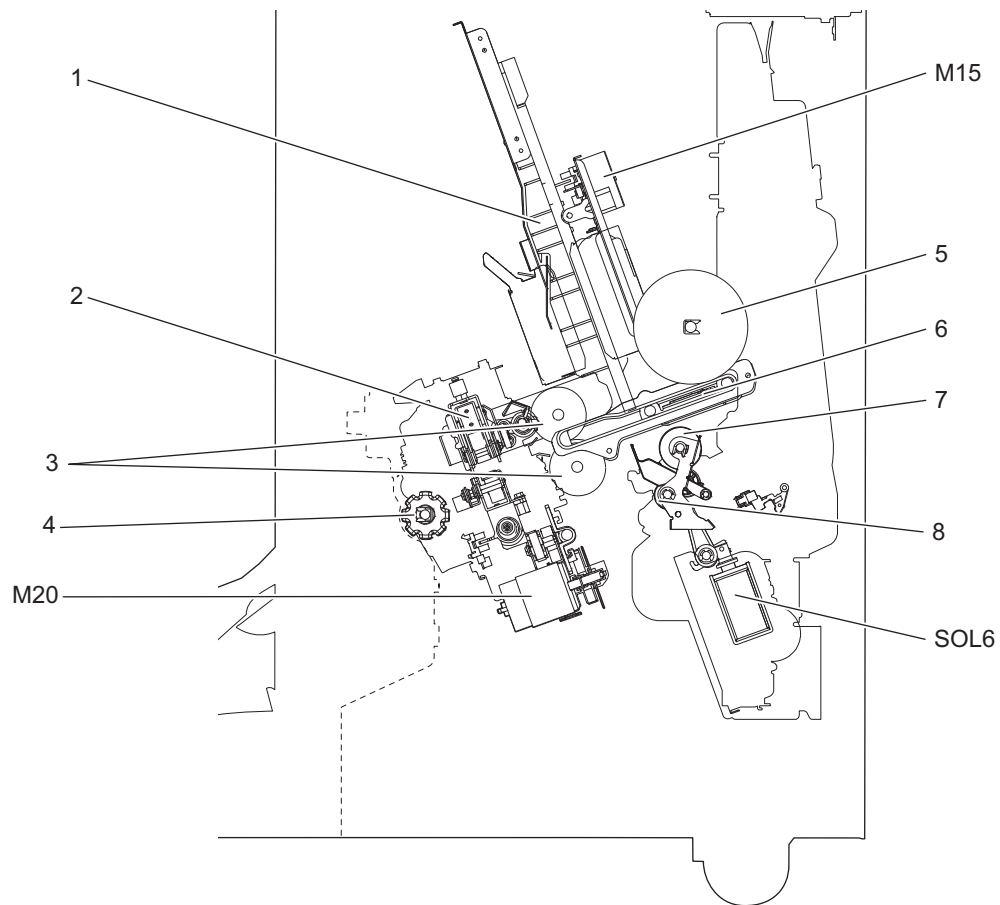

Fig. 2-5

1	Jog
2	Additional folding carrier
3	Folding roller
4	Saddle paper exit roller
5	Folding blade cam
6	Folding blade
7	Assist roller
8	Eject roller
M15	Side alignment motor
M20	Additional folding motor
SOL6	Assist roller solenoid

[B] Rear side view

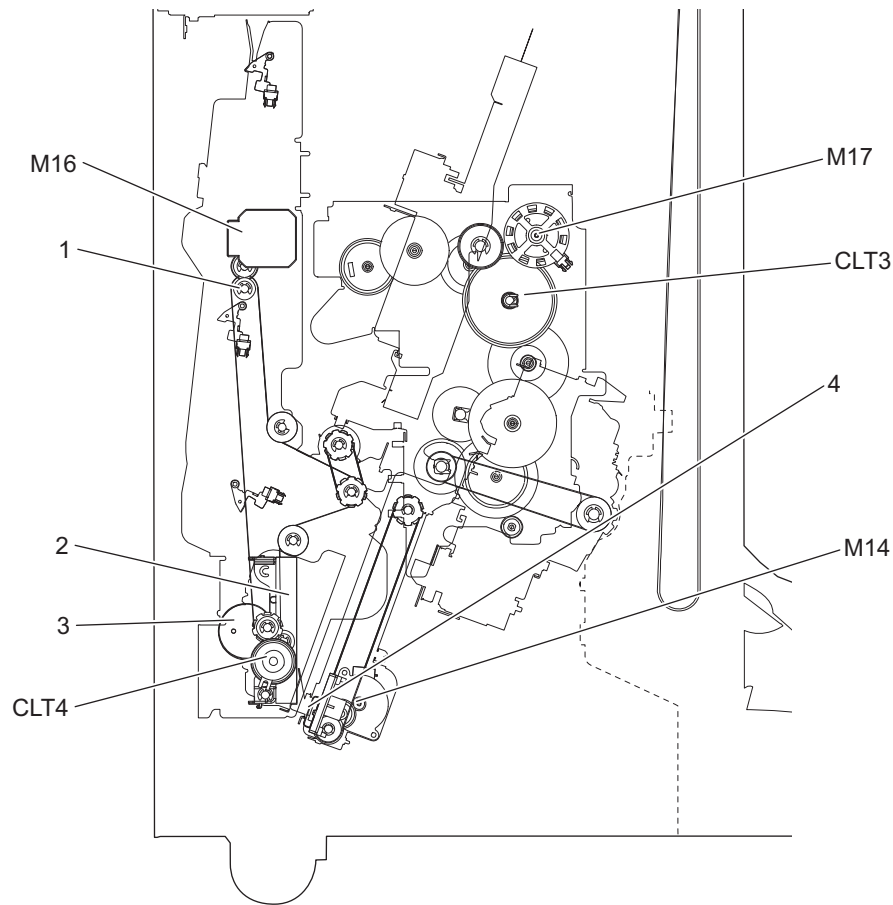

Fig. 2-6

1	Transport roller
2	Paper holding damper
3	Paper holding cam
4	Stacker carrier
M14	Stacker motor
M16	Saddle transport motor
M17	Folding motor
CLT3	Folding blade clutch
CLT4	Paper holding clutch

2.3 Electric Parts Layout

[A] Electric parts layout 1

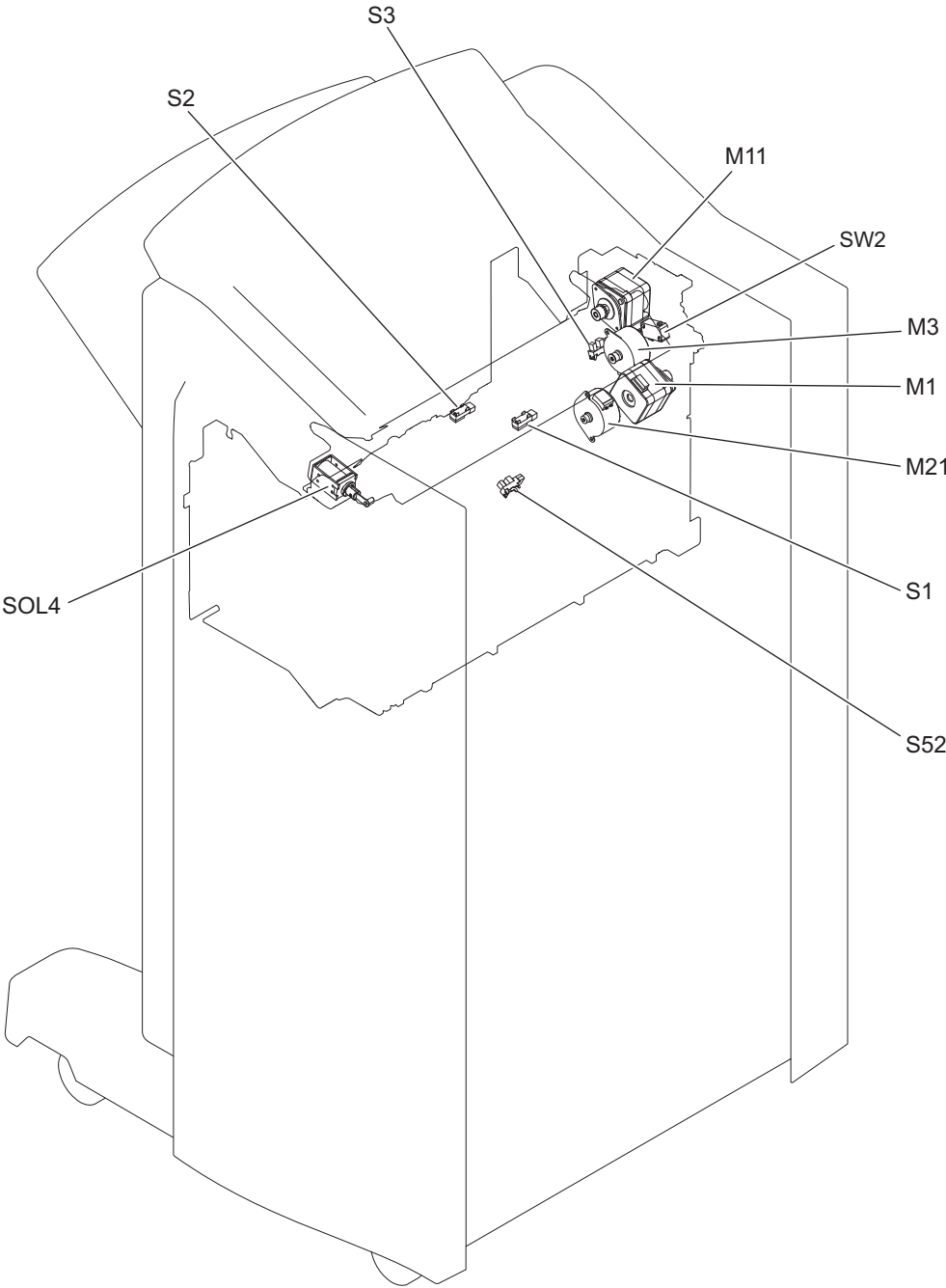

Fig. 2-7

[B] Electric parts layout 2

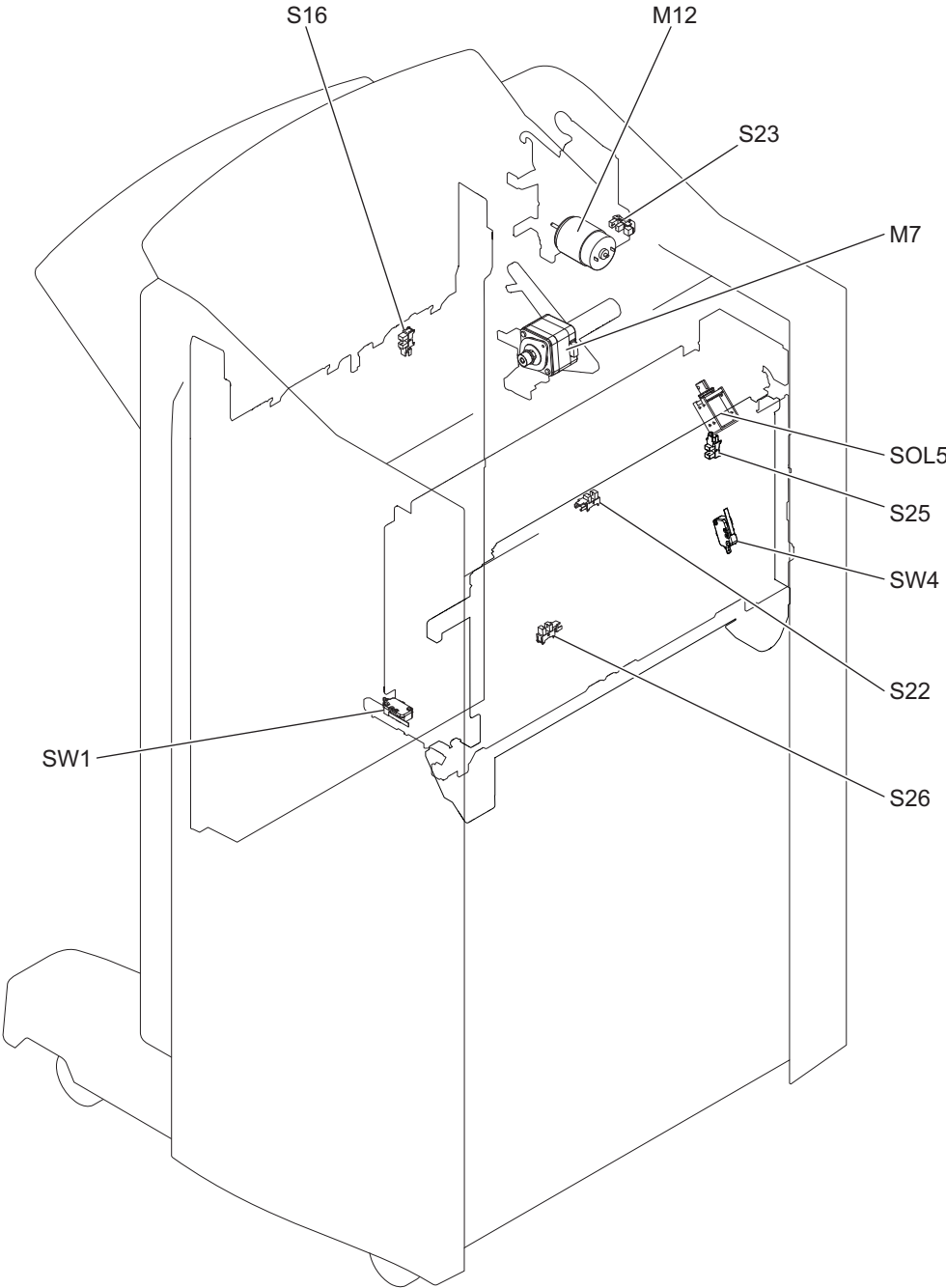

Fig. 2-8

[C] Electric parts layout 3

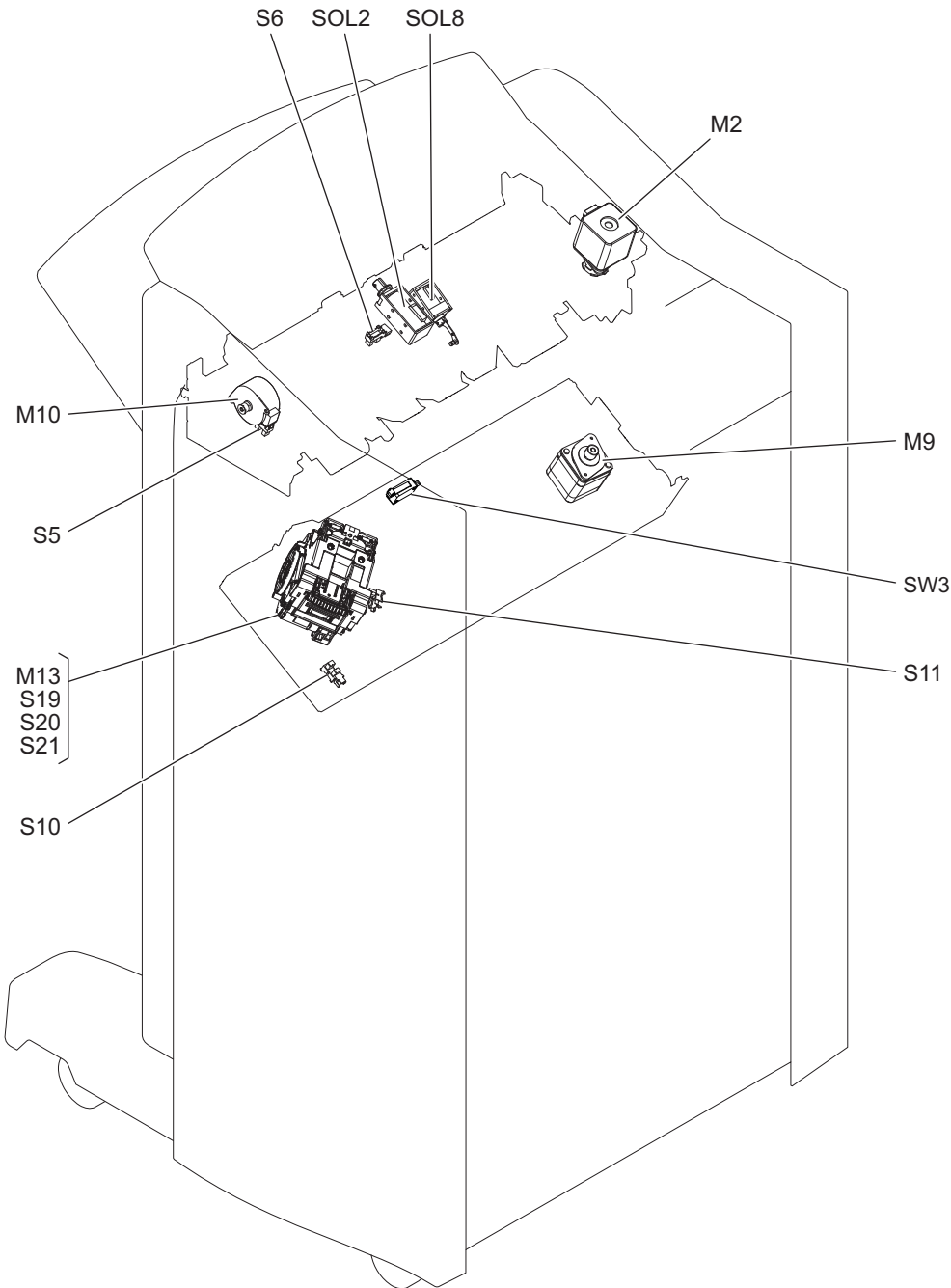

Fig. 2-9

[D] Electric parts layout 4

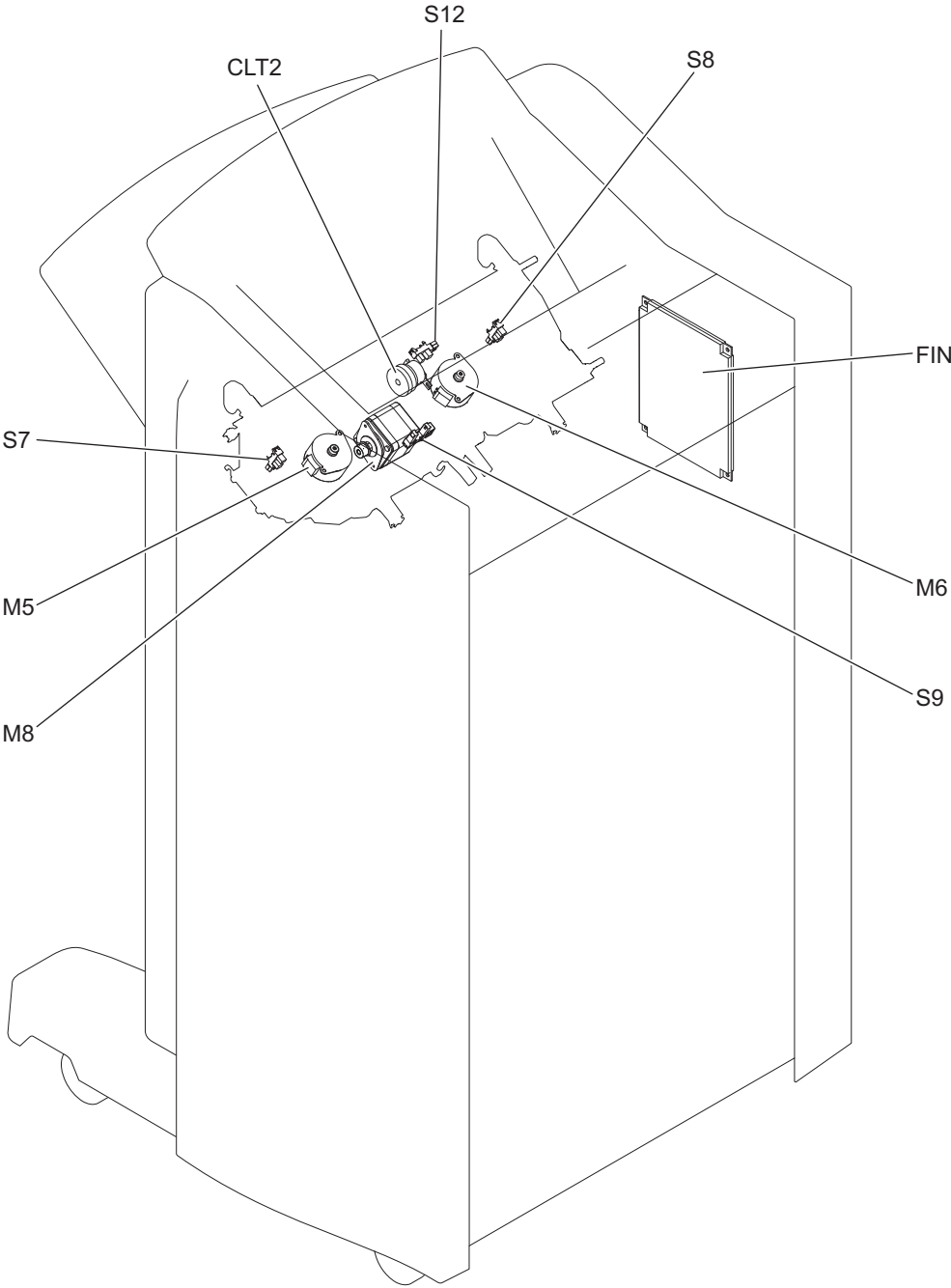

Fig. 2-10

[E] Electric parts layout 5

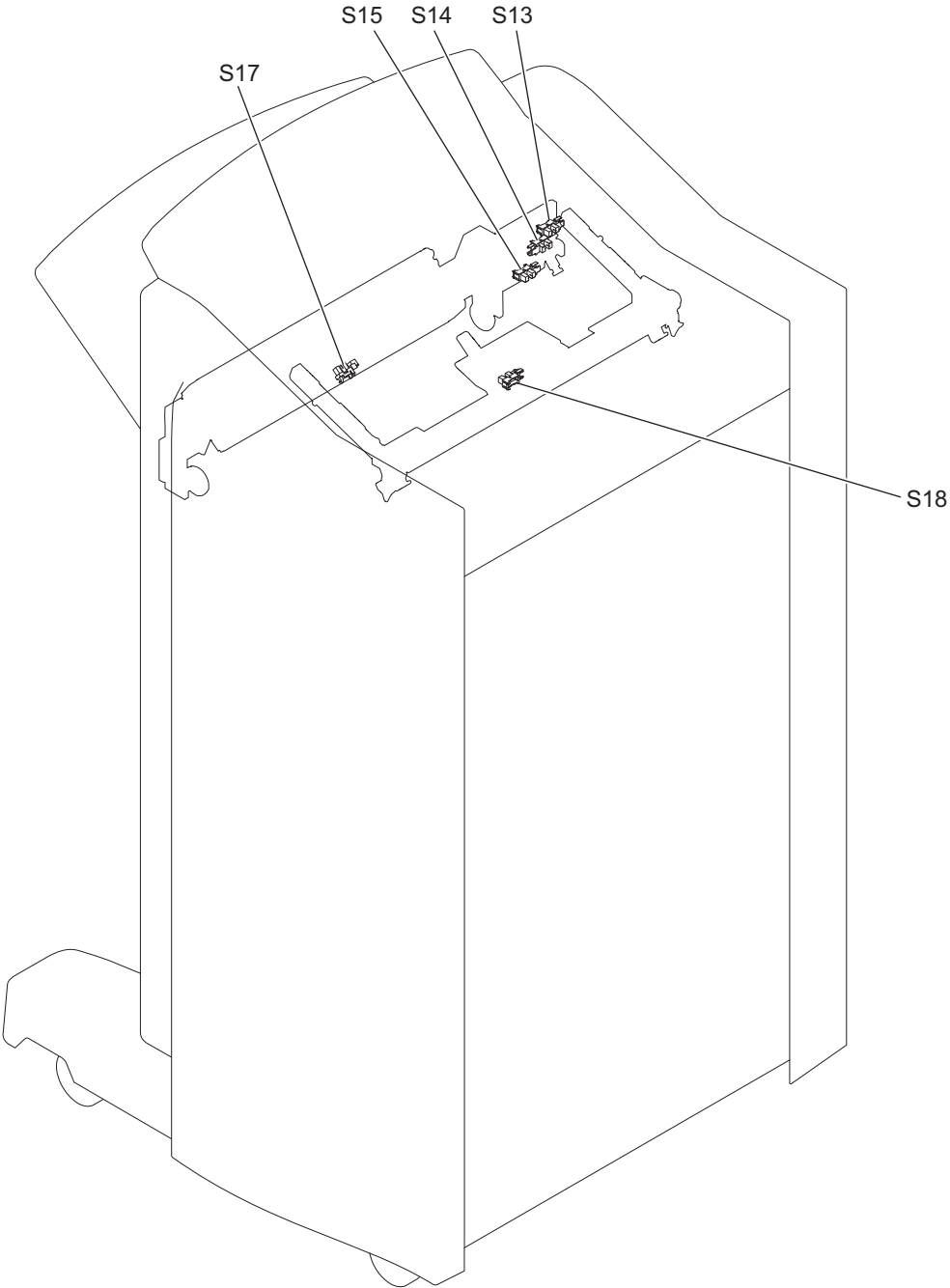

Fig. 2-11

[F] Electric parts layout 6

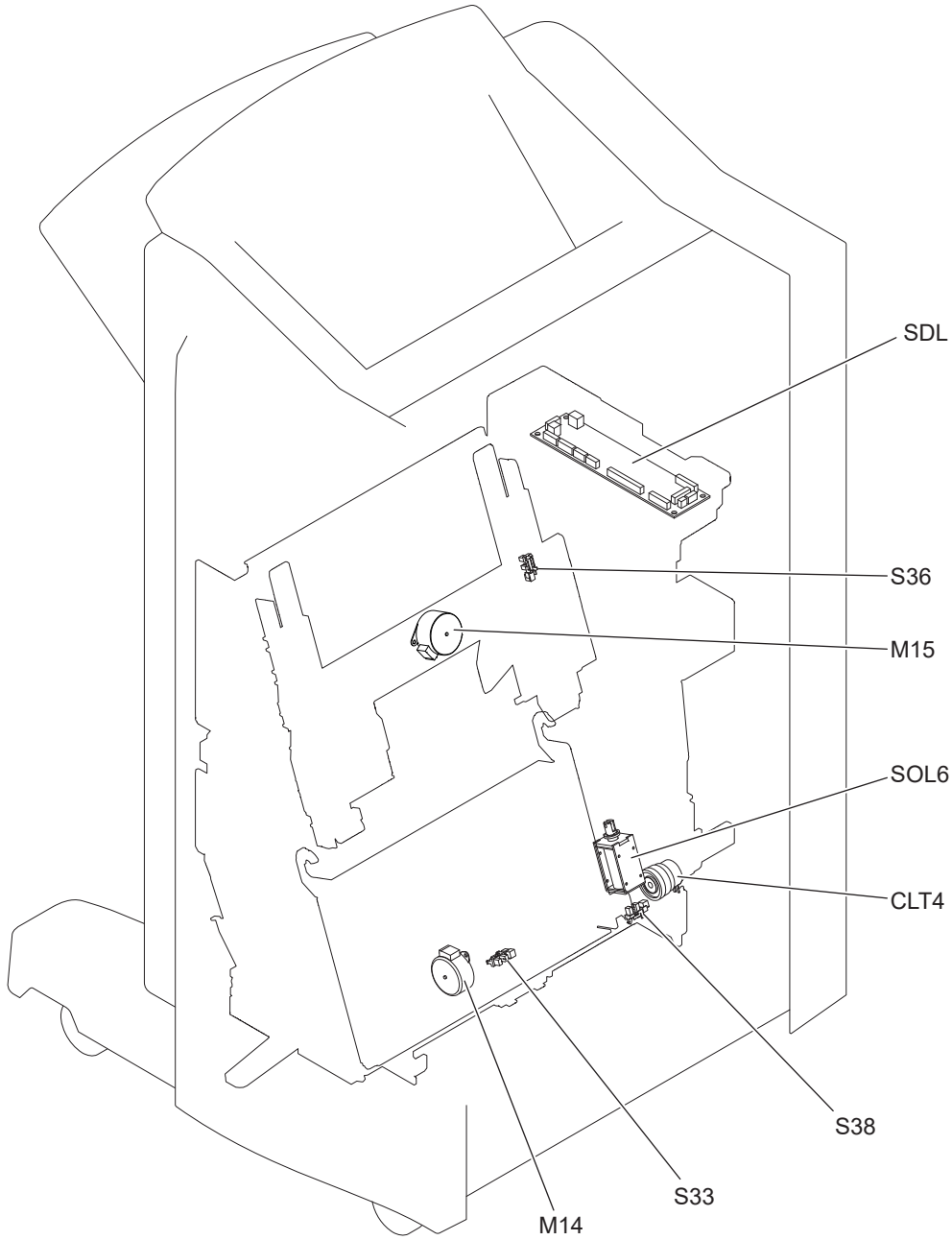

Fig. 2-12

[G] Electric parts layout 7

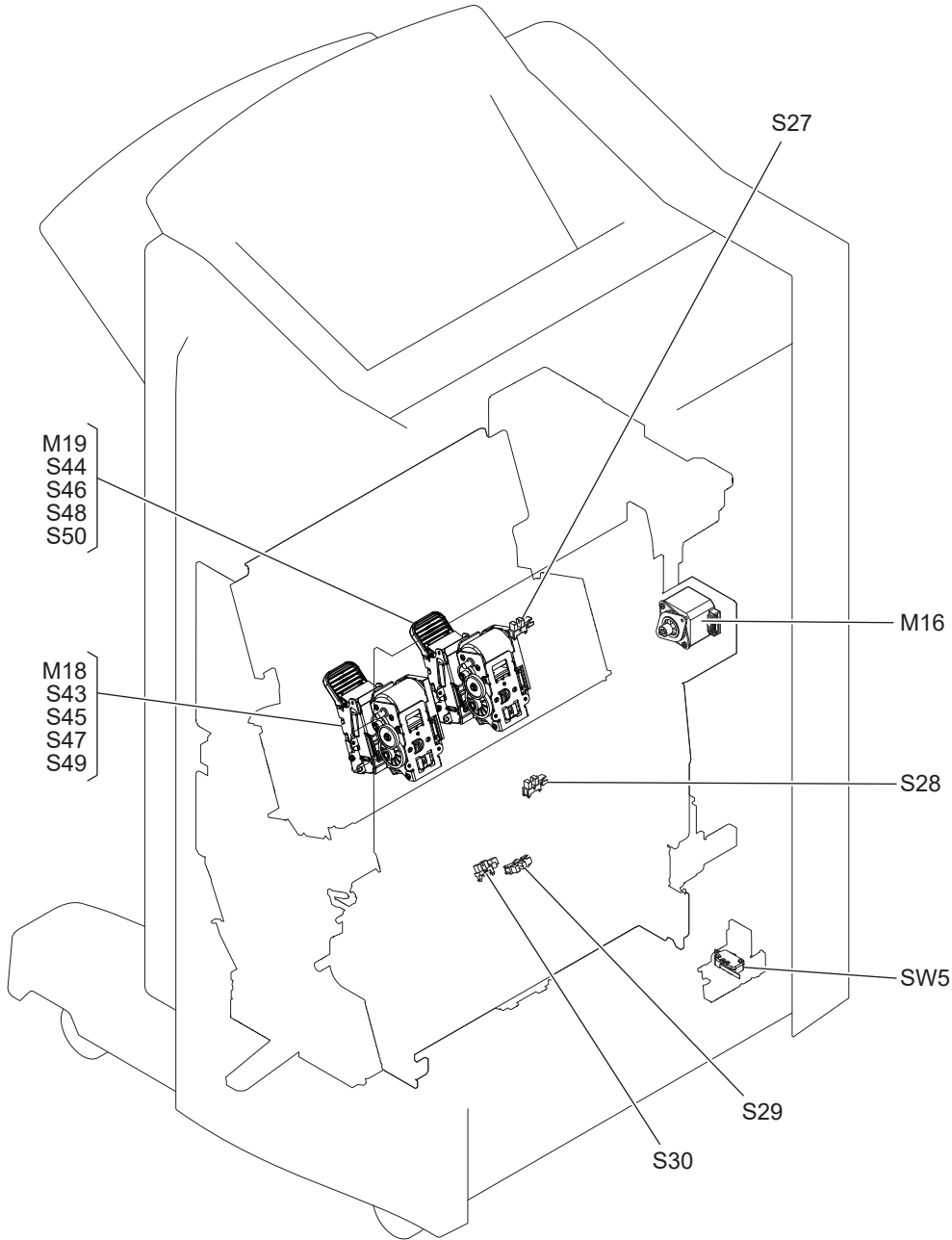

Fig. 2-13

[H] Electric parts layout 8

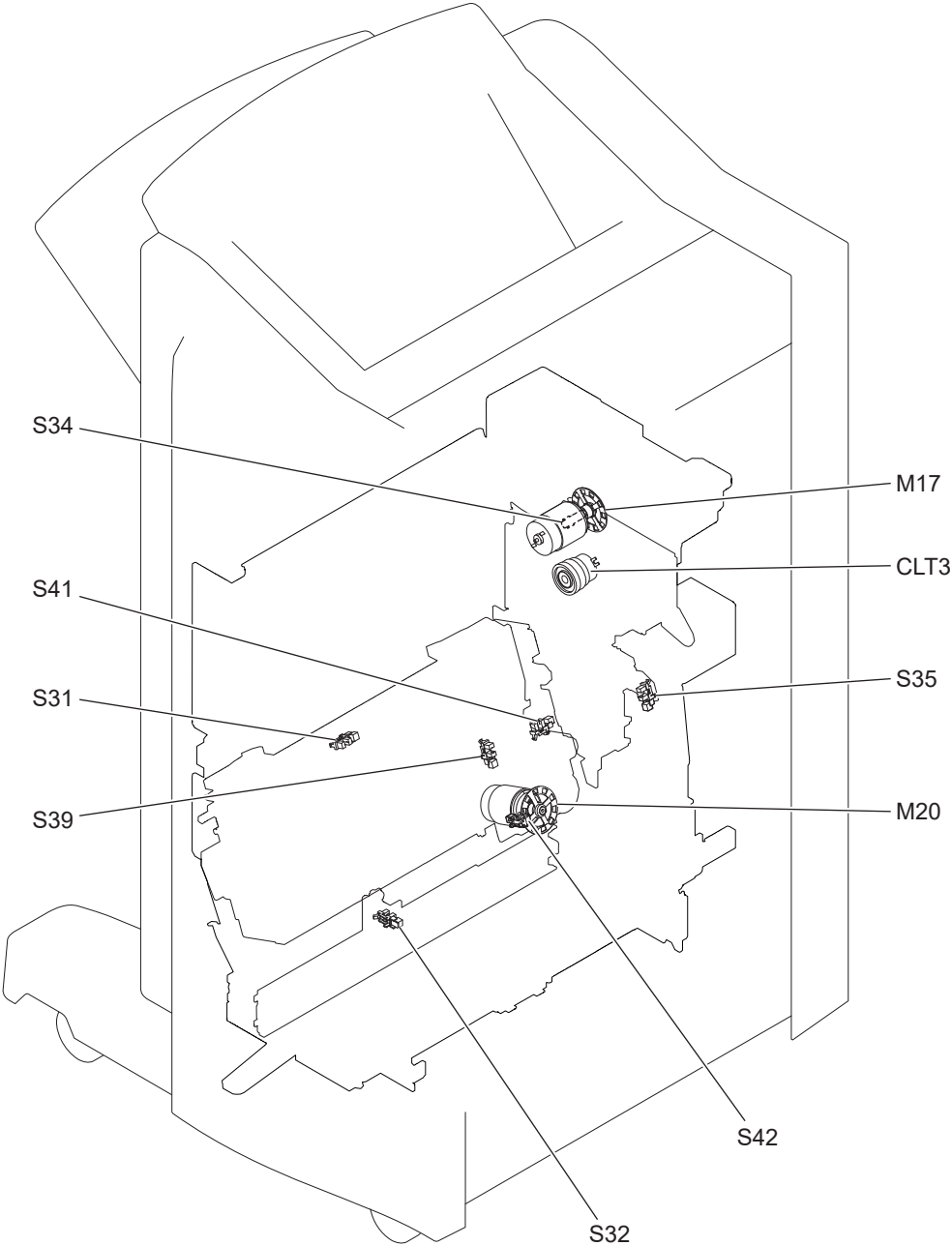

Fig. 2-14

2.4 Symbols and Functions of Various Components

The column “P-I” shows the page and item number in the parts list.

2.4.1 Motor (finisher section: common for MJ-1115 and MJ-1116)

Symbol	Name	Function	Remarks		P-I
M1	Entrance motor	Drives the entrance roller to transport paper transmitted from the junction box to the stationary tray roller or the exit roller.	[A] Electric parts layout 1	Fig. 2-7	5-26
M2	Buffer tray guide motor	Adjusts the guide width of the buffer tray.	[C] Electric parts layout 3	Fig. 2-9	8-1
M3	Paddle motor	Drives the paddle.	[A] Electric parts layout 1	Fig. 2-7	6-38
M5	Front alignment motor	Drives the front alignment plate.	[D] Electric parts layout 4	Fig. 2-10	10-6
M6	Rear alignment motor	Drives the rear alignment plate.	[D] Electric parts layout 4	Fig. 2-10	10-6
M7	Transport motor	Drives the roller of the finishing tray.	[B] Electric parts layout 2	Fig. 2-8	3-13
M8	Stack transport motor	Drives the belt and the eject arm to exit stacks of paper to the movable tray.	[D] Electric parts layout 4	Fig. 2-10	10-33
M9	Stapler unit shift motor	Moves the stapler unit to the front and rear.	[C] Electric parts layout 3	Fig. 2-9	11-1
M10	Assist guide motor	Drives the assist guide arm.	[C] Electric parts layout 3	Fig. 2-9	8-12
M11	Exit motor	Drives the exit roller to transport paper transmitted from the entrance roller to the buffer tray.	[A] Electric parts layout 1	Fig. 2-7	5-26
M12	Movable tray shift motor	Shifts the movable tray upward and downward.	[B] Electric parts layout 2	Fig. 2-8	12-25
M13	Stapler motor	Operates the stapler.	[C] Electric parts layout 3	Fig. 2-9	11-20
M21	Catching motor	Catches sheets of paper.	[A] Electric parts layout 1	Fig. 2-7	6-19

2.4.2 Motor (saddle stitch section: MJ-1116)

Symbol	Name	Function	Remarks		P-I
M14	Stacker motor	Shifts the stacker upward and downward so that it is aligned to the stapling position and the folding position.	[F] Electric parts layout 6	Fig. 2-12	20-6
M15	Side alignment motor	Opens and closes the alignment plate.	[F] Electric parts layout 6	Fig. 2-12	23-20
M16	Saddle transport motor	Transports paper from the paper feeding gate to the stacker.	[G] Electric parts layout 7	Fig. 2-13	26-29
M17	Folding motor	Drives the folding blade to fold paper and exits the folded paper.	[H] Electric parts layout 8	Fig. 2-14	19-24
M18	Front stapler motor	Operates the front stapler.	[G] Electric parts layout 7	Fig. 2-13	22-5
M19	Rear stapler motor	Operates the rear stapler.	[G] Electric parts layout 7	Fig. 2-13	22-5
M20	Additional folding motor	Adds another fold on paper already folded.	[H] Electric parts layout 8	Fig. 2-14	24-4

2.4.3 Electromagnetic spring clutch (finisher section: common for MJ-1115 and MJ-1116)

Symbol	Name	Function	Remarks		P-I
CLT2	Stack exit guide clutch	Transmits the driving force of the stack transport motor to the stack exit guide.	[D] Electric parts layout 4	Fig. 2-10	10-26

2.4.4 Electromagnetic spring clutch (saddle stitch section: MJ-1116)

Symbol	Name	Function	Remarks		P-I
CLT3	Folding blade clutch	Transmits the driving force of the folding motor to the folding blade.	[H] Electric parts layout 8	Fig. 2-14	19-19
CLT4	Paper holding clutch	Transmits the driving force of the saddle transport motor to the paper holding.	[F] Electric parts layout 6	Fig. 2-12	21-22

2.4.5 Solenoid (finisher section: common for MJ-1115 and MJ-1116)

Symbol	Name	Function	Remarks		P-I
SOL2	Buffer roller lift solenoid	Moves the buffer roller upward and downward. (ON: Upward)	[C] Electric parts layout 3	Fig. 2-9	8-19
SOL4	Gate solenoid	Switches the paper transport destination, the stationary tray or buffer tray.	[A] Electric parts layout 1	Fig. 2-7	7-19
SOL8	Exit roller lift solenoid	Contacts the paper exit roller at the paper exiting from the finishing tray.	[C] Electric parts layout 3	Fig. 2-9	8-20

2.4.6 Solenoid (saddle stitch section: MJ-1116)

Symbol	Name	Function	Remarks		P-I
SOL5	Transport path switching solenoid	Switches the paper transport destination, the finisher section or saddle stitch section.	[B] Electric parts layout 2	Fig. 2-8	16-23
SOL6	Assist roller solenoid	Opens and closes the assist roller.	[F] Electric parts layout 6	Fig. 2-12	27-14

2.4.7 Sensor (finisher section: common for MJ-1115 and MJ-1116)

Symbol	Name	Function	Remarks		P-I
S1	Entrance sensor	Detects paper transported from the junction box.	[A] Electric parts layout 1	Fig. 2-7	7-39
S2	Transport sensor	Detects the paper transportation at the entrance of the buffer tray.	[A] Electric parts layout 1	Fig. 2-7	7-39
S3	Paddle home position sensor	Detects the home position of the paddle.	[A] Electric parts layout 1	Fig. 2-7	5-31
S5	Buffer tray home position sensor	Detects that the buffer tray is at the outermost position.	[C] Electric parts layout 3	Fig. 2-9	9-25
S6	Assist guide home position sensor	Detects the home position of the assist guide cam.	[C] Electric parts layout 3	Fig. 2-9	9-25
S7	Front alignment plate home position sensor	Detects the home position of the front alignment plate.	[D] Electric parts layout 4	Fig. 2-10	10-17
S8	Rear alignment plate home position sensor	Detects the home position of the rear alignment plate.	[D] Electric parts layout 4	Fig. 2-10	10-17
S9	Stack exit belt home position sensor	Detects the home position of the stack exit belt.	[D] Electric parts layout 4	Fig. 2-10	10-52
S10	Stapler unit home position sensor	Detects if the stapler unit is at the front side (home position).	[C] Electric parts layout 3	Fig. 2-9	11-24
S11	Stapler interference sensor	Detects if the stapler unit interferes with other mechanical sections.	[C] Electric parts layout 3	Fig. 2-9	11-24
S12	Finishing tray paper sensor	Detects whether there is paper on the finishing tray or not.	[D] Electric parts layout 4	Fig. 2-10	10-17
S13	Movable tray position-A sensor	Detects the position of the movable tray.	[E] Electric parts layout 5	Fig. 2-11	4-15
S14	Movable tray position-B sensor	Detects the position of the movable tray.	[E] Electric parts layout 5	Fig. 2-11	4-15
S15	Movable tray position-C sensor	Detects the position of the movable tray.	[E] Electric parts layout 5	Fig. 2-11	4-15
S16	Movable tray stack height detection sensor	Detects the top of the stack on the movable tray.	[B] Electric parts layout 2	Fig. 2-8	4-15
S17	Movable tray paper sensor	Detects whether there is paper on the movable tray or not.	[E] Electric parts layout 5	Fig. 2-11	4-38
S18	Stationary tray stack height detection sensor	Detects the paper-full state of the stationary tray.	[E] Electric parts layout 5	Fig. 2-11	12-2
S19	Stapler home position sensor	Detects the home position in the stapler for the stapling operation.	[C] Electric parts layout 3	Fig. 2-9	11-20
S20	Staple top position sensor	Detects the staple top position in the stapler.	[C] Electric parts layout 3	Fig. 2-9	11-20
S21	Staple empty sensor	Detects the empty status of staples in the stapler cartridge.	[C] Electric parts layout 3	Fig. 2-9	11-20
S22	Paper feed sensor	Detects paper transported from the MFP to the junction box.	[B] Electric parts layout 2	Fig. 2-8	16-8
S23	Movable tray shift motor sensor	Detects the rotation of the movable tray shift motor.	[B] Electric parts layout 2	Fig. 2-8	12-63
S25	Connection sensor	Detects the contacting and releasing of the MFP and the Finisher.	[B] Electric parts layout 2	Fig. 2-8	13-28
S52	Catching home position sensor	Detects the home position of the catching lever.	[A] Electric parts layout 1	Fig. 2-7	6-20
SW1	Front cover opening/closing switch	Cuts off the drive current (24 V) when the opening status of the front cover is detected.	[B] Electric parts layout 2	Fig. 2-8	16-41
SW2	Stationary tray opening/closing switch	Cuts off the drive current (24 V) when the lifting up (opening) status of the stationary tray is detected.	[A] Electric parts layout 1	Fig. 2-7	5-32

Symbol	Name	Function	Remarks		P-I
SW3	Stapler interference switch	Detects the operation prohibited area of the stapler unit and cuts off the power supply to it.	[C] Electric parts layout 3	Fig. 2-9	11-44
SW4	Connection switch	Cuts off the drive current (24 V) when the releasing status of the MFP and the Finisher is detected.	[B] Electric parts layout 2	Fig. 2-8	13-40

2.4.8 Sensor, Switch (saddle stitch section: MJ-1116)

Symbol	Name	Function	Remarks		P-I
S26	Junction box sensor	Detects whether there is paper in the junction box or not.	[B] Electric parts layout 2	Fig. 2-8	16-8
S27	Transport path-2 sensor	Detects paper on the transport path of the switchback unit.	[G] Electric parts layout 7	Fig. 2-13	28-2
S28	Transport path-3 sensor	Detects paper on the transport path of the switchback unit.	[G] Electric parts layout 7	Fig. 2-13	28-2
S29	Eject roller sensor	Detects the drive timing of the assist roller.	[G] Electric parts layout 7	Fig. 2-13	27-10
S30	Stacker paper detection sensor	Detects whether there is paper in the stacker or not.	[G] Electric parts layout 7	Fig. 2-13	27-21
S31	Exit sensor	Detects paper exit.	[H] Electric parts layout 8	Fig. 2-14	24-7
S32	Saddle tray paper detection sensor	Detects whether there is paper on the saddle tray or not.	[H] Electric parts layout 8	Fig. 2-14	18-8
S33	Stacker home position sensor	Detects the home position of the stacker.	[F] Electric parts layout 6	Fig. 2-12	20-4
S34	Folding motor encoder sensor	Detects the rotation of the folding motor.	[H] Electric parts layout 8	Fig. 2-14	19-26
S35	Folding blade home position sensor	Detects the home position of the folding blade.	[H] Electric parts layout 8	Fig. 2-14	19-26
S36	Side alignment plate home position sensor	Detects the home position of the side alignment plate.	[F] Electric parts layout 6	Fig. 2-12	23-3
S38	Paper holding home position sensor	Detects the home position of the paper holding unit.	[F] Electric parts layout 6	Fig. 2-12	21-20
S39	Additional folding home position sensor	Detects the home position of the additional folding roller.	[H] Electric parts layout 8	Fig. 2-14	24-7
S41	Exit transport sensor	Detects the stop position of the additional folding.	[H] Electric parts layout 8	Fig. 2-14	24-7
S42	Additional folding motor encoder sensor	Detects the rotation of the additional folding motor.	[H] Electric parts layout 8	Fig. 2-14	24-7
S43	Front saddle stapler home position sensor	Detects the home position in the front stapler for the stapling operation.	[G] Electric parts layout 7	Fig. 2-13	22-5
S44	Rear saddle stapler home position sensor	Detects the home position in the rear stapler for the stapling operation.	[G] Electric parts layout 7	Fig. 2-13	22-5
S45	Front saddle staple empty sensor	Detects the empty status of front staples in the stapler cartridge.	[G] Electric parts layout 7	Fig. 2-13	22-5
S46	Rear saddle staple empty sensor	Detects the empty status of rear staples in the stapler cartridge.	[G] Electric parts layout 7	Fig. 2-13	22-5
S47	Front saddle staple top position sensor	Detects the staple top position in the front stapler.	[G] Electric parts layout 7	Fig. 2-13	22-5
S48	Rear saddle staple top position sensor	Detects the staple top position in the rear stapler.	[G] Electric parts layout 7	Fig. 2-13	22-5
S49	Front saddle stapler cartridge sensor	Detects whether there are staples in the stapler cartridge in the front stapler.	[G] Electric parts layout 7	Fig. 2-13	22-5

Symbol	Name	Function	Remarks		P-I
S50	Rear saddle stapler cartridge sensor	Detects whether there are staples in the stapler cartridge in the rear stapler.	[G] Electric parts layout 7	Fig. 2-13	22-5
SW5	Saddle stitch unit opening/closing switch	Cuts off the drive current (24 V) when the saddle stitch unit is pulled out.	[G] Electric parts layout 7	Fig. 2-13	17-10

2.4.9 PC board (finisher section: common for MJ-1115 and MJ-1116)

Symbol	Name	Function	Remarks		P-I
FIN	Finisher control PC board (FIN board)	Controls the Finisher.	[D] Electric parts layout 4	Fig. 2-10	3-37

2.4.10 PC board (saddle stitch section: MJ-1116)

Symbol	Name	Function	Remarks		P-I
SDL	Saddle control PC board (SDL board)	Controls the saddle stitch unit.	[F] Electric parts layout 6	Fig. 2-12	18-49

2.5 Signal Block Diagram

[A] Finisher section

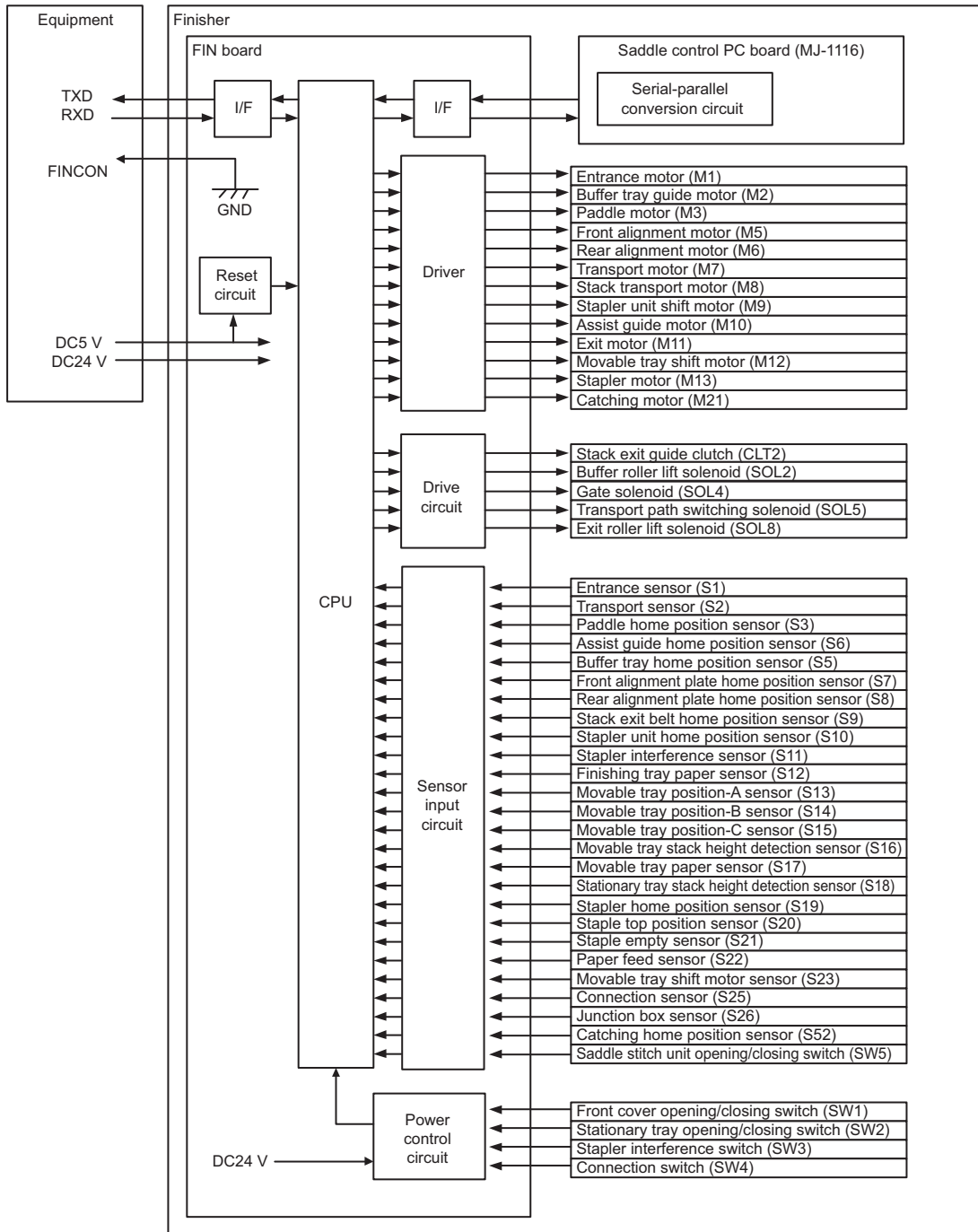

Fig. 2-15

[B] Saddle stitch section

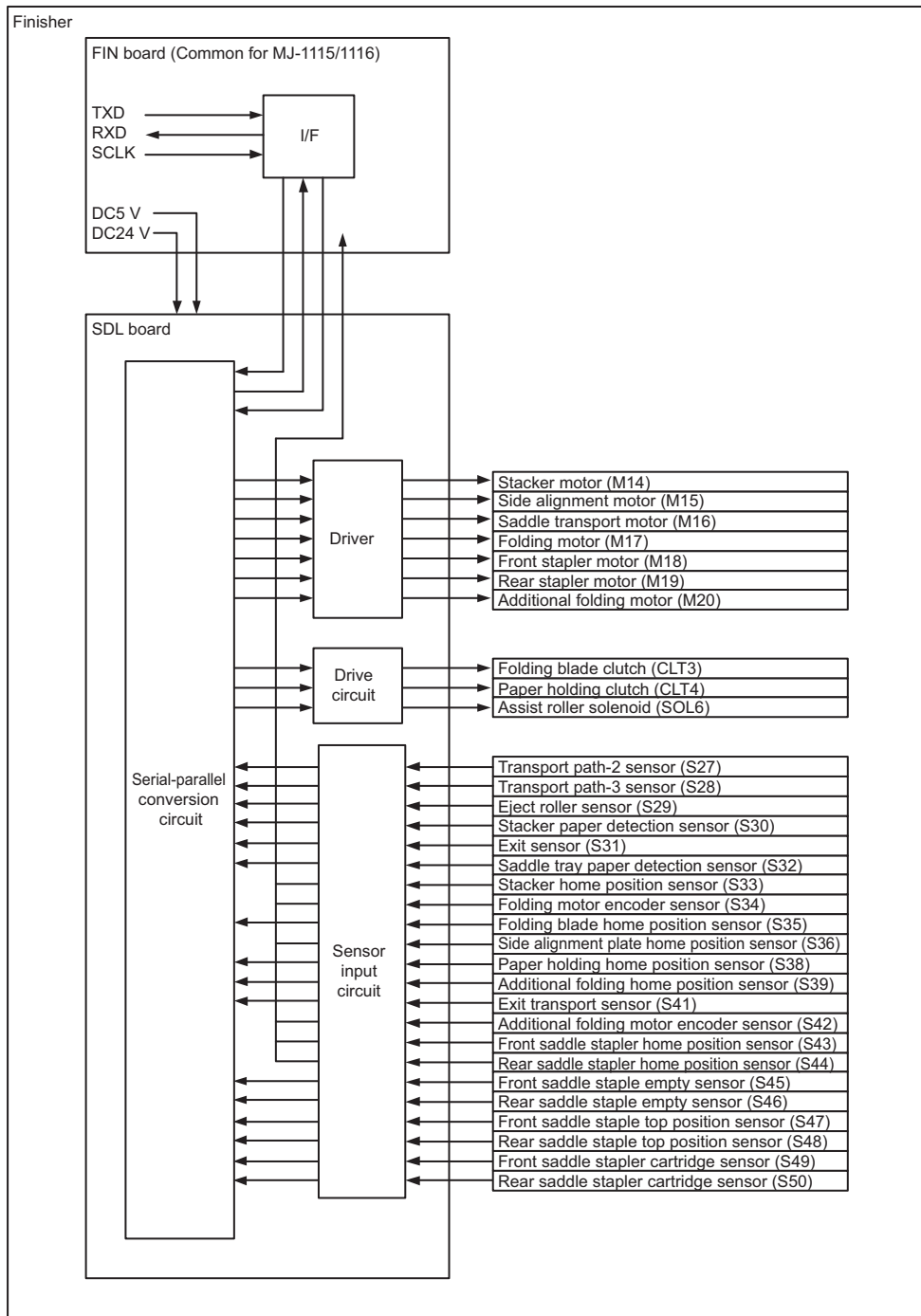

Fig. 2-16

2.6 Interface Signals

The 2 lines; TXD and RXD are used to transmit and receive signals between the MFP and this option. When this option is connected, the power supply information (MFP-24V-ON) is confirmed and the connection of this option is detected by means of the connection switch (SW4) status and the MFP-CONNECT-SEN signal of the connection sensor (S25).

TXD: Transmission data (from this option to the MFP)

RXD: Reception data (from the MFP to this option)

MFP-24V-ON: MFP 24 V power supply information (L level: 24 V power supply)

MFP-CONNECT: MFP connection switch (Connected: 24 V power supply)

MFP-CONNECT-SEN: MFP connection check signal (L level: MFP Connected)

Since the serial communication system has been adopted for data communication (RXD and TXD) between the MFP and the Finisher, whether the signals are transmitted or received properly cannot be checked using testing devices in the field.

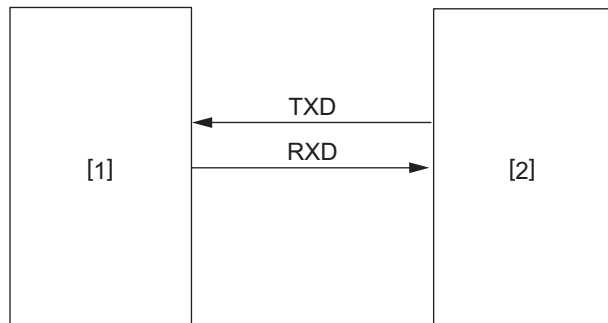

Fig. 2-17

[1] MFP

[2] This option

3. OPERATION DESCRIPTION

3.1 Basic Operations

3.1.1 Overview

This option receives paper transported from the MFP with the junction box, and then transports it to the finisher section or the saddle stitch section.

Common for MJ-1115 and MJ-1116:

The ways how the paper exits from the finisher section are as below.

- Simple stack mode
Paper directly exits to the stationary tray or the movable tray.
- Job offset stack mode
Stacks of paper are made to exit by slightly shifting them to the front and rear alternately.
- Staple stack mode
Stacks of paper are stapled and made to exit to the movable tray.

MJ-1116:

The ways how the paper exits from the saddle stitch section are as below.

- Center-binding mode
A stack of paper is bound at its center by stapling it at two positions and then is folded it in half to have it exit to the saddle tray.
- Center-folding mode
A stack of paper is folded at its center and then has it exit to the saddle tray.

- Simple stack mode (common for MJ-1115 and MJ-1116)
When the non-sort mode is set, paper exiting is carried out in the procedure shown below.
[A] Exits sheets of paper to the stationary tray.
[B] Exits sheets of paper to the movable tray via the buffer trays and the finishing tray.

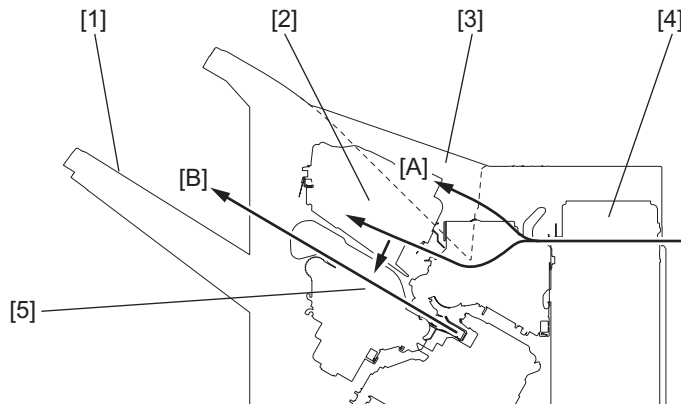

Fig. 3-1

- [1] Movable tray
- [2] Buffer tray
- [3] Stationary tray
- [4] Junction box
- [5] Finishing tray

- Job offset stack mode, Staple stack mode (common for MJ-1115 and MJ-1116)
When the sort copying and the stapling function are set, paper exits in the procedure shown below.
[A] Exits sheets of paper to the buffer trays.
[B] Drops sheets of paper from the buffer trays to the finishing tray.
[C] Aligns and staples (only when in the staple stack mode) sheets of paper to exit them to the movable tray.

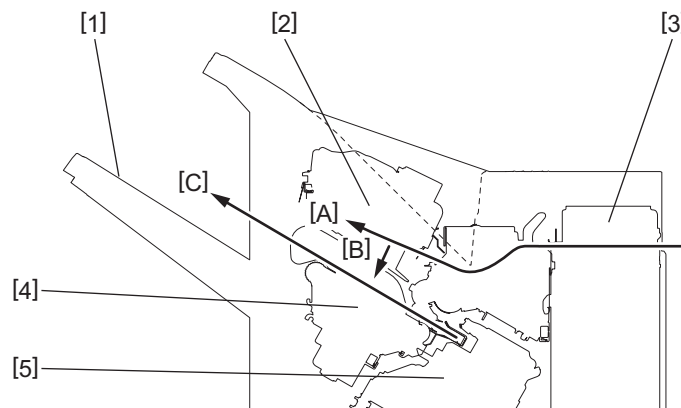

Fig. 3-2

- [1] Movable tray
- [2] Buffer tray
- [3] Junction box
- [4] Finishing tray
- [5] Stapler unit

- Center-binding mode (MJ-1116)
When the saddle stitch mode is set, paper exiting is carried out in the procedure shown below.
[A] Moves the stacker to the stapling position by aligning it to the paper size.
[B] Transports sheets of paper and performs side alignment.
[C] Performs stapling after the alignment of the last sheet is finished.
[D] Moves the stacker to the folding position to fold sheets of paper.
[E] Transports sheets of paper to the additional folding position to be folded again.
[F] Exits sheets of paper to the saddle tray.

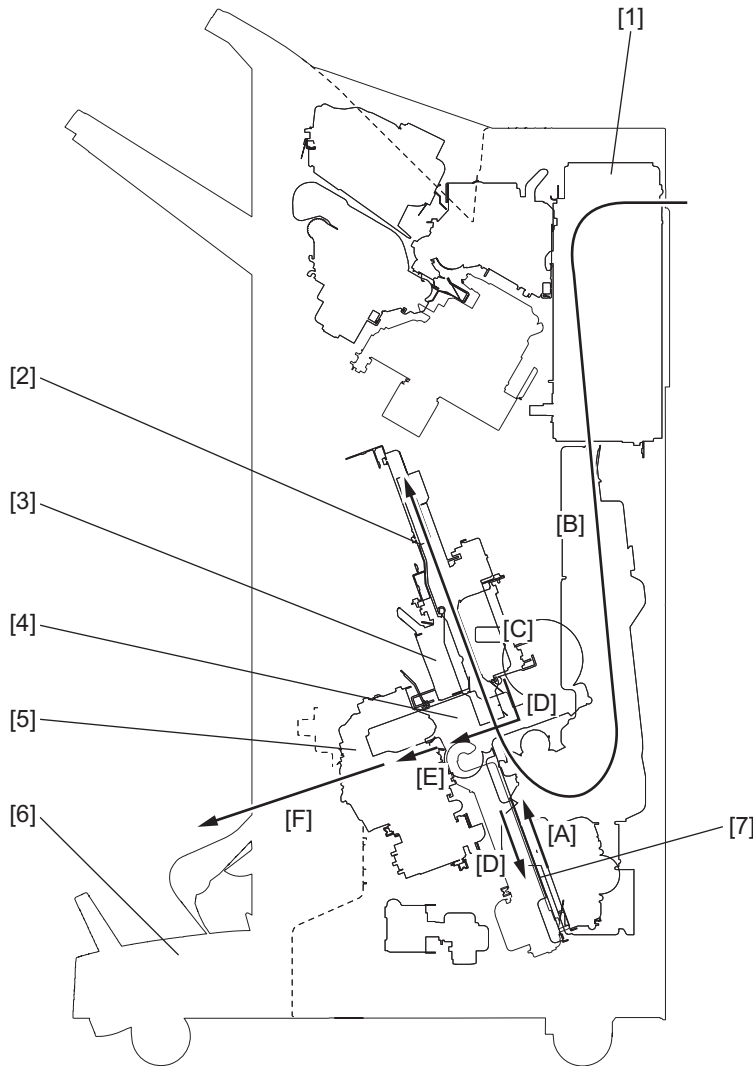

Fig. 3-3

- [1] Junction box
- [2] Side alignment unit
- [3] Stapler unit
- [4] Folding unit
- [5] Additional folding unit
- [6] Saddle tray
- [7] Stacker

- Center-folding mode (MJ-1116)

When the saddle stitch mode is set, paper exiting is carried out in the procedure shown below.

[A] Moves the stacker to the folding position by aligning it to the paper size.

[B] Transports sheets of paper and performs side alignment.

[C] Performs folding after the alignment of the last sheet is finished.

[D] Transports sheets of paper to the additional folding position to be folded again.

[E] Exits sheets of paper to the saddle tray.

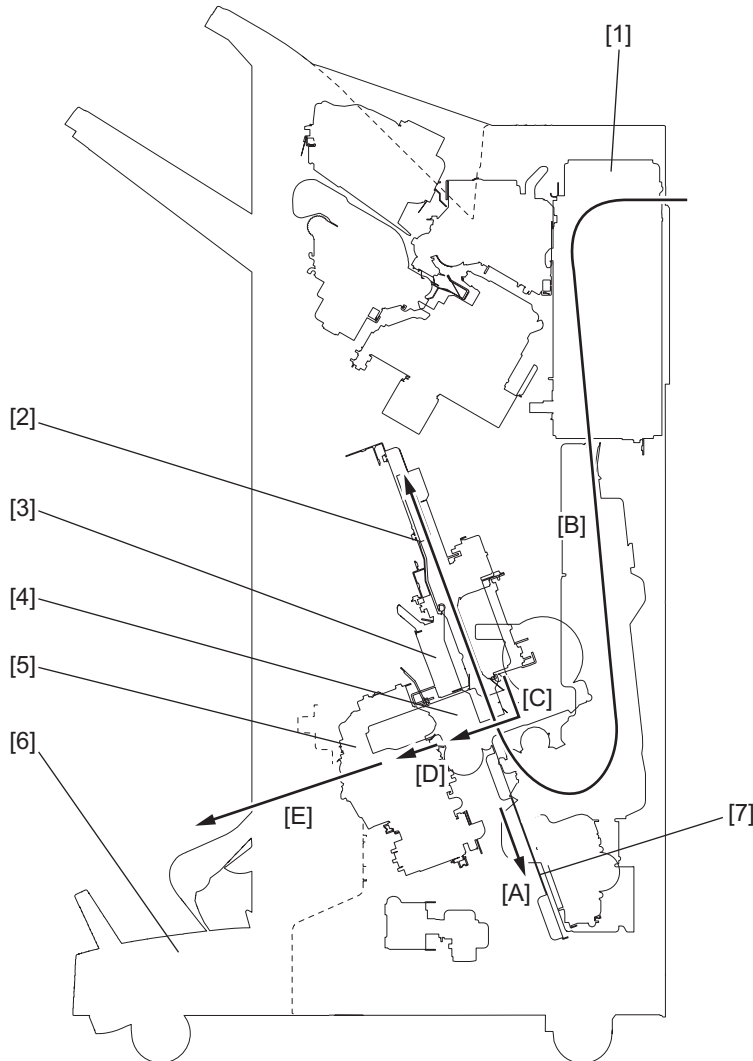

Fig. 3-4

- [1] Junction box
- [2] Side alignment unit
- [3] Stapler unit
- [4] Folding unit
- [5] Additional folding unit
- [6] Saddle tray
- [7] Stacker

3.1.2 Junction Box (MJ-1116)

Paper transported from the MFP is detected by the paper feed sensor (S22) and caught by the paper feed roller. Then it is transported to the finisher section or the saddle stitch section.

In case of transporting to the finisher section, the entrance roller transports paper without any extra operation.

In case of transporting to the saddle stitch section, the path switching solenoid (SOL5) is turned ON to switch the transport path with the flapper. The paper is then transported to the saddle stitch section by the junction roller. The junction box sensor (S26) detects the passing of the paper.

The paper feed roller and the junction roller are driven by the entrance roller moved by the entrance motor (M1) of the finisher section.

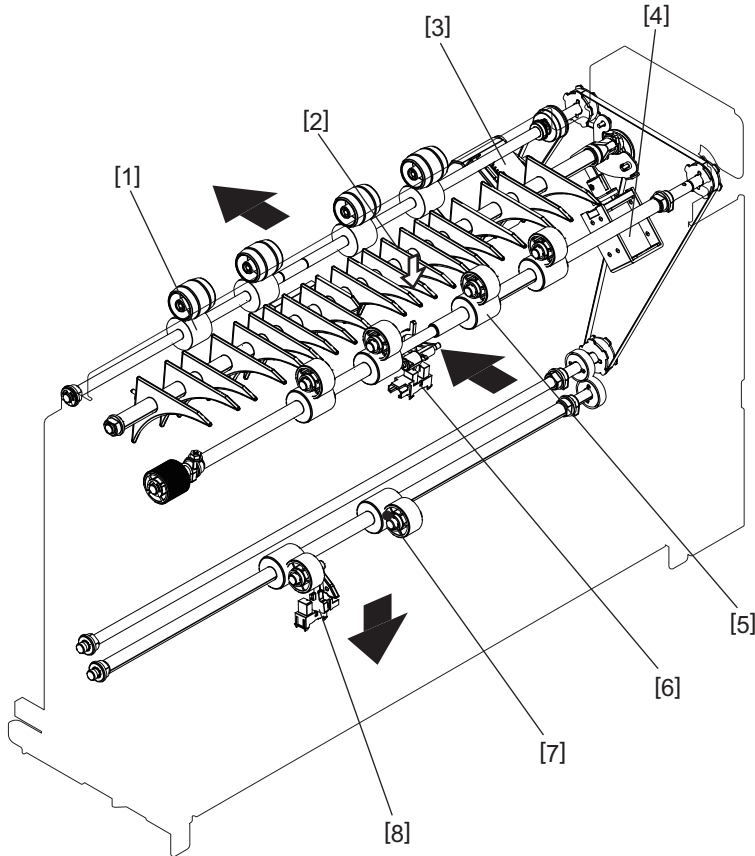

Fig. 3-5

- [1] Entrance roller
- [2] Flapper
- [3] Entrance motor
- [4] Transport path switching solenoid
- [5] Paper feed roller
- [6] Paper feed sensor
- [7] Junction roller
- [8] Junction box sensor

3.1.3 Paper exiting to the stationary tray

Paper is exiting to the stationary tray without any extra operation.

[A] Finisher paper feeding section

Paper transported from the junction box is then caught by the entrance roller driven with the entrance motor (M1).

To make the paper exit to the stationary tray, the gate solenoid (SOL4) is turned ON to lower the gate flappers.

The transportation of paper is detected by the entrance sensor (S1).

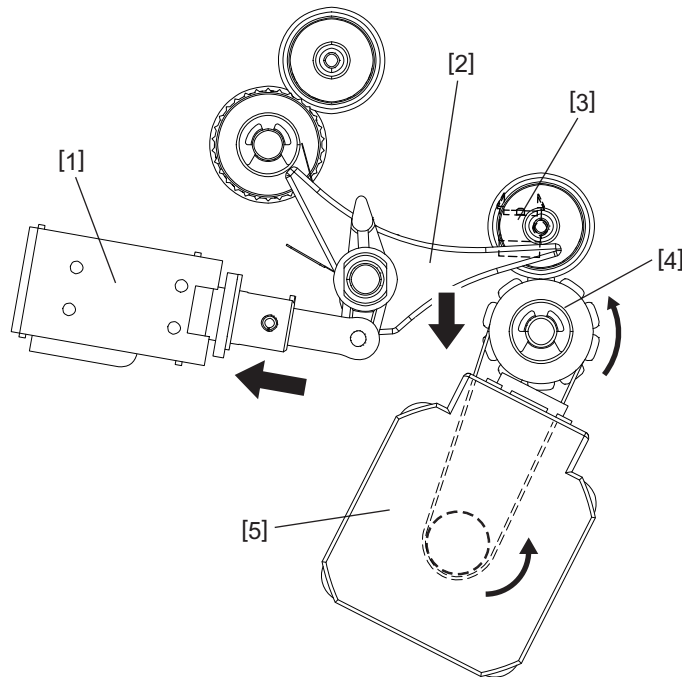

Fig. 3-6

- [1] Gate solenoid
- [2] Gate flapper
- [3] Entrance sensor
- [4] Entrance roller
- [5] Entrance motor

[B] Paper exiting operation

The paper transported from the finisher paper feeding section to the stationary tray side is then exiting to the stationary tray by the stationary tray roller driven with the exit motor (M11).

The transportation of paper is detected by the entrance sensor (S1).

The overstack of paper on the stationary tray is detected by the stationary tray stack height detection sensor (S18).

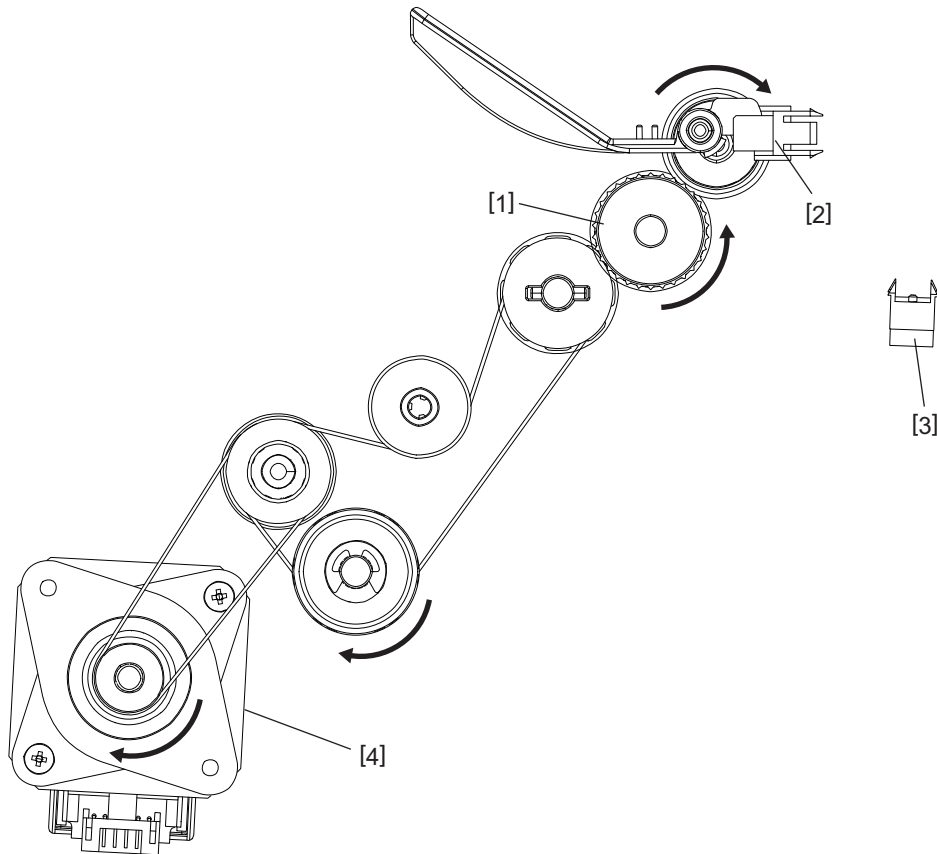

Fig. 3-7

- [1] Stationary tray roller
- [2] Stationary tray stack height detection sensor
- [3] Entrance sensor
- [4] Exit motor

3.1.4 Paper exiting to the movable tray

During exiting to the movable tray, paper transported from the finisher paper feeding section is stacked on the buffer trays in a unit of 1 to 3 sheets. The stacked paper is then transported to the finishing tray by a multi-active drop mechanism. Then the paper is transported to the movable tray by means of the following methods.

- Non-sort mode
Exits stacked paper from the finishing tray to the movable tray.
- Job offset stack mode
Performs alignment and job offsetting of the stacked paper on the finishing tray and then moves it to the movable tray.
- Staple stack mode
Performs alignment and job offsetting of the stacked paper on the finishing tray. Then performs stapling it and moves it to the movable tray.

[A] Buffer tray stacking

The buffer roller lift solenoid (SOL2) is turned ON to raise the buffer rollers and the buffer trays are moved by the buffer tray guide motor (M2) to the position where it matches the paper width. On the buffer trays, the catching motor is driven for every stacking the sheets of paper to prevent them from deviating by the catching pads.

The home position of the buffer trays is detected by the buffer tray home position sensor (S5).

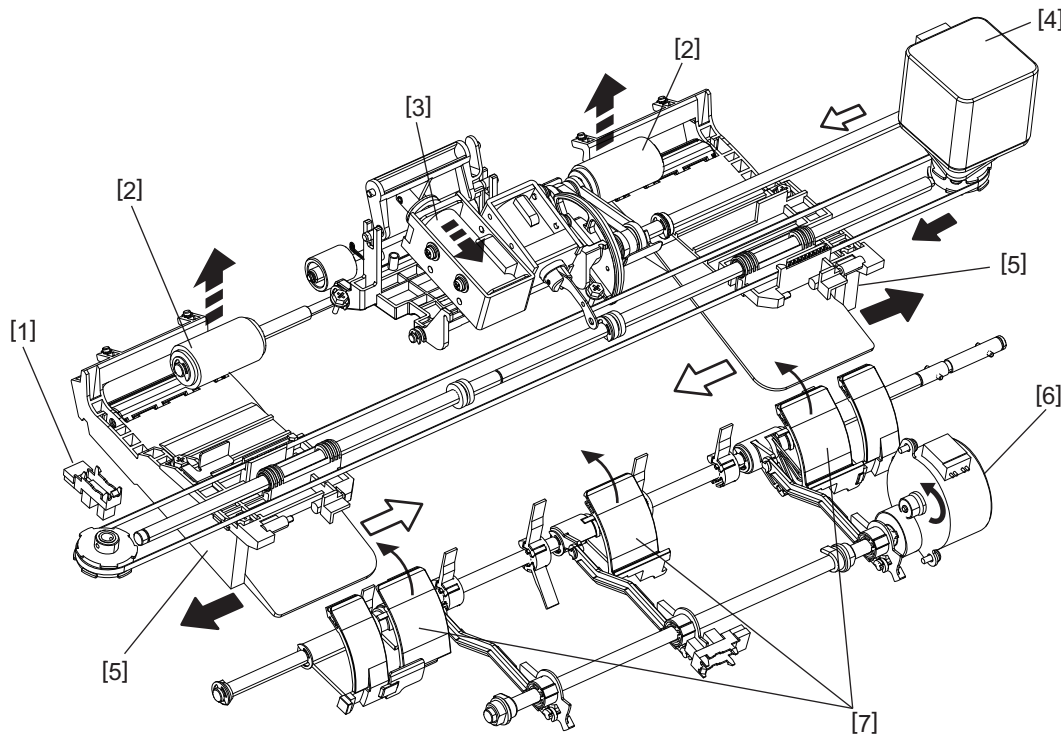

Fig. 3-8

- [1] Buffer tray home position sensor
- [2] Buffer roller
- [3] Buffer roller lift solenoid
- [4] Buffer tray guide motor
- [5] Buffer tray
- [6] Catching motor
- [7] Catching pad

[B] Multi-active drop mechanism section

The paper transported to the buffer trays is moved to the finishing tray by the multi-active drop mechanism.

- (1) The buffer roller lift solenoid (SOL2) is turned ON to raise the buffer rollers and the buffer trays are opened by the buffer tray guide motor (M2) to drop the paper on them onto the finishing tray. At that time, the assist guide motor (M10) is driven to lower the assist guide so that the paper will certainly be dropped onto the finishing tray.

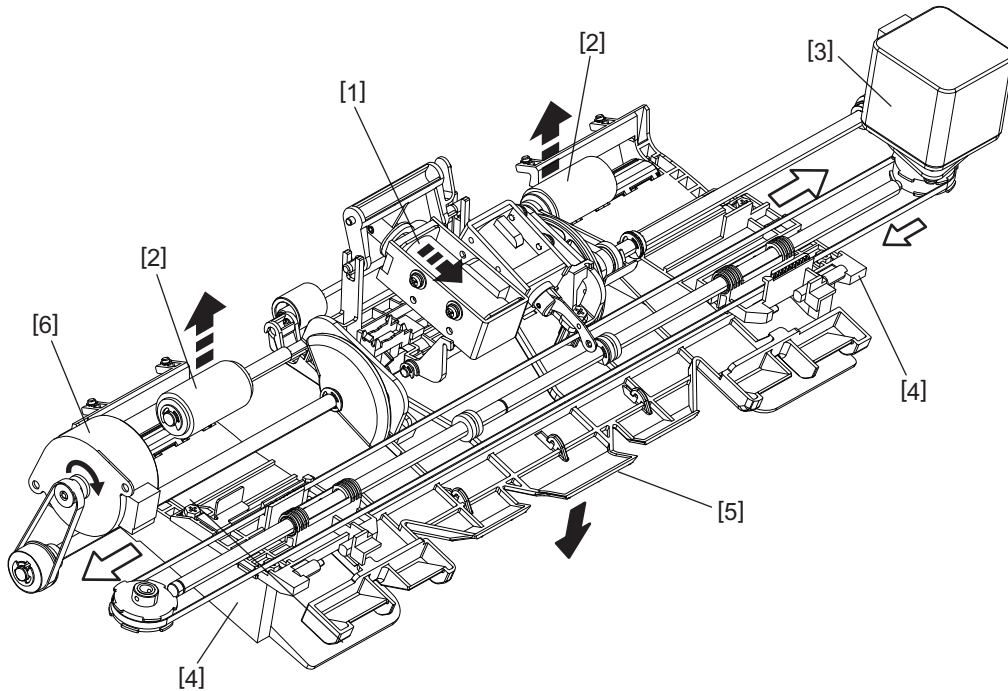

Fig. 3-9

- [1] Buffer roller lift solenoid
- [2] Buffer roller
- [3] Buffer tray guide motor
- [4] Buffer tray
- [5] Assist guide
- [6] Assist guide motor

- (2) The paper dropped onto the finishing tray is then pulled into the finishing position by the paddles driven with the paddle motor (M3) and the stack transport roller-1 and -2 driven with the transport motor (M7).
The finishing tray paper sensor (S12) detects whether there is paper on the finishing tray or not. The home position of the paddles is detected by the paddle home position sensor (S3).

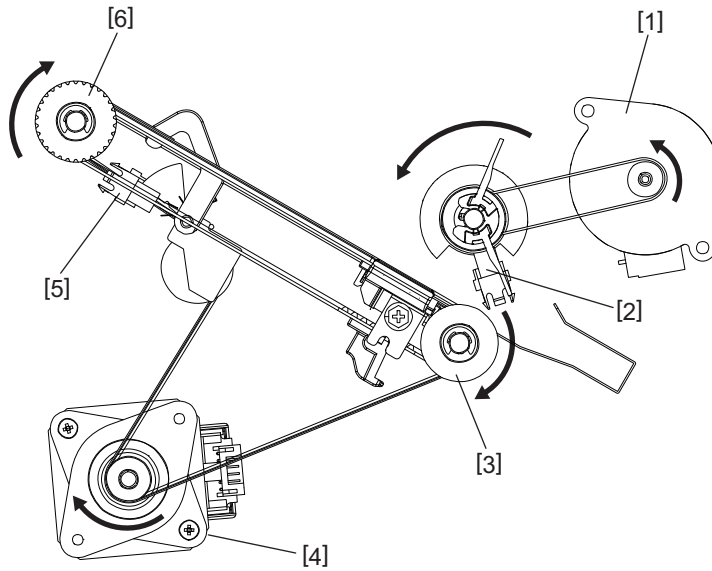

Fig. 3-10

- [1] Paddle motor
- [2] Paddle home position sensor
- [3] Stack transport roller-1
- [4] Transport motor
- [5] Finishing tray paper sensor
- [6] Stack transport roller-2

[C] Job offset stacking operation

The job offset stacking operation is to sort bundles of paper by placing the first one a little forward and placing the next one a little backward, and repeating this set of movement. The paper transported to the finishing tray is bundled and is aligned to the front and rear by the alignment plates driven with the front alignment motor (M5) and the rear alignment motor (M6). The home position of each alignment plate is detected by the front alignment plate home position sensor (S7) and the rear alignment plate home position sensor (S8).

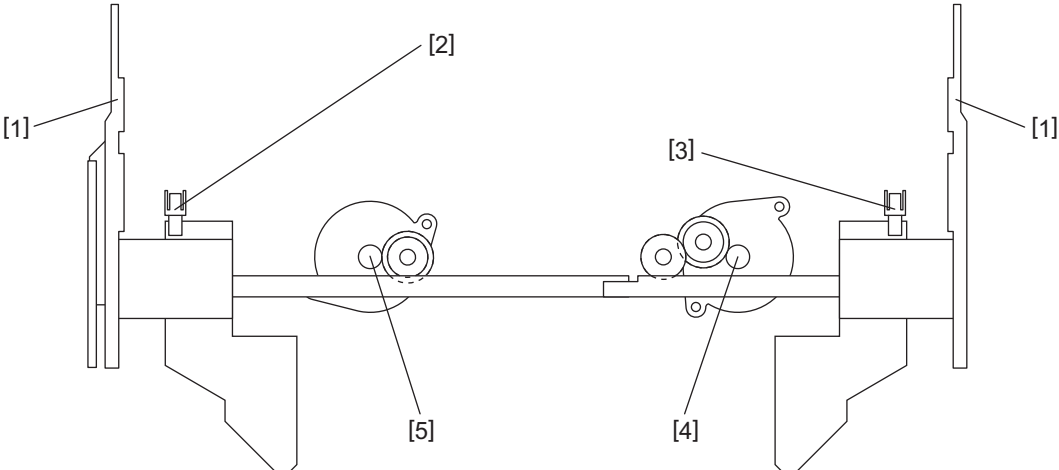

Fig. 3-11

- [1] Alignment plate
- [2] Front alignment plate home position sensor
- [3] Rear alignment plate home position sensor
- [4] Rear alignment motor
- [5] Front alignment motor

[D] Stapling operation

The stapling operation is to staple sheets of paper in the specified number with the stapler unit. The stapler unit is moved to the stapling position, corresponding to the paper size, by the stapler unit shift motor (M9).

The home position of the stapler unit is detected by the stapler unit home position sensor (S10).

The stapler interference switch (SW3) detects the operation prohibited area for stapling and cuts off the power supply to the stapler. Moreover, the stapling operation is also stopped in the area where the stapler interference sensor (S11) is being turned ON to prevent the stapler from interfering with other mechanical sections in the MFP.

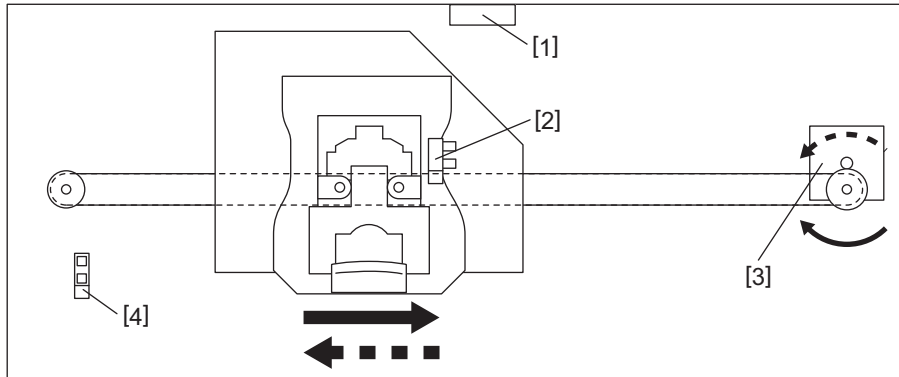

Fig. 3-12

- [1] Stapler interference switch
- [2] Stapler interference sensor
- [3] Stapler unit shift motor
- [4] Stapler unit home position sensor

[E] Paper exiting operation

The bundles of paper aligned or stapled on the finishing tray are then pulled up by the paper exit guide driven with the stack transport motor (M8) with the turning ON of the stack exit guide clutch (CLT2). Then the bundles of paper are exiting onto the movable tray by the stack exit belt driven with the stack transport motor (M8) and the stack transport roller-1 and -2 driven with the transport motor (M7). The home position of the stack exit belt is detected by the stack exit belt home position sensor (S9).

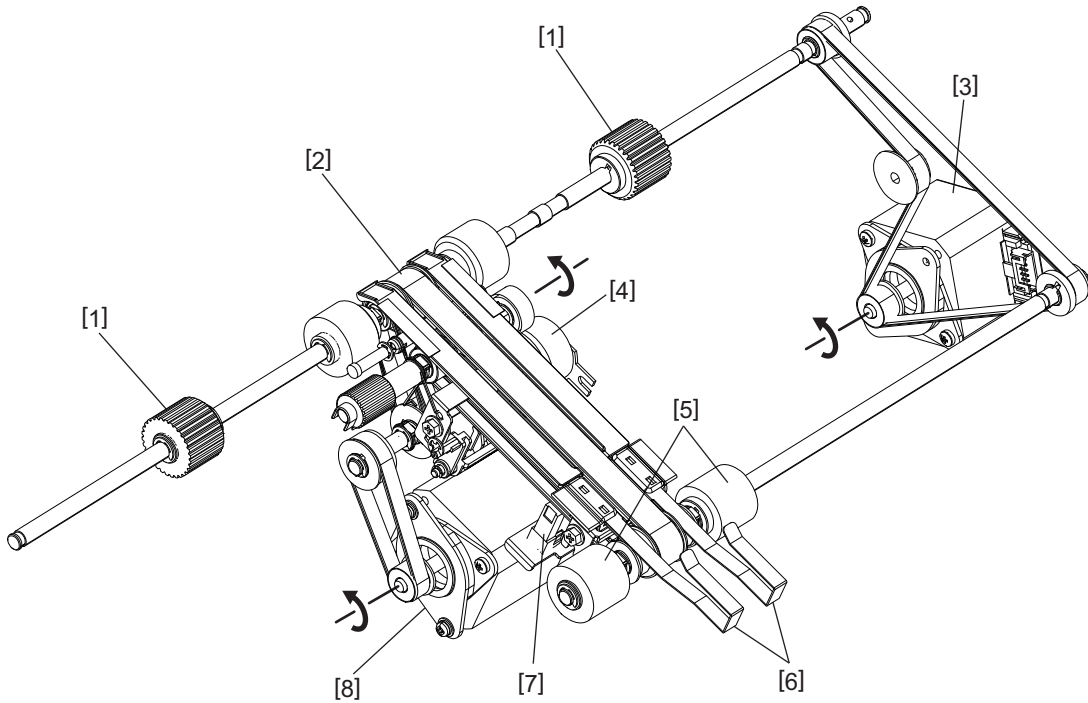

Fig. 3-13

- [1] Stack transport roller-2
- [2] Stack exit belt
- [3] Transport motor
- [4] Stack exit guide clutch
- [5] Stack transport roller-1
- [6] Stack exit guide
- [7] Stack exit belt home position sensor
- [8] Stack transport motor

[F] A3 wide paper and A6-R size paper exiting

A large size paper such as A3 wide and a small size paper such as A6-R are made to exit to the movable tray by being transported on the finishing tray without being stacked on the buffer trays. To transport such types of paper, the exit roller lift solenoid (SOL8) is turned ON to lower the pinch roller arm to the stack transport roller-2 and the stack transport motor is driven to raise the tray guides.

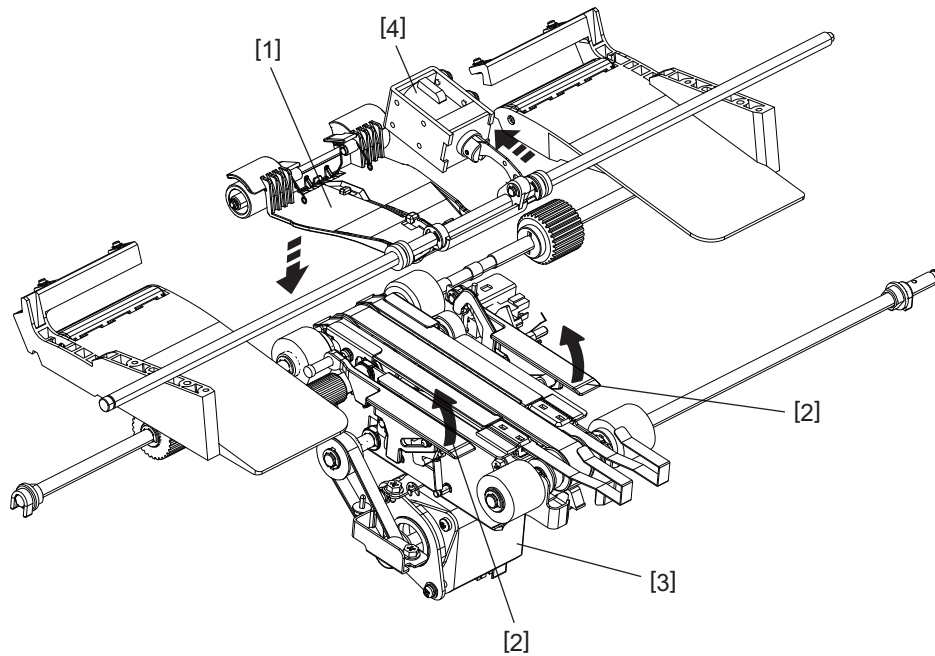

Fig. 3-14

- [1] Pinch roller arm
- [2] Tray guide
- [3] Stack transport motor
- [4] Exit roller lift solenoid

[G] Movable tray operation

The movable tray shifts upward or downward by the movable tray shift motor (M12) according to the amount of the stacked paper.

The movable tray shift motor sensor (S23) detects the rotation of the movable tray shift motor.

The movable tray paper sensor (S17) detects whether there is paper on the movable tray or not.

Detecting the position of the movable tray is performed as follows.

- (1) Start position of the movable tray
The position where the movable tray position-C sensor (S15) is turned ON will be the start position of the movable tray.
- (2) Position of the movable tray when 1,500 to 3,000 sheets of paper are stacked
When the movable tray stack height detection sensor (S16) is turned ON by means of the stacked paper on the movable tray while it is in its start position, it goes down to the position where the movable tray position-B sensor (S14) is turned ON. This will be the position of the movable tray when 1,500 to 3,000 sheets of paper are stacked.
- (3) Position of the movable tray when exceeding 3,000 sheets of paper are stacked
When the movable tray stack height detection sensor (S16) is turned ON while the movable tray is in the position for stacking of 1,500 to 3,000 sheets of paper, it goes down to the position where the movable tray position-A sensor (S13) is turned ON. This will be the position of the movable tray when exceeding 3,000 sheets of paper are stacked.

Movable tray position	Movable tray position-A sensor (S13)	Movable tray position-B sensor (S14)	Movable tray position-C sensor (S15)
(1)	ON	OFF	ON
(2)	ON	ON	ON
(3)	OFF	ON	OFF

ON: The sensor signal is interrupted by the rib of the sensor rail.

OFF: The sensor signal is not interrupted by the rib of the sensor rail.

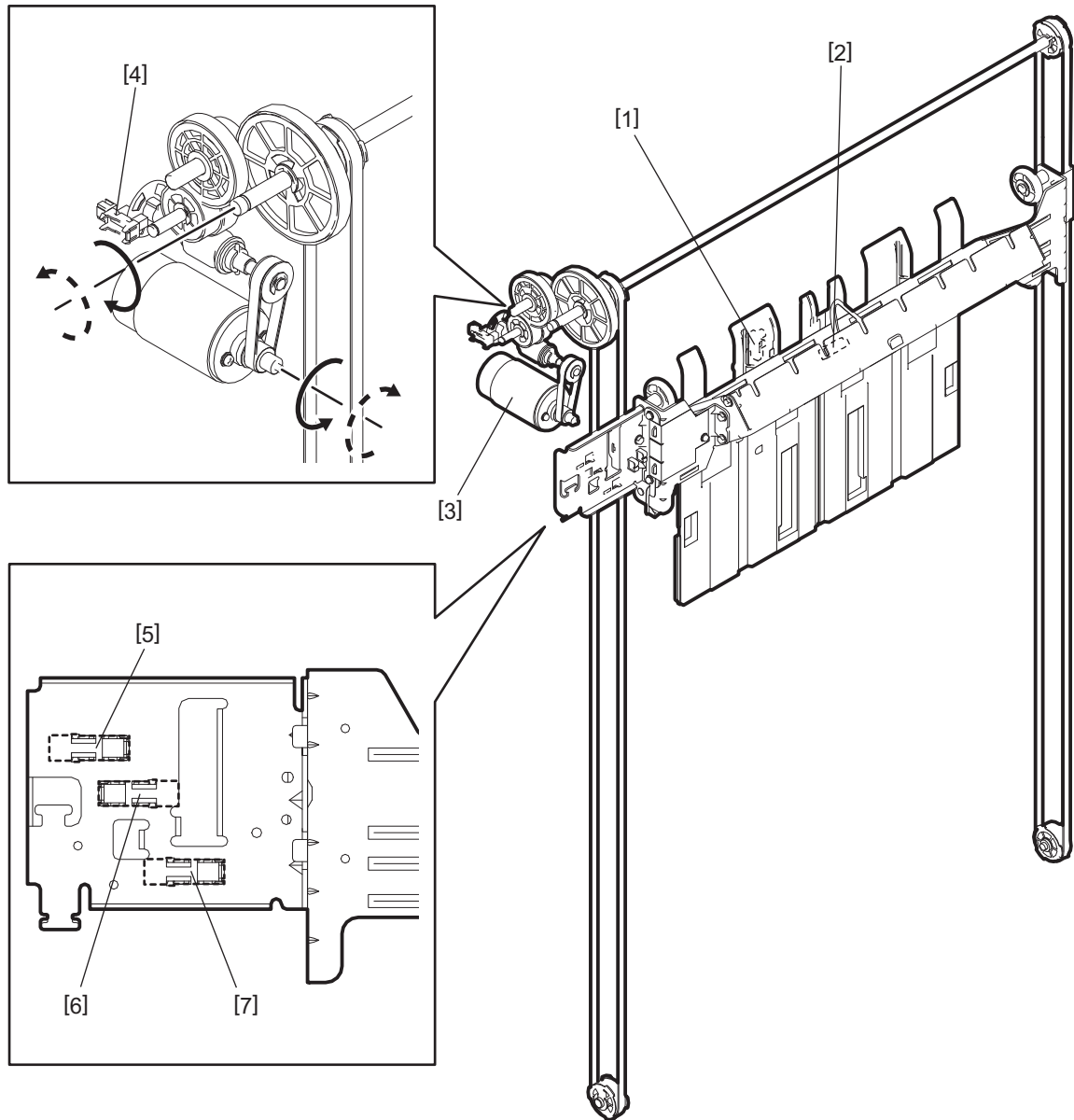

Fig. 3-15

- [1] Movable tray stack height detection sensor
- [2] Movable tray paper sensor
- [3] Movable tray shift motor
- [4] Movable tray shift motor sensor
- [5] Movable tray position-A sensor
- [6] Movable tray position-B sensor
- [7] Movable tray position-C sensor

3.1.5 Operation in the saddle stitch section (MJ-1116)

The center-binding mode binds a stack of paper at its center by stapling at two positions and then folds in half again to exit it to the saddle tray. In this mode paper transported from the paper feeding section is stacked on the stacker. The stacks of paper are aligned on the stacker and moved to the stapling position together with the stacker. The moved stacks are fixed and stapled, and then the stacker is shifted to the folding position. Then the stacks are folded with the folding blade and the folding roller. After this, the folded stacks are again folded and exiting to the saddle tray.

[A] Saddle stitch paper feeding section

Paper transmitted from the junction box is then transported to the stacker with the transport roller, eject roller and assist roller driven by the saddle transport motor (M16).

The junction box sensor (S26), transport path-2 sensor (S27), transport path-3 sensor (S28) and eject roller sensor (S29) detect the passing of the paper.

When the eject roller sensor (S29) detects the paper has passed, the assist roller solenoid (SOL6) is turned ON to contact the assist roller with the paper to transport it to the stacker.

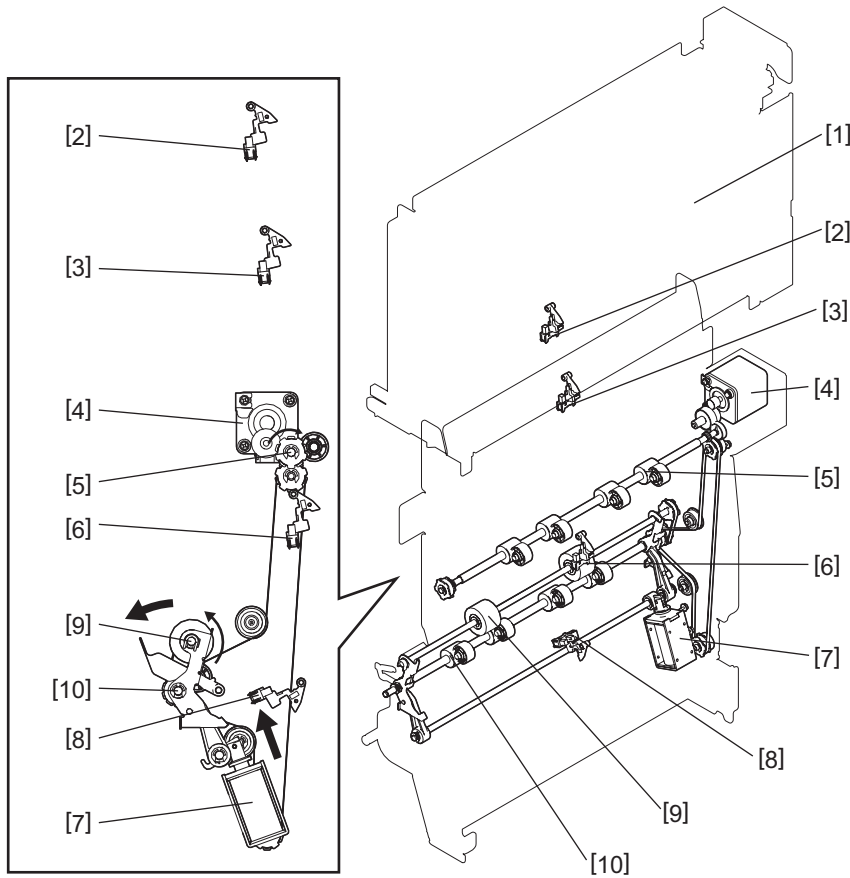

Fig. 3-16

- [1] Junction box
- [2] Junction box sensor
- [3] Transport path-2 sensor
- [4] Saddle transport motor
- [5] Transport roller
- [6] Transport path-3 sensor
- [7] Assist roller solenoid
- [8] Eject roller sensor
- [9] Assist roller
- [10] Eject roller

[B] Stack transportation

The stacker carrier is moved to the stapling or folding position by the stacker motor (M14).

The home position of the stacker is detected by the stack home position sensor (S33).

The stacker paper detection sensor (S30) detects whether there is paper in the stacker.

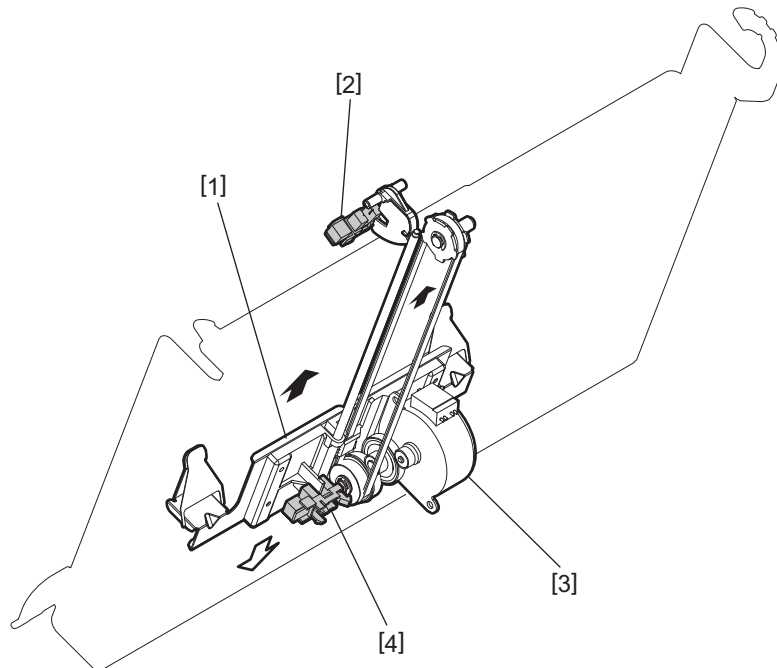

Fig. 3-17

- [1] Stacker carrier
- [2] Stacker paper detection sensor
- [3] Stacker motor
- [4] Stacker home position sensor

[C] Side alignment

Stacks of paper transported to the stacker are aligned to fix their sideways deviation with a jog moved by the side alignment motor (M15).

The home position of the jog is detected by the side alignment plate home position sensor (S36).

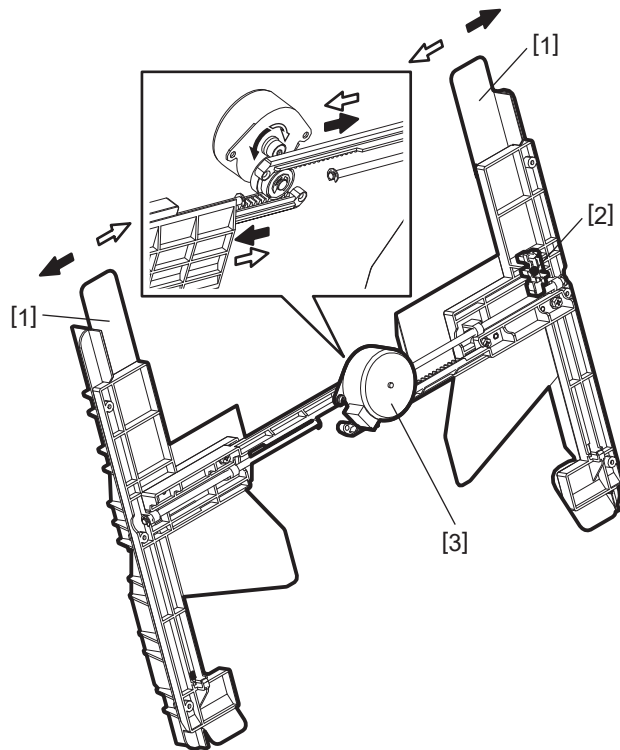

Fig. 3-18

- [1] Jog
- [2] Side alignment plate home position sensor
- [3] Side alignment motor

[D] Paper holding

The paper holding clutch (CLT4) is turned ON to let the saddle transport motor (M16) drive the paper holding cam.

The home position of the paper holding cam is detected by the paper holding home position sensor (S38).

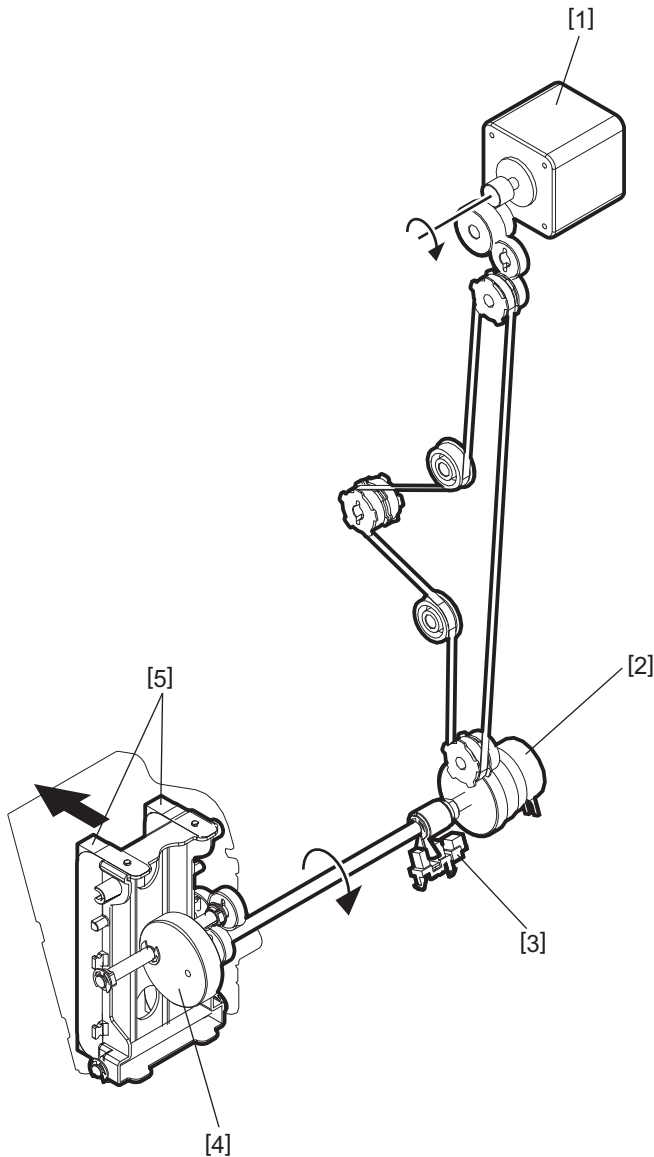

Fig. 3-19

- [1] Saddle transport motor
- [2] Paper holding clutch
- [3] Paper holding home position sensor
- [4] Paper holding cam
- [5] Paper holding damper

[E] Stapling operation

Stacks of paper aligned and fixed at the stapling position are stapled with two stapler units on the front and rear sides.

[F] Paper folding

The folding blade is pressed onto the center of the stack of paper stapled and moved to the folding position, and then the folding roller lets the stack of paper sandwich the blade so that the stack will be folded again.

The folding blade clutch (CLT3) is turned ON to press the folding blade to the stack of paper by means of the rotation of the blade cam driven with the folding motor (M17).

The rotation of the folding motor (M17) is detected by the folding motor encoder sensor (S34).

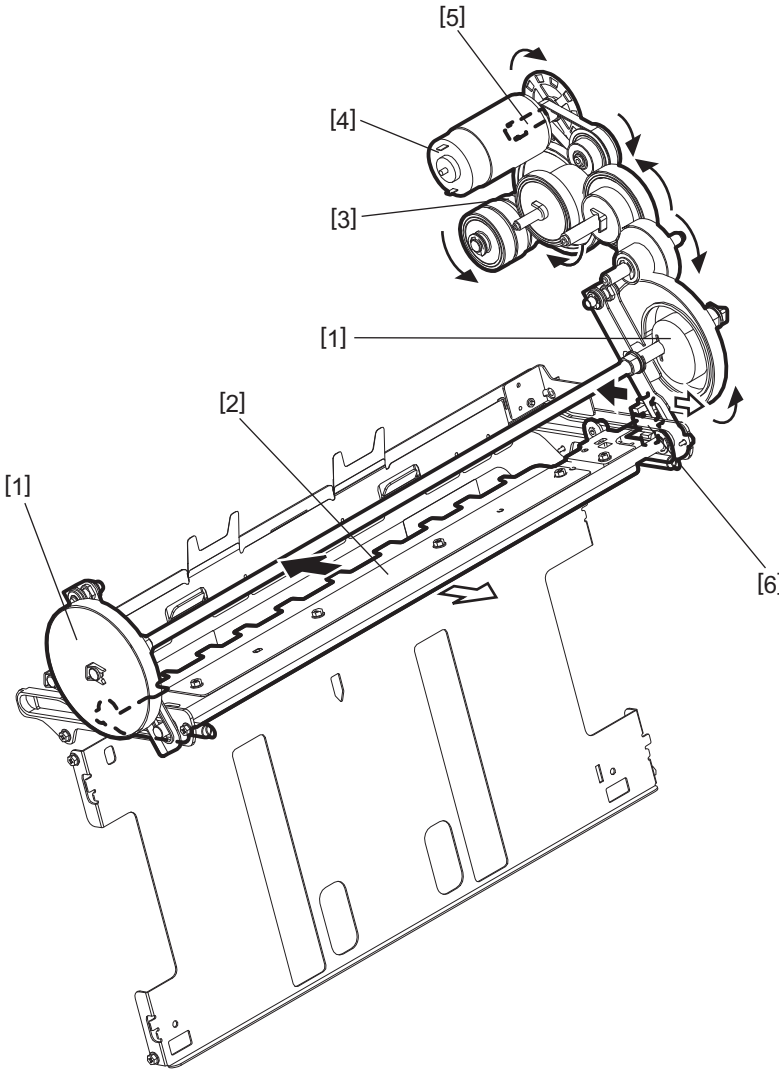

Fig. 3-20

- [1] Folding blade cam
- [2] Folding blade
- [3] Folding blade clutch
- [4] Folding motor
- [5] Folding motor encoder sensor
- [6] Folding blade home position sensor

After the folding blade is pressed to the stack of paper, it is folded as it passes the folding roller driven with the folding motor (M17).

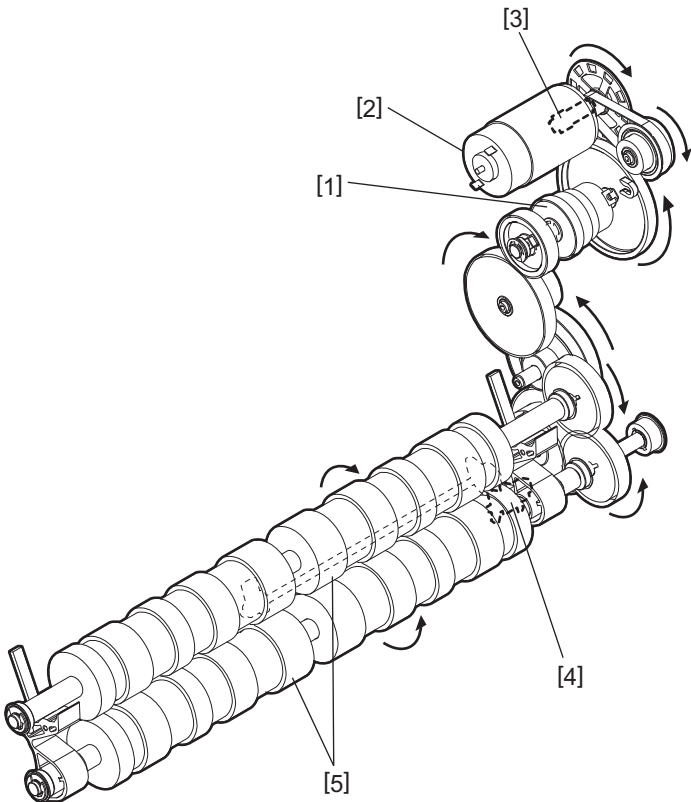

Fig. 3-21

- [1] Folding blade clutch
- [2] Folding motor
- [3] Folding motor encoder sensor
- [4] Exit transport sensor
- [5] Folding roller

[G] Additional folding and exiting

The stack of paper folded by the folding roller is stopped at the additional folding performed position with the exit transport sensor (S41). While the additional folding carrier is moved forward and backward on the folded position of the stack of paper, it is then folded again by the additional folding roller. The additional folding carrier is driven by the additional folding motor (M20). The home position of the additional folding carrier is detected by the additional folding home position sensor (S39). The rotation of the additional folding motor (M20) is detected by the additional folding motor encoder sensor (S42).

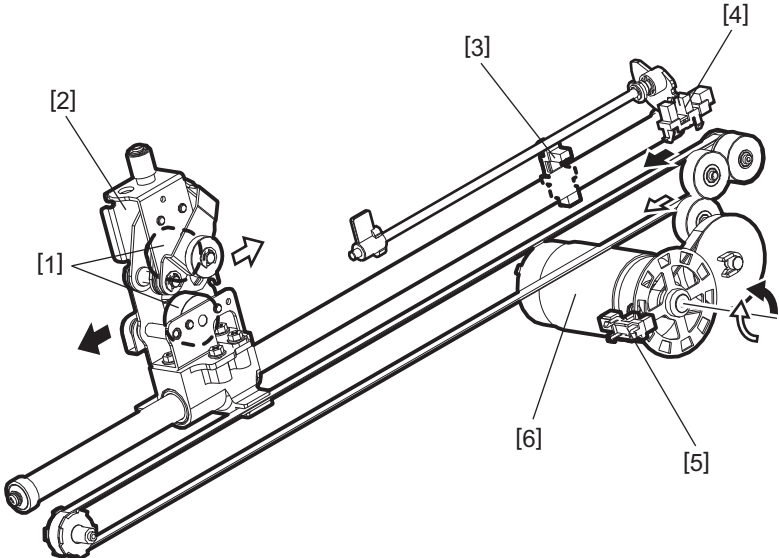

Fig. 3-22

- [1] Additional folding roller
- [2] Additional folding carrier
- [3] Additional folding home position sensor
- [4] Exit transport sensor
- [5] Additional folding motor encoder sensor
- [6] Additional folding motor

The folded stack of paper with additional folding applied is then exiting to the saddle tray by the saddle exit roller driven by the folding motor (M17).
The passing of the paper is detected by the exit sensor (S31).
The saddle tray paper detection sensor (S32) detects whether there is paper on the saddle tray or not.

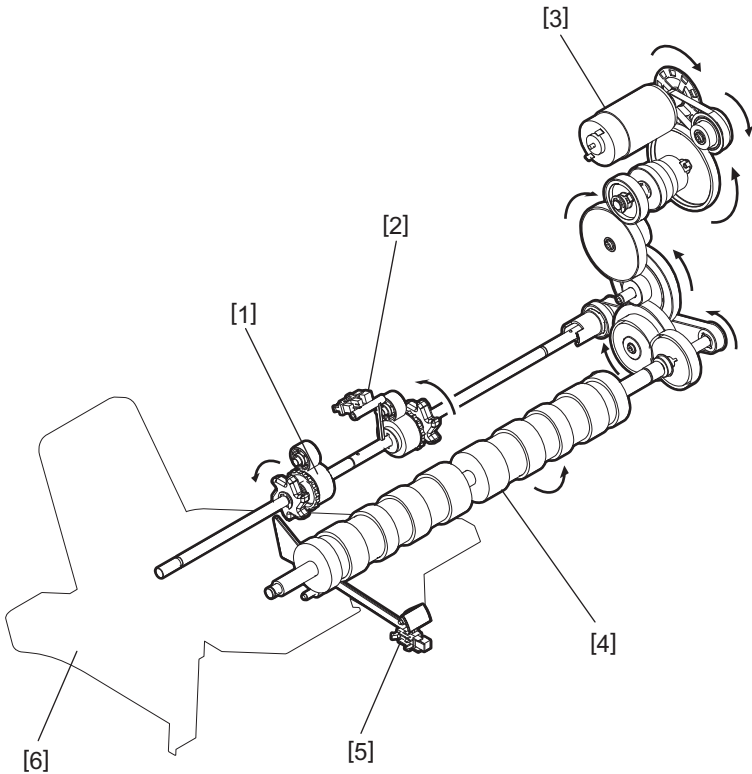

Fig. 3-23

- [1] Saddle exit roller
- [2] Exit sensor
- [3] Folding motor
- [4] Folding roller
- [5] Saddle tray paper detection sensor
- [6] Saddle tray

4. DISASSEMBLY AND REASSEMBLY

4.1 Cover

4.1.1 Stationary tray

- (1) Open the stationary tray [1].
- (2) Loosen 2 screws [2] and remove 2 screws [3] at the right-hand side.
- (3) While pulling the jam access lever [4], lift the stationary tray [1] upward to take it off.

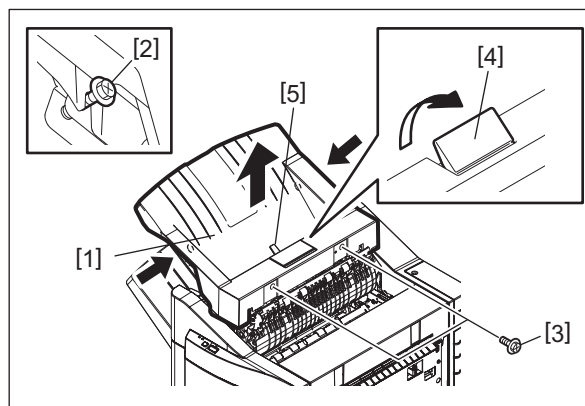

Fig. 4-1

Notes:

- Be sure to install or remove the stationary tray [1] with it being opened. Otherwise, the upper paper exit roller guide may be damaged.
- Make sure not to damage the actuator [5] of the stationary tray paper-full sensor.
- Be careful not to lose 4 pins [7] of the buffer unit-1 [6].
- Before installing the stationary tray, adjust the installing positions of 4 pins [7] of the buffer unit-1 [6] to the center position.

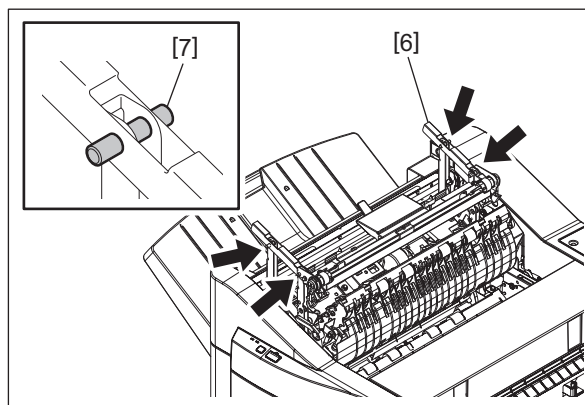

Fig. 4-2

4.1.2 Movable tray

- (1) Remove 2 screws. While lifting up the front edge of the movable tray [1], slide it upward to take it off.

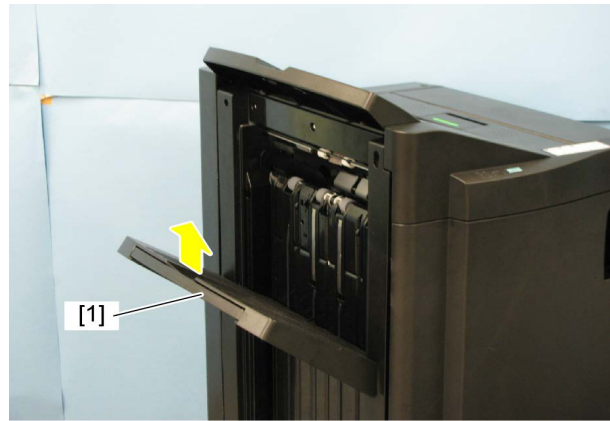

Fig. 4-3

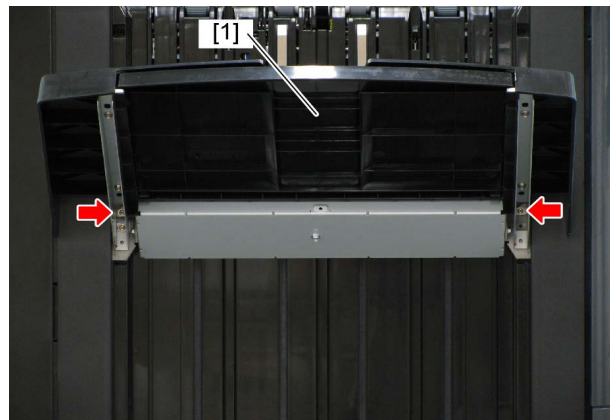

Fig. 4-4

Notes:

- When installing, hang 4 hooks of the movable tray [1] on the holes of the frame.
- When installing, engage 2 holes of the movable tray [1] with the positioning dowels.
- When removing and installing, pay attention so that the sensor actuator [2] does not come off.

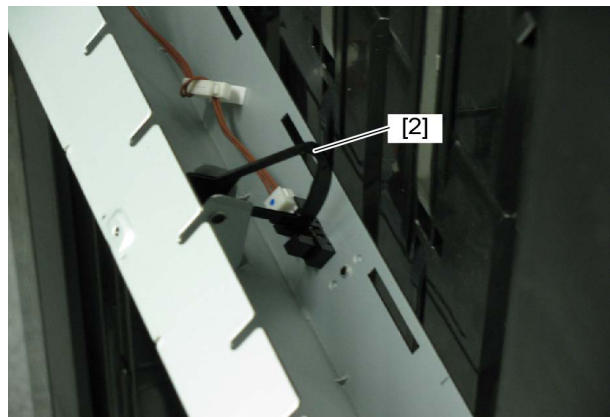

Fig. 4-5

- Be sure that the movable tray [1] does not stay at the position higher than the actuator [2] of the movable tray stack height detection sensor. If printing is performed with the sensor turned ON, a CB31 error (Movable tray paper-full detection error) will occur. The movable tray [1] must be moved lower than the actuator [2] of the sensor.

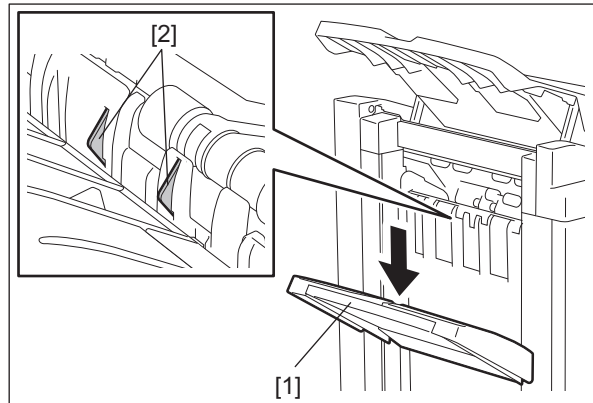

Fig. 4-6

4.1.3 Saddle tray (MJ-1116)

- (1) Remove 2 screws and take off the leveling arm [1].

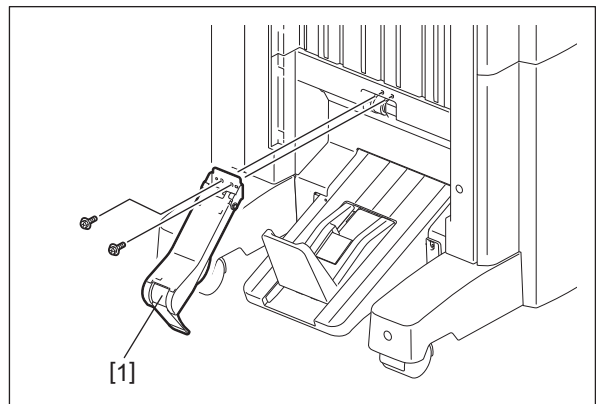

Fig. 4-7

Notes:

When installing, engage 2 holes of the leveling arm [1] with the positioning dowels.

- (2) Remove the slide tray [2].

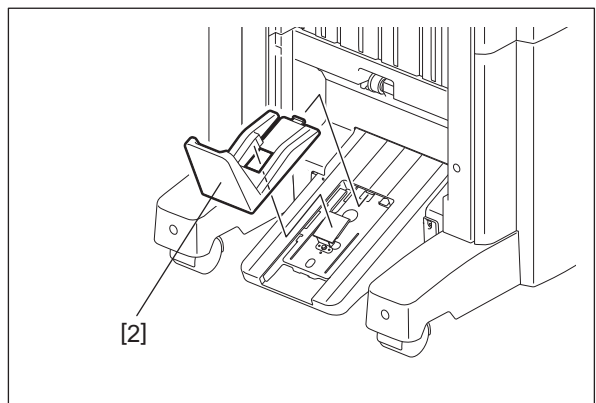

Fig. 4-8

Notes:

When installing, hang 1 hook of the slide tray [2] on the hole of saddle tray.

- (3) Remove 2 screws and take off the saddle tray [3].

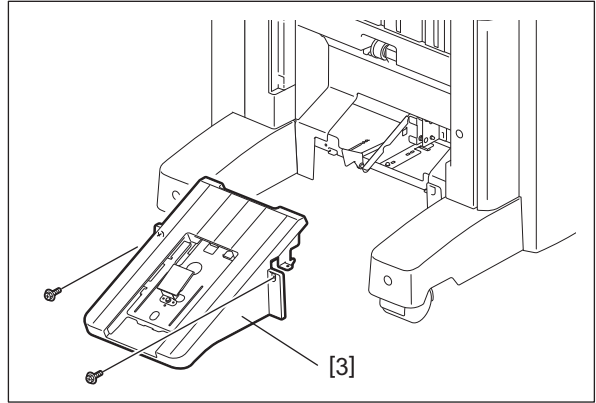

Fig. 4-9

Notes:

When installing, hang 2 hooks of the saddle tray [3] on the holes of the frame of this option.

4.1.4 Control panel unit

- (1) Remove 1 screw on the upper side of the front rail cover [1].

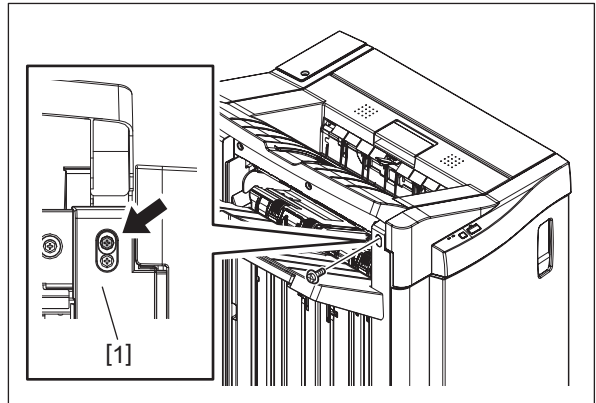

Fig. 4-10

- (2) Open the front cover (MJ-1115) or the front upper cover (MJ-1116).
(3) Remove 2 screws. Disconnect 1 connector [3] and take off the control panel unit [4].

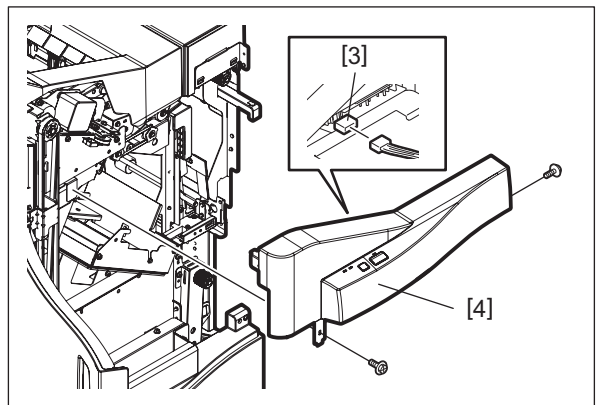

Fig. 4-11

4.1.5 Front cover (MJ-1115)

- (1) Remove 1 screw on the upper side of the front rail cover [1].

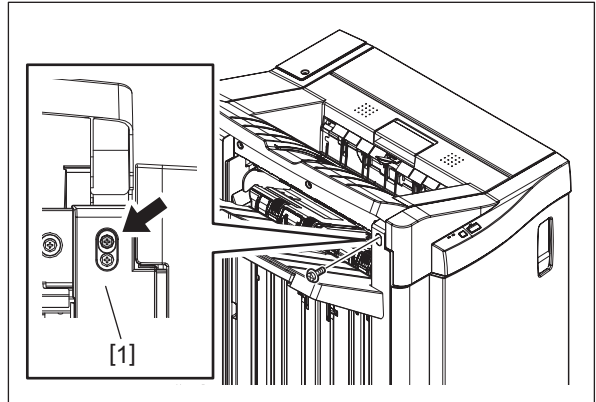

Fig. 4-12

- (2) Open the front cover [2] and remove 1 screw on the left-hand side of the control panel unit [3].
- (3) While sliding the left-hand side of the control panel unit [3] toward you, lift the front cover [2] upward to take it off.

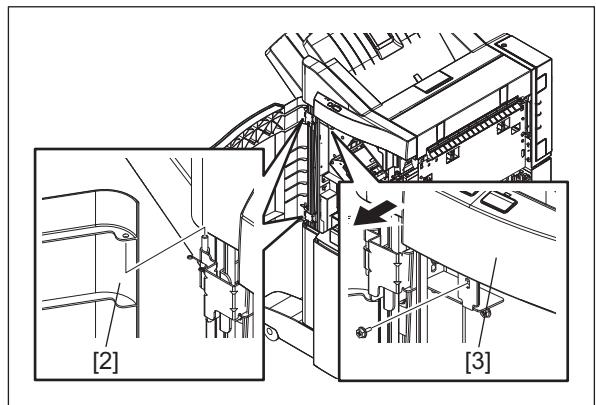

Fig. 4-13

- (4) Remove 1 screw and separate the front upper cover [4] and the front lower cover [5].

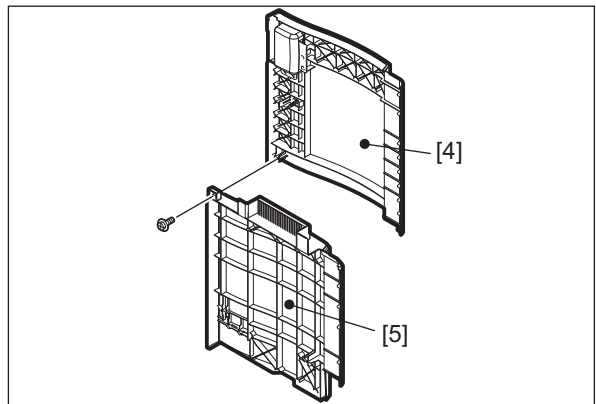

Fig. 4-14

4.1.6 Front upper cover, Front lower cover (MJ-1116)

[A] Front upper cover

- (1) Remove 1 screw on the upper side of the front rail cover [1].

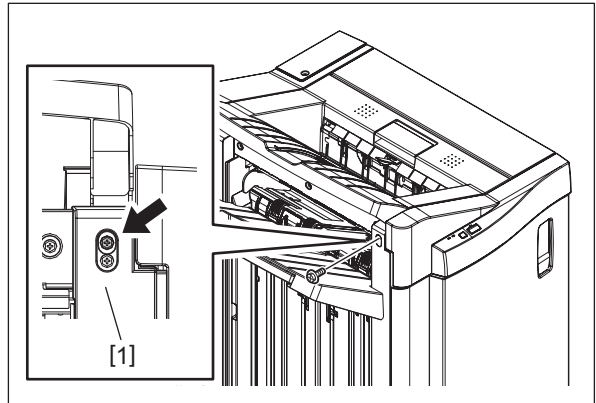

Fig. 4-15

- (2) Open the front upper cover [2] and remove 1 screw on the left-hand side of the control panel unit [3].
- (3) While sliding the left-hand side of the control panel unit [3] toward you, lift the front upper cover [2] upward to take it off.

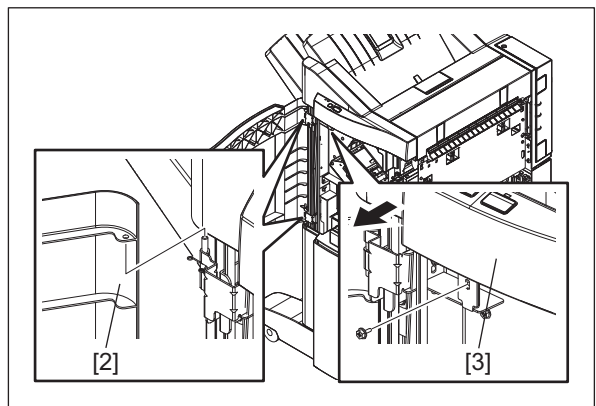

Fig. 4-16

[B] Front lower cover

- (1) Open the front upper cover [1] and pull out the saddle stitch unit [2].
- (2) Remove 4 screws and take off the front lower cover [3].

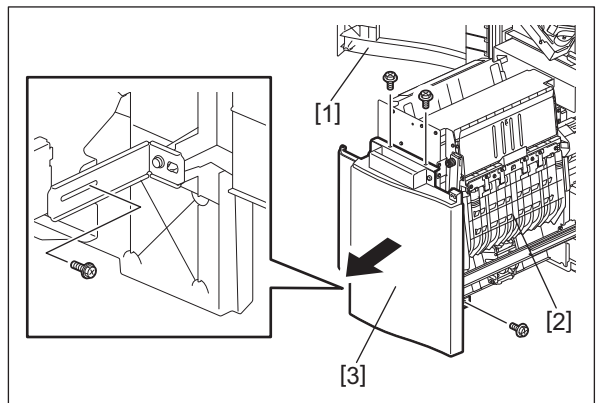

Fig. 4-17

4.1.7 Handle cover, Cover lock bracket

- (1) Open the front cover [1] (MJ-1115) or the front upper cover [1] (MJ-1116).
- (2) Remove 2 screws and take off the handle cover [2].
- (3) Remove 1 screw and take off the cover lock bracket [3].

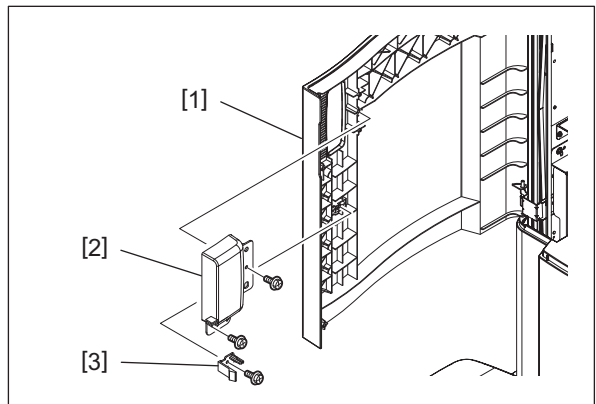

Fig. 4-18

4.1.8 Rear cover

- (1) Remove the finisher cable [1] from the groove of the rear cover [2].
- (2) Remove 5 screws and lift the rear cover [2] upward to take it off.

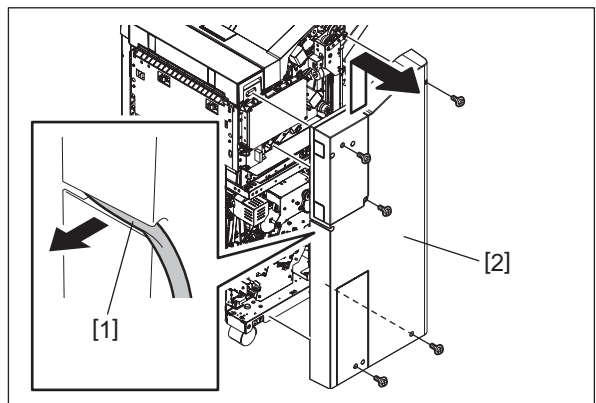

Fig. 4-19

4.1.9 Board access cover

- (1) Remove 2 screws and lift the board access cover [1] upward to take it off.

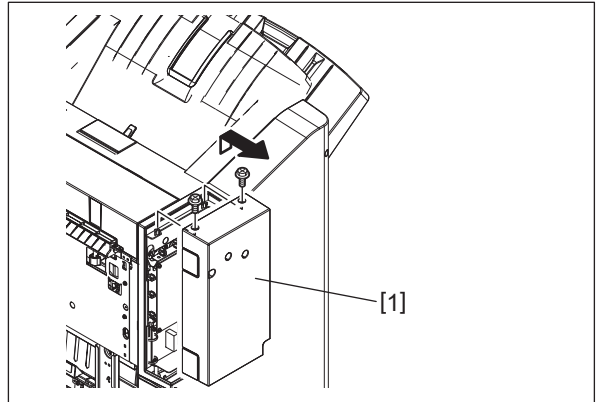

Fig. 4-20

Notes:

When installing, hang 5 hooks of the board access cover [1] on the holes of the rear cover.

4.1.10 Saddle access cover

- (1) Remove 1 screw and slide the saddle access cover [1] downward to take it off.

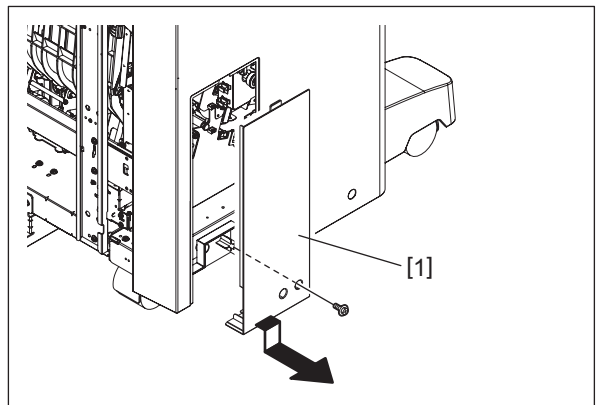

Fig. 4-21

4.1.11 Right upper cover

- (1) Take off the control panel unit.
📖 P. 4-4 "4.1.4 Control panel unit"
- (2) Take off the rear cover.
📖 P. 4-7 "4.1.8 Rear cover"
- (3) Loosen 2 screws and lift the right upper cover [1] upward to take it off.

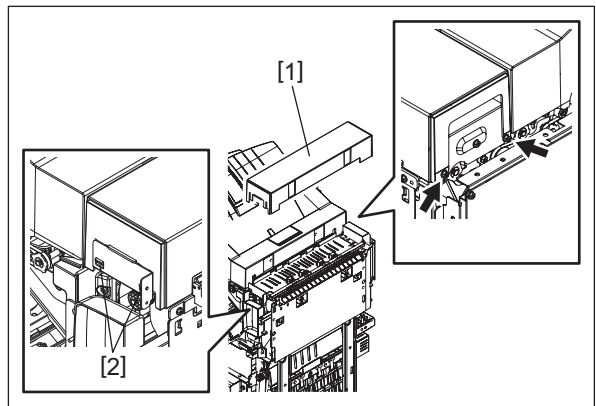

Fig. 4-22

Notes:

When installing, hang 2 hooks [2] of the right upper cover [1] on 2 holes utilizing the positions from which they were removed.

4.1.12 Relay guide, Paper feed discharge brush, Right cover

- (1) Loosen 3 screws and lift the relay guide [1] and paper feed discharge brush [2] upward to take them off.

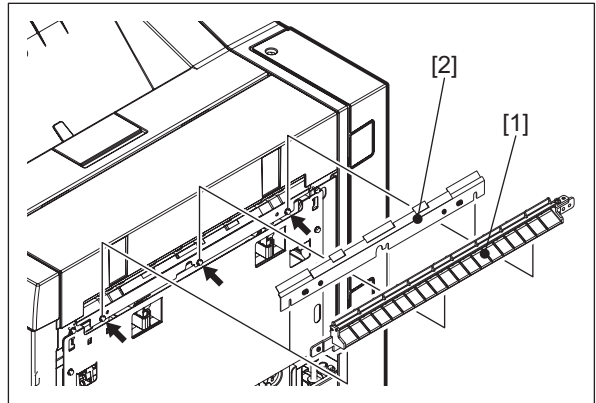

Fig. 4-23

- (2) Take off the board access cover.
P. 4-8 "4.1.9 Board access cover"
- (3) Disconnect 1 relay connector [3].

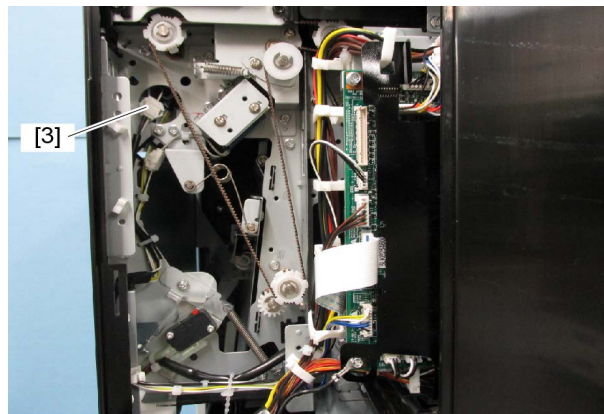

Fig. 4-24

- (4) Remove 4 screws and lift the right cover [4] upward to take it off.

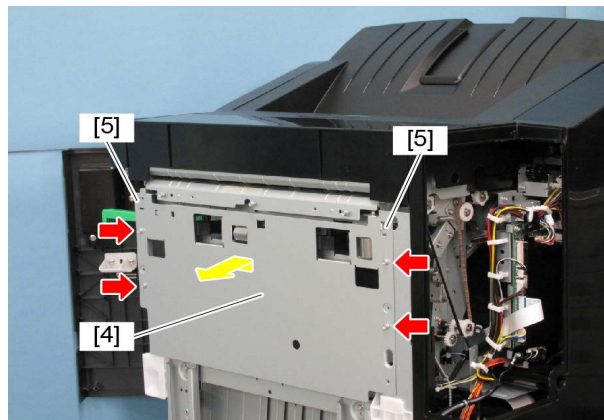

Fig. 4-25

Notes:

When installing, hang 2 hooks [5] of the right cover on the holes of the frame.

4.1.13 Left upper cover

- (1) Remove 4 screws. While sliding the upper side of the rear rail cover [2] toward you, take off the left upper cover [1].

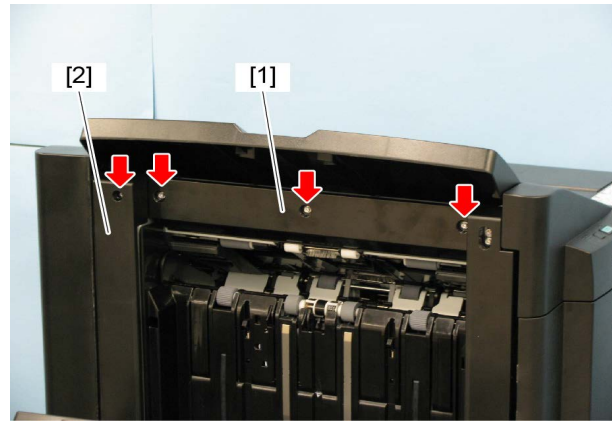



Fig. 4-26

4.1.14 Front rail cover, Rear rail cover

- (1) Take off the movable tray.
 P. 4-2 "4.1.2 Movable tray"
- (2) Open the front cover [1] (MJ-1115) or the front upper cover [1] (MJ-1116). Remove 1 screw on the left-hand side of the control panel unit [2].
- (3) Remove 3 screws. Close the front cover [1] (MJ-1115) or the front upper cover [1] (MJ-1116). Slide the front rail cover [3] upward to release the hooks [4]. Then take off the front rail cover [3] while sliding the left-hand side of the control panel unit [2] toward you.

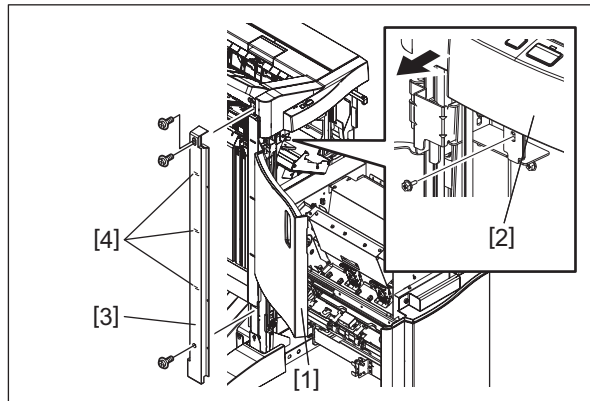

Fig. 4-27

Notes:

When installing, hang 3 hooks [4] of the front rail cover [3] on the holes of the frame.

- (4) Remove 2 screws. Slide the rear rail cover [5] upward to release 3 hooks [6]. Then take off the rear rail cover [5].

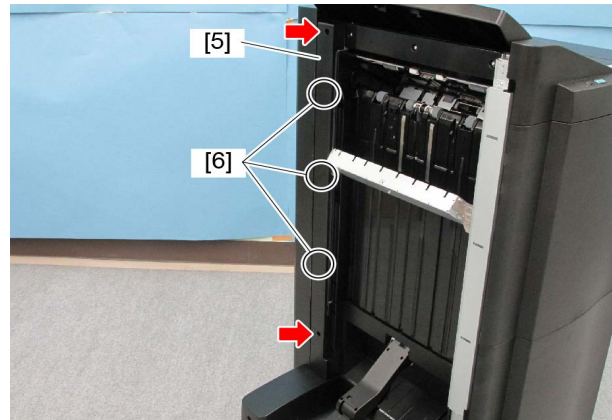

Fig. 4-28

Notes:

- When installing, hang 3 hooks [6] of the rear rail cover [5] on the holes of the frame.
- After installing the front and rear rail covers, move the movable tray up and down to check so that it does not interfere with them.
📖 P. 4-157 “4.12 Lowering Procedure of the Movable Tray”
If it does interfere, check the condition of the hooks of the rail covers and correct it.

4.1.15 Grate-shaped guide

- (1) Take off the movable tray.
📖 P. 4-2 “4.1.2 Movable tray”
- (2) Take off the rear cover.
📖 P. 4-7 “4.1.8 Rear cover”
- (3) Release the harness from 2 harness clamps [1] and disconnect 1 connector [2] from the finisher control PC board.

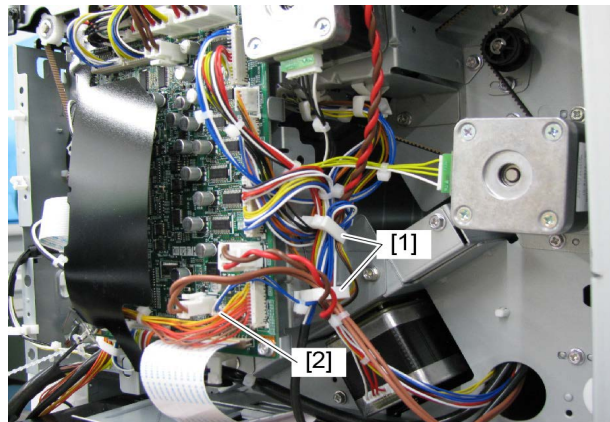

Fig. 4-29

- (4) Take off the left upper cover.
📖 P. 4-11 “4.1.13 Left upper cover”
- (5) Take off the front rail cover and the rear rail cover.
📖 P. 4-11 “4.1.14 Front rail cover, Rear rail cover”
- (6) Lower the movable tray.
📖 P. 4-157 “4.12 Lowering Procedure of the Movable Tray”

- (7) Turn the lever [10] on the alignment plate to the position as shown in the figure to release the lock. Move the front alignment plate [3] and the rear alignment plate [4] to the center and take them off by pulling them upward.

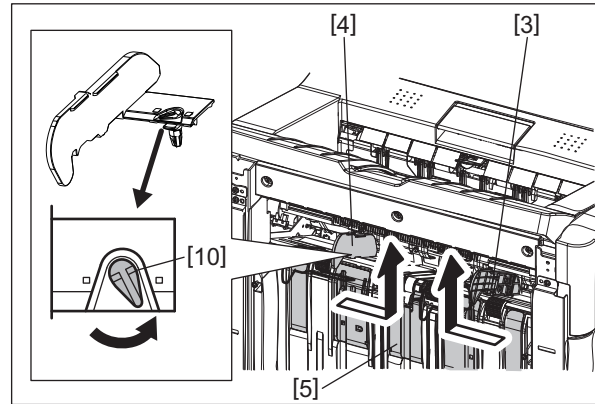

Fig. 4-30

Notes:

If the shutter [5] is raised, move it downward.

- (8) Remove 6 screws. Release the hook [7] by sliding the grate-shaped guide [6] upward to take it off.

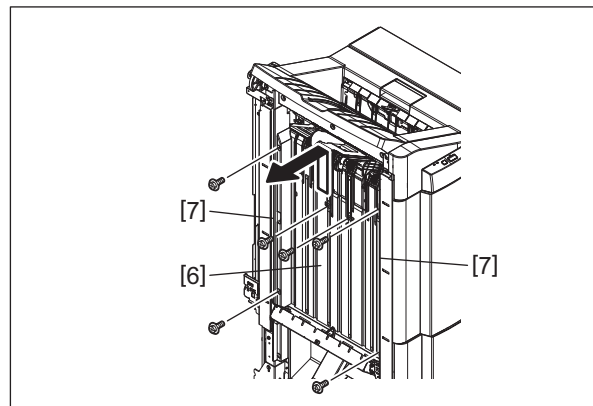

Fig. 4-31

Notes:

When installing, hang 2 hooks [7] of the grate-shaped guide [6] on the holes of the frame.

- (9) Release the harness from 1 harness clamp [8] and take off the grate-shaped guide [6].

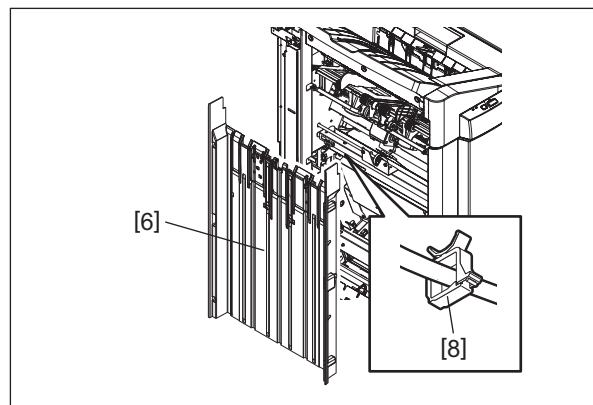

Fig. 4-32

Notes:

When installing, wire the harness [9] through the harness clamp [8] as shown in the figure.

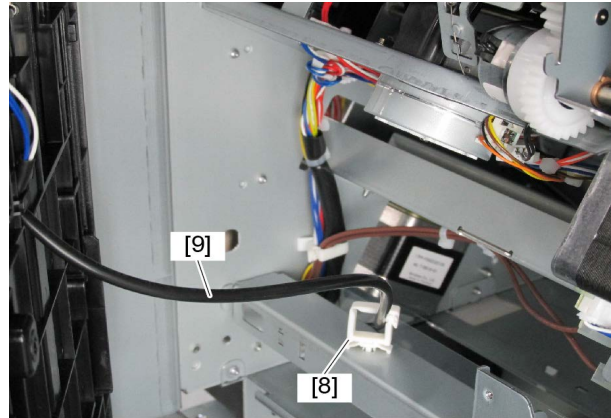

Fig. 4-33

4.1.16 Left lower cover

- (1) Take off the movable tray.
📖 P. 4-2 “4.1.2 Movable tray”
- (2) Take off the saddle tray.
📖 P. 4-3 “4.1.3 Saddle tray (MJ-1116)”
- (3) Take off the front rail cover and the rear rail cover.
📖 P. 4-11 “4.1.14 Front rail cover, Rear rail cover”
- (4) Remove 4 screws and take off the left lower cover [1].

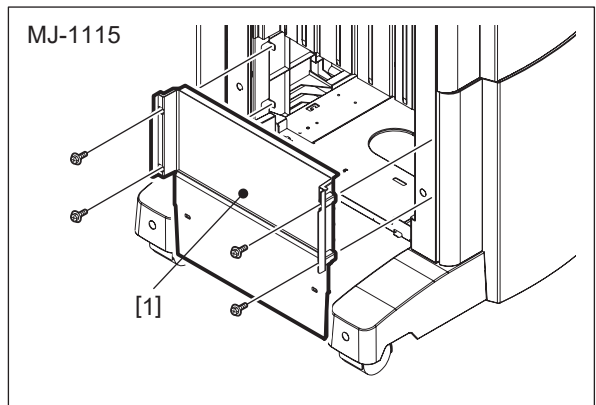

Fig. 4-34

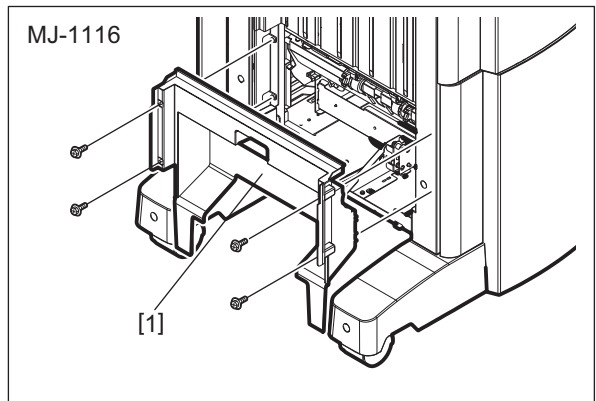

Fig. 4-35

4.1.17 Front foot cover, Rear foot cover

- (1) Remove 1 screw and take off the front foot cover [1] by moving it in the direction of the arrow.

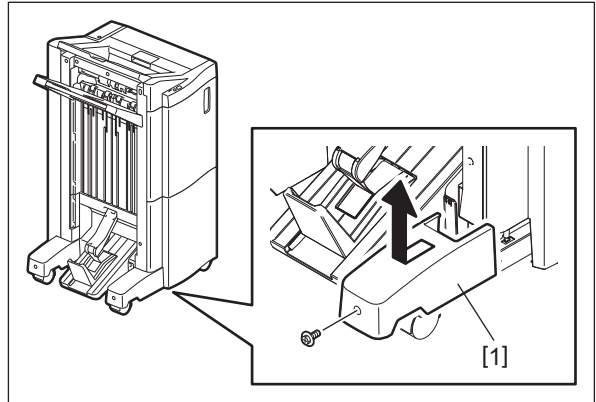

Fig. 4-36

- (2) Remove 1 screw and take off the rear foot cover [2] by moving it in the direction of the arrow.

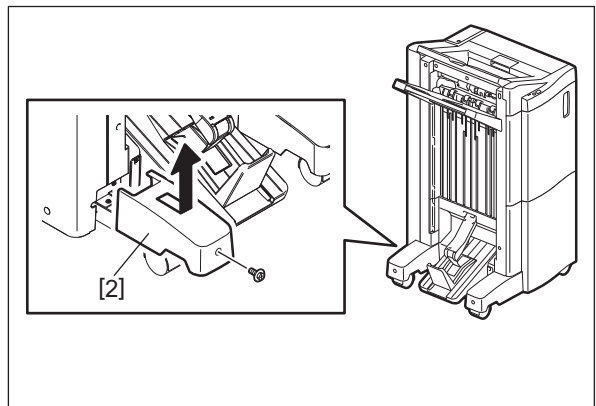

Fig. 4-37

4.2 Unit (Finisher Section)

4.2.1 Junction box unit

- (1) Take off the control panel unit.
📖 P. 4-4 “4.1.4 Control panel unit”
- (2) Take off the rear cover.
📖 P. 4-7 “4.1.8 Rear cover”
- (3) Take off the right upper cover.
📖 P. 4-9 “4.1.11 Right upper cover”
- (4) Take off the right cover.
📖 P. 4-10 “4.1.12 Relay guide, Paper feed discharge brush, Right cover”
- (5) Release the harness from 4 harness clamps [1].
- (6) Disconnect 2 connectors of the harnesses [2], [3] from the finisher control PC board.
- (7) Remove 1 spring [4].
- (8) Remove 1 shoulder screw [5] and take off the bracket [6] of the connection switch.
- (9) Remove 1 binding band [7] which bundles the harnesses.
- (10) Release the harness [9] of the connection switch from 1 harness clamp [8].

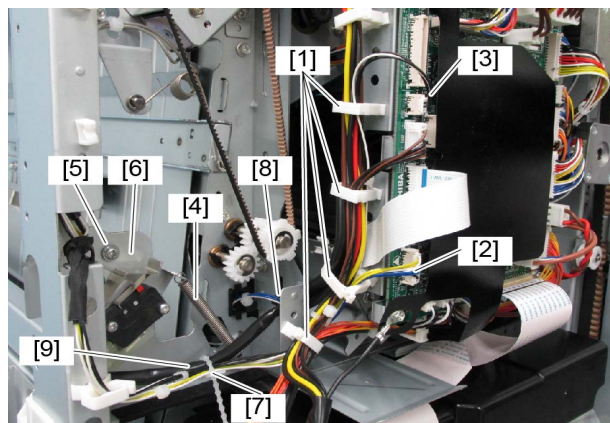

Fig. 4-38

- (11) Open the stationary tray.
- (12) Remove the spring [10] and loosen 2 screws. Release the tension of the belt [11] and remove it.

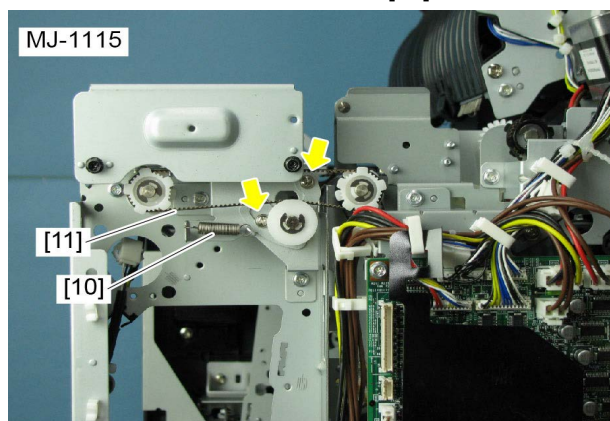

Fig. 4-39

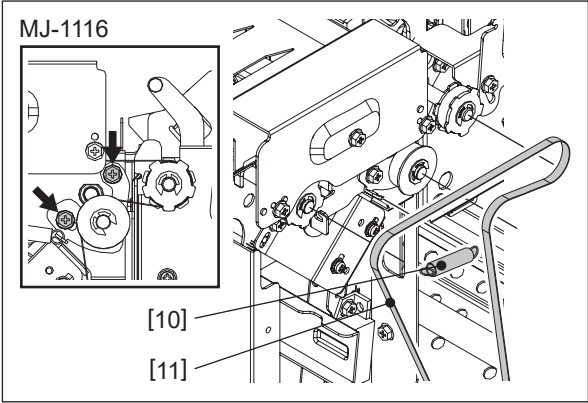

Fig. 4-40

(13) Remove 2 screws and take off the sensor plate [12].

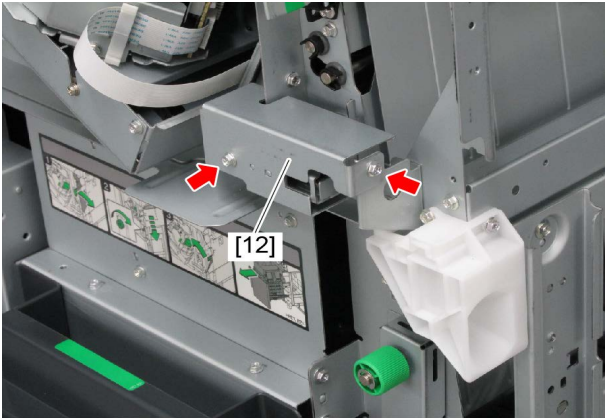

Fig. 4-41

(14) Disconnect 1 connector of the front cover opening/closing switch [13].

(15) Remove 2 screws and take off the front holder [14].

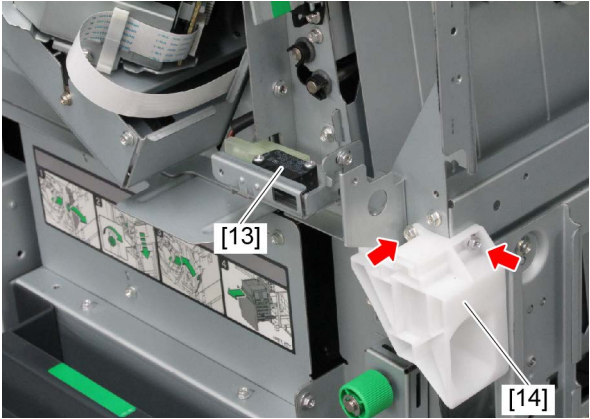

Fig. 4-42

(16) Remove 1 screw and take off the rear holder [15].

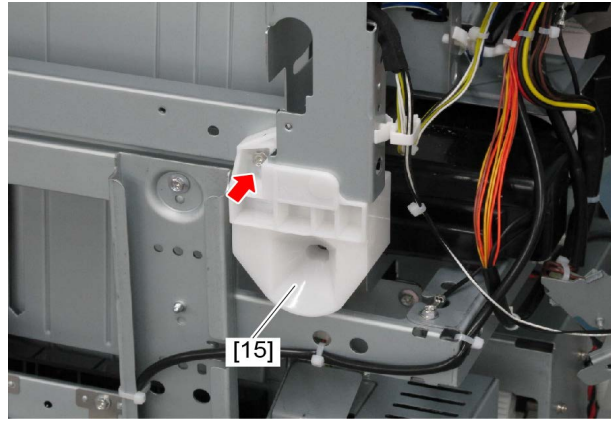

Fig. 4-43

(17) Remove 6 screws and lift the junction box unit [16] upward to take it off.

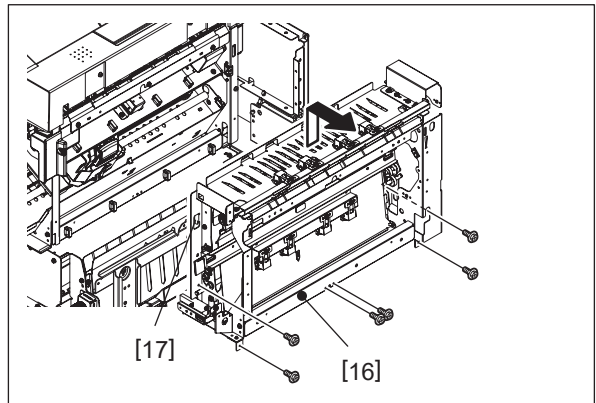

Fig. 4-44

Notes:

When installing, hang 2 hooks [17] of the junction box unit [16] on the holes of the frame.

4.2.2 Buffer unit

- (1) Take off the stationary tray.
📖 P. 4-1 “4.1.1 Stationary tray”
- (2) Take off the movable tray.
📖 P. 4-2 “4.1.2 Movable tray”
- (3) Take off the control panel unit.
📖 P. 4-4 “4.1.4 Control panel unit”
- (4) Take off the rear cover.
📖 P. 4-7 “4.1.8 Rear cover”
- (5) Take off the right upper cover.
📖 P. 4-9 “4.1.11 Right upper cover”
- (6) Take off the right cover.
📖 P. 4-10 “4.1.12 Relay guide, Paper feed discharge brush, Right cover”
- (7) Take off the left upper cover.
📖 P. 4-11 “4.1.13 Left upper cover”
- (8) Take off the junction box unit.
📖 P. 4-16 “4.2.1 Junction box unit”
- (9) Take off the front rail cover and the rear rail cover.
📖 P. 4-11 “4.1.14 Front rail cover, Rear rail cover”

- (10) Remove 2 screws and take off the front rail guide [1].
- (11) Remove 2 screws and take off the rear rail guide [2].

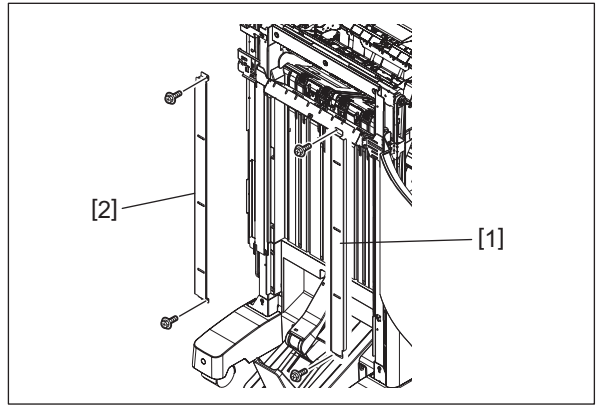

Fig. 4-45

- (12) Disconnect 5 connectors [4], [5], [6], [7] and [8] from the finisher control PC board [3].
- (13) Disconnect 1 connector [10] from the buffer tray guide motor [9].
- (14) Disconnect 1 connector [12] from the transport motor [11].
- (15) Disconnect 1 connector [14] from the movable tray shift motor sensor [13].
- (16) Release the harness from 6 harness clamps [15].
- (17) Remove 1 binding band [18] which bundles the harnesses.

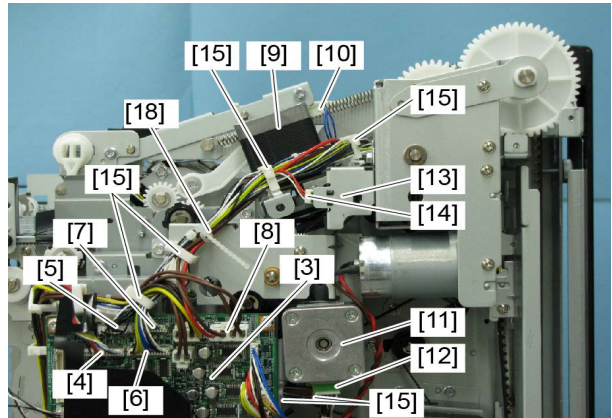

Fig. 4-46

- (18) Release the harness [16] of the finisher control PC board from 2 harness clamps [17].

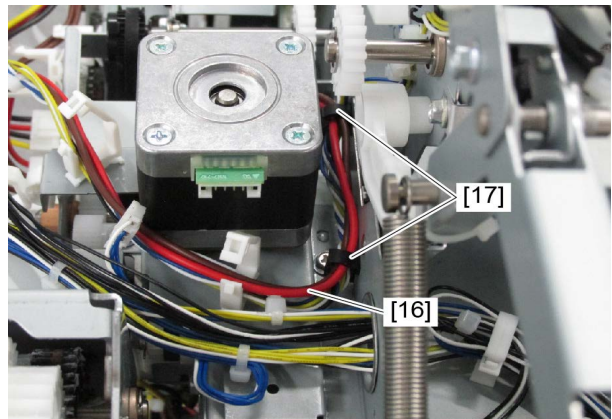

Fig. 4-47

Notes:

When installing, wire the harness [16] as shown in the figure.

(19) Remove 5 screws and take off the motor bracket [19].

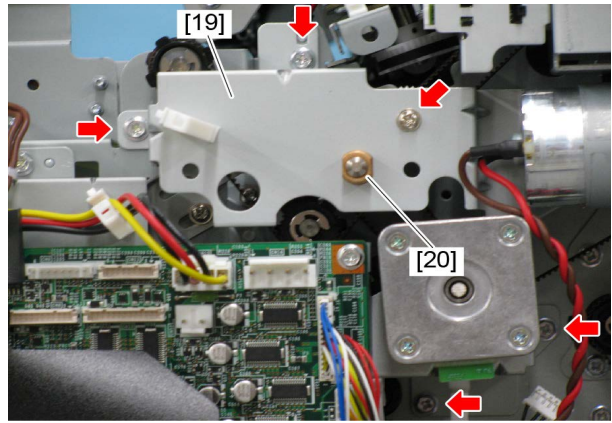

Fig. 4-48

Notes:

Be careful not to lose the bushing [20] removed while taking off the motor bracket [19].

(20) Loosen 1 screw. Push the pulley [21] in the direction indicated by the arrow so as the belt tension is loosened as a result. Then tighten the screw [19].

(21) Remove the belts [22] and [23], 1 assembled part [24] and 1 bearing.

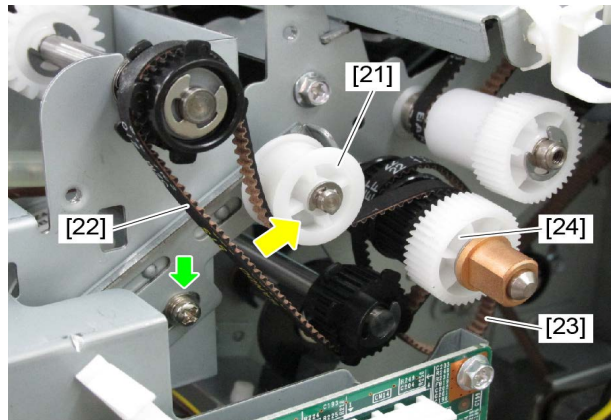

Fig. 4-49

Notes:

Be careful not to lose the bearing while taking off the assembled part [24].

(22) Remove 2 springs [25].

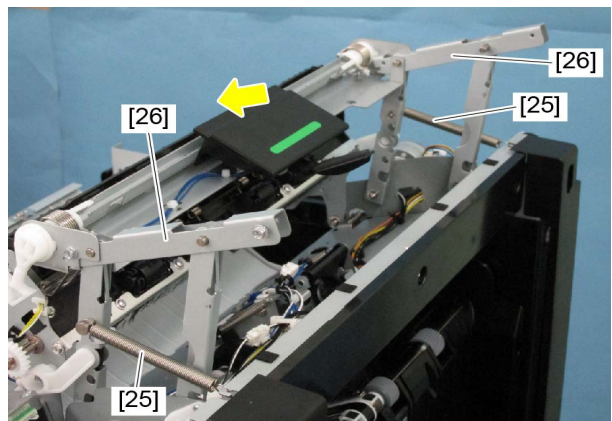

Fig. 4-50

Notes:

Be sure to support the buffer unit-1 [26] with your hand since its frame is moved in the direction indicated by the arrow to close it when you remove the springs [25].

- (23) Remove 4 screws and take off the buffer unit [27].

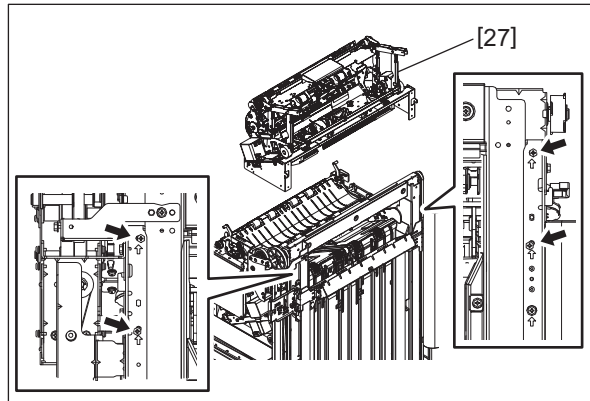

Fig. 4-51

Notes:

Be sure to place the removed buffer unit as shown in the figure. Otherwise, the buffer guide [28], assist guide [29] and transport path [30] may be damaged.

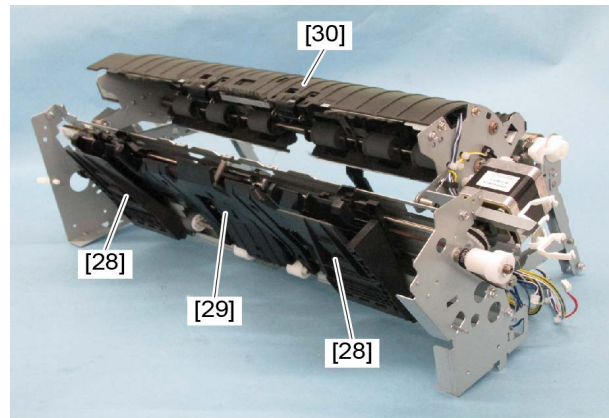

Fig. 4-52

4.2.3 Buffer unit-1

- (1) Take off the stationary tray.
P. 4-1 "4.1.1 Stationary tray"
- (2) Take off the control panel unit.
P. 4-4 "4.1.4 Control panel unit"
- (3) Take off the rear cover.
P. 4-7 "4.1.8 Rear cover"
- (4) Disconnect 4 connectors [4], [5], [6] and [7] from the finisher control PC board [3].
- (5) Disconnect 1 connector [10] from the buffer tray guide motor [9].
- (6) Disconnect 1 connector [14] from the movable tray shift motor sensor [13].
- (7) Release the harness from 4 harness clamps [15].

(8) Remove 1 binding band [8] which bundles the harnesses.

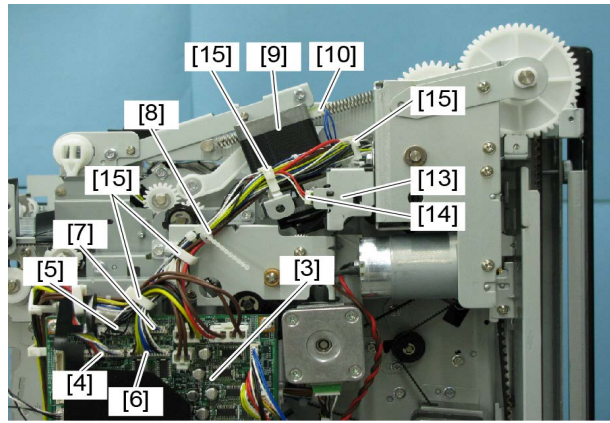

Fig. 4-53

(9) Release the harness [16] of the finisher control PC board from 2 harness clamps [17].

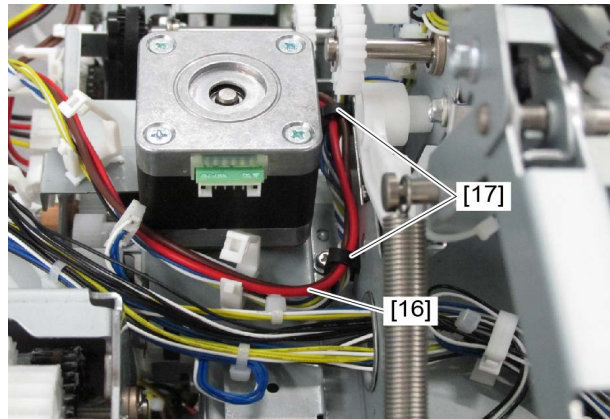

Fig. 4-54

Notes:

When installing, wire the harness [16] as shown in the figure.

(10) Remove 2 springs [18].

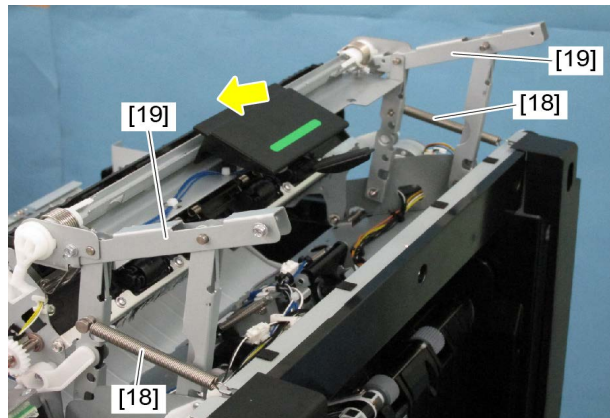

Fig. 4-55

Notes:

Be sure to support the buffer unit-1 [19] with your hand since its frame is moved in the direction indicated by the arrow to close it when you remove the springs [18].

- (11) Disconnect 1 connector [20] of the sensor and release the harness [21] from 1 harness clamp [22].
- (12) Remove 1 harness clamp [24] of the harness [23] from the frame.
- (13) Pull out the harnesses [21] and [23] through the window [25] of the frame.

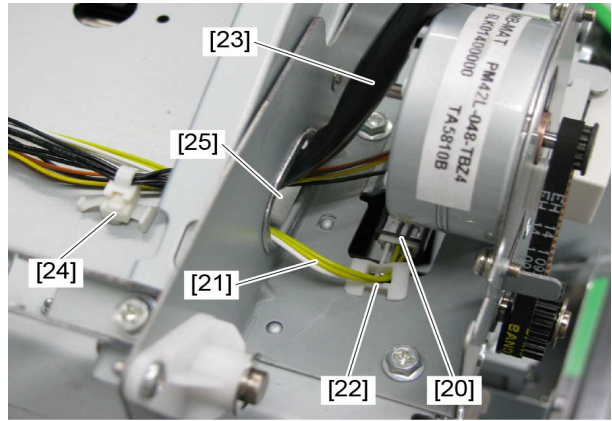

Fig. 4-56

- (14) Disconnect 1 relay connector [26] and release the harness [27] from 7 harness clamps [28].
- (15) Pull out the harness [27] through the window of the frame.

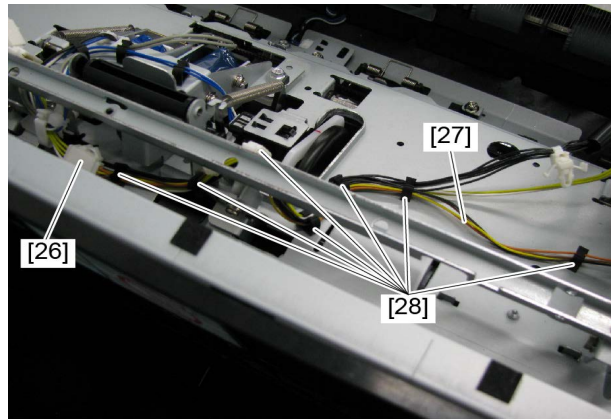

Fig. 4-57

- (16) Pull out the harness [29] through the window [30] of the frame.
- (17) Release the harness [29] from 1 harness clamp [31].

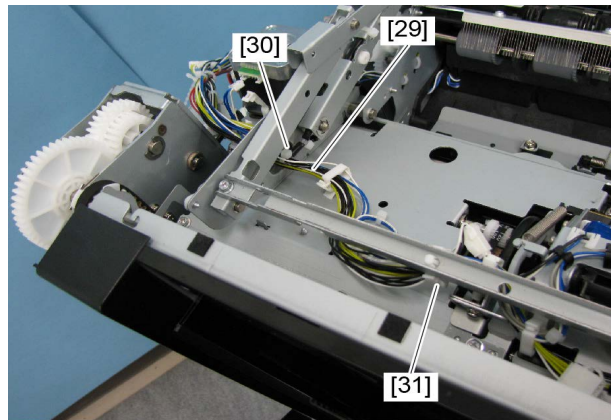

Fig. 4-58

- (18) Remove the belt [32].
- (19) Release the latch and take off the pulley cover [35].

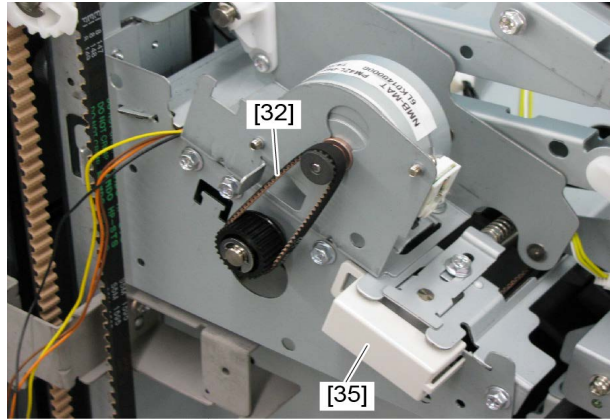

Fig. 4-59

- (20) Loosen 1 screw. Push the metal plate [33] in the direction indicated by the arrow so as the belt tension is loosened as a result. Then tighten the screw.

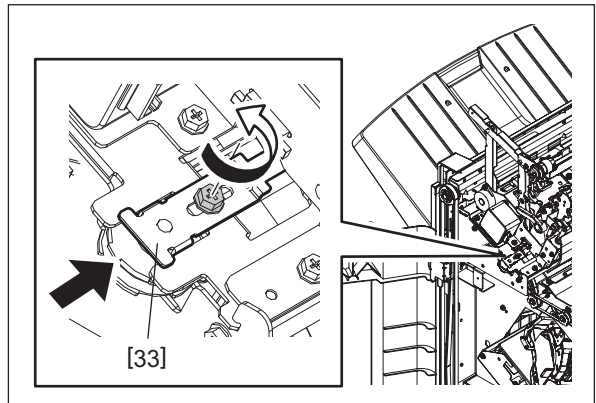

Fig. 4-60

- (21) Remove 5 screws and take off the buffer unit-1 [34] by lifting it up.

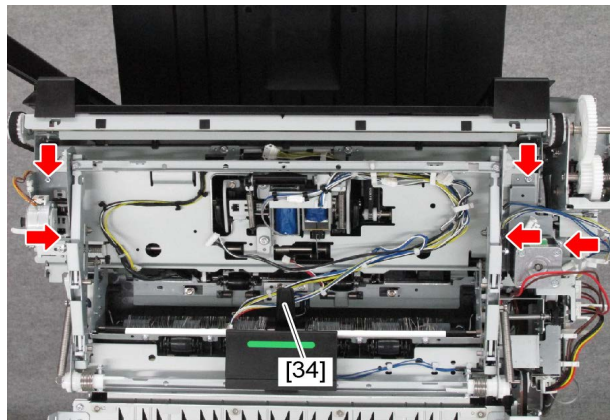









Fig. 4-61

4.2.4 Finishing tray unit

- (1) Take off the stationary tray.
 P. 4-1 "4.1.1 Stationary tray"
- (2) Take off the control panel unit.
 P. 4-4 "4.1.4 Control panel unit"
- (3) Take off the rear cover.
 P. 4-7 "4.1.8 Rear cover"
- (4) Take off the right upper cover.
 P. 4-9 "4.1.11 Right upper cover"
- (5) Take off the junction box unit.
 P. 4-16 "4.2.1 Junction box unit"
- (6) Take off the front rail cover and the rear rail cover.
 P. 4-11 "4.1.14 Front rail cover, Rear rail cover"
- (7) Take off the grate-shaped guide.
 P. 4-12 "4.1.15 Grate-shaped guide"
- (8) Take off the buffer unit.
 P. 4-18 "4.2.2 Buffer unit"
- (9) Release the harnesses and the PC board cover [4] from 3 harness clamps [1]. Disconnect the connectors [2] and [3] from the finisher control PC board.

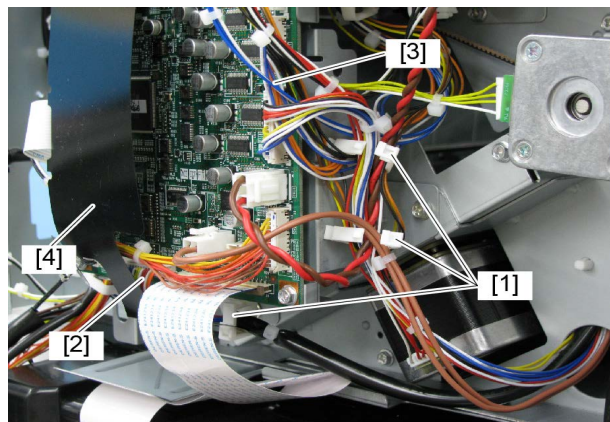

Fig. 4-62

- (10) Release the harnesses [4] and [5] from 1 harness clamp [6] and pull out them through the window [7] of the frame.

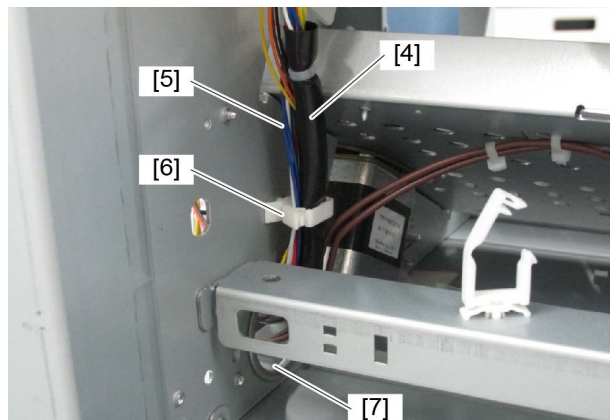

Fig. 4-63

Notes:

When installing, wire the harnesses [4] and [5] as shown in the figure.

(11) Remove 1 clip [9] on the front side of the stack transport roller-2 [8] and then 1 bushing [10].

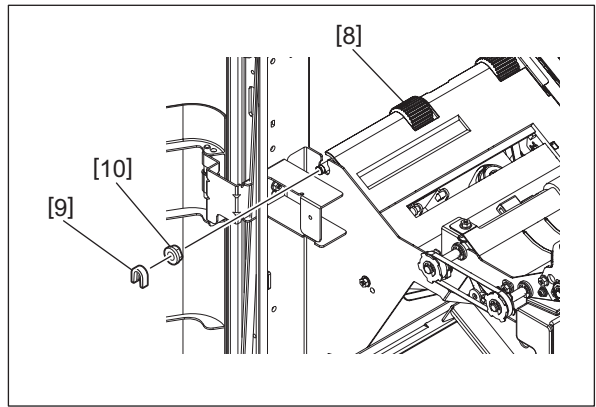

Fig. 4-64

(12) Remove the spring [11] and loosen 2 screws to release the tension of the belt [12].

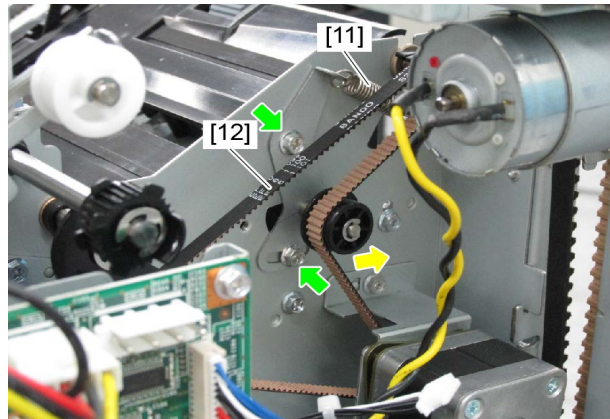

Fig. 4-65

(13) Remove 2 clips [13], 1 transport roller pulley-2 [14], 1 pin [15], 1 bushing [16] and 1 belt [12] on the rear side of the stack transport roller-2 [8].

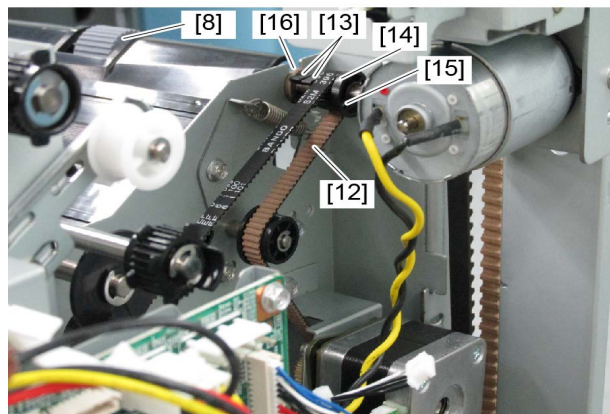

Fig. 4-66

Notes:

- Be careful not to lose the pin [15] for fixing the pulley.
- Be careful not to lose the belt [12].

- (14) Remove 2 clips [18], 1 transport roller pulley-3 [19], 1 pin [20] and 1 bushing [21] on the rear side of the stack transport roller-1 [17].

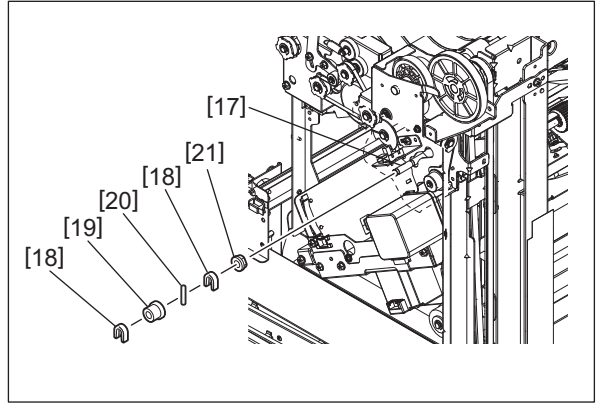

Fig. 4-67

Notes:

Be careful not to lose the pin [20] for fixing the pulley.

- (15) Move the stapler to the staple replacing position (the first position from the front).
(16) Remove 4 screws and take off the stack transport roller-2 [8] of the finishing tray unit [22] from the frame. Move the stack transport roller-1 [17] as shown in the figure. Then take off the finishing tray unit [22] by lifting its front side up.

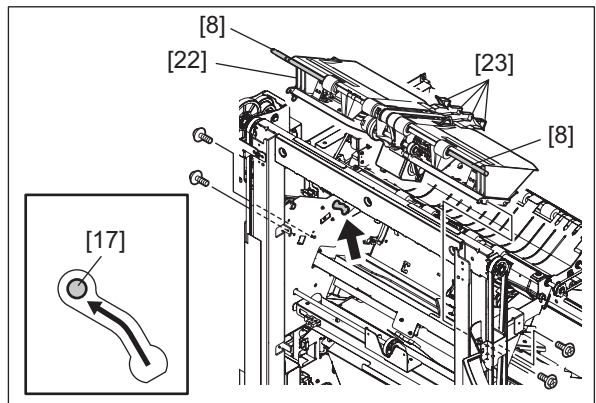

Fig. 4-68

Notes:

Be careful not to make the finishing tray guide [23] deform.

4.2.5 Stapler unit

- (1) Take off the rear cover.
📖 P. 4-7 “4.1.8 Rear cover”
- (2) Take off the front rail cover and the rear rail cover.
📖 P. 4-11 “4.1.14 Front rail cover, Rear rail cover”
- (3) Take off the grate-shaped guide.
📖 P. 4-12 “4.1.15 Grate-shaped guide”
- (4) Release the harnesses and the PC board cover [7] from 3 harness clamps [1]. Disconnect the connectors [2] and [3] from the finisher control PC board.
- (5) Remove the flat cable [4] from the finisher control PC board.
- (6) Disconnect the connector [5] from the stapler unit shift motor.

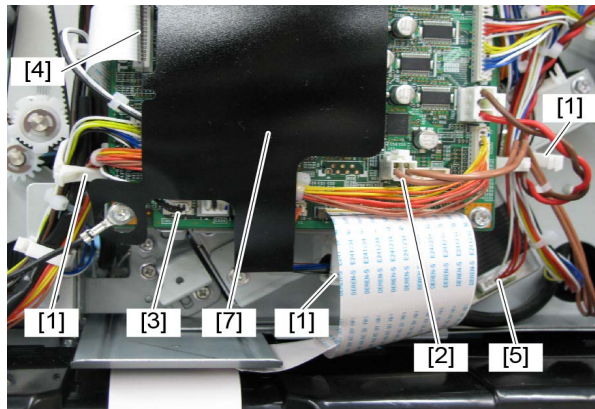

Fig. 4-69

- (7) Remove 2 screws on the rear side.

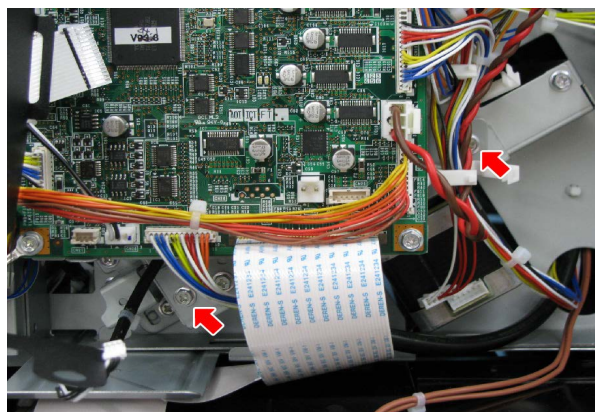

Fig. 4-70

- (8) Remove 2 screws on the front side and take off the stapler unit [6] by pulling it toward you.

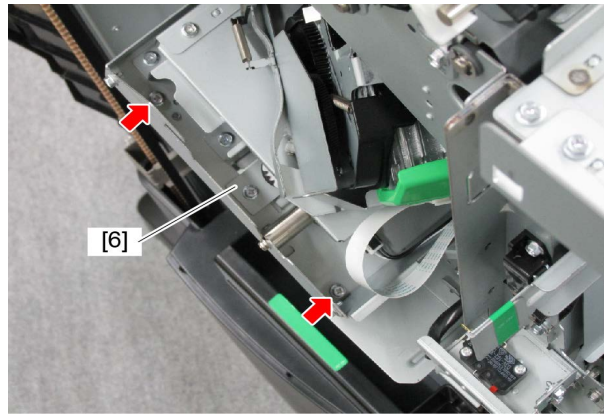

Fig. 4-71

4.2.6 Stapler

- (1) Open the front cover (MJ-1115) or the front upper cover (MJ-1116).
- (2) Move the stapler to the staple replacing position (the first position from the front).
- (3) Release the clamp [1]. Then remove the flexible cable [2] from the connector [3].

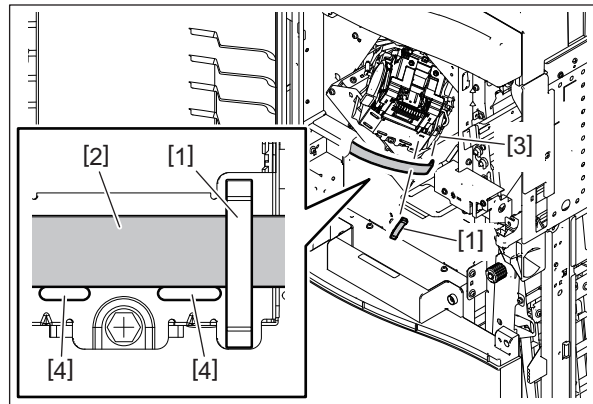

Fig. 4-72

Notes:

When installing, place the flexible cable [2] on 2 protrusions [4] and fix it with the clamp [1].

- (4) Remove 1 screw [5] and take off the stapler carrier [6].

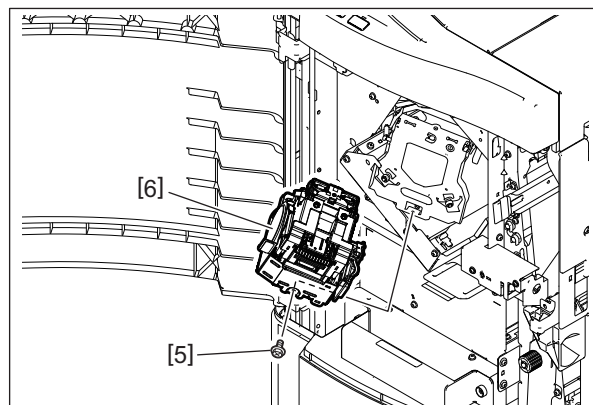

Fig. 4-73

- (5) Remove 2 screws [7], take off the stapler [8] and disconnect 2 connectors [9].

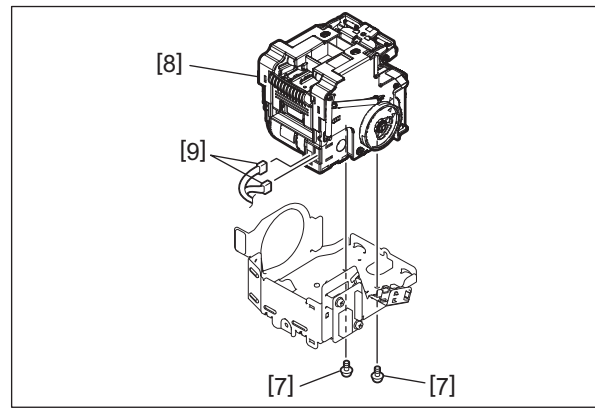

Fig. 4-74

4.2.7 Movable tray shift motor unit

- (1) Take off the rear cover.
P. 4-7 "4.1.8 Rear cover"
- (2) Move the movable tray [1] to the middle position.
If the movable tray [1] needs to be lowered, push the gear [2] of the movable tray shift motor unit in the direction of the arrow to release the lock. (Be sure to hold the movable tray [1] with your hand because it may fall when the gear is pushed.)

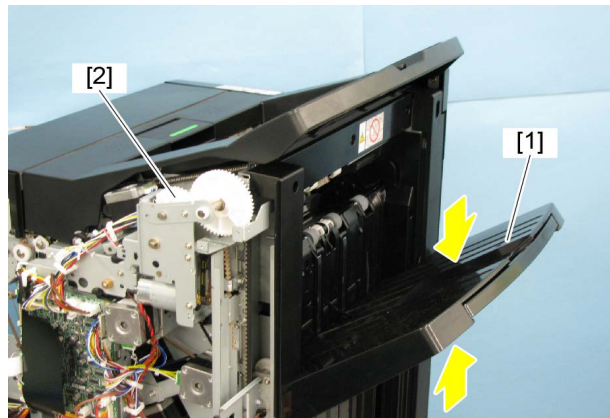

Fig. 4-75

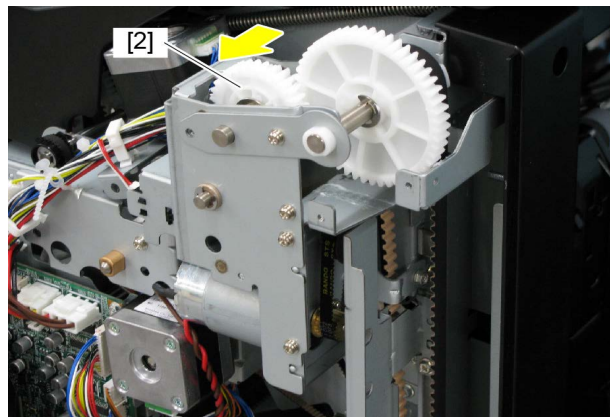

Fig. 4-76

- (3) Remove 2 screws and take off the sensor rail [3].

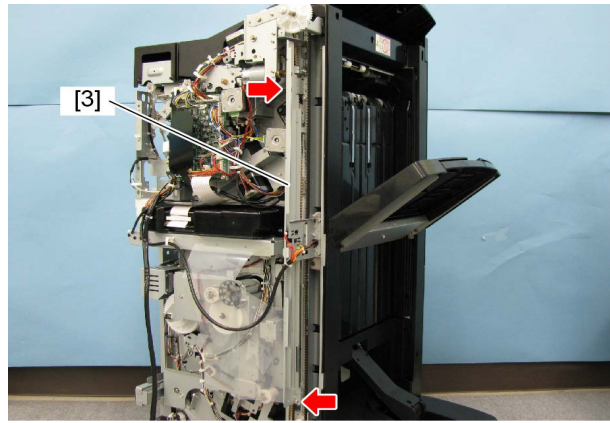

Fig. 4-77

Notes:

When installing, fix the sensor rail [3] at the position where the gap [6] between the center mark of its scale [4] and the edge of the movable tray position-A sensor [5] is from 0 to 1.0 mm. Be sure to perform the measurement on the positions at the upper and lower scales [4] on the sensor rail [3] by moving the movable tray shift frame as shown in the figure.

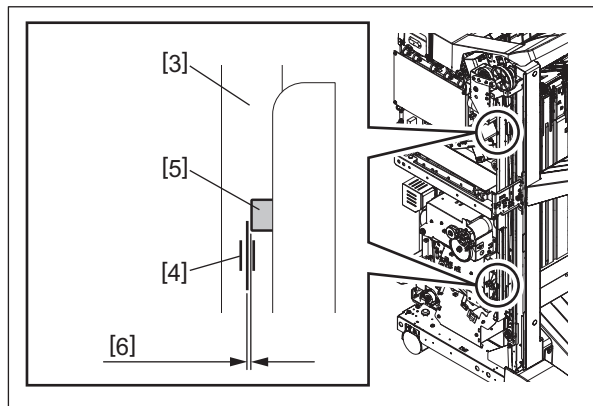

Fig. 4-78

- (4) Release the harness from 3 harness clamps [1] and disconnect 1 connector [2] from the finisher control PC board.

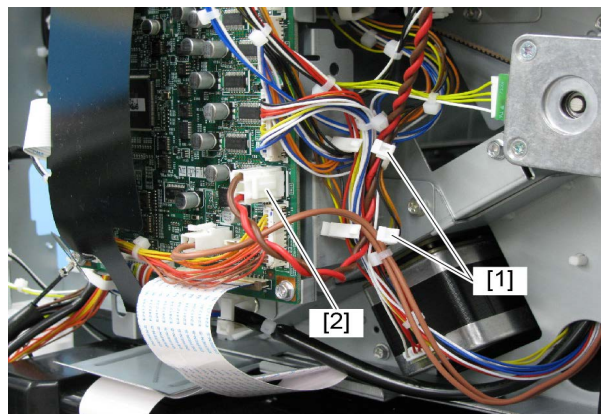

Fig. 4-79

- (5) Disconnect the connector [3] of the movable tray shift motor sensor.
- (6) Remove 1 screw, metal plate [4] and bushing [5].

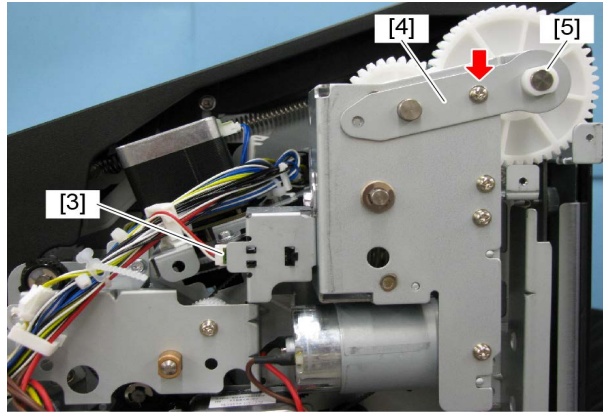

Fig. 4-80

- (7) Remove 2 screws and take off the movable tray shift motor unit [6].

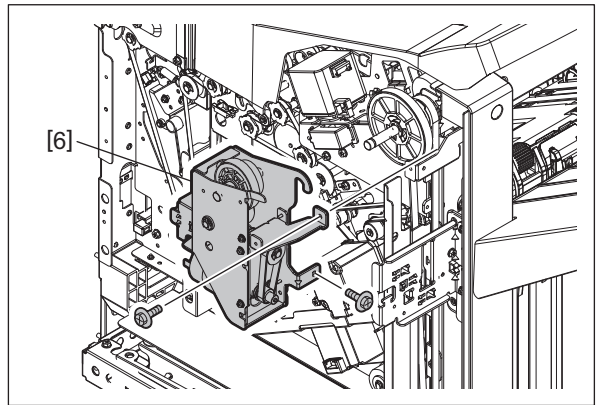

Fig. 4-81

4.3 Unit (Saddle Stitch Section: MJ-1116)

4.3.1 Saddle stitch unit

- (1) Take off the front lower cover.
📖 P. 4-6 “4.1.6 Front upper cover, Front lower cover (MJ-1116)”
- (2) Take off the rear cover.
📖 P. 4-7 “4.1.8 Rear cover”
- (3) Release 1 flat cable clamp [1]. Then remove 1 flat cable [2] from the saddle control PC board.

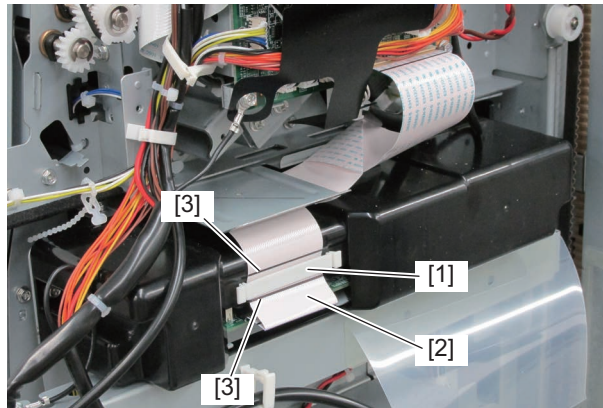

Fig. 4-82

Notes:

When installing, firmly insert the flat cable [2] into the connector and align the flat cable clamp [1] to the black line [3] of the flat cable.

- (4) Place a table [4] beneath the pulled out saddle stitch unit to make stable it.

Notes:

Store (flip up) the saddle stitch unit support [5] before placing a table [4] beneath the unit.

- (5) Remove 8 screws [6] and store the right and left rails.
- (6) Take off the saddle stitch unit.

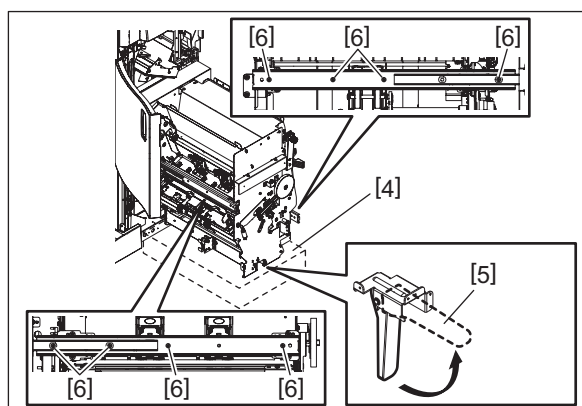

Fig. 4-83

Notes:

- Hold the parts [7] of the saddle stitch unit as shown in the figure during disassembling.
- Be sure to place the removed saddle stitch unit on a flat place with its support [5] stored (flipped up).

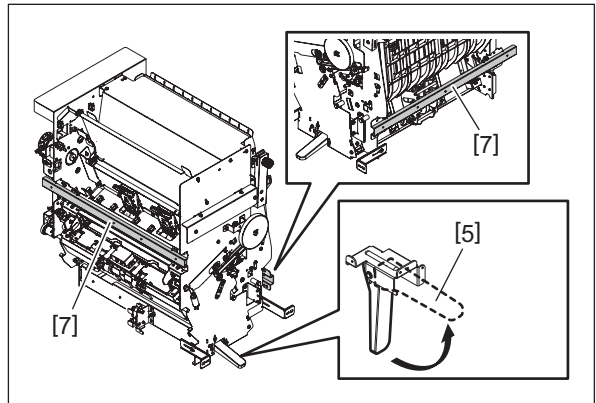

Fig. 4-84

- After the saddle stitch unit is installed, take off the saddle cover to check if the joint section of the pivot [8] on the Finisher side and the plate [9] on the saddle stitch unit side is smooth.

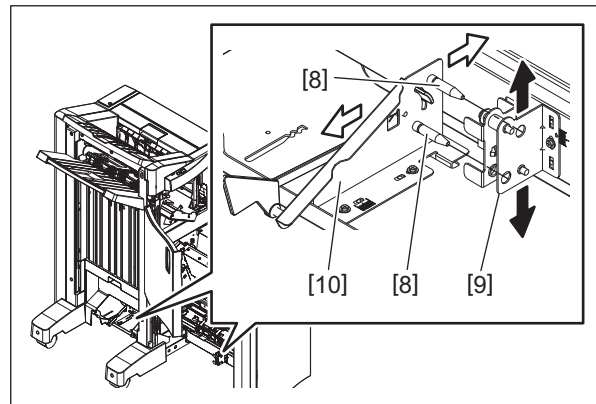

Fig. 4-85

1. Take off the saddle tray.
 ☞ P. 4-3 “4.1.3 Saddle tray (MJ-1116)”
2. Open and then close the saddle stitch unit to check the following items.
 - The joint section of the pivot on the Finisher side and the plate on the saddle stitch unit side is smooth.
 - The 4 portions [12] of the plate [11] on the saddle stitch unit side correctly contact the plate [10] on the Finisher side. (State [A])

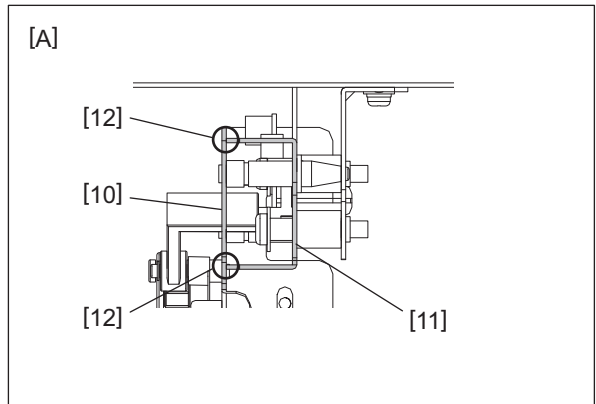

Fig. 4-86

- If the 4 portions [12] of the plate [11] do not contact correctly (State [B]), while the saddle stitch unit is closed, loosen 2 screws [13] of the bracket of the Finisher side and 1 screw [14] on the saddle stitch unit side to determine the proper positions.

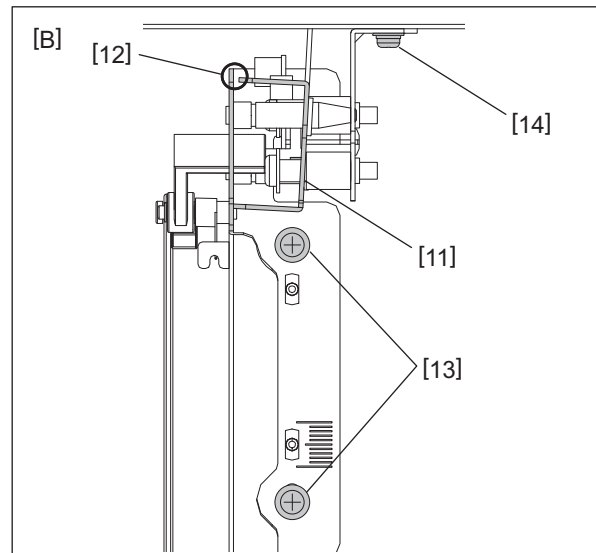

Fig. 4-87

4.3.2 Switchback unit

- (1) Take off the saddle stitch unit.
📖 P. 4-33 "4.3.1 Saddle stitch unit"
- (2) Remove 2 screws and take off the saddle control PC board cover [1].

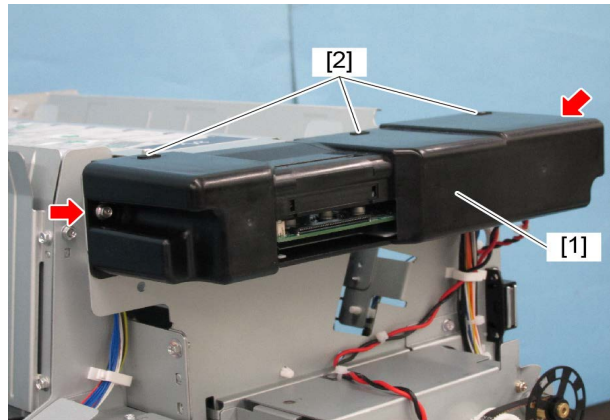

Fig. 4-88

Notes:

When installing, be sure to hang 3 holes [2] on the cover with 3 hooks on the frame.

- (3) Disconnect 2 connectors [3] from the saddle control PC board and release the harness from 1 harness clamp [4].

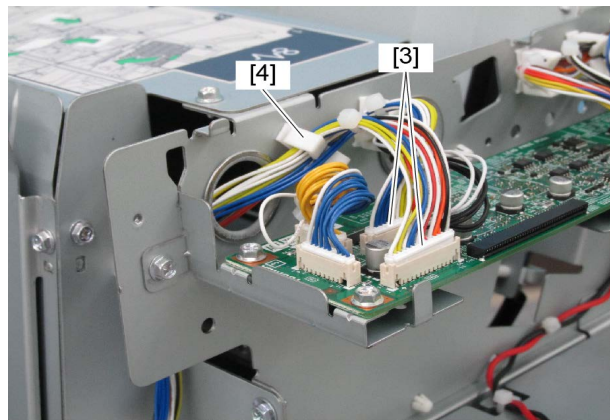

Fig. 4-89

- (4) Release the harness from 1 harness clamp [9].
Remove 4 screws and take off the support bracket [5].
- (5) Remove 4 screws and take off the front bracket [6].
- (6) Remove 4 screws and take off the rear bracket [7].
- (7) Remove 4 screws and take off the switchback unit [8].

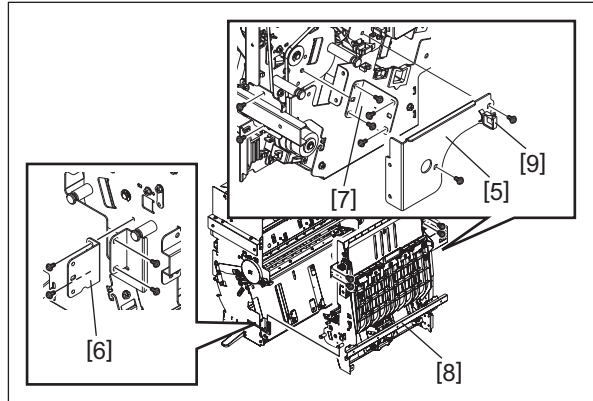

Fig. 4-90

4.3.3 Paper holding unit

- (1) Take off the front lower cover.
P. 4-6 "4.1.6 Front upper cover, Front lower cover (MJ-1116)"
- (2) Remove 2 screws and take off the paper holding unit [1].

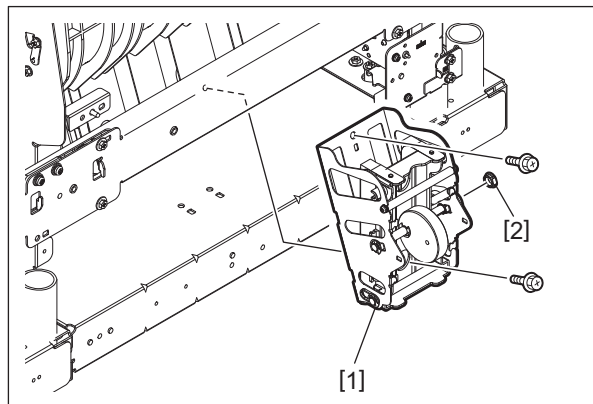



Fig. 4-91

Notes:

- Be careful not to lose the bushing [2] of the clutch shaft.
- When installing, securely engage the bushing [2] of the clutch shaft with the frame of the paper holding unit [1].

4.3.4 Side alignment unit

- (1) Take off the switchback unit.
 P. 4-36 "4.3.2 Switchback unit"
- (2) Remove 4 screws and take off the upper safety cover [1].

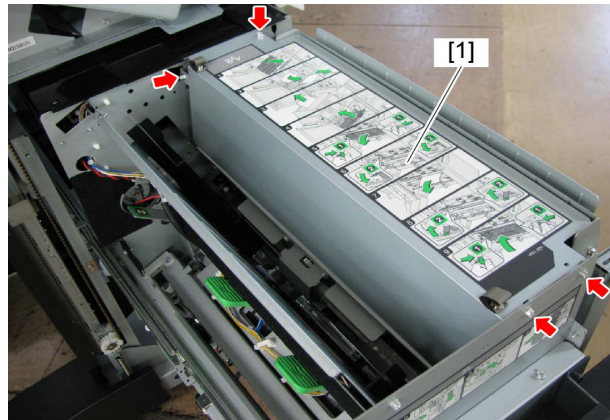

Fig. 4-92

- (3) Disconnect 1 connector [1] from the saddle control PC board and release the harness from 4 harness clamps [2].

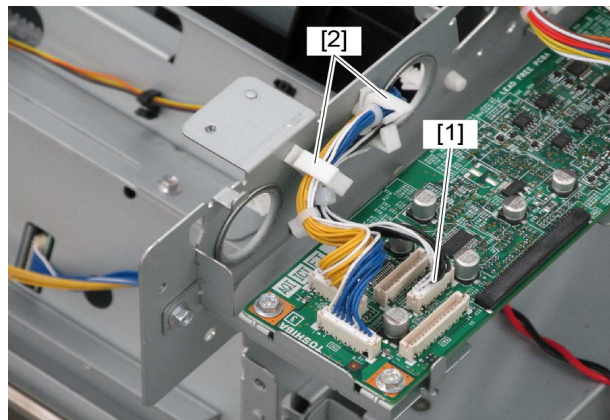

Fig. 4-93

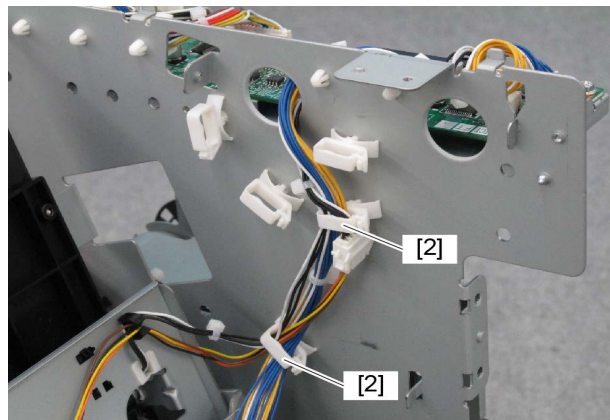

Fig. 4-94

- (4) Move the alignment plates [3] to both edges correspondingly.
- (5) Remove 4 screws and lift the side alignment unit [4] upward to take it off.

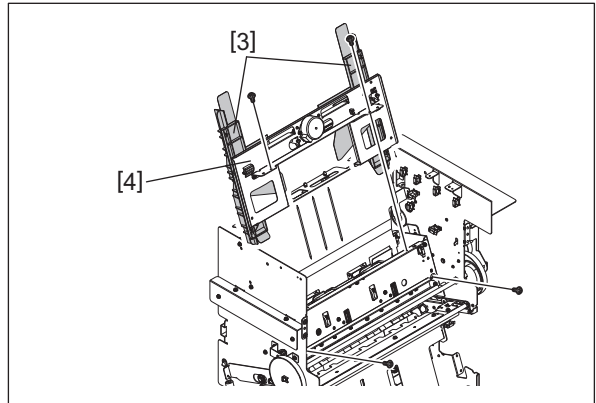

Fig. 4-95

4.3.5 Saddle stapler unit

- (1) Take off the switchback unit.
 P. 4-36 "4.3.2 Switchback unit"
- (2) Take off the side alignment unit.
 P. 4-38 "4.3.4 Side alignment unit"
- (3) Disconnect 2 connectors [2] from the saddle stapler clinch unit [1] at the front and rear sides of the upper stapler frame assembly. Then release the harness from 1 clamp [3].

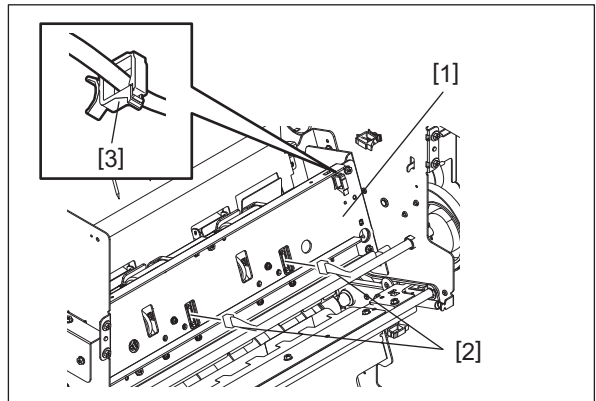

Fig. 4-96

- (4) Remove 4 screws and take off the upper stapler frame assembly [1].

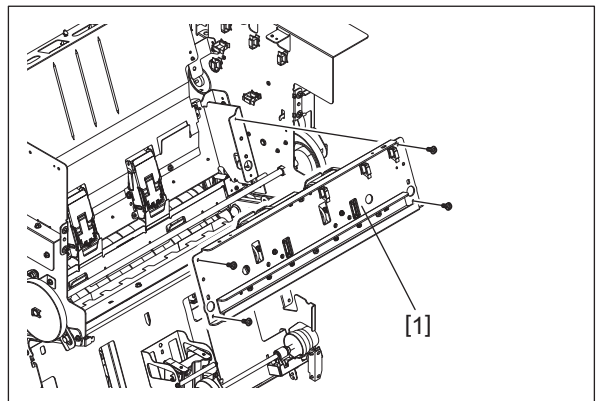

Fig. 4-97

Notes:

When installing, adjust the position of each saddle stapler clinch unit using an exclusive jig [1] following the procedure below.

Jig: 6LB29630000, JIG-STAPLE-2-SDL

1. Attach the jig [1] to the holes [2] of the lower stapler frame.

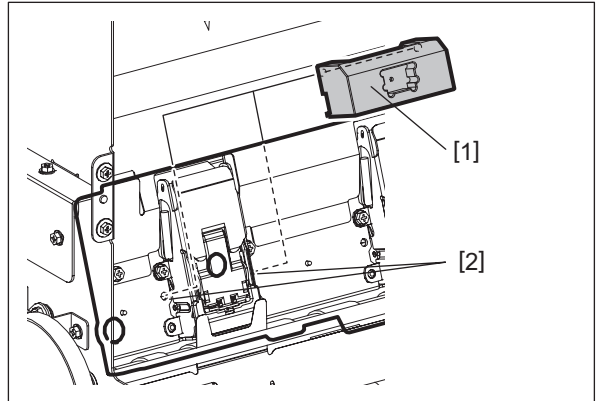

Fig. 4-98

2. Loosen 3 screws [4] fixing the front stapler clinch unit.
3. Turn the gear [1] of the front stapler clinch unit in the direction of the arrow to pull out the clinch [2]. Keep turning the gear [1] until the clinch [2] reaches the end of the hole [3] of the jig.
4. Tighten 3 screws [4] in the order from the top.
5. Return the clinch [2] of the front stapler clinch unit to its original position and remove the jig.
6. Adjust the rear stapler clinch unit in the same manner.

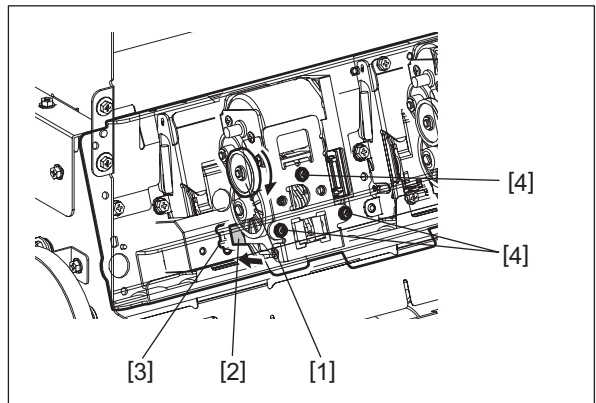

Fig. 4-99

- (5) Remove 3 screws and take off the front saddle stapler clinch unit [1].
- (6) Remove 3 screws and take off the rear saddle stapler clinch unit [2].

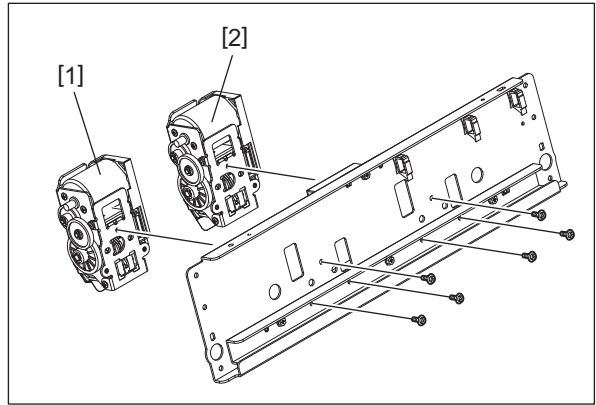

Fig. 4-100

Notes:

Replace the front saddle stapler clinch unit [1] and the front saddle staple drive unit together.
 Replace the rear saddle stapler clinch unit [2] and the rear saddle staple drive unit together.

- (7) Disconnect the connectors [1] from the front and rear saddle stapler drive units from the paper exit side.
- (8) Remove 2 screws and take off the front saddle stapler drive unit [2].
- (9) Remove 2 screws and take off the rear saddle stapler drive unit [3].

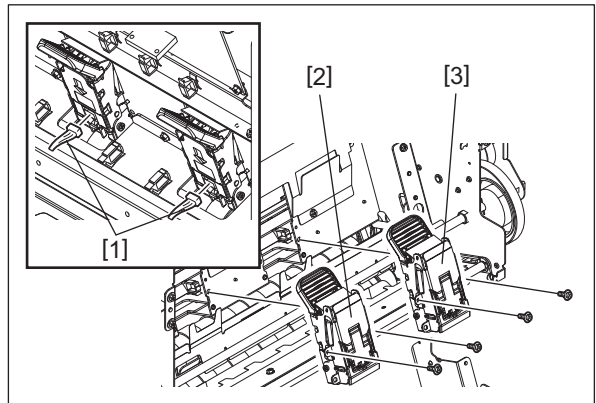

Fig. 4-101

Notes:

Replace the front saddle stapler drive unit [2] and the front saddle stapler clinch unit together.
 Replace the rear saddle stapler drive unit [3] and the rear saddle stapler clinch unit together.

(10) Remove 2 screws and take off the fold plate [4].

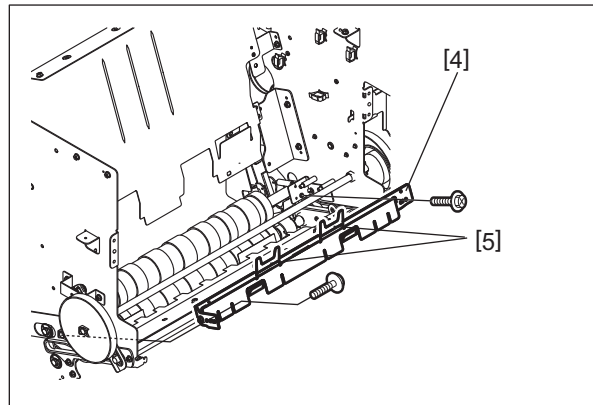

Fig. 4-102

Notes:

When replacing the fold plate (ASYS-PLT-FOLD-RLR-SDL), be careful not to damage the films [5].

4.3.6 Folding drive unit

- (1) Take off the saddle stitch unit.
P. 4-33 "4.3.1 Saddle stitch unit"
- (2) Disconnect 6 connectors [1] from the saddle control PC board and release the harness from 6 harness clamps [2].

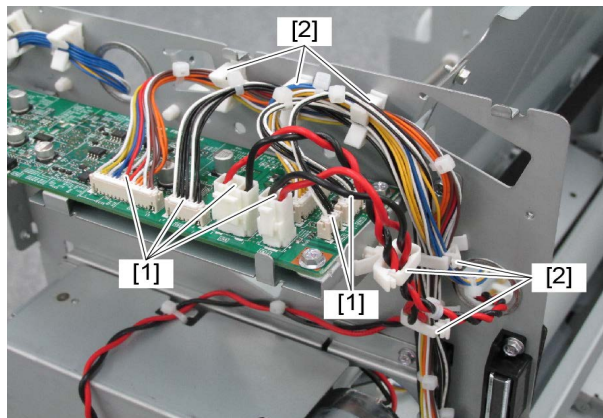

Fig. 4-103

- (3) Disconnect 1 connector [1] of the folding blade home position sensor. Cut off 4 binding bands [2] and release the harness from 7 harness clamps [3] on the folding drive unit.

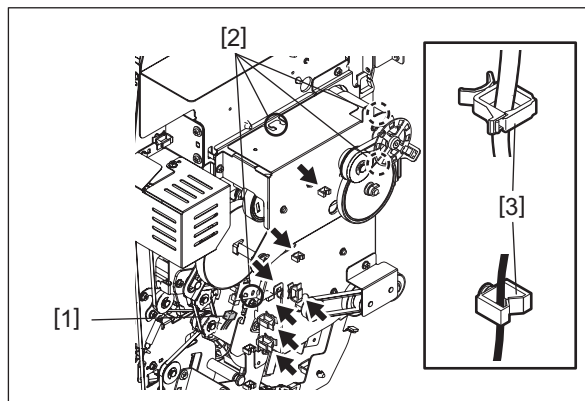

Fig. 4-104

- (4) Remove 1 clip [1] and the bushing [2].

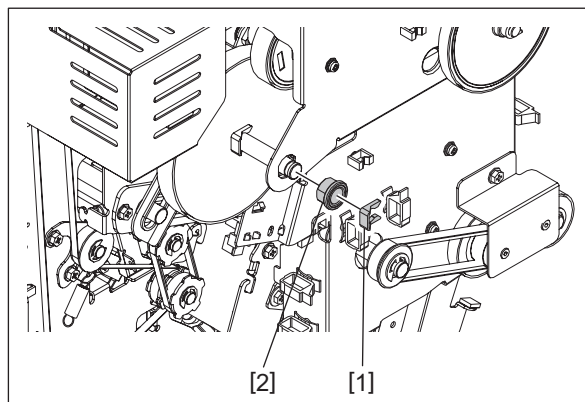

Fig. 4-105

(5) Remove 1 clip [1], 1 pulley [2] and 1 pin [3].

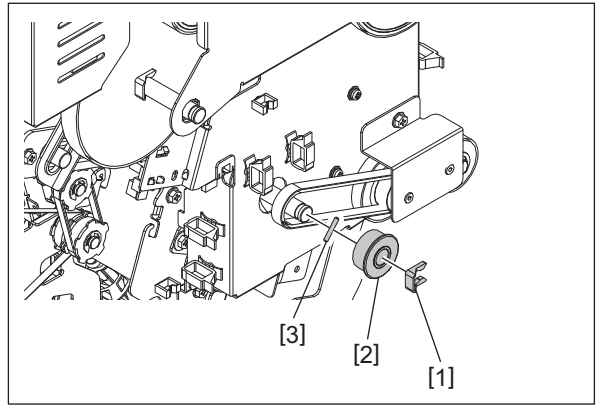

Fig. 4-106

(6) Remove 1 spring [1]. Remove 4 screws and take off the folding drive unit [2].

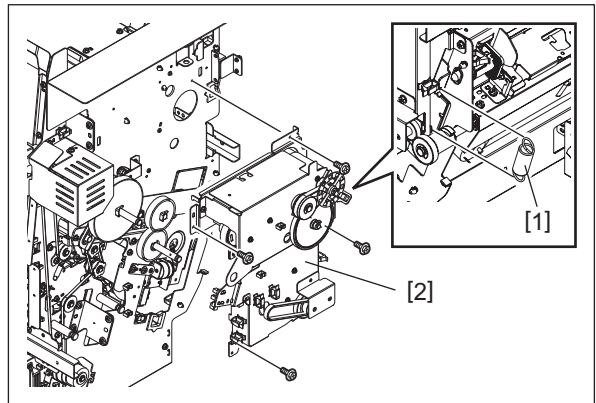

Fig. 4-107

Notes:

- When installing, hang 2 hooks [2] of the folding drive unit on the holes of the frame.
- The gear bracket [1] on the folding drive unit is installed to determine the positioning between the gear on it and the one on the additional folding unit. Before taking off the units, mark the position of the scale [2] of the frame where the mark [3] of the bracket points, so that you can reinstall them at the same positions.

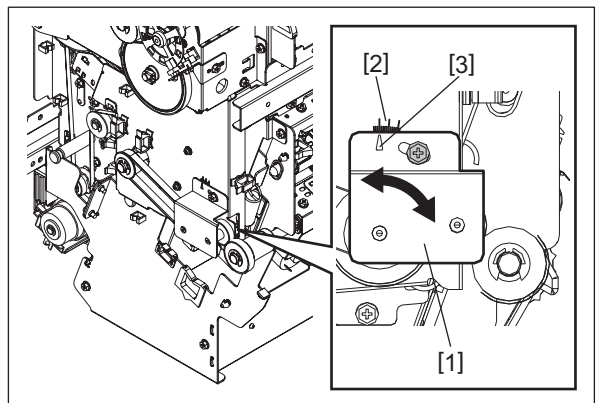



Fig. 4-108

4.3.7 Additional folding unit

- (1) Take off the folding drive unit.
 P. 4-43 "4.3.6 Folding drive unit"
- (2) Disconnect 1 connector [1] of the stacker home position sensor and 2 relay connectors [2] and [3] of the stacker motor and the saddle tray paper detection sensor. Release the harness from 3 harness clamps [4].

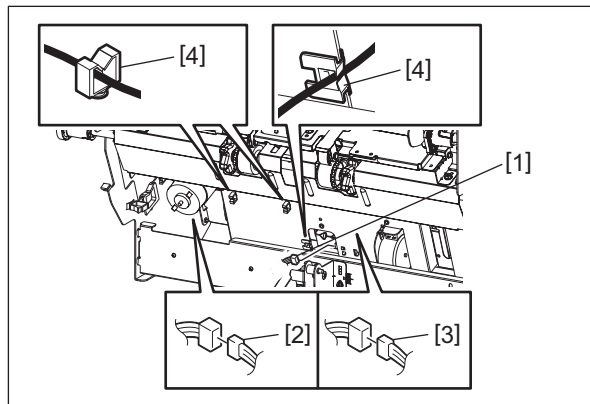

Fig. 4-109

- (3) Remove 1 spring [1].
- (4) Remove 2 screws and take off the rear bracket [2].
- (5) Remove 2 screws and take off the front bracket [3].

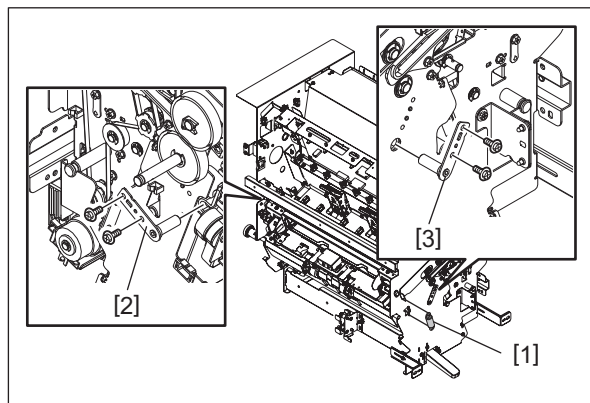

Fig. 4-110

- (6) Take off the additional folding unit [2] while pulling the additional folding unit levers [1] at the front and rear.

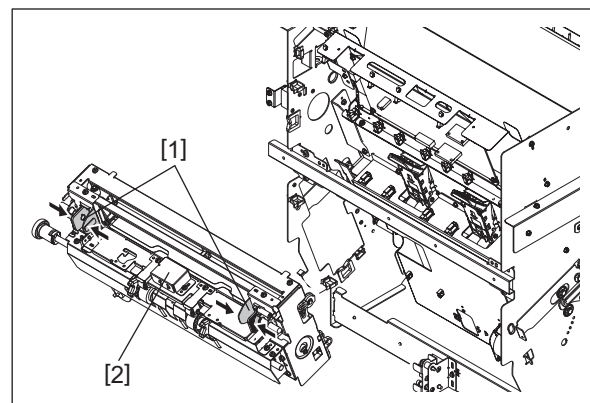

Fig. 4-111

4.3.8 Stacker unit

- (1) Take off the switchback unit.
📖 P. 4-36 "4.3.2 Switchback unit"
- (2) Take off the folding drive unit.
📖 P. 4-43 "4.3.6 Folding drive unit"
- (3) Take off the additional folding unit.
📖 P. 4-45 "4.3.7 Additional folding unit"
- (4) Remove 2 screws [2].

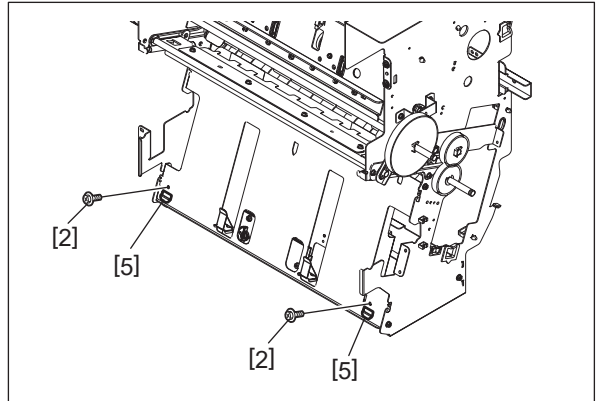

Fig. 4-112

- (5) From the additional folding unit side, lift the stacker unit [1] upward to take it off.

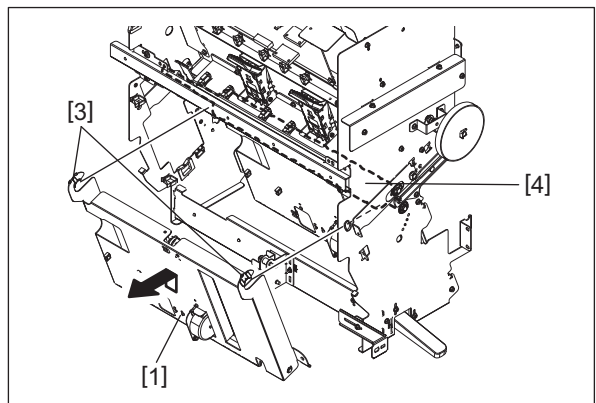

Fig. 4-113

Notes:

- When installing, hang 2 hooks [3] at the upper side of the stacker unit [1] on the lower folding roller [4].
- When installing, hang 2 hooks [5] at the lower side of the stacker unit [1] on the holes of the frame.

4.4 Roller (Finisher Section)

4.4.1 Paper feed roller (MJ-1115)

- (1) Take off the control panel unit.
📖 P. 4-4 “4.1.4 Control panel unit”
- (2) Take off the rear cover.
📖 P. 4-7 “4.1.8 Rear cover”
- (3) Take off the right cover.
📖 P. 4-10 “4.1.12 Relay guide, Paper feed discharge brush, Right cover”
- (4) Take off the right upper cover.
📖 P. 4-9 “4.1.11 Right upper cover”
- (5) Remove 3 screws and take off the front bracket [1].
- (6) Remove 2 screws and take off the rear bracket [2].
- (7) Remove 3 screws and take off the junction box upper transport guide [3].

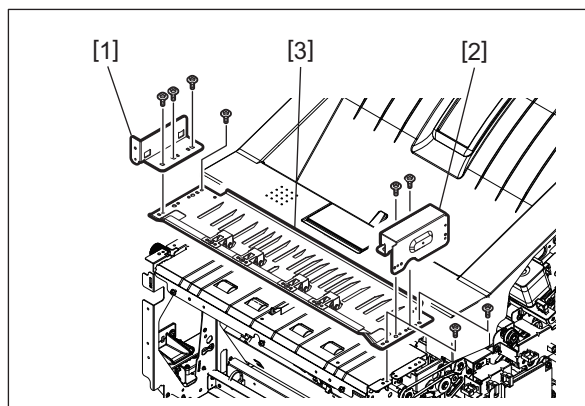

Fig. 4-114

- (8) Remove the spring [4] and loosen 2 screws.
Release the tension of the belt [5] and remove it.

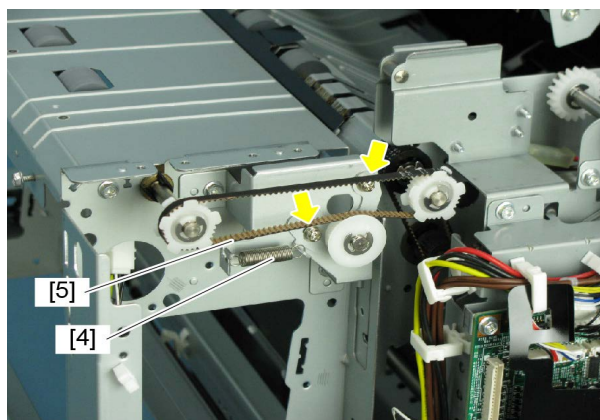

Fig. 4-115

(9) Remove 1 screw and take off the sensor bracket [6] of the paper feed sensor.

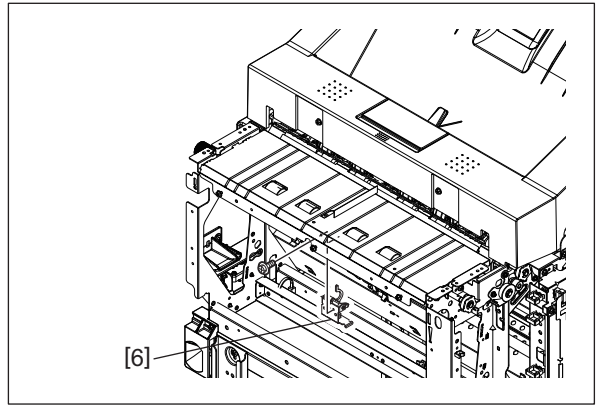

Fig. 4-116

(10) Remove 2 screws and take off the bracket [7].

(11) Remove 4 screws and take off the transport guide [8].

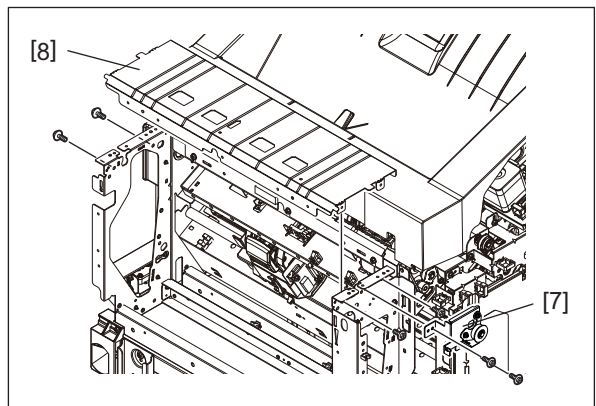

Fig. 4-117

(12) Remove 1 E-ring, 1 knob [9] and 1 pin [10] at the front side of the paper feed roller.

(13) Remove 1 clip [11] and 1 bushing [12].

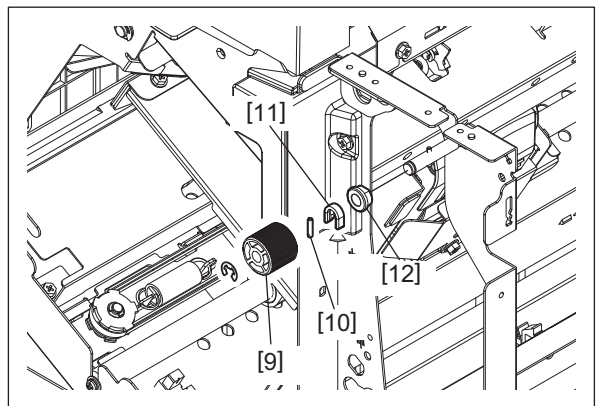

Fig. 4-118

- (14) Remove 1 E-ring, 1 pulley [14] and 1 pin [15] at the rear side of the paper feed roller [13].
- (15) Remove 1 clip [16] and 1 bushing [17] and take off the paper feed roller [13].

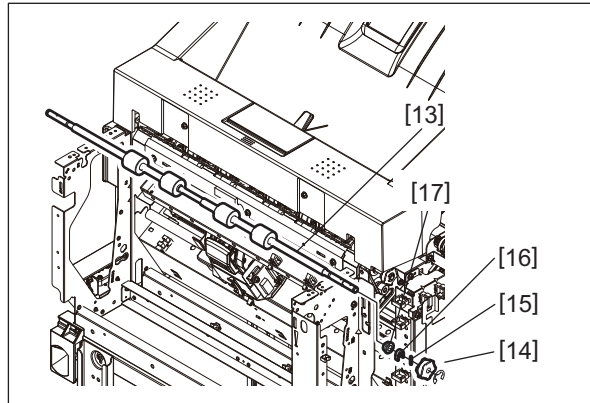

Fig. 4-119

4.4.2 Paper feed roller (MJ-1116)

- (1) Take off the control panel unit.
 ☞ P. 4-4 “4.1.4 Control panel unit”
- (2) Take off the rear cover.
 ☞ P. 4-7 “4.1.8 Rear cover”
- (3) Take off the right cover.
 ☞ P. 4-10 “4.1.12 Relay guide, Paper feed discharge brush, Right cover”
- (4) Take off the right upper cover.
 ☞ P. 4-9 “4.1.11 Right upper cover”
- (5) Remove 2 screws and take off the front bracket [1].
- (6) Remove 2 screws and take off the rear bracket [2].
- (7) Remove 3 screws and take off the junction box upper transport guide [3].

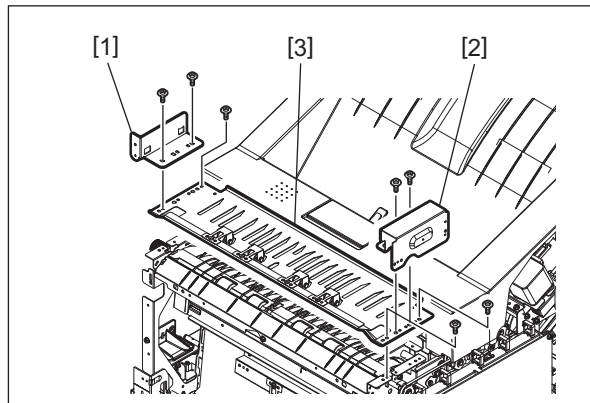

Fig. 4-120

- (8) Remove the spring [4] and loosen 2 screws.
Release the tension of the belt [5] and remove it.

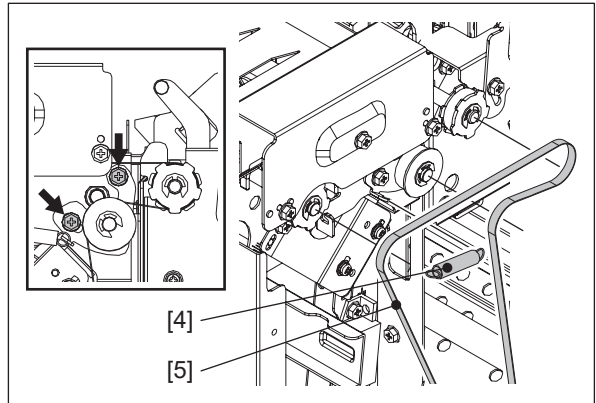

Fig. 4-121

- (9) Remove 1 screw and take off the sensor bracket [6] of the paper feed sensor.

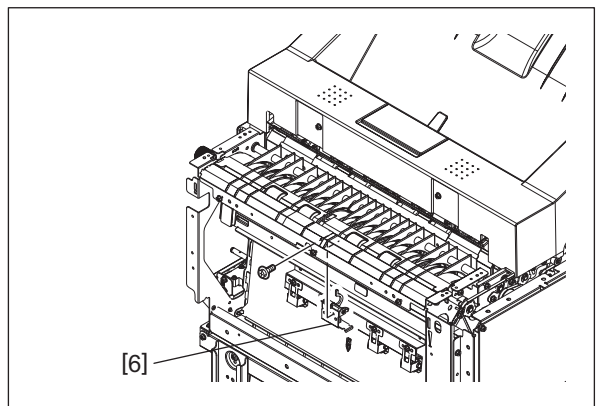

Fig. 4-122

- (10) Push the jam access lever [7] of the junction box to the right-hand side and open the transport guide.

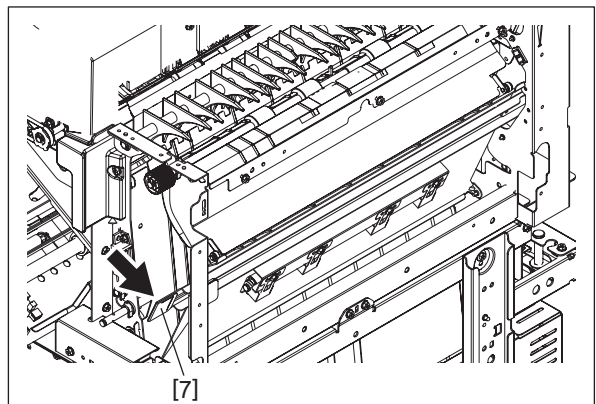

Fig. 4-123

- (11) Remove 1 E-ring, 1 knob [8] and 1 pin [9] at the front side of the paper feed roller.
- (12) Remove 1 clip [10] and 1 bushing [11].

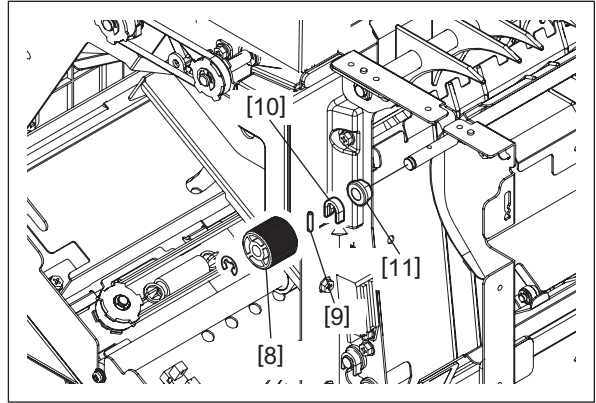

Fig. 4-124

- (13) Remove 1 E-ring, 1 pulley [13] and 1 pin [14] at the rear side of the paper feed roller [12].
- (14) Remove 1 clip [15] and 1 bushing [16] and take off the paper feed roller [12] and the transport guide [17].

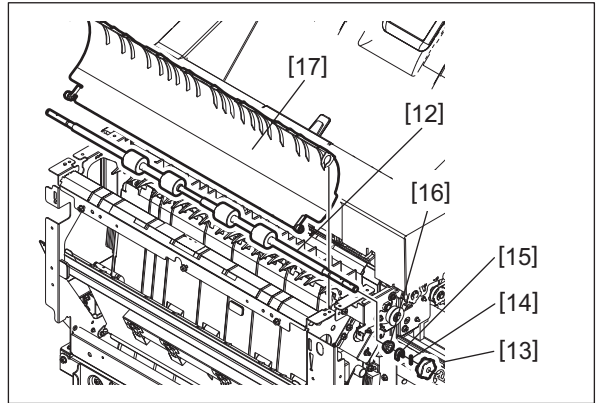

Fig. 4-125

4.4.3 Junction roller (MJ-1116)

- (1) Take off the junction box unit.
P. 4-16 "4.2.1 Junction box unit"
- (2) Remove 1 E-ring, 1 gear [1] and 1 pin [2] at the front side of the junction roller.
- (3) Remove 1 clip [3] and 1 bushing [4].

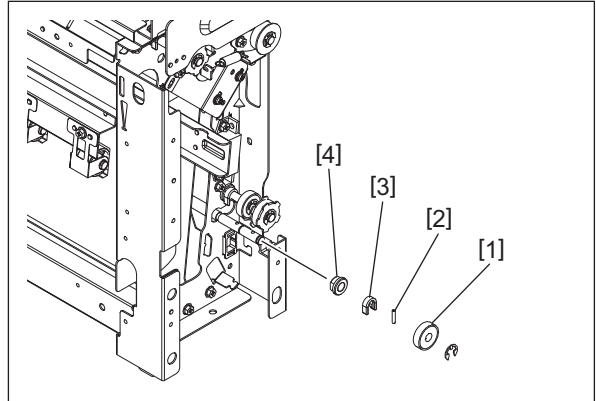

Fig. 4-126

- (4) Remove 1 clip [3] and 1 bushing [2] at the rear side of the junction roller [1] and take it off.

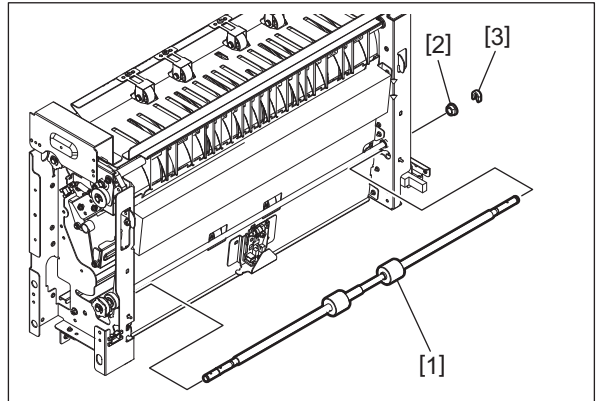

Fig. 4-127

4.4.4 Paddle-1, Paddle-2, Paddle-3, Paddle-4, Paddle-5, Paddle-6

- (1) Take off the buffer unit.
📖 P. 4-18 "4.2.2 Buffer unit"
- (2) Turn the gear so that the paddle-1 [1], -2 [2], -3 [3], -4 [4], -5 [5] and -6 [6] are positioned as shown in the figure.
- (3) Pull out the paddle-1 [1], -2 [2], -3 [3], -4 [4], -5 [5] and -6 [6] to take them off.

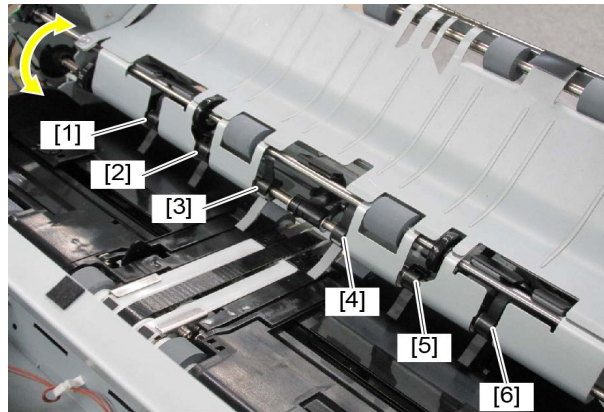

Fig. 4-128

Notes:

When installing them, be sure to place them in their original position and direction.

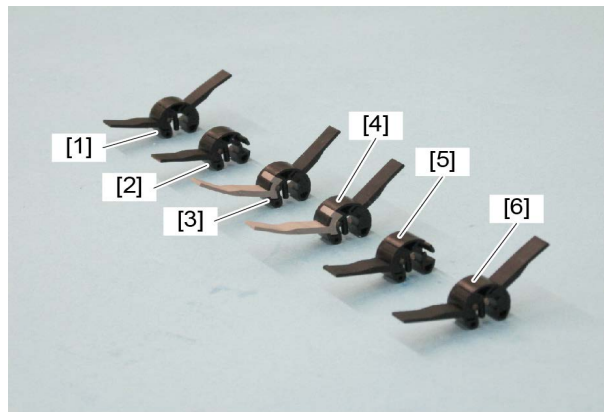

Fig. 4-129

4.4.5 Transport roller

- (1) Take off the stationary tray.
📖 P. 4-1 “4.1.1 Stationary tray”
- (2) Take off the control panel unit.
📖 P. 4-4 “4.1.4 Control panel unit”
- (3) Take off the rear cover.
📖 P. 4-7 “4.1.8 Rear cover”
- (4) Take off the right upper cover.
📖 P. 4-9 “4.1.11 Right upper cover”
- (5) Take off the right cover.
📖 P. 4-10 “4.1.12 Relay guide, Paper feed discharge brush, Right cover”
- (6) Take off the junction box unit.
📖 P. 4-16 “4.2.1 Junction box unit”
- (7) Disconnect 5 connectors [4], [5], [6], [7] and [8] from the finisher control PC board [3].
- (8) Disconnect 1 connector [10] from the buffer tray guide motor [9].
- (9) Disconnect 1 connector [12] from the transport motor [11].
- (10) Disconnect 1 connector [14] from the movable tray shift motor sensor [13].
- (11) Release the harness from 6 harness clamps [15].
- (12) Remove 1 binding band [18] which bundles the harnesses.

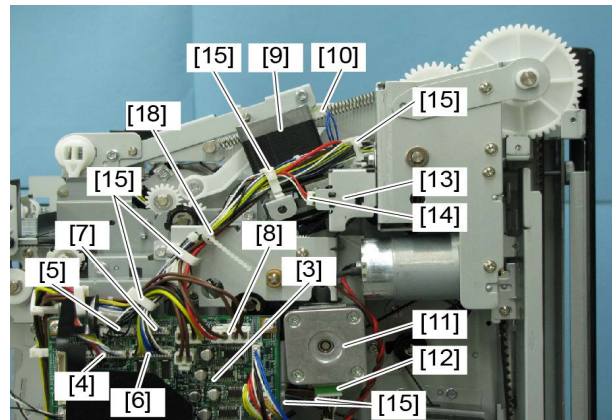

Fig. 4-130

- (13) Remove 5 screws and take off the motor bracket [19].

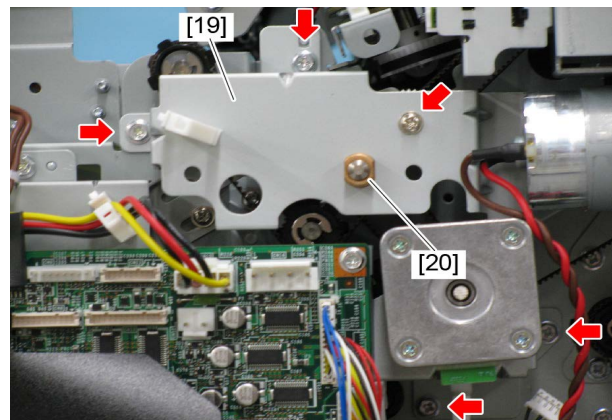

Fig. 4-131

Notes:

Be careful not to lose the bushing [20] removed while taking off the motor bracket [19].

- (14) Loosen 1 screw. Push the pulley [21] in the direction indicated by the arrow so as the belt tension is loosened as a result. Then tighten the screw.
- (15) Remove the belts [22] and [23], 1 assembled part [24] and 1 bearing.

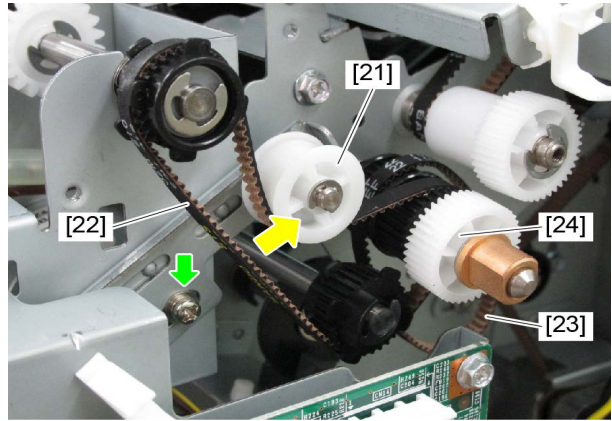

Fig. 4-132

Notes:

Be careful not to lose the bearing while taking off the assembled part [24].

- (16) Close the buffer unit-1 [25] halfway and remove 1 screw.

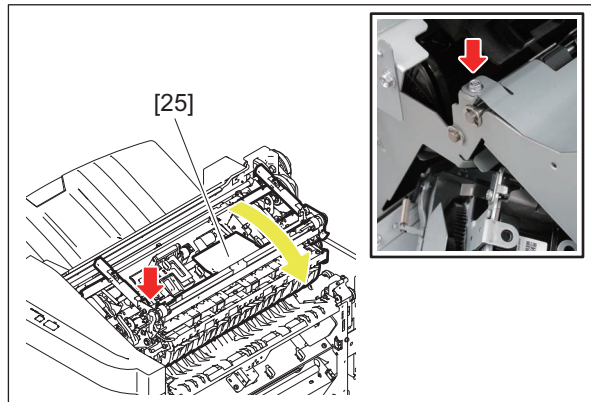

Fig. 4-133

- (17) Remove 3 screws and take off the transport guide [26].

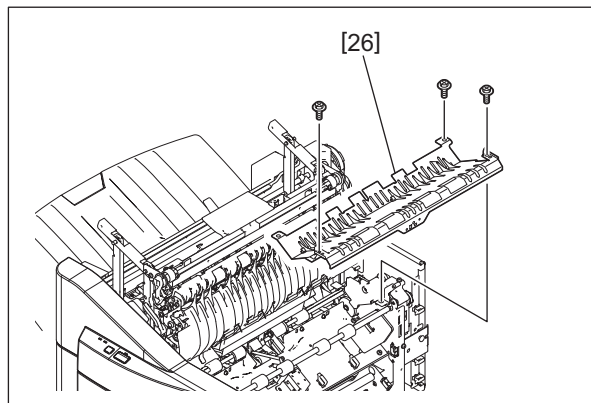

Fig. 4-134

(18) Move the buffer guides [27] to both edges correspondingly.

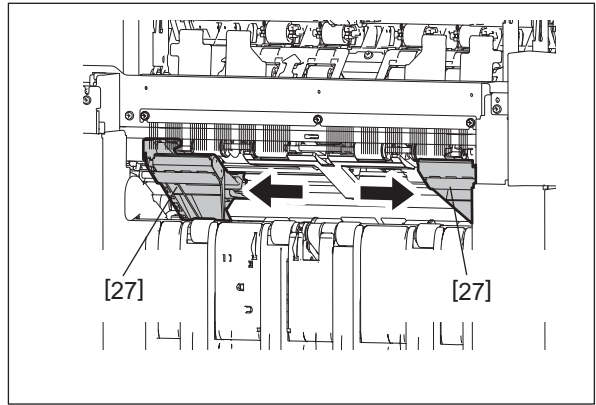

Fig. 4-135

(19) Turn the lever [28] on the alignment plate to the position as shown in the figure to release the lock. Move the front alignment plate [1] and the rear alignment plate [2] to the center and take them off by pulling them upward.

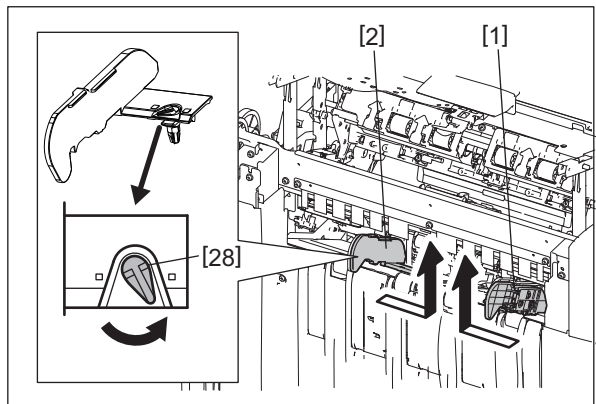

Fig. 4-136

(20) Remove 4 screws of the front pull-in guide [29] and the rear pull-in guide [30].

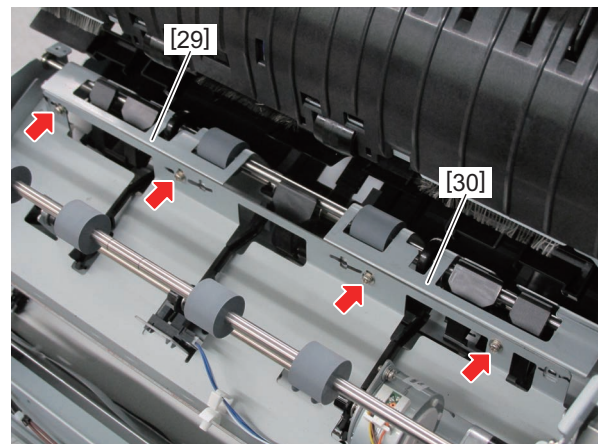

Fig. 4-137

Notes:

When installing the front and rear pull-in guides, adjust their positions with the jig. Install them based on “B” of the adjustment area [5] on the jig [2], so that the gap between the front and rear finishing tray covers is more than adjustment area A and less than C.

6LB10056000, JIG-GID-PDL-2

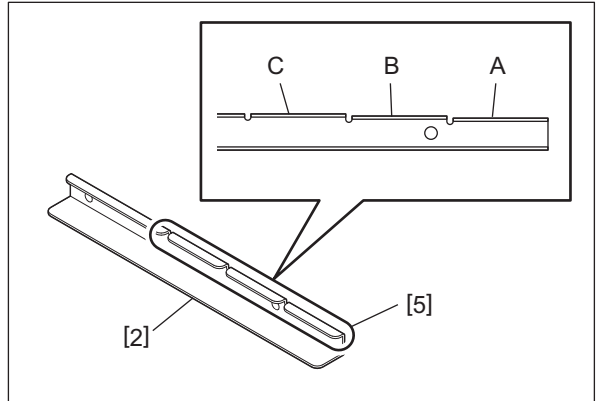

Fig. 4-138

1. Fully close the buffer unit-1.
2. Place the jig [2] on the rear finishing tray cover [1] and fix the one with the rear pull-in guide [3] by 2 screws at the position of “B” of the adjustment area [5]. The measuring should be performed at 2 positions [4] with no protrusion of the pull-in guide as shown in the figure.
3. After fixing the screws, check that the dimension of the gap is more than adjustment area [5] A and less than C.
4. Perform the adjustment of the front pull-in guide in the same manner.

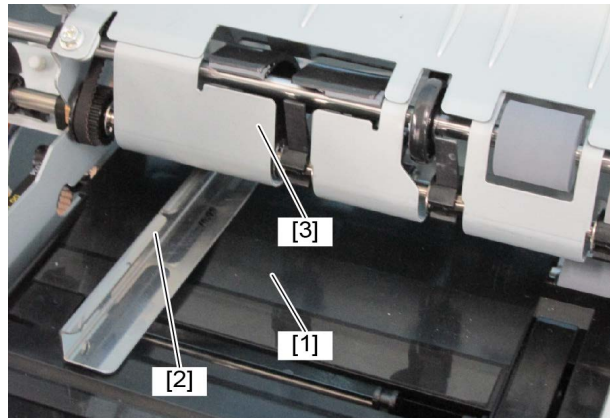

Fig. 4-139

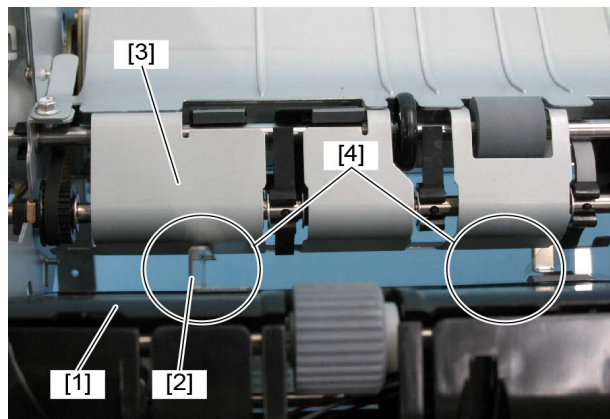

Fig. 4-140

(21) Remove 1 E-ring [31] and 1 bearing [32] at the front side of the transport roller.

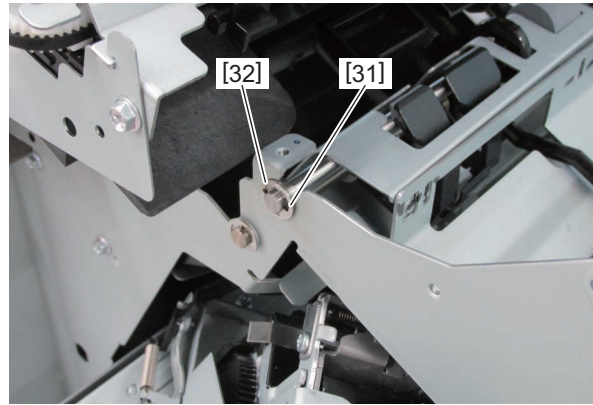

Fig. 4-141

(22) Slide 1 clip [33] and the bearing [34] at the rear side of the transport roller.

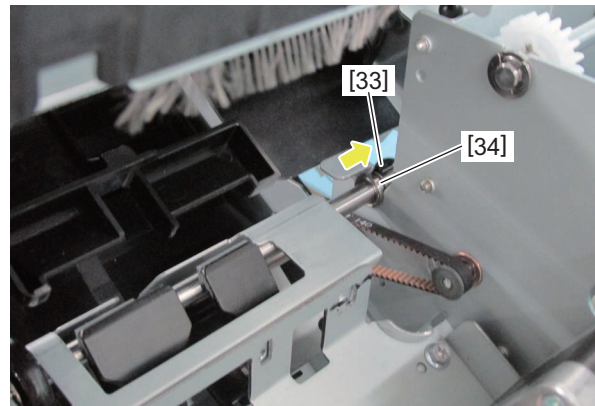

Fig. 4-142

(23) Take off the transport roller [35], front pull-in guide [36] and rear pull-in guide [37].

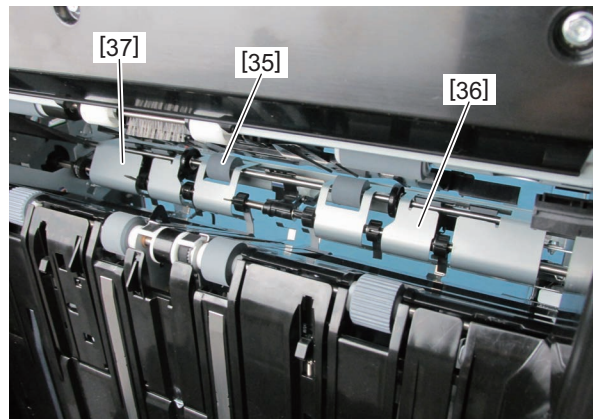

Fig. 4-143

4.4.6 Entrance roller

- (1) Take off the stationary tray.
📖 P. 4-1 “4.1.1 Stationary tray”
- (2) Take off the junction box unit.
📖 P. 4-16 “4.2.1 Junction box unit”
- (3) Close the buffer unit-1 [1] halfway and remove 1 screw.

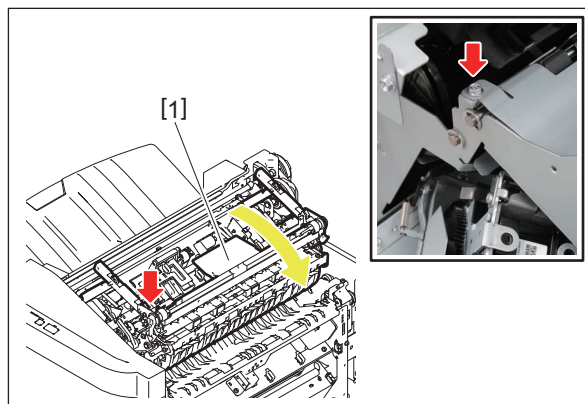

Fig. 4-144

- (4) Remove 3 screws and take off the transport guide [1].

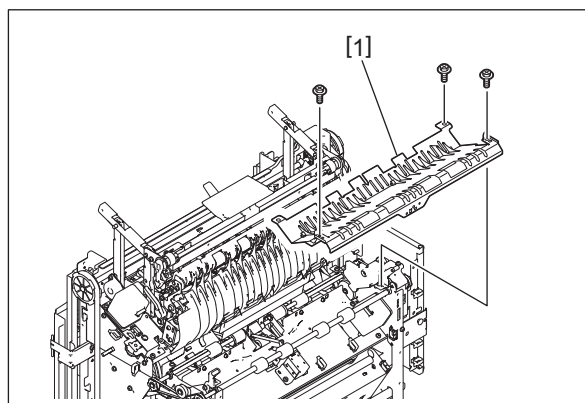

Fig. 4-145

- (5) Remove 1 E-ring [1] and 1 bushing [2].

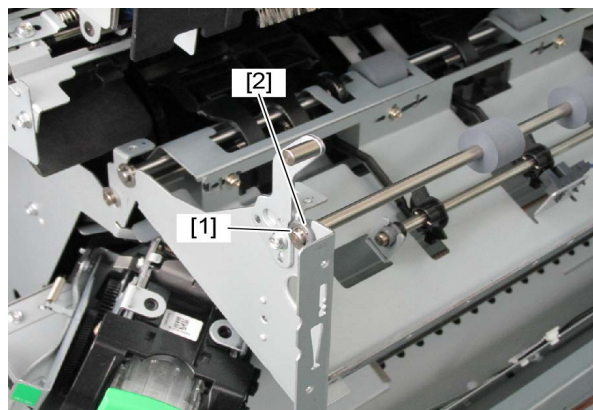

Fig. 4-146

- (6) Remove the belt [3].
- (7) Slide the entrance roller [4] to take it off.

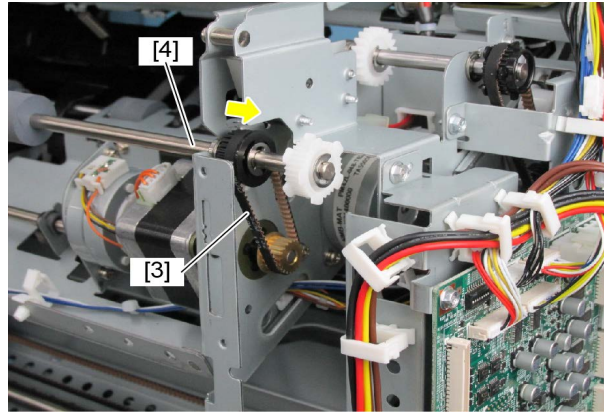

Fig. 4-147

- (8) Remove 1 E-ring, 2 pulleys [5], 1 bearing [6] and 2 pins [7] from the entrance roller.

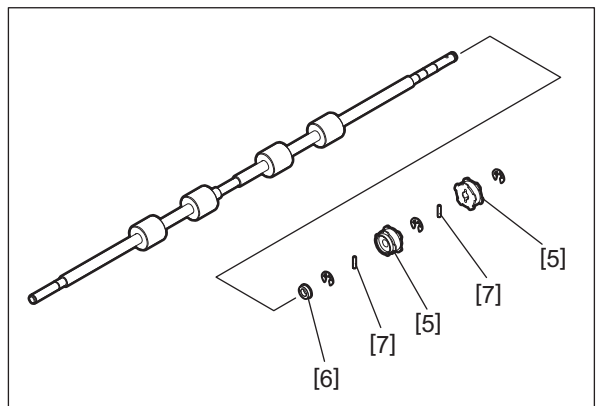

Fig. 4-148

4.4.7 Stack transport roller-1

- (1) Take off the finishing tray unit.
 📖 P. 4-25 "4.2.4 Finishing tray unit"
- (2) Remove 2 screws.

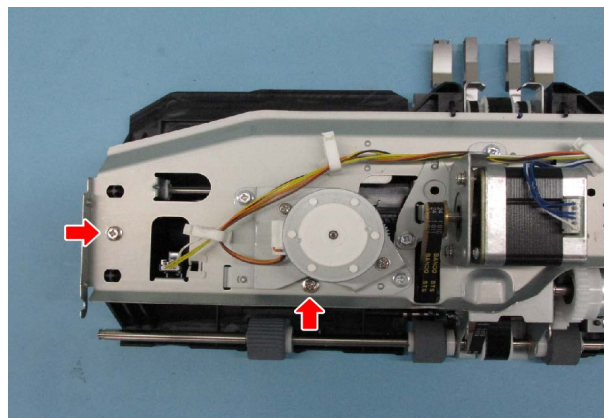

Fig. 4-149

- (3) Turn over the finishing tray unit. Slide the front finishing tray cover [1] to outside and lift it up. Release the link portion [2] inside the front finishing tray cover to take it off.

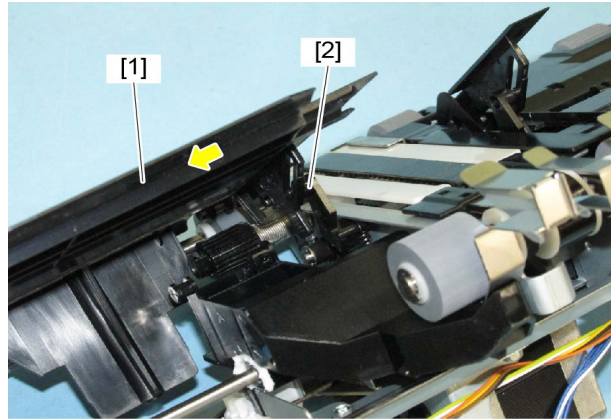

Fig. 4-150

- (4) Remove 2 screws.

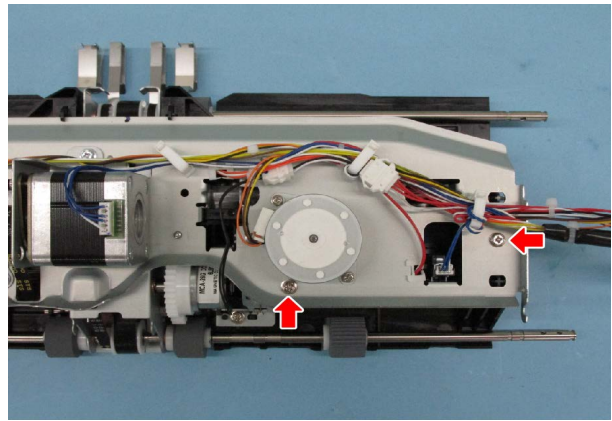

Fig. 4-151

- (5) Turn over the finishing tray unit. Slide the rear finishing tray cover [3] to outside and lift it up. Release the link portion [4] inside the rear finishing tray cover.

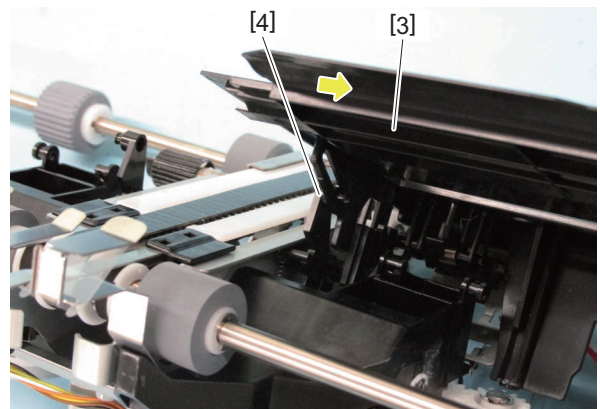

Fig. 4-152

- (6) Disconnect the connector [5] from the finishing tray paper sensor and take off the rear finishing tray cover [3].

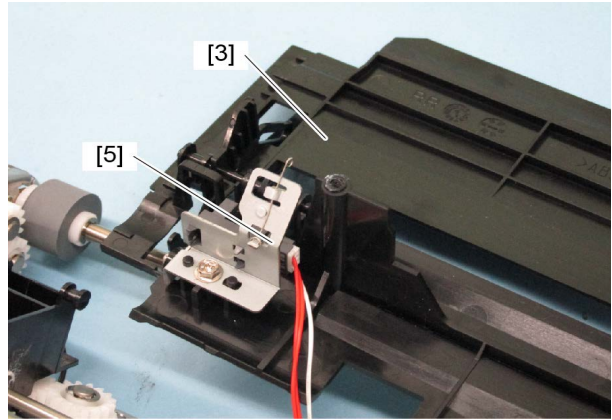

Fig. 4-153

- (7) Remove 2 E-rings and 2 pins [6]. Take off 2 stack transport roller-1 [7].

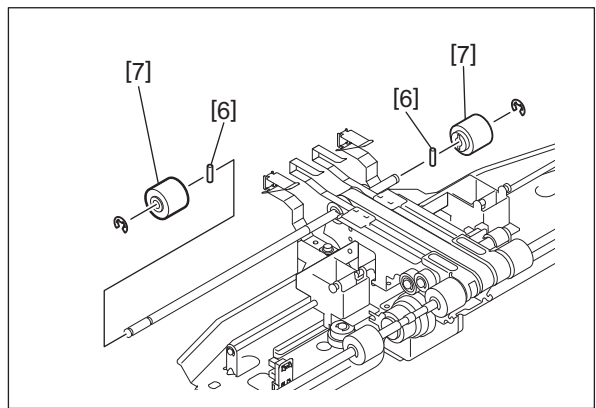

Fig. 4-154

4.4.8 Stack transport roller-2

- (1) Take off the finishing tray unit.
P. 4-25 "4.2.4 Finishing tray unit"
- (2) Remove 2 screws.

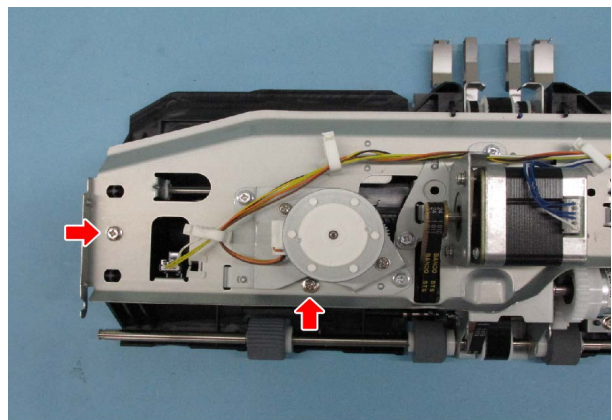

Fig. 4-155

- (3) Turn over the finishing tray unit. Slide the front finishing tray cover [1] to outside and lift it up. Release the link portion [2] inside the front finishing tray cover to take it off.

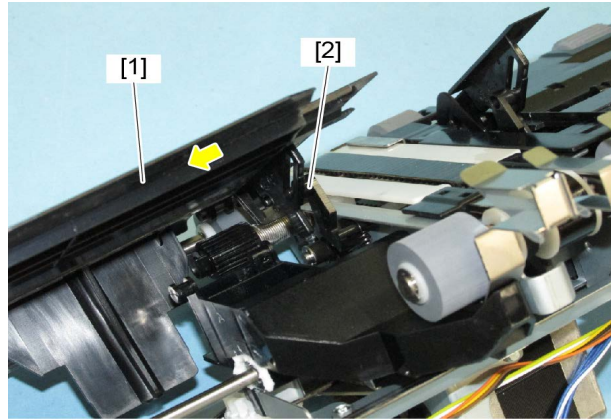

Fig. 4-156

- (4) Remove 2 screws.

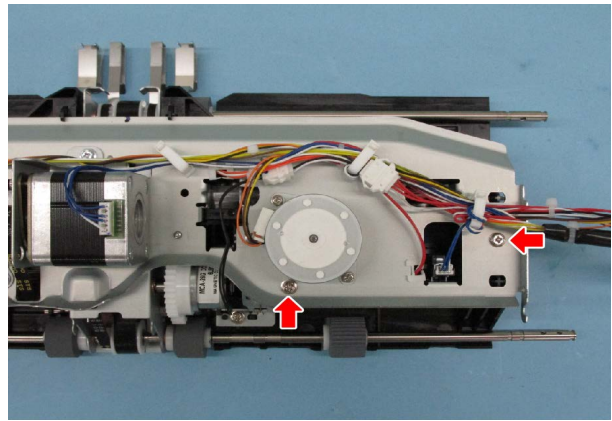

Fig. 4-157

- (5) Turn over the finishing tray unit. Slide the rear finishing tray cover [3] to outside and lift it up. Release the link portion [4] inside the rear finishing tray cover.

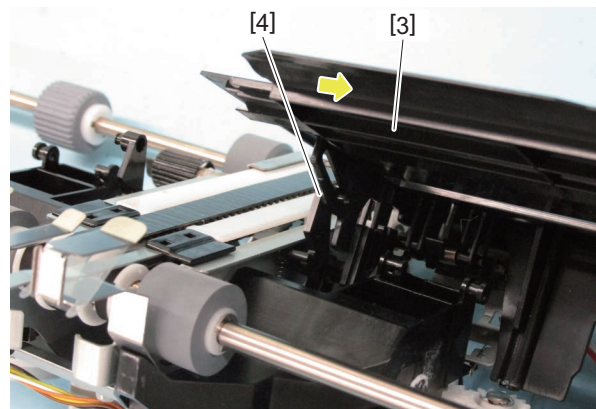

Fig. 4-158

- (6) Disconnect the connector [5] from the finishing tray paper sensor and take off the rear finishing tray cover [3].

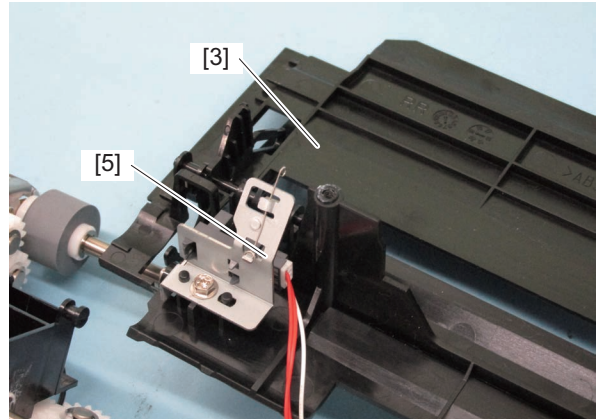

Fig. 4-159

- (7) Remove 4 E-rings and 4 pins [6]. Take off 4 stack transport roller-2 [7].

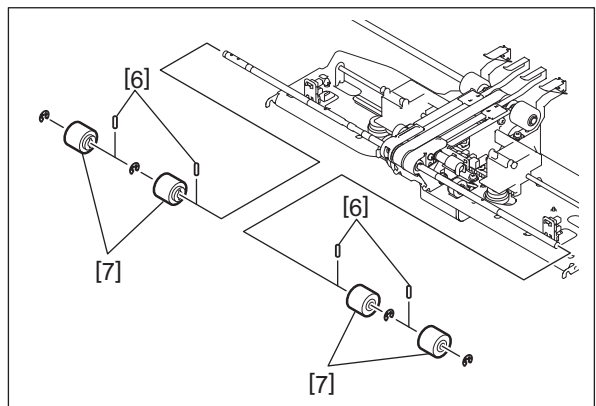

Fig. 4-160

4.4.9 Buffer roller

- (1) Take off the buffer unit.
 P. 4-18 "4.2.2 Buffer unit"
- (2) Disconnect 1 connector from the sensor [1] and release the harness [2] from 1 harness clamp [3].
- (3) Remove 1 harness clamp [5] of the harness [4] from the frame.
- (4) Pull out the harnesses [2] and [4] through the window [6] of the frame.

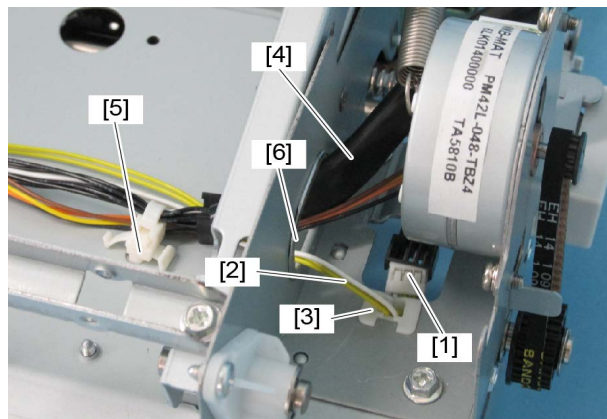

Fig. 4-161

- (5) Disconnect 1 relay connector [7] and release the harness [8] from 7 harness clamps [9].
- (6) Pull out the harness [8] through the window [6] of the frame.

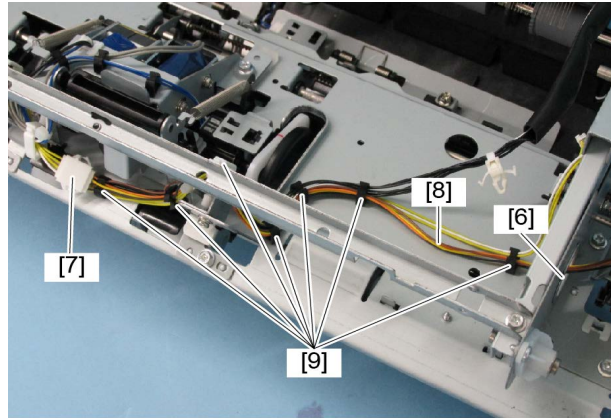

Fig. 4-162

- (7) Pull out the harness [10] through the window [11] of the frame.
- (8) Release the harness [10] from 1 harness clamp [12].

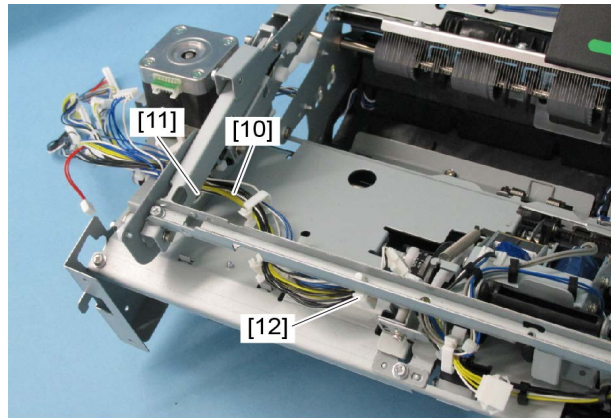

Fig. 4-163

- (9) Remove the belt [13].
- (10) Release the latch and take off the pulley cover [15].

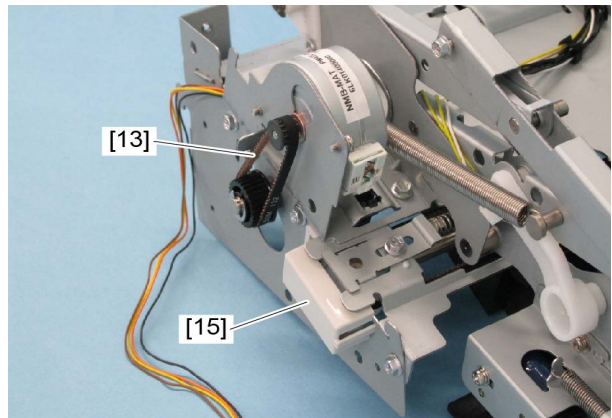

Fig. 4-164

- (11) Loosen 1 screw. Push the metal plate [14] in the direction indicated by the arrow so as the belt tension is loosened as a result. Then tighten the screw.

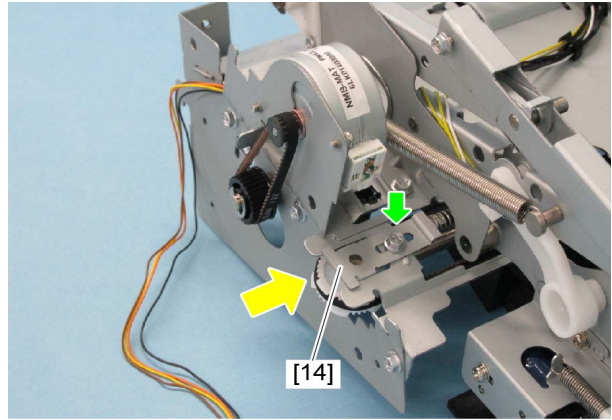

Fig. 4-165

- (12) Remove 5 screws and lift the buffer unit-1 [34] upward to take it off.

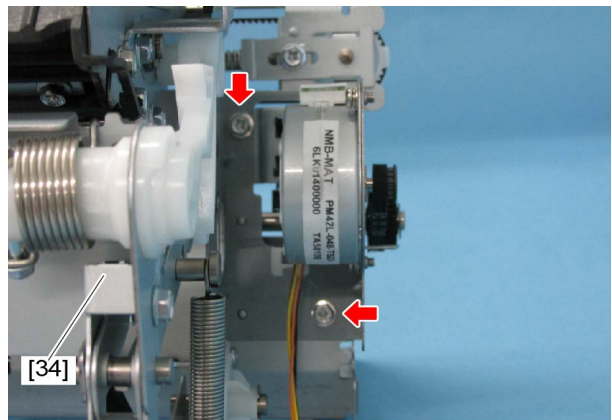

Fig. 4-166

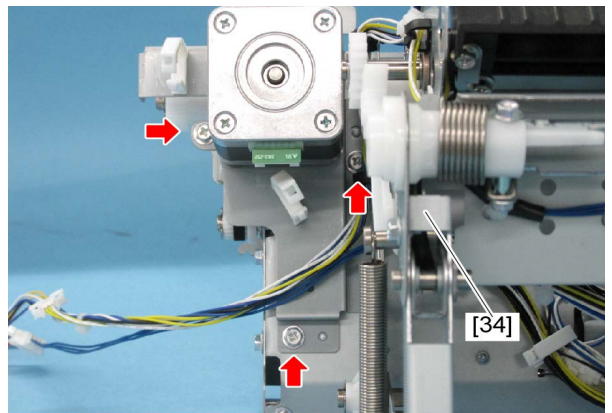

Fig. 4-167

(13) Remove the spring [35].

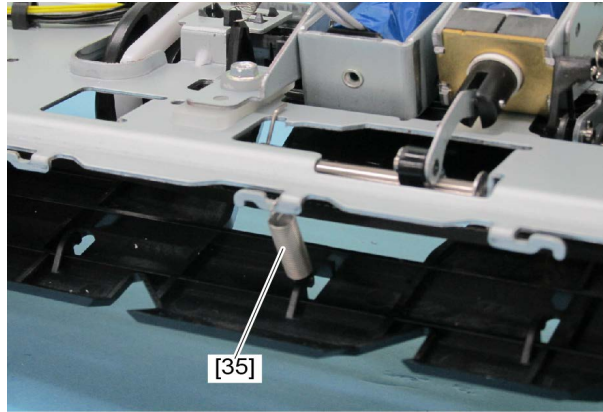

Fig. 4-168

(14) Remove 2 screws and take off 2 assist guide cam guides [36].

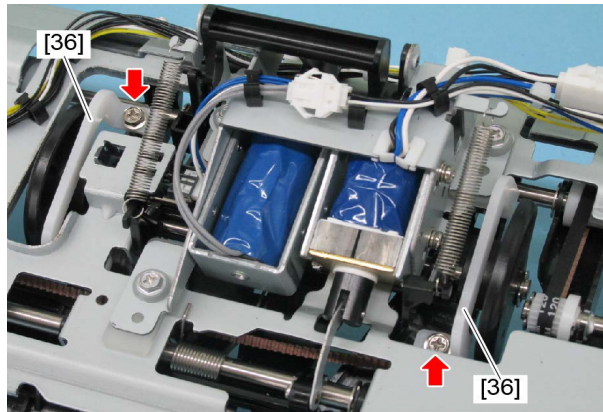

Fig. 4-169

(15) Remove 2 screws and take off 2 assist guide adjustment plates [37] and the assist guide [38].

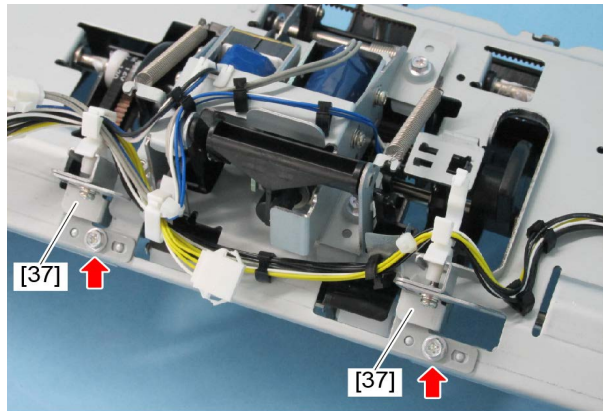

Fig. 4-170

Notes:

When installing, fix the assist guide [38] so that the height between its upper surface and that for the buffer tray [39] is within 18 to 20 mm.

Measure the height at each 1 portion (2 portions in total) at both edges of the assist guide.

1. Move the buffer tray to the position of the rotation roller.
2. Turn the cam of the assist guide so that it comes to the position where it is fixed.
3. By using a scale, measure the height between the upper surface of the assist guide and that for the buffer tray. If adjustment is necessary, loosen the screw of the assist guide adjustment plate and move the assist guide upward and downward, so that the height will become within the specified value.

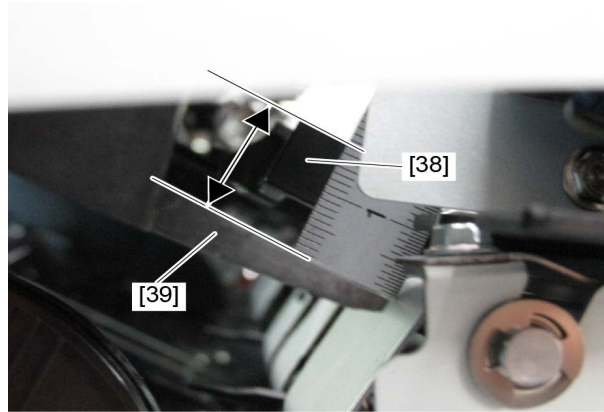

Fig. 4-171

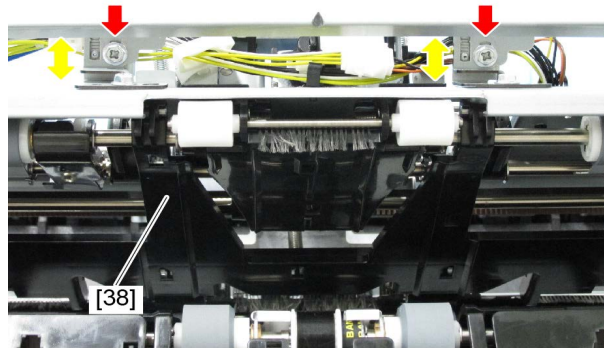

Fig. 4-172

(16) Remove 1 screw, metal plate [43] and spring [45].

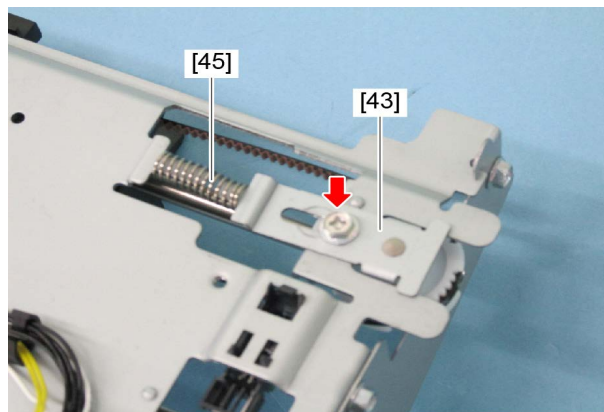

Fig. 4-173

(17) Remove 2 screws.

(18) Remove 3 E-rings [46]. Slide the shaft [47] and take off the right and left buffer guides [48], 2 metal plates [49] and the pinch roller arm [50].

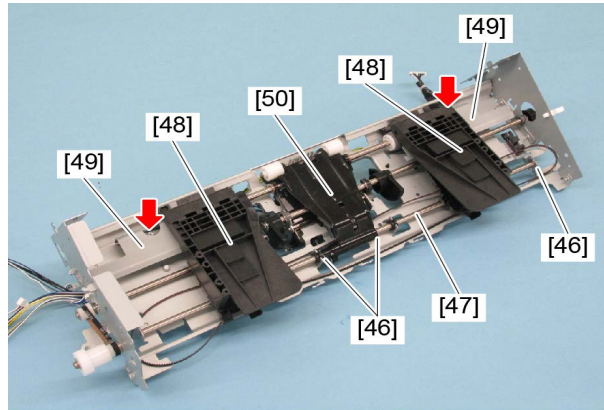

Fig. 4-174

Notes:

When installing, hook the spring [51] of the pinch roller arm [50] to the frame as shown in the figure.

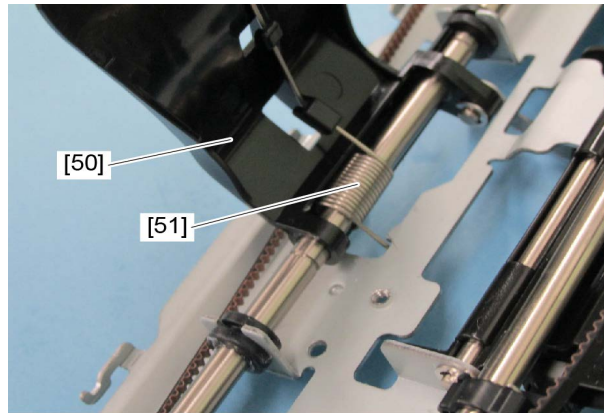

Fig. 4-175

(19) Remove 2 E-rings [52], 2 buffer rollers [53] and 2 pins.

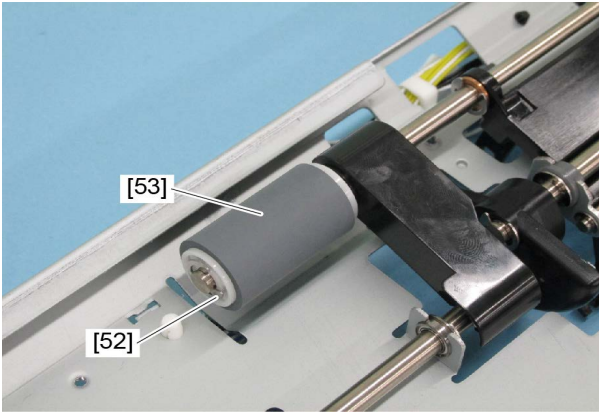

Fig. 4-176

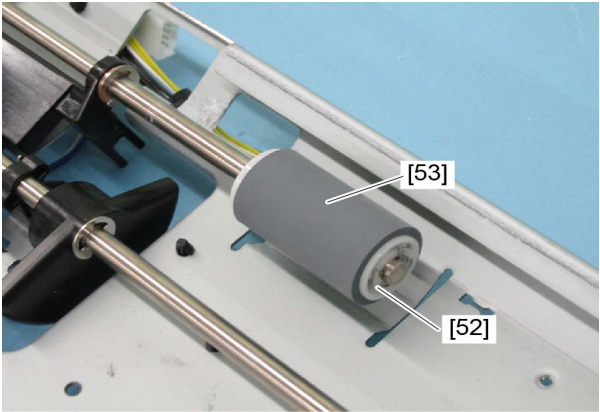

Fig. 4-177

4.4.10 Upper paper exit roller, Upper paper exit roller guide

- (1) Take off the stationary tray.
P. 4-1 "4.1.1 Stationary tray"
- (2) Take off the control panel unit.
P. 4-4 "4.1.4 Control panel unit"
- (3) Take off the rear cover.
P. 4-7 "4.1.8 Rear cover"
- (4) Take off the right cover.
P. 4-10 "4.1.12 Relay guide, Paper feed discharge brush, Right cover"
- (5) Remove 2 screws [3] at the front and rear stays. Then take off 2 stays [1] and 2 spacers [2].

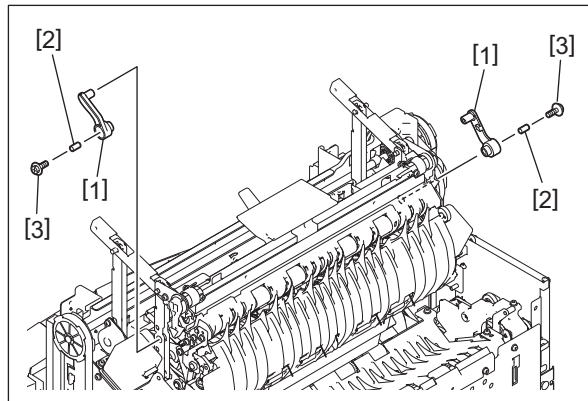

Fig. 4-178

Notes:

Be careful not to damage the harness of the entrance sensor connected to the stationary tray transport guide.

- (6) Loosen 2 screws [4] of the stationary tray discharge brush.
- (7) Remove 4 screws [5] and take off the stationary tray transport guide [6].

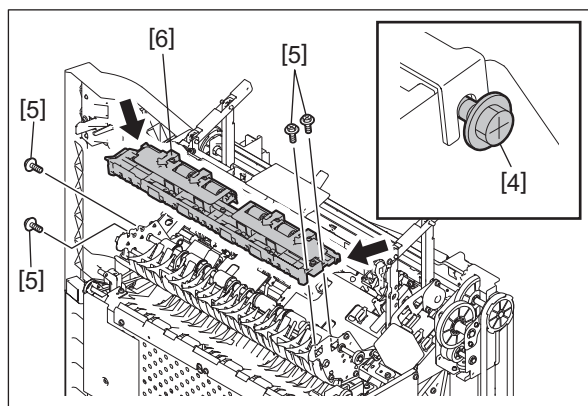

Fig. 4-179

Notes:

- Be careful not to damage the harness of the entrance sensor.
- When installing the stationary tray transport guide, fix it at the position where the gap between the trailing edge of the guide [6] and the frame is 1 mm. Check if the flap and the upper paper exit roller move smoothly after the screws are tightened.

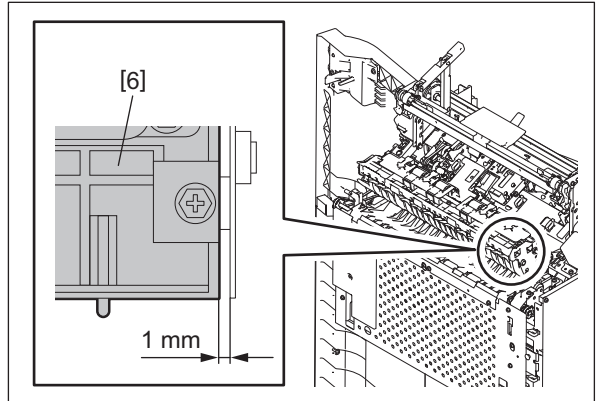

Fig. 4-180

- (8) Remove 4 screws [8] of the upper paper exit roller guide [7].

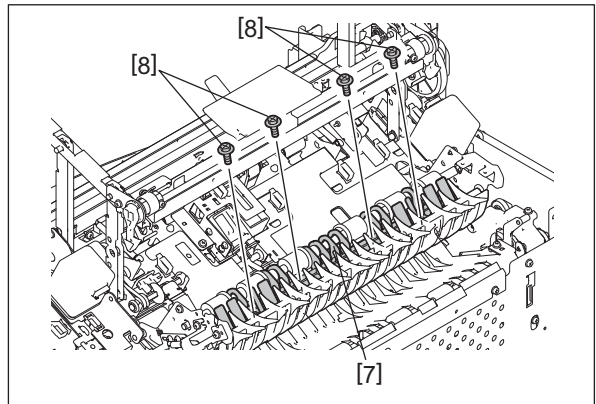

Fig. 4-181

- (9) Remove 3 E-rings [9], 1 gear [10], 1 pin [11] and 2 bushings [12].

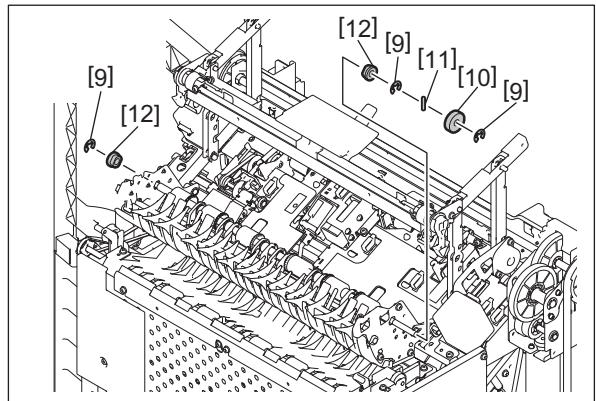

Fig. 4-182

(10) Take off the upper paper exit roller [13] and the upper paper exit roller guide [7].

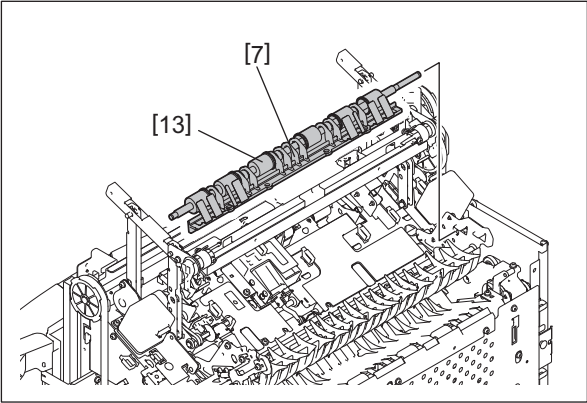



Fig. 4-183

4.5 Roller (Saddle Stitch Section: MJ-1116)

4.5.1 Switchback transport roller

- (1) Take off the switchback unit.
 P. 4-36 “4.3.2 Switchback unit”
- (2) Take off the saddle transport motor.
 P. 4-101 “4.7.3 Saddle transport motor (M16)”
- (3) Open the jam access transport guide [1].
- (4) Remove 3 screws. Take off the feed knob assembly [2] and remove the bushing [3] and the belt [4].

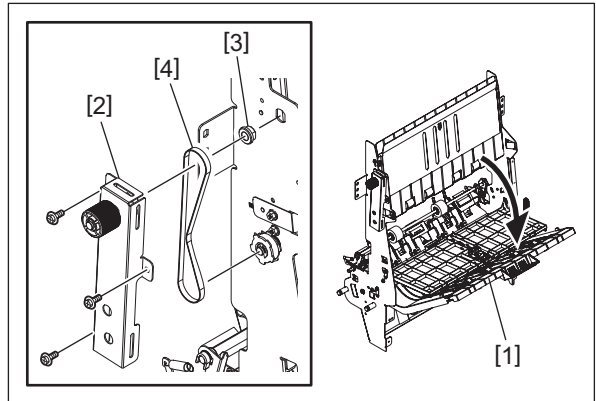

Fig. 4-184

- (5) Remove 4 E-rings, 1 pulley [1], 1 gear [2], 2 pins [3] and 2 bushings [4].

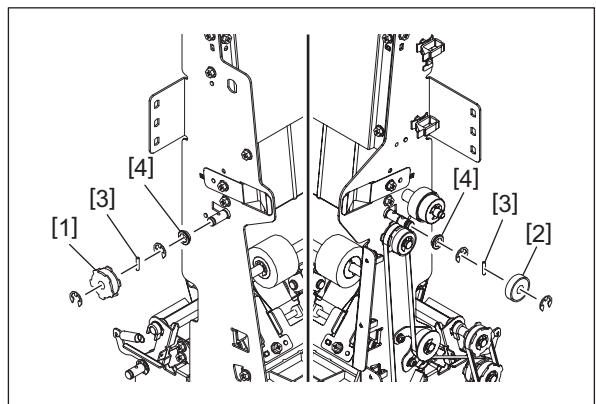

Fig. 4-185

- (6) Remove 4 screws and take off the transport guide [1]. Then take off the switchback transport roller [2].

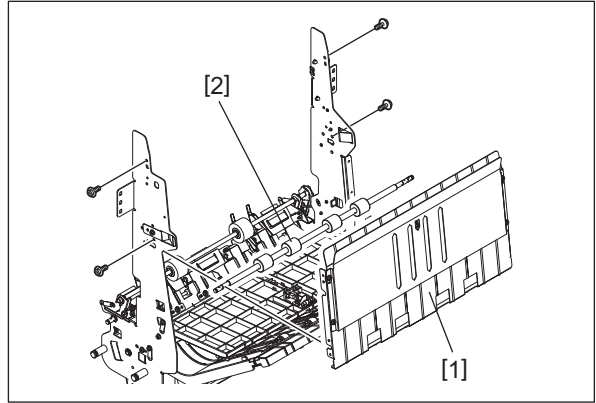

Fig. 4-186

4.5.2 Assist roller

- (1) Take off the switchback unit.
 ⓘ P. 4-36 "4.3.2 Switchback unit"
- (2) Remove 1 E-ring, 1 pulley [1], 1 pin [2] and 1 belt [3].

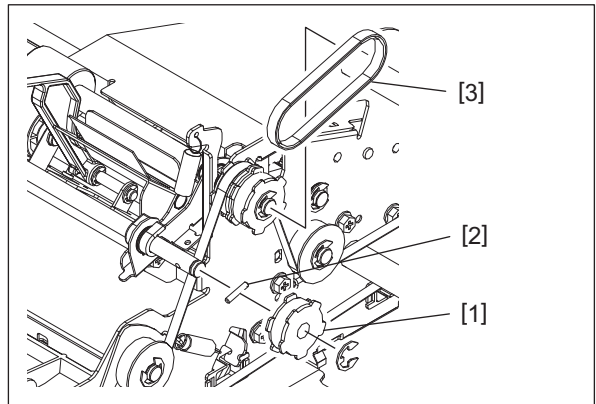

Fig. 4-187

- (3) Remove 4 clips [1], 2 bushings [2] and take off the assist roller [3].

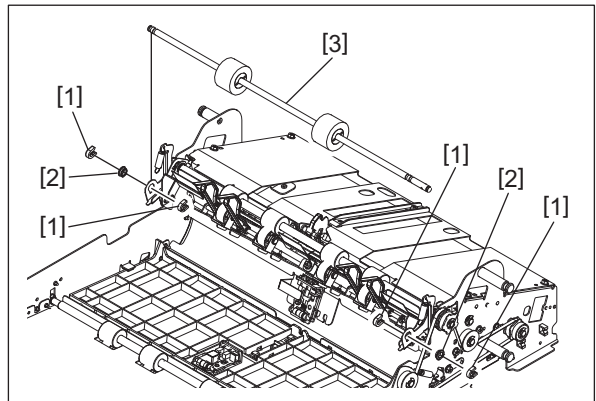

Fig. 4-188

4.5.3 Eject roller

- (1) Take off the assist roller.
📖 P. 4-75 "4.5.2 Assist roller"
- (2) Remove the spring [1] and loosen 1 screw to release the tension of the belt.

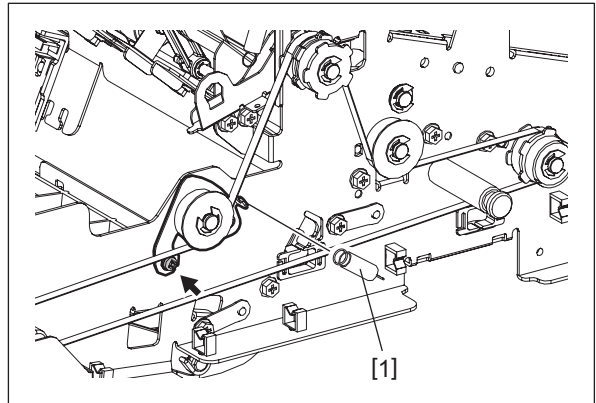

Fig. 4-189

- (3) Remove 2 springs [1].

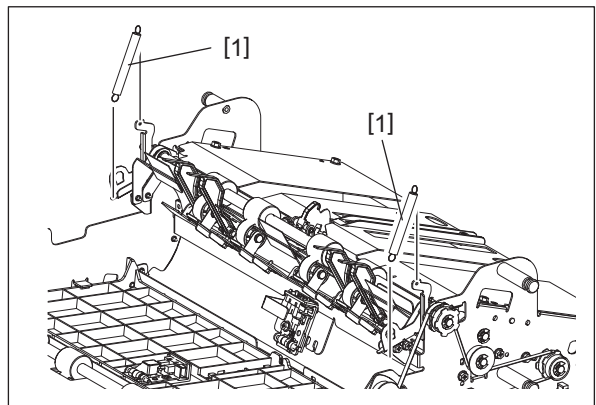

Fig. 4-190

- (4) Remove 4 E-rings, 2 pulleys [1], 2 pins [2] and 2 bushings [3]. Then take off the eject roller [4].

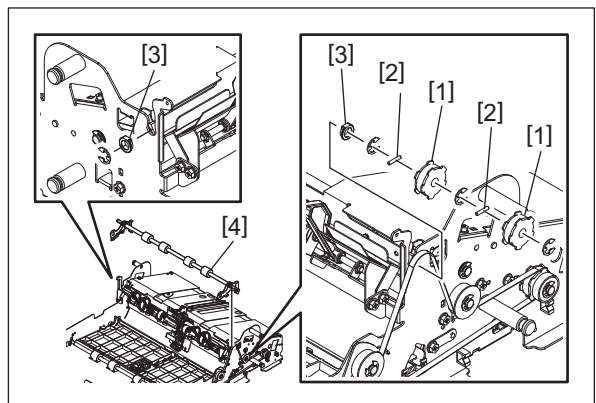

Fig. 4-191

- (5) Remove the right and left arms [2] and 4 bushings [3] from the eject roller [1].

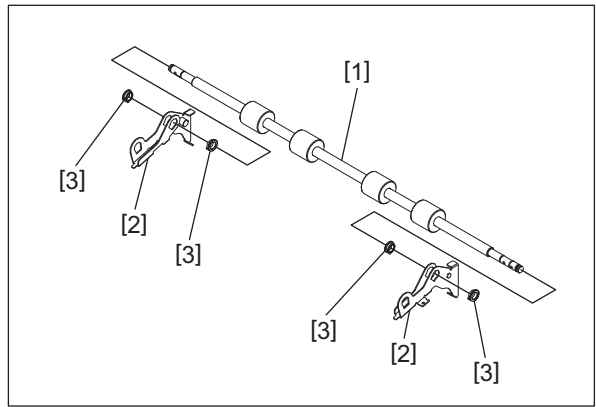

Fig. 4-192

4.5.4 Upper folding roller, Lower folding roller

- (1) Take off the saddle stapler unit.
 📖 P. 4-39 "4.3.5 Saddle stapler unit"
- (2) Take off the stacker unit.
 📖 P. 4-46 "4.3.8 Stacker unit"
- (3) Remove 1 clip [1], 1 gear [2] and 1 pin [3].

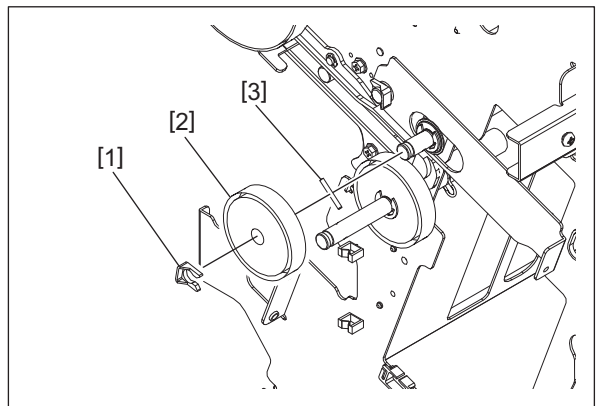

Fig. 4-193

- (4) Remove 1 spring [1].

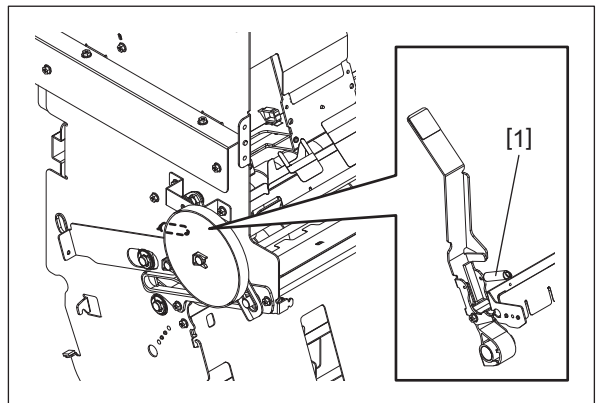

Fig. 4-194

(5) Remove 2 E-rings at both edges of the upper folding roller and 2 bearings [1].

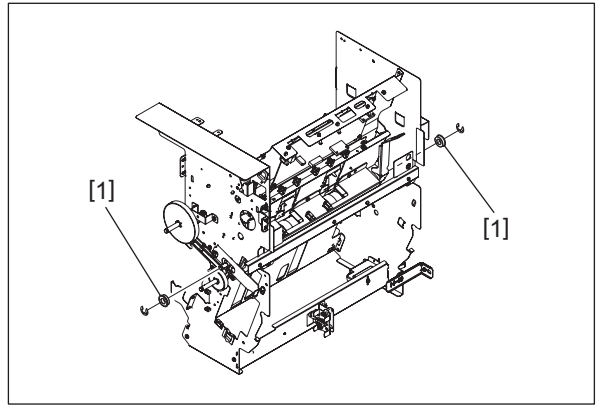

Fig. 4-195

(6) Pull the jam access lever [1] and slide the upper folding roller [2] to take it off.

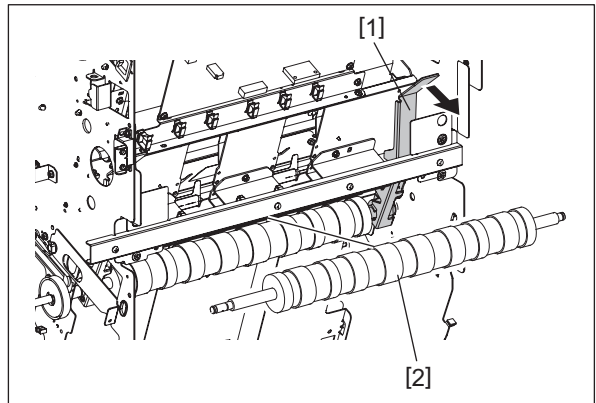

Fig. 4-196

(7) Remove 1 E-ring, 1 gear [1] and 1 pin [2].

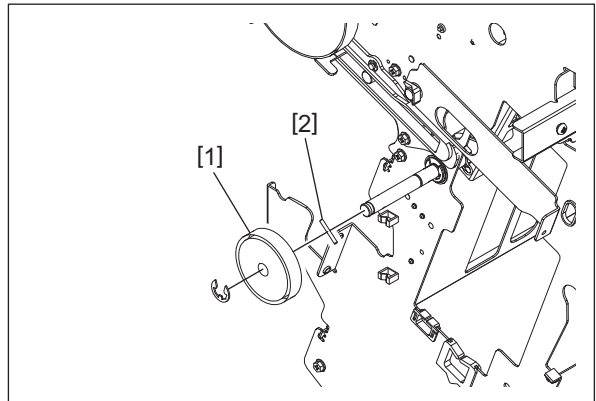

Fig. 4-197

- (8) Remove 2 E-rings at both edges of the lower folding roller and 2 bearings [1].
- (9) Remove the clip [2] of the rear jam access lever.

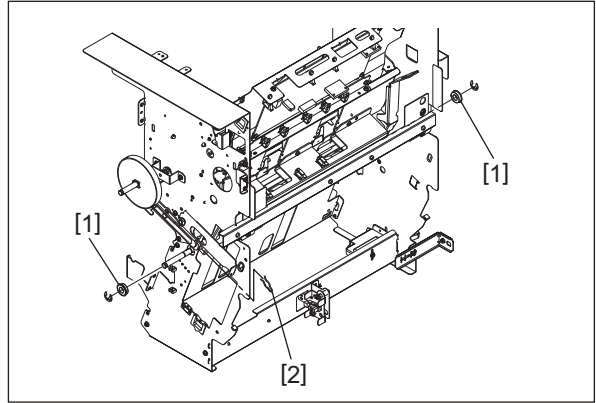

Fig. 4-198

- (10) Slide the lower folding roller [1], take off 2 jam access levers [2] and remove 2 springs [3]. Then take off the lower folding roller [1].

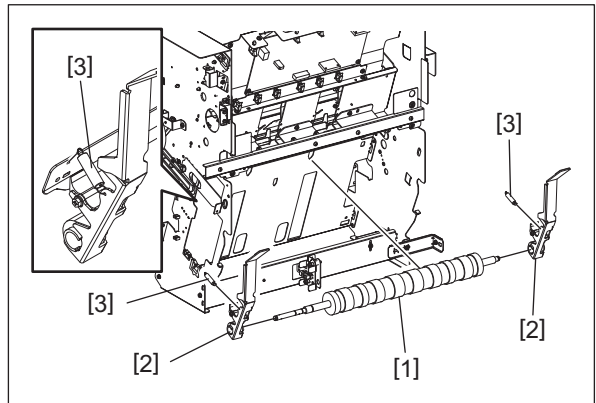

Fig. 4-199

4.5.5 Exit roller

- (1) Open the front upper cover and pull out the saddle stitch unit.
- (2) Remove 2 screws and take off the lower exit transport guide [1].

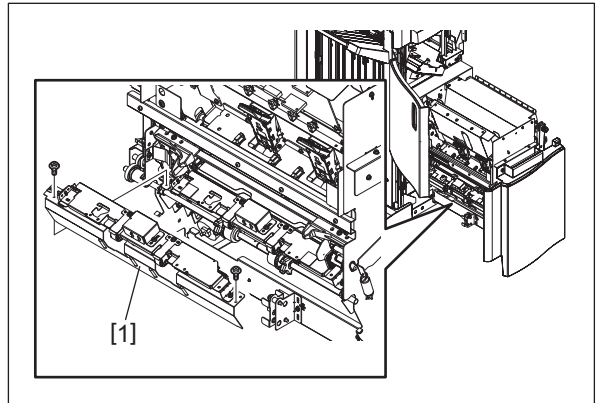

Fig. 4-200

Notes:

Be careful not to damage the harness connected to the lower exit transport guide [1].

- (3) Remove 2 clips [1], 1 bushing [2] and take off the exit roller [3].

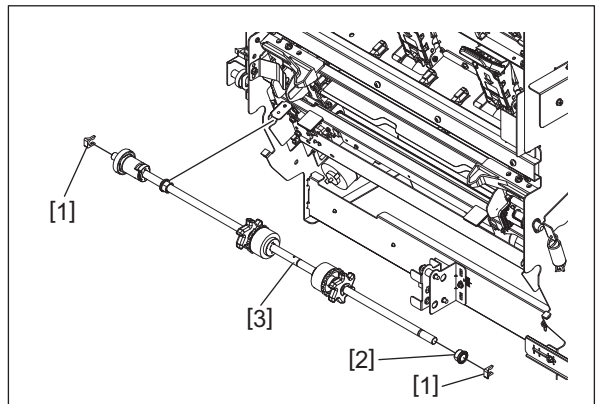

Fig. 4-201

4.6 Motor (Finisher Section)

4.6.1 Entrance motor (M1)

- (1) Take off the stationary tray.
📖 P. 4-1 “4.1.1 Stationary tray”
- (2) Take off the control panel unit.
📖 P. 4-4 “4.1.4 Control panel unit”
- (3) Take off the rear cover.
📖 P. 4-7 “4.1.8 Rear cover”
- (4) Take off the right upper cover.
📖 P. 4-9 “4.1.11 Right upper cover”
- (5) Take off the right cover.
📖 P. 4-10 “4.1.12 Relay guide, Paper feed discharge brush, Right cover”
- (6) Take off the junction box unit.
📖 P. 4-16 “4.2.1 Junction box unit”
- (7) Close the buffer unit-1 [1] halfway and remove 1 screw.

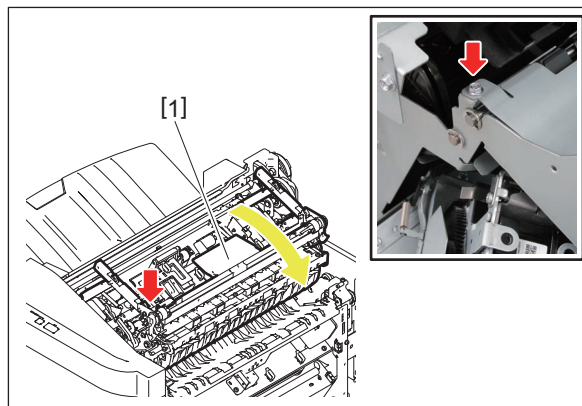

Fig. 4-202

- (8) Remove 3 screws and take off the transport guide [2].

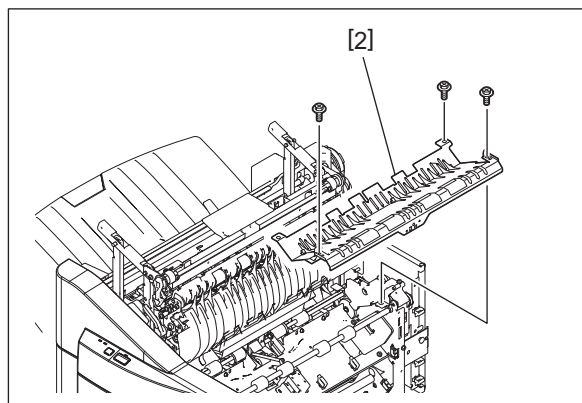

Fig. 4-203

- (9) Remove 1 screw and take off the ground wire [1].
- (10) Release the PC board cover [2] from 2 harness clamps [3].

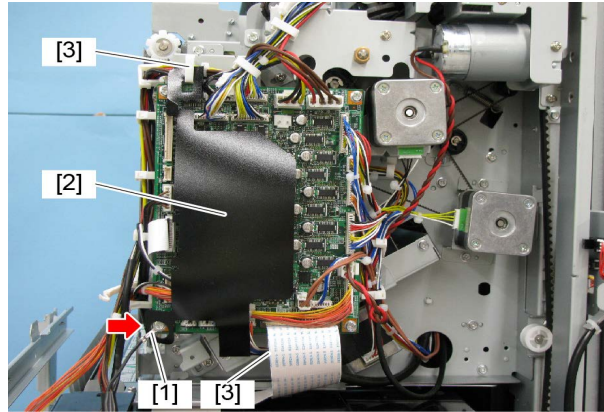

Fig. 4-204

- (11) Disconnect all the connectors on the finisher control PC board and release the harnesses from the harness clamps.
- (12) Remove 3 screws and take off the bracket [4] of the finisher control PC board.

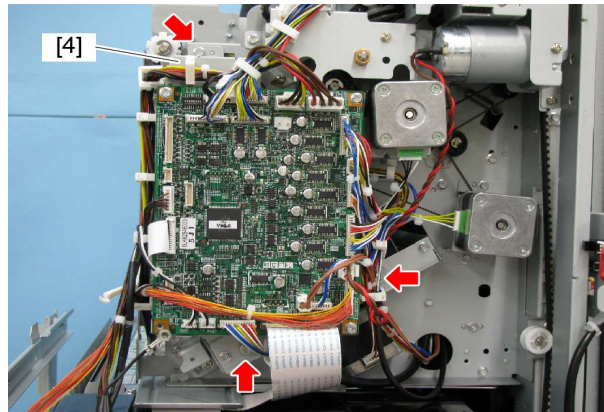

Fig. 4-205

- (13) Remove the belt [6] from the pulley of the entrance motor.
- (14) Remove 2 screws. Disconnect the connector [7] and take off the entrance motor [5].

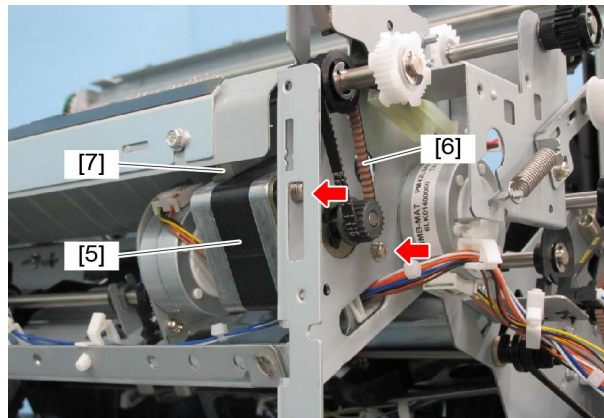

Fig. 4-206

4.6.2 Buffer tray guide motor (M2)

- (1) Take off the buffer unit-1.
📖 P. 4-21 “4.2.3 Buffer unit-1”
- (2) Remove 2 screws and take off the buffer tray guide motor [1].

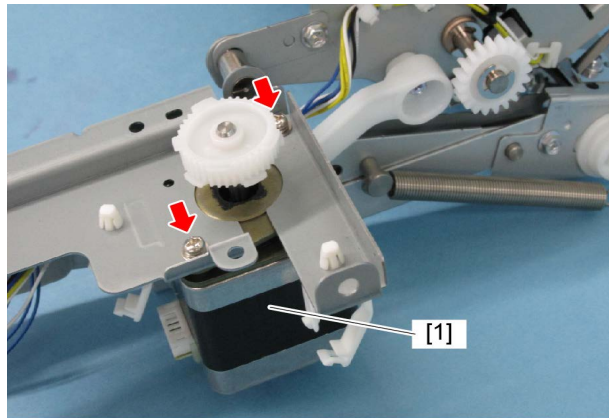

Fig. 4-207

4.6.3 Paddle motor (M3)

- (1) Take off the stationary tray.
📖 P. 4-1 “4.1.1 Stationary tray”
- (2) Take off the control panel unit.
📖 P. 4-4 “4.1.4 Control panel unit”
- (3) Take off the rear cover.
📖 P. 4-7 “4.1.8 Rear cover”
- (4) Take off the right upper cover.
📖 P. 4-9 “4.1.11 Right upper cover”
- (5) Take off the right cover.
📖 P. 4-10 “4.1.12 Relay guide, Paper feed discharge brush, Right cover”
- (6) Take off the junction box unit.
📖 P. 4-16 “4.2.1 Junction box unit”
- (7) Close the buffer unit-1 [1] halfway and remove 1 screw.

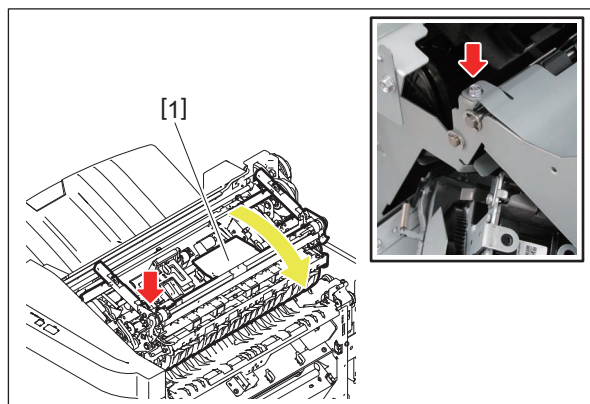

Fig. 4-208

(8) Remove 3 screws and take off the transport guide [2].

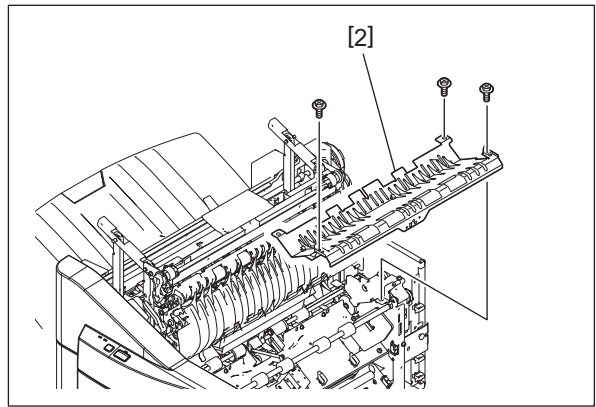

Fig. 4-209

(9) Remove 1 screw and take off the ground wire [1].

(10) Release the PC board cover [2] from 2 harness clamps [3].

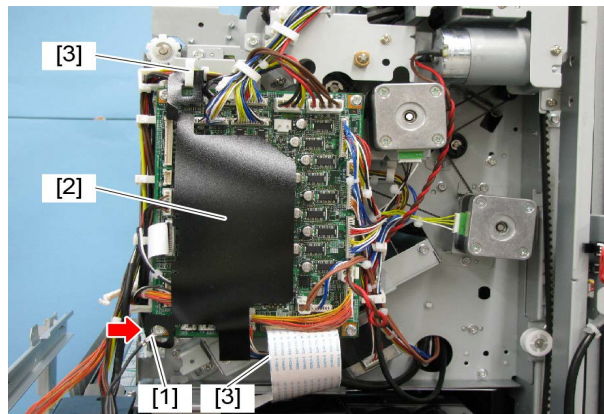

Fig. 4-210

(11) Disconnect all the connectors on the finisher control PC board and release the harnesses from the harness clamps.

(12) Remove 3 screws and take off the bracket [4] of the finisher control PC board.

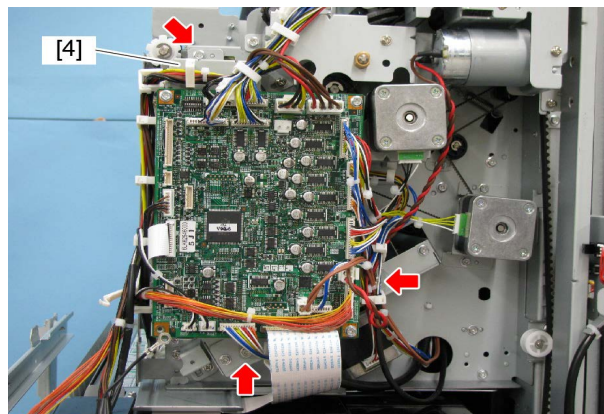

Fig. 4-211

(13) Release the harness of the paddle motor from 2 harness clamps [5].

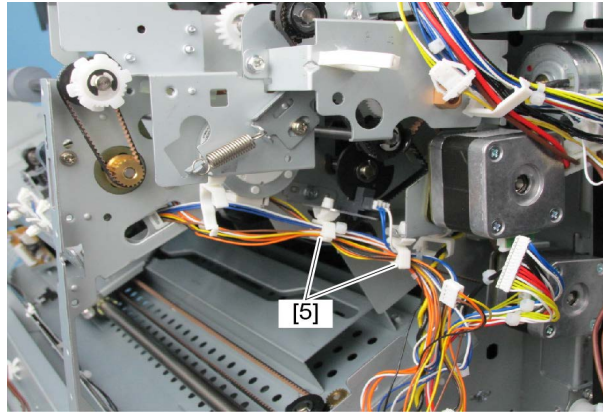

Fig. 4-212

(14) Remove 2 screws and take off the paddle motor [6].

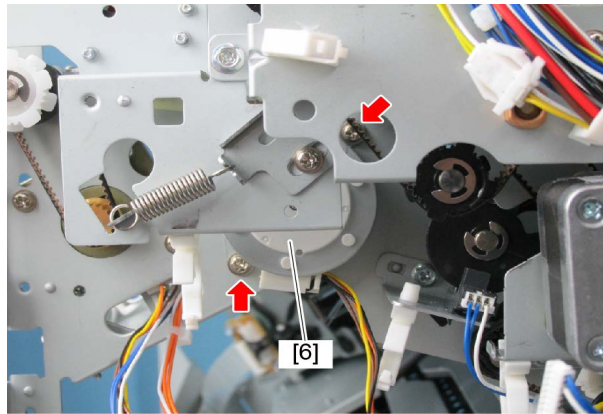

Fig. 4-213

4.6.4 Front alignment motor (M5)

- (1) Take off the grate-shaped guide.
📖 P. 4-12 "4.1.15 Grate-shaped guide"
- (2) Release the harness from the harness clamp [1] and disconnect the relay connector [2].
- (3) Remove 2 screws and take off the front alignment motor [3].

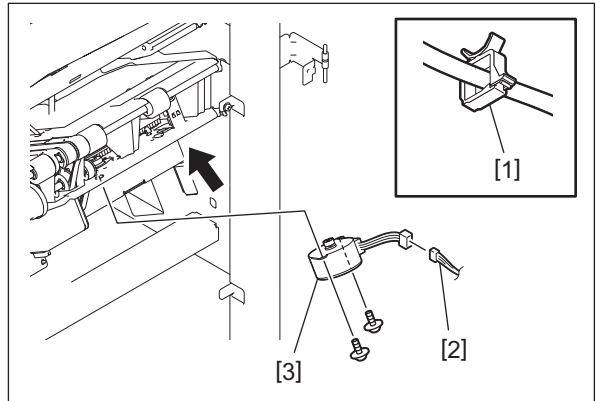

Fig. 4-214

4.6.5 Rear alignment motor (M6)

- (1) Take off the grate-shaped guide.
📖 P. 4-12 "4.1.15 Grate-shaped guide"
- (2) Remove 2 screws. Disconnect the relay connector [1] and take off the rear alignment motor [2].

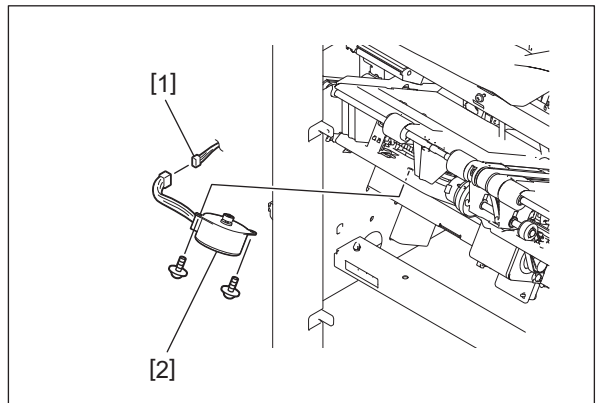

Fig. 4-215

4.6.6 Transport motor (M7)

- (1) Take off the rear cover.
📖 P. 4-7 "4.1.8 Rear cover"
- (2) Loosen 2 screws. Push the pulley [1] in the direction indicated by the arrow so as the belt tension is loosened as a result. Then tighten 2 screws.
- (3) Remove 2 screws. Disconnect 1 connector, remove the belt and take off the transport motor [2].

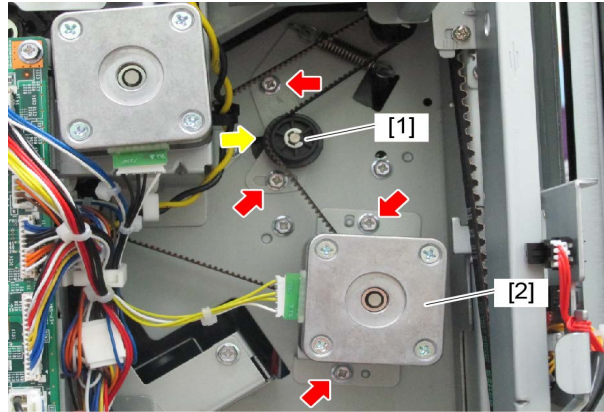

Fig. 4-216

Notes:

When installing, be sure to apply tension to the belt.

- (4) Remove 2 screws and take off the transport motor [2] from the bracket [3].

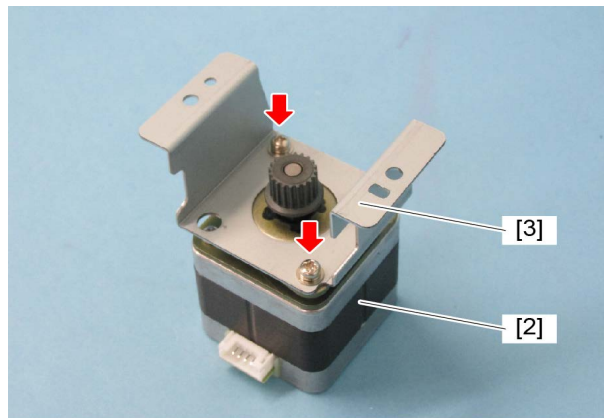

Fig. 4-217

4.6.7 Stack transport motor (M8)

- (1) Take off the grate-shaped guide.
📖 P. 4-12 “4.1.15 Grate-shaped guide”
- (2) Disconnect 1 connector. Remove the belt [1] and 2 screws. Take off the stack transport motor [2].

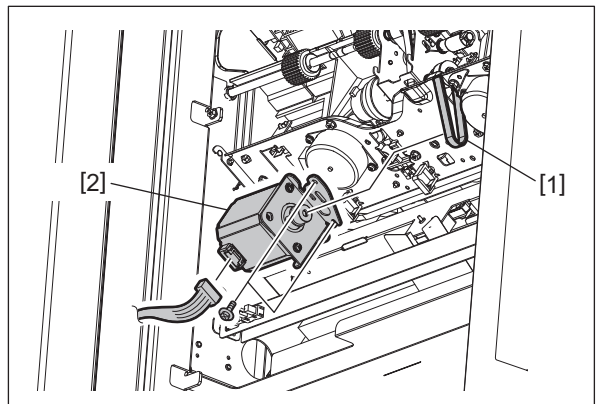

Fig. 4-218

4.6.8 Stapler unit shift motor (M9)

- (1) Take off the stationary tray.
📖 P. 4-1 “4.1.1 Stationary tray”
- (2) Take off the control panel unit.
📖 P. 4-4 “4.1.4 Control panel unit”
- (3) Take off the rear cover.
📖 P. 4-7 “4.1.8 Rear cover”
- (4) Take off the right upper cover.
📖 P. 4-9 “4.1.11 Right upper cover”
- (5) Take off the right cover.
📖 P. 4-10 “4.1.12 Relay guide, Paper feed discharge brush, Right cover”
- (6) Take off the junction box unit.
📖 P. 4-16 “4.2.1 Junction box unit”
- (7) Close the buffer unit-1 [1] halfway and remove 1 screw.

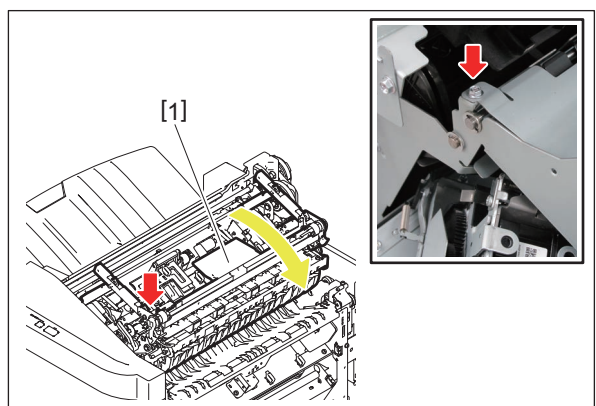

Fig. 4-219

(8) Remove 3 screws and take off the transport guide [2].

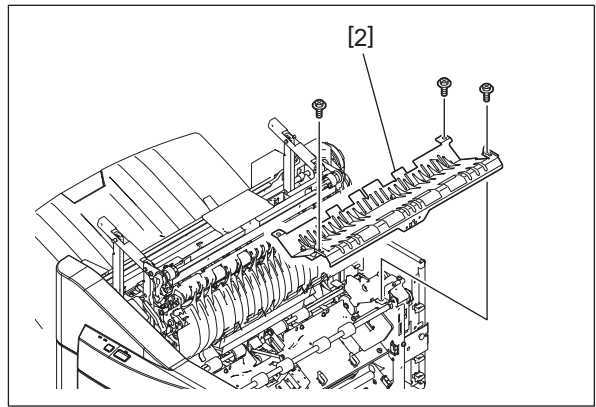

Fig. 4-220

(9) Remove 1 screw and take off the ground wire [3].

(10) Release the PC board cover [4] from 2 harness clamps [5].

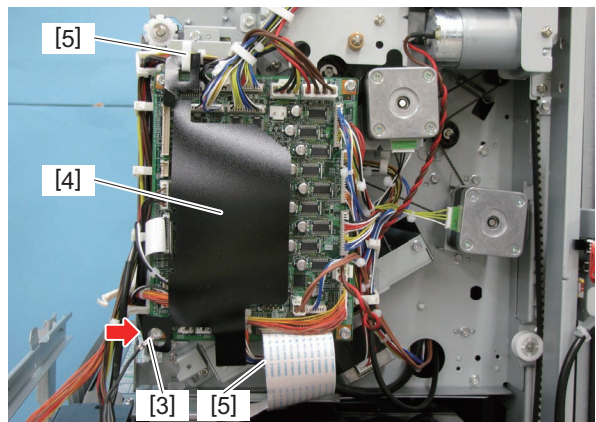

Fig. 4-221

(11) Disconnect all the connectors on the finisher control PC board and release the harnesses from the harness clamps.

(12) Remove 3 screws and take off the bracket [6] of the finisher control PC board.

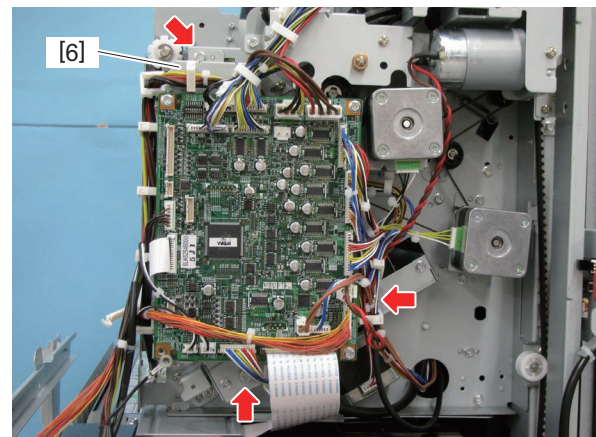

Fig. 4-222

(13) Remove 2 screws. Disconnect the connector [7] and take off the stapler unit shift motor [8].

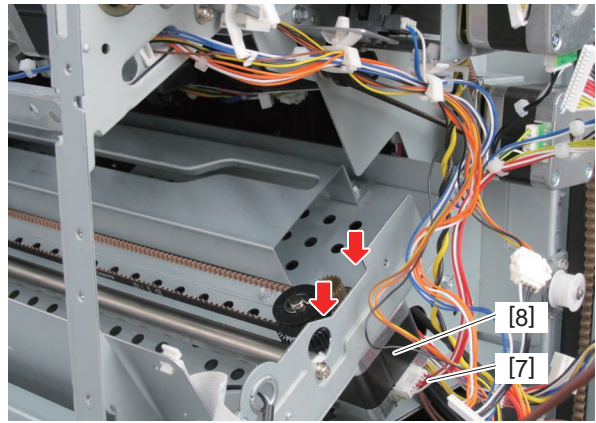

Fig. 4-223

4.6.9 Assist guide motor (M10)

- (1) Take off the stationary tray.
📖 P. 4-1 “4.1.1 Stationary tray”
- (2) Take off the control panel unit.
📖 P. 4-4 “4.1.4 Control panel unit”
- (3) Fully close the buffer unit-1.
- (4) Disconnect 1 relay connector [1] and release the harness [2] from 7 harness clamps [3].
- (5) Pull out the harness [2] through the window of the frame.

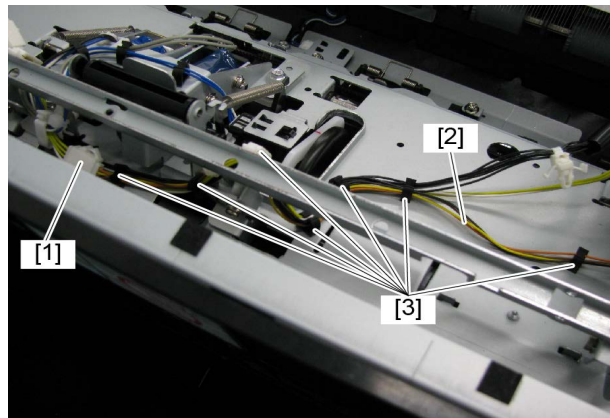

Fig. 4-224

(6) Remove 2 screws and take off the assist guide motor [5] and the belt [6].

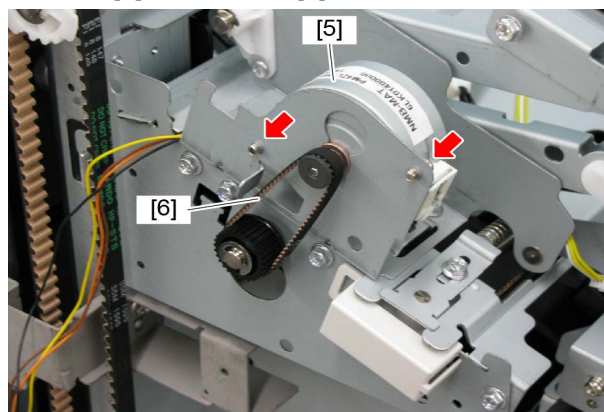

Fig. 4-225

4.6.10 Exit motor (M11)

- (1) Take off the control panel unit.
📖 P. 4-4 "4.1.4 Control panel unit"
- (2) Take off the rear cover.
📖 P. 4-7 "4.1.8 Rear cover"
- (3) Take off the right upper cover.
📖 P. 4-9 "4.1.11 Right upper cover"
- (4) Take off the right cover.
📖 P. 4-10 "4.1.12 Relay guide, Paper feed discharge brush, Right cover"
- (5) Take off the junction box unit.
📖 P. 4-16 "4.2.1 Junction box unit"
- (6) Disconnect 5 connectors [4], [5], [6], [7] and [8] from the finisher control PC board [3].
- (7) Disconnect 1 connector [10] from the buffer tray guide motor [9].
- (8) Disconnect 1 connector [12] from the transport motor [11].
- (9) Disconnect 1 connector [14] from the movable tray shift motor sensor [13].
- (10) Release the harness from 6 harness clamps [15].
- (11) Remove 1 binding band [18] which bundles the harnesses.

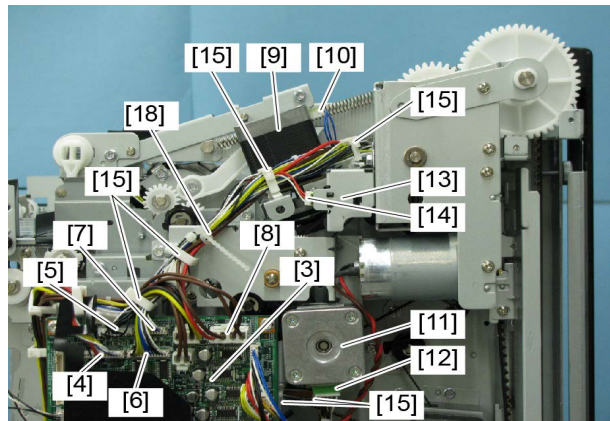

Fig. 4-226

- (12) Remove 5 screws and take off the motor bracket [19].

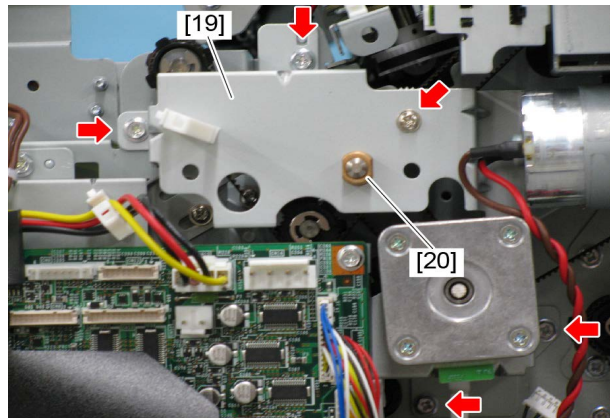

Fig. 4-227

Notes:

Be careful not to lose the bushing [20] removed while taking off the motor bracket [19].

- (13) Loosen 1 screw. Push the pulley [21] in the direction indicated by the arrow so as the belt tension is loosened as a result. Then tighten the screw.
- (14) Remove the belts [22] and [23], 1 assembled part [24] and 1 bearing.

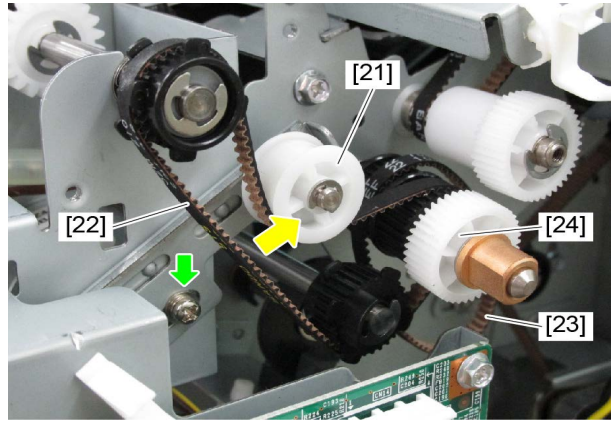

Fig. 4-228

Notes:

Be careful not to lose the bearing while taking off the assembled part [24].

- (15) Remove 2 screws and take off the exit motor [25].

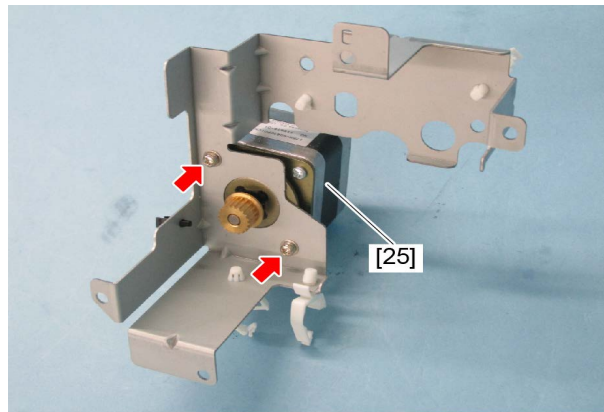

Fig. 4-229

4.6.11 Movable tray shift motor (M12)

- (1) Take off the rear cover.
📖 P. 4-7 "4.1.8 Rear cover"
- (2) Move the movable tray [1] to the middle position. If the movable tray [1] needs to be lowered, push the gear [2] of the movable tray shift motor unit in the direction of the arrow to release the lock. (Be sure to hold the movable tray [1] with your hand because it may fall when the gear is pushed.)

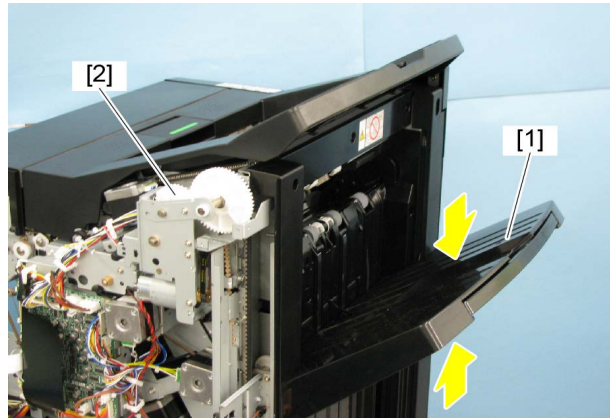

Fig. 4-230

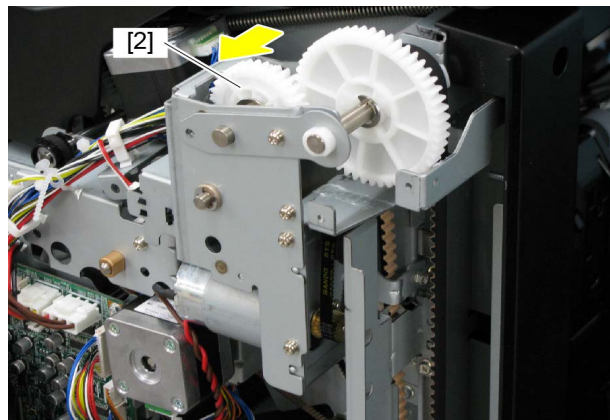

Fig. 4-231

- (3) Remove 2 screws and take off the sensor rail [3].

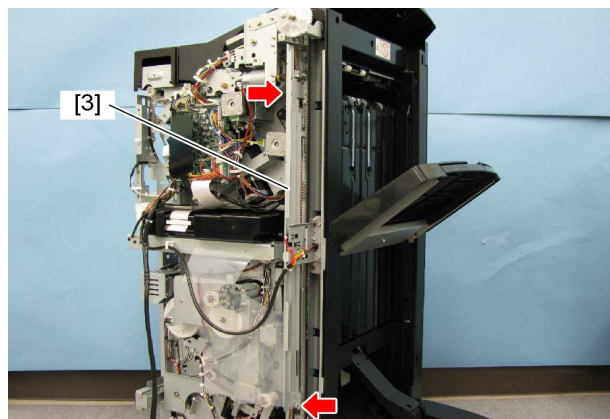

Fig. 4-232

Notes:

When installing, fix the sensor rail [3] at the position where the gap [7] between the center mark of its scale [5] and the edge of the movable tray position-A sensor [6] is from 0 to 1.0 mm. Be sure to perform the measurement on the positions at the upper and lower scales [5] on the sensor rail [3] by moving the movable tray shift frame as shown in the figure.

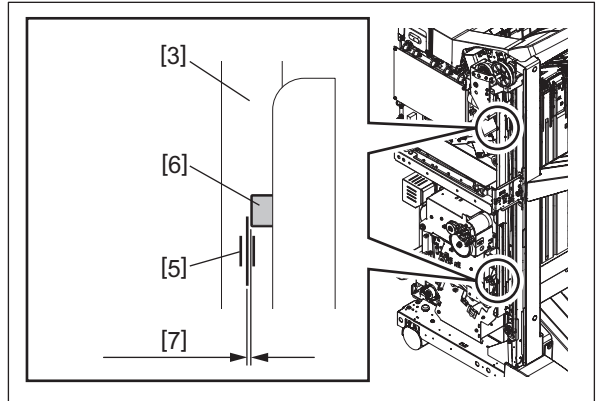

Fig. 4-233

- (4) Release the harness from 2 harness clamps [8] and disconnect 1 connector [9] from the finisher control PC board.

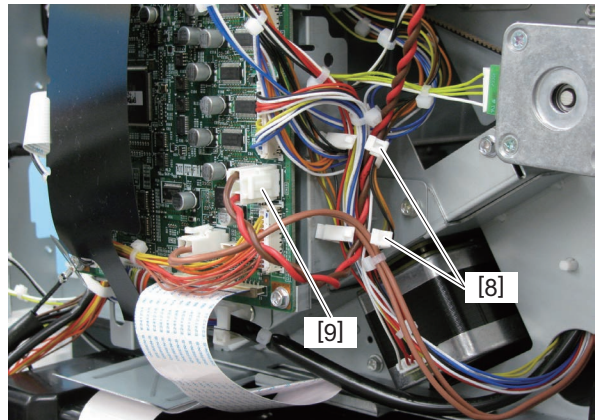

Fig. 4-234

- (5) Remove 2 screws and take off the movable tray shift motor [10] and the damper [11].

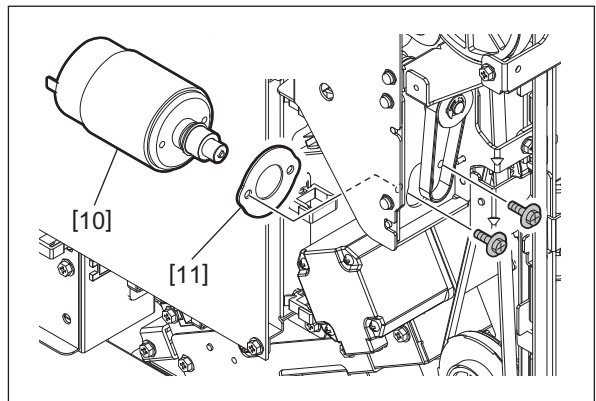

Fig. 4-235

Notes:

- Be careful not to lose the belt.
- Pay attention to the size and length of the screws. If you use the wrong ones, the motor could be damaged.

4.6.12 Catching motor (M21)

- (1) Take off the stationary tray.
📖 P. 4-1 "4.1.1 Stationary tray"
- (2) Take off the control panel unit.
📖 P. 4-4 "4.1.4 Control panel unit"
- (3) Take off the rear cover.
📖 P. 4-7 "4.1.8 Rear cover"
- (4) Take off the right upper cover.
📖 P. 4-9 "4.1.11 Right upper cover"
- (5) Take off the right cover.
📖 P. 4-10 "4.1.12 Relay guide, Paper feed discharge brush, Right cover"
- (6) Take off the junction box unit.
📖 P. 4-16 "4.2.1 Junction box unit"
- (7) Close the buffer unit-1 [1] halfway and remove 1 screw.

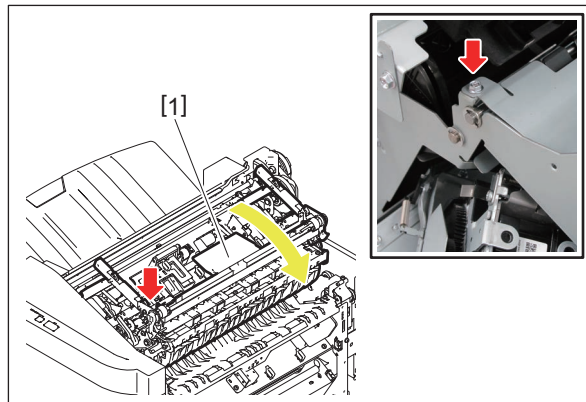

Fig. 4-236

- (8) Remove 3 screws and take off the transport guide [2].

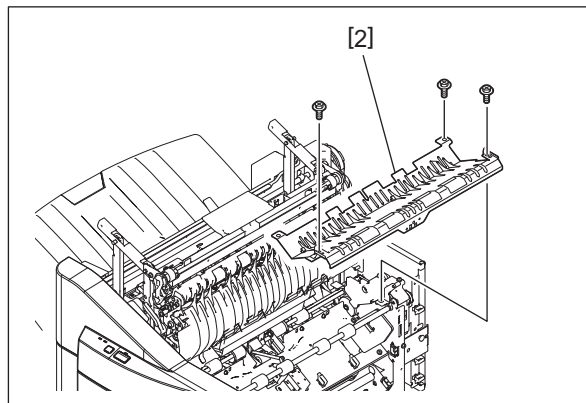

Fig. 4-237

- (9) Remove 1 screw and take off the ground wire [3].
- (10) Release the PC board cover [4] from 2 harness clamps [5].

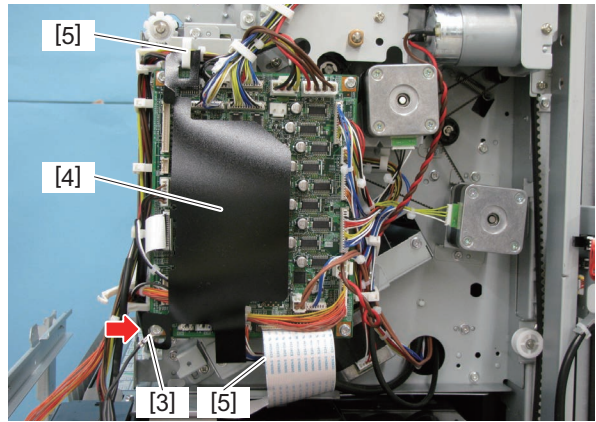

Fig. 4-238

- (11) Disconnect all the connectors on the finisher control PC board and release the harnesses from the harness clamps.
- (12) Remove 3 screws and take off the bracket [6] of the finisher control PC board.

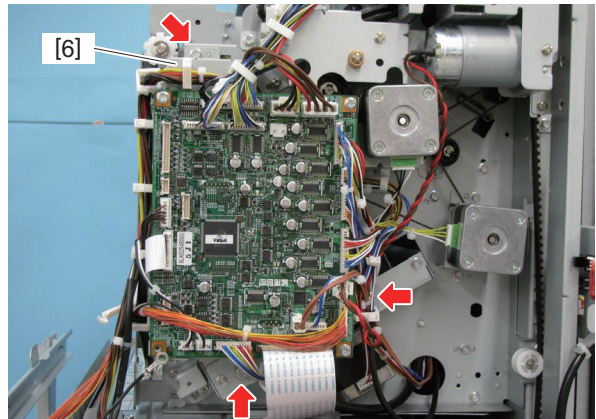

Fig. 4-239

- (13) Disconnect the relay connector [7].
- (14) Release the harness from 3 harness clamps [8].

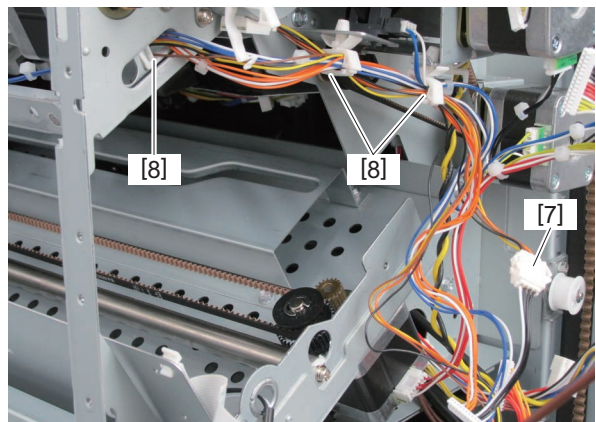

Fig. 4-240

(15) Remove 2 screws and take off the catching motor [9].

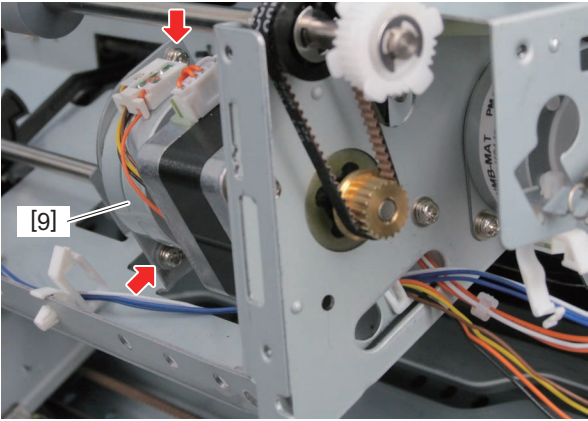



Fig. 4-241

4.7 Motor (saddle stitch section: MJ-1116)

4.7.1 Stacker motor (M14)

- (1) Take off the stacker unit.
 P. 4-46 "4.3.8 Stacker unit"
- (2) Move the stacker to the upper position.
- (3) Remove 1 E-ring.
- (4) Remove the belt [1] and 1 gear [2].

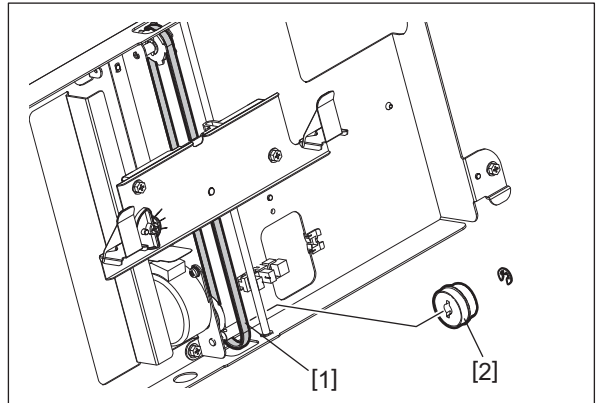

Fig. 4-242

- (5) Remove 1 E-ring and take off the stacker [1].

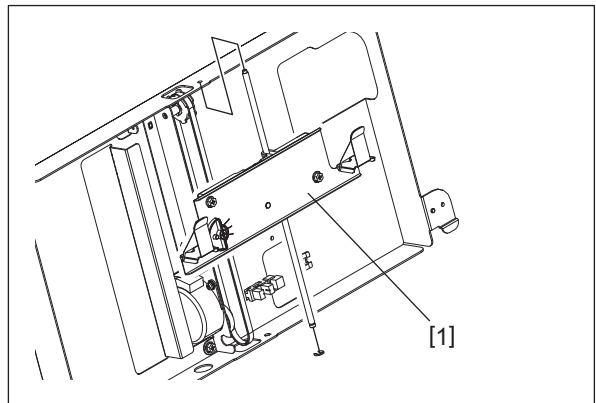

Fig. 4-243

- (6) Remove 3 screws and take off the motor bracket [1].

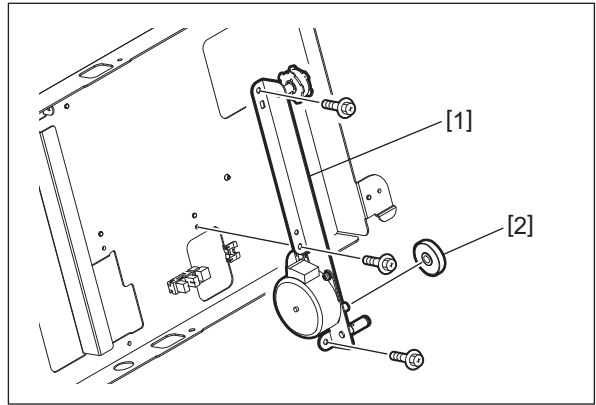

Fig. 4-244

Notes:

While taking off the motor bracket [1], 1 gear [2] is removed accordingly. Be careful not to lose it.

- (7) Remove 2 screws and release the harness from 1 harness clamp [1]. Then take off the stacker motor [2].

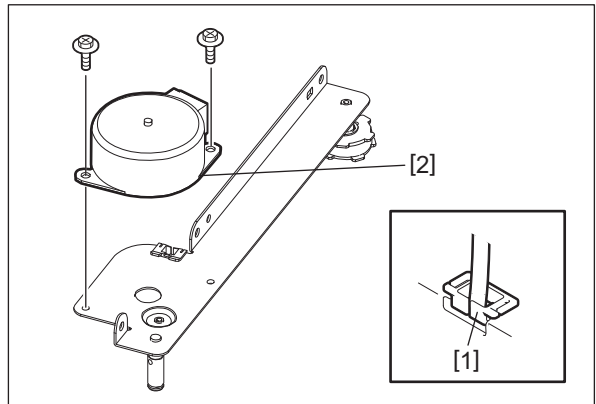

Fig. 4-245

4.7.2 Side alignment motor (M15)

- (1) Open the front upper cover and pull out the saddle stitch unit.
- (2) Remove 4 screws and take off the upper safety cover [1].

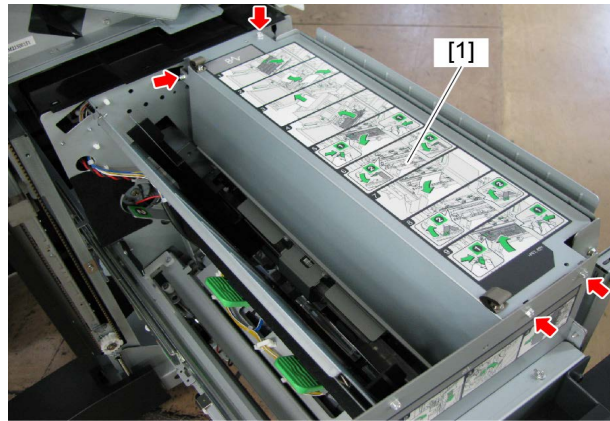

Fig. 4-246

- (3) Remove 2 screws. Disconnect 1 relay connector [1] and take off the side alignment motor [2].

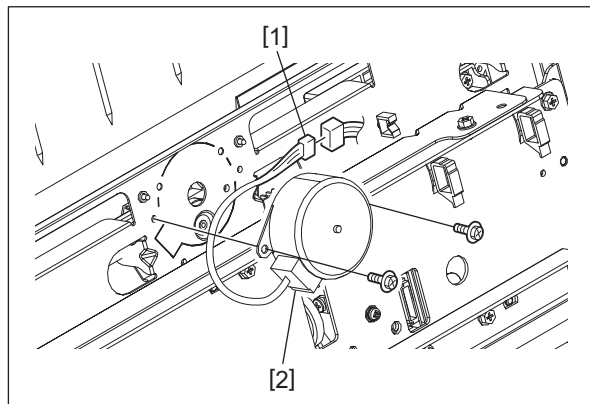

Fig. 4-247

4.7.3 Saddle transport motor (M16)

- (1) Open the front upper cover and pull out the saddle stitch unit.
- (2) Remove 2 screws and take off the motor cover [1].

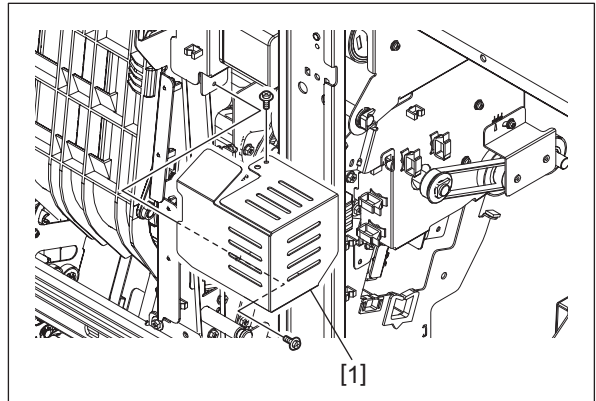

Fig. 4-248

- (3) Remove 2 screws and take off the motor bracket [1].

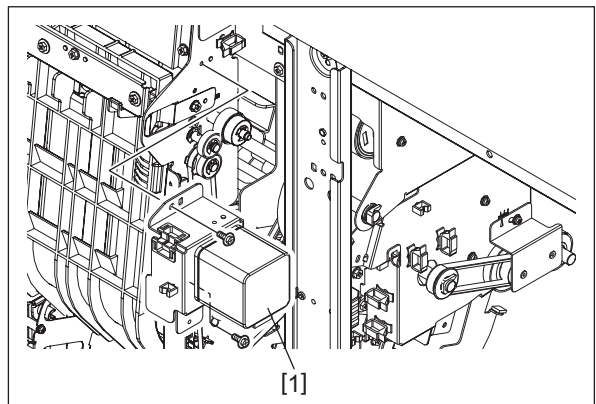

Fig. 4-249

- (4) Remove 2 screws and take off the saddle transport motor [2] from the motor bracket [1].

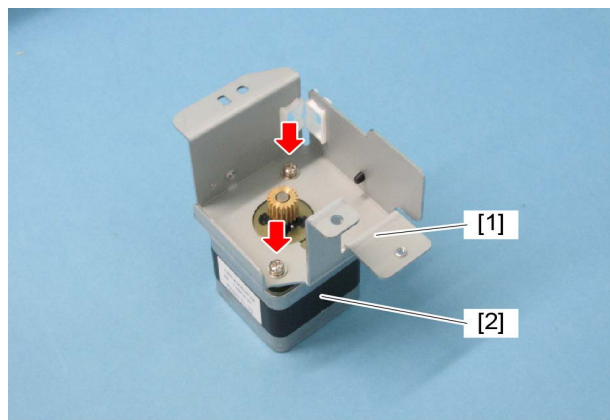

Fig. 4-250

4.7.4 Folding motor (M17)

- (1) Take off the saddle stitch unit.
P. 4-33 "4.3.1 Saddle stitch unit"
- (2) Remove 2 screws and take off the saddle control PC board cover [1].

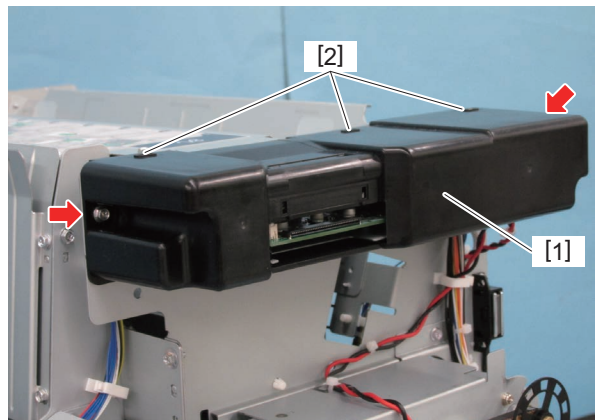

Fig. 4-251

Notes:

When installing, be sure to hang 3 holes [2] on the cover with 3 hooks on the frame.

- (3) Release the harness from 2 harness clamps [3] and disconnect 1 connector [4] from the saddle control PC board.

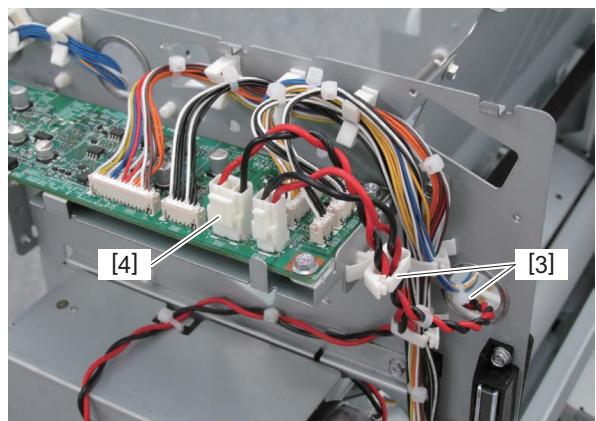

Fig. 4-252

- (4) Remove the belt [5] of the folding motor.

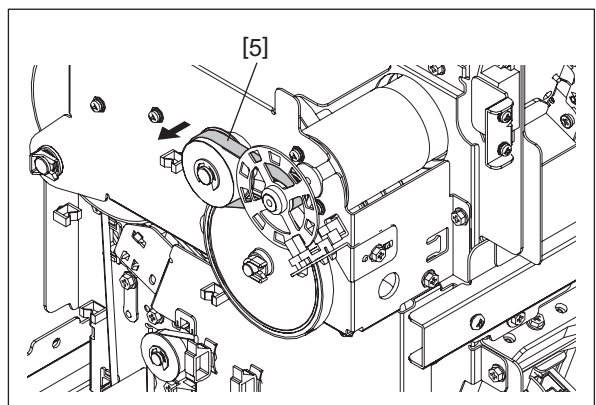

Fig. 4-253

- (5) Remove 2 screws and take off the folding motor [6].

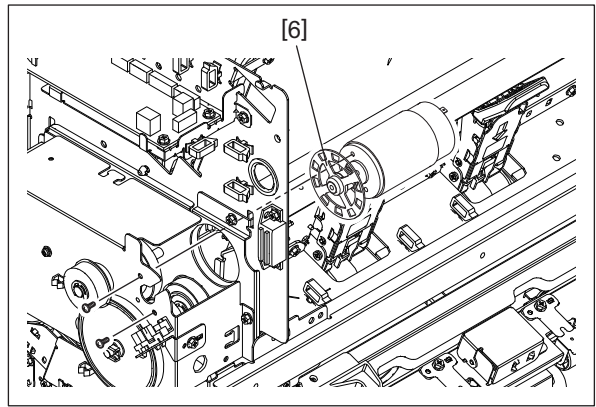

Fig. 4-254

4.7.5 Additional folding motor (M20)

- (1) Take off the additional folding unit.
P. 4-45 "4.3.7 Additional folding unit"
- (2) Disconnect 1 connector [1] of the additional folding motor encoder sensor.
- (3) Cut off 1 binding band [2] and release the harness from the harness clamp [3].

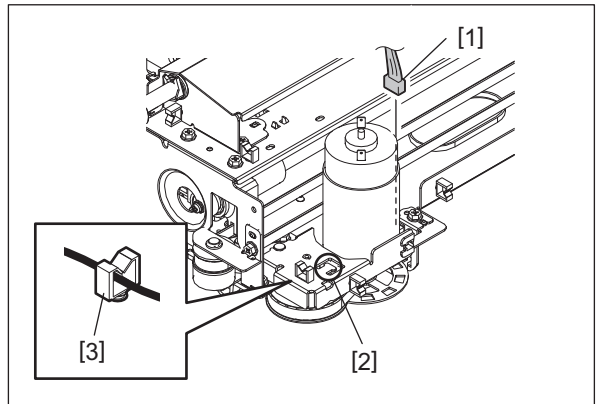

Fig. 4-255

- (4) Remove 1 clip [4].
- (5) Remove 2 screws. Then remove the gear bracket [5] and the pulley [6].

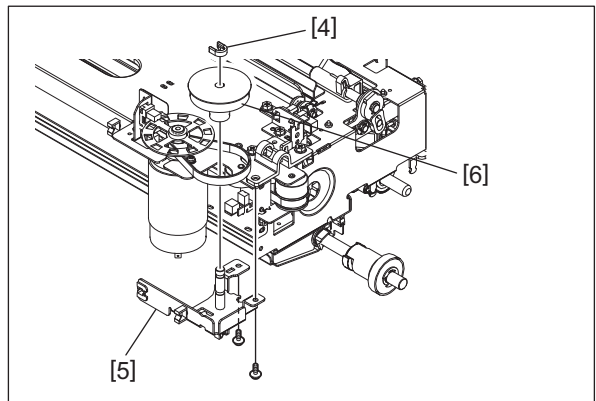

Fig. 4-256

(6) Remove 2 screws and the belt [7]. Then, take off the folding motor [8].

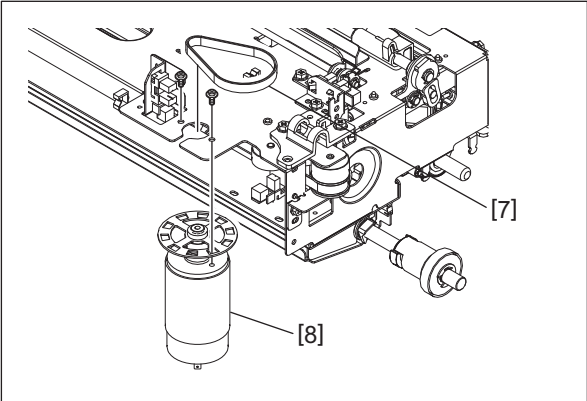

Fig. 4-257

4.8 Electromagnetic Spring Clutch, Solenoid

4.8.1 Stack exit guide clutch (CLT2)

- (1) Take off the grate-shaped guide.
📖 P. 4-12 “4.1.15 Grate-shaped guide”
- (2) Remove 4 E-rings and slide the bushing [1].

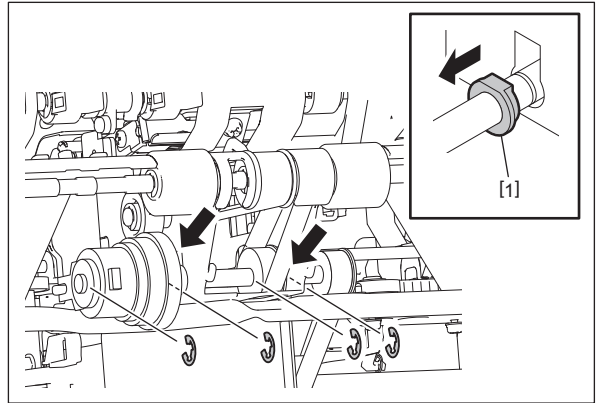

Fig. 4-258

- (3) Remove the belt [3] of the stack transport motor [2].

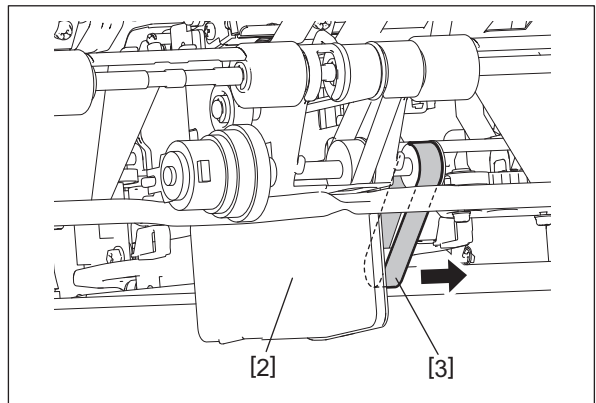

Fig. 4-259

- (4) Slide the shaft in the direction of the arrow to remove 1 pin [4].

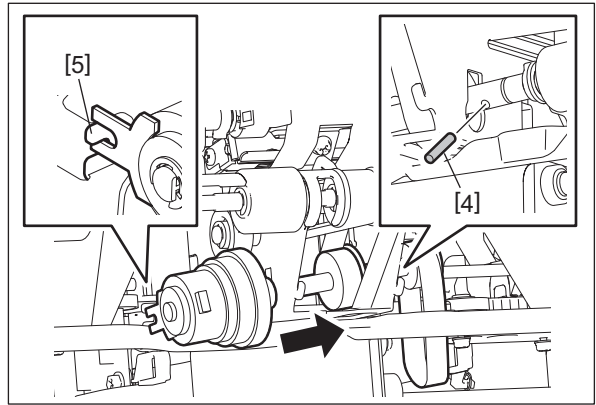

Fig. 4-260

Notes:

- Be careful not to lose the belt.
 - When installing, attach a rotation stopper [5] of the stack exit guide clutch.
- (5) Slide the shaft in the direction of the arrow and take off the stack exit guide clutch [6]. Then disconnect 1 relay connector.

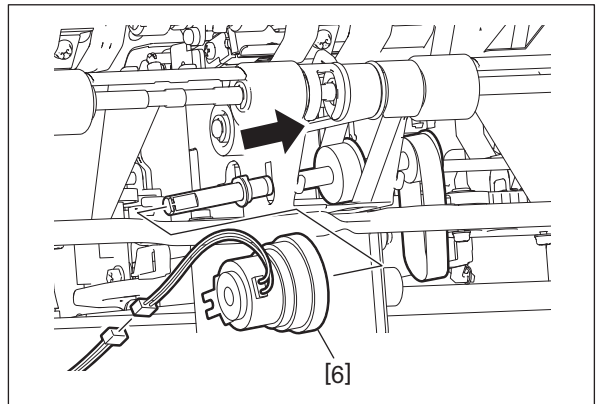



Fig. 4-261

4.8.2 Folding blade clutch (CLT3) (MJ-1116)

- (1) Take off the folding drive unit.
 P. 4-43 "4.3.6 Folding drive unit"
- (2) Remove 5 screws and 1 clip [1].

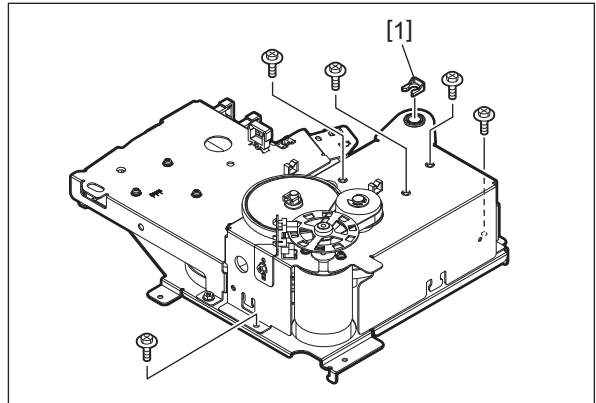

Fig. 4-262

- (3) Take off the gear bracket [1]. Disconnect the relay connector, remove 1 bearing [2] and take off the folding blade clutch [3].

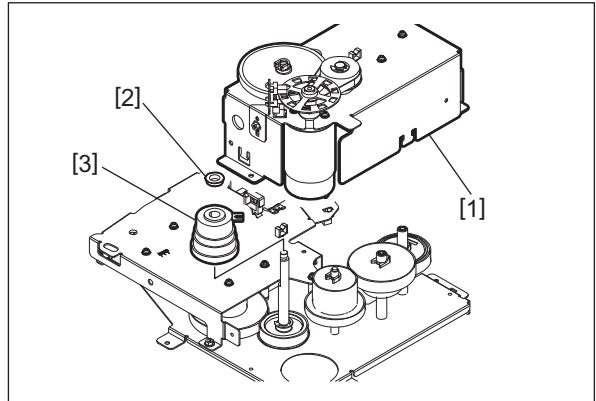

Fig. 4-263

Notes:

When installing, attach a rotation stopper of the folding blade clutch.

4.8.3 Paper holding clutch (CLT4) (MJ-1116)

- (1) Open the front upper cover and pull out the saddle stitch unit.
- (2) Disconnect the relay connector and release the harness from the harness clamp.
- (3) Remove 1 E-ring and take off the paper holding clutch [1].

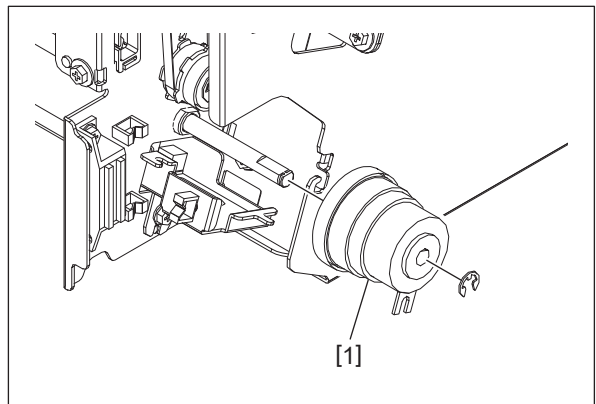

Fig. 4-264

Notes:

When installing, attach a rotation stopper.

4.8.4 Buffer roller lift solenoid (SOL2), Exit roller lift solenoid (SOL8)

- (1) Take off the stationary tray.
P. 4-1 “4.1.1 Stationary tray”
- (2) Fully close the buffer unit-1.
- (3) Remove 2 springs [1].
- (4) Release the harness from 5 harness clamps [2] and disconnect 2 relay connectors [3].

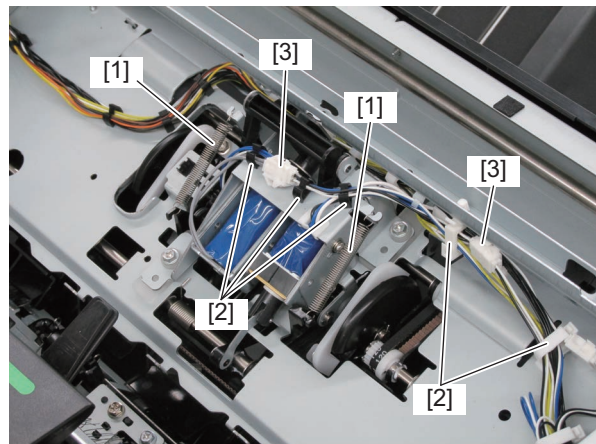

Fig. 4-265

- (5) Remove 3 screws [8] and unplug the plunger of the exit roller lift solenoid. Remove 3 spacers [4], 3 screw dampers [5], 3 solenoid dampers [6] and take off the roller lift solenoid assembly [7].

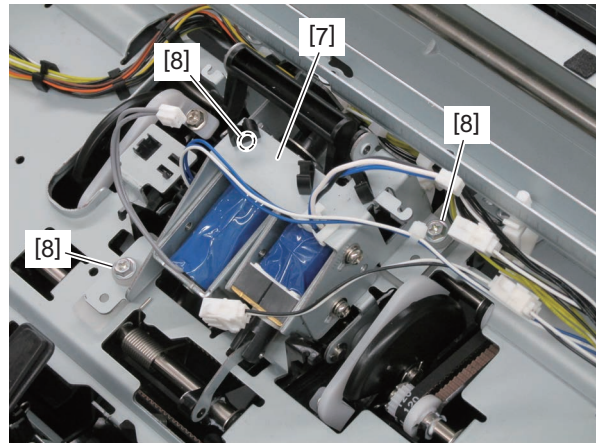

Fig. 4-266

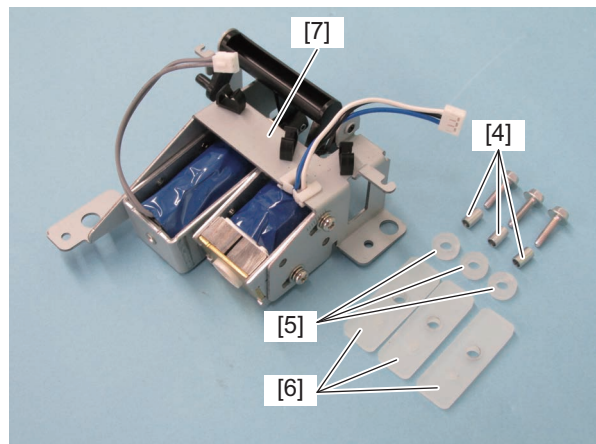

Fig. 4-267

Buffer roller lift solenoid removal procedure:

- (1) Remove 2 screws [9]. Unplug the plunger and take off the buffer roller lift solenoid [10].

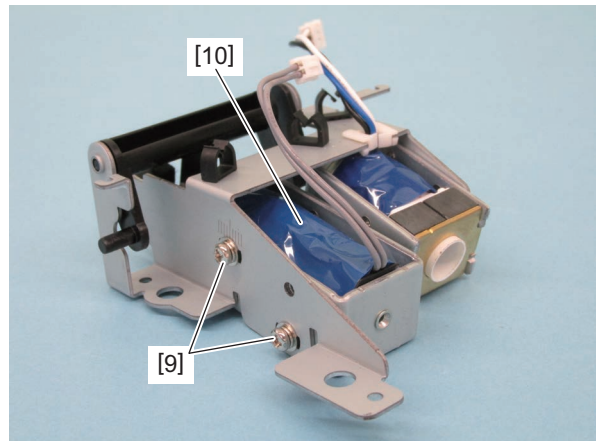

Fig. 4-268

Notes:

When installing, while the solenoid is turned ON, align the buffer roller and the buffer tray so that their gap will be within 2.0 to 3.5 mm and fix them.

Exit roller lift solenoid removal procedure:

- (1) Remove 2 screws [11]. Take off the exit roller lift solenoid [12].

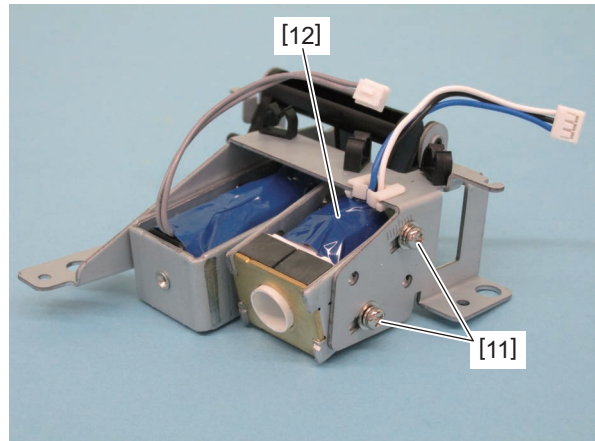

Fig. 4-269

Notes:

When installing, while the solenoid is turned ON, insert the gap adjustment jig [15] into the gap between the roller [13] of the pinch roller arm and the stack transport roller-2 [14] of the finishing tray unit. Then move the solenoid so that the roller shaft [16] of the pinch roller arm contacts the upper surface of the elongated hole [17] for the bearing to fix them.

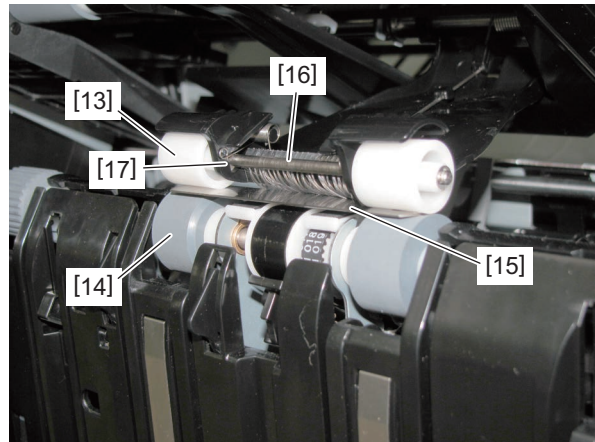

Fig. 4-270

4.8.5 Gate solenoid (SOL4)

- (1) Take off the control panel unit.
📖 P. 4-4 “4.1.4 Control panel unit”
- (2) Take off the rear cover.
📖 P. 4-7 “4.1.8 Rear cover”
- (3) Take off the right upper cover.
📖 P. 4-9 “4.1.11 Right upper cover”
- (4) Take off the right cover.
📖 P. 4-10 “4.1.12 Relay guide, Paper feed discharge brush, Right cover”
- (5) Remove 2 screws and take off the front bracket [1].
- (6) Remove 2 screws and take off the rear bracket [2].
- (7) Remove 3 screws and take off the junction box upper transport guide [3].

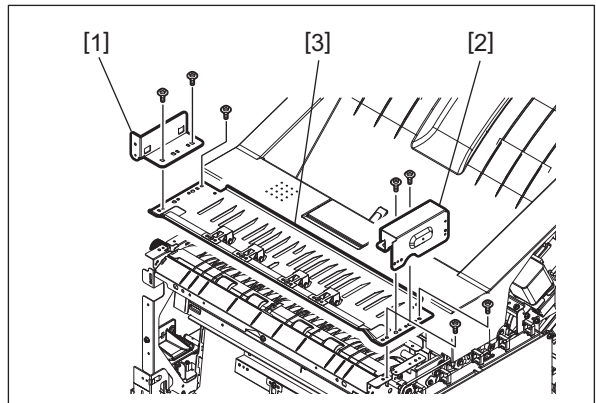

Fig. 4-271

- (8) Close the buffer unit-1 [4] halfway and remove 1 screw.

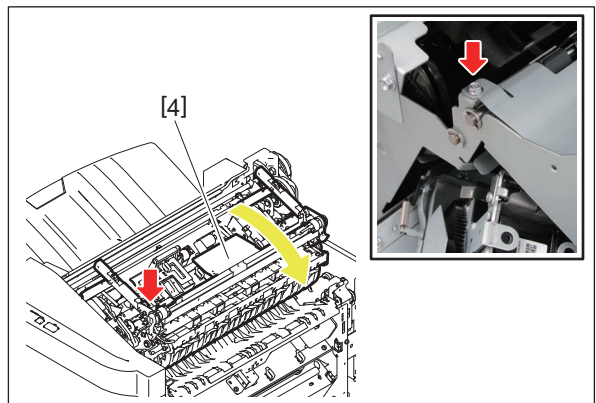

Fig. 4-272

(9) Remove 3 screws and take off the transport guide [5].

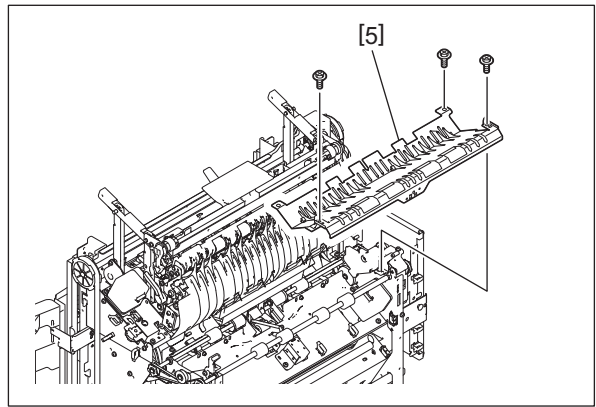

Fig. 4-273

(10) Remove the spring [6].

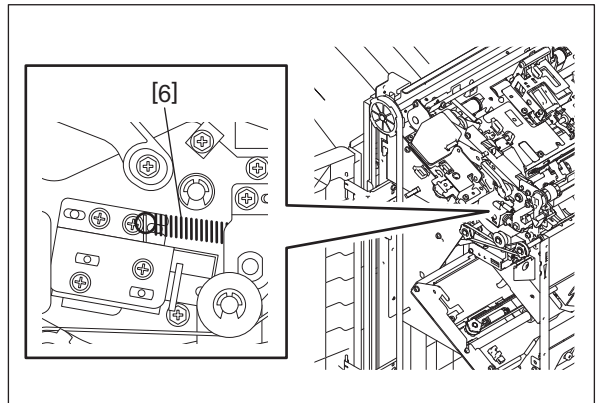

Fig. 4-274

(11) Remove 2 screws and disconnect 1 relay connector [7]. Remove the arm and take off the bracket [8].

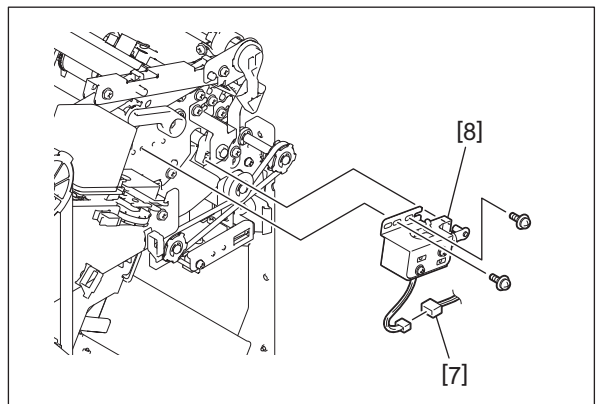

Fig. 4-275

Notes:

When installing, adjust the edge of the bracket [8] to come at the mark on the scale [9] one step left from the center as shown in the figure and fix it with 2 screws.

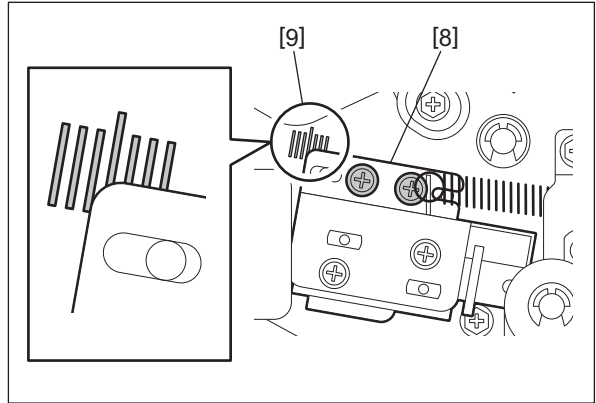

Fig. 4-276

(12) Remove 2 screws and take off the gate solenoid [10].

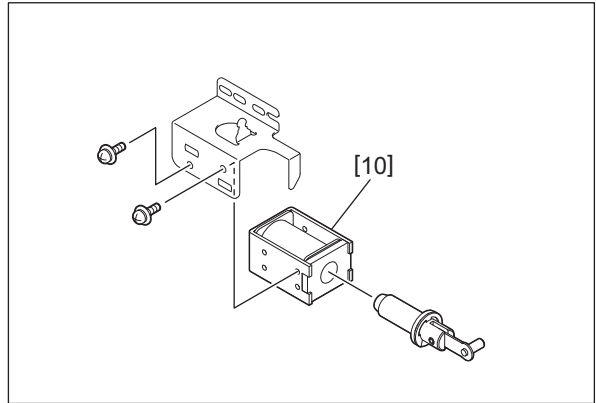

Fig. 4-277

Notes:

When the gate solenoid is not replaced with a new one: Install the bracket [8] by aligning it to the position A and fix it with 2 screws.

When the gate solenoid is replaced with a new one: Install the bracket [8] by aligning it to the position B and fix it with 2 screws while the gap [13] between the gate flap [11] and the shaft [12] of the entrance roller is within 0.4 to 0.8 mm.

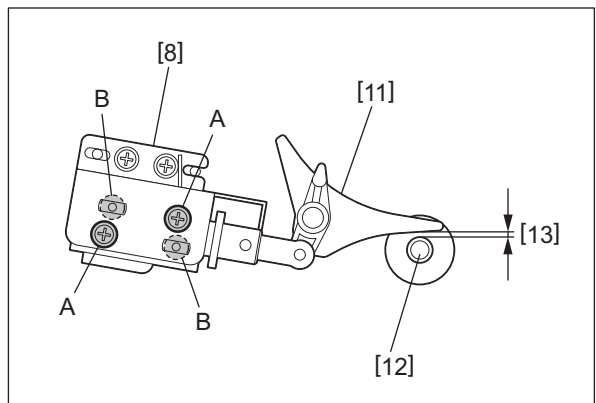



Fig. 4-278

4.8.6 Transport path switching solenoid (SOL5) (MJ-1116)

- (1) Take off the rear cover.
 P. 4-7 "4.1.8 Rear cover"
- (2) Take off the right upper cover.
 P. 4-9 "4.1.11 Right upper cover"
- (3) Remove 2 screws and take off the front bracket [1].
- (4) Remove 2 screws and take off the rear bracket [2].
- (5) Remove 3 screws and take off the junction box upper transport guide [3].

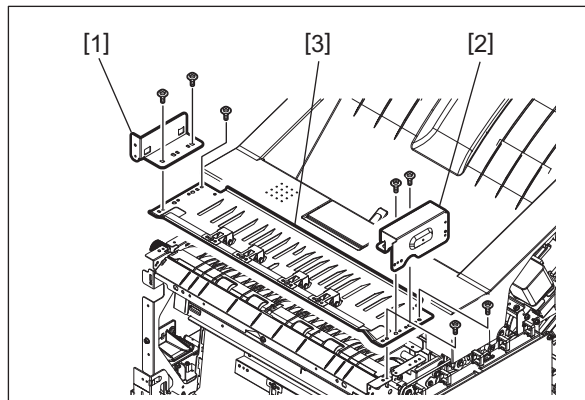

Fig. 4-279

- (6) Open the stationary tray.
- (7) Remove the spring [4] and loosen 2 screws. Release the tension of the belt [5] and remove it.

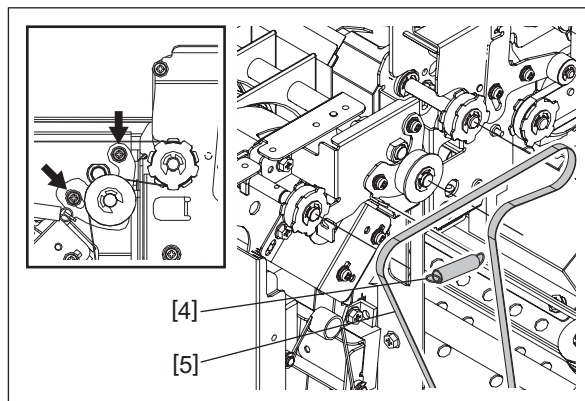

Fig. 4-280

- (8) Disconnect 1 relay connector [6] and cut off 1 binding band [7].

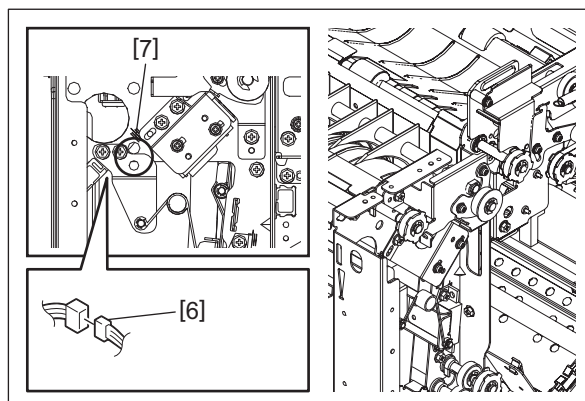

Fig. 4-281

- (9) Remove 2 screws, the arm [8] and take off the transport path switching solenoid [9].

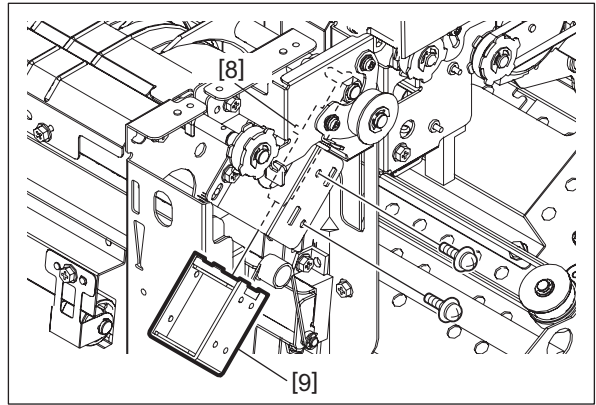

Fig. 4-282

Notes:

When installing, perform adjustment for both cases in which the solenoid is turned ON and OFF.

1. When the solenoid is turned OFF: Align the transport guide [1] so that the gap [3] between its surface and the upper side of the flap [2] edge is within 1.5 to 2.1 mm. Fix the solenoid with 2 screws.

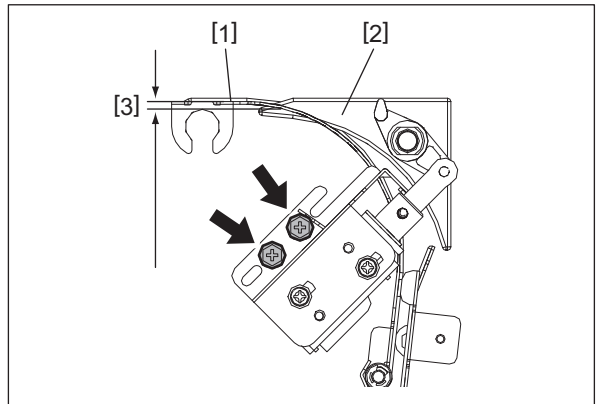

Fig. 4-283

2. When the solenoid is turned ON: Align the transport guide [1] so that the gap [3] between its surface and the upper side of the flap [2] edge is within 2.3 to 2.9 mm. Fix the solenoid with 2 screws.

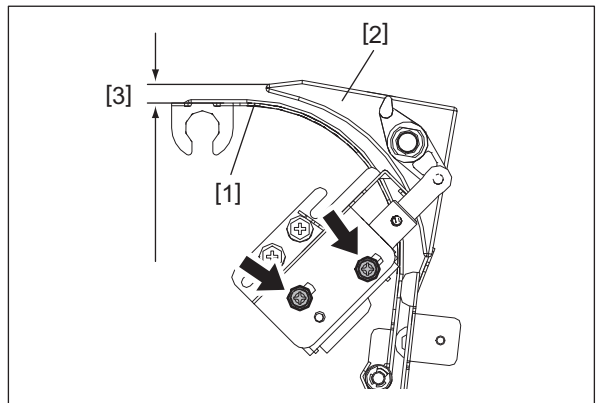

Fig. 4-284

4.8.7 Assist roller solenoid (SOL6) (MJ-1116)

- (1) Take off the switchback unit.
📖 P. 4-36 "4.3.2 Switchback unit"
- (2) Take off the paper holding unit.
📖 P. 4-37 "4.3.3 Paper holding unit"
- (3) Remove 4 screws of the stacker guide [1] and lift it up so that its back side can be seen.

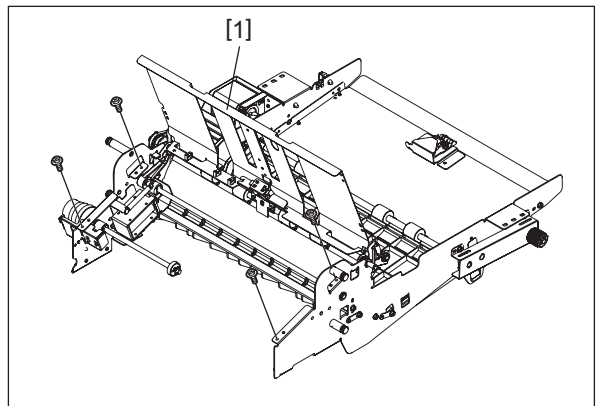

Fig. 4-285

Notes:

Be careful not to damage the harness fixed on the back side of the stacker guide [1] with a clamp.

- (4) Disconnect the relay connector [2] and release the harness from 2 harness clamps [3].

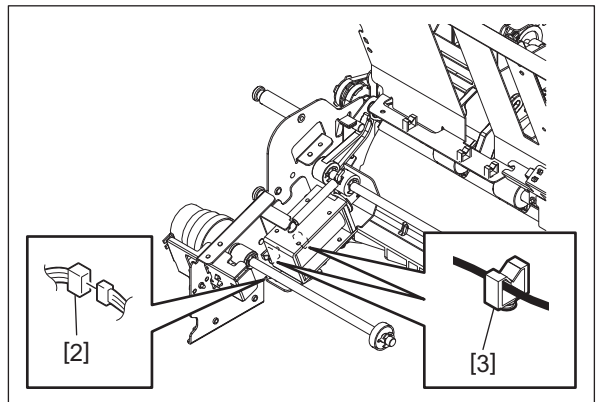

Fig. 4-286

- (5) Remove the spring [4].
- (6) Remove 2 screws and take off the assist roller solenoid [5].

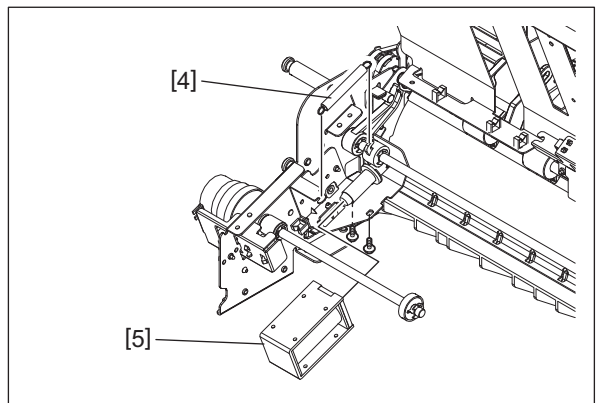

Fig. 4-287

4.9 Sensor, Switch (Finisher Section)

4.9.1 Entrance sensor (S1)

- (1) Take off the stationary tray.
📖 P. 4-1 “4.1.1 Stationary tray”
- (2) Close the buffer unit-1 halfway and remove 1 screw. Disconnect 1 connector and take off the sensor bracket [1].

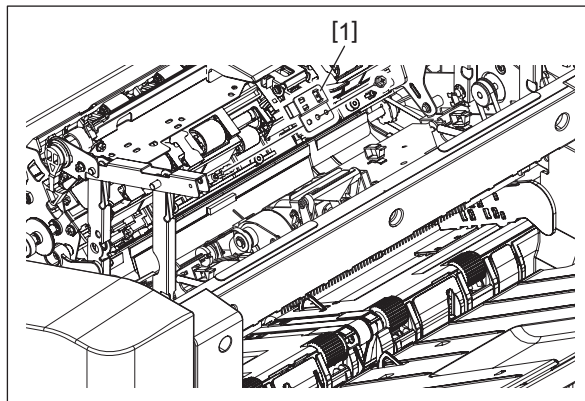

Fig. 4-288

- (3) Release the latch and take off the entrance sensor [2].

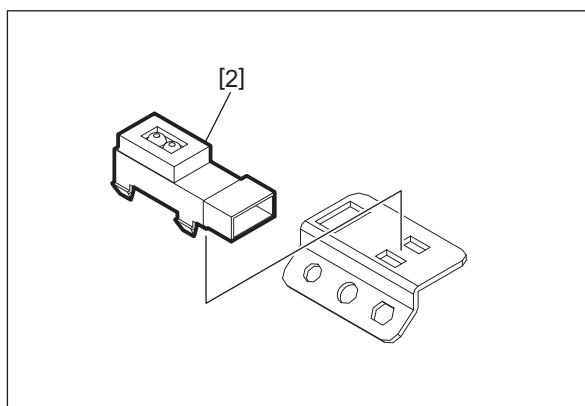

Fig. 4-289

4.9.2 Transport sensor (S2)

- (1) Take off the stationary tray.
📖 P. 4-1 “4.1.1 Stationary tray”
- (2) Close the buffer unit-1 halfway and remove 2 screws. Disconnect 1 connector [2] and take off the sensor bracket [1].

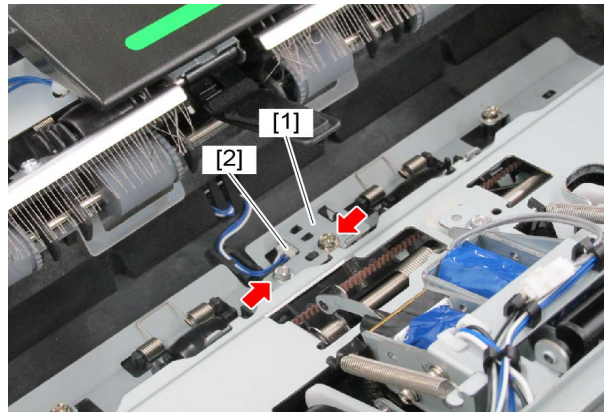

Fig. 4-290

- (3) Release the latch and take off the transport sensor [3].

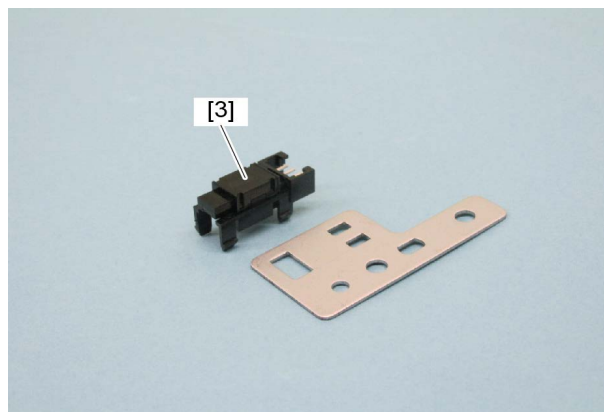

Fig. 4-291

4.9.3 Paddle home position sensor (S3)

- (1) Take off the stationary tray.
📖 P. 4-1 “4.1.1 Stationary tray”
- (2) Take off the control panel unit.
📖 P. 4-4 “4.1.4 Control panel unit”
- (3) Take off the rear cover.
📖 P. 4-7 “4.1.8 Rear cover”
- (4) Take off the right upper cover.
📖 P. 4-9 “4.1.11 Right upper cover”
- (5) Take off the right cover.
📖 P. 4-10 “4.1.12 Relay guide, Paper feed discharge brush, Right cover”
- (6) Take off the junction box unit.
📖 P. 4-16 “4.2.1 Junction box unit”
- (7) Close the buffer unit-1 [1] halfway and remove 1 screw.

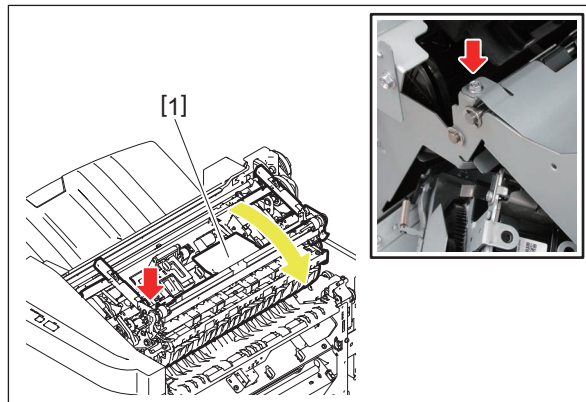

Fig. 4-292

- (8) Remove 3 screws and take off the transport guide [2].

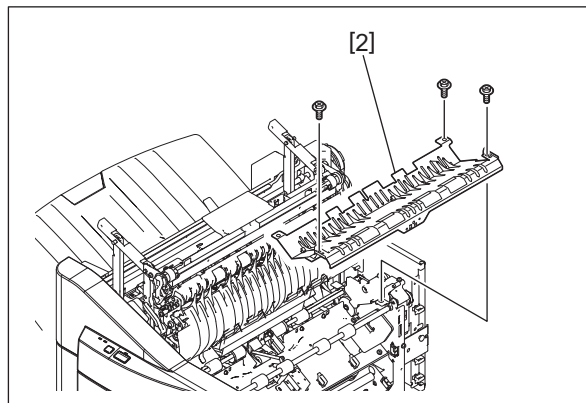

Fig. 4-293

- (9) Remove 1 screw and take off the ground wire [3].
- (10) Release the PC board cover [4] from 2 harness clamps [5].

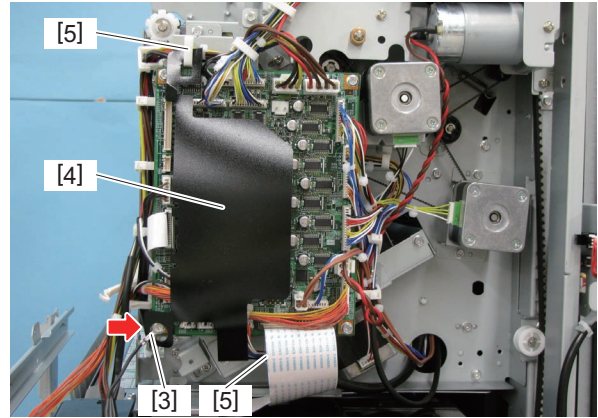

Fig. 4-294

- (11) Disconnect all the connectors on the finisher control PC board and release the harnesses from the harness clamps.
- (12) Remove 3 screws and take off the bracket [6] of the finisher control PC board.

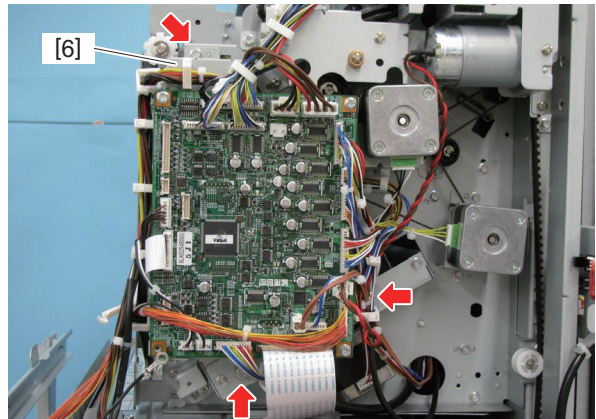

Fig. 4-295

- (13) Remove 1 screw, disconnect 1 connector and take off the sensor bracket [7].

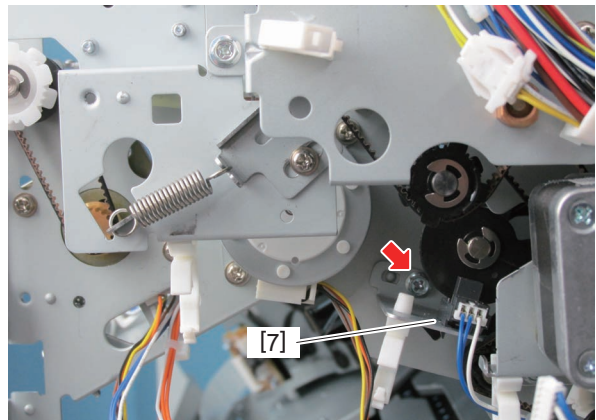

Fig. 4-296

(14) Release the latch and take off the paddle home position sensor [8].

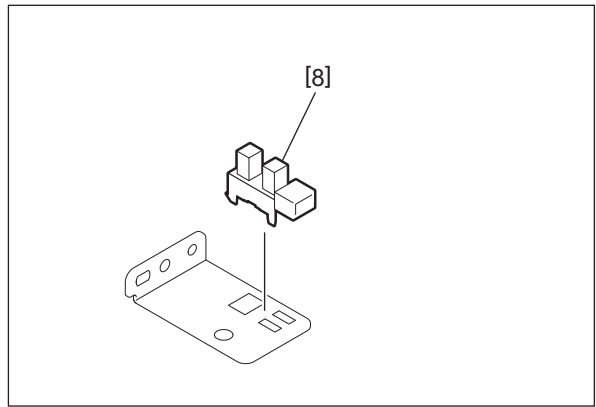

Fig. 4-297

4.9.4 Buffer tray home position sensor (S5)

- (1) Take off the stationary tray.
P. 4-1 "4.1.1 Stationary tray"
- (2) Take off the control panel unit.
P. 4-4 "4.1.4 Control panel unit"
- (3) Move the buffer guide [1] to the center.

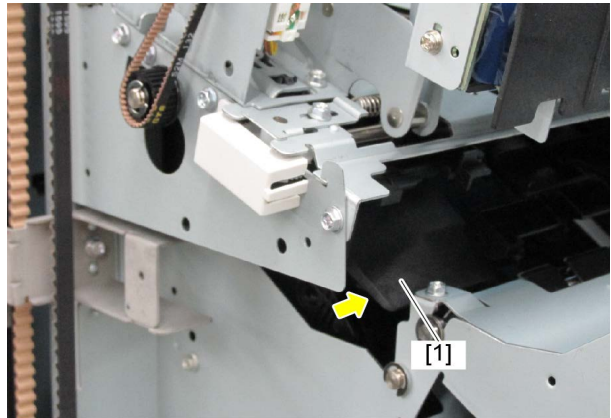

Fig. 4-298

(4) Disconnect 1 connector. Release the latch and take off the buffer tray home position sensor [2].

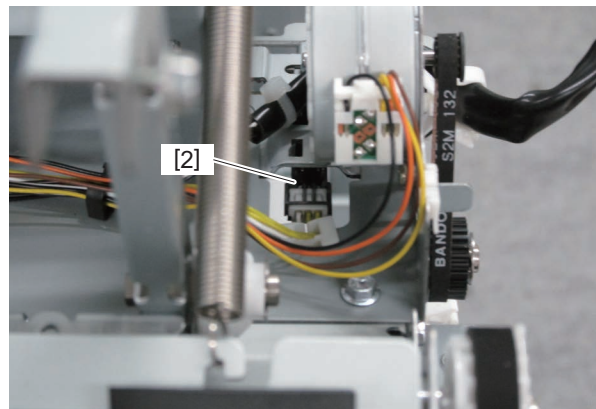

Fig. 4-299

4.9.5 Assist guide home position sensor (S6)

- (1) Take off the stationary tray.
📖 P. 4-1 “4.1.1 Stationary tray”
- (2) Take off the roller lift solenoid assembly.
📖 P. 4-108 “4.8.4 Buffer roller lift solenoid (SOL2), Exit roller lift solenoid (SOL8)”
- (3) Release the latch. Disconnect 1 connector [1] and take off the assist guide home position sensor [2].

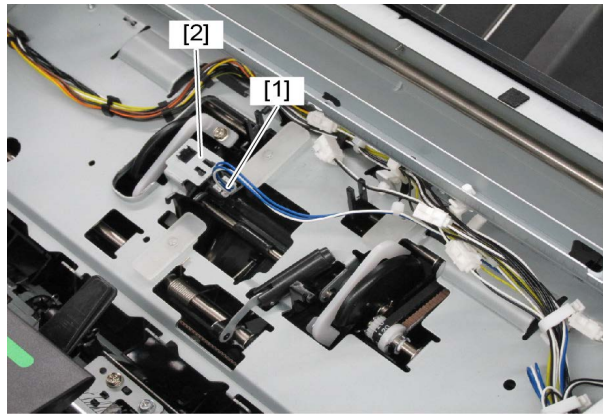

Fig. 4-300

4.9.6 Front alignment plate home position sensor (S7)

- (1) Take off the grate-shaped guide.
📖 P. 4-12 “4.1.15 Grate-shaped guide”
- (2) Release the latch. Disconnect 1 connector and take off the front alignment plate home position sensor [1].

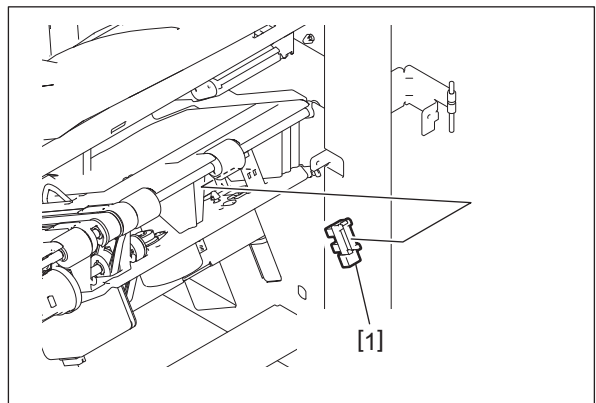

Fig. 4-301

4.9.7 Rear alignment plate home position sensor (S8)

- (1) Take off the grate-shaped guide.
📖 P. 4-12 "4.1.15 Grate-shaped guide"
- (2) Release the latch. Disconnect 1 connector and take off the rear alignment plate home position sensor [1].

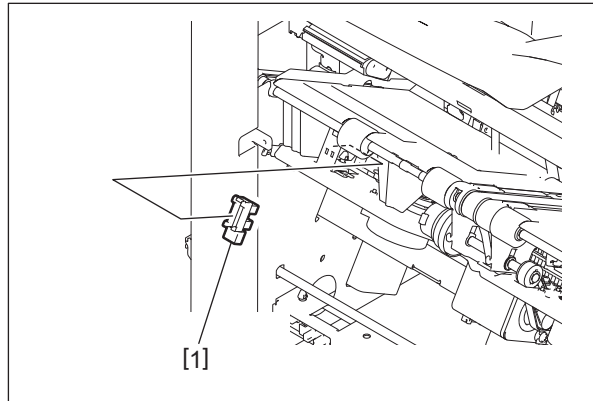

Fig. 4-302

4.9.8 Stack exit belt home position sensor (S9)

- (1) Take off the finishing tray unit.
📖 P. 4-25 "4.2.4 Finishing tray unit"
- (2) Remove 2 screws.

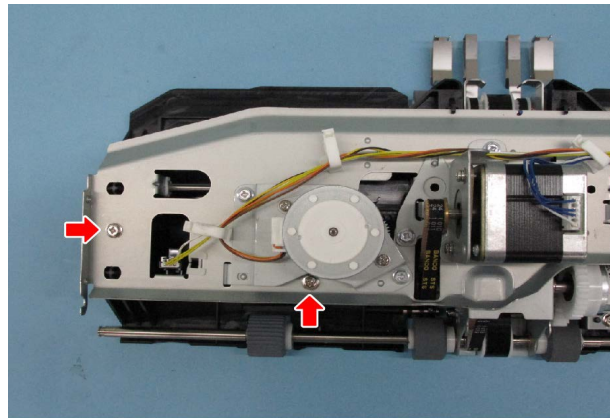

Fig. 4-303

- (3) Turn over the finishing tray unit. Slide the front finishing tray cover [1] to outside and lift it up. Release the link portion [2] inside the front finishing tray cover [1] to take it off.

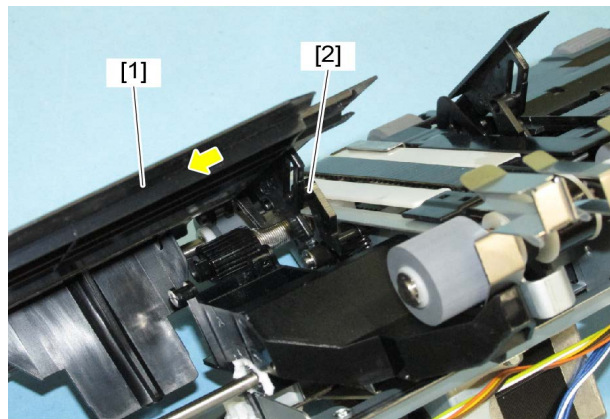

Fig. 4-304

- (4) Move the front alignment plate guide [3] in the direction of the arrow.
- (5) Remove 1 screw, disconnect 1 connector [4] and take off the sensor bracket [5].

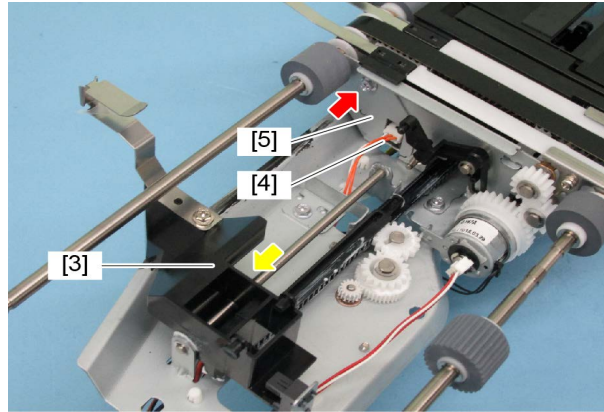

Fig. 4-305

- (6) Release the latch and take off the stack exit belt home position sensor [6].

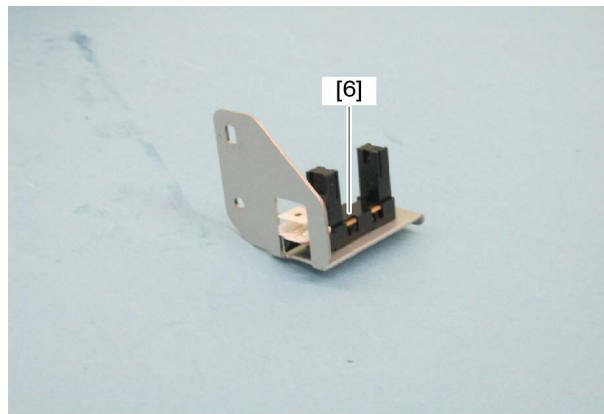

Fig. 4-306

4.9.9 Stapler unit home position sensor (S10)

- (1) Open the front cover (MJ-1115) or the front upper cover (MJ-1116).
- (2) Move the stapler to the position where the stapler unit home position sensor [1] can be seen.
- (3) Disconnect 1 connector. Release the latch and take off the stapler unit home position sensor [1].

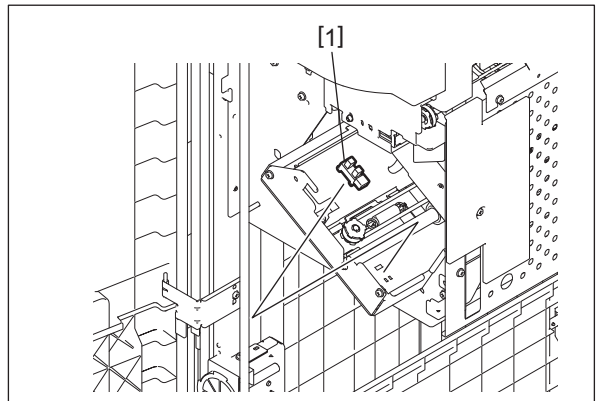

Fig. 4-307

4.9.10 Stapler interference sensor (S11), Actuator

- (1) Take off the stapler.
P. 4-29 “4.2.6 Stapler”
- (2) Disconnect 1 connector [1]. Release the latch and take off the stapler interference sensor [2].

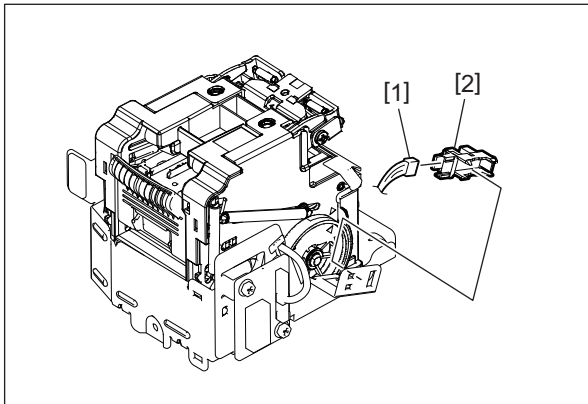

Fig. 4-308

- (3) Remove 1 clip [3] and take off the stapler base frame [4].

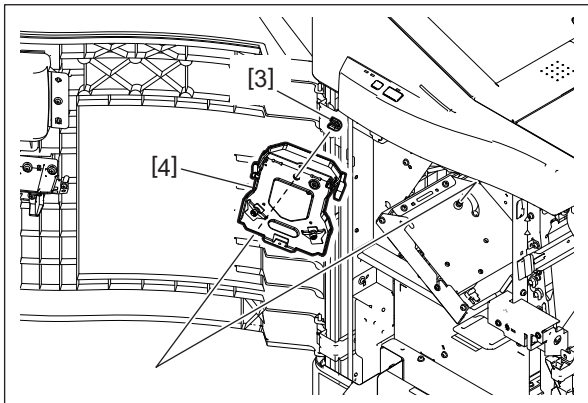

Fig. 4-309

- (4) Remove 1 spring [5], 1 clip [6] and the actuator [7].

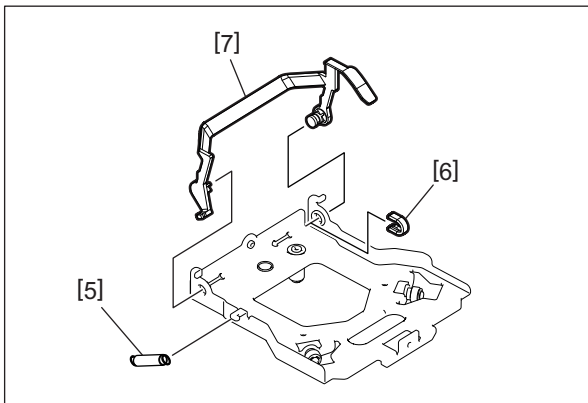

Fig. 4-310

Notes:

When installing the actuator [7], be sure to insert the clip [6] from the side of the actuator as shown in the figure.

4.9.11 Finishing tray paper sensor (S12)

- (1) Take off the finishing tray unit.
📖 P. 4-25 "4.2.4 Finishing tray unit"
- (2) Remove 2 screws.

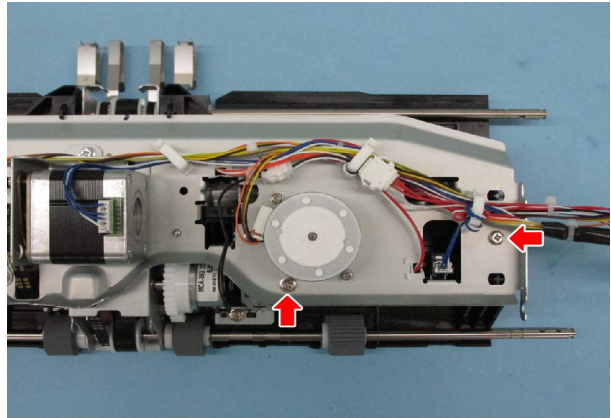

Fig. 4-311

- (3) Turn over the finishing tray unit. Slide the rear finishing tray cover [2] to outside and lift it up. Release the link portion [1] inside the rear finishing tray cover.

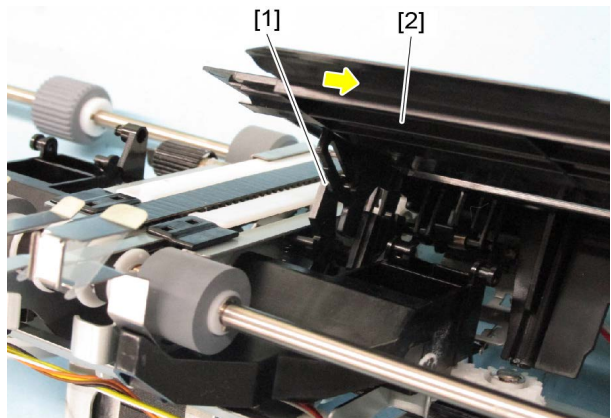

Fig. 4-312

- (4) Disconnect 1 connector [5] of the finishing tray paper sensor and take off the rear finishing tray cover [3].

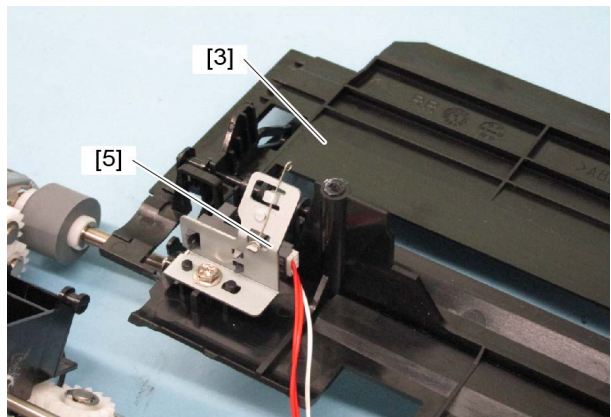

Fig. 4-313

(5) Remove 1 screw and take off the sensor bracket [6].

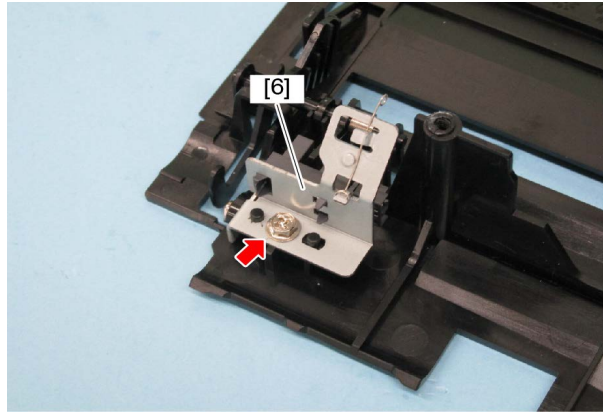

Fig. 4-314

(6) Release the latch and take off the finishing tray paper sensor [7].

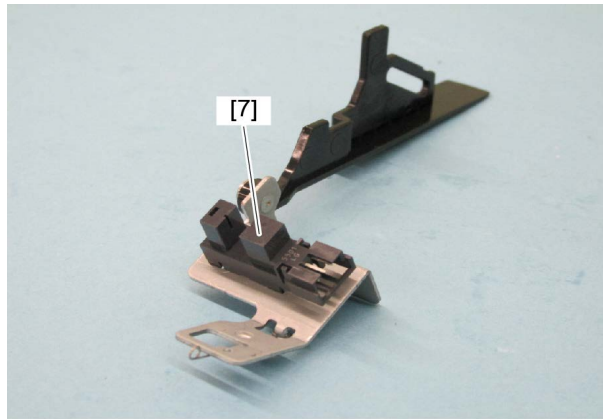

Fig. 4-315

4.9.12 Movable tray position-A sensor (S13), Movable tray position-B sensor (S14), Movable tray position-C sensor (S15)

- (1) Take off the rear cover.
📖 P. 4-7 “4.1.8 Rear cover”
- (2) Move the movable tray [1] to the middle position. If the movable tray [1] needs to be lowered, push the gear [2] of the movable tray shift motor unit in the direction of the arrow to release the lock. (Be sure to hold the movable tray [1] with your hand because it may fall when the gear is pushed.)

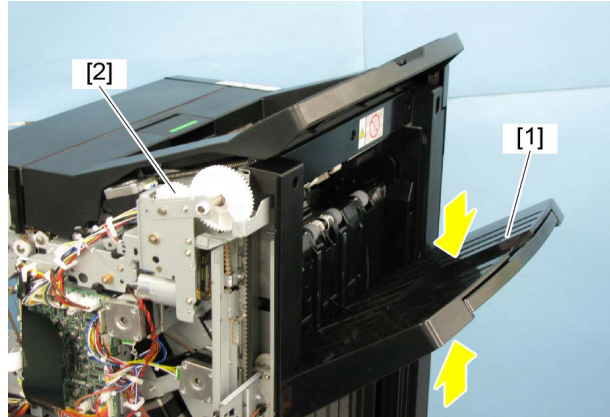

Fig. 4-316

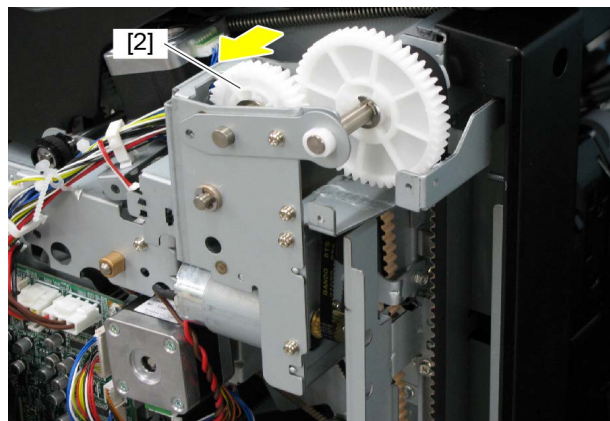

Fig. 4-317

- (3) Remove 2 screws and take off the sensor rail [3].

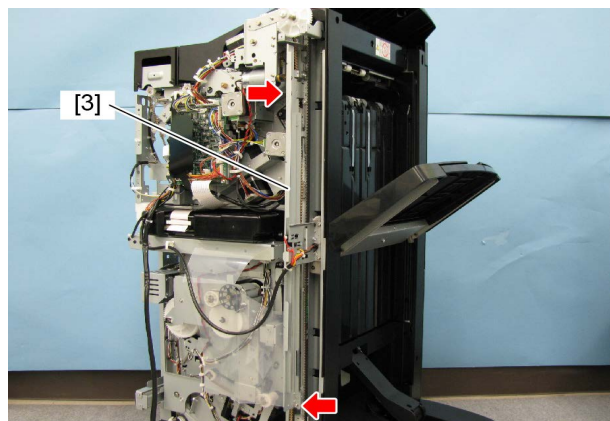
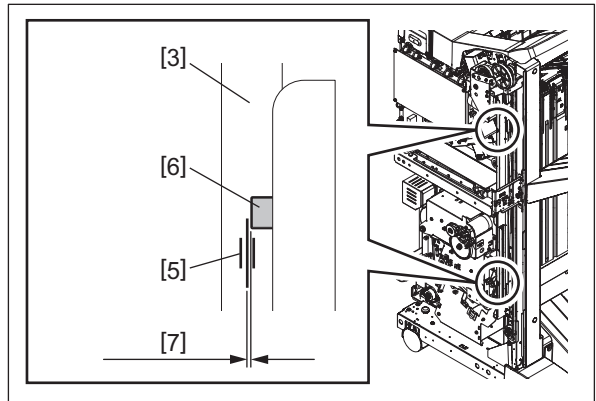

Fig. 4-318

Notes:

When installing, fix the sensor rail [3] at the position where the gap [7] between the center mark of its scale [5] and the edge of the movable tray position-A sensor [6] is from 0 to 1.0 mm. Be sure to perform the measurement on the positions at the upper and lower scales [5] on the sensor rail [3] by moving the movable tray shift frame as shown in the figure.

**Fig. 4-319**

- (4) Disconnect 3 connectors and release the latch. Take off the movable tray position-A sensor [8], movable tray position-B sensor [9] and movable tray position-C sensor [10].

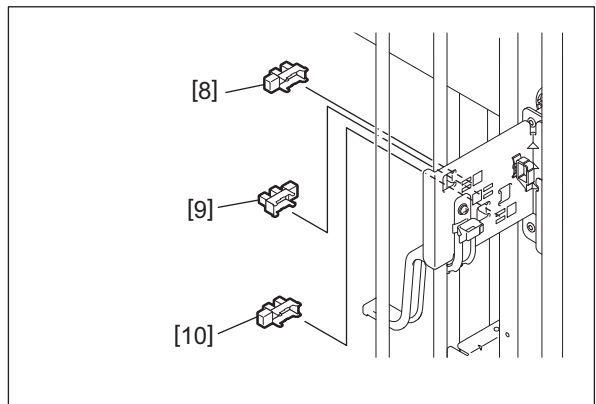
**Fig. 4-320**

4.9.13 Movable tray stack height detection sensor (S16)

- (1) Take off the grate-shaped guide.
 P. 4-12 "4.1.15 Grate-shaped guide"
- (2) Move the shutter of the grate-shaped guide upward.
- (3) Disconnect 1 connector. Release the latch and take off the movable tray stack height detection sensor [1].

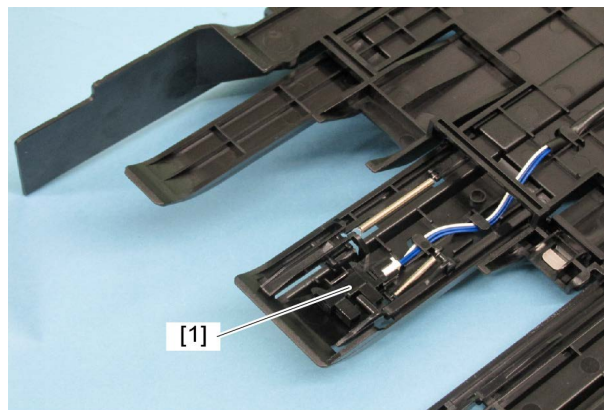
**Fig. 4-321**

4.9.14 Movable tray paper sensor (S17)

- (1) Take off the movable tray.
📖 P. 4-2 “4.1.2 Movable tray”
- (2) Disconnect 1 connector. Release the latch and take off the movable tray paper sensor [1].

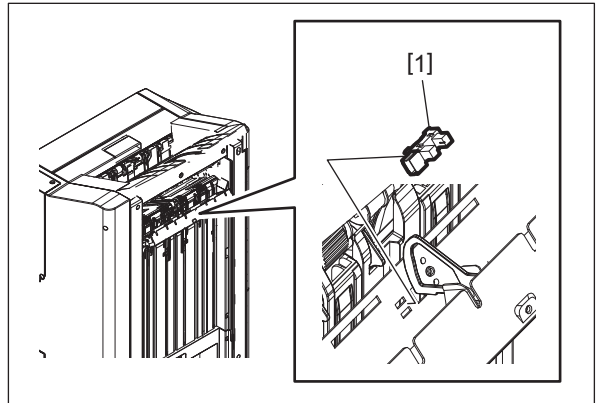

Fig. 4-322

4.9.15 Stationary tray stack height detection sensor (S18)

- (1) Take off the stationary tray.
📖 P. 4-1 “4.1.1 Stationary tray”
- (2) Hold up the jam access lever [1]. Remove 1 screw, disconnect 1 connector and take off the bracket [2].

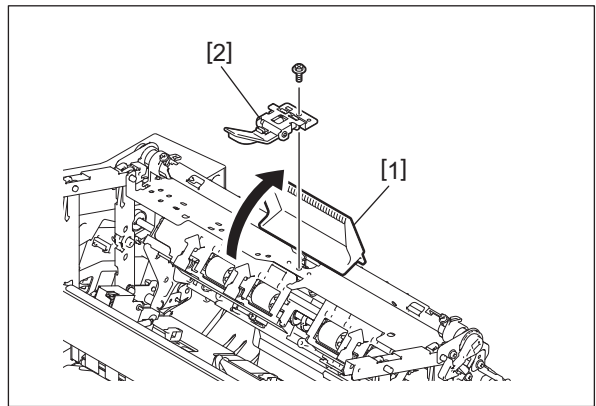

Fig. 4-323

- (3) Remove 1 screw and take off the actuator [3] and the spacer [4].

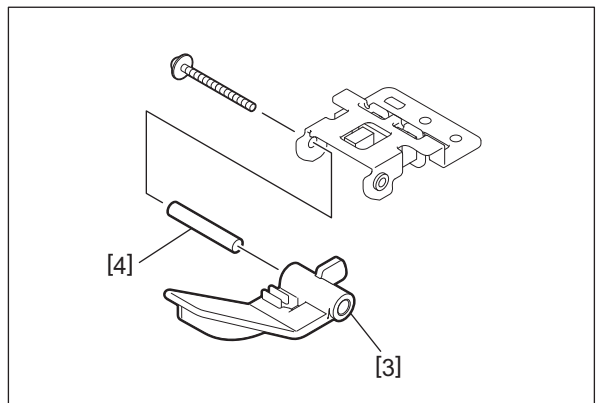

Fig. 4-324

- (4) Release the latch and take off the stationary tray stack height detection sensor [5].

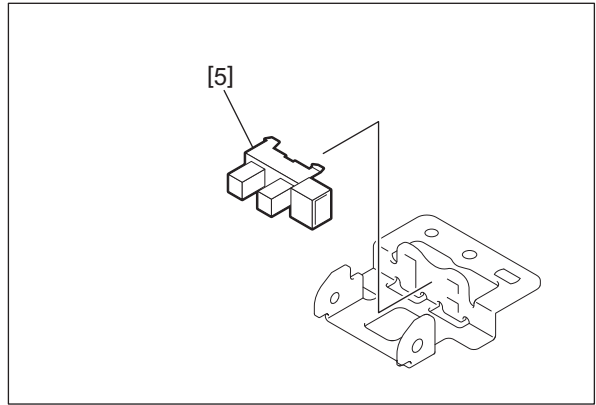

Fig. 4-325

4.9.16 Paper feed sensor (S22)

- (1) Take off the right cover.
P. 4-10 "4.1.12 Relay guide, Paper feed discharge brush, Right cover"
(2) Remove 1 screw, disconnect 1 connector and take off the sensor bracket [1].

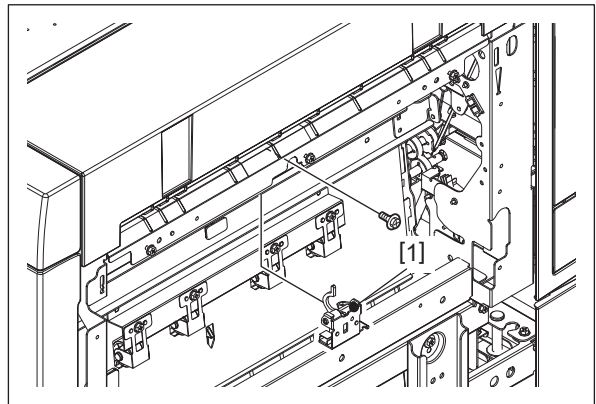

Fig. 4-326

- (3) Release the latch and take off the paper feed sensor [2].

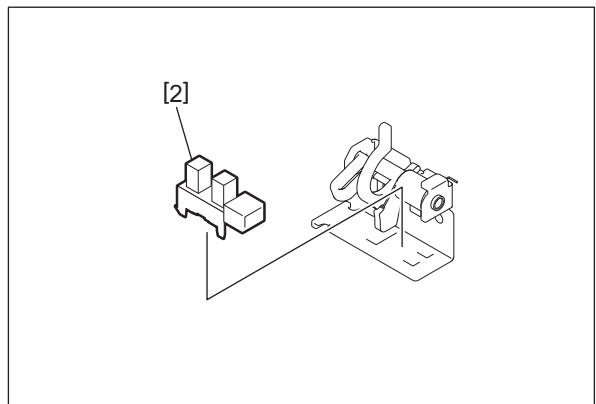

Fig. 4-327

4.9.17 Movable tray shift motor sensor (S23)

- (1) Take off the rear cover.
📖 P. 4-7 "4.1.8 Rear cover"
- (2) Remove 1 screw, disconnect 1 connector and take off the sensor bracket [1].

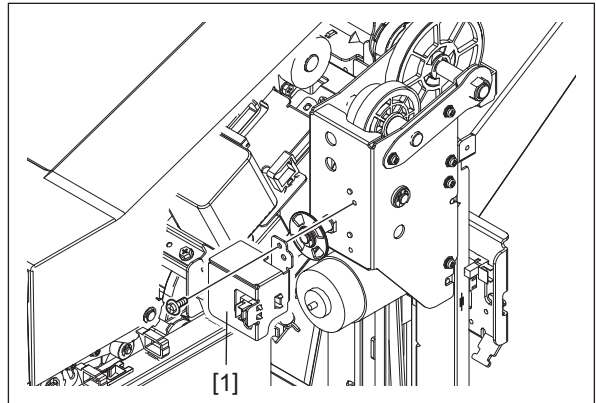

Fig. 4-328

- (3) Release the latch and take off the movable tray shift motor sensor [2].

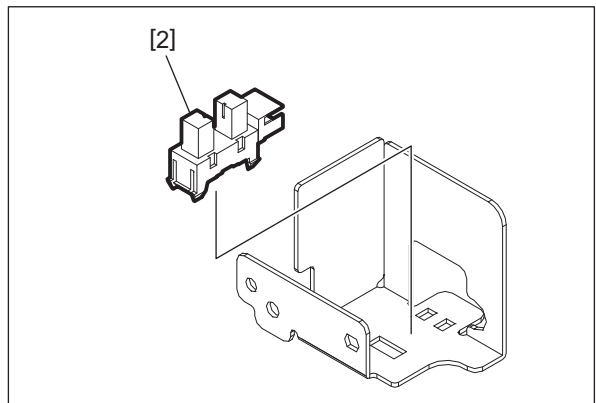

Fig. 4-329

4.9.18 Connection sensor (S25)

- (1) Take off the right cover.
📖 P. 4-10 "4.1.12 Relay guide, Paper feed discharge brush, Right cover"
- (2) Disconnect 1 connector [1]. Release the latch and take off the connection sensor [2].

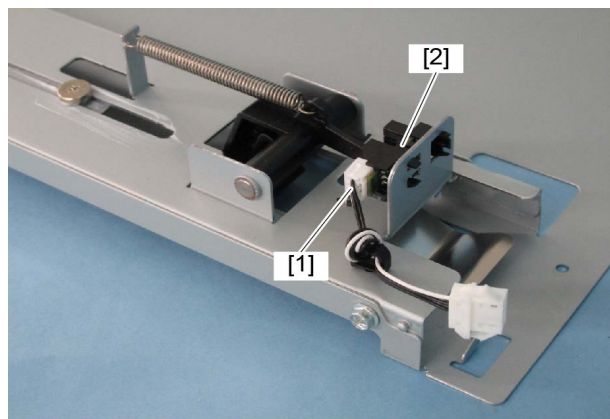

Fig. 4-330

4.9.19 Catching home position sensor (S52)

- (1) Take off the junction box unit.
P. 4-16 "4.2.1 Junction box unit"
- (2) Disconnect 1 connector [1] and take off the side catching home position sensor [2].

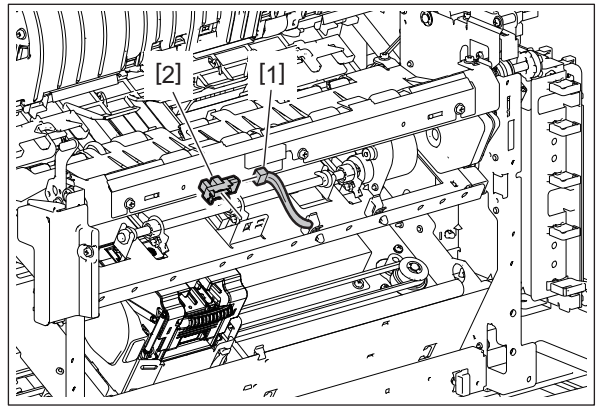

Fig. 4-331

4.9.20 Front cover opening/closing switch (SW1)

- (1) Take off the right cover.
P. 4-10 "4.1.12 Relay guide, Paper feed discharge brush, Right cover"
- (2) Open the front cover (MJ-1115) or the front upper cover (MJ-1116).
- (3) Remove 2 screws and take off the sensor plate [1].

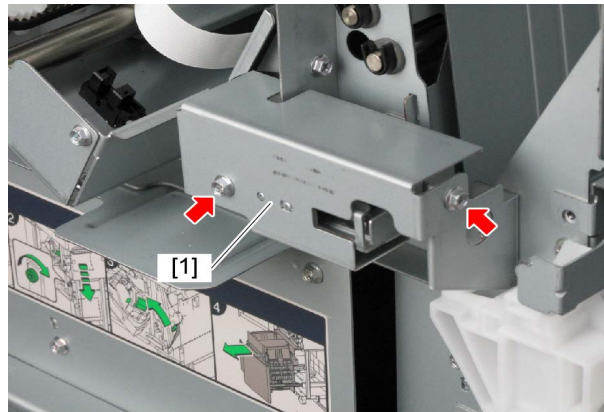

Fig. 4-332

- (4) Remove 2 screws, disconnect the connector [2] and take off the switch bracket [3].

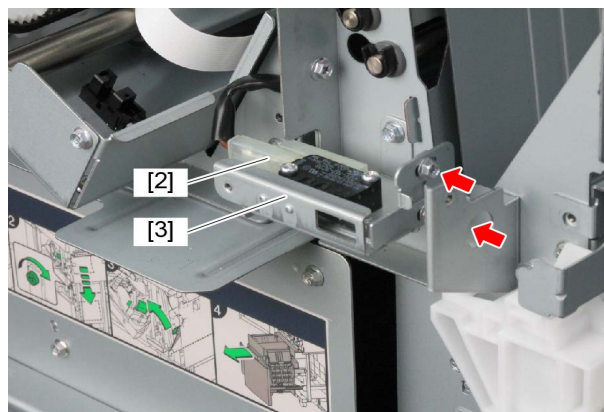

Fig. 4-333

- (5) Remove 2 screws and take off the front cover opening/closing switch [4].

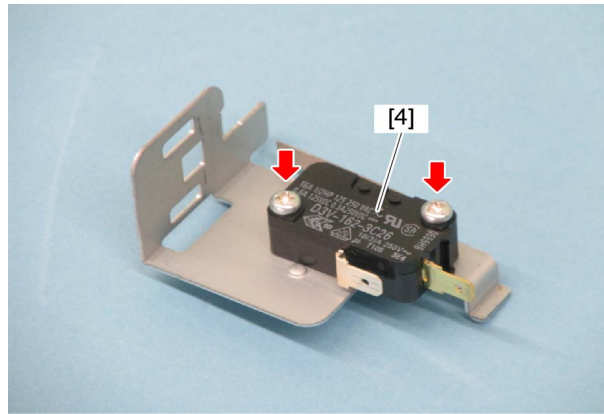

Fig. 4-334

4.9.21 Stationary tray opening/closing switch (SW2)

- (1) Take off the rear cover.
P. 4-7 "4.1.8 Rear cover"
- (2) Remove 1 screw and take off the ground wire [1].
- (3) Release the PC board cover [2] from 2 harness clamps [3].

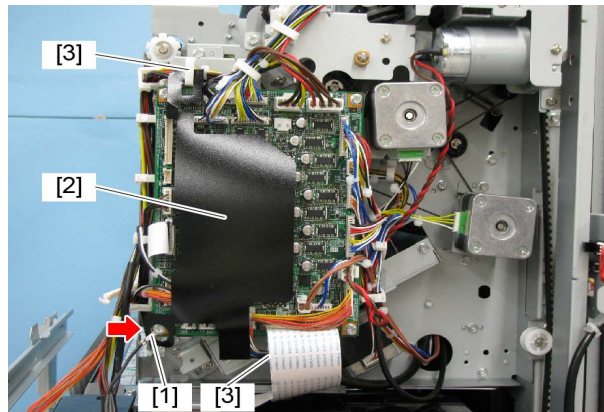

Fig. 4-335

- (4) Disconnect all the connectors on the finisher control PC board and release the harnesses from the harness clamps.
- (5) Remove 3 screws and take off the bracket [4] of the finisher control PC board.

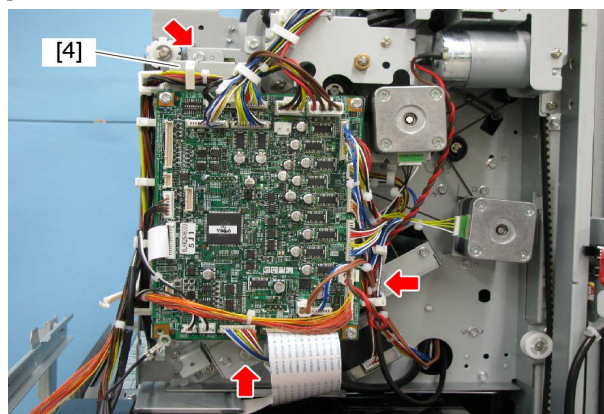

Fig. 4-336

- (6) Remove 5 screws and take off the motor bracket [7].

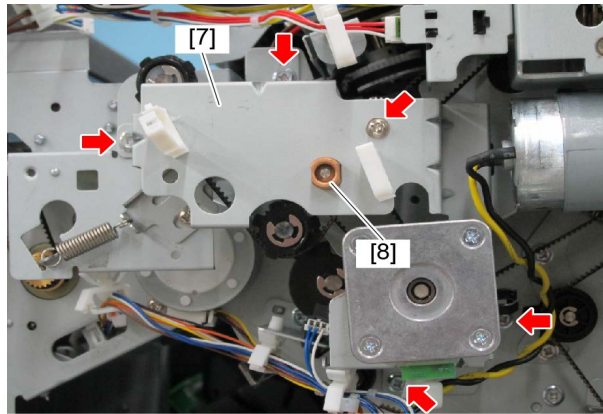

Fig. 4-337

Notes:

Be careful not to lose the bushing [8] removed while taking off the motor bracket [7].

- (7) Loosen 1 screw. Push the pulley [9] in the direction indicated by the arrow so as the belt tension is loosened as a result. Then tighten the screw.
(8) Remove the belts [10] and [11], 1 assembled part [12] and 1 bearing.

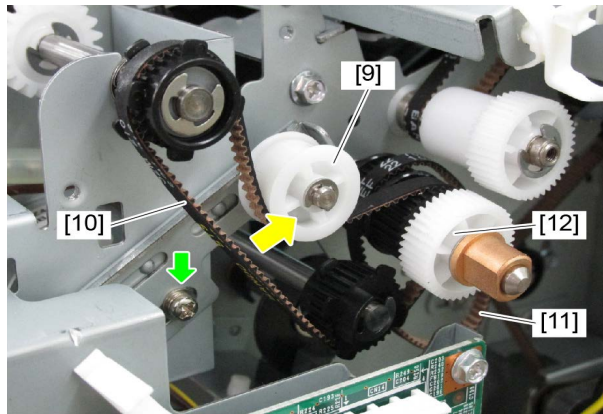

Fig. 4-338

Notes:

Be careful not to lose the bearing while taking off the assembled part [12].

- (9) Remove 1 E-ring [13]. Take off the bearing [14] and the shaft [15].

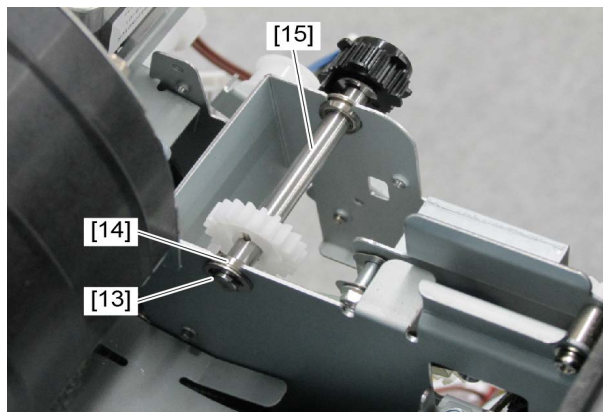

Fig. 4-339

(10) Remove 2 screws and take off the switch bracket [16].

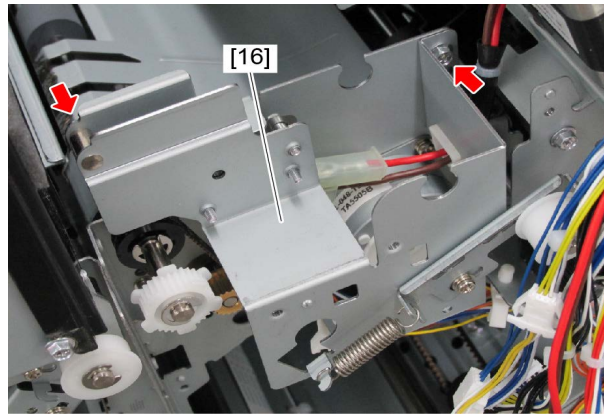

Fig. 4-340

(11) Disconnect the connector [17].

(12) Remove 2 screws and take off the stationary tray opening/closing switch [18].

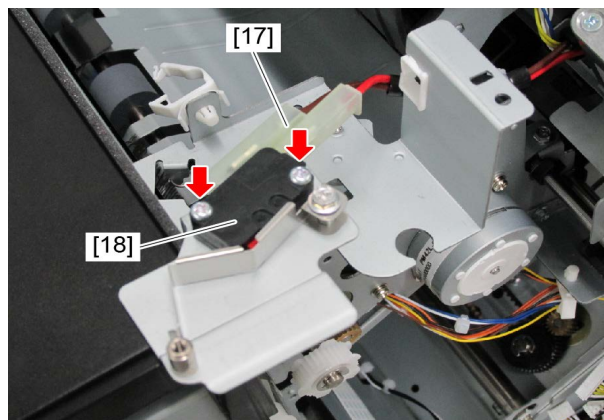

Fig. 4-341

4.9.22 Stapler interference switch (SW3)

(1) Take off the stapler unit.

📖 P. 4-28 "4.2.5 Stapler unit"

(2) Disconnect 2 connectors [1].

(3) Remove 2 screws and take off the stapler interference switch [2].

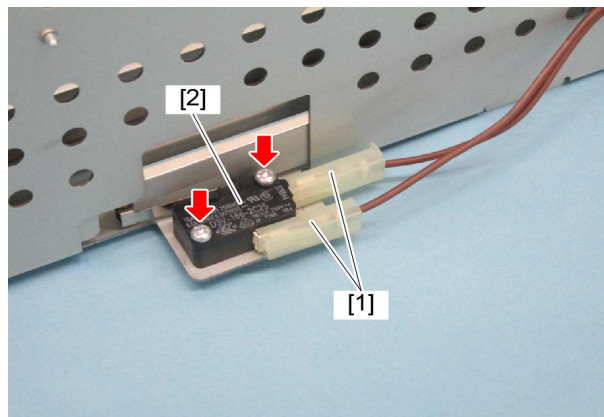

Fig. 4-342

4.9.23 Connection switch (SW4)

- (1) Take off the board access cover.
📖 P. 4-8 "4.1.9 Board access cover"
- (2) Remove 1 spring [1].
- (3) Remove 1 shoulder screw [2] and take off the bracket [3] of the connection switch.
- (4) Remove 1 binding band [4] which bundles the harnesses.
- (5) Disconnect 1 connector [5] and take off the bracket [3] of the connection switch.

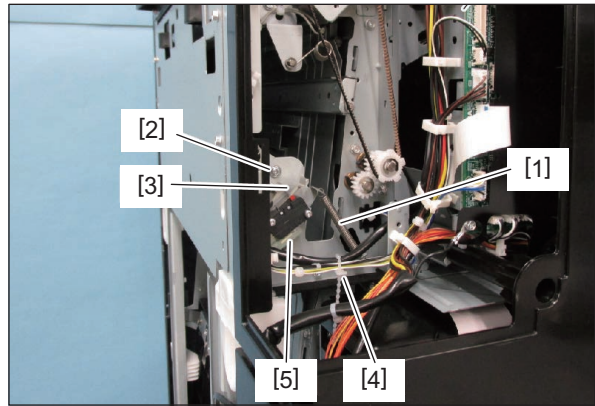

Fig. 4-343

- (6) Remove 2 screws and take off the connection switch [6].

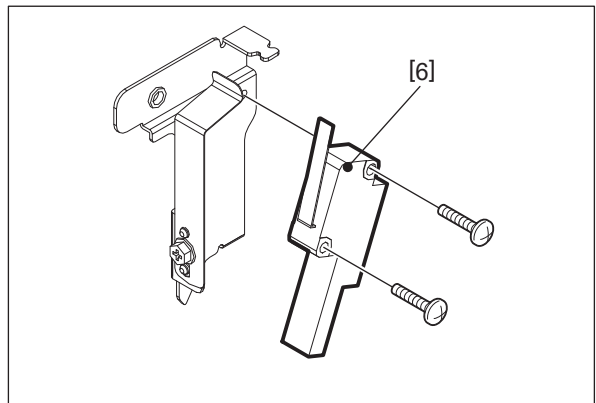



Fig. 4-344

4.10 Sensor, Switch (Saddle Stitch Section: MJ-1116)

4.10.1 Junction box sensor (S26)

- (1) Take off the junction box unit.
 P. 4-16 “4.2.1 Junction box unit”
- (2) Remove 1 screw, disconnect 1 connector and take off the sensor bracket [1].

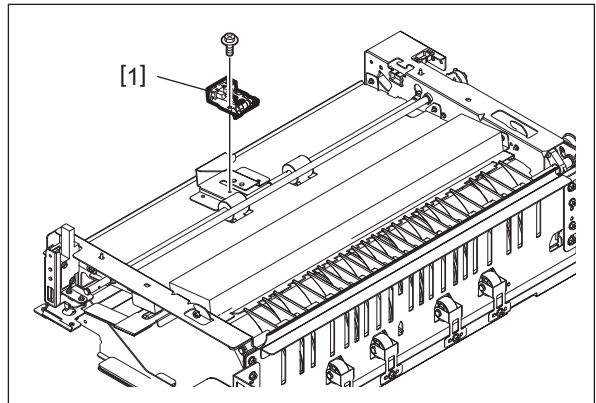

Fig. 4-345

- (3) Release the latch and take off the junction box sensor [2].

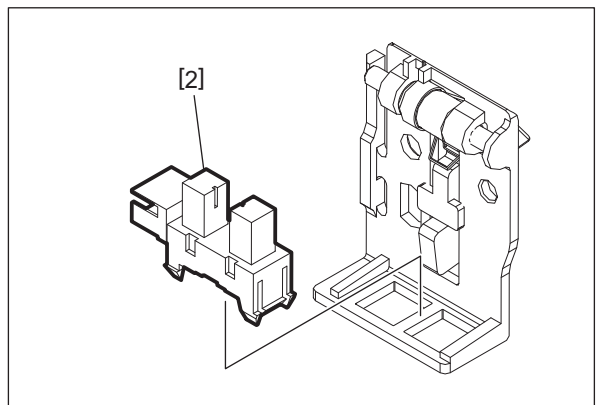

Fig. 4-346

4.10.2 Transport path-2 sensor (S27)

- (1) Open the front upper cover and pull out the saddle stitch unit.
- (2) Remove 4 screws and take off the upper safety cover [1].

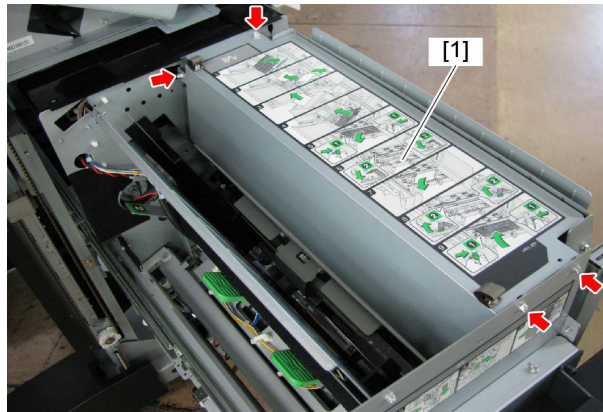

Fig. 4-347

- (3) Remove 1 screw, disconnect 1 connector and take off the sensor bracket [2].

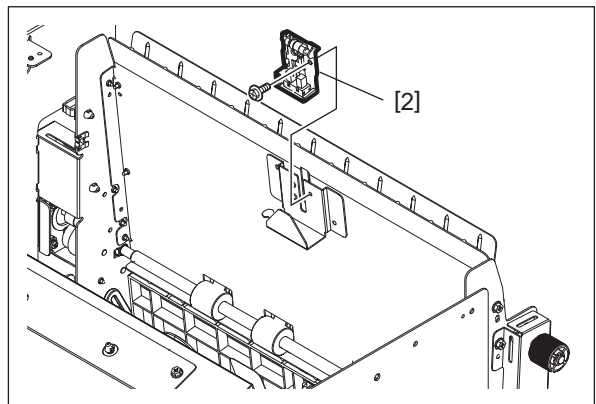

Fig. 4-348

- (4) Release the latch and take off the transport path-2 sensor [3].

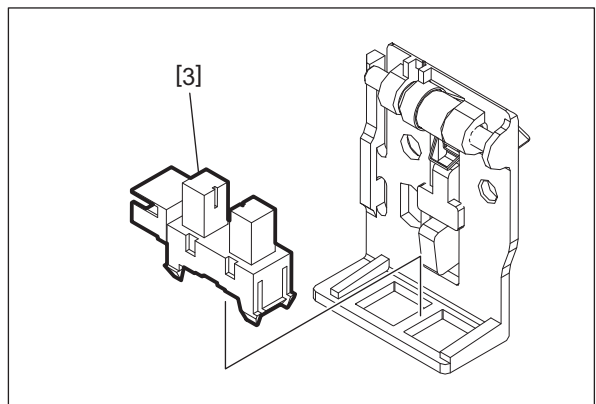

Fig. 4-349

4.10.3 Transport path-3 sensor (S28)

- (1) Open the front upper cover and pull out the saddle stitch unit.
- (2) Open the transport guide at the right-hand side.
- (3) Remove 1 screw, disconnect 1 connector and take off the sensor bracket [1].

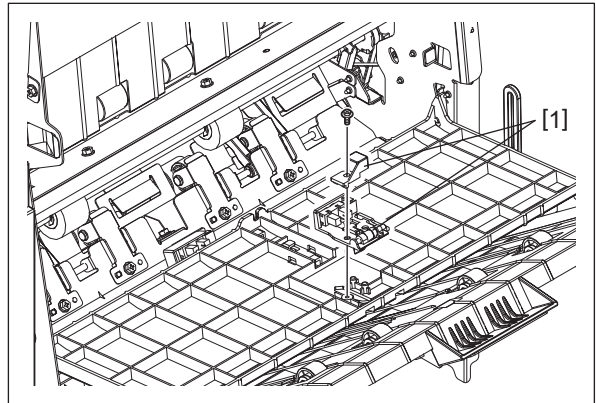

Fig. 4-350

- (4) Release the latch and take off the transport path-3 sensor [2].

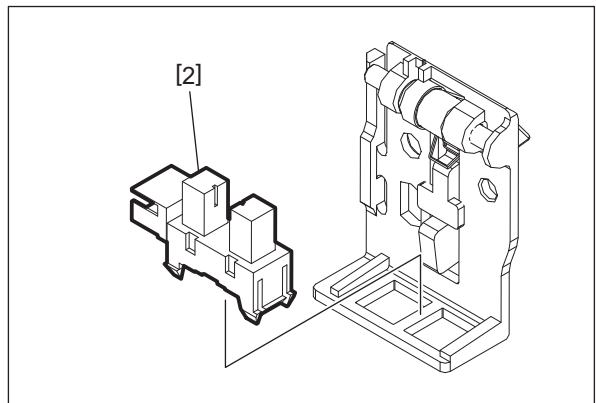

Fig. 4-351

4.10.4 Eject roller sensor (S29)

- (1) Open the front upper cover and pull out the saddle stitch unit.
- (2) Open the transport guide at the right-hand side.
- (3) Remove 1 screw, disconnect 1 connector and take off the sensor bracket [1].

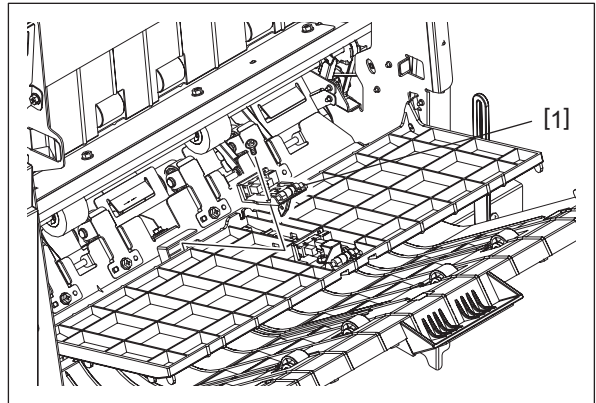

Fig. 4-352

- (4) Release the latch and take off the eject roller sensor [2].

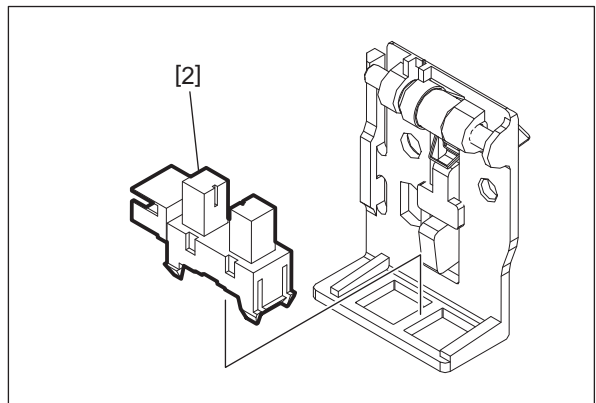



Fig. 4-353

4.10.5 Stacker paper detection sensor (S30)

- (1) Take off the switchback unit.
 P. 4-36 "4.3.2 Switchback unit"
- (2) Take off the paper holding unit.
 P. 4-37 "4.3.3 Paper holding unit"
- (3) Remove 4 screws of the stacker guide [1] and lift it up so that its back side can be seen.

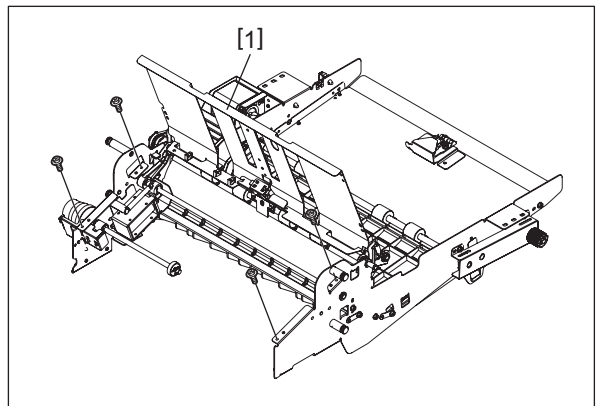

Fig. 4-354

Notes:

Be careful not to damage the harness fixed on the back side of the stacker guide [1] with a clamp.

- (4) Release the harness on the back side of the stacker guide from 3 harness clamps [2].
- (5) Remove 2 screws and take off the sensor bracket [3].

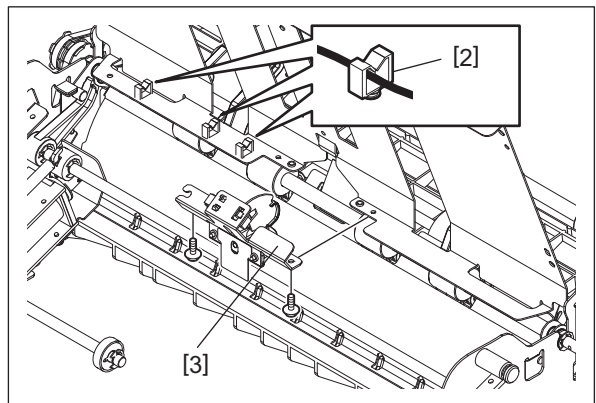

Fig. 4-355

- (6) Disconnect 1 connector. Release the latch and take off the stacker paper detection sensor [4].

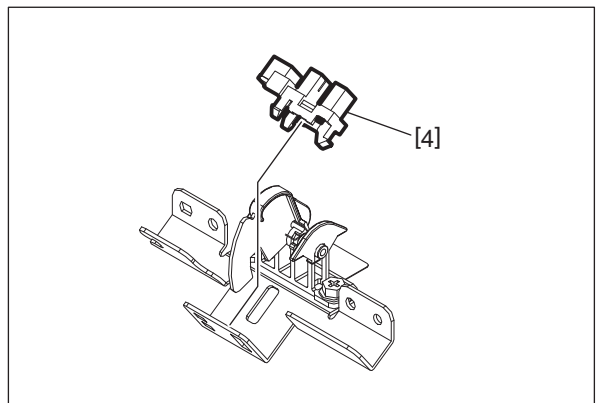

Fig. 4-356

4.10.6 Exit sensor (S31)

- (1) Open the front upper cover and pull out the saddle stitch unit.
- (2) Remove 1 screw, disconnect 1 connector and take off the sensor bracket [1].

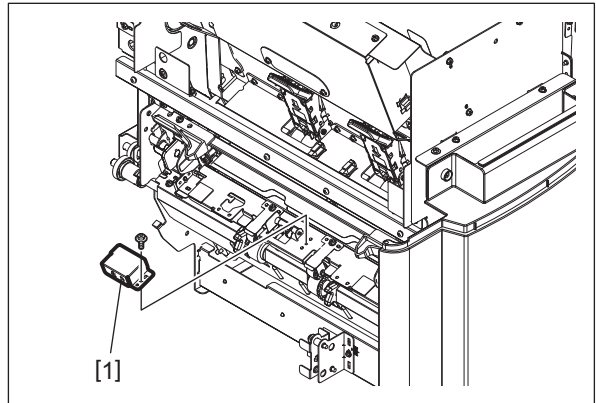

Fig. 4-357

- (3) Release the latch and take off the exit sensor [2].

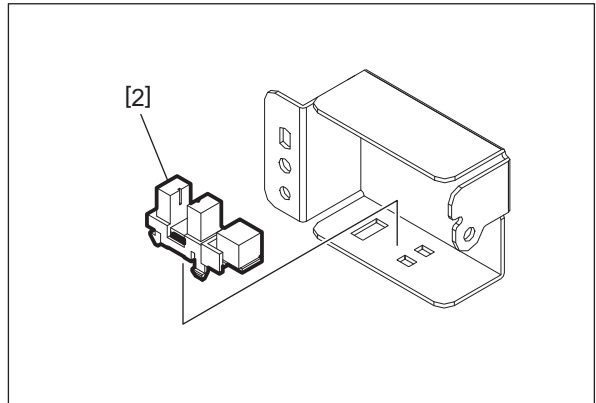

Fig. 4-358

4.10.7 Saddle tray paper detection sensor (S32)

- (1) Open the front upper cover and pull out the saddle stitch unit.
- (2) Remove 1 screw, disconnect 1 connector and take off the sensor bracket [1].

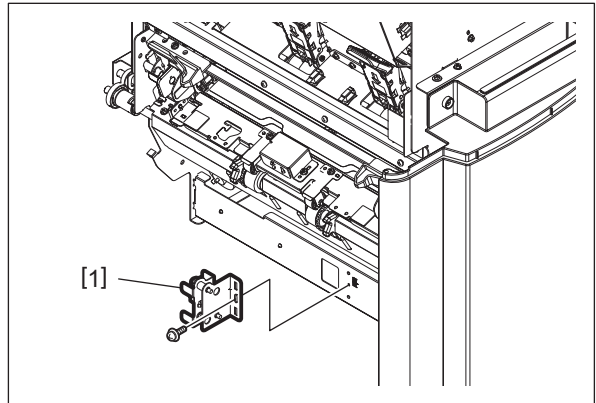



Fig. 4-359

Notes:

After installing, be sure to adjust the position of the sensor bracket [1].

 P. 4-33 "4.3.1 Saddle stitch unit"

- (3) Release the latch and take off the saddle tray paper detection sensor [2].

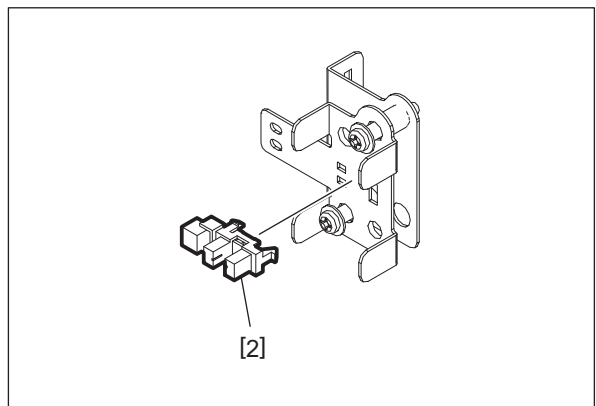

Fig. 4-360

4.10.8 Stacker home position sensor (S33)

- (1) Take off the stacker unit.
P. 4-46 "4.3.8 Stacker unit"
- (2) Move the stacker to the position where the stacker home position sensor [1] can be seen.
- (3) Release the latch and take off the stacker home position sensor [1].

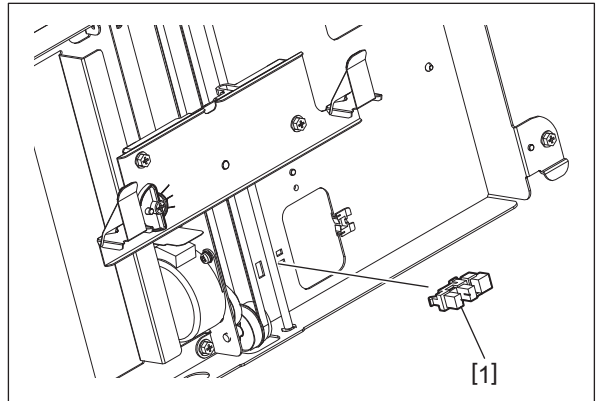

Fig. 4-361

4.10.9 Folding motor encoder sensor (S34)

- (1) Take off the saddle stitch unit.
P. 4-33 "4.3.1 Saddle stitch unit"
- (2) Remove 1 screw. Disconnect the connector and take off the folding motor encoder sensor [1].

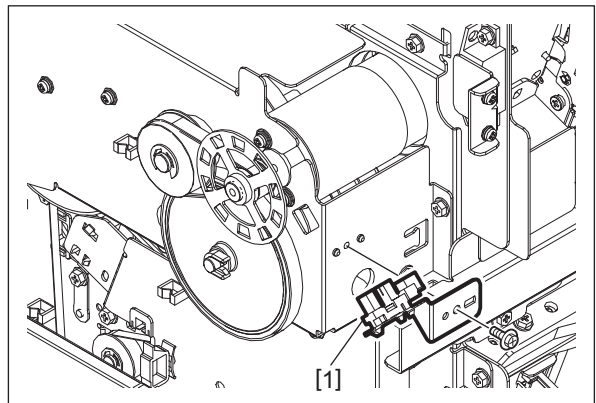

Fig. 4-362

4.10.10 Folding blade home position sensor (S35)

- (1) Open the front upper cover and pull out the saddle stitch unit.
- (2) Disconnect 1 connector. Release the latch and take off the folding blade home position sensor [1].

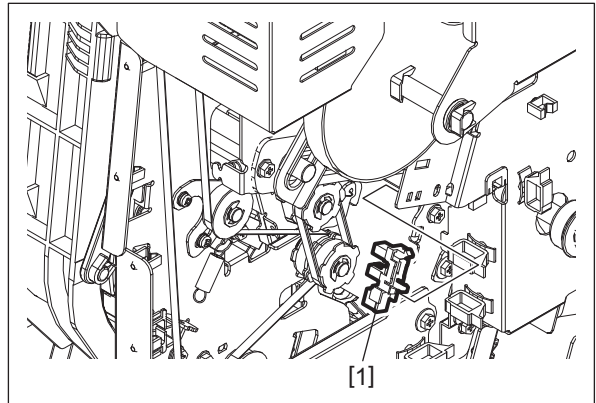

Fig. 4-363

4.10.11 Side alignment plate home position sensor (S36)

- (1) Open the front upper cover and pull out the saddle stitch unit.
- (2) Remove 4 screws and take off the upper safety cover [1].

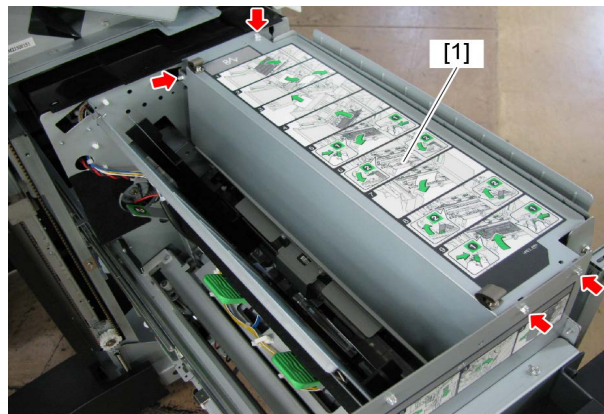

Fig. 4-364

- (3) Move the alignment plates [2] to the center.
- (4) Disconnect 1 connector. Release the latch and take off the side alignment plate home position sensor [3].

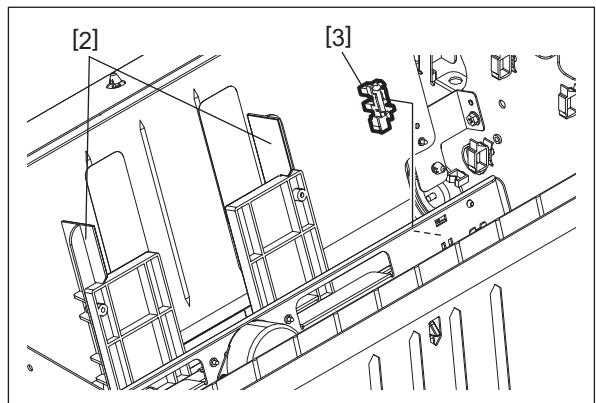

Fig. 4-365

4.10.12 Paper holding home position sensor (S38)

- (1) Take off the paper holding clutch.
P. 4-108 “4.8.3 Paper holding clutch (CLT4) (MJ-1116)”
- (2) Release the harness from 2 harness clamps.
- (3) Remove 1 screw and take off the sensor bracket [1] avoiding the actuator.

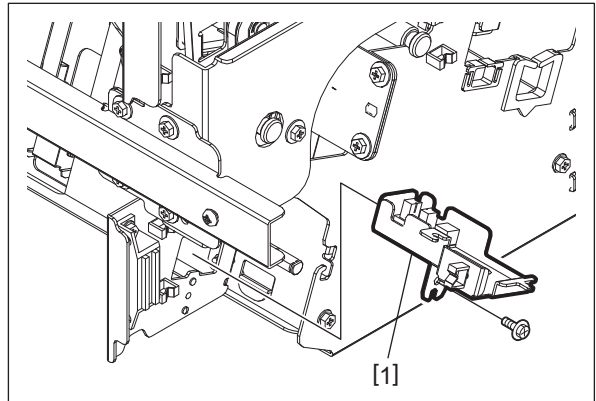

Fig. 4-366

- (4) Disconnect 1 connector. Release the latch and take off the paper holding home position sensor [2].

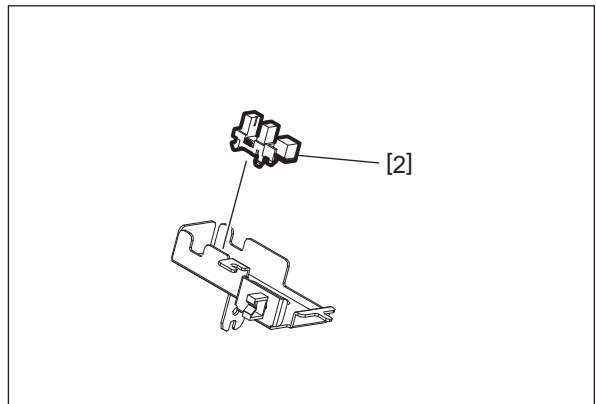

Fig. 4-367

4.10.13 Additional folding home position sensor (S39)

- (1) Take off the additional folding unit.
📖 P. 4-45 "4.3.7 Additional folding unit"
- (2) Turn the pulley [1] and move the additional folding carrier [2] to the center.
- (3) Disconnect 1 connector. Release the latch and take off the additional folding home position sensor [3].

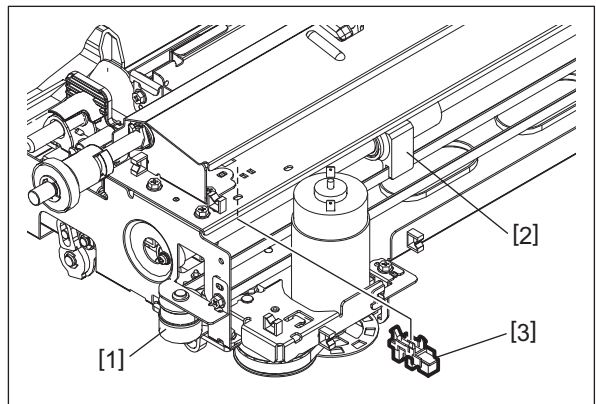

Fig. 4-368

4.10.14 Exit transport sensor (S41)

- (1) Take off the additional folding unit.
📖 P. 4-45 "4.3.7 Additional folding unit"
- (2) Remove 1 screw. Disconnect 1 connector and take off the exit transport sensor [1].

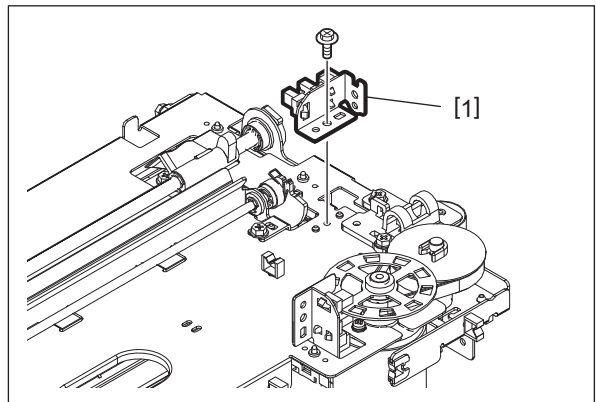

Fig. 4-369

4.10.15 Additional folding motor encoder sensor (S42)

- (1) Take off the additional folding motor.
📖 P. 4-103 “4.7.5 Additional folding motor (M20)”
- (2) Remove 1 screw and take off the sensor bracket [1].

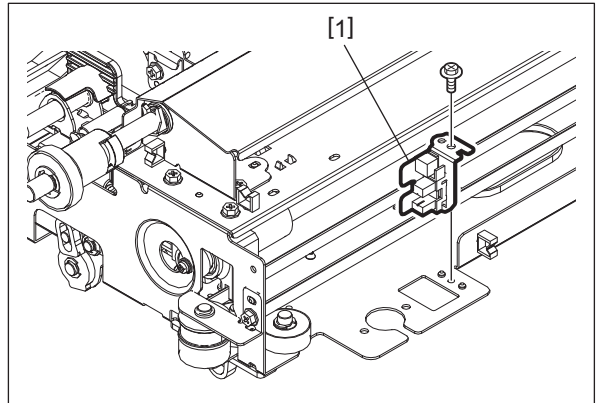

Fig. 4-370

- (3) Release the latch and take off the additional folding motor encoder sensor [2].

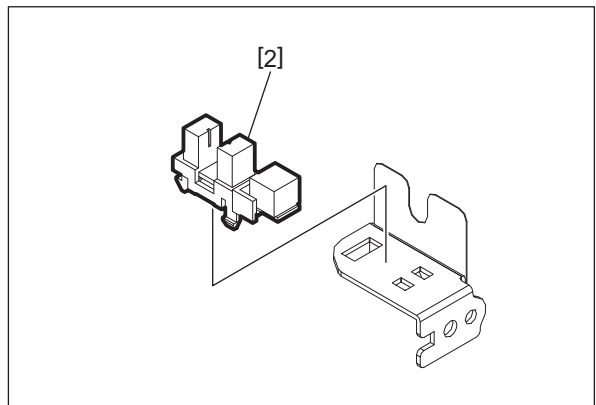

Fig. 4-371

4.10.16 Saddle stitch unit opening/closing switch (SW5)

- (1) Open the front upper cover and pull out the saddle stitch unit.
- (2) Remove 2 screws, disconnect the connector and take off the switch bracket [1].

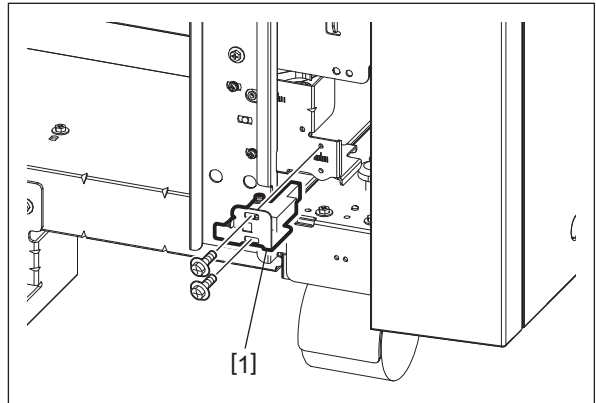

Fig. 4-372

- (3) Remove 2 screws and take off the saddle stitch unit opening/closing switch [2].

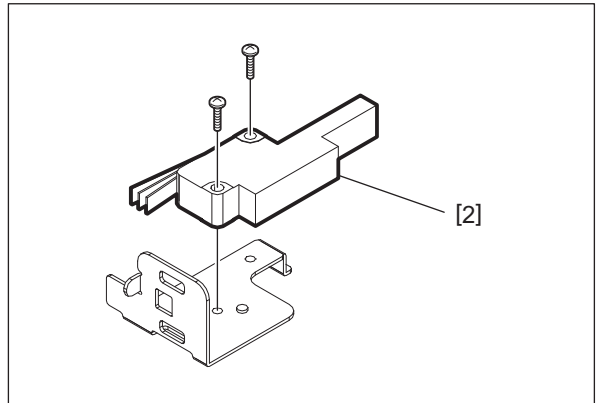

Fig. 4-373

4.11 PC Board, Discharge Brush

4.11.1 Finisher control PC board (FIN)

Notes:

When the finisher control PC board is replaced, check that the firmware is the latest version. If not, update it.

For updating the firmware, refer to “FIRMWARE UPDATING” in the Service Manual for MFP.

- (1) Take off the rear cover.
📖 P. 4-7 “4.1.8 Rear cover”
- (2) Remove 1 screw and take off the ground wire [1].
- (3) Release the PC board cover [2] from 2 harness clamps [3].

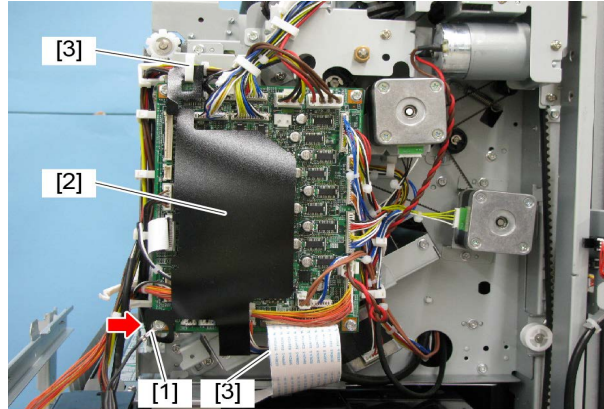

Fig. 4-374

- (4) Disconnect all the connectors on the finisher control PC board [4].
- (5) Remove 3 screws and take off the finisher control PC board [4].

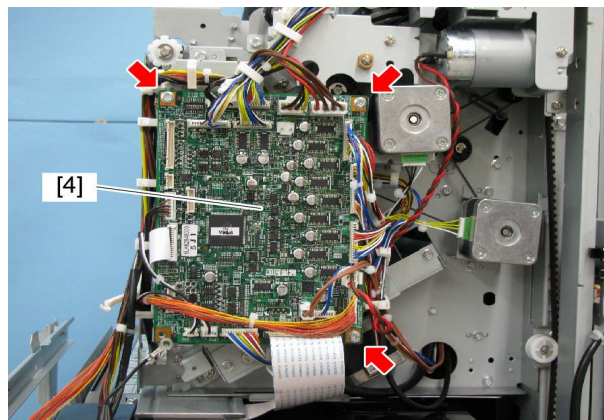

Fig. 4-375

4.11.2 Saddle control PC board (SDL) (MJ-1116)

Notes:

When the saddle control PC board is replaced, check that the firmware is the latest version. If not, update it.

For updating the firmware, refer to “FIRMWARE UPDATING” in the Service Manual for MFP.

- (1) Take off the rear cover.

 P. 4-7 “4.1.8 Rear cover”

- (2) Release 1 flat cable clamp [3]. Then remove 1 flat cable [4] from the saddle control PC board.

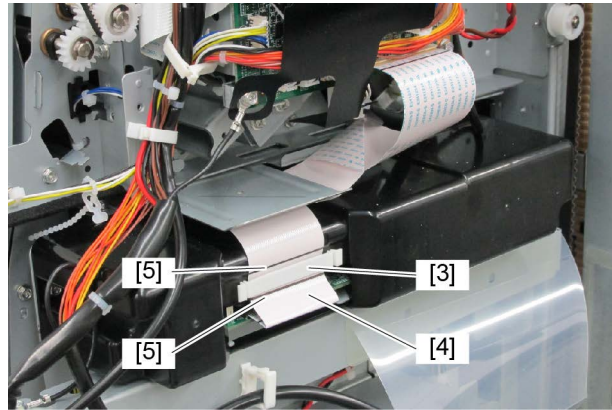

Fig. 4-376

Notes:

- When installing, firmly insert the flat cable [4] into the connector and align the flat cable clamp [3] to the black line [5] of the flat cable.
- When installing the flat cable, do not push it too strongly.
- When installing the flat cable, carefully insert it straight.
- Pay attention not to apply a load to the tip of the flat cable or not to damage it.

- (3) Remove 2 screws and take off the saddle control PC board cover [6].

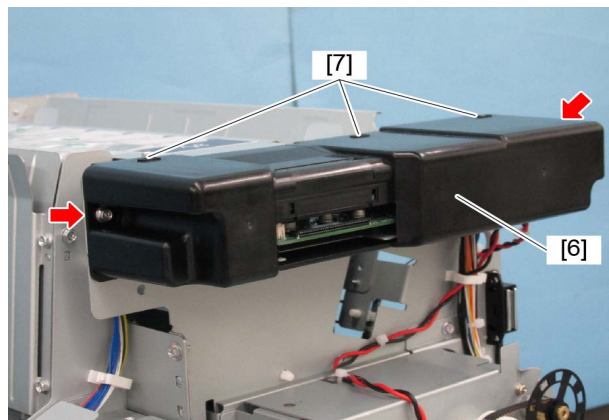

Fig. 4-377

Notes:

When installing, be sure to hang 3 holes [7] on the cover with 3 hooks on the frame.

- (4) Disconnect all the connectors on the saddle control PC board [8].
- (5) Remove 4 screws and take off the saddle control PC board [8].

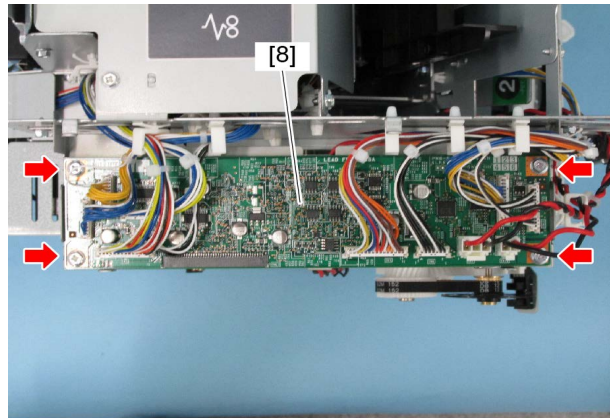

Fig. 4-378

4.11.3 Saddle flat cable (MJ-1116)

- (1) Take off the rear cover.
📖 P. 4-7 "4.1.8 Rear cover"
- (2) Release 1 flat cable clamp [3]. Then remove 1 flat cable [4] from the saddle control PC board.

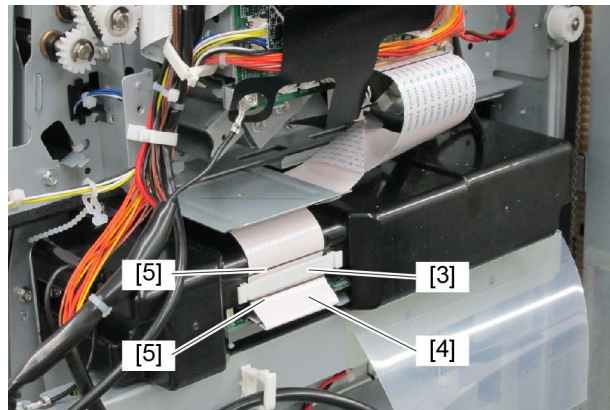

Fig. 4-379

Notes:

- When installing, firmly insert the flat cable [4] into the connector and align the flat cable clamp [3] to the black line [5] of the flat cable.
- When installing the flat cable, do not push it too strongly.
- When installing the flat cable, carefully insert it straight.
- Pay attention not to apply a load to the tip of the flat cable or not to damage it.

- (3) Remove 1 flat cable [5] from the finisher control PC board.

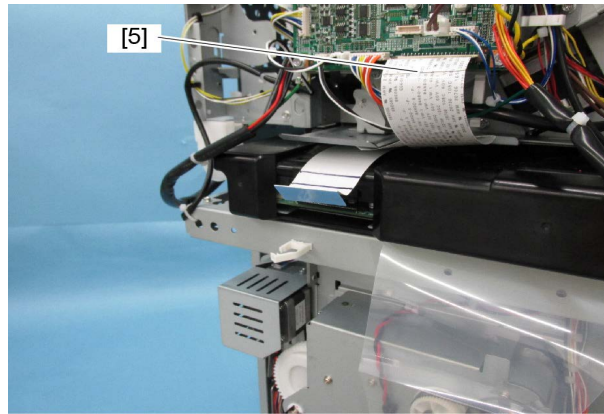

Fig. 4-380

Notes:

- When installing, firmly insert the flat cable [5] into the connector and lock it.
- When installing the flat cable, do not push it too strongly.
- When installing the flat cable, carefully insert it straight.
- Pay attention not to apply a load to the tip of the flat cable or not to damage it.

- (4) Open the front upper cover and pull out the saddle stitch unit.
(5) Remove 2 screws on the front side.

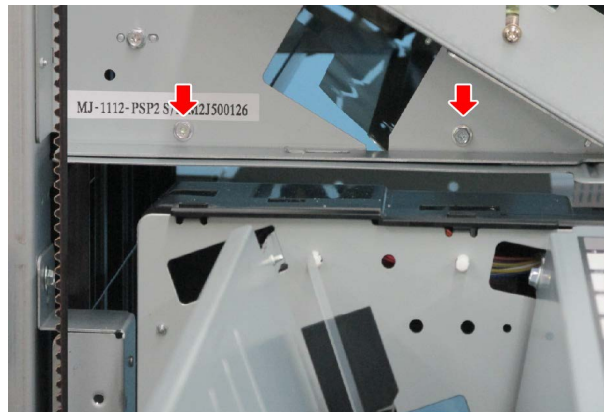

Fig. 4-381

- (6) Remove 2 screws on the rear side and slide the saddle flat cable [6] to the paper feeding side to take it off.

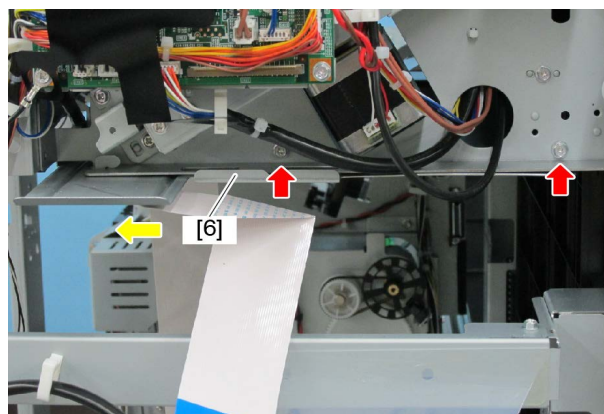

Fig. 4-382

Notes:

When installing, pay attention not to get the film [7] under the frame [8].

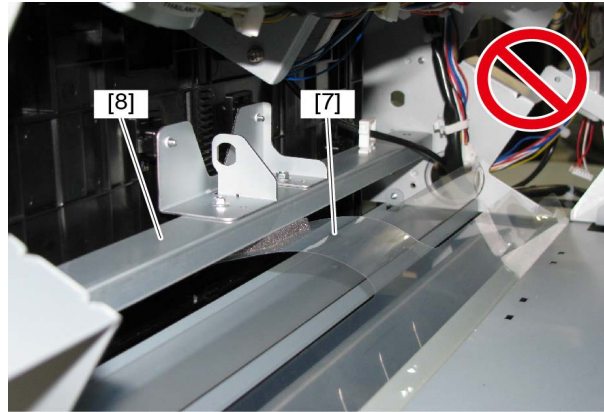

Fig. 4-383

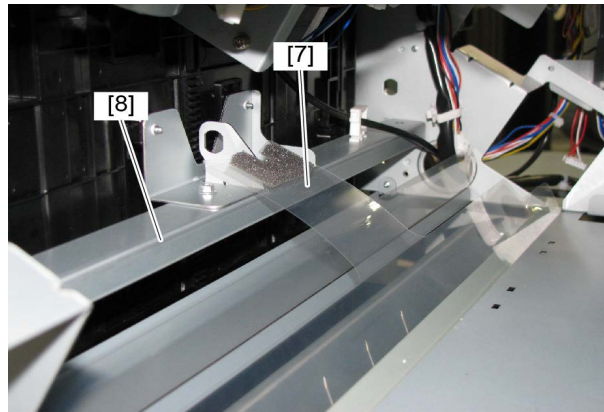

Fig. 4-384

4.11.4 Stationary tray front discharge brush, Stationary tray rear discharge brush

- (1) Take off the stationary tray.
📖 P. 4-1 “4.1.1 Stationary tray”
- (2) Loosen 1 screw on the side. Remove 2 screws and take off the stationary tray front discharge brush [1].

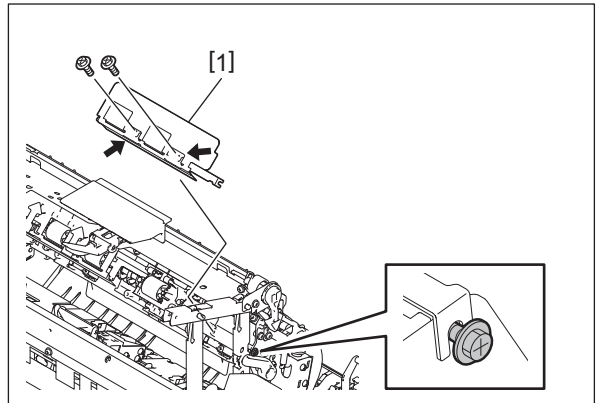

Fig. 4-385

- (3) Loosen 1 screw on the side. Remove 2 screws and take off the stationary tray rear discharge brush [2].

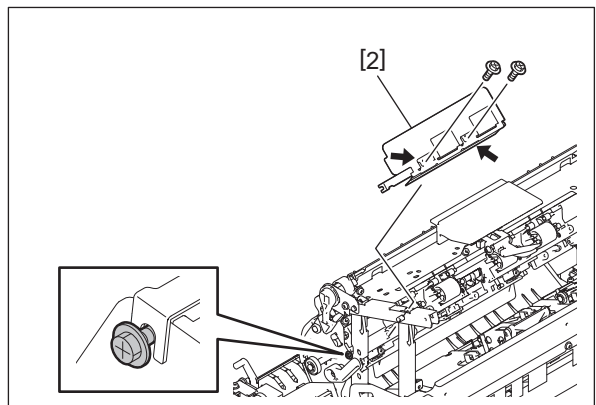

Fig. 4-386

4.12 Lowering Procedure of the Movable Tray

The movable tray can be lowered by releasing its driving gear without disassembling the Finisher.

- (1) Pull the jam access lever [1] and open the stationary tray [2].

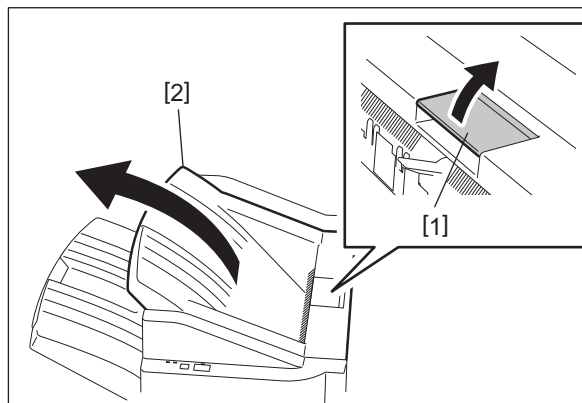

Fig. 4-387

- (2) While you hold the movable tray [3] with your hand, insert a screwdriver in the hole B [4] on the rear cover.

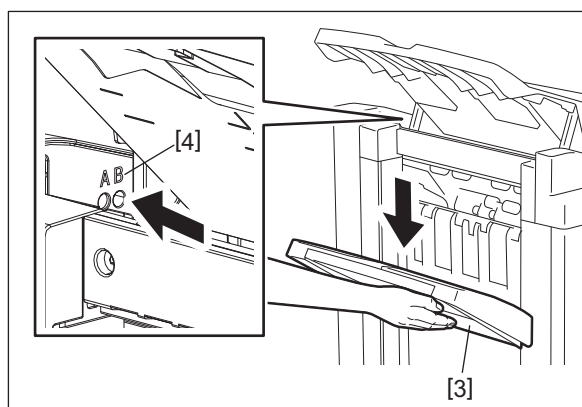

Fig. 4-388

Notes:

- Be sure to hold the movable tray [3] with your hand because it may fall when the screwdriver is inserted.
- Use a screwdriver with a diameter of 8 mm or less.

Remarks:

Since the insertion of the screwdriver has released the driving gear of the movable tray [3], it can now be lowered. If the screwdriver is taken out, the movable tray [3] will stop in that particular position.

- (3) The movable tray [3] can be moved upward by lifting it up. The operation with a screwdriver is not necessary.

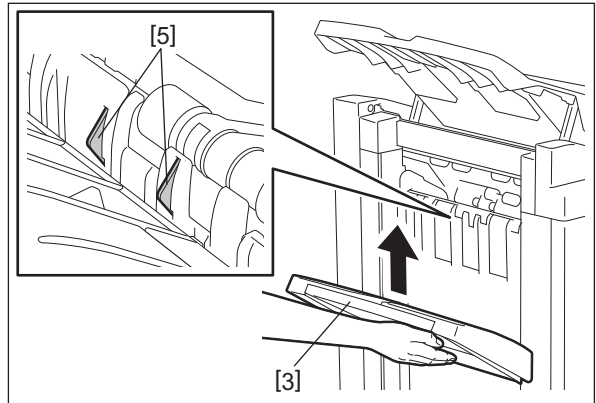

Fig. 4-389

Notes:

Be sure that the movable tray [3] does not stay at the position higher than the movable tray stack height detection sensor [5]. If printing is performed with the sensor turned ON, a CB31 error (Movable tray paper-full detection error) will occur. The movable tray [3] must be moved lower than the sensor.

5. ADJUSTMENT

Notes:

Before performing each adjustment, make sure that all covers are closed. Otherwise, the power is not supplied to the Finisher and the adjustment may not be performed properly.

5.1 Alignment position adjustment

Perform this adjustment after the finisher control PC board is replaced or when the alignment position must be changed for some reason.

[A] Reading and writing of the adjustment value with the self-diagnostic code

If the adjustment values can be confirmed from the pre-change board, check them from the connected MFP and then set them into the post-change board.

A4-size adjustment value check: Perform FS-05-4838-1.

LT-size adjustment value check: Perform FS-05-4838-2.

Item to be adjusted		Code	Remarks
Horizontal position of the paper	A-series paper	FS-05-4838-1	Adjusts the horizontal position of the paper. When a positive value is set, the pitch of the alignment plate becomes smaller. When a negative value is set, the pitch of the alignment plate becomes larger. 0: Finisher not installed 1: -2.10 mm, 2: -1.68 mm, 3: -1.26 mm, 4: -0.84 mm, 5: -0.42 mm, 6: 0.00 mm, 7: +0.42 mm, 8: +0.84 mm, 9: +1.26 mm, 10: +1.68 mm, 11: +2.10 mm
	LT-series paper	FS-05-4838-2	

If the adjustment values cannot be confirmed, perform the adjustment in the following procedure.

[B] Adjustment with the DIP-SW

Adjustment must be performed with 2 types of adjustment sheets for the A4 and LT series.

The adjustment value of A4 will be applied to the operation with A3, A4, A4-R, B4, B5, FOLIO, 8K and 16K.

The adjustment value of LT will be applied to the operation with LD, LG, LT, LT-R, COMP, 13LG and 8.5"SQ.

- (1) Turn the power OFF of the MFP.
- (2) Remove 2 screws and take off the board access cover [1].
- (3) Set SW1 on the finisher control PC board as shown in the figures below.

Adjusting for A4 size paper.
Turn ON pins 2 and 4.

Adjusting for LT size paper:
Turn ON pins 1, 2 and 4.

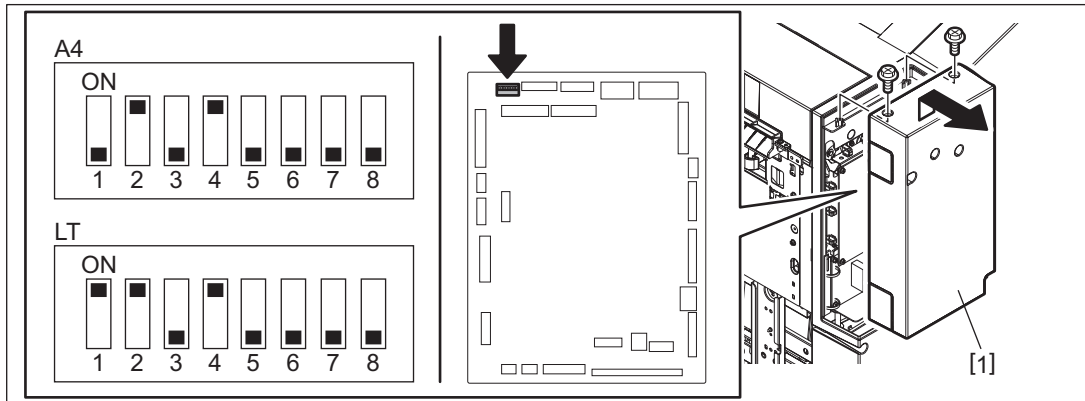

Fig.5-1

- (4) Start the MFP in the HS mode.
The alignment plate moves to the SW1 set position and stops.
- (5) Press the [Button1] button on the finisher control panel to adjust the alignment position.
Every time the [Button1] button is pressed, the alignment plate shifts by 0.42 mm. (The gap between the alignment plates becomes narrower.)

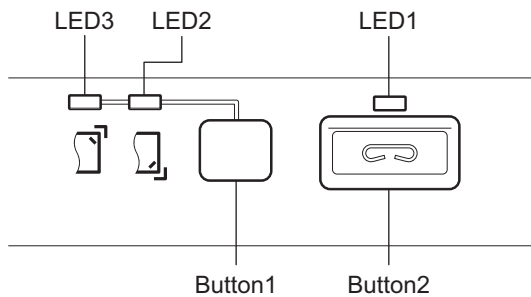

Fig.5-2

- (6) Place the adjustment sheet [1] on the process tray and adjust the position to make the gap between paper and the alignment plate [2] "0". Then setting is performed at a value that is one smaller than the adjustment value.

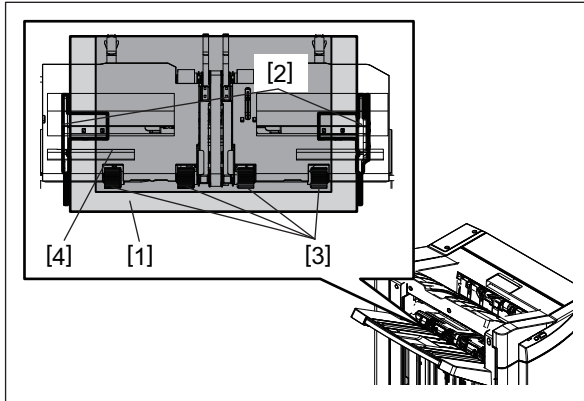

Fig.5-3

Remarks:

Use an adjustment sheet [1] made of plastic resin which is light and accurate in the measurement (e.g.: OHP film).
 To reduce frictional resistance with the vertical alignment roller [3] on the process tray, place a sheet of B5 paper [4] beneath the adjustment sheet [1] on the vertical alignment roller [3].
 Confirm the gap between the paper and the alignment plate [2] by moving the adjustment sheet [1] forward and backward.

- (7) When the adjustment is completed, press the [Button2] button on the finisher control panel to store the adjustment value in memory.
 When the value is stored normally, the [LED1] lamp on the finisher control panel will blink for a number of times that corresponds to the adjustment value set for the MFP.
 See the following table for the number of times the [LED1] lamp blinks and its corresponding adjustment value.

Number of blinking	Distance from the center value (mm)
1	-2.10
2	-1.68
3	-1.26
4	-0.84
5	-0.42
6	Center value (0.00)
7	+0.42
8	+0.84
9	+1.26
10	+1.68
11	+2.10

- (8) Turn the power OFF of the MFP.
- (9) Turn OFF all bits of the SW1 on the finisher control PC board.
- (10) Install the board access cover.

5.2 Stapling Position Adjustment

Perform this adjustment after replacing the finisher control PC board or when the stapling position must be changed for some reasons.

[A] Reading and writing of the adjustment value with the self-diagnostic code

If the adjustment values can be confirmed from the pre-change board, check them from the connected MFP and then set them into the post-change board.

Adjustment value check (common for A4-size and LT-size): Perform FS-05-4838-3.

Item to be adjusted	Code	Remarks
Stapling position	FS-05-4838-3	Adjusts the stapling position. When a positive value is set, it shifts toward the rear side. When a negative value is set, it shifts toward the front side. 0: Finisher not installed 1: -2.16 mm, 2: -1.89 mm, 3: -1.62 mm, 4: -1.35 mm, 5: -1.08 mm, 6: -0.81 mm, 7: -0.54 mm, 8: -0.27 mm, 9: ±0.00 mm, 10: +0.27 mm, 11: +0.54 mm, 12: +0.81 mm, 13: +1.08 mm, 14: +1.35 mm, 15: +1.62 mm, 16: +1.89 mm, 17: +2.16 mm

If the adjustment values cannot be confirmed, perform the adjustment in the following procedure.

[B] Adjustment with the DIP-SW

- (1) Turn the power OFF of the MFP.
- (2) Remove 2 screws and take off the board access cover [1].
- (3) Set SW1 on the finisher control PC board as shown in the figures below.

When adjusting the rear side for A4 size paper: Turn ON pins 1, 3 and 4.	When adjusting the rear side for LT size paper: Turn ON pins 1, 2, 3 and 4.
When adjusting the front side for A4 size paper: Turn ON pins 3 and 4.	When adjusting the front side for LT size paper: Turn ON pins 2, 3 and 4.

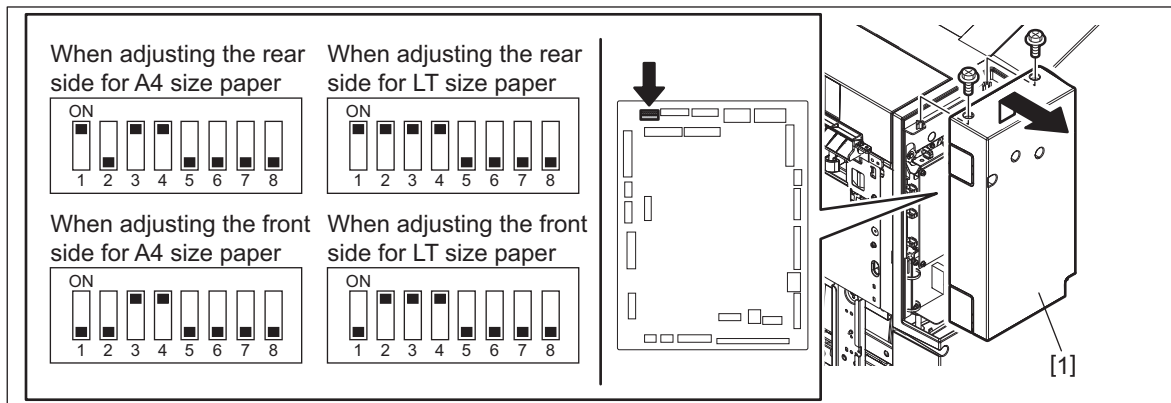

Fig.5-4

Remarks:

Although there are four setting types for the SW1 as shown above, perform only one of them since the adjustment values are used in common.

- (4) Start the MFP in the HS mode.
The staple unit moves to the rear or front side stapling position and stops. (It stops at the position of -2.16 mm (at the front side) from the center value of the adjustment range.)

- (5) Press the [Button1] button on the finisher control panel to adjust the stapling position. Every time the [Button1] button is pressed, the alignment plate shifts by +0.27 mm. (It moves toward the rear side.)
Adjustment range is from -2.16 to +2.16 mm. If the [Button1] button is pressed when the alignment position is at +2.16 mm, the unit will return to -2.16 mm.

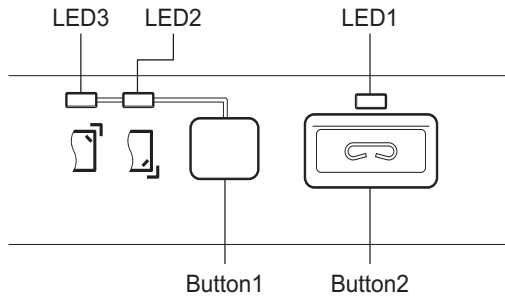

Fig.5-5

- (6) When the adjustment is completed, press the [Button2] button on the finisher control panel to store the adjustment value in memory without sheets on the finishing tray. When the value is stored normally, the [LED1] lamp on the finisher control panel will blink for a number of times that corresponds to the adjustment value set for the MFP. See the following table for the number of times the [LED1] lamp blinks and its corresponding distance.

Number of blinking	Distance from the center value (mm)
1	-2.16
2	-1.89
3	-1.62
4	-1.35
5	-1.08
6	-0.81
7	-0.54
8	-0.27
9	Center value (0.00)
10	+0.27
11	+0.54
12	+0.81
13	+1.08
14	+1.35
15	+1.62
16	+1.89
17	+2.16

- (7) Turn the power OFF of the MFP.
(8) Turn OFF all bits of the SW1 on the finisher control PC board.
(9) Install the board access cover.

5.3 Stapling and Folding Position Adjustment

Perform this adjustment when the saddle control PC board or the stapling/folding position must be changed for some reasons.

Prepare 2 types of booklet samples using the MFP and use them for adjustment accordingly.

- (1) Create 2 types of booklet samples (1 set each) using the MFP.

	Sample 1	Sample 2
Media type	Recommended paper	Recommended paper
Paper size	A4	A3
Number of sheets	5	5

- (2) Measure the stapling and folding positions of the samples and then perform adjustment accordingly. For stapling and folding, paper on the stacker of the stacker unit is moved to an exclusive mechanism for stapling or folding. Therefore, adjustment must be performed individually for the folding stopping position of the stacker and the stapling stopping position.

- Check the folding position at the centerfold page of the sample.

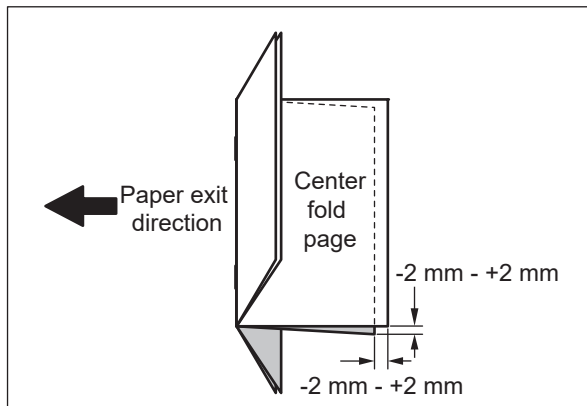

Fig.5-6

- Check the stapling position at the centerfold page of the sample.

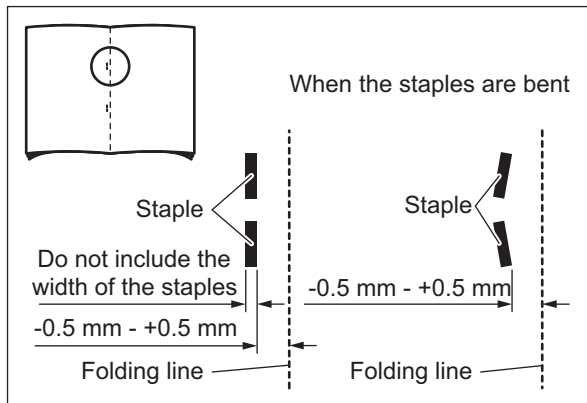
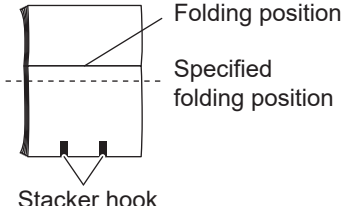

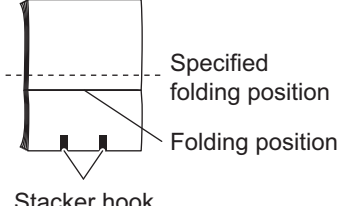

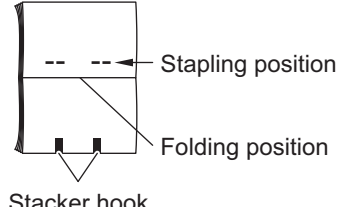

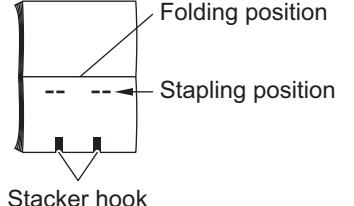



Fig.5-7

Notes:

Perform adjustment for the folding position first because the stapling position must be adjusted referring to the folding line.

Phenomenon	Contents	Adjustment
 <p>Stacker hook Fig.5-8</p>	<p>When the folding position is deviated from the specified one by more than -2.0 mm</p>	<p>Increase the value of the folding position adjustment in order to move the folding stopping position (the position of the stacker hooks) of the stacker upward.  P. 5-8 "[A] Adjustment with the self-diagnostic code"</p>
 <p>Stacker hook Fig.5-9</p>	<p>When the folding position is deviated from the specified one by more than 2.0 mm</p>	<p>Decrease the value of the folding position adjustment in order to move the folding stopping position (the position of the stacker hooks) of the stacker downward.  P. 5-8 "[A] Adjustment with the self-diagnostic code"</p>
 <p>Stacker hook Fig.5-10</p>	<p>When the stapling position is deviated from the specified one by more than -0.50 mm</p>	<p>Decrease the value of the stapling position adjustment in order to move the stapling stopping position (the position of the stacker hooks) of the stacker downward.  P. 5-8 "[A] Adjustment with the self-diagnostic code"</p>
 <p>Stacker hook Fig.5-11</p>	<p>When the stapling position is deviated from the specified one by more than 0.50 mm</p>	<p>Increase the value of the stapling position adjustment in order to move the stapling stopping position (the position of the stacker hooks) of the stacker upward.  P. 5-8 "[A] Adjustment with the self-diagnostic code"</p>

5.3.1 Folding position adjustment

[A] Adjustment with the self-diagnostic code

Perform the adjustment from the connected MFP.

If the adjustment values can be confirmed from the pre-change board, check them from the connected MFP and then set them into the post-change board.

LT-size and A3-size adjustment value check: Perform FS-05-4838-6.

LG-size, B4-size, A4-R-size and 8K-size adjustment value check: Perform FS-05-4838-7.

Item to be adjusted		Code	Remarks
Saddle stitch folding position	A3, LD	FS-05-4838-6	Adjusts the saddle stitch folding position in the paper feeding direction. When a positive value is set, it shifts toward the trailing edge of the paper (stacker hook side). When a negative value is set, it shifts toward the leading edge of the paper. 0: Finisher not installed 1: -1.4 mm, 2: -1.2 mm, 3: -1.0 mm, 4: -0.8 mm, 5: -0.6 mm, 6: -0.4 mm, 7: -0.2 mm, 8: 0.0 mm, 9: +0.2 mm, 10: +0.4 mm, 11: +0.6 mm, 12: +0.8 mm, 13: +1.0 mm, 14: +1.2 mm, 15: +1.4 mm
	Other than A3 and LD	FS-05-4838-7	

5.3.2 Stapling position adjustment

[A] Adjustment with the self-diagnostic code

Perform the adjustment from the connected MFP.

If the adjustment values can be confirmed from the pre-change board, check them from the connected MFP and then set them into the post-change board.

LT-size and A3-size adjustment value check: Perform FS-05-4838-4.

LG-size, B4-size, A4-R-size and 8K-size adjustment value check: Perform FS-05-4538-5.

Item to be adjusted		Code	Remarks
Saddle stitch stapling position	A3, LD	FS-05-4838-4	Adjusts the saddle stitch stapling position in the paper feeding direction. When a positive value is set, it shifts toward the trailing edge of the paper (stacker hook side). When a negative value is set, it shifts toward the leading edge of the paper. 0: Finisher not installed 1: -2.8 mm, 2: -2.4 mm, 3: -2.0 mm, 4: -1.8 mm, 5: -1.2 mm, 6: -0.8 mm, 7: -0.4 mm, 8: 0.0 mm, 9: +0.4 mm, 10: +0.8 mm, 11: +1.2 mm, 12: +1.6 mm, 13: +2.0 mm, 14: +2.4 mm, 15: +2.8 mm
	Other than A3 and LD	FS-05-4838-5	

5.4 Saddle Stitch Section Skew Adjustment

Perform this adjustment when the folding position for saddle stitching is tilted.

- (1) Turn the power OFF of the MFP.
- (2) Open the cover. Pull out the saddle stitch section and then loosen 2 screws.

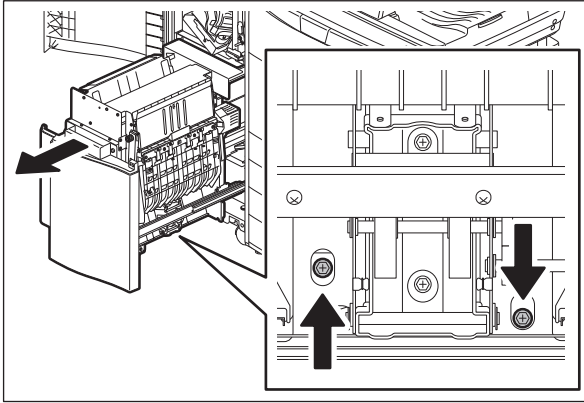

Fig.5-12

- (3) Rotate the adjustment screw slightly.

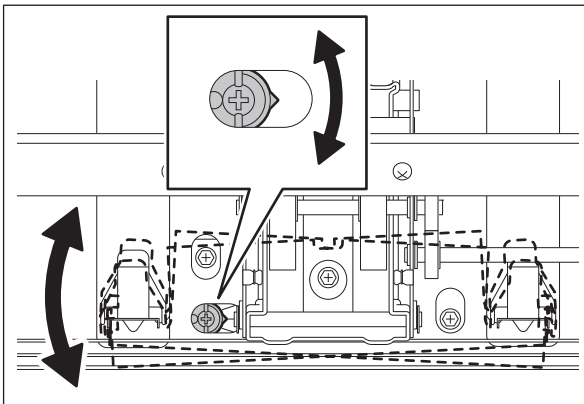

Fig.5-13

- (4) Tighten 2 screws. Return the saddle stitch section and then close the cover.

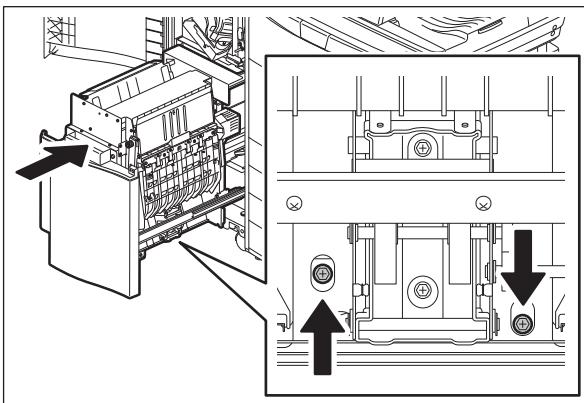

Fig.5-14

6. TROUBLESHOOTING

Notes:

When the ground wire of the MFP is not connected securely, the paper leading edge might be folded or the position of the saddle stitch finisher folding might be misaligned.

If these problems occur, make sure that the ground wire of the MFP is connected securely.
(JPD only)

The operations of electric parts, such as motors, clutches, solenoids, sensors and switches, can be checked with the self-diagnostic mode.

 P. 6-7 “6.4 Self-Diagnostic Mode”.

Notes:

When an abnormal noise occurs in the grate-shaped guide or the trailing edge of the paper stacked on the tray is dirty, apply coating material (SANKOL CFD-409M) by using a cleaning brush to the portion on the guide with which the paper edge is in contact. (Refer to “PREVENTIVE MAINTENANCE (PM)” in the Service Manual for the MFP.)

6.1 Error Code List

For details about the error codes, refer to “ERROR CODE AND TROUBLESHOOTING” in the Service Manual for the MFP.



6.2 Analysis from Error Codes

For details, refer to “ERROR CODE AND TROUBLESHOOTING” in the Service Manual for the MFP.

6.3 Other Errors

6.3.1 Countermeasure when an exit paper alignment problem occurs

When an exit paper alignment problem occurs on the movable tray during continuous printing in the sort mode, take the following countermeasure.

1. Perform "5.1 Alignment position adjustment".
 P. 5-1 "5.1 Alignment position adjustment"
2. If this problem is not cleared even after step 1 has been performed, check whether there are any scratches on the front or rear alignment plate.
If there are any scratches, replace the alignment plate.
 P. 4-12 "4.1.15 Grate-shaped guide"
Step (7)

When an exit paper alignment problem occurs during continuous printing in the non-sort mode, take the following countermeasure.

1. Check whether any sideways deviation has occurred in the MFP. If this has occurred, adjust it by following the instructions given in the Service Manual of the MFP.

6.3.2 Paper trailing edge abnormality when it is exiting to the movable tray (dents, folding, tears)

When abnormalities such as dents, folding or tears have occurred at the trailing edge of paper outputted to the movable tray of the Finisher, perform the following measures.

[A] Problems in outputted paper

The following problem will occur at the trailing edge of paper outputted to the movable tray. If the returning of the ejectors is not sufficient, latches, which output the paper from the standby position to the movable tray, strongly contact the paper upper surface (trailing edge side), resulting in damage to it.

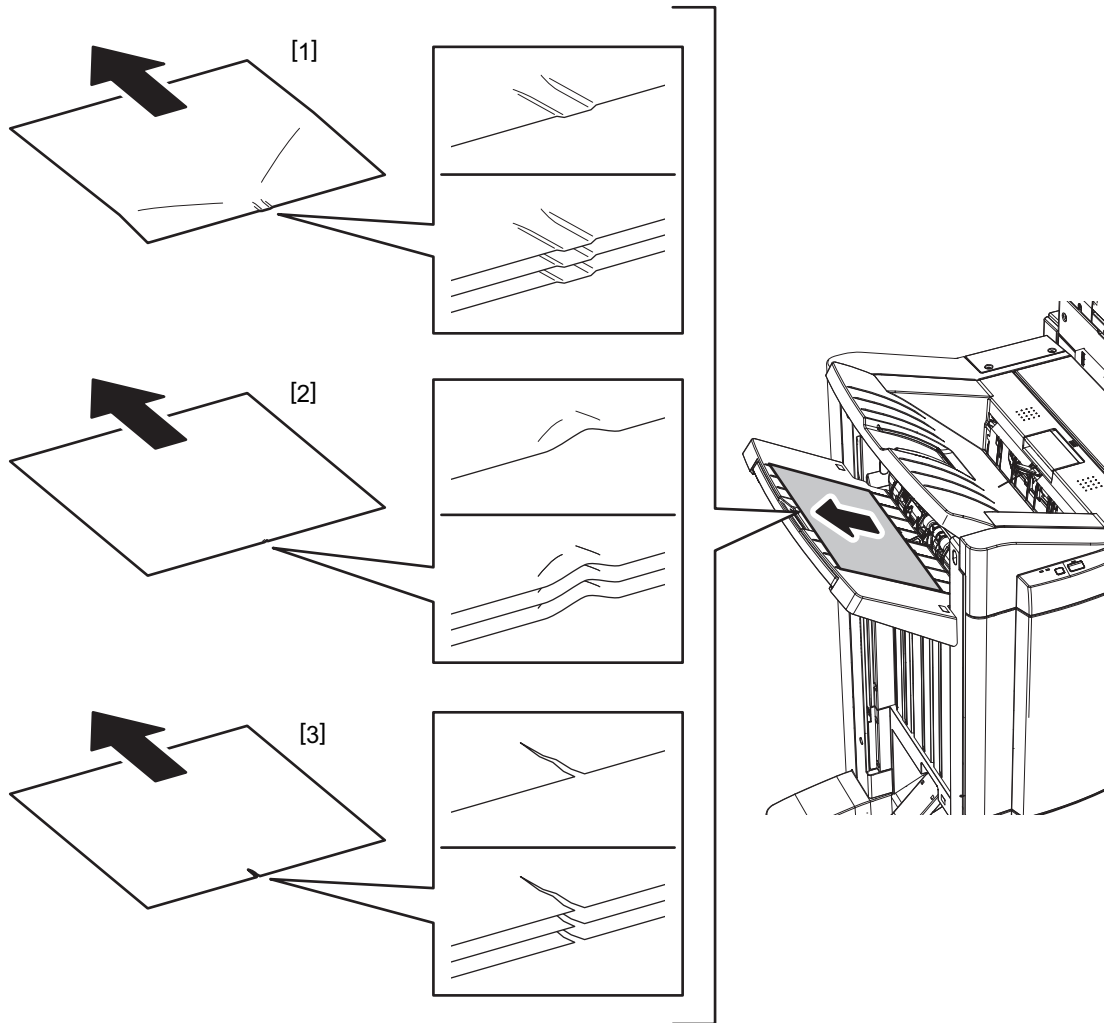

Fig.6-1

- [1] Dents
- [2] Folding
- [3] Tears

[B] Measures

- (1) Clean the ejectors with alcohol while they are in the home position.

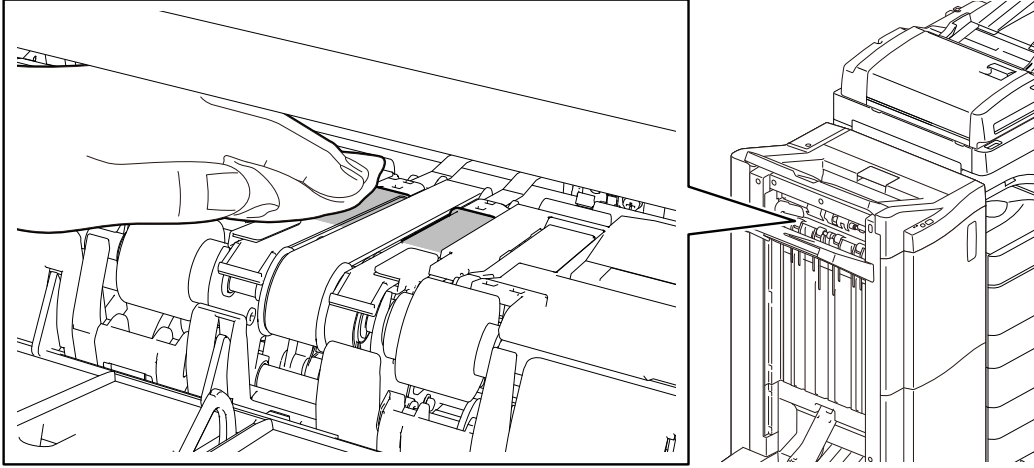

Fig.6-2

- (2) Pull out the ejectors in the finishing tray unit.

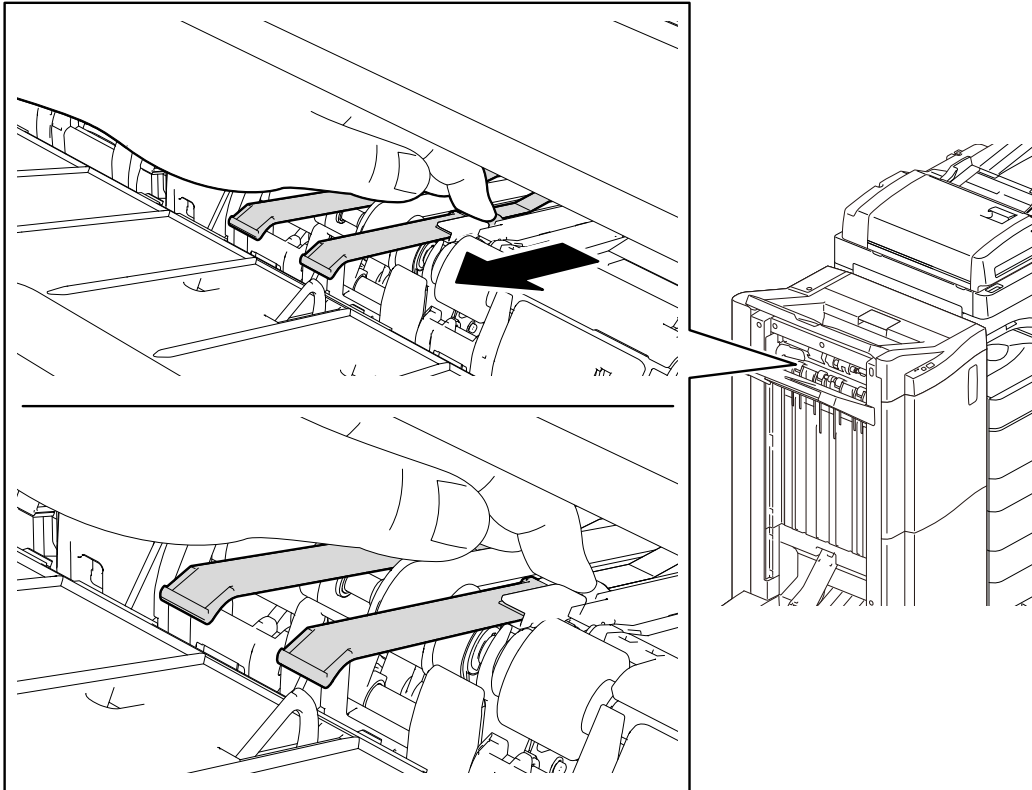

Fig.6-3

Clean both the back and front sides of the pulled out ejectors with alcohol.
If Molykote oil has adhered to the ejectors or the metal guide, wipe it all off.

- (3) Perform the operation check of the finishing tray unit.
1. Put your hand on the holder at the end of the ejectors and then pull them out toward you until they stop.

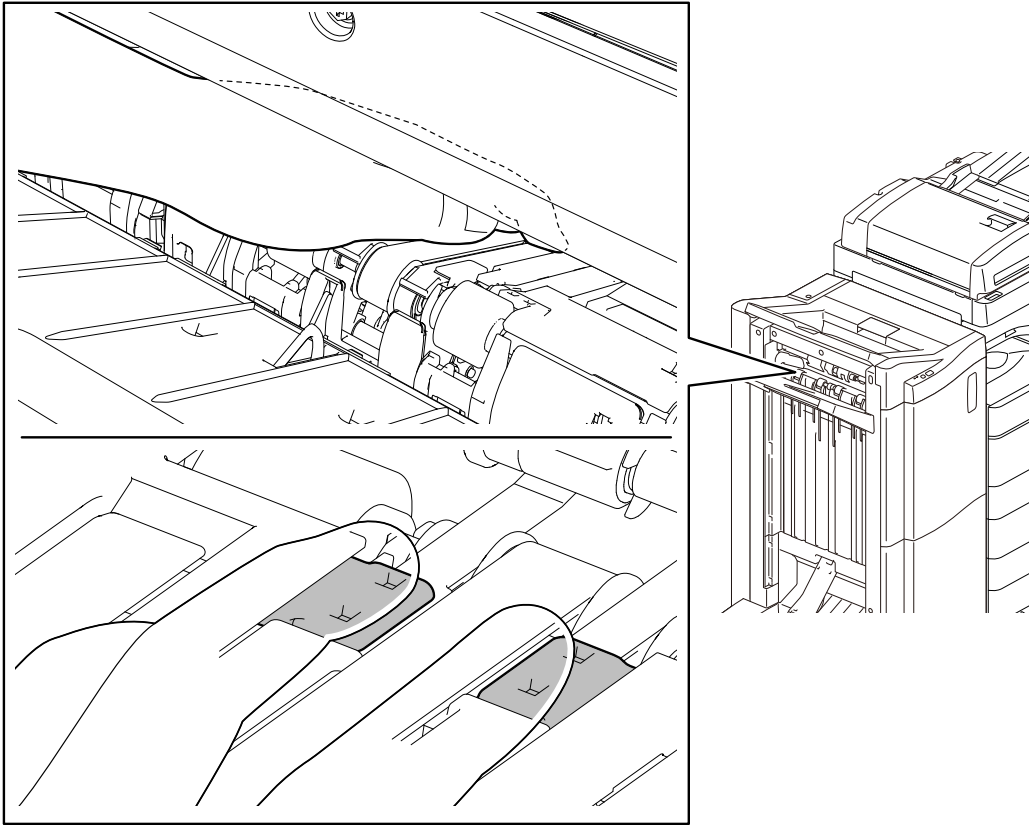

Fig.6-4

2. Release your hand from the holder and check that the ejectors are quickly returned to their home position.

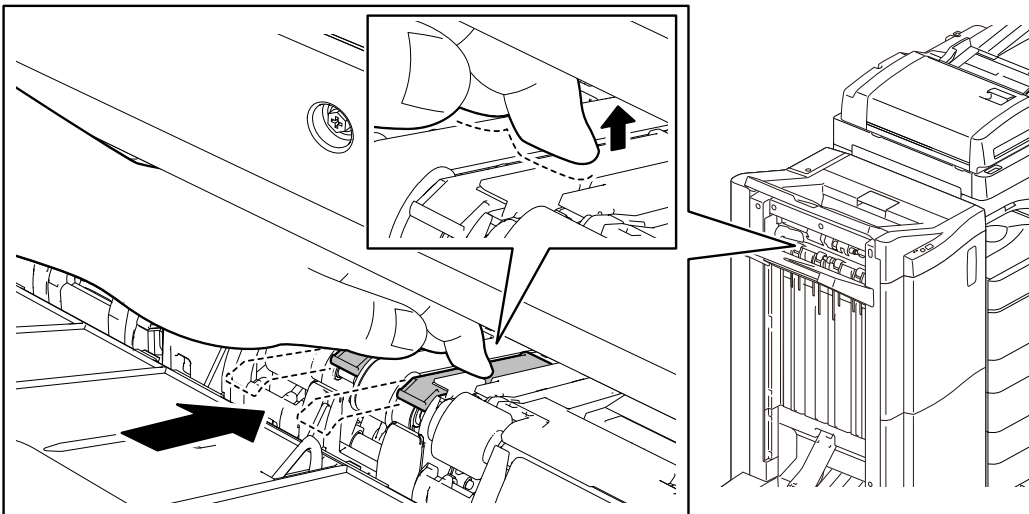

Fig.6-5

3. Check the returned position of the ejectors.

OK

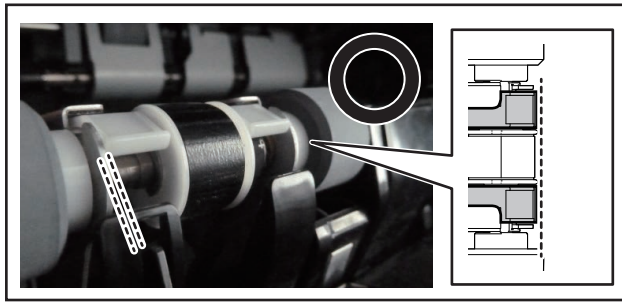

Fig.6-6

NG

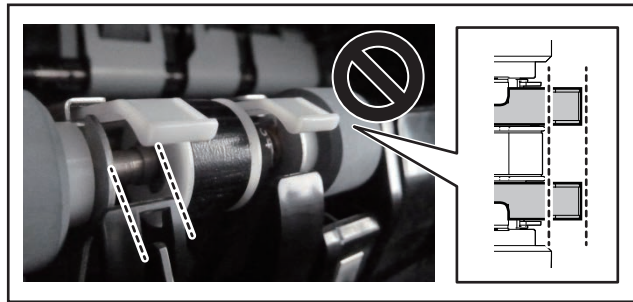

Fig.6-7

4. If the position is NG (Not Good), go to step (5).

- (4) After the operation check of the finishing tray unit has been done, clean the ejectors in the home position with alcohol again.
Clean the ejectors in the same manner as that for step (1).
- (5) Replace the finishing tray unit.
If the problem at the trailing edge of the paper still persists even after steps (1) to (3) have been performed, replace the finishing tray unit.
Finishing tray unit: ASYB-SHEAF-FEED-S20 (P-I: 10-48)

6.4 Self-Diagnostic Mode

6.4.1 Overview

Check the operations of the motors, clutches, solenoids and sensors in the finisher and saddle stitch sections.

6.4.2 Operation procedure

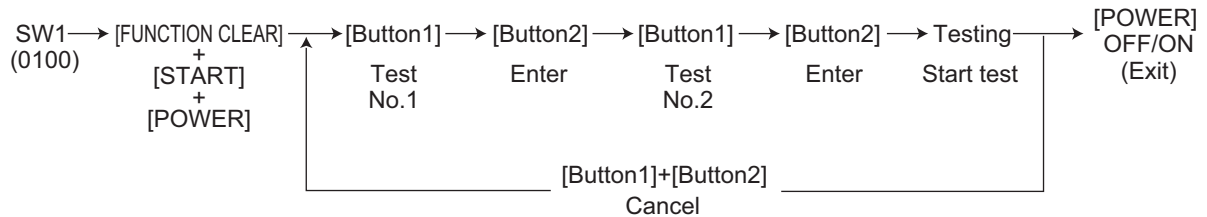

Fig.6-8

- (1) Remove 2 screws and take off the board access cover [1].
- (2) Set SW1 on the finisher control PC board as shown in the figures below.

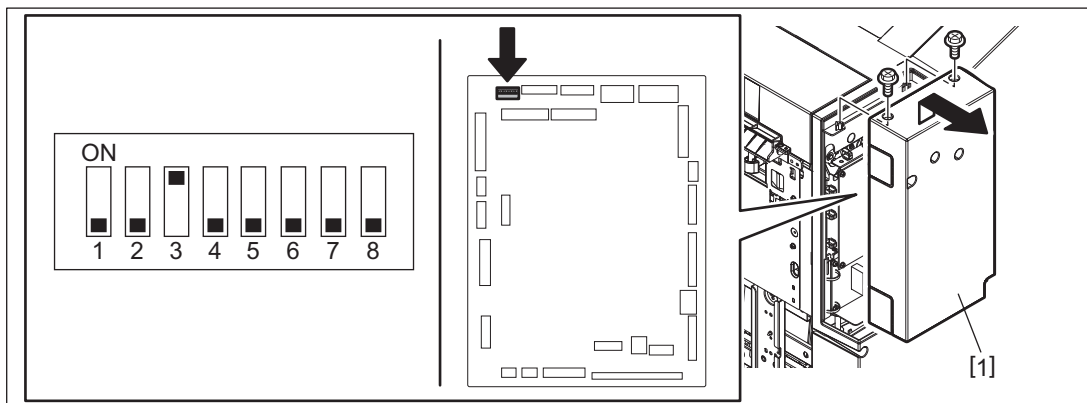

Fig.6-9

- (3) Start the FS menu by pressing the [ON/OFF] button while pushing the [FUNCTION CLEAR] and [START] buttons simultaneously.
- (4) Check the test list and press [Button1] as many times as noted for Test No. 1 whose operation you want to check.

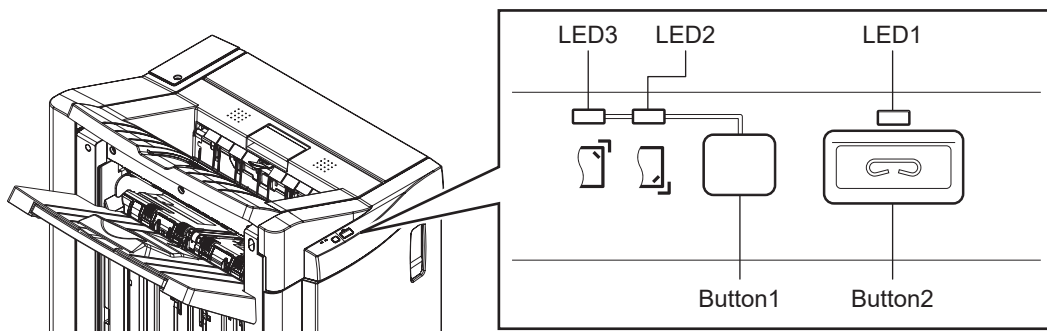

Fig.6-10

- (5) Press [Button2] once. (To enter the number of Test No. 1)
- (6) Check the test list and press [Button1] as many times as noted for Test No. 2 whose operation you want to check.
- (7) Press [Button2] once. (To enter the number of Test No. 2)

- (8) The test is started.
To cancel the test, press [Button1] and [Button2] simultaneously.
- (9) Turn OFF the power of the MFP.
e.g.:
In case of an operation check for the paddle motor, the number of Test No. 1 is “2” and the one for Test No. 2 is “3”.
Therefore, press [Button1] 2 times and press [Button2] once. Then press [Button1] 3 times and press [Button2] once. This starts the operation check for the paddle motor.

Notes:

In case of an error, open and close the front cover or the stationary tray of the Finisher to clear the error, and then start the next test.

6.4.3 Operation status check

The operational status can be checked with the LEDs on the control panel.

LED1: ON	“1” is detected in a sensor check or the operation is finished normally.
LED1: OFF	“0” is detected in a sensor check or the operation is in progress.
LED1: Blinks in a single pattern	Turning power ON, during initialization or waiting for paper insertion
LED2 and LED3: Blink in a multiple pattern	The operation finishes abnormally. 📖 P. 6-16 “6.4.5 Error indications”
LED2: ON, LED3: OFF	Waiting for Test No. 1 number to be entered
LED2: OFF, LED3: ON	Waiting for Test No. 2 number to be entered
LED2: ON, LED3: ON	Test in progress
LED2: OFF, LED3: OFF	Test finished

6.4.4 Test list

1. Aging

Test No. 1 number	Test No. 2 number	Name	Symbol	Operation content
1	1	Aging 1	-	Performs dummy 2-position stapling on 3 pages of A4 paper. Continues the operation until it is canceled. (If a staple cartridge is installed, stapling is not performed. If it is removed, dummy stapling is performed.)
1	2	Aging 2	-	Performs dummy sorting on 3 pages of A4-R paper. Continues the operation until it is canceled.
1	3	Aging 3	-	Performs dummy exiting on A4 paper to the stationary tray in the non-sort mode. Continues the operation until it is canceled.
1	4	Aging 4	-	Performs dummy exiting on A5-R paper to the movable tray in the non-sort mode. Continues the operation until it is canceled.
1	5	Aging 5	-	Performs dummy sorting on 3 pages of A4 paper. Continues the operation until it is canceled.
1	6	Punch-aging	-	Drives the entrance motor of the Finisher. Outputs a mechanical initial command to the Hole Punch Unit in every 4 seconds. Continues the operation until it is canceled.
1	7	Saddle-aging	-	Performs dummy saddle-stitching on 1 page of A4-R paper. Continues the operation until it is canceled. <ul style="list-style-type: none"> If the operation of this mode is canceled and another test is attempted, be sure to turn the power OFF and then back ON first.

2. Operation check for motors

Test No. 1 number	Test No. 2 number	Name	Symbol	Operation content
2	1	Entrance motor	M1	Drives the motor for 10 seconds and then stops it.
2	2	Buffer tray guide motor	M2	Performs initialization (stopping at the standby position after detecting the home position).
2	3	Paddle motor	M3	Performs initialization (stopping at the standby position after detecting the home position).
2	4	(Unused)	-	-
2	5	Front alignment motor	M5	Performs initialization (stopping at the standby position after detecting the home position).
2	6	Rear alignment motor	M6	Performs initialization (stopping at the standby position after detecting the home position).
2	7	Transport motor	M7	Drives the motor for 10 seconds and then stops it.
2	8	Stack transport motor	M8	Moves the latch to the exiting position and then stops it for 10 seconds. Returns it to the home position.
2	9	Stapler unit shift motor	M9	Performs initialization (stopping at the standby position after detecting the home position).
2	10	Assist guide motor	M10	Performs initialization (stopping at the standby position after detecting the home position).
3	1	Exit motor	M11	Drives the motor for 10 seconds and then stops it.
3	2	Movable tray shift motor	M12	Lowers the movable tray to its lower limit. Closes and opens the shutter. Raises the movable tray to its upper limit with the shutter open.
3	3	Stapler motor	M13	Opens the shutter. Performs stapling. Closes the shutter. (If a staple cartridge is installed, stapling is not performed. If it is removed, dummy stapling is performed.)
3	4	Stacker motor	M14	Performs initialization (home position detection). If it is already at its home position, it is temporarily removed and then the home position is detected.
3	5	Side alignment motor	M15	Performs initialization (home position detection). If it is already at its home position, it is temporarily removed and then the home position is detected.
3	6	Saddle transport motor	M16	Turns the assist roller solenoid ON to drive the saddle transport motor for 10 seconds. Then turns the assist roller solenoid OFF to stop the saddle transport motor.
3	7	Folding motor	M17	Drives the folding motor to drive the saddle paper exit roller for approx. 2 seconds.
3	8	Front stapler motor Rear stapler motor	M18 M19	Starts stapling. Before you start this test, be sure to place paper in order not to waste staples.
3	9	(Unused)	-	-
3	10	Additional folding motor	M20	Performs one full reciprocating movement for the additional folding motor. If the motor is not at its home position, it is just returned there.

Test No. 1 number	Test No. 2 number	Name	Symbol	Operation content
4	1	Catching motor	M21	Performs initialization (stopping at the standby position after detecting the home position).

3. Operation check for solenoids

Test No. 1 number	Test No. 2 number	Name	Symbol	Operation content
5	1	(Unused)	-	-
5	2	Buffer roller lift solenoid	SOL2	Turns the solenoid ON for 3 seconds and then turns it OFF.
5	3	(Unused)	-	-
5	4	Gate solenoid	SOL4	Turns the solenoid ON for 3 seconds and then turns it OFF.
5	5	Transport path switching solenoid	SOL5	Turns the solenoid ON for 3 seconds and then turns it OFF. <ul style="list-style-type: none"> Duty control is performed while the solenoid is ON.
5	6	Assist roller solenoid	SOL6	Turns the solenoid ON for 3 seconds and then turns it OFF. <ul style="list-style-type: none"> Duty control is performed while the solenoid is ON.
5	7	(Unused)	-	-
5	8	Exit roller lift solenoid	SOL8	Turns the solenoid ON for 3 seconds and then turns it OFF. <ul style="list-style-type: none"> Duty control is performed while the solenoid is ON.

4. Operation check for clutches

Test No. 1 number	Test No. 2 number	Name	Symbol	Operation content
6	1	(Unused)	-	-
6	2	Stack exit guide clutch	CLT2	Turns the clutch ON for 3 seconds and then turns it OFF.
6	3	Folding blade clutch	CLT3	Turns the folding blade clutch ON and then drives the folding motor. Performs initialization for the folding blade (home position detection). If it is already at its home position, it is temporarily removed and then the home position is detected. Turns the folding blade clutch OFF.
6	4	Paper holding clutch	CLT4	Turns the paper holding clutch ON and then drives the saddle transport motor. Performs initialization (home position detection). If it is already at its home position, it is temporarily removed and then the home position is detected. Turns the paper holding clutch OFF.

5. Real time operation check for switches

Test No. 1 number	Test No. 2 number	Name	Symbol	Operation content
7	1	Front cover opening/closing switch	SW1	The status of the switch is indicated with the LED1 in real time as follows: LED1 ON: Open, LED1 OFF: Close Continues the operation until it is canceled.
7	2	Stationary tray opening/closing switch	SW2	The status of the switch is indicated with the LED1 in real time as follows: LED1 ON: Open, LED1 OFF: Close Continues the operation until it is canceled.

Test No. 1 number	Test No. 2 number	Name	Symbol	Operation content
7	3	(Unused)	-	-
7	4	Connection switch	SW4	The status of the switch is indicated with the LED1 in real time as follows: LED1 ON: Open, LED1 OFF: Close Continues the operation until it is canceled.
7	5	Saddle stitch unit opening/closing switch	SW5	The status of the switch is indicated with the LED1 in real time as follows: LED1 ON: Open, LED1 OFF: Close Continues the operation until it is canceled.

6. Real time operation check for sensors (Finisher)

Test No. 1 number	Test No. 2 number	Name	Symbol	Operation content
8	1	Entrance sensor	S1	The status of the sensor is indicated with the LED1 in real time as follows: LED1 ON: 1, LED1 OFF: 0 Continues the operation until it is canceled.
8	2	Transport sensor	S2	The status of the sensor is indicated with the LED1 in real time as follows: LED1 ON: 1, LED1 OFF: 0 Continues the operation until it is canceled.
8	3	Paddle home position sensor	S3	The status of the sensor is indicated with the LED1 in real time as follows: LED1 ON: 1, LED1 OFF: 0 Continues the operation until it is canceled.
8	4	(Unused)	-	-
8	5	Buffer tray home position sensor	S5	The status of the sensor is indicated with the LED1 in real time as follows: LED1 ON: 1, LED1 OFF: 0 Continues the operation until it is canceled.
8	6	Assist guide home position sensor	S6	The status of the sensor is indicated with the LED1 in real time as follows: LED1 ON: 1, LED1 OFF: 0 Continues the operation until it is canceled.
8	7	Front alignment plate home position sensor	S7	The status of the sensor is indicated with the LED1 in real time as follows: LED1 ON: 1, LED1 OFF: 0 Continues the operation until it is canceled.
8	8	Rear alignment plate home position sensor	S8	The status of the sensor is indicated with the LED1 in real time as follows: LED1 ON: 1, LED1 OFF: 0 Continues the operation until it is canceled.
8	9	Stack exit belt home position sensor	S9	The status of the sensor is indicated with the LED1 in real time as follows: LED1 ON: 1, LED1 OFF: 0 Continues the operation until it is canceled.
8	10	Stapler unit home position sensor	S10	The status of the sensor is indicated with the LED1 in real time as follows: LED1 ON: 1, LED1 OFF: 0 Continues the operation until it is canceled.
9	1	Stapler interference sensor	S11	The status of the sensor is indicated with the LED1 in real time as follows: LED1 ON: 1, LED1 OFF: 0 Continues the operation until it is canceled.
9	2	Finishing tray paper sensor	S12	The status of the sensor is indicated with the LED1 in real time as follows: LED1 ON: 1, LED1 OFF: 0 Continues the operation until it is canceled.

Test No. 1 number	Test No. 2 number	Name	Symbol	Operation content
9	3	Movable tray position-A sensor	S13	The status of the sensor is indicated with the LED1 in real time as follows: LED1 ON: 1, LED1 OFF: 0 Continues the operation until it is canceled.
9	4	Movable tray position-B sensor	S14	The status of the sensor is indicated with the LED1 in real time as follows: LED1 ON: 1, LED1 OFF: 0 Continues the operation until it is canceled.
9	5	Movable tray position-C sensor	S15	The status of the sensor is indicated with the LED1 in real time as follows: LED1 ON: 1, LED1 OFF: 0 Continues the operation until it is canceled.
9	6	Movable tray stack height detection sensor	S16	The status of the sensor is indicated with the LED1 in real time as follows: LED1 ON: 1, LED1 OFF: 0 Continues the operation until it is canceled.
9	7	Movable tray paper sensor	S17	The status of the sensor is indicated with the LED1 in real time as follows: LED1 ON: 1, LED1 OFF: 0 Continues the operation until it is canceled.
9	8	Stationary tray stack height detection sensor	S18	The status of the sensor is indicated with the LED1 in real time as follows: LED1 ON: 1, LED1 OFF: 0 Continues the operation until it is canceled.
9	9	Stapler home position sensor	S19	The status of the sensor is indicated with the LED1 in real time as follows: LED1 ON: 1, LED1 OFF: 0 Continues the operation until it is canceled.
9	10	Staple top position sensor	S20	The status of the sensor is indicated with the LED1 in real time as follows: LED1 ON: 1, LED1 OFF: 0 Continues the operation until it is canceled.
10	1	Staple empty sensor	S21	The status of the sensor is indicated with the LED1 in real time as follows: LED1 ON: 1, LED1 OFF: 0 Continues the operation until it is canceled.
10	2	Paper feed sensor	S22	The status of the sensor is indicated with the LED1 in real time as follows: LED1 ON: 1, LED1 OFF: 0 Continues the operation until it is canceled.
10	3	Movable tray shift motor sensor	S23	The status of the sensor is indicated with the LED1 in real time as follows: LED1 ON: 1, LED1 OFF: 0 Continues the operation until it is canceled.
10	4	(Unused)	-	-
10	5	(Unused)	-	-
10	6	Junction box sensor	S26	The status of the sensor is indicated with the LED1 in real time as follows: LED1 ON: 1, LED1 OFF: 0 Continues the operation until it is canceled.
10	7	Transport path-2 sensor	S27	The status of the sensor is indicated with the LED1 in real time as follows: LED1 ON: 1, LED1 OFF: 0 Continues the operation until it is canceled.
10	8	Transport path-3 sensor	S28	The status of the sensor is indicated with the LED1 in real time as follows: LED1 ON: 1, LED1 OFF: 0 Continues the operation until it is canceled.

Test No. 1 number	Test No. 2 number	Name	Symbol	Operation content
10	9	Eject roller sensor	S29	The status of the sensor is indicated with the LED1 in real time as follows: LED1 ON: 1, LED1 OFF: 0 Continues the operation until it is canceled.
10	10	Stacker paper detection sensor	S30	The status of the sensor is indicated with the LED1 in real time as follows: LED1 ON: 1, LED1 OFF: 0 Continues the operation until it is canceled.
11	1	Exit sensor	S31	The status of the sensor is indicated with the LED1 in real time as follows: LED1 ON: 1, LED1 OFF: 0 Continues the operation until it is canceled.
11	2	Saddle tray paper detection sensor	S32	The status of the sensor is indicated with the LED1 in real time as follows: LED1 ON: 1, LED1 OFF: 0 Continues the operation until it is canceled.
11	3	Stacker home position sensor	S33	The status of the sensor is indicated with the LED1 in real time as follows: LED1 ON: 1, LED1 OFF: 0 Continues the operation until it is canceled.
11	4	Folding motor encoder sensor	S34	The status of the sensor is indicated with the LED1 in real time as follows: LED1 ON: 1, LED1 OFF: 0 Continues the operation until it is canceled.
11	5	Folding blade home position sensor	S35	The status of the sensor is indicated with the LED1 in real time as follows: LED1 ON: 1, LED1 OFF: 0 Continues the operation until it is canceled.
11	6	Side alignment plate home position sensor	S36	The status of the sensor is indicated with the LED1 in real time as follows: LED1 ON: 1, LED1 OFF: 0 Continues the operation until it is canceled.
11	7	(Unused)	-	-
11	8	Paper holding home position sensor	S38	The status of the sensor is indicated with the LED1 in real time as follows: LED1 ON: 1, LED1 OFF: 0 Continues the operation until it is canceled.
11	9	Additional folding home position sensor	S39	The status of the sensor is indicated with the LED1 in real time as follows: LED1 ON: 1, LED1 OFF: 0 Continues the operation until it is canceled.
11	10	(Unused)	-	-
12	1	Exit transport sensor	S41	The status of the sensor is indicated with the LED1 in real time as follows: LED1 ON: 1, LED1 OFF: 0 Continues the operation until it is canceled.
12	2	Additional folding motor encoder sensor	S42	The status of the sensor is indicated with the LED1 in real time as follows: LED1 ON: 1, LED1 OFF: 0 Continues the operation until it is canceled.
12	3	Front saddle stapler home position sensor	S43	The status of the sensor is indicated with the LED1 in real time as follows: LED1 ON: 1, LED1 OFF: 0 Continues the operation until it is canceled.
12	4	Rear saddle stapler home position sensor	S44	The status of the sensor is indicated with the LED1 in real time as follows: LED1 ON: 1, LED1 OFF: 0 Continues the operation until it is canceled.

Test No. 1 number	Test No. 2 number	Name	Symbol	Operation content
12	5	Front saddle staple empty sensor	S45	The status of the sensor is indicated with the LED1 in real time as follows: LED1 ON: 1, LED1 OFF: 0 Continues the operation until it is canceled.
12	6	Rear saddle staple empty sensor	S46	The status of the sensor is indicated with the LED1 in real time as follows: LED1 ON: 1, LED1 OFF: 0 Continues the operation until it is canceled.
12	7	Front saddle staple top position sensor	S47	The status of the sensor is indicated with the LED1 in real time as follows: LED1 ON: 1, LED1 OFF: 0 Continues the operation until it is canceled.
12	8	Rear saddle staple top position sensor	S48	The status of the sensor is indicated with the LED1 in real time as follows: LED1 ON: 1, LED1 OFF: 0 Continues the operation until it is canceled.
12	9	Front saddle stapler cartridge sensor	S49	The status of the sensor is indicated with the LED1 in real time as follows: LED1 ON: 1, LED1 OFF: 0 Continues the operation until it is canceled.
12	10	Rear saddle stapler cartridge sensor	S50	The status of the sensor is indicated with the LED1 in real time as follows: LED1 ON: 1, LED1 OFF: 0 Continues the operation until it is canceled.
13	1	(Unused)	-	-
13	2	Catching home position sensor	S52	The status of the sensor is indicated with the LED1 in real time as follows: LED1 ON: 1, LED1 OFF: 0 Continues the operation until it is canceled.

7. Real time operation check for sensors (punching section)

Test No. 1 number	Test No. 2 number	Name	Symbol	Operation content
14	1	Punch front cover sensor	S1	The status of the sensor is indicated with the LED1 in real time as follows: LED1 ON: 1, LED1 OFF: 0 Continues the operation until it is canceled.
14	2	Paper trailing edge detection sensor	S2	The status of the sensor is indicated with the LED1 in real time as follows: LED1 ON: 1, LED1 OFF: 0 Continues the operation until it is canceled.
14	3	Paper trailing edge detection sensor-1	S3	The status of the sensor is indicated with the LED1 in real time as follows: LED1 ON: 1, LED1 OFF: 0 Continues the operation until it is canceled.
14	4	Paper trailing edge detection sensor-2	S4	The status of the sensor is indicated with the LED1 in real time as follows: LED1 ON: 1, LED1 OFF: 0 Continues the operation until it is canceled.
14	5	Paper trailing edge detection sensor-3	S5	The status of the sensor is indicated with the LED1 in real time as follows: LED1 ON: 1, LED1 OFF: 0 Continues the operation until it is canceled.
14	6	Paper trailing edge detection sensor-4	S6	The status of the sensor is indicated with the LED1 in real time as follows: LED1 ON: 1, LED1 OFF: 0 Continues the operation until it is canceled.
14	7	Punch skew sensor-1	S7	The status of the sensor is indicated with the LED1 in real time as follows: LED1 ON: 1, LED1 OFF: 0 Continues the operation until it is canceled.
14	8	Punch skew sensor-2	S7	The status of the sensor is indicated with the LED1 in real time as follows: LED1 ON: 1, LED1 OFF: 0 Continues the operation until it is canceled.
14	9	Punch waste full sensor	S8	The status of the sensor is indicated with the LED1 in real time as follows: LED1 ON: 1, LED1 OFF: 0 Continues the operation until it is canceled.

6.4.5 Error indications

When an error occurs during a test, LED2 and LED3 blink in a multiple pattern to indicate the cause of the error.

The blinking pattern of the error differs depending on the error category. If the multiple errors and alerts occur at the same time, the error of the highest priority will be shown.

Priority (High > Low)

Hardware error > Paper misfeeding > Alert

In each error category, only one type of the blinking pattern is shown following the manner below: The error code of the smaller number prevails in both Error code 1 and Error code 2.

If the event of a hardware error, paper misfeeding or alert occurs, the test will not be performed unless the error condition clears.

The figure below shows the error code 32 “ED15: paddle home position error”.

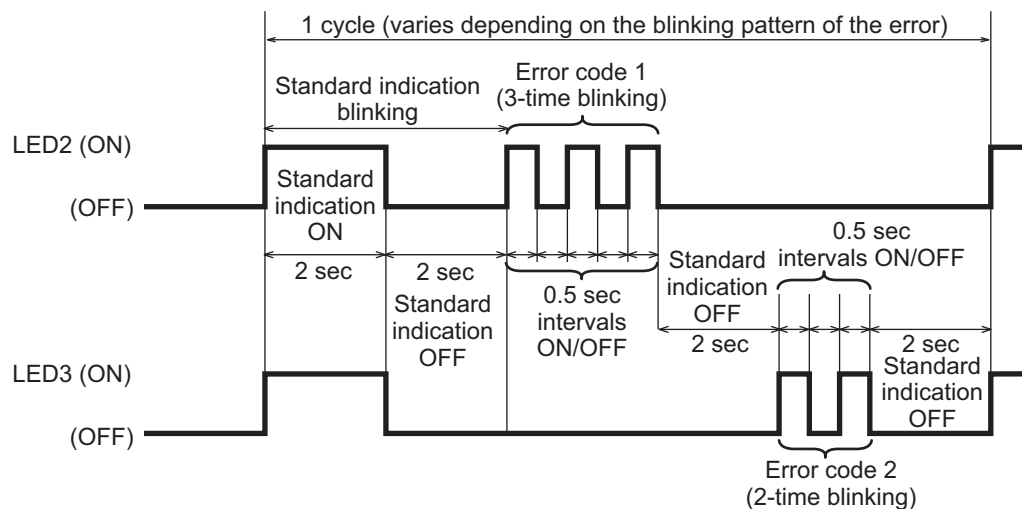

Fig.6-11

1. LED1 blinking pattern error code: Paper misfeeding

Error code 1 (LED2)	Error code 2 (LED3)	Name	Error code (When connected to the MFP)
1	1	Finisher transport path paper remaining jam	EA31
1	2	Exit paper remaining jam	EA32
1	3	Paper transport delay non-inserting jam	EA10
1	4	Short length paper jam in the Finisher (transport sensor)	EA21
1	5	Paper not supported for saddle stitch finisher	EF10
1	6	Paper transport jam in the Finisher (entrance sensor)	EA20
1	7	Finisher cover open error	EA40
1	8	Stapling jam	EA50
1	9	Saddle stitch finisher stapling error (front)	EF11
2	1	Paper remaining jam in Saddle Stitch Unit	EAA0
2	2	Saddle stitch finisher stapling error (rear)	EF12
2	3	Paper transport jam in Saddle Stitch Unit	EAB1
2	4	Saddle stitch unit paper holding home position detection error	EF13
2	5	Saddle stitch unit paper exit jam	EF14
2	6	Saddle stitch unit paper exit jam	EAB0
2	7	Saddle stitch unit open error	EA90
2	8	Stack exit belt home position error	EA70

Error code 1 (LED2)	Error code 2 (LED3)	Name	Error code (When connected to the MFP)
2	9	Early arrival jam	EA60
3	1	Buffer tray home position error	ED16
3	2	Paddle home position error	ED15
3	3	Rear alignment plate home position error	ED14
3	4	Front alignment plate home position error	ED13
3	5	(Unused)	-
3	6	Punch sideways adjustment motor home position detection abnormality	ED11
3	7	Punch skew adjustment motor home position detection abnormality	ED10
3	8	Punching jam	E9F0
3	9	Saddle stitch finisher side alignment motor home position detection abnormality	EA15
10	1	Saddle stitch finisher stacker motor home position detection abnormality	EF16
10	2	(Unused)	-
10	3	Saddle stitch finisher folding blade home position detection abnormality	EF17
10	4	Saddle stitch finisher additional folding roller home position detection abnormality	EF18
10	5	(Unused)	-
10	6	Saddle stitch unit paper folding jam	EF19
10	7	Saddle stitch unit stacker jam	EF20
10	8	Paper leading edge skew detection abnormality	EF21
10	9	Paper leading edge detection abnormality	EF22
11	1	Paper alignment abnormality	EF23
11	2	Paper trailing edge skew detection abnormality	EF24
11	3	Paper trailing edge detection abnormality	EF25
11	4	Required performance abnormality	EF29
11	5	Paper position detection error 1	EF27
11	6	Paper position detection error 2	EF28
11	7	Short length paper jam in the Finisher (punch paper edge sensor)	EA22
11	8	Paper transport jam in the Finisher (Paper remains at the transport sensor in the Finisher transport path.)	EA23
11	9	Paper transport jam in the Finisher (between the entrance sensor and transport sensor)	EA24
12	1	Paper transport jam in the Finisher (after paper stack exited)	EA25
12	2	Paper transport jam in the Finisher (MFP stop request)	EA26
12	3	Paper transport jam in the Finisher (The entrance sensor is turned ON) at a later timing than specified.)	EA27
12	4	Paper transport jam in the Finisher (paper holding delay)	EA28
12	5	Paper transport jam in the Finisher (paper stack transport delay)	EA29
12	6	Front upper cover open jam	EA41
12	7	Front cover open jam	EA42
15	1	Movable tray height abnormality	EAFD
15	2	Movable tray movement abnormality	EAFD
15	3	Assist guide motor home position detection abnormality	EAFE
15	4	Catching motor home position detection abnormality	EAFD
15	5	Stapler movement abnormality	EAFB

2. LED1 blinking pattern error code: Hardware errors

Error code 1 (LED2)	Error code 2 (LED3)	Name	Error code (When connected to the MFP)
4	1	Entrance motor abnormality	CB10
4	2	Buffer tray guide motor abnormality	CB11
4	3	Paddle motor abnormality	CDE0
4	4	(Unused)	-
4	5	Rear alignment motor abnormality	CC80
4	6	Front alignment motor abnormality	CB40
4	7	Vertical alignment motor abnormality	CC31
4	8	Stack transport motor abnormality	CC30
4	9	Stapler movement motor abnormality	CB60
5	1	Movable tray shift motor abnormality	CB30
5	2	Flash ROM abnormality	CB81
5	3	RAM abnormality	CB80
5	4	Finisher detection abnormality	CB00
5	6	(Unused)	-
5	7	(Unused)	-
5	8	Stapler shift home position error	CB51
5	9	Stapler home position error	CB50
6	1	Movable tray paper-full detection error	CB31
6	2	Catching motor abnormality	CB15
6	3	Assist guide cam home position abnormality	CC41
6	4	Saddle stitch finisher folding motor abnormality	CBE0
6	5	Saddle stitch finisher additional folding motor abnormality	CB93
6	6	Front saddle stapler home position error	CBA0
6	7	Rear saddle stapler home position error	CBB0
6	8	Saddle side alignment motor abnormality	CBC0
6	9	Saddle transport motor abnormality	CB94
7	1	Punch motor home position detection error	CC61
7	2	(Unused)	-
7	3	(Unused)	-
7	4	Punch sideways adjustment motor abnormality	CC51
7	5	(Unused)	-
7	6	Punch skew adjustment motor abnormality	CC52
7	7	Punch ROM checksum error	CC71
7	8	Punch RAM read write error	CC72
7	9	Communication error between the finisher and the punch unit	CE00
8	1	(Unused)	-
8	2	(Unused)	-
8	3	(Unused)	-
8	4	(Unused)	-
8	5	Saddle stitch communication error	CC20
8	6	Saddle tacker motor abnormality	CB95
8	7	(Unused)	-
8	8	(Unused)	-
8	9	(Unused)	-
9	1	Assist guide motor abnormality	CB14
9	2	Finisher - Main program error	CB82
9	3	(Unused)	-

Error code 1 (LED2)	Error code 2 (LED3)	Name	Error code (When connected to the MFP)
9	4	Hole punch unit - Main program error	CB84
9	5	Punching device power supply abnormality	CC73
9	6	Transport pulse abnormality	CC74
9	7	Punch motor interrupt signal error	CC60
13	1	Loop-back test No response	-
13	2	Loop-back test Data abnormality	-

3. LED1 blinking pattern error code: Alerts

Error code 1 (LED2)	Error code 2 (LED3)	Name	Error code (When connected to the MFP)
13	3	Stationary tray: Full	-
13	4	Movable tray: Full	-
13	5	Saddle tray: Full	-
13	6	Punch waste case: Full	-
13	7	(Unused)	-
13	8	Finisher staple cartridge: Empty	-
13	9	Saddle staple cartridge: Empty	-

7. PREVENTIVE MAINTENANCE (PM) AND FIRMWARE UPDATING

7.1 Maintenance and Inspection Points

Perform preventive maintenance according to the check list.
Perform preventive maintenance for the Finisher at the same interval as for the MFP to which the Finisher is connected.

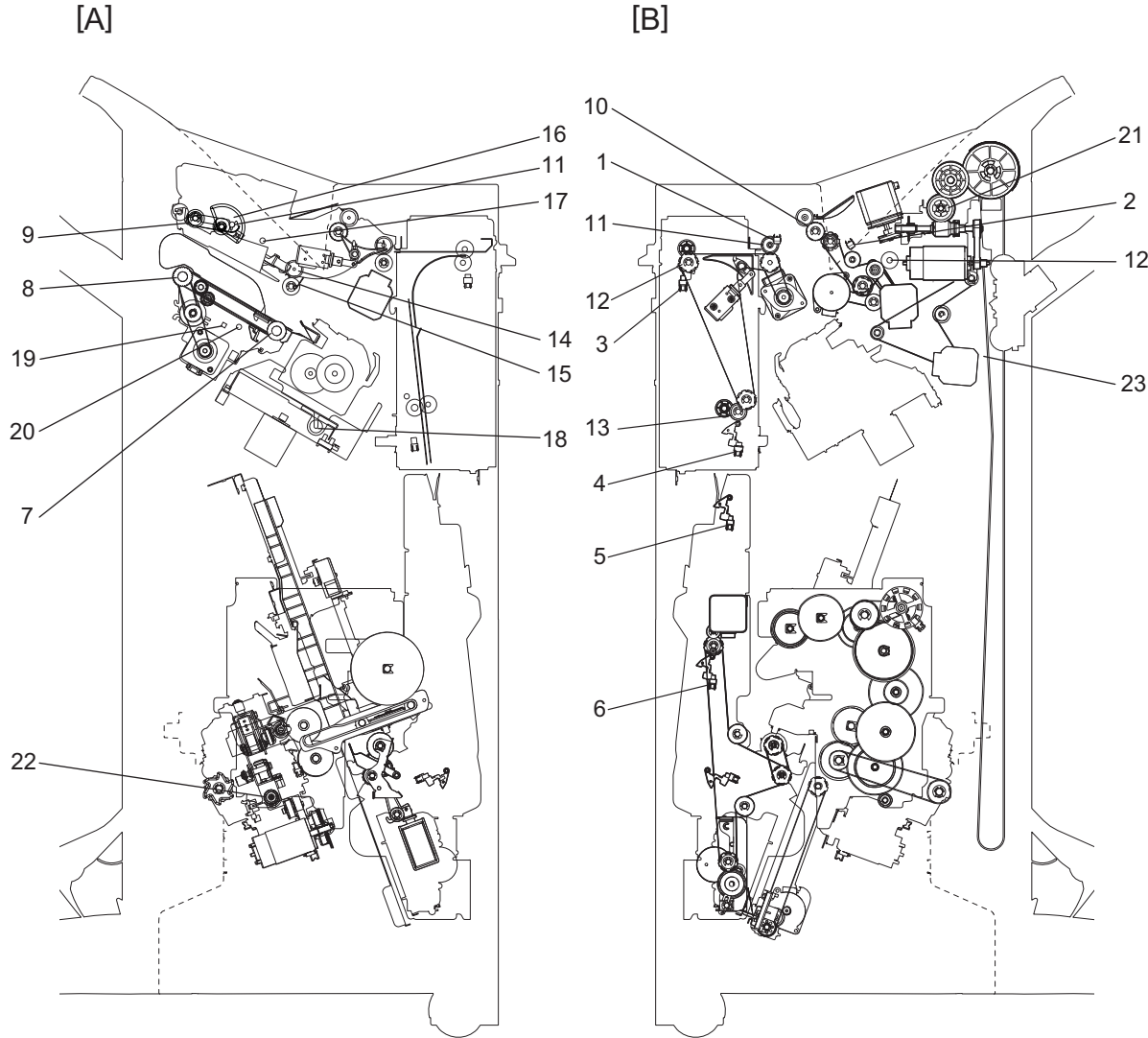

Fig. 7-1
[A] Front side
[B] Rear side

Symbols and values used in the checklist

Item	Explanation
Cleaning	A: Clean with alcohol
Lubrication/Coating	W1: White grease (Molykote EM-30L) W2: White grease (Molykote HP-300) C: Coating material (SANKOL CFD-409M)
Replacement	Value: Replacement cycle R3: Replace if deformed or damaged
Operation check	O: After cleaning or replacement, confirm there is no problem.

Preventive Maintenance Checklist

	Items to check	Cleaning	Lubrication/ Coating	Replacement (x1,000)	Operation check	Parts list (P-I)	Remarks
1	Entrance sensor (S1)	A				7-39	
2	Transport sensor (S2)	A				7-39	
3	Paper feed sensor (S22)	A				16-8	
4	Junction box sensor (S26)	A				16-8	
5	Transport path-2 sensor (S27)	A				28-2	
6	Transport path-3 sensor (S28)	A				28-2	
7	Stack transport roller-1	A				10-18	
8	Stack transport roller-2	A				10-16, 10-20	
9	Buffer roller	A				9-43	
10	Stationary tray roller	A				7-46	
11	Entrance roller, Idling roller	A	W2			5-7	*m
12	Paper feed roller, Idling roller	A	W2			16-14	*m
13	Junction roller, Idling roller (MJ-1116)	A	W2			16-60	*m
14	Exit roller	A				6-5	
15	Paddle			1,000		6-12, 6-15, 6-17	
16	Front assist guide cam, Rear assist guide cam		C			9-28 (Front), 9-29 (Rear)	*a
17	Buffer roller link		W1			9-46	*b
18	Shaft		W1			---	*c
19	Buffer tray shaft		W1			9-44	*d
20	Pinch roller shaft		W1			9-11	*e
21	Buffer roller shaft		W1			9-42	*f
22	Stapler carrier shaft		W1			11-10	*g
23	Rack and pinion gear (aligning plate)		W1			10-8, 10-13	*h
24	Finishing tray shaft		W1			10-7	*i
25	Movable tray drive gear		W2			12-59	*j
26	Additional folding unit carrier shaft (MJ-1116)		W1			---	*k
27	Grate-shaped guide	A	C			4-36	*1

*a: Front assist guide cam, Rear assist guide cam

Apply coating material (SANKOL CFD-409M) by using a cleaning brush all around the assist guide cam [1].

- Use a cleaning brush (4407915710 BRUSH-33) because cloth contaminated with the coating material has to be treated as industrial waste.
- Do not apply coating material to the rubber section.
- If any coating material adheres to your skin, rinse it off with water.
- The brush with which the coating agent (SANKOL CFD-409M) was applied must be exclusive for coating. Do not use it to clean other areas.

*b: Buffer roller link

Apply an appropriate amount of white grease (Molykote HP-300) to the buffer roller link [2].

*c: Shaft

Apply an appropriate amount of white grease (Molykote HP-300) to the entire cam [3].

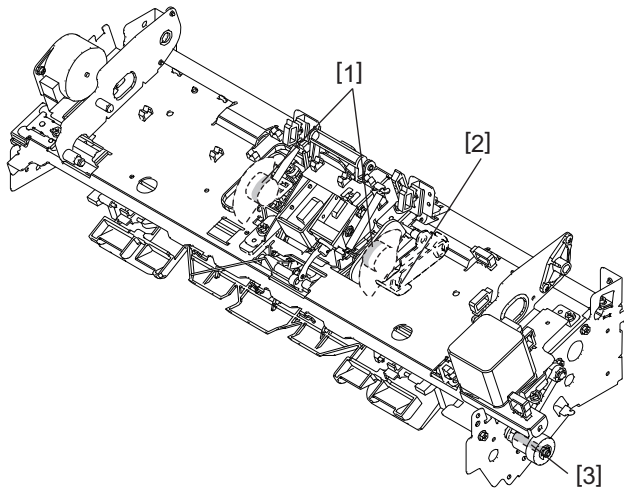

Fig. 7-2

*d: Buffer tray shaft

Apply an appropriate amount of white grease (Molykote HP-300) to the entire buffer tray shaft [1].

*e: Pinch roller shaft

Apply an appropriate amount of white grease (Molykote HP-300) to the pinch roller shaft [2].

*f: Buffer roller shaft

Apply an appropriate amount of white grease (Molykote HP-300) to the buffer roller shaft [3].

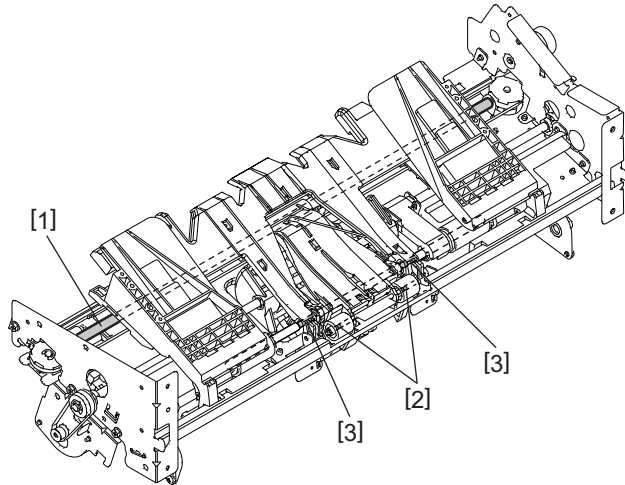

Fig. 7-3

*g: Stapler carrier shaft

Apply an appropriate amount of white grease (Molykote HP-300) to the entire stapler carrier shaft [1].

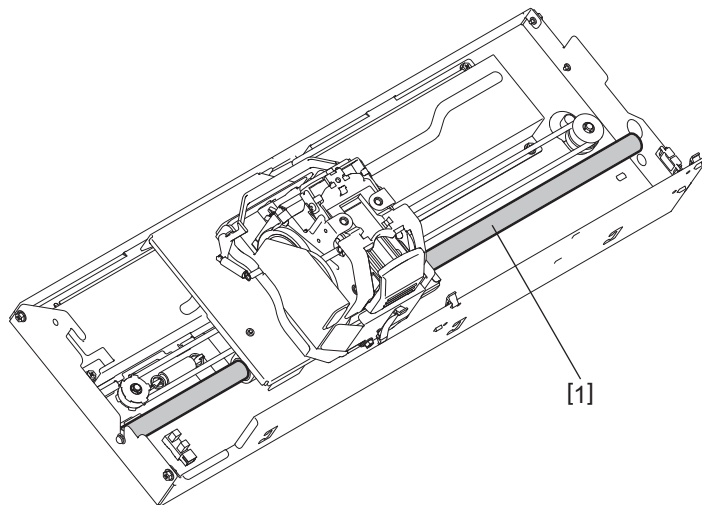

Fig. 7-4

*h: Rack and pinion gear (alignment plate)

*i: Finishing tray shaft

1. Take off the junction box unit.

 P. 4-16 "4.2.1 Junction box unit"

* If the Hole Punch Unit is installed, take it off beforehand.

2. Apply oil as follows through the opening which shows up when the junction box unit has been removed.

Apply an appropriate amount of white grease (Molykote EM-30L) to the gear teeth of the rack gear [1] which drive the aligning plate, and the entire finishing tray shaft [2].

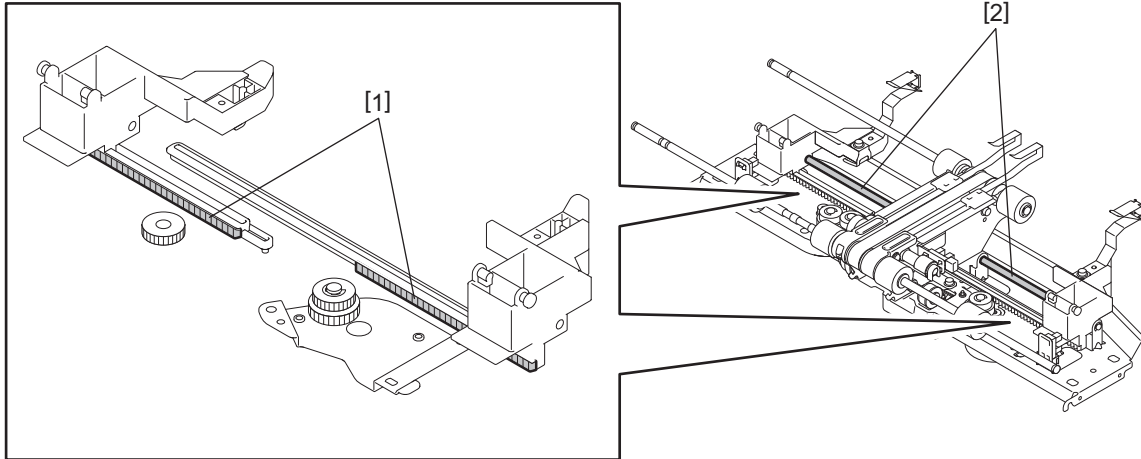

Fig. 7-5

*j: Movable tray drive gear

Apply an appropriate amount of white grease (Molykote HP-300) to the gear teeth of the movable tray drive gear [1].

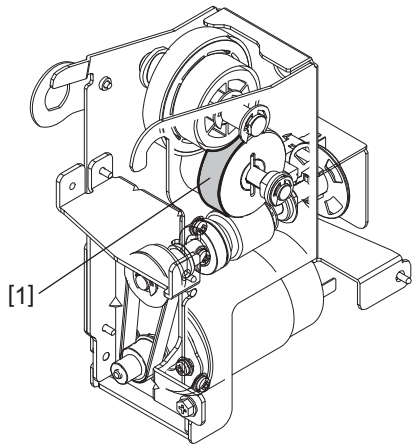

Fig. 7-6

*k: Additional folding unit carrier shaft (MJ-1116)
Apply an appropriate amount of white grease (Molykote HP-300) to the entire additional folding unit carrier shaft [1].

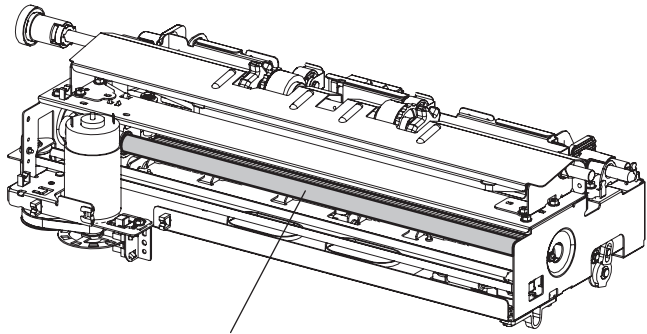

Fig. 7-7

*l: Grate-shaped guide

When an abnormal noise occurs in the grate-shaped guide [1] or the trailing edge of the paper stacked on the tray is dirty, apply coating material (SANKOL CFD-409M) by using a cleaning brush to the portion on the guide with which the paper edge is in contact.

- Use a cleaning brush (4407915710 BRUSH-33) because cloth contaminated with the coating material has to be treated as industrial waste.
- Do not apply coating material to the rubber section.
- If any coating material adheres to your skin, rinse it off with water.
- The brush with which the coating agent (SANKOL CFD-409M) was applied must be exclusive for coating. Do not use it to clean other areas.

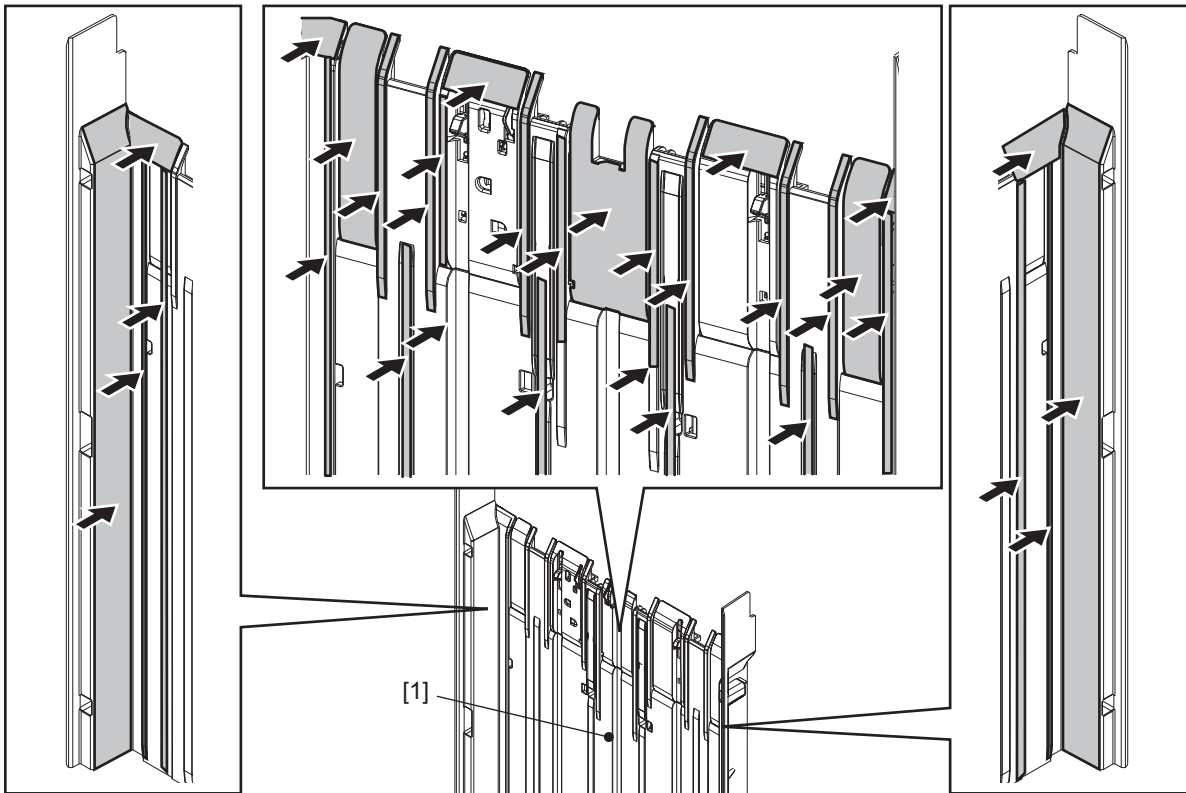

Fig. 7-8

*m: Roller

Apply white grease (Molykote HP-300) to the bushing of the roller.

7.2 Firmware Updating

Notes:

For updating the firmware, refer to “FIRMWARE UPDATING” in the Service Manual for MFP.

8. HARNESS DIAGRAM

8.1 Finisher Control PC Board

Refer to the service manual (PDF) if necessary.

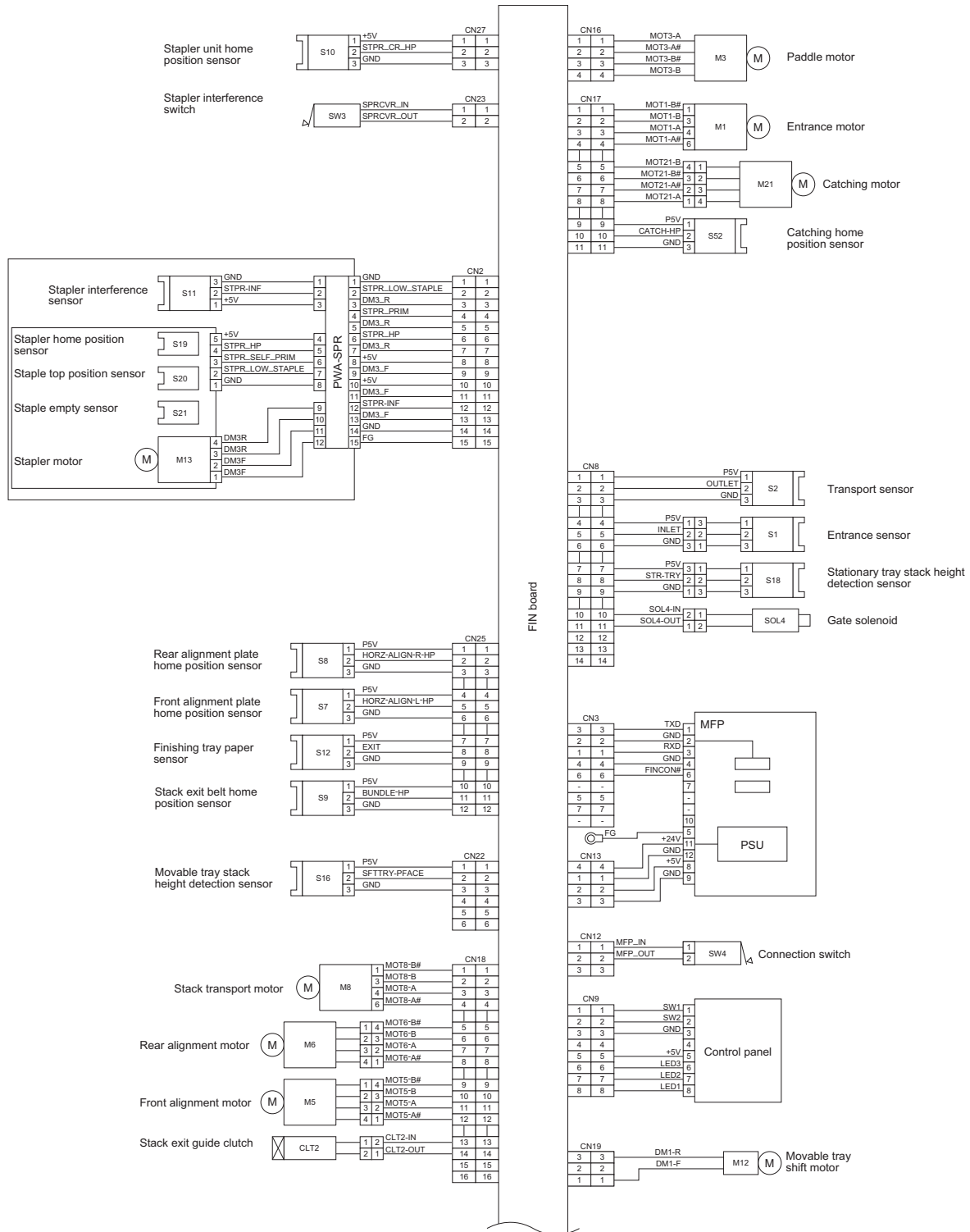

Fig.8-1

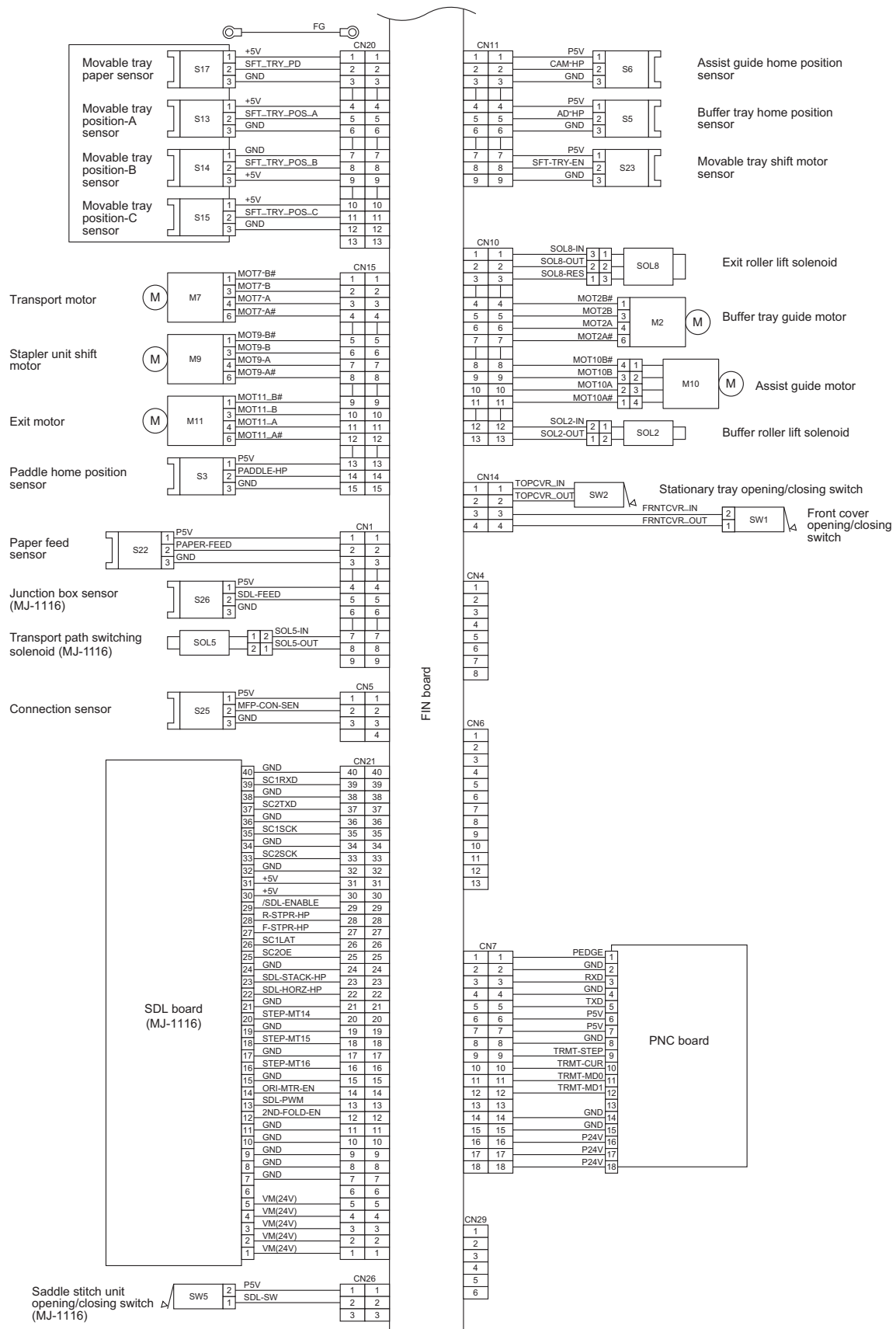

Fig.8-2

8.2 Saddle Control PC Board

Refer to the service manual (PDF) if necessary.

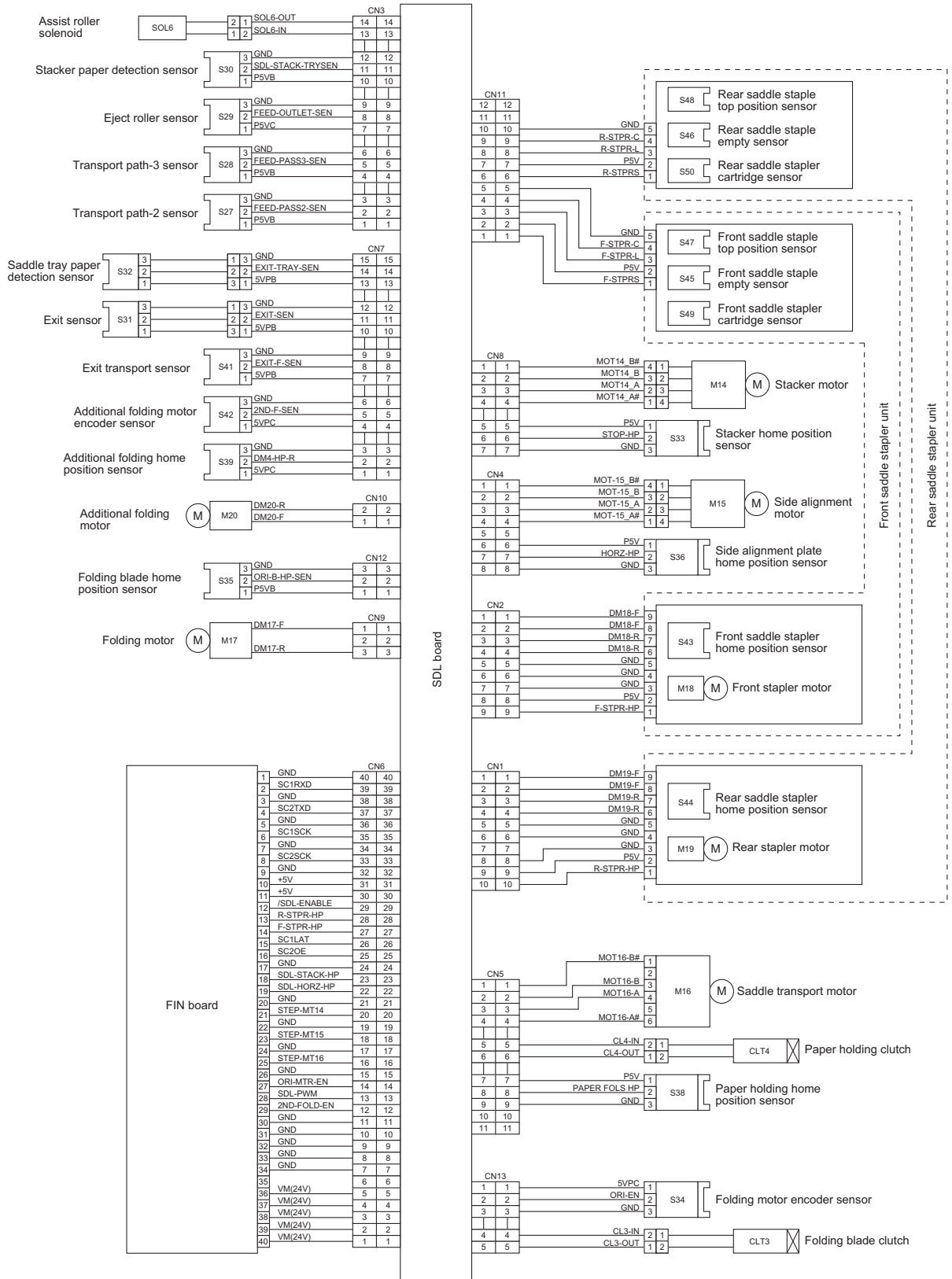

Fig.8-3

REVISION RECORD

Ver01

Ver01 <2023/2/28>	
Page	Contents
7-2	The numbers for P-I have been added.

Ver00

Ver00 <2022/11/22>	
Page	Contents
	Initial release

TOSHIBA

Toshiba Tec Corporation

1-11-1, OSAKI, SHINAGAWA-KU, TOKYO, 141-8562, JAPAN