

TOSHIBA

SERVICE MANUAL

FINISHER

MJ-1111/1112

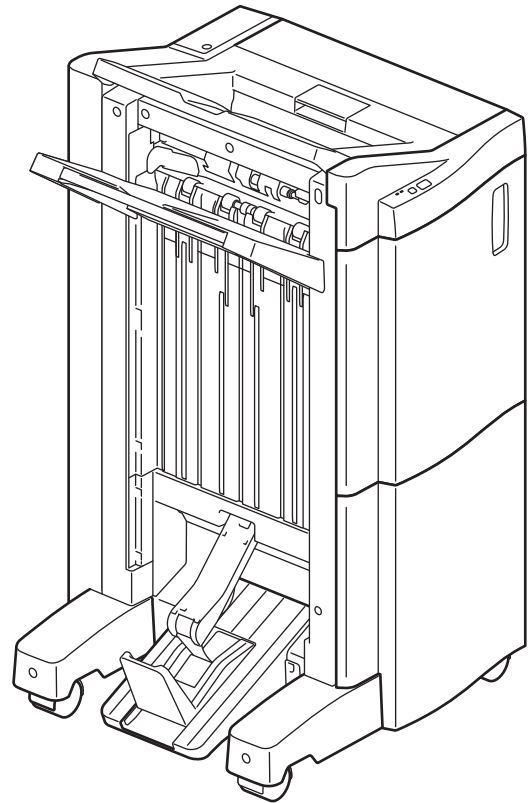

Model: MJ-1111/1112
Publish Date: June, 2016
File No. SME150038C0
R151221R9603-TTEC
Ver03 F_2019-03

Trademarks

- MOLYKOTE® is a registered trademark of Dow Corning Corporation.
- FLOIL® is a registered trademark of Kanto Kasei CO., Ltd.
- SANKOL is a registered trademark of SANKEIKAGAKU Co., Ltd.
- Other company names and product names in this manual are the trademarks of their respective companies.

© 2016 - 2019 Toshiba Tec Corporation All rights reserved

Under the copyright laws, this manual cannot be reproduced in any form without prior written permission of Toshiba Tec Corporation.

General Precautions for Installation/Service/Maintenance for this equipment

The installation and service shall be done by a qualified service technician.

1. When installing this equipment to the MFP, be sure to follow the instructions described in the "Unpacking/Set-Up Procedure for this equipment" booklet which comes with each unit of this equipment.
2. This equipment shall be installed by an authorized/qualified person.
3. The Finisher is quite heavy; MJ-1111 weighs approximately 40 kg (88.19 lb.) and MJ-1112 weighs approximately 70 kg (154.32 lb.), therefore pay full attention when handling it.
4. Before starting installation, servicing or maintenance work, be sure to turn OFF and unplug the equipment first.
5. After the power cable is disconnected, an electric charge may remain in the boards of the equipment. Therefore, be sure to disconnect or connect the connectors when about 1 minute has passed after the power cable is disconnected.
6. The fuse could be in the neutral. The mains supply shall be disconnected to de-energize the phase conductors.
7. The equipment shall be installed near the socket outlet and shall be easily accessible.
8. Be sure to fix and plug in the power cable securely after the installation so that no one trips over it.
9. When this equipment is removed from the equipment due to malfunction or other reasons but no substitute machine is to be installed, be sure to remove all the installation hardware from the equipment as well.
10. When selecting the installation site, avoid placing the finisher / hole punch unit and equipment on different levels or inclined floors.
11. When servicing or maintaining this equipment, be careful about the rotating or operation sections such as gears, pulleys, sprockets, cams, belts, etc.
12. When parts are disassembled, reassembly is basically the reverse of disassembly unless otherwise noted in this manual or other related materials.
Be careful not to reassemble small parts such as screws, washers, pins, E-rings, toothed washers, harnesses to the wrong places.
13. Basically, the machine should not be operated with any parts removed or disassembled.
14. When servicing the equipment with the power turned ON, be sure not to touch live sections and rotating/operating sections.
15. Delicate parts for preventing safety hazard problems (such as switches, sensors, etc. if any) should be handled/installed/adjusted correctly.
16. Tools and instruments
 - Use designated jigs and tools.
 - Use recommended measuring instruments or equivalents.

17. During servicing or maintenance work, be sure to check the rating plate and other cautionary labels (if any) to see if they are clean and firmly fixed. If not, take appropriate actions.

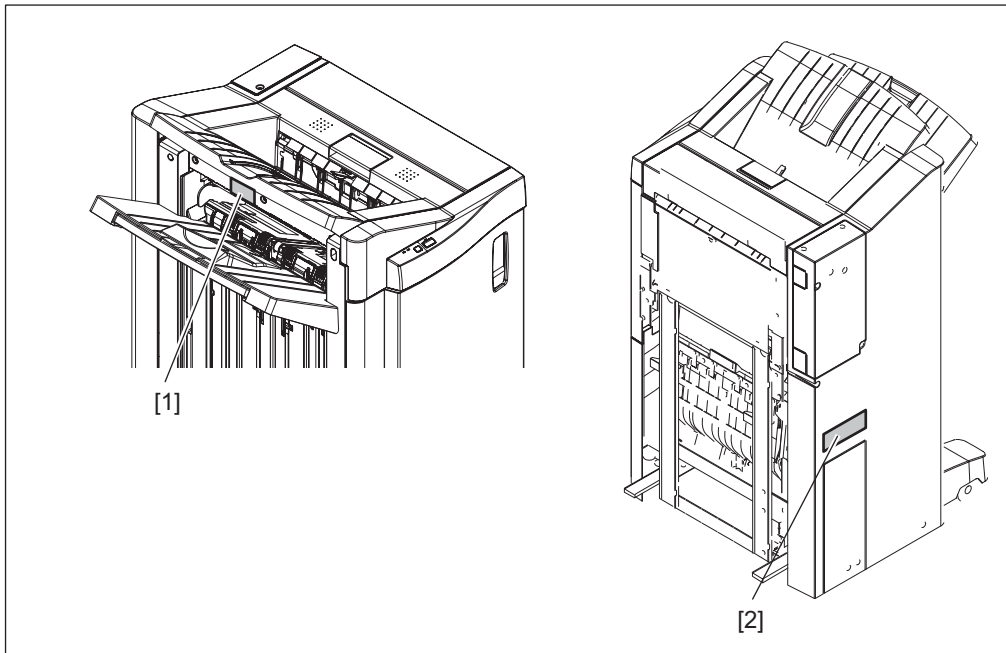

[1] Cautionary label for the paper exit section

[2] Rating plate

18. The PC board must be stored in antistatic envelope and handled carefully using a wristband, because the ICs on it may be damaged due to static electricity.

Before using the wrist band, pull out the power cable plug of the equipment and make sure that there is no uninsulated charged objects in the vicinity.

19. For the recovery and disposal of used this equipment, consumable parts and packing materials, follow the relevant local regulations/rules.

20. After completing installation, servicing and maintenance of this equipment, return this equipment to its original state, and check operation.

21. When the equipment is used after the option is removed, be sure to install the parts or the covers which have been taken off so that the inside of the equipment is not exposed.

22. When you move the finisher, do not move it in the direction of the arrow as shown in the figure below otherwise it might topple over.

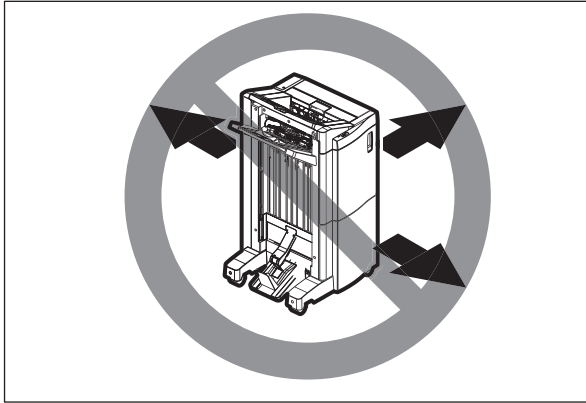

23. Unplug the power cable and clean the area around the prongs of the plug and socket outlet once a year or more. A fire may occur when dust lies on this area.

24. When you remove the finisher and then lift the equipment, do not hold its studs. This could cause injury since the studs may break off and make the equipment fall.

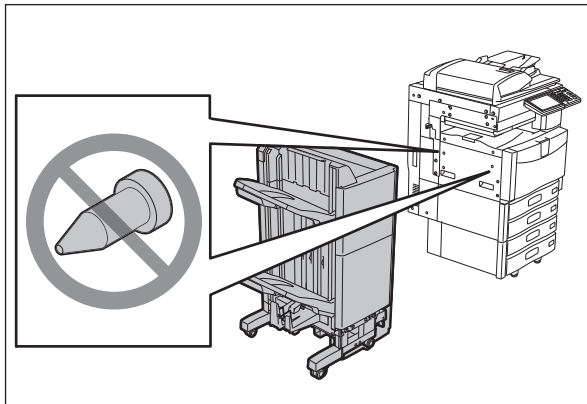

25. Check the procedures and perform them as described in the Service Manual.

26. Make sure you do not lose your balance.

27. Avoid exposure to your skin and wear protective gloves as needed.

28. Do not leave plastic bags where children can get at them. This may cause an accident such as suffocation if a child puts his/her head into a bag. Plastic bags of options or service parts must be brought back.

CONTENTS

1. SPECIFICATIONS, ACCESSORY AND CONSUMABLES	1-1
1.1 Specifications.....	1-1
1.1.1 Finisher section (Common for MJ-1111/1112).....	1-2
1.1.2 Saddle stitch section (MJ-1112).....	1-5
1.2 Accessory.....	1-6
1.3 Consumables.....	1-6
1.4 Rating label.....	1-7
1.4.1 Consumables of MJ-1111 and MJ-1111-B.....	1-7
1.4.2 Consumables of MJ-1112 and MJ-1112-B.....	1-7
2. GENERAL DESCRIPTION	2-1
2.1 Main Components.....	2-1
2.2 Sectional View.....	2-2
2.3 Electric Parts Layout.....	2-7
2.4 Symbols and Functions of Various Components.....	2-9
2.5 Diagram of Signal Blocks.....	2-13
2.6 Description of Interface Signals.....	2-15
3. DESCRIPTION OF OPERATIONS	3-1
3.1 Basic Operations.....	3-1
3.1.1 GENERAL DESCRIPTION.....	3-1
3.1.2 Junction Box (MJ-1112).....	3-5
3.1.3 Paper exit to the stationary tray.....	3-6
3.1.4 Paper exit to the movable tray.....	3-8
3.1.5 Operation in the saddle stitch section (MJ-1112).....	3-16
4. DISASSEMBLY AND INSTALLATION	4-1
4.1 Covers.....	4-1
4.2 Units (Finisher section).....	4-15
4.3 Units (Saddle stitch section: MJ-1112).....	4-32
4.4 Rollers (Finisher section).....	4-44
4.5 Rollers (Saddle stitch section: MJ-1112).....	4-69
4.6 Motor (Finisher section).....	4-75
4.7 Motor (Saddle stitch section: MJ-1112).....	4-91
4.8 Clutch / Solenoid.....	4-97
4.9 Sensors / Switches (Finisher section).....	4-108
4.10 Sensors / Switches (Saddle stitch section: MJ-1112).....	4-130
4.11 PC Boards / Discharge Brush.....	4-142
4.12 Procedure for lowering the movable tray.....	4-148
5. ADJUSTMENTS	5-1
5.1 Adjusting the Aligning Position for the Finishing Tray.....	5-1
5.2 Adjusting the Stapling Position.....	5-4
5.3 Stapling/folding position adjustment in saddle stitch unit.....	5-6
5.4 Saddle Stitch Skew Adjustment.....	5-9
6. TROUBLESHOOTING	6-1
6.1 Error Code List.....	6-1
6.1.1 Jam.....	6-1
6.1.2 Service call.....	6-5
6.2 Diagnosis and Prescription for Each Error Code.....	6-7
6.2.1 Check item.....	6-7
6.2.2 Paper jam in finisher section.....	6-7
6.2.3 Paper jam in saddle stitcher section.....	6-17
6.2.4 Paper jam in puncher unit.....	6-21
6.2.5 Other paper jam.....	6-22
6.2.6 Finisher related service call.....	6-35

6.3	Self-Diagnostic Modes	6-52
6.3.1	General description.....	6-52
6.3.2	Operation procedure.....	6-52
6.3.3	Checking operational status	6-53
6.3.4	Test list	6-53
6.3.5	Error indications.....	6-62
6.4	Other error.....	6-66
6.4.1	Countermeasure when an exit paper alignment problem occurs	6-66
6.4.2	Paper trailing edge abnormality when it is exiting to the movable tray (dents, folding, tears)6-67	
7.	PREVENTIVE MAINTENANCE (PM) / FIRMWARE UPDATE	7-1
7.1	Maintenance and Inspection Points	7-1
7.2	Firmware Update.....	7-8
8.	ELECTRIC CIRCUIT	8-1
8.1	Harness Diagram	8-1
8.2	Circuit Diagram	8-4
8.3	PC board	8-25

1. SPECIFICATIONS, ACCESSORY AND CONSUMABLES

1.1 Specifications

- Product Type
MJ-1111:Console Finisher (2 trays)
MJ-1112:Console Saddle Stitch Finisher (3 trays)
- Paper Stacking Device
Stationary Tray or Movable Tray, Saddle Tray (MJ-1112 only)
- Paper Size
A3, A4, A4-R, A5, A5-R, A6-R, B4, B5, B5-R, FOLIO, A3 wide, LD, LG, LT, LT-R, ST-R, COMPUTER, 13"LG, 8.5"SQ, 8K, 16K, 16K-R
- Paper Basis Weight
52 - 300g/m²
* Thin paper (52 to 59g/m²) is available when a single sheet is printed out to the upper tray.
- Stacking Mode
Simple, Job Offset, Staple, Composite, Center-binding and Center-folding
- Dimensions
With Sub-tray put in: W 617 x D 603 x H 1,085 (mm)
With Sub-tray drawn out: W 750 x D 603 x H 1,085 (mm)
- Gross Weight
MJ-1111:Approximately 40kg (88.19 lbs)
MJ-1112:Approximately 70kg (154.32 lbs)
- Power Supply
DC24V+10/-5% and DC5.1V±4% supplied from the main equipment.
- Power Consumption
DC24V Average 3.9A or less (Peak:11.0A or less)
DC5.1V 1.0A or less

1.1.1 Finisher section (Common for MJ-1111/1112)

- Stacking Type: Face down
- Stacking Height with

<Stationary Tray>

Paper Size	Stacking Height	Number of sheets (reference)		
		60 - 80g/m ² Paper	81 - 90g/m ² Paper	91 - 105g/m ² Paper
A4, B5, LT, A5-R, ST-R, 8.5"SQ, 16K, A6-R	36.75mm	250	225	190
A3, A4-R, B4, FOLIO, LD, LG, LT-R, COMPUTER, B5-R, 13"LG, 8K, 16K-R, A3 wide, 12" x 18", 320 x 450mm, 320 x 460mm, Non-standard	18.4mm	125	112	95
Envelope	18.4mm	50	50	50

The maximum stacking height is 18.4 mm for mixed size paper.

"Full" status is defined as when the stationary tray paper-full sensor (S18) detected the full status of paper in the size available for feeding.

<Movable tray (in the job offset stack mode)>

Paper Size	Stacking Height	Number of sheets (reference)			
		60 - 80g/m ² Paper	81 - 90g/m ² Paper	91 - 105g/m ² Paper	106 - 256g/m ² Paper
A4, B5, LT, 8.5"SQ, 16K	350mm	3,000	2,700	2,300	900
A3, A4-R, B4, FOLIO, LD, LG, LT-R, COMPUTER, 13"LG, 8K, 16K-R, A3 wide, 12" x 18"	175mm	1,500	1,350	1,150	450
ST-R, A5-R, B5-R, A6-R, Non-standard	-	500	500	500	450

The maximum stacking height is 175 mm for mixed size paper. However, ST-R, A5-R, B5-R, A6-R and non-standard sizes are not acceptable for mixed size paper.

"Full" status is defined as when the number of paper whose maximum stacking height is 350 mm has reached 3,000 or when the number of paper in other sizes has reached 1,500.

The maximum number of sheets acceptable is 1,500 for mixed size paper. However, ST-R, A5-R, B5-R, A6-R and non-standard sizes are not acceptable for mixed size paper.

<Movable tray (in the staple stack mode)>

Paper Size	Stacking Height 64 - 105 g/m ² (reference)	
	Front/Rear Single Position Stapling	Two-Position Stapling
A4, B5, LT	A paper-full status is detected either when the number of stacks reaches 100 or when the number of sheets reaches 2,000.	A paper-full status is detected either when the number of stacks reaches 150 or when the number of sheets reaches 2,000.
A3, A4-R, B4, FOLIO, LD, LG, LT-R, COMPUTER, 13"LG, 8K, 16K, 8.5"SQ	A paper-full status is detected either when the number of stacks reaches 50 or when the number of sheets reaches 1,000.	A paper-full status is detected either when the number of stacks reaches 75 or when the number of sheets reaches 1,000.

- Stapling Position

Front single position

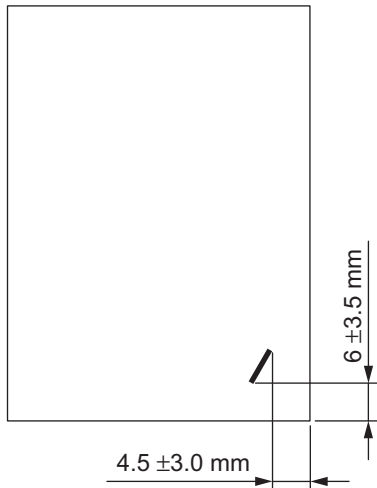

Fig. 1-1

Rear single position

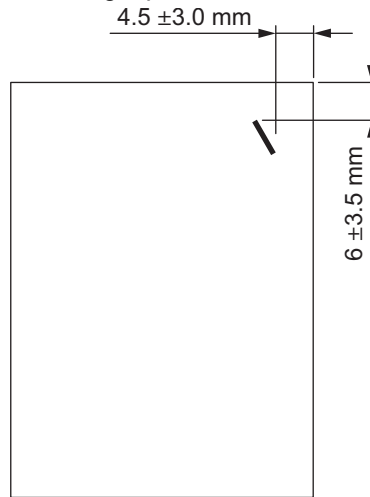

Fig. 1-2

Two-Position Stapling

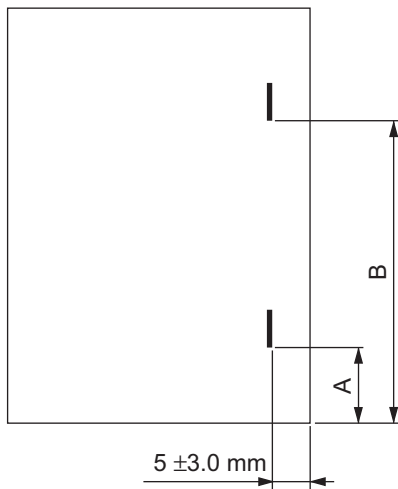

Fig. 1-3

Paper Size	A	B
A3, A4	81.0 ±3.5mm	205.0 ±3.5mm
A4-R, FOLIO	37.5 ±3.5mm	161.5 ±3.5mm
B4, B5, COMPUTER	61.0 ±3.5mm	185.0 ±3.5mm
LD, LT	72.0 ±3.5mm	196.0 ±3.5mm
LT-R, LG	40.5 ±3.5mm	164.5 ±3.5mm

- Paper Size for stapling

Stapling Position	Paper Size
Front Single	A3, A4, A4-R, B4, B5, FOLIO, LD, LG, LT, LT-R, COMPUTER, 13"LG, 8.5"SQ, 8K, 16K
Rear Single	A3, A4, A4-R, B4, B5, FOLIO, LD, LG, LT, LT-R, COMPUTER, 13"LG, 8.5"SQ, 8K, 16K
Two-Positions	A3, A4, A4-R, B4, B5, FOLIO, LD, LG, LT, LT-R, COMPUTER, 13"LG, 8.5"SQ, 8K, 16K

Stapling is not available for paper in sizes other than the above.

- Paper Basis Weight for stapling: 60 - 105g/m²

- The number of Stapleable Sheet

Paper Size	60 - 80g/m² Paper	81 - 90g/m² Paper	91 - 105g/m² Paper
A4, B5, LT, 8.5"SQ, 16K	50	50	30
A4-R, LT-R, A3, B4, FOLIO, LD, LG, COMPUTER, 13"LG, 8K	30	30	15

Maximum number of sheets acceptable for stapling:

A4, B5, LT, 8.5"SQ, 16K - 50 sheets

A3, A4-R, B4, FOLIO, LD, LG, LT-R, COMP, 13"LG, 8K - 30 sheets

* Two sheets of cover sheet (200 - 256 g/m²) can be included.

- Staple Loading: Exclusive cartridge (5,000 staples)
- Manual Stapling: Available

1.1.2 Saddle stitch section (MJ-1112)

- Binding method: Enter-binding only
- Paper Size: A3, B4, A4-R, LD, LG, LT-R, 8K
- Number of sheets available for stapling

60 - 80g/m ² Paper	81 - 90g/m ² Paper	91 - 105g/m ² Paper
15	15	10

* One sheet of cover sheet (200 - 256 g/m²) can be included.

- Paper Basis Weight for stapling: 60 - 105g/m²
- Staple Loading exclusive cartridge (2,000 staples)
- Exiting paper not folded: Not available
- Exiting paper not stapled: Exited when Center-folding is performed
- Stapling interval: 120 mm
- Number of stacks available (When Center-binding is performed)

No thick paper cover included

Number of sheets	60 - 90g/m ² Paper	91 - 105g/m ² Paper
Under 5 sheets/books	50	40
Under 10 sheets/books	30	25
Under 15 sheets/books	25	-

Thick paper cover included

Number of sheets	60 - 90g/m ² Paper	91 - 105g/m ² Paper
Under 5 sheets/books	50	30
Under 10 sheets/books	15	15
Under 15 sheets/books	10	-

- Number of stacks available (When Center-folding is performed)

No thick paper cover included

Number of sheets	60 - 105g/m ² Paper
2 to 5 sheets/books	25

Thick paper cover included

Number of sheets	60 - 90g/m ² Paper	91 - 105g/m ² Paper
2 to 5 sheets/books	25	15

1.2 Accessory

	MJ-1111	MJ-1112
Unpacking Instruction	1set	1set
Movable tray	1pc	1pc
Connect rail plate	1pc	1pc
Connect rail	1pc	1pc
Connect plate	1pc	1pc
Joint plate	1pc	1pc
Saddle tray	-	1pc
Slide tray	-	1pc
Leveling arm	-	1pc
Screw: TBID M4x8	6pcs	6pcs
Screw: TBID M4x12	5pcs	5pcs
Screw: M3x8	5pcs	7pcs
Screw: M3x8(Black)	-	2pcs

1.3 Consumables

- Staple cartridge for the Finisher section
Exclusive cartridge (STAPLE-2400: 5,000staples X 3 cartridges /box)
- Staple cartridge for the saddle stitch section (MJ-1112)
Exclusive cartridge (STAPLE-3100: 2,000staples X 4 cartridges /box)

1.4 Rating label

1.4.1 Consumables of MJ-1111 and MJ-1111-B

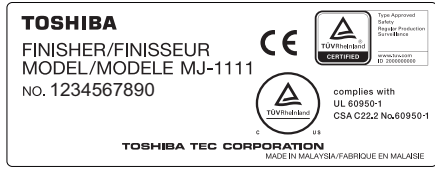
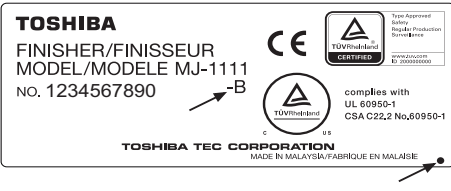
Model Name	MJ-1111	MJ-1111-B
European safety standards complied with	Safety standard: EN60950-1 RoHS2: 2011/65/EU	Safety standard: EN60950-1, EN62368-1 RoHS2: 2011/65/EU 2011/65/EU+(EU)2015/863
Applicable models	e-STUDIO5506AC/6506AC/7506AC e-STUDIO5508A/6508A/7508A/8508A	e-STUDIO5506AC/6506AC/7506AC e-STUDIO5516AC/6516AC/7516AC e-STUDIO5508A/6508A/7508A/8508A e-STUDIO5518A/6518A/7518A/8518A
Rating label	 <p>No mark applied</p>	 <p>Black dot mark and “-B” applied</p>
Notes	Purchasing this is not possible after June, 2019.	

1.4.2 Consumables of MJ-1112 and MJ-1112-B

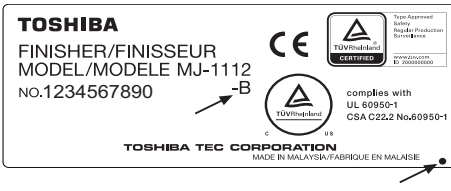
Model Name	MJ-1112	MJ-1112-B
European safety standards complied with	Safety standard: EN60950-1 RoHS2: 2011/65/EU	Safety standard: EN60950-1, EN62368-1 RoHS2: 2011/65/EU 2011/65/EU+(EU)2015/863
Applicable models	e-STUDIO5506AC/6506AC/7506AC e-STUDIO5508A/6508A/7508A/8508A	e-STUDIO5506AC/6506AC/7506AC e-STUDIO5516AC/6516AC/7516AC e-STUDIO5508A/6508A/7508A/8508A e-STUDIO5518A/6518A/7518A/8518A
Rating label	 <p>No mark applied</p>	 <p>Black dot mark and “-B” applied</p>
Notes	Purchasing this is not possible after June, 2019.	

2. GENERAL DESCRIPTION

2.1 Main Components

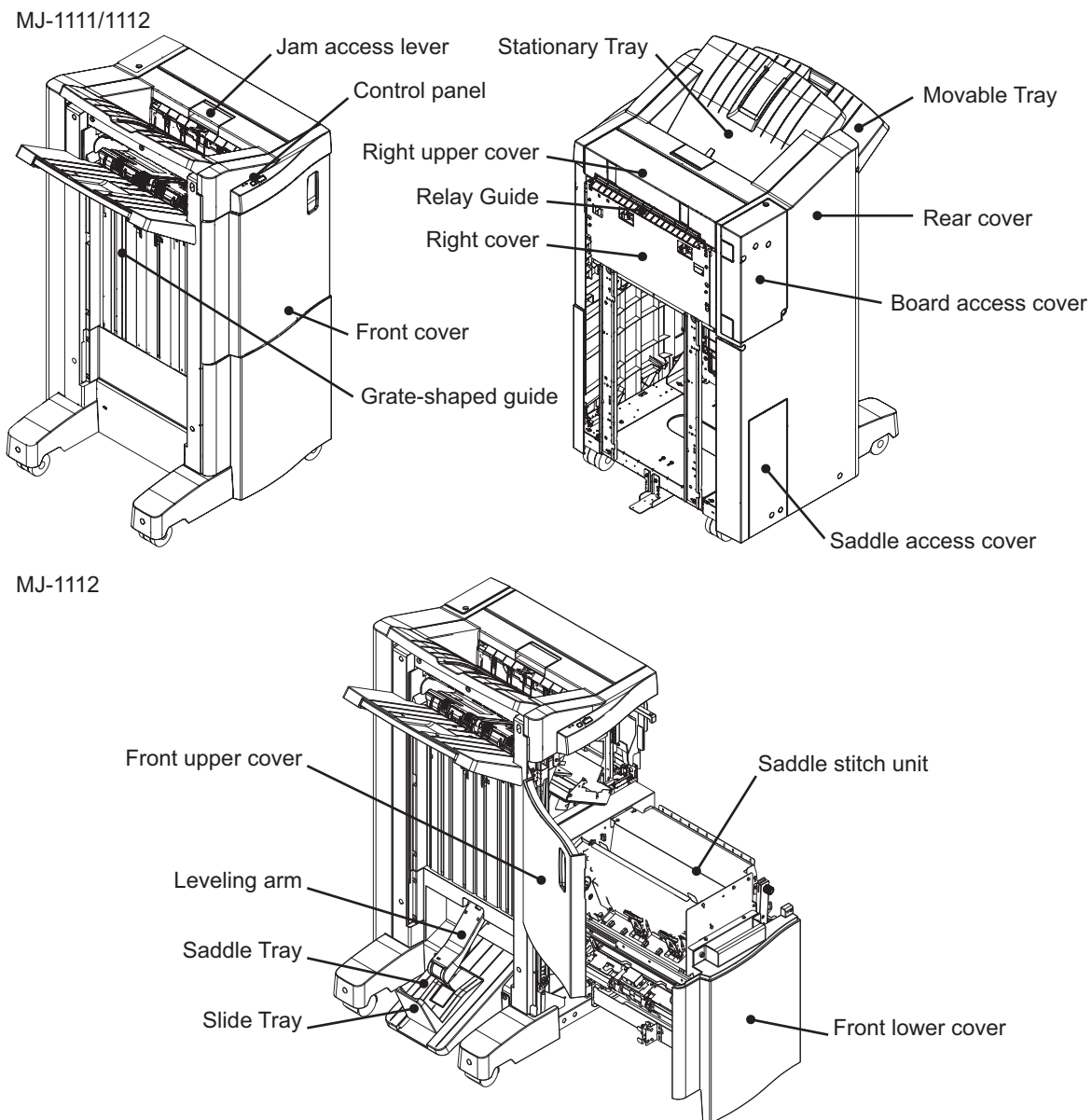

Fig. 2-1

2.2 Sectional View

[A] Units

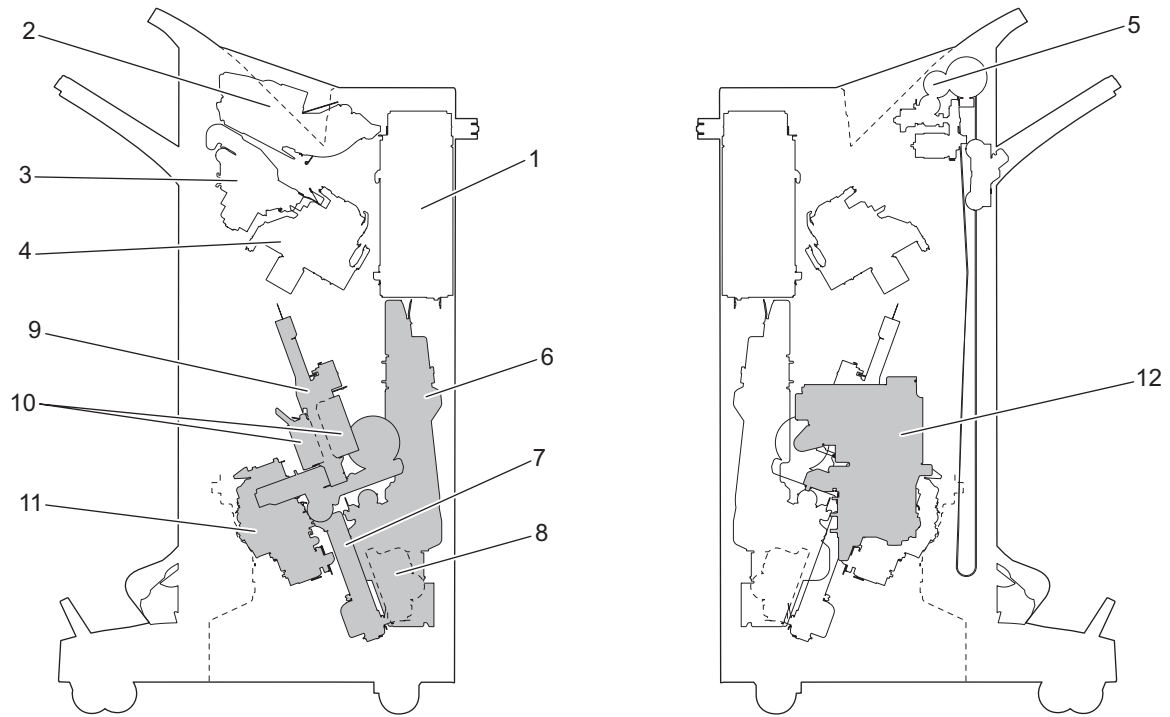

Fig. 2-2

1	Junction box unit
2	Buffer unit
3	Finishing tray unit
4	Stapler
5	Movable tray shift motor unit
6	Switchback unit (MJ-1112)
7	Stacker unit (MJ-1112)
8	Paper holding unit (MJ-1112)
9	Side alignment unit (MJ-1112)
10	Saddle stapler unit (MJ-1112)
11	Additional folding unit (MJ-1112)
12	Folding drive unit (MJ-1112)

[B] Finisher section

[B-1] Front side view

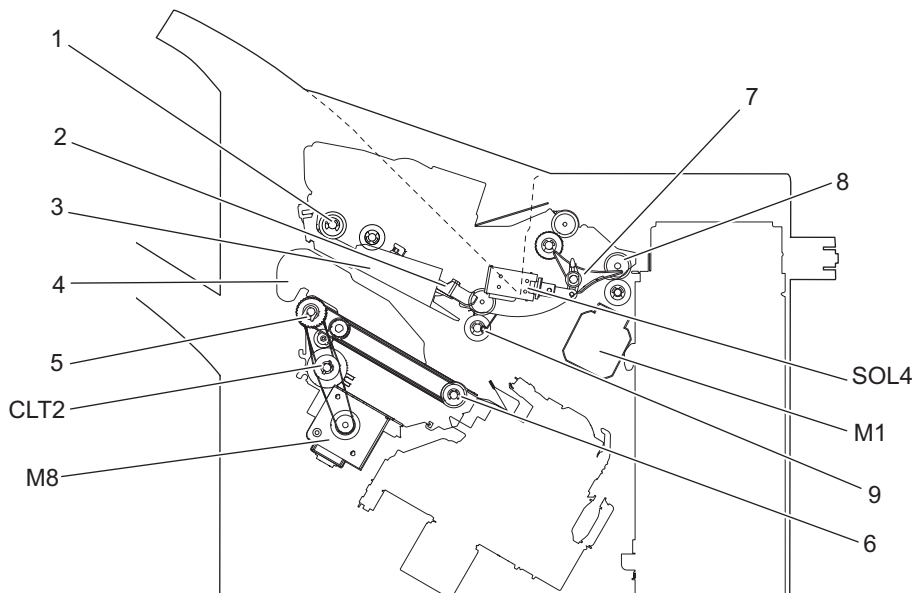

Fig. 2-3

1	Buffer roller
2	Assist guide
3	Buffer tray
4	Finishing tray
5	Stack transport roller-2
6	Stack transport roller-1
7	Gate flap
8	Entrance roller
9	Exit roller
M1	Entrance motor
M8	Stack transport motor
CLT2	Paper exit guide clutch
SOL4	Gate solenoid

[B-2] Rear side view

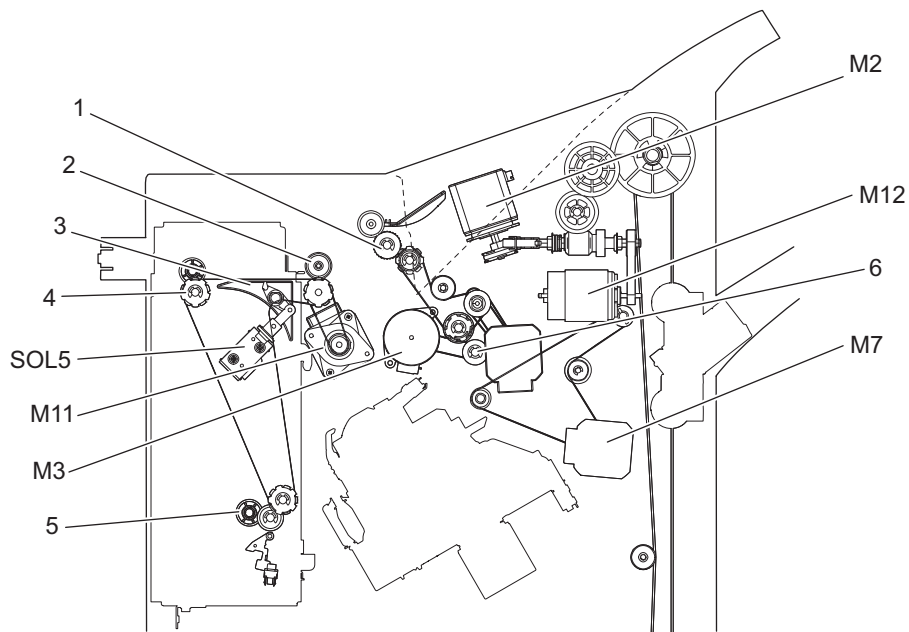

Fig. 2-4

1	Stationary tray roller
2	Entrance roller
3	Flapper
4	Feeding roller
5	Junction roller
6	Paddle
M2	Buffer tray guide motor
M3	Paddle motor
M7	Transport motor
M11	Exit motor
M12	Movable tray shift motor
SOL5	Transport path switching solenoid (MJ-1112)

[C] Saddle stitch section

[C-1] Front side view

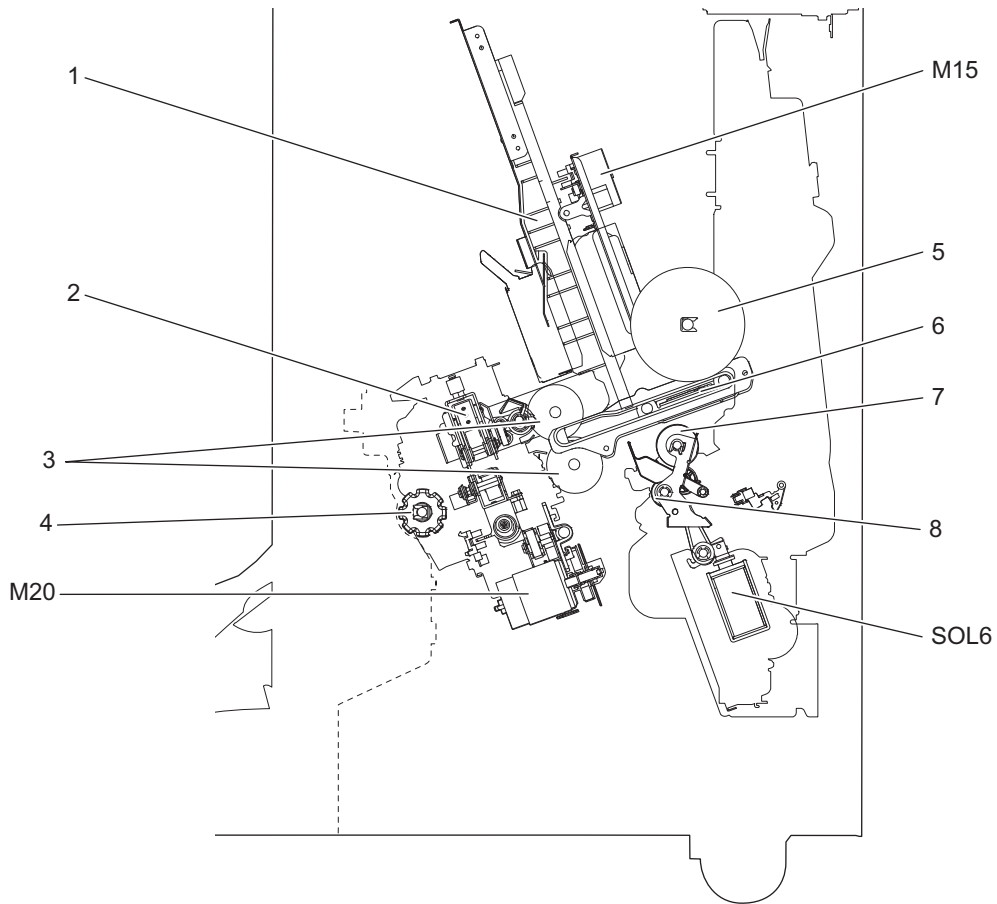

Fig. 2-5

1	Jog
2	Additional folding carrier
3	Folding roller
4	Saddle exit roller
5	Folding blade cam
6	Folding blade
7	Assisting roller
8	Ejecting roller
M15	Side alignment motor
M20	Additional folding motor
SOL6	Assisting roller solenoid

[C-2] Rear side view

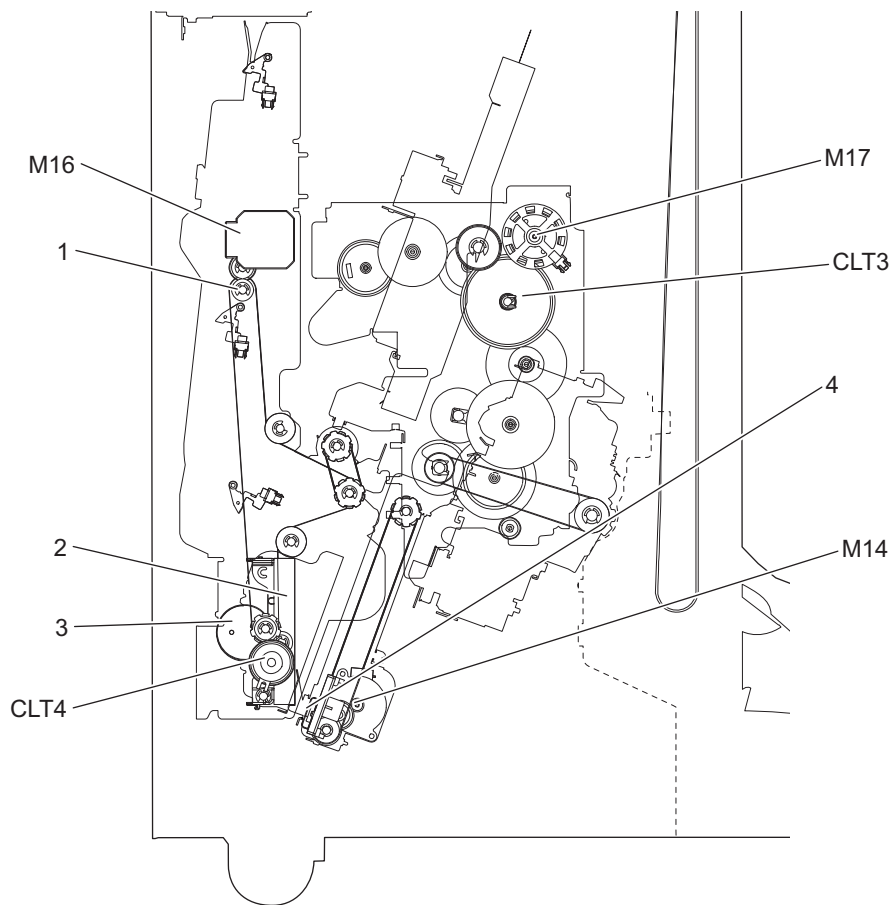

Fig. 2-6

1	Transport roller
2	Paper holding damper
3	Paper holding cam
4	Stacker carrier
M14	Stacker motor
M16	saddle transport motor
M17	Folding motor
CLT3	Folding blade clutch
CLT4	Paper holding clutch

2.3 Electric Parts Layout

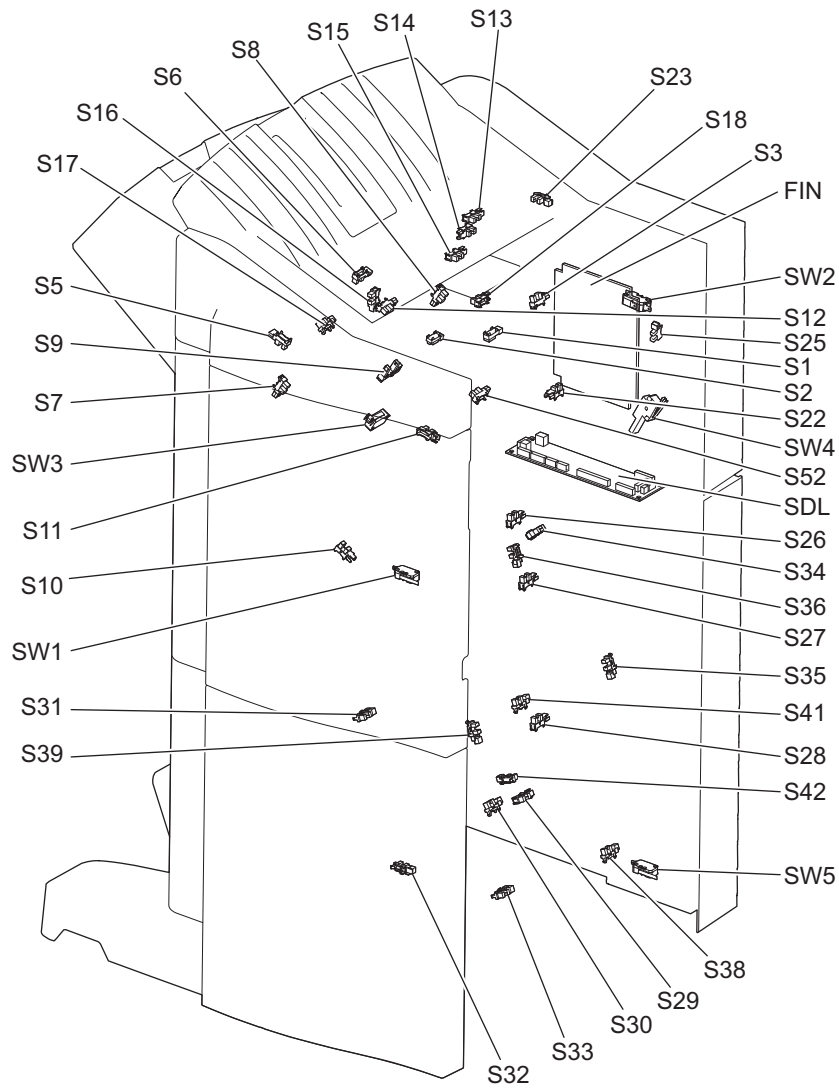

Fig. 2-7

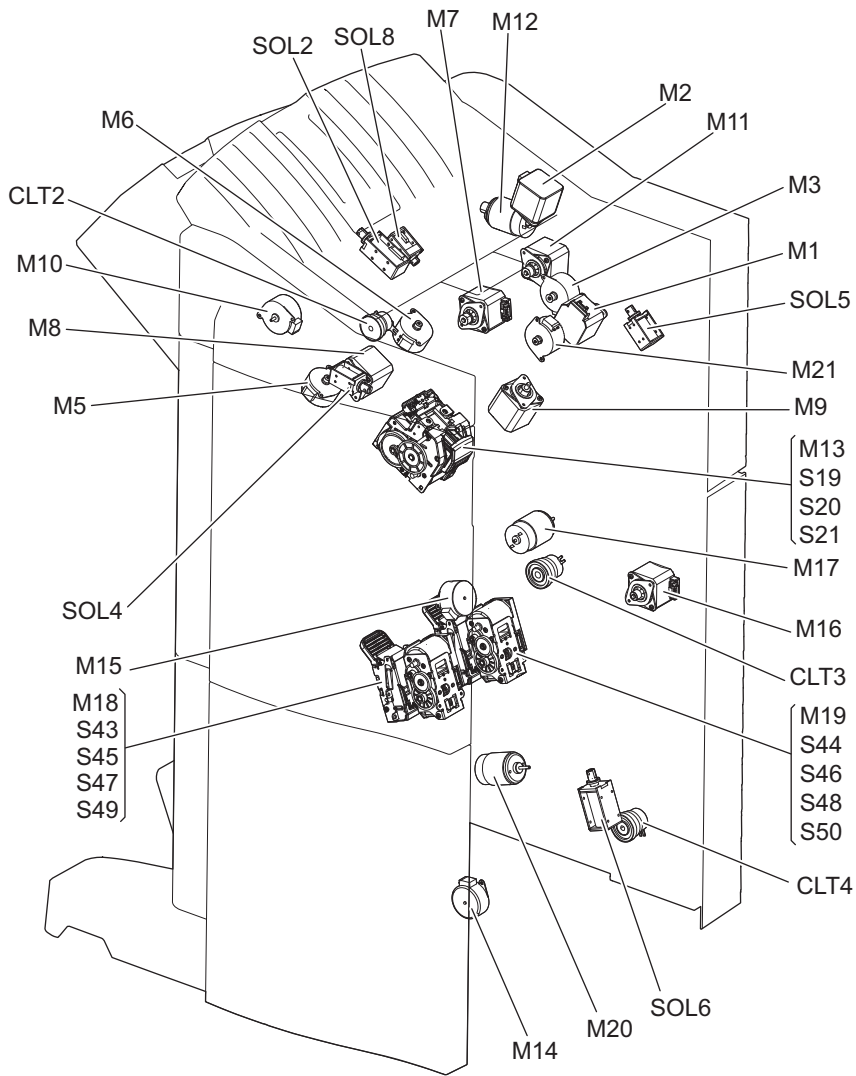

Fig. 2-8

2.4 Symbols and Functions of Various Components

The column <P-I> shows the page and item number in the parts list.

1. Motors (Finisher section: Common for MJ-1111/1112)

Symbol	Name	Function	P-I	Remarks
M1	Entrance motor	Transports paper from the junction box to the stationary tray roller or the exit roller by driving the entrance roller.	5-26	P. 2-8 "Fig. 2-8 "
M2	Buffer tray guide motor	Adjusts the width of the buffer tray guide.	8-1	P. 2-8 "Fig. 2-8 "
M3	Paddle motor	Drives the paddle.	6-38	P. 2-8 "Fig. 2-8 "
M5	Front alignment motor	Drives the front alignment plate.	10-6	P. 2-8 "Fig. 2-8 "
M6	Rear alignment motor	Drives the rear alignment plate.	10-6	P. 2-8 "Fig. 2-8 "
M7	Transport motor	Drives the roller of the finishing tray.	3-13	P. 2-8 "Fig. 2-8 "
M8	Stack transport motor	Drives the eject arm and the belt exiting stacks of paper to the movable tray.	10-33	P. 2-8 "Fig. 2-8 "
M9	Stapler unit shift motor	Shifts the stapler unit right and left.	11-1	P. 2-8 "Fig. 2-8 "
M10	Assist guide motor	Drives the assist guide.	8-12	P. 2-8 "Fig. 2-8 "
M11	Exit motor	Transports paper from the entrance roller to the buffer tray by driving the exit roller.	5-26	P. 2-8 "Fig. 2-8 "
M12	Movable tray shift motor	Lifts up/down the movable tray.	12-25	P. 2-8 "Fig. 2-8 "
M13	Stapler motor	Operates the stapler.	11-20	P. 2-8 "Fig. 2-8 "
M21	Catching motor	Catching the paper	6-19	P. 2-8 "Fig. 2-8 "

2. Motors (Saddle stitch section: MJ-1112)

Symbol	Name	Function	P-I	Remarks
M14	Stacker motor	Lifts the stacker up or down to the paper stapling/folding position.	20-6	P. 2-8 "Fig. 2-8 "
M15	Side alignment motor	Opens or closes the alignment plate.	23-20	P. 2-8 "Fig. 2-8 "
M16	Saddle transport motor	Transports paper from the paper feeding gate to the stacker.	26-29	P. 2-8 "Fig. 2-8 "
M17	Folding motor	Folds paper by driving a folding blade and exits the folded paper.	19-24	P. 2-8 "Fig. 2-8 "
M18	Front stapler motor	Operates the front stapler.	22-5	P. 2-8 "Fig. 2-8 "
M19	Rear stapler motor	Operates the rear stapler.	22-5	P. 2-8 "Fig. 2-8 "
M20	Additional folding motor	Adds another fold on paper already folded.	24-4	P. 2-8 "Fig. 2-8 "

3. Electromagnetic spring clutches (Finisher section: Common for MJ-1111/1112)

Symbol	Name	Function	P-I	Remarks
CLT2	Paper exit guide clutch	Transmits the stack transport motor drive to the paper exit guide.	10-26	📖 P. 2-8 "Fig. 2-8 "

4. Electromagnetic spring clutches (Saddle stitch section: MJ-1112)

Symbol	Name	Function	P-I	Remarks
CLT3	Folding blade clutch	Transmits the drive of the folding motor to the folding blade.	19-19	📖 P. 2-8 "Fig. 2-8 "
CLT4	Paper holding clutch	Transmits the drive of the saddle transport motor to the paper holding cam.	21-22	📖 P. 2-8 "Fig. 2-8 "

5. Solenoids (Finisher section: Common for MJ-1111/1112)

Symbol	Name	Function	P-I	Remarks
SOL2	Buffer roller lift solenoid	Moves up/down the buffer roller (Turned ON to lift up the roller).	8-19	📖 P. 2-8 "Fig. 2-8 "
SOL4	Gate solenoid	Switches paper transport destination (stationary tray / movable tray).	7-19	📖 P. 2-8 "Fig. 2-8 "
SOL8	Exit roller solenoid	Contacting the exit roller at paper exiting to the finishing tray	8-20	📖 P. 2-8 "Fig. 2-8 "

6. Solenoids (Saddle stitch section: MJ-1112)

Symbol	Name	Function	P-I	Remarks
SOL5	Transport path switching solenoid	Switches destinations where paper is to be transported (Finisher section or saddle stitch section).	16-23	📖 P. 2-8 "Fig. 2-8 "
SOL6	Assisting roller solenoid	Operates the assisting roller.	27-14	📖 P. 2-8 "Fig. 2-8 "

7. Sensors and switches (Finisher section: Common for MJ-1111/1112)

Symbol	Name	Function	P-I	Remarks
S1	Entrance sensor	Detects paper transported from the junction box.	7-39	📖 P. 2-7 "Fig. 2-7 "
S2	Transport sensor	Detects the paper transported to the entrance of the buffer tray.	7-39	📖 P. 2-7 "Fig. 2-7 "
S3	Paddle home position sensor	Detects the home position of the paddle.	5-31	📖 P. 2-7 "Fig. 2-7 "
S5	Buffer tray home position sensor	Detects that the buffer tray is at the outermost position.	9-25	📖 P. 2-7 "Fig. 2-7 "
S6	Assist guide home position sensor	Detects the home position of the Assist guide cam.	9-25	📖 P. 2-7 "Fig. 2-7 "
S7	Front alignment plate home position sensor	Detects the home position of the front alignment plate.	10-17	📖 P. 2-7 "Fig. 2-7 "
S8	Rear alignment plate home position sensor	Detects the home position of the rear alignment plate.	10-17	📖 P. 2-7 "Fig. 2-7 "
S9	Stack exit belt home position sensor	Detects the home position of the stack exit belt.	10-52	📖 P. 2-7 "Fig. 2-7 "
S10	Stapler unit home position sensor	Detects if the stapler unit is at the front side (home position).	11-24	📖 P. 2-7 "Fig. 2-7 "
S11	Stapler interference sensor	Detects when the stapler unit interferes with other mechanical section.	11-24	📖 P. 2-7 "Fig. 2-7 "

Symbol	Name	Function	P-I	Remarks
S12	Finishing tray paper detection sensor	Detects the presence/absence of the paper on the finishing tray.	10-17	📖 P. 2-7 "Fig. 2-7 "
S13	Movable tray position-A sensor	Detects the movable tray position.	4-15	📖 P. 2-7 "Fig. 2-7 "
S14	Movable tray position-B sensor	Detects the movable tray position.	4-15	📖 P. 2-7 "Fig. 2-7 "
S15	Movable tray position-C sensor	Detects the movable tray position.	4-15	📖 P. 2-7 "Fig. 2-7 "
S16	Movable tray paper-full sensor	Detects the upper surface of paper set on the movable tray.	4-15	📖 P. 2-7 "Fig. 2-7 "
S17	Movable tray paper exist sensor	Detects the presence/absence of the paper on the movable tray.	4-38	📖 P. 2-7 "Fig. 2-7 "
S18	Stationary tray paper-full sensor	Detects the paper-full state of the stationary tray.	12-2	📖 P. 2-7 "Fig. 2-7 "
S19	Stapler home position sensor	Detects the home position in the stapler for the stapling operation.	11-20	📖 P. 2-8 "Fig. 2-8 "
S20	Staple top position sensor	Detects the staple top position in the stapler.	11-20	📖 P. 2-8 "Fig. 2-8 "
S21	Staple empty sensor	Detects the empty status of staples in the stapler cartridge.	11-20	📖 P. 2-8 "Fig. 2-8 "
S22	Feeding sensor	Detects paper transported from the main unit into the junction box.	16-8	📖 P. 2-7 "Fig. 2-7 "
S23	Movable tray shift motor sensor	Detects the rotation of the movable tray shift motor.	12-63	📖 P. 2-7 "Fig. 2-7 "
S25	Connection sensor	Detects that the Finisher is released from the main unit.	13-28	📖 P. 2-7 "Fig. 2-7 "
S52	Catching home position sensor	Detecting the home position of the catching lever	6-20	📖 P. 2-7 "Fig. 2-7 "
SW1	Front cover switch	Cuts off the drive current (+24V) when the opening status of the front cover is detected.	16-41	📖 P. 2-7 "Fig. 2-7 "
SW2	Stationary tray opening/closing switch	Detects the opening (lifting) of the stationary tray.	5-32	📖 P. 2-7 "Fig. 2-7 "
SW3	Stapler interference switch	Automatically cut off the power supply to the stapler on detecting the no-operation area for the stapler unit.	11-44	📖 P. 2-7 "Fig. 2-7 "
SW4	Connection switch	Cuts off drive current (24V) when it detects that the Finisher is released from the main unit.	13-40	📖 P. 2-7 "Fig. 2-7 "

8. Sensors and switches (Saddle stitch section: MJ-1112)

Symbol	Name	Function	P-I	Remarks
S26	Junction box paper detection sensor	Detects the presence of paper within the junction box.	16-8	📖 P. 2-7 "Fig. 2-7 "
S27	Transport path-2 sensor	Detects the paper transported to the switch back Unit.	28-2	📖 P. 2-7 "Fig. 2-7 "
S28	Transport path-3 sensor	Detects the paper transported to the switch back Unit.	28-2	📖 P. 2-7 "Fig. 2-7 "
S29	Ejecting roller sensor	Detects the rotation of the assisting roller.	27-10	📖 P. 2-7 "Fig. 2-7 "
S30	Stacker paper detection sensor	Detects the presence/absence of the paper in the stacker.	27-21	📖 P. 2-7 "Fig. 2-7 "
S31	Exit sensor	Detects paper exit from the EFS Unit.	24-7	📖 P. 2-7 "Fig. 2-7 "
S32	Saddle tray paper detection sensor	Detects the presence/absence of the paper on the saddle tray.	18-8	📖 P. 2-7 "Fig. 2-7 "

Symbol	Name	Function	P-I	Remarks
S33	Stacker home position sensor	Detects the home position of the stacker.	20-4	📖 P. 2-7 "Fig. 2-7 "
S34	Folding motor encoder sensor	Detects the rotation of the Folding motor.	19-6	📖 P. 2-7 "Fig. 2-7 "
S35	Folding blade home position sensor	Detects the home position of the folding blade.	19-26	📖 P. 2-7 "Fig. 2-7 "
S36	Side alignment home position sensor	Detects the home position of the side alignment plate.	23-3	📖 P. 2-7 "Fig. 2-7 "
S38	Paper holding home position sensor	Detects the home position of the paper holding unit.	21-20	📖 P. 2-7 "Fig. 2-7 "
S39	Additional folding home position sensor	Detects the home position of the Additional folding roller.	24-7	📖 P. 2-7 "Fig. 2-7 "
S41	Exit transport sensor	Detects the stop position of the Additional folding.	24-7	📖 P. 2-7 "Fig. 2-7 "
S42	Additional folding motor encoder sensor	Detects the rotation of the Additional folding motor.	24-7	📖 P. 2-7 "Fig. 2-7 "
S43	Front saddle stapler home position sensor	Detects the home position in the front stapler for the stapling operation.	22-5	📖 P. 2-8 "Fig. 2-8 "
S44	Rear saddle stapler home position sensor	Detects the home position in the rear stapler for the stapling operation	22-5	📖 P. 2-8 "Fig. 2-8 "
S45	Front saddle staple empty sensor	Detects the empty status of front staples in the stapler cartridge.	22-5	📖 P. 2-8 "Fig. 2-8 "
S46	Rear saddle staple empty sensor	Detects the empty status of rear staples in the stapler cartridge.	22-5	📖 P. 2-8 "Fig. 2-8 "
S47	Front saddle staple top position sensor	Detects the staple top position in the front stapler.	22-5	📖 P. 2-8 "Fig. 2-8 "
S48	Rear saddle staple top position sensor	Detects the staple top position in the rear stapler.	22-5	📖 P. 2-8 "Fig. 2-8 "
S49	Front saddle stapler cartridge sensor	Detects the presence/absence of the stapler cartridge in the front stapler.	22-5	📖 P. 2-8 "Fig. 2-8 "
S50	Rear saddle stapler cartridge sensor	Detects the presence/absence of the stapler cartridge in the rear stapler.	22-5	📖 P. 2-8 "Fig. 2-8 "
SW5	Saddle stitch unit opening/closing switch	Cuts off drive current (24V) when it detects that the saddle stitch unit is opened.	17-10	📖 P. 2-7 "Fig. 2-7 "

9. PC board (Finisher section: Common for MJ-1111/1112)

Symbol	Name	Function	P-I	Remarks
FIN	Finisher control PC board (FIN board)	Controls the Finisher	3-37	📖 P. 2-7 "Fig. 2-7 "

10. PC board (Saddle stitch section: MJ-1112)

Symbol	Name	Function	P-I	Remarks
SDL	Saddle control PC board (SDL board)	Controls the Saddle Stitch Finisher.	18-49	📖 P. 2-7 "Fig. 2-7 "

2.5 Diagram of Signal Blocks

[A] Finisher section

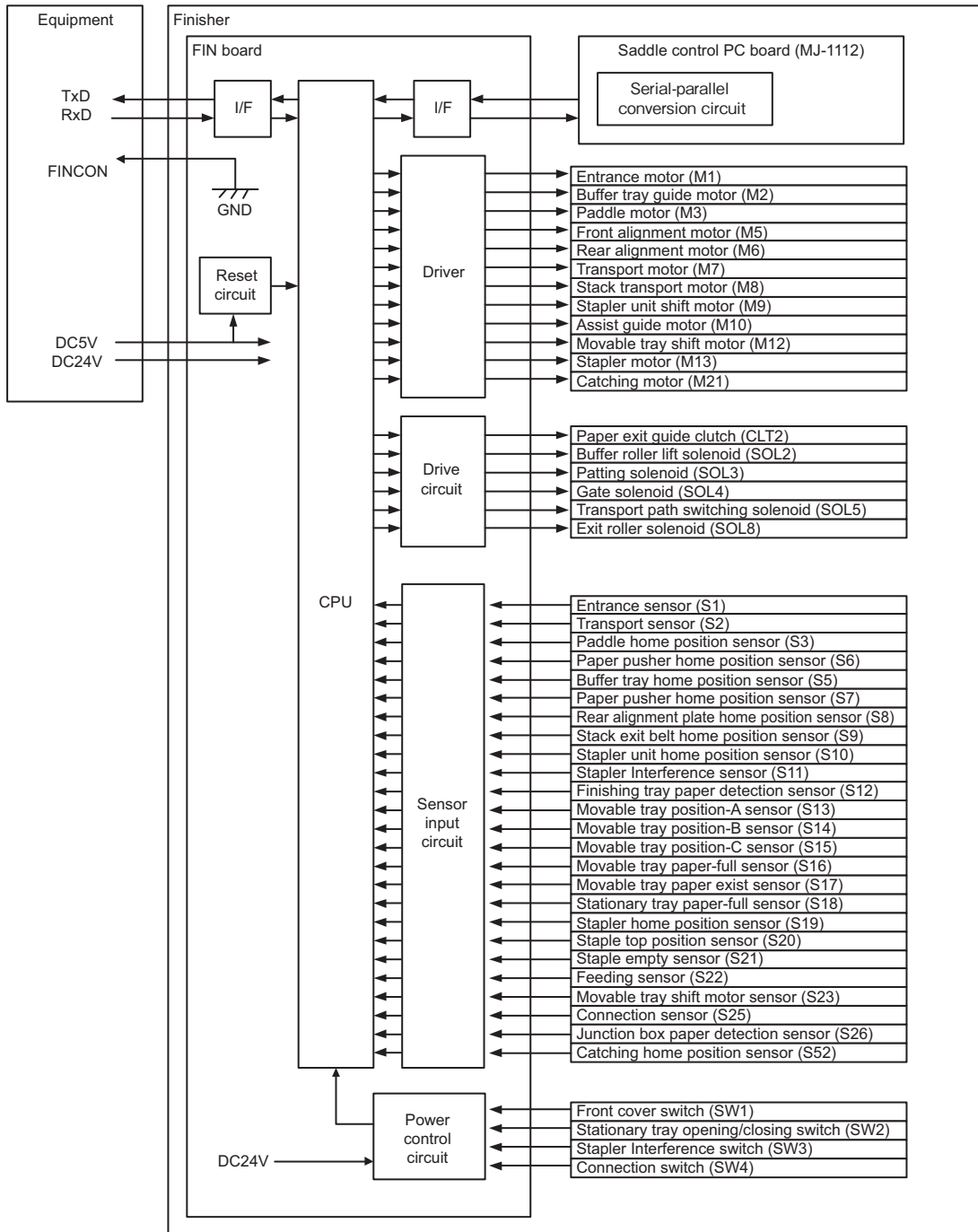

Fig. 2-9

[B] Saddle stitch section

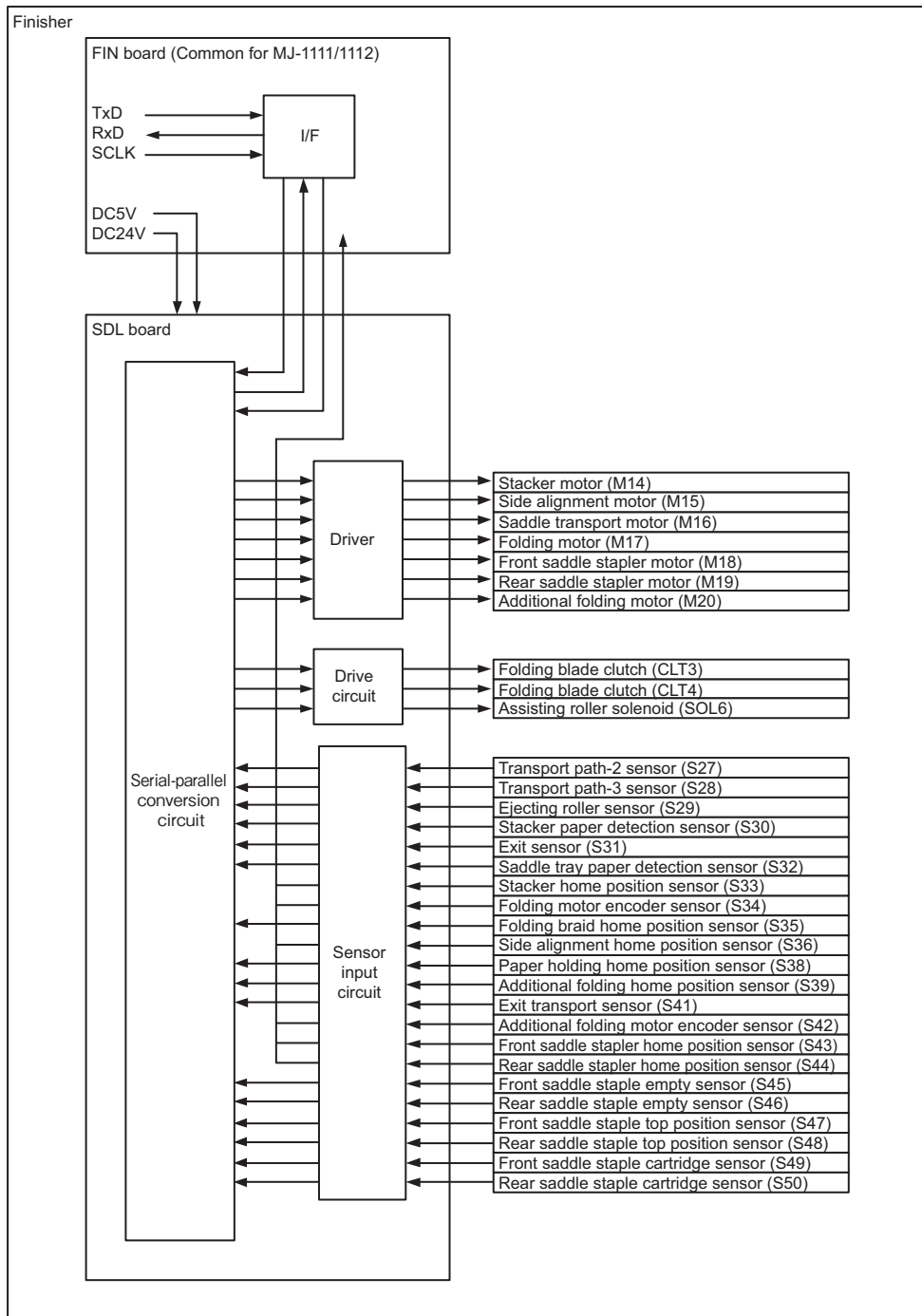

Fig. 2-10

2.6 Description of Interface Signals

The 2 lines; TxD and RxD are used to transmit/receive signals between the equipment and the Finisher. When the Finisher is connected, the equipment detects the power supply signal (MFP-24V-ON) and confirms that the Finisher is connected to it with the status of the connection switch (SW4) and an MFP-CONNECT-SEN signal from the connection sensor (S25).

- TXD: Sent data (transmitted from the Equipment to the Finisher)
- RXD: Received data (transmitted from the Finisher to the Equipment)
- MFP-24-V-ON: Equipment 24V power supply signal (Low level - 24V power supplied)
- MFP-CONNECT: Equipment connection switch (Connected - 24V power supplied)
- MFP-CONNECT-SEN: Equipment connection confirmation signal (Low level - Connected to the equipment)

Data communication (RxD and TxD) between the equipment and the Finisher has adopted the serial communication system which does not allow checking whether the signals are transmitted/ received properly using testing devices in the field.

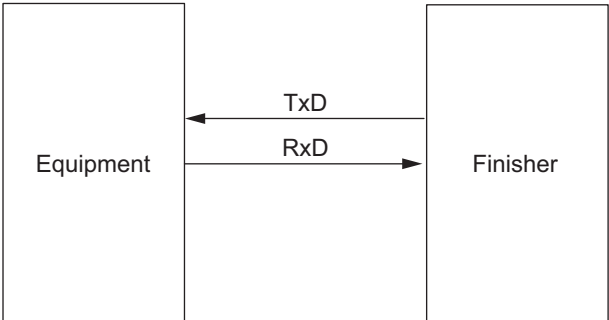

Fig. 2-11

3. DESCRIPTION OF OPERATIONS

3.1 Basic Operations

3.1.1 GENERAL DESCRIPTION

This machine receives paper transported from the connected device with its junction box, and then transports the paper to the stationary tray or the movable tray of the Finisher section or the saddle tray of the saddle stitch section.

Stack modes available in the Finisher section are; the simple stack mode which directly exits paper to the stationary tray or the movable tray, the job offset stack mode which exits stacks of paper by slightly shifting them to the front and rear alternately, and the staple stack mode which staples and exits stacks of paper. (Common for MJ-1111/1112)

In the job offset stack mode and the staple stack mode, stacks of paper are exited to the movable tray. A stack mode available in the saddle stitch section is the center-binding mode which binds a stack of paper at its center by stapling at two positions and then folds in half again to exit it to the saddle tray. (MJ-1112)

- Simple stack mode (Common for MJ-1111/1112)
When the non-sort mode is set, paper exits in the procedure shown below.
 - Ⓐ Paper is output to the stationary tray.
 - Ⓑ Paper is output to the movable tray via the buffer tray and finishing tray.

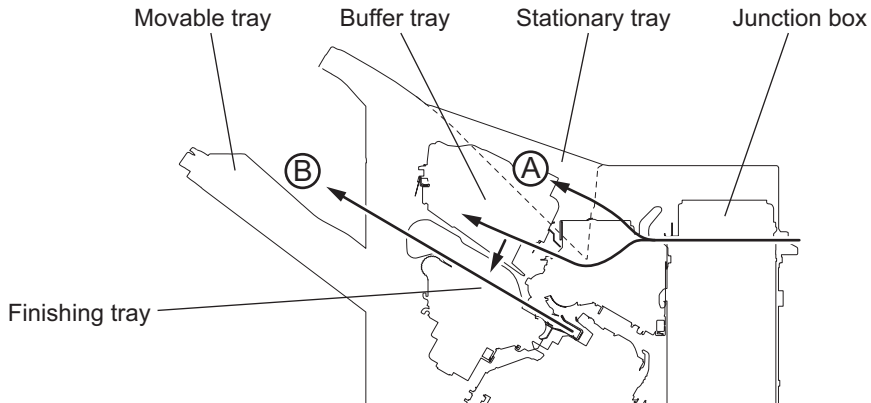

Fig. 3-1

- Bundle job offset mode/ stapling stack mode (Common for MJ-1111/1112)
When the sort copying and the stapling function are set, paper exits in the procedure shown below.
 - (1) Paper is transported to the buffer tray.
 - (2) Paper is dropped from the buffer tray onto the finishing tray.
 - (3) Paper is aligned and stapled (only when in stapling stack mode), and then the bundled paper is output to the movable tray.

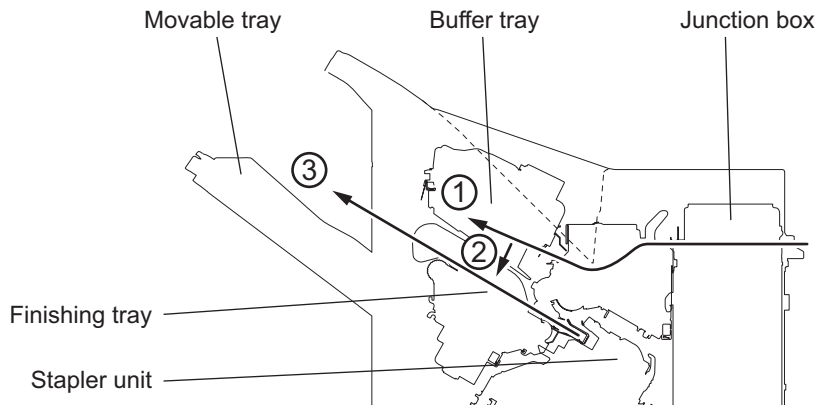

Fig. 3-2

- Center-binding mode (MJ-1112)

Paper is exited following the procedure below when the Saddle Stitch Finisher is installed.

- (1) The stacker is moved to the stapling position according to the detected paper size.
- (2) Paper is transported to the stacker and then side alignment operation is performed.
- (3) The stack of paper is stapled after the alignment for the last page is finished.
- (4) The stacker is moved to the paper folding position to fold the paper.
- (5) The paper is transported to the additional folding position to be folded again.
- (6) The paper is exited to the saddle tray.

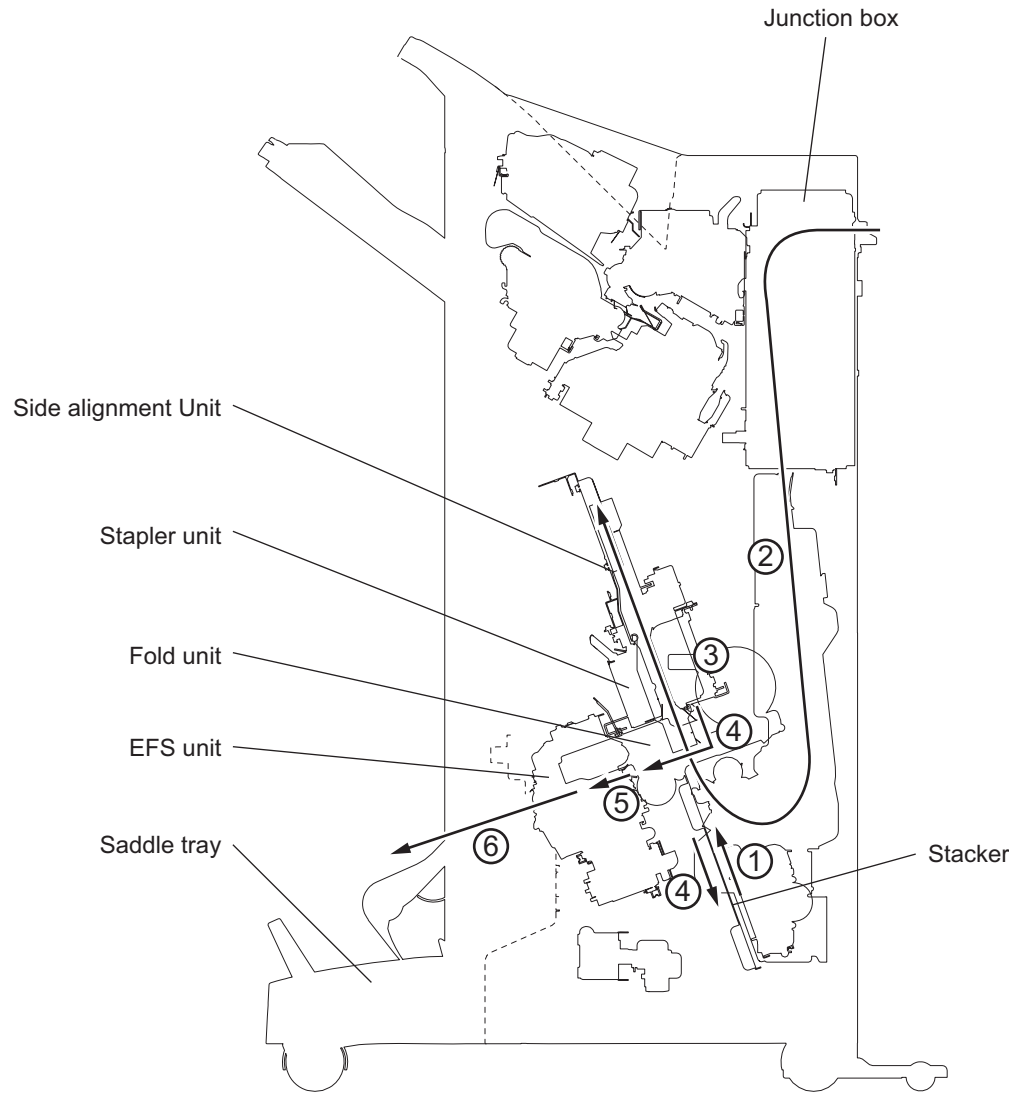

Fig. 3-3

- Center-folding mode (MJ-1112)

Paper is exited following the procedure below when the Saddle Stitch Finisher is installed.

- (1) The stacker is moved to the folding position according to the detected paper size.
- (2) Paper is transported to the stacker and then side alignment operation is performed.
- (3) The stack of paper is folded after the alignment for the last page is finished.
- (4) The paper is transported to the additional folding position to be folded again.
- (5) The paper is exited to the saddle tray.

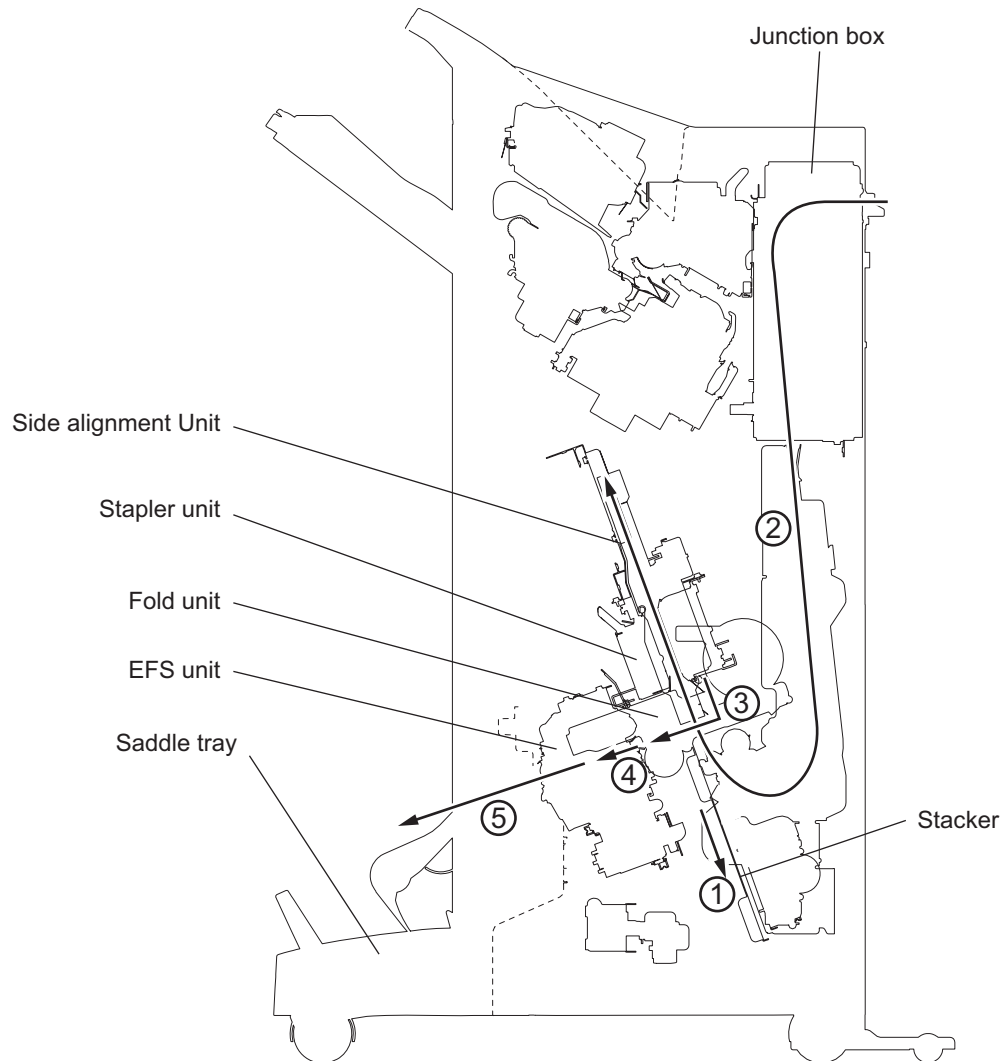

Fig. 3-4

3.1.2 Junction Box (MJ-1112)

Paper transported from the connected device is then detected by the feeding sensor (S22) and caught with the feeding roller. Then it is transported to the Finisher section or the saddle stitch section after the transport path switching solenoid (SOL5) switches its transport path with a flapper.

When it is transported to the Finisher section, the flapper does not move but the entrance roller transports it to the Finisher section.

When it is transported to the saddle stitch section, the transport path switching solenoid (SOL5) is turned ON to switch the transport path with the flapper. The paper is then transported to the saddle stitch section with the junction roller. The junction box paper detection sensor (S26) detects the passing of the paper.

The feeding roller and the junction roller are driven by the entrance motor (M1) of the Finisher section.

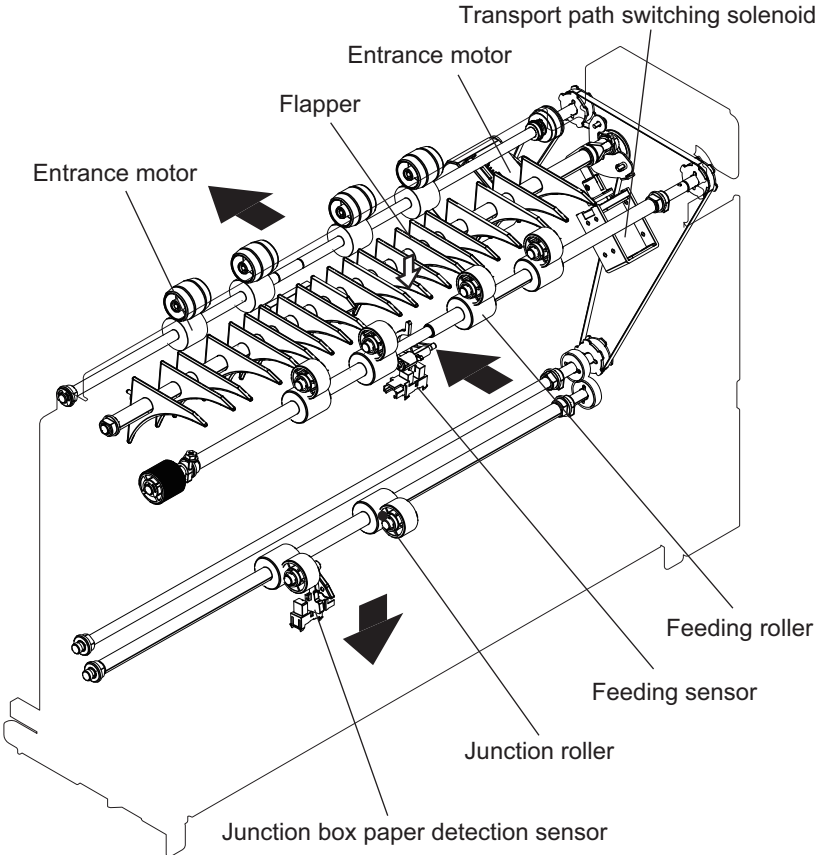

Fig. 3-5

3.1.3 Paper exit to the stationary tray

Paper is exited to the stationary tray without any extra operation.

[A] Finisher paper feeding section

Paper transported from the junction box is then caught with the entrance roller driven by the entrance motor (M1).

When paper is exited to the stationary tray, the gate solenoid (SOL4) is turned ON to move down the gate flapper. When exited to the movable tray, the gate solenoid (SOL4) is turned OFF to transport the paper to the buffer tray.

The paper transport is detected by the entrance sensor (S1).

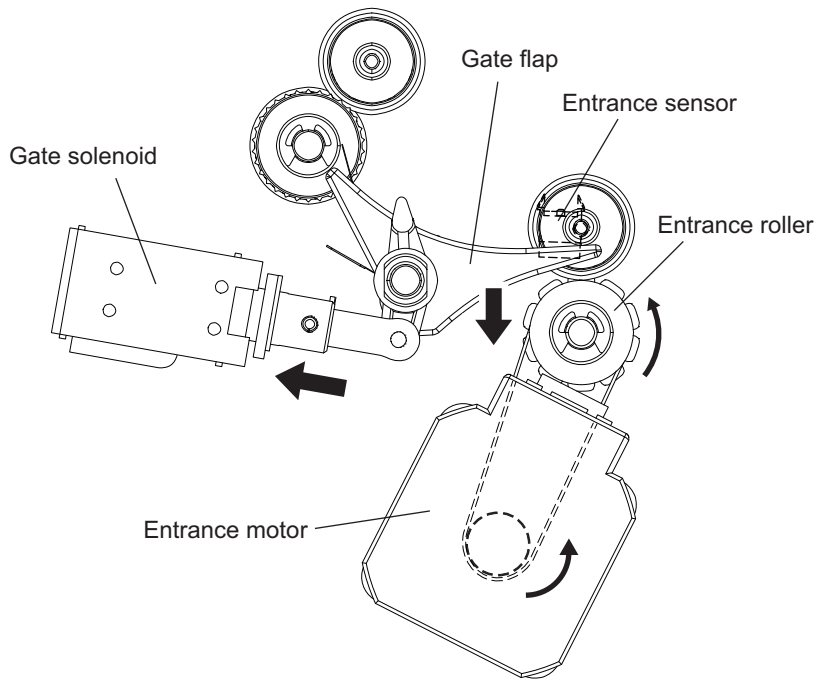

Fig. 3-6

[B] Paper exit to the stationary tray

Paper transported from the Finisher feeding section to the stationary tray side is exited to the stationary tray with the stationary tray roller driven by the exit motor (M11).
The entrance sensor (S1) detects the paper transport to the stationary tray.
The stationary tray paper-full sensor (S18) detects the overload of paper on the stationary tray.

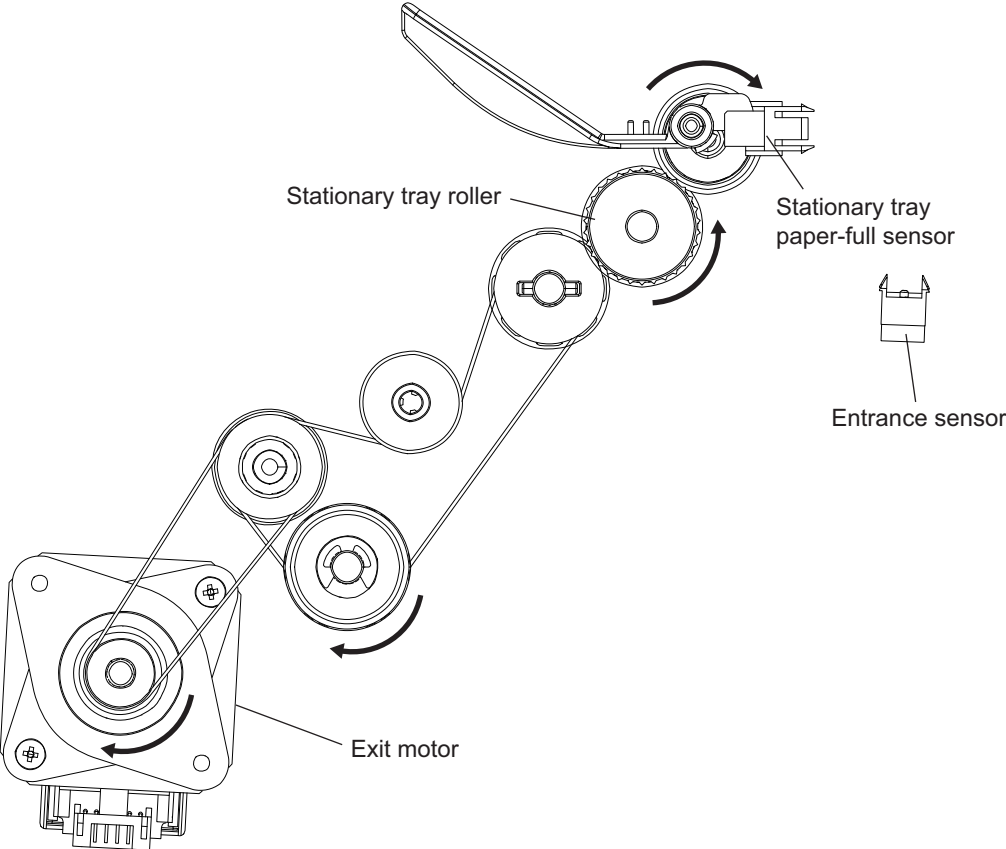

Fig. 3-7

3.1.4 Paper exit to the movable tray

Paper transported from the feeding section is stacked on the buffer tray in a unit of 1 to 3 sheets. The stacked paper is then transported to the finishing tray by a multi-active drop mechanism and next moved to the movable tray in a different way for each mode as below.

- Non-sort mode:
The stacked paper is moved from the finishing tray to the movable tray.
- Job offset stack mode:
Alignment and job offsetting of the stacked paper are performed on the finishing tray. The paper is then moved to the movable tray.
- Staple stack mode:
Stapling is performed after alignment and job offsetting of the stacked paper are carried out on the finishing tray. The paper is then moved to the movable tray.

[A] Buffer tray stack

At this stage, the buffer roller lift solenoid (SOL2) is turned ON to raise the buffer rollers and the buffer tray is moved by the buffer tray guide motor (M2) to the position where it matches the paper width. The catching motor (M21) is driven for every stacking the paper on the buffer tray to prevent the stacked paper from deviating at the trailing edge chuck. The home position of the buffer tray is detected by the buffer tray home position sensor (S5).

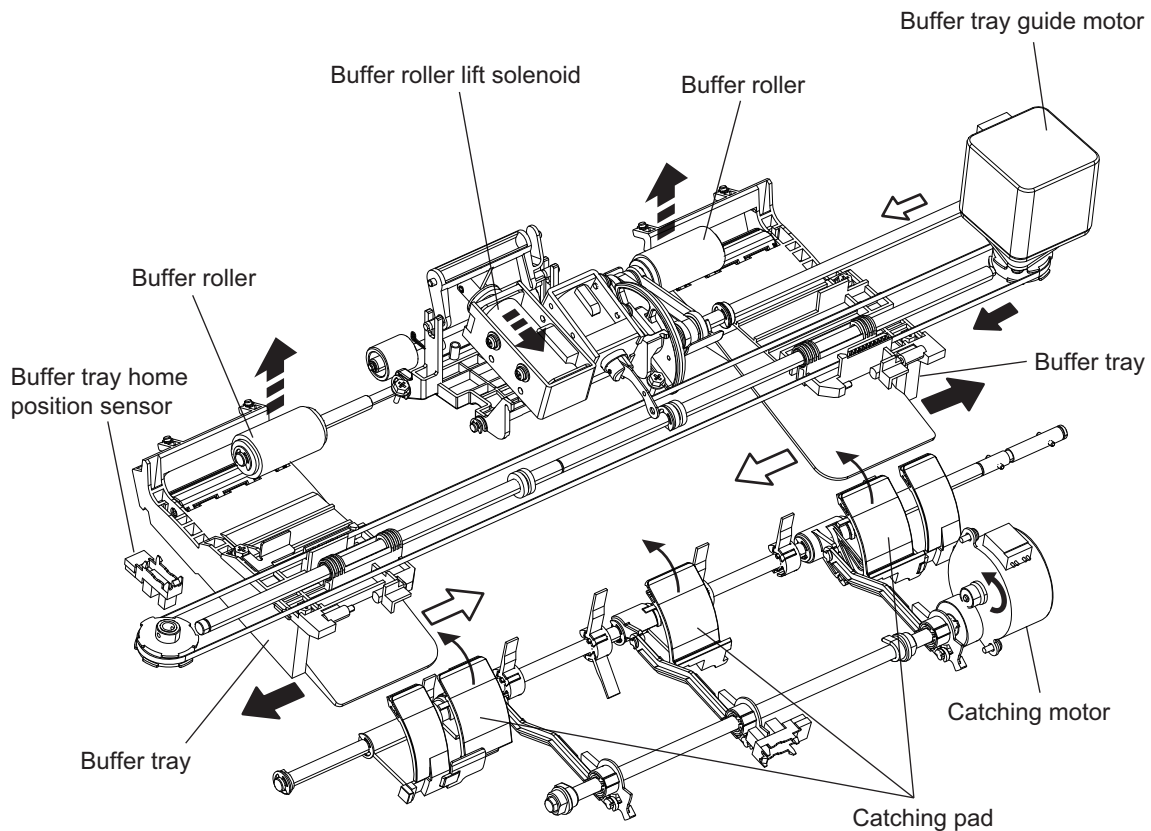

Fig. 3-8

[B] Multi-active drop mechanism section

The paper transported to the buffer tray is then moved to the finishing tray by the multi-active drop mechanism to be aligned or stapled.

- (1) At this stage, the buffer roller lift solenoid (SOL2) is turned ON to raise the buffer rollers and the buffer tray is opened by the buffer tray guide motor (M2) to drop the paper on the buffer tray onto the finishing tray. The assist guide motor (M10) is driven to lower the assist guide so that the paper will certainly be dropped onto the finishing tray.

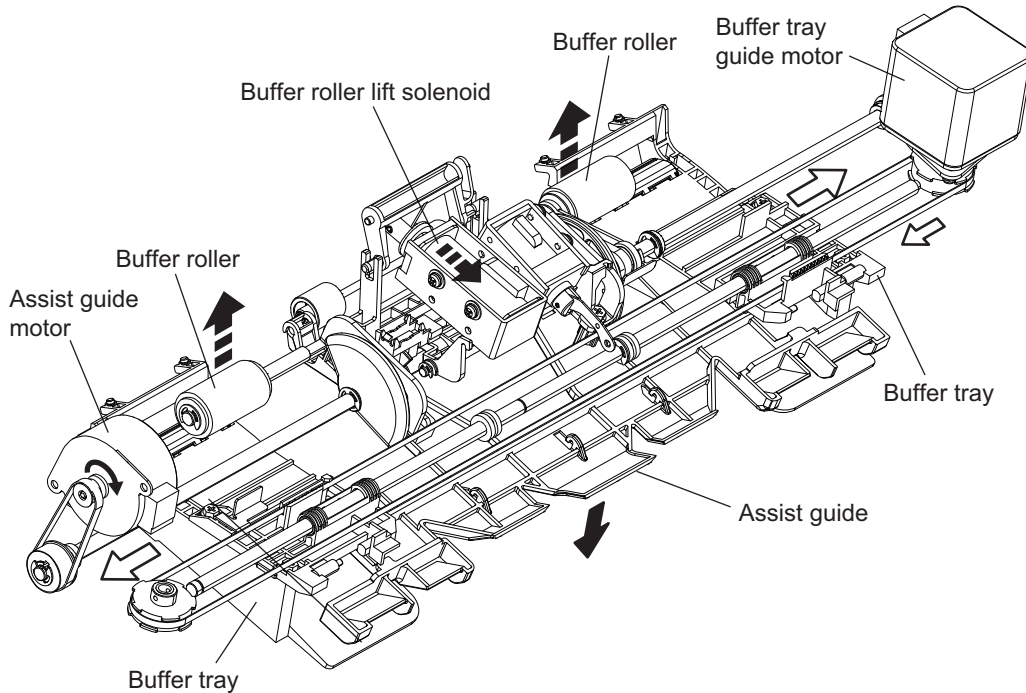

Fig. 3-9

- (2) The paper dropped onto the finishing tray is then pulled into the finishing position by the paddles driven by the paddle motor (M8) and the stack transport rollers-1 and -2 driven by the transport motor (M7).
The finishing tray paper detection sensor (S12) detects whether paper is on the finishing tray or not.
The home position of the paddles is detected by the paddle home position sensor (S3).

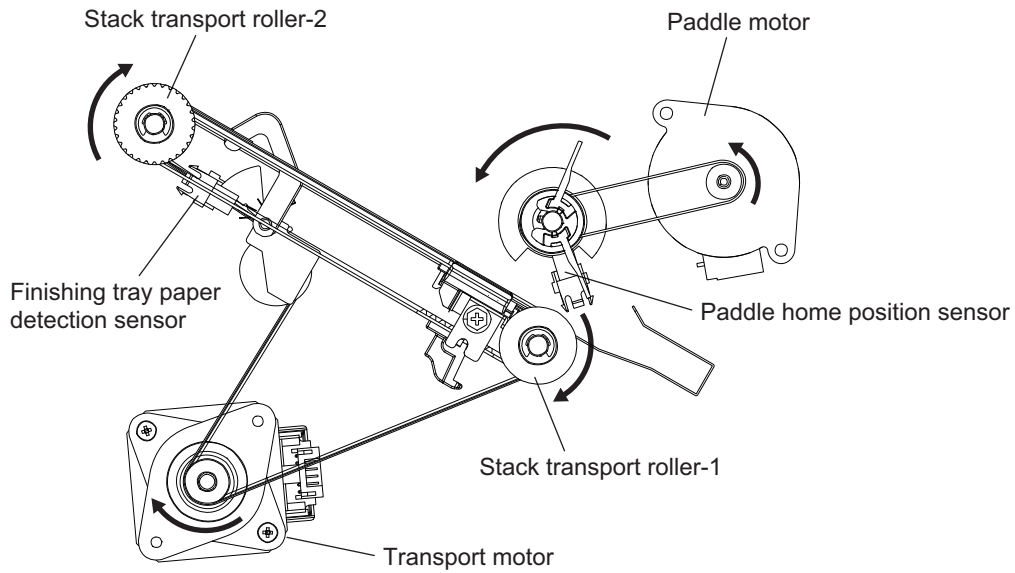

Fig. 3-10

[C] Bundle Job Offset Operation

The bundle job offset operation is to sort bundles of paper by placing the first bundle a little forward and placing the next bundle a little backward, and repeating this set of movement. The paper transported to the finishing tray is bundled and each bundle is placed by the alignment plates driven by the front alignment motor (M5) and the rear alignment motor (M6). The home position of each alignment plate is detected by the front alignment plate home position sensor (S7) and the rear alignment plate home position sensor (S8).

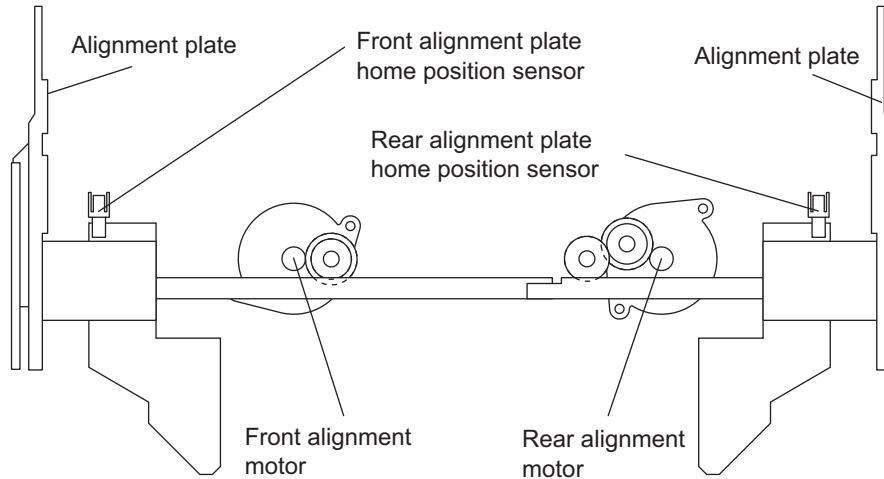

Fig. 3-11

[D] Stapling Operation

The stapling operation is to staple a specified number of paper with the stapler unit. The stapler unit is moved to the stapling position (the position differs depending on the paper size) by the stapler unit shift motor (M9). The home position of the stapler unit is detected by the stapler unit home position sensor (S10). The stapler interference switch (SW3) detects the no-operation area for the stapling operation and cuts off the power supply to the stapler while it is switched ON. The stapling operation is also stopped in the area where while the stapler interference sensor (S11) is turned ON to prevent the stapler from interfering with other mechanical sections in the equipment.

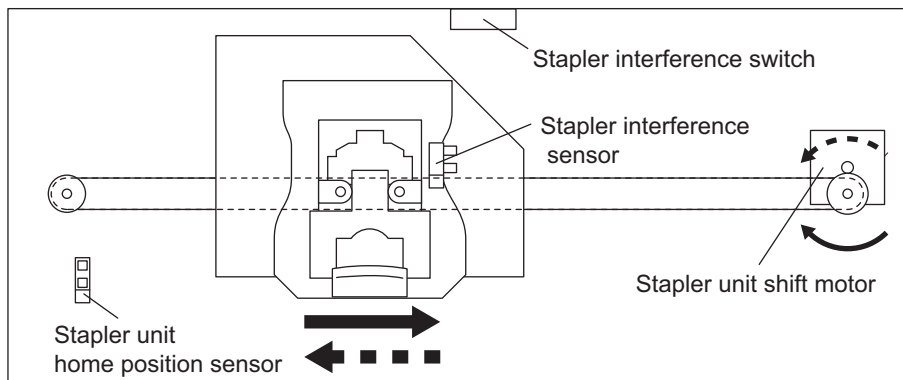

Fig. 3-12

[E] Paper exiting operation

Bundles of the paper aligned or stapled on the finishing tray are then pulled up by the paper exit guide driven by the stack transport motor (M8) with the turning ON of the paper exit guide clutch (CLT2). Then the paper is exited by the paper exit belt driven by the stack transport motor (M8) and the stack transport rollers-1 and -2 driven by the transport motor (M2) onto the movable tray. The home position of the paper exit belt is detected by the stack exit belt home position sensor (S9).

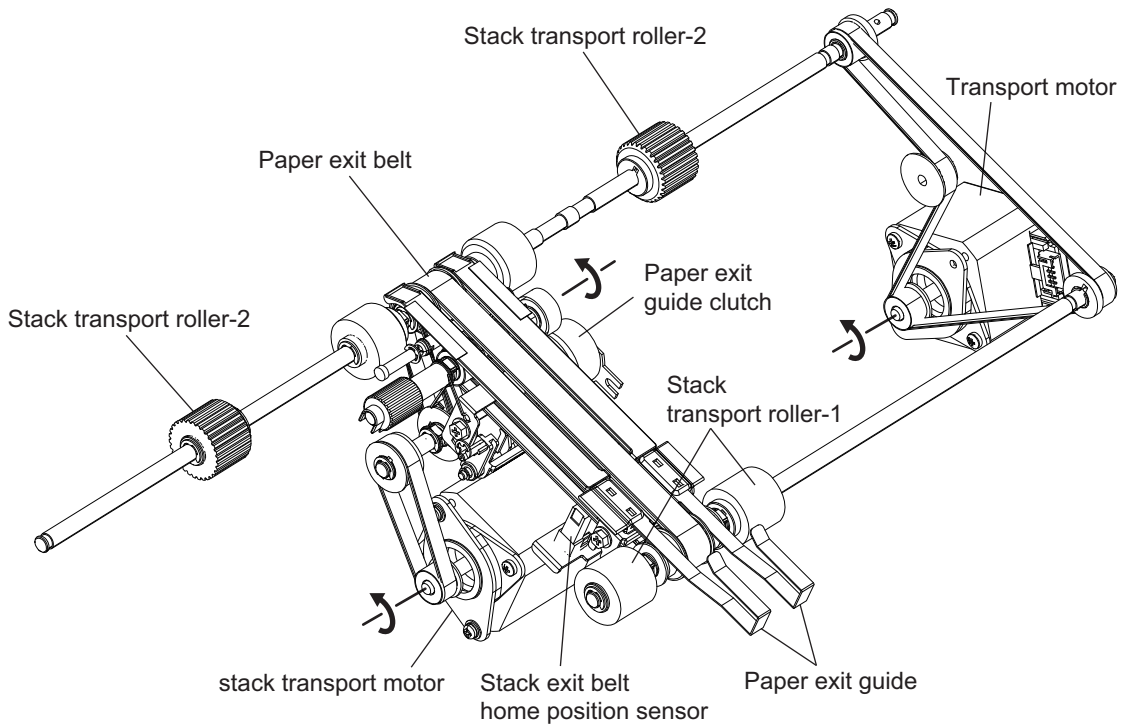

Fig. 3-13

[F] A3 wide / postcard exiting

An A3 wide sheet of paper or a small piece of paper such as a postcard is made to exit to the movable tray by being transported on the finishing tray without being stacked on the buffer tray.

To transport such types of paper, the exit roller lift solenoid (SOL8) is turned ON to lower the pinch roller arm to the stack transport roller-2 and the stack transport motor is driven to raise the tray guides.

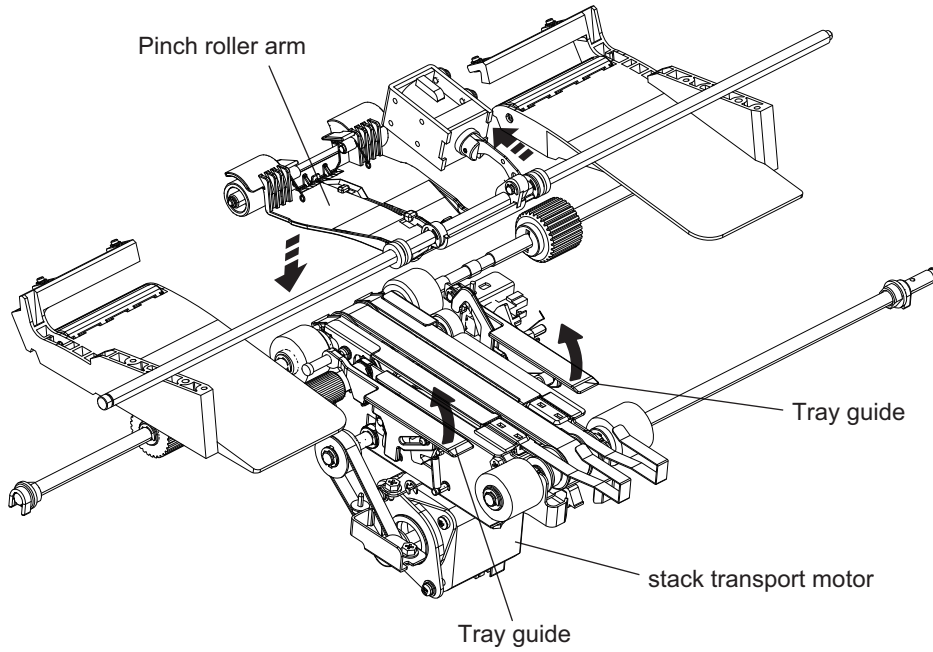

Fig. 3-14

[G] Operation of Movable Tray

The movable tray is shifted up and down by the drive from the movable tray shift motor (M12) according to the paper exit from the buffer tray or finishing tray, and the amount of the paper stack. Rotation of the movable tray shift motor is detected by the movable tray shift motor sensor (S23). Whether paper is set on the movable tray or not is detected by the movable tray paper sensor (S17).

Detecting the position of the movable tray is performed as follows.

1. Home position of the movable tray when the paper is output from the finishing tray
The movable tray is shifted down from the home position when the paper is output from the buffer tray, and the tray is stopped where the movable tray position-C sensor (S15) is turned ON. This will be the home position.
2. Position of the movable tray when the paper loading capacity is 1,500 to 3,000 sheets
If the movable tray paper-full sensor (S16) is turned ON when the movable tray is in either the home position when the paper is output from the buffer tray or the home position when the paper is output from the finishing tray, it goes down to the position where the movable tray position-B sensor (S14) is turned ON. This is the position of the movable tray when the paper loading capacity is 1,500 to 3,000 sheets.
3. Position of the movable tray when the paper loading capacity is 3,000 sheets or more
When the movable tray is in the position of the paper loading capacity of 1,500 to 3,000 sheets, and the movable tray paper-full sensor (S16) is turned ON, the tray is shifted to the position where the movable tray position-A sensor (S13) is turned OFF. This is the position of the movable tray when the paper loading capacity is 3,000 or more.

Movable tray position	Movable tray position A sensor (S13)	Movable tray position B sensor (S14)	Movable tray position C sensor (S15)
(1)	ON	OFF	ON
(2)	ON	ON	ON
(3)	ON	ON	OFF

- * ON: The sensor signal is interrupted by the rib of the sensor rail.
OFF: The sensor signal is not interrupted by the rib of the sensor rail.

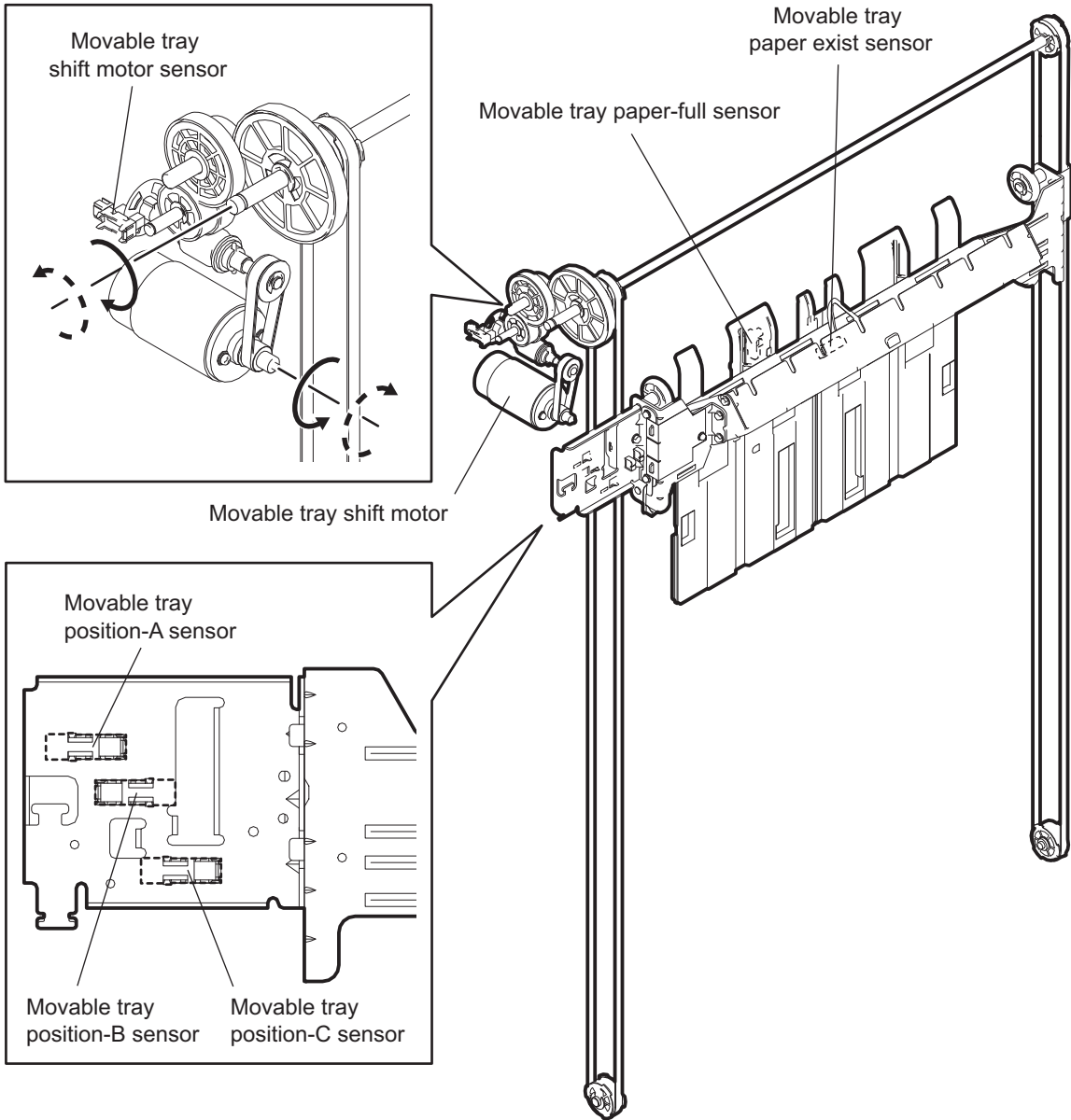

Fig. 3-15

3.1.5 Operation in the saddle stitch section (MJ-1112)

The center-binding mode binds a stack of paper at its center by stapling at two positions and then folds in half again to exit it to the saddle tray. In this mode paper transported from the feeding section is stacked on the stacker. The stacks of paper are aligned on the stacker and moved to the stapling position together with the stacker. Then the moved stacks are fixed and stapled, and then moved to the folding position. Then they are folded with the folding blade and the folding roller. After this, the folded stacks are again folded and exited to the saddle tray.

[A] Saddle stitch feeding section

Paper transported from the junction box is then transported to the stacker with the transport roller, ejecting roller and assisting roller driven by the saddle transport motor (M16).

The junction box paper detection sensor (S26), transport path-2 sensor (S27), transport path-3 sensor (S28) and ejecting roller sensor (S29) detect the passing of the paper.

When the ejecting roller sensor (S29) detects that paper has passed, the assisting roller solenoid (SOL6) is turned ON to contact the assisting roller with the paper to transport it to the stacker.

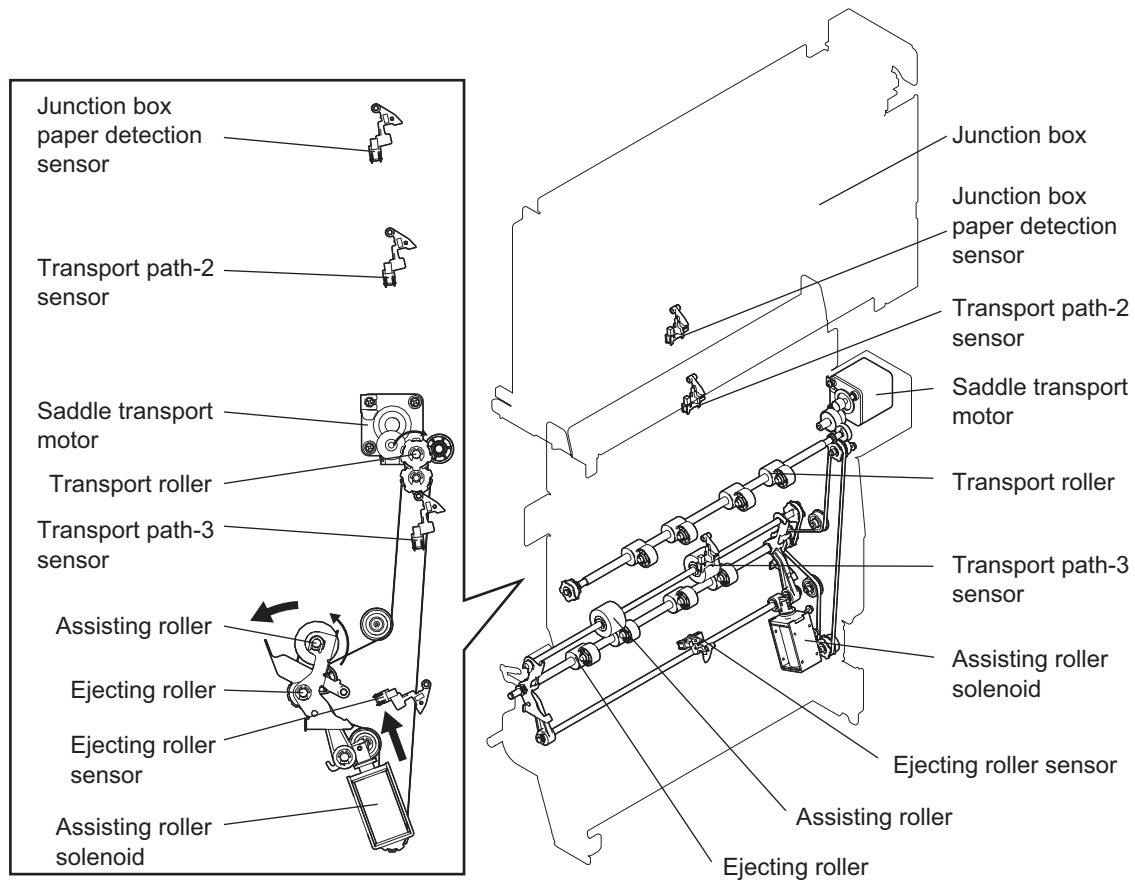

Fig. 3-16

[B] Stack transport

A stacker carrier is moved to the stapling position or the folding position by the stacker motor (M14). The home position of the stacker is detected by the stacker home position sensor (S33). The presence of paper in the stacker is detected by the stacker paper detection sensor (S30).

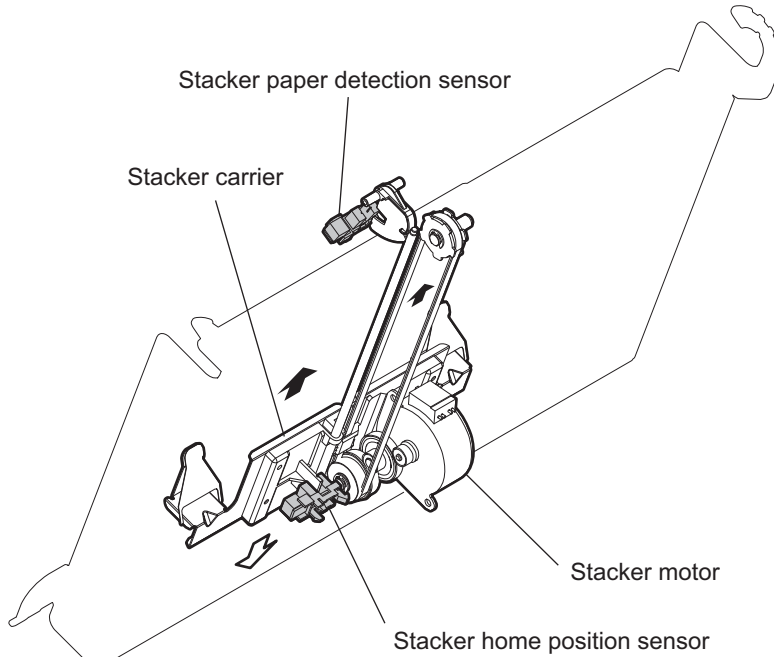

Fig. 3-17

[C] Side alignment

Stacks of paper transported to the stacker are aligned to fix their sideways deviation with a jog moved by the side alignment motor (M15). The home position of the jog is detected by the side alignment home position sensor (S36).

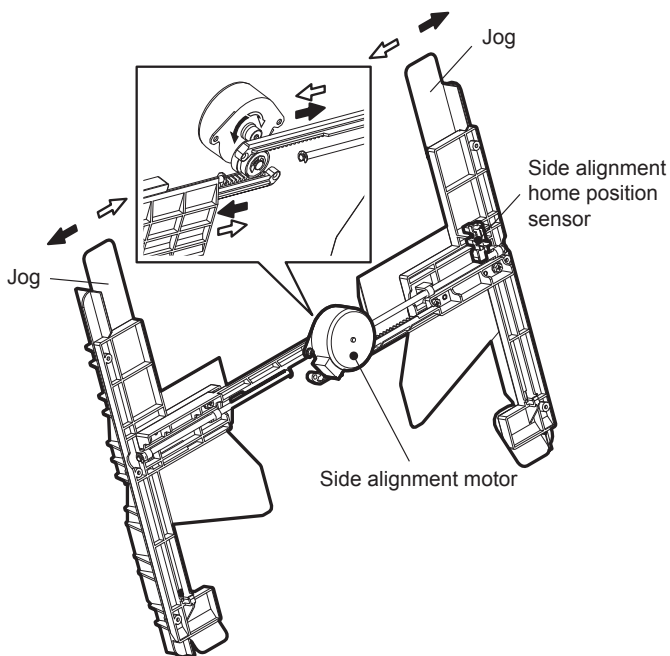

Fig. 3-18

[D] Paper holding

The paper holding clutch (CLT4) is turned ON to let the saddle transport motor (M16) drive the paper holding cam.

The home position of the paper holding cam is detected by the paper holding home position sensor (S38).

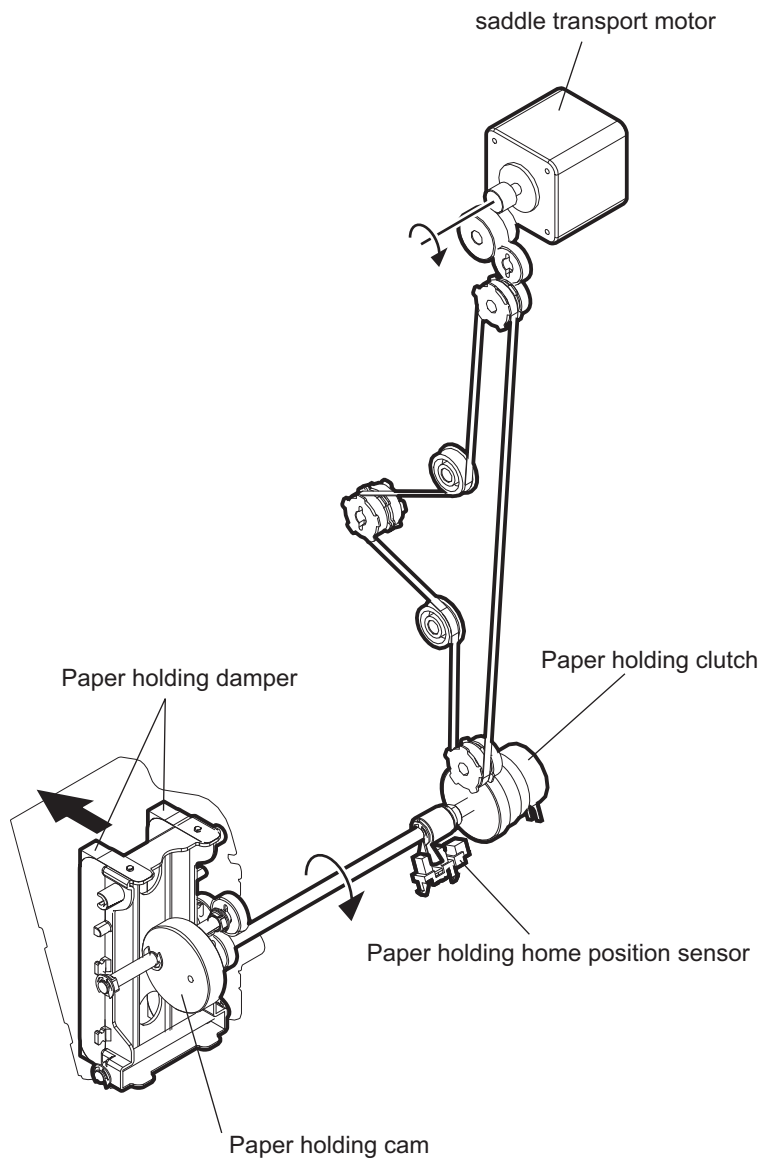

Fig. 3-19

[E] Stapling

Stacks of paper aligned and fixed at the stapling position are stapled with two stapler units on the front and rear sides.

[F] Folding

The folding blade is pressed onto the center of the stack of paper stapled and moved to the folding position, and then the folding roller lets the stack of paper sandwich the blade so that the stack will be folded again.

The folding blade clutch (CLT3) is turned ON to press the folding blade to the stack of paper by rotating the blade cam driven by the folding motor (M17).

The rotation of the folding motor (M17) is detected by the folding motor encoder sensor (S34).

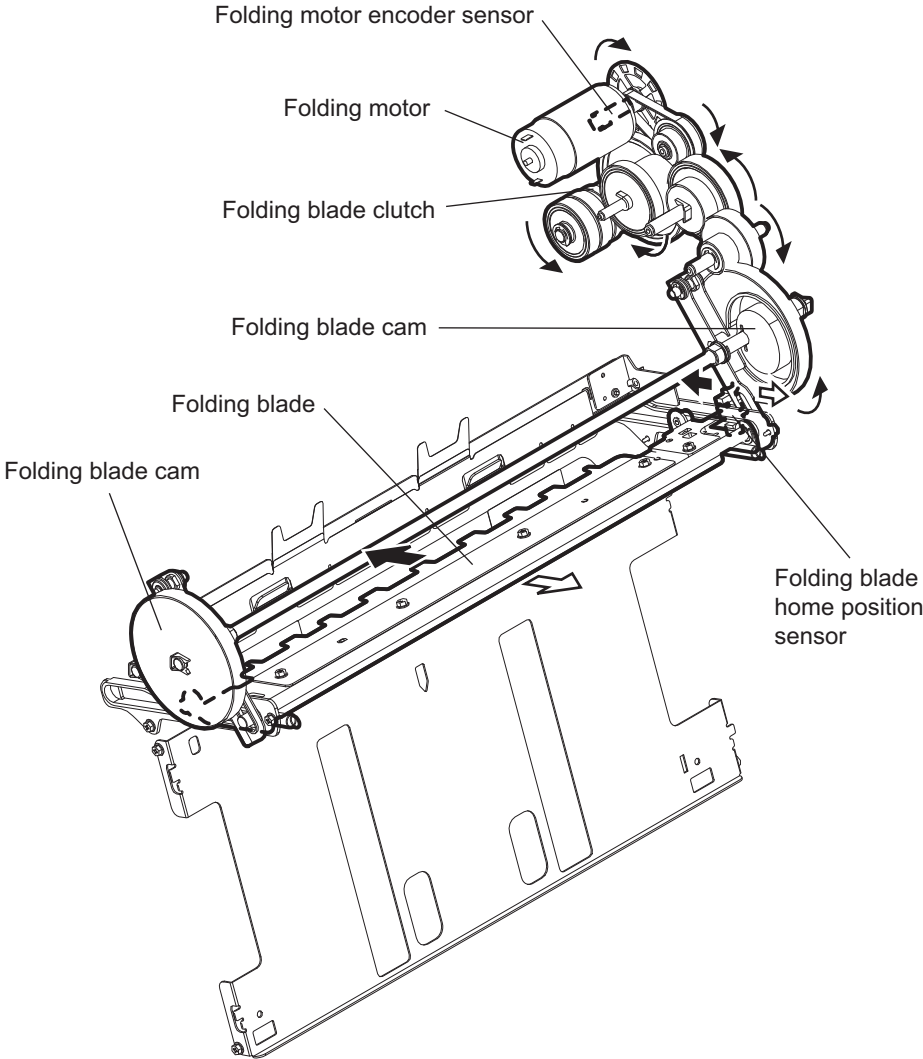

Fig. 3-20

After this, the stack of paper is folded as it passes the folding roller driven by the folding motor (M17).

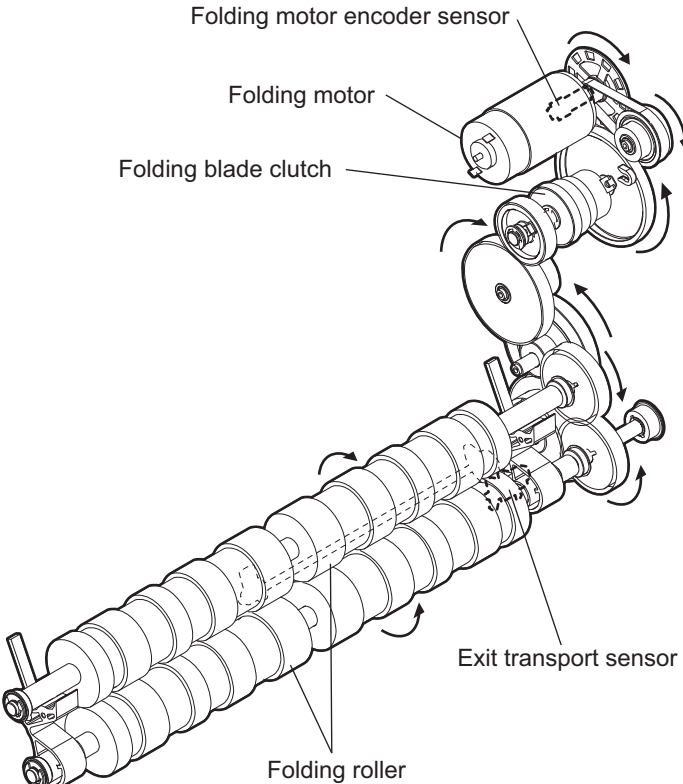

Fig. 3-21

[G] Additional folding / exiting

The stack of paper folded by the folding roller is stopped with the exit transport sensor (S41) at the stopping position. The folded paper is then folded again by moving the additional folding carrier roller forward and backward.

The home position of the additional folding carrier is detected by the additional folding home position sensor (S39).

The additional folding carrier is driven by the additional folding motor (M20). The rotation of the additional folding motor (M20) is detected by the additional folding motor encoder sensor (S42).

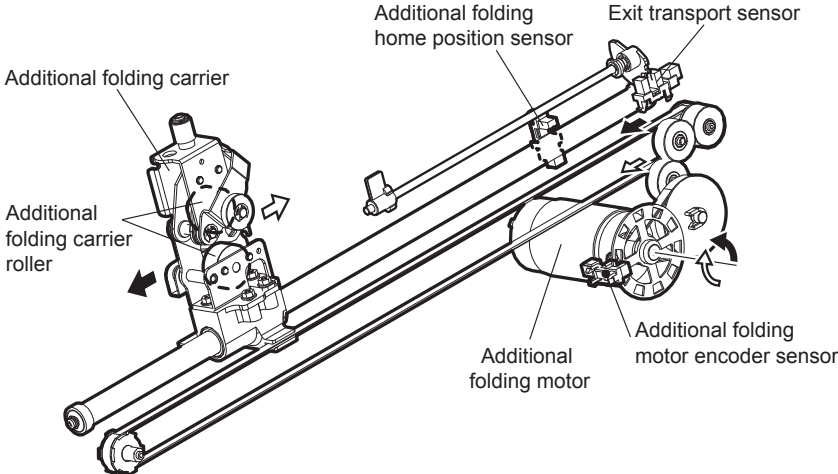

Fig. 3-22

After this, the paper is exited to the saddle tray with the saddle exit roller driven by the folding motor (M17).

The passing of the paper is detected by the exit sensor (S31).

The presence of paper on the saddle tray is detected by the saddle tray paper detection sensor (S32).

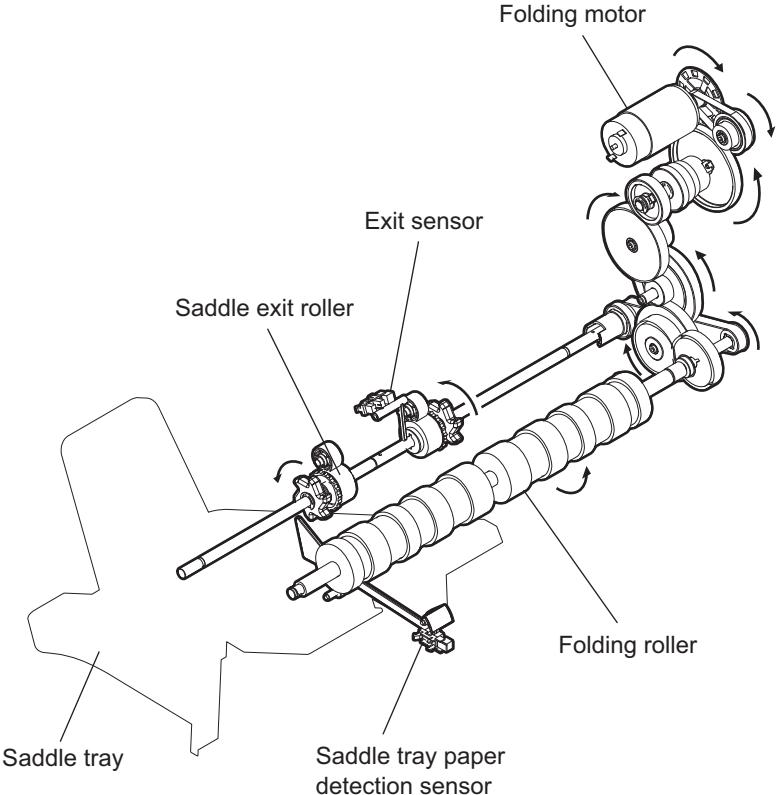

Fig. 3-23

4. DISASSEMBLY AND INSTALLATION

4.1 Covers

[A] Stationary tray

- (1) Open the stationary tray [1].
- (2) Loosen 2 screws each from the front and back side tray, and remove 2 right side screws.
- (3) Lift the stationary tray [1] upward to take off while pulling the jam access lever [2].

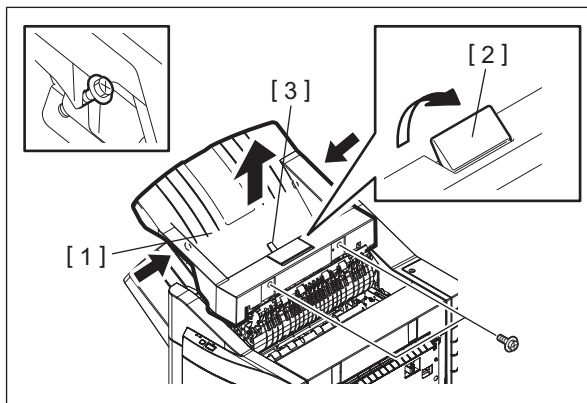

Fig. 4-1

Notes:

- Be sure to install or remove the stationary tray [1] with the stationary tray [1] being opened, otherwise the upper exit roller guide may be damaged.
- Be sure not to damage the actuator of the stationary tray paper-full sensor [3].
- Be sure not to lose 4 pins [5] of the buffer unit-1 [4].
- Before installing the stationary tray, adjust the installing positions of the 4 pins [5] of the buffer unit-1 [4] to the center position.

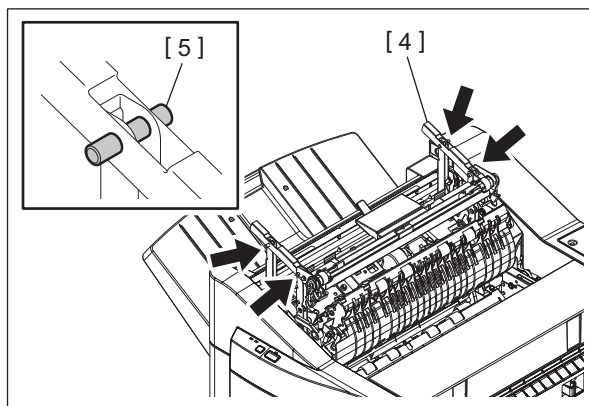

Fig. 4-2

[B] Movable tray

- (1) Remove 2 screws and slide the movable tray [1] obliquely upward to take it off.

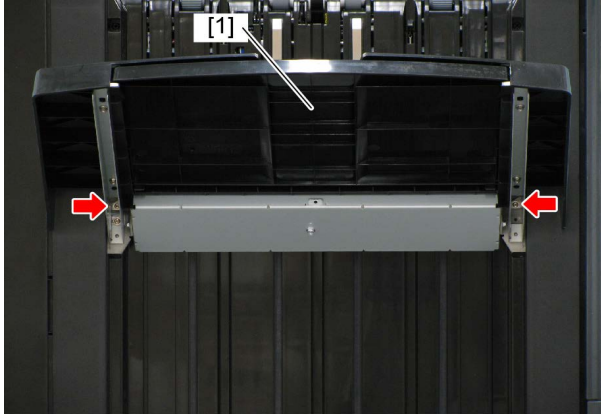

Fig. 4-3

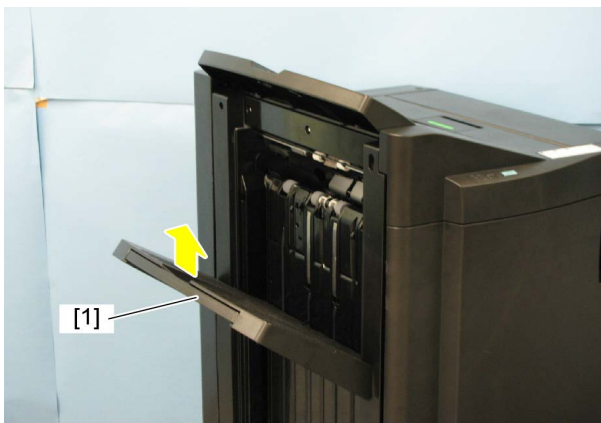

Fig. 4-4

Notes:

- When installing, hang the 4 hooks of the movable tray [1] on the holes of frame.
- When installing, engage the 2 holes of the movable tray [1] with the positioning dowels of the main unit.
- When installing or removing, be careful not to let the sensor actuator come off.

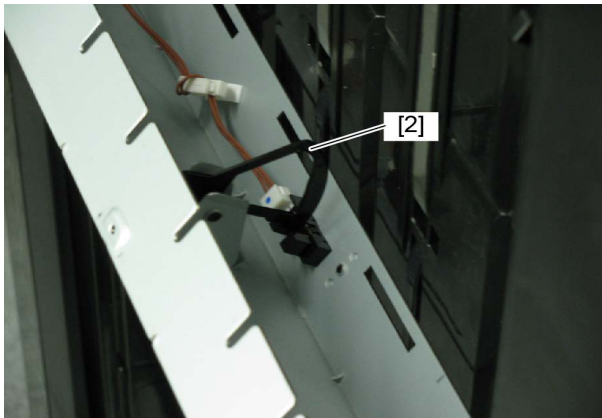

Fig. 4-5

- Be sure that the movable tray [1] does not stay above its paper-full sensor [2]. If printing is performed with the sensor turned ON, "Movable tray paper-full detection error" (CB31) will occur. The movable tray [1] must be moved lower than the sensor [2].

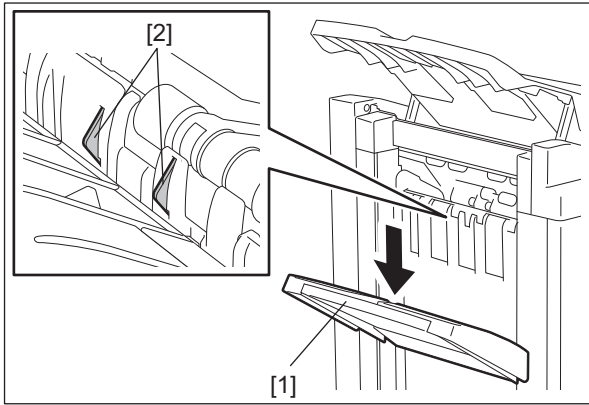

Fig. 4-6

[C] Saddle tray (MJ-1112)

- (1) Remove 2 screws, and then take off the leveling arm [1].

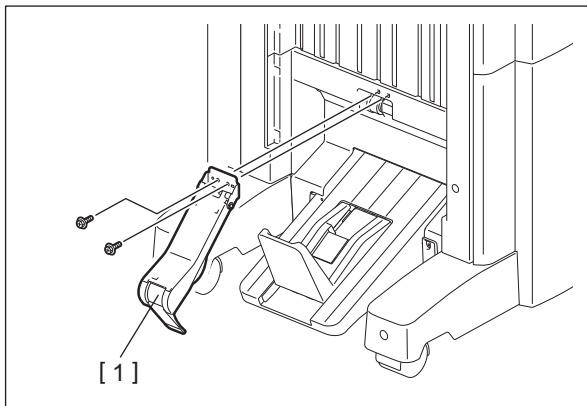

Fig. 4-7

Notes:

When installing, engage the 2 holes of the leveling arm [1] with the positioning dowels of the main unit.

- (2) Remove the slide tray.

Notes:

When installing, hang 1 hook of the sliding tray [2] on the hole of the saddle tray [3].

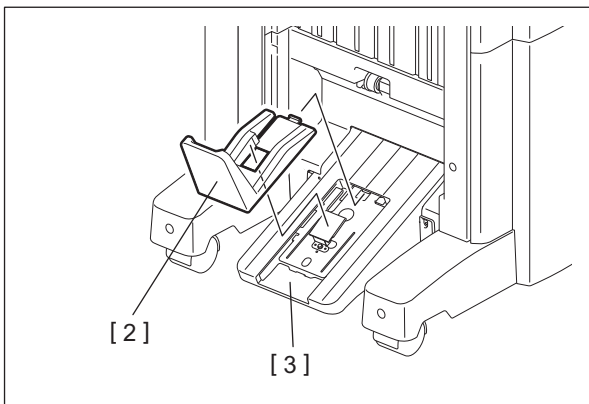

Fig. 4-8

- (3) Remove 2 screws, and then take off the saddle tray [3].

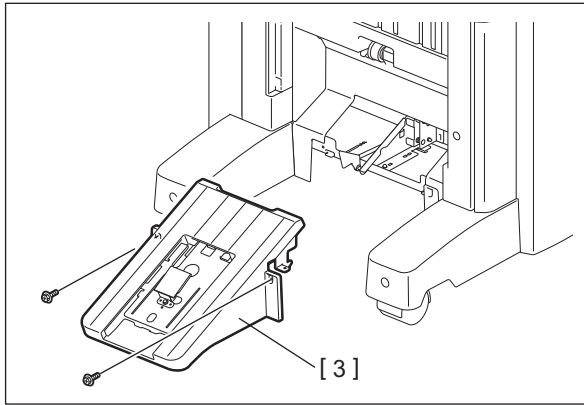

Fig. 4-9

Notes:

When installing, hang the 2 hooks of the saddle tray [3] on the hole of the main unit.

[D] Control panel unit

- (1) Remove 1 screw on the upper side of the front rail cover [1].

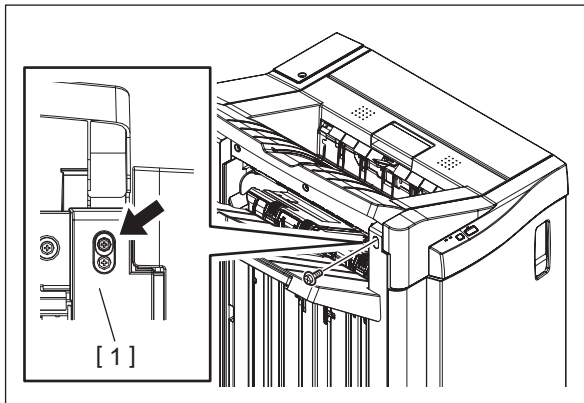

Fig. 4-10

- (2) Open the front cover [2] (MJ-1111) or the front upper cover [2] (MJ-1112).
(3) Remove 2 screws, and then disconnect the connector [3] to take off the control panel unit [4].

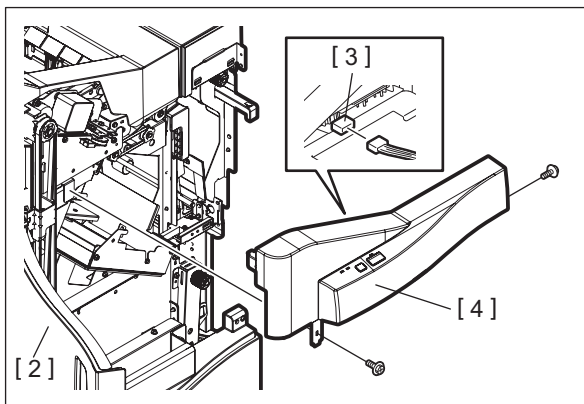

Fig. 4-11

[E] Front cover / Front upper cover / Front lower cover

[E-1] Front cover/Front upper cover/Front lower cover (MJ-1111)

- (1) Remove 1 screw on the upper side of the front rail cover [1].

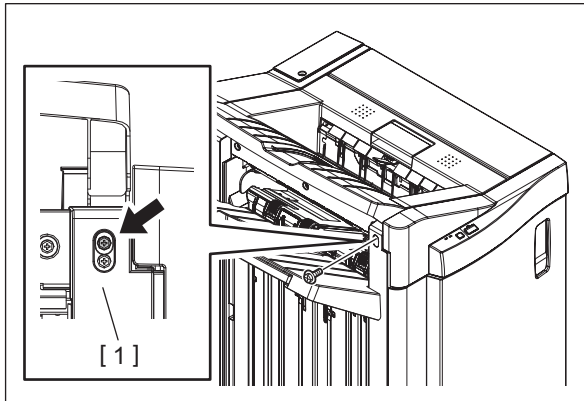

Fig. 4-12

- (2) Open the front cover [2], and then remove 1 screw on the left side of the control panel unit [3].
(3) Slide the front cover [2] upward and take it off while you are sliding the left side of the control panel unit [3] toward you.

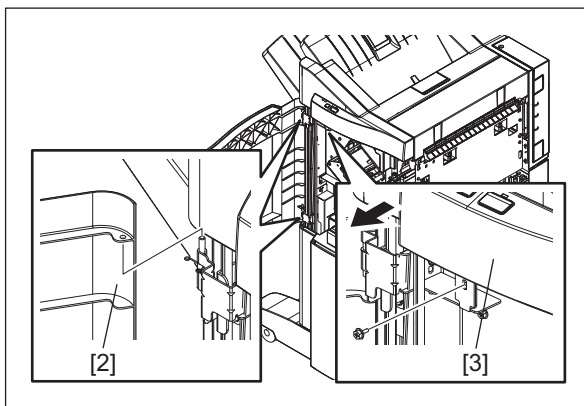

Fig. 4-13

- (4) Remove 1 screw, and then separate the front upper cover [4] and the front lower [5] cover of the front cover assembly.

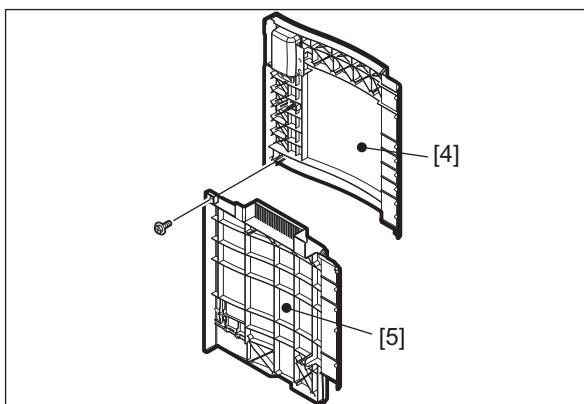

Fig. 4-14

[E-2] Front upper cover (MJ-1112)

- (1) Remove 1 screw on the upper side of the front rail cover [1].

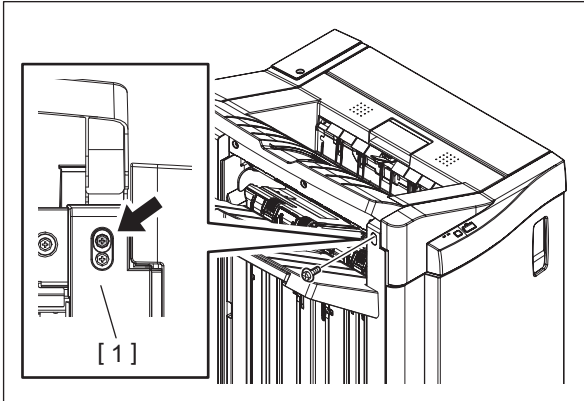

Fig. 4-15

- (2) Open the front cover [2], and then remove 1 screw on the left side of the control panel unit [3].
- (3) Slide the front cover [2] upward and take it off while you are sliding the left side of the control panel unit [3] toward you.

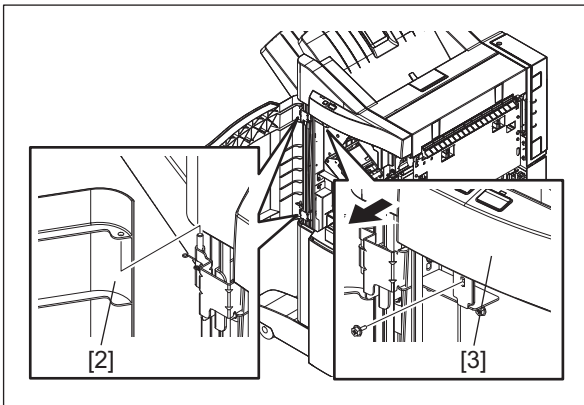

Fig. 4-16

[E-3] Front lower cover (MJ-1112)

- (1) Open the front upper cover [1] and then pull out the saddle stitch unit [2].
- (2) Remove 4 screws, and then take off the front lower cover [3].

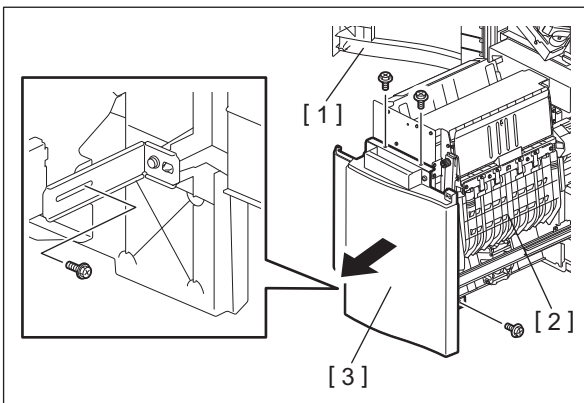

Fig. 4-17

[F] Handle cover / Cover lock bracket

- (1) Open the front cover [1] (MJ-1111) or the front upper cover [1] (MJ-1112).
- (2) Remove 2 screws, and then take off the handle cover [2].
- (3) Remove 1 screw, and then take off the cover lock bracket [3].

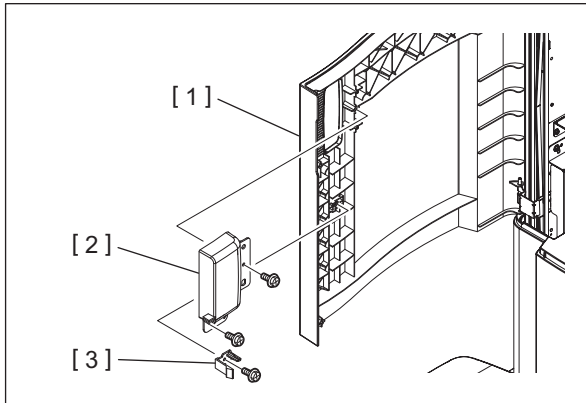

Fig. 4-18

[G] Rear cover

- (1) Remove the finisher cable [1] out of the groove of the rear cover [2].
- (2) Remove 5 screws, and then take off the rear cover [2] by sliding it upward.

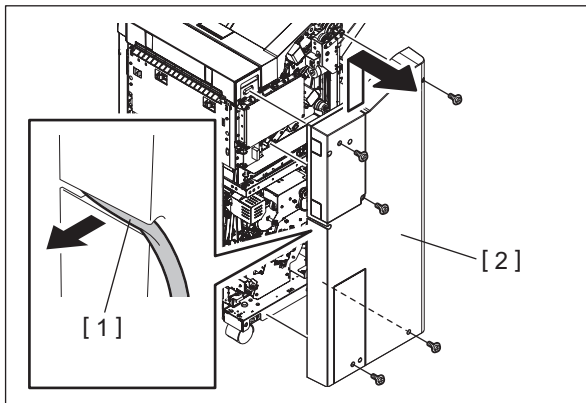

Fig. 4-19

[H] Board access cover

- (1) Remove 2 screws, and then take off the board access cover [1] by sliding it upward.

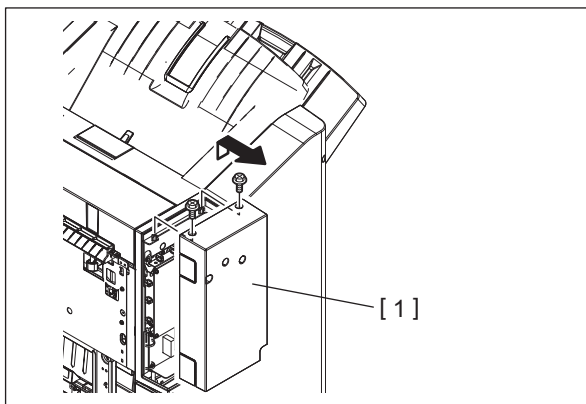

Fig. 4-20

Notes:

When installing, hang 5 hooks of the board access cover [1] on the holes of rear cover.

[I] Saddle access cover

- (1) Remove 1 screw, and then take off the saddle access cover [1] by sliding it downward.

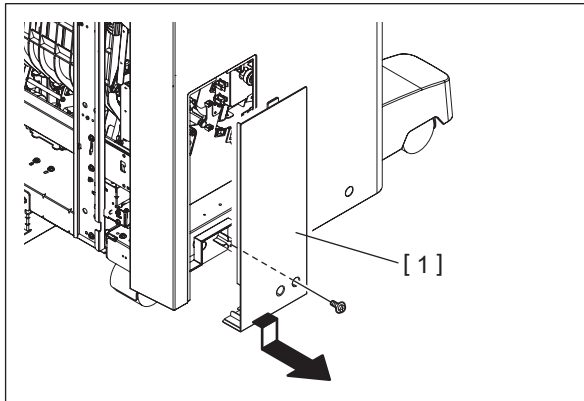

Fig. 4-21

[J] Right upper cover

- (1) Take off the control panel unit.
P. 4-4 "[D] Control panel unit"
- (2) Take off the rear cover.
P. 4-7 "[G] Rear cover"
- (3) Loosen 2 screws, and then take off the right upper cover [1].

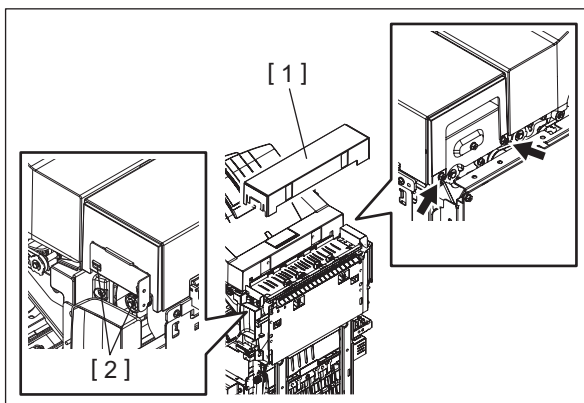

Fig. 4-22

Notes:

When installing the right upper cover [1], hang the 2 hooks [2] of the cover on the hole of the frame.

[K] Relay guide / Feeding discharge brush / Right cover

- (1) Loosen 3 screws, and then take off the relay guide [1] and feeding discharge brush [2].

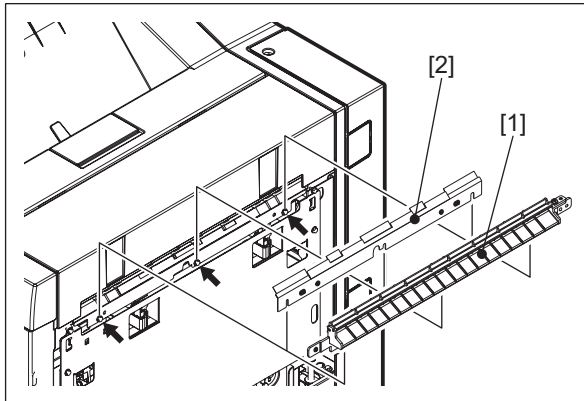

Fig. 4-23

- (2) Take off the board access cover.
📖 P. 4-7 "[H] Board access cover"
- (3) Disconnect the relay connector [3] from the connection sensor.

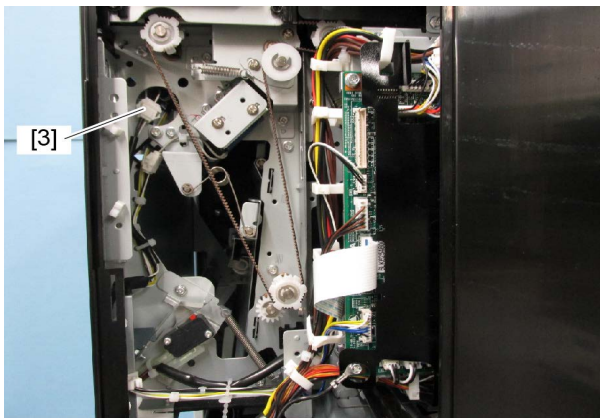

Fig. 4-24

- (4) Remove 4 screws, and then take off the right cover [4] by sliding it upward.

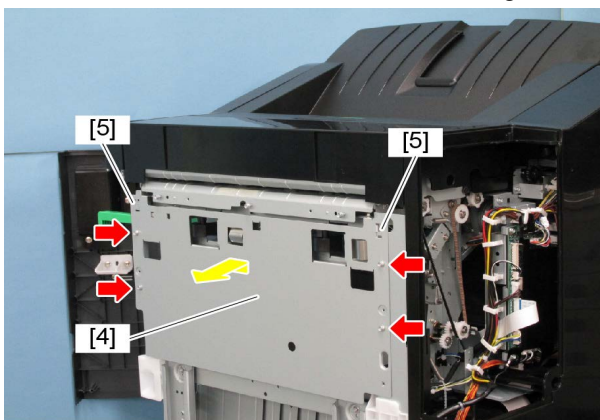

Fig. 4-25

Notes:

When installing the right cover, hang the 2 hooks [5] of the cover on the holes of the frame.

[L] Left upper cover

- (1) Remove 4 screws. While sliding the upper side of the rear rail cover [2] toward you, take off the left upper cover [1].

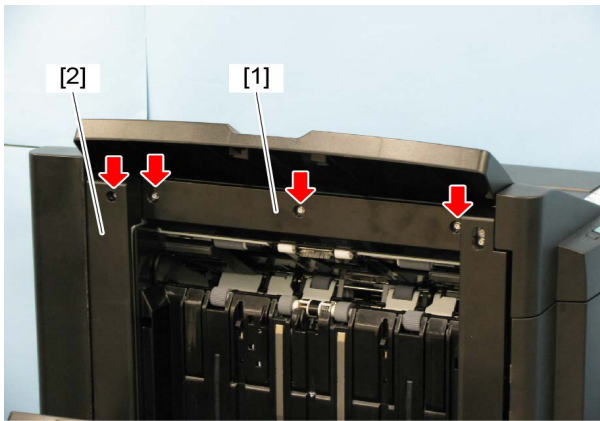

Fig. 4-26

[M] Front rail cover / Rear rail cover

- (1) Take off the movable tray.
📖 P. 4-2 "[B] Movable tray"
- (2) Open the front upper cover [1] (MJ-1111) or the front upper cover [1] (MJ-1112), and then remove 1 screw on the left side of the control panel unit [2].
- (3) Remove 3 screws and slide the front rail cover [3] upward to unhook [4] it. Then take off the front rail cover [3] from the main unit by sliding the left side of the control panel unit [2] toward you.

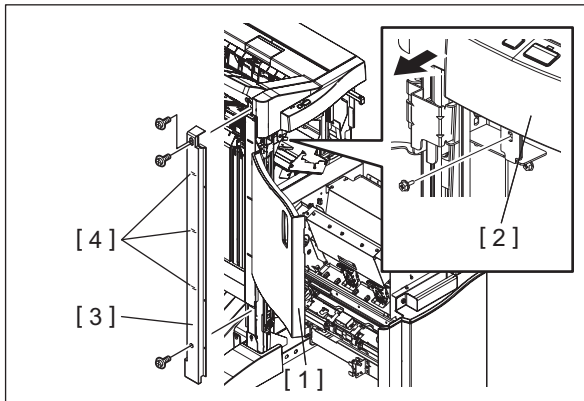

Fig. 4-27

Notes:

When installing the front rail cover [3], hang the 3 hooks [4] of the cover on the holes of the frame.

- (4) Remove 2 screws and slide the rear rail cover [5] upward to unhook [6] it. Then take off the rear rail cover from the main unit.

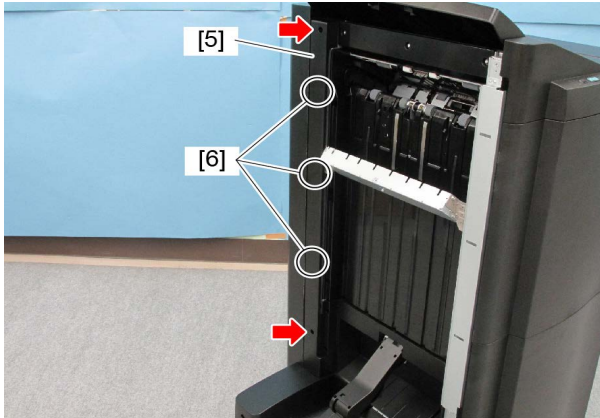

Fig. 4-28

Notes:

- When installing the rear rail cover [5], hang the 3 hooks [6] of the cover on the holes of the frame.
- After the front and rear rail covers were installed, check that the movable tray does not touch with the rail covers by moving it up and down.
- 📖 P. 4-148 "4.12 Procedure for lowering the movable tray"

[N] Grate-shaped guide

- (1) Take off the movable tray.
📖 P. 4-2 "[B] Movable tray"
- (2) Take off the rear cover.
📖 P. 4-7 "[G] Rear cover"
- (3) Release the harness from 2 harness clamps [1] and disconnect 1 connector [2] (CN22) on the finisher control PC board.

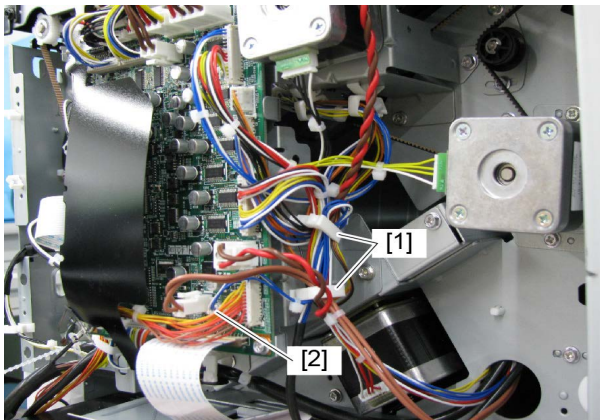

Fig. 4-29

- (4) Take off the front rail cover and rear rail cover.
📖 P. 4-10 "[M] Front rail cover / Rear rail cover"
- (5) Take off the movable tray.
📖 P. 4-148 "4.12 Procedure for lowering the movable tray"

- (6) Turn the levers on the alignment plate to unlock. Move the front alignment plate [3] and the rear alignment plate [4] to the center, and then take them off by pulling them out upward.

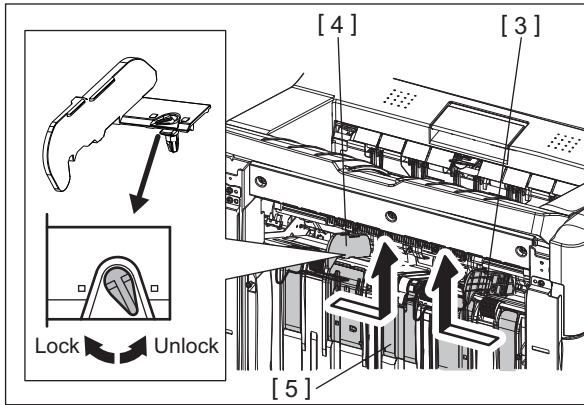

Fig. 4-30

Notes:

If the shutter [5] is raised, move the frame downward.

- (7) Remove 6 screws, and then take off the grate-shaped guide [6] by sliding it upward.

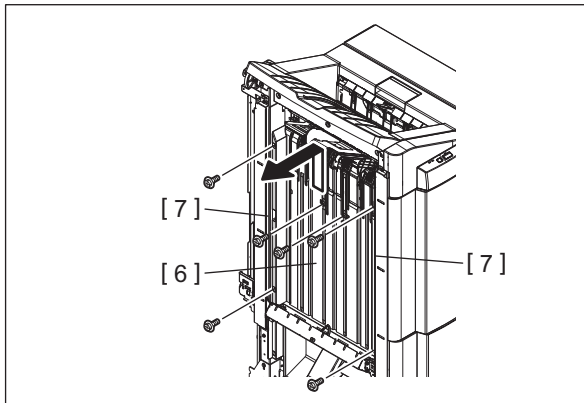

Fig. 4-31

Notes:

When installing the grate-shaped guide [6], hang the 2 hooks [7] of the cover on the hooks [7] of the frame.

- (8) Release the harness out of one clamp [8], and then take off the grate-shaped guide [6].

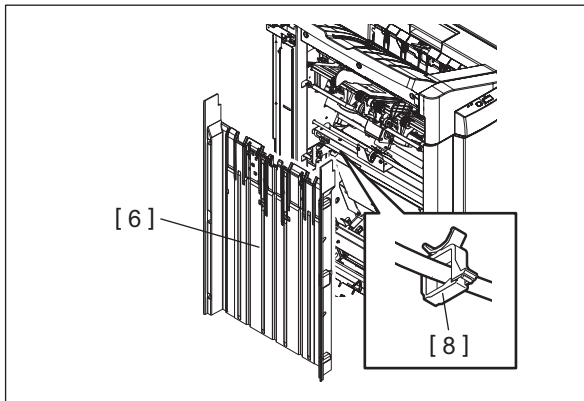

Fig. 4-32

Notes:

When installing the grate-shaped guide, install the harness [9] as shown in the figure.

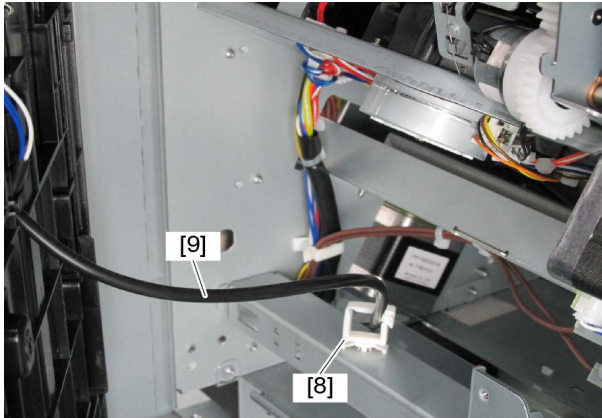

Fig. 4-33

[O] Left lower cover

- (1) Take off the movable tray.
📖 P. 4-2 "[B] Movable tray"
- (2) Take off the saddle tray.
📖 P. 4-3 "[C] Saddle tray (MJ-1112)"
- (3) Take off the front rail cover and rear rail cover.
📖 P. 4-10 "[M] Front rail cover / Rear rail cover"
- (4) Remove 4 screws, and take off the left lower cover [1].

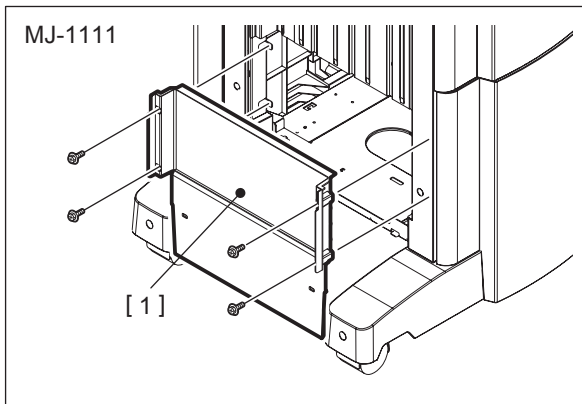

Fig. 4-34

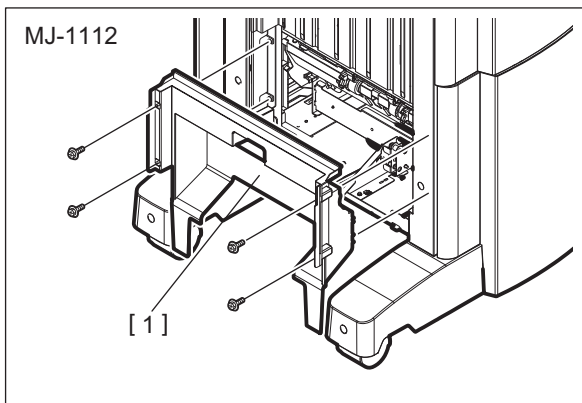

Fig. 4-35

[P] Front foot cover / Rear foot cover

- (1) Remove 1 screw, and then take off the front foot cover [1] by sliding it in the direction of the arrow.

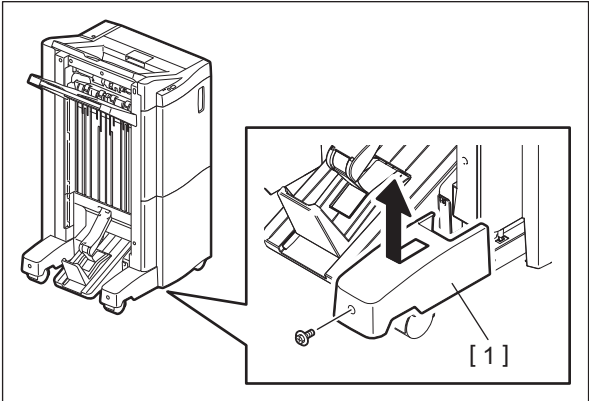

Fig. 4-36

- (2) Remove 1 screw, and then take off the rear foot cover [2] by sliding it in the direction of the arrow.

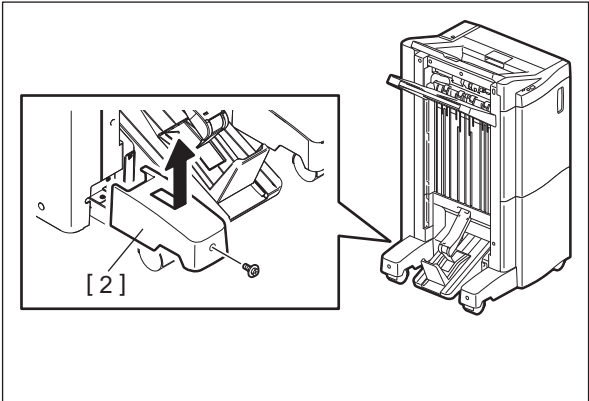

Fig. 4-37

4.2 Units (Finisher section)

[A] Junction box unit

- (1) Take off the control panel unit.
📖 P. 4-4 "[D] Control panel unit"
- (2) Take off the rear cover.
📖 P. 4-7 "[G] Rear cover"
- (3) Take off the right upper cover.
📖 P. 4-8 "[J] Right upper cover"
- (4) Take off the right cover.
📖 P. 4-9 "[K] Relay guide / Feeding discharge brush / Right cover"
- (5) Release the harness from 4 harness clamps [1].
- (6) Disconnect 2 connectors (CN1 and CN5) of the harness [2], [3] on the finisher control PC board.
- (7) Take off the 1 spring [4].
- (8) Remove 1 screw [5], and then take off the sensor bracket [6] of the connection switch.
- (9) Release the harness from 1 binding wire [7].
- (10) Release the harness [9] out of 1 clamp [8].

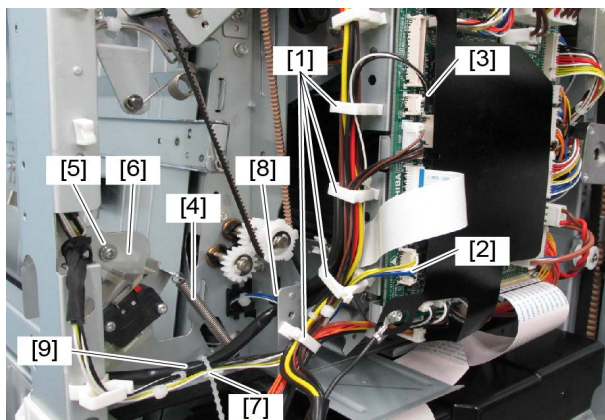

Fig. 4-38

- (11) Open the stationary tray.
- (12) Remove the spring [10], and then loosen 2 screws to free the belt [11] tension. And take off the belt [11].

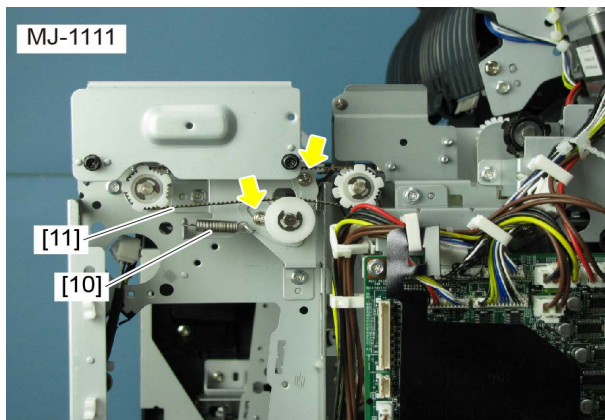

Fig. 4-39

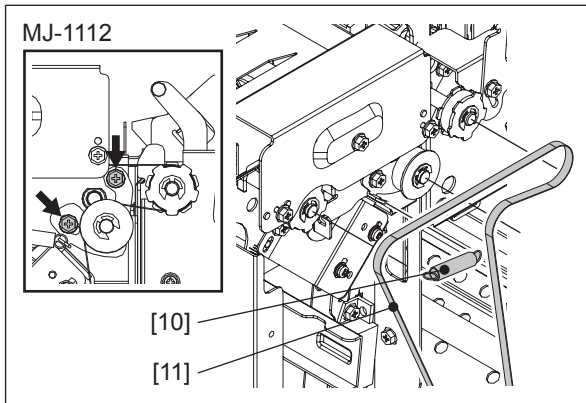

Fig. 4-40

- (13) Remove 2 screws and take off the sensor plate [12].

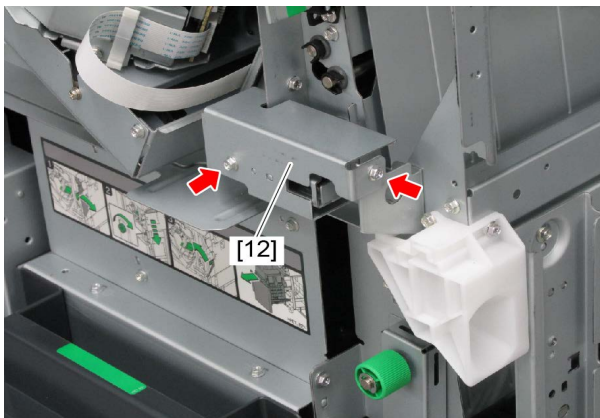

Fig. 4-41

- (14) Disconnect 1 connector of the front cover switch [13].
 (15) Remove 2 screws and take off the front holder [14].

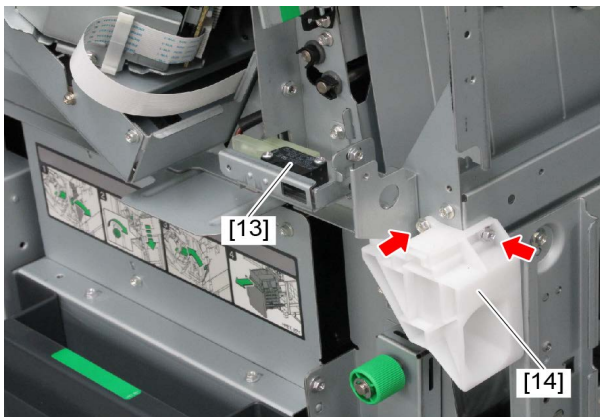

Fig. 4-42

- (16) Remove 1 screw and take off the rear holder [15].

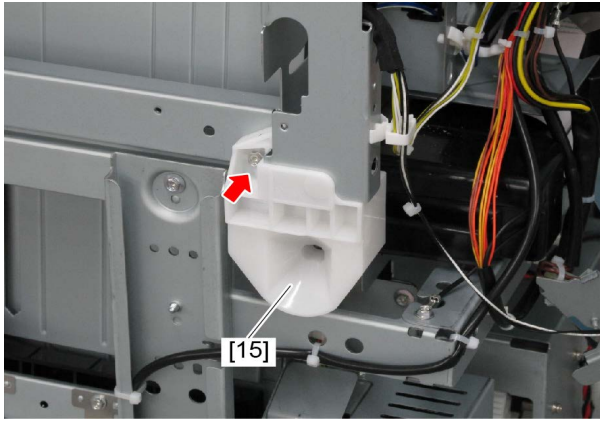

Fig. 4-43

- (17) Remove 6 screws, and then take off the junction box unit [16] by sliding it upward.

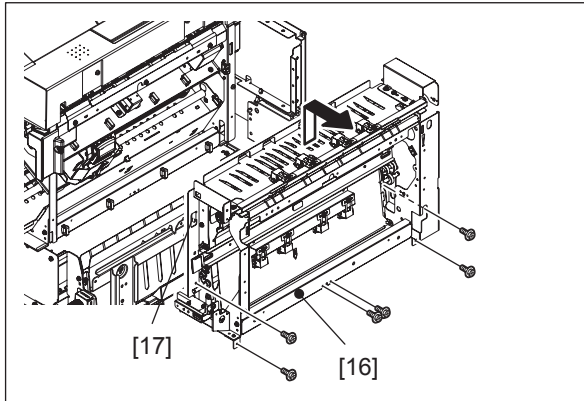

Fig. 4-44

Notes:

When installing the junction box unit [16], hang the 2 hooks [17] of the cover on the hooks of the frame.

[B] Buffer unit

- (1) Take off the stationary tray.
📖 P. 4-1 "[A] Stationary tray"
- (2) Take off the movable tray.
📖 P. 4-2 "[B] Movable tray"
- (3) Take off the control panel unit.
📖 P. 4-4 "[D] Control panel unit"
- (4) Take off the rear cover.
📖 P. 4-7 "[G] Rear cover"
- (5) Take off the right upper cover.
📖 P. 4-8 "[J] Right upper cover"
- (6) Take off the right cover.
📖 P. 4-9 "[K] Relay guide / Feeding discharge brush / Right cover"
- (7) Take off the left upper cover.
📖 P. 4-10 "[L] Left upper cover"
- (8) Take off the junction box unit.
📖 P. 4-15 "[A] Junction box unit"
- (9) Take off the front rail cover and rear rail cover.
📖 P. 4-10 "[M] Front rail cover / Rear rail cover"

- (10) Remove 2 screws, and then take off the front rail guide [1].
- (11) Remove 2 screws, and then take off the rear rail guide [2].

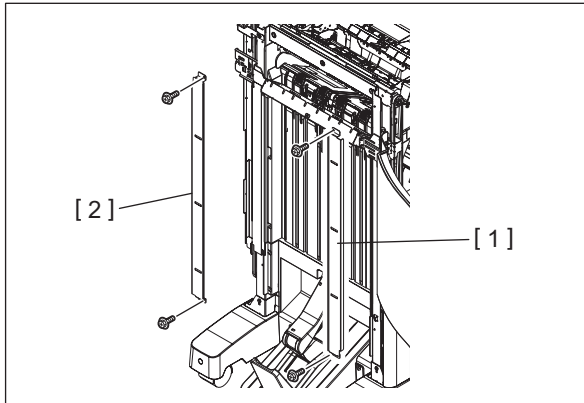

Fig. 4-45

- (12) Disconnect 5 connectors [4], [5], [6], [7] and [8] (CN8, CN9, CN10, CN11 and CN14) on the finisher control PC board [3].
- (13) Disconnect 1 connector [10] from the buffer tray guide motor [9].
- (14) Disconnect 1 connector [12] from the transport motor [11].
- (15) Disconnect 1 connector [14] from the movable tray shift motor sensor [13].
- (16) Release the harness from 6 harness clamps [15].
- (17) Release the harness from 1 binding wire [18].

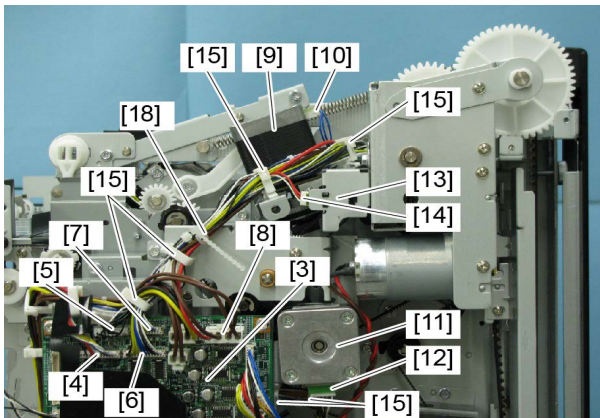

Fig. 4-46

- (18) Release the harness [16] of the connector (CN14) of the finisher control PC board from 2 harness clamps [17].

Notes:

When installing, wire the harness [16] as shown in the figure.

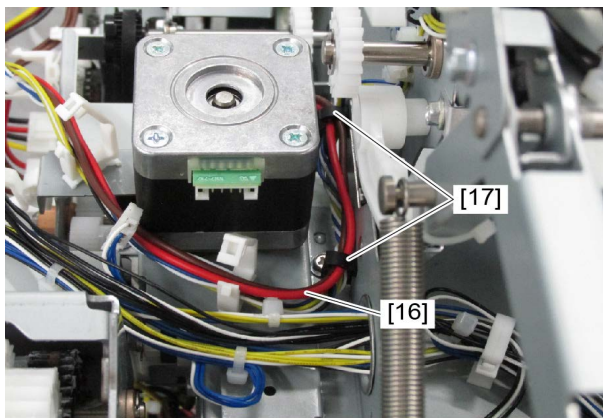

Fig. 4-47

(19) Remove 5 screws and take off the motor bracket [19].

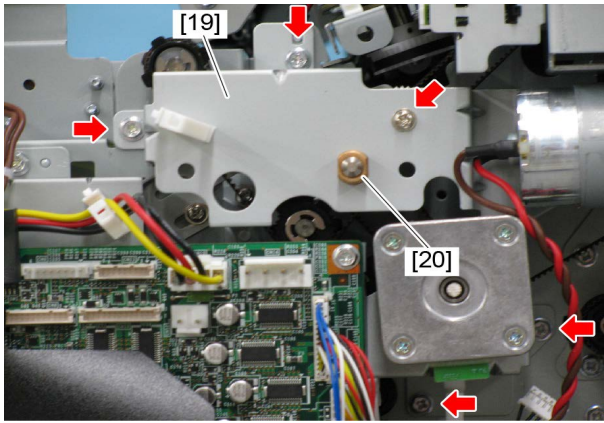

Fig. 4-48

Notes:

Pay full attention not to lose the bushing [20] while taking off the motor bracket [19].

(20) Loosen 1 screw. Push the pulley [21] in the direction indicated by the arrow to loosen the belt tension and tighten the screw.

(21) Remove the belts [22] and [23], the part assembled [24] and the bearing.

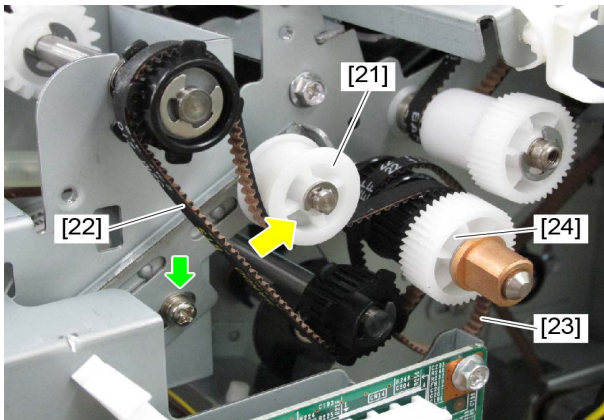

Fig. 4-49

Notes:

Pay full attention not to lose the bearing while taking off the part assembled [24].

(22) Remove 2 springs [25].

Notes:

Be sure to support the buffer unit-1 with your hand since the frames [26] of the buffer unit are moved in the direction indicated by the arrow to close them when you remove the springs [25].

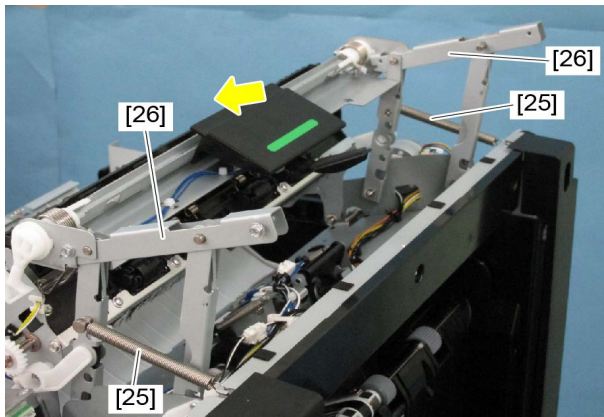

Fig. 4-50

(23) Remove 4 screws, and then take off the buffer unit [27].

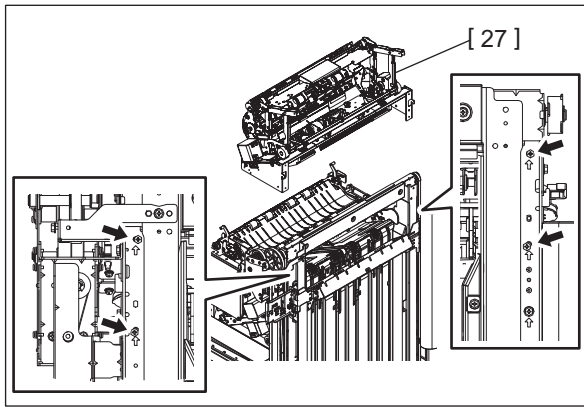

Fig. 4-51

Notes:

Be sure to place the removed buffer unit as shown in the figure to prevent damaged to the buffer guide [28], assist guide [29] and transport path [30].

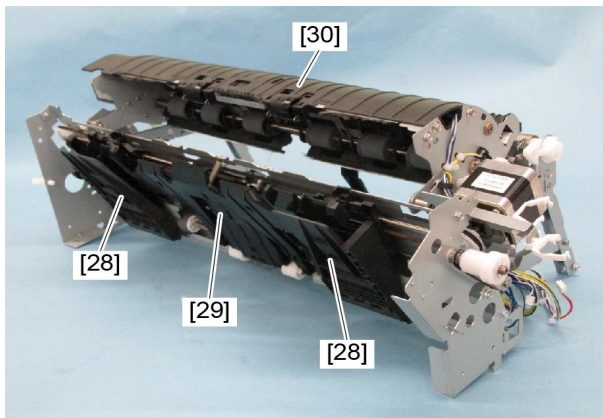

Fig. 4-52

[C] Buffer unit-1

- (1) Take off the stationary tray.
☞ P. 4-1 "[A] Stationary tray"
- (2) Take off the control panel unit.
☞ P. 4-4 "[D] Control panel unit"
- (3) Take off the rear cover.
☞ P. 4-7 "[G] Rear cover"
- (4) Disconnect 4 connectors [4], [5], [6] and [7] (CN8, CN9, CN11 and CN12) on the finisher control PC board [3].
- (5) Disconnect 1 connector [10] from the buffer tray guide motor [9].
- (6) Disconnect 1 connector [14] from the movable tray shift motor sensor [13].
- (7) Release the harness from 4 harness clamps [15].

(8) Release the harness from 1 binding wire [8].

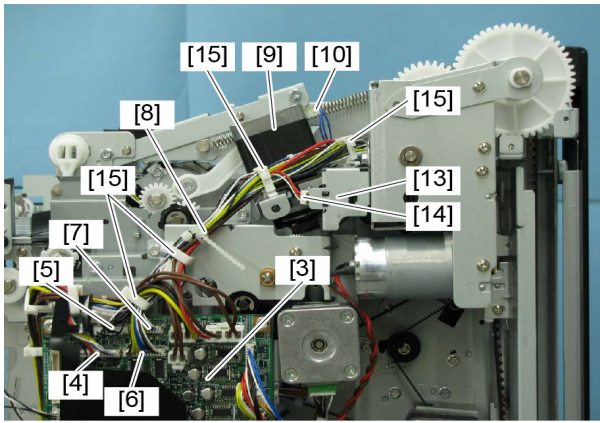

Fig. 4-53

(9) Release the harness [16] of the connector (CN14) of the finisher control PC board from 2 harness clamps [17].

Notes:

When installing, wire the harness [16] as shown in the figure.

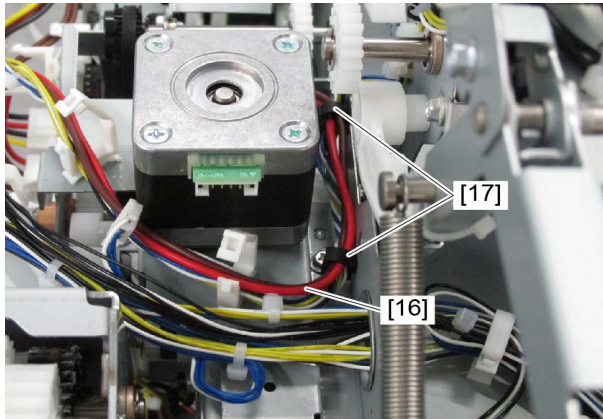

Fig. 4-54

(10) Remove 2 springs [18].

Notes:

Be sure to support the buffer unit-1 with your hand since the frames [19] of the buffer unit are moved in the direction indicated by the arrow to close them when you remove the springs [18].

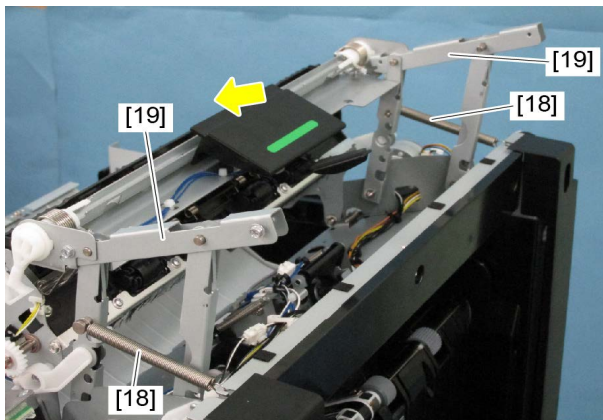

Fig. 4-55

(11) Disconnect 1 connector from the sensor [20]. Release the harness [21] from 1 harness clamp [22].

(12) Release the 1 harness clamp [24] of harness [23] from the frame.

(13) Pull out the harnesses [21] and [23] through the window [25] of the frame.

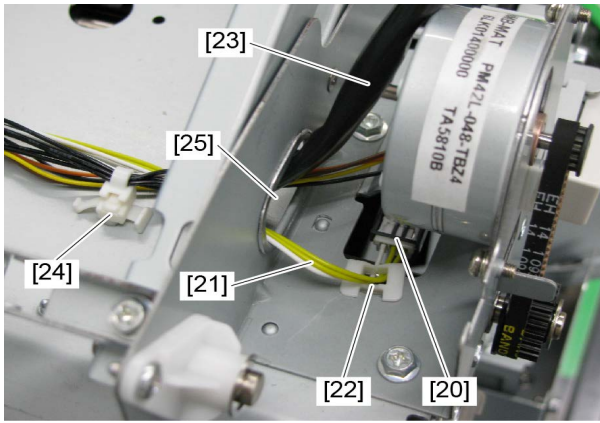

Fig. 4-56

(14) Disconnect 1 relay connector [26] and release the harness [27] from 7 harness clamps [28].

(15) Pull out the harness [27] through the window of the frame.

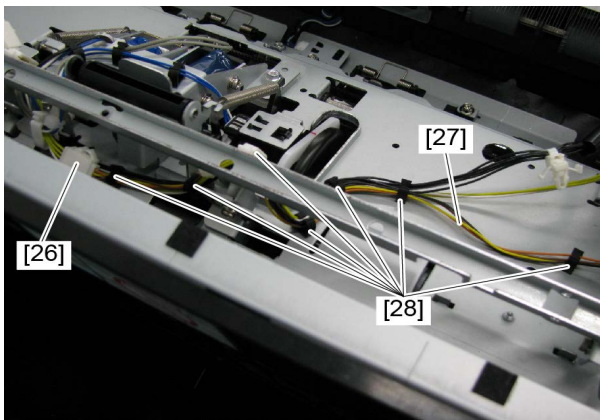

Fig. 4-57

(16) Pull out the harness [29] through the window [30] of the frame.

(17) Release the harness [29] from 1 harness clamp [31].

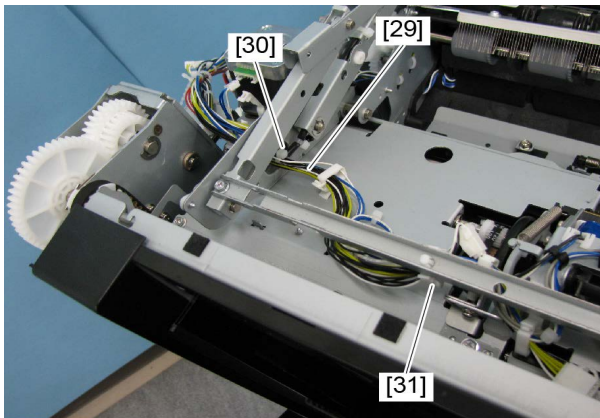

Fig. 4-58

- (18) Remove the belt [32].
- (19) Release the latch, and then take off the pulley cover [35].

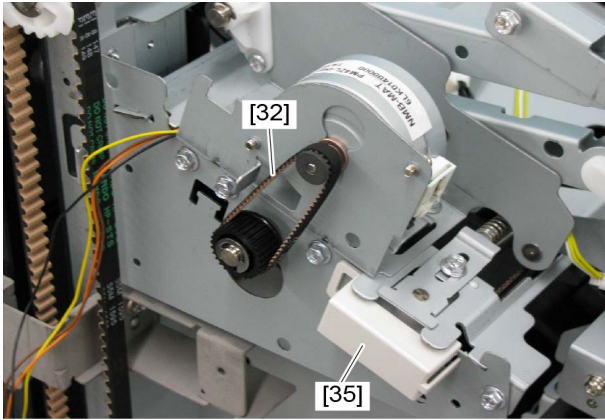

Fig. 4-59

- (20) Loosen 1 screw, and then tighten the screw by pushing the plate [33] in the direction of the arrow. (Loosen the belt tension.)

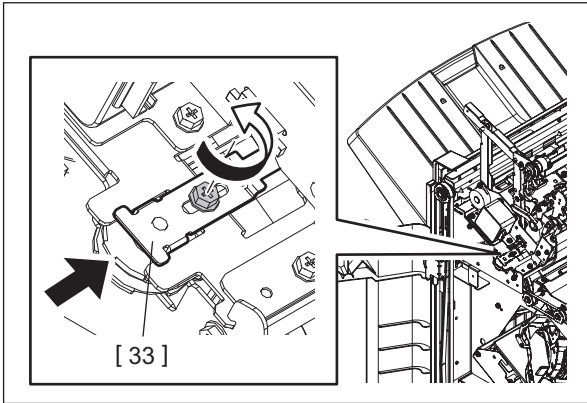

Fig. 4-60

- (21) Remove 5 screws and lift the buffer unit-1 [34] upward to take it off.

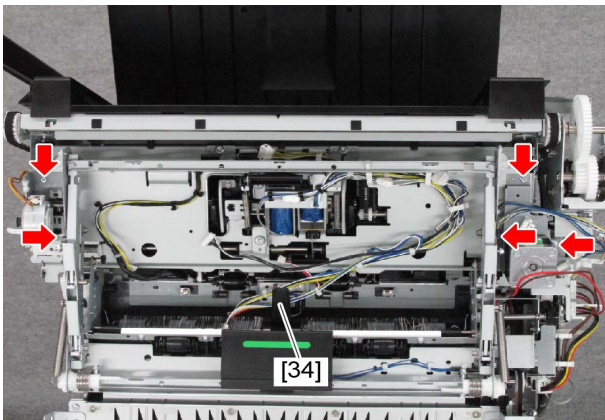

Fig. 4-61

[D] Finishing tray unit

- (1) Take off the stationary tray.
📖 P. 4-1 "[A] Stationary tray"
- (2) Take off the control panel unit.
📖 P. 4-4 "[D] Control panel unit"
- (3) Take off the rear cover.
📖 P. 4-7 "[G] Rear cover"
- (4) Take off the right upper cover.
📖 P. 4-8 "[J] Right upper cover"
- (5) Take off the junction box unit.
📖 P. 4-15 "[A] Junction box unit"
- (6) Take off the front rail cover and rear rail cover.
📖 P. 4-10 "[M] Front rail cover / Rear rail cover"
- (7) Take off the grate-shaped guide.
📖 P. 4-11 "[N] Grate-shaped guide"
- (8) Take off the buffer unit.
📖 P. 4-17 "[B] Buffer unit"
- (9) Release the harness and PC board cover [4] from 3 harness clamps [1]. Disconnect the connectors [2] and [3] (CN25 and CN18) on the finisher control PC board.

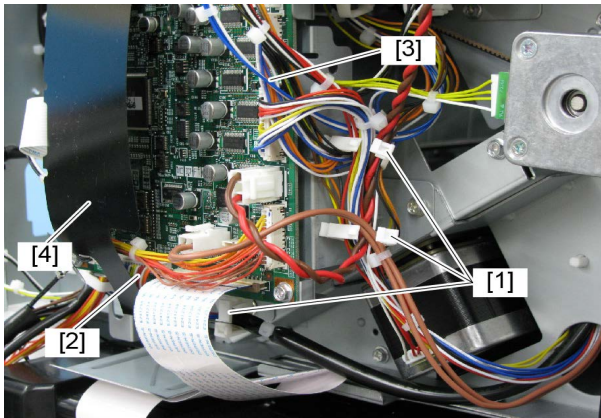

Fig. 4-62

- (10) Release the harnesses [4] and [5] from 1 harness clamp [6]. Pull out the harnesses [4] and [5] through the window [7] of the frame.

Notes:

When installing, wire the harnesses [4] and [5] as shown in the figure.

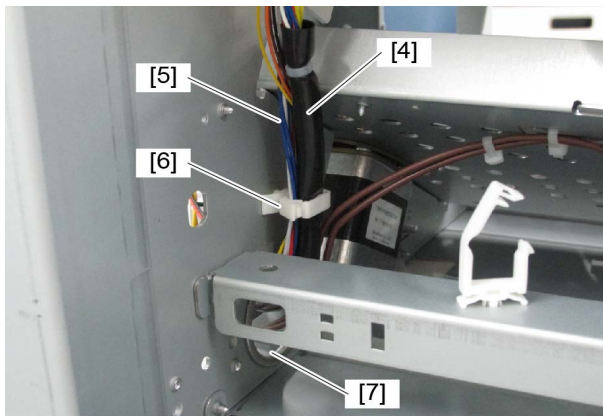

Fig. 4-63

(11) Remove 1 clip [9] on the front side of the stack transport roller-2 [8]. Then remove the bushing [10].

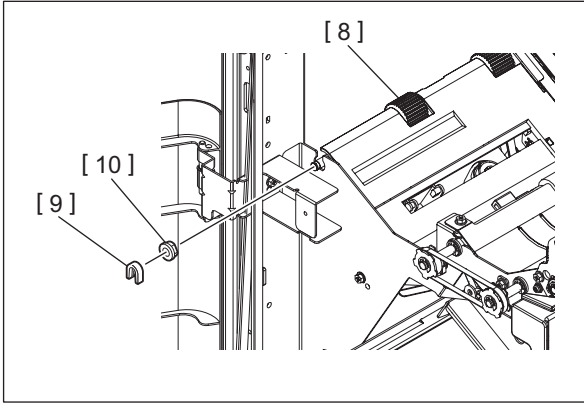

Fig. 4-64

(12) Remove the spring [11], and then loosen 2 screws to free the belt [12] tension.

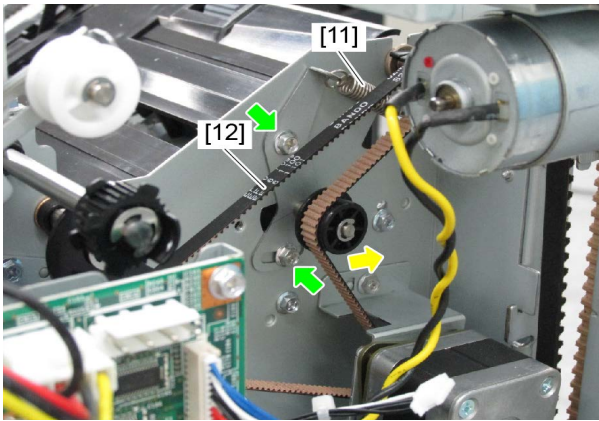

Fig. 4-65

(13) Remove 2 clips [13] at the rear side of the stack transport roller-2 [8]. Remove the transport roller pulley-2 [14], pin [15], bushing [16] and belt [12].

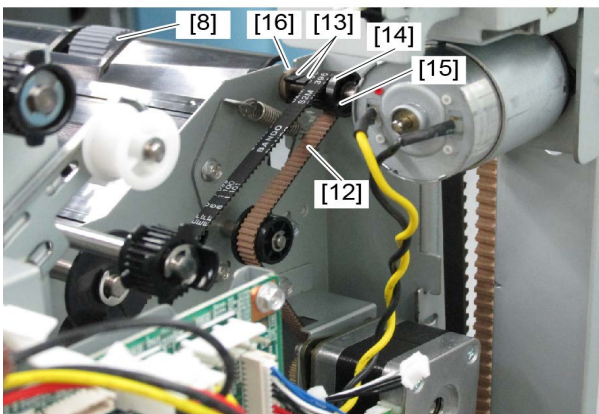

Fig. 4-66

Notes:

- Pay full attention not to lose the pin [15] for fixing the pulley.
- Pay full attention not to lose the belt [12].

- (14) Remove 2 clips [18] on the rear side of the stack transport roller-1 [17]. Then remove the transport roller pulley -3 [19], pin [20] and bushing [21].

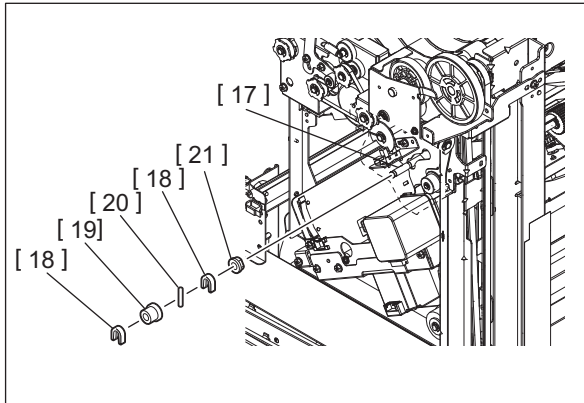

Fig. 4-67

Notes:

Be sure not to lose the fixing pins [20] for the pulleys.

- (15) Move the stapler to the staple replacing position (the first position from the front).
 (16) Remove 4 screws and take off the stack transport roller-2 [8] in the finishing tray unit [22] from the frame. Move the stack transport roller-1 [17] as shown in the figure, and then lift the front side of the finishing tray unit [22] to take it off.

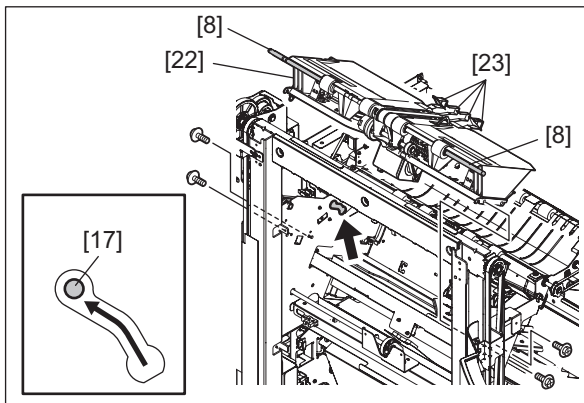

Fig. 4-68

Notes:

Be sure not to deform the finishing tray guide [23].

[E] Stapler unit

- (1) Take off the rear cover.
 📖 P. 4-7 "[G] Rear cover"
- (2) Take off the front rail cover and rear rail cover.
 📖 P. 4-10 "[M] Front rail cover / Rear rail cover"
- (3) Take off the grate-shaped guide.
 📖 P. 4-11 "[N] Grate-shaped guide"

- (4) Release the harness and PC board cover [7] from 3 harness clamps [1]. Disconnect the connectors [2] and [3] (CN23 and CN27) on the finisher control PC board.
- (5) Disconnect the flat cable [4] from the connector (CN2) on the finisher control PC board.
- (6) Disconnect the connector [5] from the stapler shift motor.

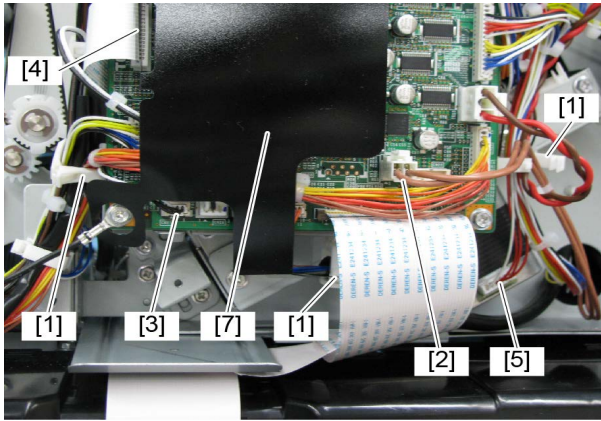

Fig. 4-69

- (7) Remove 2 screws of the rear side.

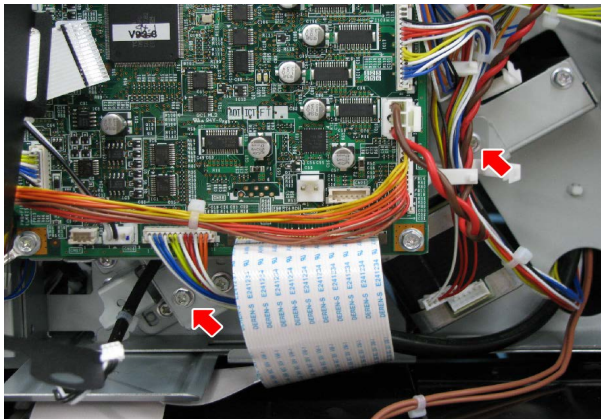

Fig. 4-70

- (8) Remove 2 screws of the front side. Slide the stapler unit [6] toward you to take it off.

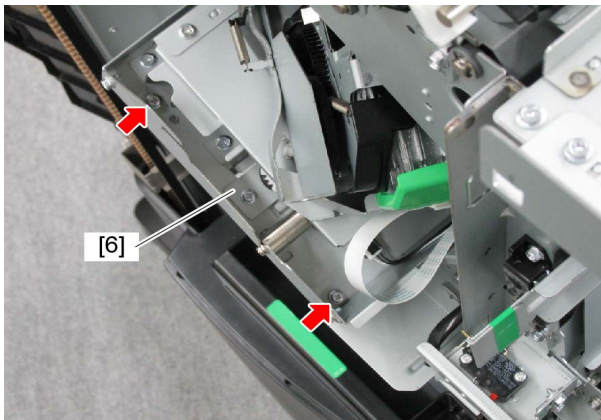

Fig. 4-71

[F] Stapler

- (1) Open the front upper cover.
- (2) Move the stapler to the staple replacing position (the first position from the front).
- (3) Release the clamp to disconnect the flexible cable out of the connector.

Notes:

When installing the stapler, place the flexible cable on the protrusion of the stapler and fix it with the clamp.

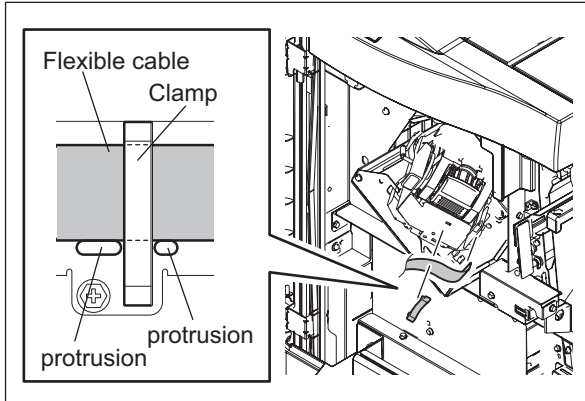

Fig. 4-72

- (4) Remove 1 screw, and then take off the staple carrier.

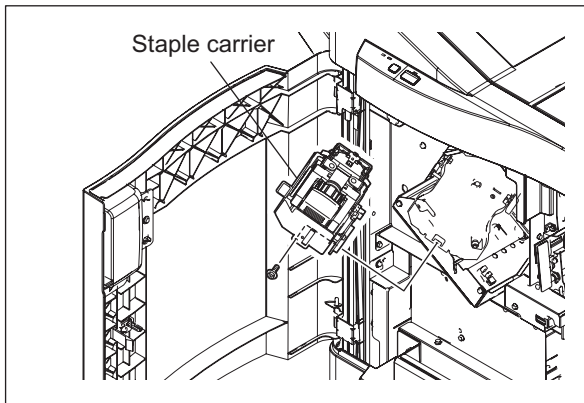

Fig. 4-73

- (5) Remove 2 screws, and then disconnect 2 connectors of the stapler to take off the stapler.

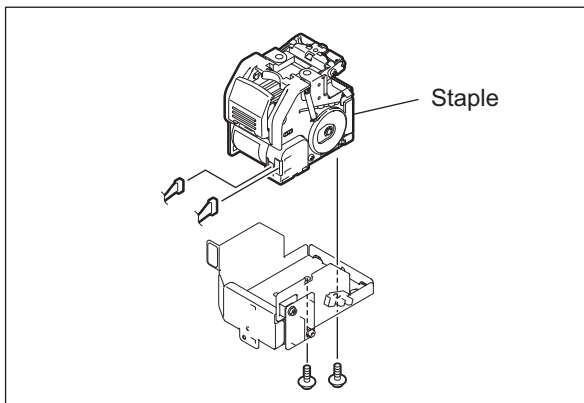

Fig. 4-74

[G] Movable tray shift motor unit

- (1) Take off the rear cover.
📖 P. 4-7 "[G] Rear cover"
- (2) Move the movable tray [1] shift frame to the middle position. If the movable tray [1] shift frame needs to be lowered, push the gear [2] of the movable tray shift motor unit in the direction of the arrow to unlock the frame. (Be sure to hold the movable tray gear frame with your hands because it may fall when the gear is pushed.)

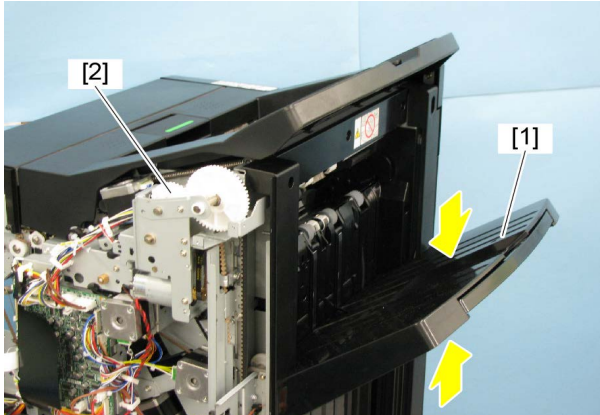

Fig. 4-75

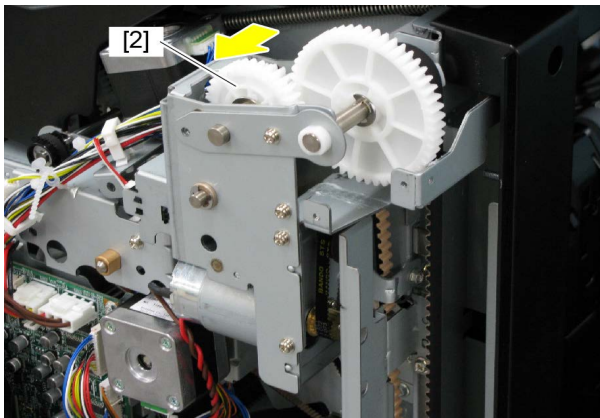

Fig. 4-76

- (3) Remove 2 screws, and then take off the sensor rail1 [3].

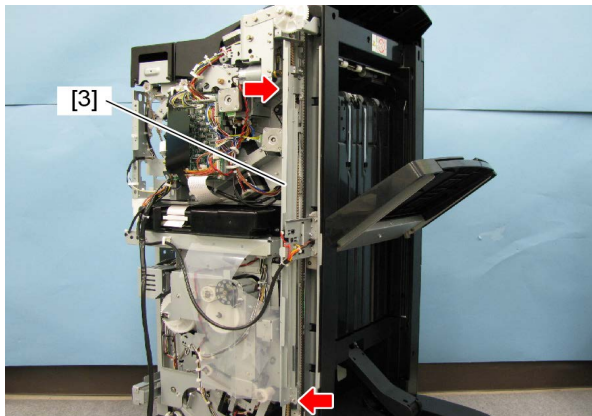

Fig. 4-77

Notes:

When installing the movable tray drive unit, fix it at the position where the gap between the center mark of the scale on the sensor rail and the edge of the movable tray position-A sensor is from 0 to 1 mm. Be sure to adjust the installation position by shifting the movable tray shift frame and measure the positions at the upper and lower measuring points on the sensor rail as shown in the figure.

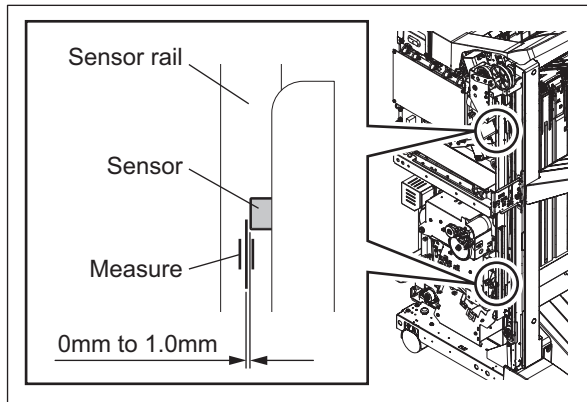

Fig. 4-78

- (4) Release the harness from 3 harness clamps [1]. Disconnect the connector [2] (CN19) on the finisher control PC board.

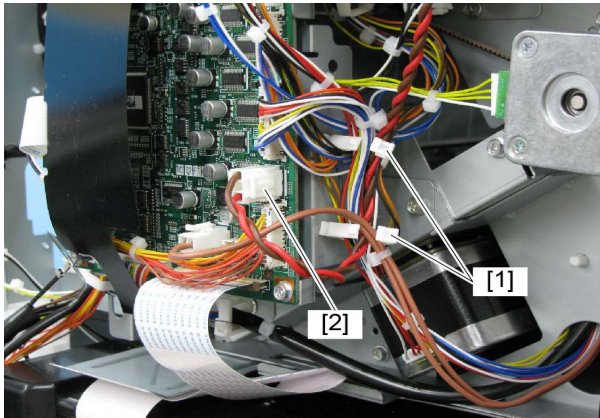

Fig. 4-79

- (5) Disconnect the connector [3] of the movable tray shift motor sensor.
- (6) Remove 1 screw. Take off the metal plate [4] and remove the bushing [5].

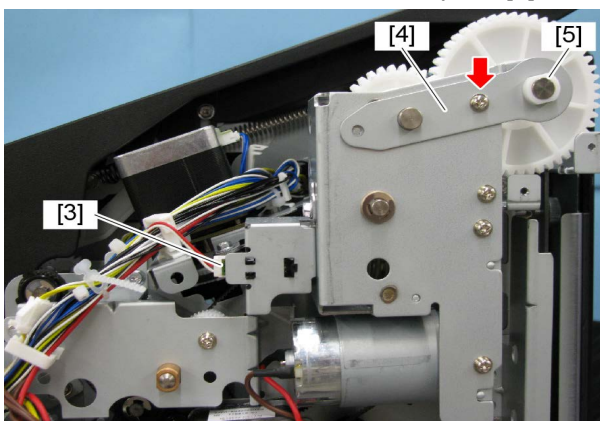

Fig. 4-80

(7) Remove 2 screws, and then take off the movable tray shift motor unit [6].

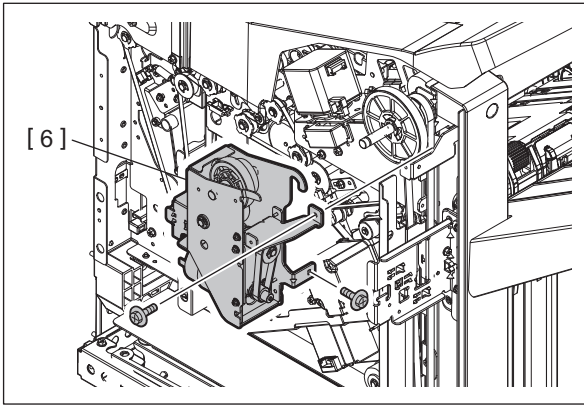



Fig. 4-81

4.3 Units (Saddle stitch section: MJ-1112)

[A] Saddle stitch unit

- (1) Take off the front lower cover.
 P. 4-5 "[E] Front cover / Front upper cover / Front lower cover"
- (2) Take off the rear cover.
 P. 4-7 "[G] Rear cover"
- (3) Remove 1 flat cable harness clamp [3] and release 1 flat cable [4] from the connector (CN5) on the saddle control PC board.

Notes:

When installing, firmly insert the flat cable [4] into the connector and be sure to align the flat cable clamp [3] to the black line [5] on the flat cable.

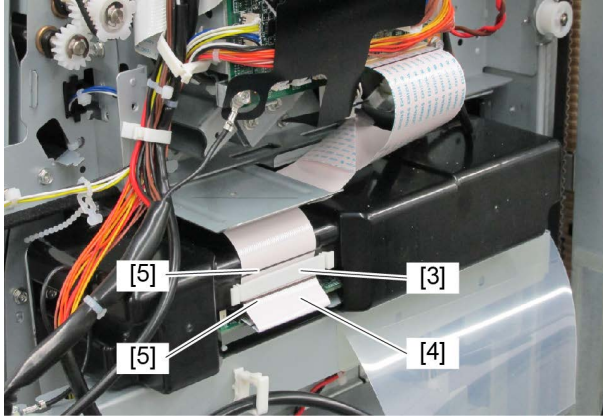

Fig. 4-82

- (4) Place a table beneath [6] the pulled-out saddle stitch unit to steady it.

Notes:

Store (flip up) the saddle stitch unit support [7] before placing a table beneath [6] the unit.

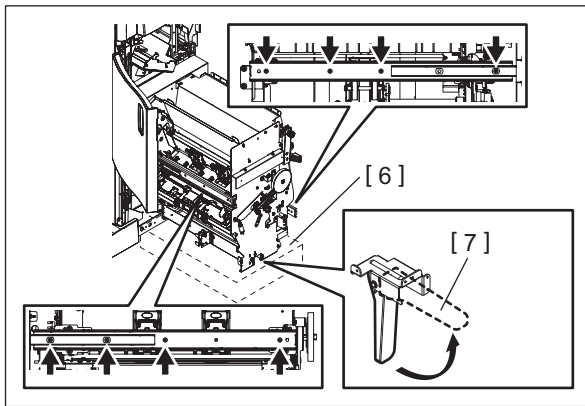

Fig. 4-83

- (5) Remove 8 screws and store the right and left rails.
- (6) Take off the saddle stitch unit from the equipment.

Notes:

- Hold the part of the saddle stitch unit as shown in the figure during disassembling [8].
- When the saddle stitch unit was taken off, place the unit on a flat place with its support [7] stored (flipped up).

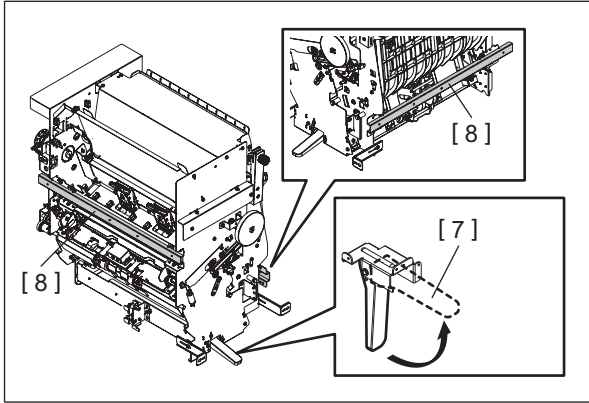

Fig. 4-84

Notes:

When the saddle stitch unit was installed, take off the saddle cover to check if the joint section of the pivot [1] on the Finisher side and the plate [2] on the saddle stitch unit side is smooth.

1. Take off the saddle tray.
 📖 P. 4-3 "[C] Saddle tray (MJ-1112)"
2. Open and close the saddle stitch unit to check if the joint section of the pivot on the Finisher side and the plate on the saddle stitch unit side is smooth, and also if the plate [3] on the Finisher side contacts with the plate on the saddle stitch unit side at 4 positions.
3. If not, loosen 2 screws of the Finisher side bracket and 1 screw on the saddle stitch unit side to determine the proper positions while the saddle stitch unit is left closed.

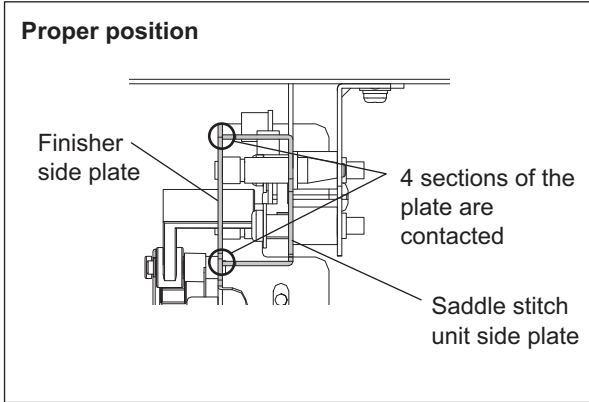

Fig. 4-85

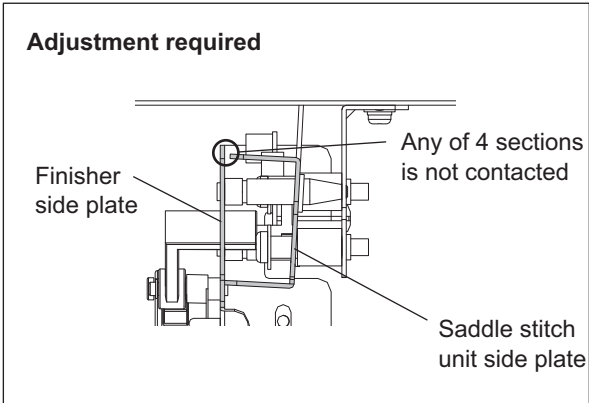

Fig. 4-86

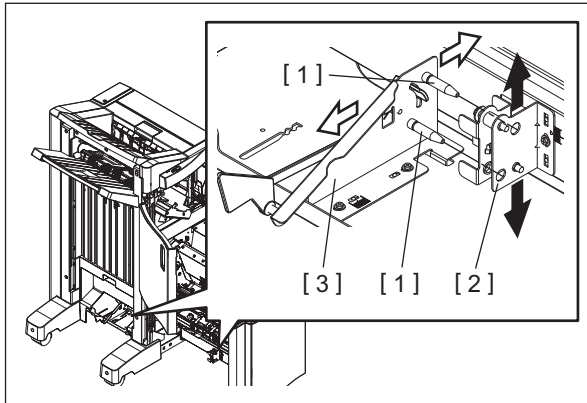



Fig. 4-87

[B] Switchback unit

- (1) Take off the saddle stitch unit.
 P. 4-32 "[A] Saddle stitch unit"
- (2) Remove 2 screws and take off the saddle control PC board cover [1].

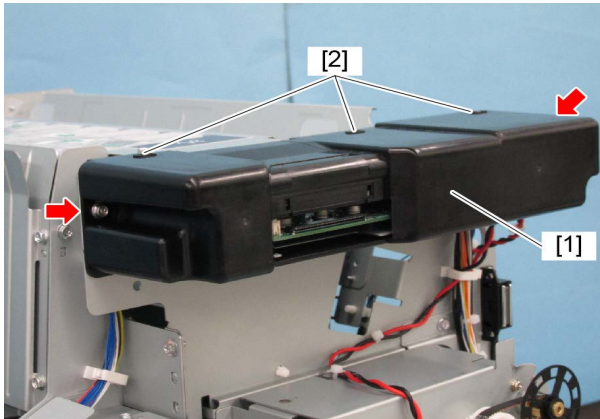

Fig. 4-88

Notes:

When installing, be sure to secure the holes [2] on the cover with 3 hooks on the frame.

- (3) Disconnect 2 connectors [2] (CN3 and CN5) on the saddle control PC board and release the harness from 1 harness clamp [4].

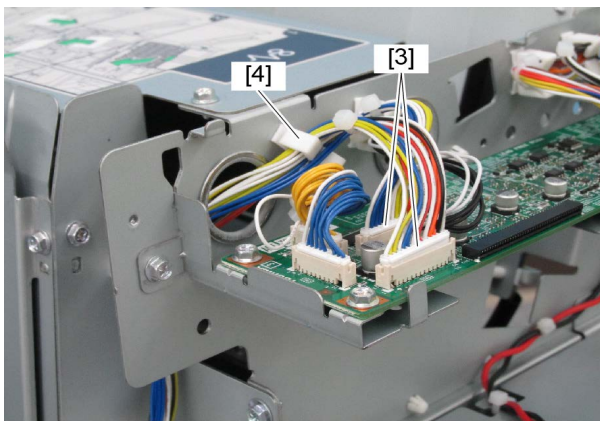

Fig. 4-89

- (4) Release the harness from 1 harness clamp [4].
 Remove 4 screws, and then take off the support bracket [5].
- (5) Remove 4 screws, and then take off the front bracket [6].

- (6) Remove 4 screws, and then take off the rear bracket [7].
- (7) Remove 4 screws, and then take off the switchback unit [8].

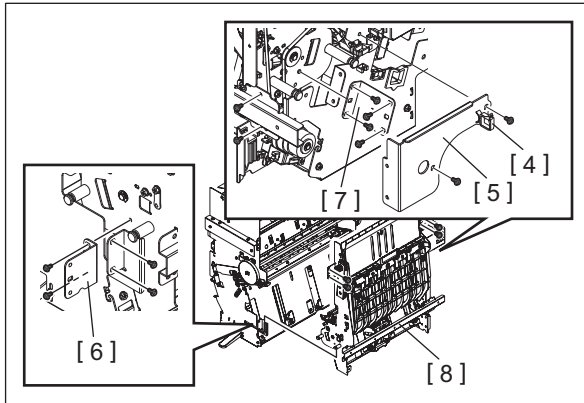



Fig. 4-90

[C] Paper holding unit

- (1) Take off the front lower cover.
 P. 4-5 "[E] Front cover / Front upper cover / Front lower cover"
- (2) Remove 2 screws, and then take off the paper holding unit [1].

Notes:

- Do not lose the clutch shaft bushing [2].
- When installing, engage the clutch shaft bushing [2] with the frame of the paper holding unit [1] securely.

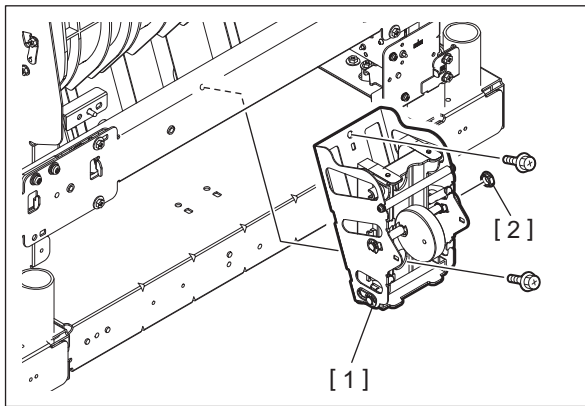

Fig. 4-91

[D] Side alignment unit

- (1) Take off the switchback unit.
📖 P. 4-34 "[B] Switchback unit"
- (2) Remove 4 screws and take off the upper safety cover [1].

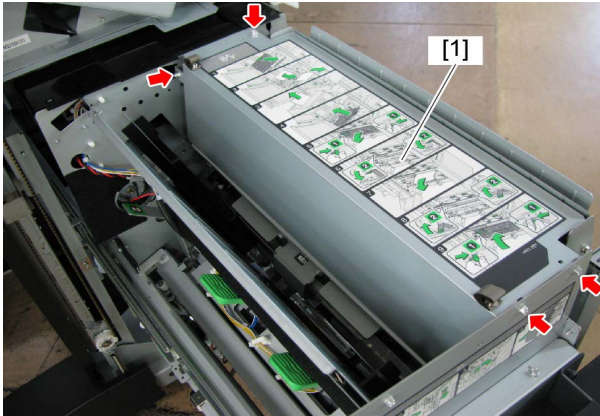

Fig. 4-92

- (3) Disconnect 1 connector [1] (CN4) on the saddle control PC board and release the harness from 4 harness clamps [2].

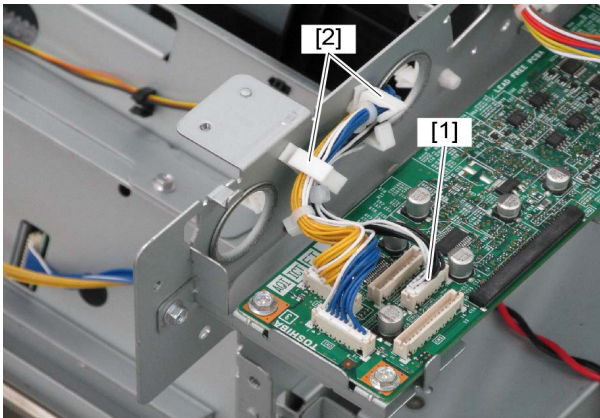

Fig. 4-93

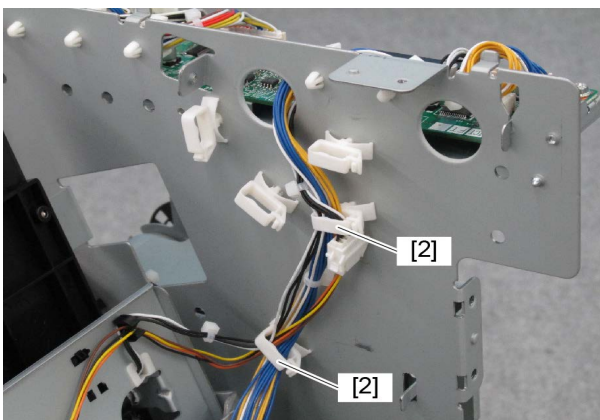

Fig. 4-94

- (4) Move each alignment plate [3] to both edges correspondingly.

- (5) Remove 4 screws and take off the side alignment unit [4] by lifting it upward.

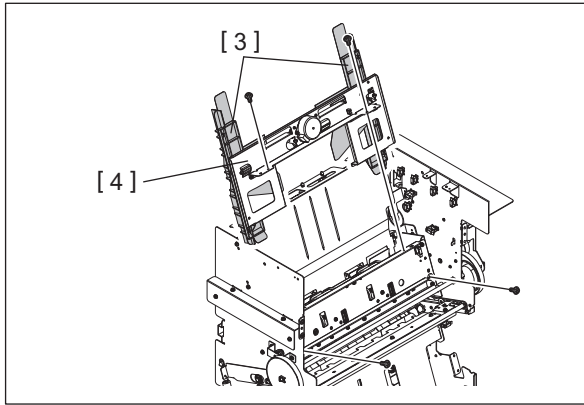

Fig. 4-95

[E] Saddle stapler unit

- (1) Take off the switchback unit.
☞ P. 4-34 "[B] Switchback unit"
- (2) Take off the side alignment unit.
☞ P. 4-36 "[D] Side alignment unit"
- (3) Disconnect the connector [2] from the saddle stapler clinch units [1] located at the front and rear sides of the upper stapler frame assembly. Then release the harness from 1 clamp [3].

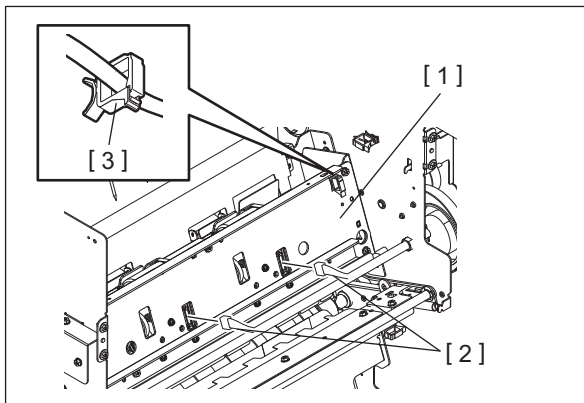

Fig. 4-96

- (4) Remove 4 screws and take off the upper stapler frame assembly [1].

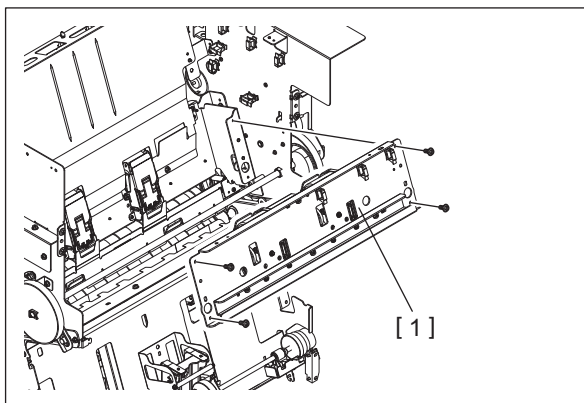

Fig. 4-97

Notes:

When installing, adjust the position of each saddle stapler clinch unit using an exclusive jig [1] following the procedure below.
6LB29630000JIG-STAPLE-2-SDL

1. Install the jig [1] on the hole [2] of the lower stapler frame.

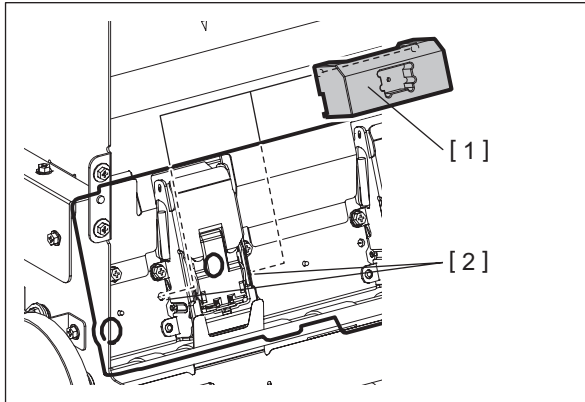

Fig. 4-98

2. Loosen 3 screws fixing the front stapler clinch unit.
3. Rotate the gear [1] of the front stapler clinch unit in the direction of the arrow to pull out the clinch [2]. Keep rotating the gear [1] until the clinch [2] is inserted all the way into the hole of the jig.
4. Tighten 3 screws in the order shown in the figure.
5. Return the clinch of the front stapler clinch [2] unit to its original position and then remove the jig.
6. Adjust the position of the rear saddle stapler clinch unit following the same procedure.

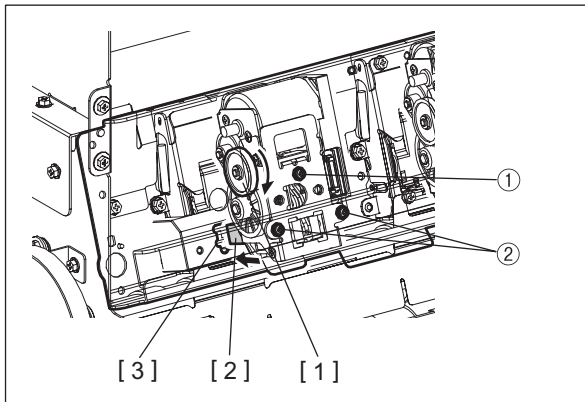

Fig. 4-99

- (5) Remove 3 screws and take off the front saddle stapler clinch unit [1].
- (6) Remove 3 screws and take off the rear saddle stapler clinch unit [2].

Notes:

Replace the front saddle stapler clinch unit [1] and the front saddle stapler drive unit [2] together. Do the same when replacing the rear ones.

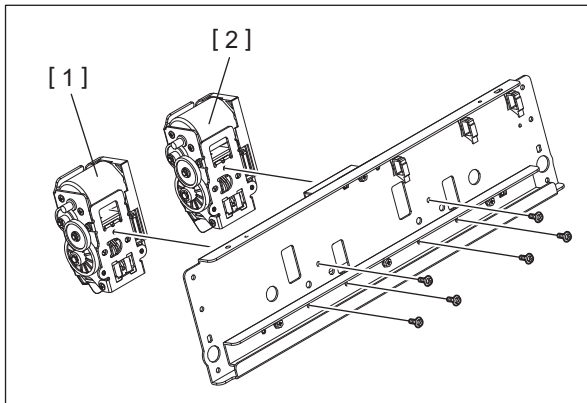

Fig. 4-100

- (7) Disconnect each connector [1] of the front and saddle stapler drive units from the SDL board side.
- (8) Remove 2 screws and take off the front saddle stapler drive unit [2].
- (9) Remove 2 screws and take off the rear saddle stapler drive unit [3].

Notes:

Replace the front saddle stapler drive unit [2] and the front saddle stapler clinch unit [3] together. Do the same when replacing the rear ones.

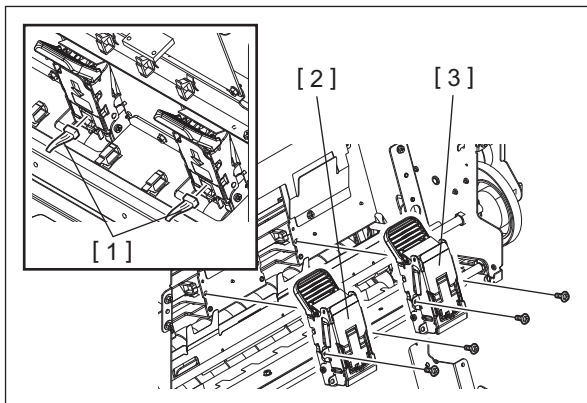

Fig. 4-101

- (10) Remove the fold plate.

Notes:

When replacing the fold plate (ASYS-PLT-FOLD-RLR-SDL), be careful not to damage the film.

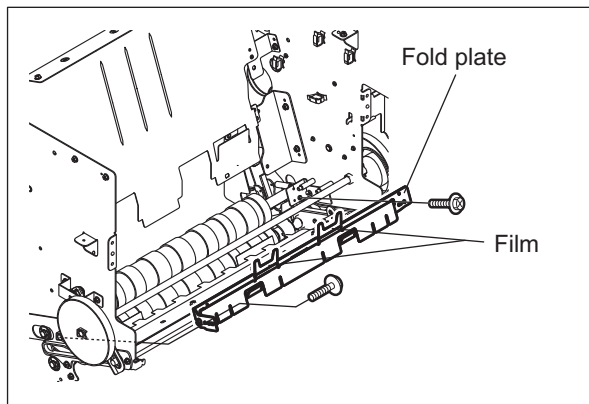

Fig. 4-102

[F] Folding drive unit

- (1) Take off the saddle stitch unit.
📖 P. 4-32 "[A] Saddle stitch unit"
- (2) Disconnect 6 connectors [1] (CN7, CN8, CN9, CN10, CN12 and CN13) on the saddle control PC board and release the harness from 6 harness clamps [2].

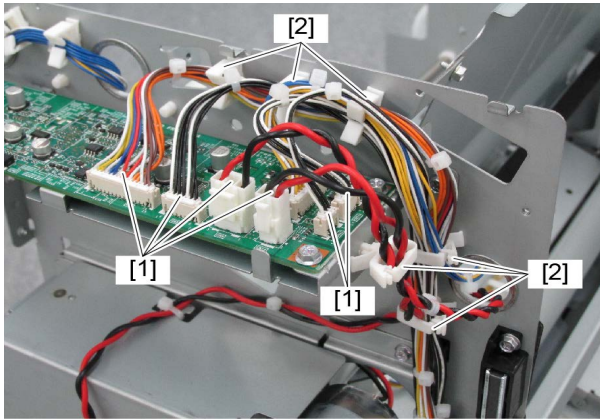

Fig. 4-103

- (3) Disconnect the connector [1] of the folding blade home position sensor. Break binding wire [2] at 4 positions and release the harness from 7 clamps [3] of the folding drive unit.

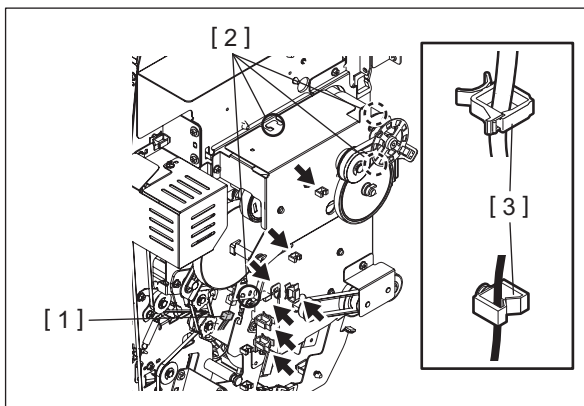

Fig. 4-104

- (4) Remove one clip [1] and then remove the bushing [2].

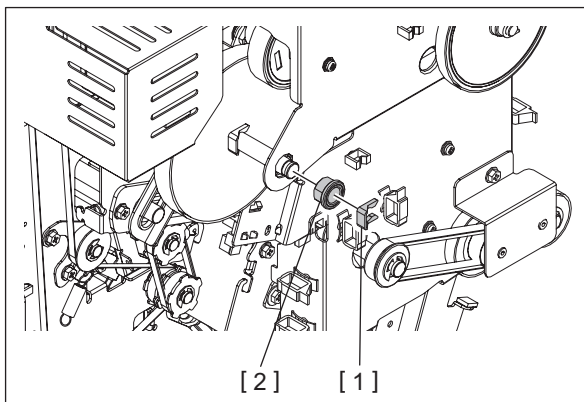

Fig. 4-105

(5) Remove one clip [1] and then remove the pulley [2] and pin [3].

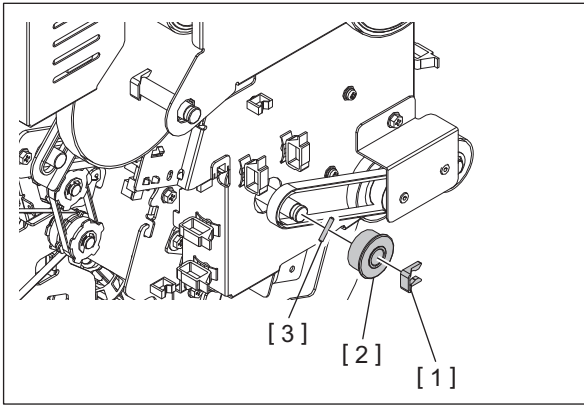

Fig. 4-106

(6) Remove the 1 spring [1]. Remove 4 screws, and then take off the folding drive unit [2].

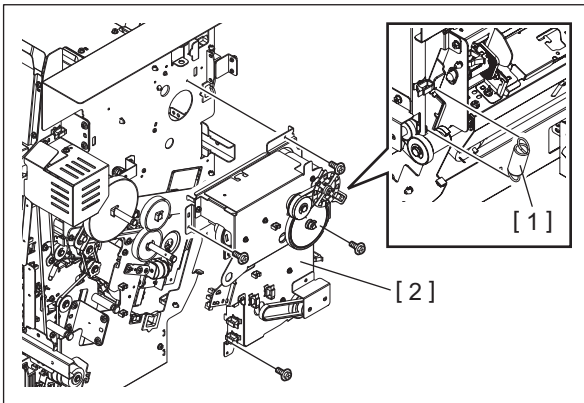

Fig. 4-107

Notes:

- When installing, hang the 2 hooks of the folding drive unit on the holes of frame.
- The gear bracket [1] of the folding drive unit is installed to determine the positioning between the gears of the folding drive unit and the additional folding unit. Before taking off the units, mark the position on the scale [2] of the frame where the mark [3] of the bracket points so that you can install them at the same positions.

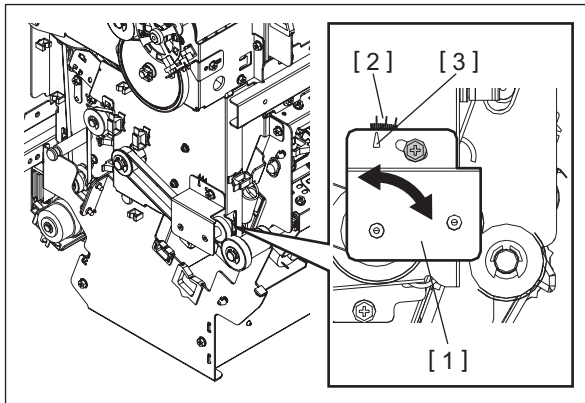

Fig. 4-108

[G] EFS unit

- (1) Take off the folding drive unit.
☞ P. 4-40 "[F] Folding drive unit"
- (2) Release the harness out of 3 clamps [3].
Disconnect the connector [1] of the stacker home position sensor. Disconnect the relay connector [2] of the stacker motor. Disconnect the relay connector [2] of the saddle tray paper detection sensor.

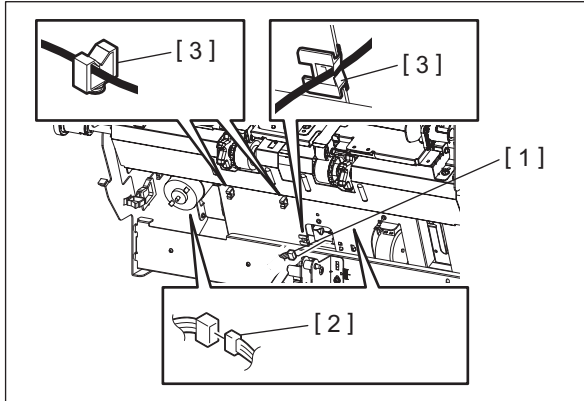

Fig. 4-109

- (3) Take off the spring [1].
- (4) Remove 2 screws and take off the front bracket [2].
- (5) Remove 2 screws and take off the rear bracket [3].

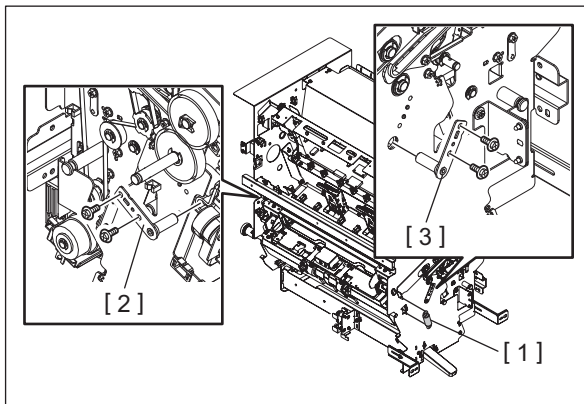

Fig. 4-110

- (6) Take off the EFS unit [2] while pulling the jam access lever [1].

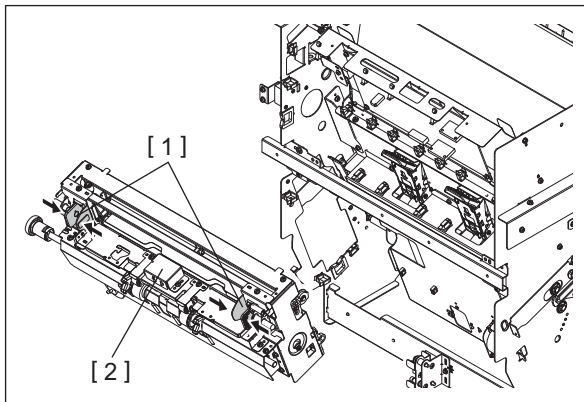

Fig. 4-111

[H] Stacker unit

- (1) Take off the switchback unit.
📖 P. 4-34 "[B] Switchback unit"
- (2) Take off the folding drive unit.
📖 P. 4-40 "[F] Folding drive unit"
- (3) Take off the EFS unit.
📖 P. 4-42 "[G] EFS unit"
- (4) Remove 2 screws, and then take off the stacker unit [1] by sliding it upward.

Notes:

- When installing, hang the 2 hooks [2] of the stacker unit [1] on the lower folding roller [3].

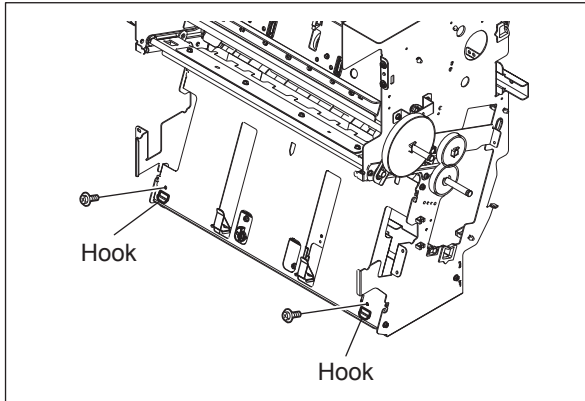

Fig. 4-112

- When installing, hang the 2 hooks of the stacker unit on the holes of frame.

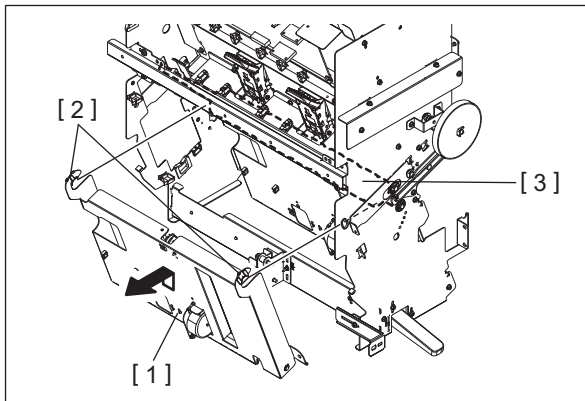

Fig. 4-113

4.4 Rollers (Finisher section)

[A] Feeding roller

[A-1] Feeding roller (MJ-1111)

- (1) Take off the control panel unit.
☞ P. 4-4 "[D] Control panel unit"
- (2) Take off the rear cover.
☞ P. 4-7 "[G] Rear cover"
- (3) Take off the right cover.
☞ P. 4-9 "[K] Relay guide / Feeding discharge brush / Right cover"
- (4) Take off the right upper cover.
☞ P. 4-8 "[J] Right upper cover"
- (5) Remove 3 screws, and then take off the front bracket [1].
- (6) Remove 2 screws, and then take off the rear bracket [2].
- (7) Remove 3 screws, and then take off the junction box upper transport guide [3].

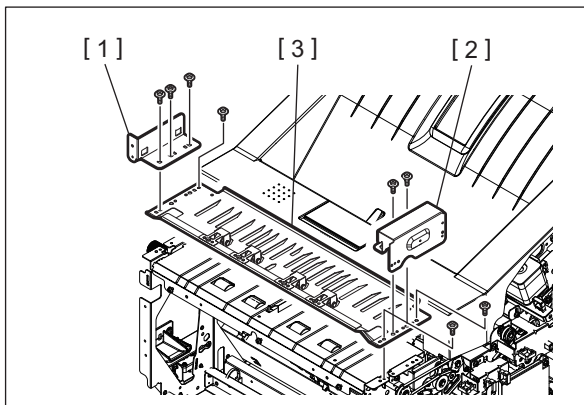

Fig. 4-114

- (8) Remove the spring [4], and then loosen 2 screws to free the belt [5] tension. Take off the belt [5].

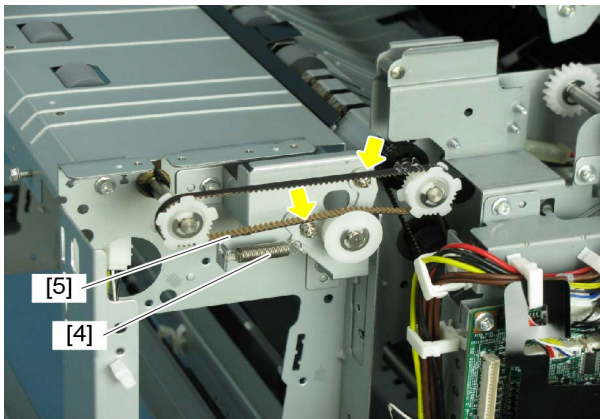

Fig. 4-115

- (9) Remove one screw, and then sensor bracket [6] of feeding sensor.

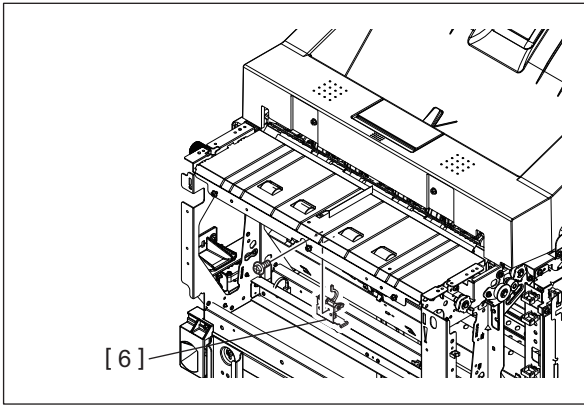

Fig. 4-116

- (10) Remove 2 screws, and then take off the bracket [7].
- (11) Remove 4 screws, and then take off the transport guide [8].

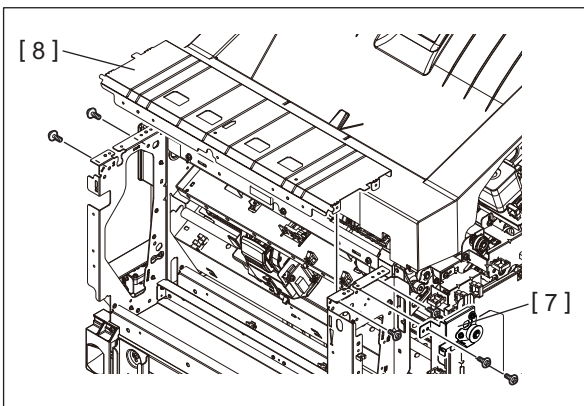

Fig. 4-117

- (12) Remove one E-ring, and then take off the knob [9] and pin [10].
- (13) Remove one clip [11], and then take off the bushing [12].

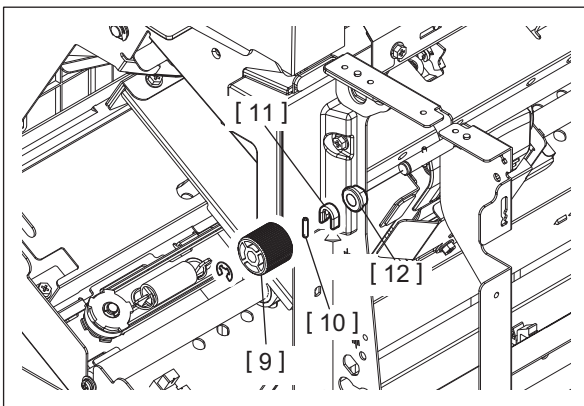

Fig. 4-118

- (14) Remove one E-ring, and then take off the pulley [14] and pin [15].

(15) Remove one clip [16], and then take off the bushing [17]. Take off the feeding roller [13].

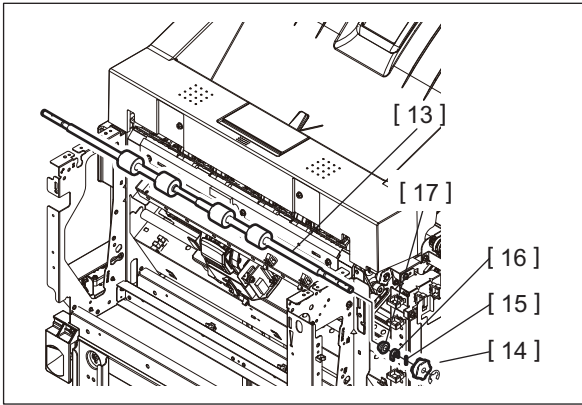

Fig. 4-119

[A-2] Feeding roller (MJ-1112)

- (1) Take off the control panel unit.
☞ P. 4-4 "[D] Control panel unit"
- (2) Take off the rear cover.
☞ P. 4-7 "[G] Rear cover"
- (3) Take off the right cover.
☞ P. 4-9 "[K] Relay guide / Feeding discharge brush / Right cover"
- (4) Take off the right upper cover.
☞ P. 4-8 "[J] Right upper cover"
- (5) Remove 2 screws, and then take off the front bracket [1].
- (6) Remove 2 screws, and then take off the rear bracket [2].
- (7) Remove 3 screws, and then take off the junction box upper transport guide [3].

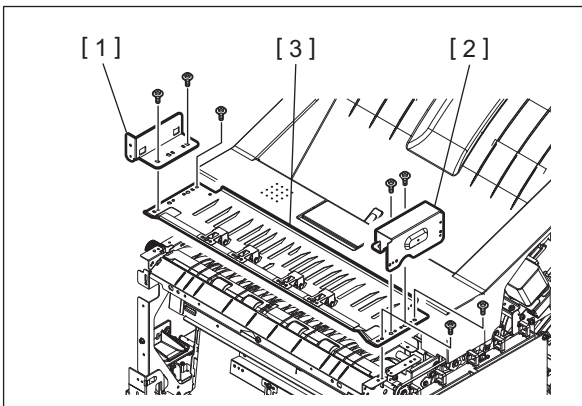

Fig. 4-120

- (8) Remove the spring [4], and then loosen 2 screws to free the belt [5] tension. Take off the belt [5].

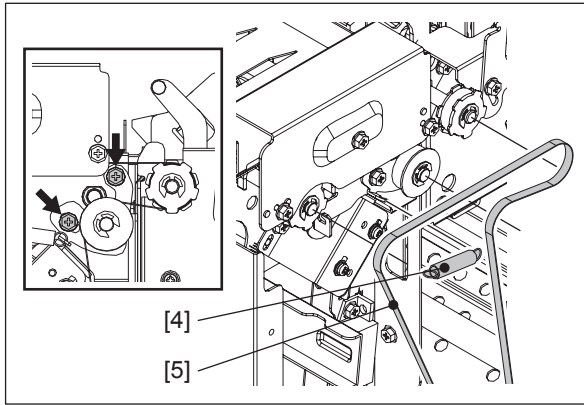

Fig. 4-121

- (9) Remove one screw, and then sensor bracket [1] of feeding sensor.

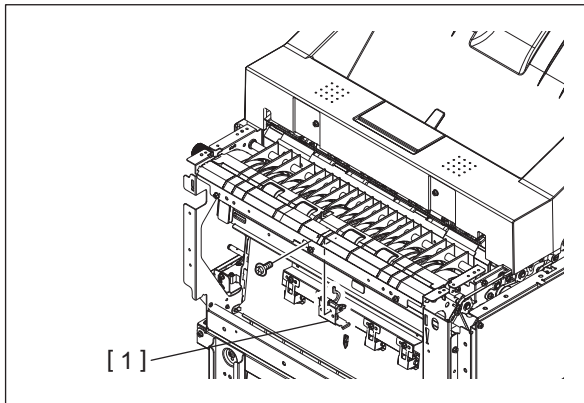

Fig. 4-122

- (10) Push the jam access lever [1] of the junction box to the right side, and then open the transport guide.

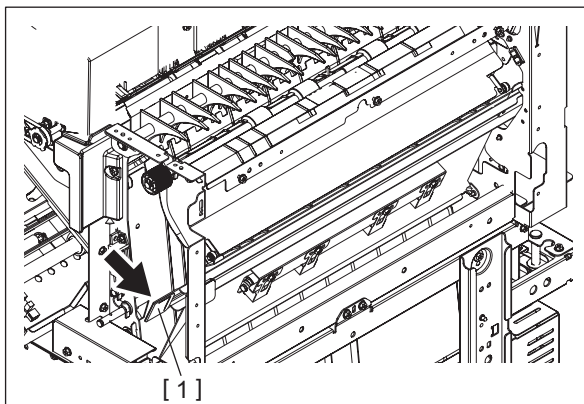

Fig. 4-123

- (11) Remove one E-ring, and then take off the knob [1] and pin [2].

- (12) Remove one clip [3], and then take off the bushing [4].

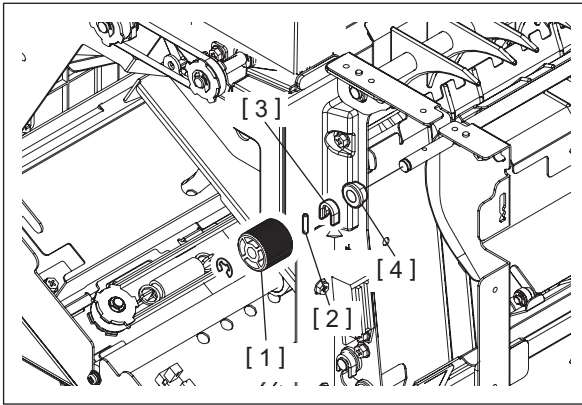

Fig. 4-124

- (13) Remove one E-ring, and then take off the pulley [2] and pin [3].

- (14) Remove one clip [4], and then take off the bushing [5]. Take off the feeding roller [1] and transport guide [6].

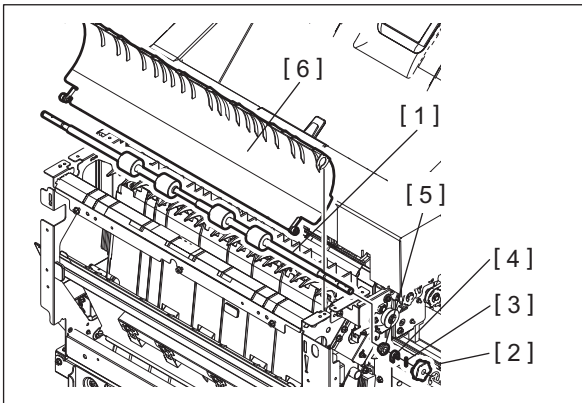

Fig. 4-125

[B] Junction roller (MJ-1112)

- (1) Take off the junction box unit.
 ☞ P. 4-15 "[A] Junction box unit"
- (2) Remove one E-ring, and then take off the gear [1] and pin [2].
- (3) Remove one clip [3], and then take off the bushing [4].

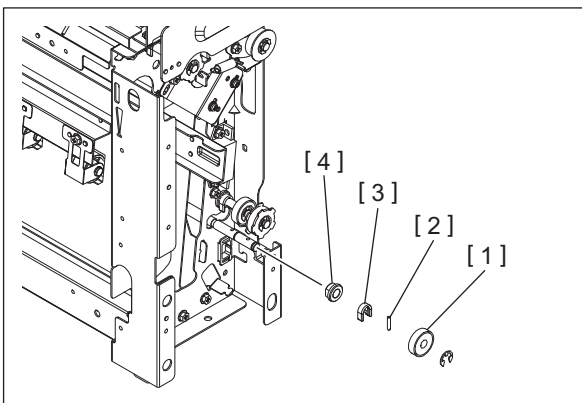

Fig. 4-126

- (4) Remove one clip [3], and then take off the bushing [2] and junction roller [1].

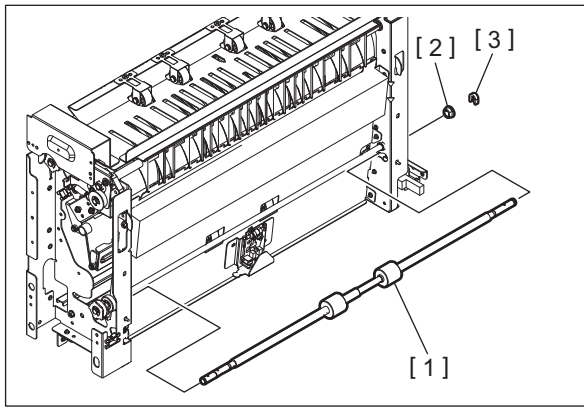

Fig. 4-127

[C] Paddle-1 / Paddle-2 / Paddle-3 / Catching pad / Paddle-4 / Paddle-5 / Paddle-6

- (1) Take off the buffer unit.
 ☞ P. 4-17 "[B] Buffer unit"
- (2) Rotate the paddle-1 [1], -2 [2], -3 [3], -4 [4], -5 [5] and -6 [6] so that they are positioned as shown in the figure.
- (3) Pull out the paddle-1 [1], -2 [2], -3 [3], -4 [4], -5 [5] and -6 [6] to take them off.

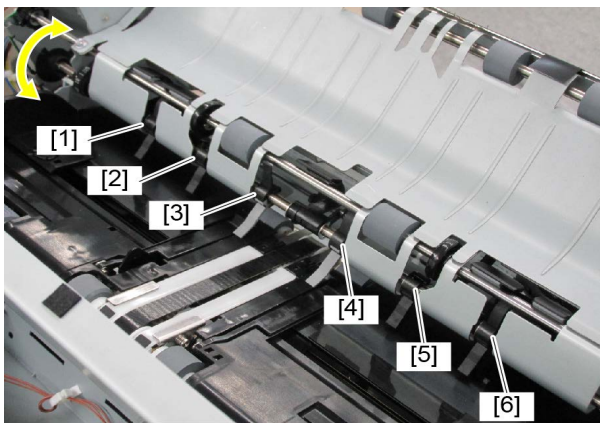

Fig. 4-128

Notes:

When installing them, be sure to place them in their original position and direction.

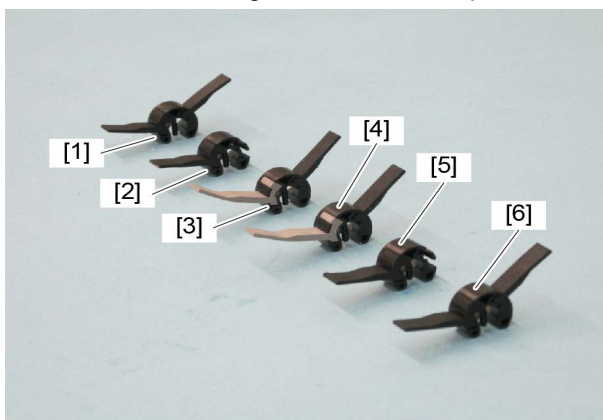

Fig. 4-129

[D] Transport roller

- (1) Take off the stationary tray.
📖 P. 4-1 "[A] Stationary tray"
- (2) Take off the control panel unit.
📖 P. 4-4 "[D] Control panel unit"
- (3) Take off the rear cover.
📖 P. 4-7 "[G] Rear cover"
- (4) Take off the right upper cover.
📖 P. 4-8 "[J] Right upper cover"
- (5) Take off the right cover.
📖 P. 4-9 "[K] Relay guide / Feeding discharge brush / Right cover"
- (6) Take off the Junction box unit.
📖 P. 4-15 "[A] Junction box unit"
- (7) Disconnect 5 connectors [4], [5], [6], [7] and [8] (CN8, CN9, CN10, CN11 and CN14) on the finisher control PC board [3].
- (8) Disconnect 1 connector [10] from the buffer tray guide motor [9].
- (9) Disconnect 1 connector [12] from the transport motor [11].
- (10) Disconnect 1 connector [14] from the movable tray shift motor sensor [13].
- (11) Release the harness from 6 harness clamps [15].
- (12) Release the harness from 1 binding wire [18].

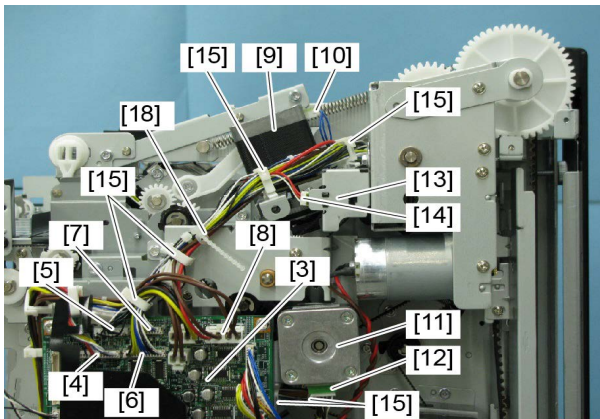

Fig. 4-130

- (13) Remove 5 screws and take off the motor bracket [19].

Notes:

Pay full attention not to lose the bushing [20] while taking off the motor bracket [19].

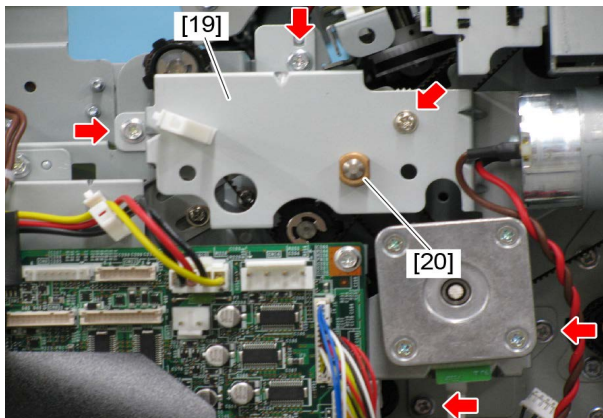

Fig. 4-131

- (14) Loosen 1 screw. Push the pulley [21] in the direction indicated by the arrow to loosen the belt tension and tighten the screw.
- (15) Remove the belts [22] and [23], the part assembled [24] and the bearing.

Notes:

Pay full attention not to lose the bearing while taking off the part assembled [24].

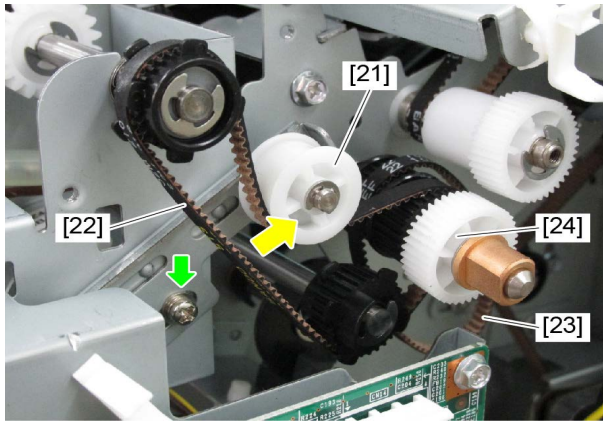

Fig. 4-132

(16) Close the buffer unit-1 [25] halfway and leave it. Then remove 1 screw.

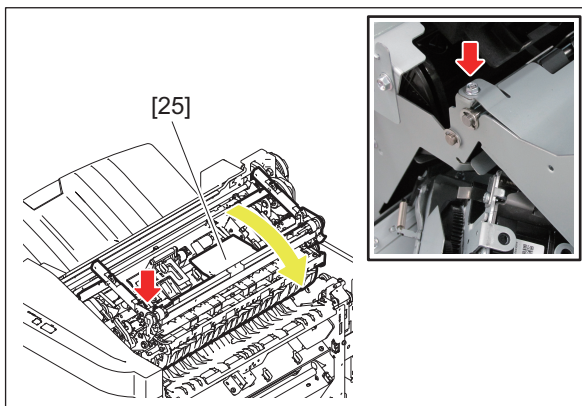

Fig. 4-133

(17) Remove 3 screws, and then take off the transport guide.

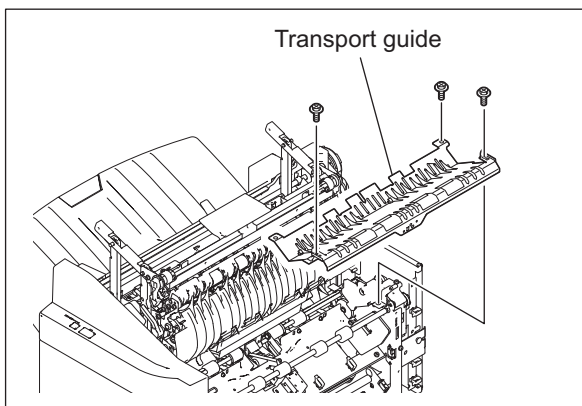

Fig. 4-134

(18) Move each of the buffer guides to each side.

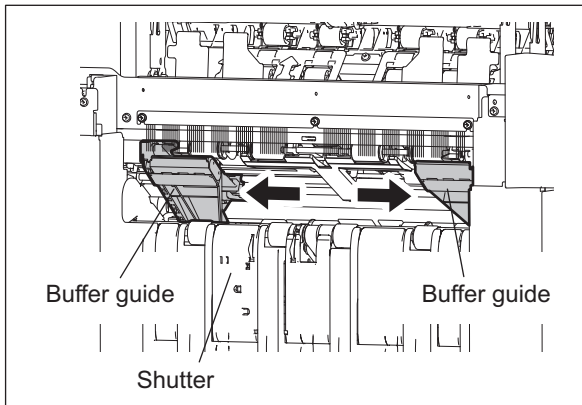

Fig. 4-135

(19) Turn the levers on the alignment plate to unlock. Move the front alignment plate [1] and the rear alignment plate [2] to the center, and then take them off by pulling them out upward.

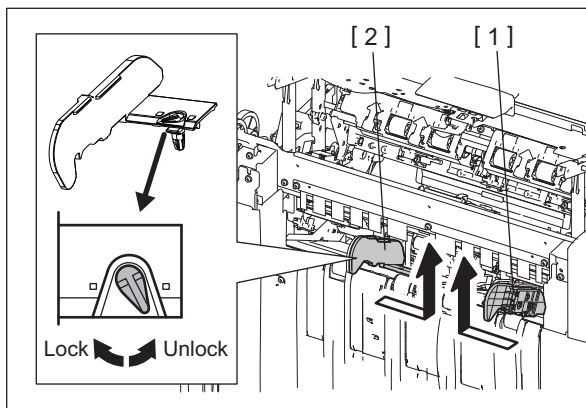

Fig. 4-136

(20) Remove 4 screws of the front pull-in guides [3] and rear pull-in guides [4].

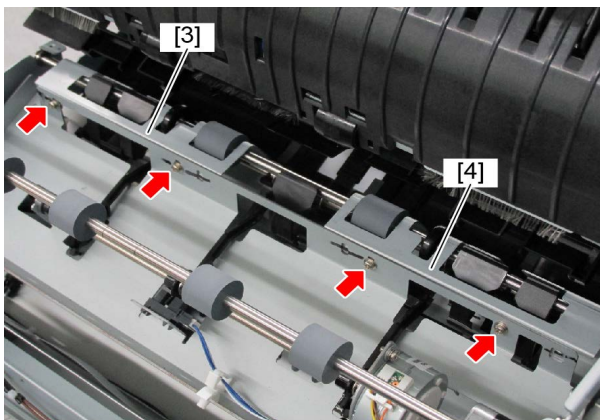

Fig. 4-137

Notes:

When replacing the front and rear pull-in guides, adjust the position with a jig. Install them based on adjustment area B of the jig so that the gap between the front and rear finishing tray covers is more than adjustment area A and less than C.
6LB10056000 JIG-GID-PDL-2

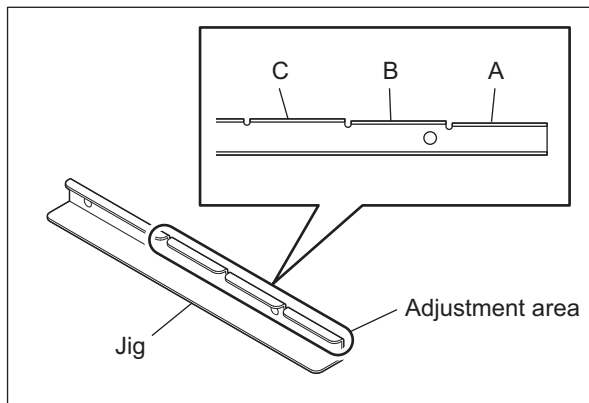

Fig. 4-138

1. Close the buffer unit 1.
2. Place the jig [2] on the rear finishing tray cover [1] and fix the one with the rear pull-in guide [3] by 2 screws at the position of adjustment area B. Measure the height at the 2 measuring points [4] where there are no protrusions of the rear pull-in guide as shown in the figure.

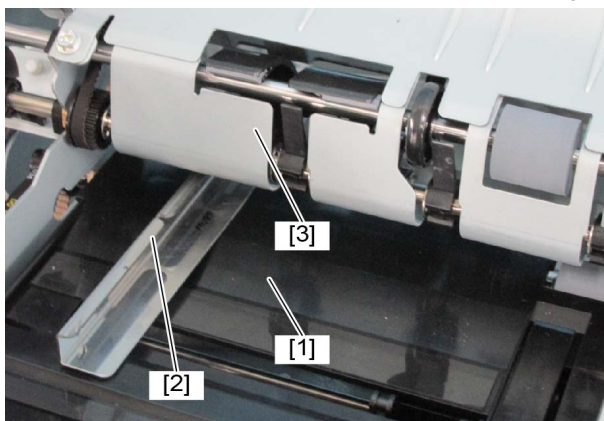

Fig. 4-139

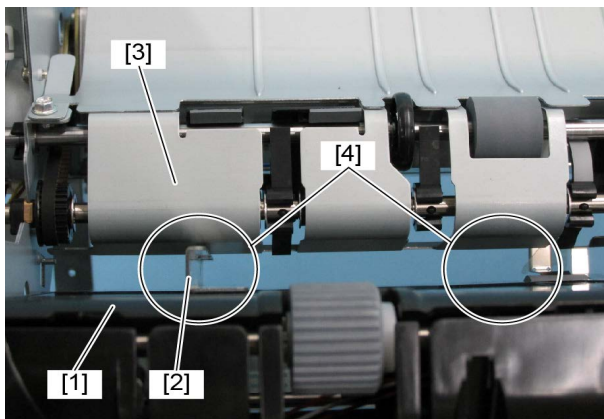

Fig. 4-140

3. After fixing the screws, check that the dimension of the gap is more than adjustment area A and less than C.
4. Adjust the front pull-in guide in the same manner.

(21) Remove 1 E-ring [5] at the front side of the transport roller and 1 bearing [6].

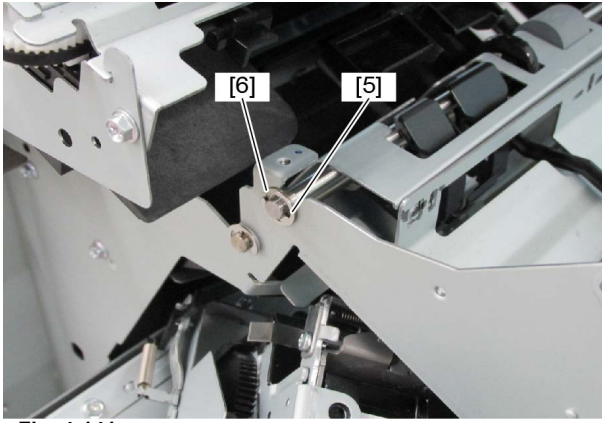

Fig. 4-141

(22) Remove 1 clip [7] at the rear side of the transport roller and slide the bearing [8].

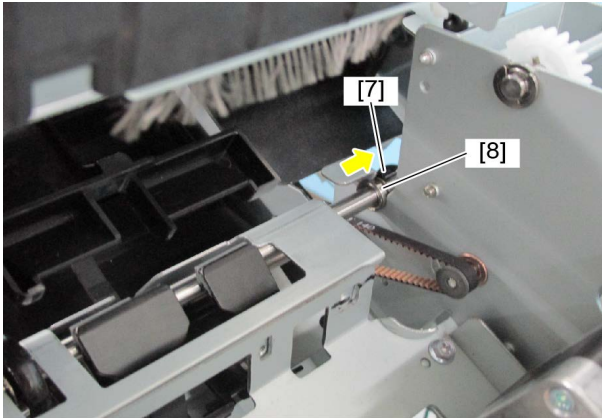

Fig. 4-142

(23) Take off the transport roller [9], front pull-in guide [10] and rear pull-in guide [11].

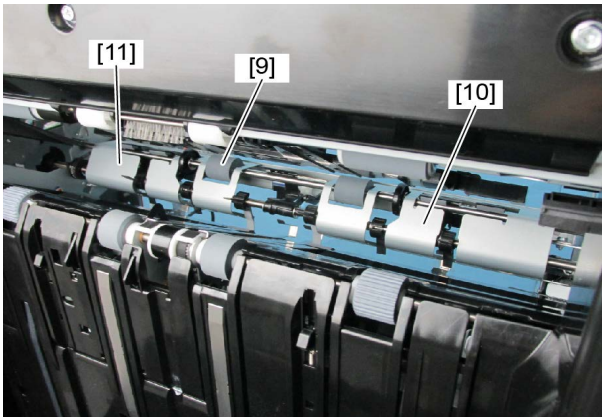

Fig. 4-143

[E] Entrance roller

- (1) Take off the stationary tray.
📖 P. 4-1 "[A] Stationary tray"
- (2) Take off the Junction box unit.
📖 P. 4-15 "[A] Junction box unit"
- (3) Close the buffer unit-1 [25] halfway and leave it. Then remove 1 screw.

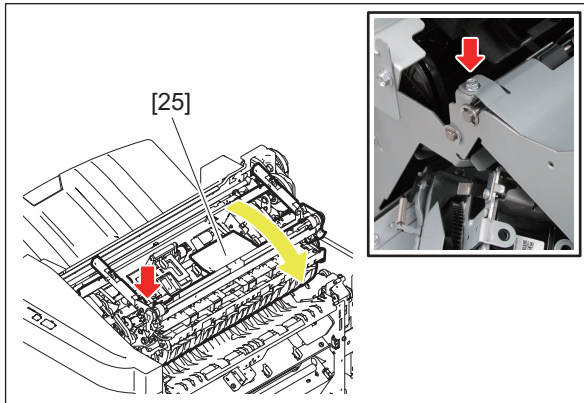

Fig. 4-144

- (4) Remove 3 screws, and then take off the transport guide.

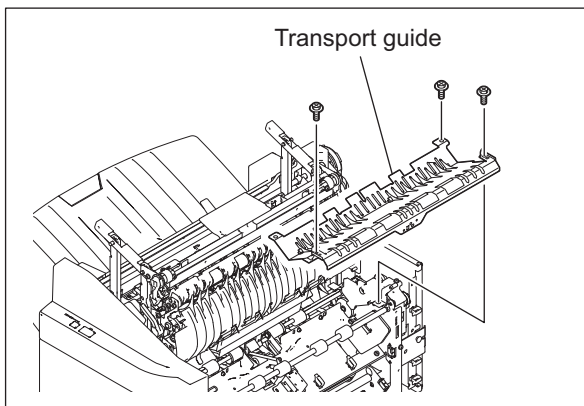

Fig. 4-145

- (5) Remove 1 E-ring [1] and 1 bushing [2].

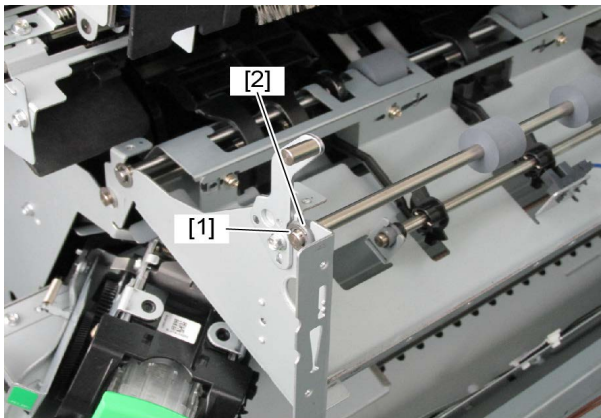

Fig. 4-146

- (6) Remove the belt [2].

- (7) Slide the entrance roller [3] to take it off.

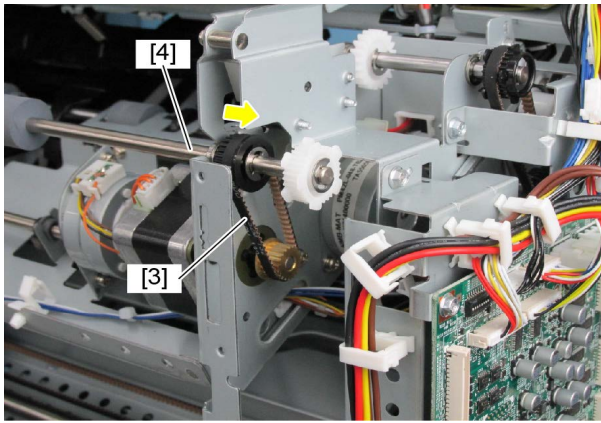

Fig. 4-147

- (8) Remove 1 E-ring. Then remove 2 pulleys [5], 1 bearing [6] and 2 pins [7] from the entrance roller.

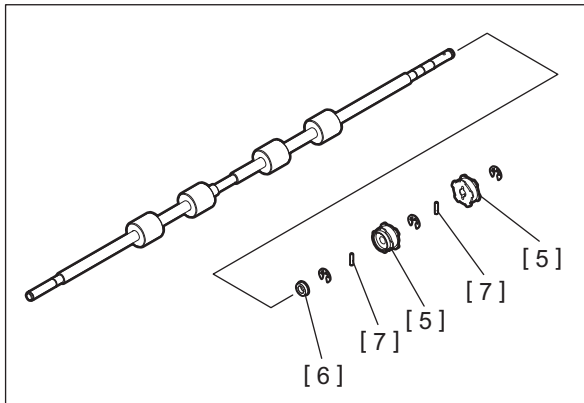

Fig. 4-148

[F] Stack transport roller-1

- (1) Take off the finishing tray unit.
📖 P. 4-24 "[D] Finishing tray unit"
- (2) Remove 3 screws, and then take off the front finishing tray cover [1].

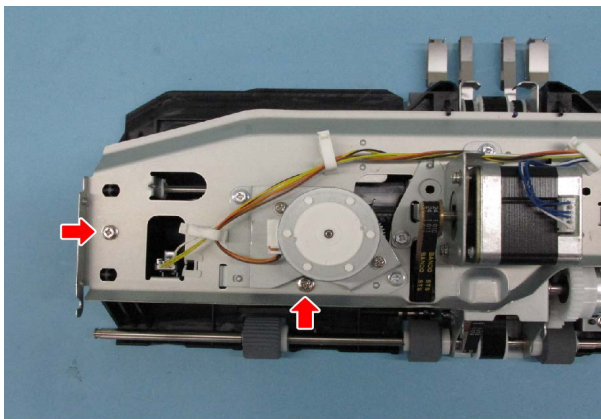

Fig. 4-149

- (3) Turn over the finishing tray unit. Slide the front finishing tray cover [1] to outside and lift it up. Release the link portion [2] inside the front finishing tray cover to take it off.

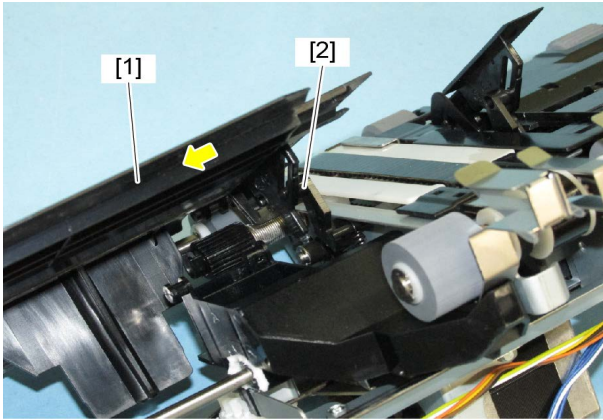

Fig. 4-150

- (4) Remove 2 screws.

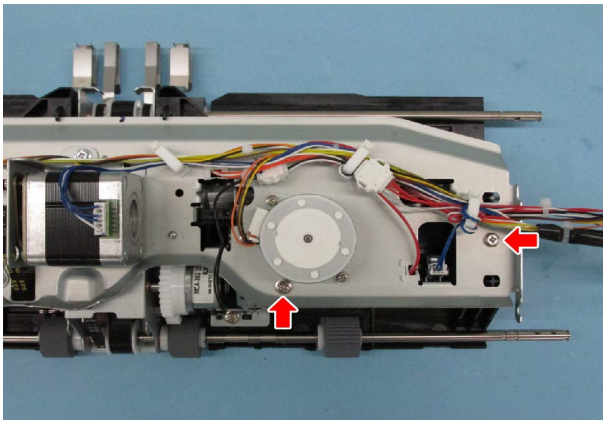

Fig. 4-151

- (5) Turn over the finishing tray unit. Slide the rear finishing tray cover [3] to outside and lift it up. Release the link portion [4] inside the rear finishing tray cover.

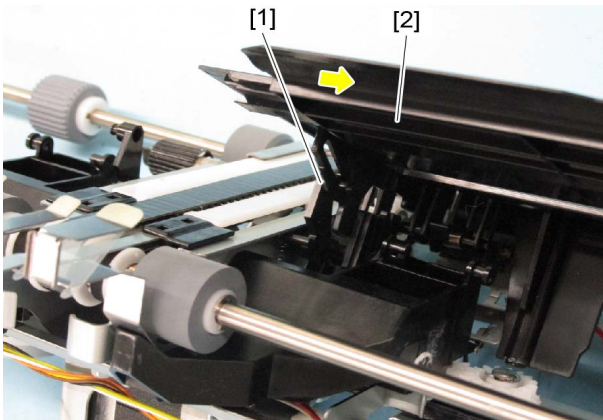

Fig. 4-152

- (6) Disconnect the connector from the finishing tray paper detection sensor [5] and take off the rear finishing tray cover [3].

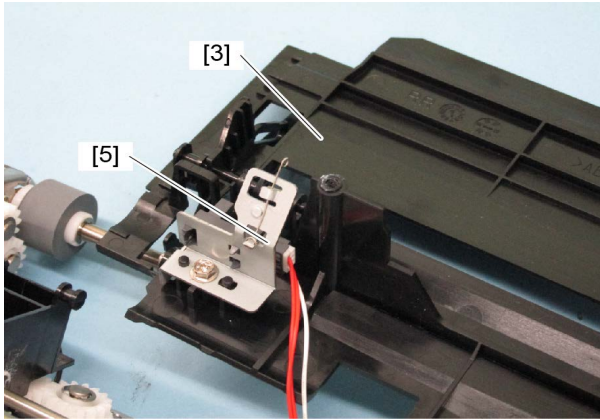

Fig. 4-153

- (7) Remove 2 E-rings, and then take off the pin and the stack transport roller-1 [7].

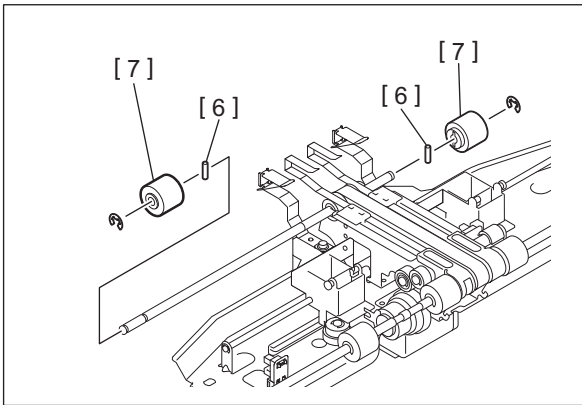

Fig. 4-154

[G] Stack transport roller-2

- (1) Take off the finishing tray unit.
📖 P. 4-24 "[D] Finishing tray unit"
- (2) Remove 2 screws.

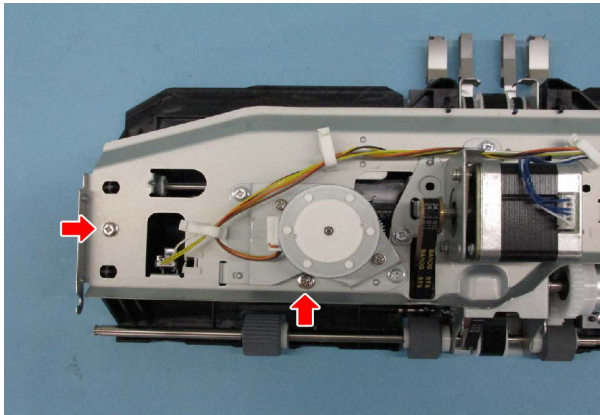

Fig. 4-155

- (3) Turn over the finishing tray unit. Slide the front finishing tray cover [1] to outside and lift it up. Release the link portion [2] inside the front finishing tray cover to take it off.

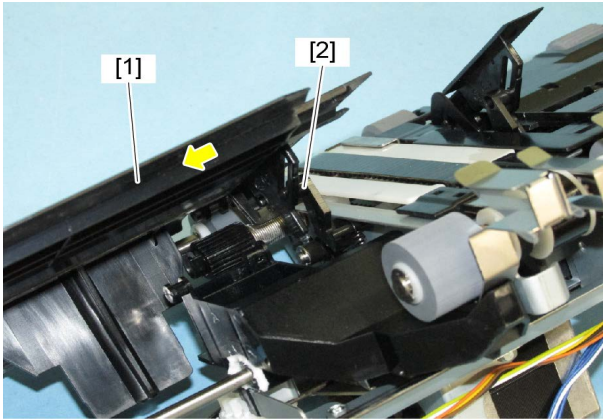

Fig. 4-156

- (4) Remove 2 screws.

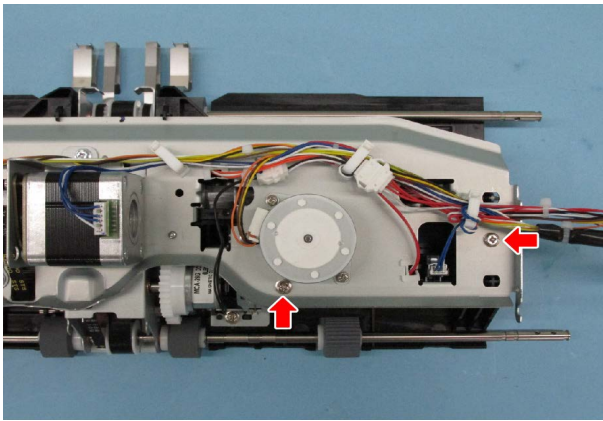

Fig. 4-157

- (5) Turn over the finishing tray unit. Slide the rear finishing tray cover [3] to outside and lift it up. Release the link portion [4] inside the rear finishing tray cover.

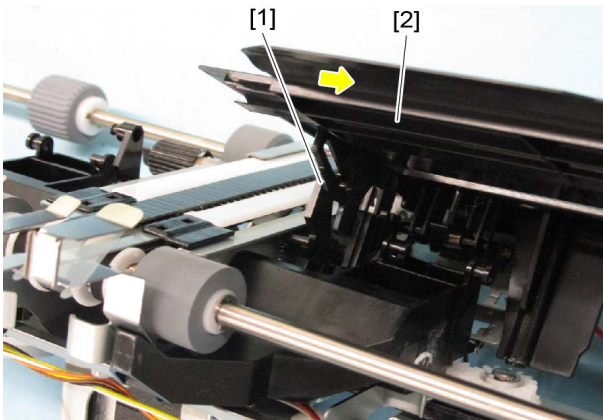

Fig. 4-158

- (6) Disconnect the connector from the finishing tray paper detection sensor [5] and take off the rear finishing tray cover [3].

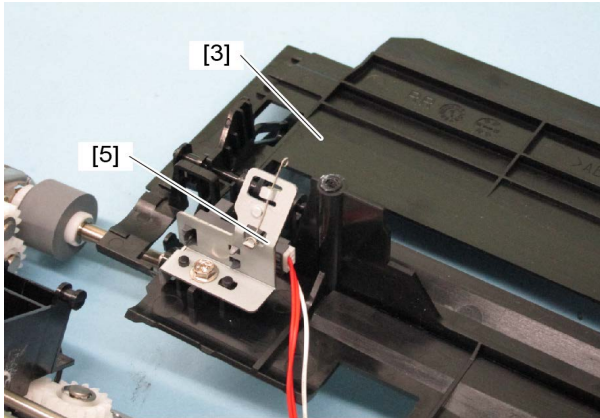

Fig. 4-159

- (7) Remove 4 E-rings and 4 pins [6], and then take off 4 stack transport rollers-2 [8].

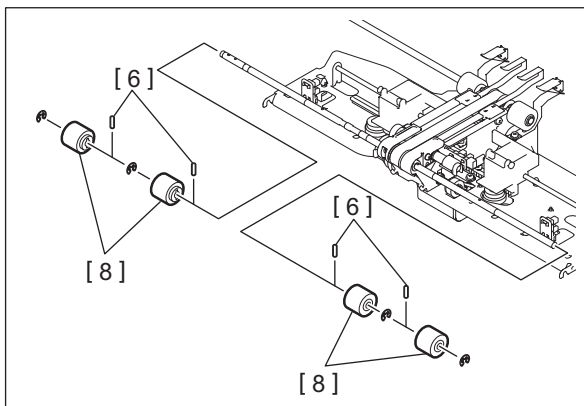

Fig. 4-160

[H] Buffer roller

- (1) Take off the buffer unit.
 ☞ P. 4-17 "[B] Buffer unit"
- (2) Disconnect 1 connector from the sensor [1]. Release the harness [2] from 1 harness clamp [3].
- (3) Release the 1 harness clamp [5] of harness [4] from the frame.
- (4) Pull out the harnesses [2] and [4] through the window [6] of the frame.

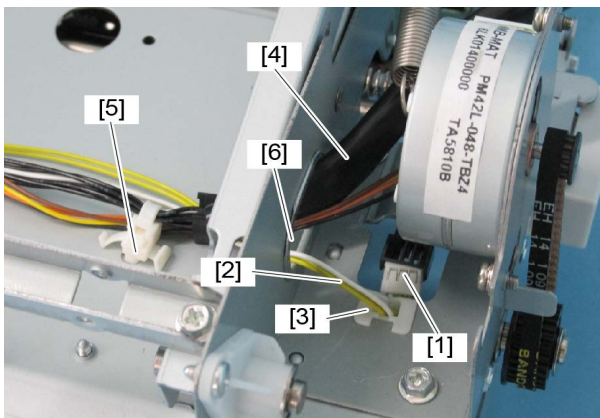

Fig. 4-161

- (5) Disconnect 1 relay connector [7] and release the harness [8] from 7 harness clamps [9].

- (6) Pull out the harness [8] through the window [6] of the frame.

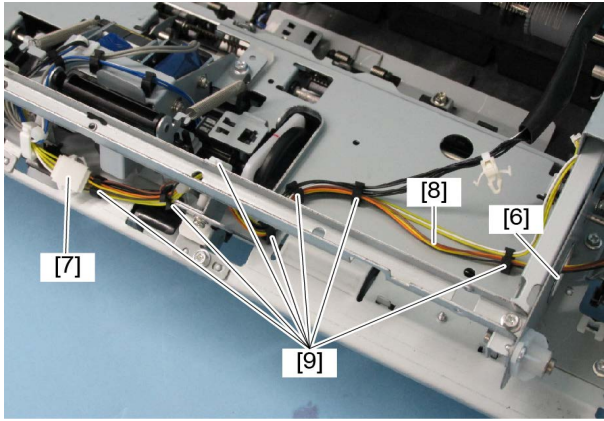

Fig. 4-162

- (7) Pull out the harness [10] through the window [11] of the frame.
- (8) Release the harness [10] from 1 harness clamp [12].

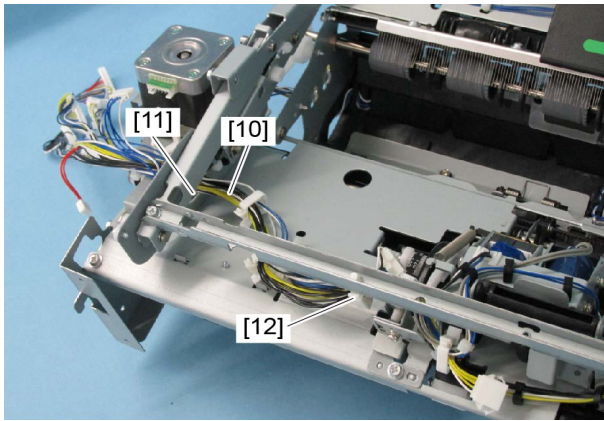

Fig. 4-163

- (9) Remove the belt [13].
- (10) Release the latch, and then take off the pulley cover [15].

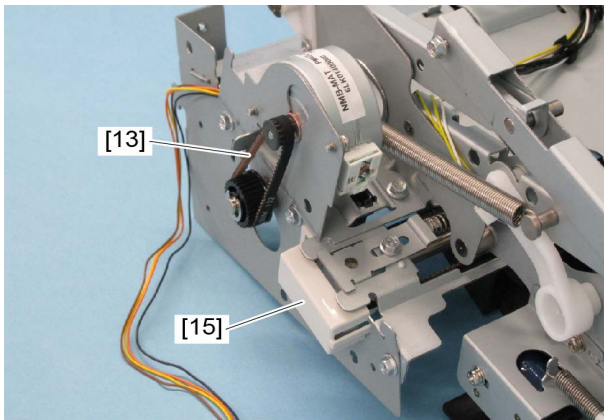

Fig. 4-164

- (11) Loosen 1 screw. Push the metal plate [14] in the direction indicated by the arrow to loosen the belt tension and tighten the screw.

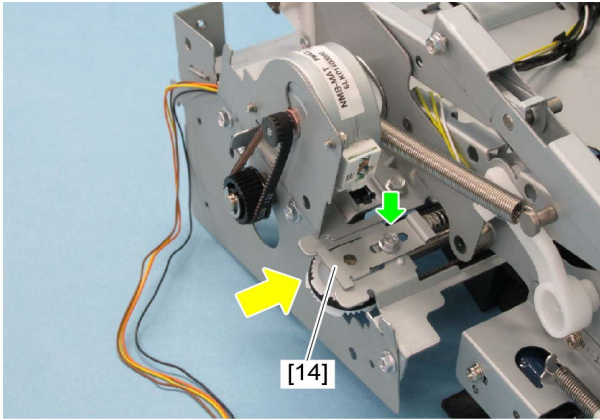

Fig. 4-165

- (12) Remove 5 screws and lift the buffer unit-1 [34] upward to take it off.

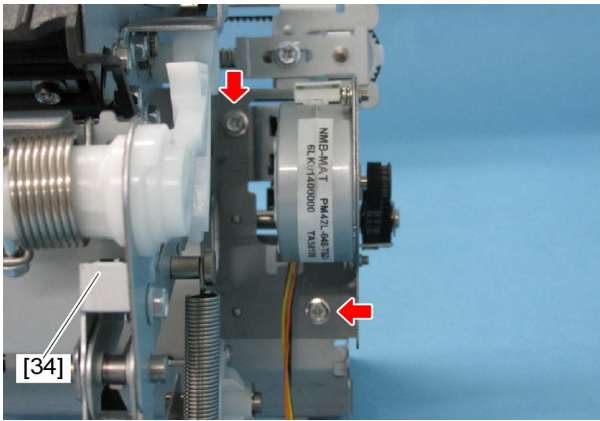

Fig. 4-166

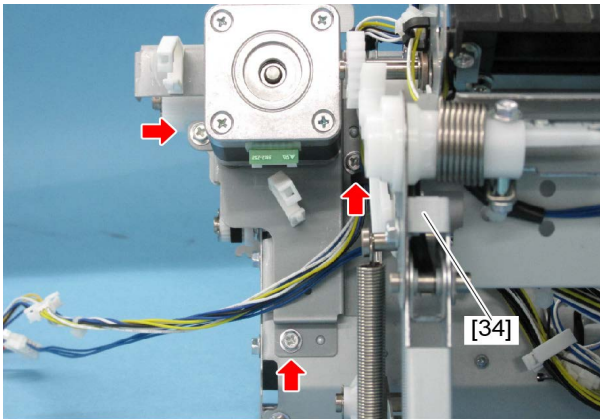

Fig. 4-167

(13) Remove the spring [35].

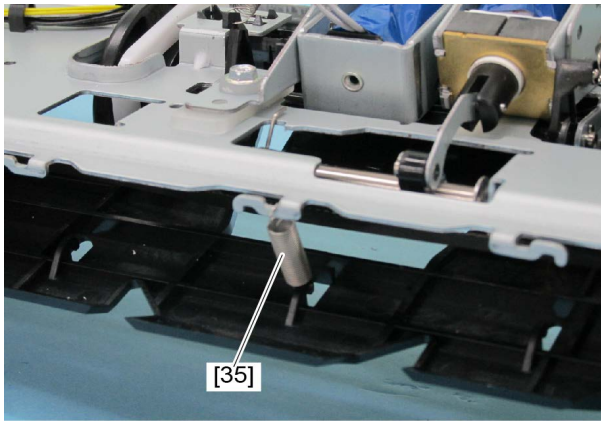

Fig. 4-168

(14) Remove 2 screws and take off 2 assist guide cam guides [36].

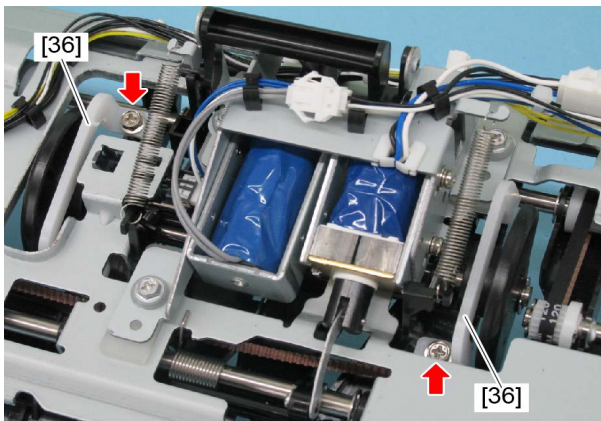

Fig. 4-169

(15) Remove 2 screws, take off 2 assist guide adjustment plates [37] and the assist guide [38].

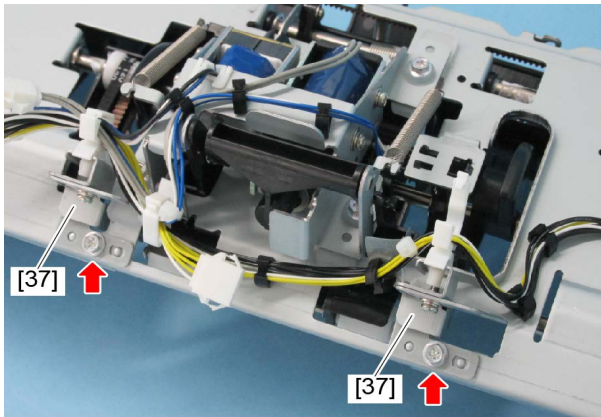

Fig. 4-170

Notes:

When installing, fix the assist guide [38] so that the height between its upper surface and that for the buffer tray is within 18 to 20 mm.
Measure the height at each 1 portion (2 portions in total) at both edges of the assist guide.

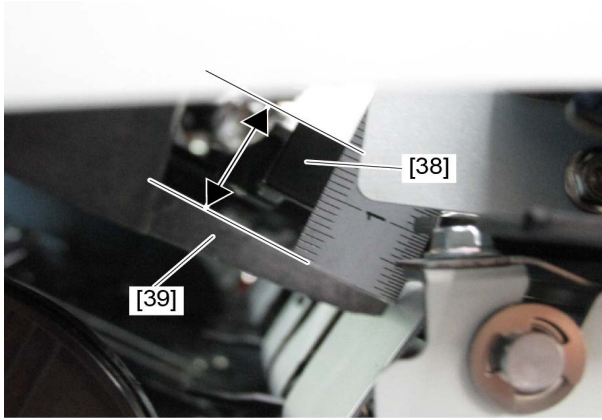

Fig. 4-171

1. Move the buffer tray to the position of the rotation roller.
2. Turn the cam of the assist guide so that it comes to the position where it is fixed.
3. By using a scale, measure the height between the upper surface of the assist guide and that for the buffer tray. If adjustment is necessary, loosen the screw of the assist guide adjustment plate and move the assist guide up and down so that the height will become within the specified value.

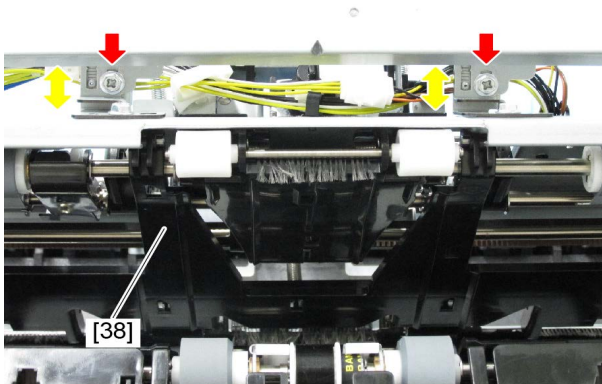

Fig. 4-172

- (16) Remove 1 screw. Take off the metal plate [43] and remove the spring [45].

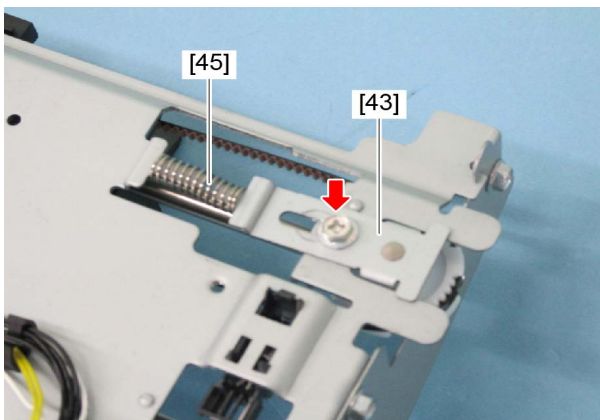

Fig. 4-173

- (17) Remove 2 screws.

- (18) Remove 3 E-rings [46]. Slide the shaft [47] and take off the buffer guides at the left and right [48], 2 metal plates [49] and pinch roller arm [50].

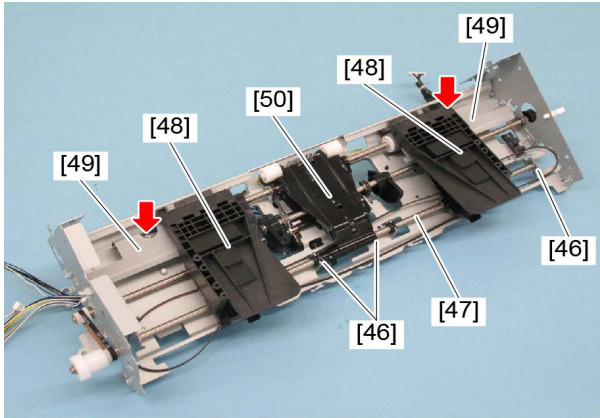

Fig. 4-174

Notes:

When installing, hook the spring [51] of the pinch roller arm [50] to the frame as shown in the figure.

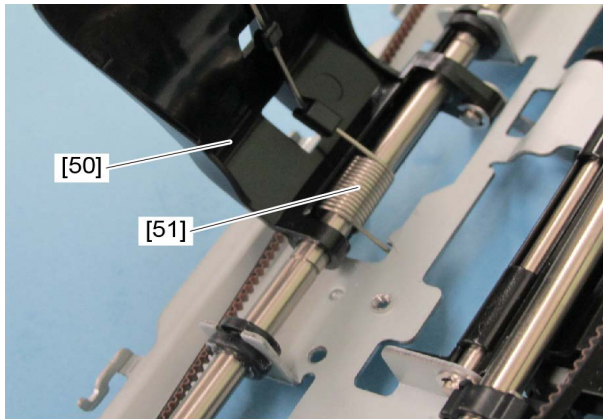

Fig. 4-175

- (19) Remove 2 E-rings [52] and 2 pins. Take off 2 buffer rollers [53].

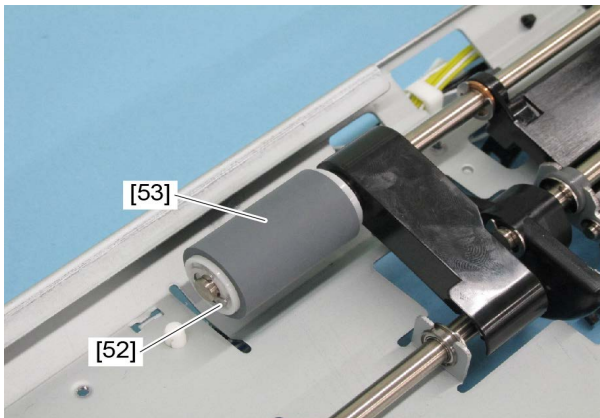

Fig. 4-176

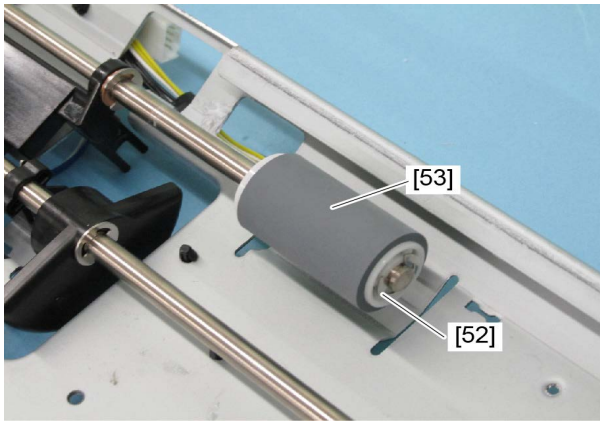

Fig. 4-177

[I] Upper exit roller / Upper exit roller guide

- (1) Take off the stationary tray.
 P. 4-1 "[A] Stationary tray"
- (2) Take off the control panel unit.
 P. 4-4 "[D] Control panel unit"
- (3) Take off the rear cover.
 P. 4-7 "[G] Rear cover"
- (4) Take off the right cover.
 P. 4-9 "[K] Relay guide / Feeding discharge brush / Right cover"
- (5) Remove 2 screws, and then take off the front and rear stays and 2 spacers.

Notes:

Be careful not to damage the harness connected to the stationary tray transport guides.

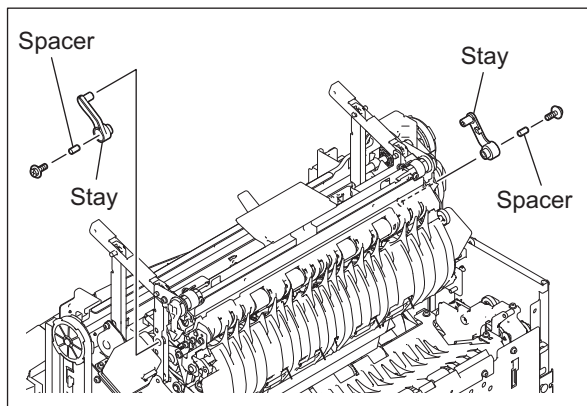

Fig. 4-178

- (6) Loosen 2 screws each for the front and rear stationary tray discharge brush.

- (7) Remove 4 screws and take off the front and rear stationary tray transport guides.

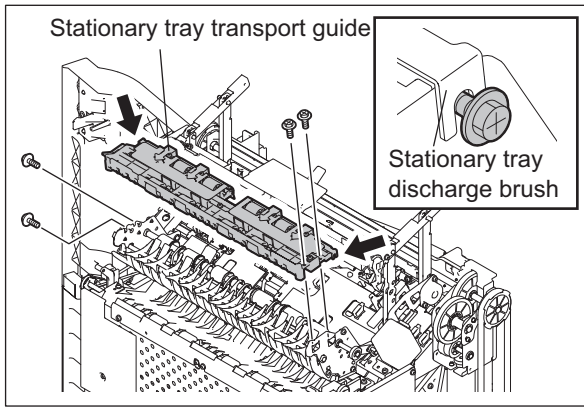

Fig. 4-179

Notes:

- Be careful not to damage the harness of entrance sensor.
- When installing the front and rear stationary tray transport guides, fix them at the positions where the gap between the trailing edges of the guides and the frame is 1 mm. Check if the flap and the upper exit roller move smoothly after screws are tightened.

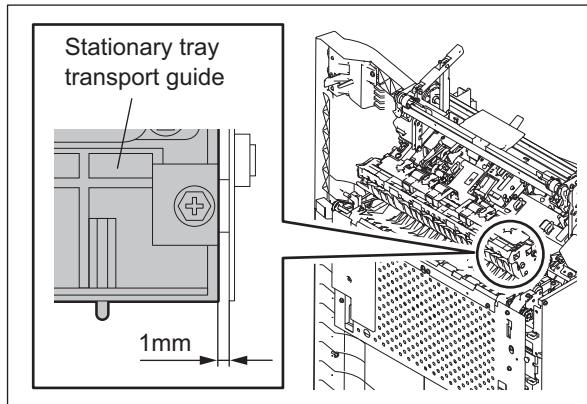

Fig. 4-180

- (8) Remove 4 screws of the upper exit roller guide.

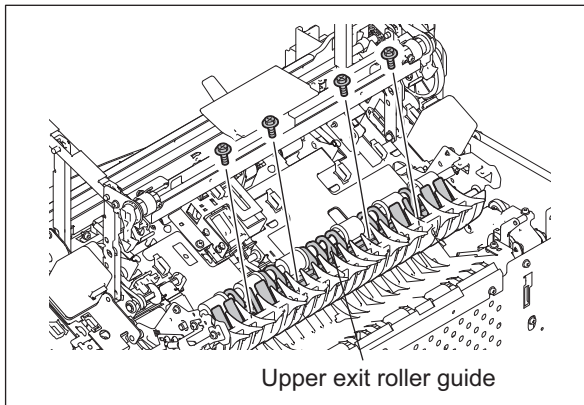

Fig. 4-181

- (9) Remove 3 E-rings [1], 1 gear [2], 1 pin [3] and 2 bushings [4].

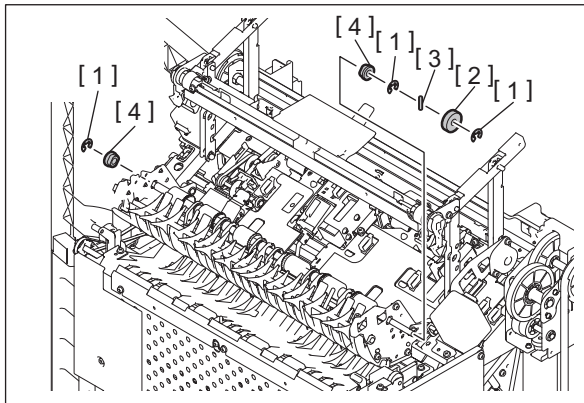

Fig. 4-182

- (10) Take off the upper exit roller and the upper exit roller guide.

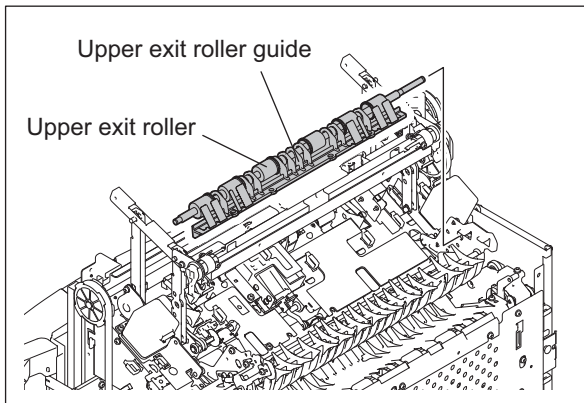



Fig. 4-183

4.5 Rollers (Saddle stitch section: MJ-1112)

[A] Switchback transport roller

- (1) Take off the switchback unit.
 P. 4-34 "[B] Switchback unit"
- (2) Take off the saddle transport motor.
 P. 4-93 "[C] Saddle transport motor (M16)"
- (3) Open the jam transport guide [1].
- (4) Remove 3 screws and take off the feed knob assembly [2], bushing [3] and belt [4].

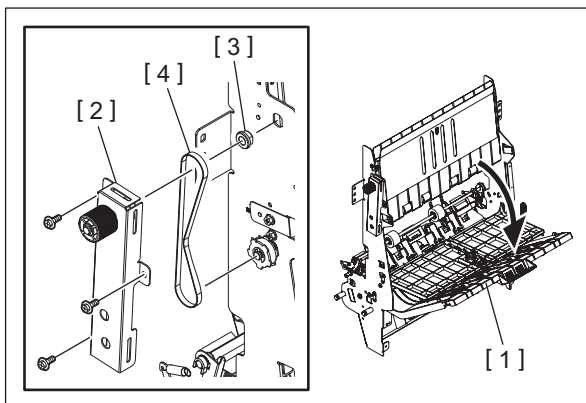

Fig. 4-184

- (5) Remove 4 E-rings and take off the 1 pulley [1], 1 gear [2], 2 pins [3] and 2 bushings [4].

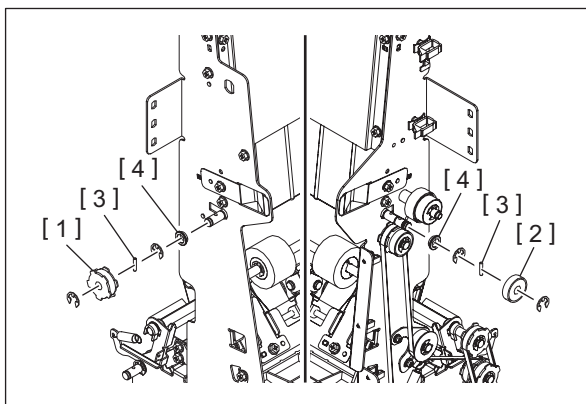

Fig. 4-185

- (6) Remove 4 screws and take off the transport guide [1] and switchback transport roller [2].

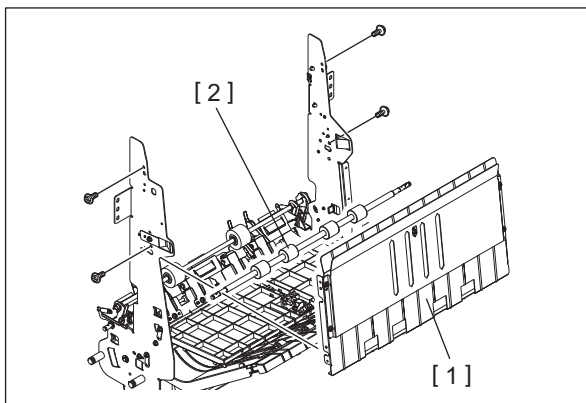

Fig. 4-186

[B] Assisting roller

- (1) Take off the switchback unit.
☞ P. 4-34 "[B] Switchback unit"
- (2) Remove 1 E-ring and take off the pulley [1], 2 pins [2] and belt [3].

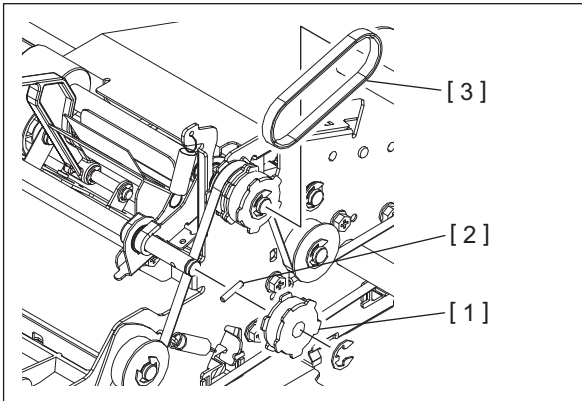

Fig. 4-187

- (3) Remove 4 clips [1] and take off the 2 bushings [2] and assisting roller [3].

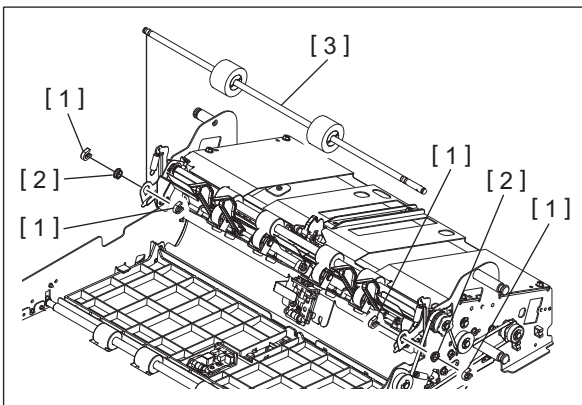

Fig. 4-188

[C] Ejecting roller

- (1) Take off the assisting roller.
☞ P. 4-70 "[B] Assisting roller"
- (2) Remove the spring [1], and then loosen 2 screws to free the belt tension.

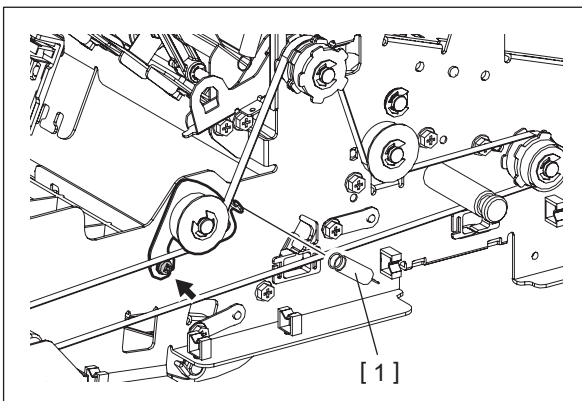

Fig. 4-189

- (3) Remove the 2 springs [1].

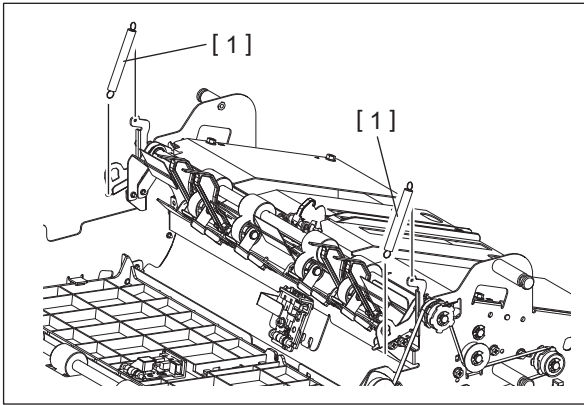

Fig. 4-190

- (4) Remove 4 E-rings and take off the 2 pulleys, [1] 2 pins [2], 2 bushings [3] and ejecting roller [4].

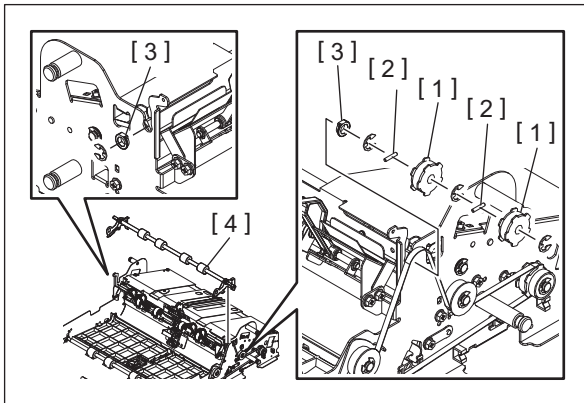

Fig. 4-191

- (5) Take off the 2 bushings [3], right arms [2], and left arms [2] from the ejecting roller [1].

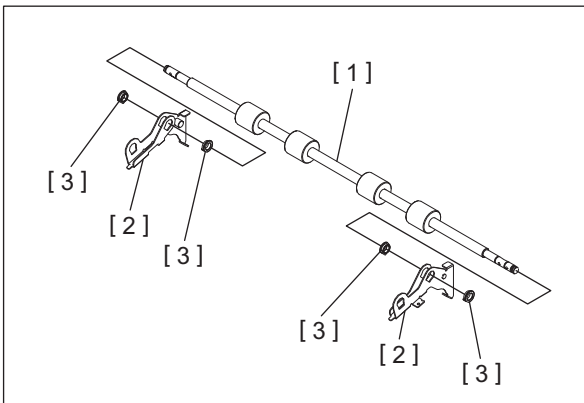

Fig. 4-192

[D] Upper folding roller / Lower folding roller

- (1) Take off the saddle stapler unit.
📖 P. 4-37 "[E] Saddle stapler unit"
- (2) Take off the saddle stacker unit.
📖 P. 4-43 "[H] Stacker unit"
- (3) Remove 1 clip [1] and take off the gear [2] and pin [3].

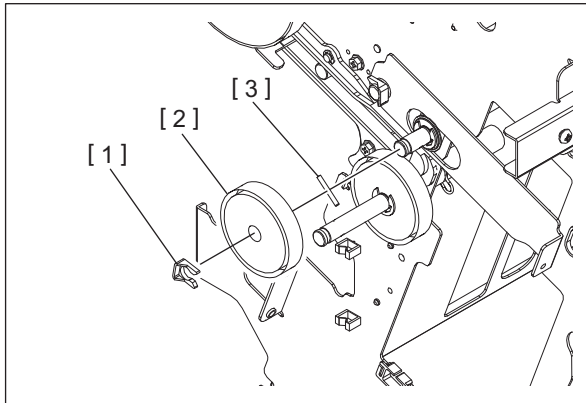

Fig. 4-193

- (4) Remove the 1 spring [1].

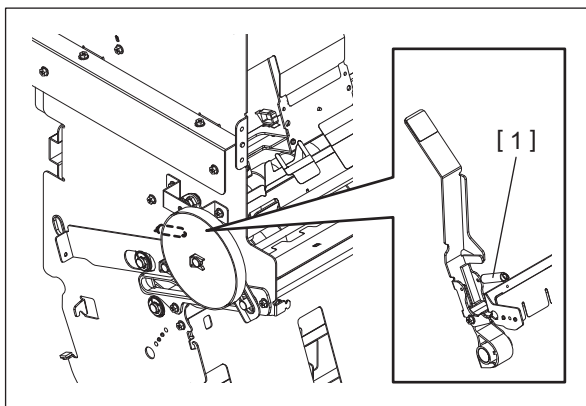

Fig. 4-194

- (5) Remove 2 E-rings and take off the 2 bearing [1].

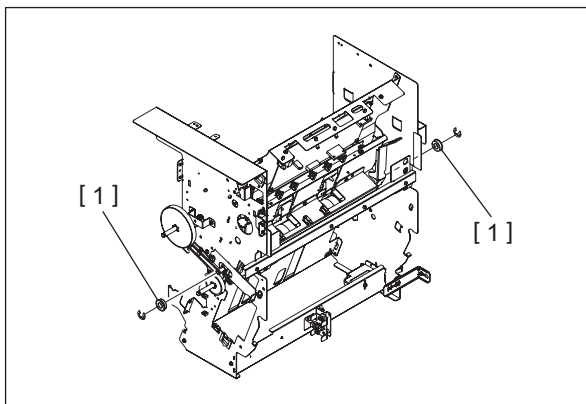

Fig. 4-195

- (6) Take off the upper folding roller [2] while pulling the jam access lever [1].

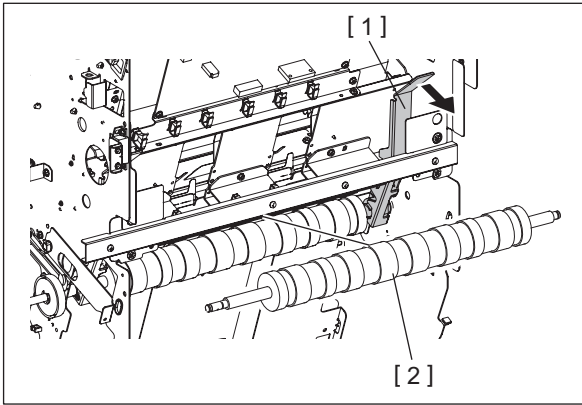

Fig. 4-196

- (7) Remove 1 E-rings and take off the gear [1] and pin [2].

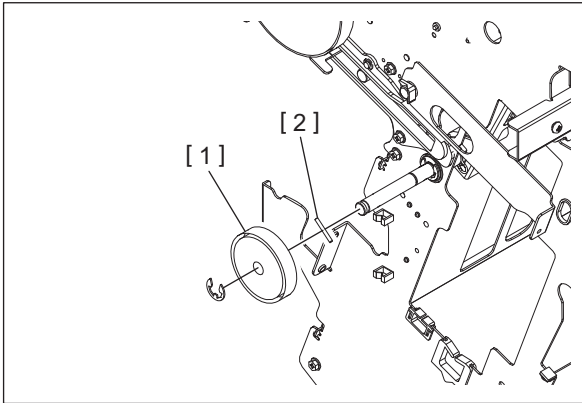

Fig. 4-197

- (8) Remove 2 E-rings and take off the 2 bearing [1].
(9) Remove 1 clip [2] of the rear jam release lever.

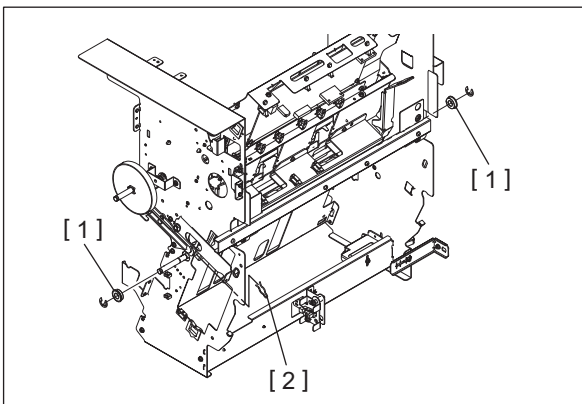

Fig. 4-198

- (10) Take off the 2 Jam release levers [2], 2 springs [3] and lower folding roller [1].

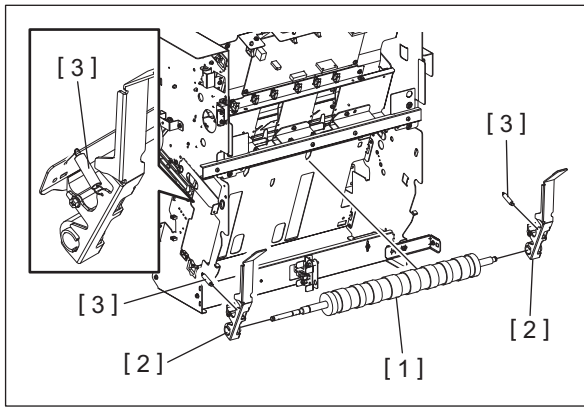

Fig. 4-199

[E] Exit roller

- (1) Open the front upper cover and then pull out the saddle stitch unit.
- (2) Remove 2 screws and take off the lower transport guide [1].

Notes:

Be careful not to damage the harness connected to the lower transport guide [1].

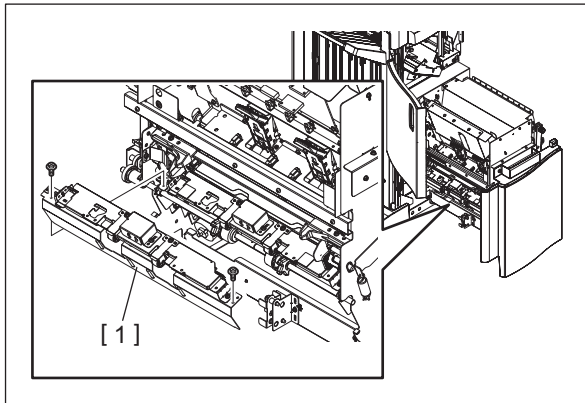

Fig. 4-200

- (3) Remove 1 clip [1] and take off the bushing [2] and exit roller [3].

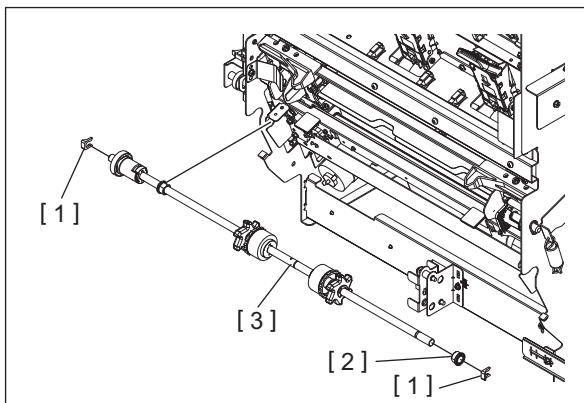

Fig. 4-201

4.6 Motor (Finisher section)

[A] Entrance motor (M1)

- (1) Take off the stationary tray.
☞ P. 4-1 "[A] Stationary tray"
- (2) Take off the control panel unit.
☞ P. 4-4 "[D] Control panel unit"
- (3) Take off the rear cover.
☞ P. 4-7 "[G] Rear cover"
- (4) Take off the right upper cover.
☞ P. 4-8 "[J] Right upper cover"
- (5) Take off the right cover.
☞ P. 4-9 "[K] Relay guide / Feeding discharge brush / Right cover"
- (6) Take off the junction box unit.
☞ P. 4-15 "[A] Junction box unit"
- (7) Close the buffer unit-1 [25] halfway and remove 1 screw.

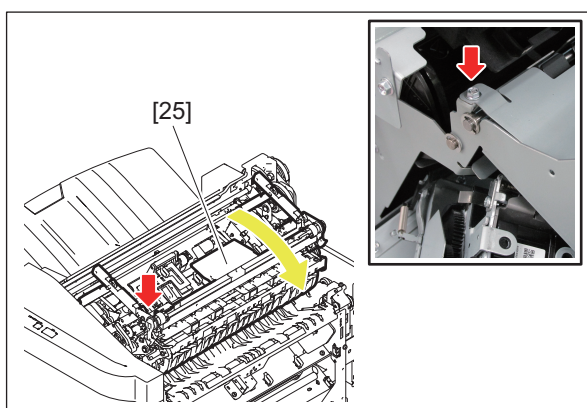

Fig. 4-202

- (8) Remove 3 screws, and then take off the transport guide.

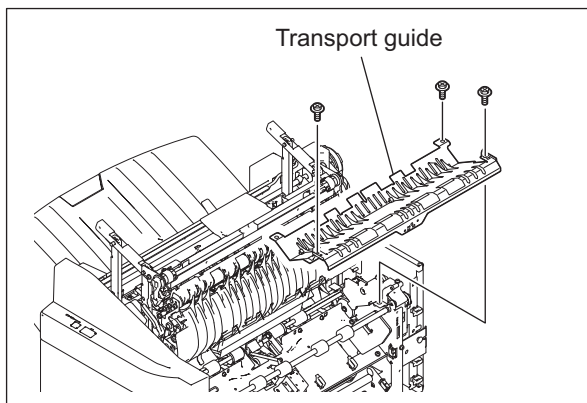

Fig. 4-203

- (9) Remove 1 screw and take off the grounding wire [1].

- (10) Release the PC board cover [2] from 2 harness clamps [3].

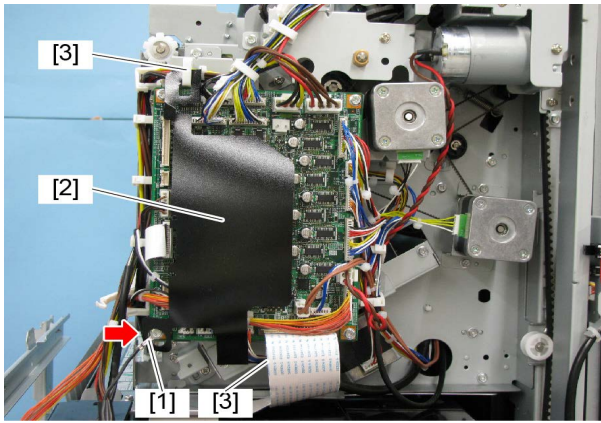

Fig. 4-204

- (11) Disconnect all the connectors on the finisher control PC board and release the harness from the harness clamp.
(12) Remove 3 screws and take off the bracket [4] of the finisher control PC board.

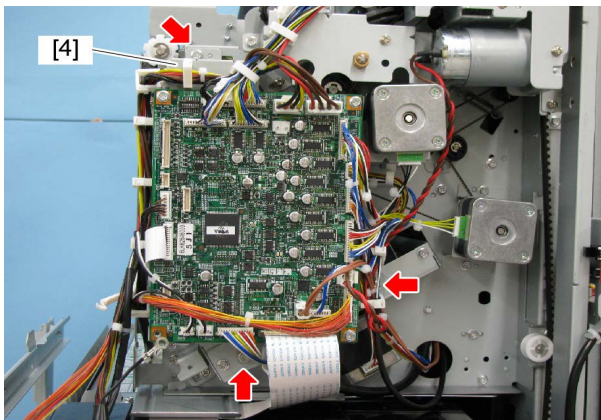

Fig. 4-205

- (13) Remove the belt [6] from the pulley of entrance motor.
(14) Remove 2 screws. Then disconnect the connector [7] to take off the entrance motor [5].

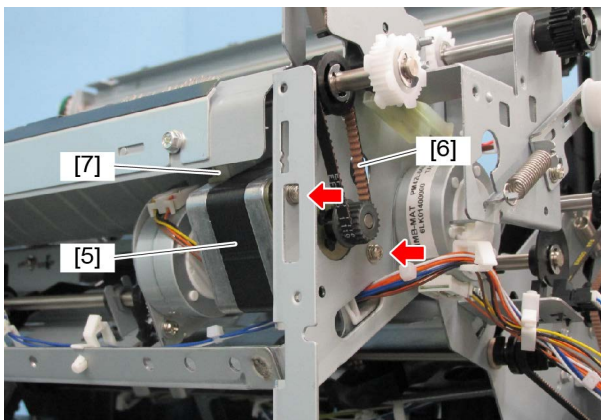



Fig. 4-206

[B] Buffer tray guide motor (M2)

- (1) Take off the buffer unit-1.
 P. 4-20 "[C] Buffer unit-1"
- (2) Remove 2 screws, and then take off the buffer tray guide motor [1].

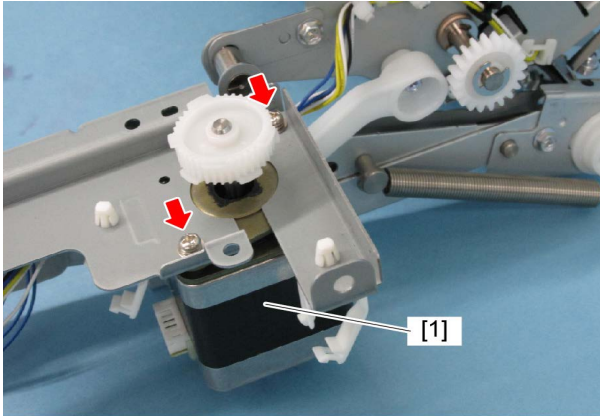







Fig. 4-207

[C] Paddle motor (M3)

- (1) Take off the stationary tray.
 P. 4-1 "[A] Stationary tray"
- (2) Take off the control panel unit.
 P. 4-4 "[D] Control panel unit"
- (3) Take off the rear cover.
 P. 4-7 "[G] Rear cover"
- (4) Take off the right upper cover.
 P. 4-8 "[J] Right upper cover"
- (5) Take off the right cover.
 P. 4-9 "[K] Relay guide / Feeding discharge brush / Right cover"
- (6) Take off the junction box unit.
 P. 4-15 "[A] Junction box unit"
- (7) Close the buffer unit-1 [25] halfway and remove 1 screw.

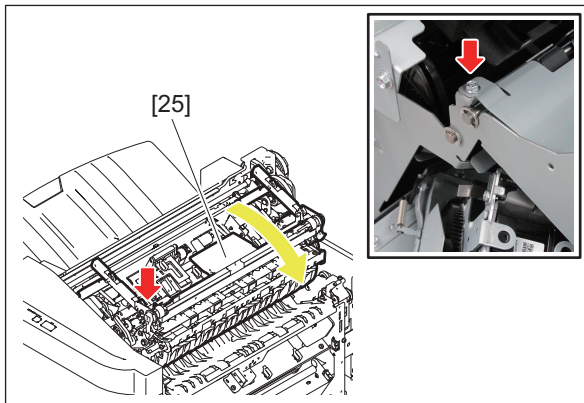

Fig. 4-208

- (8) Remove 3 screws, and then take off the transport guide.

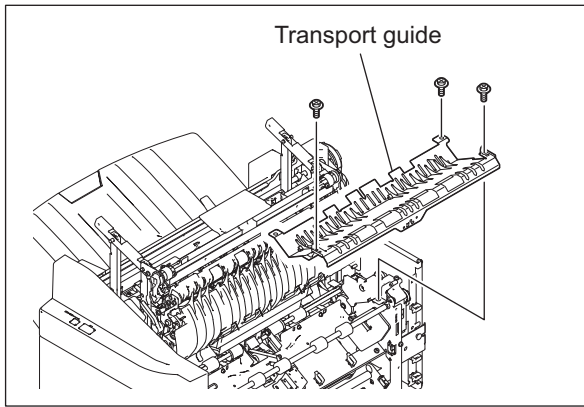

Fig. 4-209

- (9) Remove 1 screw and take off the grounding wire [1].
(10) Release the PC board cover [2] from 2 harness clamps [3].

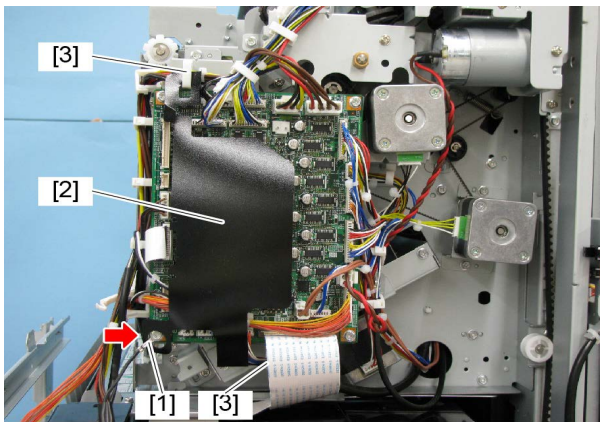

Fig. 4-210

- (11) Disconnect all the connectors on the finisher control PC board and release the harness from the harness clamp.
(12) Remove 3 screws and take off the bracket [4] of the finisher control PC board.

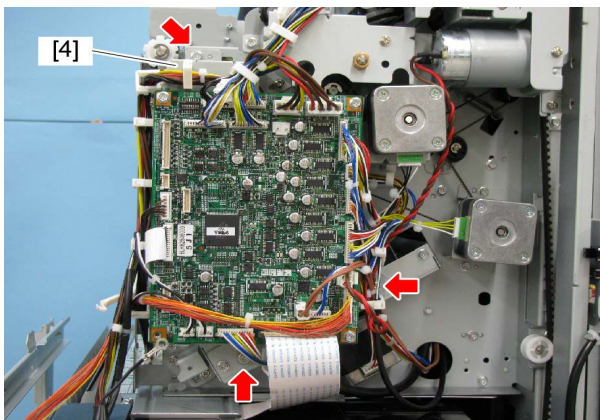

Fig. 4-211

(13) Release the harness of the paddle motor from 2 harness clamps [5].

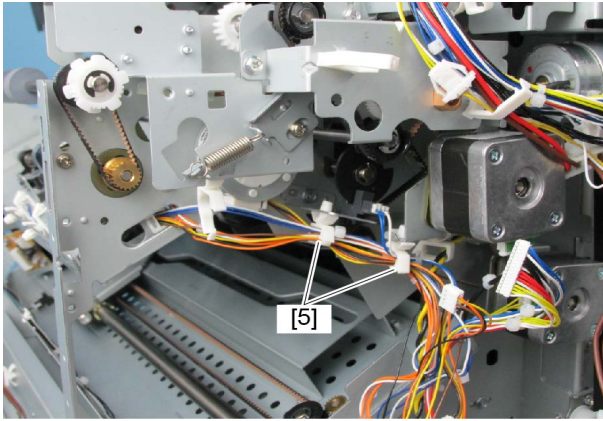

Fig. 4-212

(14) Remove 2 screws and take off the paddle motor [6].

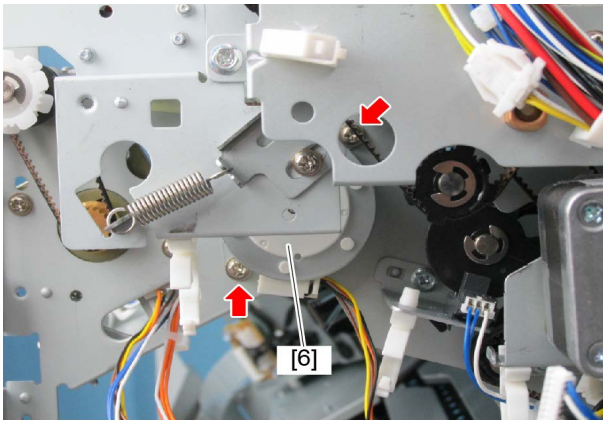

Fig. 4-213

[D] Front alignment motor (M5)

- (1) Take off the grate-shaped guide.
 ☞ P. 4-11 "[N] Grate-shaped guide"
- (2) Release the harness out of the clamp [1], and then disconnect the relay connector [2].
- (3) Remove 2 screws, and then take off the front alignment motor [3].

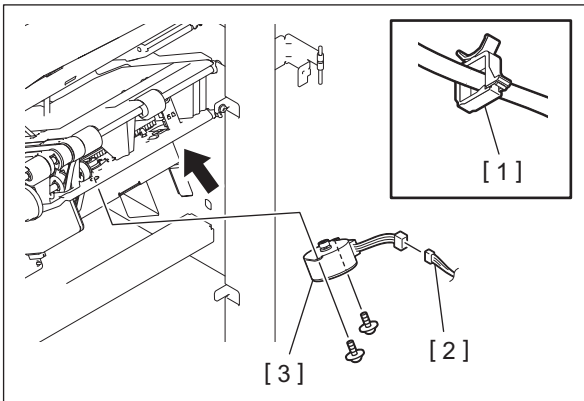

Fig. 4-214

[E] Rear alignment motor (M6)

- (1) Take off the grate-shaped guide.
📖 P. 4-11 "[N] Grate-shaped guide"
- (2) Remove 2 screws, and then disconnect the relay connector [1] to take off the rear alignment motor [2].

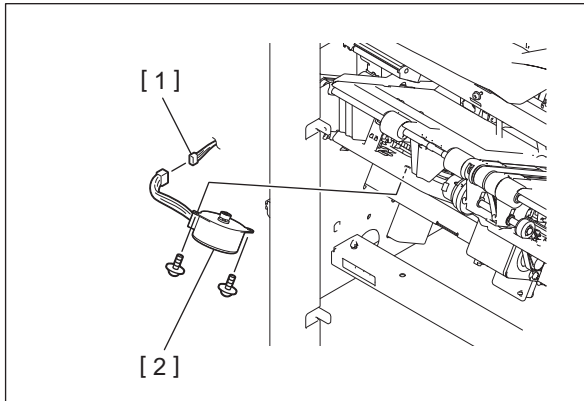

Fig. 4-215

[F] Transport motor (M7)

- (1) Take off the rear cover.
📖 P. 4-7 "[G] Rear cover"
- (2) Loosen 2 screws. Push the pulley [1] in the direction indicated by the arrow to loosen the belt tension and tighten the screws.

Notes:

When installing, be sure to apply tension to the belt.

- (3) Remove 2 screws, and then disconnect the connector and remove the belt to take off the transport motor [2].

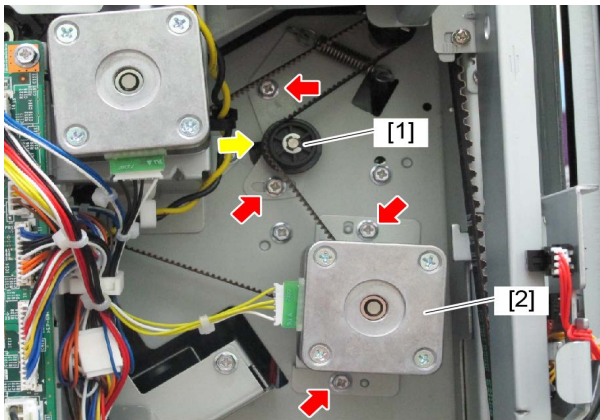

Fig. 4-216

- (4) Remove 2 screws and take off the transport motor [2] from the bracket [3].

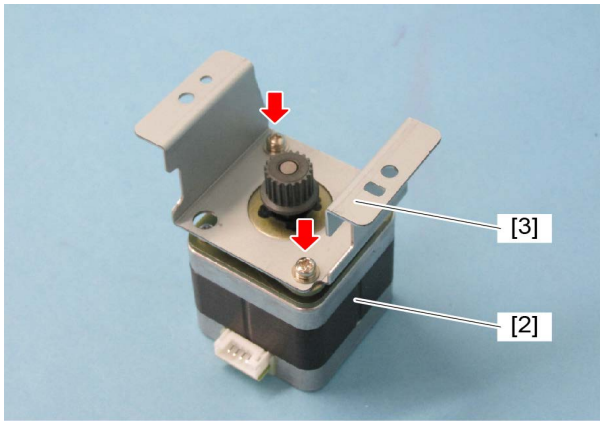

Fig. 4-217

[G] Stack transport motor (M8)

- (1) Take off the grate-shaped guide.
P. 4-11 "[N] Grate-shaped guide"
- (2) Disconnect the connector and remove the belt [1]. Then remove 2 screws to take off the stack transport motor [2].

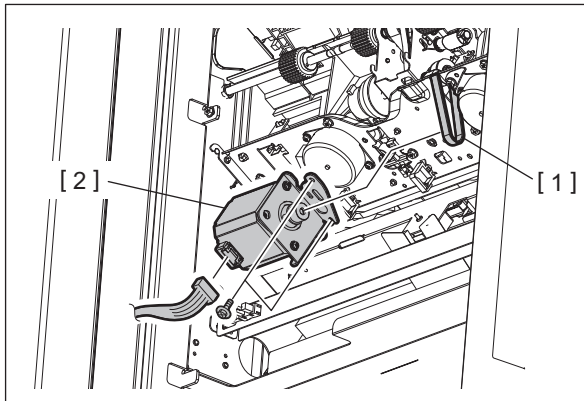

Fig. 4-218

[H] Stapler unit shift motor (M9)

- (1) Take off the stationary tray.
📖 P. 4-1 "[A] Stationary tray"
- (2) Take off the control panel unit.
📖 P. 4-4 "[D] Control panel unit"
- (3) Take off the rear cover.
📖 P. 4-7 "[G] Rear cover"
- (4) Take off the right upper cover.
📖 P. 4-8 "[J] Right upper cover"
- (5) Take off the right cover.
📖 P. 4-9 "[K] Relay guide / Feeding discharge brush / Right cover"
- (6) Take off the junction box unit.
📖 P. 4-15 "[A] Junction box unit"
- (7) Close the buffer unit-1 [25] halfway and remove 1 screw.

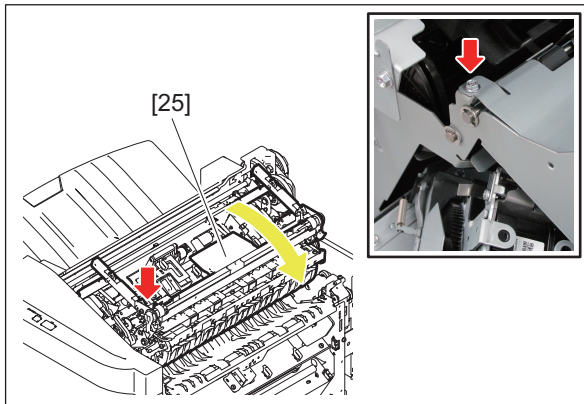

Fig. 4-219

- (8) Remove 3 screws, and then take off the transport guide.

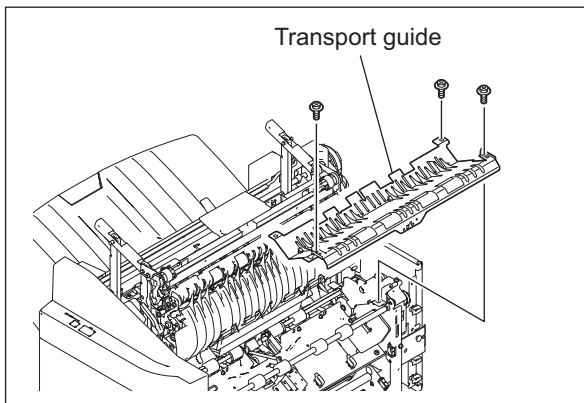

Fig. 4-220

- (9) Remove 1 screw and take off the grounding wire [1].
- (10) Release the PC board cover [2] from 2 harness clamps [3].

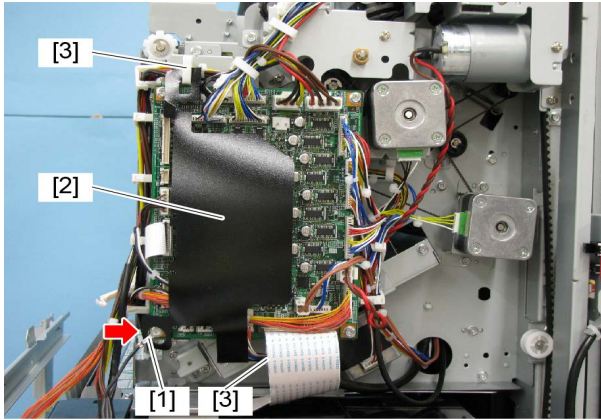

Fig. 4-221

- (11) Disconnect all the connectors on the finisher control PC board and release the harness from the harness clamp.
- (12) Remove 3 screws and take off the bracket [4] of the finisher control PC board.

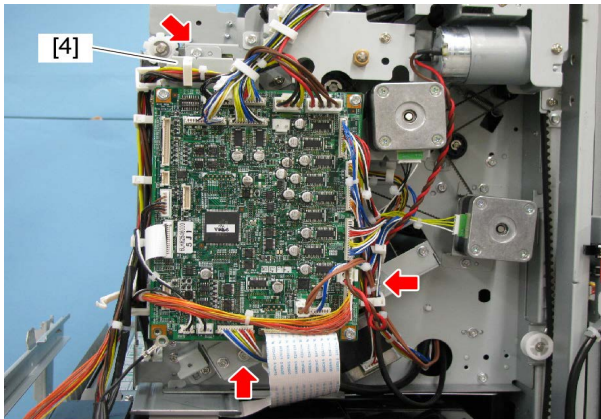

Fig. 4-222

- (13) Remove 2 screws, and then disconnect the connector [5] to take off the stapler unit shift motor [6].

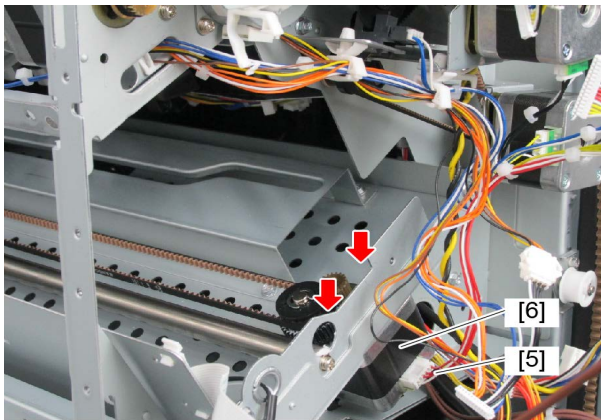

Fig. 4-223

[I] Assist guide motor(M10)

- (1) Take off the stationary tray.
📖 P. 4-1 "[A] Stationary tray"
- (2) Take off the control panel unit.
📖 P. 4-4 "[D] Control panel unit"
- (3) Close the buffer unit-1.
- (4) Disconnect 1 relay connector [1] and release the harness [2] from 7 harness clamps [3].
- (5) Pull out the harness [2] through the window of the frame.

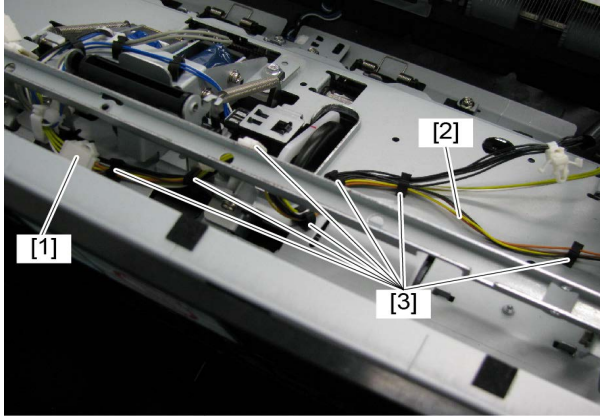

Fig. 4-224

- (6) Remove 2 screws, and then take off the assist guide motor [5] and belt [6].

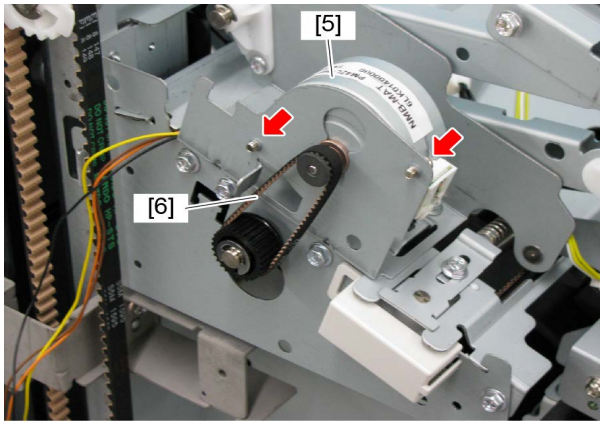

Fig. 4-225

[J] Exit motor (M11)

- (1) Take off the control panel unit.
📖 P. 4-4 "[D] Control panel unit"
- (2) Take off the rear cover.
📖 P. 4-7 "[G] Rear cover"
- (3) Take off the right upper cover.
📖 P. 4-8 "[J] Right upper cover"
- (4) Take off the right cover.
📖 P. 4-9 "[K] Relay guide / Feeding discharge brush / Right cover"
- (5) Take off the junction box unit.
📖 P. 4-15 "[A] Junction box unit"
- (6) Disconnect 5 connectors [4], [5], [6], [7] and [8] (CN8, CN9, CN10, CN11 and CN14) on the finisher control PC board [3].
- (7) Disconnect 1 connector [10] from the buffer tray guide motor [9].
- (8) Disconnect 1 connector [12] from the transport motor [11].
- (9) Disconnect 1 connector [14] from the movable tray shift motor sensor [13].
- (10) Release the harness from 6 harness clamps [15].

(11) Release the harness from 1 binding wire [18].

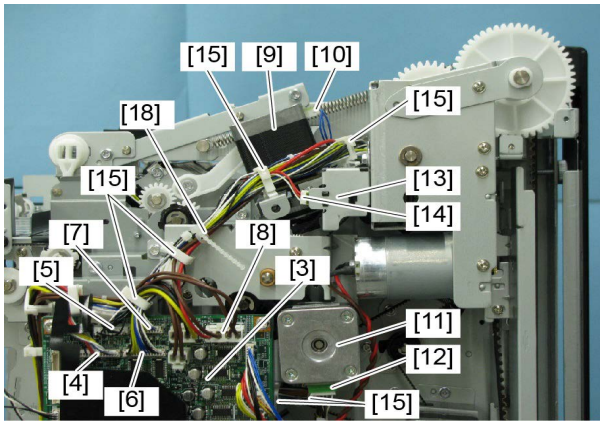

Fig. 4-226

(12) Remove 5 screws and take off the motor bracket [19].

Notes:

Pay full attention not to lose the bushing [20] while taking off the motor bracket [19].

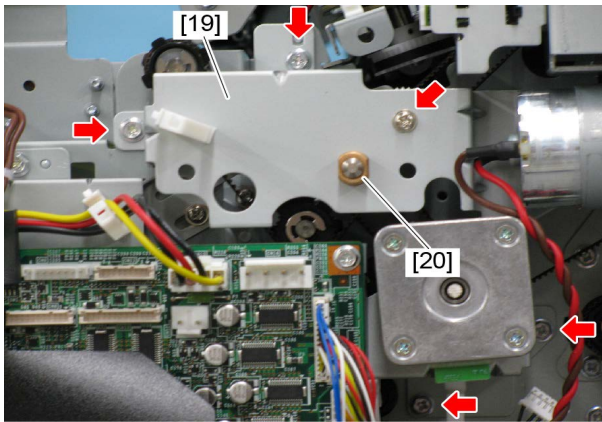

Fig. 4-227

(13) Loosen 1 screw. Push the pulley [21] in the direction indicated by the arrow to loosen the belt tension and tighten the screw.

(14) Remove the belts [22] and [23], the part assembled [24] and the bearing.

Notes:

Pay full attention not to lose the bearing while taking off the part assembled [24].

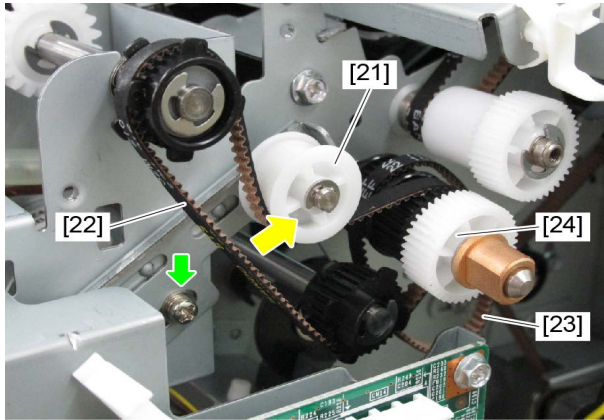

Fig. 4-228

(15) Remove 2 screws, and then take off the exit motor [25].

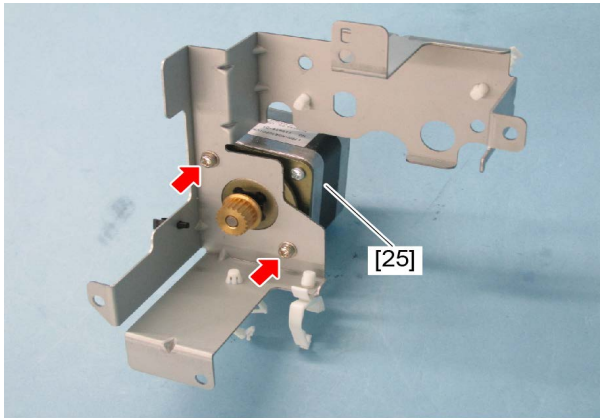



Fig. 4-229

[K] Movable tray shift motor

(1) Take off the rear cover.

 P. 4-7 "[G] Rear cover"

(2) Move the movable tray [1] shift frame to the middle position. If the movable tray [1] shift frame needs to be lowered, push the gear [2] of the movable tray shift motor unit in the direction of the arrow to unlock the frame. (Be sure to hold the movable tray gear frame with your hands because it may fall when the gear is pushed.)

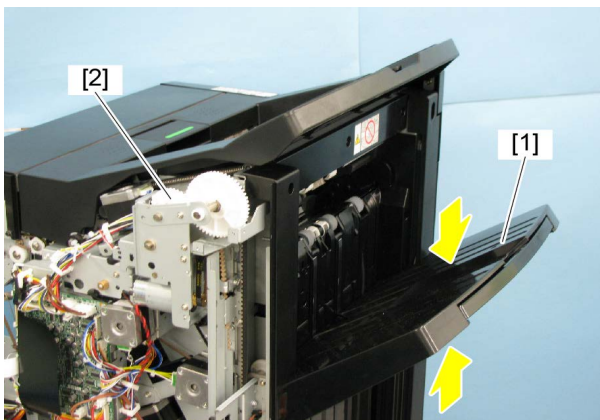

Fig. 4-230

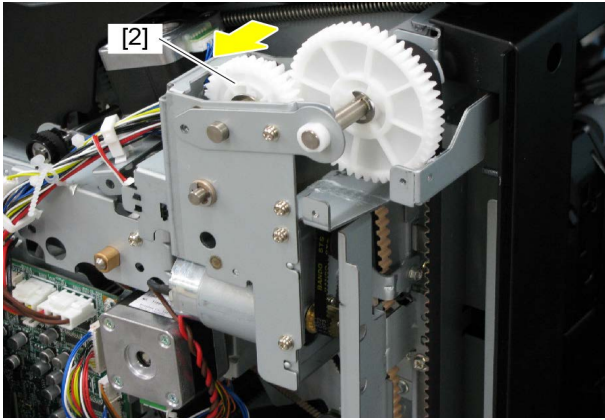

Fig. 4-231

- (3) Remove 2 screws, and then take off the sensor rail [3].

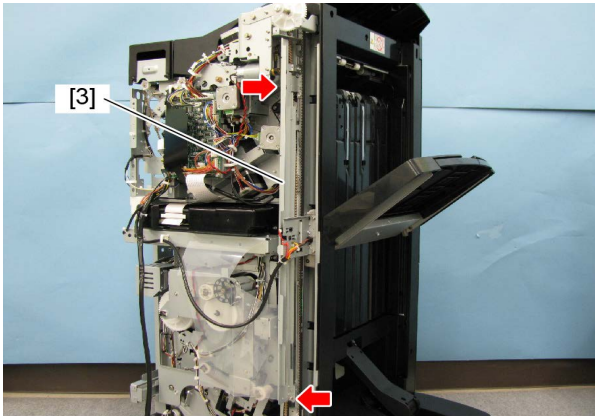

Fig. 4-232

Notes:

When installing the movable tray drive unit, fix it at the position where the gap between the center mark of the scale on the sensor rail and the edge of the movable tray position-A sensor is from 0 to 1 mm. Be sure to adjust the installation position by shifting the movable tray shift frame and measure the positions at the upper and lower measuring points on the sensor rail as shown in the figure.

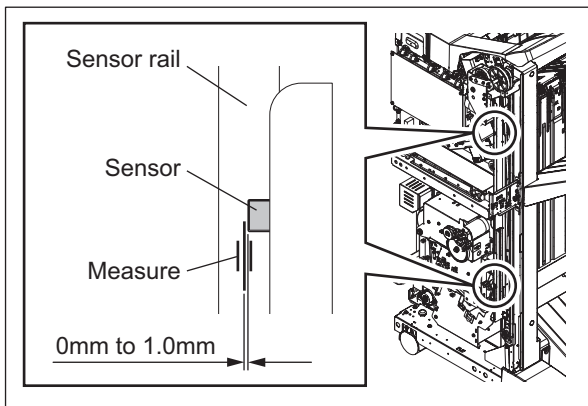

Fig. 4-233

- (4) Release the harness from 3 harness clamps [1]. Disconnect the connector [2] (CN19) on the finisher control PC board.

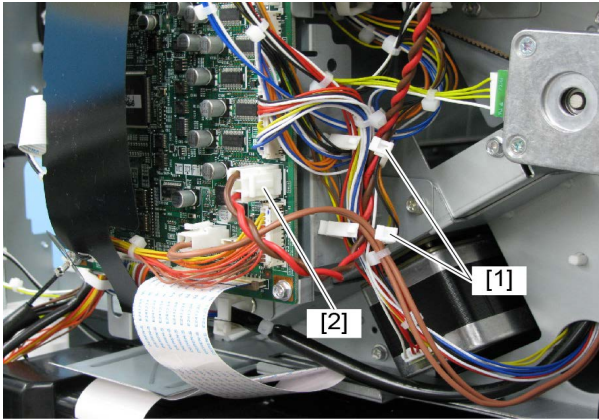

Fig. 4-234

- (5) Remove 2 screws, and then take off the movable tray shift motor [1] and the damper [2].

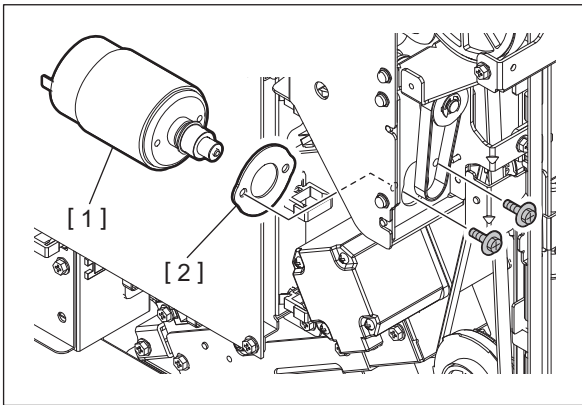

Fig. 4-235

Notes:

- Be sure not to lose the belt.
- Pay attention to the size and length of the screws. If you use the wrong ones, the motor could be damaged.

[L] Catching motor (M21)

- (1) Take off the stationary tray.
📖 P. 4-1 "[A] Stationary tray"
- (2) Take off the control panel unit.
📖 P. 4-4 "[D] Control panel unit"
- (3) Take off the rear cover.
📖 P. 4-7 "[G] Rear cover"
- (4) Take off the right upper cover.
📖 P. 4-8 "[J] Right upper cover"
- (5) Take off the right cover.
📖 P. 4-9 "[K] Relay guide / Feeding discharge brush / Right cover"
- (6) Take off the junction box unit.
📖 P. 4-15 "[A] Junction box unit"

- (7) Close the buffer unit-1 [25] halfway and remove 1 screw.

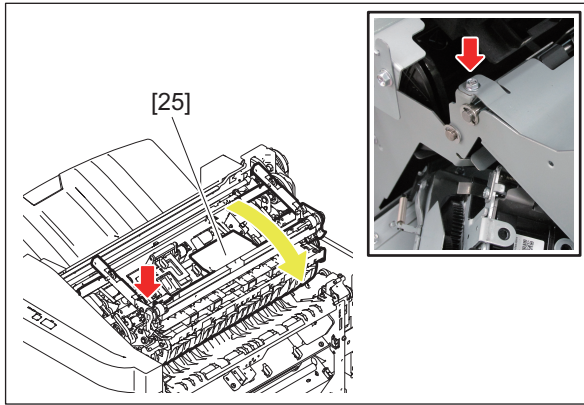

Fig. 4-236

- (8) Remove 3 screws, and then take off the transport guide.

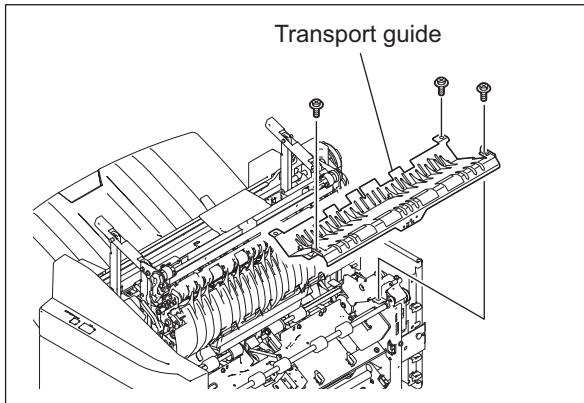

Fig. 4-237

- (9) Remove 1 screw and take off the grounding wire [1].
(10) Release the PC board cover [2] from 2 harness clamps [3].

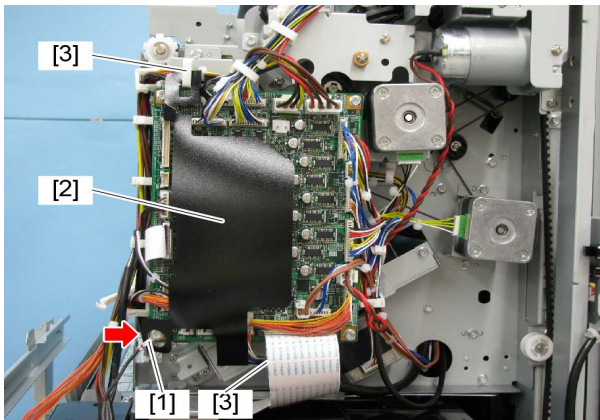

Fig. 4-238

- (11) Disconnect all the connectors on the finisher control PC board and release the harness from the harness clamp.

(12) Remove 3 screws and take off the bracket [4] of the finisher control PC board.

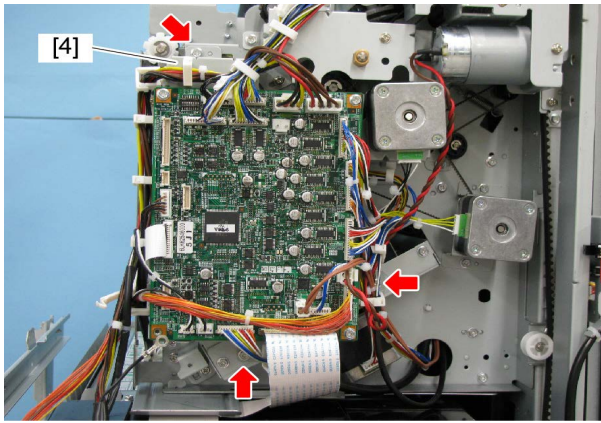

Fig. 4-239

(13) Disconnect the relay connector [5].

(14) Release the harness from 3 harness clamps [6].

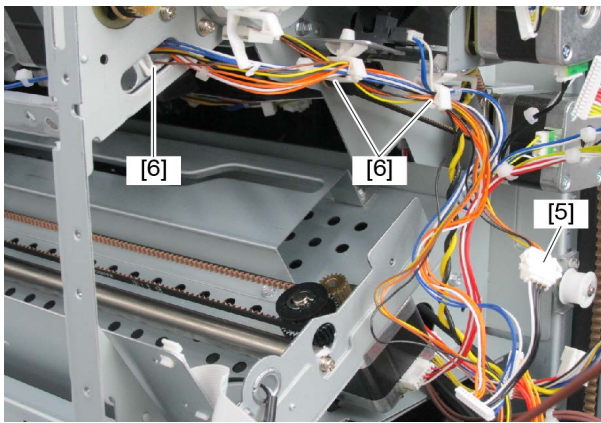

Fig. 4-240

(15) Remove 2 screws and take off the catching motor [7].

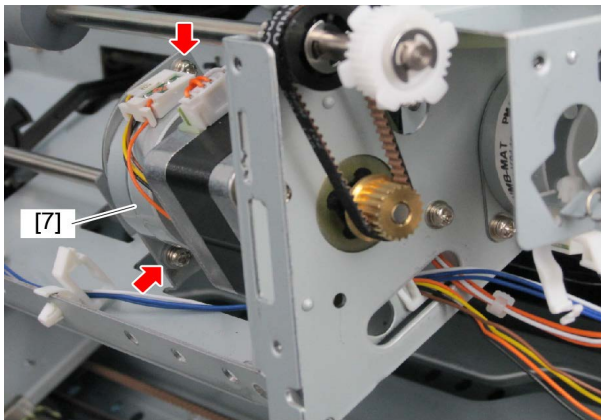



Fig. 4-241

4.7 Motor (Saddle stitch section: MJ-1112)

[A] Stacker motor (M14)

- (1) Take off the stacker unit.
 P. 4-43 "[H] Stacker unit"
- (2) Move the stacker to the upper position.
- (3) Remove 1 E-ring.
- (4) Remove the belt [1], and then take off the gear [2].

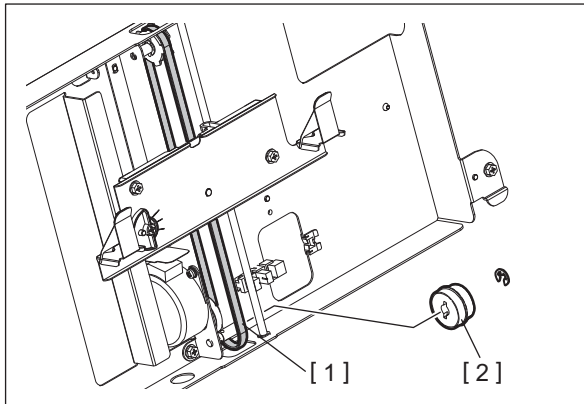

Fig. 4-242

- (5) Remove 1 E-ring, and then take off the stacker [1].

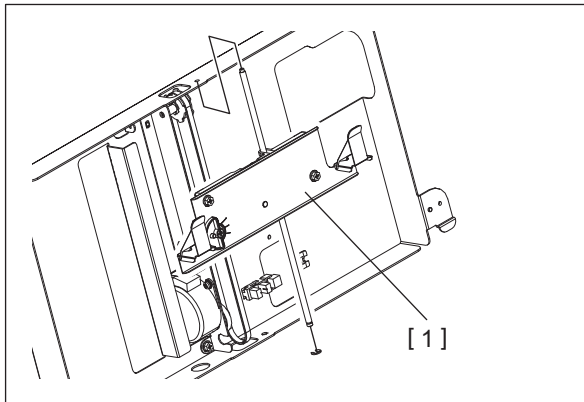

Fig. 4-243

- (6) Remove 3 screws, and then take off the motor bracket [1].

Notes:

Do not lose the removed gear of the motor bracket [1].

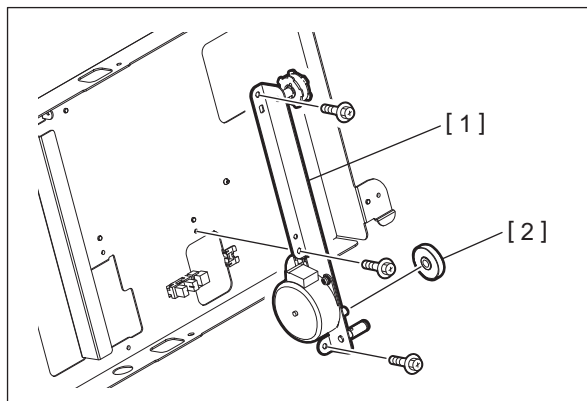

Fig. 4-244

- (7) Remove 2 screws. Release the harness out of 1 clamp [1], and then take off the stacker motor [2].

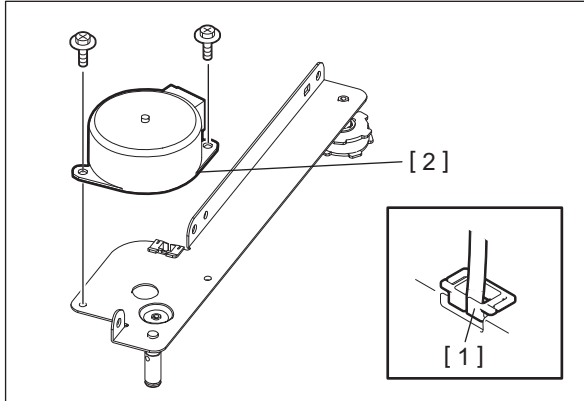

Fig. 4-245

[B] Side alignment motor (M15)

- (1) Open the front upper cover and then pull out the saddle stitch unit.
- (2) Remove 4 screws, and then take off the upper safety cover [1].

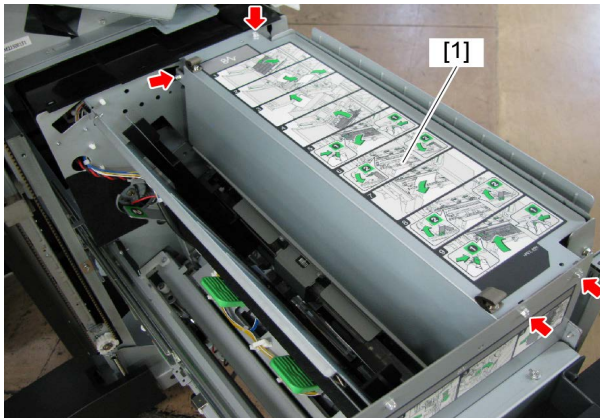

Fig. 4-246

- (3) Remove 2 screws, and then disconnect the relay connector [1] to take off the side alignment motor [2].

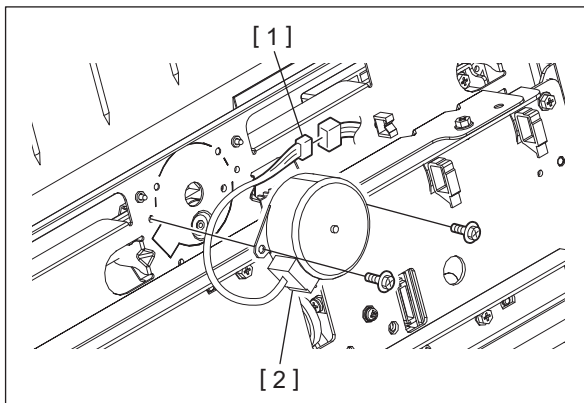

Fig. 4-247

[C] Saddle transport motor (M16)

- (1) Open the front upper cover and then pull out the saddle stitch unit.
- (2) Remove 2 screws, and then take off the motor cover [1].

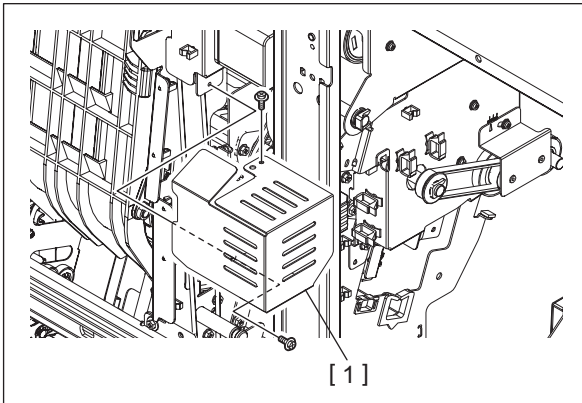

Fig. 4-248

- (3) Remove 2 screws, and then take off the motor bracket [1].

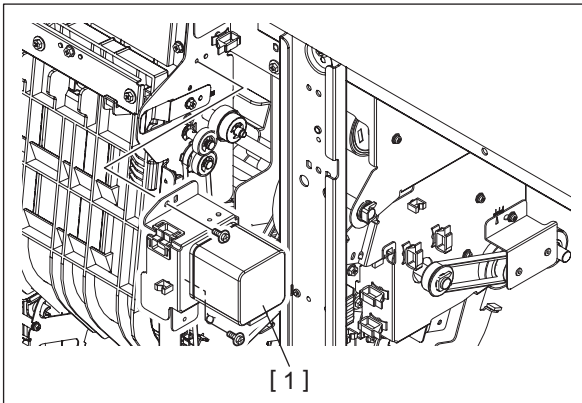

Fig. 4-249

- (4) Remove 2 screws and take off the saddle transport motor [2] from the motor bracket [1].

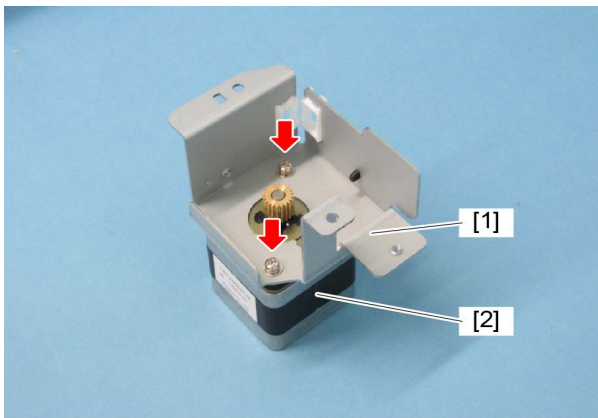

Fig. 4-250

[D] Folding motor (M17)

- (1) Take off the saddle stitch unit.
📖 P. 4-32 "[A] Saddle stitch unit"
- (2) Remove 2 screws and take off the saddle control PC board cover [6].

Notes:

When installing, be sure to secure the holes [7] on the cover with 3 hooks on the frame.

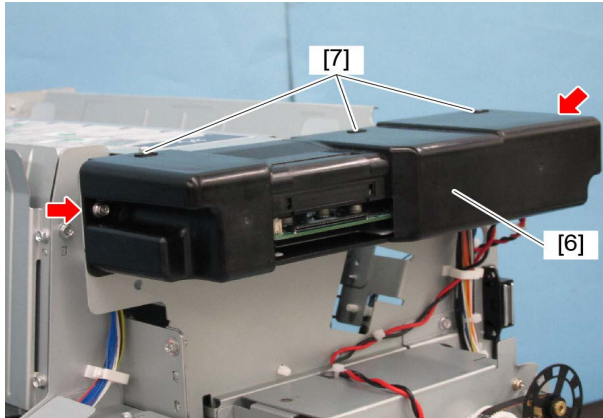

Fig. 4-251

- (3) Release the harness from 2 harness clamps [1]. Disconnect the connector [2] (CN3) on the saddle control PC board.

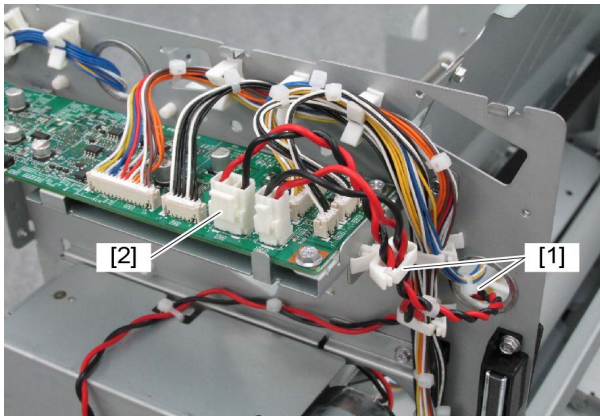

Fig. 4-252

- (4) Take off the belt [1] of folding motor.

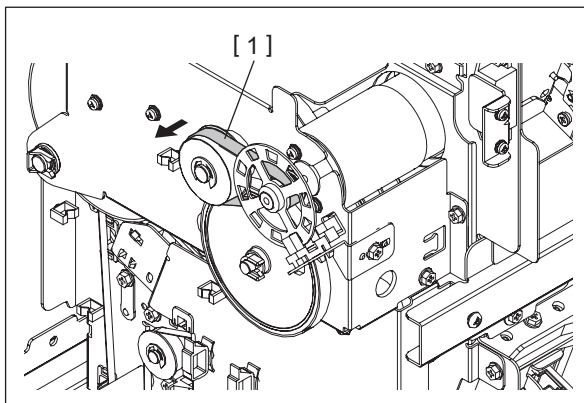

Fig. 4-253

- (5) Remove 2 screws and take off the folding motor [1].

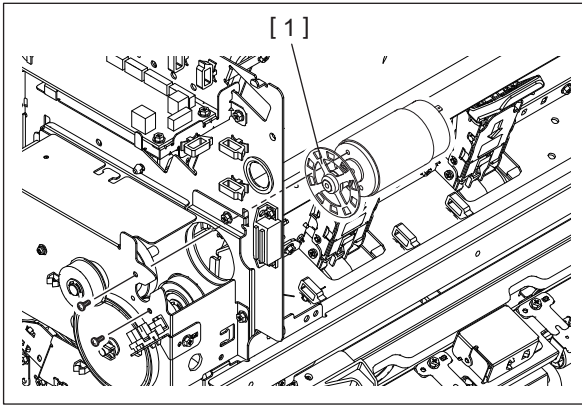

Fig. 4-254

[E] Additional folding motor (M20)

- (1) Take off the EFS unit.
P. 4-42 "[G] EFS unit"
- (2) Disconnect the connector [1] of the additional folding motor encoder sensor.
- (3) Break the binding wire [2] at 1 position and release the harness from the clamp [3].

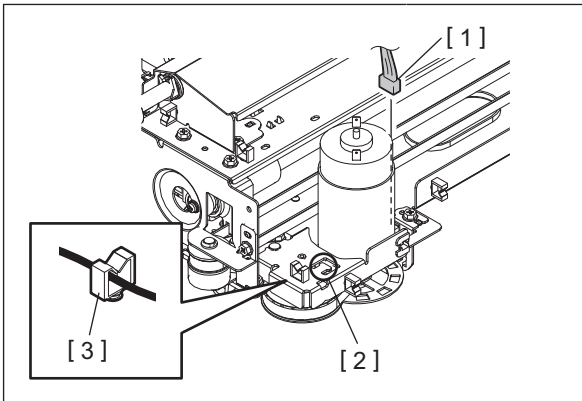

Fig. 4-255

- (4) Remove the 1 clip [1].
- (5) Remove 2 screws and take off the gear bracket [2] and pulley [3].

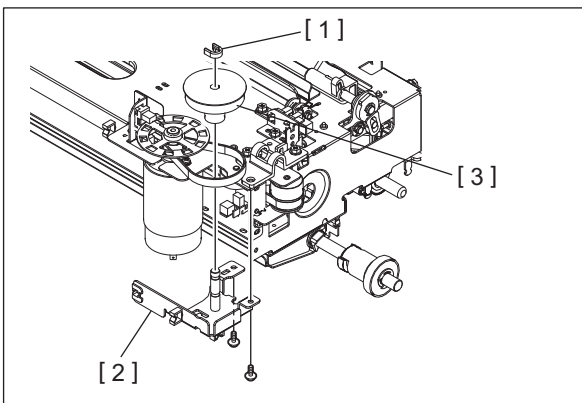

Fig. 4-256

(6) Remove 2 screws and take off the belt [1] and additional folding motor [1].

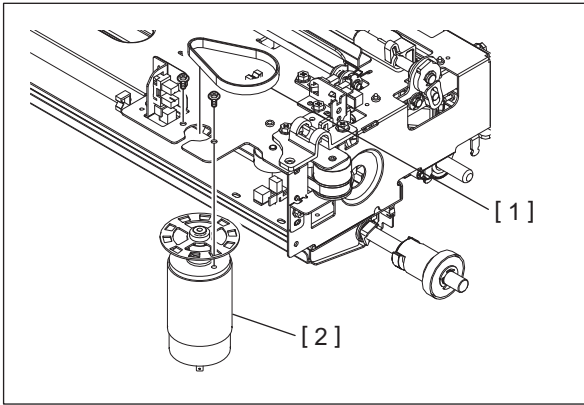

Fig. 4-257

4.8 Clutch / Solenoid

[A] Paper exit guide clutch (CLT2)

- (1) Take off the grate-shaped guide.
☞ P. 4-11 "[N] Grate-shaped guide"
- (2) Remove 4 E-rings, and then slide the bushing.

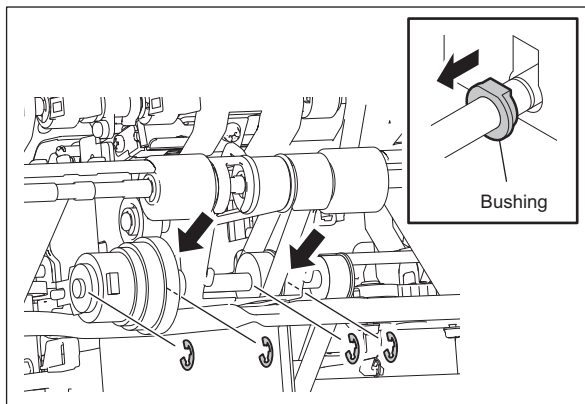

Fig. 4-258

- (3) Take off the belt of the stack transport motor.

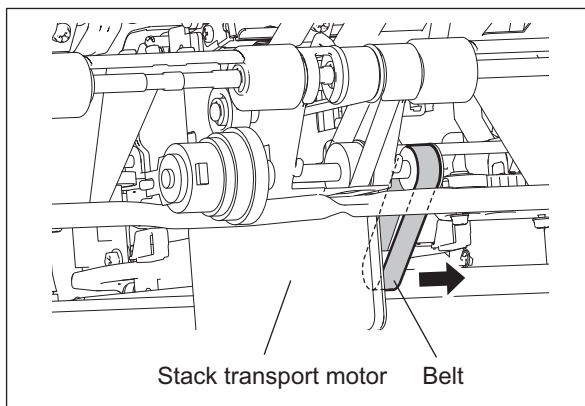

Fig. 4-259

- (4) Slide the shaft in the direction of the arrow to remove the pin.

Notes:

- Be sure not to lose the belt.
- When installing the paper exit guide clutch, attach a rotation protection.

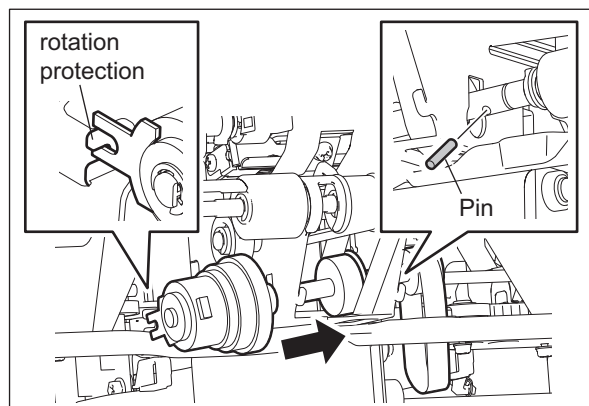

Fig. 4-260

- (5) Then take off the paper exit guide clutch by sliding the shaft. Disconnect the relay connector, and then take off the paper exit guide clutch.

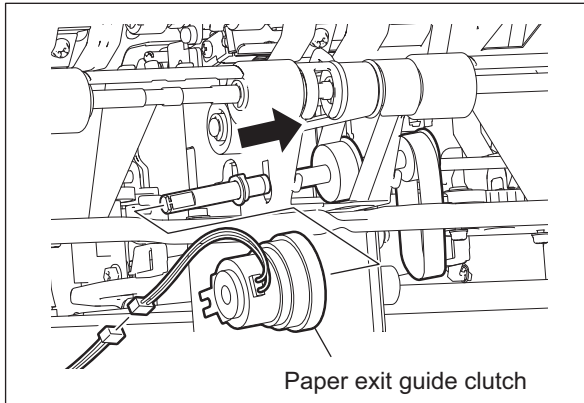

Fig. 4-261

[B] Folding blade clutch (CLT3)

- (1) Take off the folding drive unit.
 ☞ P. 4-40 "[F] Folding drive unit"
- (2) Remove 5 screws and 1 clip [1].

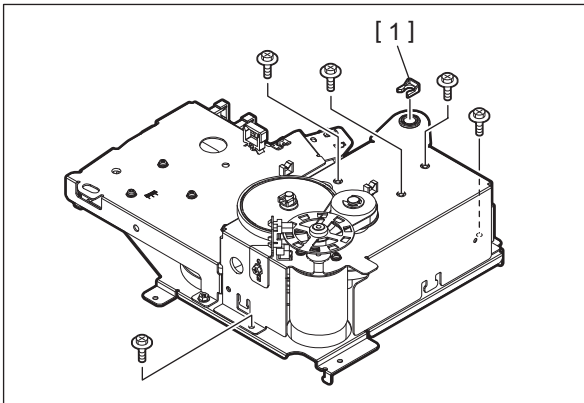

Fig. 4-262

- (3) Take off the gear bracket [1]. Disconnect the relay connector, and then take off the 1 bearing [2] and folding blade clutch [3].

Notes:

When installing the folding blade clutch, attach a rotation protection.

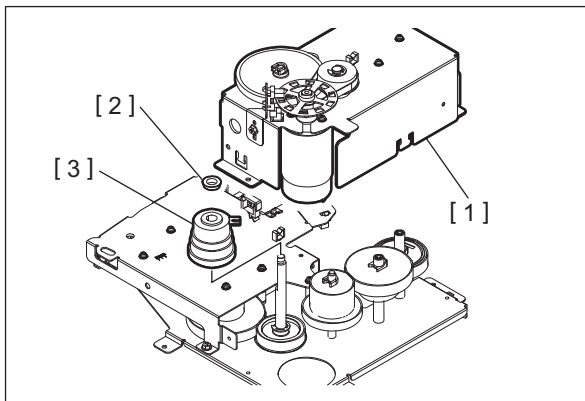

Fig. 4-263

[C] Paper holding clutch (CLT4)

- (1) Open the front upper cover and then pull out the saddle stitch unit.
- (2) Disconnect the relay connector, and then release the harness from the clamp.
- (3) Remove 1 E-ring, and then take off the paper holding clutch [1].

Notes:

When installing the paper holding clutch, attach a rotation protection.

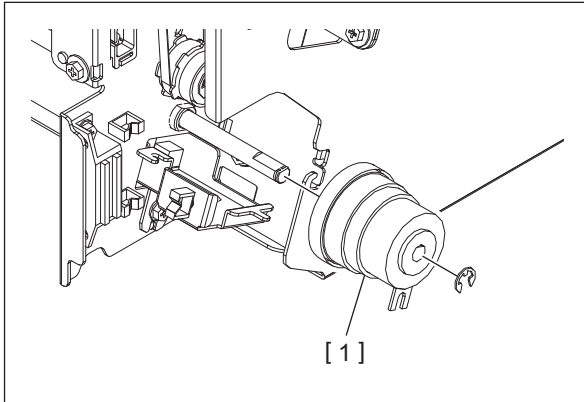

Fig. 4-264

[D] Buffer roller lift solenoid (SOL2) / Exit roller lift solenoid (SOL8)

- (1) Take off the stationary tray.
📖 P. 4-1 "[A] Stationary tray"
- (2) Close the buffer unit-1.
- (3) Remove the 2 springs [1].
- (4) Disconnect 2 relay connectors [3] and release the harness from 5 harness clamps [2].

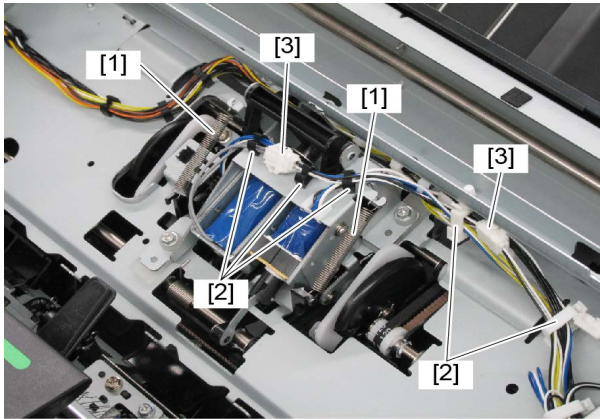

Fig. 4-265

- (5) Remove 3 screws and disconnect the plunger of the buffer roller lift solenoid. Remove 3 spacers [4], 3 screw dampers [5], 3 solenoid dampers [6] and take off the roller lift solenoid assembly [7].

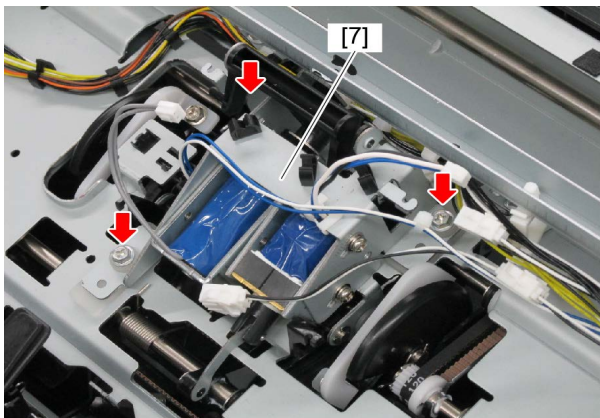

Fig. 4-266

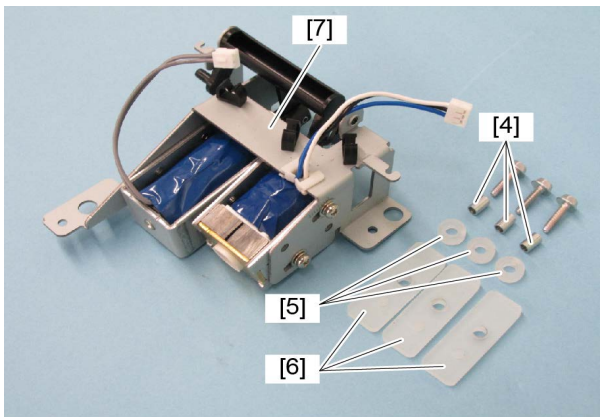

Fig. 4-267

- Exit roller lift solenoid removal procedure:
Remove 2 screws. Disconnect the plunger and take off the exit roller solenoid [8].

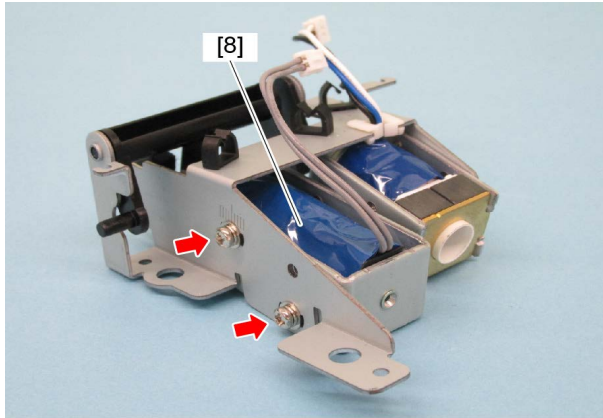

Fig. 4-268

Notes:

When installing, while the solenoid is turned ON, align the buffer roller and the buffer tray so that their gap will be within 2.0 to 3.5 mm and fix them.

- Buffer roller lift solenoid removal procedure:
Remove 2 screws and take off the buffer roller lift solenoid [9].

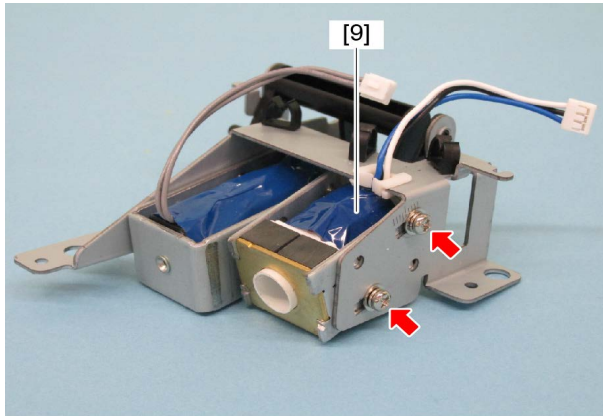

Fig. 4-269

Notes:

When installing, while the solenoid is turned ON, insert the gap adjustment jig [12] into the gap between the roller [10] of the pinch roller arm and the stack transport roller-2 [11] of the finishing tray unit. Then move the solenoid so that the roller shaft [13] of the pinch roller arm contacts the upper surface of the elongated hole [14] for the bearing to fix them.

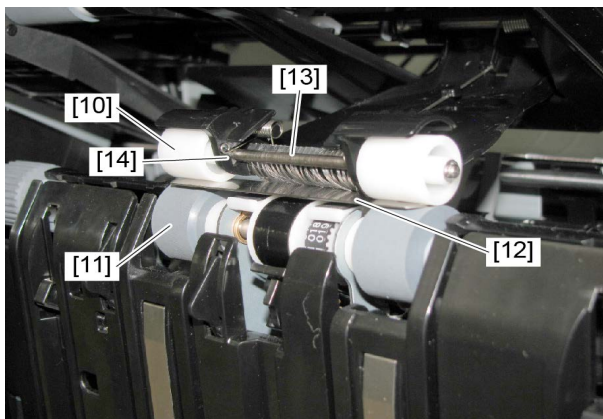

Fig. 4-270

[E] Gate solenoid (SOL4)

- (1) Take off the control panel unit.
📖 P. 4-4 "[D] Control panel unit"
- (2) Take off the rear cover.
📖 P. 4-7 "[G] Rear cover"
- (3) Take off the right upper cover.
📖 P. 4-8 "[J] Right upper cover"
- (4) Take off the right cover.
📖 P. 4-9 "[K] Relay guide / Feeding discharge brush / Right cover"
- (5) Remove 2 screws, and then take off the front bracket [1].
- (6) Remove 2 screws, and then take off the rear bracket [2].
- (7) Remove 3 screws, and then take off the junction box upper transport guide [3].

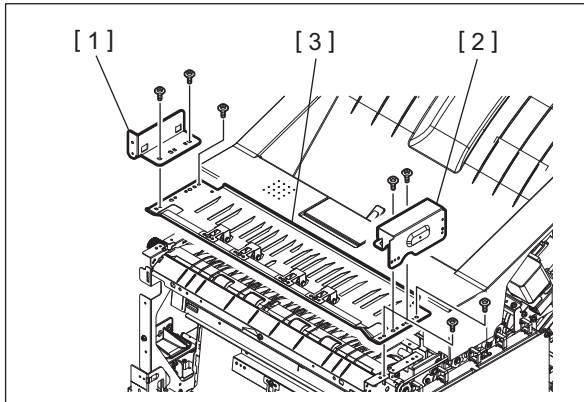

Fig. 4-271

- (8) Close the buffer unit-1 [25] halfway and leave it. Then remove 1 screw.

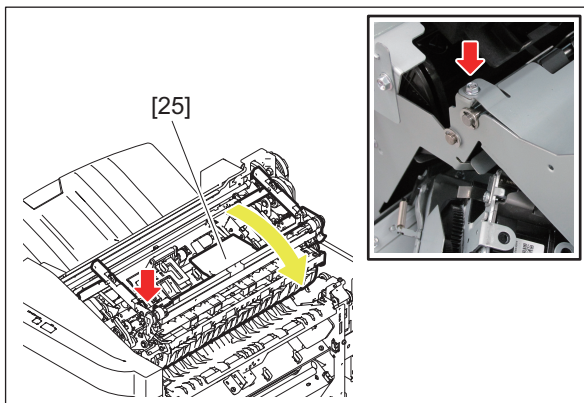

Fig. 4-272

- (9) Remove 3 screws, and then take off the transport guide.

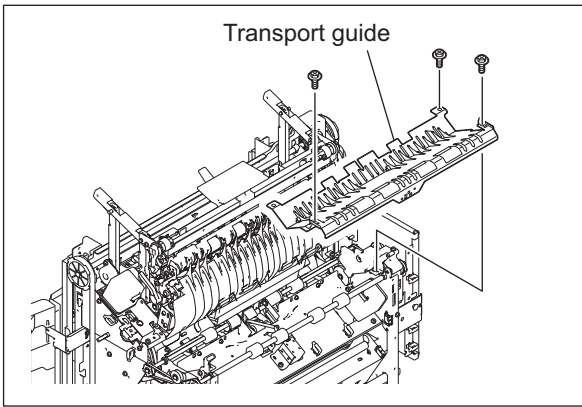

Fig. 4-273

- (10) Remove the spring.

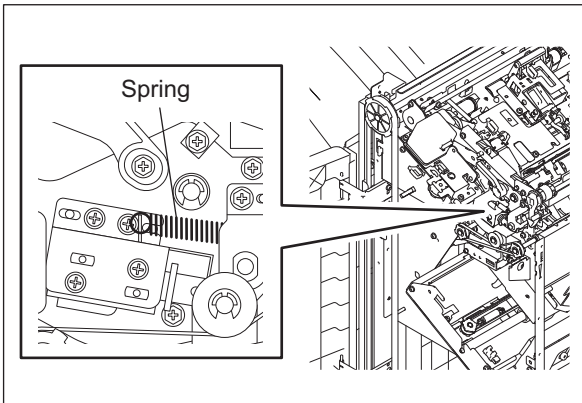

Fig. 4-274

- (11) Remove 2 screws, and then disconnect the relay connector and remove the arm to take off the bracket.

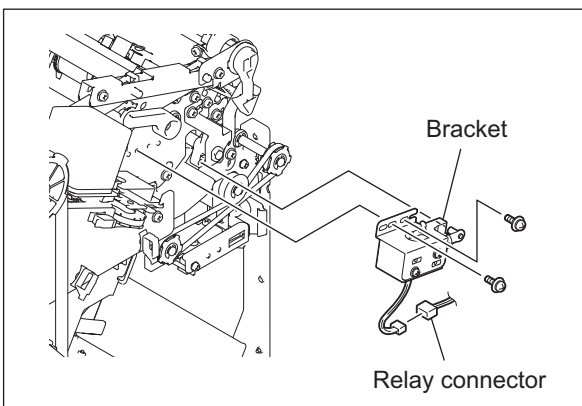

Fig. 4-275

Notes:

When installing the gate solenoid, adjust the edge of the bracket to come at the mark on the scale one step left from the center as shown in the figure and fix it with 2 screws.

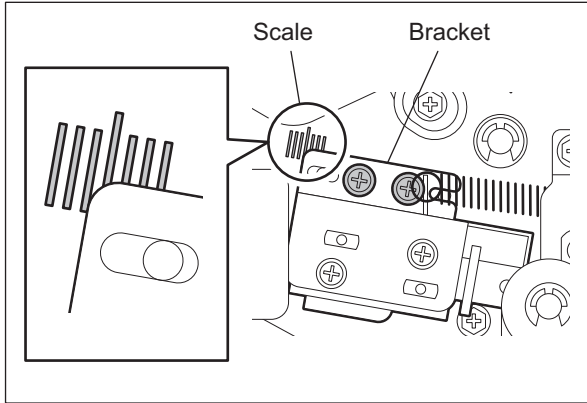

Fig. 4-276

(12) Remove 2 screws, and then take off the gate solenoid.

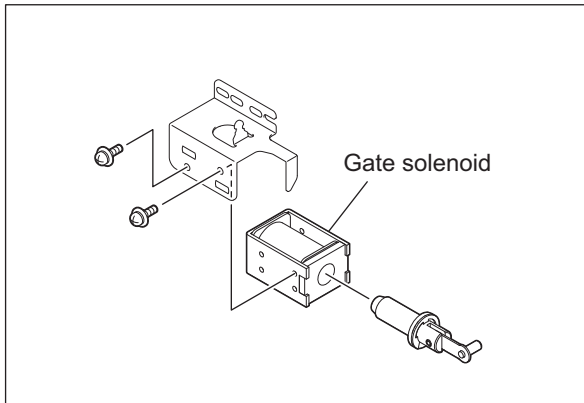

Fig. 4-277

Notes:

When installing the gate solenoid, install the bracket with 2 screws as shown in the figure, and then fix it at the position where the gap between the gate flap and the shaft of the entrance roller falls within 0.4 to 0.8 mm.

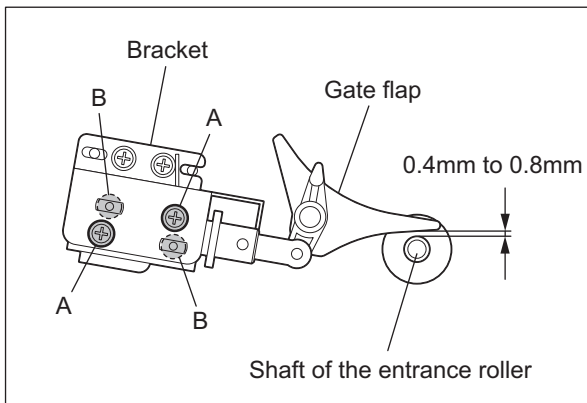

Fig. 4-278

[F] Transport path switching solenoid (SOL5)

- (1) Take off the rear cover.
📖 P. 4-7 "[G] Rear cover"
- (2) Take off the right upper cover.
📖 P. 4-8 "[J] Right upper cover"
- (3) Remove 2 screws, and then take off the front bracket [1].
- (4) Remove 2 screws, and then take off the rear bracket [2].
- (5) Remove 2 screws, and then take off the junction box upper transport guide [3].

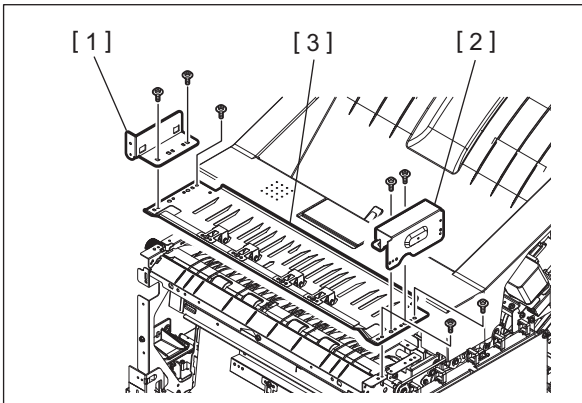

Fig. 4-279

- (6) Open the stationary tray.
- (7) Remove the spring [1], and then loosen 2 screws to free the belt [2] tension.
- (8) Take off the belt [2].

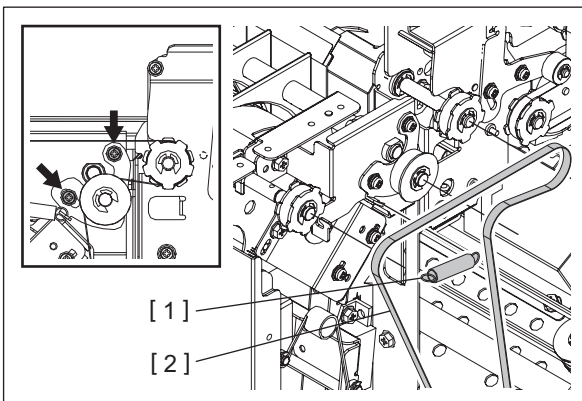

Fig. 4-280

- (9) Break binding wire [2] at one position and disconnect the relay connector [1].

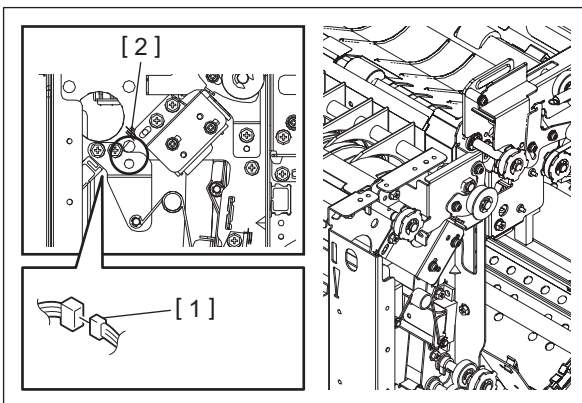

Fig. 4-281

(10) Remove 2 screws, and remove the arm [1] to take off the transport path switching solenoid [2].

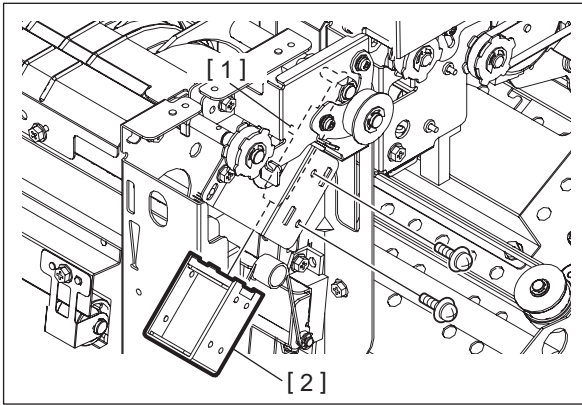

Fig. 4-282

Notes:

When installing, perform adjustment for both cases in which the solenoid is turned ON and OFF.

1. When the solenoid is turned OFF, the gap between the surface of the transport guide [1] and the upper side of the flap [2] edge must fall within 1.5 mm to 2.1 mm. Fix the solenoid with 2 screws.

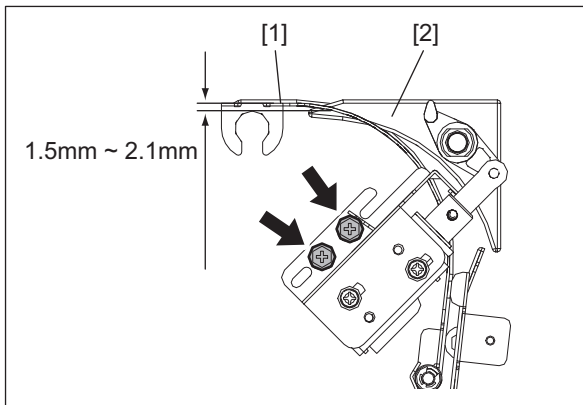

Fig. 4-283

2. When the solenoid is turned ON, the gap between the surface of the transport guide [1] and the upper side of the flap [2] edge must fall within 2.3 mm to 2.9 mm. Fix the solenoid with 2 screws.

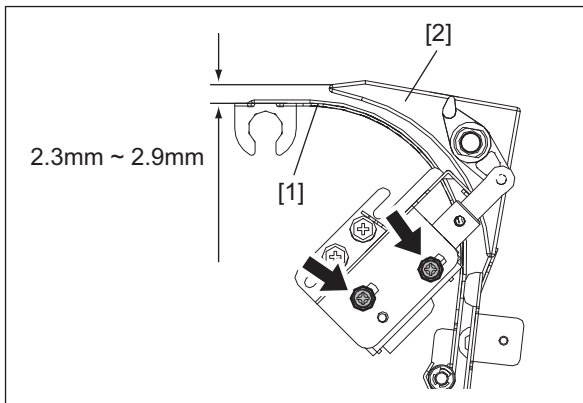

Fig. 4-284

[G] Assisting roller solenoid (SOL6)

- (1) Take off the stacker unit.
📖 P. 4-43 "[H] Stacker unit"
- (2) Take off the paper holding unit.
📖 P. 4-35 "[C] Paper holding unit"
- (3) Remove 4 screws of the stacker guide.

Notes:

Be careful not to damage the harness fixed on the back side of the stacker guide [1] with a clamp.

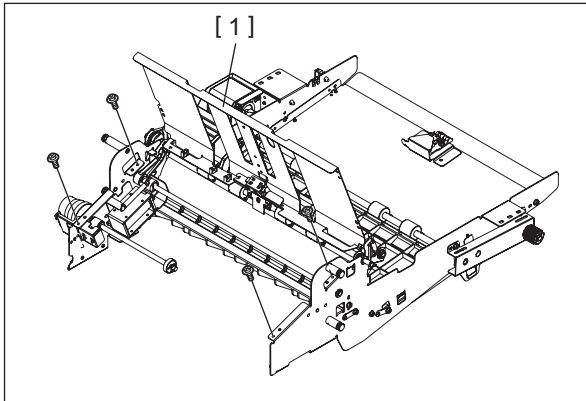

Fig. 4-285

- (4) Release the harness out of 2 clamps [2], and then disconnect the relay connector [1].

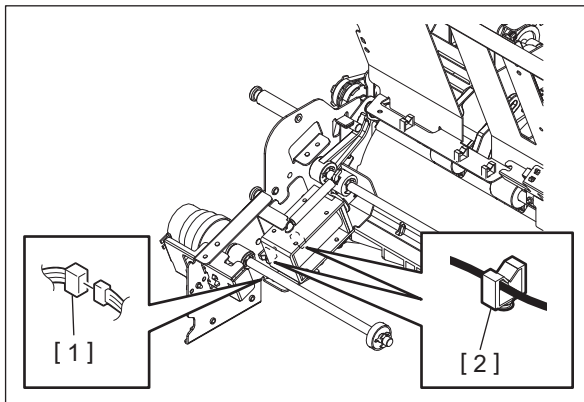

Fig. 4-286

- (5) Take off the spring [1].
- (6) Remove 2 screws, and then take off the assisting roller solenoid [2].

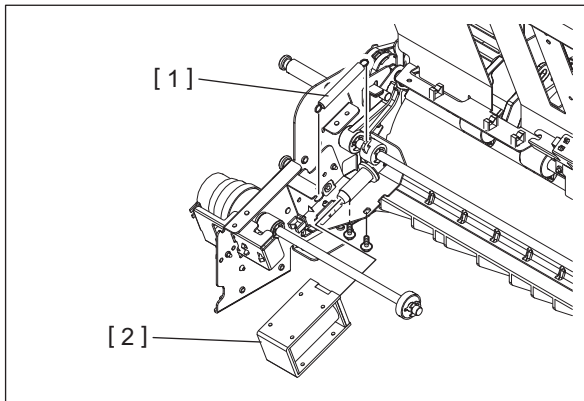



Fig. 4-287

4.9 Sensors / Switches (Finisher section)

[A] Entrance sensor (S1)

- (1) Take off the stationary tray.
 P. 4-1 "[A] Stationary tray"
- (2) Close the buffer unit-1 halfway and leave it.
Then remove 1 screw. Disconnect the connector and take off the sensor bracket [1].

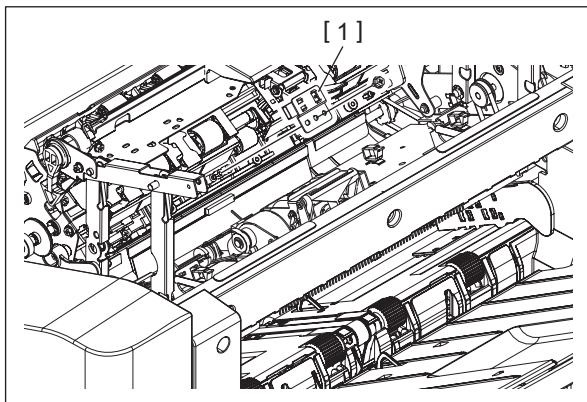

Fig. 4-288

- (3) Release the latch, and then take off the entrance sensor [1].

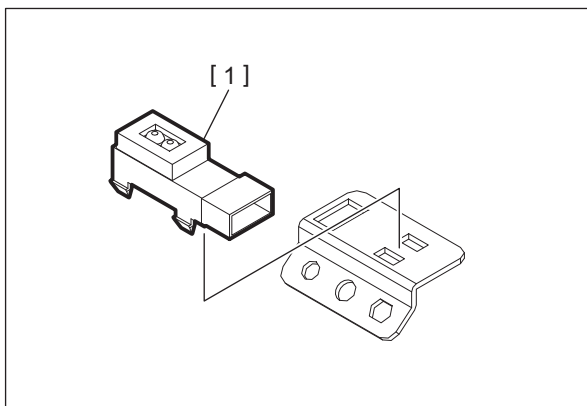

Fig. 4-289

[B] Transport sensor (S2)

- (1) Take off the stationary tray.
📖 P. 4-1 "[A] Stationary tray"
- (2) Close the buffer unit-1 halfway and leave it.
Then remove 1 screw. Disconnect the connector [2] and take off the sensor bracket [1].

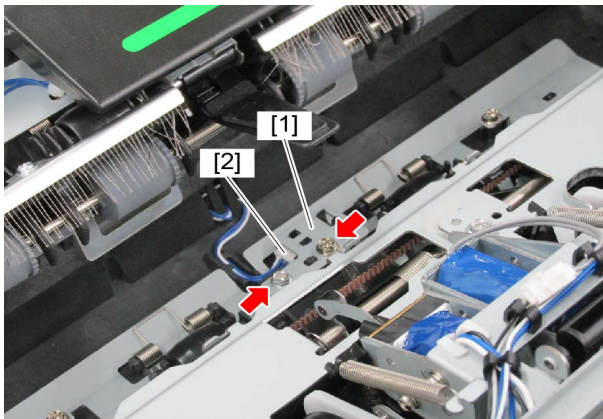

Fig. 4-290

- (3) Release the latch, and then take off the transport sensor [3].

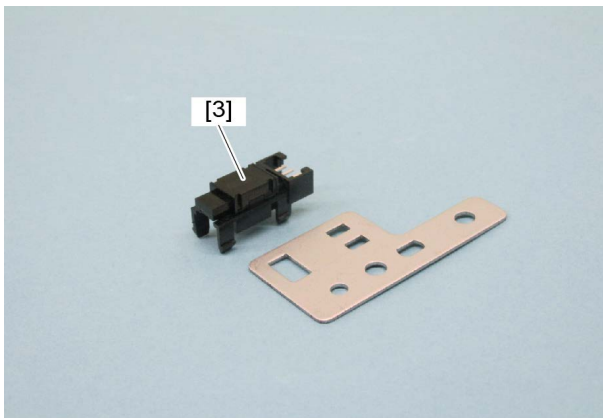

Fig. 4-291

[C] Paddle home position sensor (S3)

- (1) Take off the stationary tray.
📖 P. 4-1 "[A] Stationary tray"
- (2) Take off the control panel unit.
📖 P. 4-4 "[D] Control panel unit"
- (3) Take off the rear cover.
📖 P. 4-7 "[G] Rear cover"
- (4) Take off the right upper cover.
📖 P. 4-8 "[J] Right upper cover"
- (5) Take off the right cover.
📖 P. 4-9 "[K] Relay guide / Feeding discharge brush / Right cover"
- (6) Take off the junction box unit.
📖 P. 4-15 "[A] Junction box unit"

- (7) Close the buffer unit-1 [25] halfway and remove 1 screw.

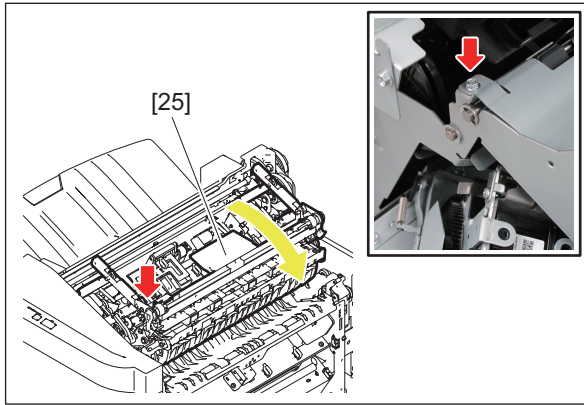

Fig. 4-292

- (8) Remove 3 screws, and then take off the transport guide.

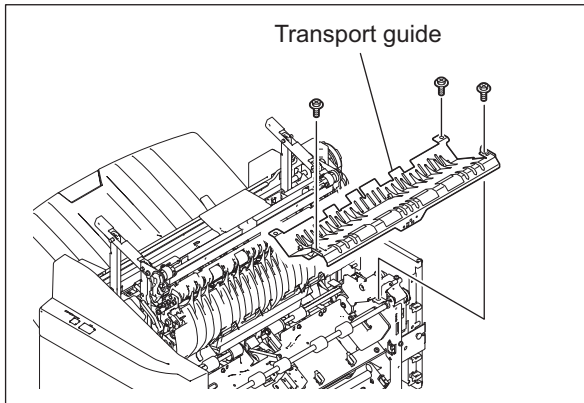

Fig. 4-293

- (9) Remove 1 screw and take off the grounding wire [1].
(10) Release the PC board cover [2] from 2 harness clamps [3].

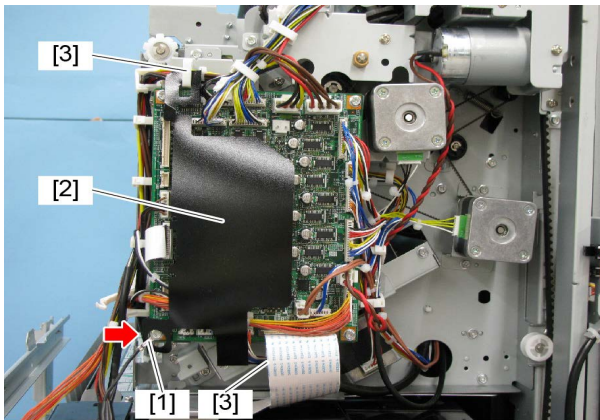

Fig. 4-294

- (11) Disconnect all the connectors on the finisher control PC board and release the harness from the harness clamp.

(12) Remove 3 screws and take off the bracket [4] of the finisher control PC board.

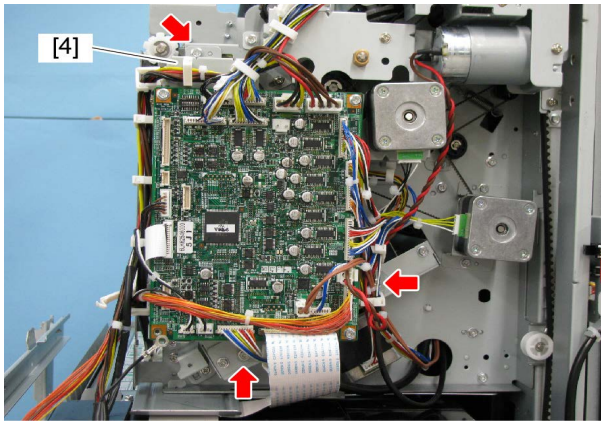

Fig. 4-295

(13) Remove 1 screw, and then disconnect the connector and take off the sensor bracket [5].

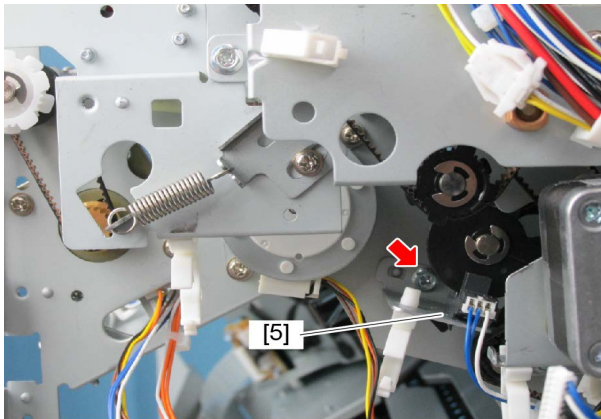

Fig. 4-296

(14) Release the latch, and then take off the paddle home position sensor.

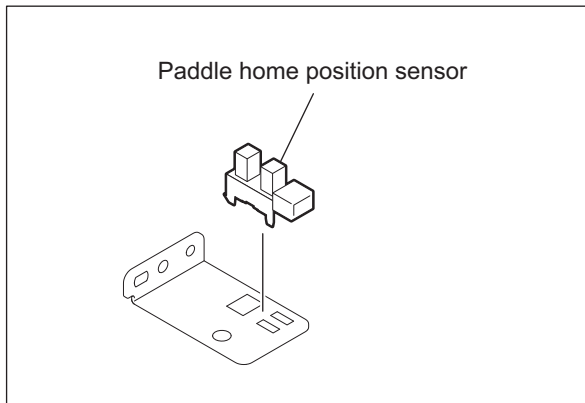

Fig. 4-297

[D] Buffer tray home position sensor (S5)

- (1) Take off the stationary tray.
📖 P. 4-1 "[A] Stationary tray"
- (2) Take off the control panel unit.
📖 P. 4-4 "[D] Control panel unit"
- (3) Move each buffer guide [1].

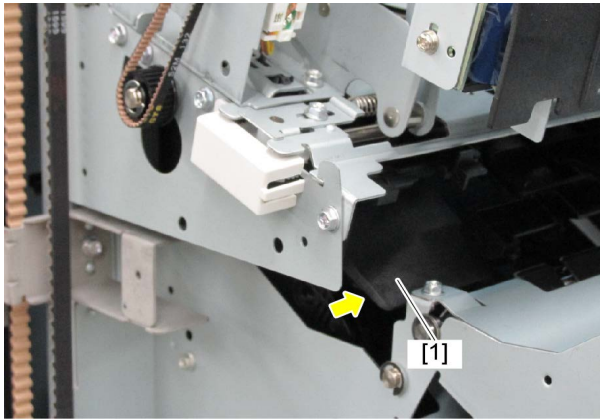

Fig. 4-298

- (4) Disconnect the connector, and then release the latch to take off the buffer tray home position sensor [1].

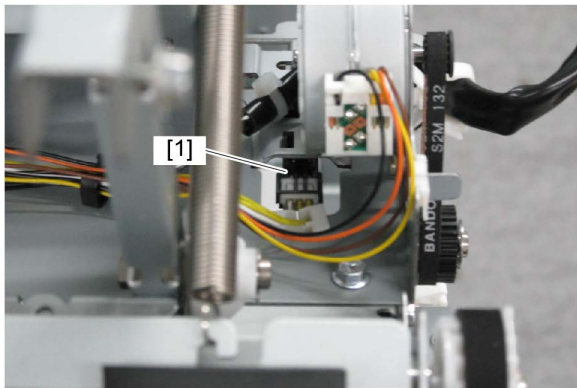

Fig. 4-299

[E] Assist guide home position sensor (S6)

- (1) Take off the stationary tray.
📖 P. 4-1 "[A] Stationary tray"
- (2) Take off the roller lift solenoid assembly.
📖 P. 4-100 "[D] Buffer roller lift solenoid (SOL2) / Exit roller lift solenoid (SOL8)"
- (3) Release the latch, and then disconnect the connector [1] to take off the Assist guide home position sensor[2].

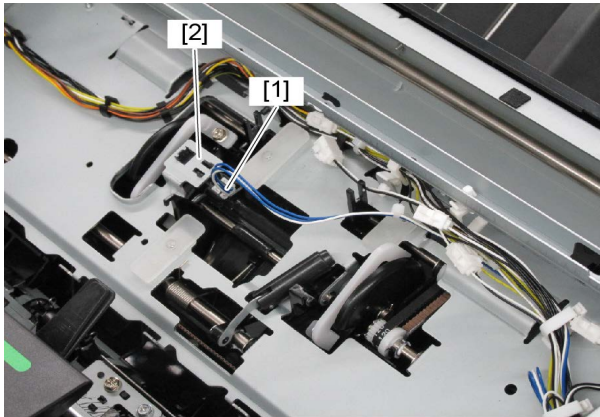

Fig. 4-300

[F] Front alignment plate home position sensor (S7)

- (1) Take off the grate-shaped guide.
📖 P. 4-11 "[N] Grate-shaped guide"
- (2) Release the latch, and then disconnect the connector to take off the front alignment plate home position sensor.

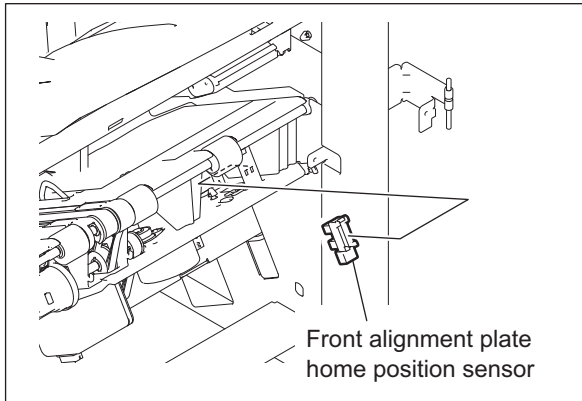

Fig. 4-301

[G] Rear alignment plate home position sensor (S8)

- (1) Take off the grate-shaped guide.
📖 P. 4-11 "[N] Grate-shaped guide"
- (2) Release the latch, and then disconnect the connector to take off the rear alignment plate home position sensor.

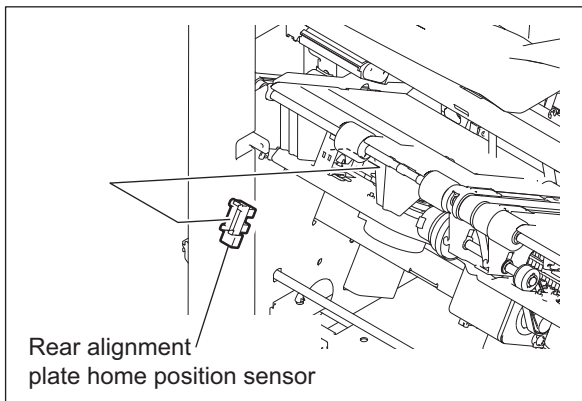

Fig. 4-302

[H] Stack exit belt home position sensor (S9)

- (1) Take off the finishing tray unit.
📖 P. 4-24 "[D] Finishing tray unit"
- (2) Remove 2 screws.

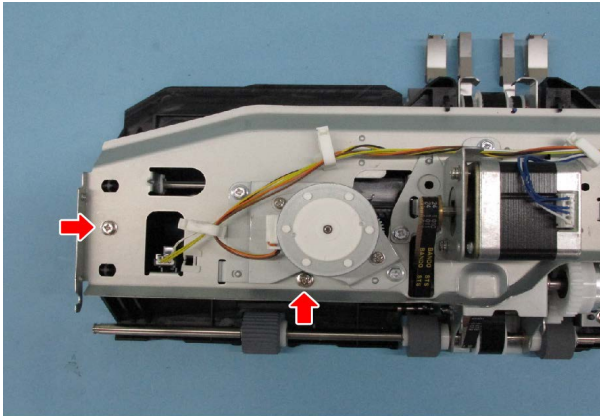

Fig. 4-303

- (3) Turn over the finishing tray unit. Slide the rear finishing tray cover [2] to outside and lift it up. Release the link portion [1] inside the rear finishing tray cover.

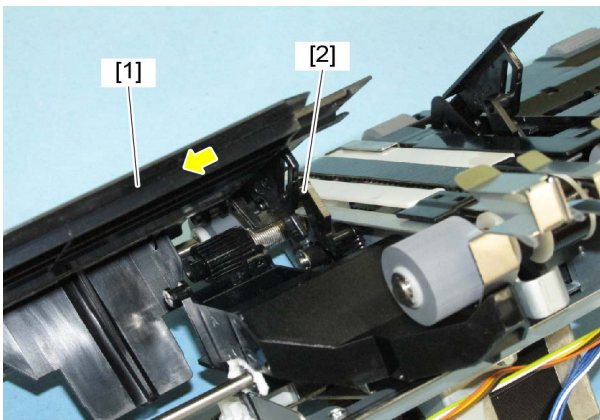

Fig. 4-304

- (4) Move the front alignment plate guide [3] in the direction of the arrow.
- (5) Remove the screw, disconnect the connector [4] and take off the sensor bracket [5].

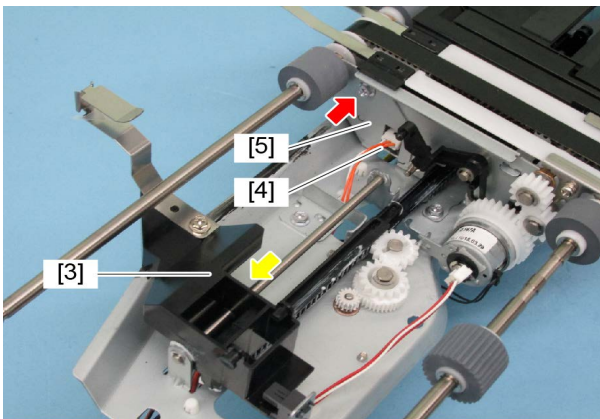

Fig. 4-305

- (6) Release the latch, and then disconnect the connector to take off the stack exit belt home position sensor [6].

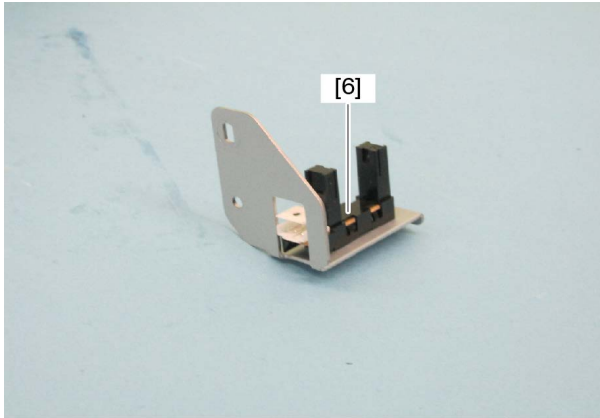

Fig. 4-306

[I] Stapler unit home position sensor (S10)

- (1) Open the front upper cover.
- (2) Move the stapler to the position where the stapler unit home position sensor is seen.
- (3) Release the latch, and then disconnect the connector to take off the stapler unit home position sensor.

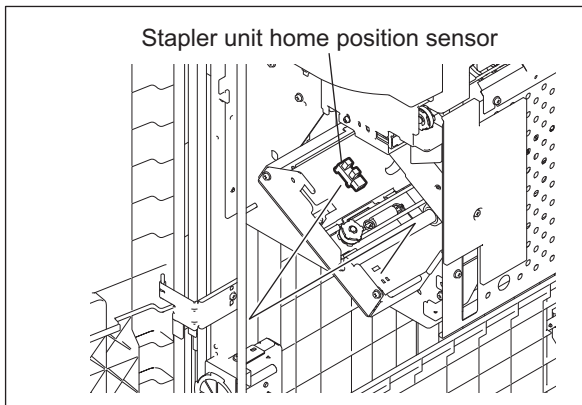

Fig. 4-307

[J] Stapler interference sensor (S11) / Actuator

- (1) Take off the stapler.
P. 4-28 "[F] Stapler"
- (2) Release the latch, and then disconnect the connector to take off the stapler interference sensor.

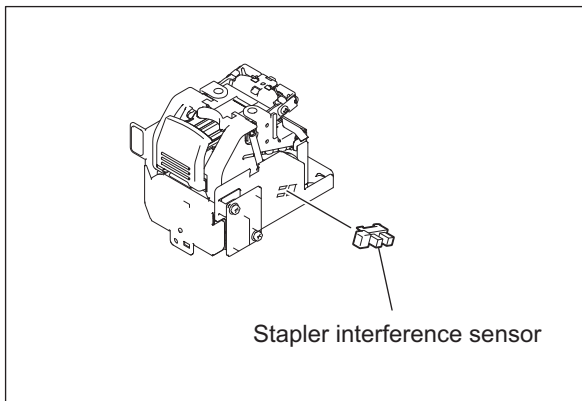

Fig. 4-308

- (3) Remove the clip, and then take off the stapler base frame.

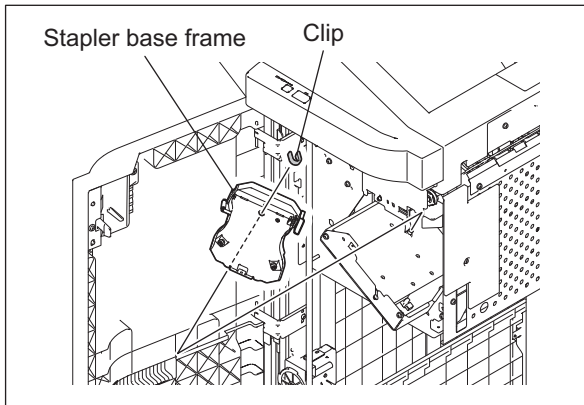

Fig. 4-309

- (4) Remove the spring, and then remove the clip to take off the actuator.

Notes:

When installing the actuator, be sure to insert the clip from the side of the actuator.

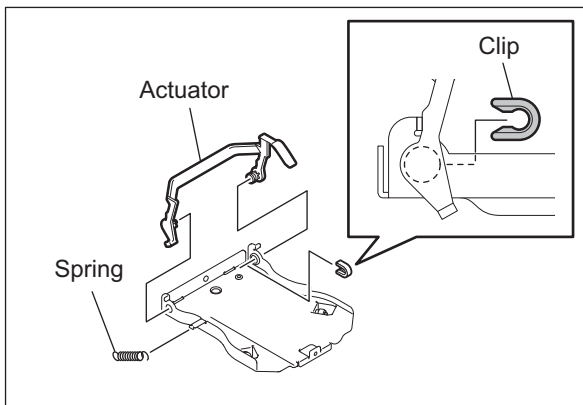

Fig. 4-310

[K] Finishing tray paper detection sensor (S12)

- (1) Take off the finishing unit.
📖 P. 4-24 "[D] Finishing tray unit"
- (2) Remove 2 screws.

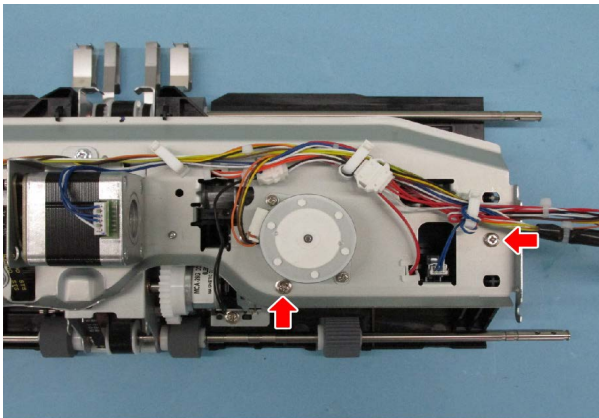

Fig. 4-311

- (3) Turn over the finishing tray unit. Slide the front finishing tray cover [1] to outside and lift it up. Release the link portion [2] inside the front finishing tray cover to take it off.

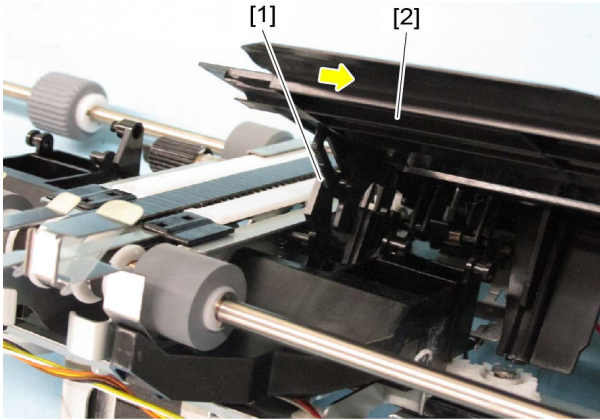

Fig. 4-312

- (4) Disconnect the connector from the finishing tray paper detection sensor [5] and take off the rear finishing tray cover [3].

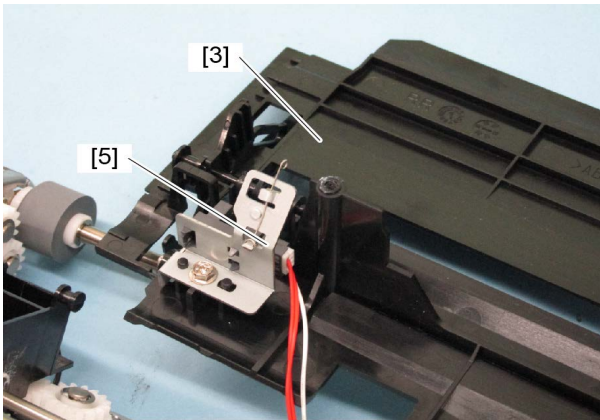

Fig. 4-313

- (5) Remove the screw and take off the sensor bracket [6].

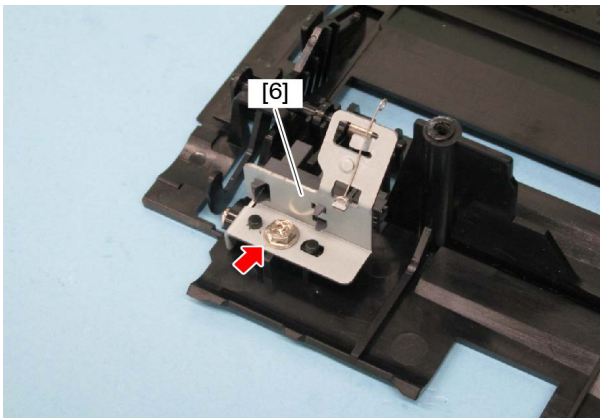

Fig. 4-314

- (6) Release the latch, disconnect the connector and take off the Finishing tray paper detection sensor [7].

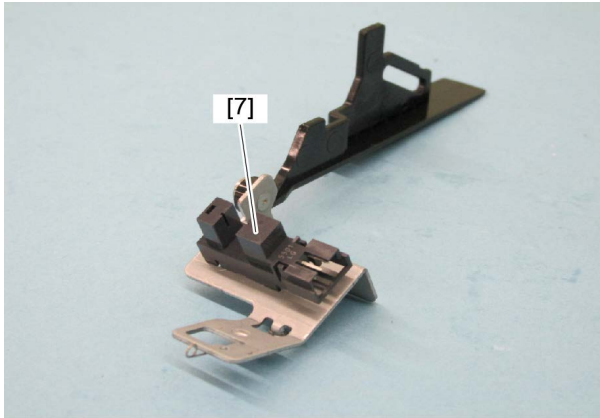

Fig. 4-315

[L] Movable tray position-A sensor (S13) / Movable tray position-B sensor (S14) / Movable tray position-C sensor (S15)

- (1) Take off the rear cover.
P. 4-7 "[G] Rear cover"
- (2) Move the movable tray [1] shift frame to the middle position. If the movable tray [1] shift frame needs to be lowered, push the gear [2] of the movable tray shift motor unit in the direction of the arrow to unlock the frame. (Be sure to hold the movable tray gear frame with your hands because it may fall when the gear is pushed.)

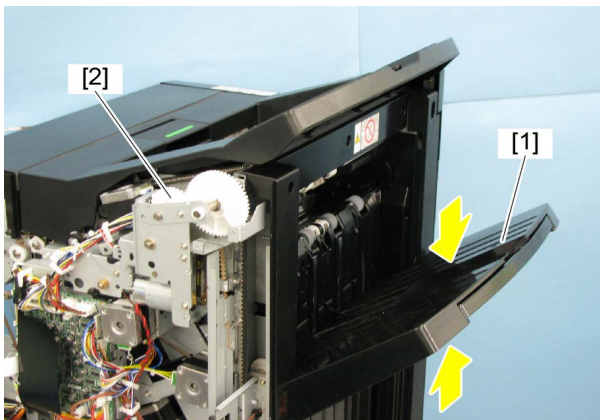

Fig. 4-316

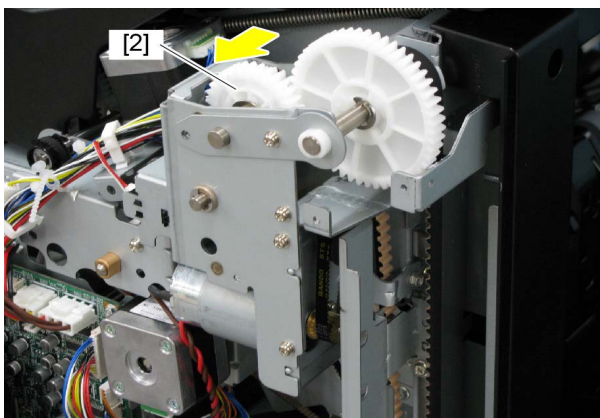

Fig. 4-317

- (3) Remove 2 screws, and then take off the sensor rail [3].

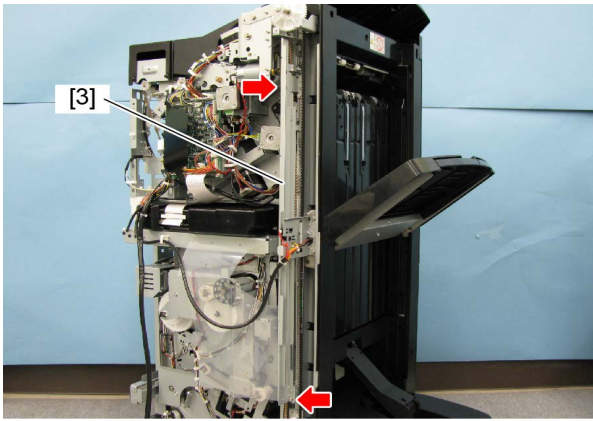

Fig. 4-318

Notes:

When installing the movable tray drive unit, fix it at the position where the gap between the center mark of the scale on the sensor rail and the edge of the movable tray position-A sensor is from 0 to 1 mm. Be sure to adjust the installation position by shifting the movable tray shift frame and measure the positions at the upper and lower measuring points on the sensor rail as shown in the figure.

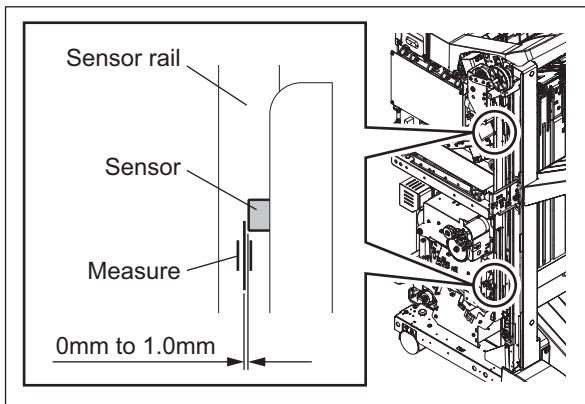

Fig. 4-319

- (4) Release the latch, and then disconnect the connectors to take off the movable tray position-A sensor, movable tray position-B sensor and movable tray position-C sensor.

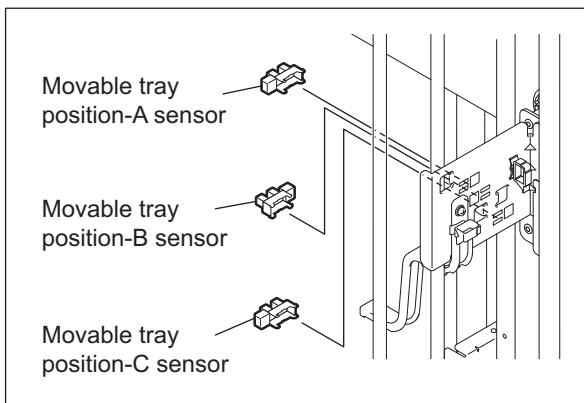

Fig. 4-320

[M] Movable tray paper-full sensor (S16)

- (1) Take off the grate-shaped guide.
☞ P. 4-11 "[N] Grate-shaped guide"
- (2) Move the shutter upward.
- (3) Release the latch, and then disconnect the connector to take off the movable tray paper-full sensor [1].

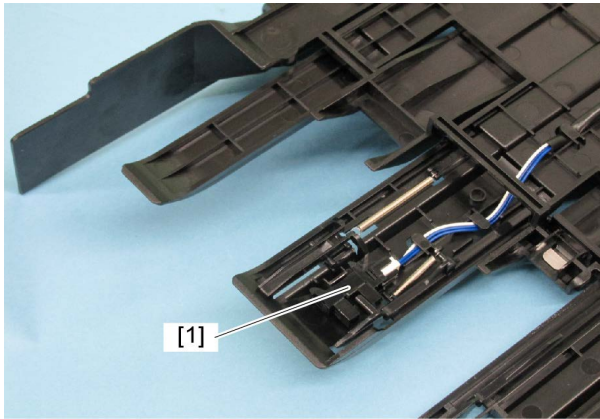

Fig. 4-321

[N] Movable tray paper exist sensor (S17)

- (1) Take off the movable tray.
☞ P. 4-2 "[B] Movable tray"
- (2) Disconnect the connector of the movable tray paper exist sensor.
- (3) Release the latch, and then take off the movable tray paper exist sensor [1].

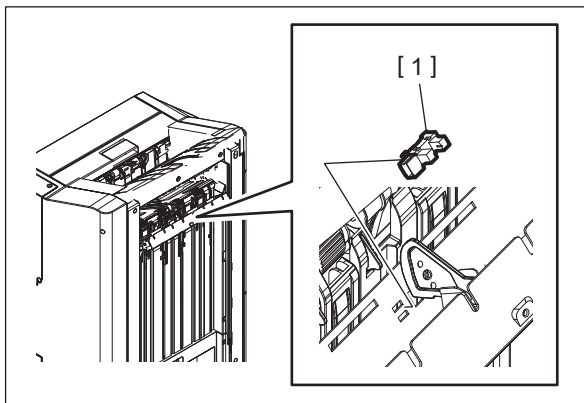

Fig. 4-322

[O] Stationary tray paper-full sensor (S18)

- (1) Take off the stationary tray.
📖 P. 4-1 "[A] Stationary tray"
- (2) Hold up the jam access lever. Then remove 1 screw and disconnect the connector to take off the bracket.

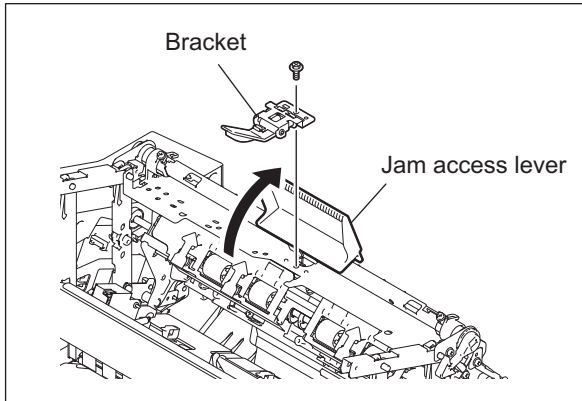

Fig. 4-323

- (3) Remove 1 screw, and then take off the actuator and the spacer.

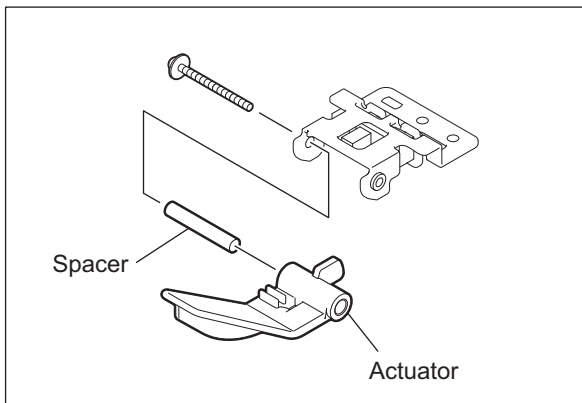

Fig. 4-324

- (4) Release the latch, and then take off the stationary tray paper-full sensor.

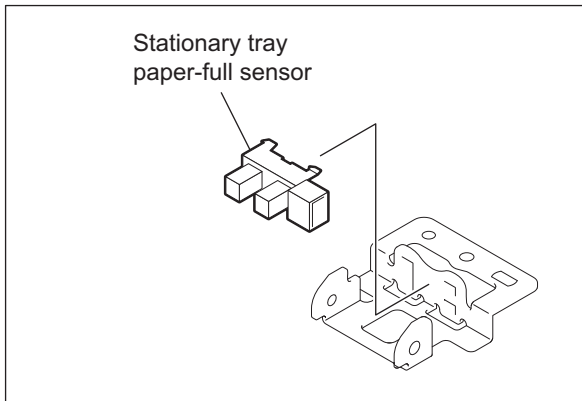

Fig. 4-325

[P] Feeding sensor (S22)

- (1) Take off the right cover.
P. 4-9 "[K] Relay guide / Feeding discharge brush / Right cover"
- (2) Remove 1 screw, and then disconnect the connector and take off the sensor bracket [1].

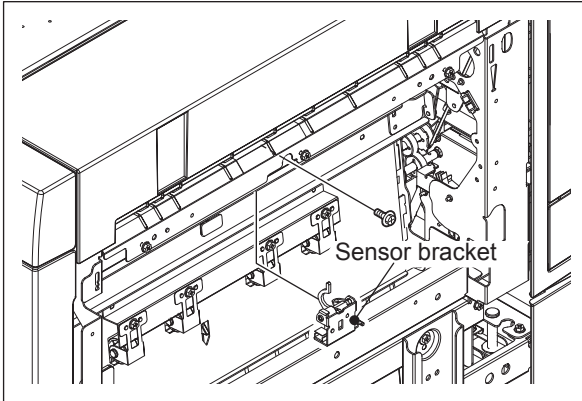

Fig. 4-326

- (3) Release the latch, and then take off the feeding sensor.

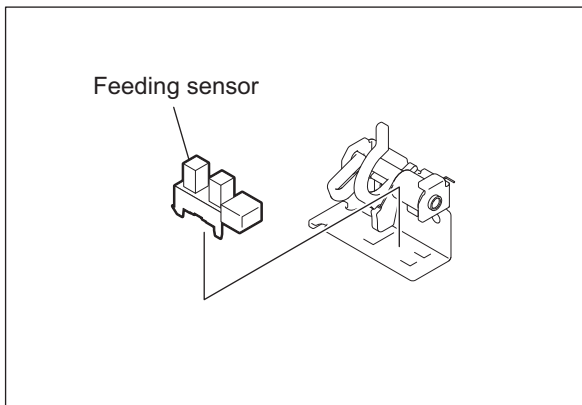

Fig. 4-327

[Q] Movable tray shift motor sensor (S23)

- (1) Take off the rear cover.
P. 4-7 "[G] Rear cover"
- (2) Remove 1 screw, and then disconnect the connector and take off the sensor bracket [1].

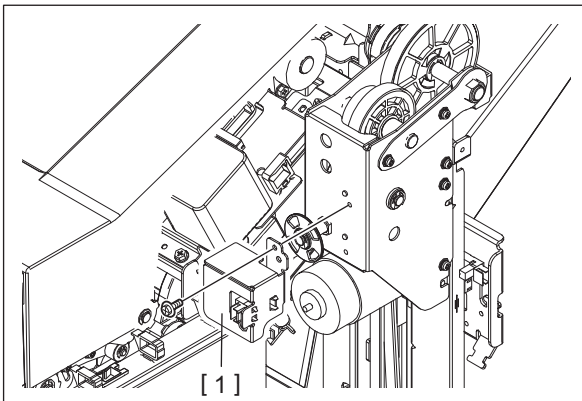

Fig. 4-328

- (3) Release the latch, and then take off the movable tray shift motor sensor [1].

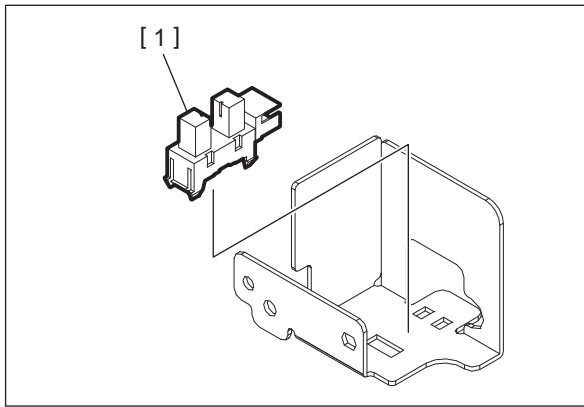

Fig. 4-329

[R] Connection sensor (S25)

- (1) Take off the right cover.
📖 P. 4-9 "[K] Relay guide / Feeding discharge brush / Right cover"
- (2) Release the latch, and then disconnect the connector [1] to take off the connection sensor [2].

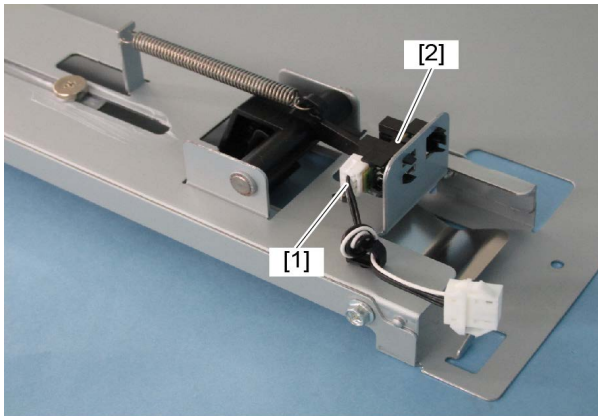

Fig. 4-330

[S] Front cover switch (SW1)

- (1) Take off the right cover.
📖 P. 4-9 "[K] Relay guide / Feeding discharge brush / Right cover"
- (2) Open the front upper cover.
- (3) Remove 2 screws, and then take off the sensor plate [1].

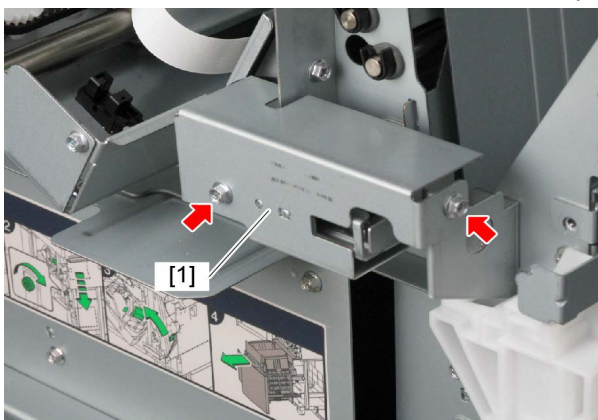

Fig. 4-331

- (4) Remove 2 screws, and then disconnect the connector [2] and then take off the switch bracket [3].

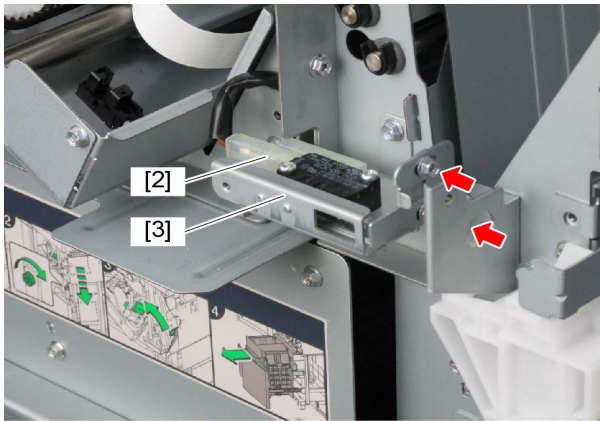

Fig. 4-332

- (5) Remove 2 screws, and then take off the front cover switch [4].

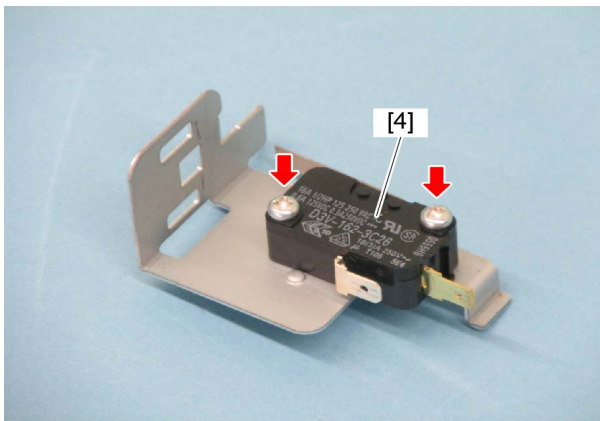

Fig. 4-333

[T] Stationary tray opening/closing switch (SW2)

- (1) Take off the rear cover.
 ☞ P. 4-7 "[G] Rear cover"
- (2) Disconnect all the connectors on the finisher control PC board and release the harness from the harness clamp.
- (3) Remove 1 screw and take off the grounding wire [1].
- (4) Release the PC board cover [2] from 2 harness clamps [3].

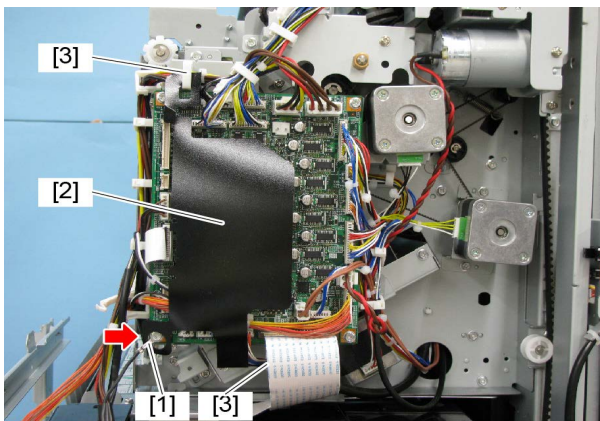

Fig. 4-334

- (5) Disconnect all the connectors on the finisher control PC board and release the harness from the harness clamp.

- (6) Remove 3 screws and take off the bracket [4] of the finisher control PC board.

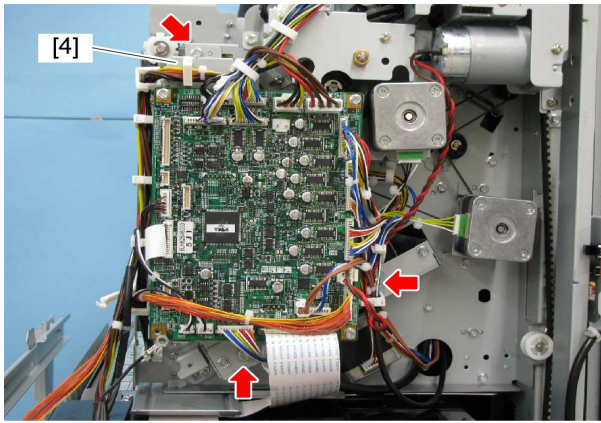

Fig. 4-335

- (7) Remove 5 screws and take off the motor bracket [7].

Notes:

Pay full attention not to lose the bushing [8] while taking off the motor bracket [7].

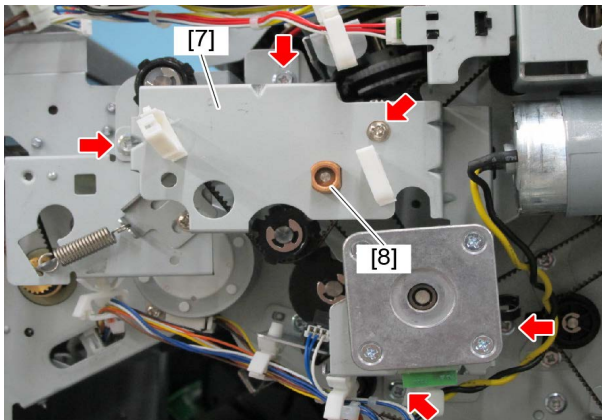

Fig. 4-336

- (8) Loosen 1 screw. Push the pulley [9] in the direction indicated by the arrow to loosen the belt tension and tighten the screw.

- (9) Remove the belts [10] and [11], the part assembled [12] and the bearing.

Notes:

Pay full attention not to lose the bearing while taking off the part assembled [12].

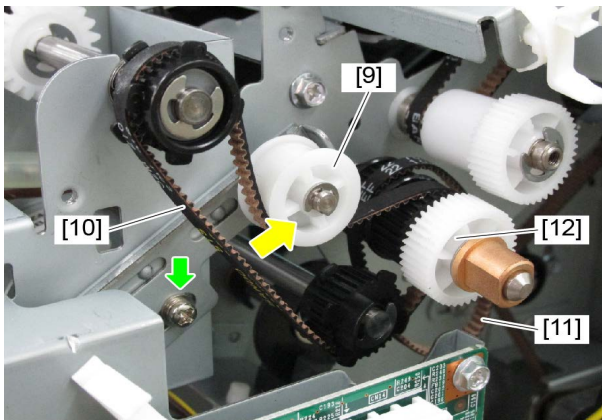

Fig. 4-337

(10) Remove 1 E-ring [13], bearing [14] and take off the shaft [15].

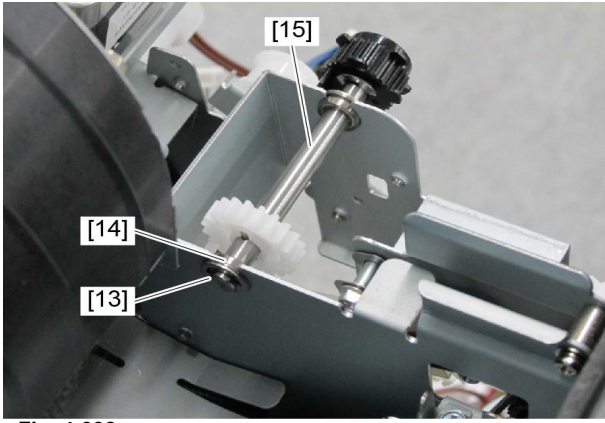

Fig. 4-338

(11) Remove 2 screws and take off the switch bracket [16].

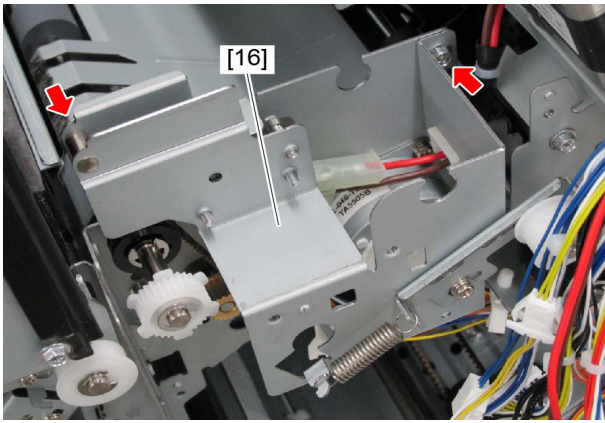

Fig. 4-339

(12) Disconnect the connector [17].

(13) Remove 2 screws and take off the stationary tray opening/closing switch [18].

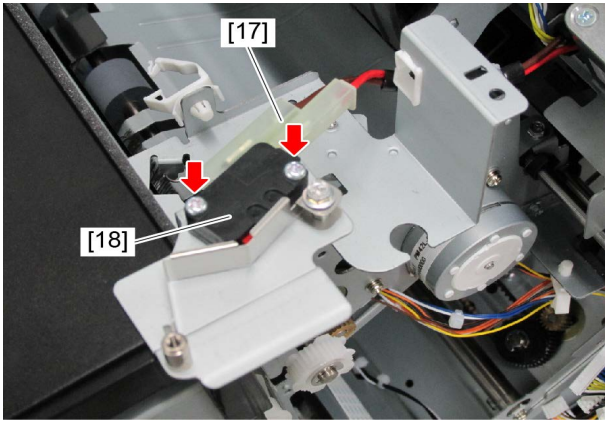

Fig. 4-340

[U] Stapler interference switch (SW3)

- (1) Take off the stapler unit.
📖 P. 4-26 "[E] Stapler unit"
- (2) Disconnect the connector [1].
- (3) Remove 2 screws and take off the stapler interference switch [2].

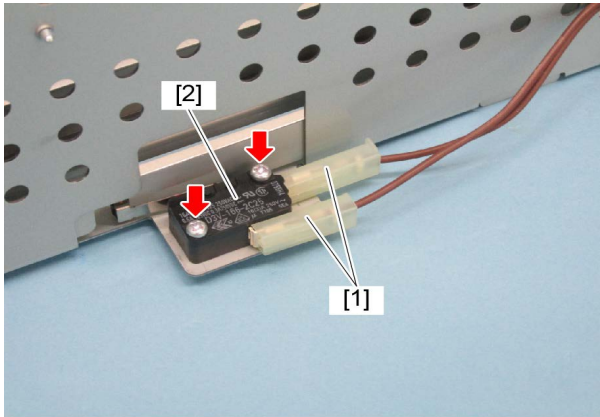

Fig. 4-341

[V] Connection switch (SW4)

- (1) Take off the board access cover.
📖 P. 4-7 "[H] Board access cover"
- (2) Take off the 1 spring [1].
- (3) Remove 1 screw [2], and then take off the sensor bracket [3] of the connection switch.
- (4) Release the harness from 1 binding wire [4].
- (5) Disconnect the connector [5] to take off the sensor bracket [3] of the connection switch.

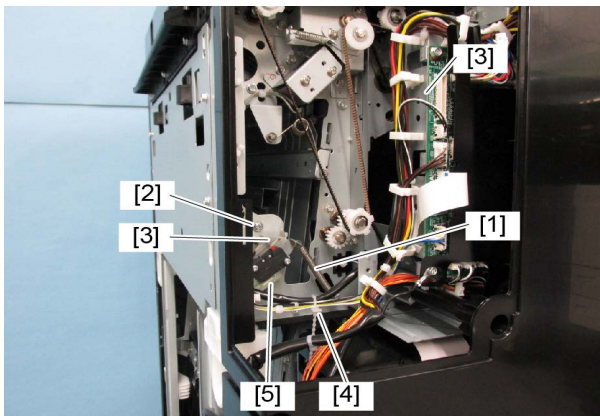

Fig. 4-342

(6) Remove 2 screws, and then take off the connection switch [6].

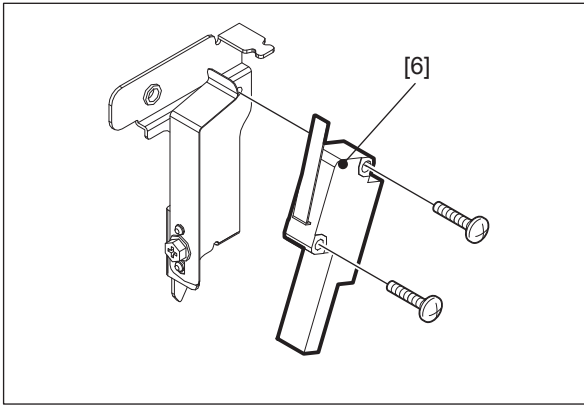

Fig. 4-343

4.10 Sensors / Switches (Saddle stitch section: MJ-1112)

[A] Junction box paper detection sensor (S26)

- (1) Take off the junction box unit.
📖 P. 4-15 "[A] Junction box unit"
- (2) Remove 1 screw, and then disconnect the connector and take off the sensor bracket [1].

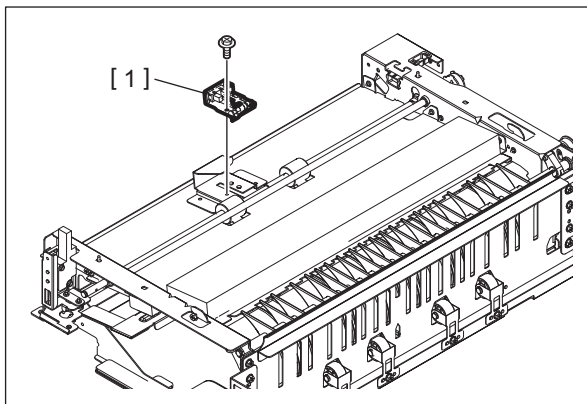

Fig. 4-344

- (3) Release the latch, and then take off the junction box paper detection sensor [1].

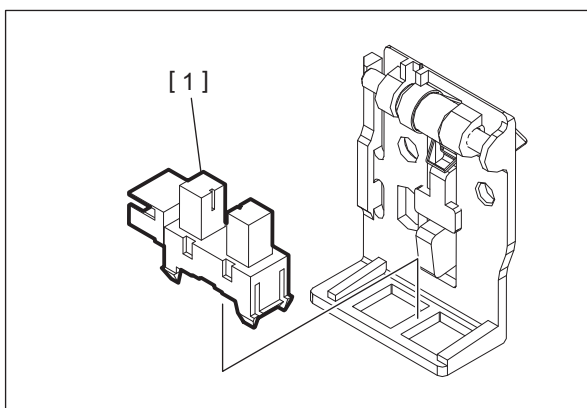

Fig. 4-345

[B] Transport path-2 sensor (S27)

- (1) Open the front upper cover and then pull out the saddle stitch unit.
- (2) Remove 4 screws, and then take off the upper safety cover [1].

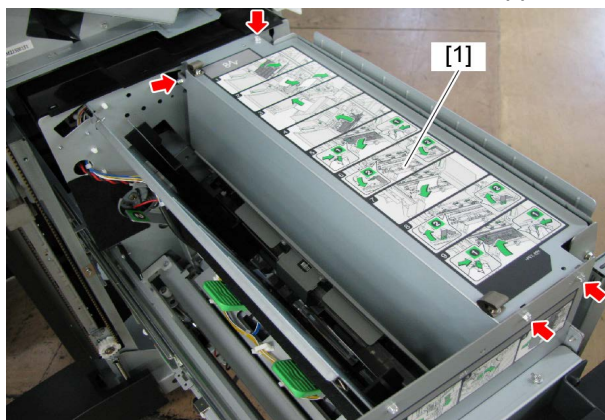

Fig. 4-346

- (3) Remove 1 screw, and then disconnect the connector and take off the sensor bracket [1].

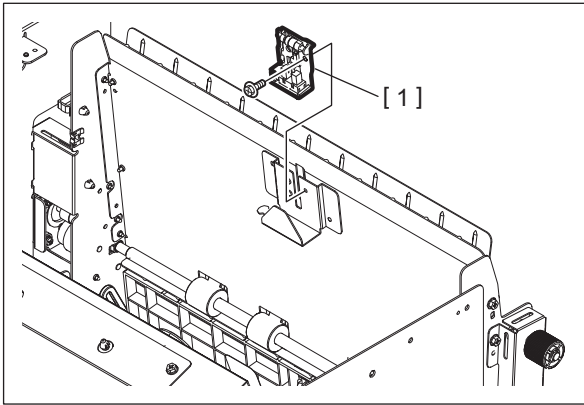

Fig. 4-347

- (4) Release the latch, and then take off the transport path-2 sensor [1].

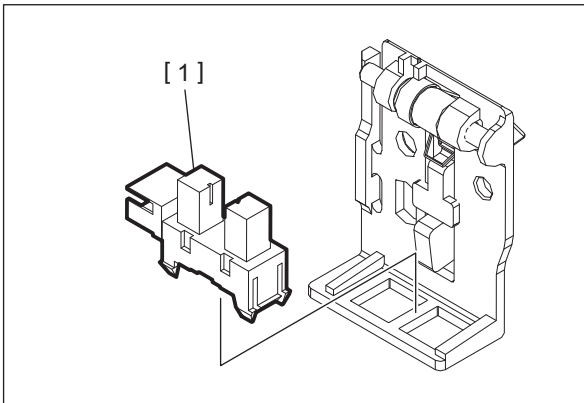

Fig. 4-348

[C] Transport path-3 sensor (S28)

- (1) Open the front upper cover and then pull out the saddle stitch unit.
- (2) Open the transport guide of right side.
- (3) Remove 1 screw, and then disconnect the connector and take off the sensor bracket [1].

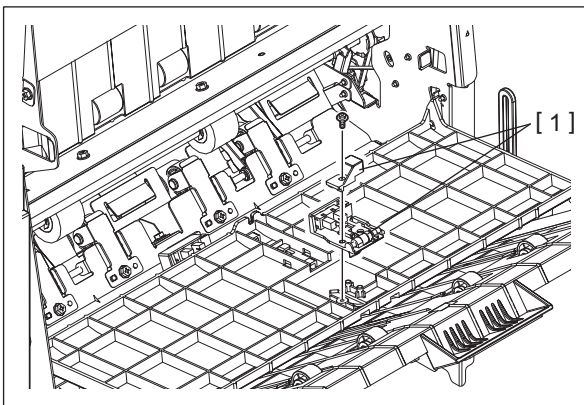

Fig. 4-349

- (4) Release the latch, and then take off the transport path-3 sensor [1].

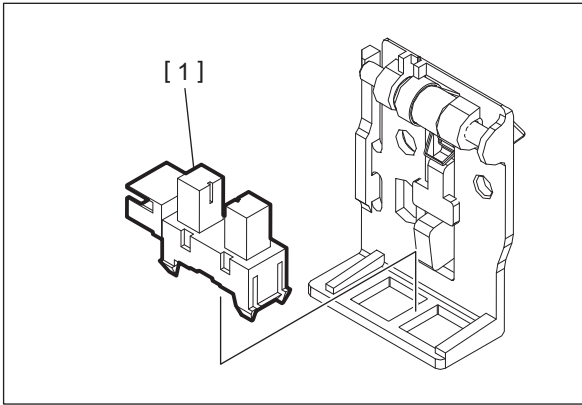

Fig. 4-350

[D] Ejecting roller sensor (S29)

- (1) Open the front upper cover and then pull out the saddle stitch unit.
- (2) Open the transport guide of right side.
- (3) Remove 1 screw, and then disconnect the connector and take off the sensor bracket [1].

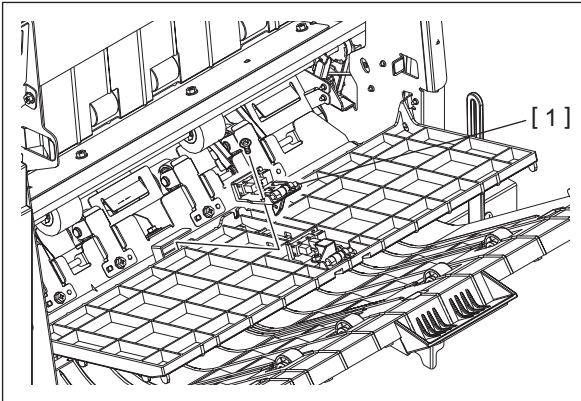

Fig. 4-351

- (4) Release the latch, and then take off the ejecting roller sensor [1].

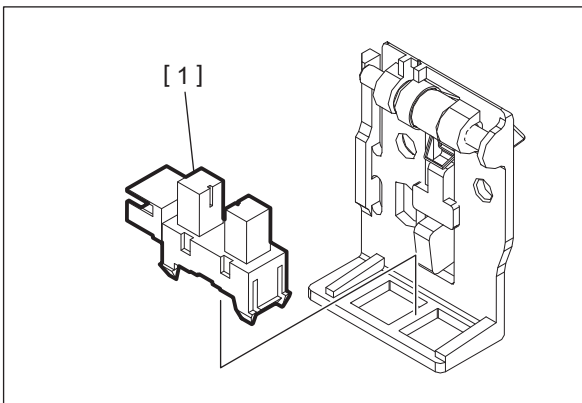

Fig. 4-352

[E] Stacker paper detection sensor (S30)

- (1) Take off the switchback unit.
📖 P. 4-34 "[B] Switchback unit"
- (2) Take off the paper holding unit.
📖 P. 4-35 "[C] Paper holding unit"
- (3) Remove 2 screws of the stacker guide [1].

Notes:

Be careful not to damage the harness fixed on the back side of the stacker guide [1] with a clamp.

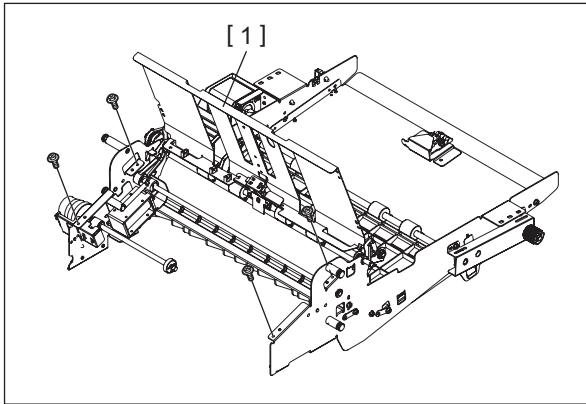

Fig. 4-353

- (4) Release the harness out of 3 clamps [1].
- (5) Remove 2 screws, and take off the sensor bracket [2].

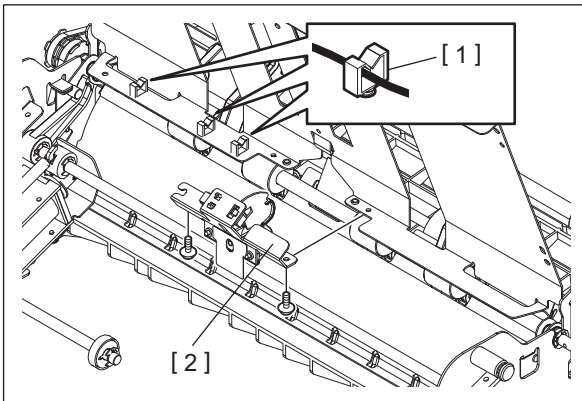

Fig. 4-354

- (6) Release the latch, and then take off the stacker paper detection sensor [1].

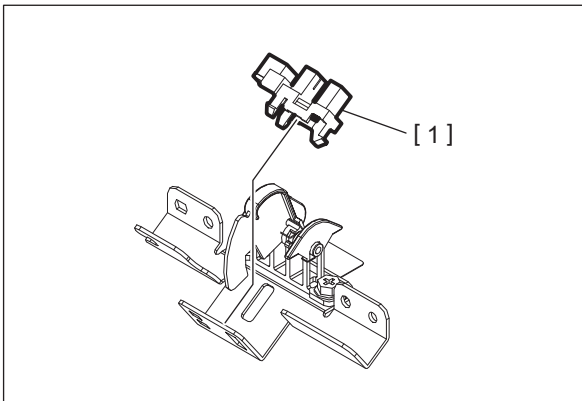

Fig. 4-355

[F] Exit sensor (S31)

- (1) Open the front upper cover and then pull out the saddle stitch unit.
- (2) Remove 1 screw, and then disconnect the connector and take off the sensor bracket [1].

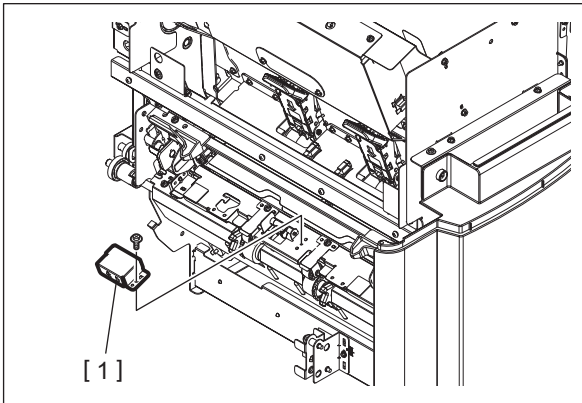

Fig. 4-356

- (3) Release the latch, and then take off the exit sensor [1].

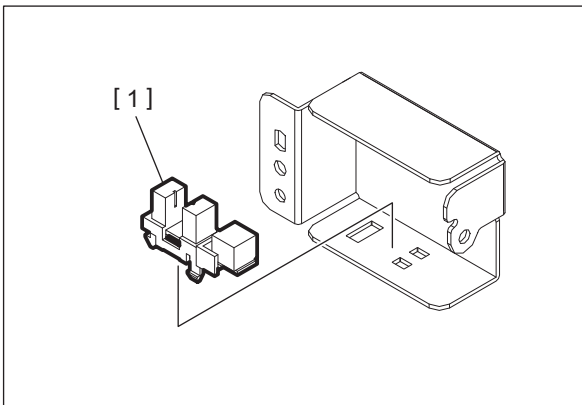

Fig. 4-357

[G] Saddle tray paper detection sensor (S32)

- (1) Open the front upper cover and then pull out the saddle stitch unit.
- (2) Remove 1 screw, and then disconnect the connector and take off the sensor bracket [1].

Notes:

When the sensor was installed, be sure to adjust the position of the sensor bracket [1].

📖 P. 4-32 "[A] Saddle stitch unit"

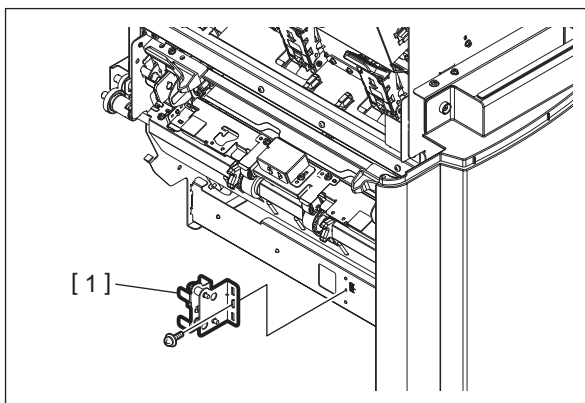

Fig. 4-358

- (3) Release the latch, and then take off the saddle tray paper detection sensor [1].

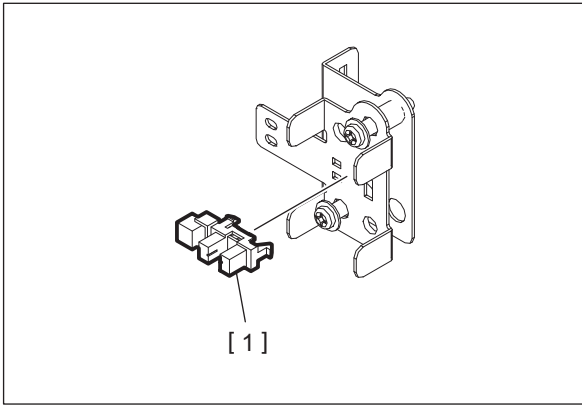

Fig. 4-359

[H] Stacker home position sensor (S33)

- (1) Take off the stacker unit.
📖 P. 4-43 "[H] Stacker unit"
- (2) Move the stacker to the position where the stacker home position sensor [1] is seen.
- (3) Release the latch, and then take off the stacker home position sensor [1].

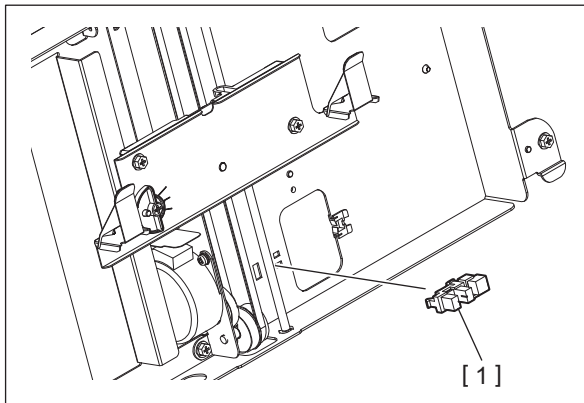

Fig. 4-360

[I] Folding motor encoder sensor (S34)

- (1) Take off the saddle stitch unit.
📖 P. 4-32 "[A] Saddle stitch unit"
- (2) Remove 1 screw, and then disconnect the connector and take off the folding motor encoder sensor [1].

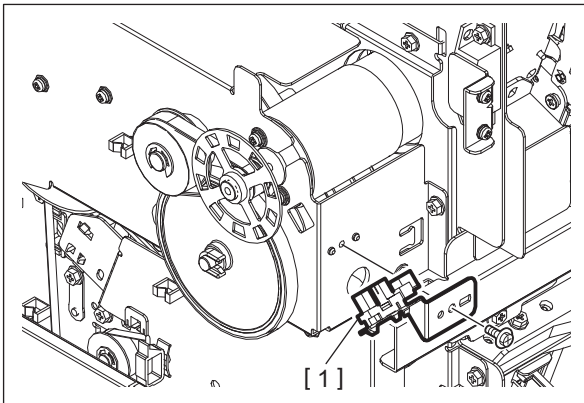

Fig. 4-361

[J] Folding blade home position sensor (S35)

- (1) Open the front upper cover and then pull out the saddle stitch unit.
- (2) Disconnect the connector, and release the latch, and then take off the folding blade home position sensor [1].

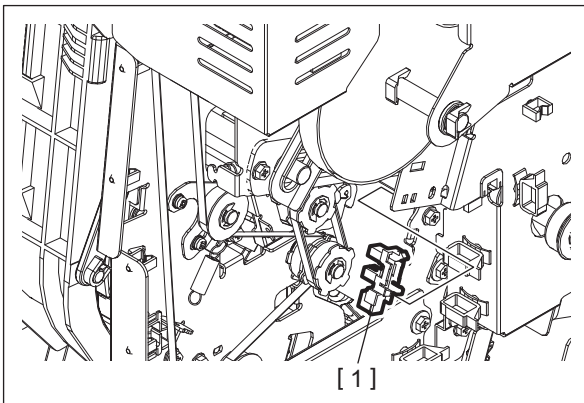

Fig. 4-362

[K] Side alignment home position sensor (S36)

- (1) Open the front upper cover and then pull out the saddle stitch unit.
- (2) Remove 4 screws, and then take off the upper safety cover [1].

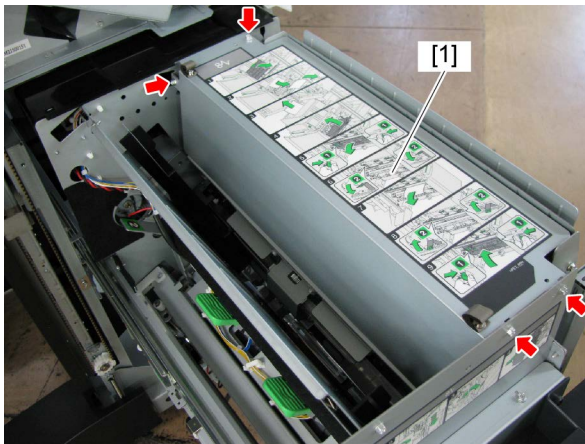

Fig. 4-363

- (3) Move the alignment plates [1] to the center.
- (4) Disconnect the connector, and release the latch, and then take off the side alignment home position sensor [2].

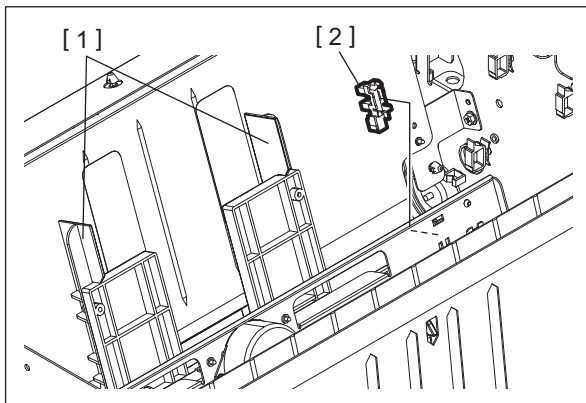

Fig. 4-364

[L] Paper holding home position sensor (S38)

- (1) Take off the paper holding clutch.
📖 P. 4-99 "[C] Paper holding clutch (CLT4)"
- (2) Release the harness out of 2 clamps.
- (3) Remove 1 screw and take off the sensor bracket [1] avoiding the actuator.

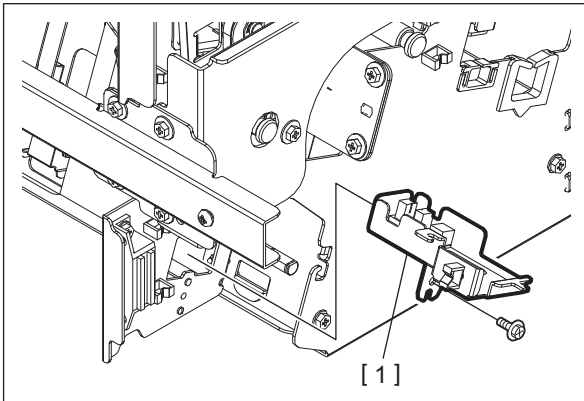

Fig. 4-365

- (4) Disconnect the connector, and release the latch, and then take off the paper holding home position sensor [1].

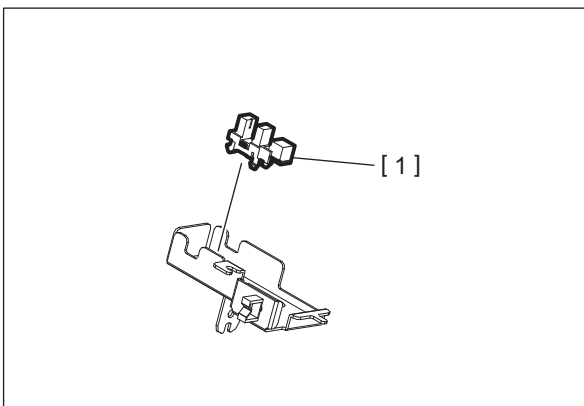

Fig. 4-366

[M] Additional folding home position sensor (S39)

- (1) Take off the EFS unit.
📖 P. 4-42 "[G] EFS unit"
- (2) Rotate the pulley [1] and move the additional folding carrier [2] to the center.
- (3) Disconnect the connector, and release the latch, and then take off the additional folding home position sensor [3].

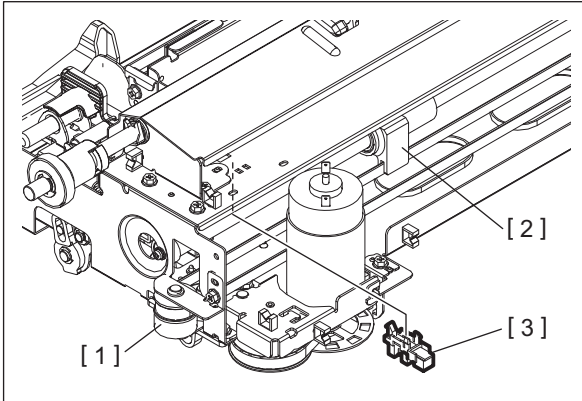

Fig. 4-367

[N] Exit transport sensor (S41)

- (1) Take off the EFS unit.
📖 P. 4-42 "[G] EFS unit"
- (2) Remove 1 screw, and then disconnect the connector and take off the exit transport sensor [1].

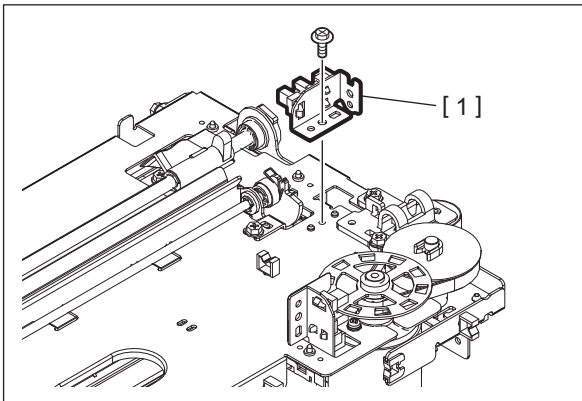

Fig. 4-368

[O] Additional folding motor encoder sensor (S42)

- (1) Take off the additional folding motor.
📖 P. 4-95 "[E] Additional folding motor (M20)"
- (2) Remove 1 screw, and then take off the sensor bracket [1].

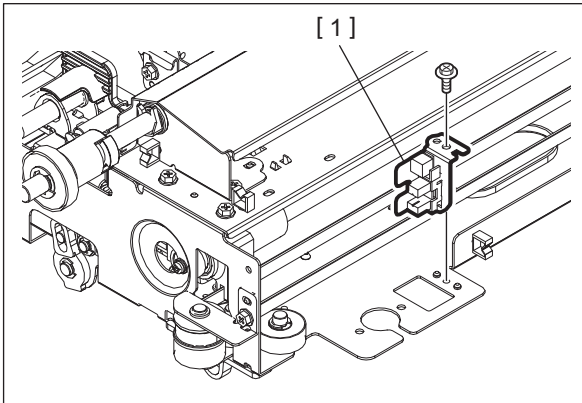

Fig. 4-369

- (3) Release the latch, and then take off the additional folding motor encoder sensor [1].

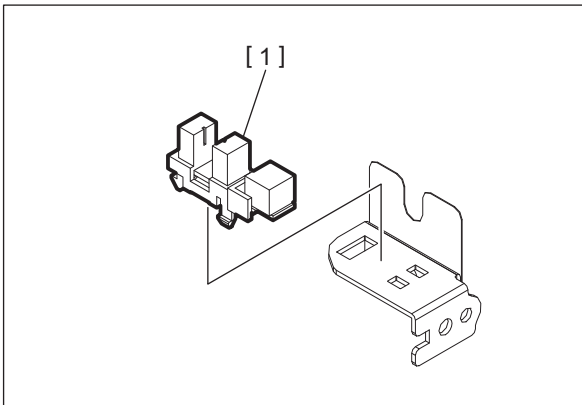

Fig. 4-370

[P] Saddle stitch unit opening/closing switch (SW5)

- (1) Open the front upper cover and then pull out the saddle stitch unit.
- (2) Remove 2 screws, and then disconnect the connector and take off the sensor bracket [1].

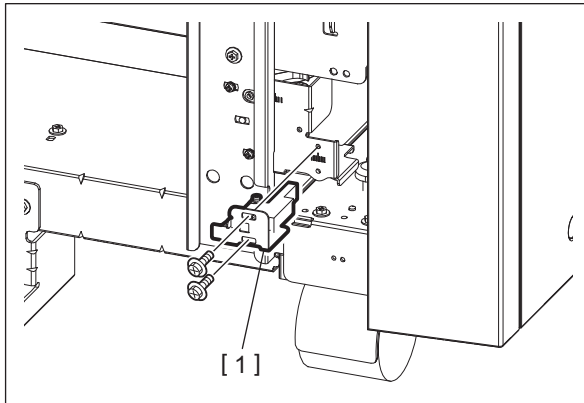

Fig. 4-371

- (3) Remove 2 screws, and then take off the saddle stitch unit opening/closing switch [1].

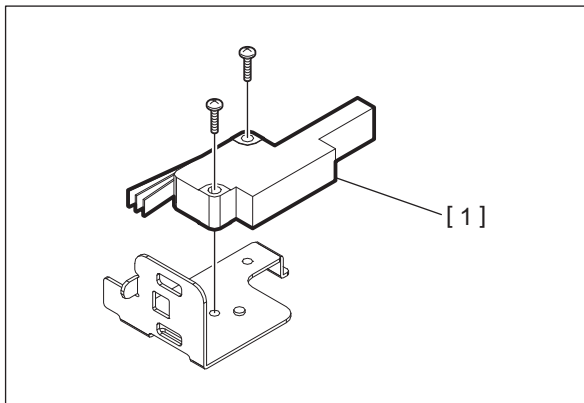

Fig. 4-372

4.11 PC Boards / Discharge Brush

[A] Finisher control PC board (FIN board)

Notes:

After the Finisher control PC board (FIN board) has been replaced, check that the firmware is the latest version. If not, upgrade it.

For updating firmware of the finisher, refer to "FIRMWARE UPDATING" in the Service Manual for MFP.

- (1) Take off the rear cover.
📖 P. 4-7 "[G] Rear cover"
- (2) Remove 1 screw and take off the grounding wire [1].
- (3) Release the PC board cover [2] from 2 harness clamps [3].

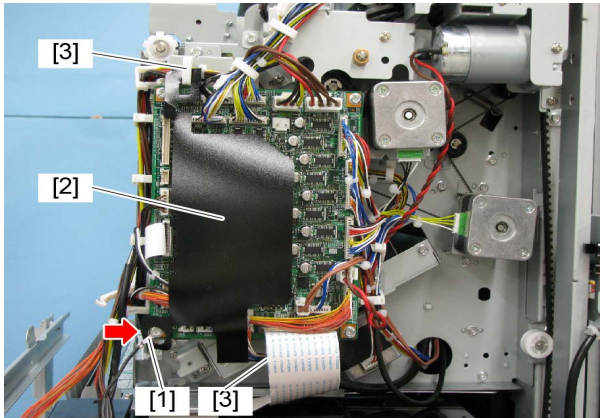

Fig. 4-373

- (4) Disconnect all connectors connecting to the FIN board [4].
- (5) Remove 4 screws, and then take off the FIN board [4].

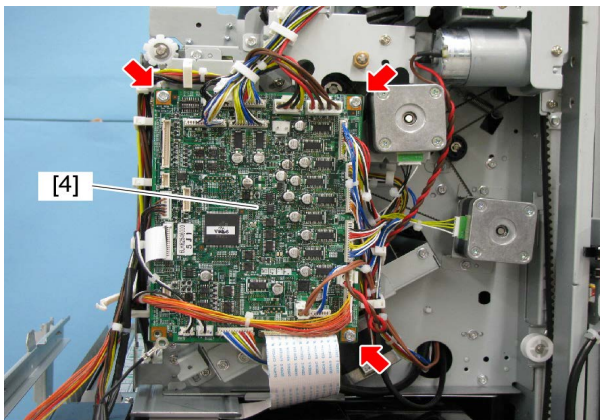

Fig. 4-374

[B] Saddle control PC board (SDL board) (MJ-1112)

Notes:

After the Saddle control PC board (SDL board) has been replaced, check that the firmware is the latest version. If not, upgrade it.

For updating firmware of the finisher, refer to "FIRMWARE UPDATING" in the Service Manual for MFP.

- (1) Take off the rear cover.

📖 P. 4-7 "[G] Rear cover"

- (2) Remove 1 flat cable clamp [3] and disconnect 1 flat cable [4] from the connector (CN5) on the saddle control PC board.

Notes:

- When installing, firmly insert the flat cable [4] into the connector and be sure to align the flat cable clamp [3] to the black line [5] on the flat cable.
- When installing the flat cable, do not push it too strongly.
- When installing the flat cable, carefully insert it straight.
- Pay attention not to apply a load to the tip of the flat cable or not to damage it.

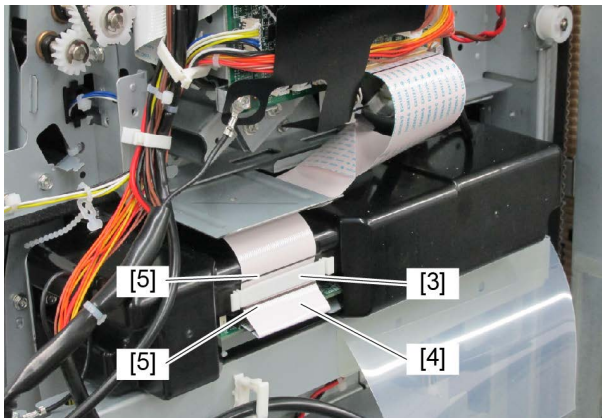

Fig. 4-375

- (3) Remove 2 screws and take off the saddle control PC board cover [6].

Notes:

When installing, be sure to secure the holes [7] on the cover with 3 hooks on the frame.

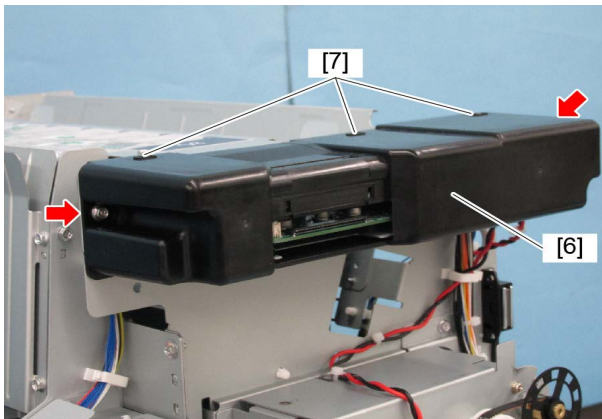

Fig. 4-376

- (4) Disconnect all the connectors connected to the saddle control PC board [8].

- (5) Remove 4 screws and take off the saddle control PC board [8].

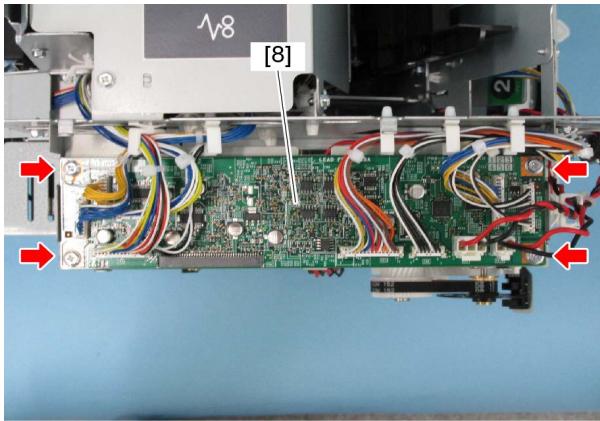

Fig. 4-377

[C] Saddle flat cable (MJ-1112)

- (1) Take off the rear cover.
📖 P. 4-7 "[G] Rear cover"
- (2) Remove 1 flat cable clamp [3] and disconnect 1 flat cable [4] from the connector (CN5) on the saddle control PC board.

Notes:

- When installing, firmly insert the flat cable [4] into the connector and be sure to align the flat cable clamp [3] to the black line [5] on the flat cable.
- When installing the flat cable, do not push it too strongly.
- When installing the flat cable, carefully insert it straight.
- Pay attention not to apply a load to the tip of the flat cable or not to damage it.

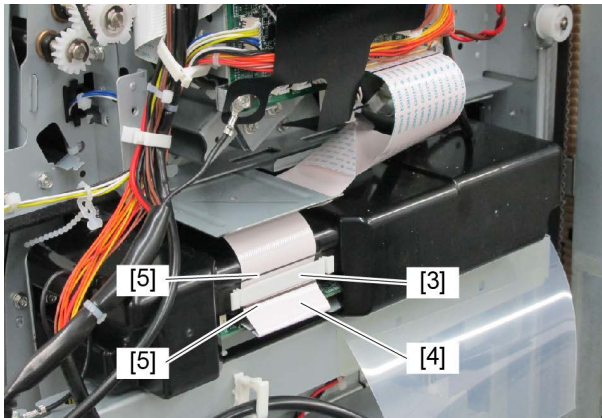

Fig. 4-378

(3) Disconnect 1 flat cable [5] from the connector (CN21) on the finisher control PC board.

Notes:

- When installing, firmly insert the flat cable [5] into the connector.
- When installing the flat cable, do not push it too strongly.
- When installing the flat cable, carefully insert it straight.
- Pay attention not to apply a load to the tip of the flat cable or not to damage it.

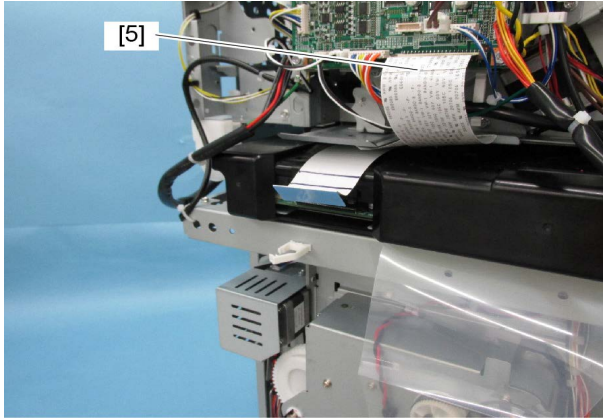

Fig. 4-379

- (4) Open the front upper cover and then pull out the saddle stitch unit.
(5) Remove 2 screws of the front side.

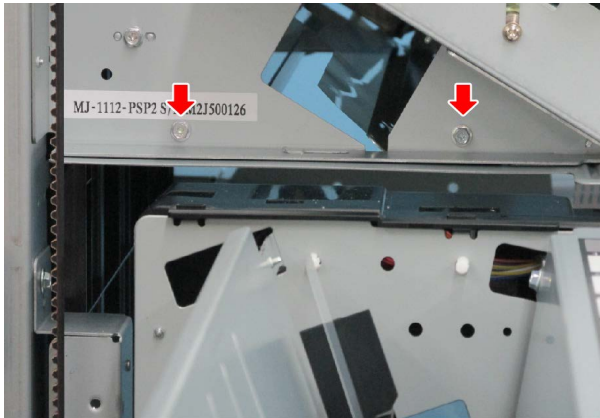

Fig. 4-380

- (6) Remove 2 screws of the rear side. Slide the bracket [6] to the paper inlet side to take it off.

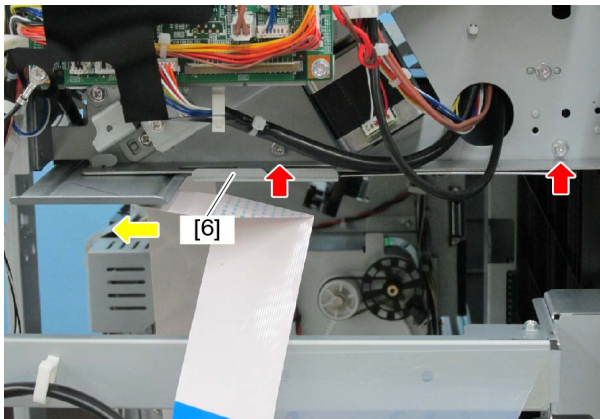

Fig. 4-381

Notes:

When installing, pay attention not to get the Mylar [7] under the frame [8].

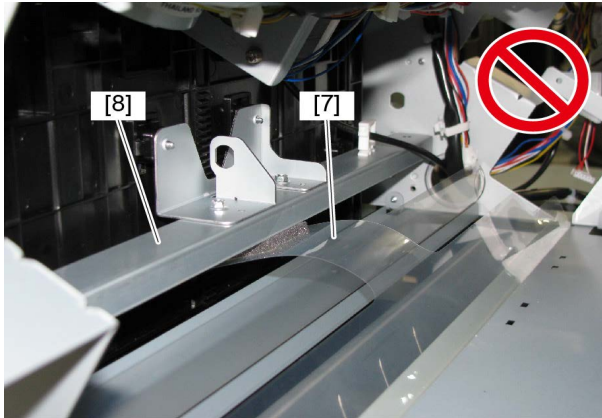

Fig. 4-382

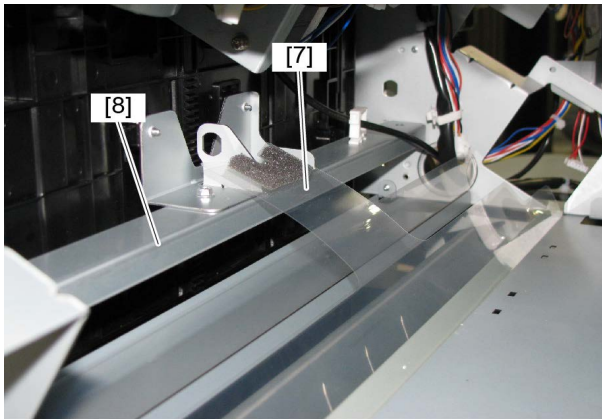

Fig. 4-383

[D] Front stationary tray discharge brush / Rear stationary tray discharge brush

- (1) Take off the stationary tray.
📖 P. 4-1 "[A] Stationary tray"
- (2) Loosen 1 side screw. Remove 2 screws, and then take off the front stationary tray discharge brush.

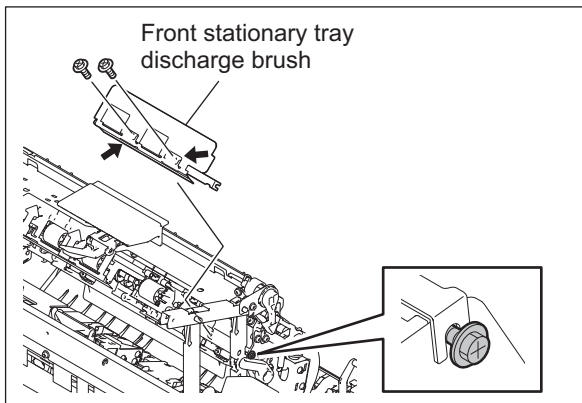

Fig. 4-384

- (3) Loosen 1 side screw. Remove 2 screws, and then take off the rear stationary tray discharge brush.

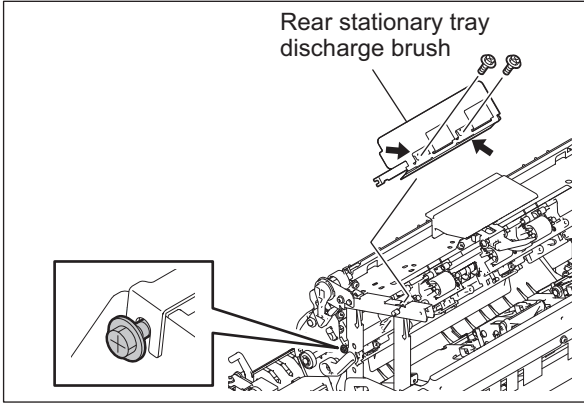

Fig. 4-385

4.12 Procedure for lowering the movable tray

The movable tray can be lowered by releasing its driving gear without disassembling the finisher.

- (1) Pull out the jam access cover [1] and open the stationary tray [2].

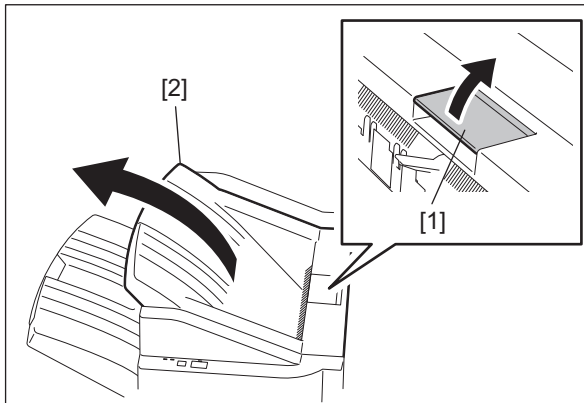

Fig. 4-386

- (2) While the movable tray [1] is held with your hand, insert the screwdriver in the hole-B on the rear cover.

Notes:

- Be sure to hold the movable tray with your hands because it may fall when the screwdriver is pushed.
- Use a screwdriver with a diameter of 8 mm or less.

Remarks:

Since the insertion of the screwdriver has released the driving gear of the movable tray [1], it can now be lowered. If the screwdriver is taken out, the movable tray [1] will stop in that particular position.

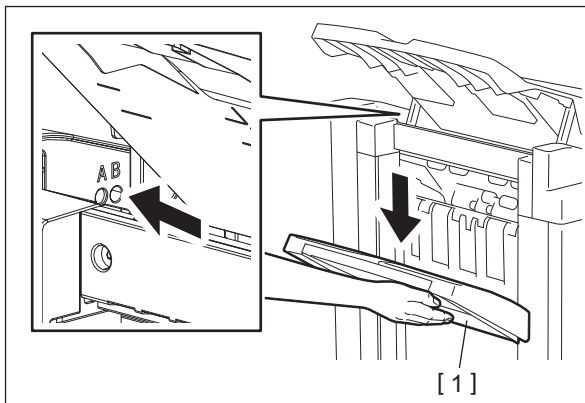

Fig. 4-387

(3) The movable tray can be moved upward without being released by the screwdriver.

Notes:

Be sure that the movable tray does not stay above its paper-full sensor. If printing is performed with the sensor turned ON, "Movable tray paper-full detection error" (CB31) will occur. The movable tray must be moved lower than the sensor.

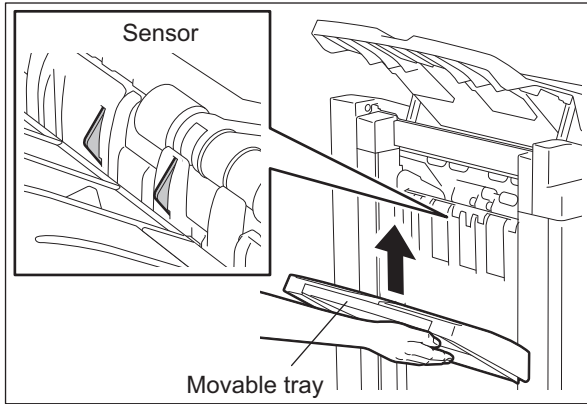

Fig. 4-388

5. ADJUSTMENTS

Notes:

Before performing each adjustment, make sure that all covers (incl. those of the finisher and host machine) are closed. Otherwise, the power is not supplied to the finisher and the adjustment may not be performed properly.

5.1 Adjusting the Aligning Position for the Finishing Tray

Perform this adjustment after replacing the Finisher control board or when the alignment position must be changed for some reasons.

[A] Reading/writing of the adjustment value with the self-diagnostic mode

Item to be adjusted		Code	Remarks
Horizontal position of the paper	A-series paper	FS-05-4838-1	0: Finisher not installed 1: -2.10mm 2: -1.68mm 3: -1.26mm 4: -0.84mm
	LT-series paper	FS-05-4838-2	5: -0.42mm 6: 0.00mm 7: +0.42mm 8: +0.84mm 9: +1.26mm 10: +1.68mm 11: +2.10mm

If the adjustment values can be confirmed from the pre-change board during its replacement, read them from the connected equipment and then enter them into the post-change one.

A4-size adjustment value check: Perform FS-05-4838-1.

LT-size adjustment value check: Perform FS-05-4838-2.

If the adjustment values cannot be confirmed, perform "[B] Adjustment with DIP-SW".

[B] Adjustment with DIP-SW

Adjustment must be performed with 2 types of adjustment sheets for the A4 and LT series.

The adjustment value of A4 will be applied to the operation with A3, A4, A4-R, B4, B5, FOLIO, 8K, 16K.

The adjustment value of LT will be applied to the operation with LD, LG, LT, LT-R, COMP, 13 LG, 8.5" SQ.

- (1) Turn OFF the power of the equipment.
- (2) Remove 2 screws and take off the board access cover.

- (3) Set the SW1 on the Finisher control board as shown in the figures below.

Adjusting for A4 size paper: Turn ON pins 2 and 4.

Adjusting for LT size paper: Turn ON pins 1, 2, and 4.

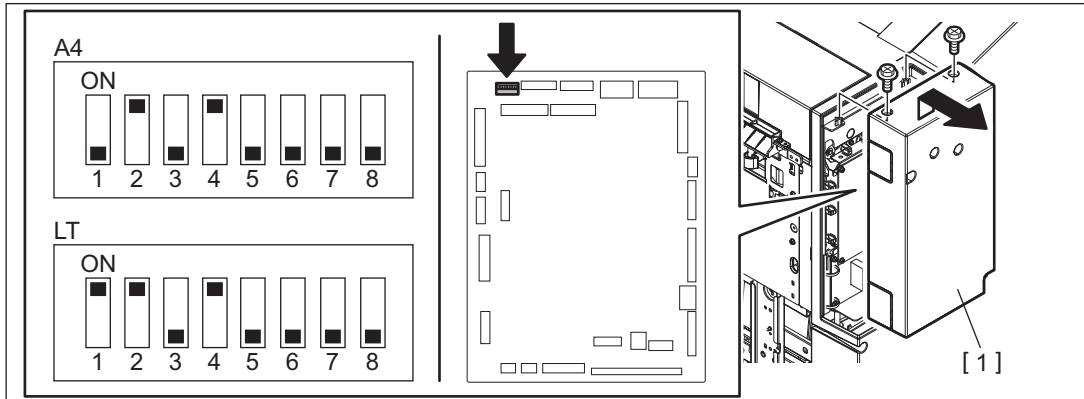

Fig.5-1

- (4) Start the equipment in the HS mode.
The alignment plate moves to the SW1 set position and then stops.
- (5) Press [Button1] to adjust the alignment position.
Every time [Button1] is pressed, the alignment plate shifts by 0.42 mm.
(The gap between the alignment plates becomes narrower.)

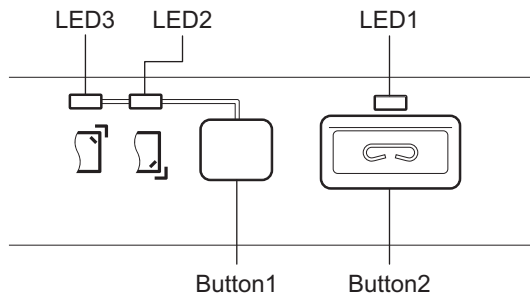

Fig.5-2

- (6) Place the adjustment sheet [1] on the process tray and adjust the position to make the gap between paper and the alignment plate [2] "0".
Then setting is performed at a value that is one smaller than the adjustment value.

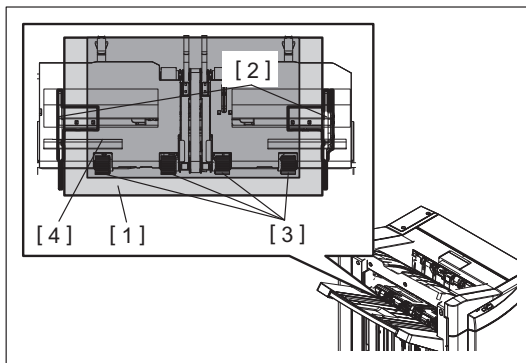

Fig.5-3

Remarks:

- Use an adjustment sheet [1] made of plastic resin which is light and accurate in measurement (e.g. OHP film).
- To reduce frictional resistance with the vertical alignment roller [3] on the process tray, place a sheet of B5 paper [4] beneath the adjustment sheet [1] on the vertical alignment roller [3].
- Confirm the gap between paper and the alignment plate [2] by moving the adjustment sheet [1] forward and backward.

(7) When the adjustment is completed, press [Button2] on the finisher control panel to store the adjustment value in memory.

When the value is stored normally, [LED1] on the control panel will blink for the number of times that corresponds to the adjustment value set for the equipment.

See the following table for the number of times [LED1] blinks and its corresponding moved amount (mm).

Number of Blinking	Distance from the center value (mm)
1	-2.10
2	-1.68
3	-1.26
4	-0.84
5	-0.42
6	Center value (0.00)
7	+0.42
8	+0.84
9	+1.26
10	+1.68
11	+2.10

(8) Turn OFF the power of the equipment.

(9) Turn OFF all bits of the SW1 on the Finisher control board.

(10) Install the board access cover.

5.2 Adjusting the Stapling Position

Perform this adjustment after replacing the Finisher control board or when the stapling position must be changed for some reasons.

[A] Reading/writing of the adjustment value with the self-diagnostic mode

Item to be adjusted	Code	Remarks
Stapling position	FS-05-4838-3	0: Finisher not installed 1: -2.16mm 2: -1.89mm 3: -1.62mm 4: -1.35mm 5: -1.08mm 6: -0.81mm 7: -0.54mm 8: -0.27mm 9: 0.00mm 10: +0.27mm 11: +0.54mm 12: +0.81mm 13: +1.08mm 14: +1.35mm 15: +1.62mm 16: +1.89mm 17: +2.16mm

If the adjustment values can be confirmed from the pre-change board during its replacement, read them from the connected equipment and then enter them into the post-change one.

Adjustment value check (common for A4-size and LT-size): Perform FS-05-4838-3.

If the adjustment values cannot be confirmed, perform "[B] Adjustment with DIP-SW".

[B] Adjustment with DIP-SW

- (1) Turn OFF the power of the equipment.
- (2) Remove 2 screws and take off the board access cover.
- (3) Set the SW1 on the Finisher control board as shown in the figures below.

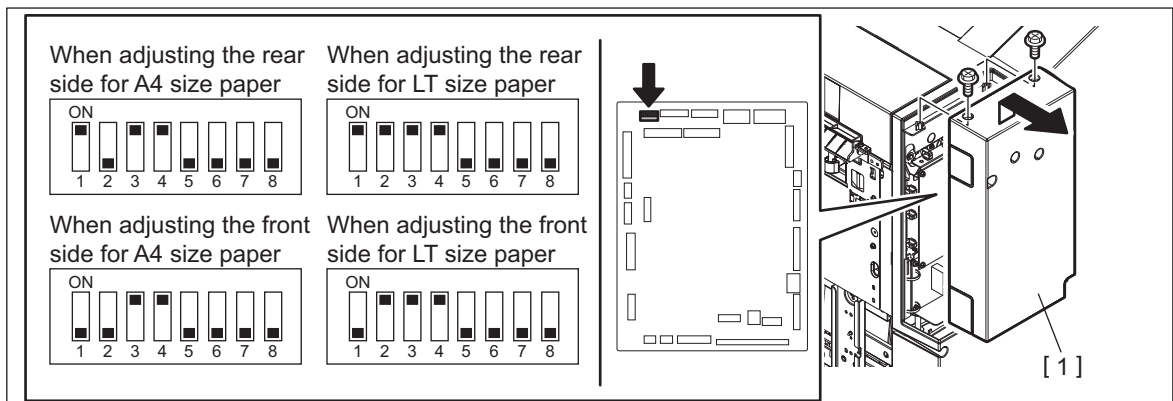

Fig.5-4

- When adjusting the rear side for A4 size paper: Turn ON pins 1, 3, and 4.
- When adjusting the front side for A4 size paper: Turn ON pins 3 and 4.
- When adjusting the rear side for LT size paper: Turn ON pins 1, 2, 3, and 4.
- When adjusting the front side for LT size paper: Turn ON pins 2, 3, and 4.

Remarks:

Although there are four setting types for the SW1 as shown above, perform only one of them since the adjustment values are used in common.

- (4) Start the equipment in the HS mode.
The staple unit moves to the rear or front side stapling position and stops. (It stops at the position of -2.16 mm (at the front side) from the center value of the adjustment range.)
- (5) Press [Button 1] to adjust the stapling position.
Every time [Button 1] is pressed, the staple unit shifts by +0.27 mm (toward the rear side).
Adjustment range is from -2.16 to +2.16 mm. If [Button 1] is pressed when the alignment position is at +2.16 mm, the unit will return to -2.16 mm.

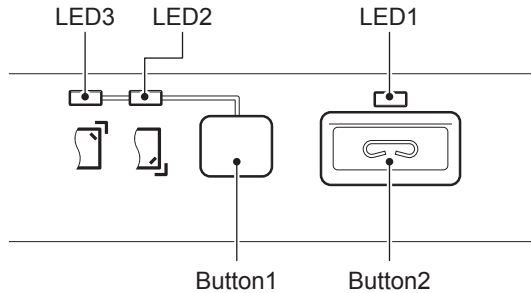

Fig.5-5

- (6) When the adjustment is completed, press [Button 2] on the finisher control panel to store the adjustment value in memory without sheets on the finishing tray.
When the value is stored normally, [LED 1] on the control panel will blink for a number of times that corresponds to the adjustment value set for the equipment.
See the following table for the number of times [LED 1] blinks and its corresponding adjustment value.

Number of blinking	Distance from the center value (mm)
1	-2.16
2	-1.89
3	-1.62
4	-1.35
5	-1.08
6	-0.81
7	-0.54
8	-0.27
9	Center value (0.00)
10	+0.27
11	+0.54
12	+0.81
13	+1.08
14	+1.35
15	+1.62
16	+1.89
17	+2.16

- (7) Turn OFF the power of the equipment.
- (8) Turn OFF all bits of the SW1 on the Finisher control board.
- (9) Install the board access cover.

5.3 Stapling/folding position adjustment in saddle stitch unit

Perform this adjustment when the saddle control PC board was replaced or the stapling/folding position must be changed for some reason.

Prepare 2 types of booklet samples using the main unit and use them for adjustment accordingly.

- (1) Create 2 types of booklet samples (1 set each) using the main unit.

	Sample 1	Sample 2
Media type	Recommended plain paper	Recommended plain paper
Paper size	A4	A3
Number of sheets	5 sheets	5 sheets

- (2) Measure the stapling and folding positions of the samples, and then perform adjustment accordingly.

For stapling and folding, paper on the stacker of the stacker unit is moved to an exclusive mechanism for stapling or folding. Therefore adjustment must be performed individually for the folding stopping position of the stacker and the stapling stopping position.

- * Check the folding position at the centerfold page of the sample.

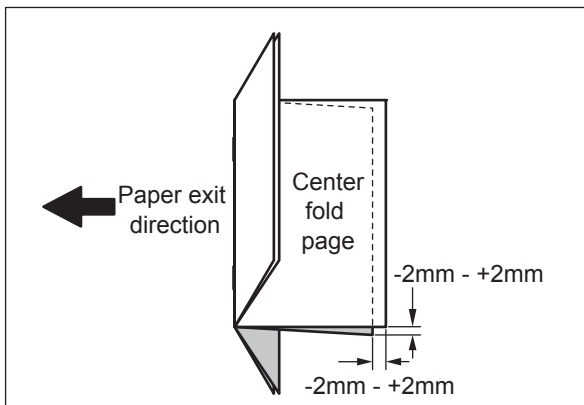

Fig.5-6

- * Check the stapling position at the centerfold page of the sample.

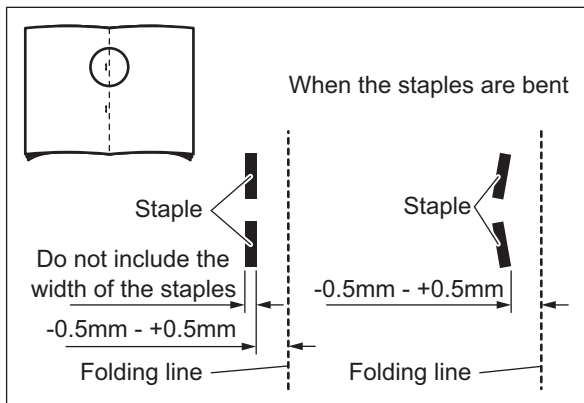
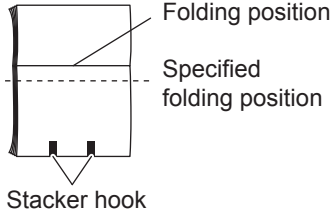
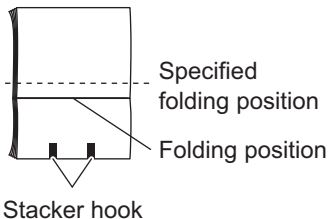
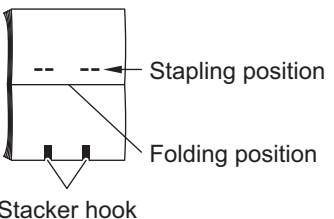
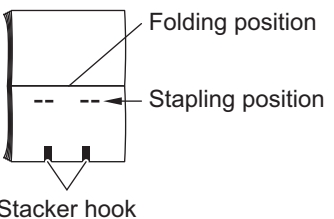

Fig.5-7

Notes:

Perform adjustment for the folding position first because the stapling position must be adjusted referring to the folding line.

Phenomenon	Contents	Adjustment
 <p>Fig.5-8</p>	<p>When the folding position is deviates from the specified one by more than -2.0 mm</p>	<p>Increase the value of the folding position adjustment in order to move the folding stopping position (the position of the stacker hooks) of the stacker upward. P. 5-8 "[A] Folding position adjustment"</p>
 <p>Fig.5-9</p>	<p>When the folding position is deviates from the specified one by more than 2.0 mm</p>	<p>Decrease the value of the folding position adjustment in order to move the folding stopping position (the position of the stacker hooks) of the stacker downward. P. 5-8 "[A] Folding position adjustment"</p>
 <p>Fig.5-10</p>	<p>When the stapling position is deviated from the specified one more than -0.50 mm</p>	<p>Decrease the value of the stapling position adjustment in order to move the stapling stopping position (the position of the stacker hooks) of the stacker downward. P. 5-8 "[B] Stapling position adjustment"</p>
 <p>Fig.5-11</p>	<p>When the stapling position is deviated from the specified one more than 0.50 mm</p>	<p>Increase the value of the stapling position adjustment in order to move the stapling stopping position (the position of the stacker hooks) of the stacker upward. P. 5-8 "[B] Stapling position adjustment"</p>

[A] Folding position adjustment

Perform the adjustment from the connected equipment.

If the adjustment values can be confirmed from the pre-change board, check them from the connected equipment and then set them into the post-change board.

LD-size and A3-size adjustment value check: Perform FS-05-4838-6.

LG-size, B4-size, A4R-size, and 8K-size adjustment value check: Perform FS-05-4838-7.

Horizontal position of the paper		Code	Remarks
Saddle stitch folding position	A3,LD	FS-05-4838-6	Adjusts the saddle stitch folding position in the paper feeding direction. When a positive value is set, it shifts toward the trailing edge of the paper (stacker hook side). When a negative value is set, it shifts toward the leading edge of the paper. 0: Finisher not installed 1: -1.4mm 2: -1.2mm 3: -1.0mm 4: -0.8mm 5: -0.6mm 6: -0.4mm 7: -0.2mm 8: 0.0mm 9: +0.2mm 10: +0.4mm 11: +0.6mm 12: +0.8mm 13: +1.0mm 14: +1.2mm 15: +1.4mm
	Other than A3 and LD	FS-05-4838-7	

[B] Stapling position adjustment

Perform the adjustment from the connected equipment.

If the adjustment values can be confirmed from the pre-change board, check them from the connected equipment and then set them into the post-change board.

LD-size and A3-size adjustment value check: Perform FS-05-4838-4.

LG-size, B4-size, A4R-size, and 8K-size adjustment value check: Perform FS-05-4838-5.

Horizontal position of the paper		Code	Remarks
Saddle stitch stapling position	A3,LD	FS-05-4838-4	Adjusts the saddle stitch folding position in the paper feeding direction. When a positive value is set, it shifts toward the trailing edge of the paper (stacker hook side). When a negative value is set, it shifts toward the leading edge of the paper. 0: Finisher not installed 1: -2.8mm 2: -2.4mm 3: -2.0mm 4: -1.8mm 5: -1.2mm 6: -0.8mm 7: -0.4mm 8: 0.0mm 9: +0.4mm 10: +0.8mm 11: +1.2mm 12: +1.6mm 13: +2.0mm 14: +2.4mm 15: +2.8mm
	Other than A3 and LD	FS-05-4838-5	

5.4 Saddle Stitch Skew Adjustment

Perform this adjustment when the folding position for saddle stitching is tilted.

- (1) Turn OFF the power of the equipment.
- (2) Open the cover, pull out the saddle stitch section, and then loosen the 2 screws.

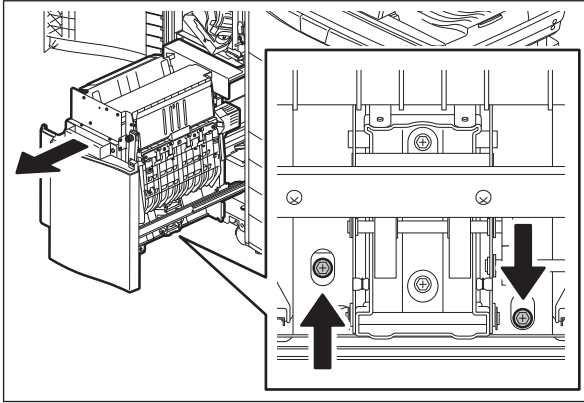
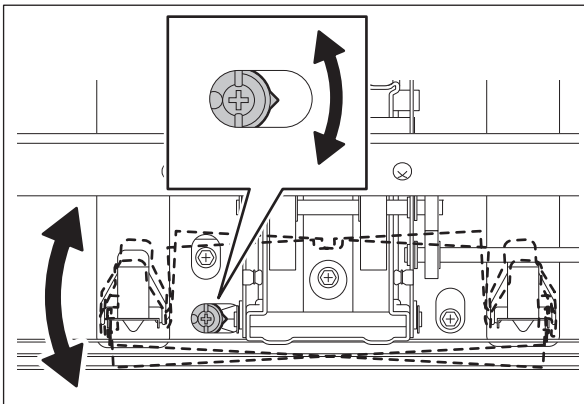
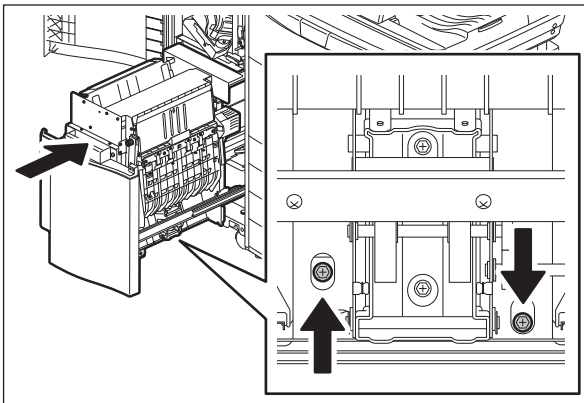

Fig.5-12

- (3) Rotate the adjustment screw slightly.



- (4) Tighten the 2 screws, return the saddle stitch section, and then close the cover.



6. TROUBLESHOOTING

Notes:

When an earth cable of the equipment is not connected securely, paper leading edge might be stapled or the position of Saddle Stitch Finisher folding might be misaligned.

If these problems occur, make sure that the earth cable of the equipment is connected securely.

You can check the operations of electric parts (motors, clutches, solenoids, sensors and switches) with self-diagnostic modes. (📖 P. 6-52 "6.3 Self-Diagnostic Modes")

Notes:

When an abnormal noise occurs in the grate-shaped guide or the trailing edge of the paper stacked on the tray is dirty, apply coating material (SANKOL CFD-409M) by using a cleaning brush to the portion on the guide with which the paper edge is in contact. (📖 P. 7-1 "7.1 Maintenance and Inspection Points")

6.1 Error Code List

The following error codes are displayed at the upper right of the screen when the "CLEAR PAPER" or "CALL SERVICE" symbol is blinking.

Remarks:

Elision character of the "Error code display media"

Panl: Operation panel

JLog: JobLog (TopAccess Print Log - Scan Log)

ML: Message Log (TopAccess Message Log)

Noti: Notification

CSV: CSV output (List print)

Y: Yes

2nd: An error status has been detected twice (= error code has been determined)

6.1.1 Jam

Error code	Classification	Message	Contents	Error code display media					Troubleshooting
				Panl	JL	ML	Noti	CSV	
E9F0	Finisher jam (Puncher unit)	Hole Punch Unit Jam in Finisher - Please Clear Hole Punch.	[MJ-6106] Paper jam at the hole punch unit	Y	-	Y	Y	-	P. 6-21
EA10	Finisher jam (Finisher section)	Paper Jam in Finisher - Please Clear Paper Path.	Paper transport delay non-inserting jam	Y	-	Y	Y	-	P. 6-7
EA20	Finisher jam (Finisher section)	Paper Jam in Finisher - Please Clear Paper Path.	Paper stopping jam	Y	-	Y	Y	-	P. 6-7
EA21	Finisher jam (Finisher section)	Paper Jam in Finisher - Please Clear Paper Path.	Paper size error jam:	Y	-	Y	Y	-	P. 6-8
EA22	Finisher jam (Finisher section)	Paper Jam in Finisher - Please Clear Paper Path.	[MJ-6106] Paper size error jam (paper position sensor)	-	-	Y	Y	-	P. 6-9
EA23	Finisher jam (Finisher section)	Paper Jam in Finisher - Please Clear Paper Path.	Paper stopping jam (Paper being transported on the finisher transport path is stopped at the transport sensor.):	-	-	Y	Y	-	P. 6-9

Error code	Classification	Message	Contents	Error code display media					Troubleshooting
				Pani	JL	ML	Noti	CSV	
EA24	Finisher jam (Finisher section)	Paper Jam in Finisher - Please Clear Paper Path.	Paper stopping jam (between the entrance and transport sensors):	-	-	Y	Y	-	P. 6-10
EA25	Finisher jam (Finisher section)	Paper Jam in Finisher - Please Clear Paper Path.	Paper stopping jam (after the exiting of a stack of the paper is completed)	-	-	Y	Y	-	P. 6-10
EA26	Finisher jam (Finisher section)	Paper Jam in Finisher - Please Clear Paper Path.	Paper stopping jam (stop command request)	-	-	Y	Y	-	P. 6-11
EA27	Finisher jam (Finisher section)	Paper Jam in Finisher - Please Clear Paper Path.	Paper stopping jam (The entrance sensor is turned ON in a slower timing than that specified.)	-	-	Y	Y	-	P. 6-11
EA28	Finisher jam (Finisher section)	Paper Jam in Finisher - Please Clear Paper Path.	Paper stopping jam (paper holder plate operation delay)	-	-	Y	Y	-	P. 6-11
EA29	Finisher jam (Finisher section)	Paper Jam in Finisher - Please Clear Paper Path.	Paper stopping jam (stack transport operation delay)	-	-	Y	Y	-	P. 6-12
EA31	Finisher jam (Finisher section)	Paper Jam in Finisher - Please Clear Paper Path.	Paper remaining jam in the transport path	Y	-	Y	Y	-	P. 6-12
EA32	Finisher jam (Finisher section)	Paper Jam in Finisher - Please Clear Paper Path.	Paper remaining jam at the paper exit	Y	-	Y	Y	-	P. 6-13
EA40	Finisher jam (Finisher section)	Paper Jam in Finisher - Please Clear Paper Path.	Cover open error	Y	-	Y	Y	-	P. 6-13
EA50	Finisher jam (Finisher section)	Staple Jam in Finisher - Please Clear Staple.	Stapling jam	Y	-	Y	Y	-	P. 6-14
EA60	Finisher jam (Finisher section)	Paper Jam in Finisher - Please Clear Paper Path.	Early arrival jam	Y	-	Y	Y	-	P. 6-16
EA70	Finisher jam (Finisher section)	Paper Jam in Finisher - Please Clear Paper Path.	Stack exit belt home position error	Y	-	Y	Y	-	P. 6-16
EA90	Finisher jam (Saddle Stitch section)	Paper Jam in Finisher - Please Clear Paper Path.	[MJ-1112] Door open jam	Y	-	Y	Y	-	P. 6-17
EAA0	Finisher jam (Saddle Stitch section)	Paper Jam in Finisher - Please Clear Paper Path.	[MJ-1112] Paper remaining jam in the saddle stitch unit	Y	-	Y	Y	-	P. 6-17
EAB0	Finisher jam (Saddle Stitch section)	Paper Jam in Finisher - Please Clear Paper Path.	[MJ-1112] Paper transport jam in the saddle stitch unit	Y	-	Y	Y	-	P. 6-18
EAB1	Finisher jam (Saddle Stitch section)	Paper Jam in Finisher - Please Clear Paper Path.	[MJ-1112] Short paper jam in the saddle stitch unit	Y	-	Y	Y	-	P. 6-19
EAFa	Finisher jam	Paper Jam in Finisher - Please Clear Paper Path.	Catching motor home position detection error (paper jam)	-	-	-	-	-	P. 6-37

Error code	Classification	Message	Contents	Error code display media					Troubleshooting
				Pani	JL	ML	Noti	CSV	
EAFB	Finisher jam	Paper Jam in Finisher - Please Clear Paper Path.	Stapler movement error (paper jam)	-	-	-	-	-	P. 6-41
E AFC	Finisher jam	Paper Jam in Finisher - Please Clear Paper Path.	Movable tray height error (paper jam)	-	-	-	-	-	P. 6-37
EAFD	Finisher jam	Paper Jam in Finisher - Please Clear Paper Path.	Movable tray movement error (paper jam)	-	-	-	-	-	P. 6-38
EAFE	Finisher jam	Paper Jam in Finisher - Please Clear Paper Path.	Paper holding cam position error (paper jam)	-	-	-	-	-	P. 6-36
ED10	Finisher jam	Paper Jam in Finisher - Please Clear Paper Path.	[MJ-6106] Skew adjustment motor (M1) home position detection error	Y	-	Y	Y	-	P. 6-22
ED11	Finisher jam	Paper Jam in Finisher - Please Clear Paper Path.	[MJ-6106] Sideways adjustment motor (M2) home position detection error	Y	-	Y	Y	-	P. 6-22
ED13	Finisher jam	Paper Jam in Finisher - Please Clear Paper Path.	Front alignment plate home position error	Y	-	Y	Y	-	P. 6-22
ED14	Finisher jam	Paper Jam in Finisher - Please Clear Paper Path.	Rear alignment plate home position error	Y	-	Y	Y	-	P. 6-23
ED15	Finisher jam	Paper Jam in Finisher - Please Clear Paper Path.	Paddle home position error	Y	-	Y	Y	-	P. 6-23
ED16	Finisher jam	Paper Jam in Finisher - Please Clear Paper Path.	Buffer tray home position error	Y	-	Y	Y	-	P. 6-24
EF10	Finisher jam (Saddle Stitcher section)	Paper Jam in Finisher - Please Clear Paper Path.	[MJ-1112] Selection of unsupported paper for the saddle stitch unit	Y	-	Y	Y	-	P. 6-24
EF11	Finisher jam (Saddle Stitcher section)	Paper Jam in Finisher - Please Clear Paper Path.	[MJ-1112] Stapling error (front) in the saddle stitch unit	Y	-	Y	Y	-	P. 6-24
EF12	Finisher jam (Saddle Stitcher section)	Paper Jam in Finisher - Please Clear Paper Path.	[MJ-1112] Stapling error (rear) in the saddle stitch unit	Y	-	Y	Y	-	P. 6-25
EF13	Finisher jam (Saddle Stitcher section)	Paper Jam in Finisher - Please Clear Paper Path.	[MJ-1112] Paper holder home position detection error in the saddle stitch unit	Y	-	Y	Y	-	P. 6-25
EF14	Finisher jam (Saddle Stitcher section)	Paper Jam in Finisher - Please Clear Paper Path.	[MJ-1112] Paper exit jam in the saddle stitch unit	Y	-	Y	Y	-	P. 6-26
EF15	Finisher jam (Saddle Stitcher section)	Paper Jam in Finisher - Please Clear Paper Path.	[MJ-1112] Side alignment motor home position detection error in the saddle stitch unit	Y	-	Y	Y	-	P. 6-31

Error code	Classification	Message	Contents	Error code display media					Troubleshooting
				Pani	JL	ML	Noti	CSV	
EF16	Finisher jam (Saddle Stitcher section)	Paper Jam in Finisher - Please Clear Paper Path.	[MJ-1112] Stacker motor home position detection error in the saddle stitch unit	Y	-	Y	Y	-	P. 6-32
EF17	Finisher jam (Saddle Stitcher section)	Paper Jam in Finisher - Please Clear Paper Path.	[MJ-1112] Folding blade home position detection error in the saddle stitch unit	Y	-	Y	Y	-	P. 6-32
EF18	Finisher jam (Saddle Stitcher section)	Paper Jam in Finisher - Please Clear Paper Path.	[MJ-1112] Additional folding roller home position detection error in the saddle stitch unit	Y	-	Y	Y	-	P. 6-33
EF19	Finisher jam Saddle Stitcher section)	Paper Jam in Finisher - Please Clear Paper Path.	[MJ-1112] Paper folding jam in the saddle stitch unit	Y	-	Y	Y	-	P. 6-33
EF20	Finisher jam Saddle Stitcher section)	Paper Jam in Finisher - Please Clear Paper Path.	[MJ-1112] Stacker jam in the saddle stitch unit	-	-	Y	Y	-	P. 6-34

6.1.2 Service call

Error code	Classification	Message	Contents	Error code display media					Troubleshooting
				Panl	JL	ML	Noti	CSV	
CB00	Finisher related service call	Fatal Error - Please Contact Service Technician.	Finisher detection abnormality	2nd	-	Y	Y	-	P. 6-35
CB10	Finisher related service call	Fatal Error - Please Contact Service Technician.	Entrance motor abnormality	2nd	-	Y	Y	-	P. 6-35
CB11	Finisher related service call	Fatal Error - Please Contact Service Technician.	Buffer tray guide motor abnormality	2nd	-	Y	Y	-	P. 6-35
CB13	Finisher related service call	Fatal Error - Please Contact Service Technician.	Finisher exit motor abnormality	2nd	-	Y	Y	-	P. 6-36
CB14	Finisher related service call	Fatal Error - Please Contact Service Technician.	Paper holding arm motor abnormality	2nd	-	Y	Y	-	P. 6-36
CB15	Finisher related service call	Fatal Error - Please Contact Service Technician.	Catching motor abnormality	2nd	-	Y	Y	-	P. 6-37
CB30	Finisher related service call	Printer Output Error.	Movable tray shift motor abnormality	2nd	-	Y	Y	-	P. 6-37
CB31	Finisher related service call	Fatal Error - Please Contact Service Technician.	Movable tray paper-full detection error.	2nd	-	Y	Y	-	P. 6-38
CB40	Finisher related service call	Printer Output Error.	Front alignment motor abnormality	2nd	-	Y	Y	-	P. 6-38
CB50	Finisher related service call	Printer Output Error.	Stapler home position error	2nd	-	Y	Y	-	P. 6-39
CB51	Finisher related service call	Fatal Error - Please Contact Service Technician.	Stapler shift home position error	2nd	-	Y	Y	-	P. 6-41
CB60	Finisher related service call	Printer Output Error.	Stapler shift motor abnormality	2nd	-	Y	Y	-	P. 6-41
CB80	Finisher related service call	Printer Output Error.	Backup RAM data abnormality	2nd	-	Y	Y	-	P. 6-41
CB81	Finisher related service call	Fatal Error - Please Contact Service Technician.	Flash ROM abnormality	2nd	-	Y	Y	-	P. 6-42
CB82	Finisher related service call	Fatal Error - Please Contact Service Technician.	Finisher - Main CPU program error	2nd	-	Y	Y	-	P. 6-42
CB84	Finisher related service call	Fatal Error - Please Contact Service Technician.	[MJ-6106] Hole punch unit - Main CPU program error	2nd	-	Y	Y	-	P. 6-42
CB93	Finisher related service call	Fatal Error - Please Contact Service Technician.	[MJ-1112] Saddle stitch finisher - Additional folding motor abnormality	2nd	-	Y	Y	-	P. 6-42
CB94	Finisher related service call	Fatal Error - Please Contact Service Technician.	[MJ-1112] Saddle stitch finisher - Transport motor abnormality	2nd	-	Y	Y	-	P. 6-43
CB95	Finisher related service call	Fatal Error - Please Contact Service Technician.	[MJ-1112] Saddle stitch finisher - Stacker motor abnormality	2nd	-	Y	Y	-	P. 6-43

Error code	Classification	Message	Contents	Error code display media					Troubleshooting
				Pani	JL	ML	Noti	CSV	
CBA0	Finisher related service call	Fatal Error - Please Contact Service Technician.	[MJ-1112] Front saddle stapler home position error	2nd	-	Y	Y	-	P. 6-44
CBB0	Finisher related service call	Fatal Error - Please Contact Service Technician.	[MJ-1112] Rear saddle stapler home position error	2nd	-	Y	Y	-	P. 6-44
CBC0	Finisher related service call	Fatal Error - Please Contact Service Technician.	[MJ-1112] Saddle stitch alignment motor abnormality	2nd	-	Y	Y	-	P. 6-45
CBE0	Finisher related service call	Fatal Error - Please Contact Service Technician.	[MJ-1112] Saddle stitch finisher folding motor (M17) abnormality	2nd	-	Y	Y	-	P. 6-45
CC20	Finisher related service call	Fatal Error - Please Contact Service Technician.	[MJ-1112] Saddle stitch communication error	2nd	-	Y	Y	-	P. 6-46
CC30	Finisher related service call	Fatal Error - Please Contact Service Technician.	Stack transport motor abnormality	2nd	-	Y	Y	-	P. 6-46
CC31	Finisher related service call	Fatal Error - Please Contact Service Technician.	Transport motor abnormality	2nd	-	Y	Y	-	P. 6-46
CC41	Finisher related service call	Fatal Error - Please Contact Service Technician.	Paper holder cam home position abnormality	2nd	-	Y	Y	-	P. 6-47
CC51	Finisher related service call	Fatal Error - Please Contact Service Technician.	[MJ-6106] Sideways adjustment motor (M2) abnormality	2nd	-	Y	Y	-	P. 6-47
CC52	Finisher related service call	Fatal Error - Please Contact Service Technician.	[MJ-6106] Skew adjustment motor (M1) abnormality	2nd	-	Y	Y	-	P. 6-48
CC61	Finisher related service call	Fatal Error - Please Contact Service Technician.	[MJ-6106] Punch motor (M3) home position detection error	2nd	-	Y	Y	-	P. 6-48
CC71	Finisher related service call	Fatal Error - Please Contact Service Technician.	[MJ-6106] Punch ROM checksum error	Y	-	Y	Y	-	P. 6-48
CC72	Finisher related service call	Fatal Error - Please Contact Service Technician.	[MJ-6106] Punch RAM read/write error	Y	-	Y	Y	-	P. 6-49
CC80	Finisher related service call	Fatal Error - Please Contact Service Technician.	Rear alignment motor abnormality	2nd	-	Y	Y	-	P. 6-49
CCF1	Finisher related service call	Fatal Error - Please Contact Service Technician.	Tray safety switch abnormality	2nd	-	Y	Y	-	P. 6-49
CDE0	Finisher related service call	Printer Output Error.	Paddle motor abnormality	2nd	-	Y	Y	-	P. 6-50
CE00	Finisher related service call	Fatal Error - Please Contact Service Technician.	[MJ-6106] Communication error between the finisher and the punch unit	2nd	-	Y	Y	-	P. 6-50
CF10	Finisher related service call	Printer Output Error.	Communication module writing failure	2nd	-	Y	Y	-	P. 6-50

6.2 Diagnosis and Prescription for Each Error Code

6.2.1 Check item

Check item	Classification
Sensor check	<ul style="list-style-type: none"> • Check the sensor in the test mode. • Check that there is no dust on the sensor. • Check that the actuator is correctly operated.
Connector check	<ul style="list-style-type: none"> • Check that the connector is not disconnected. • Check that the pins are not deformed and do not come off. • Disconnect and reconnect the connector. Even if the connector is not apparently disconnected, it may be connected loosely. Therefore check carefully that it is secure.
Harness check	<ul style="list-style-type: none"> • Check if the harnesses are open circuited. • Check that the harness is not caught.
Motor check	<ul style="list-style-type: none"> • Check the motor in the test mode. • Check that there is no abnormality in the driving section. • Check that there is no abnormality in the roller.
Board check	<ul style="list-style-type: none"> • Check if the board is short circuited or open circuited. • Check that the boards are installed properly. • Check if the boards are deformed due to a forcible installation.

6

6.2.2 Paper jam in finisher section

[EA10] Transport delay jam (paper not inserted)

Classification	Error content
Paper jam in finisher section	Transport delay jam (paper not inserted)

Check item	Measures
Sensor Paper	Check if there is any paper in the finisher or on the transport path of the equipment and remove it if there is.
Feeding sensor (S22)	Check if there is a disconnection of the connector, incorrect installation or breakage of the feeding sensor (S22). If there is, reinstall the sensor correctly or replace it.
Transport path switching solenoid (SOL5)	Check that the gap between the transfer guide surface and the upper surface of the flapper tip is in the acceptable range according to the status of the transport path switching solenoid (SOL5) (solenoid OFF: 1.5 to 2.1 mm, solenoid ON: 2.3 to 2.9 mm). If it is not, adjust it. Check the harness between the transport path switching solenoid (SOL5) and the finisher controller board (CN1). If there is any abnormality, correct it.
Entrance motor (M1)	Check the harness between the entrance motor (M1) and the finisher controller board (CN17). If there is any abnormality, correct it.
Finisher control PC board (FIN)	<ul style="list-style-type: none"> • Board check • Connector check (CN1, CN17) • Harness check

Parts to be replaced	Remark
Feeding sensor (S22)	
Transport path switching solenoid (SOL5)	
Entrance motor (M1)	
Finisher control PC board (FIN)	

[EA20] Paper transport stop jam (entrance sensor)

Classification	Error content
Paper jam in finisher section	Paper transport stop jam (entrance sensor)

Check item	Measures
Paper	Check if there is any paper in the finisher or on the transport path of the equipment and remove it if there is.
Exit paper sideways deviation	When an exit paper alignment problem occurs during continuous printing in the non-sort mode, take the following countermeasure. Check if exit paper sideways deviation has occurred in the equipment installed. If there is any, adjust it by following the Service Manual for the equipment installed.
Entrance sensor (S1)	<ul style="list-style-type: none"> • Sensor check Check if the actuator moves smoothly. • Connector check • Harness check
Finisher control PC board (FIN)	<ul style="list-style-type: none"> • Board check • Connector check (CN8) • Harness check
Assist guide	Check that there is no abnormality in the adjustment for its height.

Parts to be replaced	Remark
Entrance sensor (S1)	
Finisher control PC board (FIN)	
Assist guide	

[EA21] Paper size error jam (transport sensor)

Classification	Error content
Paper jam in finisher section	Paper size error jam (transport sensor) Paper size error jam (punch paper edge sensor)

Check item	Measures
Paper	<ul style="list-style-type: none"> • Check if there is any paper in the finisher or on the transport path of the equipment and remove it if there is. • Use paper accepted in the specifications.
Exit paper sideways deviation	When an exit paper alignment problem occurs during continuous printing in the non-sort mode, take the following countermeasure. Check if exit paper sideways deviation has occurred in the equipment installed. If there is any, adjust it by following the Service Manual for the equipment installed.
Entrance sensor (S1)	<ul style="list-style-type: none"> • Sensor check Check if the actuator moves smoothly. • Connector check • Harness check
Transport sensor (S2)	<ul style="list-style-type: none"> • Sensor check • Connector check • Harness check
Finisher control PC board (FIN)	<ul style="list-style-type: none"> • Board check • Connector check (CN8) • Harness check

Parts to be replaced	Remark
Entrance sensor (S1)	
Transport sensor (S2)	
Finisher control PC board (FIN)	

[EA22] Paper size error jam (punch paper edge sensor)

Classification	Error content
Paper jam in finisher section	Paper size error jam (transport sensor) Paper size error jam (punch paper edge sensor)

Check item	Measures
Paper	Check if there is any paper in the finisher or on the transport path of the equipment and remove it if there is.
Entrance sensor (S1)	<ul style="list-style-type: none"> • Sensor check Check if the actuator moves smoothly. • Connector check • Harness check
Transport sensor (S2)	<ul style="list-style-type: none"> • Sensor check • Connector check • Harness check
Paper position sensor (Hole punch unit)	<ul style="list-style-type: none"> • Sensor check (S6-1, S6-2) • Connector check (CN1, CN4, CN5) • Harness check
Finisher control PC board (FIN)	<ul style="list-style-type: none"> • Board check • Connector check (CN8) • Harness check

Parts to be replaced	Remark
Entrance sensor (S1)	
Transport sensor (S2)	
Paper position sensor (S6-1, S6-2)	Hole punch unit
Finisher control PC board (FIN)	

[EA23] Paper transport stop jam (Paper being transported on the finisher transport path is stopped at the transport sensor.)

Classification	Error content
Paper jam in finisher section	Paper being transported on the finisher transport path is stopped at the transport sensor.

Check item	Measures
Paper	Check if there is any paper in the finisher or on the transport path of the equipment and remove it if there is.
Exit paper sideways deviation	When an exit paper alignment problem occurs during continuous printing in the non-sort mode, take the following countermeasure. Check if exit paper sideways deviation has occurred in the equipment installed. If there is any, adjust it by following the Service Manual for the equipment installed.
Transport sensor (S2)	<ul style="list-style-type: none"> • Sensor check • Connector check • Harness check
Finisher control PC board (FIN)	<ul style="list-style-type: none"> • Board check • Connector check (CN8) • Harness check

Parts to be replaced	Remark
Transport sensor (S2)	

Parts to be replaced	Remark
Finisher control PC board (FIN)	

[EA24] Paper transport stop jam (between entrance & transport sensor)

Classification	Error content
Paper jam in finisher section	Paper transport stop jam (between entrance and transport sensor)

Check item	Measures
Paper	Check if there is any paper in the finisher or on the transport path of the equipment and remove it if there is.
Pinch roller arm	Check the position of pinch roller arm. If it is down, fix its mechanism.
Transport path switching solenoid (SOL5)	<ul style="list-style-type: none"> Check that the gap between the transfer guide surface and the upper surface of the flapper tip is in the acceptable range according to the status of the transport path switching solenoid (SOL5) (solenoid OFF: 1.5 to 2.1 mm, solenoid ON: 2.3 to 2.9 mm). If it is not, adjust it. Check the harness between the transport path switching solenoid (SOL5) and the finisher controller board (CN1). If there is any abnormality, correct it.
Entrance sensor (S1)	<ul style="list-style-type: none"> Sensor check Check if the actuator moves smoothly. Connector check Harness check
Transport sensor (S2)	<ul style="list-style-type: none"> Sensor check Connector check Harness check
Entrance motor (M1)	<ul style="list-style-type: none"> Motor check Connector check Harness check
Finisher control PC board (FIN)	<ul style="list-style-type: none"> Board check Connector check (CN8, CN17) Harness check

Parts to be replaced	Remark
Transport path switching solenoid (SOL5)	
Entrance sensor (S1)	
Transport sensor (S2)	
Entrance motor (M1)	
Finisher control PC board (FIN)	

[EA25] Paper transport stop jam (after paper stack exit)

Classification	Error content
Paper jam in finisher section	Paper transport stop jam (after paper stack exit)

Check item	Measures
Paper	Check if there is any paper in the finisher or on the transport path of the equipment and remove it if there is.
Exit paper sideways deviation	When an exit paper alignment problem occurs during continuous printing in the non-sort mode, take the following countermeasure. Check if exit paper sideways deviation has occurred in the equipment installed. If there is any, adjust it by following the Service Manual for the equipment installed.

Check item	Measures
Finishing tray paper detection sensor (S12)	<ul style="list-style-type: none"> • Sensor check • Connector check (CN25) • Harness check
Finisher control PC board (FIN)	<ul style="list-style-type: none"> • Board check • Connector check (CN25) • Harness check

Parts to be replaced	Remark
Finishing tray paper detection sensor (S12)	
Finisher control PC board (FIN)	

[EA26] Paper transport stop jam (stop command request)

[EA27] Paper transport stop jam (The entrance sensor is turned ON in a slower timing than that specified.)

Classification	Error content
Paper jam in finisher section	[EA26] Paper transport stop jam (stop command request) [EA27] The entrance sensor is turned ON in a slower timing than that specified.

Check item	Measures
Paper	Check if there is any paper in the finisher or on the transport path of the equipment and remove it if there is.
Entrance sensor (S1)	<ul style="list-style-type: none"> • Sensor check Check if the actuator moves smoothly. • Connector check (CN8) • Harness check
Finisher control PC board (FIN)	<ul style="list-style-type: none"> • Board check • Connector check (CN8) • Harness check

Parts to be replaced	Remark
Entrance sensor (S1)	
Finisher control PC board (FIN)	

[EA28] Paper transport stop jam (paper holder plate operation delay)

Classification	Error content
Paper jam in finisher section	Paper transport stop jam (paper holder plate operation delay)

Check item	Measures
Paper	Check if there is any paper in the finisher or on the transport path of the equipment and remove it if there is.
Assist guide	Is there any mechanical problem when the assist guide is rotated? If there is any mechanical problem, fix its mechanism.
Assist guide motor (M10)	<ul style="list-style-type: none"> • Sensor check • Connector check (CN10) • Harness check
Finisher control PC board (FIN)	<ul style="list-style-type: none"> • Board check • Connector check (CN10) • Harness check

Parts to be replaced	Remark
Assist guide motor (M10)	
Finisher control PC board (FIN)	

[EA29] Paper transport stop jam (stack transport delay)

Classification	Error content
Paper jam in finisher section	Paper transport stop jam (stack transport delay)

Check item	Measures
Paper	Check if there is any paper in the finisher or on the transport path of the equipment and remove it if there is.
Buffer tray guide	Is there any mechanical problem when the buffer tray guide is opened and closed while the buffer roller is kept raised? If there is any mechanical problem, fix its mechanism.
Buffer tray guide motor (M2)	<ul style="list-style-type: none"> • Motor check • Connector check (CN10) • Harness check
Finisher control PC board (FIN)	<ul style="list-style-type: none"> • Board check • Connector check (CN8) • Harness check

Parts to be replaced	Remark
Buffer tray guide motor (M2)	
Finisher control PC board (FIN)	

[EA31] Transport path paper remaining jam

Classification	Error content
Paper jam in finisher section	Transport path paper remaining jam

Check item	Measures
Paper	Check if there is any paper in the finisher or on the transport path of the equipment and remove it if there is.
Entrance sensor (S1)	<ul style="list-style-type: none"> • Sensor check Check if the actuator moves smoothly. • Connector check (CN8) • Harness check
Feeding sensor (S22)	<ul style="list-style-type: none"> • Sensor check (S22) • Connector check (CN1) • Harness check
Paper position sensor (Hole punch unit: S6-1, S6-2)	Remove any paper dust in and around the sensors (S6-1 and S6-2) and clean them. <ul style="list-style-type: none"> • Sensor check (S6-1, S6-2) • Connector check (CN1, CN4, CN5) • Harness check
Transport sensor (S2)	<ul style="list-style-type: none"> • Sensor check • Connector check (CN8) • Harness check
Finisher control PC board (FIN)	<ul style="list-style-type: none"> • Board check • Connector check (CN1, CN8) • Harness check

Parts to be replaced	Remark
Entrance sensor (S1)	
Feeding sensor (S22)	
Paper position sensor (S6-1, S6-2)	Hole punch unit
Transport sensor (S2)	
Finisher control PC board (FIN)	

[EA32] Exit paper remaining jam

Classification	Error content
Paper jam in finisher section	Exit paper remaining jam

Check item	Measures
Paper	Check if there is any paper in the finisher or on the transport path of the equipment and remove it if there is.
Finishing tray paper detection sensor (S12)	<ul style="list-style-type: none"> • Sensor check • Connector check • Harness check
Finisher control PC board (FIN)	<ul style="list-style-type: none"> • Board check • Connector check (CN25) • Harness check

Parts to be replaced	Remark
Finishing tray paper detection sensor (S12)	
Finisher control PC board (FIN)	

[EA40] Cover open error

Classification	Error content
Paper jam in finisher section	Cover open error

Check item	Measures
Cover	Close the front cover or the stationary tray if they are opened.
Front cover switch (SW1)	<ul style="list-style-type: none"> • Sensor check • Connector check • Harness check
Stationary tray opening/closing switch (SW2)	<ul style="list-style-type: none"> • Sensor check • Connector check • Harness check
Finisher controller board (FIN)	<ul style="list-style-type: none"> • Connector check (CN14) • Board check
Harness	Check if the flat cable between the finisher control PC board (FIN) and the saddle control PC board (SDL) is disconnected or open circuited. Correct if so. (Replace the harness if open circuited. Reconnect the connector securely if there is any disconnection.)

Parts to be replaced	Remark
Cover locking bracket	If it is broken.
Front cover switch (SW1)	
Stationary tray opening/closing switch (SW2)	

Parts to be replaced	Remark
Finisher control PC board (FIN)	
Flat cable	Harness

[EA50] Stapling jam

Classification	Error content
Paper jam in finisher section	Stapling jam

Check item	Measures
Stapler	<ul style="list-style-type: none"> • Check if there is any paper in the finisher or on the transport path of the equipment and remove it if there is. • Is the jam cleared by taking off the staple cartridge from the finisher and removing the staple sheet slid from the staple case? • If the actuator of the stapler safety sensor (S11) does not move smoothly, remove its clip from the side and then reattach it. • Connector check • Harness check
Finisher controller board (FIN)	<ul style="list-style-type: none"> • Connector check (CN2) • Board check • Harness check
Belt tension of the stapler unit	Check that the belt tension of the stapler unit is not loosen.

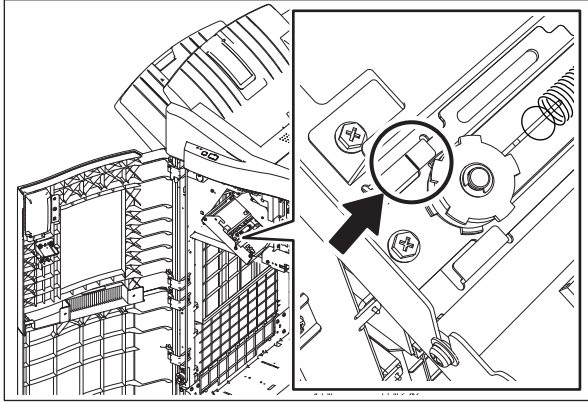
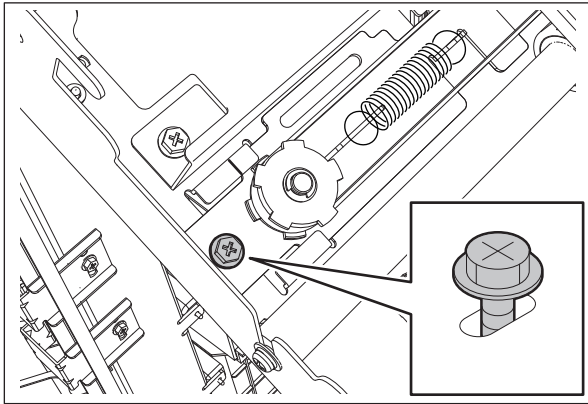
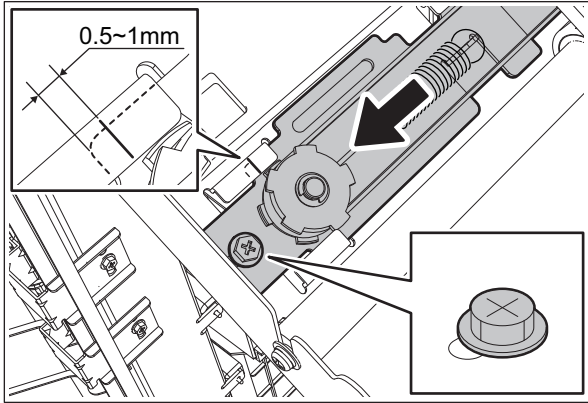
Check item	Measures
Adjustment of the belt tension of the stapler unit	<p>If the error still persists, adjust the belt tension of the stapler unit.</p> <p>1. Before adjusting the belt tension, make a mark for the initial position.</p>  <p>Fig.6-1</p> <p>2. Loosen the screw of the belt pulley bracket.</p>  <p>Fig.6-2</p> <p>3. Move the pulley to the front side by 0.5 to 1.0 mm from the marked position and then tighten the screw.</p>  <p>Fig.6-3</p>

Parts to be replaced	Remark
Stapler	
Finisher control PC board (FIN)	

[EA60] Early arrival jam

Classification	Error content
Paper jam in finisher section	Early arrival jam

Check item	Measures
Paper	Check if there is any paper in the finisher or on the transport path of the equipment and remove it if there is.
Feeding sensor (S22)	<ul style="list-style-type: none">• Sensor check (S22)• Connector check (CN1)• Harness check
Finisher control PC board (FIN)	<ul style="list-style-type: none">• Board check• Connector check (CN1)• Harness check

Parts to be replaced	Remark
Feeding sensor (S22)	
Finisher control PC board (FIN)	

[EA70] Stack exit belt home position error

Classification	Error content
Paper jam in finisher section	Stack exit belt home position error

Check item	Measures
Stack belt exit home position sensor (S9)	<ul style="list-style-type: none">• Check if there is a disconnection of the connector, incorrect installation or breakage of the stack belt exit home position sensor (S9). If there is, reinstall the sensor correctly or replace it.• Check if the connector (CN25) on the finisher controller PC board is disconnected from the stack belt exit home position sensor (S9) and the harnesses are open circuited. Correct if any.
Stack transport motor (M8)	Check if the connector (CN18) on the finisher controller PC board is disconnected from the stack transport motor (M8) and the harnesses are open circuited. Correct if any.

Parts to be replaced	Remark
Stack belt exit home position sensor (S9)	
Stack transport motor (M8)	
Finisher control PC board (FIN)	

6.2.3 Paper jam in saddle stitcher section

[EA90] Saddle stitch unit open error

Classification	Error content
Paper jam in saddle stitch section	Door open jam

Check item	Measures
Saddle stitch unit	Close the saddle stitch unit if it is open.
Paper	Remove any paper on the stacker.
Saddle stitch unit opening/closing switch (SW5)	<ul style="list-style-type: none"> Check if there is a disconnection of the connector, incorrect installation or breakage of the saddle stitch unit opening/closing switch (SW5). If there is, reinstall the sensor correctly or replace it. Check if the harness between the saddle stitch unit opening/closing switch (SW5) and the CN26 of the finisher controller PC board (FIN) is disconnected or open circuited. Correct if so.

Parts to be replaced	Remark
Saddle stitch unit opening/closing switch (SW5)	
Finisher control PC board (FIN)	

[EAA0] Paper remaining in Saddle Stitch Unit

Classification	Error content
Finisher jam (Saddle stitcher section)	Paper remaining in saddle stitch unit

Check item	Measures
Paper	<ul style="list-style-type: none"> Check if there is any paper in the finisher, saddle stitcher or the on the transport path of the equipment. Remove it if there is. Use paper accepted in the specifications. <p>Do not use the paper shorter than the specification.</p>
Junction box paper detection sensor (S26)	<ul style="list-style-type: none"> Sensor check(S26) Check if the actuator moves smoothly. Connector check(CN1) Harness check
Transport path-2 sensor (S27)	<ul style="list-style-type: none"> Sensor check(S27) Check if the actuator moves smoothly. Connector check(CN3) Harness check
Transport path-3 sensor (S28)	<ul style="list-style-type: none"> Sensor check(S28) Check if the actuator moves smoothly. Connector check (CN3) Harness check
Ejecting roller sensor(S29)	<ul style="list-style-type: none"> Sensor check(S29) Connector check(CN3) Harness check
Harness	Check if the flat cable between the finisher control PC board (FIN) and the saddle control PC board (SDL) is disconnected or open circuited. Correct if so. (Replace the harness if open circuited. Reconnect the connector securely if there is any disconnection.)
Finisher control PC board (FIN)	<ul style="list-style-type: none"> Board check Connector check(CN21) Harness check
Saddle control PC board (SDL)	<ul style="list-style-type: none"> Board check Connector check(CN3, CN6) Harness check

Parts to be replaced	Remark
Junction box paper detection sensor (S26)	
Transport path-2 sensor (S27)	
Transport path-3 sensor (S28)	
Ejecting roller sensor (S29)	
Finisher control PC board (FIN)	
Saddle control PC board (SDL)	
Flat cable	Harness

[EAB0] Paper transport jam in Saddle Stitch Unit

Classification	Error content
Finisher jam (Saddle stitcher section)	Paper transport jam in saddle stitch unit

Check item	Measures
Paper	<ul style="list-style-type: none"> Check if there is any paper in the finisher, saddle stitcher or the on the transport path of the equipment. Remove it if there is. Use paper accepted in the specifications. Do not use the paper longer than the specification.
Transport roller	Fix any mechanical problem occurring when the roller is rotated.
Feeding sensor (S22)	<ul style="list-style-type: none"> Sensor check(S22) Connector check(CN1) Harness check
Junction box paper detection sensor (S26)	<ul style="list-style-type: none"> Sensor check(S26) Check if the actuator moves smoothly. Connector check(CN1) Harness check
Transport path-2 sensor (S27)	<ul style="list-style-type: none"> Sensor check(S27) Check if the actuator moves smoothly. Connector check(CN3) Harness check
Transport path-3 sensor (S28)	<ul style="list-style-type: none"> Sensor check(S28) Check if the actuator moves smoothly. Connector check (CN3) Harness check
Ejecting roller sensor(S29)	<ul style="list-style-type: none"> Sensor check(S29) Connector check(CN3) Harness check
Saddle transport motor (M16)	<ul style="list-style-type: none"> Motor check(M16) Connector check(CN5) Harness check
Transport path switching solenoid (SOL5)	Check that the gap between the transfer guide surface and the upper surface of the flapper tip is in the acceptable range according to the status of the transport path switching solenoid (SOL5) (solenoid OFF: 1.5 to 2.1 mm, solenoid ON: 2.3 to 2.9 mm). If it is not, adjust it. Check if the harness between the transport path switching solenoid (SOL5) and the CN1 of the finisher controller PC board (FIN) is disconnected or open circuited. Correct if so.
Entrance motor (M1)	<ul style="list-style-type: none"> Motor check(M1) Connector check(CN17) Harness check
Harness	Check if the flat cable between the finisher control PC board (FIN) and the saddle control PC board (SDL) is disconnected or open circuited. Correct if so. (Replace the harness if open circuited. Reconnect the connector securely if there is any disconnection.)

Check item	Measures
Finisher control PC board (FIN)	<ul style="list-style-type: none"> Board check Connector check(CN21) Harness check
Saddle control PC board (SDL)	<ul style="list-style-type: none"> Board check Connector check(CN3, CN6) Harness check

Parts to be replaced	Remark
Junction box paper detection sensor (S26)	
Feeding sensor (S22)	
Transport path-2 sensor (S27)	
Transport path-3 sensor (S28)	
Ejecting roller sensor (S29)	
Saddle transport motor (M16)	
Entrance motor (M1)	
Transport path switching solenoid (SOL5)	
Finisher control PC board (FIN)	
Saddle control PC board (SDL)	
Flat cable	Harness

[EAB1] Short paper jam in Saddle Stitch Unit

Classification	Error content
Finisher jam (Saddle stitcher section)	Paper transport jam in saddle stitch unit

Check item	Measures
Paper	<ul style="list-style-type: none"> Check if there is any paper in the finisher, saddle stitcher or the on the transport path of the equipment. Remove it if there is. Use paper accepted in the specifications.
Feeding sensor (S22)	<ul style="list-style-type: none"> Sensor check(S22) Connector check(CN1) Harness check
Junction box paper detection sensor (S26)	<ul style="list-style-type: none"> Sensor check(S26) Check if the actuator moves smoothly. Connector check(CN1) Harness check
Transport path-2 sensor (S27)	<ul style="list-style-type: none"> Sensor check(S27) Check if the actuator moves smoothly. Connector check(CN3) Harness check
Transport path-3 sensor (S28)	<ul style="list-style-type: none"> Sensor check(S28) Check if the actuator moves smoothly. Connector check (CN3) Harness check
Ejecting roller sensor(S29)	<ul style="list-style-type: none"> Sensor check(S29) Connector check(CN3) Harness check
Harness	Check if the flat cable between the finisher control PC board (FIN) and the saddle control PC board (SDL) is disconnected or open circuited. Correct if so. (Replace the harness if open circuited. Reconnect the connector securely if there is any disconnection.)

Check item	Measures
Finisher control PC board (FIN)	<ul style="list-style-type: none"> • Board check • Connector check(CN1, CN21) • Harness check
Saddle control PC board (SDL)	<ul style="list-style-type: none"> • Board check • Connector check(CN3, CN6) • Harness check

Parts to be replaced	Remark
Feeding sensor (S22)	
Junction box paper detection sensor (S26)	
Transport path-2 sensor (S27)	
Transport path-3 sensor (S28)	
Ejecting roller sensor (S29)	
Finisher control PC board (FIN)	
Saddle control PC board (SDL)	

6.2.4 Paper jam in puncher unit

[E9F0] Punching jam

Classification	Error content
Finisher jam (Punch section)	Punching jam

Check item	Measures
Paper	Check if there is any paper on the transport path of the equipment and remove it if there is.
Punch motor (M3)	<ul style="list-style-type: none">• Motor check• Connector check• Harness check
Punch HP sensor (S4)	<ul style="list-style-type: none">• Sensor check• Connector check• Harness check
Punch sensor (S5)	<ul style="list-style-type: none">• Sensor check(S28)• Connector check (CN3)• Harness check
Hole punch control PC board (HP)	<ul style="list-style-type: none">• Board check• Connector check• Harness check

Parts to be replaced	Remark
Punch motor (M3)	
Punch HP sensor (S4)	
Punch sensor (S5)	
Hole punch control PC board (HP)	

6.2.5 Other paper jam

[ED10] Skew adjustment motor (M1) home position detection abnormality

Classification	Error content
Other paper jam	Skew adjustment motor (M1) home position detection abnormality

Check item	Measures
Paper	<ul style="list-style-type: none"> Check if there is any paper in the hole punch unit, finisher or the on the transport path of the equipment. Remove it if there is. Use paper accepted in the specifications.
Skew adjustment motor (M1)	Rotate skew adjustment motor and fix its mechanism if it does not rotate smoothly.
Skew HP sensor (S2) Skew adjustment motor (M1) Hole punch control PC board (HP)	Check if the connectors on the hole punch controller PC board (HP board) are disconnected from the skew HP sensor (S2) and the skew adjustment motor, or the harnesses are open circuited. Correct if any.

Parts to be replaced	Remark
Skew adjustment motor (M1)	
Skew HP sensor (S2)	
Hole punch control PC board (HP)	

[ED11] Sideways adjustment motor (M2) home position detection error

Classification	Error content
Other paper jam	Sideways adjustment motor (M2) home position detection error

Check item	Measures
Paper	<ul style="list-style-type: none"> Check if there is any paper in the hole punch unit, finisher or the on the transport path of the equipment. Remove it if there is. Use paper accepted in the specifications.
Sideways adjustment motor (M2)	Rotate sideways adjustment motor and fix its mechanism if it does not rotate smoothly.
Sideways deviation HP sensor (S3) Sideways adjustment motor (M2) Hole punch control PC board (HP)	Check if the connectors on the hole punch controller PC board (HP board) are disconnected from the sideways deviation HP sensor (S3) and the sideways adjustment motor, or the harnesses are open circuited. Correct if any.

Parts to be replaced	Remark
Sideways adjustment motor (M2)	
Sideways deviation HP sensor (S3)	
Hole punch control PC board (HP)	

[ED13] Front alignment plate home position error

Classification	Error content
Other paper jam	Front alignment plate home position error

Check item	Measures
Front alignment plate	Move the front alignment plate. Fix any mechanical problem.

Check item	Measures
Front alignment plate home position sensor (S7)	<ul style="list-style-type: none"> Check if there is a disconnection of the connector, incorrect installation or breakage of the front alignment plate home position sensor (S7). If there is, reinstall the sensor correctly or replace it. Check if the connector (CN25) on the finisher controller PC board is disconnected from the front alignment plate home position sensor (S7) and the harnesses are open circuited. Correct if so.
Front alignment motor (M5)	Check if the connector (CN18) on the finisher controller PC board is disconnected from the front alignment motor (M5) and the harnesses are open circuited. Correct if so.

Parts to be replaced	Remark
Front alignment plate home position sensor (S7)	
Front alignment motor (M5)	
Finisher controller PC board (FIN)	

[ED14] Rear alignment plate home position error

Classification	Error content
Other paper jam	Rear alignment plate home position error

Check item	Measures
Rear alignment plate	Move the rear alignment plate. Fix any mechanical problem.
Rear alignment plate home position sensor (S8)	<ul style="list-style-type: none"> Check if there is a disconnection of the connector, incorrect installation or breakage of the rear alignment plate home position sensor (S8). If there is, reinstall the sensor correctly or replace it. Check if the connector (CN25) on the finisher controller PC board is disconnected from the rear alignment plate home position sensor (S8) and the harnesses are open circuited. Correct if so.
Rear alignment motor (M6)	Check if the connector (CN18) on the finisher controller PC board is disconnected from the rear alignment motor (M6) and the harnesses are open circuited. Correct if so.

Parts to be replaced	Remark
Rear alignment plate home position sensor (S8)	
Rear alignment motor (M6)	
Finisher controller PC board (FIN)	

[ED15] Paddle home position error

Classification	Error content
Other paper jam	Paddle home position error

Check item	Measures
Paddle	Rotate the paddle. If there is any mechanical problem, fix its mechanism.
Paddle home position sensor (S3) Paddle motor (M3) Finisher control PC board (FIN)	Check if the connectors (CN15, CN16) on the finisher control PC board are disconnected from the paddle home position sensor (S3) and the paddle motor (M3), or the harnesses are open circuited. Correct if any.

Parts to be replaced	Remark
Paddle motor (M3)	
Paddle home position sensor (S3)	
Finisher controller PC board (FIN)	

[ED16] Buffer tray home position error

Classification	Error content
Other paper jam	Buffer tray home position error

Check item	Measures
Buffer tray guide	Open and close the buffer tray guide. Fix any mechanical problem.
Buffer tray home position sensor (S5)	<ul style="list-style-type: none"> Check if there is a disconnection of the connector, incorrect installation or breakage of the buffer tray home position sensor (S5). If there is, reinstall the sensor correctly or replace it. Check if the connector (CN11) on the finisher controller PC board is disconnected from the buffer tray home position sensor (S5) and the harnesses are open circuited. Correct if so.
Assist guide motor (M10)	Check if the connector (CN10) on the finisher controller PC board is disconnected from the Assist guide motor (M10) and the harnesses are open circuited. Correct if so.
Buffer tray guide motor (M2)	Check if the connector (CN10) on the finisher controller PC board is disconnected from the buffer tray guide motor (M2) and the harnesses are open circuited. Correct if so.

Parts to be replaced	Remark
Buffer tray home position sensor (S5)	
Assist guide motor (M10)	
Buffer tray guide motor (M2)	
Finisher controller PC board (FIN)	

[EF10] Paper not supported for Saddle Stitch Unit

Check the paper size, paper type, or number of pages for stapling. Change them if they are unsupported.

[EF11] Saddle Stitch Finisher stapling error (front)

Classification	Error content
Finisher jam (Saddle stitch section)	Front stapling is not correctly done.

Check item	Measures
Paper	<ul style="list-style-type: none"> Check if there is any paper in the hole punch unit, finisher or the on the transport path of the equipment. Remove it if there is. Use paper accepted in the specifications.
Staple cartridge (front side)	<ul style="list-style-type: none"> Is the jam released by taking off the front staple cartridge from the Finisher and removing the staple sheet slid from the staple case?

Check item	Measures
Front saddle stapler drive unit	<ul style="list-style-type: none"> • Unit check • Connector check • Harness check
Saddle control PC board (SDL)	<ul style="list-style-type: none"> • Connector check (CN2) • Board check
Harness	Check if the flat cable between the finisher control PC board (FIN) and the saddle control PC board (SDL) is disconnected or open circuited. Correct if so. (Replace the harness if open circuited. Reconnect the connector securely if there is any disconnection.)

Parts to be replaced	Remark
Front saddle stapler drive unit	
Saddle control PC board (SDL)	
Flat cable	Harness

[EF12] Saddle Stitch Finisher stapling error (rear)

Classification	Error content
Finisher jam (Saddle stitch section)	Rear stapling is not correctly done.

Check item	Measures
Paper	<ul style="list-style-type: none"> • Check if there is any paper in the hole punch unit, finisher or the on the transport path of the equipment. Remove it if there is. • Use paper accepted in the specifications.
Staple cartridge (rear side)	<ul style="list-style-type: none"> • Is the jam released by taking off the rear staple cartridge from the Finisher and removing the staple sheet slid from the staple case?
Rear saddle stapler drive unit	<ul style="list-style-type: none"> • Unit check • Connector check • Harness check
Saddle control PC board (SDL)	<ul style="list-style-type: none"> • Connector check (CN1) • Board check
Harness	Check if the flat cable between the finisher control PC board (FIN) and the saddle control PC board (SDL) is disconnected or open circuited. Correct if so. (Replace the harness if open circuited. Reconnect the connector securely if there is any disconnection.)

Parts to be replaced	Remark
Rear saddle stapler drive unit	
Saddle control PC board (SDL)	
Flat cable	Harness

[EF13] Saddle stitch unit paper holding home position detection error

Classification	Error content
Finisher jam (Saddle stitch section)	The paper holder home position cannot be detected.

Check item	Measures
Paper holding cam	<ul style="list-style-type: none"> • Is there any mechanical problem when the paper holding cam is rotated? Correct if so.
Paper holding home position sensor (S38)	<ul style="list-style-type: none"> • Sensor check • Connector check • Harness check

Check item	Measures
Paper holding clutch (CLT4)	Check if the harness between the saddle control PC board (SDL) and the paper holding clutch (CLT4) is disconnected or open circuited. Correct if so. (Replace the harness if open circuited. Reconnect the connector securely if there is any disconnection.)
Saddle transport motor (M16)	Check if the harness between the saddle control PC board (SDL) and the saddle transport motor (M16) is disconnected or open circuited. Correct if so. (Replace the harness if open circuited. Reconnect the connector securely if there is any disconnection.)
Saddle control PC board (SDL)	<ul style="list-style-type: none"> Connector check (CN5) Board check
Harness	Check if the flat cable between the finisher control PC board (FIN) and the saddle control PC board (SDL) is disconnected or open circuited. Correct if so. (Replace the harness if open circuited. Reconnect the connector securely if there is any disconnection.)

Parts to be replaced	Remark
Paper holding home position sensor (S38)	
Paper holding clutch (CLT4)	
Saddle transport motor (M16)	
Saddle control PC board (SDL)	
Flat cable	Harness

[EF14] Saddle paper exit jam

Classification	Error content
Finisher jam (Saddle stitch section)	Paper exiting is not completed within a fixed time.

Check item	Measures
Paper	<ul style="list-style-type: none"> Remove if there is any paper remaining in the paper transport path of the equipment, hole punch unit or the finisher. Use the paper specified in the specifications if a type outside of the range is selected.
Exit sensor (S31)	<ul style="list-style-type: none"> Sensor check Check if the actuator moves smoothly. Connector check (CN7) Harness check
Harness	Check if the harness between the finisher controller PC board (FIN) and the saddle control PC board (SDL) is disconnected or open circuited. Correct if so. (Replace the harness if it is open circuited. Reconnect the connector securely if there is any disconnection.)
Finisher control PC board (FIN)	<ul style="list-style-type: none"> Board check Connector check (CN21) Harness check
Saddle control PC board (SDL)	<ul style="list-style-type: none"> Connector check (CN6, CN7) Board check

Check item	Measures
EFS unit	<ul style="list-style-type: none"> • Correct the misalignment of the shaft of the EFS unit [8]. Move the screws in the direction of the arrow and secure them (both front and rear). <div data-bbox="724 271 1295 663" style="text-align: center;"> </div> • Replace the following parts <ul style="list-style-type: none"> - BRIR-ROD-EX-F-SDL-F5330 (P-I: 24-23) - PLT-BURR-ROD-EX-F-SDL (P-I: 24-24) - ASYS-PLT3-FILM3-EFS (P-I: 25-16) - FILM4-EFS (P-I: 25-51) • Check if there is a disconnection of the connector, incorrect installation or breakage of the exit transport sensor (S41) [9]. If there is, reinstall the sensor correctly or replace it. Move the bracket [10] in the direction of the arrow and secure it with the screw <div data-bbox="711 1023 1299 1426" style="text-align: center;"> </div>

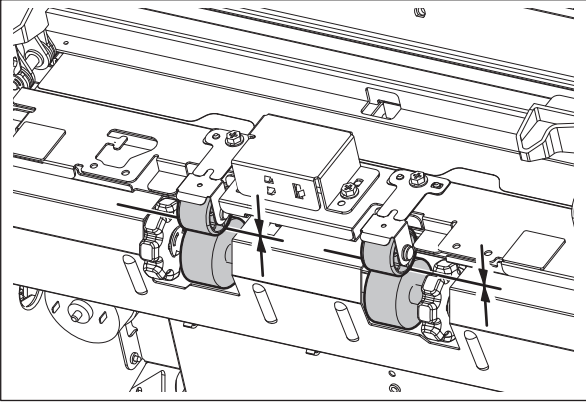
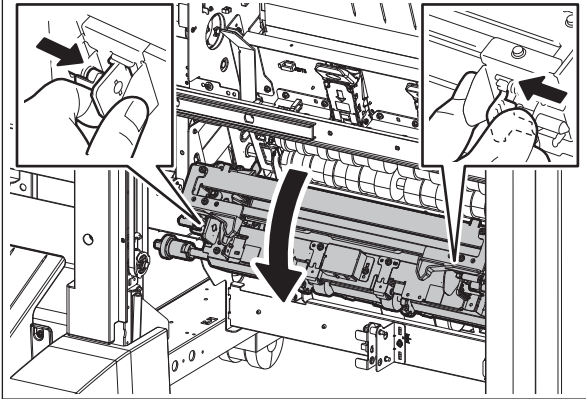
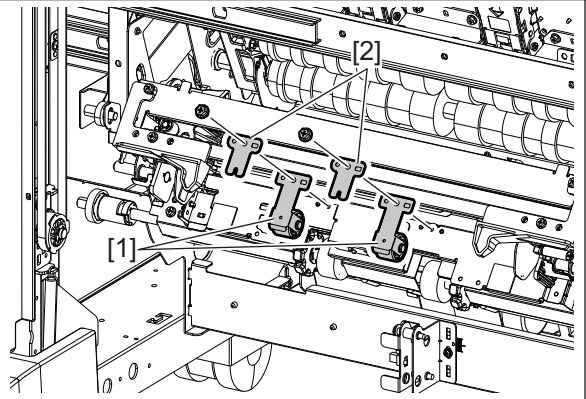
Check item	Measures
Leaf springs and assist leaf springs of the transport pinch roller (for the saddle)	<ul style="list-style-type: none">• Check if there is any gap between the exit roller (for the saddle) and the transport pinch roller (for the saddle). If there is, replace the leaf springs [1] and the assist leaf springs [2] of the transport pinch roller (for the saddle).  <p>Fig.6-4</p> <ul style="list-style-type: none">• Check if the leaf springs [1] and the assist leaf springs [2] of the transport pinch roller (for the saddle) are misshapen. If they are warped or deformed, replace them. For the removal procedure of the leaf springs [1] and the assist leaf springs [2], refer to the following figures.  <p>Fig.6-5</p>  <p>Fig.6-6</p>

Check item	Measures
<p>Leaf springs and assist leaf springs of the transport pinch roller (for the saddle)</p>	<p>Take off the leaf springs [1].</p> <div data-bbox="619 193 1209 597" data-label="Image"> </div> <p data-bbox="592 619 667 646">Fig.6-7</p> <p data-bbox="632 678 707 706">Notes:</p> <p data-bbox="668 708 1382 789">In order to confirm that there is no warpage or deformation on the leaf springs [1] and the assist leaf springs [2] of the transport pinch roller (for the saddle), remove them and put them on a flat place.</p> <div data-bbox="619 817 1209 1221" data-label="Image"> </div> <p data-bbox="592 1242 667 1270">Fig.6-8</p> <div data-bbox="619 1330 1209 1734" data-label="Image"> </div> <p data-bbox="592 1755 667 1783">Fig.6-9</p>

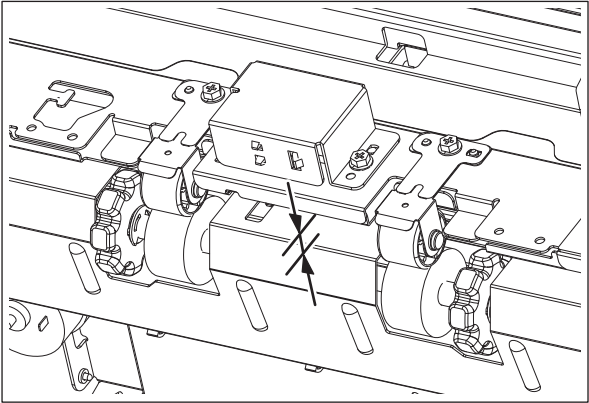
Check item	Measures
Lower transport guide	<p>Check that the gap of the lower transport guide is 15 mm or below. 15 mm or below: OK Larger than 15 mm: Not good</p>  <p>Fig.6-10</p> <p>If the gap is larger than 15 mm, check the attachment condition or replace the lower transport guide.</p>
Exit roller (for the saddle)	<ul style="list-style-type: none">• Check the engagement status of the gear [4] by rotating the exit roller [3] (for the saddle) in the direction of the arrow (opposite direction of the exiting). When not good: The gear [4] rotates without having been engaged. (The ratchet [5] does not rotate.) When OK: The ratchet [5] rotates while sliding, but the gear [4] is stopped. (The gear [4] is engaged.)

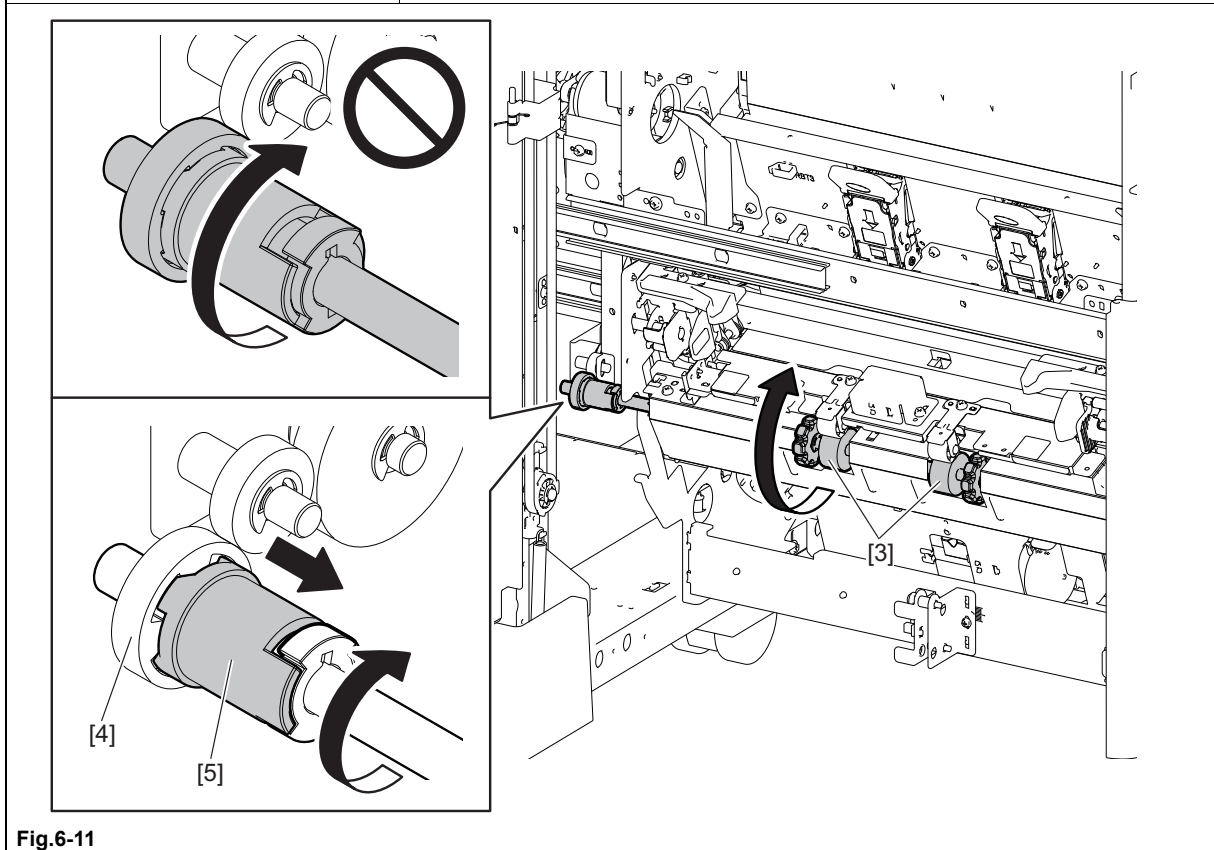

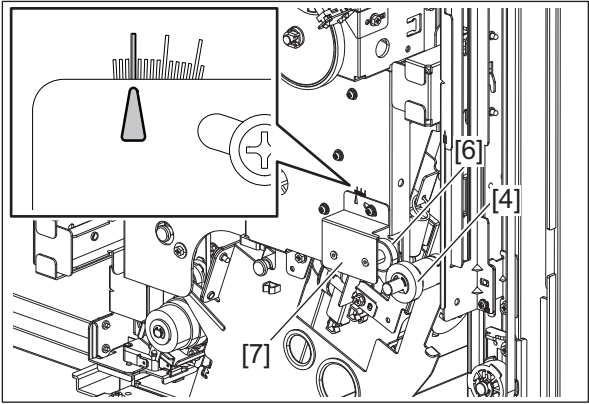
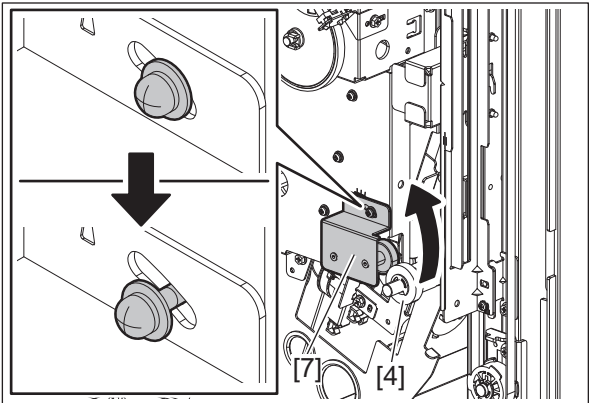
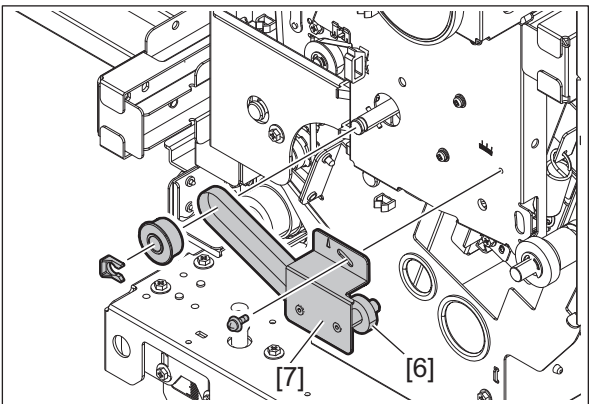
Check item	Measures
Exit roller (for the saddle)	<ul style="list-style-type: none"> <li data-bbox="593 136 1393 165">• In the case of "not good", replace the bracket [7] at the idle gear [6] side. <p data-bbox="632 172 708 197">Notes:</p> <p data-bbox="668 202 1390 278">When replacing, check the position where the pre-change bracket [7] is attached and add its marking in order to install the post-change one in the same place.</p>  <p data-bbox="593 732 676 757">Fig.6-12</p> <ul style="list-style-type: none"> <li data-bbox="593 793 1334 849">• For the removal procedure of the bracket [7], refer to the following figures.  <p data-bbox="593 1293 676 1319">Fig.6-13</p>  <p data-bbox="593 1800 676 1825">Fig.6-14</p>

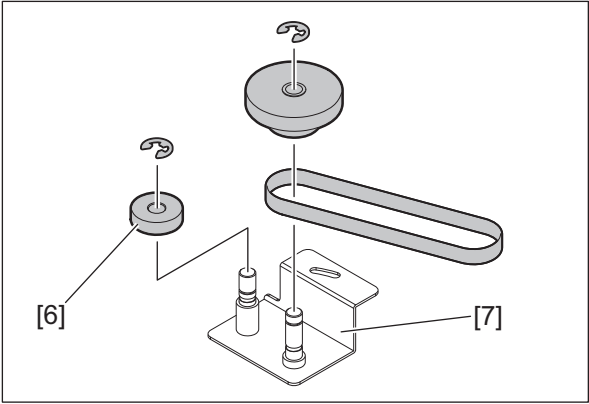
Check item	Measures
Exit roller (for the saddle)	 <p>Fig.6-15</p>

Parts to be replaced	Remark
Exit sensor (S31)	
Finisher control PC board (FIN)	
Saddle control PC board (SDL)	
Leaf springs for the transport pinch roller (for the saddle)	Even if no abnormalities have been confirmed by the check items for the lower transport guide (for the saddle) and the transport pinch roller (for the saddle), replace the leaf springs and the assist leaf springs of the transport pinch roller (for the saddle) if an EF14 error has occurred.
Assist leaf springs for the transport pinch roller (for the saddle)	
Bracket at the idle gear side	
Lower transport guide (for the saddle)	
Exit roller (for the saddle)	
Flat cable	Harness

[EF15] Saddle Stitch Finisher side alignment motor home position detection abnormality

Classification	Error content
Finisher jam (Saddle stitch section)	The side alignment motor home position cannot be detected.

Check item	Measures
Jog	Is there any mechanical problem when the jog is moved? Correct if so.
Side alignment home position sensor (S36)	<ul style="list-style-type: none"> • Sensor check • Connector check • Harness check
Side alignment motor (M15)	<ul style="list-style-type: none"> • Motor check • Connector check • Harness check
Saddle control PC board (SDL)	<ul style="list-style-type: none"> • Connector check (CN4) • Board check
Harness	Check if the flat cable between the finisher control PC board (FIN) and the saddle control PC board (SDL) is disconnected or open circuited. Correct if so. (Replace the harness if open circuited. Reconnect the connector securely if there is any disconnection.)

Parts to be replaced	Remark
Side alignment home position sensor (S36)	

Parts to be replaced	Remark
Side alignment motor (M15)	
Saddle control PC board (SDL)	
Flat cable	Harness

[EF16] Saddle Stitch Finisher stacker motor home position detection abnormality

Classification	Error content
Finisher jam (Saddle stitch section)	The stacker motor home position cannot be detected.

Check item	Measures
Stacker carrier	Is there any mechanical problem when the stacker carrier is moved? Correct if so.
Stacker home position sensor (S33)	<ul style="list-style-type: none"> • Sensor check • Connector check • Harness check
Stacker motor (M14)	<ul style="list-style-type: none"> • Motor check • Connector check • Harness check
Saddle control PC board (SDL)	<ul style="list-style-type: none"> • Connector check (CN8) • Board check
Harness	Check if the flat cable between the finisher control PC board (FIN) and the saddle control PC board (SDL) is disconnected or open circuited. Correct if so. (Replace the harness if open circuited. Reconnect the connector securely if there is any disconnection.)

Parts to be replaced	Remark
Stacker home position sensor (S33)	
Stacker motor (M14)	
Saddle control PC board (SDL)	
Flat cable	Harness

[EF17] Saddle Stitch Finisher folding blade home position detection abnormality

Classification	Error content
Finisher jam (Saddle stitch section)	The folding blade home position cannot be detected.

Check item	Measures
Folding blade cam	Is there any mechanical problem when the stacker carrier is moved? Correct if so.
Folding blade home position sensor (S35)	<ul style="list-style-type: none"> • Sensor check • Connector check (CN12) • Harness check
Folding blade clutch (CLT3)	<ul style="list-style-type: none"> • Clutch check • Connector check (CN13) • Harness check
Saddle control PC board (SDL)	<ul style="list-style-type: none"> • Connector check (CN12, CN13) • Board check
Harness	Check if the flat cable between the finisher control PC board (FIN) and the saddle control PC board (SDL) is disconnected or open circuited. Correct if so. (Replace the harness if open circuited. Reconnect the connector securely if there is any disconnection.)

Parts to be replaced	Remark
Folding blade home position sensor (S35)	
Folding blade clutch (CLT3)	
Saddle control PC board (SDL)	
Flat cable	Harness

[EF18] Saddle Stitch Finisher additional folding roller home position detection abnormality

Classification	Error content
Finisher jam (Saddle stitch section)	The additional folding roller home position cannot be detected.

Check item	Measures
Additional folding carrier	Is there any mechanical problem when the additional folding carrier is moved? Correct if so.
Additional folding home position sensor (S39) Additional folding motor encoder sensor (S42)	<ul style="list-style-type: none"> • Sensor check • Connector check (CN7) • Harness check
Additional folding motor (M20)	<ul style="list-style-type: none"> • Motor check. Check if the motor and timing belt is installed properly. • Connector check (CN10) • Harness check
Saddle control PC board (SDL)	<ul style="list-style-type: none"> • Connector check (CN7, CN10) • Board check
Harness	Check if the flat cable between the finisher control PC board (FIN) and the saddle control PC board (SDL) is disconnected or open circuited. Correct if so. (Replace the harness if open circuited. Reconnect the connector securely if there is any disconnection.)

Parts to be replaced	Remark
Additional folding home position sensor (S39)	
Additional folding motor encoder sensor (S42)	
Additional folding motor (M20)	
Saddle control PC board (SDL)	
Flat cable	Harness

[EF19] Saddle paper folding jam

Classification	Error content
Finisher jam (Saddle stitch section)	Fold processed paper cannot be transported to the additional folding roller.

Check item	Measures
Paper	Is there any paper remaining in the paper transport path in the equipment or the saddle stitch section of the Finisher?
Exit transport sensor (S41)	<ul style="list-style-type: none"> • Sensor check • Connector check (CN7) • Harness check
Saddle control PC board (SDL)	<ul style="list-style-type: none"> • Connector check (CN7) • Board check

Check item	Measures
Harness	Check if the flat cable between the finisher control PC board (FIN) and the saddle control PC board (SDL) is disconnected or open circuited. Correct if so. (Replace the harness if open circuited. Reconnect the connector securely if there is any disconnection.)

Parts to be replaced	Remark
Exit transport sensor (S41)	
Saddle control PC board (SDL)	
Flat cable	Harness

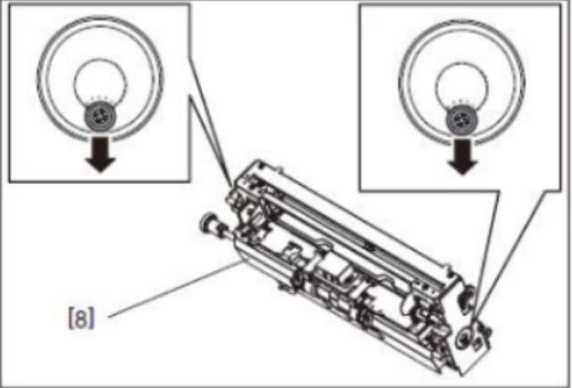
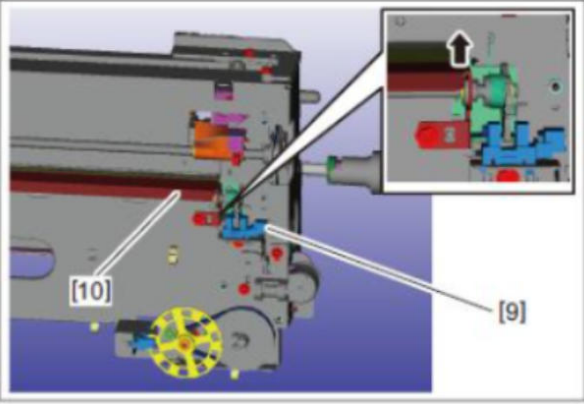
Check item	Measures
EFS unit	<ul style="list-style-type: none"> • Correct the misalignment of the shaft of the EFS unit [8]. Move the screws in the direction of the arrow and secure them (both front and rear).  <p>The diagram shows a perspective view of the EFS unit with a callout box labeled [8]. Two circular callouts show a top-down view of the shaft area, with arrows pointing downwards to indicate the direction to move the screws.</p> <ul style="list-style-type: none"> • Replace the following parts <ul style="list-style-type: none"> - BRIR-ROD-EX-F-SDL-F5330 (P-I: 24-23) - PLT-BURR-ROD-EX-F-SDL (P-I: 24-24) - ASYS-PLT3-FILM3-EFS (P-I: 25-16) - FILM4-EFS (P-I: 25-51) • Check if there is a disconnection of the connector, incorrect installation or breakage of the exit transport sensor (S41) [9]. If there is, reinstall the sensor correctly or replace it. Move the bracket [10] in the direction of the arrow and secure it with the screw  <p>The diagram shows a 3D cutaway view of the machine's internal components. A callout box labeled [9] points to the exit transport sensor assembly, with an arrow pointing upwards. Another callout box labeled [10] points to a bracket, with an arrow pointing to the right.</p>

[EF20] Saddle stacker jam

Classification	Error content
Finisher jam (Saddle stitch section)	Transported paper cannot be detected in the stacker.

Check item	Measures
Paper	Is there any paper remaining in the paper transport path in the equipment or the saddle stitch section of the Finisher?
Stacker paper detection sensor (S30)	<ul style="list-style-type: none">• Sensor check• Connector check (CN3)• Harness check
Saddle control PC board (SDL)	<ul style="list-style-type: none">• Connector check (CN3)• Board check
Harness	Check if the flat cable between the finisher control PC board (FIN) and the saddle control PC board (SDL) is disconnected or open circuited. Correct if so. (Replace the harness if open circuited. Reconnect the connector securely if there is any disconnection.)

Parts to be replaced	Remark
Stacker paper detection sensor (S30)	
Saddle control PC board (SDL)	
Flat cable	Harness

6.2.6 Finisher related service call

[CB00] Finisher detection abnormality

Classification	Error content
Finisher related service call	Finisher detection abnormality: Communication error has occurred between the equipment and finisher.

Check item	Measures
Finisher control PC board (FIN)	<ul style="list-style-type: none"> • Check if the harness connecting the equipment and the finisher control PC board is disconnected or open circuited. • Check if the conductor pattern on the finisher control PC board is open circuited or short circuited. • Update the finisher firmware. • Replace the finisher control PC board.
LGC board (LGC)	<ul style="list-style-type: none"> • Check if the harness connecting the finisher and the LGC board on the equipment is disconnected or open circuited. • Connector check (CN304) • Check if the conductor pattern on the LGC board is open circuited or short circuited. • Replace the LGC board.

Parts to be replaced	Remark
Finisher control PC board (FIN)	
LGC board (LGC)	

[CB10] Entrance motor abnormality

Classification	Error content
Finisher related service call	Entrance motor abnormality: The entrance motor is not rotating normally.

Check item	Measures
Feeding roller	Rotate the feeding roller. Fix any mechanical problem.
Entrance motor (M1)	Check if the connector (CN17) on the finisher controller PC board is disconnected from the entrance motor (M1) and the harnesses are open circuited. Correct if so.

Parts to be replaced	Remark
Entrance motor (M1)	
Finisher control PC board (FIN)	

[CB11] Buffer tray guide motor abnormality

* A [CB11] error occurs if the [ED16] error occurs three times in succession or the [ED16] error occurs during the initialization.

Classification	Error content
Finisher related service call	Buffer tray guide motor abnormality: The buffer tray guide motor is not rotating or the buffer tray guide is not moving normally.

Check item	Measures
Buffer tray guide	Raise the buffer roller and open/close the buffer tray guide. Fix any mechanical problem.

Check item	Measures
Buffer tray guide motor (M2)	Check if the connector (CN10) on the finisher control PC board is disconnected from the buffer tray guide motor (M2) and the harnesses are open circuited. Correct if so.

Parts to be replaced	Remark
Buffer tray guide motor (M2)	
Finisher control PC board (FIN)	

[CB13] Finisher exit motor (M11) abnormality

Classification	Error content
Finisher related service call	The exit motor is not rotating or the exit roller is not moving normally.

Check item	Measures
Exit roller	Is there any mechanical problem when the exit roller is rotated? Correct if so.
Exit motor (M11)	<ul style="list-style-type: none"> • Motor check • Connector check (CN15) • Harness check
Finisher control PC board (FIN)	<ul style="list-style-type: none"> • Connector check (CN15) • Board check

Parts to be replaced	Remark
Exit motor (M11)	
Finisher control PC board (FIN)	

[CB14] Assist guide motor (M10) abnormality [EAFE] Paper holding cam position error (paper jam)

Classification	Error content
Finisher related service call	The Assist guide motor is not rotating or the paper pusher cam is not moving normally.

Check item	Measures
Paper pusher cam	Is there any mechanical problem when the paper pusher cam is rotated?
Assist guide motor (M10)	<ul style="list-style-type: none"> • Motor check • Connector check (CN10) • Harness check
Finisher control PC board (FIN)	<ul style="list-style-type: none"> • Connector check (CN10) • Board check

Parts to be replaced	Remark
Assist guide motor (M10)	
Finisher control PC board (FIN)	

[CB15] Catching motor abnormality

Classification	Error content
Finisher related service call	Catching motor abnormality

Check item	Measures
Catching motor (M21)	Is there any mechanical problem when the catching motor is rotated? If there is any mechanical problem, fix its mechanism.
Harness	Check if the connector (CN17) on the finisher controller PC board is disconnected from the Catching home position sensor (S52) and the harnesses are open circuited. Correct if any.
Finisher control PC board (FIN)	<ul style="list-style-type: none"> • Connector check (CN17) • Board check

Parts to be replaced	Remark
Catching motor (M21)	
Harness	
Finisher control PC board (FIN)	

[EAFA] Catching motor home position detection error

Classification	Error content
Finisher related service call	Catching motor home position detection error

Check item	Measures
Catching motor (M21)	Is there any mechanical problem when the catching motor is rotated? If there is any mechanical problem, fix its mechanism.
Catching home position sensor (S52)	<ul style="list-style-type: none"> • Sensor check • Connector check (CN17) • Harness check
Harness	Check if the connector (CN17) on the finisher controller PC board is disconnected from the Catching home position sensor (S52) and the harnesses are open circuited. Correct if any.
Finisher control PC board (FIN)	<ul style="list-style-type: none"> • Connector check (CN17) • Board check

Parts to be replaced	Remark
Catching home position sensor (S52)	
Harness	
Finisher control PC board (FIN)	

[CB30] Movable tray shift motor abnormality

[EAFC] Movable tray height error (paper jam)

Classification	Error content
Finisher related service call	Movable tray shift motor abnormality: The movable tray shift motor is not rotating or the movable tray is not moving normally.

Check item	Measures
Movable tray	If there is mechanical problem when the movable tray is moved, fix the mechanism.
Movable tray shift motor (M12)	Check the connectors and harnesses between the movable tray shift motor (M12) and the finisher control PC board (CN19).
Movable tray position A, B, and C sensors (S13, S14 and S15)	<ul style="list-style-type: none"> • Connector check (CN20) • Sensor check • Harness check

Parts to be replaced	Remark
Movable tray shift motor (M12)	
Movable tray position A, B, and C sensors (S13, S14 and S15)	
Finisher control PC board (FIN)	

[CB31] Movable tray paper-full detection error
[EAFD] Movable tray movement error (paper jam)

Classification	Error content
Finisher related service call	Movable tray paper-full detection error: The actuator of the movable tray paper-full detection sensor does not move smoothly.

Check item	Measures
Movable tray paper-full sensor (S16)	<ul style="list-style-type: none"> • Fix any mechanical problem occurring when the actuator is moved. • Check if there is a disconnection of the connector, incorrect installation or breakage of the movable tray paper-full sensor (S16). If there is, reinstall the sensor correctly or replace it. • Check if the connector (CN22) on the finisher controller PC board is disconnected from the movable tray paper-full sensor (S16) and the harnesses are open circuited. Correct if so.
Movable tray position A, B, and C sensors (S13, S14 and S15)	<ul style="list-style-type: none"> • Connector check (CN20) • Sensor check • Harness check

Parts to be replaced	Remark
Movable tray paper-full sensor (S16)	
Movable tray position A, B, and C sensors (S13, S14 and S15)	
Finisher control PC board (FIN)	

[CB40] Front alignment motor abnormality

* You receive a [CB40] error when the [ED13] error occurs three times in succession.

Classification	Error content
Finisher related service call	Front alignment motor abnormality: The front alignment motor is not rotating or the front alignment plate is not moving normally.

Check item	Measures
Front alignment plate	If there is mechanical problem when the front alignment plate is moved, fix the mechanism.

Check item	Measures
Front alignment motor (M5)	Check the connectors and harnesses between the front alignment motor (M5) and the finisher control PC board (CN18).

Parts to be replaced	Remark
Front alignment motor (M5)	
Finisher control PC board (FIN)	

[CB50] Stapler home position error

* You receive a [CB50] error when the [EA50] error occurs three times in succession.

Classification	Error content
Finisher related service call	The stapler home position sensor does not work. You receive a [CB50] error when the [EA50] error occurs three times in succession.

Check item	Measures
Stapler	<ul style="list-style-type: none"> • Check the connectors and harnesses between the stapler and finisher controller PC board (CN2). • Check the harnesses in the stapler.
Finisher controller board (FIN)	<ul style="list-style-type: none"> • Connector check (CN2) • Board check • Harness check
Belt tension of the stapler unit	Check that the belt tension of the stapler unit is not loosen.

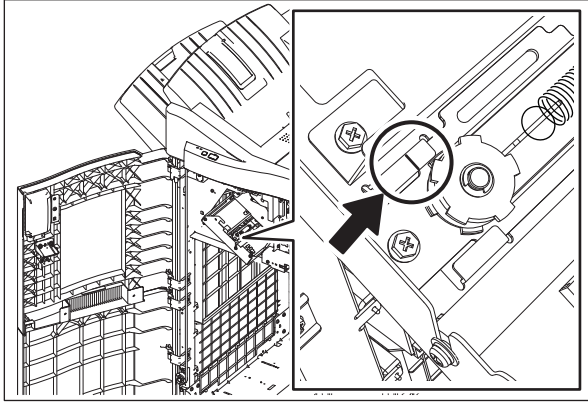
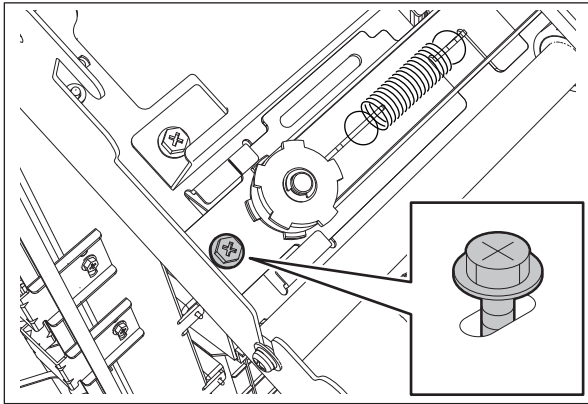
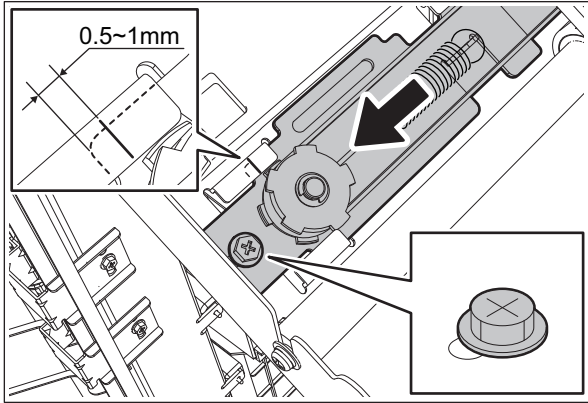
Check item	Measures
Adjustment of the belt tension of the stapler unit	<p>If the error still persists, adjust the belt tension of the stapler unit.</p> <p>1. Before adjusting the belt tension, make a mark for the initial position.</p>  <p>Fig.6-16</p> <p>2. Loosen the screw of the belt pulley bracket.</p>  <p>Fig.6-17</p> <p>3. Move the pulley to the front side by 0.5 to 1.0 mm from the marked position and then tighten the screw.</p>  <p>Fig.6-18</p>

Parts to be replaced	Remark
Stapler	
Finisher control PC board (FIN)	

[CB51] Stapler shift home position error
[EAFB] Stapler movement error (paper jam)

Classification	Error content
Finisher related service call	Stapler shift home position error: The stapler is not at the home position.

Check item	Measures
Stapler	Move the stapler. Fix any mechanical problem.
Stapler unit home position sensor (S10)	<ul style="list-style-type: none"> Check if there is a disconnection of the connector, incorrect installation or breakage of the stapler unit home position sensor (S10). If there is, reinstall the sensor correctly or replace it. Check if the connector (CN27) on the finisher controller PC board is disconnected from the stapler unit home position sensor (S10) and the harnesses are open circuited. Correct if so.
Stapler unit shift motor (M9)	Check if the connector (CN15) on the finisher control PC board is disconnected from the stapler unit shift motor (M9) and the harnesses are open circuited. Correct if so.

Parts to be replaced	Remark
Stapler unit home position sensor (S10)	
Stapler unit shift motor (M9)	
Finisher control PC board (FIN)	

[CB60] Stapler unit shift motor abnormality

Classification	Error content
Finisher related service call	Stapler shift motor abnormality: Stapler shift motor is not rotating or staple unit is not moving normally.

Check item	Measures
Stapler	If there is mechanical problem when the stapler is moved, fix the mechanism.
Stapler unit shift motor (M9)	Check the connectors and harnesses between the stapler unit shift motor (M9) and the finisher control PC board (CN15).

Parts to be replaced	Remark
Stapler unit shift motor (M9)	
Finisher control PC board (FIN)	

[CB80] Backup RAM data abnormality

Classification	Error content
Finisher related service call	Backup RAM data abnormality: Abnormality of checksum value on finisher controller PC board is detected when the power is turned ON.

Check item	Measures
Main power switch	Turn OFF the main power switch, then back ON.

Parts to be replaced	Remark
Finisher control PC board (FIN)	

[CB81] Flash ROM abnormality

Classification	Error content
Finisher related service call	Flash ROM abnormality: Abnormality of checksum value on finisher control PC board is detected when the power is turned ON.

Check item	Measures
Main power switch	Turn OFF the main power switch, then back ON.
Finisher control PC board (FIN)	Board check

Parts to be replaced	Remark
Finisher control PC board (FIN)	

[CB82] Finisher main program error

Classification	Error content
Finisher related service call	Finisher main program error

Check item	Measures
Finisher control PC board (FIN)	<ul style="list-style-type: none"> • Update the firmware version of the finisher control PC board (FIN). • Board check

Parts to be replaced	Remark
Finisher control PC board (FIN)	

[CB84] Punch unit main program error

Classification	Error content
Finisher related service call	Hole Punch Unit - Main CPU program error

Check item	Measures
Hole punch control PC board (HP)	<ul style="list-style-type: none"> • Update the firmware version of the hole punch control PC board (HP). • Board check

Parts to be replaced	Remark
Hole punch control PC board (HP)	

[CB93] Saddle Stitch Finisher additional folding motor abnormality

Classification	Error content
Finisher related service call	<p>An abnormal interruption of the encoder pulse of the additional folding motor occurs.</p> <p>The [CB93] error also occurs when the error [EF18] has occurred consecutively for 3 times.</p>

Check item	Measures
Additional folding carrier	Is there any mechanical problem when the additional folding carrier is moved? Correct if so.
Additional folding motor (M20)	<ul style="list-style-type: none"> • Motor check • Connector check (CN10) • Harness check
Saddle control PC board (SDL)	<ul style="list-style-type: none"> • Connector check (CN10) • Board check
Harness	Check if the flat cable between the finisher control PC board (FIN) and the saddle control PC board (SDL) is disconnected or open circuited. Correct if so. (Replace the harness if open circuited. Reconnect the connector securely if there is any disconnection.)

Parts to be replaced	Remark
Additional folding motor (M20)	
Saddle control PC board (SDL)	
Flat cable	Harness

[CB94] Saddle transport motor abnormality

Classification	Error content
Finisher related service call	Saddle transport motor abnormality or the motor is not moving normally. Paper holding mechanism or transport path switching solenoid abnormality. The [CB94] error also occurs when the error [EAB0] or [EF13] has occurred consecutively for 3 times.

Check item	Measures
Transport roller	Is there any mechanical problem when the transport rollers are rotated?
Saddle transport motor (M16)	<ul style="list-style-type: none"> • Motor check • Connector check (CN5) • Harness check
Saddle control PC board (SDL)	<ul style="list-style-type: none"> • Connector check (CN5) • Board check
Harness	Check if the flat cable between the finisher control PC board (FIN) and the saddle control PC board (SDL) is disconnected or open circuited. Correct if so. (Replace the harness if open circuited. Reconnect the connector securely if there is any disconnection.)

Parts to be replaced	Remark
Saddle transport motor (M16)	
Saddle control PC board (SDL)	
Flat cable	Harness

[CB95] Saddle Stitch Finisher stacker motor abnormality

Classification	Error content
Finisher related service call	The [CB95] error also occurs when the error [EF16] has occurred consecutively for 3 times.

Check item	Measures
Stacker carrier	Is there any mechanical problem when the stacker carrier is moved?

Check item	Measures
Stacker motor (M14)	<ul style="list-style-type: none"> • Motor check • Connector check (CN8) • Harness check
Saddle control PC board (SDL)	<ul style="list-style-type: none"> • Connector check (CN8) • Board check
Harness	Check if the flat cable between the finisher control PC board (FIN) and the saddle control PC board (SDL) is disconnected or open circuited. Correct if so. (Replace the harness if open circuited. Reconnect the connector securely if there is any disconnection.)

Parts to be replaced	Remark
Stacker motor (M14)	
Saddle control PC board (SDL)	
Flat cable	Harness

[CBA0] Front saddle stapler home position error

Classification	Error content
Finisher related service call	The detection of the home position of the stapler unit ends abnormally.

Check item	Measures
Front saddle stapler clinch unit	<ul style="list-style-type: none"> • Harness check • Connector check
Saddle control PC board (SDL)	<ul style="list-style-type: none"> • Connector check (CN2) • Board check
Harness	Check if the flat cable between the finisher control PC board (FIN) and the saddle control PC board (SDL) is disconnected or open circuited. Correct if so. (Replace the harness if open circuited. Reconnect the connector securely if there is any disconnection.)

Parts to be replaced	Remark
Front saddle stapler clinch unit	
Saddle control PC board (SDL)	
Flat cable	Harness

[CBB0] Rear saddle stapler home position error

Classification	Error content
Finisher related service call	The detection of the home position of the stapler unit ends abnormally.

Check item	Measures
Rear saddle stapler clinch unit	Harness check
Saddle control PC board (SDL)	<ul style="list-style-type: none"> • Connector check (CN1) • Board check
Harness	Check if the flat cable between the finisher control PC board (FIN) and the saddle control PC board (SDL) is disconnected or open circuited. Correct if so. (Replace the harness if open circuited. Reconnect the connector securely if there is any disconnection.)

Parts to be replaced	Remark
Rear saddle stapler clinch unit	

Parts to be replaced	Remark
Saddle control PC board (SDL)	
Flat cable	Harness

[CBC0] Saddle Stitch Finisher side alignment motor (M15) abnormality

Classification	Error content
Finisher related service call	The side alignment motor (M15) is not rotating or the jog is not moving normally. The [CBC0] error also occurs when the error [EF15] has occurred consecutively for 3 times.

Check item	Measures
Saddle stitch unit	Is there any mechanical problem when the jog is moved?
Side alignment motor (M15)	<ul style="list-style-type: none"> • Harness check • Connector check (CN4)
Saddle control PC board (SDL)	<ul style="list-style-type: none"> • Connector check (CN4) • Board check
Harness	Check if the flat cable between the finisher control PC board (FIN) and the saddle control PC board (SDL) is disconnected or open circuited. Correct if so. (Replace the harness if open circuited. Reconnect the connector securely if there is any disconnection.)

Parts to be replaced	Remark
Side alignment motor (M15)	
Saddle control PC board (SDL)	
Flat cable	Harness

[CBE0] Saddle Stitch Finisher folding motor (M17) abnormality

* You receive a [CBE0] error when the [EF17] error occurs three times in succession.

Classification	Error content
Finisher related service call	An encoder pulse interruption error or rotation abnormality occurs in the saddle stitch finisher folding motor.

Check item	Measures
Folding motor encoder sensor (S34)	<ul style="list-style-type: none"> • Sensor check (S34) • Connector check (CN13) • Harness check
Folding motor (M17)	<ul style="list-style-type: none"> • Harness check • Connector check (CN19)
Saddle control PC board (SDL)	<ul style="list-style-type: none"> • Connector check (CN13, CN19) • Board check
Harness	Check if the flat cable between the finisher control PC board (FIN) and the saddle control PC board (SDL) is disconnected or open circuited. Correct if so. (Replace the harness if open circuited. Reconnect the connector securely if there is any disconnection.)

Parts to be replaced	Remark
Folding motor encoder sensor (S34)	
Folding motor (M17)	

Parts to be replaced	Remark
Saddle control PC board (SDL)	
Flat cable	Harness

[CC20] Saddle communication error

Classification	Error content
Finisher related service call	Saddle communication error: Communication error between finisher control PC board and saddle control PC board

Check item	Measures
Finisher control PC board (FIN)	<ul style="list-style-type: none"> • Connector check • Harness check • Board check
Saddle control PC board (SDL)	<ul style="list-style-type: none"> • Connector check • Harness check • Board check
Finisher control PC board (FIN)	Update the firmware version of the finisher control PC board (FIN).
Saddle control PC board (SDL)	Update the firmware version of the saddle control PC board (SDL).

Parts to be replaced	Remark
Finisher control PC board (FIN)	
Saddle control PC board (SDL)	

[CC30] Stack transport motor abnormality

* You receive a [CC30] error when the [EA70] error occurs three times in succession.

Classification	Error content
Finisher related service call	Stack transport motor abnormality: The stack transport motor is not rotating or the stack transport belt is not moving normally.

Check item	Measures
Stack transport belt	Move the stack transport belt. Fix any mechanical problem.
Stack transport motor (M8)	Check if the connector (CN18) on the finisher control PC board is disconnected from the stack transport motor (M8) and the harnesses are open circuited. Correct if so.

Parts to be replaced	Remark
Stack transport motor (M8)	
Finisher control PC board (FIN)	

[CC31] Transport motor abnormality

Classification	Error content
Finisher related service call	Transport motor abnormality: The transport motor is not rotating or the stack transport roller -1 and -2 is not rotating normally.

Check item	Measures
Stack transport roller -1 Stack transport roller -2	Rotate the stack transport roller -1 and -2. Fix any mechanical problem.
Transport motor (M7)	Check if the connector (CN15) on the finisher control PC board is disconnected from the transport motor (M7) and the harnesses are open circuited. Correct if so.

Parts to be replaced	Remark
Transport motor (M7)	
Finisher control PC board (FIN)	

[CC41] Paper holder cam home position abnormality

Classification	Error content
Finisher related service call	Paper holder cam home position abnormality: The paper holder cam is not at the home position.

Check item	Measures
Paper pusher cam	Rotate the paper pusher cam. Fix any mechanical problem.
Paper holder home position sensor (S6)	Check if the connector (CN11) on the finisher control PC board is disconnected from the paper holder home position sensor (S6) and the harnesses are open circuited. Correct if so.

Parts to be replaced	Remark
Paper holder home position sensor (S6)	
Finisher control PC board (FIN)	

[CC51] Sideways adjustment motor (M2) abnormality

* You receive a [CC51] error when the [ED11] error occurs three times in succession or occurs during the initialization.

Classification	Error content
Finisher related service call	Sideways adjustment motor (M2) abnormality: Sideways adjustment motor is not rotating or puncher is not shifting normally.

Check item	Measures
Paper	If there is any paper remaining on the transport path, remove the paper.
Sideways adjustment motor (M2)	<ul style="list-style-type: none"> If there is mechanical problem when the sideways adjustment motor (M2) is rotated, fix the mechanism. Check the connector (CN10) and harnesses between the hole punch control PC board (HP) and sideways adjustment motor (M2).
Sideways deviation home position sensor (S3)	<ul style="list-style-type: none"> Sensor check Harness check Connector check (CN8)

Parts to be replaced	Remark
Sideways adjustment motor (M2)	
Sideways deviation home position sensor (S3)	
Hole punch control PC board (HP)	

[CC52] Skew adjustment motor (M1) abnormality

* The [CC52] error occurs when the [ED10] error occurs three times in succession or during the initial operation.

Classification	Error content
Finisher related service call	Skew adjustment motor (M1) abnormality: Skew adjustment motor is not rotating or puncher is not shifting normally.

Check item	Measures
Paper	If there is any paper remaining on the transport path, remove the paper.
Skew adjustment motor (M1)	<ul style="list-style-type: none">• If there is mechanical problem when the skew adjustment motor (M1) is rotated, fix the mechanism.• Check the connector (CN10) and harnesses between the hole punch control PC board (HP) and skew adjustment motor (M1).
Skew home position sensor (S2)	<ul style="list-style-type: none">• Sensor check• Harness check• Connector check (CN10)

Parts to be replaced	Remark
Skew home position sensor (S2)	
Skew adjustment motor (M1)	
Hole punch control PC board (HP)	

[CC61] Punch motor (M3) home position detection error

* The [CC61] error occurs when the [E9F0] error occurs three times in succession or during the initial operation.

Classification	Error content
Finisher related service call	Punch motor (M3) home position detection error: Punch motor is not rotating or puncher is not shifting normally.

Check item	Measures
Paper	If there is any paper remaining on the transport path, remove the paper.
Punch motor (M3)	<ul style="list-style-type: none">• If there is mechanical problem when the punch motor (M3) is rotated, fix the mechanism.• Check the connector (CN2) and harnesses between the hole punch control PC board (HP) and punch motor (M3).
Punch home position sensor (S4)	<ul style="list-style-type: none">• Sensor check• Harness check• Connector check (CN3)

Parts to be replaced	Remark
Punch home position sensor (S4)	
Punch motor (M3)	
Hole punch control PC board (HP)	

[CC71] Punch ROM checksum error

Classification	Error content
Finisher related service call	Punch ROM checksum error: Abnormality of checksum value on Hole punch controller PC board is detected when the power is turned on.

Check item	Measures
Hole punch control PC board (HP)	Board check

Parts to be replaced	Remark
Hole punch control PC board (HP)	

[CC72] Punch RAM read/write error

Classification	Error content
Finisher related service call	Punch RAM read/write error: Abnormality of checksum value on Hole punch controller PC board is detected when the power is turned on.

Check item	Measures
Hole punch control PC board (HP)	Board check

Parts to be replaced	Remark
Hole punch control PC board (HP)	

[CC80] Rear alignment motor abnormality

* You receive a [CC80] error when the [ED14] error occurs three times in succession.

Classification	Error content
Finisher related service call	Rear alignment motor abnormality: The rear alignment motor is not rotating or the rear alignment plate is not moving normally.

Check item	Measures
Rear alignment plate	If there is mechanical problem when the rear alignment plate is moved, fix the mechanism.
Rear alignment motor (M6)	Check the connectors and harnesses between the rear alignment motor (M6) and the finisher control PC board (CN18).

Parts to be replaced	Remark
Rear alignment motor (M6)	
Finisher control PC board (FIN)	

[CCF1] Tray safety switch abnormality

Classification	Error content
Finisher related service call	Tray safety switch abnormality: <ul style="list-style-type: none"> The tray safety switch turned on during tray operation (moving up or down). The tray operated with the tray safety switch turned on.

Check item	Measures
Tray safety switch (SW2)	Check the connectors and harnesses between the tray safety switch (SW2) and the connector J110 on the finisher controller PC board.
Stack tray shift motor (M2)	Check the connectors and harnesses between the stack tray shift motor (M2) and the connector J114 on the finisher controller PC board.

Parts to be replaced	Remark
Tray safety switch (SW2)	
Stack tray shift motor (M2)	
Finisher control PC board (FIN)	

[CDE0] Paddle motor abnormality

* You receive a [CDE0] error when the [ED15] error occurs three times in succession or during the Classification Contents

Classification	Error content
Finisher related service call	Paddle motor abnormality: The paddle motor is not rotating or the paddle is not rotating normally.

Check item	Measures
Paddle	Rotate the paddle. Fix any mechanical problem.
Paddle motor (M3)	Check the connectors and harnesses between the paddle motor (M3) and the finisher control PC board (CN16).

Parts to be replaced	Remark
Paddle motor (M3)	
Finisher control PC board (FIN)	

[CE00] Punch communication error

Classification	Error content
Finisher related service call	Communication error between finisher and punch unit: Communication error between finisher controller PC board and punch controller PC board

Check item	Measures
Hole punch control PC board (HP)	<ul style="list-style-type: none"> Check the connectors and harnesses between the hole punch control PC board (HP) and the finisher control PC board. Board check

Parts to be replaced	Remark
Hole punch control PC board (HP)	
Finisher control PC board (FIN)	

[CF10] Communication module writing failure

Classification	Error content
Finisher related service call	Communication module writing failure.

Check item	Measures
Finisher	<ul style="list-style-type: none"> Check if the harness connecting the equipment and the finisher control PC board is disconnected or open circuited. Check if the conductor pattern on the finisher controller PC board is open circuited or short circuited. Update the finisher firmware.

Check item	Measures
LGC board	<ul style="list-style-type: none"> • Check if the harness connecting the finisher and the LGC board on the equipment is disconnected or open circuited. • Connector check • Check if the conductor pattern on the LGC board is open circuited or short circuited.

Parts to be replaced	Remark
Finisher control PC board (FIN)	
LGC board	

6.3 Self-Diagnostic Modes

6.3.1 General description

Check the operations of the motors, clutches, solenoids and sensors in the Finisher and Saddle stitch sections.

6.3.2 Operation procedure

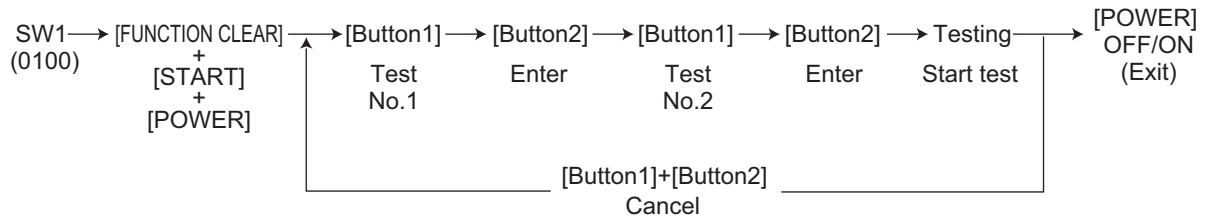

Fig.6-19

- (1) Remove 2 screws and take off the board access cover [1].
- (2) Set SW1 on the Finisher control board as shown in the figures below.

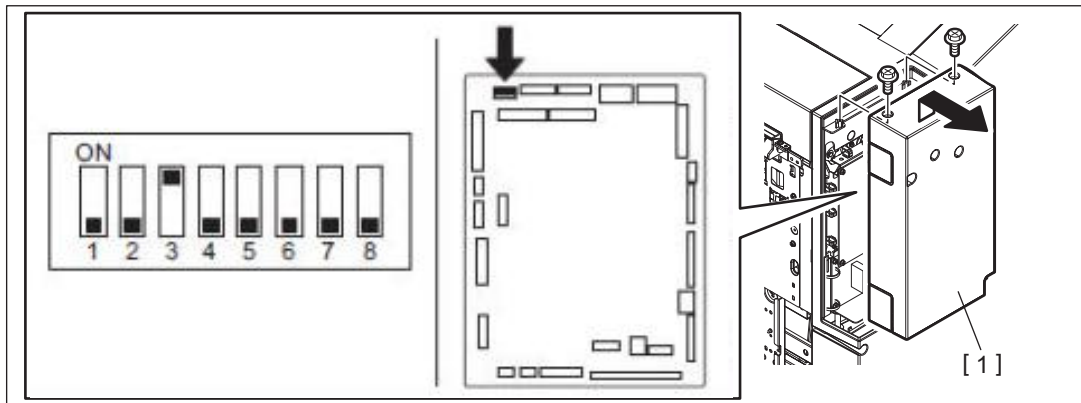

Fig.6-20

- (3) Start FS Menu by pressing the [ON/OFF] button while pushing the [FUNCTION CLEAR] and [START] buttons simultaneously.
- (4) Check the test list and press [Button1] as many times as noted for Test No. 1 whose operation you want to check.

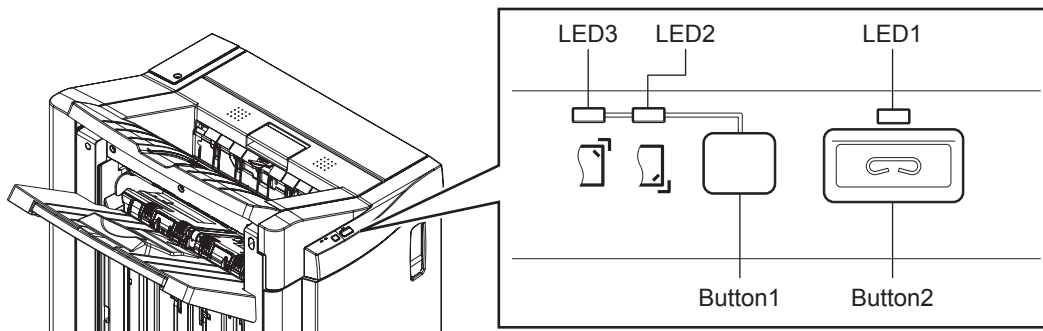

Fig.6-21

- (5) Press [Button2] once. (To enter the number of Test No. 1)
- (6) Check the test list and press [Button1] as many times as noted for Test No. 2 whose operation you want to check.

- (7) Press [Button2] once. (To enter the number of Test No. 2)
- (8) The test is started.
 - * To cancel the test, press [Button1] and [Button2] simultaneously.
- (9) Turn OFF the power of the equipment.

* Example of operation

In case of an operation check for the paddle motor, the number of Test No. 1 is "2" and the one for Test No. 2 is "3".

Therefore press [Button1] 2 times and then press [Button2] once. Then press [Button1] 3 times and then press [Button2] once. This starts the operation check for the paddle motor.

Notes:

In case of an error, open and close the front cover or the stationary tray of the Finisher to clear the error, and then start the next test.

6.3.3 Checking operational status

The operational status can be checked with LEDs on the control panel.

LED1(ON)	"1" is detected in a sensor check or the operation is finished normally.
LED1(OFF)	"0" is detected in a sensor check or the operation is in progress.
LED1(Blinks in a single pattern)	Turning power ON / during initialization / waiting for paper insertion
LED2 & LED3 (Blinks in a multiple pattern)	The operation is finished abnormally. 📖 P. 6-62 "6.3.5 Error indications"
LED2: ON, LED3: OFF	Waiting for Test No. 1 number to be entered
LED2: OFF, LED3: ON	Waiting for Test No. 2 number to be entered
LED2: ON, LED3: ON	Test in progress
LED2: OFF, LED3: OFF	Test finished

6.3.4 Test list

1. Aging

Test No. 1 number	Test No. 2 number	Description	Symbol	Contents of operation
1	1	Aging 1	-	Performs dummy 2-position stapling on 3 pages of A4 paper. Continues the operation until it is canceled. (If a staple cartridge is installed, stapling is not performed. If it is removed, dummy stapling is performed.)
1	2	Aging 2	-	Performs dummy sorting on 3 pages of A4-R paper. Continues the operation until it is canceled.
1	3	Aging 3	-	Performs dummy exiting on A4 paper to the stationary tray in the non-sort mode. Continues the operation until it is canceled.
1	4	Aging 4	-	Performs dummy exiting on A5-R paper to the movable tray in the non-sort mode. Continues the operation until it is canceled.
1	5	Aging 5	-	Performs dummy sorting on 3 pages of A4 paper. Continues the operation until it is canceled.
1	6	Punch-aging	-	Drives the entrance motor of the Finisher. Outputs a mechanical initial command to the Hole Punch unit in every 4 seconds. Continues the operation until it is canceled.

Test No. 1 number	Test No. 2 number	Description	Symbol	Contents of operation
1	7	Saddle-aging	-	Performs dummy saddle-stitching on 1 page of A4-R paper. Continues the operation until it is canceled.

2. Operation check for motors

Test No. 1 number	Test No. 2 number	Description	Symbol	Contents of operation
2	1	Entrance motor	M1	Drives the motor for 10 seconds and then stops it.
2	2	Buffer tray guide motor	M2	Performs initialization (stopping at the standby position after detecting the home position).
2	3	Paddle motor	M3	Performs initialization (stopping at the standby position after detecting the home position).
2	4	(Unused)	-	-
2	5	Front alignment motor	M5	Performs initialization (stopping at the standby position after detecting the home position).
2	6	Rear alignment motor	M6	Performs initialization (stopping at the standby position after detecting the home position).
2	7	Transport motor	M7	Drives the motor for 10 seconds and then stops it.
2	8	Stack transport motor	M8	Moves the latch to the exiting position and then stops it for 10 seconds. Returns it to the home position.
2	9	Stapler unit shift motor	M9	Performs initialization (stopping at the standby position after detecting the home position).
2	10	Assist guide motor	M10	Performs initialization (stopping at the standby position after detecting the home position).
3	1	Exit motor	M11	Drives the motor for 10 seconds and then stops it.
3	2	Movable tray shift motor	M12	Lowers the movable tray to its lower limit. Closes and opens the shutter. Raises the movable tray to its upper limit with the shutter open.
3	3	Stapler motor	M13	Opens the shutter. Performs stapling. Closes the shutter. (If the staple cartridge is installed, stapling is not performed. If it is removed, dummy stapling is performed.)
3	4	Stacker motor	M14	Performs initialization (home position detection). If it is already at its home position, it is temporarily removed and then the home position is detected.
3	5	Side alignment motor	M15	Performs initialization (home position detection). If it is already at its home position, it is temporarily removed and then the home position is detected.
3	6	Saddle transport motor	M16	Turns the assisting roller solenoid ON. Drives the saddle transport motor for 10 seconds. Turns the assisting roller solenoid OFF. Stops the saddle transport motor.
3	7	Folding motor	M17	Drives the folding motor to drive the saddle exit roller for approx. 2 seconds.
3	8	Front stapler motor Rear stapler motor	M18 M19	Starts stapling. * Before you start this test, be sure to place paper in order not to waste staples.
3	9	(Unused)	-	-

Test No. 1 number	Test No. 2 number	Description	Symb ol	Contents of operation
3	10	Additional folding motor	M20	Performs one full reciprocating movement for the additional folding motor. If the motor is not at its home position, it is just returned there.
4	1	Catching motor	M21	Performs initialization (stopping at the standby position after detecting the home position).

3. Operation check for solenoids

Test No. 1 number	Test No. 2 number	Description	Symb ol	Contents of operation
5	1	(Unused)	-	-
5	2	Buffer roller lift solenoid	SOL2	Turns the solenoid ON for 3 seconds and then turns it OFF.
5	3	(Unused)	-	-
5	4	Gate solenoid	SOL4	Turns the solenoid ON for 3 seconds and then turns it OFF.
5	5	Transport path switching solenoid	SOL5	Turns the solenoid ON for 3 seconds and then turns it OFF. * Duty control is performed while the solenoid is ON.
5	6	Assisting roller solenoid	SOL6	Turns the solenoid ON for 3 seconds and then turns it OFF. * Duty control is performed while the solenoid is ON.
5	7	(Unused)	-	-
5	8	Exit roller lift solenoid	SOL8	Turns the solenoid ON for 3 seconds and then turns it OFF. * Duty control is performed while the solenoid is ON.

4. Operation check for clutches

Test No. 1 number	Test No. 2 number	Description	Symb ol	Contents of operation
6	1	(Unused)	-	-
6	2	Paper exit guide clutch	CLT2	Turns the clutch ON for 3 seconds and then turns it OFF.
6	3	Folding blade clutch	CLT3	Turns the folding blade clutch ON and then drives the folding motor. Performs initialization for the folding blade (home position detection). If it is already at its home position, it is temporarily removed and then the home position is detected. Turns the folding blade clutch OFF.
6	4	Paper holding clutch	CLT4	Turns the paper holding clutch ON and then drives the saddle transport motor. Performs initialization (home position detection). If it is already at its home position, it is temporarily removed and then the home position is detected. Turns the paper holding clutch OFF.

5. Real time operation check for switches

Test No. 1 number	Test No. 2 number	Description	Symb ol	Contents of operation
7	1	Front cover switch	SW1	The status of the switch is indicated with the LED1 in real time as follows: LED1 ON: Open LED1 OFF: Close Continues the operation until it is canceled.
7	2	Stationary tray opening/closing switch	SW2	The status of the switch is indicated with the LED1 in real time as follows: LED1 ON: Open LED1 OFF: Close Continues the operation until it is canceled.
7	3	(Unused)	-	-
7	4	(Unused)	-	-
7	5	Saddle stitch unit opening/ closing switch	SW5	The status of the switch is indicated with the LED1 in real time as follows: LED1 ON: Open LED1 OFF: Close Continues the operation until it is canceled.

6. Real time operation check for sensors (Finisher)

Test No. 1 number	Test No. 2 number	Description	Symb ol	Contents of operation
8	1	Entrance sensor	S1	The status of the sensor is indicated with the LED1 in real time as follows: LED1 ON: 1 LED1 OFF: 0 Continues the operation until it is canceled.
8	2	Transport sensor	S2	The status of the sensor is indicated with the LED1 in real time as follows: LED1 ON: 1 LED1 OFF: 0 Continues the operation until it is canceled.
8	3	Paddle home position sensor	S3	The status of the sensor is indicated with the LED1 in real time as follows: LED1 ON: 1 LED1 OFF: 0 Continues the operation until it is canceled.
8	4	(Unused)	-	-
8	5	Buffer tray home position sensor	S5	The status of the sensor is indicated with the LED1 in real time as follows: LED1 ON: 1 LED1 OFF: 0 Continues the operation until it is canceled.
8	6	Assist guide home position sensor	S6	The status of the sensor is indicated with the LED1 in real time as follows: LED1 ON: 1 LED1 OFF: 0 Continues the operation until it is canceled.
8	7	Front alignment plate home position sensor	S7	The status of the sensor is indicated with the LED1 in real time as follows: LED1 ON: 1 LED1 OFF: 0 Continues the operation until it is canceled.
8	8	Rear alignment plate home position sensor	S8	The status of the sensor is indicated with the LED1 in real time as follows: LED1 ON: 1 LED1 OFF: 0 Continues the operation until it is canceled.
8	9	Stack exit belt home position sensor	S9	The status of the sensor is indicated with the LED1 in real time as follows: LED1 ON: 1 LED1 OFF: 0 Continues the operation until it is canceled.
8	10	Stapler unit home position sensor	S10	The status of the sensor is indicated with the LED1 in real time as follows: LED1 ON: 1 LED1 OFF: 0 Continues the operation until it is canceled.
9	1	Stapler interference sensor	S11	The status of the sensor is indicated with the LED1 in real time as follows: LED1 ON: 1 LED1 OFF: 0 Continues the operation until it is canceled.
9	2	Finishing tray paper detection sensor	S12	The status of the sensor is indicated with the LED1 in real time as follows: LED1 ON: 1 LED1 OFF: 0 Continues the operation until it is canceled.

Test No. 1 number	Test No. 2 number	Description	Symb ol	Contents of operation
9	3	Movable tray position-A sensor	S13	The status of the sensor is indicated with the LED1 in real time as follows: LED1 ON: 1 LED1 OFF: 0 Continues the operation until it is canceled.
9	4	Movable tray position-B sensor	S14	The status of the sensor is indicated with the LED1 in real time as follows: LED1 ON: 1 LED1 OFF: 0 Continues the operation until it is canceled.
9	5	Movable tray position-C sensor	S15	The status of the sensor is indicated with the LED1 in real time as follows: LED1 ON: 1 LED1 OFF: 0 Continues the operation until it is canceled.
9	6	Movable tray paper-full sensor	S16	The status of the sensor is indicated with the LED1 in real time as follows: LED1 ON: 1 LED1 OFF: 0 Continues the operation until it is canceled.
9	7	Movable tray paper exist sensor	S17	The status of the sensor is indicated with the LED1 in real time as follows: LED1 ON: 1 LED1 OFF: 0 Continues the operation until it is canceled.
9	8	Stationary tray paper-full sensor	S18	The status of the sensor is indicated with the LED1 in real time as follows: LED1 ON: 1 LED1 OFF: 0 Continues the operation until it is canceled.
9	9	Stapler home position sensor	S19	The status of the sensor is indicated with the LED1 in real time as follows: LED1 ON: 1 LED1 OFF: 0 Continues the operation until it is canceled.
9	10	Staple top position sensor	S20	The status of the sensor is indicated with the LED1 in real time as follows: LED1 ON: 1 LED1 OFF: 0 Continues the operation until it is canceled.
10	1	Staple empty sensor	S21	The status of the sensor is indicated with the LED1 in real time as follows: LED1 ON: 1 LED1 OFF: 0 Continues the operation until it is canceled.
10	2	Feeding sensor	S22	The status of the sensor is indicated with the LED1 in real time as follows: LED1 ON: 1 LED1 OFF: 0 Continues the operation until it is canceled.
10	3	Movable tray shift motor sensor	S23	The status of the sensor is indicated with the LED1 in real time as follows: LED1 ON: 1 LED1 OFF: 0 Continues the operation until it is canceled.
10	4	(Unused)	-	-
10	5	(Unused)	-	-
10	6	Junction box paper detection sensor	S26	The status of the sensor is indicated with the LED1 in real time as follows: LED1 ON: 1 LED1 OFF: 0 Continues the operation until it is canceled.

Test No. 1 number	Test No. 2 number	Description	Symb ol	Contents of operation
10	7	Transport path-2 sensor	S27	The status of the sensor is indicated with the LED1 in real time as follows: LED1 ON: 1 LED1 OFF: 0 Continues the operation until it is canceled.
10	8	Transport path-3 sensor	S28	The status of the sensor is indicated with the LED1 in real time as follows: LED1 ON: 1 LED1 OFF: 0 Continues the operation until it is canceled.
10	9	Ejecting roller sensor	S29	The status of the sensor is indicated with the LED1 in real time as follows: LED1 ON: 1 LED1 OFF: 0 Continues the operation until it is canceled.
10	10	Stacker paper detection sensor	S30	The status of the sensor is indicated with the LED1 in real time as follows: LED1 ON: 1 LED1 OFF: 0 Continues the operation until it is canceled.
11	1	Exit sensor	S31	The status of the sensor is indicated with the LED1 in real time as follows: LED1 ON: 1 LED1 OFF: 0 Continues the operation until it is canceled.
11	2	Saddle tray paper detection sensor	S32	The status of the sensor is indicated with the LED1 in real time as follows: LED1 ON: 1 LED1 OFF: 0 Continues the operation until it is canceled.
11	3	Stacker home position sensor	S33	The status of the sensor is indicated with the LED1 in real time as follows: LED1 ON: 1 LED1 OFF: 0 Continues the operation until it is canceled.
11	4	Folding motor encoder sensor	S34	The status of the sensor is indicated with the LED1 in real time as follows: LED1 ON: 1 LED1 OFF: 0 Continues the operation until it is canceled.
11	5	Folding blade home position sensor	S35	The status of the sensor is indicated with the LED1 in real time as follows: LED1 ON: 1 LED1 OFF: 0 Continues the operation until it is canceled.
11	6	Side alignment home position sensor	S36	The status of the sensor is indicated with the LED1 in real time as follows: LED1 ON: 1 LED1 OFF: 0 Continues the operation until it is canceled.
11	7	(Unused)	-	-
11	8	Paper holding home position sensor	S38	The status of the sensor is indicated with the LED1 in real time as follows: LED1 ON: 1 LED1 OFF: 0 Continues the operation until it is canceled.
11	9	Additional folding home position sensor	S39	The status of the sensor is indicated with the LED1 in real time as follows: LED1 ON: 1 LED1 OFF: 0 Continues the operation until it is canceled.
11	10	(Unused)	-	-

Test No. 1 number	Test No. 2 number	Description	Symb ol	Contents of operation
12	1	Exit transport sensor	S41	The status of the sensor is indicated with the LED1 in real time as follows: LED1 ON: 1 LED1 OFF: 0 Continues the operation until it is canceled.
12	2	Additional folding motor encoder sensor	S42	The status of the sensor is indicated with the LED1 in real time as follows: LED1 ON: 1 LED1 OFF: 0 Continues the operation until it is canceled.
12	3	Front saddle stapler home position sensor	S43	The status of the sensor is indicated with the LED1 in real time as follows: LED1 ON: 1 LED1 OFF: 0 Continues the operation until it is canceled.
12	4	Rear saddle stapler home position sensor	S44	The status of the sensor is indicated with the LED1 in real time as follows: LED1 ON: 1 LED1 OFF: 0 Continues the operation until it is canceled.
12	5	Front saddle stapler empty sensor	S45	The status of the sensor is indicated with the LED1 in real time as follows: LED1 ON: 1 LED1 OFF: 0 Continues the operation until it is canceled.
12	6	Rear saddle stapler empty sensor	S46	The status of the sensor is indicated with the LED1 in real time as follows: LED1 ON: 1 LED1 OFF: 0 Continues the operation until it is canceled.
12	7	Front saddle stapler top position sensor	S47	The status of the sensor is indicated with the LED1 in real time as follows: LED1 ON: 1 LED1 OFF: 0 Continues the operation until it is canceled.
12	8	Rear saddle stapler top position sensor	S48	The status of the sensor is indicated with the LED1 in real time as follows: LED1 ON: 1 LED1 OFF: 0 Continues the operation until it is canceled.
12	9	Front saddle stapler cartridge sensor	S49	The status of the sensor is indicated with the LED1 in real time as follows: LED1 ON: 1 LED1 OFF: 0 Continues the operation until it is canceled.
12	10	Rear saddle stapler cartridge sensor	S50	The status of the sensor is indicated with the LED1 in real time as follows: LED1 ON: 1 LED1 OFF: 0 Continues the operation until it is canceled.
13	1	(Unused)	-	-
13	2	Catching home position sensor	S52	The status of the sensor is indicated with the LED1 in real time as follows: LED1 ON: 1 LED1 OFF: 0 Continues the operation until it is canceled.

7. Real time operation check for sensors (Punch)

Test No. 1 number	Test No. 2 number	Description	Symb ol	Contents of operation
14	1	Front cover sensor	S1	The status of the sensor is indicated with the LED1 in real time as follows: LED1 ON: 1 LED1 OFF: 0 Continues the operation until it is canceled.
14	2	Paper position sensor	S2	The status of the sensor is indicated with the LED1 in real time as follows: LED1 ON: 1 LED1 OFF: 0 Continues the operation until it is canceled.
14	3	Paper position sensor-1	S3	The status of the sensor is indicated with the LED1 in real time as follows: LED1 ON: 1 LED1 OFF: 0 Continues the operation until it is canceled.
14	4	Paper position sensor-2	S4	The status of the sensor is indicated with the LED1 in real time as follows: LED1 ON: 1 LED1 OFF: 0 Continues the operation until it is canceled.
14	5	Paper position sensor-3	S5	The status of the sensor is indicated with the LED1 in real time as follows: LED1 ON: 1 LED1 OFF: 0 Continues the operation until it is canceled.
14	6	Paper position sensor-4	S6	The status of the sensor is indicated with the LED1 in real time as follows: LED1 ON: 1 LED1 OFF: 0 Continues the operation until it is canceled.
14	7	Skew sensor-1	S7	The status of the sensor is indicated with the LED1 in real time as follows: LED1 ON: 1 LED1 OFF: 0 Continues the operation until it is canceled.
14	8	Skew sensor-2	S7	The status of the sensor is indicated with the LED1 in real time as follows: LED1 ON: 1 LED1 OFF: 0 Continues the operation until it is canceled.
14	9	Punched scrap full sensor	S8	The status of the sensor is indicated with the LED1 in real time as follows: LED1 ON: 1 LED1 OFF: 0 Continues the operation until it is canceled.

6.3.5 Error indications

When an error occurs during a test, LED2 and LED3 blink in a multiple pattern to indicate the cause of the error.

The blinking pattern of the error differs depending on the error category. If the multiple errors and alerts occurs at the same time, the error of the highest priority will be shown

Priority (High →Low)
Hardware error → Jam → Alert

In each error category, only one type of the blinking pattern is shown following the manner below:
 The error code of the smaller number prevails in both Error code 1 and Error code 2.
 If the event of a hardware error, jam or alert occurs, the test will not be performed unless the error condition clears.

The figure below shows the error code 32 “paddle home position error (ED15)”.

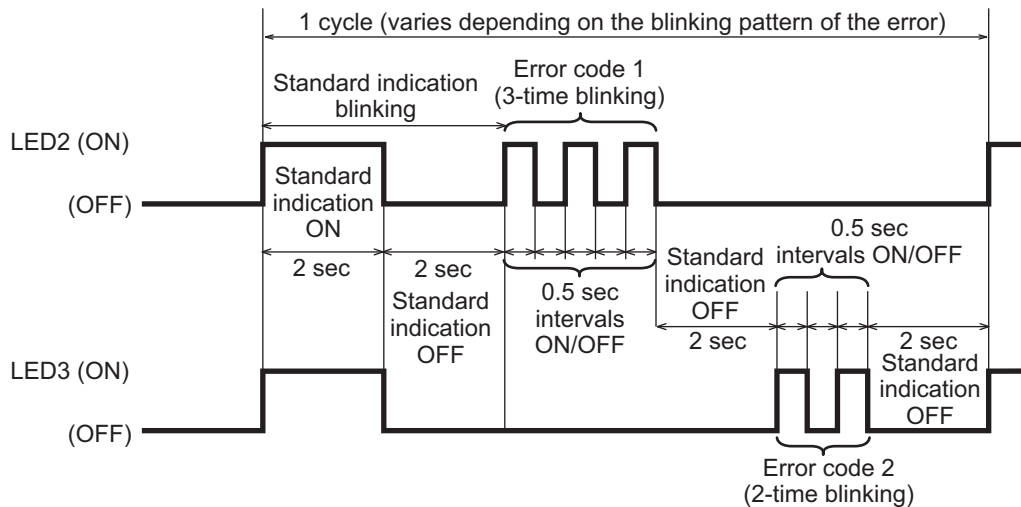

Fig.6-22

1. LED1 blinking pattern error code: Jams

Error code 1 (LED2)	Error code 2 (LED3)	Description	Error code (when connected to the equipment)
1	1	Transport path paper remaining jam in Finisher	EA31
1	2	Exit paper remaining jam	EA32
1	3	Transport delay jam (paper not inserted)	EA10
1	4	Short length paper jam in Finisher (transport sensor)	EA21
1	5	Selecting paper not supported by Saddle Stitch Finisher	EF10
1	6	Paper transport jam in Finisher (entrance sensor)	EA20
1	7	Cover open error	EA40
1	8	Stapling jam	EA50
1	9	Front saddle staple error	EF11
2	1	Paper remaining in Saddle Stitch Finisher	EAA0
2	2	Rear saddle staple error	EF12
2	3	Short paper jam in Saddle Stitch Finisher	EAB1
2	4	Saddle stitch unit paper holding home position detection error	EF13
2	5	Saddle exit jam	EF14
2	6	Paper transport jam in Saddle Stitch Finisher	EAB0
2	7	Saddle stitch unit open error	EA90

Error code 1 (LED2)	Error code 2 (LED3)	Description	Error code (when connected to the equipment)
2	8	Stack exit belt home position error	EA70
2	9	Early arrival jam	EA60
3	1	Buffer tray home position error	ED16
3	2	Paddle home position error	ED15
3	3	Rear alignment plate home position error	ED14
3	4	Front alignment plate home position error	ED13
3	5	(Unused)	-
3	6	Sideways adjustment motor (M2) home position detection error	ED11
3	7	Skew adjustment motor (M1) home position detection abnormality	ED10
3	8	Punching jam	E9F0
3	9	Saddle Stitch Finisher side alignment home position detection error	EA15
10	1	Saddle Stitch Finisher stacker motor (M14) home position detection error	EF16
10	2	(Unused)	-
10	3	Saddle Stitch Finisher folding blade home position detection error	EF17
10	4	Saddle Stitch Finisher additional folding roller home position detection error	EF18
10	5	(Unused)	-
10	6	Saddle Stitch Finisher paper folding jam	EF19
10	7	Saddle stacker jam	EF20
10	8	Paper leading edge skew detection abnormality	EF21
10	9	Paper leading edge detection abnormality	EF22
11	1	Paper alignment abnormality	EF23
11	2	Paper trailing edge skew detection abnormality	EF24
11	3	Paper trailing edge detection abnormality	EF25
11	4	(Unused)	-
11	5	Paper position detection error 1	EF27
11	6	Paper position detection error 2	EF28
11	7	Short length paper jam in Finisher (paper position sensors)	EA22
11	8	Paper transport jam in Finisher (Paper being transported on the finisher transport path is stopped at the transport sensor.)	EA23
11	9	Paper transport jam in Finisher (entrance sensor - transport sensor)	EA24
12	1	Paper transport jam in Finisher (after paper stack was exited)	EA25
12	2	Paper transport jam in Finisher (Stop signal received from equipment)	EA26
12	3	Paper transport jam in Finisher (The entrance sensor is turned ON in a slower timing than that specified.)	EA27
12	4	Paper transport jam in Finisher (paper holding delay)	EA28
12	5	Paper transport jam in Finisher (paper stack transport delay)	EA29
15	1	Movable tray position abnormality	EAFC
15	2	Movable tray ascending position detection error	EAFD
15	3	Assist guide motor home position detection error	EAFE
15	4	Catching motor home position detection error	EAFB
15	5	Stapler shift abnormality	EAFB

2. LED blinking pattern error code: Hardware errors

Error code 1 (LED2)	Error code 2 (LED3)	Description	Error code (when connected to the equipment)
4	1	Entrance motor (M1) abnormality	CB10

Error code 1 (LED2)	Error code 2 (LED3)	Description	Error code (when connected to the equipment)
4	2	Buffer tray guide motor (M2) abnormality	CB11
4	3	Paddle motor (M3) abnormality	CDE0
4	4	Buffer roller drive motor (M4) abnormality	CB12
4	5	Rear alignment motor (M6) abnormality	CC80
4	6	Front alignment motor (M5) abnormality	CB40
4	7	Transport motor (M7) abnormality	CC31
4	8	Stack transport motor (M8) abnormality	CC30
4	9	Stapler unit shift motor (M9) abnormality	CB60
5	1	Movable tray shift motor (M12) abnormality	CB30
5	2	Flash ROM abnormality	CB81
5	3	RAM abnormality	CB80
5	4	Finisher detection abnormality	CB00
5	6	(Unused)	-
5	7	(Unused)	-
5	8	Stapler shift home position error	CB51
5	9	Stapler home position error	CB50
6	1	Movable tray paper-full detection error	CB31
6	2	Catching motor abnormality	CB15
6	3	Assist guide cam home position abnormality	CC41
6	4	Saddle Stitch Finisher folding motor (M17) abnormality	CBE0
6	5	Saddle Stitch Finisher additional folding motor (M20) abnormality	CB93
6	6	Front saddle stapler home position error	CBA0
6	7	Rear saddle stapler home position error	CBB0
6	8	Saddle Stitch Finisher side alignment motor (M15) abnormality	CBC0
6	9	Saddle transport motor (M16) abnormality	CB94
7	1	Punch motor (M3) home position detection error	CC61
7	2	(Unused)	-
7	3	(Unused)	-
7	4	Sideways adjustment motor (M2) abnormality	CC51
7	5	(Unused)	-
7	6	Skew adjustment motor (M1) abnormality	CC52
7	7	Punch ROM checksum error	CC71
7	8	Punch RAM read/write error	CC72
7	9	Punch communication error	CE00
8	1	(Unused)	-
8	2	(Unused)	-
8	3	(Unused)	-
8	4	(Unused)	-
8	5	Saddle communication error	CC20
8	6	Saddle Stitch Finisher stacker motor (M14) abnormality	CB95
8	7	(Unused)	-
8	8	(Unused)	-
8	9	Exit motor (M11) abnormality	CB13
9	1	Assist guide motor (M10) abnormality	CB14
9	2	Finisher main program error	CB82
9	3	(Unused)	-
9	4	Punch unit main program error	CB84
9	5	Punching device power supply abnormality	CC73

Error code 1 (LED2)	Error code 2 (LED3)	Description	Error code (when connected to the equipment)
9	6	Transport pulse abnormality	CC74
9	7	Punch motor (M3) interrupt signal error	CC60
13	1	Loop-back test No response	-
13	2	Loop-back test Data abnormality	-

3. LED blinking pattern error code: Alerts

Error code 1	Error code 2	Description	Error code (when connected to the equipment)
13	3	The stationary tray is full.	-
13	4	The movable tray is full.	-
13	5	The saddle tray is full.	-
13	6	The punched scrap box is full.	-
13	7	(Unused)	-
13	8	The staple cartridge for the finisher section is empty.	-
13	9	The staple cartridge for the saddle stitch section is empty.	-

6.4 Other error

6.4.1 Countermeasure when an exit paper alignment problem occurs

When an exit paper alignment problem occurs on the movable tray during continuous printing in the sort mode, take the following countermeasure.

1. Perform "5.1 Adjusting the Alignment Position". (📖 P. 5-1 "5.1 Adjusting the Aligning Position for the Finishing Tray")
2. If this problem still persists even if step 1 has been performed, check if there are any scratches on the side alignment plate.
If there are any, replace the side alignment plate. (📖 P. 4-11 "[N] Grate-shaped guide")

When an exit paper alignment problem occurs on the stationary tray during continuous printing in the non-sort mode, take the following countermeasure.

1. When an exit paper alignment problem occurs during continuous printing in the non-sort mode, take the following countermeasure.
Check if exit paper sideways deviation has occurred in the equipment installed. If there is any, adjust it by following the Service Manual for the equipment installed.

6.4.2 Paper trailing edge abnormality when it is exiting to the movable tray (dents, folding, tears)

When abnormalities such as dents, folding or tears have occurred at the trailing edge of paper outputted to the movable tray of the finisher, perform the following measure.

[A] Problems in outputted paper

The following problem will occur at the trailing edge of paper outputted to the movable tray. If the returning of the ejectors is not sufficient, latches, which output the paper from the standby position to the movable tray, strongly contact the paper upper surface (trailing edge side), resulting in damage to it.

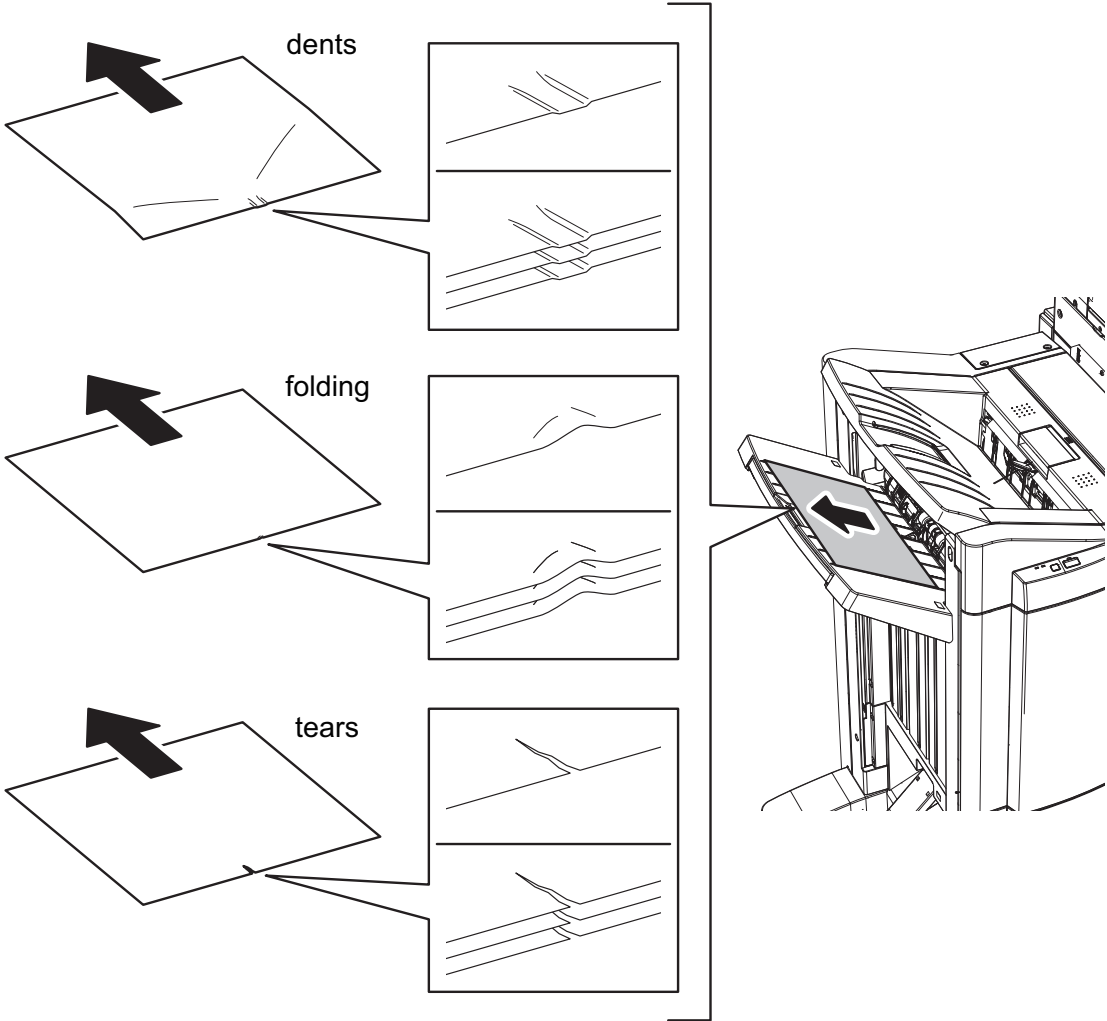

Fig.6-23

[B] Measures

- (1) Clean the ejectors with alcohol while they are in the home position.

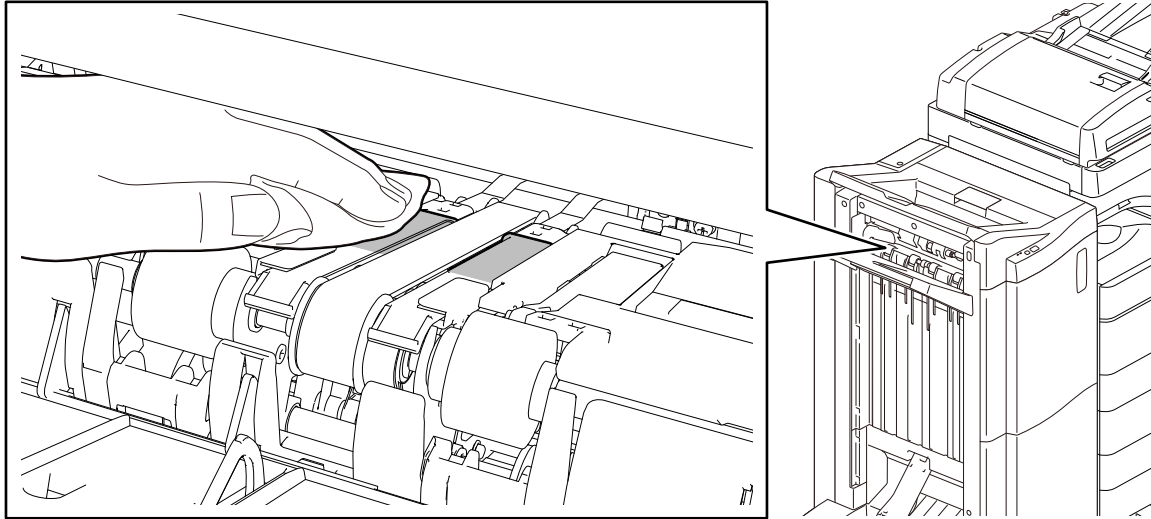

Fig.6-24

- (2) Pull out the ejectors in the finishing tray unit.
Clean both the back and front sides of the pulled out ejectors with alcohol.

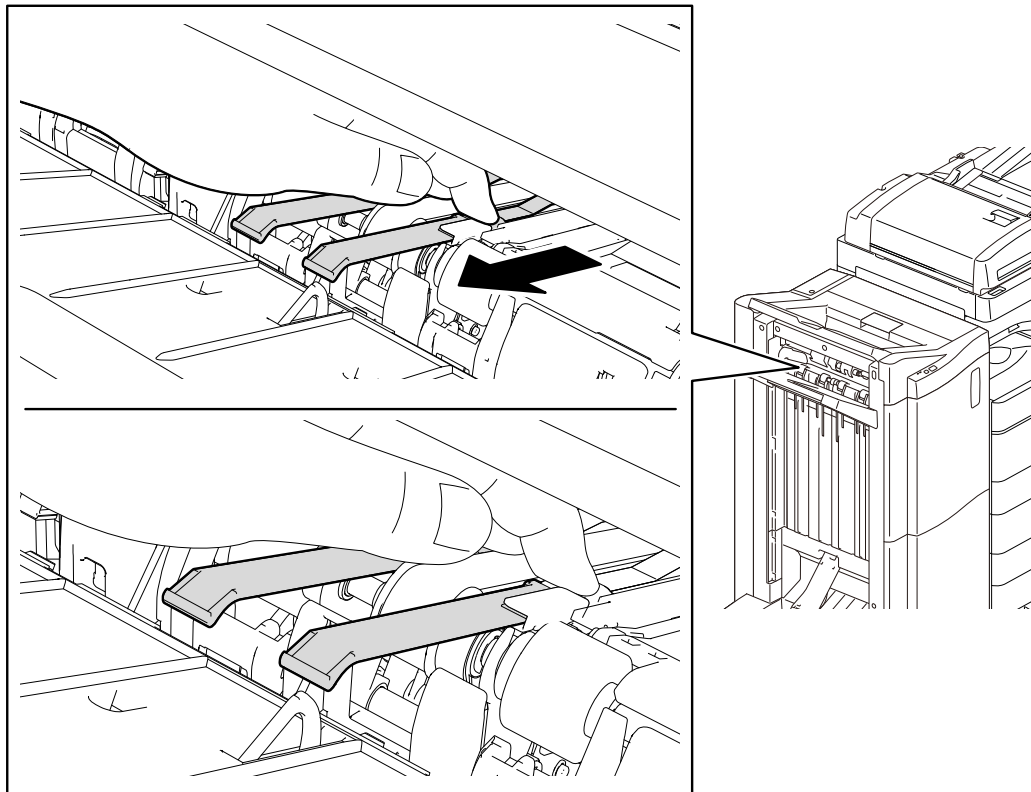

Fig.6-25

If Molykote oil has adhered to the ejectors or the metal guide, wipe it all off.

(3) Perform the operation check of the finishing tray unit.

1) Put your hand on the holder at the end of the ejectors and then pull them out toward you until they stop.

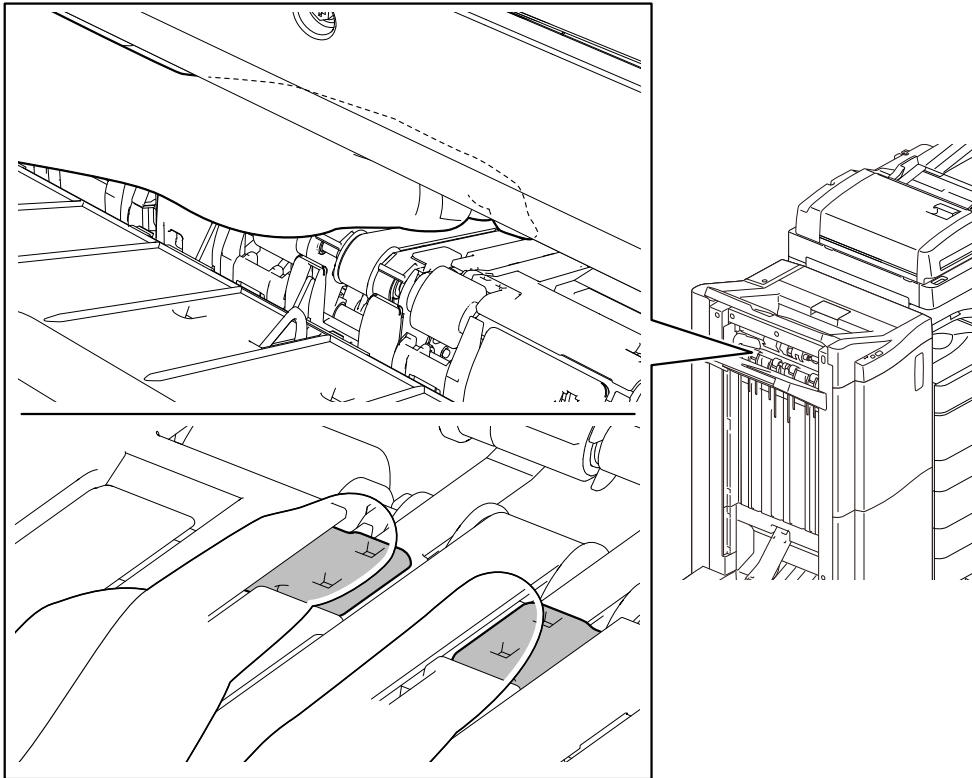

Fig.6-26

2) Release your hand from the holder and check that the ejectors are quickly returned to their home position.

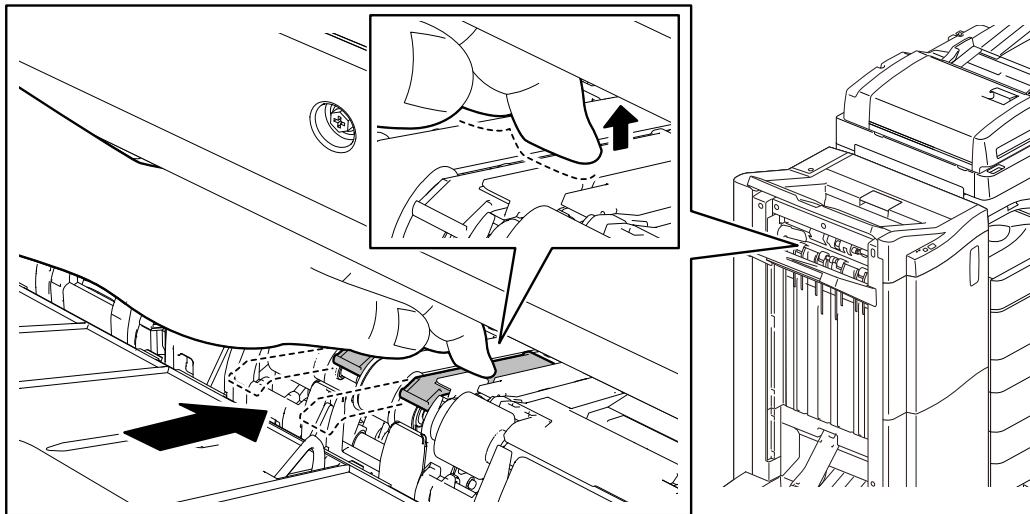

Fig.6-27

- 3) Check the returned position of the ejectors.
OK:

OK

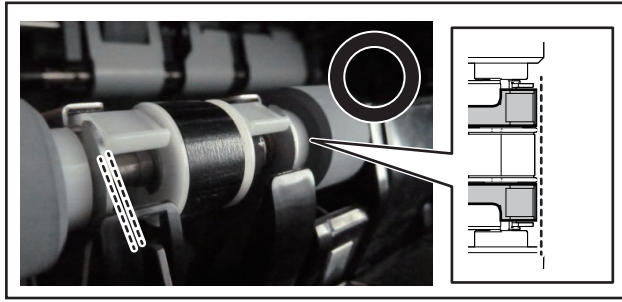

Fig.6-28

Not good

Not
good

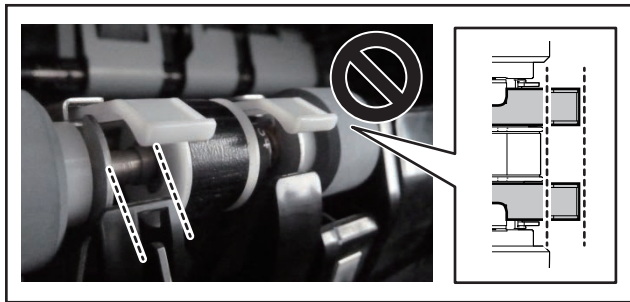

Fig.6-29

- 4) If the position is the Not good state, go to step (5).

- (4) After the operation check of the finishing tray unit has been done, clean the ejectors in the home position with alcohol again.

Remarks:

- Clean the ejectors in the same manner as that for step (1).
(5) Replace the finishing tray unit.
If the problem at the trailing edge of the paper still persists even after steps (1) to (3) have been performed, replace the finishing tray unit.

Finishing tray unit ASYB-SHEAF-FEED-RBT3 (P-I: 10-48)

7. PREVENTIVE MAINTENANCE (PM) / FIRMWARE UPDATE

7.1 Maintenance and Inspection Points

Perform preventive maintenance according to the check list.

* Perform preventive maintenance for the Finisher at the same interval as for the main equipment to which the Finisher is connected.

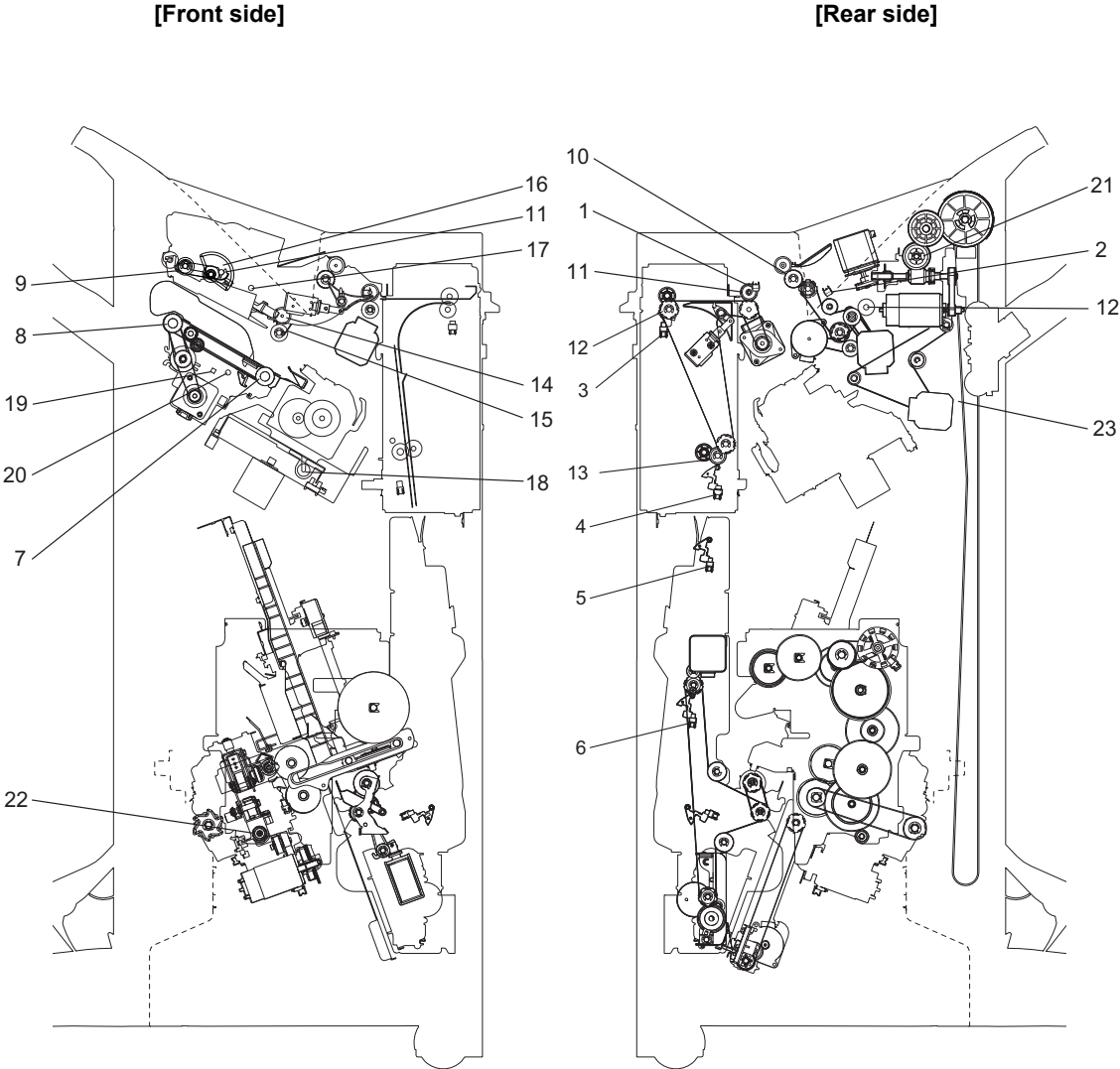

Fig. 7-1

Symbols used in the checklist

Cleaning	Lubrication/Coating	Replacement	Operation check
A: Clean with alcohol B: Clean with soft pad, cloth or vacuum cleaner	W2: White grease (Molykote HP-300) W3: White grease (Molykote EM-30L) C: Coating material (SANKOL CFD-409M)	Value: Replacement cycle (output pages or develop counts) R1: Replacement R3: Replace if deformed or damaged	O: After cleaning or replacement, confirm there is no problem.

Preventive Maintenance Checklist

Items to check		Cleaning	Lubrication	Replacement (x1,000)	Operation check	Parts list (P-I)	Remarks
1	Entrance sensor (S1)	A					
2	Transport sensor (S2)	A					
3	Feeding sensor (S22)	A					
4	Junction box paper detection sensor (S26)	A					
5	Transport path-2 sensor (S27)	A					
6	Transport path-3 sensor (S28)	A					
7	Stack transport roller-1	A					
8	Stack transport roller-2	A					
9	Buffer roller	A					
10	Stationary tray roller	A					
11	Entrance roller and idle roller	A	W2				*m
12	Feeding roller and idle roller	A	W2				*m
13	Junction roller and idle roller	A	W2				*m
14	Exit roller	A					
15	Paddle			R1 1,000			
16	Front assist guide cam/ Rear assist guide cam		C				*a
17	Buffer roller link		W3				*b
18	Shaft		W3				*c
19	Buffer tray shaft		W3				*d
20	Pinch roller shaft		W3				*e
21	Buffer roller shaft		W3				*f
22	Stapler carrier shaft		W3				*g
23	Rack gear (Aligning plate)		W3				*h
24	Finishing tray shaft		W3				*i
25	Movable tray drive gear		W2				*j
26	Additional folding unit carrier shaft		W3				*k
27	Grate-shaped guide	A	C				*l

*a. Front assist guide cam/Rear assist guide cam

Apply coating material (SANKOL CFD-409M) by using a cleaning brush to the portion on the guide with which the all around the assist guide cam [1].

- * Use a cleaning brush (4407915710 BRUSH-33) because cloth contaminated with the coating material shall be treated as industrial waste.
- * Do not apply coating material (Molykote PD-910) to the rubber section of the grate-shaped tray.
- * When coating material adheres to the skin, rinse it well with water.
- * The brush with which the coating agent (SANKOL CFD-409M) was applied must be exclusive for coating. Do not use it to clean other areas.

*b. Buffer roller link

Apply an adequate amount of white grease (Molykote EM-30L) to the entire buffer roller link [2].

*c. Shaft

Apply an adequate amount of white grease (Molykote EM-30L) to the entire shaft [3].

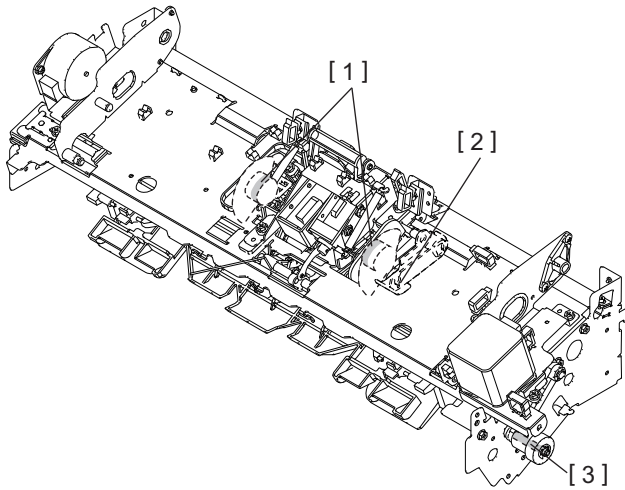

Fig. 7-2

*d. Buffer tray shaft

Apply an adequate amount of white grease (Molykote EM-30L) to the entire buffer tray shaft [1].

*e. Pinch roller shaft

Apply an adequate amount of white grease (Molykote EM-30L) to the entire pinch roller shaft [2].

*f. Buffer roller shaft

Apply an adequate amount of white grease (Molykote EM-30L) to the entire buffer roller shaft [3].

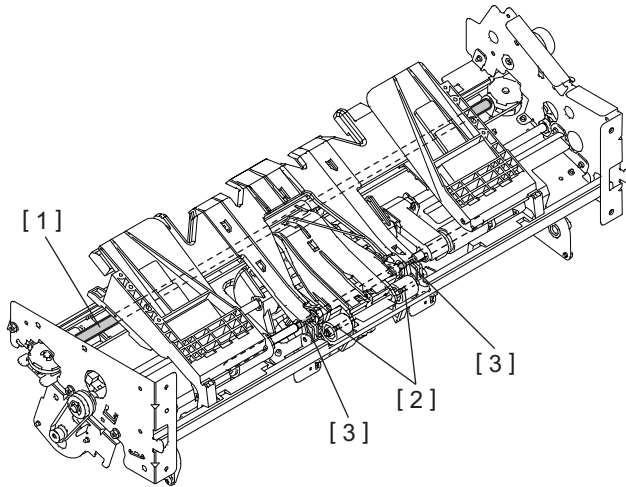

Fig. 7-3

*g. Stapler carrier shaft

Apply an adequate amount of white grease (Molykote EM-30L) to the entire stapler carrier shaft [1].

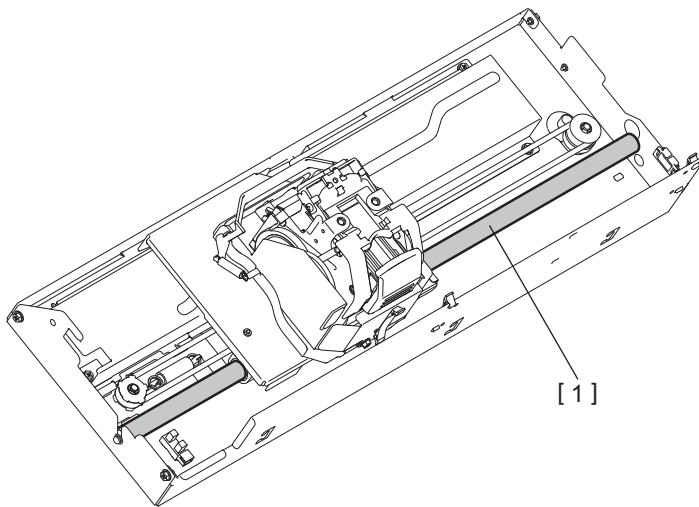



Fig. 7-4

*h. Rack gear (Aligning plate)

*i. Finishing tray shaft

1. Take off the junction box unit.

 P. 4-15 "[A] Junction box unit"

* If the hole punch unit is installed, take it off beforehand.

2. Apply oil as follows through the opening which shows up when the junction box unit has been removed.

Apply an adequate amount of white grease (Molykote EM-30L) to the gear teeth of the rack gear [1] which drive the aligning plate, and the entire finishing tray shaft [2].

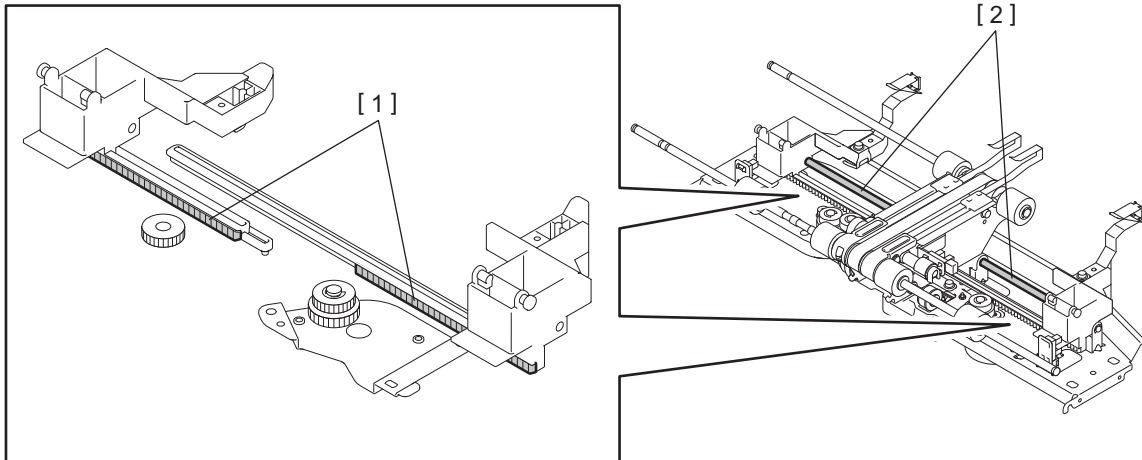

Fig. 7-5

*j. Movable tray drive gear

Apply an adequate amount of white grease (Molykote HP-300) to the gear teeth of the movable tray drive gear [1].

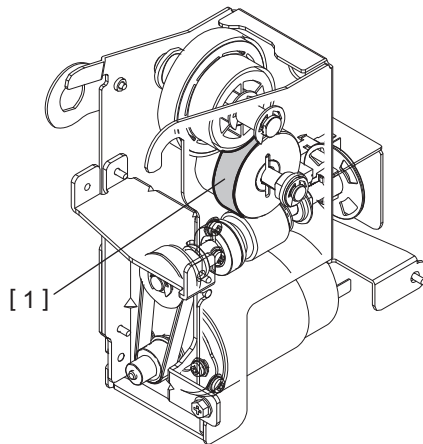

Fig. 7-6

*k. Additional folding unit carrier shaft (MJ-1112)
Apply an adequate amount of white grease (Molykote EM-30L) to the entire Additional folding unit carrier shaft [1].

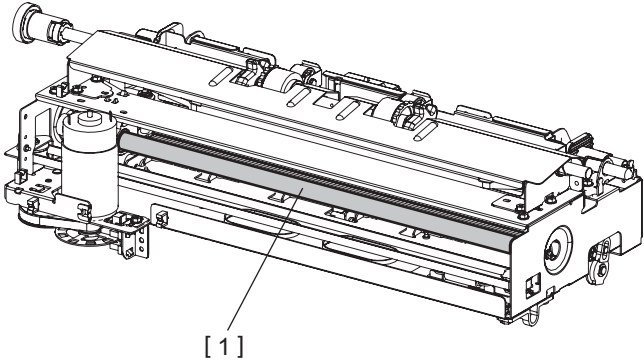

Fig. 7-7

*1. Grate-shaped guide

When an abnormal noise occurs in the grate-shaped guide or the trailing edge of the paper stacked on the tray is dirty, apply coating material (SANKOL CFD-409M) by using a cleaning brush to the portion on the guide with which the paper edge is in contact.

- * Use a cleaning brush (4407915710 BRUSH-33) because cloth contaminated with the coating material shall be treated as industrial waste.
- * Do not apply coating material (Molykote PD-910) to the rubber section of the grate-shaped tray.
- * When coating material adheres to the skin, rinse it well with water.
- * The brush with which the coating agent (SANKOL CFD-409M) was applied must be exclusive for coating. Do not use it to clean other areas.

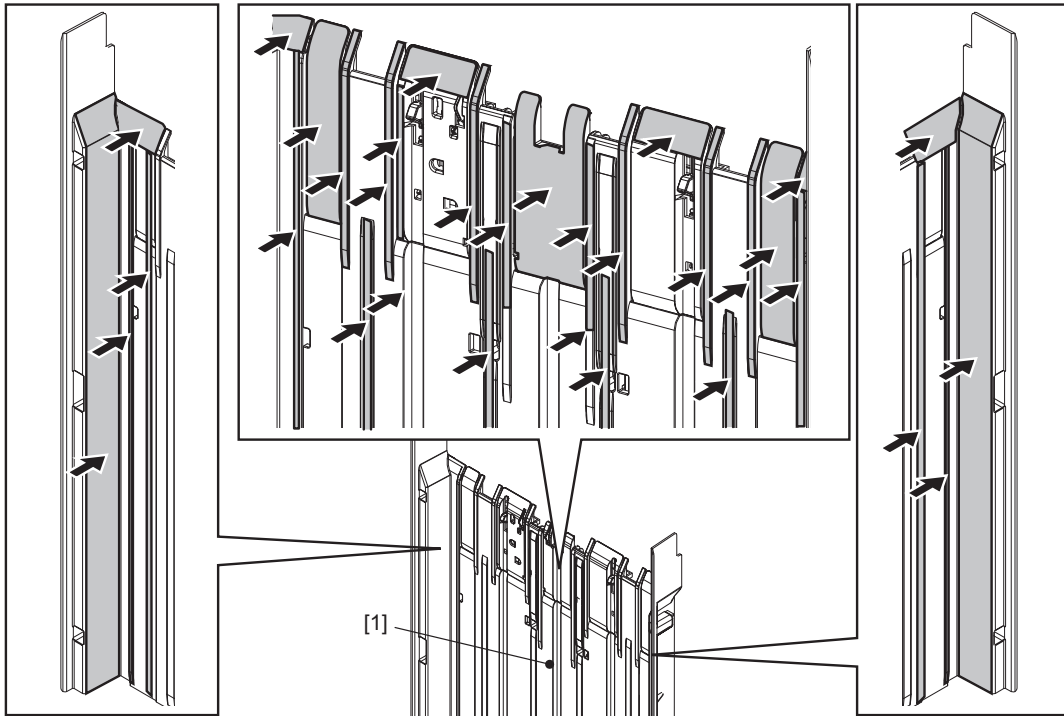

Fig. 7-8

*1. Roller

Apply white grease (Molykote HP-300) to the bushings of the roller.

7.2 Firmware Update

Notes:

For updating firmware of the finisher, refer to " FIRMWARE UPDATING" in the Service Manual for MFP.

8. ELECTRIC CIRCUIT

8.1 Harness Diagram

[A] Finisher control PC board

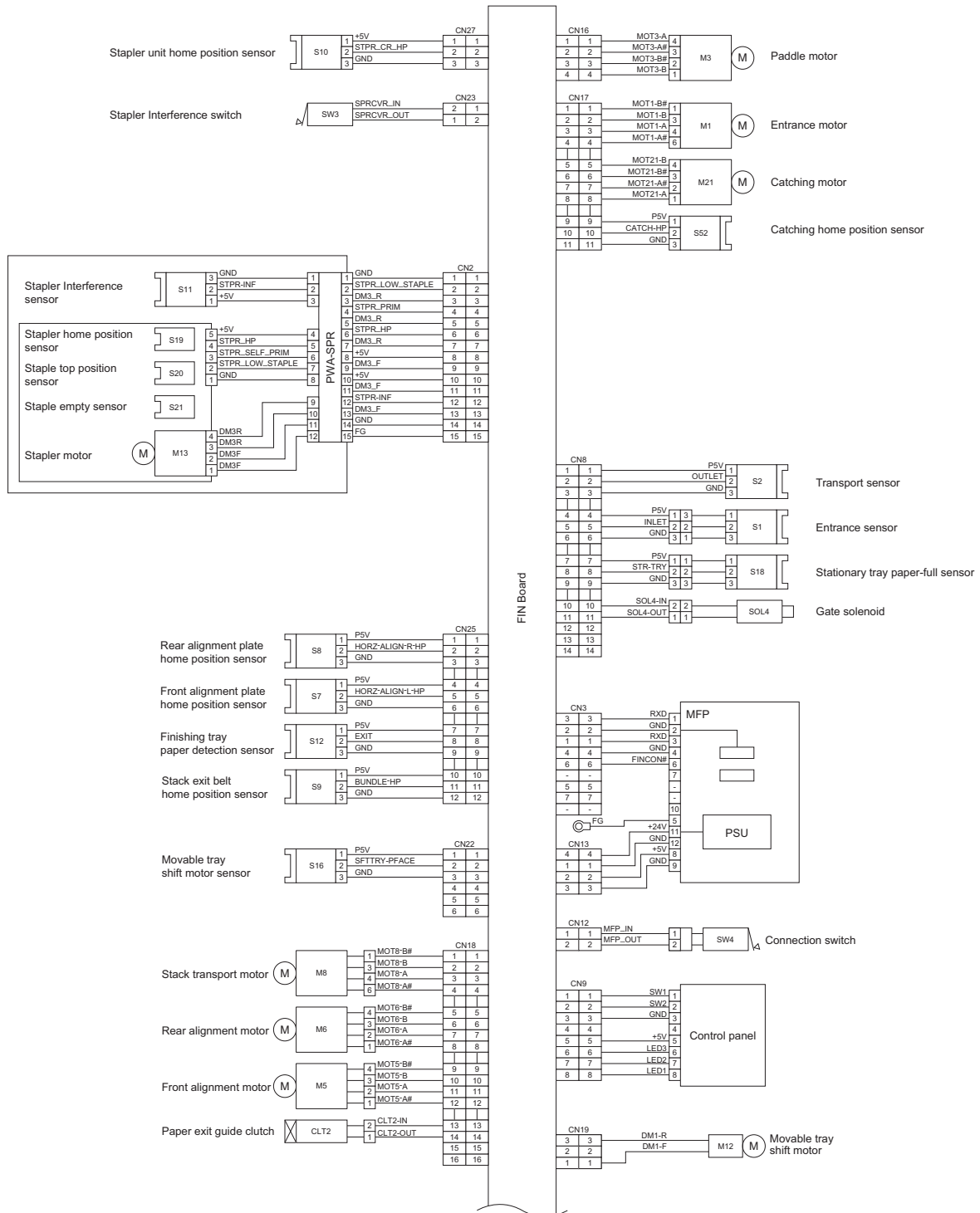

Fig.8-1

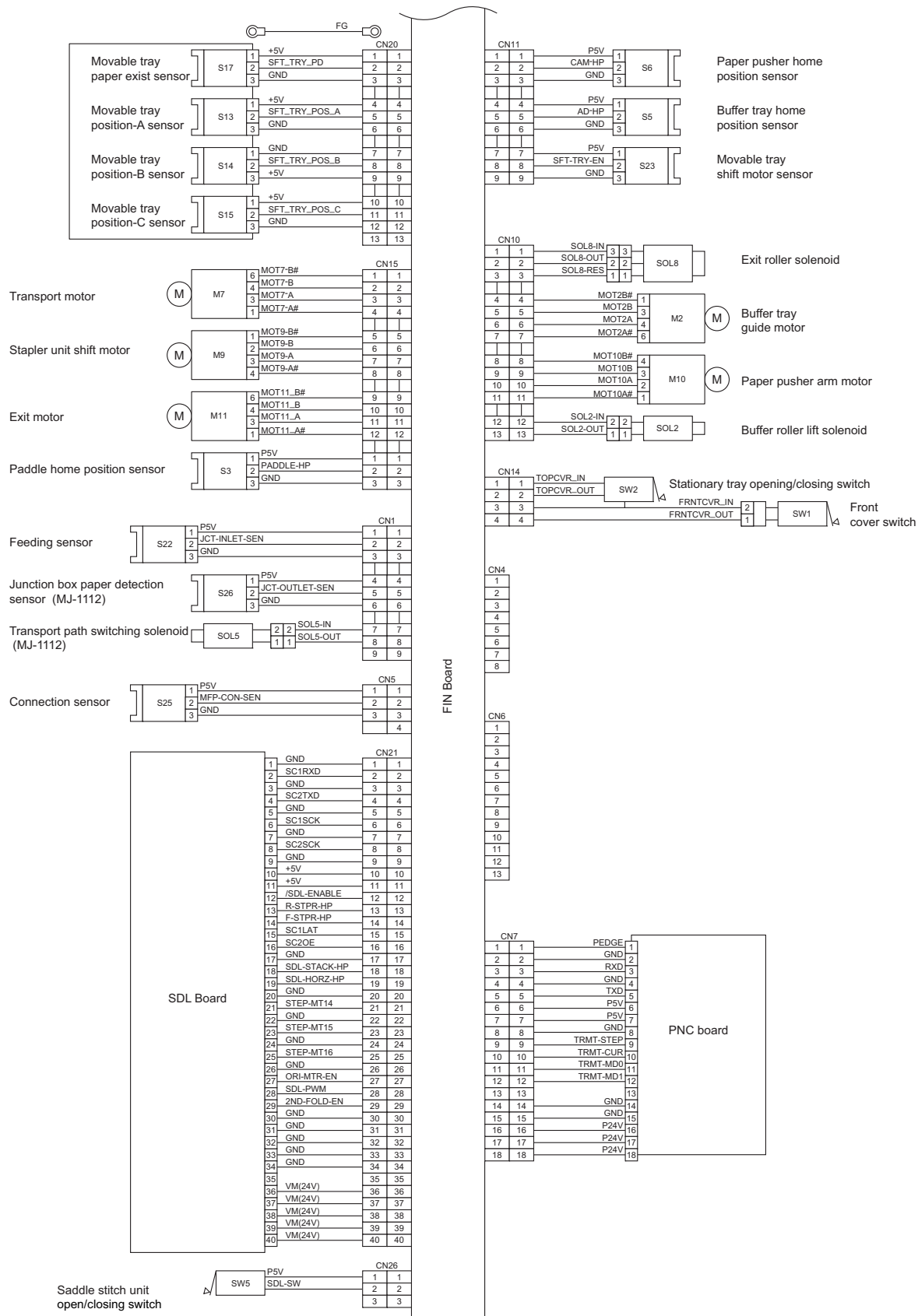

Fig.8-2

[B] Saddle control PC board

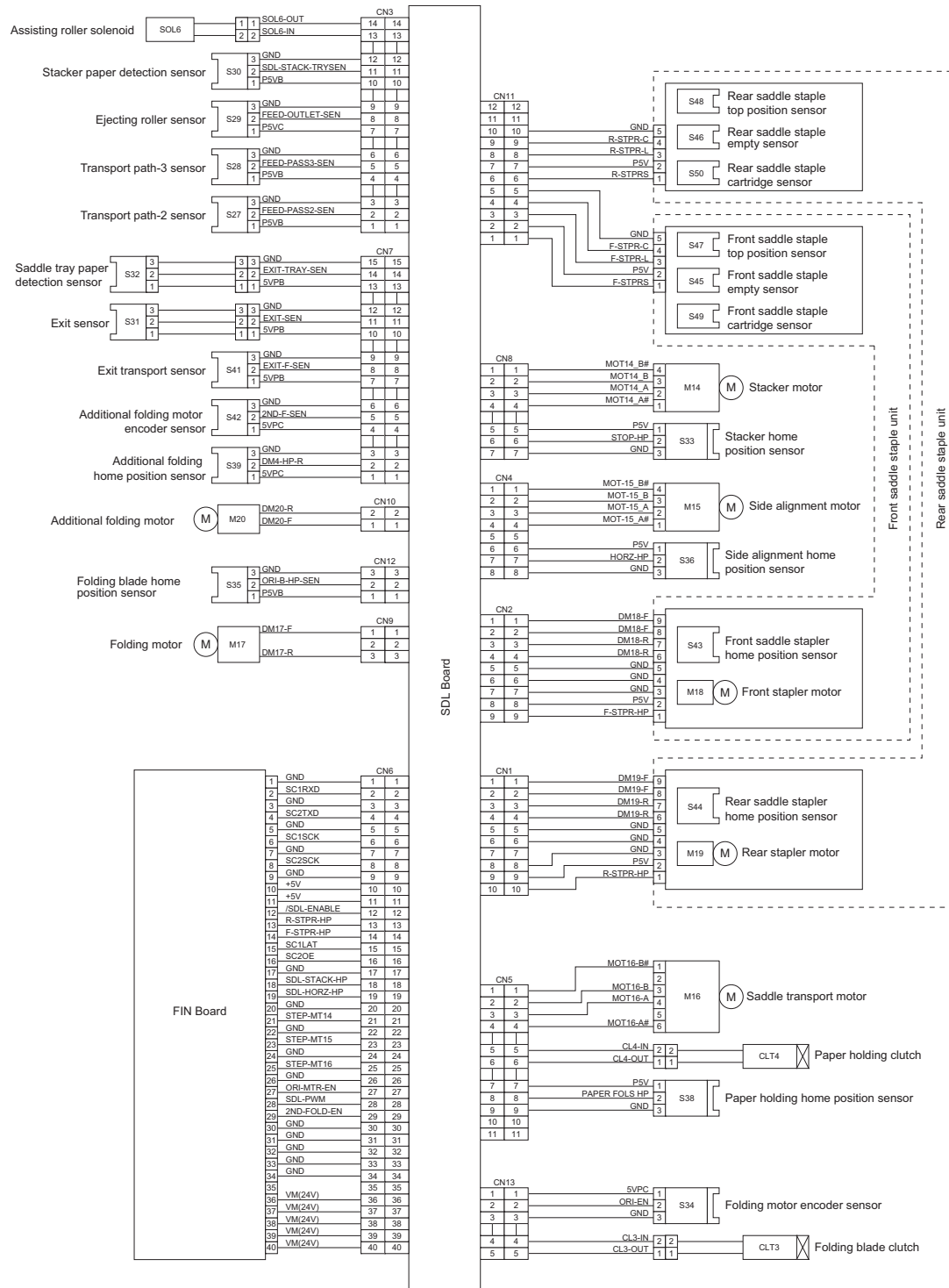

Fig.8-3

8.2 Circuit Diagram

[A] Finisher control PC board

1. Circuit Diagram (1)

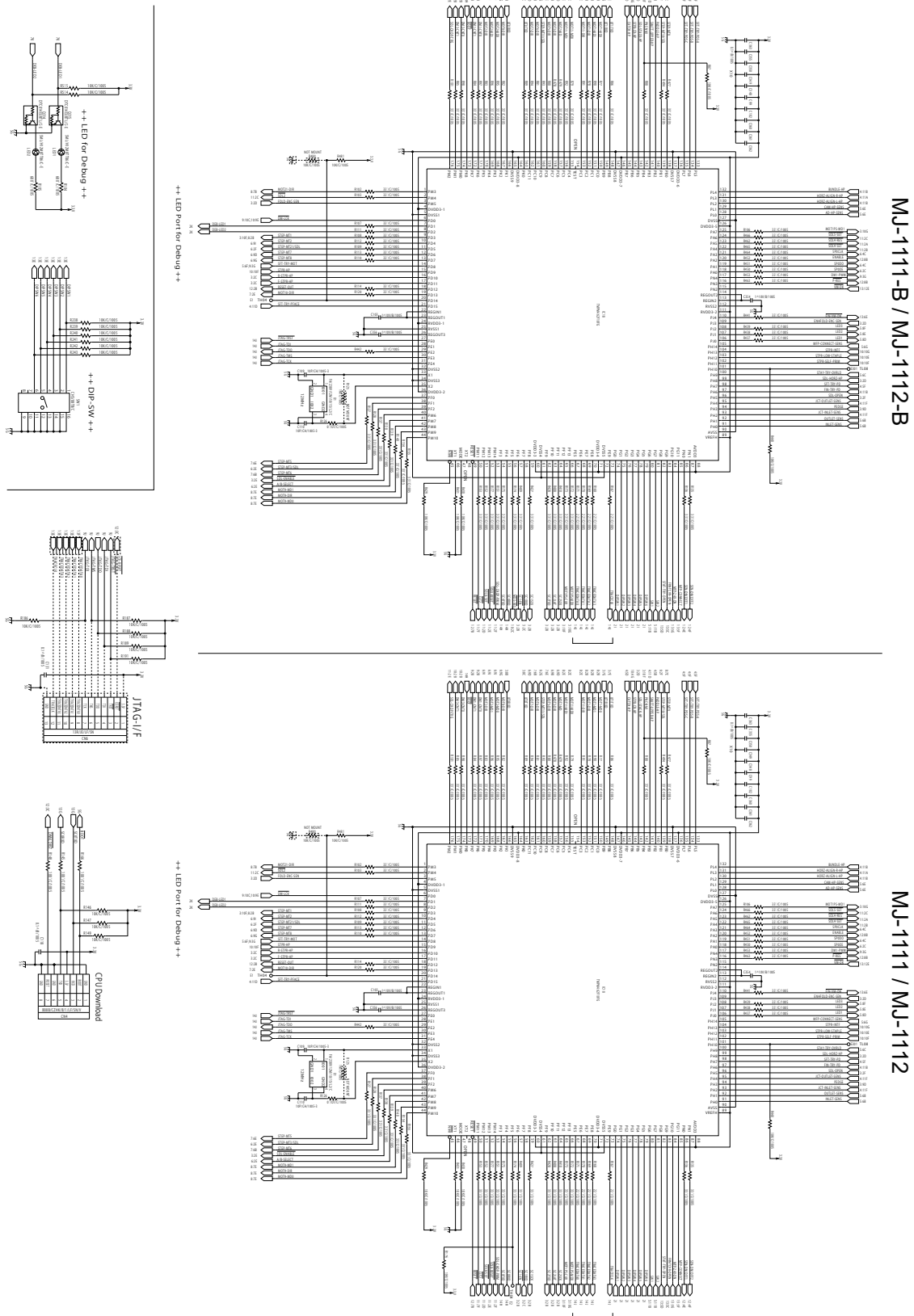

Fig.8-4

MJ-1111/1112
ELECTRIC CIRCUIT

2. Circuit Diagram (2)

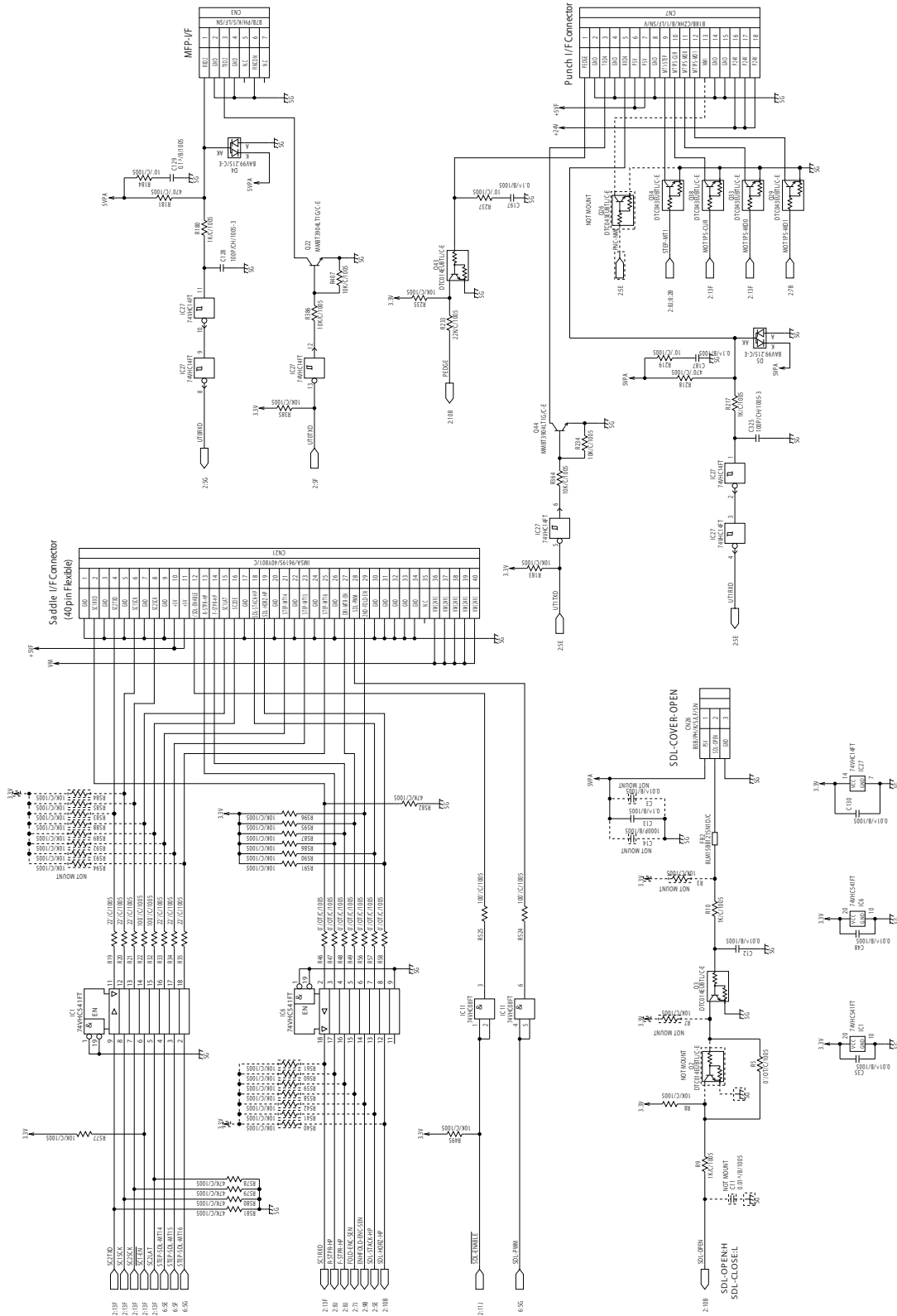

Fig.8-5

3. Circuit Diagram (3)

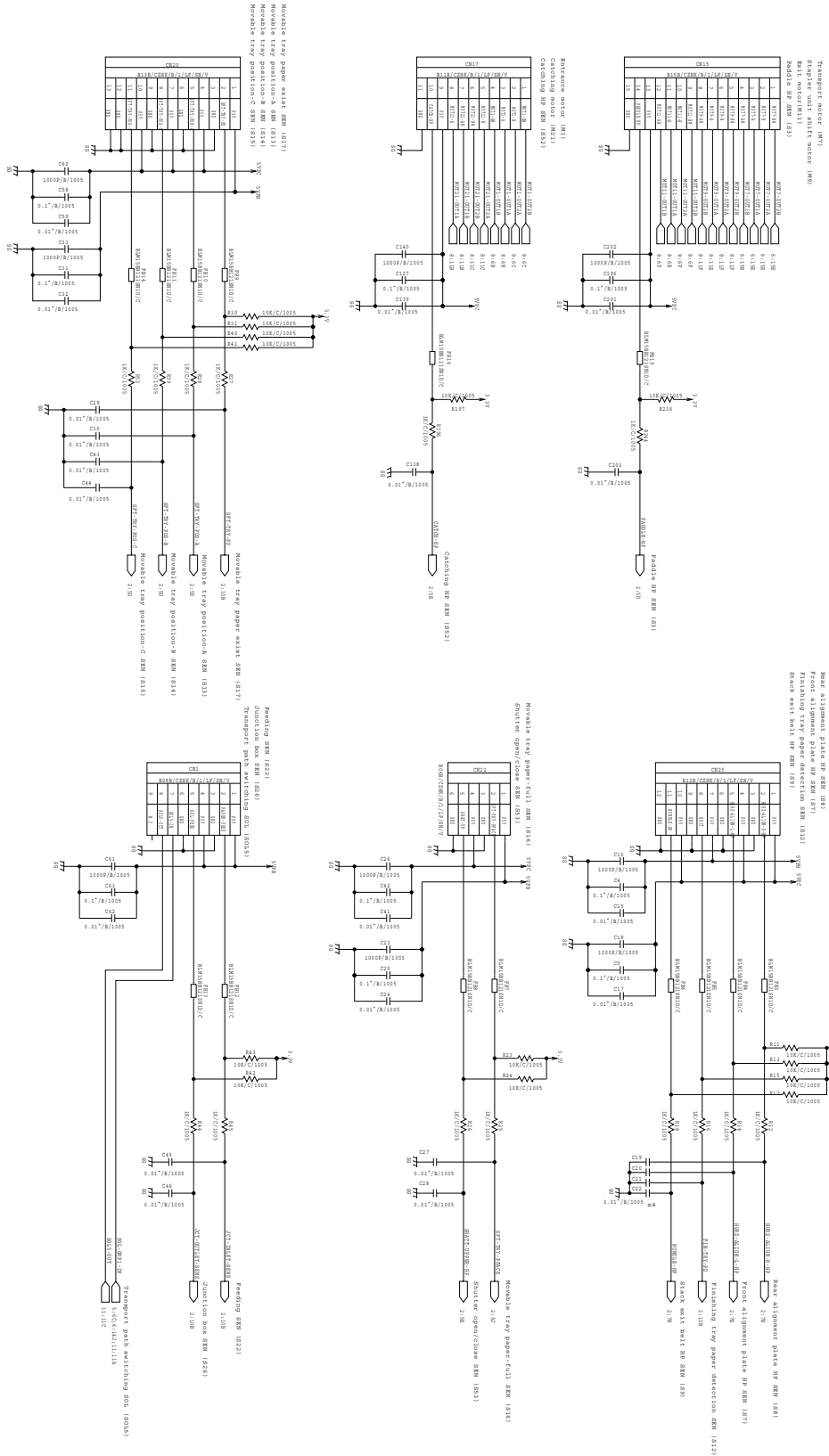

Fig.8-6

5. Circuit Diagram (5)

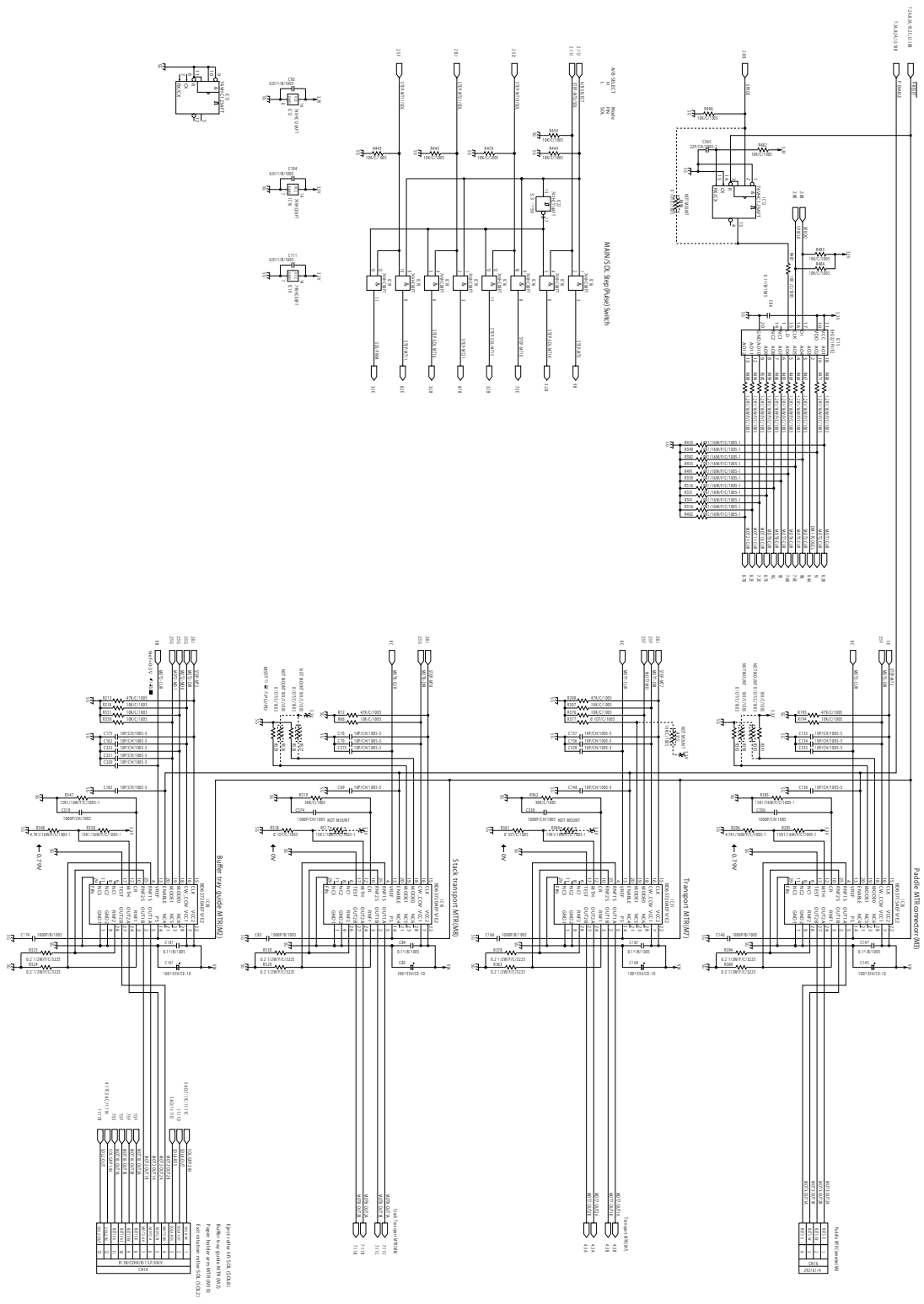

Fig.8-8

6. Circuit Diagram (6)

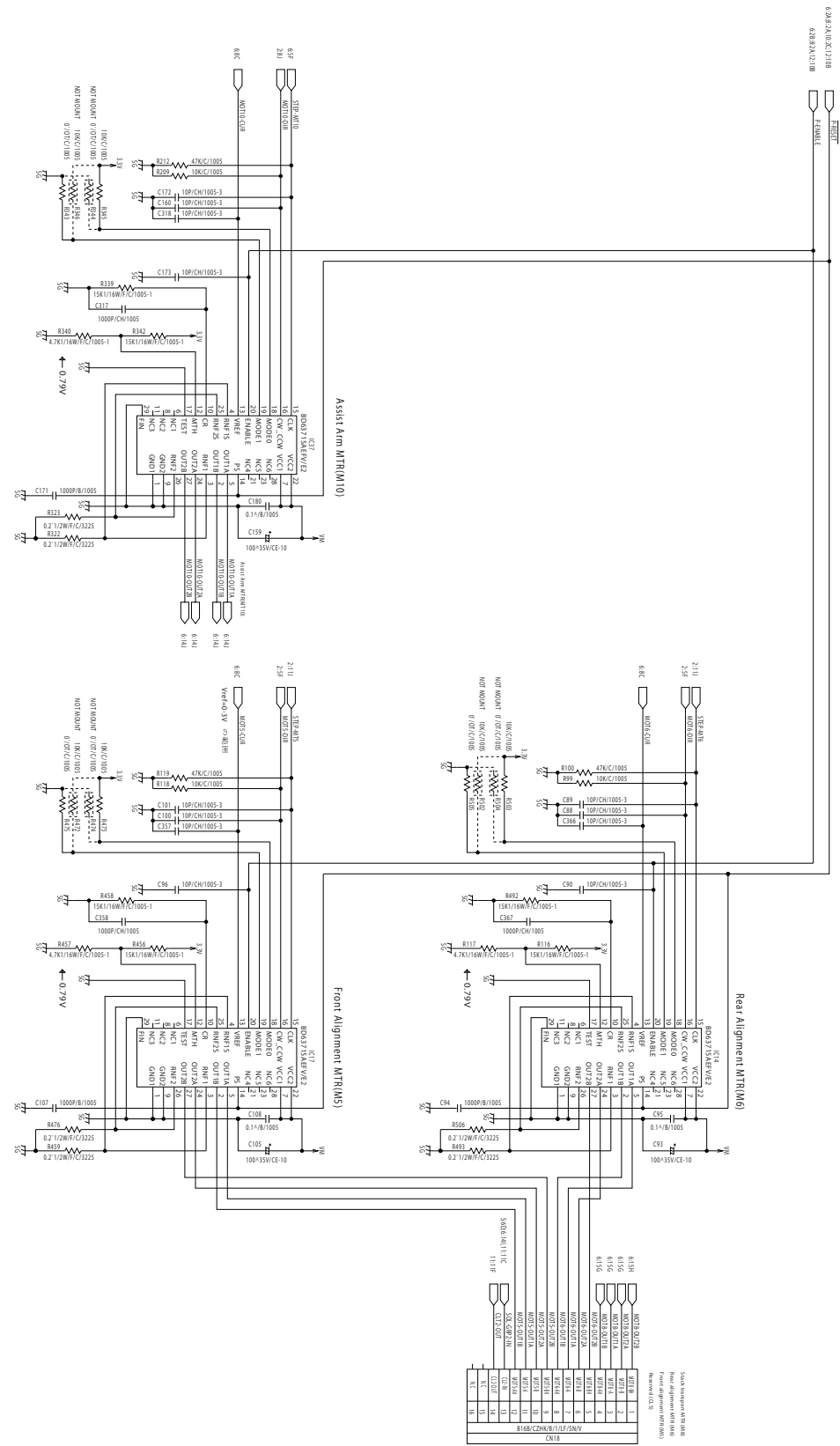

Fig.8-9

7. Circuit Diagram (7)

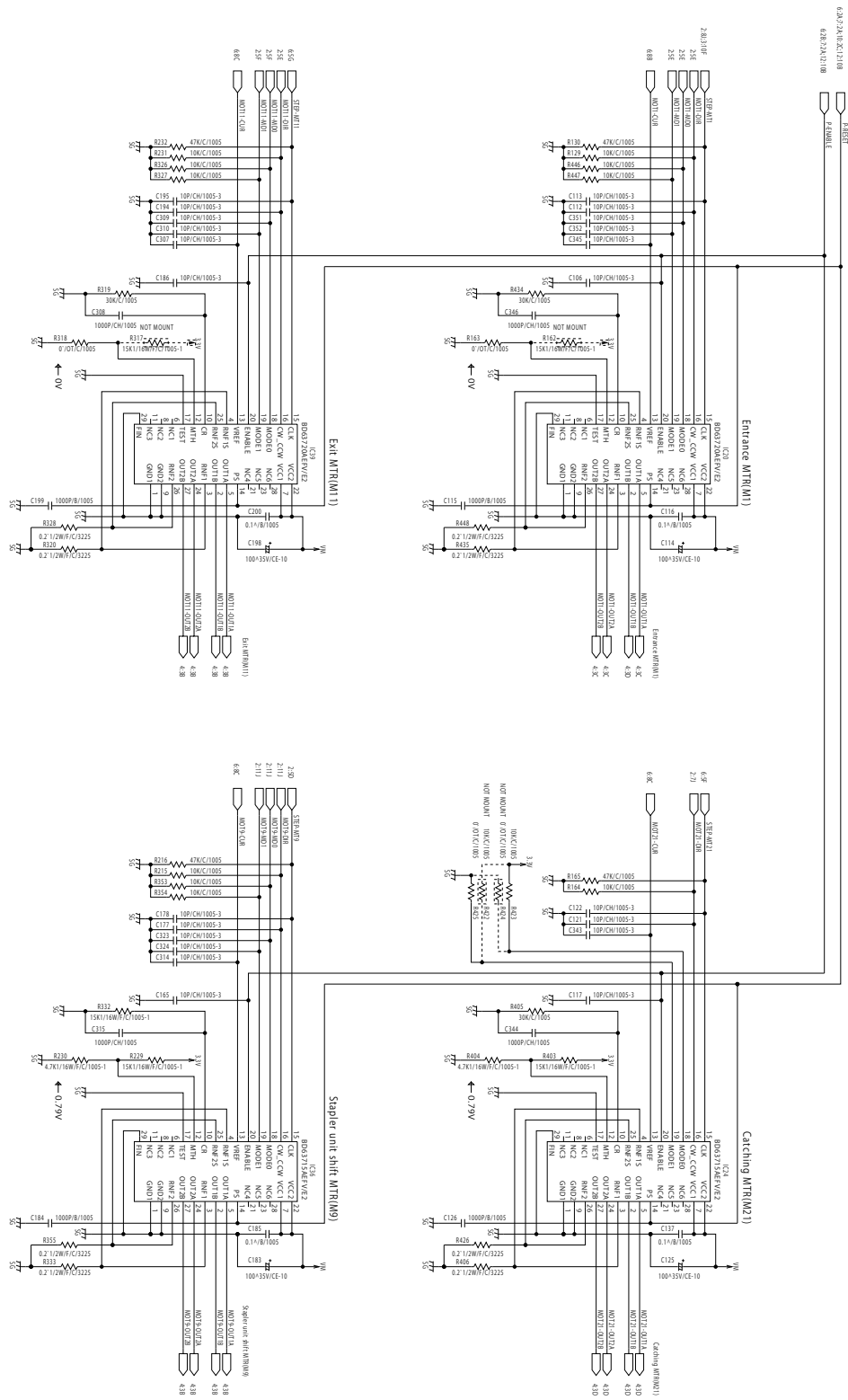

Fig.8-10

9. Circuit Diagram (9)-1 for MJ-1111-B / MJ-1112-B

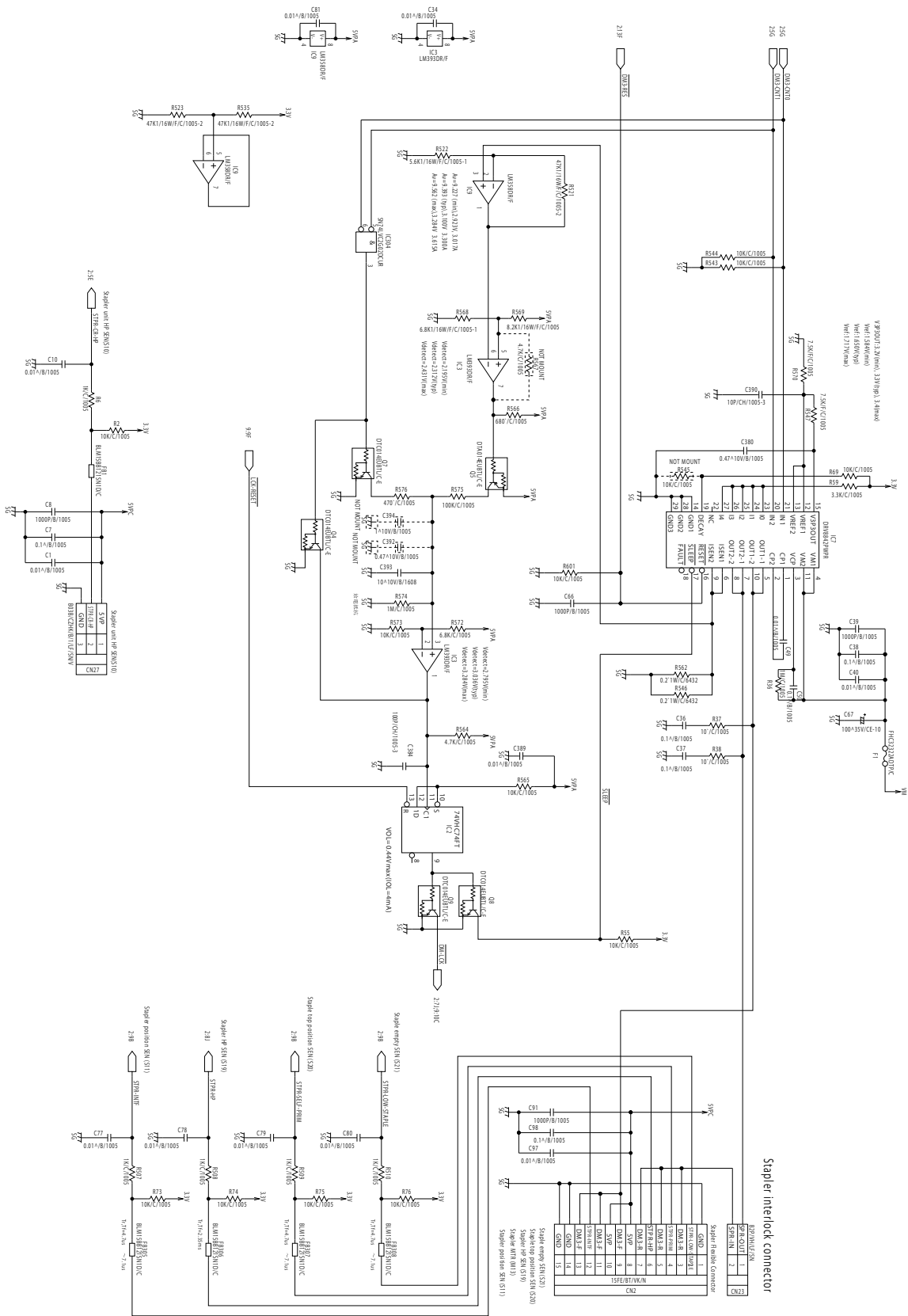

Fig.8-12

10. Circuit Diagram (9)-1 for MJ-1111 / MJ-1112

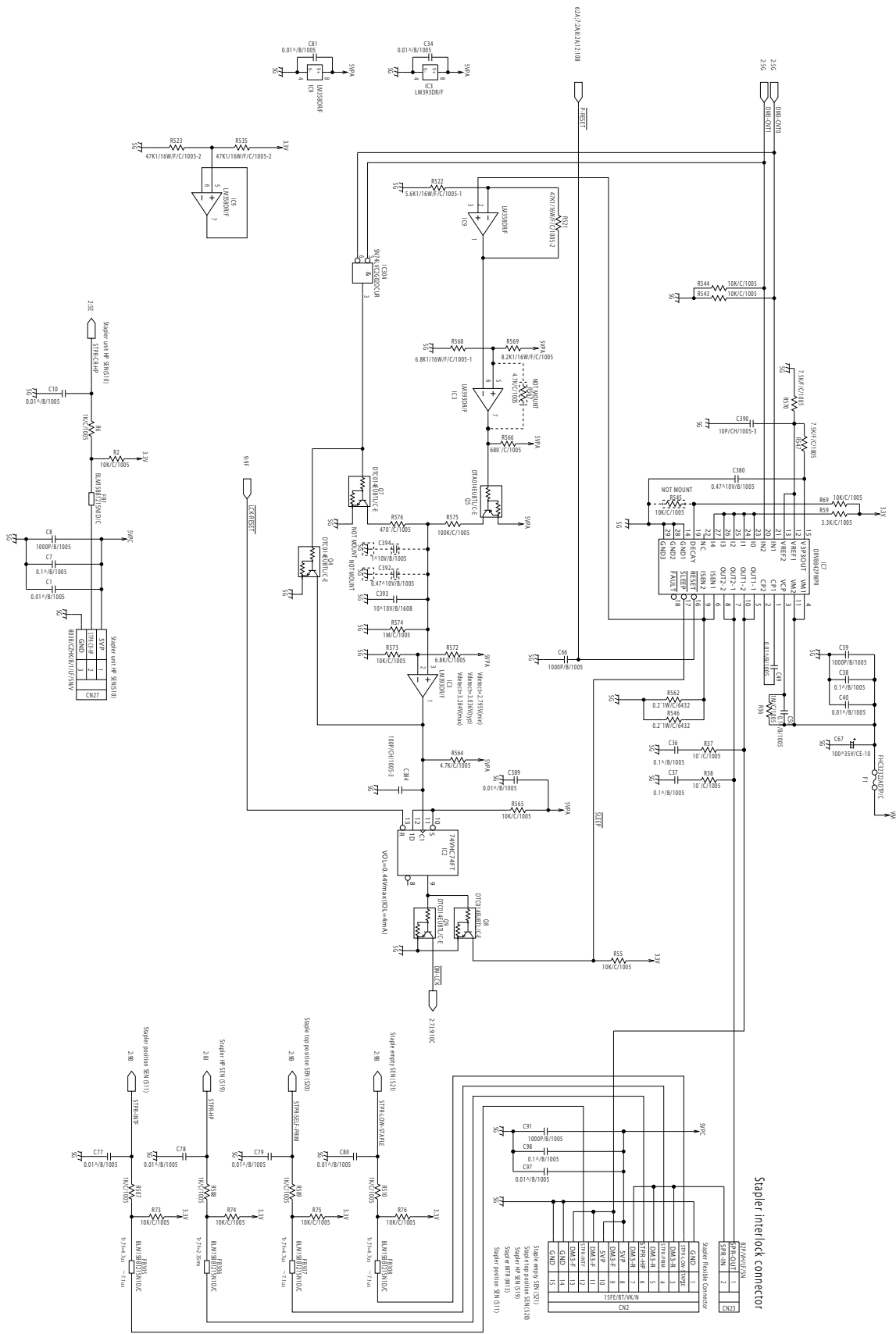

Fig.8-13

11. Circuit Diagram (10)

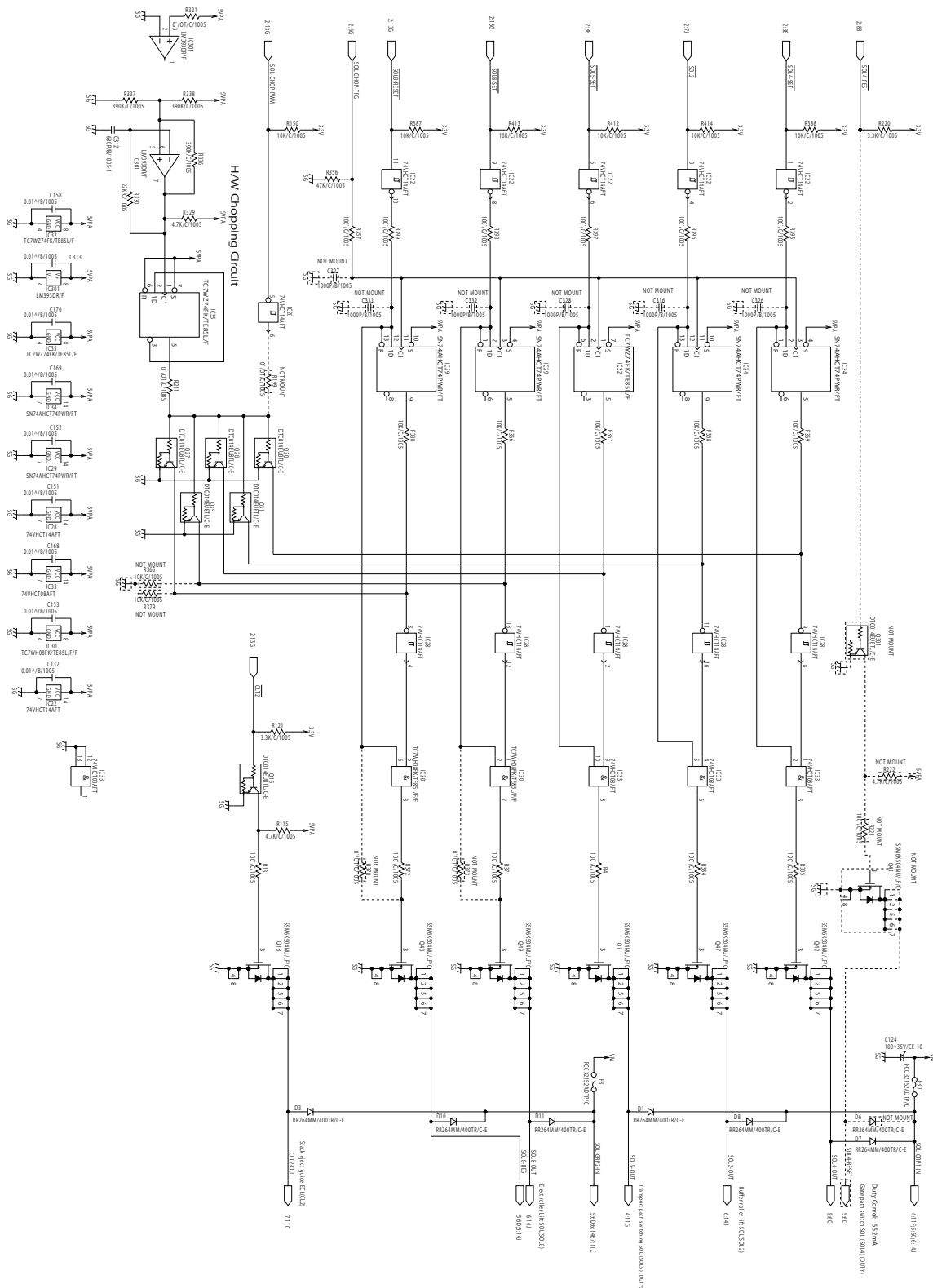

Fig.8-14

13. Circuit Diagram (12)

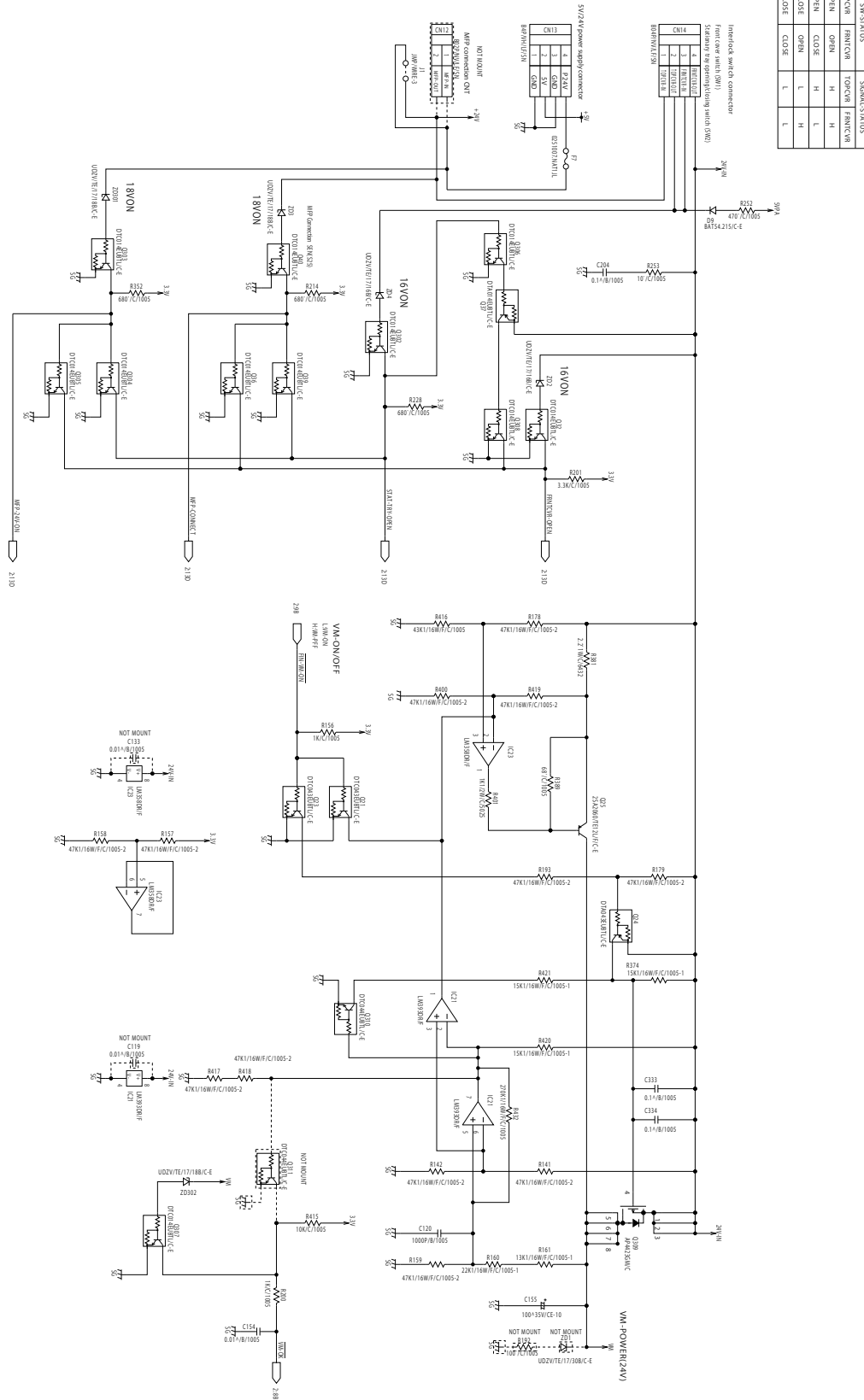

Fig.8-16

[B] Saddle control PC board

1. Circuit Diagram (1)

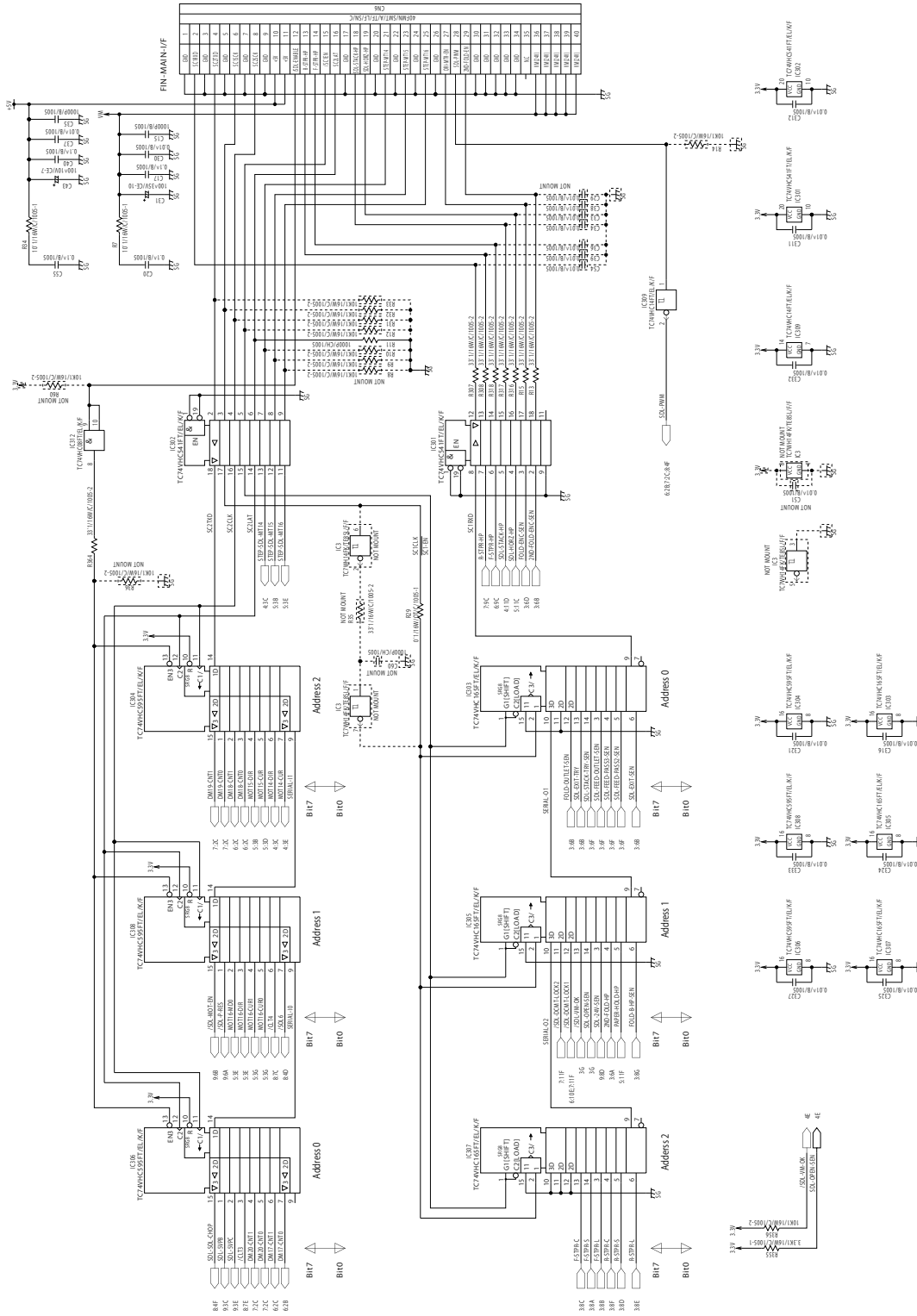

Fig.8-17

2. Circuit Diagram (2)

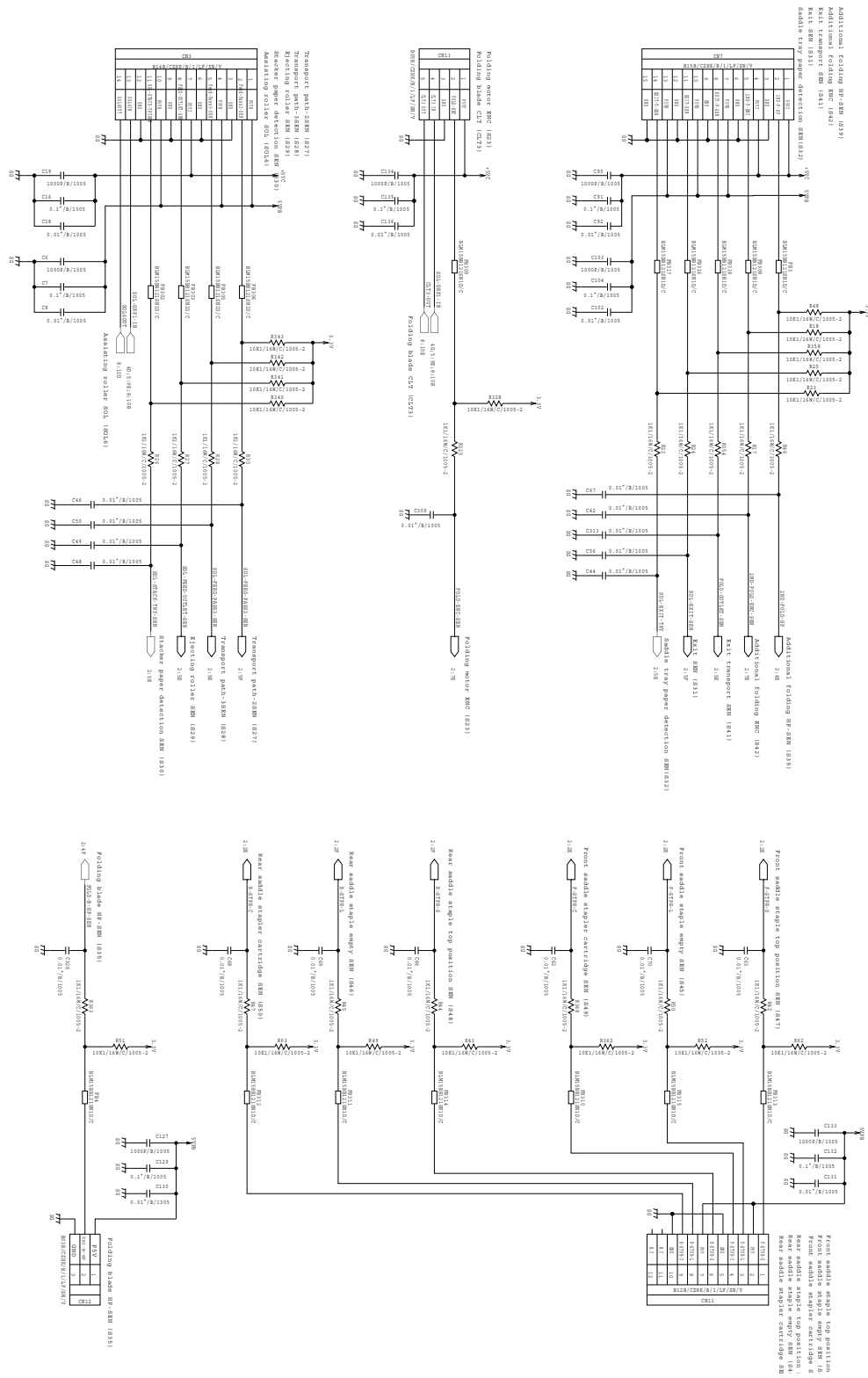

Fig.8-18

4. Circuit Diagram (4)

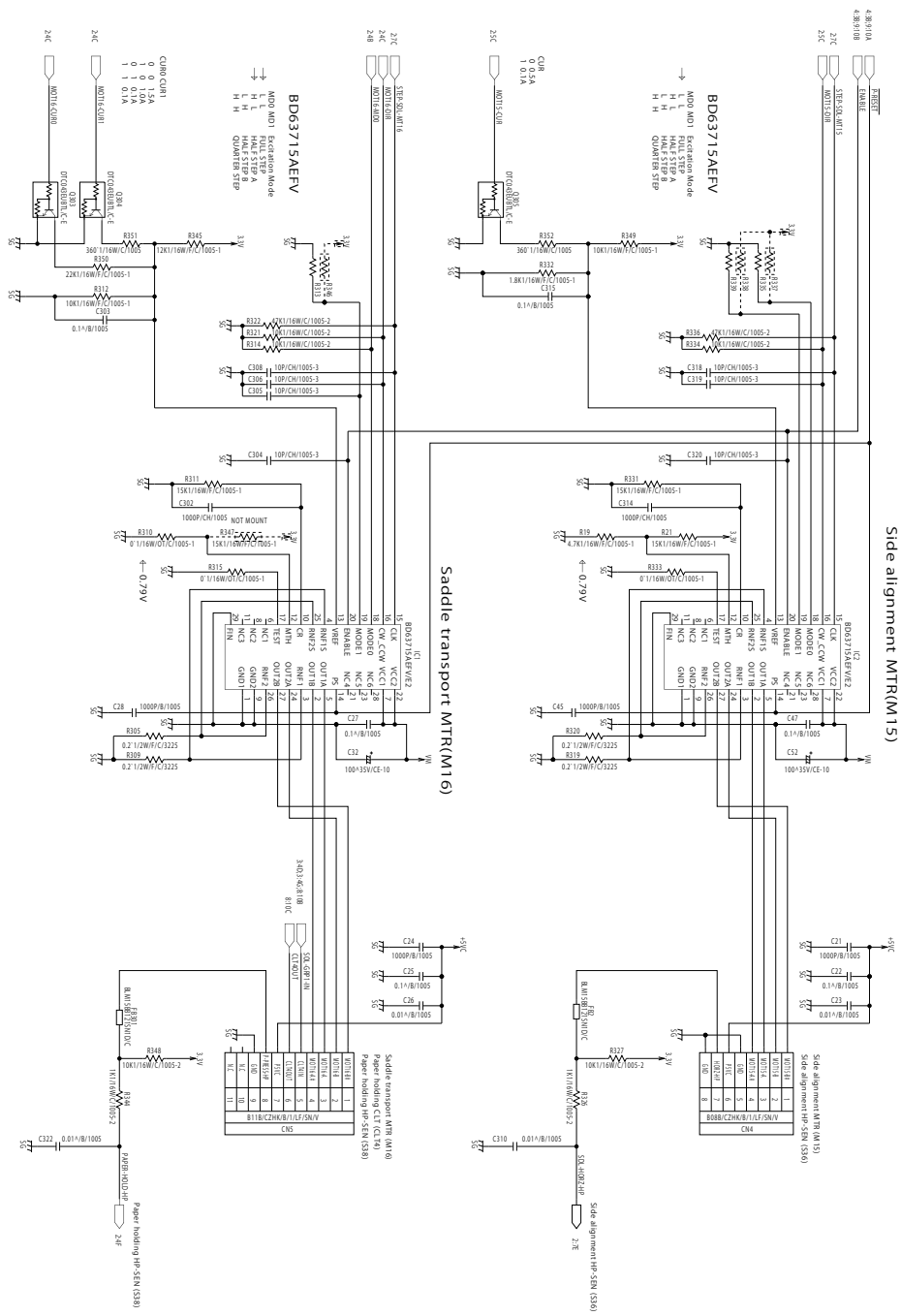

Fig.8-20

5. Circuit Diagram (5)

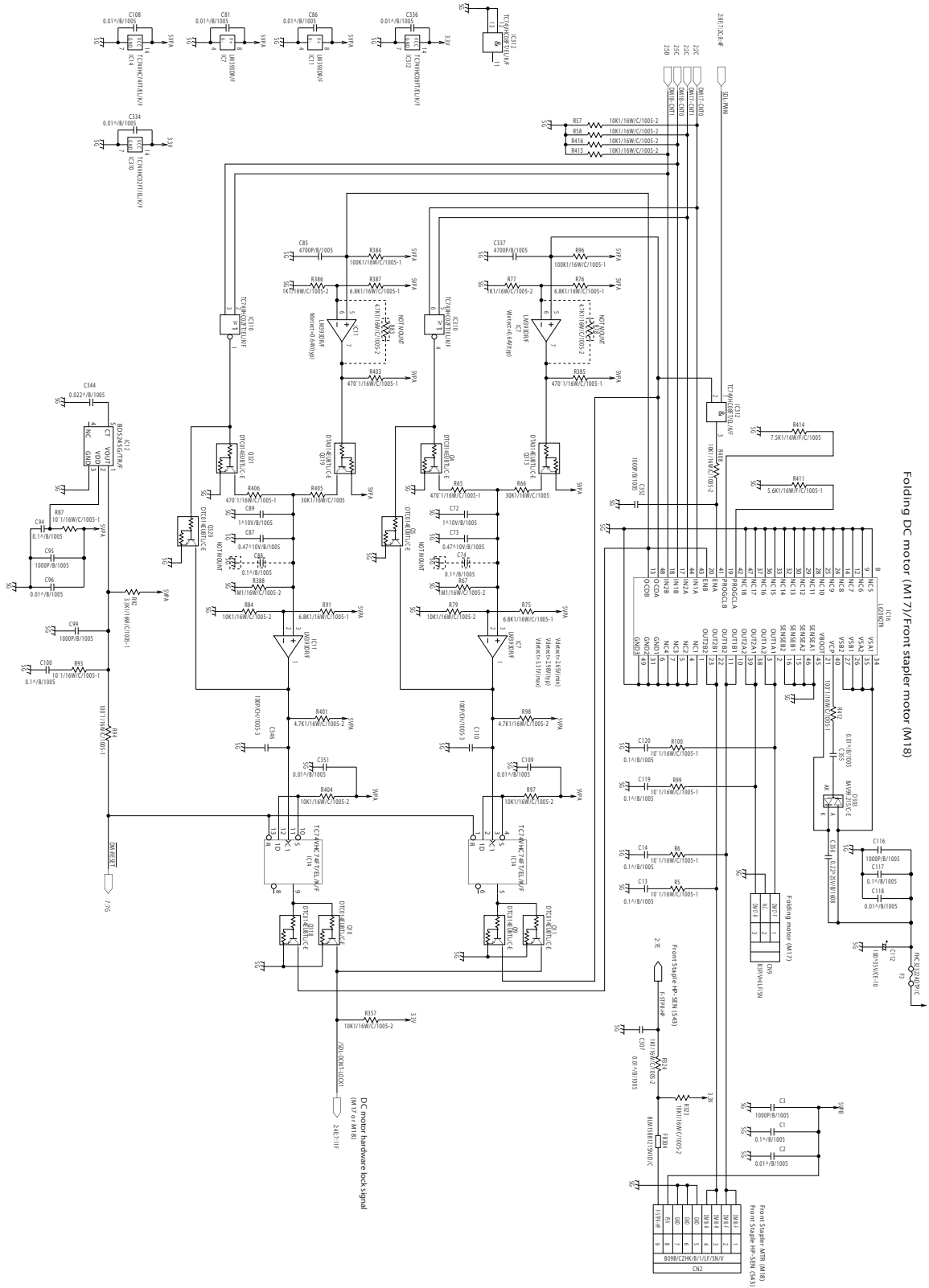

Fig.8-21

6. Circuit Diagram (6)

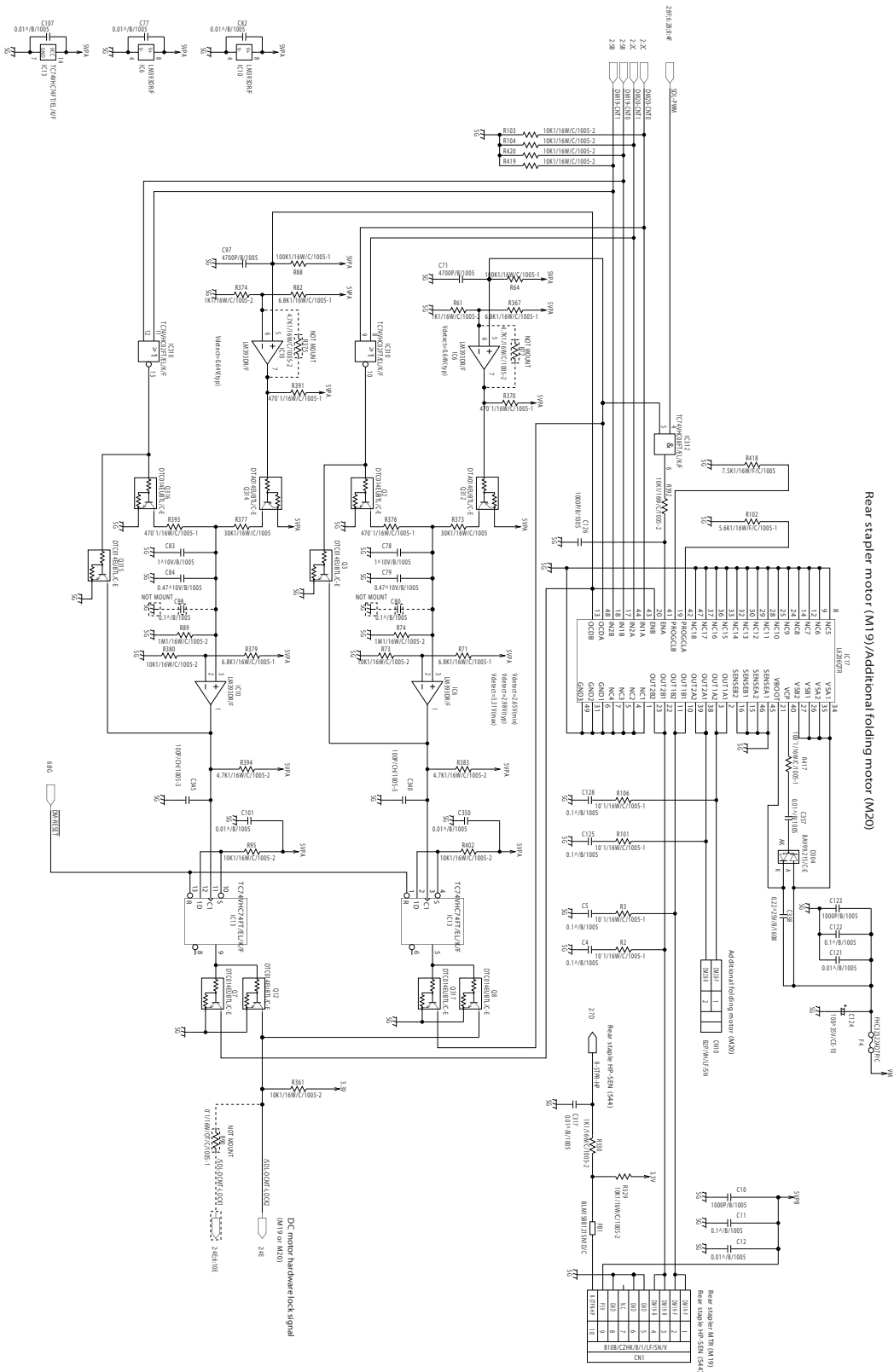

Fig.8-22

7. Circuit Diagram (7)

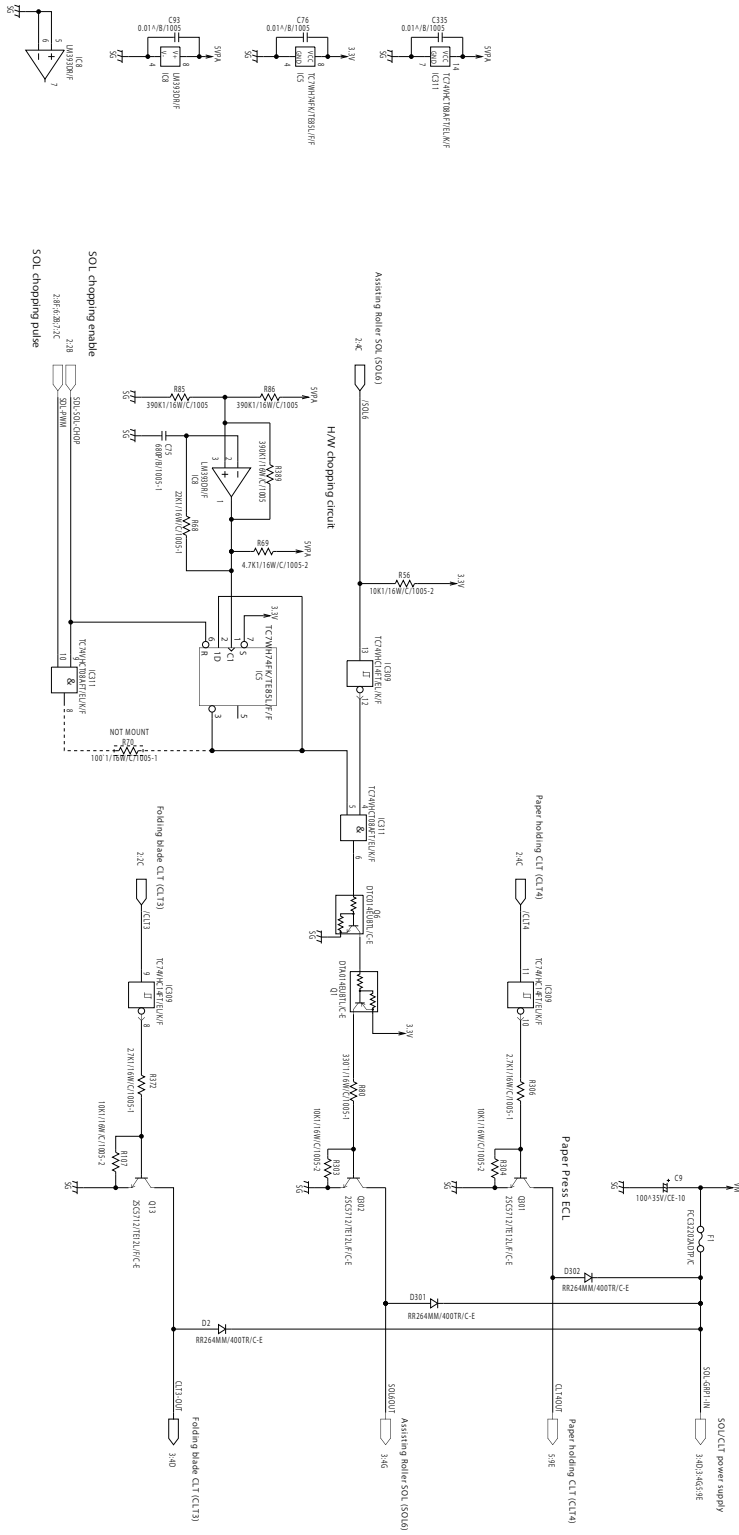

Fig.8-23

8.3 PC board

[A] Finisher controller PC board

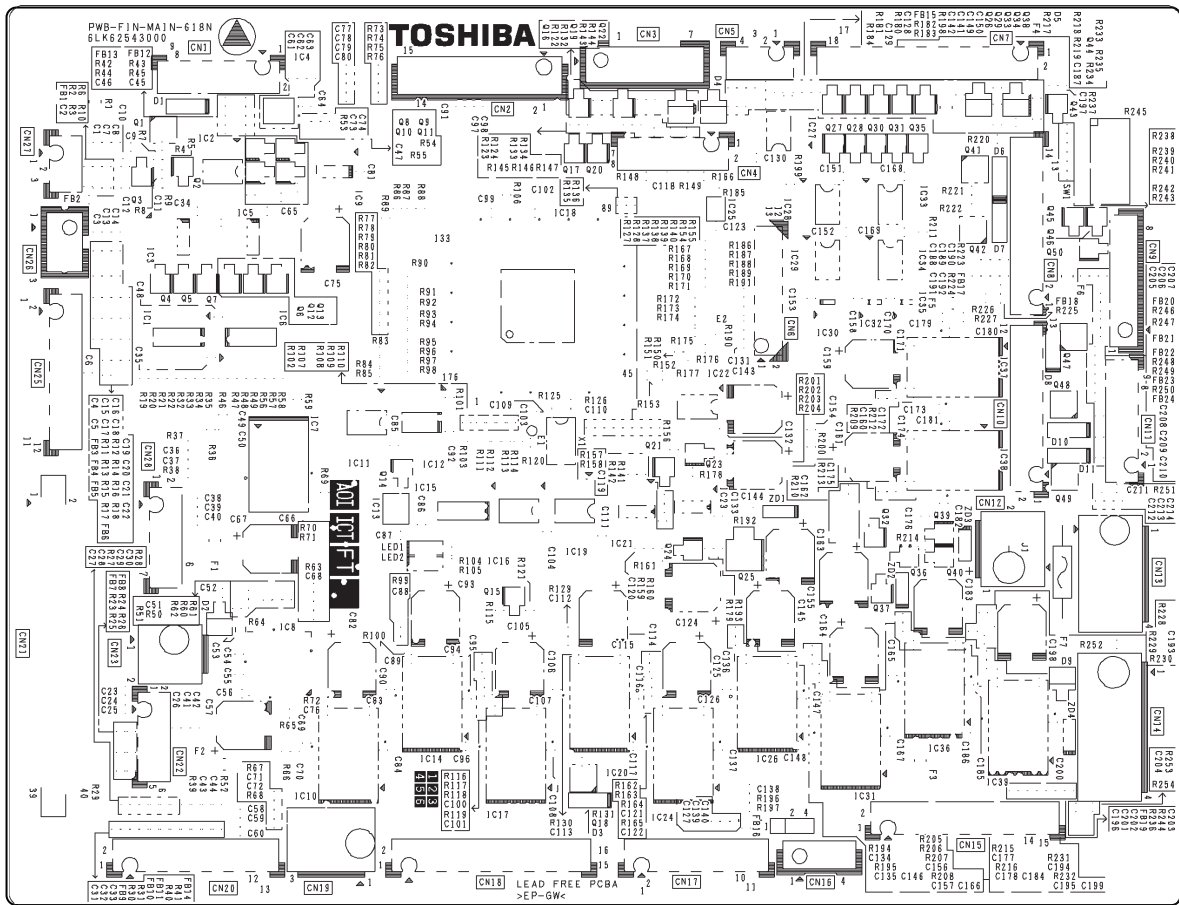

Fig.8-25

[B] Saddle control PC board

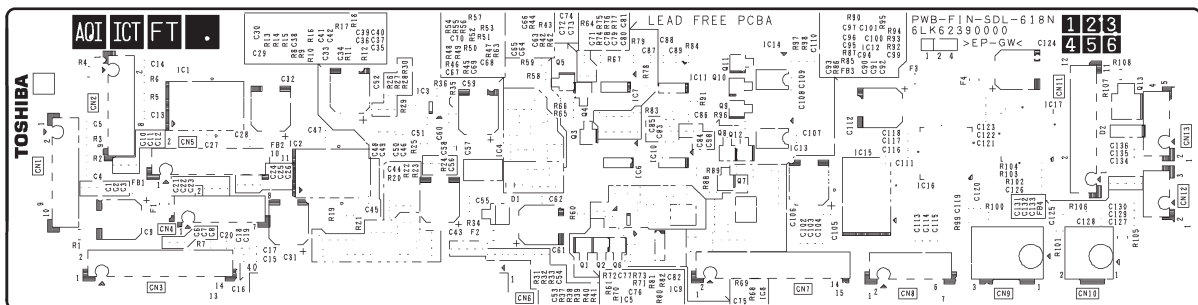

Fig.8-26

REVISION RECORD

Ver.03

Ver.03 <2019.03.28>	
Page	Contents
6-1	The contents of EA23 error has been corrected.
6-2	The contents of EA27 error has been corrected.
6-5	The contents of CB00 error has been corrected. The CB01 error has been deleted.
6-9	The troubleshooting of EA23 has been corrected.
6-11	The troubleshooting of EA27 has been corrected.
6-13	The procedure has been added. (EA40 error troubleshooting)
6-17 to 6-18	The procedure has been added. (EAA0, EAB0)
6-25 to 6-26	The procedure has been added. (EF11, EF12, EF13, EF14)
6-31 to 6-34	The procedure has been added. (EF15, EF16, EF17, EF18, EF19, EF20)
6-35	The troubleshooting of CB00 has been corrected. The troubleshooting of CB01 has been deleted.
6-43 to 6-45	The procedure has been added. (CB93, CB94, CB95, CBA0, CBB0, CBC0, CBE0)
6-52	The operation procedure has been corrected.
6-63 to 6-64	The description has been corrected.
8-12	The wire harness connection diagrams has been corrected. (Fig8-2)
8-12	"8.2 Circuit Diagram" has been changed.
8-12	"8.2 Circuit Diagram" has been changed.

Ver.02

Ver.02 <2018.09.13>	
Page	Contents
1-4	"The number of Stapleable Sheet" been corrected.
1-7	"1.4 Rating label" has been added.
6-14	The troubleshooting of EA31 has been changed.
6-15 to 6-16	The troubleshooting of EA50 has been changed.
6-40 to 6-41	The troubleshooting of CB50 has been changed.
6-68 to 6-71	The troubleshooting of "6.4.2 Paper trailing edge abnormality when it is exiting to the movable tray (dents, folding, tears)" has been added.
8-4	"8.2 Circuit Diagram" has been changed.
8-12	"8.2 Circuit Diagram" has been changed.

Ver.01

Ver.01 <2017.09.22>	
Page	Contents
5-1 to 5-5	The adjustment procedure has been changed.
5-7	"stapling" has been corrected to "stacker".
6-9	The troubleshooting of EA20 has been changed.
6-27 to 6-31	The troubleshooting of EF14 has been changed.

Ver.00

Ver.00 <2016.06.24>	
Page	Contents
-	Initial release

TOSHIBA

Toshiba Tec Corporation

1-11-1, OSAKI, SHINAGAWA-KU, TOKYO, 141-8562, JAPAN