

SERVICE PARTS LIST

JOB SEPARATOR
MJ-5006

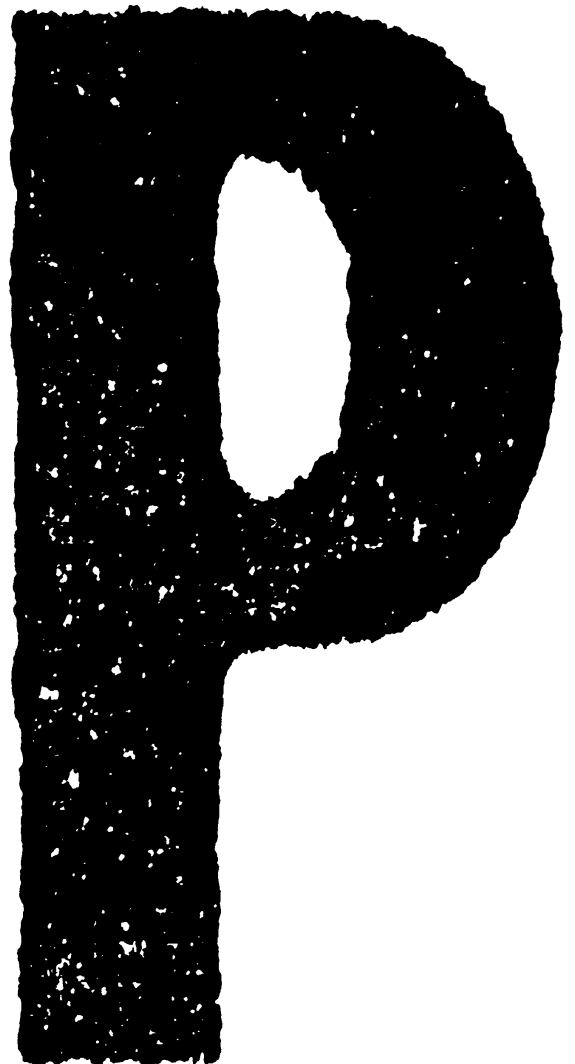

© 2009 TOSHIBA TEC CORPORATION All rights reserved

Under the copyright laws, this manual cannot be reproduced in any form without prior written permission of TOSHIBA TEC CORPORATION. No patent liability is assumed, however, with respect to the use of the information contained herein.

EXPLANATION OF SERVICE-PARTS LIST

1. HOW TO READ THE PARTS LIST

- (1) Number of pieces
The number of pieces in the list denotes total pieces used per unit. But the numbers in the list for PACKING MATERIAL and ACCESSORY denote total pieces used per machine.
- (2) One pack of screws in the list includes 50 pieces.
- (3) ABBREVIATED CODES

QTY/PAC	QTY.....	one piece
	PAC.....	one pack
	1/P.....	one piece packed in polyethylene bag
	1/S.....	one piece packed in special pack
	1/C.....	one piece packed in carton box
	1/PP.....	one piece packed in paper and polyethylene bag
	1/KP.....	one piece packed in polyethylene bag with cardboard
	1/D.....	one piece packed in polyethylene-cushion bag
	1/SB.....	one piece packed in shielding bag
	N/A.....	not available

P	P.....	PURPOSE
	A.....	ADD
	B.....	DELETE
	C.....	CHANGE
	D.....	QTY, CHANGE
	E.....	MISENTRY
	F.....	OMISSION

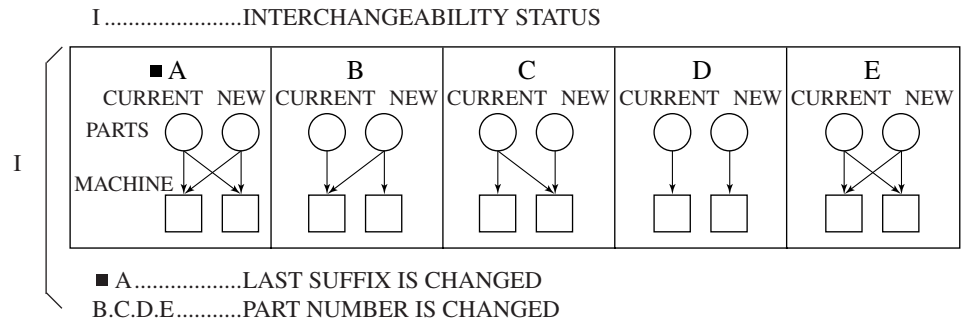

2. HOW TO PLACE ORDER FOR PARTS

- (1) The parts handled as service parts are only those with their "Q'TY/PACK" column listed with a quantity other than "N/A***" or "SUPPLY".
Those parts with "N/A***" are listed only for the purpose of showing the mechanical construction, those listed with "SUPPLY" are handled only as a sales item, and therefore both types of parts are not supplied as service parts.
- (2) Orders for any parts which form a component of a semi-assembled unit are not acceptable.
Note: All the screws and nuts used are ISO standard.

3. REGION

NAD.....	115V
	50/60Hz, NORTH AMERICA, SOUTH AMERICA
TWD.....	110/220V
	50/60Hz, TAIWAN
SAD.....	127V/60Hz, SAUDI ARABIA
ASD.....	220-240V
	50/60Hz, ASIA, SOUTH AMERICA, etc.
ASU.....	220-240V
	50/60Hz, ASIA, etc.
AUD.....	220-240V
	50/60Hz, AUSTRALIA
MJD.....	220-240V
	50/60Hz, EUROPE
CND.....	220-240V
	50/60Hz, CHINA
KRD.....	220-240V
	50/60Hz, KOREA

CONTENTS

JOB_ SEPARATOR.....	1
---------------------	---

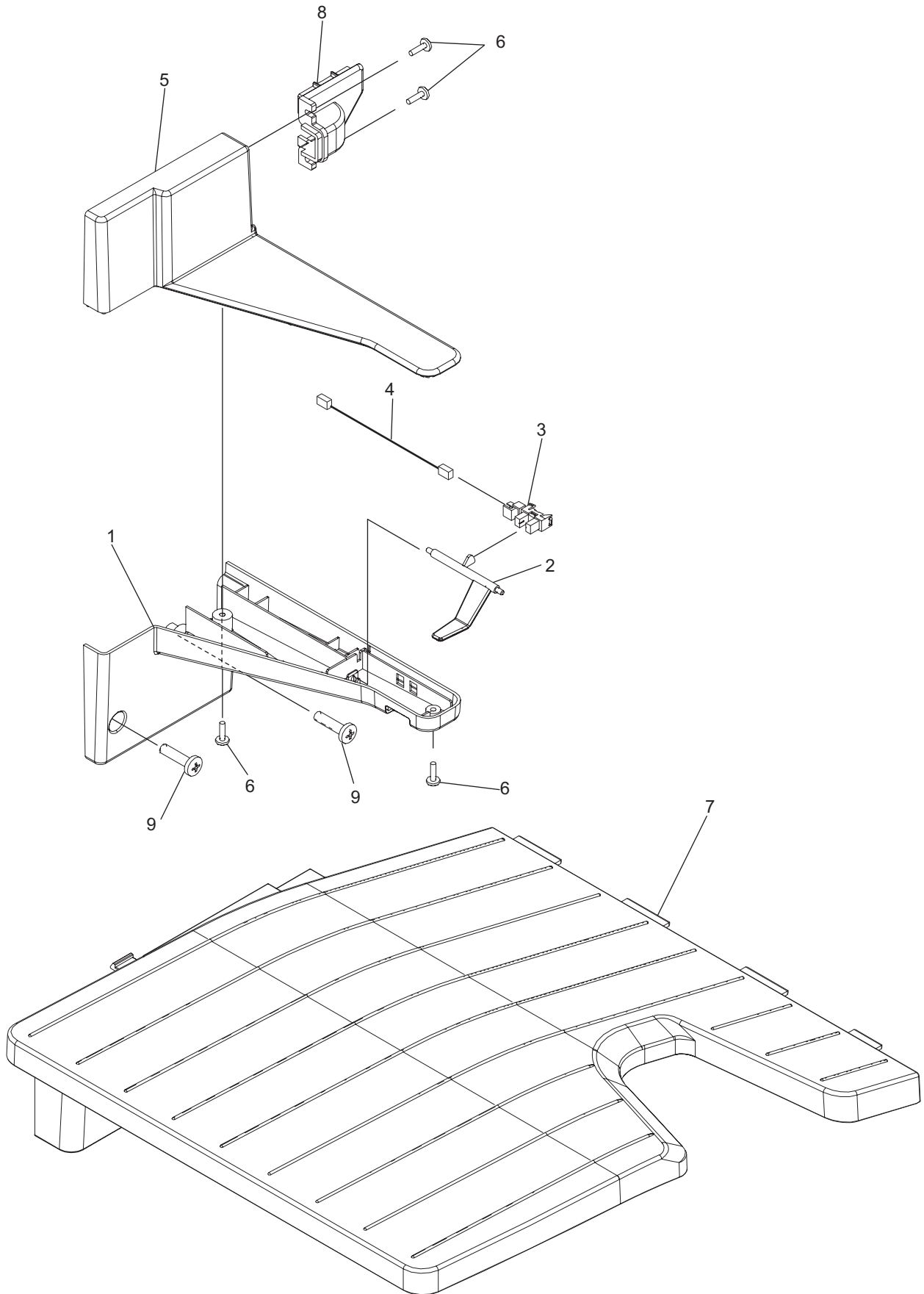

ITEM No.	PART No.	PART NAME	Q'TY / PAGE	Q'TY / PACK	REMARKS
1	6LH58251100	HLDR-SNSR-L-JSP-N	1	1/PP	
2	6LH58253000	ACT-FULL-JSP-47X	1	1/P	
3	C0-14266000	LG248BL1	1	1/C	
4	6LH61330000	HRNS-JSP-SW-506	1	1/P	
5	6LH58252100	HLDR-SNSR-U-JSP-N	1	1/PP	
6	6LA80090000	S/TPP/BID-3X8-NI	4	5/P	
7	6LH58267000	TRAY-JSP-47X-N	1	1/PP	
8	6LA75678000	COV-WH	1	1/P	
9	X0-02016000	S/BID-M4X16-NI	2	10/P	

TOSHIBA

TOSHIBA TEC CORPORATION

2-17-2, HIGASHIGOTANDA, SHINAGAWA-KU, TOKYO, 141-8664, JAPAN