

TOSHIBA

SERVICE HANDBOOK

FACSIMILE

GD-1320/1350/1260

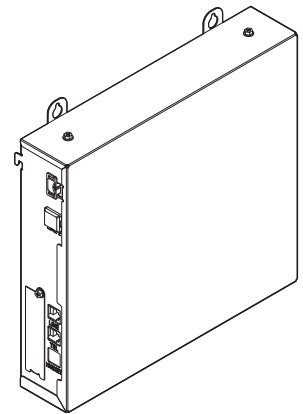

Trademarks

- The official name of Windows XP is Microsoft Windows XP Operating System.
- The official name of Windows Vista is Microsoft Windows Vista Operating System.
- The official name of Windows 7 is Microsoft Windows 7 Operating System.
- The official name of Windows 8 is Microsoft Windows 8 Operating System.
- The official name of Windows Server 2003 is Microsoft Windows Server 2003 Operating System.
- The official name of Windows Server 2008 is Microsoft Windows Server 2008 Operating System.
- The official name of Windows Server 2012 is Microsoft Windows Server 2012 Operating System.
- Microsoft, Windows, Windows NT, and the brand names and product names of other Microsoft products are trademarks of Microsoft Corporation in the US and other countries.
- Apple, AppleTalk, Macintosh, Mac, Mac OS, Safari, and TrueType are trademarks of Apple Inc. in the US and other countries.
- Adobe, Acrobat, Reader, and PostScript are either registered trademarks or trademarks of Adobe Systems Incorporated in the United States and/or other countries.
- Mozilla, Firefox and the Firefox logo are trademarks or registered trademarks of Mozilla Foundation in the U.S. and other countries.
- IBM, AT and AIX are trademarks of International Business Machines Corporation.
- NOVELL, NetWare and NDS are trademarks of Novell, Inc. in the US.
- TopAccess is a trademark of Toshiba Tec Corporation.
- Molykote is a registered trademark of Dow Corning Corporation.
- Other company names and product names in this manual are the trademarks of their respective companies.

© 2012-2014 TOSHIBA TEC CORPORATION All rights reserved

Under the copyright laws, this manual cannot be reproduced in any form without prior written permission of TOSHIBA TEC CORPORATION.

GENERAL PRECAUTIONS REGARDING THE SERVICE FOR GD-1320/1350/1260

The installation and service shall be done by a qualified service technician.

1) Transportation/Installation

- The equipment is quite heavy, therefore pay full attention when handling / transporting / installing it.
- When transporting/installing the equipment, employ four persons and be sure to move it by the casters while lifting the stoppers. The equipment is quite heavy and weighs approximately 203 kg (447 lb.), therefore pay full attention when handling it. (e-STUDIO557/657/757/857)
- Be sure not to hold the movable parts or units (e.g. the control panel, ADU or RADF) when transporting the equipment.
- Be sure to use a dedicated outlet with AC 110 V / 13.2 A, 115 V or 127 V / 12 A, 220-240 V / 8 A for its power source.
- The equipment must be grounded for safety.
- Select a suitable place for installation. Avoid excessive heat, high humidity, dust, vibration and direct sunlight.
- Provide proper ventilation since the equipment emits a slight amount of ozone.
- To insure adequate working space for the copying operation, keep a minimum clearance of 30 cm (12") on the left, 80 cm (32") on the right and 10 cm (4") on the rear.
- The equipment shall be installed near the socket outlet and shall be accessible.
- Be sure to fix and plug in the power cable securely after the installation so that no one trips over it.

2) General Precautions at Service

- Be sure to turn the power OFF and unplug the power cable during service (except for the service should be done with the power turned ON).
- Unplug the power cable and clean the area around the prongs of the plug and socket outlet once a year or more. A fire may occur when dust lies on this area.
- When the parts are disassembled, reassembly is the reverse of disassembly unless otherwise noted in this manual or other related documents. Be careful not to install small parts such as screws, washers, pins, E-rings, star washers, harnesses in the wrong places.
- Basically, the equipment should not be operated with any parts removed or disassembled.
- The PC board must be stored in an anti-electrostatic bag and handled carefully using a wristband since the ICs on it may be damaged due to static electricity.

Caution: Before using the wristband, unplug the power cable of the equipment and make sure that there are no charged objects which are not insulated in the vicinity.

- Be sure not to touch high-temperature sections such as the fuser unit, damp heater and areas around them.
- Be sure not to touch high-voltage sections such as the chargers, transfer belt, 2nd transfer roller, developer, high-voltage transformer and power supply unit. Especially, the board of these components should not be touched since the electric charge may remain in the capacitors, etc. on them even after the power is turned OFF.
- Make sure that the equipment will not operate before touching potentially dangerous places (e.g. rotating/operating sections such as gears, belts pulleys and fans).
- Be careful when removing the covers since there might be the parts with very sharp edges underneath.
- When servicing the equipment with the power turned ON, be sure not to touch live sections and rotating/operating sections.
- Use designated jigs and tools.

- Use recommended measuring instruments or equivalents.
- Return the equipment to the original state and check the operation when the service is finished.
- Be very careful to treat the touch panel gently and never hit it. Breaking the surface could cause malfunctions.
- Do not leave plastic bags where children can get at them. This may cause an accident such as suffocation if a child puts his/her head into a bag. Plastic bags of options or service parts must be brought back.

3) **General operations**

- Check the procedures and perform them as described in the Service Manual.
- Make sure you do not lose your balance.
- Avoid exposure to your skin and wear protective gloves as needed.

4) **Important Service Parts for Safety**

- The breaker, door switch, fuse, thermostat, thermofuse, thermistor, batteries, IC-RAMs including lithium batteries, etc. are particularly important for safety. Be sure to handle/install them properly. If these parts are short-circuited and their functions become ineffective, they may result in fatal accidents such as burnout. Do not allow a short-circuit and do not use the parts not recommended by Toshiba TEC Corporation.

5) **Cautionary Labels**

- During servicing, be sure to check the rating plate and cautionary labels such as “Unplug the power cable during service”, “CAUTION. HOT”, “CAUTION. HIGH VOLTAGE”, “CAUTION. LASER BEAM”, etc. to see if there is any dirt on their surface and if they are properly stuck to the equipment.

6) **Disposal of the Equipment, Supplies, Packing Materials, Used Batteries and IC-RAMs**

- Regarding the recovery and disposal of the equipment, supplies, packing materials, used batteries and IC-RAMs including lithium batteries, follow the relevant local regulations or rules.

Caution:

Dispose of used batteries and IC-RAMs including lithium batteries according to this manual.

Attention:

Se débarrasser de batteries et IC-RAMs usés y compris les batteries en lithium selon ce manuel.

Vorsicht:

Entsorgung der gebrauchten Batterien und IC-RAMs (inclusive der Lithium-Batterie) nach diesem Handbuch.

CONTENTS

1. ERROR CODES	1-1
1.1 Transmission/Reception Journal and Error Code List	1-1
1.2 Error Messages	1-4
2. SELF-DIAGNOSIS MODE	2-1
2.1 Test Mode (03)	2-2
2.2 Adjustment Mode (05)	2-4
2.3 Setting Mode (08)	2-6
2.4 Function Mode (13).....	2-7
2.5 FAX Clearing Mode (1*).....	2-62
3. TROUBLESHOOTING	3-1
3.1 Diagnosis Over Telephone	3-1
3.2 Recommend Flow Chart for Field Service	3-2
3.3 Flow Chart for Recommended Telephone Screening.....	3-3
3.4 Error Analysis Flow.....	3-6
3.4.1 Self-Diagnosis function.....	3-6
3.4.2 Precautions for diagnosis	3-6
3.5 Fault Analysis	3-7
3.5.1 Power-ON is not possible	3-7
3.5.2 Original transport error for RADF	3-7
3.5.3 Recording paper transport error	3-7
3.5.4 Image trouble	3-7
3.5.5 Communication error.....	3-8
3.6 Lists Required at Problem in the Field.....	3-9
3.6.1 List printing procedure.....	3-9
3.7 Other Information Required for Error Analysis.....	3-11
4. PRECAUTIONS FOR INSTALLATION OF FAX UNIT	4-1
4.1 Installation of FAX Unit	4-1
4.2 Country/Region Code	4-2
5. FIRMWARE UPDATING	5-1

1. ERROR CODES

1

2. SELF-DIAGNOSIS MODE

2

3. TROUBLESHOOTING

3

**4. PRECAUTIONS FOR INSTALLATION OF FAX
UNIT**

4

5. FIRMWARE UPDATING

5

1. ERROR CODES

1.1 Transmission/Reception Journal and Error Code List

The transmission journal is shown below. The error code list and status code list are available in the following pages. The reception journal is output in the same form.

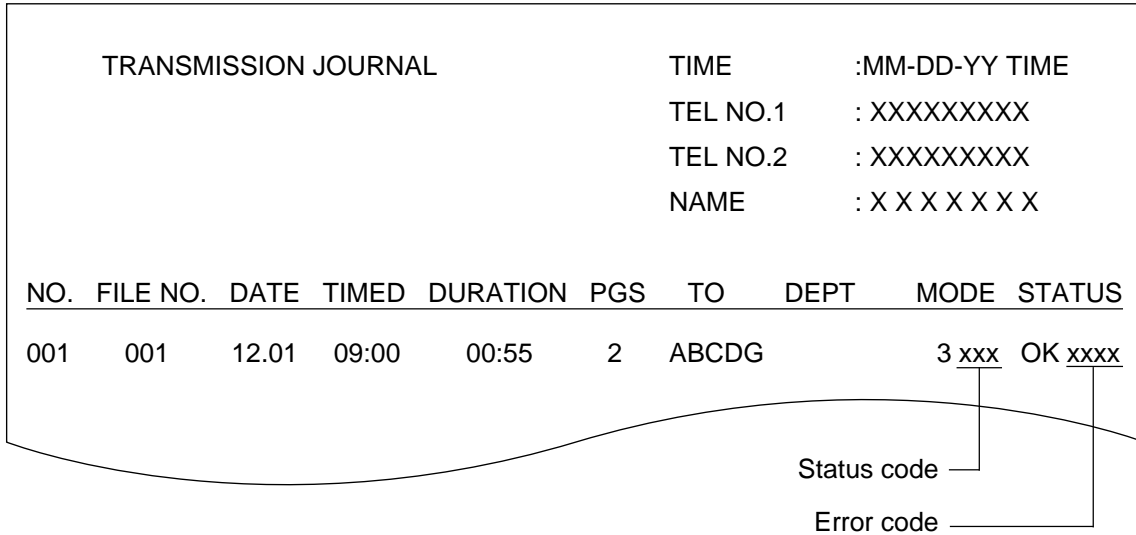

Fig. 1-1

1) Error code list

If an error has occurred during communication, an error code is indicated below "STATUS" on the transmission/reception journal.

Take the appropriate action referring to the following list.

Error code	Content	Situation and corrective action
0000	Normal	
0012	Original jam	Remove the jamming document and retransmit it.
0013	Door is open	Close the doors securely and retransmit the document.
0020	Power failure	A power failure occurred during transmission or reception, and the transmission/reception data were lost. Attempt the transmission/reception again.
0030	Stop by paper jam during the direct transmission	Remove the jamming paper and transmit it.
0033	Polling error	Polling was not performed because the polling document was not found or the security codes were mismatched. Check the polling document or security code on the other side and attempt the polling again.
0042	Memory full	The memory became full a memory abnormality occurred during reception. (The pages normally received are printed out.) Check the remaining memory space or memory status, and attempt the reception again.
0050	Line is busy	Transmission is not made because the line is busy. Attempt the transmission again. As the number of the redialings is increased, the possibility for successful transmission is increased.
0053	Security mismatch in relay or mail box transmission	Check your security code and system password of the other side as well as your own.
00B0	Initial signal not detected	NSF/DIS cannot be detected. Check the receiver and attempt the transmission again.
00B1	Terminal constants not compatible	DIS/NSF that cannot be handled by the sender was received. The receiver received NSS/DCS other than those declared by DIS/NSF. Check the transmission/reception functions, and attempt the communication again.
00B2	Reception of DCN (Phase B)	DCN was received in the phase B.
00B3	DCS/DTC not detected	DCS/DTC cannot be detected.
00B4	Training error	The sender performed fall-back but the transmission was not made. After the reception of FTT, the receiver received a time-out or DCN. Adjust the transmitter attenuator, link equalizer, etc. and retry the communication.
00B5	CFR not detected	A training signal was sent out but CFR cannot be detected. Adjust the transmitter attenuator, link equalizer, etc. and retry the transmission.
00C0	Image signal carrier not detected	A carrier was not detected on the receiving side. Adjust the transmitter attenuator, link equalizer, etc. and retry the transmission.
00C1	High speed signal not detected	A high-speed signal was not detected on the receiving side. Adjust the transmitter attenuator, link equalizer, etc. and retry the transmission.
00C2	Image signal carrier disconnected	Carrier disconnection was detected after the image signal was detected.
00C3	1st EOL not detected	1st EOL was not detected after the high-speed signal was detected.
00C4	EOL not detected	EOL cannot be detected on the receiving side. Or decoding is not possible with MMR.

Error code	Content	Situation and corrective action
00D0	Post message not detected	A post message cannot be detected. Retry the communication. MCF, RTP, RTN, PIN and PIP cannot be detected on the sending side. MPS, EOM and EOP cannot be detected on the receiving side.
00D1	Reception of DCN	DCN was received.
00D2	Poor image quality	Quality of the received image is poor. Retry the transmission.
00E8	HDD error	Hardware is defective.
00F0	Software trouble	Software is defective.
00F1	Hardware noise	Hardware is defective.

2) Status code list

Mode	Transmission speed	Resolution	Encoding system
0	2400	8 x 3.85	MH
1	4800	8 x 7.7	MR
2	7200	8 x 15.4	MMR
3	9600		JBIG
4	12000	16 x 15.4	
5	14400		
6	V.34		
7			
8		300 x 300	
9			
A			
B			
C			
D			
E			
F			

[Example of the indication of a status code]

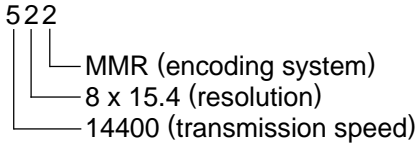

For the combination of 14400 bps, 8x15.4 and MMR, as shown above, a status of “522” is indicate.

1.2 Error Messages

Error messages are not displayed for the background jobs (memory transmission and memory reception). See the reception/transmission report for the details of the errors.

If an original jam during the direct transmission or recording paper jam during printing occurred, error messages are displayed like when original jam occurred in the equipment.

Error messages and corrective actions

Error	Symptom	Message	Remarks
Memory full	Communication was interrupted because the memory became full.	Memory overflow	Message displayed only during the memory input. It is not displayed during the memory reception.
Line is busy	Redialing was attempted for the specified number of times but the line is still busy.		Job information is stored in the memory when the final retry is finished.
Initial signal not detected	DIS is not detected.	Communication error	
Terminal constants not compatible	Received DIS unable to be handled. Received DCS which is beyond the capability of the receiver.		
Training error	Fall-back is not made successfully. Became time-out after FTT was sent out.	Communication error	
CFR not detected	CFR (FTT) is not detected.	Communication error	
Image signal carrier not detected	Image signal carrier cannot be detected.		
Image signal not detected	High-speed signal cannot be received by the receiver.		
EOL time-out	EOL timer exceeded by 13 seconds		
Post message not detected	Post message is not detected.	Communication error	
Poor image quality	TX: Received RTN/PIN/ERR RX: Transmitted RTN/PIN/ERR	Communication error	
Software overdrive	WDT communication terminated due to software overdrive	Communication error	
Hardware noise	Communication terminated due to software overdrive caused by hardware noise	Communication error	

2. SELF-DIAGNOSIS MODE

There are two types of the self-diagnosis mode for the FAX operation.

- Test mode (03), adjustment mode (05) and setting mode (08): Some items are added to the test mode (03), adjustment mode (05) and setting mode (08) of the self-diagnosis function when the optional FAX unit is installed.
- FAX function mode (13) and FAX clearing mode (1*): These two modes are newly added to the machine when the FAX unit is installed. Started up by turning ON the power while pressing the specified keys are being pressed.

The followings are the modes which are added to (or extend) the PPC self-diagnosis function.

Mode	For start	Function	Display
Test Mode	[0]+[3]+[POWER]	Output check (modem test, dialing test, CML test)	100% C Test Mode
Adjustment Mode	[0]+[5]+[POWER]	Adjustment of the various items	100% A Test Mode
Setting Mode	[0]+[8]+[POWER]	Setting the destination	100% D Test Mode
FAX Function Mode	[1]+[3]+[POWER]	Setting functions of the various items	100% F Test Mode
FAX Clearing Mode	[1]+[*]+[POWER]	Initialization of the various memory areas (user registration area, system setting area, image data area)	100% CL Test Mode
Trace List Output Mode	Operating from the screen for Service UI (without entering the self-diagnostic mode)	Outputs the protocol trace list, dump list and function setting list	-

To enter the desired mode, turn the power ON while pressing two digital keys designated to each mode (e.g. [0] and [5]) simultaneously.

Notes:

- **To finish the self-diagnosis mode, make sure to turn the power OFF and then back ON.** When the equipment is started in one of the self-diagnosis modes, the equipment is occupied by the mode until the power is turned OFF. In this case, the recovery processing for the FAX operation is not performed.
- Faxes received automatically during the self-diagnosis mode may not be printed out. Be sure to disconnect the modular code from the line connectors (LINE1, LINE2) of the equipment before starting the self-diagnosis mode. Also, be sure to finish the self-diagnosis mode by turning the power OFF and back ON before connecting the modular code.
- The trace list output mode can be used by operating from the Service UI screen for models in which Service UI is embedded. For details of Service UI, refer to the Service Manual of the MFP.

2.1 Test Mode (03)

The modem test output, dialing test output and CML test output are performed in the Test Mode (03).

- 1) Modem test / CML test
[Operation procedure]

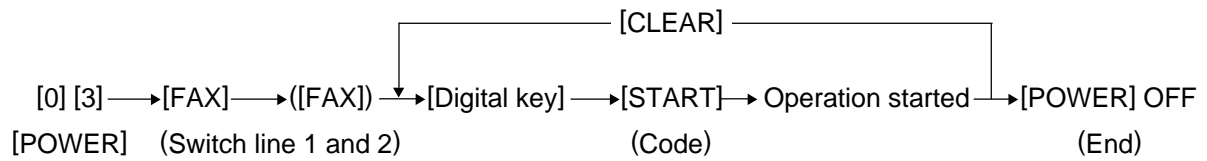

Fig. 2-1

- 2) Dialing test
[Operation procedure]

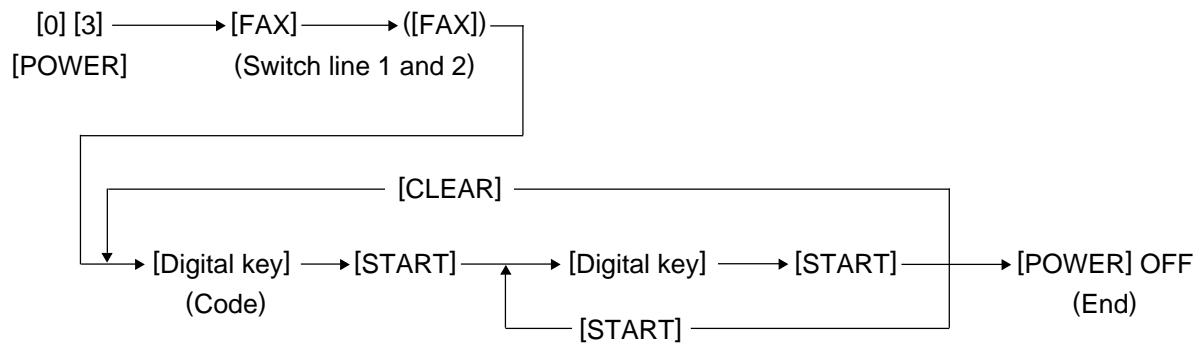

Fig. 2-2

Test code list

Code	Element	Test
03-301	FAX	Modem test 2100 Hz
03-302	FAX	Modem test 14.4 kbps (V.17)
03-303	FAX	Modem test 9.6 kbps (V.29)
03-304	FAX	Modem test 4.8 kbps (V.27)
03-305	FAX	Modem test 300 BPS
03-306	FAX	Modem test 1850 Hz
03-307	FAX	Modem test 1650 Hz
03-308	FAX	Modem test 1100 Hz
03-309	FAX	Modem test 462 Hz
03-310	FAX	Modem test 1300 Hz
03-311	FAX	Modem test 33.6 kbps (V.34)
03-312	FAX	Modem test 28.8 kbps (V.34)
03-313	FAX	Modem test 24.0 kbps (V.34)
03-314	FAX	Modem test 16.8 kbps (V.34)
03-315	FAX	Dialing test 10 PPS (Tested with the digital keys) (The dial number corresponding to the key which was pressed is kept outputting on the circuit. The pressed key is displayed on the control panel.)
03-317	FAX	Dialing test PB (Tested with the digital keys) (The dial number corresponding to the key which was pressed is kept outputting on the circuit. The pressed key is displayed on the control panel.)
03-318	FAX	Modem test 12.0 kbps (V.17)
03-319	FAX	Modem test 7.2 kbps (V.29)
03-320	FAX	Modem test 2.4 kbps (V.27ter)
03-321	FAX	Performs Read/Write test to all the image memories mounted on the FAX board and displays the test result (status) on the control panel. Also, detects automatically whether the extended memory is mounted or not.
03-322	FAX	CML test: Turning ON the CML relay

2.2 Adjustment Mode (05)

Parameter setting for the FAX image processing is performed in the Adjustment Mode (05).

- 1) Setting parameters for the FAX image processing
[Operation procedure]

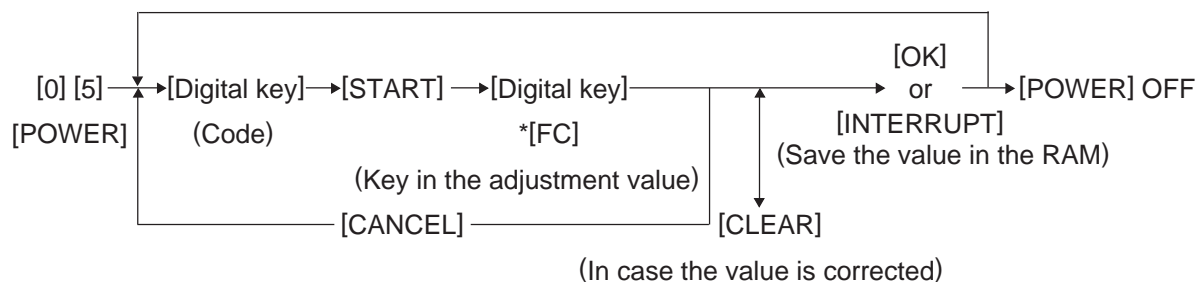

Fig. 2-3

* “-” can be entered with the [FC] button.

Adjustment codes for the image processing parameters

Code	Element	Adjustment item	Mode	Image quality mode	Default	Acceptable value
05-7534	Density	Adjustment of the threshold value for the binarization Center value	FAX	Text	128	0 to 255
05-7535	Density	Manual-density fine adjustment Error diffusion, Center value	FAX	Photo	128	0 to 255
05-7533	Density	Manual-density fine adjustment Error diffusion, Center value	FAX	Text/ Photo	128	0 to 255
05-7543	Density	Auto-density fine adjustment Error diffusion	FAX	Photo	128	0 to 255
05-7542	Density	Auto-density fine adjustment Error diffusion	FAX	Text/ Photo	128	0 to 255

1) LED emission level adjustment
[Operation procedure]

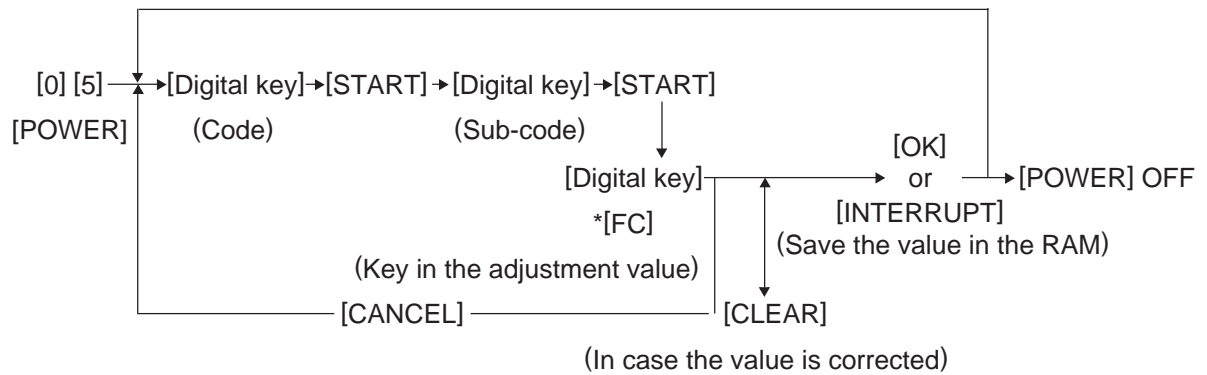

Fig. 2-4

* “-” can be entered with the [FC] button.

Code	Adjustment item	Remarks
05-7594-0	LED emission level 0/4	The smaller the value is, the smaller the LED emission level becomes. Therefore, the smaller dot is reproduced accordingly. Acceptable values: 0 to 255 (Default: Level 0/4: 0, Level 1/4: 63, Level 2/4: 127, Level 3/4: 191, Level 4/4: 255)
05-7594-1	LED emission level 1/4	
05-7594-2	LED emission level 2/4	
05-7594-3	LED emission level 3/4	
05-7594-4	LED emission level 4/4	

2.3 Setting Mode (08)

The destination is set in the Setting Mode (08).

[Operation procedure]

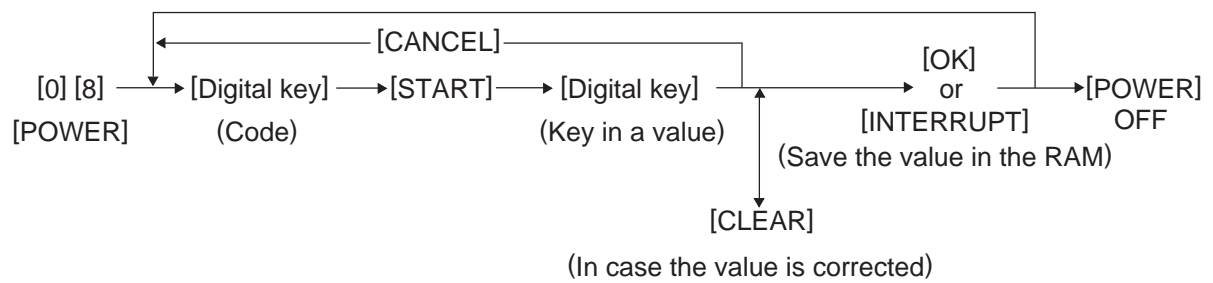

Fig. 2-5

Code	Element	Adjustment item	Mode	Image mode	Default value
08-9001	FAX	Destination 1: Asia 2: Australia 3: Hong Kong 4: U.S.A/Canada 5: Germany 6: Great Britain 7: Italy 8: Belgium 9: Holland 10: Finland 11: Spain 12: Austria 13: Switzerland 14: Sweden 15: Denmark 16: Norway 17: Portugal 18: France 19: Greece 20: Poland 21: Hungary 22: Czech Rep. 23: Turkey 24: South Africa 25: Taiwan	FAX	-	NA: 4 TW: 25 EU: 5 AU: 2 AS: 1 C: 1

2.4 Function Mode (13)

Various functions are set in the Function Mode (13).

1) Procedure to set the functions

Key in a code and change the set value.

[Operation procedure]

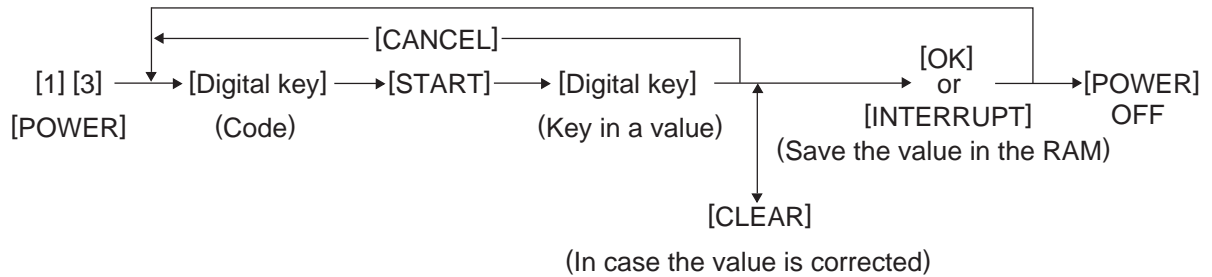

Fig. 2-6

2) Procedure to confirm the set value

[Operation procedure]

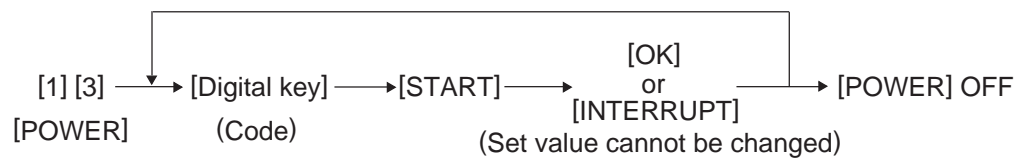

Fig. 2-7

Function code list (100-999)

100-299 Adjustment within the dialing standards

Code	Adjustment	Function	Setting	Default								
				ASM	AUS	HKG	USA	DEU	GBR	ITA	BEL	NDL
13-100	DTC frequency (PSTN) (Line 1)	Sets the dial tone frequency to be detected for the PSTN.	0: 300-600 Hz 1: 300-650 Hz 2: 390-550 Hz 3: 400-450 Hz 4: 350-480 Hz 5: 300-500 Hz	0	0	0	0	1	1	1	1	1
13-101	DTC time (PSTN) (Line 1)	Sets the time for a tone sounds to be determined as dial tone for the PSTN.	0: 2 sec. 1: 800 ms 2: 400 ms 3: 1 sec. 4: 1.3 sec.. 5: 1.8 sec.. 6: 2.5 sec.. 7: 500 ms	0	0	0	3	2	2	2	2	2
13-102	LCC allowed gaps (PSTN) (Line 1)	Sets the interruption time for the PSTN to be ignored during LCC.	0: OFF 1: 50 ms 2: 100 ms 3: 200 ms	0	0	0	3	2	2	2	2	2
13-103	DTC allowed gaps (PSTN) (Line 1)	Sets the interruption time for PSTN to be ignored during DTC.	0: OFF 1: 320 ms 2: 160 ms 3: 240 ms	1	1	1	1	1	1	1	1	1
13-104	DTC/LCC for PSTN (Line 1)	Selects which is to be used for the PSTN, DTC or LCC.	0: BZT (DTC/LCC) 1: LCC 5 sec. 2: DTC only 3: FRN (DTC/LCC) 4: DTC (JPN) 5: NO DTC&LCC	2	2	2	2	2	2	2	2	2
13-105	DTC time out (PSTN) (Line 1)	Sets how long the dial tone detection is performed.	0: 20 sec. 1: 10 sec. 2: 8 sec. 3: 15 sec. 4: 3.3 sec.	0	0	0	1	1	1	1	1	1
13-106	DTC frequency (PABX) (Line 1)	Sets the dial tone frequency to be detected for PABX.	0: 300-600 Hz 1: 300-650 Hz 2: 390-550 Hz 3: 400-450 Hz 4: 350-480 Hz 5: 300-500 Hz	0	0	0	0	1	1	1	1	1
13-107	DTC time (PABX) (Line 1)	Sets the time for a tone sounds to be determined as dial tone for the PABX.	0: 2 sec. 1: 800 ms 2: 400 ms 3: 1 sec. 4: 1.3 sec. 5: 1.8 sec. 6: 2.5 sec. 7: 150 ms	0	0	0	6	2	2	2	2	2

Default																Code
FIN	ESP	AUT	CHE	SWE	DNK	NOR	PRT	FRA	GRC	POL	HUN	CZE	TUR	ZAF	TWN	
1	1	1	1	1	1	1	1	1	1	1	1	1	0	0	1	13-100
2	2	2	2	2	2	2	2	2	2	2	2	2	0	0	2	13-101
2	2	2	2	2	2	2	2	2	2	2	2	2	0	0	2	13-102
1	1	1	1	1	1	1	1	1	1	1	1	1	1	1	1	13-103
2	2	2	2	2	2	2	2	2	2	2	2	2	2	2	2	13-104
1	1	1	1	1	1	1	1	1	1	1	1	1	0	0	1	13-105
1	1	1	1	1	1	1	1	1	1	1	1	1	0	0	1	13-106
2	2	2	2	2	2	2	2	2	2	2	2	2	0	0	2	13-107

2

Code	Adjustment	Function	Setting	Default								
				ASM	AUS	HKG	USA	DEU	GBR	ITA	BEL	NDL
13-108	LCC allowed gaps (PABX) (Line 1)	Sets the interruption time for the PABX to be ignored during LCC.	0: OFF 1: 50 ms 2: 100 ms 3: 200 ms	0	0	0	0	3	3	3	3	3
13-109	DTC allowed gaps (PABX) (Line 1)	Sets the interruption time for the PABX to be ignored during DTC.	0: OFF 1: 320 ms 2: 160 ms 3: 240 ms	1	1	1	1	1	1	1	1	1
13-110	DTC/LCC for PABX (Line 1)	Selects which is to be used for the PABX, DTC or LCC.	0: BZT (DTC/LCC) 1: LCC 5 sec. 2: DTC only 3: FRN (DTC/LCC) 4: DTC (JPN) 5: NO DTC&LCC	5	5	5	5	5	5	5	5	5
13-111	DTC time out (PABX) (Line 1)	Sets how long the dial tone detection is performed.	0: 20 sec. 1: 10 sec.. 2: 8 sec. 3: 15 sec. 4: 3.3 sec.	0	0	0	1	1	1	1	1	1
13-112	BTC frequency (Line 1)	Sets the busy tone frequency to be detected for the PSTN and PABX.	0: Not detected 1: 300-600 Hz 2: 350-550 Hz 3: 300-500 Hz 4: 300-700 Hz	0	0	0	1	1	1	1	1	1
13-116	Dial T1 timer (Line 1)	Sets the time to wait for a response from the receiver after dialing is completed.	0: 60 sec. 1: 35 sec. 2: 90 sec. 3: 55 sec. 4: 115 sec.	0	3	0	3	2	2	2	2	2
13-117	Dial stop after T1	In case of T1 time-out (no response from the receiver) during the automatic dialing, redialing is not performed and it is determined that the transmission is terminated due to error.	0: OFF 1: ON	0	0	0	1	0	0	0	0	0
13-122	CML make time before dialing	Pause before dialing	0: 0 ms 1: 10 ms 255:2550 ms	2	2	2	2	2	2	2	2	2

Default																Code
FIN	ESP	AUT	CHE	SWE	DNK	NOR	PRT	FRA	GRC	POL	HUN	CZE	TUR	ZAF	TWN	
3	3	3	3	3	3	3	3	3	3	3	3	3	0	0	2	13-108
1	1	1	1	1	1	1	1	1	1	1	1	1	1	1	1	13-109
5	5	5	5	5	5	5	5	5	5	5	5	5	5	5	5	13-110
1	1	1	1	1	1	1	1	1	1	1	1	1	0	0	1	13-111
1	1	1	1	1	1	1	1	1	1	1	1	1	0	0	1	13-112
2	2	2	2	2	2	2	2	2	2	2	2	2	0	0	3	13-116
0	0	0	0	0	0	0	0	0	0	0	0	0	0	0	0	13-117
2	2	2	2	2	2	2	2	2	2	2	2	2	2	2	2	13-122

2

Code	Adjustment	Function	Setting	Default								
				ASM	AUS	HKG	USA	DEU	GBR	ITA	BEL	NDL
13-123	CML hold time after dialing	Pause after dialing	0: 0 ms 1: 10 ms ⋮ 255:2550 ms	100	100	100	100	100	100	100	100	100
13-125	Dial information (Line 1)	Sets the definition of the DP dial. Normal: n Shift: n+1 Reverse: 10-n n=Dial No.	0: Normal 1: Shift 2: Reverse	0	0	0	0	0	0	0	0	0
13-127	Internal retry	When dialing is interrupted because any of the settings for DTC/LCC is not satisfied during redialing, that redialing is ignored since it is considered as an internal retry.	0: OFF 1: ON	0	0	0	0	1	1	0	0	0
13-128	Redialing counter	Sets the number of redialings.	0: No retry 1: 1 redialing ⋮ 14: 14 redialings	5	2	4	5	3	4	3	3	5
13-129	Time for a pause (Line 1)	Sets the time for a pause when it is inserted between the dial numbers.	0: 0 sec 1: 1 sec 2: 2 sec 3: 4 sec 4: 3.3 sec 5: 10 sec	4	2	2	4	2	2	3	2	0
13-132	Inter-digit pause (Line 1)	Sets the interval between digits for DP dialing.	0: 900 ms 1: 550 ms 2: 700 ms 3: 800 ms	0	0	2	3	0	3	3	2	2
13-135	Redialing interval (Line 1)	Sets the interval between redialings.	0: Default (3 min.) 1: 1 min. ⋮ 15: 15 min.	3	1	3	1	0	0	3	2	2

Default																Code
FIN	ESP	AUT	CHE	SWE	DNK	NOR	PRT	FRA	GRC	POL	HUN	CZE	TUR	ZAF	TWN	
100	100	100	100	100	100	100	100	100	100	100	100	100	100	100	100	13-123
0	0	0	0	1	0	2	0	0	0	0	0	0	0	0	0	13-125
0	0	1	0	0	1	1	0	0	0	0	0	0	0	0	0	13-127
3	3	1	4	5	4	9	3	5	4	3	3	3	5	5	2	13-128
2	2	2	0	2	2	2	1	2	4	4	4	4	4	4	4	13-129
0	1	3	3	2	2	2	2	0	3	3	0	0	0	0	0	13-132
0	2	2	2	1	0	0	1	3	3	3	3	3	3	3	2	13-135

Code	Adjustment	Function	Setting	Default								
				ASM	AUS	HKG	USA	DEU	GBR	ITA	BEL	NDL
13-137	DP make/break ratio (Line 1)	Sets the make/break ratio for DP dialing.	0: 60/40 (10 PPS) 1: 67/33 (10 PPS) 2: 63/37 (10 PPS) 3: 50/50 (10 PPS) 4: 67/33 (20 PPS) 5: 70/30 (20 PPS, TWN only)	1	1	1	0	0	1	0	1	0
13-138	MF timing (Line 1)	Sets the ON/OFF timing of MF signals. Do not set the value "4" for the function code 138 and 268 to ensure minimum time of the MF signal duration ruled in TBR21 (Requirement 4.8.2.4, 4.8.2.5)	0: 80/80 ms 1: 70/70 ms 2: 70/150 ms 3: 60/60 ms 4: 80/100 ms 5: 150/50 ms 6: 150/240 ms	2	0	2	4	4	0	0	1	1
13-139	DTC RX ATT (PSTN) (Line 1)	Sets the reception level when the dial tone is detected for the PSTN.	0: -24 dBm 1: -27 dBm 2: -30 dBm 3: -33 dBm 4: -36 dBm 5: -39 dBm 6: -42 dBm 7: -45 dBm	6	6	6	6	6	6	6	6	6
13-140	DTC RX ATT (PABX) (Line 1)	Sets the reception level when the dial tone is detected for the PABX.	0: -24 dBm 1: -27 dBm 2: -30 dBm 3: -33 dBm 4: -36 dBm 5: -39 dBm 6: -42 dBm 7: -45 dBm	6	6	6	6	6	6	6	6	6
13-141	MF TX-ATT (Line 1)	Sets the attenuator value for the MF signal.	0: 0 dB 1: -1 dB ⋮ 15: -15 dB (Value decreased one by one)	2	7	5	3	4	4	4	4	4

Default																Code
FIN	ESP	AUT	CHE	SWE	DNK	NOR	PRT	FRA	GRC	POL	HUN	CZE	TUR	ZAF	TWN	
0	1	0	0	0	1	0	1	1	0	1	0	0	1	1	5	13-137
0	2	0	0	1	2	0	0	0	4	0	3	1	2	2	4	13-138
6	6	6	6	6	6	6	6	6	6	6	6	6	6	6	6	13-139
6	6	6	6	6	6	6	6	6	6	6	6	6	6	6	6	13-140
4	4	4	4	4	4	4	4	4	4	4	4	4	3	3	3	13-141

2

Code	Adjustment	Function	Setting	Default								
				ASM	AUS	HKG	USA	DEU	GBR	ITA	BEL	NDL
13-142	International DTC frequency	Selects the frequency range for the dial tone of the first pause to be detected.	00: No detection 01: 300-600 Hz 02: 300-650 Hz 03: 390-550 Hz 04: 400-450 Hz 05: 350-480 Hz 06: 300-500 Hz 07: France Dual Tone (not used)	0	0	0	0	0	0	0	0	0
		Selects the frequency range for the dial tone to be detected after dialing the second international dial access code.	10: No detection 11: 300-600 Hz 12: 30-650 Hz 13: 390-550 Hz 14: 400-450 Hz 15: 350-480 Hz 16: 300-500 Hz 17: France Dual Tone (not used)									
13-143	International dial access code (Line 1)	Sets the international access code.	Numeric value of 3 digits (Default setting: 4 digits)	1000	1000	1000	1000	1000	1000	1000	1000	1000
13-149	ATT control (Line 1)	Sets the receiver attenuator.	0: OFF 1: -3 dB	0	0	0	0	0	0	0	0	0
13-150	BTC ON time (Line 1)	Sets time that a busy-tone signal is output to be determined it is ON.	0: 80-650 ms 1: 450-550 ms 2: 200-650 ms 3: 400-600 ms 4: 120-550 ms 5: 420-610 ms	2	2	2	2	2	2	2	2	2
13-151	BTC OFF time (Line 1)	Sets time that a busy-tone signal is not output to be determined it is OFF.	0: 80-650 ms 1: 450-550 ms 2: 200-650 ms 3: 400-600 ms 4: 160-600 ms 5: 170-700 ms 6: 380-630 ms 7: 150-470 ms	2	2	2	2	2	2	2	2	2

Default																Code
FIN	ESP	AUT	CHE	SWE	DNK	NOR	PRT	FRA	GRC	POL	HUN	CZE	TUR	ZAF	TWN	
0	0	0	0	0	0	0	0	0	0	0	0	0	0	0	2	13-142
1000	1000	1000	1000	1000	1000	1000	1000	1000	1000	1000	1000	1000	1000	1000	1000	13-143
0	0	0	0	0	0	0	0	0	0	0	0	0	0	0	0	13-149
2	2	2	2	2	2	2	2	2	2	2	2	2	2	2	2	13-150
2	2	2	2	2	2	2	2	2	2	2	2	2	2	2	2	13-151

2

Code	Adjustment	Function	Setting	Default								
				ASM	AUS	HKG	USA	DEU	GBR	ITA	BEL	NDL
13-152	MF dial level balance (Line 1)	Sets the difference between the high output and low output of the MF signal.	0: 0 dB 1: -1 dB : 4: -4 dB (Value decreased one by one)	2	2	2	2	2	2	2	2	2
13-153	Italian Intermittent DTC function (Line 1)	Sets Italian intermittent DTC function.	0: OFF 1: ON	0	0	0	0	0	0	1	0	0
13-200	Exchange type (Line 1)	Selects the exchange type.	0: PSTN 1: PABX	0	0	0	0	0	0	0	0	0
13-201	Dial selection (Line 1)	Selects the access type for the PABX.	0: Not defined 1: Local/Distant 2: Access Digit	1	1	1	1	1	1	1	1	1
13-203	Dialer type (Line 1)	Selects the dial type.	0: DP 1: MF	1	1	1	1	1	1	1	1	1
13-206	Local/distant dial (Line 1)	Key in an access code designated for the access type selected for the function code 201. Local: 2 digits Distant: 2 digits Access Digit: 3 digits	Numeric value of 3 digits (4 digits for the default setting)	1000	1000	1000	1000	1000	1000	1000	1000	1000
13-210	Exchange type (Line 2)	Selects the exchange type.	0: PSTN 1: PABX	0	0	0	0	0	0	0	0	0
13-211	Dial selection (Line 2)	Selects the access type for the PABX.	0: Not defined 1: Local/Distant 2: Access Digit	1	1	1	1	1	1	1	1	1
13-213	Dialer type (Line 2)	Selects the dial type.	0: DP 1: MF	1	1	1	1	1	1	1	1	1

Default																Code
FIN	ESP	AUT	CHE	SWE	DNK	NOR	PRT	FRA	GRC	POL	HUN	CZE	TUR	ZAF	TWN	
2	2	2	2	2	2	2	2	2	2	2	2	2	2	2	2	13-152
0	0	0	0	0	0	0	0	0	0	0	0	0	0	0	0	13-153
0	0	0	0	0	0	0	0	0	0	0	0	0	0	0	0	13-200
1	1	1	1	1	1	1	1	1	1	1	1	1	1	1	1	13-201
1	1	1	1	1	1	1	1	1	1	1	1	1	1	1	1	13-203
1000	1000	1000	1000	1000	1000	1000	1000	1000	1000	1000	1000	1000	1000	1000	1000	13-206
0	0	0	0	0	0	0	0	0	0	0	0	0	0	0	0	13-210
1	1	1	1	1	1	1	1	1	1	1	1	1	1	1	1	13-211
1	1	1	1	1	1	1	1	1	1	1	1	1	1	1	1	13-213

2

Code	Adjustment	Function	Setting	Default								
				ASM	AUS	HKG	USA	DEU	GBR	ITA	BEL	NDL
13-216	Local/distant dial (Line 2)	Key in an access code designated for the access type selected for the function code 211. Local: 2 digits Distant: 2 digits Access Digit: 3 digits	Numeric value of 3 digits (4 digits for the default setting)	1000	1000	1000	1000	1000	1000	1000	1000	1000
13-220	DTC frequency (PSTN) (Line 2)	Sets the dial tone frequency to be detected for the PSTN.	0: 300-600 Hz 1: 300-650 Hz 2: 390-550 Hz 3: 400-450 Hz 4: 350-480 Hz 5: 300-500 Hz	0	0	0	0	1	1	1	1	1
13-221	DTC time (PSTN) (Line 2)	Sets the time for a tone sounds to be determined as dial tone for the PSTN.	0: 2 sec 1: 800 ms 2: 400 ms 3: 1 sec 4: 1.3 sec 5: 1.8 sec 6: 2.5 sec 7: 500 ms	0	0	0	3	2	2	2	2	2
13-222	LCC allowed gaps (PSTN) (Line 2)	Sets the interruption time for the PSTN to be ignored during LCC.	0: OFF 1: 50 ms 2: 100 ms 3: 200 ms	0	0	0	3	2	2	2	2	2
13-223	DTC allowed gaps (PSTN) (Line 2)	Sets the interruption time for the PSTN to be ignored during DTC.	0: OFF 1: 320 ms 2: 160 ms 3: 240 ms	1	1	1	1	1	1	1	1	1
13-224	DTC/LCC for PSTN (Line 2)	Selects which is to be used for the PSTN, DTC or LCC.	0: BZT (DTC/LCC) 1: LCC 5 sec 2: DTC only 3: FRN (LCC/DTC) 4: DTC (JPN&USA) 5: NO DTC&LCC	2	2	2	2	2	2	2	2	2
13-225	DTC time out (PSTN) (Line 2)	Sets how long the dial tone detection is performed.	0: 20 sec 1: 10 sec 2: 8 sec 3: 15 sec 4: 3.3 sec	0	0	0	1	1	1	1	1	1

Default																Code
FIN	ESP	AUT	CHE	SWE	DNK	NOR	PRT	FRA	GRC	POL	HUN	CZE	TUR	ZAF	TWN	
1000	1000	1000	1000	1000	1000	1000	1000	1000	1000	1000	1000	1000	1000	1000	1000	13-216
1	1	1	1	1	1	1	1	1	1	1	1	1	0	0	1	13-220
2	2	2	2	2	2	2	2	2	2	2	2	2	0	0	2	13-221
2	2	2	2	2	2	2	2	2	2	2	2	2	0	0	2	13-222
1	1	1	1	1	1	1	1	1	1	1	1	1	1	1	1	13-223
2	2	2	2	2	2	2	2	2	2	2	2	2	2	2	2	13-224
1	1	1	1	1	1	1	1	1	1	1	1	1	0	0	1	13-225

2

Code	Adjustment	Function	Setting	Default								
				ASM	AUS	HKG	USA	DEU	GBR	ITA	BEL	NDL
13-226	DTC frequency (PABX) (Line 2)	Sets the dial tone frequency to be detected for the PABX.	0: 300-600 Hz 1: 300-650 Hz 2: 390-550 Hz 3: 400-450 Hz 4: 350-480 Hz 5: 300-500 Hz	0	0	0	0	1	1	1	1	1
13-227	DTC time (PABX) (Line 2)	Sets the time for a tone sounds to be determined as dial tone for the PABX.	0: 2 sec 1: 800 ms 2: 400 ms 3: 1 sec 4: 1.3 sec 5: 1.8 sec 6: 2.5 sec 7: 150 ms	0	0	0	6	2	2	2	2	2
13-228	LCC allowed gaps (PABX) (Line 2)	Sets the interruption time for the PABX to be ignored during LCC.	0: OFF 1: 50 ms 2: 100 ms 3: 200 ms	0	0	0	0	3	3	3	3	3
13-229	DTC allowed gaps (PABX) (Line 2)	Sets the interruption time for the PABX to be ignored during DTC.	0: OFF 1: 320 ms 2: 160 ms 3: 240 ms	1	1	1	1	1	1	1	1	1
13-230	DTC/LCC for PABX (Line 2)	Selects which is to be used for the PABX, DTC or LCC.	0: BZT (DTC/LCC) 1: LCC 5 sec 2: DTC only 3: FRN (LCC/DTC) 4: DTC (JPN&USA) 5: NO DTC&LCC	5	5	5	5	5	5	5	5	5
13-231	DTC time out (PABX) (Line 2)	Sets how long the dial tone detection is performed.	0: 20 sec 1: 10 sec 2: 8 sec 3: 15 sec 4: 3.3 sec	0	0	0	1	1	1	1	1	1
13-232	BTC frequency (Line 2)	Sets the busy tone frequency to be detected for the PSTN and PABX.	0: Not detected 1: 300-600 Hz 2: 350-550 Hz 3: 300-500 Hz 4: 300-700 Hz	0	0	0	1	1	1	1	1	1
13-236	Dial T1 timer (Line 2)	Sets the time to wait for a response from the receiver after dialing is completed.	0: 60 sec 1: 35 sec 2: 90 sec 3: 55 sec 4: 115 sec	0	3	0	3	2	2	2	2	2

Default																Code
FIN	ESP	AUT	CHE	SWE	DNK	NOR	PRT	FRA	GRC	POL	HUN	CZE	TUR	ZAF	TWN	
1	1	1	1	1	1	1	1	1	1	1	1	1	0	0	1	13-226
2	2	2	2	2	2	2	2	2	2	2	2	2	0	0	2	13-227
3	3	3	3	3	3	3	3	3	3	3	3	3	0	0	2	13-228
1	1	1	1	1	1	1	1	1	1	1	1	1	1	1	1	13-229
5	5	5	5	5	5	5	5	5	5	5	5	5	5	5	5	13-230
1	1	1	1	1	1	1	1	1	1	1	1	1	0	0	1	13-231
1	1	1	1	1	1	1	1	1	1	1	1	1	0	0	1	13-232
2	2	2	2	2	2	2	2	2	2	2	2	2	0	0	3	13-236

2

Code	Adjustment	Function	Setting	Default								
				ASM	AUS	HKG	USA	DEU	GBR	ITA	BEL	NDL
13-245	Dial information (Line 2)	Sets the definition of the DP dial. Normal: n Shift: n+1 Reverse: 10-n n=Dial No.	0: Normal 1: Shift 2: Reverse	0	0	0	0	0	0	0	0	0
13-247	Internal retry (Line 2)	When dialing is interrupted because any of the settings for DTC/LCC is not satisfied during redialing, that redialing is ignored since it is considered as an internal retry.	0: OFF 1: ON	0	0	0	0	1	1	0	0	0
13-249	Time for a pause (Line 2)	Sets the time for a pause when it is inserted between the dial numbers.	0: 0 sec 1: 1 sec 2: 2 sec 3: 4 sec 4: 3.3 sec 5: 10 sec	4	2	2	4	2	2	3	2	0
13-262	Inter-digit pause (Line 2)	Sets the interval between digits for DP dialing.	0: 900 ms 1: 550 ms 2: 700 ms 3: 800 ms	0	0	2	3	0	3	3	2	2
13-267	DP make/break ratio (Line 2)	Sets the make/break ratio for DP dialing.	0: 60/40(10 PPS) 1: 67/33(10 PPS) 2: 63/37(10 PPS) 3: 50/50(10 PPS) 4: 67/33(20 PPS) 5: 70/30 (10 PPS, TWN only)	1	1	1	0	0	1	0	1	0
13-268	MF timing (Line 2)	Sets the ON/OFF timing of MF signals. Do not set the value "4" for the function code 138 and 268 to ensure minimum time of the MF signal duration ruled in TBR21. (Requirement 4.8.2.4, 4.8.2.5)	0: 80/80 ms 1: 70/70 ms 2: 70/150 ms 3: 60/60 ms 4: 80/100 ms 5: 150/50 ms 6: 150/240 ms	2	0	2	4	4	0	0	1	1

Default																Code
FIN	ESP	AUT	CHE	SWE	DNK	NOR	PRT	FRA	GRC	POL	HUN	CZE	TUR	ZAF	TWN	
0	0	0	0	1	0	2	0	0	0	0	0	0	0	0	0	13-245
0	0	1	0	0	1	1	0	0	0	0	0	0	0	0	0	13-247
2	2	2	0	2	2	2	1	2	4	4	4	4	4	4	4	13-249
0	1	3	3	2	2	2	2	0	3	3	0	0	0	0	0	13-262
0	1	0	0	0	1	0	1	1	0	1	0	0	1	1	5	13-267
0	2	0	0	1	2	0	0	0	4	0	3	1	2	2	4	13-268

2

Code	Adjustment	Function	Setting	Default								
				ASM	AUS	HKG	USA	DEU	GBR	ITA	BEL	NDL
13-269	DTC RX ATT (PSTN) (Line 2)	Sets the reception level when the dial tone is detected for the PSTN.	0: -24 dB 1: -27 dB 2: -30 dB 3: -33 dB 4: -36 dB 5: -39 dB 6: -42 dB 7: -45 dB	6	6	6	6	6	6	6	6	6
13-270	DTC RX ATT (PABX) (Line 2)	Sets the reception level when the dial tone is detected for the PABX.	0: -24 dB 1: -27 dB 2: -30 dB 3: -33 dB 4: -36 dB 5: -39 dB 6: -42 dB 7: -45 dB	6	6	6	6	6	6	6	6	6
13-271	MF TX-ATT (Line 2)	Sets the attenuator value for the MF signal.	0: 0 dB 1: -1 dB ! 15: -15 dB (Value decreased one by one)	2	7	5	3	4	4	4	4	4
13-272	International DTC frequency (Line 2)	Selects the frequency range for the dial tone of the first pause to be detected.	00: No detection 01: 300-600 Hz 02: 300-650 Hz 03: 390-550 Hz 04: 400-450 Hz 05: 350-480 Hz 06: 300-500 Hz 07: France Dual Tone (not used)	0	0	0	0	0	0	0	0	0
		Selects the frequency range for the dial tone to be detected after dialing the second international dial access code.	10: No detection 11: 300-600 Hz 12: 300-650 Hz 13: 390-550 Hz 14: 400-450 Hz 15: 350-480 Hz 16: 300-500 Hz 17: France Dual Tone (not used)									
13-273	International dial access code (Line 2)	Sets the international access code.	Numeric value of 3 digits (Default setting: 4 digits)	1000	1000	1000	1000	1000	1000	1000	1000	1000
13-279	ATT control (Line 2)	Sets for the receiver attenuator.	0: OFF 1: -3 dB	0	0	0	0	0	0	0	0	0

Default																Co de
FIN	ESP	AUT	CHE	SWE	DNK	NOR	PRT	FRA	GRC	POL	HUN	CZE	TUR	ZAF	TWN	
6	6	6	6	6	6	6	6	6	6	6	6	6	6	6	6	13-269
6	6	6	6	6	6	6	6	6	6	6	6	6	6	6	6	13-270
4	4	4	4	4	4	4	4	4	4	4	4	4	3	3	3	13-271
0	0	0	0	0	0	0	0	0	0	0	0	0	0	0	2	13-272
1000	1000	1000	1000	1000	1000	1000	1000	1000	1000	1000	1000	1000	1000	1000	1000	13-273
0	0	0	0	0	0	0	0	0	0	0	0	0	0	0	0	13-279

2

Code	Adjustment	Function	Setting	Default								
				ASM	AUS	HKG	USA	DEU	GBR	ITA	BEL	NDL
13-280	BTC ON time (Line 2)	Sets the time range for the busy tone on-time.	0: 80-650 ms 1: 450-550 ms 2: 200-650 ms 3: 400-600 ms 4: 120-550 ms 5: 420-610 ms	2	2	2	2	2	2	2	2	2
13-281	BTC OFF time (Line 2)	Sets the time range for the busy tone off-time.	0: 80-650 ms 1: 450-550 ms 2: 200-650 ms 3: 400-600 ms 4: 160-600 ms 5: 170-700 ms 6: 380-630 ms 7: 150-470 ms	2	2	2	2	2	2	2	2	2
13-282	MF dial level balance (Line 2)	Sets the difference between the high output and low output of the MF signal.	0: 0 dB 1: -1 dB : 4: -4 dB (Value decreased one by one)	2	2	2	2	2	2	2	2	2
13-283	Italian intermittent DTC function (Line 2)	Sets Italian intermittent DTC function.	0: OFF 1: ON	0	0	0	0	0	0	1	0	0

Default																Code
FIN	ESP	AUT	CHE	SWE	DNK	NOR	PRT	FRA	GRC	POL	HUN	CZE	TUR	ZAF	TWN	
2	2	2	2	2	2	2	2	2	2	2	2	2	2	2	2	13-280
2	2	2	2	2	2	2	2	2	2	2	2	2	2	2	2	13-281
2	2	2	2	2	2	2	2	2	2	2	2	2	2	2	2	13-282
0	0	0	0	0	0	0	0	0	0	0	0	0	0	0	0	13-283

2

300-699 Adjustments for switching function specifications

Code	Adjustment	Function	Setting	Default								
				ASM	AUS	HKG	USA	DEU	GBR	ITA	BEL	NDL
13-312	CI history hold time (Line 1)	Sets the time for the CI history to remain.	0: 5 sec 1: 8 sec 2: 14 sec	1	1	1	2	2	2	2	2	2
13-313	CI detection frequency range (Line 1)	Sets the frequency range for CI detection.	0: 12-80 Hz 1: 16-55 Hz 2: 20-55 Hz 3: 22-55 Hz 4: 5-200 Hz	0	0	0	0	1	1	1	1	1
13-317	Handling of negative answer	Sets whether the RTN received is handled as abnormal (NG) or normal when the data are slightly abnormal. Abnormal: DCN is transmitted to stop the communication. Normal: Next page is transmitted normally.	0: Abnormal 1: Normal	1	1	1	0	0	0	0	0	0
13-325	TX attenuation value (V.17) (Line 1)	Sets the modem transmission level for communication other than V.34. The smaller the value is, the higher the transmission level becomes. If errors occur frequently or training is not sent, the transmission level should be changed.	0: 0 dB 1: -1 dB 2: -2 dB 3: -3 dB 4: -4 dB 5: -5 dB 6: -6 dB 7: -7 dB 8: -8 dB 9: -9 dB 10: -10 dB 11: -11 dB 12: -12 dB 13: -13 dB 14: -14 dB 15: -15 dB (Value decreased one by one)	10	10	10	10	12	12	12	12	12
13-328	Cable equalizer (V.17) (Line 1)	Sets the equalizer value which has frequency characteristics. For the long-distance communication, it is recommended to set a large value.	0: 0 dB 1: -4 dB 2: -8 dB 3: -12 dB	0	0	0	0	0	0	0	0	0

Default																Code
FIN	ESP	AUT	CHE	SWE	DNK	NOR	PRT	FRA	GRC	POL	HUN	CZE	TUR	ZAF	TWN	
2	2	2	2	2	2	2	2	2	2	2	2	2	1	1	2	13-312
1	1	1	1	1	1	1	1	1	1	1	1	1	0	0	0	13-313
0	0	0	0	0	0	0	0	0	0	0	0	0	1	1	0	13-317
12	12	12	12	12	12	12	12	12	12	12	12	12	10	10	13	13-325
0	0	0	0	0	0	0	0	0	0	0	0	0	0	0	0	13-328

2

Code	Adjustment	Function	Setting	Default								
				ASM	AUS	HKG	USA	DEU	GBR	ITA	BEL	NDL
13-331	Echo protection delay (high speed) (V.21)	Sets if a delay (500 ms) is inserted before sending the V.21 signal and timing is shifted to avoid the line echo.	0: OFF 1: ON (500 ms)	1	0	1	1	1	1	1	1	1
13-335	Modem speed initial value	Sets the initial modem speed to be declared by DIS/DCS.	0: 2,400 bps 1: 14.4 kbps (V.17) 4: 4,800 bps 5: 12 kbps (V.17) 8: 9,600 bps 9: 9,600 bps (V.17) 12: 7,200 bps 13: 7,200 bps (V.17)	1	1	1	1	1	1	1	1	1
13-338	Forcible line monitoring	Selects the line to monitor.	0: OFF 1: Line 1 2: Line 2	0	0	0	0	0	0	0	0	0
13-339	CI-ON determine time (Line 1)	CI ON-satiable time.	0: 175 ms 1: 125 ms 2: 800 ms 3: 145 ms	0	0	0	0	0	0	0	0	0
13-340	CI-OFF determine time (Line 1)	CI OFF-satiable time.	0: 650 ms 1: 350 ms 2: 175 ms 3: 90 ms	2	2	2	2	2	2	2	2	2
13-346	Recording width capacity declaration	Selects either one of the followings to declare the maximum recording width to the other party when the specified paper size is not available; the largest paper in the other drawer or the drawer for the largest paper.	0: Paper 1: Drawer	0	0	0	0	0	0	0	0	0
13-350	High speed carrier-OFF detection timer	Sets the time to determine the carrier signal is stopped completely.	0: 1.5 sec. 1: 6 sec. (FTZ)	1	1	1	1	1	1	1	1	1

Default																Code
FIN	ESP	AUT	CHE	SWE	DNK	NOR	PRT	FRA	GRC	POL	HUN	CZE	TUR	ZAF	TWN	
1	1	1	1	1	1	1	1	1	1	1	1	1	1	1	1	13-331
1	1	1	1	1	1	1	1	1	1	1	1	1	1	1	1	13-335
0	0	0	0	0	0	0	0	0	0	0	0	0	0	0	0	13-338
0	0	0	0	0	0	0	0	0	0	0	0	0	0	0	0	13-339
2	2	2	2	2	2	2	2	2	2	2	2	2	2	2	2	13-340
0	0	0	0	0	0	0	0	0	0	0	0	0	0	0	0	13-346
1	1	1	1	1	1	1	1	1	1	1	1	1	1	1	1	13-350

2

Code	Adjustment	Function	Setting	Default								
				ASM	AUS	HKG	USA	DEU	GBR	ITA	BEL	NDL
13-351	Off-hook alarm	Sets the volume of the alarm sounded when the handset has been left off the cradle even though the communication is finished.	0: No alarm 1: Level 1 (Min.) : 7: Level 7 (Max.)	0	0	0	0	3	3	3	3	3
13-355	Memory transmission report	Sets whether the memory transmission report is output or not. Also, selects the output conditions.	0: OFF 1: On Error (BZT) 2: ALWAYS 3: On Error (BZT/W) 5: On Error (BZT/W) 6: Always (W) 7: On Error (W)	7	7	7	7	6	6	6	6	6
13-356	Multi address transmission report	Sets whether the multi-address transmission report is printed or not. Also, selects the output condition.	0: OFF 1: Always 2: On error 3: Always (W) 4: On error (W)	4	4	4	4	3	3	3	3	3
13-357	Direct document transmission report	Sets whether the direct transmission report is printed or not. Also, selects the output condition.	0: OFF 1: Always 2: On error	1	1	1	1	1	1	1	1	1
13-359	Multi polling report	Sets whether the multi-polling transmission report is printed or not. Also, selects the output condition.	0: OFF 1: Always 2: On error	2	2	2	2	1	1	1	1	1
13-361	ITU-T Relay transmission (originator) report	Sets whether the report is printed or not. Also, selects the output condition.	0: OFF 1: Always 2: On error 3: Always (W) 4: On error (W)	3	3	3	3	3	3	3	3	3

Default																Code
FIN	ESP	AUT	CHE	SWE	DNK	NOR	PRT	FRA	GRC	POL	HUN	CZE	TUR	ZAF	TWN	
3	3	3	3	3	3	3	3	3	3	3	3	3	0	0	0	13-351
6	6	6	6	6	6	6	6	6	6	6	6	6	7	7	7	13-355
3	3	3	3	3	3	3	3	3	3	3	3	3	4	4	4	13-356
1	1	1	1	1	1	1	1	1	1	1	1	1	1	1	1	13-357
1	1	1	1	1	1	1	1	1	1	1	1	1	2	2	2	13-359
3	3	3	3	3	3	3	3	3	3	3	3	3	3	3	3	13-361

2

Code	Adjustment	Function	Setting	Default								
				ASM	AUS	HKG	USA	DEU	GBR	ITA	BEL	NDL
13-362	Result report printout for relay hub station	Sets whether the relay multi-address transmission report is printed or not. Also, selects the output condition.	0: OFF 1: Always 2: On error 3: Always (W) 4: On error (W)	4	4	4	4	3	3	3	3	3
13-363	ITU-T Relay transmission (end station) report	Sets whether the report is transported or not. Also, selects the transport condition.	0: OFF 1: Always 2: On error 3: Always (W) 4: On error (W)	2	2	2	2	2	2	2	2	2
13-365	Printing function for relay station (reception report)	Sets whether the relay multi-address reception report is printed or not.	0: OFF 1: ON	0	0	0	0	1	1	1	1	1
13-367	F-code acceptance list	Sets whether the acceptance list is printed when the data are sent into the confidential box or bulletin board or not. Also, selects the output condition.	0: OFF 1: Remote ON, local OFF 2: Remote OFF, local ON 3: ON	0	0	0	0	1	1	1	1	1
13-368	Journal auto-output	Sets whether the journal is output automatically or not.	0: OFF 1: ON	1	1	1	1	1	1	1	1	1
13-370	Communication result on journal (OK/NG)	Selects whether the communication result (OK/NG) is reported on the journal or not.	0: Not reported 1: Reported	1	1	1	1	1	1	1	1	1
13-371	Communication result on journal (error code)	Selects whether the communication error code is reported on the journal or not.	0: Not reported 1: Reported	1	1	1	1	1	1	1	1	1
13-372	CI detection counter setting for auto-RX (Line 1)	Sets the CI counter value for the machine to enter the automatic reception mode.	0: Once 1: Once : 15: 15 times (Value increased one by one)	1	4	1	2	2	2	2	2	2

Default																Code
FIN	ESP	AUT	CHE	SWE	DNK	NOR	PRT	FRA	GRC	POL	HUN	CZE	TUR	ZAF	TWN	
3	3	3	3	3	3	3	3	3	3	3	3	3	4	4	4	13-362
2	2	2	2	2	2	2	2	2	2	2	2	2	2	2	2	13-363
1	1	1	1	1	1	1	1	1	1	1	1	1	0	0	0	13-365
1	1	1	1	1	1	1	1	1	1	1	1	1	0	0	0	13-367
1	1	1	1	1	1	1	1	1	1	1	1	1	1	1	1	13-368
1	1	1	1	1	1	1	1	1	1	1	1	1	1	1	1	13-370
1	1	1	1	1	1	1	1	1	1	1	1	1	1	1	1	13-371
2	2	2	2	2	2	2	2	2	2	2	2	2	1	1	2	13-372

2

Code	Adjustment	Function	Setting	Default								
				ASM	AUS	HKG	USA	DEU	GBR	ITA	BEL	NDL
13-373	Speaker volume (monitor tone)	Sets the speaker volume for on-hook status or protocol monitor.	0: Level 0 (Min.) : 7: Level 7 (Max.)	4	4	4	3	3	3	3	3	3
13-375	Discard parameter on printing	Sets the data length to be discarded when the received data exceed the effective recording length.	0: 0 mm (No elimination) 1: 10 mm 2: 18 mm 3: 22 mm 4: 34 mm	1	1	1	1	1	1	1	1	1
13-377	Printing mode (Reduction in vertical direction)	Sets if the received document is reduced automatically in the vertical direction to appropriate recording size.	0: Auto-reduction 1: No reduction	0	0	0	0	0	0	0	0	0
13-378	Discard printing	Selects if the discard printing is performed.	0: OFF 1: ON	1	1	1	1	1	1	1	1	1
13-379	Maximum reduction rate in vertical direction	Sets the maximum reduction rate in the vertical direction.	0: 90% 1: 75%	0	1	0	1	1	1	1	1	1
13-382	Reception information on received document	Sets if the receiver information is printed on received document.	0: OFF 1: ON	0	0	0	0	0	0	0	0	0
13-389	RX mode (PSTN)	Selects the receiving mode.	0: TEL 1: FAX	1	1	1	1	1	1	1	1	1
13-391	ECM function	Sets if the ECM communication is performed.	0: OFF 1: ON	1	1	1	1	1	1	1	1	1
13-394	Recovery transmission retaining time	Sets the time for the HDD to retain data when the transmission was terminated due to an error.	1: 1 hour : 24: 24 hours	6	6	6	6	6	6	6	6	6
13-398	Line default	Sets the line default Line 1 or Line 2	0: Line 1 1: Line 2	0	0	0	0	0	0	0	0	0

Default																Code
FIN	ESP	AUT	CHE	SWE	DNK	NOR	PRT	FRA	GRC	POL	HUN	CZE	TUR	ZAF	TWN	
3	3	3	3	3	3	3	3	3	3	3	3	3	4	4	3	13-373
1	1	1	1	1	1	1	1	1	1	1	1	1	1	1	1	13-375
0	0	0	0	0	0	0	0	0	0	0	0	0	0	0	0	13-377
1	1	1	1	1	1	1	1	1	1	1	1	1	1	1	1	13-378
1	1	1	1	1	1	1	1	1	1	1	1	1	0	0	1	13-379
0	0	0	0	0	0	0	0	0	0	0	0	0	0	0	0	13-382
1	1	1	1	1	1	1	1	1	1	1	1	1	1	1	1	13-389
1	1	1	1	1	1	1	1	1	1	1	1	1	1	1	1	13-391
6	6	6	6	6	6	6	6	6	6	6	6	6	6	6	6	13-394
0	0	0	0	0	0	0	0	0	0	0	0	0	0	0	0	13-398

2

Code	Adjustment	Function	Setting	Default								
				ASM	AUS	HKG	USA	DEU	GBR	ITA	BEL	NDL
13-430	TX attenuation value (V.17) (Line 2)	This value is to set the modem transmission level for communication other than V.34. The smaller the value is, the higher the transmission level becomes. If errors occur frequently or training is not sent, the transmission level should be changed.	0: 0 dB 1: -1 dB : 15: -15 dB (Value decreased one by one)	10	10	10	10	12	12	12	12	12
13-433	Cable equalizer (V.17) (Line 2)	Sets the equalizer value which has frequency characteristics. For the long-distance communication, it is recommended to set a large value.	0: 0 dB 1: -4 dB 2: -8 dB 3: -12 dB	0	0	0	0	0	0	0	0	0
13-501	Communication control in case PPR is received four times	Sets how the communication is controlled when the 4th PPR is received during the ECM transmission.	0: EOR transmitted 1: CTC (communication terminated after the 4th 2400 bps PPR) 2: CTC (EOR transmitted after the reception of the 4th 2,400 bps PPR)	2	2	2	2	2	2	2	2	2
13-509	Modem speed for overseas communication (except V.34)	Sets the initial modem speed for overseas communication.	0: 9,600 bps 1: 7,200 bps 2: 4,800 bps	0	0	0	0	0	0	0	0	0
13-510	Position of header for transmission information	Selects the position where the header is inserted.	2: Inside 3: Outside	2	2	2	2	2	2	2	2	2

Default																Code
FIN	ESP	AUT	CHE	SWE	DNK	NOR	PRT	FRA	GRC	POL	HUN	CZE	TUR	ZAF	TWN	
12	12	12	12	12	12	12	12	12	12	12	12	12	10	10	13	13-430
0	0	0	0	0	0	0	0	0	0	0	0	0	0	0	0	13-433
2	2	2	2	2	2	2	2	2	2	2	2	2	2	2	2	13-501
0	0	0	0	0	0	0	0	0	0	0	0	0	0	0	0	13-509
2	2	2	2	2	2	2	2	2	2	2	2	2	2	2	2	13-510

2

Code	Adjustment	Function	Setting	Default								
				ASM	AUS	HKG	USA	DEU	GBR	ITA	BEL	NDL
13-511	Transmission information at header	Sets the header insertion.	0: Not inserted 1: Inserted	1	1	1	1	1	1	1	1	1
13-512	Threshold for error image (G3 mode only)	After receiving a document with more error lines than this threshold level, the machine transmits the RTN signal to the sender.	0: 5% 1: 10% 2: 15% 3: 25%	1	1	1	1	1	1	1	1	1
13-517	Regular reduction	Sets if the regular reduction printing (A3→B4 or A4, B4→A4 or B5) is performed.	0: OFF 1: ON	0	0	0	0	0	0	0	0	0
13-518	Duplex printing	Sets if duplex printing for received documents is performed.	0: OFF 1: ON	0	0	0	0	0	0	0	0	0
13-519	Paper selection for received FAX document	Selects which one has priority over the other, A4 series or LT series, to print the received document when these two series are mixed in a drawer.	0: A4 series 1: LT series	0	0	0	1	0	0	0	0	0
13-564	Control channel speed (Line 1)	Selects the control channel speed for the V.34 communication.	0: 1,200 bps 1: 2,400 bps	0	0	0	0	0	0	0	0	0
13-565	Fall-back condition for transmitter (No. of PPR reception) (V.34 Line 1)	Sets the number of the PPR reception for fall-back condition in the V.34 transmission.	0: Once 1: Twice 10: 11 times	5	5	5	5	5	5	5	5	5

Default																Code
FIN	ESP	AUT	CHE	SWE	DNK	NOR	PRT	FRA	GRC	POL	HUN	CZE	TUR	ZAF	TWN	
1	1	1	1	1	1	1	1	1	1	1	1	1	1	1	1	13-511
1	1	1	1	1	1	1	1	1	1	1	1	1	1	1	1	13-512
0	0	0	0	0	0	0	0	0	0	0	0	0	0	0	0	13-517
0	0	0	0	0	0	0	0	0	0	0	0	0	0	0	0	13-518
0	0	0	0	0	0	0	0	0	0	0	0	0	0	0	0	13-519
0	0	0	0	0	0	0	0	0	0	0	0	0	0	0	0	13-564
5	5	5	5	5	5	5	5	5	5	5	5	5	5	5	5	13-565

2

Code	Adjustment	Function	Setting	Default								
				ASM	AUS	HKG	USA	DEU	GBR	ITA	BEL	NDL
13-566	Fall-back condition for receiver (No. of PPR transmission) (V.34 Line 1)	Sets the number of the PPR transmission for fall-back condition in V.34 reception.	0: Once 1: Twice : 10: 11 times	5	5	5	5	5	5	5	5	5
13-567	TX attenuation value (V.34) (Line 1)	Sets the modem transmission attenuation level for the V.34 communication. The smaller the set value is, the higher the transmission level becomes. If errors occur frequently or training is not sent, the transmission level should be changed.	0: 0 dB 1: -1 dB : 15: -15 dB (Value decreased one by one)	10	10	10	10	12	12	12	12	12
13-569	Initial modem speed for V.34 communication (Transmission)	Sets the initial modem speed for V.34 transmission.	0: V.34 not installed 6: 14.4 kbps (V.34) 9: 21.6 kbps (V.34) 12: 28.8 kbps (V.34) 14: 33.6 kbps (V.34)	14	14	14	14	14	14	14	14	14
13-571	SUB/SEP/PWD functions	Sets SUB/SEP/PWB communication at data reception.	0: OFF 1: ON	1	1	1	1	1	1	1	1	1
13-574	Coding capability (communication capability)	Sets the coding capability to be declared to the other side during communication.	0: MH 1: MH/MR 2: MH/MR/MMR 3: MH/MR/MMR/JBIG	3	3	3	3	3	3	3	3	3
13-575	Reception end tone timing	Sets the timing to sound the reception end tone.	0: OFF 1: When printing is completed 2: When reception is completed	1	1	1	1	1	1	1	1	1

Default																Code
FIN	ESP	AUT	CHE	SWE	DNK	NOR	PRT	FRA	GRC	POL	HUN	CZE	TUR	ZAF	TWN	
5	5	5	5	5	5	5	5	5	5	5	5	5	5	5	5	13-566
12	12	12	12	12	12	12	12	12	12	12	12	12	10	10	13	13-567
14	14	14	14	14	14	14	14	14	14	14	14	14	14	14	14	13-569
1	1	1	1	1	1	1	1	1	1	1	1	1	1	1	1	13-571
3	3	3	3	3	3	3	3	3	3	3	3	3	3	3	3	13-574
1	1	1	1	1	1	1	1	1	1	1	1	1	1	1	1	13-575

2

Code	Adjustment	Function	Setting	Default								
				ASM	AUS	HKG	USA	DEU	GBR	ITA	BEL	NDL
13-576	V.34 symbol rate (Line 1)	Sets the initial value for the symbol rate for V.34 communication. Maximum modem speed for each setting are as follows. 2,400: 21,600 bps, 2,800: 26,400 bps, 3,000: 28,800 bps, 3,200: 31,200 bps, 3,492: 33,600 bps	0: 2,400 1: 2,800 2: 3,000 3: 3,200 4: 3,429	4	4	4	4	4	4	4	4	4
13-577	V.34 fall-back method (Line 1)	Sets the number of steps in which the modem speed is fall-backed.	0: 1 step 1: 2 step 2: 3 step	0	0	0	0	0	0	0	0	0
13-578	Recovery transmission	Sets whether the recovery transmission is performed or not.	0: OFF 1: ON	0	0	0	0	0	0	0	0	0
13-580	Protocol type	Selects the type of the T.30 procedure. DTS is only for Europe.	0: ITU-T 1: DTS	0	0	0	0	1	0	0	0	0
13-581	Batch transmission	Batch transmission is performed or not.	0: OFF 1: ON	1	1	1	1	1	1	1	1	1
13-584	Alternation output	Sets the alternation output.	0: OFF 1: ON	0	0	0	0	0	0	0	0	0
13-585	Search function for receiver name on transmission journal	Sets if the search function for the receiver name on the transmission journal is used. (Relay reception report is not supported.)	0: OFF 1: ON	0	0	0	0	0	0	0	0	0
13-586	Communication end tone volume	Sets the volume of the communication end tone.	0: Level 0 (Min) : 7: Level 7 (Max)	4	4	4	4	4	4	4	4	4

Default																Code
FIN	ESP	AUT	CHE	SWE	DNK	NOR	PRT	FRA	GRC	POL	HUN	CZE	TUR	ZAF	TWN	
4	4	4	4	4	4	4	4	4	4	4	4	4	4	4	4	13-576
0	0	0	0	0	0	0	0	0	0	0	0	0	0	0	0	13-577
0	0	0	0	0	0	0	0	0	0	0	0	0	0	0	0	13-578
0	0	0	0	0	0	0	0	0	0	0	0	0	0	0	0	13-580
1	1	1	1	1	1	1	1	1	1	1	1	1	1	1	1	581
0	0	0	0	0	0	0	0	0	0	0	0	0	0	0	0	13-584
0	0	0	0	0	0	0	0	0	0	0	0	0	0	0	0	13-585
4	4	4	4	4	4	4	4	4	4	4	4	4	4	4	4	13-586

2

Code	Adjustment	Function	Setting	Default								
				ASM	AUS	HKG	USA	DEU	GBR	ITA	BEL	NDL
13-587	Communication end tone sounding time	Sets how long the communication end tone sounds.	0: OFF 1: 0.5 sec. 2: 1.0 sec. 3: 1.5 sec. 4: 2.0 sec. 5: 2.5 sec. 6: 3.0 sec. 7: 3.5 sec. 8: 4.0 sec. 9: 4.5 sec. 10: 5.0 sec.	2	2	2	2	2	2	2	2	2
13-601	CI history hold time (Line 2)	Sets the time to keep the CI history.	0: 5 sec. 1: 8 sec. 2: 14 sec.	1	1	1	2	2	2	2	2	2
13-602	CI detection frequency range (Line 2)	Sets the frequency range for CI detection.	0: 12-80 Hz 1: 16-55 Hz 2: 20-55 Hz 3: 22-55 Hz 4: 5-200 Hz	0	0	0	0	1	1	1	1	1
13-605	CI-ON determine time (Line 2)	CI ON-satiable time.	0: 175 ms 1: 125 ms 2: 800 ms 3: 145 ms	0	0	0	0	0	0	0	0	0
13-606	CI-OFF determine time (Line 2)	CI OFF-satiable time.	0: 650 ms 1: 350 ms 2: 175 ms 3: 90 ms	2	2	2	2	2	2	2	2	2
13-607	CI detection counter setting for auto-RX (Line 2)	Sets the CI counter value for the machine to enter the auto-reception mode.	0: Once 1: Once 15: 15 times (Value increased one by one)	1	4	1	2	2	2	2	2	2
13-610	Control channel speed (Line 2)	Selects the control channel speed for the V.34 communication.	0: 1,200 bps 1: 2,400 bps	0	0	0	0	0	0	0	0	0
13-611	Fall-back condition for transmitter (No. of PPR reception) (V.34 Line 2)	Sets the number of the PPR reception for fall-back condition in the V.34 transmission.	0: Once 1: Twice 10: 11 times	5	5	5	5	5	5	5	5	5

Default																Code
FIN	ESP	AUT	CHE	SWE	DNK	NOR	PRT	FRA	GRC	POL	HUN	CZE	TUR	ZAF	TWN	
2	2	2	2	2	2	2	2	2	2	2	2	2	2	2	2	13-587
2	2	2	2	2	2	2	2	2	2	2	2	2	1	1	2	13-601
1	1	1	1	1	1	1	1	1	1	1	1	1	0	0	0	13-602
0	0	0	0	0	0	0	0	0	0	0	0	0	0	0	0	13-605
2	2	2	2	2	2	2	2	2	2	2	2	2	2	2	2	13-606
2	2	2	2	2	2	2	2	2	2	2	2	2	1	1	2	13-607
0	0	0	0	0	0	0	0	0	0	0	0	0	0	0	0	13-610
5	5	5	5	5	5	5	5	5	5	5	5	5	5	5	5	13-611

2

Code	Adjustment	Function	Setting	Default								
				ASM	AUS	HKG	USA	DEU	GBR	ITA	BEL	NDL
13-612	Fall-back condition for receiver (No. of PPR transmission) (V.34 Line 2)	Sets the number of the PPR transmission for fall-back condition in the V.34 reception.	0: Once 1: Twice : 10: 11 times	5	5	5	5	5	5	5	5	5
13-614	V.34 symbol rate (Line 2)	Sets the initial value for the symbol rate in the V.34 communication. Maximum modem speeds for each setting are as follows. 2,400: 21,600 bps, 2,800: 26,400 bps, 3,000: 28,800 bps, 3,200: 31,200 bps, 3,492: 33,600 bps	0: 2,400 1: 2,800 2: 3,000 3: 3,200 4: 3,429	4	4	4	4	4	4	4	4	4
13-615	V.34 fall-back method (Line 2)	Sets the number of steps in which the modem speed is fall-backed.	0: 1 step 1: 2 step 2: 3 step	0	0	0	0	0	0	0	0	0
13-616	TX attenuation value (V.34) (Line 2)	Sets the modem transmission attenuation level for the V.34 communication. The smaller the set value is, the higher the transmission level becomes. If errors occur frequently or training is not sent, the transmission level should be changed.	0: 0 dB 1: -1 dB : 15: -15 dB (Value decreased one by one)	10	10	10	10	12	12	12	12	12

Default																Code
FIN	ESP	AUT	CHE	SWE	DNK	NOR	PRT	FRA	GRC	POL	HUN	CZE	TUR	ZAF	TWN	
5	5	5	5	5	5	5	5	5	5	5	5	5	5	5	5	13-612
4	4	4	4	4	4	4	4	4	4	4	4	4	4	4	4	13-614
0	0	0	0	0	0	0	0	0	0	0	0	0	0	0	0	13-615
12	12	12	12	12	12	12	12	12	12	12	12	12	10	10	13	13-616

2

Code	Adjustment	Function	Setting	Default								
				ASM	AUS	HKG	USA	DEU	GBR	ITA	BEL	NDL
13-618	Initial modem speed for V.34 communication (RX)	Sets the initial value of the speed for V.34 communication.(RX)	0: V.34 OFF (Reservation) 6: 14.4KBPS 9: 21.6KBPS 12: 28.8KBPS 14: 33.6KBPS (Not use V.34)	14	14	14	14	14	14	14	14	14
13-619	V.34 RX capacity declaration (Line 1)	Sets the V.34 capacity declaration (Line 1)	0: OFF 1: ON	1	1	1	1	1	1	1	1	1
13-620	V.34 RX capacity declaration (Line 2)	Sets the V.34 capacity declaration (Line 2)	0: OFF 1: ON	1	1	1	1	1	1	1	1	1

Default																Code
FIN	ESP	AUT	CHE	SWE	DNK	NOR	PRT	FRA	GRC	POL	HUN	CZE	TUR	ZAF	TWN	
14	14	14	14	14	14	14	14	14	14	14	14	14	14	14	14	13-618
1	1	1	1	1	1	1	1	1	1	1	1	1	1	1	1	13-619
1	1	1	1	1	1	1	1	1	1	1	1	1	1	1	1	13-620

2

900-999 Adjustment of system setting

Code	Adjustment	Function	Setting	Default								
				ASM	AUS	HKG	USA	DEU	GBR	ITA	BEL	NDL
13-922	Format of Fax destination display after phase B	Sets either "the phone number transmitted by CSI signal" or "the name of destination in the address book or the dialed phone number" for the destination display after phase B in the transmission control.	0: Phone number by CSI signal 1: Name of destination in the address book or the dialed phone number	0	0	0	0	0	0	0	0	0
13-923	Retrieval method of sender's address name by TSI signal and the address book	Sets either the partial or perfect match retrieval when the phone number registered in the address book is searched by the one included in the TSI signal. The searched sender's address name is also used as a save file name at the time of transfer. (E-mail transmission is not supported.)	0: Partial match retrieval of the phone number by TSI signal and the registered phone number 1: Perfect match retrieval of the phone number by TSI signal and the registered phone number	0	0	0	0	0	0	0	0	0
13-924	Duplex printing for received fax documents at forwarding destination	Sets whether duplex printing is performed or not to output the received fax documents at the forwarding destination, when ON is selected at "Duplex printing for received documents" (code: 518).	0: OFF 1: ON	0	0	0	0	0	0	0	0	0
13-926	Paper width declaration in paper empty state	Selects either size, A4 or B4, to declare the paper size when "0: Paper" has been selected for the code 346 and paper in every drawer is run out.	0: A4 1: B4	0	0	0	0	0	0	0	0	0

Default																Code
FIN	ESP	AUT	CHE	SWE	DNK	NOR	PRT	FRA	GRC	POL	HUN	CZE	TUR	ZAF	TWN	
0	0	0	0	0	0	0	0	0	0	0	0	0	0	0	0	13-922
0	0	0	0	0	0	0	0	0	0	0	0	0	0	0	0	13-923
0	0	0	0	0	0	0	0	0	0	0	0	0	0	0	0	13-924
0	0	0	0	0	0	0	0	0	0	0	0	0	0	0	0	13-926

Code	Adjustment	Function	Setting	Default								
				ASM	AUS	HKG	USA	DEU	GBR	ITA	BEL	NDL
13-927	B4 declaration on B5 recording paper at data reception	Sets whether B4-size data is printed out on B5 recording paper or not. (The data size is not reduced. The later half of the original B4-size data is cut off.)	0: Not printed on B5 1: Printed on B5	0	0	0	0	0	0	0	0	0
13-940	UI display for [Tx ATT]	Sets whether the [Tx ATT] button is displayed in the Phone Book registration screen or not. When "16" is set for the TX attenuation, the transmission level of the equipment is determined by the setting values of the following items. 13-325: TX attenuation value (V.17) (Line 1) 13-430: TX attenuation value (V.17) (Line 2) 13-567: TX attenuation value (V.34) (Line 1) 13-616: TX attenuation value (V.34) (Line 2)	0: OFF 1: ON	0	0	0	0	0	0	0	0	0
13-941	UI display for TTI ON/OFF	Sets whether the button is displayed in the TTI setting screen.	0: OFF 1: ON	1	1	1	0	0	0	0	0	0
13-944	Error code reservation for protocol trace list (Line 1)	Key in an error code decimally to print out the protocol trace list not for each communication but only for that specific error.	0-255:Error code	0	0	0	0	0	0	0	0	0

Default																Code
FIN	ESP	AUT	CHE	SWE	DNK	NOR	PRT	FRA	GRC	POL	HUN	CZE	TUR	ZAF	TWN	
0	0	0	0	0	0	0	0	0	0	0	0	0	0	0	0	13-927
0	0	0	0	0	0	0	0	0	0	0	0	0	0	0	0	13-940
0	0	0	0	0	0	0	0	0	0	0	0	0	1	1	0	13-941
0	0	0	0	0	0	0	0	0	0	0	0	0	0	0	0	13-944

2

Code	Adjustment	Function	Setting	Default								
				ASM	AUS	HKG	USA	DEU	GBR	ITA	BEL	NDL
13-955	Return loss setting	Selects the NCU termination circuit.	0: ASIA 1: AUS 2: Others 3: EUR	0	1	0	0	3	3	3	3	3
13-961	Protocol trace reservation error code (Line 2)	Key in an error decimal code of the error which needs to be reported on the protocol trace list.	0-255:Error code	0	0	0	0	0	0	0	0	0
13-962	FCC type for TTI format	Sets whether FCC type for TTI format.	0: OFF 1: ON	1	1	1	1	1	1	1	1	1
13-970	Format of address for transmission/reception journal	Sets whether the format of address for transmission/reception journal.	Priority of recording items in journal 0: Name of address-book, or Direct dialing number 1: Receiver inform (CSI), or Name of address-book or Direct dialing number 2: Dialing number (direct or address-book)	0	0	0	2	1	1	1	1	1
13-971	Short protocol	Sets the short protocol.	0: OFF 1: ON	1	1	1	1	1	1	1	1	1
13-979	Reception image shift	Shift a reception image to the upper end side of the image approximately 3 mm and print it.	0: OFF 1: ON	0	0	0	0	0	0	0	0	0
13-980	V.17 use for V.34 redial	Sets whether transmission of the final redialing is performed by V.17 or not when a communication error occurs during V.34 transmission.	0: OFF 1: ON	0	0	0	0	0	0	0	0	0

Default																Code
FIN	ESP	AUT	CHE	SWE	DNK	NOR	PRT	FRA	GRC	POL	HUN	CZE	TUR	ZAF	TWN	
3	3	3	3	3	3	3	3	3	3	3	3	3	0	0	0	13-955
0	0	0	0	0	0	0	0	0	0	0	0	0	0	0	0	13-961
1	1	1	1	1	1	1	1	1	1	1	1	1	1	1	1	13-962
1	1	1	1	1	1	1	1	1	1	1	1	1	0	0	0	13-970
1	1	1	1	1	1	1	1	1	1	1	1	1	1	1	1	13-971
0	0	0	0	0	0	0	0	0	0	0	0	0	0	0	0	13-979
0	0	0	0	0	0	0	0	0	0	0	0	0	0	0	0	13-980

2

Code	Adjustment	Function	Setting	Default								
				ASM	AUS	HKG	USA	DEU	GBR	ITA	BEL	NDL
13-981	TXATT change for V.34 redial	Sets whether transmission is performed by reducing TXATT by 3 dB or not when a communication error occurs during V.34 transmission.	0: OFF 1: ON	0	0	0	0	0	0	0	0	0
13-982	Fax Recovery setting for start page	When Fax recovery transmission, restart to send from after sent page or always start from first page again.	0: Send after sent pages 1: Always send from first page	0	0	0	0	0	0	0	0	0

Default																Code
FIN	ESP	AUT	CHE	SWE	DNK	NOR	PRT	FRA	GRC	POL	HUN	CZE	TUR	ZAF	TWN	
0	0	0	0	0	0	0	0	0	0	0	0	0	0	0	0	13-981
0	0	0	0	0	0	0	0	0	0	0	0	0	0	0	0	13-982

2

2.5 FAX Clearing Mode (1*)

Various FAX memories are initialized in the FAX clearing mode (1*).

1) Memory Areas

- User registration area (SRAM)
 - ID registration area
 - Home position

- Image data area (HDD, SRAM)
 - Transmission file
 - Reception file
 - Image data file management area
 - F-code box information

- System setting area (NVRAM)
 - Settings in the Function Mode (13) Areas 100 - 999

2) Types of Initialization

- FAX Set Up
 - User registration area (SRAM)
 - Initialized so that there are no data stored.

 - System setting area (NVRAM)
 - Values are reset to the default settings.

- Clearing the image data
 - Image data area (HDD, SRAM)
 - Initialized so that there are no data stored.

 - Job clear

- Clearing the system setting area
 - System setting area (NVRAM)
 - Values are reset to the default settings.

[Operation procedure]

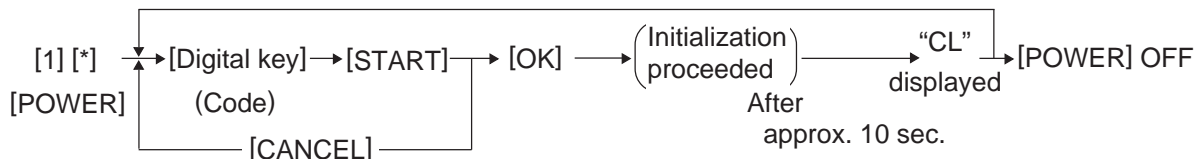

Fig. 2-8

* When "CL" is displayed instead of the set number, that indicates that the machine is in the standby mode.

Initialization codes for the FAX

Code	Element	Contents	Mode	Image quality mode	Default
1*-100	MAINT	FAX Set Up	FAX	-	-
1*-102	MAINT	Clearing the image data	FAX	-	-
1*-103	MAINT	Clearing the system setting area	FAX	-	-

Note:

It takes about 20 seconds until the digital keys become operable after the power has been turned ON while [1] and [*] are pressed simultaneously.

Note:

Before performing the initialization, confirm that the destination value is correct in the Setting Mode (08) described in the P. 2-6 "2.3 Setting Mode (08)". If the initialization is performed with the wrong destination setting, the default value of the Function Mode is changed to that for the wrong destination.

3. TROUBLESHOOTING

3.1 Diagnosis Over Telephone

Most problems end users inquire are the results of the following. Therefore, ask the nature of the trouble (in detail) first to seek the cause. These questions can lead to a speedy resolution of the trouble without the need for a service technician.

- **Simple mis-operation**

A trouble caused by a simple mis-operation can be solved by the user alone with an appropriate instruction through the telephone.

- **A failure with the telephone line**

The machine's condition can be checked by the user's operating sending/receiving documents to/from another FAX unit.

- **A failure with the other party's machine**

The other party's machine's condition can be checked by the user's operating sending/receiving documents from/to the user's machine.

Also, by verifying the error message in the LCD display or the error code on the Journal with the user, the nature of the trouble can be confirmed. This information is important in finding the cause of trouble. Whenever it can be obtained from the user, respond on the telephone by tracing the “ P. 3-3 "3.3 Flow Chart for Recommended Telephone Screening””. This will help the service technician to be prepared for the necessary service requirements.

3.2 Recommend Flow Chart for Field Service

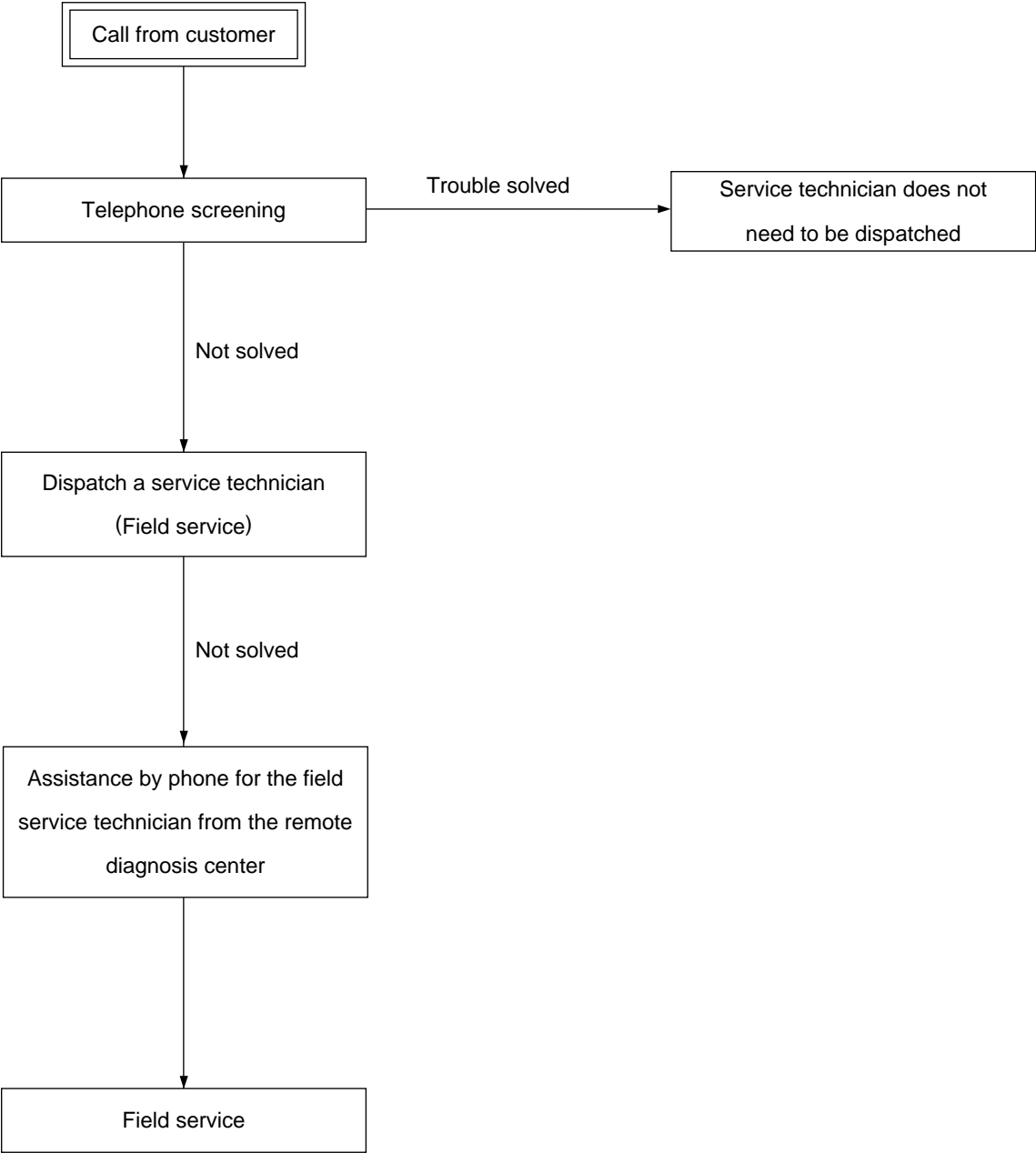

3.3 Flow Chart for Recommended Telephone Screening

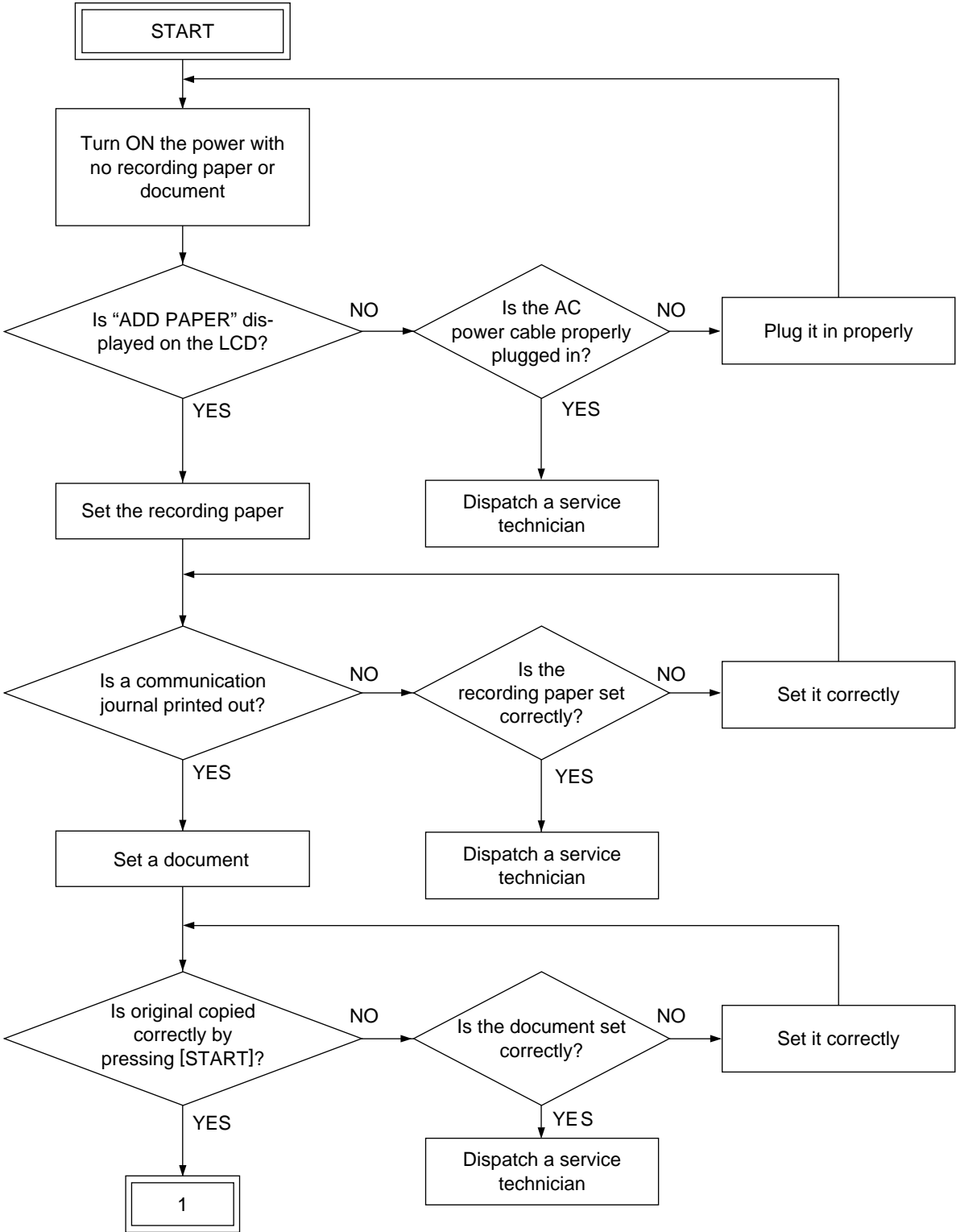

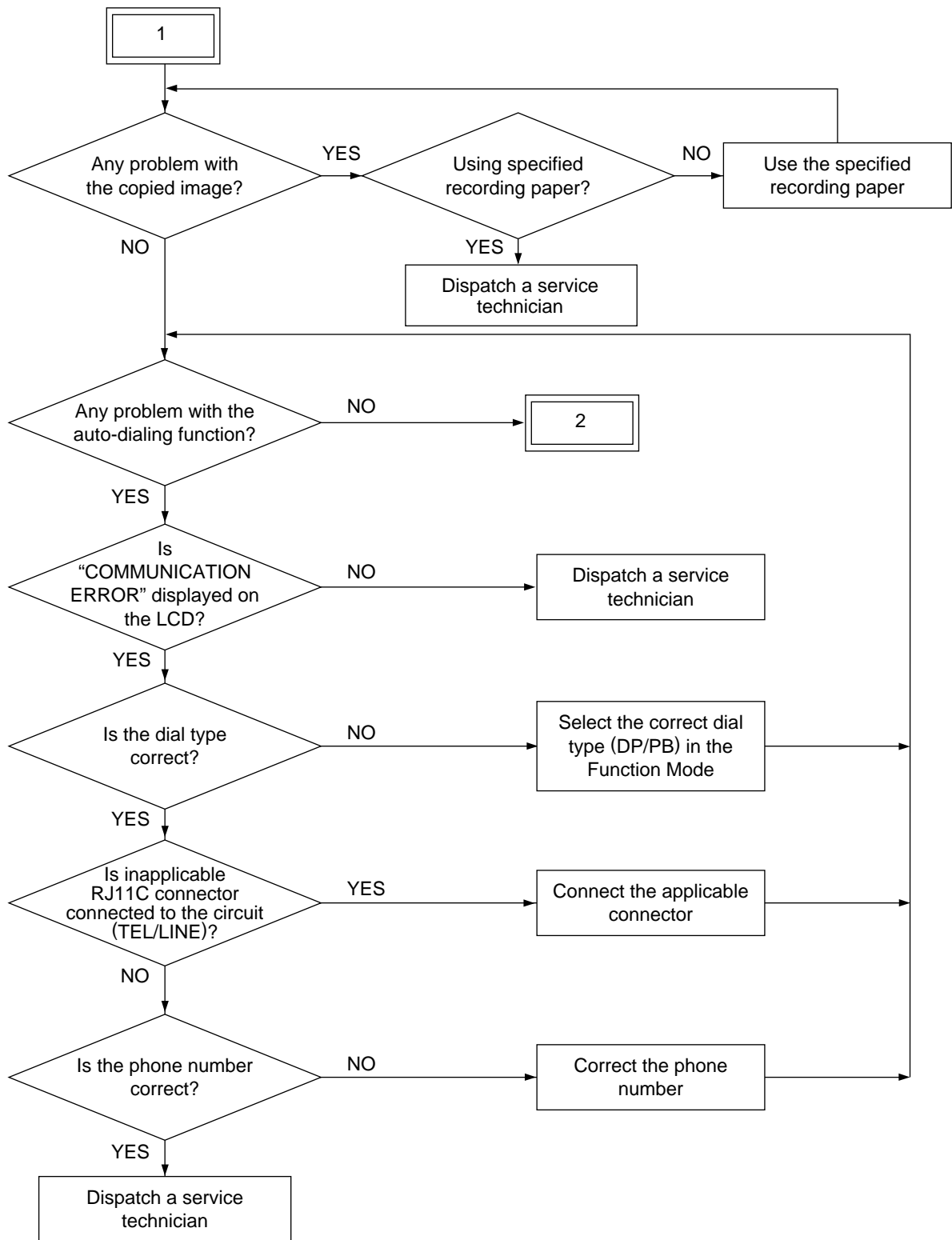

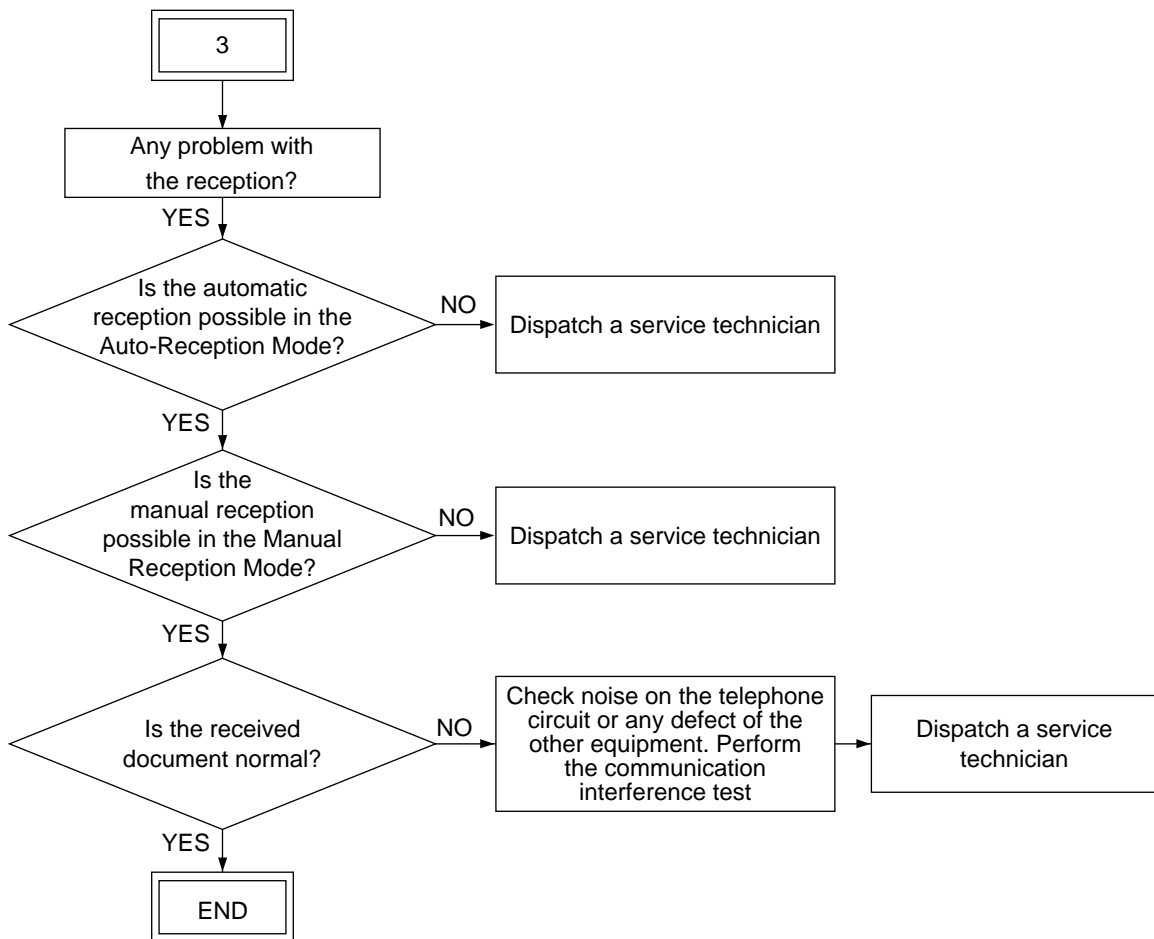
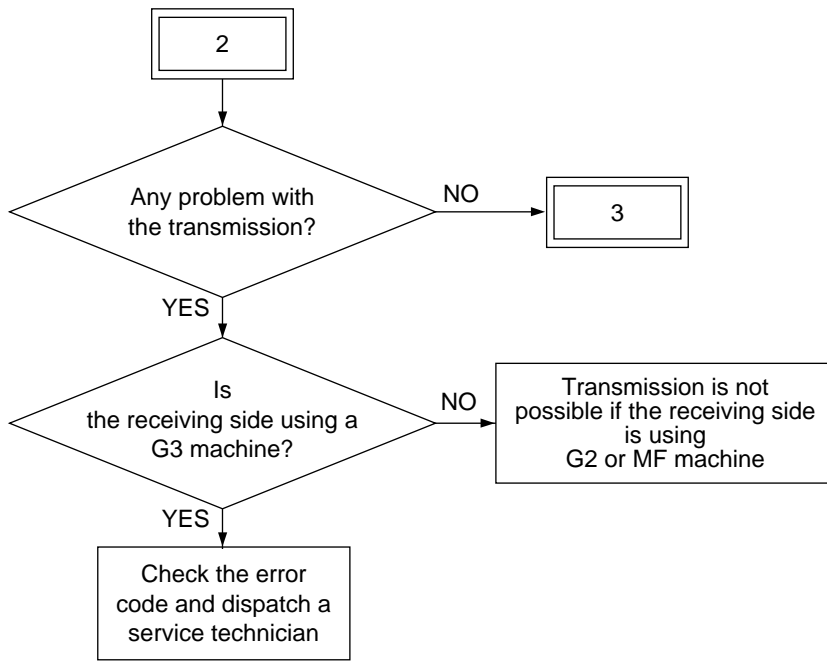

3.4 Error Analysis Flow

3.4.1 Self-Diagnosis function

Service technicians can figure out the contents of the error with the following information:

- 1) Display on the LCD panel
- 2) Error code on the transmission/reception journal

3.4.2 Precautions for diagnosis

Service technicians should output the Address Book / Group Number Information and Function List for Maintenance. Confirm that no received document data are stored in the memory by checking the "Memory RX" LED and Reservation List.

Turn OFF the power and check the following items before starting the diagnosis.:

- Check if the power cable is properly plugged in.
- Check if the connectors are securely connected.
- Pay full attention to an electric shock at the power section and a short circuit of the conductor pattern on the board when servicing with the power cable connected to the outlet while the cover is taken off.
- Make sure that there is not any connector remains disconnected or loosened screw after the error analysis.
- Make sure that the machine operates properly with a communication test every time the error analysis has been performed.

Notes:

- Before replacing the parts, confirm that there is no data to be transmitted or no received document in the memory. Turn OFF the power and unplug the power cable.
- Do not touch the terminal of the connectors. Otherwise, a poor connection may be caused.

3.5 Fault Analysis

3.5.1 Power-ON is not possible

- 1) Check if the power cable is plugged into an appropriate outlet (of the correct voltage).
- 2) Check if the rated voltages are being output from the switching power supply. When the measured voltage is not the rated value, replace the switching power supply.
- 3) Check if each connector between the DSP board and the SYS board is disconnected.
- 4) Check if each connector between the SYS board and the switching power supply is disconnected.
- 5) Check if each connector pin is removed or the harness is broken.
- 6) Check if any conductor pattern on the switching power supply, and SYS board is open- or short-circuited.
- 7) Replace the DSP board.
- 8) Replace the SYS board.

3.5.2 Original transport error for RADF

Check the error code and refer to the TROUBLESHOOTING of Service Handbook for the equipment.

3.5.3 Recording paper transport error

Check the error code and refer to the TROUBLESHOOTING of Service Handbook for the equipment.

3.5.4 Image trouble

Check the image and refer to the TROUBLESHOOTING of Service Handbook for the equipment.

3.5.5 Communication error

Communication errors may occur when the condition of a particular phone circuit happens to be bad at the time of attempting the communication job. Therefore, do the communication over again. If communication errors occur too many times, prepare another (operational) FAX unit and check the communication condition among the three FAX units, thus analyzing the troubles.

A communication error occurs between A and B.

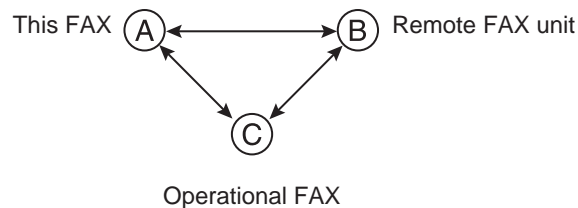

Fig. 3-1

- 1) If normal communications are possible between A and C, and the communication trouble occurs B and C, it can be assumed that FAX B is malfunctioning.
- 2) If normal communications are possible between B and C, and the communication trouble occurs A and C, it can be assumed that FAX A is malfunctioning. Therefore, adjust the transmission attenuator value (13-325, 13-430, 13-567, 13-616) and the cable equalizer value (13-328, 13-433).
- 3) If normal communications are possible between A and C and between B and C, it can be assumed that there is a problem in the line between A and B.

3.6 Lists Required at Problem in the Field

Output the following lists when problem occurs in the field. They are described in the order of the priority the most important one come first in this section. It is not necessary to output these lists immediately after the trouble has occurred, but they must be prepared for any kind of trouble regarding the FAX operation.

[Precaution]

Disconnect the telephone line to stop the communication when trouble occurs. Since the only last communication is reported on the protocol trace list, if the telephone line is not disconnected immediately after the trouble has occurred, next communication might come in before the line is disconnected and be printed out instead of the communication in question.

Do not turn OFF the power before printing the protocol trace list and memory dump list.

Otherwise, the information will be lost.

3.6.1 List printing procedure

- 1) Enter the Service Mode.
 - Turn the power of the equipment ON.
 - Press the [USER FUNCTIONS] button.
 - With the [USER FUNCTIONS] menu displayed, enter the Service Mode password provided during product training
 - The SERVICE TECHNICIAN PASSWORD menu appears. Press [OK].
(Enter a password if one is set. Then press [OK].)
 - The SERVICE MODE menu appears.
- 2) Select "FAX LIST PRINT MODE" and then press [NEXT].

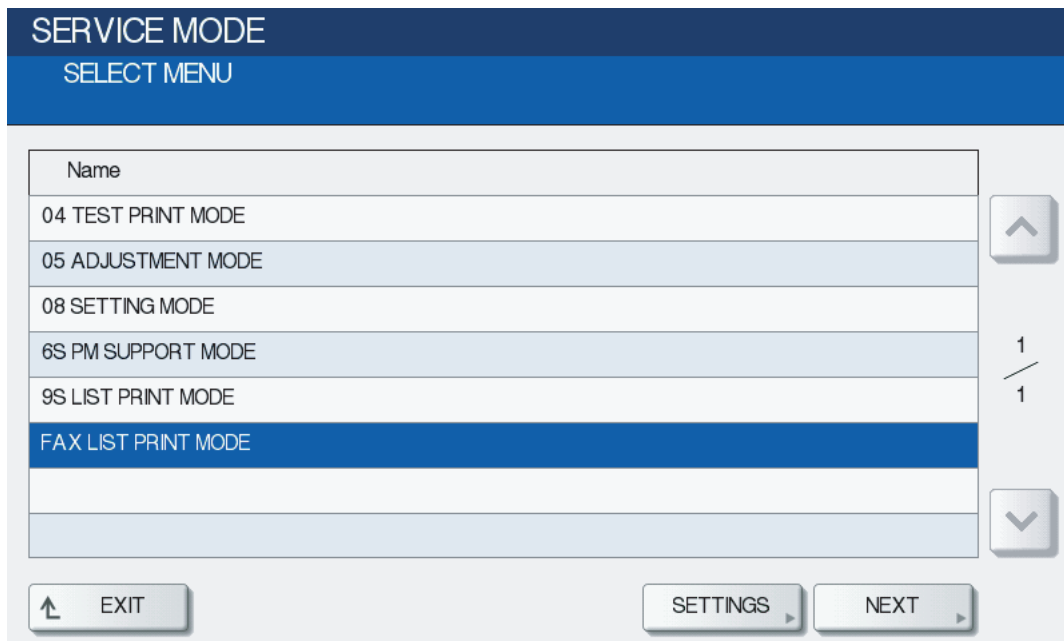

Fig. 3-2

3) Select the desired list and then press [PRINT].

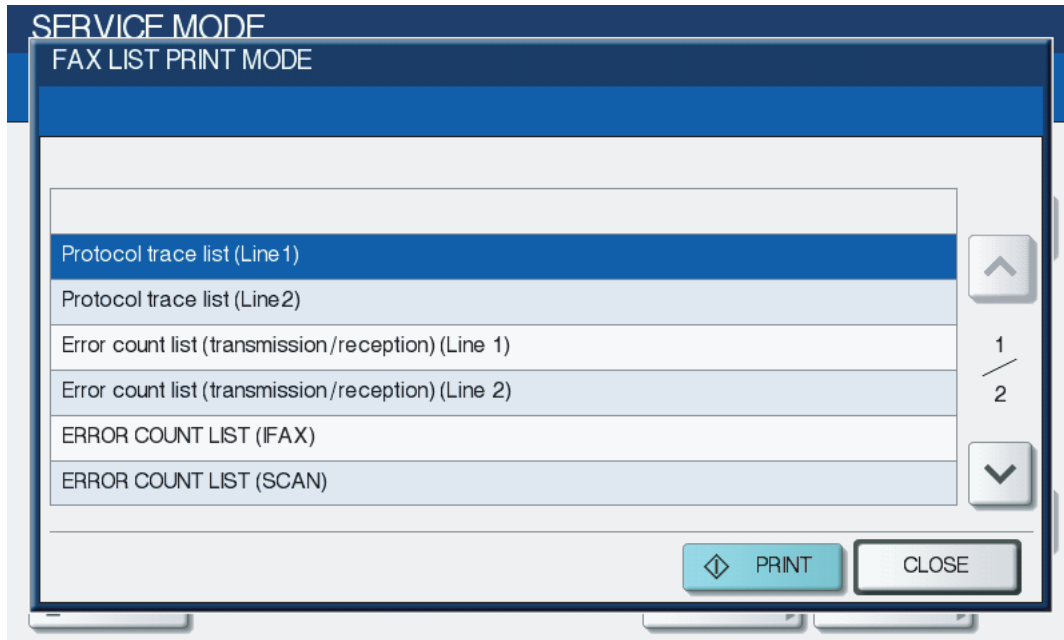

Fig. 3-3

The FAX LIST PRINT MODE menu contains the following lists to select:

- Protocol trace list (Line 1)
- Protocol trace list (Line 2)
- Error count list (transmis./recept.) (Line 1)
- Error count list (transmis./recept.) (Line 2)
- ERROR COUNT LIST (Internet FAX)
- ERROR COUNT LIST (SCAN)
- Function list for Maintenance
- Memory dump list (System)
- Memory dump list (FAX)
- SUPPLY ORDER LIST

3.7 Other Information Required for Error Analysis

The following information is also needed to analyze the malfunction (especially a communication error). Check the circles below if they are applicable.

- 1) If the error is cleared or not.
 - Cleared by turning ON/OFF the power.
 - Cleared by performing "Clearing the image data area (1*-102)".

Note:

The image data (including printer data other than FAX data) and the job being performed are erased by this operation.

- Cleared by replacing the board.
 - Not cleared.
- 2) Frequency of occurrence
 - Frequently (occurring daily or always)
 - Sometimes (about once a week)
 - Only once
 - 3) When a communication error is occurring, turn ON the circuit monitor for the line 1 or 2 (13-338), and check the condition of the FAX communication with the tone from the speaker.

Note:

Turn OFF the circuit monitoring function after the checking is finished (13-338: 0).

- Signals from the transmitter and that from the receiver clash.
 - Check the model name of the other party's machine.
- Noise occurring on the circuit.
 - Ask the telephone (or telecommunications) company if the line condition is normal.
- Busy tone is heard from the other party during the communication.
 - Ask by phone if the other party's machine has any problem. If it does not, check its model name.
- Others (describe condition): _____

4) Condition of the machine when the problem occurred

- Display
 - Control panel:
 - Copying operation screen FAX operation screen Printing operation screen
 - Energy saver screen "Auto Power Off" screen

Describe the items displayed on the control panel in detail: _____

Status of LEDs:

"MEMORY RX" ON "Communicating" ON
Power ON

- State of the machine
 - Availability of the recording paper:
 - 1st drawer (size =) No paper Paper present
 - 2nd drawer (size =) No paper Paper present
 - 3rd drawer (size =) Not installed No paper Paper present LCF
 - 4th drawer (size =) Not installed No paper Paper present LCF



- Conditions of RADF (this information is needed for transmission error)
Originals have been all exited
Abnormal (original jam, etc.)
Others (be as specific as possible):
- Condition/State of the communication
Transmission error

Reception error

ECM mode

G3 mode

Image errors such as stream image or interrupted image occur in the G3 mode when the noise occurs on the line. These are liable to occur since the line condition differs depending on each communication.

If the same errors occur to the image which was resent, they can be decreased by reducing the transmission speed of the sending side.

Communication cannot be made with a particular number.

(Information of the other side's machine: _____)

If the communication is impossible with a particular number, it is considered that the other party's machine has broken down or has been busy (there is no response) because the recording paper has run out and the memory is full. Check the condition of the terminal of the other side.

If there is no problem with the terminal, check the model name since there is a possibility that particular type of the machine has caused the problem.

Original size =	A3	B4	A4	B5	A5
Size of the received document =	A3	B4	A4	B5	A5
Resolution =	NORMAL (8*3.85)		FINE (8*7.7)		U-FINE (16 or 8*15.4)
Error occurred to the _____st/nd/rd/th sheet out of _____sheets.					

- Condition of the circuit connection
Connected directly with the public telephone circuit.

Connected via a local exchange device or the main equipment.

→ Is any other equipment connected besides this unit?

→ Does the ring tone sound normally (rings for 1 second and stops for 2 seconds)

(If it is not normal, the reception may not be started.)

Circuit switching device

→ Are the circuit settings (DP, PB) of the circuit switching device the same as those for this unit?

Connection via an ISDN circuit terminal adaptor

→ Is the circuit number of the terminal adaptor correct? Is it the same number as that for the FAX assigned to the other device (ex. data modem)?

→ Does the noise from the terminal adaptor affect the line? (Connect the TA with your machine and ground it to check.)

Configuration of the units

(Illustrate the units connected to your machine such as the telephone lines, exchange system, telephones, modems, etc.)

- Settings of the Auto Power Save and Auto Shut Off
 - Auto-clear timer (08-9110) =
 - Auto Power Save (08-9111) =
 - Auto Shut OFF (08-9112) =

4. PRECAUTIONS FOR INSTALLATION OF FAX UNIT

4.1 Installation of FAX Unit

After unpacking and installing the FAX unit following the unpacking/setup instructions, be sure to perform "FAX Clearing Mode / FAX Set Up" described with the same instructions. The unit is not turned ON without this operation.

[Operation procedure]

Perform the following operation after setting the country/region in 08-9000 and 08-9001.

[1] [*] [POWER] → [100] → [START] (It takes about 20 seconds for the digital keys to be operable after the power is turned ON.) (It takes about 10 seconds until the display changes from '100' to 'CL'.)

[About FAX Clearing Mode / FAX Set Up]

When "FAX Set Up" is performed, the following operations are performed:

Data in the ID registration, home position stored in the SRAM on the SYS board are erased.

The system setting area is initialized (the settings are reset to the default values.)

4.2 Country/Region Code

Set the country/region code after the installation of the FAX unit is finished.

Note:

All data stored in the SRAM are erased when the country/region code is set/changed.

Setting the country/region code

- 1) Turn ON the power while pressing [0] and [8] simultaneously.
- 2) Key in "9001", and press [START] button.
- 3) Key in a code, and they press the [ENTER].
(2.3 Setting Mode (08))

Country/Region	Code
ASM	1
AUS	2
HKG	3
USA/CAN	4
DEU	5
GBR	6
ITA	7
BEL	8
NLD	9
FIN	10
ESP	11
AUT	12
CHE	13
SWE	14
DNK	15
NOR	16
PRT	17
FRA	18
GRC	19
POL	20
HUN	21
CZE	22
TUR	23
ZAF	24
TWN	25

- Country/region setting using the FG harness on the NCU board
 These country/region require code setting on the NCU using the FG harness.
 All other countries/regions have only W1 connection on the board.

DEU	GBR	NLD	ITA	AUT	BEL	CHE	SWE	DNK	NOR	FIN	PRT	FRA	ESP	GRC	IRL
W2	W2	W2	W1	W2	W2	W2	W2	W1	W2	W1	W2	W2	W2	W2	W2
ZAF	SGP	HKG	AUS	NZL	RUS	POL	HUN	CZE	TUR	CHN					
W2	W2	W2	W2	W2	W2	W2	W2	W2	W2	W2					

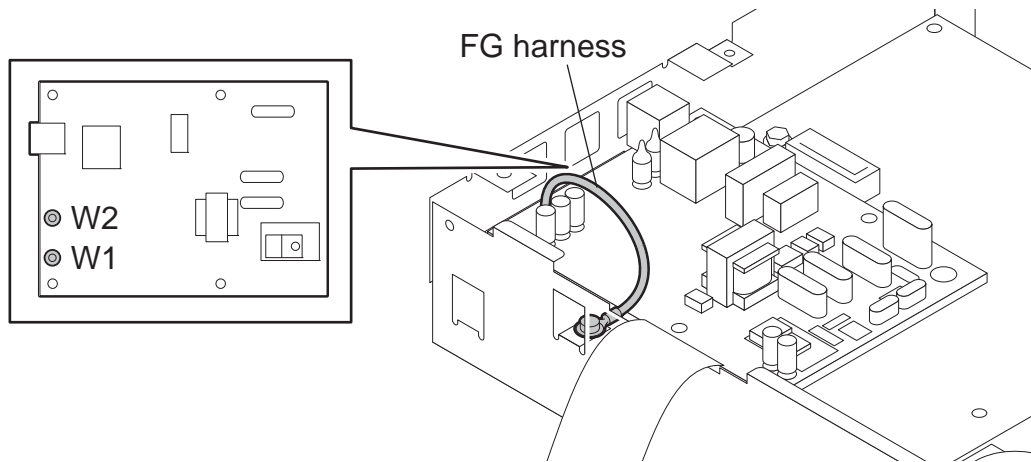

Fig. 4-1

5. FIRMWARE UPDATING

The FAX firmware FAX Function (T.30 protocol and line control) has been installed in the ROM on the FAX board. When updating the firmware to the latest version is required or the equipment does not operate properly due to the damage of the firmware for some reason, the firmware can be updated by using the download jig (K-PWA-DLM-320).

<<Update procedure>>

Important:

- Before updating the FAX firmware, make sure to print out the current Function List for Maintenance, Function List (ADMIN), Phone Book Number Information and Group Number information. In case the updating is failed and the registered information of the users is lost for some reason, re-register the user information referring to the lists and recover it.
- Confirm the following items before turning OFF the power of the equipment. Turning OFF the power may clear the data below.
 - Confirm that the "MEMORY RX" LED is OFF and there are no memory reception data.
 - Print the "Mailbox/Relay box report" and then confirm that there are no F code data.
 - Press the [JOB STATUS] button to display the screen and then confirm that there are no memory transmission data.

- (1) Install the ROM and relay board to the download jig.
Make sure the direction is correct.

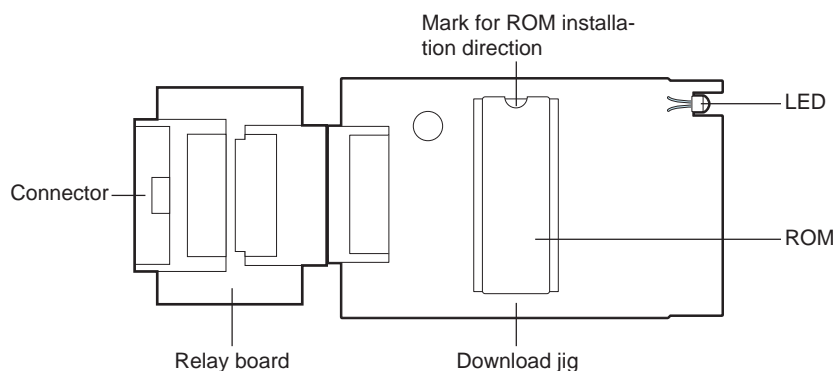

Fig. 5-1 [Jig board: K-PWA-DLM-320]

- (2) Turn OFF the power of the equipment.
- (3) Remove the jig connector cover of the FAX unit.
- (4) Connect the download jig with the jig connector on the FAX board.
- (5) Turn ON the power while [0] button and [8] button are pressed simultaneously.
Updating starts automatically and the LED on the download jig lights.

- (6) After the update is completed properly, the LED on the download jig blinks. The LED starts blinking in approx. 30 sec. since the update starts. It is assumed that the update is failed if it does not start blinking even though 1 min. has passed. In this case, turn OFF the power and check the following items. Then, clear the problem and restart updating from the beginning.
 - Is the download jig connected properly?
 - Is the ROM installed to the download jig properly?
 - Is the updating data written on the ROM of the download jig properly?
 - Do the download jig and the equipment operate properly?
- (7) Turn OFF the power, remove the download jig and install the cover plate and the connector cover.
- (8) In the FAX Clearing Mode, perform the "FAX Set Up".
 - Confirm the destination setting is correct in the Setting Mode (08).
 - 08-9000 : Destination setting of the equipment
 - 08-9001 : Destination setting of the FAX machine
 - Turn ON the power while [1] button and [*] button are pressed simultaneously.
 - Key in "100".
 - Press the [START] button.

Notes:

If the equipment does not work properly after the operation (8), follow the procedure below and then perform the "Clearing the image data" in the FAX Clearing Mode to erase the image data in the memory.

- Confirm the destination setting is correct in the Setting Mode (08).
 - 08-9000 : Destination setting of the equipment
 - 08-9001 : Destination setting of the FAX machine
- Turn ON the power while [1] button and [*] button are pressed simultaneously.
- Key in "102".
- Press the [START] button.

<<Confirmation of the updated data>>

After the updating is completed, check the data version in the Setting Mode (08) to confirm that the data was overwritten properly.

08-9905 : FAX firmware version

REVISION RECORD

Ver.04

Ver04<2014.11.21>	
Page	Contents
GENERAL PRE-CAUTIONS	The description has been changed. The description has been added.
2-14, 2-15	The default values of 13-141 has been changed.
2-26, 2-27	The default values of 13-271 has been changed.
2-60, 2-61	The code 13-982 has been added.
5-1	The description has been changed. (The illustrations have been deleted.)

Ver.03

Ver03<2014.04.17>	
Page	Contents
Cover	GD-1350 has been added.
-	The trademark has been added.
GENERAL PRE-CAUTIONS	The description has been changed. The illustration has been added. Model name has been added.
2-52	The default values of 13-619 and 13-620 has been changed.

Ver.02

Ver02<2013.06.17>	
Page	Contents
GENERAL PRE-CAUTIONS	Model name has been added.

Ver.01

Ver01<2012.12.25>	
Page	Contents
-	The trademark has been added.
GENERAL PRE-CAUTIONS	The description has been changed. The illustration has been added.
back cover	The address has been changed.

TOSHIBA

TOSHIBA TEC CORPORATION

1-11-1, OSAKI, SHINAGAWA-KU, TOKYO, 141-8562, JAPAN