

**Model RN-P1  
Machine Codes: M012/M013  
Field Service Manual**

20 January, 2010



---

# Safety Notices

---

## Important Safety Notices

---

### Prevention of Physical Injury

---

1. Before disassembling or assembling parts of the machine and peripherals, make sure that the machine power cord is unplugged.
2. The wall outlet should be near the machine and easily accessible.
3. If any adjustment or operation check has to be made with exterior covers off or open while the main switch is turned on, keep hands away from electrified or mechanically driven components.
4. The machine drives some of its components when it completes the warm-up period. Be careful to keep hands away from the mechanical and electrical components as the machine starts operation.
5. The inside and the metal parts of the fusing unit become extremely hot while the machine is operating. Be careful to avoid touching those components with your bare hands.

### Health Safety Conditions

---

Toner is non-toxic, but if you get either of them in your eyes by accident, it may cause temporary eye discomfort. Try to remove with eye drops or flush with water as first aid. If unsuccessful, get medical attention.

### Observance of Electrical Safety Standards

---

The machine and its peripherals must be serviced by a customer service representative who has completed the training course on those models.

### Safety and Ecological Notes for Disposal

---

1. Do not incinerate toner bottles or used toner. Toner dust may ignite suddenly when exposed to an open flame.
2. Dispose of used toner, the maintenance unit which includes developer or the organic photoconductor in accordance with local regulations. (These are non-toxic supplies.)
3. Dispose of replaced parts in accordance with local regulations.

### **WARNING**

- To prevent a fire or explosion, keep the machine away from flammable liquids, gases, and aerosols. A fire or an explosion might occur.

---

## Handling Toner

---

- Work carefully when removing paper jams or replacing toner bottles or cartridges to avoid spilling toner on clothing or the hands.
- If toner is inhaled, immediately gargle with large amounts of cold water and move to a well ventilated location. If there are signs of irritation or other problems, seek medical attention.
- If toner gets on the skin, wash immediately with soap and cold running water.
- If toner gets into the eyes, flush the eyes with cold running water or eye wash. If there are signs of irritation or other problems, seek medical attention.
- If toner is swallowed, drink a large amount of cold water to dilute the ingested toner. If there are signs of any problem, seek medical attention.
- If toner spills on clothing, wash the affected area immediately with soap and cold water. Never use hot water! Hot water can cause toner to set and permanently stain fabric.
- Always store toner and developer supplies such as toner and developer packages, cartridges, and bottles (including used toner and empty bottles and cartridges) out of the reach of children.
- Always store fresh toner supplies or empty bottles or cartridges in a cool, dry location that is not exposed to direct sunlight.

---

## Laser Safety

---

The Center for Devices and Radiological Health (CDRH) prohibits the repair of laser-based optical units in the field. The optical housing unit can only be repaired in a factory or at a location with the requisite equipment. The laser subsystem is replaceable in the field by a qualified Customer Engineer. The laser chassis is not repairable in the field. Customer engineers are therefore directed to return all chassis and laser subsystems to the factory or service depot when replacement of the optical subsystem is required.

### **WARNING**

- Use of controls, or adjustment, or performance of procedures other than those specified in this manual may result in hazardous radiation exposure.

 WARNING

---

**WARNING:**

Turn off the main switch before attempting any of the procedures in the Laser Optics Housing Unit section. Laser beams can seriously damage your eyes.

**CAUTION MARKING:**







m012i500

---

# Symbols, Abbreviations and Trademarks

This manual uses several symbols and abbreviations. The meaning of those symbols and abbreviations are as follows:

	See or Refer to
	Clip ring
	Screw
	Connector
	Clamp
	E-ring
SEF	Short Edge Feed
LEF	Long Edge Feed

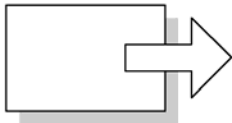

**Short Edge Feed (SEF)**

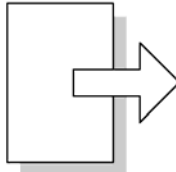

**Long Edge Feed (LEF)**

---

## Trademarks

---

Microsoft<sup>®</sup>, Windows<sup>®</sup>, and MS-DOS<sup>®</sup> are registered trademarks of Microsoft Corporation in the United States and /or other countries.

PostScript<sup>®</sup> is a registered trademark of Adobe Systems, Incorporated.

PCL<sup>®</sup> is a registered trademark of Hewlett-Packard Company.

Ethernet<sup>®</sup> is a registered trademark of Xerox Corporation.

PowerPC<sup>®</sup> is a registered trademark of International Business Machines Corporation.

Other product names used herein are for identification purposes only and may be trademarks of their respective companies. We disclaim any and all rights involved with those marks.

# TABLE OF CONTENTS

---

Safety Notices.....	1
Important Safety Notices.....	1
Laser Safety.....	2
Symbols, Abbreviations and Trademarks.....	4
Trademarks.....	4
<b>1. Product Information</b>	
Specifications.....	9
Machine Overview.....	10
Component Layout.....	10
Paper Path.....	11
Drive Layout.....	11
Machine Configuration.....	13
<b>2. Installation</b>	
Installation Requirements.....	15
Environment.....	15
Machine Level.....	16
Machine Space Requirement.....	16
Power Requirements.....	16
Installation Procedure.....	17
<b>3. Preventive Maintenance</b>	
PM Intervals.....	19
PM Parts.....	19
Yield Counter.....	19
<b>4. Replacement and Adjustment</b>	
Before You Start.....	21
Special Tools.....	22
Exterior Covers.....	23
Front Cover.....	23
Left Cover.....	25
Rear Cover.....	27
Right Cover.....	28
Top Cover.....	29
Operation Panel.....	30

---

Laser Unit.....	31
Caution Decal Locations.....	31
Laser Unit.....	31
Polygon Mirror Motor.....	32
Paper Feed and Exit.....	34
Paper Feed Roller.....	34
Friction Pad.....	35
Paper End Sensor.....	35
By-pass Feed Roller.....	35
By-pass Feed Roller Friction Pad.....	37
By-pass Feed Sensor.....	38
Paper Feed Clutch.....	38
Relay Clutch.....	40
Registration Clutch.....	40
Toner End Sensor.....	40
Paper Exit Sensor.....	41
Relay Sensor.....	41
Inverter Sensor.....	42
Registration Roller and Sensor.....	42
Paper Transfer.....	46
Transfer Roller.....	46
Fusing.....	47
Fusing Unit.....	47
Thermostat.....	49
Thermistor.....	50
Fusing Lamp.....	52
Hot Roller.....	53
Pressure Roller.....	54
Hot Roller Stripper Pawls.....	55
Motors.....	56
Main Motor.....	56
Duplex Motor (For M013).....	56
Electrical Components.....	58



---

Layout of PC Boards.....	58
PSU.....	61
Charge Terminal Case.....	64
Others.....	65
Cooling Fan.....	65
Quenching Lamp.....	65
Image Adjustment.....	67
Registration Adjustment.....	67

## 5. System Maintenance Reference

---

Smart Organizing Monitor.....	69
Overview.....	69
Printer Driver Installation (USB Connection).....	69
Entering the Printer Configuration.....	70
Printer Configuration Menu List.....	71
Configuration Page.....	95
Overview.....	95
Firmware Updating.....	97
Checking the Machine Firmware Version.....	97
Updating the Controller Firmware.....	97
Updating the Engine Firmware.....	99
Updating the Boot Loader Firmware.....	101
Updating Failure.....	101
FW Update Tool Messages.....	101

## 6. Troubleshooting

---

Service Call Conditions.....	107
Summary.....	107
Engine SC.....	107
Image Problems.....	115
Overview.....	115
Test Page Printing.....	115
Test Pattern Printing.....	117
Dark lines in halftone areas at 75mm Intervals.....	119
Jam.....	121

---

Jam Sensor Layout.....	121
Jam Message List.....	121
<b>7. Energy Saving</b>	
Energy Save.....	123
Energy Saver Modes.....	123
Paper Save.....	125
Effectiveness of Duplex/Combine Function.....	125
<b>INDEX</b> .....	129

# 1. Product Information

---

## Specifications

1

See "Appendices" for the following information:

- "General Specifications"
- "Printer"
- "Supported Paper Sizes"

# Machine Overview

## 1

### Component Layout

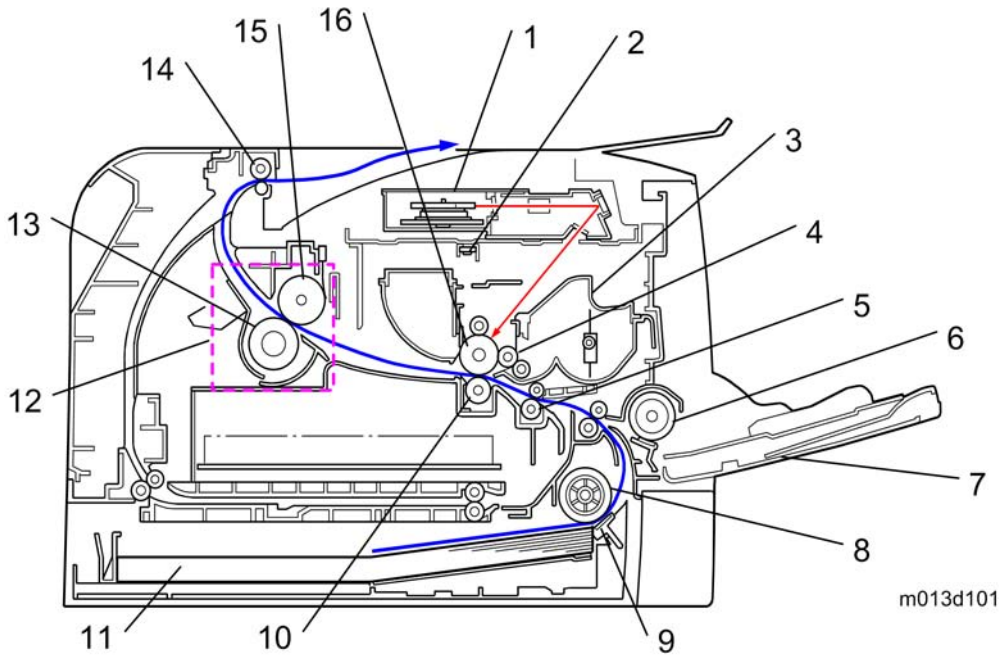

1.	Laser unit	9.	Friction pad
2.	Quenching lamp	10.	Transfer roller
3.	Cartridge (AIO-type)	11.	Paper Tray
4.	Development roller	12.	Fusing Unit
5.	Registration roller	13.	Pressure Roller
6.	By-pass feed roller	14.	Paper exit roller
7.	By-pass feed tray	15.	Hot Roller
8.	Paper feed roller	16.	Drum

## Paper Path

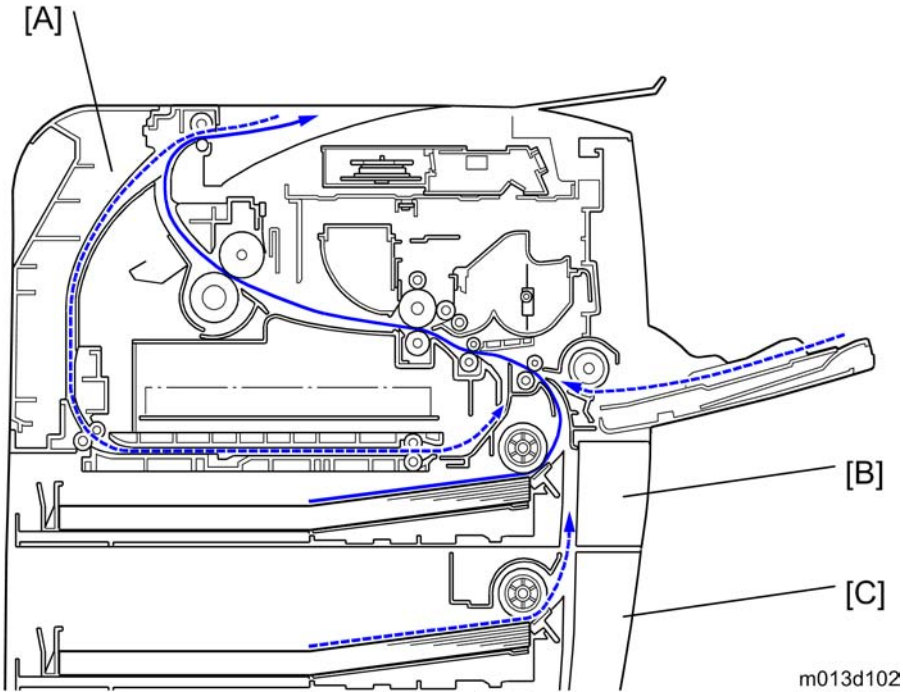

[A] Duplex section (For M013)

[B] Standard paper tray unit

[C] Optional paper tray unit

## Drive Layout

- M012 -

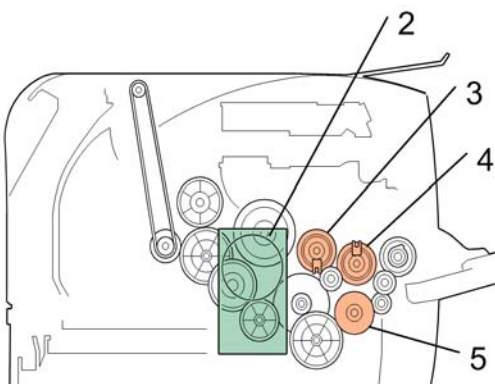

- M013 -

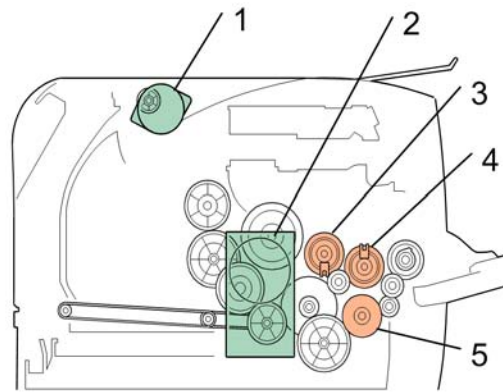

m013d103

1. Duplex Motor	4. Relay Clutch
2. Main Motor	5. Paper Feed Clutch
3. Registration Clutch	

# Machine Configuration

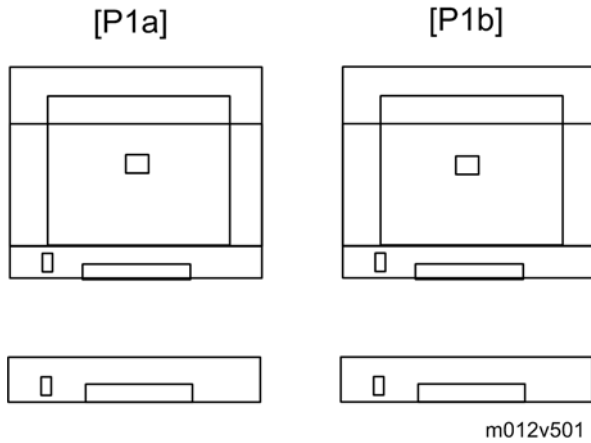

m012v501

Models	Duplex Unit	Optional Memory	Optional Tray (M355)	PCL PS
RN-P1a (M012)	NA	NA	250x1	Yes
RN-P1b (M013)	Auto	NA	250x1	Yes

NA: Not Available





## 2. Installation

### Installation Requirements

#### Environment

2

#### **⚠ CAUTION**

- This machine, which uses high voltage power sources, can generate ozone gas. High ozone density is harmful to human health. Therefore, the machine must be installed in a well-ventilated room.

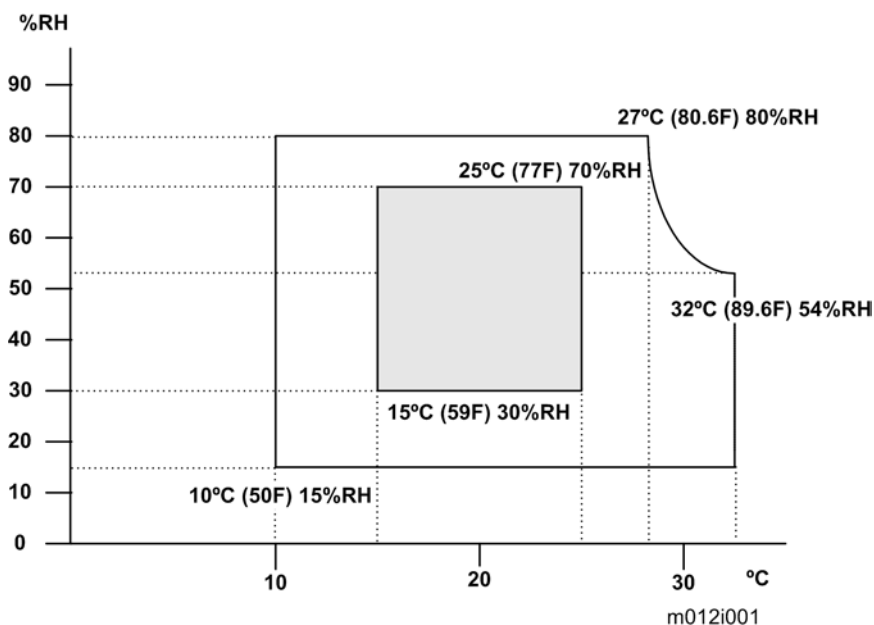

1. Temperature Range: 10°C to 32°C (50°F to 89.6°F)
2. Humidity Range: 15% to 80% RH
3. Ambient Illumination: Less than 2,000 lux (do not expose to direct sunlight)
4. Ventilation: 3 times/hr/person
5. Do not put the machine in areas with sudden temperature changes. This includes:
  - Areas directly exposed to cool air from air conditioning
  - Areas directly exposed to heat from a heating system.
6. Do not put the machine in areas exposed to corrosive gas.
7. Do not install the machine at locations over 2,000 m (6,562 ft.) above sea level.
8. Put the machine on a strong, level base. (Tilting towards any side must be no more than 3 mm.)

9. Do not put the machine in areas with strong vibrations.

---

## Machine Level

---

Front to back: Within 5 mm (0.2") of level

Right to left: Within 5 mm (0.2") of level

2

---

## Machine Space Requirement

---

Put the machine near a power source with these clearances:

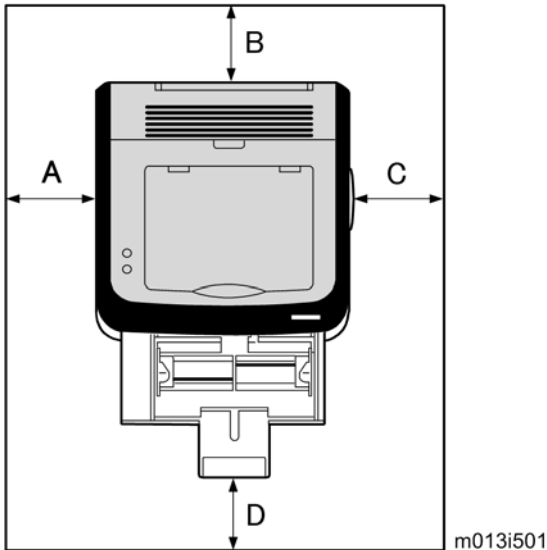

A: Over 20 cm (7.9")

B: Over 20 cm (7.9")

C: Over 10 cm (4")

D: Over 70 cm (27.6")

---

## Power Requirements

---

### **⚠ CAUTION**

- Make sure that the plug is tightly in the outlet.
- Avoid multi-wiring.
- Make sure that you ground the machine.

Input voltage level	NA: 120 V, TW: 110 V, 60 Hz: Less than 10 A EU/ Asia/ CHN: 220 V to 240 V, 50 Hz/60 Hz: Less than 5 A
Permitted voltage fluctuation: 10%	
Do not set anything on the power cord.	

---

## Installation Procedure

---

Refer to the "Hardware Guide".



# 3. Preventive Maintenance

## PM Intervals

### PM Parts

There are no PM parts in this machine.

**Note**

- Other than the three Yield Parts listed below, there are essentially no PM parts required for this product.
- These three items will need to be replaced in cases where their yield is near, however, given the APV (Average Printer Volume) for this product, these "yield parts\*1" are expected to outlast the working life of the machine.

\*1 "Yield Parts": Parts whose expected yield is longer than the machine lifetime when taking into consideration the machine's APV.

Description	Expected Yield	Q'ty/unit
Paper Feed Roller	120 K prints	1
Transfer Roller	120 K prints	1
Fusing Unit	120 K prints	1

### Yield Counter

Yield counters for each yield part can be checked by the following methods.

#### Configuration Page

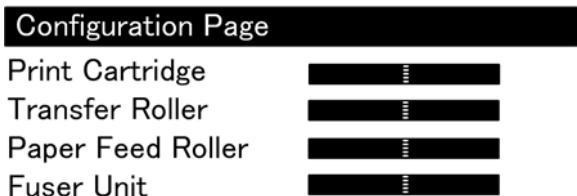

m012s115

These yield counters are printed under the supplies Info on the "Configuration Page" as shown above.

## Web Image Monitor

**Print Cartridge & Replaceable Parts Information**

Component	Yield Counter	Remaining Level
Black Toner	5	Remaining Level 5
Fuser Unit	100	Status OK
Transfer Roller Unit	100	Status OK
Paper Feed Roller Unit	100	Status OK

**Paper Tray**

Tray	Status	Size	Type
Tray 1	Status OK	A4	Plain Paper
Tray 2	Status OK	A4	Plain Paper
Bypass Tray	Out of Paper	A4	Plain Paper

m012s116

These yield counters are displayed under the "Print Cartridge & Replaceable Parts Information" on the "Status" page as shown above.

### Note

- The machine displays "Life End Feed Roller", "Life End Transfer Roller" or "Life End Fuser Unit" when one of these counters reaches each yield.

## Counter Reset

The process below shows how to reset the yield counters.

1. Enter the "Printer Configuration" in SOM.
2. Select "SP Mode 3" tab.
3. Click "Clear Fusing Unit EM Counter", "Clear Transfer Roller EM Counter" or "Clear Paper Feed Roller EM Counter" and then click "OK".
4. Exit the SOM.

# 4. Replacement and Adjustment

---

## Before You Start

### CAUTION

- If there are printer jobs in the machine, print out all jobs in the printer buffer.
- Turn off the main power switch and unplug the machine before you do the procedures in this section.

## Special Tools

- PC: Windows 2000/XP/Vista, Windows Server 2003/2003 R2, 2008.
- USB or network cable

### ↓ Note

- A computer is necessary to update the firmware.



## Exterior Covers

### Front Cover



m012i505

1. Pull out the standard paper tray [A].

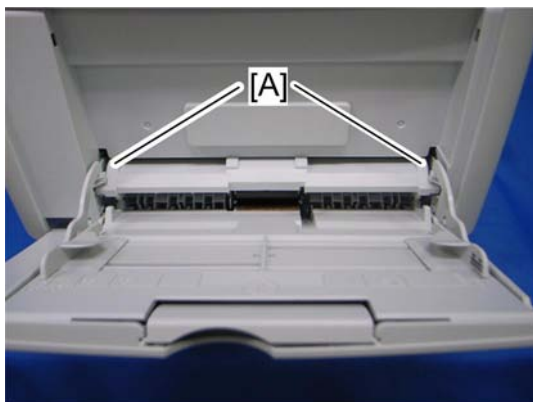

m012r511

2. Remove two tabs [A].

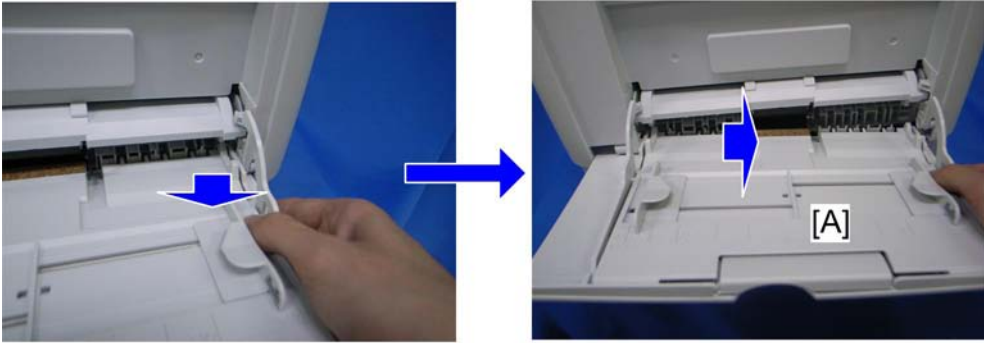

m012r512

3. On the right side, down the tab, and then slide the bypass tray [A] to the right.
4. Pull out the bypass tray [A].

4

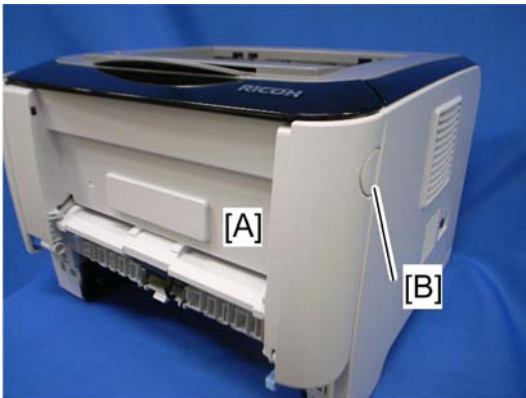

m012r693

5. Open the front cover [A].

**Note**

- To open the front cover, push the cover release button [B] and (carefully) pull the cover forward and open (it hinges downward).

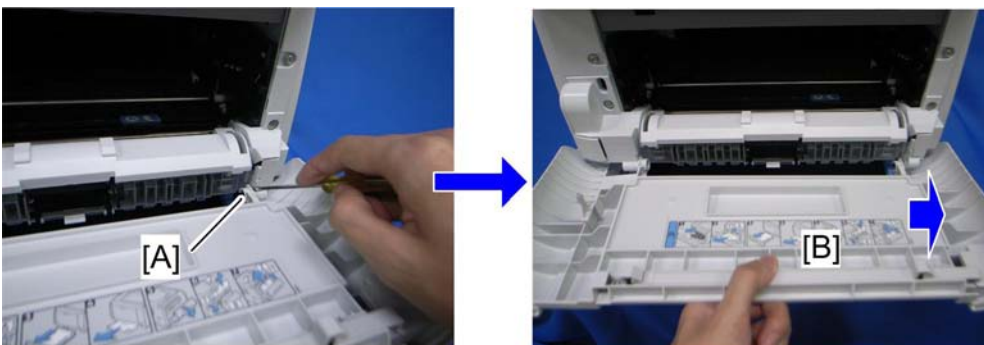

m012r691

6. Push the right hinge [A] to release.

## 7. Front cover [B]

**Left Cover**

1. Front cover (☛ p.23)
2. Rear cover (☛ p.27)

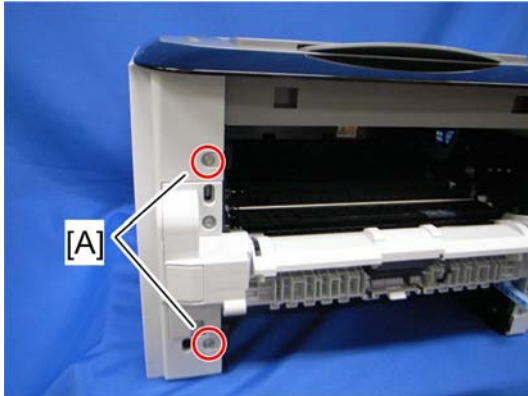

m012i502b

3. Remove two screws [A] on the left cover.



m012r688

4. Pull the front upper part [A] of the left cover (as shown above) to release the hooks.

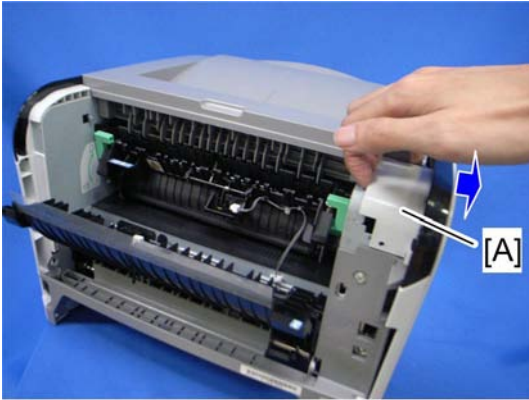

m012r689

- 4 5. Pull the rear upper part [A] of the left cover (as shown above) to release the hooks.

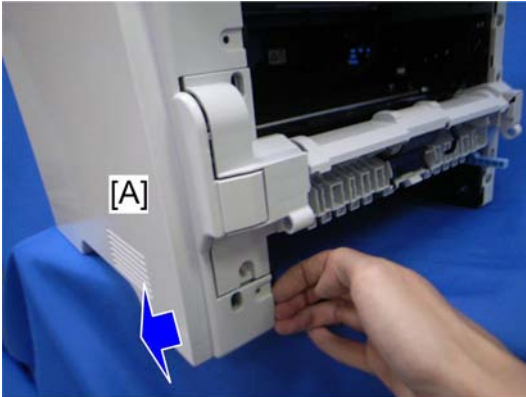

m012r690

6. Pull the front bottom part of the left cover [A] (as shown above) to release the hooks.

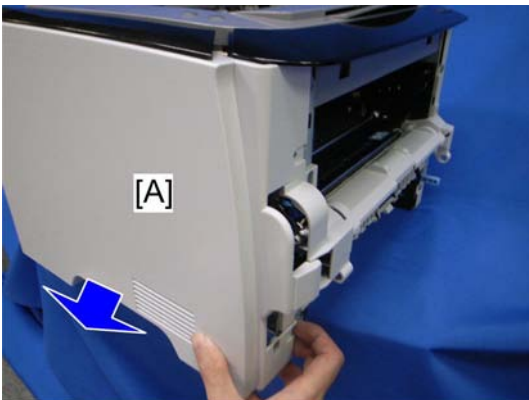

m012r691a

7. Remove the Left cover [A] as shown above.
- There are many hooks and tabs inside the left cover. See the images below in the Note section before removing the left cover.

NOTE:

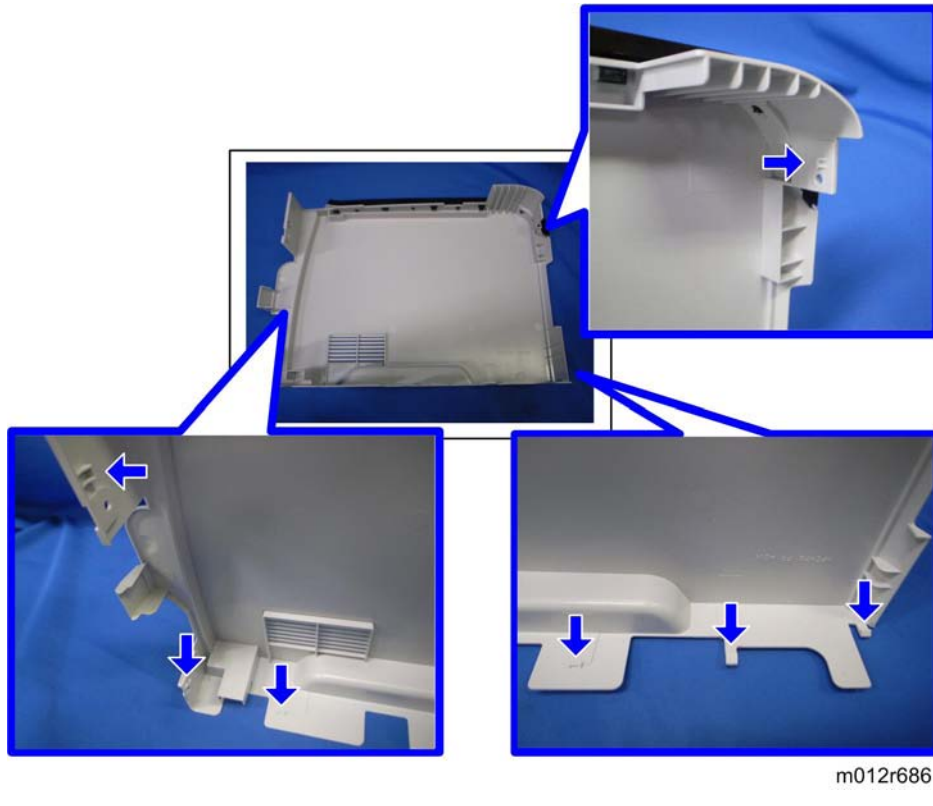

4

## Rear Cover

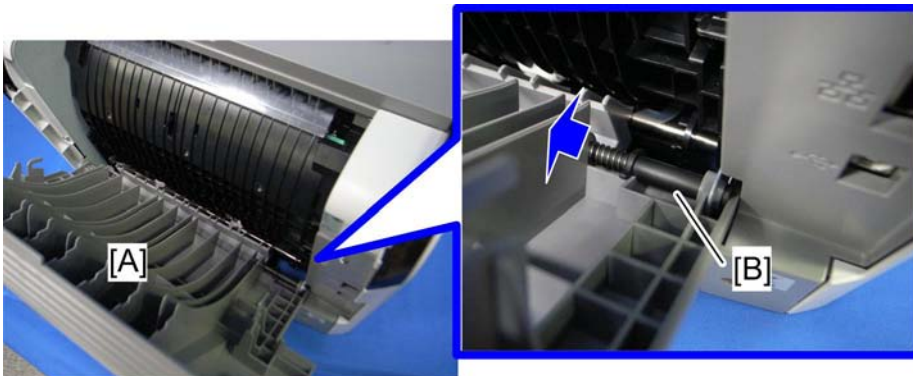

1. Open the rear cover [A]
2. Slide the shaft [B] in the direction of the blue arrow, and remove the rear cover [A].

## Right Cover

1. Front cover (☛ p.23)
2. Rear cover (☛ p.27)

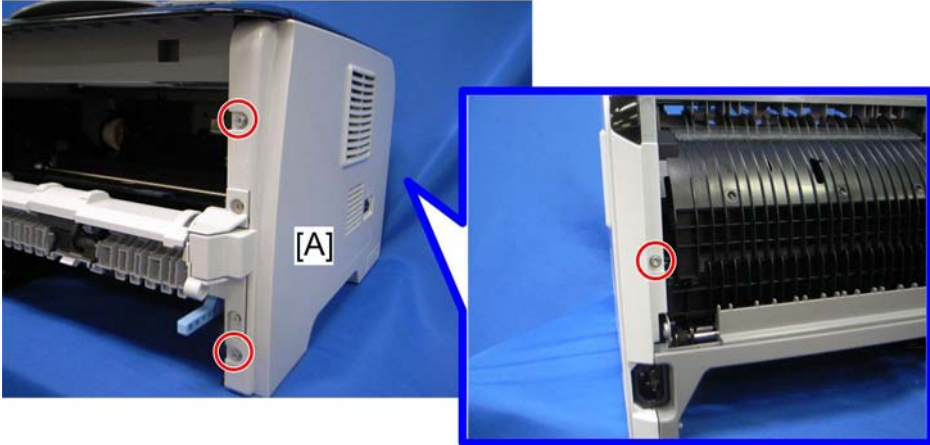

m012r504

3. Right cover [A] (☛ x 3, hook at arrow mark)

- There are many hooks and tabs inside the right cover. See the images below in the Note section before removing the right cover.

### NOTE:

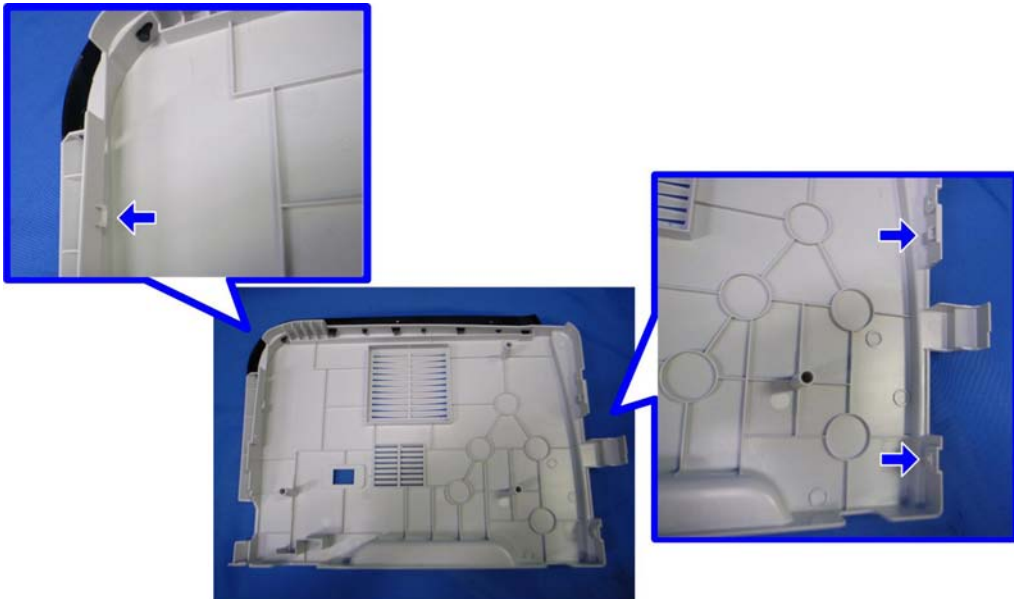

m012r687a

## Top Cover

1. Front cover (☛ p.23)
2. Rear cover (☛ p.27)
3. Left cover (☛ p.25)
4. Right cover (☛ p.28)

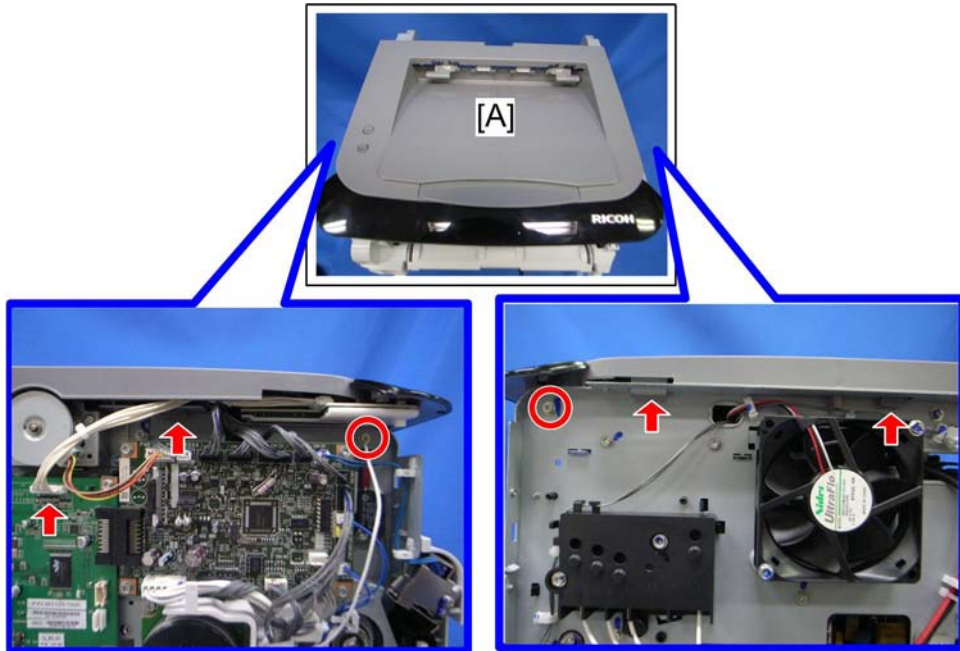

m012r506

5. Top cover [A] (☛ x 1, ☛ x 2, hook x 3)

### When installing the top cover

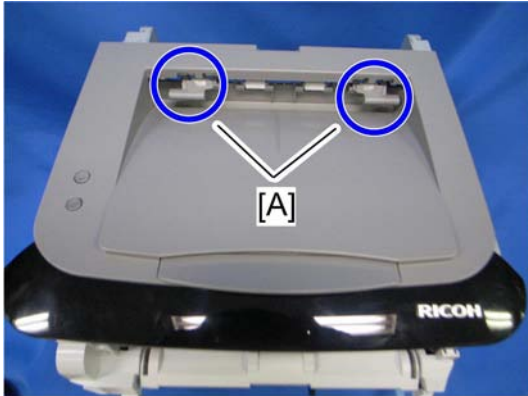

m012r685

4

- When re-installing the top cover, always verify that the two paperweights [A] are lifted. If they are not lifted to fit into the paper slot, the paperweights [A] could be damaged.
- Make sure that these paperweights [A] can be moved smoothly (up and down) after installing the top cover. If these paperweights do not move smoothly, try installing the top cover again.

### Operation Panel

1. Top cover (☛ p.29)



m012r703

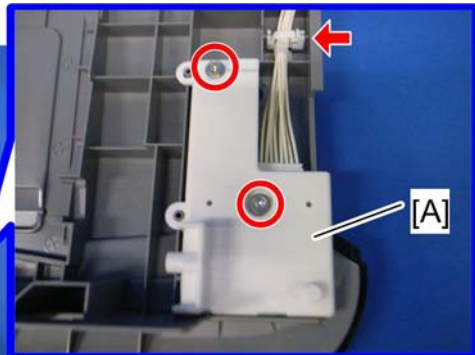

2. Operation panel [A] (☛ x 1, ☛ x 2)



## Laser Unit

### ⚠ CAUTION

- Turn off the main power switch and unplug the machine before attempting any of the procedures in this section. Laser beams can seriously damage your eyes.

### Caution Decal Locations

Caution decal is attached as shown below.

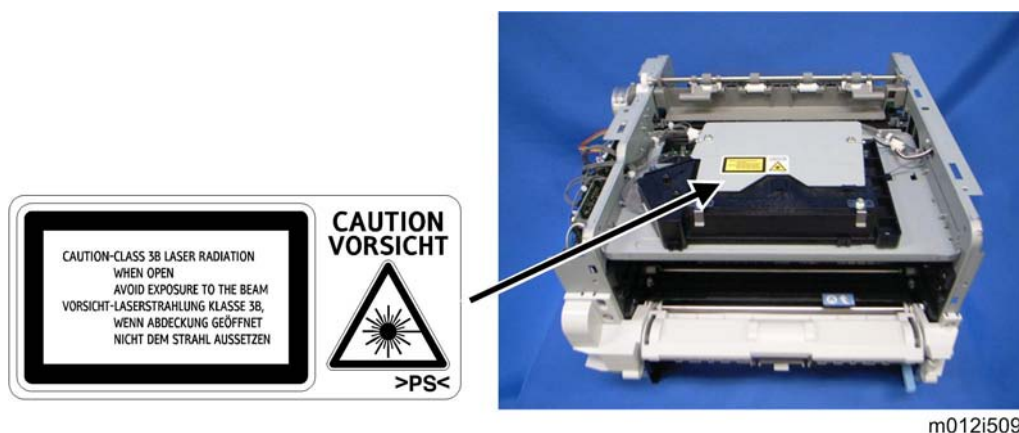

### ⚠ WARNING

- Be sure to turn off the main switch and disconnect the power plug from the power outlet before beginning any disassembly or adjustment of the laser unit. This machine uses a class IIIB laser beam with a wavelength of 648 to 663 nm and an output of 9 mW. The laser can cause serious eye injury.

### Laser Unit

1. Front cover (🔧 p.23)
2. Rear cover (🔧 p.27)
3. Left cover (🔧 p.25)
4. Right cover (🔧 p.28)
5. Top cover (🔧 p.29)

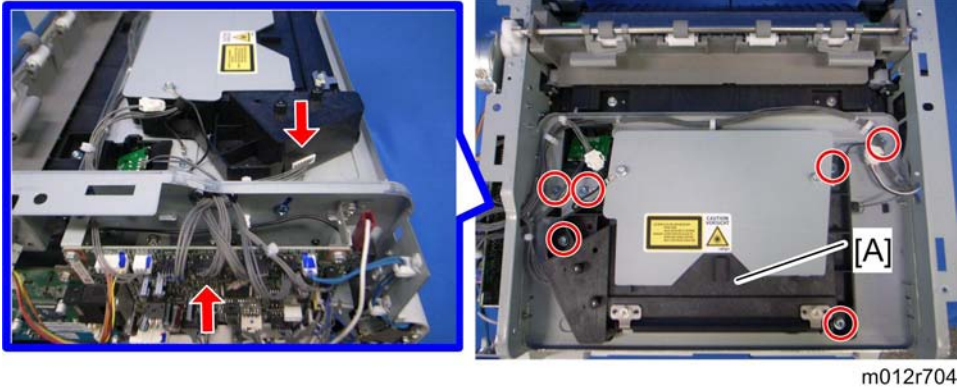

4

6. Laser unit [A] (🔩 x 3, ground screw x 3, 📏 x 2)

### Polygon Mirror Motor

#### ⚠ CAUTION

- Turn off the main switch and unplug the machine before attempting any of the procedures in this section. Laser beams can seriously damage your eyes.

1. Laser unit (🔍 p.31)

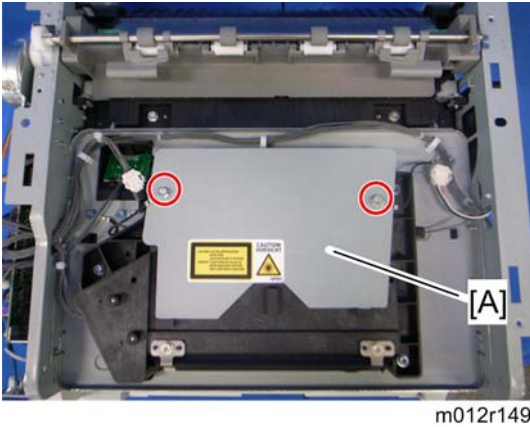

2. Polygon mirror cover [A] (🔩 x 2)

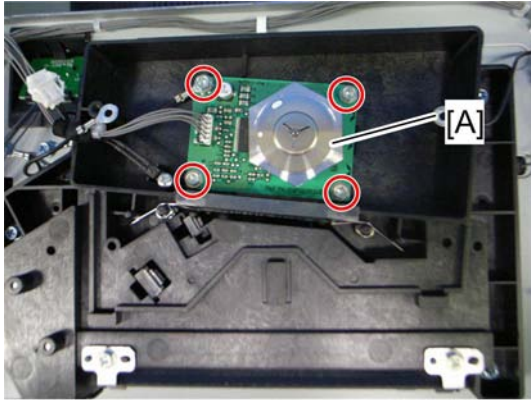

m012r150

3. Polygon mirror motor [A] (🔧 x 4, 📦 x 1)

⬇️ **Note**

- Never touch the surface of the mirror with bare hands.

# Paper Feed and Exit

## Paper Feed Roller

1. Pull out the standard paper tray.
2. Remove the AIO.



m012r127

3. Set the machine with the rear side facing down, resting on the table.

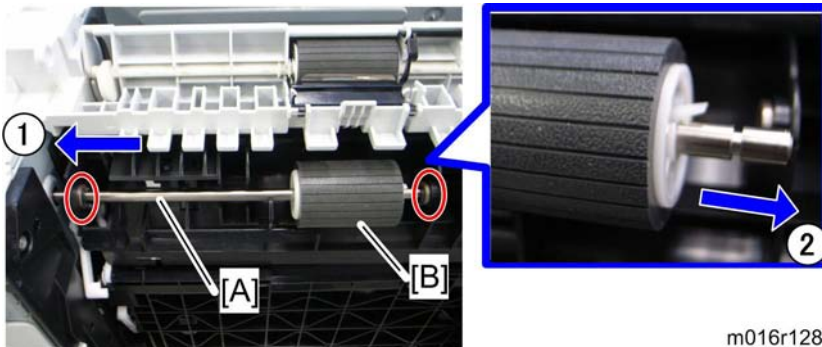

m016r128

4. Slide the paper feed shaft [A] to the left side (☞ x 2).
5. Slide the paper feed roller [B] to right side, and remove it (hook).

## After installing a new paper feed roller

1. Enter the "Printer Configuration" in SOM.
2. Select "SP Mode 3" tab.
3. Click "Clear Paper Feed Roller EM Counter" and then click "OK".
4. Exit the SOM.

## Friction Pad

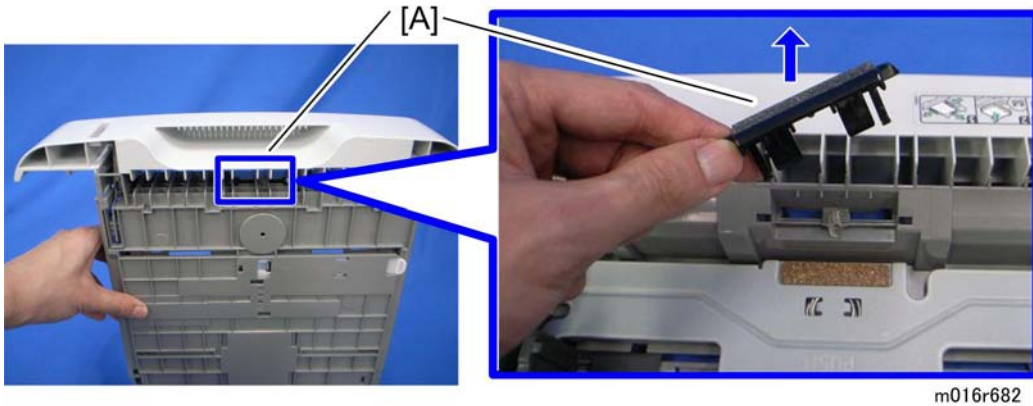

m016r682

1. Remove the paper tray unit from the machine before removing the friction pad.
2. Friction pad [A] (2 hooks, 1 spring)

**When reinstalling the friction pad follow this order:**

1. Replace the spring.
2. Insert the right side of the friction pad first, followed by the left side.
3. Gently push the friction pad down into the slot and then pull forward very slightly.

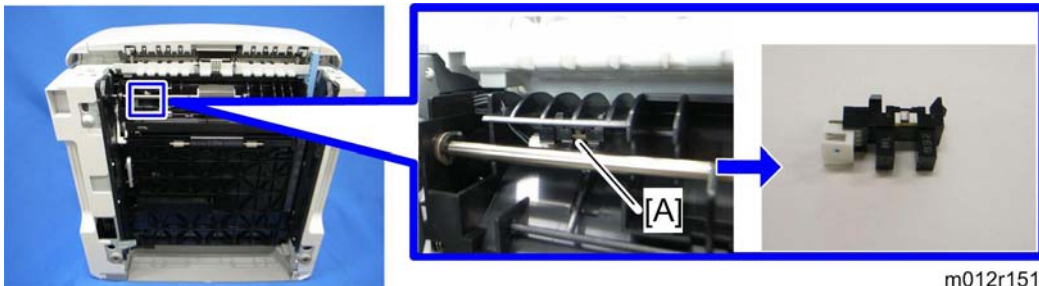

## Paper End Sensor



m012r151

1. Set the machine with the rear side facing down, resting on the table.
2. Paper end sensor [A] (hooks,  x 1)

## By-pass Feed Roller

1. Front cover ( p.23)
2. Left cover ( p.25)

3. Right cover (☛ p.28)

4. Pull out the paper tray.

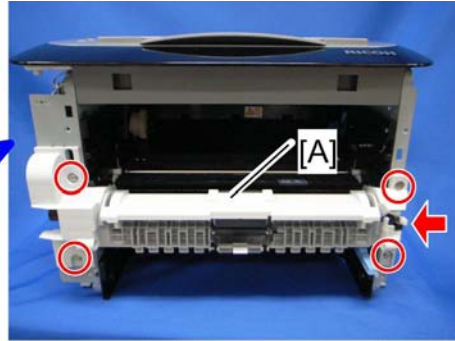
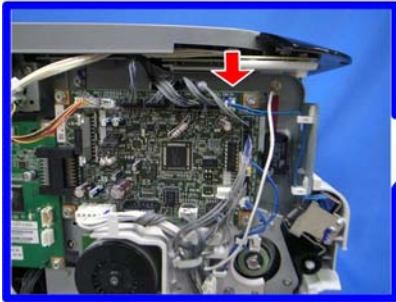

m012r153

4

5. By-pass lower guide plate [A] (⚙ x 4, 📌 x 2)

**NOTE:**

- Reinstall the by-pass lower guide plate [A] while pressing the spring [B].
- Be careful for the spring [B] and the ground plate [C] not to fall inside the machine during reinstallation.

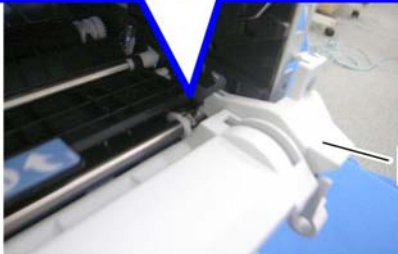
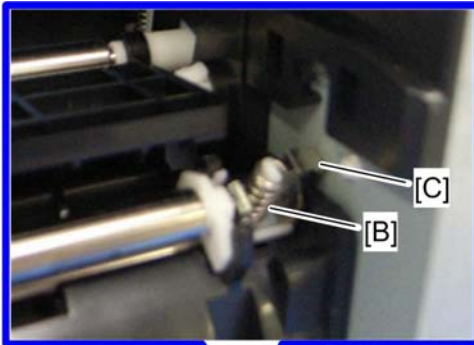

m016r703

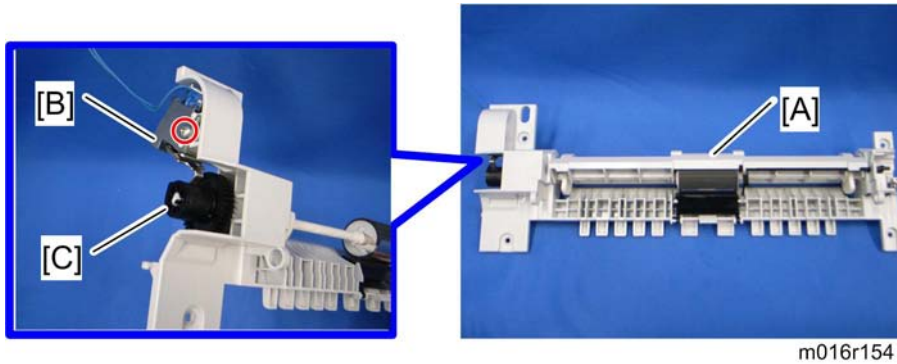

6. By-pass upper guide plate [A] (hooks)
7. By-pass solenoid cover, by-pass solenoid [B] (⌀ x 1)
8. Gear [C] (hook)

4

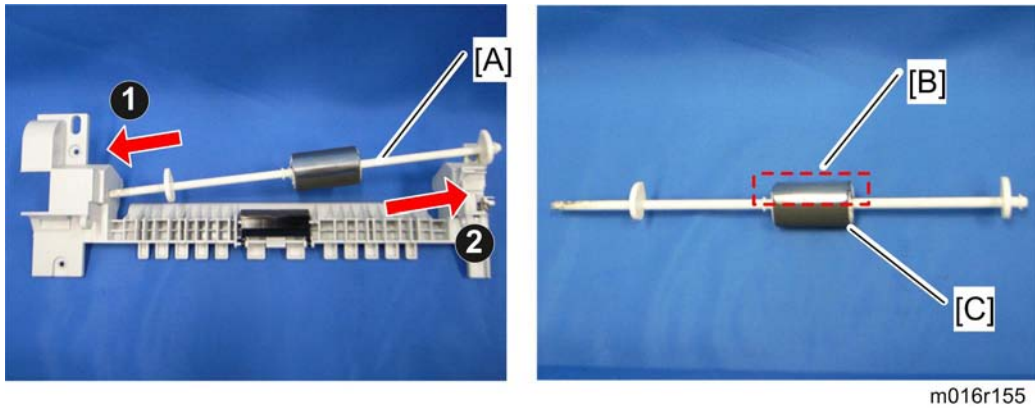

9. Slide the by-pass feed roller shaft [A] to the left side, and remove it.
10. Remove the metal cover [B] from the by-pass feed roller [C].

## By-pass Feed Roller Friction Pad

1. By-pass feed roller (☛ p.35)

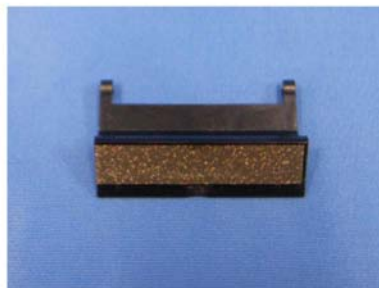
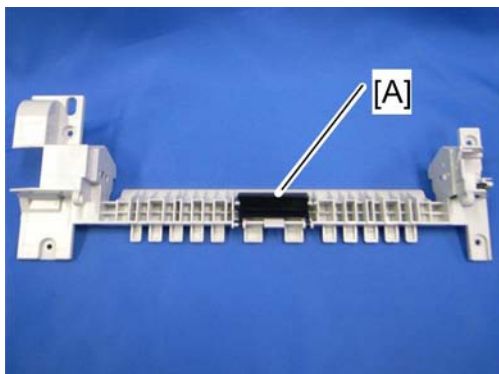

m016r156

4

2. By-pass feed roller friction pad [A] (hooks, spring x 1)

### By-pass Feed Sensor

1. Front cover (🔧 p.23)
2. Right cover (🔧 p.28)

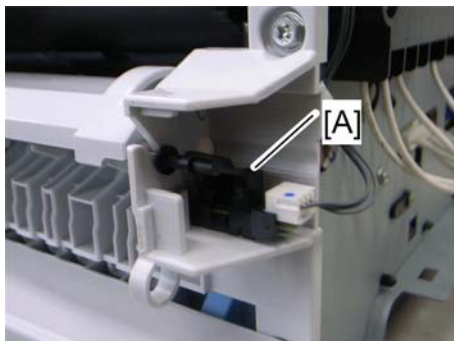

m016r152

3. By-pass feed sensor [A] (hooks, 📧 x 1)

### Paper Feed Clutch

1. Top cover (🔧 p.29)
2. ECB (🔧 p.58)
3. Controller board (🔧 p.60)



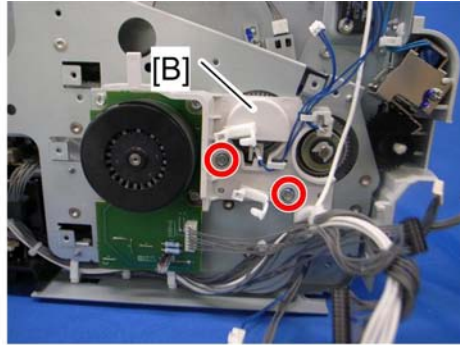
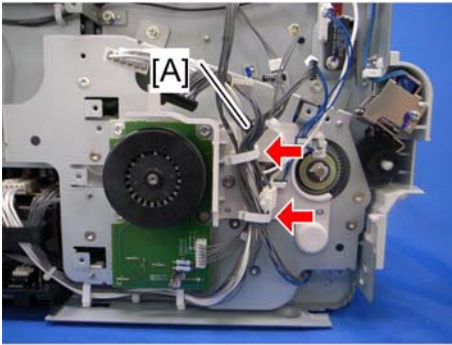

m012r109

4. Release all harnesses [A] from the clamps.
5. Harness guide plate [B] (🔩 x 2)

4

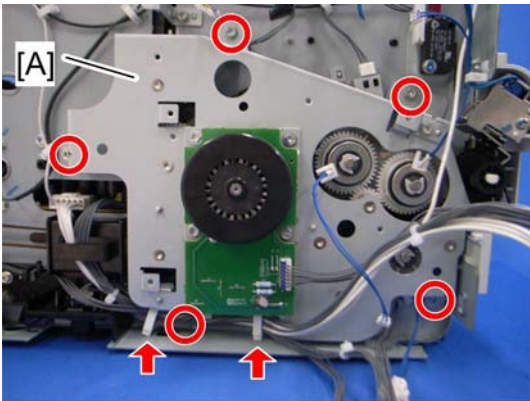

m016r704

6. Drive unit [A] (🔩 x 5, 📦 x 1, 📦 x 2, timing belt)

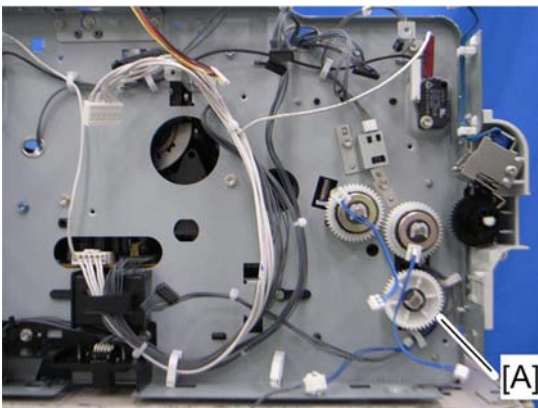

m016r113

7. Paper feed clutch [A] (📦 x 1, 📦 x 1)

---

## Relay Clutch

---

1. Drive unit (☛ p.38)

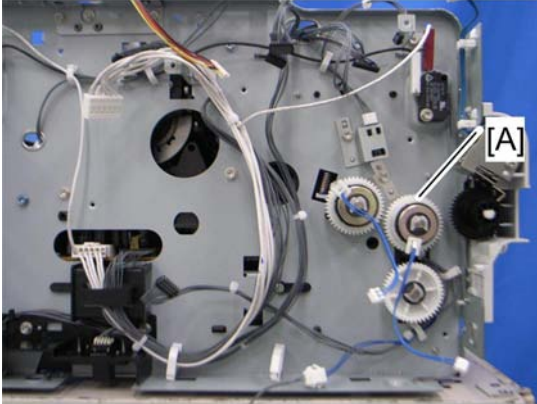

m016r111

2. Relay clutch [A] (☞ x 1)

---

## Registration Clutch

---

1. Drive unit (☛ p.38)

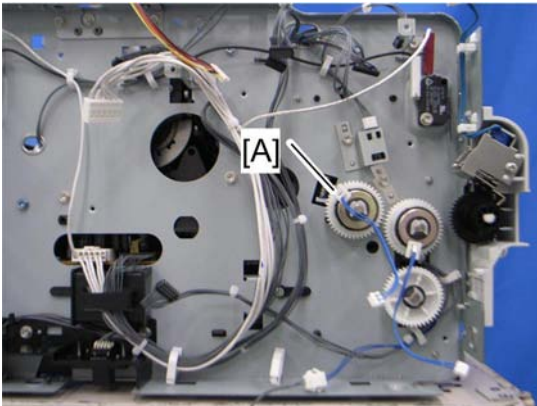

m016r112

2. Registration clutch [A] (☞ x 1)

---

## Toner End Sensor

---

1. Drive unit (☛ p.38)

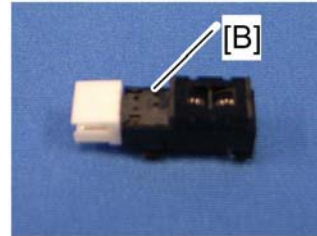
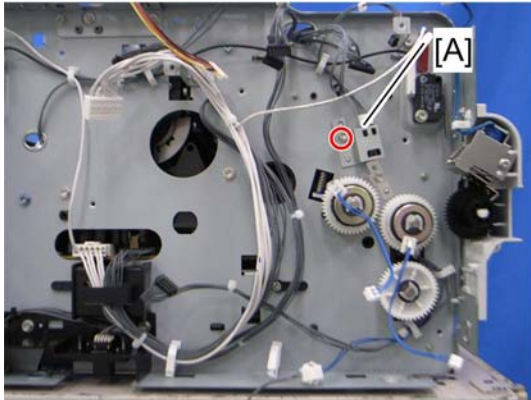

m016r147

2. Reflective sensor with bracket [A] (🔧 x 1)
3. Reflective sensor [B]

4

## Paper Exit Sensor

1. Rear cover (🔧 p.27)

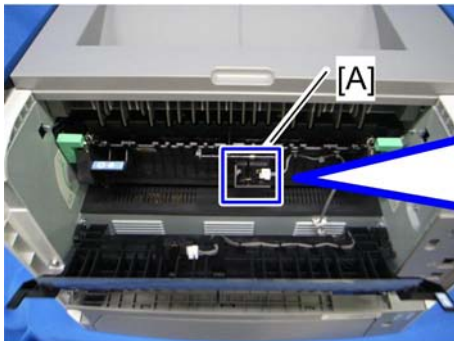

m012r158

2. Paper exit sensor [A] (🔧 x 1, hooks)

## Relay Sensor

1. Rear cover (🔧 p.27)



m012r159

2. Relay sensor [A] (🔌 x 1, hooks)

4

## Inverter Sensor

1. Duplex transport guide (🔌 p.61 "PSU")

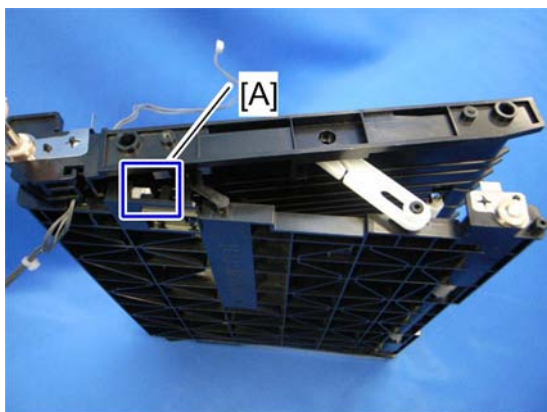

m016r160

2. Inverter sensor [A] (🔌 x 1, hooks)

## Registration Roller and Sensor

1. Pull out the paper tray.
2. PSU (🔌 p.61 "PSU")
3. Paper feed clutch (🔌 p.38)
4. Relay clutch (🔌 p.40)
5. Registration clutch (🔌 p.40)

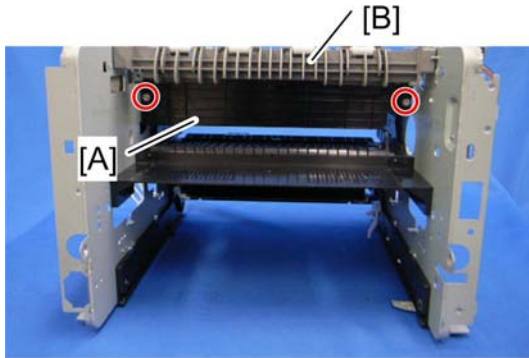

m012r696

6. Heat insulating plate [A] (⚙️ x 2)
7. Exit roller base [B] (⚙️ x 2)

4

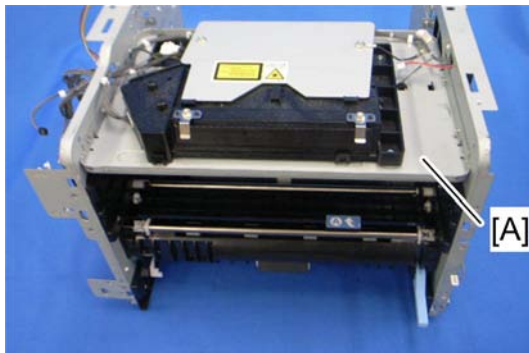

m012r694

8. Imaging unit base [A] (⚙️ x 4)

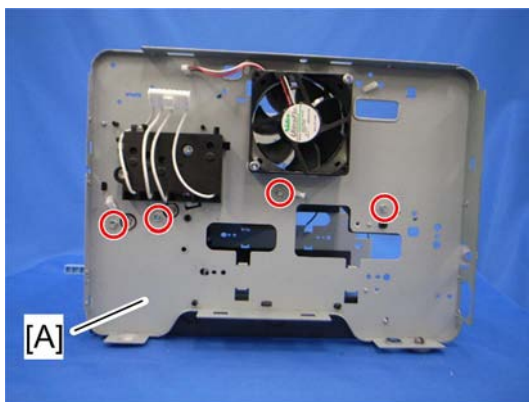

m016r697

9. Remove the four screws in the right frame [A].

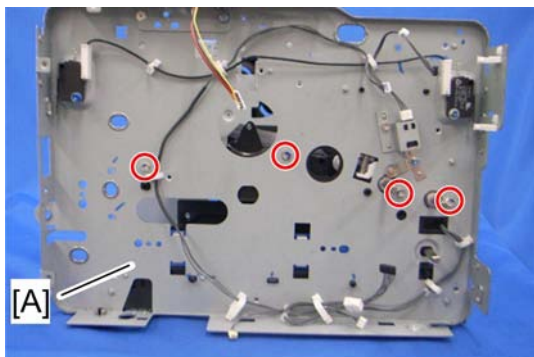

m012r698

10. Remove the four screws in the left frame [A].

4

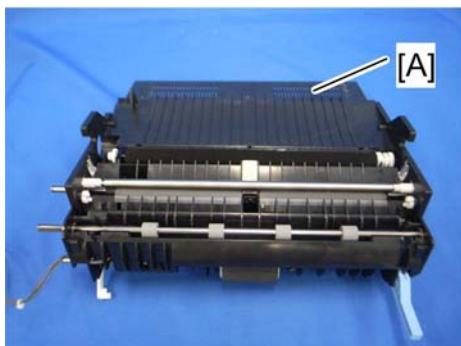

m016r699

11. Registration unit [A]

12. Upper guide plate [B]

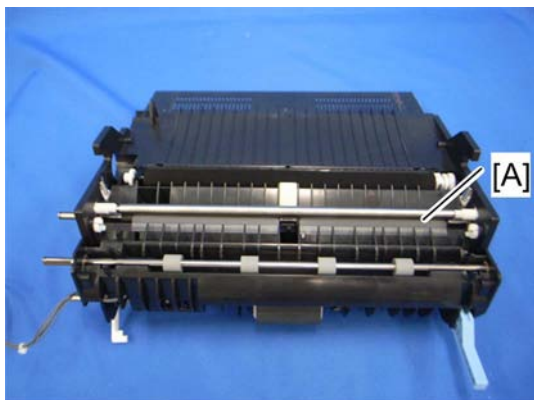

m016r700

13. Registration roller [A]

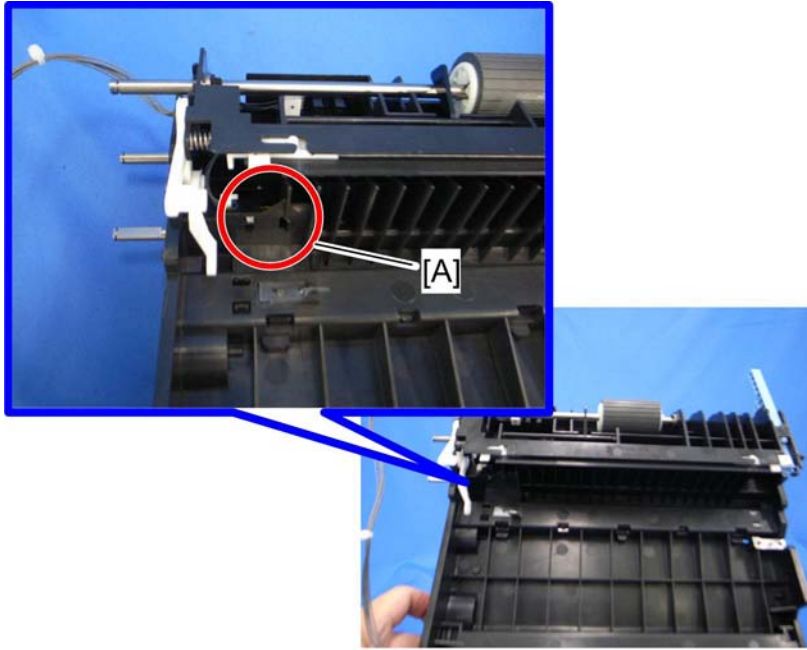

m016r701

14. Registration sensor [A]

# Paper Transfer

## Transfer Roller

1. Front cover (☛ p.23)
2. Remove the AIO.

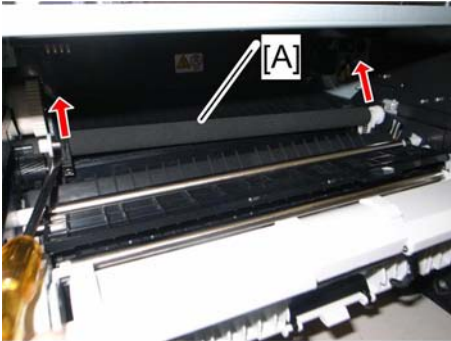

m012r146

3. Remove the transfer roller [A] (Bushing x 2, spring x 2, gear x 1, collar x 1) as shown above.

↓ **Note**

- Do not touch the transfer roller surface, when reinstalling the new transfer roller.

### After installing a new transfer roller

1. Enter the "Printer Configuration" in SOM.
2. Select "SP Mode 3" tab.
3. Click "Clear Transfer Roller EM Counter" and then click "OK".
4. Exit the SOM.



# Fusing

## ⚠ CAUTION

- Switch off the main power, unplug the machine from its power source, and allow the fusing unit to cool before removing it.

## Fusing Unit

1. Front cover (🔧 p.23)
2. Rear cover (🔧 p.27)
3. Left cover (🔧 p.25)

4

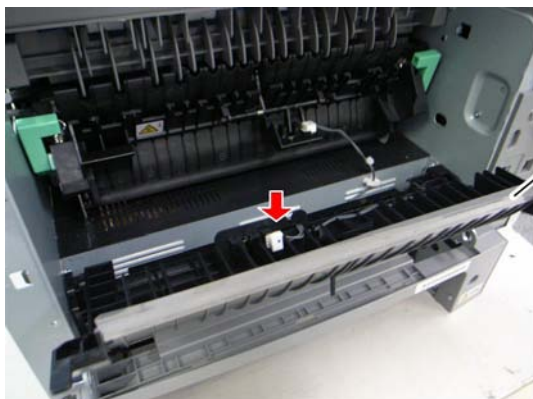

m016r169

4. Entrance guide [A] (🔧 x 1)

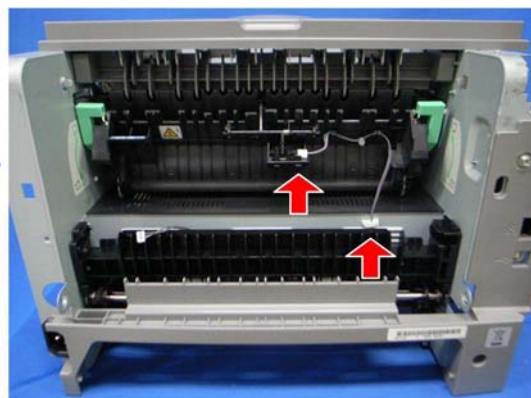
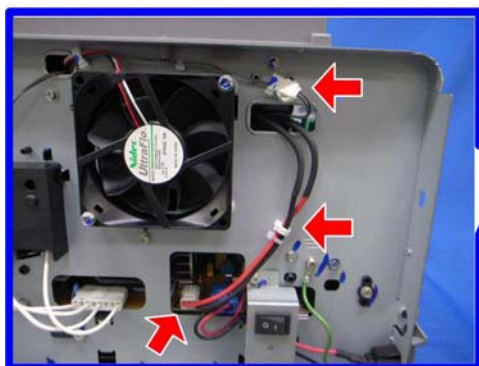

m012r130

5. Disconnect the three harnesses (🔧 x 2)

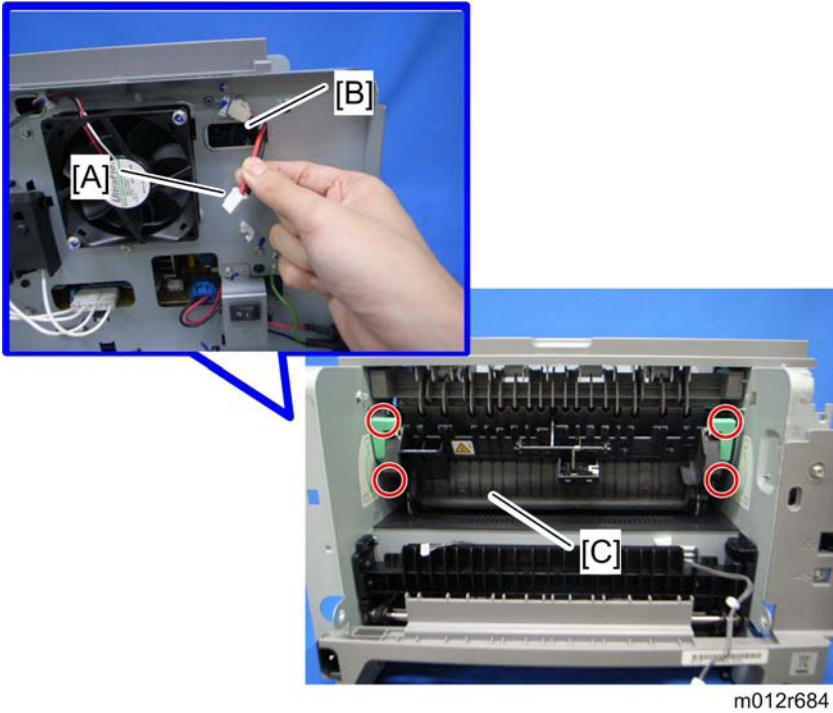

- 6. Pass the cable [A] through the hole [B] inside the machine.
- 7. Fusing unit [C] (⚙ x 4)

**NOTE:**

Make sure that the two bushings [A] remain be setting.

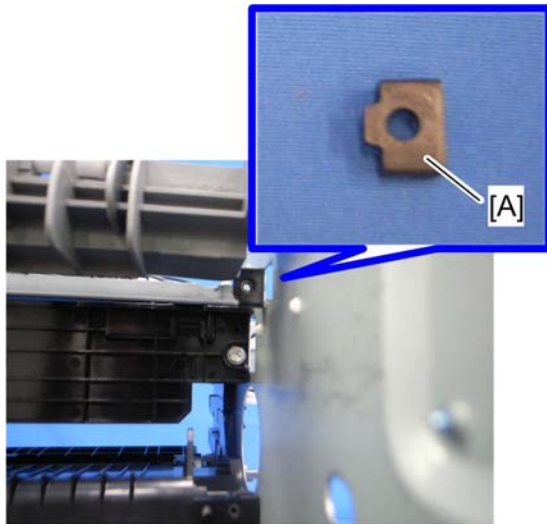

## Reinstallation

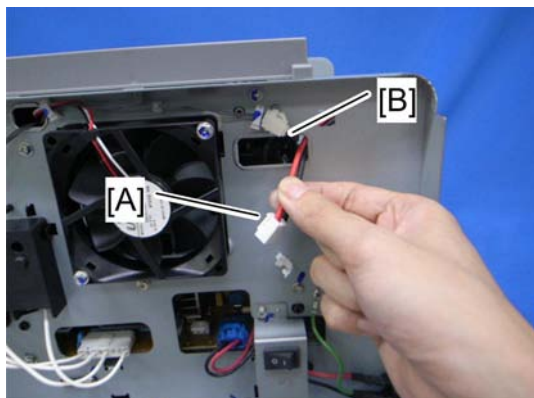

m012r702

Pass the cable [A] of fusing unit through the hole [B] outside, after setting the fusing unit.

4

## After installing a new fusing unit

1. Enter the "Printer Configuration" in SOM.
2. Select "SP Mode 3" tab.
3. Click "Clear Fusing Unit EM Counter" and then click "OK".
4. Exit the SOM.

## Thermostat

### **⚠ CAUTION**

- Do not recycle a thermostich that is already opened. Safety is not guaranteed if you do this.

1. Fusing unit (🔗 p.47)

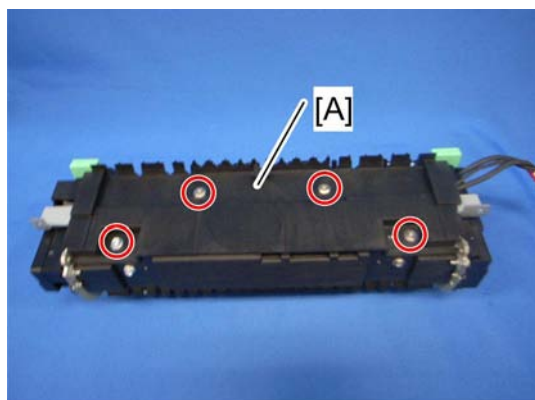

m012r141

4

2. Fusing upper cover [A] (🔩 x 4)

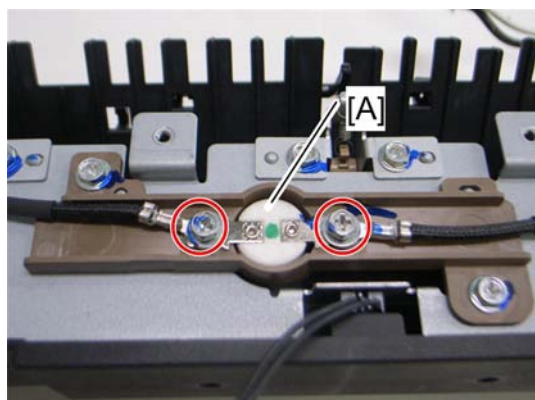

m016r142

3. Thermostat [A] (🔩 x 2)

---

## Thermistor

---

1. Fusing unit (🔩 p.47)

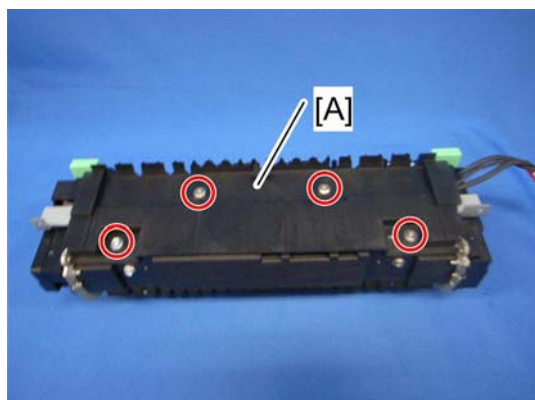

m012r141

2. Fusing upper cover [A] (🔩 x 4)

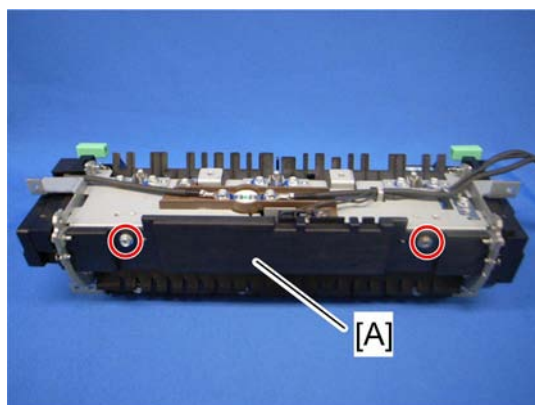

m012r132

3. Fusing front cover [A] (🔩 x 2)

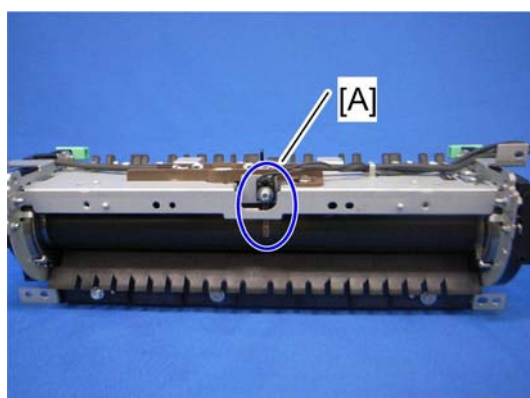

m012r131

4. Thermistor [A] (🔩 x 1)

## Fusing Lamp

1. Fusing Unit (☛ p.47)

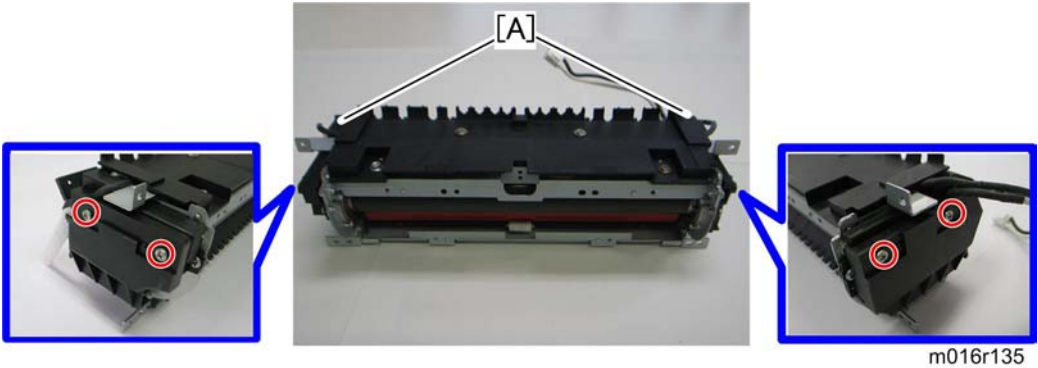

2. Fusing side covers [A] (☛ x 2 each)



3. Ground-wires (☛ x 1 each)

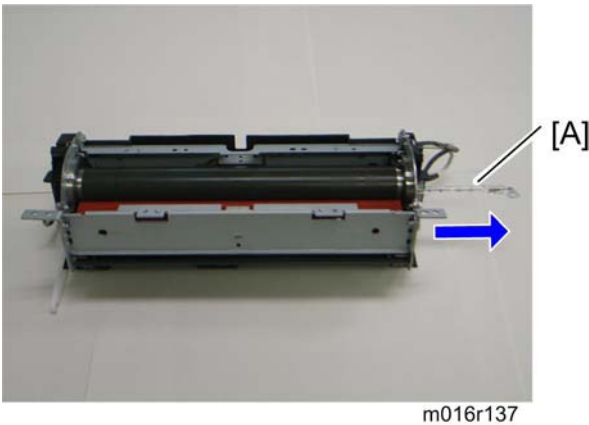

4. Fusing lamp [A]

## When reinstall the fusing lamp

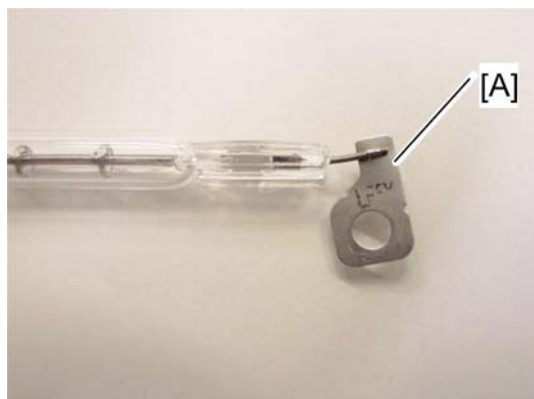

m016r138

The flat terminal [A] must be placed on the right side of the fusing unit (fusing cable side).

4

## Hot Roller

1. Thermistor (☛ p.50)
2. Fusing lamp (☛ p.52)

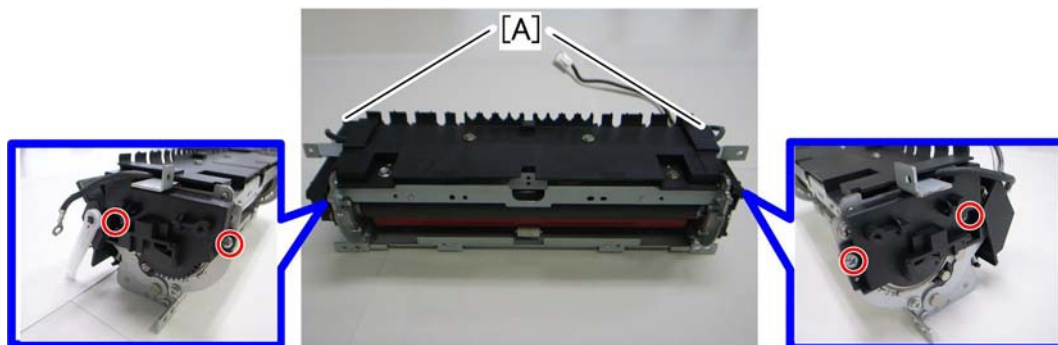

m016r139

3. Brackets [A] (☛ x 2)

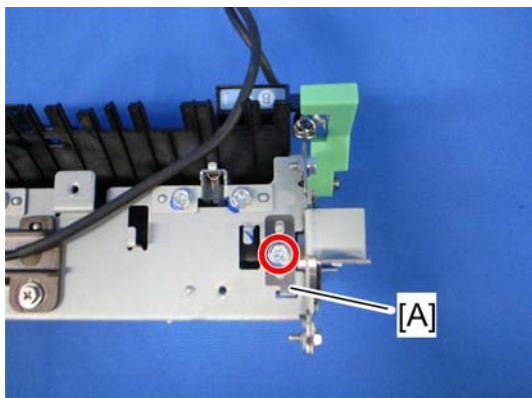

m012r705

4

4. Ground Plate [A] (⌀ x 1)

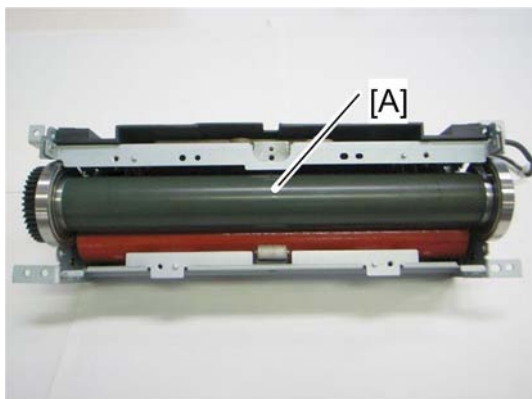

m016r140

5. Hot roller [A] (C-ring x 2, gear x 1, bushing x 2)

---

## Pressure Roller

---

1. Hot roller (☛ p.53)

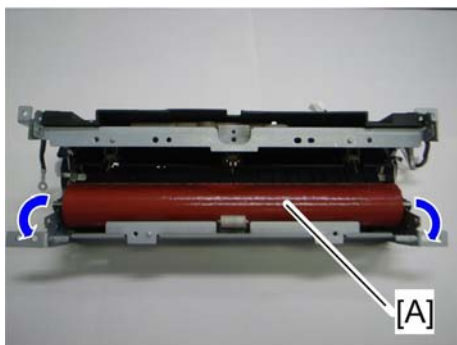

m016r148



2. Pressure roller [A] (Bearing x 2)

## Hot Roller Stripper Pawls

1. Fusing unit (☛ p.47)
2. Fusing unit upper cover (☛ p.49)

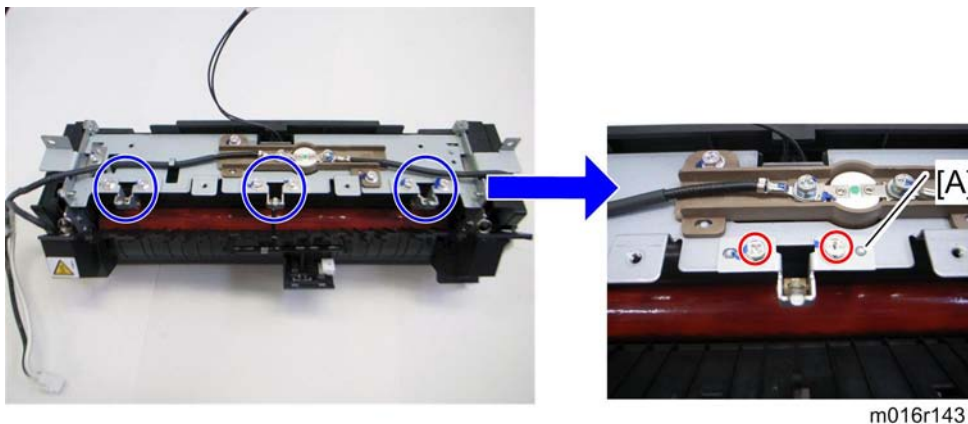

3. Metal holders [A] (1 holder for each pawl: ☛ x 2 each)

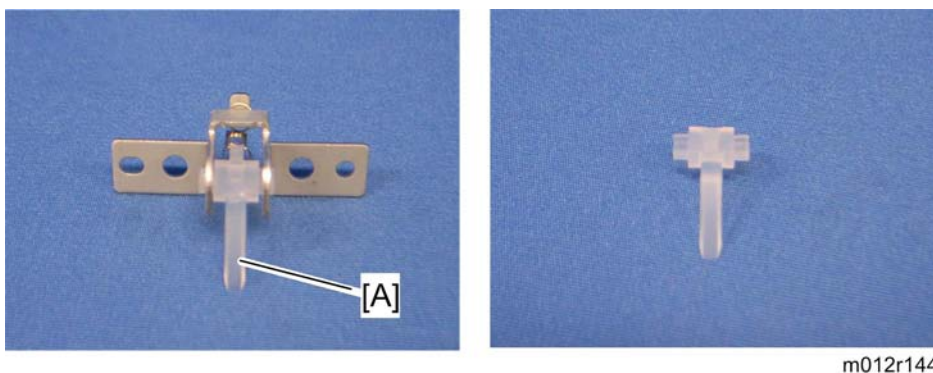

4. Hot roller stripper pawls [A] (1 spring for each pawl)

# Motors

## Main Motor

1. Front cover (🔩 p.23)
2. Left cover (🔩 p.25)

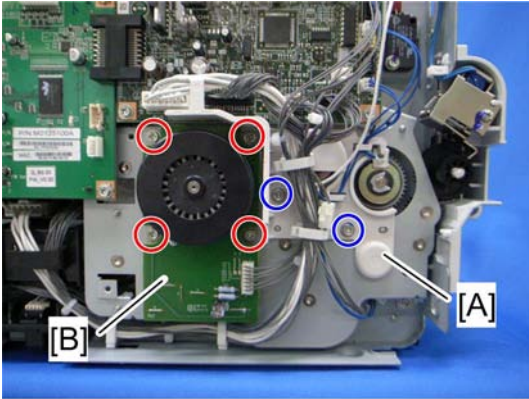

m012r108

3. Harness guide [A] (🔩 x 2)
4. Main motor [B] (🔩 x 4, 📦 x 1)

## Duplex Motor (For M013)

1. Front cover (🔩 p.23)
2. Rear cover (🔩 p.27)
3. Left cover (🔩 p.25)
4. Right cover (🔩 p.28)
5. Top cover (🔩 p.29)

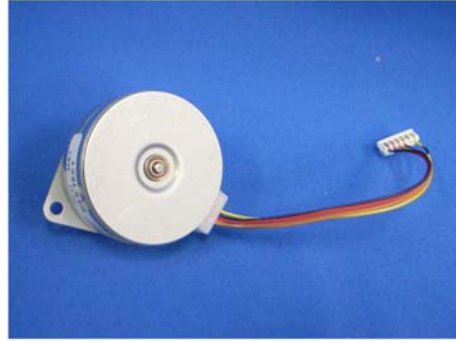
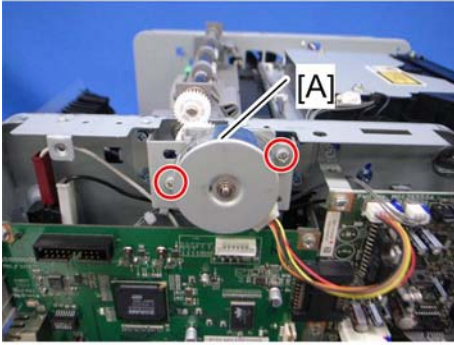

m012r123

6. Duplex motor [A] (🔧 x 2, 📏 x 1)

# Electrical Components

## ⚠ CAUTION

- Use a correct rating fuse for the fuse replacement. Never use a wrong rating fuse. If do so, the machine may be damaged.

## Layout of PC Boards

4

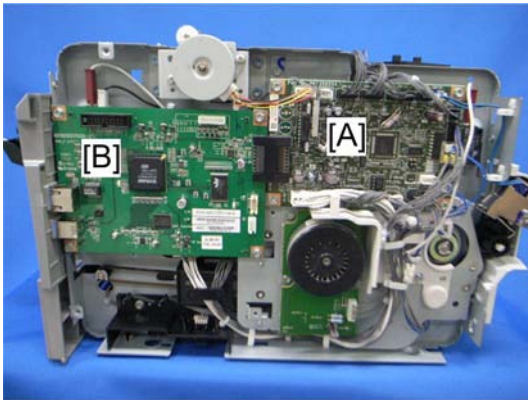

m012r114

[A]	ECB (Engine Controller Board)
[B]	Controller Board

## ECB (Engine Controller Board)

1. Front cover (🔩 p.23)
2. Left cover (🔩 p.25)

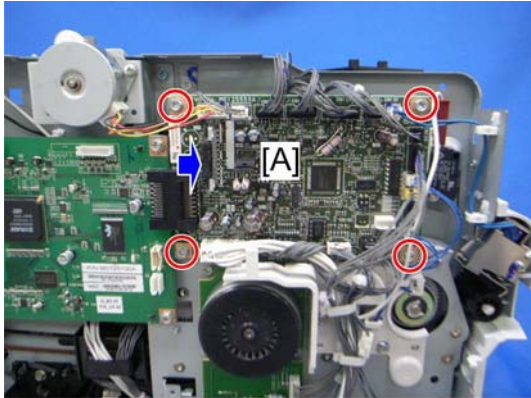

m012r115

### 3. ECB [A] (⚙️ x 4, all ⚙️s)

#### ↓ Note

- Do not connect any connectors to CN181 when reinstalling the ECB [A]. CN181 is only used for factory.
- Do not change the dip switch. The dip switch is only for factory use.

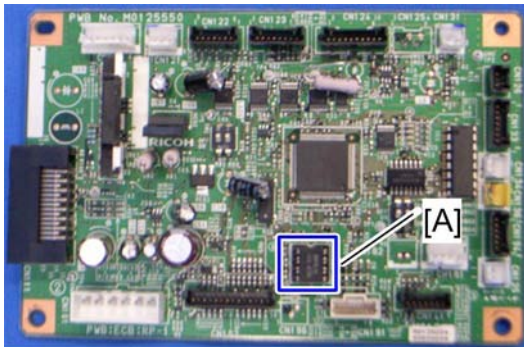

m016r118

### 4. EEPROM (Electrically Erasable Programmable Read Only Memory) [A]

#### When installing the new ECB (Engine Controller Board)

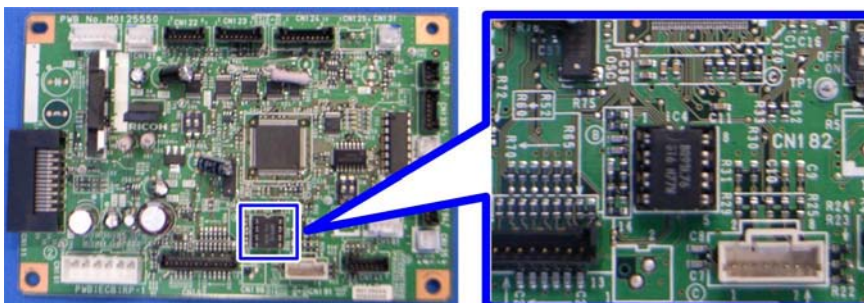

m016r117

1. Remove the EEPROM from the old ECB.
2. Install it on the new ECB after replacing the ECB.
3. Replace the EEPROM if the EEPROM on the old ECB is defective.

**Note**

- Keep the EEPROM away from any objects that can cause static electricity. Static electricity can damage EEPROM data.
- Make sure that the EEPROM is correctly installed on the ECB.

## EEPROM

---

4

- Replacement procedures for the new EEPROM are included in the "ECB (Engine Controller Board)" replacement procedure. Refer to "ECB (Engine Controller Board)" for details.
- Do the following settings after installing a "new" EEPROM.
  - Input the PnP Name, Destination with SOM.
  - Adjust registration with SOM.
  - Input serial number on the serial number input display after installing the new EEPROM

**Note**

- Ask your supervisor about how to access the serial number input display.

## Controller Board

---

1. ECB (🔧 p.58)

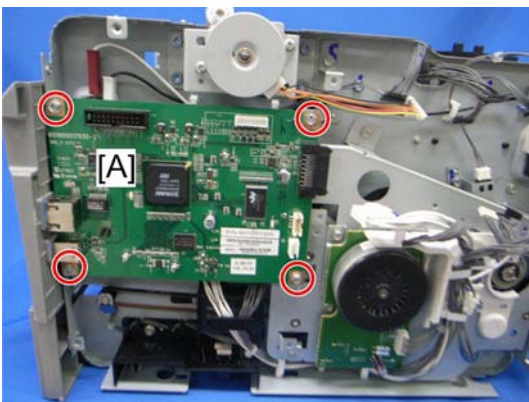

m012r116

2. Controller board [A] (🔧 x 4, flat cable x 1, all 📏s)

## PSU

1. Pull out the standard paper tray.
2. Front cover (☛ p.23)
3. Rear cover (☛ p.27)
4. Left cover (☛ p.25)
5. Right cover (☛ p.28)
6. Top cover (☛ p.29)
7. ECB (☛ p.58)
8. Drive unit (☛ p.38 "Paper Feed Clutch")

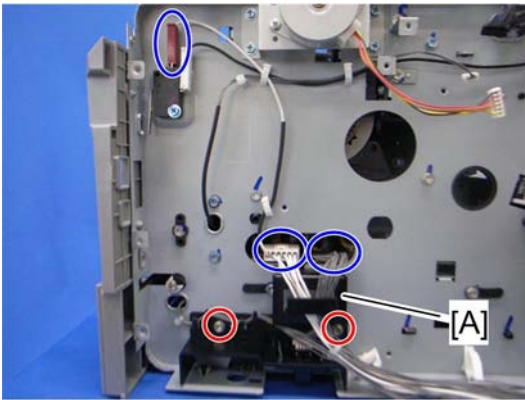

m012r166

9. Disconnect three connectors in left frame (☛ x 1)
10. Bracket [A] (☛ x 2)

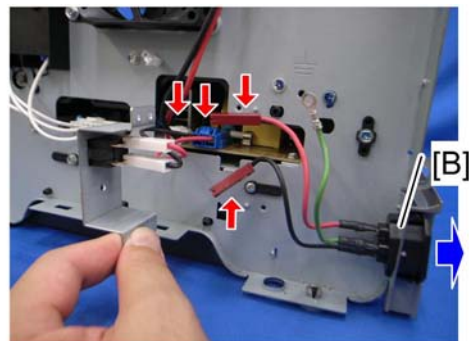
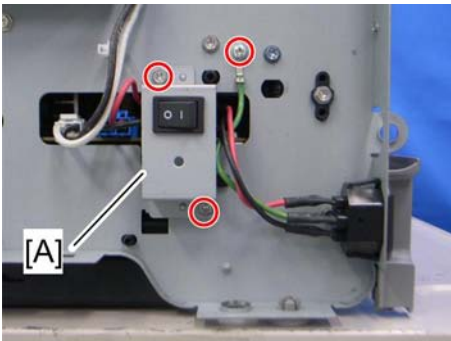

m016r167

11. Main power switch bracket [A] in right frame (☛ x 2)
12. Remove the main power cord [B] as shown above (☛ x 2).
13. Remove the ground wire and two connectors.

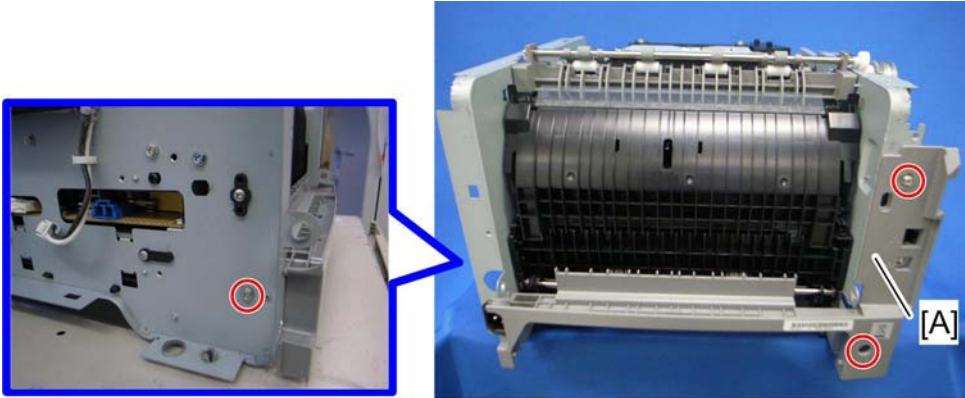

m012r168

4

14. Rear low cover [A] (🔩 x 3)

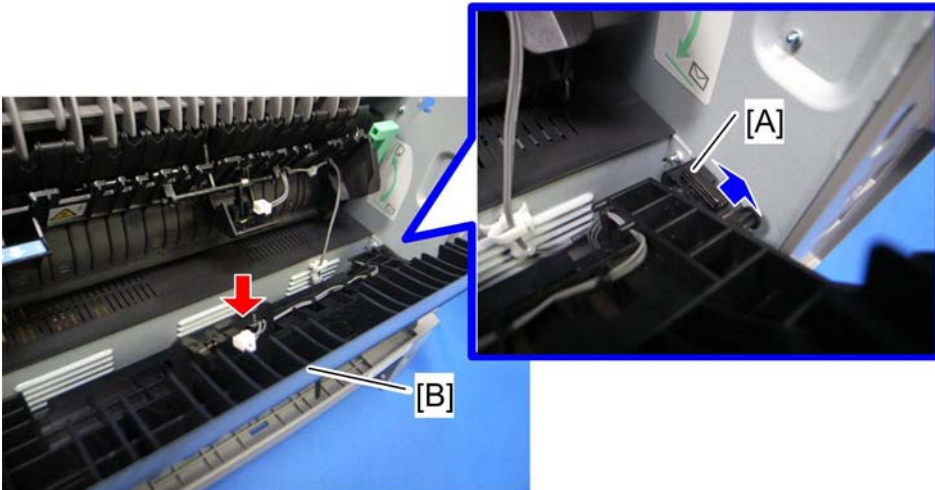

m012r169

15. Release the lock [A], and then remove the entrance guide [B] (🔩 x 1).

16. Fusing Unit(🔗 p.47)

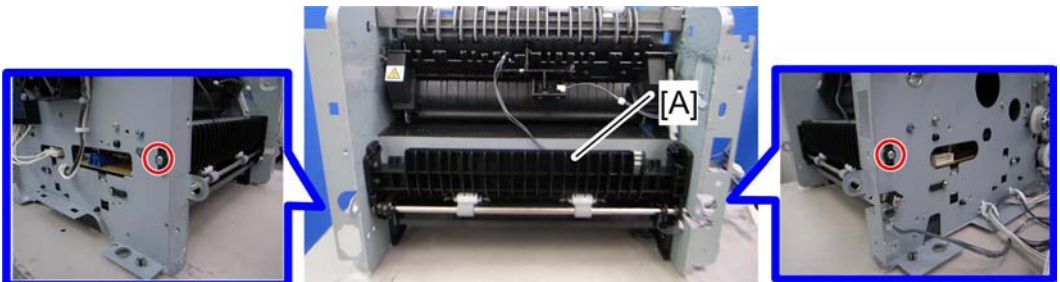

m012r170

17. **For M013 only:** Duplex transport guide [A] (🔩 x 2)



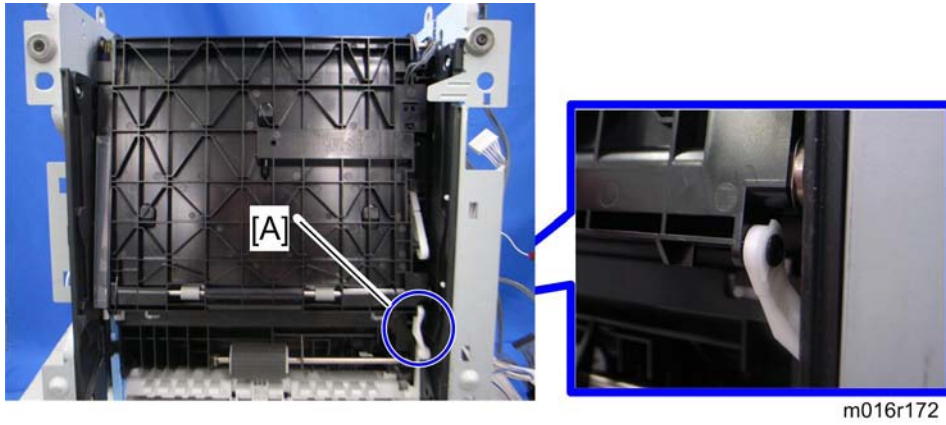

18. **For M013 only:** Set the machine with the front side facing down, resting on the table.

4

19. **For M013 only:** Release the link [A] (⚙ x 1)

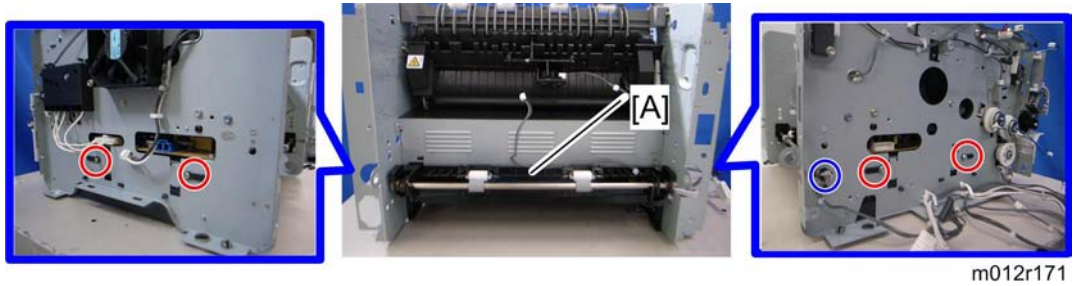

20. **For M013 only:** Duplex cover [A] (⚙ x 4, ⚙ x 1, gear x 1)

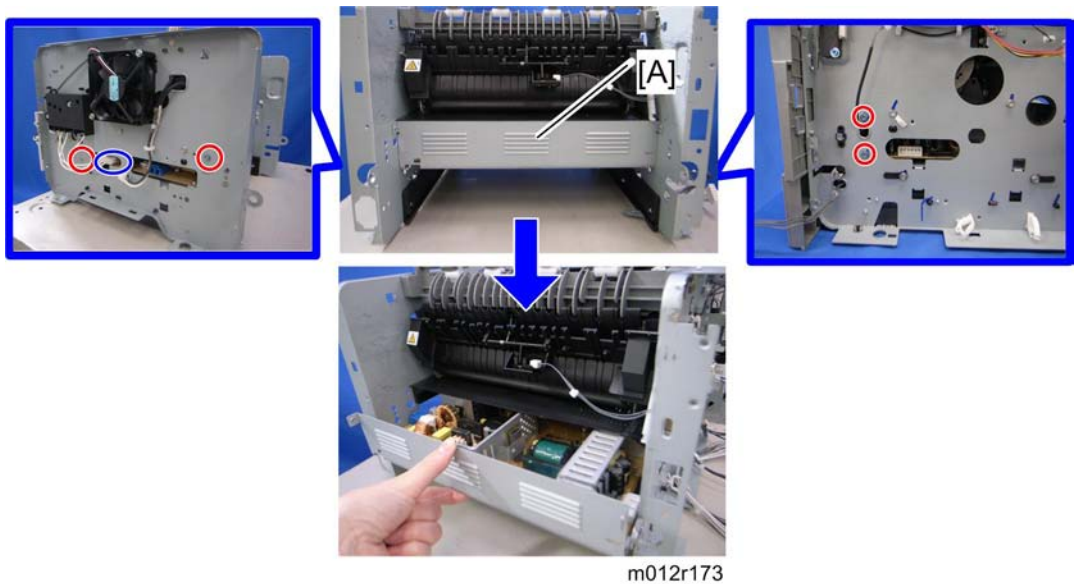

21. PSU [A] (⚙ x 4, ⚙ x 1)

## Charge Terminal Case

1. Right cover (p.28)

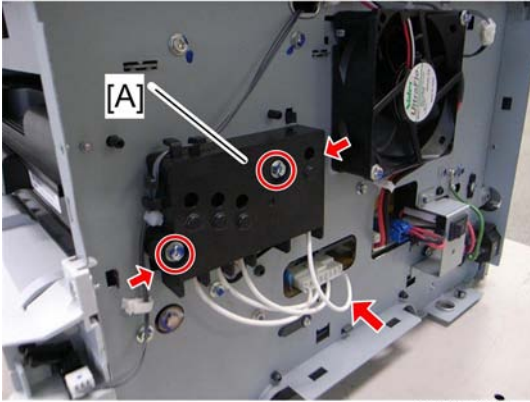

m016r174

2. Charge terminal case [A] with the harness (⚙ x 2, ⚙ x 1, hooks)

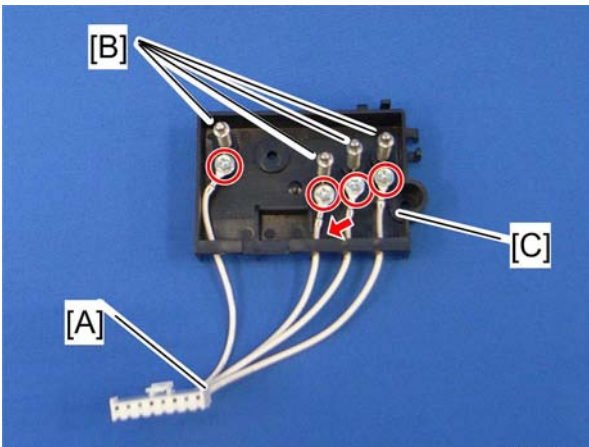

m016r175

3. Remove the harness [A] (⚙ x 4).
4. Remove the four springs and terminal pins [B].
5. Charge terminal case [C]

## Others

### Cooling Fan

1. Right cover (☛ p.28)

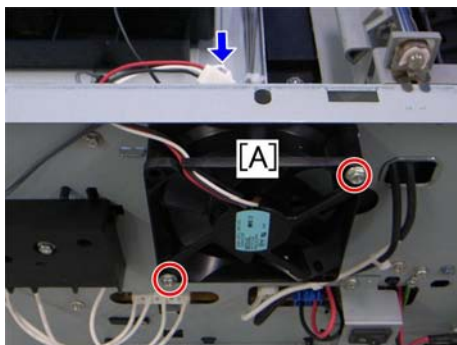

m016r124

2. Cooling fan [A] (☛ x 2, ☛ x 1)

#### **CAUTION**

- Install the Cooling fan [A] with its decal facing the outside of the machine.

### Quenching Lamp

1. Top Cover (☛ p.29)

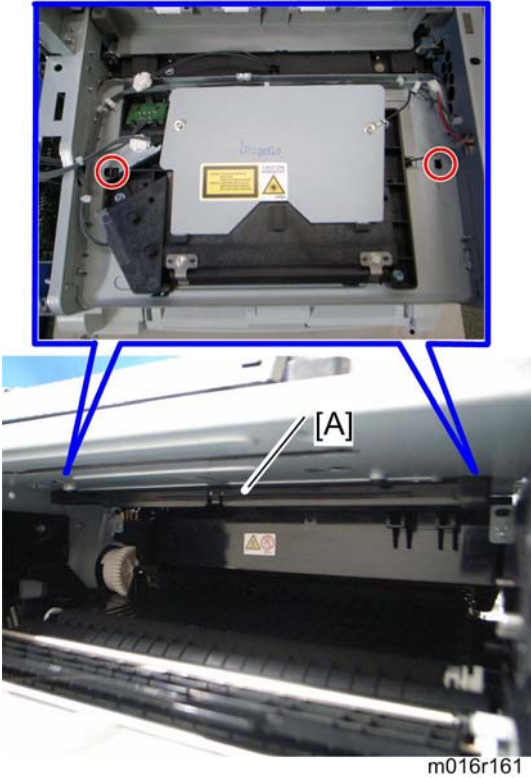

m016r161

2. Release two hooks of the quenching lamp with the case [A], and remove it.



m016r162

3. Remove the quenching lamp [A] from the case (hook x 3).

# Image Adjustment

## Registration Adjustment

### User Adjustment

The paper registration can also be adjusted with the SOM ("Printer Configuration"). For details, see the "Software Guide".

### Service Adjustment

4

1. Print the test pattern (see p. 117).
  - Print out the test pattern before changing the paper registration setting.

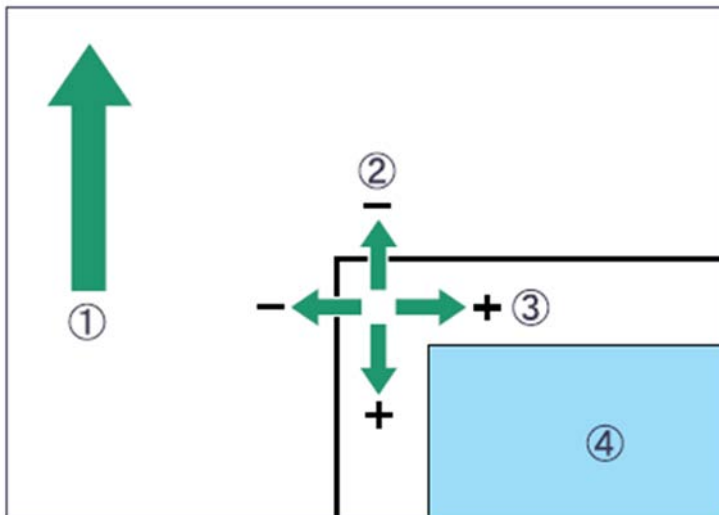

m016t500

- (1): Feed Direction  
 (2): Vertical Adjustment  
 (3): Horizontal Adjustment  
 (4): Print Area
2. Click the "Up" or "Down" to set the registration value (mm).
    - Increase the value to shift the print area in the plus direction.
    - Decrease to shift in the minus direction.
  3. Adjust the margins of the test page so that they are equal in size.



# 5. System Maintenance Reference

## Smart Organizing Monitor

### Overview

SOM (Smart Organizing Monitor) is a utility which can check the status of a printer and set up a printer from a PC. This utility is executed from a printer driver.

### Printer Driver Installation (USB Connection)

1. Close all applications currently running.
2. Check the following:
  - The printer's USB cable is disconnected
  - The printer's main power switch is turned off
3. Insert the CD-ROM into the CD-ROM drive.  
The installer starts.
4. Select the interface language, and then click [OK].
5. Click [DDST Printer Driver] or [PCL 6 Printer Driver].  
The software license agreement appears.
6. After reading the agreement, click [I accept the agreement.], and then click [Next >].
7. In the [Method to install printer driver] dialog box, clear the [Search for network printers.] check box, select the [Connect a printer using a USB cable.] check box, and then click [Next >].
8. Select this printer, and then click [Next >].  
A message appears, asking you to check that the USB cable is not connected and that the printer's main power switch is turned to off.
9. Check the USB cable and the printer status, and then click [Next >].
10. When the [<Auto-detect USB Port>] dialog box appears, connect this printer to the computer using a USB cable, and then turn the printer's main power switch on.  
USB auto detection begins.
11. When the dialog box asking you to use this printer as the default printer appears, click either key.
12. When a message appears informing you that the installation was successfully completed, click [Finish].

## Entering the Printer Configuration

To enter the service system setting;

1. Start the SOM utility.

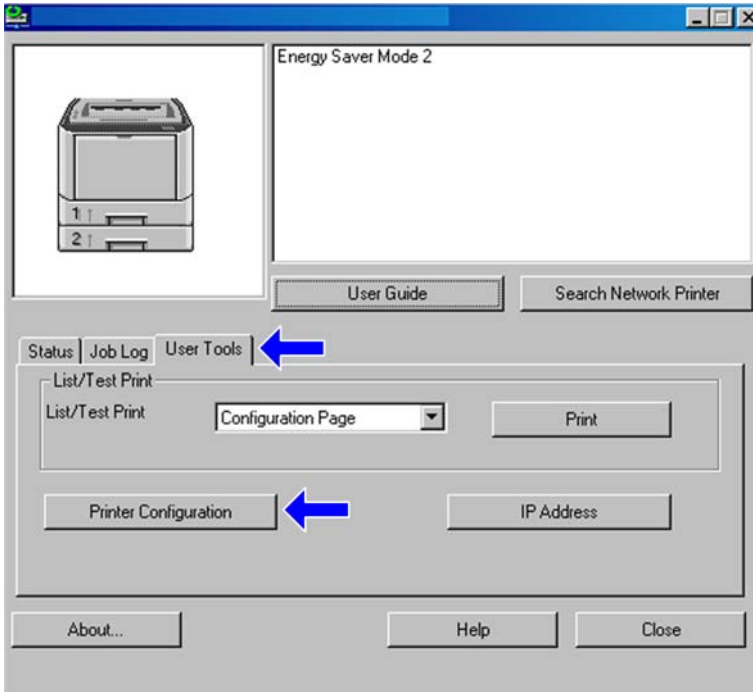

m012s501

2. Click the "User Tools" tab.
3. Click "Printer Configuration".
4. The "Access Code" entry dialog appears.

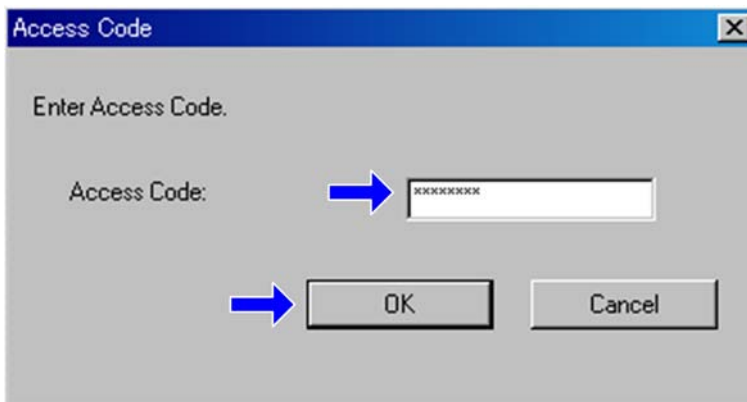

m012s502

5. Input the access code (for customer engineers).



6. Click the "OK" button.

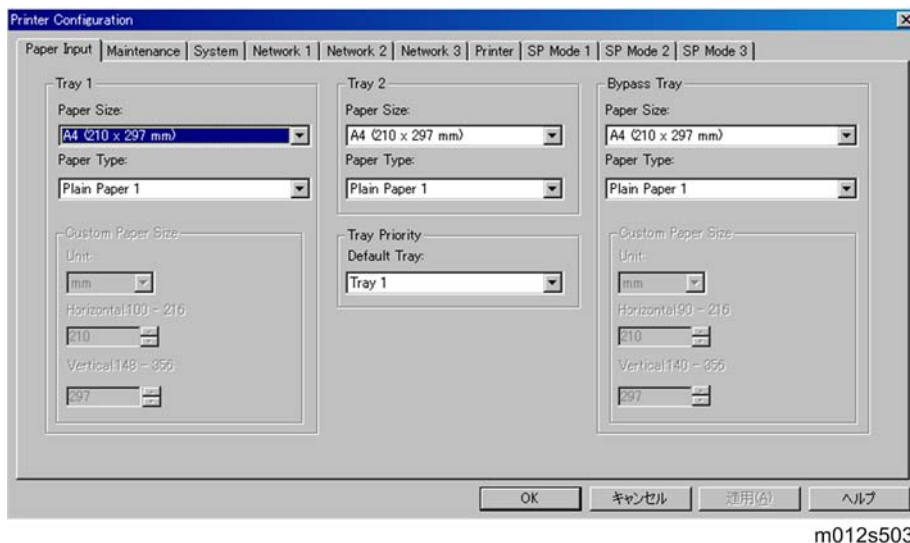

7. The "Printer Configuration" GUI appears.

5

## Printer Configuration Menu List

The SOM has the following printer configuration menus. Each menu contains various setting items. The details of each setting item are explained in this section below.

Menu	Description
Paper Input	Adjusts the paper type and size settings.
Maintenance	Adjusts the image registration and executes the color registration adjustment.
System	Adjusts the system settings of the machine.
Network 1	Adjusts network settings (Information, Interface, TCP/IP).
Network 2	Adjusts network settings (IPX, SMTP).
Network 3	Adjusts network settings (SNMP, Apple Talk).
Printer	Adjusts the printer driver settings (PCL, PS).
SP mode 1	Adjusts and executes service program modes.
SP mode 2	Adjusts and executes service program modes.
SP mode 3	Adjusts and executes service program modes.

## Paper Input

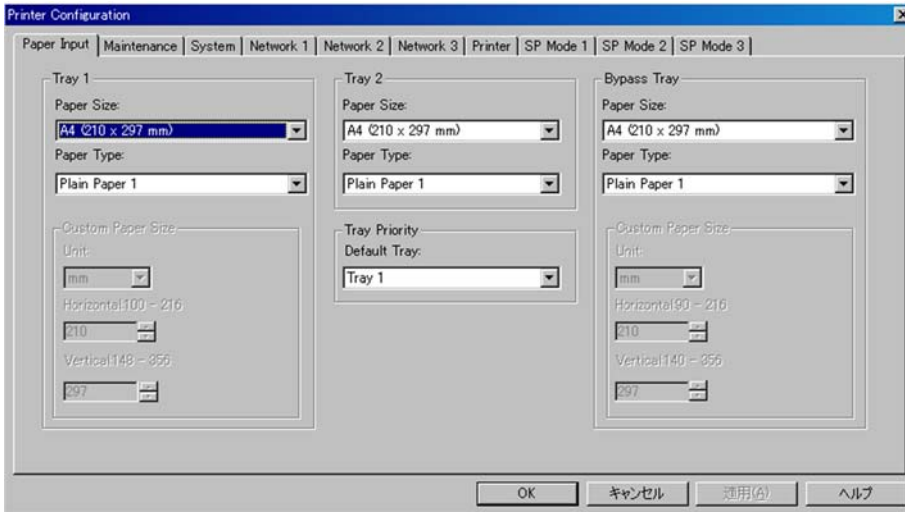

m012s503

5

Item	Selections	Remarks
Tray 1 Paper Size (standard)	A4 */ B5/ A5/ B6/ A6/ Legal/ Letter */ Half Letter/ Executive/ 8" x 13"/ 8.5" x 13"/ Folio/ 16K/ Custom Paper Size	*: Default (NA: Letter, EU: A4) The selectable paper sizes depend on the model. For details, refer to the "Supported Paper Size List".
Tray 1 Paper type (standard)	Thin Paper/ Thick Paper 1/ Thick Paper 2 / Plain Paper 1 */ Recycled Paper/ Color Paper/ Preprinted Paper/ Prepunched Paper/ Letterhead/ Bond Paper/ Cardstock/ Labels	*: Default The selectable paper types depend on the model. For details, refer to the "Supported Paper Types" in the "Specifications" chapter.
Tray 2 Paper Size (optional)	A4 */ B5/ A5/ Legal/ Letter */ Half Letter	*: Default (NA: Letter, EU: A4)
Tray 2 Paper type (optional)	Thin Paper/ Thick Paper 1/ Plain Paper 1 */ Recycled Paper/ Color Paper/ Preprinted Paper/ Prepunched Paper/ Letterhead	-

Item	Selections	Remarks
Bypass Tray Paper Size	A4 */ B5/ A5/ B6/ A6/ Legal/ Letter*/ Half Letter/ Executive/ 16K/ 4 1/8" x 9 1/2"/ 3 7/8" x 7 1/2"/ C5 Env/ C6Env/ DL Env/ Custom Paper Size	-
Bypass Tray Paper type	Thin Paper/ Thick Paper 1/ Thick Paper 2 / Plain Paper 1 */ Recycled Paper/ Color Paper/ Preprinted Paper/ Prepunched Paper/ Letterhead/ Bond Paper/ Cardstock/ Labels/ Envelope/ OHP	-
Custom Paper Size: Unit	Mm */ Inch	<p>If the paper size factory default is A4, then the custom size factory default unit is mm.</p> <p>If the paper size factory default is Letter, then the custom size factory default unit is inch.</p>
Custom Paper Size: Horizontal	100-216mm	<p>3.54 – 8.50 inch. Precision is two digits after the decimal point in inch or one digit after the decimal point in mm.</p> <p>If an input value is more than the maximum value, then it will be treated as the maximum value.</p> <p>If an input value is less than the minimum value, then it will be treated as the minimum value.</p>
Custom Paper Size: Vertical	148-356mm	<p>5.83 – 14.02 inch. Precision is two digits after the decimal point in inch or one digit after the decimal point in mm.</p> <p>If an input value is more than the maximum value, then it will be treated as the maximum value.</p> <p>If an input value is less than the minimum value, then it will be treated as the minimum value.</p>

Item	Selections	Remarks
Tray Priority: Default Tray	Tray1 *	-
	Tray2	
	Bypass Tray	

"\*" indicates the factory default value.

### Maintenance

5

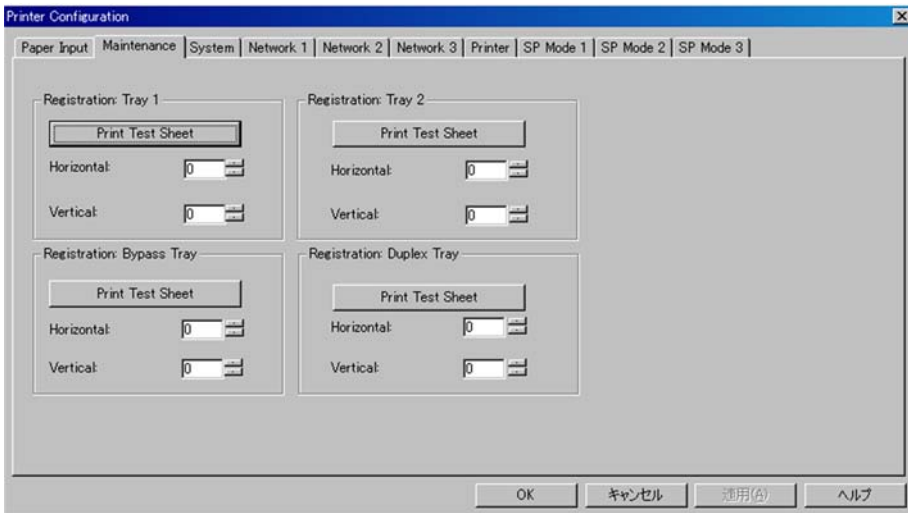

m012s504

Group (Tab)	Item	Selections	Remarks
Registration Tray 1	Print Test Sheet button		Sends a PCL command to the printer to print a test sheet. It is disabled when tray 1 is not installed.
	Adjustment Horizontal	(-15 to +15) step	0.34 mm per step. Range is -5 mm to +5 mm. If the machine settings are reset to the factory defaults, this value does not change.
	Adjustment Vertical	(-15 to +15) step	0.24 mm per step. Range is -3.6 mm to +3.6 mm If the machine settings are reset to the factory defaults, this value does not change.

Group (Tab)	Item	Selections	Remarks
Registration Tray 2	Print Test Sheet button		Sends a PCL command to the printer to print a test sheet. It is disabled when tray 2 is not installed.
	Adjustment Horizontal	(-15 to +15) step	0.34 mm per step. Range is -5 mm to +5 mm. If the machine settings are reset to the factory defaults, this value does not change.
	Adjustment Vertical	(-15 to +15) step	0.24 mm per step. Range is -3.6 mm to +3.6 mm If the machine settings are reset to the factory defaults, this value does not change.
Registration Bypass Tray	Print Test Sheet button		Sends a PCL command to printer to print a test sheet.
	Adjustment Horizontal	(-15 to +15) step	0.34 mm per step. Range is -5 mm to +5 mm.
	Adjustment Vertical	(-15 to +15) step	0.24 mm per step. Range is -3.6 mm to +3.6 mm
Registration Duplex Tray	Print Test Sheet button		Sends a PCL command to printer to print a test sheet.
	Adjustment Horizontal	(-15 to +15) step	0.34 mm per step. Range is -5 mm to +5 mm.
	Adjustment Vertical	(-15 to +15) step	0.24 mm per step. Range is -3.6 mm to +3.6 mm

"\*" indicates the factory default value.

## System

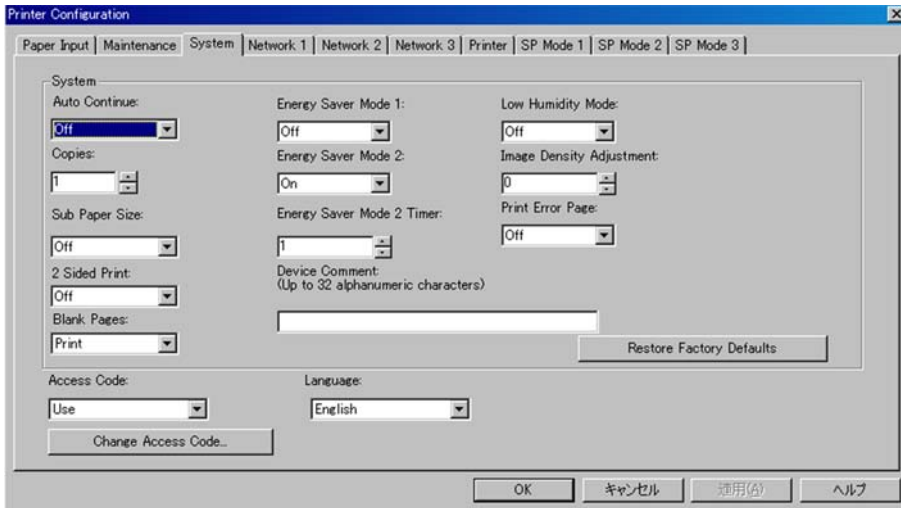

m012s505

5

Item	Selections	Remarks
Auto Continue	On/Off *	
Copies	1 *-999	
Sub Paper Size	Off * / Auto	
2 Sided Print	Off * / Short Edge Bind/ Long Edge Bind	
Blank Page Print	Print * / Not Print	"Manual Duplex/Cover" has higher priority than the "Blank Pages" setting.
Energy Saver Mode 1	On	
	Off *	
Energy Saver Mode 2	On *	
	Off	
Energy Saver Mode 2 Timer	0 *-240 min	
Low Humidity Mode	On	
	Off *	

Item	Selections	Remarks
Image Density Adjustment	-3 to 3 (0*)	
Print Error Page	On	
	Off *	
Device Comment	Null string*	Up to 32 alphanumeric characters. The factory default is 'null string'.
Restore to Factory Default button		Restores all settings to the factory default settings for the market area setting.

5

Item	Selections	Remarks
Language	English *	The factory setting is English if the market is NA or EU or ASIA.
	French	
	German	
	Italian	
	Spanish	
	Dutch	
	Danish	
	Swedish	
	Norwegian	
	Portuguese	
	Polish	
	Czech	
	Hungarian	
	Finnish	
	Japanese	
	Simplified Chinese	
Traditional Chinese		
Russian		
Brazilian		
Access Code	Use *	
	Do not use	
Access code change button		Changes the access code. The button is grey if the Access code is set to "Do not use".

"\*" indicates the factory default value.



## Network 1

The screenshot shows the 'Printer Configuration' dialog box with the 'Network 1' tab selected. The 'Information' section contains a table with the following data:

Item	Data
Device Name:	Aticio SP 3410DN
Comment:	
MAC Address:	00-00-74-EC-3C-52

The 'Interface' section includes:

- I/O Timeout (USB): 60 seconds
- Fixed USB Port: On
- I/O Timeout (Network): 60 seconds
- Ethernet Speed: Auto Select

The 'TCP/IP' section includes:

- IP Address: 133.139.166.46
- Subnet Mask: 255.255.255.0
- Default Gateway Address: 133.139.166.1
- DHCP: On
- DNS Method: Auto
- Primary DNS Server IP: 133.139.166.21
- DNS Domain Name: esdohmoriricoh.co.jp

Buttons at the bottom: OK, キャンセル, 適用(分), ヘルプ

m012s506

5

Group (Tab)	Item	Selections	Remarks
Information	Device Name		String length is 32
	Comment		String length is 32
	Mac Address		

Group (Tab)	Item	Selections	Remarks
TCP/IP	IP Address	xxx.xxx.xxx.xxx	<p>This setting is not available if DHCP is enabled.</p> <p>If this setting is changed, the printer power must be turned off/on for the new setting to take effect.</p> <p>The default setting is "192.0.0.192" when DHCP is off.</p>
	Subnet Mask	xxx.xxx.xxx.xxx	<p>This setting is not available if DHCP is enabled.</p> <p>If this setting is changed, the printer power must be turned off/on for the new setting to take effect.</p> <p>Will show all zero if network initialization is not finished. Any change will be ignored before the end of network initialization.</p> <p>The default setting is "255.255.255.0" when DHCP is off.</p>
	Default Gateway Address	xxx.xxx.xxx.xxx	<p>This setting is not available if DHCP is enabled.</p> <p>If this setting is changed, the printer power must be turned off/on for the new setting to take effect.</p> <p>Will show all zero if network initialization is not finished. Any change will be ignored before the end of network initialization.</p> <p>The default setting is "192.0.0.192" when DHCP is off.</p>

Group (Tab)	Item	Selections	Remarks
TCP/IP	DHCP	On */ Off	If this setting is changed, the printer power must be turned off/on for the new setting to take effect.
	DNS Method	Auto */ Manual	
	Primary DNS Server IP	xxx.xxx.xxx.xxx	Up to 32 alphanumeric characters. This setting is not available if DHCP is enabled. The default setting is "0.0.0.0" when DHCP is off. The setting when DHCP is changed from on to off is the previous setting when DHCP was on. If this setting is changed, the printer power must be turned off/on for the new setting to take effect.
	DNS Domain Name		Up to 32 alphanumeric characters. This setting is not available if DHCP is enabled. The default setting when DHCP is off is null string. The setting when DHCP is changed from on to off is the previous setting when DHCP was on. If this setting is changed, the printer power must be turned off/on for the new setting to take effect.

Group (Tab)	Item	Selections	Remarks
Interface	I/O Timeout (USB)	15 60 * 300	
	I/O Timeout (Network)	15 60 * 300	
	Ethernet speed	Auto* 10M half 10M full 100M half 100M full	
	Fixed USB Port	On */ Off	

"\*" indicates the factory default value.

## Network 2

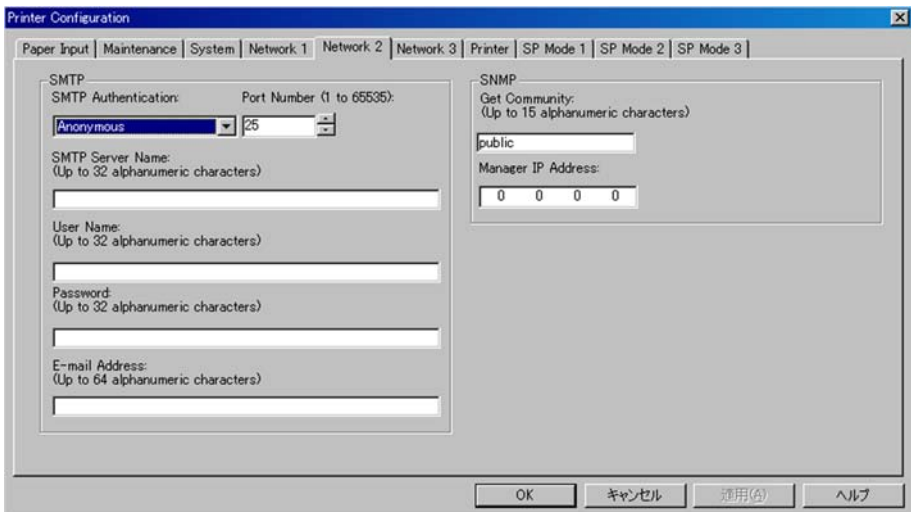

m012s507

Group (Tab)	Item	Selections	Remarks
SMTP	SMTP Authentication	Anonymous*	
		SMTP Authentication	
		POP before SMTP	
	SMTP Server Name	Null string*	Up to 32 alphanumeric characters. The factory default is 'null string'.
	Port Number	25*	1 to 65535 The factory default is 25.
	User Name	Null string*	Up to 32 alphanumeric characters. The factory default is 'null string'.
	Password	Null string*	Up to 32 alphanumeric characters. The factory default is 'null string'. User-input characters and characters read back from the printer will show "*" in order to protect the user password.
E-mail Address	Null string*	Up to 64 alphanumeric characters. (address for receiving e-mail) The factory default is 'null string'.	
SNMP	Get Community	public	Up to 15 alphanumeric characters.
	Manager IP Address	0.0.0.0 *	The factory default is 0.0.0.0 If this setting is changed, the printer power must be turned off/on for the new setting to take effect.

"\*" indicates the factory default value.

### Network 3

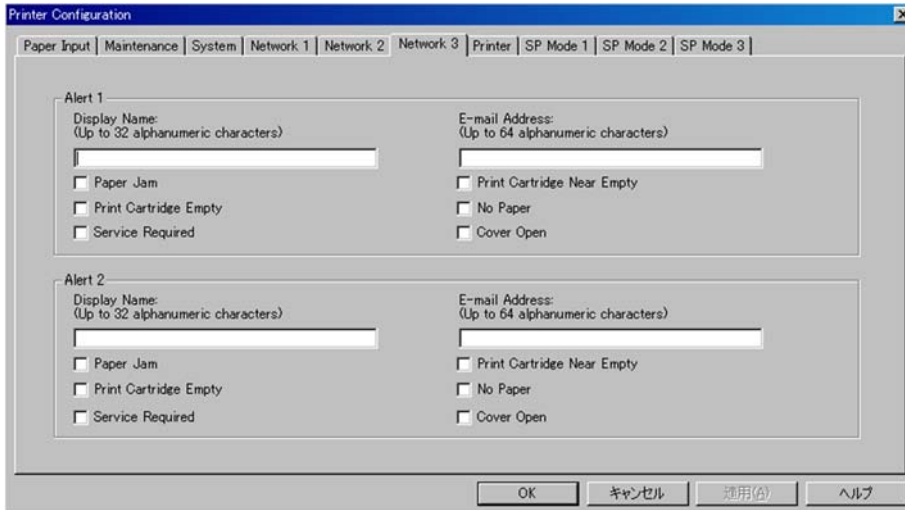

m012s508

5

Group (Tab)	Item	Selections	Remarks
Alert 1	Display Name	Paper Jam	Up to 32 alphanumeric characters.
		Print Cartridge Empty	
		Service Required	
	E-mail Address	Print Cartridge Near Empty	Up to 64 alphanumeric characters.
		No Paper	
		Cover Open	
Alert 2	Display Name	Paper Jam	Up to 32 alphanumeric characters.
		Print Cartridge Empty	
		Service Required	
	E-mail Address	Print Cartridge Near Empty	Up to 64 alphanumeric characters.
		No Paper	
		Cover Open	

"\*" indicates the factory default value.

## Printer

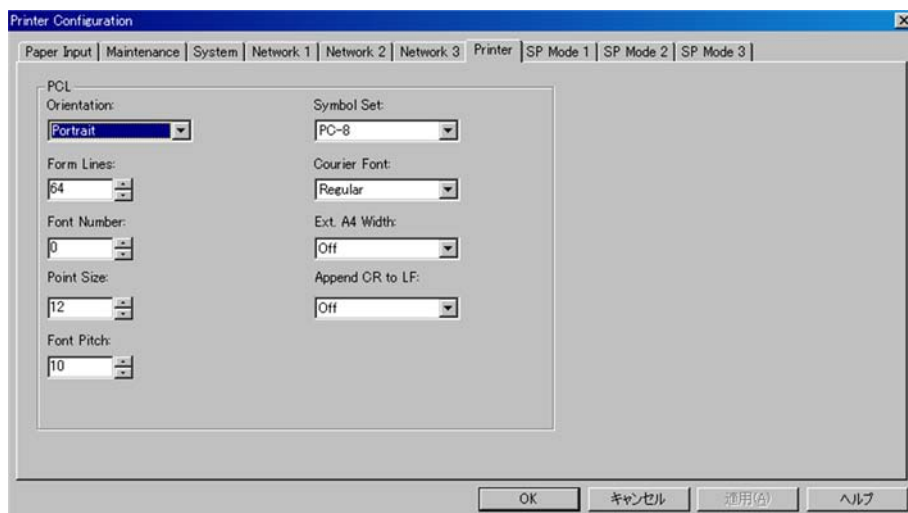

m012s509

5

Group (Tab)	Item	Selections	Remarks
PCL	Orientation	Portrait *	
		Landscape	
	Form Lines	5 to 128 by 1	If the machine settings are reset to the factory defaults, this value does not change.
	Font Number	0* -89	The factory default value is 0.
	Font Size	4 to 999.75 by 0.25 (12 *)	The factory default value is 12.
Font Pitch	0.44 to 99.99 by 0.01 (10 *)	The factory default value is 10.	

5

Group (Tab)	Item	Selections	Remarks
PCL	Symbol Set	Roman-8, Roman-9, ISO L1,	
		ISO L2, ISO L5,	
		PC-8* , PC-8 D/N,	
		PC-850, PC-852,	
		PC-858, PC-8 TK,	
		Win L1, Win L2,	
		Win L5, Desktop,	
		PS Text, VN Intl,	
		VN US, MS Publ,	
		Math-8, PS Math,	
		VN Math, Pi Font,	
	Legal, ISO 4,		
ISO 6, ISO 11,			
ISO 15, ISO 17,			
ISO 21, ISO 60,			
ISO 69, Win 3.0,			
MC Text, ISO L6,			
ISO L9, PC-775,			
PC-1004, Win Balt			
Courier Font	Regular*		
	Dark		
Ext. A4 Width	Off*		
	On		
Append CR to LF	Off *		
	On		

"\*" indicates the factory default value.



## SP Mode 1

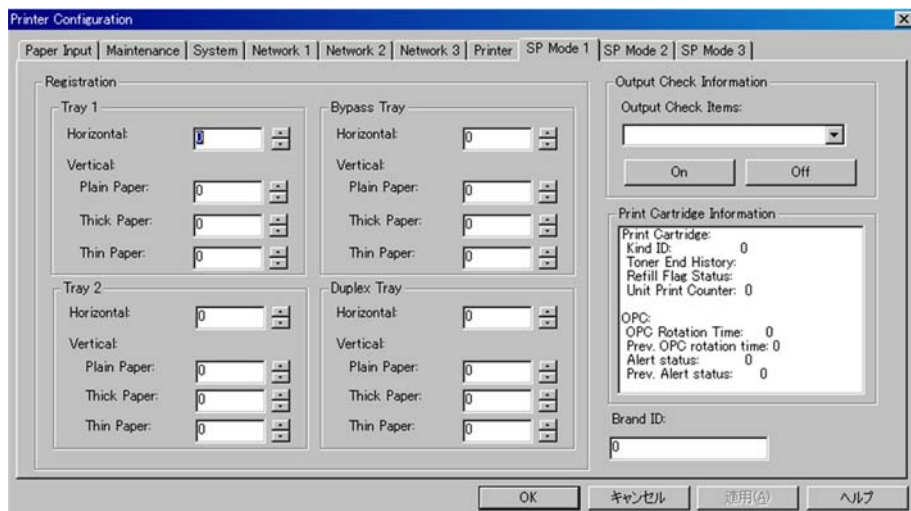

m012s510

5

Registration: Tray 1	Horizontal	Adjusts the horizontal registration for tray 1. If the machine settings are reset to the factory defaults, this value does not change. [-40 to 40 / 0 (Default) / 0.1 mm/step]
	Vertical: Plain Paper	Adjusts the vertical registration of plain paper for tray 1. If the machine settings are reset to the factory defaults, this value does not change. [-40 to 40 / 0 (Default) / 0.1 mm/step]
	Vertical: Thick Paper	Adjusts the vertical registration of thick paper for tray 1. If the machine settings are reset to the factory defaults, this value does not change. [-40 to 40 / 0 (Default) / 0.1 mm/step]
	Vertical: Thin Paper	Adjusts the vertical registration of thin paper for tray 1. If the machine settings are reset to the factory defaults, this value does not change. [-40 to 40 / 0 (Default) / 0.1 mm/step]

Registration: Tray 2	Horizontal	Adjusts the horizontal registration for tray 2. If the machine settings are reset to the factory defaults, this value does not change. [-40 to 40 / 0 (Default) / 0.1 mm/step]
	Vertical: Plain Paper	Adjusts the vertical registration of plain paper for tray 2. If the machine settings are reset to the factory defaults, this value does not change. [-40 to 40 / 0 (Default) / 0.1 mm/step]
	Vertical: Thick Paper	Adjusts the vertical registration of thick paper for tray 2. If the machine settings are reset to the factory defaults, this value does not change. [-40 to 40 / 0 (Default) / 0.1 mm/step]
	Vertical: Thin Paper	Adjusts the vertical registration of thin paper for tray 2. If the machine settings are reset to the factory defaults, this value does not change. [-40 to 40 / 0 (Default) / 0.1 mm/step]
Registration: Bypass Tray	Horizontal	Adjusts the horizontal registration for the bypass tray. If the machine settings are reset to the factory defaults, this value does not change. [-40 to 40 / 0 (Default) / 0.1 mm/step]
	Vertical: Plain Paper	Adjusts the vertical registration of plain paper for the bypass tray. If the machine settings are reset to the factory defaults, this value does not change. [-40 to 40 / 0 (Default) / 0.1 mm/step]
	Vertical: Thick Paper	Adjusts the vertical registration of thick paper for the bypass tray. If the machine settings are reset to the factory defaults, this value does not change. [-40 to 40 / 0 (Default) / 0.1 mm/step]
	Vertical: Thin Paper	Adjusts the vertical registration of thin paper for t the bypass tray. If the machine settings are reset to the factory defaults, this value does not change. [-40 to 40 / 0 (Default) / 0.1 mm/step]

Registration: Duplex Tray	Horizontal	Adjusts the horizontal registration the back side in duplex mode. If the machine settings are reset to the factory defaults, this value does not change. [-40 to 40 / 0 (Default) / 0.1 mm/step]
	Vertical: Plain Paper	Adjusts the vertical registration of plain paper for the back side in duplex mode. If the machine settings are reset to the factory defaults, this value does not change. [-40 to 40 / 0 (Default) / 0.1 mm/step]
	Vertical: Thick Paper	Adjusts the vertical registration of thick paper for the back side in duplex mode. If the machine settings are reset to the factory defaults, this value does not change. [-40 to 40 / 0 (Default) / 0.1 mm/step]
	Vertical: Thin Paper	Adjusts the vertical registration of thin paper for the back side in duplex mode. If the machine settings are reset to the factory defaults, this value does not change. [-40 to 40 / 0 (Default) / 0.1 mm/step]
Brand ID	00* – 7F Displays the current brand ID number. Do not change this setting (Designed for Factory Use).	

Output check	Main Motor	Output check (Main Motor)
	Middle Clutch	Output check (Relay Clutch)
	Tray1 Clutch	Output check (Paper Feed Clutch)
	Bypass solenoid	Output check (Bypass solenoid)
	Registration clutch	Output check (Registration Clutch)
	Reverse Clutch	Output check (Reverse Clutch)
	Fan High Speed	Output check (Fan High Speed)
	Fan Low Speed	Output check (Fan Low Speed)
	Erase Lamp	Output check (Quenching Lamp)
	Polygon Motor	Output check (Polygon Motor)
	Tray2 Motor	Output check (Tray2 Motor)
	Duplex Motor Normal	Output check (Duplex Motor Normal)
Duplex Motor Reverse	Output check (Duplex Motor Reverse)	

"\*" indicates the factory default value.

### SP Mode 2

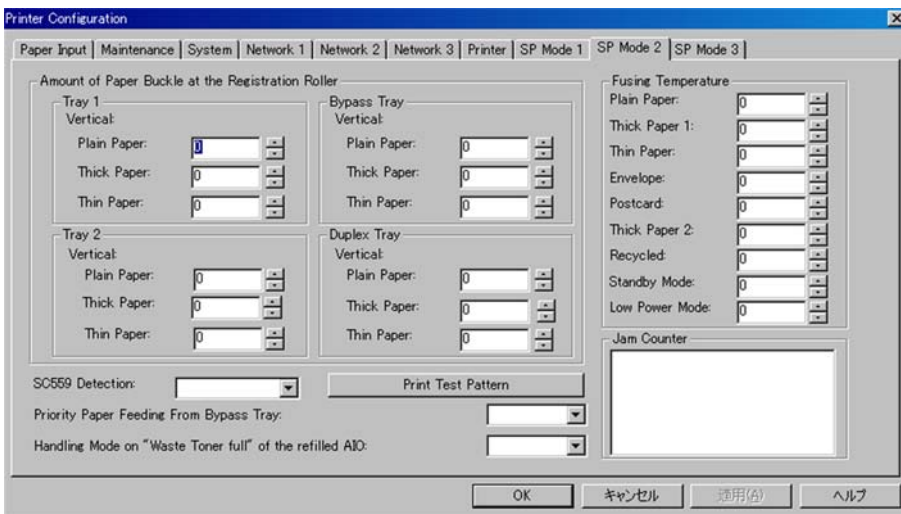

m012s511

Amount of Paper Buckle at the Registration Roller: Tray 1	Vertical: Plain Paper	Adjusts the amount of paper buckle at the registration roller for each tray and paper type. [-8 to 8 / 0 (Default) / 1 mm/step]
	Vertical: Thick Paper	
	Vertical: Thin Paper	Adjusts the amount of paper buckle at the registration roller for each tray and paper type. [-8 to 8 / -2 (Default) / 1 mm/step]
Amount of Paper Buckle at the Registration Roller: Tray 2	Vertical: Plain Paper	Adjusts the amount of paper buckle at the registration roller for each tray and paper type. [-8 to 8 / 0 (Default) / 1 mm/step]
	Vertical: Thick Paper	
	Vertical: Thin Paper	
Amount of Paper Buckle at the Registration Roller: Bypass Tray	Vertical: Plain Paper	Adjusts the amount of paper buckle at the registration roller for each tray and paper type. [-8 to 8 / 0 (Default) / 1 mm/step]
	Vertical: Thick Paper	
	Vertical: Thin Paper	
Amount of Paper Buckle at the Registration Roller: Duplex Tray	Vertical: Plain Paper	Adjusts the amount of paper buckle at the registration roller for each tray and paper type. [-8 to 8 / 0 (Default) / 1 mm/step]
	Vertical: Thick Paper	
	Vertical: Thin Paper	

Fusing Unit Temperature	Plain Paper	Adjusts the fusing temperature for plain paper. [150 to 190 / 175 (Default) / 5°C/step]
	Thick Paper 1	Adjusts the fusing temperature for thick 1 paper. [160 to 200 / 185 (Default) / 5°C/step]
	Thin Paper	Adjusts the fusing temperature for thin paper. [140 to 165 / 150 (Default) / 5°C/step]
	Envelope	Adjusts the fusing temperature for envelope. [170 to 200 / 200 (Default) / 5°C/step]
	Postcard	Adjusts the fusing temperature for postcard. [160 to 200 / 185 (Default) / 5°C/step]
	Thick Paper 2	Adjusts the fusing temperature for thick 2 paper. [160 to 200 / 185 (Default) / 5°C/step]
	Recycled	Adjusts the fusing temperature for recycled paper. [150 to 180 / 160 (Default) / 5°C/step]
	Standby Mode	Adjusts the fusing temperature in the standby mode. [120 to 175 / 155 (Default) / 1°C/step]
	Low Power Mode	Adjusts the fusing temperature in the low power mode. [80 to 135 / 120 (Default) / 5°C/step]
SC559 Detection	[On or Off (Default)]	
Print Test Pattern	Prints the test pattern.	
Priority Paper Feeding From Bypass Tray	Turns on or off the paper priority feeding from the bypass tray. [On or Off (Default)]	
Handling Mode on "Waste Toner full" of the refilled AIO	Sets the machine operation at "waste toner full" of the refilled AIO. [On or Off (Default)]	

"\*" indicates the factory default value.

## SP Mode 3

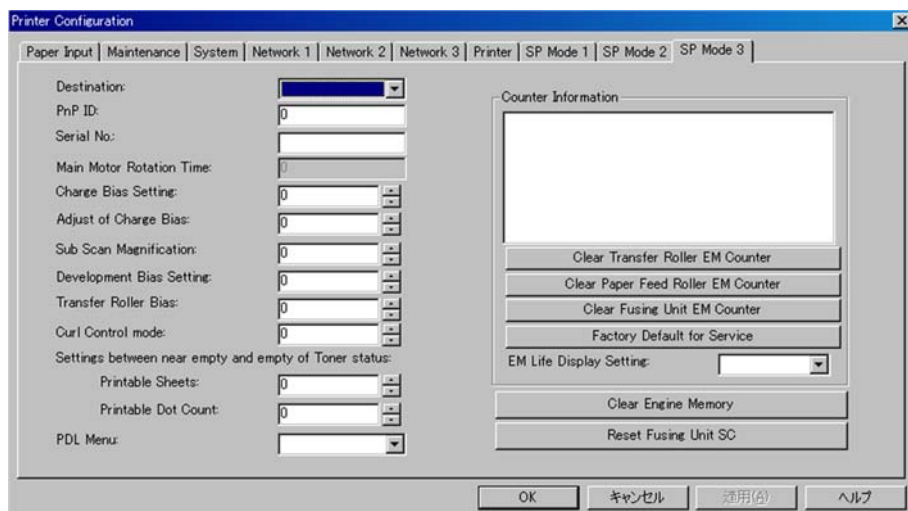

m012s512

5

Destination	Sets the destination and updates the engine setting. JPN/ NA/ EU (Default)/ ASIA/ China/ TAIWAN/ COREA
P <sub>N</sub> P ID	
Serial No	
Main Motor Rotation Time	Displays the main motor rotation time.
Charge Bias	Adjusts the charge bias. [1100 to 1300 / 1200 / 20 /step]
Adjust of Charge Bias	Charge bias correction for dirty background 0: OFF (Default) 1: ON 2 to 255: not available [0 to 255 / 0 / 1 /step]
Sub Scan Magnification	Adjusts the sub scan magnification. [-8 to 8 / 0 / 1 /step]
Development Bias Setting	Adjusts the developer bias. [270 to 330 / 300 / 15 /step]

Transfer Roller Bias	Adjusts the transfer roller bias. [-6 to 6 / 0 / 1 /step]	
Curl Control mode	Corrects the face curl of paper. 0: OFF (28ppm) 1: Sets the engine speed at 14ppm after printing 1 minute. 2: Sets the engine speed at 14ppm. 3 to 255: not available [0 to 255 / 0 / 1 /step]	
Settings between near empty and empty of Toner status	Printable Sheets	Adjusts the printable sheets between "toner near end" to "toner end". [0 to 255 / 200 / 1 sheet/step]
	Printable Dot Count	Adjusts the printable dot count between "toner near end" to "toner end". [0 to 255 / 100 / 1 dot/step]
PDL Menu	ON = "PDL Settings" is shown (Default) OFF = "PDL Settings" is hidden	
Counter Information	Display the counter information.	
Clear Transfer Roller EM Counter	Clears the EM counter of the transfer roller.	
Clear Paper Feed Roller EM Counter	Clears the EM counter of the paper feed roller.	
Clear Fusing Unit EM Counter	Clears the EM counter of the fusing unit.	
Factory Default for Service	Resets all the settings to factory default. <b>Note</b> <ul style="list-style-type: none"> <li>Clears/ resets the contents of the controller board memory (all data programmed by the user, log data) to factory default.</li> </ul> After executing, initial setup menu starts after power-on.	
Clear Engine Memory	Resets the engine settings stored in the EEPROM to factory default.	
Reset Fusing Unit SC	This button is for resetting an SC related with the fusing errors.	



# Configuration Page

## Overview

The configuration page has information about the machine's status. Print this sheet as shown below. Check the configuration page when doing machine maintenance.

## To Print the Configuration Page

1. Start the SOM utility.

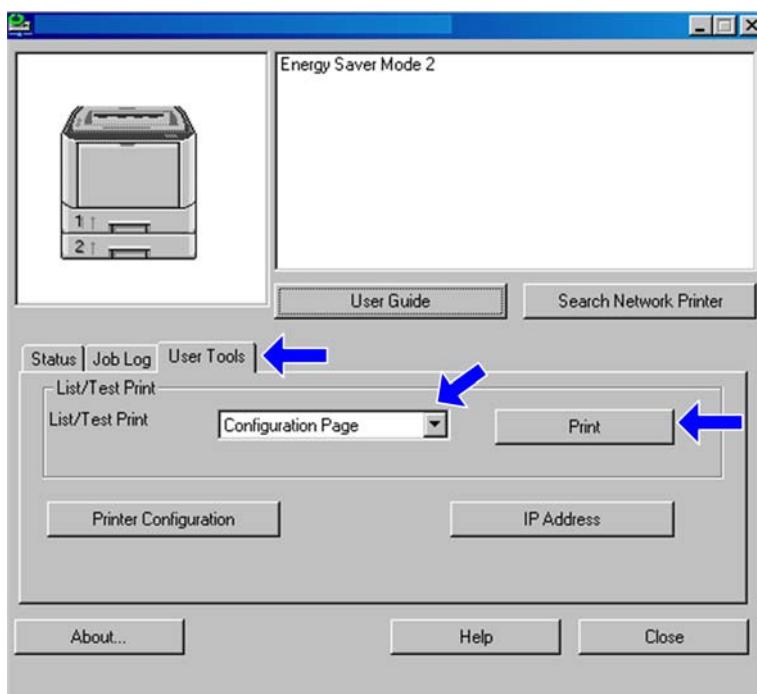

m012s501a

2. Click the "User Tools" tab.
3. Select "Configuration Page" in the "List/ Test Print".
4. Click "Print".
5. The configuration page is printed.

## Total Counter

Total Counter:

The total counter incremented by the "**engine controller board**" each time the board issues a print command to the engine.

The value is calculated as follows:

Total counter = Printer counter + Reports print

# Firmware Updating

## ★ Important

- Never turn the machine's main power off while the firmware is being updated, as this could damage the ECB or controller board.

## Checking the Machine Firmware Version

To update the firmware for this machine, you need the most recent version of the firmware (firmware file downloadable from the Internet).

1. Start the SOM utility.
2. Click the "User Tools" tab.
3. Select "Configuration Page" in the "List/ Test Print".
4. Click "Print" to print the "Configuration Page", which shows the "Firmware Version (Controller)" and "Engine FW version".

5

## Updating the Controller Firmware

Using the following procedure to update the controller firmware, be sure to print the configuration page both before and after the update. Comparing pre- and post-update configuration pages allows you to check whether or not the update was successful.

Follow the procedure carefully, and note that it will vary in parts depending on which version of the firmware is currently installed.

### Procedure

When updating firmware, always disconnect any other cable(s) than the one being used for the update operation.

(When updating firmware via USB cable, first disconnect any network and phone line cables, and when updating firmware via LAN cable, first disconnect any USB and phone line cables.)

1. Prepare:
  - Computer
  - USB cable or LAN (Local Area Network) cable
2. Download the firmware files to your computer.



3. Make a folder on a local drive of your computer and save the files there.

**Note**

- "FWUpdate ToolSP.exe": Used for Controller firmware or Engine firmware
- "FWUpdate Tool.exe": Used for Controller firmware

4. Connect a USB cable between a computer and the machine.

5. Click the "FWUpdateToolSP.exe" or "FWUpdateTool.exe" file to execute the updating program.

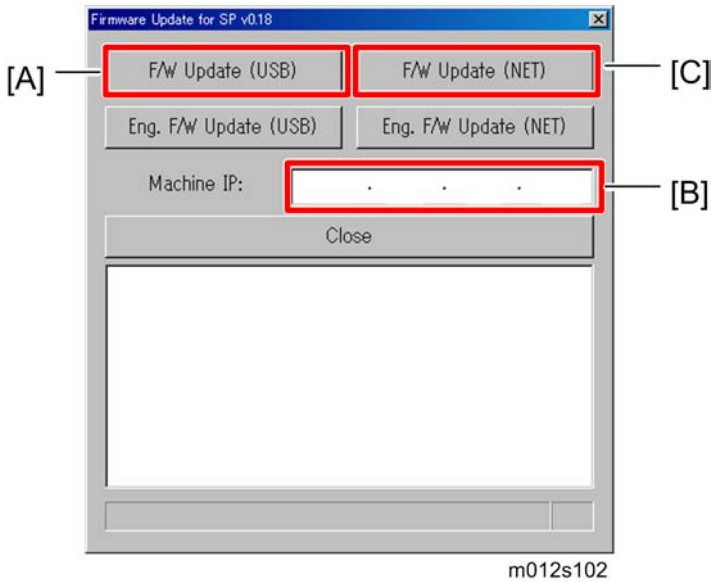

6. For a USB connection, click "F/W Update (USB)" [A]. For a network connection, enter the machine's IP address in "Machine IP" [B], and then click "F/W Update (NET)" [C].

7. The following message appears on the screen:

"Firmware is Updating ..." and the Alert LED (red) on the printer starts blinking. (The Ready LED remains lit.)

**Note**

- Do not turn the main power off from this point until the update procedure is completed.

8. Wait until the update is finished.

**Note**

- Do not touch the machine during updating!

- The update is finished when "FW Update Done. Please reboot the Machine." appears in the firmware update tool window.

The Ready LED (green) on the printer starts blinking. (The Alert LED is still blinking.)

- Turn the main power of the machine off, and then turn it back on.
- Print a configuration page to check the machine's firmware version.

---

## Updating the Engine Firmware

---

### Procedure

---

When updating firmware, always disconnect any other cable(s) than the one being used for the update operation.

(When updating firmware via USB cable, first disconnect any network and phone line cables, and when updating firmware via LAN cable, first disconnect any USB and phone line cables.)

**5**

- Prepare:
  - PC
  - USB cable or network cable
- Download the firmware file to your computer.



- Make a folder on a local drive of your computer and save the files there.
- Connect a USB cable between your computer and the machine.
- Click the "FWUpdateToolSP.exe" file to execute the updating program.



m012s103

5

6. The above updating program should appear on the screen.

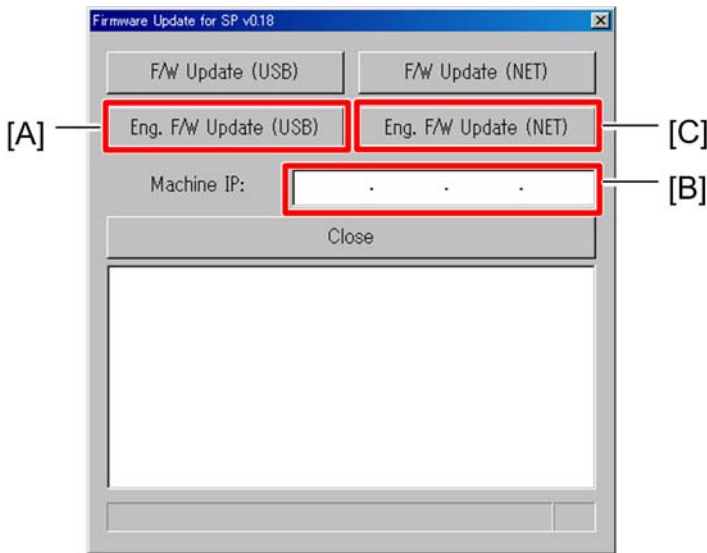

m012s106

7. For a USB connection, click "Eng. F/W Update (USB)" [A]. For a network connection, enter the machine's IP address in "Machine IP" [B], and then click "Eng. F/W Update (NET)" [C].

8. The update is in progress when "Eng Firmware is Updating" appears.  
LED (red) on the printer starts blinking. (The Ready LED remains lit.)

**Note**

- You will see the progress percentage appear while the update is in progress.
- Do NOT turn the main power of the machine off during updating.

9. The update is finished when "FW Update Done. Please reboot the Machine." appears.  
The Ready LED (green) on the printer starts blinking. (The Alert LED is still blinking.)
10. Turn the main power of the machine off, and then back on.

## Updating the Boot Loader Firmware

This is also listed on the configuration page, but this firmware is not updated in the field.

## Updating Failure

If the firmware update is not successful, the update process is suspended and an error message should display on the FW Update Tool screen. The Alert LED (red) on the printer starts lighting. (The Ready LED remains lit.) If this happens, DO NOT turn off the machine, and execute the update procedure again.

If power is turned off accidentally during a firmware update, the firmware will not be correctly updated, and the machine may not start up normally. If the machine does not start up normally, the controller firmware and/or the engine firmware will need to be updated again.

5

## FW Update Tool Messages

### FW Update Tool Messages: Information

#### Message for USB update

Messages	Comment	Action
USB Upload : End of data	Send F/W file to Printer successfully. (Transmission Time: <30 sec)	Please reboot Printer after panel shows reboot message.
USB Upload : FAIL	Can not open USB printer driver while F/W file is transmitted.	Check USB cable connection. Check the installation of USB Print Driver if it is available. Check Printer status if it is available.

Messages	Comment	Action
	F/W file transmission can not be completed. (Transmission will be canceled if timeout.)	Check USB cable connection. Check USB Print Driver if it is available. Check Printer status if it is available.
Can't open ROM file.Please check ROM file.	F/W file does not exist.	Check the download file name in setting.ini. "ImageFile="
Can't open Eng. ROM file. Please check Eng. ROM file.	Engine F/W file does not exist.	Check the download file and fw update tool is in the same folder. Check the download file name in setting.ini. "EngImageFile="
New Version: Update FW	AIO FW is transmitting	Not available
Eng FW version: Update Eng FW	Engine FW is transmitting	Not available
Firmware is Updating...	AIO FW is updating	Not available
Eng Firmware is Updating...	Engine FW is updating	Not available
FW Update Done. * * * Please reboot the Machine. * * *	F/W update is completed.	Please reboot the Machine.

### Message for Network update

Messages	Comment	Action
Connecting...	Connect to Printer.	Please wait a moment.
Net Upload : End of data	Update F/W successfully. (Transmission Time: <30 sec)	Please reboot Printer after panel shows reboot message.



Messages	Comment	Action
Net Upload : FAIL	Can not open FTP port of Printer before F/W file is transmitted. (Transmission will be canceled if timeout.)	(1) Check network cable connection. (2) Check Printer status if it is available. (3) Check Printer and PC IP address setting. (4) Check PC firewall setting about FTP.
	F/W file transmission can not be completed. (Transmission will be canceled if timeout.)	(1) Check network cable connection. (2) Check Printer status if it is available.
Can't open ROM file. Please check ROM file.	F/W file does not exist.	Check the download file name in setting.ini. "ImageFile="
Can't open Eng. ROM file. Please check Eng. ROM file.	Engine F/W file does not exist.	Check the download file name in setting.ini. "EngImageFile="
New Version: Update FW	AIO FW is transmitting	Not available
Eng FW version: Update Eng FW	Engine FW is transmitting	Not available
Firmware is Updating...	AIO FW is updating	Not available
Eng Firmware is Updating...	Engine FW is updating	Not available
FW Update Done. *** Please reboot the Machine.***	F/W update is completed.	Please reboot the Machine.

## FW Update Tool Messages: Error

### Message for USB update

Messages	Comment	Action
Machine is not ready.	Can not get Printer status form USB status channel before F/W file is transmitted.	Check USB cable connection. Check USB Print Driver if it is available. Do not update F/W when Printer is in power-on stage.
Wrong Model.	F/W file is not matched for current machine.	Please check the version of F/W file and machine if it is suitable for Printer.
Machine is busy.	F/W update is running. Other Printer functions are running.	Please wait F/W update is completed. Please wait other Printer functions are completed.
FW Update Done. *** Please reboot the Machine.***	F/W update is completed.	Please reboot the Machine.
Machine loses communication. ***Please check FW Update Done. Then reboot the Machine.***	F/W file has transmitted. Polling F/W update progress fail.	Do not reboot engine till Engine Panel display "Firmware Update Done. Please reboot". Then reboot engine.
Downloaded file is broken! Do NOT use print, scan, fax and copy function at the same time.	F/W checks the downloaded file. And get wrong checksum. So stop to modify F/W.	Check the downloaded file is not broken. Do not use Printer functions when update firmware.

**Message for Network update**

Messages	Comment	Action
Machine is not ready.	Can not get Printer status form Network status channel before F/W file is transmitted.	Check PC network settings and IP address. Check Printer network settings and IP address. Do not update F/W when Printer is in power-on stage.

Messages	Comment	Action
Wrong Model.	F/W file is not matched for current machine.	Please check the version of F/W file and machine if it is suitable for Printer.
Machine is busy.	F/W update is running. Other Printer functions are running.	Please wait F/W update is completed. Please wait other Printer functions are completed.
FW Update Done. *** Please reboot the Machine.***	F/W update is completed.	Please reboot the Machine.
Machine loses communication. ***Please check FW Update Done. Then reboot the Machine.***	F/W file has transmitted. Polling F/W update progress fail.	Do not reboot engine till Engine Panel display "Firmware Update Done. Please reboot". Then reboot engine.
Downloaded file is broken! Do NOT use print, scan, fax and copy function at the same time.	F/W checks the downloaded file. And get wrong checksum. So stop to modify F/W.	Check the downloaded file is not broken. Do not use Printer functions when update firmware.



# 6. Troubleshooting

## Service Call Conditions

See "Appendices" for the "Error Codes".

---

### Summary

---

This machine issues an SC (Service Call) code if an error occurs with the machine. The error code can be seen with the SOM (☛ p.69 "Smart Organizing Monitor").

Make sure that you understand the following points;

1. All SCs are logged.
2. At first, always turn the main switch off and on if an SC code is displayed.
3. First, disconnect then reconnect the connectors before replacing the PCBs (if the problem concerns electrical circuit boards).
4. First, check the mechanical load before replacing motors or sensors (if the problem concerns a locked motor).

6

### Fusing related SCs

---

To prevent damage to the machine, the main machine cannot be operated until the fusing related SC has been reset by a service representative.

- Enter "SP Mode 3" in the SOM.

Click "OK" in "Reset Fusing Unit SC" with "SP Mode 3", and then turn the main power switch off and on.

---

### Engine SC

---

#### SC 2xx (Laser Optics Error)

---

202	Polygon motor on timeout error
	The polygon mirror motor does not reach the targeted operating speed within 10 sec. after turning.

203	Polygon motor off timeout error
	The polygon mirror motor does not leave the READY status within 20 sec. after the polygon mirror motor switched off.
204	Polygon motor lock signal error
	The signal remains HIGH for 200 ms (or 4times in 50msec polling) while the polygon mirror motor is rotating. <ul style="list-style-type: none"> <li>• Polygon motor/driver board harness loose or disconnected</li> <li>• Polygon motor/driver board defective</li> <li>• Laser optics unit defective</li> </ul> <ol style="list-style-type: none"> <li>1. Turn the main power off/on the machine.</li> <li>2. Replace the interface harness of the laser optics unit.</li> <li>3. Replace the laser optics unit.</li> </ol>
220	Beam Synchronize error
	The laser synchronizing detection signal for LD is not output within 400msec after the LD unit has turned on. <ul style="list-style-type: none"> <li>• Disconnected cable from the laser synchronizing detection unit or defective connection</li> <li>• Defective laser synchronizing detector</li> <li>• Defective LD</li> <li>• Defective ECB</li> </ul> <ol style="list-style-type: none"> <li>1. Check the connectors.</li> <li>2. Replace the laser optics unit.</li> <li>3. Replace the ECB.</li> </ol>
268	Video thermistor error
	At power on, the temperature sensor in the optics unit detected a temperature lower than -30° C for more than 4 sec. -or- It detected a temperature higher than 105°C for more than 1sec. <ul style="list-style-type: none"> <li>• Thermistor disconnected (causes extremely low temperature reading)</li> <li>• Thermistor damaged and short circuited (causes extremely high temperature reading)</li> </ul> <ol style="list-style-type: none"> <li>1. Turn the machine's main power off, and then on.</li> <li>2. Replace the thermistor.</li> </ol>

## SC 4xx (Image Transfer and Transfer Error)

491	Bias leak
	An error signal is detected for 0.2 seconds when changing the development unit.
	<ul style="list-style-type: none"> <li>• Defective transfer roller</li> <li>• Defective high voltage power pack</li> </ul> <ol style="list-style-type: none"> <li>1. Turn the machine's main power off, and then on.</li> </ol>

## SC 5xx (Motor and Fusing Error)

500	Main motor error
	<p>The machine does not detect a main motor lock signal within 2sec after the main motor started to rotate.</p> <p>-or-</p> <p>The machine does not release a main motor lock signal within 2sec after the main motor switched off.</p> <p>-or-</p> <p>The machine detects a main motor lock signal every 100ms for seven times consecutively, after the main motor started to rotate stably.</p>
	<ul style="list-style-type: none"> <li>• Overload of</li> <li>• Torque load overload</li> <li>• Defective main motor</li> <li>• Disconnect or defective motor harness</li> </ul> <ol style="list-style-type: none"> <li>1. Turn the machine's main power off, and then on.</li> <li>2. Check or replace the main motor if the torque load is normal.</li> <li>3. Replace the motor harness.</li> </ol>
530	Fusing Fan Motor Error
	The FAN lock signal – High for 10 seconds, after the fan motor started to rotate.
	<ul style="list-style-type: none"> <li>• Disconnected or defective motor harness.</li> </ul> <ol style="list-style-type: none"> <li>1. Turn the machine's main power off, and then on.</li> </ol>

541	<p>Fuser thermistor error</p> <p>The thermistor output is less than 0°C for 5 seconds after the fusing lamp turns ON.</p> <ul style="list-style-type: none"> <li>• Disconnected or defective thermistor</li> <li>• Disconnected or defective fusing lamp</li> </ul> <ol style="list-style-type: none"> <li>1. Check the harness connection of the thermistor.</li> <li>2. Replace the fusing unit.</li> </ol> <p><b>★ Important</b></p> <ul style="list-style-type: none"> <li>• <b>Execute "Reset Fusing Unit SC" to recover the machine after completing the recovery procedure. Otherwise, the machine continues to issue this SC code and cannot be operated.</b></li> </ul>
542	<p>Fuser reload error</p> <p>This SC is issued if one of following conditions occurs:</p> <p>The fusing temperature rises 8°C or less in 1.5 seconds; and this continues 5 times consecutively.</p> <p>-or-</p> <p>The fusing temperature has not reached 45°C within 9 seconds (after the fusing lamp comes ON while the machine is warming-up).</p> <p>-or-</p> <p>The fusing unit does not attain reload temperature within 35 s. (normal temperature) or 65 s (lower temperature – the thermistor output is less than 18°C) after the fusing temperature control starts.</p> <ul style="list-style-type: none"> <li>• Defective or deformed thermistor</li> <li>• Incorrect power supply input at the main power socket</li> </ul> <ol style="list-style-type: none"> <li>1. Defective fusing lamp</li> </ol>



543	High temperature error (Software)
	<ul style="list-style-type: none"> <li>The detected temperature stays at 225°C for 1 second, and this consecutively occurs 10 times.</li> </ul>
	<ul style="list-style-type: none"> <li>Defective ECB</li> <li>Defective PSU</li> </ul> <ol style="list-style-type: none"> <li>Replace the ECB</li> <li>Replace the PSU</li> </ol> <p><b>★ Important</b></p> <ul style="list-style-type: none"> <li>Execute "Reset Fusing Unit SC" to recover the machine after completing the recovery procedure. Otherwise, the machine continues to issue this SC code and cannot be operated.</li> </ul>
544	High temperature error (Hardware)
	<ul style="list-style-type: none"> <li>During stand-by mode or a print job, the detected heating roller temperature reaches 250° C.</li> </ul>
	<ul style="list-style-type: none"> <li>Defective ECB</li> <li>Defective PSU</li> </ul> <ol style="list-style-type: none"> <li>Replace the ECB</li> <li>Replace the PSU</li> </ol> <p><b>★ Important</b></p> <ul style="list-style-type: none"> <li>Execute "Reset Fusing Unit SC" to recover the machine after completing the recovery procedure. Otherwise, the machine continues to issue this SC code and cannot be operated.</li> </ul>

545	Fusing Lamp Overheat Error
	<p>The fusing lamps remained ON at full capacity for more than 9 s after the fusing temperature attains reload temperature.</p> <ul style="list-style-type: none"> <li>• Deformed thermistor</li> <li>• Thermistor not in the correct position</li> <li>• Defective fusing lamp</li> </ul> <ol style="list-style-type: none"> <li>1. Replace the fusing unit.</li> <li>2. Replace the fusing lamp.</li> </ol> <p><b>★ Important</b></p> <ul style="list-style-type: none"> <li>• Execute "Reset Fusing Unit SC" to recover the machine after completing the recovery procedure. Otherwise, the machine continues to issue this SC code and cannot be operated.</li> </ul>
547	Zero cross error
	<ul style="list-style-type: none"> <li>• The zero cross signal is detected three times even though the fusing lamp relay is off when turning on the main power.</li> <li>• The zero cross signal is not detected for 3 seconds even though the fusing lamp relay is on after turning on the main power or closing the front door.</li> <li>• The detection error occurs twice or more in 11 zero cross signal detections. This error is defined when the detected zero cross signal is less than 45.</li> <li>• The zero cross signal is not detected three times while the main power remains ON.</li> </ul> <ul style="list-style-type: none"> <li>• Defective fusing relay</li> <li>• Defective fusing relay circuit</li> <li>• Shorted +24V fuse on the PSU</li> <li>• Unstable power supply.</li> </ul> <ol style="list-style-type: none"> <li>1. Check the power supply source.</li> <li>2. Replace the +24V fuse on the PSU.</li> <li>3. Replace the PSU</li> </ol>

557	Zero cross frequency error
	The zero cross signal is detected ten times while the fusing lamp relay remains ON after turning on the main power.
	<ul style="list-style-type: none"> <li>• Defective fusing lamp relay</li> <li>• Defective drive circuit of the fusing lamp relay</li> <li>• Unstable input power source</li> </ul> <ol style="list-style-type: none"> <li>1. Check the power supply source.</li> <li>2. Replace the fusing unit.</li> </ol> <p><b>★ Important</b></p> <ul style="list-style-type: none"> <li>• Execute "Reset Fusing Unit SC" to recover the machine after completing the recovery procedure. Otherwise, the machine continues to issue this SC code and cannot be operated.</li> </ul>
559	Fuser 3times jam error
	<p>The paper jam counter for the fusing unit reaches 3. The paper jam counter is cleared if the paper is fed correctly.</p> <p>This SC is activated only when this function is enabled with "Engine Maintenance" (default "OFF").</p>
	<ul style="list-style-type: none"> <li>• Defective fusing unit</li> <li>• Defective fusing control</li> </ul> <ol style="list-style-type: none"> <li>1. Clear this SC to send a command after a jam removal.</li> <li>2. Turn off this function after a jam removal.</li> </ol> <p><b>★ Important</b></p> <ul style="list-style-type: none"> <li>• Execute "Reset Fusing Unit SC" to recover the machine after completing the recovery procedure. Otherwise, the machine continues to issue this SC code and cannot be operated.</li> </ul>

**SC 6xx (Communication and Other Error)**

669	EEPROM communication error
	An unexpected value exists in the initialization flag of the EEPROM
	<ul style="list-style-type: none"> <li>• EEPROM not connected</li> <li>• Defective EEPROM</li> </ul> <ol style="list-style-type: none"> <li>1. Installing the EEPROM.</li> <li>2. Replacing the EEPROM.</li> </ol>
688	CTL_PRREQ_N signal does not come.
	The ECB does not receive a memory address command from the controller 20 seconds after paper is in the position for registration.
	<ul style="list-style-type: none"> <li>• Defective controller board</li> <li>• Communication error</li> </ul> <ol style="list-style-type: none"> <li>1. Turn the machine's main power off, and then on.</li> <li>2. Check if the controller board is firmly connected to the ECB.</li> </ol>

# Image Problems

## Overview

Image problems may appear at regular intervals that depend on the circumference of certain components. The following diagram shows the possible symptoms (black or white dots at regular intervals).

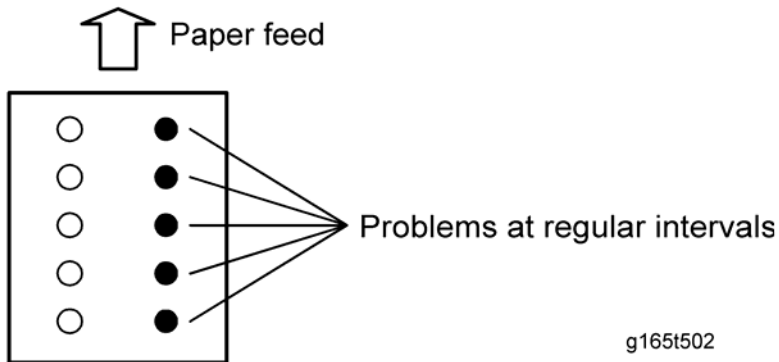

- Abnormal image at 29.8 mm intervals: Charge roller
- Abnormal image at 37.7 mm intervals: Registration roller
- Colored spots at 37.9 mm intervals: Print cartridge (Development roller)
- Abnormal image at 45.8 mm intervals: Transfer roller
- Colored spots at 75.3 mm intervals: Print cartridge (OPC drum)
- Abnormal image at 94.2 mm intervals: Fusing unit (Pressure roller)
- Abnormal image at 93.1 mm intervals: Fusing unit (Hot roller)
- Abnormal image at 100.5 mm intervals: Paper feed roller

## Test Page Printing

When you check an image problem or other problems, it might be necessary to print a test page. Follow the test page print procedure below to print a test page.

### Test Page Print Procedure

1. Start the SOM utility.

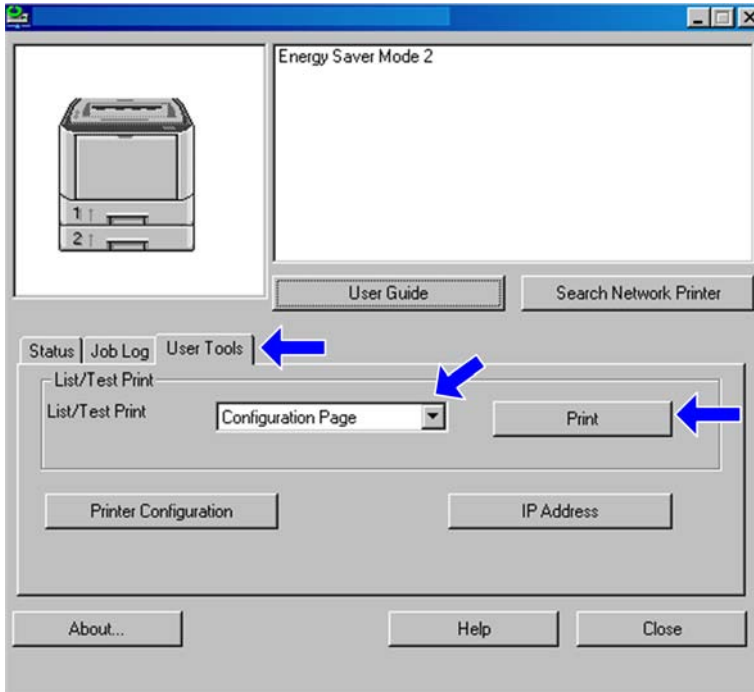

m012s501a

6

2. Click the "User Tools" tab.
3. Select "Test Page" in the "List/ Test Print".
4. Click "Print".
  - Test page sample

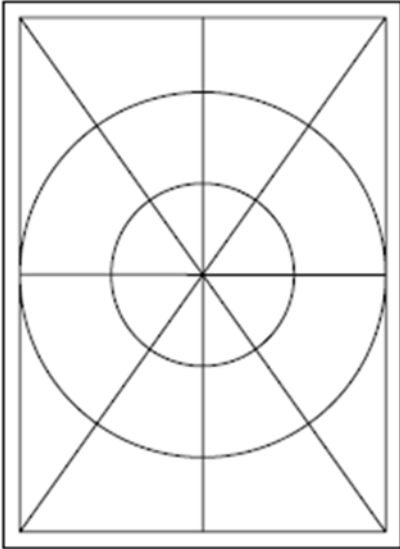

m016t501

---

## Test Pattern Printing

---

Follow the test pattern print procedure below to print a test pattern.

### Test Pattern Print Procedure

---

1. Start the SOM utility.

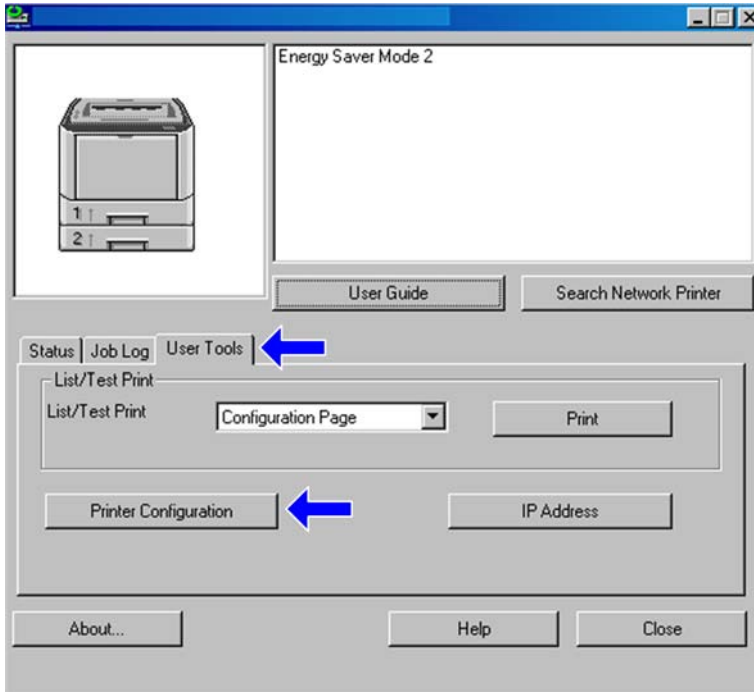

m012s501b

2. Click the "User Tools" tab.
3. Click "Printer Configuration".
4. The "Access Code" entry dialog appears.

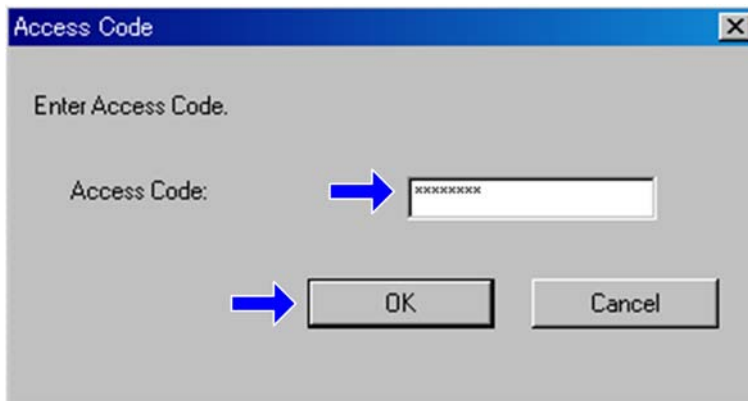

m012s502

5. Input the access code (for customer engineers), and then click "OK".



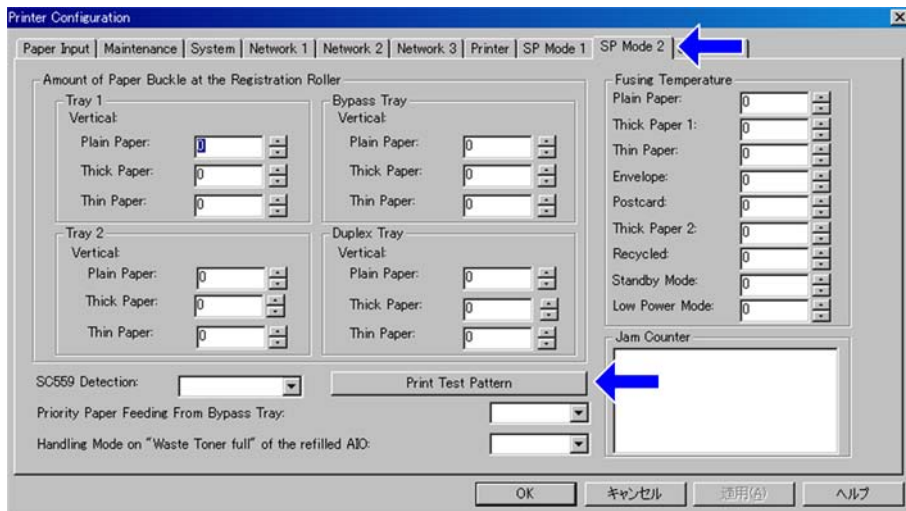

m012s511a

6. Click the "SP Mode 2" tab.
7. Click "Print Test Pattern".
8. The following three test pattern pages (Checker flag/ Grid pattern/ Trimming pattern) are printed.
  - Test pattern samples

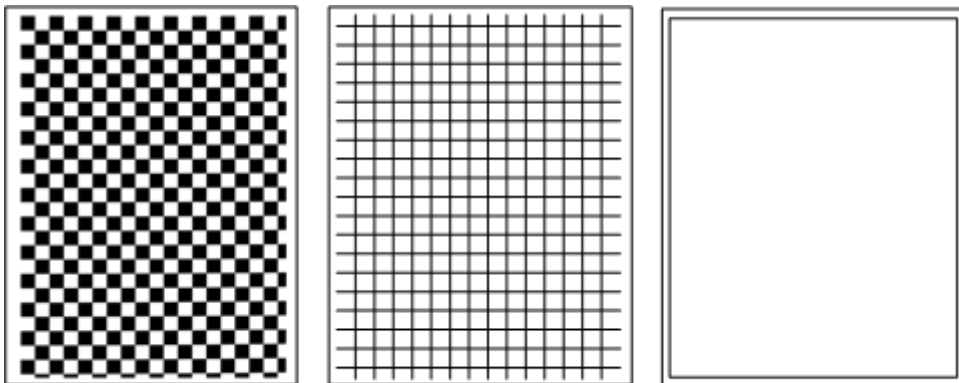

m016t502

## Dark lines in halftone areas at 75mm Intervals

Using the machine in a room where the humidity level is too low may cause dark lines in halftone areas at 75mm intervals. This is because low-humidity conditions tend to cause variations in light sensitivity across the surface of the drum.

Selecting [On] for [Low Humidity Mode] under the [System] tab in [Printer Configuration] with SOM (Smart Organizing Monitor) may help to prevent these lines from appearing.

When the humidity mode setting is enabled, the drum is rotated slightly every 15 minutes. This keeps the light sensitivity constant across the entire surface of the drum.

# Jam

## Jam Sensor Layout

There are the sensors of the jam detection as shown below.

### Paper Jam

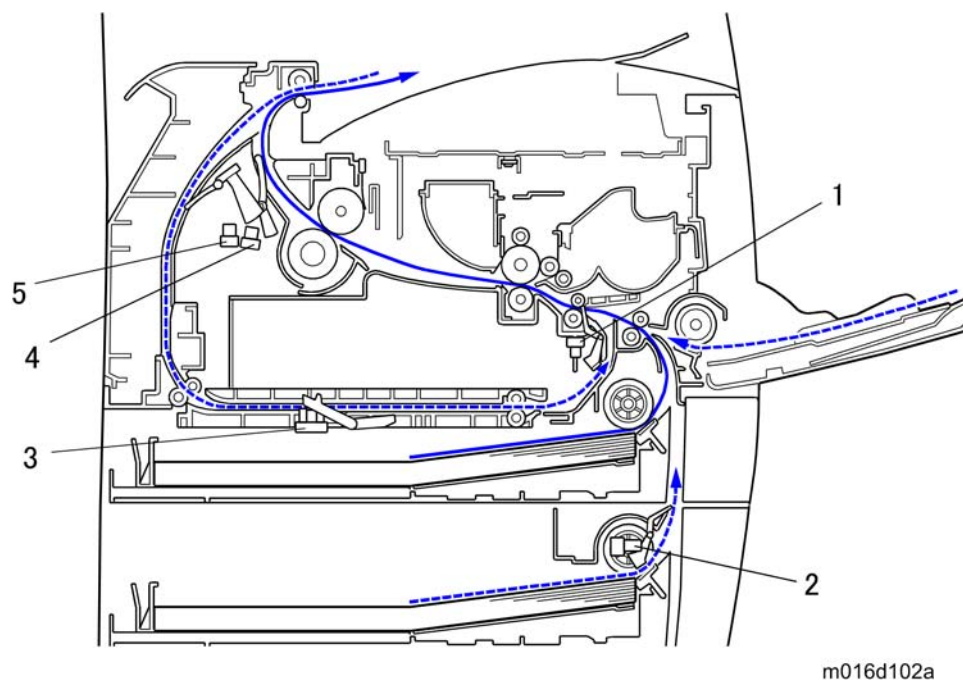

1. Registration Sensor
2. Tray2 Paper Feed Sensor
3. Inverter Sensor
4. Paper Exit Sensor
5. Relay Sensor

## Jam Message List

Here is a list of common jam messages, a description of the causes.

See the drawing shown above to check the sensor location.

## Paper Jam

Related to jam code

Jam message	Cause	Sensor
Bypass Tray Paper Misfeed Jam	Paper does not reach registration sensor (bypass tray)	Registration sensor [1]
Upper Misfeed Jam	Paper does not reach registration sensor (tray1)	Registration sensor [1]
Lower Misfeed Jam	Paper does not reach tray2 convey sensor	Tray2 paper feed sensor [2]
	Paper does not reach registration sensor	Registration sensor [1]
Duplex Jam Duplex Misfeed Jam	Paper does not reach registration sensor (duplex feed tray)	Registration sensor [1]
	Paper does not reach duplex entry sensor	Relay sensor [5]
	Paper does not reach duplex exit sensor	Inverter sensor [3]
Inner Jam	Paper stayed on registration sensor	Registration sensor [1]
	Paper does not reach exit sensor	Paper exit sensor [4]
Outer Jam	Paper stayed on exit sensor	Paper exit sensor [4]

Related to initialize jam

Jam message	Cause
Lower Misfeed Jam	Tray2 paper feed sensor [2]
Inner Jam	Registration sensor [1]
Outer Jam	Paper exit sensor [4]
Duplex Jam Duplex Misfeed Jam	Relay sensor [5]
	Inverter sensor [3]

# 7. Energy Saving

## Energy Save

### Energy Saver Modes

Customers should use energy saver modes properly, to save energy and protect the environment.

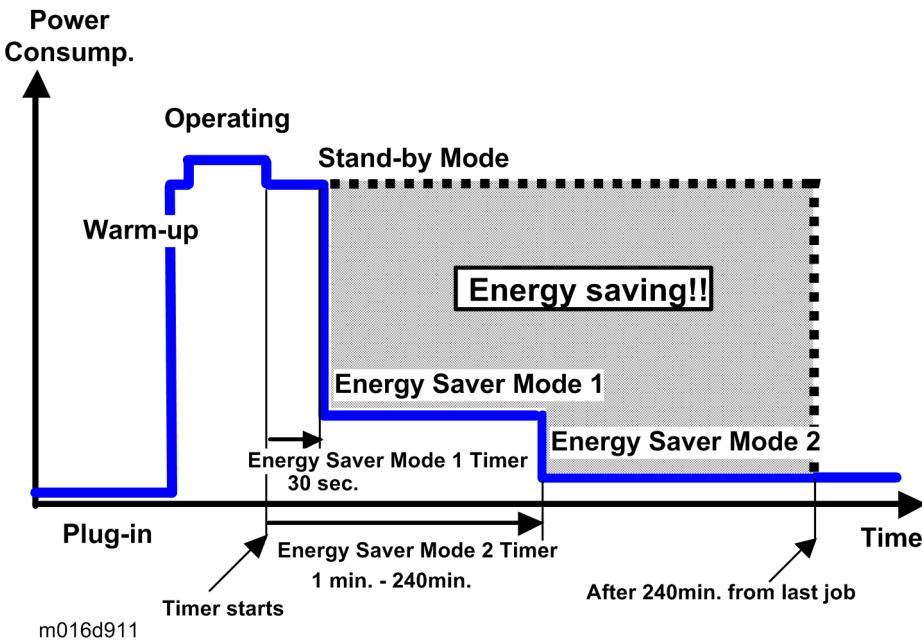

The backlight of the screen is turned off and "Energy Saver Mode1" appears on the screen, and then the fusing lamp is turned off and "Energy Saver Mode2" appears on the screen.

The area shaded grey in this diagram represents the amount of energy that is saved when the timers are at the default settings. If the timers are changed, then the energy saved will be different. For example, if the timers are all set to 240 min., the grey area will disappear, and no energy is saved before 240 min. expires.

### Timer Settings

The user can set these timers with User Tools (SOM > Printer Configuration > System > Energy Saver Mode 1 or Mode2)

- Energy Saver Mode1 (30 sec.): This can be only turned on or off.

- Energy Saver Mode2 (1 to 240 min.): This can be turned on or off and timer setting is adjustable (default: 1 min.).

## Return to Stand-by Mode

---

### Energy Saver Mode1

- Recovery time: 10 sec.

### Energy Saver Mode2

- Recovery time: 20 sec.

## Recommendation

---

We recommend that the default settings should be kept.

- If the customer requests that these settings should be changed, please explain that their energy costs could increase, and that they should consider the effects on the environment of extra energy use.
- If it is necessary to change the settings, please try to make sure that the Energy Saver Mode2 Timer is not too long. Try with a shorter setting first, such as 30 min., then go to a longer one (such as 60 min.) if the customer is not satisfied.
- If the timers are all set to the maximum value, the machine will not begin saving energy until 240 minutes has expired after the last job. This means that after the customer has finished using the machine for the day, energy will be consumed that could otherwise be saved.

# Paper Save

## Effectiveness of Duplex/Combine Function

Duplexing and the combine functions reduce the amount of paper used. This means that less energy overall is used for paper production, which improves the environment.

### 1. Duplex:

Reduce paper volume in half!

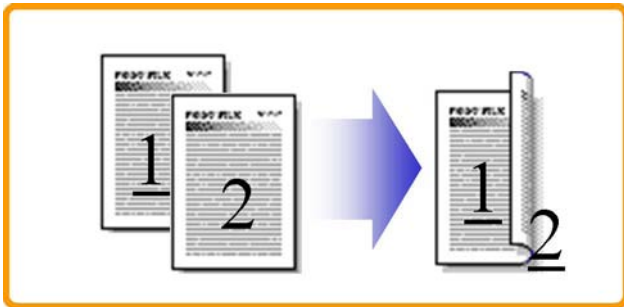

d062d102

7

### 2. Combine mode:

Reduce paper volume in half!

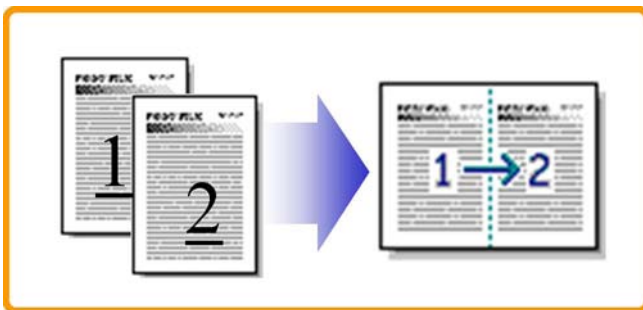

d062d100

### 3. Duplex + Combine:

Using both features together can further reduce paper volume by 3/4!

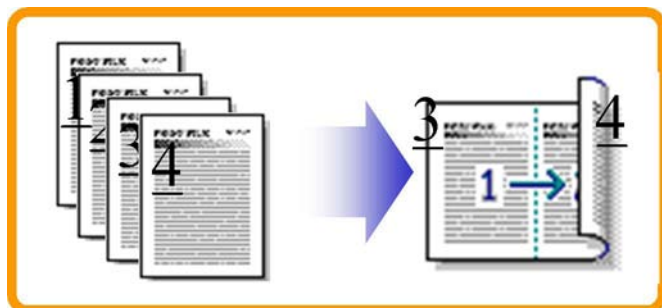

d062d101

To check the paper consumption, look at the total counter and the duplex counter.

The total counter counts all pages printed.

- For one duplex page, the total counter goes up by 2.
- For a duplex job of a three-page original, the total counter goes up by 3.

The duplex counter counts pages that have images on both sides.

- For one duplex page, the duplex counter goes up by 1.
- For a duplex job of a three-page original, the duplex counter will only increase by 1, even though two sheets are used.

## 7

### Total counter

This machine has a total sides printed counter only (so a duplex print is counted as two, not one). You can check the total counter with the SOM or on the "Configuration Page".

- Total counter: SOM > "Printer Configuration" > "SP Mode 3" > "Counter Information" or "Configuration Page"

The following table shows paper savings and how the counters increase for some simple examples of single-sided and duplex jobs

#### Duplex mode:

Originals	Simplex Sheet used	Duplex Sheets used	Paper Saved	Total counter
1	1	1	0	1
2	2	1	1	2
3	3	2	1	3
4	4	2	2	4
5	5	3	2	5



Originals	Simplex Sheet used	Duplex Sheets used	Paper Saved	Total counter
10	10	5	5	10
20	20	10	10	20

If combine mode is used, the total and duplex counters work in the same way as explained previously. The following table shows paper savings and how the counters increase for some simple examples of duplex/combine jobs.

### 2 in 1 mode:

Originals	Simplex Sheet used	Duplex Sheets used	Paper Saved	Total counter
1	1	1	0	1
2	2	1	1	1
3	3	2	1	2
4	4	2	2	2
5	5	3	2	3
10	10	5	5	5
20	20	10	10	10

### Duplex + 2 in 1 mode:

Originals	Simplex Sheet used	Duplex Sheets used	Paper Saved	Total counter
1	1	1	0	1
2	2	1	1	1
3	3	1	2	2
4	4	1	3	2
5	5	2	3	3
6	6	2	4	3
7	7	2	5	4

Originals	Simplex Sheet used	Duplex Sheets used	Paper Saved	Total counter
8	8	2	6	4
9	9	3	6	5
10	10	3	7	5
11	11	3	8	6
12	12	3	9	6

**Model RN-P1  
Machine Codes: M012/M013  
Appendices**

20 January, 2010



# TABLE OF CONTENTS

---

## 1. Appendix: Specifications

---

General Specifications.....	3
General Specifications.....	3
Printer.....	5
Supported Paper Sizes.....	6

## 2. Appendix: SP Mode Tables

---

Service Menu.....	9
-------------------	---

## 3. Appendix: Troubleshooting Guide

---

Service Call Conditions.....	11
Error Codes.....	12
Overview.....	12
Error Codes List.....	12
<b>INDEX</b> .....	15



# 1. Appendix: Specifications

## General Specifications

### General Specifications

Configuration	Desktop	
Paper capacity	Main tray	250 sheets (80g/m <sup>2</sup> ) 100 postcards
	By-pass tray	50 sheets (80g/m <sup>2</sup> ) 8 envelopes 20 postcards
	Optional paper feed unit	Plain paper: 250 sheets (80g/m <sup>2</sup> )
	Output tray	Face down: 125 sheets
Paper size	Main tray	A4, A5, Letter, Legal, B5, HLT, A6, Executive, Postcard <b>Custom size:</b> Max: 216 x 356mm (8.5 x 14 inch) Min: 100 x 148mm (3.937 x 5.8 inch)
	By-pass tray	A4, A5, A6, Letter, Legal, HLT, Executive, Postcard, B5, Envelope <b>Custom size:</b> Max.: 216 x 356mm (8.5 x 14 inch) Min.: 90 x 148mm (3.5 x 5.8 inch)
	Duplex	A4, Letter, Legal
	Optional paper feed unit	A4, LT, LG, B5, HLT, A5

Paper weight	Main tray	52-162 g/m <sup>2</sup> (14-43 lb)
	By-pass tray	52-162 g/m <sup>2</sup> (14-43 lb)
	Optional paper feed unit	60-105 g/m <sup>2</sup> (16-28 lb) A setting for outside of normal specifications paper (60 g/m <sup>2</sup> - 105 g/m <sup>2</sup> ) is provided. With this setting, it may be possible to print properly on outside of normal specifications paper.
Machine size (W x D x H)	370 x 392 x 262 mm (14.5 x 15.4 x 10.3 inch) Without Option	
Weight	M012: 11.6 Kg(25.6 lb) M013: 12.5 Kg(27.6 lb) With a starter AIO cartridge.	
Energy Saver Mode	Selectable 1 to 240 minutes (1 minute steps)	
Power consumption	Maximum	NA/TW: Less than 850 W (energy star compliant) EU/AP/CN: Less than 880 W (energy star compliant)
	Ready mode	120W
	Power save mode	70 W (energy saver mode 1) 5 W (energy saver mode 2)
Power	NA	120 V, 60Hz ± 3Hz
	TW	110 V, 60Hz ± 3Hz
	EU/AP/CN	220 - 240 V, 50/60Hz ± 3Hz
Noise	Printing	Less than 65.8 dB (A)
	Standby Mode	Less than 40 dB (A)
	Energy Save Mode	Less than 40 dB (A)
Warm up time	Less than 30 seconds	
Machine life	5 years, 200,000 prints (whichever comes first)	



Environmental Standard	Energy star program (M013)
Laser type	Class IIIB

## Printer

Print speed	Simplex	30 ppm LT, 28 ppm A4 (600 dpi)
	Duplex (M013 only)	15 ppm LT, 14 ppm A4 (600 dpi)
Printer drivers	PCL, PS3	
Font	80 fonts	
Resolution	Normal	600 x 600 dpi
	RET	1200 x 600 dpi
Toner save mode	Supported	
Warm-up time	Less than 30 seconds	
First print time	Less than 8 seconds	
Duplex print	Supported (M013 only)	
Interface option	USB 2.0, 10/ 100 Base - TX	
Network	Protocol	TCP/IP, IPP
Memory	Standard	128MB
Operation System	PCL: Windows XP, 2000/2003server, Vista, Windows 2008 server PS3: Windows XP, 2000/2003server, Vista, Windows 2008 server Macintosh 10.2.8 -	

# Supported Paper Sizes

A	Supported, with size molded into tray. Need to select paper size by operation panel/driver.
B	Supported but size is not molded into tray. Need to select paper size by operation panel/driver.
C	Need to input paper size by operation panel and driver.
N	Not supported.

Type	SEF/ LEF	Size	Input Tray			Auto Duplex
			Standard Tray	Option PFU	Bypass Tray	
A4	SEF	210x297	A	A	B	Y
B5	SEF	182x257	A	A	B	N
A5	SEF	148x210	A	A	B	N
	LEF	210x148	N	N	C	N
B6	SEF	128x182	B	N	B	N
	LEF	182x128	N	N	N	N
A6	SEF	105x148	B	N	B	N
	LEF	148x105	N	N	N	N
Postcard	SEF	100 x 148	C	N	C	N
	LEF	148 x 100	N	N	N	N
	SEF	200 x 148	C	N	C	N
	LEF	148 x 200	C	N	N	N
Legal	SEF	8 $\frac{1}{2}$ "x14"	A	A	B	Y
Letter	SEF	8 $\frac{1}{2}$ "x11"	A	A	B	Y
Half Letter	SEF	5 $\frac{1}{2}$ " x 8 $\frac{1}{2}$ "	B	B	B	N
	LEF	8 $\frac{1}{2}$ " x 5 $\frac{1}{2}$ "	N	N	N	N

Type	SEF/ LEF	Size	Input Tray			Auto Duplex
			Standard Tray	Option PFU	Bypass Tray	
Executive	SEF	7 $\frac{1}{4}$ "x10 $\frac{1}{2}$ "	A	N	N	N
F	SEF	8" x 13"	B	N	N	N
Foolscap	SEF	8 $\frac{1}{2}$ " x 13"	B	N	N	N
Folio	SEF	8 $\frac{1}{4}$ " x 13"	B	N	B	N
16 Kai	SEF	195 x 267	B	N	B	N
Env. #10	SEF	4 $\frac{1}{8}$ " x 9 $\frac{1}{2}$ "	N	N	B	N
Env. Monarch	SEF	3 $\frac{7}{8}$ " x 7 $\frac{1}{2}$ "	N	N	B	N
Env. C5	SEF	162 x 229	N	N	B	N
Env. C6	SEF	114 x 162	N	N	B	N
Env. DL	SEF	110 x 220	N	N	B	N
	Width	100-216mm	C	N	C	N
	Length	148-356mm	C	N	C	N
	Width	90-216mm	N	N	C	N
	Length	140-356mm	N	N	C	N



## 2. Appendix: SP Mode Tables

---

### Service Menu

See "Main Chapters" for "Smart Organizing Monitor".



# 3. Appendix: Troubleshooting Guide

---

## Service Call Conditions

See "Main Chapters" for "Service Call Conditions".

# Error Codes

## Overview

Error codes will be displayed in the GUI of SOM if the machine has a problem. These can be viewed by a customer.

### 3

## Error Codes List

000	Cover Open
	The front or top cover is open.
	<ol style="list-style-type: none"> <li>1. Close the front or top cover.</li> <li>2. Replace the interlock switches or actuator mechanism.</li> </ol>
010	AIO Set Error
	<ul style="list-style-type: none"> <li>• Black AIO not set</li> <li>• Defective connection of the ID chip terminal on the (black) AIO</li> </ul>
	<ol style="list-style-type: none"> <li>1. Install the AIO.</li> <li>2. Reinstall or replace the AIO.</li> </ol>
014	Waste Toner Bottle Set Error
	<ul style="list-style-type: none"> <li>• Waste toner bottle not set</li> <li>• Disconnected or defective harness of the waste toner bottle set sensor</li> <li>• Defective waste toner bottle set sensor</li> </ul>
	<ol style="list-style-type: none"> <li>1. Install the waste toner bottle.</li> <li>2. Check or replace the harness of the waste toner bottle set sensor.</li> <li>3. Replace the waste toner bottle set sensor.</li> </ol>



030	Tray/Paper Selection Error
	<ul style="list-style-type: none"> <li>No paper in the tray or tray not set in the machine</li> <li>Paper size requested by the job does not match the paper in the tray</li> </ul>
	<ol style="list-style-type: none"> <li>Install the tray or put the correct size paper in the tray.</li> <li>Check the paper setting in the user menu mode.</li> </ol>
031	Paper Selection Error: Feed and Exit
	<ul style="list-style-type: none"> <li>Paper size requested by the job does not match the paper in the tray</li> <li>Selection error for the paper feed and paper exit location in duplex mode</li> </ul>
	Check the paper feed and exit location in the user menu mode.
050	Jam Error: No Feed from Tray 1
	<ul style="list-style-type: none"> <li>Paper slipped</li> </ul>
	Remove the paper jam at tray 1.
052	Jam Error: No Feed from Optional Tray
	<ul style="list-style-type: none"> <li>Paper slipped</li> </ul>
	Remove the paper jam at the optional tray (Tray 2).
055	Inner Jam Error: Registration/ Paper Exit
	A sheet of paper stays at the registration sensor or paper exit sensor.
	<ul style="list-style-type: none"> <li>Paper slipped</li> <li>Paper double feed</li> </ul>
	Remove the paper jam at the registration sensor or paper exit sensor.

056	Paper Exit Jam Error: Paper Exit/ Fusing Unit
	<p>A sheet of paper stays at the paper exit sensor or winds around the rollers in the fusing unit.</p> <ul style="list-style-type: none"> <li>• Paper slipped</li> <li>• A sheet of paper is wound around the rollers in the fusing unit</li> </ul>
	Remove the paper jam at the paper exit sensor or in the fusing unit.

3

070	Printing Error: No Paper
	<ul style="list-style-type: none"> <li>• No paper in the tray</li> </ul>
	Put paper in the tray.

080	Toner Near End: Black AIO
081	Toner End: Black AIO
	<ul style="list-style-type: none"> <li>• Black toner near-end or end</li> </ul>
	Replace the black AIO.

088	Waste Toner Bottle: Near Full
089	Waste Toner Bottle: Full
	<ul style="list-style-type: none"> <li>• Waste toner bottle near-full or full</li> </ul>
	Replace the waste toner bottle.