

**RICOH**

**M156/M157/M176/M177 (Rm-MF1)  
M154/M155/M174/M175 (Rm-P1)  
Service Training**

Slide 1

Version 1.0

**These models are similar to the Rn series of printers and copiers.**

**RICOH**

**M156/M157/M176/M177 (Rm-MF1)  
M154/M155/M174/M175 (Rm-P1)  
Service Training**

**Product Overview**

Slide 2

**No additional notes**

**What Models are in this Series?**  
**Rm-MF1a**

- ❑ **Rm-MF1a**
  - ◆ M156: SP 311SFN, No AIO refill
  - ◆ M176: SP 310SFN, AIO can be refilled
- ❑ **Rm-MF1aw**
  - ◆ M157: SP 311SFNw, Wireless LAN, No AIO refill
  - ◆ M177: SP 310SFNw, Wireless LAN, AIO can be refilled
- ❑ **Type A and B models**
  - ◆ M15x is also known as Type A; M17x is also known as Type B
  - ◆ For Type B there are two sub-types, based on destination:
    - » For CHN: The AIO has hole through which the AIO can be refilled with toner. Bags of toner for refilling are also sold.
    - » For EU/AA/NA: The AIO has no hole. The machine is designed for refill, but bags of toner for refilling are not sold

Slide 3

**No additional notes**

## What Models are in this Series? Rm-P1a

- **Rm-P1a**
  - ◆ M154: SP 311DN, No AIO refill
  - ◆ M174: SP 310DN, AIO can be refilled
- **Rm-P1aw**
  - ◆ M155: SP 311DNw, Wireless LAN, No AIO refill
  - ◆ M175: SP 310DNw, Wireless LAN, AIO can be refilled
- **The note about Type A and Type B models on the previous slide also applies here.**

Slide 4

**No additional notes**

**Differences from Previous Models**  
**Rm-MF1 vs Rn-MF1/MF2**

	Rn-MF1	Rn-MF2	Rm-MF1
PPM (A4)	28	28	28
ADF	ADF	ADF/ARDF	ADF
Scanner	CCD	CCD	CIS
Handset	No	No	China only
Display Panel	2 lines	2 lines	4 lines
Controller and Engine Boards	2 boards	2 boards	1 board
PSU and High Voltage Power Pack	1 board	1 board	2 boards
Duplex	Some models	Some models	All models
Output Capacity	125 sheets	125 sheets	50 sheets
Wireless LAN	No	No	Some models
Machine Life	200k	350k	200k
AIO Refill	No	No	Some models (China only)
Optional Tray	Yes	Yes	No
PDL	PCL/PS3	PCL/PS3	PCL

Slide 5

**No additional notes**

**Differences from Previous Models**  
**Rm-P1 vs Rn-P1/P2**

	Rn-P1	Rn-P2	Rm-P1
PPM (A4)	28	28	28
Display Panel	No	2 lines	No
Controller and Engine Boards	2 boards	2 boards	1 board
PSU and High Voltage Power Pack	1 board	1 board	2 boards
Duplex	Some models	Some models	All models
Output Capacity	125 sheets	125 sheets	125 sheets
Wireless LAN	No	No	Some models
Machine Life	200k	350k	200k
AIO Refill	No	No	Some models (China only)
Optional Tray	Yes	Yes	No
PDL	PCL/PS3	PCL/PS3	PCL
SOM (Smart Organizing Monitor)	Yes	No	Yes

Slide 6

**No additional notes**

### Other Points

- ❑ Rm-MF1/P1 do not have a USB host or the scan to USB feature.

Slide 7

**No additional notes**

**RICOH**

**M156/M157/M176/M177 (Rm-MF1)  
M154/M155/M174/M175 (Rm-P1)  
Service Training**

**Specifications**

Slide 8

**No additional notes**



## **General Specifications (1)**

- ❑ **Printing Speed, A4(LT): 28 ppm (LT: 30 ppm)**
- ❑ **First Print Speed: Less than 8 sec (A4, LT SEF)**
- ❑ **Duplex Printing: Auto (Standard, approx 50% productivity)**
- ❑ **Memory: 128 MB (no optional memory)**
- ❑ **Resolution: 1200 x 600 / 600 x 600 dpi**
- ❑ **Interfaces**
  - ◆ MF1a/P1a: USB2.0, 10BASE-T/100BASE-TX Ethernet
  - ◆ MF1aw/P1aw: USB2.0, 10BASE-T/100BASE-TX Ethernet, IEEE802.11b/g/n
- ❑ **PDL: PCL5e, PCL6**
- ❑ **Network Protocols: TCP/IP, IPP**

Slide 9

**No additional notes**

## General Specifications (2)

- ❑ **Input capacity**
  - ◆ Standard Tray: 250 sheets (80 g/m<sup>2</sup>)
  - ◆ Bypass tray: 50 sheets (80 g/m<sup>2</sup>)
- ❑ **Output capacity (Standard Tray, Face down)**
  - ◆ MF1: Up to 50 sheets
  - ◆ P1: Up to 125 sheets (A4/LT or 80 g/m<sup>2</sup>, 20lb)
- ❑ **Input Paper Size**
  - ◆ Standard Tray: A4,B5,A5,B6,A6,Legal,Letter,HLT,Exective,F,Foolsap,Folio,16K
    - » Custom size: Min. 100mm x 148mm (3.9" x 5.92"), Max. 216mm x 356mm (8.64" x 14.24")
  - ◆ Bypass Tray: A4,B5,A5,B6,A6,Legal,Letter,HLT,Exective,16K,Envelope: #10,Monarch,C5,C6,DL
    - » Custom size: Min. 90mm x 140mm (3.6" x 5.92"), Max. 216mm x 356mm (8.64" x 14.24")
- ❑ **Media Type**
  - ◆ Standard Tray: Plain Paper, Recycled Paper, Thick Paper, Thin Paper
  - ◆ Bypass Tray: Plain Paper, Recycled Paper, Thick Paper, Thin Paper
- ❑ **Paper Weight**
  - ◆ Standard Tray: 52-162g/m<sup>2</sup> (14-43lb)
  - ◆ Bypass tray: 52-162g/m<sup>2</sup> (14-43lb)
  - ◆ Duplex: 60-105g/m<sup>2</sup> (16-28lb)
- ❑ **ADF**
  - ◆ Capacity: 35 sheets
  - ◆ Original size
    - » Min: 139.7mm x 139.7mm (5.5" x 5.5"), Max: 215.9mm x 355.6mm (8.5" x 14")
  - ◆ Original weight: 52-105g/m<sup>2</sup> (14-28lb)

Slide 10

**No additional notes**

## General Specifications (3)

### □ Power Consumption

- ◆ US version
  - » Max.: 800W
  - » Energy Saver
    - Normal mode (Energy saver 2): 5W
    - Quick mode (Energy saver 1) : 70W
- ◆ EU /CHN versions
  - » Max.: 890W
  - » Energy Saver
    - Normal mode (Energy saver 2): 5W
    - Quick mode (Energy saver 1): 70W

### □ Warm-up Time:

- ◆ MF1: Less than 30 sec
- ◆ P1: Less than 26 sec
- ◆ Energy Save Mode (MF1, P1)
  - » Normal (Energy Save Mode 2): Less than 20 sec.
  - » Quick (Energy Save Mode 1): Less than 10 sec.

Slide 11

**No additional notes**

## Options

- ❑ There are no optional units for these models.

Slide 12

- ❑ The Rn series has an optional paper tray. The Rm series does not.

## AIO Cartridges

- **There are 4 types:**
  - ◆ Starter AIO: About 1k per cartridge
  - ◆ Low yield AIO: About 2k per cartridge
    - » Two types: Refill, or no refill, depending on the model
  - ◆ High yield AIO:
    - » Type A: 3.5k, no refill
    - » Type B: 5k, refill is possible

Slide 13

**No additional notes**

## Targets

- ❑ **Monthly Print Volume**
  - ◆ Average: 0.7K
  - ◆ Maximum: 5.8K
- ❑ **Estimated Unit Life: 5 years or 200K prints whichever comes first**

Slide 14

**No additional notes**

**RICOH**

**M156/M157/M176/M177 (Rm-MF1)  
M154/M155/M174/M175 (Rm-P1)  
Service Training**

**Maintenance**

Slide 15

**No additional notes**

## PM Intervals

- ❑ There are no PM parts.
- ❑ There are three "yield parts", but given the ACV (Average Copy Volume) for this machine, these "yield parts" are expected to outlast the life of the machine.
- ❑ **Yield Parts**
  - ◆ Paper Feed Roller (120 K)
  - ◆ Transfer Roller (120 K)
  - ◆ Fusing Unit (120 K)
- ❑ **The counters for each yield part can be monitored using either of the following methods:**
  - ◆ Web Image Monitor
  - ◆ Configuration Page in the "List/Test Print" menu

Slide 16

**No additional notes**



### Note to Service Personnel

- ❑ Yield parts are rated to last for 120 K, which should be longer than the machine's rated lifespan of five years.
- ❑ For customers who are very heavy users, it may be necessary to change yield parts during the life of the machine.
  - ◆ After installing new yield parts, the counters must be reset.
  - ◆ The counter reset procedure is not a user function and must be done by a trained technician.
  - ◆ See the replacement procedures in the FSM (Field Service Manual) for the reset procedures for each yield part.

Slide 17

**No additional notes**

## Access to Service Functions

### ❑ For MF models: To access Maintenance Mode, do the following:

1. Type the following keys, in sequence:  
[Clear/Stop] .. [1] .. [0] .. [7]
2. Hold down the [Start] key until the Maintenance Mode screen is displayed.
  - » Note: This should take about 3 seconds.

### ❑ For P models

- ◆ To access the SP mode of Smart Organizing Monitor, open the Printer Configuration screen by inputting the field technician access code: "Admin074"

Slide 18

**No additional notes**

## Image Adjustment

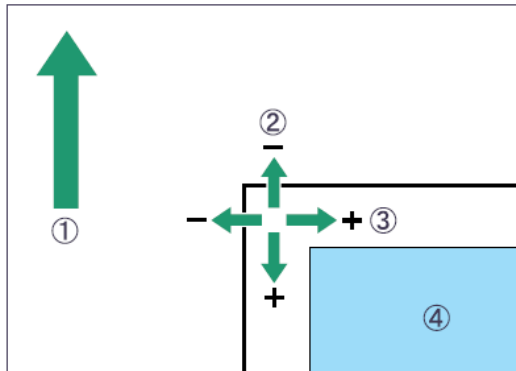

- ❑ This adjustment can be done by both technicians and users.
- ❑ **Technicians:**
  - ◆ Maintenance Mode (MF1)
  - ◆ SOM (P1)
- ❑ **Users:**
  - ◆ User Mode
- ❑ See FSMs (Field Service Manuals) for procedures.

Slide 19

**No additional notes**

### **Firmware Updating**

- A computer is necessary for updating the firmware.**
  
- Use the correct procedures (see the service manual for details) to update the firmware.**

Slide 20

**No additional notes**

**RICOH**

**M156/M157/M176/M177 (Rm-MF1)  
M154/M155/M174/M175 (Rm-P1)  
Service Training**

**Machine Overview**

Slide 21

**No additional notes**

**Component Layout – Rm-P1**

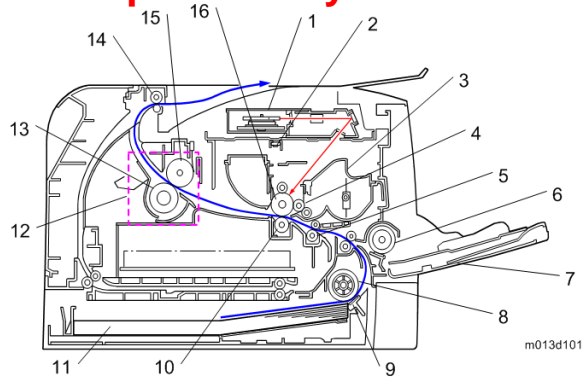

- |                         |                       |
|-------------------------|-----------------------|
| 1. Laser unit           | 9. Friction pad       |
| 2. Quenching lamp       | 10. Transfer roller   |
| 3. Cartridge (AIO-type) | 11. Paper Tray        |
| 4. Development roller   | 12. Fusing Unit       |
| 5. Registration roller  | 13. Pressure Roller   |
| 6. By-pass feed roller  | 14. Paper exit roller |
| 7. By-pass feed tray    | 15. Hot Roller        |
| 8. Paper feed roller    | 16. Drum              |

Slide 22

**No additional notes**

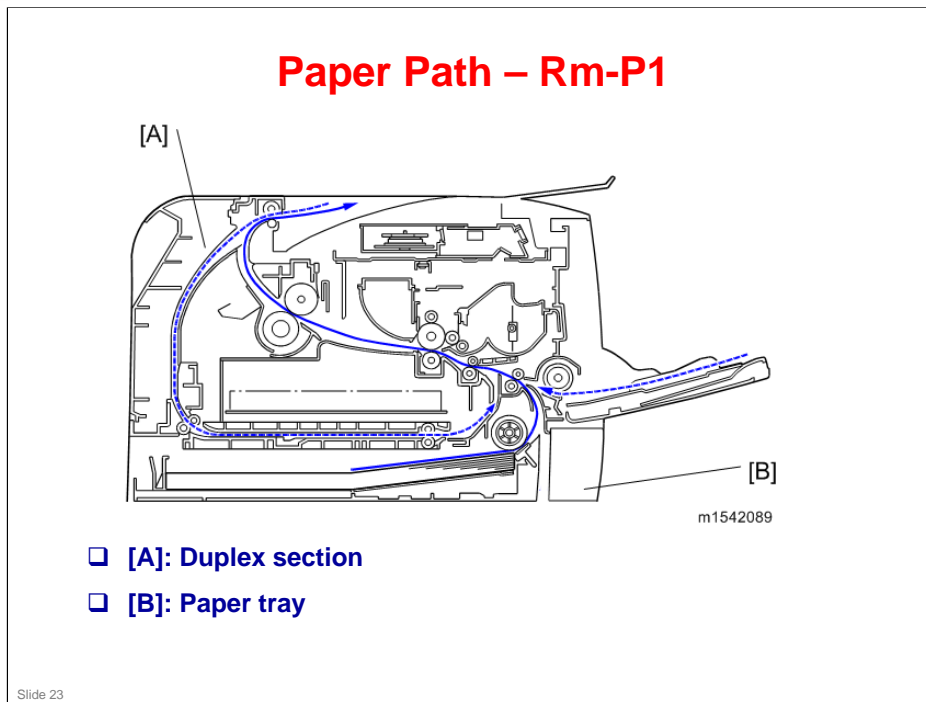

**No additional notes**

## Drive Layout – Rm-P1

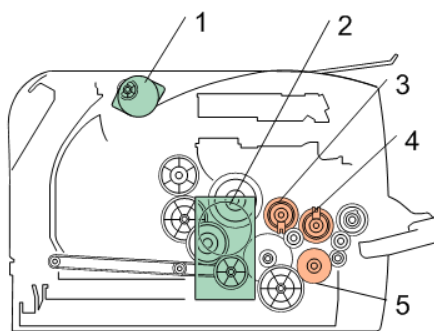

m1542090

- 1. Duplex Motor
- 2. Main Motor
- 3. Registration Clutch
- 4. Relay Clutch
- 5. Paper Feed Clutch

Slide 24

**No additional notes**



**RICOH**

**M156/M157/M176/M177 (Rm-MF1)  
M154/M155/M174/M175 (Rm-P1)  
Service Training**

**Cover Removal & Part Replacement**

Slide 25

**No additional notes**

## General Precautions

- ❑ **Before starting to work on the machine:**
  - ◆ If there are printer jobs in the machine, print out all jobs in the printer buffer.
  - ◆ Turn off the main power switch and unplug the machine.
- ❑ **The slides in this presentation only cover a few important points. For full details of all procedures, see the field service manual.**
- ❑ **Follow the notes and cautions in all procedures.**

Slide 26

**No additional notes**

## General Precautions

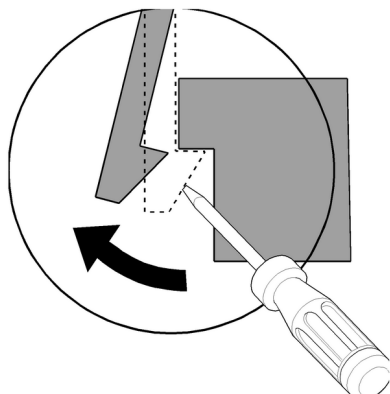

- ❑ Many of the parts are held in place with plastic latches which can break easily.
- ❑ Release them carefully, pushing the hook end of the latch away from the part to which it is latched.

Slide 27

**No additional notes**

## Removing Covers

- ❑ The covers have a lot of hooks and tabs.
- ❑ Disconnect these carefully, as explained on the previous slide.
- ❑ See the procedures in the service manual for the locations of the hooks and tabs, and follow the instructions carefully to remove the covers properly.

Slide 28

**No additional notes**

## Re-installing the Top Cover

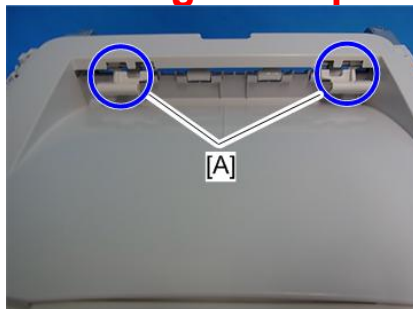

m1542017

- ❑ When re-installing the top cover, always verify that the two paperweights [A] are lifted. If they are not lifted to fit into the paper slot, the paperweights could be damaged.
- ❑ Make sure that these paperweights can be moved smoothly (up and down) after installing the top cover. If these paperweights do not move smoothly, install the top cover again.

Slide 29

**No additional notes**

## Replacing the Main Board

- ❑ Do not connect any connectors to JRS1 and JRS2 when reinstalling the main board [A]. These are only used at the factory.
- ❑ Do not adjust the dip switch. The dip switch is only for factory use.
- ❑ Remove the EEPROM from the old board (see below), and install it on the new one.

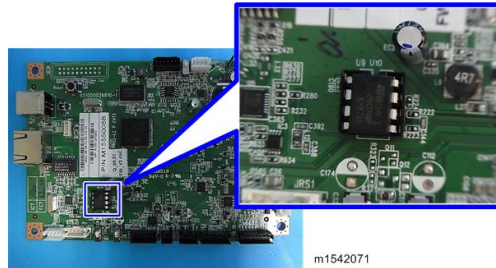

Slide 30

**No additional notes**

## If you Install a New EEPROM

- Do the following settings after installing a new EEPROM.
  - ◆ Input the PnP Name and Destination in Service Mode.
  - ◆ Adjust the Registration in Service Mode.
  - ◆ Input the serial number
    - » Ask your supervisor about how to access the serial number input display.

Slide 31

**No additional notes**

**RICOH****M156/M157/M176/M177 (Rm-MF1)  
M154/M155/M174/M175 (Rm-P1)  
Service Training****Detailed Section Descriptions****ADF**

Slide 32

- ❑ This section is different from the Rn series.



## Components

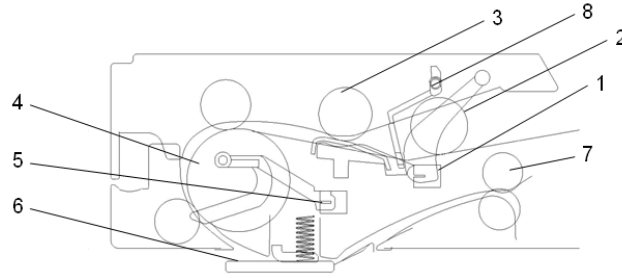

m1562026

- 1. Document Sensor
- 2. Pick Roller
- 3. Separation Roller
- 4. Feed Roller
- 5. Feed Sensor
- 6. DF Exposure Glass
- 7. Output Roller
- 8. Original Stopper

Slide 33

**No additional notes**

**Paper Path**

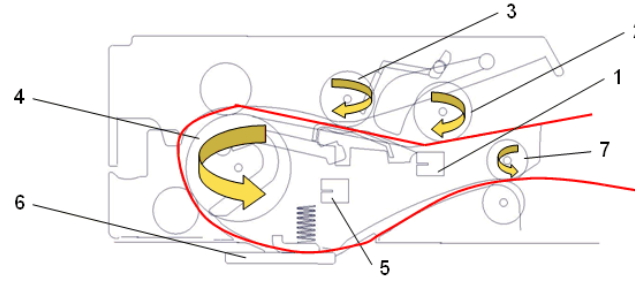

m1562027

- ❑ When the document sensor [1] detects an original, the ADF motor rotates to drive the pick roller [2], separation roller [3] and feed roller [4] to feed the original to the feed sensor [5].
- ❑ If the feed sensor [5] does not detect the paper, the machine determines that an original jam has occurred.
- ❑ If the feed sensor [5] detects paper, then scanning starts by the CIS through the DF exposure glass [6].
- ❑ After scanning, the output roller [7] will eject the paper.

Slide 34

**No additional notes**

**RICOH**

**M156/M157/M176/M177 (Rm-MF1)  
M154/M155/M174/M175 (Rm-P1)  
Service Training**

**Detailed Section Descriptions**

**Scanner**

Slide 35

- ❑ This section is different from the Rn series.

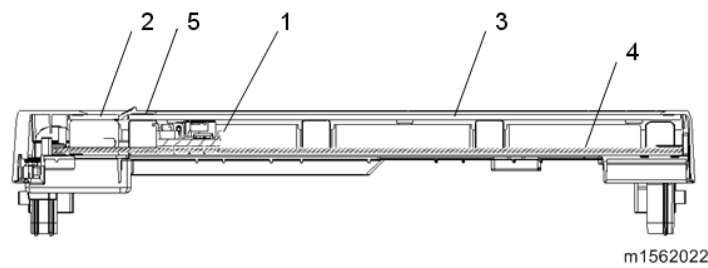
**Overview**

- 1. Scanner Carriage Unit**
- 2. DF Exposure Glass**
- 3. Scanner Exposure Glass**
- 4. Carriage Drive Shaft**
- 5. White Sheet**

Slide 36

**No additional notes**

**Drive**

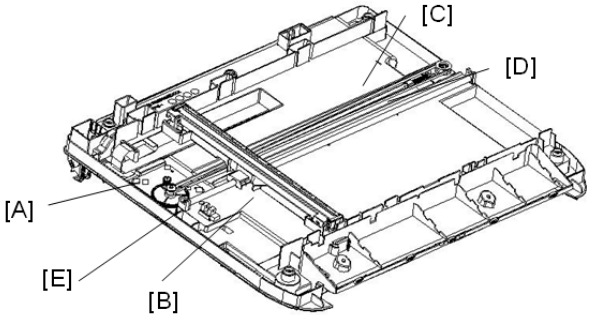

m1562023

- ❑ **Scanner motor [A]:** Drives the scanner carriage unit [B] through gears and a timing belt [C].
- ❑ **Scanner carriage unit:** Moves along the carriage drive shaft [D].
- ❑ **Carriage home position sensor [E]:** Detects home position when initializing the scanner or before/after scanning.
- ❑ **The scanner carriage unit moves to read the white sheet (see the previous slide) before every scan to adjust white level.**

Slide 37

**No additional notes**

**RICOH**

**M156/M157/M176/M177 (Rm-MF1)  
M154/M155/M174/M175 (Rm-P1)  
Service Training**

**Detailed Section Descriptions**

**Laser Exposure**

Slide 38

- ❑ This section is the same as the Rn series.

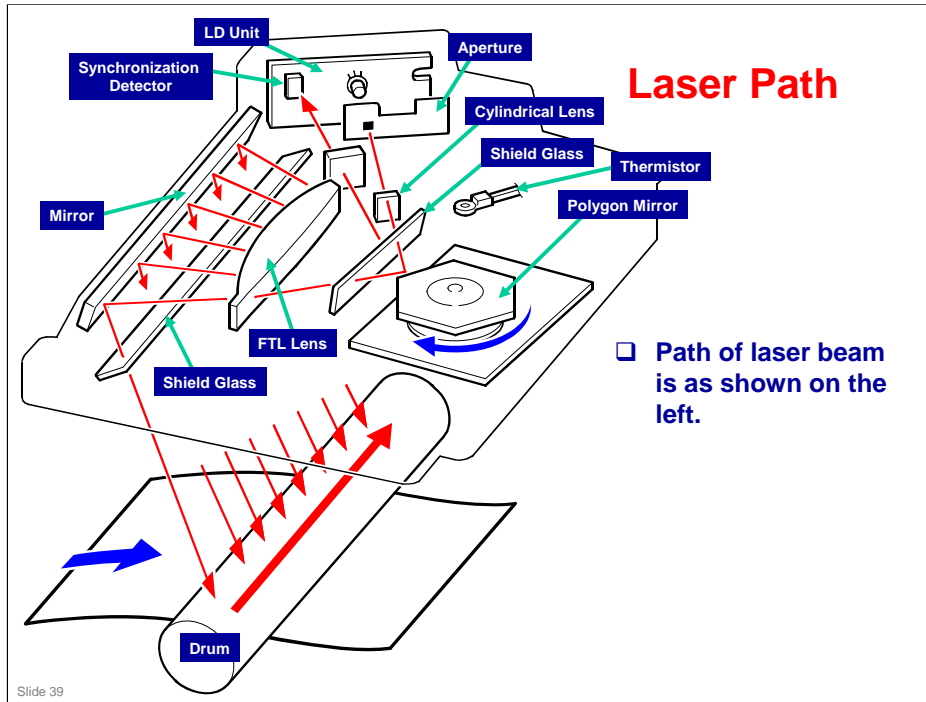

No additional notes

オンライン11

## Automatic Power Control (APC)

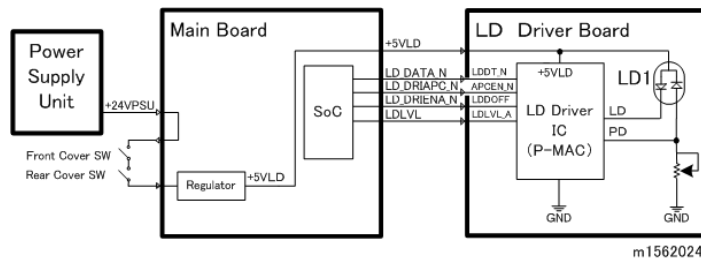

- ❑ The LD driver on the LD drive board automatically controls power for the laser diodes.
  - ◆ Laser diode power is adjusted at the factory.
- ❑ **Note: Never touch the variable resistors on the LD unit in the field.**

Slide 40

No additional notes



スライド 40

---

オブライエン11 Pix for china - next slide also  
オブライエン エドモンド, 2013/02/25

## LD Safety Switches

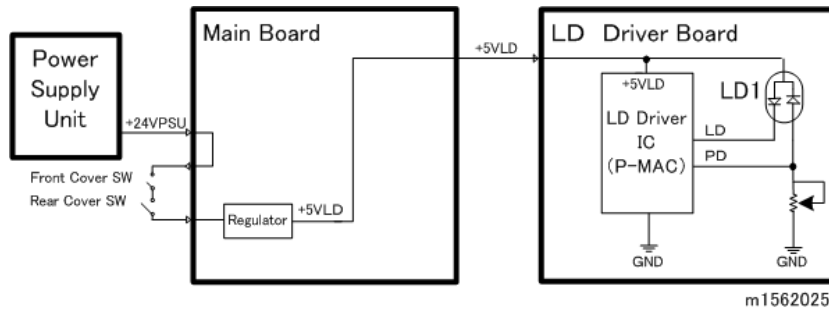

- There are safety switches on the front and rear covers, which stop the laser while the cover is open.
- If the user opens one of these covers, the +5VLD power to the laser diodes is stopped.

Slide 41

**No additional notes**

**RICOH**

**M156/M157/M176/M177 (Rm-MF1)  
M154/M155/M174/M175 (Rm-P1)  
Service Training**

**Detailed Section Descriptions**

**AIO**

Slide 42

- ❑ This section is the same as the Rn series.

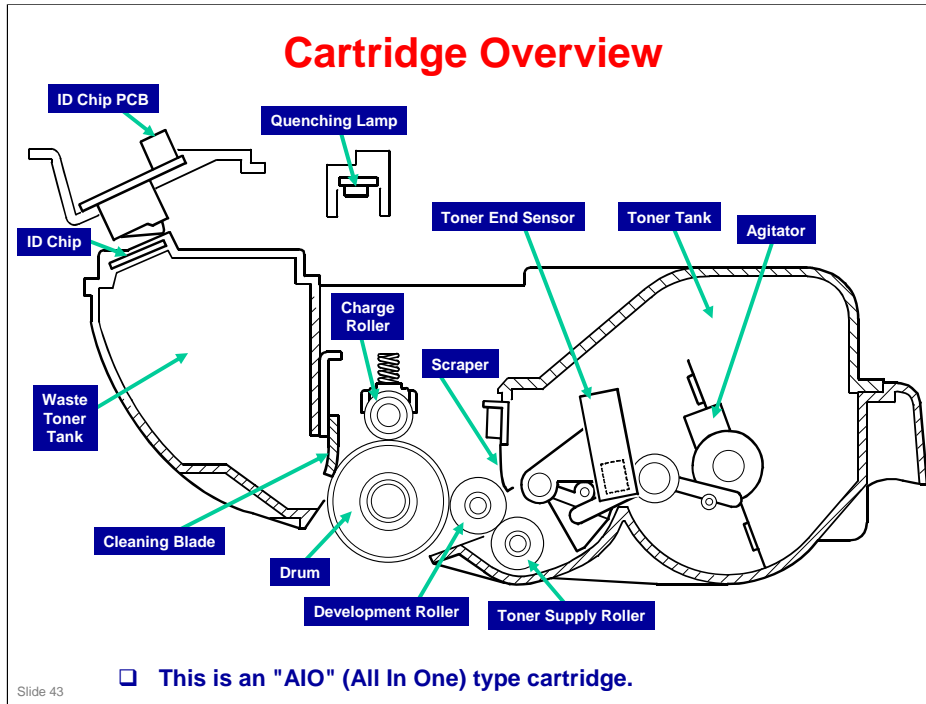

No additional notes

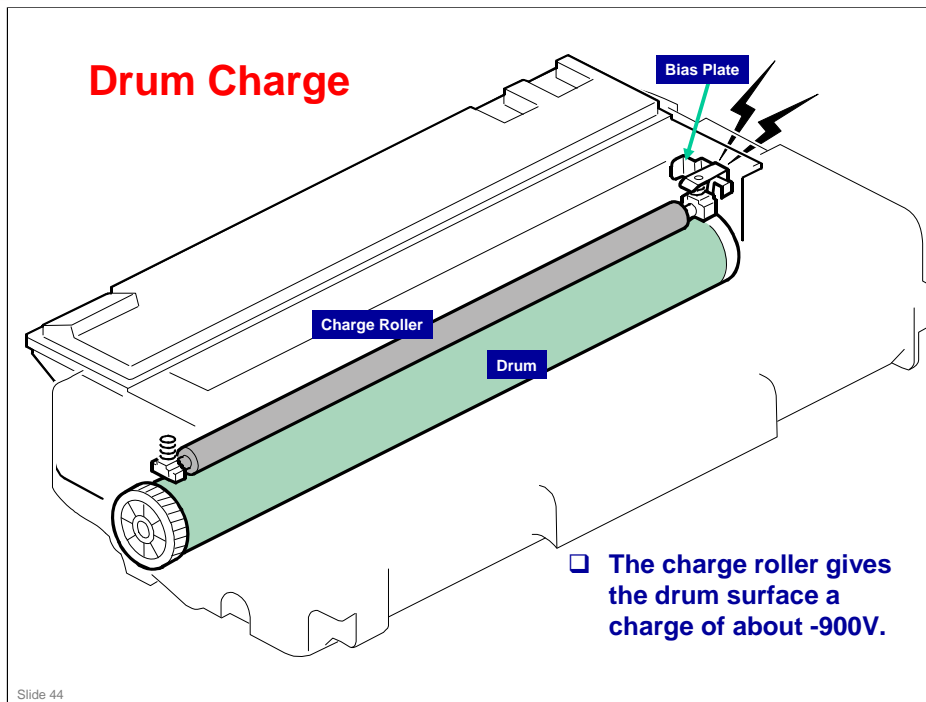

No additional notes

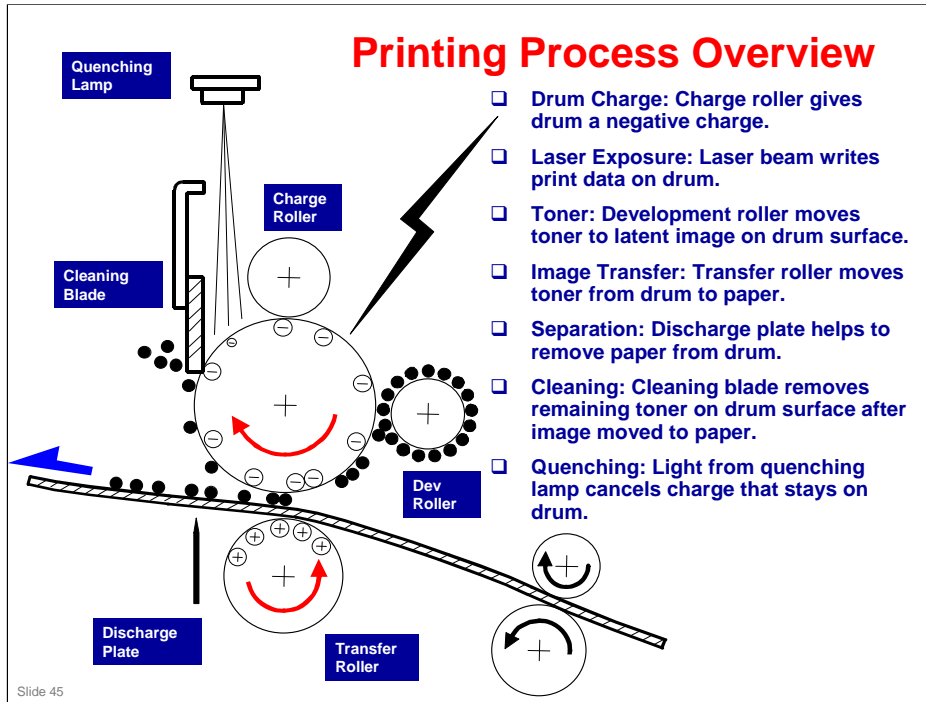

No additional notes

**RICOH**

**M156/M157/M176/M177 (Rm-MF1)  
M154/M155/M174/M175 (Rm-P1)  
Service Training**

**Detailed Section Descriptions  
Toner Supply and Development**

Slide 46

- This section is the same as the Rn series.

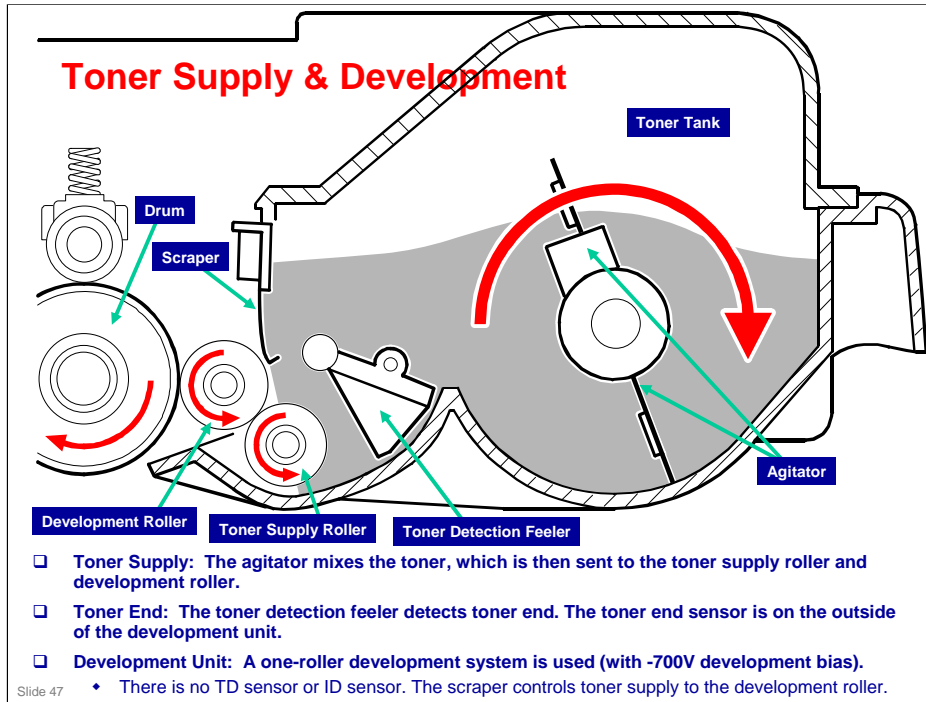

**No additional notes**



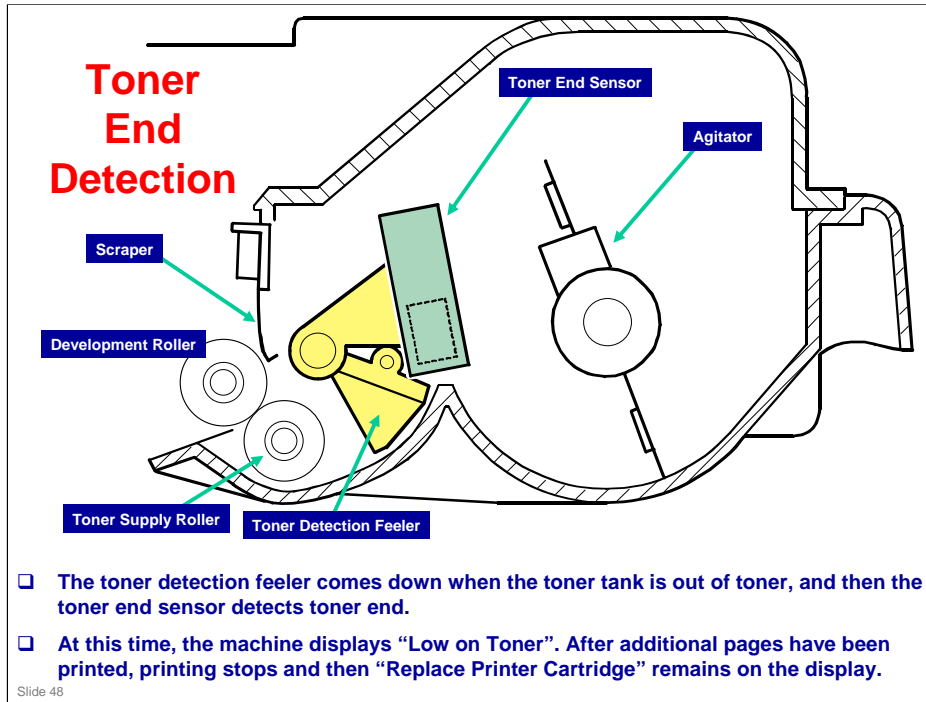

**No additional notes**

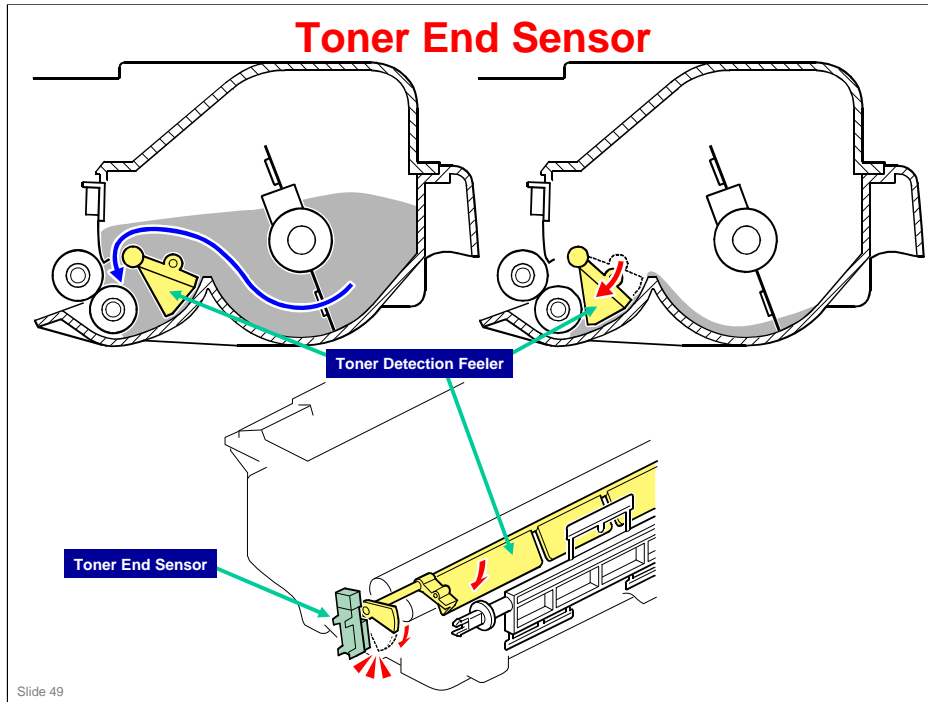

**No additional notes**

## Toner Overflow Prevention - 1/2

### ❑ Main Motor Rotation Count

- ◆ Time to replace the AIO cartridge can also be determined by the length of time the main motor has been rotating.
- ◆ When toner end is detected in this manner, 'Replace Print Cartridge' is displayed alternately with 'Ready'.

### ❑ Toner Overflow Prevention

- ◆ With the main motor rotation count feature, the machine can be set to stop printing after the print total exceeds a certain set value.
- ◆ If the print count exceeds this value, then 'Replace Print Cartridge' remains on the display. Then a new AIO cartridge must be installed.
- ◆ This feature is a safety measure to prevent the used toner tank from becoming full (there is no toner overflow detection mechanism).

Slide 50

**No additional notes**

## Toner Overflow Prevention - 2/2

### □ Why do we need this feature?

- ◆ Normally, the AIO is replaced by users. But some users will refill old AIOs with toner, and reuse them. If this occurs, the used toner tank will not be emptied. So there must be a way to stop users from repeatedly filling old AIOs with fresh toner.
- ◆ This feature is disabled by default. But if field service stations know that this practice occurs in their region, or they know a customer who is doing this, then they can enable this feature.

### □ How does the machine know if an AIO is a new one?

- ◆ Each AIO has serial number information on a chip. The machine checks this number when an AIO is placed in machine.

Slide 51

**No additional notes**

## Toner End Detection

- ❑ **About 50 pages can be printed between the toner near end alert and the final toner end alert.**
- ❑ **Type B models: Normally this system is enabled, but the operator can switch Toner End Option off with the User Tools.**
  - ◆ Enabled: User tool is set to 'Stop Printing'
  - ◆ Disabled: User tool is set to 'Continue Printing'
- ❑ **When toner end detection is switched off, there will be no warning message when the AIO is about to run out of toner. The operator refills or replaces the AIO when printed sheets become faint or blurred.**
  - ◆ Customers who use fax have to be careful about this, or they might not be able to read incoming fax messages.

Slide 52

- ❑ Note that the type B machine monitors for toner end even if 'Continue Printing' is selected. This means that the user can switch between 'Stop Printing' and 'Continue Printing' at any time, and if toner end occurs when 'Stop Printing' is selected, then the toner end alert will occur.

## Toner End Option [Type B Models only] (1)

- ❑ **When the Toner End Option is set to 'Stop Printing' (default):**
  - ◆ The toner near end and toner end alert functions are enabled.
  - ◆ The toner near end alert will appear when toner supply runs low, and then about 50 pages can be printed until toner end.
  - ◆ A toner level progress bar is displayed on the configuration page (and for the Rm-P1 it can also be seen with SOM).

```
Supplies Status
Print Cartridge      ██████████
Fusing Unit         ██████████
Paper Feed Roller   ██████████
Transfer Roller     ██████████
Toner End Option    :Stop Printing
```

**Configuration Page**

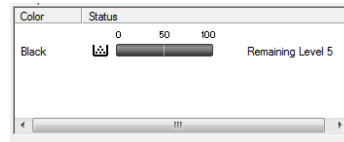

**SOM**

Slide 53

- ❑ The configuration page for the Type A models does not have the Toner End Option setting.

## Toner End Option [Type B Models only] (2)

- ❑ **When the Toner End Option is set to 'Continue Printing':**
  - ◆ The toner level in the AIO is not monitored.
  - ◆ The machine will continue printing even after toner runs out because the toner near end and toner end alerts will not appear.
  - ◆ The Configuration Page (and SOM for the Rm-P1) will display three asterisks, and no information about how much toner remains. However, SOM will show a red 'Toner End' icon if toner is run out.

```
Supplies Status
Print Cartridge      ***
Fusing Unit         *****
Paper Feed Roller   *****
Transfer Roller     *****
Toner End Option    :Continue Printing
```

**Configuration Page**



**SOM**

Slide 54

**No additional notes**

### After Toner End (Type B Models)

- ❑ The operator can force print from the AIO even after the toner end message appears by switching off the Toner End Option:
  - ◆ [User Tools] > System Settings > Toner End Option > Continue Printing
- ❑ The machine can continue to print until printouts become faint or blurred.

Slide 55

- ❑ The toner count reset can also be executed on the Service Mode screen of Smart Organizing Monitor.



## AIO Replacement

- ❑ The ID chip on the AIO tells the machine that an AIO is installed. It is also used to detect when a new AIO is installed in the machine.
- ❑ If a new AIO is detected, the toner counter is reset automatically, and Toner End Option is automatically changed to 'Stop printing'.
- ❑ The AIO can be easily removed and replaced by the user. For more details, please refer to the operating instructions.

Slide 56

**No additional notes**

**RICOH**

**M156/M157/M176/M177 (Rm-MF1)  
M154/M155/M174/M175 (Rm-P1)  
Service Training**

**Detailed Section Descriptions**

**Transfer & Separation**

Slide 57

- This section is the same as the Rn series.

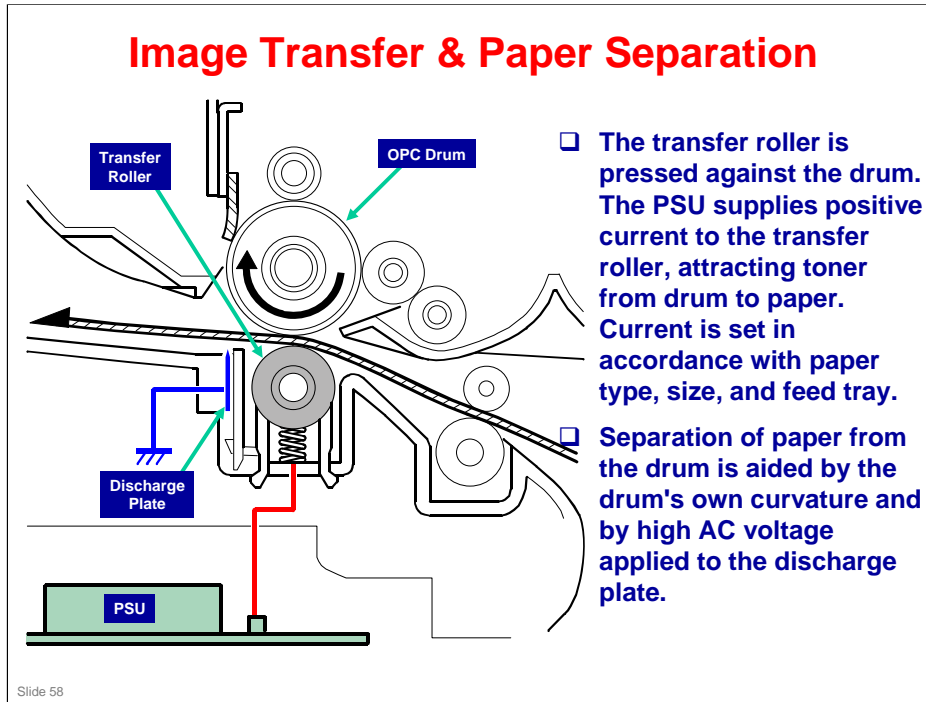

**OPC – Organic Photo-Conductor (drum)**

**PSU – Power Supply Unit**

## Image Transfer Current Timing

- ❑ **There are two transfer current levels: low and high.**
  - ◆ Low level: Before image transfer starts, the PSU supplies +10uA to the transfer roller to prevent positively charged toner from sticking to the drum.
  - ◆ High level: During image transfer, the PSU supplies high current to the transfer roller to attract toner to the paper.
- ❑ **When the trailing edge of the paper has passed the transfer roller, the PSU stops supplying transfer current.**
  - ◆ If the machine is printing more pages, the PSU supplies low level current.
- ❑ **You can adjust these levels, but when increasing the transfer current level, use caution:**
  - ◆ Increasing the transfer current level may produce ghost images.
  - ◆ Increasing the transfer current level might damage the drum.

Slide 59

**No additional notes**

## Transfer Roller Cleaning

- ❑ Toner may transfer to the roller surface following a paper jam, or if the paper is smaller than the image. Periodic cleaning of the roller is required to prevent this toner from migrating back to the rear of new printouts.
- ❑ The roller is cleaned automatically at the following times:
  - ◆ After initial power on
  - ◆ After clearing of a copy jam
  - ◆ At job end (if at least 10 sheets have been printed since last cleaning)
- ❑ To clean the roller, the PSU does the following:
  - ◆ Supplies negative cleaning current (about -4uA) to the transfer roller, causing negatively charged toner on the roller to move back to the drum.
  - ◆ Supplies positive cleaning current (+5uA) to the roller, causing any positively charged toner to migrate back to the drum.

Slide 60

**No additional notes**

**RICOH**

**M156/M157/M176/M177 (Rm-MF1)  
M154/M155/M174/M175 (Rm-P1)  
Service Training**

**Detailed Section Descriptions**

**Paper Feed**

Slide 61

- ❑ This section is the same as the Rn series. However, there are no optional feed units in this new model.

### Paper Tray

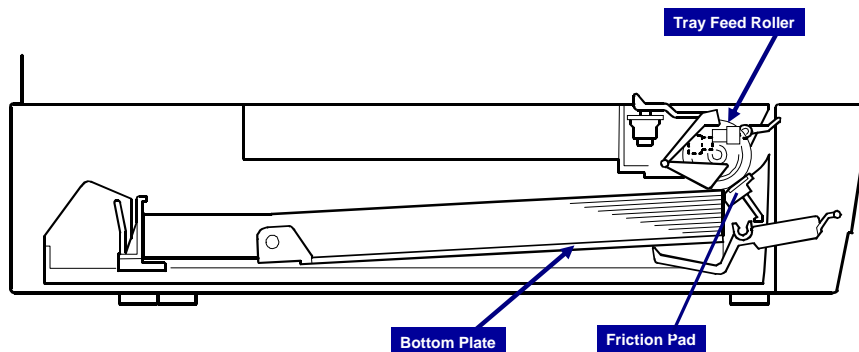

- The tray capacity is 250 sheets.

Slide 62

**No additional notes**

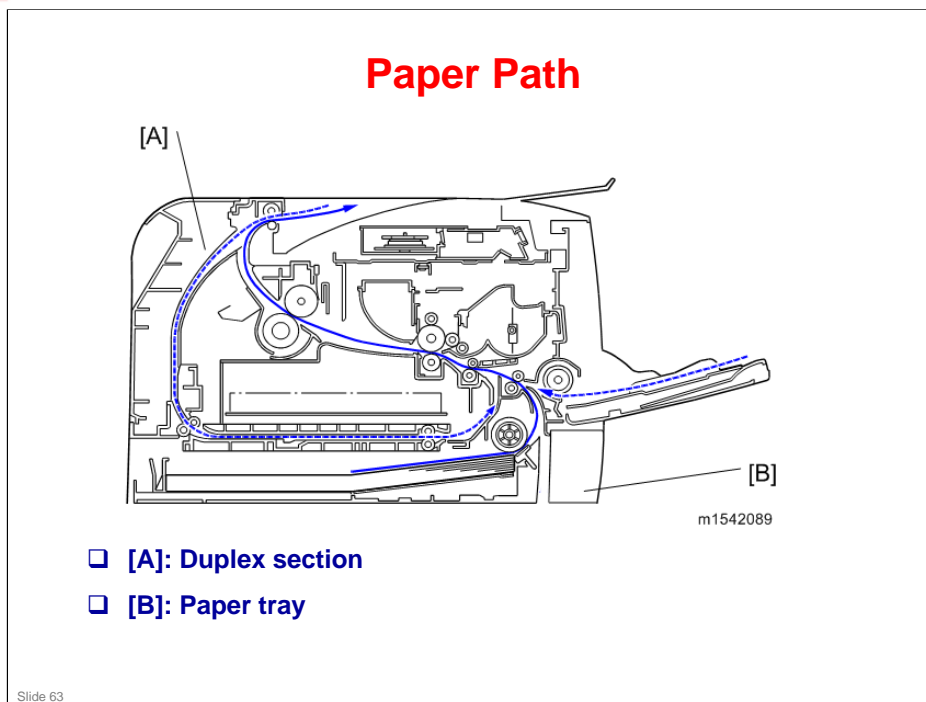

**No additional notes**



## Paper Tray Extension Locks

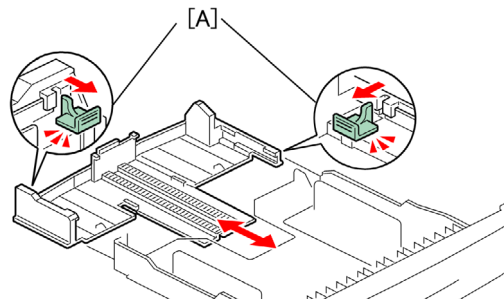

- ❑ The user can extend the tray manually to hold paper longer than A4/Letter size.
- ❑ To use longer paper:
  - ◆ Release the two locks [A]
  - ◆ Extend the tray and close the locks.
- ❑ Verify that the paper tray extension locks are properly locked before reinserting the paper tray.

Slide 64

- ❑ These paper sizes can be used:
  - Short (default): A5 (LEF/SEF), B5 (SEF), A4 (SEF), LT (SEF)
  - Long: LG (SEF), 8.5" x 13" (SEF), 8" x 13" (SEF), 8.25" x 13" (SEF)

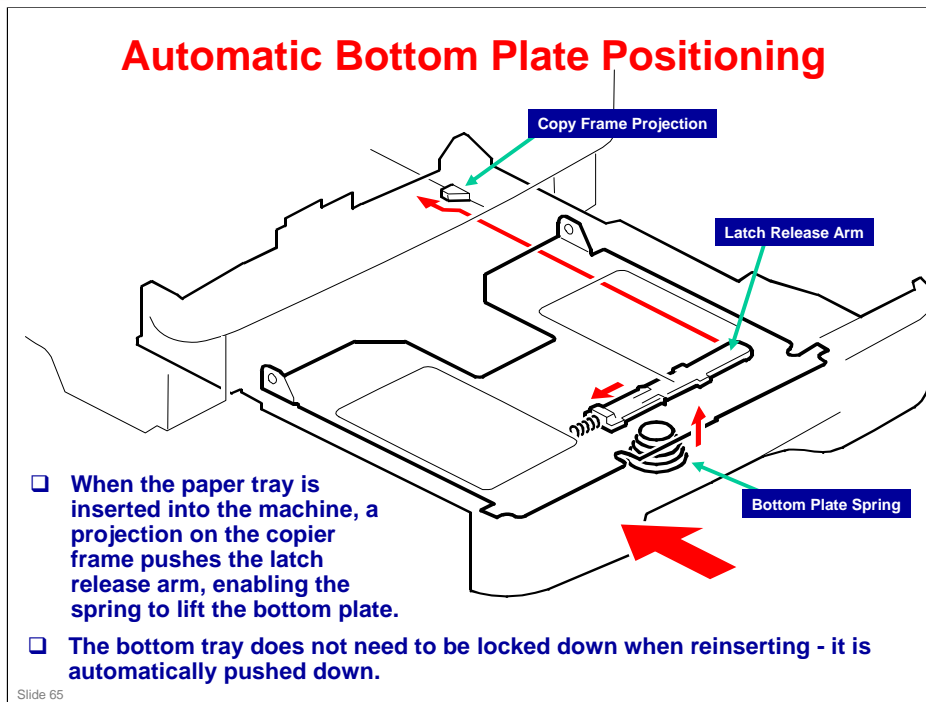

**No additional notes**

## Paper End Detection

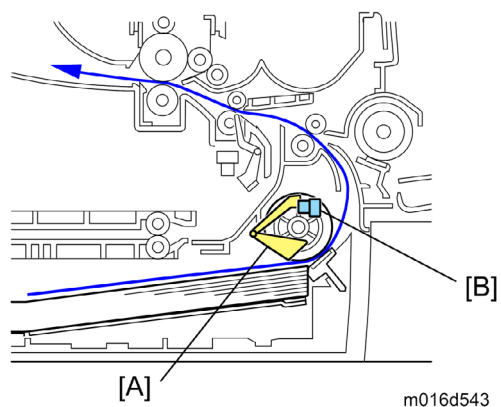

- When there is no paper in the tray, the feeler [A] falls into the cutout in the bottom plate, triggering the paper end sensor [B].

Slide 66

No additional notes

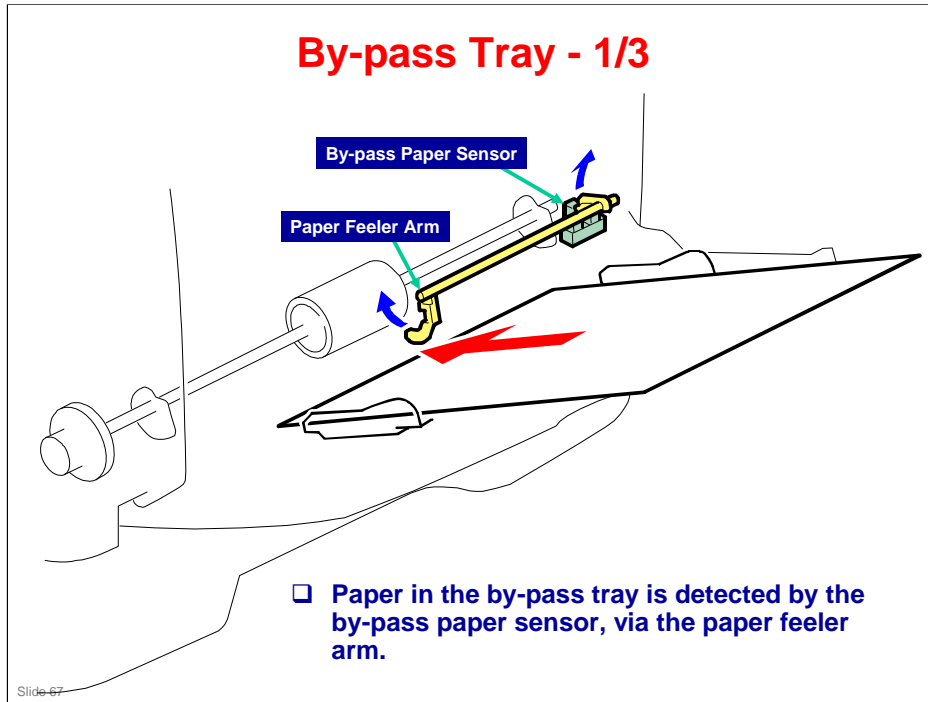

**No additional notes**

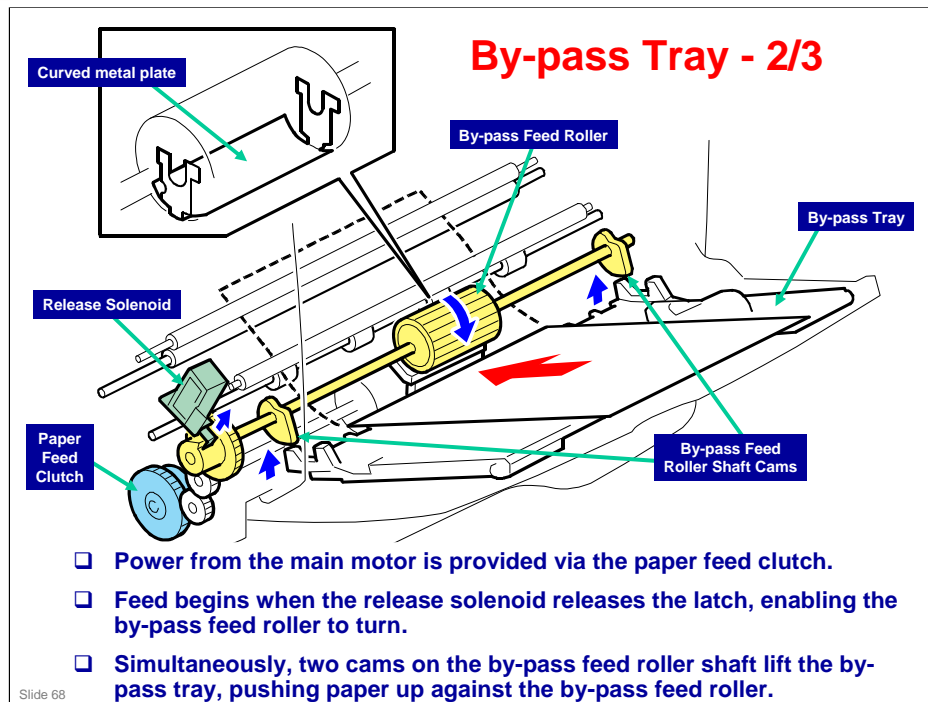

- Note: In some machines, the by-pass feed roller has a flat section to enable paper to pass by by-pass roller freely. This machine utilizes a curved metal plate on the by-pass feed roller to perform this function.

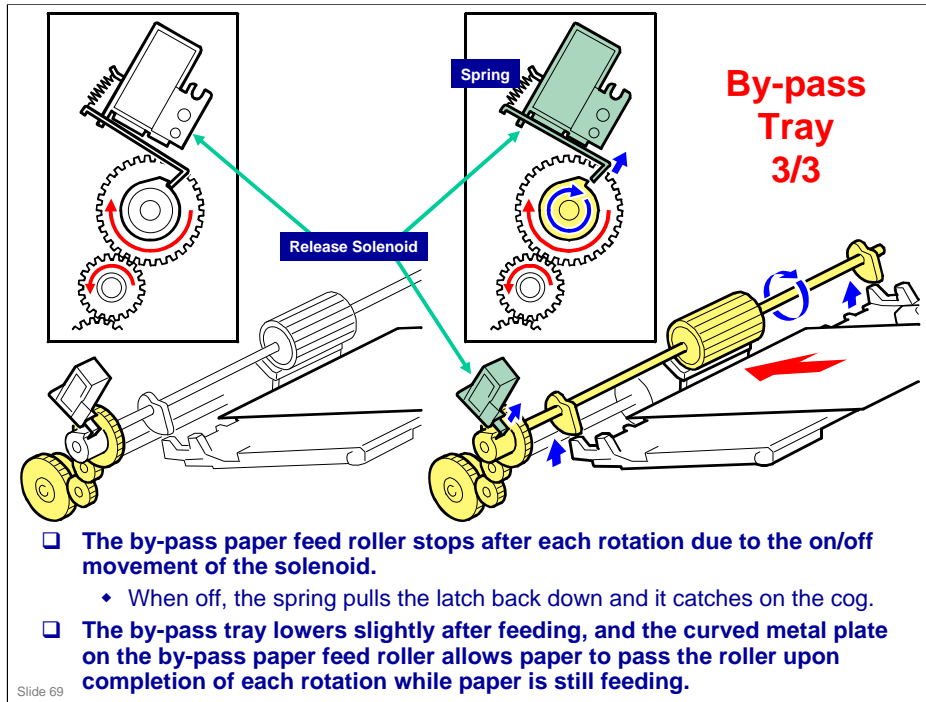

**No additional notes**

**RICOH**

**M156/M157/M176/M177 (Rm-MF1)  
M154/M155/M174/M175 (Rm-P1)  
Service Training**

**Detailed Section Descriptions**

**Fusing & Paper Exit**

Slide 70

- ❑ This section is basically the same as the Rn series. The envelope levers have been added for this model.

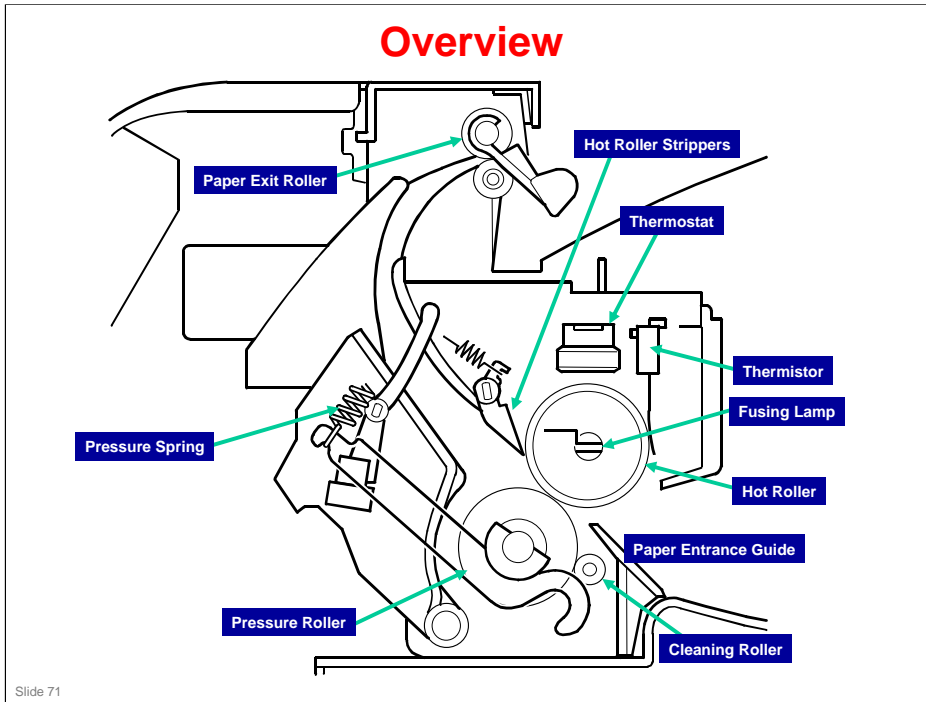

**No additional notes**



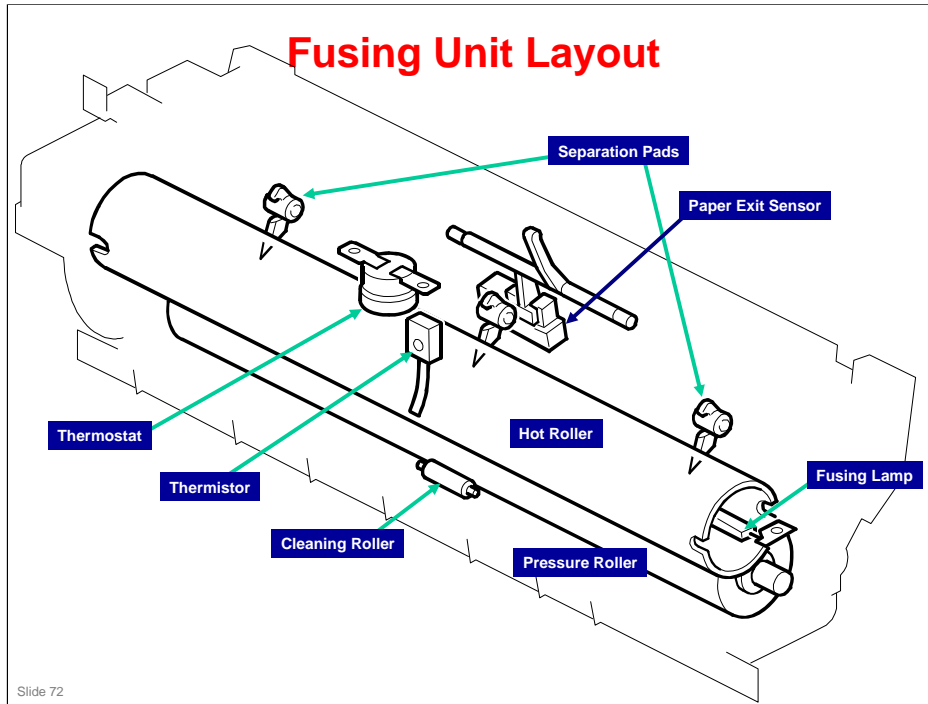

**No additional notes**

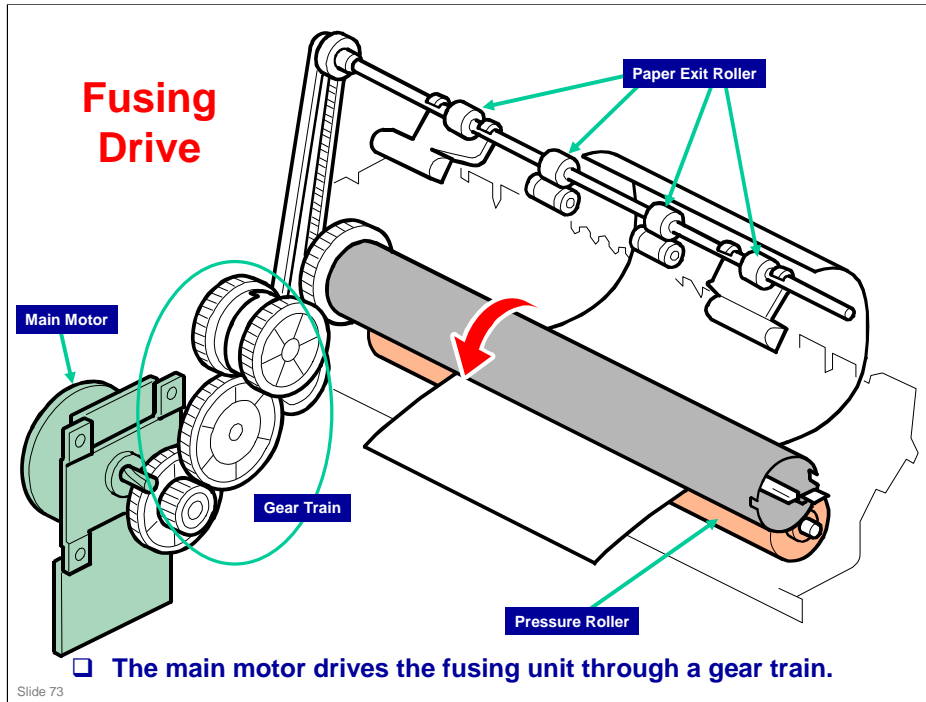

No additional notes

## Envelope Levers

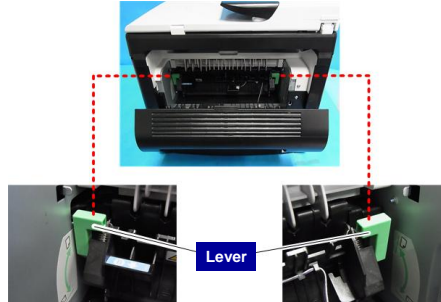

- ❑ Envelope levers are provided on the right and left sides of the fusing unit.
- ❑ When the lever is pulled down, the fusing pressure decreases (approx. 55% of normal). This reduces wrinkles on the envelope.
- ❑ There is no sensor to detect the lever position, so the user must make sure to pull up the lever after printing on an envelope.
- ❑ At the time of shipment, the lever is lowered (envelope mode) to prevent deformation of the pressure roller.
- ❑ When not using the machine for a long time, leave the lever down.

Slide 74

**No additional notes**

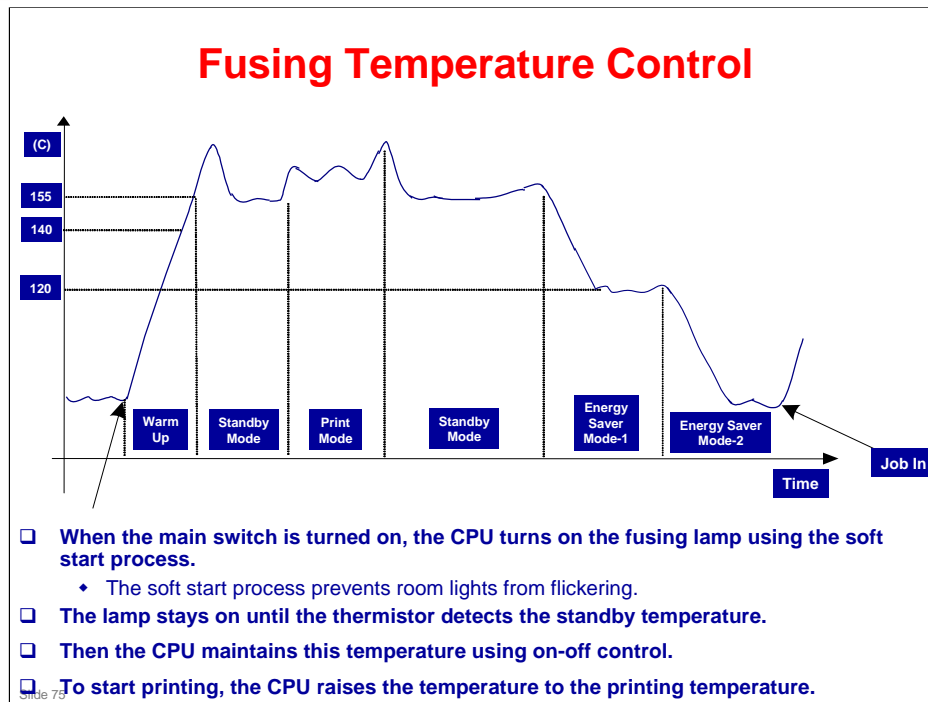

- The fusing temperature for each condition (except “Energy saver mode 2”) can be adjusted with “Fusing Unit Temperature” in the “Engine Maintenance Mode”.

## Overheat Protection

- ❑ If hot roller temperature becomes greater than 225C, the CPU cuts off power to the fusing lamp.
- ❑ If thermistor overheat protection fails, there is a thermostat in series with the common ground line of the fusing lamp.
- ❑ If the temperature of the thermostat becomes greater than 210C, the thermostat opens, removing power from the fusing lamp.
- ❑ At this time, the machine stops operation.

Slide 76

**No additional notes**

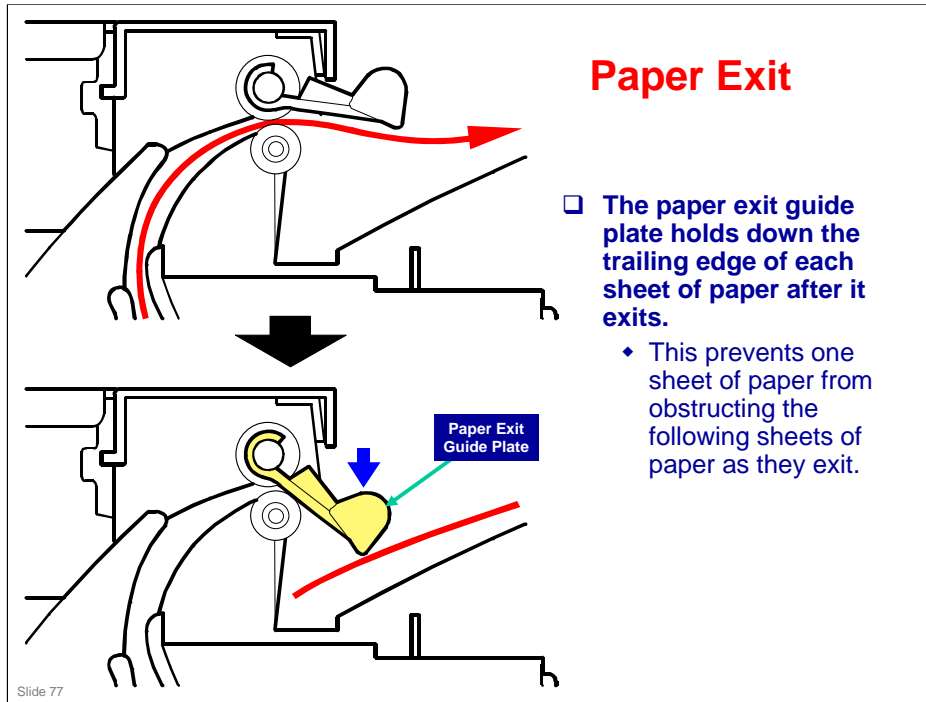

**No additional notes**

**RICOH**

**M156/M157/M176/M177 (Rm-MF1)  
M154/M155/M174/M175 (Rm-P1)  
Service Training**

**Detailed Section Descriptions**

**Duplex**

Slide 78

- ❑ This section is the same as the Rn series. However, for this new series, all models have duplex.

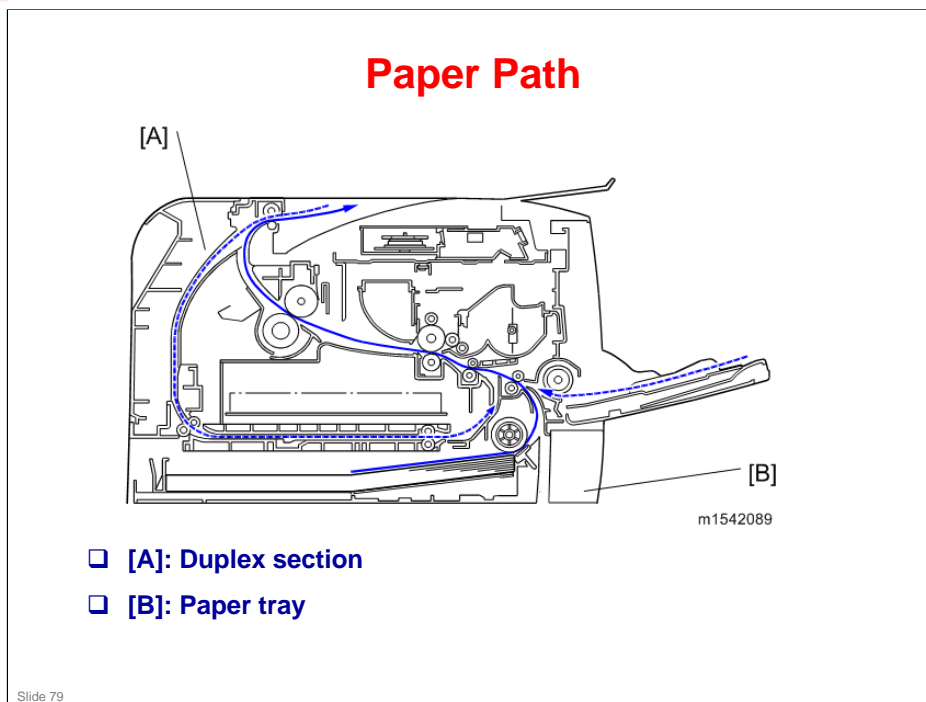

- The dotted blue line shows the path of paper back into the machine from the exit, for duplex printing.



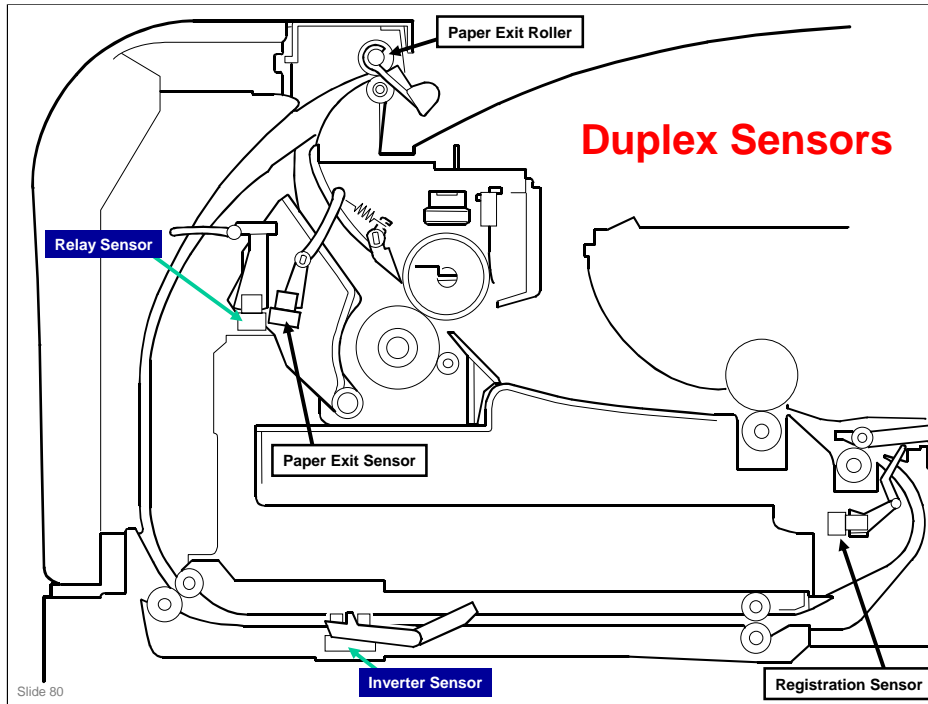

**No additional notes**

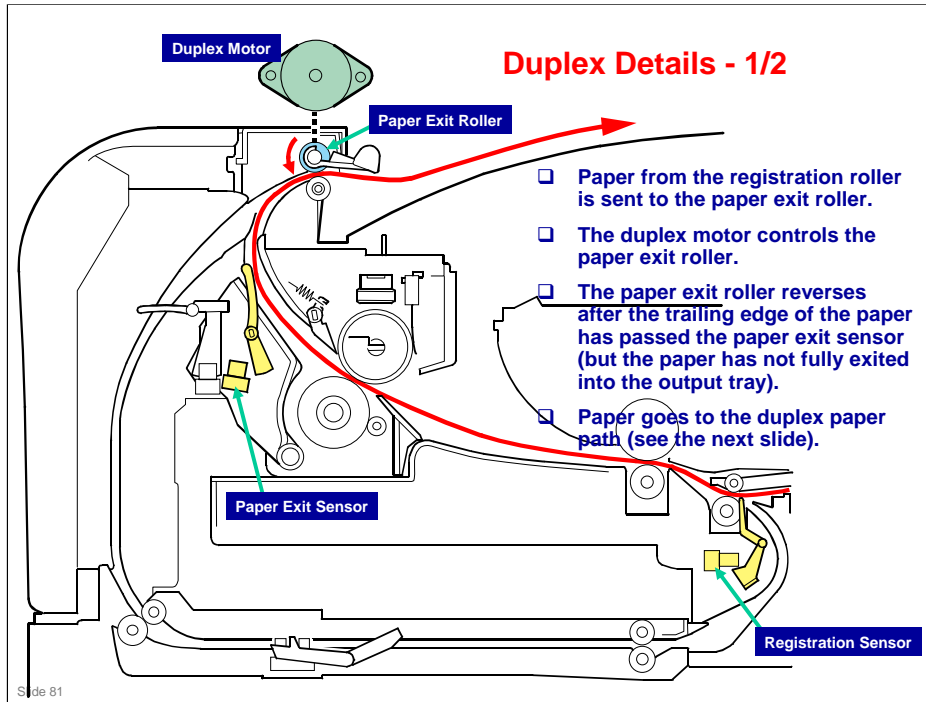

**No additional notes**

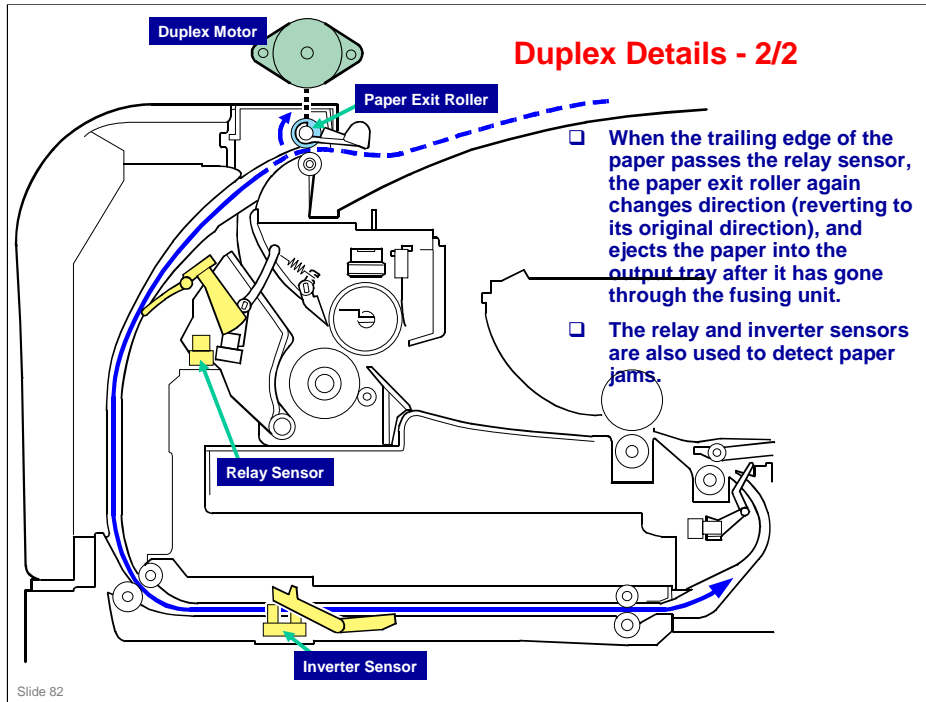

**No additional notes**

### Interleaving

□ Two sheets can be feeding through the machine at the same time.

Slide 83

No additional notes

**RICOH**

**M156/M157/M176/M177 (Rm-MF1)**

**M154/M155/M174/M175 (Rm-P1)**

**Service Training**

**Troubleshooting**

Slide 84

**No additional notes**

## Paper Jams

- ❑ **Various types of paper jams and their causes are detailed in the service manual. Some causes include:**
  - ◆ Use of a non-recommended paper type
  - ◆ End fence set incorrectly
  - ◆ Paper lift mechanism not functioning correctly
  - ◆ Defective paper feed motor
- ❑ **Go over the causes and suggested actions.**
- ❑ **When clearing jams near the fusing unit, use caution to avoid possible burns.**

Slide 85

**No additional notes**

## Printed Image Issues

- When abnormal image (black or white dots) appears at certain intervals, component part causing spots may sometimes be identified (based on circumference of certain components):

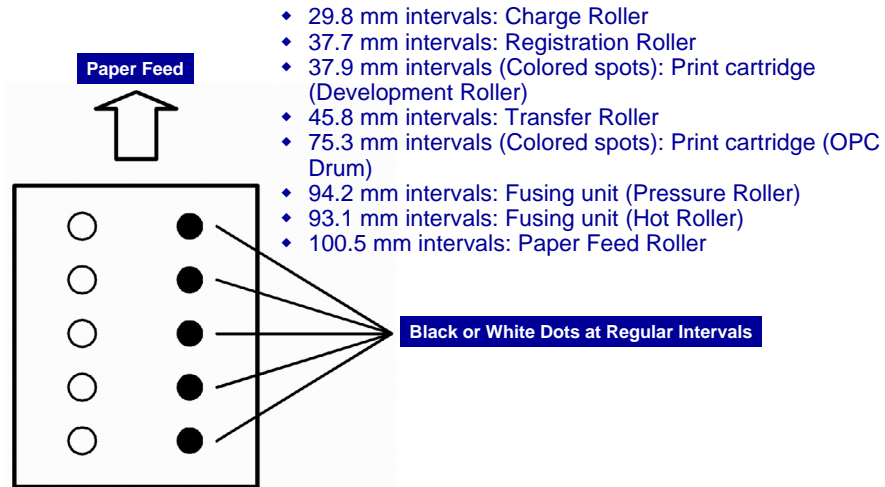

Slide 86

**No additional notes**

## Test Pattern Printing

- ❑ **Test Pattern Printing - When checking an image or other problems, it might be necessary to print a test pattern. Follow the test pattern print procedure below to print a test pattern.**
  
- ❑ **Test Pattern Print Procedure**
  - ◆ 1. Enter "Maintenance Mode".
  - ◆ 2. Select "Test Pattern", and then press "OK" key.
  - ◆ 3. The following three test pattern pages are printed.
    - » Checker flag
    - » Trimming Pattern
    - » Grid Pattern

Slide 87

**No additional notes**



**RICOH**

**M156/M157/M176/M177 (Rm-MF1)**  
**M154/M155/M174/M175 (Rm-P1)**  
**Service Training**

**Environmental Conservation**

Slide 88

**No additional notes**

## Promote Use of Energy Saving Features

### ❑ Energy Saver Mode

- ◆ Proper use of energy saver modes saves energy and is environmentally friendly.

### ❑ Duplex Settings

- ◆ Use of Duplex settings reduces amount of paper used, which results in less energy consumption for paper production.

Slide 89

**No additional notes**

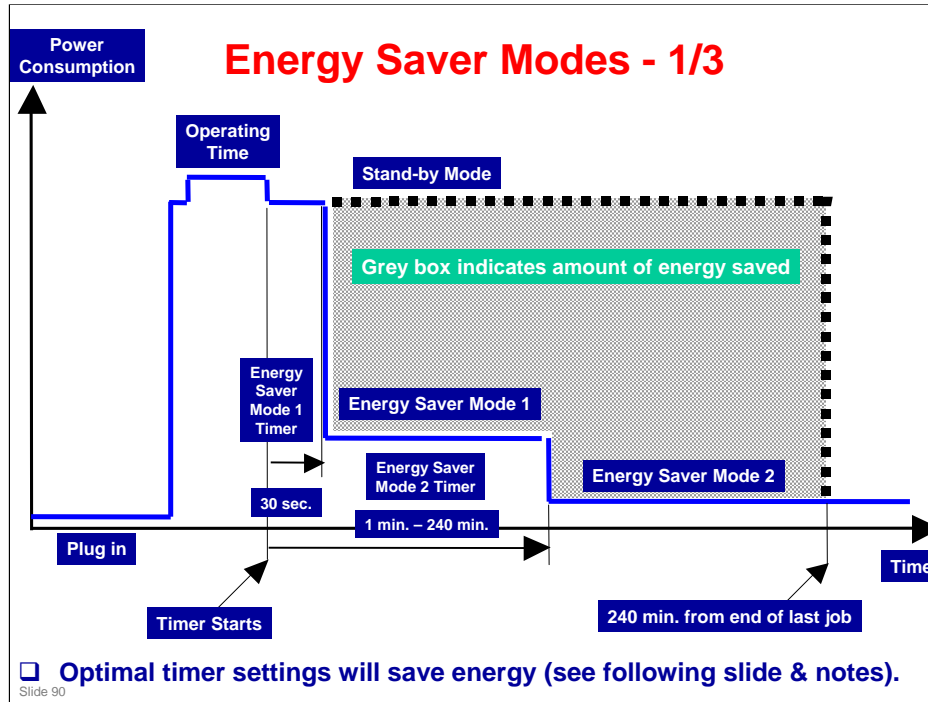

**Energy Saver Modes**

Customers should use energy saver modes properly, to save energy and protect the environment.

The area shaded grey in this diagram represents the amount of energy that is saved when the timers are at the default settings. If the timers are changed, then the energy saved will be different. For example, if the timers are all set to 240 min., the grey area will disappear, and no energy is saved before 240 min. expires.

**Timer Settings**

The user can set these timers with User Tools (Menu > Admin Settings > Power Saver > Energy Saver Mode1 or Mode2)

- Energy Saver Mode1 (30 sec.): This can be only turned on or off.
- Energy Saver Mode2 (1 to 240 min.): This can be turned on or off and timer setting is adjustable (default: 1min.).

**Return to Stand-by Mode**

**Energy Saver Mode1**

- Recovery time: 10 sec.

**Energy Saver Mode2**

- Recovery time: 23 sec.

**Recommendation**

We recommend that the default settings should be kept.

- If the customer requests that these settings should be changed, please explain that their energy costs could increase, and that they should consider the effects on the environment of extra energy use.

- If it is necessary to change the settings, please try to make sure that the Energy Saver Mode2 Timer is not too long. Try with a shorter setting first, such as 30 min., then go to a longer one (such as 60 min.) if the customer is not satisfied.

- If the timers are all set to the maximum value, the machine will not begin saving energy until 240 minutes has expired after the last job. This means that after the customer has finished using the machine for the day, energy will be consumed that could otherwise be saved.

## Energy Saver Modes - 2/3

- **There are four operating modes for this machine:**
  - ◆ Operating mode
  - ◆ Ready mode
  - ◆ Power Save-1 mode
  - ◆ Power Save-2 mode
  
- **Timer Settings - User can set these timers via:**
  - ◆ User Tools (Menu > Admin Settings > Power Saver > Energy Saver Mode1 or Mode2)
    - » Energy Saver Mode1 (30 sec.): Setting is for [On] or [Off].
    - » Energy Saver Mode2 (1 to 240 min.): Settings are for [On] or [Off] and timer is adjustable (default: 1 min.)

Slide 91

**No additional notes**

## Energy Saver Modes - 3/3

### □ How is energy saved?

- ◆ Low Energy Mode-1 - 10-second start-up mode
  - » Less than 70 W
  - » Machine starts up within 10 seconds
  - » Backlight is off
  
- ◆ Low Energy Mode-2
  - » Less than 10 W
  - » Machine starts up within 20 seconds
  - » Backlight is off
  - » Fusing lamps: Off

Slide 92

**No additional notes**

## Paper Saving Measuring the Paper Consumed - 1

1. Duplex: Reduce paper volume by half!



2. Combine mode: Reduce paper volume by half!



3. Duplex + Combine: Using both features together can further reduce paper volume by 3/4!

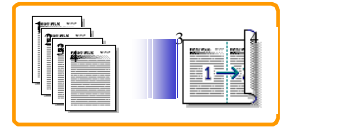

Slide 93

**No additional notes**

## Paper Saving Measuring the Paper Consumed - 2

- ❑ To check paper consumption, look at total counter and duplex counter.
- ❑ Total counter counts all pages printed.
  - ◆ For one duplex page, the total counter goes up by 2.
  - ◆ For a duplex job of a three-page original, the total counter goes up by 3.
- ❑ The duplex counter counts pages that have images on both sides.
  - ◆ For one duplex page, the duplex counter goes up by 1.
  - ◆ For a duplex job of a three-page original, the duplex counter will only increase by 2, even though two sheets are used.

Slide 94

- ❑ The following table shows paper savings and how the counters increase for some simple examples of single-sided and duplex jobs.

Originals	Simplex Sheet used	Duplex Sheets used	Paper Saved	Total counter SP8501-001	Duplex counter SP8411-001
1	1	1	<b>0</b>	1	0
2	2	1	<b>1</b>	2	1
3	3	2	<b>1</b>	3	1
4	4	2	<b>2</b>	4	2
5	5	3	<b>2</b>	5	2
10	10	5	<b>5</b>	10	5
20	20	10	<b>10</b>	20	10

**Paper Saving**  
**Measuring the Paper Consumed - 3**

- ❑ If combine mode is used, the total and duplex counters work in the same way as explained previously.

Slide 95

- ❑ The following table shows paper savings and how the counters increase for some simple examples of duplex/combine jobs.

2 in 1					
Originals	Simplex Sheet used	Combine Sheets used	Paper Saved	Total counter SP8501-001	Simplex Combine counter SP8421-004
1	1	1	0	1	1
2	2	1	1	1	1
3	3	2	1	2	2
4	4	2	2	2	2
5	5	3	2	3	2
10	10	5	5	5	5
20	20	10	10	10	10

Duplex + 2 in 1					
Originals	Simplex Sheet used	Combine Sheets used	Paper Saved	Total counter SP8501-001	Duplex Combine counter SP8421-005
1	1	1	0	1	1
2	2	1	1	1	1
3	3	1	2	2	2
4	4	1	3	2	2
5	5	2	3	3	3
6	6	2	4	3	3
7	7	2	5	4	4
8	8	2	6	4	4
9	9	3	6	5	5
10	10	3	7	5	5
11	11	3	8	6	6
12	12	3	9	6	6



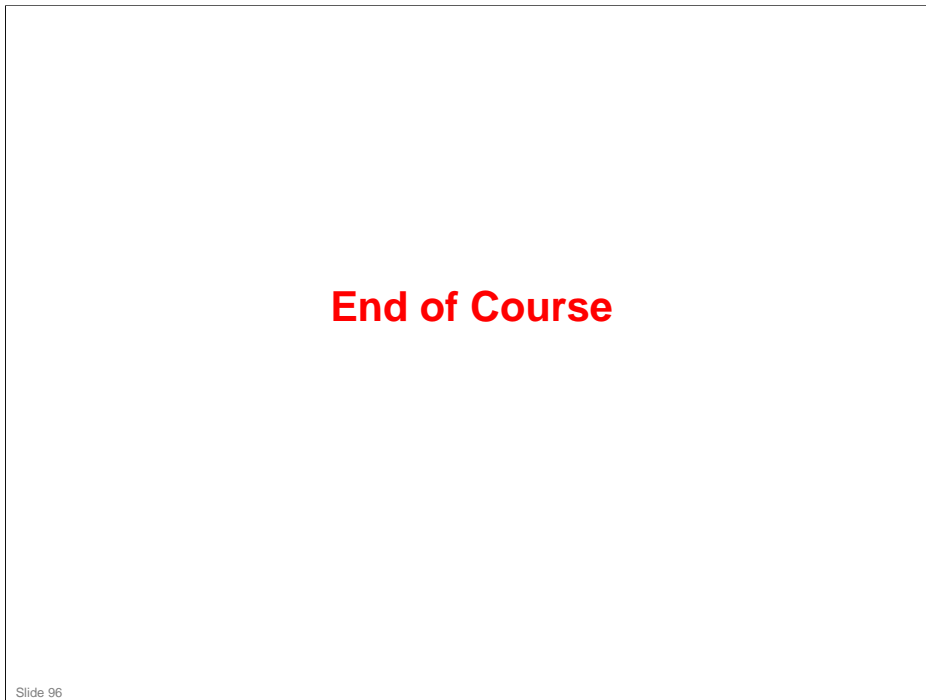

**No additional notes**