



RICOH UNIVERSITY

Learning ♦ Knowledge ♦ Performance



M156/M157/M176/M177
SERVICE MANUAL

LANIER RICOH SAVIN

It is the reader's responsibility when discussing the information contained within this document to maintain a level of confidentiality that is in the best interest of Ricoh Americas Corporation and its member companies.

NO PART OF THIS DOCUMENT MAY BE REPRODUCED IN ANY FASHION AND DISTRIBUTED WITHOUT THE PRIOR PERMISSION OF RICOH AMERICAS CORPORATION.

All product names, domain names or product illustrations, including desktop images, used in this document are trademarks, registered trademarks or the property of their respective companies.

They are used throughout this book in an informational or editorial fashion only and for the benefit of such companies. No such use, or the use of any trade name, or web site is intended to convey endorsement or other affiliation with Ricoh products.

WARNING

The Service Manual contains information regarding service techniques, procedures, processes and spare parts of office equipment distributed by Ricoh Americas Corporation. Users of this manual should be either service trained or certified by successfully completing a Ricoh Technical Training Program.

Untrained and uncertified users utilizing information contained in this service manual to repair or modify Ricoh equipment risk personal injury, damage to property or loss of warranty protection.

Ricoh Americas Corporation

LEGEND

PRODUCT CODE	COMPANY		
	LANIER	RICOH	SAVIN
M156	SP 311FN	SP 311FN	SP 311FN
M157	SP 311SFNw	SP 311SFNw	SP 311SFNw
M176	SP 310FN	SP 310FN	SP 310FN
M177	SP 310FNw	SP 310FNw	SP 310FNw

DOCUMENTATION HISTORY

REV. NO.	DATE	COMMENTS
*	09/2013	Original Printing

M156/M157/M176/M177

TABLE OF CONTENTS

1. PRODUCT INFORMATION	1-1
1.1 PRODUCT OVERVIEW.....	1-1
1.1.1 COMPONENT LAYOUT.....	1-1
1.1.2 PAPER PATH.....	1-2
1.1.3 DRIVE LAYOUT.....	1-2
1.2 MACHINE CODES AND PERIPHERALS CONFIGURATION.....	1-3
1.2.1 MAIN FRAME.....	1-3
1.3 SPECIFICATIONS.....	1-4
2. INSTALLATION	2-1
2.1 INSTALLATION REQUIREMENTS.....	2-1
2.1.1 CHECK IMAGE QUALITY / SETTINGS.....	2-1
Environment.....	2-1
2.1.2 MOVING AND TRANSPORTING THE MACHINE.....	2-1
3. PREVENTIVE MAINTENANCE	3-1
3.1 PREVENTIVE MAINTENANCE TABLES.....	3-1
3.2 IMAGE QUALITY STANDARDS.....	3-2
3.3 PAPER TRANSFER QUALITY STANDARDS.....	3-3
3.4 PM PARTS SETTINGS.....	3-4
3.4.1 PM PARTS.....	3-4
3.5 PREPARATION FOR PM.....	3-5
3.5.1 YIELD COUNTER.....	3-5
Counter Reset.....	3-5
3.6 CLEANING POINTS.....	3-6
4. REPLACEMENT AND ADJUSTMENT	4-1
4.1 GENERAL CAUTIONS.....	4-1
4.2 SPECIAL TOOLS.....	4-1
4.3 EXTERIOR COVERS.....	4-2
4.3.1 FRONT COVER.....	4-2
4.3.2 LEFT COVER.....	4-3
4.3.3 REAR COVER.....	4-5
4.3.4 RIGHT COVER.....	4-6

4.3.5 TOP COVER.....	4-7
When installing the top cover	4-7
4.4 SCANNER UNIT	4-8
4.4.1 SCANNER UNIT	4-8
4.4.2 OPERATION PANEL.....	4-9
4.5 ADF.....	4-10
4.5.1 ADF UNIT	4-10
4.5.2 ORIGINAL TRAY	4-10
4.5.3 ADF PICK-UP ROLLER.....	4-11
4.5.4 ADF FEED ROLLER.....	4-12
4.5.5 ADF SEPARATION PAD	4-12
4.5.6 ADF FRONT COVER.....	4-13
4.5.7 ADF REAR COVER.....	4-14
4.5.8 ADF MOTOR	4-15
4.5.9 ADF TOP COVER.....	4-16
4.5.10 DOCUMENT SENSOR	4-16
4.5.11 ADF FEED SENSOR	4-17
4.6 LASER UNIT.....	4-18
4.6.1 CAUTION DECAL LOCATIONS	4-18
4.6.2 LASER UNIT.....	4-19
4.6.3 POLYGON MIRROR MOTOR	4-20
4.7 PAPER FEED	4-21
4.7.1 PAPER FEED ROLLER.....	4-21
After installing a new paper feed roller	4-21
4.7.2 FRICTION PAD	4-22
When reinstalling the friction pad, do it in this order:.....	4-22
4.7.3 PAPER END SENSOR.....	4-22
4.7.4 BY-PASS FEED ROLLER	4-23
4.7.5 BY-PASS FEED ROLLER FRICTION PAD	4-24
4.7.6 BY-PASS FEED SENSOR.....	4-25
4.7.7 PAPER FEED CLUTCH.....	4-25
4.7.8 RELAY CLUTCH.....	4-26
4.7.9 REGISTRATION CLUTCH	4-26
4.7.10 REGISTRATION ROLLER.....	4-27
4.7.11 REGISTRATION SENSOR	4-30
4.8 IMAGE TRANSFER.....	4-31
4.8.1 TRANSFER ROLLER	4-31
After installing a new transfer roller	4-31
4.8.2 TONER END SENSOR.....	4-32

4.8.3	QUENCHING LAMP	4-33
4.9	FUSING AND EXIT	4-34
4.9.1	FUSING UNIT	4-34
	Reinstallation.....	4-35
	After installing a new fusing unit.....	4-36
4.9.2	THERMOSTAT	4-36
4.9.3	THERMISTOR	4-37
4.9.4	FUSING LAMP	4-38
	When reinstalling the fusing lamp	4-39
4.9.5	HOT ROLLER.....	4-39
4.9.6	PRESSURE ROLLER.....	4-41
4.9.7	HOT ROLLER STRIPPER PAWLS.....	4-42
4.9.8	PAPER EXIT SENSOR.....	4-42
4.10	DRIVE	4-43
4.10.1	MAIN MOTOR.....	4-43
4.10.2	DRIVE UNIT.....	4-43
4.10.3	DUPLEX MOTOR.....	4-44
4.11	ELECTRICAL COMPONENTS	4-45
4.11.1	LAYOUT OF PC BOARDS.....	4-45
4.11.2	MAIN BOARD	4-46
	When installing the new main board	4-46
	EEPROM.....	4-47
4.11.3	FCU.....	4-48
4.11.4	PSU.....	4-48
4.11.5	HVP.....	4-51
4.11.6	CHARGE TERMINAL CASE	4-52
4.11.7	COOLING FAN	4-53
4.11.8	SPEAKER	4-53
4.11.9	WIRELESS LAN BOARD (FOR M157, M177)	4-54
4.12	DUPLEX.....	4-55
4.12.1	RELAY SENSOR	4-55
4.12.2	INVERTER SENSOR.....	4-55
4.13	IMAGE ADJUSTMENT.....	4-56
4.13.1	REGISTRATION ADJUSTMENT	4-56
	User Adjustment.....	4-56
	Service Adjustment	4-56
5.	SERVICE TABLES.....	5-1
5.1	SERVICE PROGRAM MODE	5-1
5.1.1	OVERVIEW	5-1

5.1.2 MAINTENANCE MODE MENU	5-1
Selecting an Item	5-1
Going into the Next Level/ Returning to the Previous Level	5-1
Exiting the Maintenance Mode Menu	5-1
Menu List.....	5-1
5.1.3 FAX SERVICE TEST MENU	5-16
Entering the Fax Service Test Menu	5-16
Selecting an Item	5-16
Going into the Next Level/ Returning to the Previous Level	5-16
Exiting the Maintenance Mode Menu	5-16
Menu List.....	5-16
5.2 REPORTS.....	5-18
5.2.1 CONFIGURATION PAGE.....	5-18
To Print the Configuration Page	5-18
Total Counter	5-19
5.2.2 OTHER TYPES OF REPORTS	5-20
5.2.3 TEST PAGE.....	5-20
To Print the Test Page	5-20
5.2.4 TEST PATTERN PRINTING.....	5-21
To Print the Test Pattern	5-21
5.3 UPDATING THE FIRMWARE.....	5-22
5.3.1 CHECKING THE MACHINE FIRMWARE VERSION.....	5-22
5.3.2 UPDATING THE MAIN FIRMWARE.....	5-22
Procedure.....	5-22
5.3.3 UPDATING THE BOOT LOADER FIRMWARE.....	5-23
5.3.4 UPDATING FAILURE	5-24
5.3.5 FW UPDATE TOOL MESSAGES.....	5-24
FW Update Tool Messages: Information.....	5-24
FW Update Tool Messages: Error.....	5-26
6. TROUBLESHOOTING	6-1
6.1 SELF-DIAGNOSTIC MODE.....	6-1
6.1.1 SELF-DIAGNOSTIC MODE AT POWER ON	6-1
6.2 SERVICE CALL	6-2
6.2.1 SUMMARY	6-2
Fusing related SCs.....	6-2
6.2.2 ENGINE SC	6-2
SC 2xx (Laser Optics Error)	6-2
SC 4xx (Image Transfer and Transfer Error).....	6-4
SC 5xx (Motor and Fusing Error)	6-4

SC 6xx (Communication and Other Error).....	6-7
6.2.3 CONTROLLER SC	6-8
SC 8xx.....	6-8
6.3 JAM DETECTION	6-9
6.3.1 JAM SENSOR LAYOUT	6-9
Paper Jam.....	6-9
Original Jam (ADF)	6-9
6.3.2 JAM MESSAGE LIST	6-10
Paper Jam.....	6-10
Original Jam	6-11
6.4 IMAGE QUALITY	6-12
6.4.1 OVERVIEW	6-12
6.5 OTHER PROBLEMS	6-13
6.5.1 DARK LINES IN HALFTONE AREAS AT 75MM INTERVALS	6-13
6.6 TROUBLESHOOTING.....	6-14
6.6.1 JAM/PAPER FEED PROBLEM	6-14
6.6.2 IMAGE QUALITY PROBLEM	6-16
6.6.3 FAX PROBLEM	6-17
FAX error code.....	6-18
6.6.4 OTHER PROBLEM.....	6-19
7. ENERGY SAVE.....	7-1
7.1 ENERGY SAVE	7-1
7.1.1 ENERGY SAVER MODES	7-1
Timer Settings	7-1
Return to Stand-by Mode	7-2
Recommendation	7-2
7.2 PAPER SAVE	7-3
7.2.1 EFFECTIVENESS OF DUPLEX/COMBINE FUNCTION.....	7-3
1. Duplex:.....	7-3
2. Combine mode:.....	7-3
3. Duplex + Combine:.....	7-4
Total counter	7-4

READ THIS FIRST

Safety Notices

Important Safety Notices

Prevention of Physical Injury

1. Before disassembling or assembling parts of the machine and peripherals, make sure that the machine power cord is unplugged.
2. The wall outlet should be near the machine and easily accessible.
3. If any adjustment or operation check has to be made with exterior covers off or open while the main switch is turned on, keep hands away from electrified or mechanically driven components.
4. The machine drives some of its components when it completes the warm-up period. Be careful to keep hands away from the mechanical and electrical components as the machine starts operation.
5. The inside and the metal parts of the fusing unit become extremely hot while the machine is operating. Be careful to avoid touching those components with your bare hands.

Health Safety Conditions

Toner is non-toxic, but if you get either of them in your eyes by accident, it may cause temporary eye discomfort. Try to remove with eye drops or flush with water as first aid. If unsuccessful, get medical attention.

Observance of Electrical Safety Standards

The machine and its peripherals must be serviced by a customer service representative who has completed the training course on those models.

Safety and Ecological Notes for Disposal

1. Do not incinerate toner bottles or used toner. Toner dust may ignite suddenly when exposed to an open flame.
2. Dispose of used toner, the maintenance unit which includes developer or the organic photoconductor in accordance with local regulations. (These are non-toxic supplies.)
3. Dispose of replaced parts in accordance with local regulations.

WARNING

- To prevent a fire or explosion, keep the machine away from flammable liquids, gases, and aerosols. A fire or an explosion might occur.

CAUTION

- The Controller board on the MF model contains a lithium battery. The danger of explosion exists if a battery of this type is incorrectly replaced. Replace only with the same or an equivalent type recommended by the manufacturer. Discard batteries in accordance with the manufacturer's instructions and local regulations.

Handling Toner

- Work carefully when removing paper jams or replacing toner bottles or cartridges to avoid spilling toner on clothing or the hands.
- If toner is inhaled, immediately gargle with large amounts of cold water and move to a well ventilated location. If there are signs of irritation or other problems, seek medical attention.
- If toner gets on the skin, wash immediately with soap and cold running water.
- If toner gets into the eyes, flush the eyes with cold running water or eye wash. If there are signs of irritation or other problems, seek medical attention.
- If toner is swallowed, drink a large amount of cold water to dilute the ingested toner. If there are signs of any problem, seek medical attention.
- If toner spills on clothing, wash the affected area immediately with soap and cold water. Never use hot water! Hot water can cause toner to set and permanently stain fabric.
- Always store toner and developer supplies such as toner and developer packages, cartridges, and bottles (including used toner and empty bottles and cartridges) out of the reach of children.
- Always store fresh toner supplies or empty bottles or cartridges in a cool, dry location that is not exposed to direct sunlight.

WARNING

- Do not use the cleaner to suck spilled toner (including used toner). Sucked toner may cause firing or explosion due to electrical contact flickering inside the cleaner. However, it is possible to use the cleaner designed for dust explosion-proof purpose. If toner is spilled over the floor, sweep up spilled toner slowly and clean remainder with wet cloth.

Laser Safety

The Center for Devices and Radiological Health (CDRH) prohibits the repair of laser-based optical units in the field. The optical housing unit can only be repaired in a factory or at a location with the requisite equipment. The laser subsystem is replaceable in the field by a qualified Customer Engineer. The laser chassis is not repairable in the field. Customer engineers are therefore directed to return all chassis and laser subsystems to the factory or service depot when replacement of the optical subsystem is required.

WARNING

- Use of controls, or adjustment, or performance of procedures other than those specified in this manual may result in hazardous radiation exposure.





WARNING

- Turn off the main switch before attempting any of the procedures in the Laser Optics Housing Unit section. Laser beams can seriously damage your eyes.
- **CAUTION MARKING:**



Symbols, Abbreviations and Trademarks

This manual uses several symbols and abbreviations. The meaning of those symbols and abbreviations are as follows:

	Clip ring
	Screw
	Connector
	Clamp
	E-ring
SEF	Short Edge Feed
LEF	Long Edge Feed

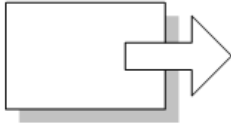

Short Edge Feed (SEF)

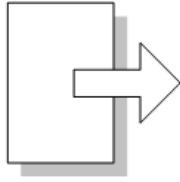

Long Edge Feed (LEF)

Trademarks

Microsoft[®], Windows[®], and MS-DOS[®] are registered trademarks of Microsoft Corporation in the United States and /or other countries.

PostScript[®] is a registered trademark of Adobe Systems, Incorporated.

PCL[®] is a registered trademark of Hewlett-Packard Company.

Ethernet[®] is a registered trademark of Xerox Corporation.

PowerPC[®] is a registered trademark of International Business Machines Corporation.

Other product names used herein are for identification purposes only and may be trademarks of their respective companies. We disclaim any and all rights involved with those marks.

PRODUCT INFORMATION

REVISION HISTORY		
Page	Date	Added/Updated/New
		None

1. PRODUCT INFORMATION

1.1 PRODUCT OVERVIEW

1.1.1 COMPONENT LAYOUT

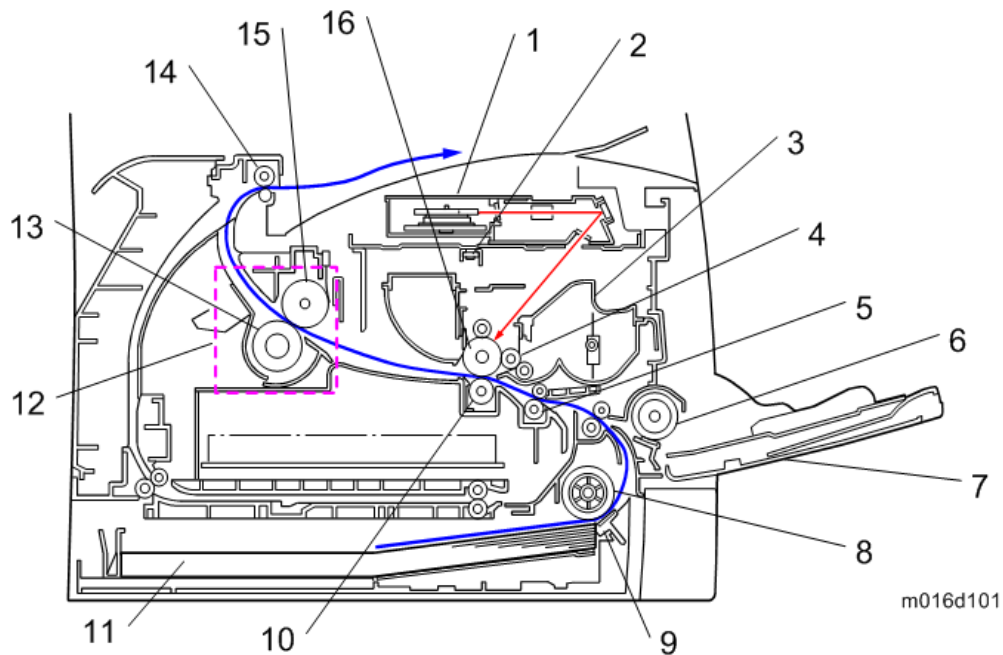

1.	Laser unit	9.	Friction pad
2.	Quenching lamp	10.	Transfer roller
3.	Cartridge (AIO-type)	11.	Paper Tray
4.	Development roller	12.	Fusing Unit
5.	Registration roller	13.	Pressure Roller
6.	By-pass feed roller	14.	Paper exit roller
7.	By-pass feed tray	15.	Hot Roller
8.	Paper feed roller	16.	Drum

1.1.2 PAPER PATH

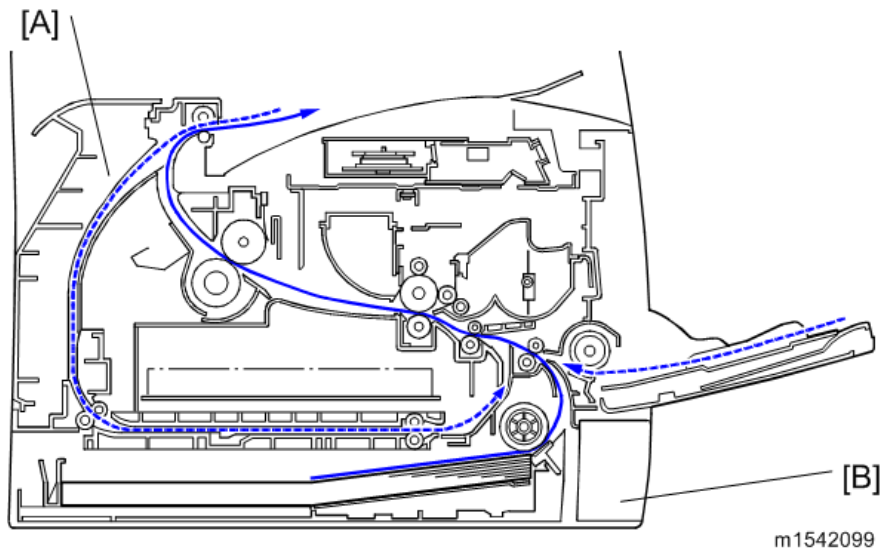

[A] Duplex section

[B] Standard paper tray unit

1.1.3 DRIVE LAYOUT

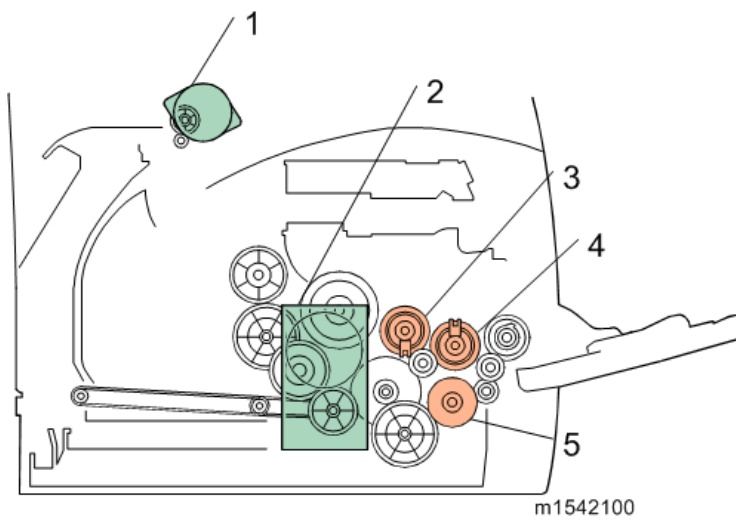

1.	Duplex Motor	4.	Relay Clutch
2.	Main Motor	5.	Paper Feed Clutch
3.	Registration Clutch		

1.2 MACHINE CODES AND PERIPHERALS CONFIGURATION

CONFIGURATION

1.2.1 MAIN FRAME

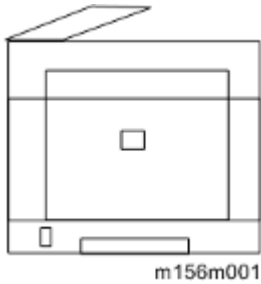

Item	Machine Code	Duplex	Optional Tray	PCL	PS	Wireless LAN	Remarks
SP 310SFN	M176	Auto	N/A	Yes	N/A	N/A	NEW
SP 310SFN w	M177	Auto	N/A	Yes	N/A	Yes	NEW
SP 311SFN	M156	Auto	N/A	Yes	N/A	N/A	NEW
SP 311SFN w	M157	Auto	N/A	Yes	N/A	Yes	NEW

NA: Not Available

1.3 SPECIFICATIONS

See "Appendices" for the following information:

- "General Specifications"
- "Supported Paper Sizes"
- "Software Accessories"

INSTALLATION

REVISION HISTORY		
Page	Date	Added/Updated/New
		None

2. INSTALLATION

2.1 INSTALLATION REQUIREMENTS

2.1.1 CHECK IMAGE QUALITY / SETTINGS

This machine is installed by the user.

Environment

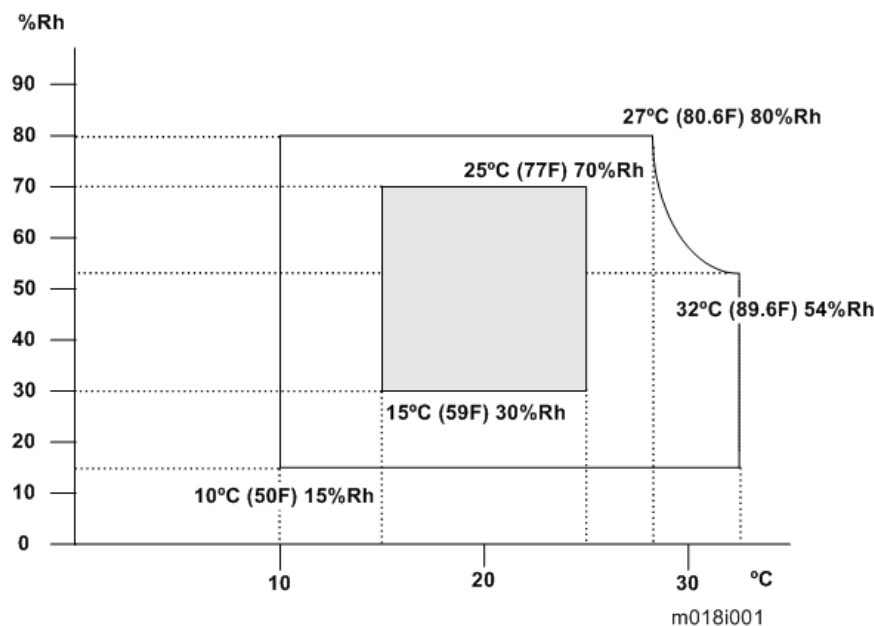

1. Temperature Range: 10°C to 32°C (50°F to 89.6°F)
2. Humidity Range: 15% to 80% RH
3. Ambient Illumination: Less than 2,000 lux (do not expose to direct sunlight)
4. Ventilation: 3 times/hr/person
5. Do not install the machine at locations over the following heights above sea level.
 - All areas: 2,000 m (6,562 ft.)
6. Atmospheric pressure: more than 740 hPa.

2.1.2 MOVING AND TRANSPORTING THE MACHINE

⚠ WARNING

- It is dangerous to handle the power cord plug with wet hands. Doing so could result in electric shock.

⚠ CAUTION

- Unplug the power cord from the wall outlet before you move the machine. While moving the machine, take care that the power cord is not damaged under the machine. Failing to take these precautions could result in fire or electric shock.

CAUTION

- When disconnecting the power cord from the wall outlet, always pull the plug, not the cord. Pulling the cord can damage the power cord. Use of damaged power cords could result in fire or electric shock.

CAUTION

- The printer weighs approximately 17.5 kg (38.6 lb.). When moving the printer, use the inset grips on both sides, and lift slowly in pairs. The printer will break or cause injury if dropped.

CAUTION

- When moving the printer after use, do not take out any of the toners, nor the waste toner bottle to prevent toner spill inside the printer.

CAUTION

- Do not hold the control panel while moving the printer. Doing so may damage the control panel, cause a malfunction, or result in injury.

Important

- Be careful when moving the printer. Take the following precautions:
- Turn off the main power.
- Close all covers and trays, including the front cover and bypass tray.
- If optional paper feed units are attached, remove them from the printer and move them separately.
- Be sure to place the printer on a smooth and stable place.
- Keep the printer level and carry it carefully, taking care not to jolt or tip it. Rough handling may cause a malfunction or damage the hard disk or memory, resulting in loss of stored files.
- Protect the printer from strong shocks. Impact can damage the hard disk and cause stored files to be lost. As a precautionary measure, files should be copied to another computer.

1. Be sure to check the following:

The power switch is turned off.

The power cord is unplugged from the wall outlet.

The interface cable is unplugged from the printer.

2. Lift the printer by using the inset grips on both sides of the printer, and then move it horizontally to the place where you want to install it.

Note

- Be sure to move the printer horizontally. To prevent toner from scattering, move the printer slowly.

PREVENTIVE MAINTENANCE

REVISION HISTORY		
Page	Date	Added/Updated/New
		None

3. PREVENTIVE MAINTENANCE

3.1 PREVENTIVE MAINTENANCE TABLES

There are no PM parts in this machine.

3.2 IMAGE QUALITY STANDARDS

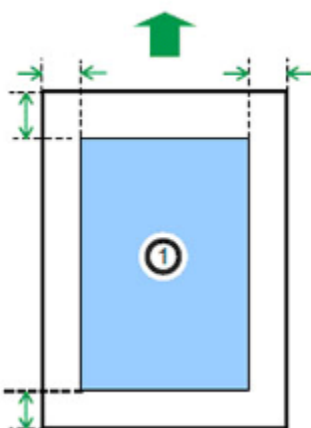
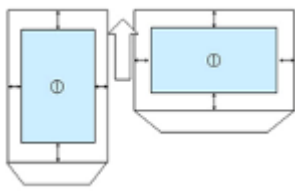
Item	Specification	Remarks
Assured Image Area	<p>Except Envelopes The standard print area of a sheet is the area enclosed by margins of 4.2 mm from all sides of the sheet.</p> <p>Envelopes The 15mm excluding the flap portion from the rear end / tip of the sheet, except for the region of the left and right ends 10mm.</p>	<p>Except Envelopes</p>  <p>Envelopes</p> 
Magnification Error	±0.75% or less	Except when duplexing.

3.3 PAPER TRANSFER QUALITY STANDARDS

Item	Specification	Remarks
Registration	<p>Single Side: Width: $0\pm 2.0\text{mm}$ (Main Scan Direction) Vertical: Office / All Environments $0\pm 1.5\text{mm}$ (Sub Scan Direction)</p> <p>Duplex: Width: $0\pm 2.0\text{mm}$ (Main Scan Direction) Vertical: Office / All Environments $0\pm 1.5\text{mm}$ (Sub Scan Direction)</p>	Scale
Skew	<p>Single Side: $\pm 1.0\text{mm}/100\text{mm}$ or less (Less than B5 SEF, tray 1) $\pm 1.0\text{mm}/200\text{mm}$ or less (B5 SEF or more, tray 1) $\pm 1.0\text{mm}/50\text{mm}$ or less (Bypass tray)</p> <p>Duplex: $\pm 1.0\text{mm}/100\text{mm}$ or less (Less than B5 SEF) $\pm 1.0\text{mm}/100\text{mm}$ or less (B5 SEF or more)</p>	Except if the paper is longer than 432mm.

These standards are determined using the standard paper with the standard conditions. The values may change depending on environmental conditions such as temperature, humidity, and paper type.

3.4 PM PARTS SETTINGS

3.4.1 PM PARTS

There are no PM parts in this machine.



- Other than the three Yield Parts listed below, there are essentially no PM parts required for this product.
- These three items will need to be replaced in cases where their yield is near, however, given the APV (Average Printer Volume) for this product, these "yield parts^{*1}" are expected to outlast the working life of the machine.

*1 "**Yield Parts**": Parts whose expected yield is longer than the machine lifetime when taking into consideration the machine's APV.

Description	Expected Yield	Q'ty/unit
Paper Feed Roller	120 K prints	1
Transfer Roller	120 K prints	1
Fusing Unit	120 K prints	1

See "page 4-1 "Replacement and Adjustment""

3.5 PREPARATION FOR PM

3.5.1 YIELD COUNTER

Yield counters for each yield part can be checked by the following methods.

- **Configuration Page in the “List/Test Print” menu**

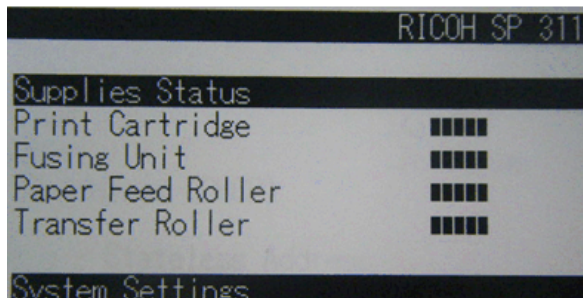

m1562078

- **Web Image Monitor**

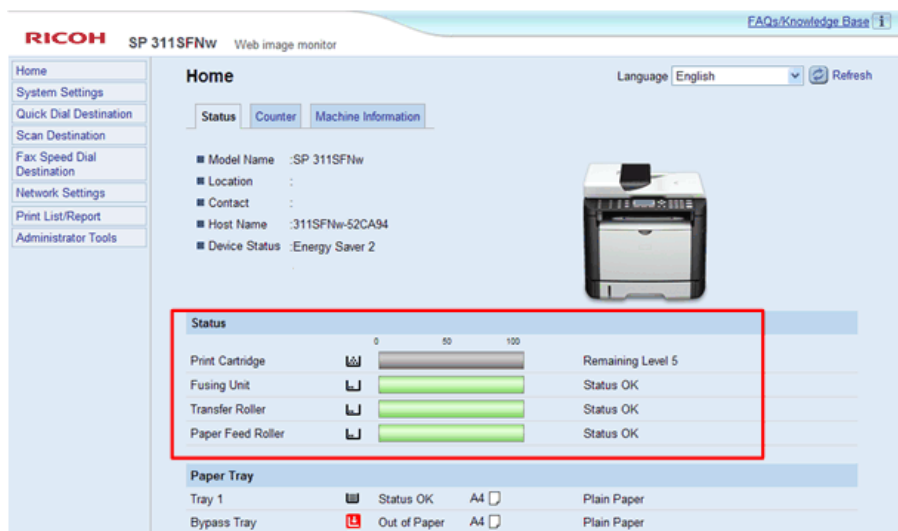

m1562079

Note

- The machine displays "Fuser life end notice", "Transfer roller life end notice" or "Life End of Paper Feed Roller Unit" when one of these counters reaches its yield.

Counter Reset

The process below shows how to reset the yield counters.

1. Enter the "Maintenance Mode".
2. Select "Engine Maintenance", and then press the "OK" key.
3. Select "Reset Fuser Unit", "Reset Transfer Unit" or "Reset Paper Feed Rol Life" and then press the "OK" key.
4. Press the left key "Execute" of the "Selection keys".
5. Exit the "Maintenance mode".

3.6 CLEANING POINTS

Item	Performer	Interval	Remarks
DF exposure glass	User	Each visit (90K image equivalency)	Carry out if streaks occur when using the ADF.
Scanner exposure glass	User	Each visit (90K image equivalency)	Carry out if contamination occurs in the image because of a dirty glass.

REPLACEMENT AND ADJUSTMENT

REVISION HISTORY		
Page	Date	Added/Updated/New
		None

4. REPLACEMENT AND ADJUSTMENT

4.1 GENERAL CAUTIONS

CAUTION

- If there are printer jobs in the machine, print out all jobs in the printer buffer.
- Turn off the main power switch and unplug the machine before you do the procedures in this section.

4.2 SPECIAL TOOLS

- PC: Windows XP/Vista/7/8, Windows Server 2003/2003 R2, 2008/2008 R2,2012
- USB or network cable

Note

- A computer is necessary to update the firmware.

4.3 EXTERIOR COVERS

4.3.1 FRONT COVER

1. Pull out the standard paper tray [A].



m1562001

2. Two tabs [A].
3. Pull out the bypass tray [B].

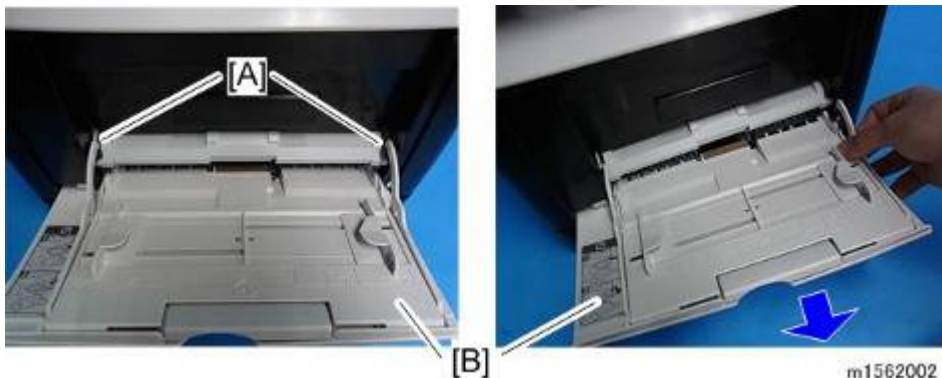

m1562002

4. Open the front cover [A].



m1562003

↓ Note

- To open the front cover, push the cover release button [B] and (carefully) pull the cover forward and open (it hinges downward).

5. Push the right hinge [A] to release.

6. Front cover [B]

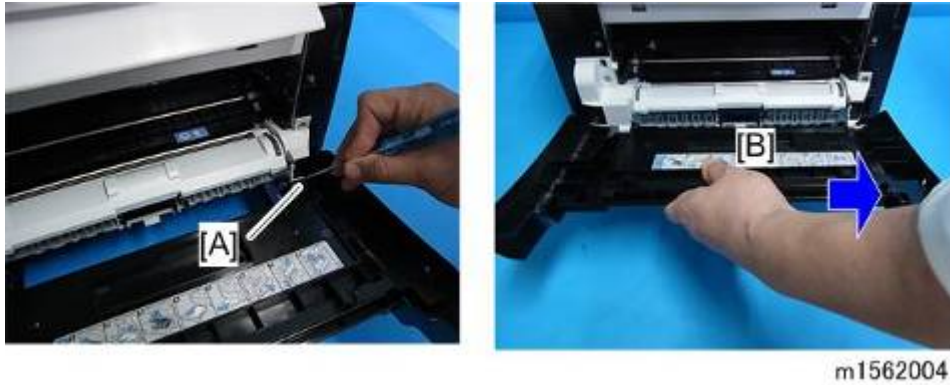

m1562004

4.3.2 LEFT COVER

1. Front cover (page 4-2 "Front Cover")
2. Remove two screws [A] on the front side of the left cover.

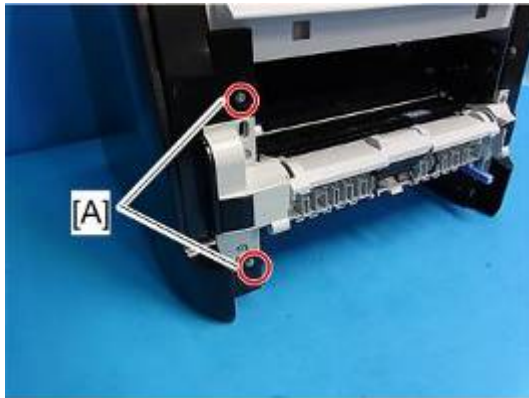

m1562005

3. Pull the front upper part [A] of the left cover to release the hooks.



m1562006

↓ Note

- The outside of the cover has marks indicating the position of the hooks.

4. Pull the rear upper part [A] of the left cover to release the hooks.

Exterior Covers



m1562007

↓ Note

- The outside of the cover has marks indicating the position of the hooks.

5. Pull the front bottom part of the left cover [A] to release the hooks.



m1562008

↓ Note

- The outside of the cover has marks indicating the position of the hooks.

6. Left cover [A]



m1562009

↓ Note

- There are many hooks and tabs inside the left cover. Before removing the left cover, see the photos below.

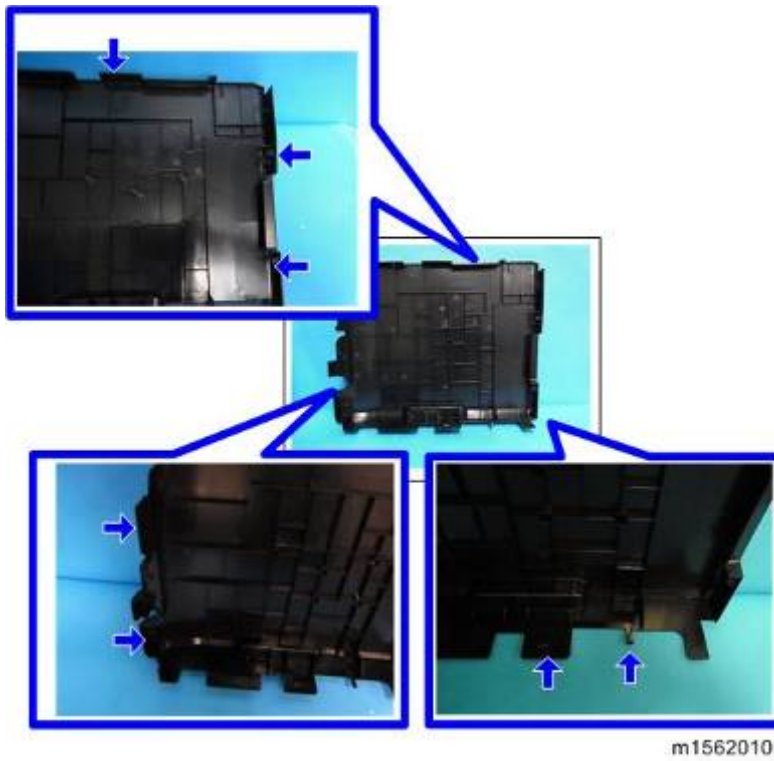

4.3.3 REAR COVER

1. Open the rear cover [A].
2. Slide the shaft [B] in the direction of the blue arrow, and remove the rear cover [A].

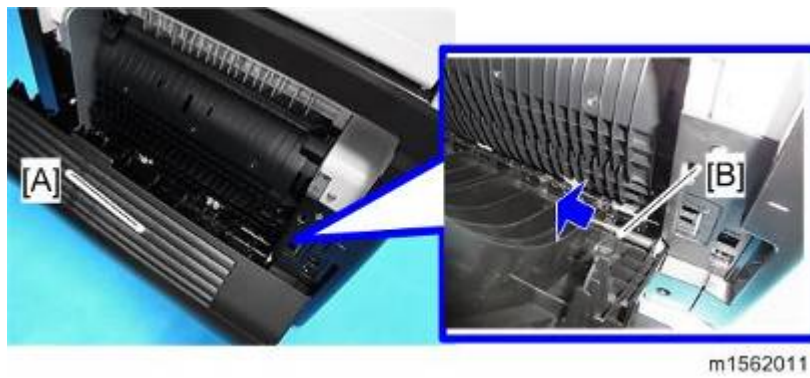

4.3.4 RIGHT COVER

1. Front cover (page 4-2 "Front Cover")
2. Rear cover (page 4-5 "Rear Cover")
3. Right cover [A] (🔑 x 3, hook at arrow mark)

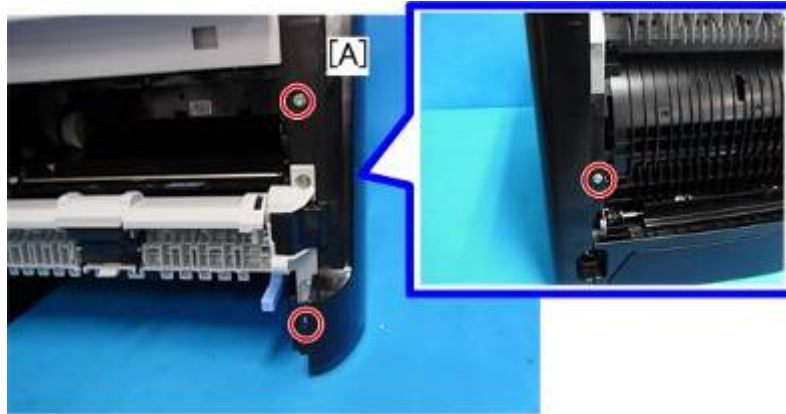

m1562012

↓ Note

- The outside of the cover has marks indicating the position of the hooks.

↓ Note

- There are many hooks and tabs inside the right cover. Before removing the right cover, see the photos below.

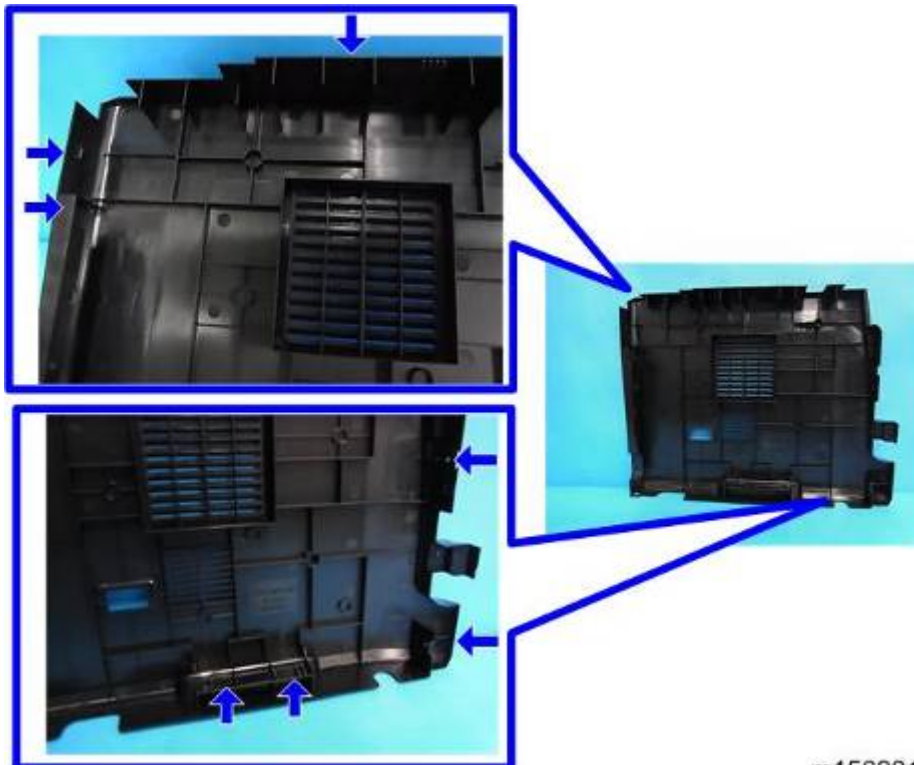

m1562013

4.3.5 TOP COVER

1. Front cover (page 4-2 "Front Cover")
2. Left cover (page 4-3 "Left Cover")
3. Rear cover (page 4-5 "Rear Cover")
4. Right cover (page 4-6 "Right Cover")
5. Scanner unit (page 4-8 "Scanner Unit")
6. Top cover [A] (🔩 x 1, 🛠️ x 5) (For M157,M177:🔩 x 2, 🛠️ x 5)

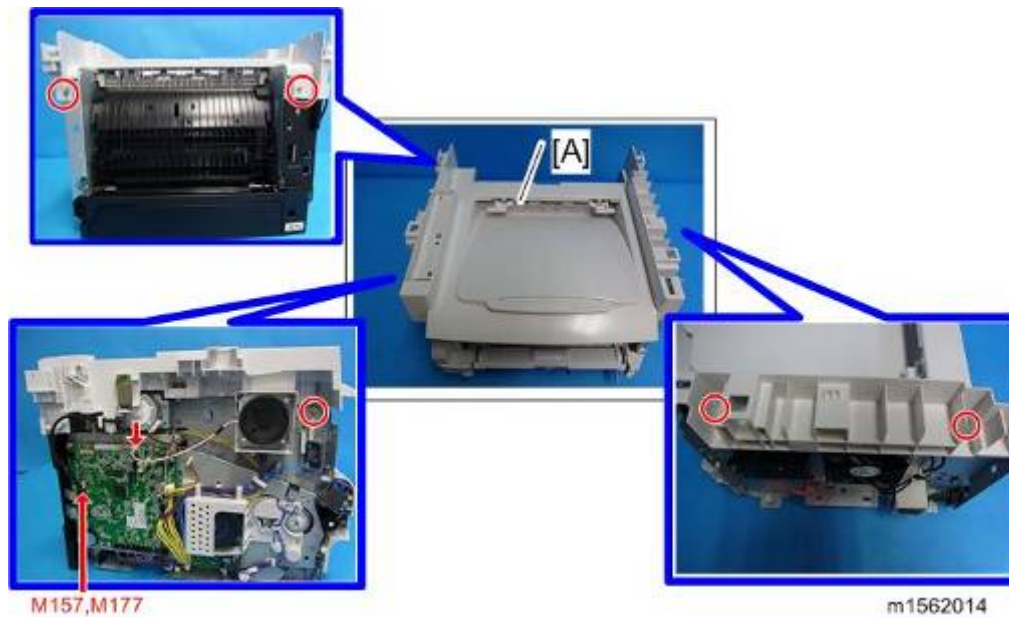

Replacement
and Adjustment

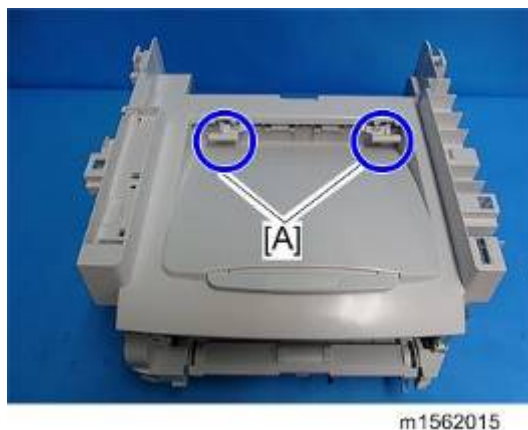

When installing the top cover

- When re-installing the top cover, always verify that the two paperweights [A] are lifted. If they are not lifted to fit into the paper slot, the paperweights [A] could be damaged.
- Make sure that these paperweights [A] can be moved smoothly (up and down) after installing the top cover. If these paperweights do not move smoothly, try installing the top cover again.



4.4 SCANNER UNIT

4.4.1 SCANNER UNIT

1. Front cover (page 4-2 "Front Cover")
2. Left cover (page 4-3 "Left Cover")
3. Rear cover (page 4-5 "Rear Cover")
4. Open the scanner unit [A] in the direction of the blue arrow.
5. Disconnect the three harnesses, flat cable x 2 and ground-wire (ground screw x 1,  x 5,  x 1)

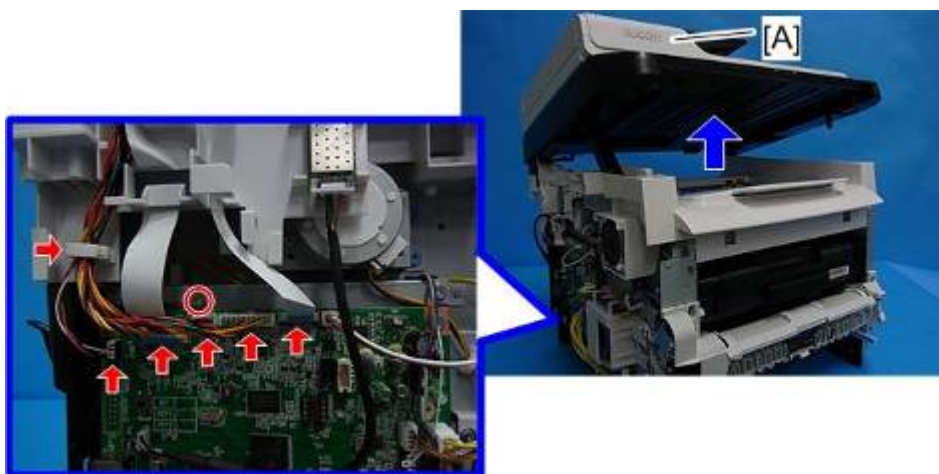

m1562016

6. Remove the scanner Unit [A] as shown below (hook, spring x 1, stopper x 1).

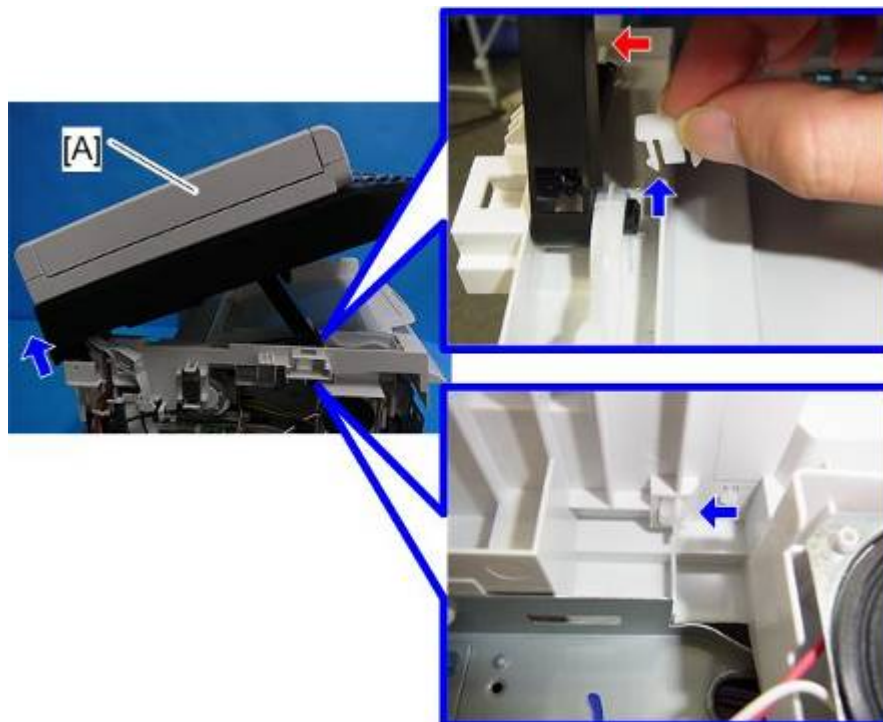

m1562017

4.4.2 OPERATION PANEL

1. Scanner unit (page 4-8 "Scanner Unit")
2. Turn the scanner unit over.
3. Operation panel [A] (🔧 x 2, hooks, 📏 x 1)

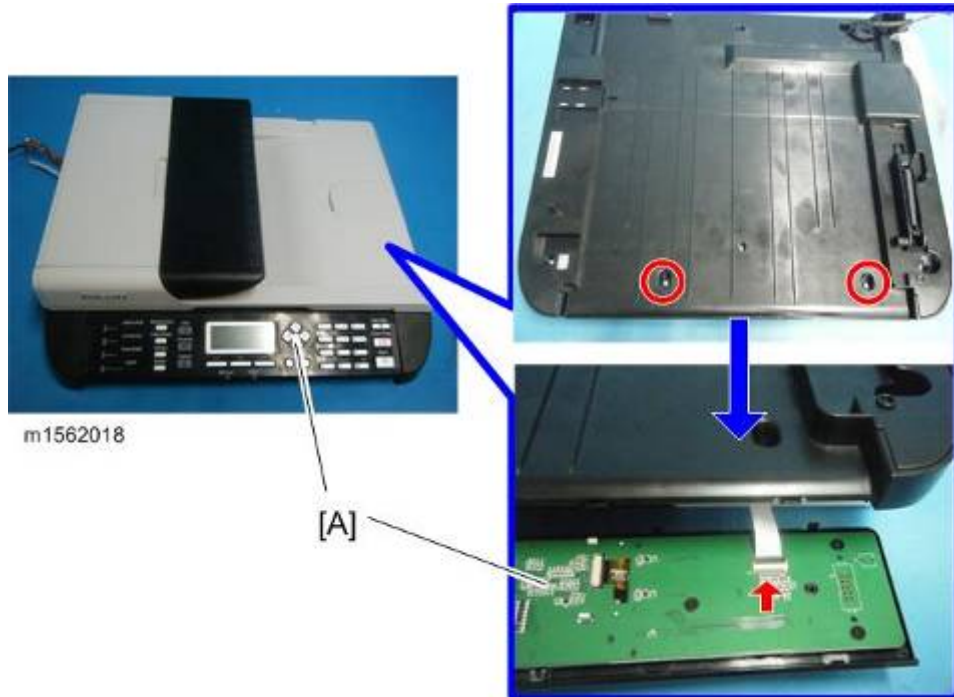

4.5 ADF

4.5.1 ADF UNIT

1. Scanner unit (page 4-8 "Scanner Unit")
2. Open the ADF unit [A] and remove it in the direction of the blue arrow (hooks).

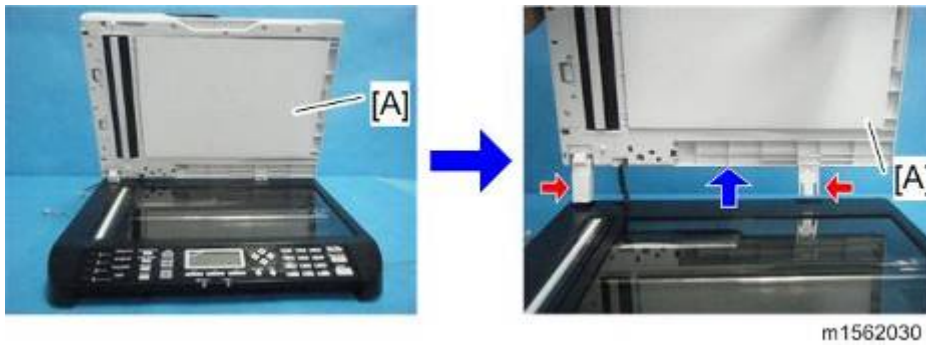

4.5.2 ORIGINAL TRAY

1. Open the Original tray [A] and remove it (Two tabs).



4.5.3 ADF PICK-UP ROLLER

1. Open the ADF top cover [A].
2. ADF feed unit [B] (tab)

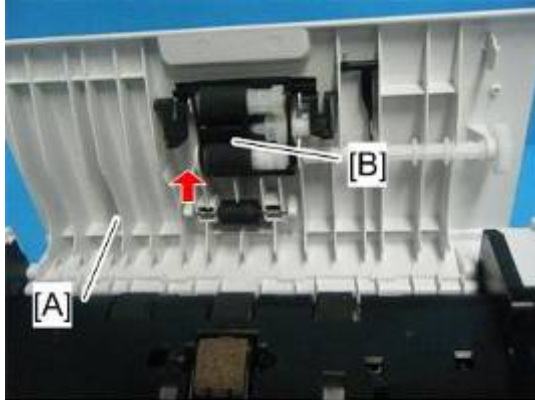

m1562032

3. ADF pick-up roller [A]

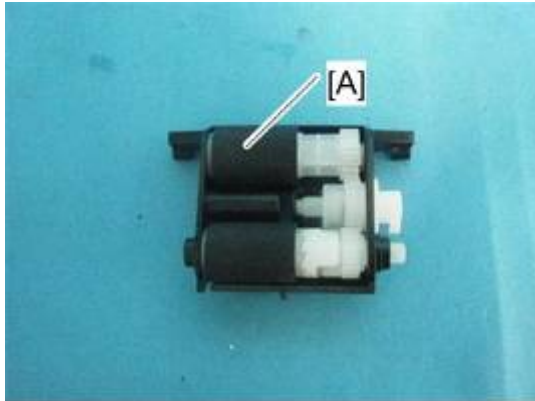

m1562033

4.5.4 ADF FEED ROLLER

1. ADF feed unit (page 4-11 "ADF Pick-Up Roller")
2. ADF Feed roller [A]

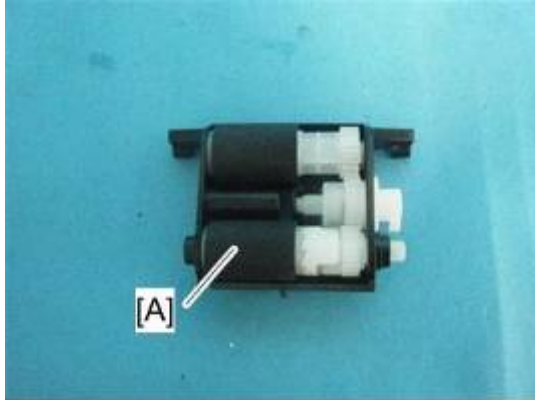

m1562034

4.5.5 ADF SEPARATION PAD

1. Open the ADF top cover.
2. ADF separation pad [A] (2 hooks, spring x 1)

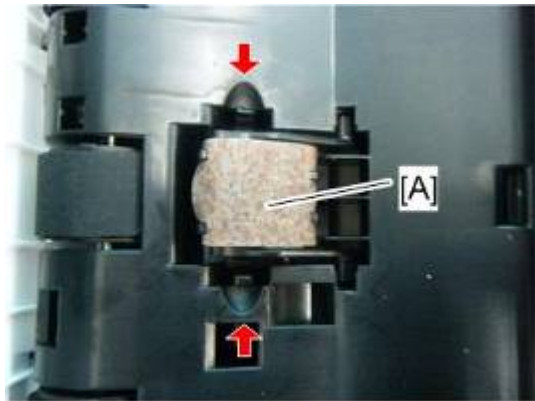

m1562035

4.5.6 ADF FRONT COVER

1. ADF unit (page 4-10 "ADF Unit")
2. Turn the ADF unit over.
3. ADF front cover [A] (🔧 x 3)

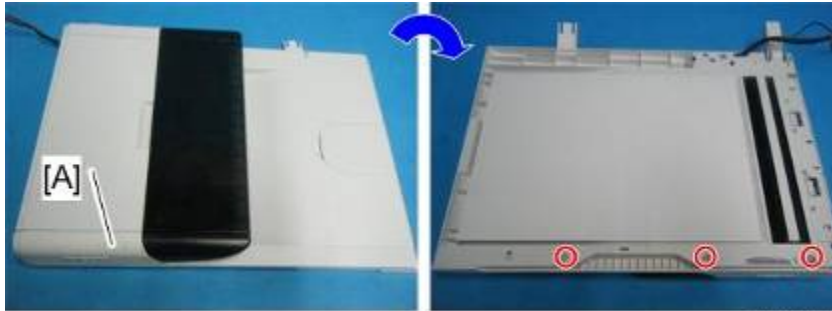

m1562036

↓ Note

- There are many hooks and tabs inside the ADF front cover [A]. Before removing the ADF front cover, see the photos below.

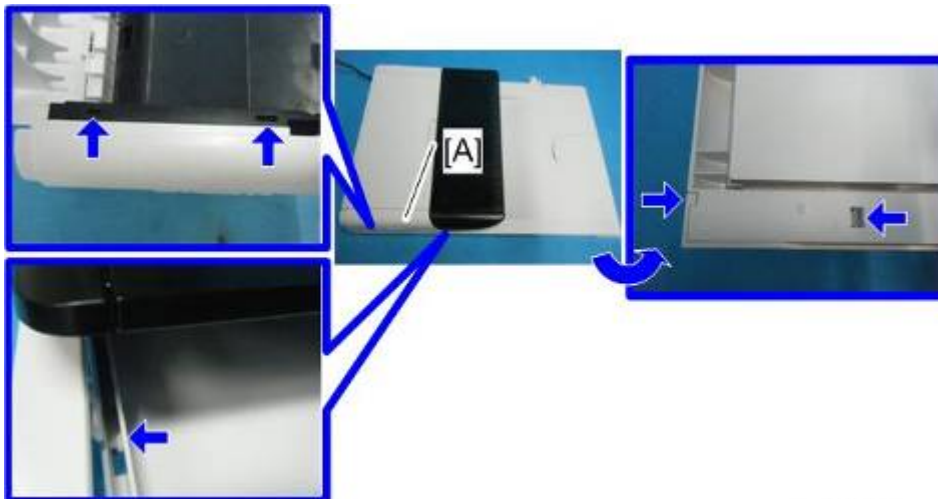

m1562037

4.5.7 ADF REAR COVER

1. ADF unit (page 4-10 "ADF Unit")
2. Turn the ADF unit over.
3. ADF rear cover [A] (🔧 x 1)

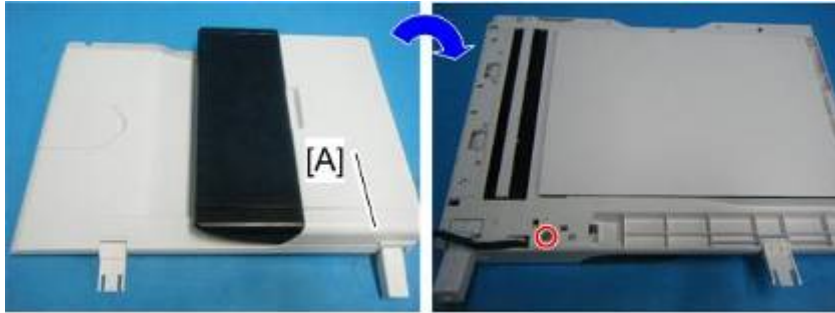

m1562038

↓ Note

- There are many hooks and tabs inside the ADF rear cover [A]. Before removing the ADF rear cover, see the photos below.

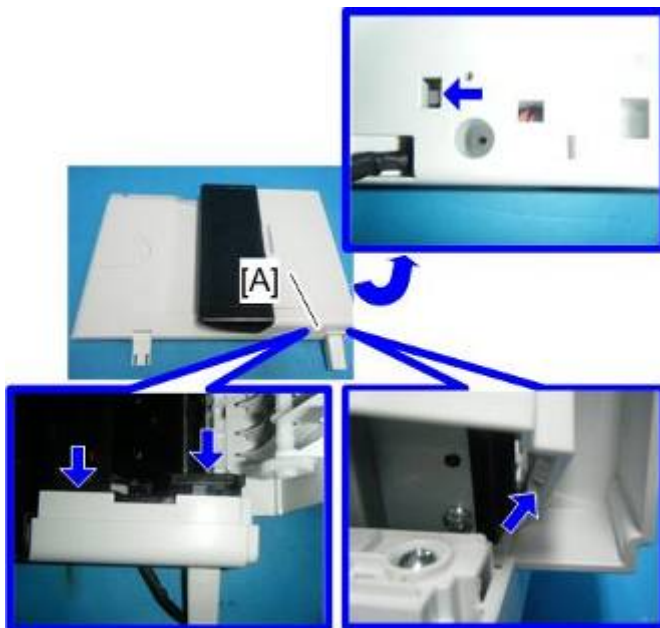

m1562039

4.5.8 ADF MOTOR

1. ADF unit (page 4-10 "ADF Unit")
2. ADF front cover (page 4-13 "ADF Front Cover ")
3. ADF rear cover (page 4-14 "ADF Rear Cover")
4. Remove the ADF drive unit [A] while the ADF top cover [B] remains closed (⚙️ x 2).

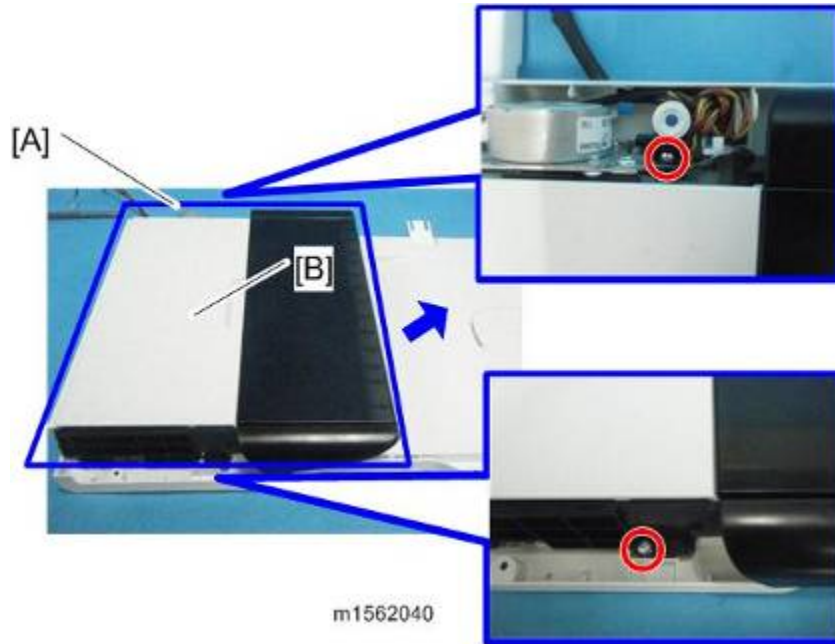

5. ADF motor assembly [A] (⚙️ x 2, ground screw x 1, ⚙️ x 1, ground plate, discharge brush)



6. ADF motor [A] (⚙️ x 2)

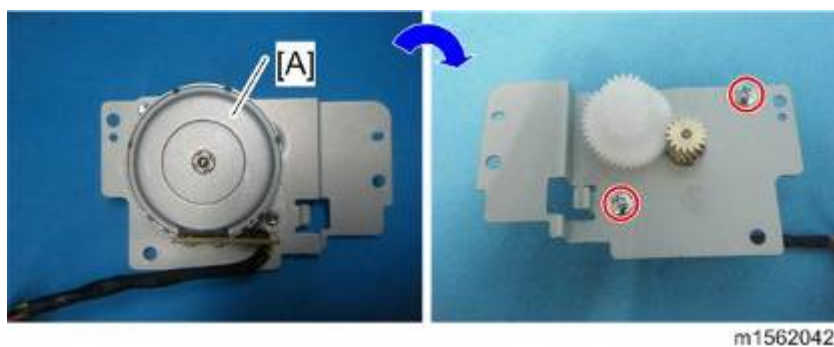

4.5.9 ADF TOP COVER

1. ADF drive unit (page 4-15 "ADF Motor")
2. Open the ADF Top Cover [A] and remove it (two tabs).



4.5.10 DOCUMENT SENSOR

1. ADF drive unit (page 4-15 "ADF Motor")
2. Turn the ADF drive unit over.
3. Pressure plate [A] (4 hooks, 2 springs)

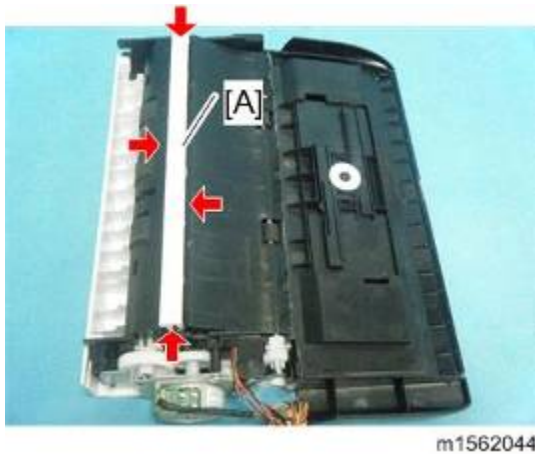

4. Lower guide [A] (⌀ x 3, ground plate, 6 hooks, 2 tabs)



m1562045

5. Document sensor [A] (4 hooks,  x 1)

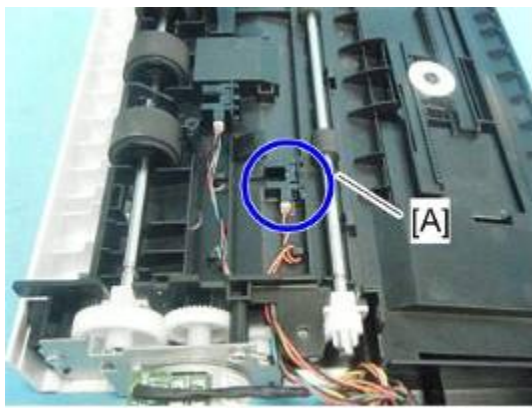

m1562046

4.5.11 ADF FEED SENSOR

1. ADF drive unit (page 4-15 "ADF Motor")
2. Lower guide (page 4-16 "Document Sensor")
3. ADF feed sensor [A] (4 hooks,  x 1)

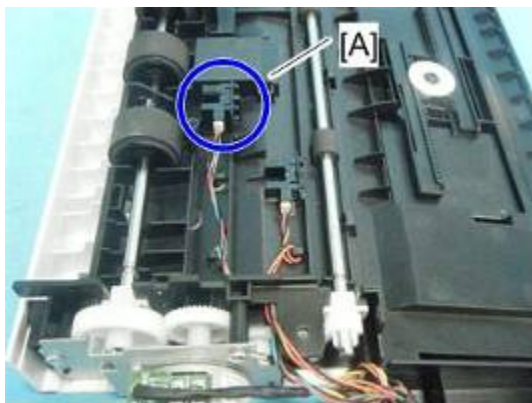

m1562047

4.6 LASER UNIT

CAUTION

- Turn off the main power switch and unplug the machine before attempting any of the procedures in this section. Laser beams can seriously damage your eyes.

4.6.1 CAUTION DECAL LOCATIONS

A caution decal is attached as shown below.

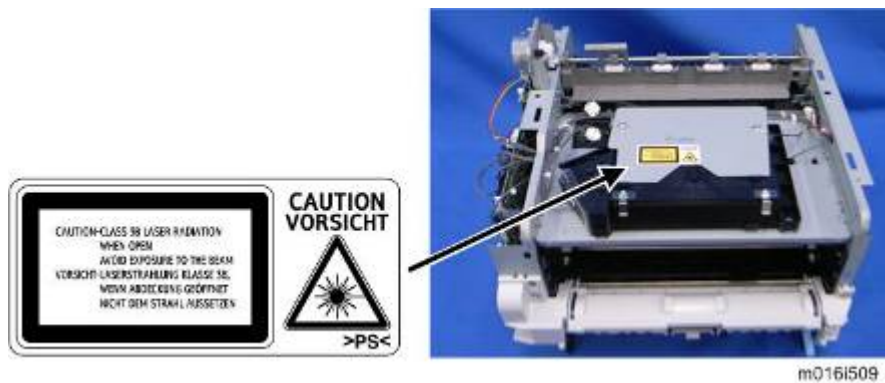

WARNING

- Be sure to turn off the main switch and disconnect the power plug from the power outlet before beginning any disassembly or adjustment of the laser unit. This machine uses a class IIIB laser beam with a wavelength of 648 to 663 nm and an output of 9 mW. The laser can cause serious eye injury.

4.6.2 LASER UNIT

1. Front cover (page 4-2 "Front Cover")
2. Rear cover (page 4-5 "Rear Cover")
3. Left cover (page 4-3 "Left Cover")
4. Right cover (page 4-6 "Right Cover")
5. Scanner unit (page 4-8 "Scanner Unit")
6. Top cover (page 4-7 "Top Cover")
7. Laser unit [A] (⚙️ x 3, ground screw x 3, 🔌 x 2, 🛠️ x 2)



4.6.3 POLYGON MIRROR MOTOR

CAUTION

- Turn off the main switch and unplug the machine before attempting any of the procedures in this section. Laser beams can seriously damage your eyes.

1. Top cover (page 4-7 "Top Cover")
2. Polygon mirror cover [A] ( x 2)



m1542020

3. Polygon mirror motor [A] ( x 4,  x 1)

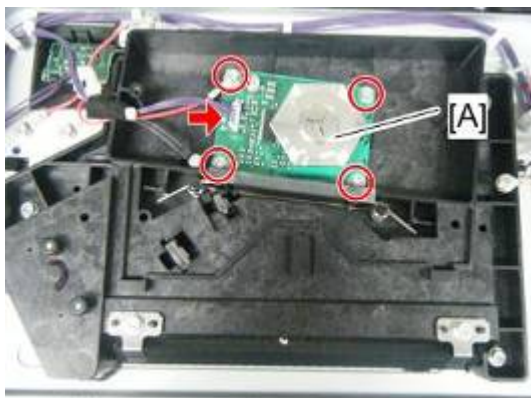

m1542021

Note

- Never touch the surface of the mirror with bare hands.

4.7 PAPER FEED

4.7.1 PAPER FEED ROLLER

1. Pull out the standard paper tray.
2. Front cover (page 4-2 "Front Cover")
3. AIO
4. Set the machine with the rear side facing down, resting on the table.



m1542022

5. Slide the paper feed shaft [A] to the left side (⚙️ x 2).
6. Slide the paper feed roller [B] to the right side, and remove it (hook).

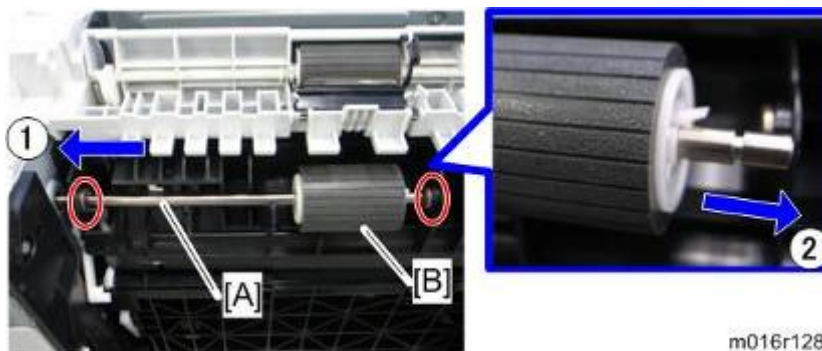

m016r128

After installing a new paper feed roller

1. Enter the "Maintenance Mode".
2. Select "Engine Maintenance", and then press the "OK" key.
3. Select "Reset Paper Feed Rol Life" and then press the "OK" key.
4. Press the left key "Execute" of the "Selection keys".
5. Exit the "Maintenance Mode".

4.7.2 FRICTION PAD

1. Remove the paper tray unit from the machine before removing the friction pad.
2. Friction pad [A] (2 hooks, 1 spring)

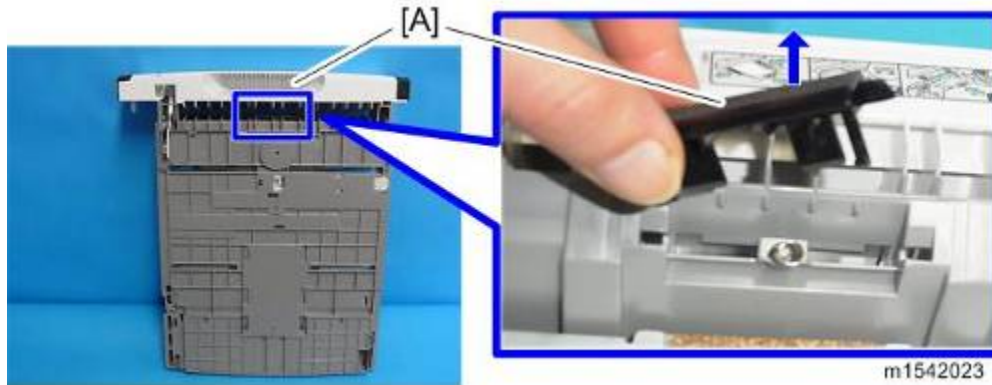

When reinstalling the friction pad, do it in this order:

1. Replace the spring.
2. Insert the right side of the friction pad first, followed by the left side.
3. Gently push the friction pad down into the slot and then pull forward very slightly.

4.7.3 PAPER END SENSOR

1. Pull out the standard paper tray.
2. Front cover (page 4-2 "Front Cover")
3. AIO
4. Set the machine with the rear side facing down, resting on the table.
5. Paper end sensor [A] (3 hooks,  x 1)



4.7.4 BY-PASS FEED ROLLER

1. Front cover (page 4-2 "Front Cover")
2. Left cover (page 4-3 "Left Cover")
3. Right cover (page 4-6 "Right Cover")
4. Pull out the paper tray.
5. By-pass lower guide plate [A] (🔧 x 4, 📏 x 2, 📏 x 2)

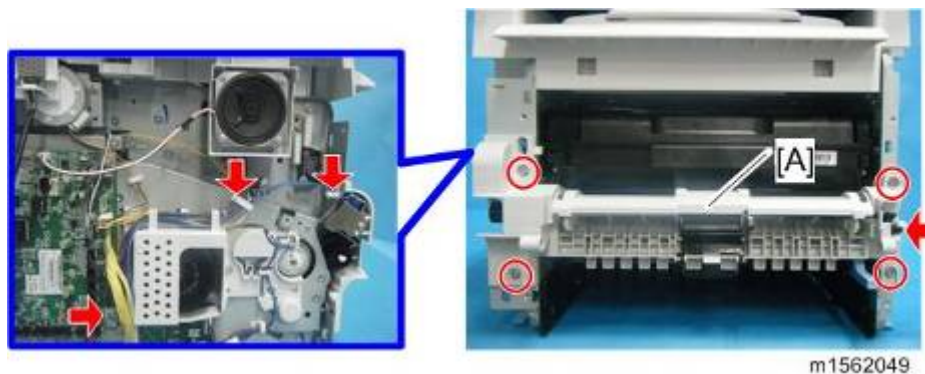

↓ Note

- Reinstall the by-pass lower guide plate [A] while pressing the spring [B].
- Be careful that the spring [B] and the ground plate [C] do not fall inside the machine during reinstallation.

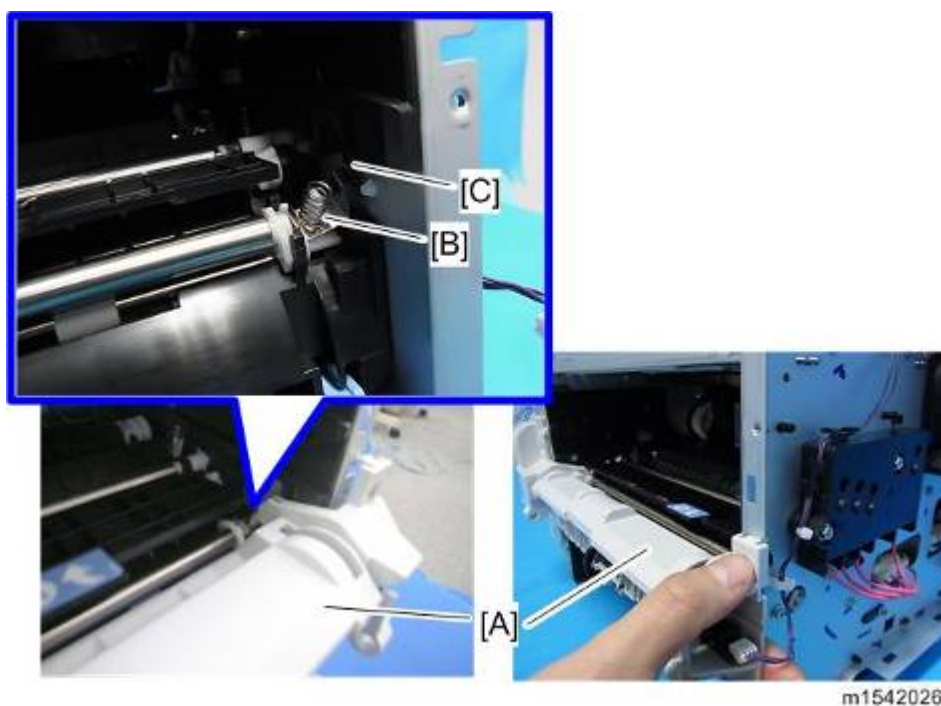

6. By-pass upper guide plate [A]
7. By-pass solenoid cover, by-pass solenoid [B] (🔧 x 1)
8. Gear [C] (hook)

Paper Feed

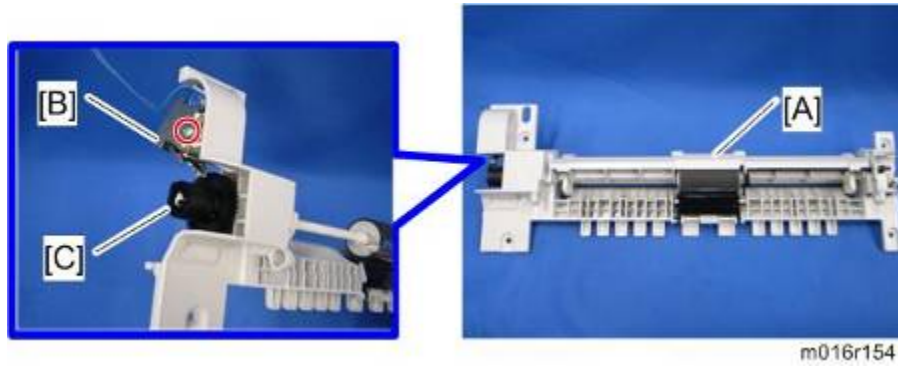

9. Slide the by-pass feed roller shaft [A] to the left side, and remove it.
10. Remove the metal cover [B] from the by-pass feed roller [C].

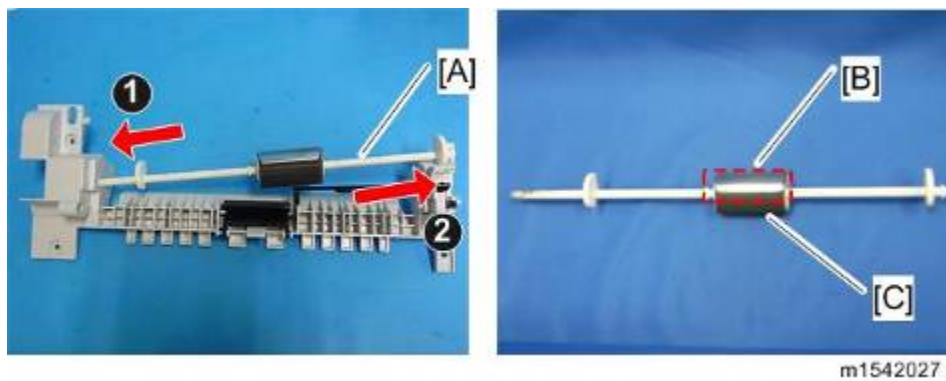

4.7.5 BY-PASS FEED ROLLER FRICTION PAD

1. By-pass feed roller (page 4-23 "By-pass Feed Roller")
2. By-pass feed roller friction pad [A] (2 hooks, spring x 1)

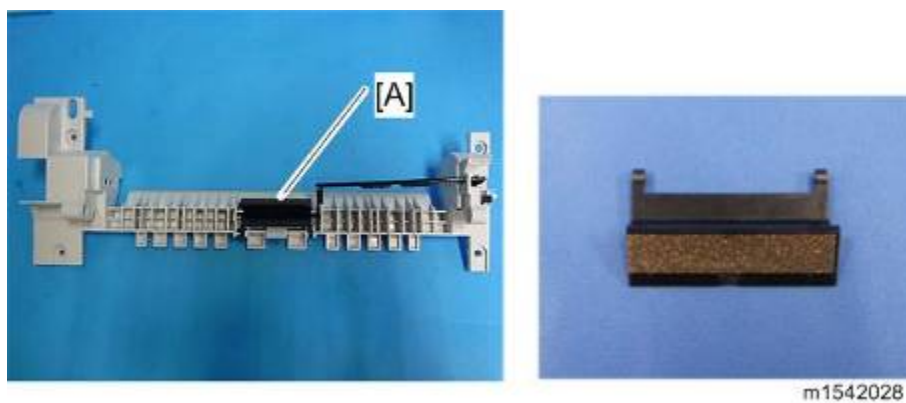

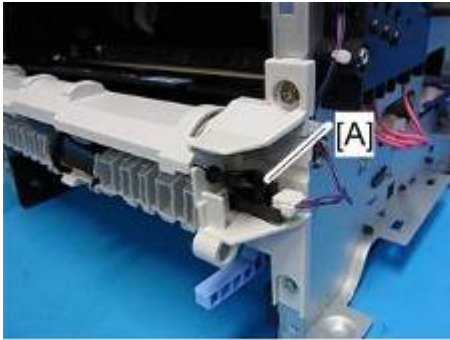

4.7.6 BY-PASS FEED SENSOR

1. Front cover (page 4-2 "Front Cover")
2. Right cover (page 4-6 "Right Cover")
3. By-pass feed sensor [A] (3 hooks,  x 1)



m1542029

4.7.7 PAPER FEED CLUTCH

1. Drive unit (page 4-43 "Drive Unit")
2. Paper feed clutch [A] ( x 1,  x 1,  x 1)

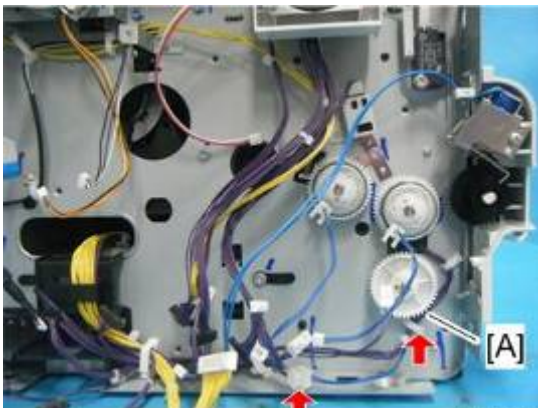

m1562050

4.7.8 RELAY CLUTCH

1. Drive unit (page 4-43 "Drive Unit")
2. Relay clutch [A] (C_x 1)



m1562051

4.7.9 REGISTRATION CLUTCH

1. Drive unit (page 4-43 "Drive Unit")
2. Registration clutch [A] (C_x 1)

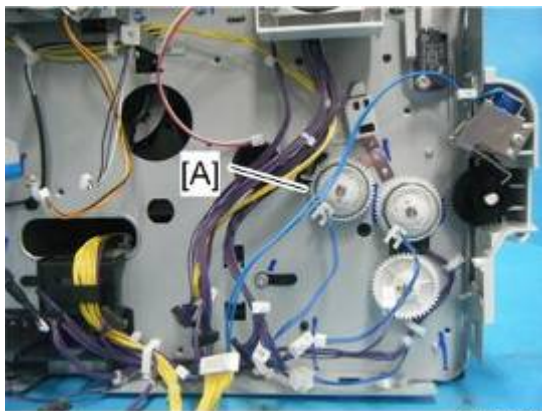

m1562052

4.7.10 REGISTRATION ROLLER

1. Pull out the paper tray.
2. AIO
3. Scanner Unit (page 4-8 "Scanner Unit")
4. Top Cover (page 4-7 "Top Cover")
5. Fusing Unit (page 4-34 "Fusing Unit")
6. PSU / HVP unit (page 4-48 "PSU")
7. By-pass lower guide plate (page 4-23 "By-pass Feed Roller")
8. Paper feed clutch (page 4-25 "Paper Feed Clutch")
9. Relay clutch (page 4-26 "Relay Clutch")
10. Registration clutch (page 4-26 "Registration Clutch")
11. Heat insulating plate [A] (🔩 x 2)

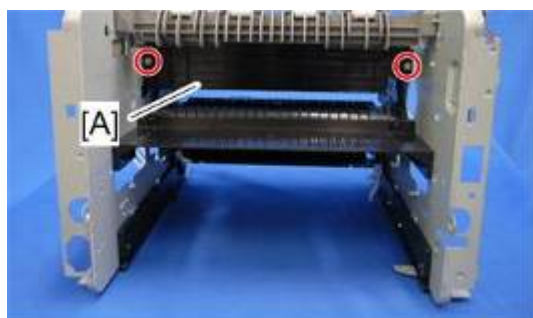

m1542033

12. Duplex motor base [A] (🔩 x 4)

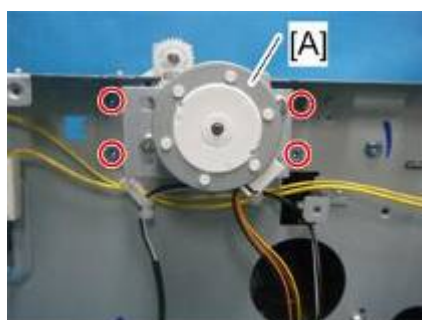

m1562053

13. Exit roller base [A] (🔩 x 2, 4 tabs)

Paper Feed

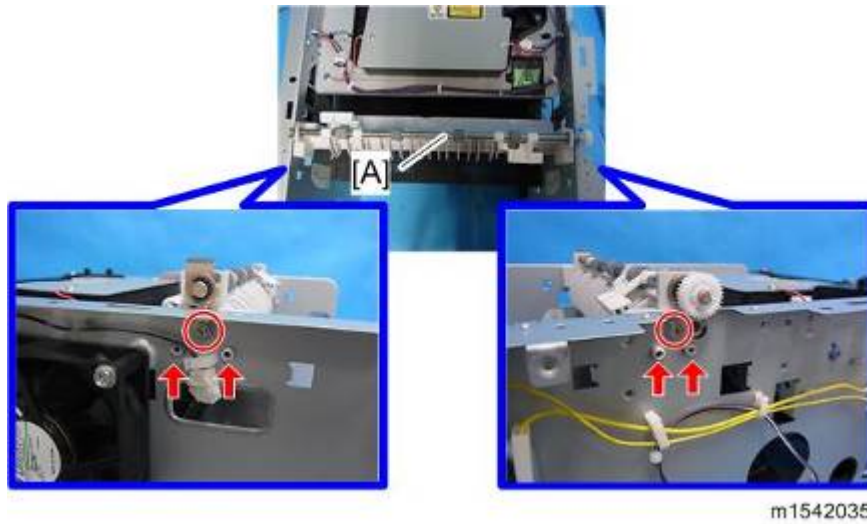

14. Imaging unit base [A] (⚙️ x 4, 📄 x 1, 🖨️ x 3)

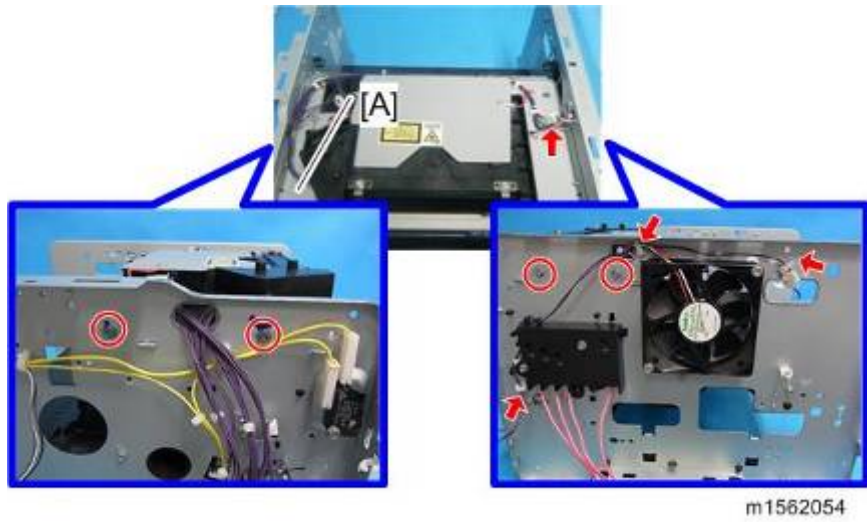

15. Registration unit [A] (⚙️ x 8, 🖨️ x 3)

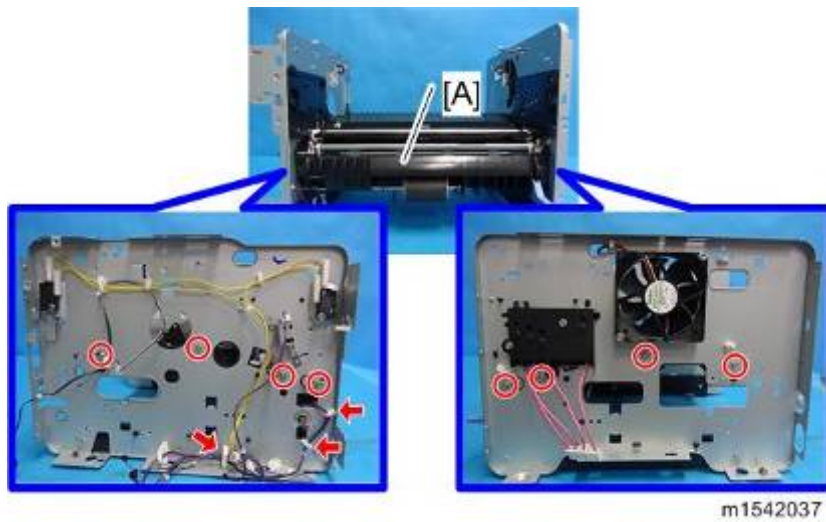

16. Upper guide plate [A] (2 hooks)

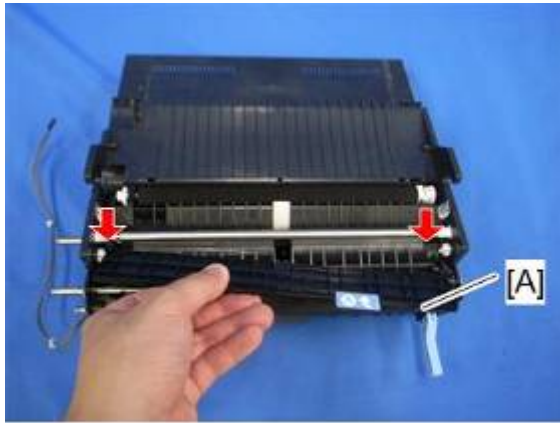

m1542038

17. Remove the Registration roller (follower) [A] as shown below (spring x 2, plastic parts x 2).

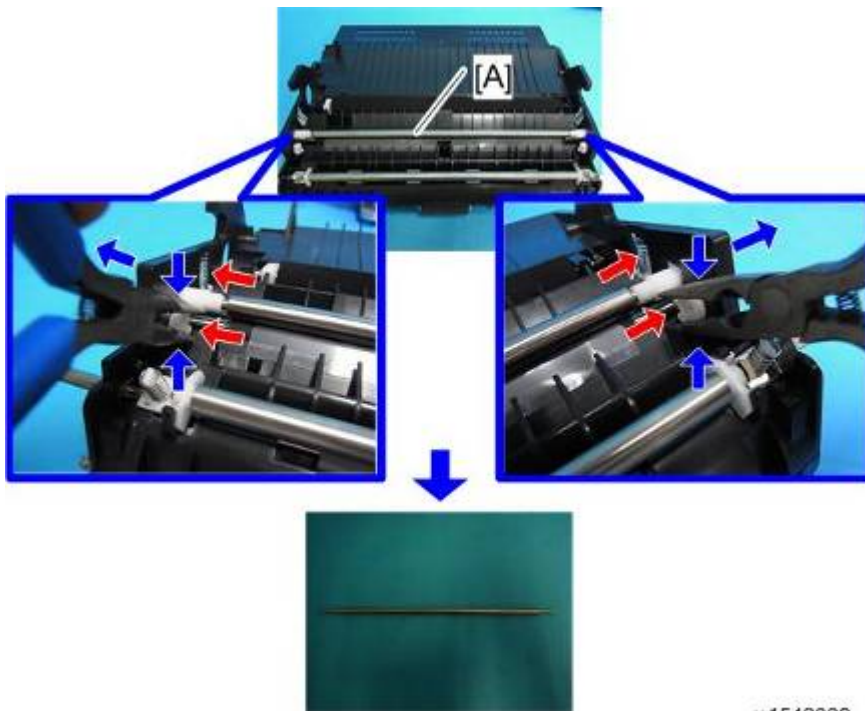

m1542039

18. Registration roller (drive) [A] (C x 2, bushing x 2).

Replacement and Adjustment

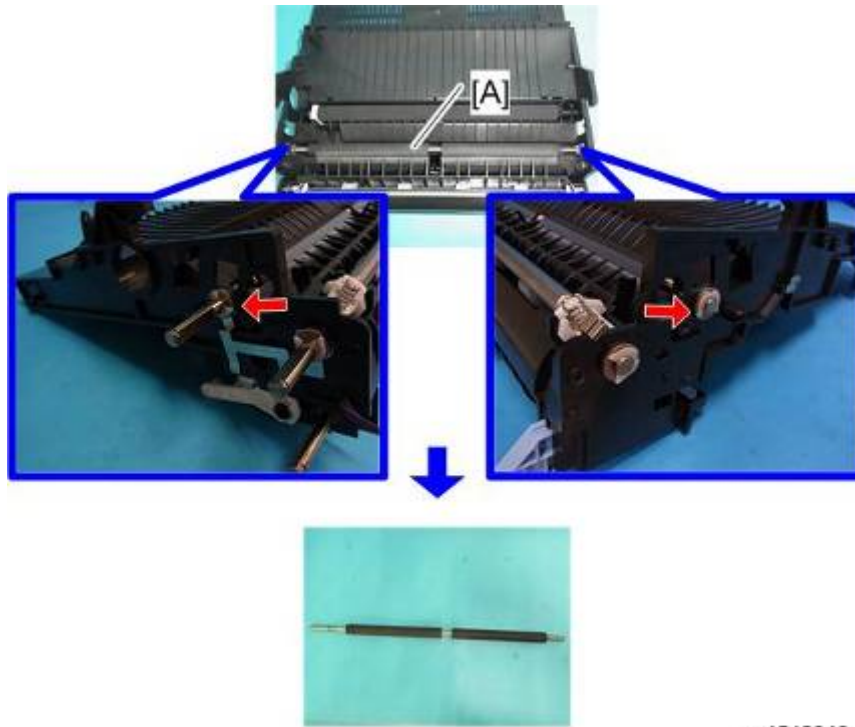

m1542040

4.7.11 REGISTRATION SENSOR

1. Registration unit (page 4-27 "Registration Roller")
2. Turn the registration unit over.
3. Registration sensor [A] ( x 1, 3 hooks)

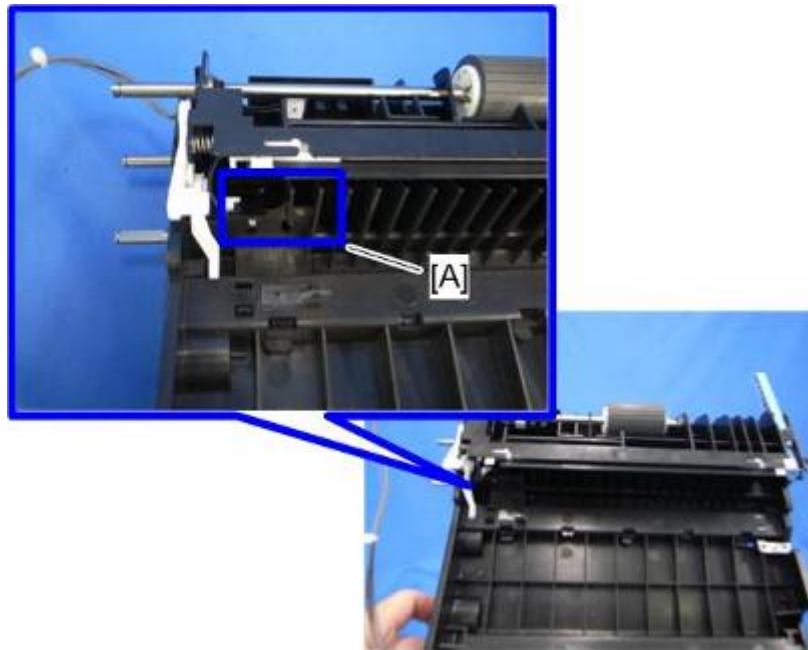

m1542041

4.8 IMAGE TRANSFER

4.8.1 TRANSFER ROLLER

1. Front cover (page 4-2 "Front Cover")
2. AIO
3. Remove the transfer roller [A] as shown below.



4. Remove the bushing x 2, spring x 2, gear x 1, collar x 1 from the transfer roller.



↓ Note

- Do not touch the transfer roller surface when reinstalling the new transfer roller.

After installing a new transfer roller

1. Enter the "Maintenance Mode".
2. Select "Engine Maintenance", and then press "OK" key.
3. Select "Reset Transfer Unit" and then press "OK" key.
4. Press the left key "Execute" of the "Selection keys".
5. Exit the "Maintenance Mode".

4.8.2 TONER END SENSOR

1. Left cover (page 4-3 "Left Cover")
2. Drive unit (page 4-43 "Drive Unit")
3. Toner end sensor [A] (4hooks)

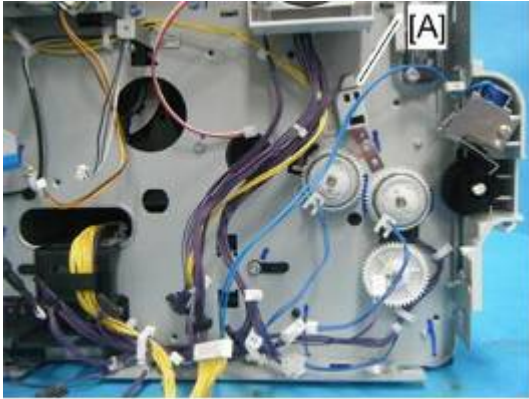

m1562055

4.8.3 QUENCHING LAMP

1. Front cover (page 4-2 "Front Cover")
2. Top cover (page 4-7 "Top Cover")
3. AIO
4. Quenching lamp with the case [A] (2 hooks  x 1).



5. Remove the quenching lamp [A] from the case (hook x 3).

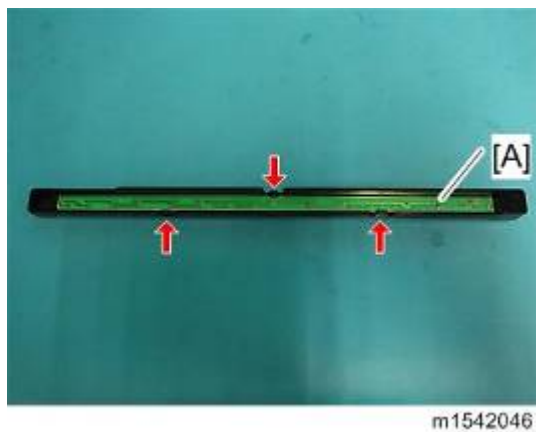

4.9 FUSING AND EXIT

CAUTION

- Switch off the main power, unplug the machine from its power source, and allow the fusing unit to cool before removing it.

4.9.1 FUSING UNIT

1. Right cover (page 4-6 "Right Cover")
2. Rear cover (page 4-5 "Rear Cover")
3. Release the lock [A], and then remove the entrance guide [B] ( x 1)

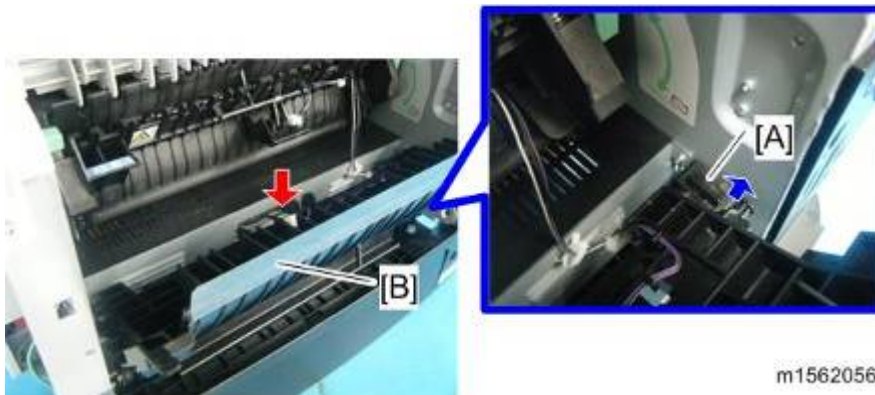

4. Disconnect the three connectors ( x 1)

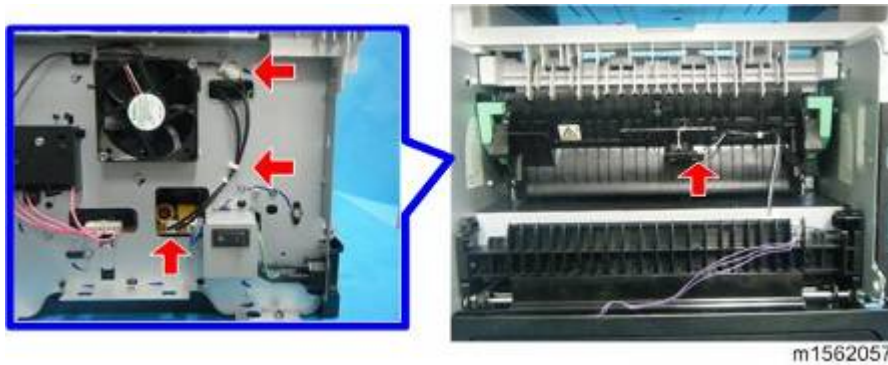

5. Pass the cable [A] through the hole [B] inside the machine.

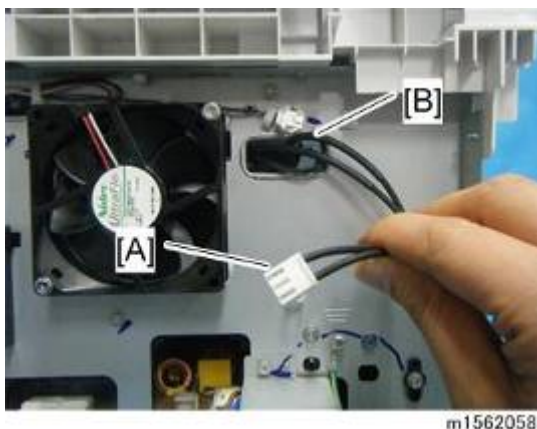

6. Fusing unit [A] (⚙️ x 4)

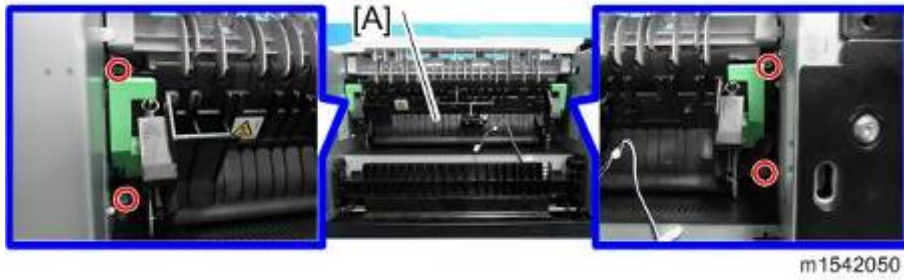

↓ Note

- Make sure that the two bushings [A] remain in position.

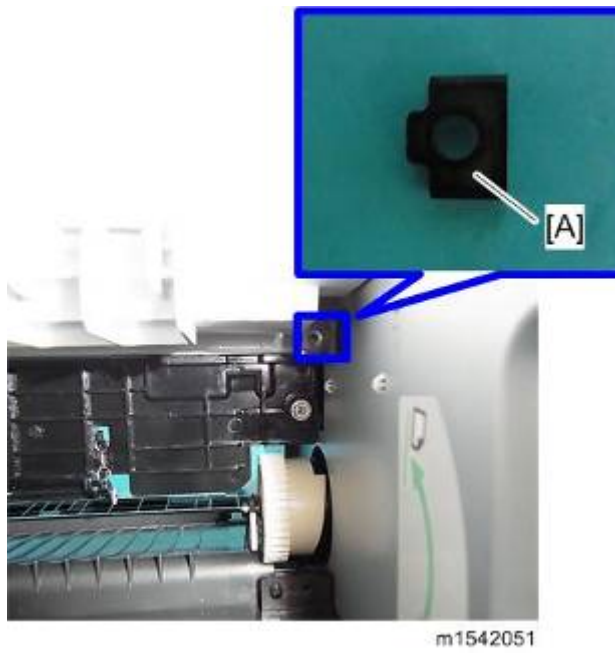

Replacement
and Adjustment

Reinstallation

Pass the cable [A] of the fusing unit through the hole [B] outside, after setting the fusing unit.

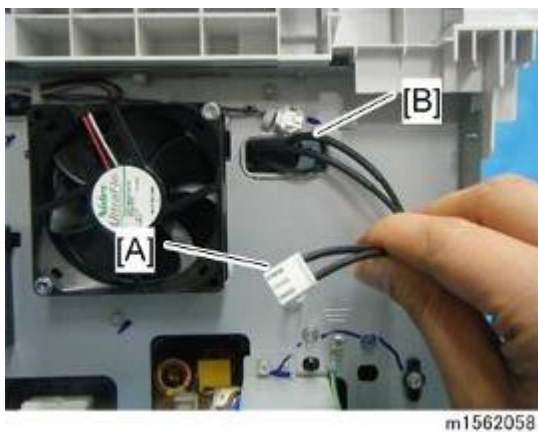

After installing a new fusing unit

1. Enter the "Maintenance Mode".
2. Select "Engine Maintenance", and then press the "OK" key.
3. Select "Reset Fuser Unit" and then press "OK" key.
4. Press the left key "Execute" of the "Selection keys".
5. Exit the "Maintenance Mode".

4.9.2 THERMOSTAT

⚠ CAUTION

- Do not recycle a thermostick that is already opened. Safety is not guaranteed if you do this.
1. Fusing unit (page 4-34 "Fusing Unit")
 2. Fusing upper cover [A] (🔩 x 4)

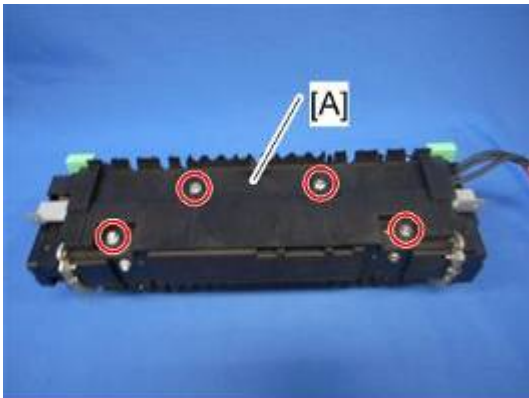

m012r141

3. Thermostat [A] (🔩 x 2)

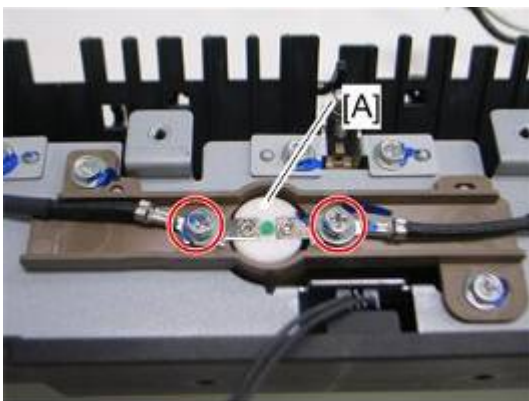

m016r142

4.9.3 THERMISTOR

1. Fusing unit (page 4-34 "Fusing Unit")
2. Fusing upper cover [A] (🔩 x 4)

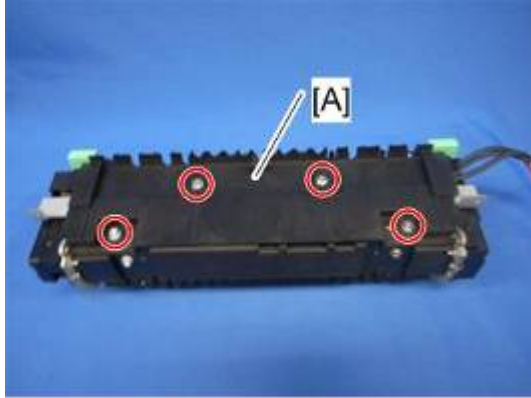

m012r141

3. Fusing front cover [A] (🔩 x 2)

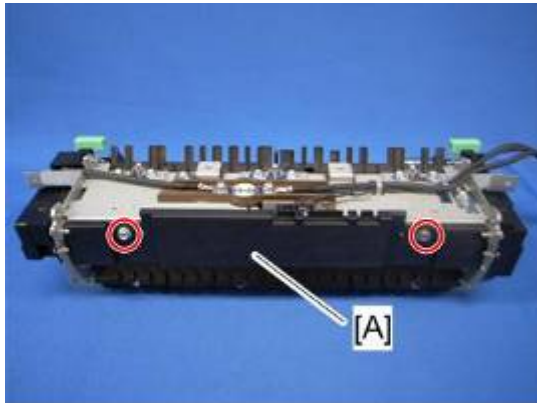

m012r132

4. Thermistor [A] (🔩 x 1)

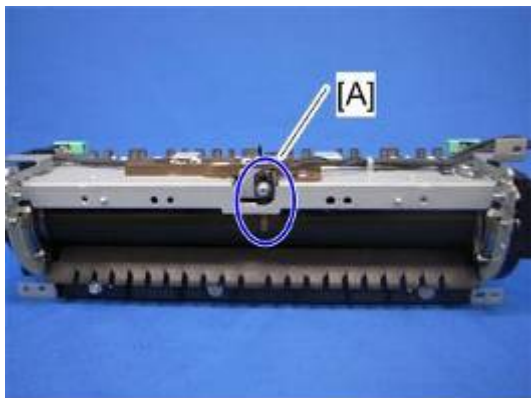

m012r131

4.9.4 FUSING LAMP

1. Fusing Unit (page 4-34 "Fusing Unit")
2. Fusing side covers [A] (🔩 x 2 each)



3. Turn over the fusing unit.
4. Ground-wires (🔩 x 1 each)



5. Fusing lamp [A]

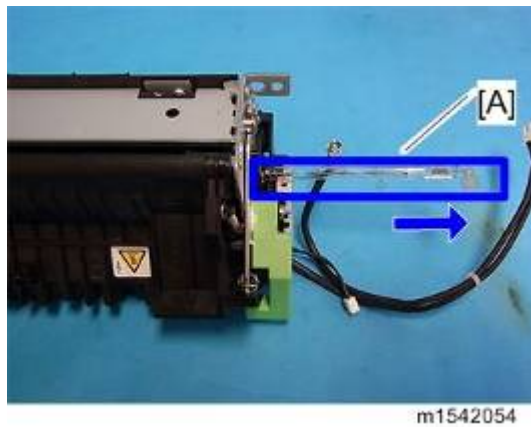

When reinstalling the fusing lamp

The flat terminal [A] must be placed on the right side of the fusing unit (fusing cable side).



4.9.5 HOT ROLLER

1. Fusing lamp (page 4-38 "Fusing Lamp")
2. Brackets [A] (🔩 x 2 each)

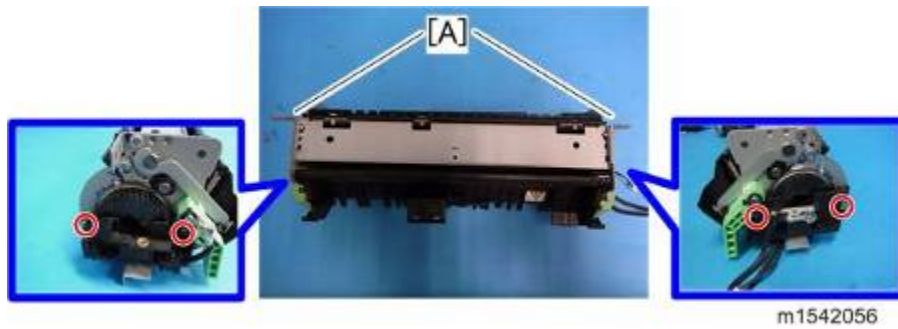

3. Turn over the fusing unit.
4. Fusing upper cover [A] (🔩 x 4)

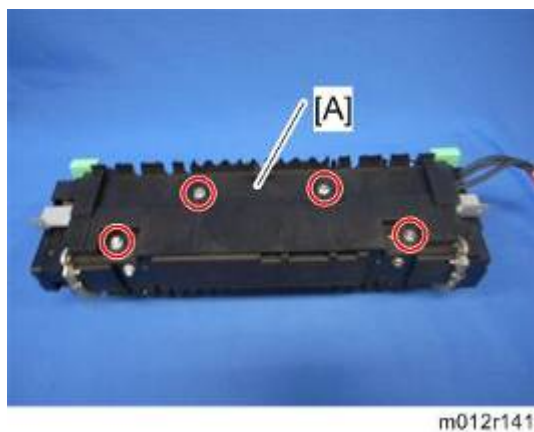

5. Fusing front cover [A] (🔩 x 2)

Replacement and Adjustment

Fusing and Exit

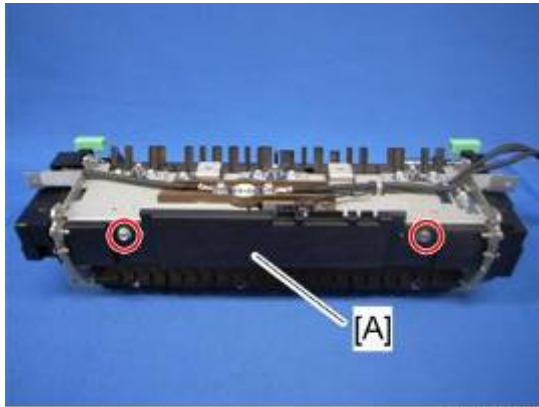

m012r132

6. Fusing entrance guide [A] (🔩 x 3)

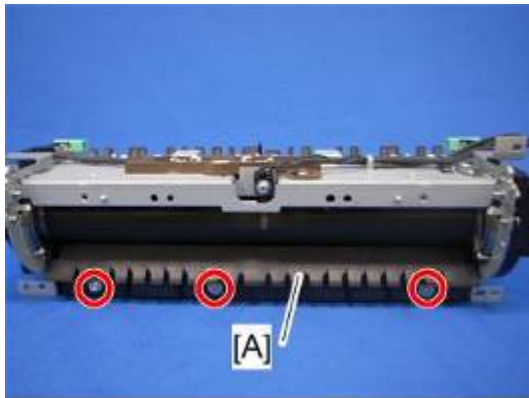

m1542057

7. Thermistor (page 4-37 "Thermistor")
8. Hot roller stripper pawls (page 4-42 "Hot Roller Stripper Pawls")
9. Ground plates [A] (🔩 x 2 each)

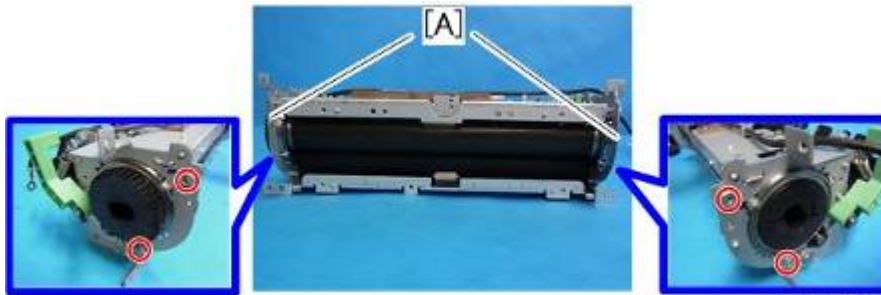

m1542058

10. Quenching brush [A] (🔩 x 1)

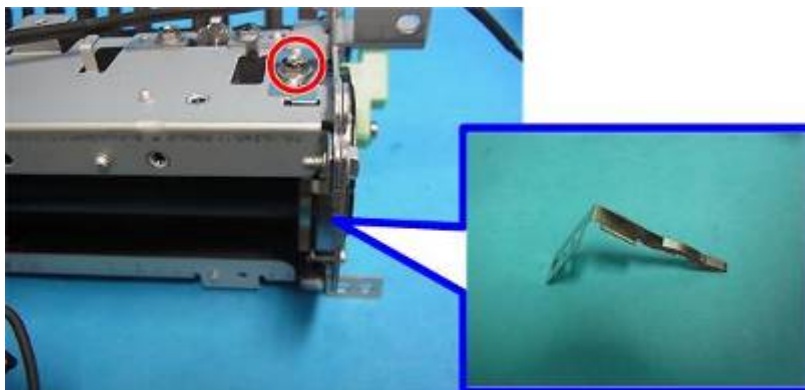

m1542059

11. Hot roller [A]

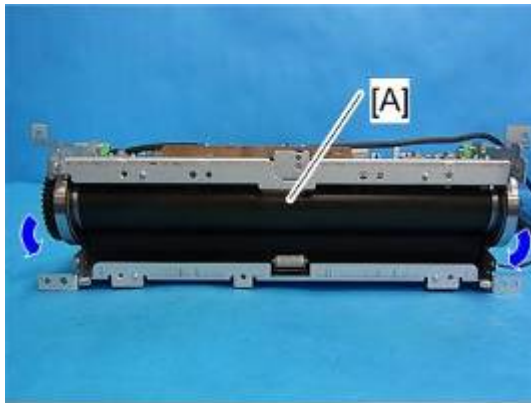

m1542060

12. Remove the C-ring x 2, gear x 1, cap x 1, bushing x 2 from the Hot Roller.



m1542061

4.9.6 PRESSURE ROLLER

1. Hot roller (page 4-39 "Hot Roller")
2. Pressure roller [A] (Bearing x 2)



m1542062

4.9.7 HOT ROLLER STRIPPER PAWLS

1. Fusing unit (page 4-34 "Fusing Unit")
2. Fusing upper cover (page 4-36 "Thermostat")
3. Metal holders [A] (1 holder for each pawl:  x 2 each)

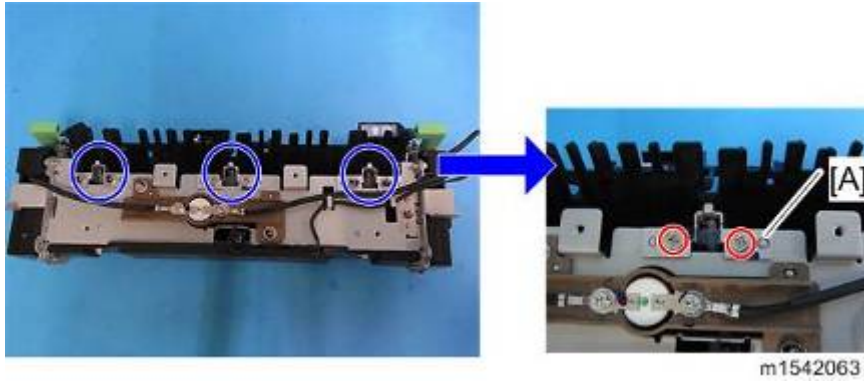

4. Hot roller stripper pawls [A] (1 spring for each pawl)

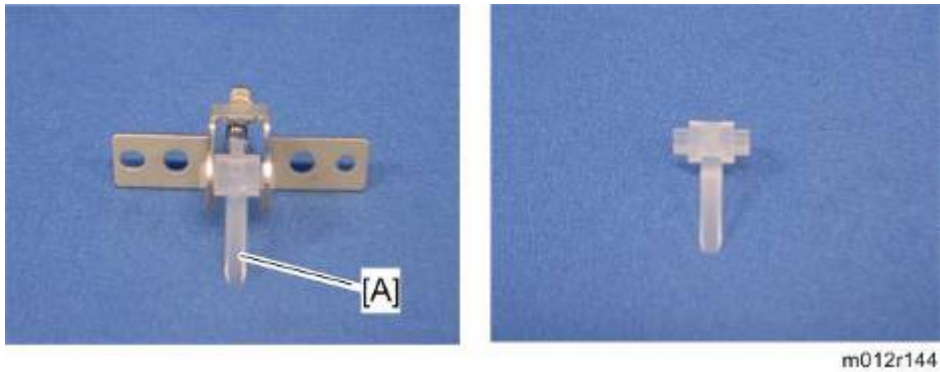

4.9.8 PAPER EXIT SENSOR

1. Rear cover (page 4-5 "Rear Cover")
2. Paper exit sensor [A] ( x 1, 3 hooks)

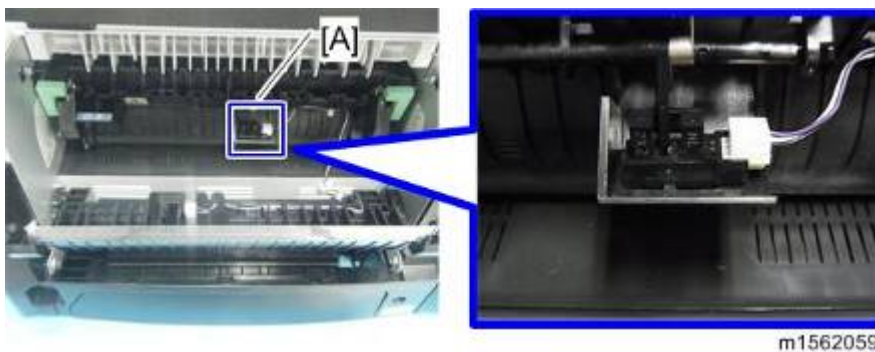

4.10 DRIVE

4.10.1 MAIN MOTOR

1. Left cover (page 4-3 "Left Cover")
2. Harness guide plate [A] (🔩 x 3, 🛠️ x 2, 📏 x 1)
3. Main motor [B] (🔩 x 4, 🛠️ x 1)

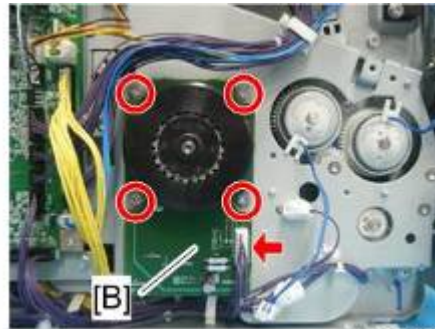
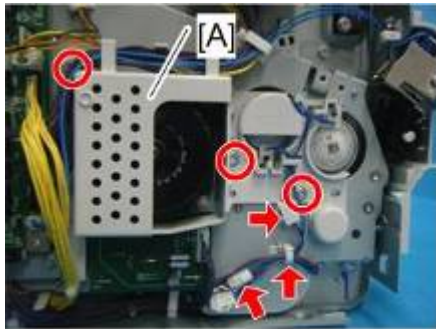

m1562060

4.10.2 DRIVE UNIT

1. Left cover (page 4-3 "Left Cover")
2. Main board (page 4-46 "Main board")
3. FCU (page 4-48 "

Drive

FCU")

4. Harness guide plate [A] (🔧 x 3, 📏 x 2, 📏 x 1)
5. Drive unit [B] (🔧 x 5, 📏 x 1, 📏 x 2, timing belt)

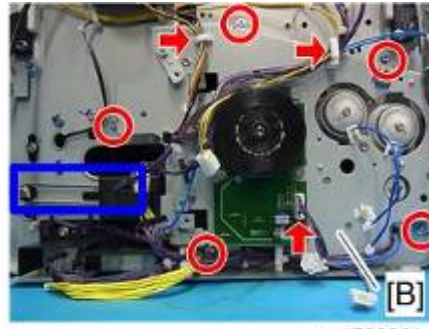
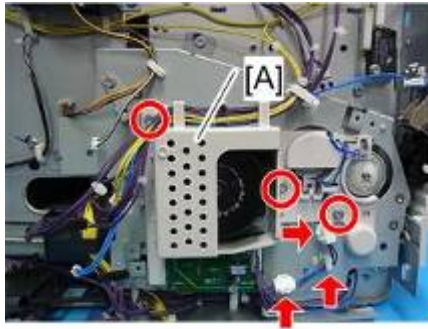

m1562061

4.10.3 DUPLEX MOTOR

1. Left cover (page 4-3 "Left Cover")
2. Top Cover (page 4-7 "Top Cover")
3. Duplex motor [A] (🔩 x 2, 🛠️ x 1, 🛠️ x 1)

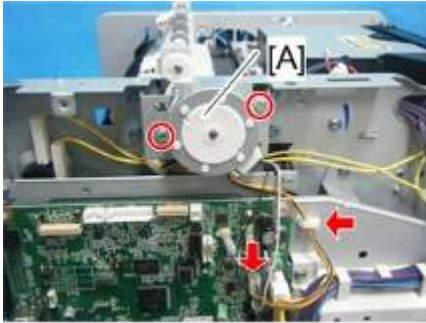

m1562062

4.11 ELECTRICAL COMPONENTS

CAUTION

- When replacing a fuse, always use a fuse of the correct rating. Never use a fuse with the wrong rating. If you do, the machine may be damaged.

4.11.1 LAYOUT OF PC BOARDS



[A]	Main board
[B]	FCU– behind the Main board

4.11.2 MAIN BOARD

1. Left cover (page 4-3 "Left Cover")
2. Main board [A] (⚙ x 4, flat cable x 2, all ⚙s)

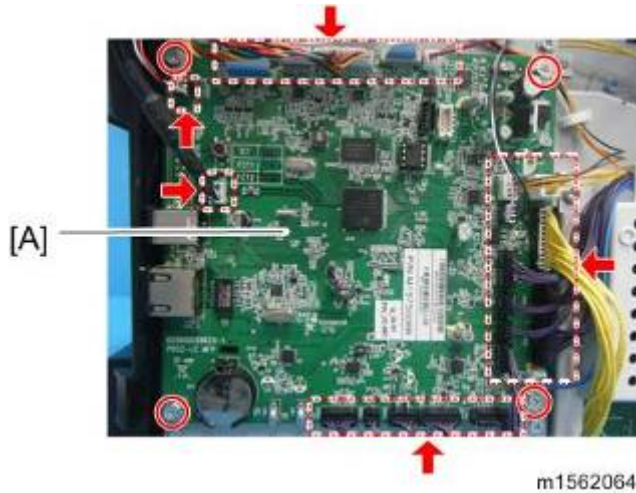

↓ Note

- Do not connect any connectors to JRS1 and JRS2 when reinstalling the main board [A]. JRS1 and JRS2 are only used at the factory.
- Do not change the dip switch. The dip switch is only for factory use.

3. EEPROM [A]



When installing the new main board

1. Remove the EEPROM from the old main board.
2. Install it on the new main board after replacing the main board.
3. Replace the EEPROM if the EEPROM on the old main board is defective.

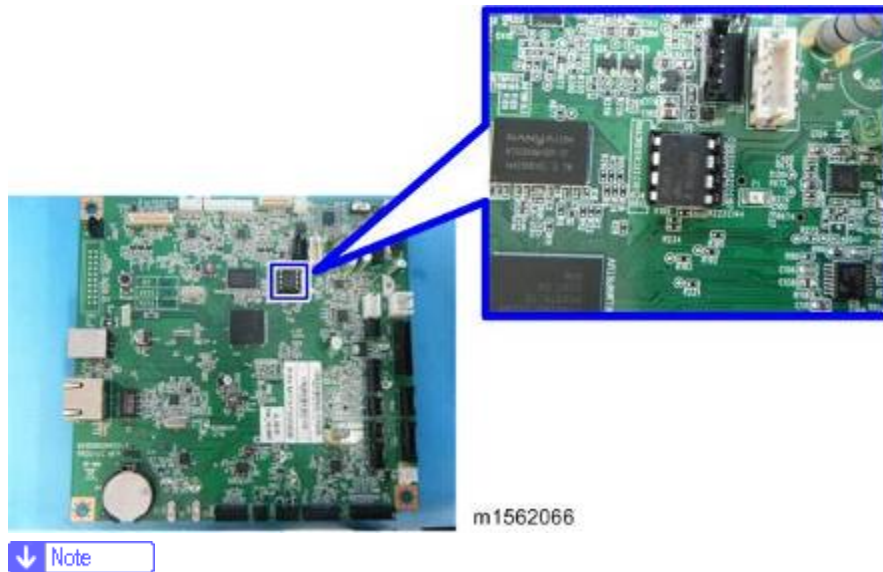

- Keep the EEPROM away from any objects that can cause static electricity. Static electricity can damage EEPROM data.
- Make sure that the EEPROM is correctly installed on the main board.

EEPROM

- Replacement procedures for the new EEPROM are included in the "page 4-46 "Main board"" replacement procedure. Refer to "page 4-46 "Main board"" for details.
- Do the following settings after installing a "new" EEPROM.
 - Input the PnP Name, Destination in Maintenance Mode.
 - Adjust the Registration in Maintenance Mode.
 - Input the serial number on the serial number input display after installing the new EEPROM



- Ask your supervisor about how to access the serial number input display.

4.11.3 FCU

1. Main board (page 4-46 "Main board")
2. Main board bracket [A] (🔩 x 4, ground screw x 1)

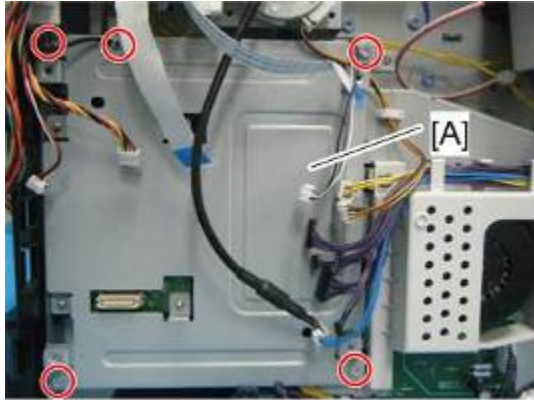

m1562067

3. FCU [A] (🔩 x 4)



m1562068

4.11.4 PSU

1. Pull out the standard paper tray.
2. Front cover (page 4-2 "Front Cover")
3. Rear cover (page 4-5 "Rear Cover")
4. Left cover (page 4-3 "Left Cover")
5. Right cover (page 4-6 "Right Cover")
6. Main board (page 4-46 "Main board")
7. FCU (page 4-48 "FCU")
8. Drive unit (page 4-43 "Drive Unit")
9. Bracket [A] (🔩 x 2, 🛠️ x 1)

Electrical Components

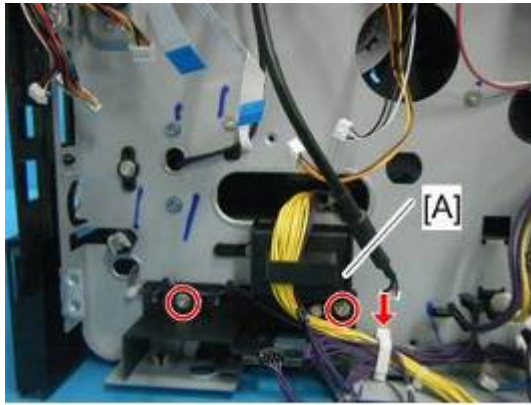

10. Disconnect three connectors on the left frame.
11. Main power switch bracket [A] on the right frame (⚙️ x 2)
12. Remove the main power cord [B] as shown below (🔌 x 2, ground screw x 1).

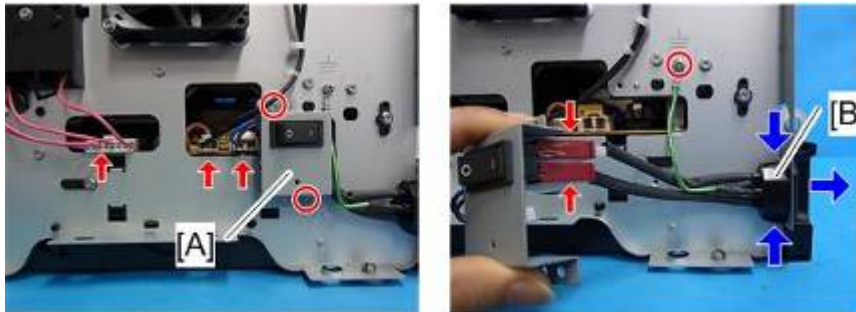

13. Rear lower cover [A] (⚙️ x 3)

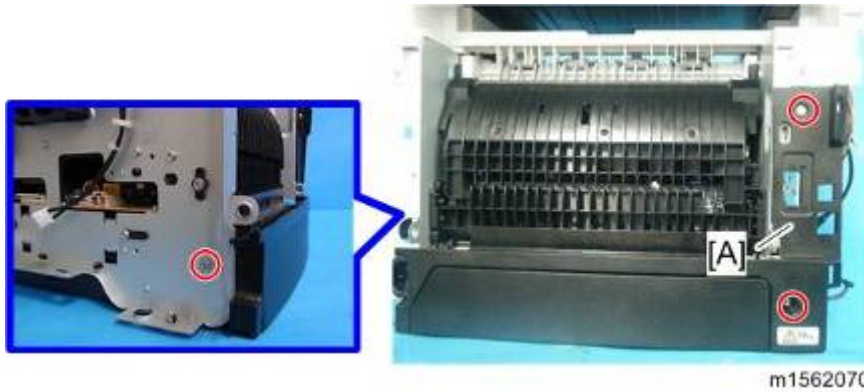

14. Release the lock [A], and then remove the entrance guide [B] (🔌 x 1).



15. Duplex cover [A] (⚙️ x 2, bushing x 2)

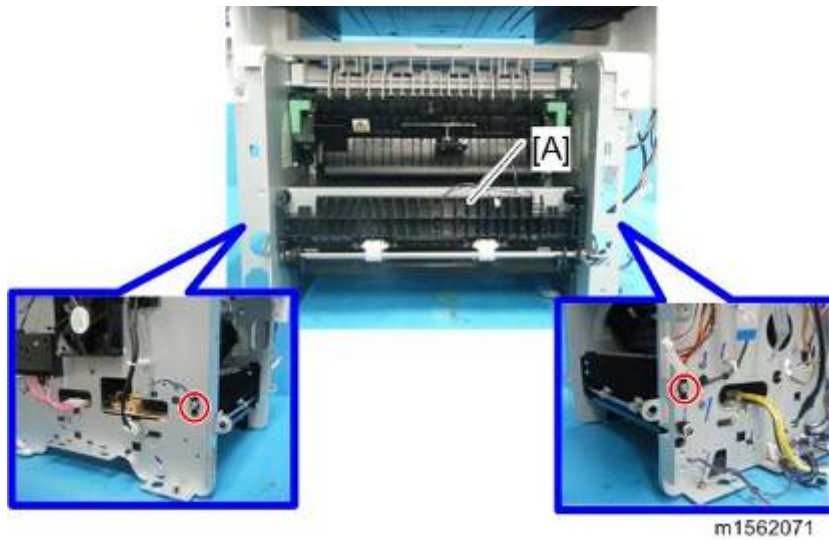

16. Set the machine with the front side facing down, resting on the table.

17. Release the link [A] (⚙️ x 1)

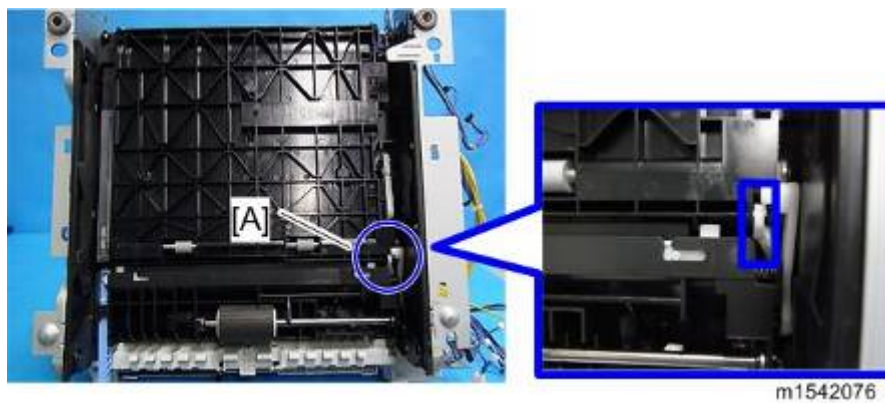

18. Duplex transport guide [A] (⚙️ x 4, bushing x 4, ⚙️ x 1, gear x 1)

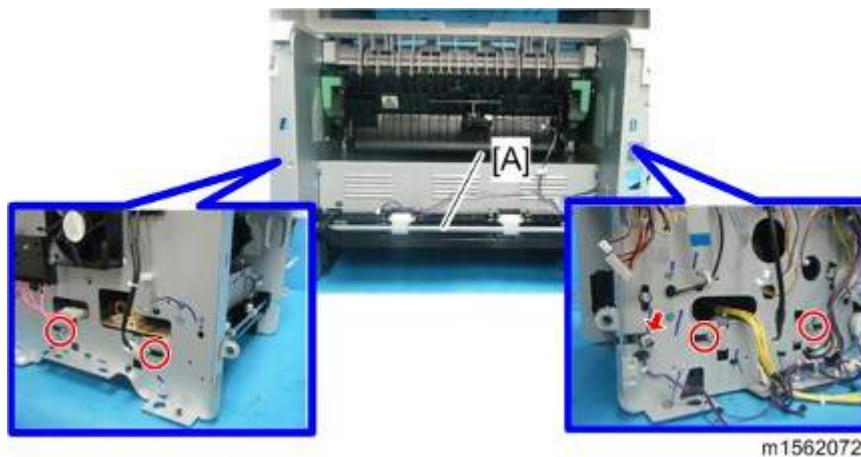

19. PSU / HVP unit [A] (⚙️ x 4, ⚙️ x 1, ⚙️ x 1)

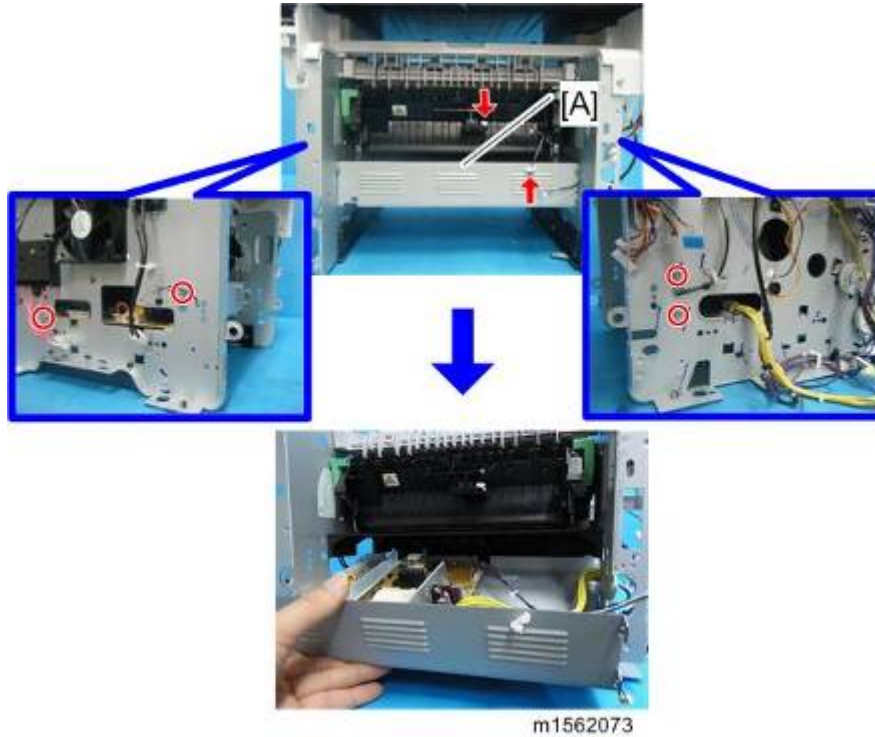

20. PSU [A] (🔧 x 4, 📏 x 1)

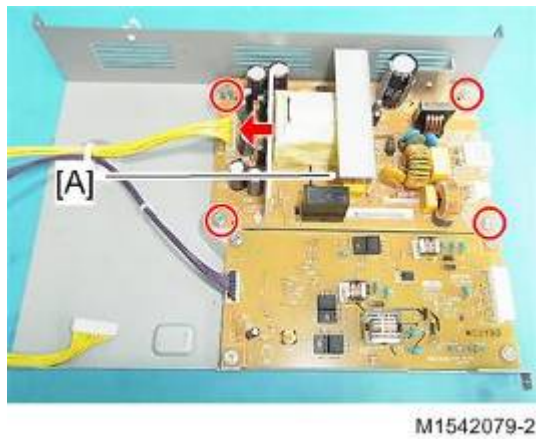

4.11.5 HVP

1. PSU / HVP unit (page 4-48 "PSU")
2. HVP [A] (🔧 x 4, 📏 x 1).



4.11.6 CHARGE TERMINAL CASE

1. Right cover (page 4-6 "Right Cover")
2. Charge terminal case [A] with the harness (🔩 x 2, 📌 x 1, 2 hooks)

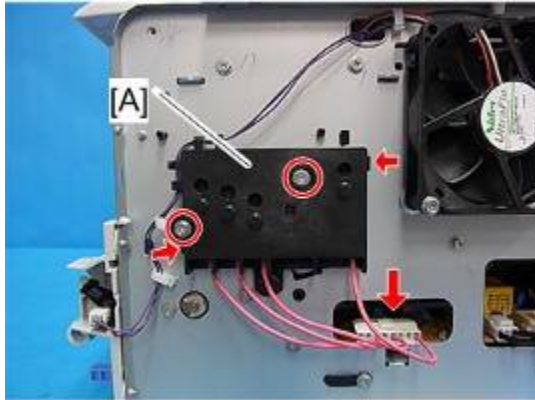

m1542080

3. Harness [A] (🔩 x 4)
4. Four springs and terminal pins [B].

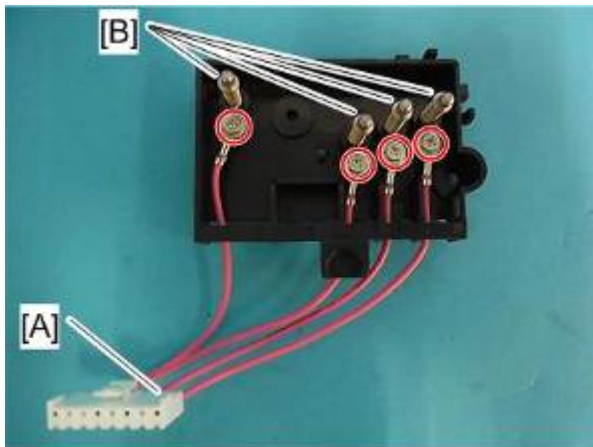

m1542081

4.11.7 COOLING FAN

1. Right cover (page 4-6 "Right Cover")
2. Top cover (page 4-7 "Top Cover")
3. Cooling fan [A] (🔧 x 2, 📏 x 1, 📏 x 1)

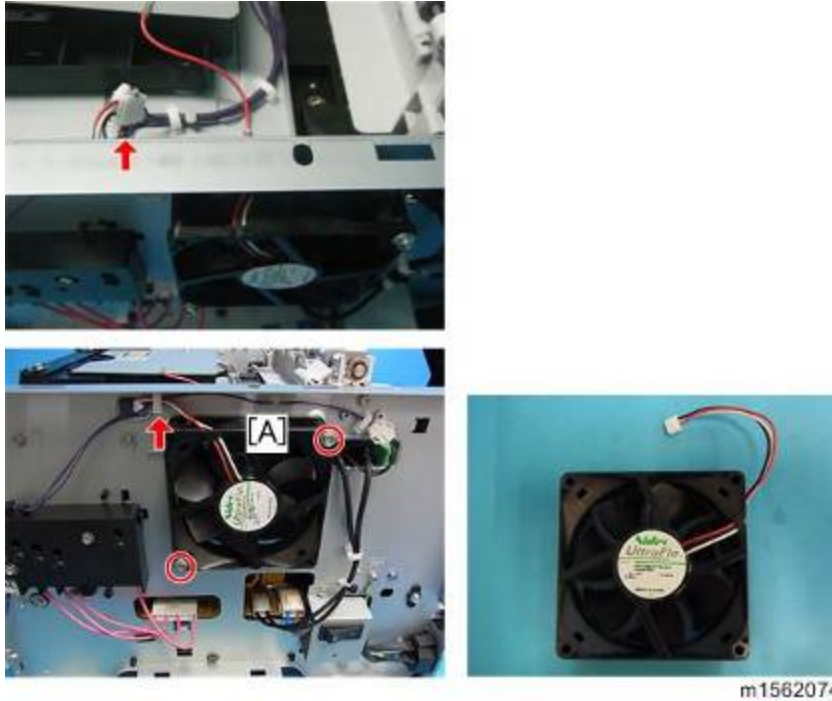

⚠ CAUTION

- Install the cooling fan [A] with its decal facing the outside of the machine.

4.11.8 SPEAKER

1. Left cover (page 4-3 "Left Cover")
2. Speaker [A] (🔧 x 2, 📏 x 1)

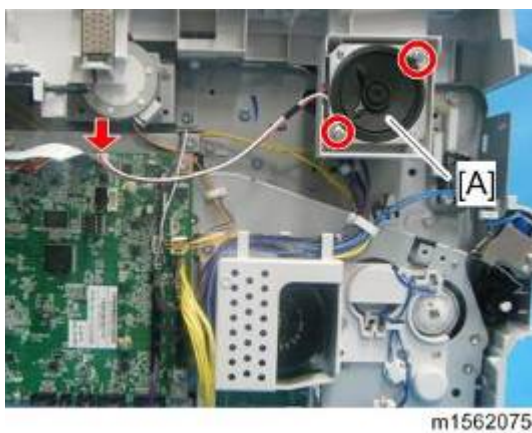

4.11.9 WIRELESS LAN BOARD (FOR M157, M177)

1. Left cover (page 4-3 "Left Cover")
2. Wireless LAN board [A] (hook,  x 1)

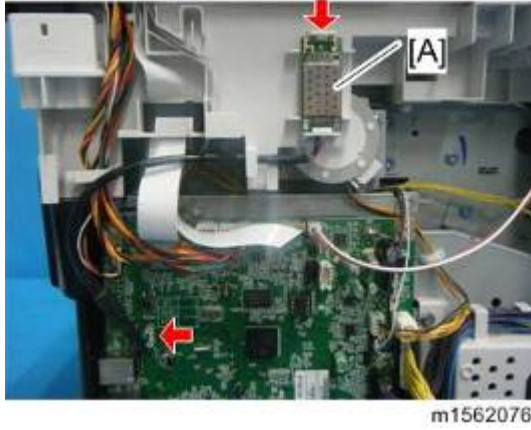

4.12 DUPLEX

4.12.1 RELAY SENSOR

1. Rear cover (page 4-5 "Rear Cover")
2. Relay sensor [A] ( x 1, 3 hooks)



4.12.2 INVERTER SENSOR

1. Duplex transport guide (page 4-48 "PSU")
2. Inverter sensor [A] ( x 1, 3 hooks)

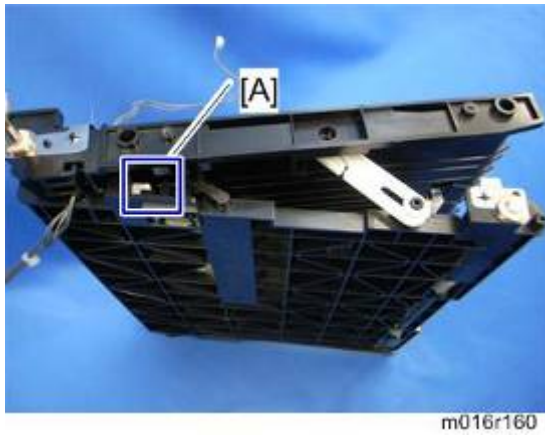

4.13 IMAGE ADJUSTMENT

4.13.1 REGISTRATION ADJUSTMENT

User Adjustment

The paper registration can also be adjusted with the user mode ("User Tools "). For details, see the "User Guide".

Service Adjustment

1. Print the test page (page 5-18 "Reports").
 - Print out the test page before changing the paper registration setting.
2. Enter the "Maintenance Mode".
3. Select "Engine Maintenance", and then the press "OK" key.
4. Select "Registration", and then press the "OK" key.
5. Select the item you want to adjust, and then press the "OK" key.
6. Press the "Up" or "Down" keys to set the registration value (mm), and then press the "OK" key.

↓ Note

- Increase the value to shift the print area in the plus direction.
- Decrease to shift in the minus direction.
- Adjust the margins of the test page so that they are equal in size.

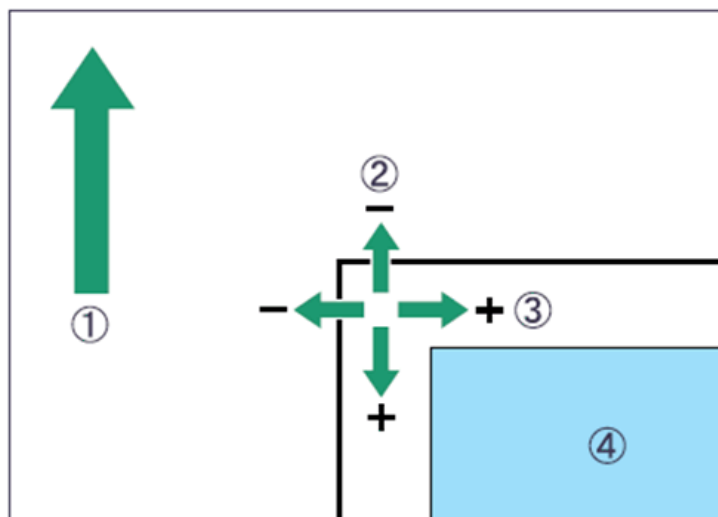

m0161500

- (1): Feed Direction
- (2): Vertical Adjustment
- (3): Horizontal Adjustment
- (4): Print Area

SERVICE TABLES

REVISION HISTORY		
Page	Date	Added/Updated/New
		None

5. SERVICE TABLES

5.1 SERVICE PROGRAM MODE

5.1.1 OVERVIEW

This model has several service menus. Each service menu has several adjustment items. This section explains how to enter each service menu and what you can do in each service menu.

5.1.2 MAINTENANCE MODE MENU

Selecting an Item

To select an item, press the "Up" or "Down" key.

Going into the Next Level/ Returning to the Previous Level

- To go into the next level of an item, select an item then press the "OK" key.
- To return to the previous level of an item, press the "Escape" key.

Exiting the Maintenance Mode Menu

To exit the maintenance mode menu, press the "Clear/Stop" or "Return" key until the "Ready" display appears.

Menu List

Display Info		
Model Name		Displays the Model Name, Depends on Engine Firmware Settings
FW Version	CTL FW Version	Displays the Firmware Version
	FAX FW Version	Displays the FAX Firmware Version.
	Engine FW Version	Displays the Engine Firmware Version
Counter	Printer Counter	Displays the following counters of the printer engine. Black image (Total Page)

Display Info		
	Scanner Counter	Displays the sum total of scanner counters for each mode. Total Page/ Color Image/ Black Image/ ADF Used
	Jam Counter	Displays the number of paper jams at each location. Jam Total/ ADF/ Printer Out Bin/ Internal/ Tray1/ Duplex

Print Reports	
G3 Protocol dump list	G3 protocol dump of the latest communication is printed. Off (Default)/ Error/ On

Engine Maintenance		
PnP Name	Do not change this setting (Designed for Factory Use). [0x00 to 0x7F]	
Adjust Charge Bias	Charge bias correction for dirty background 0: OFF (Default) 1: ON 2 to 255: not available [0 to 255 / 0 / 1 /step]	
Curl Control Mode	Corrects the face curl of paper. 0: OFF (28ppm) 1: Sets the engine speed at 14ppm after printing 1 minute. 2: Sets the engine speed at 14ppm. 3 to 255: not available [0 to 255 / 0 / 1 /step]	
Toner Near End	Sheets	Adjusts the printable sheets between "toner near end" to "toner end". [0 to 255 / 200 / 1 sheet/step]

Engine Maintenance		
	Dot Count	Adjusts the printable dot count between "toner near end" to "toner end". [0 to 255 / 100 / 1 dot/step]
Subscan Magnification	Adjusts the sub scan magnification. [-8 to 8 / 0 (Default) / 1/step]	
Trans Roller Bias	Adjusts the transfer roller bias. [-6 to 6 / 1 (Default) / 1/step]	
Developer Bias	Adjusts the developer bias. [270 to 330 / 300 (Default) / 15/step]	
Charge Bias	[1050 to 1300 / 1200 (Default) / 1/step]	
Fusing Unit Temperature	Plain Paper	Adjusts the fusing temperature for plain paper. [150 to 190 / 175 (Default) / 5deg/step]
	Recycled	Adjusts the fusing temperature for recycled paper. [150 to 180 / 160 (Default) / 5deg/step]
	Postcard	Adjusts the fusing temperature for postcard. [160 to 200 / 185 (Default) / 5deg/step]
	Envelope	Adjusts the fusing temperature for envelope. [170 to 200 / 200 (Default) / 5deg/step]
	Thin Paper	Adjusts the fusing temperature for thin paper. [140 to 165 / 150 (Default) / 5deg/step]
	Low Power	Adjusts the fusing temperature in the low power mode. [80 to 135 / 120 (Default) / 5deg/step]
	Standby	Adjusts the fusing temperature in the standby mode. [120 to 175 / 155 (Default) / 1deg/step]
	Thick2 Paper	Adjusts the fusing temperature for thick 2 paper. [160 to 200 / 185 (Default) / 5deg/step]

Engine Maintenance		
	Thick1 Paper	Adjusts the fusing temperature for thick 1 paper. [160 to 200 / 185 (Default) / 5deg /step]
Paper Buckle Amo.	Vert .Bp Plain Paper	Adjusts the amount of paper buckle at the registration roller for each tray and paper type. [-8 to 8 / -2 (Default) / 1mm/step]
	Vert .Bp Thick Paper	Adjusts the amount of paper buckle at the registration roller for each tray and paper type. [-8 to 8 / 0 (Default) / 1mm/step]
	Vert .Bp Thin Paper	Adjusts the amount of paper buckle at the registration roller for each tray and paper type. [-8 to 8 / -2 (Default) / 1mm/step]
	Vert .Tray1 Plain Paper	Adjusts the amount of paper buckle at the registration roller for each tray and paper type. [-8 to 8 / -2 (Default) / 1mm/step]
	Vert .Tray1 Thick Paper	Adjusts the amount of paper buckle at the registration roller for each tray and paper type. [-8 to 8 / 0 (Default) / 1mm/step]
	Vert .Tray1 Thin Paper	Adjusts the amount of paper buckle at the registration roller for each tray and paper type. [-8 to 8 / -2 (Default) / 1mm/step]
	Vert .Dup. Plain Paper	[-8 to 8 / 0 (Default) / 1mm/step]
	Vert .Dup. Thick Paper	[-8 to 8 / 0 (Default) / 1mm/step]
	Vert .Dup.1 Thin Paper	[-8 to 8 / 0 (Default) / 1mm/step]
	Output Check	Main Motor
Middle Clutch		Output check (Relay Clutch)
Tray1 Clutch		Output check (Paper Feed Clutch)
Bypass Solenoid		Output check (Bypass solenoid)

Engine Maintenance		
	Regist Clutch	Output check (Registration Clutch)
	Reserve Clutch	Output check (Reserve Clutch)
	Fan High Speed	Output check (Fan High Speed)
	Fan Low Speed	Output check (Fan Low Speed)
	Erase Lamp	Output check (Quenching Lamp)
	Polygon Motor	Output check (Polygon Motor)
	Dup Motor Normal	Output check (Duplex Motor Normal)
	Dup Motor Revers	Output check (Duplex Motor Reverse)
EM Life Display	Sets the display of alert when each EM parts yield of this machine is reached. [On or Off (Default)]	
SC559 Detection	[On or Off (Default)]	
Clear Engine Memory	Resets the engine settings stored in the EEPROM to factory default.	
Total Counter Info	Engine Counter	Displays the total counter (Engine).
EM Counter Info	Transfer Roller - Time	Displays the EM counter (Transfer Roller: Time).
	Paper Feed Roller – Pages	Displays the EM counter (Paper Feed Roller: pages).
	Fusing Unit - Time	Displays the EM counter (Fusing Unit: time).
	Transfer Roller - Pages	Displays the EM counter (Transfer Roller: pages).
	Fusing Unit - Pages	Displays the EM counter (Fusing Unit: pages).
	Transfer Roller Remain	Displays the total counter (Remain of Transfer Roller).

Engine Maintenance		
	Paper Feed Roller Remain	Displays the total counter (Remain of Paper Feed Roller).
OPC Life Info	OPC Rotation Time	Displays the OPC life information (OPC rotation time).
	Pre-OPC Rotation Time	Displays the OPC life information (Pre-OPC rotation time)
	OPC Alert Status	Displays the OPC life information (Alert status)
	OPC Pre-Alert Status	Displays the OPC life information (Pre-Alert status)
Prt Cartridge Info	Kind ID	Displays the toner cartridge (AIO) information (Kind ID).
	Toner End History	Displays the toner cartridge (AIO) information (Toner End History).
	Refill Flag Status	Displays the toner cartridge (AIO) information (Refill flag status).
	Unit Print Counter	Displays the toner cartridge (AIO) information (Unit Print Counter).
Motor Rotation Time	Displays the main motor rotation time.	
Reset Fuser Unit	Clears the EM counter of the fusing unit.	
Reset Paper Feed Rol Life	Clears the EM counter of the paper feed roller.	
Reset Transfer Unit	Clears the EM counter of the transfer roller.	
Fuser SC Reset	This button is for resetting an SC related with the fusing errors.	
Brand ID	[0x00 – 0x7F] Displays the current brand ID number. Do not change this setting (Designed for Factory Use).	

Engine Maintenance		
Registration	Horiz. Tray1	Adjusts the horizontal registration for tray 1. If the machine settings are reset to the factory defaults, this value does not change. [-40.0 to 40.0 / 4.0 (Default) / 0.1 mm/step]
	Vert. Tray1 Plain	Adjusts the vertical registration of plain paper for tray1. If the machine settings are reset to the factory defaults, this value does not change. [-40.0 to 40.0 / 12.0 (Default) / 0.1 mm/step]
	Vert. Tray1 Thick	Adjusts the vertical registration of thick paper for tray 1. If the machine settings are reset to the factory defaults, this value does not change. [-40.0 to 40.0 / 12.0 (Default) / 0.1 mm/step]
	Vert. Tray1 Thin	Adjusts the vertical registration of thin paper for tray 1. If the machine settings are reset to the factory defaults, this value does not change. [-40.0 to 40.0 / 12.0 (Default) / 0.1 mm/step]
	Horiz Bypass tray	Adjusts the horizontal registration for the bypass tray. If the machine settings are reset to the factory defaults, this value does not change. [-40.0 to 40.0 / -2.0 (Default) / 0.1 mm/step]
	Vert Bypass Plain	Adjusts the vertical registration of plain paper for the bypass tray. If the machine settings are reset to the factory defaults, this value does not change. [-40.0 to 40.0 / 12.0 (Default) / 0.1 mm/step]
	Vert Bypass Thick	Adjusts the vertical registration of thick paper for the bypass tray. If the machine settings are reset to the factory defaults, this value does not change. [-40.0 to 40.0 / 12.0 (Default) / 0.1 mm/step]

Engine Maintenance		
	Vert Bypass Thin	Adjusts the vertical registration of thin paper for the bypass tray. If the machine settings are reset to the factory defaults, this value does not change. [-40.0 to 40.0 / 12.0 (Default) / 0.1 mm/step]
	Horiz. Dup. Back	Adjusts the horizontal registration the back side in duplex mode. If the machine settings are reset to the factory defaults, this value does not change. [-40.0 to 40.0 / 4.0 (Default) / 0.1 mm/step]
	Vert Dup Plain	Adjusts the vertical registration of plain paper for the back side in duplex mode. If the machine settings are reset to the factory defaults, this value does not change. [-40.0 to 40.0 / 12.0 (Default) / 0.1 mm/step]
	Vert Dups Thick	Adjusts the vertical registration of thick paper for the back side in duplex mode. If the machine settings are reset to the factory defaults, this value does not change. [-40.0 to 40.0 / 0.0 (Default) / 0.1 mm/step]
	Vert Dup Thin	Adjusts the vertical registration of thin paper for the back side in duplex mode. If the machine settings are reset to the factory defaults, this value does not change. [-40.0 to 40.0 / 12.0 (Default) / 0.1 mm/step]
Destination	Sets the destination and updates the engine setting. Do not change this setting (Designed for Factory Use). DOM/ NA/ EU / ASIA/ CHN/ TAIWAN/ KOREA	
Test Pattern	Prints the test pattern.	

Engine Maintenance		
Waste toner disposal	<p>Sets the machine operation at "waste toner full" of the refilled AIO. [On or Off (Default)]</p> <p> Note</p> <ul style="list-style-type: none"> With main motor rotation count feature, machine can be set to stop printing after print total exceeds a certain set value. If print count exceeds this value, then "Replace Print Cartridge" remains in display. Then a new AIO cartridge must be installed. This feature is a safety measure to prevent the used toner tank from becoming full (there is no toner overflow detection mechanism). 	
1200DPI Power	<p>Adjusts print density (density levels by increasing the number) [31 to 155 / 112 (Default) / 1 /step]</p>	
Refill Mode Setting	Auto refill mode	Do not change this setting (Designed for Factory Use).
	Pure refill mode	Do not change this setting (Designed for Factory Use).

Scan Maintenance		
Mono Compression	<p>Sets the monochrome compression type for scanning. MH (Default)/ MR/ MMR</p>	
Registration Adjust	ADF Main Reg.	Adjusts the ADF Scan main-scan registration. [-2.0 to 2.0 / 0 (Default)/ 0.1 %/step]
	ADF Sub Reg.	Adjusts the ADF Scan sub-scan registration. [-2.0 to 2.0 / 0 (Default)/ 0.1 %/step]
	Flatbed Main Reg.	Adjusts the Flatbed Scan main-scan registration. [-2.0 to 2.0 / 0 (Default)/ 0.1 %/step]
	Flatbed Sub Reg.	Adjusts the Flatbed Scan sub-scan registration. [-2.0 to 2.0 / 0 (Default)/ 0.1 %/step]
Size Adjust	ADF Main Reg.	Adjusts the ADF Scan main-scan magnification. [-0.9 to 0.9 / 0 (Default)/ 0.1 %/step]

Scan Maintenance		
	ADF Sub Reg.	Adjusts the ADF Scan sub-scan magnification. [-0.9 to 0.9 / 0 (Default)/ 0.1 %/step]
	Flatbed Main Reg.	Adjusts the Flatbed Scan main-scan magnification. [-0.9 to 0.9 / 0 (Default)/ 0.1 %/step]
	Flatbed Sub Reg.	Adjusts the Flatbed Scan sub-scan magnification. [-0.9 to 0.9 / 0 (Default)/ 0.1 %/step]

Fax Maintenance		
Modem Settings	RX Level	Sets the reception level. [-43 dBm (Default)/ -33 dBm/ -26 dBm / -16 dBm]
	TX Level	Sets the transmission level. [-15 to -1 / -15 (Default)/ 1dBm/ step]
	Cable Equalizer	These selectors are used to improve the pass-band characteristics of analogue signals on the telephone line. [0Km (Default)/ 1.8Km/ 3.6Km/ 7.2Km]
Protocol Definition	Training Retries	This sets the number of training retries to be repeated before automatic fallback. [1 Time/ 2 Times (Default)/ 3 Times/ 4 Times]
	Encoding	Sets the compression method for Tx/Rx. [MMR+MR+MH (Default)/ MR+MH/ MH]
Protocol Definition Timer	T0 Timer	Timeout for response from the called station in automatic sending mode [35 Sec/ 45 Sec/ 55 Sec (Default)/ 60 Sec/ 90 Sec/ 140 Sec]
	T1 Timer	Set the time length for the T1 timer. [40 Sec (Default)/ 50 Sec]

Fax Maintenance		
	T4 Timer	Set the time length for the T4 timer. [3 Sec (Default)/ 4.5 Sec]
RX Settings	Silence Detection	Silence (No tone) detection time (Rx mode : FAX/ TAD Only) After the line is connected via the external telephone, the machine can detect silence (no tone) for the time length specified by this setting. [30 sec (Default)]
	CNG Tone Detection	CNG tone detection time (RX mode : FAX / TEL, FAX / TAD Only) After the line is connected via the external telephone, the machine can detect a CNG signal for the time length specified by this setting. [5 Sec (Default)/ 10 Sec]
	CNG Cycles	Number of CNG cycles to be detected This setting is only effective for FAX/TAD mode. [1.5 Cycle (Default)/ 2.0 Cycle]
RX Settings	Tone Sound Monitoring	Determines the period when tones from the line are monitored. [No Monitoring/ Up To Phase B (Default)/ All TX Phases]
	Stop/Clear Key	Pressing the Stop/Clear key can stop the current receiving operation. Received data is lost. [No Functional (Default)/ Functional]
	Off-Hook Detection	Sets the Off-Hook detection period. 200 msec (Default)/ 800 msec
TX Settings	Redial Interval	Sets the redial interval when Tx fails. [5 Min (Default)/ 6 Min]

Fax Maintenance		
	Redialings	Sets the number of redials when Tx fails. [2 times (Default)/ 3 Times/ 4 Times/ 5 Times]
Overseas Comm Mode	Overseas Comm Mode	This sets the machine to ignore a DIS signal sent from the called station once in a sending operation. [Off (Default)/ Ignore DIS Once]
	Minimum Time Length	If this setting is set to "On", the machine detects the CNG signal after the line is connected. If it is set to "Off", the machine detects the CNG signal as long as the line is connected. [100 Ms/ 200 Ms/ 300 Ms/ 400 Ms (Default)]
Dial Pulse Setting	Dial Pulse Type	This sets the number of pulses that are generated during dialing. <ul style="list-style-type: none"> ▪ N: Dialing '0' generates 10 pulses --- Dialing '9' generates 9 pulses. (Default) ▪ N+1: Dialing '0' generates 1 pulses --- Dialing '9' generates 10 pulses. ▪ 10-N: Dialing '0' generates 10 pulses --- Dialing '9' generates 1 pulse.
Tone Signal Settings	Tone Signal Transmission T	Sets the tone signal transmission time length [100 ms (Default)]
	Minimum Pause In Tone Dial	Sets the minimum pause during tone dialing [100 ms (Default)/ 150 ms/ 200 ms]
	Attenuator of Pseudo Ring	Sets the attenuator for pseudo ringback tone to the line [0 to 15 / 10 (Default)/ 1 dB/step]
	DTMF Level	Sets the transmission level of DTMF tones. [-12 dBu / -11 dBu/ -10 dBu/ -8 dBu (Default)/ -6 dBu]

Fax Maintenance		
	DTMF Delta	Sets the level difference between high band frequency signals and low band frequency signals when sending DTMF tones. [1 dBu/ 2 dBu (Default)/ 3 dBu]
1Dial Tone Detection	Wait Time	The machine starts dialing after the specified interval without detection of a dial tone when Dial tone detection is set to "No detection". [3.5 Sec (Default)/ 7.0 Sec/ 10.5 Sec / 14.0 Sec]
	Timeout Length	This setting sets the time-out length for the 1st dial tone detection. The machine waits for a dial tone for the specified time and disconnects itself from the line when no dial tone is input. [10 Sec (Default)/ 15 Sec/ 20 Sec/ 30 Sec]
BT (Busy Tone) Detection	BT Setting	DFU [Off/ On] BT: Busy tone
	BT Frequency	DFU [300-550 Hz/ 300-650 Hz/ 325-525 Hz/ 340-550 Hz/ 350-500 Hz/ 350-550 Hz/ 375-475 Hz/ 380-520 Hz]
	BT Level	DFU [-35 dB/ -36 dB/ -37 dB/ -38 dB/ -39 dB]
	BT Cadence	DFU [0.10/ 0.15/ 0.20/ 0.25/ 0.30/ 0.35/ 0.40/ 0.45/ 0.50/ 0.75]

Fax Maintenance		
Comm Settings	RTN Rate	The machine checks the actual data reconstruction errors and then transmits an RTN depending on the decoding error rate that is set by this setting (Number of lines containing an error per page / Total number of lines per page). [10% (Default)/ 15%]
	V34 Modem	DFU [Permitted (Default)/ Prohibited]
	V17 Modem	DFU [Permitted (Default)/ Prohibited]
V34 Settings	Equalizer	These selectors set the equalizer's training level to be applied if training fails due to poor line connection. [Automatic (Default)/ 4 Points/ 16 Points]
	Redialing	Resend when a communication error occurs. [Disabled (Default)/ Not Disabled]
	First TX Speed	Sets the first transmission speed choice, before fallback. [31200 Bps/ 33600 Bps (Default)]
	Symbol Rate	This setting limits the transmission speed range in V.34 mode by masking the desired symbol rate(s). [Not Used (Default)/ 3429 Sym/Sec / 3200 Sym/Sec/ 3000 Sym/Sec / 2800 Sym/Sec/ 2400 Sym/Sec]
All Document Transfer	<p>Transfers all documents in fax memory to other fax machine. Emergency use only.</p> <p>Inputs forwarding fax number.</p> <p>Max. 40 digits (includes #, *, pulse)</p> <p>To start transferring all documents, press "Start" key.</p> <p>To cancel all documents transferring and back to Fax Maintenance menu, press "Clear/Stop" key.</p>	

Factory Default		
Factory Default	Return	Does not execute anything. Returns to an upper level.
	Execute	<p>Resets all the settings to factory default.</p> <p> Note</p> <ul style="list-style-type: none"> Clears/ resets the contents of the controller memory (all data programmed by the user, log data application counters) to factory default. <p>After executing, initial setup menu starts after power-on.</p>

CTL Maintenance	
PDL Mode	<p>ON = "PDL Settings" is shown (Default)</p> <p>OFF = "PDL Settings" is hidden</p>
FW Update Mode	<p>If updating the machine that the LDAP authentication is set, execute this mode.</p> <p>[Execute/ Return]</p> <p>After pressing "Execute", the display shows "Please Restart Machine..." Turn the machine's main power off, and then on. Then the machine activates as a special boot loader mode. After that update the firmware via USB cable.</p>

5.1.3 FAX SERVICE TEST MENU

Entering the Fax Service Test Menu

Turn on the machine while pressing the "Fax" key.

Selecting an Item

To select the item, press the "Up" or "Down" key.

Going into the Next Level/ Returning to the Previous Level

- To go into the next level of an item, select an item then press the "OK" key.
- To return to the previous level of an item, press the "Escape" key.

Exiting the Maintenance Mode Menu

To exit the maintenance mode menu, press the "Clear/Stop" or "Escape" key until the "Ready" display appears.

Menu List

Fax Test		
Off-Hook Test	On Hook	Executes the on hook test.
	Off Hook	Executes the off hook test
CED Test		Executes the CED test.
CNG Test	1100 Hz	Executes the CNG test
ANSam Test		Executes the ANSam test.
Ring Tone Test		Executes the ring tone test.
DTMF Test	Tone [0] to [9]	Executes the DTMF tone 0 to 9 test.
	Tone [*]	Executes the DTMF tone * test.
	Tone [#]	Executes the DTMF tone # test.
	Tone Stop	Executes the Stop DTMF tone test.
Modem Test	[V34] 33600 Bps	Generates the [V34] 33600 bps signal.
	[V34] 28800 Bps	Generates the [V34] 28800 bps signal.

Fax Test		
	[V17] 14400 Bps	Generates the [V17] 14400 bps signal.
	[V17] 12000 Bps	Generates the [V17] 12000 bps signal.
	[V17] 9600 Bps	Generates the [V17] 9600 bps signal.
	[V17] 7200 Bps	Generates the [V17] 7200 bps signal.
	[V29] 9600 Bps	Generates the [V29] 9600 bps signal.
	[V29] 7200 Bps	Generates the [V29] 7200 bps signal.
	[V27] 4800 Bps	Generates the [V27] 4800 bps signal.
	[V27] 2400 Bps	Generates the [V27] 2400 bps signal.
	[V21] 300 Bps	Generates the [V21] 300 bps signal.
	Signal Stop	Generates the Stop signal.

5.2 REPORTS

5.2.1 CONFIGURATION PAGE

The configuration page has information about the machine's status. Print this sheet as shown below. Check the configuration page when doing machine maintenance.

To Print the Configuration Page

1. Press the "User Tools" key.

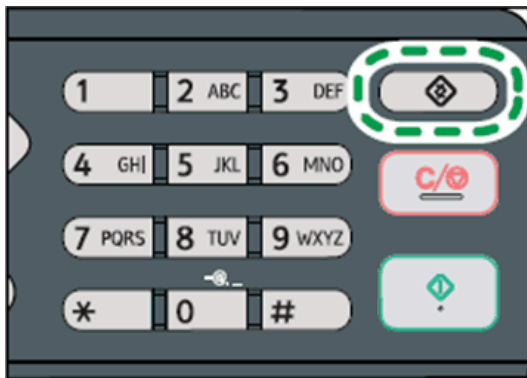

2. Press the "Up" or "Down" key to select "Print List/Report", and then press the "OK" key.
 3. Press the "Up" or "Down" key to select "Configuration Page", and then press the "OK" key.
 4. Press the left key "Yes" of the "Selection keys".
- Configuration page example

Configuration Page 1/3		RICOH SP 311SFNw	
System Reference		Supplies Status	
Model Name	:RICOH SP 311SFNw	Print Cartridge	■■■■
Machine ID	:JM157270013	Fusing Unit	■■■■
Total Memory	:128MB	Paper Feed Roller	■■■■
Bootloader Version	:V0.20	Transfer Roller	■■■■
Firmware Version	:v0.68		
Engine FW Version	:0.21		
Paper Input		System Settings	
- - - Tray 1		Adjust Sound Volume	
Paper Size	:A4	Panel Key Sound	:1
Paper Type	:Plain Paper	On Hook Mode	:2
- - - Bypass Tray		Job End Tone	:2
Paper Size	:A4	Job Error Tone	:2
Paper Type	:Plain Paper	Alarm Volume	:2
Tray Priority		Print Registration	
Tray Prio.: Printer	:Tray 1	Horizontal: Tray 1	:0
Tray Prio.: Copier	:Tray 1	Vertical: Tray 1	:0
Bypass Tray Priority	:Machine Settings(s)	Horiz.: Bypass Tray	:0
Size Mismatch Detect.	:Off	Vert.: Bypass Tray	:0
		Horiz.: Duplex: Back	:0
		Vert.: Duplex: Back	:0
Counter		I/O Timeout	
- - - Total Counter		Fixed USB Port	:Off
Page Total	:23	USB	:On 60 sec.
- - - Printer		Network	:On 60 sec.
Print Page Total	:13	Auto Continue	:Off
- - - Scanner		Toner Savins	:Off
Page Total	:0	Low Humidity Mode	:Off
Color	:0		
Black	:0	Admin Tools	
- - - Facsimile		Set Date/Time	
Page Total	:0	Set Date	:Day/Month/Year
Fax TX Page Total	:0	Set Time	:24-hour Format
Fax RX Page Total	:0	Program Fax Info	
- - - Copier		Number	:1
Page Total	:2	Name	:1
- - - Duplex		Dial/Push Phone	:Push Phone
Duplex Page Total	:0	PSTN/PBX	:PSTN
		PBX Access Number	:9
		Function Priority	:Copier
		Auto Reset Timer	:On 1 min.
		Energy Saver Mode	
		Energy Saver Mode1	:Off
		Energy Saver Mode2	:On 1 min.
		Language	:English
		Country	:UK
		Shortcut to Function	:ID Card Copy Mode

m1562081

Total Counter

Total Counter:

The total counter incremented by the "main board" each time the board issues a print command to the engine.

The value is calculated as follows:

Total counter = Copier counter + Printer counter + FAX counter + Reports print

Application Counters:

Application counters exist for each individual primary machine function (Copier, Printer, FAX, etc.), and are incremented by the "main board" each time the board issues a print request for the function in question.



- The application counters is 0 If you select "Factory Default" in the maintenance mode.

5.2.2 OTHER TYPES OF REPORTS

You can also check other reports than reports of configuration page with "Print List/Report" in the "User Tools".

- Fax Journal
Prints a fax transmission and reception journal for the last 50 jobs.
- TX Standby File List
Prints a list of fax jobs remaining in the machine's memory to be printed, sent, or forwarded.
- Quick Dial Dest. List
Prints a list of scan and fax Quick Dial entries.
- Fax Speed Dial Dest. List
Prints a list of Speed Dial entries.
 - Sort by Speed Dial No.
Prints the list with the entries sorted by Speed Dial registration number.
 - Sort by Name
Prints the list with the entries sorted by name.
- Scanner Dest. List
Prints a list of scan destinations.
- Scanner Journal
Prints a scanner journal for the last 100 Scan to E-mail, Scan to FTP, and Scan to Folder transmissions.
- Maintenance Page
Prints the maintenance status.

5.2.3 TEST PAGE

When you check an image problem or other problems, it might be necessary to print a test page. Follow the test page print procedure below to print a test page.

To Print the Test Page

1. Press the "User Tools".
 2. Press the "Up" or "Down" keys to select "Printer Features" and then press the "OK" key.
 3. Press the "Up" or "Down" keys to select "List/Test Print" and then press the "OK" key.
 4. Press the "Up" or "Down" keys to select "Test Page" and then press the "OK" key.
 5. Press the left key "Yes" of the "Selection keys" to print the test page to preview the settings.
- Test page sample

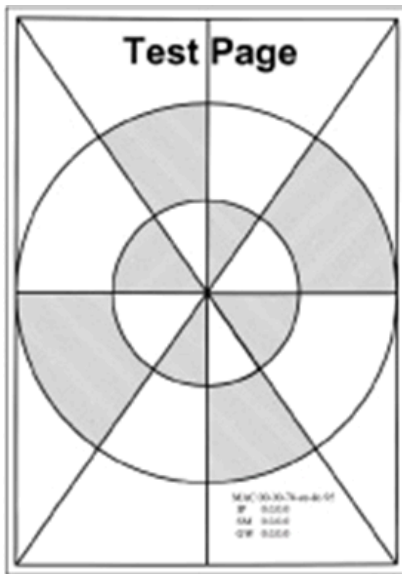

m118t100

5.2.4 TEST PATTERN PRINTING

Follow the test pattern print procedure below to print a test pattern.

To Print the Test Pattern

1. Enter the "Maintenance Mode".
2. Select "Engine Maintenance", and then press the "OK" key.
3. Select "Test Pattern", and then press the "OK" key.
4. The following three test pattern pages (Checker flag/ Grid pattern/ Trimming pattern) are printed.
 - Test pattern samples

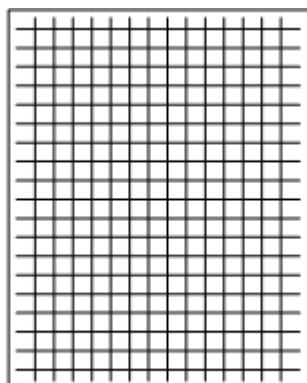
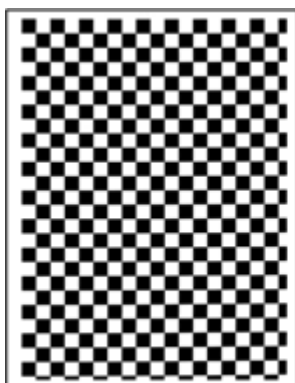

m016t502

5.3 UPDATING THE FIRMWARE



- Never turn the machine's main power off while the firmware is being updated, as this could damage the main board.

5.3.1 CHECKING THE MACHINE FIRMWARE VERSION

To update the firmware for this machine, you need the most recent version of the firmware (firmware file downloadable from the Internet).

1. Turn on the machine.
2. Press the "User Tools" key.
3. Press the "Up" or "Down" key to select "Print List/Report", and then press the "OK" key.
4. Press the "Up" or "Down" key to select "Configuration Page" or "Maintenance Page", and then press the "OK" key.
5. Check the "Firmware Version" on the list of the pages.

5.3.2 UPDATING THE MAIN FIRMWARE

Using the following procedure to update the main firmware, be sure to print the configuration page both before and after the update. Comparing pre- and post-update configuration pages allows you to check whether or not the update was successful.

Follow the procedure carefully, and note that it will vary in parts depending on which version of the firmware is currently installed.

Procedure

When updating firmware, always disconnect any other cable(s) than the one being used for the update operation.

(When updating firmware via USB cable, first disconnect any network and phone line cables, and when updating firmware via LAN cable, first disconnect any USB and phone line cables.)

1. Prepare:
 - Computer: Windows XP/Vista/7/8, Windows Server 2003/2003 R2, 2008/2008 R2, 2012
 - USB cable or LAN (Local Area Network) cable
2. Download the firmware files to your computer.
 - FwUpdateTool.exe (User Mode execute file)
 - Setting.ini (Parameter setting)
 - xxx.brn (Main Firmware)
3. Make a folder on a local drive of your computer and save the files there.
4. Connect a computer and the machine through a network or directly by USB.
5. Click the "FWUpdateTool.exe" file to execute the updating program.

6. Check the information, and then click [OK].
7. For a USB connection, click "F/W Update (USB)" [A]. For a network connection, enter the machine's IP address in "Machine IP" [B], and then click "F/W Update (NET)" [C].

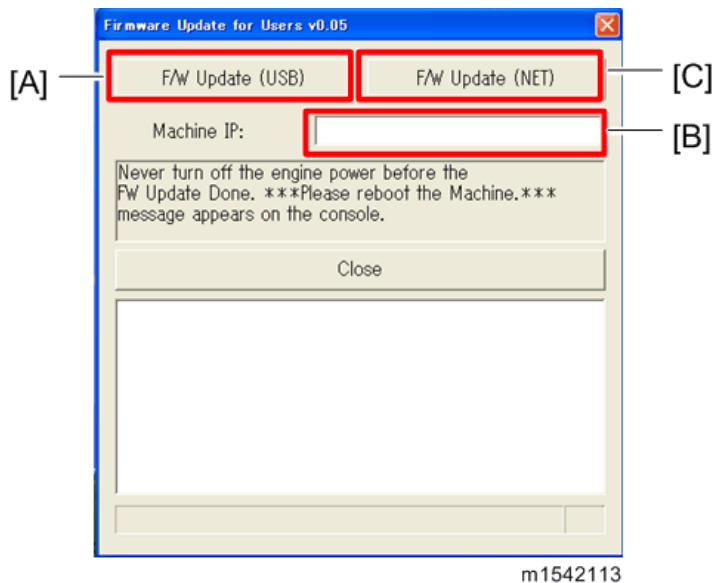

8. Check the firmware update tool window for messages and the update's current percentage of completion.

CAUTION

- Do not turn off the main power from this point until the update procedure is completed.
9. Wait until "FW Update Done.***Please reboot the Machine.***" appears in the firmware update tool window. Also check that the update completion message appears on the machine's control panel.
 10. Turn off the power of the machine, and then turn it back on.
 11. Print a configuration or maintenance page to check the machine's firmware version.

5.3.3 UPDATING THE BOOT LOADER FIRMWARE

This is also listed on the configuration page, but this firmware is not updated in the field.

5.3.4 UPDATING FAILURE

If the firmware update is not successful, the update process is suspended and an error message should appear on the FW Update Tool screen. If this happens, DO NOT turn off the machine; you must execute the update procedure again (unless the error message "Downloaded file is broken! Do NOT use print, scan, fax and copy function at the same time." is displayed).

If power is turned off accidentally during a firmware update, the firmware will not be correctly updated, and the machine may not start up normally. If the machine does not start up normally, the main firmware will need to be updated again.

When the machine does not start up normally, in most cases, the panel display will indicate one of the following two conditions:

- When attempting to restart the machine, the LCD panel display indicates "Initializing" indefinitely.

In this case, the main firmware update has failed. The main firmware must be updated again.

5.3.5 FW UPDATE TOOL MESSAGES

FW Update Tool Messages: Information

Message for USB update

Messages	Comment	Action
USB Upload : End of data	Sent FW file to MFP successfully. (Transmission Time: <30 sec)	Please reboot MFP after panel shows reboot message.
USB Upload : FAIL	Cannot open USB printer driver while FW file is transmitted.	Check USB cable connection. Check whether the USB Print Driver is available. Check whether the MFP is available.
	FW file transmission cannot be completed. (Transmission will be canceled if timeout.)	Check USB cable connection. Check whether the USB Print Driver is available. Check whether the MFP is available.

Messages	Comment	Action
Can't open ROM file. Please check ROM file.	F/W file does not exist.	Check the download file name in setting.ini. "ImageFile="
		Check that the download file and f/w update tool are in the same folder.
New Version: Update FW	Main FW is transmitting	Nothing to do; please wait
Firmware is Updating...	Main FW is updating	Nothing to do; please wait
FW Update Done. *** Please reboot the Machine.***	F/W update is completed.	Please reboot the machine.

Message for Network update

Messages	Comment	Action
Connecting...	Connect to MFP.	Please wait a moment.
Net Upload : End of data	Update F/W successfully. (Transmission Time: <30 sec)	Please reboot MFP after panel shows reboot message.
Net Upload : FAIL	Cannot open FTP port of MFP before F/W file is transmitted. (Transmission will be canceled if timeout.)	(1) Check network cable connection. (2) Check whether the MFP is available. (3) Check MFP and PC IP address setting. (4) Check PC firewall setting about FTP.
	F/W file transmission cannot be completed. (Transmission will be canceled if timeout.)	(1) Check network cable connection. (2) Check whether the MFP is available.

Updating the Firmware

Messages	Comment	Action
Can't open ROM file. Please check ROM file.	F/W file does not exist.	Check the download file name in setting.ini. "ImageFile="
		Check that the download file and f/w update tool are in the same folder.
New Version: Update FW	Main FW is transmitting	Nothing to do; please wait
Firmware is Updating...	Main FW is updating	Nothing to do; please wait
FW Update Done. *** Please reboot the Machine.***	F/W update is completed.	Please reboot the machine.

FW Update Tool Messages: Error

Message for USB update

Messages	Comment	Action
Machine is not ready.	Cannot get MFP status form USB status channel before F/W file is transmitted.	Check USB cable connection. Check whether the USB Print Driver is available. Do not update F/W when MFP is still powering up.
Wrong Model.	F/W file is not matched for current machine.	Please check the version of the F/W file and whether it is suitable for the MFP.
Machine is busy.	F/W update is running. Other MFP functions are running.	Please wait until F/W update is completed. Please wait until other MFP functions are completed.

Messages	Comment	Action
FW Update Done. *** Please reboot the Machine.***	F/W update is completed.	Please reboot the machine.
Machine loses communication. ***Please check FW Update Done. Then reboot the Machine.***	F/W file has transmitted. Polling F/W update progress fail.	Do not reboot engine until Engine Panel display "Firmware Update Done. Please reboot". Then reboot the engine.
Downloaded file is broken! Do NOT use print, scan, fax and copy function at the same time.	F/W checks the downloaded file. And get wrong checksum. So stop modifying F/W.	Check the downloaded file is not broken. Do not use MFP functions when updating firmware.

Message for Network update

Messages	Comment	Action
Machine is not ready.	Cannot get MFP status form Network status channel before F/W file is transmitted.	Check PC network settings and IP address. Check MFP network settings and IP address. Do not update F/W when MFP is still powering up.
Wrong Model.	F/W file is not matched for current machine.	Please check the version of the F/W file and whether it is suitable for the MFP.
Machine is busy.	F/W update is running. Other MFP functions are running.	Please wait until F/W update is completed. Please wait until other MFP functions are completed.
FW Update Done. *** Please reboot the Machine.***	F/W update is completed.	Please reboot the machine.
Machine loses communication. ***Please check FW Update Done. Then reboot the Machine.***	F/W file has transmitted. Polling F/W update progress fail.	Do not reboot engine until Engine Panel display "Firmware Update Done. Please reboot". Then reboot the engine.
Downloaded file is broken! Do NOT use print, scan, fax and copy function at the same time.	F/W checks the downloaded file. And get wrong checksum. So stop modifying F/W.	Check the downloaded file is not broken. Do not use MFP functions when updating firmware.

TROUBLESHOOTING

REVISION HISTORY		
Page	Date	Added/Updated/New
		None

6. TROUBLESHOOTING

6.1 SELF-DIAGNOSTIC MODE

6.1.1 SELF-DIAGNOSTIC MODE AT POWER ON

As soon as the main machine is powered on, the controller waits for the initial settings of the copy engine to take effect and then starts an independent self-diagnostic test program.

The self-diagnostic test checks the CPU, memory and so on. An SC code is displayed if the self-diagnostic program detects any malfunction or abnormal condition. If it is an error with which the machine can start, the machine records it in the System Error Log.

6.2 SERVICE CALL

See "[Appendices](#)" for the "Error Messages".

6.2.1 SUMMARY

This machine issues an SC (Service Call) code if an error occurs with the machine. The error code can be seen on the operation panel.

Make sure that you understand the following points;

1. All SCs are logged.
2. At first, always turn the main switch off and on if an SC code is displayed.
3. First, disconnect then reconnect the connectors before replacing the PCBs (if the problem concerns electrical circuit boards).
4. First, check the mechanical load before replacing motors or sensors (if the problem concerns a locked motor).

Fusing related SCs

To prevent damage to the machine, the main machine cannot be operated until the fusing related SC has been reset by a service representative.

- Enter the "Engine Maintenance" in the "Maintenance mode".

Press "Execute" in "Fuser SC Reset" with engine maintenance mode, and then turn the main power switch off and on.

6.2.2 ENGINE SC

SC 2xx (Laser Optics Error)

202	Polygon motor on timeout error
	The polygon mirror motor does not reach the targeted operating speed within 10 sec. after turning.
203	Polygon motor off timeout error
	The polygon mirror motor does not leave the READY status within 20 sec. after the polygon mirror motor switched off.
204	Polygon motor lock signal error
	The signal remains HIGH for 200 ms (or 4times in 50msec polling) while the polygon mirror motor is rotating.

	<ul style="list-style-type: none"> ▪ Polygon motor/driver board harness loose or disconnected ▪ Polygon motor/driver board defective ▪ Laser optics unit defective <ol style="list-style-type: none"> 1. Turn the machine main power off/on. 2. Replace the interface harness of the laser optics unit. 3. Replace the laser optics unit.
220	Beam Synchronize error
	The laser synchronizing detection signal for LD is not output within 400msec after the LD unit has turned on.
	<ul style="list-style-type: none"> ▪ Disconnected cable from the laser synchronizing detection unit or defective connection ▪ Defective laser synchronizing detector ▪ Defective LD ▪ Defective Main board <ol style="list-style-type: none"> 1. Check the connectors. 2. Replace the laser optics unit. 3. Replace the Main board.
268	Laser Scanning Unit thermistor error
	At power on, the temperature sensor in the optics unit detected a temperature lower than -30°C for more than 4 sec. -or- It detected a temperature higher than 105°C for more than 1sec.
	<ul style="list-style-type: none"> ▪ Thermistor disconnected (causes extremely low temperature reading) ▪ Thermistor damaged and short circuited (causes extremely high temperature reading) <ol style="list-style-type: none"> 1. Turn the machine's main power off, and then on. 2. Replace the thermistor.

SC 4xx (Image Transfer and Transfer Error)

491	Bias leak
	An error signal is detected for 0.2 seconds when changing the development unit.
	<ul style="list-style-type: none"> ▪ Defective transfer roller ▪ Defective HVP pack <ol style="list-style-type: none"> 1. Turn the machine's main power off, and then on.

SC 5xx (Motor and Fusing Error)

500	Main motor error
	<p>The machine does not detect a main motor lock signal within 2sec after the main motor started to rotate.</p> <p>-or-</p> <p>The machine does not release a main motor lock signal within 2sec after the main motor switched off.</p> <p>-or-</p> <p>The machine detects a main motor lock signal every 100ms for seven times consecutively, after the main motor started to rotate stably.</p>
	<ul style="list-style-type: none"> ▪ Overload of ▪ Torque load overload ▪ Defective main motor ▪ Disconnect or defective motor harness <ol style="list-style-type: none"> 1. Turn the machine's main power off, and then on. 2. Check or replace the main motor if the torque load is normal. 3. Replace the motor harness.
530	Exhaust fan Error
	The FAN lock signal – High for 10 seconds, after the fan motor started to rotate.
	<ul style="list-style-type: none"> ▪ Disconnected or defective motor harness. <ol style="list-style-type: none"> 1. Turn the machine's main power off, and then on.
541	Fuser thermistor error

	<p>The thermistor output is less than 0°C for 5 seconds after the fusing lamp turns ON.</p> <ul style="list-style-type: none"> ▪ Disconnected or defective thermistor ▪ Disconnected or defective fusing lamp <ol style="list-style-type: none"> 1. Check the harness connection of the thermistor. 2. Replace the fusing unit. <p>★ Important</p> <ul style="list-style-type: none"> ▪ Execute "Fuser SC Reset" to recover the machine after completing the recovery procedure. Otherwise, the machine continues to issue this SC code and cannot be operated.
542	<p>Fuser reload error</p> <p>This SC is issued if one of following conditions occurs: The fusing temperature rises 8°C or less in 1.5 seconds; and this continues 5 times consecutively. -or- The fusing temperature has not reached 45°C within 9 seconds (after the fusing lamp comes ON while the machine is warming-up). -or- The fusing unit does not attain reload temperature within 35 s. (normal temperature) or 65 s (lower temperature – the thermistor output is less than 18°C) after the fusing temperature control starts.</p> <ul style="list-style-type: none"> ▪ Defective or deformed thermistor ▪ Incorrect power supply input at the main power socket <ol style="list-style-type: none"> 1. Defective fusing lamp
543	<p>High temperature error (Soft)</p> <ul style="list-style-type: none"> ▪ The detected temperature stays at 235°C for 1 second, and this consecutively occurs 10 times. <ul style="list-style-type: none"> ▪ Defective Main board ▪ Defective PSU <ol style="list-style-type: none"> 1. Replace the Main board 2. Replace the PSU <p>★ Important</p> <ul style="list-style-type: none"> ▪ Execute "Fuser SC Reset" to recover the machine after completing the recovery procedure. Otherwise, the machine continues to issue this SC code and cannot be operated.

544	High temperature error (hard)
	<ul style="list-style-type: none"> ▪ During stand-by mode or a print job, the detected heating roller temperature reaches 250°C.
	<ul style="list-style-type: none"> ▪ Defective Main board ▪ Defective PSU <ol style="list-style-type: none"> 1. Replace the Main board 2. Replace the PSU <p>★ Important</p> <ul style="list-style-type: none"> ▪ Execute "Fuser SC Reset" to recover the machine after completing the recovery procedure. Otherwise, the machine continues to issue this SC code and cannot be operated.
545	Fuser full heater error
	The fuser full heater remained ON at full capacity for more than 9 s after the fusing temperature attains reload temperature.
	<ul style="list-style-type: none"> ▪ Deformed thermistor ▪ Thermistor not in the correct position ▪ Defective fusing lamp <ol style="list-style-type: none"> 1. Replace the fusing unit. 2. Replace the fusing lamp. <p>★ Important</p> <ul style="list-style-type: none"> ▪ Execute "Fuser SC Reset" to recover the machine after completing the recovery procedure. Otherwise, the machine continues to issue this SC code and cannot be operated.
547	Zero cross error
	<ul style="list-style-type: none"> ▪ The zero cross signal is detected three times even though the fusing lamp relay is off when turning on the main power. ▪ The zero cross signal is not detected for 3 seconds even though the fusing lamp relay is on after turning on the main power or closing the front door. ▪ The detection error occurs twice or more in 11 zero cross signal detections. This error is defined when the detected zero cross signal is less than 45. ▪ The zero cross signal is not detected three times while the main power remains ON.

	<ul style="list-style-type: none"> ▪ Defective fusing relay ▪ Defective fusing relay circuit ▪ Shorted +24V fuse on the PSU ▪ Unstable power supply. <ol style="list-style-type: none"> 1. Check the power supply source. 2. Replace the +24V fuse on the PSU. 3. Replace the PSU
559	Fuser 3times jam error
	<p>The paper jam counter for the fusing unit reaches 3. The paper jam counter is cleared if the paper is fed correctly.</p> <p>This SC is activated only when this function is enabled with "Engine Maintenance" (default "OFF").</p>
	<ul style="list-style-type: none"> ▪ Defective fusing unit ▪ Defective fusing control <ol style="list-style-type: none"> 1. Clear this SC to send a command after a jam removal. 2. Turn off this function after a jam removal. <p>★ Important</p> <ul style="list-style-type: none"> ▪ Execute "Fuser SC Reset" to recover the machine after completing the recovery procedure. Otherwise, the machine continues to issue this SC code and cannot be operated.

SC 6xx (Communication and Other Error)

669	EEPROM communication error
	An unexpected value exists in the initialization flag of the EEPROM
	<ul style="list-style-type: none"> ▪ EEPROM not connected ▪ Defective EEPROM <ol style="list-style-type: none"> 1. Installing the EEPROM. 2. Replacing the EEPROM.

6.2.3 CONTROLLER SC

SC 8xx

	Scan lock error
820	By an unexpected reason, the controller error occurred.
	Turn the machine's main power off, and then on.

6.3 JAM DETECTION

6.3.1 JAM SENSOR LAYOUT

There are the sensors of the jam detection as shown below.

Paper Jam

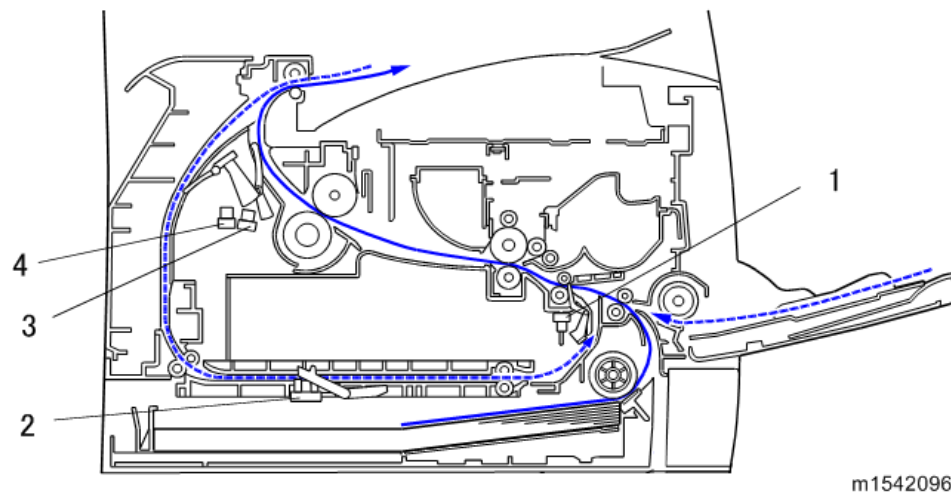

1. Registration Sensor
2. Inverter Sensor
3. Paper Exit Sensor
4. Relay Sensor

Original Jam (ADF)

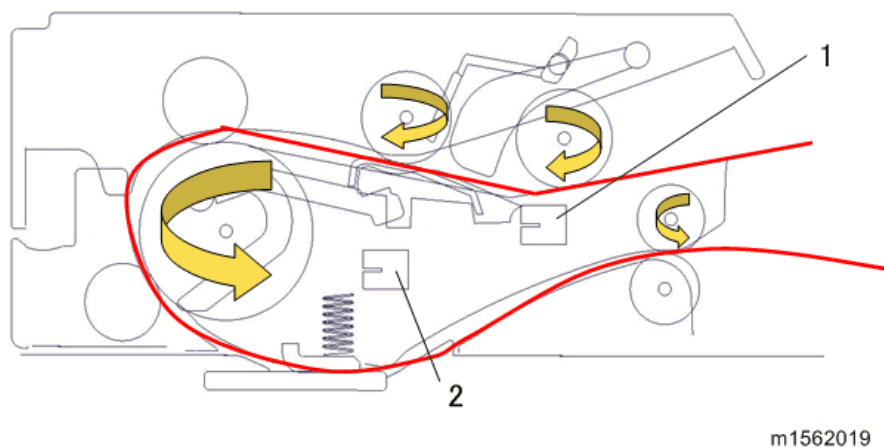

1. Document Sensor
2. ADF Feed Sensor

6.3.2 JAM MESSAGE LIST

Here is a list of common jam messages, a description of the causes.

See the drawing shown above to check the sensor location.

Paper Jam

Related to jam code

Jam message	Cause	Sensor
Misfeed: Paper Tray	Paper does not reach registration sensor (bypass tray)	Registration sensor [1]
Misfeed: Tray 1	Paper does not reach registration sensor (tray1)	Registration sensor [1]
Misfeed: Dup. Unit Remove Paper	Paper does not reach registration sensor (duplex feed tray)	Registration sensor [1]
	Paper does not reach duplex entry sensor	Relay sensor [5]
	Paper does not reach duplex exit sensor	Inverter sensor [3]
Internal Misfeed	Paper stayed on registration sensor	Registration sensor [1]
	Paper does not reach exit sensor	Paper exit sensor [4]
Misfeed: Stnd. Tray	Paper stayed on exit sensor	Paper exit sensor [4]

Related to jam at initialization

Jam message	Cause
Internal Misfeed	Registration sensor [1]
Misfeed: Stnd. Tray	Paper exit sensor [4]
Misfeed: Dup. Unit Remove Paper	Relay sensor [5]

	Inverter sensor [3]
--	---------------------

Original Jam

Jam message	Cause
ADF Original Misfeed	ADF Feed sensor [6], [8]

6.4 IMAGE QUALITY

6.4.1 OVERVIEW

Image problems may appear at regular intervals that depend on the circumference of certain components. The following diagram shows the possible symptoms (black or white dots at regular intervals).

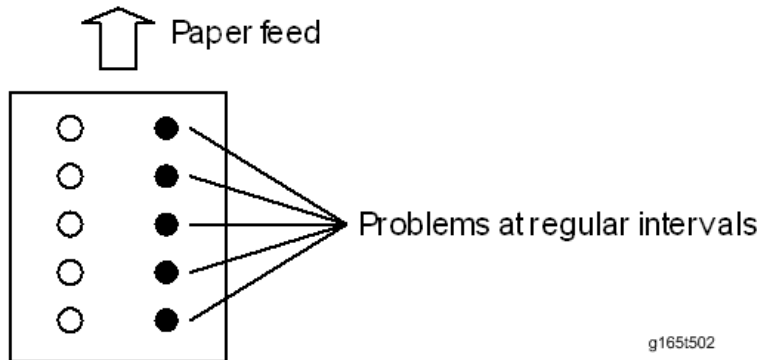

- Abnormal image at 29.8 mm intervals: Charge roller
- Abnormal image at 37.7 mm intervals: Registration roller
- Colored spots at 37.9 mm intervals: Print cartridge (Development roller)
- Abnormal image at 45.8 mm intervals: Transfer roller
- Colored spots at 75.3 mm intervals: Print cartridge (OPC drum)
- Abnormal image at 94.2 mm intervals: Fusing unit (Pressure roller)
- Abnormal image at 93.1 mm intervals: Fusing unit (Hot roller)
- Abnormal image at 100.5 mm intervals: Paper feed roller

6.5 OTHER PROBLEMS

6.5.1 DARK LINES IN HALFTONE AREAS AT 75MM INTERVALS

Using the machine in a room where the humidity is too low may cause dark lines in halftone areas at 75mm intervals. This is because low-humidity conditions tend to cause variations in light sensitivity across the surface of the drum.

Selecting [On] for [Low Humidity Mode] under [System Settings] (User Tools) may help to prevent these lines from appearing.

When the humidity mode setting is enabled, the drum is rotated slightly every 15 minutes. This keeps the light sensitivity constant across the entire surface of the drum.

6.6 TROUBLESHOOTING

6.6.1 JAM/PAPER FEED PROBLEM

problem	Cause/Solution
Paper does not feed smoothly.	<ul style="list-style-type: none"> ▪ Use supported types of paper. ▪ Load paper correctly, making sure that the paper guides are properly adjusted. ▪ If the paper is curled, straighten the paper. ▪ Take out the paper from tray and fan it well. Then, reverse the top and bottom of the paper, and put it back in the tray.
Paper jams occur frequently.	<ul style="list-style-type: none"> ▪ There remain pieces of paper in the paper path. ▪ Poor contact or disconnection of the sensor. ▪ There is some foreign body in the paper guides of the paper path. ▪ If there are gaps between the paper and the paper guides, adjust the paper guides to remove the gaps. ▪ Avoid printing on both sides of paper when printing images that contain large solid areas, which consume a lot of toner. ▪ Use supported types of paper. ▪ Load paper only as high as the upper limit markings on the paper guide. ▪ Make sure that the friction pads and paper feed rollers are clean. Clean the Friction Pad and Paper Feed Roller.

problem	Cause/Solution
Multiple sheets of paper are fed at one time.	<ul style="list-style-type: none"> ▪ Fan the paper well before loading. Also make sure that the edges are even by tapping the stack on a flat surface such as a desk. ▪ Make sure that the paper guides are in the right position. ▪ Use supported types of paper. ▪ Load paper only as high as the upper limit markings on the paper guide. ▪ Make sure that the friction pads and paper feed rollers are clean. ▪ Check that paper was not added while there was still some left in the tray. Only add paper when there is none left in the tray.
Paper gets wrinkles.	<ul style="list-style-type: none"> ▪ Deterioration of the hot roller or the pressure roller. ▪ Paper is damp. Use paper that has been stored properly. ▪ Paper is too thin. ▪ If there are gaps between the paper and the paper guides, adjust the paper guides to remove the gaps.
The printed paper is curled.	<ul style="list-style-type: none"> ▪ Load the paper upside down in the paper tray. ▪ If the paper curl is severe, take prints from the output tray more frequently. ▪ Paper is damp. Use paper that has been stored properly. ▪ Adjust with “Curl Control mode” in the Maintenance Mode.
Images are printed diagonally to the pages.	If there are gaps between the paper and the paper guides, adjust the paper guides to remove the gaps.
Printed envelopes come out creased.	Check if the levers for printing on envelopes inside the rear cover are properly set. Lower the levers.

6.6.2 IMAGE QUALITY PROBLEM

problem	Cause/Solution
Blurred or too light	<ul style="list-style-type: none"> ▪ The polygon mirror of the laser unit is dirty. ▪ Adjust the image density. ▪ Paper is damp. Use paper that has been stored properly. ▪ If you enable [Toner Saving], printing is generally less dense. User Tools > System Settings > Toner Saving: Off Printer Driver > Print Quality > Toner Saving: Off ▪ Toner is almost depleted. Replace the print cartridge. ▪ Condensation may have collected. If rapid change in temperature or humidity occurs, use this machine only after it has acclimatized.
Dirty or too dark	<ul style="list-style-type: none"> ▪ Image density is too high. Adjust the image density. ▪ Toner on the printed surface is not dry. Do not touch printed surfaces immediately after copying. Remove freshly printed sheets one by one, taking care not to touch printed areas. ▪ The exposure glass or ADF is dirty.
Dirty background	<ul style="list-style-type: none"> ▪ Replace the print cartridge. ▪ Adjust with "Charge Bias" in the Maintenance Mode.
Vertical black lines	<ul style="list-style-type: none"> ▪ The stripper pawls of the fusing Unit are dirty. ▪ The exposure glass or ADF is dirty. ▪ Replace the print cartridge.
Vertical White lines	<ul style="list-style-type: none"> ▪ The exposure glass or ADF is dirty. ▪ Toner is almost depleted. Replace the print cartridge.
Horizontal black lines	<p>Humidity level surrounding the machine may be too low. Refer to "Dark lines in halftone areas at 75mm Intervals".</p>
A moire pattern is produced.	<p>The original probably has heavily lined or dotted areas. Switching the setting for image quality between [Photo] and [Mixed] may eliminate the moire pattern.</p>

problem	Cause/Solution
Insufficient fusing	Check if the levers for printing on envelopes inside the rear cover are properly set. Pull up the levers.

6.6.3 FAX PROBLEM

problem	Cause/Solution
Cannot send faxes.	<ul style="list-style-type: none"> ▪ See the solutions provided for errors 1XXX32 to 1XXX84 in the below table. ▪ The machine cannot accept a new fax job because there are 5 unsent faxes in memory already. Wait until any of those faxes is transmitted completely, or use the [Delete TX Standby File] function to delete unnecessary faxes. User Tools > Fax Features > Delete TX Standby File <div style="border: 1px solid blue; padding: 2px; display: inline-block; margin: 5px 0;"> ↓ Note </div> <ul style="list-style-type: none"> ▪ Maximum jobs in memory: 5jobs
Cannot receive faxes.	See the solutions provided for errors 2XXX32 to 2XXX84 in the below table.
Cannot receive faxes even when sending them is possible.	<ul style="list-style-type: none"> ▪ A print cartridge is empty. Replace the print cartridge. ▪ The paper tray is empty. Load paper in the paper tray. ▪ If fax reception mode is FAX/TEL Manual mode, you must receive the fax manually.
Cannot print received faxes.	<ul style="list-style-type: none"> ▪ The paper tray is empty. Load paper in the paper tray. ▪ The paper tray does not contain paper of the right size. Load paper of the right size in the paper tray.
Dial fails when trying to send faxes.	See the solutions provided for errors 1XXX22 to 1XXX23 in the below table.

FAX error code

When an error code appears on the fax journal or transmission status report, see the below table.

*X indicates a number in an error code that appear differently depending on a specific situation.

FAX error code	Cause/Solution
1XXX11	<p>An original has been jammed inside the ADF while sending a fax in Immediate Transmission mode.</p> <ul style="list-style-type: none"> ▪ Remove jammed originals, and then place them again. ▪ Check the originals are suitable for scanning.
1XXX21	<p>The line could not be connected correctly.</p> <ul style="list-style-type: none"> ▪ Confirm that the telephone line is properly connected to the machine. ▪ Disconnect the telephone line from the machine, and connect a standard telephone in its place. Confirm that you can make calls using the telephone. If you cannot make calls this way, contact your telephone company.
1XXX22 to 1XXX23	<p>Dial fails when trying to send faxes.</p> <ul style="list-style-type: none"> ▪ Confirm that the fax number you dialed is correct. ▪ Confirm that the destination is a fax machine. ▪ Confirm that the line is not busy. ▪ You may need to insert a pause between dial digits. Press the [Pause/Redial] key after, for example, the area code. ▪ Confirm that [PSTN / PBX] under [Admin. Tools] is set properly for your connection method to the telephone network.
1XXX32 to 1XXX84	<p>An error occurred while receiving a fax.</p> <ul style="list-style-type: none"> ▪ Confirm that the telephone line is properly connected to the machine. ▪ Disconnect the telephone line from the machine, and connect a standard telephone in its place. Confirm that you can make calls using the telephone. If you cannot make calls this way, contact your telephone company.

FAX error code	Cause/Solution
2XXX14	<p>The machine was not able to print the received fax, or the machine's memory reached capacity while receiving a fax because the document was too large.</p> <ul style="list-style-type: none"> ▪ The paper tray was empty. Load paper in the paper tray. ▪ The paper tray did not contain A4, Letter, or Legal size paper. Load valid size paper in the tray, and configure the paper size settings under [System Settings] accordingly. ▪ A cover or tray was open. Close the cover or tray. ▪ There was a paper jam. Remove the jammed paper. ▪ A print cartridge was empty. Replace the print cartridge. ▪ The received fax was too large. Ask the sender to re-send the document in parts as several smaller individual faxes, or to send at a lower resolution.

6.6.4 OTHER PROBLEM

problem	Cause/Solution
The volume of the sounds produced by the machine is too loud or too quiet.	<p>Adjust the volume of the beep, ring, speaker, and alarm sounds.</p> <p>User Tools > System Settings > Adjust Sound Volume</p>

ENERGY SAVE

REVISION HISTORY		
Page	Date	Added/Updated/New
		None

7. ENERGY SAVE

7.1 ENERGY SAVE

7.1.1 ENERGY SAVER MODES

Customers should use energy saver modes properly, to save energy and protect the environment.

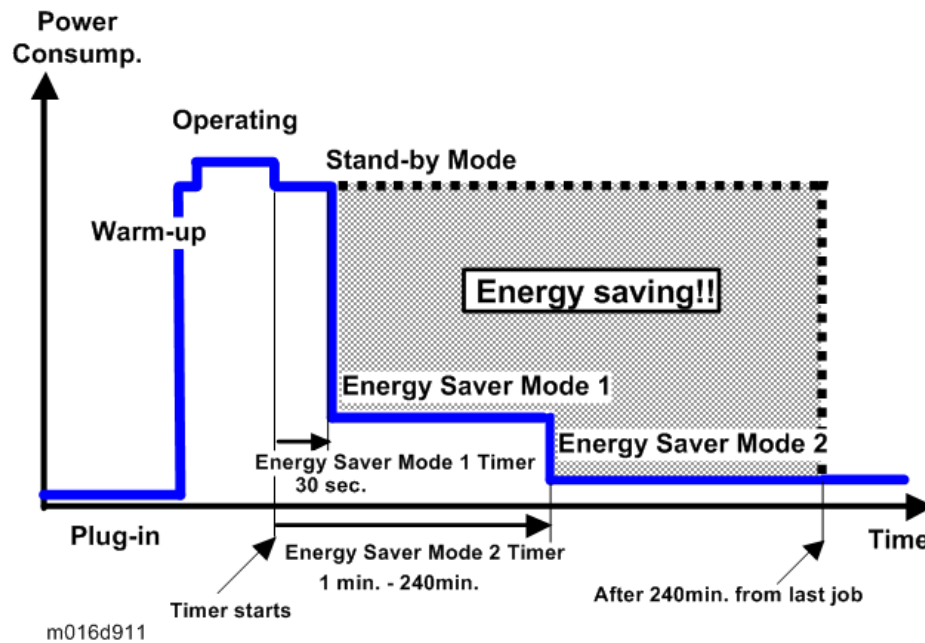

The backlight of the screen is turned off and "Energy Saver Mode1" appears on the screen, and then the fusing lamp is turned off and "Energy Saver Mode2" appears on the screen.

The area shaded grey in this diagram represents the amount of energy that is saved when the timers are at the default settings. If the timers are changed, then the energy saved will be different. For example, if the timers are all set to 240 min., the grey area will disappear, and no energy is saved before 240 min. expires.

Timer Settings

The user can set these timers with User Tools (Admin. Tools > Energy Saver Mode> EnergySaver Mode1 or Mode2)

- Energy Saver Mode 1 (30 sec.): This can be only turned on or off.
- Energy Saver Mode 2 (1 to 240 min.): This can be turned on or off and timer setting is adjustable (default: 1min.).

Return to Stand-by Mode

Energy Saver Mode 1

- Recovery time: 10 sec.

Energy Saver Mode 2

- Recovery time: 20 sec.

Recommendation

We recommend that the default settings should be kept.

- If the customer requests that these settings should be changed, please explain that their energy costs could increase, and that they should consider the effects on the environment of extra energy use.
- If it is necessary to change the settings, please try to make sure that the Energy Saver Mode 2 Timer is not too long. Try with a shorter setting first, such as 30 min., then go to a longer one (such as 60 min.) if the customer is not satisfied.
- If the timers are all set to the maximum value, the machine will not begin saving energy until 240 minutes has expired after the last job. This means that after the customer has finished using the machine for the day, energy will be consumed that could otherwise be saved.

7.2 PAPER SAVE

7.2.1 EFFECTIVENESS OF DUPLEX/COMBINE FUNCTION

Duplexing and the combine functions reduce the amount of paper used. This means that less energy overall is used for paper production, which improves the environment.

1. Duplex:

Reduce paper volume in half!



d062d102

2. Combine mode:

Reduce paper volume in half!



d062d100

3. Duplex + Combine:

Using both features together can further reduce paper volume by 3/4!



d062d101

To check the paper consumption, look at the total counter and the duplex counter.

The total counter counts all pages printed.

- For one duplex page, the total counter goes up by 2.
- For a duplex job of a three-page original, the total counter goes up by 3.

The duplex counter counts pages that have images on both sides.

- For one duplex page, the duplex counter goes up by 1.
- For a duplex job of a three-page original, the duplex counter will only increase by 1, even though two sheets are used.

Total counter

This machine has a total sides printed counter only (so a duplex print is counted as two, not one).

You can check the total counter in the "Maintenance mode" or the "User Tools".

- Maintenance mode
"Engine Maintenance" > "Total Counter Info"
- User Tools
"Print List/Report" > "Configuration Page" or "Maintenance Page"

The following table shows paper savings and how the counters increase for some simple examples of single-sided and duplex jobs

Duplex mode:

Originals	Simplex Sheet used	Duplex Sheets used	Paper Saved	Total counter
1	1	1	0	1
2	2	1	1	2
3	3	2	1	3
4	4	2	2	4
5	5	3	2	5
10	10	5	5	10
20	20	10	10	20

If combine mode is used, the total and duplex counters work in the same way as explained previously. The following table shows paper savings and how the counters increase for some simple examples of duplex/combine jobs.

2 in 1 mode:

Originals	Simplex Sheet used	Duplex Sheets used	Paper Saved	Total counter
1	1	1	0	1
2	2	1	1	1
3	3	2	1	2
4	4	2	2	2
5	5	3	2	3
10	10	5	5	5
20	20	10	10	10

Paper Save

Duplex + 2 in 1 mode:

Originals	Simplex Sheet used	Duplex Sheets used	Paper Saved	Total counter
1	1	1	0	1
2	2	1	1	1
3	3	1	2	2
4	4	1	3	2
5	5	2	3	3
6	6	2	4	3
7	7	2	5	4
8	8	2	6	4
9	9	3	6	5
10	10	3	7	5
11	11	3	8	6
12	12	3	9	6

M156/M157/M176/M177
SERVICE MANUAL APPENDICES

M156/M157/M176/M177 APPENDICES

TABLE OF CONTENTS

1. APPENDICES: SPECIFICATIONS.....	1-1
1.1 GENERAL SPECIFICATIONS.....	1-1
1.1.1 GENERAL SPECIFICATIONS.....	1-1
1.1.2 PRINTER.....	1-3
1.1.3 COPIER.....	1-3
1.1.4 SCANNER.....	1-4
1.1.5 FAX.....	1-5
Fax transmission and reception.....	1-5
1.2 SUPPORTED PAPER SIZES.....	1-7
2. ERROR MESSAGES.....	2-1
2.1 OVERVIEW.....	2-1
2.1.1 ERROR MESSAGES LIST.....	2-1
2.1.2 FAX ERROR CODE.....	2-9
Fax Error Code Structure.....	2-9
Fax Error Code Table.....	2-11
Internet Fax Error Code Table.....	2-13

APPENDIX: SPECIFICATIONS

REVISION HISTORY		
Page	Date	Added/Updated/New
		None

1. APPENDICES: SPECIFICATIONS

1.1 GENERAL SPECIFICATIONS

1.1.1 GENERAL SPECIFICATIONS

Configuration	Desktop	
Paper capacity	Main tray	250 sheets (80g/m ² , 20lb)
	By-pass tray	50 sheets (80g/m ² , 20lb)
	Output tray	Up to 50 sheets (A4/LT or 80 g/m ² , 20lb)
Paper size	Main tray	A4,B5 JIS,A5,B6 JIS,A6,Legal,Letter, HLT,Exective,F,Foolscap,Folio,16K Custom size: Min. 90 x 148 mm (3.6" x 5.8") Max. 216 x 356 mm (8.5" x 14")
	By-pass tray	A4,B5,A5,B6,A6,Legal,Letter,HLT,Exective,16K Envelope: #10,Monarc,C5,C6,DL Custom size: Min. 90 x 148 mm (3.6" x 5.8") Max. 216 x 356 mm (8.5" x 14")
	Duplex	A4, Letter, Legal
Paper weight	Main tray	52-162 g/m ² (14-43 lb)
	By-pass tray	52-162 g/m ² (14-43 lb)
ADF	Paper weight	52-105 g/m ² (14-28 lb)
	Capacity	35 sheets (80g/m ² , 20lb)
	Width	139.7 to 216mm (5.5 to 8.5 inch)
	Length	139.7 to 356mm (5.5 to 14 inch)
Machine size (W x D x H)	370 x 392 x 405mm (14.6 x 15.4 x 15.9 inches)	

General Specifications

Weight (Machine body with consumables)	Approximately 16.5 Kg (36.4lb)	
Energy Saver Mode	Selectable 1 to 240 minutes (1 minute steps)	
Power consumption	Maximum	US: Less than 800 W EU/AP: Less than 890 W CH: Less than 850 W
	Ready mode	120W
	Power save mode	US/EU/AP: <ul style="list-style-type: none"> ▪ 50 W or less (Energy Saver Mode 1) ▪ 5.0 W or less (Energy Saver Mode 2) CH: <ul style="list-style-type: none"> ▪ 70 W or less (Energy Saver Mode 1) ▪ 10 W or less (Energy Saver Mode 2)
Power	US	120V, 7A, 60Hz
	EU/AP	220 - 240 V, 4A, 50/60Hz
	CH	220 - 240 V, 5A, 50/60Hz
Noise	Printing	Less than 65.8 dB (A)
	Standby Mode	40 dB (A)
	Energy Save Mode	40 dB (A)
Warm-up time	30 seconds or less (23°C, 71.6°F)	
Machine life	5 years, 200,000 prints (whichever comes first)	
Environmental Standard	EnergyStar Tier 2 specifications	
Laser type	Class I	

1.1.2 PRINTER

Print speed	US	30 ppm (Letter)
	EU/CH/AP	28 ppm (A4)
Printer language	PCL6C	
Font	80 fonts	
Resolution	600 x 600 dpi (Maximum: 1200 x 600 dpi)	
Toner save mode	Supported	
First print speed	12 seconds or less	
Duplex print	Supported	
PC interface	<ul style="list-style-type: none"> ▪ Ethernet (10 BASE-T, 100 BASE-TX) ▪ USB 2.0 ▪ Wi-Fi 	
Network	Protocol	TCP/IP, IPP
Memory	Standard	128MB
Operation System	Win XP/Vista/7/8, server 2003/server 2008/server 2012 (32bit/64bit)	

1.1.3 COPIER

1st copy speed		13 seconds or less (A4, at 23°C, 71.6°F)	
Maximum original size		Flatbed	A4 (216 x 297mm) (8.5 x 11.7 inches)
		ADF	A4 (216 x 356mm) (8.5 x 14 inches)
Copy Speed	Single Document	Flatbed	28 cpm (A4), 30 cpm (LT)
	Multiple Copy	ADF	28 cpm (A4), 30 cpm (LT)

General Specifications

	Multiple Document Single Copy	ADF	13cpm
Copy quantity			99
Resolution (H x V)	Scanning	600 x 600 dpi (Flatbed), 600 x 300 dpi (ADF)	
	Printing	600 x 600 dpi	
Grayscale			256 levels
Reduction / Enlargement	Fix	US: 50, 65, 78, 93, 129, 155, 200, 400% EU: 50, 71, 82, 93, 122, 141, 200, 400%	
	Zoom	Flatbed:25-400% (When the resolution is 600 x 600 dpi) 1% step ADF:25-400% (When the resolution is 600 x 300 dpi) 1% step	

1.1.4 SCANNER

Scanning Device		CIS
Resolution	CIS: 1200 dpi	
	Flatbed: 600 x 600 dpi ADF: 600 x 300 dpi	
Gray scale		256 levels
Scan modes/ speed (A4, 300dpi, USB2.0)		Flatbed Black&White: less than 5 sec. / Gray Scale: less than 5 sec. / Color: less than 10 sec ADF Black&White: less than 5 sec. / Gray Scale: less than 5 sec. / Color: less than 10 sec
Maximum original size	Platen	Width max: Up to 216mm, Length max: Up to 297mm
	ADF	Width max: Up to 216mm, Length max: Up to 356mm

Scan Depth	16bit color processing (input), 8bit color processing (output)
PC Interface	USB2.0, 10BASE-T/100BASE-TX
TWAIN Compliment	TWAIN
Scanner utilities and Drivers	TWAIN Driver

1.1.5 FAX

Fax transmission and reception

Network	PSTN/ PBX	
Compatibility	ITU-T G3	
Transmission Speed	3sec *8 dots per mm x 3.85 line per mm, 33.6 kbps, MMR, ITU-T #1 chart	
Coding system	MH/MR/MMR	
Contrast control	3 level Light/ Normal/ Dark (manual setting)	
Document size	ADF Width	139.7 to 215.9mm (5.5" to 8.5")
	ADF Length	139.7 to 355.6mm (5.5" to 14")
	Flatbed Width	216mm (8.5")
	Flatbed Length	297mm (11.7")
Scanning width	Max. 215.9 mm (8.5")	
Printing width	Max. 215.9 mm (8.5")	
Gray scale	256 levels	
Polling type	None	
Resolution	Standard: 200dpi x 100dpi (8 dot/mm x 3.85 line/mm) Fine/Photo: 200dpi x 200dpi (8 dot/mm x 7.7 line/mm)	
Scanning Speed	Less than 5 sec. (A4 SEF, 200dpi)	

General Specifications

Modem Speed	Automatic Fallback: 33600, 31200, 28800, 26400, 24000, 21600, 19200, 16800, 14400, 12000, 9600, 7200, 4800, 2400bps
SAF Memory	100 sheets or more (8 dots per mm x 3.85 line per mm)
Memory Backup	Yes (Flash Memory)
One-touch dial	8 locations
Abbreviated dial	200 locations
Broadcasting	100 stations
Communication source	Public switched telephone network
PC Fax utility	Yes (Only Transmission)
Automatic re-dial	5/4/3/2 times after 5 minutes (Default 5 times)
Auto Answer	3-5 rings (Default 3 rings)
LDAP authentication	No
LDAP address search	No

1.2 SUPPORTED PAPER SIZES

A	Supported and the size is molded in the tray. Need to select paper size by operation panel/driver.
B	Supported but size is not molded in the tray. Need to select paper size by operation panel/driver. *For bypass tray, paper width is indicated.
C	Need to input paper size by operation panel and driver.
N	Not supported.

Type	SEF/LEF	Size	Input Tray		Type		
			Standard Tray	Duplex			
Plain Paper	A4	SEF	210x297mm	A	B	Y	
		LEF	297x210mm	N	N	N	
	B5	SEF	182x257mm	A	B	N	
		LEF	257x182mm	N	N	N	
	A5	SEF	148x210mm	A	B	N	
		LEF	210x148mm	N	C	N	
	B6	SEF	128x182mm	B	B	N	
		LEF	182x128mm	N	N	N	
	A6	SEF	105x148mm	B	B	N	
		LEF	148x105mm	N	N	N	
	Plain Paper	DLT	SEF	11" x 17"	N	N	N
		Legal	SEF	8 1/2"x14"	A	B	Y
Letter		SEF	8 1/2"x11"	A	B	Y	
		LEF	11"x 8 1/2"	N	N	N	

Supported Paper Sizes

Type		SEF/LEF	Size	Input Tray		Type
				Standard Tray	Duplex	
	Half Letter	SEF	5 1/2" x 8 1/2"	B	B	N
	Executive	SEF	7 1/4"x10 1/2"	A	B	N
		LEF	10 1/2"x7 1/4"	N	N	N
Plain Paper	F	SEF	8" x 13"	B	N	N
	Foolscap	SEF	8 1/2" x 13"	B	N	N
	Folio	SEF	8 1/4" x 13"	B	N	N
	8 Kai	SEF	267 x 390mm	N	N	N
	16 Kai	SEF	195 x 267mm	B	B	N
		LEF	267 x 195mm	N	N	N
Envelope	Env. #10	SEF	4 1/8" x 9 1/2"	N	B	N
	Env. Monarch	SEF	3 7/8" x 7 1/2"	N	B	N
	Env. C6	SEF	114 x 162mm	N	B	N
	Env. C5	SEF	162 x 229mm	N	B	N
	Env. DL	SEF	110 x 220mm	N	B	N
Custom	Width	-	-	100-216mm (3.6"x 8.5")	90-216mm (3.5"x 8.5")	N
	Length	-	-	148 – 356mm (5.8"x 14.24")	140-356mm (5.5"x 14.24")	N

ERROR MESSAGES

REVISION HISTORY		
Page	Date	Added/Updated/New
		None

2. ERROR MESSAGES

2.1 OVERVIEW

Error codes will be displayed on the LCD panel if the machine has a problem. These can be viewed by a customer.

2.1.1 ERROR MESSAGES LIST

Message	Causes	Solutions
2XXX14	The machine was not able to print the received fax, or the machine's memory reached capacity while receiving a fax because the document was too large.	<ul style="list-style-type: none"> ▪ The paper tray was empty. Load paper in the paper tray. See the user's guide "Loading Paper". ▪ The paper tray did not contain A4, Letter, or Legal size paper. Load valid size paper in the tray, and configure the paper size settings under [System Settings] accordingly. ▪ A cover or tray was open. Close the cover or tray. ▪ There was a paper jam. Remove the jammed paper. See the user's guide "Paper Feed Problems". ▪ A print cartridge was empty. Replace the print cartridge. See the user's guide "Replacing the Print Cartridge". ▪ The received fax was too large. Ask the sender to resend the document in parts as several smaller individual faxes, or to send at a lower resolution.
ADF Cover Open Close ADF Cover	The ADF cover is open.	<ul style="list-style-type: none"> ▪ Close the cover completely.

Message	Causes	Solutions
ADF Orig. Misfeed Open ADF Cover and remove paper.	An original has been jammed inside the ADF.	<ul style="list-style-type: none"> ▪ Remove jammed originals, and then place them again. See the user's guide "Paper Feed Problems". ▪ Check the originals are suitable for scanning. See the user's guide "Placing Originals".
Available: IDCard Copy A4 or 8 1/2 x11	ID card copy could not be performed because the tray does not contain the valid size paper, which are A4 or Letter size.	<ul style="list-style-type: none"> ▪ Set the machine to print copies using the A4 or Letter size paper in the [Select Paper] setting. See the user's guide "Copier Features Settings". ▪ Specify the A4 or Letter size paper for the tray selected for printing copies. See the user's guide "System Settings".
Busy	Fax transmission could not be completed because the destination's line was busy.	Wait for a while and send the fax again.
Cannot Copy This Setting Comb.: 2 on 1 / 4 on 1	Combined copying could not be performed because the tray does not contain the valid size paper, which are A4, Letter, or Legal size.	<ul style="list-style-type: none"> ▪ Set the machine to print copies using the A4, Letter, or Legal size paper in the [Select Paper] setting. See the user's guide "Copier Features Settings". ▪ Specify the A4, Letter, or Legal size paper for the tray selected for printing copies. See the user's guide "System Settings".

Message	Causes	Solutions
Cannot copy. Set original to ADF.	Combined copying could not be performed because the originals were not placed in the ADF.	<ul style="list-style-type: none"> ▪ Use the ADF, even when copying a single sheet. ▪ If you need to use the exposure glass, turn off combined copying in [Duplex/Combine] under copy settings, and then try again. See the user's guide "Copier Features Settings".
Check Paper Size	The paper size set for the document differs from the size of the paper in the indicated tray.	Press [FormFeed] to begin printing, or press [JobReset] to cancel the job.
Check Paper Type	The paper type set for the document differs from the type of the paper in the indicated tray.	Press [FormFeed] to begin printing, or press [JobReset] to cancel the job.
Connection Failed	The line could not be connected correctly.	<ul style="list-style-type: none"> ▪ Confirm that the telephone line is properly connected to the machine. ▪ Disconnect the telephone line from the machine, and connect a standard telephone in its place. Confirm that you can make calls using the telephone. If you cannot make calls this way, contact your telephone company.
Cover open	A cover is open.	Close the cover completely.
Dest. is not Programmed	No Quick Dial entry is associated with the One Touch button you pressed.	<ul style="list-style-type: none"> ▪ Press a different One Touch button. ▪ Assign a registered destination to the One Touch button. See the user's guide "Registering Scan Destinations".

Message	Causes	Solutions
Dial Failed	The fax could not be sent.	<ul style="list-style-type: none"> ▪ Confirm that the fax number you dialed is correct. ▪ Confirm that the destination is a fax machine. ▪ Confirm that the line is not busy. ▪ You may need to insert a pause between dial digits. Press the [Pause/ Redial] key after, for example, the area code.
Exceeded Max. E-mail Size	The scan file exceeds the size limit for files that can be sent through e-mail.	<ul style="list-style-type: none"> ▪ Configure [Resolution] under scanner settings to reduce the scanning resolution. ▪ Configure [Max. E-mail Size] under scanner settings to increase the allowed size.
Fax Job Memory Overflow	The number of fax jobs in memory (unsent or unprinted faxes) has reached maximum, so new jobs cannot be stored.	Wait until pending jobs have been transmitted or printed.
I-Fax POP3 fails	Connection to the POP3 server failed.	<ul style="list-style-type: none"> ▪ Confirm that the network cable is properly connected to the machine. ▪ Confirm that the network settings such as IP address, DNS, and POP3 settings have been configured properly (make sure that no double-byte character is used). See the user's guide "Configuring the Network Settings".
Indep.Sply.Prt.Cart.	A non-supported print cartridge is installed.	Remove and replace it with a print cartridge specified by an authorized dealer.
Internal Misfeed	Paper has been jammed in the machine.	Remove the jammed paper. See the user's guide "Paper Feed Problems".

Message	Causes	Solutions
Memory Almost Full	Memory has almost reached capacity during sort copy.	If several originals are still to be scanned, it is recommended to start printing now, and copy the remaining originals separately. If originals are being scanned from the ADF, remove any remaining pages from the ADF.
Memory Overflow	The data is too large or complex to print.	<ul style="list-style-type: none"> ▪ Select [600 × 600 dpi] in [Resolution] under [Printer Features] to reduce the size of data. See the user's guide "Printer Features Settings". ▪ If using the PCL6 printer driver, set [Resolution] in [Print Quality] to [600 × 600 dpi].
Memory Overflow	<ul style="list-style-type: none"> ▪ The machine's memory reached capacity while scanning the first page of the original to store a fax job in memory before transmission. ▪ The machine's memory reached capacity while storing a fax in memory in Memory Transmission mode. 	Resend the fax in parts as several smaller individual faxes, or send at a lower resolution.
Memory Overflow TX Cancel	Memory has reached capacity while scanning the second or later pages of the original when trying to send a fax in Memory Transmission mode.	Press [TX] to send only the pages that have been scanned in memory, or press [Cancel] to cancel.
Misfeed: BypassTray	Paper has been jammed in the bypass tray.	Remove the jammed paper. See the user's guide "Paper Feed Problems".
Misfeed: Dup. Unit Remove Paper	Paper has been jammed in the duplex unit.	Remove the jammed paper. See the user's guide "Paper Feed Problems".

Message	Causes	Solutions
Misfeed: Stnd. Tray	Paper has been jammed in the paper exit area.	Remove the jammed paper. See the user's guide "Paper Feed Problems".
Misfeed: Tray 1	Paper has been jammed in the tray 1 paper input area.	Remove the jammed paper. See the user's guide "Paper Feed Problems".
Net Communication Error	Connection with the server was lost while sending or receiving data.	Contact the network administrator.
Network is not Ready	A scanned file could not be sent because the machine has not received IP address information from the DHCP server completely.	Wait until the machine receives the IP address information completely, and then try the operation again.
On Hook or Stop key	The machine has been off-hook for an extended period of time.	Put down the handset or press the [Clear/ Stop] key.
Out of Paper: X	The indicated tray has run out of paper.	Load paper to the indicated tray. See the user's guide "Loading Paper".
Please Restart Machine	The machine needs to be restarted.	Turn off the power, and then turn it back on.
Print Cart. Set Error	The print cartridge has not been installed or has not been installed correctly.	Reinstall the print cartridge. See the user's guide "Replacing the Print Cartridge".
Remove Paper: Bypass Tray	The machine failed to proceed with the print job, because tray 1 was specified as the input tray but paper was set in the bypass tray.	Remove paper from the bypass tray.
Replace Required Soon: Print Cartridge	The print cartridge is almost empty.	Prepare a new print cartridge.

Message	Causes	Solutions
Replacement Required: Fusing Unit	The fusing unit is no longer usable, and must be replaced.	Contact your sales or service representative.
Replacement Required: Paper Feed Roller	The paper feed roller is no longer usable, and must be replaced.	Contact your sales or service representative.
Replacement Required: Print Cartridge	The machine has run out of toner.	Replace the print cartridge. See the user's guide "Replacing the Print Cartridge".
Replacement Required: Transfer Roller	The transfer roller is no longer usable, and must be replaced.	Contact your sales or service representative.
RX Comm. Error	A reception error occurred, and the fax could not be received correctly.	If possible, contact the sender of the fax and ask them to resend it.
Scan (NW) Disconnected	A scanned file could not be sent because the Ethernet cable was not connected properly.	Reconnect the Ethernet cable properly, and then try the operation again.
Scan (USB) Disconnected	The USB cable was disconnected while scanning from a computer.	Reconnect the USB cable properly, and then try the operation again.
Server Connection Failed	A scanned file could not be sent because the destination could not be reached.	Confirm that the destination is registered correctly, and then try the operation again.
Server Response Error	An error occurred in communication with the server before beginning transmission.	Confirm that the destination is registered correctly, and then try the operation again. If the problem could not be solved, contact the network administrator.

Message	Causes	Solutions
Service call - X	A fatal hardware error has occurred, and the machine cannot function.	Contact your sales or service representative.
Set Correct Paper	The paper tray does not contain A4, Letter, or Legal size paper.	While the message is displayed, press the [OK] key. A menu for changing the paper size of the current tray appears. Load A4/Letter/ Legal size paper in the tray, and then select the corresponding paper size using [▲] [▼] keys and press the [OK] key. The machine will then print out the fax. Note that the paper size setting for the tray under system settings will be changed. See the user's guide.
Set Original to ADF Cannot use exposure glass with set. in [Scan Size].	Scanning could not be performed because the originals were not placed in the ADF, even though the machine is set to scan originals larger than A4/Letter size.	<ul style="list-style-type: none"> ▪ Use the ADF, even when scanning A4/Letter or smaller size originals. ▪ If you need to use the exposure glass, set A4/Letter or smaller size in [Scan Size] under scanner settings, and then try again. See page 93 "Specifying the Scan Settings".
Sort Copy was Cancelled	The machine's memory reached capacity while originals were being scanned from the ADF to perform sort copying.	Press [Exit] to print the originals that were successfully scanned into memory. Then, copy again the originals left in the ADF.

Message	Causes	Solutions
TX Comm. Error	A transmission error occurred, and the fax could not be transmitted correctly.	If the [Auto Redial] setting is enabled, the machine will redial the number and try again. If all attempts fail, or if the machine is in Immediate Transmission mode, the fax will not be transmitted. Try the operation again.

2.1.2 FAX ERROR CODE

This section describes the dial, transmission (TX), and reception (RX) error codes that are printed on the TX Report/Activity Report.

Error codes consist of six hexadecimal digits (0-5).

Digit 5 indicates Fax/Internet Fax and TX/RX.

Digit 5 (far left)	TX or RX
1xxxxx	TX (Fax)
2xxxxx	RX (Fax)
3xxxxx	TX (Internet Fax)
4xxxxx	RX (Internet Fax)

Fax Error Code Structure

Digit 4	Coding (MH/MR/MMR/JBIG)
x1xxxx	MH
x2xxxx	MR
x3xxxx	MMR
x4xxxx	JBIG

Overview

Digit 3	MODEM mode
xx1xxx	V27ter nonECM
xx2xxx	V29 nonECM
xx3xxx	V17 nonECM
xx4xxx	V33 nonECM
xx5xxx	V34
xx9xxx	V27ter ECM
xxaxxx	V29 ECM
xxbxxx	V17 ECM
xxcxxx	V33 ECM

Digit 2	MODEM speed
xxx1xx	2400
xxx2xx	4800
xxx3xx	7200
xxx4xx	9600
xxx5xx	12000
xxx6xx	14400
xxx7xx	16800
xxx8xx	19200
xxx9xx	21600
xxxaxx	24000
xxxbxx	26400
xxxcxx	28800
xxxdxx	31200
xxxexx	33600

Fax Error Code Table

Error Code	Error Type	Error Description
0	General	Normal (No Error)
xxxx01		STOP
Xxxx1f		H/W Error
Not logged in activity report		RX T1 Time Out
1xxx11		Scanner Error during TX
2xxx14		Memory Full during RX
xxxx06		Authorized Reception = Enable, Since received TSI was not match, reception was refused.
xxxx21	Dial failure	Connection Fail
xxxx22		Dial Fail
xxxx23		Redial All Failed
xxxx31	Comm. Error	TX T1 Time Out
xxxx32	1. Phase-B Error	V8 negotiation Fail
xxxx40	Comm. Error 1. Phase-B Error	Retry Out
xxxx41		Too many FTT
xxxx42		Too many CRP
xxxx43		T2 Time Out
xxxx44		DCN received
xxxx45		Command Rec Error
xxxx46		Resp Rec Error
xxxx47		Invalid Command/Response RX

Overview

Error Code	Error Type	Error Description
xxxx48		Remoter No RX capability
xxxx49		T1 time out after EOM
xxxx50	Comm. Error 2. Phase-C Error	T2 Time Out
xxxx51		Image Data not ready
xxxx52		Phase-C Time Out
xxxx53		JBIG Buffer Full
xxxx60	Comm. Error 3. Phase-D Error	Retry Out
xxxx61		T2 Time Out
xxxx62		DCN received
xxxx63		Too many CRP
xxxx64		Too many PPR
xxxx65		RNR time Out
xxxx66		RTN/PIN Received, EOR/ERR/DCN
xxxx67		Invalid Command/Response RX
xxxx68		Command Rec Error
xxxx69		Resp Rec Error
xxxx70	Comm. Error 4. Phase-E Error	Time Out
xxxx80	Comm. Error 5. Other general Comm Error	modem hang-up
xxxx81		V34 abort received
xxxx82		V34 t1 timeout, control channel error
xxxx83		V34 t1 timeout, primary channel error
xxxx84		data not sent until guard timer expire

Internet Fax Error Code Table**Sending Error**

Error Code	Description	Solution
3xxx11	Log in error (Connection to the server failed)	Confirm that the network cable is properly connected to the machine. Confirm that the network settings such as IP address, DNS, and SMTP settings have been configured properly (make sure that no double-byte character is used).
3xxx12	Mail header Edit error (E-mail transmission failed)	Confirm that the network settings such as IP address, DNS, and SMTP settings have been configured properly (make sure that no double-byte character is used).
3xxx13	Mail part header Edit error (E-mail transmission failed)	Confirm that the network settings such as IP address, DNS, and SMTP settings have been configured properly (make sure that no double-byte character is used).
3xxx14	Mail part body Edit error (E-mail transmission failed)	Confirm that the network settings such as IP address, DNS, and SMTP settings have been configured properly (make sure that no double-byte character is used).
3xxx31	Codec error (E-mail transmission failed)	Confirm that the network settings such as IP address, DNS, and SMTP settings have been configured properly (make sure that no double-byte character is used).
3xxx32	TIFF Edit Error (E-mail transmission failed)	Confirm that the network settings such as IP address, DNS, and SMTP settings have been configured properly (make sure that no double-byte character is used).
3xxx33	Memory Overflow (The machine memory reached capacity)	The fax was too large. Resend the document in parts as several smaller individual faxes, or send at a lower resolution.

Receiving Error

Error Code	Description	Solution
4xxx21	Log in error (Connection to the server failed)	Confirm that the network cable is properly connected to the machine. Confirm that the network settings such as IP address, DNS, and SMTP settings have been configured properly (make sure that no double-byte character is used).
4xxx22	E-mail List acquisition error (E-mail reception failed)	Ask the sender to check the e-mail settings.
4xxx23	Mail header acquisition error (E-mail reception failed)	Ask the sender to check the e-mail settings.
4xxx24	Mail part header acquisition error (E-mail reception failed)	Ask the sender to check the e-mail settings. The e-mail had an invalid Content-Type, or an unsupported type of file (such as PDF or JPEG) was received. Ask the sender to check the file type.
4xxx25	Mail part body acquisition error (E-mail reception failed)	Ask the sender to check the e-mail settings.
4xxx26	Mail part body acquisition error (E-mail reception failed)	There was an error in the received TIFF file (which resulted from a condition not indicated by the error codes 4xxx43 to 4xxx45). Ask the sender to check the TIFF file.
4xxx27	Mail delete error (E-mail reception failed)	Ask the sender to check the e-mail settings.
4xxx41	Invalid mail header (E-mail reception failed)	Ask the sender to check the e-mail settings.

Error Code	Description	Solution
4xxx42	Invalid part header (E-mail reception failed)	Ask the sender to check the e-mail settings.
4xxx43	Codec Error (A TIFF file could not be received properly.)	The compression method of the received TIFF file was other than MH/MR/MMR. Ask the sender to check the TIFF file.
4xxx44	TIFF over spec (A TIFF file could not be received properly.)	The resolution of the TIFF file was not supported, or the width of the TIFF file was A3 or B4. Ask the sender to check the TIFF file.
4xxx45	TIFF Form abnormal (A TIFF file could not be received properly.)	The format of the TIFF file was other than TIFF-S/F. Ask the sender to check the TIFF file.
4xxx46	Memory Overflow (The machine memory reached capacity)	The fax was too large. Ask the sender to resend the document in parts as several smaller individual faxes, or send at a lower resolution.