

## Product Support Guide D075 / D074 / M044

RFG # 048727

### Introduction

Model Type	Color MFP	Color MFP	Color Printer
Launch Date	8/1/2011		
S/N Configuration	V91	V90	S98
Product Code	D075	D074	M044
Speed	75 ppm	65 ppm	75 ppm

### Brand/Model Name

Product Code	Lanier	Ricoh	Savin
D075	Pro C751EX	Pro C751EX	Pro C751EX
D074	Pro C651EX	Pro C651EX	Pro C651S
M044	Pro C751	Pro C751	Pro C751

### Product Concept

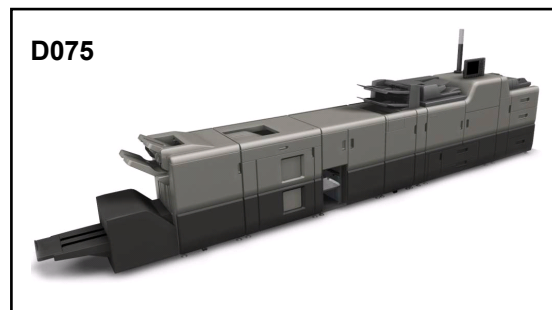

#### Introduction

The D074 and D075 are multi-function copiers, and the M044 is a printer. These units are Ricoh's new flagship light production line-up. They feature heavy production-class features, such as, an improved customizable paper library, enhanced TCRU, and a more powerful Fiery Controller. In addition, features found on Ricoh's heavy-production machines, such as enhanced image quality with chemical toner, oil less fusing, and expanded finishing options are also available on this series.

#### Key Installation Points For the Pro C751EX / C651EX / C751:

- The Paper Library .mqp file needs to be loaded at installation.
- A forklift is required to remove the main frame from the shipping pallet.
- Developer is pre-installed from the factory.
- Toner Sub Hoppers are empty and need to be primed at installation. Execute SP3051-1.
- Check Installation Section of this PSG for weight, space and power requirements.
- The Pro C751EX Series requires NEMA 6-20 receptacle. (208v-240v, 20A)
- Installation requires setting SP5193-001 to "6" for the external Fiery controller.
- 2 Network connections are required – 1 for Fiery printing / Fiery Scanning and 1 for @Remote / GW Scanning.
- Controller / Mainframe network connections – Lower network slot on Controller / Right network slot on GW Controller.

# Product Support Guide

## D075 / D074 / M044

### Order Number Main Frame

Item	Model Name	EDP Code
D075	Lanier	404448
	Ricoh	404448
	Savin	404448
D074	Lanier	404447
	Ricoh	404447
	Savin	404447
M044	Lanier	404386
	Ricoh	404386
	Savin	404386

Note: Order Numbers are provided for reference purposes only. Please use your Pricing Guide for proper order numbers to insure you receive the correct branding emblem.

### Options

Item	Description	EDP Code	Product Code	Common / Unique	Remarks
Staple Finisher	Finisher SR5030	404396	D513	U	100 Page Staple Features
Booklet Finisher	Finisher SR5040	404398	D512	U	Max 20 sheets ( 80gsm) Saddle Stitch
Punch Unit	Punch Unit PU5020	404177	D449	C / 901	Allows punching at 75ppm / 65ppm
Booklet Trimmer	Booklet Trimmer TR5040	404400	D520	U	One Side Edge Trim
LCIT	LCIT RT5060	404388	D516	U	Equipped with Air-Assist Paper Feed
Bypass tray	Multi Bypass Tray BY5010	404387	D517	U	500 sheet capacity
Buffer Pass Unit	Buffer Pass Unit	404402	D548	U	Recommended when installing the High Capacity Stacker
High Capacity Stacker	High Capacity Stacker SK5020	404394	D515	U	5000 sheets Tandem Stackers is not supported
Roll-Away Cart	Roll-Away Cart Type 5020 (additional cart)	404218	D456	C / 901	Additional cart for Stacker
Multi Fold Unit	Multi Folding Unit (FD5010 )	404390	D521	U	Supports 6 different folding patterns

## Product Support Guide

### D075 / D074 / M044

Item	Description	EDP Code	Product Code	Common / Unique	Remarks
A3/11"x17" Tray Unit	A3/11"x17" Tray Unit TK5010	404195	B331	C ( 901)	Converts Tandem tray to 11/17"
Cover Interposer Tray	Cover Interposer Tray CI5020	404389	D518	U	-
Ring Binder	Ring Binder RB5010	404392	D519	U	Produces Ring bound output
Ring Opener	Ring Opener Type A	404114	D419	C (C901)	Option to open finished Ring bound booklet to add pages
Color Controller	Type E-41A	404405	D525	U	Standard Fiery Controller (External)
Waste Toner Bottle	Type C751	404451	D074/D075/M044	U	Waste Toner Bottle Part # D0746670
TCRU Kit	TCRU Kit Type A	404440	D074/D075/M044	U	-
TCRU Kit	TCRU Kit Type B	404442	D074/D075/M044	U	Fuser Unit as TCRU Item
Java VM Card	Type R	404407	D554	U	-
EFI HDD Security	E41 EFI Server HDD Security Option	414939	D450	C ( 901 )	Same as 901

# Product Support Guide

## D075 / D074 / M044

### Supplies/Yields

Item	EDP Code/ Product Code/ Lanier ID	Name	Target Yield
<b>Ricoh / Savin /Lanier</b>			
Black Toner	828157	Pro Print Cartridge Black C751	48,500
Yellow Toner	828158	Pro Print Cartridge Yellow C751	48,500
Magenta Toner	828159	Pro Print Cartridge Magenta C751	48,500
Cyan Toner	828160	Pro Print Cartridge Cyan C751	48,500
Rings (W100)	404117	Ring Supply Type A White 100 (5 sets of 75)	375
Rings (B100)	404118	Ring Supply Type A Black 100 (5 sets of 75)	375
Rings (W50)	404118	Ring Supply Type A White 50 (5 sets of 75)	375
Rings (B50)	404120	Ring Supply Type A Black 50 (5 sets of 75)	375
Staple Type U	404235	Staple Type U for BK5020 (Saddle Stitch)	5,000
Staple Refill Type U	415010	Staple Refill Type L for BK5000 (Saddle Stitch)	10,000
Drum (Black)	D0749510	Drum	a 1200K / b 1350K
Drum (CYM)	D0749510	Drum	a 1200K / b 1350K
Developer (Black)	D0749640	Black Developer - ** Service Part/TCRU **	a 750K / b 900K
Developer (Cyan)	D0749660	Cyan Developer - ** Service Part/TCRU **	a 750K / b 900K
Developer (Magenta)	D0749670	Magenta Developer - ** Service Part/TCRU **	a 750K / b 900K
Developer (Yellow)	D0749680	Yellow Developer - ** Service Part/TCRU **	a 750K / b 900K
Waste Toner Bottle	TBA	Waste Toner Bottle Type TBA	70K
<b>Ricoh</b>			
Staple Type M	413013	Staple Type M for SR5000/SR5020	5,000
Staple Refill Type M	413026	Staple Refill Type M for SR5000/SR5020	25,000
<b>Savin</b>			
Staple Type M	9908	Staple Type M for SR5000/SR5020	5,000
Staple Refill Type M	9909	Staple Refill Type M for SR5000/SR5020	25,000
<b>Lanier</b>			
Staple Type M	4800383	Staple Type M for SR5000/SR5020	5,000
Staple Refill Type M	4800390	Staple Refill Type M for SR5000/SR5020	25,000

**\*Toner:**

- A4, 8.75% 50 Page/Job
- The condition is standard temperature and humidity.
- This yield number may change depending on the circumstances and printing conditions.

**\*\* Waste Toner Bottle:**

- A4/LT, 8.75%, 25 Pages/Job

# Product Support Guide

## D075 / D074 / M044

- Color ratio : 80%

### Option Compatibility

	1. Multi Bypass Tray (BY5010)	2. 13"x19.2" LCT (LCIT RT5060)	3. A3/DLT Tray Unit (TK5010)	4. Cover Interposer Tray (CI5020)	5. Multi-Folding Unit (FD5010)	6. Ring Binder (RB5010)	7. High Capacity Stacker (SK5020)	8. Finisher (SR5030)	9. Booklet Finisher (SR5040)	10. Punch unit US 2/3	11. Punch unit EU 2/4	12. Punch unit SC 4hole	13. Trimmer Unit (TR5040)	14. Buffer Pass Unit Type 5000	15. Decurler Unit DU5010	16. TCRU/ORU Type C751 Set A	17. TCRU/ORU Type C751 Set B	18. Waste Toner Bottle	19. Tab Sheet unit	20. Optional Counter I/F	21. Plockmatic Booklet Maker	22. GBC Stream Punch	
1. Multi Bypass Tray (BY5010)	■	M																					
2. 13"x19.2" LCT (LCIT RT5060)		■																					
3. A3/DLT Tray Unit (TK5010)			■																				
4. Cover Interposer Tray (CI5020)				■			A	1	1														
5. Multi-Folding Unit (FD5010)					■			1	1														
6. Ring Binder (RB5010)						■	A	1	1														
7. High Capacity Stacker (SK5020)							■							R	M								
8. Finisher (SR5030)								■	X														
9. Booklet Finisher (SR5040)									■	X												X	
10. Punch unit US 2/3										■	1	1											
11. Punch unit EU 2/4											■	1	1										
12. Punch unit SC 4hole												■	1	1									
13. Trimmer Unit (TR5040)													■	X	M								
14. Buffer Pass Unit Type 5000														■	A	1	1						
15. Decurler Unit DU5010															■								
16. TCRU/ORU Type C751 Set A																■							
17. TCRU/ORU Type C751 Set B																	■						
18. Waste Toner Bottle																		■					
19. Tab Sheet unit																			■				
20. Optional Counter I/F																				■			
21. Plockmatic Booklet Maker																					■		
22. GBC Stream Punch																						■	

[Remarks]

- X Cannot be installed together
- M Must be installed together
- 1 Must be select one of these options & installed together
- A High Capacity Stacker (SK5020) may be the last finishing option in the configuration, if the Multi Folding Unit (FD5010) is not included in the configuration.
- R The unit is recommended with installed when included in the configuration

# Product Support Guide

## D075 / D074 / M044

	1. Multi Bypass Tray (BY5010)	2. 13"x19.2" LCT (LCIT RT5060)	3. A3/DLT Tray Unit (TK5010)	4. Cover Interposer Tray (CI5020)	5. Multi-Folding Unit (FD5010)	6. Ring Binder (RB5010)	7. High Capacity Stacker (SK5020)	8. Finisher (SR5030)	9. Booklet Finisher (SR5040)	10. Punch unit US 2/3	11. Punch unit EU 2/4	12. Punch unit SC 4hole	13. Trimmer Unit (TR5040)	14. Buffer Pass Unit Type 5000	15. Decurler Unit DU5010	16. TCRU/ORU Type C751 Set A	17. TCRU/ORU Type C751 Set B	18. Waste Toner Bottle	19. Tab Sheet unit	20. Optional Counter I/F	21. Plockmatic Booklet Maker	22. GBC Stream Punch	23. VM Card TypeR
1. Multi Bypass Tray (BY5010)	M																						
2. 13"x19.2" LCT (LCIT RT5060)																							
3. A3/DLT Tray Unit (TK5010)																							
4. Cover Interposer Tray (CI5020)							A	1	1														
5. Multi-Folding Unit (FD5010)								1	1														
6. Ring Binder RB5010							A	1	1														
7. High Capacity Stacker (SK5020)														R	M								
8. Finisher (SR5030)								X															
9. Booklet Finisher (SR5040)								X													X		
10. Punch Unit US 2/3 (PU5020)								1	1														
11. Punch Unit EU 2/4 (PU5020)								1	1														
12. Punch Unit SC 4hole (PU5020)								1	1														
13. Trimmer Unit (TR5040)								X	M														
14. Buffer Pass Unit Type 5000							A	1	1														
15. Decurler Unit DU5010																							
16. TCRU/ORU Type C751 Set A																							
17. TCRU/ORU Type C751 Set B																							
18. Waste Toner Bottle																							
19. Tab Sheet Unit																							
20. Optional Counter I/F																							
21. Plockmatic Booklet Maker								M	X														
22. GBC Stream Punch							A	1	1														
23. VM Card TypeR																							

**[Remarks]**

- X Cannot be installed together
- M Must be installed together
- 1 Must be select one of these options & installed together
- A High Capacity Stacker (SK5020) may be the last finishing option in the configuration, if the Multi Folding Unit (FD5010) is not included in the configuration.
- R The unit is recommended with installed when included in the configuration

# Product Support Guide

## D075 / D074 / M044

### Branding Information

TBA

### Configuration

#### Main Frame Configuration

Pro C 751/751ex/651ex Paper Feed options

#### Large Paper Capacity

Standard configuration has a 2,500-sheets input paper capacity. Standard configuration with LCT and Bypass Tray Unit, makes its total capacity to 7,000 sheets.

Using Bypass Tray Unit, 330.2mm X 630mm (13"X24.8) size paper is capable which is larger than 901 paper capability.

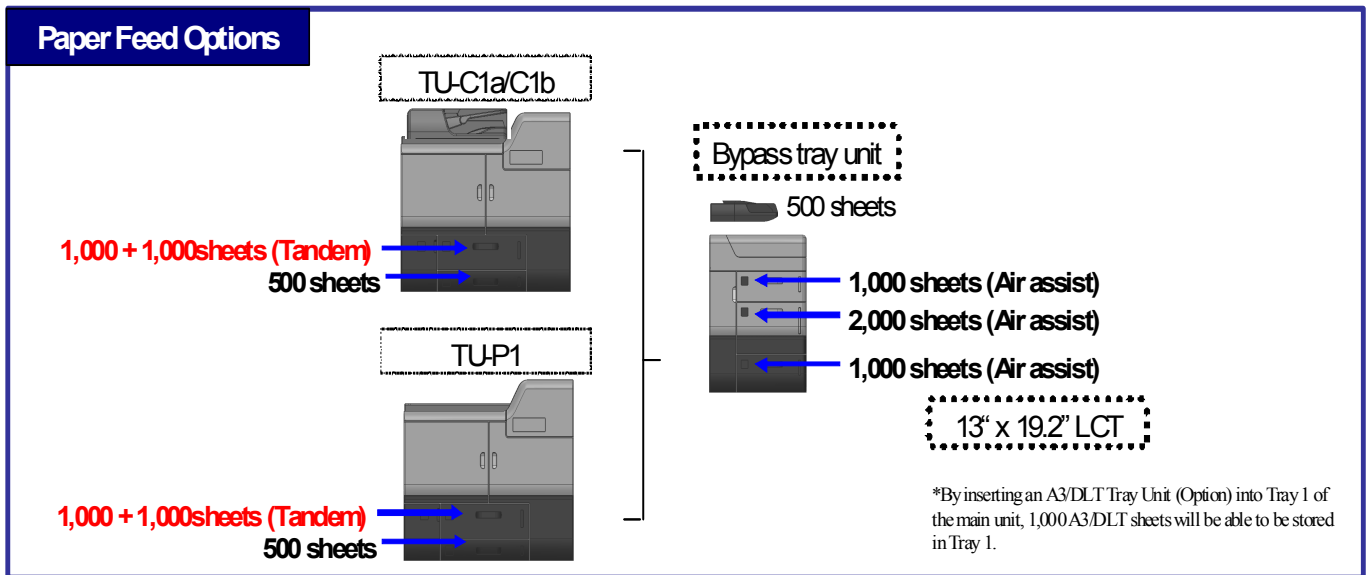

(A4/LT)	Taurus	
1 <sup>st</sup> Tray (Tandem tray)	1,000 sheets x 2	Std
2 <sup>nd</sup> Tray	500 sheets	Std
3 <sup>rd</sup> Tray (LCT)	1,000 sheets	Opt
4 <sup>th</sup> Tray (LCT)	2,000 sheets	Opt
5 <sup>th</sup> Tray (LCT)	1,000 sheets	Opt
6 <sup>th</sup> Tray (Bypass Tray)	500sheets	Opt
<b>TOTAL</b>	<b>7,000 sheets</b>	

# Product Support Guide

## D075 / D074 / M044

### Basic Configuration of Mainframe

- Main Unit Includes OPC (CMYK) and Developer (CMYK) which is installed as standard configuration.
- Main Unit doesn't include Toner (CMYK) as standard configuration.

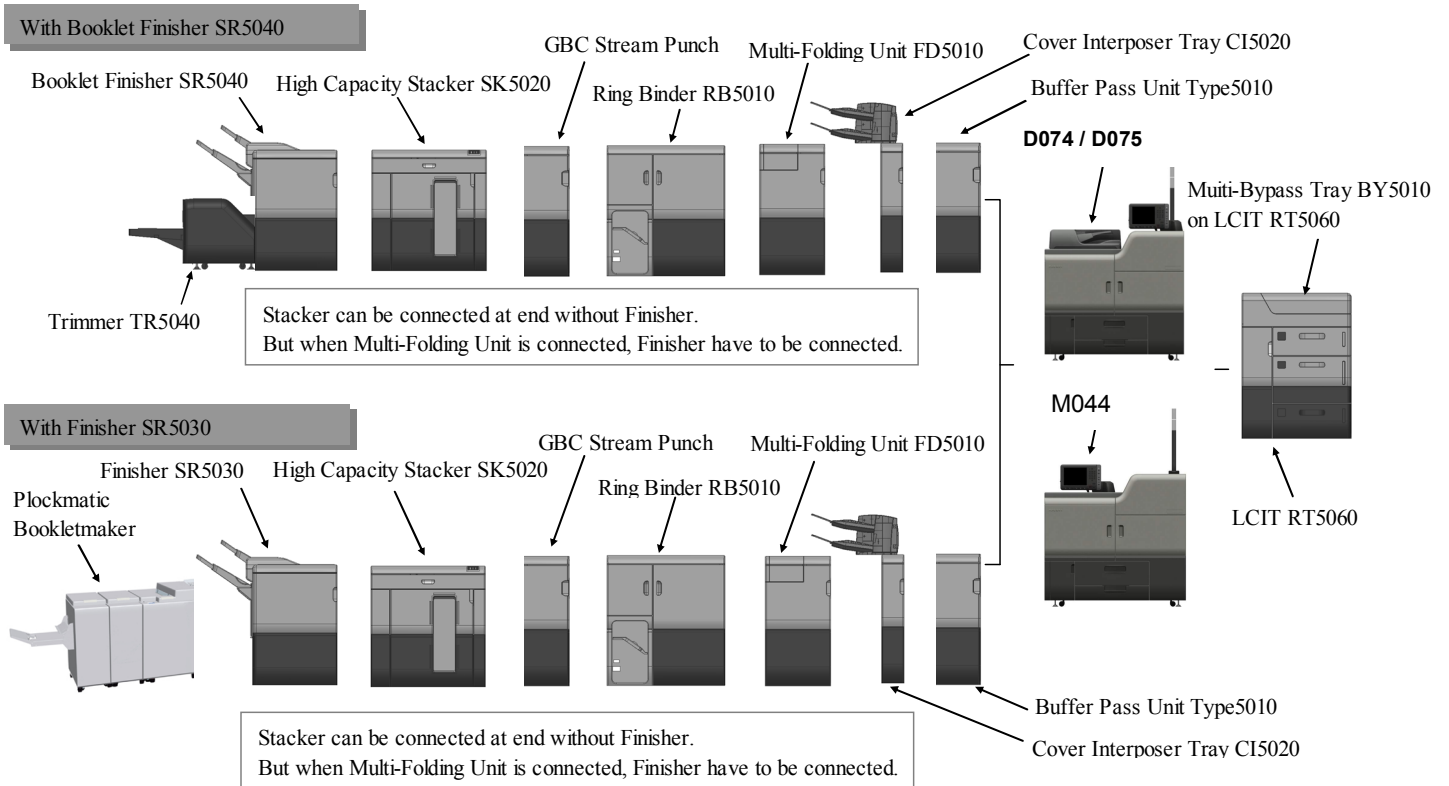



# Product Support Guide

## D075 / D074 / M044

### MFP Options

#### MFP Option Board Slot / SD Card Assignments

Slot 1 (Upper slot) – Option slot  
 Slot 2 (Lower slot) – Service slot

#### Feature Comparison to Previous version

Feature	Description	Pro C751ex/ 751 / 651ex	Pro C901
Fusing	Type of Fusing System	Oil-less	Oil less
Auto Duplexing Spec	Paper weight	256gsm duplex/ 300gsm simplex	300gsm
Toner	Toner Type	PxP (Chemical)	PxP (Chemical)
Max DV	Max Document Volume	180K	350K
Finishing	Stacker	SK5020	SK5010
	Booklet Finisher w/ Trimmer	SR5040 w Optional TR5040	SR5020 w Optional TR5020
Paper Input	LCIT	RT5060	RT5020
Paper Library*	Preload Paper Media Settings	Available	Available
Controllers	Fiery Baseline	E-41A	E-41 (External)
	Fiery Up-scale	TBA	E-81 (External)
	Creo	TBA	C-81 (External)
Operation Panel	Operation Panel Layout	Redesigned	Redesigned
Operator Call Light	Machine Status Light	Light Mast W/ Toner Out Indicator	Light Mast
TCRU Option	Trained Customer Replaceable Units	Enhanced (PC,Cleaner sec.Charge rollers,Fusersec).	Enhanced (Dust Filters, Feed Section Rollers and Fuser Unit)
Energy Star	Energy Star Compliance	1.2 Compliant	1.2 Compliant
Air Separation Unit	Air assisted Fusing Belt Pick-off	N/A	Available
Data OverWrite Security	DOS Option	Option	Standard (default = Off)

# Product Support Guide

## D075 / D074 / M044

### Installation

#### ***Installation Requirements (Environment)***

Temperature Range:	Recommended Temp. 23° C (73.4° F). Allowed Range: 10° C to 32° C (50° F to 89.6° F)
Humidity Range:	15% to 80% RH
Ambient Illumination:	Less than 1,500 lux (do not expose to direct sunlight)
Ventilation:	3 times/hr
Ambient Dust:	Less than 0.10 mg/m <sup>3</sup> (2.0 x 10 <sup>-6</sup> oz/yd <sup>3</sup> )
Avoid areas exposed to sudden temperature changes: <ul style="list-style-type: none"> <li>• Areas directly exposed to cool air from an air conditioner.</li> <li>• Areas directly exposed to heat from a heater.</li> </ul>	
Do not place machine where it will be exposed to corrosive gas or vapor.	
Do not install the machine at any location over 2,000m (6,500 ft.) above sea level.	
Place the machine on a strong and level base.	
Do not place the machine where it may be subject to strong vibrations.	
Machine level	Front to rear = Less than 5.0 mm (0.2") away from level
	Right to left = Less than 5.0 mm (0.2") away from level
Notes: <ul style="list-style-type: none"> <li>• If the machine is installed in a location where the ambient temperature is more than 30°C (86°F): (1) Do not run full color printing longer than 2 hours, and (2) never turn the main power switch off immediately after a long print job. Leave the machine on so that the fans can expel the hot air from the machine and cool the electronic components.</li> <li>• If this machine is to be used in a high temperature and high humidity condition, the tray heater is required to get the proper print quality. Connect the tray heater harness during the mainframe installation.</li> <li>• Do not connect the machine to the same power source as other electrical devices.</li> <li>• Leave the machine on so that the fans can expel the hot air and Ozone from the machine and cool the electronic components.</li> </ul>	

#### Network connections (X2):

1. Fiery Controller:
  - a. Printing is only available via the Fiery controller.
  - b. WIM access to Fiery Controller Settings.
2. GW network connection.
  - a. Allows for @Remote connection.
  - b. Web Image Monitor connection to mainframe GW settings

# Product Support Guide

## D075 / D074 / M044

### Main Unit

#### Single Phase

- The required wall outlet is a **NEMA 6-20** (receptacle) →
- 208 to 240V, 50/60 Hz: More than 20 A Single Phase.
- Power cord length: 12ft.
- Do not place anything on power cord.

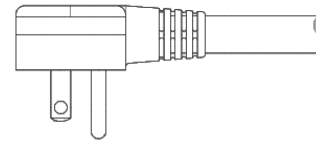
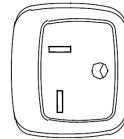

### Required Breaker





The operating area where the machine is to be installed must have a required breaker for the power line.  
North America: Listed circuit breaker, rating: 240V 20A, double pole



# Product Support Guide

## D075 / D074 / M044

### Accessories

Unit	Power Specifications	Requirements	Power Supply Plug Type	Length of Power Cord (Feet)
Multi Folder	120v, 50/60Hz; 15A	120v / 15A	NEMA 5-15	7'
Ring Binder	100v-240v, 50/60Hz; 15A	120v / 15A	NEMA 5-15	8'
Stacker	120v, 50/60Hz; 15A	120v / 15A	NEMA 5-15	6'
Buffer Pass Unit	120v, 50/60Hz; 15A	120v / 15A	NEMA 5-15	6"
Booklet Finisher	120v, 50/60Hz; 15A	120v / 15A	NEMA 5-15	7'
Trimmer	120v, 50/60Hz; 15A	120v / 15A	NEMA 5-15	7'

		Mainframe	Z folding Unit ZF4000	Trimmer TR5020	High Capacity Stacker SK5010
NA	EDP	404350, 404353	412805	404180	404215
	Power Source	208V-240V, 50/60Hz	120V, 60Hz	120V, 60Hz	120V, 60Hz
	Plug				
	Plug type	NEMA6-30P	NEMA5-15P	NEMA5-15P	NEMA5-15P
	Cable Connection	Fixed	Replacable	Replacable	Replacable

		Booklet Finisher SR5020	Ring Binder RB5000	Perfect Binder GB5000
NA	EDP	404174	404112	404099
	Power Consumption	120V, 60Hz	120V, 60Hz	200-240V, 50/60Hz
	Plug			
	Plug type	NEMA5-15P	NEMA5-15P	NEMA 6-15P
	Cable Connection	Replacable	Replacable	Fixed

# Product Support Guide

## D075 / D074 / M044

### SPACE REQUIREMENTS

#### Main Machine

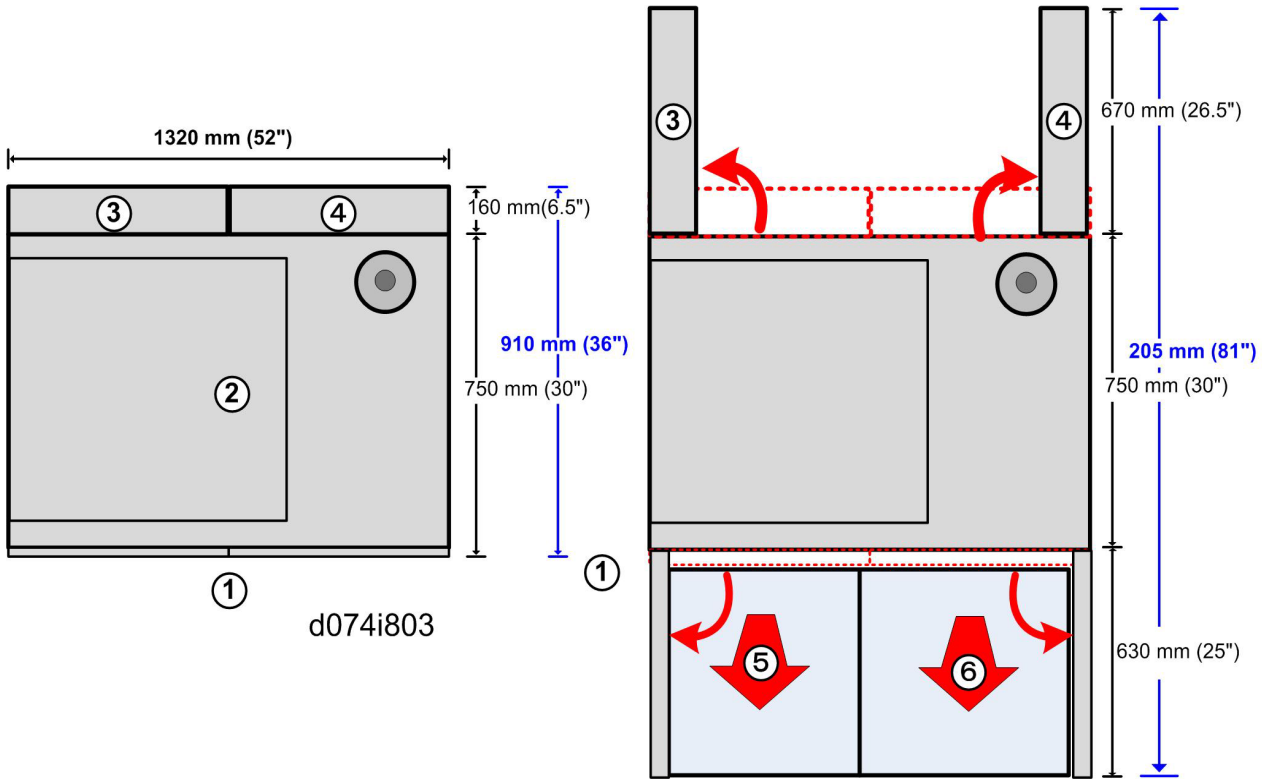

- |  |  |
|--|--|
| <ul style="list-style-type: none"> <li>1. Front Doors</li> <li>2. Main Machine</li> <li>3. Cooling Box</li> <li>4. Controller Box</li> <li>5. Left Drawer Slides</li> <li>6. Right Drawer</li> </ul> | <ul style="list-style-type: none"> <li>Both doors swing open to the front</li> <li>Remains stationary.</li> <li>Swings open to the rear</li> <li>Swings open to the rear</li> <li>open to the front for servicing (fusing unit, etc.)</li> <li>Slides open to the front for servicing (registration unit, etc.)</li> </ul> |
|--|--|

Notes	
<b>Rear Distance</b>	Approximately 670 mm (26.5 in.) clearance required behind the machine with both rear Boxes open.
Weight Distribution (When leveling feet are lowered)	
<b>Weight</b>	Less than 1212 lbs ( 550kg )
*The floor and floor surface should support the listed weights.	
*Use of the leveling bolts is recommended for all installations, even when the machine is level. This prevents the unit from being moved after installation.	

# Product Support Guide

## D075 / D074 / M044

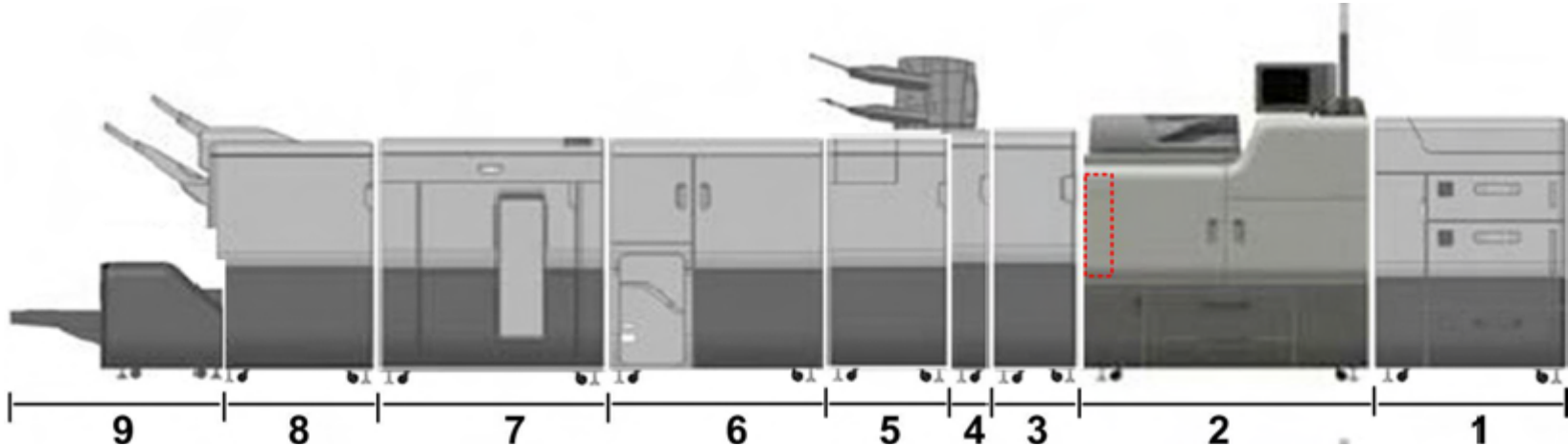

No.	Unit	mm	in.
1	A3/DLT LCIT	880	35
2	Main machine	1320	52
3	Buffer Pass Unit	330	13
4	Cover Interposer Tray	164	7
5	Multi Folding Unit	470	19
6	Ring Binder	870	35
7	High Capacity Stacker	900	36
8	Finisher	990	39
9	Trimmer Unit	1115	44

# Product Support Guide

## D075 / D074 / M044

### Foot Print

**Notes:** D074 / D075 / M044 includes Main Frame print engine ADF assembly.

4	5	6	7	8	10	11	12	13	14	15	16	17	18
Cover Interposer	Plockmatic Stackler	Plockmatic BF5010	Plockmatic TR5010	Plockmatic BK5010	SR5040 Finisher	Stacker SK5020	Ring Binder	Trimmer TR5020	Saddle Stitch SR5040	Main Frame C751 / 651	RT5040	RT5060	RT5060
540mm (21.3")	1,025mm (40.4")	360mm (14.2")	360mm (14.2")	795mm (31.3")	800mm (31.5")					1320mm (51.9")	540mm (21.3")*		
					800mm (31.5")					1320mm (51.9")		965mm (38.0")	
					800mm (31.5")			1,115mm (43.9")	990mm (40.0")	1320mm (51.9")		965mm (38.0")	965mm (38.0")*
					800mm (31.5")		870mm (34.3")			1320mm (51.9")			
					800mm (31.5")	900mm (35.4")				1320mm (51.9")			
					800mm (31.5")	900mm (35.4")				1320mm (51.9")			
						900mm (35.4")				1320mm (51.9")			

- The Depth and Height are fixed to the mainframe dimensions.
- The total length of the installation can be calculated by using the above chart.

Instruction on how to determine total length:

1. Section A / B: Determine which options are to be installed. Add the values indicated under the option and enter this value \_\_\_\_\_ (Length A/B)
2. Section C: Determine which options are to be installed. Enter the value from column 9 here..... \_\_\_\_\_ (Length C)
3. Section D: Determine which options are to be installed. Enter the value from column 21 here..... \_\_\_\_\_ (Length D)
4. If Buffer Pass Unit is installed - add 330mm (11.8") to the length..... \_\_\_\_\_ (Buffer)
5. Total length..... \_\_\_\_\_ (Total)

Dimensions (W x D x H): \_\_\_\_\_ mm x 910 mm x 1,320 mm ( \_\_\_\_\_" x 35.8" x 51.9") {W = length}

Total space required = Dimensions plus additional space requirements from "Space" section.

# Product Support Guide

## D075 / D074 / M044

### **SOUND POWER LEVEL**

	Mainframe itself	Full System
Stand-by	Less than 52.5dB – 72dB (C1a) Less than 55.5dB – 72dB (C1b/P1)	Less than 52.5dB – 72dB (C1a) Less than 55.5dB – 72dB (C1b/P1)
Printing	Less than 72dB – 75dB (All models)	Less than 78dB – 79dB (All models)

		Target
Max. Power Consumption	Printing	Less than 4,000W
	Sleep Mode	Less than 30W

NOTE: The above measurements were made in accordance with ISO 7779. The measurements were taken from the normal position of the operator.



# Product Support Guide

## D075 / D074 / M044

### Installation Times

Unit	Installation Time (Minutes)
Mainframe	50
Decurler Unit	15
Cooling Unit (Buffer Pass Unit)	15
Finisher	15
Booklet Finisher	15
Multi-Folder	15
Cover Interposer	15
A3/LT LCT	15
By-pass Tray	10
Ring Binder	15
High Capacity Stacker	15
Trimmer for Booklet Finisher	15
Punch Unit for both Finishers	10

### Storage/Transportation

	Storage	Transportation
<b>Mainframe</b>	Temperature    -30 ~ +50° C Humidity            Less than 85% RH Stack Max.         2 cartons	Temperature    -30 ~ +50° C Humidity            15% RH ~ 95% RH Stack Max.         2 cartons
<b>Toner (***)</b>	-30 ~ +45° C 15 - 90% RH	Under 30-45° C 15-90% RH
<b>Developer (***)</b>	-30 ~ +45° C 15-90% RH	Under 30-45° C 15-90% RH

- Do not exceed a month under conditions where the temperature is between 35° C and 40° C.
- Do not exceed 12 hours under conditions where the temperature is 40° C and 45° C.

# Product Support Guide

## D075 / D074 / M044

### ***Sales Unit / Service Unit Responsibilities (before delivery)***

1. Inform the customer of required power requirements (including accessories that require an independent power source).
2. Inform the customer of power source placement, including placement of power sources for accessories.
3. Remove the main unit from pallet if customer cannot provide a forklift. The Pro C751ex / Pro C751 & ProC651ex require a forklift to remove the unit from the shipping pallet.
4. Inform the customer of weight and size of main unit and accessories.
5. If the customer does not have doorways wider than 1100mm (43.3"), a technician is required to remove the rear unit of the main frame, reducing the unit depth to 750mm (30"). This will allow the unit to fit through most doorways.

### ***Customer Responsibilities***

1. Provide and stabile, level surface that can support the main unit and accessories.
2. Insure adequate space is available to allow main unit and accessories to be delivered and moved to installation area
3. Provide proper power sources for main unit and accessories.
4. Insure proper position of power source as to allow all units to plug directly into power source.
5. Insure the installation area meets environmental specifications.
6. Provide a network connections:
  - a. Minimum of 1 network connection is need for the Fiery connection.
  - b. A second network connection is needed for @Remote and GW scanning.
7. If TCRU (Trained Customer Replaceable Units) are utilized:
  - a. The customer shall provide space to store TCRUs
    - i. This storage space should meet the environmental specifications outlined in the Installation Requirements of the main unit.
    - ii. The operator and/or the technician should have access to TCRUs during main unit operation hours.
    - iii. If spare parts are to be kept on site to rebuild TCRUs, the parts should be store relative to the TCRUs. TCRU recycle program TBA.
    - iv. If TCRUs are to be rebuilt at the customer location, the customer should provide a location with a flat surface away from the main unit to allow the technician to perform the rebuild of the TCRUs so as to not interfere with the operation of the main unit.

# Product Support Guide

## D075 / D074 / M044

### Forklift

When removing the Pro C751 / 651 from the shipping pallet, refer to the fork positioning labels below.

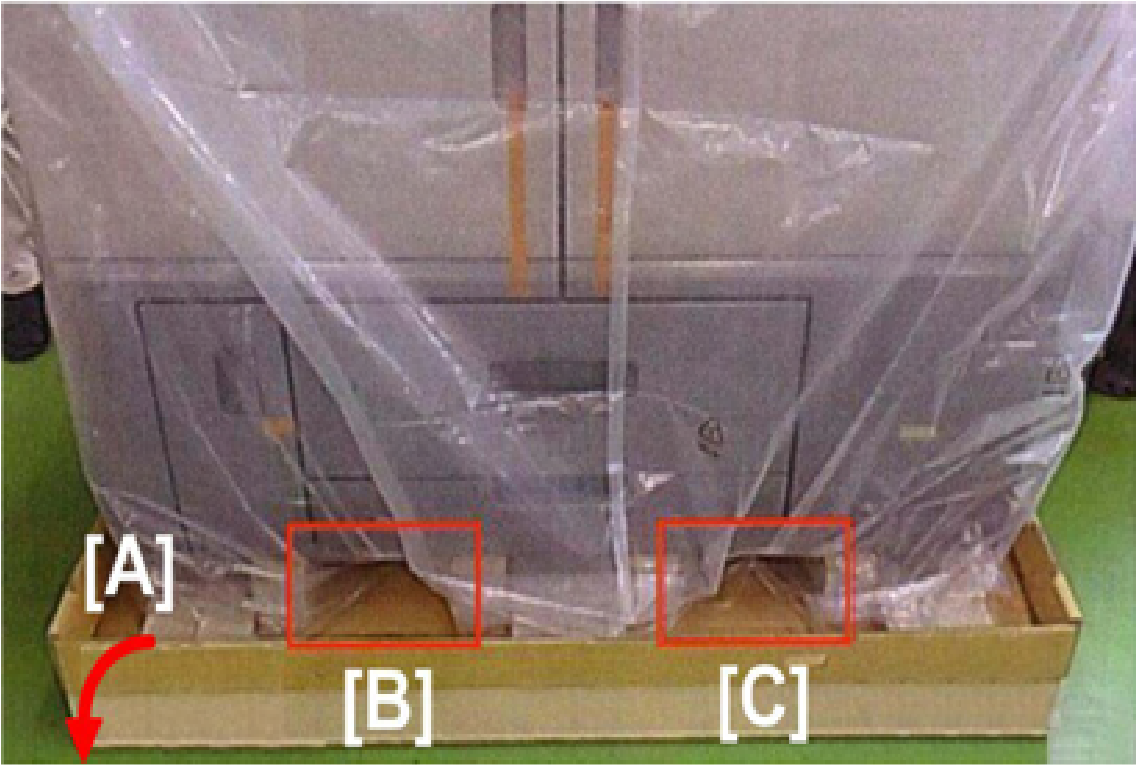

d074i896

1. Knock down the front edge of the cardboard [A].
2. Insert the arms of the forklift at [B] and [C].

# Product Support Guide

## D075 / D074 / M044

### Parts / Special Tools / Maintenance

#### PM Parts / Yields

#### Mainframe / Accessories

**Unique/Common**  
**U:** Unique for this model  
**C:** Common with listed model

Parts Number	Description	Q'ty	PM Interval	Unique or Common
<b>PCDU Development Unit</b>				
D0749680	DEVELOPER Y	1	a 750K / b900K	U
D0749670	DEVELOPER M	1	a 750K / b900K	U
D0749660	DEVELOPER C	1	a 750K / b900K	U
D0749640	DEVELOPER K	1	a 750K / b900K	U
D0743322	FILTER:DEVELOPMENT	4	a 750K / b900K	U
<b>PCDU Drum Cleaning Unit</b>				
D0742422	BLADE:CLEANING:ASS'Y	4	300K *	U
D0742454	BRUSH ROLLER:APPLY:ASS'Y	4	300K * **	U
D0742466	COATING BAR:ASS'Y	4	300K * **	U
D0742481	BLADE:APPLY:ASS'Y	4	300K *	U
D0742459	JOINT:CLEANING UNIT	4	300K * **	U
D0742424	SEAL:BLADE:CLEANING :FRONT	4	300K *	U
D0742425	SEAL:BLADE:CLEANING: REAR	4	300K *	U
D0742485	SEAL:BLADE:APPLY:FRONT	4	300K *	U
D0742486	SEAL:BLADE:APPLY:REAR	4	300K *	U
D0742458	GEAR:19Z:RIGHT	4	300K *	U
D0742501	GEAR:21Z:RIGHT	8	300K *	U
D0742502	GEAR:IDLER:20Z:LEFT	4	300K *	U
D0742503	GEAR:IDLER:31Z:LEFT	4	300K *	U
D0742150	CHARGE UNIT:TAURUS:ASS'Y	4	300K	U
<b>PCDU Drum</b>				
D0749510	OPC DRUM:DIA60:ASS'Y	4	a 1200K / b 1350K	U
<b>a = D074</b>				
<b>b = D075 / M044</b>				

## Product Support Guide

### D075 / D074 / M044

Parts Number	Description	Q'ty	PM Interval	Unique or Common
<b>ITB Unit</b>				
D0746055	FLAT BELT- TRANSFER:SERVICE PARTS:ASS'Y	1	1600K	U
D0746158	ROLLER:INTERMEDIATE TRANSFER:ASS'Y	4	1800K	U
D0746424	BLADE:CLEANING:BELT CLEANING:ASS'Y	1	600K	U
D0746446	BRUSH:APPLY:BELT CLEANING	1	600K	U
D0746450	COATING BAR:ASS'Y	1	600K	U
D0746457	BLADE:APPLY:ASS'Y	1	600K	U
<b>PTR Unit</b>				
D0746265	BLADE:TRANSFER ROLLER:ASS'Y	1	300K	U
G1786767	COATING BAR:TRANSFER ROLLER:ASS'Y	1	a 450K / b 500K	C (C900)
D0746300	SEPARATION CORONA:ASS'Y	1	300K	U
D0746250	TRANSFER ROLLER	1	300K	U
<b>Fusing Unit</b>				
D0744197	FLAT BELT- FUSING:DIA80:SEAL	1	650K	U
AE010100	HOT ROLLER:DIA54:ASS'Y	1	650K	U
AE020200	PRESSURE ROLLER:DIA65	1	650K	U
AE030058	BALL BEARING:DIA25:DIA37	1	650K	U
D0744329	WEB:GEAR:ASS'Y	1	450K	U
D0744333	ROLLER:PLATE	1	450K	U
D0744300	SPRING PLATE:CLEANING UNIT:FUSING	1	450K	U
<b>ADF ( C1 only )</b>				
B6523121	TRANSPORT BELT:SCANNING	1	120K	C (D014)
A8061295	PAPER FEED BELT	1	120K	C (D014)
A8592241	REVERSE ROLLER:PAPER FEED	1	120K	C (D014)
B4772225	PICKUP ROLLER	1	120K	C (D014)
<b>Paper Feed</b>				
AF030072	PAPER FEED ROLLER:PICKUP	2	1000K	C (D059)
AF031080	PAPER FEED ROLLER:FEED	2	1000K	C (D059)

## Product Support Guide

### D075 / D074 / M044

Parts Number	Description	Q'ty	PM Interval	Unique or Common
AF032080	PAPER FEED ROLLER	2	1000K	C (D059)
<b>Others</b>				
D0747111	FILTER:PREVENTFENCE	4	600K	U
D0747110	OZONE FILTER	1	a 1200K / b 1350K	U
<b>LCIT</b>				
AF030071	PAPER FEED ROLLER:PICKUP	3	300K	C (RT5050)
AF031071	PAPER FEED ROLLER:FEED	3	300K	C (RT5050)
AF032041	PAPER FEED ROLLER:SEPARATE:MANUAL FEED	3	300K	C (RT5050)
<b>Multi Bypass Tray</b>				
AF030080	PAPER FEED ROLLER:PICKUP	1	1000K	C (BY5000)
AF031081	PAPER FEED ROLLER:FEED:MANUAL FEED	1	1000K	C (BY5000)
AF032080	PAPER FEED ROLLER:SEPARATE	1	1000K	C (BY5000)
<b>Cover Interposer Tray CI5020</b>				
A8061295	PAPER FEED BELT	1	60K	C (CI5010)
A8592241	REVERSE ROLLER:PAPER FEED	1	60K	C (CI5010)
B4772225	PICKUP ROLLER	1	60K	C (CI5010)

#### Note 1 Conditions

- A4/LT size non-coated paper
- 8.75% coverage
- 25 pages per job
- The yield will likely decrease when printing on coated paper

# Product Support Guide

## D075 / D074 / M044

### Special Tools & Lubricants

	Part Number	Description	Q'ty	Unique or Common
1	52039502	SILICON GREASE 501	1	C
2	B1329700	LUBRICANT POWDER	1	C
3	A2579300	GREASE - BARRIERTA S552R	1	C
4	G0049698	GREASE : KS660 : SHIN-ETSU	1	C
5	B6455010	SD-CARD:ASS'Y	1	C
6	VSSG9002	FLUOTRIBO MG GREASE : 100G	1	C
7	A0069104	ADJUSTING SCANNER PIN (4PCS/SET)	1	C
8	---	Ricoh System Information Tool (Support Tool Version 2) - Basic version - Mail version - Rlogtool (for use with GW controller)	1	C (General)
9	C4019503	Loop [20x Magification Scope]	1	C (General)

### On Site Support Recommendations

Description	Installed by:	Order Number / Part Number
Additional Toner (CYMK)	Customer	Reference the Supplies Table (page 4)
Waste Toner Bottle (Toner should be disposed of as required by local or State law)	Customer	(Service Part) TBA (Supply Item)
Fuser Unit	Service / TCRU	404442 (TCRU Item)
All 300K PM kits	Used to rebuilt TCRU Units	
• PCDU (1 Set)	Used to rebuilt TCRU Units	PMM077PCUK
• ITB / PTR / Other (Balance of 300K PM parts)	Used to rebuilt TCRU Units	PMM077400K
600k PM kit	Used to rebuilt TCRU Units	PMM077800K

# Product Support Guide

## D075 / D074 / M044

### PM KITS

#### Pro C751ex / C751 / C651ex

Kit Name	Item	Description	Qty	PM cycle
<b>PMD074PCUK</b>				
	D0742150	Charge Unit: Taurus Ass'y	1	300K
	D0742422	Blade Cleaning: Ass'y	1	300K
	D0742454	Brush Roller Apply Ass'y	1	300K
	D0742466	Coating Bar: Ass'y	1	300K
	D0742481	Blade: Apply Ass'y	1	300K
	D0742459	Joint: Cleaning Unit	1	300K
	D0742424	Seal: Blade: Cleaning: Front	1	300K
	D0742425	Seal: Blade: Cleaning: Rear	1	300K
	D0742485	Seal: Blade: Apply: Front	1	300K
	D0742486	Seal: Blade: Apply: Rear	1	300K
	D0742458	Gear:19Z: Right	1	300K
	D0742501	Gear: 21Z: Right	1	300K
	D0742502	Gear: Idler:20Z: Left	1	300K
	D0742503	Gear: Idler:31Z: Left	1	300K
<b>PMD074ITBK</b>				
	D0746426	Belt: Cleaning: Belt	1	600K
	D0746446	Brush: Apply: Belt Cleaning	1	600K
	D0746450	Coating Bar: Ass'y	1	600K
	D0746457	Blade: Apply: Ass'y	1	600K



# Product Support Guide

## D075 / D074 / M044

### Target Reliability

Item	Pro C651ex	Pro C751ex / C751
Average Document Volume	50K /Month	70K /Month
Max. Monthly Volume	180k /Month	180K /Month
PM Interval	300K Prints	300K Prints
Duty	350K /month	350K /month

Note: 25 pages / job

Note: FC: BK = 8:2%

The figures above are calculated based on the following:

- PM is regularly performed
- Recommended paper types (A4/LT) are used

# Product Support Guide

## D075 / D074 / M044

### Specifications / Documentation

#### GW Controller

#### Hardware Specification (Common to Printer and Copier version)

Items		Specification	Remarks
Configuration		Console	
Copy Process		4-drum dry electrostatic transfer system with internal transfer belt	
Fusing		Oil-less Belt-fusing Method	
Toner Type		New PxP toner (Polymerized oil-less full color toner)	
Engine Speed	FC	65 / 75 ppm	A4/LT(LEF)
	BK	65 / 75 ppm	
Warm-up Time		Less than 300 sec.	23C°, rated voltage
Limitless Paper Supply		Supported	
Paper Size		Please refer to "Paper size matrix".	
Maximum Printable Area		320 mm x 480 mm / 12.7" x 18.9"	
Paper Weight	1 <sup>st</sup> tray		52.3-300g/m2 14lbs.Bond – 110lbs.Cover
	2 <sup>nd</sup> tray		52.3-256.0g/m2 14lbs.Bond – 95lbs.Cover
	A4/ LT LCIT	3 <sup>rd</sup> tray	52.3-256.0g/m2 14lbs.Bond – 95lbs.Cover
		4 <sup>th</sup> tray	52.3-300g/m2 14lbs.Bond – 110lbs.Cover
		5 <sup>th</sup> tray	52.3-256.0g/m2 14lbs.Bond – 95lbs.Cover
	Bypass Tray		52.3-220.0g/m2 14lbs.Bond – 81lbs.Cover
	Simplex		60.0 – 300.0g/m2
	Duplex		60-256.0g/m2 16lbs.Bond – 95lbs.Cover
Paper Weight Setting	Paper Weight 1		60.0 – 63.0g/m2
	Paper Weight 2		63.1 – 80.0g/m2
	Paper Weight 3		80.1 – 105.0g/m2
	Paper Weight 4		105.1 – 163.0g/m2
	Paper Weight 5		163.1 – 220.0g/m2
	Paper Weight 6		220.1 – 256.0g/m2
	Paper Weight 7		256.0 – 300.0g/m2
Power Specification	NA ver.		208-240V, 16A, 50/60Hz
	EU ver.		220-240V, 16A, 50/60Hz
Max. Power Consumption		4000W	Not including DFE and option peripherals with own power supply

# Product Support Guide

## D075 / D074 / M044

### Other Specification

		Printer version	Copier version	Remarks	
<b>Dimension (W x D x H) (*1)</b>		<b>1,320 x 910 x 1,218mm</b>	<b>1,320 x 910 x 1,230mm</b>		
Weight (*1)		Less than 550kg	Less than 580kg		
ADF			Std		
Paper Capacity	Std	1 <sup>st</sup> tray: 1,000 sheets x2 (Tandem)			
		2 <sup>nd</sup> tray: 500 sheets	Same		
	Op.	3 <sup>rd</sup> tray: 1,000 sheets 13"x19.2" LCT		Same	
		4 <sup>th</sup> tray: 2,000 sheets 13"x19.2" LCT		Same	
		5 <sup>th</sup> tray: 1,000 sheets 13"x19.2" LCT		Same	
	Multi Bypass Tray (Option)		500 sheets		
Max (System)		7,000 Sheets			

**[Remarks]**

(\*1) Not including DFE.

(\*2) Paper weight is 80g/m2.

Plug of NA model

Plug Type :NEMA 6-20

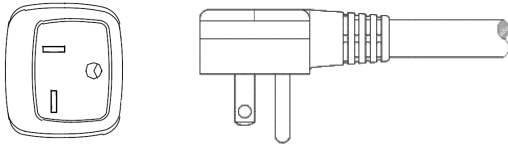

Plug Type for EU model:  
Single Phase.

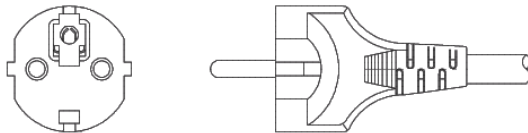

# Product Support Guide

## D075 / D074 / M044

### GW Controller

		Specification	Note
CPU		LV Dothan Pentium M1.4GHz/14076915	
Memory	P1	1.5GB (1GB + 512MB)	
	C1	2.5GB (2GB + 512MB)	
HDD		320 GB	
Interface		100/BASE-TX / 10BASE-T	
		SD Slot x 2	GW application installation Service use
		USB2.0 x 1	External appliance
Network Protocol	Network	TCP/IP (Ipv4, Ipv6)	
	Scanning e-mail	POP before SMTP, SMTP Authentication, S/MIME	
	Scan to Folder	SMB, FTP, NCP	

### COPIER FEATURE (Pro C1 only)

Items		Specifications	Remarks	
Original Type		Book/Sheet/Object		
Original size		Max: A3 / 11" x 17" Min: A5, 5 1/2" x 8 1/2"		
Copy/Print size		A3-A5, Up to 330mm x 458mm 11" x 17"-5 1/2 x 8 1/2, 13" x 18"		
First Copy Output Time	FC		<b>A4/LT(LEF)</b> 1 <sup>st</sup> input tray /Face Up/ Plain Paper / Simplex	
	Bk	(C1a) 65 cpm (C1b) 75cpm		
Multi copy speed	Memory retention	FC	(C1a) 65 cpm (C1b) 75cpm	A4/LT(LEF)
		Bk	(C1a) 65 cpm (C1b) 75cpm	
	ADF 1 to 1	FC	(C1a) 65 cpm (C1b) 75cpm	A4/LT(LEF)
		Bk	(C1a) 65 cpm (C1b) 75cpm	
Multi copy		Up to 9,999		
Resolution	Copy	1,200dpi 2bit		
	Print	1,200dpi x 4800dpi		
	Scan copy	600dpi 8bit		
	Scan send	600dpi 8bit		
Magnification	NA ver.	7 Reductions & 5 Enlargement 93%, 85%, 78%, 73%, 65%, 50%, 25% 121%, 129%, 155%, 200%, 400%		
	EU ver.	7 Reductions & 5 Enlargement 93%, 82%, 75%, 71%, 65%, 50%, 25% 115%, 122%, 141%, 200%, 400%		
Auto Magnification Select (AMS)		Supported		
Zoom		25-400%	1% step	
Size Magnification		Supported		
Directional Magnification		Supported	1 % step	
Directional Size Magnification		Supported	1 mm/0.1 inch step	

# Product Support Guide

## D075 / D074 / M044

Full Image Copy		Supported	93% & Centering
Interrupt Copy		Standard	
Image Density		Auto Image Density	
		Manual Selection	9 Levels
Color Model		Auto Color Selection	
		Full Color	
		Black & White	
		Single Color	Default: 12 colors & Black User Color: 15 colors
		Twin-Color	Black & Other color Red & Black
Original Type Setting		Text	
		Text/Photo	
		Photo	
		Map	
		Pale	
		Generation	
		Inkjet	
		Highlight Pen	
Paper selection		Auto Paper Selection	
		1 <sup>st</sup> Tray	
		2 <sup>nd</sup> Tray	
		3 <sup>rd</sup> Tray	LCT option is required
		4 <sup>th</sup> Tray	LCT option is required
		5 <sup>th</sup> Tray	LCT option is required
		6 <sup>th</sup> Tray ( Bypass tray )	LCT option and Bypass are required
Displays for kinds of paper		Plain Paper*, Recycle Paper Special Paper, Color Paper1 Color Paper2, Color (9 kinds; Yellow, Green, Blue, Purple, Ivory, Orange, Pink, Red, Gray), Envelope, Coat1, Coat2, Coat3, Preprinted paper, Letter Head, Backed Copied, Labels, Pre-punched Paper Special Paper1, Special Paper2, Special Paper3, Special Paper4, Special Paper5, Special Paper6, Bond, Tab stock	
Paper Library		Yes	
Duplex		1 side to 2 side	
		2 side to 2 side	
		Book to 2 side	
		Front & Back to 2 side	
Book / Series Combine	Book	Booklet Magazine	
	Series	Book to Simplex Book to Duplex Front & Back to 2 sided	
	Combine	Combine 2,4,8 into 1 simplex sheet Combine 4,8,16 into 1 duplex sheet	
Margin Adjustment		Supported	1mm/0.1 inch
Erase 3 edge	Inside	Supported	
	Outside		

# Product Support Guide

## D075 / D074 / M044

	Center/Border		
Cover / Slip sheet	Front	Copy or Blank	Copy: Duplex or Simplex
	Front & Back	Copy or Blank	Copy: Duplex or Simplex
	Slip	Copy or Blank	
Chaptering		Supported	Up to 100 positions
Paper Designate		Supported (can select from 3 trays)	Up to 100 positions
Image Rotation		Supported	
Electronic Sort		Supported	With finisher
Stapling		Supported, 4 positions	With finisher
Punch		USA: 2/3 switchable hole punch EU: 2/4 switchable hole punch Scandinavian: 4 holes punch	With Finisher
Stamp	Background Numbering	Not Available	
	Page Numbering	6 stamps	
	Date Stamp	5 stamps	
	User Stamp	5 stamps	
	Preset Stamp	8 stamps	
	Stamp Text	Supported	
Image Adjustment	Color Adjustment	Color Balance Adjustment	
		Color Balance Program	
		Color Registration	
	Image Adjustment	Sharp / Soft	
		Contrast	
		Background Density Adjustment	
		Under Color Removal	
		Auto Color Selection Sensitivity Adjustment	
		Text-Photo Separation Sensitivity Adjustment	
		Color Erase Sensitivity Adjustment	
Auto Color Calibration (ACC)			
User Code		8 digits / 500 user code	
Interrupt Copy		Supported	
Copy Counter	NA Model	Electrical and Mechanical counter x2	
	EU Model	Electrical and Mechanical counter x1	
Counterfeit Prevention		Bill Recognition & Invisible Marking Function	

# Product Support Guide

## D075 / D074 / M044

### **GW SCANNER FEATURE (Pro C1 only)**

#### **GENERAL SPECIFICATIONS**

		Specification
Original type		Book / Sheet / Object
Resolution		100 / 150 / 200 / 300 / 400 / 600 (Default) 200 dpi 100-1,200 dpi (Twain: BW) 100-1,200 dpi (Twain: Color)
Scan Speed (A4, 200dpi)		BW: 75 spm FC: 75 spm *Scan speed (A4 LEF, 200dpi)
Max Scan Area		297 x 432 mm / 11.7"x17"
Original Size	Standard	A3 SEF, A4 SEF, A4 LEF, A5 SEF, A5 LEF, B4 SEF, B5 SEF, B5 LEF 11"x17" SEF, 8 1/2"x14" SEF, 8 1/2"x13" SEF, 8 1/2"x11" SEF, 8 1/2"x11" LEF, 5 1/2"x8 1/2" SEF, 5 1/2"x8 1/2" LEF
	Customized	Minimum: 140 x 140 mm Maximum: 297 x 432 mm
File Format		TIFF (Multi/Single), JPEG, PDF (Multi/Single), High compression PDF (Multi/Single)
Scan Mode	Default	BW Text/Line Art
	Support	BW_Text, BW_Text-Photo, BW_Photo, Grayscale, FC_Text-Photo, FC_Photo, Auto Color Selection
Image Density	Auto Density Selection	Supported
	Manual Setting	7 Levels
Thin paper mode		Not Supported
SADF / Batch Mode		Supported
Mixed Size Mode		Supported

# Product Support Guide

## D075 / D074 / M044

### SCAN TO E-MAIL

		Specification
Requirement		SMTP Gateway and TCP/IP
Authentication		SMTP POP before SMTP  <i>S/MIME</i>
Resolution		Default: 200 dpi 100 / 150 / 200 / 300 / 400 / 600 dpi
Register E-mail Address in HDD		Max. 2,000 addresses
Register Group Address in HDD		Max. 500 Addresses <b>Max. 100 Addresses in One Group Addresses</b>
Maintain E-mail Address in HDD		Direct input on operation panel, Web image Monitor, Smart Device Monitor
Search E-mail Address in HDD		By name & E-mail address
LDAP		Yes
Max Address Number per Send		Max. 500 addresses
Address Number per send	via Address Book	Max. 500 addresses
	Direct Input	Max. 100 addresses
	via LDAP	Max. 100 addresses
Attention		To, cc, bcc
Subject	Manual Input	Max. 128 characters
Body Message	Manual Input	Max. 80 characters
	Pre-register by user	5 body message. 80 characters x 5 lines per a body message. Title name of the body message: Max. 20 characters per a name.
	Preset	Message: "This e-mail included attached file sent from xxxx (machine model name)."
E-mail Size Restriction	With restriction	128-102,400KB, Default = 2,048KB
	W/O restriction	725MB
File Type		Single Page TIFF, Single Page JPEG, Single Page PDF, Multi Page TIFF, Multi Page PDF, Single Page High-compression PDF, Multi Page High-compression PDF
Program User Setting		Yes (Up to 25 programs)
Divided & Send E-mail		Yes (By page or size) / No, Default = Yes (By size)
Resend		Yes



# Product Support Guide

## D075 / D074 / M044

### SCAN TO FOLDER

	Specification
Protocol Support	SMB, FTP, NCP
Security	Client folder log-in (log-in name and password) Encryption of log-in name and password during transmission
Resolution	Default: 200dpi 100, 150, 200, 300, 400, 600dpi
Max. Resisted Client Folder Address in HDD	Max. 2,000 folders
Maintain Client Folder Address in HDD	Via Operation Panel, Web Image Monitor
Max. Client Folders per send	Max. 50 client folders
Group Address	Max. 100 destinations (To Folder: 50, To e-mail: 100) *1
Input Subject	No
Scan file size	1 document Up to 2000MB
File size when combined Scan to Folder & Scan to E-mail	128-102,400KB, Default = 2,048KB (With restriction) 725MB (W/O restriction) (Conforming to the scan to e-mail specification)
File Type	Single Page TIFF/JPEG, Single Page PDF, Multi Page TIFF, Multi Page PDF, Single Page High-compression PDF, Multi Page High-compression PDF
Program Registration	Yes (Up to 25 programs)
Dividing file in Scan to E-mail	Yes (By page or size) / No, Default = Yes (By size) (When Scan to PC combine with Scan to e-mail)
Resend	Yes / No, Default = Yes

\*1. User can send to Max 100 destinations in the same group. But the number of folders has to be less than 50, since Max. folder destinations are 50. If there are more than 50 folder destinations registered in Group address, a message pops up.  
 100 destinations 50 folders included >>>OK  
 100 destinations 51 folders included >>>NG

#### Max. Number of address per sending (Combination between E-mail and Folder)

	Input via	Condition 1 Max. address can Select or input	Condition 2 Max. address allow in single operation	Condition 3 Combination of Address: Max.
Scan to E-mail	Address book	500	500	550
	Manual input	100	500	550
Scan to Folder	Address book	50	50	550
	Manual input	50	50	550

The number of destination which user can put has to satisfy all of above 3 conditions

### NETWORK TWAIN DRIVER

	Specification
Correspondence OS	Windows 2000/XP/Vista/7, Windows Server 2003, Server 2008
Resolution	100-1200dpi
Scan Mode	Standard, Photo, OCR, Filing
Image Adjustment	Brightness, Contrast, Threshold, Gamma Adjustment, Halftone Pattern
Stamp	Date, Page Number, Text
Endorse	Supported

# Product Support Guide

## D075 / D074 / M044

### DOCUMENT SERVER SPECIFICATION ( C1 only)

	Data Format
Copy*	Ricoh Unique Format
Print*	Ricoh Unique Format
Scan	TIFF, JPEG, PDF

\*C1 does not support File Format Converter.

	Document Server Capacity
HDD Capacity for Document Server	320GB
Maximum Stored Documents	3,000 Documents
Maximum Page per Document	5,000 pages (Copy) 3,000 pages (Print) 3,000 pages (Scanner)
Maximum Page of all stored Document	12,000 pages

**Remarks:**

Document Server capacity depends on the image coverage of each document. The actual capacity may vary in each case.

# Product Support Guide

## D075 / D074 / M044

### PERIPHERALS SPECIFICATION

The specifications described below are for the peripherals themselves. Specifications for Pro C751ex / 751 / 651ex Series mainframe are put higher priority than the peripherals when they are used together as a system.

#### **ADF SPECIFICATION (STANDARD on C 1)**

Item	Specification	Remarks
Dimensions (W x D x H)	680 x 565 x 180mm	
Weight	Less than 19.5 Kg	
Power Source	From mainframe	
Noise (Power level)	Less than 72dB	
Stack capacity	100 sheets or less than 12mm	80g/m2, 20lbs Bond
Original size	- Simplex B6-A3 (SEF), 5 1/2" x 8 1/2" – 11" x 17" (SEF) - Duplex A5-A3 (SEF) 5 1/2" x 8 1/2" – 11" x 17" (SEF)	
Original Weight	- Simplex 40-128 g/m2 11-34 lb Bond - Duplex 52-128 g/m2 14-34 lb Bond	
Original set position	Left-rear corner	
Original Feed	ADF, SADF mode	
Original Set	Face Up, First sheet on top	
Original Feeding Speed	B/W: 75 opm Color: 75 opm (200 dpi)	A4 LEF or LT LEF
Power Source	From Mainframe	

Remarks:

\* When using the GW Scanner the Original Feeding Speed is 75 opm.

# Product Support Guide

## D075 / D074 / M044

### ***13"x 19.2" Large Capacity Tray***

Item	Specification
Dimensions (W x D x H)	865 x 730 x 1218 mm
Weight	Less than 185 kg
Configuration	Console Type
Power source	From mainframe
Noise (Power level)	Less than 76 dB
Paper size	LT_LEF, HLT_SEF – 13" x 19.2" <Custom Size Paper> Width: 100 to 330.2mm (3.94 to 13.00 inch) Length: 139.7 to 487.7mm (5.50 to 19.20 inch)
Paper weight	52.3-300g/m2 14lb Bond -110lb Cover
Paper capacity	4 <sup>th</sup> Tray: 1,000 Sheets 5 <sup>th</sup> Tray 2,000 Sheets 6 <sup>th</sup> Tray 1,000 Sheets
Air Assist Paper Pickup	Yes All Trays

### ***MULTI BYPASS TRAY UNIT***

Item	Specification	Notes
Paper Capacity	500 sheets (80g/m2, 20lb Bond)	
Paper Size	A5/HLT - 13" x 19.2" <Custom Size Paper> Width: 100.0 to 330.2mm (3.94 to 13.00 inch) Length: 139.7 to 487.7mm (5.50 to 19.20 inch)*1	
Paper Weight	52~216g/m2, 16lb Bond to 80lb Cover	
Power Source	From LCT (From Mainframe→LCT)	
Paper Volume sensors	In 4 steps: Near end, 0%, 50%, 100%	
Dimension (W x D x H)	690 mm x 561 mm x 210 mm	
Weight	Less Than 20 kg	

# Product Support Guide

## D075 / D074 / M044

### Finisher SR 5030 / Booklet Finisher SR5040

Item		Specification
Dimensions (W x D x H)		996 x 730 x 1125mm *Not includes projections
Weight		SR5030 Less Than 112kg SR5040 Less Than 130kg
Configuration		Console type
Power Source		100-240V
Power Consumption		Less than 250V
Output Jogger		Standard
Proof Tray	Stack capacity	250 sheets (A4, 8 1/2" x 11 or smaller) 50 sheets (B4, 8 1/2" x 14" or larger) 80g/m2, 20 lb. Bond
	Paper size	Max up to 330.2 x 487.7 mm (13" x 19.2")
	Paper weight	Without Z-folding> 60 g/m2-216g/m2 (16-40 lb.Bond, 50-80 lb.Cover, 90-110 lb.Index) <Z-folding> 64-105 g/m2, 17-28lb Bond
Shift Tray	Stack capacity	<u>3,000 sheets</u> *SR5030 (A4 LEF, B5 LEF, LT LEF) <u>2,500 sheets</u> *SR5040 (A4 LEF, B5 LEF, 8 1/2" x 11 LEF) <u>1,500 sheets</u> (A3 SEF, A4 SEF, B4, B5 SEF, 11" x 17" SEF, 8 1/2 " x 11" SEF, SRA4, 226 x 310mm) <u>1,000 sheets</u> (12" x 18", SRA3, 13"x18", 12.6"x18.5", 12.6"x19.2", 13"x19", 13" x 19.2", 310x432mm) <u>500 sheets</u> (A5 LEF, 5 1/2" x 8 1/2" LEF) <u>100 sheet</u> (A5 SEF, 5 1/2" x 8 1/2" SEF) <u>30 sheets</u> (Z-folding paper)
	Paper size	<Without Z-folding> Max Up to 330.2 x 487.7 mm (13" x 19.2") <Z-folding> Up to 12"x18"
	Paper weight	<Without Z-folding> 52 3- 300g/m2 <Z-folding> 64-105 g/m2, 17-28lb Bond

**Remarks: The capacity to be calculated with 80 g/m2, 20 lb. Bond paper.**

# Product Support Guide

## D075 / D074 / M044

### STAPLE SPECIFICATIONS

Item		Specification
Paper size		B5-A3 8 1/2" x 11" – 11" x 17"
Paper weight		<without Z-folding> 64.- 80g/m2 ( 17 – 22 lb. Bond ) <with Z-folding> 64 – 105 g/m2 ( 17 – 28 lb Bond )
Staple position		Top, Bottom, 2 Staples, Top-slant
Staples Capacity	A4, B5, 8 1/2" x 11"	2-100 sheets
	A3, B4 11"x17", 8 1/2"x14"	2-50 sheets
	Z-folding	10 sheets
Staple Replenishment		Cartridge exchange / 5,000 pins per cartridge

Remarks: The capacity to be calculated with 80 g/m2, 20 lb Bond paper.

### PUNCH SPECIFICATIONS (OPTION)

	Specification	Remarks
Number of Punch	NA: 2 or 3 holes EU: 2 or 4 holes Scandinavian: 4 holes	Punch option is required.
Punch Registration	Yes (Resist Roller and Side Registration Sensor)	
Punch Replenishment	NA 2 holes: 15,000 sheets NA 3 holes: 10, 000 sheets EU 2holes: 25,000 sheets EU 4 holes: 15,000 sheets Scandinavian 4 holes: 15,000 sheets	
Max. Thickness	209gsm	

### STACK CAPACITY AFTER FINISHING

	Paper size	# of Pages per set	# of Sets
Without Z-folding	A4 LEF, B5 LEF 8 1/2" x11"LEF	20 - 100	125 - 25
		10 - 19	200 - 105
	A3, B4 11" x 17", 8 1/2" x 14"	10-50	150-30
		2-9	30
When mix-sized	A3 & A4, B4 & B5 11" x 17 & 11" x 8 1/2"	2-50	30
With Z – Folding (One size or mixed sized)	One size A3 Z – Folding & A4 B4 Z-Folding & B5 11 x 17 Z-Folding +11"x81/2"	1 - 10	30 - 3
When Saddle Stitch	All Sizes	2-5	30
		6-10	15
		11-15	10
		16-20	5

# Product Support Guide

## D075 / D074 / M044

### SADDLE STITCH SPECIFICATIONS

Item	Specification	
Paper size	B5-SRA3 8 1/2"x11"-13" x 19.2"	
Paper weight	64-90g/m2 (17-24 lb. Bond)	
Staple position	Center 2 position	
Staples Capacity*	64-80g/m2 (18-20lb Bond)	20 sheets
	80-90g/m2 (20-24lb Bond)	15 sheets
	Cover Sheet	One cover sheet (up to 163g/m2) can be included in the above stapling capacity.
Staple Replenishment	Cartridge exchange	

### BOOKLET TRIMMER

Item	Specification	Notes
Dimension (W x D x H)	1,115 x 591 x 555mm	
Weight	75kg	
Configuration	Console type / Optional unit for Booklet Finisher	Booklet Finisher is necessary
Power consumption	Universal Power Supply 100V – 240V NA: 60Hz EU: 50Hz Ave. 75W, Max. 250W	Plug
Trimming Type	One side edge	
Trimming Capacity	1-20 sheets (2-40 pages after folding)	20lb, 80g/m2
Paper Size	13 x 19.2", 13 x 19", 12.6 x 19.2", 12.6 x 18.5" 13 x 18", SRA3(320 x 450mm), 12 x 18", A3, B4 SRA4(320 x 225mm), 226 x 310mm, 310 x 432mm, A4, B5, DLT, LG, LT <Custom Size> Width: 182 to 330mm Length: 257 to 488mm	*sizes before folding
Stack Capacity	1 sheet: 60 sets*1 2 - 5 sheets: 60 sets 6 - 10 sheets: 35 - 40 sets*1 11 - 20 sheets: 20 - 25 sets*1	
Stacker Full Detection	Yes	
Limitless Stack	Yes*2	

\*1: The stack capacity varies according to the size of the sheets.

\*2: Note: Hardware modification by service engineer is necessary. Not applicable by end-user.

# Product Support Guide

## D075 / D074 / M044

### **COVER INTERPOSER**

Item	Specification	Notes
Dimension (W x D x H)	540 x 730 x 1290 (mm)	
Weight	Less than 45kg	
Power Source	From mainframe	
Noise (Power level)	Less than 76dB	
Paper Size	A3-A5 11"x17" – 5 1/2"x 8 1/2" MAX.13" x 19.2"/ 330mm x 487.7 mm	
Paper weight	64-216 g/m2 17lb Bond -80 lb Cover	
Paper capacity	200 sheets x 2 trays	20lb, 80g/m2
Original set position	Center position	
Original Set	Face Up, First sheet on top	
Size change	From operation panel of mainframe	User changeable

### **DLT / A3 TRAY KIT**

This option is put on the Tandem LCT in 1<sup>st</sup> tray of base-unit, and can feed DLT or A3 paper. This 1<sup>st</sup> tray can normally feed LT or A4 size paper only. So it's useful for users that require DLT or A3 paper extremely.

Item	Specification
Dimensions (W x D x H)	495 x 530 x 175 mm
Weight	10 kg
Paper size	A3 SEF, B4 SEF, A4 11"x17" SEF, 8 1/2"x14 SEF, 8 1/2"x11"
Paper capacity	1,000 sheets

**Note:**

. This option is put on the Tandem LCT in 1<sup>st</sup> tray of base-unit, and can feed DLT (11"x17") or A3 paper. This 1<sup>st</sup> tray can normally feed LT (8 1/2"x11") or A4 size paper only.



# Product Support Guide

## D075 / D074 / M044

### **RING BINDER (RB5010)**

Item		Specification	
Dimensions (W x D x H)		870 x 730 x 1,010 mm	
Weight		Less than 140kg	
Power consumption		Less than 400W	
Power Supply		100-240V, 50/60Hz	
Paper size	Binding mode	A4_LEF, 8 1/2" x 11" _LEF	
	Punching mode	A4_LEF, 8 1/2" x 11" _LEF	
Paper weight	Binding mode	64-216 g/m2 17lb Bond -80 lb Cover	
	Punching mode	64-216 g/m2 17lb Bond -80 lb Cover	
Capacity of ring bind		2-100 sheets	
Number of holes	8 1/2" x 11"	21 holes	
	A4	23 holes	
Ring Supply	Type	NA	1) 8 1/2" x 11", Black, 50 sheets 2) 8 1/2" x 11", Black, 100 sheets 3) 8 1/2" x 11", White, 50 sheets 4) 8 1/2" x 11", White, 100 sheets
		EU	1) A4, Black, 50 sheets 2) A4, Black, 100 sheets 3) A4, White, 50 sheets 4) A4, White, 100 sheets
	Replenishment	Cartridge exchange	*75 sets/cartridge
TAB Stock		Supported*1	*See the below drawings
Stack capacity	Binding mode	11 sets	*100 sheets /set
	Punching mode	100 sheets (200 pages in DPX)	

\*1: Please refer the following regarding supported TAB stock dimension.

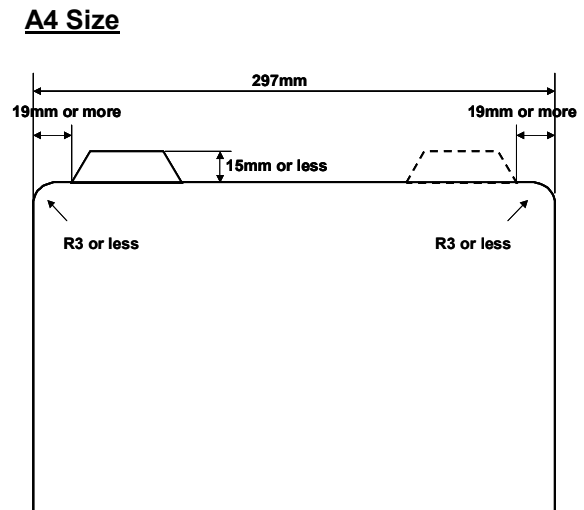
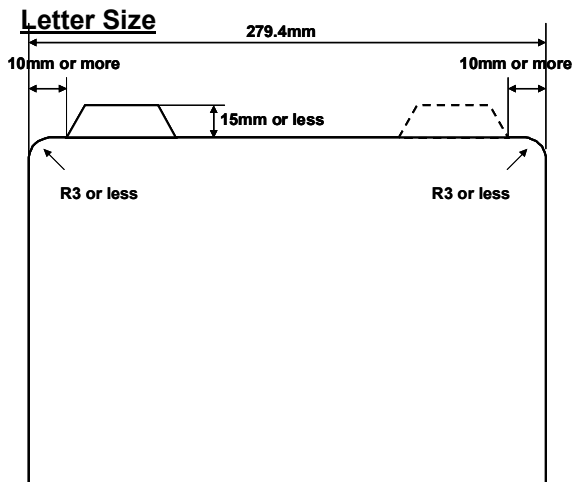

# Product Support Guide

## D075 / D074 / M044

### **HIGH CAPACITY STACKER**

Item	Specification	
Dimensions (W x D x H)	900 x 730 x 1000mm	
Weight	Stacker:120kg, Roll-away Cart 15kg	
Configuration	Console type	
Power consumption	Less than 120W	
Power Supply	NA: 120V, 60Hz EU: 220-240V, 50/60Hz <span style="float: right;">*5V, 24V needs to be supplied from the main unit</span>	
Proof tray	Paper size	A6T to 331x488mm (13"x19.2")
	Paper weight	52-300g/m2 <span style="float: right;">40-52g/m2 paper has to be tested</span>
	Stack Capacity	250 sheets
Stack tray	Paper size	139.7x139.7mm to 330.2x487.7mm (13"x19.2")
	Paper weight	52-300g/m2
	Stack Capacity	A4/LT-SRA3/13"x19.2": 5,000 sheets B5-Half LT: 2,500 sheets
	Output Jogger	Standard
Roll Away Cart	Yes (Includes one cart. Additional option cart is available)	
Door Lock	Optional (Bracket for Lock is included in the box)*2	

**\*1: Recommended Lock Type**

The following lock is recommended. Please procure it locally.

- ABUS Lock: T84MB (50 or 60mm), 84MB (50 or 60mm), EC75 (50 or 60mm)
- See the following drawing for alternative.

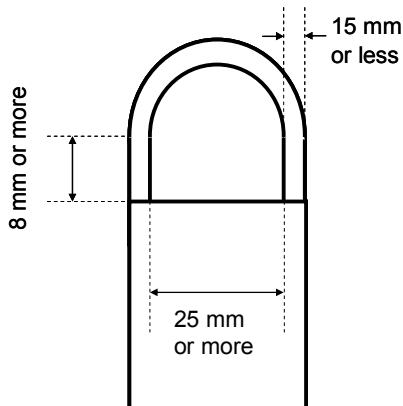

Bracket for Security Lock (Included in the box)

# Product Support Guide

## D075 / D074 / M044

### ***BUFFER PASS UNIT***

	Specification
Dimensions (W x H x D)	333 x 730 x 1010 mm
Weight	Less than 90kg
Power consumption	Less than 200W
Power Supply	NA: 100- 120V, 50/60Hz, 3A EU: 220- 240V, 50/60Hz, 1A
Paper Size	331 x 488mm (13' x 19.2') ~ A6T/Post Card
Paper Weight	52gsm – 300gsm

# Product Support Guide

## D075 / D074 / M044

### MFP Supported Environments

See Fiery PSG for E41A

### Other MFP Support Information

## Counters

- **Counter** (Operation Panel Button)

**Display in Developments:** [Default is Developments]

Color Total xxxxxxxx

B&W Total xxxxxxxx

**Display in Prints:** [Use SP5045 to change to Prints (change from “0” to “1”)]

Print Out:

Color Total xxxxxxxx

B&W Total xxxxxxxx

Color Copies xxxxxxxx

B&W Copies xxxxxxxx

Color Prints xxxxxxxx

B&W Prints xxxxxxxx

- User Tools → System Settings → Administrator Tools → Display / Print Counter

**Display:** (Prints)

Total xxxxxxxx

Copier

Full Color xxxxxxxx

B&W xxxxxxxx

Single Color xxxxxxxx

Two Color xxxxxxxx

Printer

Full Color xxxxxxxx

B&W xxxxxxxx

Single Color xxxxxxxx

Two Color xxxxxxxx

A3/DLT xxxxxxxx

Duplex xxxxxxxx

Scanner Send

Color xxxxxxxx

B&W xxxxxxxx

Send/TX Total

Color xxxxxxxx

B&W xxxxxxxx

Print Out

Same as display

- Maximum 7 digits
- Mechanical counter – behind cover to the left of the 1<sup>st</sup> paper tray. 7 digits.

# Product Support Guide

## D075 / D074 / M044

### Paper

#### Recommended Throughput Material

Refer to MQP Recommended Media List.

# Product Support Guide

## D075 / D074 / M044

### Non Recommended Throughput Material

Refer to pages in the Operators Instructions “About This Machine”.

### Special Paper

TBA

## Firmware Information

### Firmware

A 2GB SD card is needed to perform Firmware upgrades.

Firmware SD Card	M044 Firmware Type	Appx. Size	D074 / 75 Firmware Type	Appx. Size
System	System Firmware	TBA	System/Copy Firmware	17,156k
Engine	Engine Firmware	TBA	Engine Firmware	8,129k
Web Support	Web Support	TBA	Web Support	4,112k
OpePanel	Operation Panel	TBA	Operation Panel	16,385k
Network Support	Network Interface	TBA	Network Interface	5,621k
Network DocBox	Network DocBox	TBA	Network DocBox	1,727k
Language	Language	TBA	Language	14,693k
WebUapl		TBA	WebUapl	1,239k
Scanner		TBA	Scanner	1,528k
<b>Total Size</b>				<b>70,600k</b>

#### SD Card Arrangement

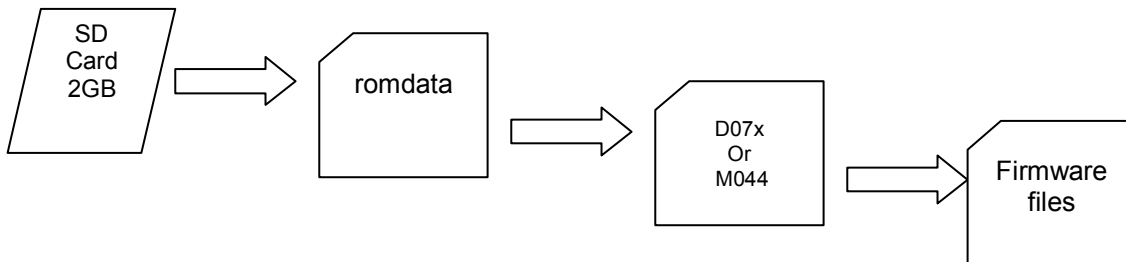

#### Note:

- The M044 Printer and the D074/D075 MFP's do **NOT** use the same mainframe firmware.

### Fiery System Software

See Fiery PSG....

# Product Support Guide

## D075 / D074 / M044

### Contact Information

Name	Contact
Technical Services Call Center (Hotline) Production Printing Support Center (PPSC)	Ricoh: (800) 537-4264 Savin: (800) 291-6044 Lanier: (800) 333-3147 All: 1-800-53-RICOH
Application Help Desk (Software Issues)	Ricoh Phone Card: 2 Call - 000781MIU, 5 Call - 000901MIU Savin Phone Card: 2 Call - 12992, 5 Call - 12993 Lanier Phone Card: 2 Call - 12994, 5 Call - 12995
HyTec Parts and Logistics Control	(800) 557-4264 <a href="http://www.nrc-usa.com">http://www.nrc-usa.com</a>
Technology Solutions Center Web Site	<a href="http://www.tscweb.net">http://www.tscweb.net</a>
Configurator	<a href="http://www.connectivity-cafe.com">http://www.connectivity-cafe.com</a>
Ricoh Web Site	<a href="http://www.ricoh-usa.com/">http://www.ricoh-usa.com/</a>
Savin iLINC Web Site	<a href="http://www.savin.com">http://www.savin.com</a>
Headquarter Web Sites	Ricoh Corporation: <a href="http://www.ricoh-usa.com">http://www.ricoh-usa.com</a> Savin Corporation: <a href="http://www.savin.com">http://www.savin.com</a> Lanier Corporation: <a href="http://www.lanier.com">http://www.lanier.com</a>
Material Safety Data Sheets	(800) 336-MSDS (6737)
Ricoh University	973.882.2200. <a href="http://www.ricohuniversity.com">http://www.ricohuniversity.com</a>

### Service Documentation Training

#### Documentation

##### M044/D074/D075

Description	EDP Code	RFG E-Source Number
Field Service Manual	006425MIU	048078
Parts Catalog	006426MIU	048689
Point to Point	006427MIU	TBA
Pro C751ex/751/651ex Operation Instructions	-	TBA

Please be aware that once a model or series is out of production, the Field Service Manual, Technical Service Bulletins and Ricoh University should be referenced for the most current information. Check the TSC website and RFG-eSource.

# Product Support Guide

## D075 / D074 / M044

### Training

Training type:

- Classroom training for untrained technicians.

Please refer to the <http://www.ricohuniversity.com/> web site for the most up to date training information.



# Product Support Guide D075 / D074 / M044

## *TCRU Addendum*

# Pro C751ex / C751 / C651ex @Remote and TCRU Implementation Guide

## @Remote

### **Concept / Objective**

The “embedded” @Remote is a key part of the Pro C751ex/751/651ex service strategy. @Remote will be considered a standard service offering.

1. Technician is automatically dispatched for RANK “A” SC codes (Un-resettable SP modes).
2. Proactive PM is scheduled using the PM alarm function of @Remote.
3. Machine information (i.e. Copy Volume, Service Codes, Jams, etc.) captured by @Remote is monitored and evaluated to ensure that the machine performance and service quality is meeting or exceeding targets and expectations.

### **@Remote Settings Required for the Pro C751ex / C751 / C651ex**

To have a “PM Call” communicated to the Customer Vision Center (CVC) for dispatching activities, a different Service Depot Number needs to be selected to obtain a Request Number for the Pro C751ex/C751/C651ex. In addition, several SP settings need to be changed at machine installation. Please refer to “**Appendix 3**” (page 16) for the detailed procedure to enable @Remote and page 12 for the SP settings.

Note: A PM Alarm will not be communicated to the CVC if the Pro C751ex/C751/C651ex is connected behind a RC Gate. The Pro C751ex/C751/C651ex must be connected directly to the network via a separate connection – one network connection for the Pro C751ex/C751/C651ex mainframe printer function and a second network connection for @Remote communication.

*For additional information on @Remote, go to the following link to view or download basic @Remote documents.*

[http://tscweb.net/atremote/atremote\\_documentation.asp](http://tscweb.net/atremote/atremote_documentation.asp)

# Product Support Guide

**D075 / D074 / M044**

## TCRU (Trained Customer Replaceable Unit)

### ***Concept / Objective***

The design of the Ricoh Pro C751ex (D075) / Pro C651ex (D074) / Pro C751 (M044) mainframe allows trained and skilled Key Operators to replace select mainframe subassemblies (TCRUs) at PM Alarm (“Replace...” message indicated on the Display Panel) and / or EM Call occurrence to ensure maximum uptime.

This concept and opportunity will allow Sales and Service to:

- Establish a strong presence in Central Reprographics Department, Print for Pay, and Facilities Management accounts.
- Challenge & replace competitor’s products that offer TCRU type service.
- Offer and provide a Shared Service that meets the response time and uptime requirements of the production-printing environment.

### ***Benefit Realizations***

#### **For Customers**

- Maximum uptime maintained by a TCRU replacement (at notification or via your Call Avoidance/Customer Assistance (CA) process).
- PM time is significantly shorter than the traditional PM (individual parts replacement) because of subassembly (TCRU) replacement that allows the replaced TCRU to be refurbished by the Technician while the machine is up and running.
- Convenience of managing required PM activity through TCRU replacement at PM Alarm or according to job workload or schedule.

#### **For Service Support Organizations**

- Call Avoidance / Customer Assistance will reduce the number of service visits - an immediate on-site service visit may not be required if an EM issue can be resolved with a TCRU replacement by the Key Operator.
- Replacement TCRU provides a subassembly troubleshooting method (swap units) to isolate root causes quicker.
- Refurbishment of TCRUs can be completed on a scheduled basis to not disrupt Customer or Technician daily activity.
- No requirement to complete PM’s during off or after hours which result in higher Service costs.

### ***TCRU Kit - Order Process, Pricing and Contents***

# Product Support Guide

## D075 / D074 / M044

Customers have the option of participating in the Shared Service (self maintenance of unit replacement) or Full Service. If Full Service is chosen, the TCRU is used as a FRU (Field Replaceable Unit) by Field Technicians as a tool to reduce service time.

TCRU Kit is available to customers as finished goods with EDP Code.

<b>EDP Code</b>	
404440	Kit A
404442	Kit B

### TCRU Kit Contents

Kit A

Components	Part No.	Description	Q'ty	Remarks
TCRU	D0746400	BELT CLEANING:ASS'Y	1	
TCRU	D0742330	DRUM CLEANING UNIT:ASS'Y	4	
TCRU	D0744450	WEB:CLEANING UNIT:ASS'Y	1	
TCRU	D0746201	TRANSFER/SEPARATION UNIT:ASS'Y	1	
TCRU	D0742150	CHARGE UNIT:TAURUS:ASS'Y	4	
TCRU	D0142380	COMPRESSION SPRING:DRUM:ASS'Y	4	
TCRU	D0742252	FRAME:PHOTOCONDUCTOR	4	
TCRU	D0749510	OPC DRUM:DIA60:ASS'Y	4	
TCRU	AF030072	PAPER FEED ROLLER:PICKUP	1	For Mainframe
TCRU	AF031080	PAPER FEED ROLLER:FEED	1	For Mainframe
TCRU	AF032080	PAPER FEED ROLLER:SEPARATE	1	For Mainframe
TCRU	AF030071	PAPER FEED ROLLER:PICKUP	3	For LCIT
TCRU	AF031071	PAPER FEED ROLLER:FEED	3	For LCIT
	AF032041	PAPER FEED ROLLER:SEPARATE:MANUAL FEED	3	For LCIT
	D0747690	BRUSH:BLOWER	1	
	D8378612	DRIVER:TCRU	1	
	G1783799	SETTING POWDER	1	Same as B1329700

Kit B

Components	Part No.	Description	Q'ty	Unique / Common
TCRU	D0744483	Fuser Unit	1	U

# Product Support Guide

## D075 / D074 / M044

### ***Fusing Unit - TCRU***

To minimize the PM or EM service time of the Fusing Unit, it is strongly recommended that TCRU Kit B be ordered. If the customer plans to run heavy weight media and different paper widths (11" / 12" / 13") an additional Fuser Unit may be required for each paper width. This will eliminate copy quality issues that occur when the paper edge wears lines into the Fuser Belt.

**The Fusing Unit is available as a service part and supply item.**

**Part Number**

D0744483

**EDP Code**

404442

### ***Addendum – Shared Service (TCRU) Agreement***

Guidelines, in the form of a Maintenance Agreement Addendum, have been developed (sample provided in Appendix 1 – Page 13) to help protect your service organization from possible increases in service related costs because of unnecessary or premature TCRU replacement by the Key Operator. These guidelines include the Key Operator's responsibilities when a TCRU is replaced at PM Alarm or for an EM issue.

As with any Service Agreement, the Addendum also reflects verbiage on issues concerning liability and requires the Customer's acknowledgement (name, signature, and date) that they have read, understand, and accept the contents of the Addendum. This part of the Agreement must be signed before deploying the Kit at the Customer's account.

The Addendum also serves as an acknowledgement by the Key Operator that they have been trained by Service personnel on the Shared Service requirements, processes, and workflows. This must be signed and dated by the Key Operator after completion of the TCRU Training by the Technician. A copy of this signed document should be given to the Customer and the original should be kept on file at the Service location.

### ***Key Operator Training Overview***

Critical to the successful implementation and management of this Shared Service Offering is the replacement of a TCRU by a Key Operator. This requires the mechanical removal as well as interaction with the Display Panel, through Super User Mode, to reset a PM Counter. The following are the established guidelines on the key areas that should be demonstrated to and reviewed with the Key Operator(s) when the Kit is deployed. (At machine installation in most cases.)

# Product Support Guide

## D075 / D074 / M044

### ***Training Activity Summary***

1. **Conducted By:** Installing Field Service Representative (FSR) or Customer Service Representative (CSR).
2. **When:** At Machine Installation and also a refresher at the 1<sup>st</sup> TCRU replacement (at PM Alarm)
3. **Critical Documents/Process to Review:**
  - a. TCRU Replacement & Troubleshooting Manuals (included in the TCRU kit)
  - b. TCRU Replacement Form (Appendix 2)
  - c. TCRU Replacement Workflows – PM & EM
  - d. Addendum – Shared Service (TCRU) Agreement
4. **Simulations Performed:**
  - a. The actual replacement of all TCRUs.
  - b. Have the Key Operator remove and replace each TCRU to verify procedures
5. **Time/Duration:** Plan on spending 45 – 60 minutes to properly train the Key Operator(s)

# Product Support Guide

## D075 / D074 / M044

### Refurbishment Options

Several refurbishment methods have been utilized and evaluated. After reviewing the results and taking into account the logistics and economic requirements or impacts to Service, the following table reflects three options with their advantages and disadvantages. **Option #1, is Ricoh's recommended approach, which was successfully employed during our field test.**

Please note that there are other options available to implement and manage the refurbishment of used TCRUs at the local level. Any of the options presented can be used as a guideline to develop and customize an implementation plan based on your organization and capabilities. Option #2 or #3 may be a consideration as your Shared Service account MIF increases.

	Activities	Benefits	Disadvantages
1	Refurbish the TCRU at the Customers site	<ul style="list-style-type: none"> <li>▪ One Visit</li> <li>▪ No additional travel time is required for transporting the TCRUs between the Customer's locations and the Service location.</li> <li>▪ The Units remain at the customers location eliminating the risk of damage during return handling or shipping</li> </ul>	<ul style="list-style-type: none"> <li>▪ The FSR has to remain on-site longer to refurbish the TCRU</li> </ul>
2	Transport the replaced TCRUs to the local service location for refurbishment and return the same unit(s) back to the original customer	<ul style="list-style-type: none"> <li>▪ The FSR's time at the customer's location is kept to a minimum</li> <li>▪ TCRU refurbishing can be scheduled at the service location</li> </ul>	<ul style="list-style-type: none"> <li>▪ Transportation of the TCRUs between the customer and the service locations is required</li> <li>▪ Potential damage to TCRUs during transportation and/or handling</li> <li>▪ Dimensions of TCRUs cartons</li> <li>▪ Replacement of TCRUs may not be available when the customer requires</li> </ul>
3	"Swap" the replaced TCRUs at the customer's location with refurbished TCRUs and transport the replaced TCRU to the local service location for refurbishment	<ul style="list-style-type: none"> <li>▪ Same as option 2</li> <li>▪ Refurbished TCRUs are immediately available to the Key Operator ensuring maximum uptime</li> </ul>	<ul style="list-style-type: none"> <li>▪ Same as option 2</li> <li>▪ An additional set of TCRUs is required at the local service location thus increasing costs</li> </ul>

**Option #1 Note:** Refurbishment components (PM Kit) should be stored at the Account to eliminate Rescheduled Calls.

# Product Support Guide

## D075 / D074 / M044

### ***Service Offering Visibility & Management thru Dispatch System***

TCRU (Shared Service) customers will demand a quicker response time and a higher service level than customers without this type of “mission critical” equipment. The FSR is required to call the customer immediately after an EM call is assigned for this type of customer.

Service Items for Ricoh Pro C751ex/C751/C651ex - (GMA) General Maintenance Agreements.

<b>Service Item</b>	<b>Item Description (Short-Customer View)</b>	<b>Item Description (Long)</b>
SVC-SILVER	Labor, Parts, Black Toner, Color Toner	Full Service GMA - Standard Double Click (11x17), Black & Color Toner Included, Technician Replaces TCRU
SVC-SILVER-D-TCRU	Labor, Parts, Black Toner, Color Toner - Cust TCRU (D-Click)	Shared Service GMA - Standard Double Click (11x17), Black & Color Toner Included, Customer Replaces TCRU
SVC-SILVER-S	Labor, Parts, Black Toner, Color Toner (S-Click)	Full Service GMA - Single Click (11x17), Black & Color Toner Included, Technician Replaces TCRU
SVC-SILVER-S-TCRU	Labor, Parts, Black Toner, Color Toner - Cust TCRU (S-Click)	Shared Service GMA - Single Click (11x17), Black & Color Toner Included, Customer Replaces TCRU
SERVICE & PARTS	Labor and Parts Only	Full Service GMA - Standard Double Click (11x17), Parts & Labor Only, Technician Replaces TCRU
SVC-PARTS-D-TCRU	Labor and Parts Only - Cust TCRU (D-Click)	Shared Service GMA - Standard Double Click (11x17), Parts & Labor Only, Customer Replaces TCRU
SVC-PARTS-S	Labor and Parts Only (S-Click)	Full Service GMA - Single Click (11x17), Parts & Labor Only, Technician Replaces TCRU
SVC-PARTS-S-TCRU	Labor and Parts Only - Cust TCRU (S-Click)	Shared Service GMA - Single Click (11x17), Parts & Labor Only, Customer Replaces TCRU

**When a FSR visits a customer to refurbish TCRU(s) that were replaced by the key Operator for EM or PM activity, “TCRU” must be entered by the FSR in the “Notes” field when debriefing the call to indicate that TCRU(s) were refurbished during the call.**

# Product Support Guide

## D075 / D074 / M044

### ***TCRU Workflows – EM & PM***

TCRU Replacement and Service Workflows are critical to the successful implementation and management of the Shared Service Offering.

While a PM Workflow is much more straightforward than an EM Workflow, the success of both is a shared responsibility between the Key Operator, your Help Desk, the Call Handling Process (Service Dispatch), and the on-site Field Service Representative.

**Note: See Suggested Workflows on the following pages.**



# Product Support Guide

## D075 / D074 / M044

### TCRU Workflows - "Shared Service" TCRU Program

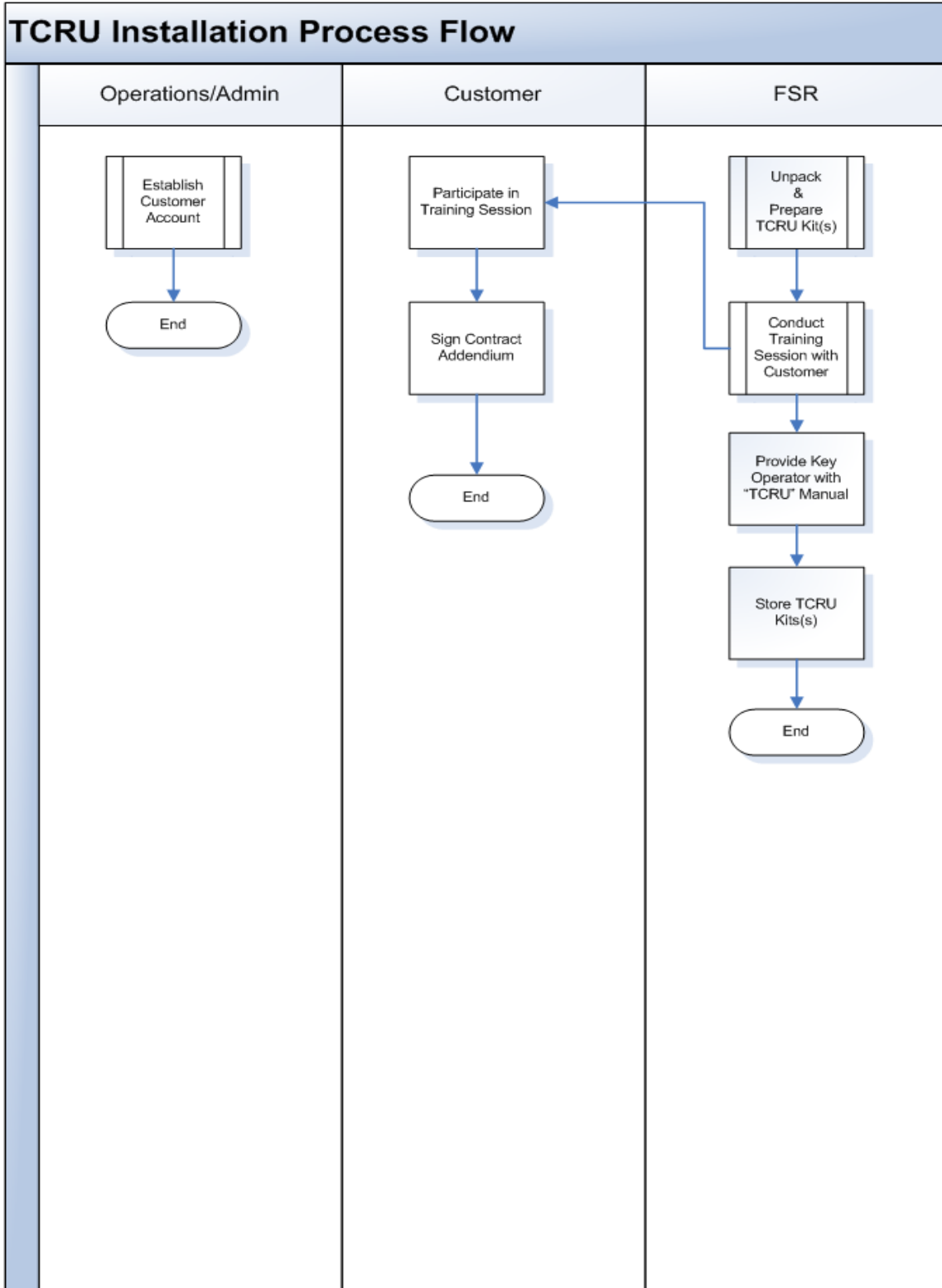

# Product Support Guide

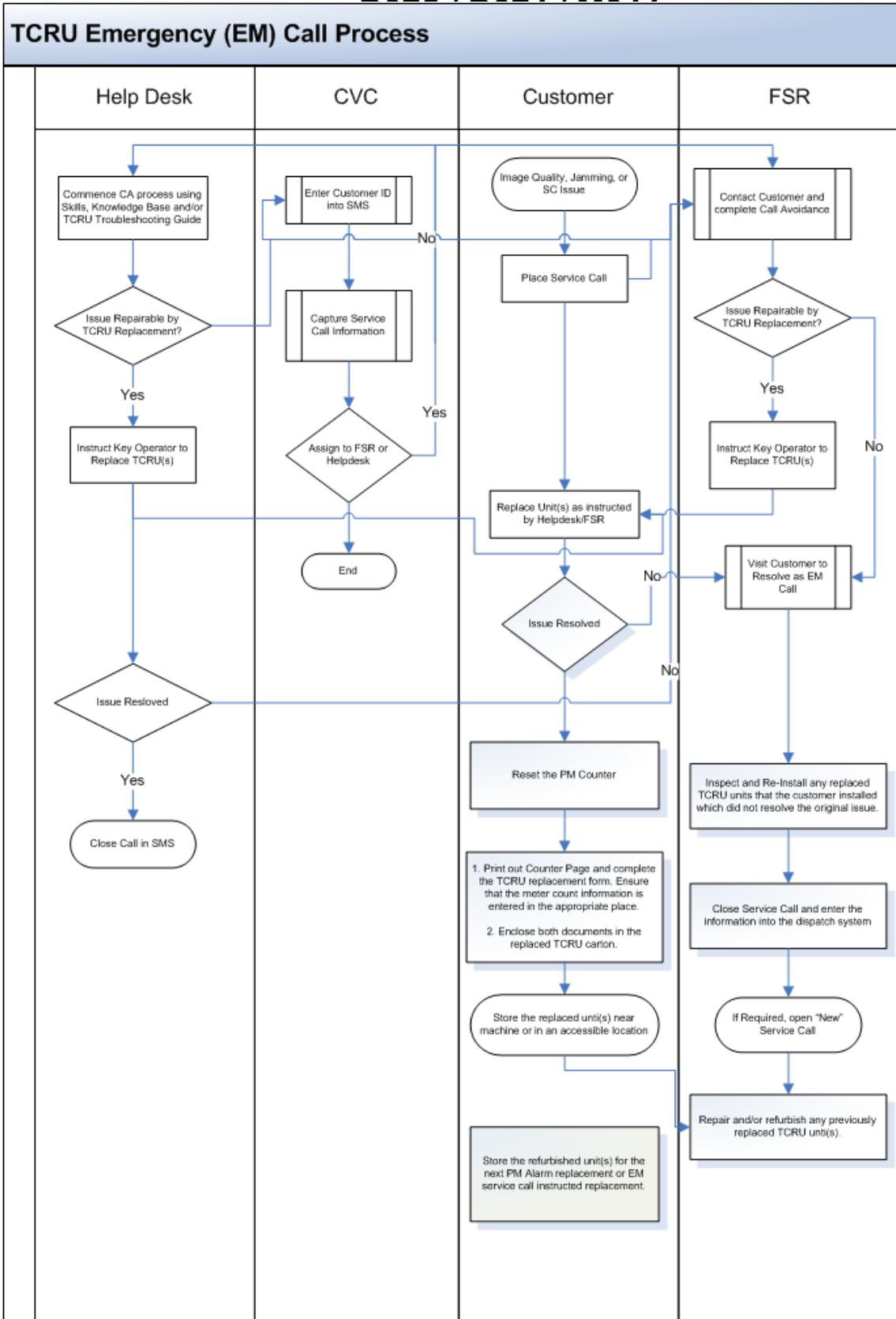

# Product Support Guide

## D075 / D074 / M044

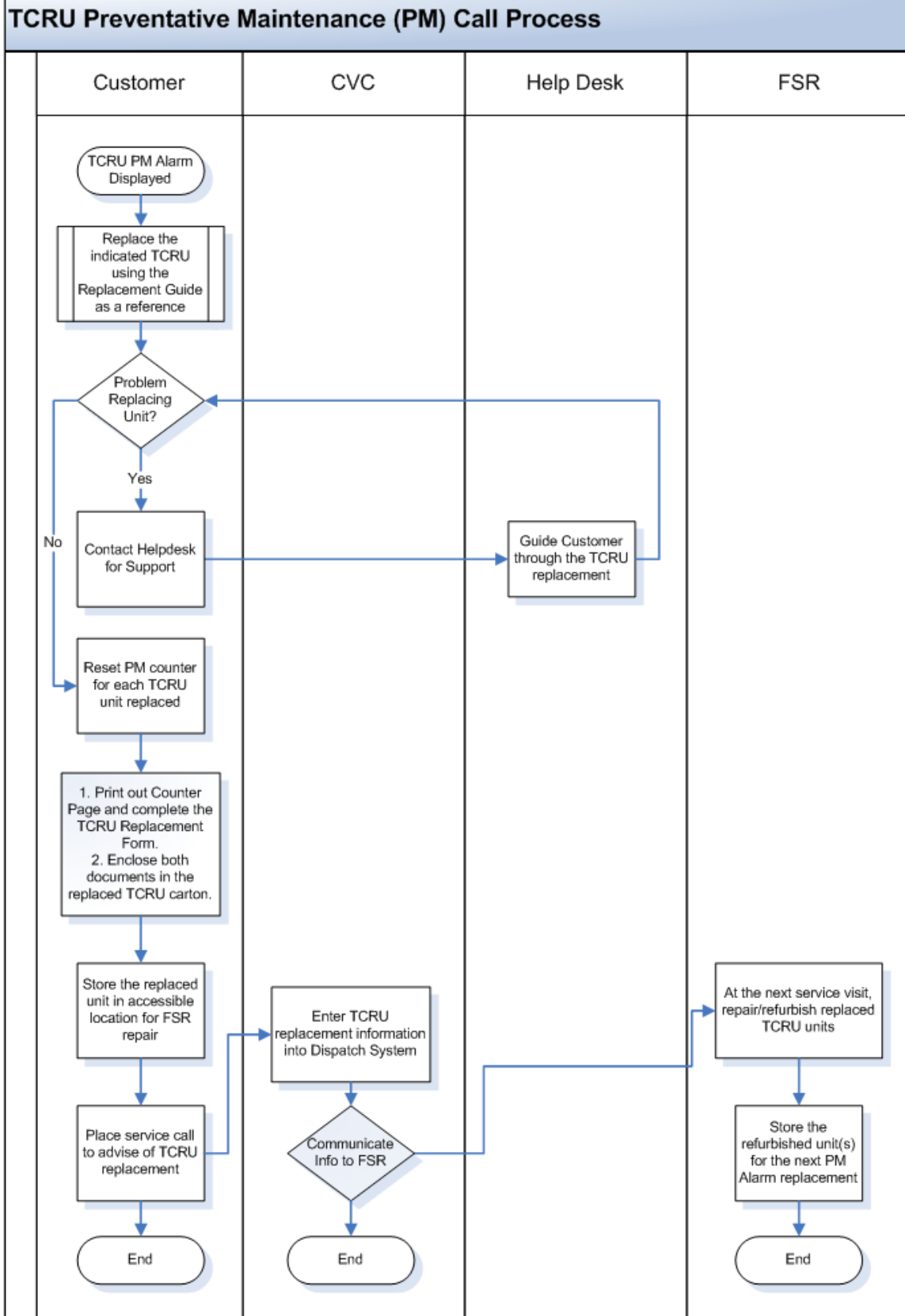

# Product Support Guide

## D075 / D074 / M044

### PM Guideline

Optimum machine performance is dependent upon quality service and scheduled maintenance; therefore, proactive and scheduled PMs are required for the Pro C751ex/C751/C651ex. The CVC (Customer Vision Center) @Remote Dispatcher creates a Service Request for a PM Call after receiving one of the following notifications from (see SP Mode Settings that are required on page 12):

1. PM Alarm is communicated via @Remote.

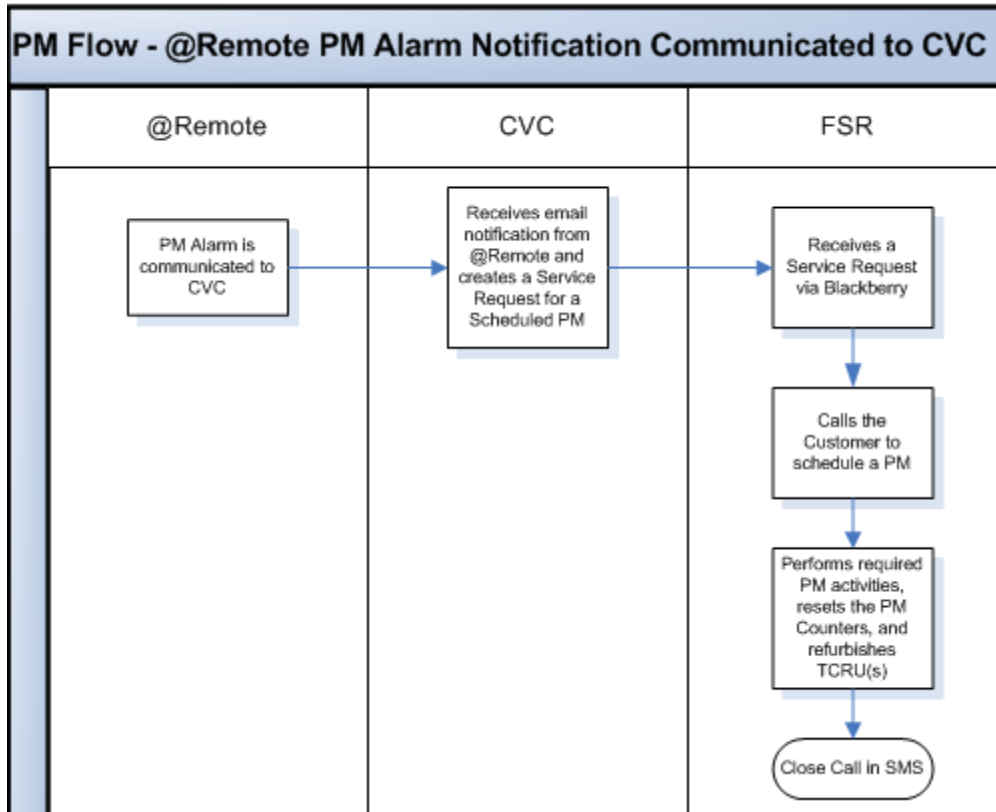

**Note: PM Parts Counter needs to be reset after performing a PM (SP7618).**

# Product Support Guide

## D075 / D074 / M044

- Customer calls CVC for PM request when a PM Alarm is displayed on the monitor > the @Remote feature is not enabled on the machine.

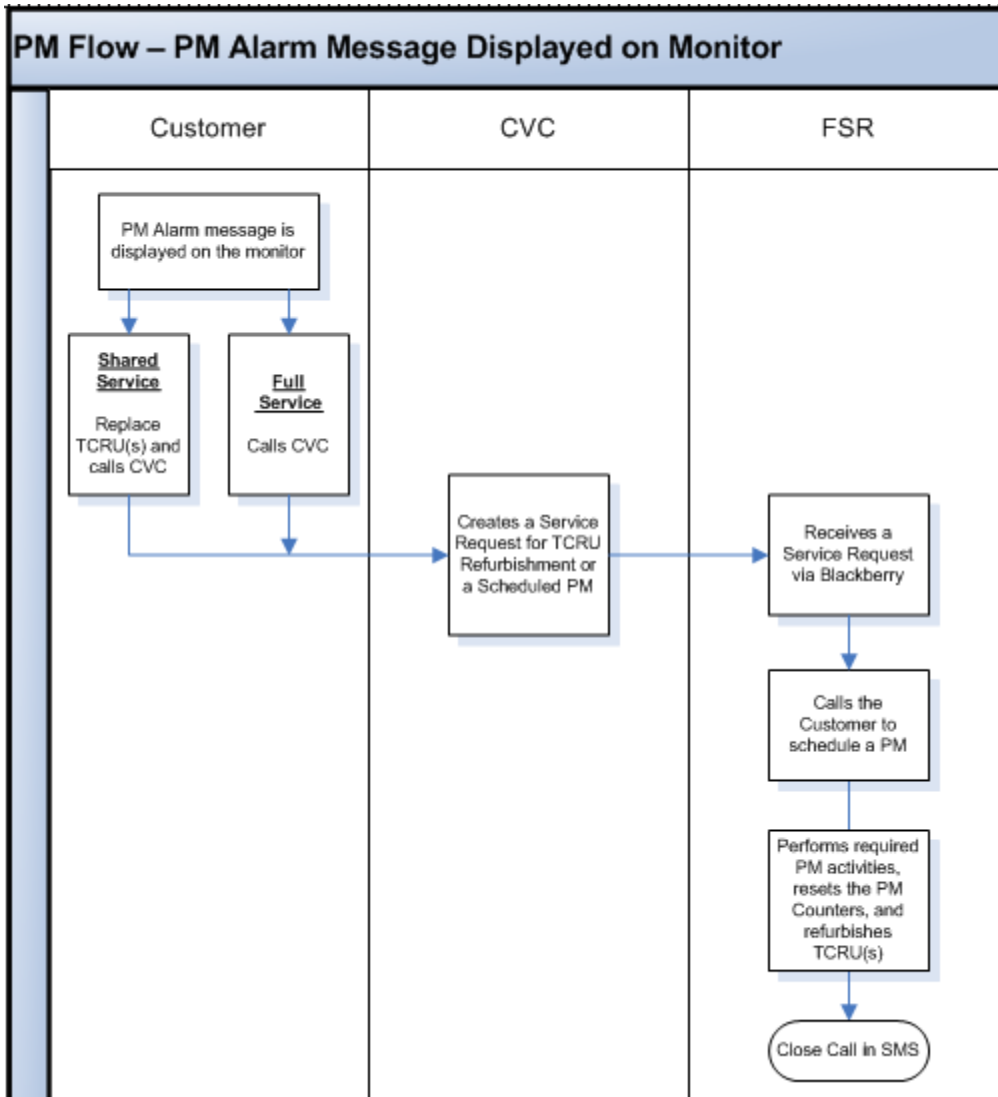

**Note: PM Counter needs to be reset after performing a PM (SP7804).**

# Product Support Guide

## D075 / D074 / M044

### PM Procedure, PM Alarm Settings, and SP Mode Settings Required for Each Service Type

Service Type	PM Procedure	PM Alarm Settings	SP Mode Settings
<b>TCRU Service with @Remote PM Alarm</b>	<p>A PM Alarm is sent via @remote to the CVC when the main PM Parts counter (SP7617-01) reaches 380K (95% of the PM target). A PM is then “scheduled” with the account by the Technician.</p> <p><u>Note:</u> This 95% of target @remote PM Alarm is not displayed on the machine.</p> <p>Technician replaces or refurbishes the Fusing Unit (FRU) and TCRU(s) if the PM counter of each TCRU is close to or has exceeded the main PM counter.</p> <p><b>Color PM Unit(s) / TCRU(s)</b> The Key Operator replaces a TCRU if the PM unit replacement alarm is displayed and a Technician's visit has not been scheduled. (i.e. Color Charge Unit).</p>	<p>Send PM alarm via @remote at 380K (95% of PM target) to dispatch a Technician to perform PM activities for the Fusing Unit and other 400K PM items.</p> <p><b>Color PM Unit(s) / TCRU(s)</b> Set the PM Alarm message for every PM unit to be displayed on the screen to notify the Key Operator that a TCRU replacement is required.</p>	<p><b>SP5062-01: ON (Default: OFF)</b> <b>SP7956-01: 1 (Default: 0)</b> SP5514-01: 1 (Default) <b>SP5513-01: 380 (Default: 300)</b> <b>SP5515-02: 0 (Default: 1)</b> <b>SP5515-03: 0 (Default: 1)</b> <b>SP5515-08: 1 (Default)</b></p>
<b>TCRU Service without @Remote PM Alarm</b>	<p>Key Operator replaces a TCRU if a PM Alarm is displayed.</p> <p>The Key Operator calls Service after replacing the TCRU(s) and the Technician visits the account to refurbish the replaced TCRU(s).</p> <p>The Technician also checks the counters for the other PM units or components and performs any additional PM activities that are required.</p>	<p>Set the PM Alarm message for every PM unit to be displayed on the screen.</p>	<p><b>SP5062-01: ON (Default: OFF)</b> <b>SP7956-01: 1 (Default: 0)</b></p>
<b>Full Service with @Remote PM Alarm</b>	<p>A PM Alarm is sent via @remote to the CVC when the main PM counter reaches 380K (95% of the PM target). This will trigger the scheduling of a PM.</p>	<p>Set the PM Alarm to 380K (95% of the PM target) for the main PM counter to send a PM Alarm via @Remote.</p>	<p>SP5062-01: OFF (Default) SP7956-01: 0 (Default) SP5514-01: 1 (Default) <b>SP5513-01: 380 (Default: 300)</b> <b>SP5515-02: 0 (Default: 1)</b> <b>SP5515-03: 0 (Default: 1)</b> <b>SP5515-08: 1 (Default)</b></p>
<b>Full Service without @Remote PM Alarm</b>	<p>A PM Alarm is displayed when the main PM counter (SP7803-01) reaches 380k (95% of the PM target). The Key Operator calls for Service.</p>	<p>Set the PM Alarm to 380k (95% of PM target) for the main PM counter to display a message on screen.</p>	<p><b>SP5501-01: 380 (Default: 0)</b></p>

**Note:** The SP Settings must be adjusted by the Technician at installation according to the Service Type (Maintenance Contract) that has been established with the account.

# Product Support Guide

## D075 / D074 / M044

### Appendix 1

## Sample Addendum to Maintenance Agreement for Pro C751ex/C751/C651ex

The Service Maintenance Agreement between “**dealer name**” and Customer is hereby amended as follows:

1. Only those Customer employees that have been trained and certified by a service representative of “**dealer name**” are authorized to provide the limited services with respect to Trained Customer Replaceable Units pursuant to this Addendum (hereinafter “Key Operators”). “**dealer name**” shall have no responsibility for and disclaims any and all liability with respect to any loss or damage to person or property resulting from or arising out of the acts or conduct of any persons other than a trained and certified Key Operator.
2. The Key Operator may replace a TCRU when a Preventive Maintenance Alarm is indicated on the Display Panel of the equipment. Replacement activities shall be limited to the following:
  - a) replacement of the TCRU
  - b) reset of the TCRU counter through the Display Panel
  - c) printing of the Counter Page
  - d) completion of the TCRU Replacement Form
  - e) repacking of the replaced TCRU and enclosing items c & d in the replacement TCRU carton
3. The Key Operator may not replace a TCRU before the Preventive Maintenance Alarm is indicated on the Display Panel without approval and instruction from a Field Service Representative. Such approval shall be initiated by the Key Operator through a Service Call.
4. If / When the Key Operator replaces a TCRU before the Preventive Maintenance Alarm is indicated on the Display Panel without approval and instruction from a Field Service Representative, the replaced TCRU shall be retained by the customer and evaluated by the Field Service Representative during the next Service visit. The Field Service Representative may determine that the TCRU has not achieved the target life and that it may be reused without refurbishment for the remainder of it's' target yield. The remaining yield of the TCRU will be noted by the Field Service Representative on the TCRU Replacement Form. The noted remaining yield (“Preventive Maintenance Target”) is to be entered by the Key Operator when the TCRU is replaced to ensure an accurate next Preventive Maintenance Alarm for the TCRU.
5. For any Emergency Maintenance issue, such as image quality, jamming, or Service Codes, the Key Operator may not replace a TCRU without approval and instruction from a Field Service Representative. The resolution to any Emergency Maintenance machine issue is to be initiated by the Key Operator placing a Service Call to the Service location. The Service location may provide immediate assistance through a Helpdesk and / or assign the Service Call to a Field Service Representative. If the Service Call is assigned, the Field Service Representative will immediately contact the Key Operator to discuss the issue and determine if the issue can be resolved with a TCRU replacement. If the issue cannot be resolved with a TCRU replacement, the Field Service Representative will visit the account to investigate.
6. If / When a TCRU is replaced for an Emergency Maintenance issue with the approval and instruction from a Field Service Representative, the Key Operator is required to:
  - a) reset of the TCRU counter through the Display Panel
  - b) print the Counter Page
  - c) complete the TCRU Replacement Form
  - d) repack the replaced TCRU and enclose Items C & D in the replacement TCRU carton

# Product Support Guide

## D075 / D074 / M044

### Sample Addendum to Maintenance Agreement – page 2

7. If a TCRU is replaced by the Key Operator and it does not resolve an Emergency Maintenance issue, the Key Operator is required to reinstall the original TCRU and return the replacement TCRU to its original carton.
8. Any TCRU that is replaced for an Emergency Maintenance issue by a Key Operator at a 24 Hour / 7 Day account without the instruction of a Field Service Representative, must be reported to the servicing location by the account the next business day (for the servicing location).
9. Replaced TCRUs are to be stored near the machine or in an accessible location for the Field Service Representative.
10. The replaced TCRU will be refurbished and / or repaired locally at the Customer's location, or will be replaced ("swapped") with a refurbished TCRU at the Service provider's earliest opportunity.
11. If a TCRU incurs non-repairable damage during normal usage or replacement, the Service location will provide a replacement TCRU unit at no charge.
12. The premature or unnecessary replacement of a TCRU outside the guidelines reflected in this "Addendum, **Shared Service** Agreement" may subject the Customer to a surcharge or to the cancellation of the Shared Service Agreement.
13. Damage to a TCRU caused by Key Operator misuse, abuse, or negligence may subject the Customer to a surcharge or to the cancellation of the Shared Service Agreement.
14. Customer hereby assumes the risk and liability for loss, damage or injury to person or property arising out of the acts and conduct of Customer taken pursuant to this Addendum. In no event shall **your dealer name** shall not be liable for any loss or any special, incidental or consequential damages caused by the use or misuse of the TCRU replacement process. In no event shall the recovery of any kind or nature exceed the price paid for the Shared Service.

This **Addendum, Trained Customer Replaceable Unit (TCRU) Shared Service Agreement** has been reviewed and is fully understood.

Date: \_\_\_\_\_

Account Name: \_\_\_\_\_

By: \_\_\_\_\_

Title: \_\_\_\_\_

### Training Acknowledgement/Agreement

I acknowledge that I have been trained on the Key Operator activities and responsibilities that are required to replace the TCRUs by a Service representative of "dealer name".

Date: \_\_\_\_\_

Service Representative: \_\_\_\_\_

Key Operator Name: \_\_\_\_\_



# Product Support Guide

## D075 / D074 / M044

### Appendix 2

## Ricoh Pro C751ex / C751 / C651ex TCRU Replacement Form

Please complete this form when replacing TCRU(s). Enclose this form and the Counter Page with the replaced TCRU in the replacement unit carton.

1. Print out the Counter Page (Press the "Counter" key and select "Print Counter List").
2. When replacing a TCRU, reset the TCRU's PM counter of each unit using "Reset PM Counter" on TCRU display.
3. If the TCRU was replaced for an image quality issue, attach an image sample.

### **Replaced (Used) TCRU Information**

Replacement Date: \_\_\_\_\_

Replaced By: \_\_\_\_\_

#### TCRU Replaced (Please indicate all replaced items with checkmark):

- |  |   |  |
|--|---|--|
| <input type="checkbox"/> Charge (Cyan)         | <input type="checkbox"/> Drum (C)                     | <input type="checkbox"/> Drum Cleaning (C)         |
| <input type="checkbox"/> Charge (Magenta)      | <input type="checkbox"/> Drum (M)                     | <input type="checkbox"/> Drum Cleaning (M)         |
| <input type="checkbox"/> Charge (Yellow)       | <input type="checkbox"/> Drum (Y)                     | <input type="checkbox"/> Drum Cleaning (Y)         |
| <input type="checkbox"/> Charge (Black)        | <input type="checkbox"/> Drum (B)                     | <input type="checkbox"/> Drum Cleaning (B)         |
| <input type="checkbox"/> Paper Transfer Roller | <input type="checkbox"/> Image Transfer Belt Cleaning | <input type="checkbox"/> Toner Filter (C)          |
| <input type="checkbox"/> Toner Filter (M)      | <input type="checkbox"/> Toner Filter (Y)             | <input type="checkbox"/> Toner Filter (B)          |
| <input type="checkbox"/> Feed Roller (Upper)   | <input type="checkbox"/> Pick Up Roller (Upper)       | <input type="checkbox"/> Separation Roller (Upper) |
| <input type="checkbox"/> Feed Roller (Lower)   | <input type="checkbox"/> Pick Up Roller (Lower)       | <input type="checkbox"/> Separation Roller (Lower) |
| <input type="checkbox"/> Fuser Unit            |   |  |

#### Reason for TCRU Replacement (Please checkmark PM or EM):

- PM (Preventive Maintenance)  
 EM (Emergency Maintenance)

Symptom: \_\_\_\_\_

Key Operator's Comments: \_\_\_\_\_

\_\_\_\_\_

*\*Make Prints of this document and keep them with the TCRU kit.*

# Product Support Guide

## D075 / D074 / M044

### Appendix 3

## How to enable the embedded @Remote Functionality for the Pro C751ex/C751/C651ex (for Ricoh Direct Service)

### Prior to activating embedded @Remote:

1. Log into the @Remote Center using the following URL:

<https://rcg.support.ricoh.com/atremotecenter/MainServlet>

2. Select New Registration (1) Pre-register the Device in the @Remote Center System after entering the Required and / or Optional Information and selecting "Register" (see 2, 3 4 below). When Obtaining a Request Number prior to installing the Pro 901C as an Embedded @Remote Device, you will have to obtain the Request Number a little differently. For these Devices and only for these devices, please select the Service Depot Name from the pull down list and choose **your** Service Depot with the "PM Call".

This Service Depot setting is designed to send PM Call notifications to the Call Center for PM Work Order Creation. In the example screen shot below, you can see that there are two Service Depot Names, one for all RC Gate and Embedded Device Installations and one for Embedded Device Installations that are going to also send PM Calls.

The screenshot shows the @Remote web interface for a "New Registration". The page title is "New Registration" with a help icon. On the left is a navigation menu with categories: "Registration" (containing "New Registration" (1), "Pre-installed Appliance", and "Appliance Replacement"), "Search" (containing "Appliance", "Device", and "Disconnected List"), "Counter CSV" (containing "New Request" and "List: Requested CSV"), "Supply CSV" (containing "New Request" and "List: Requested CSV"), "Service Call" (containing "Call List"), and "Firmware". The main content area has a "Register" button (4) and a "Load Site Information" button. Below the button is a blue bar with the text "Fields marked with an asterisk \* are required." The form fields are: "\* Customer Name/ID" (text input, 2), "\* Site Name" (dropdown menu, value: RBS Atlanta), "\* Service Depot Name" (dropdown menu, value: RBS Atlanta Svc), and "\* Operation Calendar" (dropdown menu, value: RBS Atlanta PM Call, 3). Below these is a "Registration Number Option" section with a "Number Of Registrations" input field and a note "- Input the number between 1 and 100." The "Option" section contains several text input fields: "Address", "Location", "Appliance Administrator Name", "Appliance Administrator Phone", "Appliance Administrator E-mail Address", "Note 1", "Note 2", and "Note 3". Red circles and arrows highlight the "Register" button (4), the "New Registration" menu item (1), the "Customer Name/ID" field (2), the "Operation Calendar" dropdown (3), and the "RBS Atlanta PM Call" option in the dropdown.

# Product Support Guide

## D075 / D074 / M044

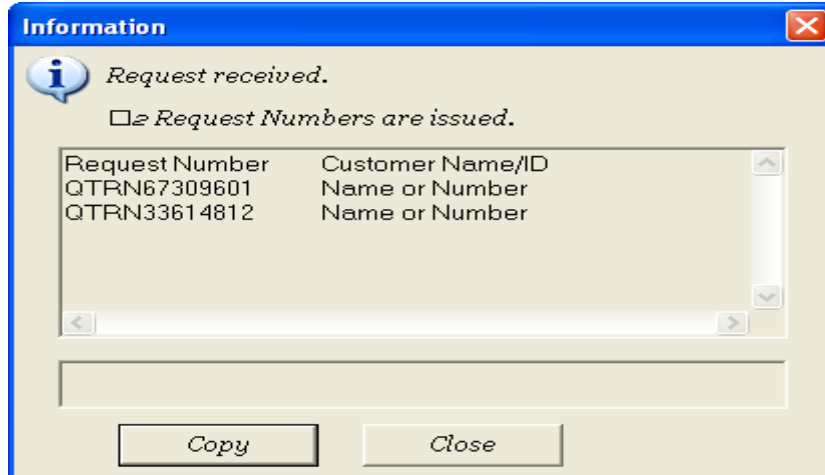

3. Record the Request Number provided by the @Remote Center System (selecting Copy in the screen above will save the Request Number(s) to your Clip Board). You will need to input this number into the Device as a part of the Registration process. Request Numbers are valid for a period of Three Months.

4. If you forget the Request Number, you can always obtain them by going to the @Remote Center System and Selecting the Pre-installed Appliance on the menu, which will display any unused Request Numbers.

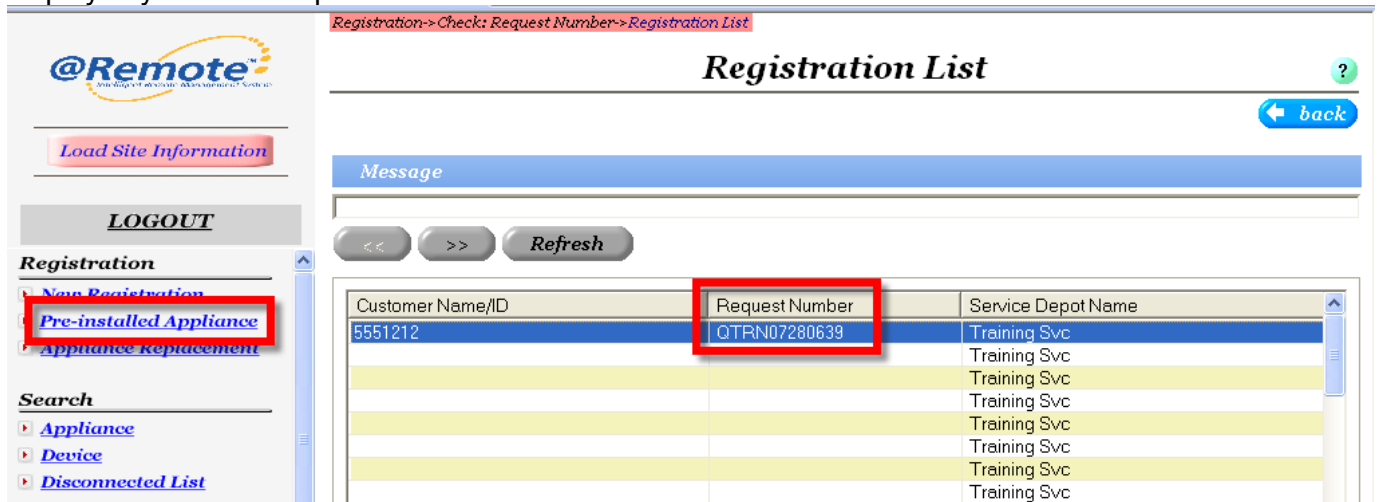

5. Complete the installation process for the Device as normal. Perform all regular post installation testing of the Device to ensure the MFPs proper operation.

Check the following setting at the Devices Op Panel, if it is set to [Prohibited], change to [Do not prohibit].

How to check and verify and / or change this setting;

**User Tools/Counter > System Settings > Administrator Tools > Extended Security > @Remote Service**

# Product Support Guide

## D075 / D074 / M044

6. Access the Device's Web Image Monitor (WIM) and select **Login**

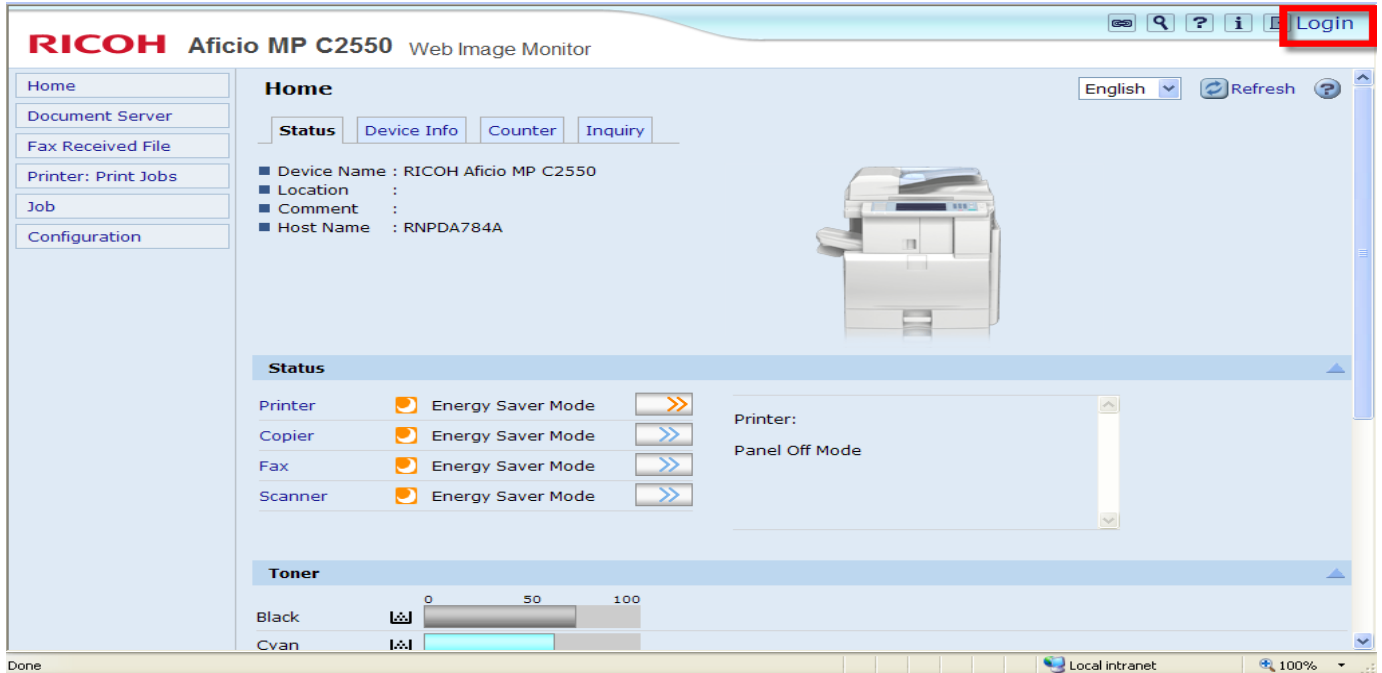

7. Log into the Device Web Image Monitor as **Admin**

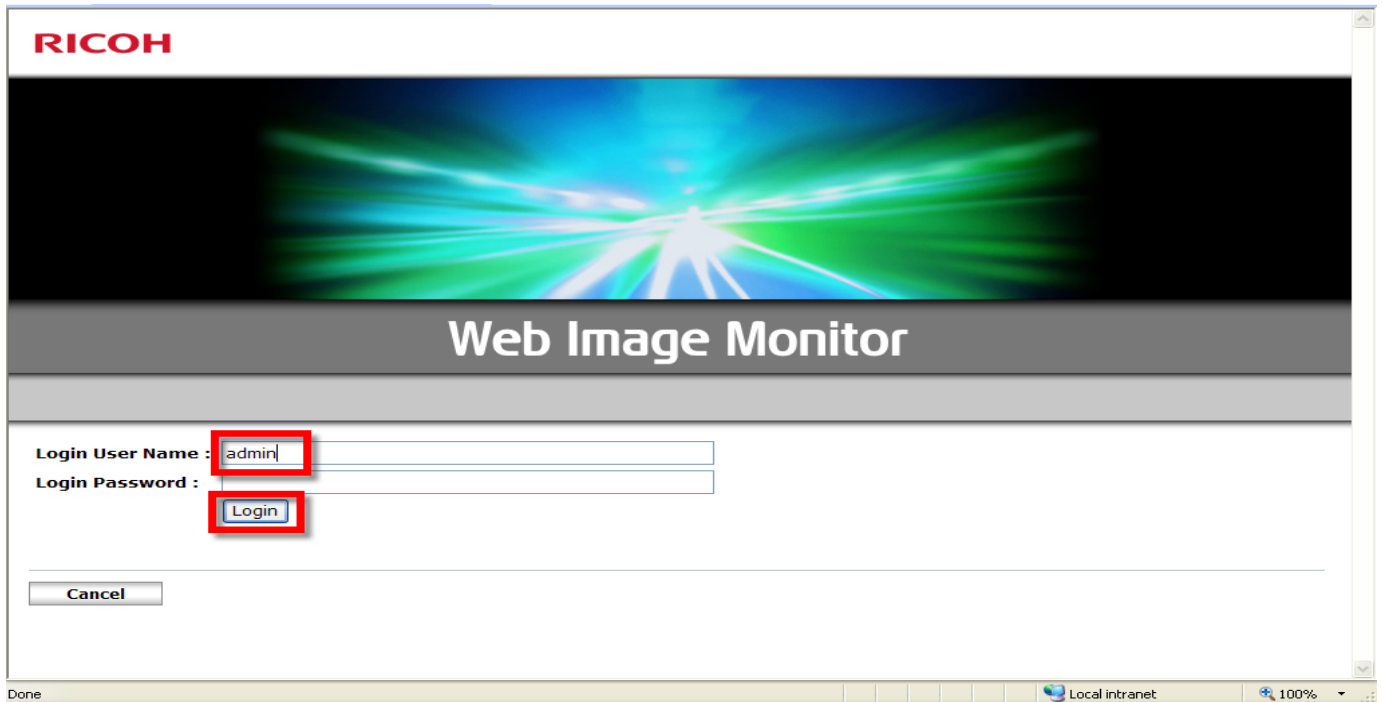

# Product Support Guide

## D075 / D074 / M044

8. Scroll down the Left Side Menu and select **Configuration**, then select **RC Gate**

The screenshot displays the Ricoh Aficio MP C2550 Web Image Monitor interface. The top navigation bar includes the Ricoh logo, the model name 'Aficio MP C2550', and the title 'Web Image Monitor'. On the right side of the top bar, there are icons for search, help, user profile, and a 'Logout' button. Below the top bar, the user is logged in as 'Administrator'. The left sidebar contains a menu with options: Home, Document Server, Printer: Print Jobs, Job, Address Book, and Configuration (highlighted with a red box). The main content area is titled 'Configuration' and is divided into several sections: Device Settings (with a printer icon), Printer (with a printer icon), Fax (with a fax icon), Scanner (with a scanner icon), and Interface (with a network cable icon). The 'Network' section is expanded, showing options like IPv4, IPv6, NetWare, AppleTalk, SMB, SNMP, and System Log. The 'Security' section is also expanded, showing options like Network Security, Access Control, and IPsec. The 'RC Gate' section is highlighted with a red box and contains three options: Setup RC Gate, Update RC Gate Firmware, and RC Gate Proxy Server. At the bottom left of the main content area, there is a 'To Top' link.

9. Note: if your Customer uses a Proxy Server to Access the Internet, then Program the RC Gate Proxy Information into the Device prior to selecting Setup RC Gate, otherwise, skip this Step.

# Product Support Guide

## D075 / D074 / M044

The screenshot shows the 'Remote Communication Gate Proxy Server' configuration page. At the top, there are navigation icons and a 'Logout' link. The page title is 'RICOH Aficio MP C2550 Web Image Monitor' and the user is logged in as 'Administrator'. Below the title, there are 'OK' and 'Cancel' buttons. The main configuration area is titled 'Remote Communication Gate Proxy' and contains the following options:

- Remote Communication Gate Proxy Server:  Enable  Disable
- Proxy Address:
- Port Number:
- User Name:
- Password:

At the bottom of the configuration area, there are 'OK' and 'Cancel' buttons.

10. Select **Setup RC Gate**, Enter the **Request Number** obtained in Step 3 above and select **Confirm** (left upper section of the web page)

The screenshot shows the 'Remote Communication Gate Setup' page. At the top, there are navigation icons and a 'Logout' link. The page title is 'RICOH Aficio MP C2550 Web Image Monitor' and the user is logged in as 'Administrator'. Below the title, there are 'Back' and 'Confirm' buttons. The main configuration area is titled 'Remote Communication Gate Setup' and contains the following options:

- Status: :Not Programmed
- Request No.:

At the bottom of the configuration area, there are 'Back' and 'Confirm' buttons. Red boxes and circled numbers are used as annotations: a red box around the 'Confirm' button is labeled with a circled '2', and a red box around the 'Request No.' input field is labeled with a circled '1'.

# Product Support Guide

## D075 / D074 / M044

11. Select **OK** (right upper section of the web page)



The screenshot shows a web page titled "Remote Communication Gate Setup". At the top, there is a navigation bar with "web image monitor" on the right. Below the title, there is a confirmation message: "Remote Communication Gate information confirmation was successful." To the left of the message is an information icon (a lowercase 'i' in a circle). At the bottom of the page, there is a single button labeled "OK".

12. Select **Program** (left upper section of the web page)

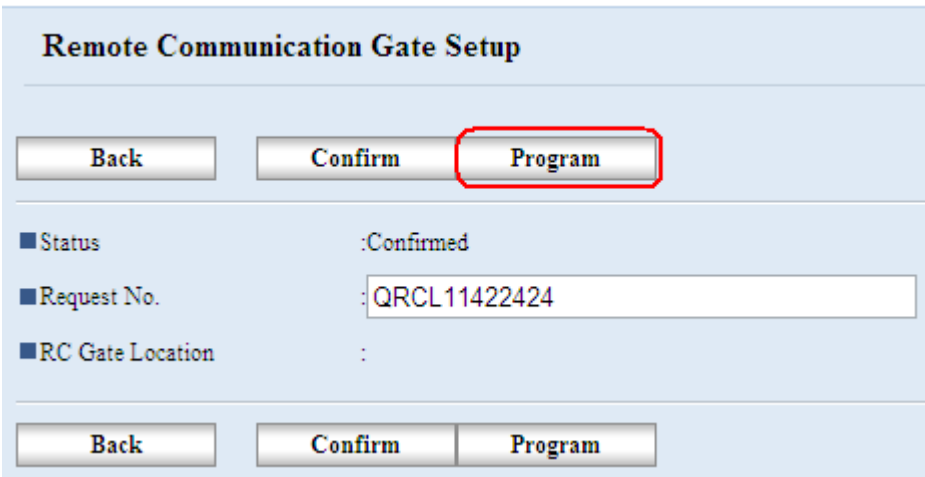

The screenshot shows the "Remote Communication Gate Setup" page. At the top, there is a navigation bar with "web image monitor" on the right. Below the title, there are three buttons: "Back", "Confirm", and "Program". The "Program" button is highlighted with a red rectangular box. Below the buttons, there is a form with three fields: "Status" with the value ":Confirmed", "Request No." with the value "QRCL11422424", and "RC Gate Location" with a blank field. At the bottom of the page, there are three buttons: "Back", "Confirm", and "Program".

13. Select **OK** (right upper section of the web page)



The screenshot shows a web page titled "Remote Communication Gate Setup". At the top, there is a navigation bar with "web image monitor" on the right. Below the title, there is a confirmation message: "Registration is successfully complete." To the left of the message is an information icon (a lowercase 'i' in a circle). At the bottom of the page, there is a single button labeled "OK".

# Product Support Guide

## D075 / D074 / M044

14. Verify that the Web Image Monitor is indicating Status: **Registered**



The @Remote Embedded Device is now Reporting into the @Remote Center and is completely registered (Managed Mode) in the @Remote Center; this is the last step to perform in the Web Image Monitor.

15. Check the Device List of the center GUI that the registered device is appeared in the list with “Registered” status as Device Condition. If Device Condition is still “Found”, it will be changed to “Registered” automatically at the time when the device sends next hourly polling.

16. Check and / or change the following SP Modes to ensure that the PM Calls are enabled for this Device.

	Shared Service Customer	Full Service Customer
<b>SP mode settings for @Remote</b>	SP5062-01: ON (Default: OFF) SP7956-01: 1 (Default: 0) SP5514-01: 1 (Default) SP5513-01: 380 (Default: 300) SP5515-02: 0 (Default: 1) SP5515-03: 0 (Default: 1)	SP5062-01: OFF (Default) SP7956-01: 0 (Default) SP5514-01: 1 (Default) SP5513-01: 380 (Default: 300) SP5515-02: 0 (Default: 1) SP5515-03: 0 (Default: 1)

### Installing Embedded @Remote using SP Mode

You can install Embedded @Remote by using the SP Modes instead of the Web Image Monitor.

Access the Service SP Modes.

Go to SP 5816-202 and enter the Request Number

Go to SP 5816-203 and select Confirmation Execute

Go to SP 5816-204 and select Confirm Result

Go to SP 5816-205 and select Confirm Place

Go to SP 5816-206 and select Register Execute

Go to SP 5816-207 and select Register Result to ensure that the configuration was successful.



# Product Support Guide

## D075 / D074 / M044

### Revisions

Rev 1.0 – 1<sup>st</sup> Release