

Product Support Guide

**Model
D059/D060/D061**

Introduction

Model Type	B/W MFP
Launch Date	7/2009
S/N Configuration	V50/V51/V52
Product Code	D059/D060/D061

Brand/Model Name

Product Code	Lanier	Ricoh	Savin
D059 D060 D061	Pro 907EX Pro 1107EX Pro 1357EX	Pro 907EX Pro 1107EX Pro 1357EX	Pro 907EX Pro 1107EX Pro 1357EX

Product Concept

The new D059/D060/D061 “Pro” series is being introduced to further show Ricoh’s commitment to the production printing market with a product line-up that provides:

- Higher Productivity, Reliability, and Durability.
- Versatile Controller Support.
- Simple & Easy Operation.
- Professional Output Quality.
- Wider range of Paper Latitude.
- Versatile Finishing.



Product Support Guide

Model D059/D060/D061

Order Number

Main Frame

Item	Model Name	EDP Code	Notes
Copier	Lanier Pro 907EX Ricoh Pro 907EX Savin Pro 907EX	404186	90 cpm
Copier	Lanier Pro 1107EX Ricoh Pro 1107EX Savin Pro 1107EX	404189	110 cpm
Copier	Lanier Pro 1357EX Ricoh Pro 1357EX Savin Pro 1357EX	404192	135 cpm

Note: Order Numbers are provided for reference purposes only. Please use your Pricing Guide for proper order numbers to insure you receive the correct branding emblem.

Options

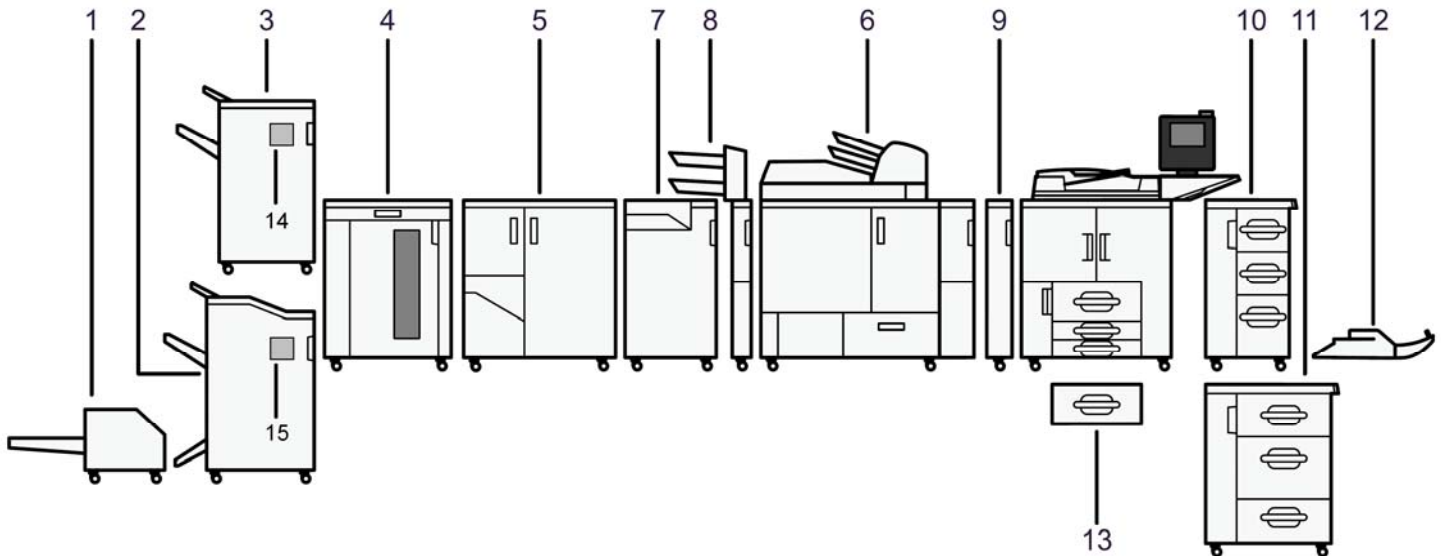

Item	Option Name	Description	EDP Code	Product Code	Common / Unique
1	TR5020	Trimmer Unit for SR5020	404180	D455	U
2	SR5020	Booklet Finisher	404174	D434	U
3	SR5000	Finisher	412981	B830	D101/D102/D103
4	SK5010	High Capacity Stacker	404215	D447	U
5	Ring Binder RB5000	Ring Binder	404112	D392	D101/D102/D103

Product Support Guide

Model D059/D060/D061

Item	Option Name	Description	EDP Code	Product Code	Common / Unique
6	Perfect Binder GB5000	Perfect Binder	404099	D391	D101/D102/D103 (All 3 items are ordered separately, but are all required for GB5000 installation)
	Type GB5000	Cover Interposer for Perfect Binder	404102		
	Transit Pass Unit Type GB5000	Transit Pass Unit for Perfect Binder	404101		
7	FD5000	Multi Folding Unit	404183	D454	U
8	CI5010	Cover Interposer	404087	B835	D101/D102/D103
9	DU5000	De curling Unit	404226	D457	U
10	RT5030	LT LCT	404220	D452	U
11	RT5040	DLT LCT	404223	D453	U
12	BY5000	Multi Bypass Tray	412974	B833	D101/D102/D103
13	TK5010	11" x 17" Tray Kit	404195	B331	U
14	PU5000	Punch 2/3 Hole for SR5000	412983	B831	D101/D102/D103
15	PU5020	2/3 Hole Punch Unit for SR5020	404177	D449	U
Options Not Shown Above					
	Ring Binder Cartridge Type RB5000	Ring Binder Cartridge	404115	D421	D101/D102/D103
	Ring Binder Opener RB5000	Ring Binder Opener	404114	D419	D101/D102/D103
	Roll-Away Cart Type 5010	Spare Cart for SK5010	404218	D456	U
	Copy Connect Kit Type 3260	Copy Connect Kit	412415	B328	D101/D102/D103
	Copy Data Security Unit Type F	Copy Data Security	412985	B829	D101/D102/D103
	IEEE 802.11a/g Interface Unit Type J	Wireless LAN Interface	414008	D377-01	D101/D102/D103
	Data Overwrite Security Unit Type H	Data Security	414002	D377-02	D101/D102/D103
	File Format Converter Type E	MLB	414007	D377-04	D101/D102/D103
	HDD Encryption Unit Type A	HDD Encryption	414021	D377-16	D101/D102/D103
	Gigabit Ethernet Type B	Gigabit Ethernet	414204	D377-21	D101/D102/D103
	Bluetooth Interface Unit Type 3245	Bluetooth	412866	B826	D101/D102/D103
	IEEE 1284 Interface Board Type A	IEEE 1284	411699	B679	D101/D102/D103
	Printer/Scanner Kit Type 1357	Printer/Scanner	404196	D451-01	U
	PostScript3 Unit Type 1357	Post Script Option	404200	D451-05	U
	IPDS Unit Type 1357EX	IPDS Option	404265	D451-12	U
	VM Card Type J	VM Card	404230	D463	U
	Optional Counter Interface Type A	External Counter Interface	413012	B870	C

Product Support Guide

Model D059/D060/D061

Drum & Developer P/N's

Name/Description	Part Number	Target Yield
Developer Type 27	B2349640	500K/bag
Drum	D0599510	2,500,000

Supplies/Yields

Name/Description	Ricoh	Target Yield
Toner Pro 1357EX	828080	60,000/btl *
Staple Type M for SR5000/SR5020 (Usual Staple)	413013	5,000/cartridge
Staple Refill Type M for SR5000/SR5020 (Usual Staple)	413026	25,000/carton
Staple Unit U for SR5020 (Saddle Stitch) Use Type T Refill	404235	5,000/cartridge
Staple Refill Type T for SR5020 (Saddle Stitch)	415010	10,000 carton
Ring Supply LT White 100 Type A – RB5000	404117	75 Binds/cartridge
Ring Supply LT Black 100 Type A – RB5000	404118	75 Binds/cartridge
Ring Supply LT White 50 Type A – RB5000	404119	75 Binds/cartridge
Ring Supply LT Black 50 Type A – RB5000	404120	75 Binds/cartridge
Glue Supply Type A for GB5000	404103	Approx 1,300 books

*Note: * A4, 6% chart is used to measure the yield*

Product Support Guide

Model D059/D060/D061

Option Compatibility

Configuration 1 SR5020 System

Configuration 1 SR5020 System		LTDLT LCT	Bypass Tray	Decurling Unit	Perfect Binder	Cover Interposer	Multi Folding Unit	Ring Binder	GBC	High Capacity Stacker (single)	High Capacity Stacker (lamden)	Trimmer	Copy Connector	VII Card	Copy Data Security	DOS Unit	File Format Converter	SR5000	Plockmatic
	RT5001 RT5040		Yes	Yes	Yes	Yes	Yes	Yes	Yes	Yes	Yes	Yes	Yes	Yes	Yes	Yes	Yes	No	No
	BY5000	•		Yes	Yes	Yes	Yes	Yes	Yes	Yes	Yes	Yes	Yes	Yes	Yes	Yes	Yes	No	No
	DL5000	Yes	Yes	Yes	Yes	Yes	Yes	Yes	Yes	Yes	Yes	Yes	Yes	Yes	Yes	Yes	Yes	No	No
	GE5000	Yes	Yes	Yes	Yes	Yes	Yes	No	Yes	Yes	No	Yes	Yes *1	Yes	Yes	Yes	Yes	No	No
	CS010	Yes	Yes	Yes	Yes	Yes	Yes	Yes	Yes	Yes	Yes	Yes	Yes	Yes	Yes	Yes	Yes	No	No
	FE5000	Yes	Yes	Yes	Yes	Yes	Yes	Yes	Yes	Yes	No	Yes	Yes	Yes	Yes	Yes	Yes	No	No
	RE5000	Yes	Yes	Yes	No	Yes	Yes	Yes	Yes	Yes	No	Yes	Yes *1	Yes	Yes	Yes	Yes	No	No
	StreamPunch III	Yes	Yes	Yes	Yes	Yes	Yes	Yes	Yes	Yes	Yes	Yes	Yes	Yes	Yes	Yes	Yes	No	No
	SK5011 (single)	Yes	Yes	•	Yes	Yes	Yes	Yes	Yes	-	-	Yes	Yes *1	Yes	Yes	Yes	Yes	No	No
	SK5010 (lamden)	Yes	Yes	•	No	Yes	No	No	Yes	-	-	Yes	Yes *1	Yes	Yes	Yes	Yes	No	No
	TR5020	Yes	Yes	Yes	Yes	Yes	Yes	Yes	Yes	Yes	Yes	Yes	Yes	Yes	Yes	Yes	Yes	No	No
	Type 320	Yes	Yes	Yes	Yes *1	Yes	Yes	Yes *1	Yes	Yes *1	Yes *1	Yes	Yes	Yes	Yes	Yes	Yes	No	No
	Type J	Yes	Yes	Yes	Yes	Yes	Yes	Yes	Yes	Yes	Yes	Yes	Yes	Yes	Yes	Yes	Yes	No	No
	Type F	Yes	Yes	Yes	Yes	Yes	Yes	Yes	Yes	Yes	Yes	Yes	Yes	Yes	Yes	Yes	Yes	No	No
	Type H	Yes	Yes	Yes	Yes	Yes	Yes	Yes	Yes	Yes	Yes	Yes	Yes	Yes	Yes	Yes	Yes	No	No
	Type E	Yes	Yes	Yes	Yes	Yes	Yes	Yes	Yes	Yes	Yes	Yes	Yes	Yes	Yes	Yes	Yes	No	No

Yes	Option Compatible
No	Option Not Compatible
•	Option Required
*1	Copy Connector Kit can be installed but marked output peripherals will not function.

Product Support Guide

Model D059/D060/D061

Configuration 2 SR5000 System

Configuration 2 SR5000 System		LT/DLT LCT	Bypass Tray	Decurling Unit	Perfect Binder	Cover Interposer	Multi Folding Unit	Ring Binder	GBC	High Capacity Stacker (single)	High Capacity Stacker (laminate)	Plockmatic	Copy Connector	VM Card	Copy Data Security	DOS Unit	File Format Converter	SFS020	Trimmer TRS020
LT/DLT LCT	RT5030 RT5040		Yes	Yes	Yes	Yes	Yes	Yes	Yes	Yes	No	Yes	Yes	Yes	Yes	Yes	Yes	No	No
Bypass Tray	B15000	•	Yes	Yes	Yes	Yes	Yes	Yes	Yes	Yes	No	Yes	Yes	Yes	Yes	Yes	Yes	No	No
Decurl Unit	DJ5000	Yes	Yes	Yes	Yes	Yes	Yes	Yes	Yes	Yes	No	Yes	Yes	Yes	Yes	Yes	Yes	No	No
Perfect Binder	GB5000	Yes	Yes	Yes	Yes	Yes	Yes	No	Yes	Yes	No	Yes	Yes* 1</td <td>Yes</td> <td>Yes</td> <td>Yes</td> <td>Yes</td> <td>No</td> <td>No</td>	Yes	Yes	Yes	Yes	No	No
Cover Interposer	C15010	Yes	Yes	Yes	Yes	Yes	Yes	Yes	Yes	Yes	No	Yes	Yes	Yes	Yes	Yes	Yes	No	No
Multi Folding Unit	FD5000	Yes	Yes	Yes	Yes	Yes	Yes	Yes	Yes	Yes	No	Yes	Yes	Yes	Yes	Yes	Yes	No	No
Ring Binder	RB5000	Yes	Yes	Yes	No	Yes	Yes	Yes	Yes	No	Yes	Yes	Yes* 1</td <td>Yes</td> <td>Yes</td> <td>Yes</td> <td>Yes</td> <td>No</td> <td>No</td>	Yes	Yes	Yes	Yes	No	No
GBC StreamPunch III	StreamPunch III	Yes	Yes	Yes	Yes	Yes	Yes	Yes	Yes	Yes	No	Yes	Yes	Yes	Yes	Yes	Yes	No	No
High Capacity Stacker	SK5010 (single)	Yes	Yes	•	No	Yes	Yes	No	Yes	-	-	Yes	Yes* 1</td <td>Yes</td> <td>Yes</td> <td>Yes</td> <td>Yes</td> <td>No</td> <td>No</td>	Yes	Yes	Yes	Yes	No	No
	SK5010 (laminate)	No	No	No	No	No	No	No	No	-	-	No	No	No	No	No	No	No	No
Plockmatic Booklet Maker	BK5010	Yes	Yes	Yes	Yes	Yes	Yes	Yes	Yes	Yes	No	Yes	Yes	Yes	Yes	Yes	Yes	No	No
Copy Connector	Type 3250	Yes	Yes	Yes	Yes* 1</td <td>Yes</td> <td>Yes</td> <td>Yes*<!--1</td--> <td>Yes</td> <td>Yes*<!--1</td--> <td>No</td> <td>Yes</td> <td>Yes</td> <td>Yes</td> <td>Yes</td> <td>Yes</td> <td>Yes</td> <td>No</td> <td>No</td> </td></td>	Yes	Yes	Yes* 1</td <td>Yes</td> <td>Yes*<!--1</td--> <td>No</td> <td>Yes</td> <td>Yes</td> <td>Yes</td> <td>Yes</td> <td>Yes</td> <td>Yes</td> <td>No</td> <td>No</td> </td>	Yes	Yes* 1</td <td>No</td> <td>Yes</td> <td>Yes</td> <td>Yes</td> <td>Yes</td> <td>Yes</td> <td>Yes</td> <td>No</td> <td>No</td>	No	Yes	Yes	Yes	Yes	Yes	Yes	No	No
VM Card	Type J	Yes	Yes	Yes	Yes	Yes	Yes	Yes	Yes	Yes	No	Yes	Yes	Yes	Yes	Yes	Yes	No	No
Copy Data Security	Type F	Yes	Yes	Yes	Yes	Yes	Yes	Yes	Yes	Yes	No	Yes	Yes	Yes	Yes	Yes	Yes	No	No
Data Overwrite Security Unit	Type H	Yes	Yes	Yes	Yes	Yes	Yes	Yes	Yes	Yes	No	Yes	Yes	Yes	Yes	Yes	Yes	No	No
File Format Converter	Type E	Yes	Yes	Yes	Yes	Yes	Yes	Yes	Yes	Yes	No	Yes	Yes	Yes	Yes	Yes	Yes	No	No

Yes	Option Compatible
No	Option Not Compatible
•	Option Required
*1	Copy Connector Kit can be installed but marked output peripherals will not function.

Product Support Guide

Model D059/D060/D061

Configuration

Main Frame Configuration

Configuration 1

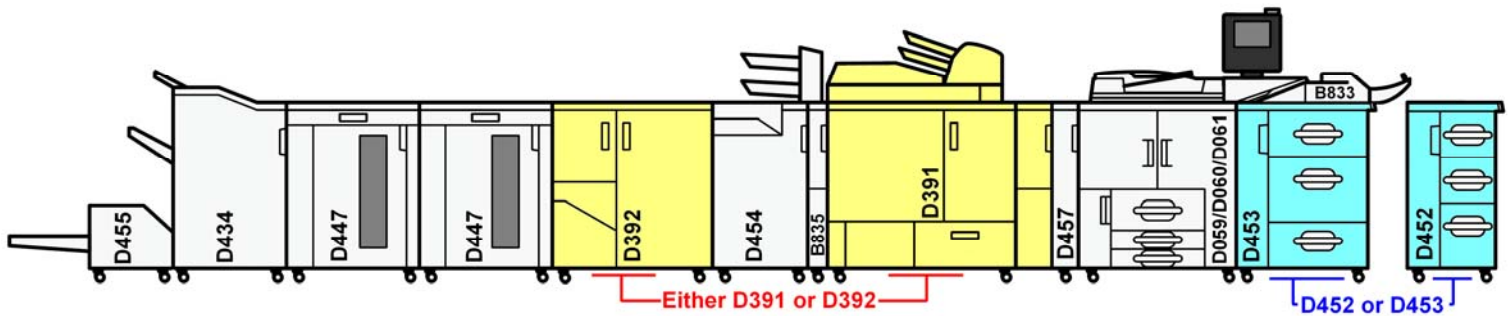

Rules for Configuration 1

Options must be installed in the order shown above.

1. Either LCT LT (D452) or LCT DLT (D453) (not both) can be installed on the right side of the main machine.
2. The Multi Bypass Tray BY5000 (B833) can be installed on top of either the LCT LT (D452) or LCT DLT (D453).
3. The De-curl Unit (D457), if installed, is the first downstream unit (left side of the main machine).
4. Either the Perfect Binder (D391) or the Ring Binder (D392) can be installed. **Both cannot be installed in the same system.**
5. Two High Capacity Stacker Units (D447) can be installed in the same system, but only one is supported if the Multi-Folding Unit (D454) is installed on that system.
6. If two High Capacity Stackers are to be installed in the same system, the second stacker must be installed in tandem with the first stacker.
7. The High Capacity Stacker (D447) can be installed as the last unit downstream, but only if the Multi-Folding Unit (D454) is not installed on that system.
8. If the Multi Folding Unit (D454) is installed on the system, the Booklet Finisher (D434) must also be installed as the last unit on the system.
 - **The GBC StreamPunch III is supported with the SR5020 Booklet Finisher (D434).**
 - **The Plockmatic BK 5010 Booklet Maker is not supported with the Booklet Finisher (D434).**
9. The Trimmer Unit (D455) can be attached only to the Booklet Finisher (D434).

Product Support Guide

Model D059/D060/D061

Configuration 2

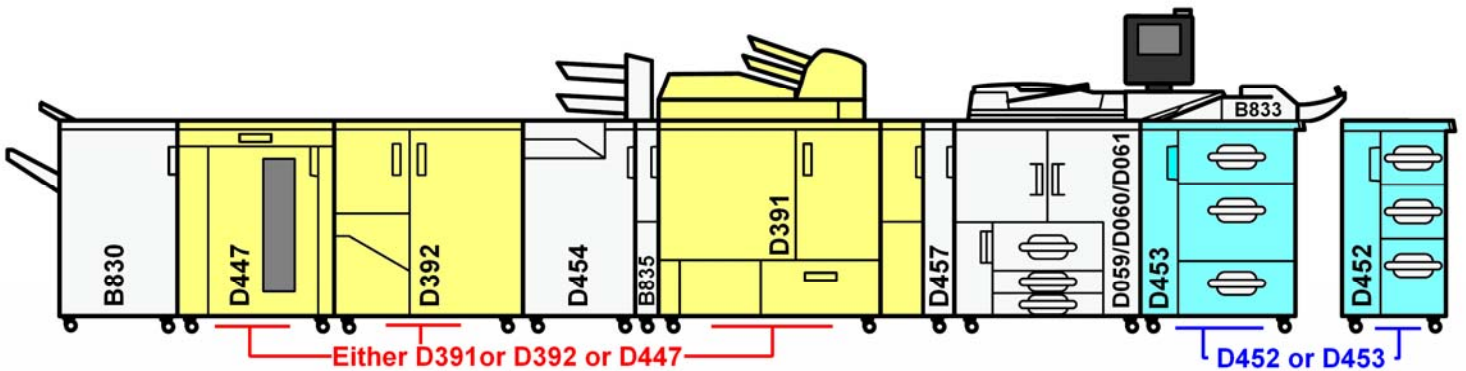

Rules for Configuration 2

Options must be installed in the order shown above.

1. Either LCT LT (D452) or LCT DLT (D453) (not both) can be installed on the right side of the main machine.
2. The Multi Bypass Tray BY5000 (B833) can be installed on top of either the LCT LT (D452) or LCT DLT (D453).
3. The De-curl Unit (D457), if installed, is the first downstream unit (left side of the main machine).
4. Only one of the following units can be installed in this system:
 - ***Perfect Binder (D391)***
 - ***Ring Binder (D392)***
 - ***High Capacity Stacker (D447)***
5. The High Capacity Stacker (D447) can be installed as the last unit downstream, but only if the Multi-Folding Unit (D454) is not installed on that system.
6. If the Multi Folding Unit (D454) is installed on the system, the SR5000 Finisher (B830) must be the last unit on that system.
 - ***The GBC StreamPunch III is supported with the SR5000 Finisher (B830).***
 - ***The Plockmatic BK 5010 Booklet Maker is supported with the Booklet Finisher (D434).***

Product Support Guide

Model D059/D060/D061

Branding Information

Branding is required as the machines are shipped as a generic version.

Ricoh version machines: You must attach the model label (provided) to the front cover.

Savin/Lanier: You must attach the model label (provided) to the front cover and set the Plug and Play name with SP 5-907.

MFP Options

MFP Option Board Slot / SD Card Assignments

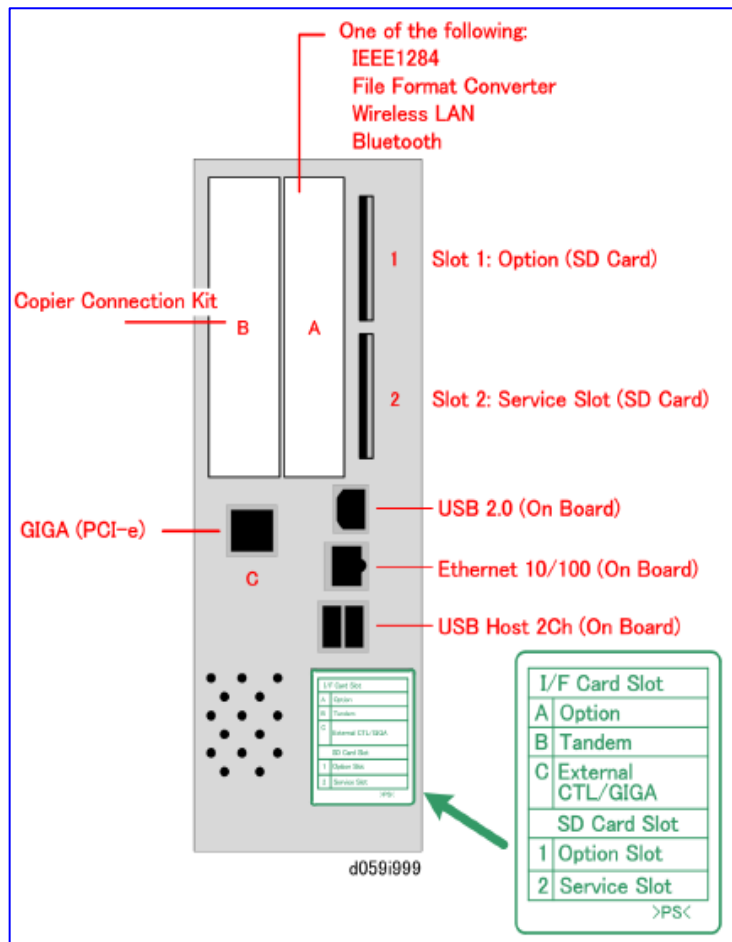

Product Support Guide

Model D059/D060/D061

Feature Comparison To Previous version

Item	D059/D060/D061	D101/D101/D102
Type	Embedded	Embedded
Print speed	90/110/135 ppm	90/110/135 ppm
CPU	Intel Pentium-M 1.4GHz	Intel Celeron LV 866MHz
Memory	Standard: 512MB Printer Scanner Unit: 1GB Total: 1.5GB	256MB (Standard), 512MB (Max)
Interface	Standard: Ethernet (100 Base-TX/10 base-T) USB2.0 Option: IEEE1284 Wireless LAN (IEEE802.11a/b/g) Bluetooth Ethernet 1000 Base-T	Standard: Ethernet (100Base-TX / 10 base-T) USB2.0 Option: IEEE1284 IEEE 1394 Wireless LAN (IEEE802.11b) USB Host Bluetooth Ethernet 1000 Base-T
Network protocol	TCP/IP (IPv4 / IPv6), IPX/SPX, Ether Talk, SMB	TCP/IP (Ipv4 / IPv6), IPX/SPX, Ether Talk, SMB
Print language	Standard: RPCS, PCL5e/6 Option: Adobe PostScript 3, IPDS	Standard: RPCS, PCL5e/6 Option: Adobe PostScript 3, IPDS
Supported OS	Win 2000, Win XP, Vista Win Server 2003, 2008 Macintosh, UNIX	Win 2000, Win XP, Vista Win Server 2003 Macintosh, UNIX
HDD	Standard 320GB (320GB x 1)	Standard 320GB (160GB x 2) RAID

Product Support Guide

Model D059/D060/D061

Installation

Installation Requirements

Temperature Range:	10° C to 32° C (50° F to 89.6° F)
Humidity Range:	15% to 80% RH
Ambient Illumination:	Less than 1,500 lux (do not expose to direct sunlight)
Ventilation:	3 times/hr/person
Ambient Dust:	Less than 0.075 mg/m ³ (2.0 x 10 ⁻⁶ oz/yd ³)
Avoid areas exposed to sudden temperature changes:	
<ul style="list-style-type: none"> • Areas directly exposed to cool air from an air conditioner. • Areas directly exposed to heat from a heater. 	
Do not place machine where it will be exposed to corrosive gases or vapor.	
Do not install the machine at any location over 2,000m (6,500 ft.) above sea level.	
Place the machine on a strong and level base floor base.	
Do not place the machine where it may be subject to strong vibrations.	
Do not connect the machine to a power source shared with another electrical appliance.	
The machine can generate an electromagnetic field that could interfere with radio or television reception.	
Machine level	<ul style="list-style-type: none"> • Front to back: within 5mm (0.2") of level
	<ul style="list-style-type: none"> • Right to left: within 5mm (0.2") of level

NOTE: The machine legs may be raised or lowered in order to level the machine. Use a carpenter's level on the exposure glass.

Main Frame Power Requirements

Input voltage level: **208 ~240, 60Hz**

The required wall outlet is **NEMA 6-20**

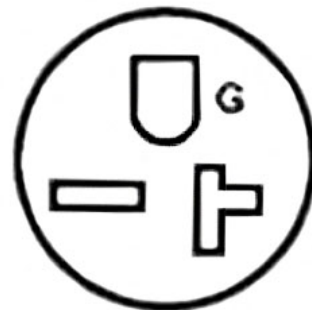

- Never turn Off the main power switch when the power LED is lit or flashing. To avoid damaging the hard disk or memory, press the operation power switch to switch the power Off, wait for the power LED to go Off, and then switch the main power switch Off.

Product Support Guide

Model D059/D060/D061

System Space Requirements

Maximum System Length For Configuration 1

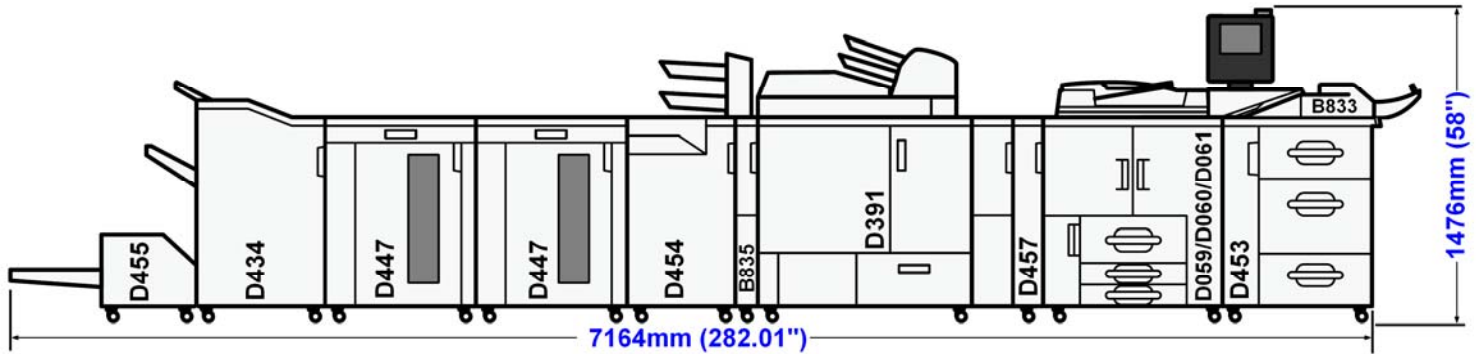

Maximum system length for Configuration 1 (shown above) is **23.5 feet or 7.2 meters**.

- Determine which peripherals will be installed, then refer to the table below. Add the widths (W) of the main machine and each peripheral device to determine the amount of space required to accommodate your installation.
- Be sure to include the minimum space requirements surrounding the unit to determine the total amount of space required.

Unit	Product Code	Dimensions: mm (in.)		
		W	D	H
Copier	D059/D060/D061	870 (35)	859 (34)	1476 (58)
RT5040	D453	850 (34)	---	---
RT5030	D452	540 (22)	---	---
DU5000	D457	160 (7)	---	---
GB5000	D391	1090 (43)	---	---
CI5010	B835	164 (7)	---	---
FD5000	D454	460 (19)	---	---
RB5000	D392	860 (34)	---	---
SK5010	D447	900 (36)	---	---
SR5020	D434	650 (26)	---	---
TR5020	D455	1120 (45)	---	---

Product Support Guide

Model D059/D060/D061

Maximum System Length For Configuration 2

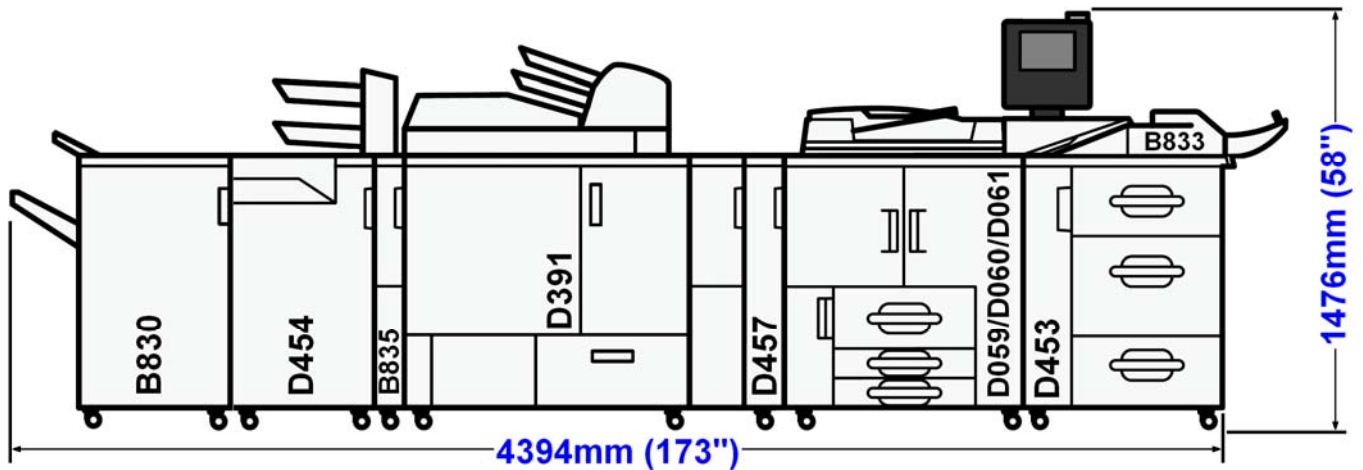

Maximum system length for Configuration 2 (shown above) is **14.5 feet or 4.4 meters**.

- Determine which peripherals will be installed, then refer to the table below. Add the widths (W) of the main machine and each peripheral device to determine the amount of space required to accommodate your installation.
- Be sure to include the minimum space requirements surrounding the unit to determine the total amount of space required.

Unit	Product Code	Dimensions: mm (in.)		
		W	D	H
Copier	D059/D060/D061	870 (35)	859 (34)	1476 (58)
RT5040	D453	850 (34)	---	---
RT5030	D452	540 (22)	---	---
DU5000	D457	160 (7)	---	---
GB5000	D391	1090 (43)	---	---
CI5010	B835	164 (7)	---	---
FD5000	D454	460 (19)	---	---
RB5000	D392	860 (34)	---	---
SK5010	D447	900 (36)	---	---
SR5000	B830	800 (32)	---	---

Product Support Guide

Model D059/D060/D061

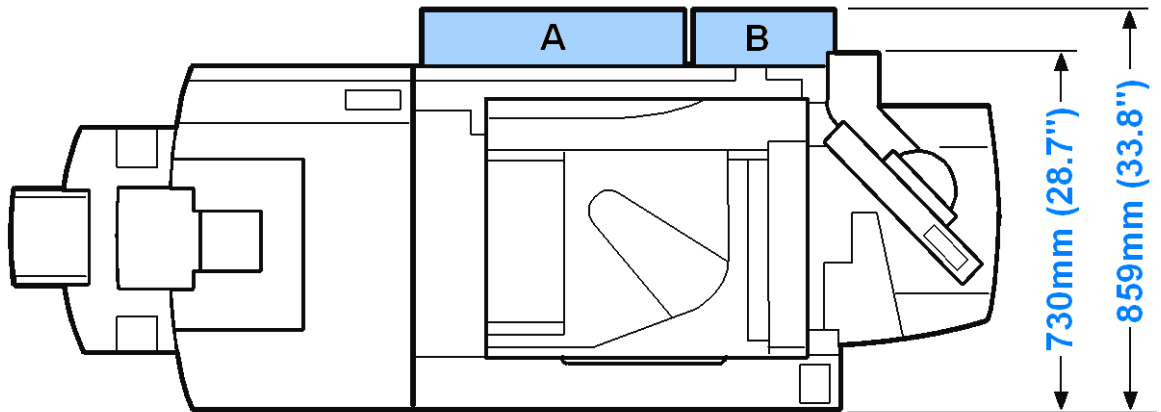

- *The controller box door [A] and PSU door [B] on the back of the machine swings open for servicing, 22 inches is required at the rear of the machine to completely swing both doors open.*
- *Both doors can be removed to allow the machine to pass through a narrow doorway.*

Minimum Space Requirements

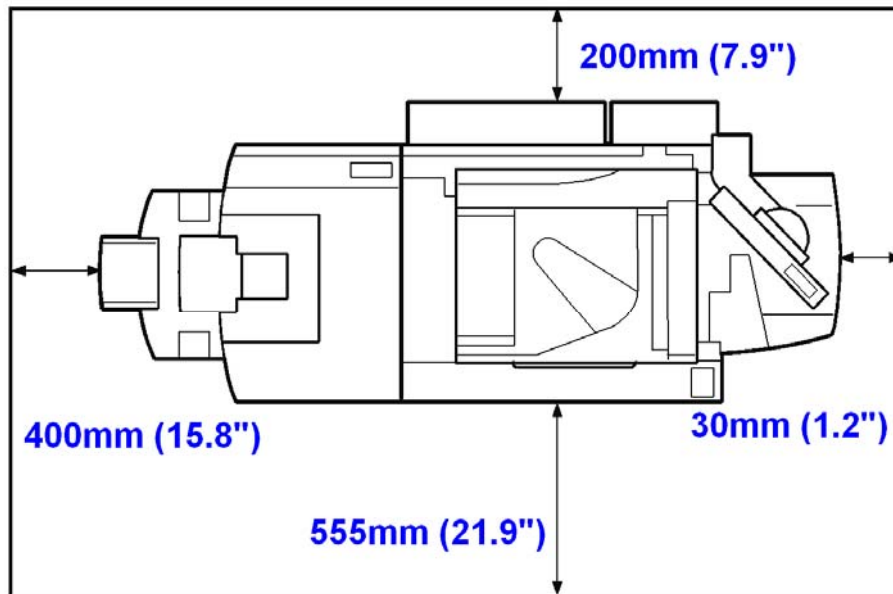

Product Support Guide

Model D059/D060/D061

Power Consumption / Noise Emission

Power Consumption

Mode	Mainframe Only			Full System*		
	D059	D060	D061	D059	D060	D061
Warm-up	1940 W	1960 W	2030 W	1980 W	2000 W	2080 W
Stand-by	309 W	243 W	336 W	335 W	389 W	373 W
Copying	1700 W	1930 W	2240 W	1780 W	2030 W	2360 W
Maximum	2950 W	2970 W	3750 W	3030 W	3050 W	3820 W

* Full System Mainframe + ADF + LCT D452 or D453 + Multi-Bypass Tray B833 + Cover Interposer Tray B835 + 3000-Sheet Finisher B830

Energy Star

	D059 (90 cpm)		D060 (110 cpm)		D061 (135 cpm)	
	Basic	MFP	Basic	MFP	Basic	MFP
Low Power Mode						
Power Consumption (W)	113.8	119.7	129.4	132.4	121.2	127.1
Default Interval (Min.)	15	15	15	15	15	15
Recovery Time (Sec.)	32	29	29	30	66	65.8
Off Mode						
Power Consumption (W)	4.2	---	4.2	---	4.2	---
Default Interval (Min.)	90	---	120	---	120	---
Sleep Mode						
Power Consumption (W)	---	35.5	---	35.3	---	35.9
Default Interval (Min.)	---	90	---	120	---	120

Product Support Guide

Model D059/D060/D061

Noise Emission

			D059	D060	D061
Sound Power Level	Main Frame	Stand-by	Less than 59.4 dB (A)	Less than 60.2 dB (A)	Less than 60.1 db (A)
		Copying	Less than 72.5 dB (A)	Less than 74.3 dB (A)	Less than 76.2 dB (A)
	Complete System	Stand-by	Less than 58.7 dB (A)	Less than 59.2 dB (A)	Less than 59.3 dB (A)
		Copying	Less than 75.0 dB (A)	Less than 75.8 dB (A)	Less than 77.2 dB (A)
Sound Pressure Level	Main Frame	Stand-by	Less than 45.4 dB (A)	Less than 46.5 dB (A)	Less than 46.4 dB (A)
		Copying	Less than 57.8 dB (A)	Less than 60.2 dB (A)	Less than 61.8 dB (A)
	Complete System	Stand-by	Less than 44.9 dB (A)	Less than 45.2 dB (A)	Less than 45.1 dB (A)
		Copying	Less than 60.3 dB (A)	Less than 61.0 dB (A)	Less than 62.6 dB (A)

- Sound power level and sound pressure level are actual values measured in accordance with ISO 7779.
- Sound power level and sound pressure measured from the position of the bystander/operator.
- The complete system consists of the mainframe, De-curling Unit (D457), Booklet Finisher (D455), and DLTCT (D453).

Installation Times

Unit	Time (Minutes)	Unit	Time (Minutes)
90/110/135 cpm Copier	30	Perfect Binder GB5000	50
11" x 17" Tray Kit TK5010	15	Ring Binder RB5000	15
Multi Folding Unit FD5000	15	Printer/Scanner Unit Type 1357	10
LT Large Capacity Tray RT5030	15	PostScript3 Unit Type 1357	10
DLT Large Capacity Tray RT5040	15	IPDS Unit Type 1357EX	10
Multi Bypass Tray BY5000	15	Gigabit Ethernet Type B	10
Finisher SR5000	15	Bluetooth Interface Unit Type 3245	10
Punch Unit PU5000	10	Copy Data Security Unit Type F	10
Booklet Finisher SR5020	15	Data Overwrite Security Unit Type H	10
Punch Unit PU5020	10	HDD Encryption Unit Type A	10
Trimmer TR5020	15	File Format Converter Type E	10
De-curling Unit DU5000	15	IEEE 802.11 a/g I/F Unit Type J	10
Cover Inserter CI5010	15	IEEE 1284 Interface Type A	10
Stacker SK5010	15	Copy Connector Kit Type 3260	10
Multi Folder FD5000	15	VM Card Type J	10

Product Support Guide

Model D059/D060/D061

Storage/Transportation

	Storage	Transportation
Mainframe	-30 ~ 40° C Less than 80% RH Max: 18 months	-30 ~ 50° C 15% ~ 95% RH
Toner	-30 to 50° C 15 ~ 80% RH Max: 24 months	-30 ~ 40°C 15 ~ 80% RH
Developer	Less than 40° C 15 ~ 80% RH Max 12 months	Less than 40° C 15 ~ 80% RH
OPC Drum	-30~ 43° C 15 ~ 90% RH Max 12 months	-30~ 43° C 15 ~ 90% RH
Glue	-20 to 40° C 5 ~ 95% RH Max: 18 months	-20 ~ 40° C 5 to 95% RH

To prevent blockages in the toner supply path, always perform the TRANSPORTING THE COPIER procedure outlined in the Field Service Manual, prior to transporting the D059/D060/D061 copier. If this procedure is not done, SC592 (Toner Bank Motor Error) or SC495 (Toner Bottle Unit Error) may occur, requiring replacement of the toner transport hose and toner supply coil.

Product Support Guide

Model D059/D060/D061

Parts / Special Tools / Maintenance

PM Parts / Yields

Unique/Common
U: Unique for this model
C: Common with listed model

D059/D060/D061 Mainframe

Part Number	Description	Q'ty/ Unit	PM Interval	Unique or Common					
Fusing									
AE011108	Hot Roller: DIA80	1	700k	D101/D102					
AE011110	Hot Roller: DIA80: Type C	1	700k	D103					
AE020177	Pressure Roller: DIA80	1	750k	U					
AE045056	Roller: Cleaning Felt: 27M:Ass'y	1	750k	U					
AE040067	Roller: Cleaning Felt: Plate	1	750k	D101/D102/D103					
AE044067	Stripper Pawls: Ring: Ass'y	5	700k	D101/D102/D103					
B0704418	Pad: Brake: Oil Supply Roller	1	750k	D101/D102/D103					
Included in 700K PM Kit PMD059700K									
					Scanner				
					B0701790	Exposure Glass: Ass'y	1	1,000K	D101/D102/D103
					Development Unit				
					B2343701	Collection Bottle: Vacuum: Ass'y	1	3,000k	D101/D102/D103
					B2343094	Air Pump: Development: Ass'y	1	2,500k	D101/D102/D103
B2349640	Developer Type 27	1	500K	D101/D102/D103					
Paper Feed									
AF031080	Paper Feed Roller: Feed	3	1,000k	D101/D102/D103					
AF030080	Paper Feed Roller: Pickup	3	1,000k	D101/D102/D103					
AF032080	Paper Feed Roller: Separation	3	1,000k	D101/D102/D103					
Around Drum									
B2343590	Brush Roller: Cleaning	1	550k	D101/D102/D103					
B2343637	Filter Cleaning	2	500k	D101/D102/D103					
D0593564	Blade: Cleaning: Ass'y	1	550k	U					
B2342128	Wire: Charge Corona	1	500k	D101/D102/D103					
B2342113	Grid: Charge Corona	1	500k	D101/D102/D103					
B2342123	Cushion: Wire	2	500k	D101/D102/D103					
A0962063	Corona Wire Cleaner	1	500k	D101/D102/D103					
B2342158	Filter: Around The Photoconductor	1	550k	D101/D102/D103					
B2342155	Grid: Charge Corona: Pre	1	500k	D101/D102/D103					
B2342156	Wire: Charge Corona: Pre	1	500k	D101/D102/D103					
AD025022	Pickoff Pawl: Swivel	2	1,100k	D101/D102/D103					
B2343971	Transfer Belt	1	1,100k	D101/D102/D103					
B2343916	Blade: Transfer Belt: No.1 2:Ass'y	1	1,100k	D101/D102/D103					
B0702076	Ozone Filter: 50x150x40	1	15,000k	D101/D102/D103					
Included in 500K PM Kit PMD059500K									
					Included in 1,100K PM Kit PMB2341100K				

Product Support Guide

Model D059/D060/D061

PM Table Continued...

Part Number	Description	Q'ty/ Unit	PM Interval	Unique or Common	
ADF					
B3011442	Transport Belt	1	140k org	D101/D102/D103	Included in ADF PM Kit PMB234ADFK
A8592241	Reverse Roller: Paper Feed	1	120k org	D101/D102/D103	
B4772225	Pickup Roller	1	120k org	D101/D102/D103	
A8061295	Paper Feed Belt	1	120k org	D101/D102/D103	

Options

Unique/Common

U: Unique for this model

C: Common with other model

LCT : D452/D453

Part Number	Description	Q'ty/ Unit	PM Interval	Unique or Common
AF031081	Paper Feed Roller: Feed: Manual Feed	3	1,000k	D101/D102/D103
AF030080	Paper Feed Roller: Pickup	3	1,000k	D101/D102/D103
AF032080	Paper Feed Roller: Separation	3	1,000k	D101/D102/D103

By-Pass Tray: B833

Part Number	Description	Q'ty/ Unit	PM Interval	Unique or Common
AF031081	Paper Feed Roller: Feed: Manual Feed	1	1,000k	D101/D102/D103
AF030080	Paper Feed Roller: Pickup	1	1,000k	D101/D102/D103
AF032080	Paper Feed Roller: Separation	1	1,000k	D101/D102/D103

Perfect Binder: D391

Part Number	Description	Q'ty/ Unit	PM Interval	Unique or Common
D3911000	Blade: Perfect Binder	1	40K cuts	D101/D102/D103
D3911271	Trimming Catcher: Perfect Binder	1	40K cuts	D101/D102/D103
D3911414	Blade Cradle: Perfect Binder	1	5.5K cuts	D101/D102/D103
D3911275	Glue Vat Unit Heater: Perfect Binder	1	2,000 hrs	D101/D102/D103

Product Support Guide

Model D059/D060/D061

PM Kits

PM Kit	Part Number	Unique or Common
500K PM Kit	PMD059500K	U
700K PM Kit	PMD059700K	U
1,100K PM Kit	PMB2341100K	D101/D102/D103
ADF PM Kit	PMB234ADFK	D101/D102/D103

Special Tools & Lubricants

Item	Part Number	Description	Q'ty	Unique or Common
1	A0069104	Scanner Positioning Pin (4pcs/set)	1	D101/D102/D103
2	A2929500	Test Chart – S5S (10 pcs/set)	1	D101/D102/D103
3	VSSM9000	Digital Multimeter – FLUKE 87	1	D101/D102/D103
4	A2579300	Grease Barrierta – S552R	1	D101/D102/D103
5	52039502	Silicon Grease G-501	1	D101/D102/D103
6	G0219350	Loop Back Connector	1	D101/D102/D103
7	B6455010	SD Card	1	D101/D102/D103
8	B6456705	PCMCIA Card Adapter	1	D101/D102/D103
9	B6456820	USB Reader/Writer	1	D101/D102/D103
10	A2949561	Paper Dust Cleaner-5pcs/set	1	D101/D102/D103
11	D3911001	Signature Thickness Jig	1	D101/D102/D103
12	B2348614	Setting Powder	1	D101/D102/D103

Product Support Guide

Model D059/D060/D061

TCRU Kits (Trained Customer Replacement Units)

Model	Description	Order Number
D059/D060	TCRU Type 1107	404271
D061	TCRU Type 1357	404273

SP 5-185 must be set to "1: ON" to enable TCRU Mode.

TCRU Type 1107 Kit Contents			
Item	Description	Part Number	Qty
Development	Development Unit	D0593100	1
	Harness Cover	B2343188	1
	Toner Supply Unit	D0593200	1
PCU	Drum Assembly	D0592309	1
PCU	Cleaning Assembly	D0593502	1
OPC	OPC Drum	D0599510	1
Charge Unit	Charge Corona Assembly	B2342111	1
Pre-Charge Unit	Pre -Charge Corona Assembly	B2342140	1
Fusing Unit	Fusing Unit Type AB (90/110ppm)	D0594012	1
Fusing Web	Fusing Unit Entrance Upper Assembly	D0594111	1
Waste Toner Bottle	Collection Bottle Assembly	B2343468	1
Pick Up Roller	Paper Feed Roller: Pickup	AF030080	4
Feed Roller For Mainframe	Paper Feed Roller: Feed	AF031080	2
Feed Roller For LCTs	Paper Feed Roller: Feed: Manual Feed	AF031081	2
Reverse Roller	Paper Feed Roller: Separate	AF032080	4
Misc. Items	Driver for TCRU	B2348612	1
	Setting power	B2348614	1
	Developer	B2349640	1
	C-Retaining Ring	D0592620	12

Product Support Guide

Model D059/D060/D061

TCRU Type 1357 Kit Contents			
Item	Description	Part Number	Qty
Development	Development Unit	D0593100	1
	Harness Cover	B2343188	1
	Toner Supply Unit	D0593200	1
PCU	Drum Assembly	D0592309	1
PCU	Cleaning Assembly	D0593502	1
OPC	OPC Drum	D0599510	1
Charge Unit	Charge Corona Assembly	B2342111	1
Pre-Charge Unit	Pre -Charge Corona Assembly	B2342140	1
Fusing Unit	Fusing Unit Type C (135ppm)	D0614012	1
Fusing Web	Fusing Unit Entrance Upper Assembly	D0594111	1
Waste Toner Bottle	Collection Bottle Assembly	B2343468	1
Pick Up Roller	Paper Feed Roller: Pickup	AF030080	4
Feed Roller For Mainframe	Paper Feed Roller: Feed	AF031080	2
Feed Roller For LCTs	Paper Feed Roller: Feed: Manual Feed	AF031081	2
Reverse Roller	Paper Feed Roller: Separate	AF032080	4
Misc. Items	Driver for TCRU	B2348612	1
	Setting power	B2348614	1
	Developer	B2349640	1
	C-Retaining Ring	D0592620	12

Target Reliability

Model	D059 (90 cpm)	D060 (110 cpm)	D061 (135 cpm)
Average Monthly Volume	120K/month	190K/month	300K/month
Max. Monthly Volume	1,000,000/month		
PM Interval	500K		
Drum Yield	2,500,000		

Product Support Guide

Model D059/D060/D061

Specifications / Documentation

Configuration	Console		
Copy Process	Dry electrostatic transfer system		
Originals	Sheet/Book/Object		
Original Size	Max.: A3, 11 x 17" Min.: A5 5½" x 8½" (with ADF) "		
Original Alignment	Rear left corner (for platen mode, ADF mode)		
Paper Weight	Tray 1-3:	52 to 216 g/m2	
	Tray 4-5(D452):	Bond: 16 to 40 lb.	
	Tray 4,6 (D453)	Cover: 50 to 80 lb.	
	Tray 7 (Bypass):	Index: 90 to 110 lb.	
	Tray 6 (D452):	52 to 163 g/m2	
		Bond: 16 to 40 lb.	
		Cover: 50 to 60 lb.	
	Tray 5 (D453):	Index: 90 lb. 52 to 216 g/m2	
		52 to 216 g/m2	
		Bond: 16 to 40 lb. Cover: 50 to 60 lb.	
Duplex Tray (Possible Weight):	Cover: 50 to 60 lb.		
	Index: 90 lb.		
	52 to 216 g/m2		
Paper Size	Tray 1 (Tandem):	8½" x 11" LEF, A4 LEF	
	Tray 2, Tray 3:	5½" x 8½" to 11" x 17", 12" x 18", A5 to A3	
	Duplex Tray (Possible Sizes):	A5 to A3, 5½" x 8½" to 11" x 17", 12" x 18", 13" x 18"	
Reproduction Ratios	7 reduction and 5 enlargement		
	Enlargement	Metric Version	Inch Version
		400%	400%
		200%	200%
		141%	155%
		122%	129%
	Reduction	115%	121%
		Full Size	100%
		93%	93%
		82%	85%
		75%	78%
		71%	73%
		65%	65%
50%		50%	
25%	25%		
Zoom	25 to 400% (allows manual adjustment in 1% steps vertically, horizontally)		
Image Density	Automatic, Manual (9 notches)		
Copy Speed	D059: 90 ppm D060: 110 ppm D061: 135 ppm	Copying with image stored in memory with A4/LT LEF feeding from the same tray.	
	Note: The speed in this mode is 80 ppm for all three models. When using ADF 1-to-1 with A4/LT LEF magnification feeding from the same tray.		

Product Support Guide

Model D059/D060/D061

Warm-up Time	Less than 360 s from Off mode at 23°C (73.4°F)		
First Copy Time	Copy Tray 1, A4, 8½" x 11" LEF		
		Face-up	Face-down
	D059 (90 cpm)	<3.5 s	< 5.0 s
	D060 (110 cpm)	<3.2 s	< 4.5 s
	D061 (135 cpm)	<3.0 s	< 4 s
Multiple Copies	Up to 9,999		
Copy Paper Capacity (Sheets):	Copier	3,000	Tray 1: (Tandem) 1,000 x 2
			Tray 2: 500
			Tray 3: 500
	Optional LT – LCT D454	4,550	Tray 4: 1,000
			Tray 5: 1,000
	Optional DLT – LCT D453	4,000	Tray 4: 1,000
Tray 5: 2,000			
Optional Bypass Tray B833	500	Tray 6: 1,000	
Memory Capacity:	RAM:	512 MB (512 x 1) Standard	
		1.5 GB (512 MB x1, 1 GB x1)	
		Optional but required for Scanner/Printer Option	
	HDD:	320 GB (320 GB x1)	
		Approximately 1,735 copies	
Toner Replenishment:	Cartridge exchange (1,650 g/cartridge)		
Toner Yield:	60 K copies, (A4 LEF, 6% chart)		
	D059 (90 cpm) 1 to 25 Repeat Copying		
	D060 (110 cpm), 1 to 50 Repeat Copying		
	D061 (135 cpm), 1 to 100 Repeat Copying		
Power Source:	North America	208 to 240 V, 60 Hz, 20 A	
Size (W x D x H)	Copier	870 x 858.5 x 1476 mm	
		32.3" x 33.8" x 58.1"	
	Full System (with B834)	3461 x 858.5 x 1476 mm	
		136.3 x 33.8 x 58 in.	
Full System (with B832)	3151 x 858.5 x 1476 mm		
	124 x 33.8 x 58 in.		
Weight:	Less than 315 kg (693 lb) including ADF, and no options		

Product Support Guide

Model D059/D060/D061

Non-reproduction area:

Leading edge:	More than 4 ± 2 mm.
Trailing edge:	0.3 - 4 mm.
Left edge:	More than 2 ± 1.5 mm.
Right edge:	More than 2 ± 1.5 mm.

Maximum Paper Size & Printing Area:

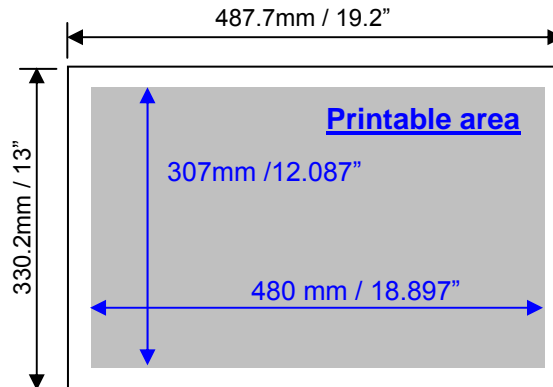

Max Paper Size - 13" x 19.2"

Max Printing Area - 12.087" x 18.897"

Max Scanning Area - 11" x 17"

Product Support Guide

Model D059/D060/D061

ADF		
Original Size	Normal Original Mode	A3 to B5, 11" x 17" to 5½" x 8½"
	Thin Original Mode	A3 to B5, 11" x 17" to 5½" x 8½"
	Duplex Original Mode	A3 to B5, 11" x 17" to 5½" x 8½"
Original Weight	Normal Original Mode	52 ~ 128 g/m2 (Note 1)
	Thin Original Mode	40 ~ 128 g/m2 (Note 1)
	Duplex Original Mode	52 ~ 105 g/m2 (Note 2)
Table Capacity	100 sheets (80 g/m2, 20 lb).	
Original Feeding Speed	80 cpm (A4/8½" x 11" LEF, 1 to 1).	
Original Standard Position	Rear left corner (Face-up).	
Separation	FRR.	
Original Transport	One flat belt.	
Original Feed Order	From the top original.	
Power Source	DC24V ± 10%, DC38V ± 10%, DC5V ± 5% (from the copier).	
Power Consumption	Less than 130 W.	
Dimensions (W x D x H)	680 x 560 x 150 mm (26.8" x 22" x 5.9").	
Level	Less than 5 mm deviation at front/back, left/right.	
Weight	Less than 17.5 kg (38.5 lb.).	

Note 1: 156 g/m2 possible, but not guaranteed.

Note 2: 128 g/m2 possible, but not guaranteed.

Options

11 x 17 Tray Kit TK5000 (B331)	
Paper Size	A3 SEF, B4 SEF, 11"x17" SEF, 8½"x14" SEF, A4 SEF, A4 LEF, 8½"x11" SEF, 11"x 8½" LEF, 305 mm x 439 mm.
Paper Weight	52 ~ 163 g/m2.
Tray Capacity	1,000 sheets.
Remaining Paper Detection	5-Step: 100%, 75%, 50%, 25%, paper end.

Product Support Guide

Model D059/D060/D061

LT LCT RT5030 (B452)					
Speed	D059 (90 cpm)	420 ~ 555 mm/s.			
	D060 (110 cpm)	500 ~ 720 mm/s.			
	D061 (135 cpm)	630 ~ 985 mm/s.			
Paper Feed System	FRR-CF (no air-knife separation).				
Tray Capacity	Tray 1, 2	1,000 sheets (Paper thickness: 0.11 mm).			
	Tray 3	2,550 sheets (Paper thickness: 0.11 mm).			
Paper Weight	Tray 1, 2	52 to 216 g/m ² .			
	Tray 3	52 to 163 g/m ² .			
Paper Size	Tray 1,2,3	A5 LEF, A5 SEF, 5½"x8½" LEF, B5 LEF, 5½" x 8½" SEF, A4 LEF, 8½" x 11" LEF.			
Paper Size Switching	Tray 1, 2	Fixed position side, end fences, adjusted for other paper sizes by the operator.			
	Tray 3	Fixed position side, end fences, adjusted by service technician.			
Anti-Condensation Heater (Option)	36W (18 x 2) available as an option.				
Dimensions (W x D x H)	540 x 730 x 980 mm (21.3 x 28.7 x 38.6 in.).				
Level	Less than 5 mm deviation at front/back, left/right.				
Weight	Less than 88 kg (193.6 lb.).				
Power Source	DC 24 V ±10% (from copier).				
Power Consumption	Less than 132 W.				
I/F Connection	Serial connection to main frame.				
Tab Sheet	Feed possible from Tray 4 or Tray 5. Requires installation of tab sheet fence.				
	Note: Only A4 LEF, 8½" x 11" LEF tab sheets can be fed.				
Remaining Paper Detection	Trays 4, 5	5 Step: 900, 625, 375, 75, paper end.			
	Tray 6	5 Step: 2250, 1525, 800, 75, paper end.			
	Accuracy	± 30 sheets (Tray 4,5,6).			
Bypass Tray (Option)	The Multi-Bypass Tray (B833) may be installed on this LCT.				
Noise Level	Mode	Stand-alone	System		
			D059	D060	D061
	Operation	< 73 dB	< 78 dB	< 80 dB	< 83 dB
	Standby	-	< 64 dB	< 70 dB	< 78 dB

Product Support Guide

Model D059/D060/D061

DLT LCT RT5040 (D453)					
Speed	D059 (90 cpm)	420~555 mm/s.			
	D060 (110 cpm)	500~720 mm/s .			
	D061 (135 cpm)	630~985 mm/s.			
Paper Feed System	Tray 1, 2, 3	FRR-CF air assist separation.			
Paper Tray Lock	Lock clasps provided, lock not provided. *				
Tray Capacity	Tray 1, 3	1,000 sheets (Paper thickness: 0.11 mm).			
	Tray 2	2,000 sheets (Paper thickness: 0.11 mm).			
Paper Level Detection	Trays 4, 5	5 Step: 900, 625, 375, 75, paper end.			
	Tray 6	5 Step: 2250, 1525, 800, 75, paper end.			
	Accuracy	± 30 sheets (Tray 4,5,6).			
Bypass Tray (Option)	The Multi-Bypass Tray (B833) may be installed on this LCT.				
Paper Weight	Tray 1	52 to 256 g/m2.			
	Tray 2	40 to 300 g/m2.			
	Tray 3	52 to 256 g/m2.			
Paper Size	Tray 1,2,3	A5 to A3.			
		5½"x 8½" to 13" x 18".			
Paper Size Switching	Side fence, end fence adjustment.				
Paper Size Detection	Automatic.				
Anti-Condensation Heater (Option)	36W (18 x 2) available as an option.				
Dimensions (W x D x H)	880 x 730 x 980 mm (33.5 x 28.7 x 38.6 in.).				
Level	Less than 5 mm deviation at front/back, left/right.				
Weight	Less than 165 kg (363 lb.).				
Power Source	DC 24 V ±10% (from copier).				
Power Consumption	Less than 150 W.				
I/F Connection	Serial connection to main frame.				
Tab Sheet	Feed possible from all trays. Requires installation of tab sheet fence.				
	Note: Only A4 LEF, 8½" x 11" LEF tab sheets can be fed.				
Noise Level	Mode	Stand-alone	System		
			D059	D060	D061
	Operation	< 73 dB	< 78 dB	< 80 dB	< 83 dB
	Standby	-	< 64 dB	< 70 dB	< 78 dB

Product Support Guide

Model D059/D060/D061

* *Recommended Lock Type specifications (please procure locally)*

- **ABUS Lock: T84MB (20mm)**
- **See the following drawing for lock requirements.**

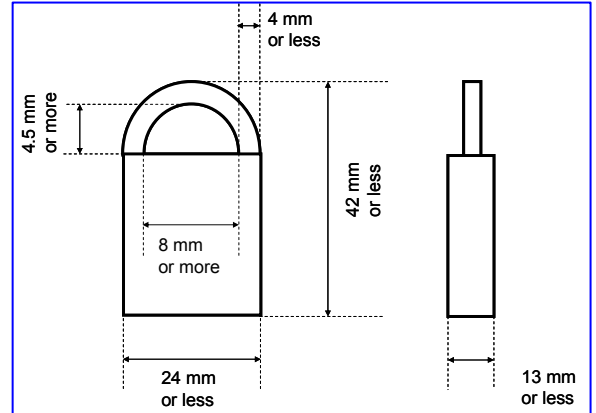

Product Support Guide

Model D059/D060/D061

Multi Bypass Tray BY5000 (B833)					
Speed	D059 (90 cpm)	420 ~ 555 mm/s			
	D060 (110 cpm)	500 ~ 720 mm/s			
	DD061 (135 cpm)	630 ~ 985 mm/s			
Paper Feed System	FRR-CF.				
Tray Capacity	500 sheets (Paper thickness: 0.11 mm) .				
Paper Weight	52 ~ 216 g/m2.				
Paper Size	A5 LEF, A5 SEF to A3 SEF, HLT LEF, HLT SEF to 13"x18" SEF.				
Paper Size Switching	Operator adjustable side fences allow variety of paper sizes.				
Paper Size Detection	Automatic (standard sizes only).				
Anti-Condensation Heater	No				
Remaining Paper Detection	Tray 7	4-Step: 500, 250, 50, paper end.			
	Accuracy	± 50 sheets			
Weight	Less than 18 kg (39.6 lb).				
Power Source	24 Vdc (from Copier), 5 Vdc (from LCT).				
Power Consumption	Less than 50 W.				
Dimensions (W x D x H)	710 x 560 x 210 mm (30 x 22 x 8.3 in.).				
Tab Sheets	A4 LEF, 8½" x 11" LEF (requires attachment of tab fence).				
Noise Level	Mode	Stand-alone	System		
			D059	D060	D061
	Operation	< 73 dB	< 78 dB	< 80 dB	< 83 dB
	Standby	-	< 64 dB	< 70 dB	< 78 dB

Note: The Bypass Tray is mounted on the top of either the LT LCT D452 or DLT LCT D453

Product Support Guide

Model D059/D060/D061

De-curl/Purge Tray Unit DU5000 (B457)						
General						
Paper Weight	40 g/m2 to 300g/m2.					
Paper Size	331 x 488 mm (13"x19.2") to A6 SEF, postcards.					
Power Supply	DC 24V±5%, 5.1V±3% from main machine.					
Power Consumption	Less than 30V .					
Size (w x d x h)	170 x 730 x 990 mm (6.7 x 28.7 x 40 in.).					
Level	Less than 5 mm deviation at front/back, left/right.					
Weight	Less than 30 Kg (66 lb.)					
Noise Level db (A)	D059		D060		D061	
	Alone	System	Alone	System	Alone	System
Operation	74	78	76	80	79	83
Standby	60	64	66	70	74	78
De-curling	Site	Corrects front/back curl, selectable with lift plate on the unit by operator.				
	Strength	5-Steps: Set by Customer.				
Purge Tray	10 Sheets					
Jam Alert	<ul style="list-style-type: none"> · Operation panel (main machine) · Jam LED front door · Inner Jam LED (paper remaining on tray) 					
Jam Removal	Tray easily opened, paper removed by operator.					
Purged Paper Count	None					
Storage	Space provided for storage of one extra used toner bottle for the main machine.					

Product Support Guide

Model D059/D060/D061

Perfect Binder Inserter (D391)		
Feed System	Automatic Paper Feed.	
Trays	Two. Tray A (upper), Tray B (lower).	
Cover Setting	Face-up stacking.	
Feed	Top to bottom.	
Transport Mode	Simplex.	
Cover Paper Type	Standard PPC, Color Paper, Coated Paper.	
	Paper type mixing not recommended.	
Cover Size	Standard:	A4 SEF, A4 LEF, B5 SEF, B5 LEF, LT SEF, LT LEF, EXE SEF.
	Width:	257 to 330.2 mm.
	Length:	182 to 487.7 mm.
	Recommended	13"x19.2", 13"x19", 13"x18", A3, B4.
Tray A, B Capacity	Up to 200 covers (80 g/m2).	
	Maximum stack thickness: 24 mm.	
Paper Weight	64 g/m2 to 300 g/m2.	
Paper Positioning	Center aligned.	
Paper Size Detection	Width:	Adjustable slide-fence contact sensors.
	Tray A, Tray B:	1 sensor each.
	Length:	Pulse count photo-sensors.
Dimensions (w x d x h)	621 x 679 x 213 mm (24.5 x 26.7 x 8.4 in.).	
Weight	Approximately 17 kg (37.4 lb.).	
Power Supply	DC 24V (supplied from host machine via Perfect Binder).	
Power Consumption	Less than 103 W (maximum at operation).	

Product Support Guide

Model D059/D060/D061

Perfect Binder GB5000 (D391)			
Paper Positioning	Center aligned.		
Delivery	Face-down.		
Signature Thickness	10 to 200 sheets (64 to 80 g/m ²) . 10 to 150 sheets (81 to 105 g/m ²). Max. Thickness: Up to 23 mm (0.9 in.).		
Paper Size	Signature	Width: 182 to 228.6 mm. Length: 257 to 320 mm.	
	Cover	Width: 257 to 330.2 mm. Length: 364 to 487.7 mm.	
Paper Thickness	Signature	64 to 163 g/m ² .	
	Cover	90 to 300 g/m ² .	
Finished Size	Width	139.7 mm to 216 mm.	
	Length	201 to 297 mm.	
Trimming Range	Top	6 to 28 mm.	
	Bottom	6 to 28 mm.	
	Fore Edge	6 to 40 mm.	
Recommended Cover/Signature Size Ratios	Target	Signature	Cover
	A4	SRA4 (225x320mm)	13"x19.2" 13"x19" 13"x18" SRA3 (320x450 mm)
	B5	A4	A3
	A5	B5	B4
	LT	9"x12"	13"x19.2" 13"x19"
Trimming Modes	3 cuts: Bottom, top, fore edge. 1 cut: Fore edge (Limit: 297 mm). No cut.		
Downstream Delivery	Straight-through, no binding.		
	Size	Width: 98.4 to 330.2 mm. Length: 139.7 to 500 mm.	
	Paper Weight	52 to 300 g/m ² .	
Book Output Tray	Max.: 25 mm (80 g/m ²). Book door locked during operation.		
Warm-up Time	Less than 380 sec. (6.3 min.).		
Glue Capacity	Glue vat 380 g (continuous pellet supply). Approximately A4 to B5 100 books.		
Trimming Box Capacity	More than 15 books. Approx. A4 to B5 of 100 sheets each, 80 g/m ² .		
Dimensions (W x D x H)	1090 x 791 x 1387 mm (43 x 31 x 53.5 in.).		
Weight	335 kg (737 lb.).		
Power Supply	NA: 208 60 Hz.		
Power Consumption	Less than 623 W (with inserter).		
Plug Type	NEMA 6-15P.		

Product Support Guide

Model D059/D060/D061

Cover Inserter CI5010 (B835)		
Speed	D059 (90 cpm)	432 mm/s
	D060 (110 cpm)	515 mm/s
	D061 (135 cpm)	649 mm/s
Paper Separation	FRR System with Feed Belt.	
Paper Sizes	Width: A5 SEF/5½" x 8½" SEF ~ 13".	
	Length: A5 LEF/5½" x 8½" LEF~ 19".	
Paper Weight	64 ~ 216 g/m2.	
Capacity	400 sheets (80 g/m2) (2 trays 200 sheets each).	
Paper Size Detection	Yes.	
Paper Size Switching	Operator adjustable side fences.	
Side Registration	Yes.	
Power Supply	24 V ± 5% (from mainframe).	
Power Consumption	Less than 50 W.	
Dimensions (W x D x H)	Less than 540 x 730 x 1200 mm.	
	21.2" x 28.7" x 47.2".	
Weight	Less than 45 kg (99 lb.).	







Product Support Guide

Model D059/D060/D061

Multi-Folding Unit FD5000 (D454)		
General		
Paper Weight	40 to 300 g/m2.	
Folding Methods	6 (see below).	
Speed	Straight-Through	100 to 700 mm/s.
	Folding	270 to 700 mm/s.
Straight-Through Feed	Size	Postcard to 13x19.2."
	Type	Used paper: A3, A4, B4, B5. OHP: A4, B5. Tap paper: A4 LEF, LT LEF.
Folding Methods	6 (FM1 to FM6)	
Paper Sizes (Folding)	FM1	FM1 A3, B4, DLT, LG, A4, LT, 12x18", 8-kai.
	FM2	A3, B4, DLT, LG, A4, B5, LT 12x18", 12.6x18.5", 12.6x19.2", 13x18", 13x19", 13x19.2", 226x310mm, 310x432 mm, SRA3, SRA4, 8-kai.
	FM3	A3, B4, DLT, LG, A4, LT, B5, 12x18", 8-kai.
	FM4	
	FM5	
	FM6	
Paper Weights (Folding)	FM1	64 to 105 g/m2.
	FM2	
	FM3	
	FM4	
	FM5	
	FM6	
Multiple Folding	FM1	Not allowed.
	FM2	Max. 3 (64 to 80 g/m2 only).
	FM3	Max. 3 (64 to 80 g/m2 only).
	FM4	Max. 3 (64 to 80 g/m2 , B4, A4, LT, B5 only).
	FM5	Not allowed.
	FM6	

Product Support Guide

Model D059/D060/D061

Line Speed (Only FM1 Z-Folded paper can exit downstream)			
No Fold	350 mm/sec. to top tray. To downstream: Same as main machine.		
FM1		700 mm/sec. to top tray (paper ≤ 355.6 mm long). 450 mm/sec. to top tray (paper < 355.6 mm long). To downstream: Same as main machine.	
FM2		1 Sheet: Same as main machine. 2-3 Sheets: 454 mm/sec. 700 mm/sec. to top tray (paper ≤ 355.6 mm long). 350 mm/sec. to top tray (paper ≤ 279.4 < 355.6 mm long). 250 mm/sec. to top tray (paper < 279.4 mm long).	
FM3/FM4			1 Sheet: Same as main machine. 2-3 Sheets: 454 mm/sec. to top tray. 350 mm/sec. to top tray (paper ≤ 420 mm long). 250 mm/sec. to top tray (paper < 420 mm long).
FM5		1 Sheet: Same as main machine. 350 mm/sec. to top tray (paper ≤ 420 mm long). 250 mm/sec. to top tray (paper < 420 mm long).	
FM6		1 Sheet: Same as main machine as far as 3rd Stopper. At 3rd stopper feeds 50 mm at 100 mm/sec. 350 mm/sec. to top tray (paper ≤ 420 mm long). 250 mm/sec. to top tray (paper < 420 mm long).	
Power Supply	AC 120V 60 Hz, 15A.		
Power Consumption	270W.		
Plug Type	NEMA 5-15P.		
Dimensions (w x d x h)	466 x 980 x 730 mm (18.4 x 38.6 x 28.7 in.).		
Level	Less than 5 mm deviation at front/back, left/right.		
Weight	92 kg (203 lb).		
Noise Level (dB A)	Mode	Alone	System
	No Folding	< 76 dB	-
	Folding	< 76 dB	< 83 dB

Product Support Guide

Model D059/D060/D061

Folder Tray Capacity						
Size	FM1		FM3		FM4	
	Weight (Standard) 64 to 80 g/m2	Weight (Heavy) 64 to 80 g/m2	Weight (Standard) 64 to 80 g/m2	Weight (Heavy) 64 to 80 g/m2	Weight (Standard) 64 to 80 g/m2	Weight (Heavy) 64 to 80 g/m2
8-kai	35	20	30	20	40	20
12x18"	35	20	30	20	40	20
A3 SEF	35	20	30	20	40	20
DLT	35	20	30	20	40	20
B4 SEF	35	20	30	20	40	20
LG SEF	35	20	30	20	50	40
A4 SEF	30	20	40	30	50	40
LT SEF	30	20	40	30	50	40
B5 SEF			40	30	50	40
Size	FM2		FM5		FM6	
8-kai	40	25	30	20	50	20
12x18"	40	25	30	20	50	20
A3 SEF	40	25	30	20	50	20
DLT	40	25	30	20	50	20
B4 SEF	40	25	30	20	50	20
LG SEF	40	25	30	20	50	20
A4 SEF	40	50	30	30	50	20
LT SEF	50	50	30	30	30	30
B5 SEF	50	50	30	30	30	30
13x19.2"	40	25				
13x19"	40	25				
12.6x19.2"	40	25				
12.6x18.5"	40	25				
13x18"	40	25				
SRA3 (320x450 mm)	40	25				
SRA4 (225x320 mm)	40	25				
226 x 310 mm	40	25				
310x432 mm	40	25				

Product Support Guide

Model D059/D060/D061

Ring Binder RB5000 (D392)			
Configuration	Console.		
Paper Transport	Centered in paper path.		
Operation Modes	Punching + ring binding.		
	Punching only.		
	Straight-through (downstream delivery).		
Signature Thickness	2 to 100 sheets.		
Paper Size	Punching, binding	A4 LEF, LT LEF.	
	Straight-through (no punching).		
	Unfolded	A6 to A3 SEF, DLT, HLT, 12"x18", 13"x19", 12.6"x19.2", 13"x19.2", Tab sheets (A4, LT, LG).	
	Z-Folded	A3, B4, A4 SEF, DLT, LG, LT SEF 12"x18" (from upstream Z-Folder unit).	
Paper Weight	64 to 216 g/m2.		
Ring Sizes	2 (50-sheet, 100-sheet).		
Punching	A4 LEF: 23 holes. LT LEF: 21 holes .		
Ring Supply	Cartridge feed: capacity: 80 rings max.		
Output Tray Capacity	11 documents (100-ring bound, A4 SEF)		
	Thickness	Ring	On Tray
	2 to 10	50	25
	11 to 50	50,100	20
	51 to 100	100	11
Punching Only	Up to 50 Sheets.		
Dimensions	870 x 730 x 980 mm (34.3 x 28.7 x 38.6 in.).		
Weight	140 kg (308 lb.).		
Power Supply	AC 120V 60 Hz, 15A.		
Power Consumption	Less than 400W.		
Plug Type	NEMA 5-15P.		

Product Support Guide

Model D059/D060/D061

High Capacity Stacker SK5010 (D447)			
General			
Speed	280 to 700 mm/s.		
Front Door Lock	Lock clasps provided, lock not provided. *		
Dimensions	900 x 980 x 730 mm (35.4 x 38.6 x 28.7).		
Weight	100 kg (220 lb.).		
Power Supply	AC 120V 60 Hz, 15A.		
Power Consumption	250W.		
Plug Type	NEMA 5-15P.		
Level	Less than 5 mm deviation at front/back, left/right		
Noise Level (dB A)	Mode	Alone	System
	Shift	< 76 dB	< 83 dB
Shift Tray			
Capacity (80 g/m2)	5,000	A3 Ext., A3 SEF, B4 SEF, A4 SEF, A4 LEF, DLT SEF, LG, SEF, LT SEF, LT LEF.	
	2,500	B5 SEF, B5 LEF, A5 SEF, A5 LEF, HLT SEF, HLT LEF.	
Paper Weight	40 to 300 g/m2.		
Tray Full Detection	4-Steps: 25%, 50%, 75%, 100%.		
Proof Tray			
Capacity	250 (A4, LT 80 g/m2).		
Paper Size	A5 SEF/Postcard to 331 x 499 mm (13" x 19.2").		
Paper Weight	40 to 300 g/m2.		
Tray Full Detection	None.		

* **Recommended Lock Type specifications (please procure locally)**

- **ABUS Lock: T84MB (50 or 60mm), 84MB (50 or 60mm), EC75 (50 or 60mm).**
- **See the following drawing for lock requirements.**

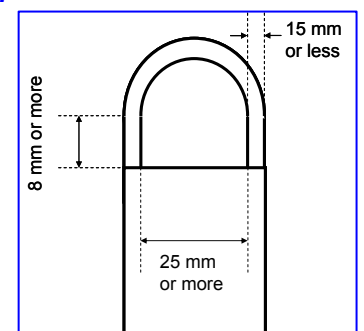

Product Support Guide

Model D059/D060/D061

Booklet Finisher SR5020 (D434)			
General			
Dimension W x D x H	990 x 730 x 1130 mm (39 x 28.7 x 44.5")		
Weight	128 kg (281.6)		
Power Supply	AC 120V 60 Hz, 15A		
Power Consumption	250W		
Plug Type	NEMA 5-15P		
Level Less	Less than 5 mm deviation at front/back, left/right		
Noise Level (dB A)	Mode	Alone	System
	Shift	< 76 dB	---
	Staple	< 78 dB	< 83 dB
Shift Tray			
Capacity	Unfolded Paper	2500	A4 LEF, B5 LEF, LT LEF
		1500	A3, A4 SEF, B4, B5 SEF, LT, LG< LT SEF, SRA4, 226x310 mm
		1000	12x18", SRA3, 13x18", 12.6x1.5", 12.6x19.2", 13x19", 13x19.2", 310x432 mm
		500	A5 LEF, HLT LEF
		100	A5 SEF, HLT SEF
	Z-Folded Paper	30	-
Paper Size	Unfolded Paper	A5 to 13x19.2"	
	Z-Folded Paper	A3, B4, A4 SEF, DLT, LG LT SEF, 12x18", 8-kai	
Paper Weight	Unfolded Paper	40 to 300 g/m2	
	Z-Folded Paper	64 to 105 g/m2	
Proof Tray			
Capacity	Unfolded Paper	250	A4, LT or smaller
		50	B4, LG or larger
	Z-Folded Paper	20	A4, LT or smaller
		20	B4, LG or larger
Paper Size	Unfolded Paper	A6 SEF to 13x19.2", Postcard SEF	
	Z-Folded Paper	A3, B4, A4 SEF, DLT, LG, LT SEF, 12x18", 8-kai	
Paper Weight	Unfolded Paper	52 to 216 g/m2	
	Z-Folded Paper	64 to 105 g/m2	

Product Support Guide

Model D059/D060/D061

Corner Stapling				
Stack Size (80 g/m ²)	Unfolded Paper	2 to 100	A4, B5, LT	
		2 to 50	A3, B4, DLT, LG	
		10	-	
	Z-folded Paper	Combined Stack		
		Z-folded	Unfolded	
		1		1 to 90
		2		0 to 80
		3		0 to 70
		4		0 to 60
		5		0 to 50
		6		0 to 40
		7		0 to 30
		8		0 to 20
	9		0 to 10	
10		0		
Paper Size	Unfolded Paper	B5 to A3, LT to DLT		
	Z-Folded Paper	A3, B4, DLT		
Paper Weight	Unfolded Paper	64 to 90 g/m ²		
	Z-Folded Paper	64 to 105 g/m ²		
Stapling Positions	1 Staple: Rear, Rear diagonal, or Front 2 Staples: Front/Rear			
Staple Supply	Cartridge with 5000-staple capacity			
Tray Capacity After Stapling				
No Folding	Pages	Stacks	Size	
	20 to 100	125 to 25	A4 LEF, B5 LEF, LT LEF	
	10 to 19	200 to 105		
	2 to 9	150		
	10 to 100	150 to 15	A4 SEF, B5 SEF, LT SEF	
	2 to 9	150		
	10 to 50	150 to 30	A3, B4, DLT, LG	
	2 to 9	150		
No Folding, Mixed Sizes	Pages	Stacks	Size	
	2 to 50	30	A3/A4 LEF B4/B5 LEF DLT/LT LEF	

Product Support Guide

Model D059/D060/D061

Z-Folded, Mixed with Unfolded	Pages	Stacks	Size
	1 to 10	30 to 3	A3 Z-fold/A4 B4 Z-fold/B5 DLT Z-fold/LT
Staple Trimming	Hopper Capacity		15,000 staples
	Hopper Full Alert		Photo-sensor
	Trimming Disposal		Alert, operator
Booklet Stapling			
Stack Size	20	64 to 80 g/m2	
	15	80 to 90 g/m2	
Paper Size	13x19.2", 13x19", 12.6x19.2", 12.6x18.5", 13x18", SRA3 (320x450 mm), 12x18", A3, B4, SRA4 (320 x 225 mm), 226x310 mm, 310 x 432 mm, A4,B5, DLT, LG, LT		
Paper Weight	60 to 90 g/m2		
Stapling Positions	2 staples, 2 fixed locations		
Staple Supply	2 cartridges, 5000 staples each		
Tray Capacity After Stapling	Pages	Stacks	Size
	2 to 5	30	All sizes
	6 to 10	15	
	11 to 15	10	
	16 to 20	5	

Note 1: Stapling & hole punching cannot be combined when using the GBC StreamPunch III to a punch job. stapling & punching is supported only with the PU5020.

Punch Unit PU5020 (D449)			
Punch Hole Positions	2/3 hole selectable		
Skew Correction	Yes		
Paper Registration	Yes		
Paper Size	Holes	Edge	Size
	2 Holes	SEF	A6 to A3, HLT to DLT
		LEF	A5 to A4, HLT to LT
	3 Holes	SEF	A6 to A3, HLT to DLT
LEF		A5 to A4, HLT to LT	
Paper Weight	Holes		Weight
	2 Holes		52 to 209 g/m2
	3 Holes		52 to 163 g/m2

Product Support Guide

Model D059/D060/D061

Trimmer Unit TR5020 (D445)			
Paper Sizes			
Standard Sizes	13x19.2", 13x19", 12.6x19.2", 12.6x18.5", 13x19", SRA3 (320x450 mm), 12x18", A3, B4, SRA4 (320x225 mm), 226x310 mm, 310 x 432 mm, A4, B5, DLT, LG, LT, 8 kai		
Custom Sizes	Width: 182 to 330 mm Length: 257 to 488 mm		
Stack Size 1 to 20 sheets (folded)	1 to 20 sheets (folded)		
Trimming	40 sheets (80 g/m2)		
Tray Capacity	Pages	Sets	
	1 to 5	60 for all sizes	
	6 to 10	35 for B5 and A4/LT 40 for B4/LG and A3/DLT	
	11 to 15	25 for all sizes	
	16 to 18	20 for B5, A4/LT and B4/LG 25 for A3/DLT	
	19 to 20	20 for B5, A4/LT and B4/LG 25 for A3/DLT	
Paper Weight	Weight: 80 g/m2 Weight: 20 lb. Bond		
Power Supply	AC 120V 60 Hz, 15A		
Power Consumption	75 W		
Plug Type	NEMA 5-15P		
Dimensions (w x d x h)	1115 x 590 x 555 mm (43.9 x 23.2 x 21.8 in.)		
Level	Less than 5 mm deviation at front/back, left/right		
Weight	70 kg or less		
Noise Level (dB A)	Made	Alone	System
	Straight-Through	< 68 dB	< 75 dB
	Trimming	< 72 dB	< 75 dB

Product Support Guide

Model D059/D060/D061

Finisher SR5000 (B830)				
Proof Tray				
Paper Capacity (80 g/m2)	500 sheets (A4, 8½" x 11" and smaller)			
	250 sheets (B4, 8½" x 14" and larger)			
Paper Size	A3 to A6 SEF, B6 SEF, 11" x 17" to 5½" x 8½", 12" x 18", 13" x 18"			
Paper Weight	52 to 216 g/m2			
Upper Tray Full Detection	Provided			
SHIFT TRAY				
Paper Capacity (80 g/m2)	3000 sheets (A4 LEF, B5 LEF, 8½" x 11" LEF)			
	1500 sheets (A3, A4 SEF, B4 and B5 SEF, 11" x 17" SEF, 8½" x 14", 8½" x 11" SEF)			
	1000 sheets 12" x 18"			
	500 sheets (A5 LEF, 5½" x 8½" LEF)			
	100 sheets (A5 SEF, 5½" x 8½" SEF)			
Paper Size	A3 to A5, 11" x 17" to 5½" x 8½", 12" x 18" (including tab paper)			
Paper Weight	52 to 300 g/m2			
Shift Tray Full Detection	Provided			
STAPLER				
Stapling Stack Size	A4, B5, 8½" x 11" (Max. 100 Sheets)			
	A3, B4, 11" x 17", 8½" x 14" (Max. 50 sheets)			
Stapling Paper Size	A3 to B5, 11" x 17" to 8½" x 11"			
	Z fold paper: A3, B4, 11" x 17"			
Stapling Paper Weight	64 to 90 g/m2 Z fold paper: 64 to 80 g/m2			
Staple Position	4 Modes			
	1 Staple: Front, Rear, Rear-Oblique			
	2 Staples: 2 Locations			
Staple Capacity	5000 staples/cartridge			
Staple Supply	Cartridge or Staple Replacement			
Stapled Stack Size	No Folding	Sheets	Sets	Sizes
		10 ~ 100	200 ~ 30	A4 SEF, B5 SEF, 8½" x 11" SEF A4 LEF, B5 LEF, 8½" x 11" LEF
		2 ~ 9	150	
		10 ~ 50	150 ~ 30	A3, B4, 11" x 17", 8½" x 14"
		2~9	150	
	Folding	Sheets	Sets	Sizes
		1 ~ 10	30 ~ 3	A3 Z fold + A4, B4 Z fold + B5 11" X 17" Z-Fold + 8½" x 11"

Product Support Guide

Model D059/D060/D061

Staple Trim Waste Capacity	15,000 or more
Waste Staple Hopper Full Detection	Provided
Power Consumption	Less than 120 W
Power Source	DC 24 V (From Mainframe)
Size (W x D x H)	800 x 730 x 980 mm (31.5 x 28.7 x 38.6 in.)
Weight	Less than 75 kg (165 lb).

Note 1: *Stapling & hole punching cannot be combined when using the GBC StreamPunch III to a punch job. Stapling & punching is supported only with the PU5000.*

Note 2: *In order to use the SR5000/PU5000 punch option with the D061 (135 ppm model), SP 6-980-001 must be enabled and the "0108 Adjust Paper Feed Speed" must be set to the "Slower" setting in "Adjustment Settings for Operators" in "User Tools". When the "Slower" mode is selected, the maximum productivity of the machine will drop to 110 ppm.*

Note 3: *In order to maintain maximum productivity with the D061 (135 ppm), install the SR5020/PU5020 Booklet Finisher and Punch Unit.*

Punch Unit PU5000 (B831)	
Punch Hole Positions	2/3-hole selectable
Punch Paper Size	
2-Hole (NA)	A6 ~ A3 SEF, 11" x 17" ~ 5 ½" x 8½" SEF
	A5 ~ A4 LEF, 8 ½" x 11" LEF, 5½" x 8½" LEF
3-Hole (NA)	A3 SEF, B4 SEF, 11" x 17" SEF A4 LEF
	A4 SEF, B5 LEF, 8½" x 11" LEF
Paper Weight	
2-Hole (NA)	52 g/m2 ~ 163 g/m2
3-Hole (NA)	52 g/m2 ~ 163 g/m2
Punch Waste Hopper Capacity	
2-Hole (NA)	10K
3-Hole (NA)	10K
Operation Modes	All (Shift, Proof, Staple)

Product Support Guide

Model D059/D060/D061

Scanner		
Items	Specification	
Resolution	100 / 150 / 200 (Default) / 300 / 400 / 600 dpi TWAIN (BW/Color): 100-1,200 dpi (1dpi step, Default 600dpi)	
Scan Speed (A4, 200dpi)	BW: 80 spm FC: 80 spm *Scan speed (A4 LEF, 200dpi)	
Max Scan Area	297 x 432 mm	
RGB	YES	
Network Interface	Ethernet 10/100 BASE-TX, Gigabit Ethernet, Wireless LAN (802.11a/b/g)	
File Format	TIFF (Multi/Single), JPEG, PDF (Multi/Single), High compression PDF	
Scan Mode	BW_Text, BW Text/Line Art(Default), BW_Text-Photo, BW_Photo, Grayscale, FC_Text-Photo, FC_Photo, Auto Color Selection	
Image Density	Auto Density Selection	Supported
	Manual Setting	7 Levels
Thin paper mode	Supported	
SADF / Batch Mode	Supported	
Mixed Size Mode	Supported	

Product Support Guide

Model D059/D060/D061

Scan to E-mail		
Items	Specification	
Requirement	SMTP Gateway and TCP/IP	
Authentication	SMTP POP before SMTP	
Resolution	Default: 200 dpi 100 / 150 / 200 / 300 / 400 / 600 dpi	
Register E-mail Address in HDD	Max. 2,000 addresses	
Register Group Address in HDD	Max. 500 Addresses Max. 100 Addresses in One Group Addresses	
Maintain E-mail Address in HDD	Direct input on operation panel, Web image Monitor, Smart Device Monitor	
Search E-mail Address in HDD	By name & E-mail address	
LDAP	Yes	
Max Address Number per Send	Max. 500 addresses	
Address Number per send	via Address Book	Max. 500 addresses
	Direct Input	Max. 100 addresses
	via LDAP	Max. 100 addresses
Attention	To, cc, bcc	
Subject	Manual Input	Max. 128 characters
Body Message	Manual Input	Max. 80 characters
	Pre-register by user	5 body message. 80 characters x 5 lines per a body message. Title name of the body message: Max. 20 characters per a name.
	Preset	Message: "This e-mail included attached file sent from xxxx (machine model name)."
E-mail Size Restriction	With restriction	128 - 102,400KB *Default = 2,048KB
	W/O restriction	725MB
File Type	Single Page TIFF, Single Page JPEG, Single Page PDF, Multi Page TIFF, Multi Page PDF, Single Page High-compression PDF, Multi Page High-compression PDF	
Program User Setting	Yes (Up to 25 programs)	
Divided & Send E-mail	Yes (By page or size) / No, Default = Yes (By size)	
Resend	Yes / No, Default = Yes	

Product Support Guide

Model D059/D060/D061

Scan to Folder	
Items	Specification
Protocol Support	SMB, FTP, NCP
Security	Client folder log-in (log-in name and password) Encryption of log-in name and password during transmission
Resolution	Default: 200dpi 100, 150, 200, 300, 400, 600dpi
Max. Resisted Client Folder Address in HDD	Max. 2,000 folders
Maintain Client Folder Address in HDD	Via Operation Panel, Web Image Monitor
Max. Client Folders per send	Max. 50 client folders
Group Address	Max. 100 destinations (To Folder: 50, To e-mail: 100) *1
Input Subject	No
Scan file size	1 document Up to 2000MB
File size when combined Scan to Folder & Scan to E-mail	128-102,400KB, Default = 2,048KB (With restriction) 725MB (W/O restriction) (Conforming to the scan to e-mail specification)
File Type	Single Page TIFF/JPEG, Single Page PDF, Multi Page TIFF, Multi Page PDF, Single Page High-compression PDF, Multi Page High-compression PDF
Program Registration	Yes (Up to 25 programs)
Dividing file in Scan to E-mail	Yes (By page or size) / No, Default = Yes (By size) (When Scan to PC combine with Scan to e-mail)
Resend	Yes / No, Default = Yes

*1. User can send to Max 100 destinations in the same group. But the number of folders has to be less than 50, since Max. folder destinations are 50. If there are more than 50 folder destinations registered in Group address, a message pops up.
 100 destinations 50 folders included >>>OK
 100 destinations 51 folders included >>>NG

Max. address numbers per sending (Combination between E-mail and Folder)				
	Input via	Condition 1 Max. address can select or input	Condition 2 Max. address allow in single operation	Condition 3 Combination of address: Max.
Scan to E-mail	Address book	500	500	550
	Manual input	100	500	550
Scan to Folder	Address book	50	50	550
	Manual input	50	50	550

Product Support Guide

Model D059/D060/D061

Network TWAIN Driver	
Items	Specification
Correspondence OS	Windows 2000/XP/Vista Windows Server 2003, 2008
Resolution	100-1200dpi
Scan Mode	Standard, Photo, OCR, Filing
Image Adjustment	Brightness, Contrast, Threshold, Gamma Adjustment, Halftone Pattern
Stamp	Date, Page Number, Text
Endorse	Not Supported
Read-Ahead Mode	Supported (Default)

WIA Driver	
Items	Specification
Correspondence OS	Windows Vista (SP1 or Later), Windows Server 2008
Resolution	100 - 1200dpi by 1dpi step
Scan Mode	Not Supported
Image Adjustment	Brightness / Contrast
Stamp	Not Supported
Endorse	Not Supported
Read-Ahead Mode	Supported (Fixed: Not selectable)

Document Server	
Items	Capability
HDD Capacity	350GB x1
Maximum stored documents	3,000 documents
Maximum pages per documents	2,000 page (STD)
Maximum pages of all stored documents	15,000 sheets

Product Support Guide

Model D059/D060/D061

Printer Controller			
Items		Specification	
CPU		Intel Pentium M 1.4GHz	
RAM	Standard	Standard: 512MB Print Scanner Unit : 1GB Total (Standard + Printer Scanner Unit): 1.5GB	
Hard Disk Drive		Standard 320GB (320GB x 1)	
PDL	Standard	RPCS, PCL6, PCL5e	
	Option	Adobe PostScript 3, Genuine IPDS	
Continuous Print Speed	Max.	135ppm/110ppm/90ppm	
Print Resolution	Max.	1200 (dpi)	
Fonts	Standard	PCL: 45 fonts, 13 International fonts	
	Option	PS3: 136 Adobe Type 1 fonts	
Connectivity	Host Interface	Standard	Ethernet (100BASE-TX/10BASE-T) USB 2.0
		Option	IEEE1284 Type C Wireless LAN Interface (IEEE802.11a/b/g) Bluetooth 1000BASE-T Note: Only one of these options can be installed.
	Network Protocol		TCP/IP, IPX/SPX, AppleTalk
	MIB support	Standard MIB	MIB-II, Host Resource, Printer MIB
		Private MIB	Ricoh Original
	Network/Operating Systems		Windows 2000, XP, Vista, Server 2003, 2008 Mac OS 8.6 - 9.2.X (OS X Classic) Mac OS 10.1.X – 10.4.X Mac OS 10.5.X

Product Support Guide

Model D059/D060/D061

MFP Supported Environments

Windows Environments						
OS	Type	PCL5e	PCL6	RPCS	PostScript3	XPS
Windows 2000	Professional	Y	Y	Y	Y *1	N
	Server	Y	Y	Y	Y *1	N
	Advanced Server	Y *2	Y *2	Y *2	Y *1	N
	Datacenter Server	N	N	N	N	N
Windows XP	Professional	Y	Y	Y *3	Y *1	N
	Home Edition	Y	Y	Y *3	Y *1	N
Windows Server 2003	Standard Edition	Y	Y	Y *2	Y *1	N
	Enterprise Edition	Y *2	Y *2	Y *2	Y *1	N
	Datacenter Edition	N	N	N	N	N
	Web Edition	N	N	N	N	N
Windows Vista	Home Basic	Y	Y	Y	Y	Y
	Home Premium	Y	Y	Y	Y	Y
	Business	Y	Y	Y	Y	Y
	Ultimate	Y	Y	Y	Y	Y
	Enterprise	Y	Y	Y	Y	Y
Windows Server 2008	Standard Edition	Y	Y	Y	Y	Y
	Enterprise Edition	Y	Y	Y	Y	Y
	Datacenter Edition	N	N	N	N	N
	Web Edition	N	N	N	N	N

[Remarks]

*1) Adobe does not release PS driver for Windows2000 and XP. Only MS-PostScript driver is available and PPD file for MS-PS is included in the Driver CD.

*2) Cluster Server configuration is not supported.

*3) RPCS driver does not support "Fast User Switching" functions of Windows XP.

Product Support Guide

Model D059/D060/D061

Point & Print					
Window OS		Drivers			
Server	Client (Push to)	PCL5e/6	RPCS	PS	XPS
Windows Server 2003	Vista	Yes	Yes*1	Yes	No
	XP	Yes	Yes*1	Yes	No
	W2K Pro	Yes	Yes*1	Yes	No
Windows XP Professional	Vista	Yes	Yes*1	Yes	No
	XP	Yes	Yes*1	Yes	No
	W2K Pro	Yes	Yes*1	Yes	No
Windows 2000 Professional, Server & Advanced Server	Vista	Yes	Yes*1	Yes	No
	XP	Yes	Yes*1	Yes	No
	W2K Pro	Yes	Yes*1	Yes	No
Windows Vista	Vista	Yes	Yes*1	Yes	Yes
	XP	Yes	Yes*1	Yes	No
	W2K Pro	Yes	Yes*1	Yes	No
Windows Server 2008	Vista	Yes	Yes*1	Yes	Yes
	XP	Yes	Yes*1	Yes	No
	W2K Pro	Yes	Yes*1	Yes	No

*1: RPCS driver for 64bit OS doesn't support following functions in Point & Print environment, "User ID", "Send to Document server", "Locked Print", "and Authentication "and" Classification code".

Terminal Service and Citrix MetaFrame			
Server	Driver		
	PCL5e/6	RPCS	PS
Windows Server 2008	Yes	Yes	Yes
Windows Server 2003	Yes	Yes	Yes
Windows 2000 Server	Yes	Yes	Yes
Win 2003 Servers + MetaFrame	Yes	Yes	Yes
Win 2000 Servers + MetaFrame	Yes*1	Yes	Yes
Win 2003 Servers + Citrix PresentationServer4.0	Yes	No	Yes
Win 2000 Servers + Citrix PresentationServer4.0	Yes	No	Yes
Win 2003 Servers + Citrix PresentationServer4.5	Yes	No	Yes
Win 2000 Servers + Citrix PresentationServer4.5	No	No	No

Product Support Guide

Model D059/D060/D061

Max OS Environment		
	PostScript3	Printer Utility for MAC
Mac OS 8.6 or later, Mac OS X classic	Yes	Yes
Mac OS X Native: v. 10.1 or later *1	Yes	Yes*2

*1: Mac OS X v.10.0.X is not supported.

*2: Mac OS X v.10.2.0 is not supported.

Unix Environment	
Unix Platforms	Version
Sun Solaris	2.6 / 7 / 8 / 9 /10
HP-UX	10.x / 11.x /11i v2 /11i v3
Red Hat Linux	6.x / 7.x / 8.x / 9.x / Enterprise
SCO OpenServer	5.0.6 /5.0.7/6.0
IBM AIX	V4.3 & 5L Version 5.1/5.2 /5.3

Novell Netware		
Netware Server	Supported Version	Netware 3.12 / 3.2 / 4.1 / 4.11 / 5.0 / 5.1 / 6.0/6.5
	Client OS	Windows 2000 / XP (Professional)

SAP R/3 Environment (Device Type / Barcode & OCR Package)		
Supported environments	R/3 version	4.x or later, mySAP ERP2004 or later
	Platform	Independent
	PDL	PCL5e
	Character Set	Latin 1(Western European), Latin 2 (Eastern European)
	Localization	English only
Supported features	i.e: Input/Output Bin, Duplex, Stapling, Punching, Resolution, Collation, EconoMode/TonerSaving, Smoothing, Page Protect, Auto Tray Change/Opt Tray select	
Supported Barcode & OCR Fonts* (* BOP is procured locally.)	Barcode Fonts (Support Latin 1 only)	Code 128, Code 39, Code 93, Codabar, 2 of 5 interleaved/Industrial/Matrix, MSI, USPS, UPC/EAN
	OCR Fonts	OCR A, OCR B

Above specification and schedule are subject to change.

Product Support Guide

Model D059/D060/D061

Print Driver Specifications							
RPCS Features	PCL5	PCL6	RPCS	PostScript3			
				Windows	Mac OS 8.6-9.2	Mac OS X	XPS
				2K/XP/Vista			
Send to Job Binding	N	N	Y	N	N	N	N
Send to Document Server	Y	Y	Y	Y	Y	Y*1	Y
Sample Print	Y	Y	Y	Y	Y	Y*1	Y
Locked Print	Y	Y	Y	Y	Y	Y*1	Y
Hold Print	Y	Y	Y	Y	Y	Y*1	Y
Stored Print	Y	Y	Y	Y	Y	Y*1	Y
Stored Print (Shared)	Y	Y	Y	N	N	N	N
Store and Print	Y	Y	Y	Y	Y	Y*1	Y
Store and Print (Shared)	Y	Y	Y	N	N	N	N
Reduce/Enlarge (Zoom/Scaling)	Y*2	Y*2	Y	Y	Y	Y	Y
Reduce/Enlarge Centering	N	N	Y	N	N	N	N
Fit to Paper size	Y	Y	Y	Y	Y	Y	N
Unauthorized Copy Control	N	N	Y	N	N	N	N
Layout (N-up, Page per Sheet)	Y	Y	Y	Y	Y	Y	Y
Poster	N	N	Y	N	Y	N	N
Duplex	Y	Y	Y	Y	Y	Y	Y
Booklet1	N	N	Y	N	N	N	N
Booklet2 (Magazine)	Y	Y	Y	Y	N	N	Y
Non-Reduction Booklet	Y	Y	N	N	N	N	N
Watermark	Y	Y	Y	Y	Y	Y	N
Overlay	N	N	Y	N	N	N	N
Header/Footer	N	N	Y	N	N	N	N
Adjust image position	N	N	Y	N	N	N	N
Binding Margins	N	N	Y	N	N	N	N
Collate	Y	Y	Y	Y	Y	Y	Y
Punch	Y	Y	Y	Y	Y	Y	Y
Staple	Y	Y	Y	Y	Y	Y	Y
Interposer	Y	Y	Y	N	N	N	Y
Perfect Binding	N	Y	Y	Y	Y	Y	N
Ring Binding	N	Y	Y	Y	Y	Y	N
Multi-Folding	N	Y	Y	Y	Y	Y	N

Product Support Guide

Model D059/D060/D061

High Capacity Stacker	N	Y	Y	Y	Y	Y	N
Booklet Trimmer	N	Y	Y	Y	Y	Y	N
Cover sheet(Front Cover)	Y	Y	Y	N	N	N	N
Front and Back Cover	Y	Y	N	N	N	N	N
Slip Sheet	Y	Y	Y	N	N	N	Y
Chaptering	Y	Y	Y	N	N	N	N
Rotate by 180 degrees	Y	Y	Y	Y	Y	Y	Y
Reverse Order Print	N	Y	Y	Y	Y	Y*5	Y
Eject Face-up	N	Y	Y	Y	Y	Y	N
Do not print Blank pages	Y*3	Y*3	Y	N	N	N	N
Dithering	Y	Y	Y	Y	Y	Y	N
Toner Saving	Y	Y	Y	Y	Y	Y	Y*4
Quality	N	N	Y	N	N	N	N
Speed	N	N	Y	N	N	N	N
High Speed	N	N	Y	N	N	N	N
User ID	Y	Y	Y	Y	Y	Y*1	Y
User Code	Y	Y	Y	Y	Y	Y*1	Y
User Authentication	Y	Y	Y	N	N	N	N
Encryption/Encoding	Y	Y	Y	N	N	N	N
Mirror Image Print	N	N	N	Y	Y	N	N
Negative Image Print	N	N	N	Y	Y	N	N
Edge to Edge Print	Y	Y	Y	N	N	N	N
Tab Stock Printing	Y	Y	Y	Y	Y	Y	Y
Limitation setting	Y	Y	Y	N	N	N	N
Classification Code	Y	Y	Y	N	N	N	N

Y: supported

N: not supported

*1: Available with MAC OS X 10.2. or later.

*2: "Centering" feature cannot be selected from PCL driver. However PCL has this feature as the original function. When printing with Reduce/Enlarge (Zoom) feature of PCL driver, the output will be automatically centered by the PCL's original centering function.

*3: This feature cannot be set from printer driver but is set "On" at "PCL setting" of MFP.

*4: This function is available only when "Black and White" is selected.

*5: Available with MAC OS X 10.3. or later.

Product Support Guide

Model D059/D060/D061

Genuine IPDS Option	
Items	Descriptions
Option Media Type	SD Card
Supported IPDS Emulation	InfoPrint 2105ES 4028
Supported IPDS Font	IBM Core Interchange IBM Coordinated 4028 Compatibility 3820 ROM Font Compatibility *Please refer to 1.2 Resident IPDS Font Support for supported IPDS Font Sets.
Supported Host Environment	OS/400 Version 5.1 or higher Graphical Data Display Manager (GDDM) Release 2.3 or higher Print Service Facility (PSF/VM) Release 2.1.1 or higher Print Service Facility (PSF for z/OS) Release 3.4 or higher Print Service Facility (PSF/VSE) Release 2.2.1 or higher Print Service Facility (PSF/400) Release 5.2 or higher Infoprint Manager for AIX Release 4.2 or higher Infoprint Manager for Windows Release 2.2 or higher Infoprint Process Director for Linux Release 1.2.1 or higher

Product Support Guide

Model D059/D060/D061

Utility Software

Software	Description
For GW Controller Font Manager	This software enables you to use screen fonts.
Smart Device Monitor for Admin	This software enables you to manage and monitor printers and other devices over the network.
DeskTopBinder – SmartDeviceMonitor for Client	This software enables you to access networked printers to print, monitor or to receive notifications. With DeskTopBinder Lite you can connect client computers to I/O devices enabling you to efficiently manage data.
Device Graphic Update Module	Device Graphic Update Module provides bitmap images used to represent the various statuses of devices graphically within Smart Device Monitor or Web Smart Device Monitor. Available on website.
Printer Utility for Mac	This is a utility for Macintosh that provides access to several network printing administrative features.
PS Descriptions	PPD for Mac By interacting with the Adobe PostScript 3 controller in the device, this PPD is able to produce an accurate representation of the screen image.
Mac OS X PPD Installer	This PPD installer is used to install a PPD (Postscript Printer Description) file on Mac OSX. PPD files contain descriptions of printer capabilities such as paper sizes, number of input trays and duplexing. Once the PPD file is installed on the system using the PPD installer, the PS driver that comes bundled with Mac OS X can use the information in the PPD to control the print device and enable full functionality. It supports the Mac OS X 10.1 or later. Please see the Readme file for information about compatibility with versions of Mac OS X.
RPCS Driver	Printer driver for Windows: It is optimized for the Windows GDI. High performance printing can be expected. Regularly used settings can be saved as a "one-click icon" in the driver interface. These settings can be reused easily by clicking the icon.
PCL 6 Driver	Printer driver for B/W printing in Windows. It supports HP PCL XL commands and is optimized for the Windows GDI. High performance printing can be expected.
PCL 5e Driver	Printer driver for printing in Windows. It supports HP PCL 5e commands.
Post Script Driver	By interacting with the Adobe PostScript 3 controller in the device, this driver is able to produce an accurate representation of the screen image.
TWAIN Driver	TWAIN scanner driver for network connections with new features Combine/Series, compatible with SNMP V3 and Network Connection Tool.

Product Support Guide

Model D059/D060/D061

Counters

Electronic Total Counter Access:

- The counter can be displayed on the Operation Panel Screen by pressing the Counter Key on the Operation Panel. (Total Counter limit is 8 digits) The info on the screen can also be printed out by pressing the Total Counter List button displayed on the screen.



- The Technician can view the Total Counter by entering SP8999-1 in SP mode.
- The counter info on SP 8999-1 can be printed out along long with other Logging Data with SP 5990-4.

Mechanical Counter Access:

- A mechanical counter is located under the left front inner cover above the fusing unit. (Total Counter limit is 8 digits)

Product Support Guide

Model D059/D060/D061

Paper

Recommended Throughput Material and Special Paper

Not Applicable

Non Recommended Throughput Material

Refer to pages in the Operators Instructions Hardware Guide.

Do not use any of the following kinds of paper or a fault might occur:

- Paper for inkjet printers
- Art paper
- Aluminum foil
- Carbon paper
- Conductive paper
- Paper with perforated lines
- Hemmed paper
- Envelopes
- Tab stock (when using the stacker tray)

Do not copy on the side of paper that has been already copied onto, misfeeds or a fault might occur.

To prevent misfeeds, do not use the following kinds of paper:

- Bent, folded, or creased paper
- Perforated paper
- Slippery paper
- Torn paper
- Rough paper
- Thin paper with low stiffness
- Paper with a dusty surface

If you copy onto rough grain paper, the image might be blurred.

The following paper types are not supported on the RB5000 and GB5000

- Heavily curled paper
- Paper with staples or clips
- Torn paper
- Paper with holes
- Rough paper
- Smooth paper
- Thin and soft paper
- Label paper
- Paper with penciled characters or images
- Folded paper
- Even supported types of paper may cause paper jams or malfunctions if the paper is not in good condition.
- Do not load sheets that have already been printed onto by another machine. (Sheets can become jammed if they have been improperly stored.)

Product Support Guide

Model D059/D060/D061

Coated and NCR Paper

Coated Paper

If coated paper will be used, replace the paper feed rollers with the following different rollers on the RT5040 DLT LCT (D453) Tray, which will be used for feeding coated paper.

Name	Part Number
Pick-up roller Feed roller	AF030071
Feed roller	AF031041
Separation roller	AF032041

The durability and yield of these rollers for coated paper is lower than the original roller.

NCR Paper

If NCR paper will be used, install the following guide plate shown below on the RT5040 DLT LCT (D453) Tray, which will be used for feeding NCR Paper. The auxiliary guide plate ensures smooth feeding of NCR paper.

Appleton Xero/Form II NCR brand paper is the only brand NCR paper approved for this model. Constant use of NCR paper will over time increase service activity and cost due to more frequent replacement of rubber components that come in contact with this type of paper.

Name	Part Number
Guide Plate: Reverse Auxiliary	D4532552

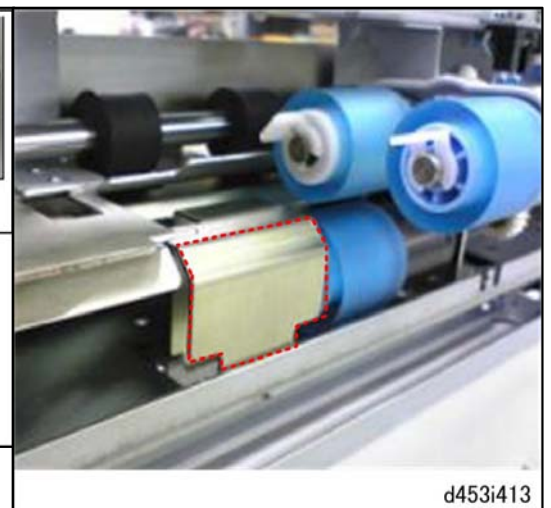
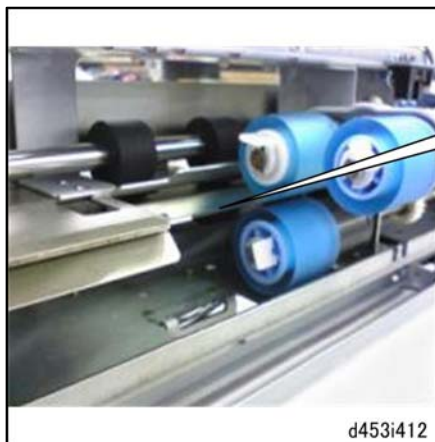

Product Support Guide

Model D059/D060/D061

Paper Size And Type Matrix

Supported Standard Paper Sized By Input Tray

Name	Direction	Size	Main Frame			DLT LCT		LT LCT	Bypass	Interposer
			Tray 1 Tandem	Tray 2, 3	A3/DLT Tray Kit	Tray 4, 5	Tray 6	Tray 4, 5, 6	Tray 7	
A3	SEF	297x420mm	No	Yes	Yes/SP	No	No	Yes	Yes	Yes
A4	SEF	210x297mm	No	Yes	SP	No	No	SP	SP	SP
A4	LEF	297x210mm	Yes/SP	Yes	SP	Yes	Yes/SP	Yes	Yes	Yes
A5	SEF	148x210mm	No	Yes	No	Yes	Yes/SP	Yes	Yes	Yes
A5	LEF	210x148mm	No	Yes	No	Yes	Yes/SP	SP	SP	SP
A6	SEF	105x148mm	No	No	No	No	No	Yes	Yes	No
B4	SEF	257x364mm	No	Yes	SP	No	No	Yes	Yes	Yes
B5	SEF	182x257mm	No	Yes	No	No	No	SP	SP	SP
B5	LEF	257x182mm	No	Yes	No	Yes	Yes/SP	Yes	Yes	Yes
B6	SEF	128x182mm	No	No	No	No	No	Yes	Yes	No
DLT	SEF	11x17in	No	Yes	Yes/SP	No	No	Yes	Yes	Yes
Legal	SEF	8.5x14in	No	Yes	SP	No	No	Yes	Yes	Yes
Foolscap	SEF	8.5x13in	No	Yes	No	No	No	Yes	Yes	Yes
Letter	SEF	8.5x11in	No	Yes	SP	No	No	Yes	Yes	Yes
Letter	LEF	11x8.5in	Yes/SP	Yes	SP	Yes	Yes/SP	Yes	Yes	Yes
Legal	SEF	8.25x14in	No	Yes	No	No	No	Yes	Yes	Yes
Folio	SEF	8.25x13in	No	Yes	No	No	No	Yes	Yes	Yes
F/GL	SEF	8x13in	No	Yes	No	No	No	Yes	Yes	Yes
Eng Quatro	SEF	8x10in	No	Yes	No	No	No	Yes	Yes	Yes
Executive	SEF	7.25x10.5in	No	Yes	No	No	No	Yes	Yes	Yes
Executive	LEF	10.5x7.25in	No	Yes	No	No	No	Yes	Yes	Yes
Half Letter	SEF	5.5x8.5in	No	Yes	No	Yes	Yes/SP	Yes	Yes	Yes
Half Letter	LEF	8.5x5.5in	No	Yes	No	Yes	Yes/SP	Yes	Yes	Yes
8K	SEF	267x390mm	No	Yes	No	No	No	Yes	Yes	Yes
16K	SEF	195x267mm	No	Yes	No	No	No	Yes	Yes	Yes
16K	LEF	267x195mm	No	Yes	No	No	No	Yes	Yes	Yes
12x18	SEF	12x18in	No	Yes	No	No	No	Yes	Yes	Yes
11x15	SEF	11x15in	No	Yes	No	No	No	Yes	Yes	Yes
11x14	SEF	11x14in	No	Yes	No	No	No	Yes	Yes	Yes
10x15	SEF	10x15in	No	Yes	No	No	No	Yes	Yes	Yes
10x14	SEF	10x14in	No	Yes	No	No	No	Yes	Yes	Yes
13x19.2	SEF	13x19.2in	No	No	No	No	No	Yes	Yes	Yes
13x19	SEF	13x19in	No	No	No	No	No	Yes	Yes	Yes
12.6x19.2	SEF	12.6x19.2in	No	No	No	No	No	Yes	Yes	Yes
12.6x18.5	SEF	12.6x18.5in	No	No	No	No	No	Yes	Yes	Yes
13x18	SEF	13x18in	No	Yes	No	No	Yes	Yes	Yes	Yes
SRA3	SEF	320x450mm	No	Yes	No	No	Yes	Yes	Yes	Yes
SRA4	SEF	225x320mm	No	Yes	No	No	Yes	Yes	Yes	Yes
SRA4	LEF	320x225mm	No	Yes	No	No	Yes	Yes	Yes	Yes
226x310	SEF	226x310mm	No	Yes	No	No	Yes	Yes	Yes	Yes
226x310	LEF	310x226mm	No	Yes	No	No	Yes	Yes	Yes	Yes
310x432	SEF	310x432mm	No	Yes	No	No	Yes	Yes	Yes	Yes

SP: Setting change in SP 5019 may be required.

Product Support Guide

Model D059/D060/D061

Supported Paper Types And Thickness

Supported Paper Types by Paper Tray

Paper Type	Mainframe		A4 LCT		A3 LCT	Bypass	Interposer
	Tray 1 (Tandem)	Tray 2, 3	Tray 4, 5, 6		Tray 4, 5, 6	Tray 7	
Plain Paper	Yes	Yes	Yes	Yes	Yes	Yes	Yes
Recycled	Yes	Yes	Yes	Yes	Yes	Yes	Yes
Special	Yes	Yes	Yes	Yes	Yes	Yes	Yes
Color (11 Colors)	Yes	Yes	Yes	Yes	Yes	Yes	Yes
Letterhead	Yes	Yes	Yes	Yes	Yes	Yes	Yes
Label paper	No	No	Yes *	Yes	Yes	No	No
Translucent	No	Yes	Yes	Yes	Yes	Yes	
Preprinted	Yes	Yes	Yes	Yes	Yes	Yes	Yes
Bond Paper	Yes	Yes	Yes	Yes	Yes	Yes	Yes
Card Stock	Yes	Yes	Yes	Yes	Yes	Yes	Yes
OHP	No	Yes	Yes	Yes	Yes	Yes	No
Pre-punched	Yes	Yes	Yes	Yes	Yes	Yes	Yes
Tab Stock	No	No	Yes	Yes	Yes	Yes	No
Coated Paper	No	No	No	Yes	Yes	No	No

* "Tray 5" only. Trays 4 and 6 do not support "Label paper".

Supported Paper Weight by Paper Tray

Paper Weight	Mainframe		A4 LCT		A3 LCT		Bypass	Interposer
	Tray 1 (Tandem)	Tray 2, 3	Tray 4, 5	Tray 6	Tray 4, 6	Tray 5	Tray 7	
Thin Paper (40 to 51gsm)	No	No	No	No	No	Yes	No	No
Normal Paper (52 to 105 gsm)	Yes	Yes	Yes	Yes	Yes	Yes	Yes	Yes
Middle Thick (106 to 163 gsm)	Yes	Yes	Yes	Yes	Yes	Yes	Yes	Yes
Thick Paper 1 (164 to 216 gsm)	Yes	Yes	Yes	No	Yes	Yes	Yes	Yes
Thick Paper 2 (217 to 256 gsm)	No	No	No	No	Yes	Yes	Yes	No
Thick Paper 3 (257 to 300 gsm)	No	No	No	No	No	Yes *	No	No

* Simplex only due to the limitation of the mainframe.

Product Support Guide

Model D059/D060/D061

Supported Paper Types by Output Peripherals

Paper Type	Finisher SR5000				Booklet Finisher SR5020					Folding Unit	
	Stack		Staple	Punch (Option)	Stack		Staple		Punch (Option)	Fold	
	Proof Tray	Shift Tray			Proof Tray	Shift Tray	Side	Center		2, 3, Z	4
Plain Paper	Yes	Yes	Yes	Yes	Yes	Yes	Yes	Yes	Yes	Yes	Yes
Recycled	Yes	Yes	Yes	Yes	Yes	Yes	Yes	Yes	Yes	Yes	Yes
Special	Yes	Yes	Yes	Yes	Yes	Yes	Yes	Yes	Yes	Yes	Yes
Color (11 Colors)	Yes	Yes	Yes	Yes	Yes	Yes	Yes	Yes	Yes	Yes	Yes
Letterhead	Yes	Yes	Yes	Yes	Yes	Yes	Yes	Yes	Yes	No	No
Label paper	Yes	No	No	No	Yes	Yes	No	No	No	No	No
Translucent	Yes	No	No	No	Yes	No	No	No	No	No	No
Preprinted	Yes	Yes	Yes	Yes	Yes	Yes	Yes	Yes	Yes	Yes	Yes
Bond Paper	Yes	Yes	Yes	Yes	Yes	Yes	Yes	Yes	Yes	Yes	Yes
Card Stock	Yes	Yes	Yes	Yes	Yes	Yes	Yes	Yes	Yes	No	No
OHP	Yes	Yes *	No	No	Yes	Yes *	No	No	No	No	No
Pre-punched	Yes	Yes	Yes	No	Yes	Yes	Yes	No	No	Yes	Yes
Tab Stock	Yes	Yes	Yes	Yes	Yes	Yes	Yes	No	No	No	No
Coated Paper	Yes	Yes	Yes	Yes	Yes	Yes	Yes	Yes	Yes	Yes	No

Paper Type	Ring Binder		Perfect Bind	Stacker		Trimmer
	Punch & Bind	Punch	Bind	Stack	Proof Tray	Trimming
Plain Paper	Yes	Yes	Yes	Yes	Yes	Yes
Recycled	Yes	Yes	Yes	Yes	Yes	Yes
Special	Yes	Yes	Yes	Yes	Yes	Yes *
Color (11 Colors)	Yes	Yes	Yes	Yes	Yes	Yes
Letterhead	Yes	Yes	Yes	Yes	Yes	Yes *
Label paper	No	No	No	Yes *	Yes	No
Translucent	No	No	No	Yes *	Yes	No
Preprinted	No	No	Yes	Yes	Yes	Yes *
Bond Paper	No	No	No	Yes	Yes	Yes *
Card Stock	No	No	No	Yes	Yes	Yes *
OHP	Yes	Yes	No	Yes *	Yes	No
Pre-punched	No	No	No	Yes	Yes	No
Tab Stock	Yes	Yes	No	No	Yes	No
Coated Paper	No	No	Yes	Yes	Yes	Yes *

* Selectable, but quality of output is not guaranteed.

Product Support Guide

Model D059/D060/D061

Supported Paper Weight by Output Peripherals

Paper Weight	Finisher SR5000				Booklet Finisher SR5020					Folding Unit	
	Stack		Staple	Punch (Option)	Stack		Staple		Punch (Option)	Fold	
	Proof Tray	Shift Tray			Proof Tray	Shift Tray	Side	Center		2, 3, Z	4
Thin Paper (40 to 51gsm)	No	Yes	No	No	No	Yes	No	No	No	No	No
Normal Paper (52 to 105 gsm)	Yes	Yes	Yes	Yes	Yes	Yes	Yes	Yes	Yes	Yes	Yes
Middle Thick (106 to 163 gsm)	Yes	Yes	Yes	Yes	Yes	Yes	Yes	Yes	Yes	No	No
Thick Paper 1 (164 to 216 gsm)	Yes	Yes	Yes	No	Yes	Yes	Yes	No	No	No	No
Thick Paper 2 (217 to 256 gsm)	No	Yes	No	No	No	Yes	No	No	No	No	No
Thick Paper 3 (257 to 300 gsm)	No	Yes*1	No	No	No	Yes*1	No	No	No	No	No

Paper Weight	Ring Binder		Perfect Binder	Stacker		Trimmer
	Punch & Bind	Punch	Bind	Stack	Proof Tray	Trimming
Thin Paper (40 to 51gsm)	Yes	Yes	No	Yes	Yes	No
Normal Paper (52 to 105 gsm)	Yes	Yes	Yes	Yes	Yes	Yes
Middle Thick (106 to 163 gsm)	Yes*2	Yes	Yes*3	Yes	Yes	Yes
Thick Paper 1 (164 to 216 gsm)	Yes*2	Yes	No	Yes	Yes	No
Thick Paper 2 (217 to 256 gsm)	Yes*2	Yes	No	Yes	Yes	No
Thick Paper 3 (257 to 300 gsm)	No	No	No	Yes*1	Yes*1	No

*1: Simplex only due to the limitation of the mainframe.

*2: Selectable, but quality of output is not guaranteed.

*3: Up to 10 sheets as chapter pages.

Product Support Guide

Model D059/D060/D061

Firmware Information

Firmware

SD Card Firmware	Firmware File Name as Posted	RFG E-Source Number
Engine	D059_Engine_vxxx_SDcard	rfg037790
Language	D059_Language_vxxx_SDcard	rfg037792
LCDC	D059_LCDC_vxxx_SDcard	rfg037793
Netfile	D059_Netfile_vxxx_SDcard	rfg037794
NIB	D059_NIB_vxxx_SDcard	rfg037795
PCL	D059_PCL_vxxx_SDcard	rfg037797
Printer	D059_Printer_vxxx_SDcard	rfg037798
PS	D059_PS_vxxx_SDcard	rfg037799
PwrSavSys	D059_PwrSavSys_vxxx_SDcard	rfg037800
RPCS	D059_RPCS_vxxx_SDcard	rfg037801
Scanner	D059_Scanner_vxxx_SDcard	rfg037802
System	D059_System_vxxx_SDcard	rfg037803
WebSys	D059_WebSys_vxxx_Sdcard	rfg037804
WebUapl	D059_WebUapl_vxxx_Sdcard	rfg037805
D434 Booklet Finisher	D434_Booklet Finisher_vxxx_Sdcard	rfg037966
D455 Trimmer	D455_trimmer_vxxx_Sdcard	rfg037969
D447 - Stacker 1 up	D447_Stacker1_up_vxxx_Sdcard	rfg038205
D447- Stacker 2 down	D447_Stacker2_down_vxxx_Sdcard	rfg038206
D454 Multi Folder	D454_MultiFolder_vxxx_Sdcard	rfg0400037
IPDS Unit Type 1357EX	D451_IPDS_vxxx_Sdcard	rfg038834
B830 Finisher	B830_Finisher_vxxx_Sdcard.zip	rfg032104
B835 Cover Interposer	B835_CoverInterposer_vxxx_Sdcard.zip	rfg032105
D391 Perfect Binder	D392_Perfect Binder_B1_vxxx_Sdcard.zip	rfg034065
	D392_Perfect Binder_B2_vxxx_Sdcard.zip	rfg034066
	D392_Perfect Binder_B3_vxxx_Sdcard.zip	rfg034067
	D392_Perfect Binder_B4_vxxx_Sdcard.zip	rfg034068
	D392_Perfect Binder_B5_vxxx_Sdcard.zip	rfg034069
D392 Ring Binder	D392_Ring Binder_B1_vxxx_Sdcard.zip	rfg034057
	D392_Ring Binder_B2_vxxx_Sdcard.zip	rfg034058

Product Support Guide

Model D059/D060/D061

Remote Firmware	Firmware File Name as Posted	RFQ E-Source Number
Engine	D059_Engine_vxxx_Remote	rfg037806
Language	N/A	N/A
LCDC	D059_LCDC_vxxx_Remote	rfg037807
Netfile	D059_Netfile_vxxx_Remote	rfg037808
NIB	D059_NIB_vxxx_Remote	rfg037809
PCL	D059_PCL_vxxx_Remote	rfg037810
Printer	D059_Printer_vxxx_Remote	rfg037811
PS	D059_PS_vxxx_Remote	rfg037812
PwrSavSys	D059_PwrSavSys_vxxx_Remote	rfg037813
RPCS	D059_RPCS_vxxx_Remote	rfg037814
Scanner	D059_Scanner_vxxx_Remote	rfg037815
System	D059_System_vxxx_Remote	rfg037816
WebSys	D059_Websys_vxxx_Remote	rfg037817
WebUapl	D059_WebUapl_vxxx_Remote	rfg037818
D434 Booklet Finisher	D434_Booklet Finisher_vxxx_Remote	rfg037967
D455 Trimmer	D455_trimmer_vxxx_Remote'	rfg037970
D447 - Stacker 1 up	D447_Stacker1_up_vxxx_Remote	rfg038207
D447 - Stacker 2 down	D447_Stacker2_down_vxxx_Remote	rfg038208
D454 Multi Folder	D454_MultiFolder_vxxx_Remote	rfg040039
IPDS Unit Type 1357EX	D451_IPDS_vxxx_Remote	rfg038835
B830 Finisher	B830_Finisher_vxxx_Remote.zip	rfg032137
B835 Cover Interposer	B835_Cover Interposer_vxxx_Remote.zip	rfg032138
D391 Perfect Binder	D392_Perfect Binder_B1_vxxx_Remote.zip	rfg034070
	D392_Perfect Binder_B2_vxxx_Remote.zip	rfg034071
	D392_Perfect Binder_B3_vxxx_Remote.zip	rfg034072
	D392_Perfect Binder_B4_vxxx_Remote.zip	rfg034073
	D392_Perfect Binder_B5_vxxx_Remote.zip	rfg034074
D392 Ring Binder	D392_Ring Binder_B1_vxxx_Remote.zip	rfg034060
	D392_Ring Binder_B2_vxxx_Remote.zip	rfg034059

Product Support Guide

Model D059/D060/D061

SD Card Arrangement

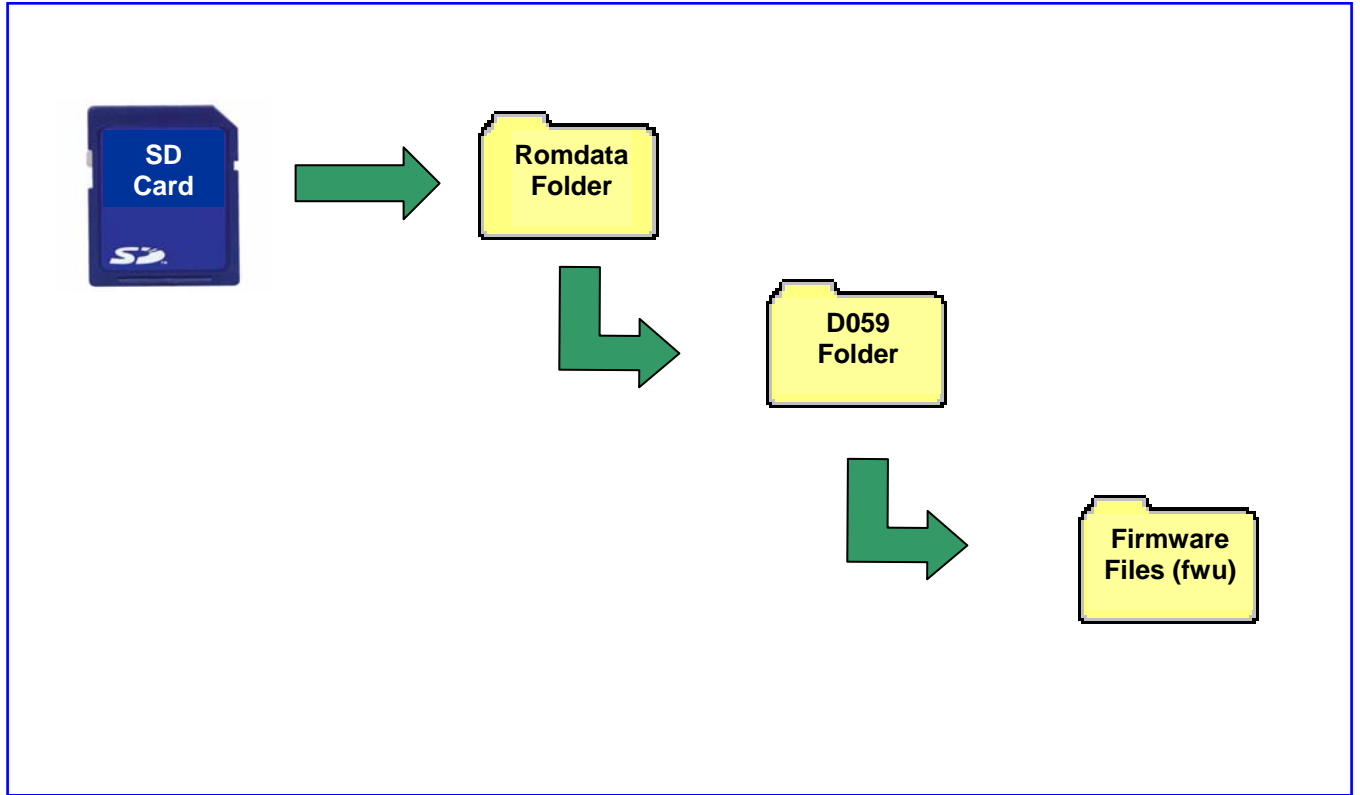

Product Support Guide

Model D059/D060/D061

@Remote

How to enable @Remote Functionality

Prior to visiting the Customer Site:

1. Obtain the customers consent to enable the embedded @Remote on their device (MFP).
2. Log into the @Remote Center <https://rcg.support.ricoh.com/atremotecenter/MainServlet>.
3. Select: **New Registration**.
4. Pre Register the customer/device in the @Remote Center System after entering the required and/or optional customer Information then select : **Regist** (see below).

The screenshot shows the @Remote web interface for 'New Registration'. The page title is 'New Registration' with a help icon. A 'Regist' button is visible. A blue banner states 'Fields marked with an asterisk * are required.' The form contains several required fields: Customer Name/ID (text input with 'XYZ Customer or 123456789'), Site Name (dropdown menu with 'Training'), Service Depot Name (dropdown menu with 'Training Svc'), and Operation Calendar (dropdown menu with 'DEF'). Below these are optional fields under an 'Option' header: Address, Location, Appliance Administrator Name, Appliance Administrator Phone, Appliance Administrator E-mail Address, Note 1, Note 2, and Note 3. The left sidebar contains navigation menus for Site Information, Logout, Registration Menu (with 'New Registration' selected), Search Menu, Replacement Menu, Counter CSV Menu, and Supply CSV Menu.



Product Support Guide

Model D059/D060/D061

- Record the Request Number provided by the @Remote Center System, you will need to input this number into the device as a part of the registration process.

At the Customers Site:

- Complete the installation process for the device as normal including installation on to the Customer's Network. Perform all regular post installation testing of the Device to ensure it's operating properly.
- Once the Device is fully operational, access the Device's Web Image Monitor (WIM) and select: **Login**.

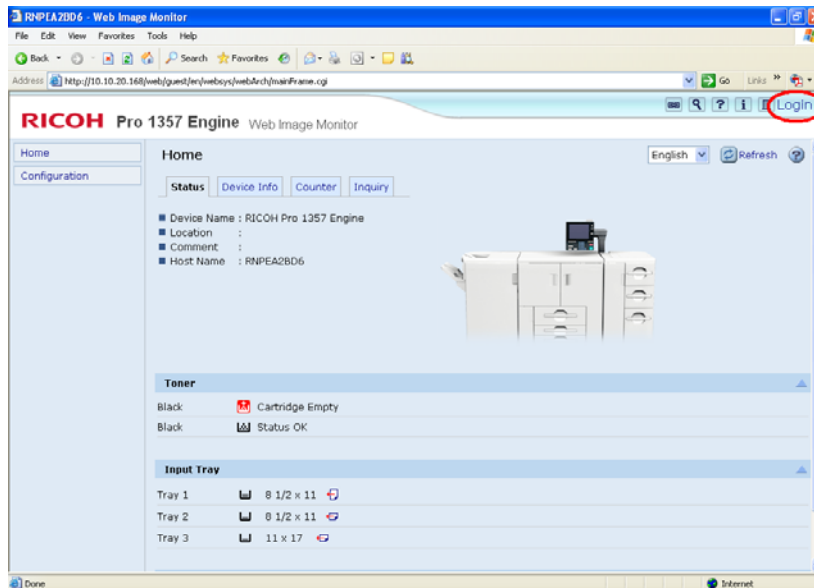

- Log into the Web Image Monitor as "admin", no password.

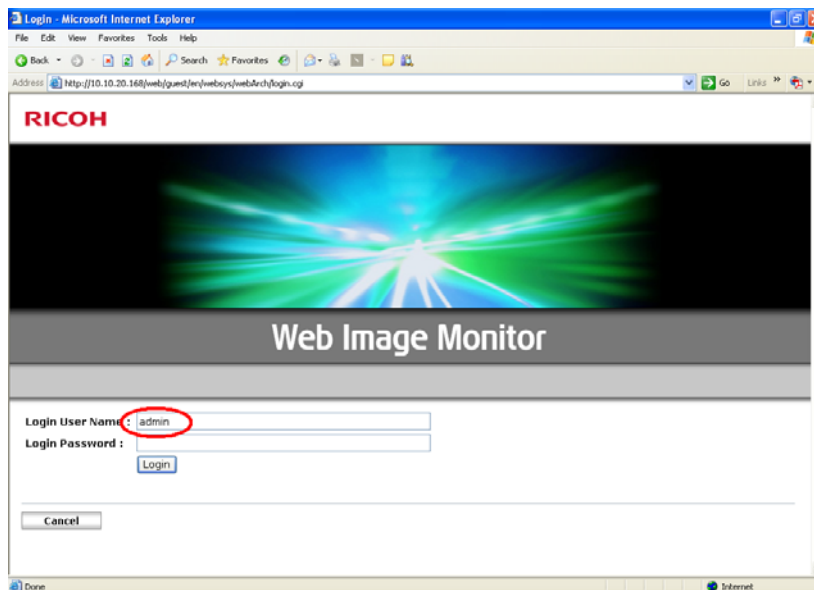

Product Support Guide

Model D059/D060/D061

9. Select: **Configuration**.

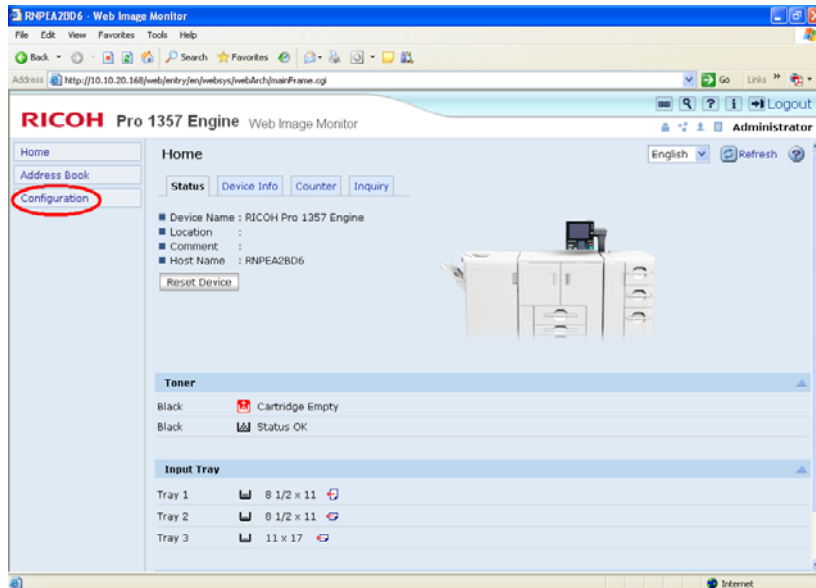

10. Scroll down and select: **Setup RC Gate** (Note: if the Customer uses a Proxy Server to access the internet, then program the RC Gate Proxy information into the device prior to selecting Setup RC Gate).

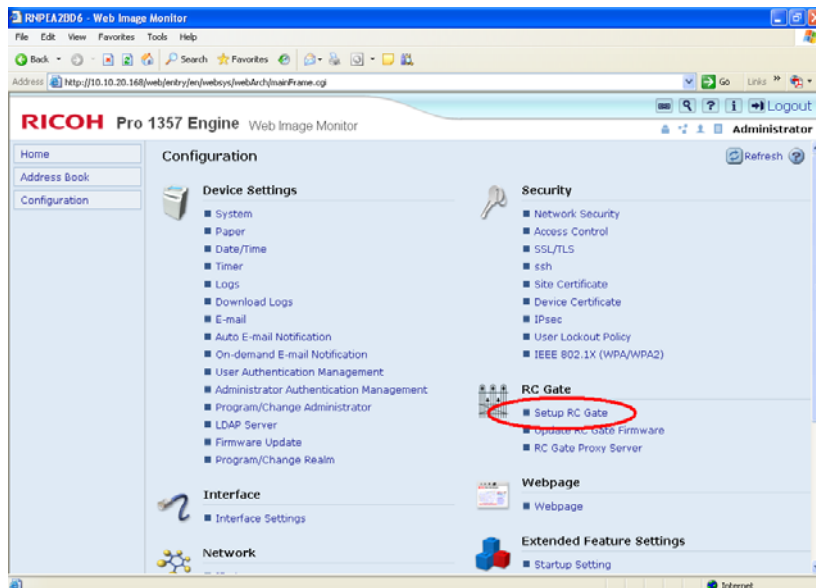

Product Support Guide

Model D059/D060/D061

11. Enter the Request Number obtained in Step 5.

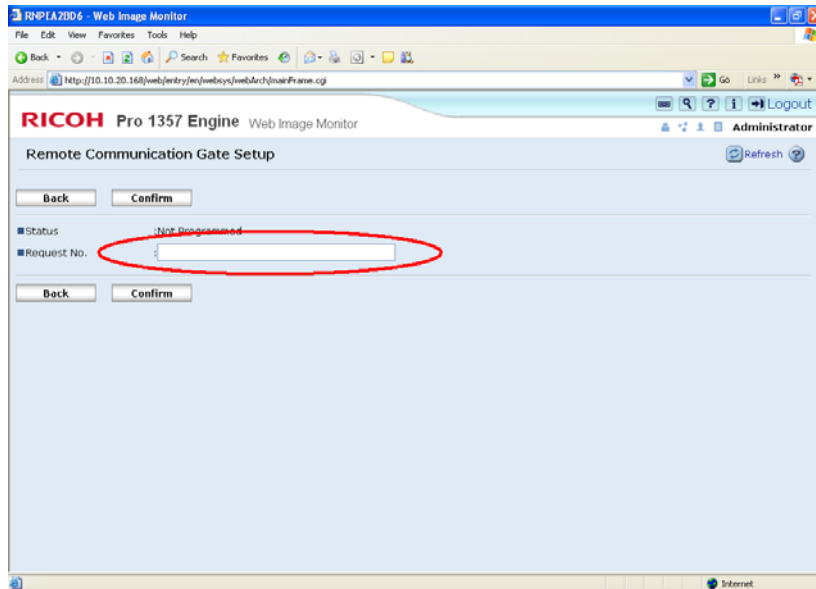

12. Select: **Confirm**.

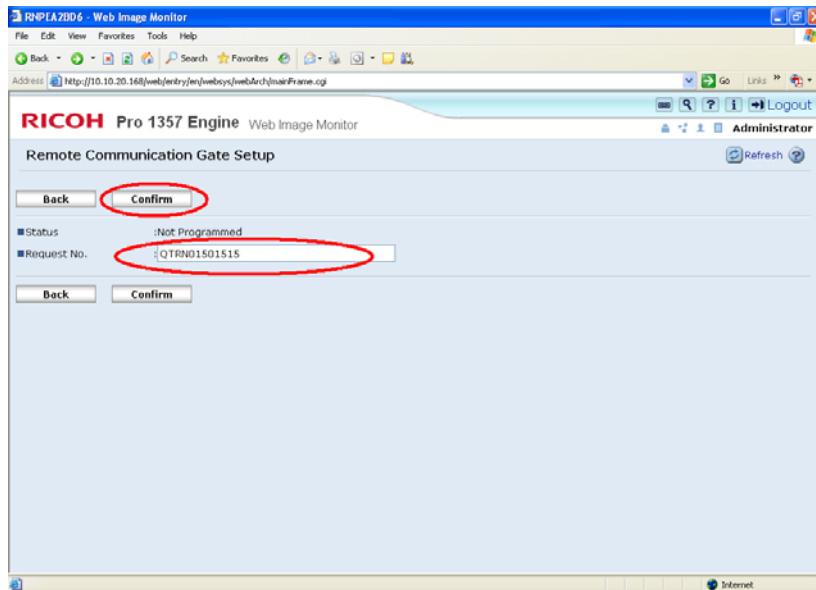

Product Support Guide

Model D059/D060/D061

13. Select: **OK**.

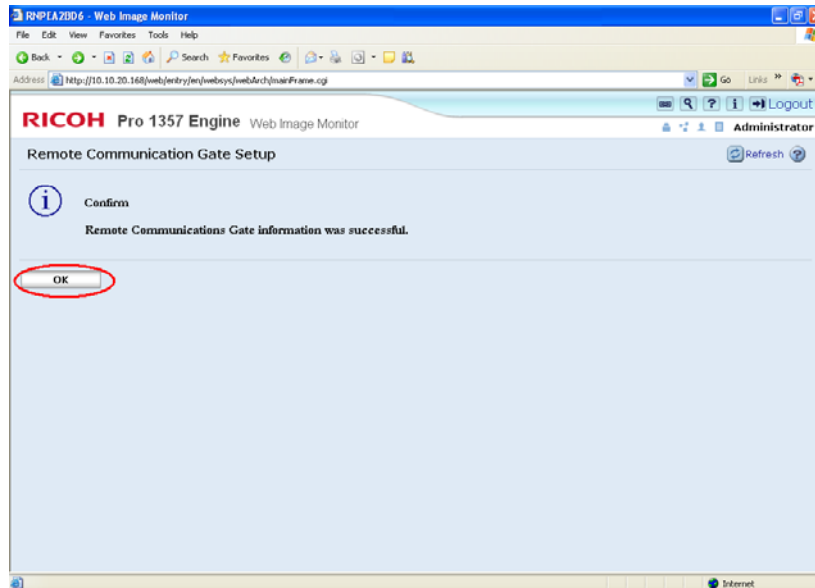

14. Select: **Program**.

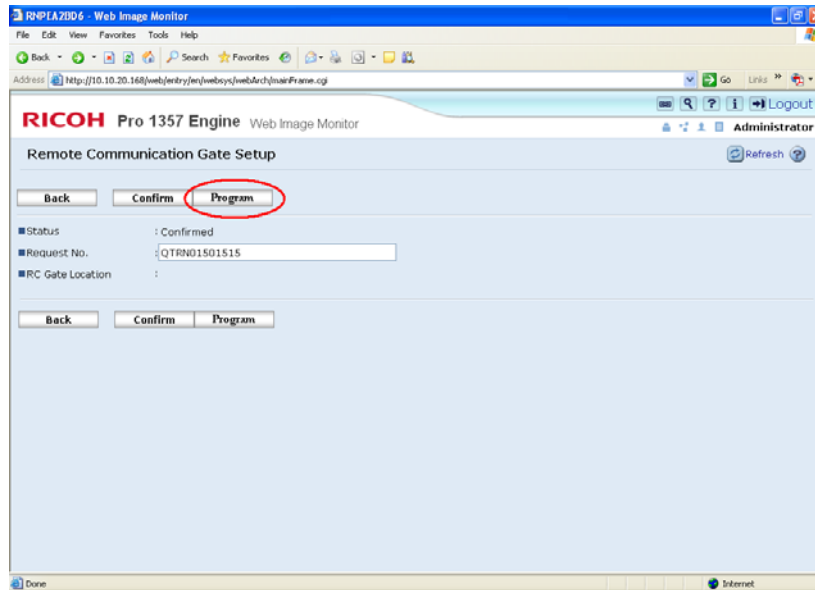

Product Support Guide

Model D059/D060/D061

15. Select: **OK**.

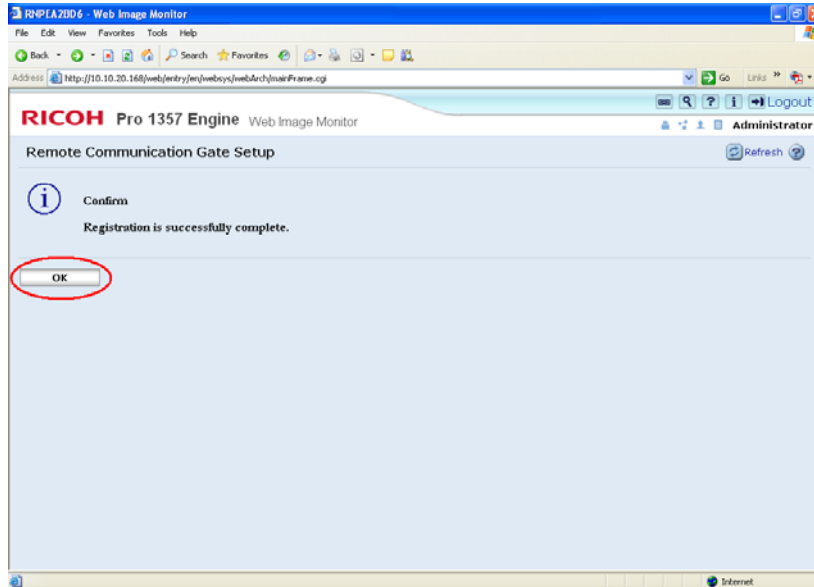

16. Verify that the Web Image Monitor is indicating Status: **Registered**.

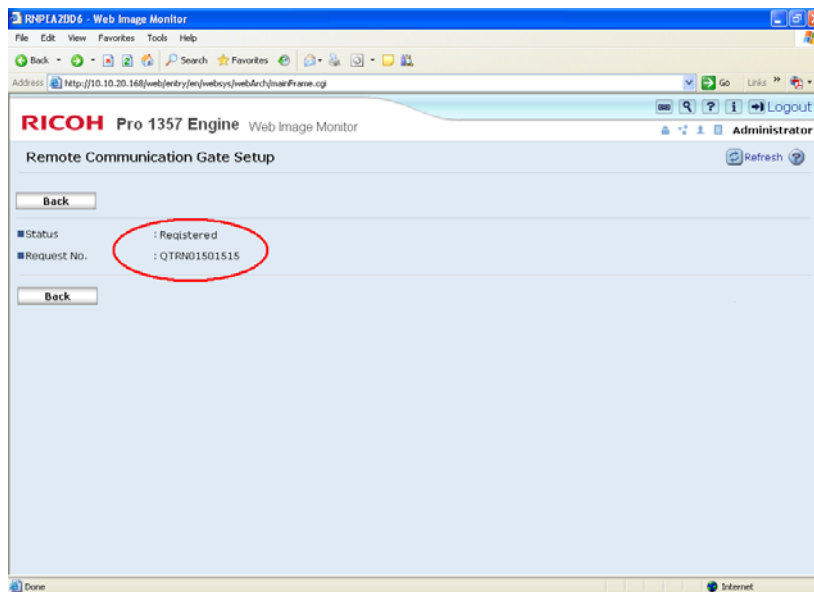



Product Support Guide

Model D059/D060/D061

The @Remote Embedded Device is now Reporting into the @Remote Center and is almost completely registered (Managed Mode) into the @Remote Center; this is the last step to perform at the Customers site.

After visiting the Customer Site:

You or your Office Administrator must complete the following steps:

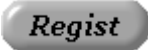
17. Log into the @Remote Center <https://rcg.support.rioh.com/atremotecenter/MainServlet>
18. Select "Appliance (App)" in the "Search Menu"
19. Ensure that your "Service Depot" name is populated and then enter some search criteria, such as Customer Name/ID and select "Search"
20. When you see the Customer that you are searching for, click once on that Customer Name/ID to highlight that Customer.
21. Select: 
22. Click once on the Device to highlight it (the Device should be in the Managed / Found Condition) and Select: 
23. Enter any information you wish to on this page, **you must input a M/R Date** (Meter Read Date) if you want to be able to obtain the Meter Read Data for this Device.
24. After entering the appropriate information and then select: 
25. Note: The Embedded @Remote Functionality is now Registered, Configured and Enabled for Meter Reading as well as Remote Service Call and Supply Usage Reporting (Note: You must program in your email information into the Legacy Center System if you intend to be able to receive these notifications).
26. **(Service and Supply Functionality)** *If you are not ready to offer these services to your customer at this time, you must complete the next step. If you do not complete this step, and for example a Service event occurs, the Customer will receive a message in the Operation Panel of their Machine indicating that a Service Call has been placed.*
27. Disabling the Service or Supply Call Function is not available via the @Remote Center System; please disable the Remote Service Call Reporting at the Device during the installation process of the Embedded @Remote. Log into the Copy Service Mode of the Device change SP5515-001~012.
28. Notice: It maybe possible to enable/disable the SC call in "Write" Menu in the @Remote Center System, under the Service Call > Call List Menu. As an example, item 100 "Call setting: SC Call" is equivalent to SP5515-001, but this would be a reactive approach, since this is occurring after a service event occurred on the device.

You have now disabled the Remote Service Call Functionality; you can enable this functionality in the future when you are ready to begin to offer Remote Service / Supply Call Service.

Product Support Guide

Model D059/D060/D061

Installing Embedded @Remote using SP Mode

Access the following Service SP Modes.

Go to SP 5816-202 and enter the Letter Number

Go to SP 5816-203 and select Confirmation Execute

Go to SP 5816-204 and select Confirm Result

Go to SP 5816-205 and select Confirm Place

Go to SP 5816-206 and select Register Execute

Go to SP 5816-207 and select Register Result to ensure that the configuration was successful.

Now go to SP 5515-001~012 and disable the Service and Supply Call Functionality if required.

For additional support information regarding @Remote please visit the @Remote Web Site at <http://www.tscweb.net/atremote/>

Product Support Guide

Model D059/D060/D061

Contact Information

Name	Contact
Technical Services Call Center (Hotline)	Ricoh: (800) 537-4264 Savin/Gestetner: (800) 291-6044 Lanier: (800) 333-3147
Application Help Desk (Software Issues)	Ricoh Phone Card: 2 Call - 000781MIU, 5 Call - 000900MIU Savin Phone Card: 2 Call - 12992, 5 Call - 12993 Gestetner Phone Card: 2 Call - 12994, 5 Call - 12995
Parts and Logistics Control	(800) 557-4264 http://www.hytecrepair.com/
Technology Solutions Center Web Site	http://www.tscweb.net
Configurator	http://www.connectivity-cafe.com
Ricoh Web Site	http://www.ricoh-usa.com/
Savin iLINC Web Site	http://www.savin.com
Headquarter Web Sites	Ricoh Corporation: http://www.ricoh-usa.com Savin Corporation: http://www.savin.com Gestetner Corporation: http://www.gestetnerusa.com/ Lanier Corporation: http://www.lanier.com
Material Safety Data Sheets	(800) 336-MSDS (6737)
Ricoh University	1-973-882-2200. http://www.ricohuniversity.com

Product Support Guide

Model D059/D060/D061

Training Information

Documentation

Ricoh University has established three certification methods for the new series:

- Service professionals currently certified on the D101/B234 series MFPs will be able to take the Self Pace Update to obtain certification on the D059 series MFPs.
- The self-pace program is available in two versions which are the Self-Pace CD-ROM and via Ricoh University Custom eLearning. The CD-ROM version must be ordered from your Regional Order Entry Department.
- A blended learning course part 1 (CBT/WBT) & part 2 (ILT) will be available for those Service Professionals who are not certified on the D101/B234 series MFPs.

Description	EDP Code	RFG E-Source Number
D059/D060/D061 Service Manual	004971MIU	rfg040208
D059/D060/D061 Parts Catalog	004972MIU	rfg040209
D059/D060/D061 Point to Points	004973MIU	rfg040210
D059/D060/D061 Operating Instruction Manual	-	rfg040211
D059 Series Self-Pace Update Training Package	004974MIU	-

Please refer to the <http://www.ricohuniversity.com/> web site for the most up to date training information.

Please be aware that once a model or series is out of production, the Field Service Manual, Technical Service Bulletins and Ricoh University should be referenced for the most current information. Check the TSRC website and e-Source.

Product Support Guide

Model D059/D060/D061

Revisions

Ver. 1.0 - Original

Ver. 1.1 - Update Service Documentation info on page 69.

Ver. 1.2 - Add @Remote info pages 68 ~ 75.

- Update options info on page 3.

Ver.1.3 - Update P/N's special tools/lubricants P/N on page 20.