



RICOH UNIVERSITY

Learning ♦ Knowledge ♦ Performance



D081/D082 **SERVICE MANUAL**

(Book 1 of 2) 005645MIU

MAINFRAME

LANIER RICOH SAVIN



D081/D082
SERVICE MANUAL
(BOOK 1 OF 2) MAINFRAME

LANIER
RICOH
SAVIN



RICOH UNIVERSITY
Learning ♦ Knowledge ♦ Performance

D081/D082
SERVICE MANUAL
BOOK 1 OF 2
MAINFRAME

005645MIU

LANIER RICOH SAVIN

WWW.SERVICE-MANUAL.NET

It is the reader's responsibility when discussing the information contained within this document to maintain a level of confidentiality that is in the best interest of Ricoh Americas Corporation and its member companies.

NO PART OF THIS DOCUMENT MAY BE REPRODUCED IN ANY FASHION AND DISTRIBUTED WITHOUT THE PRIOR PERMISSION OF RICOH AMERICAS CORPORATION.

All product names, domain names or product illustrations, including desktop images, used in this document are trademarks, registered trademarks or the property of their respective companies.

They are used throughout this book in an informational or editorial fashion only and for the benefit of such companies. No such use, or the use of any trade name, or web site is intended to convey endorsement or other affiliation with Ricoh products.

© 2010 RICOH Americas Corporation. All rights reserved.

WARNING

The Service Manual contains information regarding service techniques, procedures, processes and spare parts of office equipment distributed by Ricoh Americas Corporation. Users of this manual should be either service trained or certified by successfully completing a Ricoh Technical Training Program.

Untrained and uncertified users utilizing information contained in this service manual to repair or modify Ricoh equipment risk personal injury, damage to property or loss of warranty protection.

Ricoh Americas Corporation

LEGEND

PRODUCT CODE	COMPANY			
	GESTETNER	LANIER	RICOH	SAVIN
D081	MP C6501	LD365C	MP C6501SP	C9065
D082	MP C7501	LD375C	MP C7501SP	C9075

DOCUMENTATION HISTORY

REV. NO.	DATE	COMMENTS
*	01/2010	Original Printing

D081/D082

TABLE OF CONTENTS

NEW FEATURES OF D081/D082

1. NEW FEATURES OF D081/D082	1-1
1.1.1 OVERVIEW.....	1-1
Appearance.....	1-1
Specifications.....	1-3
Two New Options.....	1-3
D014/D015 and D081/D082 Detailed Comparison Tables.....	1-5
Other Developments.....	1-7
1.1.2 SUMMARY OF OPTIONAL PERIPHERALS.....	1-8
1.1.3 NEW ADF.....	1-12
ADF Overview.....	1-12
1.1.4 ADF DETAILS.....	1-13
1.1.5 IMPROVED PAPER FEED.....	1-14
Thick Paper Handling.....	1-14
Noise Reduction.....	1-15
Fewer Paper Jams, Easier Jam Removal.....	1-16
1.1.6 NEW ELEMENTS IN THE LD UNIT.....	1-17
1.1.7 FASTER COPY SPEED.....	1-19
1.1.8 FUSING UNIT IMPROVEMENTS.....	1-20
Shorter Warm-up Time (New WUT).....	1-21
Longer Service Lives.....	1-21
Parts Discarded in the Fusing Unit.....	1-22
Fusing Specifications Compared.....	1-23
1.1.9 SCANNER UNIT.....	1-24

PRODUCT INFORMATION

2. PRODUCT INFORMATION.....	2-1
2.1 SPECIFICATIONS	2-1
2.2 MAIN MACHINE AND PERIPHERALS	2-2
2.2.1 MAIN SYSTEM CONFIGURATIONS	2-2
Configuration 1: Finisher D373 (SR4040), Finisher D374 (SR4030)	2-2
Configuration 2: Finisher B830 (SR5000).....	2-3
2.2.2 CONTROLLER OPTIONS	2-4
2.3 GUIDANCE FOR THOSE WHO ARE FAMILIAR WITH PREDECESSOR PRODUCTS.....	2-5
2.4 OVERVIEW.....	2-6
2.4.1 MAIN MACHINE	2-6

INSTALLATION

3. INSTALLATION	3-1
3.1 INSTALLATION REQUIREMENTS.....	3-1
3.1.1 OPERATING ENVIRONMENT	3-1
3.1.2 MACHINE LEVEL	3-2
3.1.3 MINIMUM SPACE REQUIREMENTS	3-3
3.1.4 DIMENSIONS	3-3
3.1.5 POWER REQUIREMENTS.....	3-4
3.2 MAIN MACHINE D081/D082	3-6
3.2.1 ACCESSORIES	3-6
3.2.2 INSTALLATION	3-8
External Tapes and Packing Material.....	3-8
Internal Tapes and Packing Material	3-10
Shipping Retainer Removal.....	3-12
Remove Drawer Retainers and Packing Material.....	3-14
Reattach the Faceplate	3-16
Filling the PCU Units with Developer.....	3-16
Reinstall the Toner Hopper.....	3-22
Toner Installation.....	3-24
Initializing Developer and Toner	3-25
Load the Paper Trays.....	3-27
Make a Test Color Print.....	3-28

ACC (Automatic Color Calibration) Adjustment.....	3-28
Do the Color Registration Procedure for MUSIC.....	3-30
Counter Display Setting.....	3-31
Make the Machine Level	3-31
Attach the PCU Stand Rack and Store the PCU Stand.....	3-32
Attach Decals	3-33
Enable USB.....	3-35
Print an SMC Report	3-35
Connect the Upper and Lower Tray Heaters.....	3-36
Enabling App2 Me on VM/Calypso SD Card (D0815790C).....	3-36
3.3 COPY TRAY (B756-01)	3-39
3.3.1 ACCESSORIES.....	3-39
3.3.2 INSTALLATION	3-40
3.4 A3/11" X 17" PAPER SIZE TRAY TYPE 2105 (B331-01)	3-42
3.4.1 ACCESSORIES.....	3-42
3.4.2 INSTALLATION	3-43
3.5 COUNTERS.....	3-46
3.5.1 ACCESSORIES.....	3-46
Key Card Bracket B498.....	3-46
Key Counter Bracket B452 Accessories.....	3-47
Optional Counter Interface Unit Type A B870 Accessories.....	3-47
3.5.2 INSTALLATION	3-48
Assemble the Key Counter Bracket.....	3-48
Install the Key Card Bracket and Assembled Key Counter	3-49
If you are installing the key counter bracket	3-50
3.6 USB2.0/SD SLOT TYPE D (D505-01)	3-53
3.6.1 ACCESSORIES.....	3-53
3.6.2 INSTALLATION	3-53
Preparation.....	3-53
Removing the Operation Panel and Dummy Cover.....	3-54
Slot Unit Installation.....	3-56
Knockout, Upper Right Cover.....	3-59
Upper Left Cover	3-60
Slot Unit Connection.....	3-60
Right Upper Cover, Knockout.....	3-64
Harness and Cable Check	3-65

3.7 LCT (B473), LCT ADAPTER TYPE B (B699)	3-66
3.7.1 ACCESSORIES	3-66
LCT (B473).....	3-66
LCT Adapter Type B (B699)	3-67
3.7.2 INSTALLATION	3-68
Removing Tape and Accessories.....	3-68
LCT Adapter (B699) Installation	3-69
LCT Installation	3-70
Adjusting Side Fences for Paper Size	3-72
Decals	3-75
3.8 LG SIZE TRAY TYPE 1075 (B474).....	3-76
3.8.1 ACCESSORIES	3-76
3.8.2 INSTALLATION	3-77
LCT Connected to the Machine.....	3-77
3.9 LCIT RT4000 (D350).....	3-80
3.9.1 ACCESSORIES	3-80
3.9.2 LCT INSTALLATION.....	3-81
Grounding and Preparing the LCT for Docking	3-81
After Installation.....	3-85
3.9.3 ANTI-CONDENSATION HEATER TYPE B: 120V	3-86
Accessory Check.....	3-86
Installation Procedure for 120V	3-87
3.9.4 ANTI-CONDENSATION HEATER TYPE B: 240V	3-89
Accessory Check.....	3-89
Installation Procedure for 240V	3-90
Decals	3-92
3.10 COVER INTERPOSER TRAY CI5000 (B835-57)	3-93
3.10.1 ACCESSORIES	3-93
3.10.2 INSTALLATION	3-94
Setting up the Unit and Docking to the Copier.....	3-94
Docking the Next Peripheral Device.....	3-98
Mounting the Tray Unit.....	3-99
3.10.3 DOCKING THE COVER INTERPOSER TRAY B835	3-101
Firmware Update.....	3-102
3.11 MULTI FOLDING UNIT (D454)	3-103
3.11.1 ACCESSORIES	3-103

3.11.2	INSTALLATION	3-104
	Tapes	3-104
	Paper Guide, Sponge Strip.....	3-105
	Ground Plate	3-106
	Docking	3-106
	Removing Parts for the Cover Interposer Tray (B835)	3-108
	Height Adjustment.....	3-109
	Power Cord, Breaker Switch Test	3-110
	Check for Skew and Correct Side-to-Side Registration.....	3-110
	Proof Tray Auxiliary Plate	3-111
3.12	RING BINDER (D392) INSTALLATION	3-112
3.12.1	ACCESSORIES.....	3-112
3.12.2	BEFORE YOU BEGIN	3-113
3.12.3	INSTALLATION REQUIREMENTS.....	3-114
	Operating Environment	3-114
	Machine Level	3-115
	Minimum Space Requirements	3-115
	Power Supply	3-115
3.12.4	INSTALLATION PROCEDURE.....	3-116
	Remove All Shipping Materials.....	3-116
	Prepare the Finisher for Docking.....	3-118
	Prepare the Upstream Unit for Docking.....	3-119
	Dock the Finisher	3-120
	Install the Shoes and Level the Finisher.....	3-121
	Attach Ring Supply Level Indicator.....	3-121
	Test the Breaker Switch	3-122
3.12.5	CENTERING PAPER IN THE PAPER PATH	3-123
	Checking and Correcting Side-to-Side Registration	3-123
	Checking and Correcting Skew	3-125
3.12.6	AFTER INSTALLATION.....	3-128
	Selecting the Supply Name	3-129
3.13	COVER INTERPOSER TRAY TYPE 3260 (B704-17).....	3-130
3.13.1	ACCESSORIES	3-130
3.13.2	INSTALLATION	3-131
	Removing Tapes and Packing Materials	3-131
	Preparing the Finisher	3-132

	Attaching the Extensions	3-133
	Attaching the Interposer Tray	3-134
	Docking the Finisher/Interposer.....	3-134
3.14	2000/3000 SHEET FINISHERS (D373/D374)	3-137
3.14.1	ACCESSORIES	3-137
3.14.2	INSTALLATION	3-138
	Removing Tapes and Packing Materials	3-139
	Docking the Finisher to the Copier	3-140
	Attaching the Trays	3-143
	Leveling the Finisher	3-143
	Support Trays.....	3-144
	Selecting the Staple Supply Name	3-145
	Enabling Booklet Binding (D373 Only)	3-146
3.15	PUNCH UNIT (B702-17, -27, -28)	3-147
3.15.1	ACCESSORIES	3-147
3.15.2	INSTALLATION	3-148
3.16	OUTPUT JOGGER UNIT TYPE 3260 (B703)	3-152
3.16.1	ACCESSORIES	3-152
3.16.2	INSTALLATION	3-153
3.17	MAIL BOX (B762).....	3-155
3.17.1	ACCESSORIES	3-155
3.17.2	INSTALLATION	3-156
3.18	3000-SHEET FINISHER (B830-17), FINISHER ADAPTER TYPE C (D375) 3-158	
3.18.1	ACCESSORIES	3-158
	3000-Sheet Finisher B830 Accessories	3-158
	Finisher Adapter Type C Accessories	3-160
3.18.2	FINISHER ADAPTER KIT D375 INSTALLATION.....	3-161
3.18.3	FINISHER INSTALLATION.....	3-165
	Docking the Finisher B830	3-167
	Connecting the Finisher B830	3-168
3.18.4	UPDATING THE FIRMWARE.....	3-169
3.18.5	SP SETTING	3-171
3.19	PUNCH UNIT PU5000 (B831).....	3-172
3.19.1	ACCESSORIES	3-172
3.19.2	INSTALLATION	3-173

3.20	COMMON ADJUSTMENTS	3-178
3.20.1	HEIGHT AND LEVEL ADJUSTMENT.....	3-178
	Before you begin:	3-178
	Setting the Leveling Shoes.....	3-178
3.20.2	SKEW AND SIDE-TO-SIDE REGISTRATION.....	3-179
	Overview	3-179
	Checking Side-to-Side Registration.....	3-182
	Correcting Side-to-Side Registration	3-183
	Detecting Paper Skew	3-184
	Correcting Skew	3-185
3.20.3	BREAKER SWITCH TESTING	3-187
3.21	MFP CONTROLLER OPTIONS	3-188
3.21.1	OVERVIEW	3-188
3.21.2	ENABLING USB	3-190
3.21.3	ACCESSORY CARDS.....	3-191
3.21.4	SD CARD APPLICATIONS.....	3-193
3.21.5	HANDLING DIMMS AND SD CARDS	3-194
	DIMMs.....	3-194
	SD cards.....	3-195
3.21.6	MOVING APPLICATIONS TO ONE SD CARD	3-195
	Overview	3-195
	Moving Applications	3-196
	Undo Exec.....	3-198
	Storing SD Application Cards on Site.....	3-199
3.21.7	IEEE 1284 INTERFACE BOARD (B679) (CENTRONICS)	3-199
	Accessories	3-199
	Installation	3-200
3.21.8	BLUETOOTH INTERFACE UNIT TYPE 3245 (B826-17)	3-201
	Accessories	3-201
	Installation Procedure.....	3-202
3.21.9	IEEE 802.11A/G INTERFACE UNIT TYPE J (D377-01)	3-203
	Accessories	3-203
	Installation	3-203
	SP Mode Settings for 802.11a/g Wireless LAN	3-205
3.21.10	FILE FORMAT CONVERTER TYPE E (D377-04)	3-206
	Accessory Check.....	3-206

Installation	3-206
3.21.11 HDD ENCRYPTION UNIT TYPE A (D377-16).....	3-207
Before You Begin the Procedure.....	3-207
Seal Check and Removal.....	3-208
Installation Procedure.....	3-209
Recovery from a Device Problem.....	3-210
Restoring the encryption key.....	3-210
Clearing the NVRAM	3-211
3.21.12 POSTSCRIPT3 UNIT TYPE 7501 (D497-01, -03, -04)	3-212
3.21.13 DATA OVERWRITE SECURITY UNIT TYPE H (D497)	3-213
Accessory Check.....	3-213
Before You Begin.....	3-213
Seal Check and Removal.....	3-214
Installation Procedure.....	3-214
Check Operation of the DOS Application	3-216
3.21.14 COPY CONNECTOR TYPE 3260 (B328-11)	3-217
3.21.15 GIGABIT ETHERNET TYPE B (D377-21)	3-219
Accessories.....	3-219
Installation	3-219
3.21.16 BROWSER UNIT TYPE E (D497)	3-221
Accessories.....	3-221
Installation	3-221
3.21.17 COPY DATA SECURITY UNIT TYPE F (B829-07)	3-223
Accessories.....	3-223
User Tool Setting.....	3-224

PREVENTIVE MAINTENANCE

4. PREVENTIVE MAINTENANCE	4-1
4.1 OVERVIEW.....	4-1
4.1.1 REQUIRED MATERIALS.....	4-1
4.2 PM COUNTER.....	4-3
4.2.1 DISPLAYING THE PM COUNTER	4-3
4.2.2 PM PARTS SCREEN DETAILS.....	4-4
All PM Parts list: Main Menu.....	4-4
Number button submenu	4-5

Parts list for PM yield indicator	4-6
4.3 PM TABLES	4-7

REPLACEMENT AND ADJUSTMENT

5. REPLACEMENT AND ADJUSTMENTS.....	5-1
5.1 GENERAL CAUTIONS	5-1
5.1.1 DRUM	5-1
5.1.2 PCU	5-2
5.1.3 TRANSFER BELT UNIT	5-3
5.1.4 SCANNER UNIT	5-3
5.1.5 LASER UNIT	5-3
5.1.6 DEVELOPMENT	5-4
5.1.7 CLEANING.....	5-4
5.1.8 FUSING UNIT	5-5
5.1.9 PAPER FEED	5-5
5.1.10 USED TONER	5-5
5.2 COMMON PROCEDURES	5-6
5.2.1 ADF.....	5-6
5.2.2 OPERATION PANEL, TOP COVERS.....	5-7
5.2.3 LEFT COVERS	5-8
5.2.4 FRONT DOOR.....	5-9
5.2.5 RIGHT COVERS.....	5-10
5.2.6 REAR COVERS.....	5-11
5.2.7 TONER HOPPER, FACEPLATE, PCU.....	5-12
Removing Hopper, Faceplate, PCU	5-12
Reinstalling PCU, Faceplate, Toner Hopper	5-15
5.2.8 IMAGE TRANSFER UNIT.....	5-17
5.2.9 DRAWER UNIT.....	5-19
To pull out the drawer unit:	5-19
To remove the drawer unit:.....	5-19
5.2.10 DUPLEX UNIT	5-21
5.2.11 OPENING, LOCKING THE CONTROLLER BOX COVER	5-22
5.2.12 SD CARD STORAGE	5-23
5.2.13 BEFORE REMOVING AND RE-INSTALLING THE VM CARD ..	5-24
Before Removing the VM Card from the Machine	5-24

Starting Up After the VM Card Has Been Removed.....	5-25
5.3 SCANNER UNIT	5-26
5.3.1 EXPOSURE GLASS	5-26
5.3.2 LENS BLOCK, PAPER SIZE SENSORS	5-27
5.3.3 EXPOSURE LAMP	5-29
5.3.4 SCANNER MOTOR	5-30
5.3.5 SCANNER HP SENSOR	5-31
5.3.6 SCANNER INTERFACE BOARD (SIOB).....	5-32
5.3.7 SCANNER WIRE	5-33
Scanner Wire Reinstallation and Scanner Position Adjustment	5-33
5.4 LASER UNIT	5-35
5.4.1 CAUTION DECALS	5-35
5.4.2 POLYGON MOTOR	5-36
Re-installation.....	5-37
5.4.3 LASER UNIT	5-38
Reinstallation.....	5-40
5.4.4 SP ADJUSTMENTS AFTER LASER UNIT REPLACEMENT	5-41
Color Registration Errors	5-42
Skew	5-42
5.4.5 LD UNIT	5-42
Dual Beam Writing	5-42
LD Safety Switches	5-43
5.5 PCU	5-44
5.5.1 BEFORE YOU BEGIN	5-44
5.5.2 CHARGE UNITS.....	5-45
Preparation.....	5-45
Charge Roller Unit: YMC PCUs.....	5-46
K_PCU Replacement	5-47
K_PCU Charge Unit Components	5-48
5.5.3 SEPARATING DRUM/CLEANING UNIT, REMOVING THE OPC DRUM	5-60
Re-installation of the Drum	5-61
5.5.4 PCU BLADES AND ROLLERS	5-64
Drum Lubricant Bar and Drum Lubricant Blade.....	5-64
Drum Lubricant Brush Roller	5-67
Drum Cleaning Blade	5-70

5.5.5 DEVELOPER REPLACEMENT	5-72
Preparation.....	5-72
Removing Old Developer	5-74
Adding New Developer.....	5-79
Handling Problems with Developer Filling	5-85
5.5.6 NEW PCU	5-87
5.6 TONER SUPPLY	5-90
5.6.1 STC PORT CLEANING.....	5-90
5.6.2 CONNECTOR BOARD (CNB)	5-91
5.6.3 TONER PUMP	5-92
5.6.4 TONER END SENSOR.....	5-93
5.6.5 TONER SUPPLY MOTOR.....	5-94
5.7 PTR UNIT	5-95
5.7.1 RELAY SENSOR	5-95
5.7.2 DOUBLE-FEED DETECTION PHOTO-SENSOR, REGISTRATION SENSOR.....	5-96
5.7.3 PTR UNIT	5-97
5.7.4 PAPER TRANSFER ROLLER, DISCHARGE PLATE.....	5-99
5.7.5 LUBRICANT BAR, BRUSH ROLLER	5-100
5.7.6 CLEANING BLADE	5-101
5.7.7 CLEANING BRUSH ROLLER.....	5-102
Replacement	5-102
5.7.8 PAPER TRANSPORT BELT, PAPER SEPARATION POWER PACK	5-102
5.7.9 REGISTRATION MOTOR.....	5-104
5.7.10 DOUBLE-FEED DETECTION LED.....	5-105
5.8 IMAGE TRANSFER UNIT	5-106
5.8.1 EMPTYING THE DUST COLLECTION UNIT	5-106
5.8.2 SEPARATING THE BELT UNIT AND BELT CLEANING UNIT	5-106
Disassembly and ITB Replacement	5-106
5.8.3 REASSEMBLING THE BELT UNIT AND BELT CLEANING UNIT	5-108
Before You Begin...	5-108
Reassembling the Belt Unit and Cleaning Unit.....	5-109
Dusting the ITB with Lubricant Powder	5-110
5.8.4 ITB CLEANING UNIT.....	5-112
ITB Lubricant Blade.....	5-113

ITB Lubricant Brush Roller, ITB Lubricant Bar.....	5-113
ITB Cleaning Blade	5-114
ITB Brush Cleaning Roller	5-115
5.8.5 MUSIC AND ID SENSORS.....	5-116
5.8.6 IMAGE TRANSFER POWER PACK.....	5-116
5.8.7 BELT POSITION SENSOR.....	5-118
5.9 FUSING UNIT	5-119
5.9.1 BEFORE SERVICING THE FUSING UNIT.....	5-119
5.9.2 REMOVING THE FUSING UNIT	5-122
5.9.3 FUSING EXIT SENSOR, ACCORDION JAM SENSOR	5-124
5.9.4 PRESSURE ROLLER THERMOSTATS, THERMISTOR	5-125
Thermostats	5-125
Thermistor	5-125
5.9.5 FUSING CLEANING UNIT.....	5-126
Fusing Belt Strippers	5-126
Oil Supply Roller Cleaning Roller, Oil Supply Roller.....	5-128
5.9.6 FUSING BELT THERMOSTATS	5-129
5.9.7 FUSING THERMISTORS, HEATING ROLLER TEMPERATURE SENSORS	5-130
5.9.8 PRESSURE ROLLER SEPARATION PAWLS	5-131
5.9.9 FUSING LAMPS, DIVIDING THE FUSING UNIT	5-132
5.9.10 FUSING UNIT ROLLERS, FUSING BELT	5-135
Removing the Fusing Belt, Hot Roller, Heating Roller, Pressure Roller.....	5-135
Lubrication after Replacement.....	5-138
Adjusting the Gap Between Fusing Belt Strippers and Fusing Belt ..	5-138
5.9.11 IMPORTANT WARNING ABOUT THERMOSTATS	5-140
5.9.12 FEED-OUT EXIT SENSOR	5-141
5.9.13 FEED-OUT UNIT	5-142
5.10 DUPLEX UNIT.....	5-144
5.10.1 DUPLEX INVERTER MOTOR	5-144
5.10.2 DUPLEX TRANSPORT MOTOR	5-145
5.10.3 DUPLEX UNIT SENSORS.....	5-146
Duplex Entrance Sensor	5-146
Transport Sensors 1, 2.....	5-146
Transport Sensor 3.....	5-148
5.10.4 DUPLEX JOGGER MOTOR	5-149

5.10.5	DUPLEX JOGGER BELT	5-150
5.11	TANDEM TRAY (TRAY 1).....	5-151
5.11.1	TANDEM TRAY	5-151
5.11.2	REAR FENCE RETURN SENSOR REPLACEMENT	5-152
5.11.3	REAR FENCE HP SENSOR REPLACEMENT	5-153
5.11.4	TANDEM RIGHT TRAY PAPER SENSOR REPLACEMENT ...	5-154
5.11.5	PAPER HEIGHT SENSORS.....	5-155
5.11.6	BOTTOM PLATE LIFT WIRE REPLACEMENT.....	5-156
Front Wire.....		5-156
Rear Wire		5-157
Re-installation.....		5-157
5.11.7	SIDE FENCE SENSORS.....	5-158
5.11.8	TANDEM TRAY PAPER SIZE CHANGE	5-159
5.11.9	SIDE-TO-SIDE REGISTRATION CORRECTION.....	5-161
5.12	PAPER FEED (TRAYS 2, 3)	5-162
5.12.1	PICKUP, FEED, REVERSE ROLLERS	5-162
5.12.2	PAPER FEED UNIT.....	5-163
5.12.3	SEPARATION ROLLER PRESSURE ADJUSTMENT.....	5-164
5.12.4	PAPER END, TRAY LIFT, PAPER FEED SENSORS	5-165
5.12.5	VERTICAL TRANSPORT SENSOR	5-165
5.12.6	FEED MOTOR.....	5-166
5.12.7	PAPER SIZE SWITCHES.....	5-167
5.13	BYPASS UNIT.....	5-168
5.13.1	BYPASS PICKUP, FEED, REVERSE ROLLERS.....	5-168
5.13.2	BYPASS AUTO PAPER SIZE DETECTION SWITCHES	5-169
5.13.3	BYPASS UNIT	5-170
5.13.4	BYPASS PAPER END SENSOR, FEED SENSOR	5-170
5.13.5	BYPASS FEED CLUTCH	5-171
5.14	BOARDS.....	5-172
5.14.1	PCB LAYOUT	5-172
5.14.2	CONTROLLER	5-175
When installing the new controller board.....		5-176
After installing the controller board.....		5-176
5.14.3	IPU/VBCU.....	5-177
IPU/VBCU Removal		5-177
VBCU Replacement		5-178

5.14.4	PFB.....	5-179
5.14.5	HVPS.....	5-180
5.14.6	CHARGE ROLLER POWER PACK.....	5-180
5.14.7	POTENTIAL SENSOR POWER PACK.....	5-181
5.14.8	DRB.....	5-181
5.14.9	DTMB.....	5-182
5.14.10	PSU.....	5-183
5.14.11	AC DRIVE BOARD.....	5-184
5.14.12	MEMORY.....	5-185
5.14.13	NVRAM.....	5-185
	Before You Begin.....	5-185
	Upload NVRAM Data to SD Card.....	5-186
	Replace NVRAM.....	5-186
	Download NVRAM Data from SD Card.....	5-187
5.15	ADF.....	5-188
5.15.1	ADF COVERS.....	5-188
5.15.2	FEED UNIT.....	5-189
5.15.3	PICK-UP ROLLER AND FEED BELT.....	5-190
5.15.4	SEPARATION ROLLER.....	5-192
5.15.5	REGISTRATION SENSOR.....	5-193
5.15.6	ADF CONTROL BOARD.....	5-194
5.15.7	ORIGINAL WIDTH, INTERVAL, SEPARATION, SKEW CORRECTION SENSORS.....	5-194
5.15.8	ORIGINAL LENGTH SENSORS.....	5-196
5.15.9	ADF POSITION AND APS SENSORS.....	5-197
5.15.10	OTHER ADF SENSORS.....	5-198
5.15.11	BOTTOM PLATE LIFT MOTOR.....	5-199
5.15.12	FEED MOTOR.....	5-199
5.15.13	TRANSPORT MOTOR.....	5-200
5.15.14	EXIT MOTOR.....	5-201
5.15.15	PICK-UP ROLLER MOTOR.....	5-202
5.15.16	CIS UNIT.....	5-203
5.15.17	ADF EXIT SENSOR.....	5-204
5.15.18	ADF TRANSPORT BELT ASSEMBLY.....	5-205
	Removing the Belt.....	5-206
	Reinstalling the Belt.....	5-207

Reattaching the White Cover.....	5-209
5.15.19 WHITE ROLLER.....	5-209
5.16 HDD.....	5-211
5.16.1 BEFORE REPLACING THE HDD UNIT.....	5-211
5.16.2 REPLACEMENT PROCEDURE.....	5-211
5.16.3 AFTER INSTALLING THE NEW HDD UNIT.....	5-212
5.17 MOTORS.....	5-214
5.17.1 DRUM CLEANING MOTORS.....	5-214
5.17.2 DEVELOPMENT MOTORS.....	5-215
5.17.3 DRUM MOTOR.....	5-216
Drum Motor Removal.....	5-216
Drum Motor Reinstallation.....	5-217
5.17.4 FUSING/EXIT MOTOR.....	5-218
5.17.5 PTR MOTOR.....	5-219
5.17.6 ITB DRIVE MOTOR.....	5-220
5.18 AIR FILTERS AND OZONE FILTERS.....	5-222
5.18.1 UPPER FILTER BOX.....	5-223
5.18.2 MIDDLE FILTER BOX.....	5-223
5.18.3 LOWER FILTER BOX.....	5-225
5.19 IMAGE ADJUSTMENTS.....	5-226
5.19.1 SCANNING.....	5-226
Scanner sub-scan magnification.....	5-226
Scanner leading edge and side-to-side registration.....	5-226
Main scan dot position correction.....	5-227
5.19.2 ADF.....	5-228
ADF side-to-side and leading edge registration.....	5-228
5.19.3 REGISTRATION.....	5-229
Image Area.....	5-229
Adjustment Procedure.....	5-230
5.19.4 COLOR REGISTRATION.....	5-230
Forced MUSIC Adjustment.....	5-230
Adjustment of Line Speed for Thick Paper.....	5-230
Color Registration Test and Error Adjustment.....	5-231
5.19.5 SKEW ADJUSTMENT AFTER LASER UNIT REPLACEMENT.....	5-231
5.19.6 PRINTER GAMMA CORRECTION.....	5-232
Copy Mode.....	5-233

Adjustment Procedure	5-234
Adjustment Procedure	5-238
Adjustment Reference for Gamma Correction.....	5-238
5.20 TOUCH SCREEN CALIBRATION.....	5-240
5.21 FIRMWARE UPDATE	5-242
5.21.1 BEFORE YOU BEGIN.....	5-242
5.21.2 FIRMWARE UPDATE PROCEDURE	5-242

SYSTEM MAINTENANCE

6. SYSTEM MAINTENANCE	6-1
6.1 SERVICE PROGRAM MODE	6-1

TROUBLESHOOTING

7. TROUBLESHOOTING	7-1
7.1 HANDLING ERRORS	7-1
7.1.1 PROGRAM DOWNLOAD	7-1
Overview	7-1
Recovery Methods	7-1
Download Error Codes	7-2
7.1.2 IMPORTANT SP CODES	7-8
7.1.3 SPECIAL PROCEDURES.....	7-9
Correcting the Halo Effect	7-9
Image Density Light, Failure to Release from Toner End Alert.....	7-10
SP2181 030 (Alignment Result) Errors	7-14
Image Position Adjustment.....	7-18
Color Registration Error Adjustment.....	7-18
Color Skew Error Correction.....	7-21
Overall Check.....	7-22
Color Registration at the Left and Right Folds of the Test Pattern	7-23
SP3812 001 (DevSetup Execute) Errors.....	7-25
Process Control Troubleshooting	7-27
Color Adjustment for Connected Copiers	7-38
7.2 SERVICE CALL CONDITIONS	7-40
7.2.1 SERVICE MODE LOCK/UNLOCK.....	7-40
7.2.2 SERVICE CALL CONDITIONS TABLE	7-41

7.2.3 SC CODE DESCRIPTIONS.....	7-42
7.3 SERVICE CALL TABLES.....	7-43

ENERGY SAVING

8. ENERGY SAVING.....	8-1
8.1 ENERGY SAVE	8-1
8.1.1 ENERGY SAVER MODES.....	8-1
Timer Settings	8-1
Return to Stand-by Mode	8-2
Recommendation	8-2
8.1.2 ENERGY SAVE EFFECTIVENESS.....	8-3
8.2 PAPER SAVE	8-5
8.2.1 EFFECTIVENESS OF DUPLEX/COMBINE FUNCTION	8-5
1. Duplex:	8-5
2. Combine mode:.....	8-5
3. Duplex + Combine:.....	8-5
How to calculate the paper reduction ratio	8-6

D081/D082 SERVICE MANUAL APPENDICES

SEE D081/D082 SERVICE MANUAL APPENDICES SECTION FOR DETAILED TABLE OF CONTENTS

B331 TRAY TYPE 850

SEE SECTION B331 FOR DETAILED TABLE OF CONTENTS

B660 Z FOLDING UNIT ZF4000

SEE SECTION B660 FOR DETAILED TABLE OF CONTENTS

B704 COVER INTERPOSER TYPE 3260

SEE SECTION B704 FOR DETAILED TABLE OF CONTENTS

B473/B474/B475 RT43 LCT

SEE SECTION B743/B474/B475 FOR DETAILED TABLE OF CONTENTS

B762 MAILBOX CS391

SEE SECTION B762 FOR DETAILED TABLE OF CONTENTS

B804/B805/D373/D374 SR3020/SR3030/SR4010/SR4020 FINISHER

SEE SECTION B804/B805/D373/D374 FOR DETAILED TABLE OF CONTENTS

B830 SR5000 FINISHER

SEE SECTION B830 FOR DETAILED TABLE OF CONTENTS

B835 COVER INTERPOSER TRAY CI5000

SEE SECTION B835 FOR DETAILED TABLE OF CONTENTS

D350 RT4000 A3/12 X 18 LCT

SEE SECTION D350 FOR DETAILED TABLE OF CONTENTS

D454 MULTI-FOLDING UNIT FD5000

SEE SECTION B832 FOR DETAILED TABLE OF CONTENTS

D498 FAX OPTION TYPE C7501

SEE SECTION B832 FOR DETAILED TABLE OF CONTENTS

NEW FEATURES OF D081/D082

APPENDIX: SPECIFICATIONS

B802 ARDF DF3010

D346 FAX OPTION TYPE 5000

TAB
POSITION 1

PRODUCT INFORMATION

APPENDIX: PREVENTIVE MAINTENANCE

D351 PAPER FEED UNIT PB3040

TAB
POSITION 2

INSTALLATION

APPENDIX: SERVICE CALL CONDITIONS

D352 LCIT PB3050

D353 1200-SHEET LCIT RT3000

TAB
POSITION 3

PREVENTIVE MAINTENANCE

APPENDIX: SERVICE PROGRAM MODE TABLES

B408 1000-SHEET FINISHER SR790

B804/B805 BOOKLET FINISHER SR3020/FINISHER SR3030

D381 PRINTER/SCANNER OPTION TYPE 5000

B838 SCANNER ACCESSIBILITY OPTION TYPE 4045

TAB
POSITION 4

REPLACEMENT & ADJUSTMENT

APPENDIX: SERVICE PROGRAM MODE TABLES

TAB
POSITION 5

SYSTEM MAINTENANCE

D389 1-BIN TRAY BN3040

TAB
POSITION 6

TROUBLESHOOTING

D386 BRIDGE UNIT BU3030

TAB
POSITION 7







ENERGY SAVING

TAB
POSITION 8

Read This First

Safety, Conventions, Trademarks

Conventions

Symbol	What it means
	Core Tech Manual
	Screw
	Connector
	E-ring
	C-ring
	Harness clamp
FFC	Flexible Film Cable

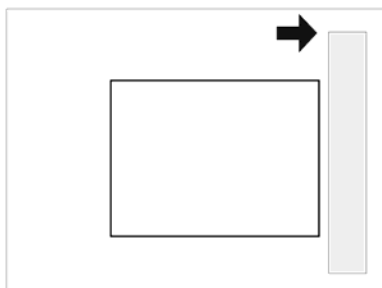

SEF (Short Edge Feed)

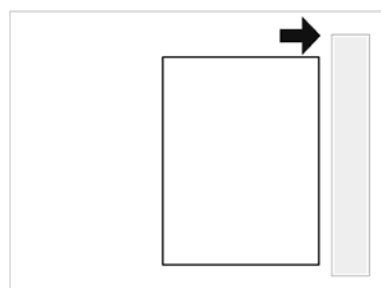

LEF (Long Edge Feed)

The notations "SEF" and "LEF" describe the direction of paper feed. The arrows indicate the direction of paper feed.

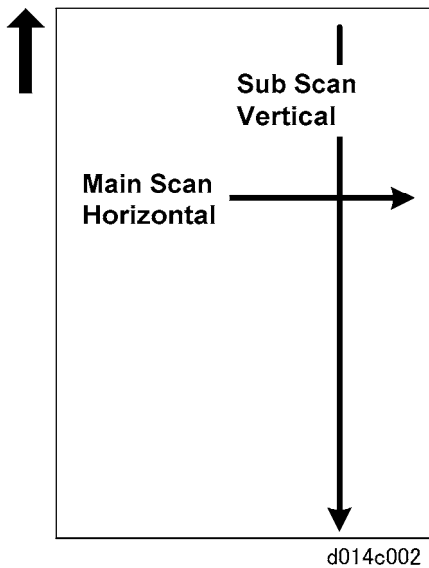

In this manual "Horizontal" means the "Main Scan Direction" and "Vertical" means the "Sub Scan Direction" relative to the paper feed direction.

Warnings, Cautions, Notes

In this manual, the following important symbols and notations are used.

WARNING

- A Warning indicates a potentially hazardous situation. Failure to obey a Warning could result in death or serious injury.

CAUTION

- A Caution indicates a potentially hazardous situation. Failure to obey a Caution could result in minor or moderate injury or damage to the machine or other property.

Important

- Obey these guidelines to avoid problems such as misfeeds, damage to originals, loss of valuable data and to prevent damage to the machine

Note

- This information provides tips and advice about how to best service the machine.

Commonly Used Terms

In the SP tables, some of the finishers are referred to by number (Fin1, Fin2, etc.), and some SP codes may appear for options that are not supported overseas:

Fin1	2000/3000-Sheet Finisher D373/D374. The D373 supports both corner and booklet folding and stapling. The D374 supports corner stapling only.
Fin2	3000-Sheet Finisher B830
Fin3	Japan Only. Please Ignore.
Fin4	Ring Binder D392
Z-Fold	This refers to the Z-Folding unit. The Z-Folding unit is available in Japan only.
ITB	Image Transfer Belt
PTR	Paper Transfer Roller

General Safety Instructions

For your safety, please read this manual carefully before you use this product. Keep this manual handy for future reference.

Safety Information

Always obey the following safety precautions when using this product.

Safety During Operation

In this manual, the following important symbols and notations are used.

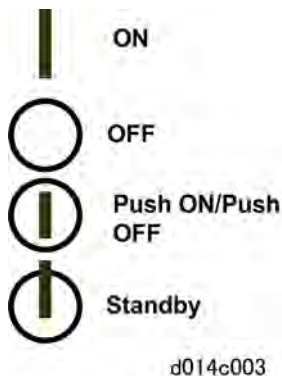

Switches and Symbols

Where symbols are used on or near switches on machines for Europe and other areas, the meaning of each symbol conforms with IEC60417.

Responsibilities of the Customer Engineer

Customer Engineer

Maintenance shall be done only by trained customer engineers who have completed service training for the machine and all optional devices designed for use with the machine.

Reference Material for Maintenance

- Maintenance shall be done using the special tools and procedures prescribed for maintenance of the machine described in the reference materials (service manuals, technical bulletins, operating instructions, and safety guidelines for customer engineers).
- In regard to other safety issues not described in this document, all customer engineers shall strictly obey procedures and recommendations described the "CE Safety Guide".
- Use only consumable supplies and replacement parts designed for use with the machine.

Before Installation, Maintenance

Shipping and Moving the Machine

CAUTION

- Work carefully when lifting or moving the machine. If the machine is heavy, two or more customer engineers may be required to prevent injuries (muscle strains, spinal injuries, etc.) or damage to the machine if it is dropped or tipped over.
- Personnel moving or working around the machine should always wear proper clothing and footwear. Never wear loose fitting clothing or accessories (neckties, loose sweaters, bracelets, etc.) or casual footwear (slippers, sandals, etc.) when lifting or moving the machine.
- Always unplug the power cord from the power source before you move the machine. Before you move the product, arrange the power cord so it will not fall under the machine.

Power

WARNING

- Always disconnect the power plug before doing any maintenance procedure. After switching off the machine, power is still supplied to the main machine and other devices. To prevent electrical shock, switch the machine off, wait for a few seconds, then unplug the machine from the power source.
- Before you do any checks or adjustments after turning the machine off, work carefully to avoid injury. After removing covers or opening the machine to do checks or adjustments, never touch electrical components or moving parts (gears, timing belts, etc.).
- After turning the machine on with any cover removed, keep your hands away from electrical components and moving parts. Never touch the cover of the fusing unit, gears, timing belts, etc.

Installation, Disassembly, and Adjustments

CAUTION

- After installation, maintenance, or adjustment, always check the operation of the machine to make sure that it is operating normally. This ensures that all shipping materials, protective materials, wires and tags, metal brackets, etc., removed for installation, have been removed and that no tools remain inside the machine. This also ensures that all release interlock switches have been restored to normal operation.
- Never use your fingers to check moving parts causing spurious noise. Never use your fingers to lubricate moving parts while the machine is operating.

Special Tools

CAUTION

- Use only standard tools approved for machine maintenance.
- For special adjustments, use only the special tools and lubricants described in the service manual. Using tools incorrectly, or using tools that could damage parts, could damage the machine or cause injuries.

During Maintenance

General

CAUTION

- Before you begin a maintenance procedure: 1) Switch the machine off, 2) Disconnect the power plug from the power source, 3) Allow the machine to cool for at least 10 minutes.
- Avoid touching the components inside the machine that are labeled as hot surfaces.

Safety Devices

WARNING

- Never remove any safety device unless it requires replacement. Always replace safety devices immediately.
- Never do any procedure that defeats the function of any safety device. Modification or removal of a safety device (fuse, switch, etc.) could lead to a fire and personal injury. Always test the operation of the machine to ensure that it is operating normally and safely after removal and replacement of any safety device.
- For replacements use only the correct fuses or circuit breakers rated for use with the machine. Using replacement devices not designed for use with the machine could lead to a fire and personal injuries.

Organic Cleaners

CAUTION

- During preventive maintenance, never use any organic cleaners (alcohol, etc.) other than those described in the service manual.
- Make sure the room is well ventilated before using any organic cleaner. Use organic solvents in small amounts to avoid breathing the fumes and becoming nauseous.
- Switch the machine off, unplug it, and allow it to cool before doing preventive maintenance. To avoid fire or explosion, never use an organic cleaner near any part that generates heat.
- Wash your hands thoroughly after cleaning parts with an organic cleaner to contamination of food, drinks, etc. which could cause illness.
- Clean the floor completely after accidental spillage of silicone oil or other materials to prevent slippery surfaces that could cause accidents leading to hand or leg injuries. Use "My Ace" Silicone Oil Remover (or dry rags) to soak up spills.

Lithium Batteries

WARNING

- Always replace a lithium battery on a PCB with the same type of battery prescribed for use on that board. Replacing a lithium battery with any type other than the one prescribed for use on the board could lead to an explosion or damage to the PCB.
- Never discard used batteries by mixing them with other trash. Remove them from the work site and dispose of them in accordance with local laws and regulations regarding the disposal of such items.

Ozone Filters

CAUTION

- Always replace ozone filters as soon as their service life expires (as described in the service manual).
- An excessive amount of ozone can build up around machines that use ozone filters if they are not replaced at the prescribed time. Excessive ozone could cause personnel working around the machine to feel unwell.

Power Plug and Power Cord

WARNING

- Before servicing the machine (especially when responding to a service call), always make sure that the power plug has been inserted completely into the power source. A partially inserted plug could lead to heat generation (due to a power surge caused by high resistance) and cause a fire or other problems.
- Always check the power plug and make sure that it is free of dust and lint. Clean it if necessary. A dirty plug can generate heat which could cause a fire.
- Inspect the length of the power cord for cuts or other damage. Replace the power cord if necessary. A frayed or otherwise damaged power cord can cause a short circuit which could lead to a fire or personal injury from electrical shock.
- Check the length of the power cord between the machine and power supply. Make sure the power cord is not coiled or wrapped around any object such as a table leg. Coiling the power cord can cause excessive heat to build up and could cause a fire.
- Make sure that the area around the power source is free of obstacles so the power cord can be removed quickly in case of an emergency.
- Make sure that the power cord is grounded (earthed) at the power source with the ground wire on the plug.
- Connect the power cord directly into the power source. Never use an extension cord.
- When you disconnect the power plug from the power source, always pull on the plug, not the cable.

After Installation, Servicing

Disposal of Used Items

WARNING

- Never incinerate used toner or toner cartridges.
- Toner or toner cartridges thrown into a fire can ignite or explode and cause serious injury. At the work site always carefully wrap used toner and toner cartridges with plastic bags to avoid spillage before disposal or removal.

CAUTION

- Always dispose of used items (developer, toner, toner cartridges, OPC drums, etc.) in accordance with the local laws and regulations regarding the disposal of such items.
- To protect the environment, never dispose of this product or any kind of waste from consumables at a household waste collection point. Dispose of these items at one of our dealers or at an authorized collection site.
- Return used selenium drums to the service center for handling in accordance with company policy regarding the recycling or disposal of such items.

Points to Confirm with Operators

At the end of installation or a service call, instruct the user about use of the machine.

Emphasize the following points.

- Show operators how to remove jammed paper and troubleshoot other minor problems by following the procedures described in the operating instructions.
- Point out the parts inside the machine that they should never touch or attempt to remove.
- Confirm that operators know how to store and dispose of consumables.
- Make sure that all operators have access to an operating instruction manual for the machine.
- Confirm that operators have read and understand all the safety instructions described in the operating instructions.
- Demonstrate how to turn off the power and disconnect the power plug (by pulling the plug, not the cord) if any of the following events occur: 1) something has spilled into the product, 2) service or repair of the product is necessary, 3) the product cover has been damaged.
- Caution operators about removing paper fasteners around the machine. They should never allow paper clips, staples, or any other small metallic objects to fall into the machine.

Special Safety Instructions for Toner

Accidental Physical Exposure

CAUTION

- Work carefully when removing paper jams or replacing toner bottles or cartridges to avoid spilling toner on clothing or the hands.
- If toner is inhaled, immediately gargle with large amounts of cold water and move to a well ventilated location. If there are signs of irritation or other problems, seek medical attention.
- If toner gets on the skin, wash immediately with soap and cold running water.
- If toner gets into the eyes, flush the eyes with cold running water or eye wash. If there are signs of irritation or other problems, seek medical attention.
- If toner is swallowed, drink a large amount of cold water to dilute the ingested toner. If there are signs of any problem, seek medical attention.
- If toner spills on clothing, wash the affected area immediately with soap and cold water. Never use hot water! Hot water can cause toner to set and permanently stain fabric.

Handling and Storing Toner

WARNING

- Toner, used toner, and developer are extremely flammable.
- Never store toner, developer, toner cartridges, or toner bottles (including empty toner bottles or cartridges) in a location where they will be exposed to high temperature or an open flame.

CAUTION

- Always store toner and developer supplies such as toner and developer packages, cartridges, and bottles (including used toner and empty bottles and cartridges) out of the reach of children.
- Always store fresh toner supplies or empty bottles or cartridges in a cool, dry location that is not exposed to direct sunlight.

Toner Disposal

WARNING

- Never attempt to incinerate toner, used toner, or empty toner containers (bottles or cartridges). Burning toner can explode and scatter, causing serious burns.
- Always wrap used toner and empty toner bottles and cartridges in plastic bags to avoid spillage. Follow the local laws and regulations regarding the disposal of such items.
- Dispose of used toner and toner cartridges at one of our dealers or at an authorized collection site. Always dispose of used toner cartridges and toner bottles in accordance with the local laws and regulations regarding the disposal of such items.

Safety Instructions for this Machine

Prevention of Physical Injury

1. Before disassembling or assembling parts of the machine and peripherals, make sure that the machine and peripheral power cords are unplugged.
2. The plug should be near the machine and easily accessible.
3. Note that some components of the machine and the paper tray unit are supplied with electrical voltage even if the main power switch is turned off.
4. If any adjustment or operation check has to be made with exterior covers off or open while the main switch is turned on, keep hands away from electrified or mechanically driven components.
5. If the [Start] key is pressed before the machine completes the warm-up period (the [Start] key starts blinking red and green), keep hands away from the mechanical and the electrical components as the machine starts making copies as soon as the warm-up period is completed.
6. The inside and the metal parts of the fusing unit become extremely hot while the machine is operating. Be careful to avoid touching those components with your bare hands.
7. To prevent a fire or explosion, keep the machine away from flammable liquids, gases, and aerosols.

Health Safety Conditions

1. Never operate the machine without the ozone filters installed.
2. Always replace the ozone filters with the specified types at the proper intervals.
3. Toner and developer are non-toxic, but if you get either of them in your eyes by accident, it may cause temporary eye discomfort. Try to remove with eye drops or flush with water as first aid. If unsuccessful, get medical attention.

Observance of Electrical Safety Standards

1. The machine and its peripherals must be installed and maintained by a customer service representative who has completed the training course on those models.
2. The NVRAM on the system control board has a lithium battery which can explode if replaced incorrectly. Replace the NVRAM only with an identical one. The manufacturer recommends replacing the entire NVRAM. Do not recharge or burn this battery. Used NVRAM must be handled in accordance with local regulations.

Safety and Ecological Notes for Disposal

1. Do not incinerate toner bottles or used toner. Toner dust may ignite suddenly when exposed to an open flame.
2. Dispose of used toner, developer, and organic photoconductors in accordance with local regulations. (These are non-toxic supplies.)
3. Dispose of replaced parts in accordance with local regulations.
4. When keeping used lithium batteries in order to dispose of them later, do not put more than 100 batteries per sealed box. Storing larger numbers or not sealing them apart may lead to chemical reactions and heat build-up.

CAUTION

- The danger of explosion exists if a battery of this type is incorrectly replaced.
- Replace only with the same or an equivalent type recommended by the manufacturer. Discard used batteries in accordance with the manufacturer's instructions.

Laser Safety

The Center for Devices and Radiological Health (CDRH) prohibits the repair of laser-based optical units in the field. The optical housing unit can only be repaired in a factory or at a location with the requisite equipment. The laser subsystem is replaceable in the field by a qualified Customer Engineer. The laser chassis is not repairable in the field. Customer engineers are therefore directed to return all chassis and laser subsystems to the factory or service depot when replacement of the optical subsystem is required.

WARNING

- Use of controls, or adjustment, or performance of procedures other than those specified in this manual may result in hazardous radiation exposure.
- Turn off the main switch before attempting any of the procedures in the Laser Unit section. Laser beams can seriously damage your eyes.

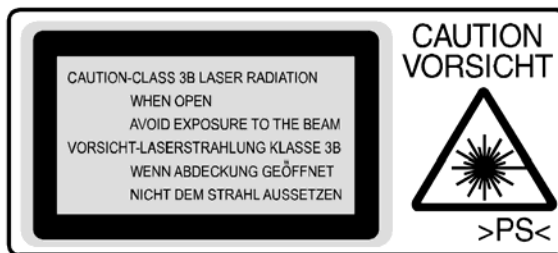

d014c-004

Trademarks

- Microsoft[®], Windows[®], and MS-DOS[®] are registered trademarks of Microsoft Corporation in the United States and /or other countries.
- PostScript[®] is a registered trademark of Adobe Systems, Incorporated.
- PCL[®] is a registered trademark of Hewlett-Packard Company.
- Ethernet[®] is a registered trademark of Xerox Corporation.
- PowerPC[®] is a registered trademark of International Business Machines Corporation.
- Other product names used herein are for identification purposes only and may be trademarks of their respective companies. We disclaim any and all rights involved with those marks.

NEW FEATURES OF D081/D082

REVISION HISTORY		
Page	Date	Added/Updated/New
		None

1. NEW FEATURES OF D081/D082

1.1.1 OVERVIEW

Appearance

A 200V version of this machine will be available in North America (NA) as well as Europe (EU) and will feature an automatic voltage detection function.

Model Voltage Table

Model	Area	Voltage
D081-17	NA	110-127 V, 20 A, 60 Hz
D082-17	NA	208-240 V, 12 A, 60 Hz
D081-19, -27, -29 D082-19, -21, -27, -29	EU/AP/TWN	220-240 V, 12-10A, 50/60 Hz



d081w023

The new ADF also features simultaneous dual side scanning. Both sides of a sheet are scanned during one pass through the ADF.

D014/D014**D081/D082**

d081w032

Specifications

The right end of the operation panel has also been changed. The recess to hold pins and paper clips on the right end of the D014/D015 has been replaced by a dummy panel on the D081/D082 which can be removed for installation of the new USB/SD card slot option (D505).



d081w019

USB 2.0/SD Slot Type C (D505) is a new option that can be installed on the right end of the operation panel. There are still slots on the control board at the back of the machine, but this new option provides easier access to the USB and SD card slots at the front of the machine. This slot option device can be installed for the SD card only, or for both SD cards and USB. Customers can use these slots to scan and save documents to either an SD card or a USB memory device.

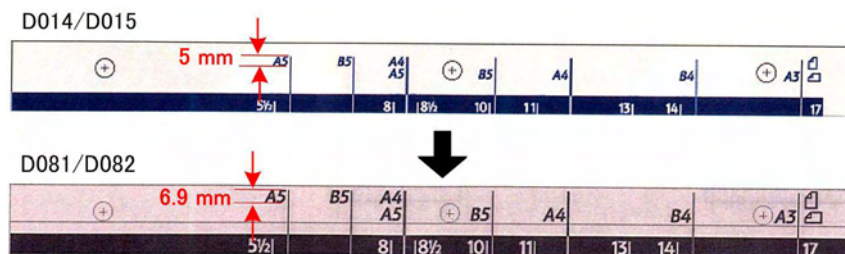

d081w016

The sizes of the characters on the rear scale of the exposure glass have been enlarged to make the scale easier to read.

Specifications

Here is a quick summary of the differences between the D014/D015 and D081/D082.

Specification Summary

Feature	D014/D015	D081/D082	Comments
cpm (BW/FC)	a: 60/55 b: 75/70	a: 65/60 b: 75/70:	Faster print speed in B&W mode.
Warm-up time	a: 90 s b: 75 s	a: 70 s b: 60 s	Much shorter warm-up time.
First copy time (BW)	a: 5.7 s b: 4.9 s	a: 5.7 s b: 4.9 s	
First copy time (FC)	a: 7.5 s b: 6.4 s	a: 7.5 s b: 6.4 s	

Two New Options

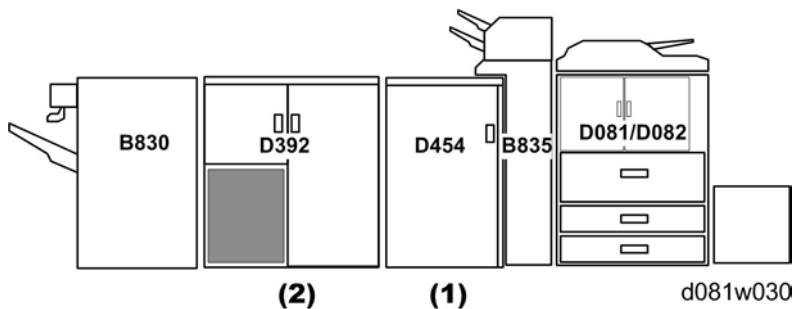

The Multi Fold Unit (D454) (1) and the Ring Binder (D392) (2) are two new options that are available for the D081/D082.

The Multi Folder (D454) replaces the Z-Fold Unit (B660). The Multi Fold Unit (D454) performs five additional types of folding in addition to Z-folding:

Specifications

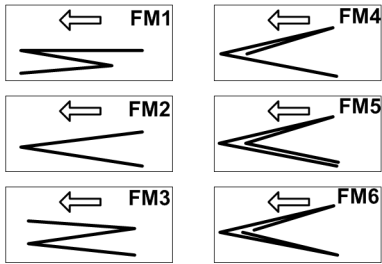

d454d900

FM1	Z-Folding (Same as Z-Fold Unit, B660)
FM2	Half Fold
FM3	Letter Fold-out
FM4	Letter Fold-in
FM5	Double Parallel Fold
FM6	Gate Fold

The Ring Binder (D392) jogs, stacks, punches up to 50 or 100 sheets (depending on the size of the rings) and then binds them with rings. The ring-bound copies are delivered to a tray inside the ring binder.

D014/D015 and D081/D082 Detailed Comparison Tables**General Comparison**

Item	D014/D015	D081/D082
ADF	ARDF. 2-side scanning by duplexing.	ADF. Simultaneous 2-side scanning with CIS scanning the rear side without duplex feeding.
Fusing unit	Employs hot roller, pressure roller, heating roller with cleaning unit.	Employs nearly identical hardware and unit layout of the previous machine. However, the following features have been improved: 1) warm-up time, 2) production capacity (cpm), 3) less frequent servicing due to longer service lives of key components
Jam reduction	There were reports from the field about duplexer jams.	Key parts have been replaced in the duplex unit to improve paper feed. Also, a knob has been added to the side of the duplex unit to facilitate the removal of jammed paper.
LD unit.	No LCD deflection elements.	Four new LCD deflection elements have been added to the LD unit to perform beam switching in the sub scan direction. This allows good-quality 1200 dpi resolution in half-speed mode using thick paper.
Rear scale (exposure glass)	5 mm font used for scale notations.	Font enlarged to 6.9 mm to improve readability.
Thick paper handling.	Up to 163 g/m ² (216 g/m ² under some conditions)	Tray 1, 2: 52.3 to 216 g/m ² Tray 3: 52.3 to 256 g/m ² The gap at the junction of the tray feed mechanism of Tray 3 where the paper

Specifications

Item	D014/D015	D081/D082
		bends into the vertical feed path has been widened to accommodate more rigid paper. This heavier paper can be fed from Tray 3 only.
USB/SD slot access	Controller box at rear of main machine.	A new option installed on right end of operation panel allows slot access at the front of the main machine.
Z-Folding	Z-Fold Unit B660 for Z-folding only.	Multi Fold Unit D454. The B660 is available in Japan only. The D454 replaces the B660 overseas and performs 5 additional folding methods in addition to Z-folding.

Controller Options: D014/D015 and D081/D082 Compared

D014/D015		D081/D082	
Bluetooth Interface Unit Type 3245	D377	Bluetooth Interface Unit Type 3245	B826-17
Browser Unit Type D	D497	Browser Unit Type E	D430
Copy Connector 2105	B328	Copy Connector 3260	B328-11
Copy Data Security Type F	B829	Copy Data Security Type F	B829-07
Data Overwrite Security Unit Type H	D497	Data Overwrite Security Unit Type H	D377-06
File Format Converter Type E	D377	File Format Converter Type E	D377-04
Gigabit Ethernet Type B	D377	Gigabit Ethernet Type B	D377-21
IEEE 1284 Interface Board Type A	B679	IEEE 1284 Interface Board Type A	B679
IEEE 802.11 a/g Interface Unit	D377	IEEE 802.11 a/g Interface Unit	D377-01

D014/D015		D081/D082	
Type J		Type J	
IEEE 802.11 g Interface Unit Type K	D377	IEEE 802.11 g Interface Unit Type K	D377-19
Java VM Card Type E	D377	VM Card/Calypso. Contains APP2 ME and comes with the machine in Slot 2 (lower slot).	D0815790C
Optional Counter Interface Unit Type A	B879	Optional Counter Interface Unit Type A	B870-11
PostScript3 Unit Type C7500	D378	PostScript3 Unit Type C7501	D497
Not Provided	---	HDD Encryption Unit Type A	D377-16

Other Developments

Lower TEC

The D081/D082 saves energy by shortening the warm-up time and lowering the amount of energy consumed in Sleep Mode. This is referred to as the TEC (Typical Energy Consumption) level.

Color Deficiency Management Mode

This new software feature improves visual communication with users who are affected by color deficiency in their eyesight. By enabling this function on the printer driver, the printout results of color letters and graphics become clearer and easier to distinguish for people with color deficiency. This color adjustment is not far from the effect intended by the author.

Users with and without color deficiency can communicate smoothly with other software to simulate colors. This feature is available with PCL6 PS3 operating on MS Office 2007.

1.1.2 SUMMARY OF OPTIONAL PERIPHERALS

This is a summary of all the peripheral devices that can be installed with the D081/D082.

List of Available Peripheral Options

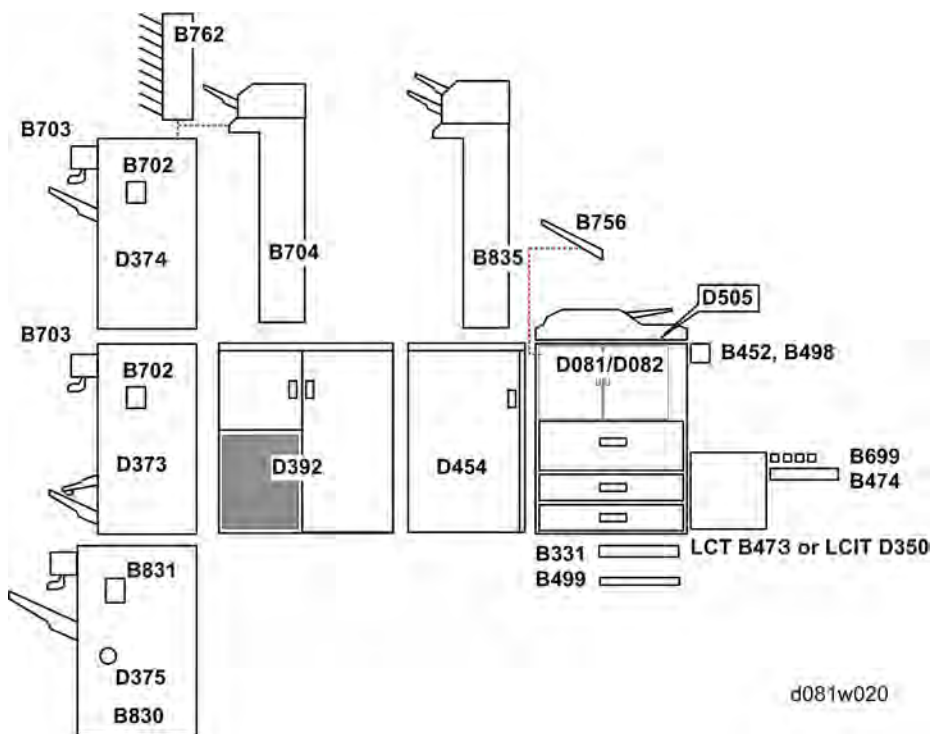

d081w020

No.	Name	Comments
D081/D082	Main Machine	Copier/printer
B331	A3/11" x 17" Tray 2105	For tandem tray (Tray 1), the top tray of the main machine. Modifies the tray so it can hold the larger paper sizes.
B452	Key Counter Bracket	Counter option for the main machine.
B473	A4/LT LCT	Only one LCT can be installed on the right side of the main machine, the B473 or D350. The LCT Adapter B699 must be installed for the B699 to adjust the height of the LCT.
B474	LG Size Tray Type 1075	Option for LCT B473. Modifies the LCT tray so it can hold legal paper.

No.	Name	Comments
B498	Card Reader Bracket Type B	Counter option for the main machine.
B499	Tab Sheet Holder Type 3260	For tandem tray (Tray 1), the top tray of the main machine.
B699	LCT Adapter	Required for installation of LCT B473.
B702	Punch Unit Type 3260	For either finisher D373 or D374. Three models are available (NA, EU, or SC).
B703	Output Jogger Unit Type 3260	Optional jogger unit attached to the left side of the finisher. It can be attached to either finisher D373 or D374 finisher.
B704	Cover Interposer	Installed on top of either finisher D373 or D374. Mail Box CS391 (B762) is also installed on the top of the finisher, so the cover interposer and mailbox cannot be installed together.
B756	Copy Tray	Holds paper output from the main machine. Must be used if no finishers are installed on the left side of the main machine.
B762	Mail Box CS391	Install on top of either the D373 or D374. Cover Interposer (B704) is also installed on the top on the finisher, so the cover interposer and mailbox cannot be installed together.
B830	Finisher SR5000	3000 sheet capacity, 100 staples. External jogger is provided pre-installed. Finisher Adapter Type C (D375) is required. The output jogger is pre-installed on this finisher (provided as standard).
B831	Punch Unit PU 5000	Designed for the SR5000 (B830). Three types are available (EU, NA, or SC).
B835	Cover Interposer Tray	Two source trays for feeding covers. Can be

Specifications

No.	Name	Comments
	CI5000	installed and used for the SR5000 (B830) only. This cover interposer tray can be installed on the Multi Folder (D454) as well as the B830
D350	LCIT 4000	Only one LCT can be installed on the right side of the machine, the B473 or D350.
D373	Finisher SR4040	2000-sheet tray capacity, corner stapling, saddle-stitch stapling, booklet folding and stapling.
D374	Finisher SR4030	3000-sheet tray capacity, corner stapling only (no saddle-stitch stapling).
D375	Finisher Adapter Type C	Installed in the SR5000 (B830) to adapt the speed of the finisher. Required for this machine.
D392	Ring Binder	This is a new option for the D081/D082. Requires Finisher SR5000 (B830) and cannot be used with either the SR4040 (D373) or SR4030 (D374).
D454	Multi Fold Unit	This is a new option for the D081/D082. Executes six types of folding. Can be used with either the SR4040 (D373) or SR5000 (B830). Cannot be used with the SR4030 (D374).
D505	USB 2.0/SD Slot Type D	Attached to the right end of the operation panel on the main machine.

Controller Options (Installed on Main Machine)

Option	No.	Shape
Bluetooth Interface Unit Type 3245	B826	Board
Browser Unit Type E	D497	SD card
Copy Connector Type 3260	B328	Board
Copy Data Security Type F	B829	Board
Data Overwrite Security Unit Type H	D497	SD card
File Format Converter Type E	D377-04	Board
Gigabit Ethernet Type B* ¹	D377-21	Board
HDD Encryption Unit Type A	D377-16	SD card
IEEE 1284 Interface Board Type A	B679	Board
IEEE 802.11 a/g Interface Unit Type J	D377-01	Board
Optional Counter Interface Unit Type A	B870-11	Board
PostScript 3 Unit Type C7501	D378	SD card

*1: The EFI (Fiery) Controller is connected through the Gigabit Ethernet Board.

Specifications

1.1.3 NEW ADF

ADF Overview

A new ADF unit has replaced the ARDF of the previous machine. One pass duplex scanning in the new ADF improves productivity significantly and also prevents damage to originals as they have to pass through the scanning path only once.

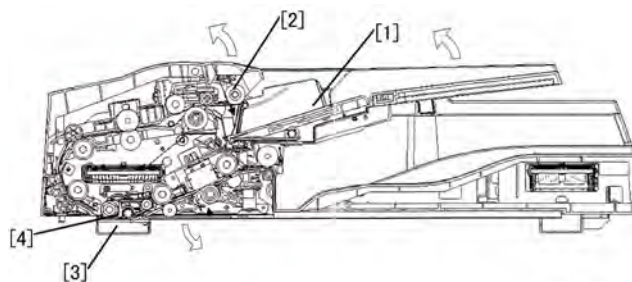

d081w026

Originals are placed face-up on the feed tray [1]. The pickup roller feed roller mechanism [2] and other rollers feed each original through the paper path. The paper makes one pass through the ADF. The scanner unit [3] below the original scans the front side through a slit near the left side of the exposure glass. A CIS unit [4] above the original scans the back side of the original. This mechanism significantly increases the speed of duplex copying.

FC	Simplex (cpm)		Duplex (cpm)	
	BW	FC	BW	FC
D014/D015	70	82	53	60
D081/D082	70	82	90	130

1.1.4 ADF DETAILS

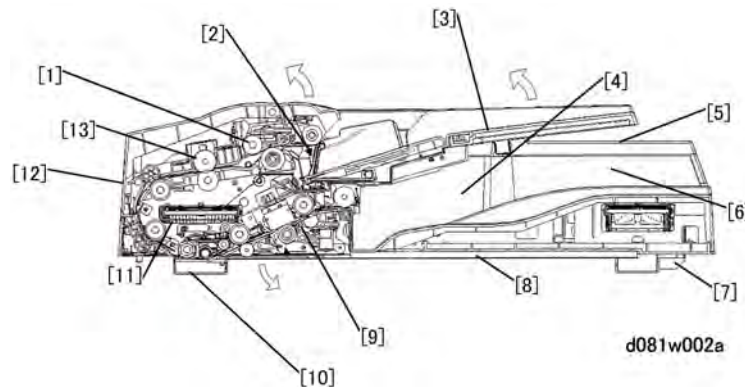

[1] Separation. A standard FRR mechanism picks up and separates each original from the top of a stack held on a movable bottom plate.

[2] Original set detection. Only one sensor detects originals on the original table.

[3] Original table. A spring that makes it easier to remove original jams from the output exit.

[4] Drive. The drive is comprised of three motors: a feed motor, a scanning motor, and an exit motor. This is identical to the arrangement in ADF of the previous machine.

[5] External covers, output tray. Like the previous machine, there are three covers: a feed cover, a front cover, a rear cover, but the output tray is new. The arrangement of I/F cables at the back of the ADF is different.

[6] Control. A CPU and ICs mounted on a built-in Flash ROM control operation of the ADF.

[7] Lift-up detection. Like the previous machine, one sensor detects when the platen is opened and closed.

[8] Platen. The platen can be raised and lowered for book mode scanning. The white plate is attached to platen with Velcro padding. The white plate can be easily released and attached for cleaning and maintenance.

[9] Back-side scanning. A combination of a color CIS and white roller mounted above the paper path is used to scan the back side of each original as it passes below.

[10] Front-side scanning. A scanning unit mounted below the exposure glass (identical to the mechanism of the previous machine) scans the front side of the original passing above while the CIS above the sheet scans the back side. This allows simultaneous scanning on both sides of the original.

[11] Frame configuration. The front/back plate and left/right stay arrangement is identical to that of the previous machine.

[12] Feed cover. The feed cover employs a play-out drive roller.

[13] Skew correction. The play-out roller under the feed roller buckles the leading edge of each original to correct skew.

Specifications

1.1.5 IMPROVED PAPER FEED

This section describes some changes that were done to improve paper feed and reduce the occurrence of paper jams.

Thick Paper Handling

Some changes have been made in Tray 3 so the machine can handle thicker paper. All of the trays can handle paper of weight up to 216 g/m² but only Tray 3 can handle thicker paper up to 256 g/m².

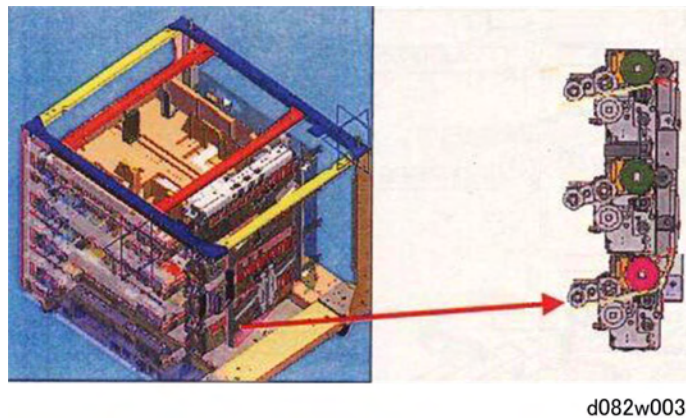

There is a wider gap here where the right edge of Tray 3 opens at the bottom of the vertical paper feed path. This makes it easier for paper up to 256 g/m² thick to pass through the angle of the junction to the vertical paper feed path. The gap has been widened for Tray 3 only, so thicker paper (from 216 to 256 g/m²) should be loaded in Tray 3.

This large junction point makes it easier for thick paper to feed into the vertical feed path and reduces the occurrence of paper jams. The large gap also makes it easier to remove jams if they do occur in the vertical feed path.

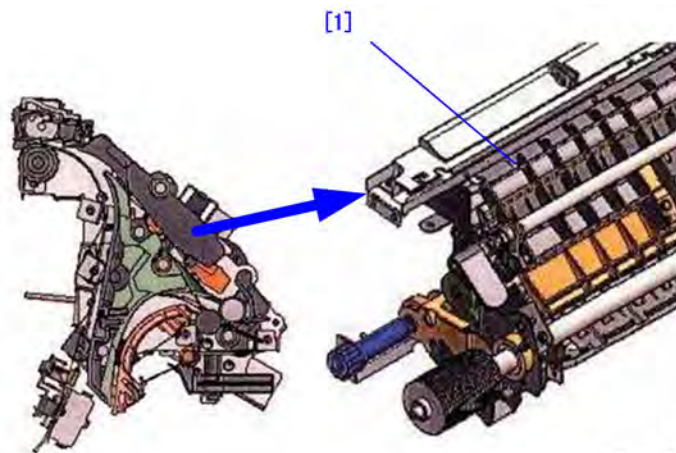
Noise Reduction

d081w004

The composite material of the guide plate [1] has been changed. High temperature inside the machine was warping the guide plate material and causing the guide to hit the stay and make noise when it was opening and closing during paper feed. (Original PET KANEKA 5402SE was replaced with PC GE LGK3020.)

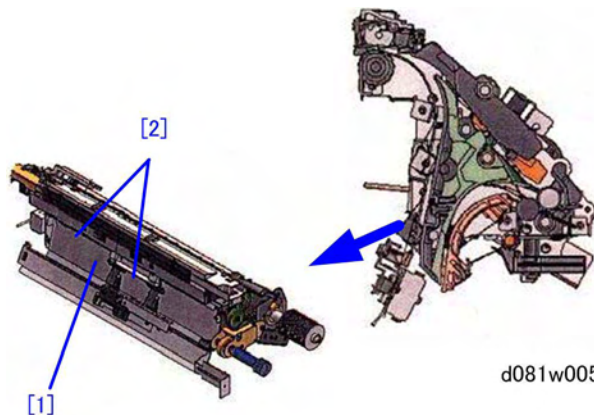

d081w005

Also, the shape of the guide plate [1] has been modified slightly to eliminate noise at [2] when the unit is removed and installed.

Specifications

Fewer Paper Jams, Easier Jam Removal

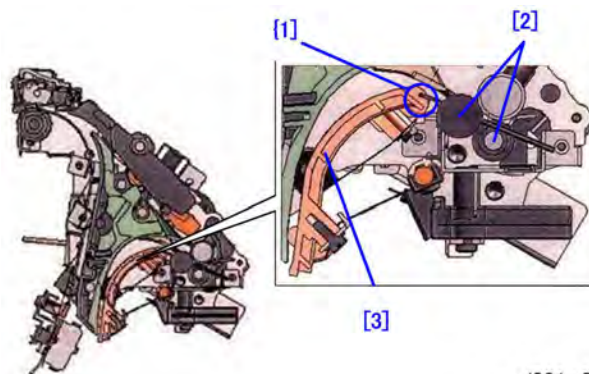

The shape of the inverter guide plate was modified and position of the spring fulcrum point was moved to maintain the gap at [1] and improve operation during paper feed.

De-curl Drive Roller

In order to prevent the de-curl drive roller from swelling due to moisture, the composite material of the drive roller [2] has been replaced with urethane. The composite material of the guide plate [3] has also been changed to prevent warping due to high temperatures inside the machine.

Jam Prevention

A series of jams were recurring in the duplex unit. After jam errors occurred, the operators could not remove jammed sheets (in some cases they could see the paper and in other cases they could not).

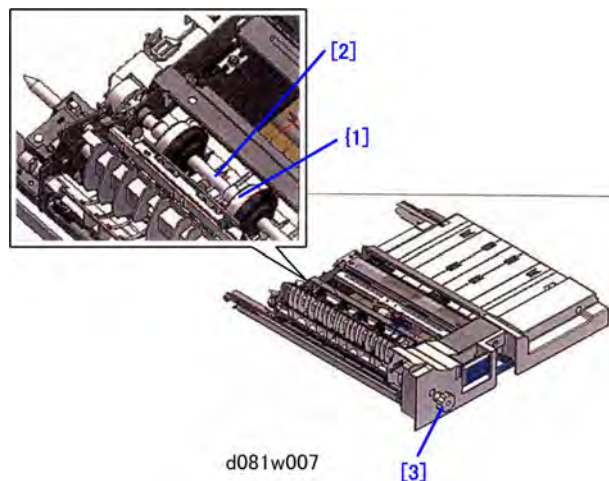

First, to prevent recurring jams the diameter of the inverter roller [1] at the inverter path entrance has been increased slightly and a roller guide [2] has been added to improve the feed of curled paper, and reduce the amount of curl. Second, a jam removal knob [3] has been added to the side of the duplex unit to make it easier to remove jams from the duplex tray.

1.1.6 NEW ELEMENTS IN THE LD UNIT

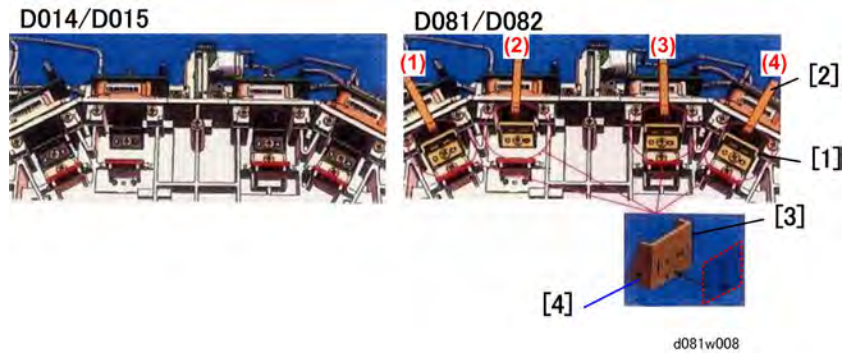

Four LCD deflection elements [1] have been added at the rear side of the laser unit chassis. Each element is connected by a flat PC (printed circuit) cable [1]. The enlargement [3] shows an LCD deflection element and its aperture [4].

Liquid crystal deflection element

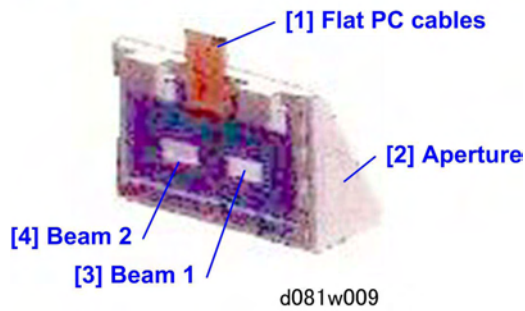

The diagram above shows a close-up view of one LCD deflection element.

[1]	Flat PC Cable
[2]	Aperture
[3]	Beam 1
[4]	Beam 2

LCD Deflection Element Cross-Section

Specifications

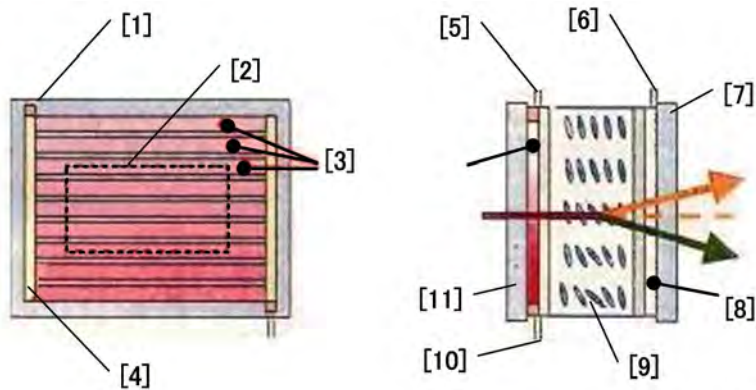

d081w010

The elements split the beam and perform switching for 1200-dpi at half-speed. This improves the accuracy of image writing. The other parts of the image writing system (optical housing, polygon mirror, optics, synchronization detect sensor, etc.) are identical to those of the previous machine.

Front View

[1]	Terminal 1
[2]	Aperture
[3]	Transparent Electrodes (Striped)
[4]	Resistance Component

Side View

[5]	Terminal 1
[6]	GND
[7]	Glass Plate
[8]	Transparent Electrode
[9]	Liquid Crystal Layer
[10]	Terminal 2
[11]	Glass Plate

1.1.7 FASTER COPY SPEED

Model	BW	FC	Faster By:
D014	60 cpm	55 cpm	
D015	75 cpm	70 cpm	
D081	65 cpm	60 cpm	D081 is faster than D014 by 5 cpm
D082	75 cpm	70 cpm	D082 is the same speed as D015

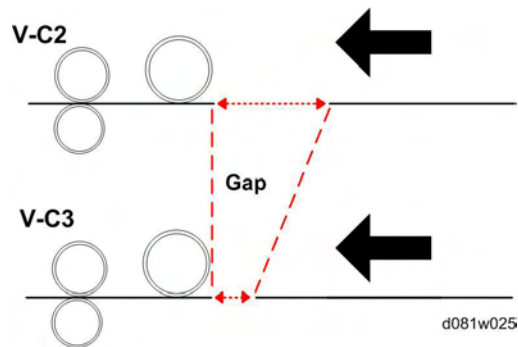

This increase in productivity has been accomplished by adjusting paper feed timing to narrow the gap at between sheets of paper in the paper path. With either the D081 or D082, if production quality cannot be maintained, the machine will drop into the CPM down mode.

1.1.8 FUSING UNIT IMPROVEMENTS

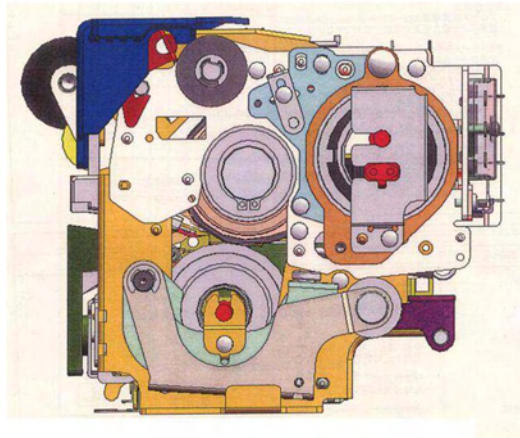

d081w011

The parts and configuration of the fusing unit (shown in cross-section above) are the same as those of the previous machine. However, there are some improvements:

- Warm-up time is shorter.
- Longer service lives for some parts.
- Some parts have been discarded, and four parts have been replaced.

★ Important

- The following four service parts for the D014/D015 and D081/D082 fusing unit are not the same; they cannot be substituted for one another when servicing these machines: 1) Hot roller, 2) Pressure roller, 3) Pressure roller bearing, 4) Oil supply roller.
- For more details, see "Fusing Unit" in the "Replacement and Adjustments" section.

Shorter Warm-up Time (New WUT)

Model	WUT: Old to New	Faster By:
D081 NA	90 s to 70 s	20 s
D081 EU, D082	75 s to 60 s	15 s

The thickness of the metal core in the hot roller has been reduced from 1.5 mm to 1.0 mm. This allows the core to reach the ready temperature much faster. The rotational speed of the hot roller during warm-up has been increased from 141 mm/s to 282 mm/s. Also, the ready temperature (re-load temperature) has been raised from 20°C to 40°C (68°F to 104°F).

Longer Service Lives

Part	Old Service Life	New Service Life	Extended
Hot roller	300 K	450 K	150 K
Cleaning unit	300 K	450 K	150 K
Pressure bearing	600 K	1200 K	600 K

- The hot roller is composed of new, low cost material of greater durability.
- The new cleaning unit uses more oil, supplies less oil, and has a new oil application roller.
- The curvature of the pressure bearing has been reduced and new rubber seals keep out foreign matter.

Specifications

Parts Discarded in the Fusing Unit

D081/D082

Heating Roller

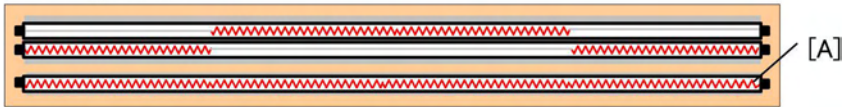

Pressure Roller

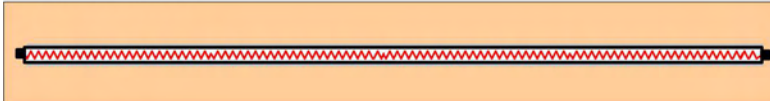

Hot Roller



d081w031

- The 100 V auxiliary fusing lamp [A] has been removed from the heating roller of the D081 NA.

D014/D015

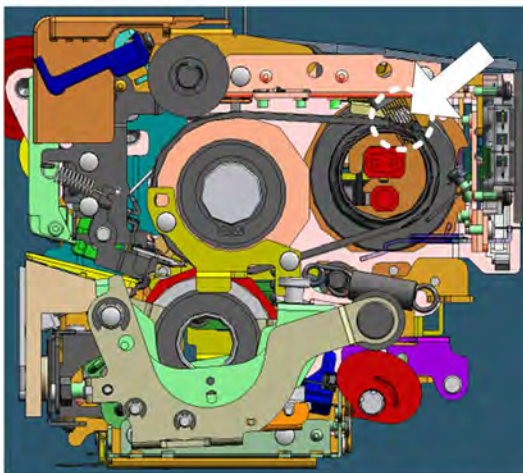

d081w035

- The belt ride-up control roller (shown above in the D014/D015) has been removed from the D081/D082 machines.

Fusing Specifications Compared

No.	Item	NA		EU	
		a	b	a	b
D014/D015	Max. Power Consumption	1920 W	2400 W	2400 W	2400 W
	FC cpm	55 cpm	70 cpm	55 cpm	70 cpm
	MC cpm	60 cpm	75 cpm	60 cpm	75 cpm
	Warm-up Time	90 s	75 s	75 s	75 s
	Line speed (mm/s)	282 mm/s	352.8 mm/s	282 mm/s	352.8 mm/s
D081/D082	Max. Power Consumption	1920 W	2400 W	2400 W	2400 W
	FC cpm	60 cpm	70 cpm	60 cpm	70 cpm
	MC cpm	65 cpm	75 cpm	65 cpm	75 cpm
	Warm-up Time	70 s	60 s	60 s	60 s
	Line speed (mm/s)	282	352.8	282	352.8

FC: Full Color, MC: Monochrome

Specifications

1.1.9 SCANNER UNIT

The connections of the harnesses at the front and rear sides of the LDB (Laser Drive Board) have changed.

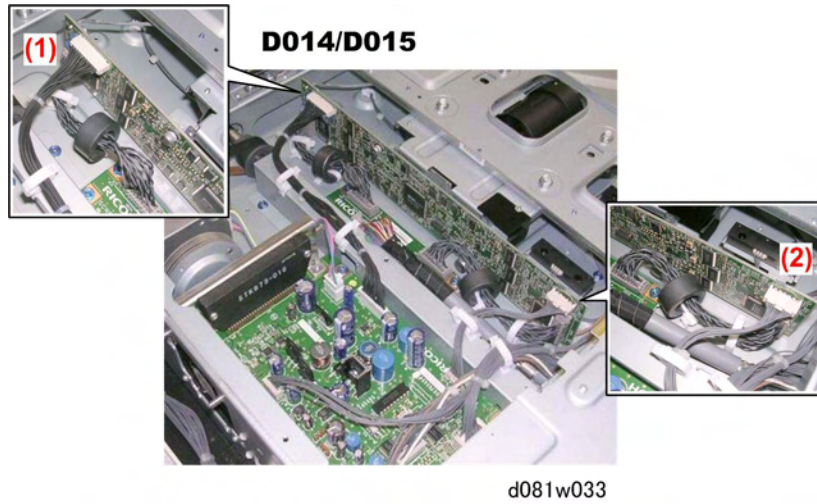

In the D014/D015 the lower harnesses at the front (1) and rear (2) of the LDB have ferrite cores.

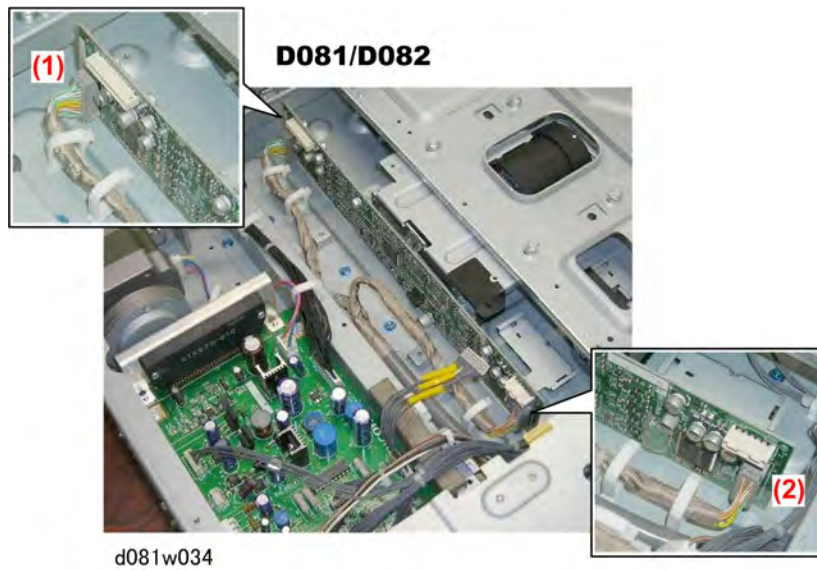

In the D081/D082 the lower harnesses at the front (1) and rear (2) of the LDB are bundled tighter and have no bulky ferrite cores.

PRODUCT INFORMATION

REVISION HISTORY		
Page	Date	Added/Updated/New
		None

2. PRODUCT INFORMATION

2.1 SPECIFICATIONS

See "Appendices" for the following information:

- Specifications

2.2 MAIN MACHINE AND PERIPHERALS

This is a list of the peripheral devices that can be installed with the copier. There are two basic configurations.

2.2.1 MAIN SYSTEM CONFIGURATIONS

Configuration 1: Finisher D373 (SR4040), Finisher D374 (SR4030)

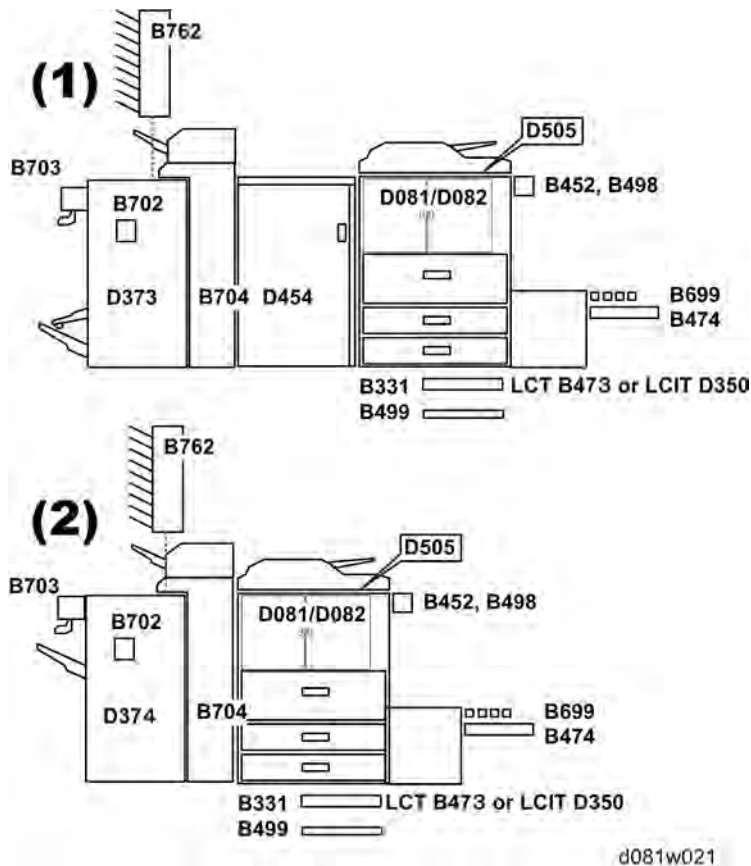

- This configuration features either the Finisher D373 (SR4040 with saddle-stitching) or Finisher D374 (SR4030 no saddle-stitching).
- At (1) above, the Multi Folder D454 can be used with the Finisher D373 but not with Finisher D374 at (2).
- In both configurations, either the Mailbox (B762) or Cover Interposer Tray (B704) can be installed on the Finisher D373/D374, but mailbox and cover interposer cannot be installed together.

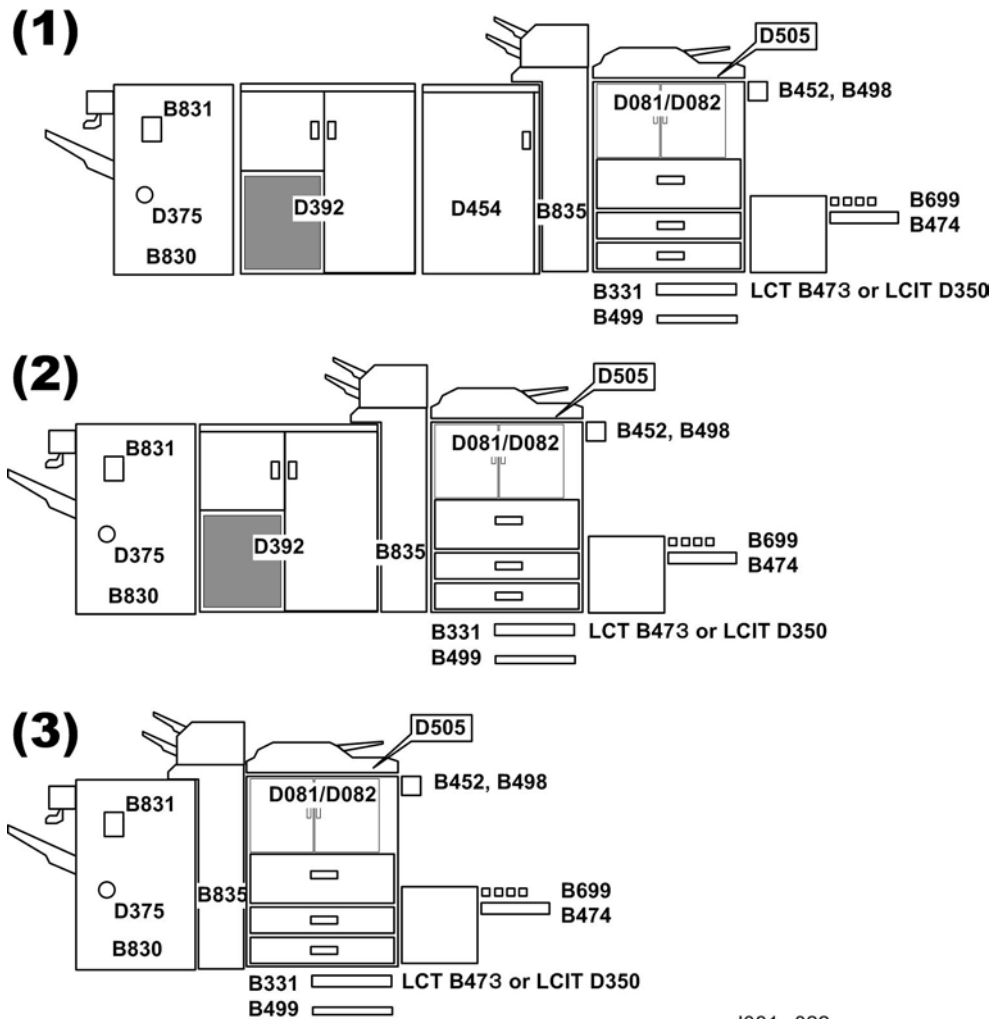
Configuration 2: Finisher B830 (SR5000)

- This configuration features the Finisher SR5000.
- The Ring Binder (D392) can be used with or without the Multi Folder (D454).
- The Ring Binder can be installed only with the Finisher B830 (SR5000). It cannot be installed with either the Finisher D473 (SR4040) or Finisher D474 (4030).
- In all three configurations above, the Cover Interposer (B835) must be installed on the left side of the main machine as the first downstream peripheral device.

2.2.2 CONTROLLER OPTIONS

Here are the common controller options listed alphabetically.

Option	No.	Shape
Bluetooth Interface Unit Type 3245	B826	Board
Browser Unit Type E	D377	SD card
Copy Connector Type 3260	B328	Board
Copy Data Security Type F	B829	Board
Data Overwrite Security Unit Type H	D377-06	SD card
File Format Converter Type E	D377-04	Board
Gigabit Ethernet Type B* ¹	D377-21	Board
HDD Encryption Unit Type A	D377-16	SD card
IEEE 1284 Interface Board Type A	B679	Board
IEEE 802.11 a/g Interface Unit Type J	D377-01	Board
IEEE 802.11 g Interface Unit Type K	D377-19	Board
Optional Counter Interface Unit Type A	B870-11	Board
PostScript 3 Unit Type C7501	D378	SD card

*1: The EFI (Fiery) Controller is connected through the Gigabit Ethernet Board.

2.3 GUIDANCE FOR THOSE WHO ARE FAMILIAR WITH PREDECESSOR PRODUCTS

The D081/D082 series are successor models to the D014/D015 series. If you have experience with the predecessor products, the following information will be of help when you read this manual.

Different Points from Predecessor Products

	D081/D082	D014/D015
Developer	No interchangeability with the predecessor products (D014/D015)	No interchangeability with the new products (D081/D082)
Toner	No interchangeability with the predecessor products (D014/D015)	No interchangeability with the new products (D081/D082)
Java VM card	Factory default SD card in lower slot	Option SD card in lower slot
Printer/Scanner function	Flash ROM on Controller Board	Option SD card in upper slot
Drum charge wire for K-PCU	Replaceable also as individual component parts	Replaceable only as drum charge wire assembly
PM interval for fusing unit component parts	<ul style="list-style-type: none"> ▪ Hot Roller: 450K copies ▪ Pressure Roller Cleaning Roller: 450K copies ▪ Oil Supply Roller: 450K copies ▪ Pressure Roller Bearing: 1200K copies 	<ul style="list-style-type: none"> ▪ Hot Roller: 300K copies ▪ Pressure Roller Cleaning Roller: 300K copies ▪ Oil Supply Roller: 300K copies ▪ Pressure Roller Bearing: 600K copies

2.4 OVERVIEW

2.4.1 MAIN MACHINE

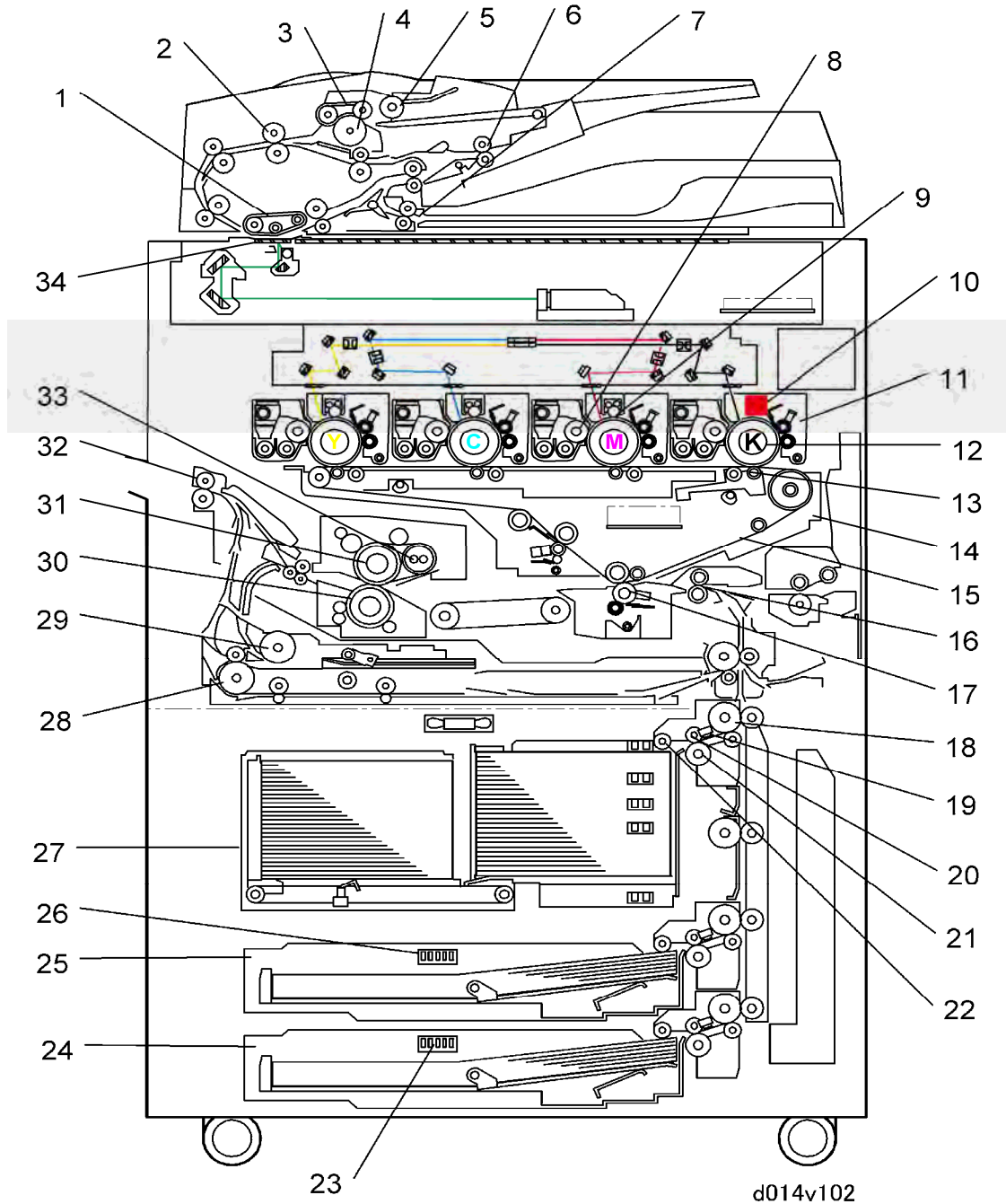

- | | |
|---------------------------------|------------------------------------|
| 1. Transport Belt (ARDF) | 18. Grip Roller |
| 2. Grip Roller (ARDF) | 19. Feed Sensor (Paper Tray) |
| 3. Feed Belt (ARDF) | 20. Feed Roller (Paper Tray) |
| 4. Separation Roller (ARDF) | 21. Separation Roller (Paper Tray) |
| 5. Pick-up Roller (ARDF) | 22. Pick-up Roller (Paper Tray) |
| 6. Upper Inverter Roller (ARDF) | 23. Paper Size Switch (Tray 3) |
| 7. Lower Inverter Roller (ARDF) | 24. Universal Tray (Tray 3) |
| 8. Development Roller | 25. Universal Tray (Tray 2) |
| 9. Charge Roller | 26. Paper Size Switch (Tray 2) |
| 10. Charge Corona Unit | 27. Tandem Tray (Tray 1) |
| 11. PCU | 28. Inverter Exit Roller |
| 12. OPC Drum | 29. Inverter Entrance Roller |
| 13. Image Transfer Roller | 30. Pressure Roller |
| 14. ITB Unit | 31. Hot Roller |
| 15. Transfer Belt | 32. Exit Roller |
| 16. Registration Roller | 33. Heating Roller |
| 17. PTR Roller | 34. Exposure Glass (ARDF) |

The color PCU units (Y,M,C) use a charge roller to charge the surface of the OPC drum. The K PCU uses a charge corona unit (Scorotron type) to charge the surface of the drum.

INSTALLATION

REVISION HISTORY		
Page	Date	Added/Updated/New
189	04/21/2010	Fax Option Name
206	07/02/2010	Updated File Format Converter Type E (D377-04)
221 ~ 223	6/15/2011	Browser Unit
221 ~ 222	10/13/2011	Important note Browser Unit

3. INSTALLATION

3.1 INSTALLATION REQUIREMENTS

3.1.1 OPERATING ENVIRONMENT

1. Temperature Range
 - Recommended Temp.: 23°C (73.4°F)
 - Allowed Temp.: 10°C to 32°C (50°F to 90°F) – See the Note below
2. Humidity Range: 15% to 80% Rh
3. Ambient Illumination: Less than 1,500 lux (do not expose to direct sunlight or strong light.)
4. Ventilation: Air must be replaced a minimum of 3 times per hour
5. Ambient Dust: Less than 0.10 mg/m³

 Note

- If the machine is installed in a location where the ambient temperature is more than 30°C (86°F).
- Do not run full color copying longer than 2 hours, and never turn the main power switch off immediately after a long copy job.
- Leave the machine on so the fans can expel the hot air from the machine and cool the electronic components.

Installation Requirements

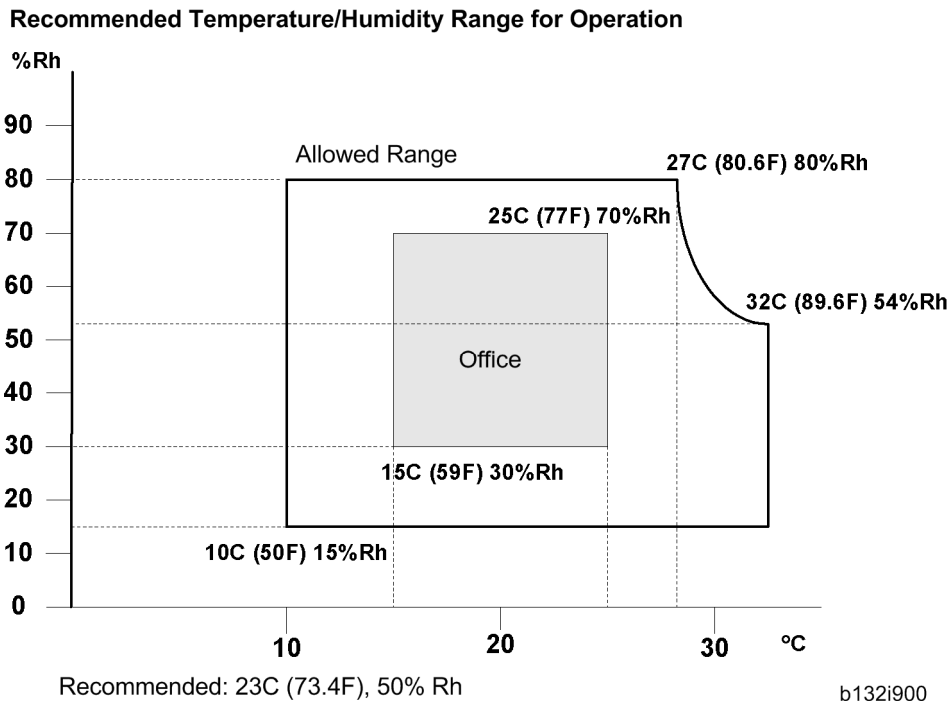

6. If the installation area has air-conditioners or heaters, put the machine in a location that agrees with these conditions:
 - Where there are no sudden temperature changes from low to high, or high to low.
 - Where it will not be directly exposed to cool air from an air conditioner in the summer.
 - Where it will not be directly exposed to reflected heat from a heater in the winter
7. Do not put the machine where it will be exposed to gases that can cause corrosion.
8. Put the machine on a strong and level surface. The front and rear of the machine must be less than 5 mm (0.2") away from level.
9. Do not put the machine where there could be strong vibrations.
10. Do not connect the machine to the same power source as other electrical devices.
11. The machine can make an electromagnetic field, and this can cause interference with radio or television reception.

3.1.2 MACHINE LEVEL

1. Front to rear: Less than 5 mm (0.2") away from level
2. Right to left: Less than 5 mm (0.2") away from level

The machine legs can be turned to adjust them up or down, to make the machine level. Put a carpenter's level on the exposure glass.

3.1.3 MINIMUM SPACE REQUIREMENTS

Put the machine near the power source. Minimum clearance must be as shown below. The same amount of clearance is necessary when optional peripheral devices are installed.

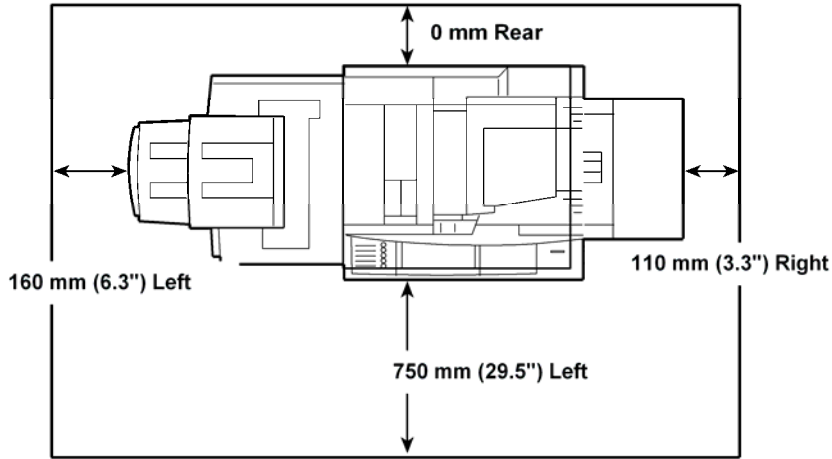

b132i111

Installation

3.1.4 DIMENSIONS

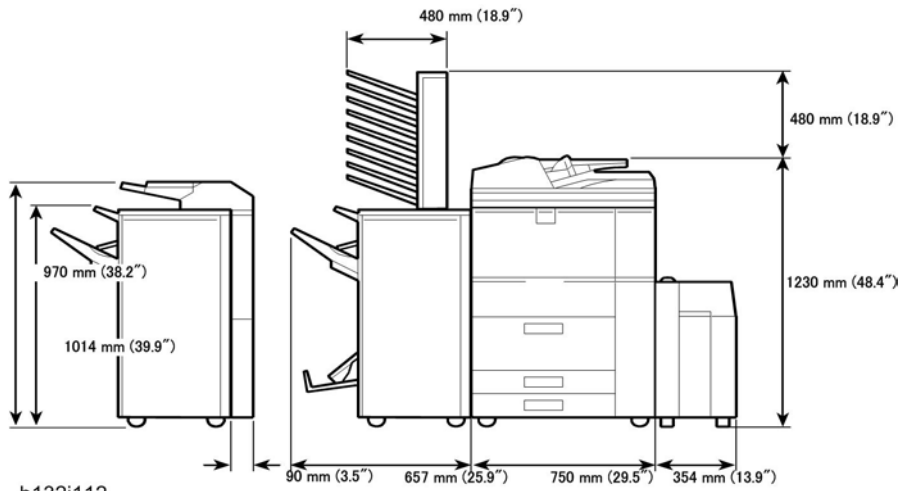

b132i112

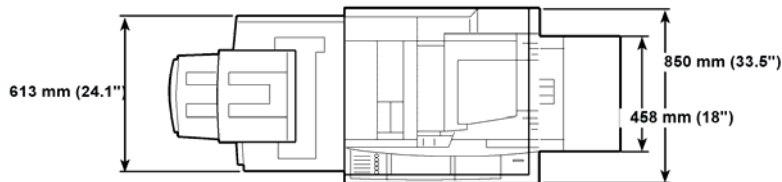

b132i113

Installation Requirements

3.1.5 POWER REQUIREMENTS

WARNING

- Make sure that the wall outlet is near the main machine and that you can get access to it easily. Make sure the plug is tightly connected to the outlet.
- Do not connect more than one electrical device to the same power outlet.
- Be sure to ground the machine.
- Do not put objects on the power cord.

Input voltage level

- North America

D081-17	110V to 127V 60 Hz, more than 20A
D082-17	208 to 240V 60 Hz, more than 12A

- Europe/Asia/China

D081-19, -27, -29 D082-19, -21, -27, -29	220 to 240V 50/60 Hz, more than 10A to 12A
---	--

Permissible voltage fluctuation: $\pm 10\%$

Important

- Some electrical components are different, depending on the power supply used.

The following components are different, depending on the power supply.

1. Power supply cord
2. AC drive board
3. Fusing unit
4. Anti-condensation heaters:
 - Paper trays
 - Paper transfer section
 - Scanner heater (option)
 - LCT (B473) heater (option)
 - LCIT (D350) heater (option)

 **CAUTION**

- Do not turn off the main power switch when the power LED is lit or flashing. To prevent damage to the hard disk or memory, push the operation switch to turn the power off, then do nothing until the power LED goes off, and then turn the main power switch off.

There are two power switches on the machine:

Main Power Switch

This is located on the front left corner of the machine and has a plastic cover. This switch must always be on unless a technician does work on the machine.

Operation Switch

This is located on the right side of the operation panel. This is the switch that the customer uses to turn the machine on and off.

3.2 MAIN MACHINE D081/D082

3.2.1 ACCESSORIES

Check the accessories and their quantities against this list.

No.	Description	Q'ty
1.	Instructions Pocket	1
2.	Exposure glass cloth holder	1
3.	Exposure glass cloth	1
4.	Leveling Shoes* ¹	2
5.	PCU stand	1
6.	PCU Cap Set (not used)	1
7.	Ferrite Core	1
8.	PCU Stand Holder	1
9.	Decals	
	Decal: Paper Size	1
	Decal: Paper Loading	1
	Decal: InkJet Caution	3

*¹: Only two leveling shoes are provided as accessories. However, more can be ordered (Part No. B1321226)

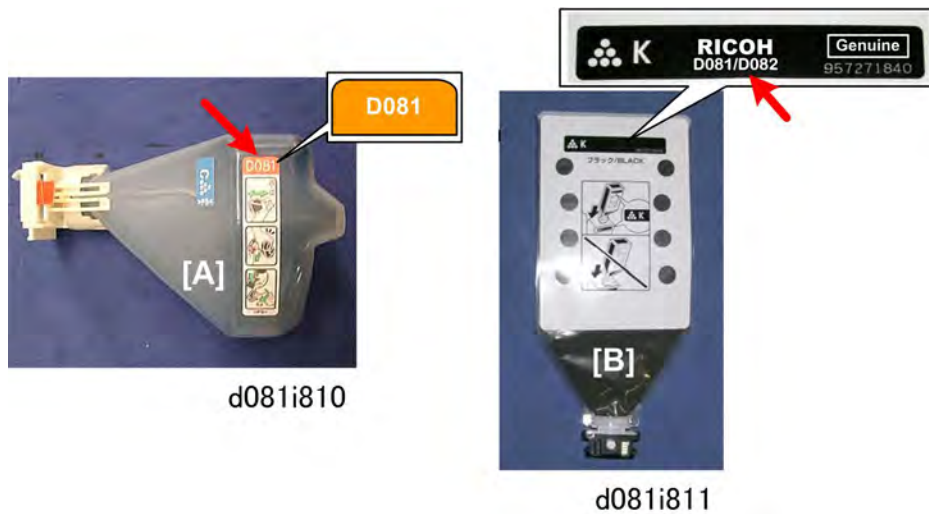
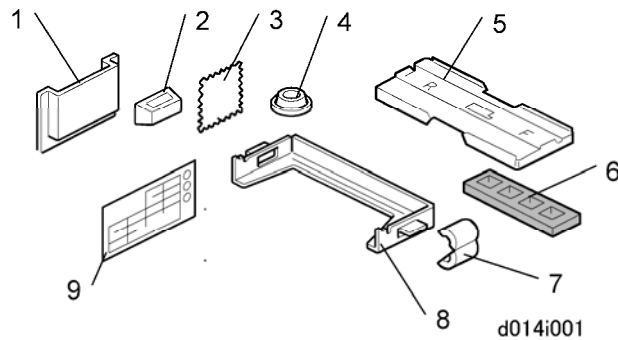

Installation

★ Important

- The developer bottles [A] and toner cartridges [B] provided with this machine are clearly marked for this machine: "D018" for the developer bottles and "D081/D021" for the toner cartridges.
- These are the developer bottles and toner cartridges that must be used with this machine.
- Never attempt to use a developer bottle or toner cartridge intended for use with any other machine.
- Please instruct the customer to use only toner cartridges that are produced for this machine.

3.2.2 INSTALLATION

External Tapes and Packing Material

⚠ WARNING

- Always turn the machine off and disconnect the machine power cord before you do these procedures.

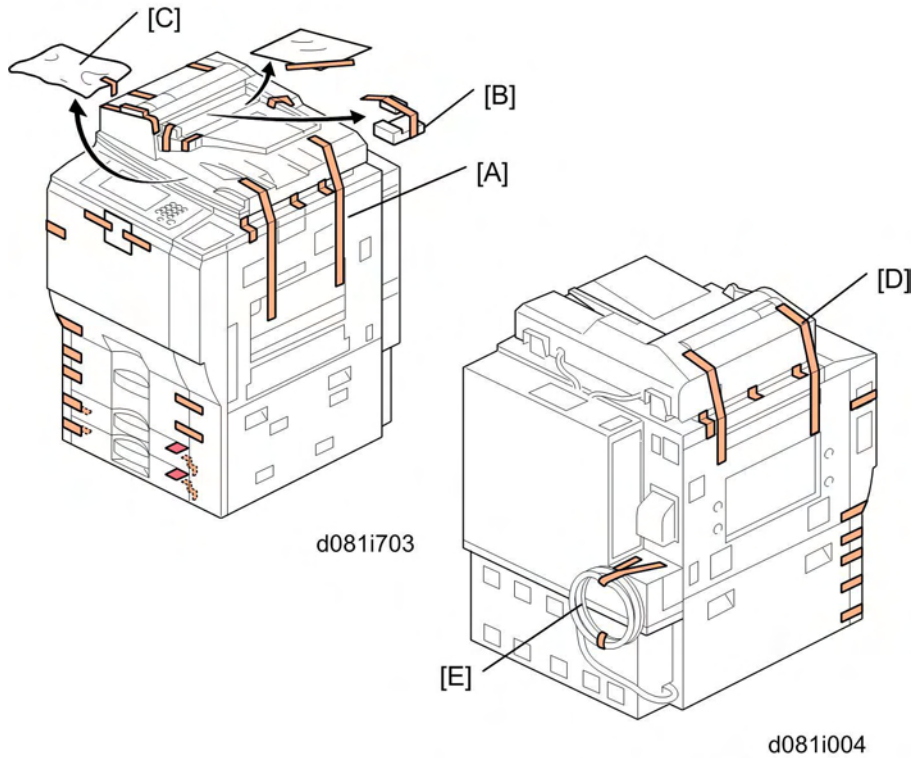

Remove all tapes and packing material from the main machine:

1. Remove:
 - [A]: ADF, right side
 - [B]: Packing block inside ADF
 - [C]: Accessories bag. Remove other accessory bags from Tray 2, Tray 3.
 - [D]: ADF, left side
 - [E]: Power cord

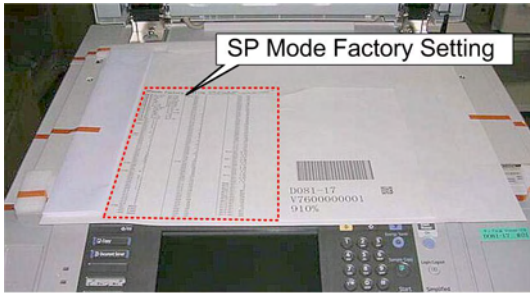

d081i812

2. Raise the ADF and remove the "SP Mode Factory Setting" sheet. Keep this sheet for future reference.

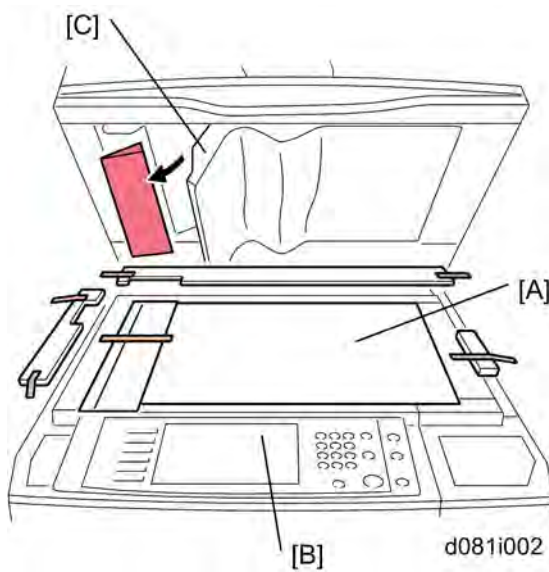

d081i002

3. Remove:
[A]: All tapes, packing material around the exposure glass.
[B]: Operation panel film
4. Pull away the white plate [C] and remove the red paper.

Internal Tapes and Packing Material

Main Machine

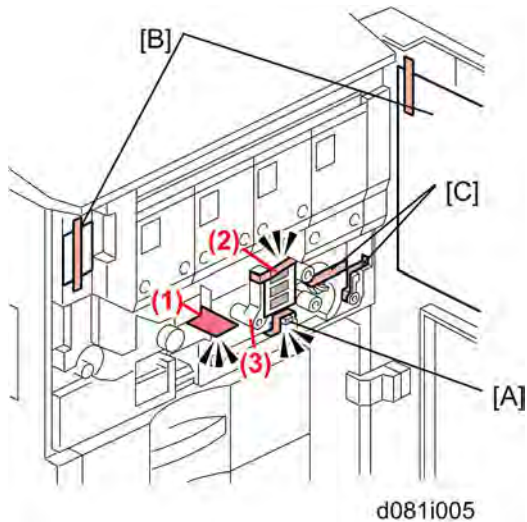

1. Open the front door.
2. Remove the transfer belt release lever [A] (1 tape). **We will install this in the correct location later.**
3. Remove the paper and tape [B] and [C] only.

★ Important

- Do not touch (1), (2), or (3) at this time. These items are removed after you remove the faceplate.
- To prevent damage to the ITB, never turn down lever (3) to pull out the drawer unit until after you have removed the rod with the red tag and wire (2). Do not remove them yet.
- The drawer must remain inside the machine until after the developer is installed in the developer cartridges of the PCUs. The tag and rod (1) are removed after the faceplate has been removed.

Tray 1

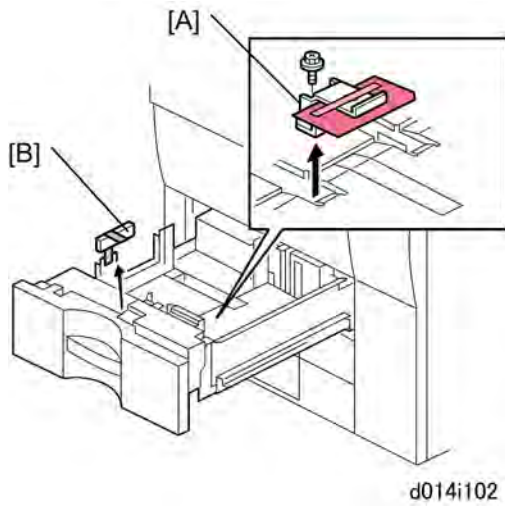

1. From Tray 1 remove:
[A]: Retainer, tag, wire (x 1)
[B]: Block, tape

Tray 2

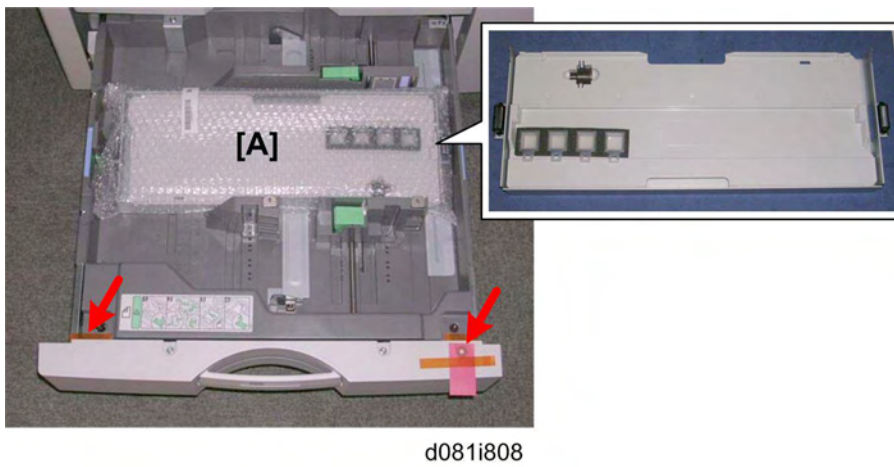

1. Remove the PCU stand [A] and all retainers and accessories from Tray 2.

Tray 3

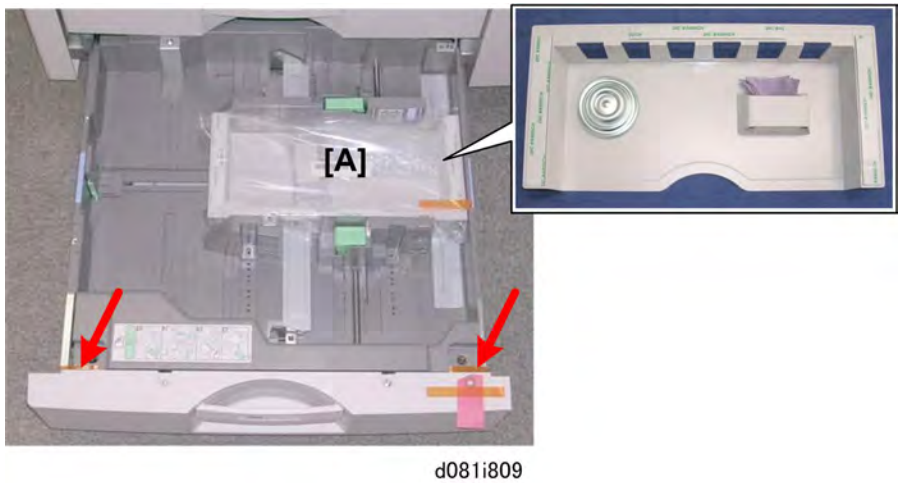

1. Remove the package [A] with the instructions pocket, exposure glass cloth holder, exposure glass cloth, and leveling shoes from Tray 3.
2. Remove all other retainers and accessories from Tray 3.

Shipping Retainer Removal

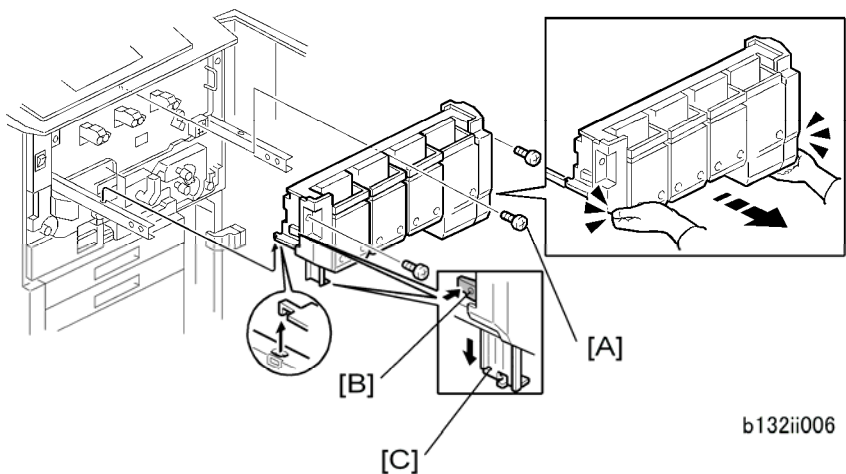

1. Prepare an open space on the floor for the hopper.
2. Remove the screws of the toner hopper cover [A] (⚙ x 3).
3. Put your hands under the left and right corners of the toner hopper, and slowly pull it out on its rails until it stops.
4. Push the lock [B] then pull down the support leg [C].
5. Make sure that the support leg is down and locked before you remove the hopper.

⚠ CAUTION

- Always make sure that the support leg is down and locked before you remove the hopper.

- Hold the toner hopper using the handles at the top left and right sides. Then lift the toner hopper off its rails and set it on the floor.

⚠ CAUTION

- The hopper is heavy! Lift it carefully. Make sure that it disengages fully from the rails on the left and right, and then set it on the floor.

- Push the hopper rails into the machine.

↓ Note

- Push in the rails until approximately an inch is out of the machine. If you push the rails in fully, you must use a pair of needle-nose (radio) pliers to pull them out again.

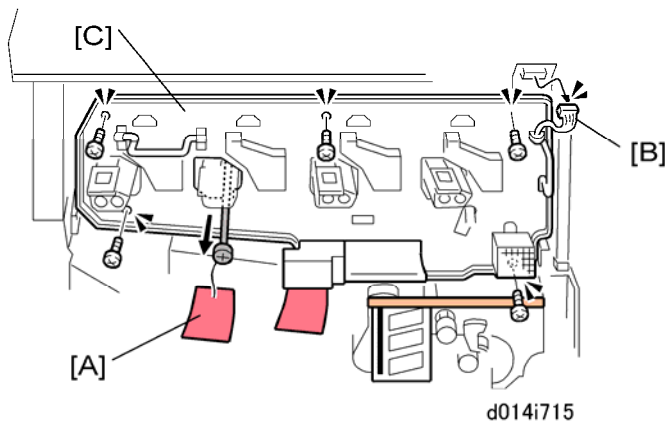

- Remove the tag and rod [A] (⚙ x 1).
- Disconnect the fan connector [B].
- Remove the faceplate [C] (⚙ x 5).

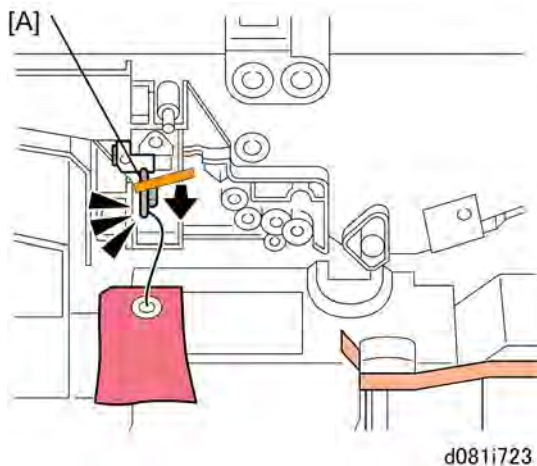

Main Machine D081/D082

11. Remove the orange tape and slowly pull out the stabilizing rod [A] with the attached red tag.

★ Important

- Never pull out the drawer unit until the stabilizing rod and tag have been removed.
- This stabilizing rod protects the ITB and PTR during shipping.

Remove Drawer Retainers and Packing Material

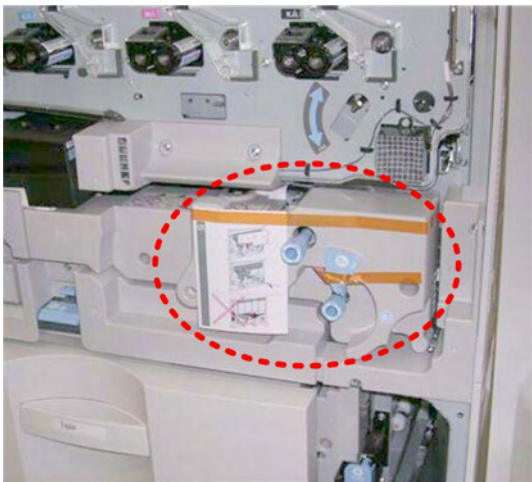

d081i807

1. Remove the tapes and decals attached to the right side of the drawer.

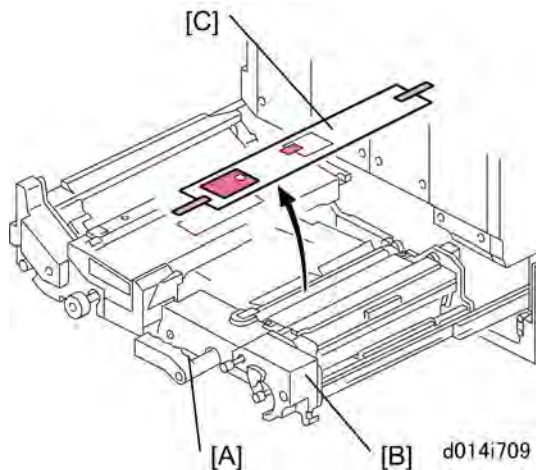

2. Turn the lever [A] down to the left, and pull the drawer unit [B] out of the machine until it stops.
3. Remove the instruction sheets [C].

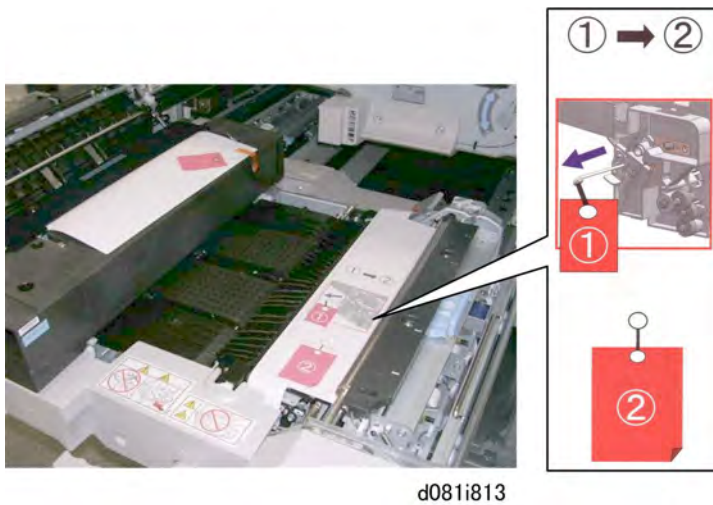

★ Important

- The instruction sheet protects the PTR during shipping and is also an important reminder that the stabilizing rod must be already removed before this sheet is removed.
- If the stabilizing rod has not been removed, do this now. See Step 11 of the previous section.
- Never push the drawer into the machine until the stabilizing rod has been removed. Pushing the drawer into the machine with the stabilizing rod in the machine will damage the ITB and PTR.

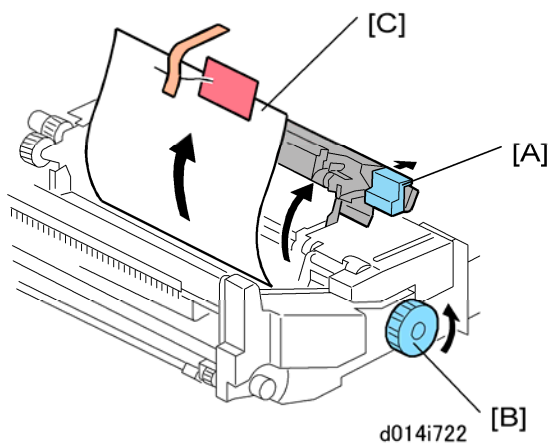

4. Raise lever **D2** [A] of the fusing unit.
5. Turn knob **D1** [B] in the direction shown by the arrow.
6. Remove protective sheet [C] with tape and red tag.
7. Lower lever **D2** [A].
8. Push the drawer into the machine until it stops.
9. Rotate handle **B2** up and to the right until it stops.

Reattach the Faceplate

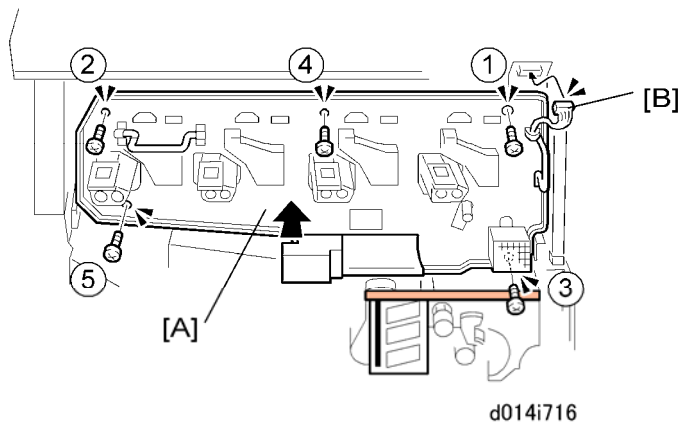

1. Attach the faceplate [A] with the screws in the sequence shown by the numbers above (x 5).

★ Important

- Do not tighten these screws too much.

2. Reattach the fan connector [B].

★ Important

- Make sure the fan connector is not pinched behind the faceplate.

Filling the PCU Units with Developer

Before You Begin...

- Follow this procedure in the order described below.
- Do not turn the machine on or off or open the front door until you are instructed to do so.
- The toner hopper unit must be off the machine (removal described above).

Setting the Developer Bottles

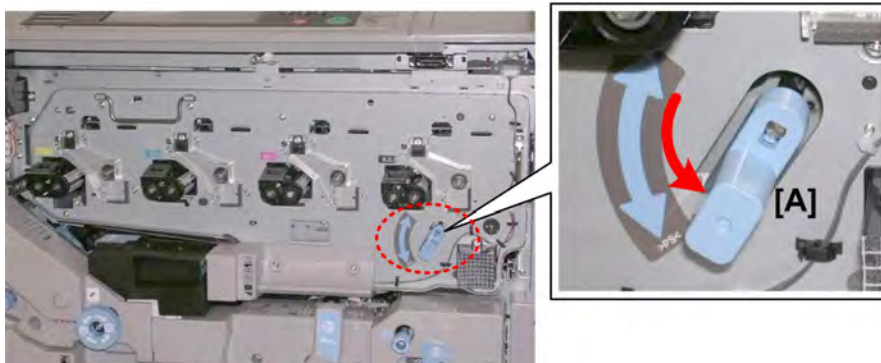

1. Attach the transfer belt release lever [A].
2. Make sure the lever is down.

★ Important

- The lever must be down to keep the transfer belt separated from the surfaces of the PCU drums.



d081i815

3. Pick up the Y (Yellow) bottle.
4. Make sure that the bottle is clearly marked "D081" for this machine.



d081i830

5. Before attaching the bottle, loosen the developer to ensure that it will drain completely.
 - Hold the bottle upside down (neck up).
 - Vigorously shake the bottle up and down 10 to 15 times.

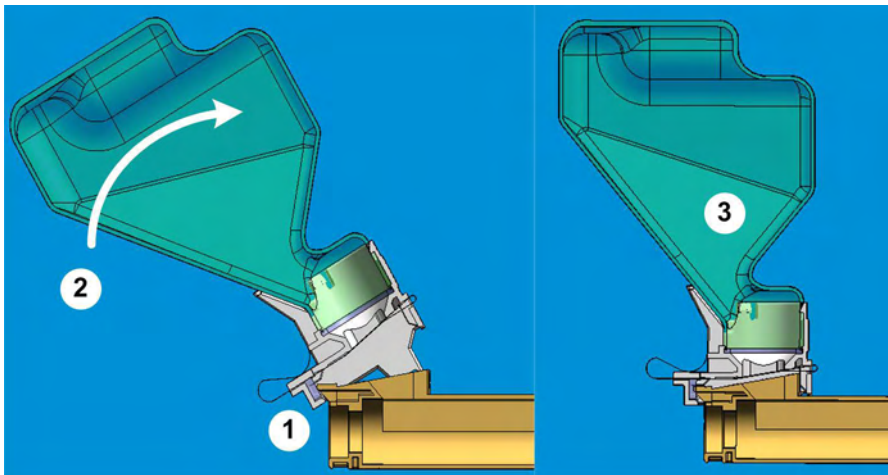

b132r801

6. Rest the neck [1] of the developer bottle on the edge of the PCU.
7. While keeping contact and pressure on the neck and PCU at [1], rotate the bottle [2] up until it locks in place at [3].

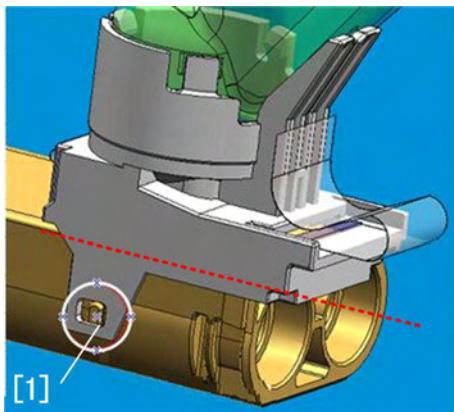

b132r802

8. Check the tab on the side of the neck [1] to make sure that the bottle is locked. The neck of the bottle should be perfectly flat on top of the PCU.

★ Important

- There should be no gap between the developer bottle and the PCU.
 - If the bottle is not locked in place, developer will spill from the bottle.
9. Repeat Steps 3 to 8 to install and lock the other bottles (M, C, K).

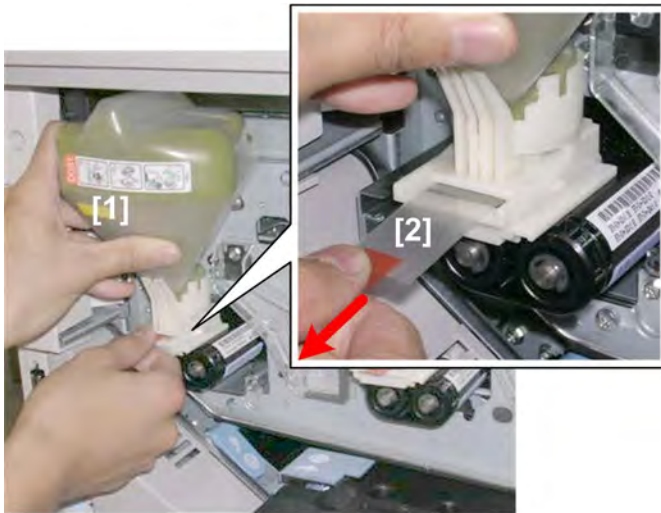

d081i816

10. Remove the heat seal from each bottle.
 - Hold the bottle [1] with one hand, slowly pull the heat seal [2] out of the developer bottle and remove it.
 - Do this for each bottle.
 - Make sure that you have removed all the seal strips (you should have four strips, one for each bottle).
11. Gently tap the sides of each bottle with a finger to make sure that the developer flows freely.



d081i835

12. Check once again to make sure that the lever is down.

★ Important

- The lever must be down. If you attempt to drain the developer bottles with SP3814 with the lever up, the machine will return "Failed".

13. **Close the front door.**

Main Machine D081/D082

★ Important

- The door must be closed before you switch the machine on.

14. Turn the machine power on and wait for the machine to beep twice.

★ Important

- The beeps indicate that the fusing unit is ready. Do not proceed until after you hear the two beeps. If you attempt to drain the developer bottles with SP3814 before you hear the two beeps, the machine will return "Failed".

15. Enter the SP mode and do the following SPs:

- **SP3814-1.** Fills all of the PCU units with developer from the attached bottles. It takes about 3 minutes. Touch [Exit] when "Completed" appears on the display.
- **SP3815.** Confirms that **SP3814-1** executed correctly. If **SP3814-1** executed correctly, you will see "1111" (K M C Y).

Display	What It Means
1	Succeeded
4	Factory default value (SP3814 has not been used yet)
7	Developer filled before doing SP3814-1
9	Failed

16. Touch [Exit] twice, open the front door and confirm that each developer bottle is completely empty.

- Each developer bottle must be completely empty.
- Even if SP3815 returned a "1" for each bottle to indicate successful completion of the operation, there may be some toner remaining in a bottle.
- It is very important that you check each bottle visually for remaining developer.

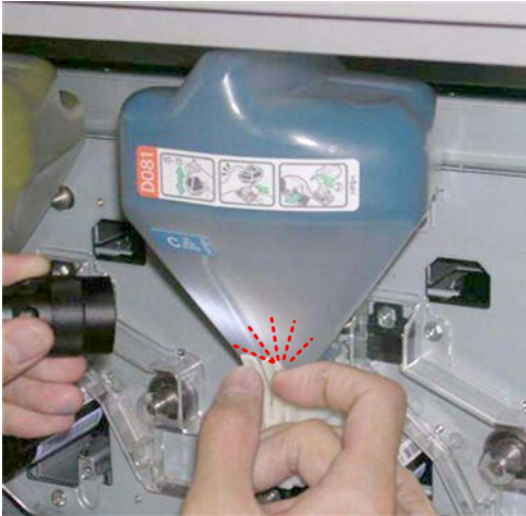

d081i817

17. Shine a flashlight on each bottle and confirm that each bottle is empty.

↓ Note

- If you see any remaining toner, gently tap the neck of the bottle to loosen the toner then execute SP3814 again to drain all the developer.

18. After all the developer has drained from each bottle, switch the machine off.

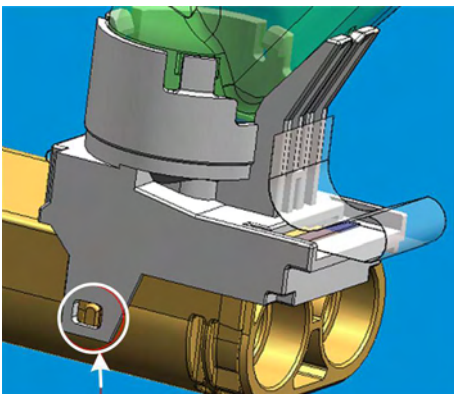

[A]

b132r803

19. Use the tip of a small screwdriver to release each locked bottle latch at [A], and remove the bottle.
20. Discard the four empty bottles.

★ Important

- Obey local laws and regulations concerning the disposal of items such as the empty bottles.

Reinstall the Toner Hopper

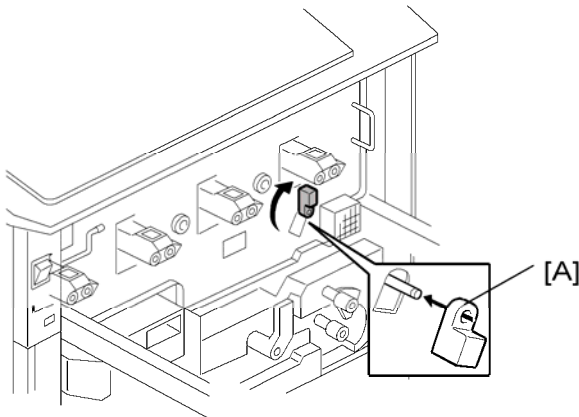

b132i707

1. Turn the lever [A] to the vertical position and make sure that it locks.

★ Important

- This lever must be up. The toner hopper cannot be re-installed if this lever is down.

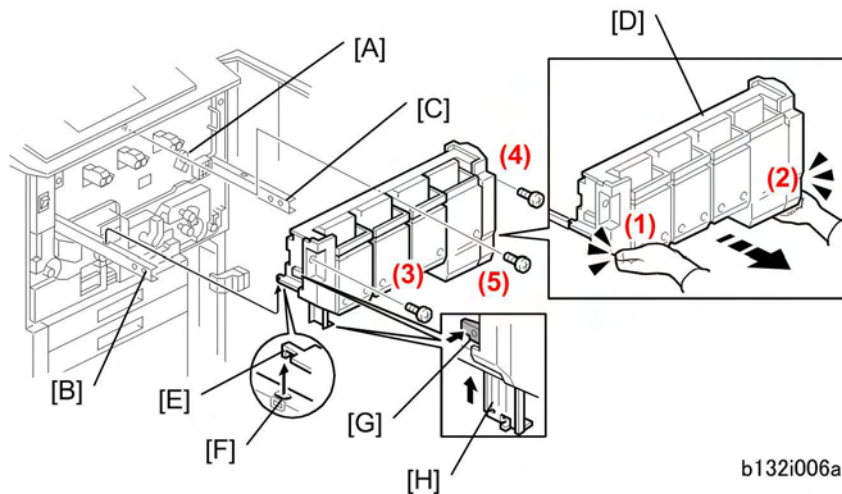

b132i006a

2. Make sure the transfer release lever [A] up and locked.

★ Important

- The transfer belt release lever must be turned up and locked before you install the toner hopper.
- If the transfer belt release lever is down, the toner hopper cannot be closed completely against the faceplate.
- If the transfer belt release lever [A] is not attached, this will cause an image transfer roller position error (SC447).

3. Pull out the toner hopper left rail [B] and right rail [C] until they are fully extended. If the rails were pushed in fully, use a pair of needle-nose pliers to pull them out of the machine.
4. Set the toner hopper [D] on the rails.
5. Make sure the steel tabs [E] of the hopper are inserted fully into the left rail hole and the right rail hole [F].
6. Push the lock [G] and push the support leg [H].
7. Make sure that the support leg is up and locked before you push the toner hopper into the machine.
8. Put your hands at the bottom of the toner hopper at (1) and (2) then push the hopper into the machine against the faceplate.

★ Important

- To prevent damage to the hopper, never push the top of the toner hopper.
9. Make sure that the hopper is flat against the faceplate on the right side.
 10. If the toner hopper [D] is not flat against the faceplate on the right side, pull it out a short distance and make sure that the transfer belt release lever is turned up fully.
 11. Attach the toner hopper (🔩 x 3). Attach the screws in this sequence: (3), (4), (5).

Toner Installation

★ Important

- These toner cartridges contain 90% toner and 10% carrier. You must use the toner cartridges provided with this machine.
- Make sure that you install each toner cartridge in the correct bin.
- The label on the toner cartridge must face the front of the machine.
- From left to right, the bins are for Y, C, M, K.
- The name of the color for each bin is on the decals that are attached to the bin release levers.

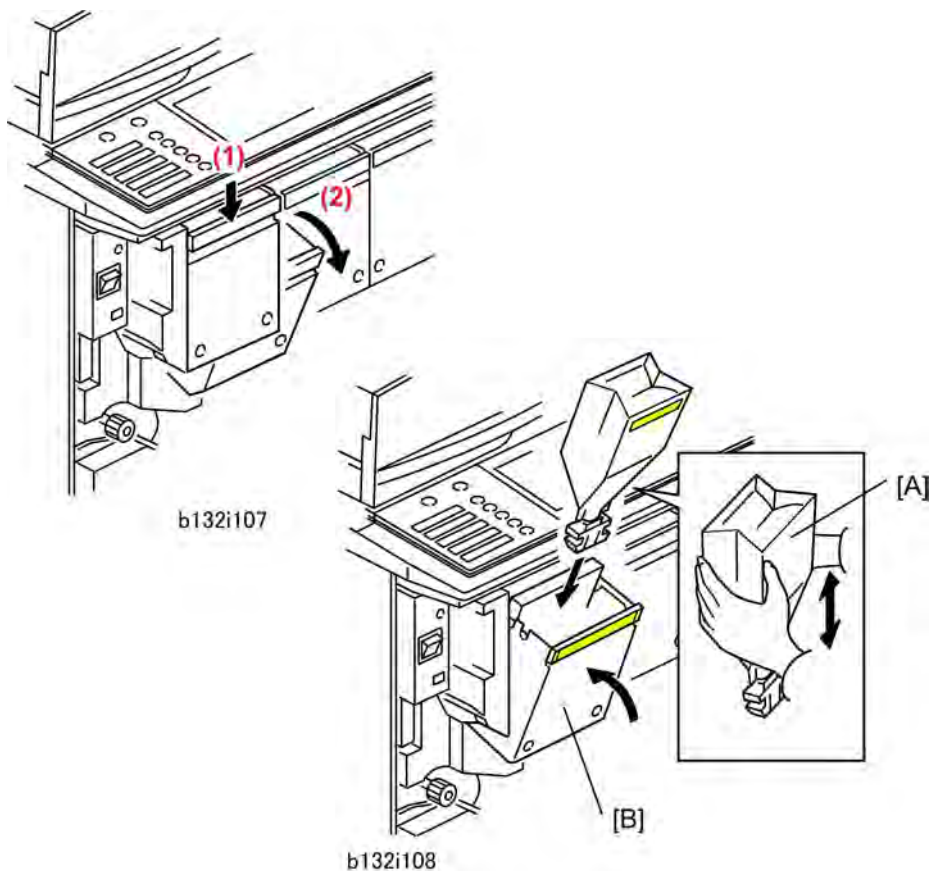

1. Push down the lock lever (1) on the top edge of the Yellow bin (the bin at the far left) to release it. Then pull the bin (2) in the direction of the front to open it.

★ Important

- To prevent damage to the bin door, do not try to pull a bin directly out. Push down on its top edge first to release it, then pull it to open it.
2. Remove the Yellow toner cartridge from its box.



d081i818

3. Make sure that the toner cartridge is marked "D081/D082" for this machine.
4. Shake the toner cartridge [A] up and down about 10 times. Never squeeze or knead the toner cartridge (this will make clumps in the toner).
5. Make sure the flat bottom of the cartridge is up.
6. Set the Yellow toner cartridge in the bin [B].
7. Push the Yellow toner cartridge bin to close and lock it.
8. Repeat this procedure for the other three toner cartridge (C, M, K)

★ Important

- Make sure that the color of each toner cartridge matches the color of the label on the bin door before you install it.

Initializing Developer and Toner

Before You Begin...

- Follow this procedure in the correct order as described below.
- Do not turn on the machine until you are instructed to do so.
- To prevent damage to the drums during this procedure, **make sure that the front door is open before you switch on the machine.**

⚠ CAUTION

- If the machine is switched on during this procedure with the front door closed, processing control executes. This causes the bare drums to rotate against the counter blades before a light coat of toner has been applied to the surfaces of the drums. This could damage the drum.

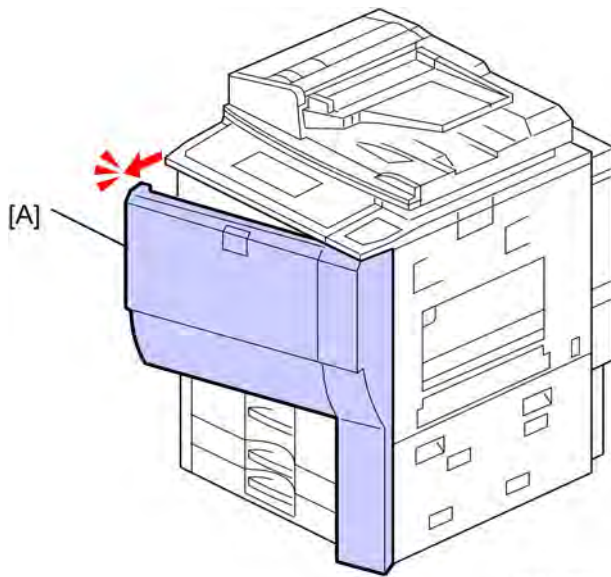

d081i721

1. **Open the front door [A].**

★ Important

- The front door must be open.
- Turning on the machine with the front door open prevents the machine from performing the initial process control self-check.
- If the front door is closed, the drums will start rotating with no toner in the PCUs.
- If the drums rotate with no toner in the PCUs, this can cause the cleaning blades to catch on a dry drum and damage the drum surface.

2. With the front door open, turn on the main power switch.

3. **Close the front door after "Open Cover" appears on the display.**

★ Important

- You must close the front door.

4. Wait for the machine to warm up and enter standby mode.

5. Enter the SP mode and do **3811-1** to send toner to the PCUs and initialize the TD sensor. This requires about 4.5 min.

★ Important

- If 'Failed' appears immediately after you start SP3811-1, the machine has not warmed up. Wait 2 minutes, and then do SP3811-1 again.
 - Do SP3811-1 only once. Executing SP3811-1 more than once can cause toner spill inside the machine. SP3811-1 initializes not only the TD sensor but initializes the developer as well.
 - SP3811 does a number of things, including initialization of the TD sensor. You must not initialize the TD sensor again. Do SP3811-1 only once. SP 3801 also initializes the TD sensor.
 - Never do SP3801-1 (Init TD Sensor) after doing SP3811. If the TD sensor is initialized twice this will cause a fatal error in toner supply control.
6. When the message tells you that the initialization is completed, touch [Close].
7. Do **SP3812-1** to confirm that **SP3811-1** executed correctly.
- If you see "1111" (K M C Y), this means **SP3811-1** executed correctly.
 - If you see any number other than "1111", this means an error. (See **SP3812** Errors.)

★ Important

- For a complete list of errors and how to solve problems related these SP codes and light images, please see "Special Procedures" in the Troubleshooting section..
8. Do SP **3821-1** to check that process control was completed successfully.
- For each color, there is a two-digit code, in the order K,M,C,Y. '10' means that process control was completed successfully. '10101010' means that all 4 colors completed process control successfully.

Load the Paper Trays

For each paper cassette tray:

1. Move the side fence and bottom fence to the correct positions for the paper.
2. Add paper to the trays.
3. Attach the paper size decals to the front of the three trays.

↓ Note

- It is not necessary to input the paper size setting for trays 2 and 3. This is detected automatically.

Make a Test Color Print

1. Make sure that A3 or DLT paper is in one of the trays.



- Use the same type of paper that the customer normally uses for color outputs.
2. Put a "Color Chart C-4" on the exposure glass.
 3. Select full color mode and print one copy of the chart. You will use this in the ACC procedure, if ACC is necessary.
 4. Check the results of the copy with the customer.
 5. With a pencil or pen, mark this copy "Before ACC".
 - If the quality of the color is satisfactory, ACC adjustment is not necessary.
 - If the quality of the color is not satisfactory, do the ACC adjustment described below.

ACC (Automatic Color Calibration) Adjustment

Automatic color calibration is done at the factory with the procedure given below. Do this procedure only if the color quality is not satisfactory for the customer.

1. Push [User Tools].
2. To print a color pattern, select Maintenance> Auto Color Calibration
3. Touch [Start] for "Copier Function"

**Machine will start self-check before
printing Test Pattern**

Press [Start Printing].

4. Touch [Start Printing].
**Now self-checking.
Test pattern will be printed.
Please wait.**

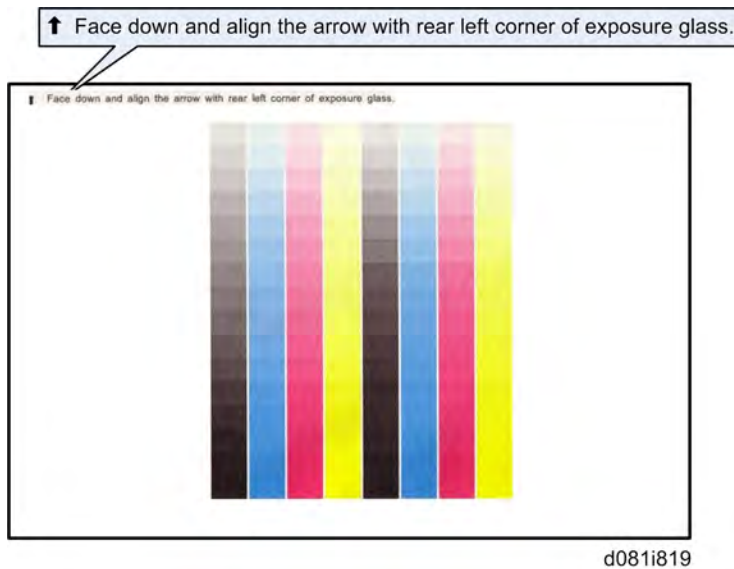

The machine does process control for a few seconds and it prints the test pattern.

5. Read the message:
Place Test Pattern on the exposure glass correctly, then press [Start Scanning]
6. Remove the C-4 test chart from the exposure glass.
7. Place the color test pattern face-down with the arrow aligned the rear left corner of the exposure glass.
8. Touch [Start Scanning] on the display. The machine scans the pattern one time.
Scanning...
Please wait.
 - If you see the "Scanning failed" error, this means the Test Pattern is not set correctly.
 - Make sure that the arrow on the test pattern is in the upper left corner of the exposure glass.
9. Remove the pattern from the exposure glass and replace it with the C-4 Color Chart.
10. Touch [Exit] three times to return to the Copy mode screen.
11. Make a full-color copy of the test chart.
12. Mark this copy of the C-4 chart "After ACC".



d081i820

13. Compare the two copies, "Before ACC" and "After ACC".

↓ Note

- Normally, the quality of the 2nd copy is better than the 1st copy ("Before ACC").

14. If the results of the 2nd copy are better than the results of the 1st copy, you are finished.

-or-

If the customer prefers the result of the 1st copy:

- Push the [User Tools] key
- Touch Maintenance> Auto Color Calibration> Previous Setting.

15. Remove the color chart from the exposure glass.

16. If the customer is not satisfied with the 1st copy or the 2nd copy, do the printer gamma adjustment (☛ p.5-232 "Printer Gamma Correction").

Do the Color Registration Procedure for MUSIC

1. Push [User Tools].
2. Touch [Maintenance]> [Color Registration].
3. Touch [OK].

This completes color registration.

Counter Display Setting

The default setting for the counter is "0" (development). Do the SP setting below to set the counter for copy/print (paper count).

1. Enter the SP mode.
2. Do **SP5045-1**.
3. Select the counter to use:
 - 0: Development counter (Default)
 - 1: Page counter

★ Important

- This setting can be switched for the D081/D082 at any time as necessary. (This setting could be done only once with the D014/D015 machines.)

Make the Machine Level

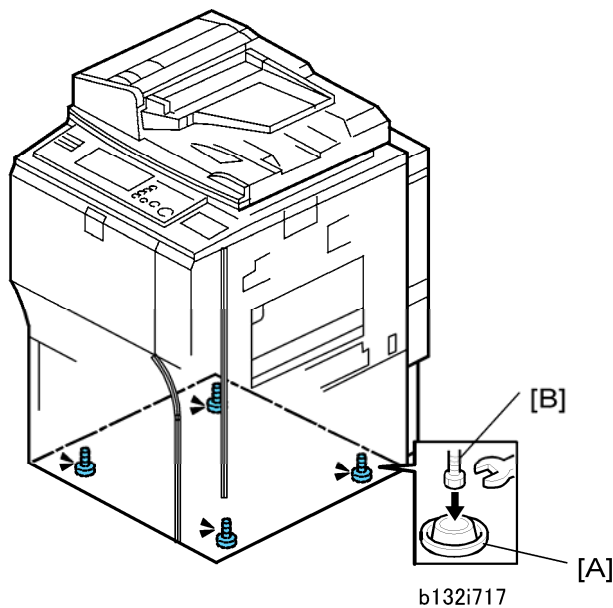

★ Important

- Only two leveling shoes are provided as accessories. However, more can be ordered (Part No. B1321226). The illustration above shows the machine being leveled with four shoes.

1. Place a shoe [A] under one corner of the machine.
2. Place the other shoe under the opposite corner of the machine.
3. Place a level on the exposure glass.
4. Use a wrench to raise or lower the nuts [B] on the leveling shoes until the machine is less than 5 mm from level (measure from front-to-rear and left-to-right).

Attach the PCU Stand Rack and Store the PCU Stand

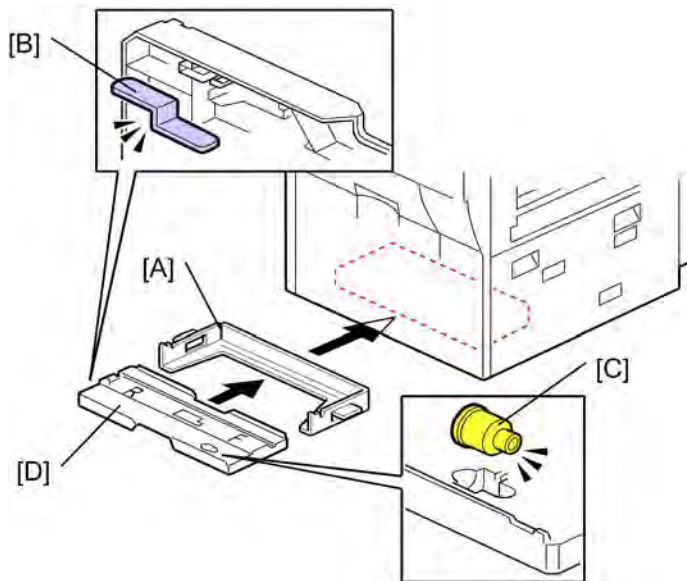

d081i718

1. Hold the PCU stand rack [A] as shown, then attach it to the bottom of the machine (magnets hold it in place).
2. Make sure long lock plate [B] and jig [C] are inserted into the bottom of the PCU stand.
3. Slide the PCU stand [D] into the rack below the main machine.

★ Important

- The PCU stand provided with the machine must remain with the machine in the field because the stand is required for servicing the PCU and OPC drum. After the PCU is removed from the machine, it should always be placed on the PCU stand.
- The PCU stand protects the OPC drum while the PCU is out of the machine, and keeps the PCU properly aligned so the development unit can be reattached easily after the OPC and PCU have been separated.
- To prevent damage to the exposed OPC drum on the bottom of the PCU, always set the PCU on the PCU stand designed for this machine. Do not use the PCU stand of any other machine.

Attach Decals

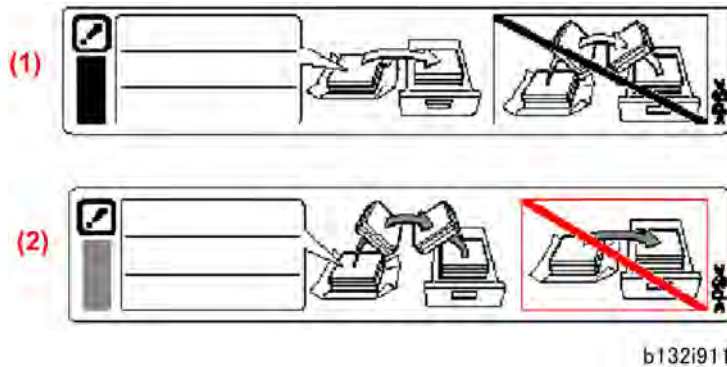

1. Attach the paper-installation decals to the trays. These tell you how to add new paper.
 - **Front set decal (1) for LCT:** Attach this decal to the LCT if one is installed. 'Front set' means that the paper should be **face up** in the tray.
 - **Back set decal (2) for main machine:** Attach these decals to the trays of the main machine. 'Back set' means that the paper should be **face down** in the tray.

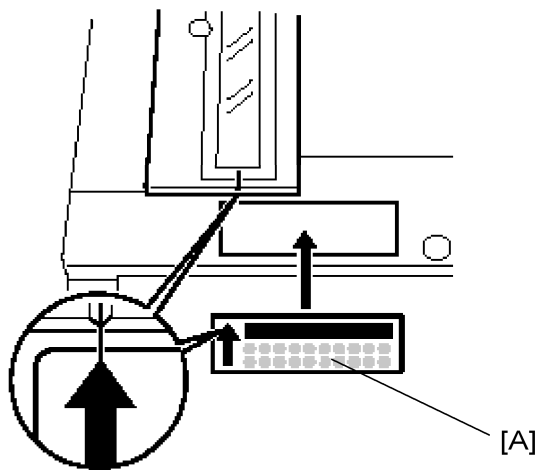

b132i912

2. Attach exposure-glass-cleaning decal [A] at the front edge of the ADF exposure glass.

Main Machine D081/D082

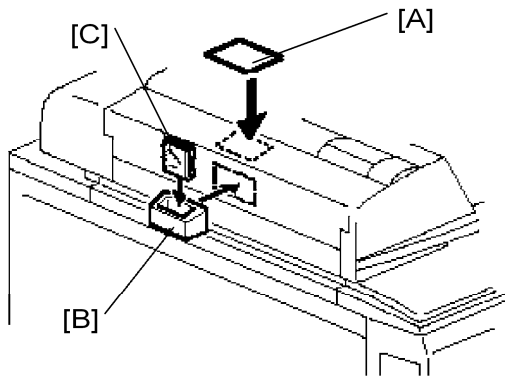

b132i913

3. Attach the original-caution decal [A], and the silicone cloth holder [B].
4. Put the silicone cloth [C] in the holder.



	Precautions for Printing	> P.5 <
	To avoid a malfunction or deterioration in print quality • Never use Inkjet paper For details about paper type and orientation, see the operating instructions.	

d081i910

5. Open the first tray (tandem tray) and attach an inkjet paper caution decal for your language to the right side of the tray as shown.
 - An English decal is already attached to the tray. If you wish to attach a decal for another language, just put the new decal on top of it.
 - Do not try to remove the English decal.

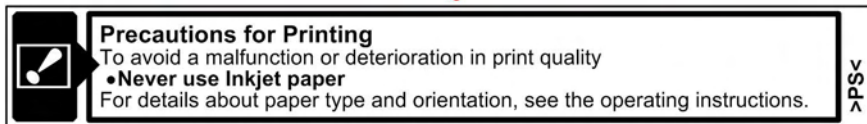
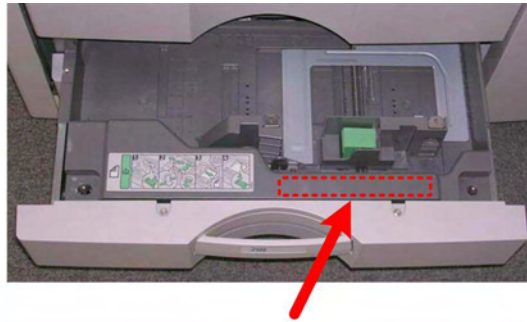

d081i911

6. Open the second tray (universal tray) and attach an inkjet paper caution decal for your language to the right side of the tray as shown.
7. Open the third tray and attach an identical decal at the same location.
 - An English decal is already attached to the tray. If you wish to attach a decal for another language, just put the new decal on top of it.
 - Do not try to remove the English decal.

Enable USB

1. Do SP5985 to enable USB.

Print an SMC Report

1. Go into the SP mode.
2. Do **SP5990-1** to print a full SMC report. Keep it in a safe location, with the Factory Setting Sheet removed from under the ADF in a previous step.

Connect the Upper and Lower Tray Heaters

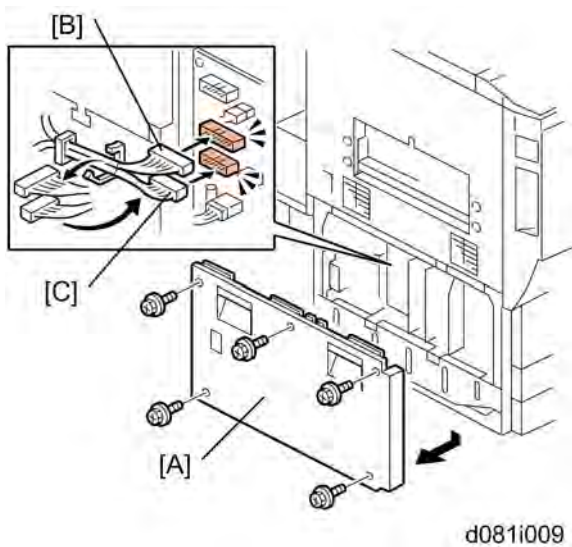

The machine comes from the factory with the tray heaters disconnected.

Note

- Heater connection is optional. Connect the heaters if the location is extremely humid. Speak with the customer before you connect the tray heaters.

1. Remove the left lower cover [A] (⚙️ x 5).
2. If the paper tray unit heater (HTS) or image transfer/scanner heater are required, attach connectors HT5 [B] and HT6 [C] (🔌 x 1, 📡 x 2)

Enabling App2 Me on VM/Calypso SD Card (D0815790C)

The machine is shipped from the factory with the VM/Calypso SD Card already installed in Slot 2 (the lower slot), but the App2 Me application must be enabled before it can be used.

Do the following procedure if a customer wants to use "App 2 Me".

1. Press the [User Tools] key on the operation panel.
2. Touch the "Extended Feature Settings" button twice.
3. Touch the "App 2 Me" line under the Startup Setting tab.
4. Touch the "Extended Feature Info" tab on the LCD.
5. Touch the "App 2 Me" line.
6. Set "Auto Start" to "On".
7. Touch the "Exit" button.
8. Exit the "User Tools" settings.

Important

- Do not remove the VM card from Slot 2 (lower slot). The VM card must remain in the machine.

Update Procedure for App 2 Me Provider

Follow this procedure to update AP2 Me if a new version is available.

1. Push the [User/Tools] key on the operation panel.
2. If an administrator setting is registered for the machine, Step 3 and Step 4 are required. Otherwise, skip to step 5.
3. Push [Login/Logout] on the operation panel.
4. Login with the administrator user name and password.
5. Touch "Extended Feature Settings" twice on the LCD.
6. Touch each of the applications until the status changes to "Stop".
7. Turn the machine off, and then remove the VM Card.

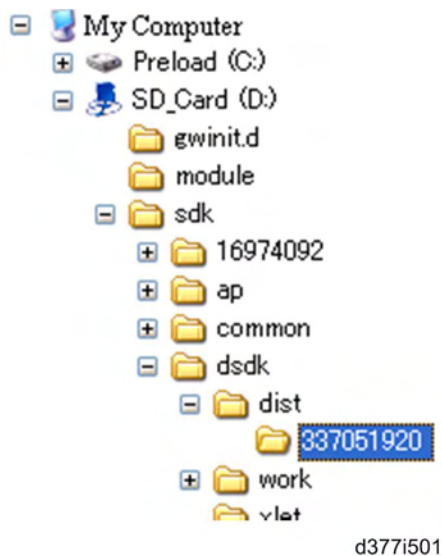

8. Prepare the newer App 2 Me Provider zip file from the Firmware Download Center, and then unzip the zip file. (The folder name is "337051920".)
9. Copy the App 2 Me Provider folder into the specified path for the VM card. The path is: "SD_Card Drive¥ sdk¥dsdk¥dist¥337051920"
 1. Turn the SD card label face to the rear of the machine, and then push it slowly into Slot 2 (lower slot) until you hear a click.
 2. Turn the main power switch on.
 3. Press [User Tools] on the operation panel.
 4. Touch the "Extended Feature Settings" button twice.
 5. Touch the "Extended Feature Info" tab on the LCD.
 6. Touch the "App2Me" line.
 7. Set the setting of the "Auto Start" to "On".
 8. Touch the "Exit" button.
 9. Exit the [User Tools/Counter] settings.

Main Machine D081/D082

★ Important

- App2 Me and all other running applications on the VM card must be shut down before the removing the VM card in order to update the main machine software, backing up NVRAM, or executing application move or undo with SP58973.
- After the VM card is re-inserted, App2 Me (and any other VM card applications used by the customer) must be switched on after the machine is switched on.
- For more about shutting down and re-starting App2 Me and other VM card applications, see "Before Removing and Re-installing the VM Card".

3.3 COPY TRAY (B756-01)

3.3.1 ACCESSORIES

Check the accessories and their quantities against this list.

Description	Q'ty
1. Copy Tray	1
2. Actuator Arm and Bracket (not used)	1
3. Tapping Screw (not used)	2
4. Large Cap	1
5. Small Cap	4
6. Tapping Screw (M4 x 8)	1
7. Harness Clamp	1
8. Paper Height Sensor	1
9. Actuator Arm Bracket	1
10. Sensor Bracket	1
11. Actuator Arm	1

Copy Tray (B756-01)

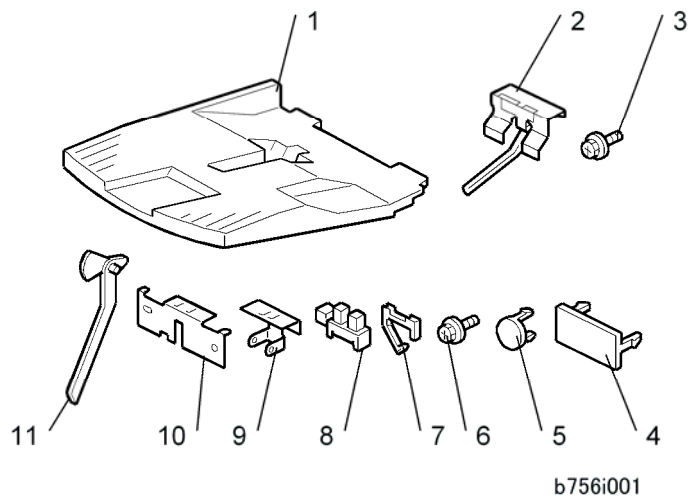

3.3.2 INSTALLATION

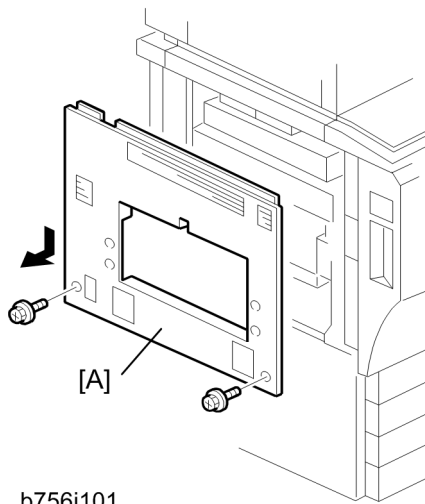

1. Remove the left upper cover [A] (🔩 x 2).

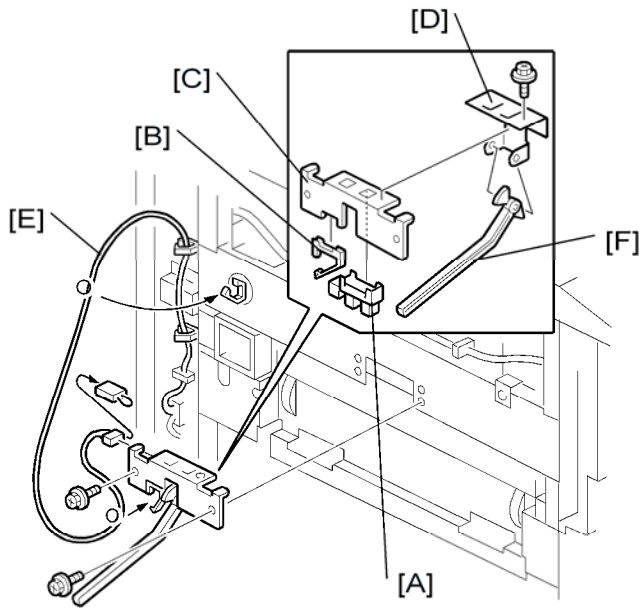

b756i003

2. Attach the paper height sensor [A] and harness clamp [B] to the sensor bracket [C].
3. Attach the sensor bracket and actuator arm bracket [D] to the copier (🔩 x 3).
4. Attach the sensor harness [E] (🔌 x 1, 🖨️ x 4).
5. Attach the actuator [F] to the arms of the actuator arm bracket.

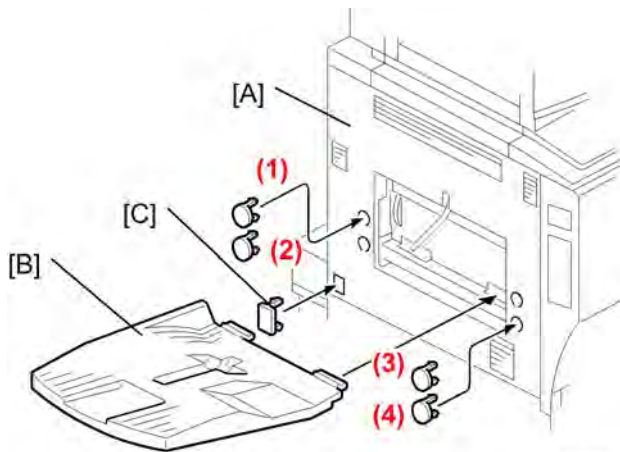

b756i002

6. Reattach the left upper cover [A] (🔩 x2).
7. Attach the tray [B].
8. Attach the small caps to the holes (1), (2), (3), (4).
9. Install the large cap [C] in the finisher power connection point.

A3/11" X 17" Paper Size Tray Type 2105 (B331-01)

3.4 A3/11" X 17" PAPER SIZE TRAY TYPE 2105 (B331-01)

The A3/11" x 17" Paper Size Tray is installed in tray 1 of the main machine.

3.4.1 ACCESSORIES

Check the accessories and their quantities against this list.

Description	Qty
1. A3/DLT Tray	1
2. Short Connector	1
3. Paper Size Decal	1

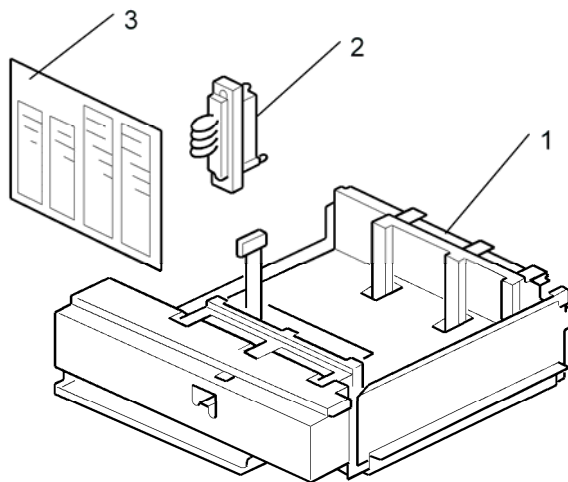

b331i001

3.4.2 INSTALLATION

⚠ WARNING

- Always turn the machine off and disconnect the machine power cord before you do the following procedure.

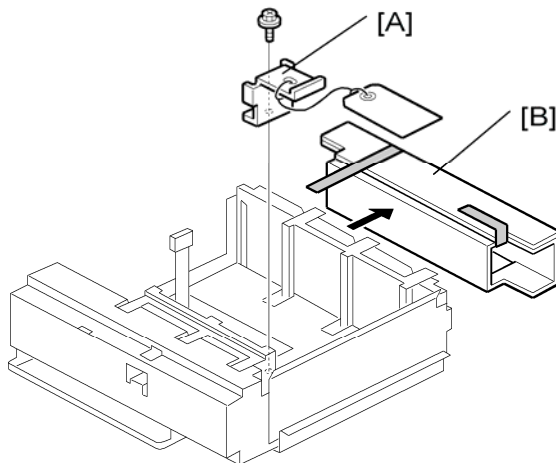

b331i011

1. Remove the metal retainer [A] and packing material [B] (🔩 x 1).
2. Check the position of the front and rear fences, and make sure that they are set for DLT or A3.

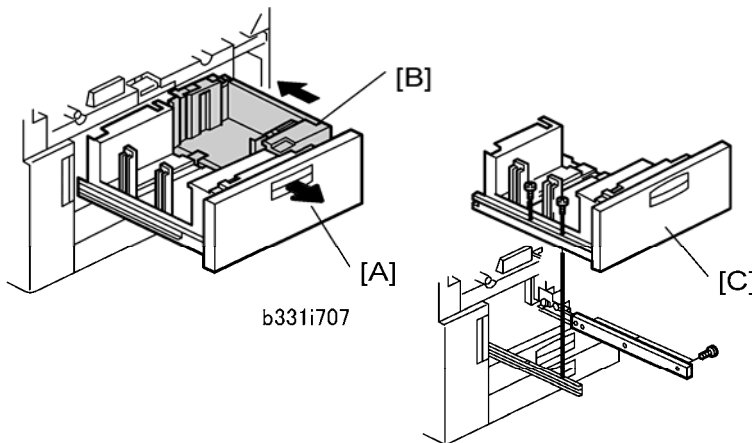

b331i707

b331i708

3. Open the front doors.
4. Pull out the tandem feed tray [A] fully.
5. Push the right tandem tray [B] into the machine.
6. Remove the left tandem tray [C] (🔩 x 2 left, 🔩 x 3 right).

A3/11" X 17" Paper Size Tray Type 2105 (B331-01)

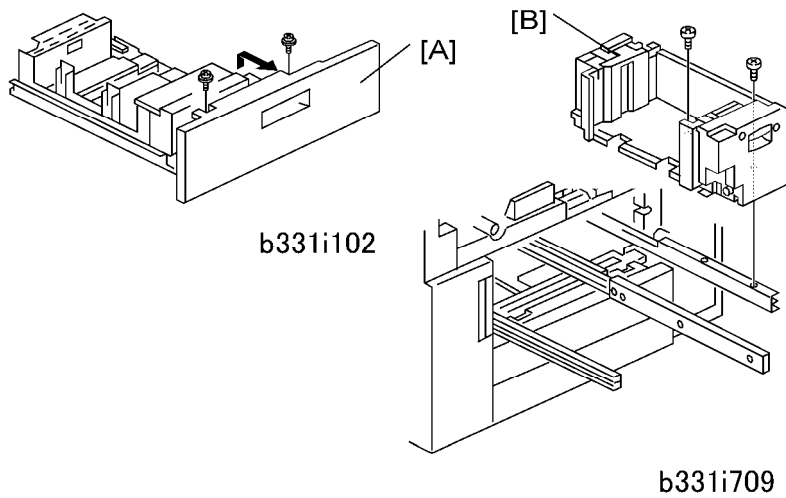

7. From the left tandem tray, remove the front cover [A] (⚙ x 2).
8. Pull out the right tandem tray [B], then remove it (⚙ x 2).

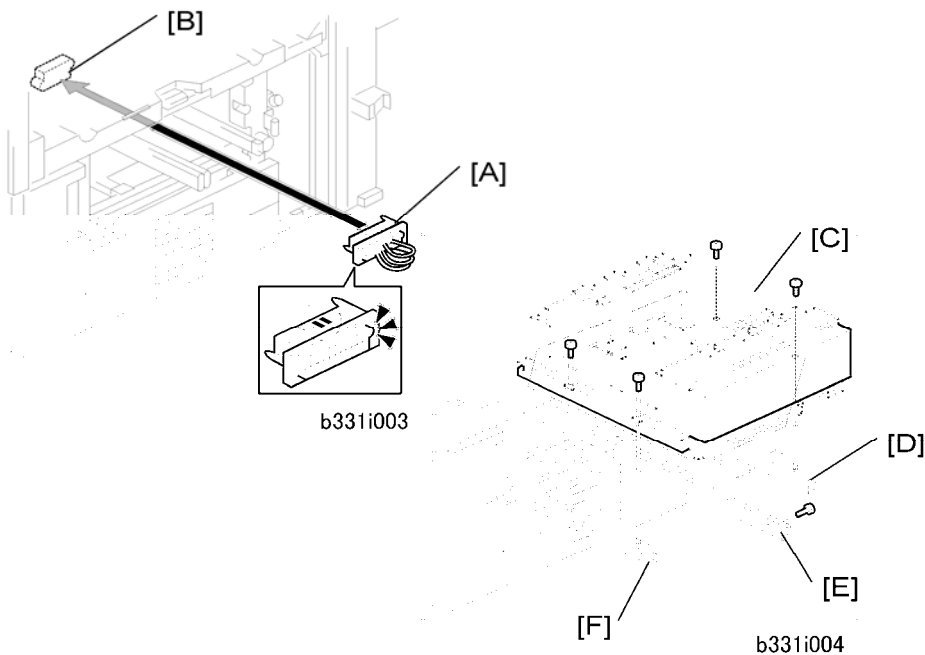

9. Put the short connector [A] into the socket in the machine [B].

↓ Note

- Hold the connector as shown in the illustration.

10. Install the A3/DLT tray [C] on the right rail [D], center rail [E], and left rail [F]. Use the screws that you removed in Steps 6 and 8.

↓ Note

- You must use the short, silver screws on the left and right rails. If you use one of the longer screws, it will stop the movement of the tray on the rails.

A3/11" X 17" Paper Size Tray Type 2105 (B331-01)

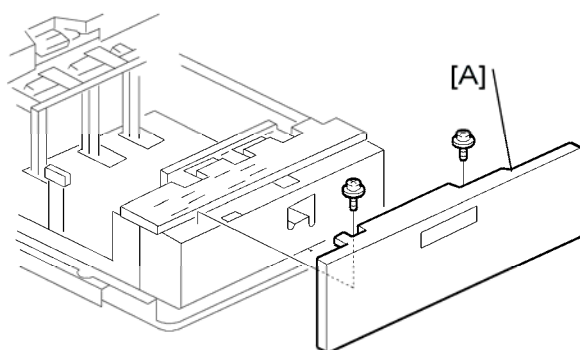

b331i105

11. Install the front cover [A] (2) that was removed from the left tandem tray.
12. Use SP5959 001 to select the paper size for Tray 1 (A3 or DLT).
13. After you select the paper size, turn the machine off and on to change the indicator on the operation panel.

3.5 COUNTERS

This section describes installation of three items:

- Key Card Bracket (B498-03)
- Key Counter Bracket Type 1027 (B452)
- Optional Counter Interface Unit Type A (B870-11)

3.5.1 ACCESSORIES

Key Card Bracket B498

Check the accessories and their quantities against this list.

Description	Qty
1. Key Card Table	1
2. Harness Clamp	1
3. Tapping Screws (M3 x 8)	4
4. Tapping Screws (M4 x 14)	2
5. Stud	1
6. Decal	1
7. Key Card Table Support	1

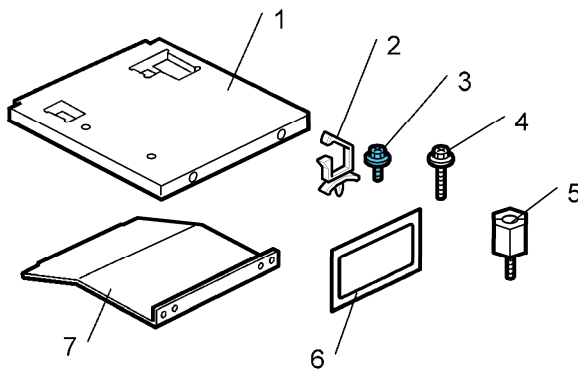

Key Counter Bracket B452 Accessories

Check the accessories and their quantities against this list.

Description	Qty
1. Plate nuts	2
2. Rear Bracket	1
3. Front Bracket	1
4. Tapping Screws (M3 x 6)	2
5. Tapping Screws (M4 x 8)	3
6. Tapping Screws (M4 x 16)	2
7. Harness	1
8. Shoulder Screw	1
9. Key Counter Bracket Cover	1
10. Key Counter Bracket	1

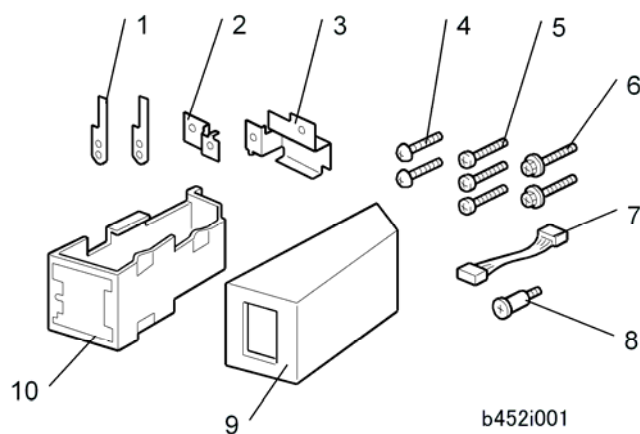
**Optional Counter Interface Unit Type A B870 Accessories**

Check the accessories and their quantities against this list.

Counters

Description	Qty
1. Interface Board (PCB)	1
2. Tapping Screws (M3x6)	4
3. Harness Clamp	1
4. PCB Support	4
5. Harness: VBCU (White)	1
6. Harness: MB (Gray) Not Used	1
7. Harness Clamp	1

3.5.2 INSTALLATION

Assemble the Key Counter Bracket

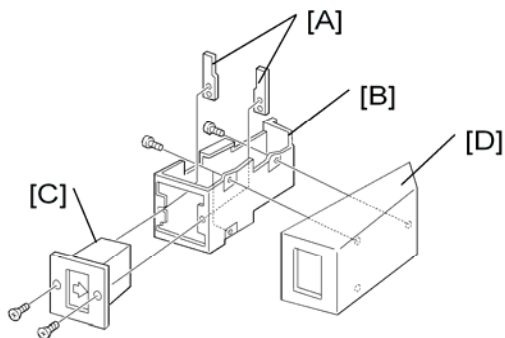

b452i002

1. Hold the key counter plate nuts [A] on the inner surface of the key counter bracket [B].
2. Attach the key counter holder [C] to the key counter bracket (🔩 x 2).
3. Attach the key counter bracket cover [D] (🔩 x 2).

Install the Key Card Bracket and Assembled Key Counter

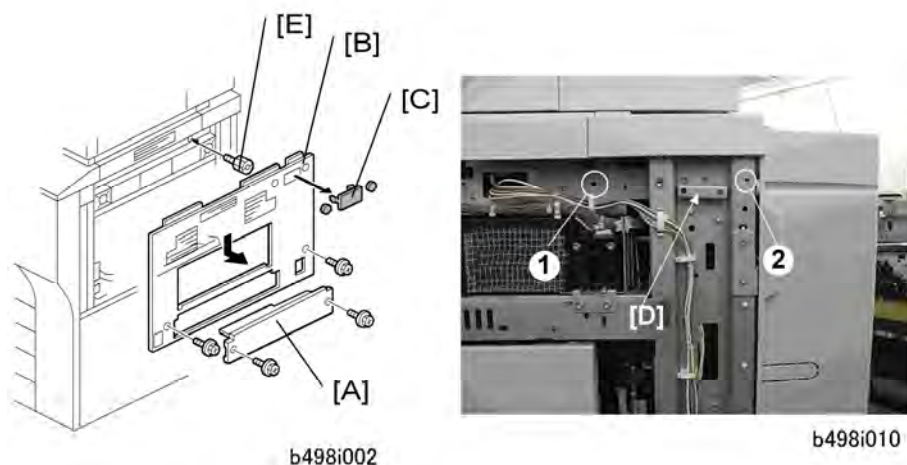

⚠ WARNING

- Always turn the machine off and disconnect the machine power cord before you do this procedure.

1. Remove the cover [A] (🔩 x 2).
2. Remove the right upper cover [B] (🔩 x 2).
3. Remove the three caps [C].
4. If you are installing the key counter bracket, remove connector cover [D] (🔩 x 2).
5. Attach stud [E].

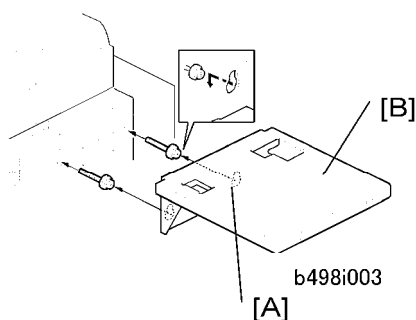

6. Put the keyholes [A] of the key card table [B] over the heads of the shoulder screws, as shown above.
7. Tighten the screws to attach the table (M4 x 14, 🔩 x 2).
8. Attach the key counter bracket or key card. (See below.)

Counters

If you are installing the key counter bracket ...

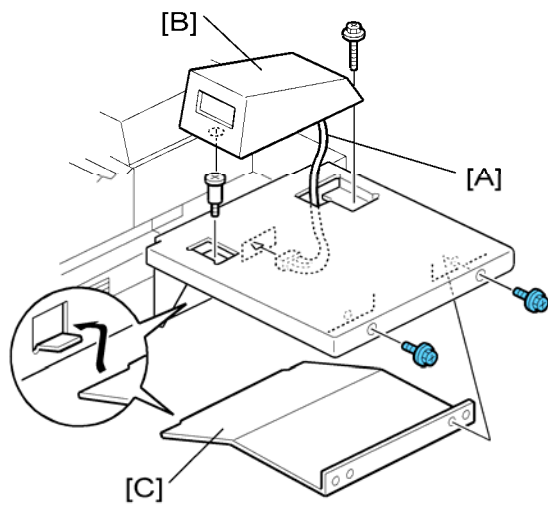

b498i004a

1. Connect one end of the harness [A] to the key counter bracket [B] (🔌 x1).
2. Connect the other end to the 4-pin connector on the right side of the copier.
3. Attach bracket support [C] to the side of the copier (🔩 x 2).

If you are installing the key card ...

1. Remove the rear cover.
2. Remove the control box cover.

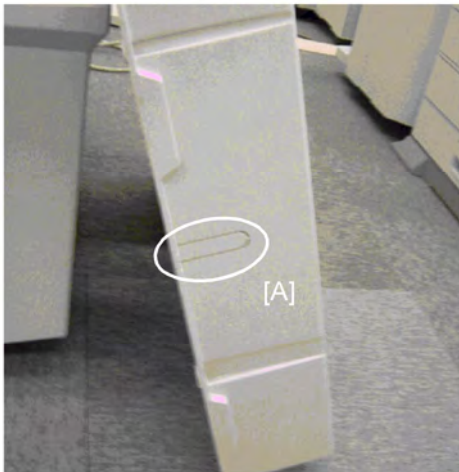

b498i011

3. Remove the cutout [A] in the rear cover.

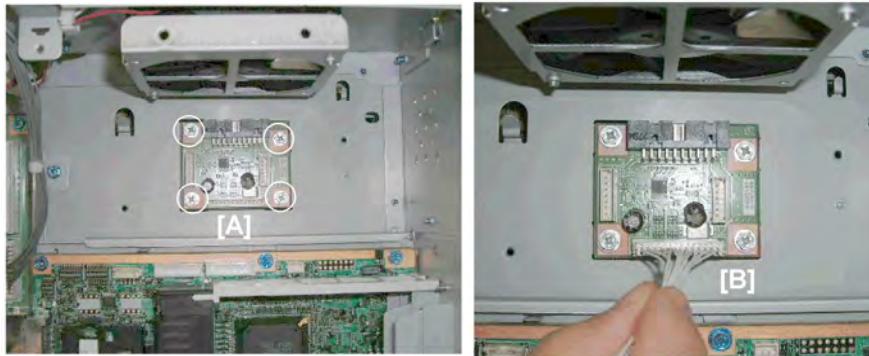

b498i020

4. Attach the circuit board [A] above the controller board (🔧 x4).
5. Connect the small cable [B] to the circuit board (🔧 x1).



b498i025

6. Route the other end of the short cable to the VBCU below (🔧 x2).
7. Connect the short cable to CN223 on the VBCU (🔧 x1).

Counters

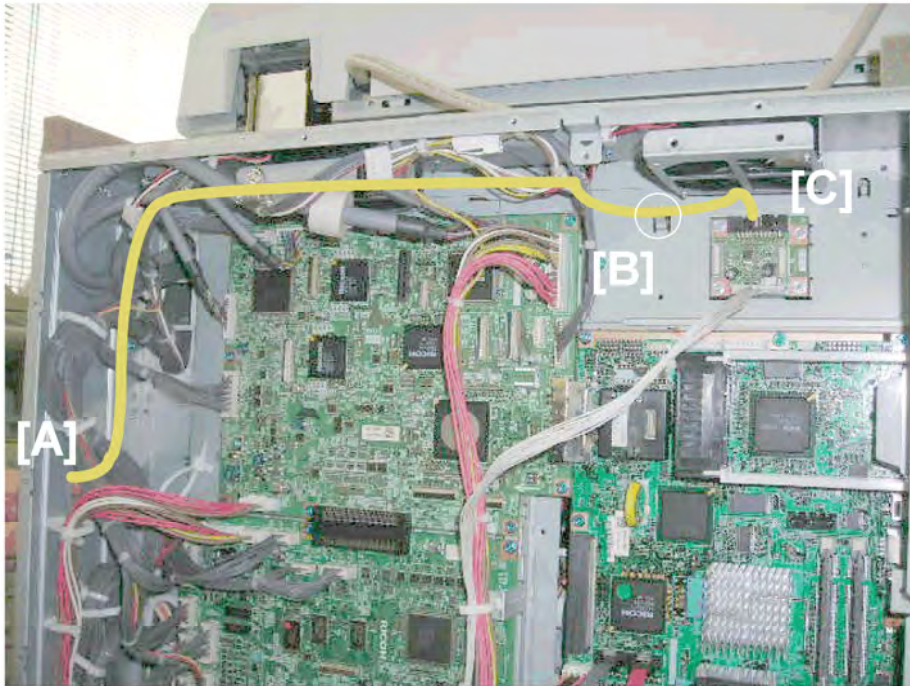

b498i030

8. Route the harness of the key card through the hole [A] in the controller box as shown above.
9. Clamp the harness at [B] then connect to the top of the circuit board [C] (🔌 x1, 🔌 x1).
10. Reattach the controller box cover and rear cover.

3.6 USB2.0/SD SLOT TYPE D (D505-01)

3.6.1 ACCESSORIES

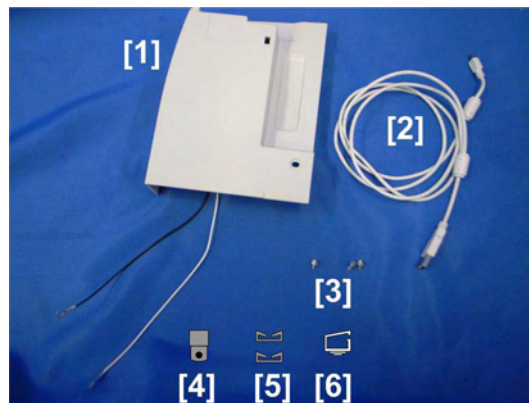

d505i000

No.	Description	Q"ty
[1]	USB2.0/SD Slot Type C	1
[2]	USB Cable	1
[3]	Screws	3
[4]	Flat Harness Clamp	1
[5]	V-Harness Clamps	2
[6]	Harness Clamp (Standoff)	1

3.6.2 INSTALLATION

Preparation

The machine must stand alone for this installation.

- Disconnect the machine from the downstream unit on the left if installed.
- Disconnect the machine from the upstream LCT on the right if installed.

USB2.0/SD Slot Type D (D505-01)

Removing the Operation Panel and Dummy Cover



d505i001

1. Remove the operation panel screws (🔩 x3).

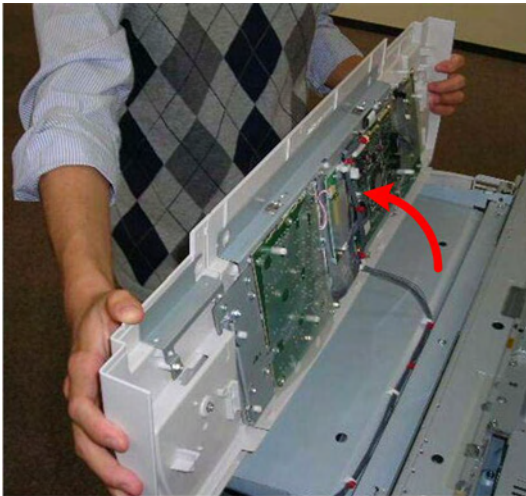

d505i002

2. Raise the operation panel and hold it in the vertical position.

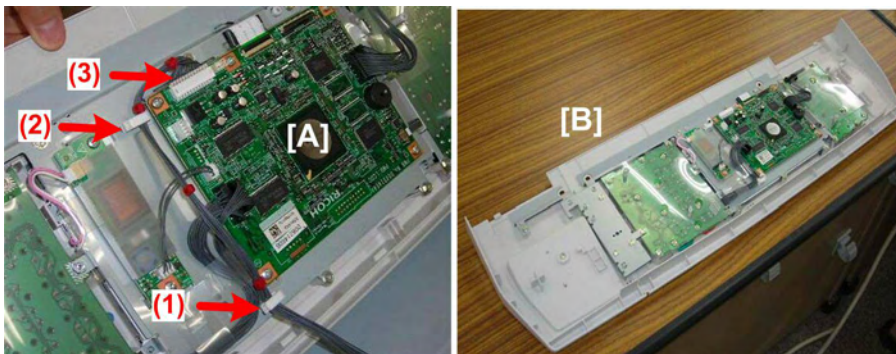

d505i003

3. Disconnect the harness at (1) and (2) (🔌 x2).
4. Disconnect the harness from the board [A] at (3) (🔌 x1).
5. Remove the operation panel [B] from the machine and place it on a flat clean surface.

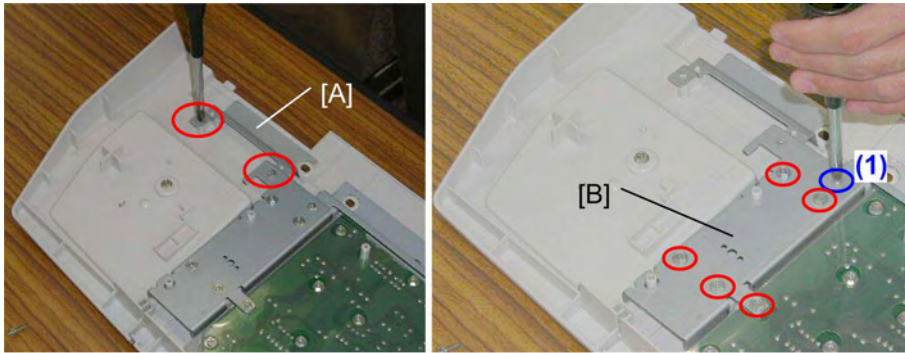

d505i004

6. Remove the screws of small bracket [A] (⌀ x2).
7. Remove the screws of large bracket [B] (⌀ x6).

↓ Note

- Screw (1) is a flat-head screw. Be sure to re-install this screw at this position.

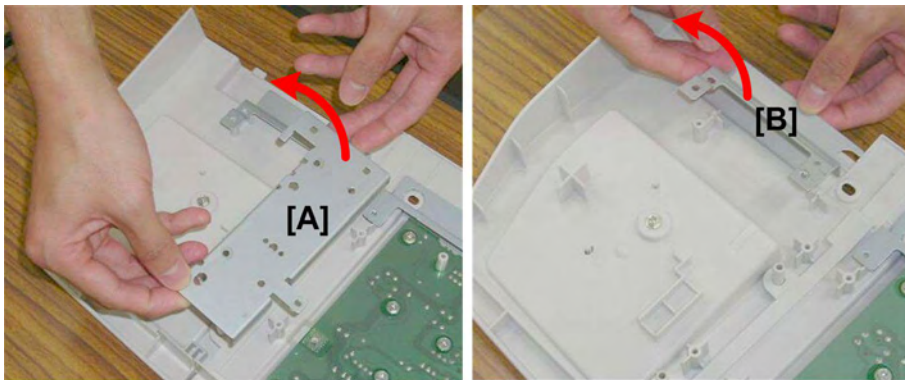

d505i005

8. Remove large bracket [A] and small bracket [B].

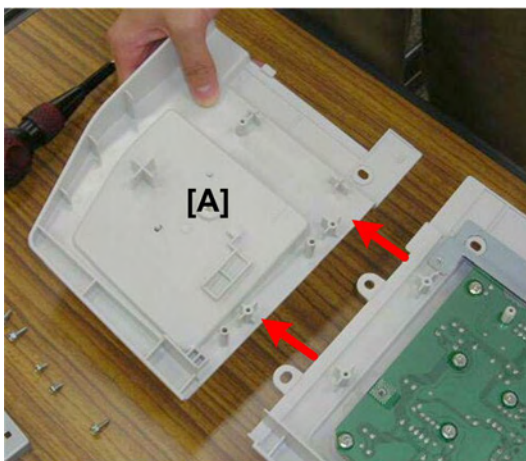

d505i006

9. Remove dummy cover [A] from the operation panel.

USB2.0/SD Slot Type D (D505-01)

Slot Unit Installation

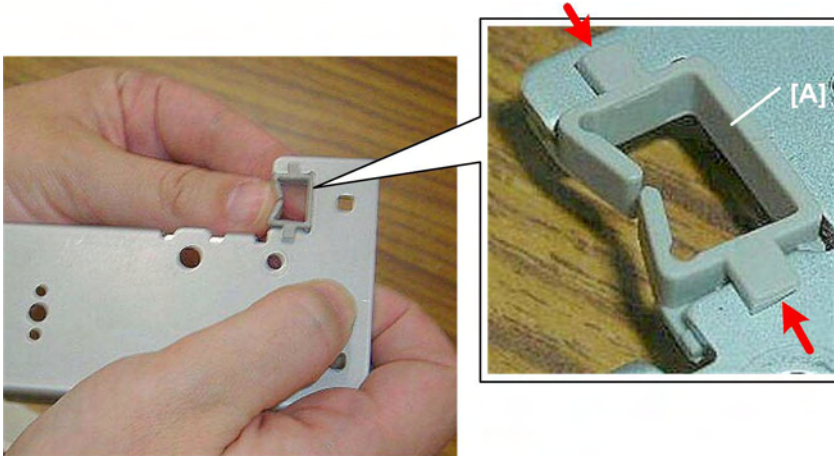

d505i007

1. Attach one accessory V-harness clamp [A]. Make sure that the tabs are on the side of the plate that will be facing down when the large bracket is re-installed.

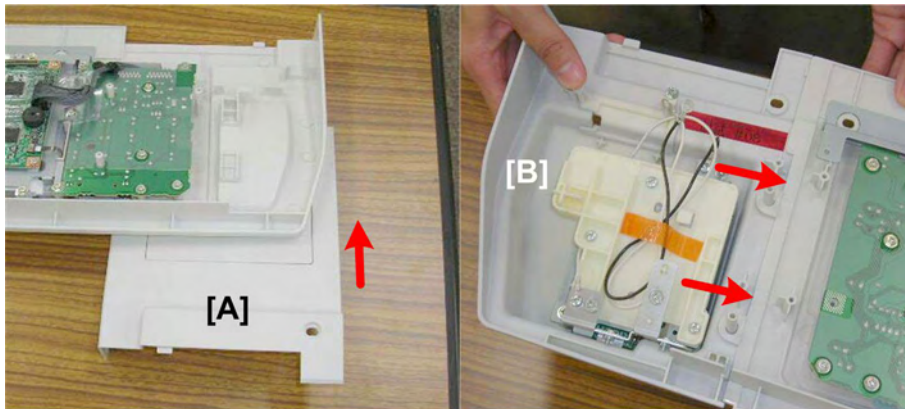

d505i008

2. Lay the dummy cover [A] under the end of the operation panel.
3. Set the slot unit [B] on the other end of the operation panel.

USB2.0/SD Slot Type D (D505-01)

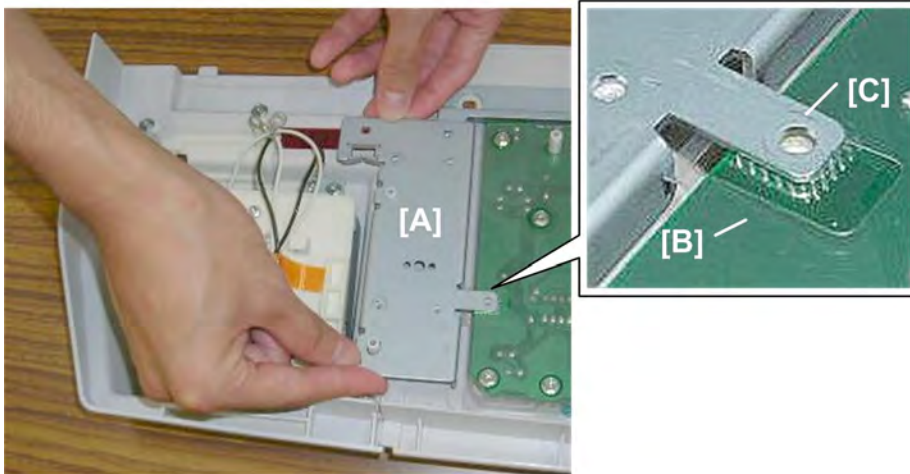

d505i009

4. Lay the large bracket [A] over the joint of the slot unit and operation panel.

★ Important

- Make sure that the plastic cover [B] is below the metal tab [C].

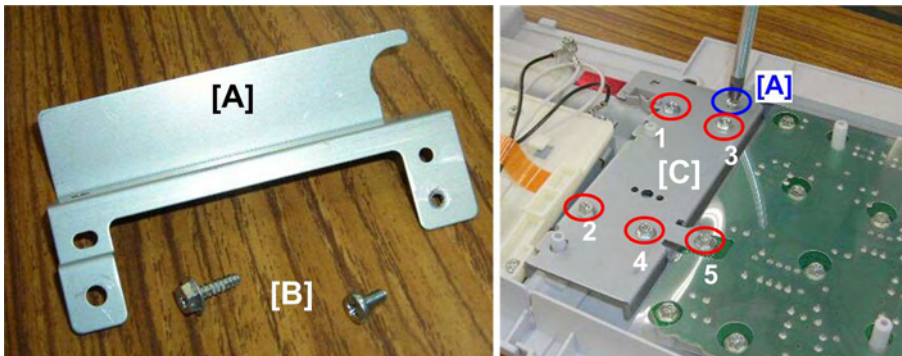

d505i010

5. Discard the short bracket [A] and screws [B] (x2).
6. Re-install large bracket [C] (x6).

★ Important

- You must fasten the flat-head screw at [A].
- Tighten the screws in the order above marked by the numbers 1 to 5. This ensures precise alignment of the bracket.

USB2.0/SD Slot Type D (D505-01)

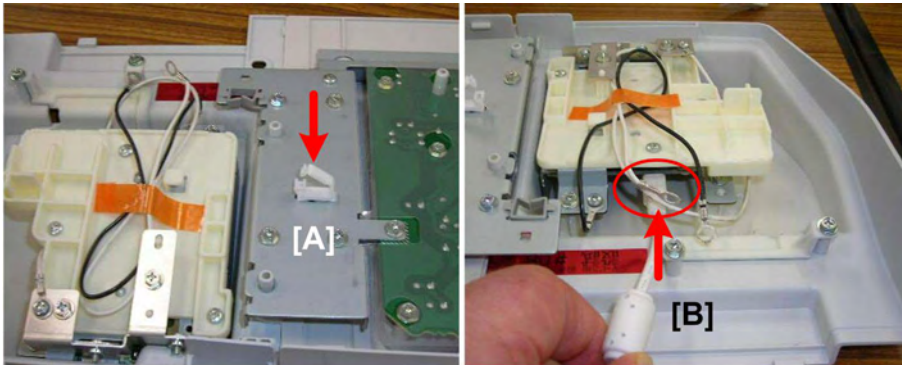

d505i011

7. Set the harness clamp (standoff) [A] on the large bracket.
8. Connect the small end of the accessory USB cable [B] to the slot unit (🔌 x1).

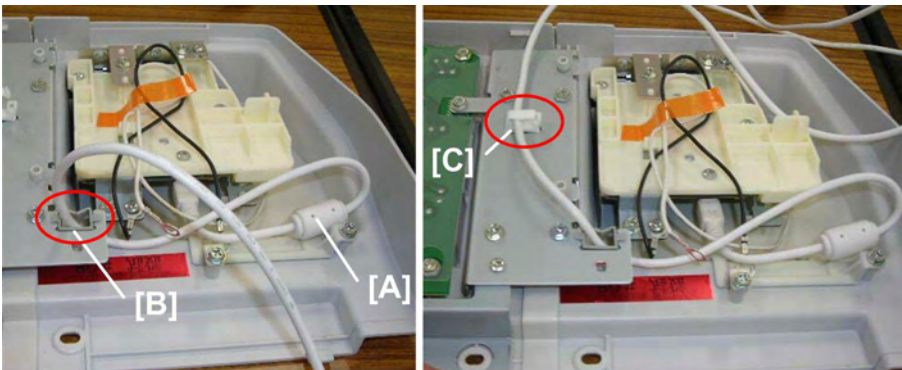

d505i012

9. Coil the USB cable and position the ferrite core [A] as shown.
10. Set the cable in the V-harness clamp [B] and close the clamp (🔌 x).
11. Set the cable in harness clamp [C] and close it (🔌 x).

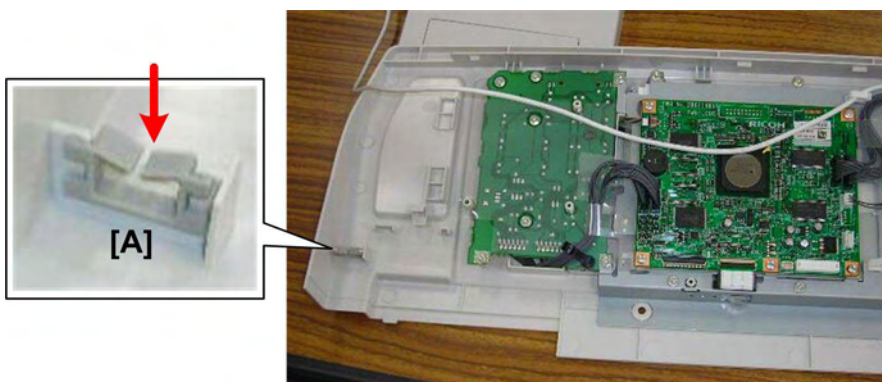

d505i013

12. Set one accessory V-harness clamp [A] at the corner of the operation panel.

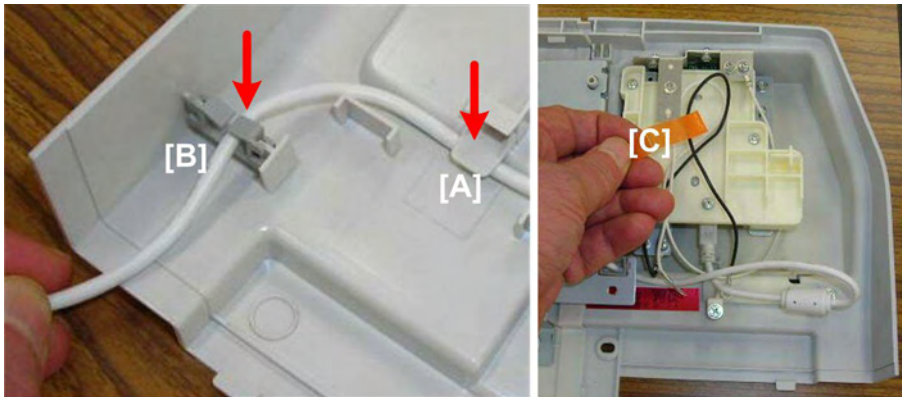

d505i014

13. Set the cable under tab [A].
14. Clamp the cable at [B] (🔧 x1).
15. Remove tape [C] to free the two ground wires.

Knockout, Upper Right Cover



d505i015

1. Remove knockout [A] (🔧 x2).

Note

- This step is not required if the LCT has been installed.



d505i016

2. Open and lower bypass tray [A].
3. Remove upper right cover [B] (🔧 x2).

USB2.0/SD Slot Type D (D505-01)

Upper Left Cover

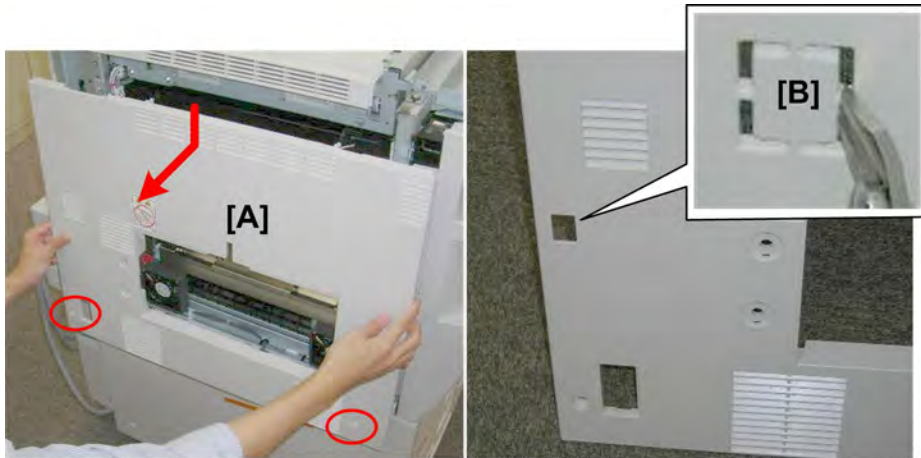

d505i017

1. Remove upper left cover [A] (⚙️ x 2).
2. Use a pair of nippers to remove knockout [B].

Slot Unit Connection

1. Lay the operation panel on the machine where it will be re-installed.



d505i018

2. At the top right corner of the machine, route the ground wires under the cover [A].
3. Fasten the short ground wire [B] (⚙️ x1).
4. Fasten the long ground wire [C] (⚙️ x1).

USB2.0/SD Slot Type D (D505-01)

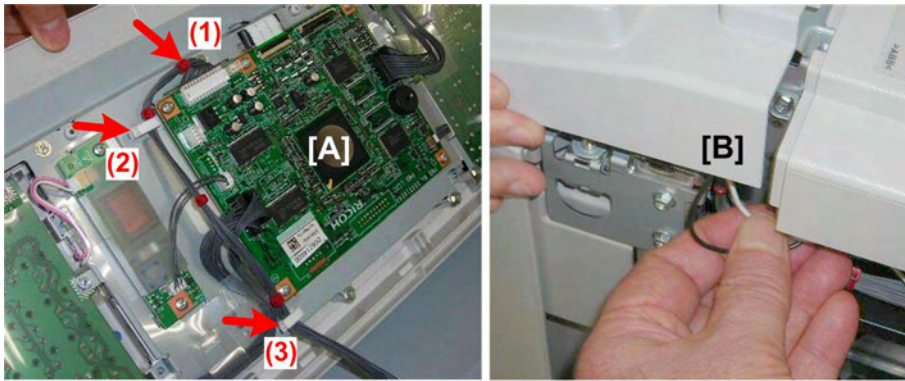

d505i019

5. Raise the operation panel on the machine to the vertical position, and then connect the board [A] (🖨️ x1, 🖨️ x2).
6. At the right side of the operation panel, make sure that the ground wires [B] are not pinched between the main machine and operation panel.

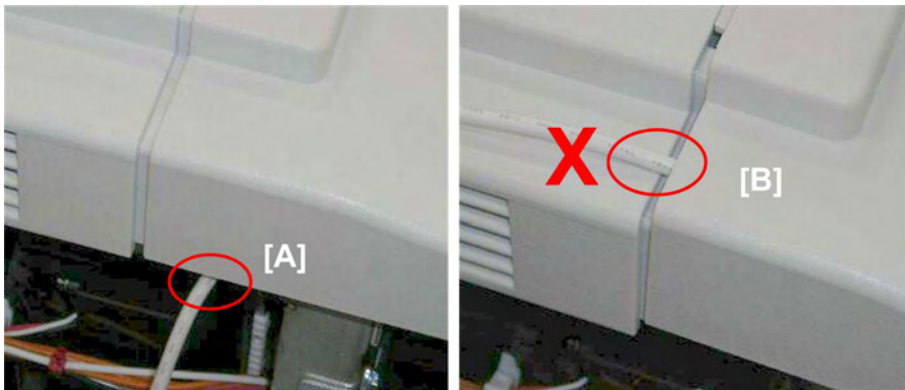

d505i020

7. At the left side of the operation panel, make sure that the USB cable [A] is below the edge of the operation panel as shown.

★ Important

- Make sure that the cable is not pinched as shown at [B].

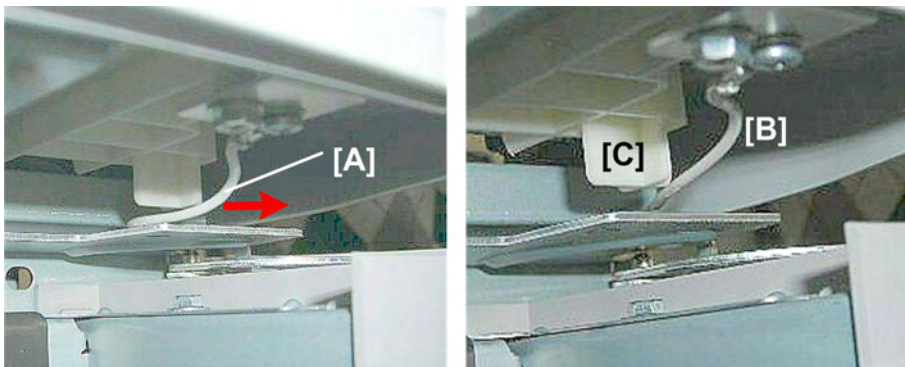

d505i021

8. Under the right corner of the operation panel, push the USB cable from [A] to [B] so that

USB2.0/SD Slot Type D (D505-01)

the cable is to the right of support [C] and not below it.



d505i022

9. Re-set and fasten the operation panel [A] (🔩 x3).

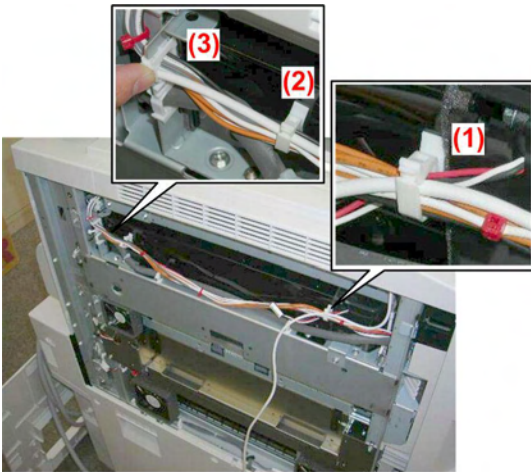

d505i023

10. On the left side of the machine, route the USB cable through the clamps (1), (2), and (3) then close the clamps (🔩 x3).

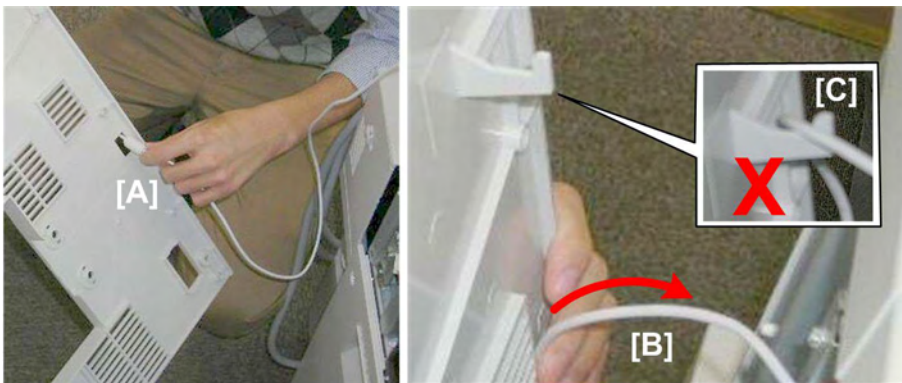

d505i024

11. Insert the USB cable [A] through the hole (where the knockout was removed).
12. Make sure that the cable [B] is free.

★ Important

- Make sure that the cable is not looped over the hook [C] on the back of the left upper cover.



d505i025

- Remove the air filter cover [A] (🔩 x1).
- Remove cover [B] from the USB connection points (🔩 x1).

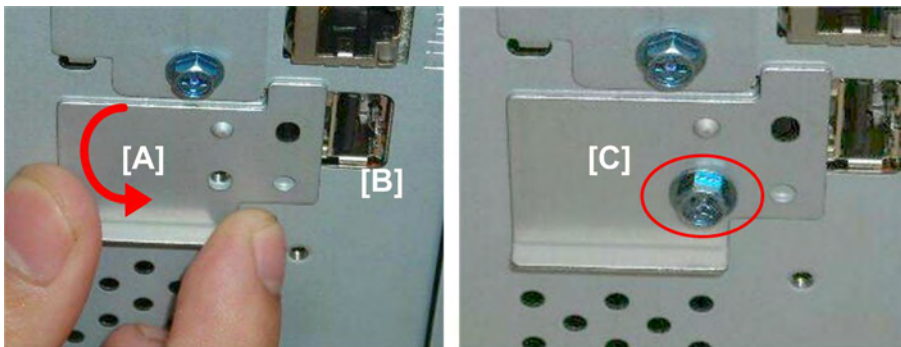

d505i026

- Rotate the cover [A] so that only one USB connection point [B] is visible.
- Fasten the cover [C] (🔩 x1).



d505i027

- Re-attach the air filter cover [A] (🔩 x1).
- Connect the flat end of the USB cable [B] to the machine.

USB2.0/SD Slot Type D (D505-01)

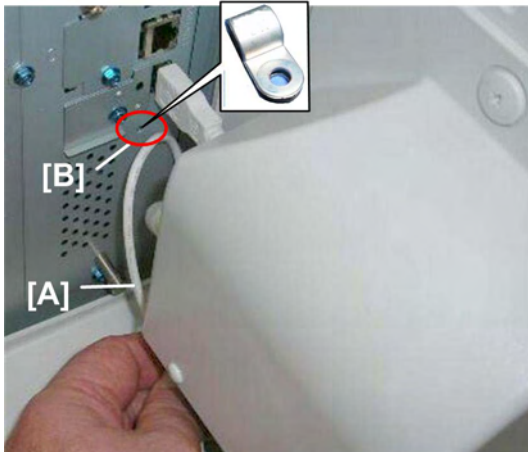

d505i028

19. Coil the USB cable [A] to take up slack.
20. Fasten the cable to the machine at [B] with the flat harness clamp (🔧 x1)

Right Upper Cover, Knockout

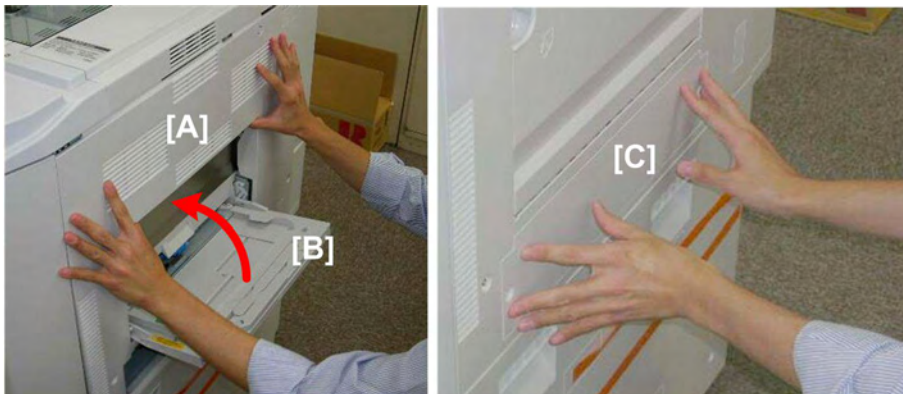

d505i029

1. Re-attach the upper right cover [A] (🔧 x2).
2. Close the bypass tray [B].
3. Re-attach the knockout [C].

↓ Note

- Do not re-attach the knockout [C] if an LCT will be installed or re-connected.

Harness and Cable Check

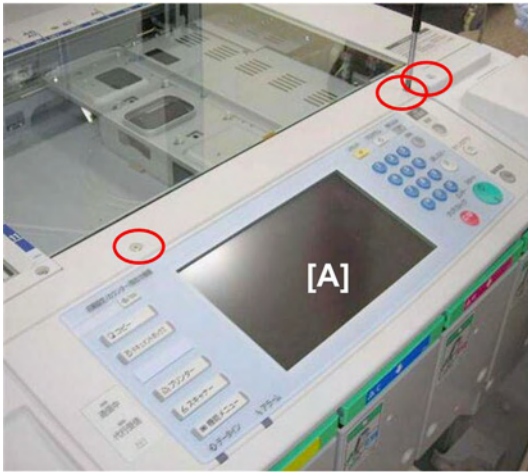

d505i030

1. Remove the operation panel screws ( x3).
2. Lift the operation panel slightly to confirm that the operation panel harness and USB cable are not hung up.
3. Plug in the machine and turn it on.
4. Enter the **Scanner SP mode** and change the setting of SP1013 from "0" to "1".
5. Exit the SP mode and check the operation of the installed unit.

LCT (B473), LCT Adapter Type B (B699)

3.7 LCT (B473), LCT ADAPTER TYPE B (B699)

3.7.1 ACCESSORIES

Check the accessories and their quantities against this list.

LCT (B473)

Description	Qty
1. Upper docking pins (grooved)	2
2. Lower docking pin (not grooved, not for B132/B181/B200)	1
3. Flat-head shoulder screw - M4x6	1
4. Paper Set Decal	1
5. InkJet Caution Decal	1

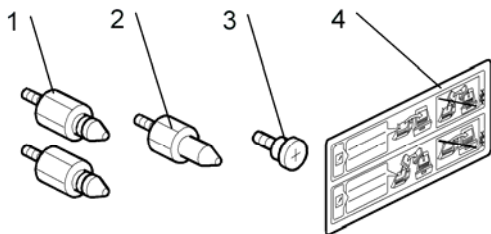

b474i101

LCT Adapter Type B (B699)

Description	Qty
1. Brackets	2
2. Supports	3
3. Machine Screws (M3x8)	3
4. Machine Screws (M4x8)	6

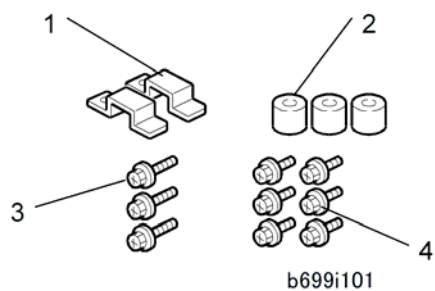

3.7.2 INSTALLATION

Removing Tape and Accessories

⚠ WARNING

- Always turn the machine off and disconnect the machine power cord before you do this procedure.

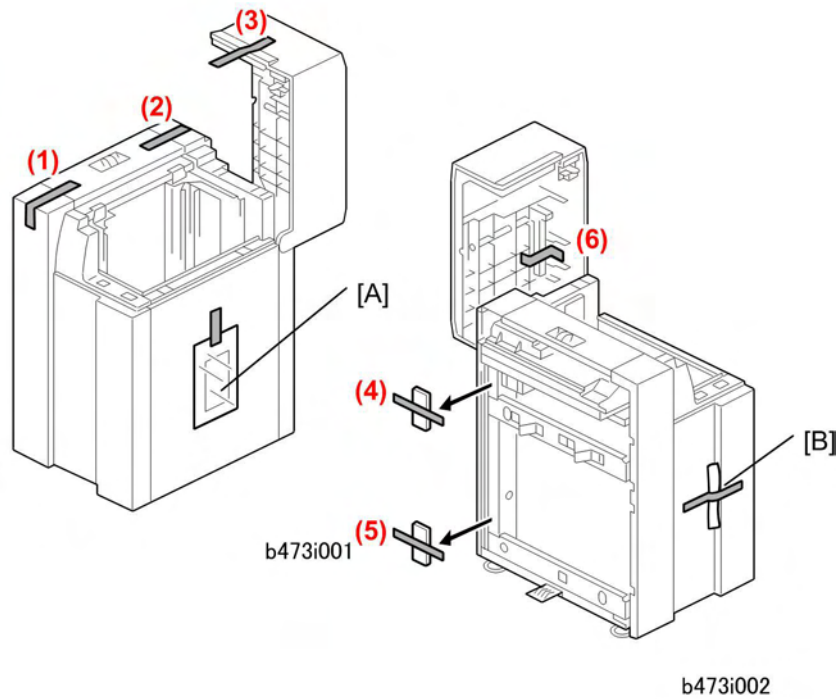

1. Remove all filament tape (1) to (6).
2. Remove:
 - [A] Decals
 - [B] Docking pins

LCT Adapter (B699) Installation

The LCT Adapter Kit B699 must be installed before you install the LCT.

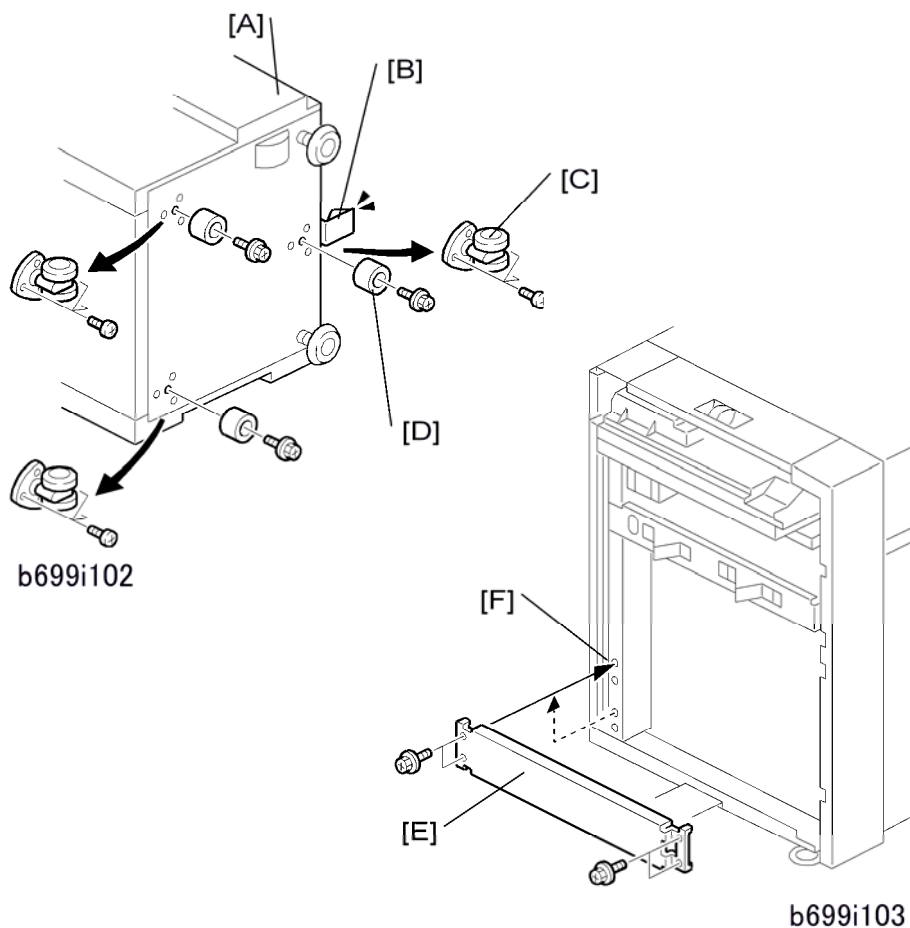

1. Put the LCT [A] on its front side.

★ Important

- Do not put the LCT on its right side (the open side), or you will bend the ground plate [B].
2. Remove the 3 casters [C] (🔩 x 3 each).
 3. Attach the 3 supports [D] (🔩 x 1 each – M3x8 thin screws).
 4. Set the LCT in a vertical position.
 5. Remove the stay [E] (🔩 x 4).
 6. Attach the stay at [F] (🔩 x 4).

LCT (B473), LCT Adapter Type B (B699)

LCT Installation

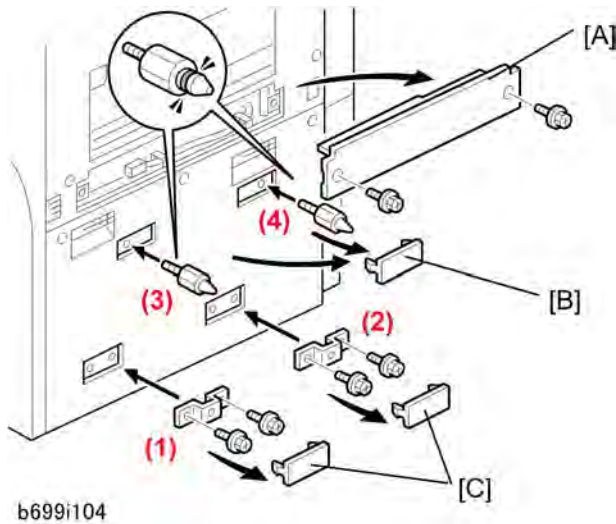

b699i104

1. Remove the LCT installation cover [A] from the right side of the machine (⚙ x 2).
2. Remove the upper covers [B].
3. Remove the lower covers [C].
4. Attach the brackets (1), (2) that are supplied with the LCT Adapter (B699) (⚙ x 2 each – M4 x 8).
5. Attach the two grooved docking pins (3), (4).

↓ Note

- The docking pin without a groove is not necessary for this installation.

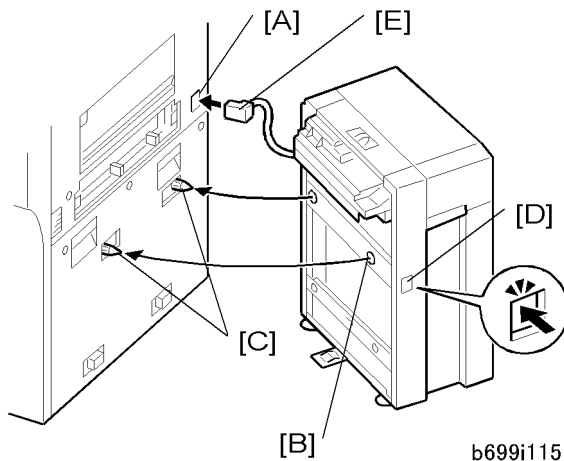

b699i115

6. Remove the connector cover [A].
7. Align the holes on the side of the LCT [B] with the docking pins [C] on the side of the machine.
8. Slowly push the LCT onto the pins.

↓ Note

- The release button [D] is used to unlock the LCT.
9. Connect the plug [E] of the LCT power connector to the side of the machine.

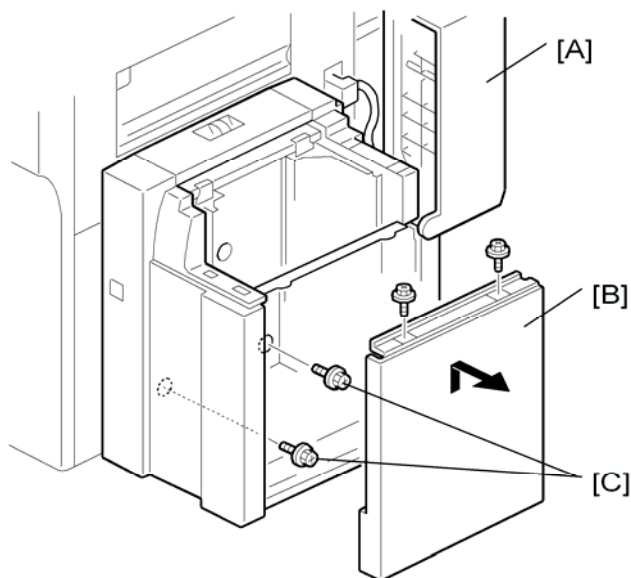

b699i107

10. Open the upper cover [A].
11. Remove the cover [B] (🔩 x 2).
12. Attach screws [C] to the brackets on the side of the machine.
13. Attach the cover [B] with the screw that you removed in Step 11.

LCT (B473), LCT Adapter Type B (B699)

Adjusting Side Fences for Paper Size

Before You Begin...

- The side fences must be adjusted manually for either A4 or LT. The procedure below is not required if the side fences are already set for A4.
 - Before doing this procedure, the LCT must be installed and connected to the copier and the copier must be switched on.
 - The procedure below shows how to move the side fences from the A4 to the LT positions.
1. Turn ON the copier main power switch.

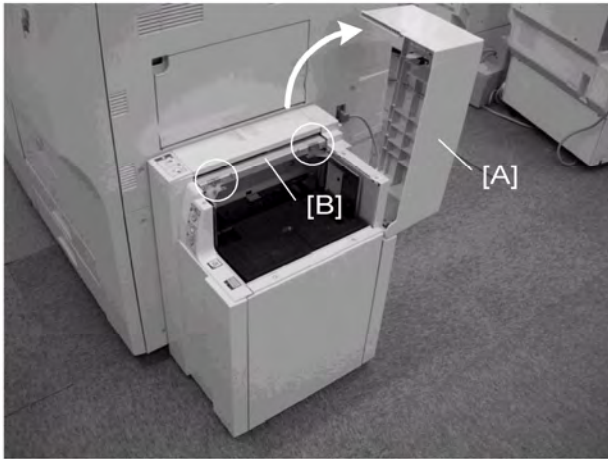

b473i200

2. Open the LCT top cover [A].
3. Check the position markers on plate [B].
 - If the fences are set for A4 and you intend to load A4, the LCT is ready and you do not need to do the following steps.
 - If the fences are set for A4 and you intend to load LT, do the steps below.

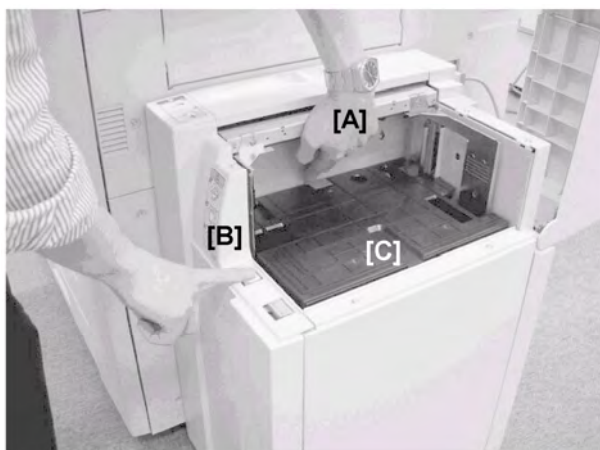

b473i201

4. Cover the photosensor [A] with your left hand.
5. Press the bottom plate operation button [B] until the bottom plate [C] is completely down, then release the button [B].

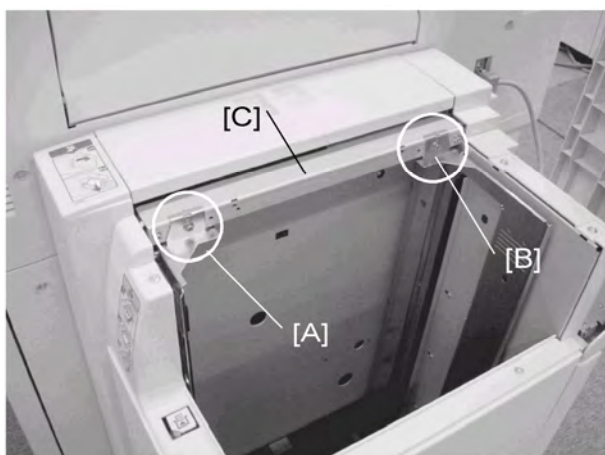

b473i203

6. Use a screw driver to remove the screws fastened to fences [A] and [B] so that the fences slide easily on plate [C].

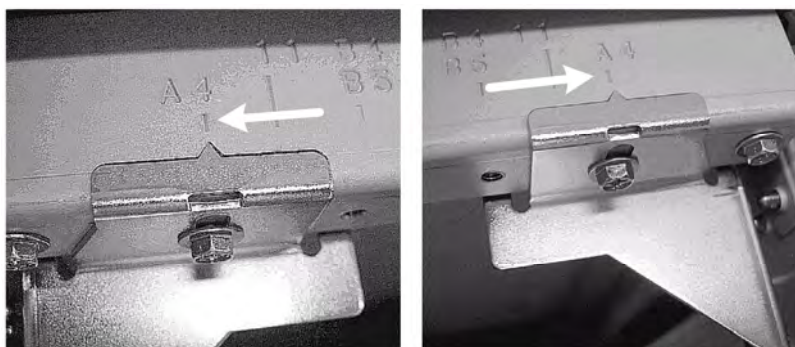

b473i203a

LCT (B473), LCT Adapter Type B (B699)

7. Move each side fence bracket from the A4 to the LT position, then reattach the screws.

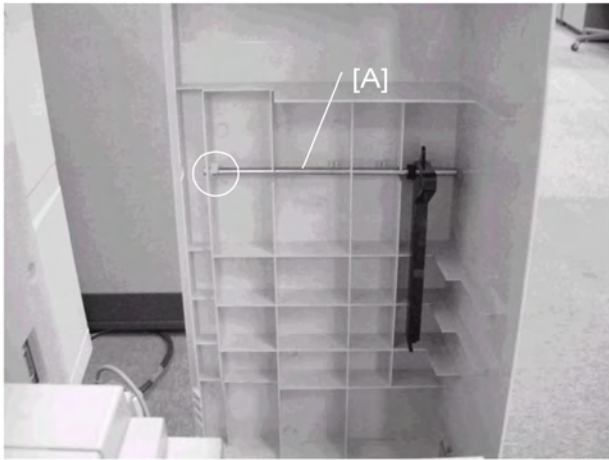

b473i204

8. Remove the shaft [A] from under the LCT top cover (⌘ x1).

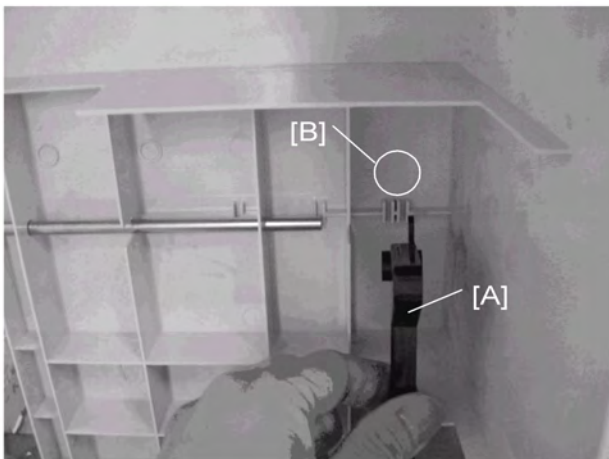

b473i205

9. Move the LCT end fence [A] from the A4 to the LT position (the position guide is written on the LCT top cover at [B]).
10. Insert the shaft [C] (⌘ x1).
11. Close the LCT top cover.
12. Do SP5959-2 and set the value to "1" (for "LT").

Decals



	<p>Precautions for Printing To avoid a malfunction or deterioration in print quality</p> <ul style="list-style-type: none">• Never use Inkjet paper <p>For details about paper type and orientation, see the operating instructions.</p>	ABS<
--	--	------

d081i912

1. Attach the InkJet caution decal for your language to the top of the LCT.

LG Size Tray Type 1075 (B474)

3.8 LG SIZE TRAY TYPE 1075 (B474)

The option can be installed in the LCT (B473).

3.8.1 ACCESSORIES

Check the accessories and their quantities against this list.

Description	Q'ty
1. Tapping screws - M4x8	4
2. Tapping hex screws - M4x8	6
3. Harness clamp	1
4. B4/LG frame	1
5. Front bracket	1
6. Rear bracket	1
7. Bottom plate extension	1
8. Cover	1

3.8.2 INSTALLATION

LCT Connected to the Machine

⚠ WARNING

- Turn the machine off and disconnect the machine power cord before you start this procedure.

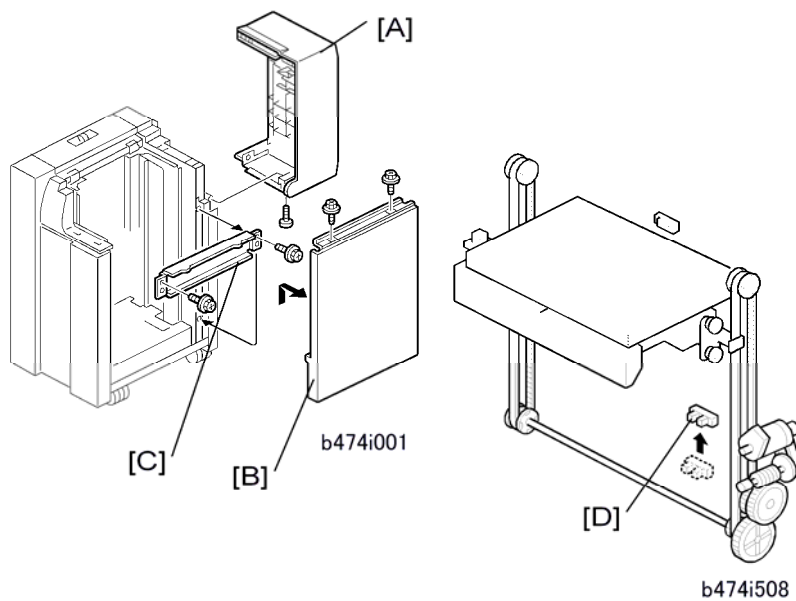

1. If the LCT is connected to the copier:
 - Open the cover and remove the paper.
 - Close the cover.
 - Turn the main power switch off.
 - Disconnect the LCT from the copier.
2. Remove the LCT cover [A] (⚙ x 1).
3. Remove the right cover [B] (⚙ x 2).
4. Remove the right stay [C] and attach it below (⚙ x 2).
5. Change the position of the lower limit sensor [D] (⚙ x 1).
6. Attach the harness clamp (not shown) to the rear of the plate. Use this clamp to hold the sensor connector wire.

LG Size Tray Type 1075 (B474)

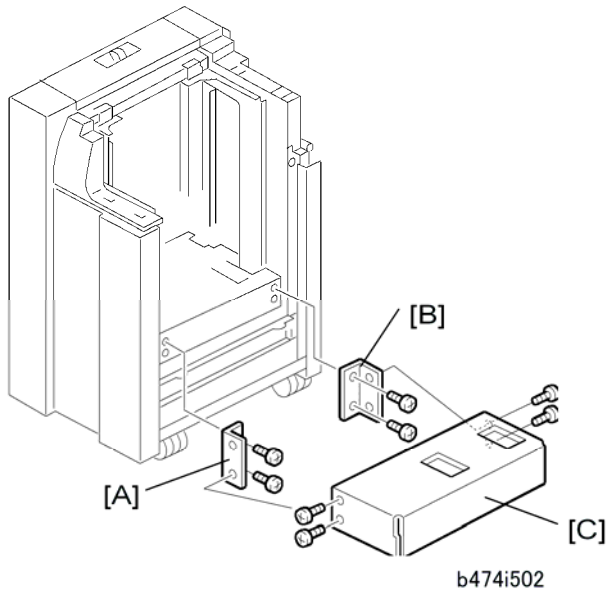

7. Attach the front bracket [A] with the beveled corner down (🔩 x 2).

↓ Note

- If the brackets are not easy to install, lift the bottom plate with your hand.

8. Attach the rear bracket [B] with the beveled corner down (🔩 x 2).
9. Attach the bottom plate extension [C] with the hex screws (🔩 x 4).

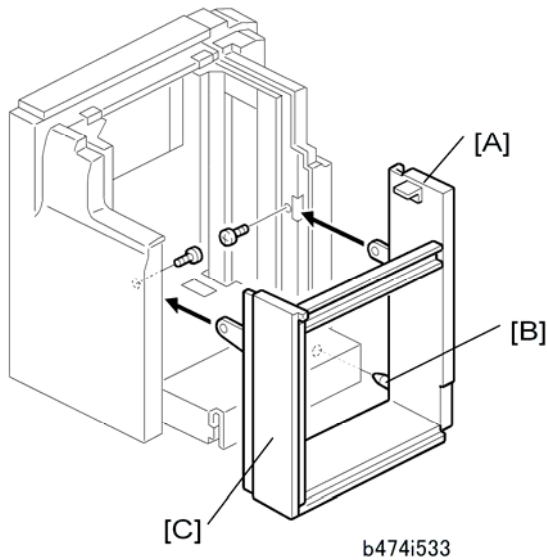

10. Remove the casters from the bottom of the B4/LG frame [A]
11. Align the positioning pin [B].
12. Attach the B4/LG frame [C] with the hex screws (🔩 x 2).

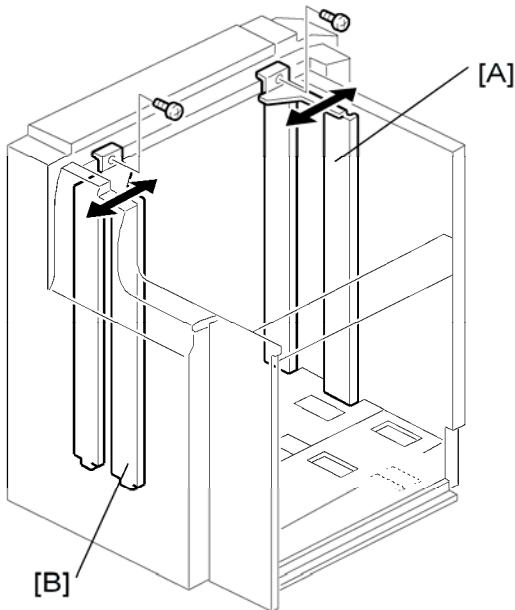

b474i555

13. Move the front side fence [A] and rear side fence [B] to the B4 or 8.5" position and attach it (🔩 x 1).

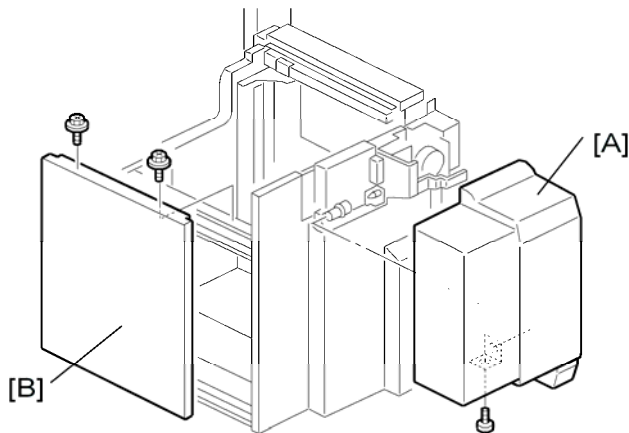

b474i506

14. Attach the cover [A] (8.5" x 14"/B4) (🔩 x 1).
15. Attach the right cover [B] (🔩 x 2).
16. Connect the LCT to the machine.
17. Turn the machine on.
18. Go into the SP mode and do **SP5959-2**.
19. Input "5" for B4 SEF or "6" for 8.5" x 14" SEF.

3.9 LCIT RT4000 (D350)

3.9.1 ACCESSORIES

Check the accessories and their quantities against this list.



- The accessory box is inside the LCIT (see the next page).

	Description	Qty
1.	Stay	1
2.	Relay Unit	1
3	Left Side Fence	1
4.	Right Side Fence	1
5.	Ground Wire	1
6.	Tab Sheet Holder	1
7.	Clamp	1
8.	Screws (M4x8)	2
9.	Screws (M4x8)	3
10.	Screws (Plastic Head)	1
11.	Joint Brackets	2
12.	Shoes	4
13.	Paper Size Decals (A3...)	1
14.	Paper Size Decals (A5...)	1
15.	Paper Loading Decals	1
16.	InkJet Caution Decal	1

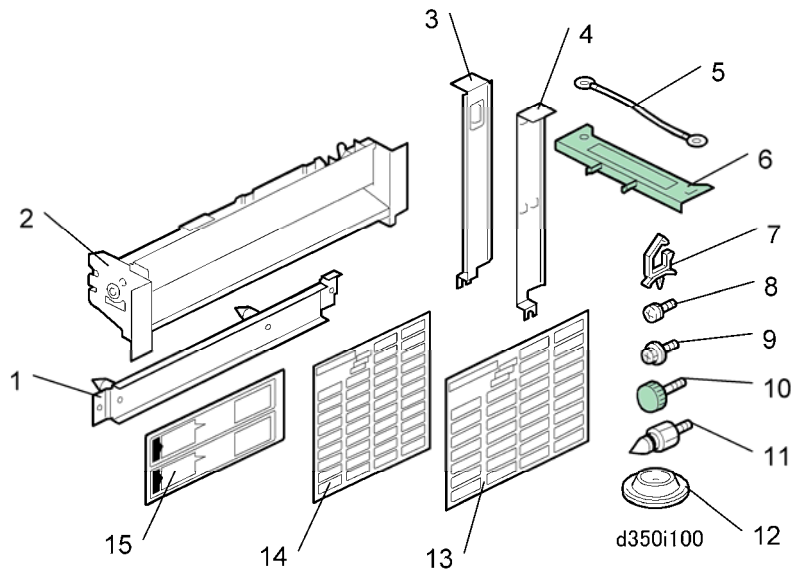

3.9.2 LCT INSTALLATION

Grounding and Preparing the LCT for Docking

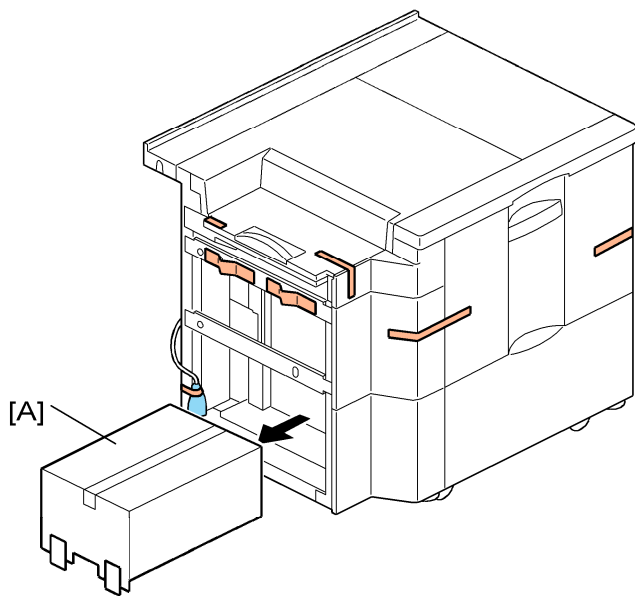

d350i101

1. Remove the accessory box [A] from inside the LCIT.
2. Remove all tapes.

LCIT RT4000 (D350)

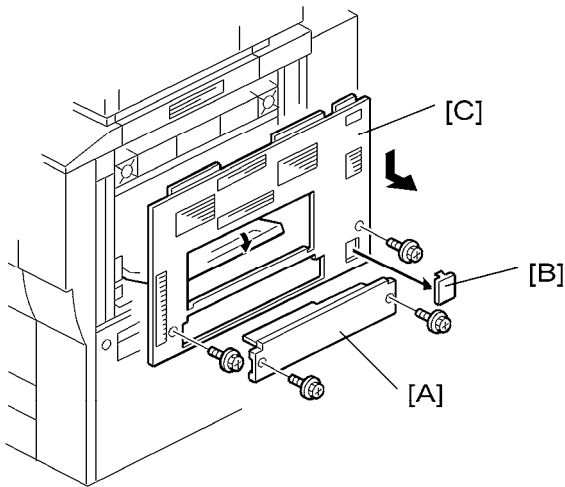

d350i102

3. Remove the paper entrance cover [A] (⚙️ x2).
4. Remove the connector cover [B].
5. Remove the right upper cover [C] (⚙️ x2).

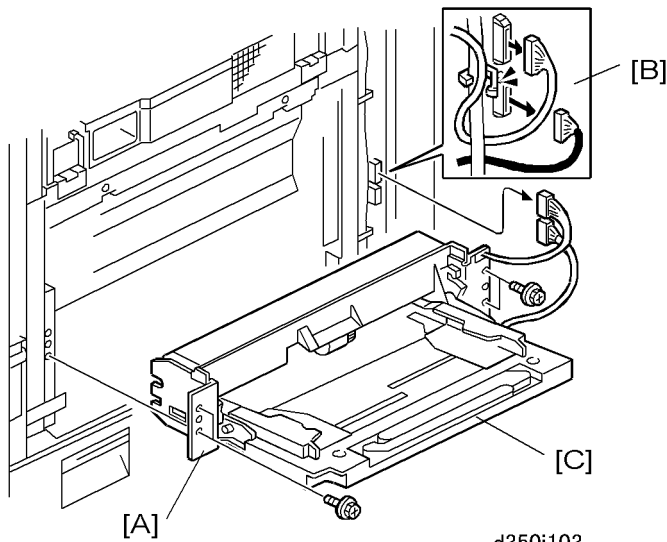

d350i103

6. Remove the plate [A] (⚙️ x2).
7. Disconnect the bypass unit connectors [B] (⚙️ x2).
8. Remove the bypass unit [C] (keep the screws) (⚙️ x4).

↓ Note

- Do not throw away the bypass tray. The customer may need it again later.

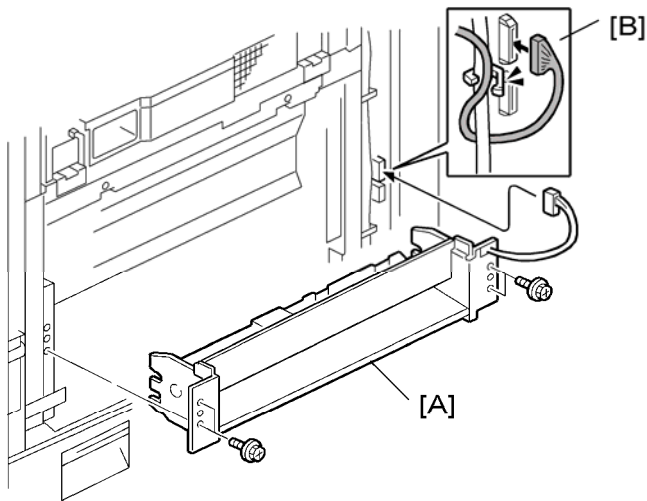

d350i104

9. Use the screws removed with the bypass tray to attach the relay unit [A] (⚙️ x4).
10. Connect the relay harness [B] (🔌 x1).

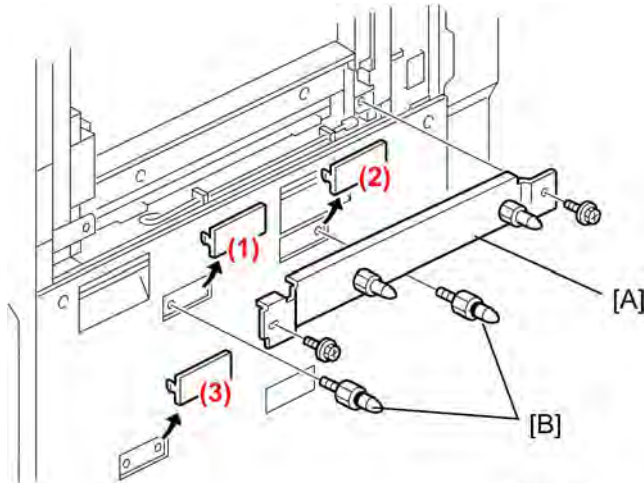

d350i105

11. Remove knockouts: (1), (2), (3).
12. Attached the stay [A] with the provided screws (⚙️ x2).
13. Attach the joint connection pins [B] (x2).
14. Re-attach the right upper cover.

LCIT RT4000 (D350)

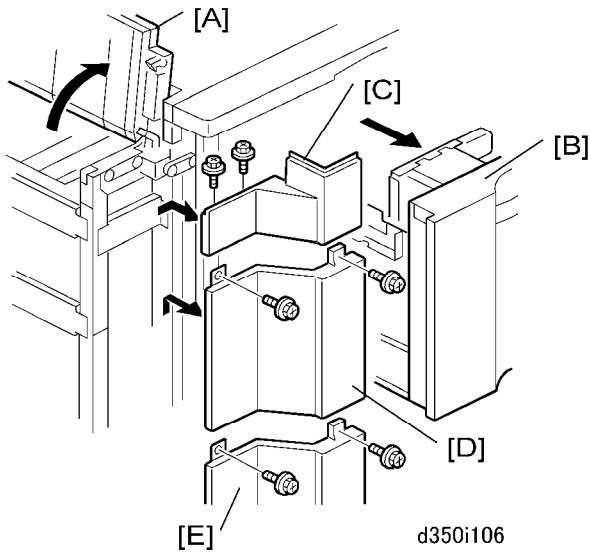

15. On the LCT, raise the paper exit cover [A].
16. Pull the paper tray [B] about halfway out of the unit.
17. Remove the left corner cover (upper) [C] (⚙ x2).
18. Remove the left corner cover (middle) [D] (⚙ x2).
19. Remove the left corner cover (lower) [E] (⚙ x2).
20. Push the paper tray [B] into the LCIT.

★ Important

- The paper tray [B] must be pushed in now. If the paper tray remains out, the LCIT is unstable and difficult to move.

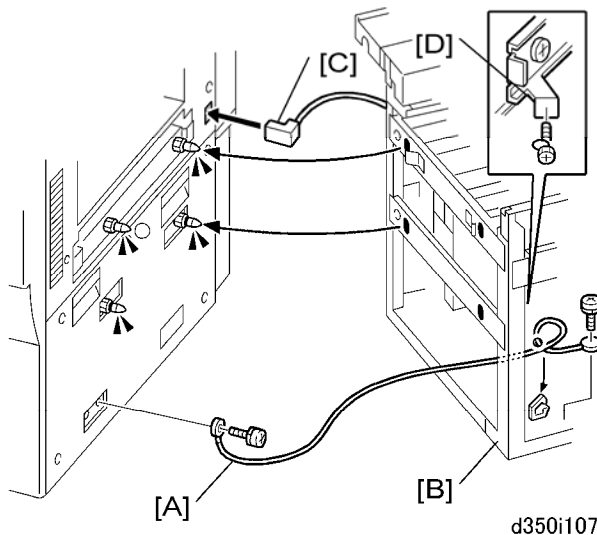

21. Attach the ground wire [A] to the main machine and LCIT (⚙ x2).

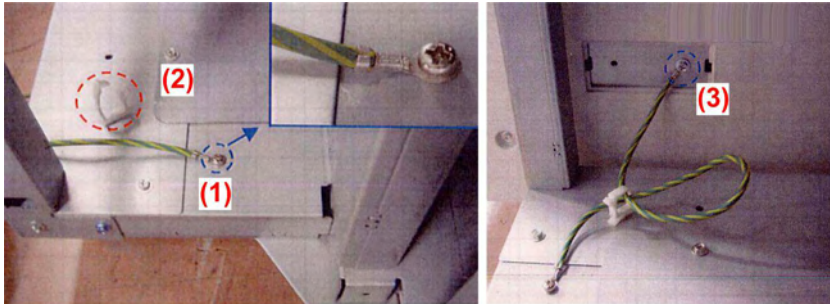

d350i107a

- On the LCIT, attach the ground wire (1) and clamp it at (2) (🔧 x1, 📏x1).
 - Attach the other end of the ground wire to the main machine at (3) (🔧 x1).
22. Push the LCIT [B] against the side of the main machine.
 23. Connect the LCIT I/F cable [C] to the main machine (📏 x1).
 24. Fasten the screw to the lock plate [D] (🔧 x1).
 25. Reattach the left corner plates (🔧 x2 each), push the paper tray into the LCIT, and close the paper exit cover.
 26. If you are going to install the heaters, do this now. See the next section.
- or-
- If you will not install the heaters, skip the next section.

After Installation



d350i120

The paper tray is large and heavy, especially when it is loaded to full capacity. Direct the customer to the warning sticker on the left side of the tray. The label is a reminder that two persons are needed to lift and handle the paper tray safely.

LCIT RT4000 (D350)

3.9.3 ANTI-CONDENSATION HEATER TYPE B: 120V

Accessory Check

No.	Description	Qty
1	PTC Heater 100V to 240V 13W	2

CAUTION

- Unplug the machine power cord before starting the following procedure.
- Do the following procedure in order to prevent damage to the harnesses.
- Check that the harnesses are not damaged or pinched after installation.

The correct wire heaters must be installed for the machine.

Main Machine	PTC Heater	Harness Color
D081-17 only (120V)	100V to 240V 13W (D3500900)	WHITE

Installation Procedure for 120V

1. Confirm that the heater unit is the correct type for the machine:
 - 120V Model: Both connector harnesses are WHITE. (Use for this installation.)

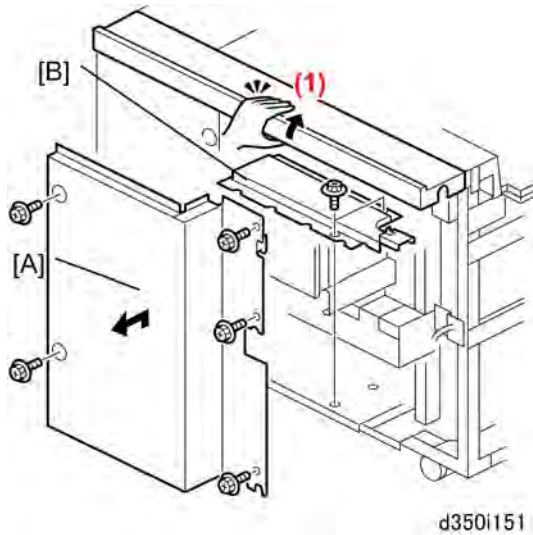

- 208 - 240V Model: Both connector harnesses are RED. (Do not use for this installation.)
2. At the back of the LCIT, remove:
 - [A] Rear cover (⚙ x5). Lift cover (1) to remove rear cover.
 - [B] Heater cover (⚙ x2)

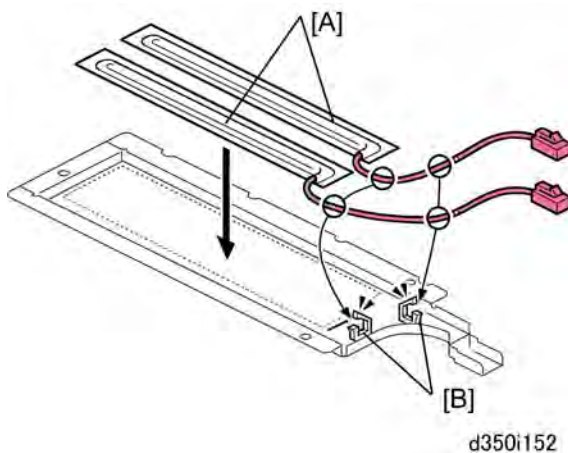

3. Remove the seals from the bottom of the heater units [A] and attach the heaters to the heater cover.
4. Confirm that the heaters are not touching or overlapping.
5. Route both harnesses through the clamps [B] and fasten the clamps.

LCIT RT4000 (D350)

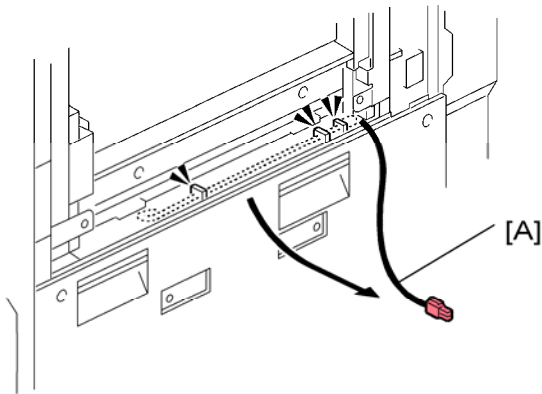

d350i153

6. Pull the heater connection harness [A] away from the right side of the main machine.

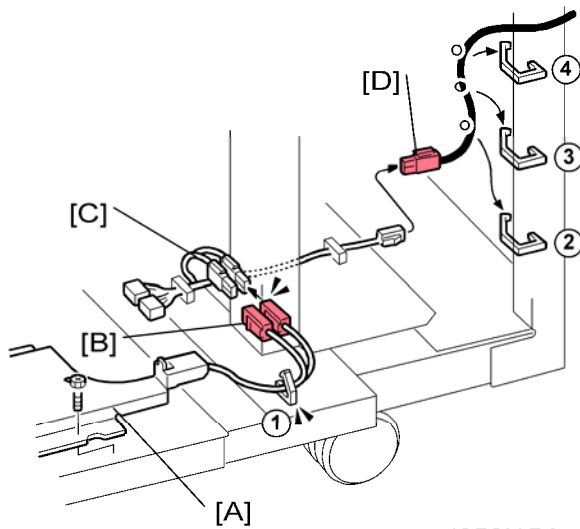

d350i154a

7. Fasten the heater cover [A] to the base plate (🔩x2).
8. Connect the heater harnesses [B] to the relay harness [C] (🔌x2).
9. Connect the harness from the main machine [D] to the relay harness [C] (🔌x1).
10. Clamp the harnesses (1) to (4) (🔧x4).

3.9.4 ANTI-CONDENSATION HEATER TYPE B: 240V

Accessory Check

No.	Description	Qty
1	Nichrome Wire Heater 230V 18W	2

CAUTION

- Unplug the machine power cord before starting the following procedure.
- Do the following procedure in order to prevent damage to the harnesses.
- Check that the harnesses are not damaged or pinched after installation.

The correct wire heaters must be installed for the machine.

Machine	Nichrome Wire Heater	Harness Color
D082-17 (208V-240V) D081-19, -27, -29 (220V-240V) D082-19, -21, -27, -29 (220V-240V)	230V 18W (D3500901)	RED

LCIT RT4000 (D350)

Installation Procedure for 240V

1. Confirm that the heater unit is the correct type for the machine:
 - 120V Model: Both connector harnesses are WHITE. (Do not use for this installation.)
 - 208V-240V Model: Both connector harnesses are RED. (Use for this installation.)

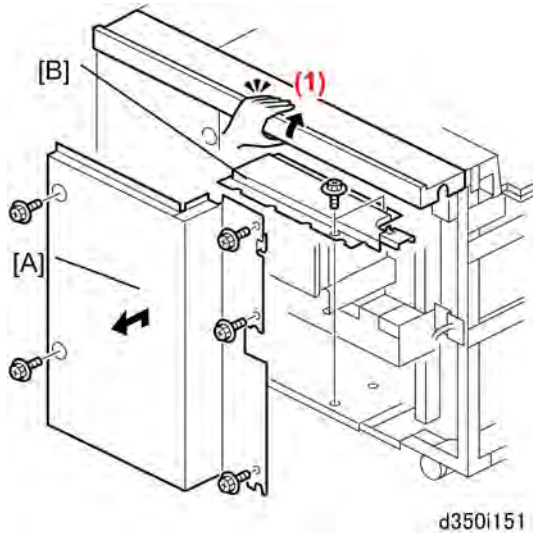

2. At the back of the LCIT, remove:
 - [A] Rear cover (⚙ x5). Lift (1) to remove the rear cover.
 - [B] Heater cover (⚙ x2)

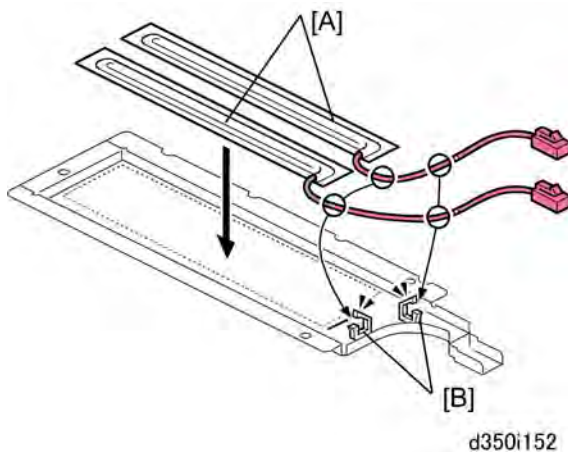

3. Remove the seals from the bottom of the heater units [A] and attach the heaters to the heater cover.
4. Confirm that the heaters are not touching or overlapping.
5. Route both harnesses through the clamps [B] and fasten the clamps.

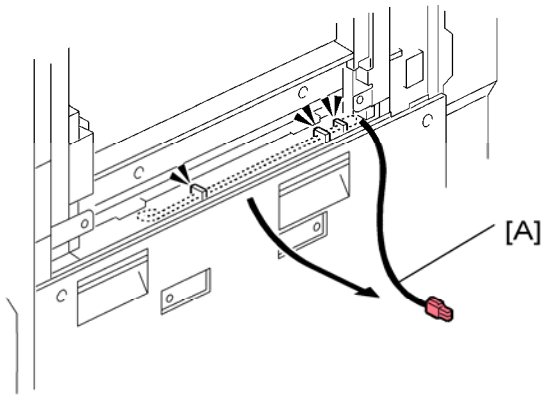

d350i153

6. Pull the heater connection harness [A] away from the right side of the main machine.

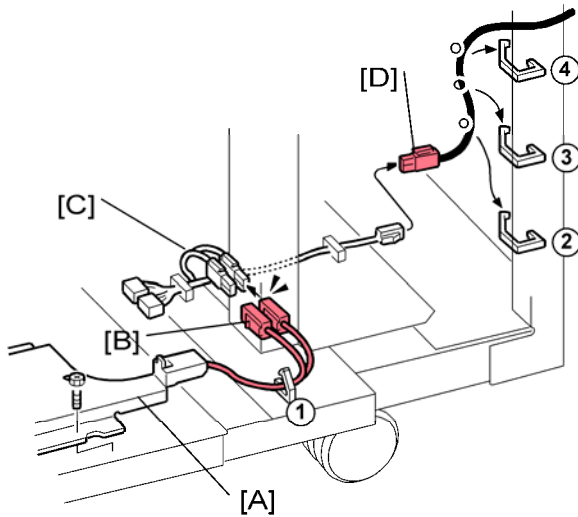

d350i154

7. Fasten the heater cover [A] to the base plate (⚙️x2).
8. Connect the heater harnesses [B] to the relay harness [C] (⚙️x2).
9. Connect the harness from the main machine [D] to the relay harness [C] (⚙️x1).
10. Clamp the harnesses as shown (⚙️x4).

LCIT RT4000 (D350)

Decals

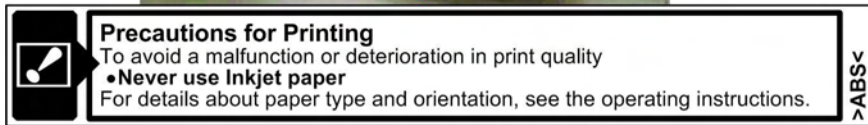
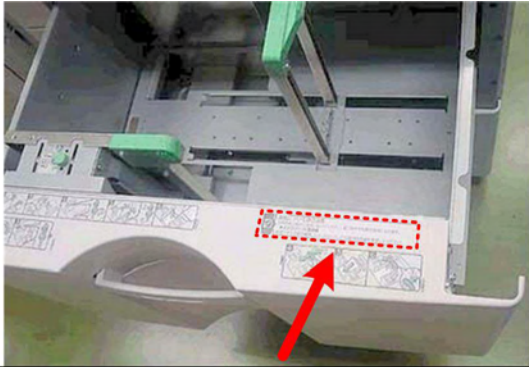

d081i913

1. Open the paper tray and attach the InkJet caution decal for your language to the right side.

3.10 COVER INTERPOSER TRAY CI5000 (B835-57)

3.10.1 ACCESSORIES

Check the quantity and condition of the accessories in the box against the following list.

	Description	Q'ty
1.	Spacer	1
2.	Black Mylar	1
3.	Relay Guide Plate – Long (for B234/B235/B236)	1
4.	"L" Hinge Pins (Tray Unit Front Cover)	2
5.	Sponge Strip	1
6.	Leveling Shoes	4
7.	Rear Docking Bracket	1
8.	Front Docking Bracket	1
9.	Flat Knob Screw	1
10.	Screw (M4 x 8)	4
11.	Screw (M3 x 6)	2
12.	Screw (M4 x 12)	2
13.	Knob Screw	3
14.	Base Cover (Tray Unit)	1
15.	Rear Cover	1
16.	Screws (M4 x 14)	4
17.	Relay Guide Plate – Short (for D014/D015/D081/D082)	

Cover Interposer Tray CI5000 (B835-57)

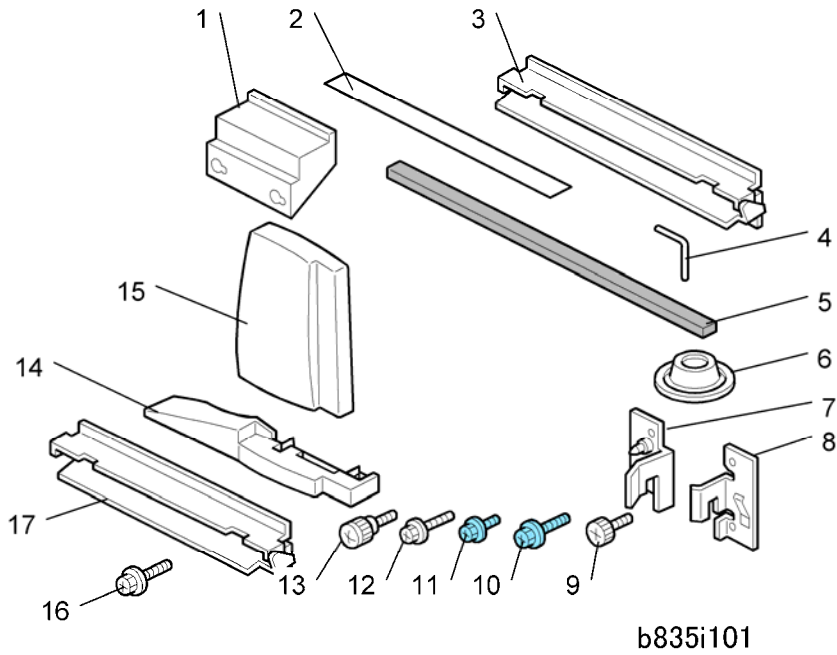

3.10.2 INSTALLATION

Setting up the Unit and Docking to the Copier

⚠ CAUTION

- Unplug the power cord before starting the following procedure.

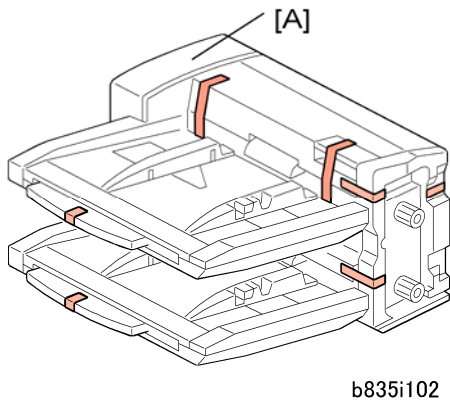

1. Remove all the tape and shipping materials from the tray unit [A].

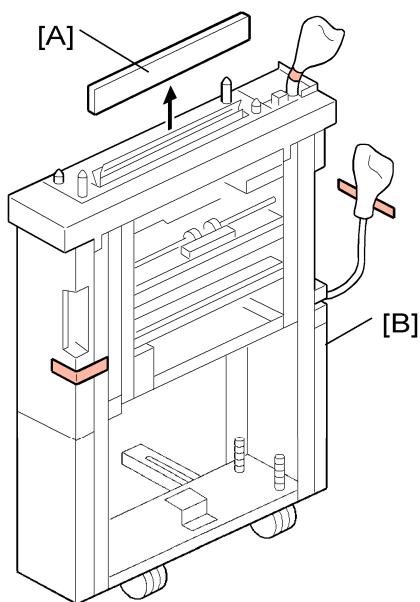

b835i103

2. Remove cover [A].
3. Remove all tape and shipping materials from the transport unit [B].

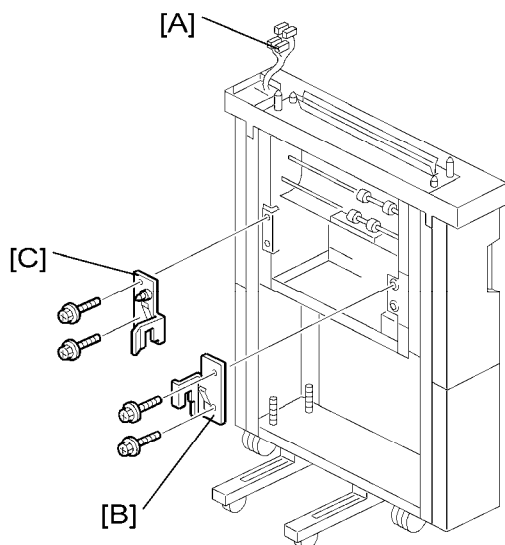

b835i105

4. Confirm that the connectors [A] are free.
5. Attach the front docking plate [B] (⚙️ x2).
 - ★ Important
 - You must use the M4 x 14 screws.
6. Attach the rear docking plate [C] (⚙️ x2). These are the docking plates for the next device to be installed in the paper feed line.

Cover Interposer Tray CI5000 (B835-57)

★ Important

- You must use the M4 x 14 screws.

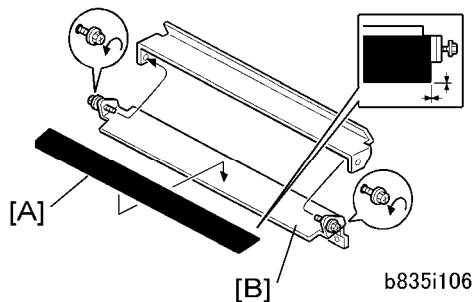

7. Attach the black mylar [A] to the relay guide plate [B] of the next finishing device to be installed to the left of the cover interposer tray.

★ Important

- Do not attach this mylar to either the long or short guide plates provided with the cover interposer tray accessories.

8. Peel the tape from the back of the sponge strip [A] and attach it as shown.
9. Attach the relay guide plate [B] (🔩 x2).

★ Important

- You must use the Relay Guide Plate – Short (12-in.)

10. Remove the ground plate [C] from the bottom cross-piece (🔩 x2).
11. Turn the ground plate over.
12. Reattach the ground plate with the same screws as shown (🔩 x2).

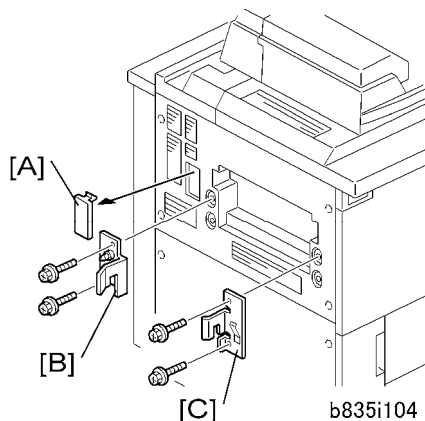

13. Remove the interface connector cover [A].
14. Attach the rear docking bracket [B] (🔩 x2).
15. Attach the front docking bracket [C] (🔩 x2).

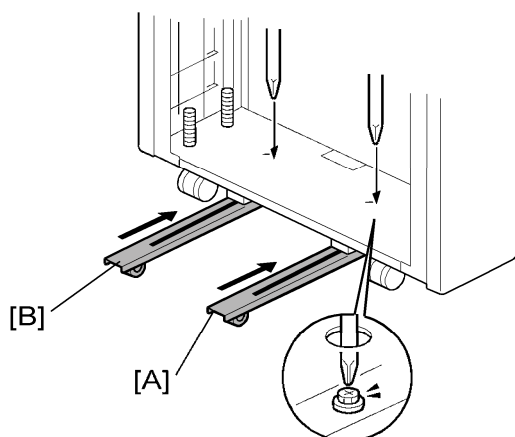

b835i109

16. Push the runners [A] and [B] in and re-fasten them again with the screws.

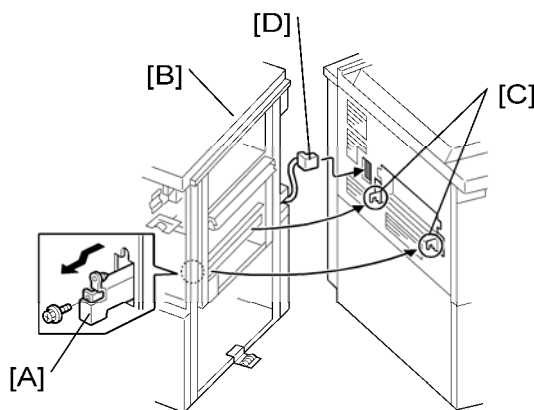

b835i108

17. Open the front door of the cover interposer tray.
18. Pull out the locking lever [A].
19. Align the finisher [B] with the joint brackets [C], then slowly push the finisher onto the brackets.
20. Connect the finisher cable [D] to the copier
21. Push in the locking lever.
22. Check that the top edges of the finisher are parallel with edges of the finisher (or copier) to the right.
23. Fasten the locking lever [A] (🔩 x 1)
24. Close the front door.

Cover Interposer Tray CI5000 (B835-57)

Docking the Next Peripheral Device

The next peripheral device to the left of the cover interposer tray must be installed before you can mount the tray unit on top of the transport unit of the cover interposer tray.

- The tray unit of the cover interposer tray is supported by the top of the next peripheral device in line to the left, as well as the transport unit of the cover interposer.
- The next peripheral device to the left of the cover interposer must be set up and docked to the cover interposer before the transport unit of the cover interposer can be mounted.

Connect the next peripheral unit now.

- 3000-Sheet Finisher B830 (See "3000-Sheet Finisher B830" in this section)

CAUTION

- Never attempt to mount the cover interposer tray unit until the next device in line has been docked to the transport unit (base) of the cover interposer tray.
- To prevent bending the frame of the tray unit and damaging its alignment, always remove the tray unit from the cover interposer tray transport unit: (1) Before disconnecting either the cover interposer tray or the next peripheral device to the left, or (2) Before doing any maintenance on either the cover interposer tray or the next peripheral device to the left.

Mounting the Tray Unit

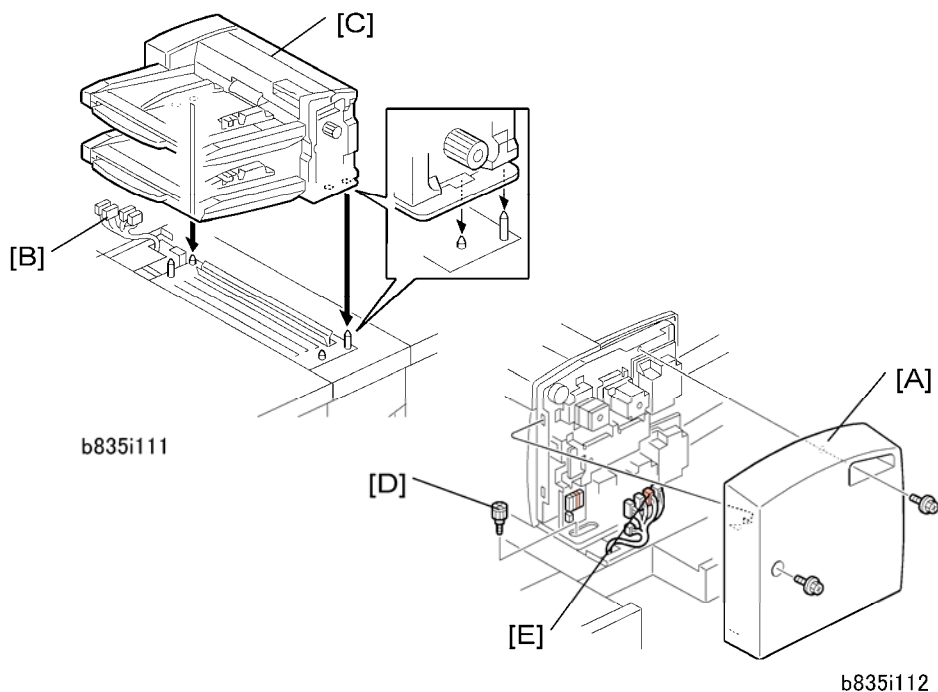

1. Remove the rear cover [A] (🔩 x2).
2. Confirm that the connectors [B] are free.
3. Place the tray unit [C] on top of the cover interposer transport unit.
4. Attach the knob screw [D] (🔩 x1).
5. Connect the harness connectors [E] (🔌 x5)
6. Reattach the rear cover.

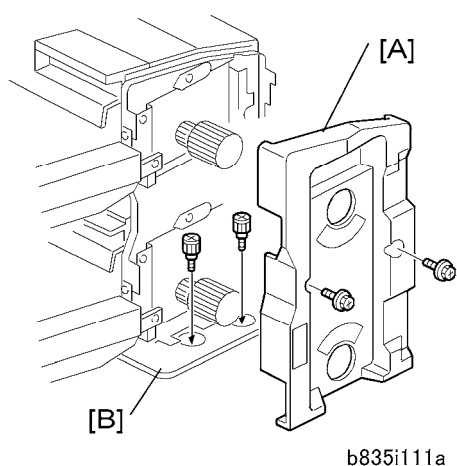

7. Remove the front inner cover [A] from the dual-tray unit (🔩 x2).
8. Fasten the tray unit to the top of the transport unit with the knob screws [B] (🔩 x2).

Cover Interposer Tray CI5000 (B835-57)

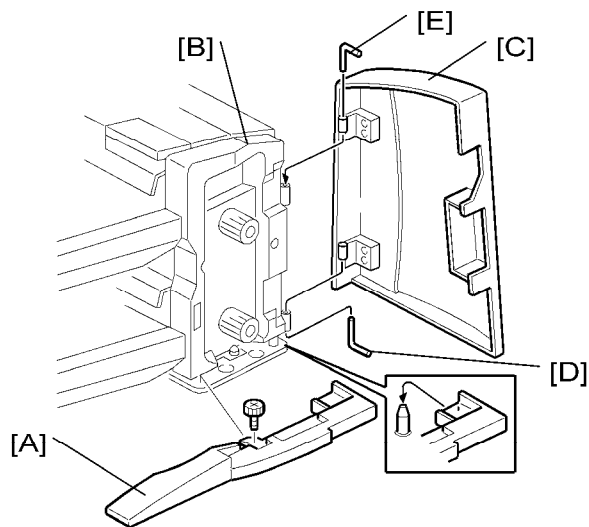

b835i113

9. Attach the base cover [A] (🔩 x1).
10. Confirm that the holes in the cover match the positions of the reference pins.
11. Re-attach the front inner cover [B] (removed at step 7 above).
12. Position the tray unit front door [C] so that its hinges match the posts on the frame of the tray unit.
13. Hold the lower L-pin [D] as shown, insert it halfway, push it up, then rotate it into its groove.
14. Hold the upper L-pin [E] as shown, insert it halfway, push it down, then rotate it into its groove.

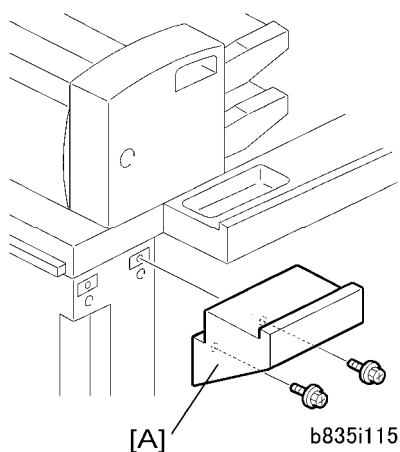

15. Attach the spacer [A] to the rear of the transport unit (🔩 x2).

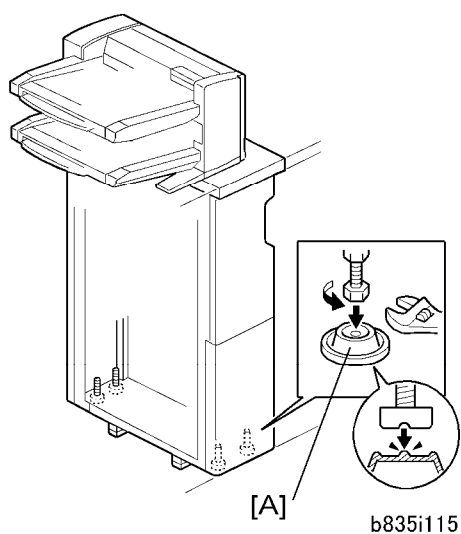

16. Set the leveling shoes [A] (x4) under the feet.
17. Turn the nuts to adjust the height of the cover interposer until it is level.

3.10.3 DOCKING THE COVER INTERPOSER TRAY B835

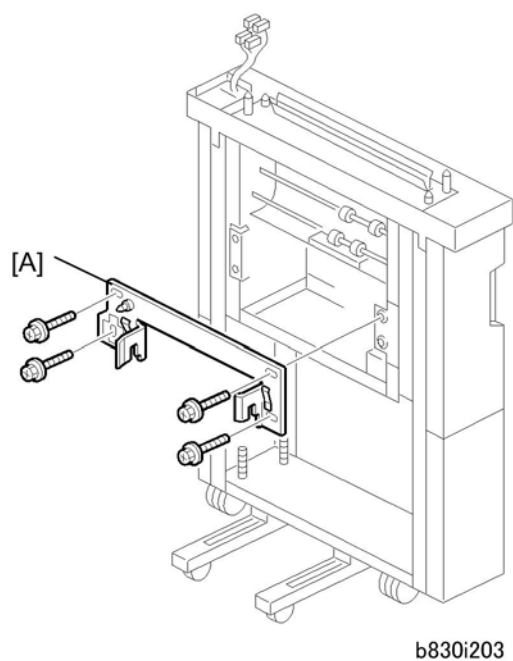

1. Fasten the joint bracket [A] to the cover interposer tray (x4).
2. Dock the finisher.

Cover Interposer Tray CI5000 (B835-57)

Firmware Update

Install the latest version of the firmware for the cover interposer tray.

The cover interposer may not operate correctly with the D081/D082 unless the most recent version of the firmware is installed.

North America Only

When the Cover Interposer Tray (B835) is installed, be sure to check the FCC Class-A decal is attached to the copier below its serial number decal.

- This decal is included with the Finisher Adapter (D375) because the Cover Interposer Tray CI5000 (B835) is always installed with Finisher Adapter (D375) and the 3000-Sheet Finisher (B830).
- For more details see "3000-Sheet Finisher (B830), Finisher Adapter (D375)" in this installation section.

3.11 MULTI FOLDING UNIT (D454)

3.11.1 ACCESSORIES

Check the quantity and condition of the accessories in the box against the following illustration and list.

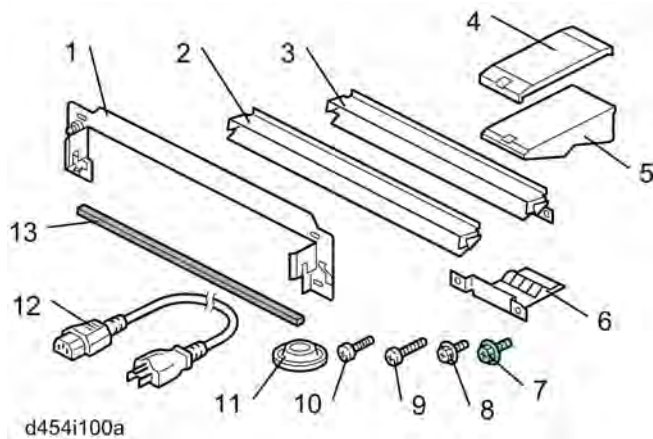

No.	Description	Q'ty
1.	Joint Bracket	1
2.	Paper Guide – Long (for D059, D060, D061, M002/M003/M004)	1
3.	Paper Guide – Short (for D062/D063/D065/D066/D081/D082)	1
4.	Proof Tray Auxiliary Plate - Top	1
5.	Proof Tray Auxiliary Plate – Bottom	1
6.	Ground Plate	1
7.	Screws M3x6	2
8.	Screws M3x6	2
9.	Screws M4x20	4
10.	Screws M4x14 (Not Used)	4

Multi Folding Unit (D454)

No.	Description	Q'ty
11.	Leveling Shoes	5
12.	Power Cord* ¹	1
13.	Sponge Strip	1

*¹: If this unit is used in China, do not use the power cord provided. Contact a supervisor and obtain the correct type of power cord for use in China.

3.11.2 INSTALLATION

CAUTION

- The unit must be connected to a power source that is close to the unit and easily accessible.
- Make sure that the main machine is switched off and that its power cord is disconnected before doing the following procedure.

Tapes

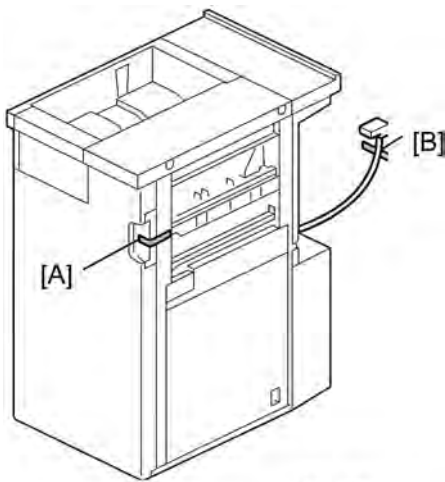

d454i101

1. Remove tape from front [A] and rear [B].

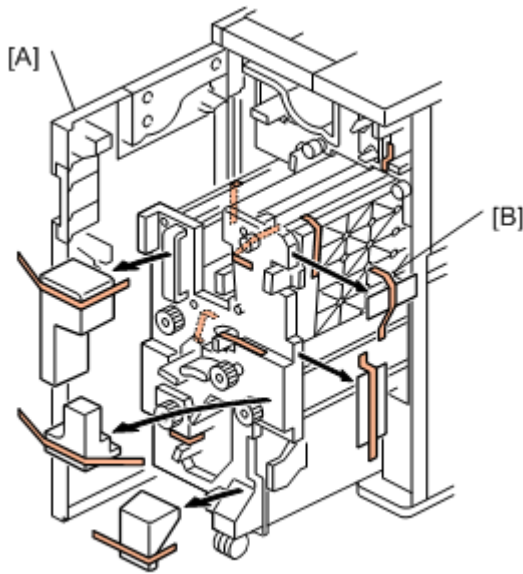

d454i102

2. Open the front door [A].
3. Remove all tape from inside [B].

Paper Guide, Sponge Strip

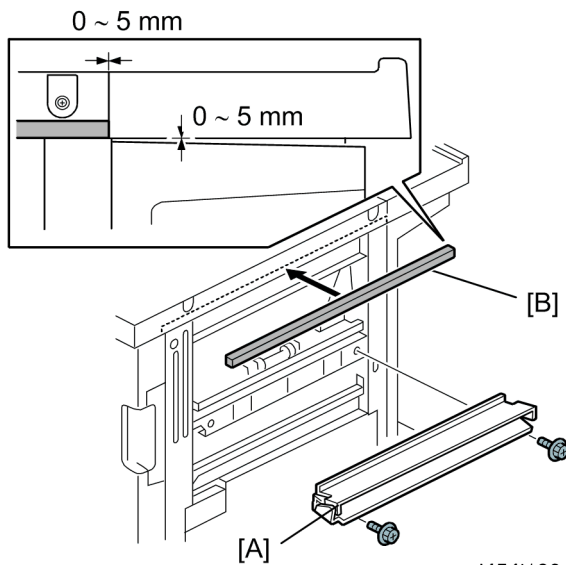

d454i103

1. Select the **short guide** for this installation.
 - Two paper guides are provided.
 - The long paper guide is for another machine

★ Important

- If the upstream peripheral device is the Cover Interposer Tray (B835), attach the black mylar provided with the cover interposer tray to this paper guide.

Multi Folding Unit (D454)

2. Attach the long paper guide [A] (🔩 x2 M3x6).
3. Peel the tape from the sponge strip [B] and attach the strip to the top right edge of the unit.

Ground Plate

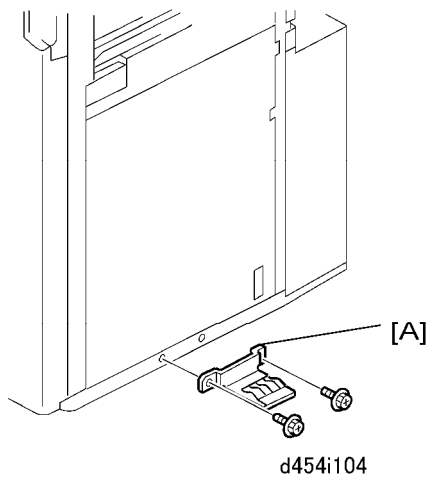

1. Attach the ground plate [A] to the lower right edge of the unit (🔩 x2 M3x6).

Docking

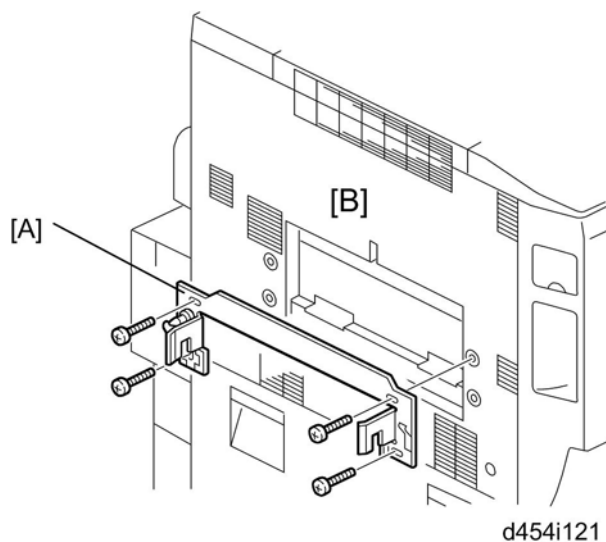

1. Fasten the joint bracket [A] to the left side of the main machine [B] (🔩 x4 M4x20).

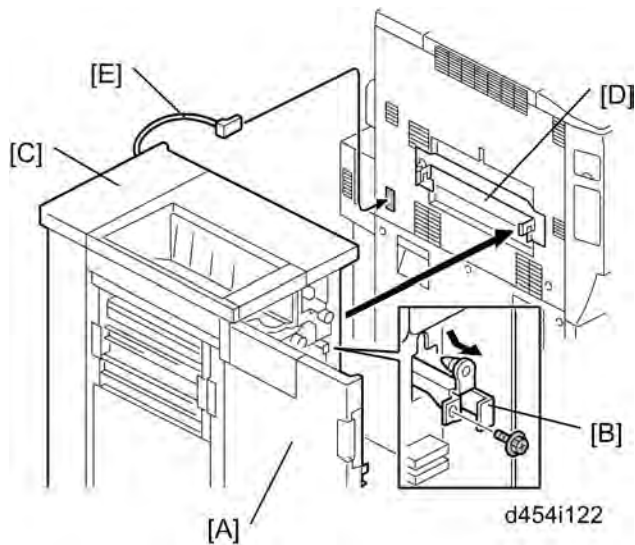

2. Open the front door [A].
3. At the front right corner, remove the screw of the lock bar [B] (🔩 x1 M3x6). **Keep this screw.**
4. Push in the lock bar.
5. Slowly push the unit [C] against the left side of the main machine so that the lock bar is directly and squarely under the arms of the joint bracket.
6. Pull out the lock bar so it slides up into the notches in the arms on both ends of the joint bracket [D].
7. Fasten the lock bar by re-attaching the screw removed in **Step 3** (🔩 x1).
8. Connect the I/F cable [E] to the upstream unit.

↓ Note

- Do the following steps only if the upstream unit is the Cover Interposer Tray.

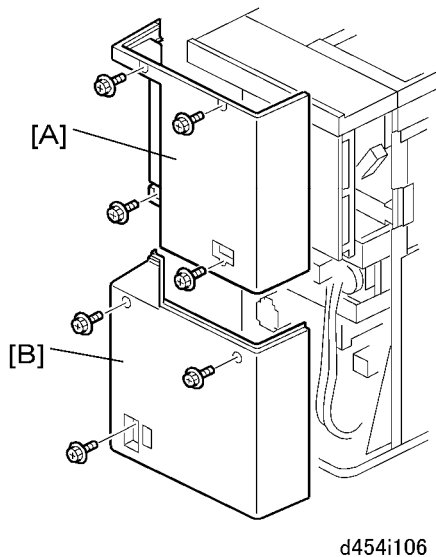

Multi Folding Unit (D454)

9. Remove:

[A] Rear upper cover (🔩 x4)

[B] Rear lower cover (🔩 x3)

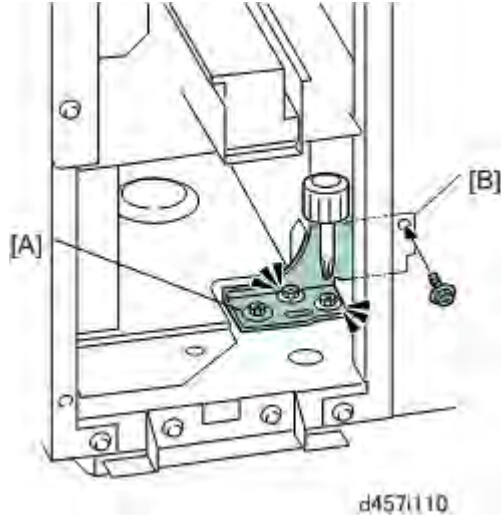

10. Remove the rear cover of the upstream unit.

11. Use a short screwdriver to loosen bracket [A] (🔩 x2).

12. Fasten the bracket to the upstream unit at [B] (🔩 x1).

13. Tighten the screws (🔩 x3).

14. Re-attach the rear covers.

Removing Parts for the Cover Interposer Tray (B835)

Three parts must be removed before the tray unit of the cover interposer tray can be mounted on top of the Multi Folding Unit.

1. Open the front door.

★ Important

- The following parts require removal only if the upstream unit is the Cover Interposer Tray (B835).
- These parts must be removed so that the tray unit of the Cover Interposer Tray will fit on top of the Multi Folding Unit.

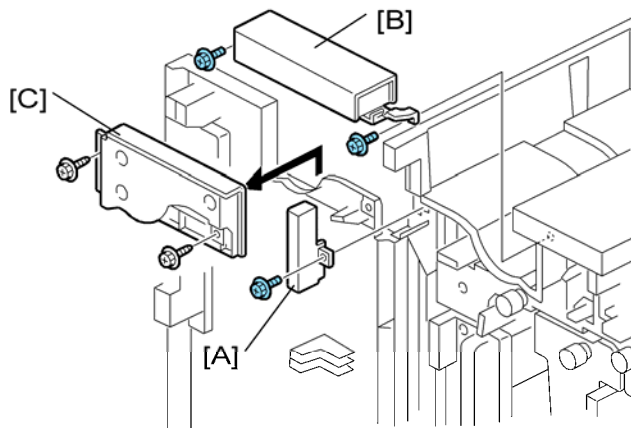

d454i109

2. Remove:
 - [A] Bracket (🔩 x1)
 - [B] Cross-piece (🔩 x2)
 - [C] Metal plate from the door (🔩 x2)
3. After removing [B] and [C], reattach [A].

Height Adjustment

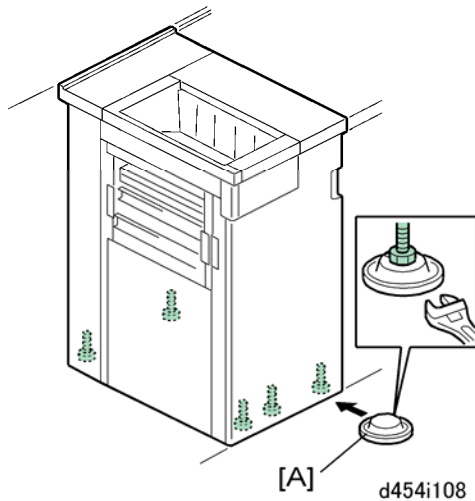

d454i108

1. Set the leveling shoes [A] (🔩 p.3-178 "Common Adjustments").
2. Adjust the height of the unit and make sure that it is level.

Multi Folding Unit (D454)

Power Cord, Breaker Switch Test

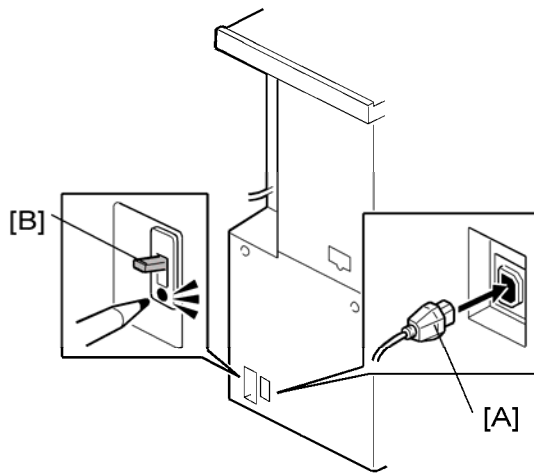

d454i107

1. Insert the power cord socket [A] into the power connection point.

★ Important

- In case of using this unit in China, do not use the power cord in the accessories of the Multi Folding Unit (D454). Ask your supervisor and use a power cord specified for China's usage.
2. Connect the power supply cord plug into a power outlet.
 3. Test the breaker switch [B] (☛ p.3-178 "Common Adjustments").

Check for Skew and Correct Side-to-Side Registration

1. Load some B4 paper in Tray 2 of the main machine.
2. Make several prints that will exit to the upper tray.
3. Watch each sheet as it exits the machine to check for the presence of skew, and check that the side-to-side registration is correct (☛ p.3-178 "Common Adjustments").

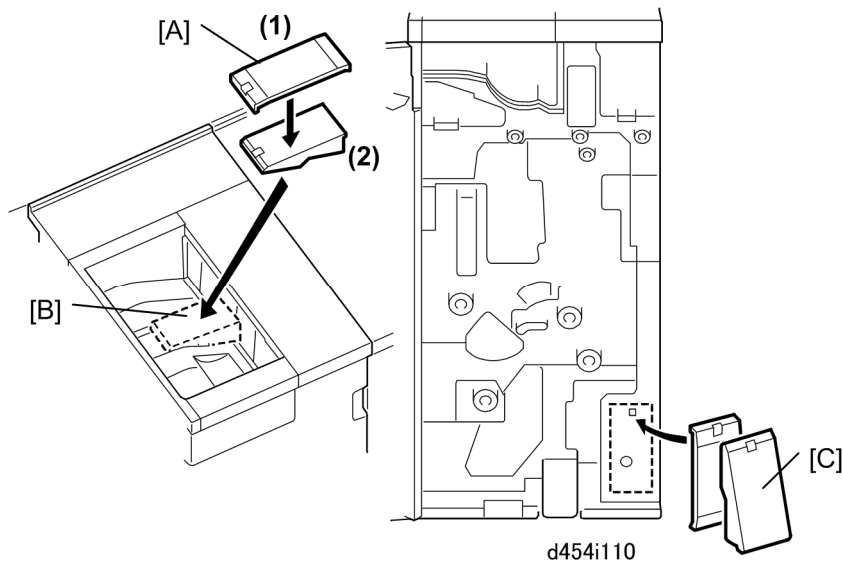
Proof Tray Auxiliary Plate

1. Install the proof tray auxiliary plate.
 - Assemble the top (1) and bottom (2) of the plate [A].
 - Set the assembled plate in the center aligned with the diagonal groove at [B].
 - The back should be flat against the end fence.
2. When the plate is not being used, open the front door and store the assembled plate at [C] inside the inner cover.
 - The plate should be used when Z-folded paper (all sizes) is output to the proof tray.
 - If the plate is not used with Z-folded output, the pages could mix and overlap.

3.12 RING BINDER (D392) INSTALLATION

3.12.1 ACCESSORIES

Check each accessory against the list below to make sure that you have everything.

No.	Item	Q'ty
1.	Docking Bracket	1
2.	Entrance Guide Plate: Long 13" (Not Used for D081/D082)	1
3.	Entrance Guide Plate: Short 12" (Use for D081/D082)	1
4.	Sponge Strip	1
5.	Power Cord	1
6.	Ring Opener	1
7.	Ring Supply Level Indicator	1
8.	Tapping Screws (M4 x 14)	4
9.	Tapping Screws (M4 x 6)	4
10	Leveling Shoes	4
11	Ground (Earth) Plate	1

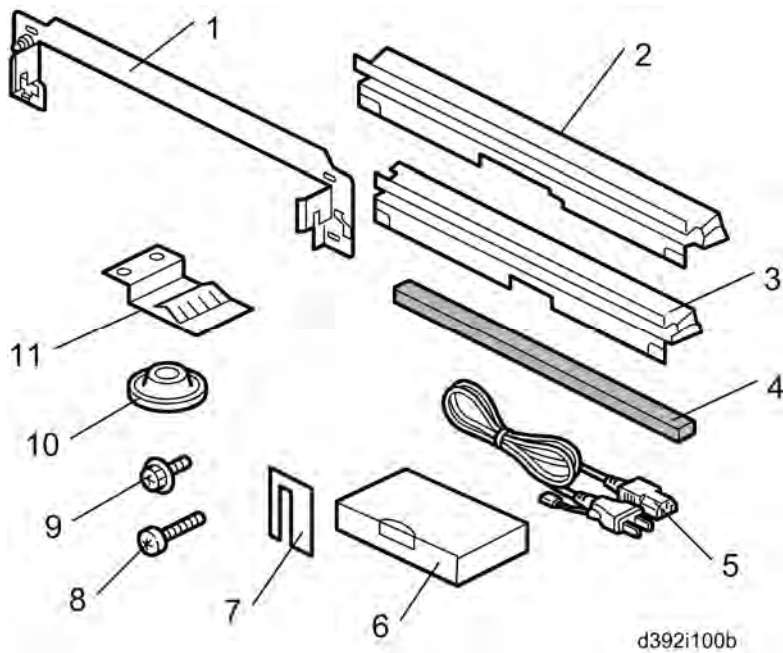

3.12.2 BEFORE YOU BEGIN

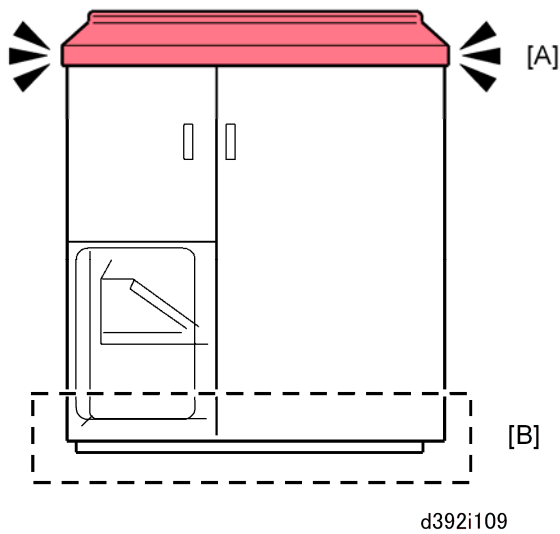

The finisher weighs 140 kg (308 lb.).

IMPORTANT: To prevent bending or breaking the top cover, never lift the finisher by its top cover [A]. Always raise the finisher from the base [B].

3.12.3 INSTALLATION REQUIREMENTS

Operating Environment

1. Temperature Range
 - Allowed: 10°C to 32°C (50°F to 90°F)
 - Recommended: 15°C to 25°C (59°F to 77°F) Rh 50%
2. Humidity Range:
 - Allowed: 15% to 80% Rh
 - Recommended: 30% to 70%
3. Ambient Illumination: Less than 1,500 lux (do not expose to direct sunlight or strong light.)
4. Ventilation: Air must be replaced a minimum of 3 times per hour
5. Ambient Dust: Less than 0.10 mg/m³

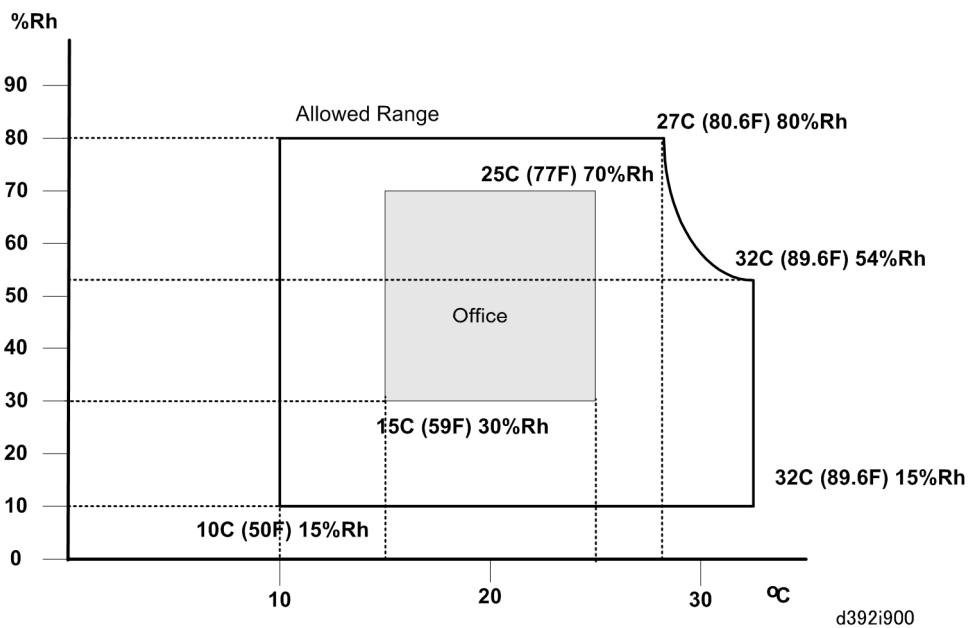

6. If the installation area has air-conditioners or heaters, put the finisher in a location that agrees with these conditions:
 - Where there are no sudden temperature changes from low to high, or high to low.
 - Where it will not be directly exposed to cool air from an air conditioner in the summer.
 - Where it will not be directly exposed to reflected heat from a heater in the winter
7. Do not put the finisher where it will be exposed to corrosive gases.
8. Put the finisher on a strong and level surface. The front and rear of the machine must be less than 5 mm (0.2") away from level.
9. Do not put the finisher where there could be strong vibrations.

10. Do not connect the finisher to a power supply shared with other electrical devices.
11. The machine generates a strong electromagnetic field. This can cause interference with radio or television reception.

Machine Level

1. Front to rear: Less than 5 mm (0.2") away from level
2. Right to left: Less than 5 mm (0.2") away from level

The finisher legs can be turned to adjust them up or down to make the machine level.

Minimum Space Requirements

The minimum clearances at the front and back are the same as the host machine.

Power Supply

Input voltage level	100 to 240V 50/60 Hz NA: 120V 50/60 Hz 5A EU: 220 to 240V 50/60 Hz 3A
---------------------	---

★ Important

- The finisher must have an independent power source. Avoid multi-wiring.
- The finisher must be properly grounded at the power source.

3.12.4 INSTALLATION PROCEDURE

Remove All Shipping Materials

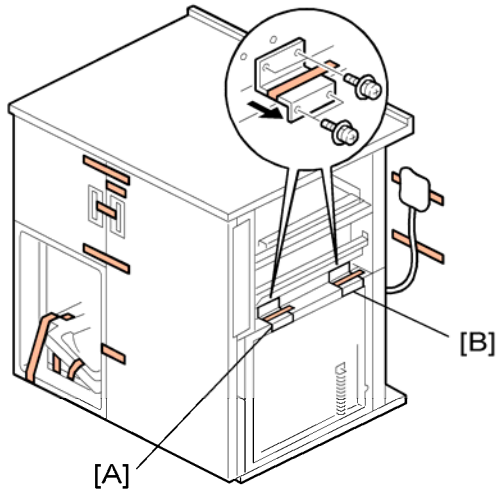

d392i101

1. Remove all visible tapes, wrapping material, and cushions attached to the outside of the finisher and the power cord.
2. Remove:
 - [A] Brace x1 (🔩 x2)
 - [B] Brace x2 (🔩 x2)

IMPORTANT: Do not discard these braces. They must be reattached to the finisher before it is moved or shipped to another location.

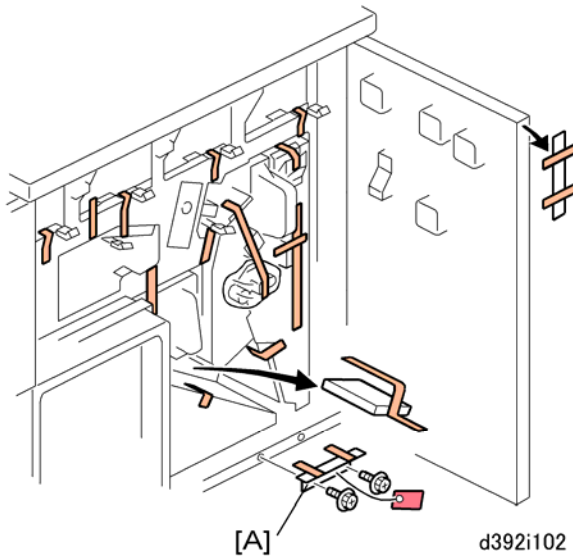

d392i102

3. Open the right door and left door.
4. Remove all tapes and packing material.

5. Remove the brace and red tag [A] (x2).

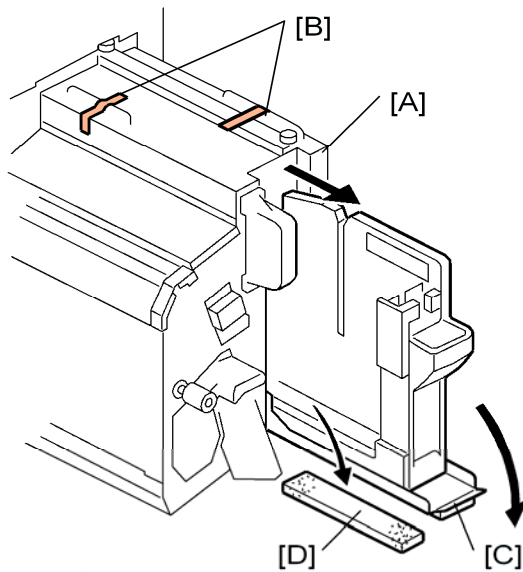

d392i103

6. Pull the binder unit [A] out of the finisher until it stops.
7. Remove the tape [B] on top of the finisher.
8. Pull down the ring cartridge handle and cover [C].
9. Pull the ring cartridge out and remove the cushion [D].
10. Push the ring cartridge in and close its cover.
11. Push the binder unit into the finisher.
12. Close the left front door and right front door.

Ring Binder (D392) Installation

Prepare the Finisher for Docking

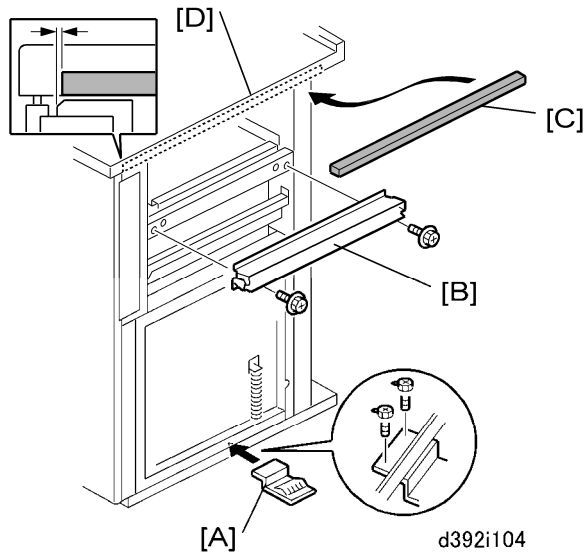



1. Attach the ground plate [A] (2).
2. Attach the **short entrance guide plate** [B] (2).
3. Remove the tape from the back of the sponge strip [C].
4. Attach the sponge strip to the top edge [D] of the finisher as shown above.

Prepare the Upstream Unit for Docking

The Ring Binder can be docked to one of the following:

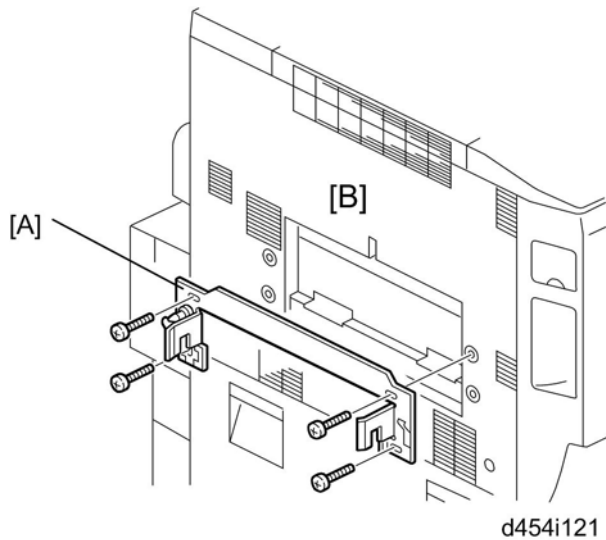
- Main machine
- Multi Folder (D454)
- Cover Interposer (B835)



1. Attach the docking bracket [A] to the upstream unit [B] (M4x14 x4).

 **Note**

- The illustration shows the left side of the main machine, but the procedure is the same for others.

Dock the Finisher

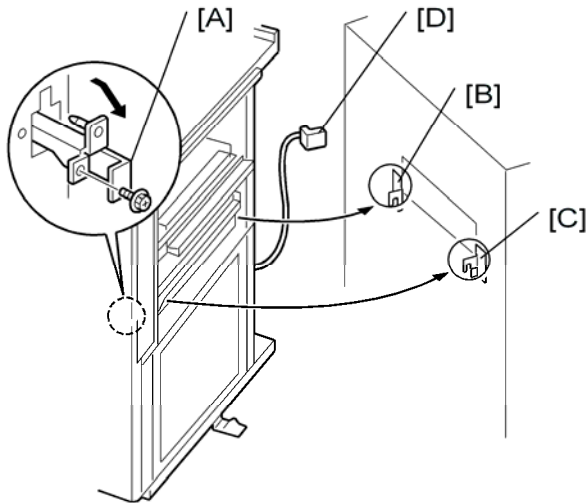

d392i106

1. Open the right door of the finisher.
2. Pull out the locking lever [A] (⚙️x1).
3. Align the right side of the finisher with the docking brackets [B] and [C] on the left side of the main machine, and then slowly push the finisher onto the brackets.
4. Connect the finisher I/F cable [D] to the main machine.
5. Push in the locking lever and check that it slides into the slots of the docking brackets.
6. Check that the top edge of the finisher is parallel with the left edge of the main machine.
7. Refasten the locking lever [A] (⚙️x1) and close the right front door.

Install the Shoes and Level the Finisher

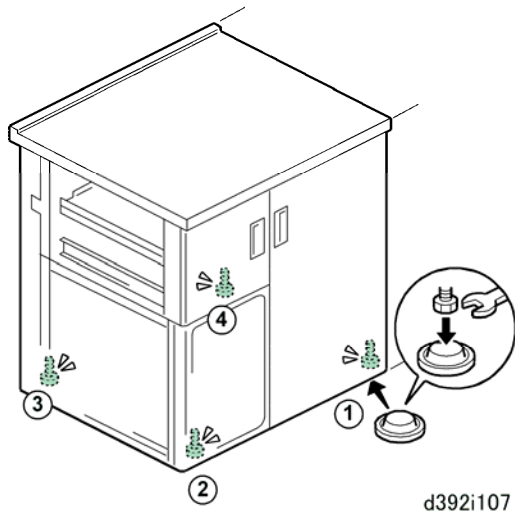

1. Set the leveling shoes (x4) under the feet of the finisher.
2. Open the right front door and left front door.
3. Place a level on the frame
4. Use a wrench to turn the nut at each foot until the machine is level.

Attach Ring Supply Level Indicator

1. Open the front door.
2. Pull out the ring binder.
3. Lift the ring supply cartridge out of the top of the binder unit.

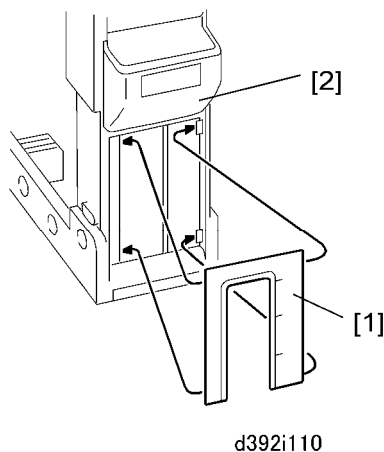

4. Set the ring supply level indicator [1] behind the tabs on the side of the ring supply cartridge [2].

Ring Binder (D392) Installation

Test the Breaker Switch

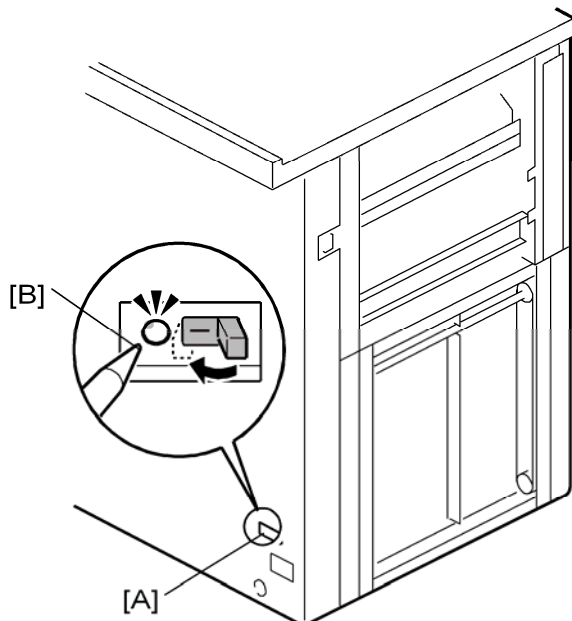

d392i108

1. If the main machine is on, turn it off.
2. Confirm that the breaker switch [A] is set to the right.
NOTE: The breaker switch is at the bottom of the left rear corner near the power cord. When it is set to the right, you should see a straight line (-).
3. Connect the power cord to the finisher, then connect the other end to a power supply outlet.
4. Use the sharp point of a pen [B] or similar tool to push in the breaker switch until it snaps to the off position. (You should see "0".)
5. If the breaker does not snap to the off position:
 - Check that the power cord is correctly connected to the finisher and power supply.
 - Push the breaker switch again to see if it snaps to the off position.
 - If the breaker switch does not snap to the off position, it must be replaced.
6. Be sure to reset the breaker switch to the on (-) position.

3.12.5 CENTERING PAPER IN THE PAPER PATH

At installation you must confirm that the paper is exiting the ring binder correctly and do the necessary correction if required. There are two checks:

- Side-to-side registration check. The paper should be centered in the paper path.
- Skew check. The paper should feed straight out of the ring binder.

Checking and Correcting Side-to-Side Registration

Checking Side-to-Side Registration

Do this check to confirm that the paper is centered in the paper path.

1. Make sure that the I/F cable of the ring binder unit is connected.
2. If the finisher is connected to the left side of the ring binder, disconnect it and pull it away from the left side of the ring binder.
3. Execute a run by feeding paper (A4 or LT) from Tray 2 of the host machine (punching only, no ring binding).

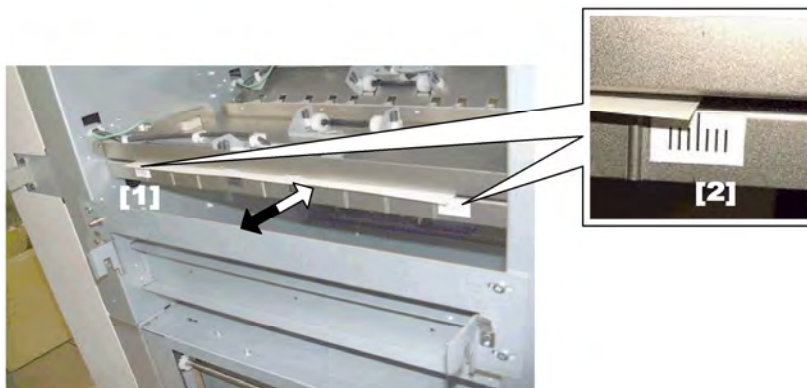

d3912r0204a

4. During the run, each sheet of paper briefly protrudes about 5 to 10 mm before it switches back into the ring binder and feeds to the punch unit, as shown above.
 - There are two scales on the left side of the ring binder below the paper exit.
 - The rear scale [1] is for LT-size paper and the front scale [2] is for A4-size paper. Be sure to read the correct scale for the paper size in use.
5. Check the position of the paper on the scale to determine if the paper is centered.

Ring Binder (D392) Installation

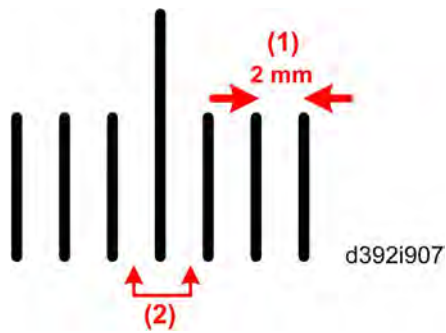

- Read the rear scale for LT-size paper and the front scale for A4-size paper.
- The lines on the scale (1) are spaced 2 mm apart.
- The paper should be at the center line or not deviate more than ± 2 mm as shown at (2).

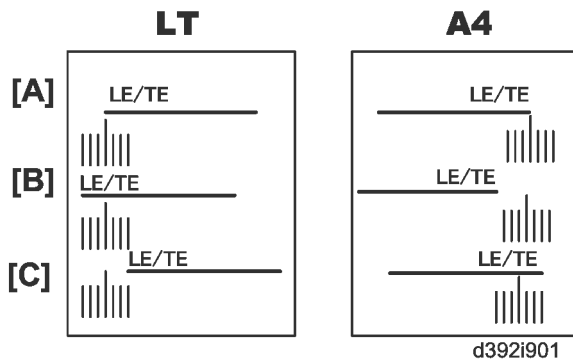

[A]	Leading/trailing edges centered. No adjustment necessary.
[B]	Leading/trailing edges offset to the rear more than 2 mm. Adjustment required.
[C]	Leading/trailing edges offset to the front more than 2 mm. Adjustment required.

6. If the edge of the paper is on the scale at the center [A], no adjustment is required.
-or-
If the edge of the paper is ± 2 mm off the center line on the scale, adjustment is required.
Do the procedure in the next section.

Checking and Correcting Skew

Checking for Paper Skew

Do this check to confirm that the paper is not skewed in the paper path.

1. Make sure that the I/F cable of the ring binder unit is connected.
2. If the finisher is connected to the left side of the ring binder, disconnect it and pull it away from the left side of the ring binder.
3. Execute a straight-through run (no ring binding, no punching) with A3 or DLT from Tray 2 of the host machine.

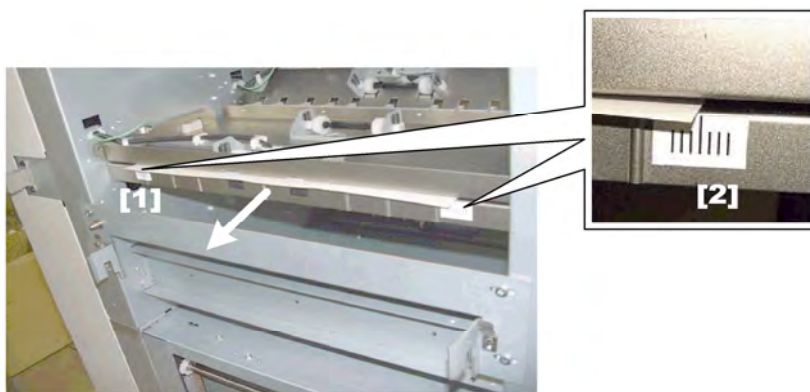

d3912r0204b

4. During the run, each sheet of paper exits the side of the ring binder, as shown above.

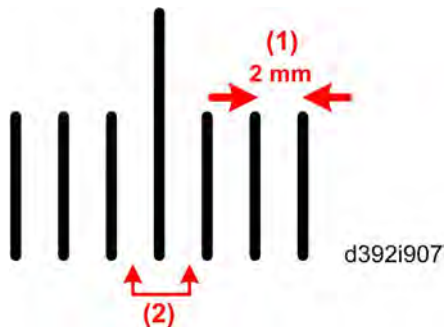

d392i907

- There are two scales on the left side of the ring binder below the paper exit.
 - The rear scale [1] is for DLT-size paper and the front scale [2] is for A3-size paper. Be sure to read the correct scale for the paper size in use.
 - The lines on the scale (1) are spaced 2 mm apart.
 - The paper should be at the center line or not deviate more than ± 2 mm as shown at (2).
5. Check the position of the paper on the scale to determine if the paper skews as it exits.

Ring Binder (D392) Installation

★ Important

- Read the rear scale for DLT-size paper and front scale for A3-size paper.
- The scale lines are spaced 1 mm apart.
- The paper must not deviate more than ± 2 mm on the scale.

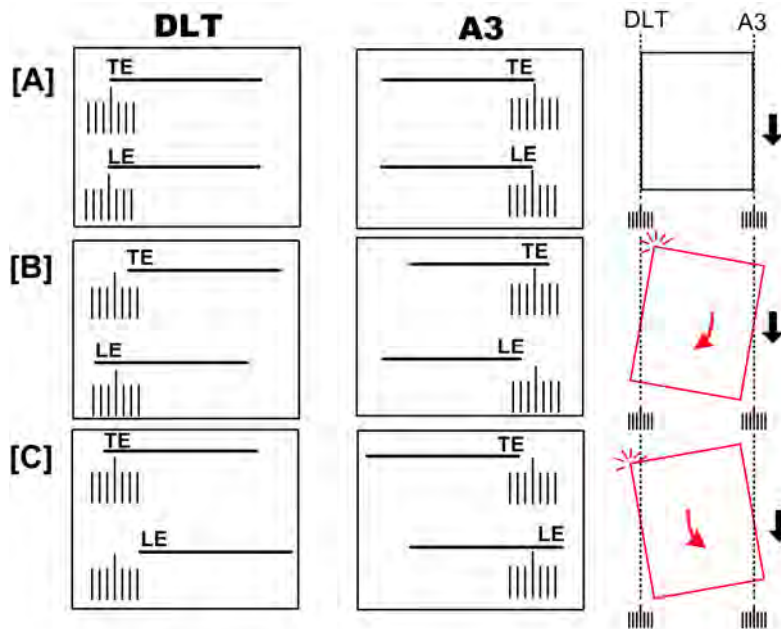

d392i904

[A]	Centered. No adjustment necessary.
[B]	Trailing edge skew to the front, total skew more than ± 2 mm. Adjustment required.
[C]	Trailing edge skew to the rear, total skew more than ± 2 mm. Adjustment required.

Correcting Skew

1. Disconnect the ring binder from the upstream unit.



d392i905

2. Remove the spacers from the right side of the ring binder at the base (🔩 x2).

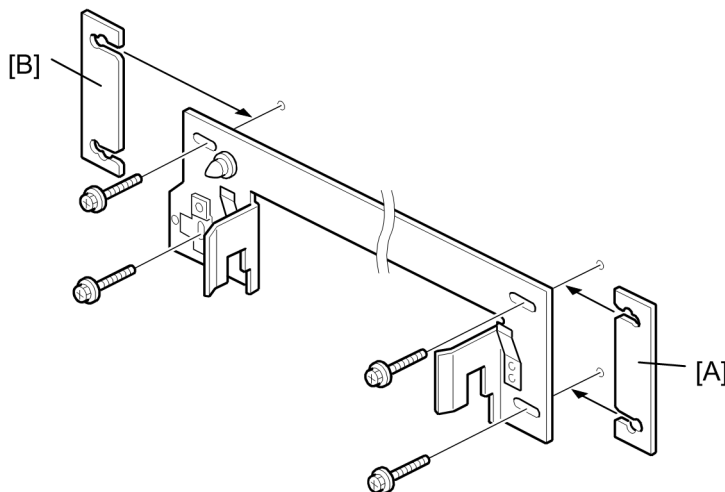

d392i906

3. On the docking bracket attached to the upstream unit, loosen the screws.
4. Insert a spacer and tighten the screws.
 If the trailing edge is skewing toward the **front** of the machine, insert a spacer [A] under the **rear** end of the bracket and tighten the screws.
 -or-
 If the trailing edge is skewing toward the **rear** of the machine, insert a spacer [B] under the **front** end of the bracket and tighten the screws.
5. To another run to check the adjustment. If skew is still present, insert another spacer.

Installation

3.12.6 AFTER INSTALLATION

Confirm that the operators understand the following important points:

- Decals attached to the machine that provide guidance for removing paper jams. Point out the decal locations.
- Detailed instructions on removing ring jams are provided in the operating instructions under "Removing Jammed Ring Combs".
- When pulling out and pushing in the binder unit on its rails, always grip the binder unit by its handle (**Mc8**).



d392r902

CAUTION

- Always grip handle **Mc8** when pulling out or pushing in the binder unit.
- Never touch any other surface of the binder unit when it is moving on its rails.
- To avoid injury the fingers, never push on the top of the binder unit to slide it back into the finisher as shown above.
- Never store paper, extra rings, manuals or any other material below the output tray. Obstacles in this area (circled in the illustration below) will interfere with the raising and lowering of the tray and cause an error.

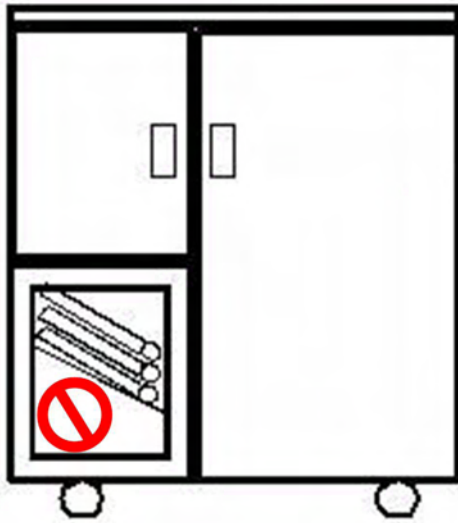

d392d910

Selecting the Supply Name

Enter the SP mode and do SP5841.

5841	Supply Name Setting
	These names show when the user prints the "Inquiry List". To print this list: Push the [Counter] key Push "Print Inquiry List". Push the [Inquiry] button on the User Tools screen.
	Select the SP code for the color and number of holes for the ring binders.
31	Ring Name (50/Black)
32	Ring Name (50/White)
33	Ring Name (100/Black)
34	Ring Name (100/White)

3.13 COVER INTERPOSER TRAY TYPE 3260 (B704-17)

3.13.1 ACCESSORIES

Check the accessories and their quantities against this list. These accessories are provided for installation for several different machines. Many of the accessory items listed below are not used for this installation. For this machine:

- Cover Interposer Tray B704 is for installation on the 2000/3000-Sheet Finishers D373/D374 only and not on 3000-Sheet Finisher D830
- Cover Interposer Tray B835 is for installation on the 3000-Sheet Finisher D830 only and not on the 2000/3000-Sheet Finishers D373/D374.

	Description	Q'ty
1.	Front door extension (top)	1
2.	Rear cover extension (bottom)	1
3.	Shoulder screws	3
4.	Tapping screws – M4 x 8	9
5.	Tapping screws – M3 x 8	2
6.	Tapping screws – M3 x 6	5
7.	Adjuster plates	2
8.	Hinge Bracket	1
9.	Plate Extension (bottom)	1
10.	Gasket Seals	2
11.	Right Rear Cover Plate (B706 only)	1
12.	Spacer	1
13.	Anti-Static Brush	1
14.	Spacer (B706 only)	1

	Description	Q'ty
15.	Spacer (Not used)	1
16.	Right front corner plate (for B706 only)	2
17.	Front door extension (bottom)	1
18,	Sponge Strip	1

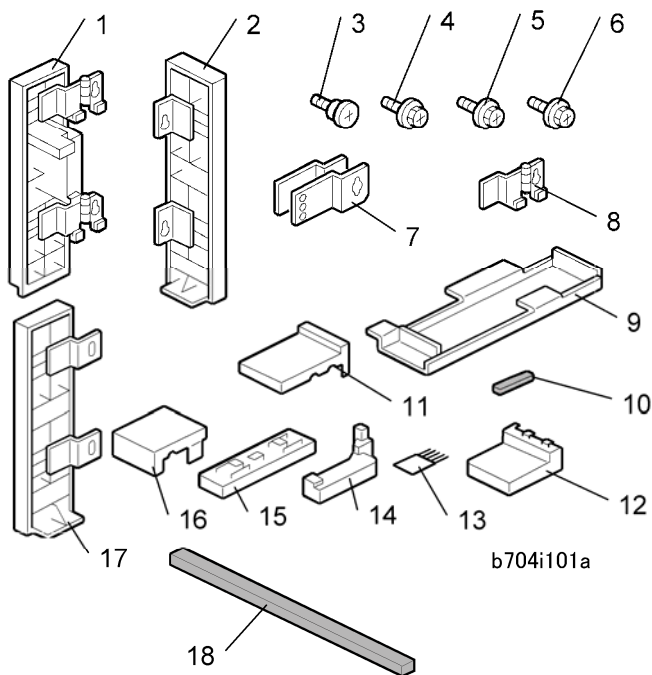

3.13.2 INSTALLATION

You can install the Cover Interposer Tray B704 on these finishers only:

- 2000-Sheet Booklet Finisher D373 (SR4040)
- 3000-Sheet Finisher D374 (SR4030)

Removing Tapes and Packing Materials

⚠ WARNING

- Make sure that the finisher is disconnected from the main machine, and that the copier is turned off and the power cord is disconnected, before you start this procedure.

Cover Interposer Tray Type 3260 (B704-17)

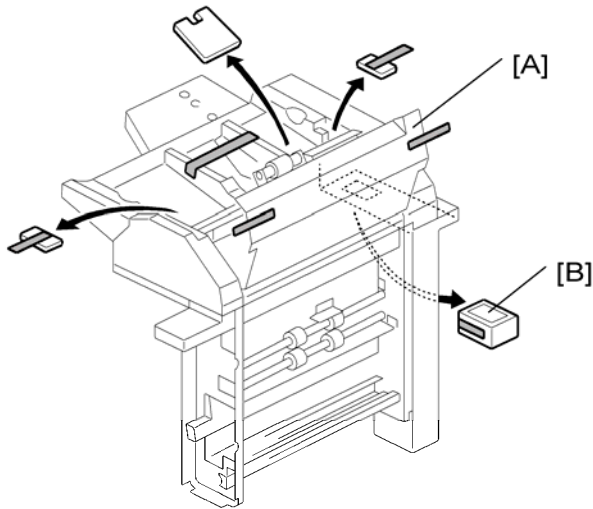

b704i102

1. If the finisher is connected to the machine, disconnect it.

CAUTION

- After disconnecting the finisher, for safety remove the front and rear finisher connectors from the copier. Reattach them just before docking the finisher to the copier.
2. Remove all tape and retainers from the cover interposer tray [A].
 3. Remove the tape and packing material [B] from the ground connector.

Preparing the Finisher

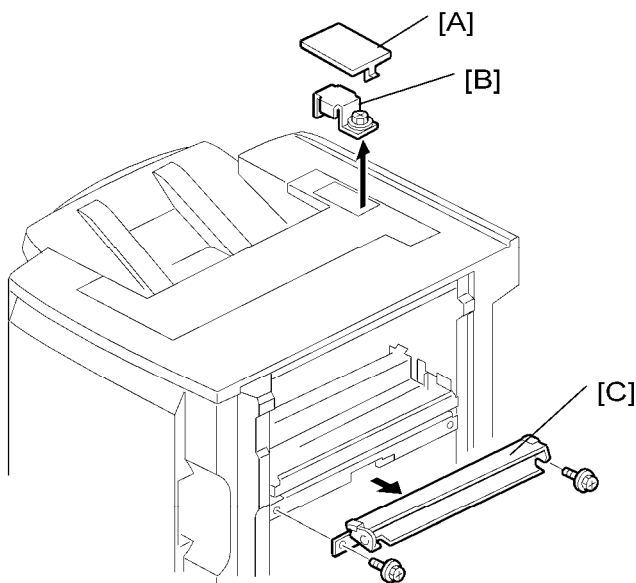

b704i103

1. Remove the cover [A] of the relay connector.

2. Loosen the screw of the bracket [B] (🔩 x 1) then remove the bracket.
3. Remove the guide plate [C]. (You will attach this guide plate to the cover interposer. Do not discard it.)

★ Important

- If you will install the cover interposer tray on a D373/D374 finisher that was installed on the machine before this time, remove the sponge strip from the finisher. Keep this strip because you must attach it later to the interposer tray.

Attaching the Extensions

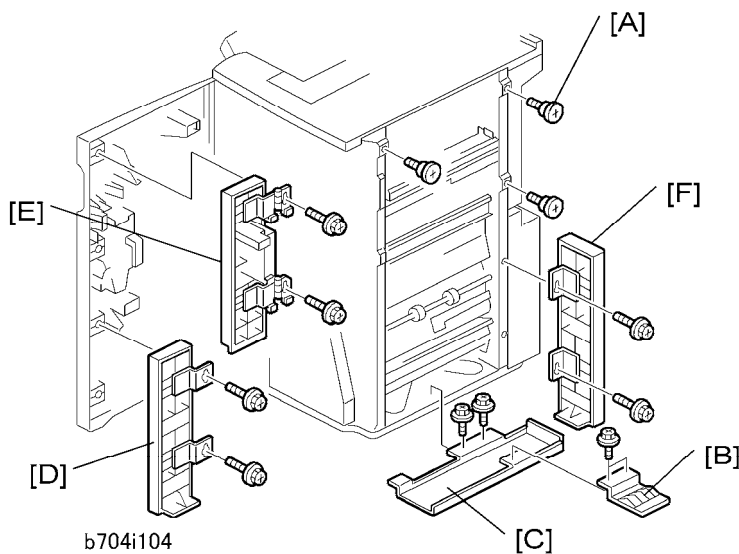

1. Attach the three shoulder screws [A] (🔩 x 3).
2. If the finisher was previously installed, remove the ground plate [B] from the finisher and keep the screws.
3. Attach the bottom plate [C] (🔩 x 2, M3 x 6) then attach the ground plate to the bottom plate (🔩 x 2).
4. Attach the bottom front cover extension [D] (🔩 x 2, M4 x 8).
5. Attach the top front cover extension [E] (🔩 x 2, M4 x 8).
6. Attach the rear cover extension [F] (🔩 x 2, M3 x 6).

Cover Interposer Tray Type 3260 (B704-17)

Attaching the Interposer Tray

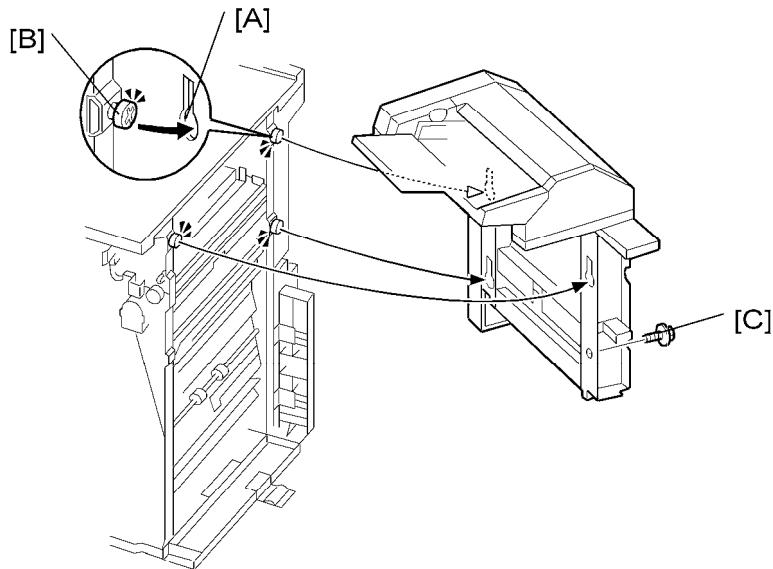

b704i105

1. Lift the cover interposer tray.
2. Align the keyholes [A] with the shoulder screws [B], and move the cover interposer down onto the screws.
3. Attach the cover interposer with the screw [C] (🔩 x 1, M3 x 6).

Docking the Finisher/Interposer

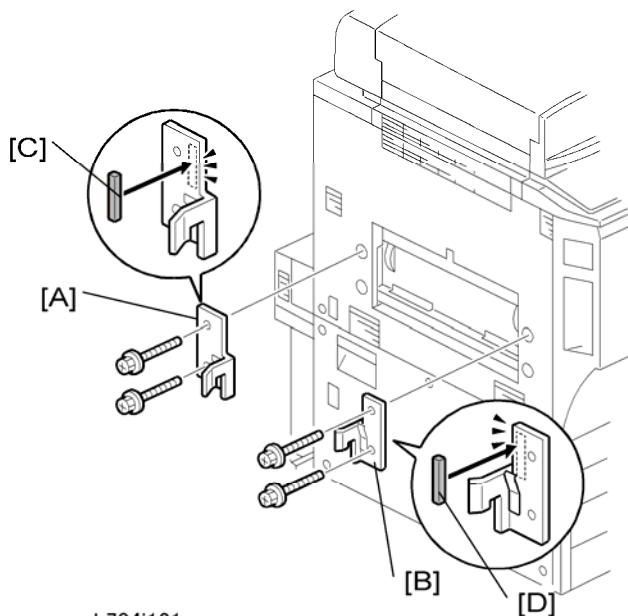

b704i121

1. Attach the rear bracket [A] (🔩 x 2, M4 x14).

2. Attach the front bracket [B] (⚙ x 2, M4 x14).
3. Attach the gasket seals [C] and [D].

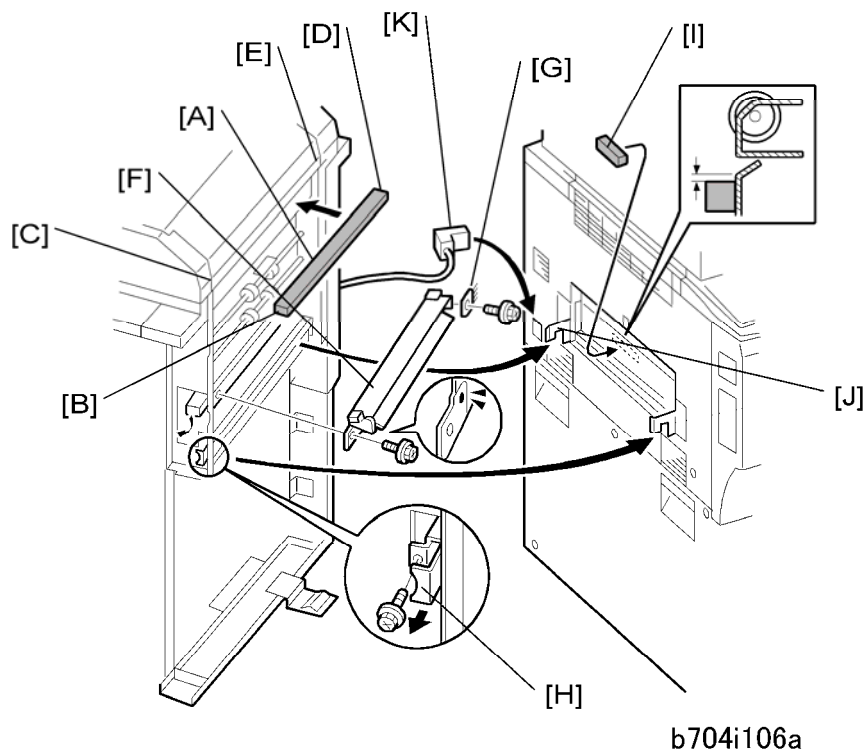

Installation

4. Attach the sponge strip [A] that is supplied with the finisher.
 - Align the sponge end [B] with the edge [C].
 - Align the sponge end [D] with the edge [E].
5. Attach the guide plate (removed from the finisher) to the cover interposer.
 - Attach the front end [F] of the plate (⚙ x 1).
 - Attach the rear end of the plate with the anti-static brush [G] (⚙ x 1).

★ Important

- Use the two small tapping screws that are supplied, and not the machine screws removed from the finisher guide plate.
6. Release the lock lever [H] (⚙ x 1).
 7. Attach the pad [I]. This pad is provided with the finisher.
 8. Slowly push the finisher against the side of the machine until the brackets [J] go into the slots.

⚠ WARNING

- Move the finisher carefully to avoid bending the entrance guide plates.
9. Attach the lock lever [H] (⚙ x 1).
 10. Connect the connector [K] to the copier.

Cover Interposer Tray Type 3260 (B704-17)

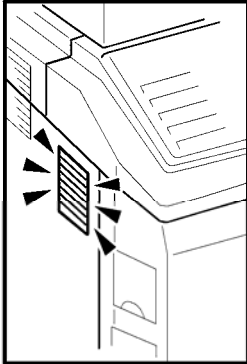

d373r734

11. Check the right side of the machine and make sure that the sponge strip does not block the air flow through the duct.

3.14 2000/3000 SHEET FINISHERS (D373/D374)

3.14.1 ACCESSORIES

	Description	Q'ty
1.	Front joint bracket	1
2.	Rear joint bracket	1
3.	Ground (earth) plate	1
4.	Screws (M4 x 14)	4
5.	Screws (M3 x 8)	1
6.	Screws (M3 x 6)	3
7.	Screw (Plastic)	2
8.	Leveling Shoes	3
9.	Upper output tray	1
10.	Tray Holder	1
11.	Lower output tray (D373 Only)	1
12.	Support Plate for Proof Tray	1
13.	Support Plate for Shift Tray	1
14.	Cushion (with double-sided tape)	1
15.	Gasket Seal	1

2000/3000 Sheet Finishers (D373/D374)

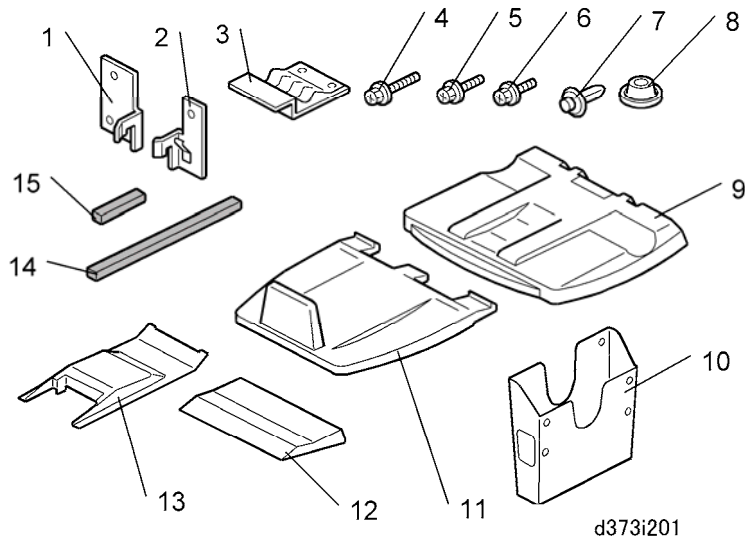

3.14.2 INSTALLATION

This section shows the installation instructions for two finishers:

- **D373 Booklet Finisher:** This finisher can do punching, shifting, stapling, and saddle-stitching with staples. This booklet finisher can be used with the D081 or D082.
- **D374 Finisher.** This finisher is capable of punching, shifting, and stapling but with no saddle-stitching unit. This finisher can be used with the D081 or D082.

↓ Note

- Differences in the installation procedures are shown as "D373" or "D374"

Removing Tapes and Packing Materials

CAUTION

- Always turn the machine off and disconnect the machine power cord before you do these procedures.

D373/D374

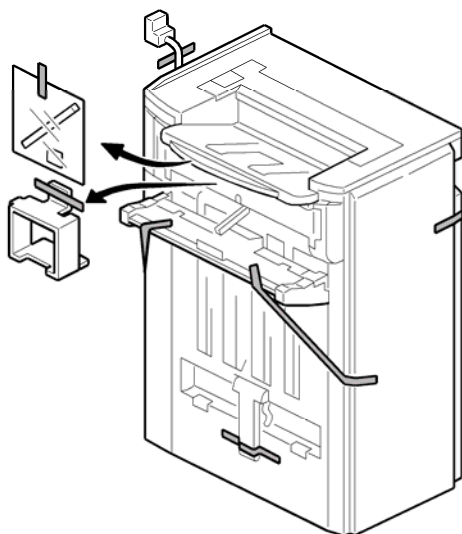

d373i102

1. Remove the machine from its box, and remove all the wrapping.
2. Remove all filament tape and packing material from the finisher.

D373/D374

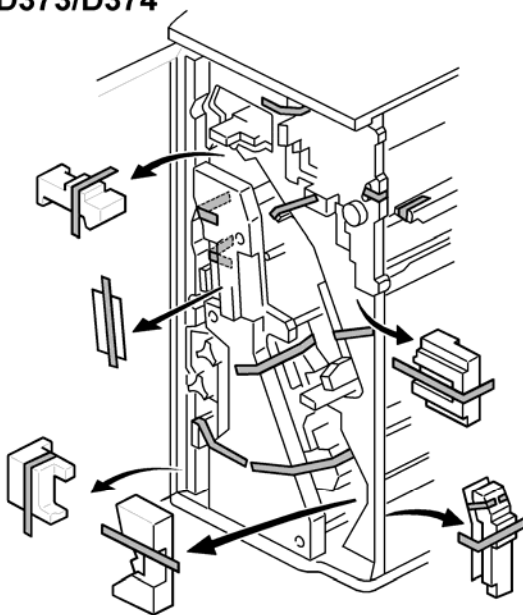

d373i202

Installation

2000/3000 Sheet Finishers (D373/D374)

3. Open the front door.
4. Remove all tapes and packing materials inside the finisher.

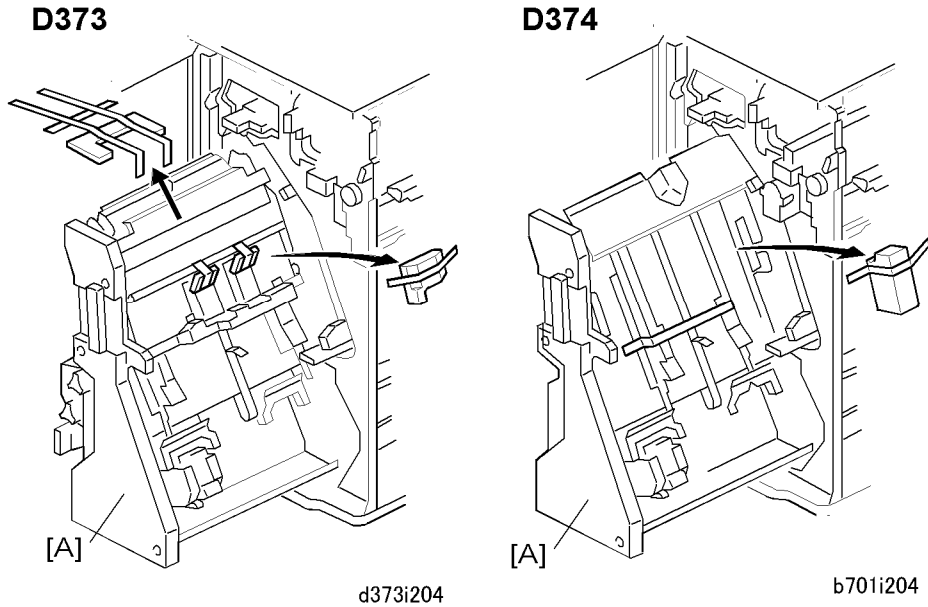

5. Pull the jogger unit [A] out of the finisher.
6. Remove the tapes and retainers.

Docking the Finisher to the Copier

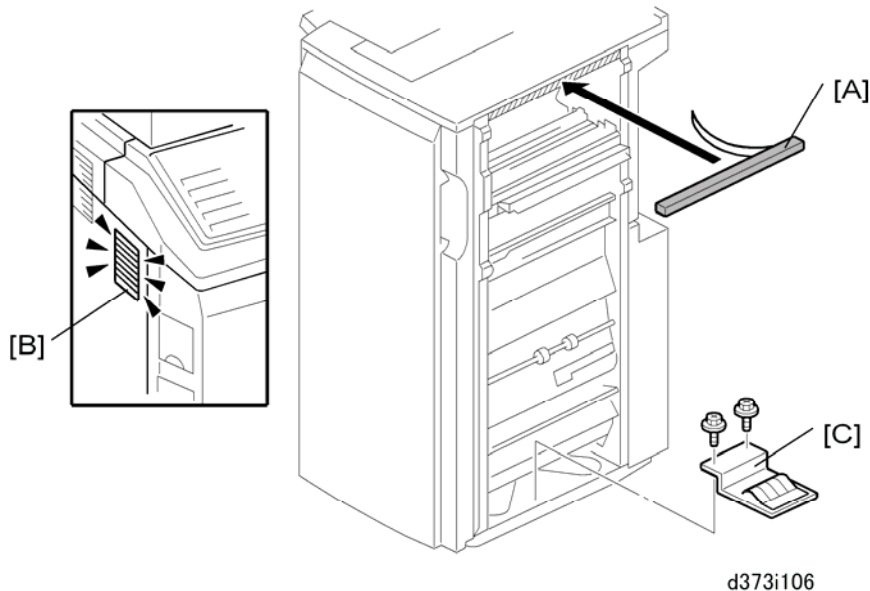

1. The first step depends on whether you will install the Cover Interposer B704.
If you will not install the Cover Interposer B704:
 - Remove the strip from the sponge cushion [A] and attach it to the finisher, then go

to Step 2.

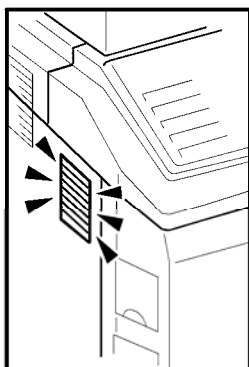

d373r734

- Do not put the sponge in a position that will prevent air flow through the air duct [B] on the copier shown above after the finisher is connected to the copier.
- Use a short screwdriver to attach the grounding plate [C] (⚙ x 2, M3 x 6).

If you will install the Cover Interposer B704:

- Do not attach the sponge cushion to the finisher. It must be attached to the cover interposer.
- Do not attach the grounding plate [C] to the finisher. It must be attached to the cover interposer.
- Install the interposer on the finisher before you dock the finisher to the copier. (🔧 p.3-130).
- After installing the interposer, continue from 'Attaching the Trays' below.

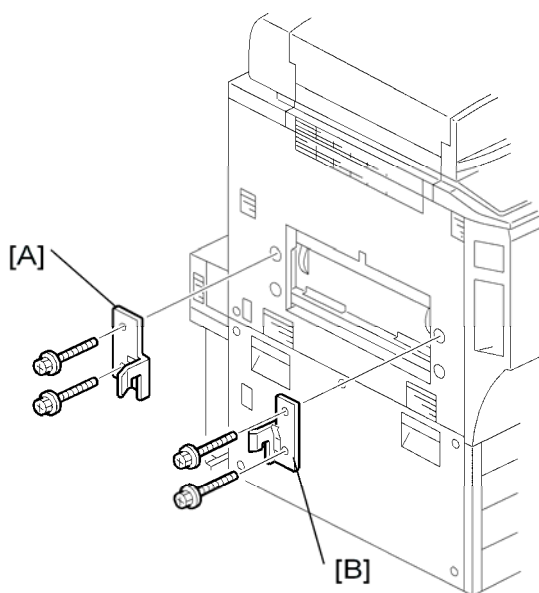

d373i105

2. Attach the rear bracket [A] (⚙ x 2, M4 x 14).

2000/3000 Sheet Finishers (D373/D374)

3. Attach the front bracket [B] (x 2, M4 x 14).

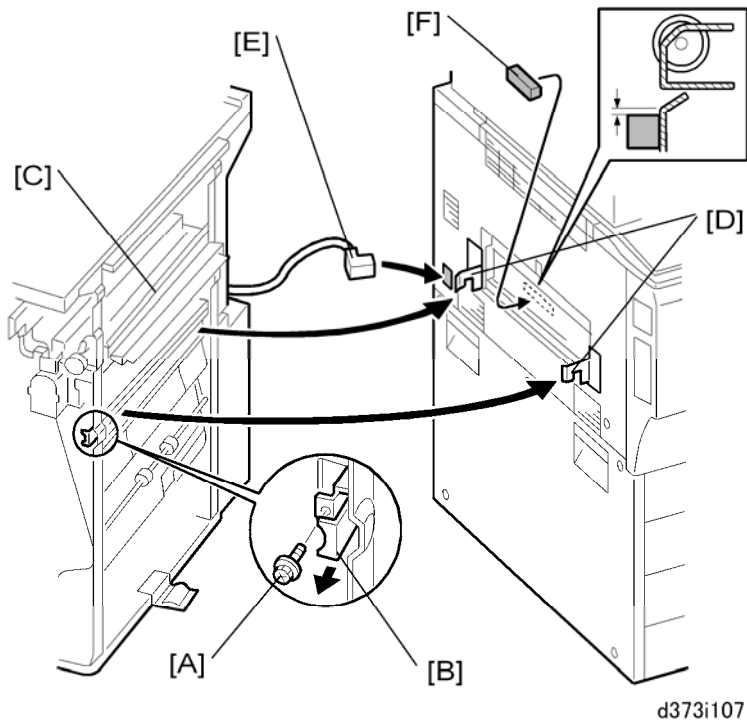

4. Remove the screw [A] to release the lock lever [B] (x 1).
5. Slowly push the finisher against the side of the machine until the brackets [D] go into their slots. If you do this too quickly, you will bend and cause damage to the paper-entrance guide plates [C].
6. Attach and tighten the screw removed in Step 4.
7. Connect finisher connector [E] to the main frame.
8. Attach the gasket seal [F] as shown.

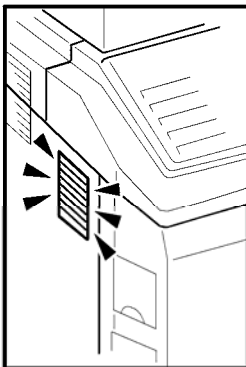

9. Check the duct on the left side of the machine shown above. Make sure that the sponge does not block this duct.

Attaching the Trays

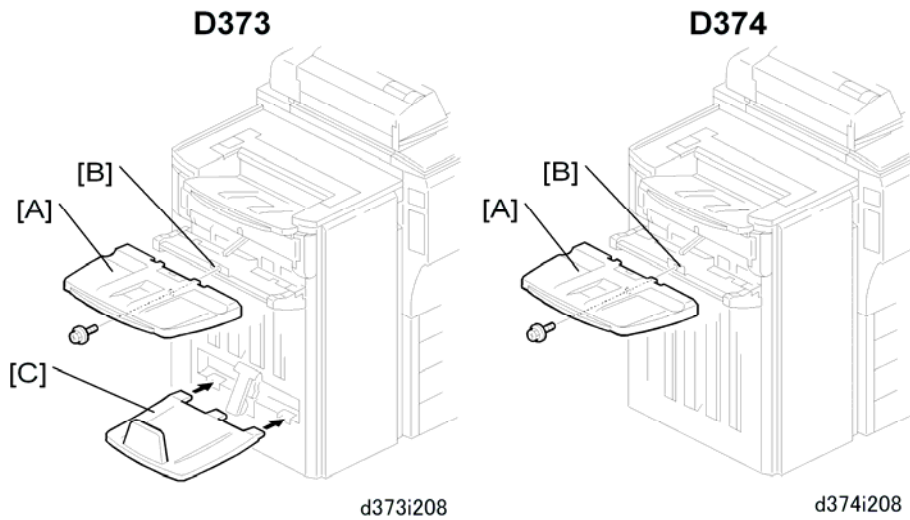

D373

1. Attach the upper output tray [A] (⚙ x 1, M3 x 6).
2. Make sure that the metal plate [B] is on the top of the tray.
3. Attach the lower output tray [C].

D374

1. Attach the output tray [A].
2. Make sure that the metal plate [B] is on the top of the tray.

Leveling the Finisher

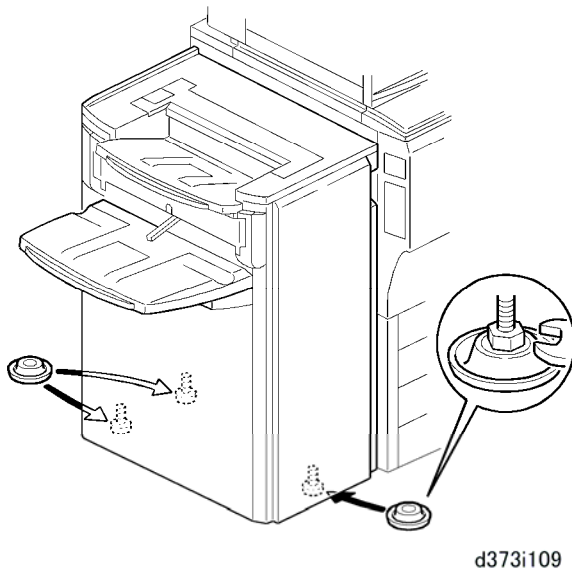

1. Put the leveling shoes (x 3) below the feet.
2. Use a wrench to adjust the height of the screws to make the machine level.

Support Trays

Tray Holder

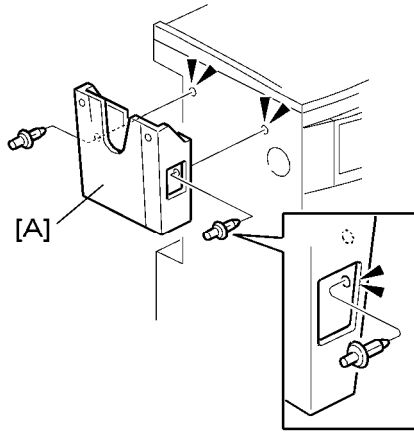

d373i303

1. Attach the tray holder [A] to the side of the finisher as shown.
2. Store the support plates for this upper tray and shift tray in this holder while they are not being used.

Support Plate for Upper Tray

Two support trays, one for the upper proof tray and one for the shift tray are provided. These support trays prevent excessively curled paper from activating the "Tray Full" message before the proof tray or shift tray is actually full.

1. Remove the paper from the paper feed tray, turn it upside down, then print.

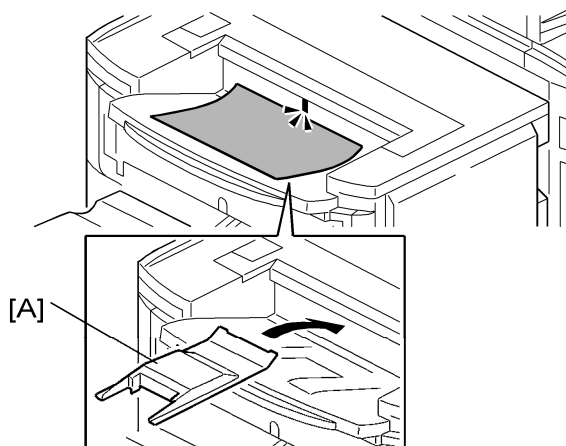

d373i301

2. If step 1 does not solve the problem, place the support tray [A] in the upper tray as shown.

Support Plate for Shift Tray

1. Remove the paper from the paper feed tray, turn it upside down, then print.

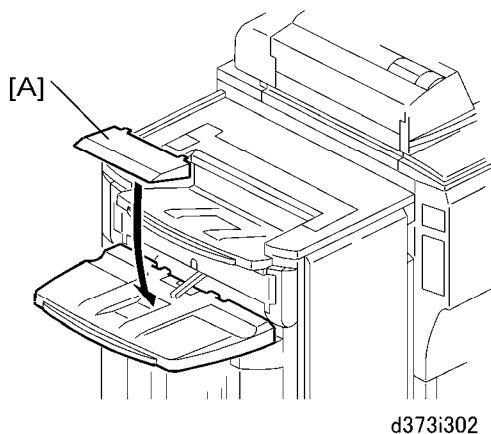

2. If step 1 does not solve the problem, place the support tray [A] on the shift tray as shown.

Selecting the Staple Supply Name

Enter the SP mode and do SP5841.

5841	Supply Name Setting
	These names show when the user prints the "Inquiry List". To print this list: Push the [Counter] key Push "Print Inquiry List". Push the [Inquiry] button on the User Tools screen.
13-14	Staple Std3 D373/D374
	Input the name of the staples that are used for corner (standard) stapling (not booklet stapling). This setting should be done for the D373 and D374.
21-23	Staple Bind2 D373 Only
	Input the name of the staples that are used for booklet stapling (saddle-stitching).

Enabling Booklet Binding (D373 Only)

To use booklet stapling, you must make sure that the center-position stapling option is displayed. If it is not, select the center-position stapling mode with a user tool.

1. Push the User Tools key.
2. Touch "Copier/Document Server Features".
3. Touch the "Input/Output" tab.
4. Select "Staple Position".
5. Touch a "Staple Position" button and touch the center (saddle-stitch) stapling symbol.
6. Go out from the User Tools mode. Set the number of copies, touch the center stapling symbol on the operation panel, then start the print job.

3.15 PUNCH UNIT (B702-17, -27, -28)

The Punch Unit B702 is installed in the 2000/3000 Sheet Finisher D373/D374 (SR4040/SR4030).

3.15.1 ACCESSORIES

Check the accessories and their quantities against this list.

Description	Qty
1. Punchout Waste Unit	1
2. Slide Drive Unit	1
3. Punch Waste Hopper	1
4. Screws (M3 x 6)	5
5. Side-to-Side Detection Unit	1
6. Punching Unit	1

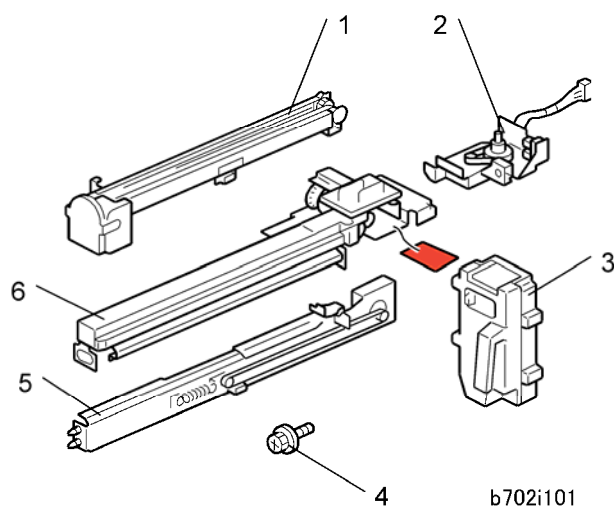

3.15.2 INSTALLATION

WARNING

- Always turn the machine off and disconnect the machine power cord before you do this procedure.

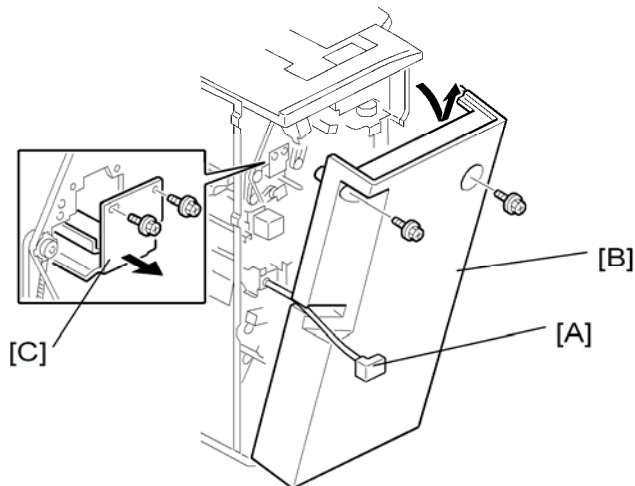

b702i102

1. If the finisher is connected to the copier, disconnect the power connector [A] and move the finisher away from the copier.
2. Remove the rear cover [B] ( x 2) and open the front door.

Note

- At the bottom of the rear cover, make sure to disconnect the tabs that attach the cover to the frame.
3. Remove the guide plate [C] ( x 2).

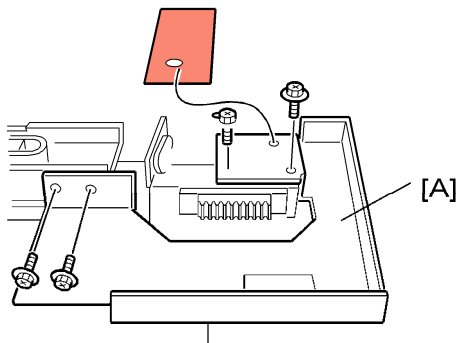

b702i201

4. Remove the shipping retainer [A] ( x 4).

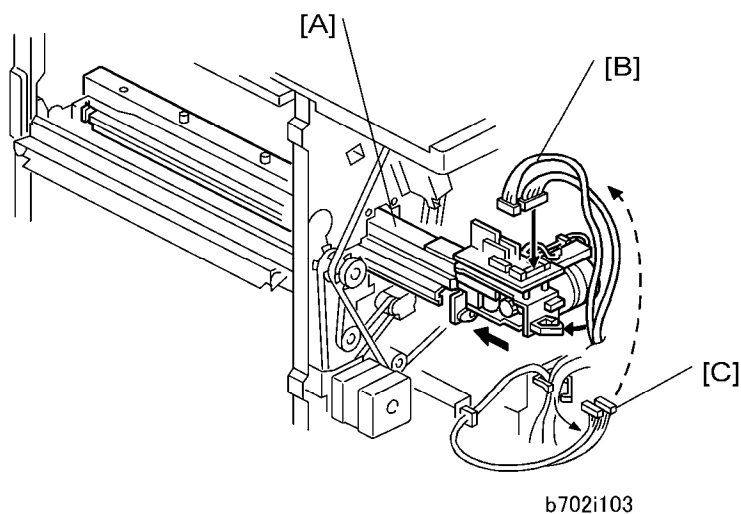

5. Slide the punch unit [A] on its rails into the finisher. Make sure that the pins engage correctly at the front and rear.
6. Connect and attach the punch unit [B] (🔌 x 2, 🖨️ x 1).
 - The cables [C] are coiled and attached to the PCB.
 - Attach connectors to CN601 and CN602.

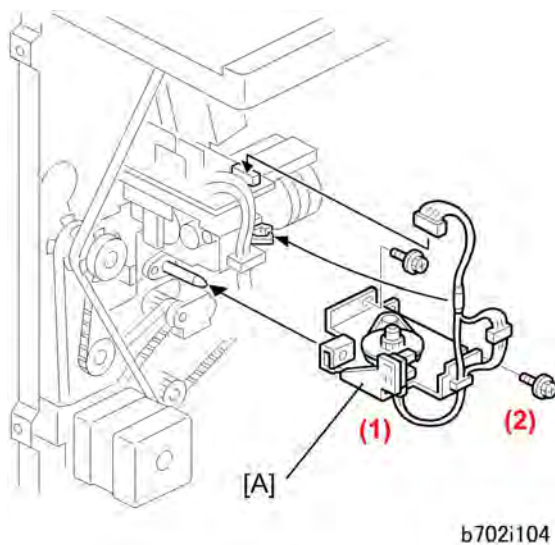

7. Attach the slide drive unit [A] to the finisher and connect it to the punch unit (🔌 x 2, 🖨️ x 1). Push in the slide drive unit at (1) when you attach screw (2).
8. Make sure that the punch unit moves freely and is not blocked by the screws.

Punch Unit (B702-17, -27, -28)

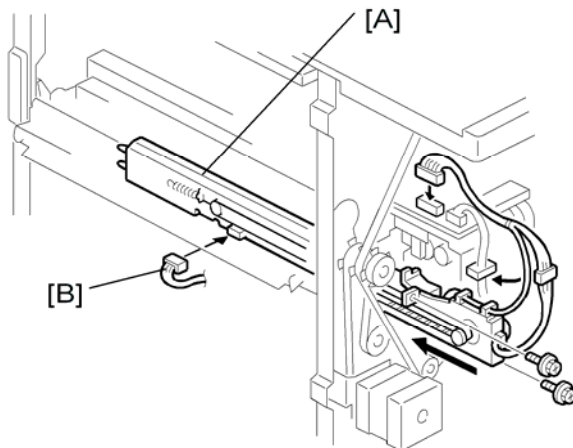

b702i105

9. Put the side-to-side detection unit [A] in the machine. Make sure that the two pins are engaged correctly at the front.
10. Make sure that the side-to-side detection unit moves smoothly on its rails. If it does not, make sure that the rails are aligned with their grooves.
11. Attach the side-to-side detection unit and connect it at the rear (🔧 x 2, 📏 x 1, 📏 x 1).
12. Pull the short connector out of the connector [B] then connect the cable (📏 x 1).

↓ Note

- This is the 3-pin connector.

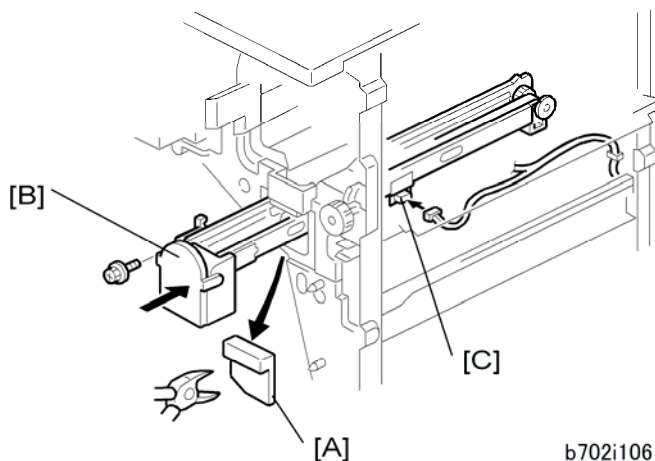

b702i106

13. At the front, use a pair of wire cutters to remove the part [A] of the cover.
14. Install the punch-waste transport unit [B] in the finisher.

↓ Note

- Make sure that the punch-waste transport unit moves smoothly on its rails. If it does not, make sure that the rails are aligned with the grooves.
15. Remove the short connector from the connector [C].

↓ Note

- This is the 4-pin connector.

16. Connect the cable and attach the punch-waste transport unit (🖨️ x 1, 🖨️ x 1, 🖨️ x 1).

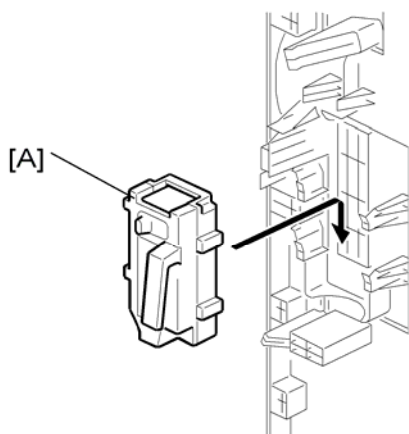

b702i107

17. Set the hopper [A] in its holder.

Output Jogger Unit Type 3260 (B703)

3.16 OUTPUT JOGGER UNIT TYPE 3260 (B703)

3.16.1 ACCESSORIES

This option is for the 2000/3000-Sheet Finishers (D373/D374) only.

Check the accessories and their quantities against this list.

Description	Qty
1. Jogger Unit	1
2. Tapping Screws M3x6	2

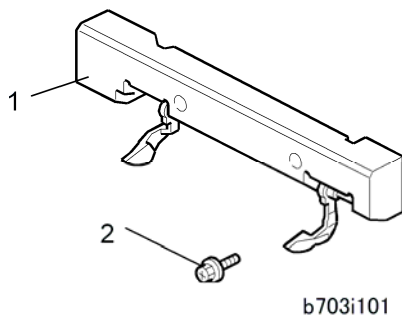

3.16.2 INSTALLATION

The Output Jogger Unit B703 is installed only on the 2000/3000-Sheet Finisher D373/D374.

WARNING

- Always switch the machine off and unplug the machine before doing any of the following procedures

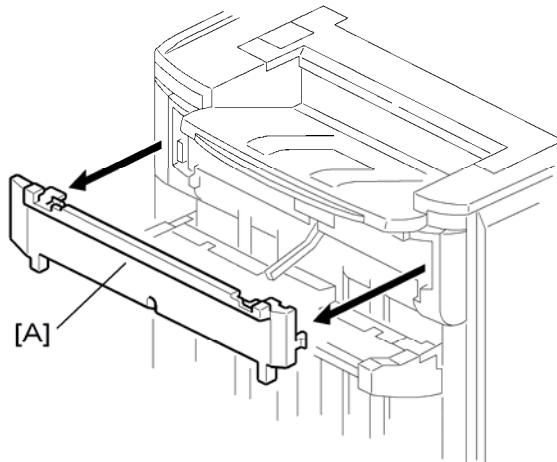

b703i103

1. Turn the main machine switch off.
2. Disconnect the finisher from the main frame.
3. Use the flat head of a screwdriver to remove the left upper cover [A].

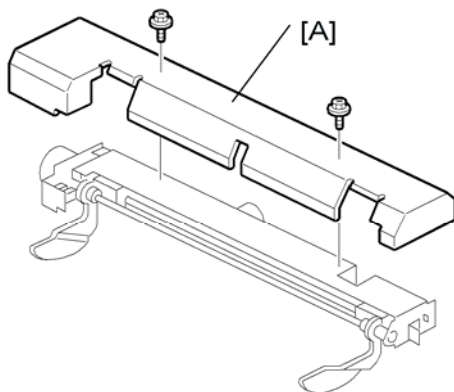

b703i102

4. Remove the cover plate [A] ( x 2). Keep the screws.

Output Jogger Unit Type 3260 (B703)

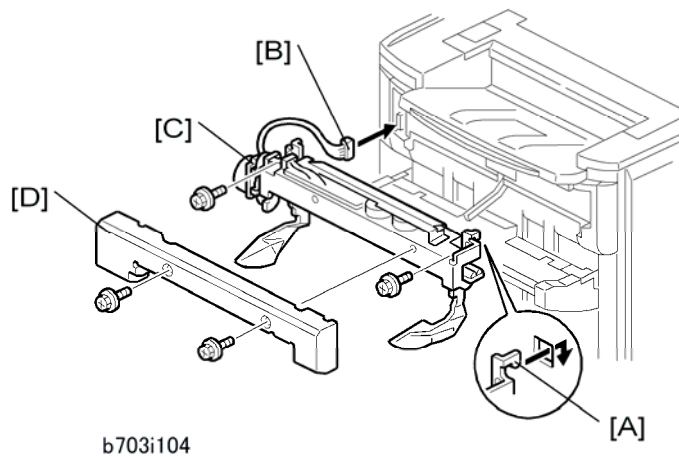

5. While holding the jogger unit with the connector on the left, put the hooks on the frame of the jogger unit [A] into the holes in the left and right side of the finisher frame.
6. Connect connector [B] to the socket (🔌 x 1).
7. Attach the jogger unit [C] to the finisher (🔩 x 2).
8. Reattach the jogger unit cover [D] to the jogger unit (🔩 x 2).

3.17 MAIL BOX (B762)

The Mail Box B762 is installed on the 2000/3000 Sheet Finisher D373/D374. It cannot be installed with the Cover Interposer Tray B704. (Either the mailbox or cover interposer tray can be installed on top of the finisher, but not both.)

3.17.1 ACCESSORIES

Check the accessories and their quantities against this list.

Description	Qty
1. Trays	9
2. Guide plate	1
3. Decals (bin display)	1
4. Tapping screws - M3x8	6

3.17.2 INSTALLATION

WARNING

- Turn the machine off and disconnect the machine power cord before you start this procedure.

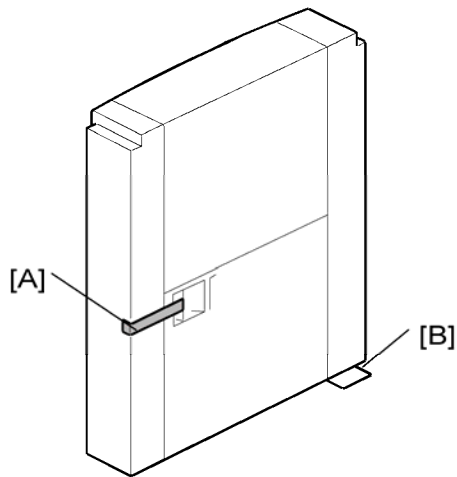

b762i101

1. Remove the filament tape [A].

Important

- Move the mailbox carefully. It is easy to cause damage to the corner leaf plate [B].

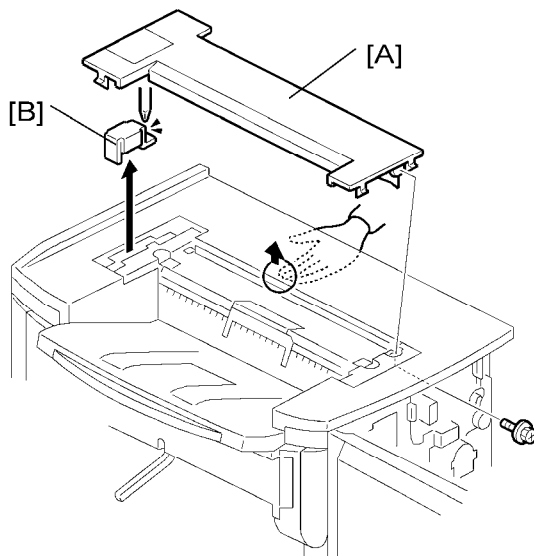

b762i102

2. If the Cover Interposer Tray B704 is installed on the D373/D374, remove it.

↓ Note

- The cover interposer tray and mailbox cannot be installed on the finisher at the same time.
3. Remove the top cover [A] of the finisher (⚙ x 1).
 4. Remove the bracket [B] (⚙ x 1).

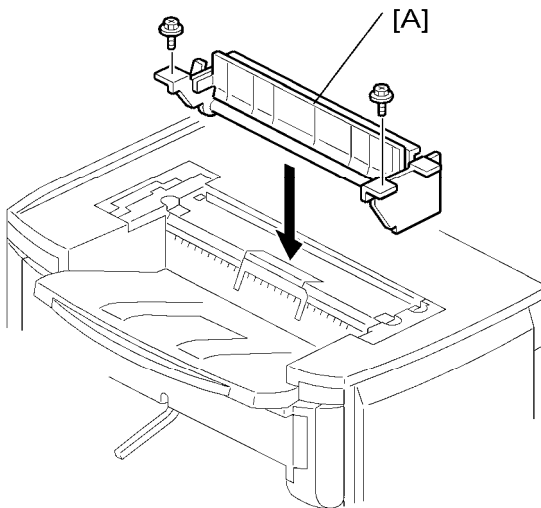

b762i103

5. Attach the guide plate [A] to the top of the finisher (⚙ x 2, M3 x 8).

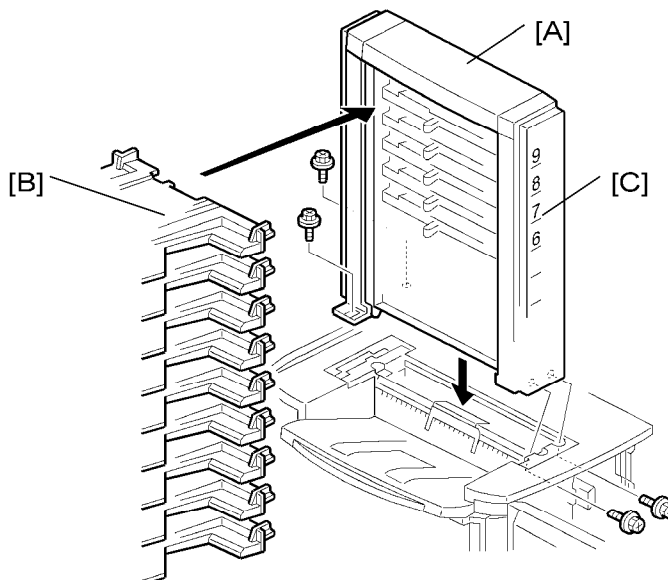

b762i104

6. Attach the mailbox [A] to the top of the finisher (⚙ x 4, M3 x 8).
7. Attach the 9 trays [B] to the mailbox.
8. Give the decals [C] to the customer. The customer will write on these and attach them at the correct location.

3000-Sheet Finisher (B830-17), Finisher Adapter Type C (D375)

3.18 3000-SHEET FINISHER (B830-17), FINISHER ADAPTER TYPE C (D375)

3.18.1 ACCESSORIES

3000-Sheet Finisher B830 Accessories

Check the accessories and their quantities against this list.

	Description	Q'ty
1.	Sponge Strip	1
2.	Entrance Guide Plate	1
3.	Ground Plate	1
4.	Joint Bracket	1
5.	Shift Tray	1
6.	Leveling Shoes	4
7.	Tapping Screws – M4 x 12	4
8.	Tapping Screws – M3 x 6	8
9.	Tapping Screws – M4 x 8	2
10.	Support Plate Pocket	1
11.	Support Plate	1
12.	Side Tray	1

3000-Sheet Finisher (B830-17), Finisher Adapter Type C (D375)

★ Important

- The output jogger unit is pre-installed on this finisher, so it is not an option.

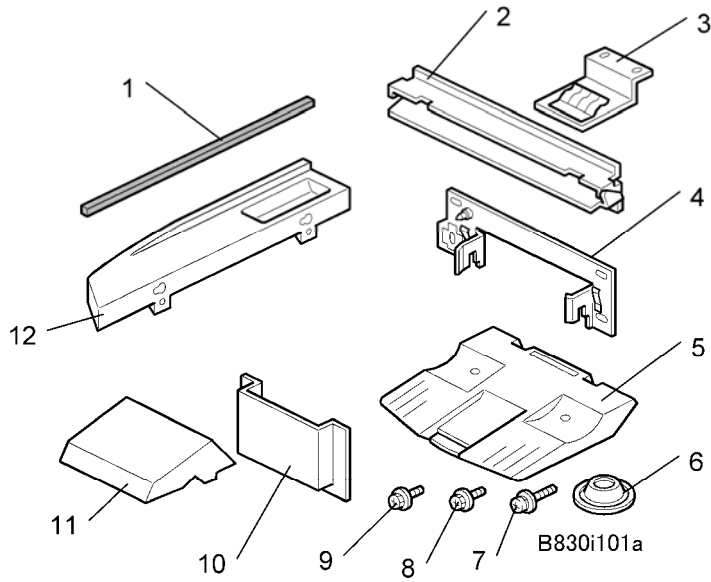

3000-Sheet Finisher (B830-17), Finisher Adapter Type C (D375)

Finisher Adapter Type C Accessories

Check the accessories and their quantities against this list.

★ Important

- This finisher adapter kit must be installed when installing this finisher on this machine.

	Description	Qty
1.	Proof Auxiliary Tray	1
2.	Entrance Guide	1
3.	SD Card (for firmware update)	1
4.	Motor Harnesses	2
5.	Motor Brackets	2
6.	Serial Number Decal	1
7.	FCC: Class-A Decal	1

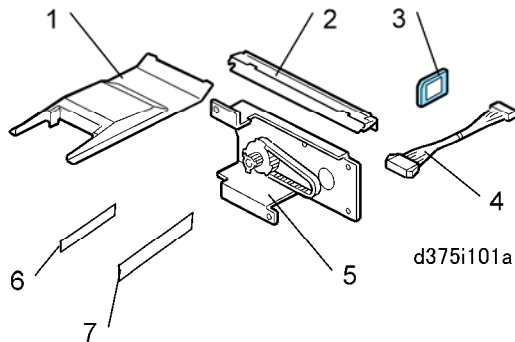

3.18.2 FINISHER ADAPTER KIT D375 INSTALLATION

★ Important

- The finisher adapter kit must be installed before the finisher and punch unit are installed.

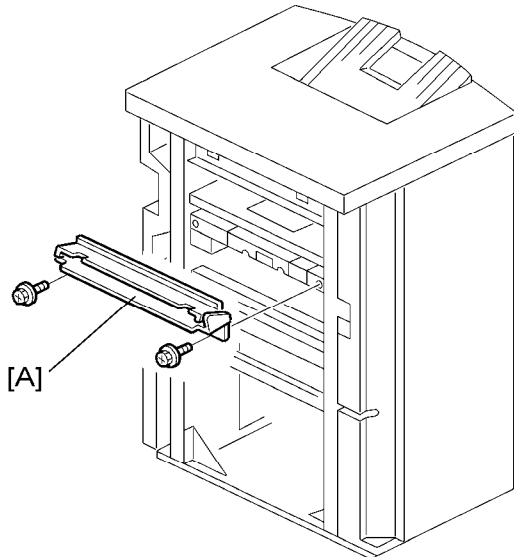

d375i102

1. Attach the entrance guide [A] (🔩 x 2).
 - Attach the entrance guide only if the finisher will be connected directly to the main machine.
 - Do not install the entrance guide if you intend to install the Cover Interposer Tray (B835).

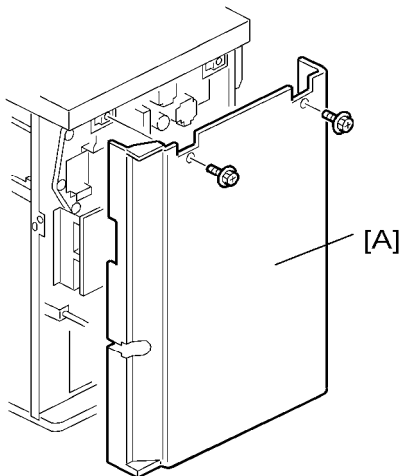

d375i103

2. Remove the finisher rear cover [A] (🔩 x 2).

3000-Sheet Finisher (B830-17), Finisher Adapter Type C (D375)

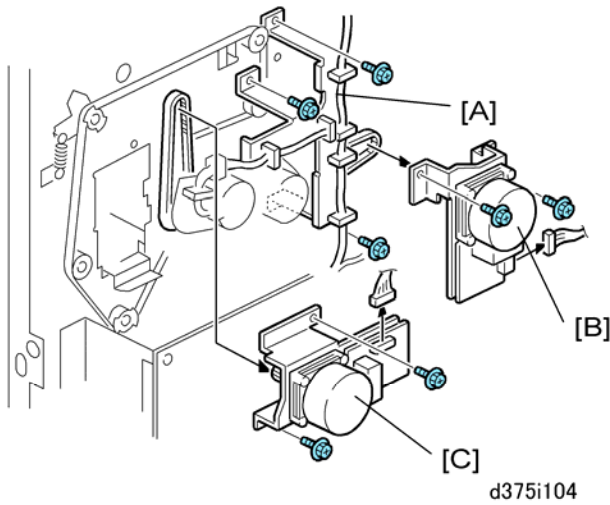

3. Remove:

[A] Harness T-bracket screws (🔩 x3). Remove the only the screws, not the bracket.

[B] Lower transport motor assembly (🔩 x 2, 📦 x1)

[C] Upper transport motor assembly (🔩 x 2, 📦 x1)

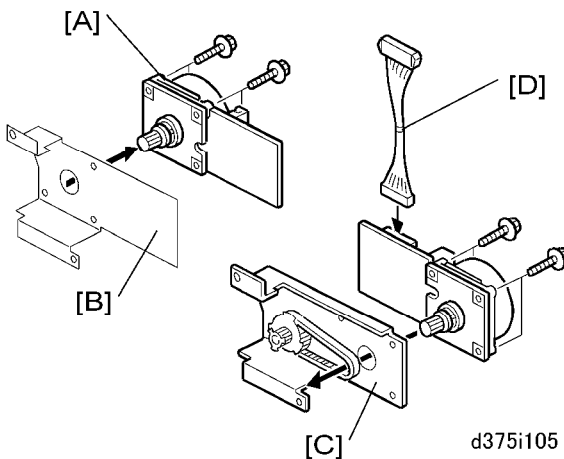

4. For both the upper and lower transport motors:

- Remove the motor [A] from its original bracket [B] (🔩 x 2)
- Attach the motor to the new bracket [C] (🔩 x 2).
- Attach the new harness [D] (📦 x 1).

5. Discard the original brackets.

- The new brackets and harnesses are provided in the finisher adapter accessory kit. The brackets are identical.

3000-Sheet Finisher (B830-17), Finisher Adapter Type C (D375)

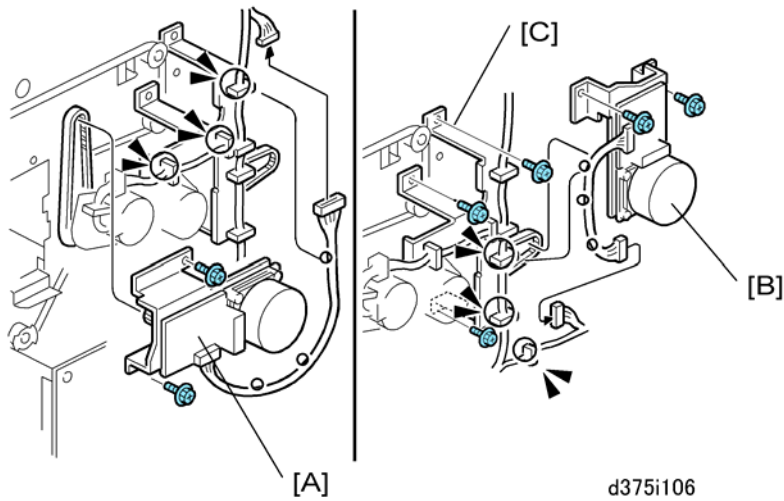

d375i106

6. Attach the upper transport motor [A] assembly as shown, with the motor pointing to the right (⚙️ x2, 🛠️ x1, 📡 x3).
7. Attach the lower transport motor assembly as shown, with the motor pointing down [B] (⚙️ x2, 🛠️ x1, 📡 x3).
8. Reattach the harness T-bracket screws [C] (⚙️ x3) that were removed earlier.

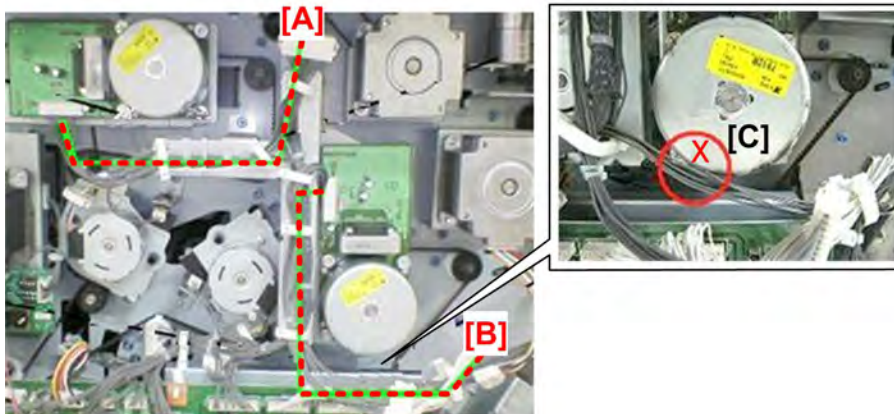

d375i002

9. Route the harnesses as shown by the dotted lines [A] and [B].

★ Important

- Never allow the harnesses to rest against either motor as shown at [C]. Heat from the motors could damage the harnesses.

10. Open the front door.

3000-Sheet Finisher (B830-17), Finisher Adapter Type C (D375)

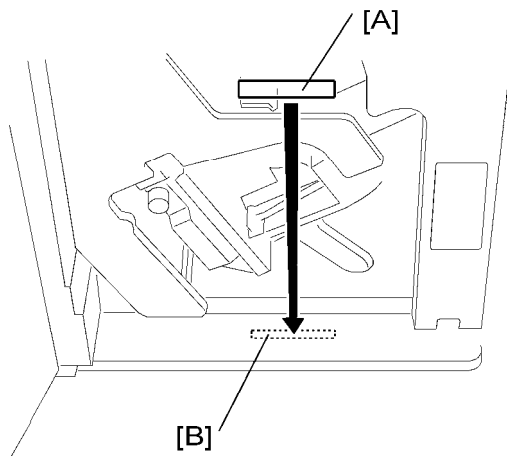

b698i107

11. Attach the serial number decal [A] below the finisher serial number decal [B] attached to the front bottom support of the frame.

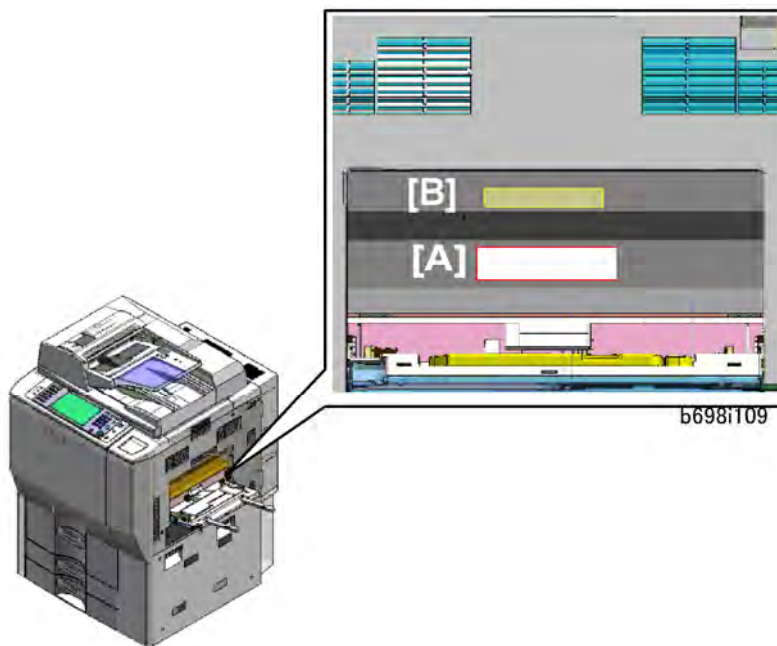

12. On the right side of the machine, attach the FCC Class A decal [A] below the copier serial number decal [B]. **(North America Only)**

3.18.3 FINISHER INSTALLATION

⚠ WARNING

- Turn the machine off and disconnect the machine power cord before you do this procedure.

1. Unplug the machine power cord before starting the following procedure.

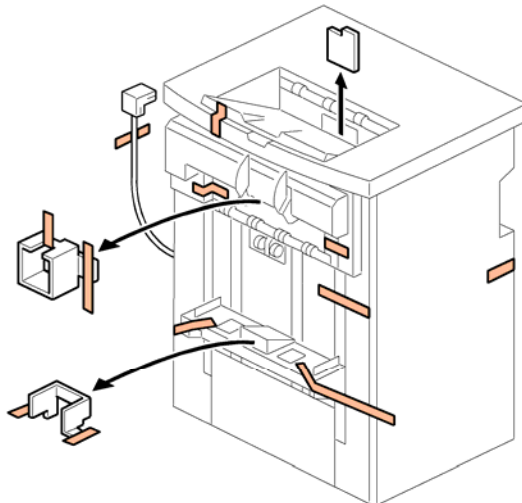

b830i102

2. Unpack the finisher and remove all tapes and shipping retainers.

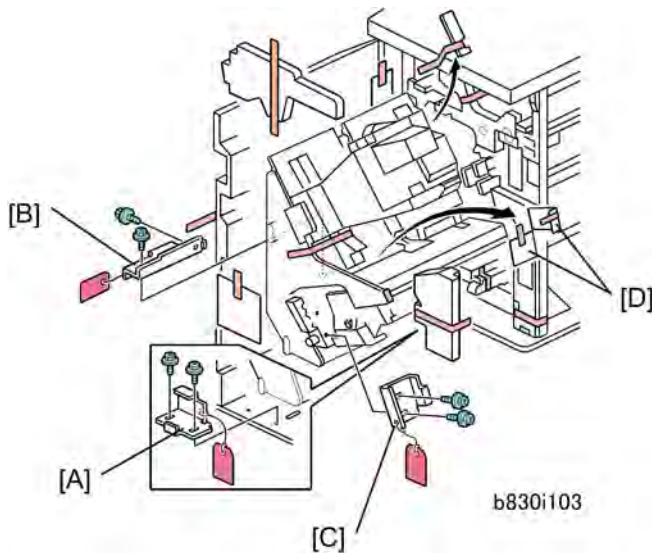

b830i103

3. Open the front door and remove the shipping retainers.
4. Remove the brackets, tags, and wires in this order: [A]> [B]> [C] (⚙ x 2 each).
5. Be sure to remove the two sheets of paper [D].

3000-Sheet Finisher (B830-17), Finisher Adapter Type C (D375)

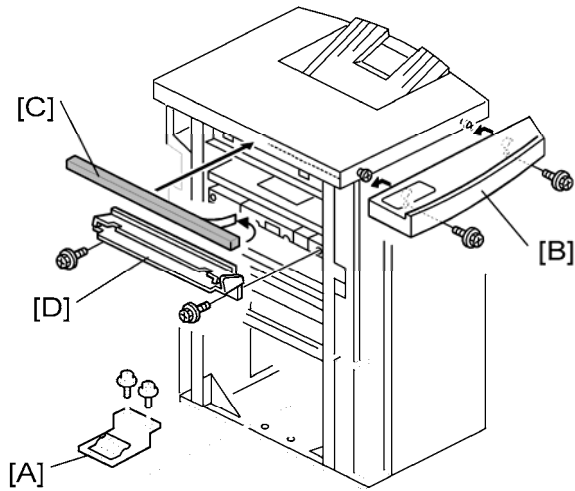

b830i105

6. Install the ground plate [A] (🔩 x 2) (M3 x 6).
Set the ground plate so that there is no gap between the plate and the bottom frame of the finisher (as shown).
7. Install the table extension [B] (🔩 x 2) (M4 x 8).
The edge of the table extension should be aligned with the edge of the finisher.
8. Attach the cushion [C] to the right side of the upper cover.
9. Install the entrance guide plate [D] (🔩 x 2) (M3 x 6).

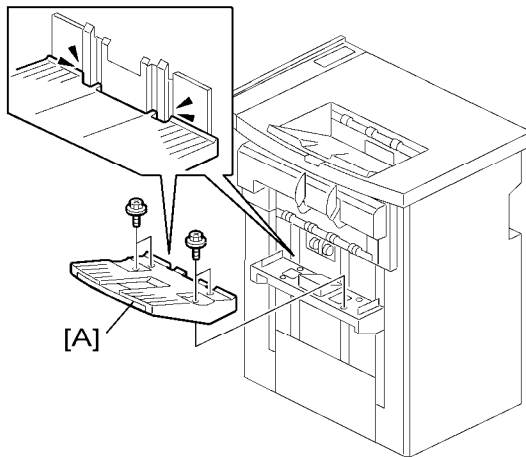

b830i109

10. Insert the shift tray [A] into the grooves and fasten it (🔩 x 4) (M3 x 6).

Docking the Finisher B830

The Finisher (B830) is docked to one of the following:

- Ring Binder (D392)
- Multi-Fold Unit (D454)
- Cover Interposer Tray (B835)
- Main Machine

Finisher B830 to Cover Interposer Tray B835

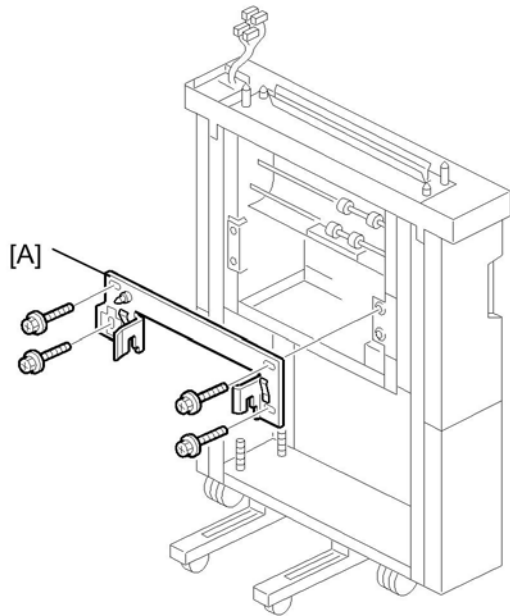

b830i203

1. Fasten the joint bracket to the Cover Interposer Tray B835.
2. Dock the finisher. (Go to 'Connecting the Finisher B830'.)

Finisher B830 to Main Machine or Other Upstream Unit

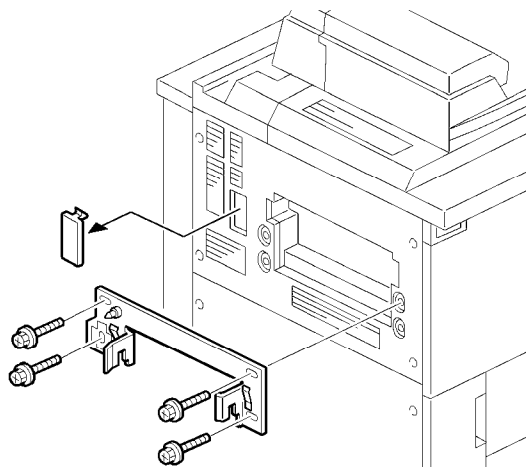

b830i201

3000-Sheet Finisher (B830-17), Finisher Adapter Type C (D375)

1. Remove the connector cover
2. Fasten the joint bracket to the Copier.
3. Dock the finisher. (Go to 'Connecting the Finisher B830'.)

Connecting the Finisher B830

1. Open the front door of the finisher.

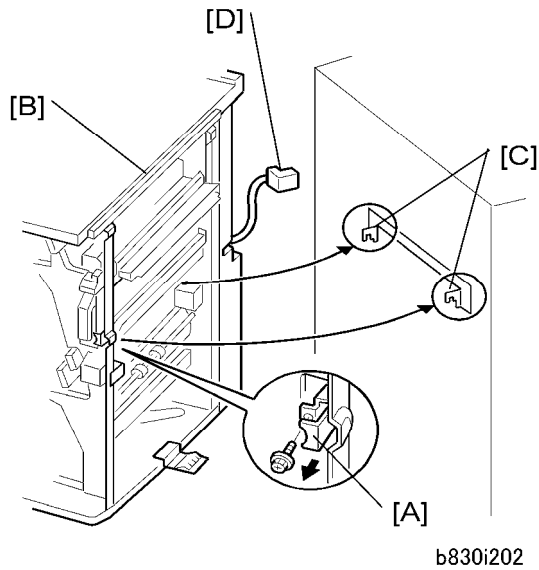

2. Pull out the locking lever [A] (🔑 x 1).
3. Align the finisher [B] with the joint brackets [C], then slowly push the finisher onto the brackets.
4. Connect the finisher cable [D] to the copier
5. Push in the locking lever [A].
6. Check that the top edges of the finisher are parallel with edges of the device (or copier) to the right.
7. Fasten the locking lever [A] (🔑 x 1)
8. Close the front door.

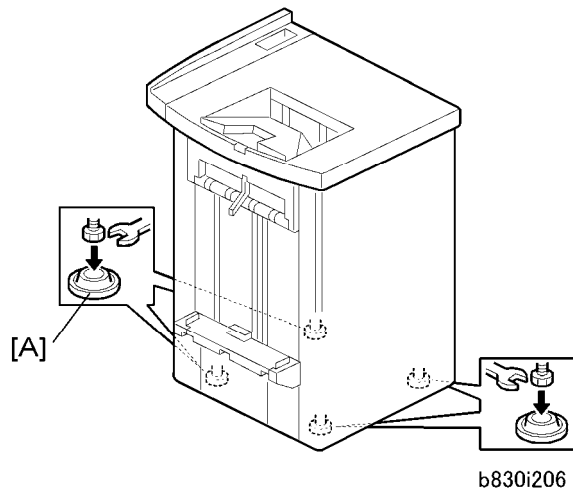

9. Set the leveling shoes [A] (x4) under the feet.
10. Turn the nuts to adjust the height of the finisher until it is level.

3.18.4 UPDATING THE FIRMWARE

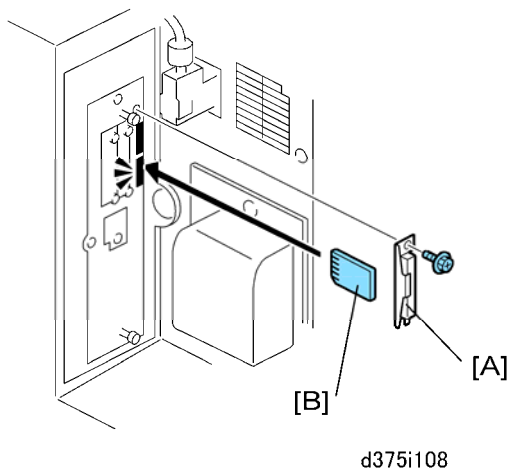

1. If the machine is on, switch it off.
2. Remove the SD card slot cover [A] from the main machine (🔧 x 1).
3. Insert an SD card [B] that contains the latest firmware for this finisher, downloaded from the web site. Insert this SD card into the service slot (lower slot).

↓ Note

- If you do not have the latest firmware, use the SD card that is provided with the finisher adapter kit. However, the firmware on this card may be old.
4. Open the front door of the main machine.
 5. Switch on the machine. A message prompts you to wait for the update procedure to begin, then the initial screen appears.

3000-Sheet Finisher (B830-17), Finisher Adapter Type C (D375)

6. Write down the NEW version numbers. (You will need these later to confirm the success of the firmware update.)
7. Touch "Finisher" then touch "Update".
8. Wait for the update procedure to begin.
 - The update may not start for 2 or 3 minutes.
 - When the first asterisk (*) appears in the progress bar this means the update has started.
 - The update procedure is very slow. Wait for all the hyphens (-) to be replaced by asterisks (*) in the progress bar.

★ Important

- Never switch off the machine while the update is in progress.
9. After asterisks have replaced all the hyphens in the progress bar, switch off the machine.
 10. Remove the SD card from the SD card slot and reattach the SD card slot cover.
 11. Close the front door.
 12. Switch on the machine.
 13. Enter the SP mode and do SP5990-5 to print the self-diagnostic report.
 14. Confirm that the finisher firmware updated successfully.
 - For "Finisher 1", you should see the numbers that you saw for the NEW column in the initial screen at Step 6.
 - If you see these numbers, the update has executed successfully.
 - If the update fails, turn the machine off and try the procedure again.
 15. Switch the machine off and remove the SD card.
 16. Switch the machine on.
- This completes the firmware update procedure.

3.18.5 SP SETTING

1. Enter the SP mode.
2. Do **SP5841-12** and enter the name of the staples used for corner stapling.
 - This is the name that shows when the user prints the Inquiry List.
 - To print this list push User Tools> [Inquiry]> [Print Inquiry List]> [Start].

Punch Unit PU5000 (B831)

3.19 PUNCH UNIT PU5000 (B831)

3.19.1 ACCESSORIES

Check the quantity and condition of the accessories in the box against the following list:

	Description	Q'ty
1.	Punch Unit	1
2.	Punch Waste Collection Hopper	1
3.	Spacer (1 mm)	2
4.	Spacer (2 mm)	1
5.	Knob	1
6.	Step Screw	1
7.	Screw (M4 x 6) Black	1
8.	Screw (M3 x 10)	2
9.	Spring	1
10.	Sensor Arm and Sensor	1

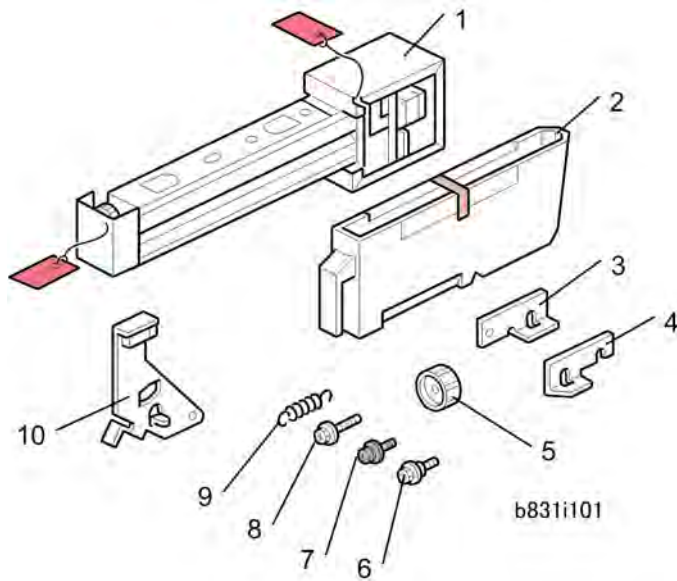

3.19.2 INSTALLATION

This punch unit is for the B830 finisher only.

⚠ CAUTION

- Switch the machine off and unplug the machine before starting the following procedure.

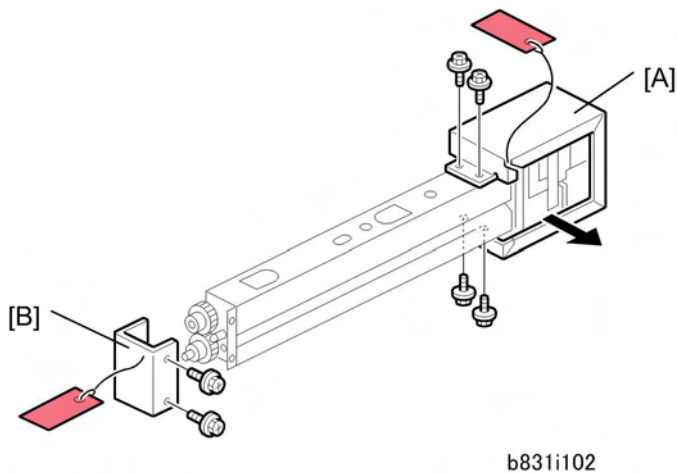

1. If the finisher is connected to the main machine, disconnect it.
2. Open the front door and remove the rear cover (🔩 x 2).
3. Unpack the punch unit and remove the motor protector plate [A] (🔩 x 4, Step screw x1).
4. Remove the cam lock plate [B] (🔩 x 1).

Punch Unit PU5000 (B831)

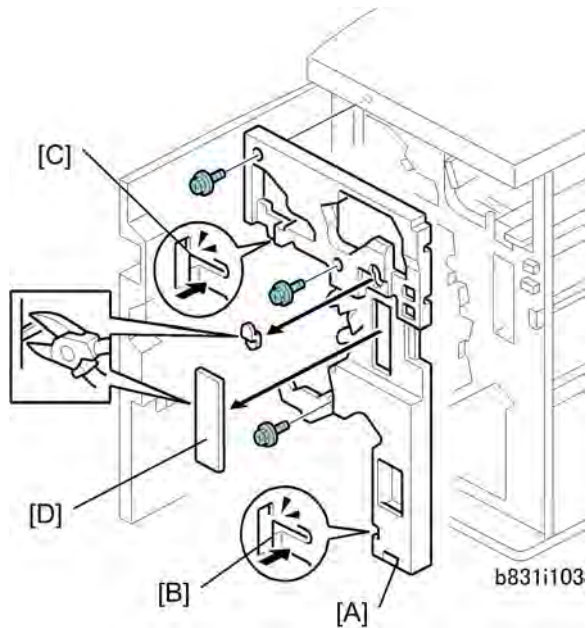

5. Remove the inner cover [A] (🔩 x 3).
6. Behind the inner cover at [B] and [C], press the lock tab to the right to release the inner cover from the frame.
7. Remove the plastic knockouts [D].

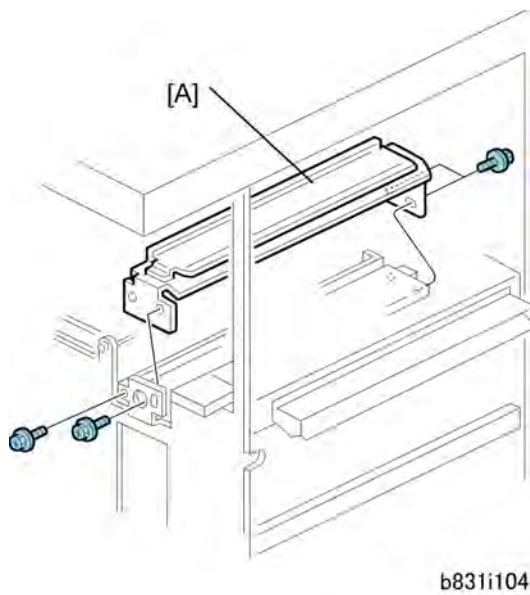

8. Remove the paper guide [A] (🔩 x 4).

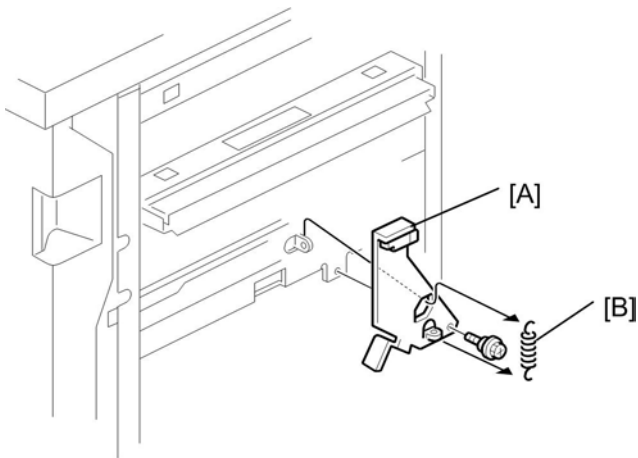

b831i106

9. Install the sensor arm [A] (🔩 x 1, small step screw (M3 x 4)). Make sure that the sensor arm swings freely on the step screw.
10. Attach the spring [B].

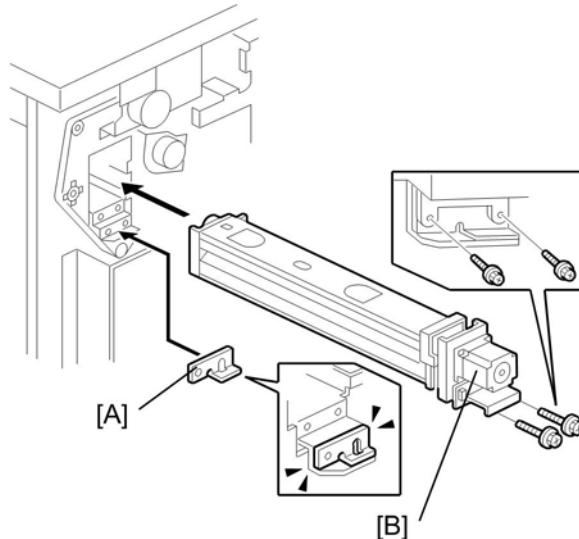

b831i105

11. Position the 2 mm spacer [A] and attach the punch unit [B] (🔩 x 2, M3 x 10).
12. Use one of the screws removed from the motor protector plate to fasten the remaining two spacers to the frame as shown.

↓ Note

- These extra spacers can be used to adjust the position of the punch holes (front to rear, across the page).

Punch Unit PU5000 (B831)

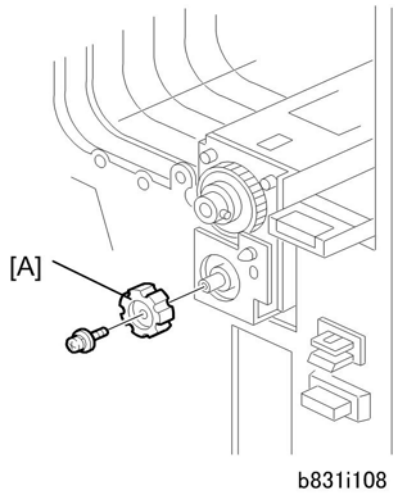

13. At the front, fasten the punch unit knob [A] (🔩 x 1).

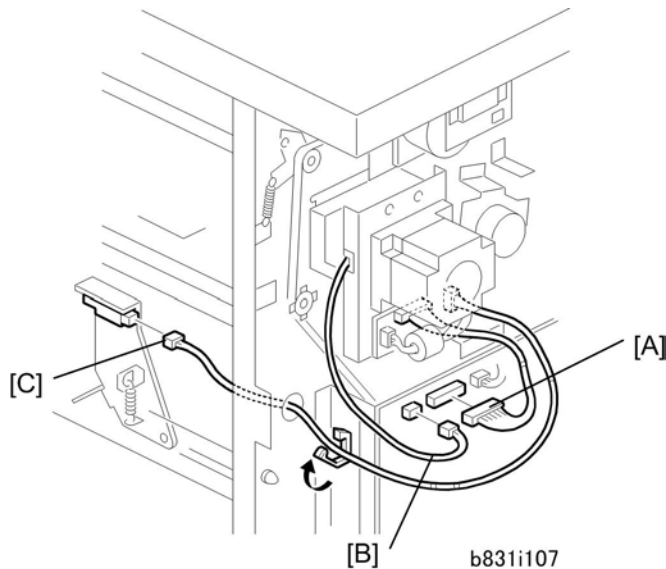

14. Connect the PCB harness connector [A] to **CN135** of the finisher PCB and to **CN600** of the punch unit PCB.
15. Connect the harness [B] to **CN136** of the finisher PCB.
16. Connect the single end of the hopper full sensor connector cable [C] to the hopper full sensor on the arm (🔌 x 1, 📡 x 2).

↓ Note

- No special DIP switch settings are required for this punch unit. A signal from the punch identifies itself by sending a signal to the copier.

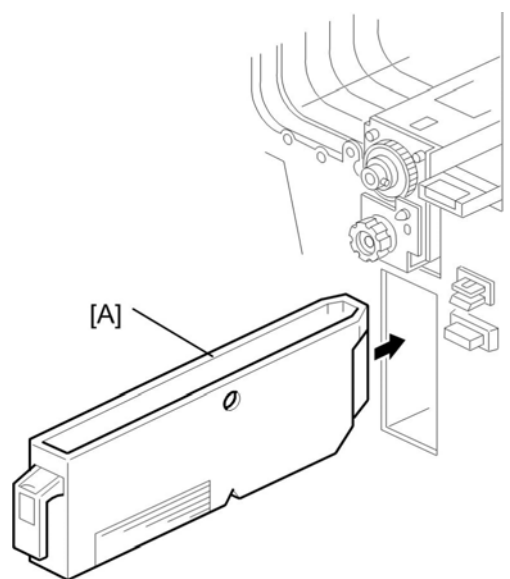

b831i109

17. Slide the punch waste collection hopper [D] into the finisher.
18. Re-attach the inner cover and rear cover.
19. Close the front door and re-connect the finisher to the machine.

3.20 COMMON ADJUSTMENTS

3.20.1 HEIGHT AND LEVEL ADJUSTMENT

Before you begin:

- The main machine should be installed first and adjusted to level within less than 5 mm front-to-back, and side-to-side.
- Due to the length of the paper path with all optional peripheral units installed, it is extremely important that every unit be level.
- The height and level of each peripheral unit must be adjusted at installation.
- The height and level of each unit must be adjusted before testing for the presence of skew and checking that side-to-side registration is correct.

Setting the Leveling Shoes

★ Important

- Do this procedure near each caster where an adjustable bolt is provided.
- The number of leveling shoes will differ, depending on the unit that you are leveling.



d059i821

1. Turn the **lower** nut to lower the bolt.

↓ Note

- The upper bold is spot-welded to the frame and does not move.
2. Set a leveling shoe below the bolt.



d059i822

3. Continue to turn the lower nut until it stops against the shoe.
4. Set a level on the front, rear, and side edges to determine if the unit is level.
5. Adjust the height at each corner until the unit is level.

3.20.2 SKEW AND SIDE-TO-SIDE REGISTRATION

Overview

The paper feed path is extremely long when many peripheral units are installed. In such a long path, the cumulative effect of paper skew or deviation in side-to-side registration may require adjustment.

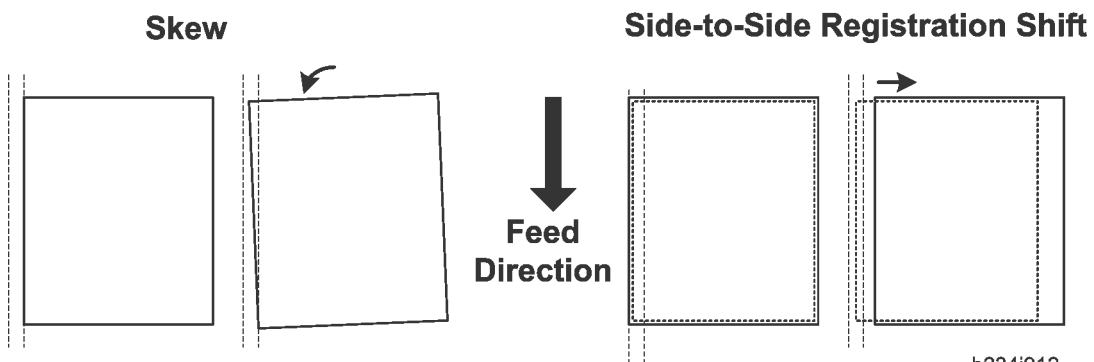

b234i912

- Skew occurs when the trailing edge of the paper rotates away from the direction of paper feed.
- If side-to-side registration occurs, the sheet remains straight but shifts left or right away from center.

Common Adjustments

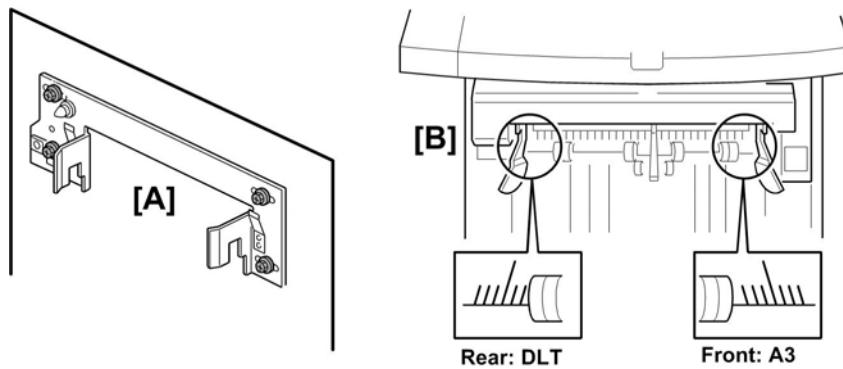

d081i904

To correct skew and side-to-side registration, the bar joint bracket [A] (provided as an accessory and attached to the upstream unit) and graduated scales [B] at the paper exit are required. These items are not provided with all the finishers.

The table below shows which adjustments are possible.

Name	Skew	S-to-S
LCT (D473)	No	No
LCIT (D350)	No	No
Ring Binder (D392)	Yes	Yes
Multi Folding Unit (D454)	Yes	Yes
Finisher (B830)	No	Yes

- Neither skew nor side-to-side registration can be corrected for either LCT unit.
- Side-to-side registration correction can be done for the 3000-Sheet Finisher (B830). No spacers are provided for this finisher so skew cannot be adjusted.
- Use either the rear scale (for DLT) or front scale (for A3), depending on the type of paper used.

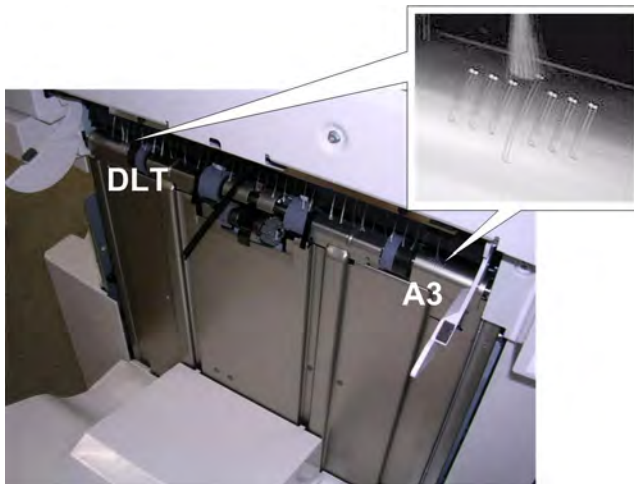

The illustration above shows the actual scale on the left side of the unit Multi Folding Unit (D454). In the illustration below, the red lines indicate the joint bracket where adjustments are done to eliminate skew and to correct side-to-side registration (this illustration shows the machine and peripherals as viewed from above the machine).

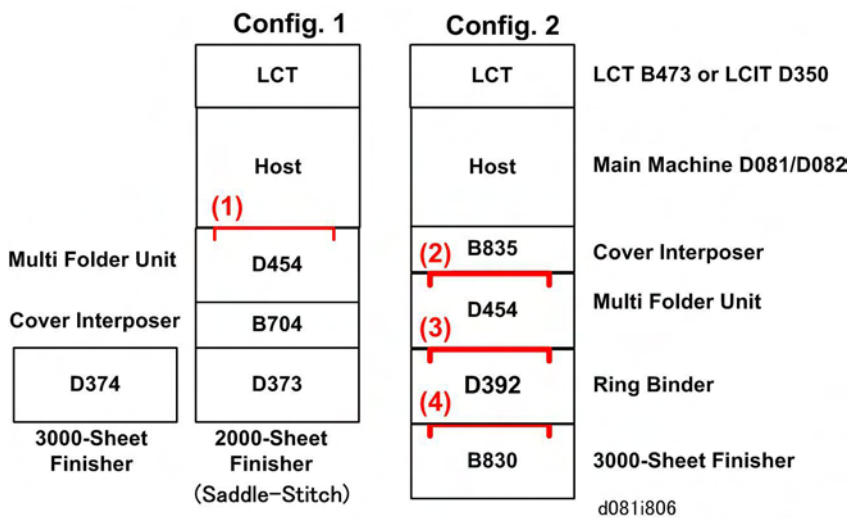

Here are some general rules for testing and adjusting for paper skew or a shift in side-to-side registration.

1. Skew and side-to-side correction can be done only where the unit is docked to the upstream unit with the bar joint connector (see above).
2. After installation of each peripheral device, do some test prints and check for the presence of skew, and check that side-to-side registration is correct.
3. If you detect a problem with skew or side-to-side registration, do the adjustment on the bar joint bracket attached to the peripheral unit **upstream of the unit where the problem occurred**.
4. Side-to-side registration is corrected by shifting the upstream joint bracket left or right.

Common Adjustments

- Skew is eliminated by inserting spacers (shims) under the rear or front end of the joint bracket. These spacers are provided with the peripheral units, attached by screws to the units at the factory.

Checking Side-to-Side Registration

Do this procedure to confirm that the paper is centered in the paper path.

- Make sure the I/F cable of the unit is connected to the upstream unit.
- Disconnect the unit to the left of the unit to be tested.
- Execute a run by feeding paper from Tray 2 of the host machine.
- When each sheet exits, check the position of the paper on the scale to see if the paper is centered.
 - Read the rear scale for DLT-size paper
 - Read the front scale for A3-size paper.
 - The scale lines are spaced 2 mm apart.
- The paper must not deviate more than ± 2 mm on the scale.

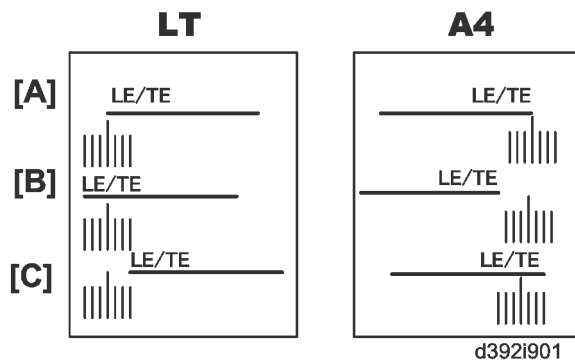

[A]	Leading/trailing edges centered. No adjustment necessary.
[B]	Leading/trailing edges offset to the rear by more than 2 mm. Adjustment required.
[C]	Leading/trailing edges offset to the front by more than 2 mm. Adjustment required.

If the edge of the paper is on the scale at the center [A], no adjustment is required.

-or-

If the edge of the paper is ± 2 mm off the center line on the scale, adjustment is required.

Do the procedure in the next section.

Correcting Side-to-Side Registration

1. Disconnect the peripheral unit from the upstream unit.

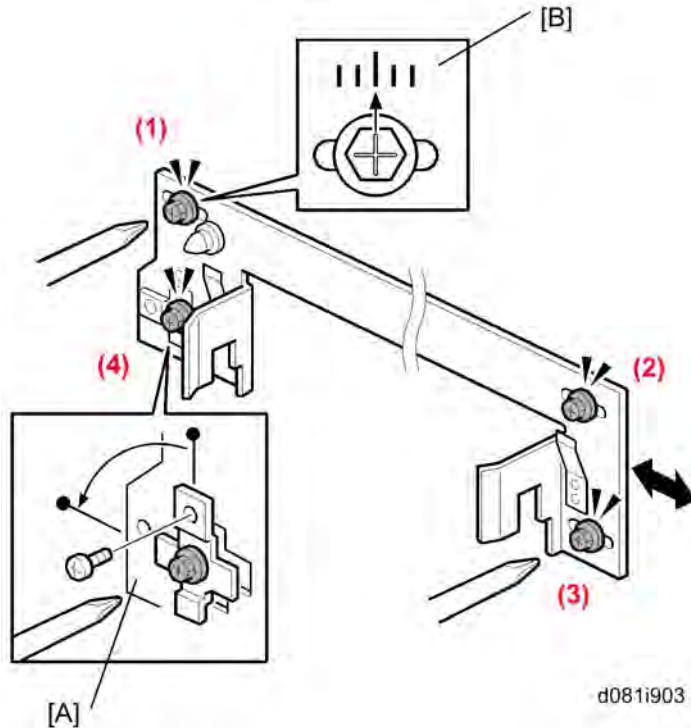

2. On the joint bracket attached to the upstream unit, loosen screws (1), (2), (3), and (4).
3. Remove bracket [A] (x1), rotate it 90 degrees, and re-fasten the screw. Changing the position of this bracket aligns the oval cut-out horizontally and frees the joint bracket so it can slide from side to side.
4. Look at the scale [B].
5. Slide the bracket to the left or right and tighten the screw.
6. If the deviation from center was toward the front, slide the bracket to the rear and tighten the screw (1).
-or-
If the deviation from center was toward the rear, slide the bracket to the front and tighten the screw (1).
7. Tighten screws (2), (3), (4).
8. Do another test run, so that you can check the results of the adjustment.

Common Adjustments

Detecting Paper Skew

Do this check to detect the presence of skew in the paper path.

1. Make sure that the I/F cable of the unit is connected to the upstream unit.
2. If a peripheral unit is connected on the left side, disconnect it and pull it away.
3. Execute a straight-through run.
4. Check the scale where each sheet exits.
 - The rear scale is for DLT-size paper.
 - The front scale [2] is for A3-size paper.
 - Be sure to read the correct scale for the paper size in use.

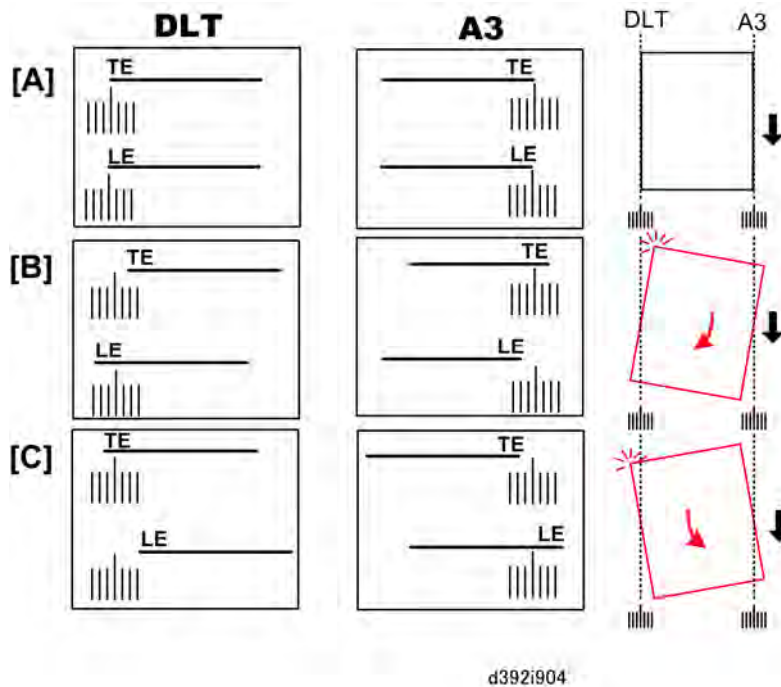

[A]	Centered. No adjustment necessary.
[B]	Trailing edge skew to the front, total skew more than ± 2 mm. Adjustment required.
[C]	Trailing edge skew to the rear, total skew more than ± 2 mm. Adjustment required.

Correcting Skew

1. Disconnect the peripheral unit from the upstream unit.
2. Locate and remove the spacers from the peripheral unit where the problem occurred.

Locating and Removing Spacers

The photos below show where you can find the spacers for each unit.

Multi Folding Unit (D454)

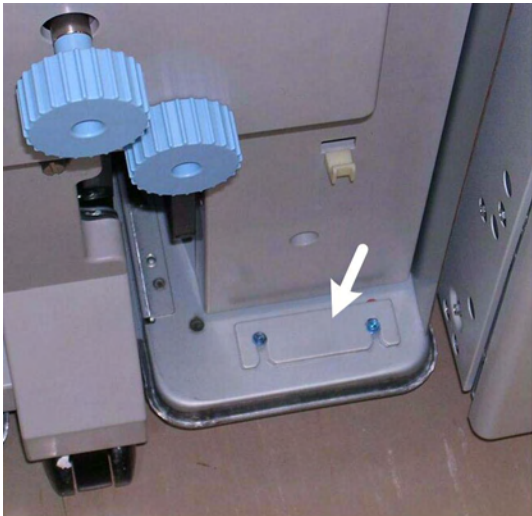

d454i111

Finisher SR5000 (B830)



d059i819

1. Look at the right side (🔩 x1).
2. Remove the spacers (🔩 x1).

Common Adjustments

Inserting Spacers

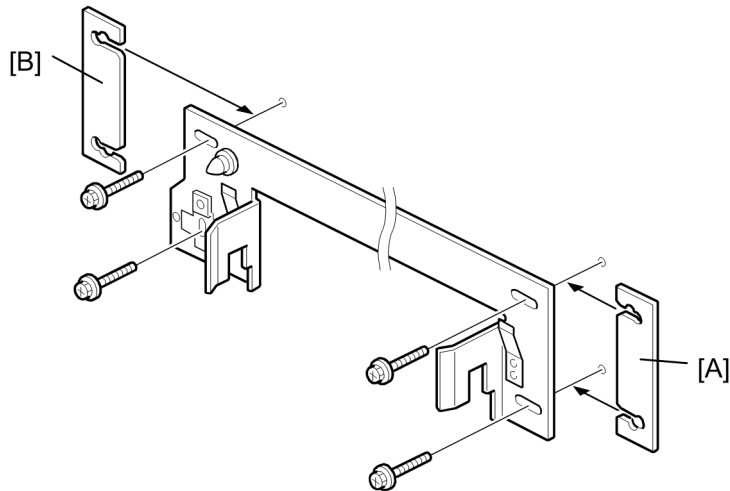

d392i906

1. Loosen the screws (🔩 x4) of the joint bracket attached to the peripheral upstream of the unit where the problem occurred.
2. Insert a spacer and tighten the screws.
If the trailing edge of the paper is **skewing toward the front** of the machine, insert a spacer [A] under the **rear end of the bracket** and tighten the screws.
-or-
If the trailing edge is **skewing toward the rear** of the machine, insert a spacer [B] under the **front end of the bracket** and tighten the screws.
3. Do another run to check the adjustment. If skew is still present, insert another spacer.
 - Each spacer is 2 mm thick.
 - Only two spacers are provided, so the maximum adjustment is 4 mm (using two spacers).

3.20.3 BREAKER SWITCH TESTING

1. Plug the power cord of the main machine or peripheral unit to be tested into its power source.

★ Important

- Do not turn on the main machine or the peripheral to be tested.
- The main machine and the peripheral to be tested must be off.

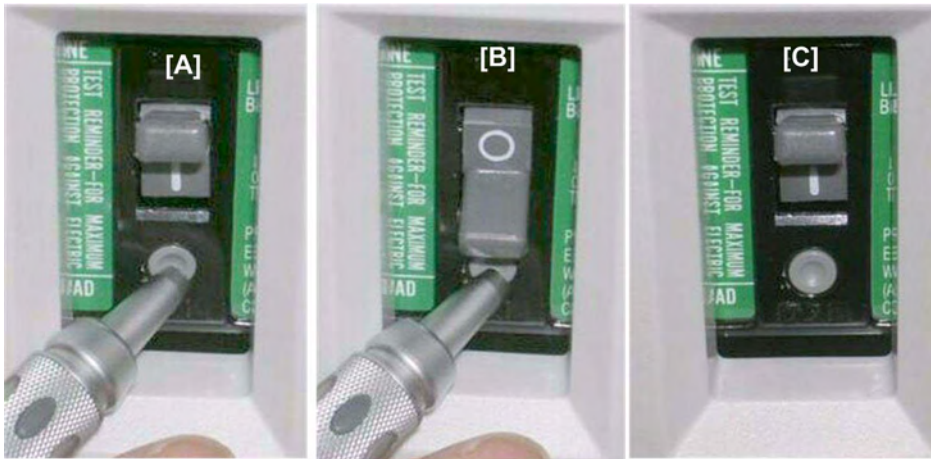

d059i820

2. Use the tip of a small screwdriver or pen to push the breaker test button [A].
 - The breaker switch should flip to the "O" position [B]. This indicates that the breaker switch is operating normally.
 - If the breaker switch does not flip to the "O" position, the switch must be replaced.
3. Return the switch to the "I" position [C] for normal operation.

★ Important

- The main machine will not turn on if the breaker switch is not returned to the "I" position.
- All breaker switches must be checked at installation, and once a year.

3.21 MFP CONTROLLER OPTIONS

3.21.1 OVERVIEW

The machine controller box has three board slots and two SD card slots. Make sure that each board and SD card is put in the correct slot.

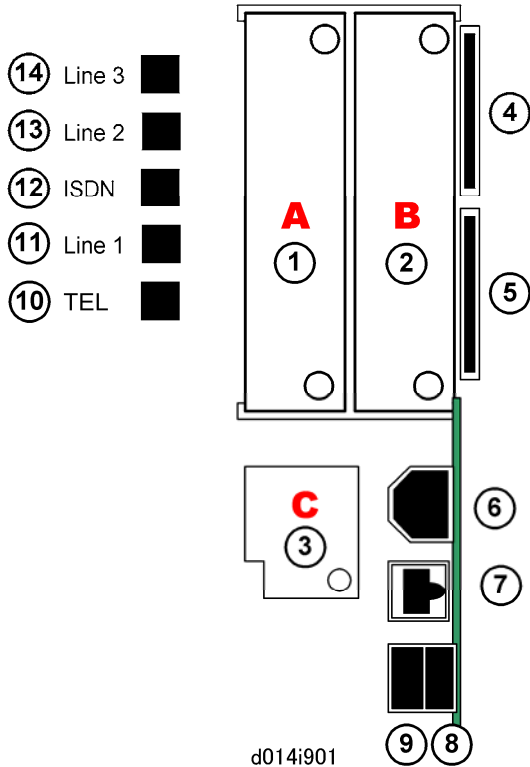

Board Slots

No.	Name	Description
①	Slot A	Copy Connector (B328) only
②	Slot B	<ul style="list-style-type: none"> ▪ IEEE1284 (B679) ▪ File Format Converter (D377) ▪ IEEE802.11a/g (D377-01 NA, -02 EU/Asia) ▪ Bluetooth (B826)
③	Slot C	Gigabit Ethernet (D377-21). The EFI (Fiery) controller is connected through Gigabit Ethernet.

No.	Name	Description
④	Upper Slot	<ul style="list-style-type: none"> ▪ Data Overwrite Security (D497) ▪ PostScript3 (D497) ▪ Browser Unit (D497) ▪ HDD Encryption Unit (D377-16)
⑤	Lower Slot	Contains the VM card when the machine leaves the factory. When used for firmware updates, and moving applications to another SD card with SP5873 (Apli Move), the VM card must be removed and then re-installed after the update procedure is completed.
⑥	USB 2.0	Built-in for connection of USB devices.
⑦	100BaseT LAN	Standard LAN connection point.
⑧	USB Ch1	For future use (PictaBridge, other application devices).
⑨	USB Ch2	Note: These connection points are covered with a plate. Remove the screw, rotate the plate and reattach it with the screw so that the slots are exposed, then attach the connector.
⑩	TEL	Jack for telephone connection
⇒ ⑪	Line 1	Jack for main telephone line from the outside for connection to Fax Option Type C7501 (D498).
⑫	ISDN	Jack for ISDN connection Japan Only
⑬	Line 2	Jack for a 2nd line connection to G3 Interface Unit Type C7500 (D357) when this option is installed.
⑭	Line 3	Jack for a 3rd line connection to G3 Interface Unit Type C7500 (D357) when this option is installed.

MFP Controller Options

Important Notes

- Only two SD Card slots are available for applications.
- The VM card is already inserted in the lower slot when the machine leaves the factory.
- Other applications must be inserted in the upper slot.
- If more than one application is required in the upper slot, the applications must be moved to the same SD card with SP5873-1.
- The PostScript3 application cannot be moved to another card. However, other applications can be moved to the PostScript3 SD card.

3.21.2 ENABLING USB

Do SP5985 to enable USB.



- USB is built-in but it must be enabled.

3.21.3 ACCESSORY CARDS

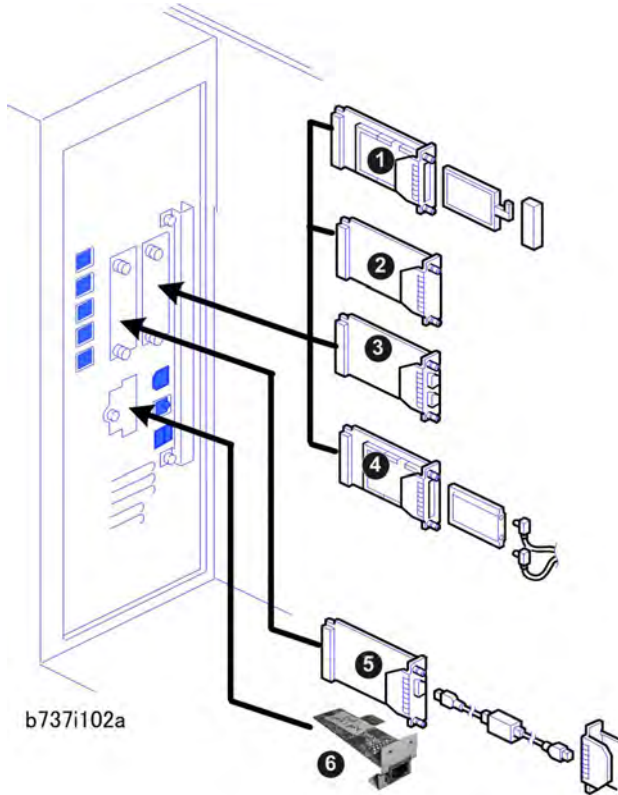

Installation

MFP Controller Options

No.	Slot	Code	Option
(1)	Slot B	B826-17	Bluetooth
(2)	Slot B	D377-04	File Format Converter
(3)	Slot B	B679-17	IEEE1284
(4)	Slot B	D377-01, -02	IEEE802.11a/g
(5)	Slot A	B328-11	Copy Connector
(6)	Slot C	D377	Gigabit Ethernet* ¹
		B829-07	Copy Data Security Unit Type F (not shown, is attached to the IPU inside the controller box.)

*¹: The EFI (Fiery) controller is connected through Gigabit Ethernet.

 **Note**

- Items (1) to (4) must be in the same slot. Only one of these cards can be installed at the same time.

3.21.4 SD CARD APPLICATIONS

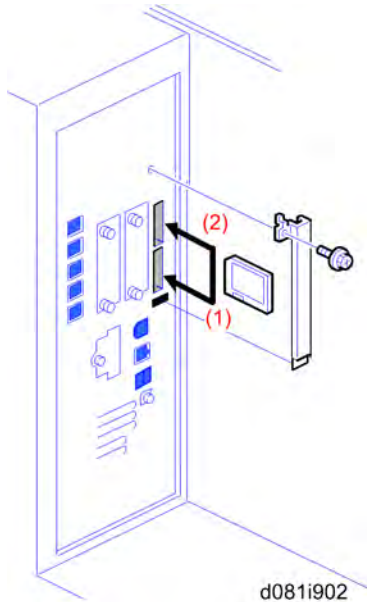

The following applications are available on SD cards.

No.	Name	SD Card Slot.
D497	Browser Unit Type E	2 (upper slot)
D497	Data Overwrite Security Unit Type H	2 (upper slot)
D377	HDD Encryption Unit Type A	2 (upper slot)
D378	PostScript 3	2 (upper slot)

Note:

- If the customer needs more than one application in the upper slot, the applications must be moved to one SD card.

3.21.5 HANDLING DIMMS AND SD CARDS

⚠ WARNING

- Always turn the machine off and disconnect the machine power cord before you install a controller option.

⚠ CAUTION

- To prevent damage to the controller box, always work carefully. Never put your hand or a tool into the box when you remove the controller box or install an option.
- To prevent damage to the circuits on the boards, always touch a metal surface to remove static charge from your hands before you handle a board..

DIMMs

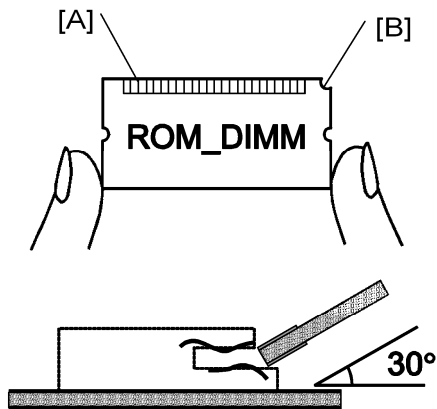

g338i901

1. Hold the ROM DIMM as shown above. The edge connector [A] points toward the slot and the notch [B] is in the top right corner.
2. Insert the edge connector [C] in the slot at a 30-degree angle from the surface of the board. If the angle is too low, the upper contact could bend.
3. Carefully move the outer edge of the ROM DIMM up and down slightly until it goes into the connector then carefully push it down until it is level with the controller board.

★ Important

- If the upper contact is pushed in with force and bends, the connection will be defective and the machine will not operate.

SD cards

SD cards are held in position by a small spring-lock mechanism.

1. To install an SD card, push it into the slot until it stops, then release it.
2. To remove an SD card, push the SD card in carefully to release it, and then remove it from the slot.

3.21.6 MOVING APPLICATIONS TO ONE SD CARD

Overview

There are only two SD card slots:

- Slot 2 (upper slot). Insert the application card in this slot.
- If more than one application is required, the applications must be moved to one SD card with SP5873-1.

Here are some important points you should keep in mind about SD cards and their applications:

- The SD card in the **upper slot** (target) must be another application SD card for this machine. The SD card in the upper slot cannot be a blank SD.
- The data necessary for authentication is transferred with the application program to the target SD card.
- Do not use an SD card if it has previously been used with a computer. Correct operation is not guaranteed if such an SD card is used.
- The SD card is the only evidence that the customer is licensed to use the application program. The service technician may occasionally need to check the SD card and its contents to solve problems. Although copied SD cards are disabled for use, they must be stored in the machine door for future use and reference. (See "Storing SD Application Cards on Site" in this section)
- A licensing agreement prohibits copying of a PostScript3 SD card. However, you can move other applications to the PS3 SD card.
- Once an SD card has been used to hold several applications, it should not be used for any other purpose.

Moving Applications

Do this procedure to put more than one application on one SD card.

1. Remove the SD card slot cover (🔩 x 2).
2. Remove the VM card from Slot 1 (lower slot).

★ Important

- Before removing the VM card from Slot 1 (lower slot) you must shut down the App2 Me application (and any other VM card applications) if it is running. See "Before Removing and Re-installing the VM Card...".
3. Turn off the main machine.

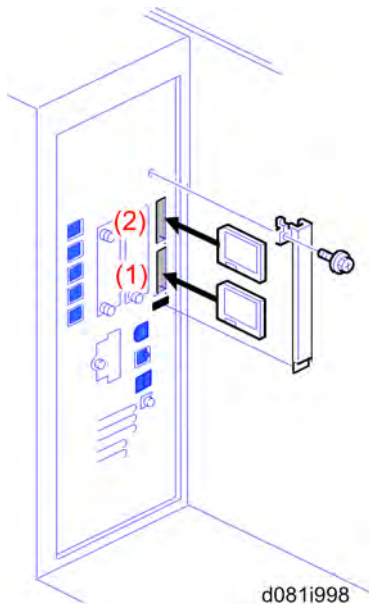

4. Remove the VM card from Slot 1 (lower slot).

★ Important

- Before removing the VM card from Slot 1 (lower slot) you must shut down the App2 Me application (and any other VM card applications) if it is running. See p.5-24 "Before Removing and Re-installing the VM Card".
5. Insert the Source SD card in the Slot 1 (lower slot). This card contains the application that you want to move to the other SD card.

↓ Note

- The PostScript3 SD card cannot be the source card because it cannot be copied.
6. Put the Target SD card in Slot 2 (upper slot).

★ Important

- This must be another application SD card for this machine. You cannot use a blank SD card.
7. Open the front door.
 8. Turn the main machine on.
 9. Go into the SP mode and do SP5873-1.
 10. Follow the instructions on the display and touch "Execute" to start copying.
 11. When the display tells you copying is completed, touch "Exit".
 12. Turn the main machine off.
 13. Remove the Source SD card from Slot 1 (lower slot), and leave the target SD card in Slot 2 (upper slot).
 14. Turn the main machine on.
 15. Go into the User Tools mode and confirm that all the applications on the SD card in Slot 2 (upper slot) are enabled.
User Tools> System Settings> Administrator Tools> Firmware Version> Next...
 16. Turn the main machine off.
 17. Remove the cover from the front door, and store the SD card that was copied. (See "Storing SD Application Cards on Site"). The SD card must be stored with the machine for these reasons:
 - Once an SD card has been copied, it can no longer be used. But it must be stored in the front door to serve as proof of purchase by the customer.
 - Also, at a later time the stored SD cards can be restored to full use with SP5873-2 (described in the next section).
 - Before you put the card in the front cover, label it so that it can be easily identified.
 18. If the client is using App2 Me or any other applications on the VM card, do the procedure to re-start these applications.

Undo Exec

1. Remove the SD card slot cover (🔑 x 2).

★ Important

- Before removing the VM card from Slot 1 (lower slot) you must shut down the App2 Me application (and any other VM card applications) if it is running. See p.5-24 "Before Removing and Re-installing the VM Card".
2. Turn the main switch off.
 3. Put the SD card with the applications in Slot 2 (upper slot).
 4. Put the original destination SD card (the one stored in the front door) in Slot 1 (lower slot).

★ Important

- The SD card in the **lower slot** must be the original (empty) SD card of the application that you want to move from the **upper slot** to the **lower slot**.
 - You cannot use any blank SD card in the **lower slot**. The application can be moved only to an original SD card.
5. Turn the main switch on.
 6. Go into the SP mode and do SP5873-2 (Undo Exec)
 7. Follow the messages on the operation panel to complete the procedure.
 8. Turn the main switch off.
 9. Remove the SD cards from the slots.
 10. Insert the VM card in Slot 1 (lower slot).
 11. Turn the main switch on.
 12. If the client is using App2 Me or any other applications on the VM card, do the procedure to re-start the App2 Me application. See p.5-24 "Before Removing and Re-installing the VM Card".

Storing SD Application Cards on Site

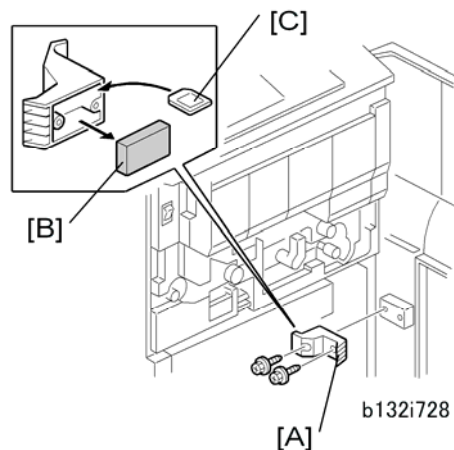

1. Open the front door.
2. Remove the cover [A] on the door (⚙ x 2).
3. Remove the block [B].
4. Store the SD cards [C] inside the cover.
5. Attach the cover to the machine.

3.21.7 IEEE 1284 INTERFACE BOARD (B679) (CENTRONICS)

Accessories

Check the accessories and their quantities against this list.

	Description	Qty
1.	IEEE 1284	1

Only one interface slot is available for one of the following options, so only one can be installed:

- Bluetooth (B826-17)
- File Format Converter (D377-04)
- IEEE1284 (B679-17)
- IEEE802.11a/g (D377-01)

Installation

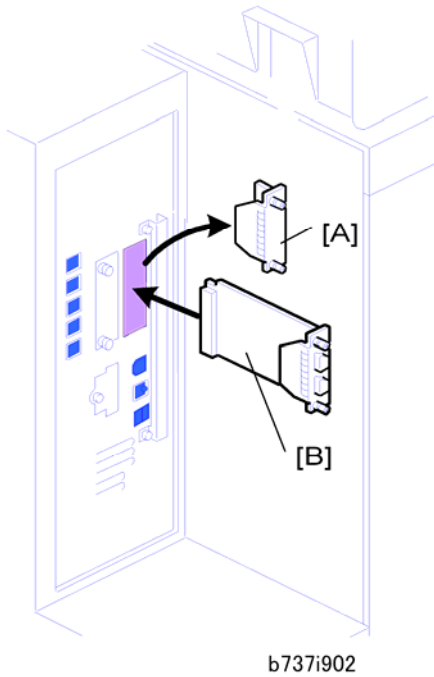

1. Remove the cover of Slot B [A] (⚙️ x 2).
2. Touch a metal surface to discharge any static electricity from your hands.
3. Install the interface board [B] in Slot B (⚙️ x 2).
4. Cycle the machine power off and on.
5. Do SP5990 to print an SMC Report.
6. Read the report and confirm that the interface board is installed correctly.

3.21.8 BLUETOOTH INTERFACE UNIT TYPE 3245 (B826-17)

Accessories

Check the quantity and condition of the accessories.

	Description	Q'ty
1	Bluetooth card	1
2	Bluetooth card cover	1
3	Bluetooth board	1

Only one interface slot is available for the following options, so only one can be installed:

- Bluetooth (B826-17)
- File Format Converter (D377-04)
- IEEE1284 (B679-17)
- IEEE802.11a/g (D377-01)

Installation Procedure

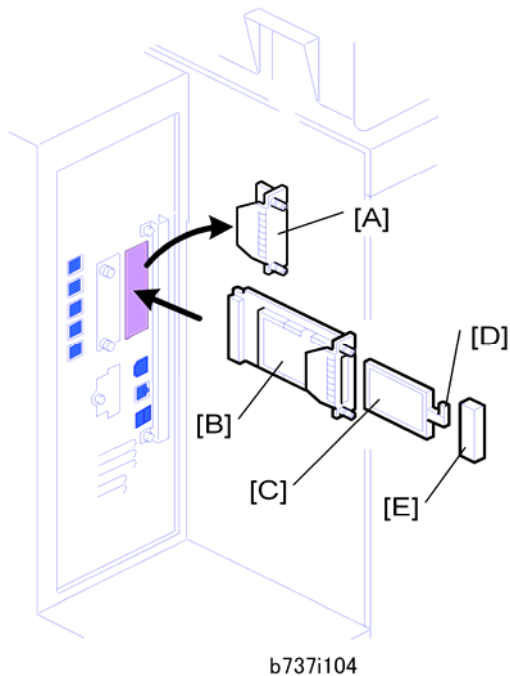

1. Remove the cover of Slot B [A] (⚙️ x 2).
2. Touch a metal surface to any static electricity from your hands.
3. Put the interface board [B] in Slot B.
4. Confirm that the board is inserted completely, then fasten it (⚙️ x 2).
5. Put the Bluetooth card [C] in the slot of the interface board.
6. Push the antenna cap [D] to extend it.
7. Attach the card cover [E] (used to prevent static electricity).
8. Turn the machine off and on.
9. Enter the SP mode and do SP5990 to print an SMC.
10. Read the report and confirm that the interface board is installed correctly.

3.21.9 IEEE 802.11A/G INTERFACE UNIT TYPE J (D377-01)

Accessories

Check the accessories and their quantities against this list.

	Description	Qty
1.	Wireless LAN PCB (GW-WLAN)	1
2.	Card (GW-WLAN)	1
3.	Wireless LAN Instructions	1

Only one interface slot is available for the following options, so only one can be installed:

- Bluetooth (B826-17)
- File Format Converter (D377-04)
- IEEE1284 (B679-17)
- IEEE802.11a/g (D377-01)

Installation

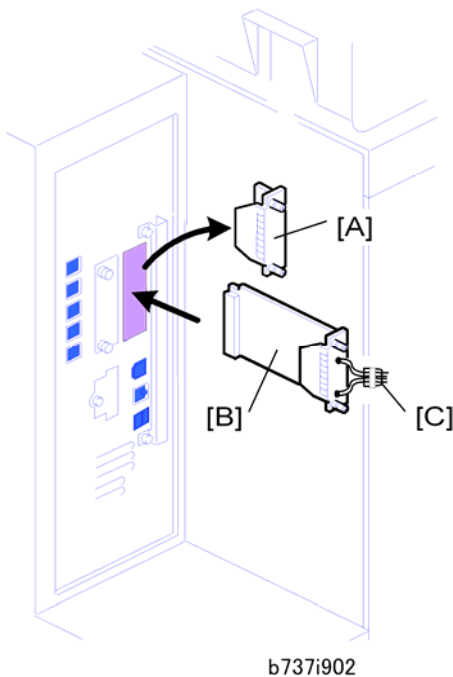

1. Remove the cover of Slot B [A] (⚙ x 2).

MFP Controller Options

2. Touch a metal surface to discharge any static electricity from your hands.
3. Put the interface board in Slot B [B].
4. Confirm that the board is inserted completely, then fasten it (🔩 x 2).
5. Pull the antennas [C] away from machine and make sure that they are not tangled.
6. Look at the markings on the antenna bracket.
 - **ANT1.** Antenna 1 transmits and receives. It must be installed on the left front corner of the main machine. (The core on the Antenna 1 cable is black.)
 - **ANT2.** Antenna 2 only receives. It is installed on the right rear corner of the machine.

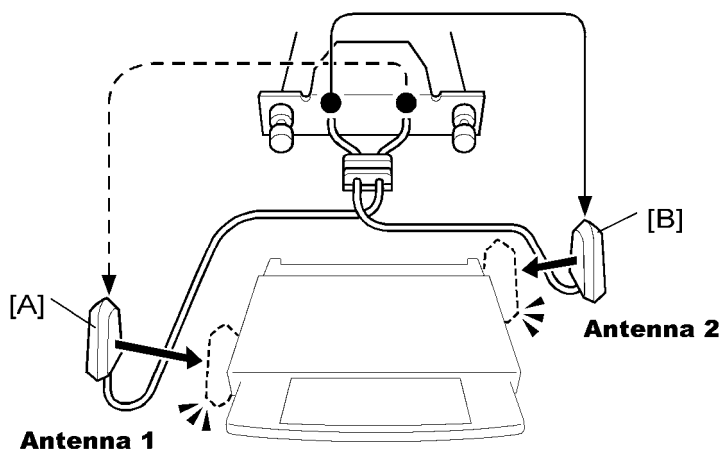

d017i508

★ Important

- To assure reliable data sending and receiving, Antenna 1 must be installed on the front left corner of the machine.

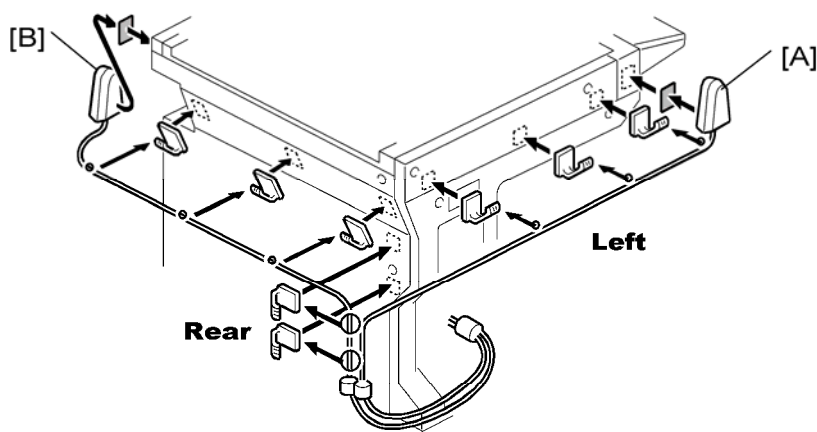

d017i509

7. Remove the seals from of the cable clamps and attach them to the left side of the machine as shown above.

8. Attach Antenna 1 [A] to the left front corner of the machine. (The core on the Antenna 1 cable is black.)
9. Set the cable of Antenna 1 in the clamps and close them.
10. Remove the seals from the cable clamps and attach them to the rear of the machine as shown above.
11. Attach Antenna 2 [B] to the right rear corner of the machine.
12. Set the cable of Antenna 2 in the clamps and close them.

SP Mode Settings for 802.11a/g Wireless LAN

The following SP commands can be set for 802.11a/g

1. Go into the SP mode
2. Touch "Copy SP" on the touch-panel to open the SP command selection screen.
3. Do SP5840-11.

SP No.	Name	Function
5840 011	WEP Key Select	Used to select the WEP key (Default: 00).

3.21.10 FILE FORMAT CONVERTER TYPE E (D377-04)

Accessory Check

Check the accessories and their quantities against this list:

	Description	Q'ty
1.	File Format Converter (MLB: Media Link Board)	1

Installation

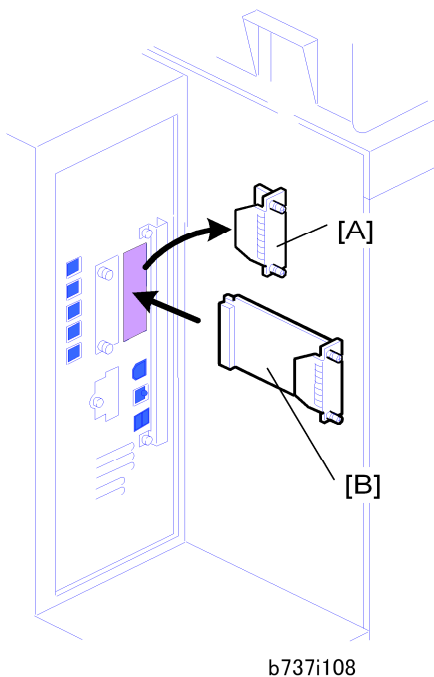

1. Remove the cover of Slot **A** [A] (⚙️ x2).
2. Touch a metal surface to discharge any static electricity from your hands.
3. Put the interface board [B] in Slot B.
4. Confirm that the board is inserted completely, then fasten it (⚙️ x 2).
5. Turn the machine OFF and ON.



↓ Note

- It is not possible to confirm whether or not the File Format Converter is installed using the SMC.

3.21.11 HDD ENCRYPTION UNIT TYPE A (D377-16)

Before You Begin the Procedure

1. Make sure that the following settings are not at the factory default settings:

- Supervisor login password
- Administrator login name
- Administrator login password

★ Important

- These settings must be set up by the customer before the encryption option can be installed.
2. Confirm that "Admin. Authentication" is on:
[User Tools]> "System Settings"> "Administrator Tools"> "Administrator Authentication Management"> "Admin. Authentication"> "On"
If this setting is "Off" tell the customer that this setting must be "On" before you can do the installation procedure.

3. Confirm that "Administrator Tools" is selected and enabled:

[User Tools]> "System Settings"> "Administrator Tools"> "Administrator Authentication Management"> "Available Settings"

↓ Note

- "Available Settings" is not displayed until "Admin. Authentication" is switch on. If this setting is not selected tell the customer that this setting must be selected before you can do the installation procedure.

Seal Check and Removal

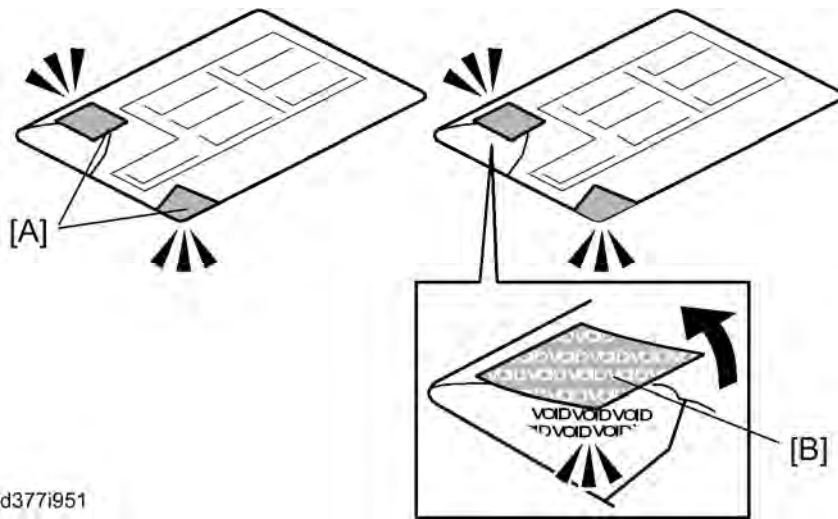

d377i951

CAUTION

- You must check the box seals to make sure that they were not removed after the items were sealed in the box at the factory before you do the installation.
1. Check the box seals [1] on each corner of the box.
 - Make sure that a tape is attached to each corner.
 - The surfaces of the tapes must be blank. If you see "VOID" on the tapes, do not install the components in the box.
 2. If the surfaces of the tapes do not show "VOID", remove them from the corners of the box.
 3. You can see the "VOID" marks [2] when you remove each seal. In this condition, they cannot be attached to the box again.

Installation Procedure

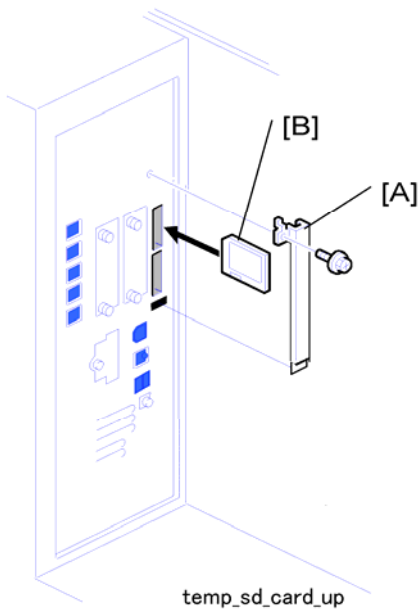

1. Remove the slot cover [A] (🔩 x 1).
2. Insert the SD card [B] into the upper slot.
3. Turn on the main power switch.
4. Enter the SP mode.
5. Select SP5878-002 (Option Setup> Encryption Option), and then touch [Execute].
6. Turn off the main power switch.
7. Remove the SD card.
8. Attach the slot cover [A] (🔩 x 1).
9. Switch the machine on.

★ Important

- Tell the customer that it takes about 6 hours 30 minutes to perform the HDD encryption function. (The D014/D015 required only about 3 hours.)

Recovery from a Device Problem

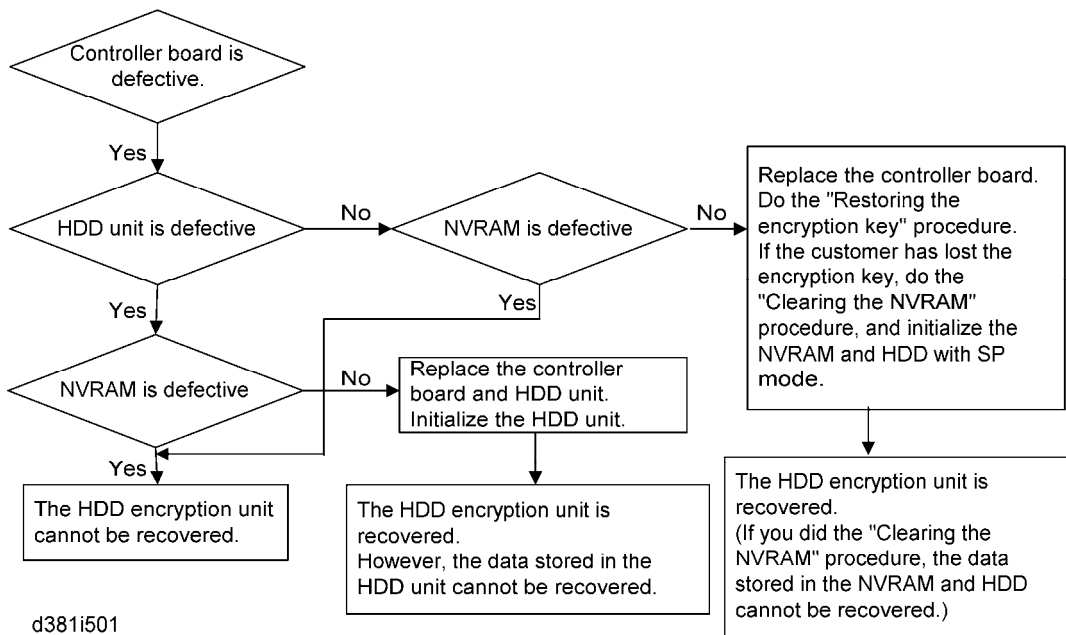

Restoring the encryption key

When replacing the controller board for a model in which the HDD encryption unit has been installed, updating the encryption key is required.

★ Important

- Before removing the VM card from Slot 1 (lower slot) you must shut down the App2 Me application (and any other VM card applications) if it is running. See "Before Removing the VM Card..."
1. Prepare an SD card which is initialized.
 2. Make the "restore_key" folder in the SD card.
 3. Make an "nvrn_key.txt" file in the "restore_key" folder in the SD card.
 4. Ask an administrator to input the encryption key (this has been printed out earlier by the user) into the "nvrn_key.txt" file.
 5. Remove only the HDD unit.
 6. Turn on the main power switch.
 7. Confirm that the prompt on the LCD tells you to install the SD card (storing the encryption key) in the machine.
 8. Turn off the main power switch.
 9. Insert the SD card that contains the encryption key into Slot 1 (lower slot).
 10. Turn on the main power switch, and the machine automatically restores the encryption key in the flash memory on the controller board.

11. Turn off the main power switch after the machine has returned to normal status.
12. Remove the SD card from Slot 1 (lower slot).
13. Reinstall the HDD unit.

Clearing the NVRAM

When replacing the controller board for a model in which the HDD encryption unit has been installed and a customer has lost the encryption key, clearing the NVRAM is required to recover the HDD encryption unit.

1. Prepare an SD card which is initialized.
2. Make the "restore_key" folder in the SD card.
3. Make an "nvram_key.txt" file in the "restore_key" folder in the SD card.
4. Input "nvclear" into the "nvram_key.txt" file.
5. Turn on the main power switch.
6. Confirm that the prompt on the LCD tells you to install the SD card (storing the encryption key) in the machine.
7. Turn off the main power switch.
8. Insert the SD card that contains "nvclear" into Slot 1 (lower slot).
9. Turn on the main power switch, and the machine automatically restores the encryption key in the flash memory on the controller board.
10. Turn off the main power switch after the machine has returned to normal status.
11. Remove the SD card from Slot 1 (lower slot).
12. Turn on the main power switch.
13. Initialize the NVRAM (SP5801-001) and HDD unit (SP5832-001) with SP mode.
14. The user must enable the HDD encryption unit with a user tool.

3.21.12 POSTSCRIPT3 UNIT TYPE 7501 (D497-01, -03, -04)

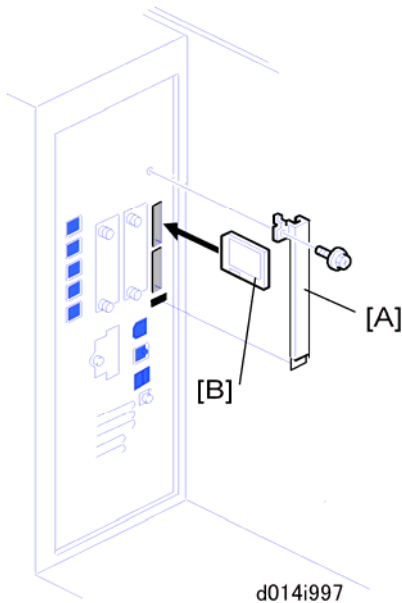

1. Remove the slot cover [A] (🔩 x1).
2. Put the PostScript3 SD card [B] in SD card the upper slot.
 - Only one SD card slot is available for applications provided on SD cards.
 - If the customer wants to use two or more applications from SD cards, the applications must be moved to a single SD card. (See "Moving Applications to One SD Card" in this section.)
 - The PostScript3 application and fonts cannot be moved to another SD card. However, other applications can be moved onto the PostScript3 SD card.

3.21.13 DATA OVERWRITE SECURITY UNIT TYPE H (D497)

Accessory Check

Check the accessories and their quantities against the table below.

Description	Qt'y
1. Data Overwrite Security SD Card	1
2. Operating Instructions CD-ROM	1
3 Comments Sheet (17 languages)	2

Before You Begin...

1. Make sure that the Data Overwrite Security unit SD card is the correct type for this machine. **The correct type for this machine is type "H"**.
2. Make sure that the following settings are not at the factory default settings:
 - Supervisor login password
 - Administrator login name
 - Administrator login password

These settings must be set up by the customer before the Data Overwrite Security unit can be installed.
3. Confirm that "Admin. Authentication" is on:
 - [User Tools]> "System Settings"> "Administrator Tools"> "Administrator Authentication Management"> "Admin. Authentication"> "On"
 - If this setting is "Off" tell the customer that this setting must be "On" before you can do the installation procedure.
4. Confirm that "Administrator Tools" is selected and enabled:
 - [User Tools]> "System Settings"> "Administrator Tools"> "Administrator Authentication Management"> "Available Settings"
 - "Available Settings" is not displayed until Step 2 above is done.
 - If this setting is not selected tell the customer that this setting must be selected before you can do the installation procedure.

Seal Check and Removal

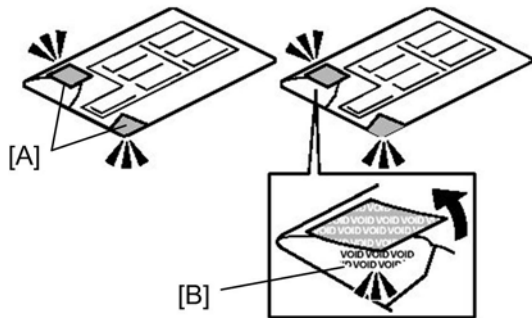

d377i900

1. Check the two seals [A] on the corners of the packet and confirm that they are firmly attached.

★ Important

- If you see "VOID" on the tapes or on the corners of the packet this means that the seals have been removed. Do not use the SD card for this installation. Contact your sales division

2. Remove the seals from both corners of the packet. The silver "VOID" notations [B] become visible only after you have removed the seals. This is normal.

Installation Procedure

♀ Preparation

- Before doing the procedure, turn off the main power switch and unplug the machine from its power source.
1. Make sure that the machine is switched off and disconnected from its power source.
 2. Disconnect the network cable.
 3. Turn the main power switch on.
 4. Turn the operation switch and main power switch off.

★ Important

- Make sure that the number and "Type" are correct (**Type H, D377**). If you install the incorrect version of this application, the NVRAM must be replaced.

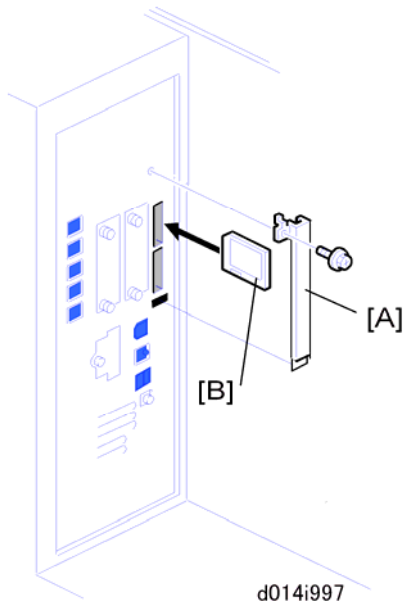

5. Remove the SD card slot cover [A] (⚙️x1).
6. Remove the security tape from the SD card wrapping.

★ Important

- If you see "VOID" on the security tape this means that the tape has been removed.
- If the "VOID" notations are visible, do not use the SD card for this installation.
Contact your sales division

7. Insert the DOS SD card [B] into the upper slot.
8. Reconnect the network cable.
9. Turn the main power switch on.
10. Do SP5878-1 and push [Execute] to enable the DOS option.
11. Go out of the SP mode.
12. Cycle the machine off/on.
13. Do SP5990-5 to print the Self Diagnosis Test.
14. Make sure the ROM number and firmware version in the diagnostic report are the same.
 - "ROM Number/Firmware Version" – "HDD Format OptionW"
 - "Loading Program" – "GW4a_zoffyx"

Diagnostic Report	"ROM No./Firmware Version"	"Loading Program"
Data Overwrite Security Unit	HDD Format Option: D3775902A/1.01x	GW4a_zoffyx: D3775902A/1.01x

Check Operation of the DOS Application

1. Turn "Auto Erase Memory Setting" on:
[User Tools]> "System Settings"> "Administrator Tools"> "Auto Erase Memory Setting"> "On"
2. Exit User Tools.

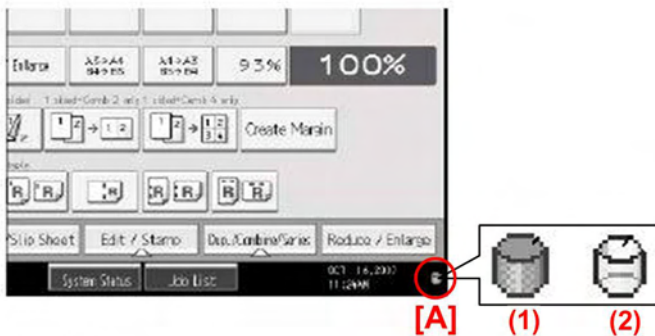

3. Check the display and make sure that the overwrite erase icon [A] is displayed.
4. Make a sample copy and check the operation of the overwrite/erase icon.
 - The icon lights (1) when there is temporary data to be overwritten and blinks during overwriting.
 - The icon (2) lights when there is no temporary data to be overwritten.

3.21.14 COPY CONNECTOR TYPE 3260 (B328-11)

Check the accessories and their quantities against the table below.

Description	Qt'y
1. Connection PCB	1
2. Power Repeater Cable	1
3. Repeater Hubs	2

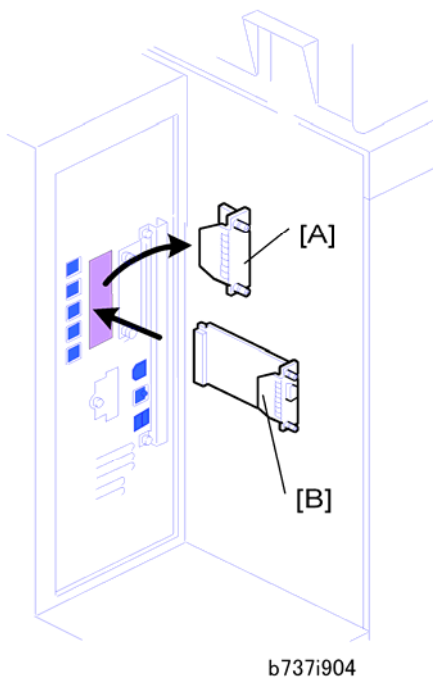

CAUTION

- Turn the machine off and unplug the machine before starting the following procedure.
1. Remove the cover [A] of Slot A (🔩 x 2).
 2. Install the Main machine Connection Kit Board B328 [B] in Slot A and fasten it (🔩 x 2).
 3. Remove the rear upper cover.

MFP Controller Options

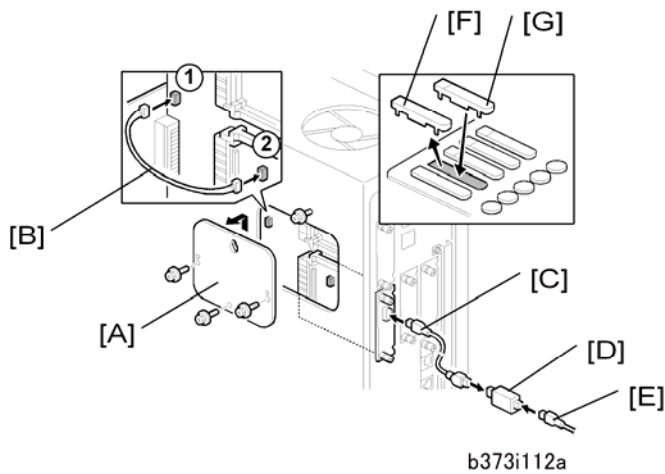

4. Remove the controller box cover [A] (⌀ x 3).
5. Connect the power repeater cable [B] to:
 - ① **CN594**
 - ② **CN4**
6. Reattach the controller box cover and rear upper cover.
7. Repeat Steps 1 to 6 to install the connection kit on the second machine.
8. Connect the end of the interface cable [C] to the connection PCB.
9. If additional cable is required, connect the cables [E] with repeater hubs [D].
10. On the operation panel of each machine, remove the second cover [F] from the bottom ("Printer").
11. Install the appropriate key on each machine.

Attach the "Printer/Other Function" key [G] (or its equivalent symbol for EU) if the printer/scanner option is installed.

-or-

Attach the "Other Function" key [G] (or its equivalent symbol for EU) if the printer/scanner option is not installed.
12. Attach the other end of the connection cable to the connection PCB installed in the other machine.

3.21.15 GIGABIT ETHERNET TYPE B (D377-21)

Accessories

Check the accessories and their quantities against the table below.

Description	Qt'y
1. Gigabit Ethernet PCB	1
2. Protector Plate	1
3. Screws	3

Installation

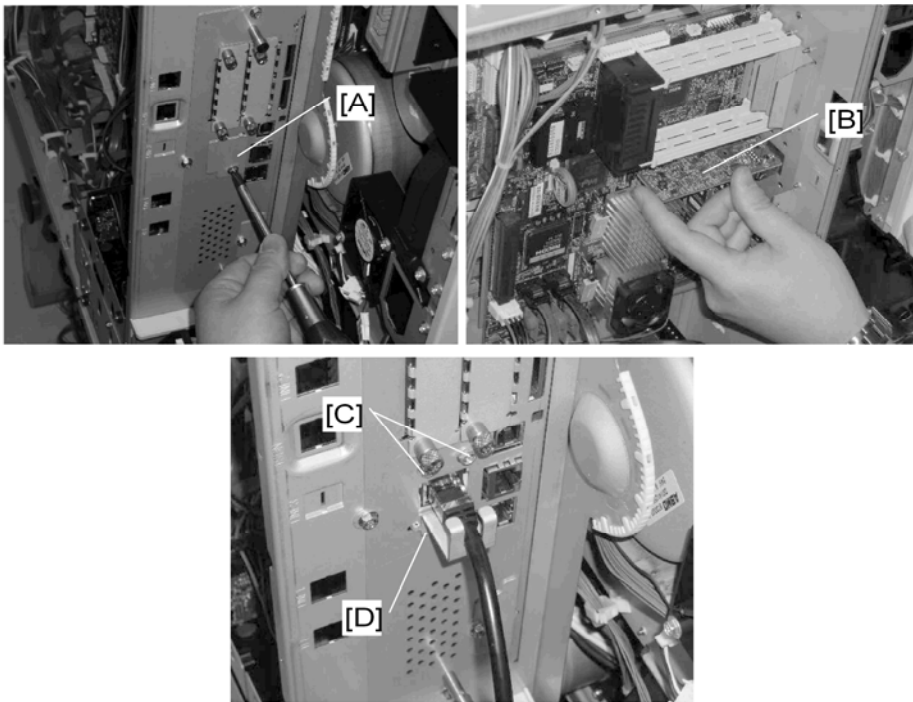

d377i200

1. Remove:
 - Rear upper cover.
 - Controller box cover
 - Cover [A] of Slot C (🔩 x1)

MFP Controller Options

2. Insert the edge connector of the gigabit Ethernet PCB [B] into its slot on the controller board.
3. On the other side of the faceplate, fasten the PCB (🔩 x2).
4. Attach the cable.
5. With the prongs of the protector plate [D] on both sides of the attached cable, fasten the protector plate to the controller box face plate (🔩 x1).

3.21.16 BROWSER UNIT TYPE E (D497)

Accessories

Check the accessories and their quantities against the table below.

1. Browser Unit SD Card	1
2. Keytops	2

⇒ **Important:** The Browser Option can only be installed on one machine. Once the installation is complete it cannot be installed on any other machine after that, even if it is uninstalled from the original machine.

Installation

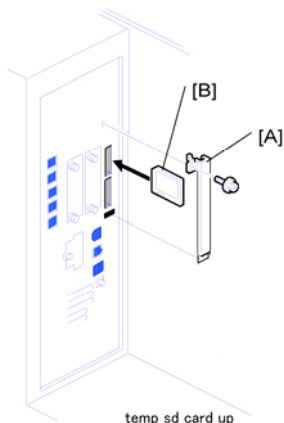

- For models which have the VM card, do the following. Then continue with step 3:
 - Press "User tools" button to enter the User Tools mode.
 - Press "Extended Feature Settings" on the LCD.
 - Press "Extended Feature Settings" on the LCD again.
 - Press "Start up" tab.
 - Stop all SDK applications with touching application lines.
 - Exit UP mode, turn off the machine and unplug the power cord
 - Remove the slot cover for SD cards [A].
 - Remove the SD card (VM/JAVA) from SD slot 2 [B].
- Turn off the machine and unplug the main machine power cord. Remove the slot cover for SD cards [A].
- Turn the Browser SD card label face to the rear of the machine. Then push it slowly into slot 2 until you hear a click.
- Plug in and turn on the main power switch.

5. Push the "User Tools" key.
If an administrator setting is registered for the machine, steps 6 and 7 are required.
Otherwise, skip to step 8.
6. Push the "Login/Logout" key.
7. Login with the administrator user name and password.
8. Touch "Extended Feature Settings" twice on the LCD.
9. Touch "Install" on the LCD.
10. Touch "SD card".
11. Touch the "Browser" line.
12. Under "Install to", touch "Machine HDD" and touch "Next".
13. When you see "Ready to Install", check the information on the screen to confirm your previous selection.
14. Touch "OK". You will see "Installing the extended feature... Please wait." and then "Completed".
15. Touch "Exit" to go back to the setting screen.
16. Touch "Change Allocation".
17. Touch "Browser" line.
18. Press one of the hard keys, which you want to use for the Browser Unit. By default, this function is assigned to the "Other Functions" key (bottom key of the function keys).
19. Touch "OK".
20. Touch "Exit" twice to go back to the copy screen.
21. Turn off the main power switch.
22. Install the function key for "Browser Unit" to the place you chose in step 18.
23. Turn on the main power switch.
24. When the reaches the Ready condition, press the key that you installed in step 22.
Note: A message will be displayed confirming that the Browser Option was successfully installed.
25. Turn off the main power switch.
26. Remove the SD card from slot 2.
27. Reinstall the JAVA card in slot 2.
28. Attach the slot cover.
29. Ask the customer to keep the SD card in a safe place after you have installed the application program from the card to the HDD. This is because:
 - The SD card is the only proof that the user is licensed to use the application program.
 - You may need to check the SD card and its data to solve a problem in the future.

3.21.17 COPY DATA SECURITY UNIT TYPE F (B829-07)

Accessories

Check the accessories and their quantities against the table below.

Description	Qt'y
1. Copy Data Security Type F PCB	1

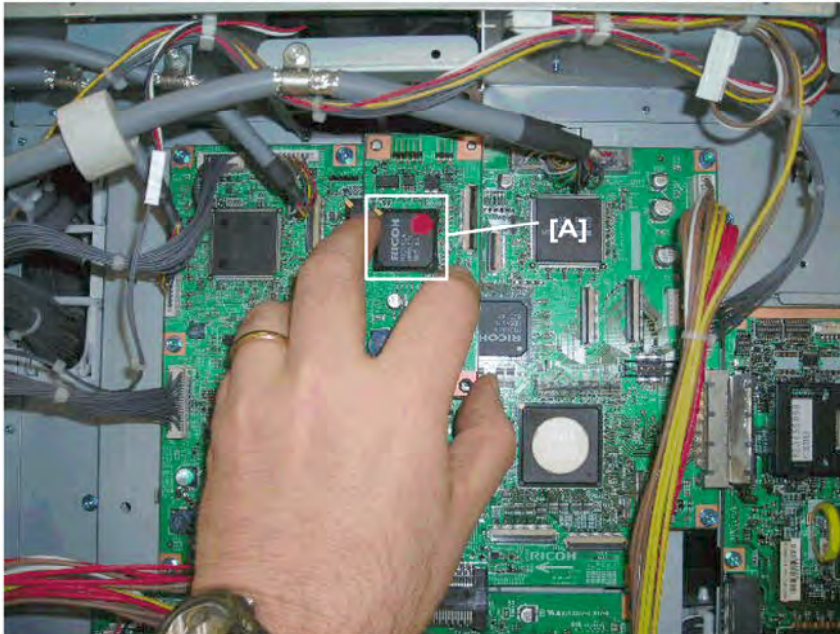

b289i001

⚠ CAUTION

- Turn the machine off and disconnect its power cord from the power source.
1. Remove
 - Rear upper cover
 - Controller box cover
 2. Touch a metal surface to discharge any static electricity from your hands.
 3. Push the connector on the underside of the Copy Data Security PCB [A] into its slot on the IPU.
 4. Carefully fasten the Copy Data Security PCB to the IPU (🔩 x2).

★ Important

- Do not touch the surface of any other board with the tip of the screwdriver.

MFP Controller Options

User Tool Setting

1. Plug in and turn on the main power switch.
2. Go into the User Tools mode, and select System Settings > Administrator Tools > Data Security for Copying > "On".
3. Exit the User Tools.
4. Check the operation.

Note

- The machine will issue an SC165 error if the machine is powered on with the ICIB-1 removed and the "Data Security for Copying" feature is set to "ON".
 - When you remove this option from the machine, first set the setting to "OFF" with the user tool before removing this board. If you forget to do this, "Data Security for Copying" feature cannot appear in the user tool settings. And then SC165 will appear every time the machine is switched on, and the machine cannot be used.
5. Make sure that the machine can recognize the option ( "Check All Connections" at the end of this section).

PREVENTIVE MAINTENANCE

REVISION HISTORY		
Page	Date	Added/Updated/New
		None

4. PREVENTIVE MAINTENANCE

4.1 OVERVIEW

The amounts mentioned (K=1,000) as the PM interval indicate the number of prints or copies unless stated otherwise. These numbers are based on the PM counter.

4.1.1 REQUIRED MATERIALS

You must use these materials to service the machine:

- Optical Cloth (A0129111)
- Alcohol
- Exposure Glass Cleaner (A1939310)
- Barrierta S552R
- Grease KS660B (D0149800)
- G104 Yellow Toner (D0159500)
- Zinc Stearate (D0159501)

Notes:

- The G104 Yellow Toner and Zinc Stearate are specially designed for this machine.
- Grease KS660B is a new conductive grease specially designed for servicing this machine. Previous grease compounds (Grease KS660, Silicone Grease 501, Grease Barrierta S552R) are non-conductive.
- Always use G104 Yellow Toner and Zinc Stearate to lubricate the ITB and drum. These compounds are specially designed for this purpose.

Overview

Important

- Never use the yellow toner of the D014/D015/D081/D082 to lubricate the ITB or drum. The yellow toner contains developer which could damage the ITB or drum and cause problems with image printing.
- Never use the previous Setting Powder (54429101) used for previous machines in any service procedure for the D081/D082. The composition of this powder is completely different. If you use Setting Powder (5442910) to service this machine, you will damage the drum charge roller and cause problems with image quality.

WARNING

- Turn off the main power switch and unplug the machine before performing any procedure in this section. Laser beams can seriously damage the eyes.

Important

- After you do the PM, do the forced music adjustment with SP 2111 001.

4.2 PM COUNTER

The PM Counter main menu and submenu allows you to review the PM counts for both units and individual components.

4.2.1 DISPLAYING THE PM COUNTER

1. Enter the SP mode.



2. Touch [PM Counter].



(1): All PM Parts List. Displays all PM items (all PM items, not only PM units). Lists all PM items regardless of PM yield indicator settings.

(2): Parts list for PM yield indicator. Displays the items that have their PM yield indicator settings set to "Yes".

(3): Clear all PM settings. Resets all PM counter settings to "0" at the same time. PM items can be reset one by one with the [Clear] button.

(4): Counter list print out. Prints the PM counter on paper.

4.2.2 PM PARTS SCREEN DETAILS

All PM Parts list: Main Menu

The "All PM Parts list" displays all PM units and individual items. This list shows all PM items, regardless of their "PM yield indicator settings".

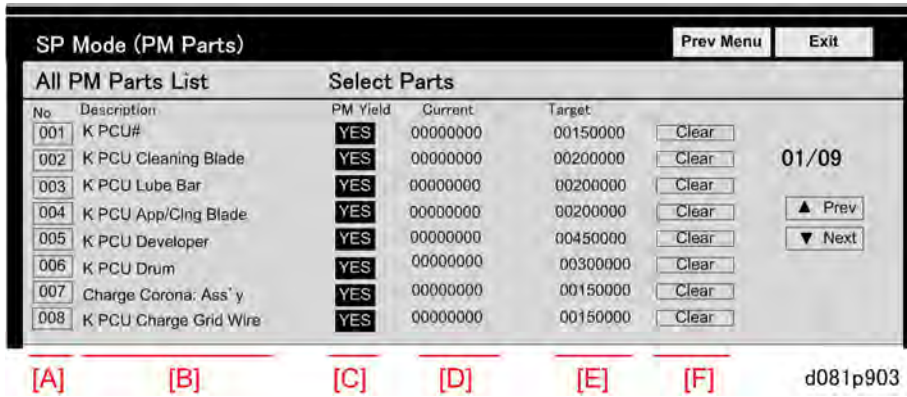

[A]	Number buttons. Pressing a number button opens the Number Button submenu (See the next section below.)
[B]	Descriptions. The # mark denotes a "unit" (not individual item).
[C]	PM yield buttons. Function is the same as the "PM yield indicator settings" button.
[D]	Current PM counter value.
[E]	Target PM interval. This can be changed by pressing a number button [A].
[F]	PM counter clear button. Function is the same as the [Clear current counter] button.

Number button submenu

Press any number button to open the submenu for a part. In the example below, the number button [001] #K:PCU was pressed.

001	#K:PCU		
Current counter	0010892	[A]	Clear current counter
Target yield	0300K	[B]	Change Target Yield
Latest1	0014846		
Latest2	[D] 0000000	[C]	PM yield indicator settings
Latest3	0000000		No Yes
Exit		▲Prev ▼Next	

d081p904

[A]: **Clear current counter.** Press to reset the selected PM counter (in this example 001 #K:PCU) to "0". You can also clear the settings by pressing the [Clear] button on the right side of the PM Counter Main Menu ([F] in the previous section).

[B]: **Change target yield.** Press the change the target PM yield. To change the setting:

- Press [Change target yield]
- Enter the number for the new target with the 10-key pad.
- Press [#] on the operation panel.

[C]: **PM yield indicator settings.** [Yes] is the default. Press [No] to remove the current item from the "Parts list for PM yield indicator".

- When set to "Yes", items marked with the # mark (# = a unit) will not have their individual items
- When set to "No", items marked with the # mark (# = a unit) only the individual components will appear in the list (the units will not appear).

[D]: **PM counter history.** This is a summary of the most recent counts

- Latest 1. The latest PM count since the unit (or part) was replaced.
- Latest 2. The previous PM count since the unit (or part) was replaced.
- Latest 3. The previous but one PM count since the unit (or part) was replaced.

PM Counter

Parts list for PM yield indicator

This list shows the PM Parts Main Menu with only items set to "Yes" displayed.

No	Description	Exceed	Current	Target	
001	#K:PCU	[A]	0010892	0300K	Clear
017	#M:PCU		0005570	0300K	Clear
033	#C:PCU		0005223	0300K	Clear
049	#Y:PCU		0005514	0300K	Clear
065	ITB		0025738	0600K	Clear
066	#ITB Cleaning Unit		0025738	0300K	Clear
070	#PTR Unit		0025738	0600K	Clear

d081p905

Note:

- The # mark denotes a unit.
- Items without the # (065 ITB, for example) denote individual components.
- An asterisk (*) will appear in the Exceed column [A] to show items that that have exceeded their target PM yields.

4.3 PM TABLES

See "Appendices" for the following information:

- PM Tables

REPLACEMENT AND ADJUSTMENTS

REVISION HISTORY		
Page	Date	Added/Updated/New
59	04/26/2010	Added Step 19, Execute SP2-222-001.

5. REPLACEMENT AND ADJUSTMENTS

5.1 GENERAL CAUTIONS

★ Important

- Never switch off either power switch while any of the electrical components are operating. Doing so might cause damage to units such as the transfer belt, drum, and development unit when they are pulled out of or put back into the main machine.

5.1.1 DRUM

An organic photoconductor (OPC) drums are more sensitive to light and ammonia gas than a selenium drum. Follow the cautions below when handling an OPC drum.

1. When a PCU unit is removed from the machine, always place it on the PCU stand provided with the machine.
2. Never expose a drum to direct sunlight.
3. Never expose a drum to direct light of more than 1,000 Lux for more than a minute.
4. Never touch a drum surface with bare hands. If the drum surface is touched with a finger or becomes dirty, wipe it with a dry cloth or clean it with wet cotton. Wipe with a dry cloth after cleaning with wet cotton.
5. Never use alcohol to clean the drum (alcohol dissolves the drum surface).
6. Store drums in a cool, dry place away from heat.
7. Take care not to scratch the drum as the drum layer is thin and is easily damaged.
8. Never expose a drum to corrosive gases such as ammonia gas.
9. Dispose of used drums in accordance with local regulations.

General Cautions

5.1.2 PCU

1. The PCU stand is stored in a rack attached to the bottom of the machine with strong magnets.
2. Before pulling a PCU unit out of the machine, spread some clean paper to catch spilt toner, remove the PCU stand from the bottom of the machine, clean it with a clean cloth, and then set the PCU stand on the paper to hold the PCU as soon as it is removed from the machine.
3. To prevent drum scratches, always set the PCU on the stand and leave it there as long as it is out of the machine.
4. Remove only one PCU at a time for servicing. Only one PCU stand is provided with the machine.

B132/B181/B200

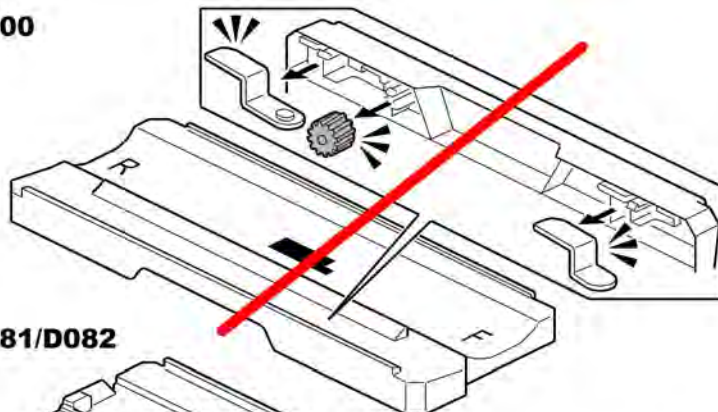

D014/D015/D081/D082

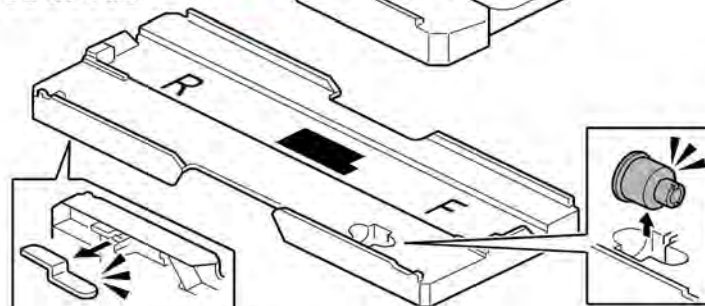

d081r420a

- The D014/D015, D081/D082 PCU stand is not the same as the PCU stand of the B132/B181/B200.
- As shown above, the B132/B181/B200 PCU stand holds two jigs and one gear. The D014/D015, D081/D082 PCU stand holds only one jig and a coupler. Also, the shapes of these two stands are not the same.
- Please note that the D081/D082 PCU stand is the same as the D014/D015 PCU stand. You can use a D014/D015 PCU stand if the D081/D082 stand is not available.

★ Important

- **Never use a B132/B181/B200 PCU stand to service a D081/D082 PCU.**
 - **The B132/B181/B200 PCU stand can damage the exposed drum on the bottom of a D081/D082 PCU.**
1. The Y, M, and C charge rollers should always be replaced together as a set.

5.1.3 TRANSFER BELT UNIT

1. Never touch the transfer belt surface with bare hands.
2. Take care not to scratch the transfer belt, as the surface is easily damaged.
3. Before installing a new transfer belt, clean all the rollers and the inner part of the transfer belt with a dry cloth to prevent the belt from slipping.

5.1.4 SCANNER UNIT

1. When installing a new exposure glass, make sure that the white paint mark is at the rear left corner.
2. Clean the exposure glass with alcohol or glass cleaner to reduce the amount of static electricity on the glass surface.
3. Use a cotton pad with water or a blower brush to clean the mirrors and lenses.
4. Never bend or crease the exposure lamp cables.
5. Never disassemble the lens unit. Doing so will throw the lens and the copy image out of focus.
6. Never adjust any CCD positioning screw. Doing so will throw the CCD out of position.

5.1.5 LASER UNIT

1. Never loosen the screws that secure the LD drive board to the laser diode casing. Doing so would throw the LD unit out of adjustment.
2. Never adjust the variable resistors on the LD unit, as they are adjusted in the factory.
3. Never open the optical housing unit. The polygon mirror and lenses are sensitive to dust.
4. Never touch the glass surface of the polygon mirror motor unit with bare hands.

5.1.6 DEVELOPMENT

1. Avoid nicking or scratching the development roller.
2. Place a development unit on a sheet of paper after removing it from a PCU.
3. Always clean the drive gears after removing used developer.
4. Always dispose of used developer in accordance with local regulations.
5. Never load types of developer and toner into the development unit other than specified for this model. Doing so will cause poor copy quality and toner scattering.
6. Immediately after installing new developer or toner during the machine installation procedure, do the SPs as described in the installation procedure.
7. Immediately after replacing the developer, do the SPs as described in the "SP Codes after Replacement" section of PCU replacement.
8. Never do **SP3801** or **SP3811** with used developer.
9. When using a vacuum cleaner to clean the development unit casing, always ground the casing with your fingers to avoid damaging the toner density sensor with static electricity.
10. The TD sensor must be initialized:
 - At installation, exactly as described in the installation procedure
 - After replacing developer. (Initialize the TD sensor only for the PCU where the developer was replaced.)

 **Important**

- Never initialize the TD sensor more than once. Initializing the TD sensor more than once can cause toner scatter inside the machine.

5.1.7 CLEANING

1. When servicing cleaning components, avoid nicking the edges of the cleaning blades.
2. Never handle a cleaning blade with bare hands.
3. Before disassembling a cleaning section, place a sheet of paper under it to catch any toner falling.

5.1.8 FUSING UNIT

1. Never handle fusing lamps and rollers with bare hands.
2. Make sure that the fusing lamps are positioned correctly and do not touch the inner surface of the rollers.

5.1.9 PAPER FEED

1. Do not touch the surfaces of the pick-up, feed, and separation rollers.
2. To avoid paper misfeeds, the side fences and end fence of the paper trays must be positioned correctly to align with the actual paper size.

5.1.10 USED TONER

1. Check the amount of used toner at every service visit.
2. Always dispose of used toner in accordance with local regulations.
3. Never throw toner into an open flame.

5.2 COMMON PROCEDURES

5.2.1 ADF

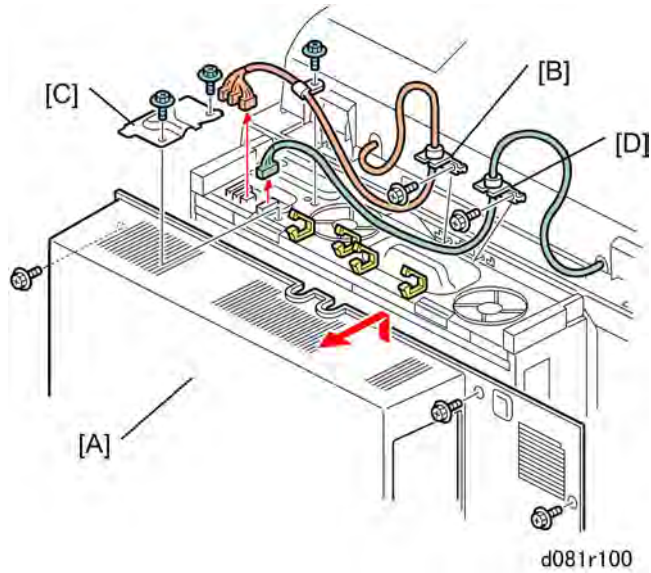

1. Remove rear cover [A] (🔧 x3).
2. Disconnect harness [B] (🔧 x2, 📡 x2, 📡 x3).
3. Remove plate [C] (🔧 x2).
4. Disconnect harness [D] (🔧 x1, 📡 x2, 📡 x1).

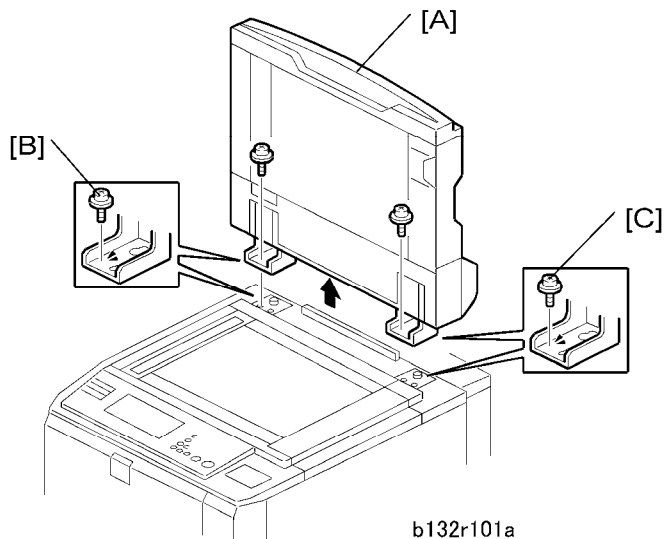





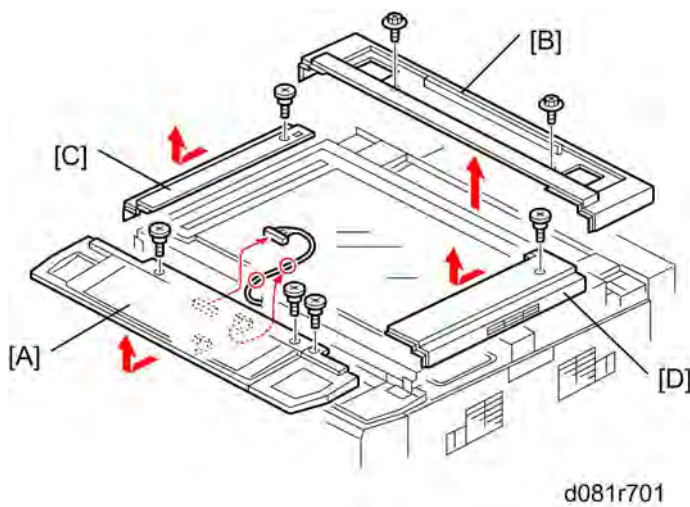

CAUTION

- The ADF is very heavy.
5. Raise the ADF [A] to the vertical position.
 6. At the rear left corner of the machine, disconnect the ADF cable.
 7. Remove the left screw [B] and right screw [C].
 8. Slide the ADF back until the heads of the screws are in the large end of the keyholes, and then lift the ADF off the machine.

5.2.2 OPERATION PANEL, TOP COVERS



1. Remove the ADF ( p.5-6).
2. Open the front door.
3. Remove:
 - [A]: Operation panel ( x3,  x1,  x1)
 - [B]: Top rear cover ( x2)
 - [C]: Left top cover ( x1)
 - [D]: Right top cover ( x1)

5.2.3 LEFT COVERS

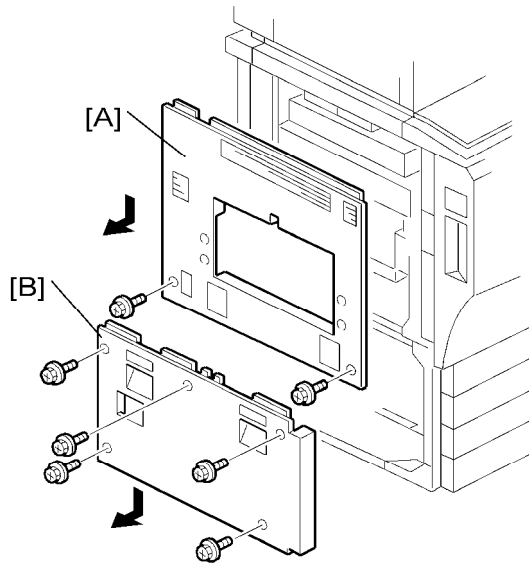

b132r702

1. If a finisher is connected:
 - Disconnect the finisher.
 - Remove the front and back finisher connection brackets.
2. Remove:
 - [A]: Left upper cover (🔩 x2)
 - [B]: Left lower cover (🔩 x5)

Reinstallation

- Make sure all cover tabs are inserted correctly before you fasten the screws.

5.2.4 FRONT DOOR

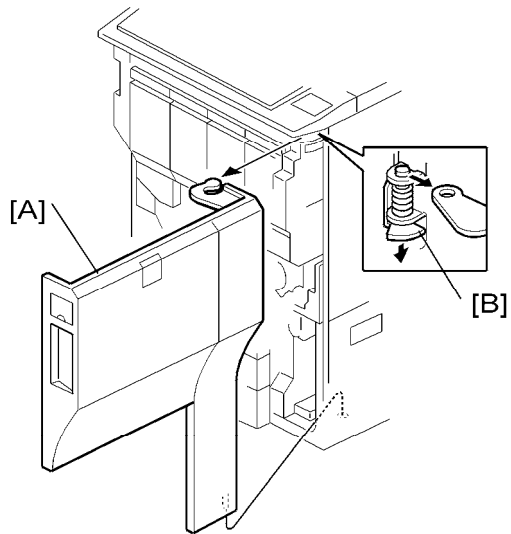

b132r703

1. Grip the front door [A] with one hand.
2. Press down the hinge bracket [B].
3. Lift the front door slightly to remove it.

★ Important

- If you must replace the front door, make sure that you put the SD cards from the storage location in the old front door into the storage location in the new front door.

5.2.5 RIGHT COVERS

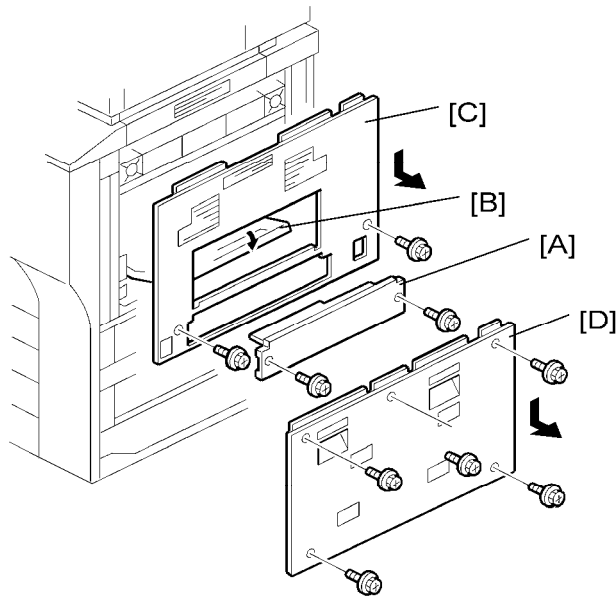

b132r704

1. Disconnect and separate the LCT if it is installed.
2. Remove:
 - [A]: Knockout (🔩 x2).
This has been removed already if the LCT has been installed.
 - [B]: Open the bypass tray.
 - [C]: Right upper cover (🔩 x2).
Pull the bottom of the cover down and toward you as you remove it.
 - [D]: Right lower cover (🔩 x5).
Pull the bottom of the cover down and toward you as you remove it.

Reinstallation

- Make sure all the cover tabs are inserted correctly before you fasten the screws.

5.2.6 REAR COVERS

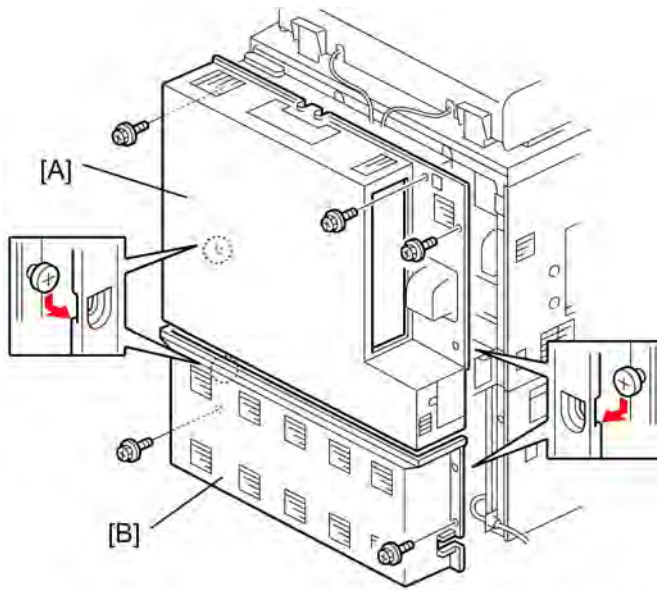

d081r705

1. Remove:
 - [A]: Rear upper cover (🔩 x3)
 - [B]: Rear lower cover (🔩 x2)
 - Remove the bottom screws
 - Do not remove the shoulder screws.

5.2.7 TONER HOPPER, FACEPLATE, PCU

Removing Hopper, Faceplate, PCU

★ Important

- To avoid damaging the toner end sensor, make sure that the main power switch is turned off and that the power cord is disconnected from the power source before you remove the hopper.

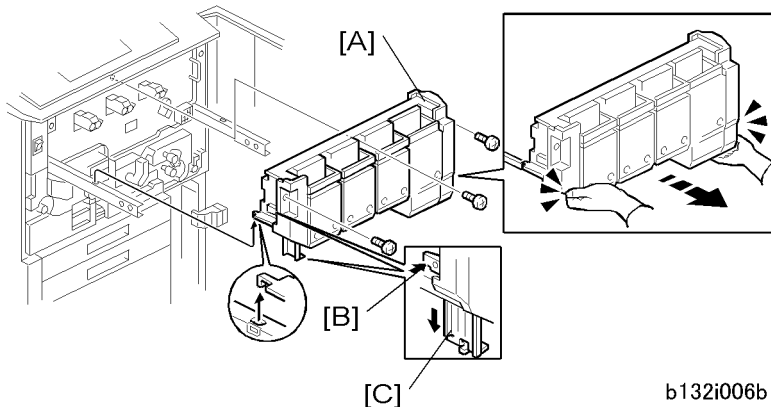

b132i006b

To remove the hopper:

1. Prepare an open space on the floor for the hopper.
2. Remove the screws of the toner hopper [A] (⚙️ x3).
3. Place your hands under the left and right corners of the toner hopper and slowly pull it out on its rails until it stops.

★ Important

- The hopper can easily slip off its rails!
4. Press the release [B] to drop the support leg [C].
 5. Confirm that the support leg is down and locked.

★ Important

- Always make sure that the support leg is down and locked before you remove the hopper.
6. Lift the toner hopper off its rails and set it on the floor.

⚠ CAUTION

- The hopper is heavy, so lift it carefully. Make sure the hopper unit tabs have disengaged completely from the rails before you try to set the unit on the floor.

7. Push the hopper rails into the machine.

To remove the faceplate

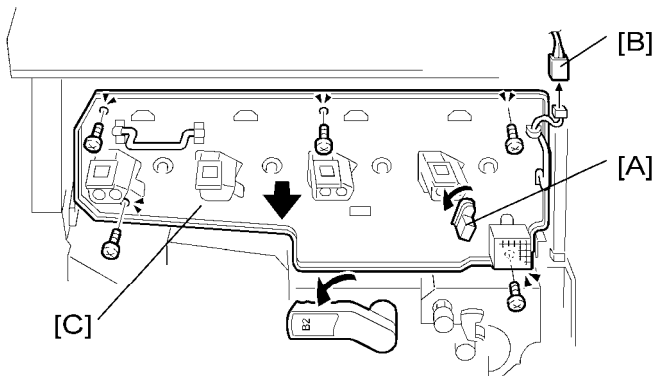

b132r201

1. Rotate the transfer belt release lever [A] counter-clockwise until it stops
2. Disconnect the fan connector [B].
3. Remove the faceplate [C] (⚙ x5).
4. Remove the PCU stand from its storage rack under the machine.

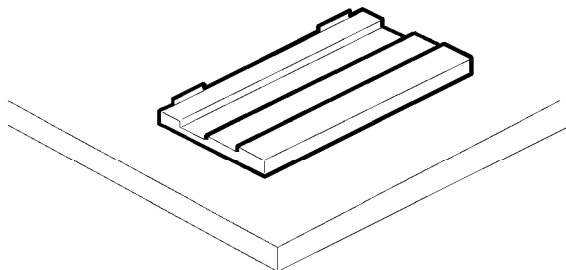

b132i902

5. Place the PCU stand on a flat surface.
6. Wipe the surface of the stand with a clean cloth to remove dust.

To remove a PCU

Common Procedures

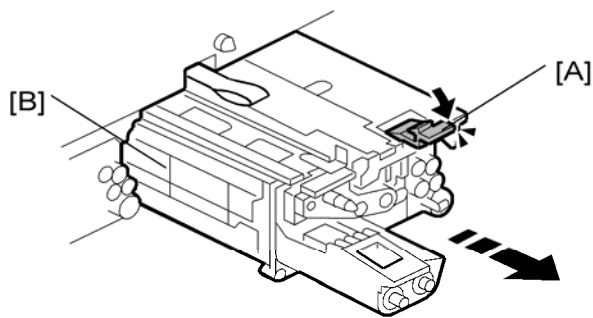

b132r202a

1. Confirm that the machine is switched off and disconnected from its power source.

★ Important

- To prevent damage to the drum potential sensor and its relay board, always make sure that the machine is turned off and that the power cord is disconnected from the power source before you remove a PCU.
2. While pressing down the release tab [A] above the PCU, pull the PCU [B] out of the machine.

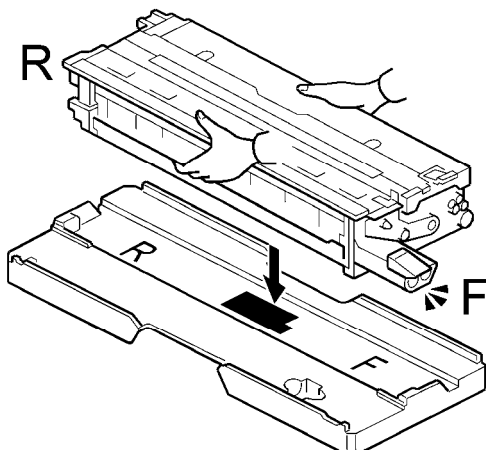

d014r214

3. With both hands on either side of the PCU [A], remove it from the machine and set it on the PCU stand [B].

★ Important

- This PCU stand was specially designed for the D014/D015/D081/D082. Do not use the PCU stand that was made for the B132/B181/B200 series machines.
- The OPC drum is exposed on the bottom of the PCU, so never place your hand under the PCU.
- Never place the PCU on any surface other than the PCU stand.

Reinstalling PCU, Faceplate, Toner Hopper

To reinstall a PCU

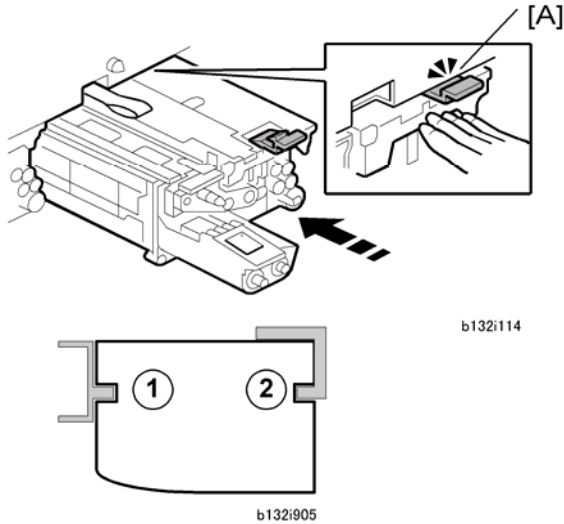

1. Hold the PCU [A] in front of the slot where you removed it
2. Engage the slots ① and ② in the sides of the PCU with the rails. The PCU will not slide smoothly into the machine until the slots and rails are engaged properly.
3. Slowly push the PCU into the slot.
4. Make sure the release tab [A] above the PCU is locked.

To reinstall the faceplate

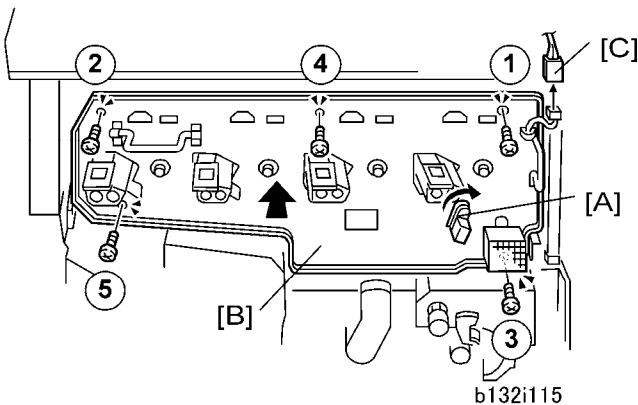

1. Rotate the transfer belt release lever [A] clockwise to lock it.
2. Attach the faceplate [B] with the screws in order as shown above (⚙ x5).
3. Reconnect the fan connector [C] (🔌 x1).

Common Procedures

To reinstall the hopper

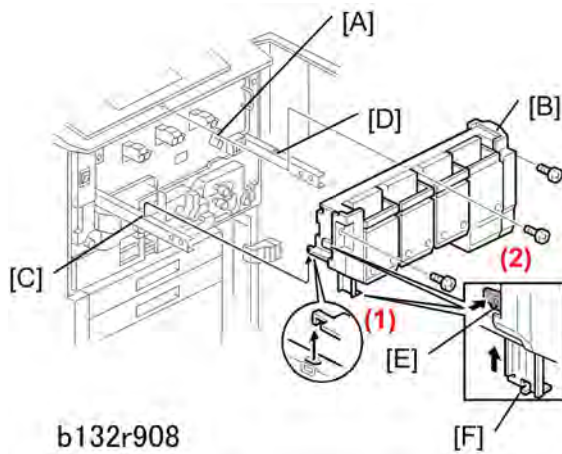

1. Confirm that the transfer belt release lever [A] is up and locked before you reattach the hopper.
2. Make sure the hopper rails are fully extended, then set the toner hopper [B] on the rails,
3. Make sure the steel tabs of the hopper are inserted into the holes in the left rail [C] and right rail [D].
4. Push up the release [E] and support leg [F].

★ Important

- Make sure that the support leg is up and locked before you push the toner hopper into the machine.
5. Place your hands at the bottom of the toner hopper at (1) and (2) then push the hopper against the face plate.

★ Important

- To avoid damaging the hopper, never press on the top of the toner hopper.
6. Check the right side and confirm that the hopper unit is flat against the faceplate.
If the toner hopper [B] is not flat against the face plate on the right side, pull it out slightly and make sure that the transfer belt release lever is rotated up completely and locked.
 7. Fasten the toner hopper to the face plate (🔩 x3).

5.2.8 IMAGE TRANSFER UNIT

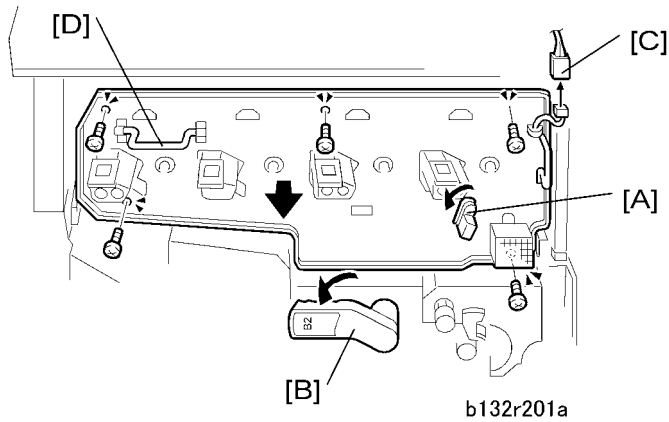

1. Cover the floor or a table with paper to prepare a place to put the image transfer unit.
2. Open the front door.
3. Remove the toner hopper, then push the hopper rails into the machine.
4. Rotate the transfer belt release lever [A] down to the left until it stops.
5. Rotate the lever **B2** [B] on the drawer unit counter-clockwise to separate the transfer roller from the ITB.
6. Disconnect [C].
7. Remove the faceplate [D] (🔧 x1, 🪛 x5).

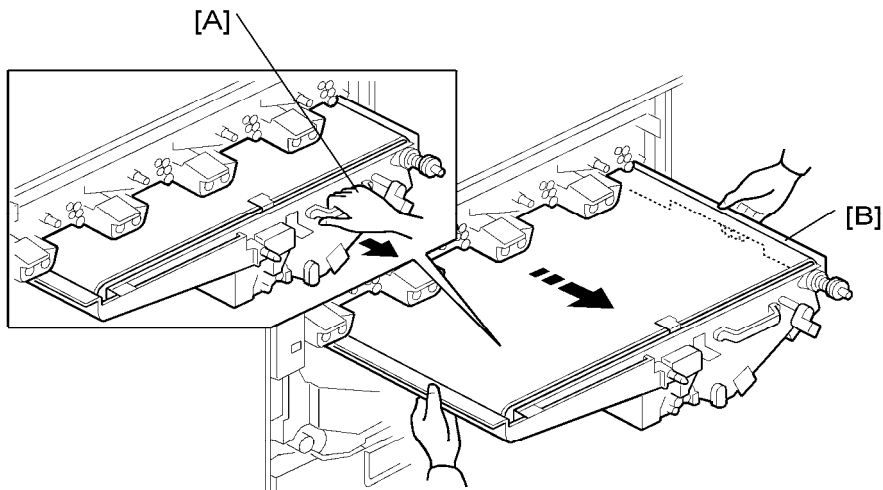

b132r309

8. Use the handle [A] on the front of the transfer unit to pull the unit [B] partially out of the machine.
9. Grip both sides of the image transfer unit and pull it slowly out of the machine.

Handling Precautions

- Remove the image transfer unit carefully. The unit is heavy and not attached to the

Common Procedures

rails with screws.

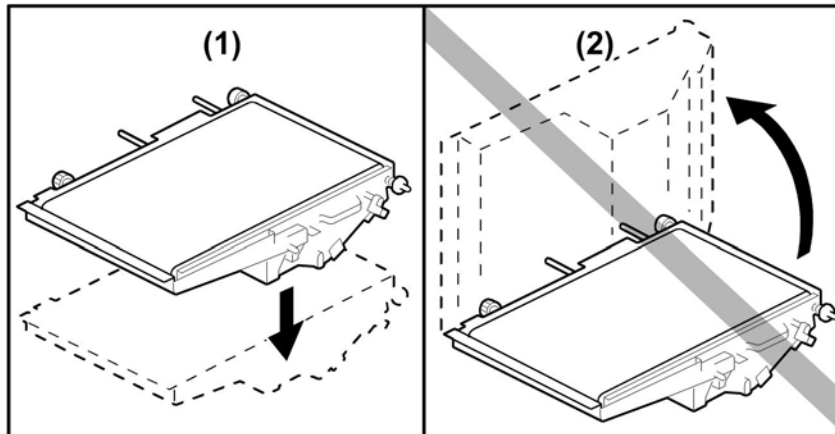

b132r309b

- To prevent toner scattering inside and outside the unit, keep the unit (1) flat when you remove it, lift it, carry it, and put it down.
- Never stand the ITB unit (2) on its edge before you remove the cleaning unit from the ITB.
 - Never place the ITB unit on a carpet where toner can scatter or where the unit will collect dust.

Reinstallation

- Re-insert the image transfer unit slowly and carefully to avoid snagging the belt on the frame of the machine.
- Make sure that the image transfer unit does not snag on the toner cap of the yellow PCU on the far left.

5.2.9 DRAWER UNIT

To pull out the drawer unit:

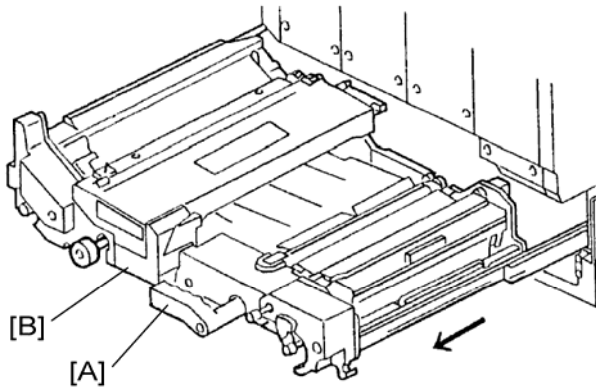

b132r900

1. Remove the front door.
2. Rotate the lever [A] down to left until it stops.
3. Grip the lever to pull the unit [B] out of the machine until it stops.

To remove the drawer unit:

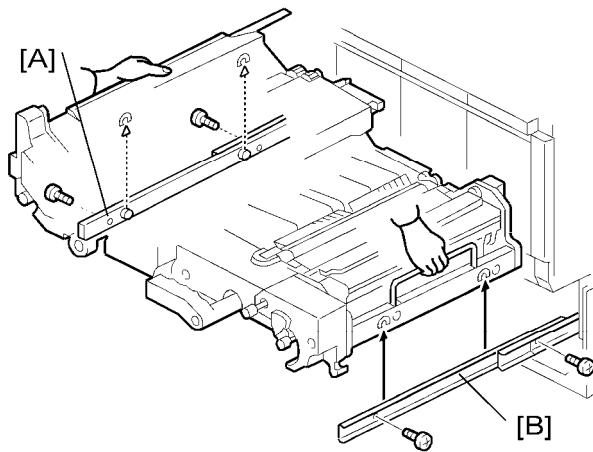



b132r301

Common Procedures

CAUTION

- The drawer unit is very heavy (30 kg/66lb.).

1. Disconnect the left rail [A] ( x2).
2. Disconnect the right rail [B] ( x2).
3. Lift the unit off the rails.
4. Push the rails into the machine.

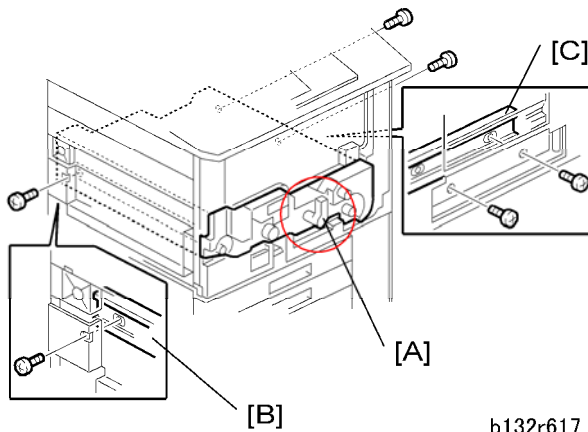

To re-install the drawer unit



1. Remove the right upper cover and the left upper cover.
2. Open the front door.
3. Pull out the left rail and right rail.
4. Set the unit on the rails.

CAUTION

- The drawer unit is very heavy (30 kg/66 lb). Make sure that hooks are engaged with the holes in the rails.

5. Slowly push the unit into the machine until it stops.
6. Rotate the lever [A] to the vertical position.
7. Fasten the screws to the left rail [B] ( x2).
8. Fasten the screws to the right rail [C] ( x2).
9. To ensure that the unit is positioned correctly, check each screw and confirm that it is fastened tightly.

5.2.10 DUPLEX UNIT

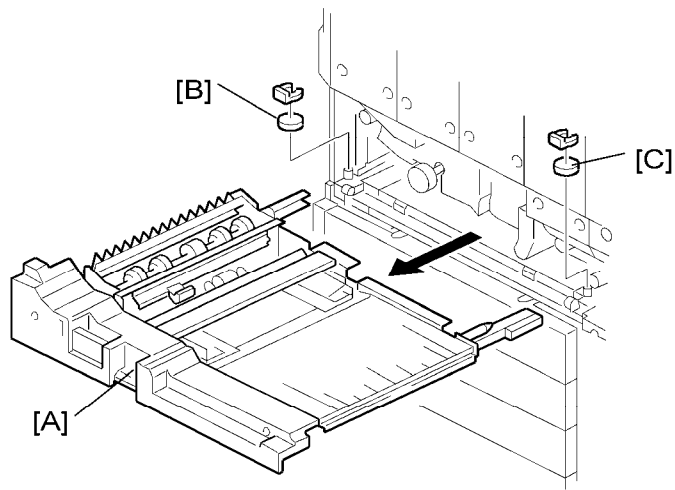

b132r501

1. Open the front door.
2. Pull the duplex unit [A] out until it stops.
3. Remove the Teflon ring [B] from the left rear corner (⌘ x1).
4. Remove the Teflon ring [C] from the right rear corner (⌘ x1).
5. Lift the duplex unit from the rails and place it on a flat, level surface.

5.2.11 OPENING, LOCKING THE CONTROLLER BOX COVER

CAUTION

- To prevent personal injury and damage to the controller box, when the controller box is open, it should always be locked as described below. Before doing the procedure, always switch the machine off and disconnect the power cord.

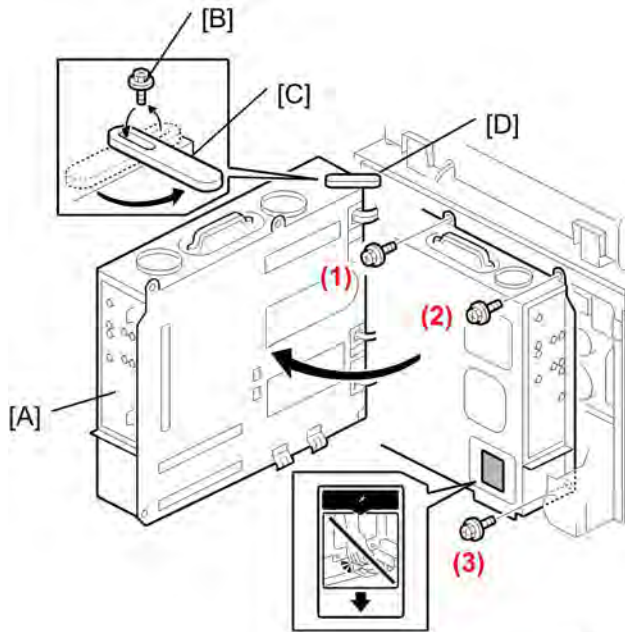

b132r715

1. Turn off the main power switch and disconnect the power cord.
2. Remove the rear covers.
3. Remove controller box screws (1), (2), and (3).
4. Open the controller box [A] to the left until it stops.

Important

- Obey the warning on the decal to avoid touching the fan blades when you open and close the controller box.
5. Remove the left screw [B].
 6. Rotate the plastic stopper [C] counter-clockwise until it is aligned with the hole below and its tip [D] is touching the machine frame.
 7. Reattach the screw removed in Step 5 to lock the arm in position.

Reinstallation

- Before closing the controller box, reattach the stopper arm at its original position.

5.2.12 SD CARD STORAGE

After an application has been moved from its original SD card to another SD card with SP5873-1, the empty SD card should be stored on site inside the front door of the machine.

- The original SD card is proof that the customer has purchased that application and must remain with the machine.
- If the front door is replaced, the stored SD cards must be removed and stored inside the new door.

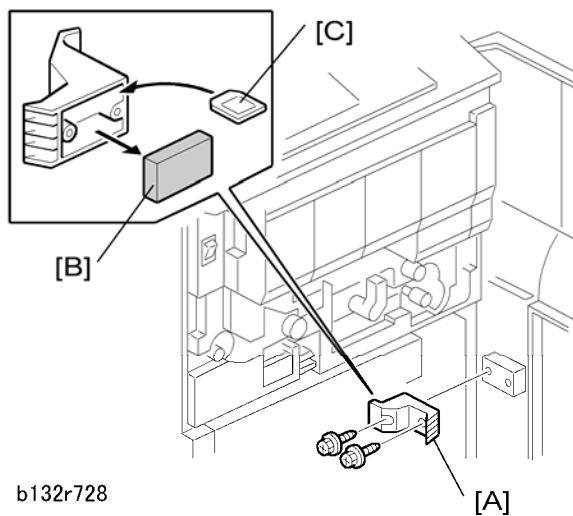

b132r728

1. Open the front door.
2. Remove the cover [A] on the door (⚙️ x2).
3. Remove the block [B].
4. Store extra SD cards [C] inside the cover.
5. Reattach the cover to the door.

5.2.13 BEFORE REMOVING AND RE-INSTALLING THE VM CARD

This machine is shipped with the VM card installed in Slot 1 (lower slot). The VM card holds the App2 Me application, and other VM applications may also be included. If App 2 Me (or any other application) has been enabled, it must be halted if you need to remove the VM card for any reason.

This needs to be done before:

- Updating the App 2 Me application firmware .
- Updating the main machine firmware
- Backing up the NVRAM
- Executing application move or undo with SP5873.

Before Removing the VM Card from the Machine

1. Push the "User/Tools" key.
If an administrator setting is registered for the machine, Step 2 and 3 are required.
Otherwise, skip to Step 4.
2. Push [Login/Logout] on the operation panel.
3. Login with the administrator user name and password.
4. Touch "Extended Feature Settings" twice on the LCD.
5. Touch the icon for each application until the status changes to "Stop".

 **Important**

- All applications must be stopped before the machine is switched off.
6. Turn the machine off, and then remove the VM Card from Slot 1 (lower slot).
 7. Do the procedure:
 - Updating the App 2 Me application firmware.
 - Updating the main machine firmware
 - Backing up the NVRAM
 - Executing application move or undo with SP5873.

Starting Up After the VM Card Has Been Removed

1. Insert the VM card in Slot 1 (lower slot).
If an administrator setting is registered for the machine, Step 2 and 3 are required.
Otherwise, skip to Step 4.
2. Push [Login/Logout] on the operation panel.
3. Login with the administrator user name and password.
4. Touch "Extended Feature Settings" twice on the LCD.
5. Touch the icon for each application that you want to start. You will see the "Starting up" status message for each application that you start.
6. Touch "Exit" on the screen.
7. Exit the "User Tools/Counter" settings.

5.3 SCANNER UNIT

5.3.1 EXPOSURE GLASS

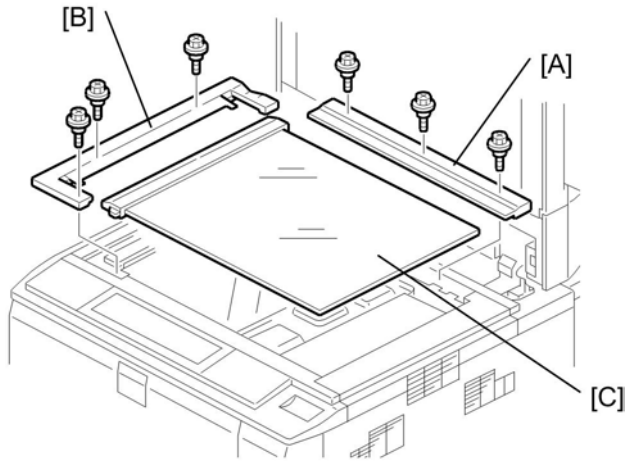

b081r128

1. Remove:

[A] Rear scale (🔩 x3)

[B] Left glass cover (🔩 x3)

[C] Exposure glass

5.3.2 LENS BLOCK, PAPER SIZE SENSORS

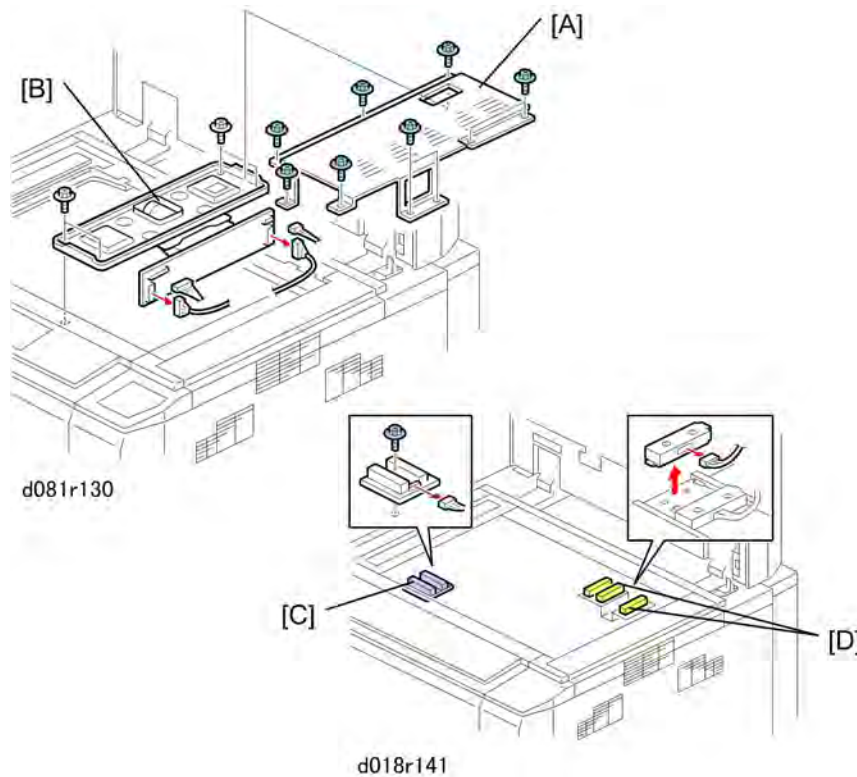

- Before you remove the lens block, note the settings of the following SP codes that are used for ADF density adjustments for R, G, B.
 - SP4609-2
 - SP4610-2
 - SP4611-2
- Remove the exposure glass.
 - [A] Lens cover (🔩 x9)
 - [B] Lens block (🔩 x4, 📦 x4)
- Remove the lens block carefully to avoid damaging the attached PCB. Do not touch the paint-locked screws on the lens block.
 - [C] Original width sensor (📦 x1, 🔩 x1)
 - [D] Original length sensors x2 (No screws, 📦 x1 each)

After replacing the lens block, do the following SP codes.

Scanner Unit

SP4008 001	Sub Scan Mag	Sub Scan Magnification Adjustment
SP4010 001	Sub Scan Reg	Sub Scan Registration Adjustment
SP4011 001	Main Scan Reg	Main Scan Registration Adjustment

4. After lens block replacement, do some copy samples with the ADF. Check these points:
- Do the copies have background?
 - Is the copy output of the ADF and platen mode different?

If these problems occur, restore the following SP codes to their previous settings (noted in Step 1):

- SP4609-2
- SP4610-2
- SP4611-2

Or, adjust these SPs until the background is acceptable.

5.3.3 EXPOSURE LAMP

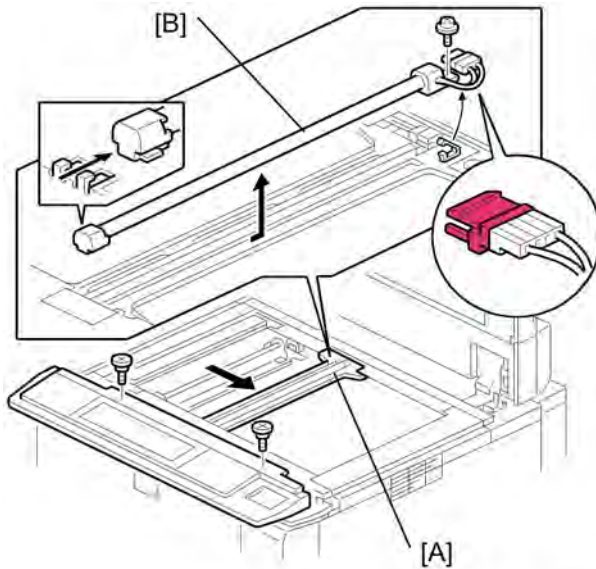

d132r129

1. Remove:
 - Exposure glass (☛ p.5-26)
 - Operation panel (☛ p.5-7 "Operation Panel, Top Covers")
2. Slide the 1st scanner [A] to the cutout in the frame.
3. Remove the exposure lamp [B] (☛ x1, ☛ x1, ☛ x1)

★ Important

- Never touch the surface of the exposure lamp with bare fingers.
- Work carefully to avoid damaging the relay plugs attached to the rear ends of the lamp.

5.3.4 SCANNER MOTOR

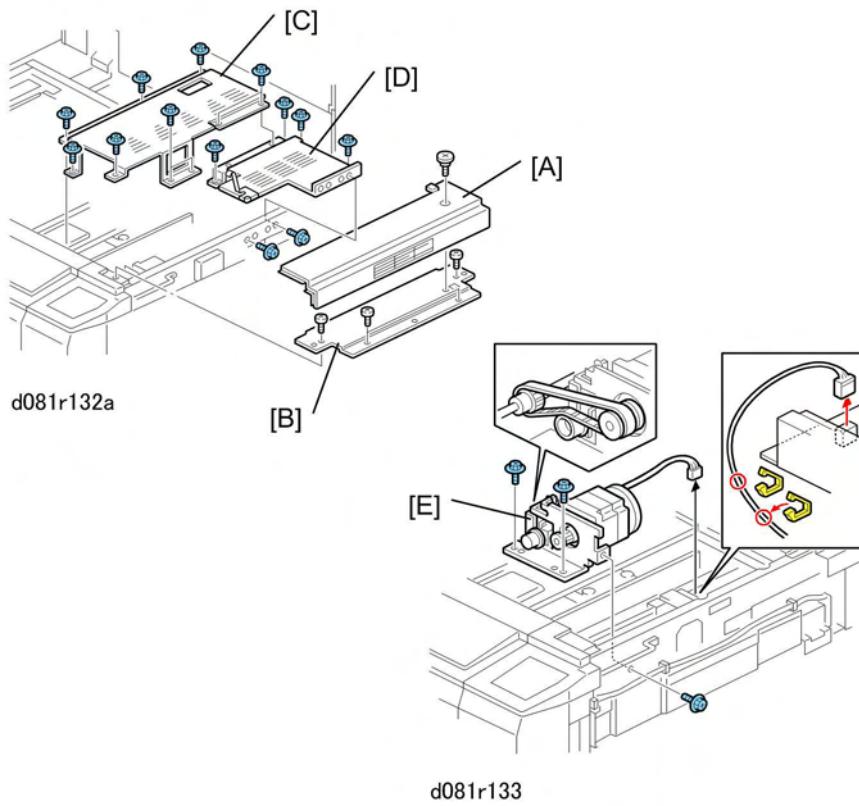

1. Remove:
 - Exposure glass (p.5-26)
2. Remove:
 - [A] Top right cover (x1)
 - [B] Bracket (x3)
 - [C] Lens cover (x9)
 - [D] Right lens cover (x5)
 - [E] Scanner motor bracket (Timing belt x1, x2, x1, x3)

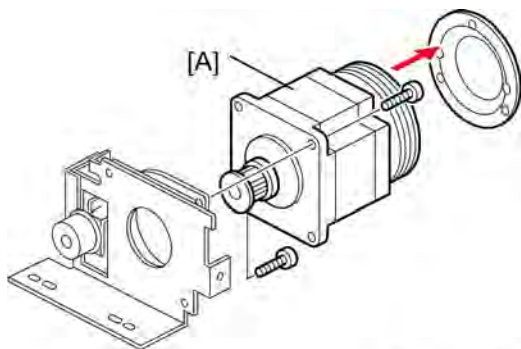

d081r133b

3. Remove scanner motor [A] (Cover x1, x2).

5.3.5 SCANNER HP SENSOR

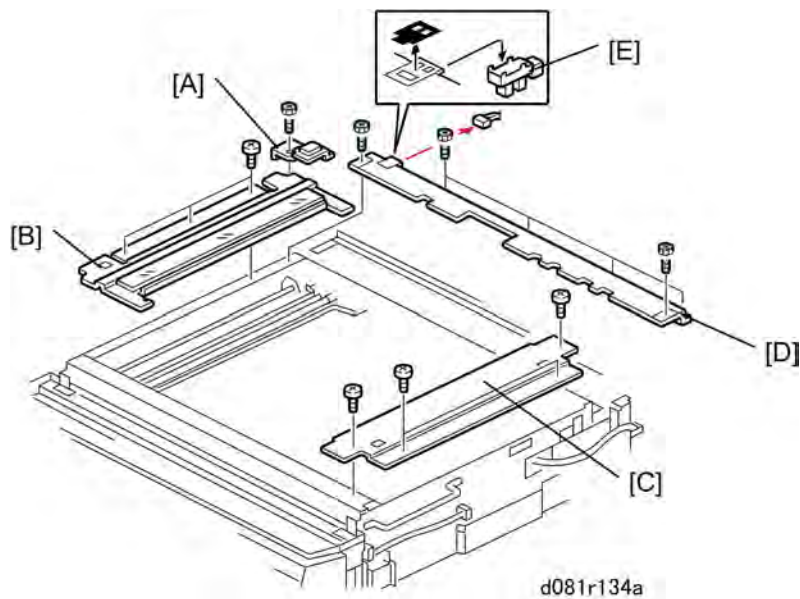

1. Remove:
 - ADF (🔧 p.5-6)
 - Exposure glass (🔧 p.5-26)
 - Top rear, left, right covers (🔧 p.5-7 "Operation Panel, Top Covers")
2. Remove:
 - [A] Ground plate (🔧 x1)
 - [B] Left stay (🔧 x3)
 - [C] Right stay (🔧 x4)
 - [D] Rear stay (🔧 x6)
 - [E] Scanner HP sensor (🔧 x1)

5.3.6 SCANNER INTERFACE BOARD (SIOB)

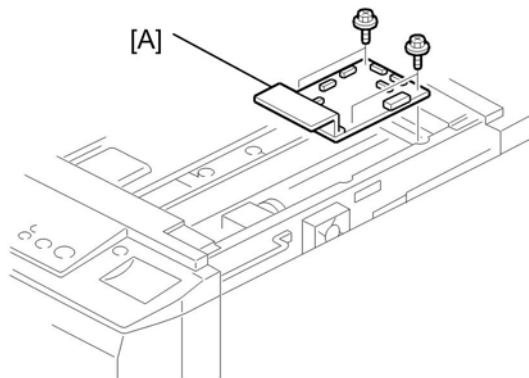

d081r133a

1. Remove:
 - ADF (🔧 p.5-6)
 - Exposure glass(🔧 p.5-26)
 - Top, rear, left, right covers (🔧 p.5-7 "Operation Panel, Top Covers")
 - Right stay, rear stay (🔧 p.5-31 "Scanner HP Sensor")
 - Lens cover (🔧 p.5-27 "Lens Block, Paper Size Sensors")
2. Remove scanner interface board [A] (🔧 x8, 🛠️ x4).

5.3.7 SCANNER WIRE

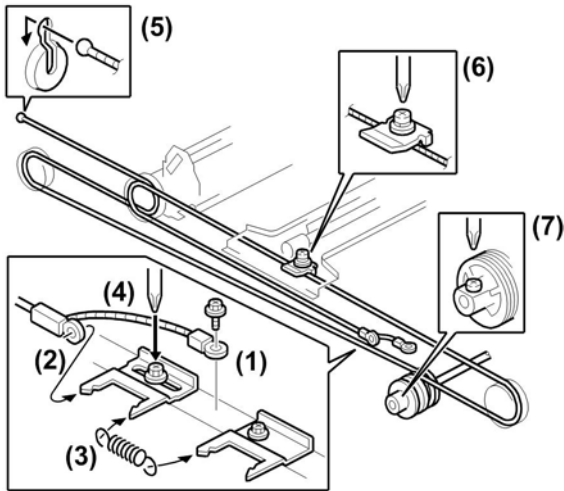

d081r137

1. Remove wire ground (1) (⚙️ x1).
2. Disconnect the head of wire (2) from tension bracket 1.
3. Remove spring (3).
4. Loosen the screw (4) of tension bracket 1.
5. Disconnect the end of wire at (5).
6. Remove lock bracket (6) of the 1st scanner (⚙️ x1).
7. Disconnect the wire from the pulley (7) (⚙️ x1).
8. Remove the wire from the scanner.

Replacement and Adjustments

Scanner Wire Reinstallation and Scanner Position Adjustment

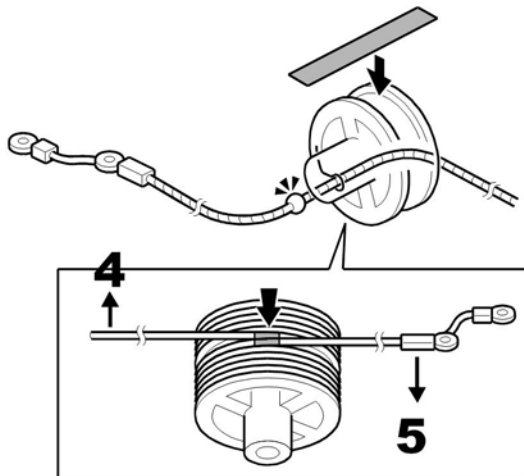

d081r136

1. Place the beads [A] on the middle of the wire on the pulley openings.

Scanner Unit

2. Wind the ball end of the wire [B] 4 times.
3. Wind the other end of the wire [C] 5 times.
4. Attach tape [D] across the pulley to temporarily hold the wires in place.

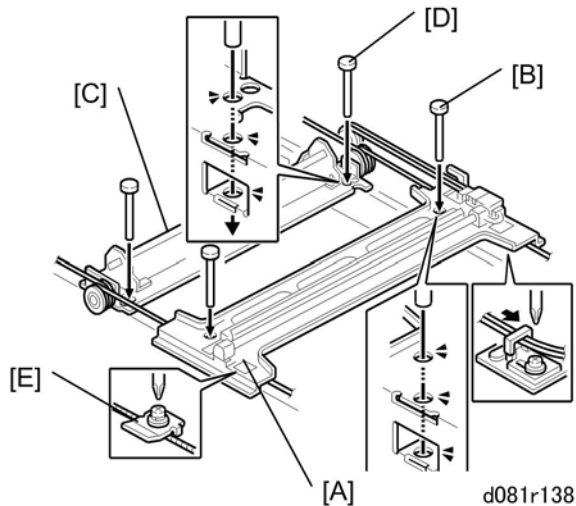

5. Position the 1st scanner [A] so the holes are aligned and insert the positioning pins [B] (x4).
6. Position the 2nd scanner [C] so its holes are aligned and insert the positioning pins [D].
7. Attach the lock bracket [E] to fasten the wire to the 1st scanner.
8. Tighten the screw of tension bracket (🔩 (4) p.5-33 "Scanner Wire").
9. Attach the pulley and tighten it lock screw (🔩 (7) p.5-33 "Scanner Wire").
10. Remove the positioning pins (x4).
11. Remove the tape from the pulley.
12. Slowly push the scanner left and right to confirm that the wires are engaged correctly.
The 1st and 2nd scanners should move smoothly.

5.4 LASER UNIT

WARNING

- This laser unit employs two laser beams produced by a Class III LD with a wavelength of 640 to 670 nm and intensity of 9 mW. Direct exposure to the eyes could cause permanent blindness.
- Before adjusting or replacing the laser unit, push the main power switch to power the machine off then unplug the machine from the power source. Allow the machine to cool for a few minutes. The polygon motor continues to rotate for approximately one to three minutes after the machine is switched off.
- Never power on the machine with any of these components removed: 1) LD unit, 2) polygon motor cover, 3) synchronization detector.

5.4.1 CAUTION DECALS

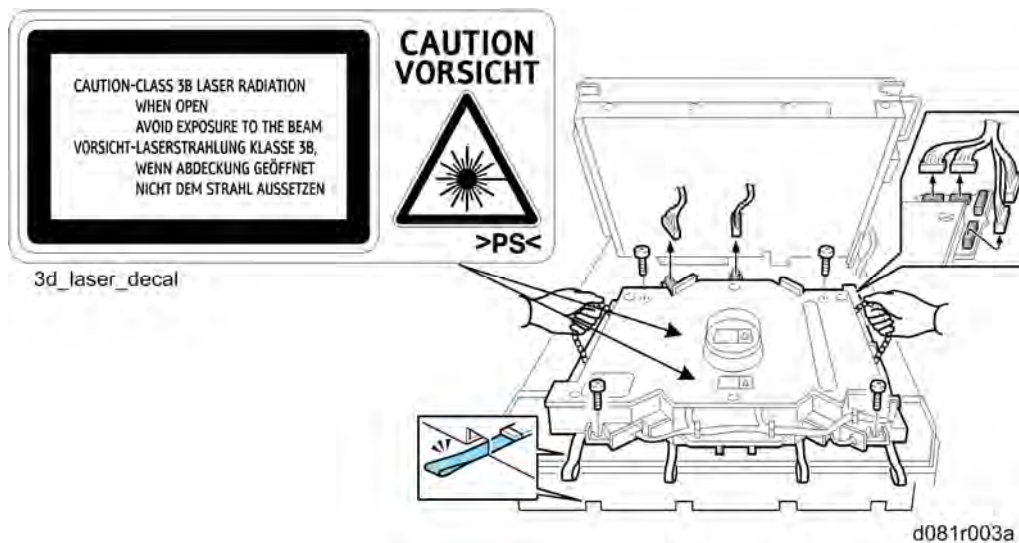

5.4.2 POLYGON MOTOR

WARNING

- Turn off the main power switch and unplug the machine before performing any procedure in this section. Laser beams can seriously damage the eyes and cause permanent blindness.

Important

- An accidental static discharge could damage the laser diode board attached to the lens block unit.
- Touch a metal surface to discharge any static electricity from your hands.
- The polygon motor rotates at extremely high speed and continues to rotate after you switch the machine off. To avoid damaging the motor, never remove the polygon motor within three minutes of switching off the main power and disconnecting the power plug.

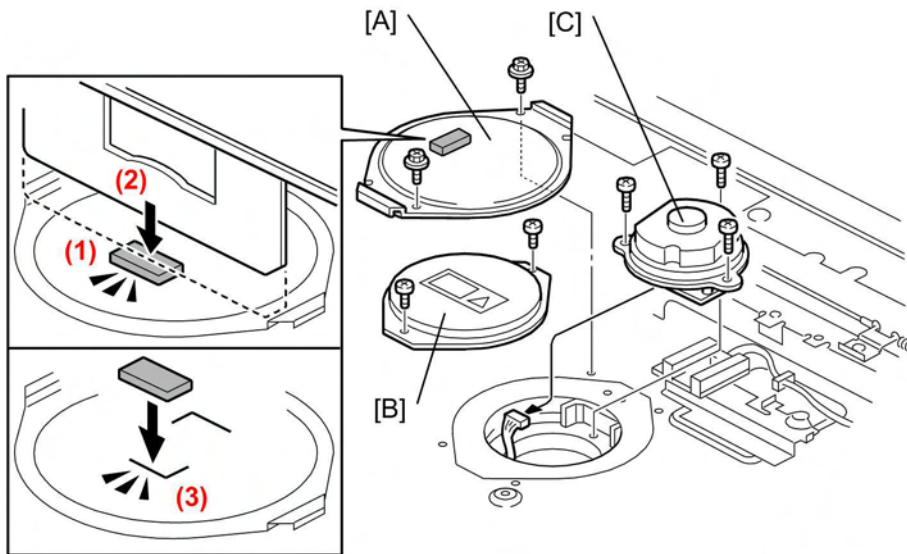

d014r131a

1. Remove:
 - Exposure glass ( p.5-26)
 - Lens block ( p.5-27)
2. Remove:
 - [A] Top cover ( x2)
 - [B] Middle cover ( x2)
 - [C] Polygon motor ( x3,  x1,  x1)

★ Important

- Never remove the paint-lock screws on top of the lens block unit.
- Never touch the glass covers of the laser ports on the sides of the polygon motor [C].

Re-installation

- The top cover [A] must be positioned correctly for reinstallation.
- When you reinstall the top cover [A], set the top cover so that gasket (1) touches lens bracket (2).

★ Important

- If the top cover is not positioned this way, the unit could generate electrical noise.
- If the gasket has peeled off during removal, install a new gasket aligned with the line (3) on the top cover. (A replacement gasket is available as a service part.)

5.4.3 LASER UNIT

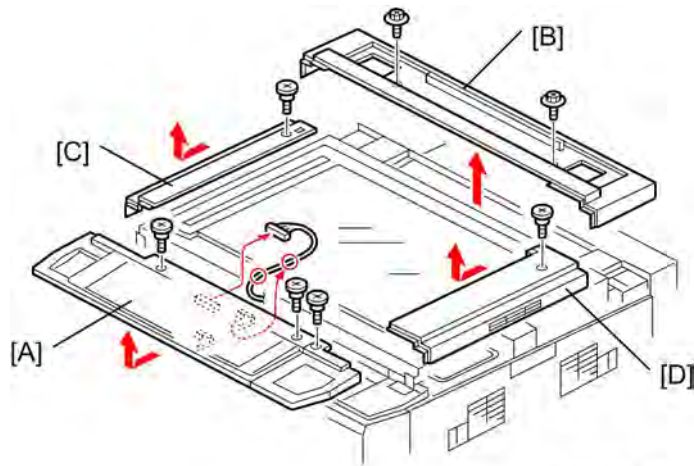

d081r701

1. Remove ADF (☛ p.5-6).
2. Remove:
 - [A]: Operation panel (🔩 x3, 📺 x1, 📺 x1)
 - [B]: Top rear cover (🔩 x2)
 - [C]: Left top cover (🔩 x1)
 - [D]: Right top cover (🔩 x1)

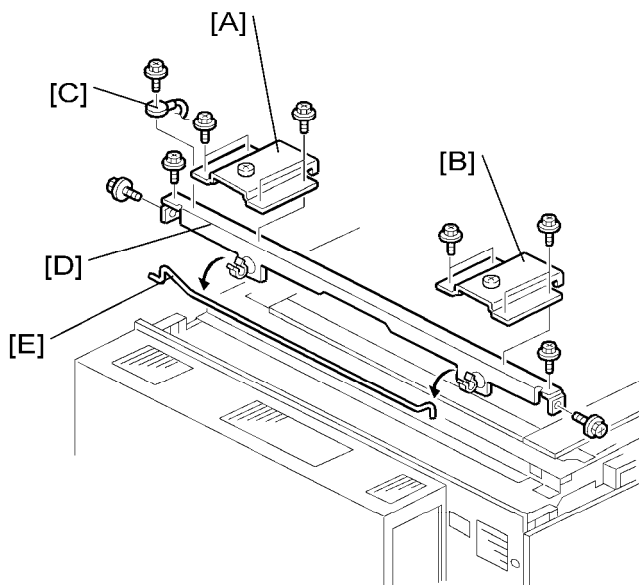

b132r001

3. Remove:
 - [A] Left plate (🔩 x4)
 - [B] Right plate (🔩 x4)

[C] Ground wire (🔩 x1)

★ Important

- Be sure to re-connect this ground wire when you re-assemble the machine.

[D] Cross piece (🔩 x4)

[E] Detach the support rod from the clamps.

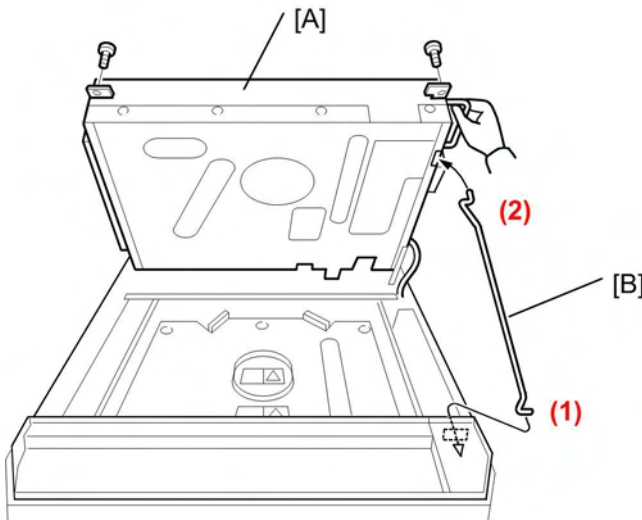

b132r002

4. Raise the scanner unit [A] (🔩 x 2).
5. Set the support rod [B] at the base (1) then under the front, right corner (2) of the scanner unit.

⚠ CAUTION

- The scanner unit is very heavy. Never remove the support rod during servicing.

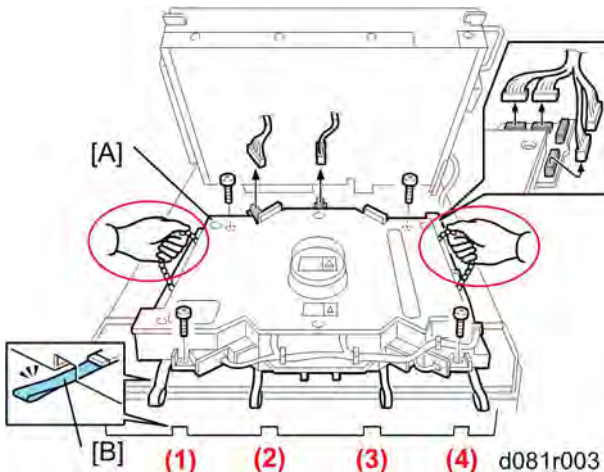

d081r003

6. Disconnect the laser unit [A] (🔩 x4, 🛠 x6)
7. Use the chains on both sides of the laser unit to lift it out of the machine.

Laser Unit

↓ Note

- The laser unit includes four LD sub units. However, the LD sub units cannot be replaced separately because factory adjustment is required.

Reinstallation

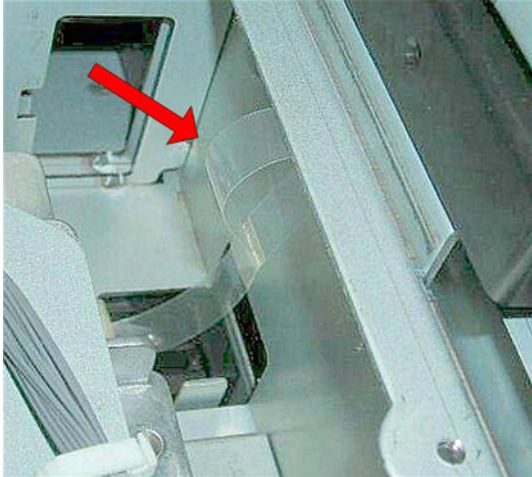

d081r975

- Make sure that the four tapes [B] at (1), (2), (3), and (4) are set correctly. All four tapes should be visible and not tucked under the laser unit.

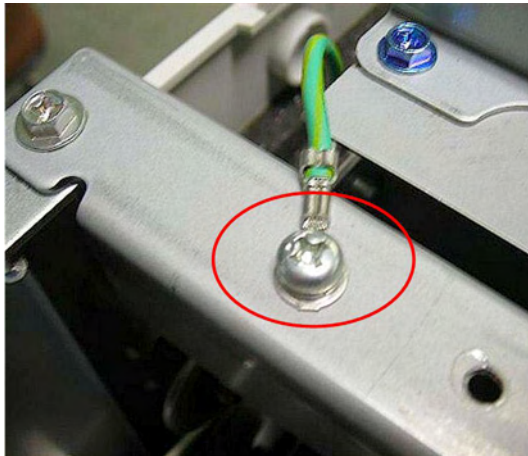

d081r976

- Be sure to reconnect the ground wire at the right rear corner of the machine when you re-assemble the machine.

5.4.4 SP ADJUSTMENTS AFTER LASER UNIT REPLACEMENT

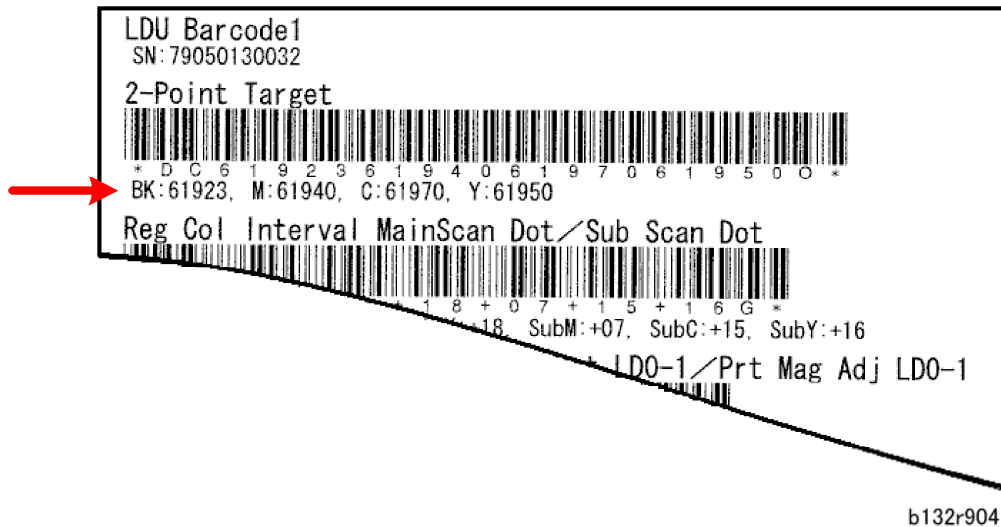

SP codes are written on an A5-size sheet of paper provided with the laser unit.

Note

- Only the settings shown with the first barcode (2-Point Target) are required. The other information on the sheet can be ignored.
1. Enter the values under the first bar code for the following SP codes. These "2-Point Target" must be entered after the LD unit has been replaced.
 - 2156-1 (K)
 - 2156-2 (M)
 - 2156-3 (C)
 - 2156-4 (Y)
 2. Set the following SP codes to "0":
 - 2102-10
 - 2102-11
 - 2102-12
 - 2102-13
 3. Next, do these SP codes and enter the values for LD0-1.
 - 2102-5
 - 2102-6
 - 2102-7
 - 2102-8
 4. Do SP2109-014, select Pattern 14, and print a test pattern. (☛ >Printing Test Patterns)

Laser Unit

Color Registration Errors

- In addition to the SP adjustments printed on the seal attached to the LD unit, if color registration errors occur immediately after you change the laser unit, an additional adjustment is required.
- This additional adjustment is normally not required in the field. Do it only if you see color registration errors in test prints.
- See "Color Registration Test and Error Adjustment" in p.5-230 "Color Registration" for instructions on how to do this adjustment.

Skew

- If skew occurs immediately after you change the laser unit, do the skew adjustment. (See p.5-231 "Skew Adjustment After Laser Unit Replacement").

5.4.5 LD UNIT

There is an LD unit for each color, and each LD unit uses a two-beam system. A photo diode (PD) in each LD unit detects the light emitted from the LD unit. The output of the PD is fed back to the LD control board. The LD control board uses this information to control the amount of light to make sure that it remains at the correct level.

Dual Beam Writing

In each LD unit, two beams move across the drum in the main scan direction.

The use of two beams:

- Makes the machine print faster.
- Reduces the number of turns of the polygon mirror for a page to prolong the service life of the motor.
- Reduces the amount motor noise.

The beam pitch is fixed at 600 dpi and is not adjustable.

LD Safety Switches

To ensure the safety of customers and customer engineers, two switches inside the cover prevent the laser beams from switching on accidentally. When the front cover is open, the +5V line connecting each LD driver on the LD control board is disconnected.

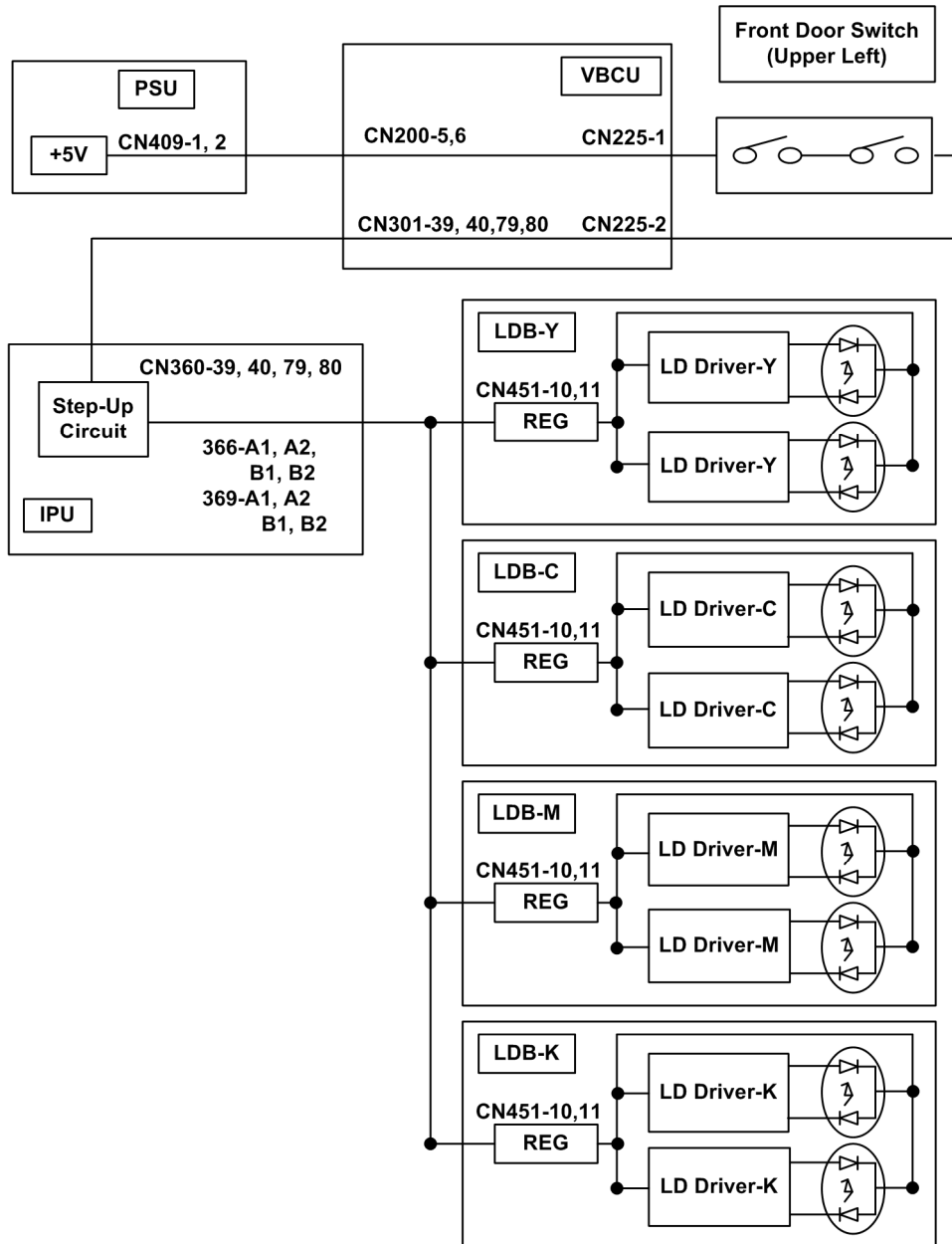

d081d900

Replacement and Adjustments

5.5 PCU

5.5.1 BEFORE YOU BEGIN

The items that are replaced determine which SP codes must be done after the machine is re-assembled and turned on. Here are some important rules that you should follow.

1. Initialize the TD sensor only once with SP3801-1 to -6.

CAUTION

- Never initialize the TD sensor more than once. Initializing the TD sensor more than once can cause toner scatter inside the machine.
2. If you replace the developer for one or more colors, do the developer set up for each color as described in this section.
 3. Initialize the TD sensor only at the following times:
 - At installation, exactly as explained in the installation procedure.
 - After you replace developer (only initialize the TD sensor for the color that you replaced) as instructed below.

Here is a summary of the important differences between SP3801 001-006 (Init TD sensor) and SP3811 001-006 (Dev Setup Exe):

- SP3801 001-006 (Init TD sensor) only initializes the TD sensor.
- SP3811 001-006 (Dev Setup Exe) initializes the TD sensor and sends toner to the sub hopper of each PCU. This covers the PCU drum with a layer of toner. Covering the drum with toner prevents the cleaning blades from scratching or bending the drums.

Important

- SP3811 is necessary only at installation or in a replacement procedure when both the developer and cleaning blade are replaced together. If you use SP3811 for any other procedure, the toner sent to the PCU is wasted.

5.5.2 CHARGE UNITS

The procedure for removing the drum charge components in the K PCU and YMC PCUs is different.

- The YMC PCUs use a charge roller to charge the OPC drum.
- The K PCU uses a charge wire unit to charge the OPC drum.

Preparation

1. Remove the PCU stand from the bottom of the machine.
2. Remove the PCU from the machine.

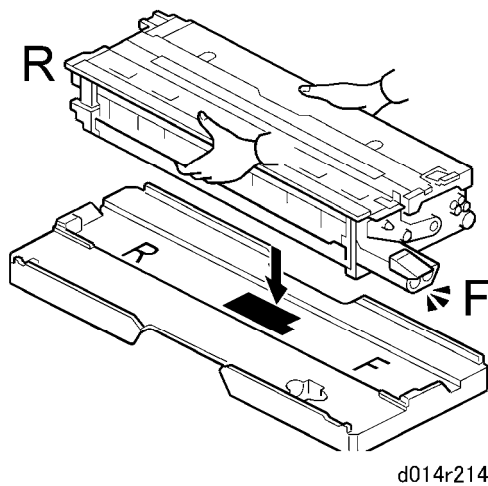

3. Set the PCU on the PCU stand.

★ Important

- Use the PCU stand provided with the machine.
- Never use a PCU stand for a B132/B181/B200 because this can damage the exposed drum on the bottom of the PCU.
- If the D081/D082 PCU stand is not available, you can use a D014/D015 PCU stand (these stands are identical.)

PCU

Charge Roller Unit: YMC PCUs

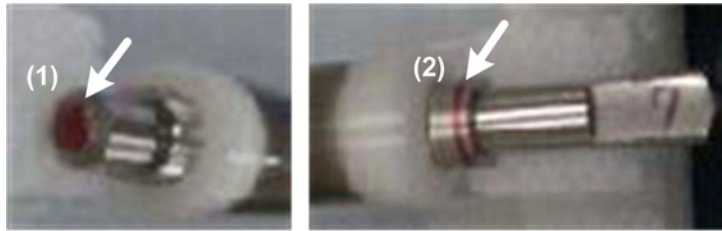

d081r977

★ Important

- The charge roller of each YMC PCU unit is marked on the tip of one end with a red stamp (1) and with a red ring (2) around the sleeve on the other end. Only the red ring (2) is visible on the PCU unit.
- The red ring (2) distinguishes the D081/D082 YMC PCU units from PCU units of previous machines. Always replace a PCU unit with a unit that has this red ring (2). Never install a PCU unit for a previous machine.

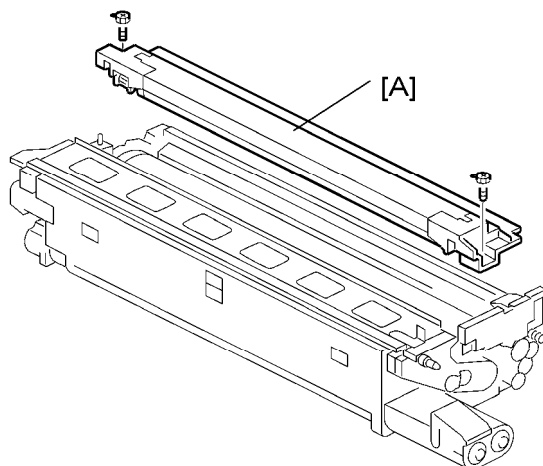

d014r452

1. Remove the charge roller unit [A] (🔧 x2).

This unit contains the charge roller and charge roller cleaning roller.

★ Important

- If you need to replace a charge roller unit, be sure to replace the C, M, Y charge roller units together.

Re-installation

After re-assembling the machine, go into the SP mode and do SP2111. This SP should be done after replacing any component of the PCU.

K_PCU Replacement

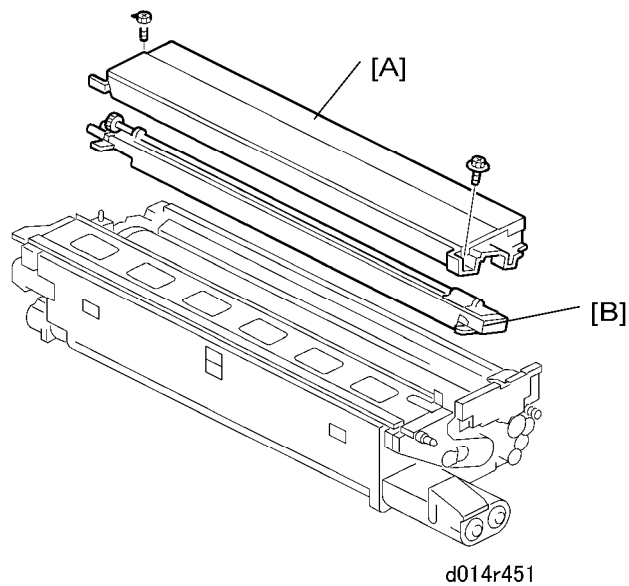

1. Remove:

[A] Cover (🔩 x2)

[B] Charge wire unit

The charge corona wire and charge corona wire cleaning mechanism comprise the charge wire unit. The unit can be replaced as you see it above and no further disassembly is required.

-or-

The charge grid wire can be replaced (see next section)

Re-installation

After re-assembling the machine, go into the SP mode and do SP2111. This SP should be done after replacing any component of the PCU.

PCU

K_PCU Charge Unit Components

The charge wires and grid of the K_PCU can be replaced.

★ Important

- Only the K_PCU uses charge wires and a grid. The other three PCU units use charge rollers.

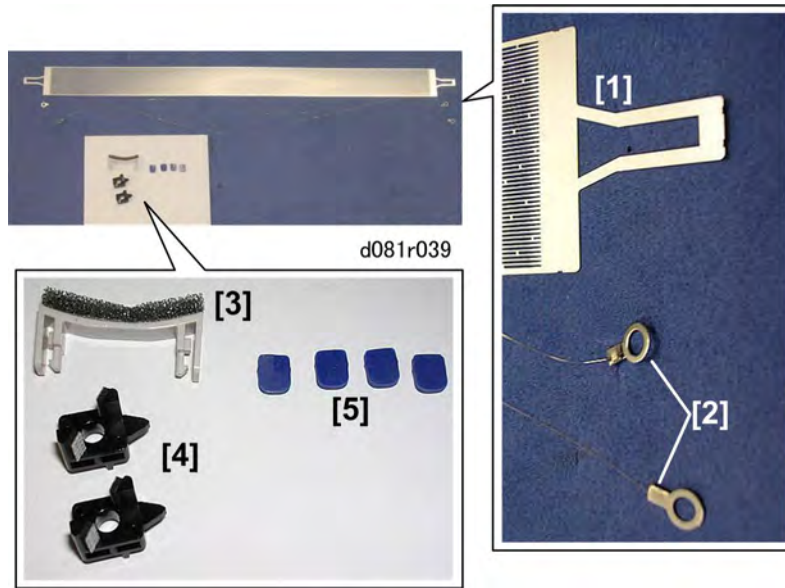

Before you begin, make sure that you have all the replacement parts for the K_PCU charge unit.

No.	Item	Qty	Part No.
[1]	Grid	1	
[2]	Corona Wires	2	
[3]	Cleaner Assembly	1	
[4]	Cleaning Pads	2	
[5]	Cushions	4	

↓ Note

- You will need pincettes, tweezers, or a pair of very thin needle-nose pliers for this procedure.

Charge Unit Removal



d081i840

1. Remove the K_PCU from the machine and place it on the PCU stand. (☞ p.5-12 "Toner Hopper, Faceplate, PCU")

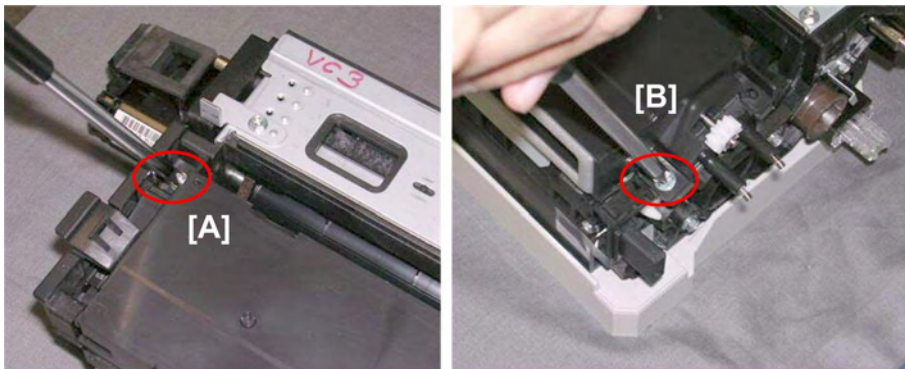

d081i841

2. Remove the front screw [A] and rear screw [B].

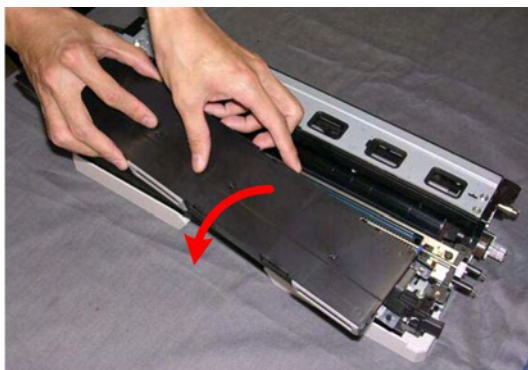

d081i842

3. Remove the K_PCU cover.

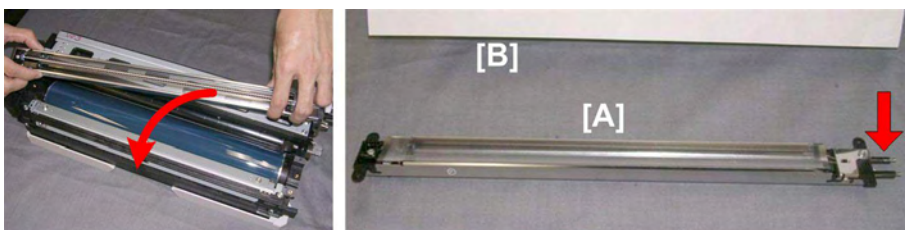

d081i843

PCU

4. Remove the charge unit [A], turn it upside down and place it on a flat, clean surface.



- The red arrow is pointing to the rear of the charge unit. This is the end with the two terminal connectors.

5. Cover the exposed drum with a sheet of clean paper [B].

Grid Removal

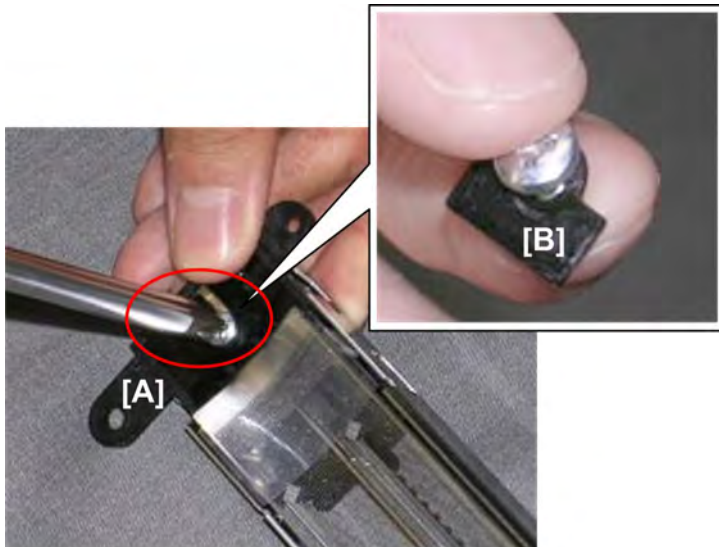

d081i844

1. At the front end [A], remove the screw and collar [B] together (🔩 x1).
2. Keep this screw and collar.

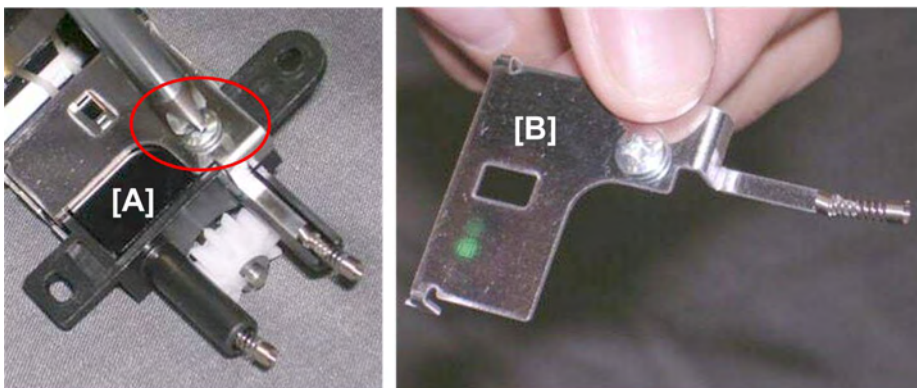

d081i845

3. At the rear [A], remove the contact plate [B] together with the screw (🔩 x1).

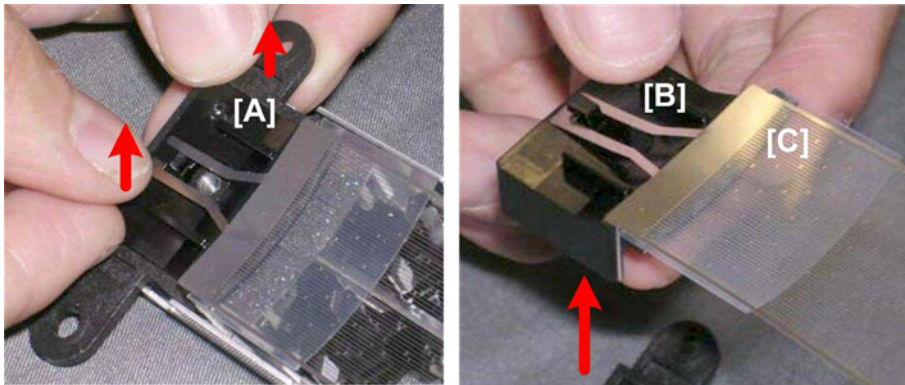

d081i846

4. At the front [A], lift out the holder [B] and grid [C] together.

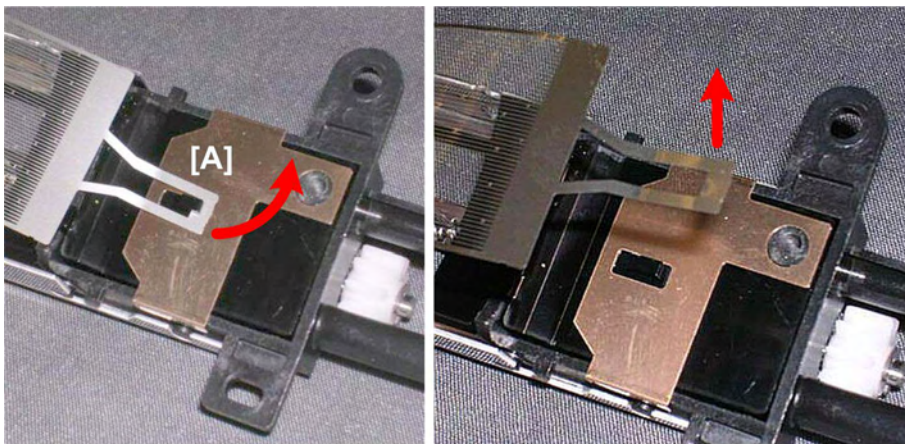

d081i847

5. At the rear, carefully disconnect the end of the grid [A] from the peg and remove the grid. Discard the grid.

Corona Wire Removal

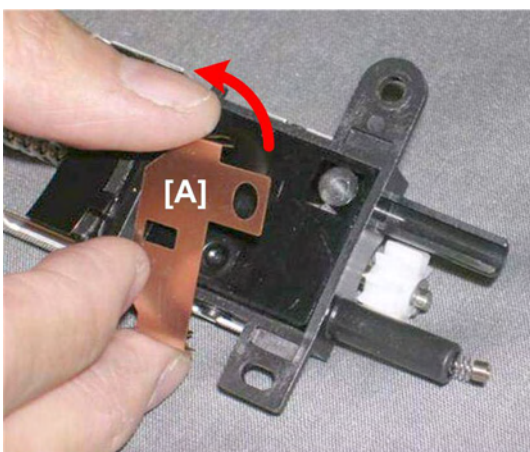

d081i848

1. Remove the contact plate [A].

PCU

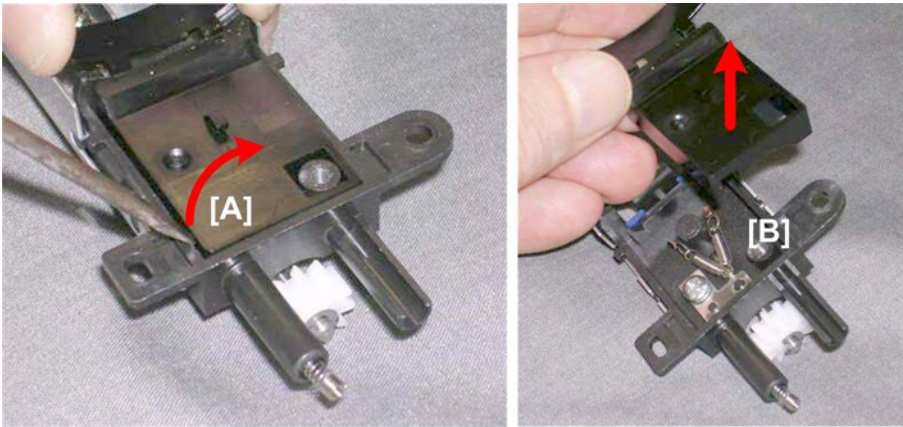

d081i849

2. Use the tip of a small screwdriver to pry loose the rear cover [A] and remove it to expose the two springs [B].

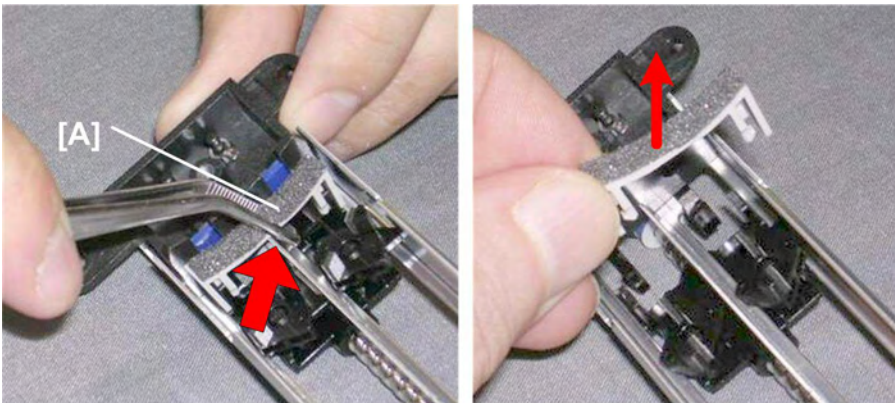

d081i850

3. At the front, use pincettes, tweezers, or thin needle-nosed pliers to remove the cleaner assembly [A].

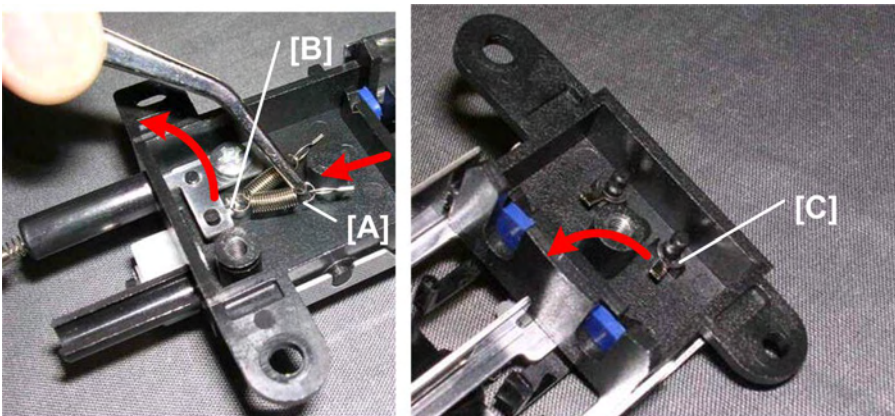

d081i851

4. At the rear, use the pincettes to pull the spring [A] gently toward the rear and lift it off its peg [B].

5. At the front, remove the other end of the corona wire from its peg [C].

★ Important

- The corona wires are extremely thin and fragile, and they break easily.
- If a wire breaks, make sure that you remove all the broken pieces from the charge unit before you discard the removed wires.

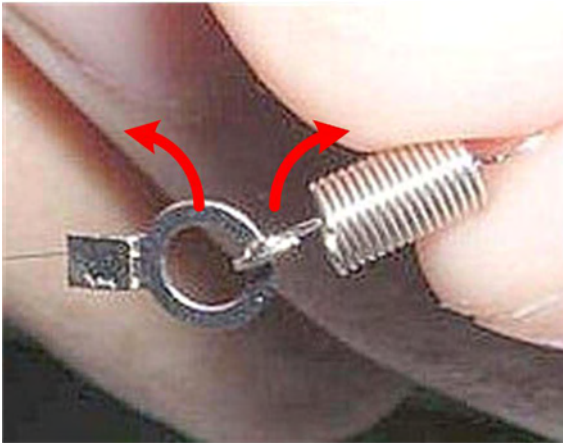

d081i852

6. Disconnect the spring from the O-ring. Keep the spring because you will need it to attach the new wire.

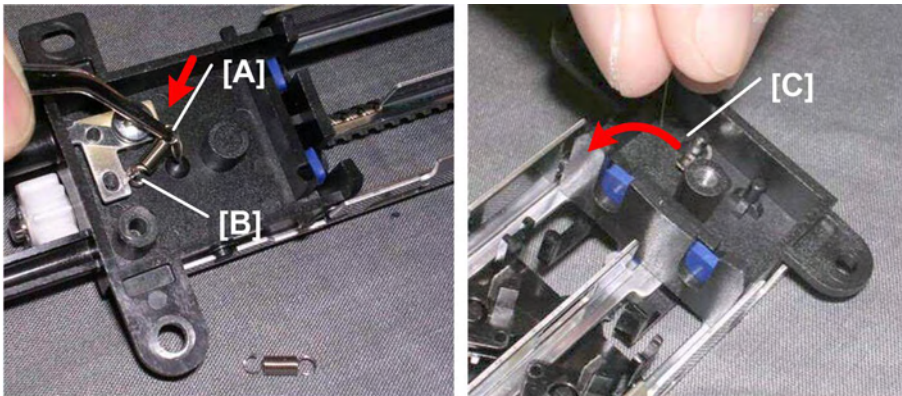

d081r853

7. At the rear, use the pincettes to pull the spring [A] of the other wire gently toward the rear and lift it off its peg [B].
8. At the front, remove the other end of the corona wire from its peg [C].

PCU

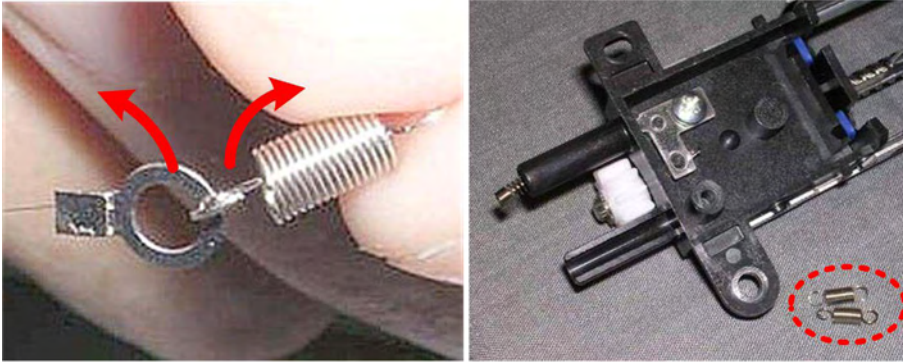

d081i854

9. Disconnect the spring from the O-ring. Keep the spring because you will need both springs to attach the new wires.

Pad and Cushion Removal

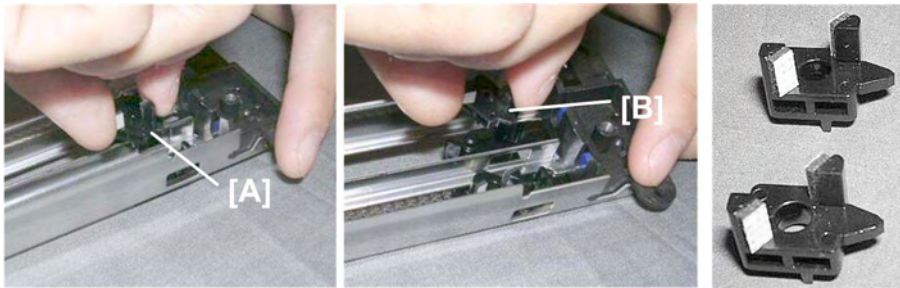

d081i855

1. At the front, disconnect and remove the first cleaning pad [A] and second cleaning pad [B].
2. Discard both pads.

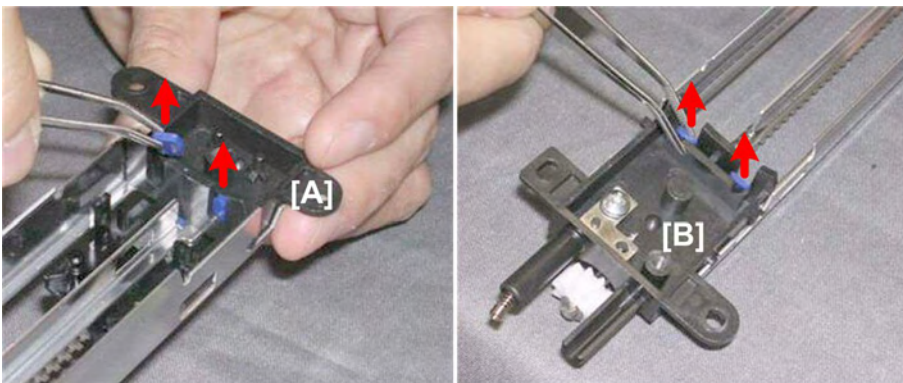

d081i856

3. At the front, remove the two cushions [A] and discard them.
 4. At the rear, remove the two cushions [B] and discard them.
- This completes the removal procedures.

Cleaning Before Installing New Parts

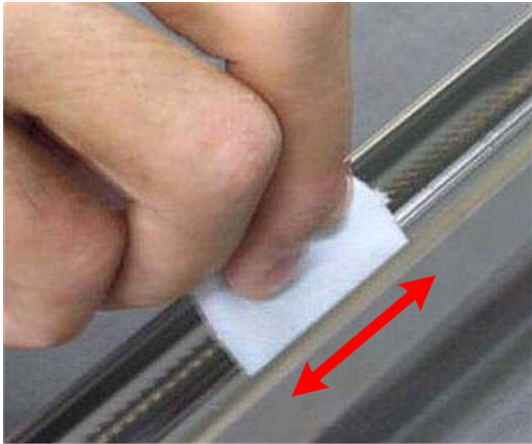

d081i857

1. Use a clean cloth moistened with water to clean the surfaces of the charge unit.

★ Important

- Use a cloth moistened with water. Do not use alcohol.

2. Use a clean dry cloth to dry the surfaces of the charge unit.

Re-Installation: K_PCU Charge Components

To avoid problems, follow the order of installation of new parts described below.

★ Important

- Handle the corona wires carefully. They are extremely fragile and break easily.
- Never touch any part of the surface of the new grid.

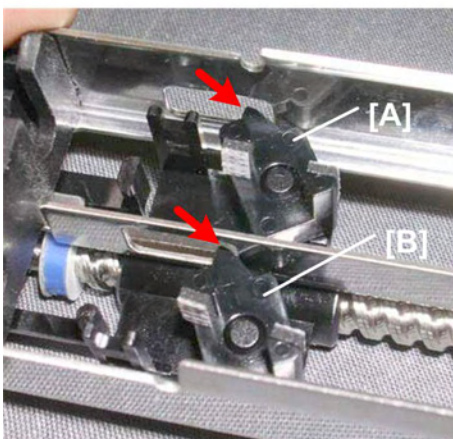

d081i858

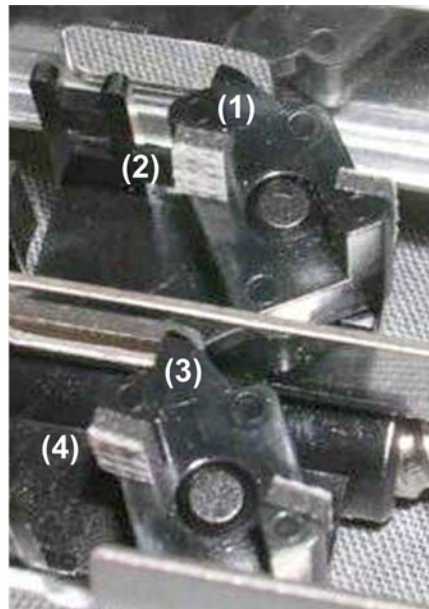

1. Set the new pads [A] and [B] as shown above.
2. Check the first pad. Make sure that the point (1) is set in the cutout and that the pad on the left (2) is facing toward you.

PCU

3. Check the second pad. Make sure that the point (3) is set in the cutout and that the pad on the left (4) is facing toward you.

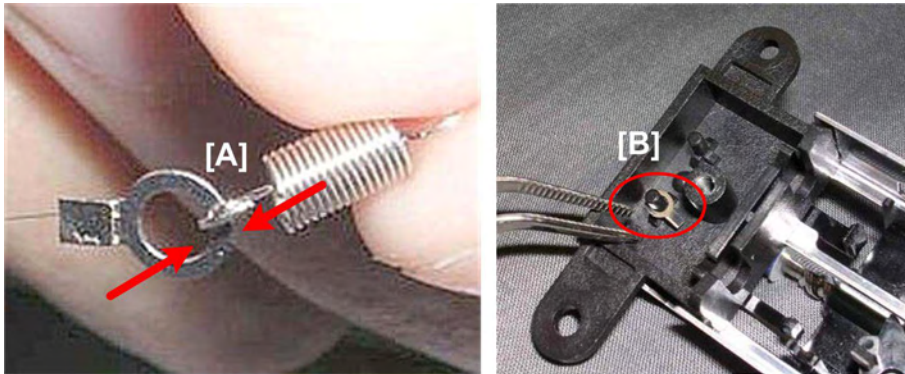

d081i859

4. At the rear, hook a spring [A] onto the O-ring of the first corona wire.
5. Hook the other end of the corona wire (without the spring) onto its front peg [B].

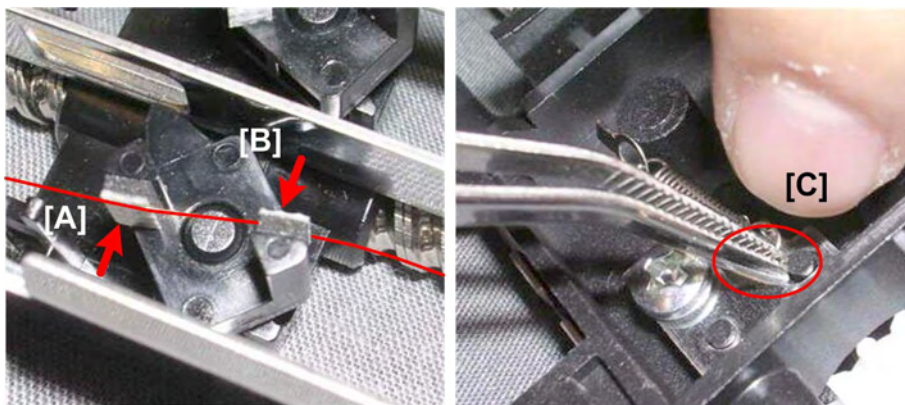

d081i860

6. At the front, thread the corona wire across the surface of pad [A] and pad [B].
7. At the rear, use pincettes to gently pull the end of the spring and hook it over the peg.

★ Important

- The wire is fragile. Do not use too much force when pulling.

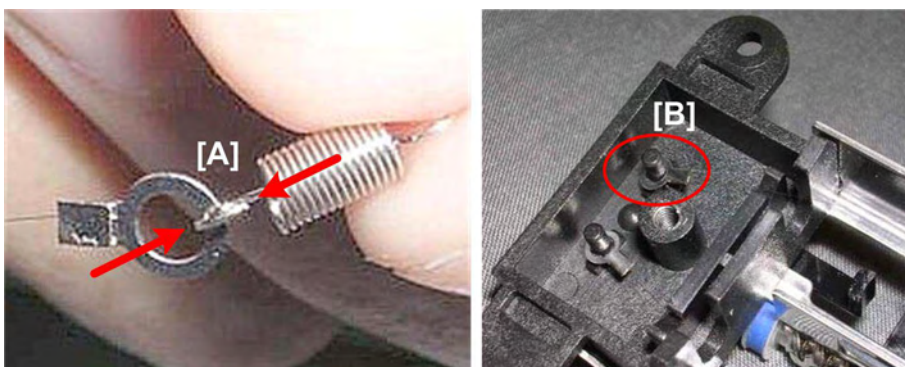

d081i861

8. At the rear, hook a spring [A] onto the O-ring of the second corona wire.
9. Hook the other end of the corona wire (without the spring) onto its front peg [B].

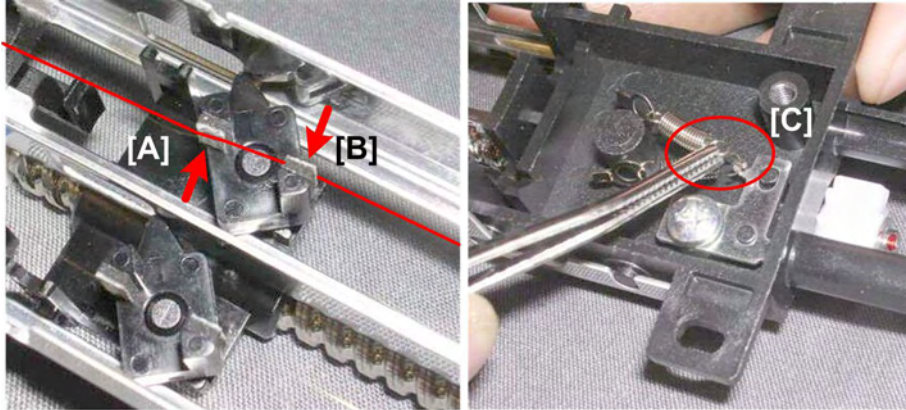

d081i862

10. At the front, thread the corona wire across the surface of pad [A] and pad [B].
11. At the rear, use pincettes to gently pull the end of the spring and hook it over the peg.

★ Important

- The wire is fragile. Do not use too much force when pulling.

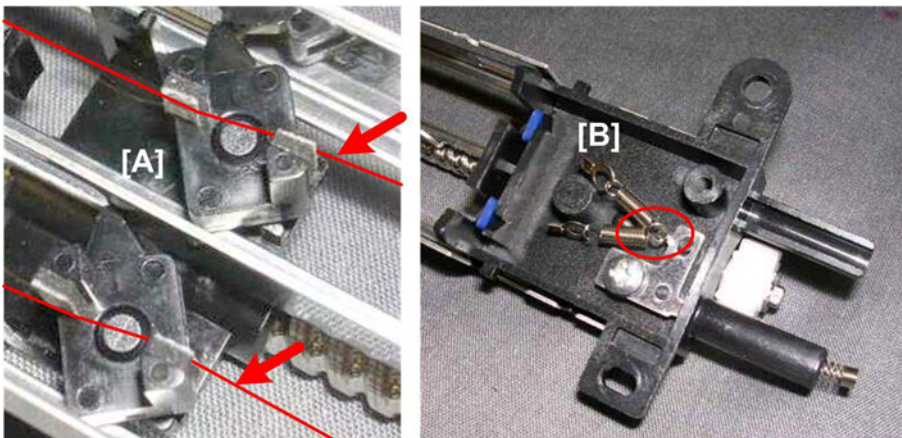

d081i863

12. Double-check both pads [A] and confirm that both wires are arranged correctly as shown above.
13. Make sure both springs [B] are securely attached at the rear.

PCU

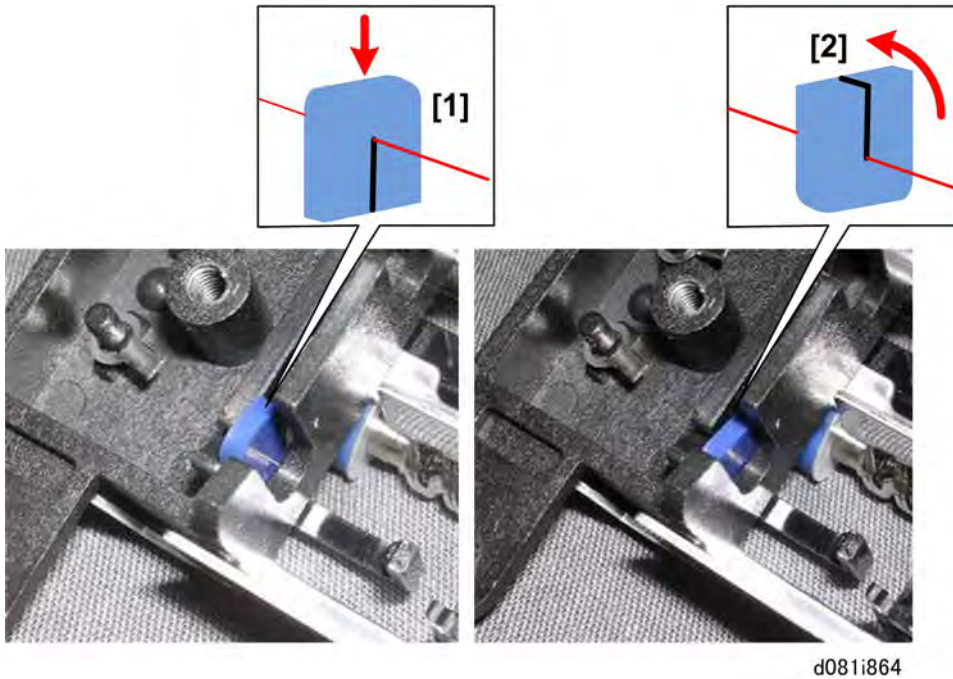

d081i864

14. Attach the four new cushions. To attach a cushion:

- Each cushion has a slit.
- Use the pincettes to set the flat side [1] of a cushion on the taut wire.
- Slowly rotate the cushion [2] until the flat side is up and the rounded side is down.

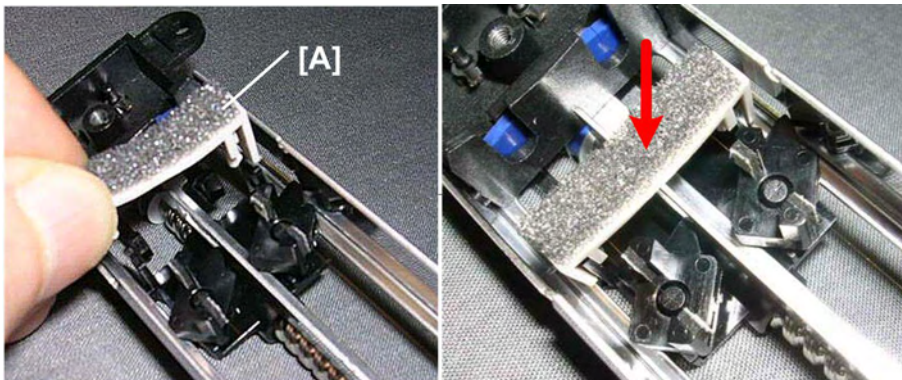

d081i865

15. Re-attach the cleaner assembly.

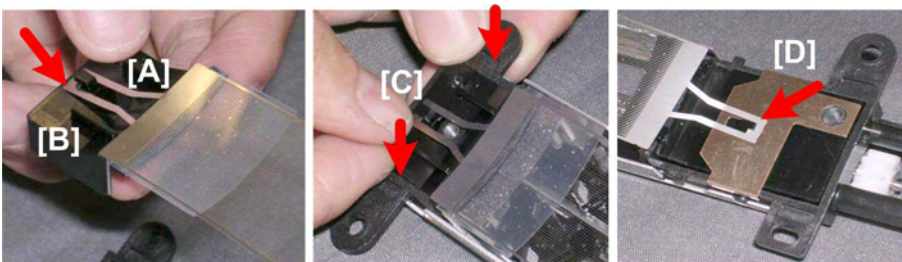

d081r866

16. Attach the new grid.

★ Important

- Never touch any part of the surface of the grid mesh.
- At the rear, set the end of the grid [A] onto the hook of the block holder [B].
- Press down both ends of the holder [C] to lock it in place.
- At the front, hook the other end of the grid [A] onto the peg.

17. Re-assemble the charge corona unit.

18. After re-assembling the machine, go into the SP mode and do SP2111.

⇒ 19. Execute SP2-222-001 (Corona Wire Cleaning) after the new parts have been attached.
This will verify that these parts are working correctly.

PCU

5.5.3 SEPARATING DRUM/CLEANING UNIT, REMOVING THE OPC DRUM

Before doing maintenance on a PCU:

- Separate the development unit and cleaning unit.
- Remove the drum and cover it with a sheet of clean paper to protect it from light.

1. Remove:

- PCU
- Charge roller unit (or charge wire unit for K PCU)

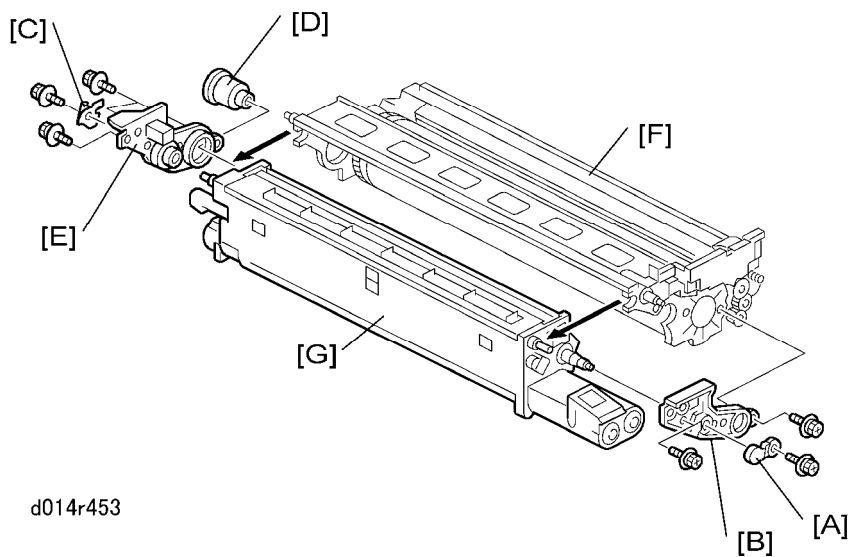

2. At the front, remove:

- [A] Small lock plate (🔩 x1)
- [B] Large lock plate (🔩 x2)

3. At the rear, remove:

- [C] Small lock plate (🔩 x1)
- [D] Brown coupling
- [E] Large lock plate (🔩 x3)

4. Separate the drum unit [F] from the development unit [G].

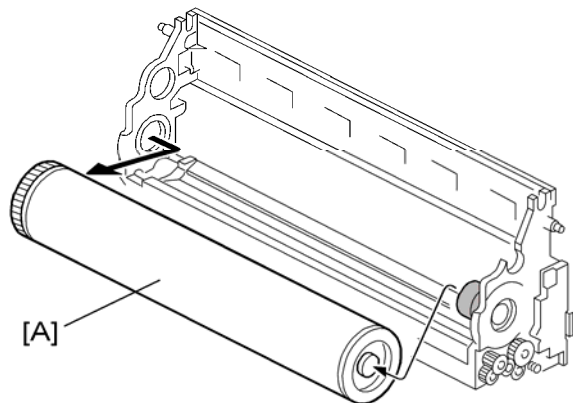

d014r454

5. Remove the drum [A] from the development unit.
6. Wrap the drum in a sheet of clean white paper to protect it from light.

Re-installation of the Drum

This procedure is the same for the YMC PCUs and the K PCU.

- Always dust the surface of a new drum before you install it.
- If you have removed the drum and intend to re-install the same drum, the surface of this drum should be dusted as well.

Before you begin...

- Make sure that you have the correct type of dusting powder for the drum. Use only Lubricant Powder B1329700 (specially designed for this machine).

★ Important

- Never use Setting Powder 54429101 because it could damage the drum and charge roller.
- Never use the yellow toner of the D081/D082 or D014/D015 copiers because it contains developer that could damage the drum and ITB.

To dust the drum:

1. Spread a small amount of lubricant powder on a clean sheet of paper.
2. Dip a clean, dry cloth into the lubricant powder.

PCU

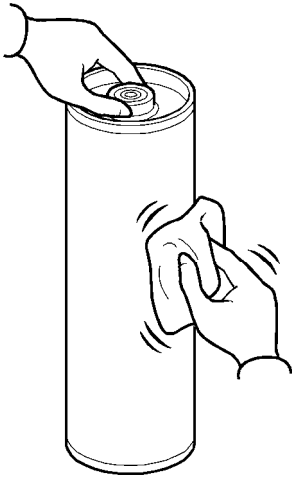

d014r960

3. Dust the surface of the drum with the cloth until the entire surface is covered.
4. When you reinstall the drum:
 - Reinstall the front end of the drum first.
 - Never rotate the drum manually after reinstalling it.

Reinstallation: Drum

1. After re-installation, turn the machine on and do the appropriate SP settings, based on what was replaced.

Items Replaced	Required SPs and What They Do
<ul style="list-style-type: none"> ▪ Drum only 	<p>Do 3820-2 to execute potential control and toner density adjustment.</p> <p>Note: Never initialize the TD sensor with SP3801-1 to 6, or SP3811-1 to 5 after this replacement.</p>
<ul style="list-style-type: none"> ▪ Drum and Developer only 	<p>Do 3801-1 to 6 to execute potential control and toner density adjustment only for the developer(s) that were replaced.</p> <p>Do 3802 to confirm that SP3801 executed successfully.</p>
<ul style="list-style-type: none"> ▪ Drum, Developer, and Drum cleaning blade 	<p>Do 3811-1 to 6 only for the developers that were replaced. This SP sends toner to the PCU and initializes the TD sensor.</p> <p>Do 3812 to confirm that SP3811 executed correctly.</p>
<ul style="list-style-type: none"> ▪ Drum and Drum cleaning blade only 	<p>Do 3820-2 to execute potential control and adjust toner density.</p> <p>Note: Never initialize the TD sensor with SP3801-1 to 6, or SP3811-1 to 5 after this replacement.</p>

2. Do SP2111-1: Force Toner Position Alignment to do the MUSIC adjustment.

PCU

5.5.4 PCU BLADES AND ROLLERS

This section describes how to replace these parts of the drum cleaning unit:

- Drum lubricant bar
- Drum lubricant blade
- Drum lubricant brush roller
- Drum cleaning blade
- Collection coil

The procedures described below apply to both a YMC PCU and K PCU.

- However, the drum lubricant bar unit is not the same for both units. The drum lubricant bar unit is marked "K" for the black PCU.

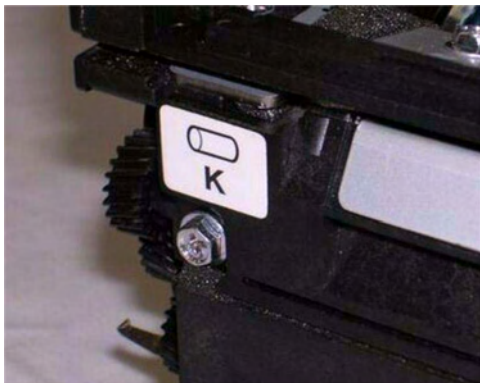

b132r801a

- If you replace a cleaning blade, apply lubricant powder to the cleaning blade and to the drum.

Drum Lubricant Bar and Drum Lubricant Blade

Preparation

- Remove the PCU from the machine.
- Separate the development unit and drum unit.
- Remove the drum, cover it with a piece of clean paper, and set it aside.

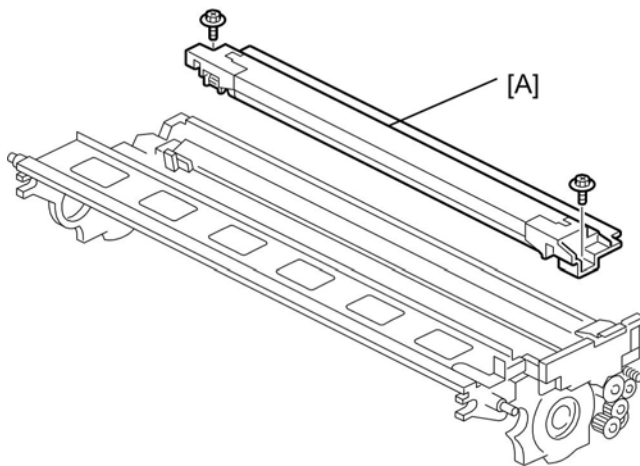

d081r452

1. Remove the charge unit [A] (🔩 x2).

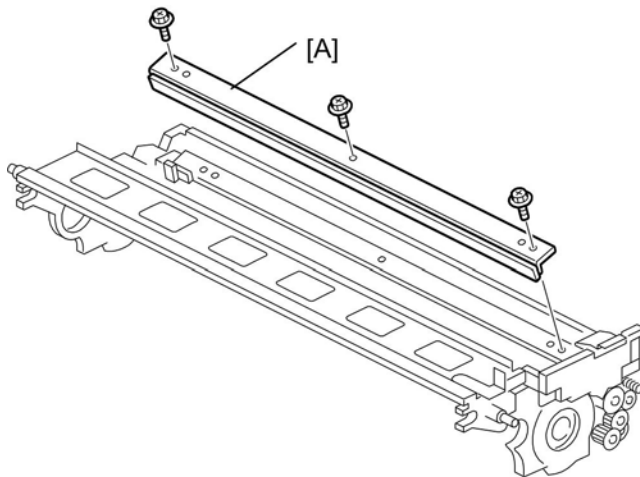

d014r455

2. Remove the drum lubricant blade [A] (🔩 x3).

PCU

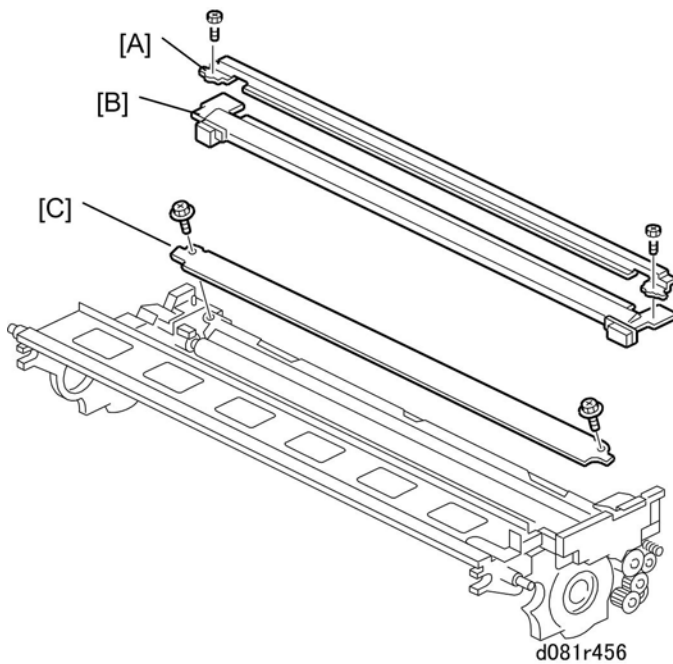

3. Remove plastic cover [A] and metal stay [B] (⚙️ x2).
4. Remove the drum lubricant bar unit cover [C] (⚙️ x2).

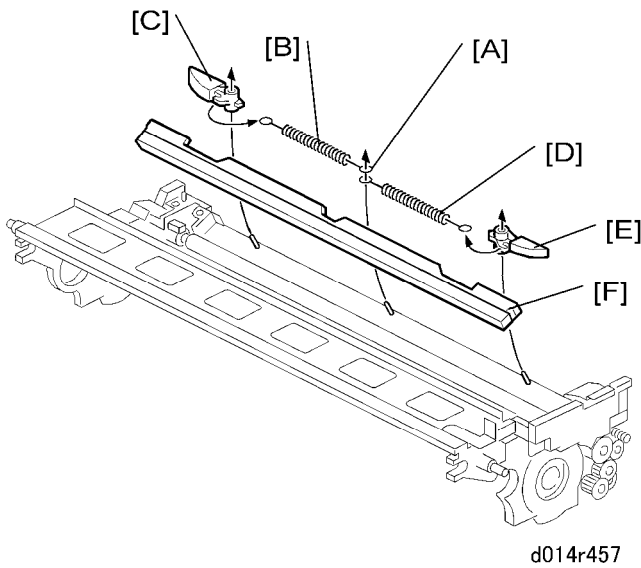

5. At the center [A], disconnect springs from the post.
6. Disconnect the rear spring [B] from the rear bar support, then remove the support [C] from its post.
7. Disconnect the front spring [D] from the front bar supports, then remove the support [E] from its post.
8. Remove the drum lubricant bar [F] and replace it with a new one.

↓ Note

- The drum lubricant bars of the K PCU and YMC PCUs are identical. The same type of drum lubricant bar can be installed in either type of PCU.

★ Important

- The springs of the drum lubricant bar units are not interchangeable. The springs of the CMY drum lubricant bar unit are brown and stronger than the springs of the K drum lubricant bar unit (the K drum lubricant bar springs are black).

Re-installation: Drum Lubricant Bar, Drum Lubricant Blade

1. Enter the SP mode.
2. If you have replaced the drum lubricant bar, drum lubricant blade, or both bar and blade, do SP2111-1 to do the MUSIC adjustment.

Drum Lubricant Brush Roller

1. Remove (see the previous section):
 - Drum charge unit
 - Drum lubricant bar
 - Drum lubricant blade

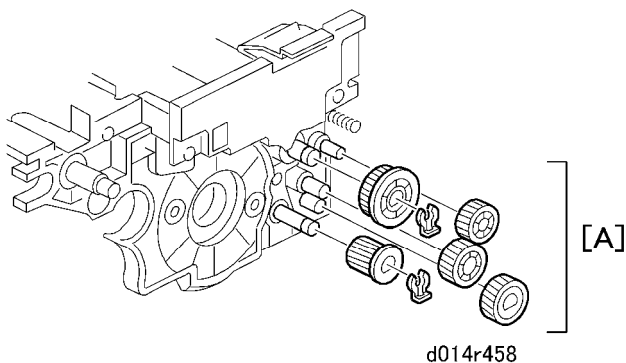

2. Remove:
 - [A] Gears (⊗ x2, Gears x5).

PCU

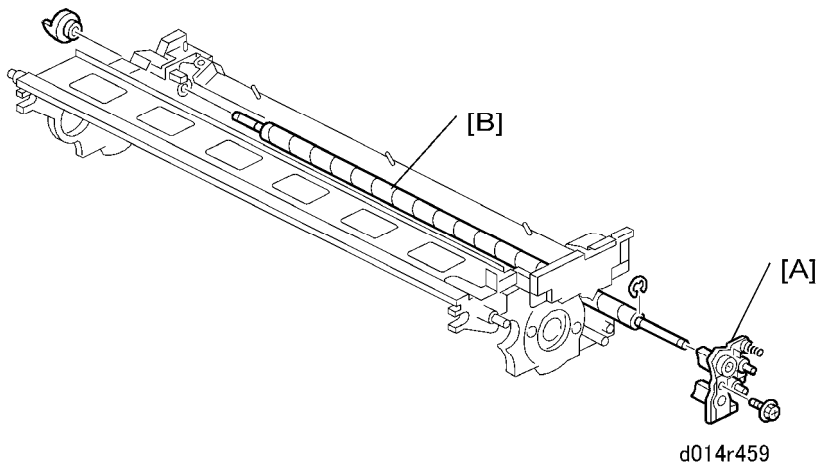

3. Remove:

[A] Shaft lock plate (🔩 x1)

[B] Drum lubricant brush roller (Coupling x1, 🌀 x1)

Re-installation: Drum Lubricant Brush Roller

Do the procedure below after replacing the drum lubricant brush roller.

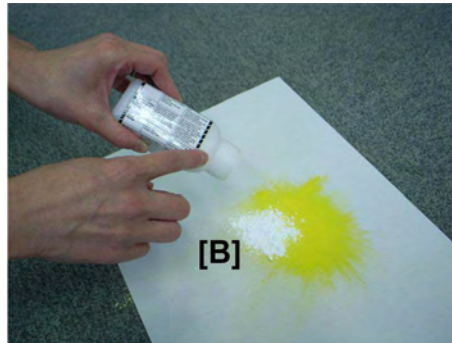
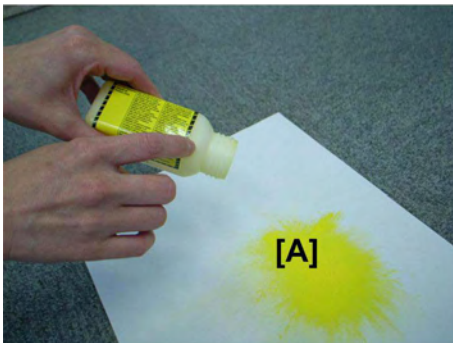

d081r465

1. Place a sheet of clean paper on a flat surface.
2. Pour a small amount of G104 Yellow Toner (D0159500) [A] onto the paper.
3. Pour an equal amount of Zinc Stearate (D0159501) [B] into the yellow toner.
4. Mix the G104 Yellow Toner and Zinc Stearate together with your finger on the paper.

★ Important

- Always use the G014 Yellow Toner, not the yellow toner of the D081/D082 or D014/D015.
- The D081/D082/D014/D015 yellow toner contains developer that could damage the surface of the drum and ITB.

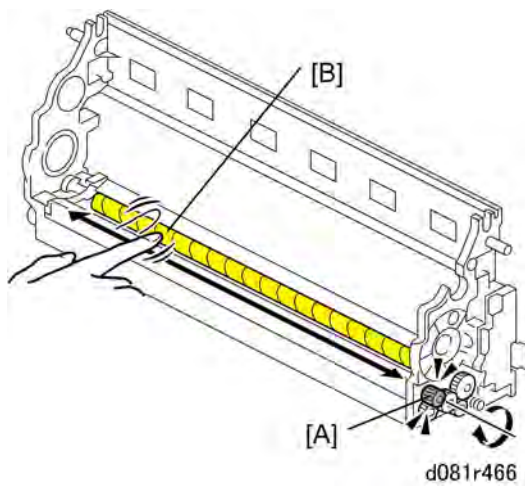

5. While rotating gear [A] in the direction of the arrow, use your finger to apply the mixture of yellow toner and zinc stearate from the paper across the surface of the PCU drum lubricant brush roller [B].

PCU

★ Important

- You must rotate gear [A] in the direction shown above.
 - Use a brush to apply the mixture if one is available.
 - Use this mixture only for the PCU drum lubricant brush roller of this machine.
Never apply this mixture to any other part of this machine, or any part of another machine.
6. Reassemble and turn the machine on.
 7. Enter the SP mode.
 8. Do SP2111-1: Force Toner Position Alignment to do the MUSIC adjustment.

Drum Cleaning Blade

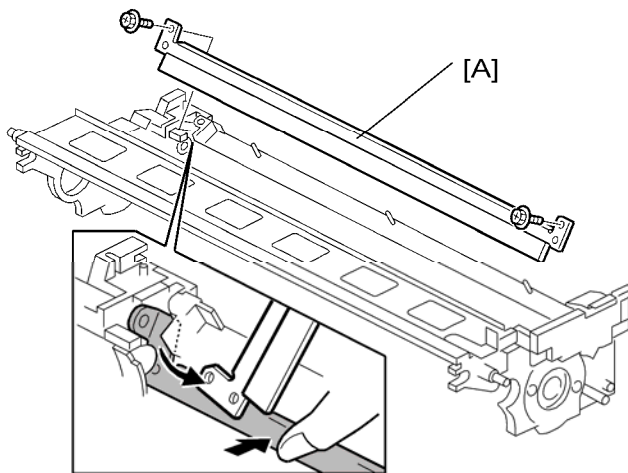

d014r460

1. Remove:
[A] Drum cleaning blade (🔩 x2).

Re-installation: Drum Cleaning Blade

1. Re-assemble the machine and turn the machine on.
2. Do the appropriate SP settings, based on what was replaced.

Items Replaced	Required SP Codes What They Do
<ul style="list-style-type: none"> ▪ Drum cleaning blade, Drum, and Developer 	<p>Do 3811-1 to 6 to initialize the TD sensor and send developer to the PCUs.</p> <p>Do 3812 to confirm that SP3811 executed successfully.</p> <p>Note: SP3811 is required only after the developer and drum cleaning blade have both been replaced.</p>
<ul style="list-style-type: none"> ▪ Drum cleaning blade and Drum only 	<p>Do 3820-2 to execute potential control and toner density adjustment.</p> <p>Note: Never initialize the TD sensor with SP3801-1 to 6, or SP3811-1 to 5 after this replacement.</p>
<ul style="list-style-type: none"> ▪ Drum cleaning blade and/or drum cleaning roller (without changing the drum or developer) 	<p>Do SP 3810.</p>

3. Do SP2111-1: Force Toner Position Alignment to do the MUSIC adjustment.

5.5.5 DEVELOPER REPLACEMENT

The developer replacement procedure is the same for the YMC PCUs and the K PCU.

★ Important

- Developer must be replaced for each PCU every 450K.
- However, developer can be replaced for only one PCU if a problem occurs. For example, the C_PCU can be replaced if Cyan is too light.

Preparation

1. Spread some paper on a flat surface to hold developer that will be dumped from the development unit.

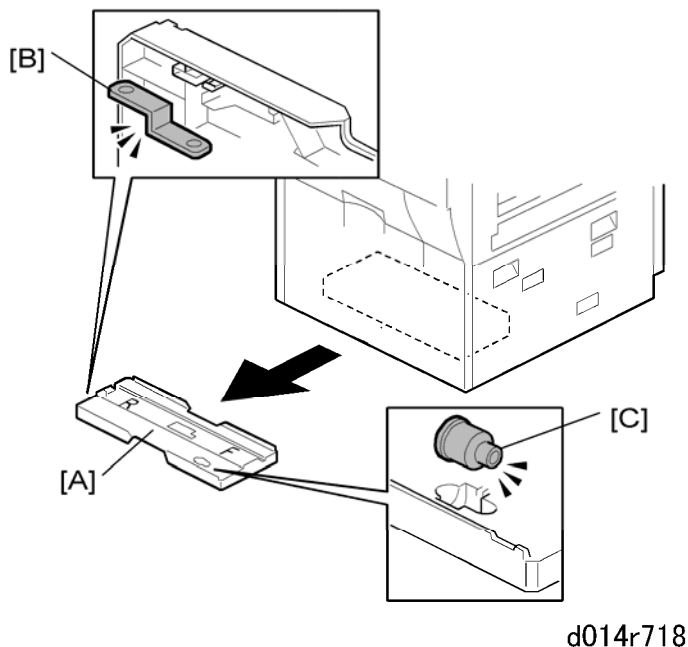

2. Remove:
 - [A] PCU stand from bottom of the machine
 - [B] Jig
 - [C] Brown coupling

★ Important

- Use the PCU stand provided with the machine.
 - Never use a PCU stand for a B132/B181/B200 because this can damage the exposed drum on the bottom of the PCU.
 - If the D081/D082 PCU stand is not available, you can use a D014/D015 PCU stand (these stands are identical.)
3. Remove the metal jig [B] and brown coupling [C] from the bottom of the PCU stand.

4. Set the PCU stand on a flat surface.
5. Remove:
 - Toner hopper
 - Faceplate
 - PCU

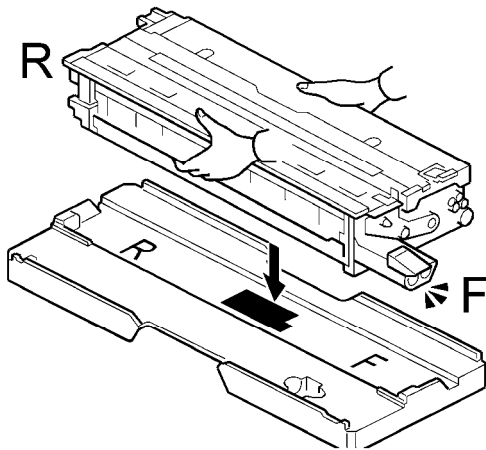

d014r214

6. Position the front and rear of the PCU so that it matches the F (front) and R (rear) markings on the PCU stand.
7. Set the PCU on the stand.
 - The front-rear alignment aligns the shape of the stand with the contours of the PCU bottom.
 - This also protects the exposed drum on the bottom of the PCU during servicing.

PCU

Removing Old Developer

Preparation

- Separate the drum unit and development unit.
- Cover the drum with a sheet of clean paper and set it aside.

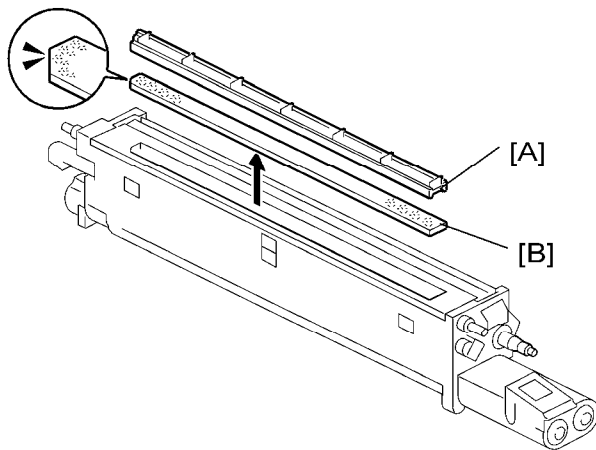

d014r461

1. Remove:
[A] Filter frame
[B] Filter

★ Important

- This filter must be replaced every time the developer is replaced.

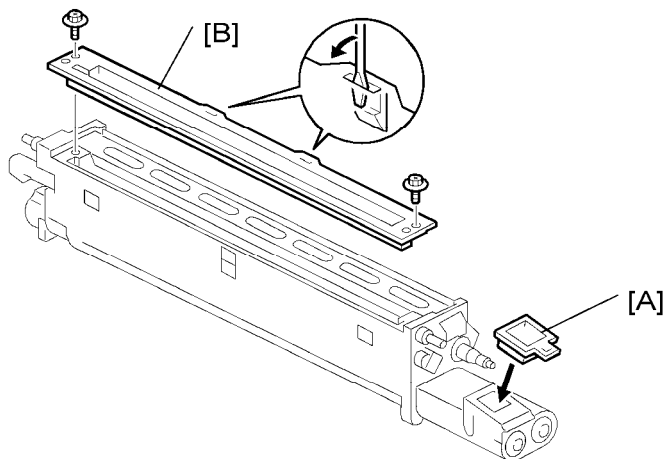

d014r462

2. Insert the plug [A] into the toner port.
3. Remove the plastic cover [B] (⚙️ x2). Use the tip of a small screwdriver to dislodge the cover.

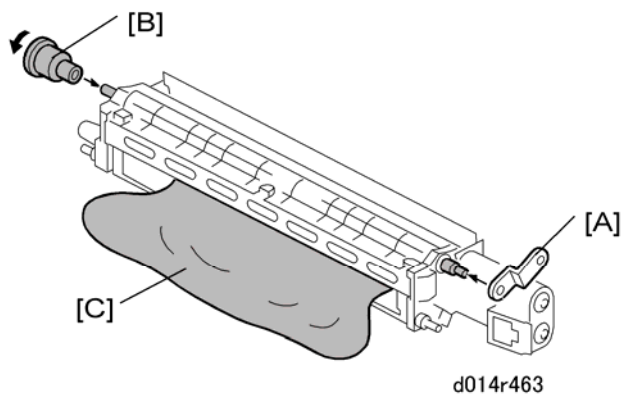

4. Attach the metal jig [A] to the end of the development roller. The jig must be set as shown.

↓ Note

- The D-shaped hole of the metal jig must fit over the D-shaped shaft tip. If the hole of the metal jig is not aligned with the shaft, rotate the D-shaped shaft tip to position the shaft so the metal jig can be attached.

5. Attach the brown coupling [B] (removed from the PCU stand) to the other end of the development roller.

★ Important

- Use the brown coupling provided with the PCU stand. Using the coupling of the PCU could break it or wear it out.

6. Rotate the brown coupling in the direction shown above so the developer [C] starts to come out of the development unit.

↓ Note

- Turning the brown coupling in the opposite direction will not damage anything but developer will fail to come out of the development unit.

PCU



b132r802a

7. Tip the development unit on its end to dump any remaining developer.



b132r803a

8. Rotate the brown coupling again to push out more developer.



b132r804

9. After the filter unit has been removed, dump the last bit of developer.

★ Important

- Never touch or attempt to remove the doctor blade. The doctor blade is set at the factory and requires no cleaning or adjustment.



b132r805

10. Vacuum clean the unit, and then clean it with a dry cloth.

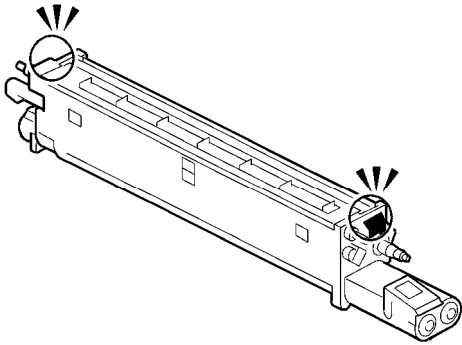

d014r464

11. Clean both ends of the unit. The ends must be clean and completely free of old developer.

PCU

Reinstallation: Re-assembly

- Always replace the filter before reinstalling the cleaned PCU. The filter must be replaced every time the developer is replaced.)

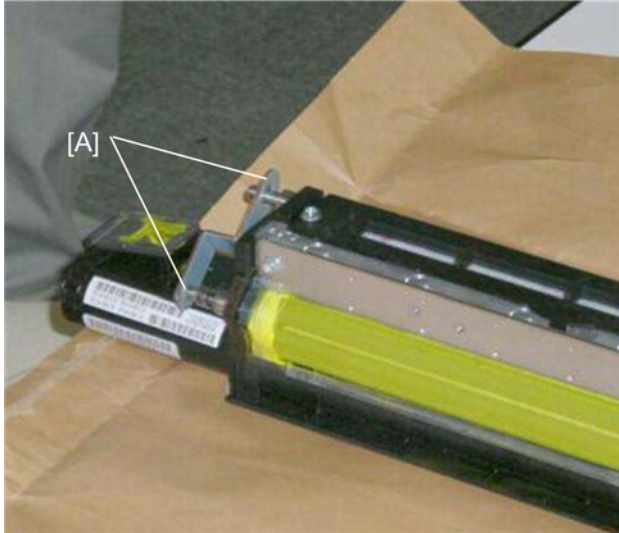

b132r806

- Attach the metal jig [A] (provided with the PCU stand) to the ends of the shafts shown above. This aligns the shafts correctly for reinstallation of the PCU.
- Reinstall the PCU and faceplate.
- Do not reinstall the toner hopper yet.

Adding New Developer

Before You Begin...

- Follow this procedure in the order described below.
- Do not turn on the machine or open the front door until you are instructed to do so.

PCU Filling Procedure

1. If you have not already done so, remove the toner hopper unit (described above).

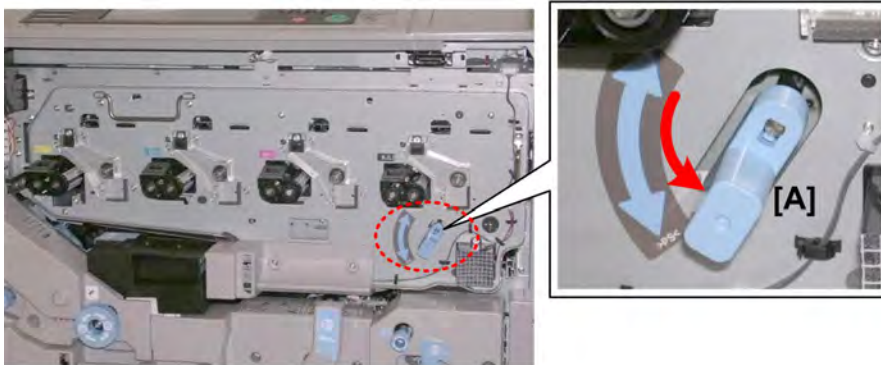

d081i814

1. Attach the transfer belt release lever [A].
2. Make sure the lever is down.

★ Important

- The lever must be down to keep the transfer belt separated from the surfaces of the PCU drums.



d081i815

3. Pick up the developer bottle.
4. Make sure that the bottle is clearly marked "D081" for this machine.

PCU



d081i830

5. Before a bottle, loosen the developer to ensure that it will drain completely. Vigorously shake the bottle up and down 10 to 15 times.

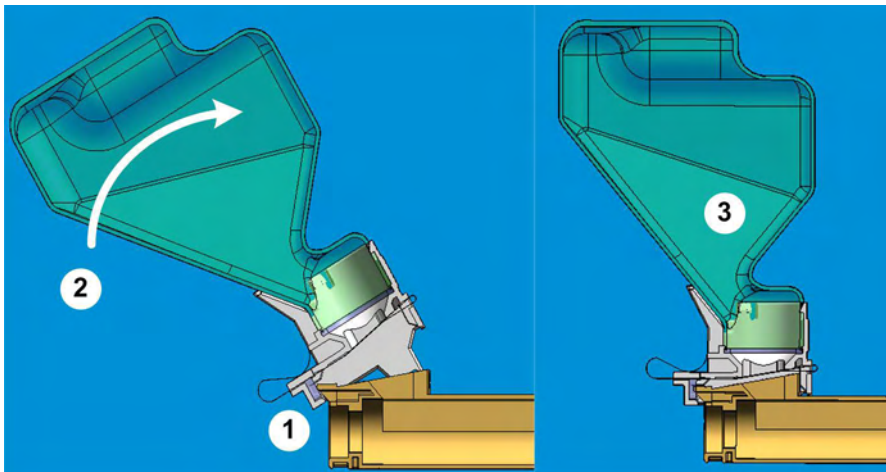

b132r801

6. Rest the neck [1] of the developer bottle on the edge of the PCU.
7. While keeping contact and pressure on the neck and PCU at [1], rotate the bottle [2] up until it locks in place at [3].

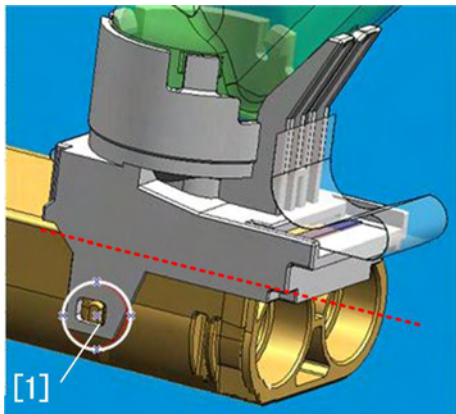

b132r802

8. Check the tab on the side of the neck [1] to make sure that the bottle is locked. The neck of the bottle should be perfectly flat on top of the PCU.

★ **Important**

- There should be no gap between the developer bottle and the PCU.
- If the bottle is not locked in place, developer will spill from the bottle

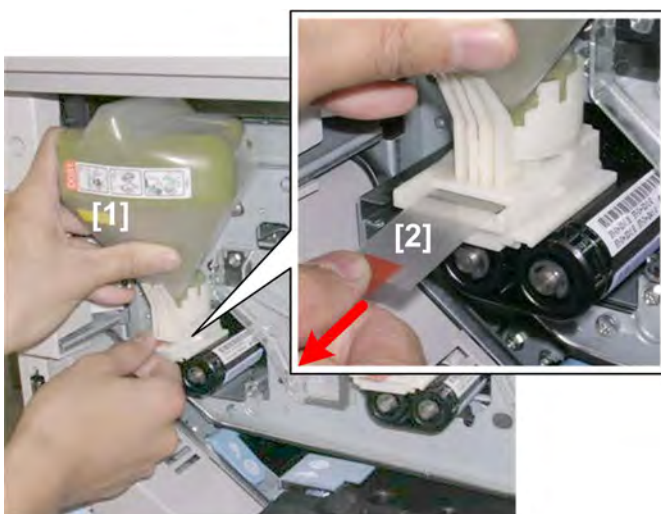

d081i816

9. Remove the heat seal from each bottle.
 - Hold the bottle [1] with one hand, slowly pull the heat seal [2] out of the developer bottle and remove it.
 - Do this for each bottle.
 - Make sure that you have removed all the seal strips (you should have four strips, one for each bottle).
10. Gently tap the sides of each bottle with a finger to make sure that the developer flows freely.
11. Close the front door.

PCU

★ Important

- The door must be closed before you switch the machine on.
12. Turn the machine on.
 13. Enter the SP mode and do the appropriate SP codes:

SP	Function
3814-1	All (KMCY)
3814-2	MCY Only
3814-3 to 6	K, M, C, Y separately as required.
3815	Confirms that SP3814 executed correctly by displaying "1111" (KMCY). A "9" indicates an error

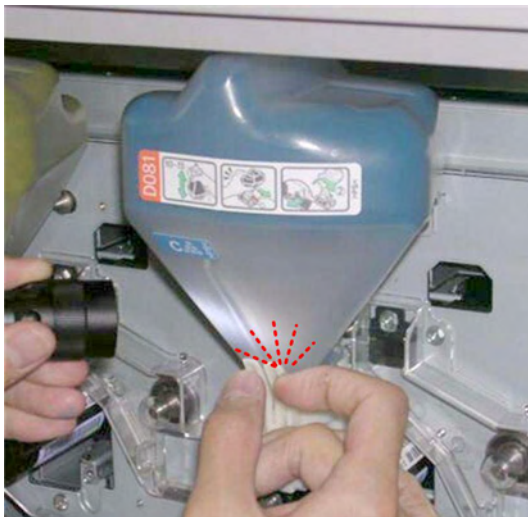

d081i817

14. Shine a flashlight on the side of the bottle and confirm that it is empty.

↓ Note

- If you see any remaining toner, gently tap the neck of the bottle to loosen the toner then execute SP3814 again to drain all the developer.
15. After all the developer has drained from the bottle, switch the machine off.

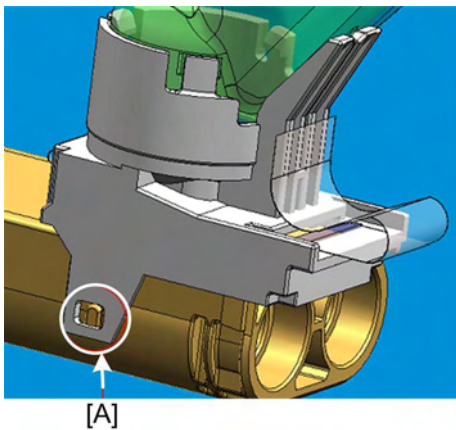

b132r803

16. Use the tip of a small screwdriver to release each locked bottle latch at [A], and remove the bottle.
17. Discard the four empty bottles.

★ Important

- Obey local laws and regulations concerning the disposal of items such as the empty bottles.

18. Rotate the transfer belt release lever back up (rotated down at Step 3).
19. Reattach the toner hopper.

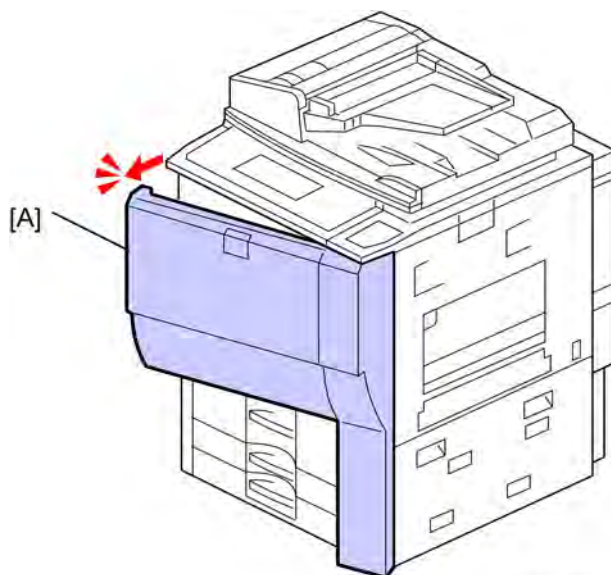

d081i721

20. Open the front door [A].

PCU

★ Important

- You must open the front door.
- Turning on the machine with the front door open prevents the machine from performing the initial process control self-check.
- If the front door is closed, the drums will start rotating with no toner in the PCUs.
- If the drums rotate with no toner in the PCUs, this can cause the cleaning blades to catch on a dry drum and damage the drum surface.

21. With the front door open, turn on the main power switch.

22. Close the front door after "Open Cover" appears on the display.

Re-installation

1. Re-assemble the machine.
2. Do the appropriate SP settings, based on what was replaced.

Items Replaced	Required SP Codes and What They Do
<ul style="list-style-type: none"> ▪ Developer 	<p>Do 3801-1 to 6 to initialize the TD sensor for the developer(s) that were replaced.</p> <p>Do 3802 to confirm that SP3801 executed successfully.</p>
<ul style="list-style-type: none"> ▪ Developer and Drum cleaning blade -or- ▪ Developer, Drum, and Drum cleaning blade 	<p>Do 3811-1 to 6 to initialize the TD sensor and send developer to the PCUs.</p> <p>Do 3812 to confirm that SP3811 executed successfully.</p> <p>Note: SP3811 is required only after the developer and drum cleaning blade have both been replaced.</p>
<ul style="list-style-type: none"> ▪ Developer and Drum 	<p>Do 3801-1 to 6 to execute potential control and toner density adjustment for the developer(s) that were replaced.</p> <p>Do 3802 to confirm that SP3801 executed successfully.</p>

3. Do SP2111-1: Force Toner Position Alignment to do the MUSIC adjustment.

Handling Problems with Developer Filling

★ Important

- If image density is too light, or if the machine fails to release the "Toner End" alert, please refer to "Special Procedures" in the Troubleshooting section.

Procedure 1

Do this procedure first. The most common cause of an SP3815 error is failure to remove the tape from one of the bottles. If you see any number other than "1" after doing SP3815:

1. Note the position of the digit where the number is displayed. For example, If the displays reads "1191" the problem occurred at the C PCU.
2. Check the attachment of the bottle at the affected PCU and make sure that the tape was removed.
3. If the tape has been removed, do Procedure 2

Procedure 2

Do this procedure only after you have done Procedure 1 immediately above.

If all tapes have been removed but developer remains in one or more bottles, do the procedure below.

1. Do SP3814-1 to 6 for the color of whichever PCU is to be filled with developer..
2. Hold the bottle to prevent it from coming off, then tap the bottle gently a few times.
3. Open the front door then switch on the main power switch.

★ Important

- The door must be open.
4. When you see the door open message on the screen, close the door.
 5. Wait about 40. sec. until the SC code appears on the screen, then turn off the power switch.
 6. Repeat this procedure until the bottle becomes empty.
 7. After 10 attempts if the bottle is still not empty, do procedure 3 below.

PCU

Procedure 3

The developer has probably clogged inside the bottle, so you must remove the developer bottle and the PCU. Do this procedure only after you have done Procedures 1 and 2 immediately above.

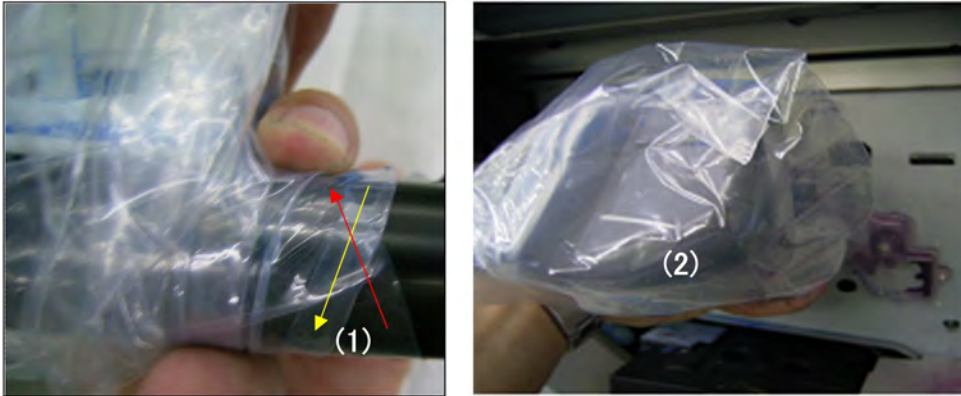

b132r810

↓ Note

- The initial process control self-check (process control after the prescribed idle time and MUSIC) is disabled after SP3814 (Developer Fill) is executed and will remain disabled until after SP3801 (TD Sensor Initialization) or SP3811 (Developer Setup) are executed.

1. Cover the toner bottle with a plastic bag, and seal the mouth of the bag (1) with your hand.
2. Remove the bottle (2).
3. Remove the faceplate (🔧 x5).
4. Remove the PCU from the machine.
5. Open the top of the development unit (🔧 x2).
6. Pour remaining developer from the bottle into the development unit.

5.5.6 NEW PCU

There are two types of PCU. Before replacing a PCU, make sure that you have the correct type:

- The K PCU contains a charge wire unit, used only for black.
- The YMC PCUs use a charge roller. This PCU type can be used to replace Y, M, or C PCU.

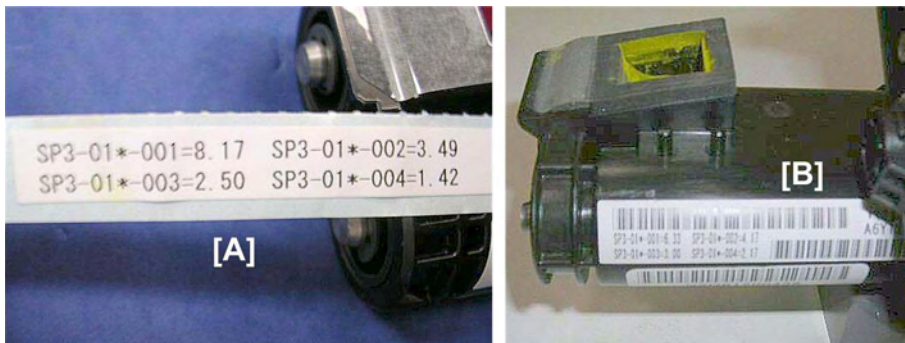

b132r811

1. Remove the seal [A] loosely attached to the end of the PCU unit.



- The SP values written on the seal are also on the sticker attached to the PCU unit [B].

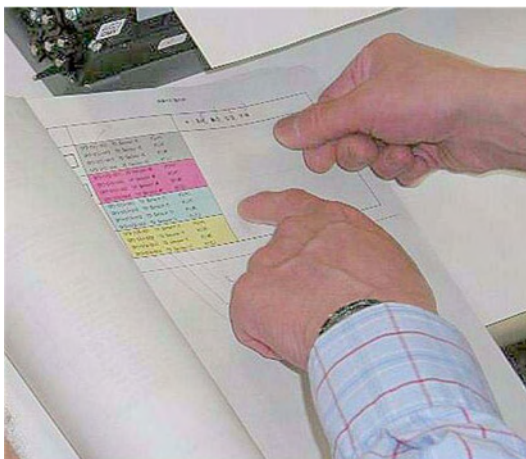

b132r812

2. Attach the seal to the guide sheet provided. This reminds you which SP codes must be set for the PCU later.

PCU

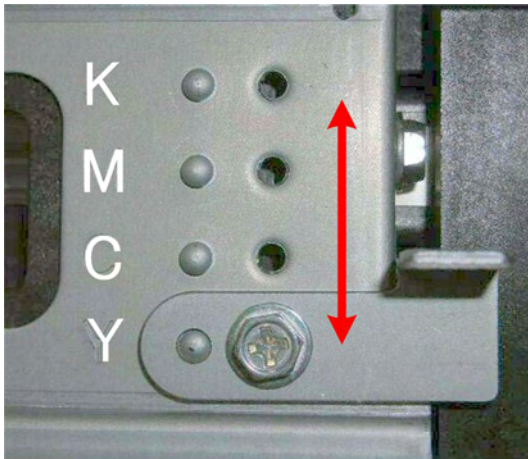

b132r813

3. Remove the screw and attach the plate to the correct position for the PCU to be replaced. This adjustment prevents the PCU from being installed in the wrong position.
4. Install the new PCU in the machine.
5. Execute the SP codes listed on the guide sheet.

★ Important

- Enter the values for the SP codes before you add developer.
6. Enter the values written on the seal for each SP code

		* : K=0, M=1, C=2, Y=3
□	SP3010-001 TD Sensor:K Vtcnt SP3010-002 TD Sensor:K Vt(H) SP3010-003 TD Sensor:K Vt(M) SP3010-004 TD Sensor:K Vt(L)	<div style="border: 1px solid black; padding: 5px; width: fit-content; margin: auto;"> <small>SP3-01*001=8.17 SP3-01*002=3.49 SP3-01*003=2.50 SP3-01*004=1.42 C7312853</small> </div>
□	SP3011-001 TD Sensor:M Vtcnt SP3011-002 TD Sensor:M Vt(H) SP3011-003 TD Sensor:M Vt(M) SP3011-004 TD Sensor:M Vt(L)	<div style="border: 1px solid black; padding: 5px; width: fit-content; margin: auto;"> <small>SP3-01*001=8.17 SP3-01*002=3.49 SP3-01*003=2.50 SP3-01*004=1.42 C7312853</small> </div>
□	SP3012-001 TD Sensor:C Vtcnt SP3012-002 TD Sensor:C Vt(H) SP3012-003 TD Sensor:C Vt(M) SP3012-004 TD Sensor:C Vt(L)	<div style="border: 1px solid black; padding: 5px; width: fit-content; margin: auto;"> <small>SP3-01*001=8.17 SP3-01*002=3.49 SP3-01*003=2.50 SP3-01*004=1.42 C7312853</small> </div>
□	SP3013-001 TD Sensor:Y Vtcnt SP3013-002 TD Sensor:Y Vt(H) SP3013-003 TD Sensor:Y Vt(M) SP3013-004 TD Sensor:Y Vt(L)	<div style="border: 1px solid black; padding: 5px; width: fit-content; margin: auto;"> <small>SP3-01*001=8.17 SP3-01*002=3.49 SP3-01*003=2.50 SP3-01*004=1.42 C7312853</small> </div>

d014s901

- The four settings on each sticker must be entered for each new PCU.
 - Execute only the SP codes on the sticker removed from the PCU and attached to the guide sheet. (The sheet above shows four stickers attached, one for each PCU.)
 - Do the SP codes only for the PCUs being replaced.
 - If you replace only the development unit, you must also do these SP modes.
7. Follow the procedure in the main machine installation procedure to fill the PCU with developer and initialize the developer. (➡ "Filling the PCU Units with Developer" in the "Main Machine D081/D082" under the "Installation" chapter)

5.6 TONER SUPPLY

5.6.1 STC PORT CLEANING

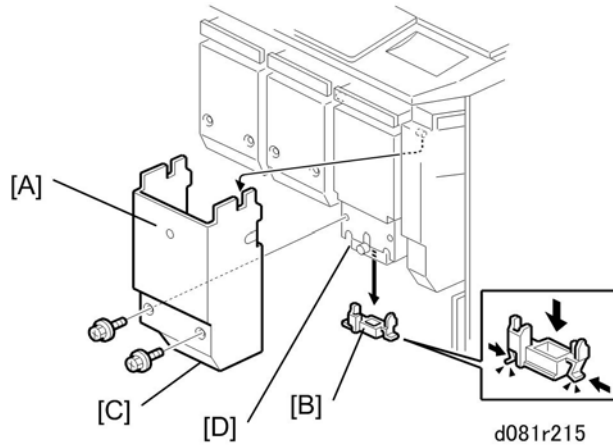

1. Open the front door.
2. Remove the STC holder front cover [A] (⚙️ x2)
3. Remove the STC bottom cover [B] (Pawls x2)
4. Wrap a clean cloth around the tip of a small screwdriver then scrape away any toner that has collected inside the bottom cover.
5. Use a clean cloth to clean the bottom of the holder cover [C] and the bottom of the holder [D].

5.6.2 CONNECTOR BOARD (CNB)

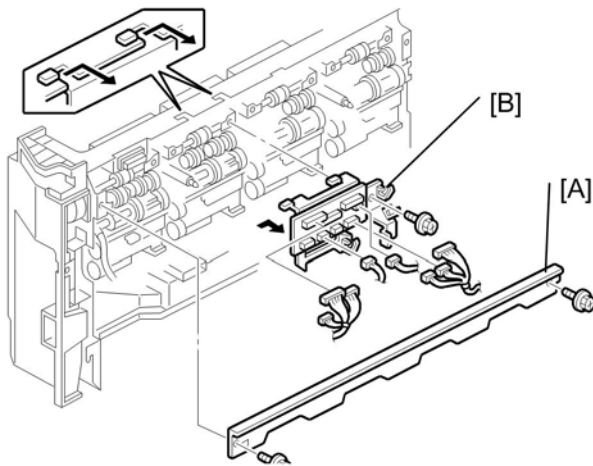

d081r216

1. Open the front door.
2. Remove the toner hopper (p.5-12).
3. Remove:
 - [A] Support bracket (x2)
 - [B] CNB (x9, x1). Slide the PCB assembly to the right and remove it.

5.6.3 TONER PUMP

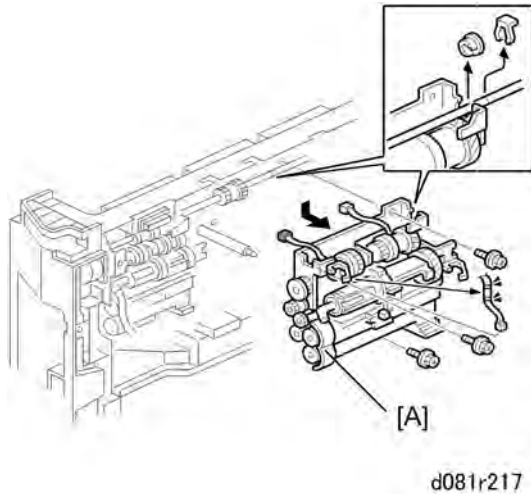

1. Open the front door.
2. Remove:
 - Toner hopper (🔧 p.5-12)
 - Support bracket (🔧 p.5-91 "Connector Board (CNB)")
 - Connector Board (🔧 p.5-91 "Connector Board (CNB)")
3. Remove toner pump assembly [A] (🔧 x3, 🛠️ x3, Bushing x1, 🛠️ x1).
4. Pull the assembly straight down and remove it.

5.6.4 TONER END SENSOR

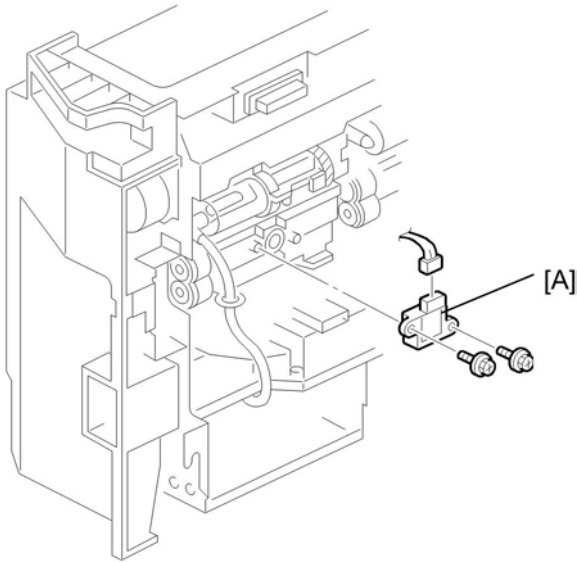

d081r213

1. Open the front door.
2. Remove:
 - Toner hopper (🔧 p.5-12)
 - [A] Toner end sensor (🔧 x1, 🛠️ x2)

5.6.5 TONER SUPPLY MOTOR

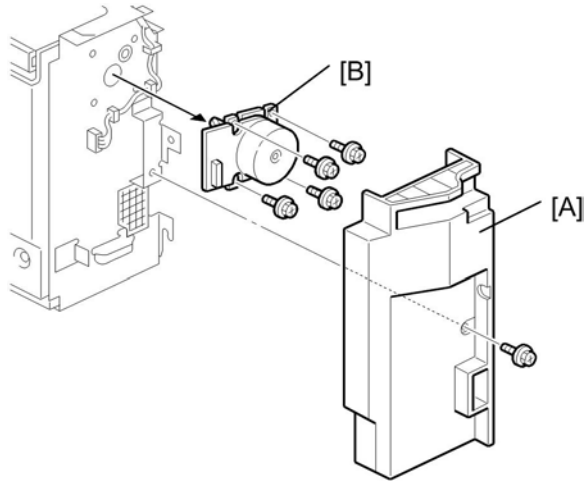

d081r211

1. Remove:
 - Toner hopper (🔧 p.5-12)
2. Remove:
 - [A] Motor cover (🔧 x1)
 - [B] Toner supply motor (🔧 x4, 🌀 x1)

5.7 PTR UNIT

5.7.1 RELAY SENSOR

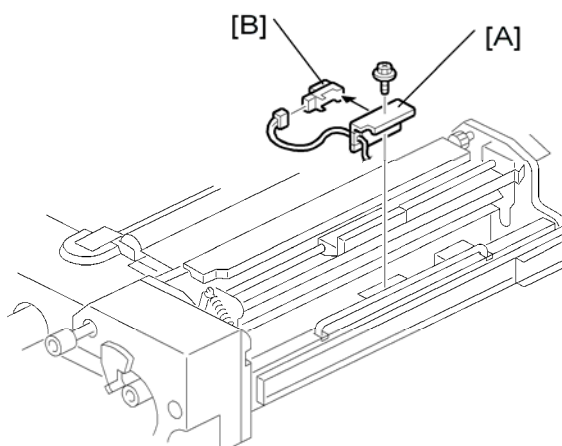

d014r615

1. Pull out the drawer unit.
2. Remove:
 - [A] Sensor bracket (🔩 x1)
 - [B] Relay sensor (🔌 x1)

Reinstallation

- Do the forced MUSIC adjustment with SP 2111 001.

5.7.2 DOUBLE-FEED DETECTION PHOTO-SENSOR, REGISTRATION SENSOR

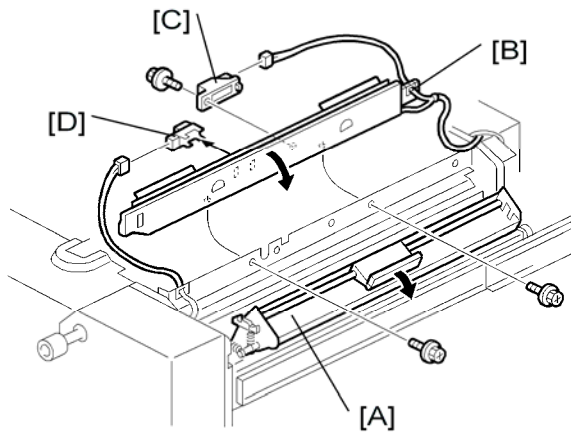

d014r616

1. Pull out the drawer unit.
2. Open the guide plate [A].
3. Remove:
 - [B] Sensor support plate (🔩 x2)
 - [C] Double-feed detection photosensor (🔩 x1, 📷 x1)
 - [D] Registration sensor (📷 x1)

Reinstallation

- Do the forced MUSIC adjustment with SP 2111 001

5.7.3 PTR UNIT

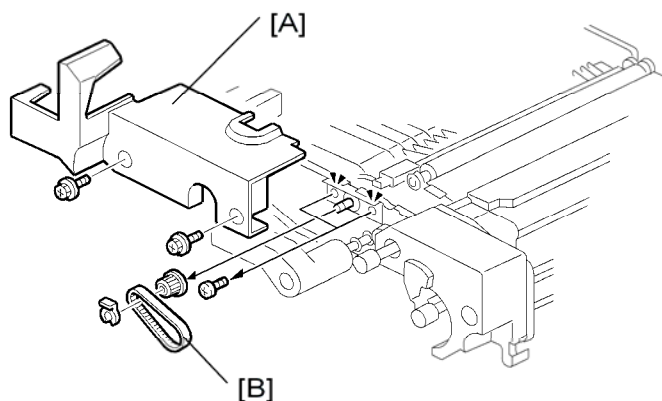

d014r302

1. Pull out the drawer unit.
2. Remove:
 - [A] Paper transport unit cover (🔩 x2)
 - [B] Timing belt, gear (🔩 x1)
 - Do not loosen or remove the paint-locked screws.

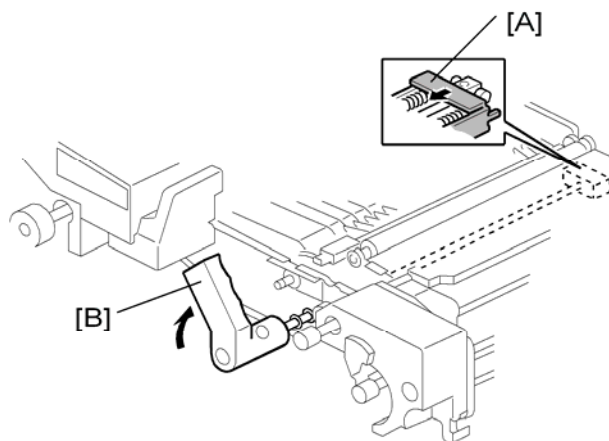

d014r302a

3. Remove:
 - [A] Press the release forward
 - [B] Raise the handle to the vertical position.

PTR Unit

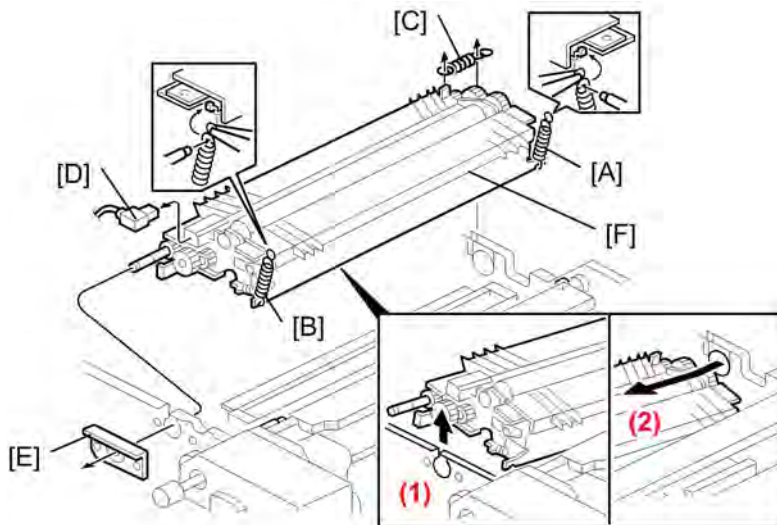

d081r303

4. Change the position of:
 - [A] Spring
 - [B] Spring
5. Remove:
 - [C] Spring
 - [D] Connector (🔌 x1) (use a pair of small pliers to remove the connector)
 - [E] Bracket (🔧 x2)
 - [F] PTR Unit
 - The handle should be up.
 - Raise the front (1).
 - Pull the rear (2).

Reinstallation

- Be sure to set springs [A], [B], and [C] in their original positions before you re-install the PTR Unit.
- Do the forced MUSIC adjustment with SP 2111 001.

5.7.4 PAPER TRANSFER ROLLER, DISCHARGE PLATE

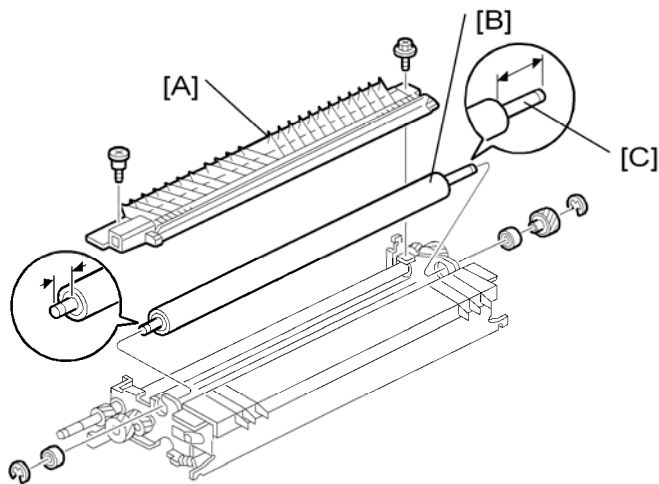

d014r304

1. Remove:

- PTR Unit

[A] Paper transfer discharge plate (🔩 x2)

[B] Paper transfer roller (Ⓒ x2, Gear x1, Shaft bearings x2)

Reinstallation

- When you install the roller, the long end [C] is at the rear.
- Do the forced MUSIC adjustment with SP 2111 001.

PTR Unit

5.7.5 LUBRICANT BAR, BRUSH ROLLER

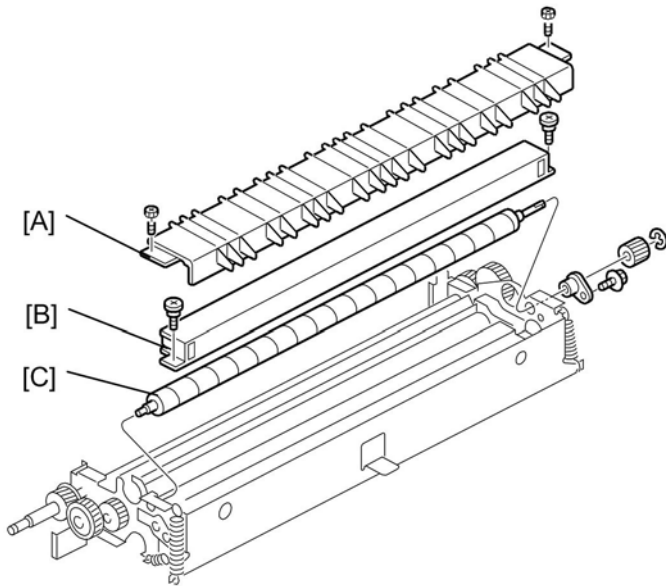

d081r305

★ Important

- Work carefully to avoid scratching the paper transfer roller.

1. Remove PTR Unit (☛ p.5-97)
 - [A] Entrance guide plate (☛ x2)
 - [B] Lubricant bar (☛ x2)
 - [C] Brush roller

Reinstallation

- Do the forced MUSIC adjustment with SP 2111 001

5.7.6 CLEANING BLADE

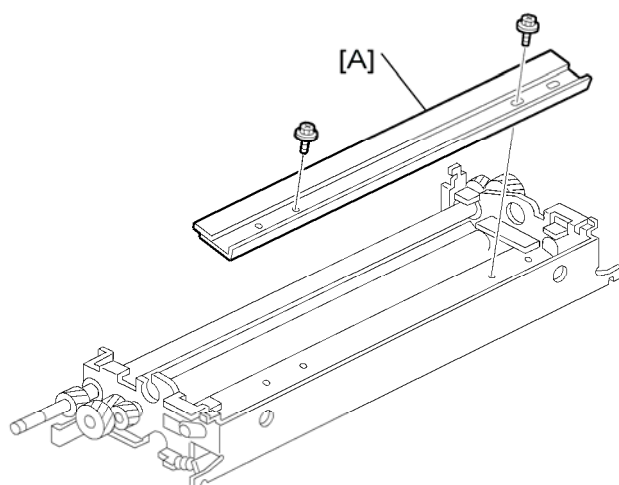

d014r306

1. Remove:

- PTR Unit
- Lubrication bar
- [A] Cleaning blade (🔩 x2)

Reinstallation

- Do the forced MUSIC adjustment with SP 2111 001.

PTR Unit

5.7.7 CLEANING BRUSH ROLLER

Replacement

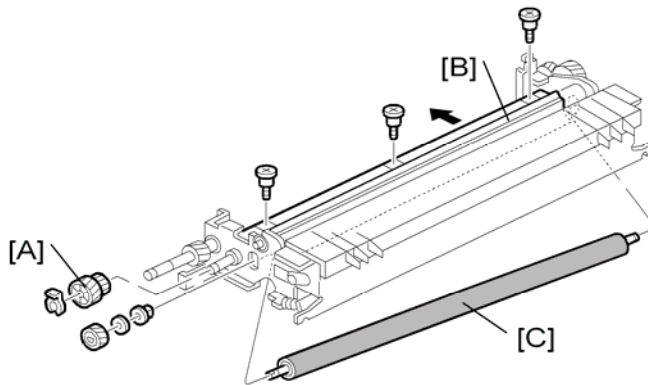

d014r307

1. Remove:

- PTR Unit
- Transfer exit guide, paper transfer roller

[A] Gear (⚙️ x1, Gear x1)

[B] Brush roller cover (🔩 x3)

[C] Cleaning brush roller (Gear x1, Washer x1, Shaft bearing x1)

5.7.8 PAPER TRANSPORT BELT, PAPER SEPARATION POWER PACK

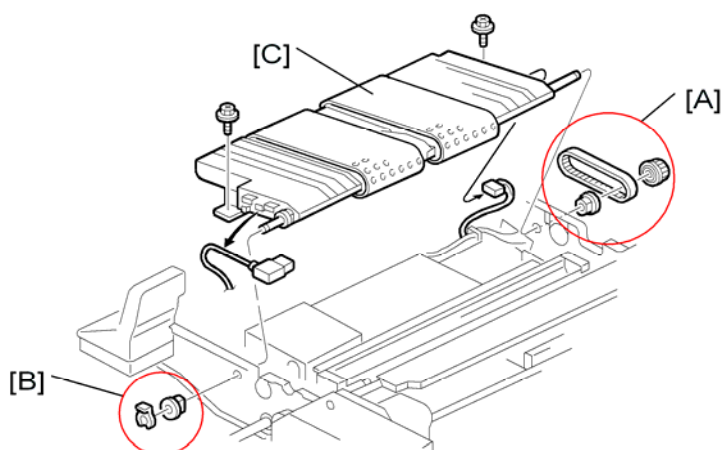

d014r308

1. Pull out the drawer unit

2. Remove:

- Paper transport unit lever and cover
 - Fusing unit
- [A] Timing belt x1, Gear x1, Shaft bearing x1
 [B] Snap ring x1, Shaft bearing
 [C] Paper transport belt (🔧 x2, 📏 x2)

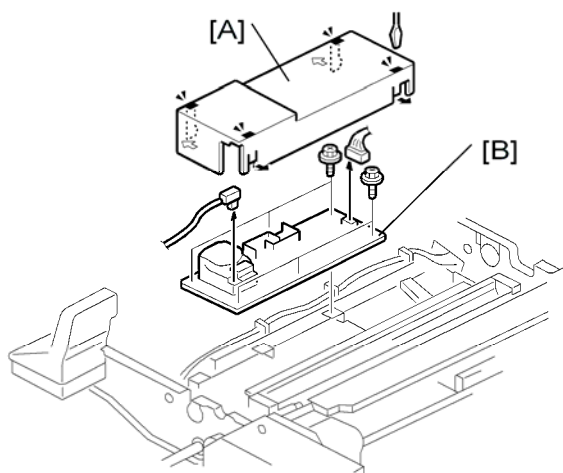

d014r308a

3. Remove:

- [A] Cover
- [B] Separation power pack (🔧 x6, 📏 x2)

Reinstallation

- Do the forced MUSIC adjustment with SP 2111 001.

5.7.9 REGISTRATION MOTOR

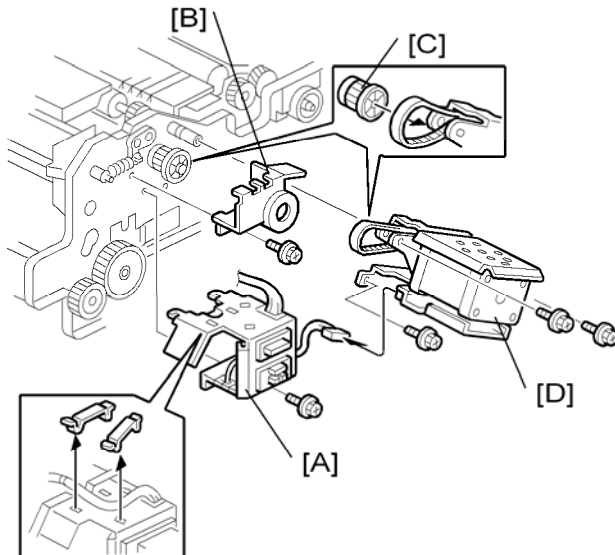

d014r618

1. Remove:

- Drawer unit

[A] Drawer unit connector bracket (🔩 x1, 📏 x3, 📏 x2)

[B] Gear cover (🔩 x1)

[C] Registration gear (⚙️ x1, Spring pin x1)

[D] Registration motor assembly (🔩 x3, 📏 x1)

Reinstallation

- Do the forced MUSIC adjustment with SP 2111 001

5.7.10 DOUBLE-FEED DETECTION LED

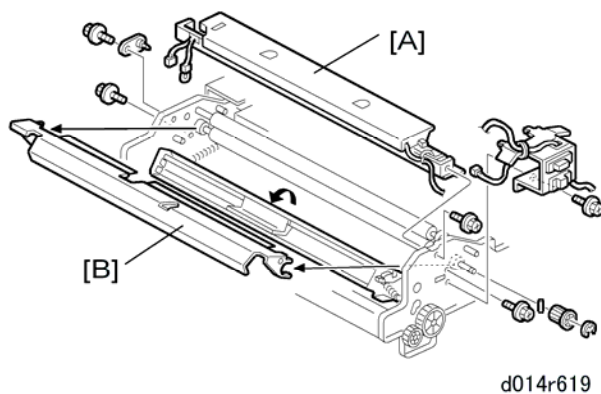

1. Remove:

- Drawer unit
- Drawer unit connector bracket
- Registration motor
- Sensor support plate
- Registration motor inner cover (🔩 x4)

[A] Upper stay (🔩 x2)

[B] Lower stay (🔩 x2, 🛠️ x1)

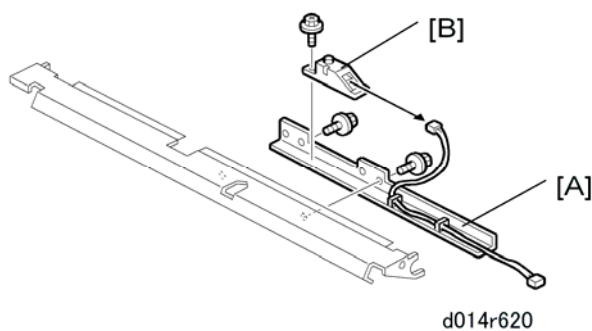

2. Remove:

[A] Sensor bracket (🔩 x2)

[B] Double-feed detection LED (🔩 x1, 🛠️ x1)

Reinstallation

- Do the forced MUSIC adjustment with SP 2111 001.

5.8 IMAGE TRANSFER UNIT

5.8.1 EMPTYING THE DUST COLLECTION UNIT

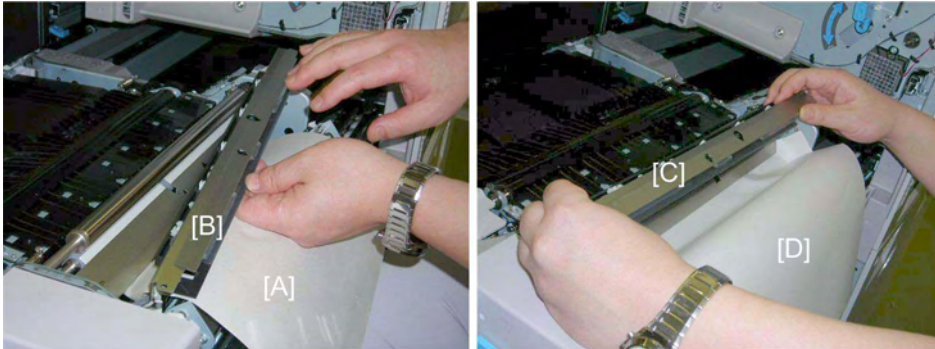

b132r814

1. Open the front door.
2. Pull out the drawer unit.
3. Insert a sheet of A3 paper [A] under the dust collection unit.
4. Disconnect the dust collection unit [B].
5. Dump the paper dust from the dust collection unit [C] onto the paper [D].
6. Carefully remove the paper and discard.

5.8.2 SEPARATING THE BELT UNIT AND BELT CLEANING UNIT

Disassembly and ITB Replacement

1. Put a clean sheet of paper on a flat surface.
2. Remove the ITB from the machine.
3. Place the ITB unit on the sheet of paper.

To prevent spilling used toner, always hold the unit level when you remove it, lift it, carry it, or set it down.

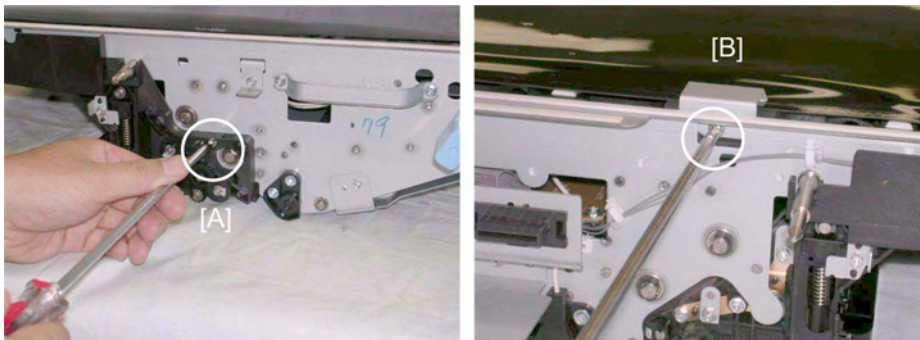

b132r815

Image Transfer Unit

4. Remove screws [A] and [B] (🔩 x2).

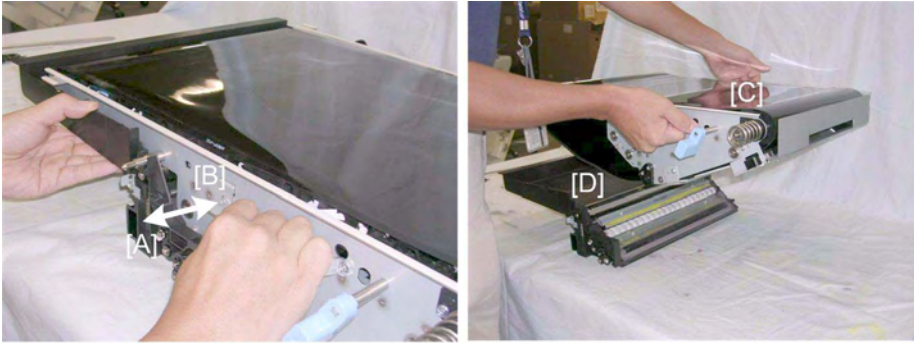

b132r816

5. Pull the ITB cleaning unit [A] forward while pushing the ITB belt unit backward to separate the cleaning unit from the belt unit.
6. Lift the belt unit [C] off the cleaning unit [D].

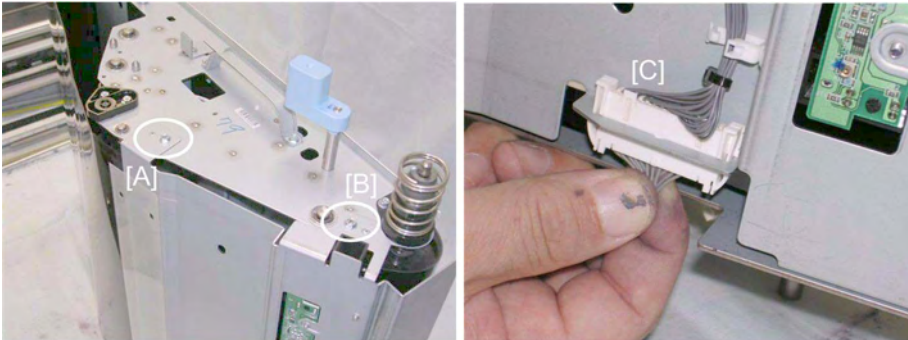

b132r817

7. Remove:
[A] Screw (🔩 x1)
[B] Screw (🔩 x1)
8. Disconnect [C] (🔌 x1)

5.8.3 REASSEMBLING THE BELT UNIT AND BELT CLEANING UNIT

Before You Begin...

Here are some important precautions you should obey when reassembling the ITB Unit.

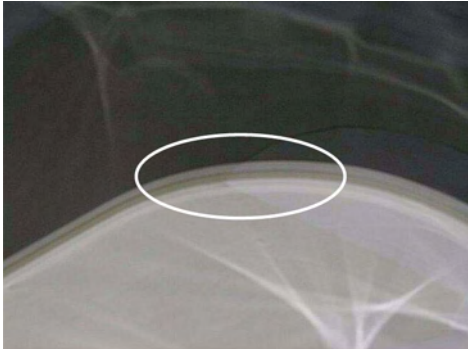

b132r818

- When you install the new belt, the edge of the belt with the encoder film strip must be at the back of the unit with the image position sensor. The encoder edge of the ITB is silver.

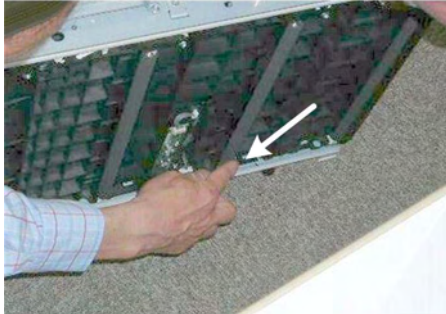

b132r819

- Never touch the ITB rollers when removing/installing the belt. If a roller (or the surface of the belt) is touched accidentally, moisten a clean cloth and clean the affected area.



b132r820

- Make sure that the belt is even with the edge of the roller as shown above.

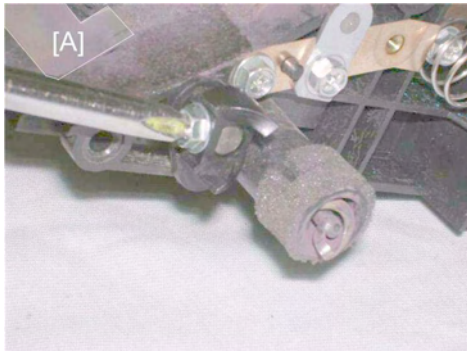

b132r821

- When reinstalling the ITB cleaning brush roller, confirm that the seal [A] is on top and visible.
- Always dust the ITB with lubricant powder before reinstalling the ITB unit in the machine.

Reassembling the Belt Unit and Cleaning Unit



b132r822

1. Insert one sheet of A4/LT paper under the ITB lubricant blade as shown to protect the corner seals of the belt cleaning unit.

★ Important

- The paper should be under the under the blade as shown above, not over the blade.
2. Lower the belt unit [A] onto the cleaning unit [B].

Image Transfer Unit

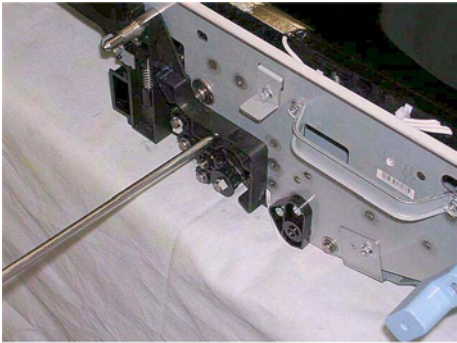

b132r823

3. Reassemble the belt unit and belt cleaning unit.

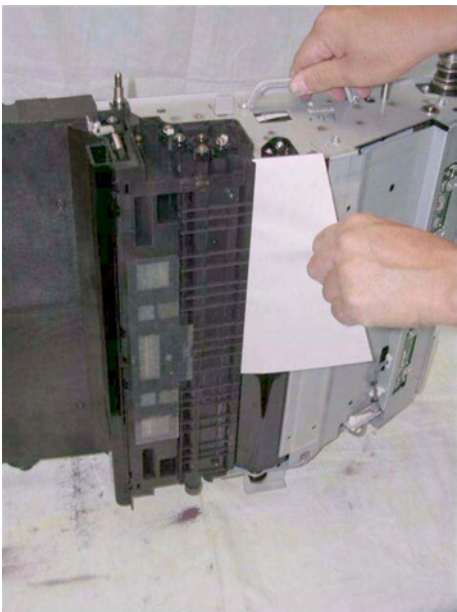

b132r824

4. Set the reassembled ITB unit on end as shown.
5. Pull the paper out slowly.
6. Check the paper.

If the paper is unmarked, go to the next step.

-or-

If the paper is creased or torn, separate the image transfer belt and cleaning unit.

Inspect the seal. If the seal is damaged, replace it.

Dusting the ITB with Lubricant Powder

1. Get a pack of Lubricant Powder B1329700.
 - The ITB must be coated with lubricant powder B1329700 before installing a new ITB.
 - The lubricant powder (B1329700) (composed of ZnSt) is specially designed for this

machine.

- Never use setting powder (54429101) for this machine. Using this setting powder will damage the drum charge roller and cause problems with image quality.

★ Important

- Do not use the yellow toner from this machine, because it contains developer, and this will damage the drum and ITB.

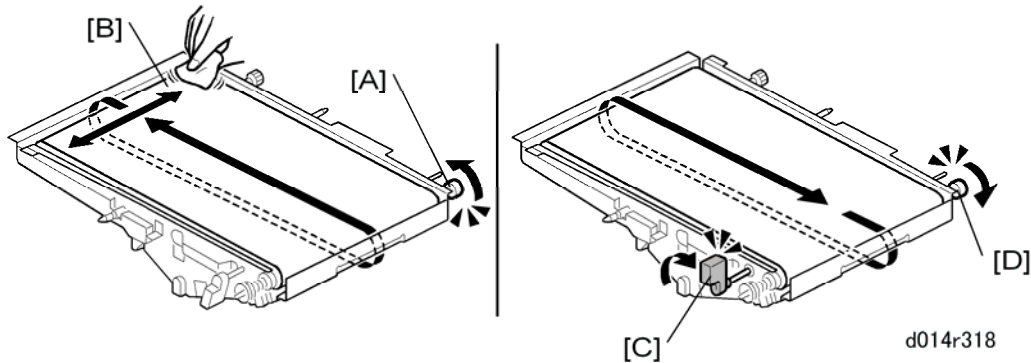

2. While rotating the knob [A] in the direction indicated by the arrow, apply powder at [B] with a soft dry cloth.
3. Keep rotating the ITB at [A] while continuing to apply the powder at [B] through one full rotation until the ITB is completely covered with powder.
4. After the ITB has been completely covered with the lubricating powder, turn lever [C] to the up position.
5. After the ITB is completely covered with powder, rotate the knob [D] in the direction indicated by the arrow.
6. Keep rotating the knob at [D] until the ITB has made one full rotation. This reverse rotation covers the edge of the belt cleaning blade with lubrication powder.

Reinstallation

- Do the forced MUSIC adjustment with SP2111-1.

5.8.4 ITB CLEANING UNIT

This is the ITB cleaning unit with the belt unit removed.

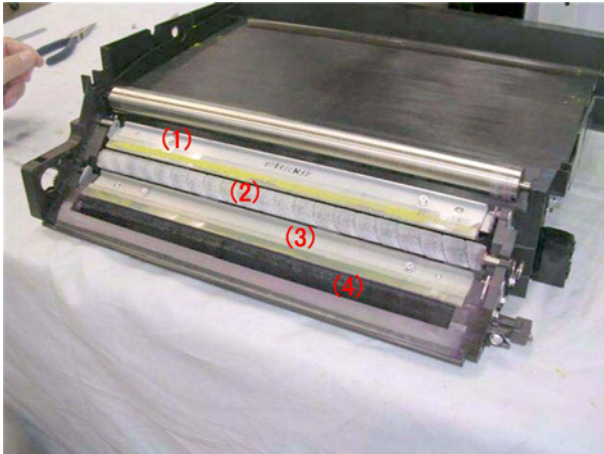

b132r825

[1]	ITB Lubricant Blade
[2]	ITB Lubricant Brush Roller* ¹
[3]	ITB Cleaning Blade
[4]	ITB Brush Cleaning Roller

*¹ A lubricant bar is under the ITB lubricant brush roller.

Before servicing the cleaning unit, please note:

- The ITB lubricant blade (1) and ITB cleaning blade [3] appear to be similar but they are not the same so they are not interchangeable.
- The PM interval of the ITB lubricant blade [1], ITB lubricant brush roller [2], and ITB cleaning blade [3], and the lubricant bar (under the ITB lubricant brush roller) is the same (300K). These four items are always replaced together. Item [4] is not a PM part, but it must be removed in order to remove the other parts.

ITB Lubricant Blade

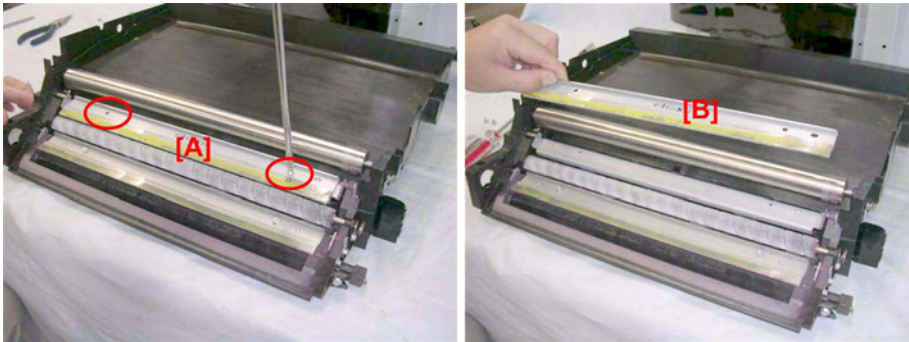

b132r826

1. Remove the screws of the ITB lubricant blade [A] (⚙️ x2).
2. Remove the ITB lubricant blade [B].

ITB Lubricant Brush Roller, ITB Lubricant Bar

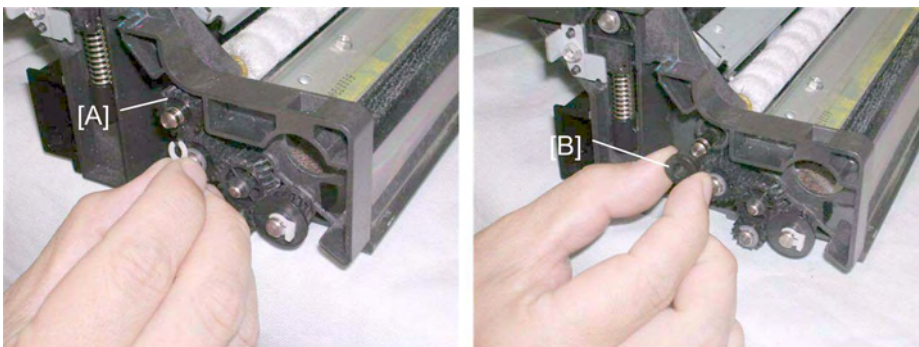

b132r827

1. At the back, remove:
 - [A] Gear (⚙️ x1)
 - [B] Coupling

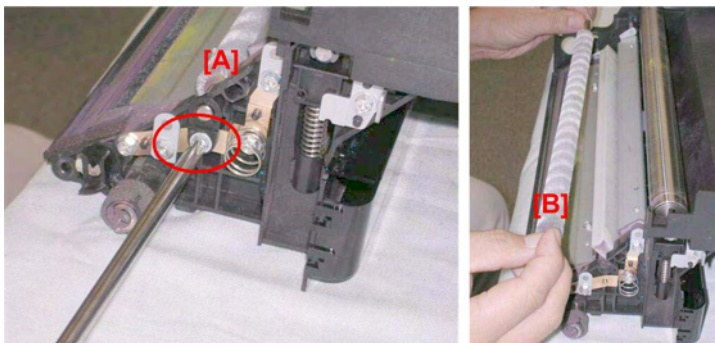

b132r828

2. At the front, remove screw [A] (⚙️ x1).
3. Remove the ITB lubricant brush roller [B].

Image Transfer Unit

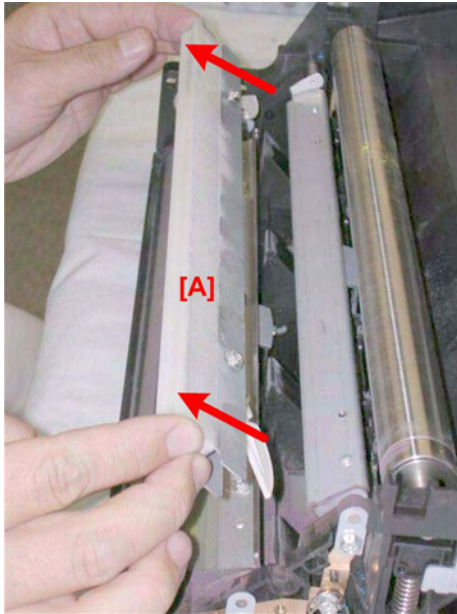

b132r829

4. Remove the lubricant bar [A]

ITB Cleaning Blade

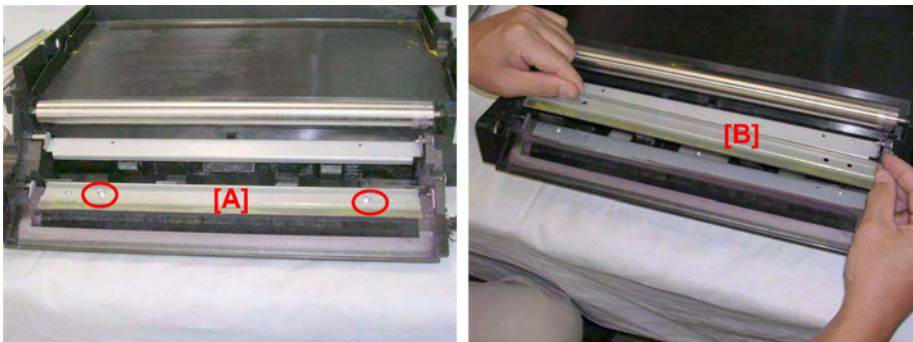

b132r830

1. Remove the screws of the ITB cleaning blade [A] (🔩 x2).
2. Remove the ITB cleaning blade [B].

ITB Brush Cleaning Roller

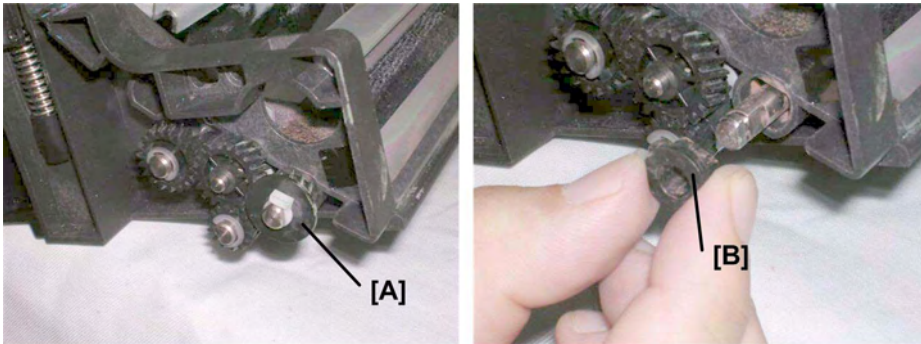

b132r831

1. Remove the ITB cleaning blade (🔩 x2).
2. At the rear:
 - Remove gear [A] (🔩 x1).
 - Remove coupling [B].

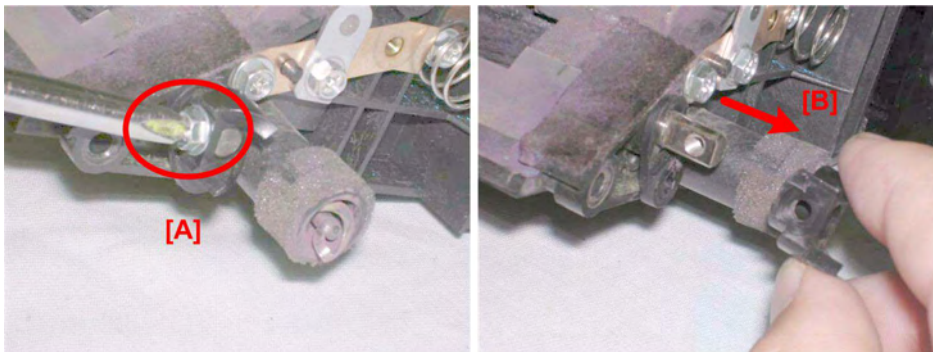

b132r832

3. At the front:
 - Remove screw [A] (🔩 x1)
 - Remove coupling [B].



b132r833

4. Remove sponge and seal casing [A].
5. Remove the ITB brush cleaning roller [B].

5.8.5 MUSIC AND ID SENSORS

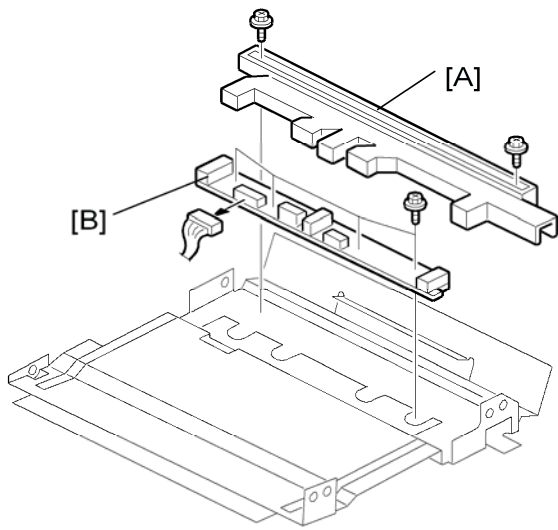

d014r332

1. Remove
 - ID sensor/MUSIC sensor plate
- [A] Cover (🔩 x2)
[B] MUSIC and ID sensors (🔩 x4, 📏 x1)

Reinstallation

- Do the forced MUSIC adjustment with SP2111-1.

5.8.6 IMAGE TRANSFER POWER PACK

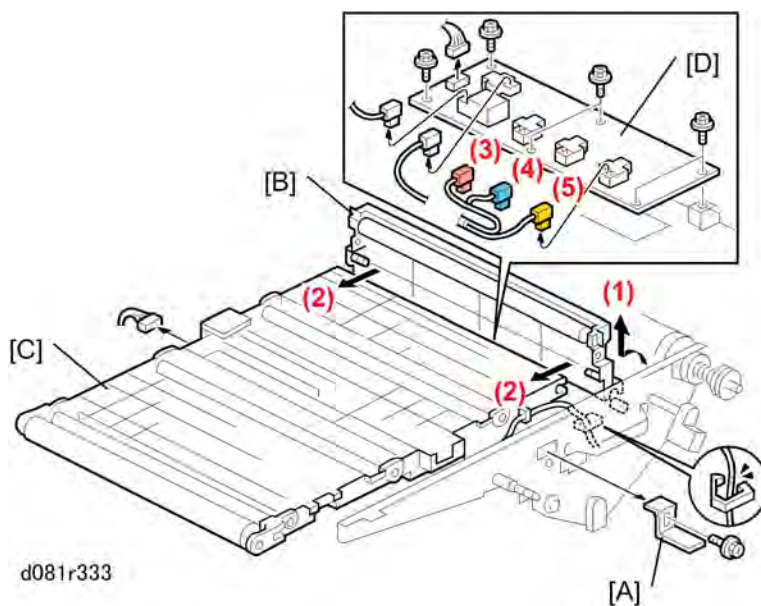

d081r333

1. Remove the ITB

2. Remove:
 - [A] Support bracket (🔩 x1)
 - [B] Small idle roller plate. Move (1) to (2) to remove.
 - [C] Large idle roller plate
 - [D] Image transfer power pack (🔩 x6, 📦 x6)
3. Note the correct positions of the color coded connectors when you disconnect them, so that you can reconnect them correctly:
 - (3) Red
 - (4) Blue
 - (5) Yellow

Reinstallation

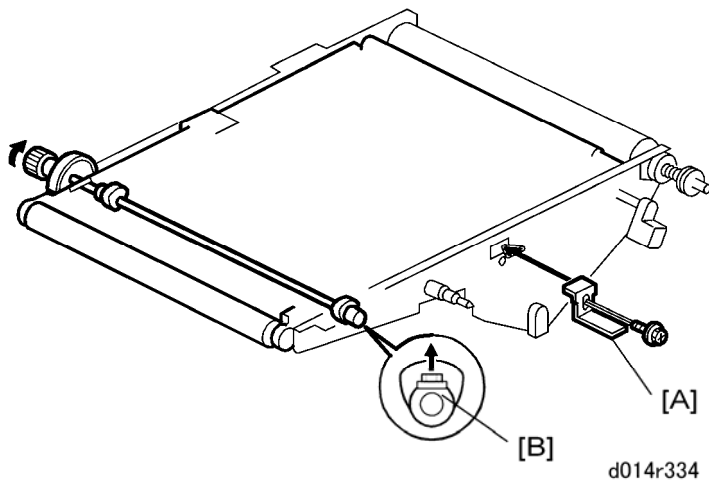

- When you reattach the support bracket [A], rotate the screw [B] up as shown, then tighten it.
- Do the forced MUSIC adjustment with SP2111-1.

5.8.7 BELT POSITION SENSOR

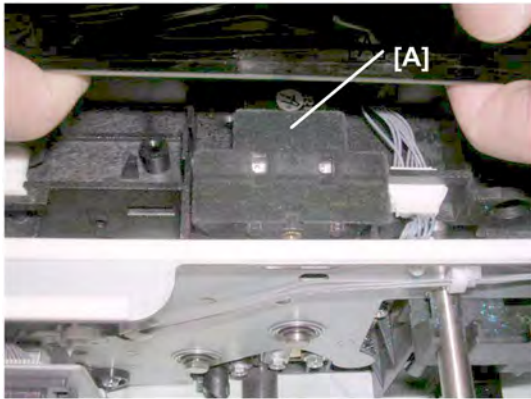

b132r834

1. Remove:

- ITB
- [A] Belt position sensor assembly (🔧 x2, 📦 x1)

Reinstallation

After the reinstallation of the new sensor, do the following SP codes:

- SP2912-1 (Encoder Sn: Adj Light)
- SP2914-1 (Encoder Sn Get 1st Phase)
- SP2111-1 (Forced MUSIC Adjustment)

5.9 FUSING UNIT

5.9.1 BEFORE SERVICING THE FUSING UNIT...

The following four service parts for the D014/D015 and D081/D082 fusing unit are not the same; they cannot be substituted for one another when servicing these machines.

- Hot roller
- Pressure roller
- Pressure roller bearing
- Oil supply roller

Comparison Table for D014/D015, D081/D082 Fusing Unit PM Parts



- Please refer to the Parts Catalog for the actual PM Part Numbers.

Part Name	Reason for Change
Hot Roller (φ52)	To extend service life by 150K (300K to 450K)
Pressure Roller (φ50)	Lighter roller core to shorten warm-up time to first copy/print.
Pressure Roller Bearing φ20x φ32x7	To double service life (600K to 1200K)
Oil Supply Roller (φ16)	To extend service life 150 K (300K to 450K)

It is important that you be able to distinguish these parts by a quick visual check.

Fusing Unit

Distinguishing Characteristics: Hot Roller

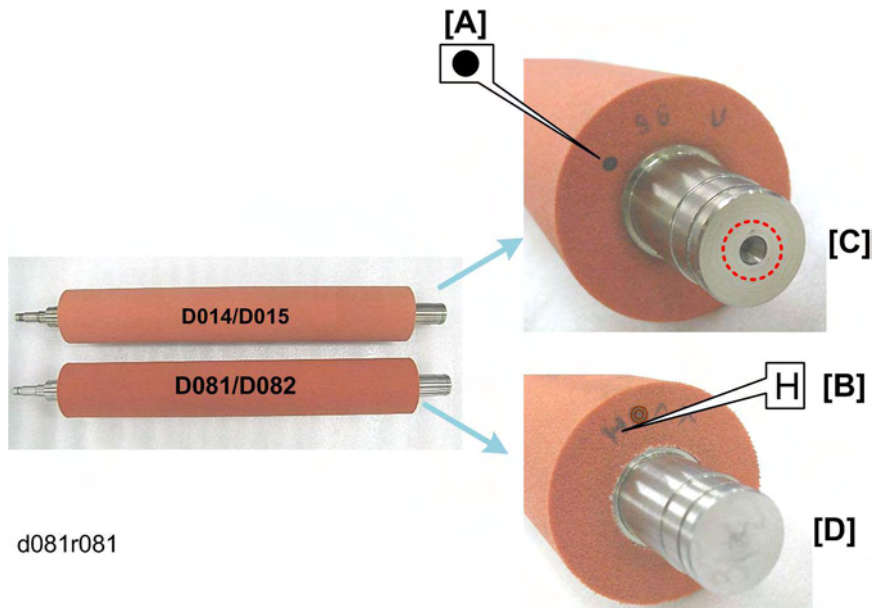

d081r081

The identification marks (black dot and "H") on the ends of the D014/D015 hot roller [A] D081/D082 hot roller [B] are different. Also, there is a hole on the end of the roller of the D014/D015 hot roller [C] and no hole on the end of the D081/D082 hot roller.

Distinguishing Characteristics: Pressure Roller

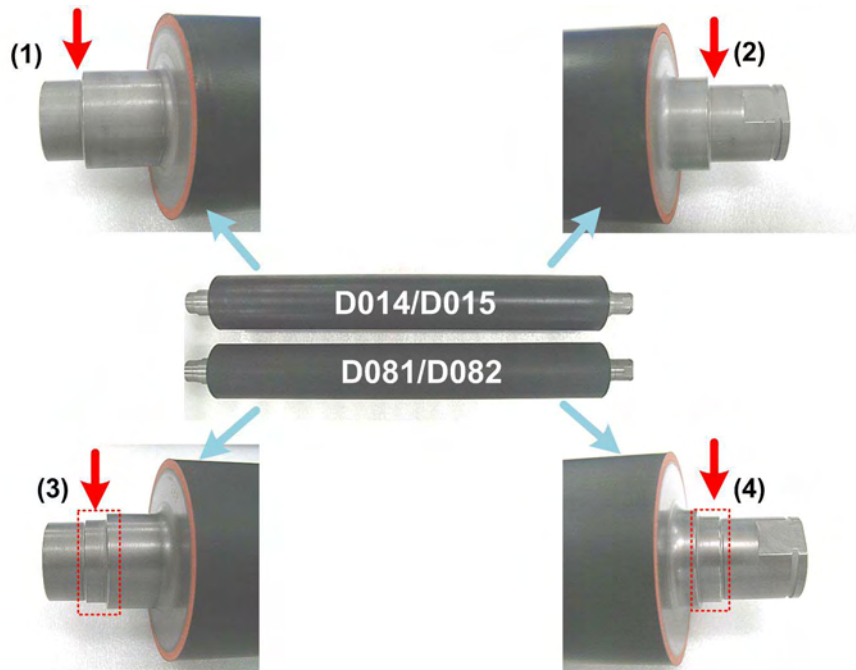

d081r082

There are two cuts on both ends of the shaft of the D014/D015 pressure roller at (1) and (2) (2 steps). But on the ends of the D081/D082 pressure roller shaft at (3) and (4), there are three cuts (3 steps).

Distinguishing Characteristics: Pressure Roller Bearing

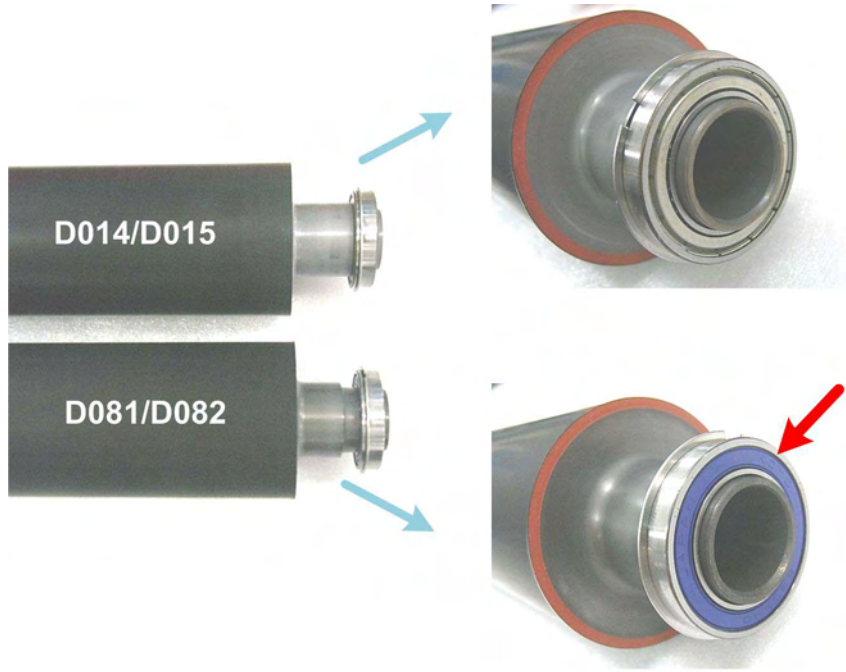

d081r083

The bearing on the end of the D081/D082 pressure roller is a distinctive blue color.

Distinguishing Characteristics: Oil Supply Roller

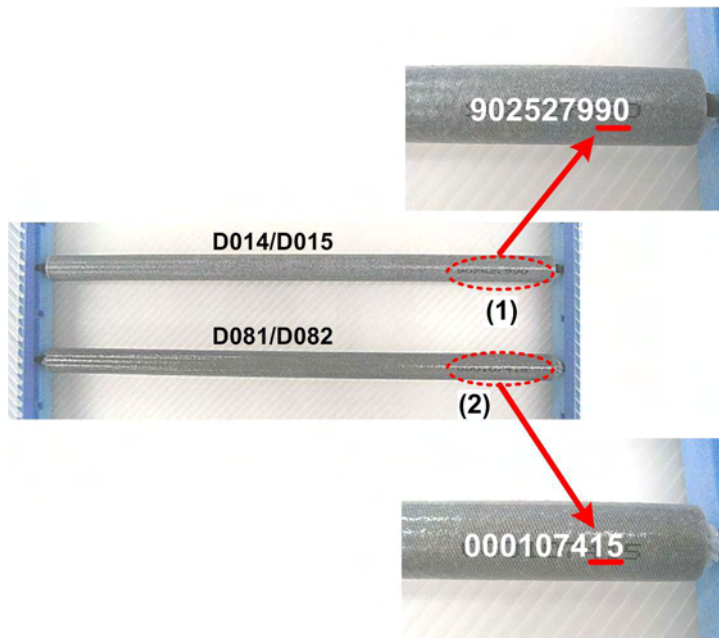

d081r084

The numbers of the D014/D015 and D081/D082 are different. The last two digits on the oil supply roller number (1) of the D014/D015 are "42" or "90". The last two digits on the oil supply roller number (2) of the D081/D082 are "15".

Fusing Unit

5.9.2 REMOVING THE FUSING UNIT

1. Turn off the copier and disconnect the power cord at the power source.
2. Open the front door.
3. Pull out the drawer unit.
4. Allow the machine to cool for at least 10 minutes.

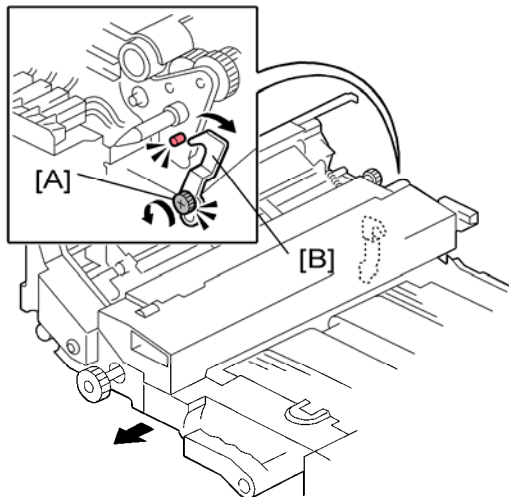

d014r401

5. At the back of the fusing unit, loosen the screw of the lock/release lever [A]. (Do not remove the screw.)
6. Rotate the lever [B] away from the pin, then tighten the screw with the lever in the open position. (Tightening the screw keeps the lever at the open position so that the fusing unit can be reinstalled easily.)

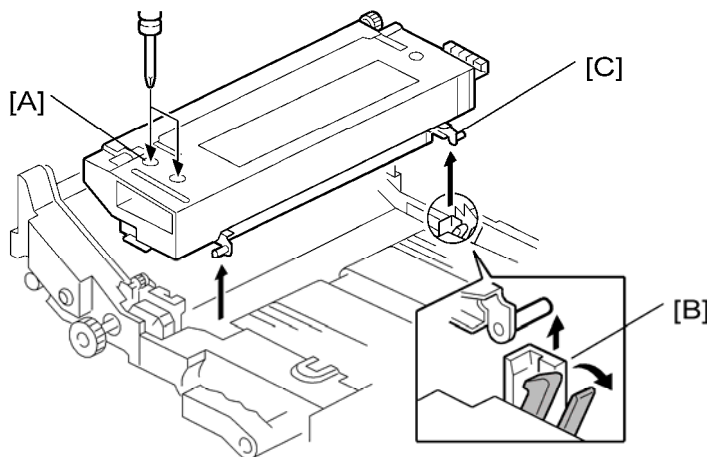

d014r402

7. Loosen both screws [A] (⌀ x2). (These screws cannot be removed.)
8. Press down both levers [B] (front and back) to unlock (to release the pins [C] at front and back).

9. Lift the fusing unit out of the drawer.
10. Set the fusing unit on a clean surface.

Reinstallation

- Before setting the fusing unit in the drawer, make sure that the lock/release lever is in the open position.
- After reinstalling the fusing unit, make sure that the lock/release lever is in the locked position and finger tight before you close the drawer unit.
- If the lock/release lever is not locked, this could cause a problem if power is turned off accidentally during copying. If this occurs, the drawer unit can be pulled out, but the user may not be able to push it back in because the fusing unit is still pressed up by the cam. Do the following to reset the cam.
 1. Remove the fusing unit from the drawer unit.
 2. Close the drawer, then close the front door.
 3. Turn the main power on. The cam moves down.
 4. Open the drawer and put the fusing unit back in the machine.
 5. Confirm that the lock/release lever is in the locked position.
 6. Close the drawer unit and front door.

5.9.3 FUSING EXIT SENSOR, ACCORDION JAM SENSOR

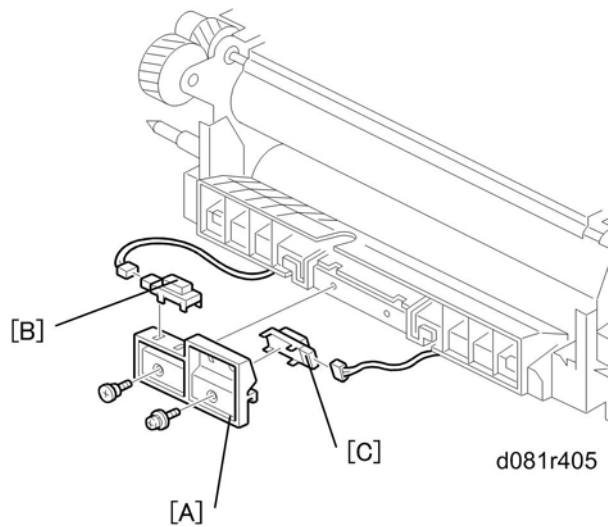

1. Remove:
 - Fusing unit (🔧 p.5-122)
2. Remove:
 - [A] Sensor bracket (🔧 x2)
 - [B] Fusing exit sensor (🔧 x1)
 - [C] Accordion jam sensor (🔧 x1)

5.9.4 PRESSURE ROLLER THERMOSTATS, THERMISTOR

Thermostats

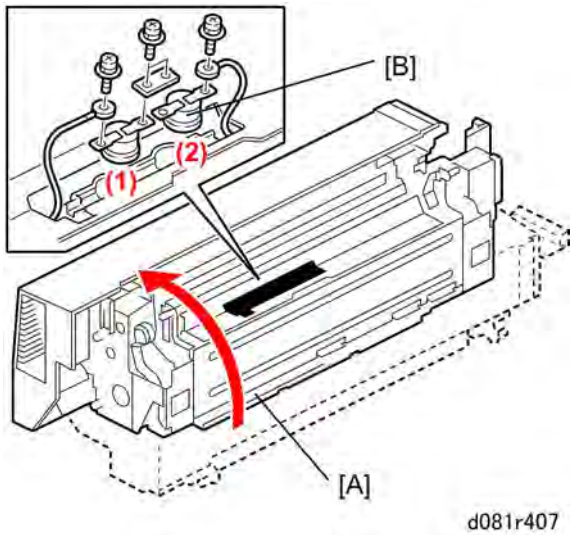

1. Remove the fusing unit (☛ p.5-122).
2. Raise the unit [A].
3. Remove two pressure roller thermostats [B] (☛ x4)

Thermistor

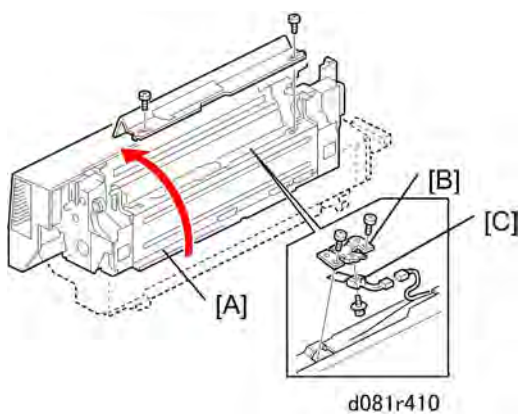

1. Remove the fusing unit (☛ p.5-122).
2. Raise the unit [A].
3. Remove:
 - [B] Thermistor bracket (☛ x2)
 - [C] Pressure roller thermistor (☛ x1, ☛ x1)

Fusing Unit

5.9.5 FUSING CLEANING UNIT

Fusing Belt Strippers

Preparation

- Remove the fusing unit from the machine.
- Allow the unit to cool for at least 10 minutes.
- Raise **D2** to a 45° slant.

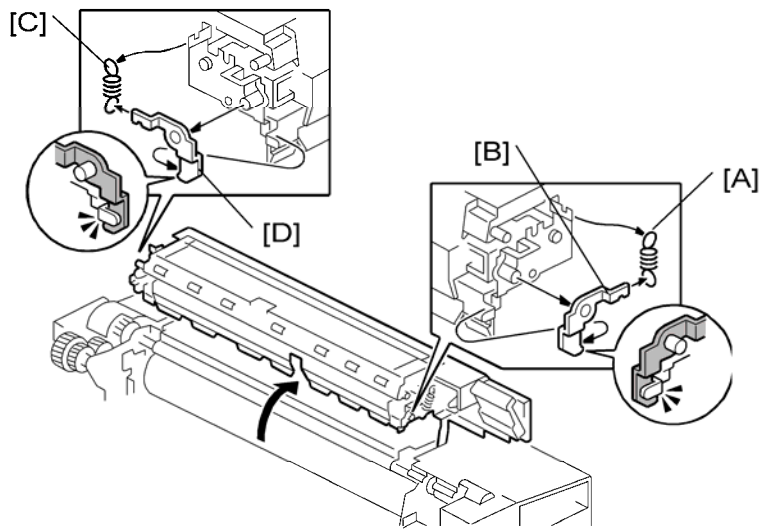

d014r405

1. Remove:
 - [A] Spring
 - [B] Plate
 - [C] Spring
 - [D] Plate

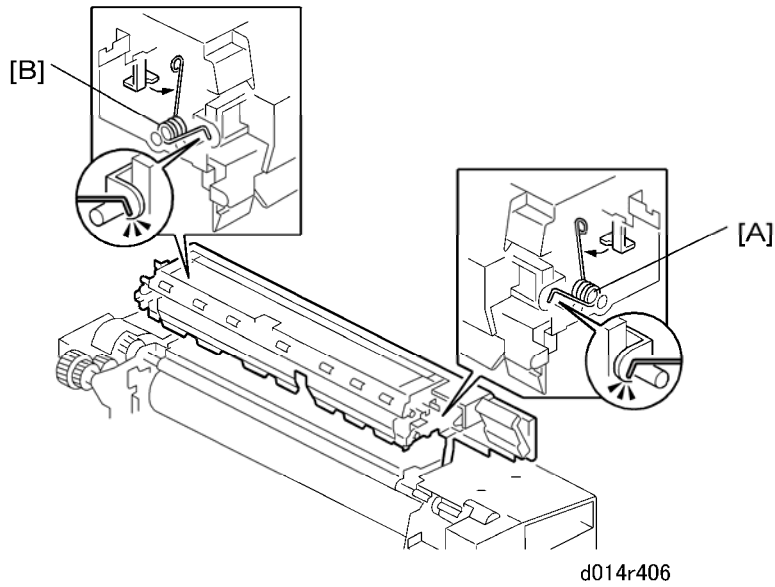

2. Remove:
[A] Spring
[B] Spring

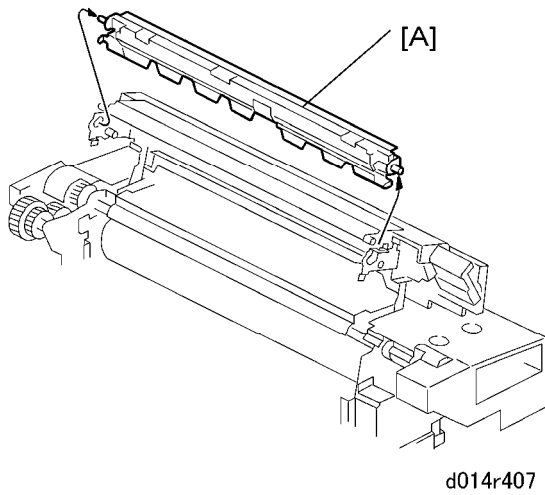

3. Remove fusing belt stripper plate [A] with strippers attached.

Fusing Unit

Oil Supply Roller Cleaning Roller, Oil Supply Roller

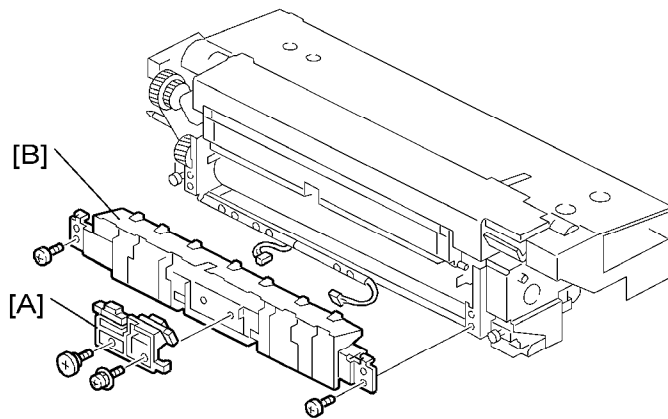

d014r403

1. Remove:

[A] Paper exit sensor bracket (🔩 x2, 📏 x2)

[B] Paper exit guide (🔩 x2)

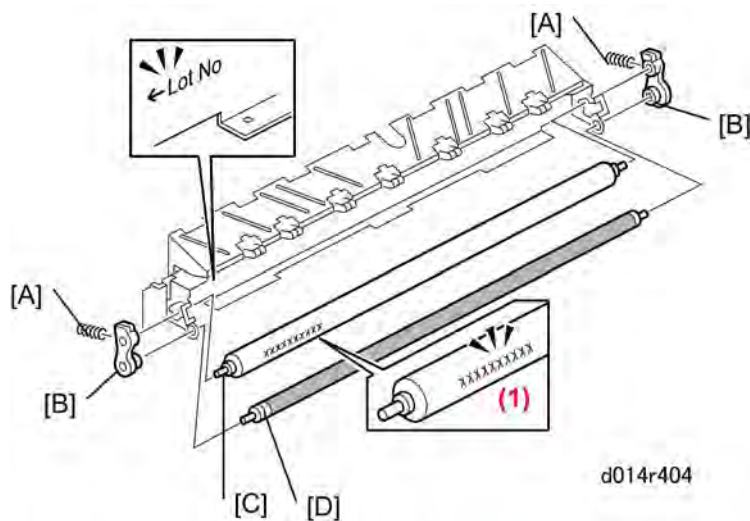

d014r404

2. Remove:

[A] Spring (Front x1, Back x1)

[B] Lock plate (Front x1, Back x1)

[C] Oil supply roller

[D] Oil supply roller cleaning roller

Reinstallation

- The end of the oil supply roller with the number (1) above must be installed at the front of the fusing cleaning belt unit.

5.9.6 FUSING BELT THERMOSTATS

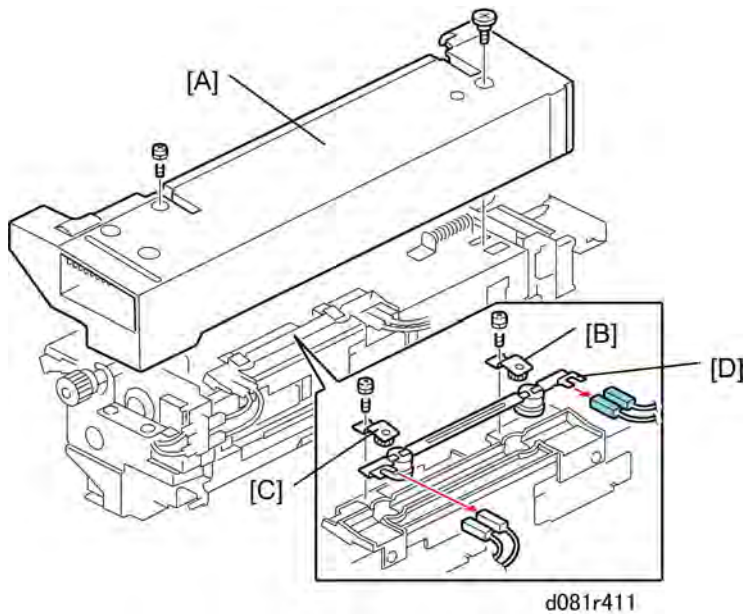

1. Remove the fusing unit (☛ p.5-122).
2. Remove:
 - [A] Top cover (🔩 x2)
 - [B] Rear bracket (🔩 x2)
 - [C] Front bracket (🔩 x2)
 - [D] Thermostats (🔧 x4).

5.9.7 FUSING THERMISTORS, HEATING ROLLER TEMPERATURE SENSORS

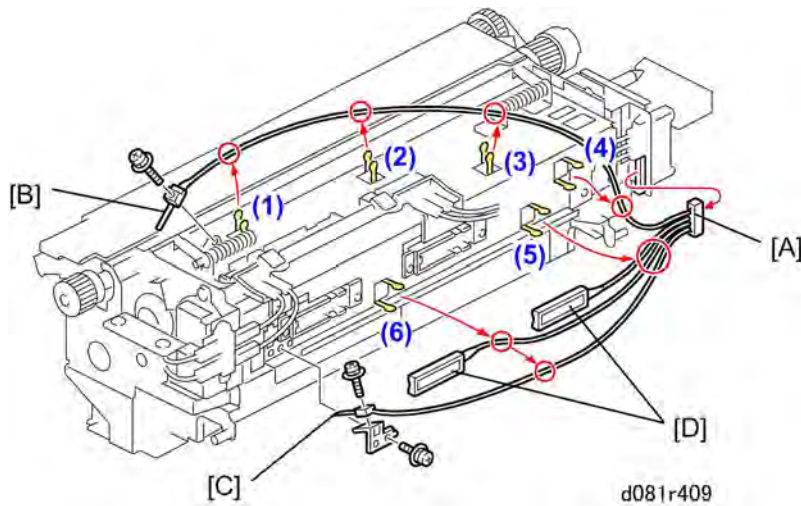

1. Remove:
 - Fusing unit (🔧 p.5-122)
 - Fusing unit cover (🔧 p.5-132 "Fusing Lamps, Dividing the Fusing Unit")
 - Fusing cleaning unit (🔧 p.5-126)
2. Open all the clamps (1) to (6) (🔧 x6)
3. Disconnect harness [A] (🔧 x1)
4. Disconnect:
 - [B] Hot roller thermistor (🔧 x1)
 - [C] Heating roller thermistor bracket and thermistor (🔧 x2)
5. Remove two heating roller temperature sensors [D] (no screws).

5.9.8 PRESSURE ROLLER SEPARATION PAWLS

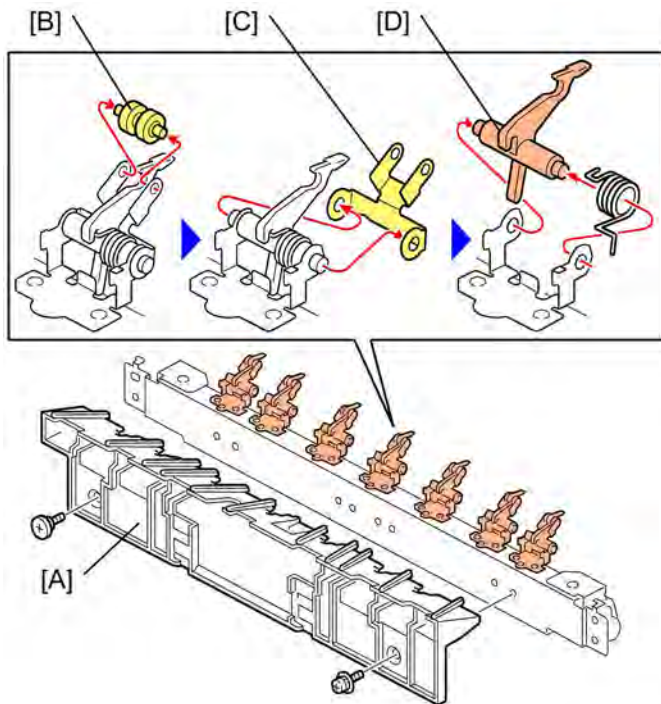

d081r418

1. Remove the fusing unit (☛ p.5-122).
2. Remove cover [A] (🔩 x2).
3. Spread the tips of the bracket arms and remove sprocket [B].
4. Spread the base of the bracket [C] and remove it.
5. Remove stripper [D] (Spring x1).
6. Repeat Steps 3 to 5 for each stripper.

Fusing Unit

5.9.9 FUSING LAMPS, DIVIDING THE FUSING UNIT

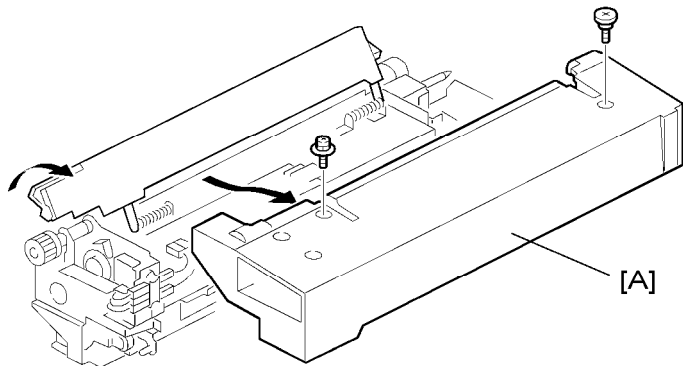

d014r408

1. Remove:

[A] Fusing unit cover (🔩 x2)

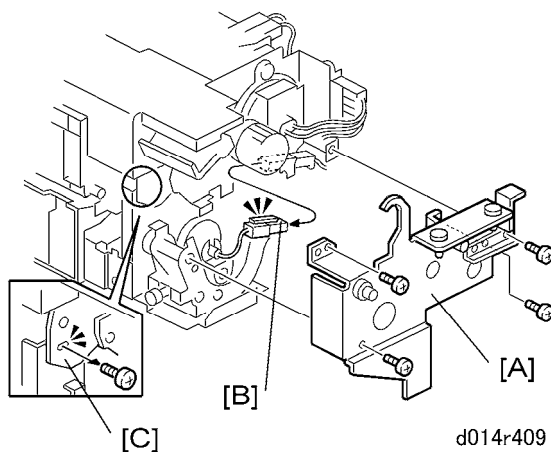

d014r409

2. Remove:



[A] Bracket (🔩 x4)

[B] Connector (🔌 x1)

[C] Screw (🔩 x1)

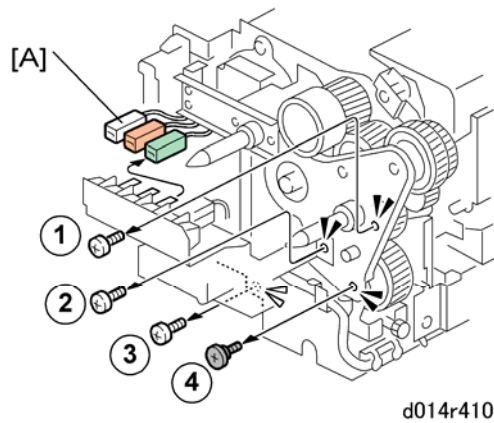
Fusing Unit



3. Disconnect
[A] Fusing lamps ( x3)
4. Remove screws (1) to (3) (normal screws) and (4) (step screw) ( x3)

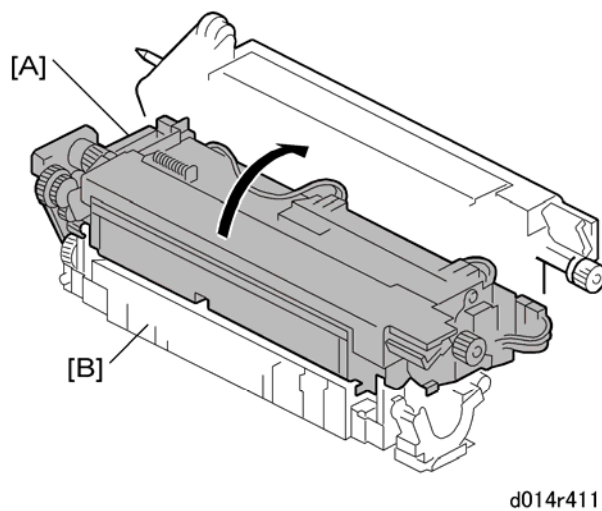

5. Separate the two halves of the fusing unit [A] and [B].

Fusing Unit

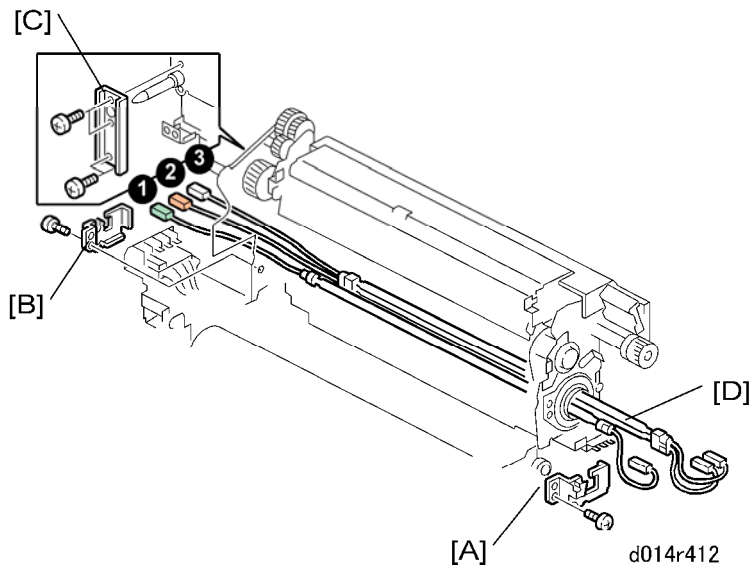

6. Remove:

- [A] Lock plate (🔩 x1)
- [B] Lock plate (🔩 x1)
- [C] Bracket (🔩 x4)
- [D] Heating roller fusing lamps (🔌 x3)

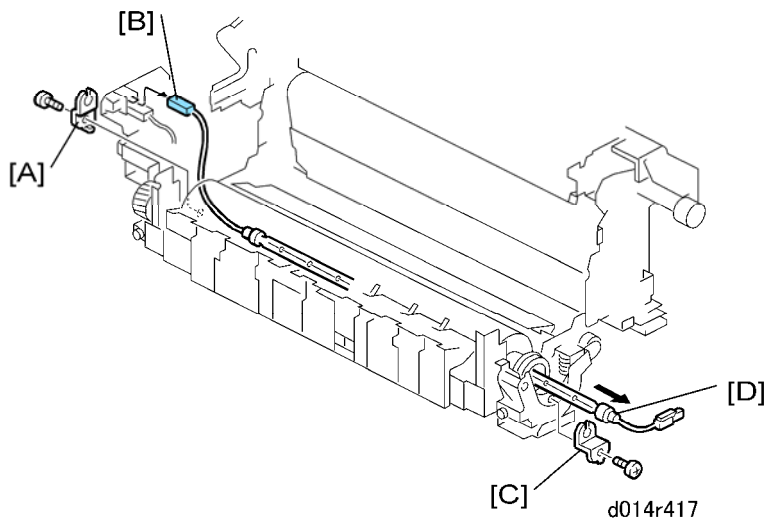

7. Remove:

- [A] Lock plate (🔩 x1)
- [B] Connector (🔌 x1)
- [C] Lock plate (🔩 x1)
- [D] Pressure roller fusing lamp (x1)

5.9.10 FUSING UNIT ROLLERS, FUSING BELT

Removing the Fusing Belt, Hot Roller, Heating Roller, Pressure Roller

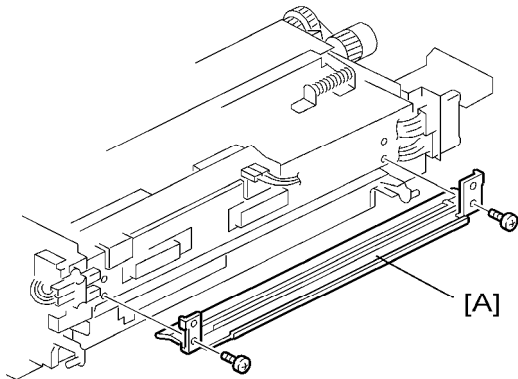

d014r413

1. Remove:

[A] Upper entrance guide plate (🔩 x2)

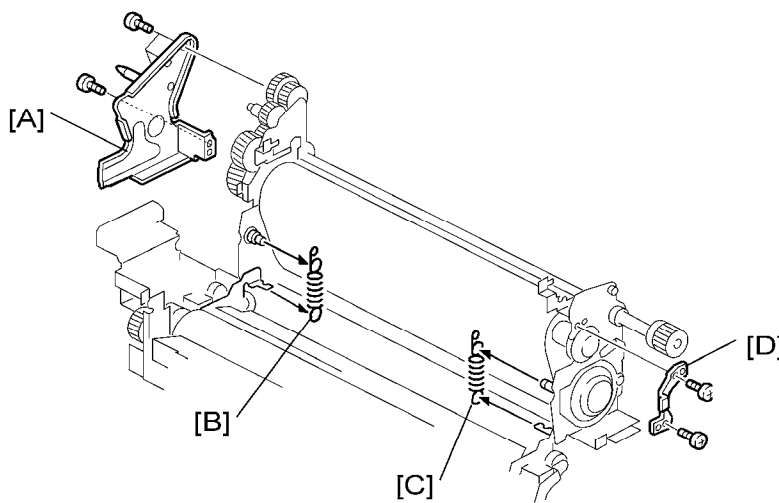

d014r414

2. Remove:

[A] Plate (🔩 x4)

[B] Spring x1

[C] Spring x1

[D] Bracket (🔩 x2)

Fusing Unit

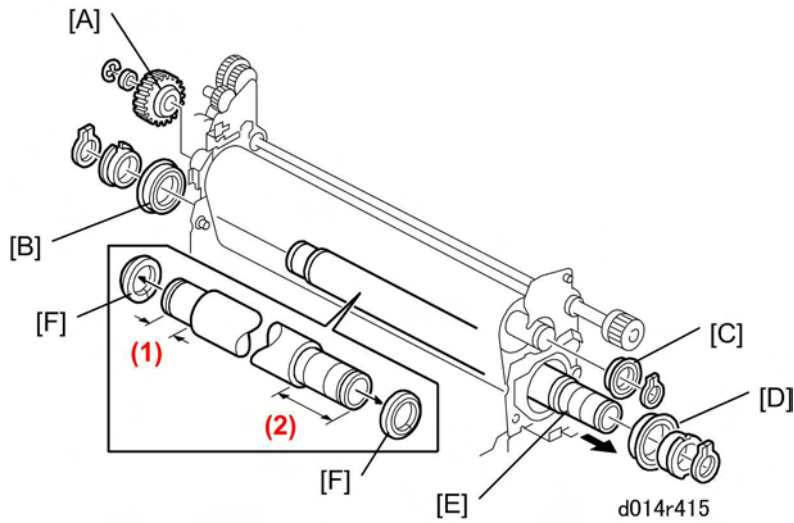

3. Remove:

[A] Gear, bushing (C x1)

[B] Bearing, bushing (C-ring x1)

Note: The flanges of the bearing and the bushing face out for reinstallation.

[C] Bearing (C-ring x1)

Note: The bearing flange faces out for reinstallation.

[D] Bearing, bushing (C-ring x1)

Note: The flanges of bearing and the bushing face out for reinstallation.

[E] Heating roller

Note:

- Flanges [F] should be separated from the heating roller.
- Flanges [F] should be reused with the new roller if the heating roller is replaced.

Reinstallation

- Make sure that the ends of the heating roller are arranged as shown by (1) and (2) in the illustration above. (1) is shorter than (2).

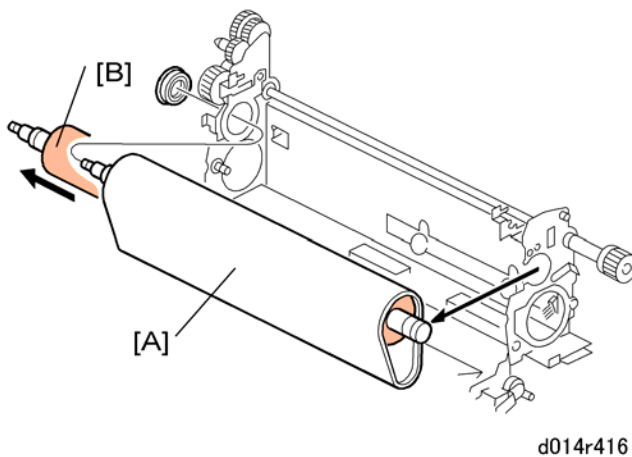

4. Remove:
 [A] Fusing belt
 [B] Hot roller

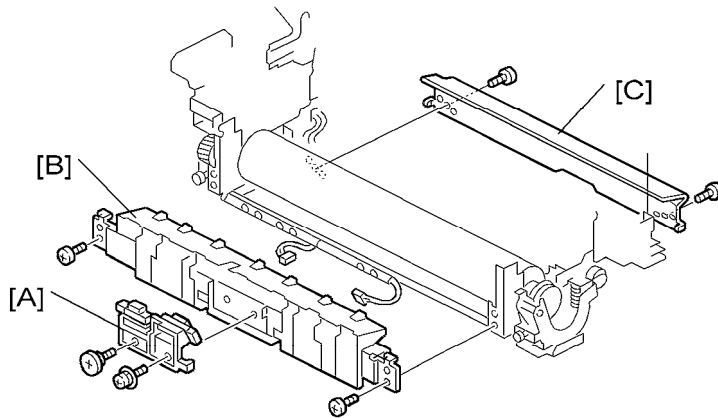

d014r418

5. Remove:
 [A] Paper exit sensor bracket (⚙️ x2, 📏 x2)
 [B] Paper exit guide (⚙️ x2)
 [C] Lower entrance guide plate (⚙️ x2)

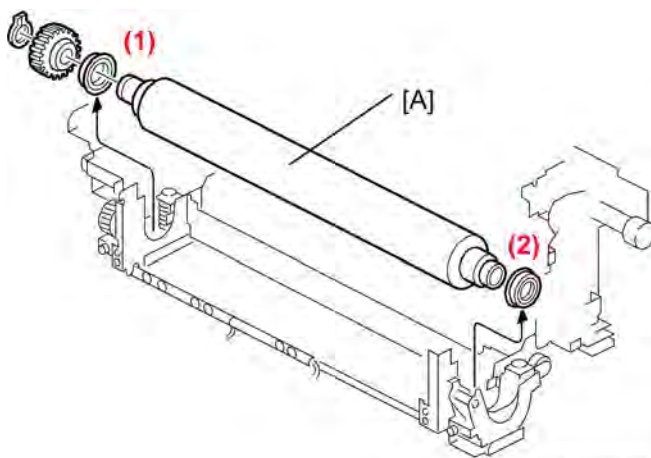

d014r419

6. Remove:
 [A] Pressure roller (C-ring x1, gear x1, bearings x2)
Note: The flanges of bearings (1) and (2) face in for reinstallation.

Fusing Unit

Lubrication after Replacement

Lubricate all bearings after replacement of the hot roller, pressure roller, and/or heating roller. For details on the lubrication points, please refer to 'Lubrication Points' in "Preventive Maintenance".

Adjusting the Gap Between Fusing Belt Strippers and Fusing Belt

After replacement of the hot roller, the gap between the fusing belt strippers and the fusing belt may need to be adjusted. Normally this procedure is not required. Do this procedure only when:

- Paper has been frequently sticking to the fusing belt and jamming the fusing unit.
- Streaking caused by fusing belt stripper pawls has been occurring frequently in solid image areas.

★ Important

- Do this procedure to adjust the gaps only after the fusing unit has been allowed to cool. If the fusing unit is still warm when the adjustments are done, the gap adjustment may not be within specification.

1. Reinstall the fusing belt and hot roller.

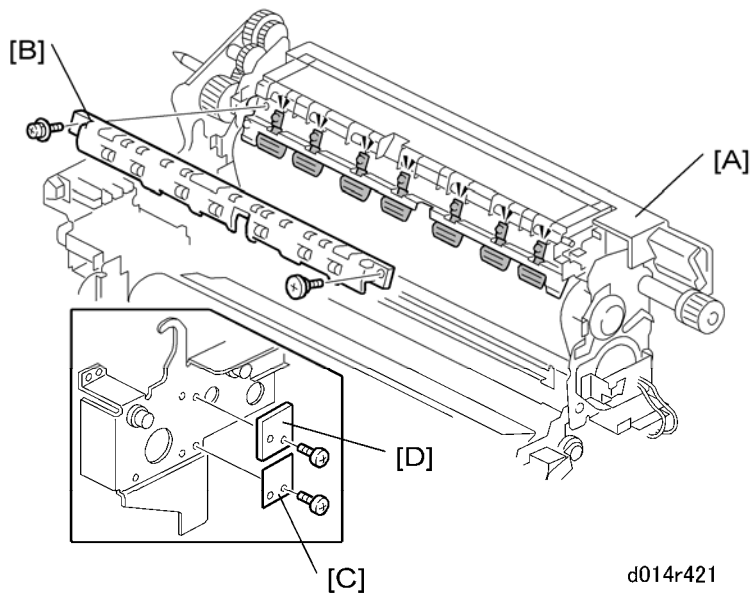

2. Separate the two halves of the fusing unit [A].
3. Remove:
 - [B] Fusing belt separation pawl guide plate (🔩 x2)
 - [C] MIN thickness plate (🔩 x1)
 - [D] MAX thickness plate (🔩 x1)

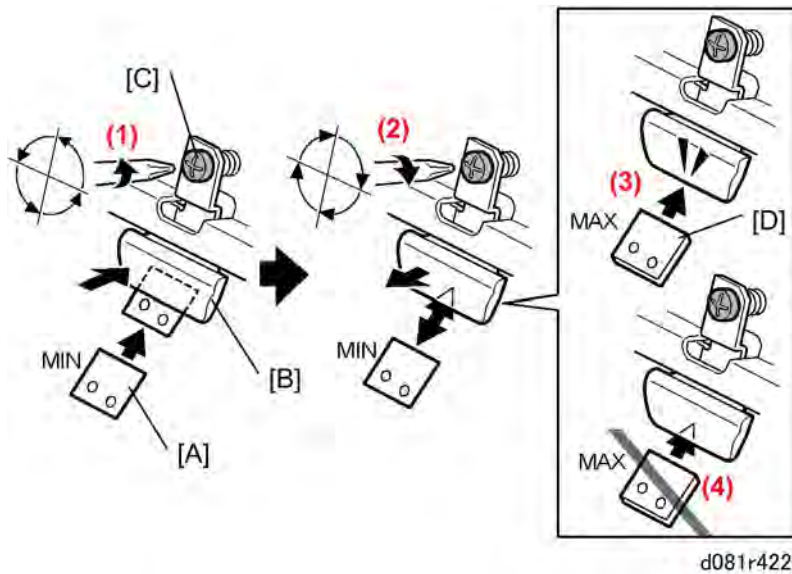

4. Insert MIN thickness plate [A] between the separation pawl [B] and fusing belt.
5. Turn screw [C] in 90 degree steps to adjust the gap to the thickness of the MIN thickness plate inserted between the pawl and belt.
 - Turning the screw 90 degrees counter-clockwise (1) reduces the gap.
 - Turning the screw 90 degrees clockwise (2) increases the gap.
6. Remove the MIN thickness plate.
7. Confirm that the MAX thickness plate [D] cannot slip between the separation pawl and the fusing belt.
 - If the MAX thickness plate cannot slip between the separation pawl and fusing belt (3), no further adjustment is necessary.
 - If the MAX thickness plate can slip between the separation pawl and fusing belt (4), repeat from Step 5 to reduce the gap.
8. Repeat this procedure from Step 4 for every separation pawl.
9. After the gaps have been adjusted for every pawl, reinstall the MIN and MAX thickness plates.

5.9.11 IMPORTANT WARNING ABOUT THERMOSTATS

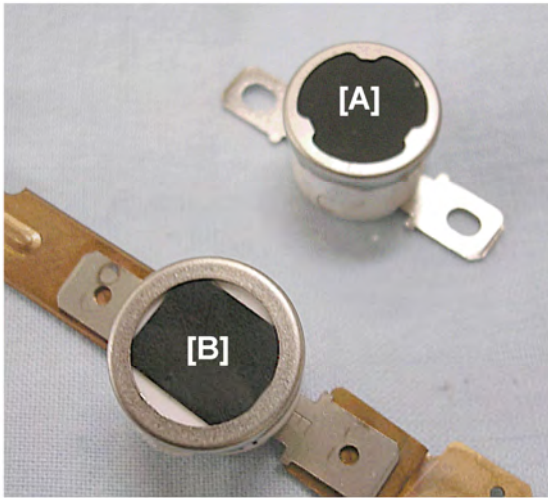

ra_0978

The old type of thermostat [A] has been replaced with a new type of thermostat [B]. The new type has a rectangular cover with exposed edges.

⚠ WARNING

- Never attempt to reset a blown thermostat by manipulating the edges of the black cover with a screw driver. Resetting a thermostat manually could cause a failure to detect overheating in the fusing unit and cause a fire hazard.

5.9.12 FEED-OUT EXIT SENSOR

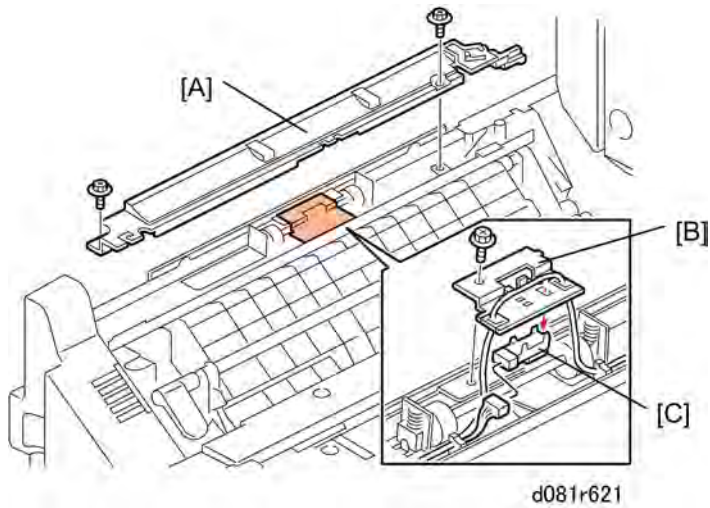

1. Pull out the fusing unit.
2. Remove:
 - [A] Cover (🔩 x2).
 - [B] Bracket [B] (🔩 x1)
 - [C] Exit sensor (🔩 x1, Pawls x4)

Fusing Unit

5.9.13 FEED-OUT UNIT

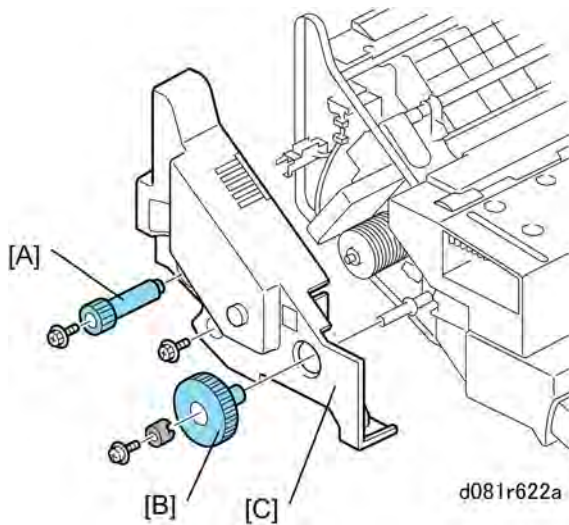

1. Pull out the fusing unit.
2. Remove the fusing unit (☛ p.5-122).
3. Remove:
 - [A] Knob **E1** (☛ x1)
 - [B] Knob **D1** (☛ x1, Collar x1)
 - [C] Feed-out unit cover (☛ x1)

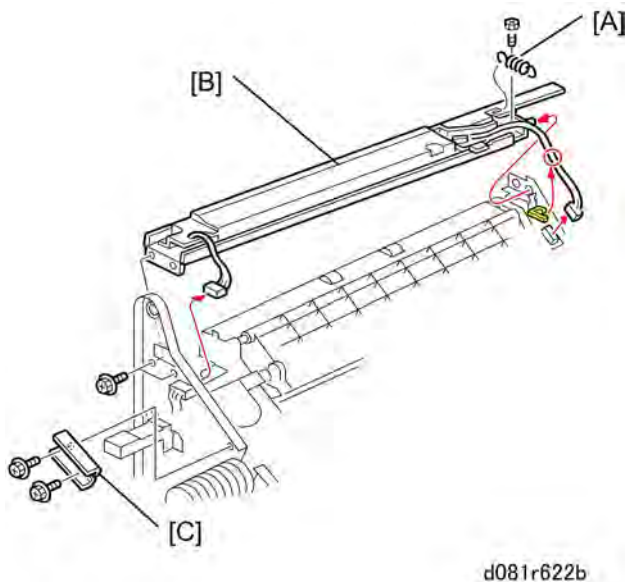

4. Remove:
 - [A] Screw and spring [A] (☛ x1, Spring x1)
 - [B] Cover [B] (Rear: ☛ x1, Front: ☛ x2, ☛ x1)
 - [C] Bracket (☛ x1)

Fusing Unit

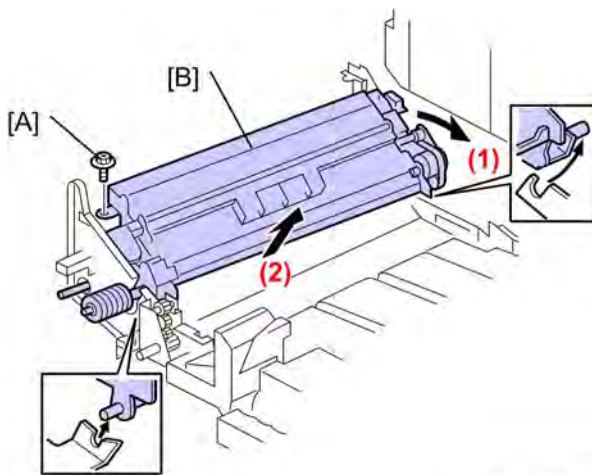

d081r622c

5. Remove:

[A] Front screw (🔩 x1)

[B] Feed-out Unit. Rotate the unit to the right (1) then lift it out (2).

5.10 DUPLEX UNIT

5.10.1 DUPLEX INVERTER MOTOR

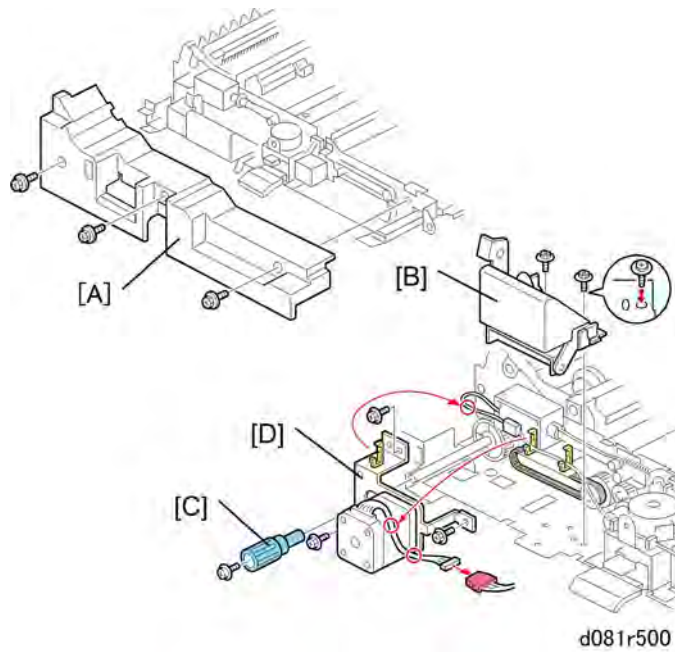

1. Pull out the duplex unit.
2. Remove:
 - [A] Duplex unit front cover (🔩 x3)
 - [B] Lever **E3** (🔩 x2)
 - [C] Knob **E2** (🔩 x1)
 - [D] Duplex inverter motor (🔩 x3, 🛠️ x3, 📦 x1)

5.10.2 DUPLEX TRANSPORT MOTOR

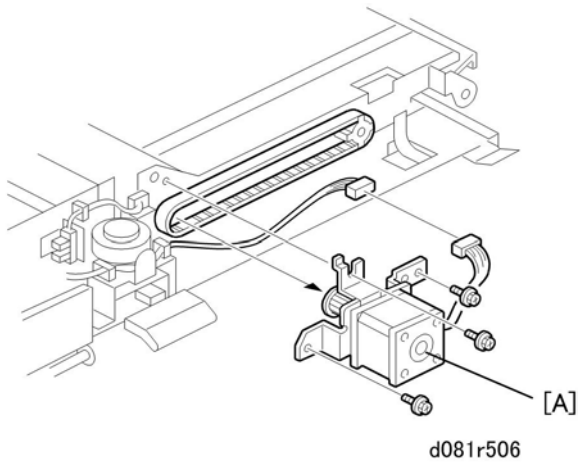

1. Pull out the duplex unit.
2. Release the lower guide plate with knob F.
3. Remove:
 - Duplex unit front cover (🔧 p.5-144 "Duplex Inverter Motor")
 - [A] Duplex transport motor (🔧 x3, 📏 x1, 📏 x2, Timing belt x 1)

Duplex Unit

5.10.3 DUPLEX UNIT SENSORS

Duplex Entrance Sensor

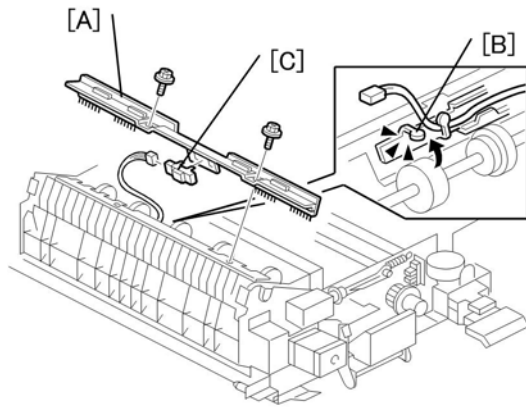

d081r502

1. Pull out the duplex unit.
2. Remove:
 - [A] Bracket (🔩 x 2)
 - [B] Release harness clamp
 - [C] Duplex entrance sensor (🔩 x 1)

Reinstallation



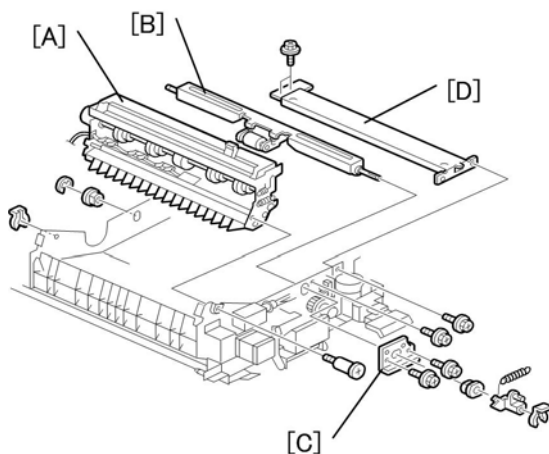

- Insert the anti-static brushes into the roller holes.

Transport Sensors 1, 2





d081r503

1. Remove the duplex unit (🔩 p.5-21)
1. Remove:
 - [A] Inverter unit (🔩 x1 front, 🛡️ x1 rear, 🛡️ x1)

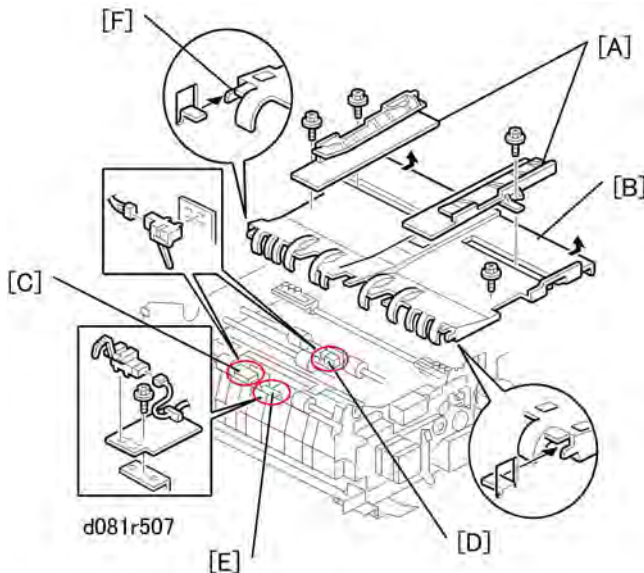
- [B] Reverse trigger roller assembly (Rear:  x1, Shaft bushing x1) (Front:  x1, Link gear x1, Spring x1, Shaft bushing x1)
- [C] Plate ( x2)
- [D] Cross-stay ( x 4)









2. Remove:

- [A] Jogger fences ( x 1 ea.)
- [B] Left transport cover ( x 2)

★ Important

- The front screw is a shoulder screw. Insert the screws in the correct holes when re-attaching.
- To avoid breaking the tabs under the left edge of the table, pull the table to the right to disengage the tabs and then remove.

3. Remove:

- [C] Transport sensor 1 ( x 1,  x 1)
- [D] Transport sensor 2 ( x 1,  x 1)
- [E] Inverter exit sensor ( x 1,  x 1,  x 1)

Reinstallation

- Make sure the end tabs [F] of the left transport cover are engaged correctly.

Duplex Unit

Transport Sensor 3

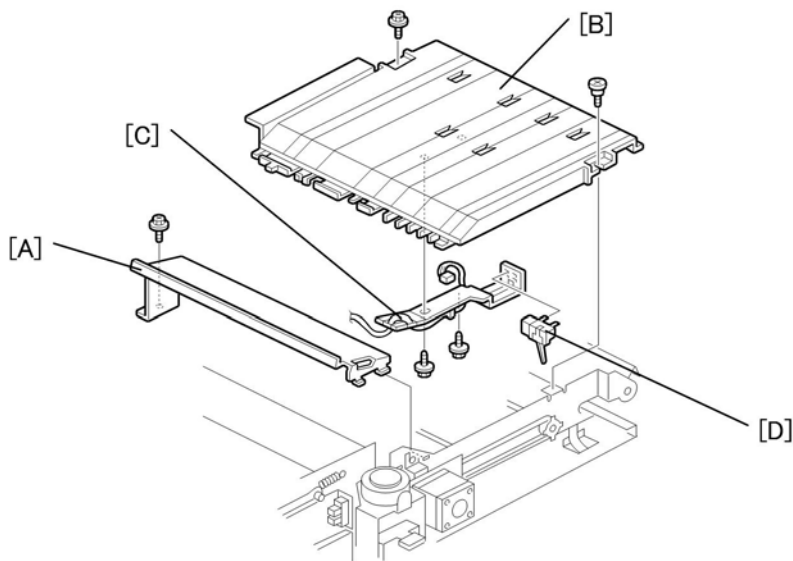

d081r508

1. Remove:

- Duplex unit (🔧 p.5-21)
- Duplex unit front cover (🔧 p.5-144 "Duplex Inverter Motor")

2. Remove:

- [A] Cross stay (🔧 x 1)
- [B] Right transport cover (🔧 x 2, 📏 x 1)

★ Important

- The front screw is a shoulder screw. Insert the screws in the correct holes when re-attaching.

3. Remove:

- [C] Transport sensor bracket (🔧 x 2)
- [D] Transport sensor 3 (📏 x 1)

5.10.4 DUPLEX JOGGER MOTOR

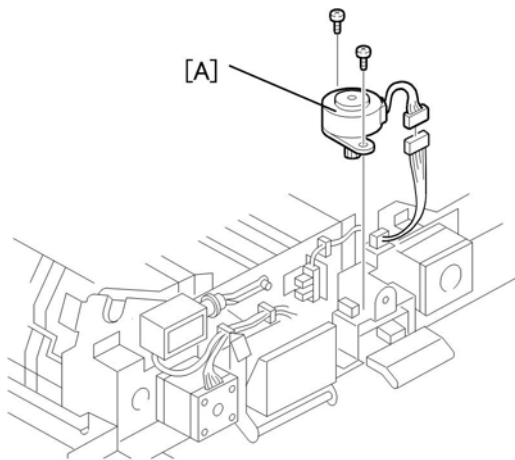

d081r505

1. Remove:
 - Duplex unit (🔧 p.5-21).
 - Duplex unit front cover (🔧 p.5-144 "Duplex Inverter Motor")
2. Remove jogger motor [A] (🔧 x2, 🛠️ x1)

5.10.5 DUPLEX JOGGER BELT

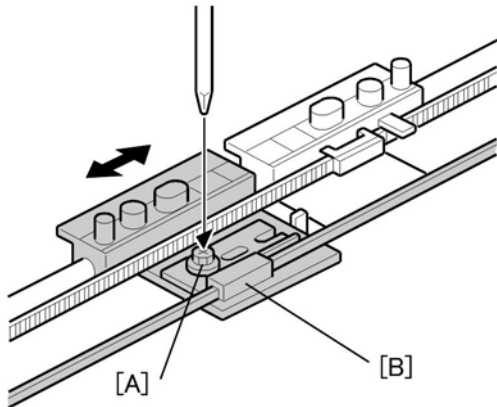

d081r819

1. Remove:
 - Inverter unit (☛ p.5-146 "Duplex Unit Sensors")
 - Cross stay (☛ p.5-146 "Duplex Unit Sensors")
 - Reverse trigger roller assembly (☛ p.5-146 "Duplex Unit Sensors")
 - Jogger fences (☛ p.5-146 "Duplex Unit Sensors")
 - Left transport cover (☛ p.5-146 "Duplex Unit Sensors")
 - Jogger motor assembly (☛ p.5-149 "Duplex Jogger Motor")
2. If you are replacing the belt, set both jogger fence brackets at the center of the belt and tighten the screw [A].
-or-
If you are adjusting the belt, loosen the screw and slide the plastic piece [B] on the belt to the left or right to adjust the position of the front fence, then tighten the screw.

5.11 TANDEM TRAY (TRAY 1)

5.11.1 TANDEM TRAY

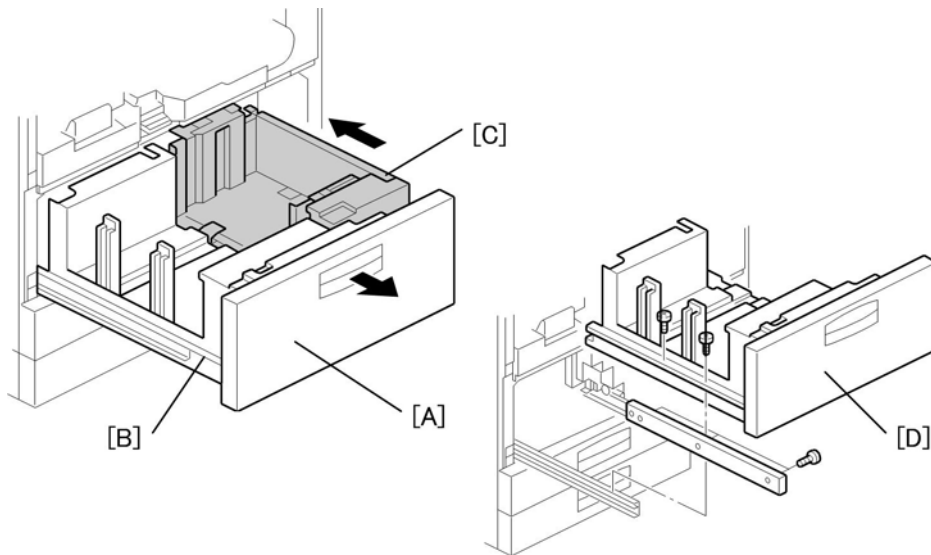

d081r820

1. Open the front door.
2. Pull out the tandem tray drawer [A] completely to separate the left [B] and right [C] sides of the tandem tray.
3. Remove the left tandem tray [D] (⚙ x 5).

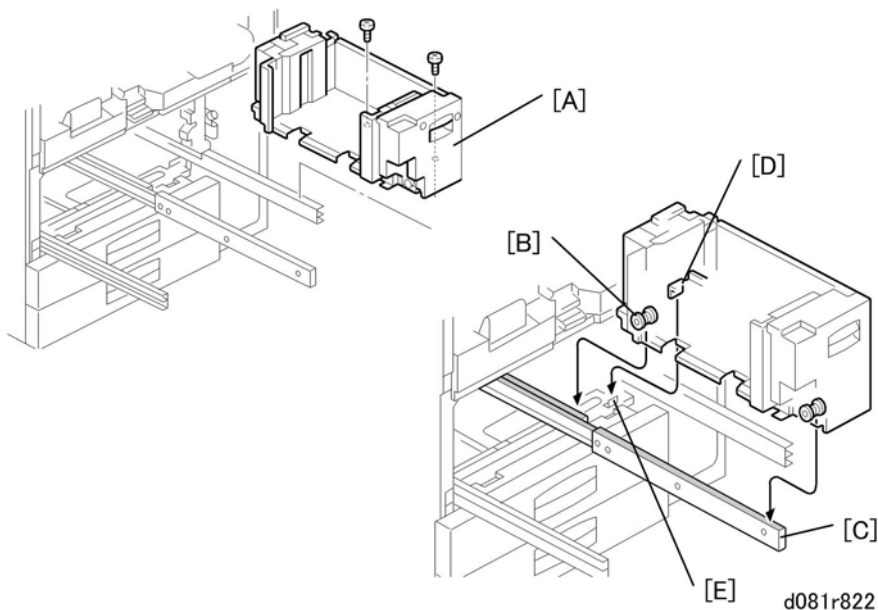

d081r822

4. Remove right tandem tray [A] (⚙ x 2).
 - When re-installing the right tandem tray, make sure that the wheels [B] ride on the

Tandem Tray (Tray 1)

slide rail [C].

- When re-installing the right tandem tray, make sure that the tandem tray stopper [D] is set behind the stopper [E] on the frame.

5.11.2 REAR FENCE RETURN SENSOR REPLACEMENT

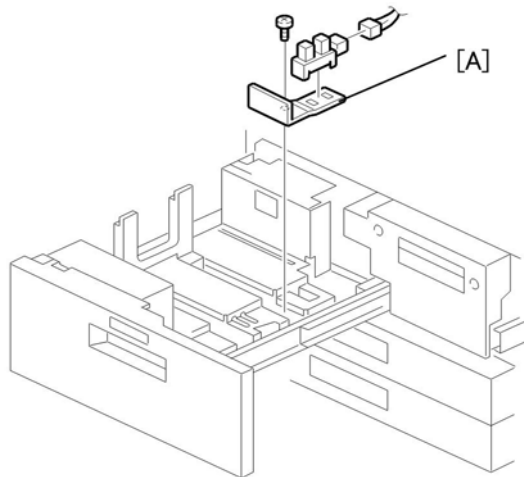

d081r623

1. Pull out the tandem feed tray.
2. Remove return sensor assembly [A] (🔧 x 1, 🛠️ x1).

5.11.3 REAR FENCE HP SENSOR REPLACEMENT

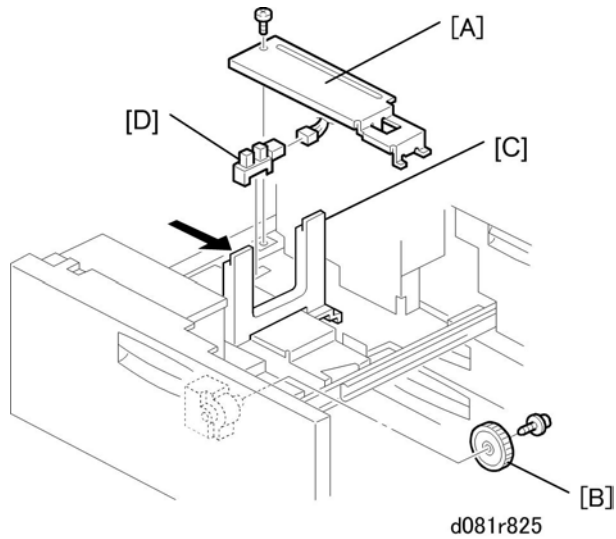

1. Pull out the tandem feed tray.
2. Remove:
 - [A] Rear bottom plate (🔩 x 1).
 - [B] Back fence transport gear (🔩 x 1)
 - [C] Move the back fence to the right.
 - [D] Rear HP sensor (🔧 x 1)

Tandem Tray (Tray 1)

5.11.4 TANDEM RIGHT TRAY PAPER SENSOR REPLACEMENT

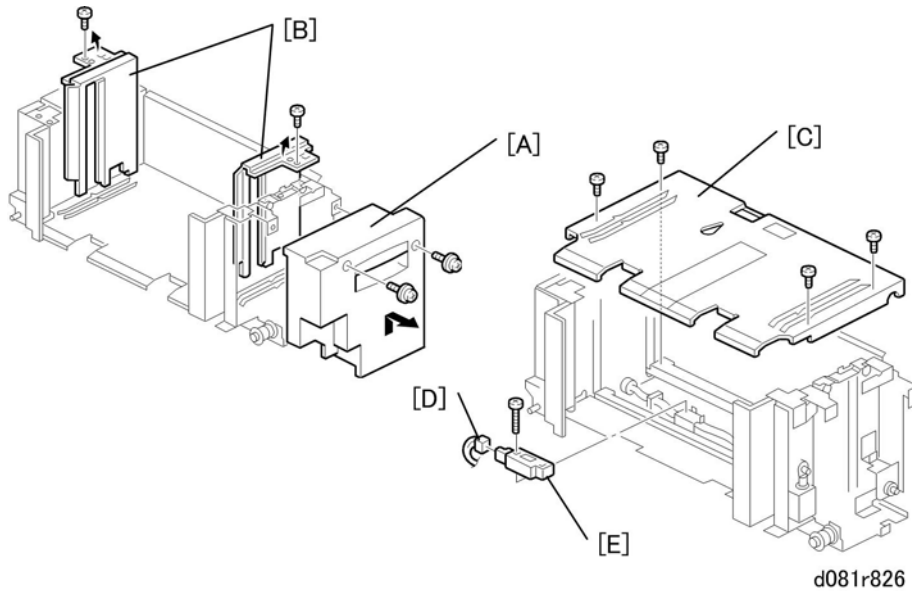

1. Remove the right tandem tray (☛ p.5-151 "Tandem Tray").
2. Remove:
 - [A] Inner cover (☛ x 2)
 - [B] Side fences (☛ x 1 each)
 - [C] Bottom plate (☛ x 4)
 - [D] Connector (☛ x 1)
 - [E] Sensor (☛ x 1)

5.11.5 PAPER HEIGHT SENSORS

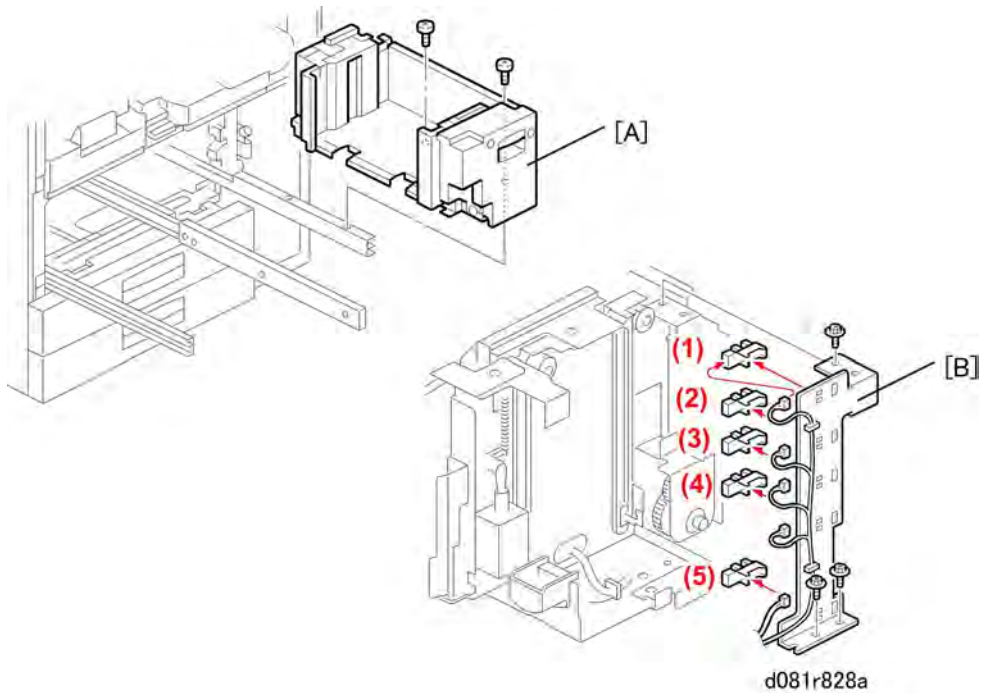

1. Pull out the tandem tray (Tray 1).
2. Remove:
 - [A] Right tandem tray (🔧 x2)
 - [B] Sensor bracket (🔧 x3)
 - [C] Paper height sensors (🔧 x5)

Tandem Tray (Tray 1)

5.11.6 BOTTOM PLATE LIFT WIRE REPLACEMENT

Before replacing the rear bottom plate lift wire, remove the front bottom plate lift wire. It is necessary to remove the shaft for replacing the rear bottom plate lift wire.

Front Wire

1. Remove the right tandem tray (🔧 p.5-151 "Tandem Tray").
2. Remove the paper height sensor bracket (🔧 p.5-155 "Paper Height Sensors").
3. Remove:
 - [A] Remove the inner cover (🔧 x 2)
 - [B] Remove the left stay.
 - [C] Wire stoppers
4. Lift the front bottom plate slightly and unhook it.
5. Remove:
 - [D] Wire covers (Ⓢ x 1 each)
 - [E] Bracket (🔧 x 1, Ⓢ x 1, bushing x 1)
 - [F] Gear
 - [G] Bottom plate lift wire

Rear Wire

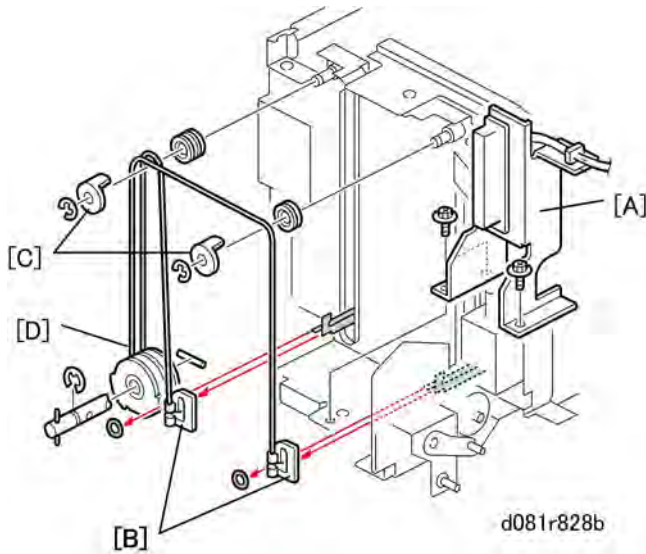

1. Remove:
 - [A] Support (x2)
 - [B] Wire stoppers
 - [C] Wire covers (x2)
 - [D] Bottom plate lift wire

Re-installation

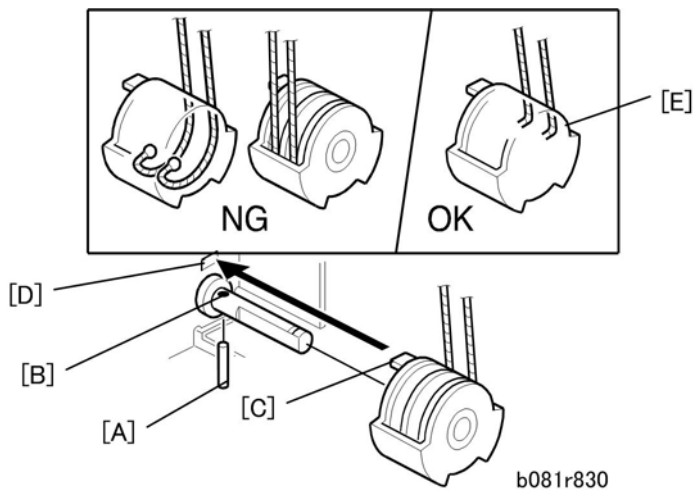

When re-installing the bottom plate lift wire:

- Set the positioning pin [A] in the hole [B], and set the projection [C] in the hole [D].
- Position the wire as shown [E].
- Do not cross the wires.

Tandem Tray (Tray 1)

5.11.7 SIDE FENCE SENSORS

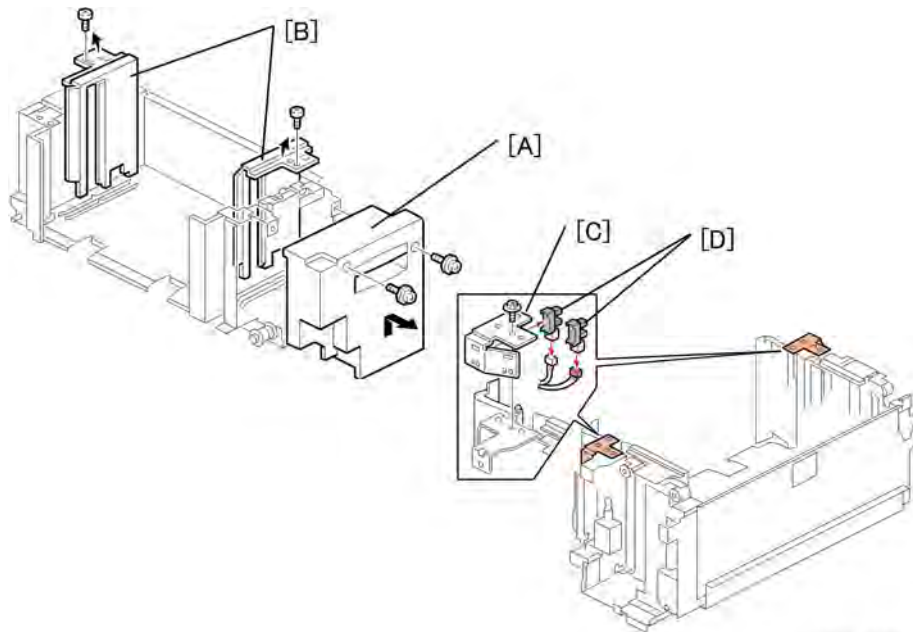

d081r828c

1. Remove:
 - [A] Inner cover (🔩 x2)
 - [B] Two side fences (🔩 x1 each)
 - [C] Sensor bracket (🔩 x1)
 - [D] Two sensors (🔩 x1 each, Pawls x4 each)

5.11.8 TANDEM TRAY PAPER SIZE CHANGE

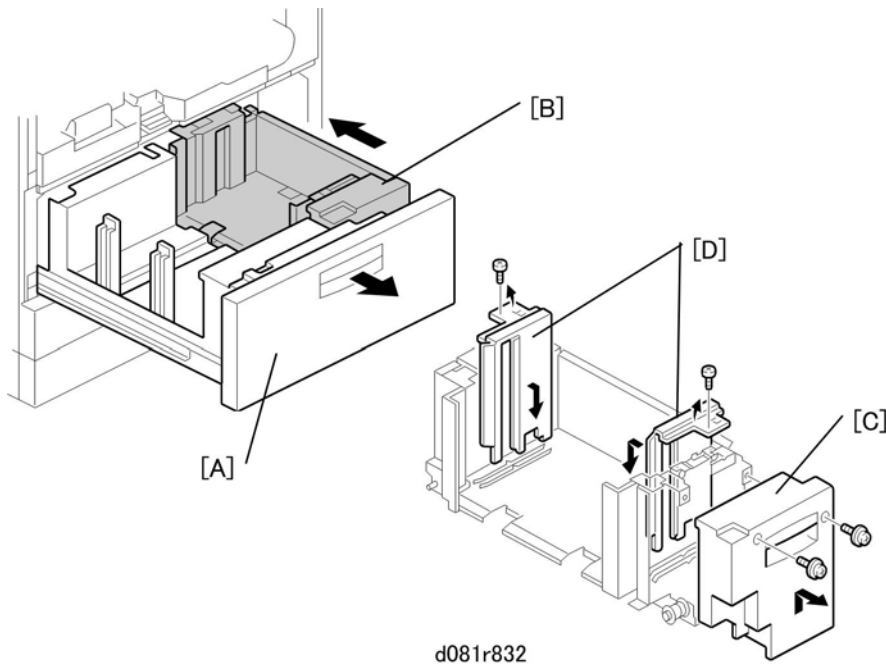

At the factory, this tray is set for A4 or LT LEF so only A4 or LT LEF paper can be used for tandem feed at this setting.

1. Open the front cover.
2. Pull out the tandem feed tray [A] out completely to separate the right tandem tray [B] from the left tandem tray.

Right Tray

1. Remove the right tandem inner cover [C] (⚙️ x 2).
2. Re-position the side fences [D] (⚙️ x 1 each).
 - A4: Outer slot position
 - LT: Inner slot position
3. Re-install the right tandem inner cover.

Tandem Tray (Tray 1)

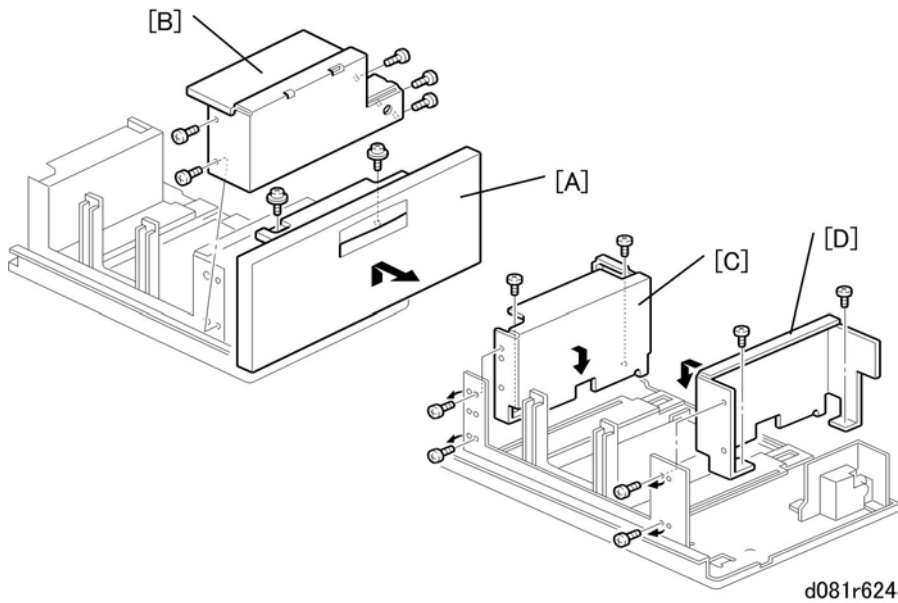

Left Tray

1. Remove the tray cover [A] (⚙️ x 2).
2. Remove the DC motor cover [B] (⚙️ x 5).
3. Remove the rear side fence [C] and front side fence [D] (⚙️ x 4 ea.).
4. Re-position the side fences (⚙️ x 4 ea.).
 - A4: Outer slot position
 - LT: Inner slot position
5. Re-install the DC motor cover and the tray cover.

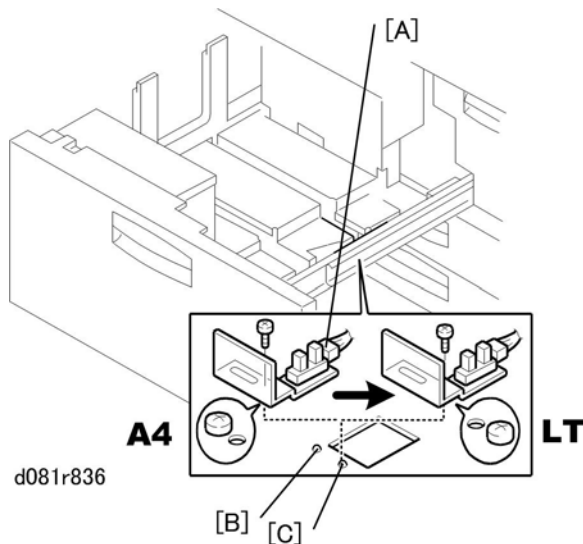

1. Re-position the return position sensor bracket [A] (⚙️ x 1).
 2. For A4 set the screw in the left hole [B].
- or-

For LT set the screw in the right hole [C].

3. Input the new paper size into SP5959 001.

Reinstallation

- Do the scanner and registration adjustments (☛ p.5-226 "Image Adjustments").

5.11.9 SIDE-TO-SIDE REGISTRATION CORRECTION

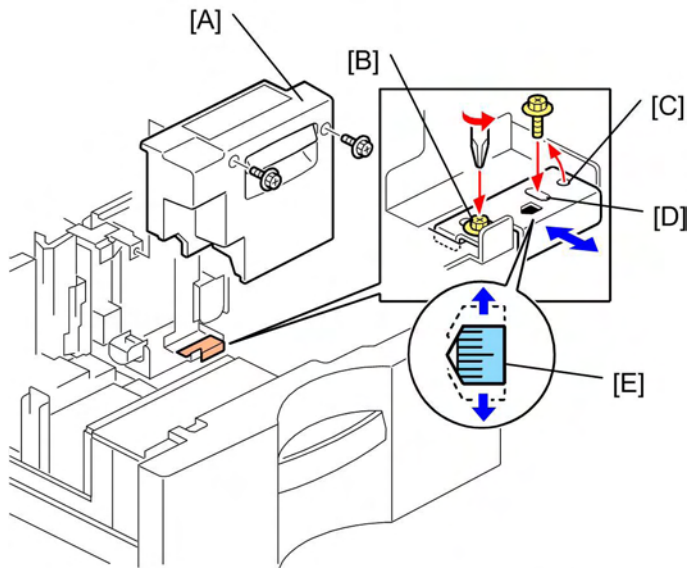

d081r651

1. Open the tandem tray.
2. Remove front cover [A] of the right tray (☛ x2).
3. Loosen screw [B].
4. Remove the screw from round hole [C] and move it to oval hole [D].
5. Look at the scale [E] through the cut-out.
6. Shift the plate forward or back, check the position on the scale, and then tighten both screws to set the plate at the new position.

5.12 PAPER FEED (TRAYS 2, 3)

5.12.1 PICKUP, FEED, REVERSE ROLLERS

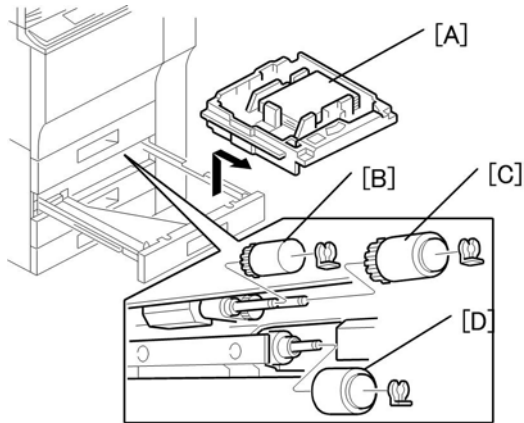

d081d601

1. Remove:

[A] Tray.

[B] Feed roller (☞ x 1)

[C] Pick-up roller (☞ x 1)

[D] Separation roller (☞ x 1)

★ Important

- The operation of the FRR mechanisms for the tandem tray (Tray 1), universal trays (Tray 2, Tray 3), by-pass tray, and ADF are similar. However, the only rollers that are interchangeable are the tandem and universal tray rollers (Trays 1, 2, 3).
- Do not touch the surface of new rollers during replacement.

5.12.2 PAPER FEED UNIT

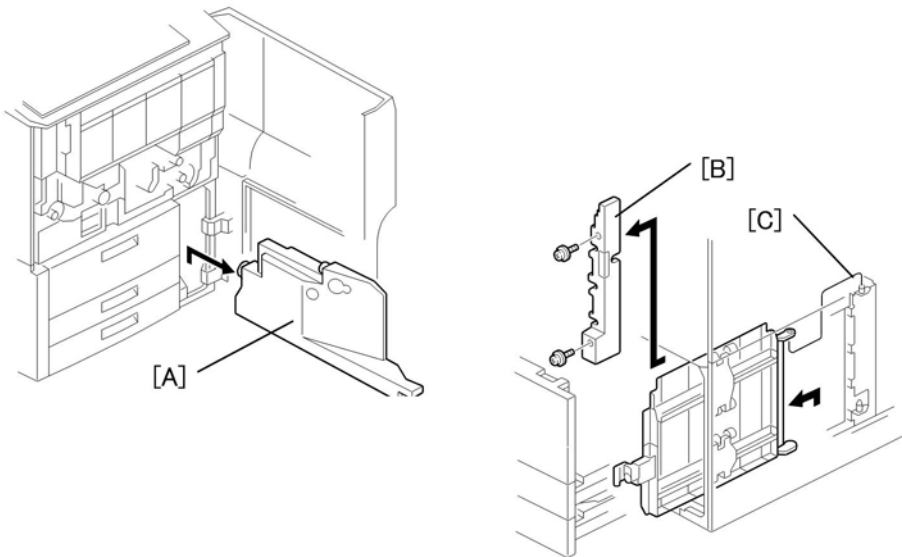

d081r602

1. Remove the front door (☛ p.5-9)
2. If the LCT is connected, disconnect it and pull it away from the machine, then remove the LCT entrance guide cover and right lower cover
3. Pull out all three trays (do not remove).
4. Remove:
 - [A] Toner collection bottle
 - [B] Vertical transport guide
 - [C] Inner cover (🔩 x 2)

Re-installation

- When re-installing the vertical transport guide, remove the lower right cover then insert from it.

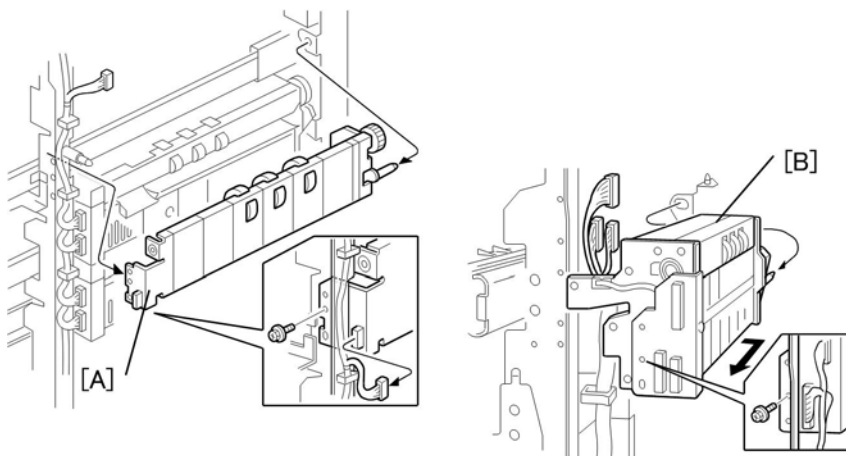

d081r625

Paper Feed (Trays 2, 3)

[A] Guide plate (🔩 x 1)

1st feed unit only.

[B] Feed unit (🔩 x 1, 📦 x 3)

Insert your hand from the right and pull the feed unit forward.

To avoid hitting the unit on the sides of the machine, remove it carefully and slowly.

If the paper feed motor must be replaced, replace the paper feed unit.

5.12.3 SEPARATION ROLLER PRESSURE ADJUSTMENT

The position of the drive gear for the separation roller can be changed in order to change the amount of pressure exerted by the separation roller. This adjustment can be done:

- When feeding special paper, especially thick paper
- When the customer is experiencing feed problems

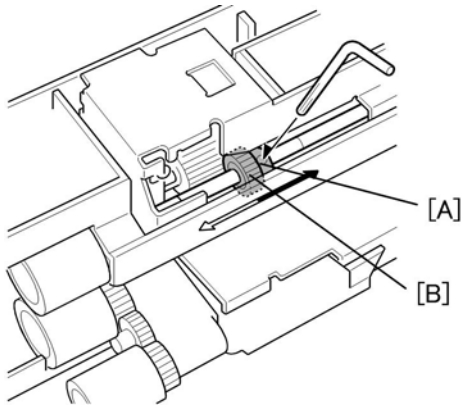

d081r605

1. Remove the feed unit
2. Loosen the hex screw [A].
3. The separation roller gear [B] is positioned at the groove before shipping.

To adjust for thick paper, move the separation roller gear to the left to decrease the pressure.

-or-

To correct misfeeds, move the separation roller gear to the right to increase the pressure.

5.12.4 PAPER END, TRAY LIFT, PAPER FEED SENSORS

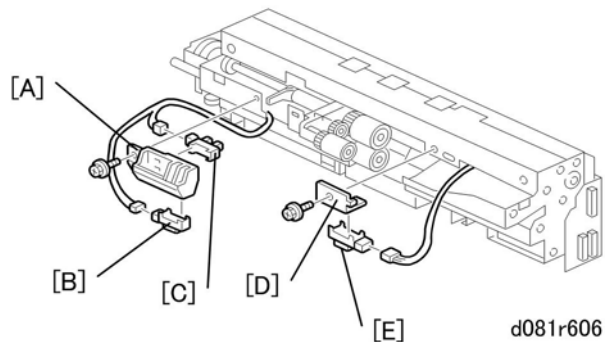

1. Remove paper feed unit (☛ p.5-163).
2. Remove:
 - [A] Sensor bracket (🔩 x1)
 - [B] Paper end sensor (🔌 x1)
 - [C] Tray lift sensor (🔌 x1)
 - [D] Sensor bracket (🔩 x1)
 - [E] Paper feed sensor (🔌 x1)

5.12.5 VERTICAL TRANSPORT SENSOR

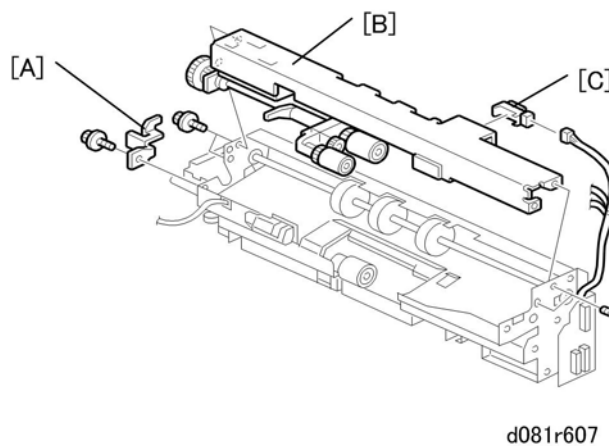

1. Remove paper feed unit (☛ p.5-163).
- [A] Bracket (🔩 x1)
- [B] Upper unit (🔩 x4)
- [C] Vertical transport sensor (🔌 x1)

5.12.6 FEED MOTOR

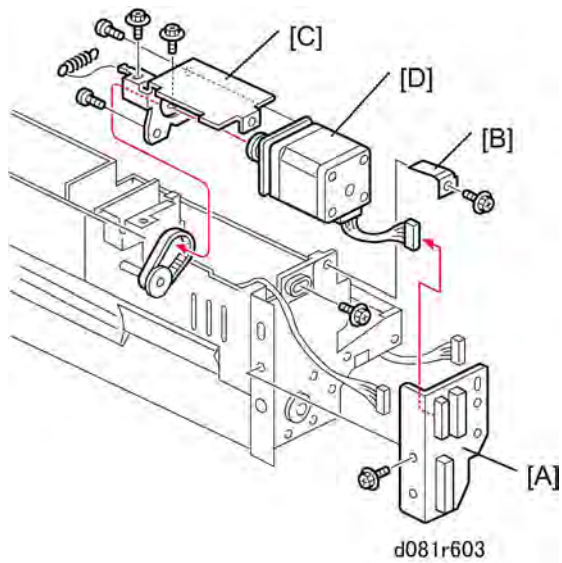

1. Remove the paper feed unit (● p.5-163).
2. Remove:
 - [A] Connector cover (● x1)
 - [B] Ground plate (● x1)
 - [C] Bracket (● x3, Spring x1)
 - [D] Feed motor (● x2)

5.12.7 PAPER SIZE SWITCHES

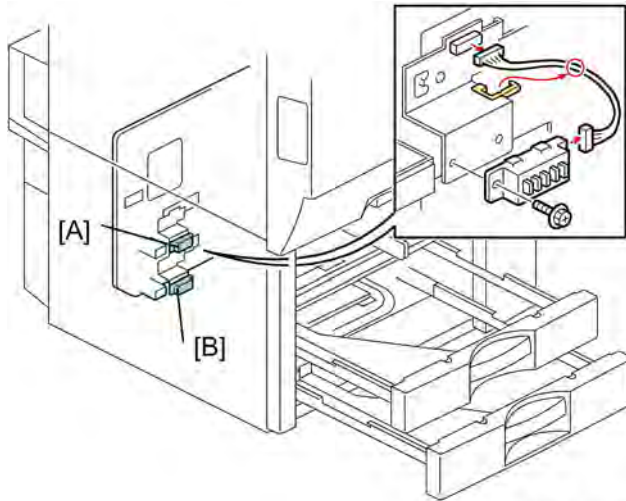

d081r604

1. Remove Tray 1 (tandem tray), Tray 2 and Tray 3.
2. Remove:
 - [A] Paper size switch (Tray 2) and harness (🔌 x1, 🔧 x1, 📏 2)
 - [B] Paper size switch (Tray 3) and harness (🔌 x1, 🔧 x1, 📏 2)

5.13 BYPASS UNIT

5.13.1 BYPASS PICKUP, FEED, REVERSE ROLLERS

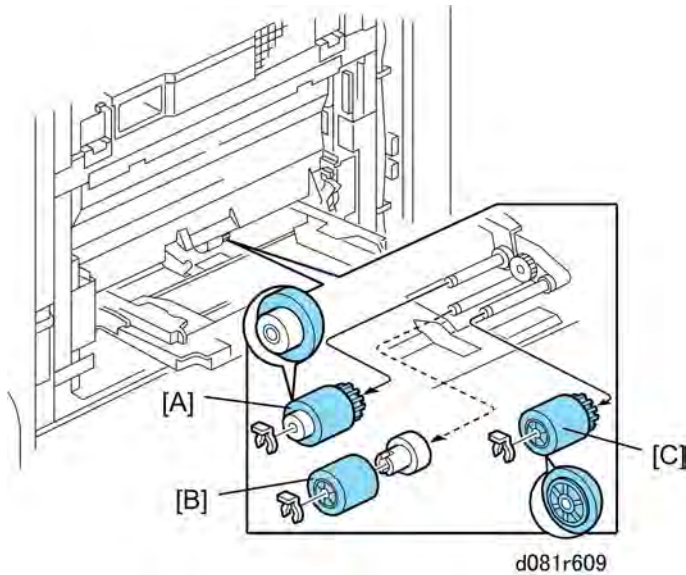

1. Remove right covers (☛ p.5-10).
2. Open the bypass tray.
3. Remove:
 - Bypass unit (☛ p.5-170)
 - Unit upper cover (☛ p.5-170 "Bypass Paper End Sensor, Feed Sensor")
4. Remove:
 - [A] Feed roller (☞ x1)
 - [B] Reverse roller (☞ x1)
 - [C] Pickup roller (☞ x1)

5.13.2 BYPASS AUTO PAPER SIZE DETECTION SWITCHES

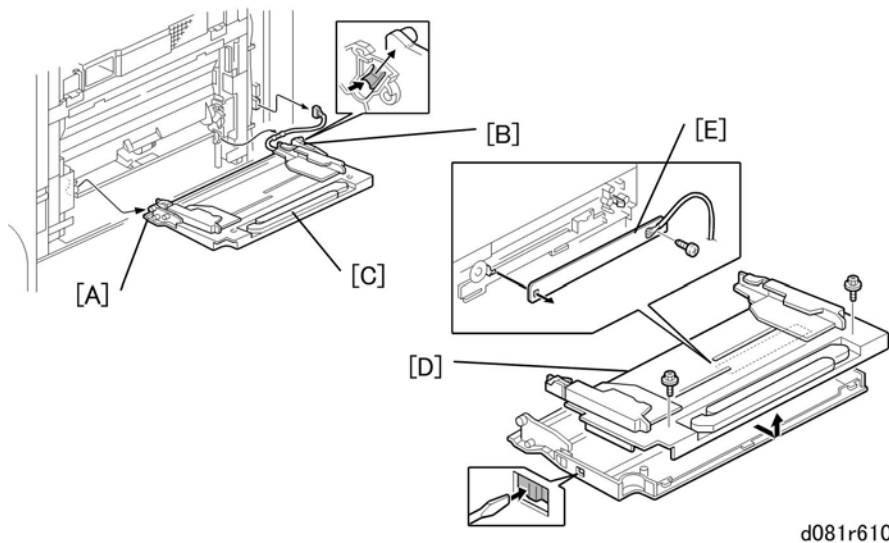

1. Remove right covers
2. Open the bypass tray
3. Disconnect:
 - [A] Front hinge
 - [B] Rear hinge
4. Remove:
 - [C] Bypass tray (🔧 x1)
 - [D] Bypass table (🔧 x2, Pawls x2)
 - [E] Paper size detection board (Pawl x1, 🔧 x1)

5.13.3 BYPASS UNIT

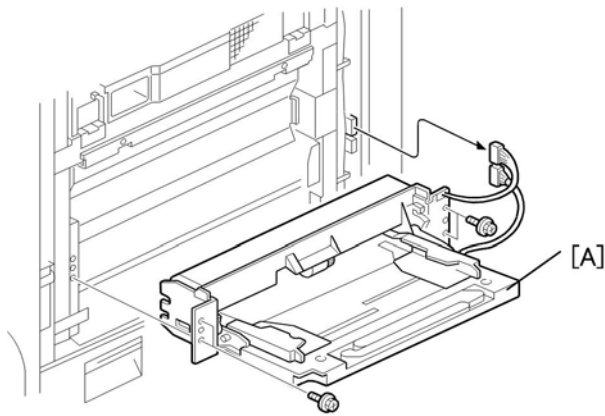

b081r626

1. Remove right covers (🔧 p.5-10).
2. Open the bypass tray
3. Remove:
[A] Bypass unit (🔧 x4, 📦 x2)

5.13.4 BYPASS PAPER END SENSOR, FEED SENSOR

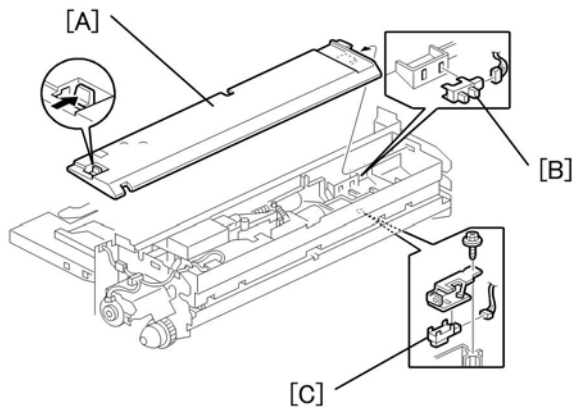

d081r613

1. Remove the bypass unit (🔧 p.5-170).
[A] Unit upper cover (Release x1)
[B] Paper end sensor (📦 x1)
[C] Feed sensor (🔧 x1, 📦 x1)

5.13.5 BYPASS FEED CLUTCH

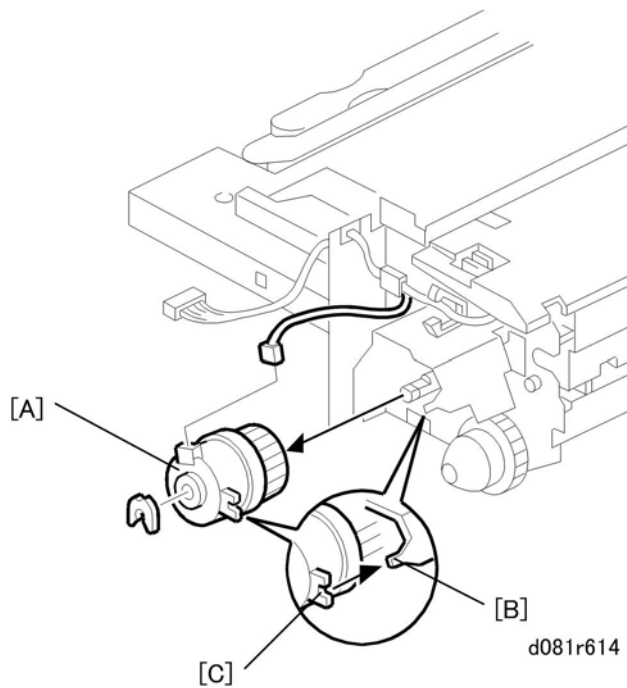

1. Remove the bypass unit (☛ p.5-170).
2. Remove bypass feed clutch [A] (☛ x1, ☛ x1)

Reinstallation

- Make sure the arm [B] fits correctly into the notch bracket [C] of the clutch.

Boards

5.14 BOARDS

5.14.1 PCB LAYOUT

Controller Box Closed

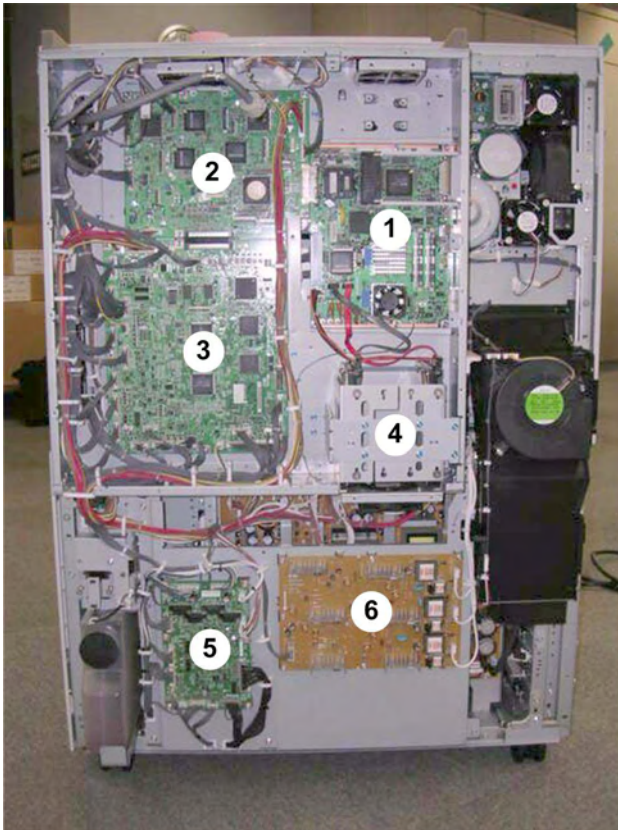

b132r835

①	Controller Board
②	IPU Board
③	VBCU Board
④	HDD Unit
⑤	PFB (Paper Feed Board)
⑥	HVPS (High Voltage Power Supply)

Controller Box Open

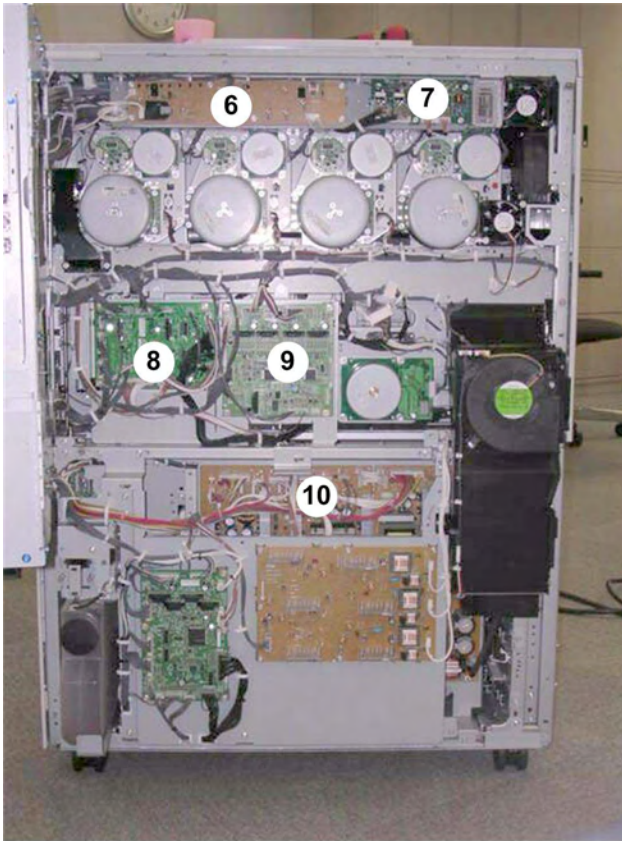

b132r836

⑥	Charge Roller Power Pack
⑦	Potential Sensor Power Pack
⑧	DRB (Motor Drive Board)
⑨	DTMB (Drum Transfer Motor Board)
⑩	PSU

Boards

Left Lower Cover Removed



b132r837

⑪	AC Drive Board
---	----------------

5.14.2 CONTROLLER

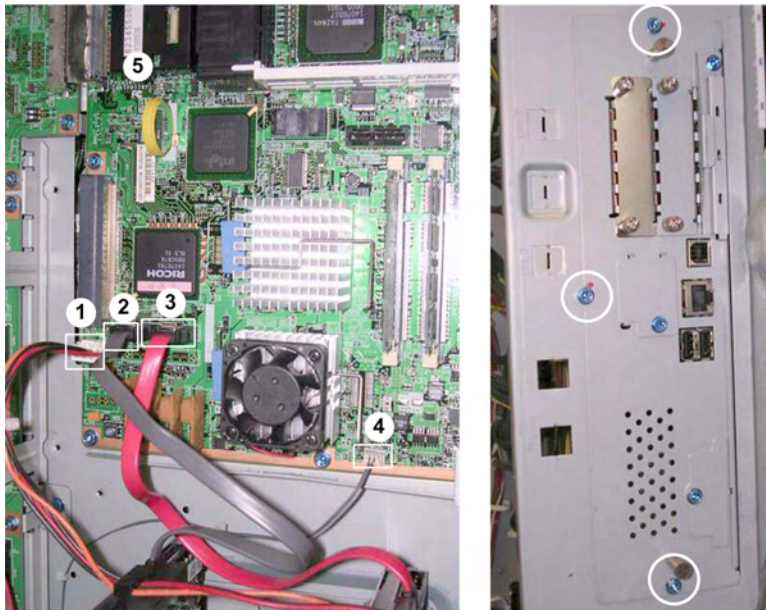

b132r838

★ Important

- The controller box cover should always be removed so that the controller board can be disconnected before removal of the controller board.
- Never attempt to pull the controller unit out of the machine until you have removed the box cover and disconnected the controller board.
- If you attempt to pull the controller unit out of the machine without first disconnecting the board, you will break or damage the connectors.

1. Remove the controller box cover (🔧 x16)
2. Disconnect connectors ①, ②, ③, ④ (🔧 x4).
3. Remove the screws (🔧 x3).
4. Remove the controller board.

When installing the new controller board

★ Important

- The machine will issue SC195 (Machine Serial Number Error) if you fail to do the procedure below.
1. Remove the NVRAMs ⑤ from the old controller board. (See previous illustration.)
 2. Install them on the new controller board after you replace the controller board.
 3. Replace the NVRAMs if the NVRAM on the old controller board is defective.

↓ Note

- Make sure you print out the SMC reports ("SP Mode Data" and "Logging Data") before you replace the NVRAMs.

★ Important

- Keep NVRAMs away from any objects that can cause static electricity. Static electricity can damage NVRAM data.
- Make sure the NVRAMs are correctly installed on the controller board.
- Make sure that the DIP-switch settings on the old controller board are the same for the new controller board. Do not change the DIP switches on the controller board in the field.

After installing the controller board

1. For a model in which the HDD encryption unit has been installed, restoring the encryption key is required. Refer to "Recovery from a Device Problem" in the installation procedure for the HDD Encryption Unit.
2. Turn the main power switch off/on.

5.14.3 IPU/VBCU

IPU/VBCU Removal

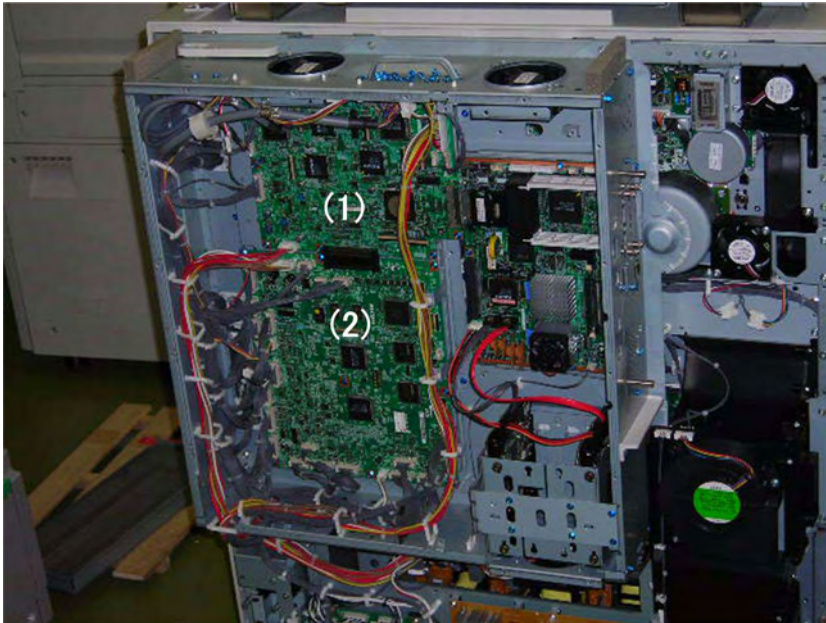

b132r839

Before You Begin...

- The IPU (1) and VBCU (2) are connected and mounted on same plate. They must be removed together.
- The controller board must be removed before the IPU/VBCU can be removed.



b132r840

1. Remove the controller board.
2. Disconnect the boards.
 - [A] IPU (🔌 x8)
 - [B] VBCU (🔌 x26)
3. Slide the plate with the boards attached to the right.

Boards

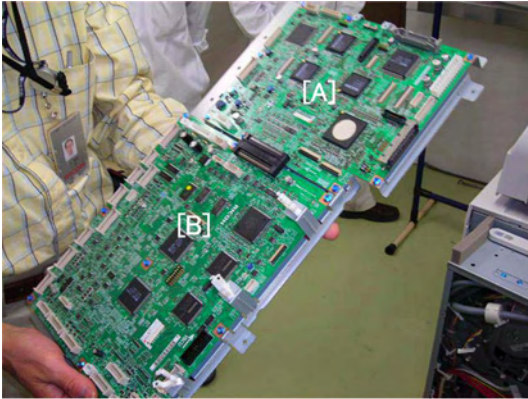

b132r841

4. Remove the boards from the frame.

[A] IPU (🔧 x8)

[B] VBCU (🔧 x9)

VBCU Replacement

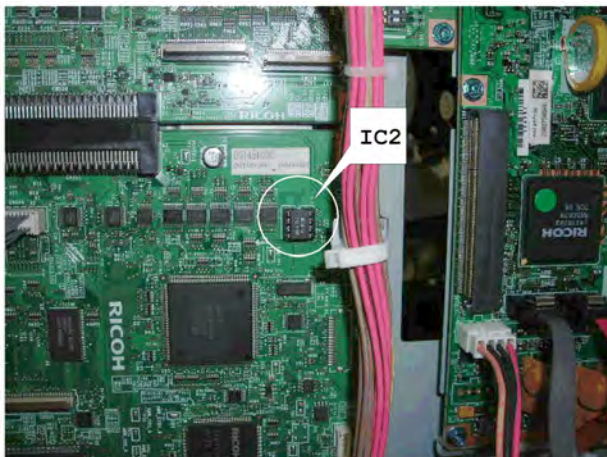

d014r501

1. Remove the EEPROM from the old VBCU. (The EEPROM shown above is marked "IC2" with a notation on the board.)
2. Install the EEPROM on the new VBCU.
3. Set the DIP SW (SW2) for the machine as shown below.

D081/D082-17

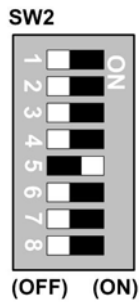

D081/D082-27

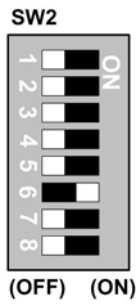

D081/D082-29

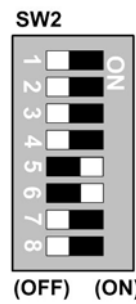

d081r915

5.14.4 PFB

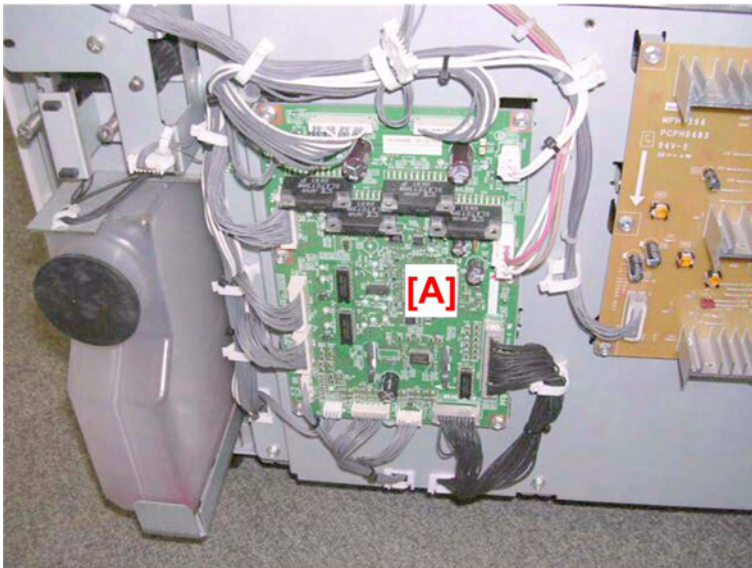

b132r842

1. Remove the PFB [A] (🔧 x14, 🛠️ x6).

Boards

5.14.5 HVPS

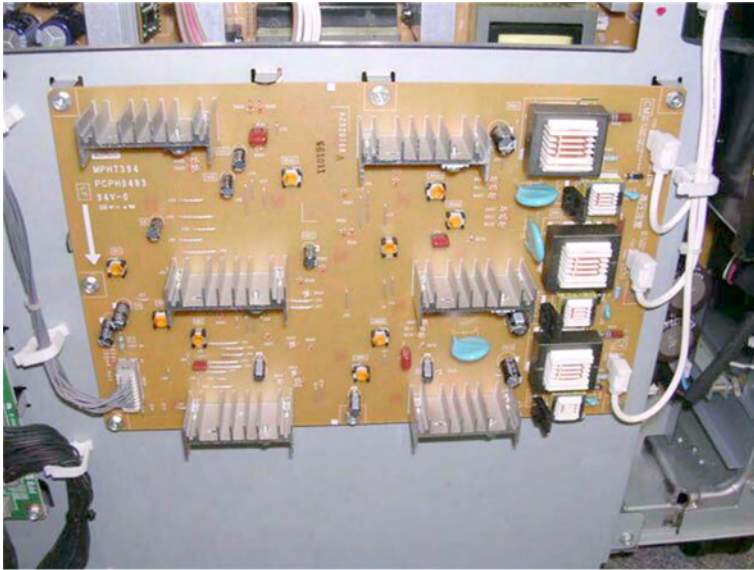

b132r843

1. Remove the HVPS (🔧 x4, 🪛 x8).

5.14.6 CHARGE ROLLER POWER PACK

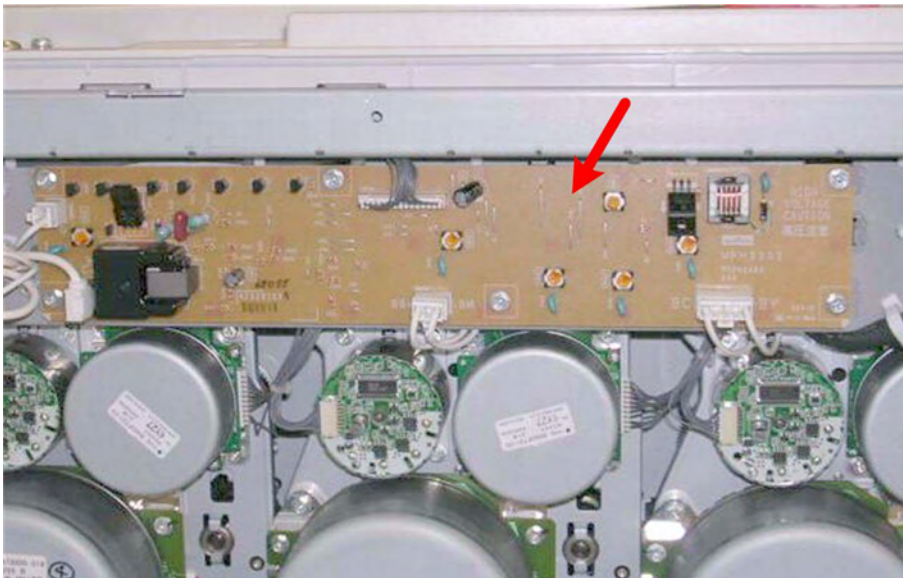

b132r844

1. Remove the charge roller power pack (🔧 x5, 🪛 x6).

5.14.7 POTENTIAL SENSOR POWER PACK

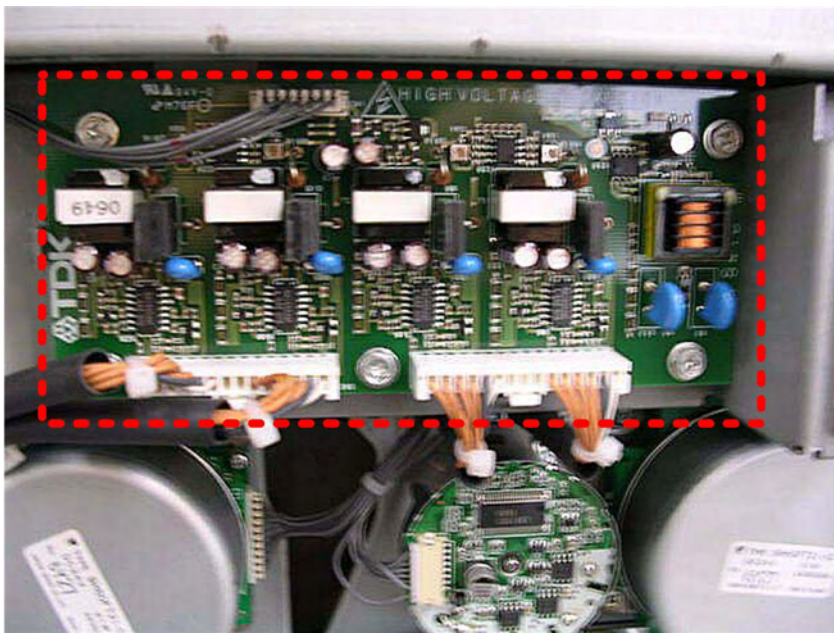

b132r845

1. Remove the potential sensor power pack (🔧 x3, 🛠️ x5).

5.14.8 DRB

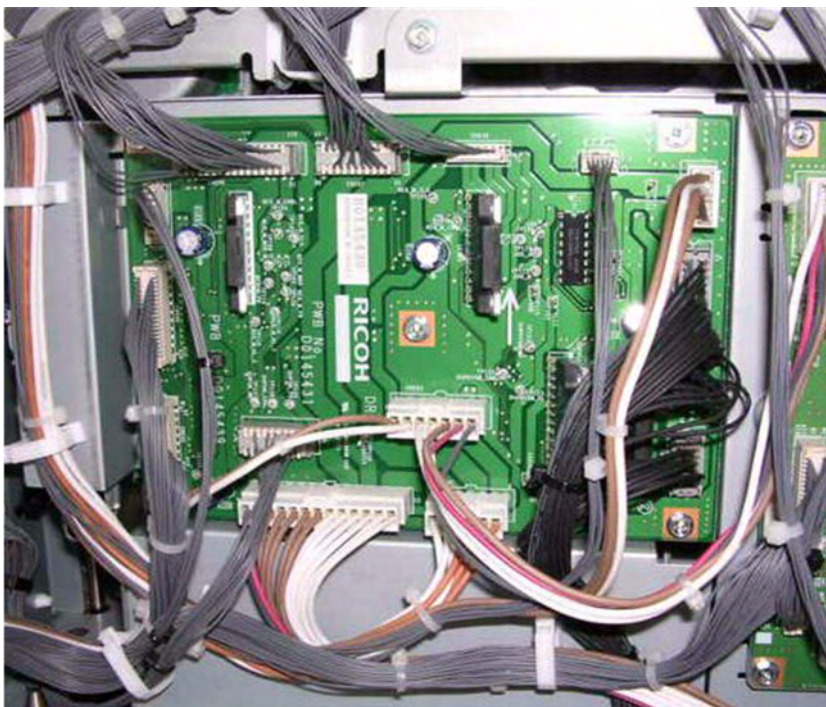

b132r846

1. Remove the DRB (🔧 x14, 🛠️ x5).

Boards

5.14.9 DTMB

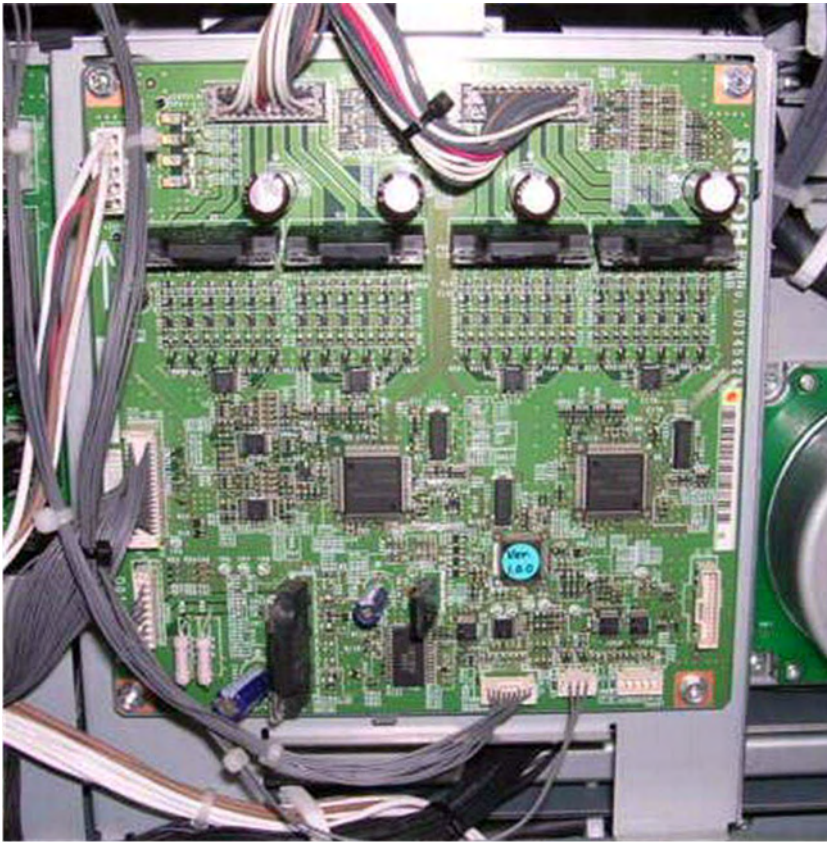

b132r847

1. Remove the DTMB (🔌 x7, 🛠️ x4).

5.14.10 PSU

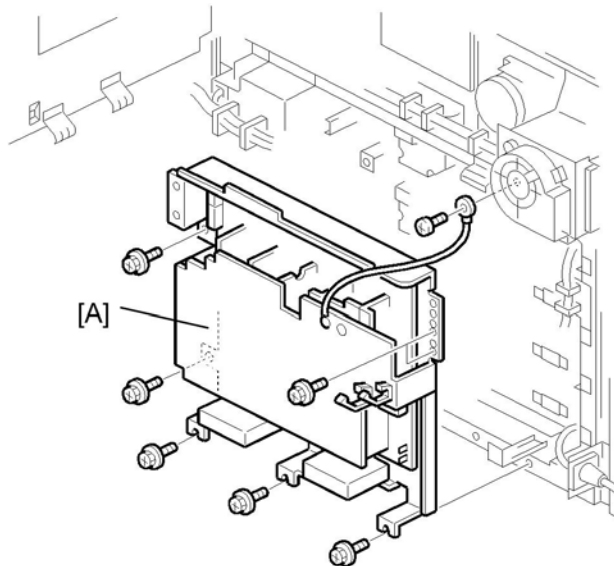

b132r848

1. Remove the rear covers.
2. Open the controller box door.
3. Remove the PFB/HVPS board frame.
4. Remove:
[A] PSU (🔩 x9, 🛠️ x8).

5.14.11 AC DRIVE BOARD

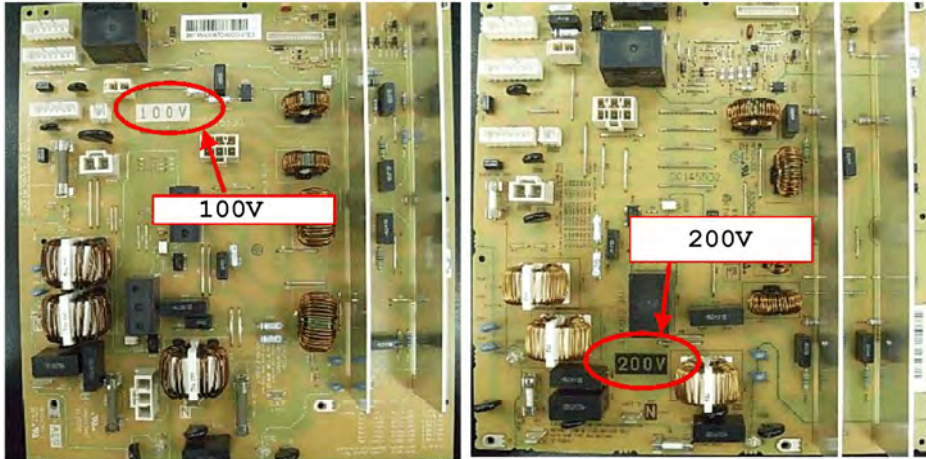

d014r505

1. Make sure that you have to correct type of board for the machine.
 - There are two types of AC drive boards: 100V and 200V.
 - The boards are clearly marked at the locations shown above.
 - Confirm the marking before installing the AC drive board.
2. Remove the AC drive board (🔧 x7, 🛠️ x8).

5.14.12 MEMORY

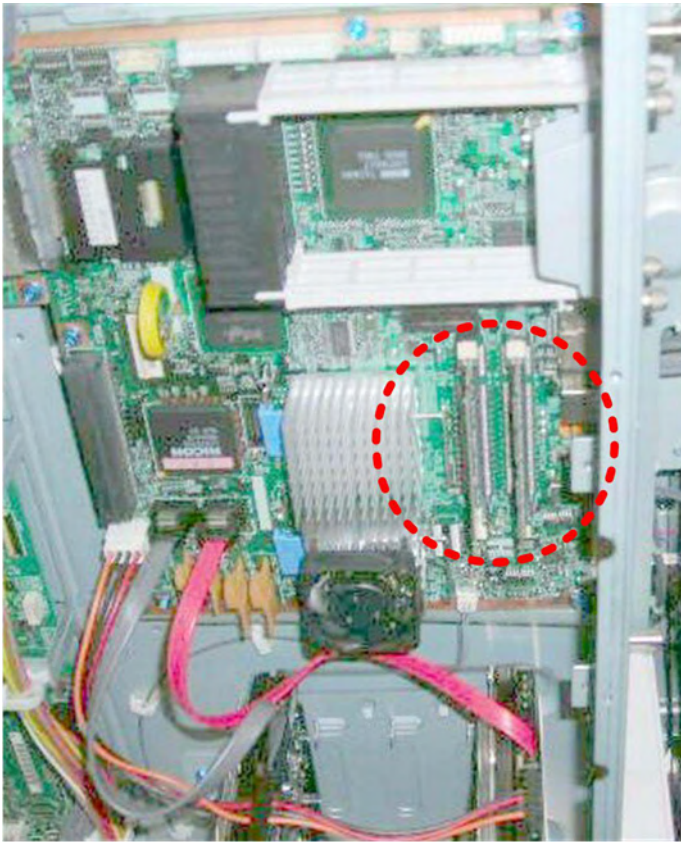

b132r850

1. Install memory chips.

5.14.13 NVRAM

Before You Begin...

- Never remove the NVRAM until you have uploaded its contents.
- Always touch a metal surface to discharge any static on your hands before you touch the controller board.
- Work carefully when removing the NVRAM to avoid damaging other components on the controller board or short circuiting the pins of other chips.

Boards

Upload NVRAM Data to SD Card

1. Do SP5990 001 to print the SMC report.

★ Important

- Before removing the VM card from Slot 1 (lower slot) you must shut down the App2 Me application if it is running (all running VM applications must be shut down at this time). See p.5-24 "Before Removing and Re-installing the VM Card".
2. Turn the copier main power switch off.
 3. Insert an SD card in Slot 1 (lower slot).
 4. Execute SP5824 to upload the data to the SD card.

★ Important

- The following items cannot be uploaded from NVRAM to the SD card: Total counter values, the C/O, P/O counter values, the Duplexing, A3/DLT/Over 420 mm counter values, stapler counter values, scanner counter values, and Engine SP settings.
5. Switch the machine off and disconnect the power cord.

Replace NVRAM

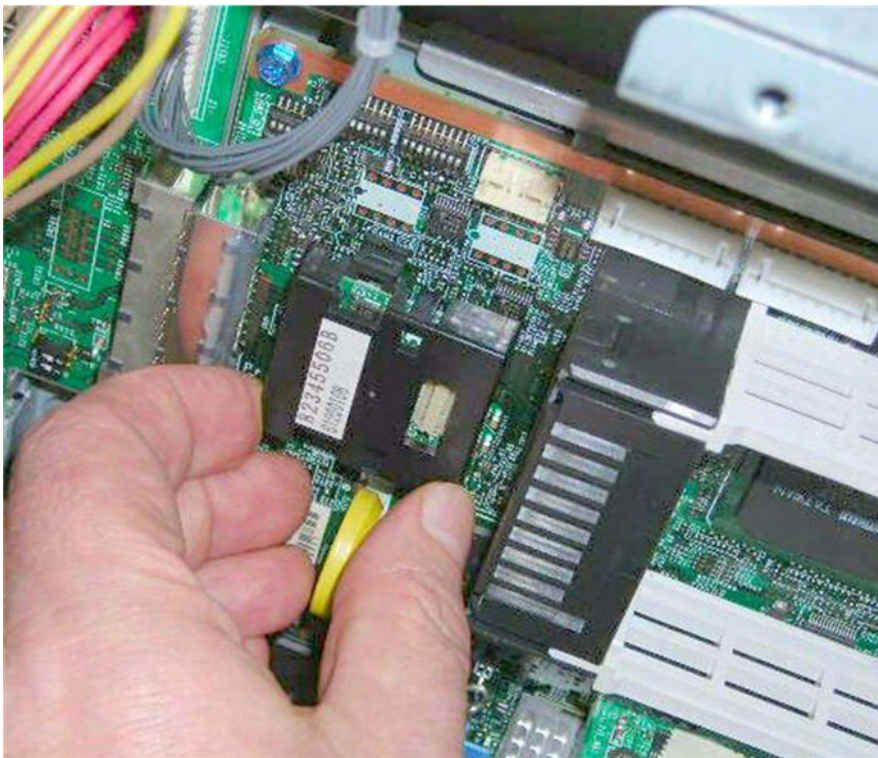

b132r851

1. Remove the old NVRAM.
2. Attach the new NVRAM.

Download NVRAM Data from SD Card

1. Turn the copier main power switch off.
2. Put the SD card with the NVRAM data into Slot 1 (lower slot).
3. Open the front door of the copier.
4. Turn the copier main power switch on.

If the NVRAM is new, SC195 (Machine Serial Number Error) may appear. If this occurs:

- Enter the SP mode and do SP5801 001 to reset the memory to the defaults (All).
- Switch the machine off/on and start from Step 1.

★ Important

- If SC195 occurs, the serial number must be input. You must contact your technical supervisor.
5. Execute SP5825 to download the data uploaded from the old NVRAM.
 6. Switch the machine off and remove the SD card.
 7. Switch the machine on, then do SP5990-1 to print another SMC report.
 8. Compare this new SMC report with the report you printed in Step 1. If any of the SP settings are different, enter the SP settings of the first report.
 9. Execute SP5907 and enter the brand and model name of the machine for Windows Plug & Play capability.

★ Important

- If the client is using any VM card applications, such as App2 Me, you must do the procedure to re-start these VM applications. (☛ p.5-24 "Before Removing and Re-installing the VM Card")

ADF

5.15 ADF

5.15.1 ADF COVERS

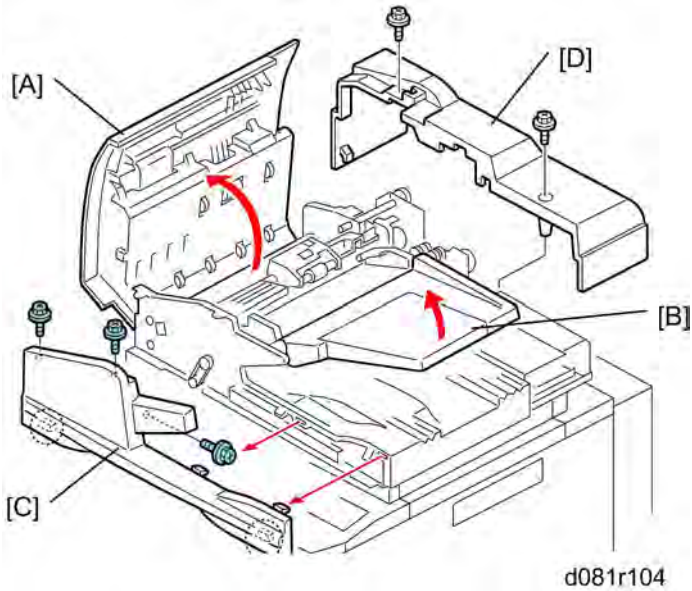

1. Raise:
 - [A] Feed cover
 - [B] Original tray
2. Remove:
 - [C] Front cover (🔩 x 3)
 - [D] Rear cover (🔩 x 2)

5.15.2 FEED UNIT

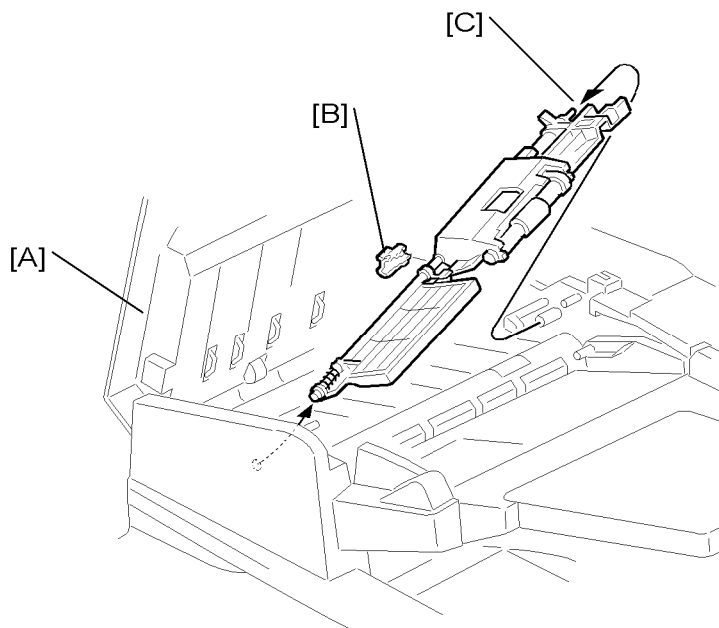

b246r867

1. Open the feed cover [A].
2. Remove the snap fitting [B].
3. Push the feed unit slowly to the left to disengage the shaft [C] on the right, and lift it out.

5.15.3 PICK-UP ROLLER AND FEED BELT

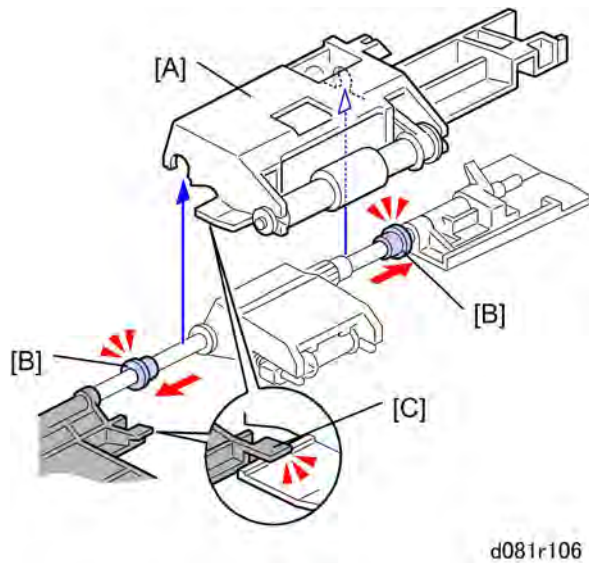

1. Remove the feed unit (☛ p.5-189).
2. Remove:
[A] Pick-up roller unit
[B] Bushings (x2)

↓ Note

- At re-assembly, make sure that the tab [C] on the front guide plate is above the pick-up roller.

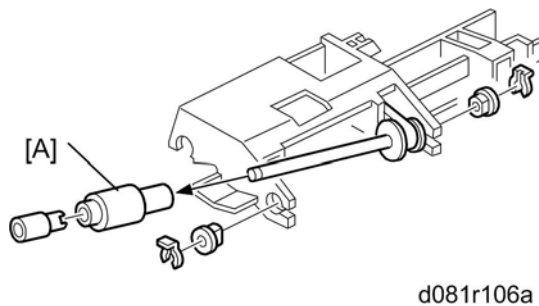

3. Remove pick-up roller [A]. (☛ x2, Bushing x2)

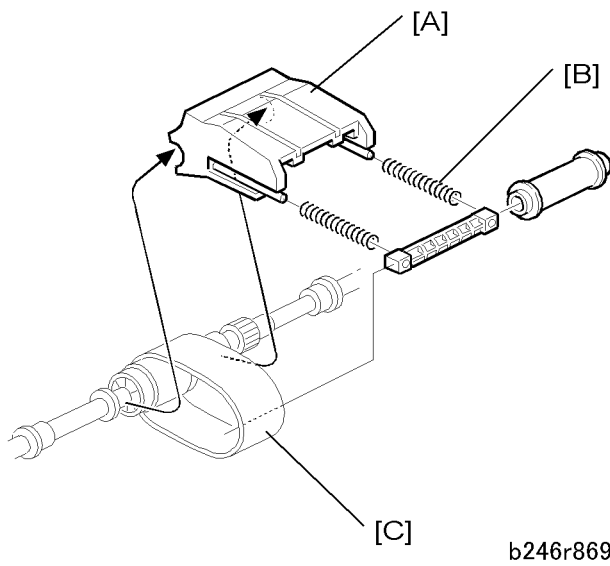

4. Grip the holding feed belt holder [A] on both sides, and then carefully pull it off the bushing. Do not let the springs [B] fall.
5. Remove the feed belt [C].

↓ Note

- When re-assembling, set the pick-up roller springs first.

ADF

5.15.4 SEPARATION ROLLER

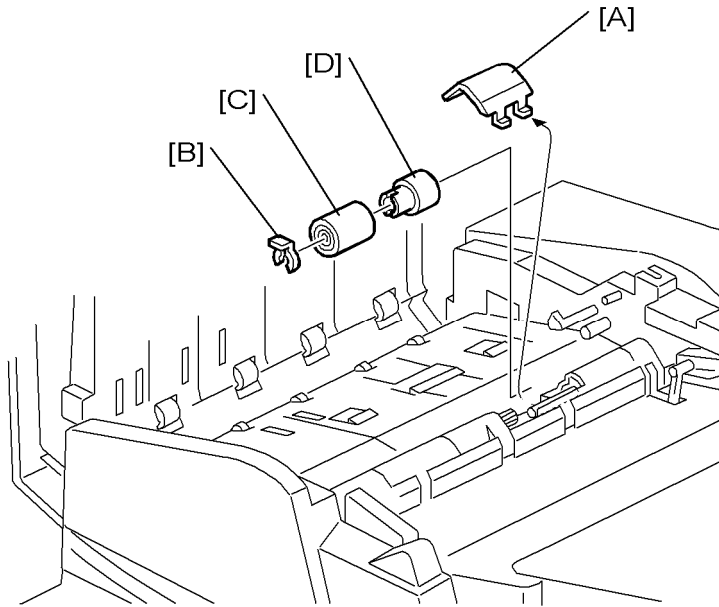

b246r870

1. Open the feed cover.
2. Remove the feed unit (➡ p.5-189).
3. Remove:
 - [A] Separation roller cover. Use the tip of a screwdriver to push up the cover.
 - [B] Clip (🔗 x 1)
 - [C] Separation roller
 - [D] Torque limiter clutch

5.15.5 REGISTRATION SENSOR

1. Open the feed cover.
2. Remove the feed unit (p.5-189).

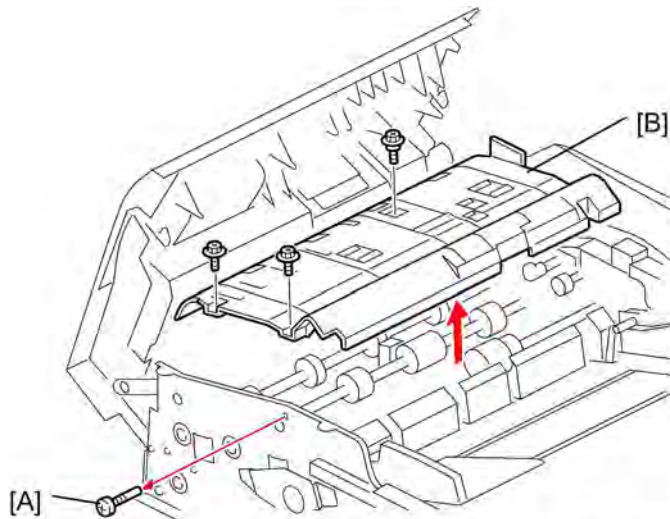

d081r112

3. Remove:
 - [A] Pivot screw (x1)
 - [B] Guide plate [A] (x 3)

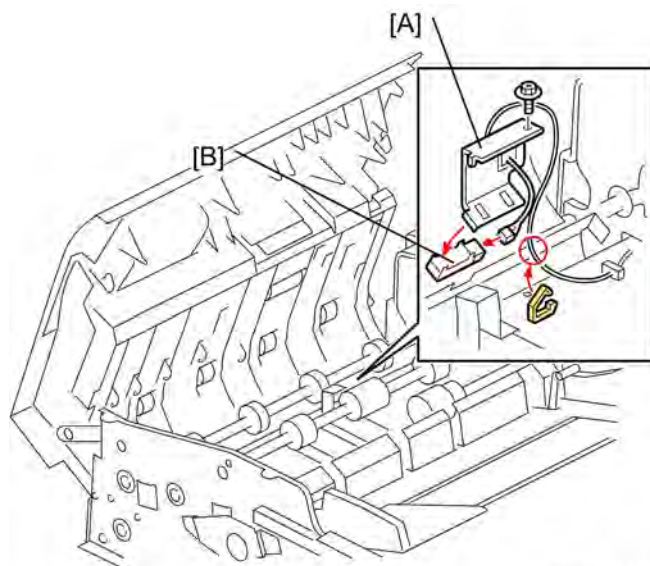

d081r113

4. Remove:
 - [A] Registration sensor bracket (x 1, x1)
 - [B] Registration sensor (x 1)

ADF

5.15.6 ADF CONTROL BOARD

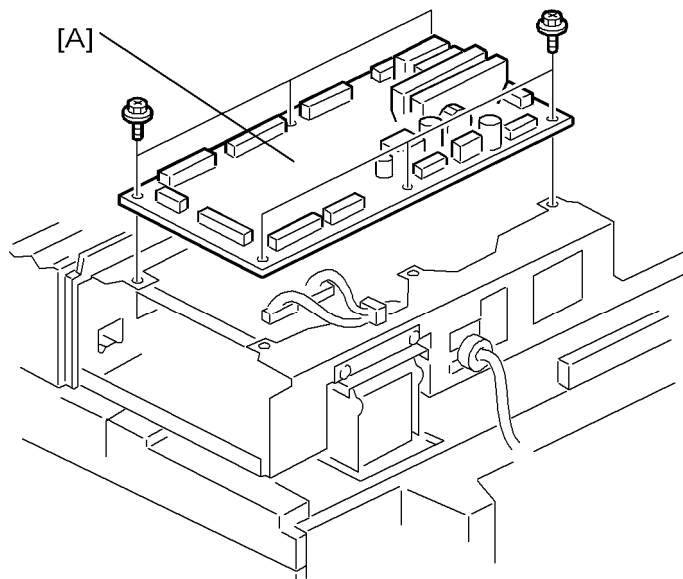

b246r873

1. Remove ADF rear cover (🔧 p.5-188 "ADF Covers").
2. Remove: ADF board [A] (🔧 x 4, 📦 x all)

5.15.7 ORIGINAL WIDTH, INTERVAL, SEPARATION, SKEW CORRECTION SENSORS

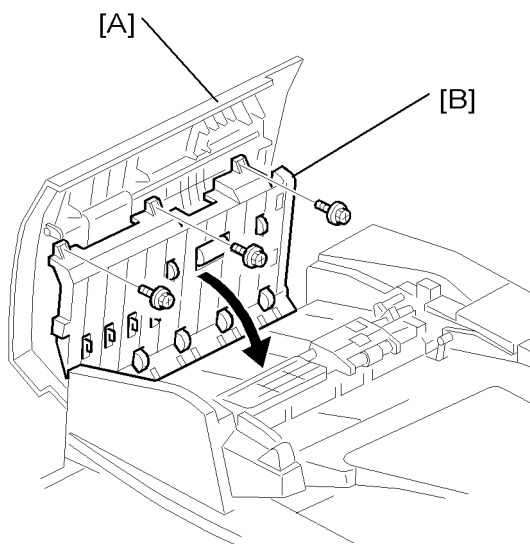



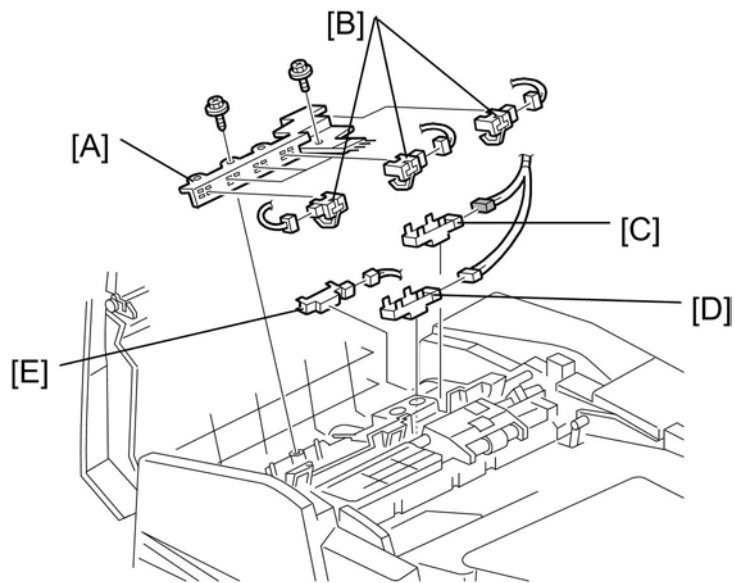

b246r874

1. Open the feed cover [A].
2. Remove guide plate [B] (🔧 x 3)



b132r111

3. Remove:

- [A] Width sensor guide plate ( x 2)
- [B] Original width sensors (x 5,  x 5)
- [C] Separation sensor ( x 1)
- [D] Skew correction sensor ( x 1)
- [E] Interval sensor ( x 1)

5.15.8 ORIGINAL LENGTH SENSORS

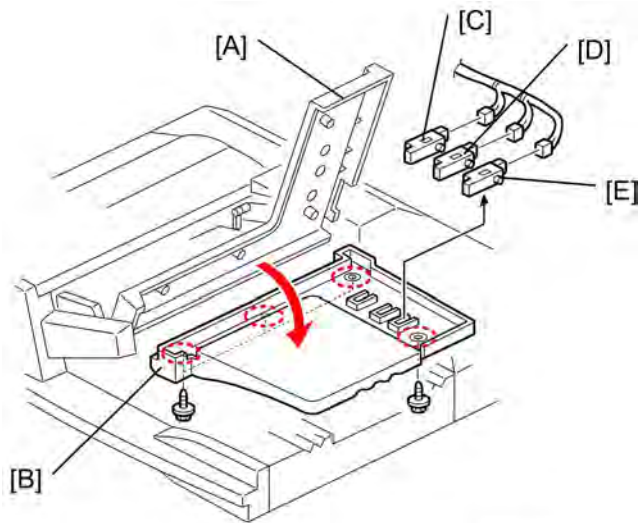

d081r109

1. Open the original tray [A].
1. Remove:
 - [B] Lower cover (🔩 x 4)
 - [C] Original length sensor 1 – B5 (🔩 x 1)
 - [D] Original length sensor 2 – A4 (🔩 x 1)
 - [E] Original length sensor 3 – LG (🔩 x 1)

5.15.9 ADF POSITION AND APS SENSORS

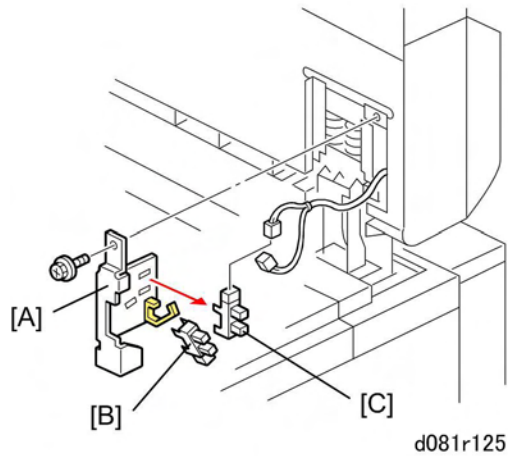

1. Open the ADF.
1. Remove ADF rear cover (☛ p.5-188 "ADF Covers").
2. Remove:
 - [A] Bracket (☛ x 1)
 - [B] ADF position sensor (☛ x 1, ☛ x 2)
 - [C] APS sensor (☛ x 1)

5.15.10 OTHER ADF SENSORS

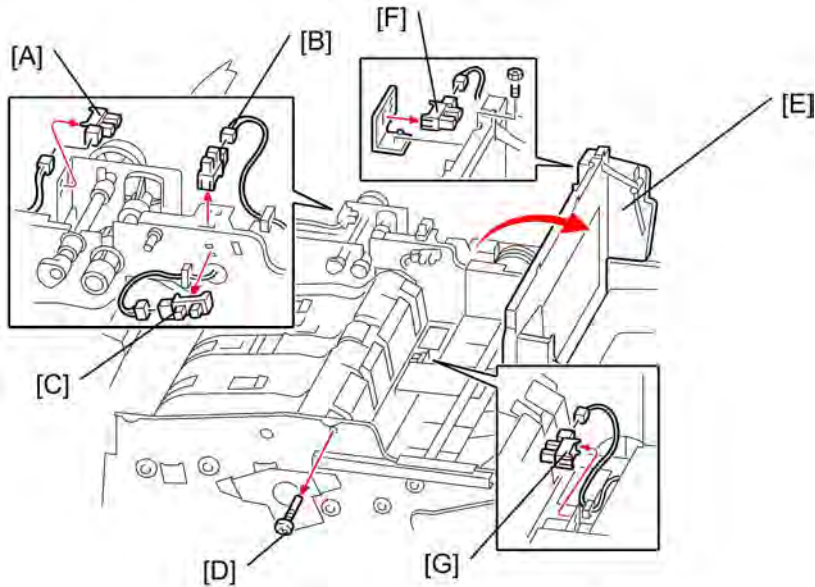

d081r118

1. Open the feed cover.
1. Remove rear cover (🔧 p.5-188 "ADF Covers").
 - [A] Original set sensor (🔧 x 1)
 - [B] Pick-up roller HP sensor (🔧 x 1)
 - [C] Feed cover sensor (🔧 x 1)
2. Remove front cover (🔧 p.5-188 "ADF Covers").
3. Remove pivot screw [D] (🔧 x 1)
4. Raise original tray [E].
5. Remove:
 - [F] Bottom plate HP sensor (🔧 x1, 📏 x1)
 - [G] Bottom plate position sensor (🔧 x1)

5.15.11 BOTTOM PLATE LIFT MOTOR

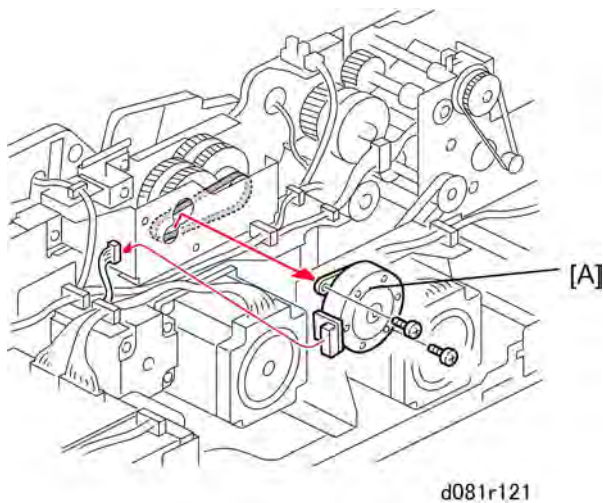

1. Open the feed cover.
2. Remove rear cover (☛ p.5-188 "ADF Covers").
3. Remove bottom plate lift motor [A] (☛ x 2, ☛ x 1, timing belt x 1)

5.15.12 FEED MOTOR

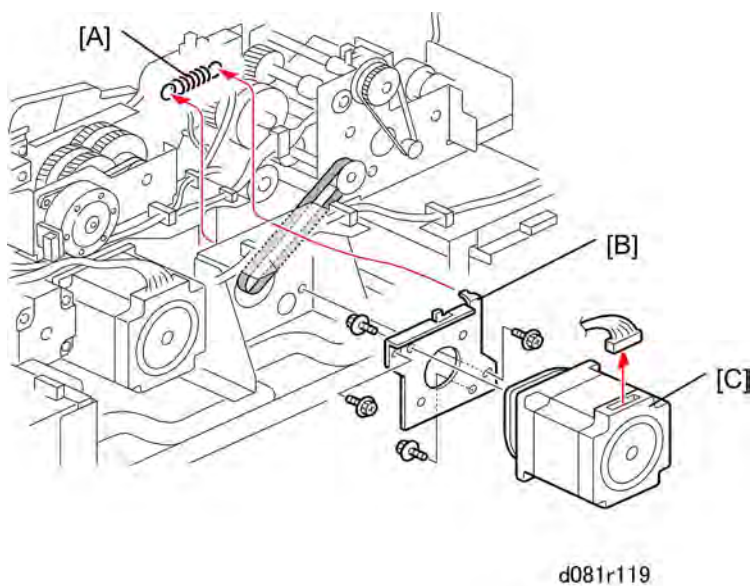

1. Rear cover (☛ p.5-188 "ADF Covers").
1. Remove spring [A].
2. Remove feed motor bracket [B] (☛ x 2, ☛ x 1, belt x 1)
3. Remove feed motor [C] (☛ x 2)

ADF

5.15.13 TRANSPORT MOTOR

1. Open the feed cover.
1. Remove the front and rear covers (☛ p.5-188 "ADF Covers").

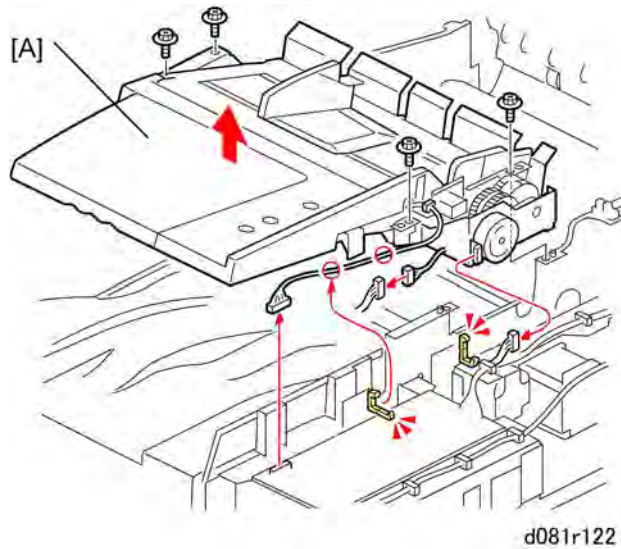

2. Remove tray unit [A] (☛ x4, ☛ x2, ☛ x3).

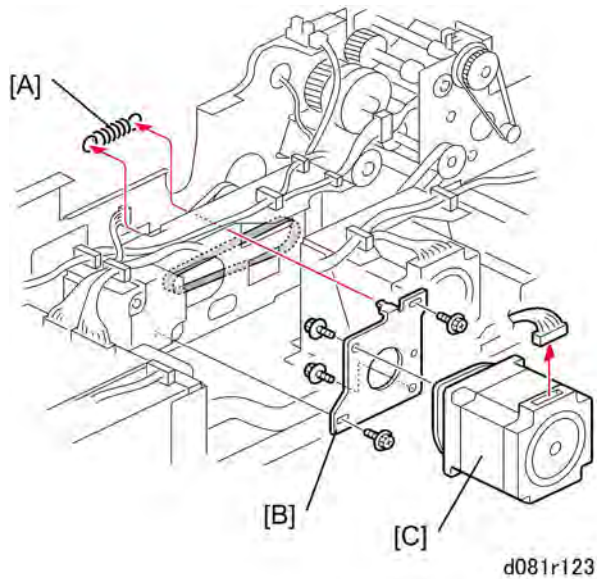

3. Remove:
[A] Spring [A]
[B] Transport motor bracket [B] (☛ x 2, ☛ x 1, Timing belt x1)
[C] Transport motor [C] (☛ x 2)

5.15.14 EXIT MOTOR

1. Open the feed cover.
1. Remove the front and rear covers (☛ p.5-188 "ADF Covers").

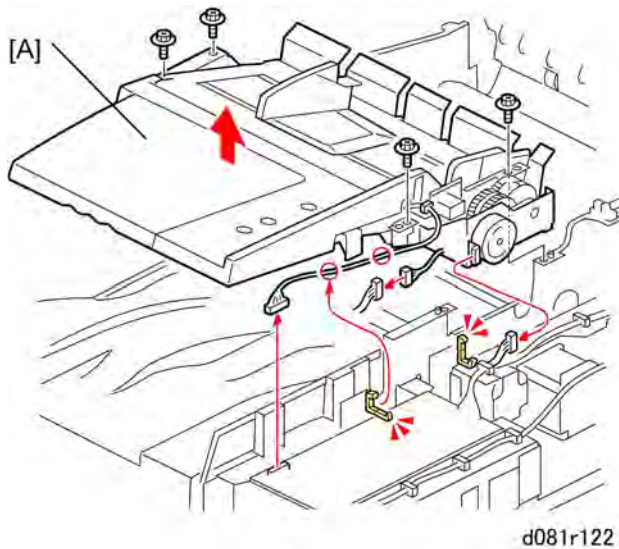

2. Remove tray unit [A] (☛ x4, ☛ x2, ☛ x3).

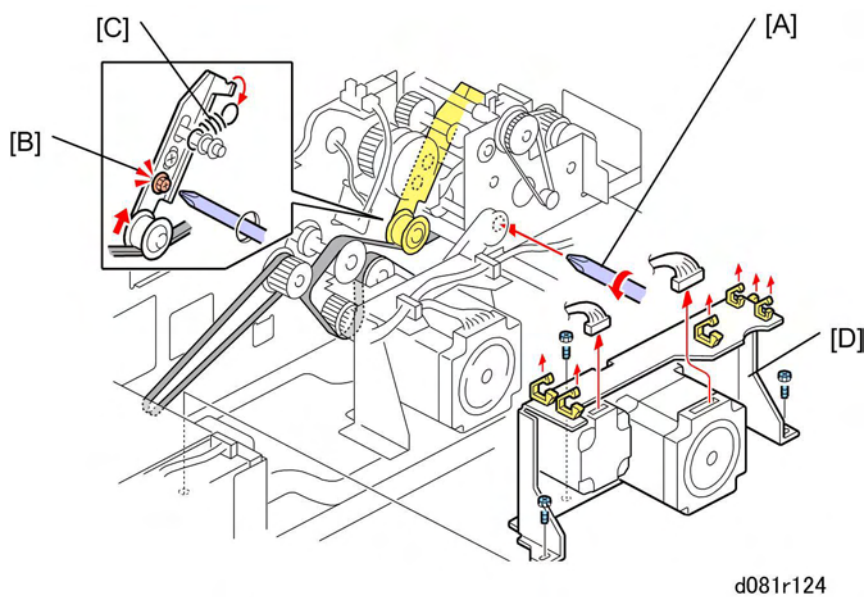

3. Insert a screw driver through the cutout [A].
4. Loosen screw [B] (do not remove) to release tension on the belt.
5. Remove spring [C].
6. Remove motor bracket [D] (☛ x5, ☛ x2, ☛ x3).

ADF

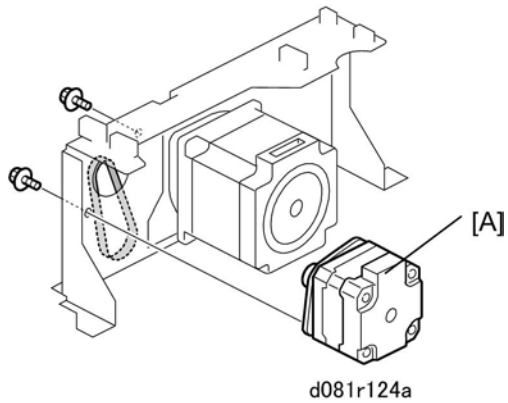

7. Remove exit motor [A] (🔩 x2, Timing belt x1).

5.15.15 PICK-UP ROLLER MOTOR

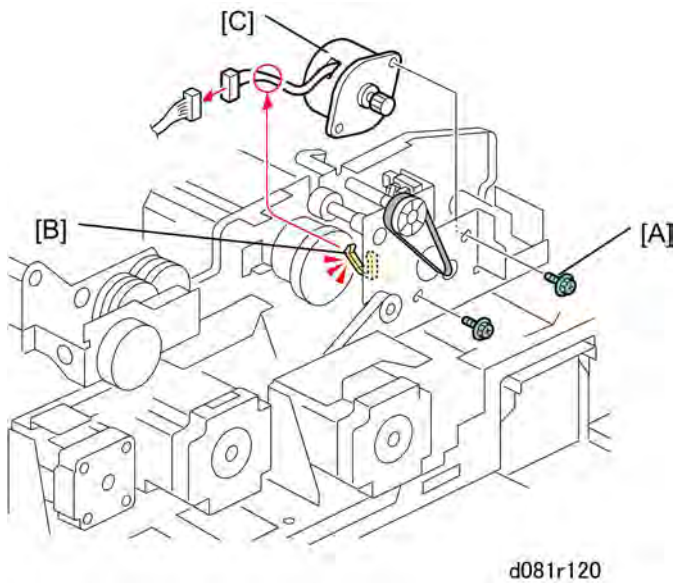

1. Open the feed cover.
2. Remove screws [A] (🔩 x2).
3. Open clamp [B] (🔧 x1).
4. Remove pick-up roller [C] (🔧 x1).



5.15.16 CIS UNIT

WARNING

- Turn off the main power switch and unplug the machine before performing this procedure.

1. Open the feed cover.

1. Remove:

- Rear and front covers ( p.5-188 "ADF Covers")
- Feed unit ( p.5-189)
- Guide plate ( p.5-193 "Registration Sensor")

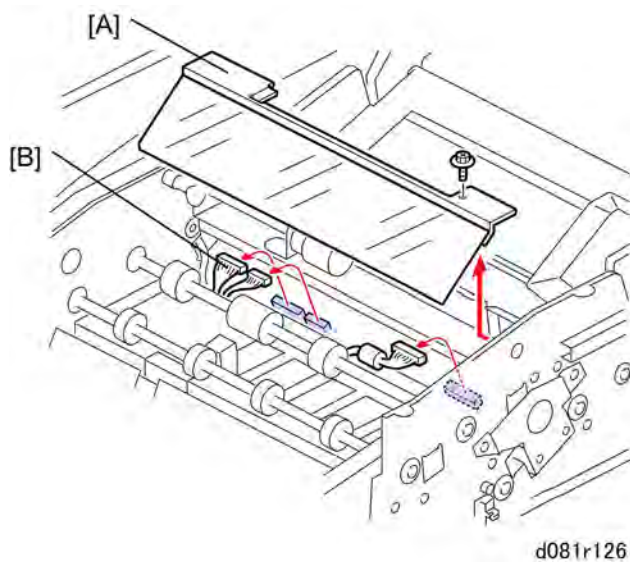

2. Remove guide plate mylar [A] ( x 1)

3. Disconnect the CIS unit connectors [B] ( x 3)

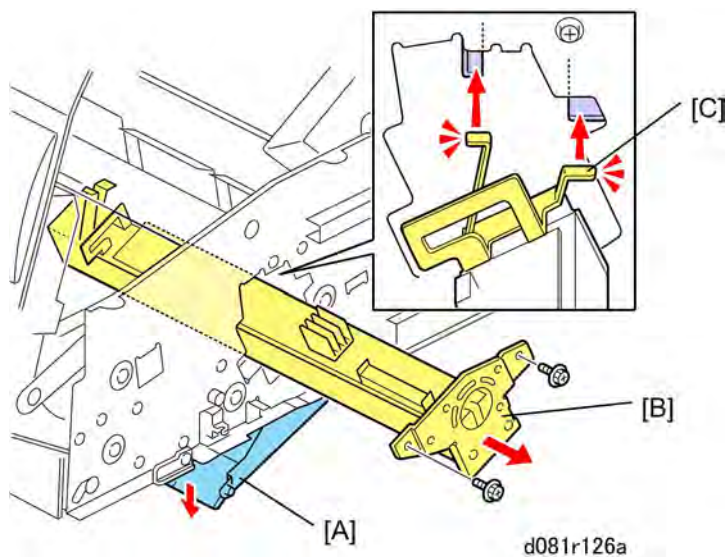

ADF

4. Release plate [A].
5. Remove CIS [B].

★ Important

- Pull out the CIS unit slowly to avoid scratching the glass.

Re-installation

Set the arms [C] of the CIS on the rails and insert it slowly.

5.15.17 ADF EXIT SENSOR

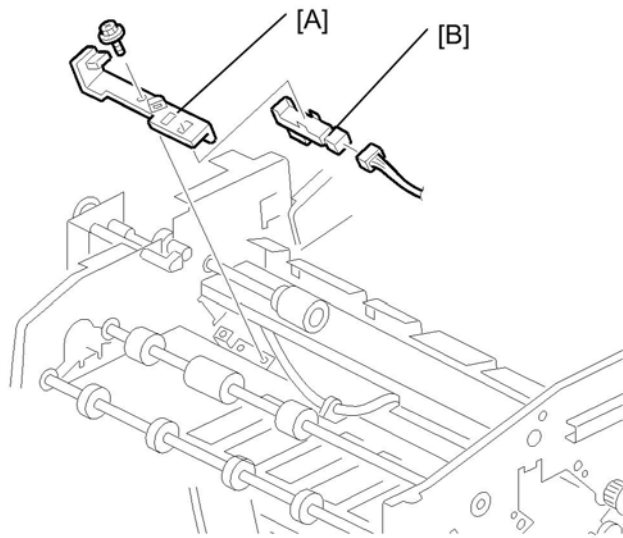

b246r886

1. Remove the CIS unit (☛ p.5-203).
2. Remove:
 - [A] Exit sensor bracket (☛ x 1)
 - [B] Exit sensor (☛ x 1)

5.15.18 ADF TRANSPORT BELT ASSEMBLY

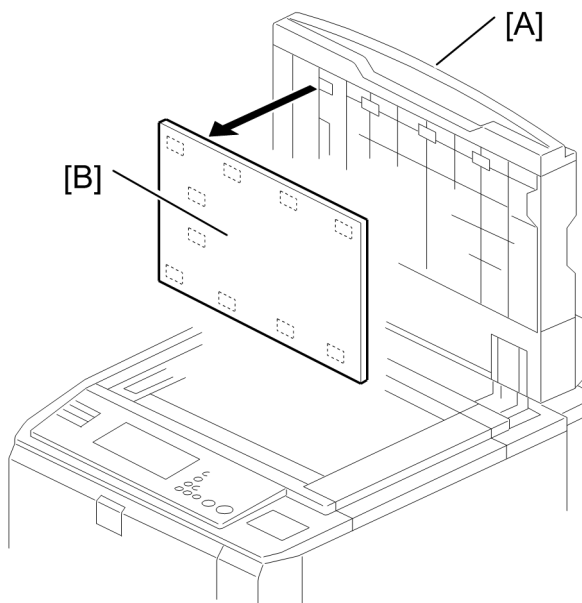

B132R102

1. Raise the ADF [A] to the vertical position.
2. Pull off the white cover [B] (Velcro fasteners)

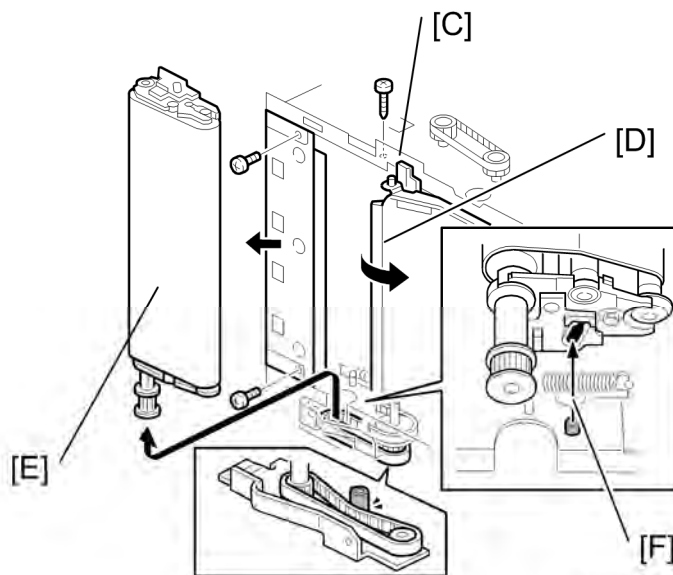

b132r126

3. Release the stopper pin [C] of the transport guide [D].
4. Remove the transport belt unit [E] (Pin screw  x1, Timing belt x1)

Reinstallation

- Attach the timing belt as shown, then insert the pin screw [F] as shown.

ADF

Removing the Belt

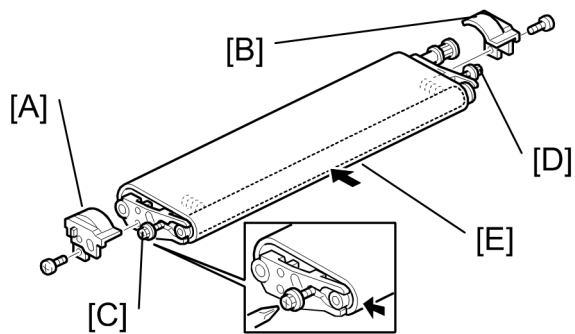

b132r127

1. Remove the front plastic cover [A] (⚙️ x1)
2. Remove the rear plastic cover [B] (⚙️ x1)
3. Loosen front lock screw [C]. Do not remove.
4. Loosen rear lock screw [D]. Do not remove. This releases the spring-loaded tension on the belt.
5. Grip the roller in the center [E], then squeeze the belt to bring the rollers together.
6. While squeezing the belt and rollers together in the center, tighten screws [C] and [D]. This compresses the spring and releases tension on the belt.

★ Important

- To avoid stripping the threads of the screws, do not apply excessive torque to these screws!
7. Release the belt and make sure that the belt is loose and that the rollers do not move.
 8. Repeat Steps 5 and 6 if the rollers expand then tighten the belt.

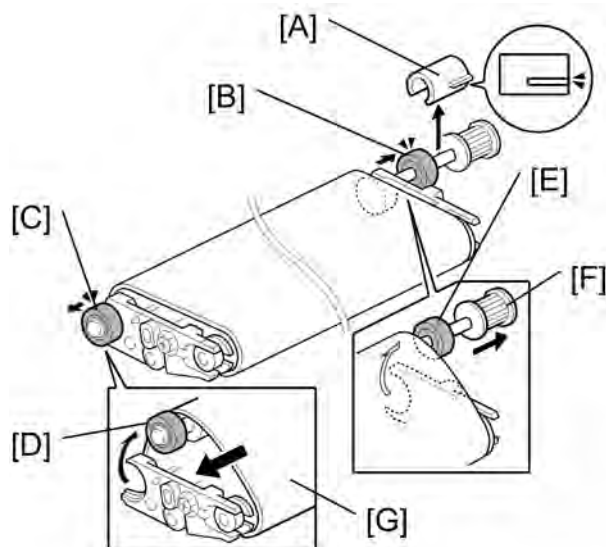

b132r139

9. Remove the Teflon sleeve [A].

10. Push the rear shaft bearing [B] out of its bracket.
11. Push the front shaft bearing [C] out of its bracket.
12. Push the front end of the shaft [D] over the top of the bracket.
13. Push the rear end of the shaft [E] over the top of the bracket.
14. Pull the shaft [F] out of the belt.
15. Pull the belt [G] toward the front to remove it.
16. Slide the new belt over the assembly.
17. Insert the shaft [F] into the new belt, snap the shaft into its brackets, and push in the shaft bearings.

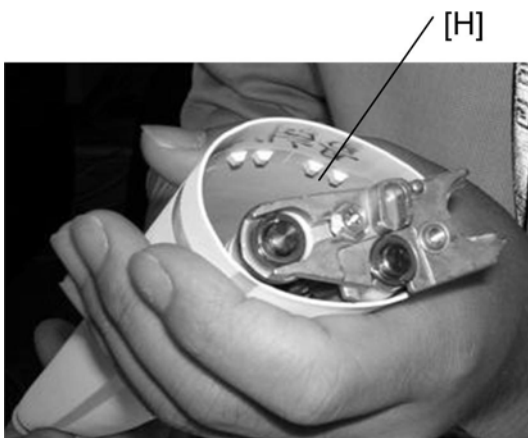

OrgB536

18. Make sure that studs on the underside of the belt [H] are aligned with the grooves in the Teflon rollers on each end of the shaft below.

Reinstalling the Belt

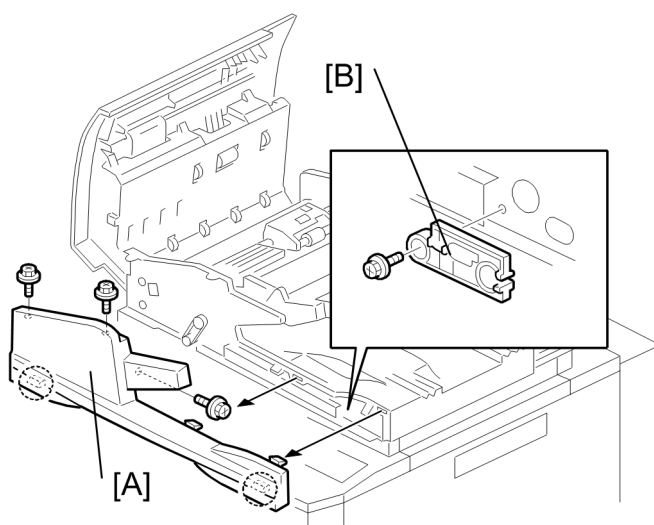

B132R104A

1. Remove the ADF front cover [A]

ADF

2. Take out the special tool [B].

↓ Note

- The special tool [B] is attached to the front side plate. It is used to adjust the tension on the belt on both ends of the shaft.

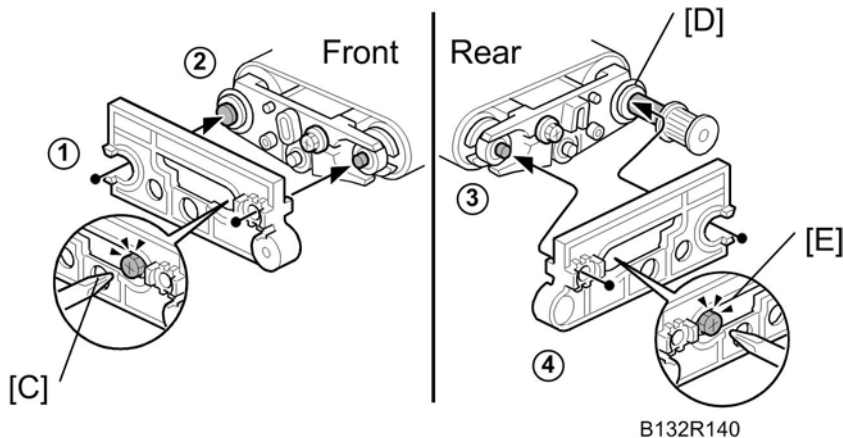

3. At the front (see above) fit the special tool onto the front.
4. Slowly loosen the front lock screw [C] until you see the tip of the shaft (1) aligned with the hole (2), then tighten the screw.

★ Important

- To avoid stripping the threads of the screws, do not apply excessive force.
5. Remove the special tool and fit it onto the rear (see above).

↓ Note

- If the Teflon sleeve has been reattached at [D], remove it. Do not reattach the sleeve until after adjusting the belt tension. (The special tool does not fit over the rear end with the Teflon sleeve attached.)
6. Slowly loosen the rear lock screw [E] until you see the tip of the shaft (3) aligned with the hole (4), then tighten the screw.
 7. Re-attach the Teflon sleeve.
 8. Re-attach the front and rear plastic cover.
 9. Re-attach the transport belt assembly in the ADF.

Reattaching the White Cover

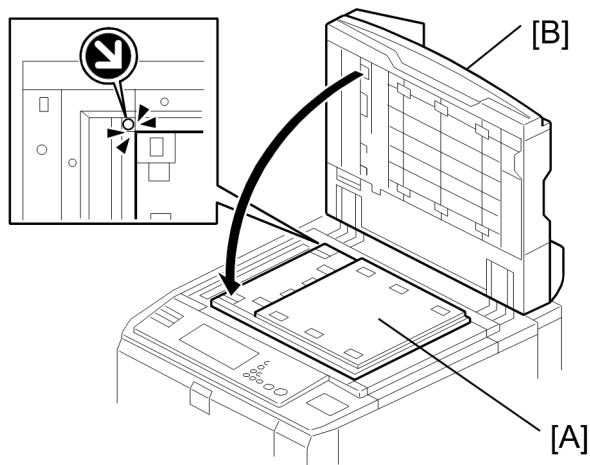

b132r103

1. With its white side down, set the cover [A] on the exposure glass.
2. Make sure the upper left corner is aligned with the arrow at the corner of the exposure glass.
3. Close the ADF [B].

5.15.19 WHITE ROLLER

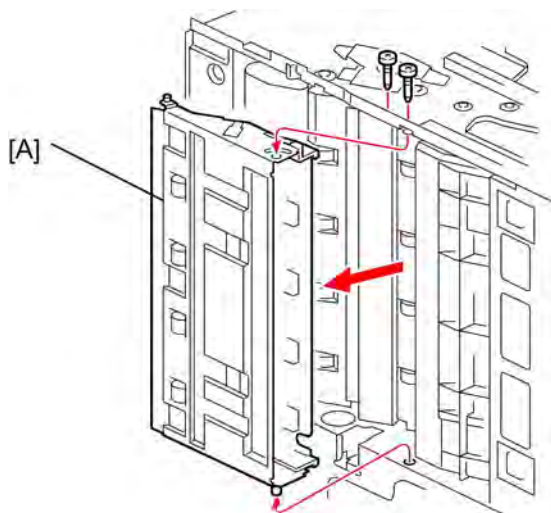

d081r127

1. Raise the ADF to the vertical position.
2. Remove the white cover (Velcro fasteners).
3. Remove white roller assembly [A] (⚙ x2).
4. Lay the white roller assembly on a flat surface with the white roller facing up.

ADF

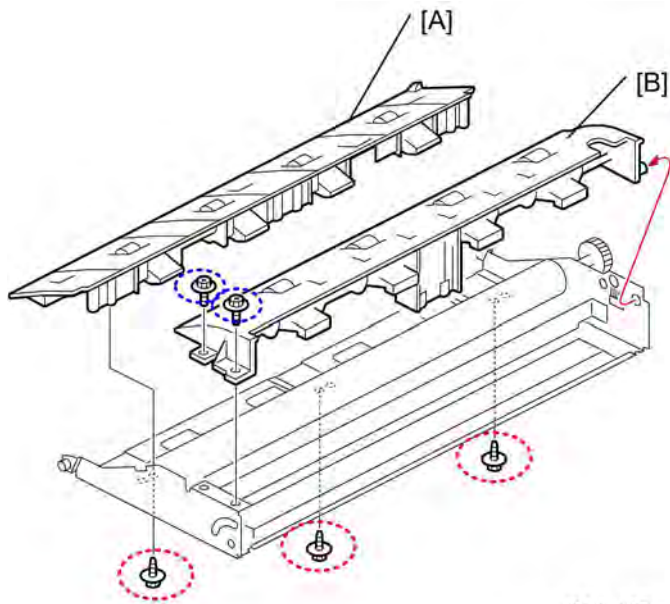

d081r127a

5. Remove:

- [A] Left plate (🔩 x3)
- [B] Right plate (🔩 x2)

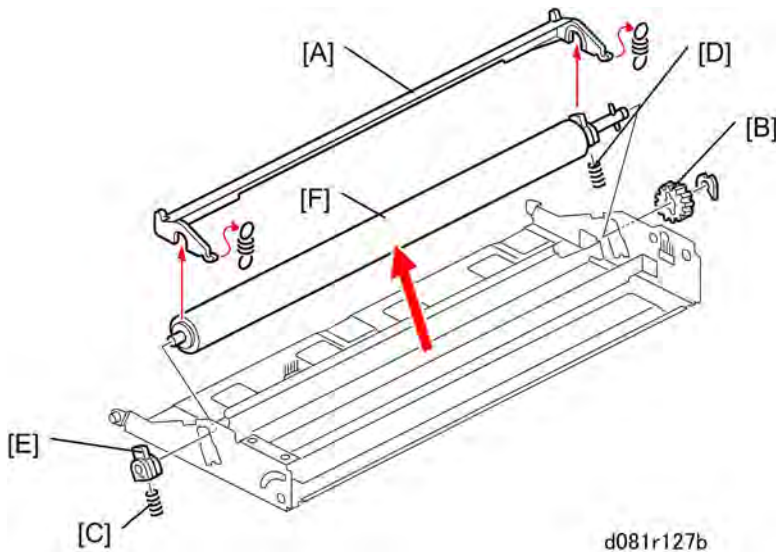

d081r127b

6. Remove:

- [A] Roller bracket [A] (Springs x2)
- [B] Rear (🌀 x1, Gear x1)
- [C] Front (Spring x1)
- [D] Rear (Spring x1)
- [E] Lock piece
- [F] White roller

5.16 HDD

The HDD contains two separate hard disks (160 Gigabytes each x2 = 320 Gigabytes).

★ Important

- The two disks are always replaced together as a unit. Never attempt to replace a single disk.

5.16.1 BEFORE REPLACING THE HDD UNIT

Copy the address book data to an SD card from the HDD with **SP5846-051** if possible.

5.16.2 REPLACEMENT PROCEDURE

1. Remove:
 - Rear covers
 - Controller box cover
2. Mark the harness connectors before you disconnect them:
 - Gray: Left
 - Red: Right

★ Important

- The connectors fit either socket but they must be connected in the correct order as shown above: Gray: Left, Red: Right
- If the connections are reversed, the machine will issue an error at startup.
- If this occurs just reconnect the HDD correctly and start again. The HDD will not be damaged by such an incorrect startup.

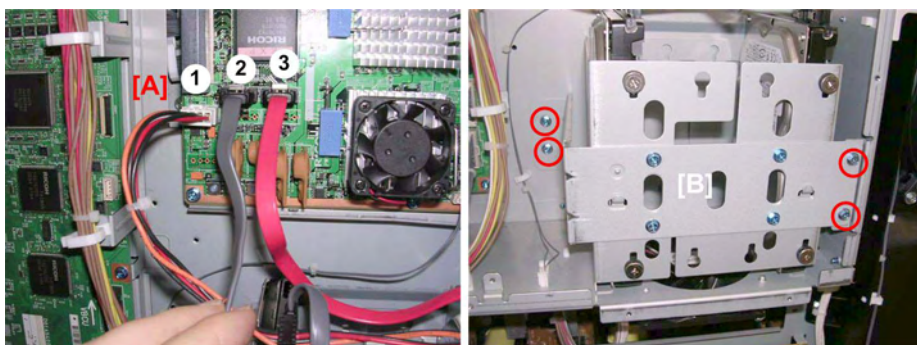

b132r852

3. Disconnect the HDD unit from the controller board [A] (🔧 x3).
4. Remove the HDD unit [B] (🔧 x4).

HDD

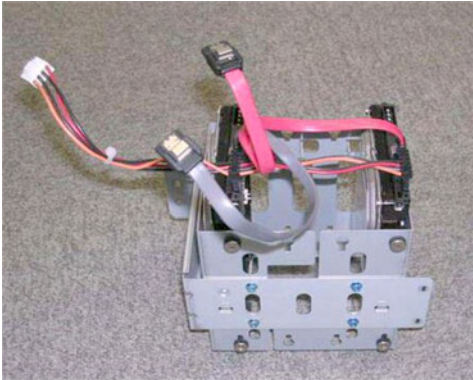

b132r853

5. Install the new HDD unit.
6. Reassemble the machine.
7. Enter the SP mode and do SP5832-1 to format the hard disks.

↓ Note

- Formatting the hard disks is recommended, even if they have already been formatted.
8. Do SP5853-1 to download the fixed stamps from the ROM to the HDD.
 9. Cycle the machine power off/on to enable the fixed stamps for use.

5.16.3 AFTER INSTALLING THE NEW HDD UNIT

1. Do **SP5832-001** to format the hard disk.
2. Do **SP5853-001** to copy the preset stamp data from the firmware to the hard disk.
3. Do **SP5846-052** to copy back the address book to the hard disk from the SD card to which you have already copied the address book data if possible.
4. Turn the main power switch off/on.

Disposal of HDD Units

- Never remove an HDD unit from the work site without the consent of the client.
- If the customer has any concerns about the security of any information on the HDD, the HDD must remain with the customer for disposal or safe keeping.
- The HDD may contain proprietary or classified (Confidential, Secret) information. Specifically, the HDD contains document server documents and data stored in temporary files created automatically during copy job sorting and jam recovery. Such data is stored on the HDD in a special format so it cannot normally be read but can be recovered with illegal methods.

Reinstallation

- Explain to the customer that the following information stored on the HDD is lost when the HDD is replaced: document server documents, fixed stamps, document server address book
- The address book and document server documents (if needed) must be input again.
- If the customer is using the Data Overwrite Security or the Data Encryption feature, these applications must be installed again. For more, see Section "1. Installation".
- If the customer is using the HDD Encryption Unit, the encryption key must be restored after replacing the HDD unit. For details, see the installation procedure for the HDD Encryption Unit.

5.17 MOTORS

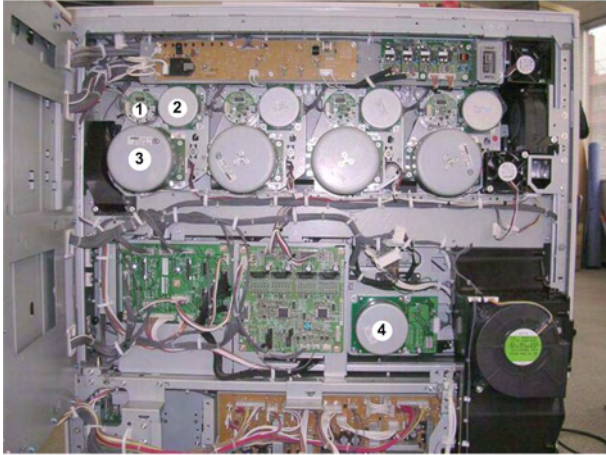

b132r854

①	Development Motor
②	Drum Cleaning Motor
③	Drum Motor
④	Fusing/Exit Motor

1. Remove the rear covers.
2. Open and lock the controller box.

5.17.1 DRUM CLEANING MOTORS

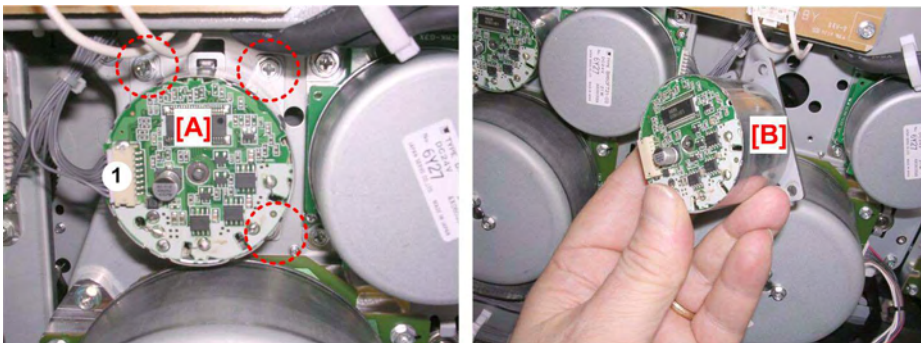

b132r855

1. Disconnect the drum cleaning motor [A] (⚙️ x1, 🔧 x3).
2. Remove the drum cleaning motor [B].

5.17.2 DEVELOPMENT MOTORS

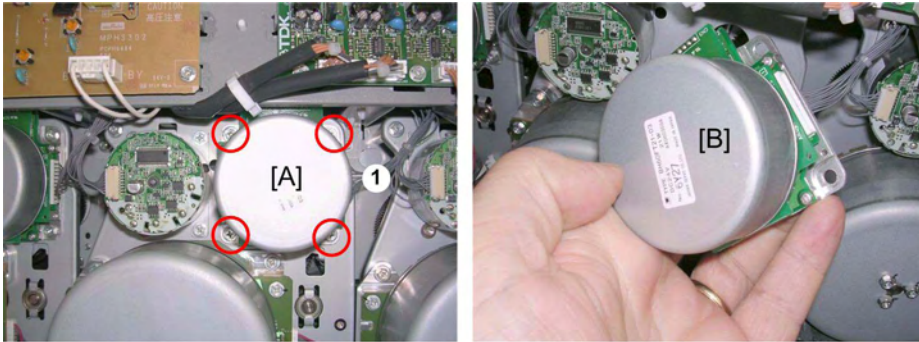

b132r856

1. Disconnect the development motor [A] (🔌 x1, 🔧 x4).
2. Remove the development motor [B].

5.17.3 DRUM MOTOR

Drum Motor Removal

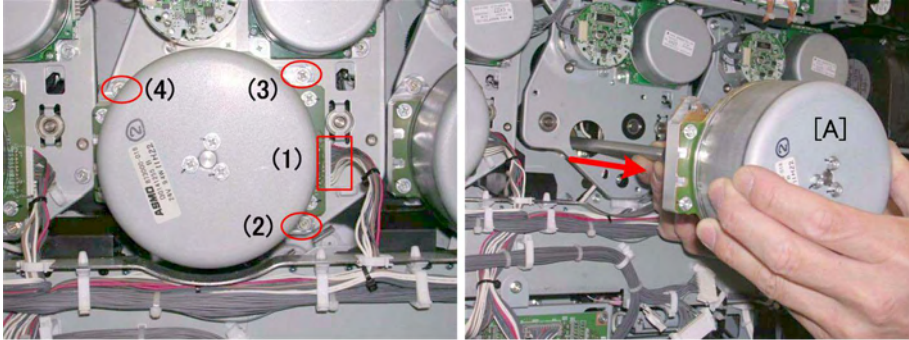

b132r857

1. Remove the Toner Hopper, Faceplate, PCU.
2. Disconnect the connector (1) (⚡ x1).
3. Remove screws (2), (3), (4) (🔩 x3).
4. Remove the ITB unit.

↓ **Note**

- Removing the ITB unit is recommended to prevent the tip of the drum motor shaft from scratching the surface of the ITB when the motor is removed or reinstalled.
5. Pull out the motor [A] with its drive shaft.

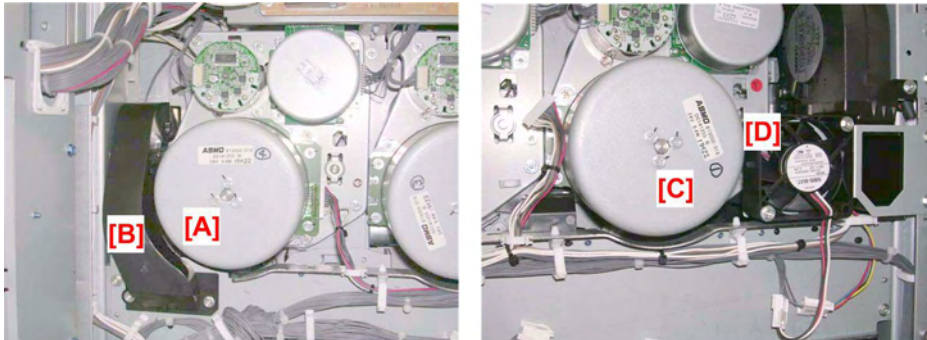

b132r858

★ **Important**

- In order to remove the K PCU motor [A], you must first loosen the duct [B].
- Before removing the Y PCU motor [C], you must first loosen the fan [D].

Drum Motor Reinstallation

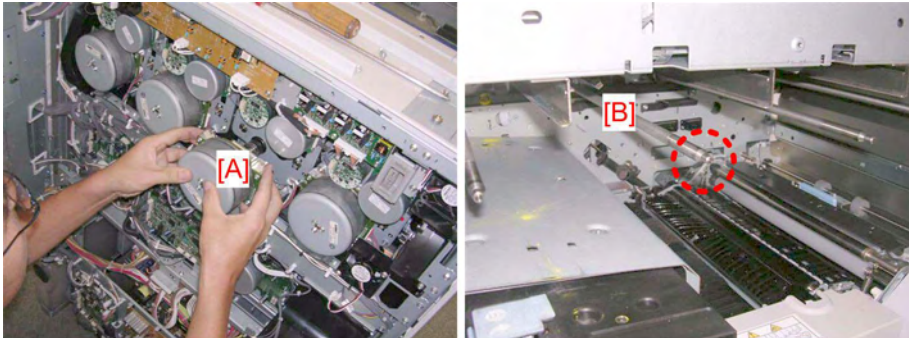

b132r859

1. Push the shaft into the machine and set the motor [A], so that it is straight.
2. Attach the screws and tighten them only halfway. This leaves the motor shaft loose so it can float slightly.
3. Check the front of the machine and confirm that the shaft [B] is straight.

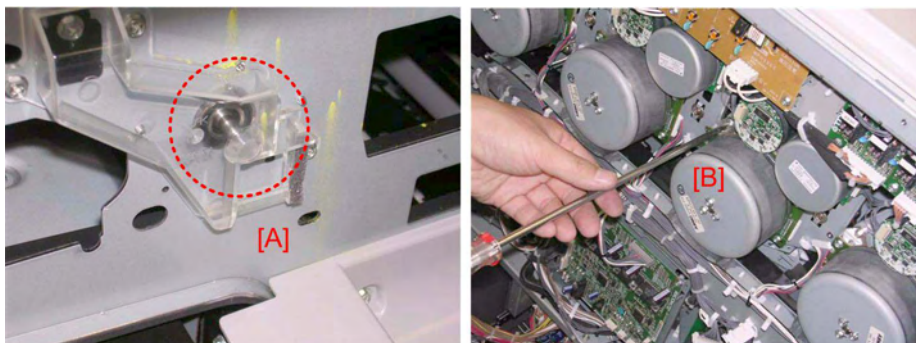

b132r860

4. At the front, set the faceplate set the shaft [A] as shown above.
5. Fasten the faceplate with its screws (🔩 x3).
6. At the back, tighten the screws (🔩 x3) of the drum motor [B] and attach its connector (🔌 x1).

Motors

5.17.4 FUSING/EXIT MOTOR

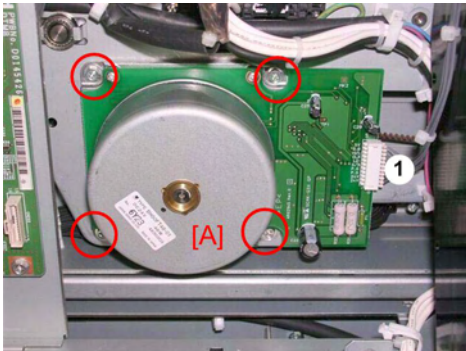

b132r861

1. Remove the fusing/exit motor [A] (🔧 x1, 🪛 x4).

5.17.5 PTR MOTOR

- Remove the rear covers.
- Open the controller box door.

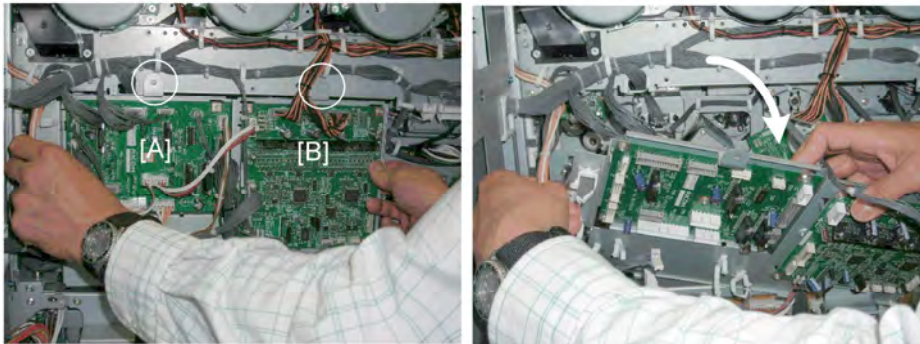

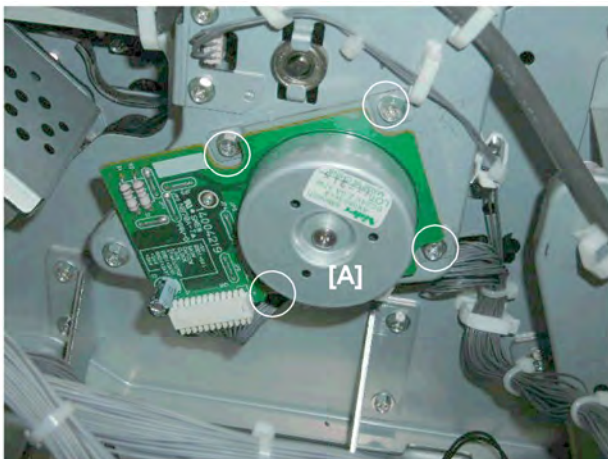

d014r510

1. Remove the plate that holds the DRB [A] and DTMB [B] ( x2,  x all)



d014r511

2. Remove the PTR motor [A] ( x4,  x1).

Motors

5.17.6 ITB DRIVE MOTOR

- Remove the rear covers.
- Open the controller box door.

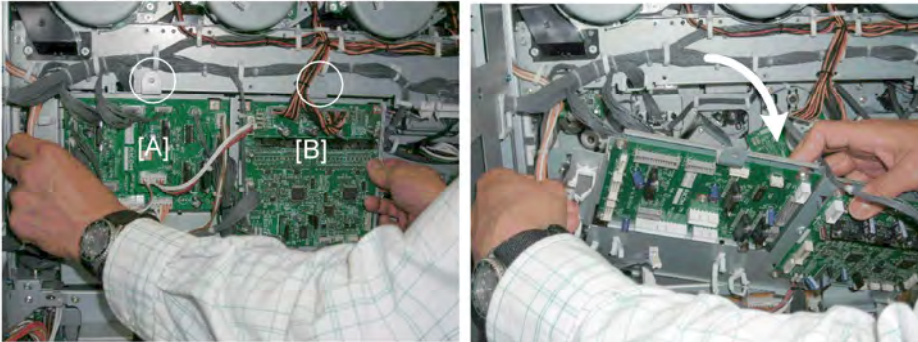

d014r510

1. Remove the plate that holds the DRB [A] and DTMB [B] (🔧 x2, 📏 x All)

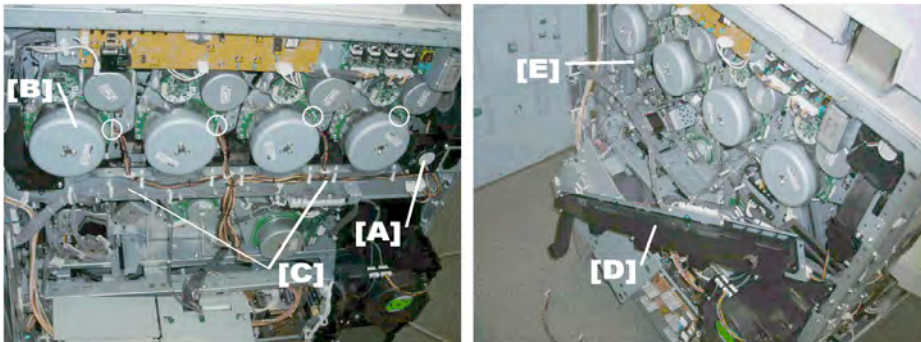

d014r520

1. Remove the fan plate with fan [A] attached (🔧 x2).
2. Disconnect the drum motors [B] (📏 x4).
3. Disconnect the cross-brace [C]. (There are two screws on each end of the cross-brace.)

★ Important

- Do not release the harnesses that are permanently locked. Release only enough harnesses so you can pull the cross-brace [D] away from the machine so that you can see the ITB motor [E].



d014r521

4. Remove the ITB drive motor [A] (🔩 x4, 🛠️ x1).

5.18 AIR FILTERS AND OZONE FILTERS

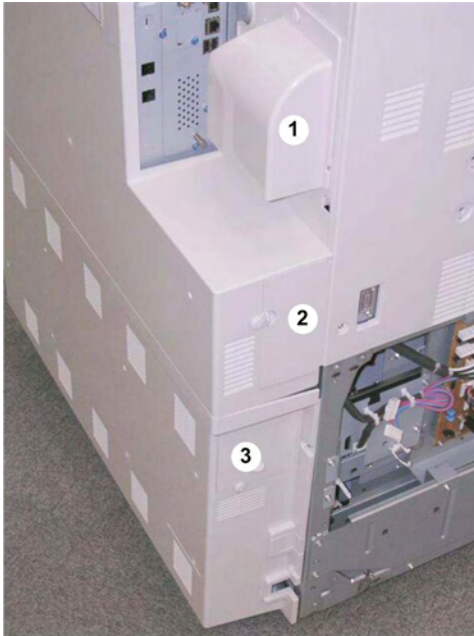

b132r862

①	Upper Filter Box
②	Middle Filter Box
③	Lower Filter Box

This machine has three filter boxes on the left rear corner. These boxes contain air filters and one ozone filter each.

5.18.1 UPPER FILTER BOX

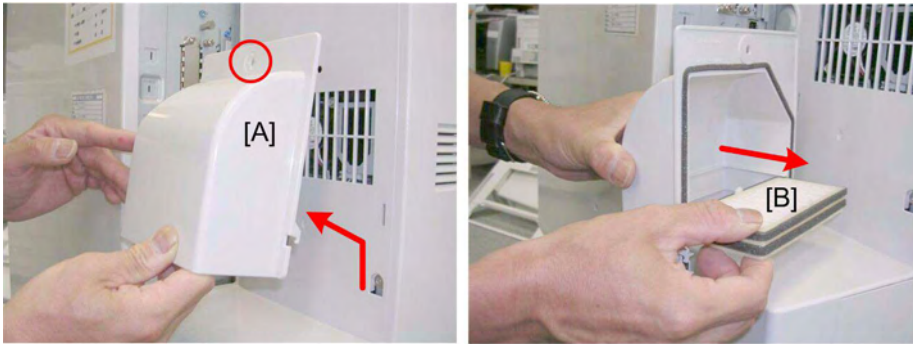

b132r863

1. Remove:
[A] Upper filter box cover (🔩 x1)
[B] Air filters

5.18.2 MIDDLE FILTER BOX

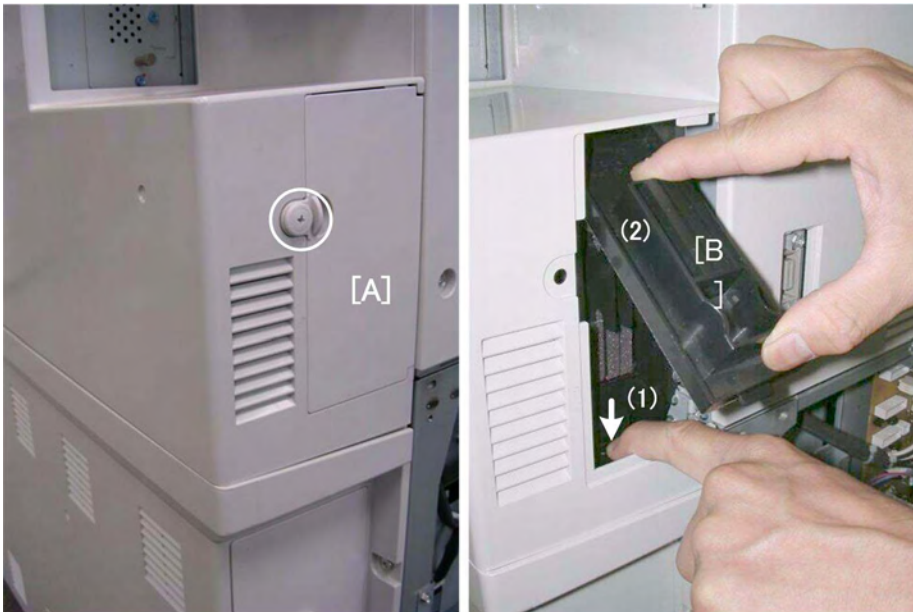

b132r864

1. Remove:
[A] Middle filter box cover (🔩 x1)
[B] Inner cover. Depress at (1) then pull out (2).

Air Filters and Ozone Filters

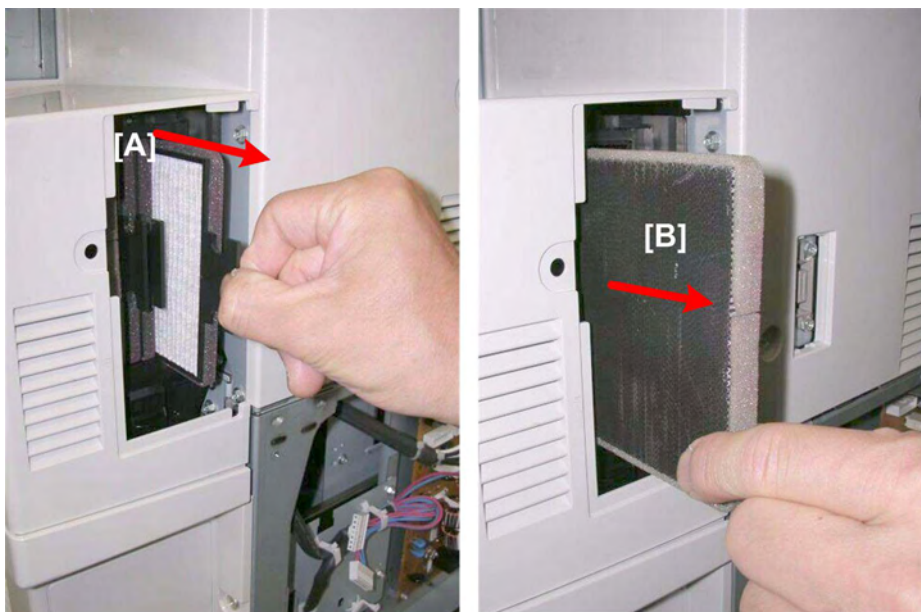

b132r865

2. Remove:
 - [A] Air filters
 - [B] Ozone filter

5.18.3 LOWER FILTER BOX



b132r866

1. Remove:
[A] Lower filter box cover (⚙️ x1)
[B] Inner cover. Depress at (1) then remove.

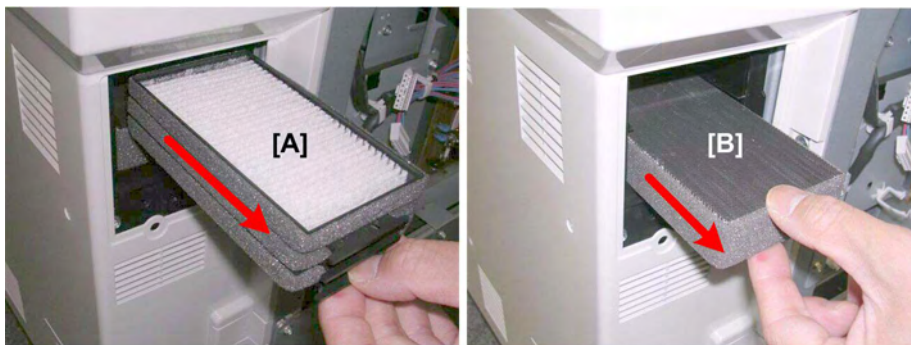

b132r867

2. Remove:
[A] Air filters
[B] Ozone filter

5.19 IMAGE ADJUSTMENTS

5.19.1 SCANNING

Before doing the following scanner adjustments check the printing registration/side-to-side adjustment and the blank margin adjustment. Use a C4 Test Chart to perform the following adjustments.

Scanner sub-scan magnification

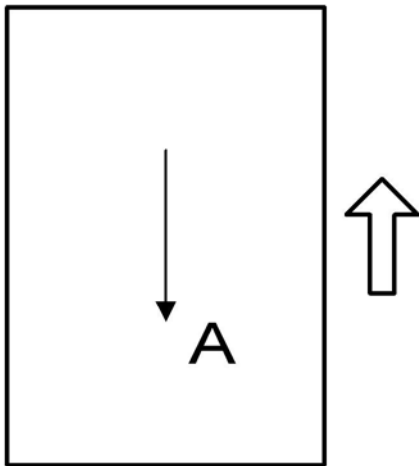

d081962

1. Place the test chart on the exposure glass and make a copy.
2. Check the magnification ratio. Use SP4008 (Sub Scan Mag) to adjust if necessary.
Standard: $\pm 1.0\%$.

Scanner leading edge and side-to-side registration

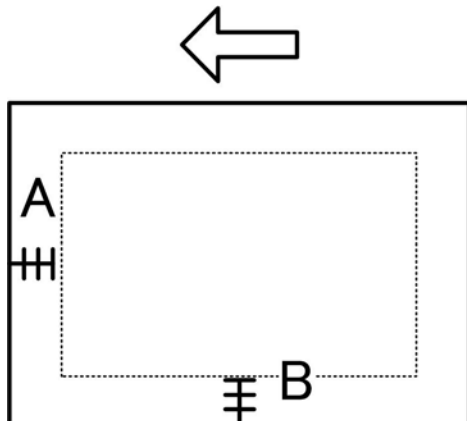

d081r965

1. Place the C4 Test Chart on the exposure glass and make a copy.
2. Check the leading edge and side-to-side registration.
3. Adjust with the following SP modes if necessary. Standard: 0 ±2mm.

	SP mode
Sub Scan Reg	SP4010 001
Main Scan Reg	SP4011 001

Main scan dot position correction

Adjust the printer registration before adjusting the scanner.

1. Enter the SP mode.
2. Open SP4010 and SP4011.
3. Make sure that each value is equal to the factory default.
4. Touch [COPY Window] and copy the C-4 Test Chart in the full-color photo mode.

★ Important

- Be sure to copy in the photo mode. Color displacement cannot be checked correctly in text mode.
5. Use a loupe to check the color vertical lines.
If they exactly overwrite the black line at the edges of the copy, exit the SP mode. No adjustment is necessary
-or-
If the color lines significantly extend beyond the black lines, go to the next step.
 6. Touch [SP Mode] to return to the SP mode.
 7. Do SP4932. (Main Scan Dot Adj) Compare the current values against the table.

SP4932 001	R:Left
SP4932 002	R:Right
SP4932 003	B:Left
SP4932 004	B:Right

5.19.2 ADF

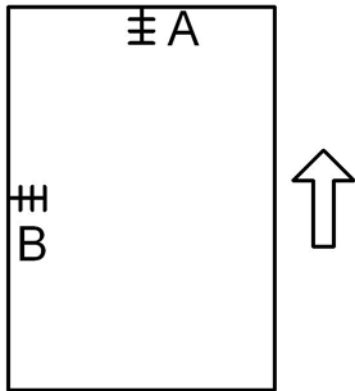

d081r965

ADF side-to-side and leading edge registration

1. Make a copy of the C4 Test Chart on A3/DLT paper.
2. Check the registration, and adjust using the following SP modes if necessary.

SP Code	What It Does	Adjustment Range
6006 001	ADF Main Reg Adj: Front	± 3.0 mm
6006-002	ADF Main Reg Adj: Rear	± 3.0 mm
6006 003	ADF Sub Reg Adj: Front	± 5 mm
6006-004	ADF Sub Reg Adj: Rear	± 5 mm
6006 005	ADF Buckle Adj: Amount 1	± 3 mm
6006 006	ADF Buckle Adj: Amount 2	± 5 mm
6006-007	ADF TEdge Erase Margin: Front	+3 to -2 mm
6006 008	ADF TEdge Erase Margin: Rear	± 5 mm

5.19.3 REGISTRATION

Image Area

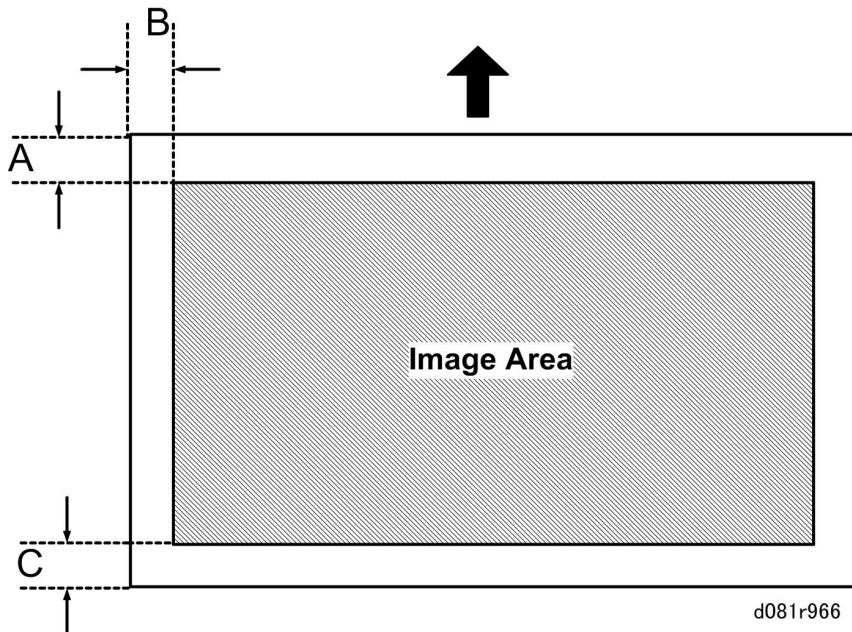

$$A = B = C = 4.2 \text{ mm (1.6")}$$

The image area must be configured correctly. Adjust the registration within the adjustment standard range as described below.

Leading Edge. Adjusts the leading edge registration for each paper type and process line speed.

Side to Side. Adjusts the side-to-side registration for each paper feed station. The side-to-side registration for the LCT can be adjusted with SP1003 007.

Adjustment Standards

- Leading edge (sub-scan direction): 3 ± 0 mm
- Side to side (main-scan direction): 2 ± 0 mm

Paper Registration Standard

The registration in both main- and sub-scan directions may fluctuate within the following tolerance.

1st side

- Sub-scan direction: 0 ± 1.5 mm
- Main-scan direction: 0 ± 2 mm

2nd side in duplex

- Sub-scan direction: 0 ± 3 mm
- Main-scan direction: 0 ± 4 mm

Adjustment Procedure

1. Enter SP mode and open SP2109-2.
2. Select Pattern #10 (Trim Area), and touch [OK].
3. Print several printing patterns and average the measured values of the leading edge and side-to-side registration values.
4. Do the leading edge registration adjustment.
 - Check the leading edge registration and adjust it with SP1001.
 - Select the adjustment conditions (paper type and process line speed).
 - Input the value and press the [#] key.
 - Check the leading edge adjustment by printing Pattern 10 with SP2109.
5. Do the side to side registration adjustment.
 - Check the side-to-side registration and adjust it with SP1003.
 - Select the adjustment conditions for the paper feed station.
 - Input the value and press the [#] key.
 - Check the side-to-side adjustment by printing Pattern 10 with SP2109-2.

5.19.4 COLOR REGISTRATION

Forced MUSIC Adjustment

The line position adjustment optimizes the quality of color prints. You can do forced MUSIC adjustment with SP 2111 001 (Force Tnr Pos):

We recommend that you do the forced MUSIC adjustment at the customer location immediately after installation, or after servicing or adjusting any parts or components of the following units:

- Around the drum
- ITB unit (especially after belt replacement)
- Paper Transfer Roller
- Laser unit

Adjustment of Line Speed for Thick Paper

Adjust the line speed of the fusing unit (the speed of the K development motor) when:

- Color shift corrected with the line position adjustment.
- Color registration shifts more at the trailing edge than at the leading edge.

Color Registration Test and Error Adjustment

Before you start this procedure, make sure that the exposure glass is clean. Also, make sure that the ITB is installed correctly, especially at the edge.

1. Load A3/DLT paper and select full-color (FC) mode.
2. Start SP2109 002 and select Pattern #1 (1: Grid pattern), and then touch "OK".
3. Push the "Copy Window" button. Then select A3/DLT paper, and push the "Start" button to print the pattern. Make sure that "Full Color Mode" is selected before you push the Start button.
4. Look at the printout. The horizontal and vertical lines must show no color (must be black). In that condition, the K, C, M, and Y images are deposited exactly on top of each other.
5. If there is color on the printout, there is a color registration error, and we must correct the problem. To correct the problem, do the MUSIC process with SP2111 001. This takes about 50 seconds.
6. Do step 2 again.
7. If there are color registration errors, then do the procedure described in the Troubleshooting section "Color Registration Error Adjustments"

5.19.5 SKEW ADJUSTMENT AFTER LASER UNIT REPLACEMENT

To Print the Trim Pattern:

1. Do SP2109 002 (Test Pattern - Select Pattern) and select pattern 10.
2. Touch [Execute] on the display.
3. Touch [Copy Screen] on the display to switch to the normal copier screen.
4. Select the paper size and color then press the [Start] key to print the pattern.
5. Touch [SP Screen].
6. Do SP2109 002 and select pattern 0 and touch the [Execute] button.
7. Check the test pattern to determine whether the image is perpendicular at the corners. If the image pattern is correct, no further adjustment is necessary.

-or-

If the pattern is not correct (a skewed parallelogram), go to the next step.

Image Adjustments

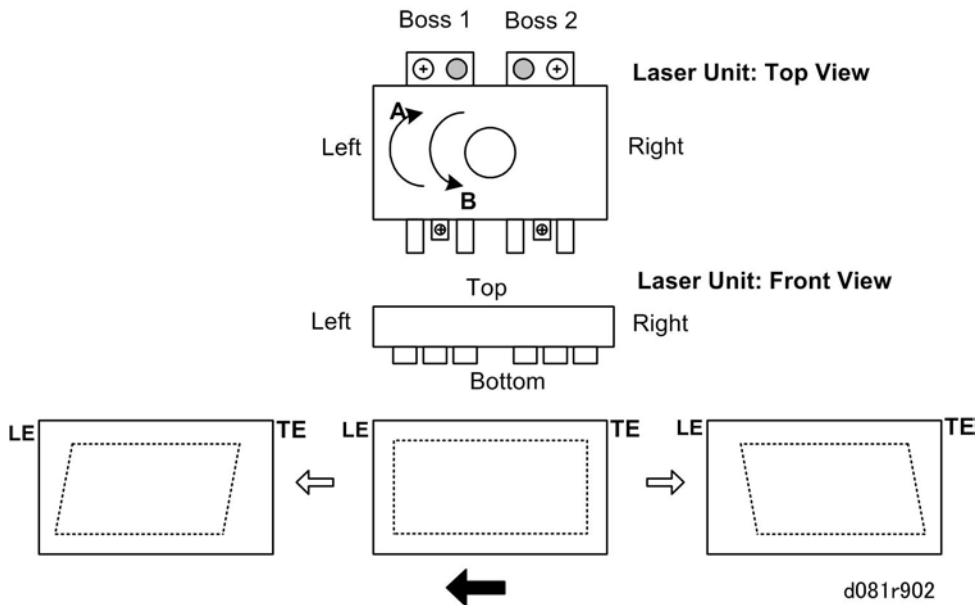

To Adjust the Pattern Output:

1. Remove the exposure glass (☛ p.5-26).
2. Remove the lens cover and lens block (☛ p.5-27 "Lens Block, Paper Size Sensors").
3. Loosen the screws of the laser unit (1), (2), (3), (4) (☛ x4).
4. Determine the direction of skew in the printed pattern.
5. Refer to the illustration, then shift the LD unit toward the rear (A) or toward the front (B) to adjust the skew.
 - If the skew resembles the left pattern [1], turn the LD unit slightly counter-clockwise in the B direction.
 - If the skew resembles the right pattern [2], turn the LD unit slightly clockwise in the A direction.
 - Boss 1, and Boss 2 provide the reference points for correct alignment.
6. Reassemble the copier and print another trim pattern to confirm that the skew has been corrected.

5.19.6 PRINTER GAMMA CORRECTION

ACC adjustment done at installation is usually sufficient to adjust the color balance for optimum performance.

- Printer gamma correction is required for fine adjustment to meet a customer requirement.
- The printer gamma curve created during ACC can be modified with SP modes.
- The gamma data for highlight, middle, shadow areas, and IDmax can be adjusted. The adjustable range is from 0 to 30 (31 steps).

Copy Mode

KCMY Color Balance Adjustment

The adjustment uses only "Offset" values.



- Never change "Option" values (default value is 0).

Highlight (Low ID)	Levels 2 through 5 in the C4 chart 10-level scale
Middle (Middle ID)	Levels 3 through 7 in the C4 chart 10-level scale
Shadow (High ID)	Levels 6 through 9 in the C4 chart 10-level scale
ID max	Level 10 in the C4 chart 10-level scale (affects the entire image density.)
Offset	The higher the number in the range associated with the low ID, middle ID, high ID, and ID max, the greater the density.

There are four adjustable modes. You can access these with SP4918 (Man Gamma Adj):

- Copy: Photo (Photo Mode)
- Copy: Letter (Text Mode Full Color)
- Copy: Letter (SC) (Text Single Color Mode)
- Copy: Photo (SC) (Photo Mode Single Color)

Replacement and Adjustments

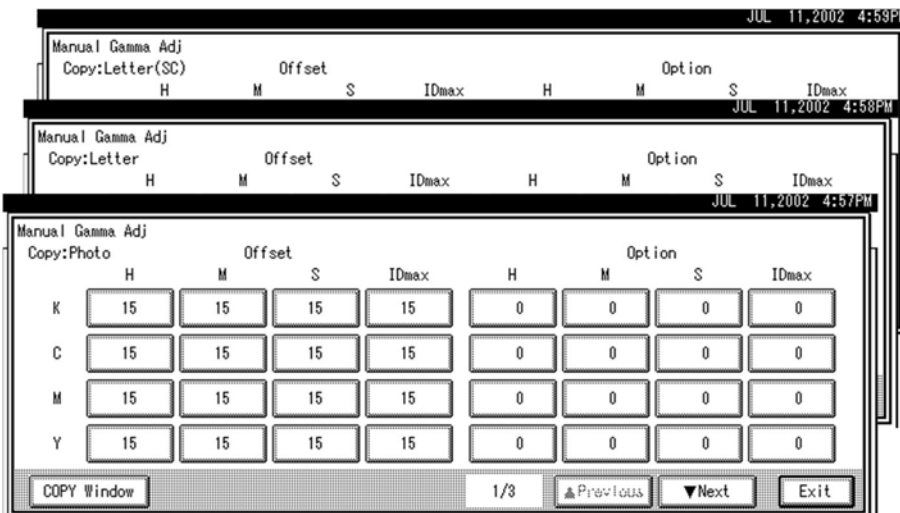

d081r967

Image Adjustments

Adjustment Procedure

Copy the C-4 chart in mode that you want to adjust.

1. Enter the SP mode.
2. Touch "Copy SP."
3. Open SP4918.
4. Adjust the offset values until the copy quality conforms to the standard. (Refer the tables below.)

★ Important

- Never change "Option" value (default value is 0).
- Always adjust the density in order: ID Max> Middle> Shadow> Highlight.

Copy: Photo (Photo Mode Full Color)

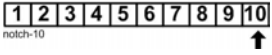
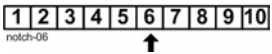
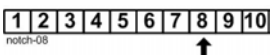
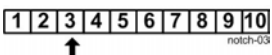
Step	Item to Adjust	Level on the C-4 chart
IDMax	ID max: (K, C, M, and Y) Adjust the offset value so that the density of level 10 matches that of level 10 on the C-4 chart.	
M	Middle (Middle ID) (K, C, M, and Y) Adjust the offset value so that the density of level 6 matches that of level 6 on the C-4 chart.	
S	Shadow (High ID) (K, C, M, and Y) Adjust the offset value so that the density of level 8 matches that of level 8 on the C-4 chart.	
H	Highlight (Low ID) (K, C, M, and Y) Adjust the offset value so that dirty background is not visible on the copy and the density of level 3 is slightly lighter that of level 3 on the C-4 chart.	

Copy: Photo (SC) (Photo Mode Single Color)

Step	Item to Adjust	Level on the C-4 chart
IDMax	ID max: (K) Adjust the offset value so that the density of level 10 matches that of level 10 on the C-4 chart.	 A C-4 chart notch labeled 'notch-10' with levels 1 through 10. An upward-pointing arrow is positioned below level 10.
M	Middle (Middle ID) (K) Adjust the offset value so that the density of level 6 matches that of level 6 on the C-4 chart.	 A C-4 chart notch labeled 'notch-06' with levels 1 through 10. An upward-pointing arrow is positioned below level 6.
S	Shadow (High ID) (K) Adjust the offset value so that the density of level 8 matches that of level 8 on the C-4 chart.	 A C-4 chart notch labeled 'notch-08' with levels 1 through 10. An upward-pointing arrow is positioned below level 8.
H	Highlight (Low ID) (K) Adjust the offset value so that dirty background is not visible on the copy and the density of level 3 is slightly lighter that of level 3 on the C-4 chart.	 A C-4 chart notch labeled 'notch-03' with levels 1 through 10. An upward-pointing arrow is positioned below level 3.

Image Adjustments

Copy: Letter (SC) (Text Mode Single Color)

Step	Item to Adjust	Level on the C-4 chart (K)
IDMax	ID max: (K, C, M, and Y) Adjust the offset value so that the density of level 10 matches that of level 10 on the C-4 chart.	 <p>notch-10</p>
M	Middle (Middle ID) (K, C, M, and Y) Adjust the offset value so that the density of level 6 matches that of level 6 on the C-4 chart.	 <p>notch-06</p>
S	Shadow (High ID) (K, C, M, and Y) Adjust the offset value so that the density of level 8 matches that of level 8 on the C-4 chart.	 <p>notch-08</p>
H	Highlight (Low ID) (K, C, M, and Y) Adjust the offset value so that dirty background is not visible on the copy and the density of level 3 is slightly lighter that of level 3 on the C-4 chart.	 <p>notch-03</p>

Copy: Letter (SC) (Text Single Color Mode)

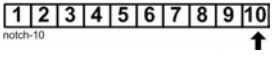
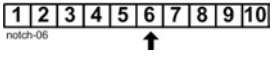
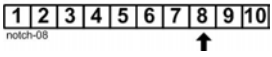
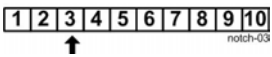
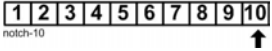
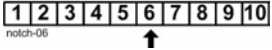
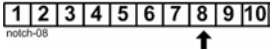
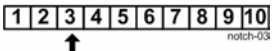
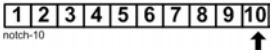
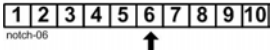
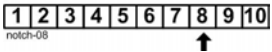
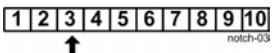
Step	Item to Adjust	Level on the C-4 chart (K)
IDMax	ID max: (K) Adjust the offset value so that the density of level 10 matches that of level 10 on the C-4 chart.	 A horizontal row of 10 numbered boxes (1-10) with 'notch-10' written below. An upward arrow points to the right side of the row.
M	Middle (Middle ID) (K) Adjust the offset value so that the density of level 6 matches that of level 6 on the C-4 chart.	 A horizontal row of 10 numbered boxes (1-10) with 'notch-06' written below. An upward arrow points to the middle of the row.
S	Shadow (High ID) (K) Adjust the offset value so that the density of level 8 matches that of level 8 on the C-4 chart.	 A horizontal row of 10 numbered boxes (1-10) with 'notch-08' written below. An upward arrow points to the right side of the row.
H	Highlight (Low ID) (K) Adjust the offset value so that dirty background is not visible on the copy and the density of level 3 is slightly lighter that of level 3 on the C-4 chart.	 A horizontal row of 10 numbered boxes (1-10) with 'notch-03' written below. An upward arrow points to the left side of the row.

After "Shadow" adjustment, if text in the test pattern does not print clearly:

- Check to determine whether the 5 line/mm pattern at each corner is printed clearly.
- If it is not, adjust the offset value of 'shadow' again until the pattern prints clearly.
- Printer Mode

There are eight adjustable modes. Select these modes with in the **Printer SP mode** with SP1102:

*1200 x 1200 Photo (Default)	2400 x 600 Photo
1800 x 600 Photo	600 x 600 Photo
1200 x 1200 Text	2400 x 600 Text
1800 x 600 Text	600 x 600 Text

Image Adjustments

Printer SP Mode: SP1104

Note: These are Printer SP Mode settings, not System SP Mode Settings.

	K	C	M	Y
Highlight	SP1104 001	SP1104 021	SP1104 041	SP1104 061
Middle	SP1104 002	SP1104 022	SP1104 042	SP1104 062
Shadow	SP1104 003	SP1104 023	SP1104 043	SP1104 063
IDmax	SP1104 004	SP1104 024	SP1104 044	SP1104 064

Adjustment Procedure

1. Do the ACC adjustment for the printer mode.
2. Turn the main power off and on.
3. Enter SP mode.
4. Touch "Printer SP"
5. Select SP1102 (Resolution Settings) and select the print mode that you want to adjust.
6. To review the image quality for these settings, do SP1103 002 (Color Pattern) to print out a color tone control test sheet.
7. Adjust the color density with SP1104 as shown below while comparing the tone control test sheet with the C4 test chart.

★ Important

- Always adjust the density in order: ID Max> Middle> Shadow> Highlight.

Adjustment Reference for Gamma Correction

The following tables show the adjustment reference for gamma correction. The tables show the level of the color scale on the C4 test chart and on the tone control test sheet printed in the printer SP mode. For example, for K at text mode, grade 12 on the tone control test sheet should be the same as grade 7 on the C4 chart.

Normally, it is not necessary to adjust the gamma data as shown in the table since ACC adjusts the gamma curve automatically. The fine-tuning of color balance by gamma data adjustment is necessary only when the results of ACC and Color Calibration do not meet customer requirements.

K	Test sheet	C4 test chart										
		1	2	3	4	5	6	7	8	9	10	
	Photo	600 x 600	-	1	3	5	6	9	10	11	16	-
		1800 x 600	-	1	3	5	6	8	10	11	16	-
		1200 x 1200	-	1	3	4	6	8	10	12	15	16
	Text	600 x 600	-	1	3	5	6	9	10	11	16	-
		1800 x 600	-	1	3	5	6	9	10	12	16	-
		1200 x 1200	-	1	3	5	6	9	11	12	15	16

d081r971

C	Test sheet	C4 test chart										
		1	2	3	4	5	6	7	8	9	10	
	Photo	600 x 600	-	1	3	5	6	9	10	12	13	14
		1800 x 600	-	1	3	5	6	8	10	11	12	13
		1200 x 1200	-	1	3	4	5	8	10	11	12	13
	Text	600 x 600	-	1	3	4	5	8	10	11	12	13
		1800 x 600	-	1	3	5	6	9	10	11	12	14
		1200 x 1200	-	1	3	4	5	9	10	11	12	13

d081r972

M	Test sheet	C4 test chart										
		1	2	3	4	5	6	7	8	9	10	
	Photo	600 x 600	-	1	4	6	8	11	12	14	16	-
		1800 x 600	-	1	4	6	8	11	12	15	16	-
		1200 x 1200	-	1	4	6	7	10	12	14	16	-
	Text	600 x 600	-	1	4	6	7	10	12	14	16	-
		1800 x 600	-	1	4	6	8	11	13	14	16	-
		1200 x 1200	-	1	4	6	7	10	12	13	16	-

d081r973

Y	Test sheet	C4 test chart										
		1	2	3	4	5	6	7	8	9	10	
	Photo	600 x 600	1	3	4	9	11	12	14	15	16	-
		1800 x 600	1	3	5	8	10	11	14	15	16	-
		1200 x 1200	1	3	5	8	10	11	14	15	16	-
	Text	600 x 600	1	2	5	8	10	11	14	14	15	16
		1800 x 600	1	3	6	9	10	12	14	15	16	-
		1200 x 1200	1	2	4	7	9	10	13	15	16	-

d081r974

5.20 TOUCH SCREEN CALIBRATION

After clearing memory, or if the touch screen detection function is not working correctly, calibrate the touch screen.

★ Important

- Do not attempt to use items [2] to [9] on the Self-Diagnostic Menu. These items are for design use only.
- To avoid causing an error, do not touch the Reset key while doing this procedure.
- Push [Clear], push 1993, and then press [Clear/Stop] 5 times.

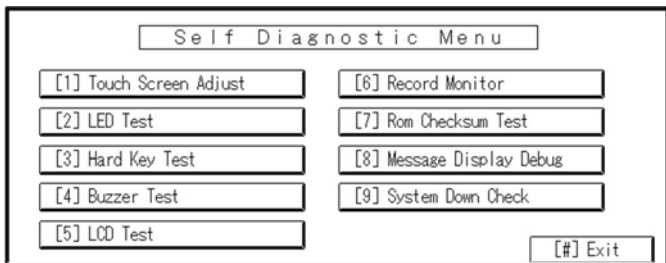

d081r892

1. Push "Touch Screen Adjust" (or push "1").

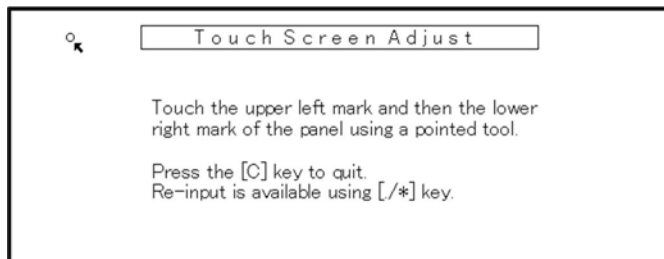

d081r893

2. Use a soft point (not sharp!) to press the upper left mark (⊙).
3. Press the lower right mark (⊙) after it appears.

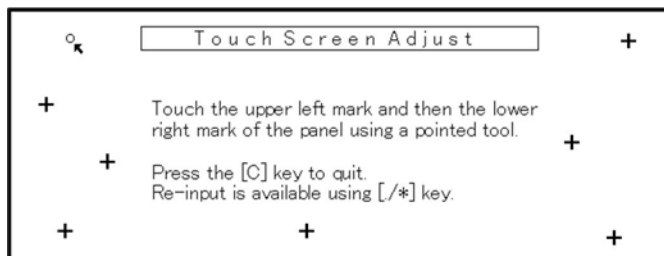

d081r894

4. Touch a few random spots on the touch screen to confirm that the marker (+) appears exactly where the screen is touched.

Touch Screen Calibration

5. If the (mark does not appear where the screen is touched, push [Cancel] and repeat from Step 2.
6. When you are finished, touch [#] OK on the screen (or push [#] on the operation panel).
7. Touch [#] Exit on the screen to close the Self-Diagnostic menu and save the settings.

5.21 FIRMWARE UPDATE

5.21.1 BEFORE YOU BEGIN...

Always obey these rules when handling and using SD cards:

- Never connect or remove an SD card with the machine on.
- Never turn the power off while the machine is downloading data from an SD card.
- The SD card is a precision item. Use it carefully. Do not keep the card in a location where there is high temperature, high humidity, or light from the sun.
- Handle SD cards carefully to avoid bending, scratching, or dropping them.
- If a power failure occurs during the firmware update, turn the machine power off/on without removing the SD card. The firmware update procedure should start again.

5.21.2 FIRMWARE UPDATE PROCEDURE

1. Obtain the System SD card.
2. Disconnect the network cable and other interface cables. This prevents outside interference caused by data transfers to the machine while the software is being uploaded.
3. Turn the main switch off.
4. Remove the SD card slot cover (🔑 x1).
5. Remove the VM card from the lower slot.

★ Important

- Before removing the VM card from Slot 1 (lower slot) you must shut down the App2 Me application (and all other VM card applications) if it is running. See p.5-24 "Before Removing and Re-installing the VM Card".
6. Insert the SD card into Slot 1 (lower slot).
 7. Open the front door of the machine. This prevents generation of electrical noise from motors during the update procedure.
 8. Switch the machine on.
You will see "Please Wait" then "Preparing to start firmware update."
The first screen appears after about 60 to 90 sec.

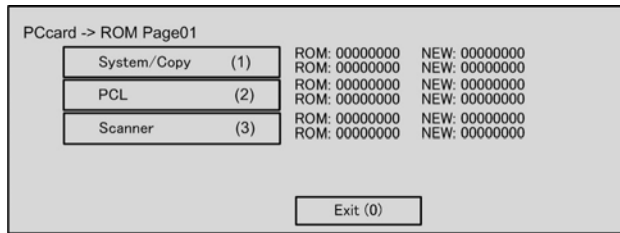

d081r912

9. Check the notations to the right.
 - "ROM" shows the module number and version of the currently installed software.
 - "NEW" shows the module number and version of software on the SD card in Slot 1 (lower slot).
10. Touch item that you want to update. The selected item appears in reverse black and white, and you can select more than one
11. Touch [Update] or push [#] on the 10-key pad to start the update.

While the Update Is in Progress

- Remain with the machine. Do not leave it unattended.
- Never close the front door during firmware update.
- You will see a progress bar on the screen while the update is in progress.
- For some updates the [Start] key LED may flash RED slowly, while the update is in progress. When it starts to flash RED rapidly, this means the update is nearly finished. When the LED flashes GREEN this means the update is completed.
- Never switch the machine off while the [Start] key is flashing RED.
- If the machine is switched off or accidentally unplugged before the update is finished, do not remove the SD card. Just switch the machine on again. The firmware update should restart automatically. If the firmware update does not recover, obtain a new System SD card.

The following screen sequence appears after selecting one "OpePanel" selected for update.

Firmware Update

Example: System/Copy Update

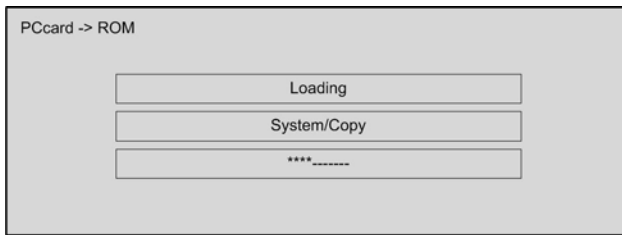

d081r913

- The middle bar tells you the name of the item that you are updating.
- The bottom bar shows the progress of the update procedure.

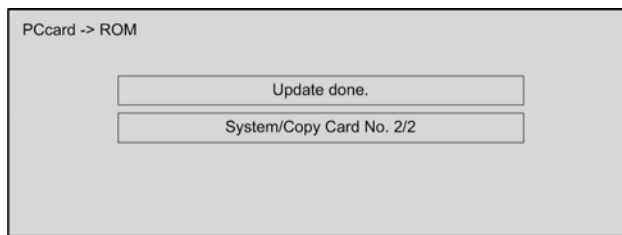

d081r914

- The update is complete when you see the "Update done" message.
 - The update requires about 2.5 minutes.
12. When you see the update completed message, turn the machine off.
 13. Remove the SD card from the SD card slot.
 14. Re-insert the VM card in the lower slot.
 15. Switch the machine on.



If the client is using App2 Me (or any other VM card applications) on the VM card, you must do the procedure to re-start the App2 Me applications.

SYSTEM MAINTENANCE

6. SYSTEM MAINTENANCE

6.1 SERVICE PROGRAM MODE

See "Appendices" for "Service Program Mode" information,

TROUBLESHOOTING

REVISION HISTORY		
Page	Date	Added/Updated/New
8	04/21/2010	Deleted SP5802
38 ~ 39	06/02/2010	Corrected " <i>Color Adjustment for Connected Copiers</i> "

7. TROUBLESHOOTING

7.1 HANDLING ERRORS

7.1.1 PROGRAM DOWNLOAD

Overview

Here are some important points to keep in mind when downloading software:

- If an error interrupts download processing, the machine cannot operate normally with the program software only partially downloaded.
- When download processing execution starts, "Downloading..." is displayed and when downloading has completed successfully, the message is cleared.
- If the download is interrupted when the "Downloading ..." message is displayed, the machine does not attempt a re-try.
- The program that downloads firmware from an SD card is part of the GW controller software. If downloading this software is interrupted, the program stored in the machine may be corrupted. Because of this, it may not be possible to restart the downloading program. (In addition, if the GW controller software cannot be downloaded, other software on other SD cards cannot be downloaded.) However, it may be possible to restart the program without replacing the board by setting DIP SW 1 on the controller to ON, and re-starting.

Recovery Methods

When an error occurs during downloading, an error code is displayed on the operation panel.

- If the download procedure can be re-started, re-start the download procedure.
- If the download procedure cannot be downloaded for other than the GW controller, replace the board where the downloaded program is stored.
- If the download procedure cannot be downloaded for the GW controller, set DIP SW 1 to ON. Power the machine off and on to start the downloading program. After downloading has completed, set the DIP SW to OFF then power the machine off and on again.

Download Error Codes

No.	Display	Error Description/Recovery
01	Reboot after card insert E01 Module ID Card No. xx/xx	<p>Controller ROM update error 1</p> <p>When the update break data was stored in NVRAM, the break module information and the decompression module capable of writing did not match.</p> <p>Recovery</p> <ul style="list-style-type: none"> ▪ Use the correct card
02	Download Error E02 Power off/on	<p>Controller ROM update error 2.</p> <p>Error occurred during ROM update program initialization.</p> <p>Recovery</p> <ul style="list-style-type: none"> ▪ Cycle the machine off/on to rewrite
03	Download Error E03 Power off/on	<p>Controller ROM update error 3</p> <p>The ROM for the write operation does not exist.</p> <p>Recovery</p> <ul style="list-style-type: none"> ▪ Cycle the machine off/on ▪ Install the missing ROM DIMM
04	Download Error E04 Power off/on	<p>Controller ROM update error 4</p> <p>GZIP data confirmation failed. (CRC value check)</p> <p>Recovery</p> <ul style="list-style-type: none"> ▪ Cycle the machine off/on ▪ Set DIP SW 1 to ON and retry ▪ Replace RAM DIMM ▪ Replace controller board
05	Download Error E05 Power off/on	<p>Controller ROM update error 5</p> <p>Error occurred when writing to the device.</p> <p>Recovery</p> <ul style="list-style-type: none"> ▪ Cycle the machine off/on ▪ Set DIP SW 1 to ON and retry ▪ Replace RAM DIMM ▪ Replace controller board

No.	Display	Error Description/Recovery
06	Download Error E06 Power off/on	<p>Controller ROM update error 6 CPU clock error occurred.</p> <p>Recovery</p> <ul style="list-style-type: none"> ▪ Turn the machine power off/on. ▪ Set controller DIPSW-1 to ON to force the machine to write to ROM. ▪ If you cannot force the machine to write, replace the controller board.
19	Download Error E19 Power off/on	<p>Controller ROM update error 7 Schedule data is unclear.</p> <p>Recovery</p> <ul style="list-style-type: none"> ▪ Software defective
20	Down Error E20 Power Off/On	<p>System error 1 (+SC991) The physical address could not be mapped due to defective software or hardware.</p> <p>Recovery</p> <ul style="list-style-type: none"> ▪ Cycle the machine off/on and re-try ▪ Replace controller board
21	Download Error E21 Power Off/On	<p>System error 2 (+SC991) There was not sufficient memory to download.</p> <p>Recovery</p> <ul style="list-style-type: none"> ▪ Cycle the machine off/on and re-try. ▪ Replace RAM ▪ Replace the controller board
22	Download Error E22 Module ID Card No xx/xx	<p>System error 3 (+SC991) Data failed to decompress due to defective card.</p> <p>Recovery</p> <ul style="list-style-type: none"> ▪ Cycle the machine off/on and re-try. ▪ Replace card ▪ Replace controller board

Handling Errors

No.	Display	Error Description/Recovery
---	SC991	<p>System error 4</p> <p>“Selfupdate” did not execute due to defective software.</p> <p>Recovery</p> <ul style="list-style-type: none"> ▪ Cycle the machine off/on and re-try ▪ Set DIP SW 1 to ON and re-try ▪ Replace the controller board
23	Download Error E24 Power Off/On	<p>System error 5</p> <p>Card read/write error occurred or software or card defective.</p> <p>Recovery</p> <ul style="list-style-type: none"> ▪ Cycle the machine off/on and re-try ▪ Replace the card ▪ Replace the controller board
30	No Valid Data E30	<p>Download dysfunction 1</p> <p>Could not download to HDD because HDD is not not installed or HDD is defective.</p> <p>Recovery</p> <ul style="list-style-type: none"> ▪ HDD defective ▪ HDD harness disconnected, defective
31	Reboot After Card Insert E31 Module ID Card No. xx/xx	<p>Download dysfunction 2</p> <p>Download continuity error occurred with more than one card. The second or later card was not compatible.</p> <p>Recovery</p> <ul style="list-style-type: none"> ▪ Set the correct cards in the correct order
32	Reboot After Card Insert E32 Module ID Card No. xx/xx	<p>Download dysfunction 3</p> <p>Download interrupted because card wrong card was used, or a power failure interrupted the download operation.</p> <p>Recovery</p> <ul style="list-style-type: none"> ▪ Use the correct card ▪ If power failure caused the failure, remove the card and insert another.

No.	Display	Error Description/Recovery
33	No Valid Data E33	<p>Download dysfunction 4</p> <p>Card version error. Attempted to download program using a card with the wrong version number.</p> <p>Recovery</p> <ul style="list-style-type: none"> ▪ Use the correct card
34	No Valid Data E34	<p>Download dysfunction 5</p> <p>Specification error. DOM card was set in EXP machine, or vice versa.</p> <p>Recovery</p> <ul style="list-style-type: none"> ▪ Use the correct card
35	No Valid Data E35	<p>Download dysfunction 6</p> <p>Wrong model. The inserted card is for another model.</p> <p>Recovery</p> <ul style="list-style-type: none"> ▪ Use the correct card
36	No Valid Data E36	<p>Download dysfunction 7</p> <p>Module error. The program that you are attempted to download does not exist on the machine, or the contact points at the card and the machine slot are not connected.</p> <p>Recovery</p> <ul style="list-style-type: none"> ▪ Use the correct card, inserted correctly ▪ Install a ROM DIMM if none is installed
37	No Valid Data E37	<p>Download dysfunction 8</p> <p>Edit option card error. You attempted to employ a used card.</p> <p>Recovery</p> <ul style="list-style-type: none"> ▪ Use an unused card
40	Download Error E40 Module ID Card No. xx/xx	<p>Download result failure 1</p> <p>Engine download failure.</p> <p>Recovery</p> <ul style="list-style-type: none"> ▪ Cycle the machine off/on and re-try

Handling Errors

No.	Display	Error Description/Recovery
41	Download Error E41 Module ID Card No. xx/xx	<p>Download result failure 2</p> <p>Fax download failure.</p> <p>Recovery</p> <ul style="list-style-type: none"> ▪ Cycle the machine off/on and re-try
42	Download Error E42 Module ID Card No. xx/xx	<p>Download result failure 3</p> <p>Operation panel or language download failed. For this error, sometimes the message may not be displayed.</p> <p>Recovery</p> <ul style="list-style-type: none"> ▪ Cycle the machine off/on and re-try
43	Download Error E43 Module ID Card No. xx/xx	<p>Download result failure 4</p> <p>Print download failed.</p> <p>Recovery</p> <ul style="list-style-type: none"> ▪ Cycle the machine off/on and re-try
44	Download Error E44 Module ID Card No.	<p>Download result failure 5</p> <p>The data targeted for the write operation could not be accessed.</p> <p>Recovery</p> <ul style="list-style-type: none"> ▪ Turn the machine power off/on. ▪ Replace the SD card with the start-up SD card that has the source data ▪ Set controller DIPSW-1 to ON to force the machine to write ▪ If you cannot force the machine to write, replace the controller board.
50	No Valid Data E50	<p>Download invalid</p> <p>The source data for the update could not be authenticated.</p> <p>Recovery</p> <ul style="list-style-type: none"> ▪ Use the correct SD card.

No.	Display	Error Description/Recovery
51	(no display)	<p>Remote ROM update failure 1</p> <p>The source data for the ROM update is corrupted because the machine is operating and an SC code has been issued.</p> <p>Recovery</p> <ul style="list-style-type: none"> ▪ Cycle the machine power off/on and try again.
52	(no display)	<p>Remote ROM update failure 2</p> <p>The source data received for the ROM update is corrupted; it failed a SUM check due to its abnormal length.</p> <p>Recovery</p> <ul style="list-style-type: none"> ▪ Try again with the correct data.
53	(no display)	<p>Download result failure 6</p> <p>The previous download in progress was cancelled.</p> <p>Recovery</p> <ul style="list-style-type: none"> ▪ Do the download procedure again.

7.1.2 IMPORTANT SP CODES

Here is a list of important SP codes that you may need during troubleshooting. For more information about these and other SP codes, refer to the Service Tables.

⇒ SP5802	SP has been deleted	Not Used
SP5803	Input Check	Displays the signals received from sensors and switches.
SP5804	Output Check	Switches electrical components one by one for testing.
SP5810	Cancel Fusing SC Code	Use this to cancel a fusing unit SC code to return the machine to normal operation after you repair the machine.
SP5990	SMC Printout	Prints the SMC Report. Some SC codes (logged SPs) are listed only in the SMC Report and do not appear on the operation panel display.
SP7401	SC Codes	Displays the total number of SC codes logged.
SP7403	SC History	Displays information about the 10 most recent service calls (Code, Total, Date, and Details).
SP7801	ROM Ver	Displays the ROM version numbers of the main machine and connected peripheral devices.
SP7832	Self-Diagnostic Report Details	Push [#] to display a list of error codes. Nothing is displayed if no errors have occurred.

7.1.3 SPECIAL PROCEDURES

Correcting the Halo Effect

Images printed with the GW controller may show a "halo" effect when printing in 2-bit mode (1800x600dpi) and in 4-bit mode (9600x600dpi).

Problem

- This problem is most visible when text is overlaid onto halftone areas in 2-bit mode or 4-bit mode. The greater the difference in image density between text and halftone areas, the more noticeable the halo effect.
- This problem is also evident when the mode is changed to 2-bit mode. (The default dithering pattern for 2-bit mode is designed to improve gradation, but this can also make the halo effect more visible.)
- This problem is a product limitation for this model, as announced in the SLG (User/Sales/Service Remarks #12).

Solution

The following solution is only effective when using the GW controller. There are two ways to reduce the halo effect:

1. Print out the image using 1-bit mode (600x600dpi) instead, or
2. Change the dither pattern used in 2-bit mode (1800x600dpi).
As mentioned above, the default dither pattern for 2-bit mode is provided to improve gradation. However, there is one more dither pattern ("Low halo effect dither") that can be selected to reduce the halo effect.

Procedure: To Change the Dither Pattern for 2-Bit Mode

Do the following procedure manually to change the dither pattern used in 2-bit mode to "Low halo effect dither".

1. Confirm that the Printer/Scanner firmware is Ver1.00.1 (D3765902A) or newer.
2. Execute SP5801-008 (Memory Clear Printer Application).

When you execute this SP, the following will be reset to factory settings:

- The gamma curve adjusted at the last Printer ACC execution.
 - All Group SP1000 settings in Printer SP mode, which includes SP1104 (Gamma Adjustment) and SP1106 (Toner Limit).
3. When you see the "Completed. You have to reboot." message, turn the machine on.
 4. Open Printer SP1001-002 (Bit Switch – Bit Switch 2 Settings).
 5. Touch the "6" key, and then the [#] key on the operation panel.

The LCD display will change:

Handling Errors

Before (default): 00000000 (0) [00H]

After (Low Halo Effect Dither): 01000000 (0) [40H]

6. Exit Printer SP mode, and then turn the main power switch OFF and ON.
7. Execute Printer ACC using Test Pattern 2 (1800X600dpi).
Now, when the user selects 2-bit mode (1800x600dpi) in the printer driver, the Low Halo Effect Dither function will be applied automatically.

Procedure: To Restore the Default

To change the dither pattern for 2-bit mode back to the default pattern, do this procedure.

1. Execute SP5801-008 (Memory Clear Printer Application).
2. Cycle the machine off/on.

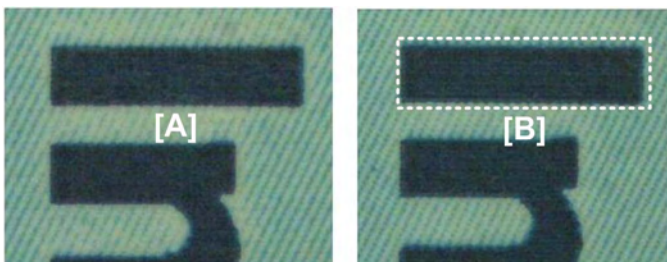

d081t016

[A] Factory default dither pattern

[B] Low halo effect type dither pattern

Image Density Light, Failure to Release from Toner End Alert

If the image density is too light, or if the machine fails to release the "Toner End" alert, this can be caused by one of the following problems:

- Developer Filling (SP3814) was not successful.
- Developer Setup (SP3811) or TD sensor initialization (SP3801) was not done or was not done correctly after Developer Filling (SP3814).
- Developer Setup (SP3811) or TD sensor initialization (SP3801) was done more than once.

1. First, do the following SP value checks.

Check 1-1. SP3815-001 (Developer Fill Disp Result) displays "1111"?

"1111" should be displayed for all colors, K, M, C, Y reading from left to right.

Result	Comment
1	Success
4	Factory default (Nothing has been done)
7	Developer Filling (SP3814) has been performed more than once for the color, whose developer has already completely filled the development unit.
9	Failed. No developer inside the development unit, or the amount of developer inside the development unit is insufficient.

Check 1-2. SP3817-001 to 004 (Developer Filling Admission) are all "0"?

"0000" should be displayed for all colors, K, M, C, Y

"0" = Developer filling has completed successfully.

"1" = Developer Filling has not completed successfully yet.

Check 1-3. SP3812-001 (Developer Setup Execute): displays 1111?

"1111" should display for all colors, K, M, C, Y, reading left to right.

Result	Comment
1	Succeeded.
2	Interrupted abnormally
3	Vt lower limit error
4	Default (nothing done yet)
8	Toner supply error
9	Vtcnt error

2. Next, do the following procedures according to the results of SP value checking.

Handling Errors

Case 1	If one of Check 1-1, Check 1-2, or Check 1-3 failed do Procedure 1 .
Case 2	If all of Check 1-1, Check 1-2 and Check 1-3 all succeeded, the toner supply mechanism may be broken. First do Procedure 2 , and then do Procedure 1 .
Case 3	If only Check 1-2 did not succeed (returned "1"), do Procedure 3 as a temporary solution. However, for a permanent solution be sure to do Procedure 1 after performing Procedure 3 . Otherwise, the image density will be abnormal.

Procedure 1

1. Replace the toner cartridge causing the problem (density too light or no "Toner End" release) with a new toner cartridge.

↓ Note

- After the "Toner End" alert appears for a color, this "Toner End" information is written into the ID chip on the toner cartridge, even though a lot of toner may remain inside the cartridge. This means that machine will detect that the toner cartridge is empty.
2. Follow the procedure in the service manual to replace the developer for all colors.
3. After the TD sensor initialization (SP3801-001 to 006) has been completed, check these SP values:
- SP3812-001 = 1111 (Display Result of Developer Setup Execution)
 - SP3821-001 = 10101010 (Display Result of Process Control)

Procedure 2

1. Replace the toner cartridge causing the problem (density too light or no "Toner End" release) with a new toner cartridge.

↓ Note

- After the "Toner End" alert appears for a color, this "Toner End" information is written into the ID chip on the toner cartridge, even though a lot of toner may remain inside the cartridge. This means that machine will detect that the toner cartridge is empty.
2. Do SP2251-001 to 004 "Forced Toner Supply for the color (K, M, C, or Y) for the color whose image density is too light.

↓ Note

- To avoid damage to the toner supply mechanism, never perform "Forced Toner Supply for K, M, C, or Y more than three times.

3. Check the image density to see if it is darker.

4. Do SP3820-002 (Manual ProCon).

5. Do SP3821-001 (ProCon OK?) to confirm that SP3820-002 succeeded. You should see "10101010" displayed if SP3820-002 executed successfully.

↓ Note

- If SP3820-002 displays any values other than "10101010" (successful execution), the toner supply mechanism may be broken. Replace the toner supply mechanism.

6. If SP3820-002 shows "10101010" (successful execution), perform Steps 2 and 3 of

Procedure 1 for the color causing the problem (light image or failure to release from "Toner End" alert).

Procedure 3

★ Important

- For this procedure there must be developer in the development unit.

1. Replace the toner cartridge causing the problem (density too light or no "Toner End" release) with a new toner cartridge.

↓ Note

- After the "Toner End" alert appears for a color, this "Toner End" information is written into the ID chip on the toner cartridge, even though a lot of toner may remain inside the cartridge. This means that machine will detect that the toner cartridge is empty.

2. Do SP3817-005 (Developer Filling Admission: Clear). This SP forces the settings of SP3817-001 to 004 to change from "1" to "0" and forces toner supply from toner cartridges to toner subhoppers.

3. Do SP2251-001 to 004 (Forced Toner Supply K, M, C, or Y) for the color whose image density is too light.

↓ Note

- To prevent damaging the toner supply mechanism, never perform "Forced Toner Supply K, M, C, Y" more than three times.

4. Check the image density to see if it is darker.

5. Do SP3820-002 "Manual ProCon".

6. Do SP3821-001 "ProCon OK?" to confirm if SP3820-002 succeeded. You should see "10101010" displayed if SP3820-002 executed successfully.

7. If SP3820-002 shows "10101010" (successful execution), perform the Steps 2 and 3 of

Handling Errors

Procedure 1 for the color causing the problem (light image or failure to release from "Toner End" alert).

SP2181 030 (Alignment Result) Errors

After SP2181 030 executes normally, you should see a "1" replace the "0" (default display). If you see any number other than a "1", this indicates an error.

Code.	Error, Problem, Solution
2	Failure
	Problem 1 <ul style="list-style-type: none">▪ Large amount of skew.▪ Large amount of K skew.▪ Large amount of skew in every color. Solution <p>Print a trim pattern with SP2109 002 Pattern #10 (Trim Area).</p>
	Problem 2 <ul style="list-style-type: none">▪ Density too light. Solution <ul style="list-style-type: none">▪ Print a coverage pattern with SP2109 002 Pattern #1 (1: Grid pattern).▪ Check the images.
	Problem 3 <ul style="list-style-type: none">▪ ITB scratched. Solution <p>Replace the ITB.</p>
12	Abnormal detection pattern
	Problem 1 <ul style="list-style-type: none">▪ ITB misaligned. Solution <ul style="list-style-type: none">▪ Reinstall ITB

Code.	Error, Problem, Solution
	<p>Problem 2</p> <ul style="list-style-type: none"> ▪ SP2153 023 set to 1 (OFF). <p>Solution</p> <ul style="list-style-type: none"> ▪ Set SP2153 023 to 0 (ON).
	<p>Problem 3</p> <ul style="list-style-type: none"> ▪ Image density too light. <p>Solution</p> <ul style="list-style-type: none"> ▪ Output a coverage pattern with SP2109 002 Pattern 1. ▪ Check the images.
	<p>Problem 4</p> <ul style="list-style-type: none"> ▪ Dirty, abnormal images. <p>Solution</p> <ul style="list-style-type: none"> ▪ Output Pattern 1, 18, or 20 with SP2109 002 and check the images.
21-23	Auto density out of range (over or lower)
	<p>Problem 1</p> <ul style="list-style-type: none"> ▪ ITB misaligned <p>Solution</p> <ul style="list-style-type: none"> ▪ Reinstall ITB
	<p>Problem 2</p> <ul style="list-style-type: none"> ▪ Image density too light, uneven. <p>Solution</p> <ul style="list-style-type: none"> ▪ Output a coverage pattern with SP2109 002 Pattern #1 (1: Grid pattern). ▪ Check the images.

Handling Errors

Code.	Error, Problem, Solution
	<p>Problem 3</p> <ul style="list-style-type: none"> ▪ Connector loose. ▪ Connector dirty. ▪ Harness defective. <p>Solution</p> <ul style="list-style-type: none"> ▪ Check the ID sensor and its connection.
31-33	<p>Amount of skew calculated in the coverage pattern abnormal.</p>
	<p>Problem 1</p> <ul style="list-style-type: none"> ▪ ITB misaligned <p>Solution</p> <ul style="list-style-type: none"> ▪ Reinstall ITB.
	<p>Problem 2</p> <ul style="list-style-type: none"> ▪ SP2153 023 set to 1 (OFF). <p>Solution</p> <ul style="list-style-type: none"> ▪ Set SP2153 023 to 0 (ON).
	<p>Problem 3</p> <ul style="list-style-type: none"> ▪ Large amount of K skew. <p>Solution</p> <ul style="list-style-type: none"> ▪ Print a trim pattern with SP2109 002 Patten #10 (10: Trim Area).
	<p>Problem 4</p> <ul style="list-style-type: none"> ▪ Image density too light, uneven. <p>Solution</p> <ul style="list-style-type: none"> ▪ Output a coverage pattern with SP2109 002 Pattern #1 (1: Grid pattern). ▪ Check the images.
41-43	<p>Intersecting lines of the grid pattern.</p>
	<p>Problem 1</p> <ul style="list-style-type: none"> ▪ ITB misaligned <p>Solution</p> <ul style="list-style-type: none"> ▪ Reinstall ITB.

Code.	Error, Problem, Solution
	<p>Problem</p> <ul style="list-style-type: none"> ▪ Image density too light. <p>Solution</p> <ul style="list-style-type: none"> ▪ Output a coverage pattern with SP2109 002 Pattern 1. ▪ Check the images.
	<p>Problem</p> <ul style="list-style-type: none"> ▪ Dirty, abnormal images. <p>Solution</p> <ul style="list-style-type: none"> ▪ Output Pattern 1, 18, or 20 with SP2109 002 and check the images.
51-53	
	<p>Problem</p> <ul style="list-style-type: none"> ▪ ITB misaligned <p>Solution</p> <ul style="list-style-type: none"> ▪ Reinstall ITB.
	<p>Problem</p> <ul style="list-style-type: none"> ▪ SP2153 001 set to 1 (OFF). <p>Solution</p> <ul style="list-style-type: none"> ▪ Set SP2153 001 to 0 (ON).
	<p>Problem</p> <ul style="list-style-type: none"> ▪ Dirty, abnormal images. <p>Solution</p> <ul style="list-style-type: none"> ▪ Output Pattern 1, 18, or 20 with SP2109 002 and check the images.
	<p>Problem</p> <ul style="list-style-type: none"> ▪ Connector loose. ▪ Connector dirty. ▪ Harness defective. <p>Solution</p> <ul style="list-style-type: none"> ▪ Check the ID sensor and its connection.

Handling Errors

Image Position Adjustment

A MUSIC error occurs when a large amount of skew occurs beyond the acceptable range, or when the K sensor is out of position. Such errors can be corrected manually to correct skew. However, these adjustments cannot correct problems caused by physical damage to the ITB, filming, density degradation, or a dirty sensor.

1. Load some A3 paper in Tray 1. Make sure that the side and bottom fences are set properly.
2. Do SP1003 001 (Side-to-Side Reg – Tray 1) and set it to "0".
3. Do SP2109 002 (Test Pattern) then select and print Pattern #10: Trim Area.
4. Do SP2101 001 so the left and right margins are 1.5 mm.
5. If any color is separated from black more than 1 mm, do SP2101 002 to 004 to bring each color closer to K.

Important

- Black skew can cause part of the image to shift off the paper.
- Normally, the settings of SP2102-1, -5, -6, -7 should be reset to the values in the SMC report or the values printed on the A5 sheet provided with a new laser unit.
- Normally, these values do not change unless the NVRAM becomes corrupted.
- Most machines can be adjusted with these values: K: -40, M:-20, C:-10, Y: -5. Use these values if other information is not available.

Color Registration Error Adjustment

Color Registration Error Correction

1. Start SP 2109 002 and select Pattern #1 (1: Grid pattern), then push the "OK" button.
2. Push the "Copy Window" button.
3. Make sure "Full Color Mode" is selected.
4. Select A3/DLT paper, and push the [Start] button to print the pattern.

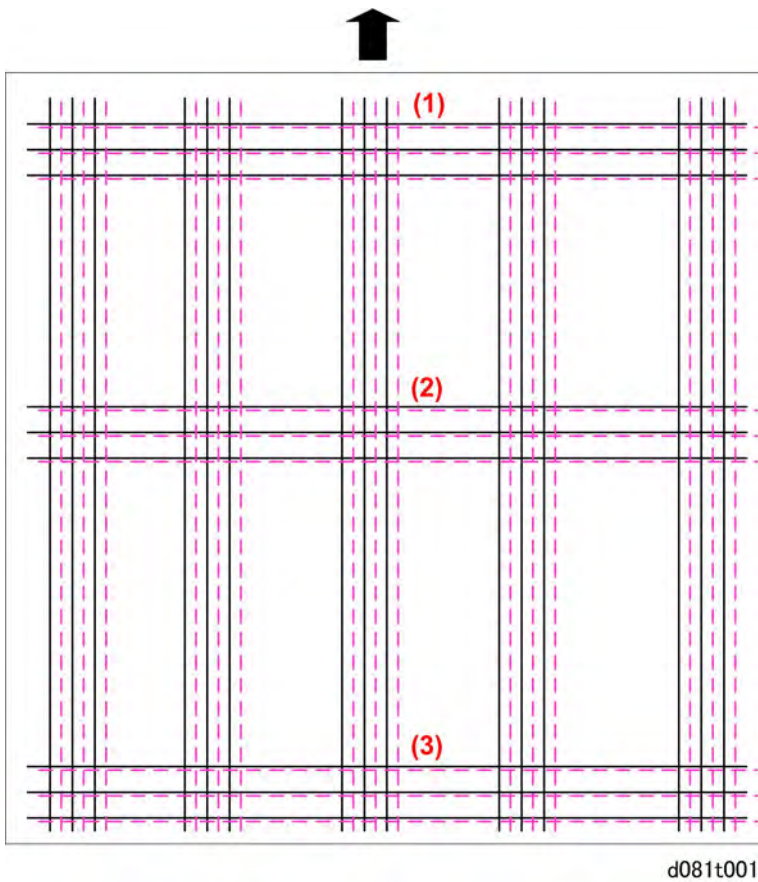

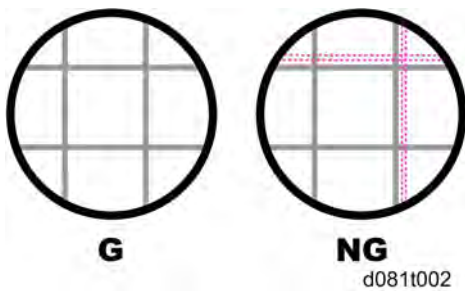

5. Lay the test pattern flat, and use a loupe to examine the grid patterns at the top (1), middle (2) and bottom (3). In the example above, the solid lines are black, and the dotted lines are magenta (as shown), cyan, or yellow.



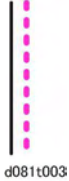

6. Correct the errors in the vertical lines (this corrects errors in the main scan direction). See the following table for how to do this.
In the table, a dotted line indicates a colored line (C, M, or Y). For example, the first row of the table shows you how to adjust the machine if a colored line is to the right of the black line on the test pattern.

Trouble-shooting

Handling Errors

SP Codes to Adjust	Unit of adjustment: 43.2 μ m	
2101 002 (M) -or- 2101 003 (C) -or- 2101 004 (Y)	 <p>d081t003</p>	Decrease the value
	 <p>d081t004</p>	Increase the value

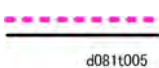
7. Correct the errors in the horizontal lines (this corrects errors in the sub scan direction). See the following table for how to do this.

SP Codes to Adjust	Unit of adjustment: 84.6 μ m	
2101 020 (M) -or- 2101 021 (C)	 <p>d081t005</p>	Increase the value
-or- 2101 022 (Y)	 <p>d081t006</p>	Decrease the value

8. Do steps 1 and 2 again.
9. If there are color registration errors, then do steps 1 through 6 again.

Color Skew Error Correction

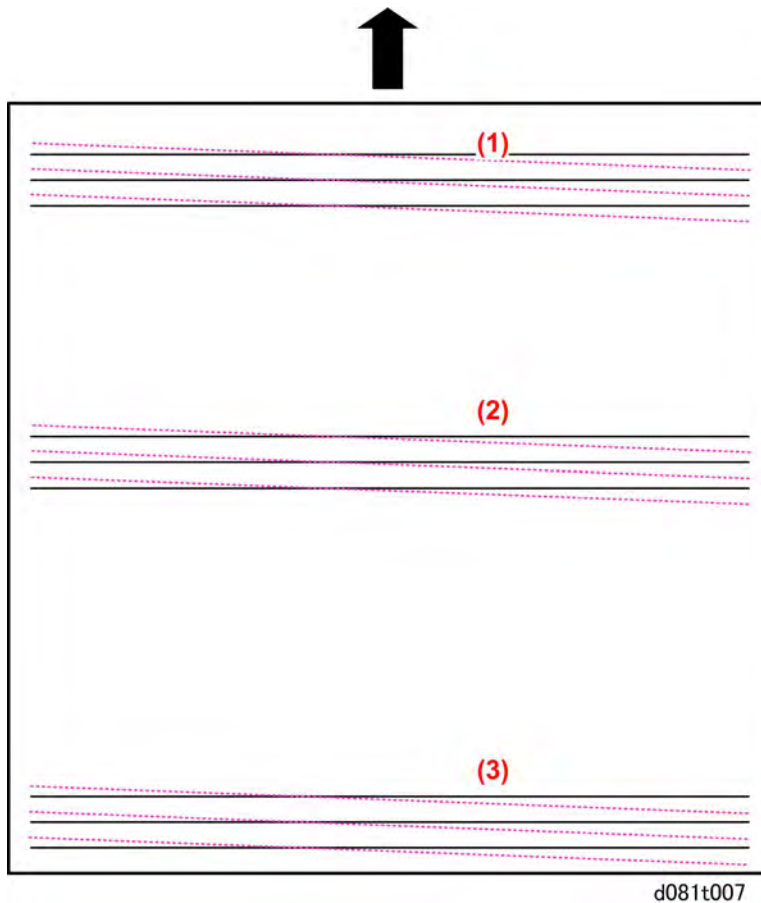

1. Start SP2109 002 and select Pattern #1 (1: Grid pattern), then push the “OK” button.
2. Make sure that “Full Color Mode” is selected before you push the [Start] button.
3. Push the “Copy Window” button. Then select A3/DLT paper, and push the “Start” button to print the pattern.



4. Inspect the lines with a loupe at the top (1), middle (2), and bottom (3). In the example above, the dotted lines are magenta, cyan, or yellow, and the solid lines are black.
5. Correct the skew.
6. See the following table for how to do this

Trouble-shooting

Handling Errors

SP Codes to Adjust	Unit of adjustment: 43.2 um	
2104 001 (M)		Increase the value
-or- 2104 002 (C) -or- 2104 003 (Y)		Decrease the value

Overall Check

1. After you do the color registration error and color skew corrections, do a forced MUSIC again, with SP2111 001.
2. Do SP2109 002 and print Pattern #1 (1: Grid pattern) on A3/DLT paper again. Check the skew and color registration. If they are still not acceptable, do the forced MUSIC again.
3. Do SP2181-001 (Alignment Result – General) to make sure that the forced MUSIC was done correctly.
 - If the result is '1', then each color was aligned correctly.
 - If "1" is not shown, then please see "SP2181 030 (Alignment Result) Errors" in this section under "Special Procedures"..

Color Registration at the Left and Right Folds of the Test Pattern

Do this procedure after you complete “Color Registration Error Correction” and “Color Skew Error Correction”.

1. Do SP2109 002 and print Pattern #1 (1: Grid pattern) on A3/DLT paper.
2. Make sure that “Full Color Mode” is selected.
3. Push the [Start] button.

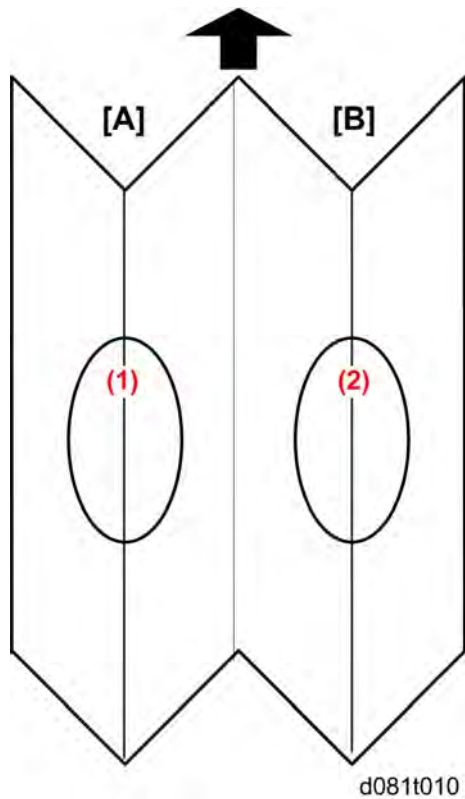

4. Fold the test pattern lengthways in half, then fold it in half again as shown above.
5. Lay the test pattern flat, and use a loupe to examine the grid patterns at the first crease [A] and third crease [B].

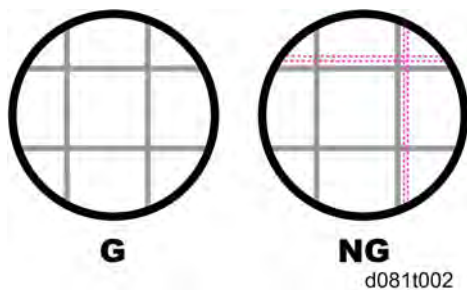



When viewed through the loupe, the grid lines on the left and right side should be perfectly aligned (G) and not misaligned (NG).

Trouble-shooting

Handling Errors

6. If the lines are misaligned (NG), use a loupe to measure distance between the black vertical lines and each of the colored vertical lines (C, M, Y). Measure this on the left and right folds:
7. If there is a gap between the black lines and a colored line, measure it and correct it with SPs as shown in the tables below.

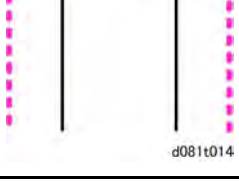
SP Codes to Adjust	Unit of adjustment: 50 um	
2112 001 (M) Left (Fold) -or- 2112 002 (M) Right (Fold) -or- 2112 003 (C) Left (Fold) -or- 2112 004 (C) Right (Fold) -or- 2112 005 (Y) Left (Fold) -or- 2112 006 (Y) Right (Fold)	 d081t011	Gap on the left is different from the gap on the right
	 d081t012	
	 d081t013	Gaps are the same.
	 d081t014	

- To move a color toward the left edge, decrease the SP value.
- To move a color toward the right edge, increase the SP value.

SP3812 001 (DevSetup Execute) Errors

After SP3812 001 executes normally, you should see four 1s: "1111"

Reading from left to right, each "1" indicates the status of the PCUs: K, M, C, Y.

If you see any number other than a "1", this indicates an error.

SP3812 001 Error Codes

Code	Error, Problem, Recovery
2	Execution Interrupted
	<p>Problem</p> <ul style="list-style-type: none"> ▪ Door was opened, or another color returned an error. ▪ Execution halts at the first error encountered or if the front door is opened during execution. <p>Recovery</p> <ul style="list-style-type: none"> ▪ Check the preceding error codes. ▪ Never open the front door during execution.
3	Vt Abnormal
	<p>Problem</p> <ul style="list-style-type: none"> ▪ The reading of Vt (TD sensor output) is less than 5 V. <p>Recovery</p> <ul style="list-style-type: none"> ▪ Check the operation panel for a developer set error (SC336 to SC339). ▪ Check the PCUs and confirm that all the film seals have been removed to release the developer from the developer cartridge.
4	Did Not Execute
	<p>Problem</p> <ul style="list-style-type: none"> ▪ SP Default <p>Recovery</p> <ul style="list-style-type: none"> ▪ Displayed when you open this SP code. No action is necessary.

Handling Errors

Code	Error, Problem, Recovery
8	Toner Supply Abnormal
	<p>Problem</p> <ul style="list-style-type: none"> ▪ At the end of the toner filling cycle, the toner end sensor detected no toner. <p>Recovery</p> <ul style="list-style-type: none"> ▪ Check the toner supply unit.
9	Vtcnt Abnormal
	<p>Problem</p> <ul style="list-style-type: none"> ▪ Vtref (control reference voltage) could not be adjusted to within 0.2 V of Vt (TD sensor output). <p>Recovery</p> <ul style="list-style-type: none"> ▪ This is a TD sensor adjustment error (SC372 to SC375). Execute SP3801 again for the PCU that returned the error. If this does not recover operation, check the next four points. ▪ Film seal not removed from a new developer pack ▪ TD harness sensor disconnected, loose or defective ▪ TD sensor defective ▪ Harness between TD sensor and drawer disconnected, defective

Process Control Troubleshooting

Summary of Process Control SC Codes

This is a list of SC codes that may occur during process control. For more, please refer to the process control tables on the following pages.

Pre-Processing Check

SC316 to SC319	Vpp is not within the normal range (Vpp: the AC current applied to the charge roller to compensate for changes in the ambient temperature and humidity). Insufficient charge causes white spotting and too much charge causes toner to film on the surface of the drum. Vpp must be > 2.8 kV.
SC400	ID sensor could not be calibrated. An abnormal ID sensor condition is detected when before calibration begins, Vsg < 0.5V or after calibration, Vsg cannot be adjusted to 4.0±0.2V.
SC418	Correct current could not be supplied to the ID sensor.
SC436 to SC439	A problem is detected with a potential sensor during calibration.

Potential Control

SC410 to SC413	The development gamma is out of range (not between 0.3 and 6.0) for a color.
SC414 to SC417	Vk is out of range (not within ±150V) for a color. If the development potential is less than Vk, toner is not applied to the drum.
SC420 to SC423	Vd cannot be adjusted to the target voltage for a drum.
SC424 to SC427	The potential sensor detects that Vpl is not ±10V of the target Vpl after exposure of the ID sensor patterns.
SC432 to SC435	The residual voltage on a drum is greater than -200V.

Handling Errors

TD Sensor Output Calibration

SC360 to SC367	An abnormal condition is detected when output of one of the TD sensors fails to fall within the range of 0.5V to 4.5V.
----------------	--

Process Control Gamma Correction

SC410 to SC413	The development gamma for black, magenta, cyan, or yellow is not within range (0.3 to 6.0).
SC414 to SC417	The development start voltage (Vk) for black, magenta, cyan, or yellow PCU is not within range ($\pm 150V$)

Process Control Self-Check: SP3821

After the process control self-check is executed manually with SP3820, you can execute SP3821 to check the results of the self-check. The possible error codes are listed in the "Displayed Code" column in the table below.

When you do SP3821, the normal display (no errors) will look like this:

10101010

Reading from left to right each "10" represents a color: K, M, C, Y.

If a problem occurs, the code will appear in the column for the color PCU where the error has occurred. For example, If a Vdhome error (Code 15) (see table below) occurs in the M PCU, the display will look like this:

10151010

Or if an ID sensor error (Code 21) (see table below) occurs in the Y PCU:

10101021

"99" displays while SP3821 executes.

★ Important

- Noise and static electricity can damage the many sensors that are used during the process control self-check. Because of this, always turn the machine off before doing any procedure described below that requires disassembly.

Potential Sensors

Code	Error, Problem, Solution
15	VdHome Error 1
	<p>Problem</p> <ul style="list-style-type: none"> V0 (SP3571) above -700V, or VdHome (SP3572) above -700V. The window of the potential sensor probe fouled with toner Potential sensor damaged <p>Solution</p> <ul style="list-style-type: none"> Do SP2260 001 to check the function of the potential sensor. Do SP2261 to check the Vd, Voffset readings. Development has recovered if the Vd is 700V and offset is 10V. Remove the PCU. Use a blower brush to clean the window of the potential sensor probe, and then check the sensor again with SP2260-001. If normal operation cannot be restored, replace the potential sensor probe.
16	VdHome Error 2
	<p>Problem</p> <ul style="list-style-type: none"> V0 (SP3571) below -700V, or VdHome (SP3772) below -500V. Potential sensor relay board damaged Drum abnormal Charge roller damaged Drum motor not operating <p>Solution</p> <ul style="list-style-type: none"> Do SP2260 001 to check the function of the potential sensor. Do SP2261 to check the Vd reading. Development has recovered if the Vd is -700V. Remove the malfunctioning PCU with a functioning PCU, turn the machine off then on, then do the potential sensor check again. If the replaced PCU does not function normally, then the problem is on the

Troubleshooting

Handling Errors

Code	Error, Problem, Solution
	<p>machine side, or the potential sensor relay board is malfunctioning.</p> <ul style="list-style-type: none"> If the replaced PCU functions normally, then there may be a problem with the drum or the charge unit. Replace the PCU.
17	VdHome Calculation Error
	<p>Problem</p> <ul style="list-style-type: none"> VdHome could not be calculated. This is a software calculation error (not a hardware problem). <p>Problem</p> <ul style="list-style-type: none"> Switch the machine off/on then execute SP3820 001.

ID Sensors

Code	Error, Problem, Solution
21	ID Sensor Vsg Adjust Error
	<p>Problem</p> <ul style="list-style-type: none"> Vsg_reg (SP3121) is out of range (not within $4.0 \pm 0.2V$). ID sensor fouled with dust, toner ITB undulating or out of position <p>Solution</p> <ul style="list-style-type: none"> Remove the ITB unit. Make sure the belt is mounted correctly. Clean the windows of the ID sensors with alcohol and a clean cloth. Be sure to wipe the sensor apertures with a wet cloth. A dry cloth may generate static which can attract dust.
22	ID Sensor LED Current Error
	<p>Problem</p> <ul style="list-style-type: none"> LED PWM (SP3131) greater than 3000. ID sensor fouled with dust, toner ID sensor deteriorated <p>Solution</p>

Code	Error, Problem, Solution
	<ul style="list-style-type: none"> ▪ Remove the ITB unit and check the ID sensors. ▪ Clean the windows of the ID sensors with alcohol and a clean cloth. ▪ Be sure to wipe the sensor apertures with a wet cloth. A dry cloth may generate static which can attract dust. ▪ If the apertures are clean, then the LED of an ID sensor may have deteriorated. Replace the ID sensor plate.
23	ID Sensor Output Error
	<p>Problem</p> <ul style="list-style-type: none"> ▪ Vsg_reg (SP3121-001) less than 0.5V. ▪ ID sensor harness loose, disconnected, damaged ▪ ID sensor damaged <p>Note: Vsg_reg refers to the reading of the drum surface done with the direct reflection sensors in both the color and black ID sensors.</p> <p>Solution</p> <ul style="list-style-type: none"> ▪ Remove the ITB unit. ▪ Check the ID sensor harness connections and make sure that they are tight. ▪ Check the harnesses for breaks. ▪ If the harnesses are undamaged and tightening the connections does not solve the problem, replace the ID sensor plate.

Handling Errors

AC Charge

Code	Error, Problem, Solution
31	AC Charge Adjust Error 1
	<p>Problem</p> <ul style="list-style-type: none">▪ Vpp could not be adjusted after 20 attempts.▪ Bias path defective▪ Charge gap abnormal (too large)▪ Charge roller dirty▪ Drum coated with film <p>Solution</p> <ul style="list-style-type: none">▪ Make sure that the bias path and drum are grounded correctly.▪ Check the drum and both ends of the charger roller for any foreign matter.▪ Check the gap between the charge roller and the drum to confirm that it is not too large.▪ If the grounds and gap is normal, clean the charger roller or replace it.
32	AC Charge Adjust Error 2
	<p>Problem</p> <ul style="list-style-type: none">▪ Vpp greater than 2.80 kV.▪ Bias path defective▪ Charge gap abnormal▪ Charge roller dirty, defective <p>Solution</p> <ul style="list-style-type: none">▪ Make sure that the bias path and drum are grounded correctly.▪ Check the drum and both ends of the charger roller for any foreign matter.▪ Check the gap between the charge roller and the drum to confirm that it is not too large.▪ If the grounds and gap is normal, clean the charger roller or replace it.

ID Sensor Pattern Detection

Code	Error, Problem, Solution
55	Development Gamma Error 1
	<p>Problem</p> <ul style="list-style-type: none"> ▪ Development gamma (SP3561) greater than 6.0 (mg/cm²/-kV). <p>Solution</p> <ul style="list-style-type: none"> ▪ Switch the machine off and on then do SP3820 002. ▪ Do SP3561 005 to 008 to confirm that development gamma is within the target range (-0.15 to +0.25) ▪ If not within the target range, do the procedure again. <p>If the machine returns SC410 to SC413 and process control does not end normally, do this procedure:</p> <ol style="list-style-type: none"> 1. Change the settings for SP3301 001 to 004 from "1" (PID) to "0" (Prescribed Amount). 2. Do SP2109 002 and select Pattern 12. 3. Change the settings of SP2109 005 to 008 from 63 to 0, except for the color which showed a development gamma error. 4. Return to the copy window and do the test print at least 10 patterns. 5. Do SP3820 002. <ul style="list-style-type: none"> ▪ If the patterns are normal, do Steps 2 and 3. ▪ If the patterns are not normal, repeat Steps 2 to 5. 6. Do SP3301 001 to restore PID toner supply.
56	Development Gamma Error 2
	<p>Problem</p> <ul style="list-style-type: none"> ▪ Development gamma (SP3561) less than 0.3 (mg/cm²/-kV) ▪ Toner supply abnormal ▪ Image transfer power pack defective ▪ Toner shield glass dirty <p>Solution</p> <ol style="list-style-type: none"> 1. Do SP2109 002 and select Pattern 12. 2. Do SP2109 005 to 008 and change the settings of these SP codes from 63 (default) to 0.

Handling Errors

Code	Error, Problem, Solution
	<ol style="list-style-type: none"> 3. Return to the copy window and do the test print 1 pattern. 4. Check the pattern to determine whether the image density is extremely light. 5. Turn the machine off. 6. Open the front door, remove the toner supply unit and check the toner shield glass for dirt. 7. Remove the face plate, replace the malfunctioning PCU with a functioning PCU, then turn the machine on and repeat Steps 1 to 3 to print the coverage test pattern. 8. If normal operation cannot be recovered: <ul style="list-style-type: none"> ▪ Replace the image transfer power pack. ▪ Open the development unit to see if there is too much or too little developer. ▪ If the developer supply is normal, remove the toner end sensor to see if there is toner in the sub hopper. ▪ If the sub hopper is empty, the powder pump is defective. Replace the toner supply unit. ▪ If the sub hopper is full, the toner end sensor is defective. Replace the toner supply unit. ▪ If the level of developer is either too high or too low, replace the developer.
57	Vk Error 1
	<p>Problem</p> <ul style="list-style-type: none"> ▪ Vk (development start voltage) greater than 150V. <p>Solution</p> <ul style="list-style-type: none"> ▪ Replace the developer.
58	Vk Error 2
	<p>Problem</p> <ul style="list-style-type: none"> ▪ Vk (development start voltage) less than -150V. <p>Solution</p> <ul style="list-style-type: none"> ▪ Replace the developer.

Code	Error, Problem, Solution
59	Insufficient Active Data
	Problem <ul style="list-style-type: none">▪ Not enough active data to calculate development gamma (only "0" or "1"). Solution <ul style="list-style-type: none">▪ Do the procedure for no. "55" described above.

Handling Errors

Potential Adjustment

Code	Error, Problem, Solution
61	LD Failure
	<p>Problem</p> <ul style="list-style-type: none"> ▪ A laser diode failed to fire and write the ID sensor pattern. ▪ Toner shield glass dirty ▪ PCU set incorrectly ▪ Laser diode defective <p>Solution</p> <ol style="list-style-type: none"> 1. Copy the color test pattern to determine which color is abnormal. 2. Turn the machine off. 3. Open the front door, remove the toner supply unit and check the toner shield glass for dirt. 4. Reassemble the machine, switch the machine on, then do SP3820 001. <p>Notes</p> <ul style="list-style-type: none"> ▪ The probes of the potential sensors of each PCU are located at different positions. This failure can be caused by installing a potential sensor at the incorrect position. However, you can eliminate this as a cause if a new PCU is installed. (A guide ensures prevents a PCU from being installed at the wrong location.) ▪ If the machine fails to return SC240 to SC243, you can eliminate a defective LD as the cause of the problem.
62	Vr Error
	<p>Problem</p> <ul style="list-style-type: none"> ▪ Vr (residual voltage) greater than $-200V$. ▪ Drum deteriorated ▪ Toner shield glass dirty <p>Solution</p> <ul style="list-style-type: none"> ▪ Open the front door, remove the toner supply unit, and check the toner shield glass for dirt. ▪ Clean the glass then do SP3820 001. ▪ If this does not solve the problem, replace the drum.

Code	Error, Problem, Solution
63	Vd Adjust Error
	<p>Problem</p> <ul style="list-style-type: none"> ▪ Vd could not be adjusted within $\pm 10V$. ▪ Charge roller dirty ▪ Drum defective <p>Solution</p> <ul style="list-style-type: none"> ▪ Replace the charge roller ▪ Replace the drum.
64	Vpl Adjust Error
	<p>Problem</p> <ul style="list-style-type: none"> ▪ Vpl could not be adjusted within $\pm 5V$. ▪ Drum deteriorated due to filming ▪ Charge roller dirty <p>Solution</p> <ul style="list-style-type: none"> ▪ Replace the charge roller ▪ Replace the drum.

Abnormal End

Code	Error, Problem, Solution
90	Potential Adjust Error
	<p>Problem</p> <ul style="list-style-type: none"> ▪ SP3501-001 (potential control method) is set to 1 (Fixed). <p>Solution</p> <ul style="list-style-type: none"> ▪ Do SP3501 001 and select "0" (Auto).
99	Forced Termination
	<p>Problem</p> <ul style="list-style-type: none"> ▪ Door open, power off, or other problem interfering with process control self-check. <p>Solution</p> <ul style="list-style-type: none"> ▪ Make sure the machine is turned on. ▪ Make sure the front door is closed completely.

Color Adjustment for Connected Copiers

⇒ This procedure may be required for copiers after they are connected with the Copy Connector Type 3260 B328-11. Do this procedure only if you or the customer notices that the color quality between the two copiers is different.

The scanner masking parameter and printer gamma curve are adjusted at the factory for each machine. However, small differences between machines may arise due to fluctuations in the tolerances of scanner or image processing components.

The following two adjustments calibrate these differences to within acceptable standards.

1. Color Adjustment with Connection Kit Color Test Chart (P/N VSST9502)

This adjusts the scanner masking parameter of each machine [A], [B] connected with the Copier Connection Kit B328. The scanner masking parameter is adjusted to equalize the scanner input with the scanner output.

2. ACC (Auto Color Calibration)

This adjusts the printer gamma curves [E], [F] of each machine connected with the Copy Connector Type 3260 B328-11.

- ⇒ [A] Scanner Masking Curve – Machine 1
 [B] Scanner Masking Curve – Machine 2
 [C] HDD – Machine 1
 [D] HDD – Machine 2
 [E] Printer Gamma Curve – Machine 1
 [F] Printer Gamma Curve – Machine 2

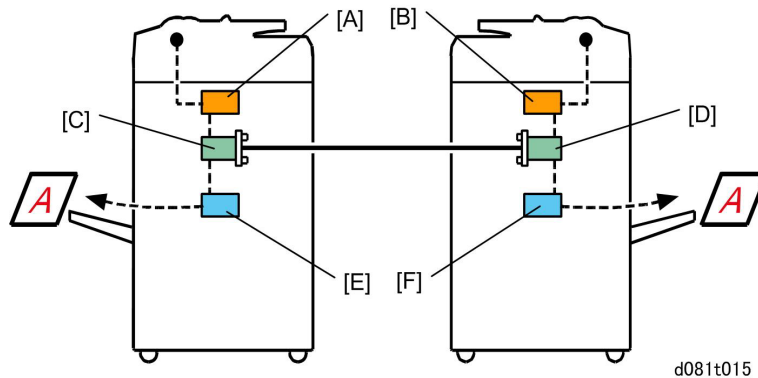

For Scanner Glass

To adjust the main machine:

1. Place the Connection Kit Color Test Chart (**P/N: VSST9502**) on the exposure glass, with the arrow mark on the chart aligned with the left rear corner.
2. Do SP4954 001 and touch [Execute] and confirm the "Completed" message appears. If "Failed" message appears after touching [Execute], do the procedure again.
3. After doing SP4954 001, do the ACC procedure described in the "Installation" section for the main machine.

To adjust the sub machine:

1. Do Steps 1 to 3 for the sub machine.

Compare the results

1. Set the two machines for full color, and do some sample color copies.
2. Compare the results from the two copiers. If the results are not same, do the procedure again from step 1.

For CIS of ADF

To adjust the main machine:

1. Load the Connection Kit Color Test Chart (P/N: VSST9502) in the ADF so that the blank side is facing up and the arrow on the chart is at the ADF's left rear corner.
2. Do SP4958 001 and touch [Execute] and confirm the "Completed" message appears. If "Failed" message appears after touching [Execute], do the procedure again.
3. After doing SP4958 001, do the ACC procedure described in the "Installation" section for the main machine.

To adjust the sub machine:

1. Do Steps 1 to 3 for the sub machine.

Compare the results

1. Set the two machines for full color, and do some sample color copies.
2. Compare the results from the two copiers. If the results are not same, do the procedure again from step 1.

7.2 SERVICE CALL CONDITIONS

7.2.1 SERVICE MODE LOCK/UNLOCK

At locations where the machine contains sensitive data, the customer engineer cannot operate the machine until the Administrator turns the service mode lock off. This function makes sure that work on the machine is always done with the permission of the Administrator.

1. If you cannot go into the SP mode, ask the Administrator to log in with the Operator Tool and then set "Service Mode Lock" to OFF. After he or she logs in:
2. Operator Tools > System Settings > Administrator Tools > Service Mode Lock > OFF
 - This unlocks the machine and lets you get access to all the SP codes.
 - The CE can do servicing on the machine and turn the machine off and on. It is not necessary to ask the Administrator to log in again each time the machine is turned on.
3. If you must use the printer bit switches, go into the SP mode and set SP 5169 to "1".
4. After machine servicing is completed:
 - Change SP 5169 from "1" to "0".
 - Turn the machine off and on. Tell the administrator that you completed servicing the machine.
 - The Administrator will then set the "Service Mode Lock" to ON.

7.2.2 SERVICE CALL CONDITIONS TABLE

There are 4 levels of service call conditions.

Level	Definition	Reset Procedure
A	Fusing unit SCs are displayed on the operation panel. The machine is disabled, and operator cannot reset the SC.	Enter SP mode and do SP5810 to release the machine for servicing.
B	SCs that disable only the features that use the defective item. These SCs are not shown to the operator under normal conditions. They are displayed on the operation panel only when the defective feature is selected.	Turn the main power switch off and on.
C	SCs that are not shown on the operation panel. They are internally logged.	Logging only
D	Turning the operation switch (or main power switch) off then on resets these SCs. These SCs are displayed on the operation panel and displayed again if the error reoccurs.	Turn the operation switch (or main power switch) off and on, or the machine reboots automatically. (See below.)

When a Level "D" SC code occurs

When a Level D SC occurs, a screen opens on the operation panel to tell the operator:

- An error occurred
- The job in progress will be erased
- The machine will reboot automatically after approximately 30 seconds.

The operator can wait until the machine reboots automatically or touch "Reset" on the screen to reset the machine immediately and go back to the copy screen.

If the operator does not touch "Reset"

The next message tells the operator that the machine will reset automatically and that the previous job was lost and must be started again. After reading the message, the operator touches "Confirm" on the screen. The next screen shows the number and title of the SC code, and stops until the operator turns the machine off and on.

If the operator touches "Reset"

Service Call Conditions

If the operator touches "Reset" to bypass the 30-second interval for the machine to reboot, the machine reboots immediately and the operation panel displays the copy screen.



- Do not try to use the operation panel during an automatic reboot. If the @Remote Service System is in use, the SC code is sent immediately to the Service Center

7.2.3 SC CODE DESCRIPTIONS

Before You Begin...

- If a problem concerns a circuit board, disconnect and reconnect the connectors and then test the machine. Often a loose or disconnected harness is the cause of the problem. Always do this before you decide to replace the PCB.
- If a motor lock error occurs, check the mechanical load before you decide to replace the motor or sensors.
- When a Level "A" or "B" SC occurs while in an SP mode, the machine cannot display the SC number. If this occurs, check the SC number after leaving the SP mode.
- The machine reboots automatically when the machine issues a Level "D" SC code. This is done for Level "D" SC codes only.

CAUTION

- Never turn off the main power switch when the power LED is lit or flashing. To avoid damaging the hard disk or memory, press the operation switch to switch the power off, wait for the power LED to go off, and then switch the main power switch off.

The main power LED () lights or flashes while the platen cover or ARDF is open, while the main machine is communicating with a facsimile or the network server, or while the machine is accessing the hard disk or memory for reading or writing data.

7.3 SERVICE CALL TABLES

See "Appendices" for "Service Call Tables" information,

ENERGY SAVING

REVISION HISTORY		
Page	Date	Added/Updated/New
		None

8. ENERGY SAVING

8.1 ENERGY SAVE

8.1.1 ENERGY SAVER MODES

Customers should use energy saver modes properly, to save energy and protect the environment.

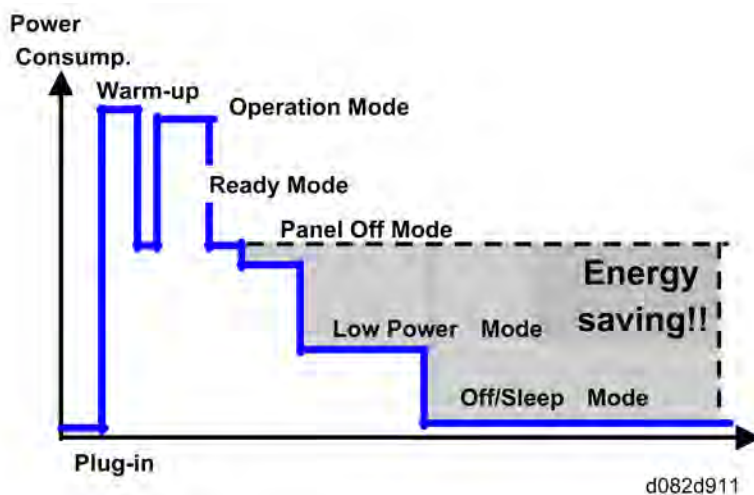

The area shaded grey in this diagram represents the amount of energy that is saved when the timers are at the default settings. If the timers are changed, then the energy saved will be different. For example, if the timers are all set to 240 min., the grey area will disappear, and no energy is saved before 240 min. expires.

Timer Settings

The user can set these timers with User Tools (System settings > Timer setting)

- Panel off timer (10 sec – 240 min): Panel Off Mode. Default setting: 60 sec.
- Energy saver timer (1 – 240 min): Low Power Mode. Default setting: 15 min.
- Auto off timer (1 – 240 min): Off/Sleep Mode. Default setting: 30 min.

Normally, Panel Off timer < Energy Saver timer < Auto Off timer. But, for example, if Auto Off timer < or = Panel Off timer and Energy Saver timer, the machine goes immediately to Off mode when the Auto Off timer expires. It skips the Panel Off and Energy Saver modes.

Example

- Panel off: 1 min.
- Low power: 15 min.

Energy Save

- Auto Off: 1 min.
- The machine goes to Off mode after 1 minute. Panel Off and Low Power modes are not used.

Return to Stand-by Mode

Low Power Mode

The recovery time depends on the model and the region.

- 45 sec.

Off/Sleep Mode

Recovery time.

- V-C3a: 90 sec.
- V-C3b: 75 sec.

Recommendation

We recommend that the default settings should be kept.

- If the customer requests that these settings should be changed, please explain that their energy costs could increase, and that they should consider the effects on the environment of extra energy use.
- If it is necessary to change the settings, please try to make sure that the Auto Off timer is not too long. Try with a shorter setting first, such as 30 min., then go to a longer one (such as 60 min.) if the customer is not satisfied.
- If the timers are all set to the maximum value, the machine will not begin saving energy until 240 minutes has expired after the last job. This means that after the customer has finished using the machine for the day, energy will be consumed that could otherwise be saved.
- If you change the settings, the energy consumed can be measured using SP8941, as explained below.

8.1.2 ENERGY SAVE EFFECTIVENESS

SP 8941 (Machine Status) keeps a record of the amount of time that the machine spends in each mode.

- 8941-001: Operating mode
- 8941-002: Standby mode
- 8941-003: Panel off mode
- 8941-004: Low power mode
- 8941-005: Off/sleep mode

With this data, and the power consumption values from the specifications, we can estimate the amount of energy that is used by the machine.

This should only be used as a reference value, because the power consumption specifications are measured in a controlled environment with a constant power supply.

To get an exact measurement at the customers site, a watt meter must be used to measure the actual energy consumed.

To use SP8941 to calculate the energy consumed:

- At the start of the measurement period, read the values of SP8941 001 to 005.
- At the end of the measurement period, read the values of SP8941 001 to 005 again.
- Find the amount of time spent in each mode (subtract the earlier measurement from the later measurement).
- Multiply this by the power consumption spec for each mode.
- Convert the result to kWh (kilowatt hours)

Here is an example calculation.

Energy Save

Machine Condition	SP8941: Machine Status	Time at Start (min.) ①	Time at End (min.) ②	Running time (hour) $(②-①)/60$ = ③	Power consumption Spec. (W) ④	Power consumption (KWH) $(③ \times ④)/1000$ = ⑤
Operating	001: Operating Time	21089.0	21386.0	5.0	1081.8	5.35
② Stand by (Ready)	002: Standby Time	306163.0	308046.0	31.4	214.0	6.72
③ Energy save (Panel off)	003: Energy Save Time	71386.0	75111.0	62.1	214.0	13.29
④ Low power	004: Low Power Time	154084.0	156340.0	37.6	146.0	5.49
⑤ Off/Sleep	005: Off Mode Time	508776.0	520377.0	193.4	7.0	1.35
Total ⑥						32.20

8.2 PAPER SAVE

8.2.1 EFFECTIVENESS OF DUPLEX/COMBINE FUNCTION

Duplexing and the combine functions reduce the amount of paper used. This means that less energy overall is used for paper production, which improves the environment.

1. Duplex:

Reduce paper volume in half!



d062d102

2. Combine mode:

Reduce paper volume in half!

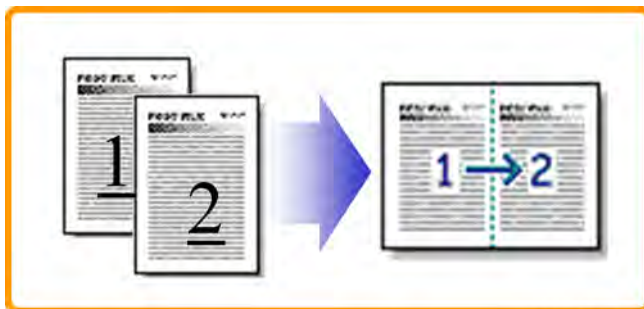

d062d100

3. Duplex + Combine:

Using both features together can further reduce paper volume by 3/4!

Paper Save



d062d101

To check the paper consumption, look at the total counter and the duplex counter.

The total counter counts all pages printed.

- For one duplex page, the total counter goes up by 2.
- For a duplex job of a three-page original, the total counter goes up by 3.

The duplex counter counts pages that have images on both sides.

- For one duplex page, the duplex counter goes up by 1.
- For a duplex job of a three-page original, the duplex counter will only increase by 1, even though two sheets are used.

How to calculate the paper reduction ratio

How to calculate the paper reduction ratio, when compared with Single-sided copying, with no 2-in-1 combine mode

Paper reduction ratio (%) = Number of sheets reduced: A/Number of printed original images: B x 100

- Number of sheets reduced: A
= Output pages in duplex mode/2 + Number of pages in Single-sided with combine mode + Number of pages in Duplex with combine mode x 3/2
 $A = ((2) + (3) + (4))/2 + (5) + (6) \times 3/2$
- Number of printed original images: B
= Total counter6 + Number of pages in Single-sided with combine mode + Number of pages in Duplex with combine mode
 $B = (1) + (5) + (6)$
- (1) Total counter: SP 8581 001 (pages)
- (2) Single-sided with duplex mode: SP 8421 001 (pages)
- (3) Double-sided with duplex mode: SP 8421 002 (pages)
- (4) Book with duplex mode: SP 8421 003 (pages)
- (5) Single-sided with combine mode: SP 8421 004 (pages)
- (6) Duplex with combine mode: SP 8421 005 (pages)**No index entries found.**

D081/D082
SERVICE MANUAL APPENDICES

D081/D082 APPENDICES

TABLE OF CONTENTS

1. APPENDIX: SPECIFICATIONS	1-1
1.1 SPECIFICATIONS.....	1-1
1.1.1 MAIN FRAME D081/D082.....	1-1
General and Copying.....	1-1
Printing.....	1-6
Scanning.....	1-7
ADF	1-8
1.1.2 OPTIONAL PERIPHERALS	1-9
LCT B473.....	1-9
LCT 4000 D350	1-10
8½ x 14" Paper Size Tray B474.....	1-11
Multi-Folding Unit FD5000 (D454)	1-11
Ring Binder RB5000 (D392)	1-20
9-Bin Mailbox B762.....	1-22
Cover Interposer Tray B704.....	1-23
Cover Interposer Tray B835.....	1-24
3000-Sheet Finisher B830	1-25
Punch Unit B831	1-27
2000-Sheet Finisher D373	1-28
3000-Sheet Finisher D374	1-33
Punch Unit B702.....	1-36
Z-Folding Unit ZF4000 B660.....	1-37
A3/11"x17" Tray B331.....	1-37
Copy Tray B476.....	1-38
1.1.3 ELECTRICAL COMPONENTS.....	1-39
Main machine	1-39
ADF	1-66

2. APPENDIX: PM TABLES.....	2-1
2.1 PM TABLES	2-1
2.1.1 MAIN MACHINE.....	2-1
Main Machine PM Parts.....	2-2
ADF PM Parts.....	2-10
2.1.2 LCT B473	2-11
2.1.3 LCT D350	2-11
2.1.4 MULTI-FOLDING UNIT FD5000 (D454).....	2-12
2.1.5 RING BINDER (D392).....	2-13
2.1.6 2000/3000-SHEET FINISHERS D373/D374	2-14
2.1.7 PUNCH B702	2-15
2.1.8 COVER INTERPOSER TRAY B704	2-15
2.1.9 3000-SHEET FINISHER B830	2-16
2.1.10 PUNCH B831	2-16
2.1.11 COVER INTERPOSER TRAY B835.....	2-17
2.2 LUBRICATION POINTS	2-18
2.2.1 OPC, ITB REPLACEMENT	2-18
2.2.2 FUSING UNIT	2-19
2.2.3 DEVELOPMENT UNIT	2-21
3. APPENDIX: SERVICE CALL CONDITIONS.....	3-1
3.1 SERVICE CALL TABLES	3-1
3.1.1 SC CODES GROUP 1: SCANNING.....	3-1
3.1.2 SC CODES GROUP 2: EXPOSURE.....	3-7
3.1.3 SC CODES GROUP 3: IMAGE DEVELOPMENT – 1	3-16
3.1.4 SC CODES GROUP 4: IMAGE DEVELOPMENT - 2.....	3-25
3.1.5 SC CODES GROUP 5: PAPER FEED.....	3-39
3.1.6 SC CODES GROUP 6: DEVICE COMMUNICATION	3-54
3.1.7 SC CODES GROUP 7: PERIPHERALS.....	3-58
3.1.8 SC CODES GROUP 8: OVERALL SYSTEM	3-96
3.1.9 SC CODES GROUP 9: MISCELLANEOUS	3-109
3.1.10 ADDITIONAL SC CODES PRINTED IN SMC REPORTS.....	3-115

4. APPENDIX: SERVICE PROGRAM MODE TABLES..... 4-1

4.1 SERVICE PROGRAM MODE..... 4-1

4.2 GROUP 1000 4-2

4.3 GROUP 2000 4-21

4.4 GROUP 3000 4-90

4.5 GROUP 4000 4-129

4.6 GROUP 5000 4-160

4.7 GROUP 6000 4-250

4.8 GROUP 7000 4-304

4.9 GROUP 8000 4-337

4.10 PRINTER, SCANNER SP TABLES 4-395

 4.10.1 PRINTER SERVICE MODE 4-395

 SP1-XXX (Service Mode) 4-395

 4.10.2 SCANNER SERVICE MODE..... 4-404

 SP1XXX System and Others 4-404

 SP2XXX Scanning Image Quality..... 4-406

4.11 COPIER INPUT/OUTPUT CHECK..... 4-407

 4.11.1 COPIER INPUT CHECK: SP5803..... 4-407

 4.11.2 COPIER OUTPUT CHECK: SP5804..... 4-420

APPENDIX:

SPECIFICATIONS

REVISION HISTORY		
Page	Date	Added/Updated/New
4	06/01/2010	Corrected DX Mode Paper Weight
39	10/27/2010	Added NOTE to Heaters Section of Electrical Components

1. APPENDIX: SPECIFICATIONS

1.1 SPECIFICATIONS

1.1.1 MAIN FRAME D081/D082

General and Copying

Configuration	Console	
Dimensions (w x d x h)		
No ADF	750 x 850 x 1050 mm (29.5 x 33.5 x 41.3 in.)	
With ADF	750 x 850 x 1230 mm (29.5 x 33.5 x 48.4 in.)	
Memory	On board	2 GB
	HDD	320 GB
Weight (with ADF)	Less than 298 kg (655.6 lb)	
Interfaces		
Network	Ethernet (standard), Gigabit Ethernet (option), Wireless LAN (option)	
Counter I/F	Parallel (20-pin), Parallel (4-pin), Serial	
USB 2.0 Type A (2- Board)	Standard	
USB 2.0 Type B (1-Board)	Standard	
IEEE 1284 ECP	Option	
Bluetooth	Option	
Peripheral Connection	Standard	
SD Card I/F Slots	2 slots, Slot 1 (lower for service), Slot 2 (upper for applications)	

Specifications

SD Card D505	Option	
Original Scanning	Flatbed with moving 3-line CCD array, image scanning	
Copy Process	4-drum dry electrostatic transfer system with internal transfer belt	
ADF	Simultaneous dual scan, front and back	
Development	Dry dual-component magnetic brush development	
Fusing	Oil-less belt fusing system	
Engine speed	D081	BW 65 cpm, FC 60 cpm,
	D082	BW 75 cpm, FC 70 cpm,
Warm-up time	D081	70 sec.
	D082	60 sec.
First copy time	D081	BW: 5.0 sec. FC: 5.8 sec.
	D082	BW: 4.2 sec. FC: 5.4 sec.
Original types	Book mode, Single-sheet feed with ADF	
Max. original size	Book Mode: 297 x 432 mm (11.7 x 17 in.) ADF: A3/DLT SEF	
Resolution	Copy	600 dpi
	Print	200/300/400/600/1200 dpi
	Scan (Send)	600
	Gradation	200, 300, 400 dpi (1-bit) 600 dpi (1-, 2-, 4-bit) 1200 dpi (1-bit)
Image Size	Default	297 (+4) x 457 mm (Note 1)
	Max.	297 (+4) x 600 mm (Note 2)

Note 1: Size depends on the D081/ D082 application "+4" not guaranteed.

Note 2:

- Size depends on the D081/ D082 application "+4" not guaranteed.
- Setting with SP mode is required.
- The max. setting cannot be selected if the SR5000 is installed.

Magnification	NA	7 Reduction, 5 Enlargement: 93%, 85%, 78%, 73%, 65%, 50%, 25%, 121%, 129%, 155%, 200%, 400%	
	EU/AP	7 Reduction, 5 Enlargement: 93%, 82%, 75%, 71%, 65%, 50%, 25%, 115%, 122%, 141%, 200%, 400%	
Zoom	25% to 400% (1% Steps)		
Paper capacity (Number of sheets calculated with 80 g/m ² 20 lb bond paper)	Tray 1	1,100 x2	2,200
	Tray 2	550	550
	Tray 3	550	550
	Bypass	100	100
	Main Total		3,400
	With LCT B473	4,000	7,400
	With LCIT D350	2,000	5,400
Original size detection: exposure glass	NA	11"x17", 8½"x14" SEF, 8½"x11" LEF/SEF	
	EU/AP	A3/A4 SEF, B4 SEF, A4/B5 LEF/SEF, 8½ "x13" SEF (8K, 16K available with SP mode)	

Original size detection (ADF)	NA	11"x17", 10"x14", 8½ x 14" SEF 8½"x11", 5½"x8½" SEF/LEF 7¼"x10½", A3 SEF A4 SEF/LEF
	EU, Asia	A3, B4 SEF A4, B5, A5, B6 SEF/LEF 8½"x13", 8K SEF 16K SEF
Paper Size		
Standard Copying	A3, B4, A4, B5, A5, 12" x 18", DLT, LG, LT, HLT, F/F4	
Duplex Copying	A3/DLT to A5/HLT LEF, 12" x 18" LEF	
Width Range	139.7 to 305 mm (5.5 to 12 in.)	
Length Range	139.7 to 457.2 mm (5.5 to 18 in.)	
Paper weight	Tray 1	52.3 – 216 g/m ²
	Tray 2	14 Bond – 80 lb Cover
	Tray 3	52.3 – 256 g/m ² 14 Bond – 90 lb Cover
	Bypass	52.3 – 300 g/m ² 14 lb Bond– 110 lb Cover
	Duplex mode	60 – 169 g/m ² 17 lb Bond – 90 lb Index
Output capacity	500 sheet (A4, 8½"x11") (with copy tray)	



Power	D081	110 to 127 V 20A 60Hz (NA)
	D082	208 to 240 V 12 A 60Hz (NA)
	D081/D082	220 to 240 V 12 to 10A 50 to 60 Hz (EU/AP/TWN)
Max. power consumption	NA	D081: Less than 1920 W D082: Less than 2400 W
	EU/AP	Less than 2400 W (full system)
TEC (Typical Energy Consumption)		
	NA	D081: 8.72 kWh/w D082: 9.66 kWh/w
	EU	D081: 8.07 kWh/w D082: 9.66 kWh/w
Sleep Mode	3 W	
Energy Star	Compliant	
Counter	NA	Electric counter, mechanical counter x2
	EU/AP	Electric counter, mechanical counter x1
Counterfeit prevention	Bill recognition, invisible marking function	

Specifications

Printing

CPU	Intel Celeron LV 733 MHz	
RAM	1384 MB (shared with copying, scanning)	
HDD	320 GB (80 GB x 4)	
Printer Languages	Standard	RPCS, PCL6, PCL5e, PCL5c, RTIFF
	Option	PS3, R55, PDF Direct
Print Resolution (max.)	600 x 600 dpi (4-bit)	
Fonts	Standard	45 PCL fonts, 13 International
	Option	PS3, 136 Adobe PostScript Type 1 fonts
Connectivity		
Host interface	Standard	Ethernet RJ-45, 10-BaseT, 100BaseTX, USB 2.0
	Options*1	IEEE1284 ECP, IEEE1394 (FireWire), IEEE802.11b (Wireless LAN), Bluetooth
Network Protocol	TCP IP, IPX/SPX, Apple Talk	
MIB support	Private MIB	Ricoh original
	Standard MIB	MIB-II (RFC1213), HostResource (RFC1514), PrinterMib (RFC1759)
Network, operating systems	Windows 2000, Windows XP, Windows Vista, Windows 2003 Server, MetaFrame, CPS, XenApp Mac OS 8.6 and higher, Mac OSX 10.1 to 10.6 and later	

Scanning

Optical resolution	100, 150, 200 (default), 300, 400, 600 dpi		
Scanning speed	TBA		
Max. scan area	297 x 432 mm (11.7"x17")		
Auto scan size detection	Exposure glass	Supported (conforms with main machine specifications)	
	ADF	Supported (conforms with main machine specifications)	
Original size	Standard	A3, A4 SEF, A4 LEF, A5 SEF/LEF, B4, B5 SEF, B5 LEF, 11"x17" SEF, 8½"x14" SEF, 8½"x13" SEF, 8½"x11" SEF/LEF, 5½ "x8½" SEF/LEF	
	Customized	Min.	10 x 10 mm (0.04"x0.04")
		Max.	297 x 432 mm (11.7"x17")
Compression Method	BW Binary: TIFF MH, MR, MMR Grayscale/Full Color: JPEG		
Interface support	10/100BaseTX, IEEE802.11b (Wireless LAN), IEEE1394 (FireWire)		
Scan mod	Default	BW Text	
	Supported	BW OCR, BW Text-Photo, BW Photo, Grayscale, FC Photo, FC Text Photo	
	Options*1	Auto Color Selection, sRGB Photo, sRGB Text Photo	
Image Density	Auto Density Selection, Manual Setting (7 levels)		
Image Rotation	TBA		
SADF/Batch mode	Supported		
Mixed size originals	Supported		

*1: File Format Converter D377 is necessary.

Specifications

ADF

Original Size	Simplex: A3/11" x 17" – B6/5.5" x 8.5" Duplex: A3/11" x 17" – B5/5.5" x 8.5"
Original Weight	Simplex: 40 to 128 g/m ² (11 to 34 lb.) Duplex: 52 to 128 g/m ² (14 to 34 lb.)
Table Capacity (A4 SEF, LT SEF)	250 sheets: 69g/m ² (150 sheets: 80g/m ² , 20 lb. Bond)
Original Standard Position	Rear left corner
Separation	Feed belt and separation roller
Original Transport	Roller transport
Original Feed Order	From top original
Reproduction Range	100%
Power Source	DC 24 V from the main machine
Power Consumption	Less than 110 W
Rated Voltage of Output Connector	Max. DC 24 V
Permissible voltage fluctuation	±10%
Dimensions (W x D x H)	680 x 560 x 180 mm (26.8" x 22.0" x 7.1")
Weight	18 kg (39.6 lb.)

1.1.2 OPTIONAL PERIPHERALS

LCT B473

Installation of the LCT Adapter B699 is required to adjust the height of LCT B473.

Dimensions (w x d x h)	Stand-alone	314 x 458 x 659 mm (12.4 x 18 x 25.9 in.)
	With LG/B4 Option	462 x 458 x 659 mm (18.2 x 18 x 25.9 in.)
Weight	Standalone	Less than 20 kg (44 lb)
	With LG/B4 Option	Less than 27 kg (59.4 lb)
Power Consumption		Less than 50 W
Noise		Less than 74dB
Paper Size		A4, B5, 11"x 8½" LEF
Paper Weight		52 - 128g/m ² 14 lb – 34 lb Bond
Paper Capacity (80 g/m ² or 20 lb bond)		4,000 sheets** 2,500 sheets*

Specifications

LCT 4000 D350

Expected Service Life	5 Years or 9,000K
Paper Feed System:	FRR-CF
Paper Capacity	2,000 sheets (Paper thickness: 0.11 mm)
Remaining Paper Detection (Accuracy: ±30 sheets)	5-Step including Near-End
Paper Weight	52 to 300 g/m ²
Paper Size	A5 to A3, HLT to 12 x 19.2 in. Postcards (100 mm wide) Custom Size: Length: 139.7 to 487.6 mm Custom Size: Width: 100 mm to 305.0 mm (Small Size: 100 to 139.2 mm)
Paper Size Switching	Side fence, end fence adjustment.
Paper Size Detection	Automatic
Anti-Condensation Heater	Available as option
Dimensions (w x d h)	865 x 730 x 746 mm (34 x 28.7 x 29.4 in.)
Weight	Less than 86 kg (190 lb)
Power Source	DC 24 V ±10% (from main machine)
Power Consumption:	Less than 120 W
I/F	Serial
Tab Sheet:	Requires installation of tab sheet fence. Note: Only A4 LEF, 8½"x11" LEF tab sheets can be fed.

8½ x 14" Paper Size Tray B474

This option converts LCT B473 so it can hold and feed LG size paper.

Paper Size	8½"x14", 8½"x11", A4, B4 SEF
Paper Weight	52 - 128g/m ² 14 lb - 34 lb Bond

Multi-Folding Unit FD5000 (D454)

General

Operating Environment	Temperature and humidity ranges: Same as main machine.	
Service Life	Expected: 5 years or 60,000 K (A4 LEF)	
Paper Weight	40 to 300 g/m ²	
Folding Methods	6 (see below)	
Speed	Straight-Through	100 to 700 mm/s
	Folding	270 to 700 mm/s
Straight-Through Feed	Size	Postcard to 13x19.2"
	Type	Used paper: A3, A4, B4, B5 OHP: A4, B5 Tap paper: A4 LEF, LT LEF
Folding Methods	6 (FM1 to FM6)	

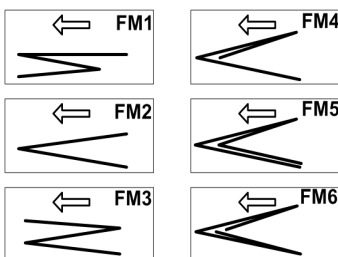

- FM1: Z-Folding
- FM2: Half Fold
- FM3: Letter Fold-out
- FM4: Letter Fold-in
- FM5: Double Parallel Fold
- FM6: Gate Fold

d454v900

Specifications

Paper Sizes (Folding)	FM1	A3, B4, DLT, LG, A4, LT, 12x18", 8-kai
	FM2	A3, B4, DLT, LG, A4, B5, LT 12x18", 12.6x18.5", 12.6x19.2", 13x18", 13x19", 13x19.2", 226x310 mm, 310x432 mm, SRA3, SRA4, 8-kai
	FM3	A3, B4, DLT, LG, A4, LT, B5, 12x18", 8-kai
	FM4	
	FM5	
	FM6	
Paper Weights (Folding)	FM1	64 to 105 g/m ²
	FM2	
	FM3	
	FM4	
	FM5	
	FM6	
Multiple Folding	FM1	Not allowed
	FM2	Max. 3 (64 to 80 g/m ² only)
	FM3	Max. 3 (64 to 80 g/m ² only)
	FM4	Max. 3 (64 to 80 g/m ² , B4, A4, LT, B5 only)
	FM5	Not allowed
	FM6	

Line Speed (Only FM1 Z-Folded paper can exit downstream)		
No Fold	350 mm/sec. to top tray To downstream: Same as main machine.	
FM1	700 mm/sec. to top tray (paper \leq 355.6 mm long) 450 mm/sec. to top tray (paper $<$ 355.6 mm long) To downstream: Same as main machine.	
FM2	1 Sheet: Same as main machine 2-3 Sheets: 454 mm/sec. 700 mm/sec. to top tray (paper \leq 355.6 mm long) 350 mm/sec. to top tray (paper \leq 279.4 $<$ 355.6 mm long) 250 mm/sec. to top tray (paper $<$ 279.4 mm long)	
FM3 FM4	1 Sheet: Same as main machine 2-3 Sheets: 454 mm/sec. to top tray 350 mm/sec. to top tray (paper \leq 420 mm long) 250 mm/sec. to top tray (paper $<$ 420 mm long)	
FM5	1 Sheet: Same as main machine 350 mm/sec. to top tray (paper \leq 420 mm long) 250 mm/sec. to top tray (paper $<$ 420 mm long)	
FM6	1 Sheet: Same as main machine as far as 3rd Stopper. At 3rd stopper feeds 50 mm at 100 mm/sec. 350 mm/sec. to top tray (paper \leq 420 mm long) 250 mm/sec. to top tray (paper $<$ 420 mm long)	
Power Supply	NA	AC 120V 60 Hz, 15A
	EU	AC 220 to 240V, 50/60 Hz 10A
Power Consumption	270 W	
Dimensions (w x d x h)	470 x 980 x 730 mm (18.5 x 38.6 x 28.7 in.)	
Level	Less than 5 mm deviation at front/back, left/right	
Weight	92 kg (203 lb)	

Specifications

Noise Level (dB A)		Mode	Alone	System
		No Folding	≤ 76 dB	---
		Folding	≤ 78 dB	≤ 83 dB

Tray Capacity

The capacity of the tray on top of the unit for folded paper is determined by these variables:

- Folding Methods (FM1 to FM6)
- Paper size
- Paper weight

Folding Mode FM1

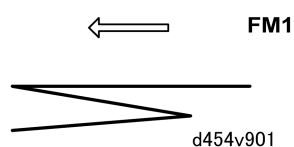

Size	Weight (Standard) 64 to 80 g/m ²	Weight (Heavy) 64 to 80 g/m ²
8-kai	35	20
12x18"	35	20
A3 SEF	35	20
DLT	35	20
B4 SEF	35	20
LG SEF	35	20
A4 SEF	30	20
LT SEF	30	20

Folding Mode FM2

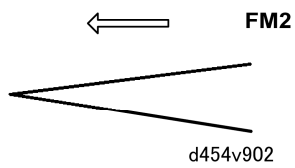

Size	Weight (Standard) 64 to 80 g/m ²	Weight (Heavy) 64 to 80 g/m ²
13x19.2"	40	25
13x19"	40	25
12.6x19.2"	40	25
12.6x18.5"	40	25
13x18"	40	25
SRA3 (320x450 mm)	40	25
SRA4 (225x320 mm)	40	25
226x310 mm	40	25
310x432 mm	40	25
8-kai	40	25
12x18"	40	25
A3 SEF	40	25
DLT	40	25
B4 SEF	40	25
LG SEF	40	25
A4 SEF	50	50
LT SEF	50	50
B5 SEF	50	50

Specifications

Folding Mode FM3

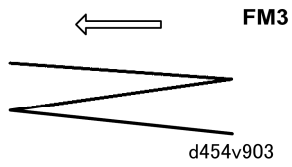

Size	Weight (Standard) 64 to 80 g/m ²	Weight (Heavy) 64 to 80 g/m ²
8-kai	30	20
12x18"	30	20
A3 SEF	30	20
DLT	30	20
B4 SEF	30	20
LG SEF	30	20
A4 SEF	40	30
LT SEF	40	30
B5 SEF	40	30

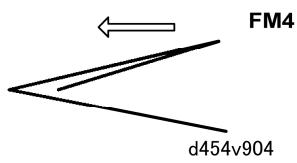
Folding Mode FM4

Size	Weight (Standard) 64 to 80 g/m ²	Weight (Heavy) 64 to 80 g/m ²
8-kai	40	20
12x18"	40	20
A3 SEF	40	20
DLT	40	20
B4 SEF	40	20
LG SEF	40	20
A4 SEF	50	40
LT SEF	50	40
B5 SEF	50	40

Specifications

Folding Mode FM5

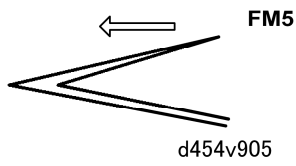

Size	Weight (Standard) 64 to 80 g/m ²	Weight (Heavy) 64 to 80 g/m ²
8-kai	30	20
12x18"	30	20
A3 SEF	30	20
DLT	30	20
B4 SEF	30	20
LG SEF	30	20
A4 SEF	30	30
LT SEF	30	30
B5 SEF	30	30

Folding Mode FM6

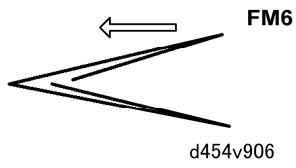

Size	Weight (Standard) 64 to 80 g/m ²	Weight (Heavy) 64 to 80 g/m ²
8-kai	50	20
12x18"	50	20
A3 SEF	50	20
DLT	50	20
B4 SEF	50	20
LG SEF	50	20
A4 SEF	30	30
LT SEF	30	30
B5 SEF	30	30

Specifications

Ring Binder RB5000 (D392)

Configuration	Console	
Paper Transport	Centered in paper path	
Operation Modes	Punching + ring binding Punching only Straight-through (downstream delivery)	
Signature Thickness	2 to 100 sheets	
Paper Size	Punching, binding	A4 LEF, LT LEF
	Straight-through (no punching)	
	Unfolded	A6 to A3 SEF, DLT, HLT, 12"x18", 13"x19", 12.6"x19.2", 13"x19.2", Tab sheets (A4, LT, LG)
	Z-Folded	A3, B4, A4 SEF, DLT, LG, LT SEF 12"x18" (from upstream Z-Folder unit).
Paper Weight	64 to 216 g/m2	
Ring Sizes	2 (50-sheet, 100-sheet)	
Punching	A4 LEF: 23 holes LT LEF: 21 holes	
Ring Supply	Cartridge feed: capacity: 80 rings max.	

Output Tray Capacity	11 documents (100-ring bound, A4 SEF)		
	Thickness	Ring	On Tray
	2 to 10	50	25
	11 to 50	50, 100	20
	51 to 100	100	11
Punching Only	Up to 50 sheets		
Dimensions	870 x 730 x 980 mm (34.3 x 28.7 x 38.6 in.)		
Weight	140 kg (308 lb.)		
Power Consumption	Less than 400 W		

Specifications

9-Bin Mailbox B762

- The mailbox can be installed on top of the 2000-Sheet Finisher D373 or the 3000-Sheet Finisher D374 (not 3000-Sheet Finisher B830).
- The mail box must be removed to install Cover Interposer Tray B704. The mail box and cover interposer tray cannot be installed at the same time.

Dimensions (w x d x h)	540 x 600 x 660 mm (21.3 x 23.6 x 26 in.)
Weight	Less than 15 kg (33 lb)
Power Consumption	Less than 48 W
Noise	Less than 74 dB
Number of Bins	9 bins
Stack Capacity of each Bin	100 sheets*
Paper Size	A5, A4, A3 5½"x8½", 8½" x11", 8½" x14", 11"x17"
Paper Weight	60 to 128g/m ² ; 16 lb – 34 lb Bond

Cover Interposer Tray B704

- Cover Interposer Tray B704 can be used with the 2000-Sheet Finisher D373 or 3000-Sheet Finisher D374 between the mainframe and finisher. The interposer tray and the Mailbox B762 cannot be installed together.
- This tray cannot be installed on the 3000-Sheet Finisher B830.

Dimensions (w x d x h)	500 x 600 x 600 mm (19.7 x 23.6 x 23.6 in.)	
Weight	Less than 12 Kg (26.4 lb)	
Power Consumption	Less than 43 W	
Noise	Less than 65 db	
Stack Capability*	200 Sheets	
Paper Size	A5-A3, 5½"x8½" - 11"x17"	
Paper Weight	64 g/m ² -216 g/m ² 17 lb Bond- 58 lb Index, 80 lb Cover	
Original Set Position	Center	
Original Set	Normal Feed	Face-up
	Booklet Feed	Face-down

Specifications

Cover Interposer Tray B835

Cover Interposer Tray B835 can be used only with the 3000-Sheet Finisher B830. It cannot be installed on the 2000/3000-Sheet Finishers D373/D374.

Speed	B234 (90 cpm)	432 mm/s
	B235 (110 cpm)	515 mm/s
	B236 (135 cpm)	649 mm/s
Paper Separation	FRR System with Feed Belt	
Paper Sizes	Width: A5 SEF/5½"x8½" SEF - 13" Length: A5 LEF/5½"x8½" LEF - 19"	
Paper Weight	64 - 216 g/m ²	
Capacity	400 sheets (80 g/m ²) (2 trays 200 sheets each)	
Paper Size Detection	Yes	
Paper Size Switching	Operator adjustable side fences	
Side Registration	Yes	
Power Supply	24 V ± 5% (from mainframe)	
Power Consumption	Less than 50 W	
Dimensions (w x d x h)	Less than 540 x 730 x 1200 mm 21.2" x 28.7" x 47.2"	
Weight	Less than 45 kg (99 lb)	

3000-Sheet Finisher B830

This machine requires installation of the Finisher Adapter D375 in this finisher.

Finisher					
Dimensions (w x d x h)		800 x 730 x 980 mm (31.5 x 28.7 x 38.6 in.)			
Weight		Less than 75 kg (165 lb)			
Power Consumption		Less than 120W			
Noise		Less than 75 dB			
Configuration		Console type attached base-unit with Finisher Adapter			
Power Source		From base-unit			
Proof Tray	Stack Capacity*	500 sheets	A4, 8½"x11" or smaller		
		250 sheets	B4, 8½"x14" or larger		
	Paper Size	A6 SEF-A3 SEF 5½ " x8½ " - 11"x17"			
	Paper Weight	52 g/m ² -216 g/m ² 14 lb Bond- 68 lb Bond / 140 lb Index / 90 lb Cover			

Specifications

Shift Tray	Stack Capacity*	3000 sheets	A4 LEF, B5 LEF, 8½"x11" LEF		
		1500 sheets	A3, A4, B4, B5 SEF 11"x17", 8½"x14", 8½"x11" SEF		
		500 sheets	A5 LEF, 5½"x8½" LEF		
		100 sheets	A5 SEF, 5½"x8½" SEF		
	Paper Size	A5 - A3 SEF 5½"x8½", 11"x17", 12"x18", 13"x19"			
	Paper Weight	52 g/m ² -300 g/m ² 14 lb Bond- 68 lb Bond / 140 lb Index / 90 lb Cover			
Staples					
Paper Size		B5-A3, 8½"x11"-11"x17"			
Paper Weight		64 g/m ² -84 g/m ² , 17 lb Bond-20 lb Bond			
Staple Position		Top, Bottom, 2 Staple, Top-slant			
Staple Replenishment		Cartridge exchange / 5000 pins per cartridge			
Stack Capacity with Stapler					
		Paper Size	Pages/Set	Sets	
		A4, B5	10-100 pages	200-30 sets	
		8½"x11"	2-9 pages	150 sets	
		A3, B4, 11"x17",	10-50 pages	150-30 sets	
		8½"x14"	2-9 pages	150 sets	

Punch Unit B831

This punch unit is for the 3000-Sheet Finisher B830.

Punch Unit Types		NA	2/3 holes
		EU	2/4 holes
		Scandinavia	4 holes
Punch Waste Hopper Capacity		NA 2/3 hole	10,000 sheets
		EU 2/4 hole	15,000 sheets
Paper Weight		52 g/m ² -127.9 g/m ² 14 lb Bond –34 lb Bond	
Paper Size	NA 2-holes	SEF	A6 - A3, 5½"x8½" - 8½"x11"
		LEF	A5 - A4, 5½"x8½", 8½"x11"
	NA 3-holes	SEF	A3, B4, 11"x17"
		LEF	A4, B5, 8½"x 11"
	EU 2-holes	SEF	A6 - A3, 5½"x8½" - 11"x17"
		LEF	A5 - A4, 5½"x8½", 8½"x11"
	EU 4-holes	SEF	A3, B4, 11"x17"
		LEF	A4, B5, 8½"x11"
	Scandinavia 4-holes	SEF	B6 - A3, 5½"x8½" - 11"x17"
		LEF	A5 - A4, 5½"x8½", 8½"x11"

Specifications

2000-Sheet Finisher D373

This finisher provides booklet as well as corner stapling. Equipped with two trays, the upper tray holds stapled and shifted copies, and the lower tray holds booklet stapled and folded copies.

Dimensions w x d x h		657 x 613 x 960 mm (25.9 x 24.1 x 37.8")
Weight		Less than 63 kg (138.6 lb) (no punch unit) Less than 65 kg (143 lb) (with punch unit)
Power Consumption		Less than 96 W
Noise		Less than 75 db
Configuration		Console type attached base-unit
Power Source		From base-unit
Proof Tray	Stack Capacity*	250 sheets A4, 8½"x11" or smaller 50 sheets B4, 8½"x14 or larger
	Paper Size	A5-A3 SEF, A6 SEF, A6 LEF 5½" x8½" to 11"x17" SEF, 12"x18" SEF
	Paper Weight	52 g/m ² -163 g/m ² 14 lb Bond- 43 lb Bond / 90 lb Index / 60 lb Cover

Shift Tray	Stack Capacity*	2,000 sheets	A4 LEF, 8½"x11" LEF
		1,000 sheets	A3 SEF, A4 SEF, B4 SEF, B5 11"x17" SEF, 8½" x14" SEF, 8½"x11" SEF, 12"x18" SEF
		500 sheets	A5 LEF
		100 sheets	A5 SEF, B6 SEF, A6 SEF, 5½" x8½" SEF
	Paper Size	A5 - A3 SEF, A6 SEF, B6 SEF 5½" x8½" to 11"x17" SEF, 12"x18" SEF	
Paper Weight	52 g/m ² -256 g/m ² 14 lb Bond- 68 lb Bond / 140 lb Index / 90 lb Cover		
Staple			
Paper Size		B5-A3, 8½"x11"-11"x17", 12"x18"	
Paper Weight		64 g/m ² -90 g/m ² , 17 lb Bond-28 lb Bond	
Staple Position		Top, Bottom, 2 Staple, Top-slant	
Staples Capacity*	Same Paper Size	50 sheets	A4, 8½"x11" or smaller
		30 sheets	B4, 8½"x14" or larger
	Mixed Paper Size	30 sheets	A4 LEF & A3 SEF, B5 LEF & B4 SEF, 8½"x11" LEF & 11" x17" SEF
	Booklet Stapling	15 sheets	A4 SEF, A3 SEF, B5 SEF, B4 SEF, 8½"x11" SEF, 8½"x14" SEF, 11"x17" SEF, 12"x18" SEF

Specifications

Staple Replenishment		Corner staple	5,000 staples per cartridge
		Booklet staple	2,000 staples per cartridge
Corner Staple Capacity	Same Size	A4 LEF, 8½"x11" LEF	13-50 pages
			2-12 pages
		A4 SEF, B5, 8½"x11" SEF	10-50 pages
			2-9 pages
	Others	10-30 pages	
		2-9 pages	
Mixed Size	A4 LEF + A3 SEF B5 LEF + B4 SEF 8½"x11" LEF + 11" x17" SEF	2-30 pages	

	Paper Size	Sheets per Booklet	Booklets per Stack (Lower Tray)
Booklet Staple Capacity	A4 SEF, A3 SEF, B5 SEF, B4 SEF, 8½"x11" SEF, 8½"x14" SEF, 11"x17" SEF, 12"x18" SEF	2-5 pages	30
		6-10 pages	15
		11-15 pages	10

D373/D374 Paper Specifications

Paper Size	Plain Paper			Paper Type	
	Main machine PPC	Used Paper	Recycled Paper	Colored Paper	Translucent Blueprint
A3 SEF	BSFS	—	BSFS	BSFS	SN
B4 SEF	BSFS	SN	BSFS	BSFS	SN
A4 SEF	BSFS	SN	BSFS	BSFS	SN
A4 LEF	CSS	SN	CSS	CSS	SN
B5 SEF	BSFS	SN	BSFS	BSFS	SN
B5 LEF	CSS	SN	CSS	CSS	SN
A5 SEF	SO	—	—	—	—
A5 LEF	SO	—	—	—	—
B6 SEF	SN	—	—	—	—
B6 LEF	SN	—	—	—	—
12"x18" SEF	BSFS	—	BSFS	BSFS	—
11"x17" SEF	BSFS	—	BSFS	BSFS	SN
8½"x14"	BSFS	—	BSFS	BSFS	SN
8½"x11" SEF	BSFS	—	BSFS	BSFS	SN
8½"x11" LEF	CSS	—	CSS	CSS	SN
5½"x8½"	SO	—	—	SO	—
5½"x8½"	SO	—	—	SO	—

Specifications

Table Key

CSS	Corner stapling, Shift, YES
BSFS	Booklet stapling/folding, Shift, YES
SO	Shift ONLY
SN	Shift NO
—	Not available

3000-Sheet Finisher D374

This finisher provides corner stapling only.

Finisher		
Dimensions (w x d x h)		657 x 613 x 960 mm
Weight		Less than 54 kg Less than 56 kg with Punch Unit
Power Consumption		Less than 96 W
Noise		Less than 75 db
Configuration		Console type attached base-unit
Power Source		From base-unit
Proof Tray	Stack Capacity*	250 sheets: A4, 8½"x11" or smaller 50 sheets: B4, 8½"x14 or larger
	Paper Size	A5-A3 SEF, A6 SEF, A6 SEF 5½"x8½"-11"x17"SEF, 12"x18" SEF
	Paper Weight	52 g/m ² -163 g/m ² 14 lb Bond- 43 lb Bond / 90 lb Index / 60 lb Cover

Specifications

Shift Tray	Stack Capacity*	3,000 sheets	A4 LEF, 8½"x11" LEF "
		1,500 sheets	A3 SEF, A4 SEF, B4 SEF, B5, 11"x17" SEF, 8½"x14" SEF, 8½"x11" SEF, 12"x18" SEF
		500 sheets	A5 LEF**
		100 sheets	A5 SEF, B6 SEF, A6 SEF, 5½"x8½",SEF
	Paper Size	A5 - A3 SEF, A6 SEF, B6 SEF, 5½"x8½"- 11"x17" SEF, 12"x18" SEF	
Paper Weight	52 g/m ² - 256 g/m ² 14 lb Bond - 68 lb Bond / 140 lb Index / 90 lb Cover		
Staples			
Paper Size		B5-A3 8½"x11"-11"x17", 12"x18"	
Paper Weight		64 g/m ² - 90 g/m ² 17 lb Bond - 28 lb Bond	
Staple Position		Top, Bottom, 2 Staple, Top-slant	
Stapling Capacity	Same Paper Size	50 sheets	A4, 8½"x11" or smaller
		30 sheets	B4, 8½"x14" or larger
	Mixed Paper Size	30 sheets	A4 LEF + A3 SEF, B5 LEF + B4 SEF, 8½"x11" LEF + 11"x17" SEF
Staple Replenishment		Cartridge exchange / 5000 pins per cartridge	

	Paper Size	Pages/Set	Sets
Stapled Stack Capacity (same size)	A4 LEF, 8½"x11" LEF	20-50 pages	150-60 sets
		2-19 pages	150 sets
	A4 SEF, B5, 8½"x11" SEF	15-50 pages	100-30 sets
		2-14 pages	100 sets
	Others	15-30 pages	100-33 sets
		2-14 pages	100 sets
Stapled Stack Capacity (mixed sizes)	A4 LEF & A3 SEF, B5 LEF & B4 SEF, 8½"x11" LEF & 11" x17" SEF	2-30 pages	50 set

Specifications

Punch Unit B702

This punch unit is designed for use with the 2000-Sheet Stapler D373 (both corner and booklet stapling) and 3000-Sheet Stapler D374 (corner stapling only).

Available Punch Units		NA	2/3 hole switchable
		EU	2/4 holes switchable
		Scandinavia	4 holes
Punch Waste Replenishment		NA 2-hole	Up to 5,000 sheets
		NA 3-hole	Up to 5,000 sheets
		EU 2-hole	Up to 14,000 sheets
		EU 4-hole	Up to 7,000 sheets
		Scandinavia 4-hole	Up to 7,000 sheets
Paper Weight		52 g/m ² - 163 g/m ² , 14 lb Bond - 43 lb Bond / 90 lb Index / 60 lb Cover	
Paper Sizes	NA 2-hole	SEF	A5 to A3, 5½"x8½" to 11"x17"
		LEF	A5 - A4, 5½"x8½", 8½"x11"
	NA 3-hole	SEF	A3, B4, 11"x17"
		LEF	A4, B5, 8½"x11"
	EU 2-hole	SEF	A5 - A3, 5½"x8½" to 11"x17"
		LEF	A5 - A4, 5½"x8½", 8½"x11"
	EU 4-hole	SEF	A3, B4, 11"x17"
		LEF	A4, B5, 8½"x11"
	Scandinavia 4-hole	SEF	A5 to A3, 5½"x8½" to 11"x17"
		LEF	A5 - A4, 5½"x8½", 8½"x11"

Z-Folding Unit ZF4000 B660

Paper Size		
No Folding (52-300 g/m ²)	A3, A4, A5, A6 SEF, B4, B5, B6 SEF 11"x17", 8½"x14", 8½"x11" SEF, 5½"x8½", 12"x18"	
Folding (64-80 g/m ²)	A3, B4, A4 SEF 11"x17", 8½"x14", 8½"x11" SEF, 12"x18"	
Dimensions (w x d x h)	177 x 620 x 960 mm 7 x 24.5 x 37.8 in.	
Weight	Less than 55 kg (121 lb)	
Power Consumption	100 W max.	
Power Supply	North America	120 V, 60 Hz, 1A
	Europe/Asia	220-240 V, 50/60 Hz, 0.5A

A3/11"x17" Tray B331

This option is installed in Tray 1 (tandem tray) of the main machine so that Tray 1 can feed larger paper. Tray 1 normally feeds LT or A4 only.

Dimensions (w x d x h)	495 x 215 x 535 mm (19.5 x 8.5 x 21.1 in.)
Weight	11 kg (24.2 lb)
Paper Size	A3 SEF, B4 SEF, A4 11"x17" SEF, 8½"x14" SEF, 8½"x11"
Paper Capacity	1,000 Sheets

Specifications

Copy Tray B476

The copy tray is installed receive copies when the main machine is used without a finisher.

Dimensions (w x d x h)	400 x 335 x 70 mm (15.8 x 13.2 x 2.8 in.)	
Weight	640 g (1.4 lb)	
Paper Capacity	500 Sheets	A4, 8½"x11"
	250 Sheets	A3, 11"x 17"

1.1.3 ELECTRICAL COMPONENTS

Main machine

COUNTERS

No.	Component	Function
TC1	Total Counter: FC	The mechanical counter for full color printing.
TC2	Total Counter: K	The mechanical counter for black-and-white printing.

HEATERS

No.	Component	Function
H1	Lower Tray Heater	Keeps paper dry. Provided with machine, connection is optional.
H2	Anti-condensation Heater – Scanner (Option)	Prevents the formation of condensation in the scanner unit.



These heaters are turned ON under the following conditions:

- The machine's Main Switch is turned OFF.
- The machine goes into Sleep Mode.
- The machine goes into OFF Mode.

HARD DISKS

No.	Component	Function
HDD1	Hard Disk Drives	The HDDs hold temporary files spooled for processing and also store permanent files for the document server application.
HDD2		2nd HDD in a set of 4.
HDD3		3rd HDD in a set of 4.
HDD4		4th HDD in a set of 4.

Specifications

LAMPS

No.	Component	Function
L1	Exposure Lamp	Projects high intensity light on the original for exposure.
L2	Heating Roller Fusing Lamp 3 (Center)	Heats only center of heating roller.
L3	Heating Roller Fusing Lamp 2 (Ends)	Heats only the ends of heating roller.
L4	Hot Roller Fusing Lamp 1 (Main)	Heats entire length of heating roller.
L5	Pressure Roller Fusing Lamp	Heats pressure roller. NA, EU: 400W

MOTORS

No.	Component	Function
M1	Scanner Motor	Drives the scanner unit
M2	Lower Relay Motor	Drives the lower relay roller of the relay unit at the vertical transport section.
M3	Paper Feed Motor: Tray 1	Drives the paper feed roller and grip roller of tray 1 (tandem tray).
M4	Paper Feed Motor: Tray 3	Drives the paper feed roller and grip roller of tray 3 (bottom tray).
M5	Paper Feed Motor: Tray 2	Drives the paper feed roller and grip roller of tray 2 (middle tray).
M6	Waste Toner Distribution Motor	Drives the coil that spans the top of the waste toner bottle.

No.	Component	Function
M7	Lift Motor - Tray 2	Switches on and drives a shaft and coupling that raises a lift arm against the bottom plate under the paper stack in tray 2
M8	Lift Motor: Tray 3	Drives a shaft and coupling that raises a lift arm against the bottom plate under the paper stack in tray 3.
M9	Lift Motor: Tray 1	Drives pulleys and cables that lift the bottom plate of tray 1 (tandem tray) until the top of the paper stack reaches the correct height for feeding.
M10	Rear Fence Motor - Tray 1	Switches on when the right paper tray sensor of the tandem paper tray unit detects paper out and the left paper tray sensor detects paper present.
M11	ITB Lift Motor	Rotates the cam that raises and lowers the ITB belt.
M12	Ozone Fan Motor	Draws air from around the drums and through the ozone filter.
M13	Fusing Fan Motor	Cools the fusing unit.
M14	Fusing Cooling Fan Motor: Lower	Cools the fusing unit.
M15	Fusing Exhaust Fan Motor	Draws the hot air away from the heat sink mounted above the fusing unit and expels the hot air through a vent
M16	Fusing/Exit Motor	Drives the fusing unit and paper exit.
M17	PTR Motor	Drives the paper transfer roller (PTR).

Specifications

No.	Component	Function
M18	Bypass Feed Motor	Drives the upper relay roller that feeds each sheet to the registration roller.
M19	Duplex Jogger Motor	Moves the jogger fences in the duplex unit.
M20	Duplex Unit Fan Motor	Cools the duplex unit.
M21	Duplex Transport Motor	Drives transport rollers 3, 4 in the duplex unit.
M22	Duplex Inverter Motor	Feeds paper to the jogger section.
M23	Registration Motor	Rotates the registration roller.
M24	Belt Cleaning Fan	Cools the upper area of the transfer unit where the PCUs contact the ITB.
M25	Pipe Cooling Fan Motor	Pulls in air draws it over the fins attached to the front end of the heat pipe roller.
M26	Paper Transport Fan Motor - Rear	1 of 2 vacuum fans that produce suction to keep paper on the transport belt.
M27	Paper Transport Fan Motor - Front	1 of 2 vacuum fans that produce suction to keep paper on the transport belt.
M28	Paper Exit Fan Motor	Draws hot air from around the paper exit area and expels it from the left side of the machine.
M29	Front Duplex Fan Motor	Draws hot air out of the duplex unit.
M30	Rear Duplex Fan Motor	Draws hot air out of the duplex unit.
M31	Potential Sensor Fan	Circulates air around the potential sensors.
M32	Cooling Fan Motor	Draws air and sends it through a duct to the four PCU cooling fans.
M33	Circulation Fan Motor	Circulates air.

No.	Component	Function
M34	Laser Unit Cooling Fan Motor - Front	Draws cool air into the machine.
M35	Laser Unit Cooling Fan Motor - Rear	Expels hot air from the machine on the left side.
M36	Development Motor: Y	Drives the Y development unit.
M37	Development Motor: C	Drives the C development unit.
M38	Development Motor: M	Drives the M development unit.
M39	Development Motor: K	Drives the K development unit.
M40	Controller Box Exhaust Fan Motor 2	1 of 2 fans that cool the printed circuit boards at the back of the machine.
M41	Controller Box Exhaust Fan Motor 1	1 of 2 fans that cool the printed circuit boards at the back of the machine.
M42	Drum Motor: Y	Drives the drum in the Yellow PCU.
M43	Drum Motor: C	Drives the drum in the Cyan PCU.
M44	Drum Motor: M	Drives the drum in the Magenta PCU.
M45	Drum Motor: K	Drives the drum in the Black PCU.
M46	ITB Drive Motor	Rotates the image transfer roller that drives the ITB.
M47	3rd Mirror Motor - M	Fine adjusts the position of the 3rd mirror of the optics for M (magenta) during MUSIC adjustment.
M48	Polygon Mirror Motor	Rotates the polygon mirror in the laser optics unit

Specifications

No.	Component	Function
M49	3rd Mirror Motor - Y	Fine adjusts the position of the 3rd mirror of the optics for Y (Yellow) during MUSIC adjustment.
M50	3rd Mirror Motor - C	Fine adjusts the position of the 3rd mirror of the optics for C (Cyan) during MUSIC adjustment.
M51	Toner Hopper Motor	Drives the toner pump clutch and sub hopper clutch of each PCU.
M52	PCU Fan Motor: Y	Cools the Yellow PCU.
M53	PCU Fan Motor: C	Cools the Cyan PCU.
M54	PCU Fan Motor: M	Cools the Magenta PCU
M55	Scanner Unit Fan Motor - Rear Left	Cools the left, rear corner of the SIOB.
M56	Scanner Unit Fan Motor - Rear Center	Cools the rear, center area of the SIOB.
M57	Scanner Unit Fan Motor - Right	Exhausts warm air from the SIOB area.
M58	Waste Toner Collection Bottle Motor	Drives the waste toner bottle transport coil that moves the toner from the central collection point into the waste toner bottle.
M59	Development Intake Fan: K	Cools K development Unit
M60	Development Intake Fan: M	Cools M development Unit
M61	Development Intake Fan: C	Cools C development Unit
M62	Development Intake Fan: Y	Cools Y development Unit
M63	Drum Cleaning Motor: Y	Drives the Y drum cleaning rollers.

No.	Component	Function
M64	Drum Cleaning Motor: C	Drives the C drum cleaning rollers.
M65	Drum Cleaning Motor: M	Drives the M drum cleaning rollers.
M66	Drum Cleaning Motor: K	Drives the K drum cleaning rollers.
M67	Charge Wire Cleaning Motor	Drives the corona wire cleaning pad front and back to clean the charge corona wire of the K_PCU. Switches on at power on and at the end of every job.
M68	Ozone Fan	Draws in air containing ozone.
M69	Drive Ventilation Fan	Cools drive area around fusing unit.
M70	Ozone Exhaust Fan	Draws air from around the drums and blows it through the ozone filter.
M71	PTR Lift Motor	Raises the PTR and presses it against the bias roller above during transfer and separation, then lowers the PTR when the machine is not operating.
M72	Fusing Pressure Release Motor	Pulls and pushes the pressure roller to separate and press it against the hot roller. The pressure roller is a soft sponge roller that would warp out of shape if it were allowed to press against the hot roller while the machine is idle.
M73	HDD Cooling Fan Motor	Cools the HDDs.
M74	CPU Fan	Cools the CPU on the controller board.

Specifications

MECHANICAL CLUTCHES

No.	Component	Function
MC1	Bypass Feed Clutch	Engages and operates the pick-up roller at the bypass feed tray.
MC2	Toner Pump Clutch: M	Engages the and drives the Magenta toner pump to pull toner from the Magenta STC.
MC3	Toner Supply Clutch: M	Engages the toner supply coils in the sub hopper of the Magenta PCU to send toner to the development unit below.
MC4	Toner Pump Clutch : K	Engages the and drives the Black toner pump to pull toner from the Black STC.
MC5	Toner Supply Clutch : K	Engages the toner supply coils in the sub hopper of the Black PCU to send toner to the development unit below.
MC6	Toner Pump Clutch: Y	Engages the drive shaft and rotor of the Yellow toner pump to pull toner from the Yellow STC when more toner is needed.
MC7	Toner Supply Clutch: Y	Engages the toner supply coils in the sub hopper of the Yellow PCU to send toner to the development unit below.
MC8	Toner Pump Clutch: C	Engages the and drives the Cyan toner pump to pull toner from the Cyan STC.
MC9	Toner Supply Clutch: C	Engages the toner supply coils in the sub hopper of the Cyan PCU to send toner to the development unit below.

PCBs

No.	Component	Function
PCB1	PFB (Paper Feed Board)	Controls paper trays and paper feed.
PCB2	AC Drive Board	Controls the power supply to the fusing lamps, heaters, and PSU.
PCB3	PSU (Power Supply Unit)	Supplies DC current to the machine and contains the AC drive that controls the fusing lamp power supply.
PCB4	DRB (Drive Board)	Contains the circuits for the stepping motors that drive the printer engine, and distributes electrical power to all other PCBs.
PCB5	Power Pack: Development Bias	Supplies the voltage for the bias applied to the developer in the PCUs by the development rollers.
PCB6	Power Pack: Charge	Supplies the voltage for the charge applied to the OPC drums by the charge roller.
PCB7	Power Pack: Transfer	Supplies charge to 1) the four image transfer rollers that pull the toner images from the four from the four drums (Y, M, C, K), and 2) to the paper transfer roller that pulls the image off the ITB onto paper.
PCB8	Power Pack - Separation	Supplies the dc/ac charges for paper separation.
PCB9	DTMB (Drum/Transfer Motor Board)	Controls the motors that drive the OPC drums and ITB.
PCB10	IPU	Performs: 1) Image processing control, 2) GW controller interface, 3) peripheral timing control.
PCB11	Potential Sensor Board	Processes data from the Y, M, C, K, potential sensors.

Specifications

No.	Component	Function
PCB12	CNB (Connector Board)	Sorts and routes signals to electrical components.
PCB13	IDCB: C1	One of two ID control boards at the base of the Cyan STC. The CPU reads the board to confirm that the correct STC is inserted into the correct bin.
PCB14	IDCB: M1	One of two ID control boards at the base of the Magenta STC. The CPU reads the board to confirm that the correct STC is inserted into the correct bin.
PCB15	IDCB: K1	One of two ID control boards at the base of the Black STC. The CPU reads the board to confirm that the correct STC is inserted into the correct bin.
PCB16	IDCB: Y1	One of two ID control boards at the base of the Yellow STC. The CPU reads the board to confirm that the correct STC is inserted into the correct bin.
PCB17	SBU (Sensor Board Unit)	Contains the CCD. Converts CCD analog signals to digital signals.
PCB18	SIOB (Scanner Interface Board)	Controls all the sensors in the scanner unit and controls the carriage drive stepping motors.
PCB19	Lamp Regulator	Converts the dc power input to a stable, high frequency ac output to the exposure lamp.
PCB20	VBCU	<p>VBCU: 1) Engine sequence control (all sensors, motors, fusing temperature monitoring circuits), 2) Scanning control, 3) Exposure control, 3) Image processing control, 4) GW controller I/F, 5) Peripheral timing control.</p> <p>The I/O control board controls 1) Input/output ports for all sensors, motor, solenoids, 2) drivers, 3) high voltage power supply for PWM, and 4) analog input signals.</p>

No.	Component	Function
PCB21	LDB (K) with LCD Deflection Element (K)	Contains and controls the laser diodes that fire a laser beam at the rotating polygon mirror. Splits the laser beam in the sub-scan direction to improve 1200-dpi resolution of Black, Yellow, Cyan and Magenta.
PCB22	LDB (M) with LCD Deflection Element (Y)	
PCB23	LDB (C) with LCD Deflection Element (C)	
PCB24	LDB (Y) with LCD Deflection Element (Y)	
PCB25	LSDB: K Front	Front Laser Synchronization Detector Board for Laser Diode 4.
PCB26	LSDB: M Front	Front Laser Synchronization Detector Board for Laser Diode 3.
PCB27	LSDB: C Front	Front Laser Synchronization Detector Board for Laser Diode 2.
PCB28	LSDB: Y Front	Front Laser Synchronization Detector Board for Laser Diode 1.
PCB29	LSDB: Y Rear	Rear Laser Synchronization Detector Board for Laser Diode 1.
PCB30	LSDB: C Rear	Rear Laser Synchronization Detector Board for Laser Diode 2.
PCB31	LSDB: M Rear	Rear Laser Synchronization Detector Board for Laser Diode 3.
PCB32	LSDB: K Rear	Rear Laser Synchronization Detector Board for Laser Diode 4.
PCB33	Controller Board	Incorporates the GW architecture, and connects to the BICU and PCI I/F. All the options for the printer are controlled by this board.

Specifications

No.	Component	Function
PCB34	SCNB	Scanner Connector Board. Harnesses from the SBU run through the SCNB to reduce the number of harness from 2 to 1.
PCB35	OPU	Controls operation of the operation panel.

QUENCHING LAMPS

No.	Component	Function
QL1	Quenching Lamp : K	Eliminates electrical charge and neutralizes the surface of the drum in the Black PCU.
QL2	Quenching Lamp: C	Eliminates electrical charge and neutralizes the surface of the drum in the Cyan PCU.
QL3	Quenching Lamp: M	Eliminates electrical charge and neutralizes the surface of the drum in the Magenta PCU.
QL4	Quenching Lamp: Y	Eliminates electrical charge and neutralizes the surface of the drum in the Yellow PCU.

SENSORS

No.	Component	Function
S1	ID Sensor: Black	Reads 1) light reflected from the bare surface of the ITB, and 2) reads light reflected from the black ID sensor patterns on the ITB.
S2	ID Sensor: Color	Reads 1) light reflected from the bare surface of the ITB, and 2) reads light reflected from the color ID sensor patterns on the ITB. This sensor has one additional receptor to collect diffuse light reflected from color toner to improve calculation of the toner density.
S3	ITB Lift Sensor (FC)	This sensor switches the ITB lift motor off when the ITB comes into contact the drums of the four PCUs.
S4	MUSIC Sensor: Center	Reads the center MUSIC pattern. This feedback is used to control the MUSIC process to correct color registration errors.
S5	MUSIC Sensor: Front	Reads the front MUSIC pattern. This feedback is used to control the MUSIC process to correct color registration errors.
S6	MUSIC Sensor: Rear	Reads the Rear MUSIC pattern. This feedback is used to control the MUSIC process to correct color registration errors.
S7	Paper Feed Sensor: Tray 2	Detects the leading edge of each sheet of paper from the pick-up roller of tray (middle tray) and switches off the pick-up roller solenoid so the pick-up roller lifts.

Specifications

No.	Component	Function
S8	Vertical Transport Sensor: Tray 2	Detects the leading edge and trailing edge of each sheet fed from tray 2 and signals a jam if the edges do not pass at the prescribed time.
S9	Paper End Sensor: Tray 2	Receives light reflected from the paper until the last sheet is fed from tray 2 (middle tray), then signals paper end.
S10	Lift Sensor: Tray 2	Detects when the pick-up roller (pushed up by the top of the paper stack in the right side of the tandem tray) has reached the correct height for paper feed and then switches off the tray 2 (middle tray) lift motor.
S11	Paper Feed Sensor: Tray 3	Detects the leading edge of each sheet of paper from the pick-up roller of tray 3 (bottom tray) and switches off the pick-up roller solenoid so the pick-up roller lifts.
S12	Vertical Transport Sensor: Tray 3	Detects the leading edge and trailing edge of each sheet fed from tray 3 and signals a jam if the edges do not pass at the prescribed time.
S13	Paper End Sensor: Tray 3	Receives light reflected from the paper until the last sheet is fed from tray 3 (bottom tray), then signals paper end.
S14	Lift Sensor: Tray 3	Detects when the pick-up roller (pushed up by the top of the paper stack in the right side of the tandem tray) has reached the correct height for paper feed and then switches off the tray 3 (bottom tray) lift motor.

No.	Component	Function
S15	Bottom Temperature/Humidity Sensor	Near the waste toner bottle. Detects ambient temperature and humidity and then this output is used to control the amount of current applied to the paper transfer roller and ITB when the image is transferred to paper. Also used to correct the fusing temperature, and to extend the fusing unit idle time at low room temperatures.
S16	Waste Toner Bottle Set Sensor	Detects the position of the waste toner bottle and confirms whether it is set correctly.
S17	Waste Toner Bottle Near-Full Sensor	When the level of the waste toner rises high enough to move the actuator of this sensor out of its normal position, the sensor signals the machine that the waste toner bottle is nearly full.
S18	Waste Toner Bottle Full Sensor	Signals an alert when the waste toner bottle is full.
S19	Paper Feed Sensor - Tray 1	Detects the leading edge of each sheet of paper from the pick-up roller of tray 1 (tandem tray) and switches off the pick-up roller solenoid so the pick-up roller lifts.
S20	Vertical Transport Sensor - Tray 1	Detects the leading edge and trailing edge of each sheet fed from tray 1, 2, and 3 and signals a jam if the edges do not pass at the prescribed time.
S21	Paper End Sensor - Tray 1	Detects when the last sheet is fed from tray 1.

Specifications

No.	Component	Function
S22	Lift Sensor - Tray 1	Detects when the pick-up roller (pushed up by the top of the paper stack in the right side of the tandem tray) has reached the correct height for paper feed and then switches off the tray 1 (tandem tray) lift motor.
S23	Paper Near End Sensor - Tray 2	Detects the near end condition for tray 2 (middle tray, a universal cassette).
S24	Paper Near End Sensor: Tray 3	Detects the near end condition for tray 3 (middle tray, a universal cassette).
S25	Front Side Fence Open Sensor	Detects the actuator on the front side fence after it has reached the open position in the tandem tray.
S26	Front Side Fence Closed Sensor	Detects the actuator on the front side fence after it has reached the closed position in the tandem tray.
S27	Rear Side Fence Open Sensor	Detects the actuator on the rear side fence after it has reached the open position in the tandem tray.
S28	Rear Side Fence Closed Sensor	Detects the actuator on the rear side fence after it has reached the closed position in the tandem tray.
S29	Right Tray Down Sensor	Detects the bottom plate of the right tray and switches off the tray 1 lift motor and stops the bottom plate.
S30	Paper Near End Sensor - Tray 1	Signals 10% paper remaining when the actuator on the right rail of the right tray in the tandem tray passes.
S31	Paper Height Sensor	Signals 100% paper remaining until activated. Signals 50% paper remaining when the actuator on the left rail of the right tray in the tandem tray passes.

No.	Component	Function
S32	Paper Height Sensor	Signals 30% paper remaining when the actuator on the left rail of the right tray in the tandem tray passes.
S33	Paper Height Sensor	When near end sensor 1 on right rail of the right tray of the tandem tray is actuated, and paper height sensor 3 has detected the passing of the actuator on the left rail, then the near end sensor signals 10% paper remaining.
S34	Right Tray Paper Sensor	Detects paper in the right side of the tandem paper tray.
S35	Rear Fence HP Sensor	Detects the actuator on the rear fence in the tandem tray and switches off the rear fence motor.
S36	Rear Fence Return Sensor	Detects the actuator on the rear fence in the tandem tray and reverses the rear fence motor.
S37	Left Tray Paper Sensor	Detects the presence of paper in the left tray of the tandem tray.
S38	Internal Temperature Sensor	Located near the Y_PCU, this thermistor monitors the internal temperature of the machine.
S39	Waste Toner Lock Sensor	Signals an alert if the waste toner collection coil locks and stops rotating.
S40	Duplex Transport Sensor 1	The feeler of this sensor detects the leading edge and trailing edge of each sheet as it passes from the jogger unit above and into the horizontal feed path of the duplex unit below. Signals a jam if the paper does not arrive at or reach the sensor location at the prescribed time.

Specifications

No.	Component	Function
S41	Duplex Inverter Sensor	Detects the leading edge of the paper at the inverter exit roller and signals to switch off the reverse trigger roller solenoid to signal a jam if the paper does not arrive at the prescribed time.
S42	Duplex Entrance Sensor	Detects paper jams at the entrance of the duplex unit.
S43	Duplex Transport Sensor 3	Detects the leading edge and trailing edge of each sheet as it passes from the jogger unit above through the horizontal feed path of the duplex unit below. Signals a jam if the paper does not arrive at or reach the sensor location at the prescribed time.
S44	Duplex Transport Sensor 2	Detects the leading edge and trailing edge of each sheet as it passes from the jogger unit above and into the horizontal feed path of the duplex unit below. Signals a jam if the paper does not arrive at or reach the sensor location at the prescribed time.
S45	Duplex Jogger HP Sensor	At power on, detects the actuators on the jogger fences of the duplex unit, switches off the jogger motor and stops the fences at their home positions.
S46	Double-Feed Detection Sensor	Receives the light emitted from the double-feed detection LED and reflected from the surface of each sheet in the paper path. Signals an error if the thickness of the paper is not the same as the previous sheet.
S47	Guide Plate Position Sensor	Monitors the opened/closed status of the guide plate.
S48	Relay Sensor	Detects jams at the top of the vertical paper path.

No.	Component	Function
S49	Registration Sensor	Detects the leading edge of the paper and switches off the registration motor and stops the registration roller briefly but long enough to correct buckle the paper.
S50	Paper Exit Sensor	Detects the leading and trailing edge of each sheet at the paper exit slot to check timing and detect jams.
S51	Bypass Paper Sensor	Detects the presence of paper in the bypass tray.
S52	Bypass Paper End Sensor	Signals paper out when the last sheet feeds from the bypass tray.
S53	Bypass Paper Size Sensor	Reads the positions of the side fences (manually adjusted) to detect the width of the paper in the bypass tray. (Paper length is read with pulse counts from the registration sensor.)
S54	Paper Exit Relay Sensor	Detects paper jams at the paper exit if the paper does not arrive or leave the machine at the prescribed time.
S55	Copy Tray Full Sensor (Option)	Detects when the Copy Paper Tray B75 is full and temporarily pauses printing so the operator can remove the stack from the tray and continue.
S56	TD Sensor: M	Monitors the amount of toner in the developer/toner mixture in the development unit of the Magenta PCU.
S57	TD Sensor : K	Monitors the amount of toner in the developer/toner mixture in the development unit of the Black PCU.

Specifications

No.	Component	Function
S58	Temperature/Humidity Sensor : PCU K	The temperature and humidity readings of this sensor are referenced to a lookup table stored in the ROM to 1) Correct the charge roller voltage , and 2) Set the length of time the agitators in the development unit rotate to mix the toner and developer.
S59	TD Sensor: Y	Monitors the amount of toner in the developer/toner mixture in the development unit of the Yellow PCU.
S60	TD Sensor: C	Monitors the amount of toner in the developer/toner mixture in the development unit of the Cyan PCU.
S61	ITB Lift Sensor (BW)	Switches the ITB lift motor off when the ITB contacts the drum of the K_PCU
S62	Fusing Pressure Release Sensor	Pulls and pushes the pressure roller to separate it from and push it against the hot roller. The pressure roller is a soft sponge roller that would warp out of shape if it were allowed to press against the hot roller while the machine is idle.
S63	Potential Sensor : K	Reads the potential sensor pattern from the surface of the drum in the black PCU.
S64	Potential Sensor: M	Reads the potential sensor pattern from the surface of the drum in the magenta PCU.
S65	Potential Sensor: C	Reads the potential sensor pattern from the surface of the drum in the cyan PCU.
S66	Potential Sensor: Y	Reads the potential sensor pattern from the surface of the drum in the yellow PCU.
S67/S68	Laser Unit Temperature Sensor	A sensor pair that reads the temperature in the optics unit. The readings are used in MUSIC processing.

No.	Component	Function
S69	Toner End Sensor: M	Detects toner end for magenta toner.
S70	Toner End Sensor : K	Detects toner end for black toner.
S71	Toner End Sensor: Y	Detects toner end for yellow toner.
S72	Toner End Sensor: C	Detects toner end for cyan toner.
S73	Scanner HP Sensor	Detects the home position of the scanner.
S74	Original Width Sensors	APS1 (a board) holds two original width sensors under the exposure glass. The detection combinations of these sensors determine the width of the original on the exposure glass positioned for LEF.
S75	Original Length Sensors - 1	APS2 (a board) holds two original length sensors under the exposure glass. The detection combinations of these sensors determine the length of the original on the exposure glass positioned for SEF.
S76	Original Length Sensor -2	APS3 (a board) holds one original length sensor under the exposure glass. The detection combination of this sensor and other sensors determine the length of the original on the exposure glass positioned for SEF.
S77	Accordion Jam Sensor	Detects jams at the fusing exit by confirming that paper arrives at the prescribed time.
S78	Fusing Exit Sensor	Detects jams at the fusing exit by confirming that paper leaves at the prescribed time.
S79	LCT Relay Sensor	Confirms whether the LCT is set correctly.

Specifications

No.	Component	Function
S80	Original Length Sensor 3	APS4 holds one original length sensor under the exposure glass. The detection combination of this sensor with other sensors determines the length of the original on the exposure glass positioned for SEF.
S81	Encoder	Monitors the rotation of the encoder wheel in the ITB drive motor unit.
S82	PTR Contact Sensor	Detects when the PTR is lifted and lowered.
S83	ITB Position Sensor	Monitors the speed of the ITB.

LEDs

No.	Component	Function
LED1	Double-Feed Detection LED	Emits light which is reflected from the paper to the double-feed detection sensor to test the translucence of each sheet for double-feed detection.
LED2	Accordion Jam Sensor (LED)	Flashes to show the user which lever to release to remove a paper jam from the fusing rollers.
LED3	Fusing Exit Sensor (LED)	Flashes to show the user which lever to release to remove a paper jam from the fusing unit.

SOLENOIDS

No.	Component	Function
SOL1	Pick-up Solenoid: Tray 2	Switches on when the tray 2 (middle tray) lift motor switches on. This solenoid lowers the pick-up roller of tray 3.
SOL2	Separation Roller Solenoid: Tray 2	When tray 2 (middle tray) is selected as the paper source, this solenoid energizes and brings the separation roller in contact with the feed roller until the leading edge of the sheet feeds to the paper feed sensor.
SOL3	Pick-up Solenoid: Tray 3	Switches on when the tray 3 (bottom tray) lift motor switches on. This solenoid lowers the pick-up roller of tray 3.
SOL4	Separation Roller Solenoid: Tray 3	When tray 3 (bottom tray) is selected as the paper source, this solenoid energizes and brings the separation roller in contact with the feed roller until the leading edge of the sheet feeds to the paper feed sensor.
SOL5	Pick-up Solenoid – Tray 1	Switches on when the tray 1 (tandem tray) lift motor switches on. This solenoid lowers the pick-up roller of tray 1.
SOL6	Separation Roller Solenoid – Tray 1	When tray 1 (tandem tray) is selected as the paper source, this solenoid energizes and brings the separation roller in contact with the feed roller until the leading edge of the sheet feeds to the paper feed sensor.

Specifications

No.	Component	Function
SOL7	Front Side Fence Solenoid –Tray 1	When the right tray paper sensor in the tandem tray signals paper out, and the left tray paper sensor signals paper present, this energizes this solenoid which pulls open the front side fence until the front side fence open sensor detects the actuator of the front side fence and switches off the solenoid, leaving it locked in the open position, to allow the rear fence to push the paper stack from the left tray into the right tray.
SOL8	Rear Side Fence Solenoid – Tray 1	When the right tray paper sensor in the tandem tray signals paper out, and the left tray paper sensor signals paper present, this energizes this solenoid which pulls open the rear side fence until the rear side fence open sensor detects the actuator of the rear side fence and switches off the solenoid, leaving it locked in the open position, to allow rear fence to push the paper stack from the left tray into the right tray.
SOL9	Right Tray Lock Solenoid – Tray 1	Releases the lock lever when the left tray paper sensor in the tandem tray signals that there is no paper in the left tray.
SOL10	Left Tray Lock Solenoid – Tray 1	When the rear fence motor in the tandem tray switches on, this energizes the left tray lock solenoid. This locks the left tray so it does not move while the rear fence pushes the stack from the left tray to the right tray.
SOL11	Duplex Junction Gate Solenoid	Controls the opening and closing of the duplex junction gate at the mouth of the inverter unit.

No.	Component	Function
SOL12	Reverse Trigger Roller Solenoid	After a sheet is detected by the duplex entrance sensor, this solenoid energizes and pushes down the reverse trigger roller.
SOL13	Guide Plate Solenoid	Energizes when a jam occurs between the vertical transport rollers and registration roller to force the guide plate open and divert paper fed from below into the duplex tray.
SOL14	Inverter Junction Gate Solenoid	Operates the inverter junction gate. The inverter junction gate turns paper into the path to the inverter unit below where it is 1) inverted for face-down output or 2) inverted for 2nd side printing.
SOL15	Bypass Pick-up Solenoid	Switches on and lowers the pick-up roller to the top of the stack in the bypass tray
SOL16	Charge Cleaning Solenoid: Y	Raises and lowers the Y charge roller cleaning roller.
SOL 17	Charge Cleaning Solenoid: C	Raises and lowers the C charge roller cleaning roller.
SOL 18	Charge Cleaning Solenoid: M	Raises and lowers the M charge roller cleaning roller.
SOL 19	Duplex Inverter Solenoid	Operates the duplex inverter junction gate.

Specifications

SWITCHES

No.	Component	Function
SW1	Lower Front Door Switch	Detects whether the front door is open or closed.
SW2	Main Power Switch	Switches the machine off and on.
SW3	Upper Front Door Switches (x5)	Detect whether the front door is open or closed.
SW4	Paper Size Switch: Tray 2	The switch detects the position of the dial (set manually), and signals the paper size with a simple 5–digit binary code.
SW5	Paper Size Switch: Tray 3	The switch detects the position of the dial (set manually), and signals the paper size with a simple 5–digit binary code.
SW6	Interlock Switches	Mounted at the upper left corner of the front door, detect when the door is opened and closed.

THERMISTORS

No.	Component	Function
TH1	Heating Roller Thermistor	Monitors the end of the heating roller and breaks the circuit to the heating lamps if a lamp overheats.
TH2	Hot Roller Thermistor	Detects and monitors the temperature of the hot roller for fusing temperature control.
TH3	Pressure Roller Thermistor	Detects the temperature of the hot roller for fusing temperature control.
TH4	Heating Roller Center Thermistor	A non-contact thermistor that monitors the surface temperature of the heating roller center and breaks the circuits to the fusing lamps if the heating roller overheats.
TH5	Heating Roller End Thermistor	A non-contact thermistor that monitors the surface temperature of the heating roller end and breaks the circuits to the fusing lamps if the heating roller overheats.

THERMOSTATS

No.	Component	Function
TS1/S2	Thermostats (Pressure Roller)	Monitors the temperature of the pressure roller and cuts the circuit if the pressure roller fusing lamp overheats.
TS3/4	Thermostats (Fusing Belt)	Monitors the temperature of the fusing belt and cuts the circuit if the heating roller fusing lamp overheats.

Specifications

ADF

MOTORS

No.	Component	Function
M1	Feed Motor	Drives the feed belt, and the separation, pick-up, and transport as far as the 1st transport roller.
M2	Transport Motor	Controls the original scanning speed.
M3	Exit Motor	Feeds paper out of the ADF and onto the original exit table.
M4	Pick-up Motor	Raises and lowers the pick-up roller.
M5	Bottom Plate Lift Motor	Raises and lowers the bottom under the original stack.

PCB

No.	Component	Function
PCB1	ADF Main Board	Controls the ADF and communicates with the main main machine boards.

SENSORS

No.	Component	Function
S1	Entrance Sensor	Detects the leading edge of the original when it enters the ADF
S2	Original Width Sensor 2	Detects paper wider than 191.5 mm (7.5 in.) measured from the reference point.
S3	Original Width Sensor 3	Detects paper wider than 230 mm (9.1 in.) measured from the reference point.
S4	Original Width Sensor 4	Detects paper wider than 263.5 mm (10.4 in.) measured from the reference point.
S5	Original Width Sensor 5	Detects paper wider than 288 mm (11.3 in.) measured from the reference point.
S6	Original Width Sensor 1	Detects paper wider than 138 mm (5.4 in.) measured from the reference point.
S7	Original Set Sensor	Detects whether an original is on the table.
S8	Bottom Plate HP Sensor	Detects whether the bottom plate is in the down position or not.
S9	Feed Cover Sensor	Detects whether the feed cover is open or not.
S10	Bottom Plate Position Sensor	Detects when the original is at the correct position for feeding.
S11	Original LG Detection Sensor	Detects paper longer than 318 mm (12.5 in.) on the original table.
S12	Original A4 Detection Sensor	Detects paper longer than 291 mm (11.5 in.) on the original table.
S13	Original B5 Detection Sensor	Detects paper longer than 240 mm (9.5 in.) on the original table.

Specifications

No.	Component	Function
S14	Skew Correction Sensor	After pick-up and separation, the skew correction sensor detects the leading edge of the original. This signal slows the rotation of the entrance roller for a prescribed number of pulses to buckle the original and correct skew.
S15	Separation Sensor	Detects the separation of the original.
S16	Exit Sensor	Detects the leading and trailing edges of paper feed out to the original table and detects misfeeds. Also signals when to stop the scanning belt.
S17	Registration Sensor	Detects the leading edge and trailing edges of the original to detect jams and stops the original at the ADF exposure glass to correct buckle.
S18	Pick-up Roller HP Sensor	Detects whether the pick-up roller is up or not.
S19	ADF Position Sensor	Detects whether the ADF unit is up or down for scanning on the main exposure glass (book mode).
S20	APS Start Sensor	Signals the CPU when the DF is opened and closed (for platen mode) so that the original size sensors in the main machine can check the original size.

APPENDIX:

PM TABLES

REVISION HISTORY		
Page	Date	Added/Updated/New
		None

2. APPENDIX: PM TABLES

2.1 PM TABLES

2.1.1 MAIN MACHINE

Symbol Key for PM Tables

I	Inspect. Clean, replace, or lubricate as needed.
C	Cleaning required.
R	Replacement required.
L	Lubrication required with: <ul style="list-style-type: none"> ▪ Grease KS660B (D0149800) ▪ Heat Resisting Grease MT-78 ▪ Launa Oil 40 ▪ Lubricant Powder B1329700 ▪ G104 Yellow Toner (D0159500) ▪ Zinc Stearate (D0159501)

PM Tables

Main Machine PM Parts

OPTICS

	150K	200K	300K	450K	600K	Note
Reflector			C			Optical cloth
1st Mirror			C			Optical cloth
2nd Mirror			C			Optical cloth
3rd Mirror			C			Optical cloth
Scanner Rails			C			Alcohol then dry cloth
Exposure Glass			C			Exposure glass cleaner
Toner Shield Glass			C			Optical cloth
APS Sensor			C			Dry cloth
ADF Exposure Glass			C			Exposure glass cleaner
Dust Filters			C			Blower brush

PCU

	150K	200K	300K	400K	450K	600K	Note
Development Unit	L						Sleeve shaft, Grease KS660B
OPC Drums					R		KYMC:450K
Charge Roller Units* ¹	R						Replace YMC together
Cushion Wire T1.5* ¹		R					
Cleaner Grid Assy* ¹		R					
Cleaner Corona Wire Assy* ¹		R					
Drum Charge Corona Wire* ¹		R					
Grid Drum Charge Wire* ¹		R					
Drum Cleaning Blade	R	R					YMC:150K K:200K
Drum Lubricant Blade	R	R					YMC:150K K:200K
Drum Lubricant Bar (x2)* ²	R	R					

Appendix:
PM
Tables

PM Tables

	150K	200K	300K	400K	450K	600K	Note
Drum Lubricant Brush Roller			R (Y,C,M)	R (K)			Apply G104 Yellow Toner and Zinc Stearate after replacement
PCU Joint			R	R			YMC: 300K K: 400K
Drum Lubricant Brush Gear			R	R			
Idle Gear 1			R	R			
Idle Gear 2			R	R			
Used Toner Collection Gear			R	R			
Drum Cleaning Brush Gear			R	R			
Developer K					R		
Developer Y, M, C					R		
Quenching LED	C		C			C	

*1: These items comprise the K_PCU which uses a charge corona system, and can be replaced individually. (The YMC_PCUs use a charge roller system.)

*2 The lubricant bar is the same for both K and YMC PCUs when replaced as an individual part. However, the drum lubricant bar assembly which contains the springs is not the same. The K assembly is clearly marked "K" to prevent installation of the wrong type in a PCU.

TRANSFER UNITS

	150K	300K	450K	600K	Note
ITB Unit					
ITB (Image Transfer Belt)				R	
ITB Unit Rollers		I		C	Wipe with dry cloth
ITB Encoder Sensor		C			Wipe with damp cloth (alcohol)
ID and MUSIC Sensors		C			
ITB Cleaning Blade		R			These items are always replaced as a set.
ITB Lubricant Bar		R			
ITB Lubricant Blade		R			
ITB Lubricant Brush Roller		R			
PTR Unit					
PTR (Paper Transfer Roller)				R	
PTR Cleaning Blade		R			
PTR Lubrication Bar		R			
Paper Transfer Discharge Plate		R			

Appendix:
PM
Tables

PM Tables

FUSING UNIT

	150K	300K	450K	600K	Note
Fusing Belt				R	
Hot Roller			R		
Pressure Roller				R	
Pressure Roller Cleaning Roller			R		
Oil Supply Roller			R		
Heating Roller				C	
Heating Roller Shaft Bearings				C, L* ¹	
Hot Roller Shaft Bearings				C, L* ¹	
Pressure Roller Shaft Bearings				L* ¹	Replace at 1200k
Pressure Roller Stripper Pawls		I, C			Dry cloth
Fusing Belt Stripper Plate		I, C			
Thermistors		I, C			Dry cloth
Upper Entrance Guide Plate	I	C			Damp cloth (alcohol)
Lower Entrance Guide Plate	I	C			
Gears	L* ¹				

*¹: The lubrication points for the fusing unit are described in the "Lubrication Points" section.

PAPER FEED: COPIER

	150K	300K	450K	600K	Note
Registration Rollers		C			Alcohol, dry cloth
Paper Dust Removal Unit		C			Dry cloth
Registration Sensor		C			Blower brush
Vertical Transport Roller Sensors		C			Blower brush
LCT Relay Sensor		C			Blower brush
Bypass Feed Sensor		C			Blower brush
Bypass Paper End Sensor		C			Blower brush

PAPER FEED: Trays

	150K	300K	450K	600K	Note
Feed Guide Plate		C			Dry cloth
Grip Rollers (Drive & Idle)		C			Alcohol, dry cloth
Pick-up Rollers (Tray 1 to Tray 3)					Service Life: 1000K Replace if jams, double-feeds occur with increasing frequency.
Paper Feed Rollers (Tray 1 to Tray 3)					
Separation Rollers (Tray 1 to Tray 3)					
Grip Roller (Drive Roller)		C			Dry cloth
Paper Feed Sensor		C			Blower brush

PM Tables

	150K	300K	450K	600K	Note
Vertical Feed Sensors		C			Blower brush
Paper-End Sensor		C			Blower brush

DUPLEX UNIT

	150K	300K	450K	600K	Note
Duplex Entrance Sensor		C			Blower brush
Reverse Rollers (Drive & Idle)		C			Alcohol, dry cloth
Inverter Exit Roller		C			Dry cloth
Transport Rollers (x4)		C			Dry cloth
Duplex Entrance Anti-Static Brush		C			Dry cloth
Inverter Junction Gate		C			Dry cloth
Inverter Entrance Roller		C			Dry cloth

PAPER EXIT

	150K	300K	450K	600K	Note
Heat Dissipation Roller		C			Alcohol, dry cloth
Exit Anti-Static Brush		C			Inspect, replace if deformed.
Paper Exit Rollers (Upper, Lower)		C			Alcohol, dry cloth
Paper Exit Sensor		C			Blower brush
Transport Rollers		C			Blower brush

OTHER

	150K	300K	450K	600K	Note
Upper Dust Filter		R			
Lower Dust Filters	I,C		R		
Ozone Filters					Service Life: 1200K
Development Filters			R		
Used toner bottle* ¹	I,R	I,R	I,R	I,R	Empty and clean every inspection

*¹: We recommend that the customers be provided with a spare used toner bottle so they can replace the bottle when it becomes full. The service technician can collect the full bottle at the next scheduled service call. This arrangement eliminates EM visits in response to SC484 (Used Toner Bottle Full) errors.

PM Tables

ADF PM Parts

The "K" number in the table below is the number of originals that have been fed.

AN: As necessary

	300K	400K	600K	AN	Exp.	Note
Pick-up Roller						Alcohol, belt cleaner for paper feed belt. Replace these items together.
Separation Roller						
Paper Feed Belt						
ADF Transport Belt						
CIS Glass	C	C	C			Dry cloth
White Guide Plate		R		C		Alcohol, or dry cloth
Sensors	C	C	C			Blower brush
Platen Cover Sheet	C	C	C			Water or alcohol
Drive Gears	L	L	L			Grease G501
Transport Belt	C	C	C			Water or alcohol
Entrance Roller	C	C	C			
White Platen Roller	C	C	C			
Pre-Scanning Roller	C	C	C			
Scanning Roller	C	C	C			
Exit Roller	C	C	C			

2.1.2 LCT B473

	1000K	2000K	3000K	Expected	Note
Paper feed roller	R	R	R		
Pick-up roller	R	R	R		
Separation roller	R	R	R		
Transport guide plate	Inspect and clean every 350K.				
Grip roller	Inspect and clean every 350K.				

Appendix:
PM
Tables

2.1.3 LCT D350

	500K	1000K	Note
Paper feed roller x3		R	
Pick-up rollers x3		R	
Separation rollers x3		R	
Transport guide plate	I		
Grip rollers (drive, idle rollers)	I		

2.1.4 MULTI-FOLDING UNIT FD5000 (D454)

Part	PM Visit	Notes
Rollers (drive, idle rollers)	IC	Alcohol, clean cloth
Anti-static brush	IC	
Shafts	IC	Lubricate with silicone oil if noisy.
Sensors	IC	Blower brush
Positioning roller	IC	Inspect for scratches or nicks
Fold rollers (1st, 2nd, 3rd)	IC	Alcohol, clean cloth
Crease rollers (drive, idle roller)	IC	

2.1.5 RING BINDER (D392)

Part	PM Visit	Notes
Horizontal Transport Path		
Anti-static brushes	IC	Blower brush
Horizontal transport path sensors	IC	Blower brush
Driver rollers, idle rollers	IC	Damp cloth
Switchback Unit		
Anti-static brushes	IC	Blower brush
Switchback area sensors	IC	Blower brush
Drive rollers, idle rollers	IC	Damp cloth
Binder Unit		
Paddle roller	IC	Blower brush
Transport path sensors	IC	Blower brush
Driver rollers, idle rollers	IC	Damp cloth

Appendix:
PM
Tables

2.1.6 2000/3000-SHEET FINISHERS D373/D374

	300K	2400K	3000K	4000K	EM	Note
Covers					I,C	Alcohol or water, dry cloth
Drive Rollers					C	Damp cloth, dry cloth
Idle Rollers					C	Damp cloth, dry cloth
Anti-Static Brush					C	Dry cloth
Sensors					C	Blower brush
Corner Stapler				R		Print an SMC report with SP5990. Replace the unit if the staple count is 500K.
Booklet Stapler				R		Print an SMC report with SP5990. Replace the unit if the staple count is 200K.

2.1.7 PUNCH B702

	300K	2400K	3000K	4000K	EM	
Punch Waste Hopper	I	I	I	I	I	Remove and empty
Punch Unit						Replace after 1000k punches.

2.1.8 COVER INTERPOSER TRAY B704

The PM interval is for the number of sheets that have been fed.

	60K	120K	180K	EM	Note
Feed Belt	R	R	R		Replace as a set.
Pick-up Roller	R	R	R		Replace as a set.
Separation Roller	R	R	R		Replace as a set.
Driver Rollers	C	C	C		Damp clean cloth.
Idle Rollers	C	C	C		Damp clean cloth.
Discharge Brush	C	C	C		Damp clean cloth.
Sensors	C	C	C		Blower brush.

2.1.9 3000-SHEET FINISHER B830

	350K	700K	1050K	Note
FINISHER				
Driver rollers	I	I	I	Alcohol
Idle rollers	I	I	I	Alcohol
Discharge brush	I	I	I	Alcohol
Shaft Bearings	I	I	I	Lubricate with silicone oil if noisy.
Sensors	I	I	I	Blower brush.
Jogger fences	I	I	I	Make sure that the screws are tight.
Staple waste hopper	C	C	C	Empty staple waste.

2.1.10 PUNCH B831

	300K	450K	600K	EM	Note
Punch Waste Hopper	I	I	I		Remove and empty

2.1.11 COVER INTERPOSER TRAY B835

The PM interval is for the number of sheets that have been fed.

	60 K	As Needed	Note
Drive rollers		C	Dry cloth
Idle rollers		C	Dry cloth
Feed belt	R		
Separation roller	R		
Pick-up roller	R		
Sensors		C	Blower brush.
Drive gears		I	Lubricate with a very small amount of G501.

2.2 LUBRICATION POINTS

2.2.1 OPC, ITB REPLACEMENT

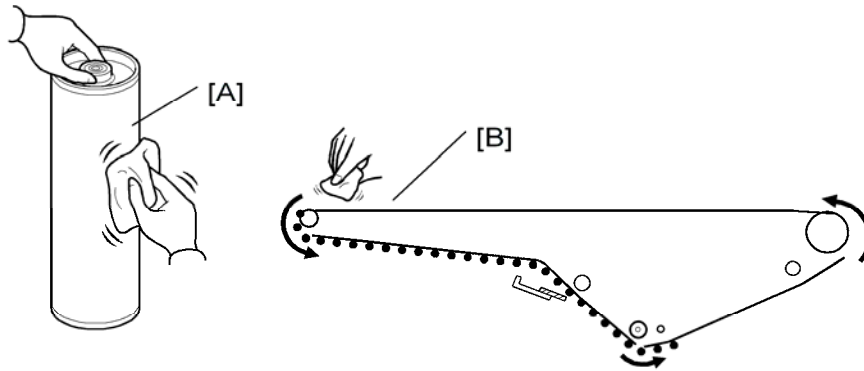

b132r319

Be sure to apply Lubricant Powder B1329700 before re-installing the drum [A] or ITB [B].
For more, please refer to "Replacement and Adjustment".

2.2.2 FUSING UNIT

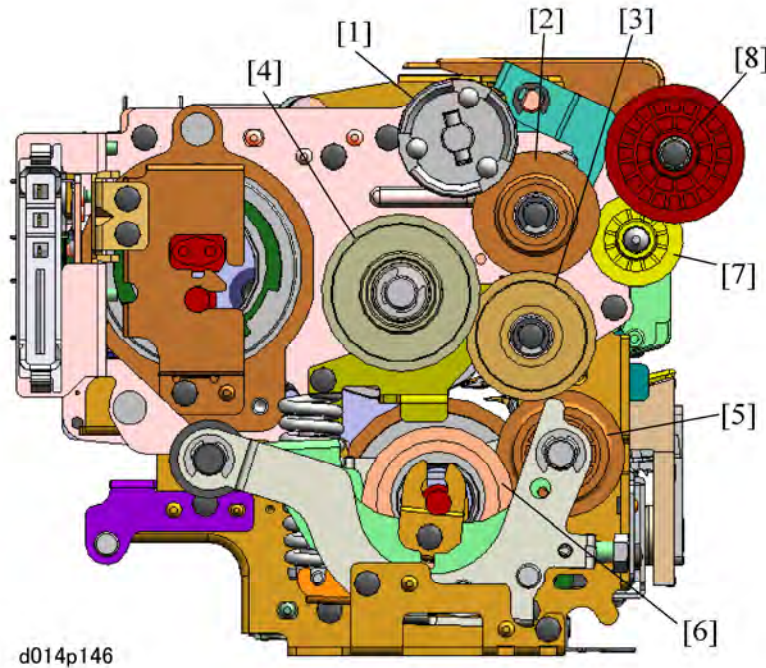

d014p146

	Part Name	Lubricant	Comment
[1]	Drive Gear	Barrierta S552R	Brush all gear teeth
[2]	Idle Gear	Barrierta S552R	Brush all gear teeth
[3]	Hot roller Idle Gear	Barrierta S552R	Brush all gear teeth
[4]	Hot roller Drive Gear	Barrierta S552R	Brush all gear teeth
[5]	Pressure roller Idle Gear	Barrierta S552R	Brush all gear teeth
[6]	Pressure roller Drive Gear	Barrierta S552R	Brush all gear teeth
[7]	Exit Idle Gear	Barrierta S552R	Brush all gear teeth
[8]	Exit Drive Gear	Barrierta S552R	Brush all gear teeth

d081p146a

Lubricate gears [2] and [5] at every 150K. Lubrication applied to these gears will lubricate the other gears during fusing unit operation.

Lubrication Points

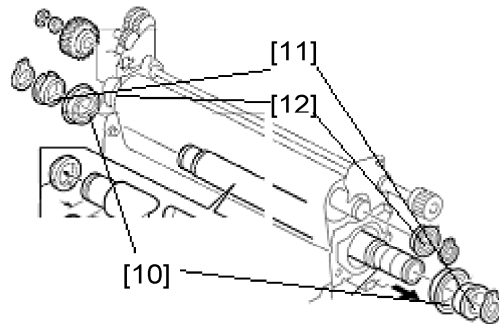
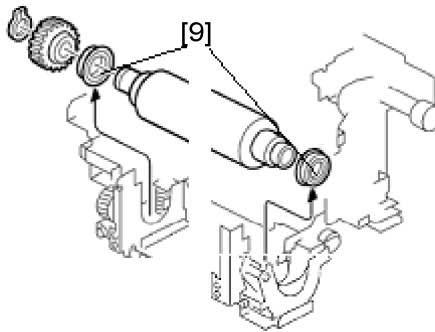

d014p145

	Part Name	Lubricant	Comment
[9]	Bearing Race $\phi 20 \times \phi 32 \times 7$	Barrierta S552R	Brush both ends
[10]	Bearing Race $\phi 35 \times \phi 47 \times 7$	Barrierta S552R	Brush both ends
[11]	Bushing Race	Barrierta S552R	Brush both ends
[12]	Bearing Race $\phi 20 \times \phi 32 \times 7$	Barrierta S552R	Brush both ends

d014p145a

Lubricate all bearings after replacement of the hot roller, pressure roller, and/or heating roller.

2.2.3 DEVELOPMENT UNIT

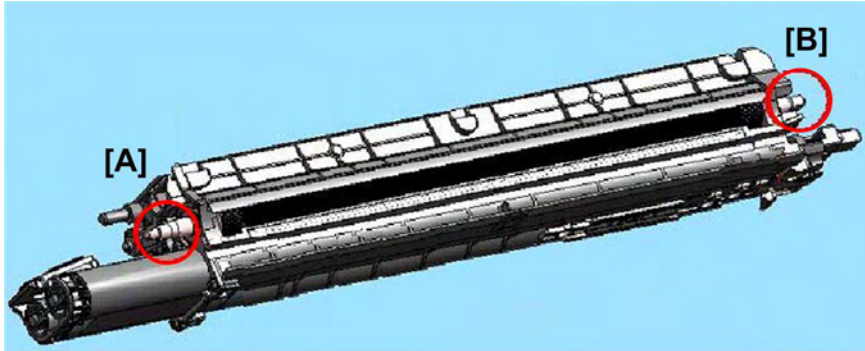

d081p001

1. Points [A] and [B] are the lubrication points on the development unit.

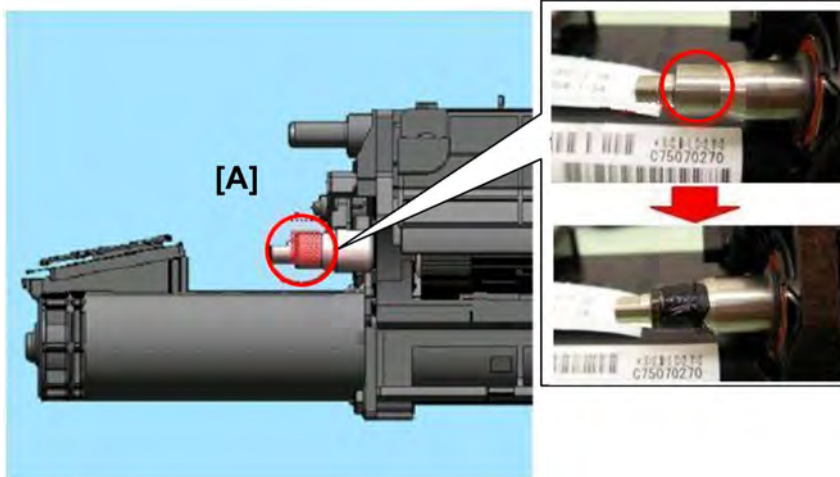

d081p002

2. Apply a thin layer of Grease KS660B around the surface at [A] as shown.

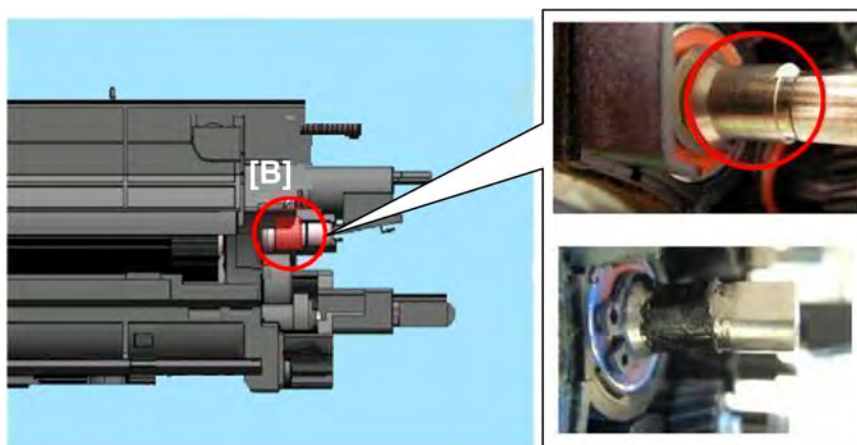

d018p003

3. Apply a thin layer of Grease KS660B around the surface at [B] as shown.

APPENDIX:

SERVICE CALL CONDITIONS

REVISION HISTORY		
Page	Date	Added/Updated/New
15	08/02/2010	Added SC285
25	05/04/2011	Updated SC402 – Black toner supply unit not Yellow
39 ~ 40	12/19/2011	Updated SC501, 503 and 504. Deleted SC502.
57	10/27/2010	Added SC672

3. APPENDIX: SERVICE CALL CONDITIONS

3.1 SERVICE CALL TABLES

3.1.1 SC CODES GROUP 1: SCANNING

SC101	D	Exposure lamp error
		The white level peak did not reach the prescribed threshold when the white plate was scanned.
		<ul style="list-style-type: none"> ▪ Dirty optics ▪ Dirty white plate ▪ Exposure lamp defective ▪ Exposure lamp does not turn on ▪ Lamp stabilizer defective ▪ High voltage line leak ▪ SIOB defective ▪ SBU defective

SC120	D	Scanner home position error 1
		The scanner home position sensor did not detect the home position (did not go OFF) after the scanner moved forward 20 mm..
		<ul style="list-style-type: none"> ▪ Scanner motor defective ▪ Scanner HP sensor defective ▪ Harness between scanner motor and SIOB disconnected or broken. ▪ SIOB defective

SC121	D	Scanner home position error 2
		The scanner home position sensor did not go ON after the scanner moved forward 6 mm and the feeler entered the HP sensor.

Appendix:
Service Call
Conditions

Service Call Tables

		<ul style="list-style-type: none"> ▪ Scanner motor harness loose, broken, defective ▪ Scanner motor defective ▪ Scanner HP sensor disconnected, defective ▪ SIOB defective
--	--	--

SC141	D	Black level detection error
		During AGC the value for black level was not within ± 3 of the prescribed value.
		<ul style="list-style-type: none"> ▪ SBU defective ▪ Harness defective ▪ Check harnesses between SBU and IPU ▪ IPU defective ▪ VBCU defective

SC142	D	White level detection error
		During AGC the value for white level was not within -7 of the prescribed value.
		<ul style="list-style-type: none"> ▪ Exposure lamp defective ▪ Harness disconnected, damaged ▪ Dirty exposure glass, optics ▪ Scanner motor, drive assembly defective ▪ SBU board defective

SC144	D	SBU communication error
		<p>When the machine is switched on, or when the machine returns to full operation from the energy save mode, the machine can not access the SBU register, or the SBU register values are abnormal.</p> <p>Note: The ASIC IDs read during automatic adjustment of the SBU can be displayed with SP4600.</p>
		<ul style="list-style-type: none"> ▪ SBU harness loose, disconnected, defective ▪ SBU board defective ▪ VBCU defective

SC161	D	IPU error
SC161-1	D	An error occurred when the ASIC executed a self-diagnostic report on the BICU.
		<ul style="list-style-type: none"> ▪ Defective BICU ▪ Defective connection between BICU and SBU
SC161-2	D	The machine detects an error during an access to the Ri.
		<ul style="list-style-type: none"> ▪ Defective BICU board
SC161-3	D	The IPU fails to configure or initialize the DRAM.
		<ul style="list-style-type: none"> ▪ Defective BICU board

SC165	D	Illegal Copy Prevention Error
		An abnormality was detected with the ICIB board at power on.
		<ul style="list-style-type: none"> ▪ ICIB connected incorrectly ▪ ICIB defective

Service Call Tables

SC180	D	Scanner fan lock (left fan)
		The fan motor next to the SIOB did not switch on within 10 sec. after the CPU issued the ON signal.
		<ul style="list-style-type: none"> ▪ Fan defective ▪ Foreign object interfering with operation of fan ▪ Motor harness loose, disconnected, or broken ▪ SIOB defective

SC181	D	Scanner fan lock: lamp stabilizer
		The exposure lamp regulator fan is not rotating.
		<ul style="list-style-type: none"> ▪ Check the fan connections ▪ Fan defective ▪ Check SBU connection ▪ Check SIOB connection ▪ SBU defective ▪ SIOB defective

SC182	D	Scanner fan lock: right fan
		The fan located on the right side of the exposure unit is not rotating.
		<ul style="list-style-type: none"> ▪ Check the fan connections ▪ Fan defective ▪ Check SBU connection ▪ Check SIOB connection ▪ SBU defective ▪ SIOB defective

SC185	D	CIS communication error
		Error caused during ASIC register's automatic initialization on the CIS, or during transmission between the CIS – DF.
	<ul style="list-style-type: none"> ▪ Harness between the CIS – DF is disconnected ▪ CIS defective 	

Appendix:
Service Call
Conditions

SC186	D	CIS LED error
		<p>LED on the CIS caused an error</p> <ul style="list-style-type: none"> ▪ During initializing, the ratio of the average between leading-edge area and rear-edge is out of range (0.7 to 1.43). ▪ During scanning, the shading data peak is under 32 (8 bit).
		<ul style="list-style-type: none"> ▪ Harness CN210 and CN220 on ADF are disconnected. ▪ Replace CIS.

SC187	D	CIS black level error
		<p>The black level scanned by CIS is abnormal. The black level average of R, G or B is not within range (2 to 62). 0 < Calibrated Black data level < 255(10bit).</p>
		<ul style="list-style-type: none"> ▪ Turn off the machine. ▪ Make sure CN210 and CN220 are connected securely. ▪ Turn on the machine.

Service Call Tables

SC188	D	CIS white level error
		The shading data peak detected from the CIS is abnormal.
		<ul style="list-style-type: none"> ▪ CIS defective
		<ul style="list-style-type: none"> ▪ Make sure CN210 and CN220 are connected firmly. ▪ Replace the CIS.

SC189	D	CIS gray balance adjustment error
		The adjustment error occurs during the test after adjusting the gray balance.
		<ul style="list-style-type: none"> ▪ CIS defective
		<ol style="list-style-type: none"> 1. Retry the gray balance adjustment. 2. If the machine does not recover, do the following steps. <ul style="list-style-type: none"> ▪ Turn off the machine. ▪ Make sure CN210 and CN220 are connected firmly. ▪ Turn on the machine. 3. If the machine does not recover, replace the CIS.

SC195	D	Machine serial number error
		The number registered for the machine serial number does not match.
		<ul style="list-style-type: none"> ▪ Confirm the correct serial number of the machine in the specifications ▪ Re-input the serial number. <p>Important: When SC195 occurs, the serial number must be input. Please contact your technical supervisor.</p>

3.1.2 SC CODES GROUP 2: EXPOSURE

SC202	D	Polygon motor error: ON timeout
		The polygon mirror motor does not reach the targeted operating speed within the prescribed time.
		<ul style="list-style-type: none"> ▪ Harness to polygon motor drive board disconnected, defective ▪ Polygon motor defective ▪ Polygon motor drive board defective ▪ Polygon motor defective.

SC203	D	Polygon motor error: OFF timeout
		The polygon mirror motor does leave the READY status within 3 seconds after the polygon motor switches off.
		<ul style="list-style-type: none"> ▪ Harness to polygon motor driver board disconnected, defective ▪ Polygon motor defective ▪ Polygon motor driver board defective ▪ Polygon motor defective.

SC204	D	Polygon motor error: XSCRDY signal error
		The polygon motor stopped operating while the LD unit was firing.
		<ul style="list-style-type: none"> ▪ Harness to polygon motor driver board disconnected, defective ▪ Polygon motor defective ▪ Polygon motor driver board defective

SC210	B	Laser beam detection error: K (Black)
SC211	B	Laser beam detection error: Y (Yellow)
SC212	B	Laser beam detection error: M (Magenta)

Appendix:
Service Call
Conditions

Service Call Tables

SC213	B	Laser beam detection error: C (Cyan)
		The laser synchronization sensor failed to detect the beginning and end of the laser beam flash for the designated color onto the polygon mirror while the mirror is rotating at the prescribed number of revolutions.
		<ul style="list-style-type: none"> ▪ Laser synchronization detector sensor connection loose, not connected ▪ Laser synchronization detector sensor defective ▪ LD unit defective ▪ IPU defective ▪ VBCU defective

SC220	D	Laser synchronization detector error: K leading edge: LD0
		While the polygon motor is rotating normally, no synchronizing detection signal is output for LD0 black, or leading edge, even after the laser diode has been firing for 2 sec.
		<ul style="list-style-type: none"> ▪ Harness between the laser synchronizing detector and I/F unit is disconnected, defective ▪ Check all connections between LD unit, LDB, IPU ▪ LD unit ▪ LDB defective ▪ IPU defective

SC221	D	Laser synchronization detector error: K leading edge (not LD0)
		While the polygon motor is rotating normally, no synchronizing detection signal is output for black, leading edge for any LD other than LD0.
		<ul style="list-style-type: none"> ▪ Harness between the laser synchronizing detector and I/F unit is disconnected, defective ▪ Check all connections between LD unit, LDB, IPU ▪ LD unit ▪ LDB defective ▪ IPU defective

SC222	D	Laser synchronization detector error: Y leading edge: LD0
		While the polygon motor is rotating normally, no synchronizing detection signal is output for LD0 yellow, leading edge.
		<ul style="list-style-type: none"> ▪ Harness between the laser synchronizing detector and I/F unit is disconnected, defective ▪ Check all connections between LD unit, LDB, IPU ▪ LD unit ▪ LDB defective ▪ IPU defective

SC223	D	Laser synchronization detector error: Y leading edge (not LD0)
		While the polygon motor is rotating normally, no synchronizing detection signal is output for yellow, leading edge for any LD other than LD0.
		<ul style="list-style-type: none"> ▪ Harness between the laser synchronizing detector and I/F unit is disconnected, defective ▪ Check all connections between LD unit, LDB, IPU ▪ LD unit ▪ LDB defective ▪ IPU defective

Appendix:
Service Call
Conditions

Service Call Tables

SC224	D	Laser synchronization detector error: M leading edge: LD0
		While the polygon motor is rotating normally, no synchronizing detection signal is output for LD0 magenta, leading edge.
		<ul style="list-style-type: none"> ▪ Harness between the laser synchronizing detector and I/F unit is disconnected, defective ▪ Check all connections between LD unit, LDB, IPU ▪ LD unit ▪ LDB defective ▪ IPU defective

SC225	D	Laser synchronization detector error: M leading edge (not LD0)
		While the polygon motor is rotating normally, no synchronizing detection signal is output for magenta, leading edge for any LD other than LD0.
		<ul style="list-style-type: none"> ▪ Harness between the laser synchronizing detector and I/F unit is disconnected, defective ▪ Check all connections between LD unit, LDB, IPU ▪ LD unit ▪ LDB defective ▪ IPU defective

SC226	D	Laser synchronization detector error: C leading edge: LD0
		While the polygon motor is rotating normally, no synchronizing detection signal is output for LD0 cyan, leading edge.
		<ul style="list-style-type: none"> ▪ Harness between the laser synchronizing detector and I/F unit is disconnected, defective ▪ Check all connections between LD unit, LDB, IPU ▪ LD unit ▪ LDB defective ▪ IPU defective

SC227	D	Laser synchronization detector error: C leading edge (not LD0)
		While the polygon motor is rotating normally, no synchronizing detection signal is output for cyan, leading edge for any LD other than LD0.
		<ul style="list-style-type: none"> ▪ Harness between the laser synchronizing detector and I/F unit is disconnected, defective ▪ Check all connections between LD unit, LDB, IPU ▪ LD unit ▪ LDB defective ▪ IPU defective

SC230	D	FGATE error: Feedback remains HIGH for K write
		After the start of timing to create the black image, the PFGATE register of the GAVD did not assert.
		<ul style="list-style-type: none"> ▪ Harness between the VBCU and LDB unit disconnected, loose, or defective. ▪ LD unit defective ▪ IPU defective ▪ Controller board disconnected, defective ▪ HDD defective

SC231	D	FGATE error: Feedback remains LOW for K write
		After the start of timing to create the black image, the PFGATE register of the GAVD did not assert.
		<ul style="list-style-type: none"> ▪ Harness between the VBCU and LDB unit disconnected, loose, or defective. ▪ LD unit defective ▪ IPU defective ▪ Controller board disconnected, defective ▪ HDD defective

Appendix:
Service Call
Conditions

Service Call Tables

SC232	D	FGATE error: Feedback remains HIGH for Y write
		After the start of timing to create the yellow image, the PFGATE register of the GAVD did not assert.
		<ul style="list-style-type: none"> ▪ Harness between the VBCU and LDB unit disconnected, loose, or defective. ▪ LD unit defective ▪ IPU defective ▪ Controller board disconnected, defective ▪ HDD defective

SC233	D	FGATE error: Feedback remains LOW for Y write
		After the start of timing to create the yellow image, the PFGATE register of the GAVD did not assert.
		<ul style="list-style-type: none"> ▪ Harness between the VBCU and LDB unit disconnected, loose, or defective. ▪ LD unit defective ▪ IPU defective ▪ Controller board disconnected, defective ▪ HDD defective

SC234	D	FGATE error 1: Feedback remains HIGH for M write
		After the start of timing to create the magenta image, the PFGATE register of the GAVD did not assert.
		<ul style="list-style-type: none"> ▪ Harness between the VBCU and LDB unit disconnected, loose, or defective. ▪ LD unit defective ▪ IPU defective ▪ Controller board disconnected, defective ▪ HDD defective

SC235	D	FGATE error: Feedback remains LOW for M write
		After the start of timing to create the magenta image, the PFGATE register of the GAVD does not assert.
		<ul style="list-style-type: none"> ▪ Harness between the VBCU and LDB unit disconnected, loose, or defective. ▪ LD unit defective ▪ IPU defective ▪ Controller board disconnected, defective ▪ HDD defective

SC236	D	FGATE error 1: Feedback remains HIGH for C write
		After the start of timing to create the cyan image, the PFGATE register of the GAVD did not assert.
		<ul style="list-style-type: none"> ▪ Harness between the VBCU and LDB unit disconnected, loose, or defective. ▪ LD unit defective ▪ IPU defective ▪ Controller board disconnected, defective ▪ HDD defective

SC237	D	FGATE error: Feedback remains LOW for C write
		After the start of timing to create the cyan image, the PFGATE register of the GAVD does not assert.
		<ul style="list-style-type: none"> ▪ Harness between the VBCU and LDB unit disconnected, loose, or defective. ▪ LD unit defective ▪ IPU defective ▪ Controller board disconnected, defective ▪ HDD defective

Appendix:
Service Call
Conditions

Service Call Tables

SC240	C	LD error: K
SC241	C	LD error: Y
SC242	C	LD error: M
SC243	C	LD error: C
		An error occurred at the LD error terminal of the K, Y, M, or C LD driver after initialization of the LD because the power to the LD was higher or lower than the prescribed limit.
		<ul style="list-style-type: none"> ▪ LD defective due to wear, damage, short circuit ▪ LDB harness disconnected, loose or defective

SC268	C	Optical unit thermistor error
		At power on, one of the two temperature sensors in the optics unit detected a temperature lower than -10°C. -or- It detected a temperature higher than 80°C.
		<ul style="list-style-type: none"> ▪ Thermistor disconnected (causes extremely low temperature reading) ▪ Thermistor damaged and short circuited (causes extremely high temperature reading) ▪ VBCU defective

SC270	C	Skew control upper lower limit: Y
		The pulse total for Yellow skew control is not within the prescribed range.
		<ul style="list-style-type: none"> ▪ ITB not installed correctly. ▪ ITB defective ▪ Optical unit installed incorrectly ▪ Optical unit defective

SC271	C	Skew control upper lower limit: M
		The pulse total for Magenta skew control is not within the prescribed range.
		<ul style="list-style-type: none"> ▪ ITB not installed correctly. ▪ ITB defective ▪ Optical unit installed incorrectly ▪ Optical unit defective

SC272	C	Skew control upper lower limit: C
		The pulse total for Cyan skew control is not within the prescribed range.
		<ul style="list-style-type: none"> ▪ ITB not installed correctly. ▪ ITB defective ▪ Optical unit installed incorrectly ▪ Optical unit defective

⇒ SC285	D	MUSIC Continuous Failure
		The MUSIC adjustment failed after four attempts.
		<ul style="list-style-type: none"> ▪ ITB installed incorrectly ▪ ITB surface scoured, scratched ▪ MUSIC sensors dirty, defective

Appendix:
Service Call
Conditions

3.1.3 SC CODES GROUP 3: IMAGE DEVELOPMENT – 1

SC300	D	Drum charge corona wire error: K
		The output of the charge corona wire of the black PCU is abnormal.
		<ul style="list-style-type: none"> ▪ CGB power pack connection loose, broken defective ▪ Check CGB power pack connection to BCU ▪ CGB power pack defective ▪ BCU defective ▪ Replace OPC drum

SC301	D	AC charge output error: M
SC302	D	AC charge output error: C
SC303	D	AC charge output error: Y
		An interrupt checks the status of the power pack every 10 ms. This SC is issued if the VBCU detects a short in the AC charge for M, C, Y.
		<ul style="list-style-type: none"> ▪ Disconnect the high voltage cable from Terminal C of the multiple high-voltage supply board. ▪ Attach a voltmeter to the terminal. ▪ If there is no output from the terminal, replace the high voltage power supply. <p>-or-</p> <ul style="list-style-type: none"> ▪ If there is output from the terminal, test the resistance between the high voltage cable and the ground. If resistance is nearly "0", check the high-voltage harness for defects and replace it if necessary. ▪ Test the conductivity between the OPC unit and the ground. If there is no conductivity between the OPC unit and ground, replace the OPC unit. ▪ If there is no charge PWM signal, replace the harness and/or VBCU.

SC304	D	Charge corona error: charge leak (K PCU)
		A abnormal detection signal (H) was detected for longer than 250 ms.
		<ul style="list-style-type: none"> ▪ Turn the machine power off/on ▪ CGB power pack harness connectors loose, broken, defective ▪ Corona wire caps loose, missing ▪ CGB power pack defective Charge corona unit connectors loose, broken, defective

SC308	D	Charge corona error: wire cleaner error (K PCU)
		The charge corona wire cleaner motor remained locked after the motor was switched on, or failed to switch off within the prescribed time after cleaning started.
		<ul style="list-style-type: none"> ▪ Turn the machine power off/on ▪ Motor overloaded due to a physical obstruction ▪ Motor defective

SC313	D	Charge, development error: M
SC314	D	Charge, development error: C
SC315	D	Charge, development error: Y
		After the M, C, or Y drum started to rotate, the feedback for the charge unit of the color dropped below 0.3V.
		<ul style="list-style-type: none"> ▪ Make sure that the settings of SP2202 are at the defaults. ▪ Check harness connections between charge roller and transfer power pack. ▪ Defective charge roller ▪ Defective power pack

Appendix:
Service Call
Conditions

Service Call Tables

SC316	D	Drum charge error: K
SC317	D	Drum charge error: M
SC318	D	Drum charge error: C
SC319	D	Drum charge error: Y
		Drum charge output voltage (Vpp) exceeded 2.8 kV.
		<ul style="list-style-type: none"> ▪ Check the connections of the charge unit of the PCU where the problem occurred. ▪ Replace the charge unit of the PCU (CBG power pack for the K PCU, charge roller unit for YMC PCUs)

SC320	D	Development power pack error: K
SC321	D	Development power pack error: M
SC322	D	Development power pack error: C
SC323	D	Development power pack error: Y
		This SC is issued if the VBCU detects a short in the development DC charge for K, M, C, Y.
		<ul style="list-style-type: none"> ▪ Development power pack defective ▪ High voltage power supply defective ▪ High voltage power supply harness defective ▪ Development unit defective ▪ IOB harness disconnected or defective ▪ IOB defective

		<ol style="list-style-type: none"> 1. Disconnect the high voltage cable from Terminal B of the high-voltage supply board. 2. Attach a voltmeter to the terminal. 3. If there is no output from the terminal, replace the high voltage power supply. <p>-or-</p> <ol style="list-style-type: none"> 1. If there is output from the terminal, test the resistance between the high voltage cable and the ground. 2. If resistance is "0" or nearly "0", check the high-voltage harness for defects and replace it if necessary. 3. If replacing the harness does not solve the problem, 4. Test the resistance between the development unit terminal and the ground. If there is no resistance (0Ω) between the development unit and the ground, replace the development unit. 5. If there is no development PWM signal, replace the harness and/or IOB.
--	--	--

SC324	D	Development motor error: K
SC325	D	Development motor error: M
SC326	D	Development motor error: C
SC327	D	Development motor error: Y
		The PLL lock signal remained HIGH or LOW for longer than the prescribed time for the K, M, C, or Y, development motor.
		<ul style="list-style-type: none"> ▪ Development motor shaft locked, blocked by obstruction ▪ Development motor defective ▪ DRB defective

SC336	D	Developer set error: K
SC337	D	Developer set error: M

Service Call Tables

SC338	D	Developer set error: C
SC339	D	Developer set error: Y
		The value of Vcnt is set at the maximum or minimum setting when the TD sensor is initialized.
		<ol style="list-style-type: none"> 1. Open the front door. 2. Pull out the film seal from the black, magenta, cyan, or yellow developer bottle. 3. Do the correct SP for the affected color: <ul style="list-style-type: none"> ▪ SP3801 003 to initialize the TD sensor for K. ▪ SP3801 004 to initialize the TD sensor for M. ▪ SP3801 005 to initialize the TD sensor for C. ▪ SP3801 006 to initialize the TD sensor for Y

SC348	D	Toner supply motor error
		2 sec. after the motor START signal is output, a LOCK signal cannot be detected.
		<ul style="list-style-type: none"> ▪ Motor harness disconnected, loose, or defective ▪ Toner pump overload ▪ Sub hopper overload ▪ Toner hopper motor defective

SC350	D	Developer Fill Error: K
SC351	D	Developer Fill Error: M
SC352	D	Developer Fill Error: C

SC353	D	Developer Fill Error: Y
		The PCU failed to fill with developer from the developer bottle when SP3814-1 was executed.
		<ul style="list-style-type: none"> ▪ Developer bottle not set correctly ▪ Developer in the bottle is clogged and not flowing <p>Note: For detailed information about how to handle problems developer filling, see "Handling Problems with Developer Filling" under "PCU" in Section 3.</p>

SC356	D	Toner Supply Error 1: K
		The machine detected 10 times that the amount of toner applied to create the black ID sensor pattern on the drum between sheets (SP3101-1 ID Pattern Display - Applied K) was less than the minimum threshold setting (0.0 mg/cm ²). Also, the total time for the operation of the sub hopper clutch (SP3251-1 Tnr Supply Time - Sub Hopper CL: K) exceeded the threshold of 65K ms.
		<ul style="list-style-type: none"> ▪ Toner end sensor cleaning spring broken, mechanism defective ▪ Toner end sensor loose, broken, or defective ▪ Replace toner supply unit

SC357	D	Toner Supply Error 2: M
		The machine detected 10 times that the amount of toner applied to create the magenta ID sensor pattern on the drum between sheets (SP3101-2 ID Pattern Display - Applied M) was less than the minimum threshold setting (0.0 mg/cm ²). Also, the total time for the operation of the sub hopper clutch (SP3251-2 Tnr Supply Time - Sub Hopper CL: M) exceeded the threshold of 65K ms.
		<ul style="list-style-type: none"> ▪ Toner end sensor cleaning spring broken, mechanism defective ▪ Toner end sensor loose, broken, or defective ▪ Replace toner supply unit

Appendix:
Service Call
Conditions

Service Call Tables

SC358	D	Toner Supply Error 3: C
		The machine detected 10 times that the amount of toner applied to create the cyan ID sensor pattern on the drum between sheets (SP3101-3 ID Pattern Display - Applied C) was less than the minimum threshold setting (0.0 mg/cm ²). Also, the total time for the operation of the sub hopper clutch (SP3251-3 Tnr Supply Time - Sub Hopper CL: C) exceeded the threshold of 65K ms.
		<ul style="list-style-type: none"> ▪ Toner end sensor cleaning spring broken, mechanism defective ▪ Toner end sensor loose, broken, or defective ▪ Replace toner supply unit

SC359	D	Toner Supply Error 4: Y
		The machine detected 10 times that the amount of toner applied to create the yellow ID sensor pattern on the drum between sheets (SP3101-4 ID Pattern Display - Applied Y) was less than the minimum threshold setting (0.0 mg/cm ²). Also, the total time for the operation of the sub hopper clutch (SP3251-4 Tnr Supply Time - Sub Hopper CL: Y) exceeded the threshold of 65K ms.
		<ul style="list-style-type: none"> ▪ Toner end sensor cleaning spring broken, mechanism defective ▪ Toner end sensor loose, broken, or defective ▪ Replace toner supply unit

SC360	D	TD sensor (Vt high) error: K
SC361	D	TD sensor (Vt high) error: M
SC362	D	TD sensor (Vt high) error: C

SC363	D	TD sensor (Vt high) error: Y
		The Vt value of the black, magenta, cyan, or yellow TD sensor exceeds 0.5V for 10 counts.
		<ul style="list-style-type: none"> ▪ Black, magenta, cyan, or yellow TD sensor disconnected ▪ Harness between TD sensor and PCU defective ▪ Defective TD sensor, replace the PCU <p>Note: The TD sensor cannot be replaced independently. The PCU must be replaced if the TD sensor is defective.</p>

SC364	D	TD sensor (Vt low) error: K
SC365	D	TD sensor (Vt low) error: M
SC366	D	TD sensor (Vt low) error: C
SC367	D	TD sensor (Vt low) error: Y
		The Vt value of the black, magenta, cyan, or yellow TD sensor is below 0.5V for 10 counts.
		<ul style="list-style-type: none"> ▪ TD sensor harness disconnected, loose, defective ▪ A drawer connector (located on the rear of a development unit) disconnected, loose, defective ▪ TD sensor defective, replace the PCU <p>Note: The TD sensor cannot be replaced independently. The PCU must be replaced if the TD sensor is defective.</p>

Service Call Tables

SC372	D	TD sensor adjustment error: K
SC373	D	TD sensor adjustment error: M
SC374	D	TD sensor adjustment error: C
SC375	D	TD sensor adjustment error: Y
		During TD sensor initialization with SP3801, the output value of the black, magenta, cyan, or yellow TD sensor is not within the range of $2.5 \pm 0.2V$
		<p>TD harness sensor disconnected, loose or defective Harness between TD sensor and drawer disconnected, defective</p> <ul style="list-style-type: none"> ▪ TD sensor defective, replace the PCU <p>Note: The TD sensor cannot be replaced independently. The PCU must be replaced if the TD sensor is defective.</p>

SC396	D	Drum motor error: K
SC397	D	Drum motor error: M
SC398	D	Drum motor error: C
SC399	D	Drum motor error: Y
		The motor is trying to rotate at power on or during normal operation but there is an excessive load on the drum shaft. The motor has no traction (due to a bent cleaning blade, for example).
		<ul style="list-style-type: none"> ▪ Drum motor harness loose, broken, defective ▪ Drum motor defective ▪ DTMB defective

3.1.4 SC CODES GROUP 4: IMAGE DEVELOPMENT - 2

SC400	D	ID sensor error: Calibration
		Before adjustment Vsg_reg<0.5 but Vsg_reg could not be adjusted to the target Vsg_reg = 4.0±0.2V during process control.
		<ul style="list-style-type: none"> ▪ ID sensor harness disconnected, loose, defective ▪ ID sensor dirty ▪ ID sensor defective ▪ ITB unit drawer connector dirty
		<p>Note: Vsg_reg is the voltage reading of the light reflected directly from the bare surface of the ITB. The additional receptor on the color sensor is not used to read the bare surface of the belt. For more, see Section "6. Details".</p>

Appendix:
Service Call
Conditions

SC402	D	ID Sensor Pattern Maximum Coverage Error 1: K
		The amount of toner applied to create the black ID sensor pattern between sheets (SP3101-1 ID Pattern Display - Applied: K) exceeded the maximum threshold of 0.3 mg/cm ² due to an over supply of black toner.
⇒		<ul style="list-style-type: none"> ▪ Black toner supply unit defective

SC403	D	ID Sensor Pattern Maximum Coverage Error 2: M
		The amount of toner applied to create the magenta ID sensor pattern between sheets (SP3101-2 ID Pattern Display - Applied: M) exceeded the maximum threshold of 0.7 mg/cm ² due to an over supply of magenta toner.
		<ul style="list-style-type: none"> ▪ Magenta toner supply unit defective

Service Call Tables

SC404	D	ID Sensor Pattern Maximum Coverage Error 3: C
		The amount of toner applied to create the cyan ID sensor pattern between sheets (SP3101-3 ID Pattern Display - Applied: C) exceeded the maximum threshold of 0.7 mg/cm ² due to an over supply of cyan toner.
		<ul style="list-style-type: none"> ▪ Cyan toner supply unit defective

SC405	D	ID Sensor Pattern Maximum Coverage Error 4: Y
		The amount of toner applied to create the yellow ID sensor pattern between sheets (SP3101-4 ID Pattern Display - Applied: Y) exceeded the maximum threshold of 0.7 mg/cm ² due to an over supply of yellow toner.
		<ul style="list-style-type: none"> ▪ Yellow toner supply unit defective

SC406	D	ID Sensor Pattern Minimum Coverage Error 1: K
		The machine detected 10 times that the amount of toner applied to create the black ID sensor pattern on the drum between sheets (SP3101-1 ID Pattern Display - Applied K) was less than the minimum threshold setting (0.0 mg/cm ²). Also, the total time for the operation of the sub hopper clutch (SP3251-1 Tnr Supply Time - Sub Hopper CL: K) was less than or equal to the threshold of 65K ms.
		<ul style="list-style-type: none"> ▪ Toner shield glass dirty ▪ Development unit defective ▪ Image transfer unit defective

SC407	D	ID Sensor Pattern Minimum Coverage Error 2: M
		The machine detected 10 times that the amount of toner applied to create the magenta ID sensor pattern on the drum between sheets (SP3101-2 ID Pattern Display - Applied M) was less than the minimum threshold setting (0.2 mg/cm ²). Also, the total time for the operation of the sub hopper clutch (SP3251-2 Tnr Supply Time - Sub Hopper CL: M) was less than or equal to the threshold of 65K ms.
		<ul style="list-style-type: none"> ▪ Toner shield glass dirty ▪ Development unit defective ▪ Image transfer unit defective

SC408	D	ID Sensor Pattern Minimum Coverage Error 3: C
		The machine detected 10 times that the amount of toner applied to create the cyan ID sensor pattern on the drum between sheets (SP3101-3 ID Pattern Display - Applied C) was less than the minimum threshold setting (0.2 mg/cm ²). Also, the total time for the operation of the sub hopper clutch (SP3251-3 Tnr Supply Time - Sub Hopper CL: C) was less than or equal to the threshold of 65K ms.
		<ul style="list-style-type: none"> ▪ Toner shield glass dirty ▪ Development unit defective ▪ Image transfer unit defective

Appendix:
Service Call
Conditions

Service Call Tables

SC409	D	ID Sensor Pattern Minimum Coverage Error 4: Y
		The machine detected 10 times that the amount of toner applied to create the yellow ID sensor pattern on the drum between sheets (SP3101-4 ID Pattern Display - Applied Y) was less than the minimum threshold setting (0.2 mg/cm ²). Also, the total time for the operation of the sub hopper clutch (SP3251-4 Tnr Supply Time - Sub Hopper CL: Y) was less than or equal to the threshold of 65K ms.
		<ul style="list-style-type: none"> ▪ Toner shield glass dirty ▪ Development unit defective ▪ Image transfer unit defective

SC410	D	ID sensor error: Development γ K
SC411	D	ID sensor error: Development γ M
SC412	D	ID sensor error: Development γ C
SC413	D	ID sensor error: Development γ Y
		Development gamma for black, magenta, cyan, or yellow is not within range (0.3 to 6.0). Process control halts when this SC is issued.
		<ul style="list-style-type: none"> ▪ Toner density abnormal. Refer to the image troubleshooting section in Section 4 of the Venus-C1 B132 Service Manual (Self-Check Error Codes 55 to 59, 61). ▪ LD sensor harness loose, broken, defective ▪ Potential sensor defective ▪ LD unit not firing ▪ ITB separation for CMY abnormal ▪ Transfer power pack defective

SC414	D	ID sensor error: Development start voltage K
-------	---	--

SC415	D	ID sensor error: Development start voltage M
SC416	D	ID sensor error: Development start voltage C
SC417	D	ID sensor error: Development start voltage Y
		The development start voltage in the development of the black, magenta, cyan, or yellow PCU is not within the correct range ($\pm 150V$)
		<ul style="list-style-type: none"> ▪ Toner density abnormal. Refer to the image troubleshooting section in Section 4 of the Venus-C1 B132 Service Manual (Self-Check Error Codes 55 to 59, 61). ▪ Potential sensor defective ▪ LD unit not firing ▪ ITB separation for CMY abnormal <p>Transfer power pack defective</p>

Appendix:
Service Call
Conditions

SC418	C	LED error during Vsg adjustment
		<p>PWM value: Ifsg>3000</p> <p>This means one or more of the following sensors is not functioning correctly:</p> <ul style="list-style-type: none"> ▪ ITB encoder sensor ▪ ID sensor ▪ MUSIC sensors
		<ul style="list-style-type: none"> ▪ ID sensor dirty ▪ ID sensor defective
		<p>Note:</p> <ul style="list-style-type: none"> ▪ This error can occur as a result of cleaning the sensors with a dry cloth, which can cause a static charge to build up on the sensor and attract particles of paper dust. ▪ Always clean these with a clean cloth moistened with alcohol as described in the PM table.

Service Call Tables

SC420	C	Potential sensor error: Vd Adjustment K
SC421	C	Potential sensor error: Vd Adjustment M
SC422	C	Potential sensor error: Vd Adjustment C
SC423	C	Potential sensor error: Vd Adjustment Y
		The development potential of the drum before exposure (Vd) cannot be adjusted to within ± 8 V of the target voltage (-900V).
	<ul style="list-style-type: none"> ▪ 	<ul style="list-style-type: none"> ▪ Drum potential sensor harness, connector is loose, broken, defective ▪ Drum potential sensor dirty ▪ Drum potential sensor defective ▪ Drum connector, harness loose, broken, defective ▪ Development power pack defective ▪ VBCU defective

SC424	C	Potential sensor error 5: VI adjustment K
SC425	C	Potential sensor error 6: VI adjustment M
SC426	C	Potential sensor error 7: VI adjustment C
SC427	C	Potential sensor error 8: VI adjustment Y
		Vpl could not be adjusted to within ± 5 V of the target Vpl after exposure of the ID sensor patterns.
		<ul style="list-style-type: none"> ▪ Drum worn ▪ LD unit dirty ▪ Poor drum ground connection

SC432	C	Potential sensor error 1: Vr K
SC433	C	Potential sensor error 2: Vr M
SC434	C	Potential sensor error 3: Vr C
SC435	C	Potential sensor error 4: Vr Y
		Vr > 200V. The residual voltage (Vr), the amount of voltage that remains on the surface of the drum after the QL fires is greater than 200V.
		<ul style="list-style-type: none"> ▪ Potential sensor dirty ▪ Potential sensor defective ▪ Charge roller defective ▪ Charge power pack defective ▪ OPC defective

SC436	D	Potential sensor error: Vd K
SC437	D	Potential sensor error: Vd M
SC438	D	Potential sensor error: Vd C
SC439	D	Potential sensor error: Vd Y
		The VdHome reading, the first step of the process control self-check, detected that the development potential of the unexposed areas of the drum are not within the prescribed range (-500 to -800)
		<ul style="list-style-type: none"> ▪ Potential sensor dirty ▪ Potential sensor defective ▪ Charge roller defective ▪ Charge power pack defective ▪ OPC defective

SC440	D	Image transfer power pack error: K
-------	---	------------------------------------

Service Call Tables

SC441	D	Image transfer power pack error: M
SC442	D	Image transfer power pack error: C
SC443	D	Image transfer power pack error: Y
		An interrupt checks the status of the power pack every 10 ms. This SC is issued if the VBCU detects a short in the power pack for K, M, C, or Y.
		<ul style="list-style-type: none"> ▪ Transfer belt damaged, insulation damaged ▪ Insulation on high voltage cable damaged ▪ Another hot point inside the machine has damaged insulation ▪ Insulation around high-voltage power supply damaged

SC445	D	Image transfer motor error
		The control board of the ITB motor belt generated signals that indicate there is problem with the image transfer belt motor.
		<ul style="list-style-type: none"> ▪ ITB motor defective ▪ ITB control board defective ▪ ITB overloaded ▪ Encoder strip on the edge of the ITB damaged.

SC446	D	ITB lift motor error
		The state of the ITB lift sensor does not change its state (switching from off to on or vice versa), even after the ITB lift motor starts rotating.
		<ul style="list-style-type: none"> ▪ ITB lift sensor dirty, disconnected, defective ▪ ITB lift motor disconnected, defective ▪ ITB sensor defective ▪ ITB lift motor defective

SC447	D	Image transfer roller position error
		The machine checks for the presence of the K STC and the checks the status of the K image transfer roller lift sensor after the door is closed.
		<ul style="list-style-type: none"> ▪ Transfer belt release lever down ▪ Lift sensor connector loose, broken, dirty ▪ Lift sensor defective

SC450	D	Transfer power pack output error
		An interrupt checks the status of the power pack every 2 ms. This SC is issued if the VBCU detects a short in the power pack 250 times at T2 within 500 ms.
		<ul style="list-style-type: none"> ▪ Damaged insulation on the high-voltage supply cable ▪ Damaged insulation around the high-voltage power supply. ▪ Check SIOB harness connections ▪ SIOB defective

SC452	D	PTR lift mechanism error
		The PTR was not detected at the home position within 2 sec. after the PTR lift motor turned on.
		<ul style="list-style-type: none"> ▪ PTR HP sensor dirty, disconnected, defective ▪ PTR lift motor disconnected, defective

Appendix:
Service Call
Conditions

Service Call Tables

SC455	D	PTR motor error
		The lock signal from the paper transfer motor was not detected within 1 sec. after the motor switched on.
		<ul style="list-style-type: none"> ▪ Motor disconnected ▪ PTR shaft locked, needs cleaning, blocked by obstruction ▪ Drive shaft of the ITB locked and overloaded, needs cleaning, or blocked by obstruction ▪ DRB disconnected, defective

SC460	D	Separation power pack output error
		This SC is issued if the VBCU detects a short in the transfer power pack.
		<ul style="list-style-type: none"> ▪ Damaged insulation on the high-voltage supply cable (replace cable) ▪ Damaged insulation around the transfer power pack

SC465	C	Image Transfer Roller End: K
SC466	C	Image Transfer Roller End: M
SC467	C	Image Transfer Roller End: C
SC468	C	Image Transfer Roller End: Y
		The machine detected an abnormal reading of the resistance of the transfer roller because it is near the end of its service life.
		<ul style="list-style-type: none"> ▪ Check the connections between the transfer roller power pack the roller ▪ Replace image transfer roller ▪ Image transfer power pack defective

SC472	C	ITB Bias Roller End
		The machine detected an abnormal reading of the resistance of the ITB bias roller because it is near the end of its service life.
		<ul style="list-style-type: none"> ▪ Check the connections between the transfer power pack ▪ Replace image transfer roller ▪ Transfer power pack defective

SC480	B	Drum cleaning motor error: K
SC481	B	Drum cleaning motor error: M
SC482	B	Drum cleaning motor error: C
SC483	B	Drum cleaning motor error: Y
		The drum cleaning motor failed to switch on (motor lock), or failed to reach the required speed within the prescribed time.
		<ul style="list-style-type: none"> ▪ Motor block by physical obstruction ▪ Motor harness loose, broken, defective ▪ Motor defective

SC484	D	Used toner bottle full
		The toner full sensor has detected that the used toner bottle is full.
		<ul style="list-style-type: none"> ▪ Remove the used toner bottle ▪ Empty the used toner bottle and reinstall it

Service Call Tables

SC485	D	Used toner bottle motor error
		The lock signal of the used toner bottle motor remains HIGH for more than 600 ms.
		<ul style="list-style-type: none"> ▪ Used toner bottle harness loose, broken, defective ▪ Used toner bottle motor defective

SC487	D	Used toner bottle set error
		The set sensor of the used toner bottle remains LOW for more than 500 ms. (The sensor goes HIGH when the bottle is installed correctly.)
		<ul style="list-style-type: none"> ▪ Used toner bottle not installed ▪ Remove used toner bottle and reinstall correctly

SC488	D	Used toner transport lock
		Used toner cannot be transported to the used toner bottle.
		<ul style="list-style-type: none"> ▪ Blockage in the line to the used toner bottle

SC490	C	MUSIC sensor error
		One or more of the MUSIC sensors is not functioning normally.
		<ul style="list-style-type: none"> ▪ MUSIC sensor harness loose, broken, defective ▪ Sensor defective

SC495	D	ITB encoder sensor error
		The ITB encoder sensor that reads the encoded strip on the ITB is not functioning properly.
		<ul style="list-style-type: none"> ▪ Sensor dirty ▪ Sensor harness loose, broken, defective ▪ Sensor out of position because installed incorrectly ▪ ITB installed incorrectly

SC496	C	MUSIC sensor error
		The MUSIC sensor detected an abnormal pattern on the ITB because: <ul style="list-style-type: none"> ▪ ADC exceeded upper or lower limit. ▪ The pattern used to calculate the amount of skew is abnormal. ▪ The reading of the pattern exceeded the length of time the LED projected light. ▪ LED light could not be adjusted correctly.
		<ul style="list-style-type: none"> ▪ ITB installed incorrectly ▪ Inspect ITB belt for damage, replace ▪ MUSIC pattern abnormal; do a forced process control (SP3821) and check the result. ▪ MUSIC sensor defective or disconnected

SC497	C	Temperature and humidity sensor error: M PCU
		The thermistor output of the temperature and humidity sensor above the M PCU was not within the prescribed range (0.5V to 4.2V)
		<ul style="list-style-type: none"> ▪ Temperature and humidity sensor harness disconnected, loose, defective ▪ Temperature and humidity sensor defective

Appendix:
Service Call
Conditions

Service Call Tables

SC498	C	Temperature and humidity sensor error: Toner Bottle
		The thermistor output of the temperature and humidity sensor below the used toner bottle was not within the prescribed range (0.5V to 4.2V)
		<ul style="list-style-type: none"> ▪ Temperature and humidity sensor harness disconnected, loose, defective ▪ Temperature and humidity sensor defective

SC499	C	ITB encoder sensor error
		The ITB sensor that reads the encoded film strip on the edge of the image transfer belt is operating correctly.
		<ul style="list-style-type: none"> ▪ ITB encoder sensor dirty ▪ Sensor harness disconnected or damaged ▪ Encoded scale on the edge of the ITB is damaged or dirty ▪ ITB installed incorrectly

3.1.5 SC CODES GROUP 5: PAPER FEED

⇒	SC501	B	Tray 1 (Tandem Tray) Lift Malfunction
			<ul style="list-style-type: none"> ▪ The tray lift sensor is not activated within 10s after the tray lift motor starts lifting the bottom plate. ▪ The tray lift sensor is not deactivated within 1.5s after the tray starts lowering. ▪ A tray overload is detected when the tray is pushed in. ▪ The lower limit sensor of the LCT does not detect the lower limit within 10s.
			<ul style="list-style-type: none"> ▪ Tray lift motor defective or disconnected ▪ Paper or other obstacle trapped between tray and motor ▪ Pick-up solenoid disconnected or blocked by an obstacle ▪ Too much paper loaded in tray <p>See NOTE for SC501, SC503 and SC504</p>

Appendix:
Service Call
Conditions

NOTE for SC501, SC503 and SC504:

- At first, the machine displays a message asking the operator to reset the tray.
- This SC will not be displayed until the operator has pulled the tray out and pushed it in three times.
- If the operator turns the machine OFF/ON before the third opening and closing of the tray, this three-count is reset.

⇒	SC503	B	Tray 2 Lift Malfunction
			<ul style="list-style-type: none"> ▪ The tray lift sensor is not activated within 10s after the tray lift motor starts lifting the bottom plate. ▪ The tray lift sensor is not deactivated within 1.5s after the tray starts lowering. ▪ A tray overload is detected when the tray is pushed in.
			<ul style="list-style-type: none"> ▪ Tray lift motor defective or disconnected ▪ Paper or other obstacle trapped between tray and motor ▪ Pick-up solenoid disconnected or blocked by an obstacle ▪ Too much paper loaded in tray <p>See NOTE for SC501, SC503 and SC504 on previous page.</p>

⇒	SC504	B	Tray 3 Lift Malfunction
			<ul style="list-style-type: none"> ▪ The tray lift sensor is not activated within 10s after the tray lift motor starts lifting the bottom plate. ▪ The tray lift sensor is not deactivated within 1.5s after the tray starts lowering. ▪ A tray overload is detected when the tray is pushed in.
			<ul style="list-style-type: none"> ▪ Tray lift motor defective or disconnected ▪ Paper or other obstacle trapped between tray and motor ▪ Pick-up solenoid disconnected or blocked by an obstacle ▪ Too much paper loaded in tray <p>See NOTE for SC501, SC503 and SC504 on previous page.</p>

	SC505	C	Tandem tray rear fence motor error
			The return sensor does not switch on within 10 sec. after the rear fence motor switches on.
			The HP sensor does not switch on 10 sec. after the rear fence motor switches on.
			The HP sensor and return sensor switch on at the same time.
			<ul style="list-style-type: none"> ▪ Rear fence motor defective or poor connection ▪ Paper or other obstacle interfering with operation of the sensors ▪ Paper or other obstacle trapped between tray and motor ▪ Motor mechanical overload due to obstruction ▪ Return sensor or HP sensor defective or dirty

SC510	B	LCT tray error: B473/D350
		<p>When the bottom plate is lifted, the upper limit sensor does not come on for 30 sec.</p> <p>When the bottom plate is lowered, the lower limit sensor does not come on for 30 sec.</p> <p>After lift begins, the upper limit sensor does not switch on before the pick-up solenoid switches on.</p> <p>The paper end sensor switches on during lift and the upper limit sensor does not switch on for 2.5 s, and a message prompts user to reset paper.</p>
		<ul style="list-style-type: none"> ▪ Tray lift motor harness, disconnected, loose, or defective ▪ Tray lift motor defective ▪ Lift sensor defective or disconnected ▪ Pick-up solenoid defective or disconnected ▪ Paper end sensor defective

SC515	C	Duplex jogger motor error 1
		<p>When the jogger fence moves to the home position, the jogger fence HP sensor does not switch on even after the jogger motor has moved the jogger fence 153.5 mm.</p>
		<ul style="list-style-type: none"> ▪ Jogger fence motor defective or poor connection ▪ Paper or other obstacle interfering with operation of the sensors or motor ▪ Return sensor or HP sensor defective, dirty, or disconnected ▪ Paper or other obstacle has jammed mechanism ▪ HP sensor connector disconnected or defective ▪ HP sensor defective

Appendix:
Service Call
Conditions

Service Call Tables

SC516	C	Duplex jogger motor error 2
		When the jogger fence moves from the home position, the jogger fence HP sensor does not turn off even if the jogger motor has moved the jogger fence 153.5 mm.
		<ul style="list-style-type: none"> ▪ Jogger fence motor defective or poor connection ▪ Paper or other obstacle interfering with operation of the sensors or motor ▪ Return sensor or HP sensor defective, dirty, or disconnected ▪ Paper or other obstacle has jammed mechanism ▪ HP sensor connector disconnected or defective ▪ HP sensor defective

SC517	D	LCIT air assist front fan error
		The front air assist fan is not functioning properly.
		<ul style="list-style-type: none"> ▪ Fan harness disconnected or damaged ▪ Fan blocked by an obstruction ▪ Fan damaged, defective

SC518	D	LCIT air assist rear fan error
		The rear air assist fan is not functioning properly.
		<ul style="list-style-type: none"> ▪ Fan harness disconnected or damaged ▪ Fan blocked by an obstruction ▪ Fan damaged, defective

SC530	D	Fusing unit exit fan error
		The VBCU did not receive the lock signal 5 seconds after the fusing unit fan switches on.
		<ul style="list-style-type: none"> ▪ Fan harness disconnected or damaged ▪ Fan blocked by an obstruction ▪ Fan damaged

SC531	C	Fusing fan error: Front
		The lock signal remained HIGH for 5 sec. while the fan at the front of the fusing unit near the heat dissipation fins was operating.
		<ul style="list-style-type: none"> ▪ Fan harness disconnected or damaged ▪ Fan blocked by an obstruction ▪ Fan damaged

SC532	D	Controller box fan error
		The lock signal remained HIGH for 5 sec. while the fan that cools the printed circuit boards was operating.
		<ul style="list-style-type: none"> ▪ Fan harness disconnected or damaged ▪ Fan blocked by an obstruction ▪ Fan damaged

SC533	B	Fusing unit intake fan error
		The lock signal remained HIGH for 5 sec. while the fan that draws air out of the fusing unit was operating.
		<ul style="list-style-type: none"> ▪ Fan harness disconnected, damaged ▪ Fan blocked by an obstruction ▪ Fan damaged

Appendix:
Service Call
Conditions

Service Call Tables

SC533-1	B	Fusing exit fan error
		The machine detected a fan lock signal 5 times at 1 sec. intervals. This indicates that the fan is not operating and the machine stops.
		<ul style="list-style-type: none"> ▪ Fan connection loose, broken, defective ▪ Fan is blocked by an obstruction ▪ Fan motor is defective

SC534	D	Duplex unit fan error
		A lock signal remained HIGH for 5 sec. while the front duplex fan motor or rear duplex fan motor was operating.
		<ul style="list-style-type: none"> ▪ Fan harness disconnected or damaged ▪ Fan blocked by an obstruction ▪ Fan damaged

SC535	D	Development intake fan error
		The lock signal remained HIGH for 5 sec. while the fan in the Y development unit was operating.
		<ul style="list-style-type: none"> ▪ Fan harness disconnected or damaged ▪ Fan blocked by an obstruction ▪ Fan damaged

SC536	D	Development Intake Fan Error: Y
SC537	D	Development Intake Fan Error: C
SC538	D	Development Intake Fan Error: M
SC539	D	Development Intake Fan Error: K
		The lock signal remained HIGH for 5 sec. while the fan in the development unit was operating.
		<ul style="list-style-type: none"> ▪ Fan harness disconnected or damaged ▪ Fan blocked by an obstruction ▪ Fan damaged

SC540	D	Fusing/exit motor error
		Motor operation was detected abnormal at power on.
		<ul style="list-style-type: none"> ▪ Check inside the fusing unit for any obstructions ▪ Motor harness loose, broken, defective ▪ Motor or its driver board defective

SC541	A	Heating roller thermistor (center) error 1
		The "floating" (non-contact) thermistor at the center of the heating roller is not operating correction.
		<ul style="list-style-type: none"> ▪ Thermistor harness connection loose, disconnected, defective ▪ Thermistor installed incorrectly ▪ Thermistor defective

SC543	A	Heating roller thermistor (center) error 2
		The thermistor at the center of the heating roller detected an abnormally high temperature (over 250°C)
		<ul style="list-style-type: none"> ▪ Do SP5810 to cancel the SC fusing code.

Service Call Tables

		<ul style="list-style-type: none"> ▪ TRIAC short, AC drive board defective ▪ VBCU defective
--	--	---

SC544	A	Heating roller thermistor (center) error 3
		The thermistor detected a temperature over 260°C.
		<ul style="list-style-type: none"> ▪ Do SP5810 to cancel the SC fusing code. ▪ TRIAC short, AC drive board defective ▪ VBCU defective

SC545	A	Lamp remains on
		After hot roller reaches warm-up temperature, the center fusing lamps in the heating roller remained on at full capacity after reaching the warm-up temperature while the hot roller was not rotating.
		<ul style="list-style-type: none"> ▪ Do SP5810 to cancel the SC fusing code. ▪ Heating roller thermistor damaged, or out of position ▪ Fusing lamp disconnected, broken

SC546	A	Heating roller thermistor error (side)
		The temperature measured by the heating roller thermistor does not reach 0°C after 50 sec. and remains over this temperature for 10 readings.
		<ul style="list-style-type: none"> ▪ Loose connection of the heating roller thermistor ▪ Defective heating roller thermistor

SC547	A	Zero cross error
		<p>When the main switch is turned on, the machine checks how many zero-cross signals are generated within 500 ms. This SC code is issued if the number of zero-cross signals detected is not within specification.</p> <p>Note: Zero cross signals, generated from an ac power supply, are used to generate a trigger pulses to control the applied power accurately.</p>
		<ul style="list-style-type: none"> ▪ Do SP5810 to cancel the SC fusing code. ▪ Electrical noise on the power supply line ▪ Fusing relay damaged, replace the AC drive board.

SC549	A	Heating roller thermistor (center): software error
		The thermistor detected a temperature over 250°C 10 times within 1 sec.
		<ul style="list-style-type: none"> ▪ Do SP5810 to cancel the SC fusing code. ▪ TRIAC short, AC drive board defective ▪ VBCU defective

SC550	A	Heating roller thermistor 3 (side): hardware error
		The thermistor detected a temperature over 260°C.
		<ul style="list-style-type: none"> ▪ Do SP5810 to cancel the SC fusing code. ▪ TRIAC short, AC drive board defective ▪ VBCU defective

Service Call Tables

SC551	A	Pressure roller thermistor error 1
		The temperature measured by the pressure roller thermistor did not reach 0°C after 10 attempts.
		<ul style="list-style-type: none"> ▪ Do SP5810 to cancel the SC fusing code. ▪ Loose connection of the pressure roller thermistor ▪ Thermistor positioned incorrectly ▪ Defective pressure roller thermistor

SC552	A	Pressure roller thermistor error 2
		After the main switch is turned on or the cover is closed, the heating roller temperature did not reach the ready temperature (45°C) within 80 sec. after the fusing lamp switches on.
		-or- If the fusing unit did not reach the reload temperature after 350 sec.
		<ul style="list-style-type: none"> ▪ Pressure roller thermistor harness loose, disconnected, defective ▪ Pressure roller thermistor defective

SC553	A	Pressure roller thermistor (software) error
		The thermistor detected a temperature over 220°C 12 times within 1 sec.
		<ul style="list-style-type: none"> ▪ Do SP5810 to cancel the SC fusing code. ▪ TRIAC short, AC drive board defective ▪ VBCU defective

SC554	A	Pressure roller thermistor (hardware) error
		The thermistor detected a temperature over 230°C.
		<ul style="list-style-type: none"> ▪ Do SP5810 to cancel the SC fusing code ▪ TRIAC short, AC drive board defective ▪ VBCU defective

SC555	A	Pressure roller fusing lamp remains on
		After hot roller reaches warm-up temperature, the pressure roller fusing lamp remained for 300 sec. while the hot roller is not rotating.
		<ul style="list-style-type: none"> ▪ Do SP5810 to cancel the SC fusing code. ▪ Thermistor damaged, or out of position ▪ Fusing lamp disconnected, broken

SC556	A	Heating roller fusing lamp error
		After hot roller reaches warmup temperature, the heating roller fusing lamp (ends) remains for 10 sec. while the hot roller is not rotating.
		<ul style="list-style-type: none"> ▪ Thermistor damaged, or out of position ▪ Fusing lamp disconnected, broken

SC557	A	Zero cross over error
		At power on the fusing relay was detected as defective.
		<ul style="list-style-type: none"> ▪ Replace the AC drive board.

SC559	A	Three successive paper jams in fusing unit
		This SC only occurs if SP1159 is on, and a jam occurred in the fusing unit for three consecutive sheets of paper. With SP1159 set to "1" the machine operation can be restored only by the service technician.
		The paper cooling job time sensor detected paper late for 3 counts.
		<ul style="list-style-type: none"> ▪ Remove the paper that is jammed in the fusing unit. ▪ Make sure that the fusing unit is clean and has no obstacles in the paper feed path.

Appendix:
Service Call
Conditions

Service Call Tables

SC561	A	Heating roller non-contact thermistor error 1
		The temperature measured by the heating roller thermistor (non-contact) on the end of the heating roller did not reach the prescribed warm-up temperature within 1 sec.
		<ul style="list-style-type: none"> ▪ Loose, broken, damaged connector ▪ Defective thermistor

SC562	A	Heating roller non-contact thermistor error 2
		After the main switch is turned on or the cover is closed, the heating roller temperature does not reach the ready temperature within 100 sec. after the heater switches on. -or- The heating roller did not reach the ready temperature within 150 sec.
		<ul style="list-style-type: none"> ▪ Note: Thermistor 2 stops monitoring the temperature when Thermistor 1 detects the ready temperature.
		<ul style="list-style-type: none"> ▪ Do SP5810 to cancel the SC fusing code ▪ Defective hot roller thermistor ▪ Heating roller disconnected, defective

SC563	A	Heating roller non-contact thermistor error 3
		The thermistor 2 (of the heating roller) detected a temperature over 250°C 10 times within 1 sec.
		<ul style="list-style-type: none"> ▪ Do SP5810 to cancel the SC fusing code. ▪ TRIAC short, AC drive board defective ▪ VBCU defective

SC564	A	Heating roller non-contact thermistor error 3
		The thermistor detected a temperature over 260°C.
		<ul style="list-style-type: none"> ▪ Do SP5810 to cancel the SC fusing code. ▪ TRIAC short, AC drive board defective ▪ VBCU defective

SC565	A	Heating roller fusing lamp on error
		After fusing belt reached warm-up temperature, the heating roller fusing lamp remained on for 20 sec. while the hot roller was not rotating.
		<ul style="list-style-type: none"> ▪ Do SP5810 to cancel the SC fusing code. ▪ Thermistor damaged, or out of position ▪ Fusing lamp disconnected, broken

SC566	A	Heating roller non-contact thermistor 3
		Thermistor detected a temperature less than 0 degrees more than three times.
		<ul style="list-style-type: none"> ▪ Do SP5810 to cancel the error. ▪ Hot roller thermistor connector disconnected, loose, broken, or defective.

SC569	D	Pressure roller lift error 2
		Pressure roller lift motor not operating correctly. (No signal to indicate completion of operation.)
		<ul style="list-style-type: none"> ▪ Pressure roller lift sensor connection loose, broken, damaged ▪ Clean the pressure roller lift sensor ▪ Pressure roller lift harness loose, broken, damage ▪ Pressure roller lift motor blocked by an obstruction ▪ Pressure roller lift motor defective

Appendix:
Service Call
Conditions

Service Call Tables

SC570	D	Development intake fan error
		Fan motor not operating correctly.
		<ul style="list-style-type: none"> ▪ Fan harness loose, broken, defective ▪ Fan overload due to physical obstruction ▪ Fan motor defective

SC571	B	Ozone exhaust fan (FC) error
		The fan of the middle ozone filter box not operating correctly.
		<ul style="list-style-type: none"> ▪ Fan harness loose, broken, defective ▪ Fan overload due to physical obstruction ▪ Fan motor defective

SC572	D	Ozone exhaust fan (K) error
		The fan of the lower ozone filter box not operating correctly.
		<ul style="list-style-type: none"> ▪ Fan harness loose, broken, defective ▪ Fan overload due to physical obstruction ▪ Fan motor defective

SC573	D	Ozone intake fan error
		The ozone filter intake fan not operating correctly.
		<ul style="list-style-type: none"> ▪ Fan harness loose, broken, defective ▪ Fan overload due to physical obstruction ▪ Fan motor defective

SC574	C	Y thermistor error
		The thermistor near the Y PCU has short circuited or otherwise not operating correctly.
		<ul style="list-style-type: none"> ▪ Harness loose, broken, defective ▪ Thermistor defective

SC585	C	Double-feed detection sensor error
		The ADC output value of the double-feed sensor LED was not within range (2 to 250).
		<ul style="list-style-type: none"> ▪ Sensors are covered with paper dust or other matter and require cleaning ▪ Sensor harness connection loose, broken, defective ▪ There is an obstruction between the emitter/receptor sensor pair. ▪ Sensors defective

SC599	B	Tray 1 lift motor error
		An error was detected in the operation of the lift motor for Tray 1 (tandem tray).
		<ul style="list-style-type: none"> ▪ Motor harness loose, broken, defective ▪ Motor overload due to an obstruction ▪ Motor defective

Appendix:
Service Call
Conditions

3.1.6 SC CODES GROUP 6: DEVICE COMMUNICATION

SC620	D	ADF communication error
		A BREAK signal occurs after the machine detects the ADF, or a communication timeout occurs.
		<ul style="list-style-type: none"> ▪ ADF board harness loose, broken, defective ▪ CNB board harness loose, broken, defective ▪ BCU board harness loose, broken, defective ▪ ADF defective ▪ CNB defective ▪ BCU defective

SC621	D	Mailbox-to-Finisher communication error
		Communication between the mailbox and finisher is interrupted. An ACK/NCK signal was not received within 100 ms after a data frame is sent and 3 retries failed.
		<ul style="list-style-type: none"> ▪ Connection cable between mailbox and finisher disconnected, defective ▪ Finisher main board defective ▪ VBCU defective ▪ PSU defective

SC622	D	PFB communication error
		Communication between the VBCU and PFB was interrupted. (Communication status is monitored at 30 ms intervals.)
		<ul style="list-style-type: none"> ▪ Connection cable between the VBCU and PFB is disconnected, defective ▪ VBCU defective ▪ PFB defective

SC624	D	Mailbox-to-copier communication error
		Communication between the mailbox and copier is interrupted. An ACK/NCK signal was not received within 100 ms after a data frame is sent and 3 retries failed.
		<ul style="list-style-type: none"> ▪ Mailbox cable disconnected, defective ▪ Mailbox main board defective ▪ VBCU defective ▪ PSU defective

SC625	D	VBCU-DTMB (DMC1) communication error
		Communication between the VBCU and DMC (main) was interrupted. An ACK/NAK signal was not received within 100 ms after a data frame was sent and three retries failed.
		<ul style="list-style-type: none"> ▪ Check the DTMB harness connections at the DTMB and VBCU ▪ DTMB defective ▪ PSU defective ▪ VBCU defective ▪ 5V power supply defective

SC626	D	VBCU-DTMB (DMC2) communication error
		Communication between the VBCU and DMC (sub) was interrupted. An ACK/NAK signal was not received within 100 ms after a data frame was sent and three retries failed.
		<ul style="list-style-type: none"> ▪ Check the DTMB harness connections at the DTMB and VBCU ▪ DTMB defective ▪ VBCU defective ▪ PSU defective

Appendix:
Service Call
Conditions

Service Call Tables

SC627	D	VBCU-DTMB (TMB) communication error
		Communication between the VBCU and TMC was interrupted. An ACK/NAK signal was not received within 100 ms after a data frame was sent and three retries failed.
		<ul style="list-style-type: none"> ▪ DTMB harness loose, broken, defective ▪ DTMB defective ▪ VBCU defective ▪ PSU defectiv

SC636-001	B	SD card error
		Expanded authentication module error
		<p>One or more of the following conditions exists:</p> <ul style="list-style-type: none"> ▪ There is no expanded authentication module in the machine. ▪ The SD card is damaged or the authentication module is corrupted. ▪ There is no DESS module in the machine.
		<ul style="list-style-type: none"> ▪ Install the correct SD card with the expanded module file. ▪ Install the DESS module.
SC636-002	B	Expanded authentication module version error
		The version of the expanded authentication module is incorrect.
		Install correct version of the expanded authentication module.

SC641	D	Engine-Controller Communication Error: No Response	GW
		There was no response to a frame sent from the controller board to the engine.	
		<ul style="list-style-type: none"> ▪ Cycle the machine off/on. 	

SC670	D	Engine start failure	GW
		The engine did not respond within 30s after power on, or the engine went down suddenly at power on or during warm up because a communication reset occurred between the VBCU and the controller.	
		<ul style="list-style-type: none"> ▪ VBCU installed incorrectly ▪ VBCU defective 	

SC671	D	Incorrect board detected	GW
		An illegal engine board was detected at power on.	
		<ul style="list-style-type: none"> ▪ Replace BICU 	

Appendix:
Service Call
Conditions

⇒ SC672	D	Controller-to-operation panel communication error at startup	
		<ul style="list-style-type: none"> • After the machine is powered on, the communication between the controller and the operation panel is not established, or communication with controller is interrupted after a normal startup. • After startup reset of the operation panel, the attention code or the attention acknowledge code is not sent from the controller within 15 seconds. • After the controller issues a command to check the communication line with the controller at 30-second intervals, the controller fails to respond twice. 	
		<ul style="list-style-type: none"> ▪ Controller stalled ▪ Controller board installed incorrectly ▪ Controller board defective ▪ Operation panel connector loose or defective ▪ The controller is not completely shutdown when you turn the main switch OFF. 	

SC687	D	PER (memory address) command error	
		The VBCU does not receive a memory address command from the controller 120 seconds after paper is in the position for registration.	
		<ul style="list-style-type: none"> ▪ Turn the machine power OFF/ON ▪ Check the controller board connections ▪ Controller defective 	

3.1.7 SC CODES GROUP 7: PERIPHERALS

SC701	D	ADF original pickup operation error
		Even though the pickup motor is rotating clock-wise, the pickup roller home position sensor cannot detect the position of the pickup roller.
		<ul style="list-style-type: none"> ▪ Pickup roller HP sensor harness loose, disconnected, defective ▪ Pickup roller HP sensor defective ▪ Pickup motor harness loose, disconnected, defective ▪ Pickup motor defective ▪ ADF control board defective

SC705	D	ADF bottom plate lift motor
		<p>The bottom plate HP sensor did not detect the home position of the bottom plate after the bottom plate lift motor switches on and lowers the bottom plate.</p> <p>The bottom plate position sensor does not detect the position of the plate after the lift motor switches on and raises the bottom plate.</p>
		<ul style="list-style-type: none"> ▪ ADF feed motor disconnected, defective ▪ Bottom plate HP sensor disconnected, defective ▪ ADF main board defective

SC720	C	Finisher lower transport motor error (D373/D374/B830)
		<p>No encoder pulse signal was detected for the transport motor within the prescribed time, or the motor did not attain the required speed within the prescribed time.</p> <p>The 1st failure causes a jam message, and the 2nd failure causes this SC code.</p>
		<ul style="list-style-type: none"> ▪ Lower transport motor harness, loose, broken ▪ Motor overload due to an obstruction

SC721	B	Finisher jogger motor error (D373/D374/B830)
		The jogger fences move out of the home position but the HP sensor output does not change within the specified number of pulses. The 1st failure causes an original jam message, and the 2nd failure causes this SC code.
		<ul style="list-style-type: none"> ▪ Jogger HP sensor disconnected, defective ▪ Jogger motor disconnected, defective ▪ Jogger motor overloaded due to obstruction ▪ Finisher main board and jogger motor connection loose, defective ▪ Finisher main board defective

SC723	B	Finisher feed-out motor (B830)
		The stack feed-out belt HP sensor does not activate within the specified time after the stack feed-out belt motor turns on. The 1st detection failure causes a jam error, and the 2nd failure causes this SC code.
		<ul style="list-style-type: none"> ▪ Stack feed-out HP sensor disconnected, defective ▪ Feed-out motor disconnected, defective ▪ Finisher main board connection to feed out motor disconnected, defective ▪ Motor overload due to obstruction

SC724	B	Finisher stapler hammer motor error (B830)
		Stapling does not finish within the prescribed time after the staple hammer motor turns on. The 1st detection failure causes a jam error, and the 2nd failure causes this SC code.
		<ul style="list-style-type: none"> ▪ Stapler hammer motor overloaded due to obstruction, jammed staple, number of sheets exceeds limit for stapling ▪ Stapler hammer motor disconnected, defective ▪ Staple hammer motor HP sensor disconnected, defective

Appendix:
Service Call
Conditions

Service Call Tables

SC725	B	Finisher exit guide plate motor error (D373/D374, B830)
		After moving away from the guide plate position sensor, the exit guide is not detected at the home position within the prescribed time. The 1st detection failure causes a jam error, and the 2nd failure causes this SC code.
		<ul style="list-style-type: none"> ▪ Guide plate motor disconnected, defective ▪ Guide plate motor overloaded due to obstruction ▪ Guide plate position sensor disconnected, defective

SC726	B	Shift jogger motor 1 error (D373/D374, B830)
		The side fences do not retract within the prescribed time after the shift jogger motor switches on. The 1st detection failure causes a jam error, and the 2nd failure causes this SC code.
		<ul style="list-style-type: none"> ▪ Shift jogger motor disconnected, defective ▪ Shift jogger motor overloaded due to obstruction ▪ Shift jogger HP sensor disconnected, defective

SC727	B	Shift jogger motor 2 error (D373/D374)
		The side fences do not retract within the prescribed time after the shift jogger motor switches on. The 1st detection failure causes a jam error, and the 2nd failure causes this SC code.
		<ul style="list-style-type: none"> ▪ Motor harness disconnected, loose, defective ▪ Motor defective ▪ Motor overload ▪ HP defective

SC728	B	Shift jogger retraction motor error (D373/D374)
		The side fences do not retract within the prescribed time after the retraction motor switches on. The 1st detection failure causes a jam error, and the 2nd failure causes this SC code.
		<ul style="list-style-type: none"> ▪ Motor harness disconnected, loose, defective ▪ Motor defective ▪ Motor overload ▪ HP defective

SC730	B	Transport motor error (B830)
		No pulse signal was detected for the transport motor within the prescribed time, or the shift roller HP sensor of the upper tray did not activate within the prescribed time after the shift tray starts to move toward or away from the home position. The 1st failure causes a jam error, and the 2nd failure causes this SC code.
		<ul style="list-style-type: none"> ▪ Motor harness loose, broken, defective ▪ Motor overload due to an obstruction ▪ Shift tray HP sensor of the upper tray disconnected, defective ▪ Motor defective ▪ Sensor defective

SC731	B	Upper Transport Motor Error (Proof Tray): B830
		No encoder pulse signal is detected for the upper transport motor within 600 ms. The 1st failure causes this SC code.
		<ul style="list-style-type: none"> ▪ Upper transport motor disconnected, defective ▪ Finisher connection to upper transport motor loose, defective ▪ Upper transport motor blocked by an obstruction ▪ Upper transport motor defective ▪ Finisher main board defective

Appendix:
Service Call
Conditions

Service Call Tables

SC732	B	Shift Tray Exit Motor: 3K Finisher B830
		The shift tray exit motor is not operating.
		<ul style="list-style-type: none"> ▪ Motor harness loose, broken, defective ▪ Motor is blocked by an obstruction ▪ Motor defective ▪ Finisher main control board defective

SC733	B	Stapler Exit Motor: B830
		The stapler exit motor is not operating.
		<ul style="list-style-type: none"> ▪ Motor harness loose, broken, defective ▪ Motor is blocked by an obstruction ▪ Motor defective ▪ Finisher main control board defective

SC734	B	Upper Tray Junction Gate Motor: 3K Finisher B830
		<p>The upper tray junction gate HP sensor did not detect the gate at the home position within 200 ms after two attempts.</p> <p>-or-</p> <p>The HP sensor twice detected the gate at the home position for more than 200 ms after it was supposed to open.</p>
		<ul style="list-style-type: none"> ▪ Junction gate did not arrive at the home position within the specified time ▪ Junction gate did not leave the home position within the specified time

SC735	D	Staple Junction Gate Motor Error: B830
		The staple tray junction gate HP sensor did not detect the gate at the home position within 200 ms after two attempts. -or- The HP sensor twice detected the gate at the home position for more than 200 ms after it was supposed to open.
		<ul style="list-style-type: none"> ▪ Junction gate did not arrive at the home position within the specified time ▪ Junction gate did not leave the home position within the specified time

SC736	B	Pre-Stack Junction Gate Motor Error: 3K Finisher B830
		The pre-stack junction gate HP sensor did not detect the gate at the home position for within 200 ms after two attempts. -or- The HP sensor twice detected the gate at the home position for more than 200 ms after it was supposed to open.
		<ul style="list-style-type: none"> ▪ Junction gate did not arrive at the home position within the specified time ▪ Junction gate did not leave the home position within the specified time

SC737	B	Pre-Stack Transport Motor Error: B830
		The pre-stack transport motor is not operating.
		<ul style="list-style-type: none"> ▪ Motor harness loose, broken, defective ▪ Motor is blocked by an obstruction ▪ Motor defective ▪ Finisher main control board defective

Appendix:
Service Call
Conditions

Service Call Tables

SC738	B	Pre-Stack Junction Gate Release Motor Error: B830
		The pre-stack junction gate release HP sensor did not detect the gate at the home position within 200 ms after two attempts. -or- The HP sensor twice detected the gate at the home position for more than 200 ms after it was supposed to open.
		<ul style="list-style-type: none"> ▪ Junction gate did not arrive at the home position within the specified time ▪ Junction gate did not leave the home position within the specified time

SC740	B	Finisher corner stapler motor error (D373/D374, B830)
		The stapler motor does not switch off within the prescribed time after operating. The 1st detection failure causes a jam error, and the 2nd failure causes this SC code.
		<ul style="list-style-type: none"> ▪ Staple jam ▪ Number of sheets in the stack exceeds the limit for stapling ▪ Stapler motor disconnected, defective

SC741	B	Finisher corner stapler rotation motor error (D373/D374)
		The stapler does not return to its home position within the specified time after stapling. The 1st detection failure causes a jam error, and the 2nd failure causes this SC code.
		<ul style="list-style-type: none"> ▪ Stapler rotation motor disconnected, defective ▪ Stapler rotation motor overloaded due to obstruction ▪ Stapler rotation HP sensor disconnected, defective

SC742	B	Finisher stapler movement motor error (D373/D374)
		The stapler HP sensor is not activated within the specified time after the stapler motor turned on. The 1st detection failure causes a jam error, and the 2nd failure causes this SC code.
		<ul style="list-style-type: none"> ▪ Stapler movement motor disconnected, defective ▪ Stapler movement motor overloaded due to obstruction ▪ Stapler HP sensor disconnected, defective

SC743	B	Booklet stapler motor error 1 (D373)
		The front stapler unit saddle-stitch motor does not start operation within the specified time. The 1st detection failure causes a jam error, and the 2nd failure causes this SC code.
		<ul style="list-style-type: none"> ▪ Front motor disconnected, defective ▪ Front motor overloaded due to obstruction

SC744	B	Booklet stapler motor error 2 (D373)
		The rear stapler unit saddle-stitch motor does not start operation within the specified time. The 1st detection failure causes a jam error, and the 2nd failure causes this SC code.
		<ul style="list-style-type: none"> ▪ Rear motor disconnected, defective ▪ Rear motor overloaded due to obstruction

Service Call Tables

SC745	B	Feed-Out Belt Motor Error (D373/D374, B830)
		The stack feed-out belt HP sensor does not activate within the specified time after the stack feed-out belt motor turns on. The 1st detection failure causes a jam error, and the 2nd failure causes this SC code.
		<p>If the motor is operating</p> <ul style="list-style-type: none"> ▪ Stack feed-out HP sensor harness loose, broken, defective ▪ Stack feed-out HP sensor defective <p>If the motor is not operating:</p> <ul style="list-style-type: none"> ▪ Feed-out motor blocked by an obstruction ▪ Feed-out motor harness loose, broken, defective ▪ Feed-out motor defective ▪ Booklet finisher main board defective

SC746	B	Stack Plate Motor Error 1: Front Motor (B830)
		The stack plate HP sensor (front) does not activate within 500 ms after the motor turns on. The 1st detection failure causes a jam error, and the 2nd failure causes this SC code.
		<p>If the motor is operating</p> <ul style="list-style-type: none"> ▪ Front stack plate HP sensor harness loose, broken, defective ▪ Front stack plate HP sensor defective <p>If the motor is not operating:</p> <ul style="list-style-type: none"> ▪ Motor blocked by an obstruction ▪ Motor harness loose, broken, defective ▪ Motor defective ▪ Booklet finisher main board defective

SC747	B	Stack Plate Motor Error 2: Center Motor (B830)
		The stack plate HP sensor (center) does not activate within 500 ms after the motor turns on. The 1st detection failure causes a jam error, and the 2nd failure causes this SC code.
		<p>If the motor is operating</p> <ul style="list-style-type: none"> ▪ Center stack plate HP sensor harness loose, broken, defective ▪ Center stack plate HP sensor defective <p>If the motor is not operating:</p> <ul style="list-style-type: none"> ▪ Motor blocked by an obstruction ▪ Motor harness loose, broken, defective ▪ Motor defective ▪ Booklet finisher main board defective

Appendix:
Service Call
Conditions

SC748	B	Stack Plate Motor Error 3: Rear Motor (B830)
		The stack plate HP sensor (rear) does not activate within 500 ms after the motor turns on. The 1st detection failure causes a jam error, and the 2nd failure causes this SC code.
		<p>If the motor is operating</p> <ul style="list-style-type: none"> ▪ Rear stack plate HP sensor harness loose, broken, defective ▪ Rear stack plate HP sensor defective <p>If the motor is not operating:</p> <ul style="list-style-type: none"> ▪ Motor blocked by an obstruction ▪ Motor harness loose, broken, defective ▪ Motor defective ▪ Booklet finisher main board defective

Service Call Tables

SC750	B	Finisher tray 1 (upper tray lift) motor error (D373/D374)
		The upper tray paper height sensor does not change its status with the specified time after the tray raises or lowers. The 1st detection failure causes a jam error, and the 2nd failure causes this SC code.
		<ul style="list-style-type: none"> ▪ Tray lift motor disconnected, defective ▪ Upper tray paper height sensor disconnected, defective ▪ Finisher main board connection to motor loose ▪ Finisher main board defective

SC753	B	Stacking Roller Motor Error (D373/D374, B830)
		<p>The return drive HP sensor did not detect the stacking roller at the HP sensor within 1 sec.</p> <p>-or-</p> <p>The stacking roller did not leave the home position at the specified time.</p>
		<p>If the motor is operating</p> <ul style="list-style-type: none"> ▪ Return drive HP sensor harness loose, broken, defective ▪ Return drive HP sensor defective <p>If the motor is not operating:</p> <ul style="list-style-type: none"> ▪ Motor blocked by an obstruction ▪ Motor harness loose, broken, defective ▪ Motor defective ▪ Finisher main board defective

SC754	B	Stacking Roller Drag Motor Error (D373/D374, B830)
		The stacking roller drag motor did not turn on.
		<ul style="list-style-type: none"> ▪ Motor harness loose, broken, defective ▪ Motor defective ▪ Finisher control board defective

SC755	B	Shift Motor Error: 3K Finisher (D373/D374, B830)
		<p>The shift tray half-turn sensors: Failed twice to detect the shift tray at the home position at the specified time.</p> <p>-or-</p> <p>Failed twice to detect that the shift tray had left the home position.</p>
		<p>If the motor is operating</p> <ul style="list-style-type: none"> ▪ Half-turn sensor 1, 2 harnesses loose, broken, defective ▪ One of the half-turn sensors defective <p>If the motor is not operating:</p> <ul style="list-style-type: none"> ▪ Motor blocked by an obstruction ▪ Motor harness loose, broken, defective ▪ Motor defective ▪ Finisher main board defective

Appendix:
Service Call
Conditions

SC760	D	Finisher punch motor error (D373/D374, B830)
		The punch HP sensor is not activated within the specified time after the punch motor turned on. The 1st detection failure causes a jam error, and the 2nd failure causes this SC code.
		<ul style="list-style-type: none"> ▪ Punch HP sensor disconnected, defective ▪ Punch motor disconnected, defective ▪ Punch motor overload due to obstruction

SC761	B	Finisher folder plate motor error (D373)
		The folder plate moves but is not detected at the home position within the specified time. The 1st detection failure causes a jam error, and the 2nd failure causes this SC code.
		<ul style="list-style-type: none"> ▪ Folder plate HP sensor disconnected, defective ▪ Folder plate motor disconnected, defective ▪ Folder plate motor overloaded due to obstruction.

Service Call Tables

SC763	D	Punch movement motor error (D373/D374)
		Occurs during operation of the punch unit. The 1st detection failure causes a jam error, and the 2nd failure causes this SC code.
		<ul style="list-style-type: none"> ▪ Motor harness disconnected, loose, defective ▪ Motor defective

SC764	D	Paper position sensor slide motor error (D373/D374)
		Occurs during operation of the punch unit. The 1st detection failure causes a jam error, and the 2nd failure causes this SC code.
		<ul style="list-style-type: none"> ▪ Motor harness disconnected, loose, defective ▪ Motor defective

SC765	B	Fold Unit Bottom Fence Lift Motor Error (D373)
		The fold unit bottom fence did not return to the home position within the specified time.
		<ul style="list-style-type: none"> ▪ Fold bottom fence mechanism overloaded due to an obstruction ▪ Fold bottom fence HP sensor connector loose, broken, defective ▪ Fold bottom fence HP sensor defective ▪ Fold bottom fence lift motor connector loose, broken, defective ▪ Fold bottom fence lift motor defective ▪ Main control board defective

SC766	B	Clamp Roller Retraction Motor (D373)
		The clamp roller did not return to the home position within the specified time.
		<ul style="list-style-type: none"> ▪ Clamp roller mechanism overloaded due to an obstruction ▪ Clamp roller HP sensor connector loose, broken, defective ▪ Clamp roller HP sensor defective ▪ Clamp roller retraction motor connector loose, broken, defective ▪ Clamp roller retraction motor defective ▪ Main control board defective

SC767	B	Stack Junction Gate Motor (D373)
		The stack junction gate did not return to the home position within the specified time.
		<ul style="list-style-type: none"> ▪ Stack junction mechanism overloaded due to an obstruction ▪ Stack junction gate HP sensor connector loose, broken, defective ▪ Stack junction gate HP sensor defective ▪ Stack junction gate motor connector loose, broken, defective ▪ Stack junction gate motor defective ▪ Main control board defective

Appendix:
Service Call
Conditions

Service Call Tables

SC770	B	Cover Interposer Lift Motor 1 Error
		<p>In the first tray:</p> <ul style="list-style-type: none"> ▪ The upper limit sensor did not detect the bottom plate within the specified time after the lift motor switched on to lift the bottom plate. ▪ The lower limit sensor did not direct the bottom plate within the specified time after the lift motor switched on to lower the bottom plate. <p>Note: In both cases, 1 error count indicates a jam, 2 error counts cause this SC code.</p>
		<ul style="list-style-type: none"> ▪ Lift motor, upper limit sensor, lower limit sensor harnesses, connectors loose, broken, defective ▪ Lift motor defective ▪ Upper limit sensor defective ▪ Lower limit sensor defective

SC771	B	Cover Interposer Lift Motor 2 Error
		<p>In the second tray:</p> <ul style="list-style-type: none"> ▪ The upper limit sensor did not detect the bottom plate within the specified time after the lift motor switched on to lift the bottom plate. ▪ The lower limit sensor did not direct the bottom plate within the specified time after the lift motor switched on to lower the bottom plate. <p>Note: In both cases, 1 error count indicates a jam, 2 error counts cause this SC code.</p>
		<ul style="list-style-type: none"> ▪ Lift motor, upper limit sensor, lower limit sensor harnesses, connectors loose, broken, defective ▪ Lift motor defective ▪ Upper limit sensor defective ▪ Lower limit sensor defective

SC772	B	Cover Interposer Pickup Motor 1 Error
		<p>In the first tray:</p> <ul style="list-style-type: none"> ▪ While the pick-up roller motor was on, the pick-up roller HP sensor did not detect the pick-up roller at the home position within the specified number of pulses. ▪ While the pick-up roller motor was on, the pick-up roller HP sensor did not detect the pick-up roller at the home position above the specified number of pulses. <p>Note: In both cases, 1 error count indicates a jam, 2 error counts cause this SC code.</p>
		<ul style="list-style-type: none"> ▪ The pick-up motor, pick-up roller HP sensor harnesses, connectors were loose, broken, defective ▪ Pick-up motor overload due to an obstruction ▪ Pick-up motor defective ▪ Pick-up roller HP sensor defective

SC773	B	Cover Interposer Pickup Motor 2 Error
		<p>In the second tray:</p> <ul style="list-style-type: none"> ▪ While the pick-up roller motor was on, the pick-up roller HP sensor did not detect the pick-up roller at the home position within the specified number of pulses. ▪ While the pick-up roller motor was on, the pick-up roller HP sensor did not detect the pick-up roller at the home position above the specified number of pulses. <p>Note: In both cases, 1 error count indicates a jam, 2 error counts cause this SC code.</p>
		<ul style="list-style-type: none"> ▪ The pick-up motor, pick-up roller HP sensor harnesses, connectors were loose, broken, defective ▪ Pick-up motor overload due to an obstruction ▪ Pick-up motor defective ▪ Pick-up roller HP sensor defective

Service Call Tables

SC775	B	Jogger Top Fence Motor: 3K Finisher B830
		<p>The top fence HP sensor detected that: The top fence did not arrive at the home position within the specified number of pulses. -or- The top fence failed to leave the home position within the specified number of pulses.</p>
		<p>If the jogger top fence motor is operating:</p> <ul style="list-style-type: none"> ▪ Top fence HP sensor harness loose, broken, defective ▪ Top fence HP sensor defective <p>If the jogger top fence motor is not operating:</p> <ul style="list-style-type: none"> ▪ Motor blocked by an obstruction ▪ Motor harness loose, broken, defective ▪ Motor defective ▪ Finisher main board defective

SC776	B	Jogger Bottom Fence Motor (B830)
		<p>The bottom fence HP sensor detected that: The bottom fence did not arrive at the home position at the specified time. -or- The bottom fence failed to leave the home position at the specified time.</p>
		<p>If the jogger bottom fence motor is operating:</p> <ul style="list-style-type: none"> ▪ Bottom fence HP sensor harness loose, broken, defective ▪ Bottom fence HP sensor defective <p>If the jogger bottom fence motor is not operating:</p> <ul style="list-style-type: none"> ▪ Motor blocked by an obstruction ▪ Motor harness loose, broken, defective ▪ Motor defective ▪ Finisher main board defective

SC778-1	D	Horizontal Transport Motor Error	Multi Folder (D454)
		The motor drive PCB detected an error at the motor.	
		<ul style="list-style-type: none"> ▪ Motor harness or connector loose, broken, defective ▪ Motor or motor drive board defective 	

SC778-2	D	Top Tray Exit Motor	Multi Folder (D454)
		The motor drive PCB detected an error at the motor.	
		<ul style="list-style-type: none"> ▪ Motor harness or connector loose, broken, defective ▪ Motor or motor drive board defective 	

SC778-3	D	Top Tray JG Motor	Multi Folder (D454)
		The top tray JG HP sensor did not detect the top tray junction gate at (or out of) its home position. The 1st occurrence causes a jam, and the 2nd occurrence causes this SC code.	
		<ul style="list-style-type: none"> ▪ Top tray JG HP sensor dirty ▪ Sensor harness or connector loose, broken, defective ▪ Top tray JG motor harness or connector loose, broken, defective ▪ Sensor defective ▪ Motor or motor drive board defective 	

Appendix:
Service Call
Conditions

Service Call Tables

SC778-4	D	Entrance JG Motor	Multi Folder (D454)
		The entrance junction gate HP sensor did not detect the entrance junction gate at (or out of) its home position. The 1st occurrence causes a jam, and the 2nd occurrence causes this SC code.	
		<ul style="list-style-type: none"> ▪ Entrance JG HP sensor dirty ▪ Sensor harness or connector loose, broken, defective ▪ Entrance JG motor harness or connector loose, broken, defective ▪ Sensor defective ▪ Motor or motor drive board defective 	

SC779	B	1st Stopper Motor Error	Multi Folder (D454)
		The 1st stopper HP sensor did not detect the 1st stopper in (or out of) its home position within the prescribed time. The 1st occurrence causes a jam, and the 2nd occurrence causes this SC code.	
		<ul style="list-style-type: none"> ▪ 1st stopper HP sensor dirty ▪ Sensor harness or connector loose, broken, defective ▪ 1st stopper motor harness or connector loose, broken, defective ▪ Sensor defective ▪ Motor or motor drive board defective 	

SC780	B	Z-Fold Feed Motor Error Japan Only	
		The feed motor that drives the feed rollers and exit rollers in the Z-fold unit is not operating. The 1st alert signals a jam, the 2nd alert triggers this SC.	
		<ul style="list-style-type: none"> ▪ Motor harness loose, broken, defective ▪ Motor blocked by an obstruction ▪ Motor defective 	

SC781	B	Z-Fold Lower Stopper Motor Error Japan Only	
		<p>The lower stopper failed to leave the home position with the specified number of motor pulses.</p> <p>Note: The 1st detection failure causes a jam error, and the 2nd failure causes this SC code.</p>	
		<ul style="list-style-type: none"> ▪ Lower stopper motor disconnected, defective ▪ Lower stopper motor overloaded due to obstruction ▪ Lower stopper HP sensor disconnected, defective 	

SC782	B	Z-fold Upper Stopper Motor Japan Only	
		<p>The upper stopper failed to leave the home position with the specified number of motor pulses.</p> <p>Note: The 1st detection failure causes a jam error, and the 2nd failure causes this SC code.</p>	
		<ul style="list-style-type: none"> ▪ Upper stopper motor disconnected, defective ▪ Upper stopper motor overloaded due to obstruction ▪ Upper stopper HP sensor disconnected, defective 	

SC783-1	B	2nd Stopper Motor Error	Multi Folder (D454)
		<p>The 2nd stopper HP sensor did not detect the 2nd stopper in (or out of) its home position within the prescribed time. The 1st occurrence causes a jam, and the 2nd occurrence causes this SC code.</p>	
		<ul style="list-style-type: none"> ▪ 2nd stopper HP sensor dirty ▪ Sensor harness or connector loose, broken, defective ▪ 2nd stopper motor harness or connector loose, broken, defective ▪ Sensor defective ▪ Motor or motor drive board defective 	

Service Call Tables

SC783-2	B	3rd Stopper Motor Error	Multi Folder (D454)
		The 3rd stopper HP sensor did not detect the 3rd stopper in (or out of) its home position within the prescribed time. The 1st occurrence causes a jam, and the 2nd occurrence causes this SC code.	
		<ul style="list-style-type: none"> ▪ 3rd stopper HP sensor dirty ▪ Sensor harness or connector loose, broken, defective ▪ 3rd stopper motor harness or connector loose, broken, defective ▪ Sensor defective ▪ Motor or motor drive board defective 	

SC783-3	B	1st Fold Motor Error	Multi Folder (D454)
		The motor drive PCB detected an error at the motor.	
		<ul style="list-style-type: none"> ▪ Motor harness or connector loose, broken, defective ▪ Motor or motor drive board defective 	

SC783-4	B	2nd Fold Motor Error	Multi Folder (D454)
		The motor drive PCB detected an error at the motor.	
		<ul style="list-style-type: none"> ▪ Motor harness or connector loose, broken, defective ▪ Motor or motor drive board defective 	

SC783-5	B	Crease Motor Error	Multi Folder (D454)
		The motor drive PCB detected an error at the motor.	
		<ul style="list-style-type: none"> ▪ Motor harness or connector loose, broken, defective ▪ Motor or motor drive board defective 	

SC783-6	B	Dynamic Roller Transport Motor Error	Multi Folder (D454)
		The motor drive PCB detected an error at the motor.	
		<ul style="list-style-type: none"> ▪ Motor harness or connector loose, broken, defective ▪ Motor or motor drive board defective 	

SC783-7	B	Reg. Roller Transport Motor Error	Multi Folder (D454)
		The motor drive PCB detected an error at the motor.	
		<ul style="list-style-type: none"> ▪ Motor harness or connector loose, broken, defective ▪ Motor or motor drive board defective 	

SC783-8	B	Dynamic Roller Lift Motor Error	Multi Folder (D454)
		The dynamic roller HP sensor did not detect the dynamic roller in (or out of) its home position within the prescribed time. The 1st occurrence causes a jam, and the 2nd occurrence causes this SC code.	
		<ul style="list-style-type: none"> ▪ Dynamic roller HP sensor dirty ▪ Sensor harness or connector loose, broken, defective ▪ Dynamic roller lift motor harness or connector loose, broken, defective ▪ Sensor defective ▪ Motor or motor drive board defective 	

Appendix:
Service Call
Conditions

Service Call Tables

SC783-9	B	Registration Roller Release Motor Error	Multi Folder (D454)
		The registration roller HP sensor did not detect the registration roller in (or out of) its home position within the prescribed time. The 1st occurrence causes a jam, and the 2nd occurrence causes this SC code.	
		<ul style="list-style-type: none"> ▪ Registration roller HP sensor dirty ▪ Sensor harness or connector loose, broken, defective ▪ Registration roller release motor harness or connector loose, broken, defective ▪ Sensor defective ▪ Motor or motor drive board defective 	

SC783-10	B	Fold Plate Motor Error	Multi Folder (D454)
		The fold plate HP sensor did not detect the fold plate in (or out of) its home position within the prescribed time. The 1st occurrence causes a jam, and the 2nd occurrence causes this SC code.	
		<ul style="list-style-type: none"> ▪ Fold plate HP sensor dirty ▪ Sensor harness or connector loose, broken, defective ▪ Fold plate motor harness or connector loose, broken, defective ▪ Sensor defective ▪ Motor or motor drive board defective 	

SC783-11	B	Jogger Fence Motor	Multi Folder (D454)
		The jogger fence HP sensor did not detect the jogger fence in (or out of) its home position within the prescribed time. The 1st occurrence causes a jam, and the 2nd occurrence causes this SC code.	
		<ul style="list-style-type: none"> ▪ Jogger fence HP sensor dirty ▪ Sensor harness or connector loose, broken, defective ▪ Jogger fence motor harness or connector loose, broken, defective ▪ Sensor defective ▪ Motor or motor drive board defective 	

SC783-12	B	Positioning Roller Motor Error	Multi Folder (D454)
		The positioning roller HP sensor did not detect the positioning roller in (or out of) its home position within the prescribed time. The 1st occurrence causes a jam, and the 2nd occurrence causes this SC code.	
		<ul style="list-style-type: none"> ▪ Positioning roller HP sensor dirty ▪ Sensor harness or connector loose, broken, defective ▪ Positioning roller motor harness or connector loose, broken, defective ▪ Sensor defective ▪ Motor or motor drive board defective 	

Appendix:
Service Call
Conditions

Service Call Tables

SC783-13	B	FM2 Direct-Send JG Motor	Multi Folder (D454)
		The direct-send JG HP sensor did not detect the direct-send JG in (or out of) its home position within the prescribed time. The 1st occurrence causes a jam, and the 2nd occurrence causes this SC code.	
		<ul style="list-style-type: none"> ▪ FM2 direct-send JG HP sensor dirty ▪ Sensor harness or connector loose, broken, defective ▪ FM2 direct-send JG motor harness or connector loose, broken, defective ▪ Sensor defective ▪ Motor or motor drive board defective 	

SC783-14	B	FM6 Pawl Motor	Multi Folder (D454)
		The FM6 pawl HP sensor did not detect the FM6 pawl in (or out of) its home position. The 1st occurrence causes a jam, and the 2nd occurrence causes this SC code.	
		<ul style="list-style-type: none"> ▪ FM6 pawl HP sensor dirty ▪ Sensor harness or connector loose, broken, defective ▪ FM6 pawl motor harness or connector loose, broken, defective ▪ Sensor defective ▪ Motor or motor drive board defective 	

SC784	B	Z-Fold Timing Sensor Adjustment Error 1 Japan Only	
		The output voltage light emitted from the sensor changed, but the return input was not sufficient to attain V0.	
		<ul style="list-style-type: none"> ▪ Sensor, mirror dirty from paper dust, other particles ▪ Harness loose, broken, defective ▪ Mirror out of position 	

SC785	B	Z-Fold Timing Sensor Adjustment Error 2 Japan Only	
		The output voltage light emitted from the sensor changed, but the return input was not sufficient to attain V0.	
		<ul style="list-style-type: none"> ▪ Sensor, mirror dirty from paper dust, other particles ▪ Harness loose, broken, defective ▪ Mirror out of position 	

SC786	B	Z-Fold Memory Error Japan Only	
		Several attempts to write to the Z-fold memory failed.	
		<ul style="list-style-type: none"> ▪ Turn the machine power off/on ▪ EEPROM on Z-Folder main board defective 	

SC789	B	Proof Tray Exit Motor Error	Multi Folder (D454)
		The motor drive PCB detected an error at the motor due to overload, overheating. Paper cannot exit at proof tray.	
		<ul style="list-style-type: none"> ▪ Motor, motor drive board defective 	

Important: The S792-** SC Codes apply to the Ring Binder D392.

Service Call Tables

SC792-1	B	Junction gate error
		<p>Detected at HP after the time prescribed to leave the HP had elapsed (more than 36 pulses) (1 detection, jam, twice detected, SC error)</p> <p>-or-</p> <p>Not detected at HP after the time prescribed to arrive at the HP had elapsed (more than 22 pulses) (1 detection, jam, twice detected, SC error)</p>
		<ul style="list-style-type: none"> ▪ Path JG motor (M201) defective ▪ Motor connector loose, broken, defective ▪ Motor overload ▪ Path JG sensor (S203) connector loose, broken, defective ▪ Sensor (S203) defective

SC 792-2	B	Pre-punch side fence HP error
		<p>Detected at HP after the time prescribed to leave the HP had elapsed (more than 400 pulses) (1st detection, jam, 2nd detection, SC error)</p> <p>-or-</p> <p>Not detected at HP after the time prescribed to arrive at the HP had elapsed (more than 600 pulses) (1st detection, jam, 2nd detection, SC error)</p>
		<ul style="list-style-type: none"> ▪ Side jogger motor (M302) connector loose, broken, defective ▪ Motor overload ▪ Motor defective ▪ Pre-punch jogger HP sensor (S301) connector loose, broken, defective ▪ Sensor (S301) defective

SC792-3	B	Pre-punch jogger roller HP error
		<p>Detected at HP after the time prescribed to leave the HP had elapsed (more than 36 pulses) (1st detection, jam, 2nd detection, SC error)</p> <p>-or-</p> <p>Not detected at HP after the time prescribed to arrive at the HP had elapsed (more than 22 pulses) (1st detection, jam, 2nd detection, SC error)</p>
		<ul style="list-style-type: none"> ▪ Jog roller lift motor (M305) connector loose, broken, defective ▪ Motor overload ▪ Motor defective ▪ Jog roller lift HP sensor (S309) connector loose, broken, defective ▪ Sensor defective

Appendix:
Service Call
Conditions

SC792-4	B	Punch defective
		<p>One or more of the following occurred:</p> <ul style="list-style-type: none"> ▪ Punch unit not detected at initialization. ▪ No motor rotation detected at HP at 30 ms after the DC motor turned on ▪ No encoder pulse detected at HP at 5 ms after the DC motor turned on ▪ Not detected at HP at 400 ms after the DC motor turned on
		<ul style="list-style-type: none"> ▪ Punch motor (M304) connector loose, broken, defective ▪ Motor overload ▪ Motor defective ▪ Punch HP sensor (S302) connector loose, broken, defective, or sensor defective ▪ Punch encoder sensor (S303) connector loose, broken, defective, or sensor defective

Service Call Tables

SC792-5	B	Paddle roller HP error
		Not detected at HP after the time prescribed to arrive at the HP had elapsed (more than 400 ms) (1st detection, jam, 2nd detection, SC error) -or- Detected at HP after the time prescribed to leave the HP had elapsed (more than 400 ms) (1st detection, jam, 2nd detection, SC error)
		<ul style="list-style-type: none"> ▪ Paddle roller lift motor (M603) connector loose, broken, defective ▪ Motor overload ▪ Motor defective ▪ Paddle roller HP sensor (S602) connector loose, broken, defective ▪ Sensor defective

SC792-6	B	Jogger fence 1 error
		Not detected at HP after the time prescribed to arrive at the HP had elapsed (more than 400 ms) (1st detection, jam, 2nd detection, SC error) -or- Detected at HP after the time prescribed to leave the HP had elapsed (more than 400 ms) (1st detection, jam, 2nd detection, SC error)
		<ul style="list-style-type: none"> ▪ Jog fence 1 motor (M604) connector, loose, broken, defective ▪ Motor defective ▪ Motor overload ▪ Side fence 1 HP sensor (S601) connector, loose, broken, defective ▪ Sensor defective

SC792-7	B	Jogger fence 2 error
		Not detected at HP after the time prescribed to arrive at the HP had elapsed (more than 400 ms) (1st detection, jam, 2nd detection, SC error) -or- Detected at HP after the time prescribed to leave the HP had elapsed (more than 400 ms) (1st detection, jam, 2nd detection, SC error)
		<ul style="list-style-type: none"> ▪ Jog fence 2 motor (M606) connector, loose, broken, defective ▪ Motor defective ▪ Motor overload ▪ Side fence HP sensor 1 (S611) connector loose, broken, defective ▪ Sensor defective

SC792-8	B	Stack tamper HP error
		Not detected at HP after the time prescribed to arrive at the HP had elapsed (more than 400 ms) (1st detection, jam, 2nd detection, SC error) -or- Detected at HP after the time prescribed to leave the HP had elapsed (more than 400 ms) (1st detection, jam, 2nd detection, SC error)
		<ul style="list-style-type: none"> ▪ Stack tamper motor (M607) connector, loose, broken, defective ▪ Motor defective ▪ Motor overload ▪ Stack tamper HP sensor (S612) connector loose, broken, defective ▪ Sensor defective

Appendix:
Service Call
Conditions

Service Call Tables

SC792-9	B	Pre-bind jogger clamp HP error
		Not detected at HP after the time prescribed to arrive at the HP had elapsed (more than 400 ms) (1st detection, jam, 2nd detection, SC error) -or- Detected at HP after the time prescribed to leave the HP had elapsed (more than 400 ms) (1st detection, jam, 2nd detection, SC error)
		<ul style="list-style-type: none"> ▪ Spine clamp motor (M605) connector loose, broken, defective ▪ Motor defective ▪ Motor overload ▪ Clamp HP sensor (S603) connector loose, broken, defective ▪ Sensor defective

SC792-10	B	Binder unit runout error
		Not detected at HP after the time prescribed to arrive at the HP had elapsed (more than 400 ms) (1st detection, jam, 2nd detection, SC error) -or- Detected at HP after the time prescribed to leave the HP had elapsed (more than 400 ms) (1st detection, jam, 2nd detection, SC error)
		<ul style="list-style-type: none"> ▪ Runout press roller motor (M610) connector loose, broken, defective ▪ Motor defective ▪ Motor overload ▪ Runout roller HP sensor (S614) connector loose, broken, defective ▪ Sensor defective

SC792-11	B	Clamp thickness error
		50-sheet detection sensor (S606) went OFF during pre-bind jogging when a 100-sheet thickness was detected. (1st detection jam, 2nd detection SC error) -or- 50-sheet detection sensor went OFF at initialization when the clamp moved to the open position.
		<ul style="list-style-type: none"> ▪ 50-sheet detection sensor (S606) connector loose, broken, defective ▪ Sensor defective

SC792-12	B	Alignment pin error
		Not detected at HP after the time prescribed to arrive at the HP had elapsed (more than 400 ms) (1st detection, jam, 2nd detection, SC error) -or- Detected at HP after the time prescribed to leave the HP had elapsed (more than 400 ms) (1st detection, jam, 2nd detection, SC error)
		<ul style="list-style-type: none"> ▪ Alignment pin motor (M602) connector loose, broken, defective ▪ Motor overload ▪ Motor defective ▪ Alignment pin HP sensor (S604) connector loose, broken, defective ▪ Sensor defective

Appendix:
Service Call
Conditions

Service Call Tables

SC792-13	B	Pre-bind jogger shutter error
		Not detected at HP after the time prescribed to arrive at the HP had elapsed (more than 400 ms) (1st detection, jam, 2nd detection, SC error) -or- Detected at HP after the time prescribed to leave the HP had elapsed (more than 400 ms) (1st detection, jam, 2nd detection, SC error)
		<ul style="list-style-type: none"> ▪ Shutter motor (M608) connector loose, broken, defective ▪ Motor overload ▪ Motor defective ▪ Shutter HP sensor (S605) connector loose, broken, defective ▪ Sensor defective

792-14	B	50/100 clamp adjustment error
		Not detected at HP after the time prescribed to arrive at the HP had elapsed (more than 400 ms) (1st detection, jam, 2nd detection, SC error) -or- Detected at HP after the time prescribed to leave the HP had elapsed (more than 400 ms) (1st detection, jam, 2nd detection, SC error)
		<ul style="list-style-type: none"> ▪ 50/100 adjustment motor (M702) connector loose, broken, defective ▪ Motor overload ▪ Motor defective ▪ Ring switch HP sensor (S706) connector loose, broken, defective, or sensor defective ▪ Ring switch timing sensor (S707) connector loose, broken, defective, or sensor defective

SC792-15	B	Timing sensor interval error
		The bind timing sensor (S702) remained ON or OFF longer than the prescribed time (1500 ms) during initialization or ring binding (1st detection: jam, 2nd detection: SC error)
		<ul style="list-style-type: none"> ▪ Clamp unit motor (M701) connector loose, broken, defective ▪ Motor overload ▪ Motor defective ▪ Bind timing sensor (S702) connector loose, broken, defective ▪ Sensor defective

SC792-16	B	Clamp unit HP error
		At initialization or during ring binding, did not arrive at the home position within the prescribed time (1500 ms) (1st detection: jam, 2nd detection: SC error) -or- Detected at HP after the time prescribed to leave the HP had elapsed (more than 1500 ms) (1st detection, jam, 2nd detection, SC error)
		<ul style="list-style-type: none"> ▪ Clamp unit motor (M701) connector loose, broken, defective ▪ Motor overload ▪ Motor defective ▪ Clamp unit HP sensor (S701) connector loose, broken, defective ▪ Sensor defective

Appendix:
Service Call
Conditions

Service Call Tables

SC792-17	B	Spine alignment error
		During pin alignment operation, the pin did not reach the up position or return to the home position with the prescribed time (400 ms), and one retry failed within the same time limit.
		<ul style="list-style-type: none"> ▪ Alignment pin motor (M602) connector loose, broken, defective ▪ Motor overload ▪ Motor defective ▪ Alignment pin HP sensor (S604) connector loose, broken, defective, or sensor defective ▪ Alignment pin up sensor (S610) connector loose, broken, defective, or sensor defective ▪ Stack not jogged correctly, or not punched correctly

SC792-18	B	Binder unit not detected
		The binder unit could not be detected at initialization.
		<ul style="list-style-type: none"> ▪ Drawer connector loose, broken, defective ▪ Drawer connector defective

792-19	B	Output belt unit rotation error
		<p>Detected at HP after the time prescribed to leave the HP had elapsed (more than 800 pulses) (1st detection, jam, 2nd detection, SC error)</p> <p>-or-</p> <p>Not detected at HP after the time prescribed to arrive at the HP had elapsed (more than 2300 pulses) (1st detection, jam, 2nd detection, SC error)</p>
		<ul style="list-style-type: none"> ▪ Output belt rotation motor (M403) connector loose, broken, defective ▪ Motor overload ▪ Motor defective ▪ Output belt rotation HP sensor (S403) connector loose, broken, defective ▪ Sensor defective

SC792-20	B	Output belt 1 HP error
		<p>Detected at HP after the time prescribed to leave the HP had elapsed (more than 200 pulses) (1st detection, jam, 2nd detection, SC error)</p> <p>-or-</p> <p>Not detected at HP after the time prescribed to arrive at the HP had elapsed (more than 2125 pulses) (1st detection, jam, 2nd detection, SC error)</p>
		<ul style="list-style-type: none"> ▪ Output belt 1 motor (M401) connector loose, broken, defective ▪ Motor overload ▪ Motor defective ▪ Output belt 1 HP sensor (S401) connector loose, broken, defective ▪ Sensor defective

Appendix:
Service Call
Conditions

Service Call Tables

SC792-21	B	Output belt 2 HP error
		<p>Detected at HP after the time prescribed to leave the HP had elapsed (more than 200 pulses) (1st detection, jam, 2nd detection, SC error)</p> <p>-or-</p> <p>Not detected at HP after the time prescribed to arrive at the HP had elapsed (more than 3130 pulses) (1st detection, jam, 2nd detection, SC error)</p>
		<ul style="list-style-type: none"> ▪ Output belt 2 motor (M402) connector loose, broken, defective ▪ Motor overload ▪ Motor defective ▪ Output belt 2 HP sensor (S402) connector loose, broken, defective ▪ Sensor defective

SC792-22	B	Stack height error
		<p>Stack height sensor remained ON while moving toward the top.</p> <p>-or-</p> <p>The sensor did not go ON within 6 sec. after the motor turned on.</p>
		<ul style="list-style-type: none"> ▪ Stacker motor (M501) connector loose, broken, defective ▪ Motor overload ▪ Stack height sensor (S502) connector loose, broken, defective ▪ Sensor defective

SC792-23	B	Stacker error
		<p>Although the stacker was full at the start and end of stacker operation with the stacker full (stacker sensors ON together), no documents were detected (also when documents were leaning) -or- Although the stacker was detected full with the stacker stopped, no documents were detected within 2 sec. (1st detection jam, 2nd detection SC error)</p>
		<ul style="list-style-type: none"> ▪ Stacker HP sensor (S501) connector loose, broken, defective, or sensor defective ▪ Stacker height HP sensor (S502) connector loose, broken, defective, or sensor defective ▪ Stacker detect sensor (S504) loose, broken, defective, or sensor defective

Appendix:
Service Call
Conditions

3.1.8 SC CODES GROUP 8: OVERALL SYSTEM

SC816	D	Energy save I/O subsystem error		GW	
		An error was detected in the signal from the ASIC (controller board) which controls the STR (Suspend to RAM) function. Note: STR is a feature of this machine that minimizes energy consumption while the machine is in the energy saver mode.			
		<ul style="list-style-type: none"> ▪ Reboot the machine. ▪ Replace the controller board. 			
		SC816-5	SCS		
			Machine attempted to enter STR mode before engine was OFF.		
		SC816-39	Sub System		
			Error occurred during system start up.		
		SC816-50	Hardware		
			Printer version only. Not used for this machine.		
		SC816-67	NCS (Network Control Service)		
An error occurred in the access control port list: <ul style="list-style-type: none"> ▪ Number of registrations exceeded 125 ▪ Data notifications exceeded 12 ▪ Data extension incorrect 					
SC816-79	Sub System				
	Message mismatch.				
SC816-90	Hardware/System				
	A forced system reset (WDOG) occurred.				

SC819	D	Fatal kernel error		GW	
		Due to a control error, a RAM overflow occurred during system processing. One of the following messages was displayed on the operation panel.			
		<ul style="list-style-type: none"> ▪ System program defective ▪ Controller board defective ▪ Optional board defective ▪ Replace controller firmware 			
		0x5032	HAIC-P2 decompression error		
			Error occurred in the compression/decompression module of ASIC Veena in HAIC-P2. If EFI (Fiery Controller) is connected, refer to the EFI manual. If EFI is not connected: <ul style="list-style-type: none"> ▪ HDD defective ▪ System memory defective 		
		0x6261	HDD Defective		
			There was no response from HDD. The power supply to the HDD may have been interrupted suddenly. <ul style="list-style-type: none"> ▪ Re-format HDD. ▪ Replace HDD 		
		554C	USB loader defect		
			USB loader was detected as defective.		

Appendix:
Service Call
Conditions

Note: For more details about this SC code error, execute SP5990 to print an SMC report so you can read the error code list. The error code is not displayed on the operation panel.

Service Call Tables

SC 820	D	0008	Self-diagnostic Error: CPU: System Call Exception	GW
		0612	Self-diagnostic Error: CPU: ASIC Interrupt Error	GW
		<ul style="list-style-type: none"> ▪ System program defective ▪ Controller board defective ▪ Optional board defective ▪ Replace controller firmware <p>Note: For more details about this SC code error, execute SP5990 to print an SMC report so you can read the error code. The error code is not displayed on the operation panel.</p>		

SC833	D	Self-diagnostic error 8: Engine I/F ASIC *GW		GW
0F30 0F31		ASIC (Mandolin) for system control could not be detected. After the PCI configuration, the device ID for the ASIC could not be checked.		
		<ul style="list-style-type: none"> ▪ Replace the VBCU 		
0F41		The read/write check done for resident RAM on the mother board could not be done correctly.		
		<ul style="list-style-type: none"> ▪ Replace the VBCU. 		
50B1		Could not initialize or read the bus connection.		
		<ul style="list-style-type: none"> ▪ Check for loose connections at VBCU. ▪ Replace VBCU 		
50B2		Value of the SSCG register is incorrect.		
		<ul style="list-style-type: none"> ▪ Check for loose connections at VBCU. ▪ Replace VBCU 		

SC853	B	Wireless LAN Error 1	GW
		During machine start-up, the machine can access the board that holds the wireless LAN (Bluetooth), but not access the wireless LAN card.	
		<ul style="list-style-type: none"> ▪ Wireless LAN card missing (was removed) 	

SC854	B	Wireless LAN Error 2	GW
		The board that holds the wireless LAN card (Bluetooth) could be accessed, but the wireless LAN card could not be accessed while the machine was operating.	
		<ul style="list-style-type: none"> ▪ Wireless LAN card has been removed. 	

SC855	B	Wireless LAN Error 3	GW
		An error was detected for the wireless LAN card (802.11b or Bluetooth).	
		<ul style="list-style-type: none"> ▪ Wireless card not installed correctly. ▪ Wireless LAN card defective 	

SC856	B	Wireless LAN Error 4	GW
		An error was detected for the wireless LAN board (Bluetooth).	
		<ul style="list-style-type: none"> ▪ Wireless LAN card board defective. ▪ PCI connector loose, broken, defective. 	

SC857	B	USB I/F Error	GW
		The USB driver is unstable and generated an error.	
		<ul style="list-style-type: none"> ▪ USB board defective ▪ Controller board defective 	

Appendix:
Service Call
Conditions

Service Call Tables

SC858	A	Data Encryption Error 1	GW
		These are errors of the HDD Data Encryption Option D377.	
	0	Key Acquisition	
		Key could be acquired. <ul style="list-style-type: none"> ▪ Replace the controller board 	
	1	HDD Key Setting Error	
		The key was acquired but the HDD could not be set. <ul style="list-style-type: none"> ▪ Turn the machine power off/on several times. ▪ Replace the controller board. 	
	2	NVRAM Read Error	
		NVRAM data conversion failed (mismatch with nvram.conf) <ul style="list-style-type: none"> ▪ Replace the NVRAM 	
	30	NVRAM Before Replace Error	
		DFU. May occur during development. <ul style="list-style-type: none"> ▪ Turn the machine power off/on several times. ▪ Replace the controller board. 	
	31	Other Error	
		An unexpected error occurred while data was being converted. This error is the same as SC991. See SC991 below.	

SC859	B	Data Encryption Error 2	GW
		These are errors of the HDD Data Encryption Option D377.	
	8	HDD Check Error	
		Data conversion was attempted with no HDD unit present. <ul style="list-style-type: none"> ▪ Confirm that HDD unit installed correctly ▪ Initialize HDD with SP5832-1 Note: After installation, a new HDD should be formatted with SP5832-1	
	9	Power Loss During Data Conversion	
		Data conversion stopped before NVRAM/HDD data was converted. Format HDD with SP5832-1	
	10	Data Read Command Error	
		More than two illegal DMAC communications were returned. <ul style="list-style-type: none"> ▪ HDD defective ▪ Format HDD with SP5832-1 Replace HDD	

SC860	B	HDD startup error at power on	GW
		HDD is connected but a driver error is detected, or the driver did not respond with the status of the HDD within 30 s.	
		<ul style="list-style-type: none"> ▪ HDD is not initialized ▪ Level data is corrupted ▪ HDD is defective (attempt to initialize the HDD with SP5832-001) 	

Appendix:
Service Call
Conditions

Service Call Tables

SC861	D	HDD re-try failure	GW
		At power on with the HDD detected, power supply to the HDD is interrupted, after the HDD is awakened from the sleep mode, the HDD is not ready within 30 s.	
		<ul style="list-style-type: none"> ▪ Harness between HDD and board disconnected, defective ▪ HDD power connector disconnected ▪ HDD defective ▪ Controller board defective 	

SC863	D	HDD data read failure	GW
		The data written to the HDD cannot be read normally, due to bad sectors generated during operation.	
		<ul style="list-style-type: none"> ▪ HDD defective <p>Note: If the bad sectors are generated at the image partition, the bad sector information is written to NVRAM, and the next time the HDD is accessed, these bad sectors will not be accessed for read/write operation.</p>	

SC864	D	HDD data CRC error	GW
		During HDD operation, the HDD cannot respond to an CRC error query. Data transfer did not execute normally while data was being written to the HDD.	
		<ul style="list-style-type: none"> ▪ HDD defective 	

SC865	D	HDD access error	GW
		HDD responded to an error during operation for a condition other than those for SC863, 864.	
		<ul style="list-style-type: none"> ▪ HDD defective. 	

SC866	B	SD card error 1: Confirmation	GW
		<p>The machine detected an electronic license error in the application on the SD card in the controller slot immediately after the machine was turned on.</p> <p>Note:</p> <ul style="list-style-type: none"> ▪ The program on the SD card contains electronic confirmation license data. ▪ If the program does not contain this license data, or if the result of the check shows that the license data in the program on the SD card is incorrect, then the checked program cannot execute and this SC code is displayed. 	
		<ul style="list-style-type: none"> ▪ Program missing from the SD card ▪ Download the correct program for the machine to the SD card 	

SC867	D	SD card error 2: SD card removed	GW
		The SD card was removed while the machine is on.	
		<ul style="list-style-type: none"> ▪ Insert the SD card. ▪ Turn the machine off and on. 	

Appendix:
Service Call
Conditions

Service Call Tables

SC868	D	SD card error 3: SD card access	GW
		An error occurred while an SD card was in use.	
		<ul style="list-style-type: none"> ▪ SD card not inserted correctly ▪ SD card defective ▪ Controller board defective <p>Note: You can try to reformat the SD with the SD Formatter Ver. 1.1</p>	

SC870	B	Address book data error	GW
		The address book data cannot be read from the HDD or SD card where it is stored, or the data read from the media is defective.	
		<ul style="list-style-type: none"> ▪ Cycle the machine off/on. ▪ Software defective. ▪ Replace controller firmware. ▪ HDD defective. 	
		<p>More Details</p> <ul style="list-style-type: none"> ▪ Do SP5846-50 to reset all address book data. ▪ Reset the user information with SP5832-6. ▪ Replace the HDDs. 	

SC872	B	HDD mail receive data error	GW
		An HDD error was detected immediately after power on, or the machine detected that the HDD was not operating correctly (data read or write) while receiving mail. The HDD may be defective or the machine was accidentally powered off while the HDD was being accessed.	
		<ul style="list-style-type: none"> ▪ Reformat the mail RX data on the HDD with SP5832-7 ▪ Replace the HDD 	

SC873	B	HDD mail send data error	GW
		An error was detected on the HDD immediately after the machine was turned on, or power was turned of while the machine was using the HDD.	
		<ul style="list-style-type: none"> ▪ Do SP5832-007 (Format HDD – Mail TX Data) to initialize the HDD. ▪ Replace the HDD. 	

SC874	D	Delete All error 1: HDD	GW
		A data error was detected for the HDD/NVRAM after the Delete All option was used. Note: The source of this error is the Data Overwrite Security Unit running from an SD card.	
		<ul style="list-style-type: none"> ▪ Turn the main switch off/on and try the operation again. ▪ Install the Data Overwrite Security Unit again.. ▪ HDD defective 	

SC875	D	Delete All error 2: Data area	GW
		An error occurred while the machine deleted data from the HDD. Note: The source of this error is the Data Overwrite Security Unit D377 running from an SD card.	
		<ul style="list-style-type: none"> ▪ Cycle the machine off/on. ▪ Try the operation again. 	

Service Call Tables

SC876	D	Log data errors		GW
		876-1	Log data error 1	
			An error was detected in the handling of the log data at power on or during machine operation. This can be caused by switching the machine off while it is operating.	
			<ul style="list-style-type: none"> ▪ Initialize the HDD with SP5832-4 	
		876-2	Log data error 2	
			HDD encryption unit not installed.	
			<ul style="list-style-type: none"> ▪ Install the HDD encryption unit. 	
		876-3	Log data error 3	
			Invalid log encryption key due to defective NVRAM data.	
			<ul style="list-style-type: none"> ▪ Initialize the HDD with SP5832-4 ▪ Request customer's system administrator to disable HDD encryption with the User Tool. 	
		876-4	Log data error 4	
			Erratic HDD encryption due to defective NVRAM data.	
			<ul style="list-style-type: none"> ▪ Initialize HDD with SP5832-4 	
		876-5	Log data error 5	
			<ul style="list-style-type: none"> ▪ Re-install the previous NVRAM or HDD. ▪ Initialize the HDD with SP5832-4. 	
876-99	Log data error 6			
	An error other than Log Data Errors 1 to 5 occurred.			
	<ul style="list-style-type: none"> ▪ Request assistance from your supervisor. 			

SC877	B	Data Overwrite Security SD card error	GW
		An error occurred, preventing successful execution of the Data Overwrite Security function, even though it has been set up and enabled.	
		<ul style="list-style-type: none"> ▪ DOS card is not inserted completely into the SD card slot ▪ DOS card has been removed from the SD card slot. ▪ DOS card is damaged. <p>Note:</p> <ul style="list-style-type: none"> ▪ If the SD card has been removed (or was not installed correctly), switch the machine off, insert the SD card, then switch on the machine again. ▪ If the SD card has been damaged, procure a new SD card, replace the NVRAM, then do the DOS option installation. 	

SC878	D	TPM authentication error	GW
		The system firmware could not be authenticated by the TMP security chip.	
		<ul style="list-style-type: none"> ▪ System firmware updated incorrectly. ▪ Flash ROM on controller board defective. ▪ Replace controller board. 	

SC880		File format converter (MLB) error	GW
		No response within the prescribed time to a request to access the MLB.	
		<ul style="list-style-type: none"> ▪ MLB defective ▪ Replace MLB 	

Appendix:
Service Call
Conditions

Service Call Tables

SC881	D	Management area error	GW
		This is a software error than can occur:	
		<ul style="list-style-type: none"> ▪ At login ▪ When a print job was received ▪ When WEB browser was opened 	
		<ul style="list-style-type: none"> ▪ Cycle the machine off/on. 	

SC899	D	Software error	GW
		A software error occurred in the GW controller.	
		<ul style="list-style-type: none"> ▪ Cycle the machine off/on ▪ Update controller firmware ▪ Controller board defective 	

3.1.9 SC CODES GROUP 9: MISCELLANEOUS

SC900	D	Electrical total counter error	GW
		The total counter contains data that is not a number.	
		<ul style="list-style-type: none"> ▪ NVRAM incorrect type ▪ NVRAM defective or corrupted ▪ Unexpected error from external source 	

SC901	D	Mechanical Counter 1 error	
		Mechanical Counter 1 was not set correctly at power on, or the operator disconnected the counter while machine was operating.	
		<ul style="list-style-type: none"> ▪ Mechanical Counter 1 connection loose or defective ▪ Mechanical Counter 1 defective 	

SC902	D	Mechanical Counter 2 error	
		Mechanical Counter 2 was not set correctly at power on, or the operator disconnected the counter while machine was operating.	
		<ul style="list-style-type: none"> ▪ Mechanical Counter 2 connection loose or defective ▪ Mechanical Counter 2 defective 	

SC920	B	Printer Error 1	GW
		An internal application error was detected and operation cannot continue.	
		<ul style="list-style-type: none"> ▪ Software defective, switch off/on, or change the controller firmware ▪ Insufficient memory 	

Service Call Tables

SC921	D	Printer Error 2: Font error	GW
		When the printer application started, the specified font could not be found on the SD card.	
		<ul style="list-style-type: none"> ▪ The specified font is not on the SD card ▪ SD card data corrupted 	

SC925	B	Net File function error *GW	
		<p>The NetFile file management on the HDD cannot be used, or a NetFile management file is corrupted and operation cannot continue. The HDDs are defective and they cannot be debugged or partitioned, so the Scan Router functions (delivery of received faxes, document capture, etc.), Web services, and other network functions cannot be used.</p> <p>HDD status codes are displayed below the SC code:</p>	
		<ul style="list-style-type: none"> ▪ Refer to the four procedures below (Recovery from SC 925). 	

Here is a list of HDD status codes:

Display	Meaning
(-1)	HDD not connected
(-2)	HDD not ready
(-3)	No label
(-4)	Partition type incorrect
(-5)	Error returned during label read or check
(-6)	Error returned during label read or check
(-7)	“filesystem” repair failed
(-8)	“filesystem” mount failed
(-9)	Drive does not answer command
(-10)	Internal kernel error
(-11)	Size of drive is too small
(-12)	Specified partition does not exist
(-13)	Device file does not exist

Recovery from SC 925

Procedure 1

If the machine shows SC codes for HDD errors (SC860 to SC865) with SC 925, do the recovery procedures for SC860 to SC865.

Procedure 2

1. If the machine does not show one of the five HDD errors (SC860 to SC865), turn the machine power off and on.
2. If this is not the solution for the problem, then initialize the NetFile partition on the HDD with SP5832-11 (HDD Formatting – Ridoc I/F).

NetFiles: These are jobs printed from the document server using a PC and DeskTopBinder. Before you initialize the NetFile partition on the HDD, tell the customer:

Service Call Tables

- Received faxes on the delivery server will be erased
 - All captured documents will be erased
 - DeskTopBinder/Print Job Manager/Desk Top Editor job history will be erased
 - Documents on the document server, and scanned documents, will not be erased.
 - The first time that the network gets access to the machine, the management information must be configured again (this will use a lot of time).
3. Before you initialize the Netfile partition with SP5832-11, do these steps:
 4. Go into the User Tools mode and do “Delivery Settings” to print all received fax documents that are scheduled for delivery. Then erase them.
 5. In the User Tools mode, do Document Management> Batch Delete Transfer Documents.
 6. Do SP5832-11, then turn the machine power off and on.

Procedure 3

1. If “Procedure 2” is not the solution for the problem, do SP5832-1 (HDD Formatting – All)
2. Cycle the machine off/on.

★ Important

- SP5832-001 erases all document and address book data on the hard disks. Consult with the customer before you do this SP code.

Procedure 4

If “Procedure 3” does not solve the problem, replace the HDD.

SC990	D	Software error 1	GW
		An unexpected operation was encountered by the software.	
		<ul style="list-style-type: none"> ▪ Software crash, reboot the machine ▪ If the HDDs have just been replaced, be sure to download the stamp data (SP 5853). ▪ With SP5990 004(SMC Report – Logging Data), print the most recent information for SC990. ▪ The SC990 information displays the file name, line number, and value. Report this information to your technical supervisor. For example: Funciton.c LINE: 123 VAL: 0 	

SC991	C	Software Error 2	GW
		The software performed an unexpected function and the program cannot continue. Recovery processing allows the program to continue.	
		<ul style="list-style-type: none"> ▪ Software defective, re-boot 	

In order to get more details about SC991:

1. Execute SP7403 or print an SMC Report (SP5990) to read the history of the 10 most recent logged errors.
2. If you press the zero key on the operation panel with the SP selection menu displayed, you will see detailed information about the recently logged SC991, including the software file name, line number, and so on. Of these two methods, 1) is the recommended method, because another SC could write over the information for the previous SC.

Appendix:
Service Call
Conditions

SC992	D	Undefined Error (No SC Code)	GW
		An error not controlled by the system occurred (the error does not come under any other SC code).	
		<ul style="list-style-type: none"> ▪ Software defective ▪ Turn the machine power off and on. The machine cannot be used until this error is corrected. ▪ Re-install firmware 	

SC997	B	Application selection error 1	GW
		An application did not start after pressing the appropriate key on the operation panel.	
		<ul style="list-style-type: none"> ▪ Software bug (change the firmware for the application that failed) ▪ A RAM or DIMM option required by the application is not installed or not installed correctly. 	

Service Call Tables

SC998	D	Application selection error 2	GW
		Register processing did not execute for an application within 60 s after the machine was switched on. No applications start correctly, and all end abnormally.	
		<ul style="list-style-type: none"> ▪ Software bug (change the firmware for the application that failed) ▪ A RAM or DIMM option required by the application is not installed or not installed correctly. 	

3.1.10 ADDITIONAL SC CODES PRINTED IN SMC REPORTS

These codes are also used in the SMC report. Codes that have the same number in this series are identified by an additional 4-digit hexadecimal number.

SC No.	Symptom	Possible Cause	
SC853	D	IEEE802 11b card startup error	
		Not used.	
SC854	D	IEEE802 11b card access error	
		Not used.	
SC855	D	IEEE802 11b card error	
		Not used.	
SC856	D	IEEE802 11b card connection board error	
		Not used.	
SC870	B	Address book data error	
		The address book in the hard disk is accessed. → An error is detected in the address book data; address book data is not read; or data is not written into the address book.	<ul style="list-style-type: none"> ▪ Data corruption ▪ Defective hard disk ▪ Defective software
		<p>To recover from the error, do any of the following countermeasures:</p> <ul style="list-style-type: none"> ▪ Format the address book by using SP5-832-8. All data in the address book (including the user codes and counters) is initialized) ▪ Initialize the user data by using SP5-832-6 and -7 (the user codes and counters are recovered when the main 	

Service Call Tables

		switch is turned on). Replace the hard disk (the user codes and counters are recovered when the main switch is turned on).
--	--	---

SC920	D	Printer error	
		The printer program cannot be continued.	<ul style="list-style-type: none"> ▪ Defective hardware ▪ Data corruption ▪ Defective software
SC925	D	Net file error	
		The management file for net files is corrupted; net files are not normally read. Netfiles: Jobs to be printed from the document server using a PC and the DeskTopBinder software	<ul style="list-style-type: none"> ▪ Defective hardware ▪ Data corruption ▪ Defective software
SC992	C	Other system SCs	
		The controller received an unknown SC code from the engine.	<ul style="list-style-type: none"> ▪ Contact your product specialist.
SC993	D	Network error	
		The ASIC program of GW controller cannot be continued.	<ul style="list-style-type: none"> ▪ Defective GW controller

APPENDIX:

SERVICE PROGRAM

MODE TABLES

REVISION HISTORY		
Page	Date	Added/Updated/New
11	03/16/2011	Removed SP1109 (High Adhesion Mode)
48	04/26/2010	Added NOTE to SP2-222-001
174	5/10/2011	SP5227-202
180	2/9/2012	SP5420 User Authentication
188	09/14/2010	Added reference to Section 4.11.1 Copier Input Check
189	09/14/2010	Added reference to Section 4.11.2 Copier Output Check
307	08/10/2010	SP7504-146
316	10/13/2011	Added NOTE to SP7509
400	12/28/2010	Added BitSwitch 9 Bit 4
400 ~ 403	1/10/2011	BitSwitch 9 Bit 4
407 ~ 422	09/14/2010	Added Copier Input/Output Check sections

4. APPENDIX: SERVICE PROGRAM MODE

TABLES

4.1 SERVICE PROGRAM MODE

Notation	What it means
[range/step]	Example: [-9 to +9/0.1 mm] The default setting can be adjusted in 0.1mm steps in the range ± 9 . Note: The default setting for each SP mode is shown on the screen in the "Initial" box immediately below the entry box.
DFU	Denotes "Design or Factory Use". Do not change this value.
Japan Only	The feature or item is for Japan only. Do not change this value.
LEF	Long Edge Feed
SEF	Short Edge Feed
Fin1	2000/3000-Sheet Finisher D373/D374
Fin2	3000-Sheet Finisher B830
Fin3	Japan Only. Please ignore.
Fin4	Ring Binder D392

4.2 GROUP 1000

1001	Lead Edge Reg
	Adjusts the printing leading edge registration using the trimming area pattern (SP2109-2, Pattern No. 10). [-9 to +9/ 0.1 mm] Specification: 3 ±2mm

1002	Fine Adj LEdge (Thick)	
	Fine adjusts leading edge registration for thick paper (Thick 2, Thick 3). [-9 to +9/ 0.1 mm]	
1	Thick 2	Thick 2: 164 to 249.9 g/m ²
2	Thick 3	Thick 3: 250 to 300 g/m ²

1003	Side-to-Side Reg	
	Side-to-Side Registration Adjustment. Adjusts printing side-to-side registration for each feed station, using the test pattern (SP2109-2, Pattern No. 10). These SP's should be adjusted after replacing the laser synchronization detector or the laser optical unit.	
1	Tray 1	[-9 to +9/ 0.1 mm]
2	Tray 2	
3	Tray 3	
4	Tray 4	Japan Only
5	Bypass Tray	
6	Dupx Tray	

7	LCT	LCT1: B473
8	WIDE LCT	LCT2: D350

1004	Reg Buckle Adj	
	Registration Buckle Adjustment. Adjusts the registration motor timing. This timing determines the amount of paper buckle at registration. (A higher setting causes more buckling.)	
1	Trays & LCT	[-9 to +9/1 mm]
2	Dupx Tray	
3	Bypass Tray	

1005	Reg Buckle Adj (Thick)	
	Registration Buckle Adjustment (Thick Paper) Adjusts the registration motor timing for thick paper only. This timing determines the amount of paper buckle at registration. (A higher setting causes more buckling.)	
1	Thick 2	Thick 2: 164 to 249.9 g/m ²
2	Thick 3	Thick 3: 250 to 300 g/m ²

1006	Bypass Size Disp	
	Bypass Paper Size Detection Display. Use this SP to display and confirm the size of the paper detected in the by-pass tray if paper is skewing during feeding. [0 to 255/1 mm]	

Group 1000

1007	Duplex Fence Adj	
	Duplex Side Fence Position Adjustment. Allows fine adjustment of the distance between the edges of the sheet and the jogger fences when the fences come together to position the sheet in the duplex unit. [-3 to +3/0.1 mm]	

1008	Reg Roller Adj	
	Sets the length of time the paper is force pre-fed and stopped at the registration roller for normal speed and half-speed.	
1	Half Speed 2	[-3 to +3/ 0 /0.1
2	Half Speed 1	[-3 to +3/ -0.6 /0.1

1009	PreFeed Time Adj	
	Sets the length of time the paper is force pre-fed and stopped at the registration roller for each paper feed source.. [0 to 3/ 0 / 1]	
1	Tray 1	
2	Tray 2	
3	Tray 3	
4	Tray 4	
5	LCT 1	
6	LCT 2	
7	Bypass Tray	

1010	Fine Adj Mtr Speed DFU	
	These SP codes are used to fine adjust the speed of the motors. [-3 to 3/-0.3/0.1	
1	Drum Motor:K	
2	Drum Motor:M	
3	Drum Motor:C	
4	Drum Motor:Y	
5	K Dev Motor: Norm2	
6	M Dev Motor: Norm2	
7	C Dev Motor: Norm2	
8	Y Dev Motor: Norm2	
9	K Drum CL Mtr: Norm2	
10	M Drum CL Mtr: Norm2	
11	C Drum CL Mtr: Norm2	
12	Y Drum CL Mtr: Norm2	
13	ITB Motor: Norm2	
14	PTR Motor: Norm2	
15	Fusing Motor: Norm2	

Appendix:
Service
Program
Mode Table

Group 1000

1011	Motor Adj.: Norm 1 DFU	
	These SP codes are used to adjust the speed of the motors for Normal speed 1.. [-3 to 3/0/0.1	
5	K Dev Motor	
6	M Dev Motor	
7	C Dev Motor	
8	Y Dev Motor	
9	K Drum CL Mtr	
10	M Drum CL Mtr	
11	C Drum CL Mtr	
12	Y Drum CL Mtr	
13	ITB Motor	
14	PTR Motor	
15	Fusing Motor	

1012	Mtr Adj.: Half 2 DFU	
	These SP codes are used to adjust the speed of the motors for Half speed 2. [-3 to 3/0/0.1	
5	K Dev Motor	
6	M Dev Motor	
7	C Dev Motor	
8	Y Dev Motor	
9	K Drum CL Mtr	
10	M Drum CL Mtr	

11	C Drum CL Mtr	
12	Y Drum CL Mtr	
13	ITB Motor	
14	PTR Motor	
15	Fusing Motor	

1013	Motor Adj.: Half 1 DFU	
	These SP codes are used to adjust the speed of the motors for Half speed 1. [-3 to 3/0/0.1	
5	K Dev Motor	
6	M Dev Motor	
7	C Dev Motor	
8	Y Dev Motor	
9	K Drum CL Mtr	
10	M Drum CL Mtr	
11	C Drum CL Mtr	
12	Y Drum CL Mtr	
13	ITB Motor	
14	PTR Motor	
15	Fusing Motor	

Appendix:
Service
Program
Mode Table

Group 1000

1105	Hot Htg Press Roll Temp DFU	
	[140 to 200/ 170 / 1 deg.]	
1	Htg Roll Ctr:Reload	
2	Htg Roll Ctr:Idle:Reload	
3	Htg Roll Ctr:Wait:Norm	
4	Htg Roll Ctr:Wait:Low	
5	Htg Roll Ctr:Wait:High	
6	Htg Roll Ctr:1-S:Norm1:Normal	
7	Htg Roll Ctr:1-S:Norm1:high adhesion	
8	Htg Roll Ctr:1-S:Norm2:Normal	
9	Htg Roll Ctr:1-S:Norm2:high adhesion	
10	Htg Roll Ctr:1-S:Trace:Normal	
11	Htg Roll Ctr:1-S:Trace:high adhesion	
12	Htg Roll Ctr:1-S:Mid Thk:Normal	
13	Htg Roll Ctr:1-S:Mid Thk:high adhesion	
14	Htg Roll Ctr:1-S:Thk1:Normal	
15	Htg Roll Ctr:1-S:Thk1:high adhesion	
16	Htg Roll Ctr:Thk2:Normal	
17	Htg Roll Ctr:Thk2:high adhesion	
18	Htg Roll Ctr:Thk3:Normal	
19	Htg Roll Ctr:Thk3:high adhesion	
20	Htg Roll Ctr:OHP:Normal	
21	Htg Roll Ctr:OHP:high adhesion	

32	Htg Roll End:Reload: Adj	
33	Htg Roll End:Idle:Reload:Adj	
34	Htg Roll End:Wait:Norm:Adj	
35	Htg Roll End:Wait:Low:Adj	
36	Htg Roll End:Wait:High:Adj	
37	Htg Roll End:Feed:Adj	
38	Press Roll:Reload	
39	Press Roll:Idle:Reload	
40	Press Roll:Wait:Norm	
41	Press Roll:Wait:Low	
42	Press Roll:Wait:High	
43	Press Roll:1-S:Norm1	
44	Press Roll:1-S:Norm2	
45	Press Roll:1-S:Trace	
46	Press Roll:1-S:Mid Thk	
47	Press Roll:1-S:Thk1	
48	Press Roll:Thk2	
49	Press Roll:Thk3	
50	Press Roll:OHP	
56	Hot Roll:Wait:Norm	
57	Hot Roll:Wait:Low	
58	Hot Roll:Wait:High	
59	Hot Roll L3:Ctr Corr Temp	

Group 1000

60	Hot Roll L3:End correction Temp	
61	Hot Roll:High Rot Temp	

1106	Fusing Temp Disp	
	These SP codes control the temperature control of the hot roller and display the temperatures of the hot roller, pressure roller, heating roller, and heating roller lamps.	
2	Htg Roll Ctr Temp	Displays the temperature in centigrade of the fusing lamp (center) in the heating roller. Range: 0 to 230
3	Htg Roll End Temp	Displays the temperature in centigrade of the fusing lamp (ends) in the heating roller. Range: 0 to 230
4	Press Roll Temp	Displays the temperature in centigrade of the pressure roller. Range: 0 to 230
5	Hot Roll Temp	Displays the temperature in centigrade of the hot roller. Range: 0 to 230

1107	Mode Shift DFU	
1	Low Temp On/Off	
2	High Temp On/Off	
3	Low Temp:Reload	
4	High Temp:Reload	
5	Low Temp:Feed	
6	High Temp:Feed	
7	L-Limit:Htg Roll:Reload	
8	L-Limit:Press Roll:Reload	

9	H-Limit:Htg Roll:Reload	
11	L-Limit:Htg Roll:Feed	
12	L-Limit:Press Roll:Feed	
13	H-Limit:Htg Roll:Feed	
15	Press Temp:Norm1	
16	Press Temp:Norm2	
17	Press Temp:Trace	
18	Press Temp:Mid Thk	
19	Press Temp:Thk1	
20	Press Temp:Thk2	
21	Press Temp:Thk3	
22	Press Temp:OHP	
25	Idle:Reload:Time	
26	Idle:Wait/Time,Low	
27	Ready:Feed:Time	
28	Press:Time	
29	Idle:End:Time	
35	Idle:Wait:Time,High	
36	Low Temp Reload Time Extend	
37	Extend Start Time Allowed: Line Feed	

Appendix:
Service
Program
Mode Table



Group 1000

1110	Change Temp		
1	Norm1	13	Large Size:2-S: 1st
2	Norm2	14	Large Size:2-S: 2nd
3	Trace	15	Small Size:1-S: 1st
4	Mid Thk	16	Small Size:1-S: 2nd
5	Thk1	17	Small Size:2-S: 1st
6	Thk2	18	Small Size:2-S: 2nd
7	Thk3	21	Large Size: Ctrl Time 1
8	OHP	22	Large Size: Ctrl Time 2
11	Large Size:1-S: 1st	23	Small Size: Ctrl Time 1
12	Large Size:1-S: 2nd	24	Small Size: Ctrl Time 2

1111	Measure Mode	
	Nip Width Measurement Setting Mode	
1	Nip Width:Execute	Determines whether the nip at the hot roller and pressure roller is calibrated. Touch [Execute].
2	Nip Width:Stop Time	Determines the down time of the fusing/exit motor in the fusing nip band calibration mode. [1 to 100/1 sec.]
3	Nip Width:Stop Interval	Determines the intervals between the down times of the fusing/exit motor in the nip band calibration mode. [0 to 2000/100 msec.]
4	Nip Width:Htg Roll Temp:Ctr	

5	Nip Width:Htg Roll Temp:End	
6	Nip Width:Press Roll Temp	
11	Belt:0:off 1:on	
12	Belt:Rotation Time	
13	Belt:Htg Roll Temp:Ctr	
14	Belt:Htg Roll Temp:End	
15	Belt:Press Roll Temp	

1112	Fuser Unit In/Out DFU
	<p>Fusing Unit: In/Out: Start Fusing Unit Determines whether the fusing unit operates during the copy cycle for image creation and paper feed. [*1: In] [0: Out]</p>

1113	Fusing SC Issue Time Info DFU
------	--------------------------------------

Appendix:
 Service
 Program
 Mode Table

Group 1000

1159	Fusing SC Settings	
	These SP codes determine whether the fusing unit SC codes are displayed.	
1	SC On:1/Off:0 for 3 Jams	This SP determines whether the machine stops and displays an SC if three consecutive jams occur in the fusing unit. [0 to 1/0/1] 0: Disable. SC code is not displayed. 1: Enable. SC code is displayed.
2	SC On:0/Off:1 for No Fusing Pressure	This SP determines whether an SC is displayed if the fusing pressure mechanism is not operating. 0: Enable. SC code is displayed. 1: Disable. SC code is not displayed. Note: A jam does not necessarily occur in the fusing unit if the pressure roller lift mechanism is not operating.

1201	CPM Down DFU	
	Adjusts the CPM down.	
1	L Temp:Judge Down Temp	Down Judgment Temp
2	L Temp:Judge Up _Temp	Up Judgment Temp
3	L Temp:1st CPM Down	CPM
4	L Temp:2nd CPM Down	
5	L Temp:3rd CPM Down	
6	Unit Low Temp:Judge Temp	Judgment Temp
7	H Temp:1st CPM Down	CPM
8	H Temp:2nd CPM Down	
9	H Temp:3rd CPM Down	

10	Down Temp: HiTemp 1: 1st CPM	Down Judgment Temp
11	Down Temp: HiTemp 1: 2nd CPM	
12	Down Temp: HiTemp 1: 3rd CPM	
13	Down Temp: HiTemp 2: 1st CPM	
14	Down Temp: HiTemp 2: 2nd CPM	
15	Down Temp: HiTemp 2: 3rd CPM	
16	Determine CPM Interval	

1202	Htg Press Roll:Panel Off/Low Power DFU	
1	Htg Roll Ctr:Panel off mode	
2	Htg Roll Ctr:Low Power Mode	
3	Htg Roll End:Panel off mode	
4	Htg Roll End:Low Power Mode	
5	Press Roll:Panel off mode	
6	Press Roll:Low Power Mode	

1203	Power Control DFU
	[-4 to +4/ 0 / 1]

Appendix:
Service
Program
Mode Table

Group 1000

1301	Paper Type Detect	
	<p>These SP settings switch the on/off the paper type detection function.</p> <p>Two sensors, one mounted above and one below the paper at the registration rollers, detect the opacity of the first sheet and compares this reading for every subsequent sheet. If the reading is higher (thicker paper) or lower (thinner paper), the sensor triggers an error.</p> <p>[0 to 1/1] 0: Enable, 1: Disable</p>	
1	Tray 1	
2	Tray 2	
3	Tray 3	
4	Tray 4	Japan Only
5	Bypass Tray	
6	LCT	B473
7	Wide LCT	D359

1302	Double-Feed Detect	
	<p>These SP settings switch the on/off the double-feed detect function.</p> <p>[0 to 1/1] 0: Enable, 1: Disable</p> <p>Two sensors, one mounted above and one below the paper at the registration rollers, detect the opacity of the first sheet and compares this reading for every subsequent sheet. If the reading is higher (thicker paper) or lower (thinner paper), the sensor triggers an error.</p>	
1	Tray 1	
2	Tray 2	
3	Tray 3	

4	Tray 4	Japan Only
5	Bypass Tray	
6	LCT	
7	Wide LCT	

1801	Reg Rol Speed Fine Adj	
	SPs 001 to 008 adjust the speed of the registration roller for different paper thicknesses.	
001	Thin	[-3 to +3/ 0 / 0.1%]
002	Norm1	
003	Norm2	
004	Mid Thk	
005	Thk1	[-3 to +3/ -0.2 / 0.1%]
006	Thk2	[-3 to +3/ -0.6 / 0.1%]
007	Thk3	
008	OHP	
	PTR Speed Adj	
	SPs 011 to 016 adjust the speed of the PTR for different paper thicknesses.	
011	Thin	[-3 to +3/ 0 / 0.1%]
012	Norm1	
013	Norm2	
014	Mid Thk	
015	Thk1	[-3 to +3/ -0.2 / 0.1%]
016	Thk2	[-3 to +3/ -0.4 / 0.1%]

Group 1000

017	Thk3	
018	OHP	
	PTR Speed Ambient Adj	
	SPs 021 to 026 adjust the speed of the PTR for ambient temperature and humidity.	
021	LLL (very low)	[-3 to +3/ 0.2 / 0.1%]
022	LL (low)	[-3 to +3/ 0.1 / 0.1%]
023	ML (medium low)	[-3 to +3/ 0 / 0.1%]
024	MM (medium)	
025	MH (medium high)	[-3 to +3/ -0.2 / 0.1%]
026	HH (very high)	[-3 to +3/ -0.3 / 0.1%]

1902	CPM Down Set	
1	Custom (0:Off 1:On)	
2	Pre-Punch (0:Off 1:On)	

1903	Thick Mode (Re-Pickup)	
1	Tray 2 (0:Off 1:On)	
2	Tray 2 (0:Off 1:On)	
3	Tray 3 (0:Off 1:On)	
4	Tray 4 (0:Off 1:On)	
5	Bypass (0:Off 1:On)	

1905	Bypass Feed Restart	
1	0:Timer 1:[Start]	

2	Timer: 0:1s 1:2s 2:3s	
---	-----------------------	--

1906	PType Det Light Amt	
1	Norm Paper Light Amt	
2	Trans Paper Light Amt	
3	OHP Light Amt	

1907	Ptype Det Corr Amt	
1	Normal Paper	
2	Translucent Paper	
3	OHP	

1909	Force Jam Feed	
1	0:Off 1:On	

1920	WideLCT Fan Duty	
1	Fan F	
2	Fan R	

1921	WideLCT Fan time – Start Time	
------	-------------------------------	--

1922	WideLCT Fan ON/OFF	
1923	Wide LCT Pickup Assist	
	[*0: Auto Select] [1: Force On] [2: Force Off]	

Appendix:
Service
Program
Mode Table

Group 1000

1924	Adj Start Timing: Paper Type Dbl Feed	
1	Line Speed 1	
2	Line Speed 2	

1925	Adj Value: Paper Type Dbl Feed	
1	Main Tray/LCT	
2	Bypass/Wide LCT	

1950	Set Fan Operation	
1	Fan Op Temp	
2	To Standby Mode Time	
3	Fan Off:LCT T/H Sensor	
4	Fan Off:Y Thermistor	
5	Fan Off Time	
11	To Standby EngA:Sn	
12	To Standby EngB:Ozone	
13	To Standby EngC:Envir	

4.3 GROUP 2000

2101	Reg Col Interval	Color Interval Registration Adjustment.
	Use these SPs to correct problems with color registration. Color registration problems can be detected by checking the results of 2901 002 Pattern 1. Before doing these adjustments, try to solve the problem by doing SP2111. For more, see "4. Troubleshooting" in the B132/B181/B200 Service Manual.	
1	Main Scan Dot:K	
2	Main Scan Dot:M	
3	Main Scan Dot:C	
4	Main Scan Dot:Y	
5	Main/Sub Scan:K	
6	Main/Sub Scan:M	
7	Main/Sub Scan:C	
8	Main/Sub Scan:Y	
9	Main/Sub Scan:K1-2	
10	Main/Sub Scan:M1-2	
11	Main/Sub Scan:C1-2	
12	Main/Sub Scan:Y1-2	
20	SubScan Line:K-M	
21	SubScan Line:K-C	
22	SubScan Line:K-Y	
23	SubScan M Adj:K-M	
34	SubScan M Adj:K-C	

Group 2000

25	SubScan M Adj:K-Y	
30	M Diff:Main	
31	C Diff:Main	
32	Y Diff:Main	
33	M Diff:Main/Sub	
34	C Diff:Main/Sub	
35	Y Diff:Main/Sub	
40	M Diff:Sub	
41	C Diff:Sub	
42	Y Diff:Sub	
43	M Diff:Sub D Motor	
44	C Diff:Sub D Motor	
45	Y Diff:Sub D Motor	
60	Spd Diff Offset:K Main	
61	Spd Diff Offset:M Main	
62	Spd Diff Offset:C Main	
63	Spd Diff Offset:Y Main	

2102	Prt Mag Adj	
	These SP codes adjust the print magnification in the main scan direction.	
1	Main Scan Mag	
5	Mag Rate:K 1-2	
6	Mag Rate:M 1-2	
7	Mag Rate:C 1-2	

8	Mag Rate:Y 1-2	
10	Mag Diff:K1-2	
11	Mag Diff:M1-2	
12	Mag Diff:C1-2	
13	Mag Diff:Y1-2	

2103	Prt Erase Margin	
	Adjusts the white space at the leading edge. This adjustment can be done for each paper source (Tray 1, Tray 2, etc.)	
1	LEdge:Tray 1	
2	Adj TEdge Margin	
3	Adj Left Margin	
4	Adj Right Margin	
5	TEdge Margin:Tray1	
6	TEdge Margin:Tray2	
7	TEdge Margin:Tray3	
8	TEdge Margin:Tray4	Japan Only
9	LEdge Custom:Bypass	
10	LEdge Custom:LCT	
11	LEdge: Tray 2	
12	LEdge: Tray 3	
13	LEdge: Tray 4	

Group 2000

14	LEdge: Bypass	
15	LEdge: LCT	
16	LEdge: Duplex	

2104	Skew Adj	
	Use these SPs to correct skew in color registration. For more, see "4. Troubleshooting" in the B132/B181/B200 Service Manual.	
1	Bk-M	
2	Bk-C	
3	Bk-Y	
11	Skew Corr Total M	
12	Skew Corr Total C	
13	Skew Corr Total Y	

2105	LD Syn PM Adj DFU	LD Pulse Modulation Synchronization Adjustment	
	Raises the pulse modulation for the LD0 beam of K.		
1	Bk1		
2	M1		
3	C1		
4	Y1		
5	Bk2		
6	M2		
7	C2		
8	Y2		

Appendix:
Service
Program
Mode Table

2106	Poly Mtr OFF - Time Until Stop	Polygon Motor Off Setting
	The polygon mirror motor turns off if the machine receives no print job for the time specified in this SP mode after the previous job was completed. [0 to 180/1 sec]	

2107	Prt Param On/Off	
	Switches gamma correction off/on.	
1	Shade Corr Flag	[0 to 1/ 1 /1] 0: OFF, 1: ON

Group 2000

2108	Col Prt Stop	
	This SP determines which color to switch off for printing.	
1	Bk	[0 to 1/0] 0: Off. Color prints 1: On. Color does not print
2	M	
3	C	
4	Y	

2109	Test Pattern	
	Write Test Pattern. Some of these test patterns are used for copy image adjustments but most are used primarily for design testing. These test patterns do not use the IPU.	
1	Image Add	Select "1" to have the patterns selected with SP2109 002 print overlapped on one another. [0 to 1/1] 0: Off, 1: On
2	Select Pattern	Allows you to select the pattern to print. [0 to 20/1]
	0	Off
	1	Grid Pattern
	2	Slant Grid Pattern
	3	2-Dot Horizontal Line
	4	2-Dot Vertical Line
	5	1-Dot Horizontal Line
	6	1-Dot Vertical Line
	7	1-Dot Independent
	8	2-Dot Independent

	9	4-Dot Independent
	10	Trim Area
	11	Belt Pattern
	12	100% Coverage
	13	Vertical Cross-Stitch
	14	Horizontal Cross-Stitch
	15	Crop Marks
	16	Vertical Belt
	17	Checkered Flag
	18	20 mm Grid
	19	Horizontal Grayscale
	20	Horizontal Grayscale-White Stripes
4	Col Select:All C M Y	Selects test pattern color: [0 to 4/ 1 / 1] 0: All 1: All Colors 2: Cyan 3: Magenta 4: Yellow
5	Density:K	[0 to 15/1]
6	Density:M	[0 to 15/1]
7	Density:C	[0 to 15/1]
8	Density:Y	[0 to 15/1]
11	Gray Density 1	[0 to 15/1]
12	Gray Density 2	[0 to 15/1]

Group 2000

13	Gray Density 3	[0 to 15/1]
14	Gray Density 4	[0 to 15/1]
15	Gray Density 5	[0 to 15/1]
16	Gray Density 6	[0 to 15/1]
17	Gray Density 7	[0 to 15/1]
18	Gray Density 8	[0 to 15/1]
19	Gray Density 9	[0 to 15/1]
20	Gray Density 10	[0 to 15/1]
21	Gray Density 11	[0 to 15/1]
22	Gray Density 12	[0 to 15/1]
23	Gray Density 13	[0 to 15/1]
24	Gray Density 14	[0 to 15/1]
25	Gray Density 15	[0 to 15/1]

2110	Force Tnr Cycle	
	Force Toner Supply Cycle.	
1	Do Correction	
2	Do With LD Wavelength	

2111	Force Tnr Pos
	<p>Force Toner Position Alignment. Touch [EXECUTE] to execute the MUSIC feature. MUSIC is the "Mirror Unit for Skew and Interval Correction".</p> <p>Three MUSIC sensors mounted above the ITB read three MUSIC sensor patterns developed on the ITB.</p> <p>The sensors read the patterns and the machine uses this feedback to adjust: 1) the positions of the 3rd scanner mirrors to correct skew (main scan), and 2) the speed of the drum motors to correct the intervals (sub scan) between the patterns.</p> <p>If the vertical alignment of the patterns or the intervals are not correct, this causes color offset. This adjustment is done for each color (Y, M, C, K).</p> <p>MUSIC executes automatically:</p> <ul style="list-style-type: none"> ▪ When the machine is turned on or returns from an energy save mode. ▪ At the interval prescribed by SP2153 015 (Default: 8 min.) ▪ After completion of the process control cycle. ▪ When the machine receives a job after remaining idle for a long period. ▪ After the fusing unit exceeds the prescribed temperature.

Group 2000

2112	Mag Point Adj	
	<p>Magnification Point Adjustment. Corrects the difference in magnification for each color in the left and right direction.</p> <p>[-4 to +4/0/1]</p> <p>Do SP2109 002 and print Pattern 1 on A3 size paper. Examine the pattern with a scaled loupe. For every 50 μm adjust the setting in the left or right direction. A 1 step correction corrects 50 μm. For more, see "4. Troubleshooting" in the B132/B181/B200 Service Manual.</p>	
1	M Left	
2	M Right	
3	C Left	
4	C Right	
5	Y Left	
6	Y Right	

2150	Prt Area Pulse DFU	
	<p>Pulse Setting: Print Area Only. These SPs fine adjust magnification in the main scan direction in increments of 1/32 dots.</p>	
1-10	K Area 1 to 10	[-120 to +120/32 sub dot]
11-20	M Area 1 to 10	
21 – 30	C Area 1 to 10	
31 – 40	Y Area 1 to 10	

2152	Shading Coeff DFU	
	Shading Correction Coefficient. These SPs set the shading correction coefficient for Areas 01 to 19 for each color. For a list of the ranges and default settings, print the SMC report with SP5990.	
1 – 15	K Area 1 to 15	
21 – 35	M Area 1 to 15	
41 – 55	C Area 1 to 15	
61 – 75	Y Area 1 to 15	

2153	MUSIC Settings DFU	
	These SPs determine how MUSIC executes. In the settings below 0: On, 1:Off.	
1	Auto Execute	Sets MUSIC to execute automatically. [0 to 1/1]
2	During ProCon	Sets MUSIC to execute after completion of the process control self-check. [0 to 1/1]
3	Initialization	Sets MUSIC to execute after the machine is switched on. [0 to 1/1]
4	During Data In	Sets MUSIC to execute before image data output. [0 to 1/1]
5	Writing	Sets MUSIC to execute during long print jobs. [0 to 1/1]
6	MUSIC Temp Intervals	
20	MUSIC:Temp Chg	

Group 2000

23	2-Point Page Interval	
24	Assign Page Interval	
29	MUSIC Density Lvl	
30	Clear Main Slip	
31	Clear Sub Slip	
32	Clear Skew Amt	
33	2-Pt Corr:Clr Offset	
39	Get Init 2-Pt Setting	
50	Add M Weight	
51	Add C Weight	
52	Add Y Weight	

2154	Music Settings 2 DFU	
	These SP settings switch off feedback during MUSIC for the elements listed below.	
1	Feed Back mode	
2	Sensor Light 1	
3	Sensor Light 2	
4	Sensor Light 3	
5	AutoLight	
6	AdjCoeff:FrontKf	
7	AdjCoeff:CtrKc	
8	AdjCoeff:RearKr	
9	MinPatchDiff:MainFine	

10	MinPatchDiff:SubFine	
11	MinPatchDiff:MainRough	
12	MinPatchDiff:SubRough	
13	ColBaseDiff:Min Value	
14	ColMidDiff:Min Value	
15	ColBaseDiff:Max Value	
16	Patch Min Gap	
17	Laser Target Adj	
18	MY Laser Max	
19	AD Upper Limit	
20	AD Lower Limit	
21	Sense Start:Norm2:Fine	
22	Sense Start:Norm2:Rough	
23	Sense Start:Norm1:Fine	
24	Sense Start:Norm1:Rough	
25	BeforeFilter:a1:Norm2:Fine	
26	BeforeFilter:a2:Norm2:Fine	
27	BeforeFilter:b0:Norm2:Fine	
28	BeforeFilter:b1:Norm2:Fine	
29	BeforeFilter:b2:Norm2:Fine	
30	AfterFilter:a1:Norm2:Fine	
31	AfterFilter:a2:Norm2:Fine	
32	AfterFilter:b0:Norm2:Fine	

Group 2000

33	AfterFilter:b1:Norm2:Fine	
34	AfterFilter:b2:Norm2:Fine	
35	BeforeFilter:a1:Norm2:Rough	
36	BeforeFilter:a2:Norm2:Rough	
37	BeforeFilter:b0:Norm2:Rough	
38	BeforeFilter:b1:Norm2:Rough	
39	BeforeFilter:b2:Norm2:Rough	
40	AfterFilter:a1:Norm2:Rough	
41	AfterFilter:a2:Norm2:Rough	
42	AfterFilter:b0:Norm2:Rough	
43	AfterFilter:b1:Norm2:Rough	
44	AfterFilter:b2:Norm2:Rough	
45	BeforeFilter:a1:Norm:1Fine	
46	BeforeFilter:a2:Norm:1Fine	
47	BeforeFilter:b0:Norm:1Fine	
48	BeforeFilter:b1:Norm:1Fine	
49	BeforeFilter:b2:Norm:1Fine	
50	AfterFilter:a1:Norm:1Fine	
51	AfterFilter:a2:Norm:1Fine	
52	AfterFilter:b0:Norm:1Fine	
53	AfterFilter:b1:Norm:1Fine	
54	AfterFilter:b2:Norm:1Fine	
55	BeforeFilter:a1:Norm:1Rough	

56	BeforeFilter:a2:Norm:1Rough	
57	BeforeFilter:b0:Norm:1Rough	
58	BeforeFilter:b1:Norm:1Rough	
59	BeforeFilter:b2:Norm:1Rough	
60	AfterFilter:a1:Norm:1Rough	
61	AfterFilter:a2:Norm:1Rough	
62	AfterFilter:b0:Norm:1Rough	
63	AfterFilter:b1:Norm:1Rough	
64	AfterFilter:b2:Norm:1Rough	
65	Filter QF:Norm2:Fine	
66	Filter QF:Norm2:Rough	
67	Filter QF:Norm:1Fine	
68	Filter QF:Norm:1Rough	
69	Filter Switch	
70	Adj to Target Light Amt	
71	Auto Adj to Target Light Amt	

Appendix:
Service
Program
Mode Table

2155	MUSIC Settings 3 DFU	
1	ADC Cycle:Norm2:Fine	
2	ADC Cycle:Norm2:Rough	
3	ADC Cycle:Norm:1Fine	
4	ADC Cycle:Norm:1Rough	
5	Store Point:Norm2:Fine	

Group 2000

6	Store Point:Norm2:Rough	
7	Store Point:Norm2:Sub	
8	Store Point:Norm:1Fine	
9	Store Point:Norm:1Rough	
10	Store Point:Norm:1Sub	
11	M Main Offset Amt1	
12	M Main Offset Amt2	
13	M Main Offset Amt3	
14	C Main Offset Amt1	
15	C Main Offset Amt2	
16	C Main Offset Amt3	
17	Y Main Offset Amt1	
18	Y Main Offset Amt2	
19	Y Main Offset Amt3	
20	M Sub Offset Amt1	
21	M Sub Offset Amt2	
22	M Sub Offset Amt3	
23	C Sub Offset Amt1	
24	C Sub Offset Amt2	
25	C Sub Offset Amt3	
26	Y Sub Offset Amt1	
27	Y Sub Offset Amt2	
28	Y Sub Offset Amt3	

29	Tigger V:Fine:Sub	
30	Tigger V:Fine:Main	
31	Tigger V:Roug:Sub	
32	Tigger V:Rough:Main	
33	Largest Main Offset Amt1	
34	Largest Main Offset Amt2	

2156	2-Point Measure DFU	
	These SP codes set the initial values for 2-point calibration.	
1	Target K	
2	Target M	
3	Target C	
4	Target Y	
21	K Differential	
22	M Differential	
23	C Differential	
24	Y Differential	
41	Focus Value:K	
42	Focus Value:M	
43	Focus Value:C	
44	Focus Value:Y	

Group 2000

2180	MUSIC Monitor	
	Displays the current and previous lens temperature readings.	
1	Lens Temp	
10	Previous Temp	

2181	Alignment Result	
	These SPs display the amount of shift correction for each color, the amount of correction done at each sensor in both the main scan and sub scan direction. [0 to 9 999 999]	
1	General	
2	M Skew Amt	
3	C Skew Amt	
4	Y Skew Amt	
10	M Main Skew 1	
11	M Main Skew 2	
12	M Main Skew 3	
13	C Main Skew 1	
14	C Main Skew 2	
15	C Main Skew 3	
16	Y Main Skew 1	
17	Y Main Skew 2	
18	Y Main Skew 3	
20	M Sub Skew 1	
21	M Sub Skew 2	

22	M Sub Skew 3	
23	C Sub Skew 1	
24	C Sub Skew 2	
25	C Sub Skew 3	
26	Y Sub Skew 1	
27	Y Sub Skew 2	
28	Y Sub Skew 3	

2182	MUSIC Converge Patch:Min DFU	
	Sets the minimum value for convergence during MUSIC for the sensors in the main and sub scan directions.	
1	M Main 1	
2	M Main 2	
3	M Main 3	
4	M Sub 1	
5	M Sub 2	
6	M Sub 3	
11	C Main 1	
12	C Main 2	
13	C Main 3	
14	C Sub 1	
15	C Sub 2	
16	C Sub 3	
21	Y Main 1	

Appendix:
Service
Program
Mode Table

Group 2000

22	Y Main 2	
23	Y Main 3	
24	Y Sub 1	
25	Y Sub 2	
26	Y Sub 3	

2184	Write Pulse Result DFU	
	Displays the pulse setting rate for main scanning in black areas (Units: 1/16th dot)	
1	K Area 0	
2	K Area 1	
3	K Area 2	
4	K Area 3	
5	K Area 4	
6	K Area 5	
7	K Area 6	
8	K Area 7	
9	K Area 8	
10	K Area 9	
11	K Area 10	
12	K Area 11	
21	M Area 0	
22	M Area 1	
23	M Area 2	

24	M Area 3	
25	M Area 4	
26	M Area 5	
27	M Area 6	
28	M Area 7	
29	M Area 8	
30	M Area 9	
31	M Area 10	
32	M Area 11	
41	C Area 0	
42	C Area 1	
43	C Area 2	
44	C Area 3	
45	C Area 4	
46	C Area 5	
47	C Area 6	
48	C Area 7	
49	C Area 8	
50	C Area 9	
51	C Area 10	
52	C Area 11	
61	Y Area 0	
62	Y Area 1	

Appendix:
Service
Program
Mode Table

Group 2000

63	Y Area 2	
64	Y Area 3	
65	Y Area 4	
66	Y Area 5	
67	Y Area 6	
68	Y Area 7	
69	Y Area 8	
70	Y Area 9	
71	Y Area 10	
72	Y Area 11	

2202	Set AC (Fixed) Charge	
	<p>These SPs set the AC bias for the standard speed mode and low speed mode, but take effect only when SP3501 001 is set to "1" (Fixed). The default ac bias for each color is 2.2 kV (220) The ac bias is normally adjusted by process control self-check, but when automatic process control is switched off (by setting SP3501 001 to "1"), these values are used for the charge potential.</p>	
1	Wire Current:K	
2	AC Bias :M	
3	AC Bias :C	
4	AC Bias :Y	

2203	Set Charge Current	
	<p>Sets and adjusts current for charge applied to the OPC drums.</p>	
1	Norm2:LL	

6	Norm2:ML	
11	Norm2:MM	
16	Norm2:MH	
21	Norm2:HH	
26	Norm1:LL	
31	Norm1:ML	
36	Norm1:MM	
41	Norm1:MH	
46	Norm1:HH	
51	Half-Speed2:LL	
56	Half-Speed2:ML	
61	Half-Speed2:MM	
66	Half-Speed2:MH	
71	Half-Speed2:HH	
76	Half-Speed1:LL	
81	Half-Speed1:ML	
86	Half-Speed1:MM	
91	Half-Speed1:MH	
96	Half-Speed1:HH	

2204	Set AC Environ Corr	
	Sets the target value for adjustment of the charge rollers of the YMC PCUs.	
2	Norm2:LL:Target:M	

Appendix:
Service
Program
Mode Table

Group 2000

3	Norm2:LL:Target:C	
4	Norm2:LL:Target:Y	
7	Norm2:ML:Target:M	
8	Norm2:ML:Target:C	
9	Norm2:ML:Target:Y	
12	Norm2:MM:Target:M	
13	Norm2:MM:Target:C	
14	Norm2:MM:Target:Y	
17	Norm2:MH:Target:M	
18	Norm2:MH:Target:C	
19	Norm2:MH:Target:Y	
22	Norm2:HH:Target:M	
23	Norm2:HH:Target:C	
24	Norm2:HH:Target:Y	
27	Norm1:LL:Target:M	
28	Norm1:LL:Target:C	
29	Norm1:LL:Target:Y	
32	Norm1:ML:Target:M	
33	Norm1:ML:Target:C	
34	Norm1:ML:Target:Y	
37	Norm1:MM:Target:M	
38	Norm1:MM:Target:C	
39	Norm1:MM:Target:Y	

42	Norm1:MH:Target:M	
43	Norm1:MH:Target:C	
44	Norm1:MH:Target:Y	
47	Norm1:HH:Target:M	
48	Norm1:HH:Target:C	
49	Norm1:HH:Target:Y	
52	Half-Speed2:LL:Target:M	
53	Half-Speed2:LL:Target:C	
54	Half-Speed2:LL:Target:Y	
57	Half-Speed2:ML:Target:M	
58	Half-Speed2:ML:Target:C	
59	Half-Speed2:ML:Target:Y	
62	Half-Speed2:MM:Target:M	
63	Half-Speed2:MM:Target:C	
64	Half-Speed2:MM:Target:Y	
67	Half-Speed2:MH:Target:M	
68	Half-Speed2:MH:Target:C	
69	Half-Speed2:MH:Target:Y	
72	Half-Speed2:HH:Target:M	
73	Half-Speed2:HH:Target:C	
74	Half-Speed2:HH:Target:Y	
77	Half-Speed1:LL:Target:M	
78	Half-Speed1:LL:Target:C	

Group 2000

79	Half-Speed1:LL:Target:Y	
82	Half-Speed1:ML:Target:M	
83	Half-Speed1:ML:Target:C	
84	Half-Speed1:ML:Target:Y	
87	Half-Speed1:MM:Target:M	
88	Half-Speed1:MM:Target:C	
89	Half-Speed1:MM:Target:Y	
92	Half-Speed1:MH:Target:M	
93	Half-Speed1:MH:Target:C	
94	Half-Speed1:MH:Target:Y	
97	Half-Speed1:HH:Target:M	
98	Half-Speed1:HH:Target:C	
99	Half-Speed1:HH:Target:Y	

2205	Adj/Display AC Charge	
	Sets the time intervals for the application of ac charge during printing.	
1	Execution Interval	
2	Temp Threshold 1	
3	Temp Threshold 2	
4	Previous Temp	

2207	Chg AC Reduction: Set	
	Sets the low voltage of the ac charge to be applied while an image is not being created.	

2208	Chg AC Adj:Execute DFU
	Touch [EXECUTE] to manually executes an ac charge on the charge rollers of the YMC PCUs.

2209	Chg AC Adj: Result DFU
	Displays the results of the ac charge applied manually to the charge rollers of the YMC PCUs with SP2208.

2220	Chg Wire Cleaning Timing	
	Selects when the charge wire of the K PCU and the charge rollers of the YMC PCUs are cleaned.. [0~2 / 2 / 1] 0: OFF 1: With process control and at intervals selected with SP2221 2: At intervals selected with SP2221 only.	
1	Execution Timing: K	
2	Execution Timing: Y,M,C	

2221	Chg Wire Cleaning Int/Dist	
	Selects the interval corona wire (K PCU) and charge roller cleaning (YMC PCUs).	
1	Execution Interval:K	[0 to 9 999 999/ 200 000/ 1 cm]
2	Execution Interval:M	
3	Execution Interval:C	
4	Execution Interval:Y	
5	Distance: K	[0 to 9 999 999/ 0/ 1 cm]
6	Distance: M	
7	Distance: C	

Appendix:
Service
Program
Mode Table

8	Distance: Y	
9	Delay at Power On: K	[0 to 99 999/ 5000 / 100 cm]
10	Delay at Power On: M	
11	Delay at Power On: C	
12	Delay at Power On: Y	



2222	Execute Wire Cleaning	
	These SP codes manually execute wire cleaning (K PCU) and charge roller cleaning (YMC PCUs). NOTE: Execute SP2-222-001 after replacing the Cleaner Grid Assembly or the Corona Wire Cleaner Assembly to verify correct operation.	
1	K	[0 to 1 / 0 / 0]
2	Y,M,C	
3	M	
4	C	
5	Y	
	Chg Wire Cleaning Time	
	These SPs display the duration of wire cleaning after the wires were cleaned using SP codes 001 to 005 above.	
6	Result: Forward	[0 to 45/ 0 / 0.1 sec.]
7	Result: Back	

2223	OPC Rev After Idle Time	
	These SP codes allow you to set up how long the OPC will idle at the start of a print job after it has remained inactive.	
1	Execution Setting	Switches this SP code on/off. Default: Off (0) This SP must be set on for the other values (2 to 5 below) to take effect.

2	Execution Timing	Sets the amount of time for the OPC drum to idle before the start of the job. [0 to 360/ */1 sec.] * Default setting: D014: 75 sec. D015: 60 sec.
3	Exec Threshold:Rel Humidity	Sets the threshold of relative humidity to trigger idling of the OPCu. [0 to 99/ 65/ 1 %rH]
4	Exec Threshold:Idle Time	Sets the length of time for the OPC to idle, once the idle time has been triggered by the rH threshold. [0 to 6000/ 360/ 10 min.]
5	Exec Threshold:OPC Usage	Sets the threshold value to trigger OPC idling, depending of the number of pages printing. [0 to 400 000 / 60 000/ 10 000 sheets]
6	Chg Usage	Sets the threshold of the charge for the rotation of the OPC drum by page count after the machine has been moved to a high-humidity environment. [0 to 200,000/60,000/10,000 Sheets]

2225	Cleaning Speed: K DFU	
	These settings affect the speed of rotation of the drum cleaning brush roller for monochrome printing.	
1	Norm2	[0.1 to 3/ 0.45/ 0.01]
2	Norm1	
3	Half-Speed2	
4	Half-Speed1	

Group 2000

5	Period of Revs	[100 to 15 000 000/100 000/10 cm]
6	Post Switching Coefficient	[0.5 to 2/ 1 0.1]

2226	Cleaning Speed: Col	
	These settings affect the speed of rotation of the drum cleaning brush roller for color printing.	
1	Norm2	[0.1 to 3/ 0.45/ 0.01]
2	Norm1	
3	Half-Speed2	
4	Half-Speed1	
5	Period of Revs	[100 to 15 000 000/100 000/10 cm]
6	Post Switching Coefficient	[0.5 to 2/ 1 0.1]

2230	QL Power Setting	
	These SPs set the power level of the quenching lamp.	
1	Norm2 Image	[0 to 99 / 21/ 1%]
2	Norm2 Margin	[0 to 99 / 40/ 1%]
3	Norm1 Image	[0 to 99 / 20/ 1%]
4	Norm1 Margin	[0 to 99 / 39/ 1%]
5	Half-Speed2 Image	[0 to 99 / 17 / 1%]
6	Half-Speed2 Margin	[0 to 99 / 25/ 1%]
7	Half-Speed1 Image	[0 to 99 / 16 / 1%]
8	Half-Speed1 Margin	[0 to 99 / 24 / 1%]

2251	Force Tnr Supply
------	------------------

	<p>Force Toner Supply:Execute. Use SPs to increase manually the supply of toner to the sub hopper of the development unit to determine if toner supply is abnormal or to recover normal operation of a color toner supply when image density becomes light. After you touch "Execute" the toner supply switches on for 0.1 sec. and then off for 0.2 sec. four times for the select color or colors.</p>	
1	Execute:K	<p>Executes forced toner supply to the selected development unit. [0 to 1/1]</p>
2	Execute:M	
3	Execute:C	
4	Execute:Y	
5	Execute:Col	<p>Executes forced toner supply to the Y, M, C development units only. [0 to 1/1]</p>
6	Execute:All Col	<p>Executes forced toner supply to all development units (Y, M, C, K). [0 to 1/1]</p>

Appendix:
 Service
 Program
 Mode Table

2252	Set Tnr Supply	
	<p>Forced Toner Supply: Setting. Use these SPs to adjust the number of rotations done by the toner supply clutch when SP2251 001 to 006 is executed manually. The number of toner supply clutch rotations can be adjusted for each color. A high setting increases the number of rotations and increases the amount of toner supply to the development unit, resulting in a darker image for the selected color.</p>	
1	Supply Times:K	[0 to 30/1]
2	Supply Times:M	[0 to 30/1]
3	Supply Times:C	[0 to 30/1]
4	Supply Times:Y	[0 to 30/1]

Group 2000

2253	Manual Tnr. Fill
	<p>Fill Development Unit Sub Hoppers: Manual. Touch [EXECUTE] to start force filling of all development units with toner/developer from the STC units if toner supply is abnormal or to recover normal operation of a color toner supply when image density becomes light.</p> <p>The toner supply clutch switches on for 2 sec. and then off for 0.4 sec. to fill the sub hopper of the development unit. This on/off sequence is repeated up to 20 times or until the toner end sensor detects that toner is present in the sub hopper.</p>

2260	Pot.Sn Check
	Potential Sensor Check. Touch [EXECUTE] to execute a check of all potential sensors.

2261	Pot.Sn Chk Disp		
	Displays the results of the potential sensor check executed with SP2260.		
1	Vd:K	7	Vr:C
2	Vd:M	8	Vr:Y
3	Vd:C	9	Voffset:K
4	Vd:Y	10	Voffset:M
5	Vr:K	11	Voffset:C
6	Vr:M	12	Voffset:Y

Notes for SP2261

Reading	Definition	Abnormal Reading
Vd	Charge bias (Cdc). This is the output of the potential sensor after -700V is applied to the drum. Range: -500 to -700 V	If the reading is out of range: <ul style="list-style-type: none"> ▪ Potential sensor damaged ▪ Charge unit malfunction ▪ Charge power pack malfunction
Vr	Residual voltage. This is the output of the potential sensor after the LD fires at full power. Normal: -200 V	If above -200V: <ul style="list-style-type: none"> ▪ Drum worn ▪ Toner shield glass dirty ▪ Potential sensor out of position
Voffset	This is the reading of the potential sensor with no charge applied to the drum. Normal: 0 ±10V	If reading is out of range: <ul style="list-style-type: none"> ▪ Potential sensor dirty ▪ Potential sensor out of position

Appendix:
Service
Program
Mode Table

2262	TD Sn Chk
	TD Sensor Check: Execute. Touch [EXECUTE] to execute a check of all TD sensors.

Group 2000

2263	TD Sn Chk Disp	
	Toner Density Check: Display. Displays results of 2262. Vt is the most recent output of the TD sensor.	
1	Vt:K	
2	Vt:M	
3	Vt:C	
4	Vt:Y	

2264	ID Sn Chk	
	ID Sensor Check: Touch [EXECUTE] to check the ID sensor.	

2265	ID Sn Chk Disp	
	<p>Displays the most recent ID sensor Vsg and Voffset readings.</p> <p>Notes:</p> <ul style="list-style-type: none"> Vsg_reg is the reading of the direct sensors in the black and color ID sensors that detect the reflectivity of the bare surface of ITB. If Vsg_reg is less than 3.8V, the ID sensor may be dirty, damaged, or disconnected 	
1	Vsg_reg	

2302	Temp/Humid Disp	
	This SP displays the current temperature and humidity. These readings are output by the temperature humidity display located on the bottom of the machine below the used toner bottle.	
1	Temp Disp	Room temperature (°C). [0 to 100/ 0/1 deg.]
2	Rel Humidity Disp	Relative humidity (saturation point at current temperature). [0 to 100/0 /1 %rh.]
3	Abs Humidity Disp	Absolute humidity. [0 to 63/ 0/ 0.01 g/m ³]
4	Current Env Disp	Displays the current environment control mode. The control modes are divided into 5 levels: LL, ML, MM, MH, HH.

Group 2000

2303	Force Temp Corr DFU	
	<p>Force Ambient Temperature Correction. The temperature/humidity sensor reading is used to adjust settings during process control when this SP is set to zero (the default). The value of the absolute humidity reading displayed by SP2302 003, as well as the other readings of the conditions around the machine displayed with SP2302, are used in the process control calculations. If you touch any key (1 to 6) below, the value you select is used and the readings of the temperature/humidity sensor are ignored.</p> <p>Note: After you press any key (1 to 6), the setting you select remains in effect only while the machine is in the SP mode. Once you leave the SP mode, this SP is reset to zero automatically.</p>	
	0: Sensor Detect 1: LLL 2: LL 3: ML	4: MM 5: MH 6: HH

2304	Set Humid Thresh	
	<p>Ambient Humidity Threshold Setting. Sets the threshold values for the absolute humidity of the current LL and ML settings for the main machine in the present environment.</p>	
1	Abs Humid:Thresh1	[0 to 63/ 2.5/ 0.01 g/m ³
2	Abs Humid:Thresh2	[0 to 63/ 5/ 0.01 g/m ³
3	Abs Humid:Thresh3	[0 to 63/ 8.4/0.01 g/m ³
4	Abs Humid:Thresh4	[0 to 63/ 15/ 0.01 g/m ³
5	Abs Humid:Thresh5	[0 to 64/ 24/ 0.01 g/m ³]

2307	Set Ptype Link	
	<p>Paper Type Link Setting. For the copy mode selected, these SPs 1) switch the image transfer bias for each color and 2) switch the paper transfer and separation</p>	

	bias	
1	Norm	[0 to 2/1] 0: Normal Paper 1: Thick Paper 2: OHP
2	Recycled Paper	
3	Special Paper	
4	Color 1	
5	Color 2	
6	Letterhead	
7	Tab Sheet	
8	Labels	
9	Tracing Paper	
10	OHP	

Appendix:
Service
Program
Mode Table

2308	Set Psize Thresh	
	Set Paper Size Thresholds. Sets the correction values (Threshold 1, 2, 3, 4) for paper size.	
1	Psize:Thresh1	[0 to 350-/1 mm]
2	Psize:Thresh2	
3	Psize:Thresh3	
4	Psize:Thresh4	

Group 2000

2309	Eng Spd Coeff	
1	Norm Spd 1:ITB	[10 to 200 / 125 / 1%]
2	Norm Spd 2:ITB	[10 to 200 / 100 / 1%]
3	Half Spd 1: ITB	[10 to 200 / 63 / 1%]
4	Half Spd 2: ITB	[10 to 200 / 50 / 1%]
5	Norm Spd 1:PTR	[10 to 200 / 125 / 1%]
6	Norm Spd 2:PTR	[10 to 200 / 100 / 1%]
7	Half Spd 1: PTR	[10 to 200 / 58 / 1%]
8	Half Spd 2: PTR	[10 to 200 / 42 / 1%]
11	Norm d1: Spec DC	[10 to 200 / 100 / 1%]
12	Norm d2 Spec DC	
13	Half d1: Spec DC	
14	Half d2: Spec DC	
21	Norm d1: Spec AC	[10 to 200 / 100 / 1%]
22	Norm d2: Spec AC	
23	Half d1: Spec AC	[10 to 200 / 93 / 1%]
24	Half d1: Spec AC	[10 to 200 / 90 / 1%]
31	Thin: PTR	Adjusts the strength of the charge applied by the charge roller to the paper transfer belt (It2). [10 to 200 / 58 / 1%]
32	Normal 1: PTR	
33	Normal 2: PTR	
34	Mid Thk: PTR	
2312	Margin K Bias	

1	ITB	Sets the value of image transfer bias for K in the areas of the image where nothing is printed. [0 to 70/0.1]
2	PTR	[0 to 1/0.01 kV]
3	SepDC	[0 to 10/0.1 µa]
4	SepAC	[8 to 12/0.1 kV]

2313	Margin FC Bias	
	This SP sets the image transfer bias for each in areas of the image where nothing is printed in the full-color mode.	
2	ITB:K	[0 to 70/ 0.1 ua]
3	ITB:M	
4	ITB:C	
5	ITB:Y	
7	PTR	
8	SepDC	
9	SepAC	

2321	Manual Vltg Meas	
	Takes a reading of the Vltg value for the ITB and PTR.	
2	ITB	
3	PTR	

Appendix:
Service
Program
Mode Table

Group 2000

2322	Vltg Meas Result	
	Displays the reading of the ITB and PTR voltages.	
1	ITB:K	
2	ITB:M	
3	ITB:C	
4	ITB:Y	
5	PTR	

2323	Vltg Meas Env Disp	
1	ITB	
2	PTR	

2324	R Coeff ON/OFF	
1	ITB	
2	PTR	

2325	Current R Level Disp	
1	ITB: K	
2	ITB: M	
3	ITB: C	
4	ITB: Y	
5	PTR	

2326	Set Voltage Detect Interval	
------	-----------------------------	--

1	Execution Interval	[0 to 20000 / 200 / 1 sheet]
2	Page Count:FC	[0 to 20000 / 0 / 1 sheet]
3	Page Count:BW	

2330	Set R Thresh:LLL DFU	
2331	Set R Thresh:LL DFU	
2332	Set R Thresh:ML DFU	
2333	Set R Thresh:MM DFU	
2334	Set R Thresh:MH DFU	
2335	Set R Thresh:HH DFU	
1	R Thresh1:ITB	
2	R Thresh2:ITB	
3	R Thresh3:ITB	
4	R Thresh4:ITB	
5	R Thresh5:ITB	
6	R Thresh1:PTR	
7	R Thresh2:PTR	
8	R Thresh3:PTR	
9	R Thresh4:PTR	
10	R Thresh5:PTR	

2360	Resist Coeff DFU	
1	R Level:R-2	
2	R Level:R-1	

Appendix:
Service
Program
Mode Table

Group 2000

3	R Level:R0	
4	R Level:R+1	
5	R Level:R+2	
6	R Level:R+3	

2361	Size Coeff:R-2 DFU	
2362	Size Coeff:R-1 DFU	
2363	Size Coeff:R0 DFU	
2364	Size Coeff:R+1 DFU	
2365	Size Coeff:R+2 DFU	
2366	Size Coeff:R+3 DFU	
1	Side1:Size1	
2	Side2:Size1	
3	Side1:Size2	
4	Side2:Size2	
5	Side1:Size3	
6	Side2:Size3	
7	Side1:Size4	
8	Side2:Size4	
9	Side1:Size5	
10	Side2:Size5	

2380	Margin K:LLL DFU
2381	Margin K:LL DFU
2382	Margin K:ML DFU
2383	Margin K:MM DFU
2384	Margin K:MH DFU
2385	Margin K:HH DFU

2390	Margin FC:LLL DFU
2391	Margin FC:LL DFU
2392	Margin FC:ML DFU
2393	Margin FC:MM DFU
2394	Margin FC:MH DFU
2395	Margin FC:HH DFU

Appendix:
Service
Program
Mode Table

Group 2000

2401	Norm K Bias	
	Sets the standard value of bias voltages at image transfer, and paper separation in areas where black is used on plain paper during black-and-white printing.	
1	ITB	[0 to 70 / 0.1 ua]
7	Side1:PTR	[-100 to 0/ 1 ua]
8	Side1:SepDC	[0 to 10 / 0.1 ua]
9	Side1:SepAC	[8 to 12 / 0.1 ua]
12	Side2:PTR	[-100 to 0/ 0.1 ua]
13	Side2:SepDC	[0 to 10/ 0.1 ua]
14	Side2:SepAC	[8 to 12/ 0.1 ua]

2406	Norm FC Bias	
	Set Bias for Plain Paper: FC. Sets the standard value of bias voltages at image transfer, and paper separation in areas the four colors are used on plain paper during full color printing.	
1	ITB:K	[0 to 70/0.1 μa]
2	ITB:M	[0 to 70/0.1 μa]
3	ITB:C	[0 to 70/0.1 μa]
4	ITM:Y	[-100 to 0/1 μa]
13	Side1:PTR	[-100 to 0/1 μa]
14	Side1:SepDC	[0 to 10/0.1 μa]
15	Side1:SepAC	[8 to 12/0.1 μa]
21	Side1:PTR	[-100 to 0/1 μa]

22	Side1:SepDC	[0 to 10/0.1 μ a]
23	Side1:SepAC	[8 to 12/1 μ a]

2421	LEdge Cor:Norm K	
	<p>Leading Edge Correction for Plain Paper: K. This SP sets the coefficient used to 1) correct bias at the leading edge for black image transfer (ITB) 2) bias at image to paper transfer, and 3) correct the dc and ac voltages applied at paper separation.</p> <p>Notes: These settings apply:</p> <ul style="list-style-type: none"> ▪ To the distance from the leading edge set with SP2422 ▪ Only to black printing on plain paper at full speed (even when full-color is selected). 	
7	Side1:PTR	[0 to 250/ 1%]
8	Side1:SepDC	
9	Side1:SepAC	
12	Side2:PTR	
13	Side2:SepDC	
14	Side2:SepAC	

Appendix:
Service
Program
Mode Table

Group 2000

2422	LEdge SWT:Norm K	
	Leading Edge Switch Timing for Plain Paper: K. Sets the switch off timing SP2421. The value selected is the number of mm from the leading edge of the paper. These settings 1) apply only to black printing on plain paper at full speed (even when full-color is selected), and 2) apply to both sides of a duplex page.	
2	PTR	[0 to 30/1 mm]
3	SepDC	
4	SepAC	

2423	TEdgeCor:Norm K	
	Trailing Edge Correction for Plain Paper: K. This SP sets the coefficient used to correct bias at image to paper transfer for each side of the paper. These settings are applied to the trailing edge for black printing on plain paper at full speed and apply to black, even when printing in full color mode.	
7	Side1:PTR	[0 to 250/1%]
12	Side2:PTR	

2424	TEdgeSWT:Norm K (PTR)	
	Trailing Edge Switch Timing for Plain Paper: K. This setting sets the start timing for application of SP2423 at the trailing edge of each sheet (Side 1, Side 2). This setting is applied to the trailing edge for black printing on plain paper at full speed and apply to black, even when printing in full color mode. [-100 to 0/1 mm] The mm distance is measured away from the trailing edge of the image.	

2426	LEdgeCor:Norm FC	
	<p>Leading Edge Correction for Plain Paper: FC. This SP sets the coefficient used to 1) correct bias at the leading edge for full-color image transfer (ITB) bias at image to paper transfer when using plain paper, and 3) correct the dc and ac voltages applied at paper separation.</p> <p>Notes: These settings apply:</p> <ul style="list-style-type: none"> ▪ Only the distance from the leading edge set with SP2427. ▪ Only to full color printing on plain paper at full speed. 	
7	Side1:PTR	[0 to 250/1%]
8	Side1:SepDC	
9	Side1:SepAC	
12	Side2:PTR	
13	Side2:SepDC	
14	Side2:SepAC	

2427	LEdgeSWT:Norm FC	
	<p>Leading Edge Switch Timing for Plain Paper: FC. This SP sets switch timing that sets the distance from the leading edge where the settings of SP2426 are to apply. The value selected is the number of mm from the leading edge of the paper. These settings 1) apply only full-color printing on plain paper at full speed, and 2) apply to both sides of a duplex page.</p>	
2	PTR	[0 to 30/1 mm]
3	SepDC	[0 to 30/1 mm]
4	SepAC	[0 to 30/1 mm]

Group 2000

2428	TEdgeCor:Norm FC	
	Trailing Edge Correction for Plain Paper: FC. This SP sets the coefficient used to correct bias at image to paper transfer for each side of the paper. These settings are applied to the trailing edge for full-color printing on plain paper at full speed as far as where SP2429 takes effect.	
7	Side1:PTR	[0 to 250/1%]
12	Side2:PTR	

2429	TEdgeSWT:Norm FC – PTR	
	Switch Timing for Plain Paper: FC. This setting sets the start timing for application of SP2428 007, 2428 012 at the trailing edge of each sheet (Side 1, Side 2). These settings are applied to the trailing edge for black printing on plain paper at full speed and apply to black, even when printing in full color mode. [-100 to 0/1 mm] The mm distance is measured away from the trailing edge of the image.	

2430	Norm:K:LLL	Plain Paper: K Very Low
2431	Norm:K:LL	Plain Paper: K Low
2432	Norm:K:ML	Plain Paper: K Medium Low
2433	Norm:K:MM	Plain Paper: K Medium
2434	Norm:K:MH	Plain Paper: K Medium High
2435	Norm:K:HH	Plain Paper: K High
	<p>These SPs set the paper size correction coefficient for the image to paper transfer bias threshold values calculated based on the reading of the absolute humidity from the temperature/humidity sensor and the thresholds set with SP2304.</p> <p>SP2430 – Up to SP2304 001: Threshold 1</p> <p>SP2431 – More than SP2304 001 Threshold 1, up to SP23204 002 Threshold 2.</p> <p>SP2432 – More than SP2304 002 Threshold 2, up to SP2304 003 Threshold 3</p>	

	SP2433 – More than SP2304 003 Threshold 3, up to SP2304 004 Threshold 4 SP2434 – More than SP2304 004 Threshold 4, up to SP2305 005 Threshold 3 SP2435 – More than SP2304 005 Threshold 5 These settings apply 1) only where the image is created in black (in either black-and-white or full-color mode) on plain paper at full speed.	
1	ITB	[10 to200/ 1%]
7	Side1:PTR	
8	Side1:SepDC	
9	Side1:SepAC	
12	Side2:PTR	
13	Side2:SepDC	
14	Side2:SepAC	

2440	Norm:FC:LLL	Plain Paper: FC Very Low
2441	Norm:FC:LL	Plain Paper: FC Low
2442	Norm:FC:ML	Plain Paper: FC Medium Low
2443	Norm:FC:MM	Plain Paper: FC Medium Medium
2444	Norm:FC:MH	Plain Paper: FC Medium High
2445	Norm:FC:HH	Plain Paper: FC High
	These SPs set the paper size correction coefficient for the image to paper transfer bias threshold values calculated based on the reading of the absolute humidity from the temperature/humidity sensor and the thresholds set with SP2304. SP2440 – Up to SP2304 001: Threshold 1 SP2441 – More than SP2304 001 Threshold 1, up to SP23204 002 Threshold 2. SP2442 – More than SP2304 002 Threshold 2, up to SP2304 003 Threshold 3 SP2443 – More than SP2304 003 Threshold 3, up to SP2304 004 Threshold 4 SP2444 – More than SP2304 004 Threshold 4, up to SP2305 005 Threshold 3 SP2445 – More than SP2304 005 Threshold 5	

Appendix: Service Program Mode Table

Group 2000

	These settings apply 1) only where the image is created in full-color on plain paper at full speed.	
1	ITB	[10 to 200/ 1%]
17	Side1:PTR	
18	Side1:SepDC	
19	Side1:SepAC	
27	Side2:PTR	
28	Side2:SepDC	
29	Side2:SepAC	

2751	Sp1 K Bias	
	Set Bias for Special Paper 1: K. These SPs set the standard values of the electrical charges that are applied to 1) create bias for image transfer from drum to ITB, 2) create bias for image transfer from ITB to paper (PTR), and 3) neutralize the charges on the both sides of the paper to separate the paper from the ITB (SepDC, SepAC). These settings are used when printing on Special Paper 1 in the black-and-white mode and are applied only to the image area.	
1	ITB	[0 to 70/0.1 μ a]
7	Side1:PTR	[-100 to 0/1 μ a]
8	Side1:SepDC	[0 to 10/0.1 μ a]
9	Side1:SepAC	[8 to 12/0.1 kV]
12	Side2:PTR	[-100 to 0/0.1 μ a]
13	Side2:SepDC	[0 to 10/0.1 μ a]
14	Side2:SepAC	[8 to 12/0.1 kV]

2756	Sp1 FC Bias	
	Set Bias for Special Paper 1: K. These SPs set the standard values of the electrical charges that are applied to 1) create bias for image transfer from drum of each color (Y, M, C, K) to the ITB, 2) create bias for image transfer from ITB to paper (PTR), and 3) neutralize the charges on the both sides of the paper to separate the paper from the ITB (SepDC, SepAC). These settings are used only for Y, M, C, K when printing on Special Paper 1 in the full-color mode and are applied only to the image area.	
1	ITB:K	[0 to 70/0.1 μ a]
2	ITB:M	[0 to 70/0.1 μ a]
3	ITB:C	[0 to 70/0.1 μ a]
4	ITB:Y	[0 to 70/0.1 μ a]
13	Side1:PTR	[-100 to 0/1 μ a]
14	Side1:SepDC	[0 to 10/0.1 μ a]
15	Side1:SepAC	[8 to 12/0.1 kV]
21	Side2:PTR	[-100 to 0/1 μ a]
22	Side2:SepDC	[0 to 10/0.1 μ a]
23	Side1:SepAC	[8 to 12/0.1 kV]

These SPs set the paper size correction coefficients for Special Paper 1 relative to the settings done with SP2308 (Set Psize Thresh). All of these settings:

- Apply to printing on Special Paper 1 in the black-and-white mode
- Apply only to the image area

The title of each SP tells you the side and size where the setting is applied at ITB-to-paper transfer, for example: "Side1:Size1:PTR" means the setting applies to only the first side of Size 1 when the image is transferred from belt to paper.

Group 2000

2771	LEdge Cor:Sp1:K	
	Leading Edge Correction for Special Paper 1: K. Sets the leading edge correction coefficient when bias is applied as far as allowed by the setting of SP2772 for drum to image transfer of the image during black and white copying on Special Paper 1.	
7	Side1:PTR	[0 to 250/ 1%]
8	Side1:SepDC	
9	Side1:SepAC	
12	Side2:PTR	
13	Side2:SepDC	
14	Side2:SepAC	

2772	LEdge SWT:Sp1:K	
	Leading Edge Switch Timing for Special Paper 1: K. Sets the switch off timing of SP2771. The selected value is the number of mm from the leading edge. Applies only to printing in black-and-white mode on Special Paper 1.	
2	PTR	[0 to 30/1 mm]
3	SepDC	
4	SepAC	

2773	TEdge Cor:Sp1 K	
	Trailing Edge Correction for Special Paper 1: K. Sets the bias applied at the trailing edge when the image is transferred from ITB to paper by setting the start timing for SP2774 at the trailing edge. Applied to the trailing edge for black-and-white mode on Special Paper 1 only.	

7	Side1:PTR	[0 to 250/1%]
12	Side2:PTR	

2774	TEdge SWT:Sp1 K
	<p>Trailing Edge Switch Timing for Special Paper 1: K.</p> <p>Sets the switch timing that determines the distance from the leading edge where the settings of SP2773 are applied during image transfer from ITB to paper.</p> <p>Applied only when in black-and-white mode on Special Paper 1.</p> <p>[-100 to 0/ 1 mm]</p>

2776	LEdge Cor:Sp1 FC	
	<p>Leading Edge Correction for Special Paper 1: FC.</p> <p>These SPs do the following settings when printing on Special Paper 1 in the full-color mode:</p> <p>1) ITB: Sets strength/timing of the correction coefficient for the application of bias when the image is transferred from the drum to the ITB.</p> <p>2) PTR: Sets the strength/timing of the correction coefficient for the application of bias when the image is transferred from ITB.</p> <p>3) SepDC, SepAC: Set the strength/timing of the dc and ac charges applied to neutralize the charges on the belt and paper so they will separate more easily.</p> <p>Note: SP2776 selects the strength of the bias coefficient, and SP2777 sets the start timing of the bias application.</p>	
7	Side1:PTR	[0 to 250/ 1%]
8	Side1:SepDC	
9	Side1:SepAC	
12	Side2:PTR	
13	Side2:SepDC	

Group 2000

14	Side2:SepAC	
----	-------------	--

2777	LEdge SWT:Sp1 FC	
	Leading Edge Switch Timing for Special Paper 1: FC. Sets the switch off timing of SP2776. The selected value is the number of mm from the leading edge. Applies only to printing in full-color mode on Special Paper 1.	
2	PTR	[0 to 30/1 mm]
3	SepDC	
4	SepAC	

2778	TEdge Cor:Sp1 FC	
	Trailing Edge Correction for Special Paper 1: FC. Sets the strength of the bias coefficient for the bias applied at the trailing edge when the image is transferred from ITB to paper. Applied when printing in full-color mode on Special Paper 1.	
7	Side1:PTR	[0 to 250/1%]
12	Side2:PTR	

2779	TEdge SWT:Sp1 FC (PTR)	
	Switch Timing for Special Paper 1: FC. Sets the switch timing that determines the distance from the leading edge where the SP2778 settings are applied during image transfer from ITB to paper. Applied only when printing in full-color mode on Special Paper 1. [-100 to 0/1 mm]	

2780	Sp1:K:LLL	Special Paper 1: K Very Low
2781	Sp1:K:LL	Special Paper 1: K Low

2782	Sp1:K:ML	Special Paper 1: K Medium Low
2783	Sp1:K:MM	Special Paper 1: K Medium
2784	Sp1:K:MH	Special Paper 1: K Medium High
2785	Sp1:K:HH	Special Paper 1: K High
	<p>These SPs set the paper size correction coefficient for the image to paper transfer bias threshold values calculated based on the reading of the absolute humidity from the temperature/humidity sensor and the thresholds set with SP2304.</p> <p>SP2780 – Up to SP2304 001: Threshold 1 SP2781 – More than SP2304 001 Threshold 1, up to SP23204 002 Threshold 2. SP2782 – More than SP2304 002 Threshold 2, up to SP2304 003 Threshold 3 SP2783 – More than SP2304 003 Threshold 3, up to SP2304 004 Threshold 4 SP2784 – More than SP2304 004 Threshold 4, up to SP2305 005 Threshold 3 SP2785 – More than SP2304 005 Threshold 5</p> <p>These settings apply only to the image area printed on Special Paper 1 in black-and-white mode.</p>	
1	ITB	[10 to 200/ 1%]
7	Side1:PTR	
8	Side1:SepDC	
9	Side1:SepAC	
12	Side2:PTR	
13	Side2:SepDC	
14	Side2:SepAC	
2790	Sp1:FC:LLL	Special Paper 1: FC Very Low
2791	Sp1:FC:LL	Special Paper 1: FC Low
2792	Sp1:FC:ML	Special Paper 1: FC Medium Low

Group 2000

2793	Sp1:FC:MM	Special Paper 1: FC Medium
2794	Sp1:FC:MH	Special Paper 1: FC Medium High
2795	Sp1:FC:HH	Special Paper 1: FC High
<p>These SPs set the paper size correction coefficient for the image to paper transfer bias threshold values calculated based on the reading of the absolute humidity from the temperature/humidity sensor and the thresholds set with SP2304.</p> <p>SP2790 – Up to SP2304 001: Threshold 1 SP2791 – More than SP2304 001 Threshold 1, up to SP23204 002 Threshold 2. SP2792 – More than SP2304 002 Threshold 2, up to SP2304 003 Threshold 3 SP2793 – More than SP2304 003 Threshold 3, up to SP2304 004 Threshold 4 SP2794 – More than SP2304 004 Threshold 4, up to SP2305 005 Threshold 3 SP2795 – More than SP2304 005 Threshold 5</p> <p>These settings apply only to the image area printed on Special Paper 1 in full-color mode.</p>		
1	ITB	[10 to 200/ 1%]
17	Side1:PTR	
18	Side1:SepDC	
19	Side1:SepAC	
27	Side2:PTR	
28	Side2:SepDC	
29	Side2:SepAC	

2801	Sp2 K Bias	Set Bias for Special Paper 2: K
<p>These SPs set the standard values of the electrical charges that are applied to 1) create bias for image transfer from drum to ITB, 2) create bias for image transfer from ITB to paper (PTR), and 3) neutralize the charges on the both sides of the paper to separate the paper from the ITB (SepDC, SepAC). These settings are used when printing on Special Paper 2 in the black-and-white mode and are</p>		

	applied only to the image area.	
1	ITB	[0 to 70/0.1 μa]
7	Side1:PTR	[-100 to 0/1 μa]
8	Side1:SepDC	[0 to 10/0.1 μa]
9	Side1:SepAC	[8 to 12/0.1 kV]
12	Side2:PTR	[-100 to 0/1 μa]
13	Side2:SepDC	[0 to 10/0.1 μa]
14	Side2:SepAC	[8 to 12/0.1 kV]

2806	Sp2 FC Bias	
	Set Bias for Special Paper 2: K. These SPs set the standard values of the electrical charges that are applied to 1) create bias for image transfer from drum of each color (Y, M, C, K) to the ITB, 2) create bias for image transfer from ITB to paper (PTR), and 3) neutralize the charges on the both sides of the paper to separate the paper from the ITB (SepDC, SepAC). These settings are used only for Y, M, C, K when printing on Special Paper 1 in the full-color mode and are applied only to the image area.	
1	ITB:K	[0 to 70/0.1 μa]
2	ITB:M	[0 to 70/0.1 μa]
3	ITB:C	[0 to 70/0.1 μa]
4	ITB:Y	[0 to 70/0.1 μa]
13	Side1:PTR	[-100 to 0/1 μa]
14	Side1:SepDC	[0 to 10/0.1 μa]
15	Side1:SepAC	[8 to 12/0.1 kV]

Group 2000

21	Side2:PTR	[-100 to 0/1 μ a]
22	Side2:SepDC	[0 to 10/0.1 μ a]
23	Side2:SepAC	[8 to 12/0.1 kV]

These SPs set the paper size correction coefficients for Special Paper 2 relative to the settings done with SP2308 (Set Psize Thresh). All of these settings:

- Apply to printing on Special Paper 2 in the black-and-white mode
- Apply only to the image area

The title of each SP tells you the side and size where the setting is applied at ITB-to-paper transfer, for example: "Side1:Size1:PTR" means the setting applies to only Side 1 of Size 1 when the image is transferred from belt to paper at the PTR.

2821	LEdge Cor:Sp2:K	
	Leading Edge Correction for Special Paper 2: K. Sets the leading edge correction coefficient when bias is applied as far as allowed by the setting of SP2822 for drum to image transfer of the image during black and white copying on Special Paper 2.	
7	Side1:PTR	[0 to 250/1%]
8	Side1:SepDC	
9	Side1:SepAC	
12	Side2:PTR	
13	Side2:SepDC	
14	Side2:SepAC	

2822	LEdge SWT:Sp2:K	
	Leading Edge Switch Timing for Special Paper 2: K. Sets the switch off timing. The selected value is the number of mm from the leading edge. Applies only to printing in black-and-white mode on Special Paper 2.	

2	PTR	[0 to 30/ 1mm]
3	SepDC	
4	SepAC	

2823	TEdge Cor:Sp2 K – PTR	
	Trailing Edge Correction for Special Paper 2: K. Sets the bias applied at the trailing edge when the image is transferred from ITB to paper by setting the start timing for SP2824 at the trailing edge. Applied to the trailing edge for black-and-white mode on Special Paper 2 only.	
7	Side1:PTR	[0 to 250/1%]
12	Side2:PTR	

2824	TEdge SWT:Sp2 K (PTR)	
	Trailing Edge Switch Timing for Special Paper 2: K. Sets the switch timing that determines the distance from the leading edge where the settings of SP2823 is applied during image transfer from ITB to paper. Applied only when in black-and-white mode on Special Paper 2. [-100 to 0/1 mm]	

Appendix:
Service
Program
Mode Table

Group 2000

2826	LEdge Cor:Sp2 FC	
	<p>Leading Edge Correction for Special Paper 2: FC. These SPs do the following settings when printing on Special Paper 2 in the full-color mode:</p> <p>1) PTR: Sets the strength/timing of the correction coefficient for the application of bias when the image is transferred from ITB.</p> <p>2) SepDC, SepAC: Set the strength/timing of the dc and ac charges applied to neutralize the charges on the belt and paper so they will separate more easily.</p> <p>Note: SP2826 selects the strength of the bias coefficient, and SP2827 sets the start timing of the bias application.</p>	
7	Side1:PTR	[0 to 250 / 1%]
8	Side1:SepDC	
9	Side1:SepAC	
12	Side2:PTR	
13	Side2:SepDC	
14	Side2:SepAC	

2827	LEdge SWT:Sp2 FC	
	<p>Leading Edge Switch Timing for Special Paper 2: FC. Sets the switch off timing of SP2826. The selected value is the number of mm from the leading edge. Applies only to printing in full-color mode on Special Paper 2.</p>	
2	PTR	[0 to 30/ 1 mm]
3	SepDC	
4	SepAC	

2828	TEdge Cor:Sp2 FC	
	Trailing Edge Correction for Special Paper 2: FC. Sets the strength of the bias coefficient for the bias applied at the trailing edge when the image is transferred from ITB to paper. Applied when printing in full-color mode on Special Paper 2.	
7	Side1:PTR	[0 to 250/1%]
12	Side2:PTR	

2829	TEdge SWT:Sp2 FC	
	Switch Timing for Special Paper 2: FC. Sets the switch timing that determines the distance from the leading edge where the SP2828 settings are applied during image transfer from ITB to paper. Applied only when printing in full-color mode on Special Paper 2. [-100 to 0/1 mm]	

2830	Sp2:K:LLL	Special Paper 2: K Very Low
2831	Sp2:K:LL	Special Paper 2: K Low
2832	Sp2:K:ML	Special Paper 2: K Medium Low
2833	Sp2:K:MM	Special Paper 2: K Medium
2834	Sp2:K:MH	Special Paper 2: K Medium High
2835	Sp2:K:HH	Special Paper 2: K High
	<p>These SPs set the paper size correction coefficient for the image to paper transfer bias threshold values calculated based on the reading of the absolute humidity from the temperature/humidity sensor and the thresholds set with SP2304 8.</p> <p>SP2830 – Up to SP2304 001: Threshold 1 SP2831 – More than SP2304 001 Threshold 1, up to SP23204 002 Threshold 2. SP2832 – More than SP2304 002 Threshold 2, up to SP2304 003 Threshold 3 SP2833 – More than SP2304 003 Threshold 3, up to SP2304 004 Threshold 4</p>	

Group 2000

	SP2834 – More than SP2304 004 Threshold 4, up to SP2305 005 Threshold 3 SP2835 – More than SP2304 005 Threshold 5 These settings apply only to the image area printed on Special Paper 2 in black-and-white mode.	
1	ITB	[10 to 200/ 1%
7	Side1:PTR	
8	Side1:SepDC	
9	Side1:SepAC	
12	Side2:PTR	
13	Side2:SepDC	
14	Side2:SepAC	

2840	Sp2:FC:LLL	Special Paper 2: FC Very Low
2841	Sp2:FC:LL	Special Paper 2: FC Low
2842	Sp2:FC:ML	Special Paper 2: FC Medium Low
2843	Sp2:FC:MM	Special Paper 2: FC Medium
2844	Sp2:FC:MH	Special Paper 2: FC Medium High
2845	Sp2:FC:HH	Special Paper 2: FC High
	These SPs set the standard values of the electrical charges that are applied to 1) create bias for image transfer from drum to ITB, 2) create bias for image transfer from ITB to paper (PTR), and 3) neutralize the charges on the both sides of the paper to separate the paper from the ITB (SepDC, SepAC). These settings are used when printing on Special Paper 2 in the full-color mode and are applied only to the image area.	
1	ITB	[10 to 200/ 1%
17	Side1:PTR	

18	Side1:SepDC	
19	Side1:SepAC	
27	Side2:PTR	
28	Side2:SepDC	
29	Side2:SepAC	

2901	Disp T/H Sn:PCU	
	<p>Temperature/Humidity Sensor: PCU. This SP displays the temperature (°C) and humidity (both relative and absolute) readings of the temperature and humidity sensor located above the M PCU on the right side of the machine. These readings are updated every 60 sec.</p> <ul style="list-style-type: none"> ▪ 001 to 004 display the current readings. ▪ 005 to 008 display the previous readings. 	
1	Humid:Recent	[0 to 100/ 1 deg (or %rH)]
2	Rel Humid:Recent	
3	Abs Humid:Recent	
4	Environ:Recent	
5	Humid:JobEnd	
6	Rel Humid:JobEnd	
7	Abd Humid:JobEnd	
8	Environ:JobEnd	

Appendix:
Service
Program
Mode Table

Group 2000

2902	Env Set:PCU	
	Use these settings to turn off the temperature/humidity sensor, and raise or lower the level of detection. [0 to 6/1	
	0: Sensor Detect 1: LLL 2: LL 3: ML	4: MM 5: MH 6: HH

2903	Env Thresh: PCU	
	This SP sets the threshold value of LL and ML for the current room temperature.	
1	Abs Humid: 1	[0 to 100/0.01 g/m ³]
2	Abs Humid: 2	
3	Abs Humid: 3	
4	Abs Humid: 4	
5	Abs Humid: 5	

2904	Prevent Blade Bending	
	<p>A blade-bend prevention pattern is created with K toner on the ITB between every copy image to lubricate the ITB cleaning blade so it will not bend or scour the surface of the ITB. These SPs set 1) pattern creation interval, 2) density of the pattern, 3) whether the pattern is displayed, 4) the temperature at which the operation is done.</p> <p>Note: This function is OFF. Changing this setting is normally not required for this machine.</p>	
1	Pattern Create Interval	Sets the number of pages between patterns. [0 to 200/1 pg.]

2	Pattern Light Intensity	Sets the density of the pattern. [0 to 63/1]
3	Op Pg Count Display	Displays the count for the number of blade prevention patterns. [0 to 200/1 pg.]
4	Set Operation Temp	Sets the threshold temperature for this SP code to start operating. [0 to 50/ 1 deg]

2905	Used Toner Mtr 2	Used Toner Motor 2 Control
	The used toner bottle is provided with a near-full sensor and an auger that evenly distributes the used toner inside the bottle. To extend the life of the used toner bottle near-full motor that rotates this auger, the motor and auger do not operate continuously. The motor is turned on only after a prescribed amount of toner has been consumed.	
1	Tnr Consumed	Sets the amount of toner to be consumed before the used toner bottle is switched on. [1 to 10/1 g]
2	Tnr Mtr On Time	Sets the amount of time the motor remains on. [1 to 10/1 sec.]

Group 2000

2906	Stop Time Reverse Ctrl	
	<p>The K drum motor, YMC drum motor, ITB motor, and PTR motor can be set to reverse slightly immediately after they stop. This removes dust from the edges of the cleaning blades. These SP codes:</p> <ul style="list-style-type: none"> ▪ Switch this feature on/off (Default: OFF) ▪ Set the absolute intervals (distance) for execution of stop/reverse timing ▪ Set the intervals (distance) for execution of stop/reverse timing during long print jobs. 	
1	Set Rev Execute:K	<p>These SP codes switch on/off the stop/reverse feature for the K PCU drum motor, YMC PCU drum motor, ITB motor, and PTR motor.</p> <p>Default: Off</p>
2	Set Rev Execute:YCM	
3	Set Rev Execute:ImgTrans	
4	Set Rev Execute:PaperTrans	
5	Set Rev Execute Interval	<p>Sets the distance interval between motor stop/reverse executions.</p> <p>[1 to 500/ 1 m] Default: 30 m</p>
6	Assign Execution	<p>Switches on the time interval that controls motor reverse executions during continuous print jobs.</p>
7	Set Execute Interval	<p>Sets the distance interval between motor reverse executions during continuous print jobs.</p> <p>[1 to 500/ 1 m] Default: 250 m</p>
8	Op Time Setting:Bk	<p>Sets the length of time for the K PCU drum motor to reverse.</p> <p>[2 to 500/30/2 msec]</p>
9	Op Time Setting:YCM	<p>Sets the length of time for the YMC PCU drum motors to reverse.</p> <p>[2 to 500/30/2 msec]</p>
10	Op Time Setting:ImgTrans	<p>Sets the length of time for the ITB motor</p>

		to reverse. [2 to 500/30/2 msec]
11	Op Time Setting:PaperTrans	Sets the length of time for the PTR motor to reverse. [2 to 500/30/2 msec]
12	Adj Reverse Start Time	Synchronizes the timing for the K PCU drum motor, ITB motor and PTR motor to reverse simultaneously. [2 to 500/0/2 msec]

2907	PTR Lift DFU	
	<p>This SP switches the operation of the PTR lift motor off and on. The PTR lift motor presses the PTR against the fusing belt above during belt-to-paper image transfer and lowers the PTR when it is idle. This prevents the PTR from warping.</p> <p>[*0: Lift Operation On] [1: Lift Operation Off]</p>	

2911	Environ Ctrl	
	<p>These SP codes control the operation of the Peltier unit.</p> <p>Note: The Peltier unit is not provided as a standard component of this machine. However, it is available as an option.</p>	
1	Environ Ctrl On	Switches Peltier unit control on/off. *OFF/ON
4	Op Humidity	Sets the humidity level for the Peltier unit to operate. [0 to 100/60/1%]
5	Stop Humidity	Sets the humidity level for the Peltier unit to switch off. [0 to 100/35/1%]

Group 2000

6	Op On Time	Sets the timer for the humidity level for the Peltier unit to switch on, regardless of the humidity level control settings done with SP2911-4, -5. [1 to 60/10/1 min.]
7	Op Off Time	Sets the timer for the humidity level for the Peltier unit to switch off, regardless of the humidity level done with SP2911-4, -5. [1 to 60/5/1 min.]

2912	Encoder Sn:Adj Light	
1	Adj Light Amt	
2	Light Amt Adj:Pass/Fail	
3	Vref_Dis:Main Setting	
4	Vref_Dis:Sub Setting	
5	Analog Out:Main:After F Adj	
6	Analog Out:Sub:After F Adj	
7	Light Amt Change Flag	

2913	Encoder Sn:Output Disp	
1	Analog:Ave:Main	
2	Analog:Max:Main	
3	Analog:Min:Main	
4	Analog:Ave:Sub	
5	Analog:Max:Sub	
6	Analog:Min:Sub	

2914	Encoder Sn:Get 1stPhase	
1	Get Phases:Execut All	
2	352.8 Line Speed:Execute	
3	282.0 Line Speed:Execute	
4	176.4 Line Speed:Execute	
5	141.0 Line Speed:Execute	
6	352.8 Phase Disp/Set	
7	282.0 Phase Disp/Set	
8	176.4 Phase Disp/Set	
9	141.0 Phase Disp/Set	

2915	Encoder Sn Ctrl Condition DFU	
1	SC499 Occurrences	
2	SC499 Causes	
3	ITB Encoder Sn Ctrl	
4	No Scale Counts	
5	Scale Abnormal Counts	
6	Ctrl Unstable Counts	

Appendix:
Service
Program
Mode Table

4.4 GROUP 3000

3001	TD Sn:Vt Display	
	<p>Displays the current value of Vt (output voltage of the TD sensor). This is the value that the machine uses to calculate the density of the toner in each development unit. The toner density is checked after every page prints. The TD sensor output voltage is inversely proportional to the toner density:</p> <ul style="list-style-type: none"> ▪ If toner density is high, the voltage is low. ▪ If toner density is low, the voltage is high. <p>Note: These readings are used to control toner supply. When the machine uses PID logic to control the machine (the default method selected with SP3301 001). The difference between Vt and Vtref is calculated and this result is used to control the on time of the sub hopper clutches that control the supply of toner to the PCUs.</p>	
	1	Current Val:K
	2	Current Val:M
	3	Current Val:C
	4	Current Val:Y
	[0 to 5./0.01 V]	

3002	Vtcnt:Disp/Set	
	<p>Display Vtcnt (TD Sensor Control Voltage).</p> <p>Use SP 3002-001 to 004 to display and confirm the present Vtcnt setting. Vtcnt is the TD sensor control voltage. If there is a large difference between this value and the value of SP3002-005 to 008 (Initial Vtcnt), this means that over time Vtcnt will require large adjustments due to environmental conditions. The initial value of Vtcnt is determined when the developer is initialized. This value is used as a reference to adjust Vt during the auto process control self check and when the TD sensor checks the toner density between pages.</p>	
	1	Current Val:K
	[0 to 12/0.01 V]	

2	Current Val:M	
3	Current Val:C	
4	Current Val:Y	
5	Initial Val:K	[0 to 12/0.01 V]
6	Initial Val:M	
7	Initial Val:C	
8	Initial Val:Y	

3003	Vtref:Disp/Set	
	<p>This SP displays the TD sensor target voltage. This target voltage is inversely proportional to the density of the toner:</p> <ul style="list-style-type: none"> ▪ If the target is high, toner density is lowered. ▪ If the target is low, toner density is raised. <p>The machine uses readings of the ID sensor patterns between pages to determine the amount of toner coverage and compared with the threshold values for the upper and lower limit of coverate. The result of this calculation is used to calculate Vtref.</p> <p>Note: Vtref is the TD sensor reference voltage. It is frequently updated to stabilize the toner concentration in the development unit.</p>	
1	Current Val:K	[0 to 5/0.01 V]
2	Current Val:M	
3	Current Val:C	
4	Current Val:Y	
5	Initial Val:K	[0 to 5/0.01 V]
6	Initial Val:M	
7	Initial Val:C	
8	Initial Val:Y	

Group 3000

3004	Vtref: Disp/Set
1	Upper: K
2	Upper: C
3	Upper: M
4	Upper: Y
5	Lower: K
6	Lower: C
7	Lower: M
8	Lower: Y

3010	TD Sn: Factory Data: K	
3011	TD Sn: Factory Data: M	
3012	TD Sn: Factory Data: C	
3013	TD Sn: Factory Data: Y	
	These SP codes display the factory default settings for TD sensor initialization for the K, M, C, and Y PCUs.	
1	Vtcnt	
	Gain value calculated during TD sensor initialization. This is used to adjust the Vt (TD sensor output). A large gain increases Vt, and a small gain decreases it. The result of this calculation is also used to calibrate Vt during TD sensor initialization.	
2	Vt(H)	"x" is K, M, C, or Y. The Vt readings are H (High), M (Medium), L (Low).
3	Vt(M)	
4	Vt(L)	

3021	Set Vt Shift	
	Use this SP to correct Vt (TD sensor output voltage) in the low speed mode (128 to 256 g/m ²). The machine then uses this value to calculate Vt for low speed mode.	
1	Shift (Stdd1)	V-C2a [0 to 5/ 0/ 0.01 V] V-C2b [0 to 5/ 0.2/0.01 V]
2	Shift (Half d2)	
3	Shift (Half d1)	

3042	Set Vtref Cor	
	<p>Set Vtref Correction.</p> <p>Vtref is frequently updated in the toner supply cycle to stabilize the concentration of toner in the developer. Vtref is corrected between every printed page in the paper path using the correction amounts listed below for each color. This is the default setting (0) for SP3042 001. However, you can use this SP to switch this function off.</p> <p>Vtref (TD sensor reference voltage). It is frequently updated to stabilize the toner concentration in the development unit.</p>	
1	Vtref Corr Mode	[0 to 1/1] 0: On, 1: Off Setting this SP to 1 switches off Vtref correction between pages.
2	Corr Amt(+):K	[0 to 1/0.01 V]
3	Corr Amt(+):M	
4	Corr Amt(+):C	
5	Corr Amt(+):Y	
6	Corr Amt(-):K	
7	Corr Amt(-):M	
8	Corr Amt(-):C	

Group 3000

9	Corr Amt(-):Y	
10	Vtref Corr Target:K	[-0.1 to 0.1/0.001 mg/cm ²]
11	Vtref Corr Target:M	
12	Vtref Corr Target:C	
13	Vtref Corr Target:Y	
14	Corr Thresh:K	[-0.1 to 0.1/0/ mg/cm ²]
15	Corr Thresh:M	
16	Corr Thresh:C	
17	Corr Thresh:Y	

3044	Img Area	
	These SP codes display the percentage of coverage on printed pages.	
1	Latest:K	[0 to 9999/ 1 cm ²]
2	Latest:M	
3	Latest:C	
4	Latest:Y	
5	Ave.S:K	[0 to 100/ 0.01%]
6	Ave.S:M	
7	Ave.S:C	
8	Ave.S:Y	
9	Ave.M:K	
10	Ave.M:M	
11	Ave.M:C	
12	Ave.M:Y	

13	Ave.L:K	
14	Ave.L:M	
15	Ave.L:C	
16	Ave.L:Y	
17	Set N Pgs Ave.:S	[0 to 100/ 1 sheet]
18	Set N Pgs Ave.:M	
19	Set N Pgs Ave.:L	
24	DotCoverage	[0 to 100/ 0.01%]
25	DotCoverage	
26	DotCoverage	
27	DotCoverage	

Appendix:
Service
Program
Mode Table

3101	ID Pattern:Display	
	<p>ID Sensor Pattern Coverage Display. Displays the amount toner to be used (coverage) to create the ID sensor patterns between pages. The ID sensors cannot accurately detect the patterns if there is too much reflectivity from the black toner. This SP changes the solid ID sensor pattern to a hatched pattern.</p> <p>Note: SP3101-1 to 4 sets detection and update timing for the creation of the ID sensor patterns.</p>	
1	Applied:K	
2	Applied:M	
3	Applied:C	
4	Applied:Y	
5	Target Apply:K	
6	Target Apply:M	

Group 3000

7	Target Apply:C	
8	Target Apply:Y	

3102	ID Pattern:Int	
	These SP patterns set the time interval for creation of the ID sensor pattern on the drum.	
1	Create Int:K	[0 to 200/10/ 1 page]
2	Create Int:M	
3	Create Int:C	
4	Create Int:Y	
5	K Page Cnt	[0 to 200/0/ 1 page]
6	M Page Cnt	
7	C Page Cnt	
8	Y Page Cnt	

3111	ID Sn:Voffset DFU	
	Displays the output voltage of the directly reflected light when the LED of the ID sensor is switched off.	
1	Voffset_Reg	[0 to 5/0.01 V]
2	Voffset_Dif	

3121	Adjusted Vsg DFU	
	This SP displays the 1) results of the most recent Vsg adjustment.	
1	Vsg_Reg:Col	[0 to 5/0.01 V]
2	Vsg_Dif:Col	

3131	Ifsg After Vsg	
	Displays as a PWM value (pulse width modulation) the level of the ID sensor LED after Vsg has been adjusted. Normal Vsg readings of the ITB bare surface reflectivity should be in the range 4.0 ±0.2V.	
1	Ifsg: Ctr	[0 to 4096/1]
3	Ifsg: Ini	

3141	ID Sn:Vmin	
	Displays the minimum values read from the graduated patterns read by the ID sensor during process control.	

Appendix:
Service
Program
Mode Table

Group 3000

3194	ID Coeff Display	
	Displays the most recent and averaged readings of the sensitivity correction coefficients (K2 and K5).	
1	K2:Last	[0 to 5/0.0001]
2	K5:Last	
5	K2:Ave	
6	K5:Ave	

3251	Tnr Supply Time	
	Toner Calibration Time: Display Displays for confirmation the length of time the sub hopper clutch remained on to send toner to the sub hopper after a new toner cartridge was installed.	
1	Sub Hopper CL:K	[0 to 99 999 999/1 ms]
2	Sub Hopper CL:M	
3	Sub Hopper CL:C	
4	Sub Hopper CL:Y	
5	Toner Pump CL:K	Use these SPs to display the accumulated drive time for each powder pump clutch before installing a new one. [0 to 99 999 999/1 ms]
6	Toner Pump CL:M	
7	Toner Pump CL:C	
8	Toner Pump CL:Y	

3301	Tnr Supply	
	Select toner supply method	
1	K	[0 to 1/1] 0: Fixed toner supply 1: PID Toner Supply
2	M	
3	C	
4	Y	

3302	Tnr Supply	
	Sets the toner supply rate for fixed toner supply mode. The rate is set by adjusting the on time of the toner supply clutch. This setting is used only if SP3301 is set to "0".	
1	Supply Rate:K	[0 to 100/ 1%]
2	Supply Rate:M	
3	Supply Rate:C	
4	Supply Rate:Y	

Appendix:
 Service
 Program
 Mode Table

Group 3000

3303	Tnr Supply Rate	
	<p>Displays for confirmation the toner supply rate of toner supply control using the PID method. The toner supply rate is calculated as:</p> $\text{Toner Supply Rate} = \text{Toner Supply Time} / \text{Time Allowed for Toner Supply} \times 100$ <p>where:</p> <ul style="list-style-type: none"> ▪ Time is measured in msec. ▪ "Time Allowed for Toner Supply (ms)" = Length of the paper (mm) + Width of the gap between sheets (mm) / Drum speed (mm/s) x 1000. <p>Note: The toner supply control method is selected with SP3301.</p>	
1	Last Val:K	[0 to 100/1%]
2	Last Val:M	
3	Last Val:C	
4	Last Val:Y	

3304	Tnr SupplyLimits	
	<p>Set Upper/Lower Limits for Toner Supply.</p> <p>Sets the upper and lower limits for toner supply rate with the fuzzy logic (PID) used as the toner supply control method.</p> <p>Note: This SP takes effect only if 1 is selected for SP3301 to enable fuzzy logic as the toner supply method.</p> <p>The machine reads 1) the maximum and minimum settings of this SP and 2) the toner consumption of the output image surface (pixel count data). Then it calculates the maximum and minimum amount of toner for that image. After this is done, toner supply amount will not change during the job, even if Vt or any other measurement determines that more toner is necessary.</p>	
1	Max Supply Rate:K	[0 to 150/1%]
2	Max Supply Rate:M	

3	Max Supply Rate:C	[0 to 255/1 ms]
4	Max Supply Rate:Y	
5	Min Supply Time:K	
6	Min Supply Time:M	
7	Min Supply Time:C	
8	Min Supply Time:Y	

3306	Tnr Supply Coeff	
	Set Toner Supply Coefficient These SPs set the toner supply coefficients for the fuzzy logic method of toner supply control. Note: These SP codes operate only when 1 is selected for SP3301.	
1 – 4	Ratio Coeff1:K, M, C, Y	[0 to 4300/1]
21 – 24	P_Vt_Coeff:K, M, C, Y	[0 to 150/1%]
25 – 28	I_Vt_Coeff:K, M, C, Y	
29 – 32	Si:K, M, C, Y	[-5 to 5/0.01]
33 – 36	P_Px1_Coeff1:K, M, C, Y	[0 to 150/1%]
37 – 40	P_Px1_Coeff3:K, M, C, Y	[0 to 2.55/0.01]
41 – 44	P_Px1_Coeff3:K, M, C, Y	

Group 3000

3310	Next Tnr Supply	
	Displays information about the next toner supply: Amount, Image Area (coverage), Wait Time	
1	K Amount	[0 to 65 535 / 1 mg]
2	M Amount	
3	C Amount	
4	Y Amount	
5	K Image Area	[0 to 65 535 / 1 cm ²]
6	M Image Area	
7	C Image Area	
8	Y Image Area	
9	K Wait Time	[0 to 65 535 / 1 mg]
10	M Wait Time	
11	C Wait Time	
12	Y Wait Time	

3401	TE Detect Set DFU	
	This SP code switches operation of the toner end sensor off/on. [*0:Detect], [1: No Detect]	

3410	Toner Remains	
	These SP codes display the estimated amount of toner remaining.	
1	K	These SP codes display the estimated amount of toner remaining.
2	M	

3	C	[0 to 10 / 1]
4	Y	10 to 2: Full to sufficient toner remaining 2: Estimated near end 1: Measured near end 0: Toner end
5	K Remain	These SP codes display by weight (mg) the amount of toner remaining. [0 to 99 999 999/ 1 mg]
6	M Remain	
7	C Remain	
8	Y Remain	
9	K % Remain	These SP codes display the percent of toner remaining. [0 to 100/ 1%]
10	M % Remain	
11	C % Remain	
12	Y % Remain	

3411	TNE Detect Disp/Set	
	This SP sets the number of pages to print after the toner near-end alert has been issued.	
1	TNE:K Sheets	Sets toner end to be measured by the number of sheets printed (toner end sensor input is ignored). [0 to 30/ 1 Sheet]
2	TNE:YMC Sheets	
3	K Pg Count	Displays the number of continuous sheets detected for toner end while the toner end sensor input is ignored. [0 to 30/ 1 Sheet]
4	M Pg Count	
5	C Pg Count	
6	Y Pg Count	
7	Disp Timing:K	This setting displays the percentage of toner remaining for toner near end.
8	Disp Timing:M	

Group 3000

9	Disp Timing:C	[0 to 100/ 1%]
10	Disp Timing:Y	

3412	TE Detect:Disp/Set	
	These SP codes determine how many pages print before toner supply reaches toner end.	
1	TE:Sheets:Min:K	These SPs set the minimum number of monochrome and color pages guaranteed to print after the machine has determined near end until the toner-end message is displayed. [0 to 50 / 10/ 1 Sheet]
2	TE:Sheets:Min:Col	
3	TE:Sheets:Max:K	These SPs set the maximum number of pages for monochrome and color guaranteed to print after the machine has determined near end until the toner-end message is displayed. [0 to 2000/ 600/ 1 Sheet]
4	TE:Sheets:Max:Col	
5	TE:Pixel:K	These SP codes set the number of pages for monochrome and color pages to be output based on 100% A4 coverage after the machine has determined near end until the toner-end message is displayed. [0 to 100/ 30/ 1 Sheet]
6	TE:Pixel:Col	
7	K Page Cnt	These SP codes determine for each color how many pages will be output after the machine has determined near end. [0 to 2000/ 0/ 1 Sheet]
8	M Page Cnt	
9	C Page Cnt	
10	Y Page Cnt	
11	K Pixel Cnt	These SP codes display the number of pages for monochrome and color pages to output
12	M Pixel Cnt	

13	C Pixel Cnt	based on the amount of toner consumed (cm ²) after the machine determined near end. [0 to 1 000 000/ 0/ 1 cm ²]
14	Y Pixel Cnt	
15	Page Cnt Stop:Coverage	This SP sets the number of pages to print after the machine has determined near end based on percent of A4 coverage until the toner pump is switched off. [0 to 100/ 0/ 1%]

3501	Select ProCon	
	Select Process Control Method The settings of these SP codes modify the operation of the automatic process control self-check. Automatic process control is done at these times:	
	<ul style="list-style-type: none"> ▪ When the machine is turned on ▪ At the end of the job, if the number of pages since the previous process control, exceeds the value of SP 3551 ▪ Before ACC adjustment ▪ When the developer is initialized with SP3811. 	
	For more about process control, see "Process Control" in Section 6.	
1	Recover Min: Col [0 to 2/1] 0: Auto , 1: Fixed When the machine starts (with the front door closed), the process control self-check begins using as reference bias voltages set with the Group 3 SP codes. The referenced voltages are different, depending on whether "Auto" or "Fixed" is set:	
	Referenced SPs with "Auto" Selected	
	SP3575 001 to 016	Dev DC Control
	SP3576 001 to 016	Chrg DC Control
	SP3577 001 to 004	Chrg AC Control
	SP3581 001 to 008	LD Power Control

Group 3000

	SP3551 001, 002	Procon Int
	SP3554 001	Init ProCon Set
	SP3801 001	DevSetup Execute
	SP3811 001 to 006	DevSetup Execute
	Reference SPs with "Fixed" Selected	
	SP2201 001 to 004	Set DC Charge
	SP2202 001 to 004	Set AC Charge
	SP2211 001 to 004	Set LD Power
	SP2212 001 to 004	Set Dev DC
3	Density Adj Mode	<p>Sets the execution timing of toner density adjustment with the automatic process control self-check.</p> <p>[0 to 3/1]</p> <p>0: Do not execute, 1: 1st Power On, 2: 1st Power On & Job End</p>
4	ACC Before ProCon	<p>Determines whether process control is executed before a gradation test pattern is printed using the operation panel with: [User Tools]> Maintenance> Auto Color Calibration</p> <p>[0 to 3/2/1]</p> <p>0:Do not execute 1:Execute Potential Control 2:Execute Potential Control and Toner Density Adjustment</p>
5	DnstyAdjTimes	<p>Sets the upper limit of the loop wherein density is adjusted during process control. Default: 5</p>

6	DevGamma(Env Corrct)	Switches correction of the development gamma adjustment with the readings of the temperature/humidity sensor off and on. Touch either the "OFF" or "ON" button to toggle the setting.
7	DevGamma(Time Corrct)	Switches the timing of the development gamma adjustment during process control off and on. Touch either the "OFF" or "ON" button to toggle the setting.

3511	Poten Tbl:Disp	
	<p>Display Potential Table</p> <p>Displays the numbers in the Potential Table selected for process control. The Potential Table is the lookup table that contains the potential target values (Vd, Vb, VI) for adjustment of the development potential.</p> <ul style="list-style-type: none"> ▪ Vd: Initial charge applied to the drum by the charge roller. ▪ Vb: Development bias ▪ VI: Value used to correct the strength of the lasers. <p>A 4-grade pattern is first created on the drum and then transferred to the ITB:</p> <ul style="list-style-type: none"> ▪ On the drum, the potential sensor uses their readings of this pattern to determine development potential. ▪ On the ITB, the ID sensors use their readings of this pattern to determine the amount of toner coverage necessary. <p>For more about process control, see "Process Control" in Section 6.</p>	
1	Value: K	Displays the current numbers in the Potential Table for each color. [1 to 99/1]
2	Value: M	
3	Value: C	
4	Value: Y	
5	Target: K	Displays the target values for Vd, Vb, VI after

Appendix:
Service
Program
Mode Table

Group 3000

6	Target: M	measurements of ambient conditions and compensating for residual charge on the drum (Vr). If the actual development gamma is less than the target development gamma, this SP shows a smaller value than the selected pointer table value. If the actual development gamma is greater than the target development gamma, this SP shows a larger value than the selected pointer table value. [1 to 99/1]
7	Target: C	
8	Target: Y	
9	Upper Limit	
10	Lower Limit	

3531	ProCon Target	
	<p>Set Target Amount for Process Control</p> <p>This SP sets the value for the maximum coverage to be achieved by the process control self-check. Process control then analyzes the readings of the 4-grade pattern, calculates the potentials required for development gamma and Vk (starting voltage), and then determines the drum charge levels, development biases, and LD power levels necessary to achieve the target coverage.</p> <p>Note</p> <ul style="list-style-type: none"> This SP can be used to darken printed images. <p>After this SP is changed, process control must be executed manually with SP3820.</p>	
1	Max Tnr Amt:K	[0 to 1/ 0.001 mg/cm ²]
2	Max Tnr Amt:M	
3	Max Tnr Amt:C	
4	Max Tnr Amt:Y	

3540	Image Quality Adjust: Interval	
	Adjusts the interval between image quality adjustments.	
1	During Job	Sets the page interval for image quality adjustment. [0 to 100/30/1 Page]
2	During Standby	Sets the time interval for image quality adjustment while the machine is in standby mode. [0 to 100/10/1 Min.]

3551	Set Procon:Job End	
	This SP sets timing of the process control self-check for job end. The process control self-check never interrupts a job to execute, even if it is time for the next self-check.	
1	B/W Mode	
	This SP sets the page interval for execution of process control at job end for monochrome printing. [0 to 5000/250/1]	
2	Color Mode	
	This SP sets the page interval for execution of process control at job end for color printing. [0 to 5000/250/1]	
3	Pg Cnt:B&W Mode	Displays the current page interval counts for the execution of process control execution for both monochrome and color printing. [0 to 5000/0/1]
4	Pg CntColor Mode	

Group 3000

3552	Set Procon:Interrupt	
	These SP codes settings determine whether a long print job is interrupted temporarily in order to execute process control. (Normally long print jobs are not interrupted for process control unless these settings are changed.)	
1	B/W Mode	
	Sets the page interval to trigger process control during a long monochrome print job. [0 to 2000/0/ 1 sheet]	
2	Color Mode	
	Sets the page interval to trigger process control during a long color print job. [0 to 1000/0/ 1 sheet]	
3	Pg Cnt:B&W Mode	Displays the current page counts that will interrupt long monochrome or color print jobs in order to execute process control. [0 to 5000/ 0/ 1 sheet]
4	Pg Cnt:Color Mode	

3554	Init ProCon Set	
	<p>The machine determines the amount of time elapsed since the drum motors stopped (print end, process control end, etc.) and the amount of change in the temperature and humidity since the last cold start.</p> <p>In order to determine if initial processing control self-check executes, the machine compares:</p> <ul style="list-style-type: none"> ▪ The time the drum stop last stopped (SP3556-1 to 5: Last Print Date/Time) ▪ The temperature and humidity when the drum last stopped (SP2901-5 to 8) <p>If the difference between temperature and humidity is higher than the temperature/humidity threshold for a cold start, then initial process control self-check executes again.</p>	
1	Non-use Time Setting	

	Sets the amount of time to elapse for the K drum motor to remain idle after power on. [0 to 1440/360/1 min.]
2	Temperature Range
	Sets the temperature for the K drum motor idle time at power on. [0 to 99/ 10/ 1 degC]
3	Relative Humidity Range
	Sets the relative humidity for the K drum motor idle time at power on. [0 to 99/ 50/ 1 % rh]
4	Absolute Humidity Range
	Sets the absolute humidity for the K drum motor idle time at power on. [0 to 99/ 6 1 g/m ³]

3555	Non-use Time Procon Set
	After the time set with SP3540-2 has elapsed the current temperature and humidity are compared with the temperature and humidity the last time the drum stopped. If the difference is greater than the threshold values set with this SP, initial process control executes.
1	Non-use Time Setting
	Sets the amount of time to elapse from the last time the K drum motor stopped. The reading is updated every 10 minutes. [0 to 1440/360/1 min.]
2	Temperature Range
	Sets the temperature to be compared with the temperature from the last time the K drum motor stopped. The reading is updated every 10 minutes. [0 to 99/ 10/ 1 degC]

Appendix:
Service
Program
Mode Table

Group 3000

3	Relative Humidity Range
	Sets the relative humidity to be compared with the relative humidity from the last time the K drum motor stopped. The reading is updated every 10 minutes. [0 to 99/ 50/ 1 % rh]
4	Absolute Humidity Range
	Sets the absolute humidity to be compared with the relative humidity from the last time the K drum motor stopped. The reading is updated every 10 minutes. [0 to 99/ 6 1 g/m ³]
5	Max Times
	Sets the maximum number of times for these SP codes to execute while the machine remains in standby mode. [0 to 99/ 10/ 1 times]

3556	Latest Print Date Time	
	These SP settings display the date of the most recent print job.	
1	Year	[1 to 12/1/1 year]
2	Month	[1 to 31/1/1 month]
3	Day	[1 to 23/1/1 day]
4	Hour	[1 to 23/1/1 hour]
5	Min.	[1 to 59/1/1 min.]

3561	Dev gamma:Disp/Set	
	<p>Displays the value of development gamma, an indicator of development capacity. In order for the machine to determine the development potential to obtain the target coverage. During processing control the graduated patterns are created first on the drums and then on the ITB. The potential sensors read the development potential, and the ID sensors read the amount of coverage on the ITB.</p> <p>Plotting the development potential on the X axis against coverage on the Y-axis results in the development gamma curve. For more, see "Process Control" in Section 6.</p>	
1-4	Actual Val:K,M,C,Y	
5-8	Target Val:K,M,C,Y	
9-12	Initial Val:K,M,C,Y	
13	Environ Corr:Bk	
14	Environ Corr:Col	
15-18	Time Lapse Corr:K,M,C,Y	
19-22	Tnr Density Corr:K,M,C,Y	
23-26	Toner Use Count:K,M,C,Y	
27-30	TnrDensity:K,M,C,Y	
31-38	Environ Corr 1-8:K	
39-46	Environ Corr 1-8:Col	
47-56	Time Lapse Corr 1-10:K	
57-71	Time Lapse Corr 1-15:Col	

Group 3000

3562	Display Vk	
	<p>Display Vk (Development Start Voltage)</p> <p>Displays Vk, the development start voltage. This development start voltage is used to indicate whether the developer has deteriorated. However, this is only a rough measurement due to other factors:</p> <ul style="list-style-type: none"> ▪ A low threshold setting for the target development gamma. ▪ Operational variations between machines ▪ Precision of the ID sensor measurements <p>Normal range for Vk: -150V to +150V</p>	
1	K	[-300 to +300/1 V]
2	M	
3	C	
4	Y	

3563	Display Vr	
	<p>Display Vr (Residual Potential)</p> <p>Vr is the potential that remains on the surface of the drum after full exposure to the laser. The existence of this residual voltage is used as an indicator to determine the level of deterioration of the drum. Vr becomes larger as the drum deteriorates.</p> <p>Normal range for Vr: -200V to 0V</p>	
1	K	[-300 to +300/1 V]
2	M	
3	C	
4	Y	

3571	Display V0	
------	------------	--

	Display Vd (Value for Control of Charge Potential) Displays the value for V0, the measure of drum potential on dark areas of the drum before laser exposure. Normal range: -700 V to -500 V	
1	K	[-999 to 0/1 V]
2	M	
3	C	
4	Y	

3572	Display Vdhome	
	Display Vd (Value for Control of Charge Potential) Displays the value for Vdhome, the electrical potential of the drum after a fixed dc bias (dc -700V) is applied by the drum charge roller. Normal range: -700V to -500V	
1	K	[-999 to 0/1 V]
2	M	
3	C	
4	Y	

Appendix:
 Service
 Program
 Mode Table

Group 3000

3573	Target Poten:Vd	
	<p>Display Target Potential (VdDisplay)</p> <p>Vd (read by the potential sensor) is the potential of dark areas of a drum before full laser exposure. This SP displays the value of Vd used by processing control to determine the target potential (Vd). The machine performs a calculation using development gamma, Vk and the maximum coverage, and then uses the result to lookup and retrieve the correct voltage from the Potential Table. This retrieved value is used to raise the charge of the charge roller that charges the drums.</p>	
1	K	[-999 to 0/1 V]
2	M	
3	C	
4	Y	

3574	Target Poten:VI	
	<p>Display Target Potential (VIDisplay)</p> <p>VI (read by the potential sensor) is the potential of the exposed areas after full laser exposure. This SP displays the value of VI used by processing control to determine the target potential (VI). The machine performs a calculation using development gamma, Vk and the maximum coverage, and then uses the result to lookup and retrieve the correct voltage from the Potential Table. This retrieved value is used to raise the input current of the laser diode.</p>	
1	K	[-999 to 0/1 V]
2	M	
3	C	
4	Y	

3575	Dev DC Control	
	Display Value for Control of Development DC Displays the development bias that was referenced during processing control and used in the previous jobs (Used if process control is set for Auto with SP3501 001.)	
1	Std Spd2:K	[-999 to -200/ 1V]
2	Std Spd2:M	
3	Std Spd2:C	
4	Std Spd2:Y	
5	Std Spd1:K	[-999 to -200/ 1V]
6	Std Spd1:M	
7	Std Spd1:C	
8	Std Spd1:Y	
9	Low Spd2:K	[-999 to -200/ 1V]
10	Low Spd2:M	
11	Low Spd2:C	
12	Low Spd2:Y	
13	Low Spd1:K	[-999 to -200/ 1V]
14	Low Spd1:M	
15	Low Spd1:C	
16	Low Spd1:Y	

Appendix:
 Service
 Program
 Mode Table

Group 3000

3576	Chrg DC Control	
	Displays the value for control of development dc. (Used if process control is set for Auto with SP3501 001.)	
1	Std d2:K	
2	Std d2:M	
3	Std d2:C	
4	Std d2:Y	
5	Std d1:K	
6	Std d1:M	
7	Std d1:C	
8	Std d1:Y	
9	Low d2:K	
10	Low d2:M	
11	Low d2:C	
12	Low d2:Y	
13	Low d1:K	
14	Low d1:M	
15	Low d1:C	
16	Low d1:Y	

3577	Chrg AC Control	
	Displays the ac bias that was referenced during processing control and used in the previous jobs. Used if process control is set for Auto with SP3501 001.	
1	K	[0.5 to 1.5/ 1/ 0.01 mA]
2	M	[1.6 to 3/ 2.2/ 0.01 kV]
3	C	
4	Y	

3581	LD Power Control	
	Displays the LD power that was referenced during processing control and used in the previous jobs. Used if process control is set for Auto with SP3501 001.	
1	K	NorM2&Low2:K
2	M	NorM2&Low2:M
3	C	NorM2&Low2:C
4	Y	NorM2&Low2:Y
5	K	Norm1&Low1:K
6	M	Norm1&Low1:M
7	C	Norm1&Low1:C
8	Y	Norm1&Low1:Y

Appendix:
Service
Program
Mode Table

Group 3000

3701	Tnr Refresh Mode	
	These SP settings determine how the toner refresh mode is activated.	
5	Image Area Thresh:K	Sets the threshold (percentage of coverage) to trigger toner refresh mode. [0 to 25.5/5/0.1%]
6	Image Area Thresh:M	
7	Image Area Thresh:C	
8	Image Area Thresh:Y	
9	Max Pattern Length	Sets the threshold (number of sheets) to trigger toner refresh mode. [0 to 25/25/1 mm]
10	Need Ref Length:K	Displays the amount of fresh toner required. [0 to 65 535/ 0/1 mm]
11	Need Ref Length:M	
12	Need Ref Length:C	
13	Need Ref Length:Y	
14	Interrupt Thresh:K	Sets the threshold for the amount of toner consumption to trigger toner refresh mode. [0 to 65 535/ 300/1 mm]
15	Interrupt Thresh:M	
16	Interrupt Thresh:C	
17	Interrupt Thresh:Y	

3702	Set Expel Dev Mode	
1	Set Expel Dev Mode	Switches toner purging off/on. Default: ON
2	Required Expel Time:K	Displays the length of time required to purge K, M, C, Y toner. [0 to 655.35/ 0/0.01 sec.]
3	Required Expel Time:M	
4	Required Expel Time:C	
5	Required Expel Time:Y	

6	Execution Threshold Value	Sets the time threshold for toner purging. [2 to 255/15/ 1 sec.]
7	Calculated Value:Half-Speed	Sets the time needed to calculate filling toner for half-speed (thick paper). [0 to 655.35/ 31/ 0.01 sec.]

3710	Tnr Density Adj DFU	
1	K SuppTime Coeff	
2	M SuppTime Coeff	
3	C SuppTime Coeff	
4	Y SuppTime Coeff	
5	K UseTime Coeff	
6	M UseTime Coeff	
7	C UseTime Coeff	
8	Y UseTime Coeff	

3801	Init TD Sensor
	<p>Execute Developer Setup</p> <p>Do this SP after replacing the developer in one or more of the PCUs when servicing the machine. This SP:</p> <ul style="list-style-type: none"> ▪ Checks for the presence of developer in the development unit. This ensures that the development unit has been filled. ▪ Initializes TD sensor. (Calibrates Vtcnt). ▪ Calibrates development gamma and calibrates toner density. Also does the MUSIC check and correction. <p>Note: Do SP3811 after drum and cleaning blade replacement. SP3811 should always be done:</p> <ul style="list-style-type: none"> ▪ During the machine installation procedure after the developer and toner have been installed, and

Group 3000

	<ul style="list-style-type: none"> ▪ During machine maintenance after a drum and cleaning blade have been replaced. <p>In both cases, SP3811 prevents the blade from scouring a dry drum.</p>	
1	All Colors	
2	Col	
3	K	
4	M	
5	C	
6	Y	
7	Dev Auger Time	

3802	TD Sn Init OK?
	<p>This SP displays the results of the TD sensor initialization with SP3801 001 to 006. The machine returns the status of the previous initialization with numbers, 1 digit for each PCU. The numbers are read in order as "K, M, C, Y".</p> <p>Four numbers are used to indicate the status of the execution.</p> <p>1: OK (success)</p> <p>2: Cancelled (door opened, etc.)</p> <p>4: Not executed (not selected for execution; this is not an error)</p> <p>9: Vtcnt abnormal. Vtcnt (TD sensor control voltage) could not be adjusted to within $2.5 \pm 0.2V$. The machine issued a TD sensor error for the PCU where there is a problem (SC372 to SC375).</p> <p>Note!: The "1111" display is read from left to right: KMCY.</p>

3810	CInglNitSetExe	
	<p>These SPs should be executed after replacement of the drum cleaning roller or drum cleaning blade. This SP:</p> <ol style="list-style-type: none"> 1. Checks and confirms that each PCU is installed and filled with developer. 2. Switches on toner supply and sends toner to the sub hopper of each PCU. 3. Sends toner to the PCU to coat the drum with toner. This prevents the cleaning blades from bending and scouring the drums. <p>Note: This SP should be done after replacing the drum cleaning roller or drum cleaning blade.</p>	
1	All Colors	Y, M, C, K
2	Col	Excludes Black (Y, M, C only)
3	K	
4	M	
5	C	
6	Y	
7	A3 Page Cover	<p>Sets the number of sheets for A3 coverage to prevent scouring of the OPC drum.</p> <p>[0 to 100/ 3/ 1 sheet]</p>

3811	DevSetup Execute	
	<p>Execute Developer Setup</p> <p>Do this SP during the installation procedure after the developer and toner cartridges have been installed in the machine, or after the drum and cleaning blade have been replaced. This SP:</p> <ol style="list-style-type: none"> 1. Checks and confirms each PCU is installed and filled with developer. 2. Switches on toner supply and sends toner to the sub hopper of each PCU. 3. Sends toner to the PCU to coat the drum with toner. This prevents the cleaning blades from bending and scouring the drums. 4. Initializes the TD sensors. 	

Group 3000

	<p>5. Starts the process control self-check to set the target for development gamma and adjusts toner density.</p> <p>6. Starts the MUSIC sequence to check and correct color image offset.</p> <p>Note:</p> <ul style="list-style-type: none"> ▪ After doing SP3811, always do SP3812 to confirm that SP3811 executed correctly. ▪ SP3811 001 is done only at machine installation, or after a drum and cleaning blade has been replaced in the PCU. ▪ SP3801 001 to 006 is done after developer replacement for one or more PCUs. 	
1	Devr Setup:All	[0 to 1/1]
2	Devr Setup:Col	
3	K	
4	M	
5	C	
6	Y	

3812	DevSetup Execute
	<p>Display Result of Developer Setup Execution</p> <p>Do this SP to confirm that SP3811 executed correctly. After execution the machine displays a "1" to confirm that SP3811 executed correctly for each PCU. The "1111" display indicates the return value for each PCU: K, M, C, Y</p> <p>Note!: The "1111" display is read from left to right: KMCY.</p>

3813	Used Tnr Mode Exe	
	Used Toner Mode Execute When the machine is printing in full-color mode, the waste toner in the PCUs is transported to the waste toner bottle for the amount of time specified with SP3813 003 below.	
1	All Colors	[0 to 1/1] 0:Off, 1: On
2	K Only	
3	Set Op. Time	[10 to 240/1 sec.]

3814	Execute Developer Fill	
	These SP codes fill the PCUs with developer from the developer bottle. After doing one or more of these SP codes, always do SP3815 to confirm that the PCUs filled successfully.	
1	All (KMCY)	
2	MCY Only	
3	K	
4	M	
5	C	
6	Y	

Group 3000

3815	Developer Fill:Disp Result
	Always execute this SP code to confirm successful execution of SP3814. Note! : The "1111" display is read from left to right: KMCY.

3816	Developer Fill:Set DFU	
1	Belt Form Start Time:A	
2	Developer Fill Time:B	
3	Belt Length:C	

3817	Developer Filling: Admission	
	When SP3814 (Execute Developer Fill) is executed, the process control self-check, but the MUSIC adjustment are disabled until after one of the SP codes has been executed after developer filling: <ul style="list-style-type: none"> ▪ SP3811 (Developer Setup) ▪ SP3801 (TD Sensor Initialization) This is the condition normally in effect. (SP codes 1 to 4 will display "1").	
1	K	Display the permission status of each PCU for developer filling after SP3814 was executed. 1: Developer filling enabled. No process control self-check, no MUSIC adjustment until SP3811 or SP3801 have been execute. 0: Developer filling disabled
2	M	
3	C	
4	Y	
5	Clear	Forcibly resets the status to "0" for all.

3820	Manual ProCon
	Use these SP codes to execute process control manually. You must do SP3820 to enable any values you change with SP3531 (Procon Target). Use SP3561 to display the results of SP3820 execution.

	<p>Note:</p> <ul style="list-style-type: none"> ▪ Process control is disabled during machine warm-up. ▪ If you execute this SP code during machine warm-up, "Completed" is displayed immediately. However, the manual process control setting was not actually done. 	
1	Normal ProCon	Does potential control only.
2	Exe Density Adj	Does potential control and toner density adjustment.
3	ACC RunTime ProCon	Executes process control again just before ACC executes.

3821	ProCon OK?		
	<p>Use this SP to display the history of process control executions. These SP codes are used to troubleshoot processing control. [0 to 99999999/1]</p>		
1	History:Last	6	History:Last 6
2	History:Last 2	7	History:Last 7
3	History:Last 3	8	History:Last 8
4	History:Last 4	9	History:Last 9
5	History:Last 5	10	History:Last 10

Appendix:
Service
Program
Mode Table

Group 3000

3900	RsetProConSP
	<p>Reset All Process Control SP Codes</p> <p>Press [EXECUTE] to reset all process control related SP codes to their default values.</p>
3910	Forbid LD Write DFU
3920	Recovery Operation Request DFU
3930	Sheet Threshold Disp
	<p>This setting determines sets the threshold to determine when the machine switches from FC to BW printing during a long print job.</p> <p>[0 to 99/1/1]</p> <p>0: ITB does not separate from the CMY_PCUs if even one page with B&W images comes during full-color printing.</p> <p>1: ITB separates from the CMY_PCUs if even one page with B&W images comes during full-color printing.</p> <p>2 to 99: Releases and separates the ITB from the CMY_PCUs only after the specified number of continuous B&W pages have printed (3 to 99).</p>

4.5 GROUP 4000

4008	Sub Scan Magnification Adj
	Adjusts the sub-scan magnification by changing the scanner motor speed. [-10 to +10/0.1%]

4010	Sub Scan Registration Adj
	Adjusts the leading edge registration by changing the scanning start timing in the sub-scan direction. [-30 to +30/0.1 mm]

4011	Main Scan Reg
	Adjusts the side-to-side registration by changing the scanning start timing in the main scan direction. Note: This adjustment is done for the ADF with SP6006 (ADF Reg. Adj.). [-25 to +25/0.1 mm]

4012	Set Scale Mask	
	These settings adjust the margins (erase margins) of the scanned area on the sheet. The leading, trailing, right, and left margins can be set independently.	
1	Book: Sub: LEdge	[0 to 3/0.1 mm]
2	Book: Sub: TEdge	
3	Book: Main: LEdge (Rear)	

Group 4000

4	Book: Main: TEdge (Front)	
5	ADF: Sub: LEdge	
7	ADF: Main: LEdge (Rear)	
8	ADF: Main: Edge (Front)	

4013	Scanner Free Run	
	Free Run: Scanner Performs the scanner free run with the exposure lamp on or off for full-color, full size (A3 or DLT).	
1	Book Mode: Lamp Off	[0 to 1/1] 0: Off, 1: On
2	Book Mode: Lamp On	

4014	Scan DFU	
	Touch [Execute] to execute one scanning operation with the scanner at the home position.	

4020	DF Dust Check
	<p>This feature checks the ADF exposure glass for dust that can cause black lines in copies. If dust is detected, a message is displayed, but the process does not stop.</p> <p>[0 to 1/ 0 / 1] 0: OFF, 1: ON</p>
1	Dust Detect: On/Off
	<p>Issues a warning if there is dust on the narrow scanning glass of the ADF when the original size is detected before a job starts. This function can detect dust on the white plate above the scanning glass, as well as dust on the glass.</p> <p>Sensitivity of the level of detection is adjusted with SP4020-002.</p> <p>[0 to 8/ 4 / 1]</p> <p>0: Off. No dust warning.</p> <p>0> 4: Lower > Normal sensitivity</p> <p>4> 8: Normal > High sensitivity</p> <p>Note: Always clean the ADF scanning glass and the white plate above the scanning glass before you switch this setting on.</p>
2	Dust Detect: Lvl
	<p>Adjusts the sensitivity for dust detection on the ADF scanning glass. This SP is available only after SP4020-001 is switched on.</p> <p>[0 to 8/1]</p> <ul style="list-style-type: none"> ▪ If you see black streaks in copies when no warning has been issued, raise the setting to increase the level of sensitivity. ▪ If warnings are issued when you see no black streaks in copies, lower the setting. ▪ Dust that triggers a warning could move be removed from the glass by the originals in the feed path. If the dust is removed by passing originals, this is not detected and the warning remains on.

Appendix:
Service
Program
Mode Table

Group 4000

3	<p>Lvl Dust Reject: Lvl</p> <p>Sets the level for vertical line correction (the black vertical lines caused by dust on the ADF exposure glass).</p> <p>[0 to 4/ 0 / 1]</p> <p>0: No vertical line correction.</p> <p>1-4: Enables and sets the level for vertical line correction.</p> <p>If you select a higher number, this can decrease unwanted lines caused by dust but can also erase thin vertical lines of the original.</p>
11	<p>Dust Detect Level: Rear</p> <p>Adjusts the sensitivity for dust detection on the ADF scanning glass. This SP is available only after SP4020-001 is switched on.</p> <p>[0 to 1/ 0 / 1]</p> <ul style="list-style-type: none"> ▪ If you see black streaks in copies when no warning has been issued, raise the setting to increase the level of sensitivity. ▪ If warnings are issued when you see no black streaks in copies, lower the setting. <p>Dust that triggers a warning could move be removed from the glass by the originals in the feed path. If the dust is removed by passing originals, this is not detected and the warning remains on.</p>
12	<p>Correction Level: Rear</p>
	<p>Sets the level for vertical line correction (the black vertical lines caused by dust on the ADF exposure glass).</p> <p>[0 to 8/ 4 / 1]</p> <p>0: No vertical line correction.</p> <p>1-8: Enables and sets the level for vertical line correction.</p> <p>If you select a higher number, this can decrease the unwanted lines caused by dust but can also erase thin vertical lines of the original.</p>

4301	Operation Check APS Sensor
	<p>This SP confirms that the APS sensors are operating correctly. Place a sheet of paper on the exposure glass, then execute this SP code. For example, and A3 sheets returns the display 1111 1111 to indicate that all sensors are activated and operating normally.</p> <p>Note: Only the first 5 bits are used:</p> <p>Bit 0: APS Sensor 1 Bit 1: APS Sensor 2 Bit 2: APS Sensor 3 Bit 3, APS Sensor 4 Bit 4: APS Sensor 5</p>
4303	Min Size for APS
	<p>Sets the minimum size that the will be detected by APS</p> <p>[0 to 2/1]</p> <p>[*0: Unknown Document Size] [1 A5-Lengthwise (HLT Lengthwise)] [2 A5 Sideways HLT Sideways]</p>
4305	8K/16K Detection
	<p>This SP enables the machine to recognize 8K/16K size paper automatically.</p> <p>[*0: Normal] [1: A4-Sideways LT-Lengthwise] [2: A4-Lengthwise LT-Sideways] [3: 8KAI, 16 KAI]</p>

Group 4000

4400	Org Edge Mask	
	<p>This SP sets the mask area to remove shadows when scanning originals from the exposure glass in Book mode.</p> <p>Note: "LE" denotes "leading edge" and "TE" denotes "trailing edge".</p>	
1	Book:Sub:LEdge	[0 to 3/0/0.1 mm]
2	Book:Sub:TEdge	
3	Book:Main:LEdge	
4	Book:Main:TEdge	
5	ADF: Sub: LEdge	[0 to 3/2/0.1 mm]
7	ADF: Main: LEdge	[0 to 3/0/0.1 mm]
8	ADF: Main: TEdge	

4417	IPU Test Pattern			
	Use this SP to select the IPU test pattern to print.			
		Test Pattern [0 to 24/1]		
0	Scanned Image	13	Grid Pattern CMYK	
1	Gradation Main Scan A	14	Color Patch CMYK	
2	Gradation Main Scan B	15	Gray Pattern (1)	

3	Gradation Main Scan C	16	Gray Pattern (2)	
4	Gradation Main Scan D	17	Gray Pattern (3)	
5	Gradation Sub Scan 1	18	Shading Pattern	
6	Grid Pattern	19	Thin Line Pattern	
7	Slant Grid Pattern	20	Scanned + Grid Pattern	
8	Gradation RGBCMYK	21	Scanned + Grayscale	
9	UCR Pattern	22	Scanned + Color Patch	
10	Color Patch 16 (1)	23	Scanned + Slant Grid C	
11	Color Patch 16 (2)	24	Scanned + Slant Grid D	

Group 4000

12	Color Patch 16 64			
----	-------------------	--	--	--

4429	Select Copy Data Security		
	[0 to 3/3/1]		
1	Copying		
2	Scanning		
3	Fax Operation		

4450	Scan Image Pass Selection		
	These SP codes switch the operation of black reduction and shading correction off/on.		
1	Black Subtraction ON/OFF		
	Switches the black reduction function in scanner data off/on. [0 to 1 / 1/ 1]		
2	Shading Correction ON/OFF		
	Switches shading reduction function in scanner data off/on. [0 to 1 / 1/ 1]		

4460	Digital AE DFU	
	These SP codes set parameters for the AE function.	
1	Low Limit Value	This setting determines the lower limit for level of background to be skipped for the AE function. The higher the setting, the more background will be ignored. [0 to 1023/ 392/ 1]
2	Background Level	This setting determines the level of background to be output for the AE function. [0 to 1023/888/1]

4490	FL Correction ON/OFF	
	This SP switches FL correction on/off. 0 (OFF): The linear settings of the gamma correction table are used to correct differences in FL. 1 (ON): Generates a gamma correction table and writes the settings to Ri20 using the values of SP4492 set at the factory.	
1	RED	
2	GREEN	
3	BLUE	

Group 4000

4501	ACC Target Den(sity)	
	This SP sets the target density for the ACC adjustment for machines connected with the Copier Connection Kit. For more, see "Troubleshooting – Special Procedures – Color Adjustment for Connected Copiers" in the Venus-C1 (B132/B181/B200) Service Manual.	
1	Copy:K:Text	[0 to 50/1]
2	Copy:C:Text	
3	Copy:M:Text	
4	Copy:Y:Text	
5	Copy:K:Photo	
6	Copy:C:Photo	
7	Copy:M:Photo	
8	Copy:Y:Photo	

4505	ACC Cor:Bright	
	Sets correction for bright areas for ACC correction.	
1 to 4	Master:K, M, C, Y	[-128 to +128/1]
5 to 8	Slave:K, M, C, Y	

4506	ACC Cor:Dark	
	Sets correction for dark areas for ACC correction.	
1 to 4	Master:K, M, C, Y	[-128 to +128/1]
5 to 8	Slave:K, M, C, Y	

4540	Print Coverage	
	This SP corrects printer coverage of 12 hues (RY, YR, YG, etc. x 4 Colors (K, C, M, Y) for a total of 48 parameters.	
1	RY Phase: Option	[0 to 255 / 0 / 1]
2-4	RY Phase: R, G, B	[-256 to 255 / 0 / 1]
5	YR Phase: Option	[0 to 255 / 0 / 1]
6-8	YR Phase: R, G, B	[-256 to 255 / 0 / 1]
9	YR Phase: G	[0 to 255 / 0 / 1]
10-12	YR Phase: R, G, B	[-256 to 255 / 0 / 1]
13	GY Phase: Option	[0 to 255 / 0 / 1]
14-16	GY Phase: R, G, B	[-256 to 255 / 0 / 1]
17	GC Phase: Option	[0 to 255 / 0 / 1]
18-120	GC Phase: R, G, B	[-256 to 255 / 0 / 1]
21	CG Phase: Option	[0 to 255 / 0 / 1]
22-24	CG Phase: R, G, B	[-256 to 255 / 0 / 1]
25	CB Phase: Option	[0 to 255 / 0 / 1]
26-28	CB Phase: R, G, B	[-256 to 255 / 0 / 1]
29	BC Phase: Option	[0 to 255 / 0 / 1]
30-32	BC Phase: R, G, B	[-256 to 255 / 0 / 1]
33	BM Phase: Option	[0 to 255 / 0 / 1]
34-36	BM Phase: R, G, B	[-256 to 255 / 0 / 1]
37	MB Phase: Option	[0 to 255 / 0 / 1]
38-40	MB Phase: R, G, B	[-256 to 255 / 0 / 1]
41	MR Phase: Option	[0 to 255 / 0 / 1]

Group 4000

42-44	MR Phase: R, G, B	[-256 to 255 / 0 / 1]
45	RM Phase: Option	[0 to 255 / 0 / 1]
46-48	RM Phase: R, G, B	[-256 to 255 / 0 / 1]
49	WHITE: Option	[0 to 255 / 0 / 1]
50-52	WHITE: R, G, B	[-256 to 255 / 0 / 1]
53	BLACK: Option	[0 to 255 / 0 / 1]
54-56	BLACK: R, G, B	[-256 to 255 / 0 / 1]

4550	Scan Apli:Txt/Print
4551	Scan Apli:Txt
4552	Scan Apli:Txt Dropout
4553	Scan Apli:Txt/Photo
4554	Scan Apli:Photo
4565	Scan Apli:GrayScale
4570	Scan Apli:Col Txt/Photo
4571	Scan Apli:Col Gloss Photo
4572	Scan Apli:AutoCol
4580	Fax Apli:Txt/Chart
4581	Fax Apli:Txt
4582	Fax Apli:Txt/Photo
4583	Fax Apli:Photo
4584	Fax Apli:Original 1
4585	Fax Apli:Original 2
5	MTF: 0(Off) 1-15 (Weak-Strong)

	Sets the MTF level (Modulation Transfer Function) designed to improve image contrast. Set higher for stronger effect, lower for weaker effect. [0 to 15/1]
6	Smoothing: 0(x1) 1-7 (Weak-Strong)
	Use to remove "jaggies" if they appear. Set higher for smoother. [0 to 7/1]
7	Brightness: 1-255
	Set higher for darker, set lower for lighter. [1 to 255/1]
8	Contrast: 1-255
	Set higher for more contrast, set lower for less contrast. [1 to 255/1]
9	Ind Dot Erase: 0(Off) 1-7 (Weak-Strong)
	Use to remove individual dots in the background if they appear. Set higher for removal of more background. [0 to 7/1]

Appendix:
Service
Program
Mode Table

4600	Get ID
	These SP codes display the readings of four ID codes read during automatic adjustment of the SBU every time the machine is turned on. An incorrect ID reading SC144.
1	SBU
	Displays the ID code (1-byte hexadecimal) read for the SBU . [0 to 255 / 0 / 1]
2	GASBU-N
	Displays the ID code (1-byte hexadecimal) read for the GASBU-N . [0 to 255 / 0 / 1]

Group 4000

3	VSP_F
	Displays the ID code (1-byte hexadecimal) read for the VSP5100_F . [0 to 255 / 0 / 1]
4	VSP_L
	Displays the ID code (1-byte hexadecimal) read for the VSP5100_ . [0 to 255 / 0 / 1]

4602	Scanner Memory Access DFU
------	----------------------------------

4609	Gray Balance Adj Value R DFU
4610	Gray Balance Adj Value G DFU
4611	Gray Balance Adj Value B DFU
	These SP codes display the reference voltages stored in NVRAM at the factory for Red, Green, and Blue before the machine was shipped. The SBU acquires these settings every time the machine is switched on.
1	B: Book Adj Value [0 to 1023 / 0 / 1 Step]
2	B: DF Adj Value [0 to 255 / 0 / 1 Step]

4623	Black Level Adj Value DFU	
1	R:FE	[0 to 163838 / 0 / 1]
2	R:FO	
3	R:LE	
4	R:LO	

4624	Black Level Adj Value DFU
------	----------------------------------

1	G:FE	[0 to 163838 / 0 / 1]
2	G:FO	
3	G:LE	
4	G:LO	

4625	Black Level Adj Value DFU	
1	B:FE	[0 to 163838 / 0 / 1]
2	B:FO	
3	B:LE	
4	B:LO	

4628	Gain Rough Adj. Value DFU	
1	R:F	[0 to 7 / 0 / 1]
2	R:L	

4629	Gain Rough Adj. Value DFU	
1	G:F	[0 to 7 / 0 / 1]
2	G:L	

4630	Gain Rough Adj. Value DFU	
1	B:F	[0 to 7 / 0 / 1]
2	B:L	

Appendix:
Service
Program
Mode Table

Group 4000

4631	Gain Fine Adj Value: DFU	
	When switched on, this SP displays the current range for the E (EVEN) or O (ODD) in the ASCI on the SBU after white level adjustment every time the machine is switched on. [0 to 1023 / 0 / 1 digit]	
1	R:FE	
2	R:FO	
3	R:LE	
4	R:LO	

4632	Gain Adj Fine Value DFU	
	When switched on, this SP displays the current range for E (EVEN) or O (ODD) gain of GREEN or B/W in the ASCI on the SBU after white level adjustment every time the machine is switched on. [0 to 1023 / 0 / 1 digit]	
1	G:FE	
2	G:FO	
3	G:LE	
4	G:LO	

4633	Gain Fine Adj Value:B DFU	
	When switched on, this SP displays the current range for E (EVEN) or O (ODD) gain of GREEN or B/W in the ASCI on the SBU after white level	

	adjustment every time the machine is switched on. [0 to 1023 / 0 / 1 digit]	
1	B:FE	
2	B:FO	
3	B:LE	
4	B:LO	

4635	SSCG Noise Cancel DFU	
	Switches SSCG noise cancellation on/off. 0: Off 1: On	
1	Correction ON/OFF	[0 to 1 / 1 / 1]
2	Adj ON/OFF	[0 to 1 / 1 / 1]

4636	SSCG Correction DFU	
1	Execution	[0 1 / 0 / 0]
2	Error Flag	[0 to 2 / 0 / 1] 0: Normal end 1: End during update 2: Do not apply correction
3	SSCG Result Apply Execution	[0 to 2 / 0 / 1]

4637	SSCG Noise Cancel Correction DFU	
1	R:FE	[0 to 255 / 128 / 1 digit]
2	R:FO	
3	G:FE	

Group 4000

4	G:FO	
5	B:FE	
6	B:FO	
7	R:LE	
8	R:LO	
9	G:LE	
10	G:LO	
11	B:LE	
12	B:LO	

4638	Nose Cancel Correction DFU	
1	Previous:R:FE	[0 to 255 / 128 / 1 digit]
2	Previous:R:FO	
3	Previous:G:FE	
4	Previous:G:FO	
5	Previous:B:FE	
6	Previous:B:FO	
7	Previous:R:LE	
8	Previous:R:LO	
9	Previous:G:LE	
10	Previous:G:LO	
11	Previous:B:LE	
12	Previous:B:LO	

4639	Nose Cancel Correction DFU	
1	Factory :R:FE	[0 to 255 / 128 / 1 digit]
2	Factory :R:FO	
3	Factory :G:FE	
4	Factory :G:FO	
5	Factory :B:FE	
6	Factory :B:FO	
7	Factory :R:LE	
8	Factory :R:LO	
9	Factory :G:LE	
10	Factory :G:LO	
11	Factory :B:LE	
12	Factory :B:LO	

4640	Amplitude at Adj DFU	
1	Before Adj:R:FE	[0 to 1023/ 0 / 1]
2	Before Adj:R:FO	
3	Before Adj:G:FE	
4	Before Adj:G:FO	
5	Before Adj:B:FE	
6	Before Adj:B:FO	
7	Before Adj:R:LE	
8	Before Adj:R:LO	

Group 4000

9	Before Adj:G:LE	
10	Before Adj:G:LO	
11	Before Adj:B:LE	
12	Before Adj:B:LO	
13	After Adj:R:FE	
14	After Adj:R:FO	
15	After Adj:G:FE	
16	After Adj:G:FO	
17	After Adj:B:FE	
18	After Adj:B:FO	
19	After Adj:R:LE	
20	After Adj:R:LO	
21	After Adj:G:LE	
22	After Adj:G:LO	
23	After Adj:B:LE	
24	After Adj:B:LO	

4646	Scan Adjust Error Flag DFU	
1	White level:F	[0 to 65535 / 0 / 0]
2	White level:L	
3	Black level:F	[0 to 255 / 0 / 0]
4	Black level:L	
5	FL Correction	

4647	Scanner Hardware Error Flag DFU	
	[0 to 1023 / 0 / 1]	

4654	Black Level Adj Value DFU	
1	Previous: R: FE	[0 to 16383 / 0 / 1]
2	Previous: R: FO	
3	Previous: R: LE	
4	Previous: R: LO	

4655	Black Level Adj Value DFU	
1	Previous:G:FE	[0 to 16383 / 0 / 1]
2	Previous:G:FO	
3	Previous:G:LE	
4	Previous:G:LO	

4656	Black Level Adj Value DFU	
1	Previous: B: FE	[0 to 16383 / 0 / 1]
2	Previous: B: FO	
3	Previous: B: LE	
4	Previous: B: LO	

Appendix:
Service
Program
Mode Table

Group 4000

4658	Gain Rough Adj Value DFU	
1	Previous: R: F	[0 to 7 / 0 / 1 digit]
2	Previous: R: L	

4659	Gain Rough Adj Value DFU	
1	Previous:G:F	[0 to 7 / 0 / 1 digit]
2	Previous:G:L	

4660	Gain Rough Adj Value DFU	
1	Previous: B:F	[0 to 7 / 0 / 1 digit]
2	Previous: B:L	

4661	Digital Gain Adj Value DFU	
1	Previous: R: FE	[0 to 1023 / 0 / 1 digit]
2	Previous: R: FO	
3	Previous: R: LE	
4	Previous: R: LO	

4662	Digital Gain Adj Value DFU	
1	Previous:G:FE	[0 to 1023 / 0 / 1 digit]
2	Previous:G:FO	
3	Previous:G:LE	
4	Previous:G:LO	

4663	Digital Gain Adj Value DFU	
1	Previous:B:FE	[0 to 1023 / 0 / 1 digit]
2	Previous:B:FO	
3	Previous:B:LE	
4	Previous:B:LO	

4673	Black Level Adj Value DFU	
1	Factory: R: FE	[0 to 16383 / 0 / 1 digit]
2	Factory: R: FO	
3	Factory: R: LE	
4	Factory: R: LO	

4674	Black Level Adj Value DFU	
1	Factory:G:FE	[0 to 16383 / 0 / 1 digit]
2	Factory:G:FO	
3	Factory:G:LE	
4	Factory:G:LO	

4675	Black Level Adj Value DFU	
1	Factory:B:FE	[0 to 16383 / 0 / 1 digit]
2	Factory:B:FO	
3	Factory:B:LE	
4	Factory:B:LO	

Group 4000

4677	Gain Rough Adj Value: R DFU
4678	Gain Rough vAdj Value: G DFU
4679	Gain Rough Adj Value: B DFU

4680	Gain Fine Adj Value: R DFU
4681	Gain Fine Adj Value: G DFU
4682	Gain Fine Adj Value: B DFU
	When switched on, these SP codes display the settings done at the factory for Red (Green, Blue) O (ODD) and E (EVEN) gain in the ASIC on the SBU after white level adjustment every time the machine is switched on.

4690	White Level Peak Data:R DFU
4691	White Level Peak Data:G DFU
4692	White Level Peak Data: B DFU
	When switched on, these SP codes display E (EVEN) or O (ODD) for the white level peak Red (Green, Blue) data after white level detection (AGC) after the machine is switched on.

4693	Black Level Data:R DFU
4694	Black Level Data:G DFU
4695	Black Level Data: B DFU
	When switched on, these SP codes display E (EVEN) or O (ODD) for the black level check done in the SBU for RED after the machine is switched on.

4699	Test Pattern
------	--------------

	Selects the scan test pattern.	
1	Select Pattern: SBU F	[0 to 4 / 0 / 1]
	0	Normal Image Output
	1	Fixed Value Output
	2	Main Scan Gradation
	3	Sub Scan Gradation
	4	Grid Pattern
2	Output Level: SBU F	[0 to 1023/ 512 / 1]
3	Select Pattern: SBU L	[0 to 4 / 0 / 1]
	0	Normal Image Output
	1	Fixed Value Output
	2	Main Scan Gradation
	3	Sub Scan Gradation
	4	Grid Pattern
4	Output Level: SBU L	[0 to 1023/ 512 / 1]

4700	CIS ID Display
	Reads and displays the CIS hexadecimal ID (Marble Register) when a CIS communication error is detected.

4709	GB Chart Level R DFU
4710	GB Chart Level G DFU
4711	GB Chart Level B DFU
4712	GB Adj Value R DFU

Group 4000

4713	GB Adj Value G DFU
4714	GB Adj Value B DFU
4745	Image Level Error Flag DFU
4746	GB Adj Error Flag DFU

4747	CIS Hard Error Flag
	<p>Reads and displays CIS hard errors. [0 to 7 / 0 / 1] 0: Opal register read error flag 1: Marble register rear error flag 2: Marble boot error flag</p>

4748	Main Scan White Level Ave: R	
1	Leading Edge	[0 to 255 / 0 / 1]
2	Trailing Edge	

4749	Main Scan White Level Ave: G	
1	Leading Edge	[0 to 255 / 0 / 1]
2	Trailing Edge	

4750	Main Scan White Level Ave: B	
1	Leading Edge	[0 to 255 / 0 / 1]
2	Trailing Edge	

4784	White Level Peak Range: R DFU
4785	White Level Peak Range: G DFU

4786	White Level Peak Range: B DFU
4787	White Level Peak Data: R DFU
4788	White Level Peak Data: G DFU
4789	White Level Peak Data: B DFU
4790	White Level Peak Data: R DFU
4791	White Level Peak Data: G DFU
4792	White Level Peak Data: B DFU

4793	Black Level Data R DFU	
4794	Black Level Data G DFU	
4795	Black Level Data B DFU	
1 to 24	Chip1 to Chip 24	[0 to 255 / 0 / 1 digit]

4796	Low Density Color Adj DFU	
1	Front Side	[0 to 1 / 0 / 1]
2	Rear Side	

4797	Rear Side Digital: AE DFU	
1	Low Limit Setting	[0 to 1023/ 364 / 1]
2	Background Erase Level	[512 to 1535/ 972 / 1]

4798	LED Duty DFU
	[0 to 65535 / 0 / 1]

Group 4000

4799	CIS Test Pattern DFU	
1	Select Pattern	[0 to 4 / 0 / 1]
2	Set Output Level	

4802	Scanner Free Run	
	This SP sets the scanner in the free run mode for testing. The free run can be set with the exposure lamp off or on.	
1	DF mode :Lamp Off	Touch [OFF] or [ON]
2	DF mode :Lamp On	

4804	Home Position Operation	
	Touch [Execute] to do the home position operation once.	

4805	Scanner Carriage Retraction Operation DFU	
	[0 to 1 / 0 / 1]	

4902	Disp ACC Data		
	This SP outputs the final data read at the end of ACC execution. A zero is returned if there was an error reading the data.		
1	R_DATA1	Photo C Patch Level 1 (8-bit)	[0 to 255/1]
2	G_DATA1	Photo M Patch Level 1 (8-bit)	
3	B_DATA1	Photo Y Patch Level 1 (8-bit)	
4	R_DATA2	Photo C Patch Level 17 (8-bit)	
5	G_DATA2	Photo M Patch Level 17 (8-bit)	
6	B_DATA2	Photo Y Patch Level 17 (8-bit)	

4905	Select Gradation Level
	This SP changes the threshold parameters of error diffusion. [0 to 255/1]

4918	Man Gamma Adj DFU
------	--------------------------

4948	ACC Execute Time:Present DFU	
4949	ACC Execute Time:Previous DFU	
1	yy/mm/dd	
2	hh/mm/ss	

4954	Read/Restore Std	
	Use this SP to calibrate the scanner gamma on each machine connected with the Copier Connection Kit.	
1	Read New Chart	Reads the "Standard Color Test Chart" to calibrate the scanner gamma curve for two machines connected with the Copier Connection Kit. Do this SP with the test chart on each connected machine.
2	Recall Prev Chart	Restores the scanner gamma to the previous value (not the factory setting).
4	Set Std Chart	

Appendix:
Service
Program
Mode Table

Group 4000

4958	Read/Restore Std: Rear DFU	
1	Read New Chart	[0 to 1 / 0 / 1]
2	Recall Prev Chart	
4	Set Std Chart	

4991	IPU Image Path Selection	
	Use this SP to use the 10-key pad to enter the number to determine the image path.	
	IPU	[0 to 14/1]
	0	DFID input RGB images (upper 8 bits)
	1	Synchronous RGB images in DFID
	2	Data with shading correction on
	3	Data with shading correction off
	4	Data before black offset correction
	5	Data after black offset correction
	6	Shading data
	7	Test pattern data (grayscale)
	8	RGB image after line interval correction
	9	RGB image after dot correction and pre-gamma
	10	RGB image after vertiial line correction
	11	RGB image after scanner gamma correction
	12	RTB image after filtering with MTF
	13	RTB image after ADS

	14	RGB image after color processing
--	----	----------------------------------

4993	High Light Correction DFU	
	1	Sensitivity Selection
	2	Range Selection

4994	Adj Txt/Photo Recognition Level DFU	
------	--	--

4996	White Paper Detection Level DFU	
------	--	--

4.6 GROUP 5000

5024	mm/inch Display Selection
	<p>Selects the unit of measurement. After selection, turn the main power switch off and on.</p> <p>[0 to 1/1] 0: mm 1: inch</p>
5037	Status Lamp Mode Not Used
5040	Custom Size: Main Scan
	<p>This SP adjusts the width (main scan direction) for custom size paper used with the LCIT D350.</p> <p>[100 to 330.2/297/0.1 mm]</p>
5041	Custom Size: Sub Scan
	<p>This SP adjusts the length (sub scan direction) for custom size paper used with the LCIT D350.</p> <p>[139.7 to 482.6/210/0.1 mm]</p>
5045	Accounting Counter
	<p>Selects the counting method if the meter charge mode is enabled.</p> <p>Note: You can change the setting only one time.</p> <p>[0 to 1/ 1]</p>
	<p>0: Development counter. Shows the total counts for color (Y,M,C) and black (K).</p> <p>1: Paper counter. Shows the total page counts for: Color Total, Black Total, Color Copies, Black Copies, Color Prints, Black Prints</p>

5047	Reverse Paper Display
	Determines whether the tray loaded with paper printed on one side is displayed. [0 to 1/1]
	0: Not displayed 1: Displayed

5051	Toner Refill Detection Display Japan Only
------	--

5055	Display IP Address
	Switches the IP address display on the operation panel on/off. OFF: IP address not displayed on operation panel ON: IP address displayed on operation panel.

5056	Coverage Counter Display
	Display or does not display the coverage counter on the LCD. [0 to 1 / 0 / 1] 0: Not displayed, 1: Displayed

5061	Toner Remaining Icon Display
	This SP switches the toner remaining icon on/off. Default: Off

Group 5000

	Part Replacement Alert Display
5062	Enables/disables the appearance of the PM parts in the yield list on the operation panel. PM parts can be selected independently for display. [ON] OFF Note: SP5066 must be set to "1: Display".
1	#K PCU
2	K PCU Cleaning Blade
3	K PCU Lube Bar
4	K PCU Lube App/Cleaning Blade
5	K PCU Developer
6	K PCU Drum
7	Charge Corona: Ass'y
8	K PCU Charge Grid Wire
9	K PCU Idle Gear
10	K PCU Lube App/Clnng Brush
11	K PCU Toner Cleaning Brush
12	K PCU Joint
13	#M PCU
14	M PCU Cleaning Blade
15	M PCU Lube Bar
16	M PCU Lube App/Clnng Blade
17	M PCU Developer
18	M PCU Drum
19	M PCU Charge Roller Unit

20	M PCU Idle Gear
21	M PCU Lube App/CIng Brush
22	M PCU Toner Cleaning Brush
23	M PCU Joint
24	#C PCU
25	C PCU Cleaning Blade
26	C PCU Lube Bar
27	C PCU Lube App/CIng Blade
28	C PCU Developer
29	C PCU Drum
30	C PCU Charge Roller Unit
31	C PCU Idle Gear
32	C PCU Lube App/CIng Brush
33	C PCU Toner Cleaning Brush
34	C PCU Joint
35	#Y PCU
36	Y PCU Cleaning Blade
37	Y PCU Lube Bar
38	Y PCU Lube App/CIng Blade
40	Y PCU Developer
41	Y PCU Charge Roller Unit
42	Y PCU Idle Gear
43	Y PCU Lube App/CIng Brush

Group 5000

44	Y PCU Toner Cleaning Brush
45	Y PCU Joint
46	#ITB
47	#ITB Cleaning Unit
48	ITB Cleaning Blade
49	ITB Lube Bar
50	Lube Application Blade
51	#PTR
52	PTR Blade
53	PTR
54	Discharge Roller
55	PTR Lube Bar
56	#Fusing Unit
57	Fusing Belt
58	Hot Roller
59	Pressure Roller
60	Lube Roller: Press Roller
61	Cing Roller: Press Roller
62	Shaft Bearings: Press Roll
63	#Used Toner Botrle
64	#ADF Pickup Roller
65	#ADF Feed Belt
64	#ADF Pickup Roller

65	#ADF Belt
66	#ADF Reverse Roller
67	#ADF Transport Belt
68	#Dust Filter 1
69	#Dust Filter 2
70	#Dust Filter 3

5067	Part Replacement Operation Type
	Configures the PM parts display for either the customer engineer (Service) or user. [*0: Service] [1: User] Note: SP5066 must be set to "1: Display".
1	#K PCU
2	K PCU Cleaning Blade
3	K PCU Lube Bar
4	K PCU Lube App/Cleaning Blade
5	K PCU Developer
6	K PCU Drum
7	Charge Corona: Ass'y
8	K PCU Charge Grid Wire
9	K PCU Idle Gear
10	K PCU Lube App/Clnng Brush
11	K PCU Toner Cleaning Brush
12	K PCU Joint
13	#M PCU

Group 5000

14	M PCU Cleaning Blade
15	M PCU Lube Bar
16	M PCU Lube App/Cing Blade
17	M PCU Developer
18	M PCU Drum
19	M PCU Charge Roller Unit
20	M PCU Idle Gear
21	M PCU Lube App/Cing Brush
22	M PCU Toner Cleaning Brush
23	M PCU Joint
24	#C PCU
25	C PCU Cleaning Blade
26	C PCU Lube Bar
27	C PCU Lube App/Cing Blade
28	C PCU Developer
29	C PCU Drum
30	C PCU Charge Roller Unit
31	C PCU Idle Gear
32	C PCU Lube App/Cing Brush
33	C PCU Toner Cleaning Brush
34	C PCU Joint
35	#Y PCU
36	Y PCU Cleaning Blade

37	Y PCU Lube Bar
38	Y PCU Lube App/CIng Blade
40	Y PCU Developer
41	Y PCU Charge Roller Unit
42	Y PCU Idle Gear
43	Y PCU Lube App/CIng Brush
44	Y PCU Toner Cleaning Brush
45	Y PCU Joint
46	#ITB
47	#ITB Cleaning Unit
48	ITB Cleaning Blade
49	ITB Lube Bar
50	Lube Application Blade
51	#PTR
52	PTR Blade
53	PTR
54	Discharge Roller
55	PTR Lube Bar
56	#Fusing Unit
57	Fusing Belt
58	Hot Roller
59	Pressure Roller
60	Lube Roller: Press Roller

Group 5000

61	Cing Roller: Press Roller
62	Shaft Bearings: Press Roll
63	#Used Toner Botrle
64	#ADF Pickup Roller
65	#ADF Feed Belt
66	#ADF Pickup Roller
67	#ADF Belt
68	#ADF Reverse Roller
69	#ADF Transport Belt
70	#Dust Filter 1

5071	Set Bypass Paper Size Display

5112	Non-Std. Paper Sel.
	<p>Determines whether a non-standard paper size can be input for the universal cassette trays (Tray 2, Tray 3)</p> <p>[0 to 1/1]</p> <p>0: No</p> <p>1: Yes. If "1" is selected, the customer will be able to input a non-standard paper size using the UP mode.</p>

5113	Optional Counter Type
1	Default Optional Counter Type
	<p>Selects the type of counter:</p> <p>0: None</p> <p>1: Key card (RK3, 4) Japan only</p>

	<p>2: Key card down 3: Pre-paid card 4: Coin Lock 5: MF key card 11: Exp Key Card (Add) 12: Exp Key Card (Deduct)</p>
2	External Optional Counter Type
	<p>Enables the SDK application. This lets you select a number for the external device for user access control. Note: "SDK" refers to software on an SD card. [0 to 3/1] 0: None 1: Expansion Device 1 2: Expansion Device 2 3: Expansion Device 3</p>

5114	Optional Counter I/F
	<p>This SP sets the machine for use with the optional counter. Default: Off</p>

5118	Disable Copying
	<p>Temporarily denies access to the machine. Japan Only [0 to 1/1] 0: Release for normal operation 1: Prohibit access to machine</p>

Group 5000

5120	Mode Clear Opt. Counter Removal
	<p>Do not change. Japan Only</p> <p>[0 to 2/1]</p> <p>0: Yes. Normal reset</p> <p>1: Standby. Resets before job start/after completion</p> <p>2: No. Normally no reset</p>

5121	Counter Up Timing
	<p>Determines whether the optional key counter counts up at paper feed-in or at paper exit. Japan Only</p> <p>[0 to 1/1]</p> <p>0: Feed count</p> <p>1: No feed count</p>

5126	Set F-Size Document
	<p>Set F Original Size Selection</p> <p>Sets the original size that the machine detects for F sizes.</p> <p>[*0: 8½ x 13]</p> <p>[1: Folio 8¼ x 13]</p> <p>[2: F 8 x 13]</p>

5127	APS Mode
	<p>This SP can be used to switch APS (Auto Paper Select) off when a coin lock or pre-paid key card device is connected to the machine.</p> <p>[0 to 1/1]</p> <p>0: On</p> <p>1: Off</p>

5128	Code Mode With Key/Card Option Japan Only
------	--

5131	Paper Size/Type Selection
	<p>Selects the paper size type (for originals and copy paper). (Only needs to be adjusted if the optional printer controller is installed)</p> <p>[0 to 2/1]</p> <p>0: JP (Japan)</p> <p>1: NA (North America)</p> <p>2: EU (Europe)</p> <p>After changing the value, turn the main power switch off and on.</p>

Group 5000

5150	Bypass Length Setting
	<p>Sets up the by-pass tray for long paper. [0 to 1/1] 0: Off 1: On. Sets the tray for feeding paper up to 600 mm long. With this SP selected on, paper jams are not detected in the paper path.</p>

5162	App. Switch Method
	<p>Controls if the application screen is changed with a hardware switch or a software switch. [0 to 1/1] 0: Soft Key Set 1: Hard Key Set</p>

5165	Z-Fold Position Japan Only			
	<p>Adjusts the Z-fold position for different paper sizes. Note: In the table below "T" means "SEF"</p>			
	1	A3T	5	LGT
	2	B4T	6	LTT
	3	A4T	7	12x18
	4	DLTT	8	Other

5167	Fax Printing Mode Optional Counter OFF
	<p>Enables or disables automatic print out without an accounting device. This SP is used when the receiving fax is control by an external accounting device. 0: Automatic printing 1: No automatic printing</p>

5169	CE Login
	<p>If you will change the printer bit switches, you must 'log in' to service mode with this SP before you go into the printer SP mode.</p> <p>[0 to 1/1]</p> <p>0: Off. Printer bit switches cannot be adjusted.</p> <p>1: On. Printer bit switches can be adjusted.</p>
5188	Copy NV Version
	Displays the version number of the NVRAM on the controller board.
5191	Mode Set DFU
5193	External Controller Info. Settings DFU
5195	Limitless SW DFU DFU
5196	90 Degree Rotation (Copy)
5199	Paper Exit After Staple End

5212	Page Numbering
3	Duplex Printout Left/Right Position
	Horizontally positions the page numbers printed on both sides during duplexing. [-10 to +10/1 mm] 0 is center, minus is left, + is right.
4	Duplex Printout High/Low Position
	Vertically positions the page numbers printed on both sides during duplexing. [-10 to +10/1 mm] 0 is center, minus is down, + is up.

5227	Page Numbering
200	Change Page No. Display
	Determines whether the page number adjustment is ON or OFF. [0~1/0/1] 0: Display OFF, 1: Display ON
201	Allow Page No. Entry
	Specifies the number of digits to display for the entry of the starting page number. [2~9/9/1]
⇒ 202	Zero Surplus Setting
	Determines whether page numbers are prefixed with excess 0s when the number is smaller than the number of assigned digits. For example, with the setting ON and 3 digits have been specified, the number "5" will appear as "005". With the setting OFF, the number "5" will appear as a "5" without the 0s. [0~1/0/1] 0: Excess 0s are displayed 1: No excess 0s are displayed

5302	Set Time DFU
	Sets the time clock for the local time. This setting is done at the factory before delivery. The setting is GMT expressed in minutes. [-1440 to 1440/1 min.] JA: +540 (Tokyo) NA: -300 (NY) EU: +6- (Paris) CH: +480 (Peking) TW: +480 (Taipei) AS: +480 (Hong Kong)

5307	Summer Time	
	<p>Lets you set the machine to adjust its date and time automatically with the change to Daylight Savings time in the spring and back to normal time in the fall. This SP lets you set these items:</p> <ul style="list-style-type: none"> ▪ Day and time to go forward automatically in April. ▪ Day and time to go back automatically in October. ▪ Set the length of time to go forward and back automatically. <p>The settings for 002 and 003 are done with 8-digit numbers:</p>	
	Digits	Meaning
	1st, 2nd	Month. 4: April, 10: October (for months 1 to 9, the first digit of 0 cannot be input, so the eight-digit setting for 002 or 003 becomes a seven-digit setting)
	3rd	Day of the week. 0: Sunday, 1: Monday
	4th	The number of the week for the day selected at the 3rd digit. If "0" is selected for "Sunday", for example, and the selected Sunday is the start of the 2nd week, then input a "2" for this digit.
	5th, 6th	The time when the change occurs (24-hour as hex code). Example: 00:00 (Midnight) = 00, 01:00 (1 a.m.) = 01, and so on
	7th	The number of hours to change the time. 1 hour: 1
	8th	If the time change is not a whole number (1.5 hours for example), digit 8 should be 3 (30 minutes).
1	Setting	Enables/disables the settings for 002 and 003. [0 to 1/1] 0: Disable 1: Enable
3	Rule Set (Start)	The start of summer time
4	Rule Set (End)	The end of summer time

Group 5000

5401	Access Control (DFU)	
	This SP stores the settings that limit uses access to SDK application data.	
103	Default Document ACL	
	<p>Whenever a new login user is added to the address book in external certification mode (for Windows, LDAP, RDH), the default document ACL is updated according to this SP setting.</p> <p>[0 to 3 / 0 / 1]</p> <p>0: View 1: Edit 2: Edit/Delete 3: Full control</p> <p>Note: This SP setting is ignored on a machine that is not using document server.</p>	
104	Authentication Time	
162	Extend Certification Detail	
200	SDK1 Unique ID	<p>"SDK" is the "Software Development Kit". This data can be converted from SAS (VAS) when installed or uninstalled.</p> <p>(DFU)</p>
201	SDK1 Certification Method	
210	SDK2 Unique ID	
211	SDK2 Certification Method	
220	SDK3 Unique ID	
221	SDK3 Certification Method	
230	SDK certification device	
240	Detail Option	
5404	User Code Count Clear	
	Touch [EXECUTE] to clear all user code counters.	

5411	LDAP Certification
4	<p>Easy Certification Determines whether easy LDAP certification is done.</p> <p>[0 to 1/1/1] 1: On 0: Off</p>
5	<p>Password Null Not Permit This SP is referenced only when SP5411-4 is set to "1" (On).</p> <p>[0 to 1/0/1] 0: Password NULL not permitted. 1: Password NULL permitted.</p>

5413	Lockout Setting
1	<p>Lockout On/Off Switches on/off the lock on the local address book account.</p> <p>[0 to 1/0/1] 0: Off 1: On</p>
2	<p>Lockout Threshold Sets a limit on the frequency of lockouts for account lockouts.</p> <p>[1 to 10/5/1]</p>
3	<p>Cancellation On/Off Determines whether the system waits the prescribed time for input of a correct user ID and password after an account lockout has occurred.</p> <p>[0 to 1/0/1] 0: Off (no wait time, lockout not cancelled) 1: On (system waits, cancels lockout if correct user ID and password are entered).</p>

Group 5000

4	<p>Cancellation Time</p> <p>Determines the length of time that the system waits for correct input of the user ID and password after a lockout has occurred. This setting is used only if SP5413-3 is set to "1" (on).</p> <p>[1 to 999/60/1 min.]</p>
---	---

5414	Access Mitigation
1	<p>Mitigation On/Off</p> <p>Switches on/off masking of continuously used IDs and passwords that are identical.</p> <p>[0 to 1/0/1]</p> <p>0: Off</p> <p>1: On</p>
2	<p>Mitigation Time</p> <p>Sets the length of time for excluding continuous access for identical user IDs and passwords.</p> <p>[0 to 60/15/1 min.]</p>

5415	Password Attack
1	<p>Permissible Number</p> <p>Sets the number of attempts to attack the system with random passwords to gain illegal access to the system.</p> <p>[0 to 100/30/1 attempt]</p>
2	<p>Detect Time</p> <p>Sets the time limit to stop a password attack once such an attack has been detected.</p> <p>[1 to 10/5/1 sec.]</p>

5416	Access Information
1	<p>Access User Max Number</p> <p>Limits the number of users used by the access exclusion and password attack detection functions.</p> <p>[50 to 200/200/1 users]</p>
2	<p>Access Password Max Number</p> <p>Limits the number of passwords used by the access exclusion and password attack detection functions.</p> <p>[50 to 200/200/1 passwords]</p>
3	<p>Monitor Interval</p> <p>Sets the processing time interval for referencing user ID and password information.</p> <p>[1 to 10/3/1 sec.]</p>

5417	Access Attack
1	<p>Access Permissible Number</p> <p>Sets a limit on access attempts when an excessive number of attempts are detected for MFP features.</p> <p>[0 to 500/100/1]</p>
2	<p>Attack Detect Time</p> <p>Sets the length of time for monitoring the frequency of access to MFP features.</p> <p>[10 to 30/10/1 sec.]</p>
3	<p>Productivity Fall Wait</p> <p>Sets the wait time to slow down the speed of certification when an excessive number of access attempts have been detected.</p> <p>[0 to 9/3/1 sec.]</p>
4	<p>Attack Max Number</p> <p>Sets a limit on the number of requests received for certification in order to slow down the certification speed when an excessive number of access attempts have been detected.</p>

	[50 to 200/200/1 attempt]
--	---------------------------

⇒	5420	User Authentication
		These settings should be done with the System Administrator. Note: These functions are enabled only after the user access feature has been enabled.
	1	Copy
		Determines whether certification is required before a user can use the copy applications. [0 to 1/0/1] 0: On 1: Off
	2	Color Security Setting
		Enables or disables the color copy limitation for each copy mode when the user authentication is "ON". 0: Enable (default), 1: Disable Bit 0: B/W mode Bit 1: Mono color mode Bit 2: Two colors mode Bit 3: Full color mode Bit 4: Automatic color mode Bit 5 to 7: Reserved
	21	Fax Determines whether certification is required before a user can use the fax application. [0 to 1/0/1] 0: On 1: Off
	31	Scanner Determines whether certification is required before a user can use the scan applications. [0 to 1/0/1] 0: On

	1: Off	
41	Printer Determines whether certification is required before a user can use the printer applications. [0 to 1/0/1] 0: On 1: Off	
51	SDK1	[0 or 1/ 0 / 1] 0: ON. 1: OFF Determines whether certification is required before a user can use the SDK application.
61	SDK2	
71	SDK3	

5430	Auth Dialog Message Change	
1	Message Change On/Off	
2	Message Text Download	
3	Message Text ID	

5431	External Auth User Preset	
10	Tag	
11	Entry	
12	Group	
20	Mail	
31	Fax Sub	
32	Folder	
33	Protect Code	

Appendix:
Service
Program
Mode Table

Group 5000

34	SMTP Auth
35	LDAP Auth
36	SMB FTP Folder Auth
37	Acnt Acl
38	Document Acl
40	Cert Crypt

5481	Authentication Error Code
	These SP codes determine how the authentication failures are displayed.
1	<p>System Log Disp</p> <p>Determines whether an error code appears in the system log after a user authentication failure occurs.</p> <p>[0 to 1/0/1]</p> <p>0: Off</p> <p>1: On</p>
2	<p>Panel Disp</p> <p>Determines whether an error code appears on the operation panel after a user authentication failure occurs.</p> <p>[0 to 1/1/1]</p> <p>1: On</p> <p>0: Off</p>

5490	MF Keycard Japan Only
	<p>Sets up operation of the machine with a keycard.</p> <p>[0 to 1/0/1]</p> <p>0: Disabled. Cancels operation if no code is input.</p> <p>1: Enabled. Allows operation if another code is input and decrements the counter once for use of the entered code.</p>
1	Job Permit Setting

2	Count Mode Setting
---	--------------------

5501	PM Alarm
	<p>Sets the count level for the PM alarm. [0 to 9999/1] 0: Alarm disabled The PM alarm goes off when the print count reaches this value multiplied by 1,000.</p>

5504	Jam Alarm Japan Only
5505	Error Alarm Japan Only
5507	Supply Alarm Japan Only

Appendix:
Service
Program
Mode Table

5508	CC Call Japan Only		
	1	Jam Remains	Enables/disables initiating a call. [0 to 1/1] 0: Disable 1: Enable
	2	Continuous Jams	
	3	Continuous Door Open	
	4	Low Call Mode	
		Enables/disables the new call specifications designed to reduce the number of calls. [0 to 1/1] 0: Normal mode 1: Reduced mode	
	11	Jam Detection: Time Length	

Group 5000

	<p>Sets the length of time to determine the length of an unattended paper jam. [03 to 30/1] This setting is enabled only when SP5508-004 is enabled (set to 1).</p>
12	Jam Detection Continuous Count
	<p>Sets the number of continuous paper jams required to initiate a call. [02 to 10/1] This setting is enabled only when SP5508-004 is enabled (set to 1).</p>
13	Door Open: Time Length
	<p>Sets the length of time the remains opens to determine when to initiate a call. [03 to 30/1] This setting is enabled only when SP5508-004 is enabled (set to 1).</p>

5513	Parts Alarm Level Count Japan Only	
1	Normal	<p>Sets the parts replacement alarm counter to sound for the number of copies. [1 to 999/1 K]</p>
2	DF	<p>Sets the parts replacement alarm counter to sound for the number of scanned originals. [1 to 999/1 K]</p>

5514	Parts Alarm Level Japan Only	
1	Normal	
2	DF	

5610	Base Gamma Ctrl Pt:Execute DFU	
4	Get Factory Default	
5	Set Factory Default	
6	Restore Orginal Value	

5611	Toner Color in 2C DFU	
	Adjusts the toner ratio between color pairs: Black, Cyan, Magenta, Green, and Yellow.	
1	B-C	
2	B-M	
3	G-C	
4	G-Y	
5	R-M	
6	R-Y	

5618	Color Mode Display Selection	
	This SP switches the color display for the operation panel LCD. [0 to 1/1/1] 0: Domestic Japan 1: Overseas (Outside Japan)	

5792	MCS Debug SW DFU	
------	-------------------------	--

5793	ECS Debug SW DFU	
------	-------------------------	--

5801	Memory Clear	
------	--------------	--

Group 5000

	Resets NVRAM data to the default settings. Before executing this SP, print an SMC Report.
1	All Clear
	Initializes items 2 to 15 below.
2	Engine
	Initializes all registration settings for the engine and copy process settings.
3	SCS
	Initializes default system settings, SCS (System Control Service) settings, operation display coordinates, and ROM update information.
4	IMH Memory Clear
	Initializes the image file system. (IMH: Image Memory Handler)
5	MCS
	Initializes the automatic delete time setting for stored documents. (MCS: Memory Control Service)
6	Copier application
	Initializes all copier application settings.
7	Fax application
	Not used.
8	Printer application
	Initializes the printer defaults, programs registered, the printer SP bit switches, and the printer CSS counter.
9	Scanner application
	Initializes the defaults for the scanner and all the scanner SP modes.
10	Web Service

	Deletes the Netfile (NFA) management files and thumbnails, and initializes the Job login ID. Netfiles: Jobs to be printed from the document server using a PC and the DeskTopBinder software
11	NCS
	Initializes the system defaults and interface settings (IP addresses also), the SmartNetMonitor for Admin settings, WebStatusMonitor settings, and the TELNET settings. (NCS: Network Control Service)
14	Clear DCS Setting
	Initializes the DCS (Delivery Control Service) settings.
15	Clear UCS Setting
	Initializes the UCS (User Information Control Service) settings.
16	MIRS Setting
	Initializes the MIRS (Machine Information Report Service) settings.
17	CCS
	Initializes the CCS (Certification and Charge-control Service) settings.
18	SRM Memory Check
	Initializes the SRM (System Resource Manager) settings.
19	LCS
	Initializes the LCS (Log Count Service) settings.
20	Web Uapli
	Initializes the web user application settings.
21	ECS
	Initializes the ECS settings.

⇒ 5803	Input Check (☛ Section 4.11.1 Copier Input Check: SP5803)
	Use these SPs to do the input check for the electrical components of the main machine.
1	Paper Feed 1
2	Paper Feed 2
3	Paper Feed 3
4	Paper Feed 4
5	Paper Feed 5
6	Paper Feed 6
7	Paper Feed 7
8	Paper Trans 1
9	Paper Trans 2
10	Paper Trans 3
11	Paper Trans 4
12	Paper Trans 5
13	Paper Trans 6
14	Drum Mtr Lock
15	Development Mtr Lock
16	OPC Cleaning Mtr Lock
17	Other Motor Lock
18	Fan System 1
19	Fan System 1
20	Fan System 1
21	Fan System 1

22	Hi Volt SC 1
23	Hi Volt SC 2
24	Paper Transfer
25	Toner Supply
26	Set Detection
27	Fusing Temp Detect
28	Door
29	Used Toner Trans
30	Peltier Unit (Not Used)
200	HP Sensor
202	Scan Fan Lock Signal

Appendix:
Service
Program
Mode Table

⇒ 5804	Output Check (☛ Section 4.11.2 Copier Output Check: SP5804)
	Use these SPs to do the output check for the electrical components of the main machine.
1	Fuse Fan: Front NS
2	Fuse Fan: Front HS
3	Fuse Fan: Back NS
4	Fuse Fan: Back HS
5	Opt. Fan: Front NS
7	Opt. Fan: Back NS
9	Exit Pipe Fan
10	Sub Fuse Fan: NS
11	Sub Fuse Fan: HS

Group 5000

14	Dupx Fan: NS
15	Dupx Fan: Front: NS
16	Dupx Fan: Front: HS
17	Dupx Fan: Back: NS
18	Dupx Fan: Back: HS
19	Exit Fan: NS
20	Exit Fan: HS
21	PCB Box Fan1:NS
23	PCB Box Fan2:NS
25	PSU Fan 1:NS
26	PSU Fan 1:HS
27	PSU Fan 2:NS
28	PSU Fan 2:HS
29	PT Fan 1:NS
30	PT Fan 2:NS
31	Pelt. Cool Fan:NS
32	Pelt. Cool Fan:HS
33	Potential Sn Fan
34	Ozone Fan
35	PCU Fan:Y
36	PCU Fan:C
37	PCU Fan:M
38	PCU Fan:K

39	PCU Fan:Y:HS
40	Pelt. Cir. Fan
41	Sub Hopper CL:Y
42	Sub Hopper CL:C
43	Sub Hopper CL:M
44	Sub Hopper CL:K
45	Hopper Mtr:Fwd
46	P.Pump Drv CL:Y
47	P.Pump Drv CL:C
48	P.Pump Drv CL:M
49	P.Pump Drv CL:K
50	Used Toner Mtr 1
51	Used Toner Mtr 2
52	Charge dc:Y
53	Charge dc:C
54	Charge dc:M
55	Charge Grid K
56	Charge ac:Y
57	Charge ac:C
58	Charge ac:M
59	Charge Wire Current K
60	Dev dc:Y
61	Dev dc:C

Group 5000

62	Dev dc:M
63	Dev dc:K
64	Image Transfer:Y
65	Image Transfer:C
66	Image Transfer:M
67	Image Transfer:K
68	Paper Transfer:-
69	Paper Transfer:+
70	Paper Separate dc
71	Paper Separate ac
72	ID Sensor
73	Potential Sn LED:Front
74	Potential Sn LED:Center
75	Potential Sn LED:Rear
76	QL:Y
77	QL:C
78	QL:M
79	QL:K
80	LD:Y
81	LD:C
82	LD:M
83	LD:K
84	Polygon Mtr

85	ITB Lift M
86	ITB Lift Motor FC
87	Chg Cleaning Sol (M)
88	Chg Cleaning Sol (C)
89	Chg Cleaning Sol (Y)
95	Bk Drum Motor: High Speed 2
96	M Drum Motor: High Speed 2
97	C Drum Motor: High Speed 2
98	Y Drum Motor: High Speed 2
99	Bk Development Motor: High Speed 2
100	M Development Motor: High Speed 2
101	C Development Motor: High Speed 2
102	Y Development Motor: High Speed 2
103	Bk Cleaning Motor: High Speed 2
104	M Cleaning Motor: High Speed 2
105	C Cleaning Motor: High Speed 2
106	Y Cleaning Motor: High Speed 2
107	ITB Motor: High Speed 2
108	PRT Motor: High Speed 2
109	Fusing/Exit Motor: High Speed 2
110	Feed Mtr 1 Fwd:Rev2
111	Feed Mtr 1 Fwd:Haf2
112	Feed Mtr 1 Fwd:Hi2

Group 5000

113	Feed Mtr 1 Fwd:Hi2:Haf
114	Feed Mtr 1 Rev:Nor2
115	Feed Mtr 1 Rev:Haf2
116	Feed Mtr 2 Fwd:Rev2
117	Feed Mtr 2 Fwd:Haf2
118	Feed Mtr 2 Fwd:Hi2
119	Feed Mtr 2 Fwd:Hi2:Haf
120	Feed Mtr 2 Rev:Nor2
121	Feed Mtr 2 Rev:Haf2
122	Feed Mtr 3 Fwd:Rev2
123	Feed Mtr 3 Fwd:Haf2
124	Feed Mtr 3 Fwd:Hi2
125	Feed Mtr 3 Fwd:Hi2:Haf
126	Feed Mtr 3 Rev:Nor2
127	Feed Mtr 3 Rev:Haf2
128	Feed Mtr 4 Fwd:Rev2
129	Feed Mtr 4 Fwd:Haf2
130	Feed Mtr 4 Fwd:Hi2
131	Feed Mtr 4 Fwd:Hi2:Haf
132	Feed Mtr 4 Rev:Nor2
133	Feed Mtr 4 Rev:Haf2
134	Bypass Feed CL
135	Pickup SOL:Tray 1

136	Pickup SOL:Tray 2
137	Pickup SOL:Tray 3
138	Pickup SOL:Tray 4
139	Bypass Pickup SOL
142	Rev SOL:Tray 1
143	Rev SOL:Tray 2
144	Rev SOL:Tray 3
145	Rev SOL:Tray 4
146	Tan Conn Rel SOL
147	Tan Lock SOL
149	Tandem Back Fence SOL: F
150	Tandem Back Fence SOL: R
151	Relay Mtr:Fwd:Nor2
152	Relay Mtr:Fwd:Haf2
153	Relay Mtr:Fwd:Hi1
154	Relay Mtr:Fwd:Hi1:Haf
155	Relay Mtr:Rev: Nor2
156	Relay Mtr:Rev: Haf2
157	Registration Mtr:Nor2
158	Registration Mtr:Haf2
159	Guide Rel SOL
160	Exit JG SOL
161	Dup/Inv Mtr:Fwd:Nor2

Group 5000

162	Dup/Inv Mtr:Fwd:Haf2
163	Dup/Inv Mtr:Fwd:Hi2
164	Dup/Inv Mtr:Fwd:Hi2:Haf
165	Dup/Inv Mtr:Rev:Nor2: Tab Shts
166	Dup/Inv Mtr:Rev:Haf2: Tab Shts
167	DupTrans Mtr:Fwd:Nor2
168	DupTrans Mtr:Fwd:Haf2
169	DupTrans Mtr:Fwd:Hi2
170	DupTrans Mtr:Fwd:Hi2: Haf
171	Dup JG SOL
172	Inv Pos SOL
174	Dup Jog M:HP Sn
180	Fan K:Nor
181	Ozone Fan K:Nor
182	Ozone Fan K:Haf
183	Main Fan:Nor
184	Main Fan:Haf
185	Dev Fan Y:Nor
186	Dev Fan C:Nor
187	Dev Fan M:Nor
188	Dev Fan K:Nor
189	ITB CIng Fan:Nor
190	ITB CIng Fan:Haf

195	Jam LED:Fusing
196	Jam LED:Exit
200	Scananer fanmotor
202	Scananer Lamp
203	Scanner Motor
205	Bk Drum Motor: High Speed 1
206	M Drum Motor: High Speed 1
207	C Drum Motor: High Speed 1
208	Y Drum Motor: High Speed 1
209	Bk Development Motor: High Speed 1
210	M Development Motor: High Speed 1
211	C Development Motor: High Speed 1
212	Y Development Motor: High Speed 1
213	Bk Cleaning Motor: High Speed 1
214	M Cleaning Motor: High Speed 1
215	C Cleaning Motor: High Speed 1
216	Y Cleaning Motor: High Speed 1
217	ITB Motor: High Speed 1
218	PTR Motor: High Speed 1
219	Fusing/Exit Motor: High Speed 1
220	Bk Drum Motor: Half Speed 2
221	M Drum Motor: Half Speed 2
222	C Drum Motor: Half Speed 2

Group 5000

223	Y Drum Motor: Half Speed 2
224	Bk Development Motor: Half Speed 2
225	M Development Motor: Half Speed 2
226	C Development Motor: Half Speed 2
227	Y Development Motor: Half Speed 2
228	Bk Cleaning Motor: Half Speed 2
229	M Cleaning Motor: Half Speed 2
230	C Cleaning Motor: Half Speed 2
231	Y Cleaning Motor: Half Speed 2
232	ITB Motor: Half Speed 2
233	PTR Motor: Half Speed 2
234	Fusing/Exit Motor: Half Speed 2
235	Bk Drum Motor: Half Speed 2
236	M Drum Motor: Half Speed 1
237	C Drum Motor: Half Speed 1
238	Y Drum Motor: Half Speed 1
239	Bk Development Motor: Half Speed 1
240	M Development Motor: Half Speed 1
241	C Development Motor: Half Speed 1
242	Y Development Motor: Half Speed 1
243	Bk Cleaning Motor: Half Speed 1
244	M Cleaning Motor: Half Speed 1
245	C Cleaning Motor: Half Speed 1

246	Y Cleaning Motor: Half Speed 1
247	ITB Motor: Half Speed 1
248	PTR Motor: Half Speed 1
249	Fusing/Exit Motor: Half Speed 1

5810	Cancel Fusing SC
	<p>When the machine issues one of the "Level A" SC codes shown below, this indicates a serious problem in the fusing unit. The machine is disabled and the operator cannot reset the SC. The machine requires servicing immediately. Touch [EXECUTE] release the machine for servicing.</p> <ul style="list-style-type: none"> ▪ SC542 – SC545 Heating roller thermistor 1 ▪ SC547 – Zero Cross ▪ SC548 – SC550 Heating roller thermistor 2 ▪ SC551 – Pressure roller thermistor ▪ SC553 – SC555 Pressure roller thermistor ▪ SC662 – SC665 Hot roller thermistor

5811	Machine Serial
	This SP displays the machine serial number.

5812	Service Tel. No. Setting
1	Service
	Inputs the telephone number of the CE (displayed when a service call condition occurs.)
2	Facsimile
	Use this to input the fax number of the CE printed on the Counter Report (UP mode). Not Used
3	Supply

Group 5000

	Displayed on the initial SP screen.
4	Operation
	Allows the service center contact telephone number to be displayed on the initial screen.

5816	Remote Service
1	I/F Setting
	Turns the remote diagnostics off and on. [0 to 2/1] 0: Remote diagnostics off. 1: Serial (CSS or NRS) remote diagnostics on. 2: Network remote diagnostics.
2	CE Call
	Lets the customer engineer start or end the remote machine check with CSS or NRS; to do this, push the center report key.
3	Function Flag
	Enables and disables remote diagnosis over the NRS network. [0 to 1/1] 0: Disables remote diagnosis over the network. 1: Enables remote diagnosis over the network.
5	Device Information Call
	Controls if the item for initial setting of the screen for the NRS device-information notification-call is shown. [0 to 1/1] 0: Enabled. Item initial setting not shown. 1: Disable. Item for initial setting shown.
7	SSL Disable

	Controls if RCG (Remote Communication Gate) confirmation is done by SSL during an RCG send for the NRS over a network interface. [0 to 1/1] 0: Yes. SSL not used. 1: No. SSL used.
8	RCG Connect Timeout
	Sets the length of time (seconds) for the time-out when the RCG (Remote Communication Gate) connects during a call via the NRS network. [1 to 90/1 sec.]
9	RCG Write to Timeout
	Sets the length of time (seconds) for the time-out when sent data is written to the RCG during a call over the NRS network. [0 to 100/1 sec.]
10	RCG Read Timeout
	Sets the length of time (seconds) for the timeout when sent data is written from the RCG during a call over the NRS network. [0 to 100/1 sec.]
11	Port 80 Enable
	Controls if permission is given to get access to the SOAP method over Port 80 on the NRS network. [0 to 1/1] 0: No. Access denied 1: Yes. Access granted.
12	@Remote Communication Permission
13	RFU Timing

21	RCG – C Registered
	This SP displays the embedded RCG-N installation end flag. 1: Installation completed

Group 5000

	2: Installation not completed
23	Connect Type (N/M)
	This SP displays and selects the embedded RCG-N connection method. 0: Internet connection 1: Dial-up connection
61	Cert. Expire Timing (DFU)
	Proximity of the expiration of the certification.
62	Use Proxy
	This SP setting determines if the proxy server is used when the machine communicates with the service center.
63	Proxy Host
	This SP sets the address of the proxy server used for communication between the RCG device and the gateway. Use this SP to set up or display the customer proxy server address. The address is necessary to set up the embedded RCG-N. Note: The address display is limited to 128 characters. Characters beyond the 128 character are ignored. This address is customer information and is not printed in the SMC report.
64	proxy Port Number
	This SP sets the port number of the proxy server used for communication between the embedded RCG-N and the gateway. This setting is necessary to set up the embedded RCG-N. Note: This port number is customer information and is not printed in the SMC report.
65	Proxy User Name
	This SP sets the HTTP proxy certification user name. Note: The length of the name is limited to 31 characters. Any character beyond the 31st character is ignored. This name is customer information and is not printed in the SMC report.

66	Proxy Password	
	<p>This SP sets the HTTP proxy certification password.</p> <p>Note: The length of the password is limited to 31 characters. Any character beyond the 31st character is ignored. This name is customer information and is not printed in the SMC report.</p>	
67	CERT: Up State	
	Displays the status of the certification update.	
	0	The certification used by the embedded RCG-N is set correctly.
	1	The certification request (setAuthKey) for update has been received from the GW URL and certification is presently being updated.
	2	The certification update is completed and the GW URL is being notified of the successful update.
	3	The certification update failed, and the GW URL is being notified of the failed update.
	4	The period of the certification has expired and new request for an update is being sent to the GW URL.
	11	A rescue update for certification has been issued and a rescue certification setting is in progress for the rescue GW connection.
	12	The rescue certification setting is completed and the GW URL is being notified of the certification update request.
	13	The notification of the request for certification update has completed successfully, and the system is waiting for the certification update request from the rescue GW URL.
	14	The notification of the certification request has been received from the rescue GW controller, and the certification is being stored.
15	The certification has been stored, and the GW URL is being notified of the successful completion of this event.	

Group 5000

	16	The storing of the certification has failed, and the GW URL is being notified of the failure of this event.
	17	The certification update request has been received from the GW URL, the GW URL was notified of the results of the update after it was completed, but an certification error has been received, and the rescue certification is being recorded.
	18	The rescue certification of No. 17 has been recorded, and the GW URL is being notified of the failure of the certification update.
68	CERT: Error	
	Displays a number code that describes the reason for the request for update of the certification.	
	0	Normal. There is no request for certification update in progress.
	1	Request for certification update in progress. The current certification has expired.
	2	An SSL error notification has been issued. Issued after the certification has expired.
	3	Notification of shift from a common authentication to an individual certification.
	4	Notification of a common certification without ID2.
	5	Notification that no certification was issued.
6	Notification that GW URL does not exist.	
69	CERT: Up ID	
	The ID of the request for certification.	
83	Firmware Up Status	
	Displays the status of the firmware update.	

	Firm Up User Check
85	This SP setting determines if the operator can confirm the previous version of the firmware before the firmware update execution. If the option to confirm the previous version is selected, a notification is sent to the system manager and the firmware update is done with the firmware files from the URL.
	Firmware Size
86	Allows the service technician to confirm the size of the firmware data files during the firmware update execution.
	CERT: Macro
87	Displays the macro version of the @Remote certification
	CERT: PAC Ver.
88	Displays the PAC version of the @Remote certification.
	CERT: ID2 Code
89	Displays ID2 for the @Remote certification. Spaces are displayed as underscores (_). Asterisks (****) indicate that no NRS certification exists.
	CERT: Subject
90	Displays the common name of the @Remote certification subject. CN = the following 17 bytes. Spaces are displayed as underscores (_). Asterisks (****) indicate that no DESS exists.
	CERT: Serial No.
91	Displays serial number for the @Remote certification. Asterisks (****) indicate that no DESS exists.
	CERT: Issuer
92	Displays the common name of the issuer of the @Remote certification. CN = the following 30 bytes. Asterisks (****) indicate that no DESS exists.

Group 5000

93	CERT: Valid Start
	Displays the start time of the period for which the current @Remote certification is enabled.
94	CERT: Valid End
	Displays the end time of the period for which the current @Remote certification is enabled.
95	Server CN Check
96	GW Host
97	GW URL Path
99	Debug Rescue G/WURL Set
150	Selection Country
	<p>Select the country where embedded RCG-M is installed in the machine. After selecting the country, you must also set the following SP codes for embedded RCG-M:</p> <ul style="list-style-type: none"> ▪ SP5816-153 ▪ SP5816-154 ▪ SP5816-161 <p>0: Japan, 1: USA, 2: Canada, 3: UK, 4: Germany, 5: France 6: Italy, 7: Netherlands, 8: Belgium, 9: Luxembourg, 10: Spain</p>
151	Line type Automatic Judgment
	<p>Press [Execute].</p> <p>Setting this SP classifies the telephone line where embedded RCG-M is connected as either dial-up (pulse dial) or push (DTMF tone) type, so embedded RCG-M can automatically distinguish the number that connects to the outside line.</p> <ul style="list-style-type: none"> ▪ The current progress, success, or failure of this execution can be displayed with SP5816-152. ▪ If the execution succeeded, SP5816-153 will display the result for confirmation and SP5816-154 will display the telephone number for the connection to the outside line.

152	<p>Line Type Judgment Result</p> <p>Displays a number to show the result of the execution of SP5816-151. Here is a list of what the numbers mean.</p> <p>0: Success 1: In progress (no result yet). Please wait. 2: Line abnormal 3: Cannot detect dial tone automatically 4: Line is disconnected 5: Insufficient electrical power supply 6: Line classification not supported 7: Error because fax transmission in progress – ioctl() occurred. 8: Other error occurred 9: Line classification still in progress. Please wait.</p>
153	<p>Selection Dial/Push</p> <p>This SP displays the classification (tone or pulse) of the telephone line to the access point for embedded RCG-M. The number displayed (0 or 1) is the result of the execution of SP5816-151. However, this setting can also be changed manually.</p> <p>[0 to 1 / 0 / 1 /step]</p> <p>0: Tone Dialing Phone 1: Pulse Dialing Phone</p>
154	<p>Outside Line Outgoing Number</p> <p>The SP sets the number that switches to PSTN for the outside connection for embedded RCG-M in a system that employs a PBX (internal line).</p> <ul style="list-style-type: none"> ▪ If the execution of SP5816-151 has succeeded and embedded RCG-M has connected to the external line, this SP display is completely blank. ▪ If embedded RCG-M has connected to an internal line, then the number of the connection to the external line is displayed. ▪ If embedded RCG-M has connected to an external line, a comma is displayed with the number. The comma is inserted for a 2 sec. pause. ▪ The number setting for the external line can be entered manually (including

Group 5000

	commas).
156	<p>Dial Up User Name</p> <p>Use this SP to set a user name for access to remote dial up. Follow these rules when setting a user name:</p> <ul style="list-style-type: none"> ▪ Name length: Up to 32 characters ▪ Spaces and # allowed but the entire entry must be enclosed by double quotation marks (").
157	<p>Dial Up Password</p> <p>Use this SP to set a password for access to remote dial up. Follow these rules when setting a user name:</p> <ul style="list-style-type: none"> ▪ Name length: Up to 32 characters ▪ Spaces and # allowed but the entire entry must be enclosed by double quotation marks (").
161	<p>Local Phone Number</p> <p>Use this SP to set the telephone number of the line where embedded RCG-M is connected. This number is transmitted to and used by the Call Center to return calls.</p> <p>Limit: 24 numbers (numbers only)</p>
162	<p>Connection Timing Adjustment Incoming</p> <p>When the Call Center calls out to an embedded RCG-M modem, it sends a repeating ID tone (*#1#). This SP sets the time the line remains open to send these ID tones after the number of the embedded RCG-M modem is dialed up and connected.</p> <p>[0 to 24 / 1 / 1 /step]</p> <p>The actual amount of time is this setting + 2 sec. For example, if you set "2", the line will remain open for 4 sec.</p>

163	Access Point
	<p>This is the telephone number of the dial-up access point for embedded RCG-M. If no setting is done for this SP code, then a preset value (determined by the country selected) is used.</p> <p>Default: 0</p> <p>Allowed: Up to 16 numeral characters</p>
164	Line Connecting
	<p>This SP sets the connection conditions for the customer. This setting dedicates the line to embedded RCG-M only, or sets the line for sharing between embedded RCG-M and a fax unit.</p> <p>[0 or 1 / 0 / -]</p> <p>0: Line shared by embedded RCG-M/Fax</p> <p>1: Line dedicated to embedded RCG-M only</p> <ul style="list-style-type: none"> ▪ If this setting is changed, the copier must be cycled off and on. ▪ SP5816-187 determines whether the off-hook button can be used to interrupt an embedded RCG-M transmission in progress to open the line for fax transaction.
173	Modem serial No.
	This SP displays the serial number registered for the embedded RCG-M.
174	Retransmission Limit
	<p>Normally, it is best to allow unlimited time for certification and ID2 update requests, and for the notification that the certification has been completed. However, embedded RCGM generates charges based on transmission time for the customer, so a limit is placed upon the time allowed for these transactions.</p> <p>If these transactions cannot be completed within the allowed time, do this SP to cancel the time restriction.</p>

Group 5000

186	RCG - C M Debug Bit SW			
187	FAX TX Priority			
	<p>This SP determines whether pushing the off-hook button will interrupt an embedded RCGM transmission in progress to open the line for fax transaction. This SP can be used only if SP5816-164 is set to "0".</p> <p>[0 or 1/ 0 / -]</p> <p>0: Disable. Setting the fax unit off-hook does not interrupt a fax transaction in progress. If the off-hook button is pushed during a embedded RCG-M transmission, the button must be pushed again to set the fax unit on-hook after the embedded RCG-M transmission has completed.</p> <p>1: Enable. When embedded RCG-M shares a line with a fax unit, setting the fax unit off-hook will interrupt a embedded RCG-M transmission in progress and open the line for a fax transaction.</p>			
200	Manual Polling			
	No information is available at this time.			
201	Regist: Status			
	Displays a number that indicates the status of the @Remote service device.			
	0	Neither the registered device by the external nor embedded RCG device is set.		
	1	The embedded RCG device is being set. Only Box registration is completed. In this status, this unit cannot answer a polling request from the external RCG.		
	2	The embedded RCG device is set. In this status, the external RCG unit cannot answer a polling request.		
	3	The registered device by the external RCG is being set. In this status the embedded RCG device cannot be set.		
4	The registered module by the external RCG has not started.			

202	Letter Number	
	Allows entry of the number of the request needed for the embedded RCG.	
203	Confirm Execute	
	Executes the inquiry request to the @Remote Gate Way URL.	
204	Confirm Result	
	Displays a number that indicates the result of the inquiry executed with SP5816-203.	
	0	Succeeded
	1	Inquiry number error
	2	Registration in progress
	3	Proxy error (proxy enabled)
	4	Proxy error (proxy disabled)
	5	Proxy error (Illegal user name or password)
	6	Communication error
	7	Certification update error
	8	Other error
205	Confirm Place	
	Displays the result of the notification sent to the device from the GW URL in answer to the inquiry request. Displayed only when the result is registered at the GW URL.	
206	Register Execute	
	Executes "Embedded RCG Registration".	

Group 5000

207	Register Result	
	Displays a number that indicates the registration result.	
	0	Succeeded
	2	Registration in progress
	3	Proxy error (proxy enabled)
	4	Proxy error (proxy disabled)
	5	Proxy error (Illegal user name or password)
	6	Communication error
	7	Certification update error
	8	Other error
9	Registration executing	

208	Error Code		
	Displays a number that describes the error code that was issued when either SP5816 204 or SP5816 207 was executed.		
	Cause	Code	Meaning
	Illegal Modem Parameter	-11001	Chat parameter error
-11002		Chat execution error	
-11003		Unexpected error	
	Operation Error, Incorrect Setting	-12002	Inquiry, registration attempted without acquiring device status.
-12003		Attempted registration without execution of an inquiry and no previous registration.	
-12004		Attempted setting with illegal entries for certification and ID2.	
-12005		@Remove communication prohibited	
-12006		Confirmation requested again after confirmation completed.	
-12007		Different numbers were used for registration and confirmation.	
-12008		Update certification failed because device was in use.	
	Error Caused by Response from GW URL	-2385	Attempted dial up overseas without the correct international prefix for the telephone number.
-2387		Not supported at the Service Center	
-2389		Database out of service	

Group 5000

-2390		Program out of service
-2391		Two registrations for same device
-2392		Parameter error
-2393		External RCG not managed
-2394		Device not managed
-2395		Box ID for external RCG is illegal
-2396		Device ID for external RCG is illegal
-2397		Incorrect ID2 format
-2398		Incorrect request number format
209	Inst Clear	
	Releases the machine from its embedded RCG setup.	
250	CommLog Print	
	Prints the communication log.	

5821	Remote Service Address

5824	NVRAM Data Upload
	Set the SD card in the Slot 1 (lower slot) then touch [EXECUTE] to upload the NVRAM data to an SD card. Note: When uploading in this SP mode data, the front door must be open.

5825	NVRAM Data Download
	Set the SD card in the Slot 1 (lower slot) then touch [EXECUTE] to download data from the card to the NVRAM in the machine. After downloading is completed, remove the card and turn the machine power off and on.

5828	Network Setting
1	IPv4 Address (Ethernet/IEEE 802.11)
	This SP allows you to confirm and reset the IPv4 address for Ethernet and wireless LAN (802.11): aaa.bbb.ccc.ddd
2	IPv4 Subnet Mask (Ethernet/IEEE 802.11)
	This SP allows you to confirm and reset the IPv4 subnet mask for Ethernet and wireless LAN (802.11): aaa.bbb.ccc.ddd
3	IPv4 default Gateway (Ethernet/IEEE 802.11)
	This SP allows you to confirm and reset the IPv4 default gateway used by the network for Ethernet and wireless LAN (802.11): aaa.bbb.ccc.ddd
6	DHCP (Ethernet/IEEE 802.11)
	This SP code allows you confirm and change the setting that determines whether the IP address is used with DHCP on an Ethernet or wireless (802.11) LAN network. [0 to 1 / 1 / 1] 0: Not used (manual setting) 1: Used
21	Active IPv4 Address
	This SP allows you to confirm the IPv4 address that was used when the machine started up with DHCP.

Group 5000

22	Active IPv4 Subnet Mask	
	This SP allows you to confirm the IPv4 subnet mask setting that was used when the machine started up with DHCP.	
23	Active IPv4 Gateway Address	
	This SP allows you to confirm the IPv4 default gateway setting that was used when the machine started up with DHCP.	
50	1284 Compatibility (Centro)	Enables and disables bi-directional communication on the parallel connection between the machine and a computer. [0 to 1 / 1 / 1] 0:Off, 1: On
52	ECP (Centro)	Disables and enables the ECP feature (1284 Mode) for data transfer. [0 to 1 / 1 / 1] 0: Disabled, 1: Enabled
65	Job Spooling	Switches the job spooling on and off. [0 to 1 / 0 / 1] 0: No spooling, 1: Spooling enabled
66	Job Spooling Clear: Start Time	This SP determines whether the job interrupted at power off is resumed at the next power on. This SP operates only when SP5828-065 is set to "1". [0 to 1 / 1 / 1] 1: Resumes printing spooled jog. 0: Clears spooled job.
69	Job Spooling (Protocol)	This SP determines whether job spooling is enabled or disabled for each protocol. This is a 8-bit setting. [0 to 1 / 1 / 1] 0: No spooling, 1: Spooling enabled

	0	LPR	4	BMLinks (Japan Only)
	1	FTP (Not Used)	5	DIPRINT
	2	IPP	6	Reserved (Not Used)
	3	SMB	7	Reserved (Not Used)
90	TELNET (0:OFF 1:ON)		Disables or enables Telnet operation. If this SP is disabled, the Telnet port is closed. [0 to 1 / 1 / 1] 0: Disable, 1: Enable	
91	Web (0:OFF 1:ON)		Disables or enables the Web operation. [0 to 1 / 1 / 1] 0: Disable, 1: Enable	
145	Active IPv6 Link Local Address		This is the IPv6 local address referenced on the Ethernet or wireless LAN (802.11) in the format: "Link-Local address" + "Prefix Length" The IPv6 address consists of a total 128 bits configured in 8 blocks of 16 bits each. These notations can be abbreviated. See "Note: IPV6 Addresses " below this table.	
147	Active IPv6 Stateless Address 1		These SPs are the IPv6 stateless addresses (1 to 5) referenced on the Ethernet or wireless LAN (802.11b) in the format: "Stateless Address" + "Prefix Length" The IPv6 address consists of a total 128 bits configured in 8 blocks of 16 bits each.	
149	Active IPv6 Stateless Address 2			
151	Active IPv6 Stateless Address 3			
153	Active IPv6 Stateless Address 4			
155	Active IPv6 Stateless Address 5			

156	IPv6 Manual Address
	<p>This SP is the IPv6 manually set address referenced on the Ethernet or wireless LAN (802.11) in the format: "Manual Set Address" + "Prefix Length" The IPv6 address consists of a total 128 bits configured in 8 blocks of 16 bits each. These notations can be abbreviated. See "Note: IPV6 Addresses" below this table.</p>
158	IPv6 Gateway
	<p>This SP is the IPv6 gateway address referenced on the Ethernet or wireless LAN (802.11). The IPv6 address consists of a total 128 bits configured in 8 blocks of 16 bits each. These notations can be abbreviated. See "Note: IPV6 Addresses" below this table.</p>

Note: IPV6 Addresses

Ethernet and the Wireless LAN (802.11) reference the IPV6 "Link-Local address + Prefix Length". The IPV6 address consists of 128 bits divided into 8 blocks of 16 bits:
aaaa:bbbb:cccc:dddd:eeee:ffff:gggg:hhhh:

The prefix length is inserted at the 17th byte (Prefix Range: 0x0 to 0x80). The initial setting is 0x40 (64).

For example, the data: "2001123456789012abcdef012345678940h" is expressed:
"2001:1234:5678:9012:abcd:ef01:2345:6789": prefixlen 64

However, the actual IPV6 address display is abbreviated according to the following rules.

Rules for Abbreviating IPV6 Addresses

The IPV6 address is expressed in hexadecimal delimited by colons (:) with the following characters:
0123456789abcdefABCDEF

1. A colon is inserted as a delimiter every 4th hexadecimal character.
fe80:0000:0000:0000:0207:40ff:0000:340e
2. The notations can be abbreviated by eliminating zeros where the MSB and digits following the MSB are zero. The example in "2" above, then, becomes
fe80:0:0:0207:40ff:0:340e
3. Sections where only zeros exist can be abbreviated with double colons (::). This

abbreviation can be done also where succeeding sections contain only zeros (but this can be done only at one point in the address). The example in "2" and "3" above then becomes:

fe80::207:40ff:0:340e (only the first null sets zero digits are abbreviated as "::")

-or-

fe80:0:0:0:207:40ff::340e (only the last null set before "340e" is abbreviated as "::")

161	IPv6 Stateless Auto Setting	Enable or disables the automatic setting for IPv6 stateless.
236	Web Item visible	
	Displays or does not display the Web system items. [0 x 0000 to 0 x ffff / 0 x ffff] 0: Not displayed, 1: Displayed bit0: Net RICOH bit1: Consumable Supplier bit2-15: Reserved (all)	
237	Web shopping link visible	
	Displays or does not display the link to Net RICOH on the top page and link page of the web system. [0 to 1 / 1 / 1] 0: Not display, 1:Display	
238	Web supplies Link visible	
	Displays or does not display the link to Consumable Supplier on the top page and link page of the web system. [0 to 1 / 1 / 1] 0: Not display, 1:Display	
239	Web Link1 Name	
	This SP confirms or changes the URL1 name on the link page of the web system. The maximum characters for the URL name are 31 characters.	

Group 5000

240	Web URL	
	This SP confirms or changes the link to URL1 on the link page of the web system. The maximum characters for the URL are 127 characters.	
241	Web visible	
	Displays or does not display the link to URL1 on the top page of the web system. [0 to 1 / 1 / 1] 0: Not display, 1:Display	
242	Web Link2 Name	Same as "-239"
243	Web Link2 URL	Same as "-240"
244	Web Link2 visible	Same as "-241"

5832	HDD	HDD Formatting
	Enter the SP number for the partition to initialize, then press #. When the execution ends, cycle the machine off and on.	
1	HDD Formatting (All)	
2	HDD Formatting (IMH)	
3	HDD Formatting (Thumbnail)	
4	HDD Formatting (Job Log)	
5	HDD Formatting (Printer Fonts)	
6	HDD Formatting (User Info.)	
7	Mail RX Data	
8	Mail TX Data	
9	HDD Formatting (Data for Design)	
10	HDD Formatting (Log)	

11	HDD Formatting (Ridoc I/F DeskTopBinder)
----	--

5840	IEEE 802.11	
6	Channel MAX	
	Sets the maximum range of the bandwidth for the wireless LAN. This bandwidth setting varies for different countries. [1 to 14/1]	
7	Channel MIN	
	Sets the minimum range of the bandwidth for operation of the wireless LAN. This bandwidth setting varies for different countries. [1 to 14/1]	
8	Transmission Speed	[0 x 00 to 0 x FF / 0 x FF to Auto / -]
	0 x FF to Auto [Default]	
	0 x 11 – 55M Fix	0 x 07 – 11M Fix
	0 x 10 – 48M Fix	0 x 05 – 5.5M Fix
	0 x 0F – 36M Fix	0 x 08 – 1M Fix
	0 x 0E – 18M Fix	0 x 13 – 0 x FE (reserved)
	0 x 0D – 12M Fix	0 x 12 – 72M (reserved)
	0 x 0B – 9M Fix 0 x 0A – 6M Fix	0 x 09 – 22M (reserved)
11	WEP Key Select	
	Determines how the initiator (SBP-2) handles subsequent login requests. [0 to 1/1] 0: If the initiator receives another login request while logging in, the request is refused. 1: If the initiator receives another login request while logging in, the request is refused and the initiator logs out. Note: Displayed only when the wireless LAN card is installed.	

Appendix:
Service
Program
Mode Table

Group 5000

	Fragment Thresh
42	Adjusts the fragment threshold for the IEEE802.11 card. [256 to 2346 / 2346 / 1] This SP is displayed only when the IEEE802.11 card is installed.
	11g CTS to Self
43	Determines whether the CTS self function is turned on or off. [0 to 1 / 1 / 1] 0: Off, 1: On This SP is displayed only when the IEEE802.11 card is installed.
	11g Slot Time
44	Selects the slot time for IEEE802.11. [0 to 1 / 0 / 1] 0: 20 μm, 1: 9 μm This SP is displayed only when the IEEE802.11 card is installed.
	WPA Debug Lvl
45	Selects the debug level for WPA authentication application. [1 to 3 / 3 / 1] 1: Info, 2: warning, 3: error This SP is displayed only when the IEEE802.11 card is installed.

5841	Supply Name Setting
	Press the User Tools key. These names appear when the user presses the Inquiry button on the User Tools screen.
1	Toner Name Setting: Black
2	Toner Name Setting: Cyan
3	Toner Name Setting: Yellow
4	Toner Name Setting: Magenta
7	Org Stamp
8	Paste Name

11	StapleStd1	
12	StapleStd2	
13	StapleStd3	Standard Staples for D373/D374
14	StapleStd4	
21	StapleBind1	Booklet Staples for D374
22	StapleBind2	
23	StapleBind3	
31	Ring Name (50/Black)	Ring Binders for D392
32	Ring Name (50/White)	
33	Ring Name (100/Black)	
34	Ring Name (100/White)	

Group 5000

5842	GWWS Analysis DFU		
1	Settings 1		
2	Settings 2		
	<p>This is a debugging tool. It sets the debugging output mode of each Net File process. Bit SW 0011 1111</p>	Bit	Groups
0		System & other groups (LSB)	
1		Capture related	
2		Authentication related	
3		Address book related	
4		Machine management related	
5		Output related (printing, delivery)	
6		Repository related	

5844	USB	
	Transfer Rate	
1	Sets the speed for USB data transmission. [Full Speed] [Auto Change]	
	Vendor ID	
2	Sets the vendor ID: Initial Setting: 0x05A Ricoh Company [0x0000 to 0xFFFF/1] DFU	
	Product ID	
3	Sets the product ID. [0x0000 to 0xFFFF/1] DFU	
	Device Release Number	
4	Sets the device release number of the BCD (binary coded decimal) display. [0000 to 9999/1] DFU Enter as a decimal number. NCS converts the number to hexadecimal number recognized as BCD.	
5	Fixed USB Port	
6	PnP Model Name	
7	PnP Serial Number	
100	Notify Unsupport	

Group 5000

5845	Delivery Server Setting
	These are delivery server settings.
1	FTP Port No. [0 to 65535/1]
2	IP Address (Primary) Use this SP to set the Scan Router Server address. The IP address under the transfer tab can be used with the initial system setting. [0 to FFFFFFFF/1]
6	Delivery Error Display Time Use this setting to set the length of time that the message is shown when a test error occurs during document transfer with the NetFile application and an external device. [0 to 999/1]
8	IP Address (Secondary) Sets the IP address that is given to the computer that is the secondary delivery server for Scan Router. This SP lets you set only the IP address, and does not refer to the DNS setting.
9	Delivery Server Model Lets you change the model of the delivery server that is registered by the I/O device. [0 to 4/1] 0: Unknown 1: SG1 Provided 2: SG1 Package 3: SG2 Provided 4: SG2 Package
10	Delivery Svr. Capability Changes the functions that the registered I/O device can do.

	<p>[0 to 255/1]</p> <p>Bit7 = 1 Comment information exists</p> <p>Bit6 = 1 Direct specification of mail address possible</p> <p>Bit5 = 1 Mail RX confirmation setting possible</p> <p>Bit4 = 1 Address book automatic update function exists</p> <p>Bit3 = 1 Fax RX delivery function exists</p> <p>Bit2 = 1 Sender password function exists</p> <p>Bit1 = 1 Function to link MK-1 user and Sender exists</p> <p>Bit0 = 1 Sender specification required (if set to 1, Bit6 is set to "0")</p>
11	Delivery Svr.Capability (Ext)
	<p>These settings are for future use. They will let you increase the number of registered devices (in addition to those registered for SP5845 010). There are eight bits (Bit 0 to Bit 7). All are unused at this time.</p>

13	Server Scheme (Primary)	
14	Server port Number (Primary)	[1 to 65535 / 80 / 1]
15	Server URL Path (Primary)	
16	Server Scheme (secondary)	
17	Server Port Number (Secondary)	[1 to 65535 / 80 / 1]
18	Server URL Path (Secondary)	
22	Rapid Sending Control	
	<p>[0 to 1 / 0 / -]</p> <p>0: Disable, 1: Enable</p> <p>Enables or disables the prevention function for the continuous data sending error.</p>	

Group 5000

5846	UCS Setting
1	Machine ID (for Delivery Server)
	<p>Displays the unique device ID in use by the delivery server directory.</p> <ul style="list-style-type: none"> ▪ The value is only displayed and cannot be changed. ▪ This ID is created from the NIC MAC or IEEE 1394 EUI. ▪ The ID is displayed as either 6-byte or 8-byte binary.
2	Machine ID Clear (for Delivery Server)
	<p>Clears the unique ID of the device used as the name in the file transfer directory. Execute this SP if the connection of the device to the delivery server is unstable. After clearing the ID, the ID will be established again automatically by cycling the machine off and on.</p>
3	Maximum Entries
	<p>Changes the maximum number of entries that UCS can handle. [2000 to 20000 / 2000 / 1 step] If a value smaller than the present value is set, the UCS managed data is cleared, and the data (excluding user code information) is displayed.</p>
6	Delivery Server Retry Timer
	<p>Sets the interval for retry attempts when the delivery server fails to acquire the delivery server address book. [0 to 255 / 0 / 1 step] 0: No retries</p>
7	Delivery Server Retry Times
	<p>Sets the number of retry attempts when the delivery server fails to acquire the delivery server address book. [0 to 255 / 0 / 1step]</p>
8	Delivery Server Maximum Entries
	<p>Lets you set the maximum number of account entries and information about the users of the delivery server controlled by UCS.</p>

	[20000 to 20000 / 2000 / 1 step]
20	WSD Maximum Entries
21	Folder Auth Change
10	LDAP Search Timeout
	Sets the length of the time-out for the search of the LDAP server. [1 to 255 / 60 /1 step]
40	Addr Book Migration (USB -> HDD)
	<p>This SP moves the address book data from the SD card or flash ROM on the controller board to the HDD. You must cycle the machine off and on after executing this SP.</p> <ol style="list-style-type: none"> 1. Turn the machine off. 2. Install the HDD. 3. Turn the machine on. 4. Do SP5846 040. 5. Turn the machine off/on. <p>Note: Executing this SP overwrites any address book data already on the HDD with the data from the flash ROM on the controller board.</p> <p>We recommend that you back up all directory information to an SD card with SP5846-051 before you execute this SP.</p> <p>After the address book data is copied to HDD, all the address book data is deleted from the flash ROM. If the operation fails, the data is not erased from the flash ROM.</p>
41	Fill Addr Acl Info.
	<p>This SP must be executed immediately after installation of an HDD unit in a basic machine that previously had no HDD. The first time the machine is powered on with the new HDD installed, the system automatically takes the address book from the NVRAM and writes it onto the new HDD. However, the new address book on the HDD can be accessed only by the system administrator at this stage. Executing this SP by the service technician immediately after power on grants full address book access to all users.</p> <p>Procedure</p>

Group 5000

	<ol style="list-style-type: none"> 1. Turn the machine off. 2. Install the new HDD. 3. Turn the machine on. 4. The address book and its initial data are created on the HDD automatically. However, at this point the address book can be accessed by only the system administrator or key operator. 5. Enter the SP mode and do SP5846 041. After this SP executes successfully, any user can access the address book. 	
43	Addr Book Media	
	Displays the slot number where an address book data is in. [0 to 30 / - /1]	
	0: Unconfirmed 1: SD Slot 1 2: SD Slot 2 4: USB Flash ROM	20: HDD 30: Nothing
46	Initialize All Settings & Address Book	
47	Initialize Local Address Book	
	Clears all of the address information from the local address book of a machine managed with UCS.	
48	Initialize Delivery Addr Book	
	Push [Execute] to delete all items (this does not include user codes) in the delivery address book that is controlled by UCS.	
49	Initialize LDAP Addr Book	
	Push [Execute] to delete all items (this does not include user codes) in the LDAP address book that is controlled by UCS.	
50	Initialize All Addr Book	
	Clears everything (including users codes) in the directory information managed by UCS. However, the accounts and passwords of the system administrators are not deleted.	

51	Backup All Addr Book	
	Copies all directory information to the SD card. Do this SP before replacing the controller board or HDD. The operation may not succeed if the controller board or HDD is damaged.	
52	Restore All Addr Book	
	Copies back all directory information from the SD card to the flash ROM or HDD. Upload the address book from the old flash ROM or HDD with SP5846-51 before removing it. Do SP5846 52 after installing the new HDD.	
53	Clear Backup Info.	
	<p>Deletes the address book uploaded from the SD card in the Slot 1 (lower slot). Deletes only the files uploaded for that machine. This feature does not work if the card is write-protected.</p> <p>Note: After you do this SP, go out of the SP mode, turn the power off. Do not remove the SD card until the Power LED stops flashing.</p>	
60	Search Option	
	This SP uses bit switches to set up the fuzzy search options for the UCS local address book.	
	Bit	Meaning
	0	Checks both upper/lower case characters
	1	Japan Only
	2	
	3	
	4	--- Not Used ---
	5	--- Not Used ---
	6	--- Not Used ---
7	--- Not Used ---	

Appendix:
Service
Program
Mode Table

Group 5000

62	<p>Complexity Option 1</p> <p>Use this SP to set the conditions for password entry to access the local address book. Specifically, this SP limits the password entry to upper case and sets the length of the password.</p> <p>[0 to 32 / 0 / 1step]</p> <p>Note:</p> <ul style="list-style-type: none"> ▪ This SP does not normally require adjustment. ▪ This SP is enabled only after the system administrator has set up a group password policy to control access to the address book.
63	<p>Complexity Option 2</p> <p>Use this SP to set the conditions for password entry to access the local address book. Specifically, this SP limits the password entry to lower case and defines the length of the password.</p> <p>[0 to 32 / 0 / 1step]</p> <p>Note:</p> <ul style="list-style-type: none"> ▪ This SP does not normally require adjustment. ▪ This SP is enabled only after the system administrator has set up a group password policy to control access to the address book.
64	<p>Complexity Option 3</p> <p>Use this SP to set the conditions for password entry to access the local address book. Specifically, this SP limits the password entry to numbers and defines the length of the password.</p> <p>[0 to 32 / 0 / 1step]</p> <p>Note:</p> <ul style="list-style-type: none"> ▪ This SP does not normally require adjustment. ▪ This SP is enabled only after the system administrator has set up a group password policy to control access to the address book.
65	<p>Complexity Option 4</p> <p>Use this SP to set the conditions for password entry to access the local address book. Specifically, this SP limits the password entry to symbols and defines the length of the password.</p> <p>[0 to 32 / 0 / 1step]</p>

	<p>Note:</p> <ul style="list-style-type: none"> ▪ This SP does not normally require adjustment. ▪ This SP is enabled only after the system administrator has set up a group password policy to control access to the address book.
91	FTP Auth Port Setting
	<p>Sets the FTP port to get the delivery server address book that is used in the individual authorization mode.</p> <p>[0 to 65535 / 3671 / 1step]</p>
94	Encryption Start
	<p>Shows the status of the encryption function of the address book on the LDAP server.</p> <p>[0 to 255 / 1] No default</p>

5847	Rep Resolution Reduction		
	<ul style="list-style-type: none"> ▪ 5847 1 through 5847 6 changes the default settings of image data sent externally by the Net File page reference function. ▪ [0 to 2/1] ▪ 5847 21 sets the default for JPEG image quality of image files controlled by NetFile. ▪ "NetFile" refers to jobs to be printed from the document server with a PC and the DeskTopBinder software. 		
1	Rate After Copy Col	[0 to 5/1]	0: 1x 1: 1/2x 2: 1/3x 3: 1/4x 4: 1/6x 5: 1/8x 6: 2/3x1 1: "6: 2/3x" applies to 003, 005, 006 only.
2	Rate for Copy B&W Text	[0 to 6/1]	
3	Rate for Copy B&W Other	[0 to 6/1]	
4	Rate for Printer Color	[0 to 5/1]	
5	Rate for Printer B&W	[0 to 6/1]	
6	Rate for Printer Color 1200 dpi		

Group 5000

7	Rate for Printer B&W 1200 dpi	
21	Network Quality Default for JPEG	
	Sets the default value for the quality of JPEG images sent as NetFile pages. This function is available only with the MLB (Media Link Board) option installed. [5 to 95/1]	

5848	Web Service	
	5848-2 sets the 4-bit switch assignment for the access control setting. Setting of 0001 has no effect on access and delivery from Scan Router. 5848-100 sets the maximum size of images that can be downloaded. The default is equal to 1 gigabyte.	
1	Access Control.: NetFile (Lower 4 Bits Only)	
	Bit switch settings. 0000: No access control 0001: Denies access to Desk Top Binder. Access and deliveries from Scan Router have no effect on capture.	
2	Acc. Ctrl.: Repository (only Lower 4 Bits)	0000: No access control 0001: Denies access to DeskTop Binder.
3	Acc. Ctrl.: Doc. Svr. Print (Lower 4 Bits)	Switches access control on and off. 0000: OFF, 0001: ON
4	Acc. Ctrl.: User Directory (Lower 4 Bits)	
7	Acc. Ctrl Comm. Log Fax (Lower 4 Bits)	
9	Acc. Ctrl.: Job Control (Lower 4 Bits)	
11	Acc. Ctrl: Device Management (Lower 4 Bits)	
21	Acc. Ctrl: Delivery (Lower 4 Bits)	
22	Acc. Ctrl: User Administration (Lower 4 Bits)	
99	Repository Download Image Set	

100	Repository: Download Image Max. Size	Specified the max size of the image data that the machine can download/ [1 to 1024 / 1024 / 1 K]
210	Setting: Log Type: Job 1	
	No information is available at this time.	
211	Setting: Log Type: Job 2	
	No information is available at this time.	
212	Setting: Log Type: Access	
	No information is available at this time.	
213	Setting: Primary Srv	
	No information is available at this time.	
214	Setting: Secondary Srv	
	No information is available at this time.	
215	Setting: Start Time	
	No information is available at this time.	
216	Setting: Interval Time	
	No information is available at this time.	
217	Setting: Timing	
	No information is available at this time.	

Appendix:
Service
Program
Mode Table

5849	Installation Date
	Displays or prints the installation date of the machine.
1	Display
	The "Counter Clear Day" has been changed to "Installation Date" or "Inst. Date".

Group 5000

2	Switch to Print
	<p>Determines whether the installation date is printed on the printout for the total counter.</p> <p>[0 to 1/1]</p> <p>0: No Print</p> <p>1: Print</p>
3	Total Counter

5850	Address Book Function Japan Only
	<p>The machine is sold ready to use with a G3 line. Touch [Replacement] to switch all at once to convert to G4 after you add a G4 line. Conversely, if for some reason the G4 line becomes unusable, you can easily switch back to G3.</p>

	Bluetooth
5851	<p>Sets the operation mode for the Bluetooth Unit. Press either key.</p> <p>[0: Public] / [1: Private]</p>

	Stamp Data Download
5853	<p>Touch [EXECUTE] to download the fixed stamp data from the machine ROM onto the hard disk. Then these stamps can be used by the system. If this is not done, the user will not have access to the fixed stamps ("Confidential", "Secret", etc.).</p> <p>You must always execute this SP after replacing the HDD or after formatting the HDD. Always switch the machine off and on after executing this SP.</p>

5856	Remote ROM Update
	<p>When set to "1" allows reception of firmware data via the local port (IEEE 1284) during a remote ROM update. This setting is reset to zero after the machine is cycled off and on. Allows the technician to upgrade the firmware using a parallel cable</p> <p>[0 to 1/1]</p> <p>0: Not allowed</p> <p>1: Allowed</p>

5857	Save Debug Log
1	On/Off (1:ON 0:OFF)
	<p>Switches on the debug log feature. The debug log cannot be captured until this feature is switched on.</p> <p>[0 to 1/1]</p> <p>0: OFF</p> <p>1: ON</p>
2	Target (2: HDD 3: SD Card)
	<p>Selects the destination where the debugging information generated by the event selected by SP5858 will be stored if an error is generated</p> <p>[2 to 3 /1]</p> <p>2: HDD</p> <p>3: SD Card</p>
5	Save to HDD
	Specifies the decimal key number of the log to be written to the hard disk.
6	Save to SD Card
	Specifies the decimal key number of the log to be written to the SD Card.

Appendix:
Service
Program
Mode Table

Group 5000

9	Copy HDD to SD Card (Latest 4 MB)
	<p>Takes the most recent 4 MB of the log written to the hard disk and copies them to the SD Card.</p> <p>A unique file name is generated to avoid overwriting existing file names on the SD Card. Up to 4MB can be copied to an SD Card. 4 MB segments can be copied one by one to each SD Card.</p>
10	Copy HDD to SD Card Latest 4 MB (Any Key)
	<p>Takes the log of the specified key from the log on the hard disk and copies it to the SD Card.</p> <p>A unique file name is generated to avoid overwriting existing file names on the SD Card. Up to 4 MB can be copied to an SD Card. 4 MB segments can be copied one by one to each SD Card. This SP does not execute if there is no log on the HDD with no key specified.</p>
11	Erase HDD Debug Data
	Erases all debug logs on the HDD
12	Erase SD Card Debug Data
	<p>Erases all debug logs on the SD Card. If the card contains only debugging files generated by an event specified by SP5858, the files are erased when SP5857 010 or 011 is executed.</p> <p>To enable this SP, the machine must be cycled off and on.</p>
13	Free Space on SD Card
	Displays the amount of space available on the SD card.
14	Copy SD to SD (Latest 4MB)
	Copies the last 4MB of the log (written directly to the card from shared memory) onto an SD card.
15	Copy SD to SD (Latest 4MB Any Key)
	This SP copies the log on an SD card (the file that contains the information written directly from shared memory) to a log specified by key number.

16	Make HDD Debug
	This SP creates a 32 MB file to store a log on the HDD.
17	Make SD Debug
	This SP creates a 4 MB file to store a log on an SD card.

Group 5000

5858	Debug Save When	
	<p>These SPs select the content of the debugging information to be saved to the destination selected by SP5857 002.</p> <p>SP5858 3 stores one SC specified by number. Refer to Section 4 for a list of SC error codes.</p>	
1	Engine SC Error (0:OFF 1:ON)	
	<p>Stores SC codes generated by copier engine errors.</p> <p>[0 to 1/1] 0: OFF 1: ON</p>	
2	Controller SC Error (0:OFF 1:ON)	
	<p>Stores SC codes generated by GW controller errors.</p> <p>[0 to 1/1] 0: OFF 1: ON</p>	
3	Any SC Error	
	[0 to 65535/1]	
4	Jam (0:OFF 1:ON)	
	<p>Stores jam errors.</p> <p>[0 to 1/1] 0: OFF 1: ON</p>	

5859	Debug Save Key No.	
1 to 10	Key 1 to Key 10	<p>These SPs allow you to set up to 10 keys for log files for functions that use common memory on the controller board.</p> <p>[-9999999 to 9999999/1]</p>

5860	SMTP/POP3/IMAP4
20	Partial Mail Receive Timeout
	[1 to 168 / 72 / 1] Sets the amount of time to wait before saving a mail that breaks up during reception. The received mail is discarded if the remaining portion of the mail is not received during this prescribed time.
21	MDN Response RFC2298 Compliance
	Determines whether RFC2298 compliance is switched on for MDN reply mail. [0 to 1 / 1 / 1] 0: No, 1: Yes
22	SMTP Auth. From Field Replacement
	Determines whether the FROM item of the mail header is switched to the validated account after the SMTP server is validated. [0 to 1 / 0 / 1] 0: No. "From" item not switched. 1: Yes. "From" item switched.
25	SMTP Auth Direct Sending
	Select the authentication method for SMPT. Bit 0: LOGIN Bit 1: PLAIN Bit 2: CRAM_MD5 Bit 3: DIGEST_MD5 Bit 4 to Bit 7: Not Used Note: This SP is activated only when SMTP authentication is enabled by UP mode.

Group 5000

	S/MIME: MIME Header Setting
26	<p>Selects the MIME header type of an E-mail sent by S/MIME.</p> <p>[0 to 2 / 0 / 1]</p> <p>0: Microsoft Outlook Express standard</p> <p>1: Internet Draft standard</p> <p>2: RFC standard</p>

5866	E-Mail Report
1	Report Validity
	<p>Enables or disables the email alert function.</p> <p>[0 or 1 / 0 / -] 0: Enabled, 1: Disabled</p>
5	Add Date Field
	<p>Adds or does not add the date field to the header of the alert mail.</p> <p>[0 or 1 / 0 / -]</p> <p>0: Not added, 1: Added</p>

5870	Common Key Info Writing
	Writes to flash ROM the common proof for validating the device for NRS specifications.
1	Writing
3	Initialize
Note: These SPs are for future use and currently are not used.	

5873	SD Card Apli Move
	Allows you to move applications from one SD card another. For more, see "Moving Applications to One SD Card" in Section 1.
1	Move Exec
2	Undo Exec
	Executes the move from one SD card to another.
	This is an undo function. It cancels the previous execution.

5875	SC Auto Reboot
	This SP determines whether the machine reboots automatically when an SC error occurs. Note: The machine does not reboot for Type A (fatal) SC code errors.
1	Reboot Setting
	[0 to 1 / 0 / 1] 0: The machine reboots automatically when the machine issues an SC error and logs the SC error code. If the same SC occurs again, the machine does not reboot. 1: The machine does not reboot when an SC error occurs.
2	Reboot Type
	[0 to 1 / 0 / 1] 0: Manual reboot, 1: Automatic reboot

5876	Security Clear
1	All Clear
11	Clear NCS Security
15	Clear UCS Security

5878	Option Setup
	Select the option to enable then touch [EXECUTE].
1	Data Overwrite Security
2	HDD Encryption

5881	Fixed Phase Block Erasing DFU
	Detects fixed phase.

Group 5000

5885	Set WIM Function	
20	DocSvr Acc Ctrl	<p>Allows or disallows the functions of web image monitor.</p> <p>0: OFF, 1: ON</p> <p>Bit:</p> <p>0: Forbid all document server access</p> <p>1: Forbid user mode access</p> <p>2: Forbid print function</p> <p>3: Forbid Fax</p> <p>4: Forbid scan sending</p> <p>5: Forbid download</p> <p>6: Forbid delete</p> <p>7: Forbid guest user</p>
	DocSvr Format	
50	<p>Selects the display type for the document box list.</p> <p>[0 to 2 / 0 / 1]</p> <p>0: Thumbnail, 1: Icon, 2: Details</p>	
	DocSvr Trans	
51	<p>Sets the number of documents to be displayed in the document box list.</p> <p>[5 to 20 / 10 / 1]</p>	
	Set Signature	
100		
	Set Encryption	
101	<p>Determines whether the scanned documents with the WIM are encrypted when they are transmitted by an e-mail.</p> <p>[0 to 1 / 0 / 1]</p> <p>0: Not encrypted, 1:Encryption</p>	
200	Detect Mem Leak	
201	DocSvr Timeout	

5887	SD Get Counter
	<p>This SP sends a text file to an SD card inserted in SD card Slot 1 (lower slot). The operation stores. The file is stored in a folder created in the root directory of the SD card called SD_COUNTER. The file is saved as a text file (*.txt) prefixed with the number of the machine.</p> <ol style="list-style-type: none"> 1. Insert the SD card in SD card Slot 1 (lower slot). 2. Select SP5887 then touch [EXECUTE]. 3. Touch [Execute] in the message when you are prompted.

5888*	Personal Information Protect
	<p>Selects the protection level for logs. [0 to 1 / 0 / 1}</p> <p>0: No authentication, No protection for logs 1: No authentication, Protected logs (only an administrator can see the logs)</p>

5893	SDK Application Counter
1	SDK-1
2	SDK-2
3	SDK-3
4	SDK-4
5	SDK-5
6	SDK-6

5894	External Charge Unit Setting
------	------------------------------

Appendix:
Service
Program
Mode Table

Group 5000

5895	Application Invalidation
1	Printer
2	Scanner

5907	Plug & Play Maker/Model Name
	<p>Selects the brand name and the production name for Windows Plug & Play. This information is stored in the NVRAM. If the NVRAM is defective, these names should be registered again.</p> <p>After selecting, press the "Original Type" key and "#" key at the same time. When the setting is completed, the beeper sounds five times.</p>

5913	Switchover Permission Time
	Print Application Timer
2	<p>Sets the length of time to elapse before allowing another application to take control of the display when the application currently controlling the display is not operating because a key has not been pressed.</p> <p>[3 to 30/1 s]</p>
102	Print Application Set
	<p>No information is available at this time.</p> <p>[0 to 1/1/1]</p>

5959	Paper Size	
	Tray 1 (tandem tray) and the LCT do not have automatic paper size detection. Use these SP codes to set the paper size for Tray 1 and the optional LCT when it is installed.	
1	Tray 1	
	The following paper sizes can be set. If the A3 DLT kit is not installed, you can only use settings 0 and 1	
	0: A4	4: A4 SEF
	1: 8 1/2*11	5: 11 * 17
	2: A3 SEF	6: 8 1/2 * 14 SEF
	3: B4 SEF	7: 8 1/2 * 11 SEF
	LCT	
2	The LCT accepts the paper sizes below. Enter the correct number of the size of the paper loaded in the LCT:	
	0: A4	4: 8 1/2 * 11 SEF
	1: 8 1/2*11	5: B4 SEF
	2: B5	6: 8 1/2 * 14 SEF
	3: A4 SEF	

Appendix:
Service
Program
Mode Table

Group 5000

5967	Copy Server: Set Function
	<p>Enables and disables the document server. This is a security measure that prevents image data from being left in the temporary area of the HDD. After changing this setting, you must switch the main switch off and on to enable the new setting.</p> <p>[0 to 1/1]</p> <p>0: ON</p> <p>1: OFF</p>

5974	Cherry Server
	<p>Selects which version of the Scan Router application program, "Light" or "Full (Professional)", is installed.</p> <p>[0 to 1 / 0 / 1 /step]</p> <p>0: Light version (supplied with this machine)</p> <p>1: Full version (optional)</p>

5985	Device Setting
	<p>The NIC and USB support features are built into the GW controller. Use this SP to enable and disable these features. In order to use the NIC and USB functions built into the controller board, these SP codes must be set to "1".</p>
1	On Board NIC
	<p>[0 to 2 / 1 / 1 /step]</p> <p>0: Disable, 1: Enable, 2: Function limitation</p> <p>When the "Function limitation" is set, "On board NIC" is limited for use with only NRS or LDAP/NT authentication.</p> <p>Note:</p> <ul style="list-style-type: none"> ▪ Other network applications than @Remote or LDAP/NT authentication are not available when this SP is set to "2". ▪ Even if you can change the initial settings of those network applications,

	the settings will not work
2	On Board USB
	[0 or 1 / 0 / 1/step] 0: Disable, 1: Enable

5990	SP Print Mode (SMC Print)
	In the SP mode, press Copy Window to move to the copy screen, select the paper size, then press Start. Select A4/LT (Sideways) or larger to ensure that all the information prints. Press SP Window to return to the SP mode, select the desired print, and press Execute.
1	All (Data List)
2	SP (Mode Data List)
3	User Program
4	Logging Data
5	Diagnostic Report
6	Non-Default (Prints only SPs set to values other than defaults.)
7	NIB Summary
8	Capture Log
21	Copier User Program
22	Scanner SP
23	Scanner User Program
24	SDK/J Summary
25	SDK/J Application Info

4.7 GROUP 6000

6006	Reg Adj
1	<p>ADF Main Reg Adj: Front</p> <p>Adjusts the side-to-side registration for the front in ADF mode.</p> <p>[-3 to +3/0/0.1 mm]</p>
2	<p>ADF Main Reg Adj: Rear</p> <p>Adjusts the side-to-side registration for the back in ADF mode.</p> <p>[-3 to +3/0/0.1 mm]</p>
3	<p>ADF Sub Reg Adj: Front</p> <p>Adjusts the vertical registration for the front in ADF mode.</p> <p>[-5 to +5/0/0.1 mm]</p>
4	<p>ADF Sub Reg Adj: Rear</p> <p>Adjusts the vertical registration for the back in ADF mode.</p> <p>[-5 to +5/0/0.1 mm]</p>
5	<p>ADF Buckle Adj: Amount 1</p> <p>Adjusts the roller timing at the skew correction sensor/entrance roller. A higher setting causes more buckling.</p> <p>[-3 to +3/0/0.1 mm]</p>
6	<p>ADF Buckle Adj: Amount 2</p> <p>Adjusts the roller timing at the interval sensor/scanning roller. A higher setting causes more buckling.</p> <p>[3 to -2/0/0.1 mm]</p>
7	<p>ADF TEdge Erase Margin: Front</p> <p>These settings adjust the erase margin for the trailing edges for the front.</p> <p>[-5 to +5/-1/0.1 mm]</p>
8	<p>ADF TEdge Erase Margin: Rear</p> <p>These settings adjust the erase margin for the trailing edges for the back.</p> <p>[-5 to +5/-1/0.1 mm]</p>

6007	ADF Input Check		
	Open SP mode SP6007. 1. Select the SP number that corresponds to the component you wish to check. (Refer to the table below.) 2. Press On then press Off to test the selected item. You cannot exit and close this display until you click Off to switch off the output check currently executing.		
	Description	Reading	
0		1	
1	Original Tray B5 Detect Sensor	No paper	Paper detected
2	Original Tray A4 Detect Sensor	No paper	Paper detected
3	Original Tray LG Detect Sensor	No paper	Paper detected
4	Original Width Sensor 1	No paper	Paper detected
5	Original Width Sensor 2	No paper	Paper detected
6	Original Width Sensor 3	No paper	Paper detected
7	Original Width Sensor 4	No paper	Paper detected
8	Original Width Sensor 5	No paper	Paper detected
9	Original Set Sensor	No paper	Paper detected
10	Separation Sensor	No paper	Paper detected
11	Skew Correction Sensor	No paper	Paper detected
12	Entrance Sensor	No paper	Paper detected
13	Registration Sensor	No paper	Paper detected
14	Exit Sensor	No paper	Paper detected

Group 6000

15	Cover Sensor	Open	Close
16	ADF Position Sensor	Open	Close
18	Pick-up Roller HP Sensor	Not HP	HP
20	APS Start Sensor	Not Start	Start
21	Bottom Plate HP Sensor	Not HP	HP
22	Bottom Plate Position Sensor	Not Correct Position	Correct Position

6008	ADF Output Check
	<p>Turns on the ADF electrical components individually for testing.</p> <ol style="list-style-type: none"> 1. Open SP mode SP6008. 2. Select the SP number that corresponds to the component you wish to check. 3. Press [On] then press [Off]to test the selected item. You cannot exit and close this display until you click Off to switch off the output check currently executing.
001	ADF Feed M: Fwd
002	ADF Feed M: Rev
003	ADF Trans M: Fwd
004	ADF Exit M: Fwd
009	ADF Pickup M: Fwd
010	ADF BotPlt M: Fwd/Rev

6009	ADF Free Run	
	This SP does an ADF free run in duplex original mode.	
1	Simplex	
2	Dupx	

6016	ADF OrgSizePrior	
	ADF Original Size Detection Priority. Allows selection of alternate settings for automatic original size detection. (7) 0000 0000 (1)	

6017	ADF Mag Adj	
	ADF Magnification Adjustment	
	This changes the magnification by adjusting the speed of scanning. [-50(-5%) to +50(+5%)/0.1%]	

6020	ADF Mag Adj – ADF Buckle Op Set	
	This SP switches on stopping the scanning entrance roller for all paper sizes. Normally, the scanning entrance roller stops briefly to correct skew of small paper sizes in the ADF paper path. Setting this SP to "1" sets the ADF to stop the scanning entrance roller for all paper sizes to correct for skew a second time.	
1	ADF Buckle Op Set	[0 to 1/1]

Group 6000

6020	ADF Skew Correction Mode In/Out	
	<p>If the original is small (B6, A5, HLT), the delay sensor detects the leading edge of the sheet and delays the original at the entrance roller for the prescribed number of pulses to buckle the leading edge and correct skew.</p> <p>[0 to 1/1]</p> <p>0: Delay skew correction only for small originals</p> <p>1: Delay skew correction for all originals, regardless of size. (May reduce the scanning speed of the ADF)</p>	

6090	LCT Output Chk	A4/LT LCT (MAUI) B473
	Use these SPs to do the output check for the optional LCT.	
1	LCT Feed M	
2	LCT Pickup SOL	

6091	LCT Input Chk	LCIT RT4000 D350
	Use these SPs to do the input check for the optional LCIT.	
1	Wide LCT Feed Sn	
2	Wide LCT Trans Sn	
3	Wide LCT Exit Sn	
4	Wide LCT Door Switch	

6092	LCT Output Chk	LCIT RT4000 D350
	Use these SPs to do the output check for the optional LCIT.	
1	Wide LCT Feed M Lo1	
2	Wide LCT Feed M Lo2	
3	Wide LCT Feed M Hi1	

4	Wide LCT Feed M Hi2	
5	Wide LCT Trans M Lo1	
6	Wide LCT Trans M Lo2	
7	Wide LCT Trans M Hi1	
8	Wide LCT Trans M Hi2	
9	Wide LCT Exit M Lo1	
10	Wide LCT Exit M Lo2	
11	Wide LCT Exit M Hi1	
12	Wide LCT Exit M Hi2	
13	Wide LCT Pickup SOL	
14	Wide LCT Fan F	
15	Wide LCT Fan R	

Appendix:
Service
Program
Mode Table

6100	Adj Punch Pos 1	
1	2-Hole: DOM	
2	3-Hole: NA	
3	4-Hole: EU	
4	4-Hole: SCAN	
5	2-Hole: NA	
6	2-Hole: DOM FM2	

Group 6000

6101	Adj Punch Pos 2	Punch B702 for Finishers D373/D374
	<p>Punch Position Adjustment Adjusts the punch hole positions in the direction of paper feed.</p> <ul style="list-style-type: none"> ▪ NA: North America ▪ DOM: Japan ▪ EU: Europe ▪ SCAN: Scandinavia 	
1	2-Hole:DOM	<p>[-75 to +75/0.5 mm] + Value: Shifts punch unit in the direction of feed. - Value: Shifts punch unit against direction of feed.</p>
2	3-Hole:NA	
3	4-Hole:EU	
4	4-Hole:SCAN	
5	2-Hole:NA	

6102	Punch Hole Reg 1	Punch B702 for Finishers D373/D374
	<p>This SP corrects punch hole alignment by correcting the skew of each by adjusting the amount of time the finisher entrance roller remains off while the exit roller of the machine remains on. This buckles the leading edge of the sheet slightly against the finisher entrance roller while it remains off.</p>	
1	A3 SEF	<p>[-5~+5/0.25 mm] ▪ + Value:Increases time finisher entrance roller remains off. ▪ - Value: Decreases time finisher entrance roller remains off.</p>
2	B4 SEF	
3	A4 SEF	
4	A4 LEF	
5	B5 SEF	
6	B5 LEF	

7	DLT SEF	
8	LG SEF	
9	LT SEF	
10	LT LEF	
11	12"x18"	
12	Custom	

6103	Punch Hole Reg 2	Punch B702 for Finishers D373/D374
	This SP determines whether the finisher entrance roller stops to correct skew when paper enters the finisher.	
1	A3 SEF	<p>[0 to 1/1/1] 0: Paper stops for skew correction 1: Paper does not stop</p>
2	B4 SEF	
3	A4 SEF	
4	A4 LEF	
5	B5 SEF	
6	B5 LEF	
7	DLT SEF	
8	LG SEF	
9	LT SEF	
10	LT LEF	
11	12"x18"	
12	Custom	

Appendix:
Service
Program
Mode Table

Group 6000

6104	Fine Adj Staple:Fin1	2000/3000-Sheet Finishers D373/D374
This SP corrects the distance between the jogger fences and the sides of the stack on the finisher stapling tray.		
1	A3 SEF	<p>[-15~+1.5/0.5 mm]</p> <ul style="list-style-type: none"> ▪ + Value: ncreases distance between jogger fences and the sides of the stack. ▪ - Value: Decreases the distance between the jogger fences and the sides of the stack.
2	B4 SEF	
3	A4 SEF	
4	A4 LEF	
5	B5 SEF	
6	B5 LEF	
7	DLT SEF	
8	LG SEF	
9	LT SEF	
10	LT LEF	
11	12"x18"	
12	Custom	

6105	Adj Staple Pos:Fin1	2000/3000-Sheet Finishers D373/D374
This SP corrects the stapling position of the corner stapler.		
1	A3 SEF	<p>[-3.5~+3.5/0.5 mm]</p> <ul style="list-style-type: none"> ▪ - Value: Moves stapling position toward the rear of the machine. ▪ + Value: Shifts the stapling position toward the front of the machine.
2	B4 SEF	
3	A4 SEF	
4	A4 LEF	
5	B5 SEF	
6	B5 LEF	

7	DLT SEF	
8	LG SEF	
9	LT SEF	
10	LT LEF	
11	12"x18"	
12	Custom	

6106	Adj Out Jog Fences		
1	A3 SEF	9	DLT SEF
2	B4 SEF	10	LG SEF
3	A4 SEF	11	LT SEF
4	A4 SEF	12	LT SEF
5	B5 SEF	13	HLT SEF
6	B5 LEF	14	HLT LEF
7	A5 SEF	15	Other
8	A5 LEF		

Appendix:
Service
Program
Mode Table

Group 6000

6107	Fine Adj Jog Fences:Fin1	2000/3000-Sheet Finishers D373/D374
	This SP corrects the distance between the output jogger fences and the sides of the stack when the output jogger unit attached to the side of the machine jogs sheets as they exit the finisher.	
1	A3 SEF	<p>[-15. to +1.5/0/0.5 mm]</p> <ul style="list-style-type: none"> ▪ + Value: Increases distance between jogger fences and the sides of the stack. ▪ - Value: Decreases the distance between the jogger fences and the sides of the stack.
2	B4 SEF	
3	A4 SEF	
4	A4 LEF	
5	B5 LEF	
6	A5 LEF	
7	DLT SEF	
8	LG SEF	
9	LT SEF	
10	LT LEF	
11	HLT LEF	
12	Other	

6108	Adj Prestack Shts:Fin1	2000/3000-Sheet Finishers D373/D374
	<p>This SP sets the number of sheets sent to the pre-stack tray. With this SP set to the default (3):</p> <ul style="list-style-type: none"> ▪ 3 sheets are sent to the pre-stack tray. ▪ When the 4th sheet feeds, the 4th sheet and 3 sheets from the pre-stack tray are sent to the stapling tray together. <p>Note: You may need to adjust this setting or switch it off when feeding thick or slick paper.</p>	
1	A4 LEF	[0 to 4/3/1 sheet]

2	LT LEF	0: None 1: 1 sheet 2: 2 sheets 3: 3 sheets 4: 4 sheets
3	B5 LEF	
4	10.5"x7.25" LEF	
5	A4 SEF	
6	LT SEF	
7	B5 SEF	
8	10.5"x7.25" SEF	
9	Other	

6109	Book Fold Adj	
	This SP corrects the folding position when paper is stapled and folded by the 2000-Sheet Finisher (D373)	
1	A3 SEF	[-3 to +3/0.2 mm] + : Shifts staple position toward crease - : Shifts staple position away from crease.
2	B4 SEF	
3	A4 SEF	
4	B5 SEF	
5	DLT SEF	
6	LG SEF	
7	LT SEF	
8	12x18	
9	Custom	

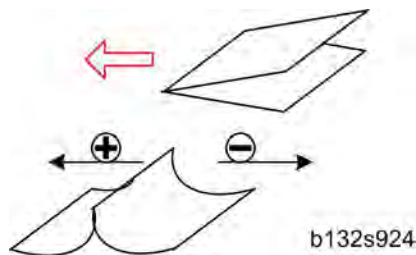

Appendix:
Service
Program
Mode Table

Group 6000

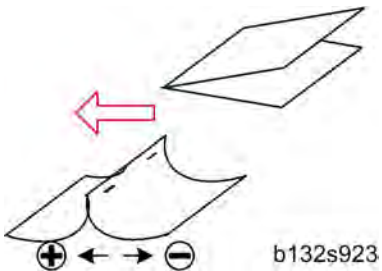
6110	Book Staple Adj	
	This SP corrects the stapling position of the booklet stapler when paper is staple and folded by the 2000-Sheet Finisher (D373).	
1	A3 SEF	<p>[-3 to +3/0.2 mm]</p> <p>+ : Shifts staple position toward crease</p> <p>- : Shifts staple position away from crease.</p>  <p>b132s923</p>
2	B4 SEF	
3	A4 SEF	
4	B5 SEF	
5	DLT SEF	
6	LG SEF	
7	LT SEF	
8	12x18	
9	Custom	

6111	Booklet Fold Repeat	2000-Sheet Finisher D373
	<p>This SP sets the number of times the folding rollers are driven forward and reverse to sharpen the crease of a folded booklet before it exits the folding unit.</p> <p>When set at the default (0):</p> <ul style="list-style-type: none"> ▪ The folding blade pushes the center of the stack into the nip of the folding roller. ▪ The folding rollers rotated ccw to crease the booklet, reverse cw, then rotate ccw again crease the booklet fold twice before feeding to the folding unit exit rollers. 	
1	A3 SEF	[0 to 6/0/1]
2	B4 SEF	0: No repeated fold
3	A4 SEF	1: 2
4	B5 SEF	2: 5
		3: 10

5	DLT SEF	4: 15
6	LG SEF	5: 25
7	LT SEF	6: 30
8	12x18	
9	Other	

6114	FIN Free Run: Fin2	3000-Sheet Finisher B830
	These SPs set the switch the following free run modes for Finisher 2 (B830). Touch [ON] to switch on, [OFF] to switch off.	
1	Free Run 1	System Free Run
2	Free Run 1	Free Run (Endurance Testing)
3	Free Run 3	Free Run
4	Free Run 4	Shift, Free Run

Appendix:
Service
Program
Mode Table

Group 6000

6115	Input Check:Fin1	2000/3000-Sheet Finishers D373/D374
	<p>Use these SP codes to perform the input checks for either the 2000-Sheet Finisher D373 or 3000-Sheet Finisher D374.</p> <p>The following abbreviations are used below:</p> <ul style="list-style-type: none"> ▪ Sn: Sensor ▪ HP: Home Position ▪ Stp: Staple ▪ BStapler: Booklet Stapler (D373 only) 	
1	Entrance Sn	
2	Proof Exit Sn	
3	Proof Full Sn	
4	Up Tray Exit Sn	
5	Staple Exit Sn	
6	Shift Roll HP Sn	
7	Exit Sn	
8	Exit Guide HP Sn	
9	Low Tray Hgt Sn	
10	Up Tray Hgt Sn	
11	Up Tray Full Sn	
12	Stack Roll HP Sn	
13	Jogger HP Sn	
14	Feed Out HP Sn	
15	Stp Tray Ppr Sn	
16	Stp Tray HP Sn	
17	Stp Rotate HP Sn	

18	Up Tray LimitSW	
19	Door Switch	
20	Corner Stp Oper	
21	Corner Stp In	
22	Corner Staples	
23	Punch HP Sn	
24	Punch Unit Hp Sn	
25	Punch Ppr HP Sn	
26	Punch Full Sn	
27	Punch HP Sn	
28	Punch DIP SW1	
29	Punch DIP SW2	
30	Stack Junc HP Sn	
31	Stack Present Sn	
32	Clamp Roll HP Sn	
33	Fold Entrance Sn	
34	Bot Fence HP Sn	
35	Fold Cam HP Sn	
36	Fold Plate HP Sn	
37	Fold Exit Sn	
38	Book Full Sn 1	
39	Book Full Sn 2	
40	BStapler 1 Op	

Group 6000

41	BStapler 1 In	
42	BStaples 1 In	
43	BStapler 2 Op	
44	BStapler 2 In	
45	BStaples 2 In	
46	Up TrayFull:3000	
47	Out Jog HP Sn 1	
48	Out Jog HP Sn 2	
49	OutJog RetractSn	

6116	Output Check:Fin1	2000/3000-Sheet Finishers D373/D374
	<p>Use these SP codes to perform the output checks for either the 2000-Sheet Finisher D373 or 3000-Sheet Finisher D374.</p> <p>The following abbreviations are used below:</p> <ul style="list-style-type: none"> ▪ M: Motor ▪ JG: Junction Gate ▪ SOL: Solenoid ▪ Stp: Staple ▪ Bot: Bottom 	
1	Entrance M	
2	Up Trans M	
3	Low Trans M	
4	Exit M	
5	Pos Roll M	
6	Shift M	
7	Exit Guide M	

8	Tray Lift M	
9	Stack Roller M	
10	Jogger M	
11	Feed Out M	
12	Stp Shift M	
13	Stp Rot M	
14	Corner Stp M	
15	Up JG SOL	
16	Dn JG SOL	
17	Pos Roll SOL	
18	Stp Edge Plate SOL	
19	Book Press SOL	
20	Stack JG M	
21	Fold Bot Fence M	
22	Book Stp M:Front	
23	Book Stp M:Back	
24	Fold Plate M	
25	Fold Roll M	
26	Clamp Roll M	
27	Punch M	
28	Punch Move M	
29	Punch Reg M	
30	OutJog M:Front	

Group 6000

31	OutJog M:Rear	
32	OutJog Retract M	

6150	Fine Adj Staple:Fin2	3000-Sheet Finisher B830
	This SP corrects the distance between the jogger fences and the sides of the stack on the finisher stapling tray.	
1	A3 SEF	<p>[-15~+1.5/-2/0.5 mm]</p> <ul style="list-style-type: none"> ▪ + Value: ncreases distance between jogger fences and the sides of the stack. ▪ - Value: Decreases the distance between the jogger fences and the sides of the stack.
2	B4 SEF	
3	A4 SEF	
4	A4 LEF	
5	B5 SEF	
6	B5 LEF	
7	DLT SEF	
8	LG SEF	
9	LT SEF	
10	LT LEF	
11	Custom	

6151	Adj Staple Pos:Fin2	3000-Sheet Finisher B830
This SP corrects the stapling position of the corner stapler.		
1	A3 SEF	<p>[-2~+2/0/0.5 mm]</p> <ul style="list-style-type: none"> ▪ - Value: Moves stapling position toward the rear of the machine. ▪ + Value: Shifts the stapling position toward the front of the machine.
2	B4 SEF	
3	A4 SEF	
4	A4 LEF	
5	B5 SEF	
6	B5 LEF	
7	DLT SEF	
8	LG SEF	
9	LT SEF	
10	LT LEF	
11	Other	

Appendix:
Service
Program
Mode Table

Group 6000

6152	Fine Adj Out Jog:Fin2	3000-Sheet Finisher B830
	This SP corrects the distance between the output jogger fences and the sides of the stack when the output jogger unit attached to the side of the machine jogs sheets as they exit the finisher.	
1	A3 SEF	<p>[-3 to +3/0/0.01 mm]</p> <ul style="list-style-type: none"> ▪ + Value: Increases distance between jogger fences and the sides of the stack. ▪ - Value: Decreases the distance between the jogger fences and the sides of the stack.
2	B4 SEF	
3	A4 SEF	
4	A4 LEF	
5	B5 SEF	
6	B5 LEF	
7	A5 SEF	
8	A5 LEF	
9	DLT SEF	
10	LG SEF	
11	LT SEF	
12	LT LEF	
13	HLT SEF	
14	HLT LEF	
15	Custom	

6153	Adj Prestack Shts:Fin2	3000-Sheet Finisher B830
	<p>This SP sets the number of sheets sent to the pre-stack tray. With this SP set to the default (3):</p> <ul style="list-style-type: none"> ▪ 3 sheets are sent to the pre-stack tray. ▪ When the 4th sheet feeds, the 4th sheet and 3 sheets from the pre-stack 	

	<p>tray are sent to the stapling tray together.</p> <p>Note: You may need to adjust this setting or switch it off when feeding thick or slick paper.</p>	
1	A4 LEF	<p>[0 to 2/2/1 sheet]</p> <p>0: None</p> <p>1: 1 sheet</p> <p>2: 2 sheets</p>
2	B5 LEF	
3	LT LEF	
4	Other	

6154	Adj Top Fence Pos	3000-Sheet Finisher B830
	<p>Use this SP to adjust the timing of the top fence motor that positions the top fence.</p> <p>Note: After all the pages of a stack have been fed onto the stapling tray, the top fence jogs the stack vertically to align the leading edge of the stack for stapling.</p>	
1	A4 LEF	[-5 to 10/0/0.1 mm]
2	B5 LEF	[-5 to 2/0/0.1 mm]
3	LT LEF	[-5 to 10/0/0.1 mm]
4	Other	

6155	Staple Stack Jogging	
	<p>Touch [1:+1 Time] to have the jogger fences press against the sides of the stack on the staple tray one more time to align the stack for corner stapling.</p> <p>[0:Default] [1:+1 Time]</p>	

Group 6000

6156	Input Check:Fin2	3000-Sheet Finisher B830
	<p>Use these SP codes to perform the input checks for either the 3000-Sheet Finisher B830. The following abbreviations are used below:</p> <ul style="list-style-type: none"> ▪ Sn: Sensor ▪ Hgt: Height ▪ HP: Home Position ▪ Stp: Staple ▪ BStapler: Booklet Stapler (D373 only) 	
1	Entrance Sn	
2	Proof Exit Sn	
3	Shift Exit Sn 1	
4	Stp Exit Sn	
5	Tray Bot Plt Sn	
6	Tray Near Bot Sn	
7	Release HP Sn	
8	Jogger HP Sn	
9	Shift HP Sn 1	
10	Stapler Side HP Sn	
11	Stapler HP Sn	
12	Stapler Sn	
13	Stapler Tray Sn	
14	Door Open Sn	
15	Punch Sn	
16	Punch HP Sn 1	
17	Punchout Full Sn	

18	Paper Hgt Sn:Stp	
19	Paper Hgt Sn:Shift	
20	Paper Jam Sensor	
21	Proof Full Sn	
22	Stapler Rotation Sn 1	
23	S Hopper Full Sn	
24	Prestack Sn	
25	Stack Plate HP Sn	
26	Exit Guide HP Sn	
27	Stapler Rotation Sn 2	
28	Stapler Ready Sn	
29	StackPlate HP Sn 1	
30	StackPlate HP Sn 2	
31	Stp Hammer HP Sn	
32	Return Drv HP Sn	
33	Paper Hgh Sn	
34	Tray Limit SW	
35	Punch HP Sn 2	
36	Shift Jog Sn	
37	Shift Jog HP Sn	
38	OutJog RetractSn	
39	Emergency Stop SW	
40	Top Fence HP Sensor	

Group 6000

41	Bottom Fence HP Sensor	
42	Shift Tray Full Sn:Z-Fold	
43	Shift Tray Exit Sensor 2	
44	Upper Tray JG HP Sensor	
45	Stapler JG HP Sensor	
46	Prestack JG HP Sensor	
47	Stop Prestack Sensor	
48	Prestack Stopper HP Sensor	
49	Shift Tray HP Sensor 2	
50	Staple Trim Hopper Set Sn	

6157	Output Check:Fin2	3000-Sheet Finisher B830
	<p>Use these SP codes to perform the output checks for either the 3000-Sheet Finisher B830. The following abbreviations are used below:</p> <ul style="list-style-type: none"> ▪ Mtr: Motor ▪ M: Motor ▪ JG: Junction Gate ▪ SOL: Solenoid ▪ Stp: Staple ▪ Bot: Bottom 	
1	Upper Transport Motor	
2	Shift Exit M:Cont	
3	Upper Tray JG Mtr:Cont	
4	Tray Lift M:1 Op	
5	Jogger M:1 Op	
6	Stp M:1 Op Horiz	

7	Stp M:1 Op	
8	Punch M:1 Op	
9	Stapler JG Mtr:Cont	
10	Stp Hammer M:1 Op	
11	Feed Out M:1 Op	
12	Shift M:1 Op	
13	Stapler Rot Mtr:Cont	
14	Stp Exit M:Cont	
15	Open Exit M:1 Op	
16	Fold Plate M:1 Op	
17	Prestack JG Mtr:1 Op	
18	Prestack Stop Mtr:1 Op	
19	Fold M:Front:1 Op	
20	Fold M:Back:1 Op	
21	Return Drv M:1 Op	
22	Return TransM:Cont	
23	Shift Jog M:1 Op	
24	ShiftJogShuntM:1 Op	
25	Top Fence Motor:1 Op	
26	Bottom Fence Motor:1 Op	
27	Lower Transport Mtr:Cont	
28	Upper Tray Exit Mtr:Cont	
29	Positioning Roller Mtr:Cont	

Group 6000

30	Prestack Trans Mtr:Cont	
31	Staple Trim Chute SOL:1 Op	

6250	Input Check:Fin3 Japan Only
------	------------------------------------

6251	Output Check:Fin3 Japan Only
------	-------------------------------------

6252	Free Run:Fin3 Japan Only
------	---------------------------------

6301	Fine Adj 1st, 2nd Z-Fold Japan Only
	Use these SP codes to adjust the positions of the Z-folds done with the Z-Fold Unit B660. The 1st and 2nd folds can be adjusted separately.

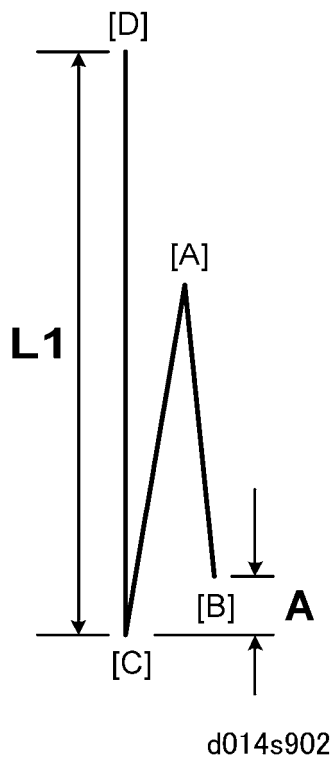

1	1st Fold:A3 SEF	<p>[-4 ~ +4/0/ 0.2 mm] Refer to the illustration above. Adjusts the position of the first fold [A] to decrease or increase the distance A between the leading edge [B] and the crease of the 2nd fold [C].</p>
2	1st Fold:B4 SEF	
3	1st Fold:A4 SEF	
4	1st Fold:DLT SEF	
5	1st Fold:LG SEF	
6	1st Fold:LT SEF	
7	1st Fold:12"x18"	
8	1st Fold:Other	
9	2nd Fold:A3 SEF	<p>[-4 ~ +4/0/ 0.2 mm] Refer to the illustration above. Adjusts the position of the 2nd fold [C] to decrease or increase the length L1 of the sheet between the trailing edge [D] and the 2nd fold.</p>
10	2nd Fold:B4 SEF	
11	2nd Fold:A4 SEF	
12	2nd Fold:DLT SEF	
13	2nd Fold:LG SEF	
14	2nd Fold:LT SEF	
15	2nd Fold:12"x18"	
16	2nd Fold:Other	

Group 6000

6309	Input Check: Folder (D454)	
1	Entrance Sensor	
2	Entrance JG HP Sensor	
4	Registration Sensor	
5	Dynamic Roller HP Sensor	
6	Registration Roller HP Sensor	
7	Fold Plate HP Sensor	
8	Jogger Fence HP Sensor	
9	Positioning Roller HP Sensor	
10	1st Stopper Paper Sensor	
11	1st Stopper HP Sensor	
12	2nd Stopper Paper Sensor	
13	2nd Stopper HP Sensor	
14	3rd Stopper Paper Sensor	
15	3rd Stopper HP Sensor	
16	Direct-Send JG HP Sensor	
17	FM6 Pawl HP Sensor	
18	Top Tray Paper Path Sensor	
19	Top Tray Exit Sensor	
20	Horizontal Path Exit Sensor	
21	Top Tray Full Sensor (E)	
23	Front Door Switch (SW1)	
24	Horizontal Path Paper Sensor	

25	Vertical Path Paper Sensor	
26	Bypass Entrance Paper Sensor	
27	Bypass Exit Paper Sensor	

6310	Output Check: Folder (D454)	
1	Horizontal Transport Motor	
2	Top Tray Transport Motor	
3	Top Tray Exit Motor	
4	Dynamic Roller Transport Motor	
5	Registration Roller Transport Motor	
7	Entrance JG Motor	
8	1st Stopper Motor	
9	2nd Stopper Motor	
10	3rd Stopper Motor	
11	Dynamic Roller Lift Motor	
12	Registration Roller Release Motor	
13	Fold Plate Motor	
14	Jogger Fence Motor	
15	Positioning Roller Motor	
16	Direct-Send JG Motor	
17	FM6 Pawl Motor	
18	1st Fold Motor	
19	2nd Fold Motor	

Group 6000

20	Crease Motor	
21	Bypass JG Solenoid	
22	Exit JG Solenoid	
23	Top Tray JG Solenoid	
24	LE Stop Pawl Solenoid	
25	Reverse JG Solenoid	

6311	Folder Free Run (D454)	
1	Free Run 1	
	System free run. A4 LEF at 90 ppm, with simulated staple mode.	
2	Free Run 2	
	Free run for durability testing. All motors and solenoids operate to simulate full staple mode run for durability testing.	
3	Free Run 3	
	Shipping free run. Simulates standby conditions during shipping.	
4	Free Run 4	
	Shift free run. A4 LEF at 90 ppm with simulated output jogging with the shift jogger unit mounted on the side of the finisher.	

6312	FM1 Z-Fold: Fine Adjust 1st Fold (D454)	
1	A3 SEF	[-4 to +4 / 0 / 0.2 mm]
2	B4 SEF	
3	A4 SEF	
4	DLT SEF	
5	LG SEF	

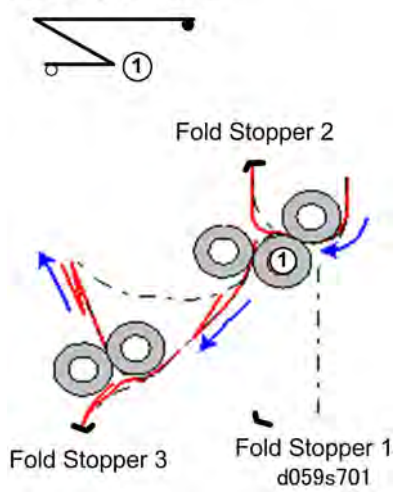
6	LT SEF	FM1: 1st Fold 
7	12x18	
8	8-Kai	
19	Other	

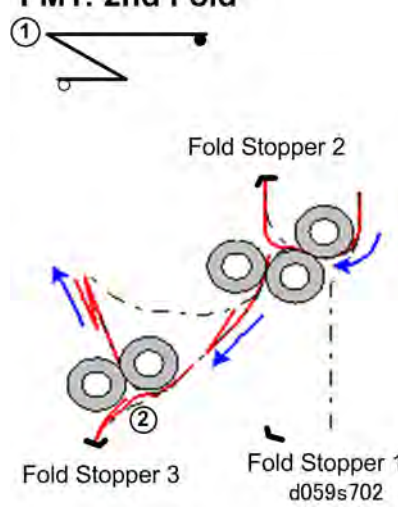
6313	FM1 Z-Folding: Fine Adj 2nd fold (D454)	
1	A3 SEF	FM1: 2nd Fold 
2	B4 SEF	
3	A4 SEF	
4	DLT SEF	
5	LG SEF	
6	LT SEF	
7	12x18	
8	8-Kai	
19	Other	

6314	FM2 Half Fold Fine Adj (D454)	
1	A3 SEF	[-4 to +4 / 0 / 0.2 mm]
2	B4 SEF	
3	A4 SEF	

Appendix:
Service
Program
Mode Table

Group 6000

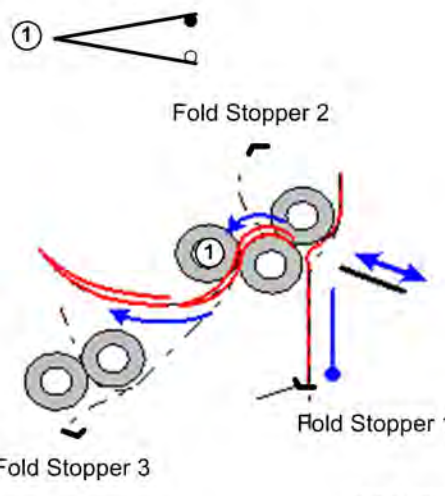
4	DLT SEF	<p>FM2: 1st Fold</p>  <p>d059s703</p>
5	LG SEF	
6	LT SEF	
7	12x18	
8	8-Kai	
9	B5 SEF	
10	13x19.2	
11	13x19	
12	12.6x19.2	
13	12.6x18.5	
14	13x18	
15	SR A3	
16	SR A4	
17	226x310	
18	310x432	
19	Other	

6315	FM3 Letter Fold-out: Find Adj 1st (D454)	
1	A3 SEF	[-4 to +4 / 0 / 0.2 mm]
2	B4 SEF	
3	A4 SEF	
4	DLT SEF	
5	LG SEF	
6	LT SEF	

7	12x18	<p>FM3: 1st fold</p>
8	8-Kai	
9	B5 SEF	
19	Other	

6316	FM3 Letter Fold-out: Find Adj 2nd (D454)	
1	A3 SEF	<p>[-4 to +4 / 0 / 0.2 mm]</p> <p>FM3: 2nd fold</p>
2	B4 SEF	
3	A4 SEF	
4	DLT SEF	
5	LG SEF	
6	LT SEF	
7	12x18	
8	8-Kai	
9	B5 SEF	
19	Other	

6317	FM4 Letter Fold-in: Fine Adj 1st (D454)	
1	A3 SEF	[-4 to +4 / 0 / 0.2 mm]

Appendix:
Service
Program
Mode Table

Group 6000

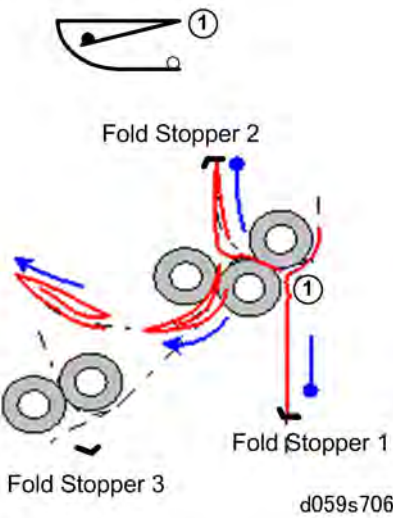
2	B4 SEF	<p>FM4: 1st Fold</p>  <p>Fold Stopper 2</p> <p>Fold Stopper 1</p> <p>Fold Stopper 3</p> <p>d059s706</p>
3	A4 SEF	
4	DLT SEF	
5	LG SEF	
6	LT SEF	
7	12x18	
8	8-Kai	
9	B5 SEF	
19	Other	

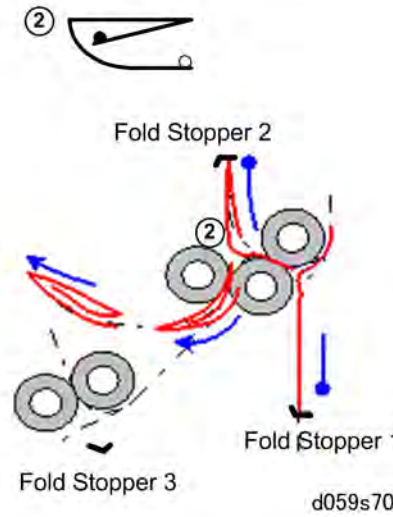
6318	FM4 Letter Fold-in: Fine Adj 2nd (D454)	
1	A3 SEF	<p>[-4 to +4 / 0 / 0.2 mm]</p> <p>FM4: 2nd Fold</p>  <p>Fold Stopper 2</p> <p>Fold Stopper 1</p> <p>Fold Stopper 3</p> <p>d059s707</p>
2	B4 SEF	
3	A4 SEF	
4	DLT SEF	
5	LG SEF	
6	LT SEF	
7	12x18	
8	8-Kai	
9	B5 SEF	
19	Other	

6319	FM5 Double Parallel: Fine Adj 1st (D454)	
1	A3 SEF	[-4 to +4 / 0 / 0.2 mm]

2	B4 SEF	<p>FM5: 1st Fold</p>
3	A4 SEF	
4	DLT SEF	
5	LG SEF	
6	LT SEF	
7	12x18	
8	8-Kai	
9	B5 SEF	
19	Other	

6320	FM5 Double Parallel: Fine Adj 2nd (D454)	
1	A3 SEF	[-4 to +4 / 0 / 0.2 mm]
2	B4 SEF	<p>FM5: 2nd Folds</p>
3	A4 SEF	
4	DLT SEF	
5	LG SEF	
6	LT SEF	
7	12x18	
8	8-Kai	
9	B5 SEF	
19	Other	

6321	FM6 Gate Fold: Fine Adj 1st (D454)	
1	A3 SEF	[-4 to +4 / 0 / 0.2 mm]

Appendix:
Service
Program
Mode Table

Group 6000

2	B4 SEF	<p>FM6: 1st Fold</p> <p>Fold Stopper 2</p> <p>Fold Stopper 1</p> <p>Fold Stopper 3</p> <p>d059s710</p>
3	A4 SEF	
4	DLT SEF	
5	LG SEF	
6	LT SEF	
8	8-Kai	
9	B5 SEF	
19	Other	

6322	FM6 Gate Fold: Fine Adj 2nd (D454)	
1	A3 SEF	[-4 to +4 / 0 / 0.2 mm]
2	B4 SEF	<p>FM6: 2nd Fold</p> <p>Fold Stopper 2</p> <p>Fold Stopper 1</p> <p>Fold Stopper 3</p> <p>d059s711</p>
3	A4 SEF	
4	DLT SEF	
5	LG SEF	
6	LT SEF	
8	8-Kai	
9	B5 SEF	
19	Other	

6323	FM6 Gate Fold: Fine Adj 3rd (D454)	
------	------------------------------------	--

1	A3 SEF	<p>[-4 to +4 / 0 / 0.2 mm]</p> <p>FM6: 2nd Fold</p> <p>Fold Stopper 2</p> <p>Fold Stopper 1</p> <p>Fold Stopper 3</p> <p>d059s712</p>
2	B4 SEF	
3	A4 SEF	
4	DLT SEF	
5	LG SEF	
6	LT SEF	
7	12x18	
8	8-Kai	
9	B5 SEF	
19	Other	

6324	Jogger Fence Position Adjust (D454)	
1	A3 SEF	<p>[+1 to 1 / 0 / 0.5 mm]</p>
2	B4 SEF	
3	A4 SEF	
4	DLT SEF	
5	LG SEF	
6	LT SEF	
7	12x18	
8	8-Kai	
9	B5 SEF	
19	Other	

6325	Registration Buckle Adjust (D454)	
------	-----------------------------------	--

Appendix:
Service
Program
Mode Table

Group 6000

001	A3 SEF	[+1 to 1 /0/ 0.5 mm]
002	B4 SEF	
003	A4 SEF	
004	DLT SEF	
005	LG SEF	
006	LT SEF	
007	12x18	
008	8-Kai	
009	B5 SEF	
019	Other	

6326	Registration Buckle Adjust Select (D454)
	[0: With Buckle Control] [1: Without Buckle Control]

6350	Input Check:Mail Box	9-Bin Mailbox B762
	Use these SP codes to perform the input checks for sensors and switches in the mailbox.	
1	Paper Detect Sn 1	
2	Vert Transport Sn:Bin1	
3	Paper Overflow Sn 1	
4	Paper Detect Sn 2	
5	Vert Transport Sn2:Bin3	
6	Paper Overflow Sn 2	
7	Paper Detect Sn 3	

8	Paper Overflow Sn 3	
9	Paper Detect Sn 4	
10	Vert Transport Sn3:Bin5	
11	Paper Overflow Sn 4	
12	Paper Detect Sn 5	
13	Paper Overflow Sn 5	
14	Paper Detect Sn 6	
15	Vert Transport Sn4:Bin7	
16	Paper Overflow Sn 6	
17	Paper Detect Sn 7	
18	Paper Overflow Sn 7	
19	Paper Detect Sn 8	
20	Vert Transport Sn 5:Bin9	
21	Paper Overflow Sn 8	
22	Paper Detect Sn 9	
23	Paper Overflow Sn 9	
24	Door Open Switch	

Appendix:
Service
Program
Mode Table

Group 6000

6351	Output Check:Mail Box	9-Bin Mailbox B762
	Use these SP codes to perform the output checks of the motor and solenoids in the mailbox.	
1	Vert Transport Motor	
2	Junction Gate SOL1	
3	Turn Gate SOL1	
4	Turn Gate SOL2	
5	Turn Gate SOL3	
6	Turn Gate SOL4	
7	Turn Gate SOL5	
8	Turn Gate SOL6	
9	Turn Gate SOL7	
10	Turn Gate SOL8	

6352	Free Run:Mail Box
	Press [ON] and [OFF] to switch on/off the mailbox for free run testing.

6400	Input Check: 2-Tray CIT	Cover Interposer Tray B835
	Use these SP codes to perform the sensor and switch input checks for the Cover Interposer Tray B835.	
1	Feed Sn1	
2	Feed Sn2	
3	Pullout Sn1	
4	Pullout Sn2	

5	Trans Sn1		
6	Trans Sn2		
7	Trans Exit Sn		
8	Entrance Sn		
9	Exit Sn		
10	Pickup HP Sn1		
11	Pickup HP Sn2		
12	Limit Sn1		
13	Limit Sn2		
14	Bot Sn1		
15	Bot Sn2		
16	Near End Sn1		
17	Near End Sn2		
18	Paper End Sn1		
19	Paper End Sn2		
20	Length Sn1		
21	Length Sn2		
22	Tray1 Size Sn1		
23	Tray1 Size Sn2		
24	Tray1 Size Sn3		
25	Tray1 Size Sn4		
26	Tray1 Size Sn5		
27	Tray2 Size Sn1		

Group 6000

28	Tray2 Size Sn2		
29	Tray2 Size Sn3		
30	Tray2 Size Sn4		
31	Tray2 Size Sn5		
32	Feed Door Sn1		
33	Feed Door Sn2		
34	Trans Door SW		
35	Front Door SW		

6401	Output Check:2-Tray CIT	Cover Interposer Tray B835	
	Use these SP codes to perform the output checks for the motors of the Cover Interposer Tray B835.		
1	Stop		
2	Pickup M1		
3	Pickup M2		
4	Feed M1		
5	Feed M2		
6	Pullout M1		
7	Pullout M2		
8	Trans M		
9	Horizontal Trans M		

6450	Interposer Size	CIT B704
	Controls the paper size for the cover interposer tray. Select a paper size and push [Execute]	

1	A3SEF/12"*18"
	[0~1/1] 0: A3 SEF, 1: 12" x 18"
2	EU/China
	[0 to 2/1] 0: 8½" x 13", 1: 8" x 13", 2: 8¼ " x 13"
3	NA 1
	[0 to 1/1] 0: 8½" x 14", 1: 8½" x 13"
4	NA 2
	[0 to 1/1] 0: LT LEF, 1: 10½" x 7¼"
5	NA 3
	[0 to 1/1] 0: LT SEF, 1: 8" x 10"
6	EU/Taiwan 1
	[0 to 1/1] 0: 8-Kai, 1: DLT
7	EU/Taiwan 2
	[0 to 1/1] 0: 16-Kai SEF, 1: LT
8	EU/Taiwan 3
	[0 to 1/1] 0: 16-Kai SEF, 1: LT SEF

Group 6000

6451	Input Check:1-Tray CIT	Cover Interposer B704
	Use these SP codes to perform the input checks for the sensors of the Cover Interposer Tray B704.	
1	Paper Feed Cover Sensor	
2	Bottom Plate HP Sensor	
3	Paper Near End Sensor	
4	Paper Set Sensor	
5	Bottom Plate HP Sensor	
6	Grip Sensor	
7	Guide Plate Set Sensor	
8	Exit Sensor	
9	Paper Set Sensor	
10	Width Sensor 1	
11	Width Sensor 2	
12	Width Sensor 3	
13	Length Sensor 1	
14	Length Sensor 2	
15	Length Sensor 3	

6502	Adj Binding Position 1	Ring Binder D392
1	A4 LEF	
2	LT LEF	

6503	Adj Binding Position 2	Ring Binder D392
1	A4 LEF	
2	LT LEF	

6504	Adj Jog: Punching	Ring Binder D392
<p>Shifts the punch hole position horizontally (front-to-rear, rear-to-front) This SP must be adjusted after replacement of one or more of the following items:</p> <ul style="list-style-type: none"> ▪ Ring binder main board ▪ Binder unit control board ▪ Pre-punch side jogger assembly ▪ Pre-punch jogger HP sensor (S301) <p>Notes: The correct value for this setting is written on the label attached to the pre-punch jog unit.</p>		
 <p style="text-align: center;">d392r0407a</p>		
<p>The value must be divided by "10". For example, "19" is actually "1.9 mm)</p>		
1	A4 LEF	[-4 to +4/0/0.1 mm]
2	LT LEF	

Group 6000

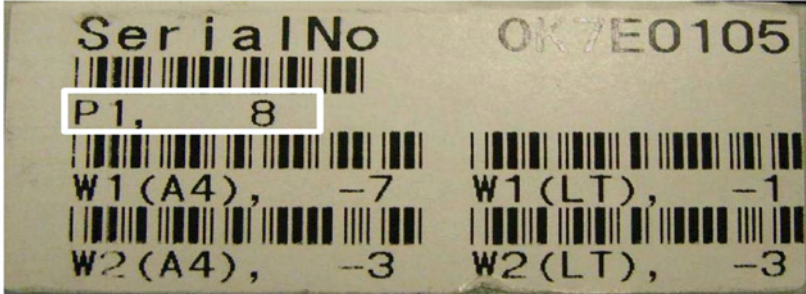
6505	Adj Jog: Paddle	Ring Binder D392
<p>Adjusts the height of the paddle roller at initialization. If the correct number is not entered, the stack will not be jogged correctly before binding. [-3 to +3/0/0.1 mm]</p> <p>This SP must be adjusted after replacement of one or more of the following items:</p> <ul style="list-style-type: none"> ▪ Ring binder main board ▪ Binder unit control board ▪ Pre-bind jogger unit <p>The correct value to be entered for the adjustment is written in the first line of the label. This label is attached to the front cover of the pre-bind jogger unit.</p>  <p style="text-align: right;">d392s901</p> <p>Note: The value must be divided by "10". For example, "8" is actually "0.8 mm)</p>		

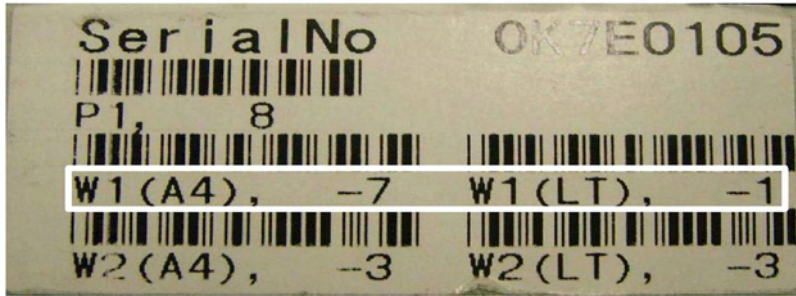
6506		Adj Jog: Binding 1	Ring Binder D392
1	A4 LEF	<p>Adjusts the stop position of the front jog fence. If the correct number is not entered, the stack will not be jogged correctly before binding.</p> <p>[-2 to +2/0/0.1 mm]</p> <p>This SP must be adjusted after replacement of one or more of the following items:</p> <ul style="list-style-type: none"> ▪ Ring binder main board ▪ Binder unit control board ▪ Pre-bind jogger unit <p>The correct value to be entered for the adjustment is written in the second line of the label. This label is attached to the front cover of the pre-bind jogger unit.</p>  <p style="text-align: right;">d392s902</p>	
2	LT LEF		
		<p>Note: The value must be divided by "10". For example, "-7" is actually "-0.7 mm)</p>	

Appendix:
Service
Program
Mode Table

Group 6000

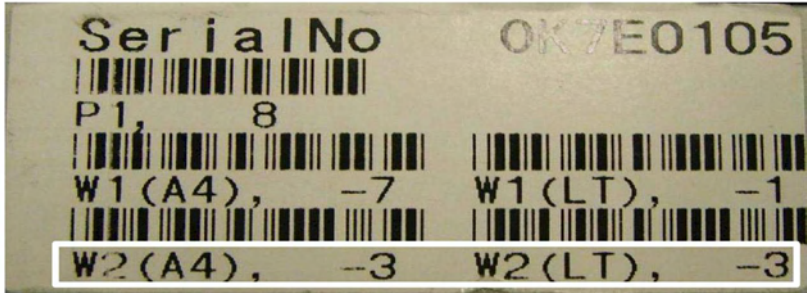
6507	Adj Jog: Binding 2	Ring Binder D392
1	A4 LEF	<p>Shifts the operating position of the rear jog fence. If the correct number is not entered, the stack will not be jogged correctly before binding.</p> <p>[-2 to +2/0/0.1 mm]</p> <p>This SP must be adjusted after replacement of one or more of the following items:</p> <ul style="list-style-type: none"> ▪ Ring binder main board ▪ Binder unit control board ▪ Pre-bind jogger unit <p>The correct value to be entered for the adjustment is written in the third line of the label. This label is attached to the front cover of the pre-bind jogger unit.</p>  <p style="text-align: right;">d392s903</p> <p>Note: The value must be divided by "10". For example, "-3" is actually "-0.3 mm")</p>
2	LT LEF	

6508	Input Check: Fin4	Ring Binder D392
1	Entrance Sensor	
2	Transport Sensor	
3	Paper Exit Sensor	
4	Standard Punch Sensor	
5	Standard Sensor	

6	Junction Gate SOL
7	Paper Jog Sensor
8	Jog Roller Lift Sensor
9	Punch HP Sensor
10	Punch Encoder Sensor
11	Unit Detect Sensor
12	Punch Size Detect: A4/LT
13	Punch Type Detect
14	Overflow Sensor
15	Punchout Box Detect Sn
16	Feedout Belt HP Sn 1
17	Feedout Belt HP Sn 2
18	Feedout Belt Rotation Sn
19	Exit/Entrance Sensor
20	Booklet Pass Sensor
21	Stack HP Sensor
22	Stack Height Sensor 1
24	Stack Detect Sensor
25	Tray Detect Sensor
26	Obstruction Detect Sensor
27	Booklet Position Sensor
28	Bind Detection Unit Sensor
29	Width Adjust HP Sensor 1

Group 6000

30	Paddle Roller HP Sensor
31	Clamp HP Sensor
32	Alignment HP Sensor
33	Shutter HP Sensor
34	50-Sheet Detect Sensor
35	Thick Paper Sensor
37	Paper Detect Sn: LEdge
38	Alignment Pin Tip Sensor
39	Width Adjust HP Sensor
40	Decurl Motor HP Sensor
41	Shutter Motor HP Sensor
42	Roller Lift Mtr HP Sensor
43	Binder HP Sensor
44	Binding Timing Sensor
45	Consumable JG JP Sn
46	Consumable JG Timing Sn
47	Consumable Detect Sn
48	Cutter Detect Sensor
49	Consumable NE Sensor
50	Consumable 50/100 Sn
51	Consumable A4/LT Sn

6509	Output Check: Ring Binder	Ring Binder D392
1	Entrance Motor	

2	Transport Motor
3	Paper Feedout Motor
4	Path JG Motor
5	Jog Roller Motor
6	Side Fence Motor
7	After-Punch Feedout Motor
8	Jog Roller Lift Mtr
9	Punch Hole Open Mtr
10	Top Fence SOL
11	Feedout Belt 1 Mtr
12	Feedout Belt 2 Mtr
13	Feedout Belt Rotation Motor
14	Stacker Motor
15	Decurl Motor
16	Shutter Motor
17	Paddle Roller Motor
18	Alignment Pin Motor
19	Paddle Roller Lift Motor
20	Width Adjust Motor 1
21	Clamp Motor
22	Width Adjust Motor 2
23	Roller Motor
24	Roller Lift Motor

Group 6000

25	Standard Op Lift Motor
26	50/100 Adjust Motor

6800	Sheet Conversion (Thick Paper)
	<p>Permits punching, including tab sheets. Note: Do not change this setting. [1 to 3/3/1 sheet] 1: 1 Sheet 2: 2 Sheets 3: 3 Sheets</p>

6810	Ring Binding Thick Paper	Ring Binder D392
------	--------------------------	------------------

6830	Extra Staples
1	0 to 50 (Initial 0)
2	0 to 50 (Initial 0)

6900	ADF Bottom Lift
	<p>This SP setting determines whether the bottom plate lift motor of the of the ADF switches on:</p> <ul style="list-style-type: none"> ▪ When the original is set in the ADF original tray <p>-or-</p> <ul style="list-style-type: none"> ▪ When the [Start] key is pressed. <p>The ADF bottom plate lift motor raises the bottom plate that pushes up the original tray and raises it to the optimum feed position. [0~1/1] 0: Bottom plate lifts immediately after originals are set (Default) 1: Bottom plate does not lift until [Start] key is pushed.</p>

6910	Intermittent Shading	
1	Switch On/Off	[0 to 1 / 1 / 1]
2	Shading Interval 1	[1 to 60 / 5 / 1]
3	Shading Interval 2	[1 to 60 / 10 / 1]
4	Interval 1 Repetitions	[1 to 60 / 7 / 1]

Group 7000

4.8 GROUP 7000

7401	Total SC Counter
	Displays the total number of SCs logged.

7403	SC History	
	Displays the latest 10 SC codes.	
1	Latest	
---	---	
010	Latest 9th	

7502	Total Paper Jam Counter
	Displays the total number of copy jams.

7503	Total Original Jam Counter
	Displays the total number of copy jams.

7504	Paper Jam Loc	D014/D015 Copier
	Displays the list of possible locations where a jam could have occurred in the copier. Press the appropriate key to display the jam count for that location. These jams are caused by the failure of a sensor to activate.	
	Operation Panel	Actual Component Name
1	At Power On	
3	Tray 1: No Feed	Jam at Tray 1
4	Tray 2: No Feed	Note used. Always "0"
5	Tray 3: No Feed	Jam at Tray 2.
6	Tray 4: No Feed	Jam at Tray 3.
7	LCT: No Feed	
8	Trans 1 Sn:Late	1st Vertical Transport Sensor
9	Trans 2 Sn:Late	2nd Vertical Transport Sensor
10	Trans 3 Sn:Late	3rd Vertical Transport Sensor
11	Trans 4 Sn:Late	4th Vertical Transport Sensor
12	Relay Sn: Late	Relay Sensor
13	Reg Sn:Late	Registration Sensor
14	Fusing Ex Sn:Late	Fusing Exit Sensor
16	Main Ex Sn:Late	Paper Exit Sensor
19	Dup Ent Sn:Late	Duplex Entrance Sensor
20	Dup Trans Sn1:Late	Duplex Transport Sensor 1
21	Dup Trans Sn2:Late	Duplex Transport Sensor 2
22	Dup Trans Sn3:Late	Duplex Transport Sensor 3

Group 7000

23	Dup Ent Sn:Late	Duplex Entrance Sensor
24	LCT Relay: Late	
25	LCT Exit Sensor	
34	Bypass PE Sn:Off	Bypass Paper End Sensor
53	1st Feed Sn:Lag	1st Paper Feed Sensor:Lag
54	2nd Feed Sn:Lag	2nd Paper Feed Sensor:Lag
55	3rd Feed Sn:Lag	3rd Paper Feed Sensor:Lag
56	4th Feed Sn:Lag	4th Paper Feed Sensor:Lag
57	LCT Feed Sn:Lag	LCT Paper Feed Sensor
58	Trans 1 Sn:Lag	1st Vertical Transport Sensor:Lag
59	Trans 2 Sn:Lag	2nd Vertical Transport Sensor:Lag
60	Trans 3 Sn:Lag	3rd Vertical Transport Sensor:Lag
61	Trans 4 Sn:Lag	4th Vertical Transport Sensor:Lag
62	Relay Sn:Lag	Relay Sensor:Lag
63	Reg Sn:Lag	Registration Sensor
64	Fusing Ex Sn:Lag	Fusing Exit Sensor:Lag
66	Main Ex Sn:Lag	Main Exit Sensor
69	Dup Ent Sn:Lag	Duplex Entrance Sensor
71	Dup Trans Sn2:Lag	Duplex Transport Sensor 1
72	Dup Trans Sn3:Lag	Duplex Transport Sensor 2
74	LCT Relay Sn:Lag	LCT Relay Sensor:Lag
75	LCT Exit Sn	
84	Bypass Feed Sn	Bypass Paper Feed Sensor

98	Paper Type	Paper Type
99	Bypass Paper Feed Sn	Bypass Paper Feed Sensor

7504	Paper Jam Loc (Fin2)	3000-Sheet Feeder B830
	Displays the list of possible locations where a jam could have occurred. Press the appropriate key to display the jam count for that location. These jams are caused by the failure of a sensor to activate.	
	On Operation Panel	Actual Component Name
141	Entrance Sn	Entrance Sensor
142	Proof Tray Exit Sn	Proof Tray Exit Sn
143	Shift Exit Sn	Shift Exit Sn
144	Stapler Exit	Stapler Exit Sensor
145	Feed Out	Feed Out
⇒ 146	Pre-Stack Jam	Jam at Pre-Stack
148	Upper Trans M	Upper Transport Motor
149	Shift Tray Motor	Shift Tray Motor
150	Jogger Fence Motor	Jogger Fence Motor
151	Shift Roller Motor	Shift Roller Motor
153	Stapling Motor	Stapling Motor
154	Pre-Stack Jam	
155	Feed Out Belt Motor	Feed Out Belt Motor
156	Paper Punch Motor	Paper Punch Motor
157	Z-Fold Motor Jam	
158	Insufficient Data	

Group 7000

159	Upper Stopper Motor Lock	
160	Stream Punch Jam	

7504	Paper Jam Loc	9-Bin Mailbox B762
	Displays the list of possible locations where a jam could have occurred. Press the appropriate key to display the jam count for that location. These jams are caused by the failure of a sensor to activate.	
	On Operation Panel	Actual Component Name
161	Vert Trans Sn 1	Vertical Transport Sensor 1
162	Vert Trans Sn 2	Vertical Transport Sensor 2
163	Vert Trans Sn 3	Vertical Transport Sensor 3
164	Vert Trans Sn 4	Vertical Transport Sensor 4
165	Vert Trans Sn 5	Vertical Transport Sensor 5

7504	Paper Jam Loc	Cover Interposer Tray B704
	Displays the list of possible locations where a jam could have occurred. Press the appropriate key to display the jam count for that location. These jams are caused by the failure of a sensor to activate.	
	On Operation Panel	Actual Component Name
166	Paper Feed Sn	Paper Feed Sensor
167	Vert Transport Path	Vertical Transport Path
168	BotPlt Pos Sn	Bottom Plate Position Sensor

7504	Paper Jam Loc	3000-Sheet Finisher D374
	Displays the list of possible locations where a jam could have occurred. Press the appropriate key to display the jam count for that location. These jams are caused by the failure of a sensor to activate.	
	On Operation Panel	Actual Component Name
171	Entrance Trans	Entrance Sensor
172	Proof Tray Exit Sn	Proof Tray Exit Sn
173	Shift Exit Sn	Shift Exit Sensor
174	Stapler Exit Sn	Stapler Exit Sensor
175	Belt Feed Out	Belt Feed Out
179	Shift Tray Motor	Shift Tray Motor
180	Jogger Fence Motor	Jogger Fence Motor
181	Shift Roller Motor	Shift Roller Motor
182	Stapler Shift M	Stapler Shift Motor
183	Stapling Motor	Stapling Motor
185	Feed Out Belt Motor	Feed Out Belt Motor
186	Paper Punch Motor	Paper Punch Motor
187	Insufficient Data	

Group 7000

7504	Paper Jam Loc	3000-Sheet Finisher D374
	Displays the list of possible locations where a jam could have occurred. Press the appropriate key to display the jam count for that location. These jams are caused by the failure of a sensor to activate.	
	On Operation Panel	Actual Component Name
191	Entrance Sn	Entrance Sensor
192	Stapler Exit	Stapler Exit Sensor
193	Shift Exit Sn	Shift Exit Sensor
194	Stapler Exit	Stapler Exit Sensor
195	Belt Feed Out	Belt Feed Out
198	Paper Folding	Paper Folding
199	Shift Tray Motor	Shift Tray Motor
200	Jogger Fence Motor	Jogger Fence Motor
201	Shift Roller Motor	Shift Roller Motor
202	Stapler Shift M	Stapler Shift Motor
203	Stapling Motor	Stapling Motor
204	Paper Folding	Paper Folding
205	Feed Out Belt Motor	Feed Out Belt Motor
206	Paper Punch Motor	Paper Punch Motor
207	Insufficient Data	

7504	Paper Jam Loc (Z-Folder)	Z-Folding Unit B660 Japan Only
	Displays the list of possible locations where a jam could have occurred. Press the appropriate key to display the jam count for that location. These jams are caused by the failure of a sensor to activate.	
	On Operation Panel	Actual Component Name
211	Paper Feed:Late	Paper Feed Sensor: Late
212	Paper Feed:Lag	Paper Feed Sensor: Lag
213	Fold Timing Sn:Late	Fold Timing Sensor: Late
214	Fold Timing Sn:Lag	Fold Timing Sensor: Lag
215	Lead Edge Sn:Late	Leading Edge Sensor:Late
216	Lead Edge Sn:Lag	Leading Edge Sensor:Lag
217	Up Stopper Sn:Late	Upper Stopper Path Sensor:Late
218	Up Stopper Sn:Lag	Upper Stopper Path Sensor:Lag
219	Lower Ex Sn:Late	Lower Exit Sensor:Late
220	Lower Ex Sn1:Lag	Lower Exit Sensor:Lag
223	Up Ex Sn:Late	Upper Exit Sensor:Late
224	Up Ex Sn:Lag	Upper Exit Sensor:Lag
225	Paper Fold M	Paper Fold Motor
226	Lower Stopper M	Lower Stopper Motor Lock
227	Upper Stopper M	Upper Stopper Motor Lock

Group 7000

7504	Paper Jam Loc	Cover Interposer Tray B835
	Displays the list of possible locations where a jam could have occurred. Press the appropriate key to display the jam count for that location. These jams are caused by the failure of a sensor to activate.	
	On Operation Panel	Actual Component Name
230	Tray 1: No Feed	
231	Tray 2: No Feed	
232	Tray 1: Grip Sn	
233	Tray 2: Grip Sn	
234	Tray 1: Trans Jam	
235	Tray 2: Trans Jam	
236	Exit Jam	
237	Entrance Sn Jam	
238	Exit Sn Jam	
239	Tray 1: Lift Motor	
240	Tray 2: Lift Motor	
241	Tray 1: Pickup Motor	
242	Tray 2: Pickup Motor	
250	RB Entrance Late Jam	
251	RB Entrance Lag Jam	
252	RB Horiz Path Late Jam	
253	RB Horiz Path Lag Jam	
254	RB Exit Late Jam	

255	RB Exit Lag Jam	
-----	-----------------	--

7505	Original Jam Det (ADF)
	Displays the list of possible locations where a jam could have occurred. Press the appropriate key to display the jam count for that location. These jams are caused by the failure of a sensor to activate.
	On Operation Panel
1	At Power On
3	Separation Sensor On
4	Skew Correction Sensor On
5	Interval Sensor On
6	Registration Sensor On
7	Original Exit Sensor On
53	Separation Sensor Off
54	Skew Correction Sensor Off
55	Interval Sensor Off
56	Registration Sensor Off
57	Original Exit Sensor Off

Group 7000

7506	Jam Count by Paper Size	
	Displays the total number of jams by paper size.	
5	A4 LEF	Displays the total number of jams by paper size.
6	A5 LEF	
14	B5 LEF	
38	LT LEF	
44	HLT LEF	
132	A3	
133	A4 SEF	
134	A5 SEF	
141	B4 SEF	
142	B5 SEF	
160	DLT SEF	
164	LG SEF	
166	LT SEF	
172	HLT SEF	
255	Others	

7507	Plotter Jam History	
1	Latest	Displays the following items for the last 10 copy paper jams: 1) Jam code, 2) Paper size, 3) Total count when jam occurred, 4) Date of jam. The "jam codes" are listed in the SMC report under SP7504.
2	Latest 1	
3	Latest 2	

4	Latest 3	
5	Latest 4	
6	Latest 5	
7	Latest 6	
8	Latest 7	
9	Latest 8	
10	Latest 9	

7508	Original Jam History	
1	Original Latest	<p>Displays the following items for the Latest 10 original jams: 1) Jam code, 2) Paper size, 3) Total count when jam occurred, 4) Date of jam. The "jam codes" are listed in the SMC report under SP7504.</p>
2	Latest 1	
3	Latest 2	
4	Latest 3	
5	Latest 4	
6	Latest 5	
7	Latest 6	
8	Latest 7	
9	Latest 8	
10	Latest 9	

7509	Paper Jam Loc	Ring Binder (D392)
	<p>Displays the list of possible locations where a jam could have occurred. Press the appropriate key to display the jam count for that location. These jams are</p>	

	caused by the failure of a sensor to activate.
1	RB Before-Punch Jam
2	RB After-Punch Jam
3	RB Binder Trailing Edge Jam
4	RB Binder Leading Edge Jam
5	RB Ring Feed Jam
6	RB Binder Unit Not Detected
7	RB Output Belt 1 Jam
8	RB Output Belt 2 Jam
9	RB Stacker Book Jam
10	RB Punch Motor Jam
11	RB Shutter Motor Jam
12	RB Pin Alignment Motor Jam
13	RB Binder Jogger Jam
14	RB Pin Alignment Jam
15	RB Binder Main Motor Jam
16	RB 50/100 Clamp Adjust Motor Jam
17	RB Output Belt Rotation Motor Jam
18	RB Job Data Jam

7509	Paper Jam Loc	Multi Folder (D454)
⇒	<p>Displays the list of possible locations where a jam could have occurred. Press the appropriate key to display the jam count for that location. These jams are caused by the failure of a sensor to activate.</p> <p>NOTE: To find jam locations above 255, subtract 255 from the original job code, and then go to SP Mode 7905 and look up code. For example, a code of 270 would be $270-255= 15$, RB Binder Main Motor Jam from the SP 7905 table.</p>	

25	Output Jam
46	Entrance: Late Jam
47	Entrance: Lag Jam
48	Top Tray Exit: Late Jam
49	Top Tray Exit: Lag Jam
50	Straight-Through Exit: Late Jam
51	Straight-Through Exit: Lag Jam
52	1st Stopper: Late Jam
53	1st Stopper: Lag Jam
54	2nd Stopper: Late Jam
55	2nd Stopper: Lag Jam
56	3rd Stopper: Late Jam
57	3rd Stopper: Lag Jam
58	Skew Correction Jam
59	Top Tray Transport Jam
60	Entrance/Top Tray JG Motor Error
61	Entrance/Fold JG Motor Error
62	1st Stopper Motor Error
63	2nd Stopper Motor Error
64	3rd Stopper Motor Error
65	Dynamic Roller Transport Motor Error
66	Registration Roller Release Motor
67	Fold Plate Motor Error

Group 7000

68	Jogger Fence Motor Jam	
69	Positioning Roller Motor Jam	
70	FM2 Direct Send Motor Error	
71	FM6 Pawl Motor	
95	Fin: No Exit End	

7617	Parts PM Counter Display	
1	Normal	Japan Only
2	DF	Japan Only

7618	PM Parts Counter Reset (Japan Only)	
1	Normal	Push [Execute] to clear the parts replacement alarm counter for the main machine.
2	DF	Push [Execute] to clear the parts replacement alarm counter for the ADF.

7621	Current Value	
7622	Reset	
7623	Standard Value	
7624	Part Replacement Operation On/Off	
1	K PCU#	
2	K PCU Cleaning Blade	
3	K PCU Lube Bar	
4	K PCU Lube App/Cling Blade	
5	K PCU Developer	

6	K PCU Drum	
7	K PCU Charge Grid Unit	
8	K PCU Charge Grid Wire	
9	K PCU Idle Gear	
10	K PCU Lube App/Cing Brush	
11	K PCU Toner Cleaning Brush	Not Used
12	K PCU Joint	
13	M PCU#	
14	M PCU Cleaning Blade	
15	M PCU Lube Bar	
16	M PCU Lube App/Cing Blade	
17	M PCU Developer	
18	M PCU Drum	
19	M PCU Charge Roller Unit	
20	M PCU Idle Gear	
21	M PCU Lube App/Cing Brush	
22	M PCU Toner Cleaning Brush	Not Used
23	M PCU Joint	
24	C PCU#	
25	C PCU Cleaning Blade	
26	C PCU Lube Bar	
27	C PCU Lube App/Cing Blade	
28	C PCU Developer	

Group 7000

29	C PCU Drum	
30	C PCU Charge Roller Unit	
31	C PCU Idle Gear	
32	C PCU Lube App/Cling Brush	
33	C PCU Toner Cleaning Brush	Not Used
34	C PCU Joint	
35	Y PCU#	
36	Y PCU Cleaning Blade	
37	Y PCU Lube Bar	
38	Y PCU Lube App/Cling Blade	
39	Y PCU Developer	
40	Y PCU Drum	
41	Y PCU Charge Roller Unit	
42	Y PCU Idle Gear	
43	Y PCU Lube App/Cling Brush	
44	Y PCU Toner Cleaning Brush	Not Used
45	Y PCU Joint	
46	ITB #	
47	ITB Cleaning Unit #	
48	ITB Cleaning Blade	
49	ITB Lube Bar	
50	Lube Application Blade	
51	PTR Unit #	

52	PTR Blade	
53	PTR	
54	Discharge Roller	
55	PTR Lube Bar	
56	Fusing Unit #	
57	Fusing Belt	
58	Hot Roller	
59	Pressure Roller	
60	Lube Roller:Press Roller	
61	Cing Roller:Press Roller	
62	Shaft Bearings:Press Roll	
63	#Used Toner Bottle	
64	#ADF Pickup Roller	
65	#ADF Feed Belt	
66	#ADF Reverse Roller	
67	#ADF Transport Belt	
68	#Dust Filter 1	
69	#Dust Filter 2	
70	#Dust Filter 3	

7625	Pg Count History:Latest 1
7626	Pg Count History:Latest 2
7627	Pg Count History:Latest 3

Group 7000

1	K PCU#	
2	K PCU Cleaning Blade	
3	K PCU Lube Bar	
4	K PCU Lube App/Cling Blade	
5	K PCU Developer	
6	K PCU Drum	
7	K PCU Charge Grid Unit	
8	K PCU Charge Grid Wire	
9	K PCU Idle Gear	
10	K PCU Lube App/Cling Brush	
11	K PCU Toner Cleaning Brush	
12	K PCU Joint	
13	M PCU#	
14	M PCU Cleaning Blade	
15	M PCU Lube Bar	
16	M PCU Lube App/Cling Blade	
17	M PCU Developer	
18	M PCU Drum	
19	M PCU Charge Roller Unit	
20	M PCU Idle Gear	
21	M PCU Lube App/Cling Brush	
22	M PCU Toner Cleaning Brush	
23	M PCU Joint	

24	C PCU#	
25	C PCU Cleaning Blade	
26	C PCU Lube Bar	
27	C PCU Lube App/Cing Blade	
28	C PCU Developer	
29	C PCU Drum	
30	C PCU Charge Roller Unit	
31	C PCU Idle Gear	
32	C PCU Lube App/Cing Brush	
33	C PCU Toner Cleaning Brush	
34	C PCU Joint	
35	Y PCU#	
36	Y PCU Cleaning Blade	
37	Y PCU Lube Bar	
38	Y PCU Lube App/Cing Blade	
39	Y PCU Developer	
40	Y PCU Drum	
41	Y PCU Charge Roller Unit	
42	Y PCU Idle Gear	
43	Y PCU Lube App/Cing Brush	
44	Y PCU Toner Cleaning Brush	
45	Y PCU Joint	
46	ITB #	

Group 7000

47	ITB Cleaning Unit #	
48	ITB Cleaning Blade	
49	ITB Lube Bar	
50	Lube Application Blade	
51	PTR Unit #	
52	PTR Blade	
53	PTR	
54	Discharge Roller	
55	PTR Lube Bar	
56	Fusing Unit #	
57	Fusing Belt	
58	Hot Roller	
59	Pressure Roller	
60	Lube Roller:Press Roller	
61	Cing Roller:Press Roller	
62	Shaft Bearings:Press Roll	
63	#Used Toner Bottle	
64	#ADF Pickup Roller	
65	#ADF Feed Belt	
66	#ADF Reverse Roller	
67	#ADF Transport Belt	
68	#Dust Filter 1	
69	#Dust Filter 2	

70	#Dust Filter 3	
----	----------------	--

7628	Clear PM Counter	
1	Clear Exceeded Counts	
	Do this SP to clear all PM counts that have exceeded their limits.	
2	Reset All Counts	
	Do this SP to clear all PM counts, including those that have not exceeded their limits.	

7801	Serial No./ROM Version	
	Displays the ROM version numbers of the main machine and connected peripheral devices.	
	Serial Number	
002	Engine	
005	ADF	
007	Finisher	
010	LCT	
011	Mail Box	
020	Cover Interposer	
025	Z-Fold Unit Japan Only	
029	Ring Binder: PCB 1	
030	Ring Binder: PCB 2	
	ROM Version	
102	Engine	

Group 7000

105	ADF
107	Finisher
110	LCT
111	Mail Box
120	Cover Feeder
125	Z-Fold Unit Japan Only
129	Ring Binder: PCB 1
130	Ring Binder: PCB 2

7803	PM Counter Display
	Displays the PM count since the last PM.

7804	PM Counter Reset
	Resets the PM count.

7807	SC/Jam Counter Reset
	Push [Start] to reset the SC and jam counters.

7826	MF Error Counter (Japan Only)	
	Displays the number of counts requested of the card/key counter.	
1	Error Total	A request for the count total failed at power on. This error will occur if the device is installed but disconnected.
2	Error Staple	The request for a staple count failed at power on. This error will occur if the device is installed but disconnected.

7827	MF Error Counter Clear (Japan Only)	
	Press Execute to reset to 0 the values of SP7826.	

7832	Self-Diagnostic Result Display	
	Push [#] to display a list of error codes. Nothing is displayed if no errors have occurred.	

7835	ACC Counter	
	No information is available at this time.	
1	Copy ACC	
2	Printer ACC	

Group 7000

7836	Total Memory Size
	Displays the contents of the memory on the controller board.

7852	ADF Scan Glass
	Displays the count for the number of times the machine has detected dust over the entire length the ADF scanning glass at the beginning of copy jobs. This SP operates only after SP4020 001 has been turned on. Note: Dust or dirt on the scanning glass causes vertical lines in printouts.
1	Dust Counter
	This SP records the counts for dust detection on the ADF scanning glass. A count is recorded only when SP4020-1 is turned ON. This counter counts up once for every three detections of dust on the glass. [0 to 65535 / 0 / 1 count]
2	Clear Counter
	This SP clears the dust count of SP7852-1. [0 too 65535 / 0 / 1 count]
3	Dust Count: Rear
	This SP records the counts for dust detection on the ADF scanning glass during scanning of the reverse side of the originals. A count is recorded only when SP4020-1 is turned ON. [0 too 65535 / 0 / 1 count]
10	Dust Counter Clear DFU
	This SP clears the count of SP7852-3.

7855	Coverage Range DFU
1	Coverage Range 1
2	Coverage Range 2

7901	Assert Info. DFU	
1	File Name	Used for debugging.
2	Number of Files	
3	Locations	

7931	Toner Bottle Bk	Toner Information: Black
7932	Toner Bottle M	Toner Information: Magenta
7933	Toner Bottle C	Toner Information: Cyan
7934	Toner Bottle Y	Toner Information: Yellow
	Displays detailed information about the toner used in the machine.	
1	Model ID	
2	Cartridge Ver	
3	Brand ID	
4	Area ID	
5	Production ID	
6	Color ID	
7	Maintenance ID	
8	New	
9	Recycle Count	
10	Product Date	
11	Serial No	
12	EDP Code	
13	Toner Remaining	

Group 7000

14	Toner End	
15	Toner Refill	
16	Total Count Start	
17	Color Count:Start	
18	Total Count End	
19	Color Count:End	
20	Set Date	
21	End Date	

7935	Toner Bottle Log 1: Bk	
7936	Toner Bottle Log 1: M	
7937	Toner Bottle Log 1: C	
7938	Toner Bottle Log 1: Y	
1	Serial No	
2	Set Date	
3	Total Count Start	
4	Toner Refill	
11	Serial No	
12	Set Date	
13	Total Count Start	
14	Toner Refill	
21	Serial No	
22	Set Date	
23	Total Count Start	

24	Toner Refill	
31	Serial No.	
32	Set Date	
33	Total Count Start	
34	Toner Refill	
41	Serial No.	
42	Set Date	
43	Total Count Start	
44	Toner Refill	

7940	PM MotdrvdistanceDisp	
7942	Motdrvdistance%Disp	
7944	Motor Drv Distance	
1	PCU:K	
2	PCU:M	
3	PCU:C	
4	PCU:Y	

Appendix:
Service
Program
Mode Table

Group 7000

7954	Pg Count %Display	
	This SP displays the current usage (listed as percent of usage) of the components listed below: Current Usage/Standard Usage Service Life x 100	
1	K PCU#	
2	K PCU Cleaning Blade	
3	K PCU Lube Bar	
4	K PCU App/Clng Blade	
5	K PCU Developer	
6	K PCU Drum	
7	K PCU Charge Grid Unit	
8	K PCU Charge Grid Wire	
9	K PCU Idle Gear	
10	K PCU Lube App/Clng Brush	
11	K PCU Toner Cleaning Brush	
12	K PCU Joint	
13	M PCU#	
14	M PCU Cleaning Blade	
15	M PCU Lube Bar	
16	M PCU Lube App/Clng Blade	
17	M PCU Developer	
18	M PCU Drum	
19	M PCU Charge Roller Unit	

20	M PCU Idle Gear	
21	M PCU Lube App/Cing Brush	
22	M PCU Toner Cleaning Brush	
23	M PCU Joint	
24	C PCU#	
25	C PCU Cleaning Blade	
26	C PCU Lube Bar	
27	C PCU Lube App/Cing Blade	
28	C PCU Developer	
29	C PCU Drum	
30	C PCU Charge Roller Unit	
31	C PCU Idle Gear	
32	C PCU Lube App/Cing Brush	
33	C PCU Toner Cleaning Brush	
34	C PCU Joint	
35	Y PCU#	
36	Y PCU Cleaning Blade	
37	Y PCU Lube Bar	
38	Y PCU Lube App/Cing Blade	
39	Y PCU Developer	
40	Y PCU Drum	
41	Y PCU Charge Roller Unit	
42	Y PCU Idle Gear	

Group 7000

43	Y PCU Lube App/Clng Brush	
44	Y PCU Toner Cleaning Brush	
45	Y PCU Joint	
46	ITB#	
47	ITB Cleaning Unit	
48	ITB Cleaning Blade	
49	ITB Lube Bar	
50	Lube Application Blade	
51	PTR Unit#	
52	PTR Blade	
53	PTR Roller	
54	Discharge Roller	
55	PTR Lube Bar	
56	Fusing Unit #	
57	Fusing Belt	
58	Hot Roller	
59	Pressure Roller	
60	Lube Roller: Press Roller	
61	Press Roller	
62	Shaft Bearings: Press Roll	
63	Used Toner Bottle#	
64	ADF Pickup Roller#	
65	ADF Feed Belt#	

66	ADF Reverse Roller#	
67	ADF Transport Belt	
68	Dust Filter 1#	
69	Dust Filter 2#	
70	Dust Filter 3#	

7958	Display Mtr Drv Distance	
1	Drum Motor:K	
2	Drum Motor:M	
3	Drum Motor:C	
4	Drum Motor:Y	
5	Cleaning Motor:K	
6	Cleaning Motor:M	
7	Cleaning Motor:C	
8	Cleaning Motor:Y	
9	Development Motor:K	
10	Development Motor:M	
11	Development Motor:C	
12	Development Motor:Y	
13	ITB Drive Motor	
14	PTR Motor	
15	Fusing Motor	

Appendix:
Service
Program
Mode Table

Group 7000

7959	Motor Drv Total
	Displays the total run distance in meters (m).

7960	Motor Drv Distance Reset	
1	Drum Motor: K	
2	Drum Motor: M	
3	Drum Motor: C	
4	Drum Motor: Y	
5	Cleaning Motor: K	
6	Cleaning Motor: M	
7	Cleaning Motor: C	
8	Cleaning Motor: Y	
9	Development Motor: K	
10	Development Motor: M	
11	Development Motor: C	
12	Development Motor: Y	
13	ITB Drive Motor	
14	PTR Motor	
15	Fusing Motor	

4.9 GROUP 8000

These new SP counters are provided for MFP, LP, and Wide Format machines that employ GW Architecture. These SP codes have been created in response to requests by customers, sales personnel and customer engineers, and R&D staff for a standardized set of counters that can be used to log more detailed information about machine operation. These SPs are absolutely essential to provide more detailed counters and job logs to match similar features that are being developed by competitors.

Current Status of the SP8xxx Counters

Many of these counters are provided for features that are currently not available, such as sending color faxes, and so on. However, here are some Group 8 codes that when used in combination with others, can provide useful information.

SP Numbers	What They Do
SP8211 to SP8216	The number of pages scanned to the document server.
SP8401 to SP8406	The number of pages printed from the document server
SP8691 to SP8696	The number of pages sent from the document server

Specifically, the following questions can be answered:

- How is the document server actually being used?
- What application is using the document server most frequently?
- What data in the document server is being reused?

Group 8 Service Table Keys

Many of the SPs in this group are prefixed with a letter that indicates the mode of operation (the mode of operation is referred to as an 'application'). Before reading the Group 8 Service Table, make sure that you understand what these prefixes mean.

Group 8000

Prefixes	Meaning	
T:	Total: (Grand Total).	Grand total of items counted for all applications (C, F, P, etc.).
C:	Copy application.	Totals (pages, jobs, etc.) executed for each application when the job was not stored on the document server.
F:	Fax application	
P:	Print application.	
S:	Scan application.	
L:	Local storage (document server)	Totals (jobs, pages, etc.) for the document server. The L: counters work differently case by case. Sometimes, they count jobs/pages stored on the document server; this can be in document server mode (from the document server window), or from another mode, such as from a printer driver or by pressing the Store File button in the Copy mode window. Sometimes, they include occasions when the user uses a file that is already on the document server. Each counter will be discussed case by case.
O:	Other applications (external network applications, for example)	Refers to network applications such as Web Image Monitor. Utilities developed with the SDK (Software Development Kit) will also be counted with this group in the future.

The Group 8 SP codes are limited to 17 characters, forced by the necessity of displaying them on the small LCDs of printers and faxes that also use these SPs. Read over the list of abbreviations below and refer to it again if you see the name of an SP that you do not understand.

Abbreviation	What It Means
/	"By", e.g. "T:Jobs/Apl" = Total Jobs "by" Application
>	More (2> "2 or more", 4> "4 or more")
AddBook	Address Book
Apl	Application
B/W	Black & White
Bk	Black
C	Cyan
ColCr	Color Create
ColMode	Color Mode
Comb	Combine
Comp	Compression
Deliv	Delivery
DesApl	Designated Application. The application (Copy, Fax, Scan, Print) used to store the job on the document server, for example.
Dev Counter	Development Count, no. of pages developed.
Dup, Duplex	Duplex, printing on both sides
Emul	Emulation
FC	Full Color
FIN	Post-print processing, i.e. finishing (punching, stapling, etc.)
Full Bleed	No Margins
GenCopy	Generation Copy Mode
GPC	Get Print Counter. For jobs 10 pages or less, this counter does not

Group 8000

Abbreviation	What It Means
	count up. For jobs larger than 10 pages, this counter counts up by the number that is in excess of 10 (e.g., for an 11-page job, the counter counts up 11-10 =1)
IFax	Internet Fax
ImgEdt	Image Edit performed on the original with the copier GUI, e.g. border removal, adding stamps, page numbers, etc.
K	Black (YMCK)
LS	Local Storage. Refers to the document server.
LSize	Large (paper) Size
Mag	Magnification
MC	One color (monochrome)
NRS	New Remote Service, which allows a service center to monitor machines remotely. "NRS" is used overseas, "CSS" is used in Japan.
Org	Original for scanning
OrgJam	Original Jam
Palm 2	Print Job Manager/Desk Top Editor: A pair of utilities that allows print jobs to be distributed evenly among the printers on the network, and allows files to moved around, combined, and converted to different formats.
PC	Personal Computer
PGS	Pages. A page is the total scanned surface of the original. Duplex pages count as two pages, and A3 simplex count as two pages if the A3/DLT counter SP is switched ON.
PJob	Print Jobs
Ppr	Paper

Abbreviation	What It Means
PrtJam	Printer (plotter) Jam
PrtPGS	Print Pages
R	Red (Toner Remaining). Applies to the wide format model A2 only. This machine is under development and currently not available.
Rez	Resolution
SC	Service Code (Error SC code displayed)
Scn	Scan
Sim, Simplex	Simplex, printing on 1 side.
S-to-Email	Scan-to-E-mail
SMC	SMC report printed with SP5990. All of the Group 8 counters are recorded in the SMC report.
Svr	Server
TonEnd	Toner End
TonSave	Toner Save
TXJob	Send, Transmission
YMC	Yellow, Magenta, Cyan
YMCK	Yellow, Magenta, Cyan, Black

Note: All of the Group 8 SPs are reset with SP5801 1 Memory All Clear, or the Counter Reset SP7808.

Group 8000

8001	T:Total Jobs	<p>These SPs count the number of times each application is used to do a job.</p> <p>[0 to 9999999/ 1]</p> <p>Note: The L: counter is the total number of times the other applications are used to send a job to the document server, plus the number of times a file already on the document server is used.</p>
8002	C:Total Jobs	
8003	F: Total Jobs	
8004	P:Total Jobs	
8005	S:Total Jobs	
8006	L:Total Jobs	

These SPs reveal the number of times an application is used, not the number of pages processed.

- When an application is opened for image input or output, this counts as one job.
- Interrupted jobs (paper jams, etc.) are counted, even though they do not finish.
- Only jobs executed by the customer are counted. Jobs executed by the customer engineer using the SP modes are not counted.
- When using secure printing (when a password is required to start the print job), the job is counted at the time when either "Delete Data" or "Specify Output" is specified.
- A job is counted as a fax job when the job is stored for sending.
- When a fax is received to fax memory, the F: counter increments but the L: counter does not (the document server is not used).
- A fax broadcast counts as one job for the F: counter (the fax destinations in the broadcast are not counted separately).
- A fax broadcast is counted only after all the faxes have been sent to their destinations. If one transmission generates an error, then the broadcast will not be counted until the transmission has been completed.
- A printed fax report counts as one job for the F: counter.
- The F: counter does not distinguish between fax sending or receiving.
- When a copy job on the document server is printed, SP8022 also increments, and when a print job stored on the document server is printed, SP8024 also increments.
- When an original is both copied and stored on the document server, the C: and L: counters both increment.
- When a print job is stored on the document server, only the L: counter increments.
- When the user presses the Document Server button to store the job on the document server, only the L: counter increments.

- When the user enters document server mode and prints data stored on the document server, only the L: counter increments.
- When an image received from Palm 2 is received and stored, the L: counter increments.

8011	T:Jobs/LS	<p>These SPs count the number of jobs stored to the document server by each application, to reveal how local storage is being used for input. [0to99999999/ 1]</p> <p>The L: counter counts the number of jobs stored from within the document server mode screen at the operation panel.</p>
8012	C:Jobs/LS	
8013	F:Jobs/LS	
8014	P:Jobs/LS	
8015	S:Jobs/LS	
8016	L:Jobs/LS	
8017	O:Jobs/LS	

- When a scan job is sent to the document server, the S: counter increments. When you enter document server mode and then scan an original, the L: counter increments.
- When a print job is sent to the document server, the P: counter increments.
- When a network application sends data to the document server, the O: counter increments.
- When an image from Palm 2 is stored on the document server, the O: counter increments.
- When a fax is sent to the document server, the F: counter increments.

Group 8000

8021	T:Pjob/LS	<p>These SPs reveal how files printed from the document server were stored on the document server originally.</p> <p>[0 to 9999999/ 1]</p> <p>The L: counter counts the number of jobs stored from within the document server mode screen at the operation panel.</p>
8022	C:Pjob/LS	
8023	F:Pjob/LS	
8024	P:Pjob/LS	
8025	S:Pjob/LS	
8026	L:Pjob/LS	
8027	O:Pjob/LS	

- When a copy job stored on the document server is printed with another application, the C: counter increments.
- When an application like DeskTopBinder merges a copy job that was stored on the document server with a print job that was stored on the document server, the C: and P: counters both increment.
- When a job already on the document server is printed with another application, the L: counter increments.
- When a scanner job stored on the document server is printed with another application, the S: counter increments. If the original was scanned from within document server mode, then the L: counter increments.
- When images stored on the document server by a network application (including Palm 2), are printed with another application, the O: counter increments.
- When a copy job stored on the document server is printed with a network application (Web Image Monitor, for example), the C: counter increments.
- When a fax on the document server is printed, the F: counter increments.

8031	T:Pjob/DesApl	<p>These SPs reveal what applications were used to output documents from the document server.</p> <p>[0 to 9999999/ 1]</p> <p>The L: counter counts the number of jobs printed from within the document server mode screen at the operation panel.</p>
8032	C:Pjob/DesApl	
8033	F:Pjob/DesApl	
8034	P:Pjob/DesApl	
8035	S:Pjob/DesApl	
8036	L:Pjob/DesApl	
8037	O:Pjob/DesApl	

- When documents already stored on the document server are printed, the count for the application that started the print job is incremented.
- When the print job is started from a network application (Desk Top Binder, Web Image Monitor, etc.) the L: counter increments.

Appendix:
Service
Program
Mode Table

8041	T:TX Jobs/LS	<p>These SPs count the applications that stored files on the document server that were later accessed for transmission over the telephone line or over a network (attached to an e-mail, or as a fax image by I-Fax).</p> <p>[0 to 9999999/ 1]</p> <p>Note: Jobs merged for sending are counted separately.</p> <p>The L: counter counts the number of jobs scanned from within the document server mode screen at the operation panel.</p>
8042	C:TX Jobs/LS	
8043	F:TX Jobs/LS	
8044	P:TX Jobs/LS	
8045	S:TX Jobs/LS	
8046	L:TX Jobs/LS	
8047	O:TX Jobs/LS	

- When a stored copy job is sent from the document server, the C: counter increments.
- When images stored on the document server by a network application or Palm2 are sent as an e-mail, the O: counter increments.

Group 8000

8051	T:TX Jobs/DesApl	<p>These SPs count the applications used to send files from the document server over the telephone line or over a network (attached to an e-mail, or as a fax image by I-Fax). Jobs merged for sending are counted separately.</p> <p>[0 to 9999999/ 1]</p> <p>The L: counter counts the number of jobs sent from within the document server mode screen at the operation panel.</p>
8052	C:TX Jobs/DesApl	
8053	F:TX Jobs/DesApl	
8054	P:TX Jobs/DesApl	
8055	S:TX Jobs/DesApl	
8056	L:TX Jobs/DesApl	
8057	O:TX Jobs/DesApl	

- If the send is started from Desk Top Binder or Web Image Monitor, for example, then the O: counter increments.

8061	T:FIN Jobs	[0 to 9999999/ 1]	
	<p>These SPs total the finishing methods. The finishing method is specified by the application.</p>		
8062	C:FIN Jobs	[0 to 9999999/ 1]	
	<p>These SPs total finishing methods for copy jobs only. The finishing method is specified by the application.</p>		
8063	F:FIN Jobs	[0 to 9999999/ 1]	
	<p>These SPs total finishing methods for fax jobs only. The finishing method is specified by the application.</p>		
8064	P:FIN Jobs	[0 to 9999999/ 1]	
	<p>These SPs total finishing methods for print jobs only. The finishing method is specified by the application.</p>		
8065	S:FIN Jobs	[0 to 9999999/ 1]	
	<p>These SPs total finishing methods for scan jobs only. The finishing method is specified by the application.</p>		

	Note: Finishing features for scan jobs are not available at this time.	
8066	L:FIN Jobs	[0 to 9999999/ 1]
	These SPs total finishing methods for jobs output from within the document server mode screen at the operation panel. The finishing method is specified from the print window within document server mode.	
8067	O:FIN Jobs	[0 to 9999999/ 1]
	These SPs total finishing methods for jobs executed by an external application, over the network. The finishing method is specified by the application.	
806x 1	Sort	Number of jobs started in Sort mode. When a stored copy job is set for Sort and then stored on the document server, the L: counter increments. (See SP8066 1)
806x 2	Stack	Number of jobs started out of Sort mode.
806x 3	Staple	Number of jobs started in Staple mode.
806x 4	Booklet	Number of jobs started in Booklet mode. If the machine is in staple mode, the Staple counter also increments.
806x 5	Z-Fold	Number of jobs started in any mode other than the Booklet mode and set for Z-folding. (Multi Fold Unit D394)
806x 6	Punch	Number of jobs started in Punch mode. When Punch is set for a print job, the P: counter increments. (See SP8064 6.)
806x 7	Other	Reserved. Not used.
806x 8	Inside Fold	Half-Fold (FM2) (Multi Fold Unit D394)
806x 9	Three-IN-Fold	Letter Fold-in (FM4) (Multi Fold Unit D394)
806x 10	Three-OUT-Fold	Letter Fold-out (FM3) (Multi Fold Unit D394)

Group 8000

806x 11	Four Fold	Double Parallel Fold (FM5) (Multi Fold Unit D394)
806x 12	KANNON-Fold	Gate Fold (FM6) (Multi Fold Unit D394)
806x 13	Perfect-Bind	Perfect Binder D391 Not Used
806x 14	Ring-Bind	Ring Binder D392

8071	T:Jobs/PGS	[0 to 9999999/ 1]
	These SPs count the number of jobs broken down by the number of pages in the job, regardless of which application was used.	
8072	C:Jobs/PGS	[0 to 9999999/ 1]
	These SPs count and calculate the number of copy jobs by size based on the number of pages in the job.	
8073	F:Jobs/PGS	[0 to 9999999/ 1]
	These SPs count and calculate the number of copy jobs by size based on the number of pages in the job.	
8074	P:Jobs/PGS	[0 to 9999999/ 1]
	These SPs count and calculate the number of print jobs by size based on the number of pages in the job.	
8075	S:Jobs/PGS	[0 to 9999999/ 1]
	These SPs count and calculate the number of scan jobs by size based on the number of pages in the job.	
8076	L:Jobs/PGS	[0 to 9999999/ 1]
	These SPs count and calculate the number of jobs printed from within the document server mode window at the operation panel, by the number of pages in the job.	

8077	O:Jobs/PGS	[0 to 9999999/ 1]	
	These SPs count and calculate the number of "Other" application jobs (Web Image Monitor, Palm 2, etc.) by size based on the number of pages in the job.		
807x 1	1 Page	807x 8	21 to 50 Pages
807x 2	2 Pages	807x 9	51 to 100 Pages
807x 3	3 Pages	807x 10	101 to 300 Pages
807x 4	4 Pages	807x 11	301 to 500 Pages
807x 5	5 Pages	807x 12	501 to 700 Pages
807x 6	6 to 10 Pages	807x 13	701 to 1000 Pages
807x 7	11 to 20 Pages	807x 14	1001 to Pages

- For example: When a copy job stored on the document server is printed in document server mode, the appropriate L: counter (SP8076 0xx) increments.
- Printing a fax report counts as a job and increments the F: counter (SP 8073).
- Interrupted jobs (paper jam, etc.) are counted, even though they do not finish.
- If a job is paused and re-started, it counts as one job.
- If the finisher runs out of staples during a print and staple job, then the job is counted at the time the error occurs.
- For copy jobs (SP 8072) and scan jobs (SP 8075), the total is calculated by multiplying the number of sets of copies by the number of pages scanned. (One duplex page counts as 2.)
- The first test print and subsequent test prints to adjust settings are added to the number of pages of the copy job (SP 8072).
- When printing the first page of a job from within the document server screen, the page is counted.

Group 8000

8111	T:FAX TX Jobs	[0 to 99999999/ 0 / 1]
	These SPs count the total number of jobs (color or black-and-white) sent by fax, either directly or using a file stored on the document server, on a telephone line.	
8113	F:FAX TX Jobs	[0 to 99999999/ 0 / 1]
	These SPs count the total number of jobs (color or black-and-white) sent by fax directly on a telephone line.	
1	B/W	
2	Color	

- These counters count jobs, not pages.
- This SP counts fax jobs sent over a telephone line with a fax application, including documents stored on the document server.
- If the mode is changed during the job, the job will count with the mode set when the job started.
- If the same document is faxed to both a public fax line and an I-Fax at a destination where both are available, then this counter increments, and the I-Fax counter (812x) also increments.
- The fax job is counted when the job is scanned for sending, not when the job is sent.

8121	T:IFAX TX Jobs	[0 to 99999999/ 0 / 1]
	These SPs count the total number of jobs (color or black-and-white) sent, either directly or using a file stored on the document server, as fax images using I-Fax.	
8123	F:IFAX TX Jobs	[0 to 99999999/ 0 / 1]
	These SPs count the number of jobs (color or black-and-white) sent (not stored on the document server), as fax images using I-Fax.	
1	B/W	
2	Color	

- The counters for color are provided for future use; the color fax feature is not available at this time.
- The fax job is counted when the job is scanned for sending, not when the job is sent.

8131	T:S-to-Email Jobs	[0 to 9999999/ 1]
	These SPs count the total number of jobs scanned and attached to an e-mail, regardless of whether the document server was used or not.	
8135	S:S-to-Email Jobs	
	These SPs count the number of jobs scanned and attached to an e-mail, without storing the original on the document server.	
1	B/W	Count for the number of jobs with black-and-white.
2	Color	Count for the number of jobs with color.
3	ACS	Count for the number of jobs using ACS mode.

- These counters count jobs, not pages.
- If the job is stored on the document server, after the job is stored it is determined to be color or black-and-white then counted.
- If the job is cancelled during scanning, or if the job is cancelled while the document is waiting to be sent, the job is not counted.
- If the job is cancelled during sending, it may or may not be counted, depending on what stage of the process had been reached when the job was cancelled.
- If several jobs are combined for sending to the Scan Router, Scan-to-Email, or Scan-to-PC, or if one job is sent to more than one destination. each send is counted separately. For example, if the same document is sent by Scan-to-Email as well as Scan-to-PC, then it is counted twice (once for Scan-to-Email and once for Scan-to-PC).

Group 8000

8141	T:Deliv Jobs/Svr	[0 to 9999999/ 1]
	These SPs count the total number of jobs scanned and sent to a Scan Router server.	
1	B/W	Count for the number of jobs with black-and-white.
2	Color	Count for the number of jobs with color.
3	ACS	Count for the number of jobs using ACS mode.
3	ACS	Count for the number of jobs using ACS mode.
8145	S:Deliv Jobs/Svr	
	These SPs count the number of jobs scanned in scanner mode and sent to a Scan Router server.	
1	B/W	Count for the number of jobs with black-and-white.
2	Color	Count for the number of jobs with color.
3	ACS	Count for the number of jobs using ACS mode.

- These counters count jobs, not pages.
- The jobs are counted even though the arrival and reception of the jobs at the Scan Router server cannot be confirmed.
- If even one color image is mixed with black-and-white images, then the job is counted as a "Color" job.
- If the job is cancelled during scanning, or if the job is cancelled while the document is waiting to be delivered, the job is not counted.
- If the job is cancelled during sending, it may or may not be counted, depending on what stage of the process had been reached when the job was cancelled.
- Even if several files are combined for sending, the transmission counts as one job.

8151	T:Deliv Jobs/PC		[0 to 9999999/ 1]
	These SPs count the total number of jobs scanned and sent to a folder on a PC (Scan-to-PC). Note: At the present time, 8151 and 8155 perform identical counts.		
1	B/W	Count for the number of jobs with black-and-white.	
2	Color	Count for the number of jobs with color.	
3	ACS	Count for the number of jobs using ACS mode.	
8155	S:Deliv Jobs/PC		
	These SPs count the total number of jobs scanned and sent with Scan-to-PC.		
1	B/W	Count for the number of jobs with black-and-white.	
2	Color	Count for the number of jobs with color.	
3	ACS	Count for the number of jobs using ACS mode.	

- These counters count jobs, not pages.
- If the job is cancelled during scanning, it is not counted.
- If the job is cancelled while it is waiting to be sent, the job is not counted.
- If the job is cancelled during sending, it may or may not be counted, depending on what stage of the process had been reached when the job was cancelled.
- Even if several files are combined for sending, the transmission counts as one job.

Group 8000

8161	T: PC FAX TX Jobs	
8163	F: PC FAX TX Jobs	

8171	T: Deliv Jobs/WSD	
8175	S: Deliv Jobs/WSD	
8181	T: Scan to Media Jobs	
8185	S: Scan to Media Jobs	
1	B/W	
2	Color	
3	ACS	

8191	T:Total Scan PGS	<p>These SPs count the pages scanned by each application that uses the scanner to scan images. [0 to 9999999/ 1]</p>
8192	C:Total Scan PGS	
8193	F:Total Scan PGS	
8195	S:Total Scan PGS	
8196	L:Total Scan PGS	

- SP 8191 to 8196 count the number of scanned sides of pages, not the number of physical pages.
- These counters do not count reading user stamp data, or reading color charts to adjust color.
- Previews done with a scanner driver are not counted.
- A count is done only after all images of a job have been scanned.
- Scans made in SP mode are not counted.

Examples

- If 3 B5 pages and 1 A3 page are scanned with the scanner application but not stored, the S: count is 4.
- If both sides of 3 A4 sheets are copied and stored to the document server using the

Store File button in the Copy mode window, the C: count is 6 and the L: count is 6.

- If both sides of 3 A4 sheets are copied but not stored, the C: count is 6.
- If you enter document server mode then scan 6 pages, the L: count is 6.

8201	T:LSize Scan PGS	[0 to 9999999/ 1]
	This SP counts the total number of large pages input with the scanner for scan and copy jobs. Note: These counters are displayed in the SMC Report, and in the User Tools display.	
8203	F:LSize Scan PGS	[0 to 9999999/ 1]
	This SP counts the total number of large pages input with the scanner for fax jobs only. Note: These counters are displayed in the SMC Report, and in the User Tools display.	
8205	S:LSize Scan PGS	[0 to 9999999/ 1]
	This SP counts the total number of large pages input with the scanner for scan jobs only Note: These counters are displayed in the SMC Report, and in the User Tools display..	

Appendix:
Service
Program
Mode Table

8211	T:Scan PGS/LS	These SPs count the number of pages scanned into the document server . [0 to 9999999/ 1] The L: counter counts the number of pages stored from within the document server mode screen at the operation panel, and with the Store File button from within the Copy mode screen
8212	C:Scan PGS/LS	
8213	F:Scan PGS/LS	
8215	S:Scan PGS/LS	
8216	L:Scan PGS/LS	

- Reading user stamp data is not counted.
- If a job is cancelled, the pages output as far as the cancellation are counted.
- If the scanner application scans and stores 3 B5 sheets and 1 A4 sheet, the S: count is 4.

Group 8000

- If pages are copied but not stored on the document server, these counters do not change.
- If both sides of 3 A4 sheets are copied and stored to the document server, the C: count is 6 and the L: count is 6.
- If you enter document server mode then scan 6 pages, the L: count is 6.

	ADF Org Feeds	
8221	[0 to 99999999/ 0 / 1] These SPs count the number of pages fed through the ADF for front and back side scanning.	
1	Front	Number of front sides fed for scanning: With an ADF that can scan both sides simultaneously, the Front side count is the same as the number of pages fed for either simplex or duplex scanning. With an ADF that cannot scan both sides simultaneously, the Front side count is the same as the number of pages fed for duplex front side scanning. (The front side is determined by which side the user loads face up.)
2	Back	Number of rear sides fed for scanning: With an ADF that can scan both sides simultaneously, the Back count is the same as the number of pages fed for duplex scanning. With an ADF that cannot scan both sides simultaneously, the Back count is the same as the number of pages fed for duplex rear-side scanning.

- When 1 sheet is fed for duplex scanning the Front count is 1 and the Back count is 1.
- If a jam occurs during the job, recovery processing is not counted to avoid double counting. Also, the pages are not counted if the jam occurs before the first sheet is output.

8231	Scan PGS/Mode	
	[0 to 99999999/ 0 / 1] These SPs count the number of pages scanned by each ADF mode to determine the work load on the ADF.	
1	Large Volume	Selectable. Large copy jobs that cannot be loaded in the ADF at one time.
2	SADF	Selectable. Feeding pages one by one through the ADF.
3	Mixed Size	Selectable. Select "Mixed Sizes" on the operation panel.
4	Custom Size	Selectable. Originals of non-standard size.
5	Platen	Book mode. Raising the ADF and placing the original directly on the platen.
6	1side/2side	

- If the scan mode is changed during the job, for example, if the user switches from ADF to Platen mode, the count is done for the last selected mode.
- If the user selects "Mixed Sizes" for copying in the platen mode, the Mixed Size count is enabled.
- In the SADF mode if the user copies 1 page in platen mode and then copies 2 pages with SADF, the Platen count is 1 and the SADF count is 3.

Group 8000

8241	T:Scan PGS/Org	[0 to 9999999/ 1]				
	These SPs count the total number of scanned pages by original type for all jobs, regardless of which application was used.					
8242	C:Scan PGS/Org	[0 to 9999999/ 1]				
	These SPs count the number of pages scanned by original type for Copy jobs.					
8243	F:Scan PGS/Org	[0 to 9999999/ 0 / 1]				
	These SPs count the number of pages scanned by original type for Fax jobs.					
8245	S:Scan PGS/Org	[0 to 9999999/ 1]				
	These SPs count the number of pages scanned by original type for Scan jobs.					
8246	L:Scan PGS/Org	[0 to 9999999/ 1]				
	These SPs count the number of pages scanned and stored from within the document server mode screen at the operation panel, and with the Store File button from within the Copy mode screen					
	8241	8242		8243	8245	8246
824x 1: Text	Yes	Yes	Yes	Yes	Yes	Yes
824x 2: Text/Photo	Yes	Yes	Yes	Yes	Yes	Yes
824x 3: Photo	Yes	Yes	Yes	Yes	Yes	Yes
824x 4: GenCopy, Pale	Yes	Yes	Yes	Yes	Yes	
824x 5: Map	Yes	Yes	Yes	Yes	Yes	
824x 6: Normal/Detail	Yes		Yes			
824x 7: Fine/Super Fine	Yes		Yes			
824x 8: Binary	Yes		Yes			
824x 9: Grayscale	Yes		Yes			
824x 10: Color	Yes		Yes			

824x 11: Other	Yes	Yes	Yes	Yes	Yes
----------------	-----	-----	-----	-----	-----

- If the scan mode is changed during the job, for example, if the user switches from ADF to Platen mode, the count is done for the last selected mode.

8251	T:Scan PGS/ImgEdt	<p>These SPs show how many times Image Edit features have been selected at the operation panel for each application. Some examples of these editing features are:</p> <p>Erase> Border Erase> Center Image Repeat Centering Positive/Negative [0 to 9999999/ 1]</p> <p>Note: The count totals the number of times the edit features have been used. A detailed breakdown of exactly which features have been used is not given.</p>
8252	C:Scan PGS/ImgEdt	
8255	S:Scan PGS/ImgEdt	
8256	L:Scan PGS/ImgEdt	
8257	O:Scan PGS/ImgEdt	

- The L: counter counts the number of pages stored from within the document server mode screen at the operation panel, and with the Store File button from within the Copy mode screen.

Group 8000

8261	T:Scn PGS/ColCr	[0 to 9999999/ 1]
	These SPs count the total number of scanned pages by the color processing mode used.	
8262	C:Scn PGS/ColCr	[0 to 9999999/ 1]
	These SPs count the number of pages by the color processing mode used for Copy jobs only.	
8265	S: Scn PGS/ColCr	[0 to 9999999/ 1]
8266	L: Scn PGS/TWAIN	[0 to 9999999/ 1]
8261 1	Color Conversion	
8261 2	Color Erase	
8261 3	Background	
8261 4	Other	

- These counters are enabled only for MFP machines that support color. The wide format machines do not support the "Background" or "Other" counters.

8281	T:Scan PGS/TWAIN	These SPs count the number of pages scanned using a TWAIN driver. These counters reveal how the TWAIN driver is used for delivery functions. [0 to 9999999/ 1] Note: At the present time, these counters perform identical counts.
8285	S:Scan PGS/TWAIN	

8291	T:Scan PGS/Stamp	These SPs count the number of pages stamped with the stamp in the ADF unit. [0 to 9999999/ 1] The L: counter counts the number of pages stored from within the document server mode screen at the operation panel, and with the Store File button
8293	F:Scan PGS/Stamp	
8295	S:Scan PGS/Stamp	

		from within the Copy mode screen
--	--	----------------------------------

8301	T:Scan PGS/Size	[0 to 9999999/ 1]
	These SPs count by size the total number of pages scanned by all applications. Use these totals to compare original page size (scanning) and output (printing) page size [SP 8-441].	
8302	C:Scan PGS/Size	[0 to 9999999/ 1]
	These SPs count by size the total number of pages scanned by the Copy application. Use these totals to compare original page size (scanning) and output (printing) page size [SP 8-442].	
8303	F:Scan PGS/Size	[0 to 9999999/ 0 / 1]
	These SPs count by size the total number of pages scanned by the Fax application. Use these totals to compare original page size (scanning) and output page size [SP 8-443].	
8305	S:Scan PGS/Size	[0 to 9999999/ 1]
	These SPs count by size the total number of pages scanned by the Scan application. Use these totals to compare original page size (scanning) and output page size [SP 8-445].	
8306	L:Scan PGS/Size	[0 to 9999999/ 1]
	These SPs count by size the total number of pages scanned and stored from within the document server mode screen at the operation panel, and with the Store File button from within the Copy mode screen. Use these totals to compare original page size (scanning) and output page size [SP 8-446].	
830x 1	A3	
830x 2	A4	
830x 3	A5	
830x 4	B4	

Group 8000

830x 5	B5	
830x 6	DLT	
830x 7	LG	
830x 8	LT	
830x 9	HLT	
830x 10	Full Bleed	
830x 254	Other (Standard)	
830x 255	Other (Custom)	

8311	T:Scan PGS/Rez	[0 to 9999999/ 1]
	These SPs count by resolution setting the total number of pages scanned by applications that can specify resolution settings.	
8315	S:Scan PGS/Rez	[0 to 9999999/ 1]
	These SPs count by resolution setting the total number of pages scanned by applications that can specify resolution settings. Note: At the present time, 8311 and 8315 perform identical counts.	
831x 1	1200dpi to	
831x 2	600dpi to 1199dpi	
831x 3	400dpi to 599dpi	
831x 4	200dpi to 399dpi	
831x 5	to 199dpi	

- Copy resolution settings are fixed so they are not counted.
- The Fax application does not allow finely-adjusted resolution settings so no count is done for the Fax application.

8381	T:Total PrtPGS	<p>These SPs count the number of pages printed by the customer. The counter for the application used for storing the pages increments.</p> <p>[0 to 9999999/ 1]</p> <p>The L: counter counts the number of pages stored from within the document server mode screen at the operation panel. Pages stored with the Store File button from within the Copy mode screen go to the C: counter.</p>
8382	C:Total PrtPGS	
8383	F:Total PrtPGS	
8384	P:Total PrtPGS	
8385	S:Total PrtPGS	
8386	L:Total PrtPGS	
8387	O:Total PrtPGS	

- When the A3/DLT double count function is switched on with SP5104, 1 A3/DLT page is counted as 2.
- When several documents are merged for a print job, the number of pages stored are counted for the application that stored them.
- These counters are used primarily to calculate charges on use of the machine, so the following pages are not counted as printed pages:
 - Blank pages in a duplex printing job.
 - Blank pages inserted as document covers, chapter title sheets, and slip sheets.
 - Reports printed to confirm counts.
 - All reports done in the service mode (service summaries, engine maintenance reports, etc.)
 - Test prints for machine image adjustment.
 - Error notification reports.
 - Partially printed pages as the result of a copier jam.

8391	LSize PrtPGS	[0 to 9999999/ 1]
	<p>These SPs count pages printed on paper sizes A3/DLT and larger.</p> <p>Note: In addition to being displayed in the SMC Report, these counters are also displayed in the User Tools display on the copy machine.</p>	

Group 8000

8401	T:PrtPGS/LS	<p>These SPs count the number of pages printed from the document server. The counter for the application used to print the pages is incremented.</p> <p>The L: counter counts the number of jobs stored from within the document server mode screen at the operation panel.</p> <p>[0 to 9999999/ 1]</p>
8402	C:PrtPGS/LS	
8403	F:PrtPGS/LS	
8404	P:PrtPGS/LS	
8405	S:PrtPGS/LS	
8406	L:PrtPGS/LS	

- Print jobs done with Web Image Monitor and Desk Top Binder are added to the L: count.
- Fax jobs done with Web Image Monitor and Desk Top Binder are added to the F: count.

8411	Prints/Duplex	<p>This SP counts the amount of paper (front/back counted as 1 page) used for duplex printing. Last pages printed only on one side are not counted.</p> <p>[0 to 9999999/ 1]</p>
------	---------------	--

8421	T:PrtPGS/Dup Comb	[0 to 9999999/ 1]
	<p>These SPs count by binding and combine, and n-Up settings the number of pages processed for printing. This is the total for all applications.</p>	
8422	C:PrtPGS/Dup Comb	[0 to 9999999/ 1]
	<p>These SPs count by binding and combine, and n-Up settings the number of pages processed for printing by the copier application.</p>	
8423	F:PrtPGS/Dup Comb	[0 to 9999999/ 0 / 1]
	<p>These SPs count by binding and combine, and n-Up settings the number of pages processed for printing by the fax application.</p>	
8424	P:PrtPGS/Dup Comb	[0 to 9999999/ 1]

	These SPs count by binding and combine, and n-Up settings the number of pages processed for printing by the printer application.		
8425	S:PrtPGS/Dup Comb	[0 to 9999999/ 1]	
	These SPs count by binding and combine, and n-Up settings the number of pages processed for printing by the scanner application.		
8426	L:PrtPGS/Dup Comb	[0 to 9999999/ 1]	
	These SPs count by binding and combine, and n-Up settings the number of pages processed for printing from within the document server mode window at the operation panel.		
8427	O:PrtPGS/Dup Comb	[0 to 9999999/ 1]	
	These SPs count by binding and combine, and n-Up settings the number of pages processed for printing by Other applications		
842x 1	Simplex> Duplex		
842x 2	Duplex> Duplex		
842x 3	Book> Duplex		
842x 4	Simplex Combine		
842x 5	Duplex Combine		
842x 6	2>	2 pages on 1 side (2-Up)	
842x 7	4>	4 pages on 1 side (4-Up)	
842x 8	6>	6 pages on 1 side (6-Up)	
842x 9	8>	8 pages on 1 side (8-Up)	
842x 10	9>	9 pages on 1 side (9-Up)	
842x 11	16>	16 pages on 1 side (16-Up)	
842x 12	Booklet		
842x 13	Magazine		

Group 8000

- These counts (SP8421 to SP8427) are especially useful for customers who need to improve their compliance with ISO standards for the reduction of paper consumption.
- Pages that are only partially printed with the n-Up functions are counted as 1 page.
- Here is a summary of how the counters work for Booklet and Magazine modes:

Booklet		Magazine	
Original Pages	Count	Original Pages	Count
1	1	1	1
2	2	2	2
3	2	3	2
4	2	4	2
5	3	5	4
6	4	6	4
7	4	7	4
8	4	8	4

8431	T:PrtPGS/ImgEdt	[0 to 9999999/ 1]
	These SPs count the total number of pages output with the three features below, regardless of which application was used.	
8432	C:PrtPGS/ImgEdt	[0 to 9999999/ 1]
	These SPs count the total number of pages output with the three features below with the copy application.	
8434	P:PrtPGS/ImgEdt	[0 to 9999999/ 1]
	These SPs count the total number of pages output with the three features below with the print application.	

8436	L:PrtPGS/ImgEdt	[0 to 9999999/ 1]
	These SPs count the total number of pages output from within the document server mode window t the operation panel with the three features below.	
8437	O:PrtPGS/ImgEdt	[0 to 9999999/ 1]
	These SPs count the total number of pages output with the three features below with Other applications.	
843x 1	Cover/Slip Sheet	Total number of covers or slip sheets inserted. The count for a cover printed on both sides counts 2.
843x 2	Series/Book	The number of pages printed in series (one side) or printed as a book with booklet right/left pagination.
843x 3	User Stamp	The number of pages printed where stamps were applied, including page numbering and date stamping.

8441	T:PrtPGS/Ppr Size	[0 to 9999999/ 1]
	These SPs count by print paper size the number of pages printed by all applications.	
8442	C:PrtPGS/Ppr Size	[0 to 9999999/ 1]
	These SPs count by print paper size the number of pages printed by the copy application.	
8443	F:PrtPGS/Ppr Size	[0 to 9999999/ 0 / 1]
	These SPs count by print paper size the number of pages printed by the fax application.	
8444	P:PrtPGS/Ppr Size	[0 to 9999999/ 1]
	These SPs count by print paper size the number of pages printed by the printer application.	

Group 8000

8445	S:PrtPGS/Ppr Size	[0 to 9999999/ 1]
	These SPs count by print paper size the number of pages printed by the scanner application.	
8446	L:PrtPGS/Ppr Size	[0 to 9999999/ 1]
	These SPs count by print paper size the number of pages printed from within the document server mode window at the operation panel.	
8447	O:PrtPGS/Ppr Size	[0 to 9999999/ 1]
	These SPs count by print paper size the number of pages printed by Other applications.	
844x 1	A3	
844x 2	A4	
844x 3	A5	
844x 4	B4	
844x 5	B5	
844x 6	DLT	
844x 7	LG	
844x 8	LT	
844x 9	HLT	
844x 10	Full Bleed	
844x 100	A2	Not supported with this printer.
844x 101	B3	Not supported with this printer.
844x 254	Other (Standard)	
844x 255	Other (Custom)	

- These counters do not distinguish between LEF and SEF.

8451	PrtPGS/Ppr Tray		[0 to 9999999/ 1]
	These SPs count the number of sheets fed from each paper feed station.		
1	Bypass	Bypass Tray	
2	Tray 1	Copier	
3	Tray 2	Copier	
4	Tray 3	Paper Tray Unit (Option)	
5	Tray 4	Paper Tray Unit (Option)	
6	Tray 5	LCT (Option)	
7	Tray 6	Currently not used.	
8	Tray 7	Currently not used.	
9	Tray 8	Currently not used.	
10	Tray 9	Currently not used.	
11	Tray 10		
12	Tray 11		
13	Tray 12		
14	Tray 13		
15	Tray 14		
16	Tray 15		

Appendix:
Service
Program
Mode Table

Group 8000

8461	T:PrtPGS/Ppr Type	[0 to 9999999/ 1]
	<p>These SPs count by paper type the number pages printed by all applications.</p> <p>These counters are not the same as the PM counter. The PM counter is based on feed timing to accurately measure the service life of the feed rollers. However, these counts are based on output timing.</p> <p>Blank sheets (covers, chapter covers, slip sheets) are also counted.</p> <p>During duplex printing, pages printed on both sides count as 1, and a page printed on one side counts as 1.</p>	
8462	C:PrtPGS/Ppr Type	[0 to 9999999/ 1]
	<p>These SPs count by paper type the number pages printed by the copy application.</p>	
8463	F:PrtPGS/Ppr Type	[0 to 9999999/ 0 / 1]
	<p>These SPs count by paper type the number pages printed by the fax application.</p>	
8464	P:PrtPGS/Ppr Type	[0 to 9999999/ 1]
	<p>These SPs count by paper type the number pages printed by the printer application.</p>	
8466	L:PrtPGS/Ppr Type	[0 to 9999999/ 1]
	<p>These SPs count by paper type the number pages printed from within the document server mode window at the operation panel.</p>	
846x 1	Normal	
846x 2	Recycled	
846x 3	Special	
846x 4	Thick	
846x 5	Normal (Back)	
846x 6	Thick (Back)	

846x 7	OHP
846x 8	Other

8471	PrtPGS/Mag	[0 to 9999999/ 1]
	These SPs count by magnification rate the number of pages printed.	
1	to 49%	
2	50% to 99%	
3	100%	
4	101% to 200%	
5	201% to	

- Counts are done for magnification adjusted for pages, not only on the operation panel but performed remotely with an external network application capable of performing magnification adjustment as well.
- Magnification adjustments done with printer drivers with PC applications such as Excel are also counted.
- Magnification adjustments done for adjustments after they have been stored on the document server are not counted.
- Magnification adjustments performed automatically during Auto Reduce/Enlarge copying are counted.
- The magnification rates of blank cover sheets, slip sheets, etc. are automatically assigned a rate of 100%.

8481	T:PrtPGS/TonSave	These SPs count the number of pages printed with the Toner Save feature switched on. Note: These SPs return the same results as this SP is limited to the Print application. [0 to 9999999/ 1]
8484	P:PrtPGS/TonSave	

Group 8000

8491	T:PrtPGS/Col Mode	[0 to 9999999/ 1]
	These SPs count by color mode the total number of pages output by the Copy, document server, and Fax applications.	
8492	C:PrtPGS/Col Mode	[0 to 9999999/ 1]
	These SPs count by color mode the total output by the Copy application only	
8492	C:PrtPGS/Col Mode	[0 to 9999999/ 1]
	These SPs count by color mode the total output by the Copy application only	
8493	F:PrtPGS/Col Mode	[0 to 9999999/ 1]
	These SPs count by color mode the total output by the Fax application only	
8496	L:PrtPGS/Col Mode	[0 to 9999999/ 1]
	These SPs count by color mode the total output from within the document server mode window at the operation panel.	
8497	O:PrtPGS/Col Mode	[0 to 9999999/ 1]
849x 1	B/W	
849x 2	Single Color	Color MFP/2-color MFP machines only.
849x 3	Two Color	Color MFP/2-color MFP machines only.
849x 4	Full Color	Color MFP machines only

Notes for SP8491 to SP8496

- These SPs apply to the Copy, document server, and Fax applications only. They do not apply to the Print application.
- When the ACS feature is used to select the color settings automatically, the results of the ACS execute is used to increment the appropriate counter.
- If a color stamp is selected for printing on a monochrome document, the count is for B/W.
- If the output is black and white even if color print mode was selected, the pages count as Full Color.

- The color mode selected for a document stored on the document server is counted. (The color selection cannot be changed once the document is stored on the document server.)

8501	T:PrtPGS/Col Mode	[0 to 9999999/ 1]
	These SPs count by color mode the total number of pages printed.	
8504	P:PrtPGS/Col Mode	[0 to 9999999/ 1]
	These SPs count by color mode the number of pages printed with the Print application.	
8507	O:PrtPGS/Col Mode	[0 to 9999999/ 1]
These SPs count by color mode the number of pages printed with the other applications.		
1	B/W	
2	Mono Color	Color MFP and 2-Color MFP machines only.
3	Full Color	Color MFP and Color LP machines only.
4	Single Color	B081/D082 only
5	Two Color	B081/D082 only

- At the present time, 8501 and 8504 perform identical counts, because they are both limited to the Print application.

Group 8000

8511	T:PrtPGS/Emul	[0 to 9999999/ 1]	
	These SPs count by printer emulation mode the total number of pages printed.		
8514	P:PrtPGS/Emul	[0 to 9999999/ 1]	
	These SPs count by printer emulation mode the total number of pages printed.		
851x 1	RPCS		
851x 2	RPDL		
851x 3	PS3		
851x 4	R98		
851x 5	R16		
851x 6	GL/GL2		
851x 7	R55		
851x 8	RTIFF		
851x 9	PDF		
851x 10	PCL5e/5c		
851x 11	PCL XL		
851x 12	IPDL-C		
851x 13	BM-Links	Japan Only	
851x 14	Other		
851x 15	IPDS		

- SP8511 and SP8514 return the same results as they are both limited to the Print application.
- Print jobs output to the document server are not counted.

8521	T:PrtPGS/FIN	[0 to 9999999/ 1]	
	These SPs count by finishing mode the total number of pages printed by all applications.		
8522	C:PrtPGS/FIN	[0 to 9999999/ 1]	
	These SPs count by finishing mode the total number of pages printed by the Copy application.		
8523	F:PrtPGS/FIN	[0 to 9999999/ 1]	
	These SPs count by finishing mode the total number of pages printed by the Fax application.		
8524	P:PrtPGS/FIN	[0 to 9999999/ 1]	
	These SPs count by finishing mode the total number of pages printed by the Print application.		
8525	S:PrtPGS/FIN	[0 to 9999999/ 1]	
	These SPs count by finishing mode the total number of pages printed by the Scanner application.		
8526	L:PrtPGS/FIN	[0 to 9999999/ 1]	
	These SPs count by finishing mode the total number of pages printed from within the document server mode window at the operation panel.		
852x 1	Sort		
852x 2	Stack		
852x 3	Staple		
852x 4	Booklet		
852x 5	Z-Fold		
852x 6	Punch		
852x 7	Other		

Group 8000

806x 8	Inside Fold	Half-Fold (FM2) (Multi Fold Unit D394)
806x 9	Three-IN-Fold	Letter Fold-in (FM4) (Multi Fold Unit D394)
806x 10	Three-OUT-Fold	Letter Fold-out (FM3) (Multi Fold Unit D394)
806x 11	Four Fold	Double Parallel Fold (FM5) (Multi Fold Unit D394)
806x 12	KANNON-Fold	Gate Fold (FM6) (Multi Fold Unit D394)
806x 13	Perfect-Bind	Perfect Binder D391 Not Used
806x 14	Ring-Bind	Ring Binder D392

Note:

- If stapling is selected for finishing and the stack is too large for stapling, the unstapled pages are still counted.
- The counts for staple finishing are based on output to the staple tray, so jam recoveries are counted.

8531	Staples	This SP counts the amount of staples used by the machine. [0 to 9999999/ 1]
------	---------	--

8551	T: PrtBooks/FIN	
8552	O: PrtBooks/FIN	
8554	P: PrtBooks/FIN	
8556	L: PrtBooks/FIN	
1	Perfect-Bind	
2	Ring-Bind	

	T:Counter	[0 to 9999999/ 1]
8581	<p>These SPs count the total output broken down by color output, regardless of the application used. In addition to being displayed in the SMC Report, these counters are also displayed in the User Tools display on the copy machine.</p> <p>Note: These SPs are supported by color MFP and LP machines only.</p>	
1	Total	
2	Total: Full Color	
3	B&W/Single Color	
4	Development: CMY	
5	Development: K	
6	Copy: Color	
7	Copy: B/W	
8	Print: Color	
9	Print: B/W	
10	Total: Color	
11	Total: B/W	
12	Full Color: A3	
13	Full Color: B4 JIS or smaller	
14	Full Color Print	
15	Mono Color Print	
16	Full Color GPC	
17	Twin Color Mode Print	
18	Full Color Print (Twin)	

Group 8000

19	Mono Color Print (Twin)
20	Full Color Total (CV)
21	Mono Color Total (CV)
22	Full Color Print (CV)

8582	C:Counter	[0 to 9999999/ 1]		
	<p>These SPs count the total output broken down by color output for the Copy application only.</p> <p>Note: These SPs are supported by color copy MFP machines only.</p> <p>These counters are displayed in the SMC Report, and in the User Tools display on the copy machine.</p>			
1	B/W			
2	Single Color			
3	Two Color			
4	Full Color			

8583	F:Counter	[0 to 9999999/ 1]		
	<p>These SPs count the total output broken down by color output for the Fax application only.</p> <p>These SPs is supported by color copy MFP machines only.</p> <p>These counters are displayed in the SMC Report, and in the User Tools display on the copy machine.</p>			
1	B/W			
2	Single Color			

8584	P:Counter		[0 to 9999999/ 1]
	<p>These SPs count the total output broken down by color output for the Print application only. These counters are displayed in the SMC Report, and in the User Tools display on the copy machine.</p> <p>Note: These SPs are supported by color MFP and LP machines only.</p>		
1	B/W		
2	Mono Color		
3	Full Color		
4	Single Color		
5	Two Color		

8586	L:Counter		[0 to 9999999/ 1]
	<p>These SPs count the total output broken down by color for output from within the document server mode window at the operation panel. These counters are displayed in the SMC Report, and in the User Tools display on the copy machine.</p> <p>Note: These SPs are supported only by color copy MFP machines only with the fax application installed.</p>		
		MFP Color	Replaced:
1	B/W	Yes	---
2	Single Color	Yes	---
3	Two Color	Yes	---
4	Single Color	Yes	---

Appendix:
Service
Program
Mode Table

Group 8000

8591	O:Counter		[0 to 9999999/ 1]
	These SPs count the totals for A3/DLT paper use, number of duplex pages printed, and the number of staples used. These totals are for Other (O:) applications only.		
1	A3/DLT		
2	Duplex		

8601	Coverage Counter		
1	B/W		
2	Color		
11	B/W Printing Pages		
12	Color Printing Pages		
21	Coverage Counter 1		
22	Coverage Counter 2		
23	Coverage Counter 3		

8617	SDK Apli Counter		
1	SDK-1		
2	SDK-2		
3	SDK-3		
4	SDK-4		
5	SDK-5		
6	SDK-6		

8621	Func Use Counter DFU
1 to 64	Function 001 to Function 064

8631	T:FAX TX PGS	[0 to 9999999/ 0 / 1]
	These SPs count by color mode the number of pages sent by fax to a telephone number.	
8633	F:FAX TX PGS	[0 to 9999999/ 0 / 1]
	These SPs count by color mode the number of pages sent by fax to a telephone number.	
1	BW	
2	Color	

- If a document has color and black-and-white pages mixed, the pages are counted separately as B/W or Color.
- At the present time, this feature is provided for the Fax application only so SP8631 and SP8633 are the same.
- The counts include error pages.
- If a document is sent to more than one destination with a Group transmission, the count is done for each destination.
- Polling transmissions are counted but polling RX are not.
- Relay, memory, and confidential mailbox transmissions and are counted for each destination.

Group 8000

8641	T:FAX TX PGS	[0 to 9999999/ 0 / 1]
	These SPs count by color mode the number of pages sent by fax to as fax images using I-Fax.	
8643	F:FAX TX PGS	[0 to 9999999/ 0 / 1]
	These SPs count by color mode the number of pages sent by Fax as fax images using I-Fax.	
1	BW	
2	Color	

- counted separately as B/W or Color.
- At the present time, this feature is provided for the Fax application only so SP8641 and SP8643 are the same.
- The counts include error pages.
- If a document is sent to more than one destination with a Group transmission, the count is done for each destination.
- Polling transmissions are counted but polling RX are not.
- Relay, memory, and confidential mailbox transmissions and are counted for each destination.

8651	T:S-to-Email PGS	[0 to 9999999/ 1]
	These SPs count by color mode the total number of pages attached to an e-mail for both the Scan and document server applications.	
1	B/W	
2	Color	Supported by Color MFP machines only.
8655	S:S-to-Email PGS	[0 to 9999999/ 1]
	These SPs count by color mode the total number of pages attached to an e-mail for the Scan application only.	
1	B/W	

2	Color	Supported by Color MFP machines only.
---	-------	---------------------------------------

Notes

- The count for B/W and Color pages is done after the document is stored on the HDD. If the job is cancelled before it is stored, the pages are not counted.
- If Scan-to-Email is used to send a 10-page document to 5 addresses, the count is 10 (the pages are sent to the same SMTP server together).
- If Scan-to-PC is used to send a 10-page document to 5 folders, the count is 50 (the document is sent to each destination of the SMB/FTP server).
- Due to restrictions on some devices, if Scan-to-Email is used to send a 10-page document to a large number of destinations, the count may be divided and counted separately. For example, if a 10-page document is sent to 200 addresses, the count is 10 for the first 100 destinations and the count is also 10 for the second 100 destinations, for a total of 20.).

8661	T:Deliv PGS/Svr		[0 to 9999999/ 1]
	These SPs count by color mode the total number of pages sent to a Scan Router server by both Scan and LS applications.		
1	B/W		
2	Color	Supported by Color MFP machines only.	
8665	S:Deliv PGS/Svr		[0 to 9999999/ 1]
	These SPs count by color mode the total number of pages sent to a Scan Router server by the Scan application.		
1	B/W		
2	Color	Supported by Color MFP machines only.	

Appendix:
Service
Program
Mode Table

Group 8000

Notes

- The B/W and Color counts are done after the document is stored on the HDD of the Scan Router server.
- If the job is canceled before storage on the Scan Router server finishes, the counts are not done.
- The count is executed even if regardless of confirmation of the arrival at the Scan Router server.

8671	T:Deliv PGS/PC		[0 to 9999999/ 1]
	These SPs count by color mode the total number of pages sent to a folder on a PC (Scan-to-PC) with the Scan and LS applications.		
1	B/W		
2	Color	Supported by Color MFP machines only.	
8675	S:Deliv PGS/PC		[0 to 9999999/ 1]
	These SPs count by color mode the total number of pages sent with Scan-to-PC with the Scan application.		
1	B/W		
2	Color	Supported by Color MFP machines only.	

8681	T:PCFAX TXPGS	These SPs count the number of pages sent by PC Fax. These SPs are provided for the Fax application only, so the counts for SP8681 and SP8683 are the same. [0 to 9999999/ 0 / 1]
8683	F:PCFAX TXPGS	

- This counts pages sent from a PC using a PC fax application, from the PC through the copier to the destination.
- When sending the same message to more than one place using broadcasting, the pages are only counted once. (For example, a 10-page fax is sent to location A and location B. The counter goes up by 10, not 20.)

8691	T:TX PGS/LS	<p>These SPs count the number of pages sent from the document server. The counter for the application that was used to store the pages is incremented.</p> <p>[0 to 9999999/ 1]</p> <p>The L: counter counts the number of pages stored from within the document server mode screen at the operation panel. Pages stored with the Store File button from within the Copy mode screen go to the C: counter.</p>
8692	C:TX PGS/LS	
8693	F:TX PGS/LS	
8694	P:TX PGS/LS	
8695	S:TX PGS/LS	
8696	L:TX PGS/LS	

Notes

- Print jobs done with Web Image Monitor and Desk Top Binder are added to the count.
- If several documents are merged for sending, the number of pages stored are counted for the application that stored them
- When several documents are sent by a Fax broadcast, the F: count is done for the number of pages sent to each destination.

Appendix:
Service
Program
Mode Table

8701	TX PGS/Port	[0 to 9999999/ 1]	
	<p>These SPs count the number of pages sent by the physical port used to send them. For example, if a 3-page original is sent to 4 destinations via ISDN G4, the count for ISDN (G3, G4) is 12.</p>		
1	PSTN-1		
2	PSTN-2		
3	PSTN-3		
4	ISDN (G3,G4)		
5	Network		

Group 8000

8711	T:Scan PGS/Comp		[0 to 9999999/ 1]
	These SPs count the number of compressed pages scanned into the document server, counted by the formats slisted below.		
1	JPEG/JPEG2000		
2	TIFF (Multi/Single)		
3	PDF		
4	Other		
5	PDF/Comp		

8715	S:Scan PGS/Comp		[0 to 9999999/ 1]
	These SPs count the number of compressed pages scanned by the scan application, counted by the formats slisted below.		
1	JPEG/JPEG2000		
2	TIFF (Multi/Single)		
3	PDF		
4	Other		
5	PDF/Comp		

8721	T: Deliv PGS/WSD		
8725	S: Deliv PGS/WSD		
8731	T: Scan PGS/Media		
8735	S: Scan PGS/Media		
1	B/W		
2	Color		

8741	RX PGS/Port	[0 to 9999999/ 1]	
	These SPs count the number of pages received by the physical port used to receive them.		
1	PSTN-1		
2	PSTN-2		
3	PSTN-3		
4	ISDN (G3,G4)		
5	Network		

8771	Dev Counter	[0 to 9999999/ 1]	
	<p>These SPs count the frequency of use (number of rotations of the development rollers) for black and other color toners.</p> <p>Note: For machines that do not support color, the Black toner count is the same as the Total count.</p>		
1	Total	All toners (YMCK)	
2	K	Black toner	
3	Y	Yellow toner	
4	M	Magenta toner	
5	C	Cyan toner	
6	R	Red toner (Wide Format A2 machines only)	

Appendix:
Service
Program
Mode Table

Group 8000

8781	Toner Use Count: Color		[0 to 65 535]
	These SPs count the frequency of use (number of rotations of the development rollers) for black and other color toners.		
1	BK	Black toner	
2	Y	Yellow toner	
3	M	Magenta toner	
4	C	Cyan toner	

8791	LS Memory Remain		
This SP displays the percent of space available on the document server for storing documents. [0 to 100/ 1]			

8801	Toner Remain		[0 to 100/ 1]
	This SP displays the percent of toner remaining for each color. This SP allows the user to check the toner supply at any time. Note: This precise method of measuring remaining toner supply (1% steps) is better than other machines in the market that can only measure in increments of 10 (10% steps).		
1	K	Black.	Supported by B/W, Color, Wide Format A2, Wide Format Roll machines.
2	Y	Yellow	Color machines only.
3	M	Magenta	
4	C	Cyan	
5	R	R	Wide Format A2 machines only.

8851	Toner Coverage 0-10%		[0 to 65 535]
	These SPs count the percentage of dot coverage for black other color toners.		
11	0-2%: BK		
12	0-2%: Y		
13	0-2%: M		
14	0-2%: C		
21	3-4%: BK		
22	3-4%: Y		
23	3-4%: M		
24	3-4%: C		
31	5-7%: BK		
32	5-7%: Y		
33	5-7%: M		
34	5-7%: C		
41	8-10%: BK		
42	8-10%: Y		
43	8-10%: M		
44	8-10%: C		

Appendix:
Service
Program
Mode Table

Group 8000

8861	Toner Coverage 11-20%		[0 to 65 535]	
	These SPs count the percentage of dot coverage for black other color toners.			
8871	Toner Coverage 21-30%		[0 to 65 535]	
	These SPs count the percentage of dot coverage for black other color toners.			
8881	Toner Coverage 31 -%		[0 to 65 535]	
	These SPs count the percentage of dot coverage for black other color toners.			
8891	Pages: Current Toner		[0 to 65 535]	
	These SPs count the number of pages for the current set toner.			
8901	Page/Toner_Prev1 DFU			
8911	Page/Toner_Prev2 DFU			
1	BK	Black toner		
2	Y	Yellow toner		
3	M	Magenta toner		
4	C	Cyan toner		

8921	Cvr Cnt/Total	
1	Coverage (%): BK	
2	Coverage (%): Y	
3	Coverage (%): M	
4	Coverage (%): C	
11	Coverage/P: BK	
12	Coverage/P: Y	
13	Coverage/P: M	
14	Coverage/P: C	

8941	Machine Status	[0 to 9999999/ 1]
	These SPs count the amount of time the machine spends in each operation mode. These SPs are useful for customers who need to investigate machine operation for improvement in their compliance with ISO Standards.	
1	Operation Time	Engine operation time. Does not include time while controller is saving data to HDD (while engine is not operating).
2	Standby Time	Engine not operating. Includes time while controller saves data to HDD. Does not include time spent in Energy Save, Low Power, or Off modes.
3	Energy Save Time	Includes time while the machine is performing background printing.
4	Low Power Time	Includes time in Energy Save mode with Engine on. Includes time while machine is performing background printing.

Group 8000

5	Off Mode Time	Includes time while machine is performing background printing. Does not include time machine remains powered off with the power switches.
6	SC	Total down time due to SC errors.
7	PrtJam	Total down time due to paper jams during printing.
8	OrgJam	Total down time due to original jams during scanning.
9	Supply PM Unit End	Total down time due to toner end.

8951	AddBook Register		
	These SPs count the number of events when the machine manages data registration.		
1	User Code	User code registrations.	[0 to 9999999/ 1]
2	Mail Address	Mail address registrations.	
3	Fax Destination	Fax destination registrations.	
4	Group	Group destination registrations.	
5	Transfer Request	Fax relay destination registrations for relay TX.	
6	F-Code	F-Code box registrations.	
7	Copy Program	Copy application registrations with the Program (job settings) feature.	[0 to 255 / 255]
8	Fax Program	Fax application registrations with the Program (job settings) feature.	

9	Printer Program	Printer application registrations with the Program (job settings) feature.	
10	Scanner Program	Scanner application registrations with the Program (job settings) feature.	

8999	Admin Counter List		
1	Total		
2	Copy: Full Color		
3	Copy: BW		
4	Copy: Single Color		
5	Copy: Two Color		
6	Printer: Full Color		
7	Printer: BW		
8	Printer: Single Color		
9	Printer: Two Color		
10	Fax Print: BW		
11	Fax Print: Single Color		
12	A3/DLT		
13	Duplex		
14	Coverage: Color (%)		
15	Coverage: BW (%)		
16	Coverage: Color Print Page		
17	Coverage: BW Print Page		

Appendix:
Service
Program
Mode Table

Group 8000

20	Full Color: GPC	
101	Transmission Total: Color	
102	Transmission Total: BW	
103	Fax Transmission	
104	Scanner Transmission: Color	
105	Scanner Transmission: BW	

4.10 PRINTER, SCANNER SP TABLES

4.10.1 PRINTER SERVICE MODE

SP1-XXX (Service Mode)

1001	Bit Switch			
001	Bit Switch 1		0	1
	bit 0	DFU	-	-
bit 1	DFU	-	-	
bit 2	DFU	-	-	
	bit 3	No I/O Timeout	0: Disable	1: Enable
		Enable: The MFP I/O Timeout setting will have no effect. I/O Timeouts will never occur.		
	bit 4	SD Card Save Mode	0: Disable	1: Enable
		Enable: Print jobs will be saved to an SD Card in the GW SD slot.		
	bit 5	DFU	-	-
bit 6	DFU	-	-	
bit 7	DFU	-	-	

1001	Bit Switch			
002	Bit Switch 2		0	1
	bit 0	DFU	-	-
bit 1	DFU	-	-	
	bit 2	Applying a Collate Type	0: Shift Collate	1: Normal Collate

Printer, Scanner SP Tables

		<p>A collate type (shift or normal) will be applied to all jobs that do not explicitly define a collate type.</p> <p>Note: If BitSwitch 5-0 is enabled, this BitSwitch has no effect.</p>		
	bit 3	[PCL5e/c,PS]: PDL Auto Switching	0: Enable	1: Disable
		<p>Disable: The MFPs ability to change the PDL processor mid-job.</p> <p>Some host systems submit jobs that contain both PS and PCL5e/c. If Auto PDL switching is disabled, these jobs will not be printed properly.</p>		
	bit 4	DFU	-	-
bit 5	DFU	-	-	
bit 6	DFU	-	-	
	bit 7	Switch dither	0: Use normal dither	1: Use alternative dither
		Please refer to RTB#RD014018.		

1001	Bit Switch			
003	Bit Switch 3		0	1
	bit 0	DFU	-	-
bit 1	DFU	-	-	
	bit 2	[PCL5e/c]: Legacy HP compatibility	0: Disable	1: Enable
		<p>Enable: Uses the same left margin as older HP models such as HP4000/HP8000.</p> <p>In other words, the left margin defined in the job (usually "<ESC>*r0A") will be changed to "<ESC>*r1A"</p>		
	bit 3	DFU	-	-
bit 4	DFU	-	-	
bit 5	DFU	-	-	

bit 6	DFU	-	-	
bit 7	DFU	-	-	

1001	Bit Switch			
004	Bit Switch 4 DFU	-	-	

1001	Bit Switch			
005	Bit Switch 5	0	1	
		Show "Collate Type", "Staple Type" and "Punch Type" buttons on the operation panel.		
		0: Disable	1: Enable	
	bit 0	<p>If enabled, users will be able to configure a Collate Type, Staple Type, and Punch Type from the operation panel. The available Types will depend on the device and configured options.</p> <p>After enabling this BitSw, the settings will appear under: "User Tools > Printer Features > System"</p>		
	bit 1	Multiple copies if a paper size or type mismatch occurs		
		0: Disable (Single copy)	1: Enable (Multiple copy)	
		<p>If a paper size or type mismatch occurs during the printing of multiple copies, only a single copy is output by default. Using this BitSw, the device can be configured to print all copies even if a paper mismatch occurs.</p>		
	bit 2	Prevent SDK applications from altering the contents of a job.		
		0: Disable	1: Enable	
		<p>If this BitSw is enabled, SDK applications will not be able to alter print data. This is achieved by preventing SDK applications from accessing a module called the "GPS Filter".</p> <p>Note: The main purpose of this BitSw is for troubleshooting the effects of SDK applications on data.</p>		

Appendix:
Service
Program
Mode Table

Printer, Scanner SP Tables

	bit 3	[PS] PS Criteria	0: Pattern3	1: Pattern1
		<p>Change the number of PS criterion used by the PS interpreter to determine whether a job is PS data or not.</p> <p>Pattern3: includes most PS commands.</p> <p>Pattern1: A small number of PS tags and headers</p>		
	bit 4	Increase max number of the stored jobs to 1000 jobs.	0: Disable (100)	1: Enable (1000)
		<p>Enable: Changes the maximum number of jobs that can be stored on the HDD via Job Type settings to 1000. The default is 100.</p>		
	bit 5	Face-up output	0: Disable	1: Enable (Face-up)
		<p>All print jobs will be output face-up in the destination tray.</p>		
	bit 6	Method for determining the image rotation for the edge to bind on.	0: Disable	1: Enable
		<p>If enabled, the image rotation will be performed as they were in the specifications of older models for the binding of pages of mixed orientation jobs.</p> <p>The old models are below:</p> <ul style="list-style-type: none"> - PCL: Pre-04A models - PS/PDF/RPCS:Pre-05S models 		
	bit 7	DFU	-	-

1001	Bit Switch		
006	Bit Switch 6 DFU	-	-

1001	Bit Switch		
007	Bit Switch 7	0	1
		Print path	0: Disable 1: Enable
	bit 0	If enabled, simplex pages (in mixed simplex/duplex PS/PCL5 jobs only) and the last page of an odd paged duplex job (PS, PCL5, PCL6), are always routed through the duplex unit. Not having to switch paper paths increases the print speed slightly.	
	bit 1 to 7	DFU	- -

Appendix:
Service
Program
Mode Table

1001	Bit Switch		
008	Bit Switch 8	0	1
	bit 0 to 2	DFU	- -
	bit 3	[PCL,PS]: Allow BW jobs to print without requiring User Code	0: Disable 1: Enable (allow BW jobs to print without a user code)
		BW jobs submitted without a user code will be printed even if user code authentication is enabled. Note: Color jobs will not be printed without a valid user code.	
	bit 4 to 7	DFU	- -

1001	Bit Switch			
009	Bit Switch 9		0	1
	bit 0	PDL Auto Detection timeout of jobs submitted via USB or Parallel Port (IEEE 1284).	0: Disable (Immediately)	1: Enable (10 seconds)
		To be used if PDL auto-detection fails. A failure of PDL auto-detection does not necessarily mean that the job cannot be printed. This bit switch tells the device whether to time-out immediately (default) upon failure or to wait 10 seconds.		
	bit 1	DFU	-	-
	bit 2	Job Cancel	Disable (Not cancelled)	Enable (Cancelled)
		If this bit switch, all jobs will be cancelled after a jam occurs. Note: If this bitsw is enabled, printing under the following conditions might result in problems: - Job submission via USB or Parallel Port - Spool printing (WIM >Configuration > Device Settings > System)		
	bit 3	DFU	-	-
⇒	bit 4	Timing of the PjL Status ReadBack (JOB END) when printing multiple collated copies.		
		This bitsw determines the timing of the PjL USTATUS JOB END sent when multiple collated copies are being printed. 0 (default): JOB END is sent by the device to the client after the first copy has completed printing. This causes the page counter to be incremented after the first copy and then again at the end of the job. 1: JOB END is sent by the device to the client after the last copy has finished printing. This causes the page counter to be incremented at the end of each job.		
	bit 5 to 7	DFU	-	-

1003	Clear Setting
1	Initialize Printer System
	Initializes settings in the "System" menu of the user mode.
3	Delete Program
	*This SP is for Japan model only.

1004	Print Summary
	Prints the service summary sheet (a summary of all the controller settings).

1005	Display Version
	Displays the version of the printer application.

1006	Sample/Locked Print
	Enables and disables the document server. When you select "0," the document server is enabled or disabled in accordance with Copy Service Mode SP5-967. When you select "1," the document server is enabled regardless of Copy Service Mode SP5-967. 0: Linked, 1: On

1101	Data Recall	
	Recalls a set of gamma settings. This can be either a) the factory setting, b) the previous setting, or c) the current setting.	
1	Factory	
2	Previous	

3	Current	
4	ACC	

1102	Resolution Setting	
	Selects the printing mode (resolution) for the printer gamma adjustment. 2400x600 Photo, 1800x600 Photo, 600 x 600 Photo, 2400x600 Text, 1800x600, Text, 600x600 Text	

1103	Test Page	
	Prints the test page to check the color balance before and after the gamma adjustment.	
1	Color Gray Scale	
2	Color Pattern	

1104	Gamma Adjustment	
	Adjusts the printer gamma for the mode selected in the "Mode Selection" menu.	
1	Black: Highlight	[0 to 30 / 15 / 1/step]
2	Black: Shadow	
3	Black: Middle	
4	Black: IDmax	
21	Cyan: Highlight	
22	Cyan: Shadow	
23	Cyan: Middle	

24	Cyan: IDmax	
41	Magenta: Highlight	
42	Magenta: Shadow	
43	Magenta: Middle	
44	Magenta: IDmax	
61	Yellow: Highlight	
62	Yellow: Shadow	
63	Yellow: Middle	
64	Yellow: IDmax	

1105	Save Tone Control Value
	Stores the print gamma adjusted with the "Gamma Adj." menu item as the current setting. Before the machine stores the new "current setting", it moves the data currently stored as the "current setting" to the "previous setting" memory storage location.

1106	Toner Limit DFU
	Adjusts the maximum toner amount for image development. [100 to 400 / 260 / 1 %/step]

Appendix:
Service
Program
Mode Table

4.10.2 SCANNER SERVICE MODE

SP1XXX System and Others

1001	Scan Nv Version
	Displays the scanner firmware version stored in NVRAM in a 9-digit format: Func. Name_Model Name_History No.

	Compression Type
1004	Selects the compression type for binary picture processing. [1-3/1/1] 1: MH, 2: MR, 3: MMR

	Erase Margin (Remote Scan)
1005	Creates an erase margin for all edges of the scanned image. If the machine has scanned the edge of the original, create a margin. [0 to 5/0/1 mm]

	Remote Scan Disable
1009	This SP switches the TWAIN scanner function on/off. This is one of the scanner application functions. [0 to 1 / 0 / 1] 0: ON (enabled- 1: OFF (disabled)

1010	Non Display Clear Light PDF
	<p>This SP switches the Clear Light PDF display off/on. [0 to 1 / 0 / 1] 0: Display ON 1: Display OFF</p>

1011	Org Count Display
	<p>This SP codes switches the original count display on/off. [0 to 1 / 0 / 1] 0: OFF (no display) 1: ON (count displays)</p>

1012	User Info Release
	<p>This SP code sets the machine to release or not release the following items at job end]</p> <ul style="list-style-type: none"> ▪ Destination (E-mail/Folder/CS) ▪ Sender name ▪ Mail Text ▪ Subject line ▪ File name <p>[0 to 1 / 1 / 1] 1: Release 0: Do not release</p>

1013	Multi Media Func
	<p>This SP code enables/disables the multi-media function. [0 to 1 / 0 / 1] 0: Disable 1: Enable</p>

Appendix:
Service
Program
Mode Table

SP2XXX Scanning Image Quality

2021	Compression Level (Gray-scale)	
	Selects the compression ratio for grayscale processing mode (JPEG) for the three settings that can be selected at the operation panel.	
1	Comp1: 5-95	[5 to 95 / 40 / 1 /step]
2	Comp2: 5-95	[5 to 95 / 50 / 1 /step]
3	Comp3: 5-95	[5 to 95 / 30 / 1 /step]
4	Comp4: 5-95	[5 to 95 / 60 / 1 /step]
5	Comp5: 5-95	[5 to 95 / 20 / 1 /step]

2024	Compression ratio of ClearLight PDF	
	Selects the compression ratio for Clear Light PDF for the two settings that can be selected at the operation panel.	
1	Compression Ratio (Normal image)	[5 to 95 / 25 / 1 /step]
2	Compression Ratio (High comp image)	[5 to 95 / 20 / 1 /step]

2025	Compression ratio of Clear Light PDF JPEG2000	
	Selects the compression ratio for Clear Light PDF (JPEG2000) for the two settings that can be selected at the operation panel.	
1	Compression Ratio (Normal image) JPEG2000	[5 to 95 / 25 / 1 /step]
2	Compression Ratio (High comp image) JPEG2000	[5 to 95 / 20 / 1 /step]

⇒ 4.11 COPIER INPUT/OUTPUT CHECK

4.11.1 COPIER INPUT CHECK: SP5803

This procedure allows you to test sensors and other components of the machine. After you select one of the categories below by number, you will see a small 8-bit table with the number of the bit and its current setting (0 or 1). The bits are numbered 0 to 7, reading right to left.

1. Enter the SP mode and select SP5803.
2. Enter the number (1 to 13) for the item that you want to check. A small box will be displayed on the SP mode screen with a series of 0's and 1's.

The meaning of the display is as follows.

Bit	7 6 5 4 3 2 1 0
Setting	1 1 0 0 1 0 1 0

3. Check the status of each item against the corresponding bit numbers listed in the table below.

5803	Input Check	Bit		
	Use these SPs to do the input check for the electrical components of the main machine.			
-001	Paper Feed 1	7	Front Side Fence Open Sensor	0: Off 1:On
		6	Rear Side Fence Open Sensor	0: Off 1:On
		5	Front Side Fence Close Sensor	0: Off 1:On
		4	Rear Side Fence Close Sensor	0: Off 1:On
		3	Tandem Tray Near End Sensor	See Table Below ("Tandem Tray Paper Height Sensors")
		2	Tandem Tray Paper Height Sensor1	
		1	Tandem Tray Paper Height Sensor2	
		0	Tandem Tray Paper Height Sensor3	

Tandem Tray Paper Height Sensors

The percentage below shows remaining amount of paper.

	100%		50%		30%		10%	
Near End	0	0	0	0	0	0	1	1
Paper Height1	0	0	0	0	1	1	1	0
Paper Height2	0	0	1	1	1	0	0	0
Paper Height3	0	1	1	0	0	0	0	0

-002	Paper Feed 2	7	Tandem Tray Left Paper Detection	0:Not Set 1:Set
		6	Tandem Tray Right Paper Detection	0:Not Set 1:Set
		5	Tandem Transport Fence HP Sensor	0: Off 1:On
		4	Tandem Transport Fence Push Sensor	0: Off 1:On
		3	Tandem Tray Right Bottom Plate Sensor	0: Off 1:On
		2	Tandem Tray Left Paper End Sensor	0:Not Detected 1:Detected
		1	Not Used	-
		0	Tray Type Detection	Always "0"

-003	Paper Feed 3	7	2nd Tray Paper Size Detection 1	See Table Below ("Paper Size Table")
		6	2nd Tray Paper Size Detection 2	
		5	2nd Tray Paper Size Detection 3	
		4	2nd Tray Paper Size Detection 4	
		3	2nd Tray Paper Size Detection 5	
		2	Not Used	-
		1	Not Used	-
		0	Not Used	-

-004	Paper Feed 4	7	3rd Tray Paper Size Detection 1	See Table Below ("Paper Size Table")
		6	3rd Tray Paper Size Detection 2	
		5	3rd Tray Paper Size Detection 3	
		4	3rd Tray Paper Size Detection 4	
		3	3rd Tray Paper Size Detection 5	
		2	Not Used	-
		1	Not Used	-
		0	Not Used	-

Paper Size Table

Paper Size	Bit 7	Bit 6	Bit 5	Bit 4	Bit 3
12"x18"	1	1	1	1	1
A3	1	1	0	0	1
B4	1	0	0	1	1
A4SEF	0	1	0	0	1
A4LEF	1	1	0	0	0
B5SEF	1	0	1	0	1
B5LEF	0	0	0	1	1
A5SEF	1	1	1	0	1
A5LEF	0	1	1	0	1
11"x17"	1	1	1	0	0
8.5"x14"	1	0	1	1	0
LTSEF	1	1	0	1	0
LTLEF	0	1	1	0	0
HLTSEF	0	1	1	1	0
HLTLEF	1	1	1	1	0
8.5"x13"	1	1	0	1	1
8.25"x13"	0	1	0	1	1
8"x13"	0	1	1	1	1
7.25"x10.5"SEF	1	0	1	0	0
7.25"x10.5"LEF	0	0	1	1	1
8KSEF	0	0	1	1	0
16KSEF	1	0	0	1	0
16KLEF	1	0	1	1	1

-005	Paper Feed 5	7	Not Used	-
		6	Not Used	-
		5	2nd Tray Paper Detection	See table below ("Paper Height, Near End")
		4	3rd Tray Paper Detection	
		3	Not Used	-
		2	Not Used	-
		1	2nd Tray Paper Near End Detection	See table below ("Paper Height, Near End Table")
		0	3rd Tray Paper Near End Detection	

Paper Height, Near End Table

	100%	50%	30%	10%
Paper Height	0	1	1	0
Near End	0	0	1	1

-006	Paper Feed 6	7	1st Tray Upper Limit Sensor	0:Upper Limit 1:Not Upper Limit
		6	Not Used	-
		5	2nd Tray Upper Limit Sensor	0:Upper Limit 1:Not Upper Limit
		4	3rd Tray Upper Limit Sensor	0:Upper Limit 1:Not Upper Limit
		3	1st Tray Paper End Detection	0:Not Detected 1:Detected
		2	Not Used	-
		1	2nd Tray Paper End Detection	0:Not Detected 1:Detected
		0	3rd Tray Paper End Detection	0:Not Detected 1:Detected

-007	Paper Feed 7	7	1st Feed Sensor	0:Paper Not Detected 1:Paper Detected
		6	Not Used	-
		5	2nd Feed Sensor	0:Paper Not Detected 1:Paper Detected
		4	3rd Feed Sensor	0:Paper Not Detected 1:Paper Detected
		3	1st Vertical Transport Sensor	0:Paper Not Detected 1:Paper Detected
		2	Not Used	-
		1	2nd Vertical Transport Sensor	0:Paper Not Detected 1:Paper Detected
		0	3rd Vertical Transport Sensor	0:Paper Not Detected 1:Paper Detected

-008	Paper Trans 1	7	Duplex Transport Sensor: Left	0:Paper Not Detected 1:Paper Detected
		6	Duplex Transport Sensor: Middle	0:Paper Not Detected 1:Paper Detected
		5	Duplex Transport Sensor: Right	0:Paper Not Detected 1:Paper Detected
		4	Duplex Exit Sensor	0:Paper Not Detected 1:Paper Detected
		3	Duplex Entrance Sensor	0:Paper Not Detected 1:Paper Detected
		2	Not Used	-
		1	Not Used	-
		0	Not Used	-

-009	Paper Trans 2	7	Not Used	-
		6	Relay Sensor	0:Paper Not Detected 1:Paper Detected
		5	Registration Sensor	0:Paper Not Detected 1:Paper Detected
		4	Opening-Closing Guide Sensor	0:Open 1:Close
		3	Not Used	-
		2	Paper Exit: Exit Sensor	0:Paper Not Detected 1:Paper Detected
		1	Paper Exit: Relay Sensor	0:Paper Not Detected 1:Paper Detected
		0	Not Used	-

-010	Paper Trans 3	7	Paper Exit Tray Sensor	0:Not Full 1:Full
		6	Not Used	-
		5	Fusing: Paper Detection Sensor	0:Paper Not Detected 1:Paper Detected
		4	Fusing Exit Sensor	0:Paper Not Detected 1:Paper Detected
		3	Fusing Pressure Sensor	0:OFF 1:ON
		2	Not Used	-
		1	Not Used	-
		0	Not Used	-

-011	Paper Trans 4	7	DFU	-
		6	DFU	-
		5	DFU	-
		4	DFU	-
		3	Bypass Paper End Detection	0:Paper Detected 1:Paper Not Detected
		2	Not Used	-
		1	Not Used	-
		0	Not Used	-

-012	Paper Trans 5	7	LCT Feed Sensor	0:Paper Detected 1:Paper Not Detected
		6	LCT Transport Sensor	0:Paper Detected 1:Paper Not Detected
		5	LCT Exit Sensor	0:Paper Detected 1:Paper Not Detected
		4	LCT Upper Cover Open Detection SW	0:Close 1:Open
		3	LCT Transport Cover Open Detection SW	0:Close 1:Open
		2	Not Used	-
		1	Not Used	-
		0	Not Used	-

Appendix:
Service
Program
Mode Table

COPIER INPUT/OUTPUT CHECK

Rev. 09/14/2010

-013	Paper Trans 6	7	Not Used	-
		6	Not Used	-
		5	Not Used	-
		4	Not Used	-
		3	Not Used	-
		2	Not Used	-
		1	Not Used	-
		0	Not Used	-

-014	Drum Motor Lock	7	Y Drum Motor Lock	0:Normal 1:Lock
		6	C Drum Motor Lock	0:Normal 1:Lock
		5	M Drum Motor Lock	0:Normal 1:Lock
		4	Bk Drum Motor Lock	0:Normal 1:Lock
		3	Not Used	-
		2	Not Used	-
		1	Not Used	-
		0	Not Used	-

-015	Development Motor Lock	7	Y Development Motor Lock	0:Normal 1:Lock
		6	C Development Motor Lock	0:Normal 1:Lock
		5	M Development Motor Lock	0:Normal 1:Lock
		4	Bk Development Motor Lock	0:Normal 1:Lock
		3	Not Used	-
		2	Not Used	-
		1	Not Used	-
		0	Not Used	-

-016	Drum Cleaning Motor Lock	7	Y Drum Cleaning Motor Lock	0:Normal 1:Lock
		6	C Drum Cleaning Motor Lock	0:Normal 1:Lock
		5	M Drum Cleaning Motor Lock	0:Normal 1:Lock
		4	Bk Drum Cleaning Motor Lock	0:Normal 1:Lock
		3	Not Used	-
		2	Not Used	-
		1	Not Used	-
		0	Not Used	-

-017	Motor Lock: Others	7	ITB Motor Lock	0:Normal 1:Lock
		6	PTR Motor Lock	0:Normal 1:Lock
		5	DFU	-
		4	Used Toner Transport Motor Lock	0:Normal 1:Lock
		3	Hopper Motor Lock	0:Normal 1:Lock
		2	Used Toner Motor Lock	0:Normal 1:Lock
		1	Not Used	-
		0	Not Used	-

-018	Fan System 1	7	Paper Exit Fan Lock	0:Normal 1:Lock
		6	Duplex Fan Lock: Front	0:Normal 1:Lock
		5	Duplex Fan Lock: Rear	0:Normal 1:Lock
		4	Not Used	-
		3	Not Used	-
		2	Not Used	-
		1	Not Used	-
		0	Not Used	-

-019	Fan System 2	7	Fusing Fan Lock Front	0:Normal 1:Lock
		6	Fusing Fan Lock Rear	0:Normal 1:Lock
		5	Fusing Fan Sub Lock	0:Normal 1:Lock
		4	Peltier Fan Lock	0:Normal 1:Lock
		3	Not Used	-
		2	Not Used	-
		1	Not Used	-
		0	Not Used	-

Appendix:
Service
Program
Mode Table

-020	Fan System 3	7	Controlling Box Cooling Fan Motor 2 Lock	0:Normal 1:Lock
		6	Controlling Box Cooling Fan Motor 1 Lock	0:Normal 1:Lock
		5	Not Used	-
		4	Not Used	-
		3	Not Used	-
		2	Not Used	-
		1	Not Used	-
		0	Not Used	-

-021	Fan System 4	7	Y PCU Fan Lock	0:Normal 1:Lock
		6	C PCU Fan Lock	0:Normal 1:Lock
		5	M PCU Fan Lock	0:Normal 1:Lock
		4	Bk PCU Fan Lock	0:Normal 1:Lock
		3	Air Intake Fan: Drive Lock	0:Normal 1:Lock
		2	Ozone Intake Fan Lock	0:Normal 1:Lock
		1	Ozone Exhaust Fan Lock	0:Normal 1:Lock
		0	Not Used	-

-022	High Volt SC1	7	Y SC:Charge	0:No SC 1:SC Detected
		6	C SC:Charge	0:No SC 1:SC Detected
		5	M SC:Charge	0:No SC 1:SC Detected
		4	Bk SC:Charge	0:No SC 1:SC Detected
		3	Y SC:Development	0:No SC 1:SC Detected
		2	C SC:Development	0:No SC 1:SC Detected
		1	M SC:Development	0:No SC 1:SC Detected
		0	Bk SC:Development	0:No SC 1:SC Detected

-023	High Volt SC2	7	Y SC:ITB	0:No SC 1:SC Detected
		6	C SC:ITB	0:No SC 1:SC Detected
		5	M SC:ITB	0:No SC 1:SC Detected
		4	Bk SC:ITB	0:No SC 1:SC Detected
		3	SC:PTR	0:No SC 1:SC Detected
		2	SC: Separation	0:No SC 1:SC Detected
		1	Not Used	-
		0	Not Used	-

-024	Paper Transfer	7	FC: ITB Separation Sensor	0:Separated 1:Contact
		6	Bk: ITBSeparation Sensor	0:Separated 1:Contact
		5	PTR Separation Sensor	0:Separated 1:Contact
		4	Not Used	-
		3	Not Used	-
		2	ITB Control Signal	See table below (Bit Table:24)
		1	ITB Control Signal	
		0	Not Used	-

Appendix:
Service
Program
Mode Table

Bit Table: 24

Bit 1	Bit 0	Function
0	0	Belt Scale Control
0	1	Encoder Control
1	0	Belt or Sensor Defective
1	1	Belt or Sensor Defective

-025	Toner Supply	7	Y Toner End Sensor	0 Detected 1:Not Detected
		6	C Toner End Sensor	0 Detected 1:Not Detected
		5	M Toner End Sensor	0 Detected 1:Not Detected
		4	Bk Toner End Sensor	0 Detected 1:Not Detected
		3	Not Used	-
		2	Not Used	-
		1	Not Used	-
		0	Not Used	-

-026	Set Detect	7	Pressure Roller Thermostat . High Temp	0: Normal 1:Abnormal
		6	Hot Roller Thermistor . High Temp	0: Normal 1:Abnormal
		5	Heating Roller Temperataure Sensor . High Temp	0: Normal 1:Abnormal
		4	Not Used	-
		3	Not Used	-
		2	Not Used	-
		1	Not Used	-
		0	Not Used	-

-027	Fusing Temp Detect	7	Key Card Set	0:Not Set 1:Set
		6	Key Counter Set	0:Not Set 1:Set
		5	Bk Mechanical Counter Set	0:Not Set 1:Set
		4	FC Mechanical Counter Set	0:Not Set 1:Set
		3	Fusing Unit Set	0:Not Set 1:Set
		2	Duplex Unit Set	0:Not Set 1:Set
		1	Drawer Set	0:Not Set 1:Set
		0	Not Used	-

-028	Door	7	Front Door Open Detect	0:Open 1:Close
		6	Bank Door Open Detect	0:Open 1:Close
		5	DFU	-
		4	Not Used	-
		3	Not Used	-
		2	Not Used	-
		1	Not Used	-
		0	Not Used	-

-029	Used Toner Trans	7	Not Used	-
		6	Waste Toner Motor Lock	0:Normal 1:Lock
		5	Waste Toner Bottle Full Detect	0:OFF 1:ON
		4	Waste Toner Bottle Set Detect	0:Set 1:Not Set
		3	Waste Toner Bottle Near Full Detect	0:OFF 1:ON
		2	Not Used	-
		1	Not Used	-
		0	Not Used	-

-030	Peltier Unit	7	Peltier Unit Abnormal	0:Normal 1:Abnormal
		6	Peltier Fan Lock	0:Normal 1:Lock
		5	Not Used	-
		4	Not Used	-
		3	Not Used	-
		2	Not Used	-
		1	Not Used	-
		0	Not Used	-

Appendix:
Service
Program
Mode Table

⇒ **4.11.2 COPIER OUTPUT CHECK: SP5804**

1. Open SP Mode 5804.
2. Select the SP number that corresponds to the component you wish to check. (Refer to the table below.)
3. Press ON then press OFF to test the selected item.

NOTE: You cannot exit and close this display until you press off to switch off the output check currently executing. Do not keep an electrical component switched on for a long time.

5804	Output Chk	Output Check	
1	Fuse Fan: Front NS	47	P.Pump Drv CL:C
2	Fuse Fan: Front HS	48	P.Pump Drv CL:M
3	Fuse Fan: Back NS	49	P.Pump Drv CL:K
4	Fuse Fan: Back HS	50	Used Toner Mtr 1
5	Opt. Fan: Front NS	51	Used Toner Mtr 2
7	Opt. Fan: Back NS	52	Charge dc:Y
9	Exit Pipe Fan	53	Charge dc:C
10	Sub Fuse Fan: NS	54	Charge dc:M
11	Sub Fuse Fan: HS	55	Charge Grid K
14	Dupx Fan: NS	56	Charge ac:Y
15	Dupx Fan: Front: NS	57	Charge ac:C
16	Dupx Fan: Front: HS	58	Charge ac:M
17	Dupx Fan: Back: NS	59	Charge Wire Current K
18	Dupx Fan: Back: HS	60	Dev dc:Y
19	Exit Fan: NS	61	Dev dc:C
20	Exit Fan: HS	62	Dev dc:M
21	PCB Box Fan1:NS	63	Dev dc:K
23	PCB Box Fan2:NS	64	Image Transfer:Y
25	PSU Fan 1:NS	65	Image Transfer:C
26	PSU Fan 1:HS	66	Image Transfer:M
27	PSU Fan 2:NS	67	Image Transfer:K
28	PSU Fan 2:HS	68	Paper Transfer:-
29	PT Fan 1:NS	69	Paper Transfer:+
30	PT Fan 2:NS	70	Paper Separate dc
31	Pelt. Cool Fan:NS	71	Paper Separate ac
32	Pelt. Cool Fan:HS	72	ID Sensor
33	Potential Sn Fan	73	Potential Sn LED:Front
34	Ozone Fan	74	Potential Sn LED:Center
35	PCU Fan:Y	75	Potential Sn LED:Rear
36	PCU Fan:C	76	QL:Y
37	PCU Fan:M	77	QL:C
38	PCU Fan:K	78	QL:M
39	PCU Fan:Y:HS	79	QL:K
40	Pelt. Cir. Fan	80	LD:Y
41	Sub Hopper CL:Y	81	LD:C
42	Sub Hopper CL:C	82	LD:M
43	Sub Hopper CL:M	83	LD:K
44	Sub Hopper CL:K	84	Polygon Mtr
45	Hopper Mtr:Fwd	85	ITB Lift M
46	P.Pump Drv CL:Y	86	ITB Lift Motor FC

5804	Output Chk	Output Check	
95	Drum Mtr:K	135	Pickup SOL:Tray 1
96	Drum Mtr:M	136	Pickup SOL:Tray 2
97	Drum Mtr:C	137	Pickup SOL:Tray 3
98	Drum Mtr:Y	138	Pickup SOL:Tray 4
99	K Development Mtr	139	Bypass Pickup SOL
100	M Development Mtr	142	Rev SOL:Tray 1
101	C Development Mtr	143	Rev SOL:Tray 2
102	Y Development Mtr	144	Rev SOL:Tray 3
103	K Drum Cleaning Mtr	145	Rev SOL:Tray 4
104	M Drum Cleaning Mtr	146	Tan Conn Rel SOL
105	C Drum Cleaning Mtr	147	Tan Lock SOL
106	Y Drum Cleaning Mtr	149	Tandem Back Fence SOL: F
107	ITB Motor	150	Tandem Back Fence SOL: R
108	PRT Motor	151	Relay Mtr:Fwd:Nor2
109	Fusing/Exit M	152	Relay Mtr:Fwd:Haf2
110	Feed Mtr 1 Fwd:Rev2	153	Relay Mtr:Fwd:Hi1
111	Feed Mtr 1 Fwd:Haf2	154	Relay Mtr:Fwd:Hi1:Haf
112	Feed Mtr 1 Fwd:Hi2	155	Relay Mtr:Rev: Nor2
113	Feed Mtr 1 Fwd:Hi2:Haf	156	Relay Mtr:Rev: Haf2
114	Feed Mtr 1 Rev:Nor2	157	Registration Mtr:Nor2
115	Feed Mtr 1 Rev:Haf2	158	Registration Mtr:Haf2
116	Feed Mtr 2 Fwd:Rev2	159	Guide Rel SOL
117	Feed Mtr 2 Fwd:Haf2	160	Exit JG SOL
118	Feed Mtr 2 Fwd:Hi2	161	Dup/Inv Mtr:Fwd:Nor2
119	Feed Mtr 2 Fwd:Hi2:Haf	162	Dup/Inv Mtr:Fwd:Haf2
120	Feed Mtr 2 Rev:Nor2	163	Dup/Inv Mtr:Fwd:Hi2
121	Feed Mtr 2 Rev:Haf2	164	Dup/Inv Mtr:Fwd:Hi2:Haf
122	Feed Mtr 3 Fwd:Rev2	165	Dup/Inv Mtr:Rev:Nor2: Tab Shts
123	Feed Mtr 3 Fwd:Haf2	166	Dup/Inv Mtr:Rev:Haf2: Tab Shts
124	Feed Mtr 3 Fwd:Hi2	167	DupTrans Mtr:Fwd:Nor2
125	Feed Mtr 3 Fwd:Hi2:Haf	168	DupTrans Mtr:Fwd:Haf2
126	Feed Mtr 3 Rev:Nor2	169	DupTrans Mtr:Fwd:Hi2
127	Feed Mtr 3 Rev:Haf2	170	DupTrans Mtr:Fwd:Hi2: Haf
128	Feed Mtr 4 Fwd:Rev2	171	Dup JG SOL
129	Feed Mtr 4 Fwd:Haf2	172	Inv Pos SOL
130	Feed Mtr 4 Fwd:Hi2	174	Dup Jog M:HP Sn
131	Feed Mtr 4 Fwd:Hi2:Haf	180	Fan K:Nor
132	Feed Mtr 4 Rev:Nor2	181	Ozone Fan K:Nor
133	Feed Mtr 4 Rev:Haf2	182	Ozone Fan K:Haf
134	Bypass Feed CL	183	Main Fan:Nor

5804	Output Chk	Output Check	
184	Main Fan:Haf	233	PTR Motor: Half Speed 2
185	Dev Fan Y:Nor	234	Fusing/Exit Motor: Half Speed 2
186	Dev Fan C:Nor	235	Bk Drum Motor: Half Speed 2
187	Dev Fan M:Nor	236	M Drum Motor: Half Speed 1
188	Dev Fan K:Nor	237	C Drum Motor: Half Speed 1
189	ITB CIng Fan:Nor	238	Y Drum Motor: Half Speed 1
190	ITB CIng Fan:Haf	239	Bk Development Motor: Half Speed 1
195	Jam LED:Fusing	240	M Development Motor: Half Speed 1
196	Jam LED:Exit	241	C Development Motor: Half Speed 1
200	Scananer fanmotor	242	Y Development Motor: Half Speed 1
202	Scananer Lamp	243	Bk Cleaning Motor: Half Speed 1
203	Scanner Motor	244	M Cleaning Motor: Half Speed 1
205	Bk Drum Motor: High Speed 1	245	C Cleaning Motor: Half Speed 1
206	M Drum Motor: High Speed 1	246	Y Cleaning Motor: Half Speed 1
207	C Drum Motor: High Speed 1	247	ITB Motor: Half Speed 1
208	Y Drum Motor: High Speed 1	248	PTR Motor: Half Speed 1
209	Bk DeveMotor: High Speed 1	249	Fusing/Exit Motor: Half Speed 1
210	M Dev. Motor: High Speed 1		
211	C Dev. Motor: High Speed 1		
212	Y Dev. Motor: High Speed 1		
213	Bk Cleaning Motor: High Speed 1		
214	M Cleaning Motor: High Speed 1		
215	C Cleaning Motor: High Speed 1		
216	Y Cleaning Motor: High Speed 1		
217	ITB Motor: High Speed 1		
218	PTR Motor: High Speed 1		
219	Fusing/Exit Motor: High Speed 1		
220	Bk Drum Motor: Half Speed 2		
221	M Drum Motor: Half Speed 2		
222	C Drum Motor: Half Speed 2		
223	Y Drum Motor: Half Speed 2		
224	Bk Dev. Motor: Half Speed 2		
225	M Dev. Motor: Half Speed 2		
226	C Dev. Motor: Half Speed 2		
227	Y Dev. Motor: Half Speed 2		
228	Bk Cleaning Motor: Half Speed 2		
229	M Cleaning Motor: Half Speed 2		
230	C Cleaning Motor: Half Speed 2		
231	Y Cleaning Motor: Half Speed 2		
232	ITB Motor: Half Speed 2		



RICOH UNIVERSITY

Learning ♦ Knowledge ♦ Performance



D081/D082
SERVICE MANUAL

(Book 2 of 2) 005645MIU

ACCESSORIES

LANIER RICOH SAVIN

WWW.SERVICE-MANUAL.NET



D081/D082
SERVICE MANUAL
(BOOK 2 OF 2) ACCESSORIES

LANIER
RICOH
SAVIN



RICOH UNIVERSITY
Learning ♦ Knowledge ♦ Performance

D081/D082
SERVICE MANUAL
BOOK 2 OF 2
ACCESSORIES

005645MIU

LANIER RICOH SAVIN

WWW.SERVICE-MANUAL.NET

It is the reader's responsibility when discussing the information contained within this document to maintain a level of confidentiality that is in the best interest of Ricoh Americas Corporation and its member companies.

NO PART OF THIS DOCUMENT MAY BE REPRODUCED IN ANY FASHION AND DISTRIBUTED WITHOUT THE PRIOR PERMISSION OF RICOH AMERICAS CORPORATION.

All product names, domain names or product illustrations, including desktop images, used in this document are trademarks, registered trademarks or the property of their respective companies.

They are used throughout this book in an informational or editorial fashion only and for the benefit of such companies. No such use, or the use of any trade name, or web site is intended to convey endorsement or other affiliation with Ricoh products.

© 2010 RICOH Americas Corporation. All rights reserved.

WARNING

The Service Manual contains information regarding service techniques, procedures, processes and spare parts of office equipment distributed by Ricoh Americas Corporation. Users of this manual should be either service trained or certified by successfully completing a Ricoh Technical Training Program.

Untrained and uncertified users utilizing information contained in this service manual to repair or modify Ricoh equipment risk personal injury, damage to property or loss of warranty protection.

Ricoh Americas Corporation

LEGEND

PRODUCT CODE	COMPANY			
	GESTETNER	LANIER	RICOH	SAVIN
D081	MP C6501	LD365C	MP C6501SP	C9065
D082	MP C7501	LD375C	MP C7501SP	C9075

DOCUMENTATION HISTORY

REV. NO.	DATE	COMMENTS
*	01/2010	Original Printing

B331

A3/DLT TRAY KIT

B331 A3/DLT TRAY KIT REVISION HISTORY		
Page	Date	Added/Updated/New
		None

A3/DLT TRAY KIT B331

TABLE OF CONTENTS

1. INSTALLATION	1
2. REPLACEMENT AND ADJUSTMENT.....	2
2.1 BOTTOM PLATE LIFT WIRE REPLACEMENT	2
3. DETAILED DESCRIPTIONS	4
3.1 SECTIONAL DESCRIPTION.....	4

1. INSTALLATION

For details about installing the A3/DLT Kit B331, please refer to the instructions you received with the instructions or the “1. Installation” in the main machine service manual.

A3/DLT Tray
Kit
B331

REPLACEMENT AND ADJUSTMENT

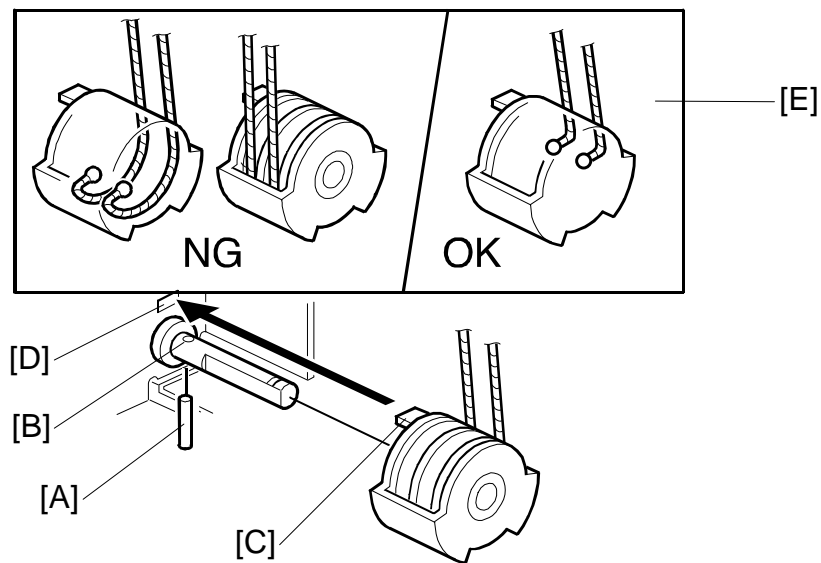

NOTE: When re-installing the bottom plate lift wire:

- 1) Set the positioning pin [A] in the hole [B] and set the projection [C] in the hole [D].
- 2) Position the wire as shown [E].
- 3) Do not cross the wires.

3. DETAILED DESCRIPTIONS

3.1 SECTIONAL DESCRIPTION

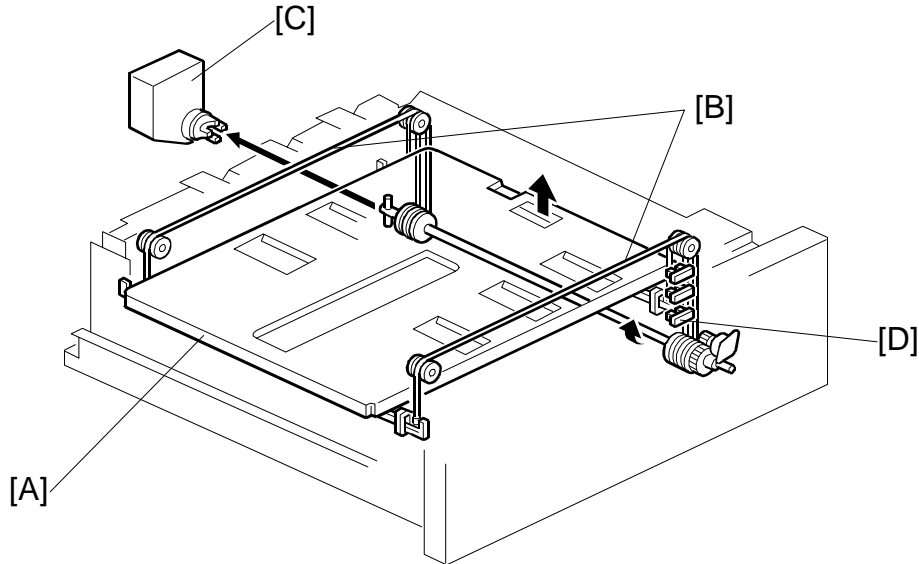

This tray mechanism is basically same as the tandem LCT. This tray bottom plate [A] is lifted through the tray wires [B] by the lift motor [C] rotation. There is no remaining paper capacity detection.

The paper remaining sensors [D] trigger messages on the LCD to let the user know how much paper remains in the tray.

The operation panel LCD displays “full” whether there is paper in the tray. Except for the above matter, refer to the main copier tandem LCT section for details.

Z-FOLDING UNIT ZF4000 B660

B660 Z-FOLDING UNIT ZF4000 REVISION HISTORY		
Page	Date	Added/Updated/New
		None

Z-FOLDING UNIT B660

TABLE OF CONTENTS

1. REPLACEMENT AND ADJUSTMENT	1
1.1 BEFORE YOU BEGIN	1
1.2 COVERS.....	2
1.3 FEED MOTOR	3
1.4 UPPER EXIT SENSOR.....	4
1.5 UPPER STOPPER MOTOR/HP SENSOR, FEED SENSOR.....	5
1.6 FOLD TIMING SENSOR.....	6
1.7 LOWER STOPPER MOTOR/HP SENSOR, RELAY BOARD.....	7
1.8 LEADING EDGE SENSOR, LOWER EXIT SENSOR.....	8
1.9 ANTI-STATIC BRUSH	9
1.10 FOLD ROLLER MOTOR.....	10
1.11 MAIN CONTROL BOARD.....	11
1.12 PSU.....	12
1.13 UNEVEN FOLDING ADJUSTMENT	13
1.13.1 OVERVIEW.....	13
1.13.2 Z-FOLD ADJUSTMENT SCREWS	14
1.13.3 Z-FOLD ADJUSTMENT PROCEDURE	15
1st Fold Adjustment.....	15
2nd Fold Adjustment	16
1.13.4 Z-FOLD ADJUSTMENT REFERENCE TABLE.....	17
2. SERVICE TABLES	18
3. DETAILS	19
3.1 OVERVIEW.....	19
3.2 Z-FOLDING UNIT PAPER PATH.....	21
3.2.1 PAPER PATH WITH NO FOLDING	21
3.2.2 PAPER PATH WITH Z-FOLDING	22
3.3 DRIVE LAYOUT.....	26
3.4 ELECTRICAL COMPONENTS	27
3.4.1 OVERVIEW.....	27
3.4.2 ELECTRICAL COMPONENT SUMMARY	28

1. REPLACEMENT AND ADJUSTMENT

1.1 BEFORE YOU BEGIN

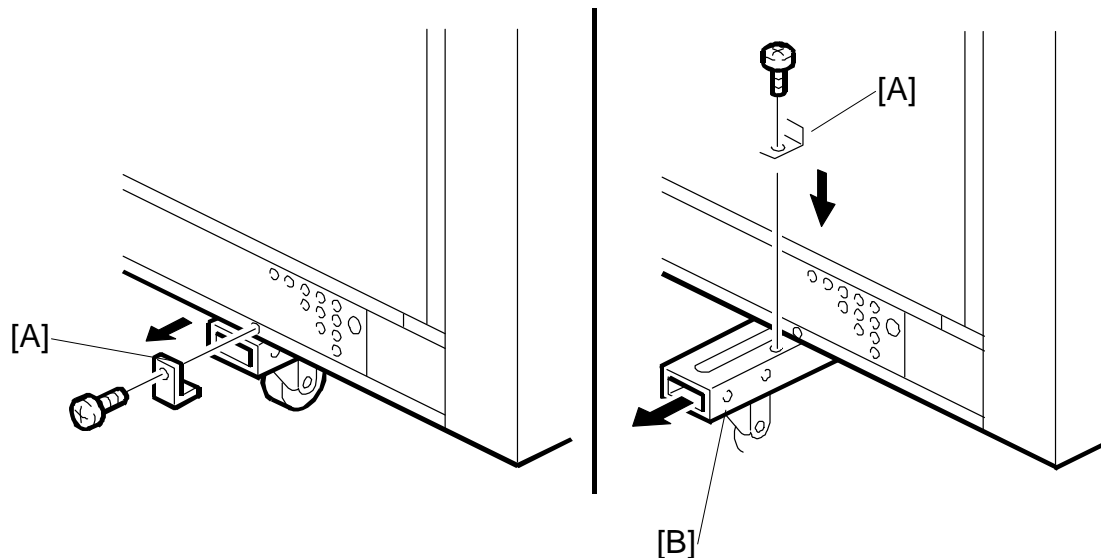

1. Disengage the Z-folding unit from the machine.
2. Disengage the Z-folding unit from the finisher (or cover sheet feeder).
3. At the bottom on the sides of the Z-folding unit:
 - Remove the lock bracket [A] (⚙ x 1).
 - Pull out the foot extension [B].
 - Re-attach the bracket [A] to lock the foot in the open position (⚙ x 1).

Reinstallation

Do this procedure in the opposite sequence to retract and lock the extensions below the Z-folding unit.

⚠ CAUTION

The Z-folding unit is not stable, with or without the feet extended. Do your work carefully; do not tilt the unit.

1.2 COVERS

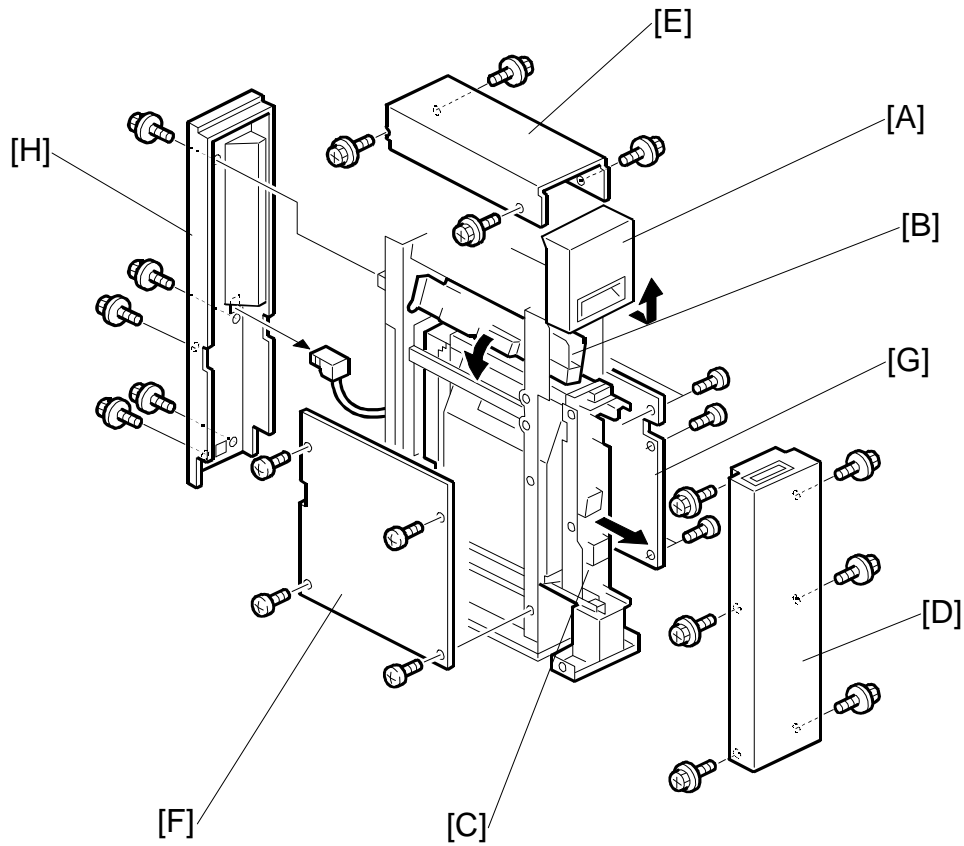

- Open the front door [A].
- Lift the horizontal transport plate [B] to the left until it locks on the left side.
- Pull out the Z-fold mechanism [C].

[D] Front cover (🔩 x 6)

[E] Top cover (🔩 x 4)

[F] Left cover (🔩 x 4)

[G] Right cover (🔩 x 5)

[H] Rear cover (🔩 x 6)

1.3 FEED MOTOR

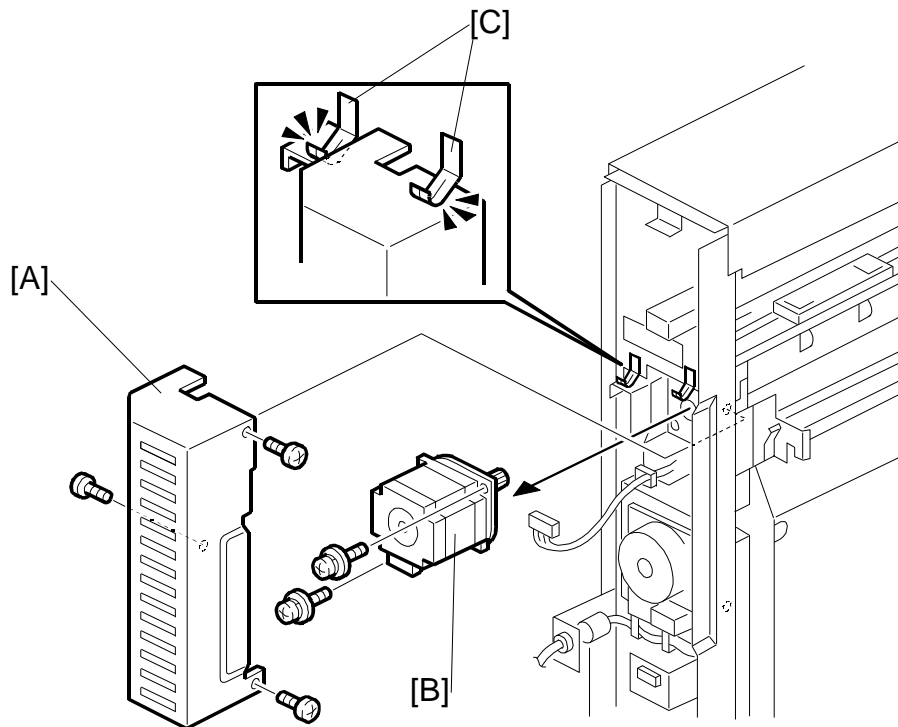

1. Pull the Z-folding mechanism out of the unit, but not fully.

2. Remove: (☞1.2)

- Left cover
- Right cover
- Rear cover

[A]: Motor cover (🔩 x 3)

[B]: Feed Motor (🔩 x 2, ⚙️ x 1, timing belt x 1)

Reinstallation

- Confirm that the motor cover is below the leaf springs at [C].

1.4 UPPER EXIT SENSOR

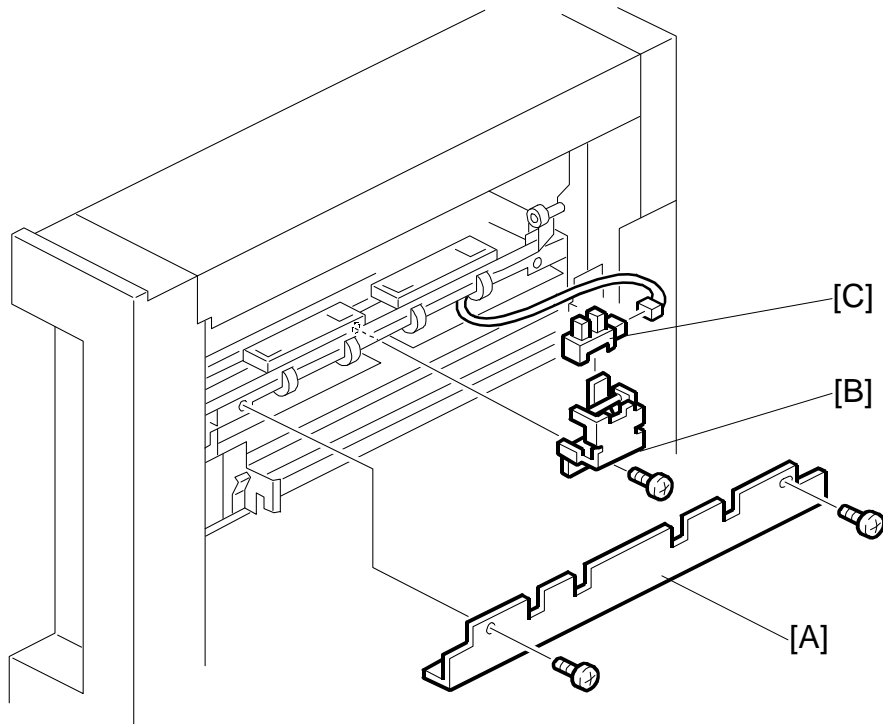

Left cover (☛1.2)

[A]: Bracket (🔩 x 2)

[B]: Upper exit sensor unit (🔩 x 1, ⏪ x 1, 📡 x 1)

[C]: Upper exit sensor

1.5 UPPER STOPPER MOTOR/HP SENSOR, FEED SENSOR

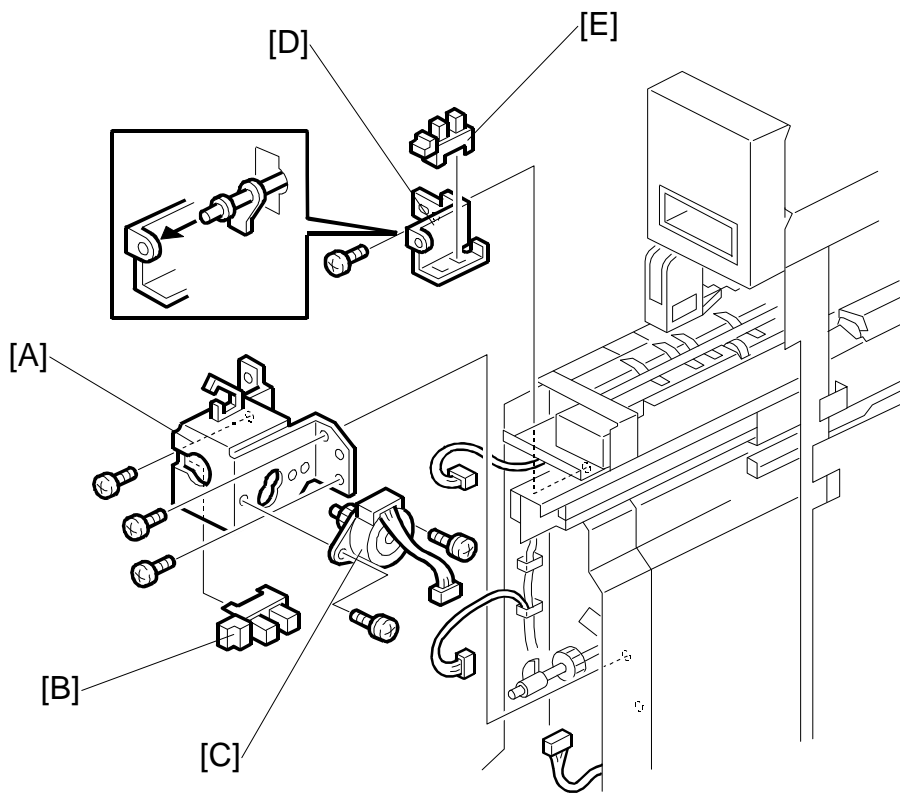

Front cover (☛1.2)

[A]: Upper stopper motor unit (⚙️ x 3, ⚙️ x 2, ⚙️ x 2)

[B]: Upper stopper motor HP sensor

[C]: Upper stopper motor (⚙️ x 2)

[D]: Feed sensor unit (⚙️ x 1, ⚙️ x 1)

[E]: Feed sensor

1.6 FOLD TIMING SENSOR

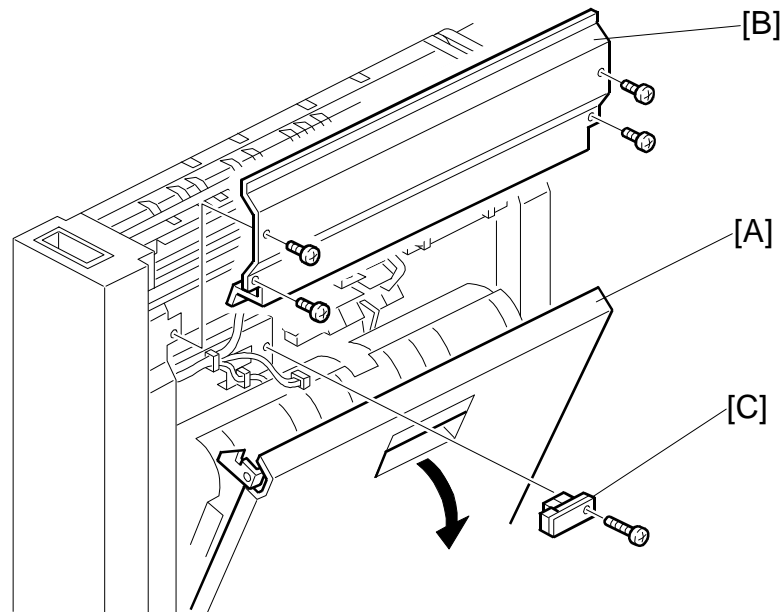

Pull the Z-fold mechanism out of the unit.

[A]: Open the right vertical transport unit cover.

[B]: Plate (🔩 x 4)

[C]: Fold timing sensor (🔩 x 1, 📏 x 1)

1.7 LOWER STOPPER MOTOR/HP SENSOR, RELAY BOARD

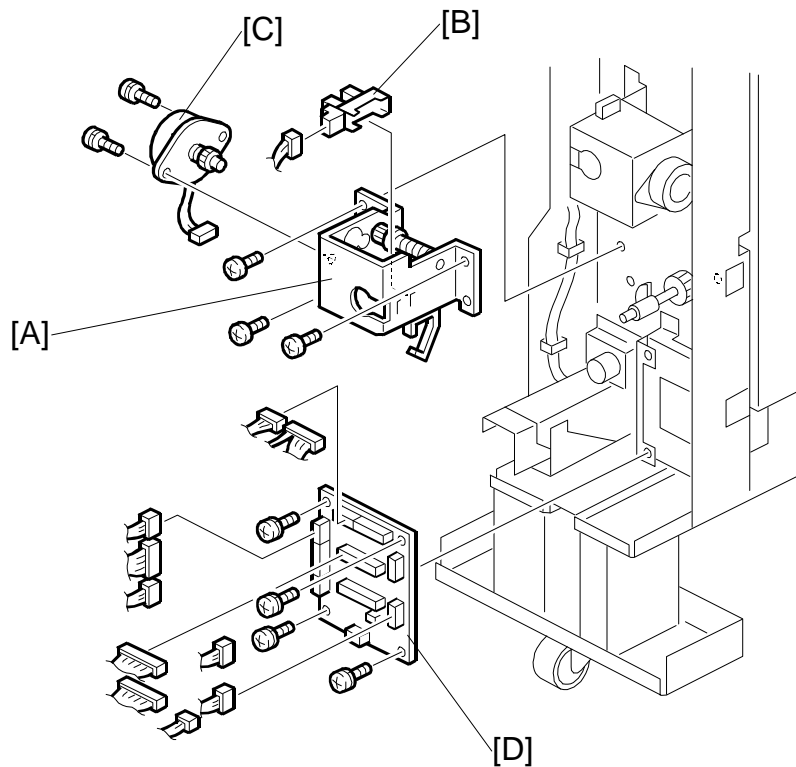

Front cover (☛1.2)

[A]: Lower stopper motor unit (⚙️ x 3, ⚙️ x 2, ⚙️ x 2),

[B]: Lower stopper HP sensor

[C]: Lower stopper motor (⚙️ x 2)

[D]: Relay board (⚙️ x 4, ⚙️ x 3, ⚙️ x 10)

1.8 LEADING EDGE SENSOR, LOWER EXIT SENSOR

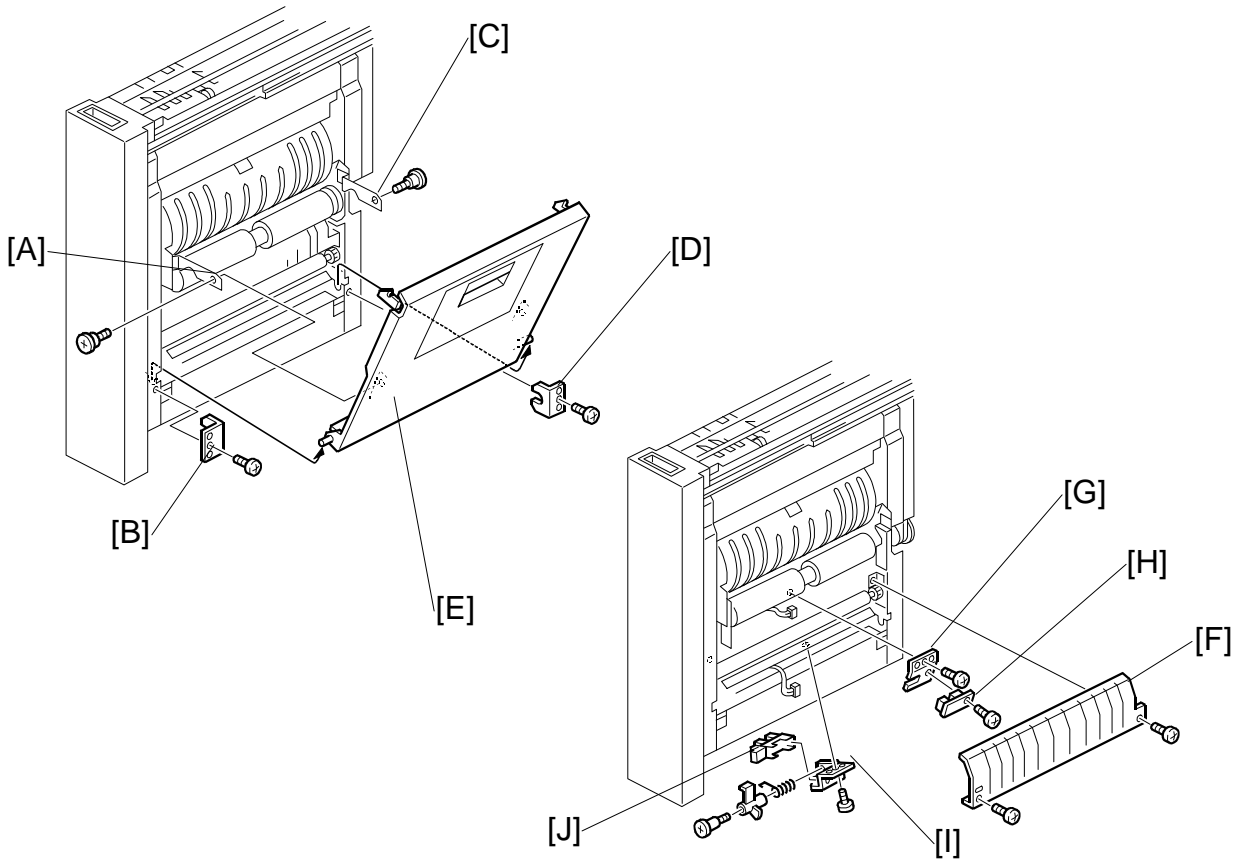

Pull out the Z-folding mechanism.

Open the right vertical transport cover [E].

- [A]: Left link arm (🔩 x 1)
- [B]: Left corner bracket (🔩 x 1)
- [C]: Right link arm (🔩 x 1)
- [D]: Right corner bracket (🔩 x 1)
- [E]: Vertical transport cover.
- [F]: Lower fold roller cover (🔩 x 2)
- [G]: Leading edge sensor unit (🔩 x 1, 📡 x 1)
- [H]: Leading edge sensor (🔩 x 1)
- [I]: Lower exit sensor unit (🔩 x 1, 📡 x 1)
- [J]: Lower exit sensor

1.9 ANTI-STATIC BRUSH

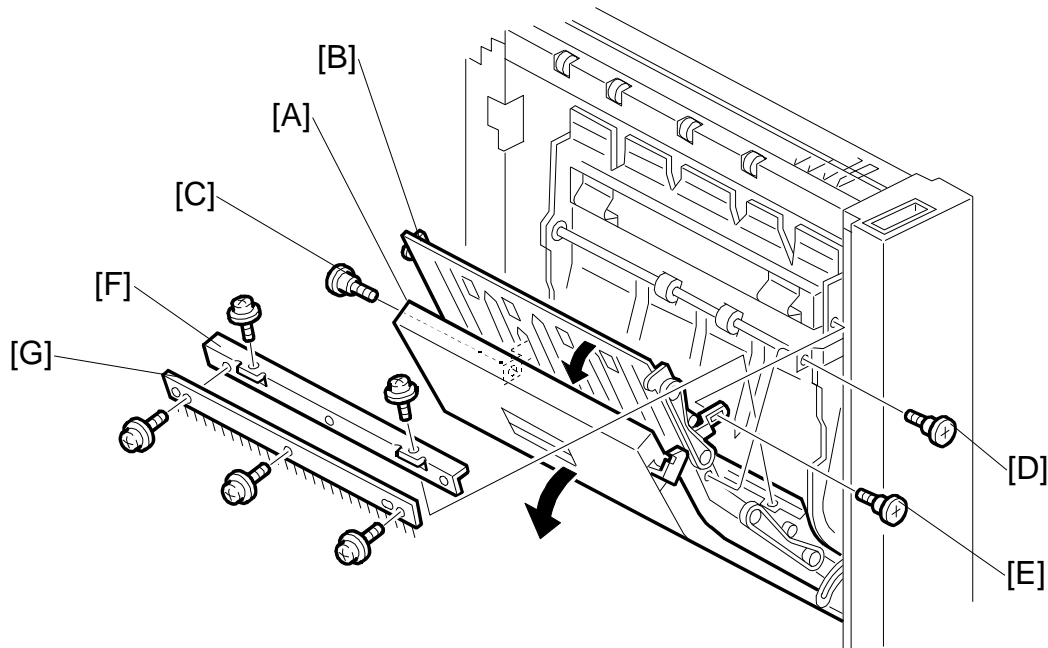

1. Pull out the Z-folding mechanism.
2. Open the left vertical transport cover [A].
3. Open the vertical transport assembly [B].

Remove:

- [C] Left link screw
- [D] Right link screw
- [E] Link screw [E]
- [F] Bracket
- [G] Anti-static brush

Z-Folding Unit
B660

1.10 FOLD ROLLER MOTOR

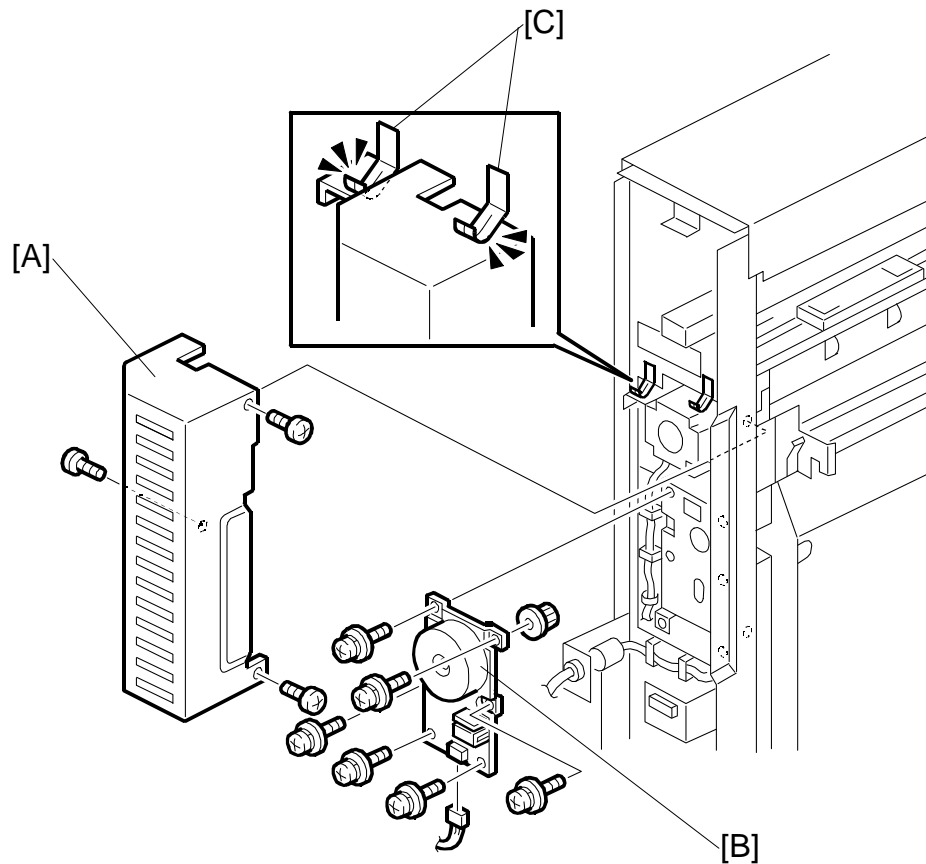

1. Pull the Z-folding mechanism out of the unit, but not fully.
2. Remove: (☛1.2)
 - Left cover
 - Right cover
 - Rear cover

[A]: Motor cover (☛ x 3)

[B]: Fold roller motor (☛ x 6, ☛ x 1, timing belt x 1)

Reinstallation

Make sure that the motor cover is below the leaf springs [C].

1.11 MAIN CONTROL BOARD

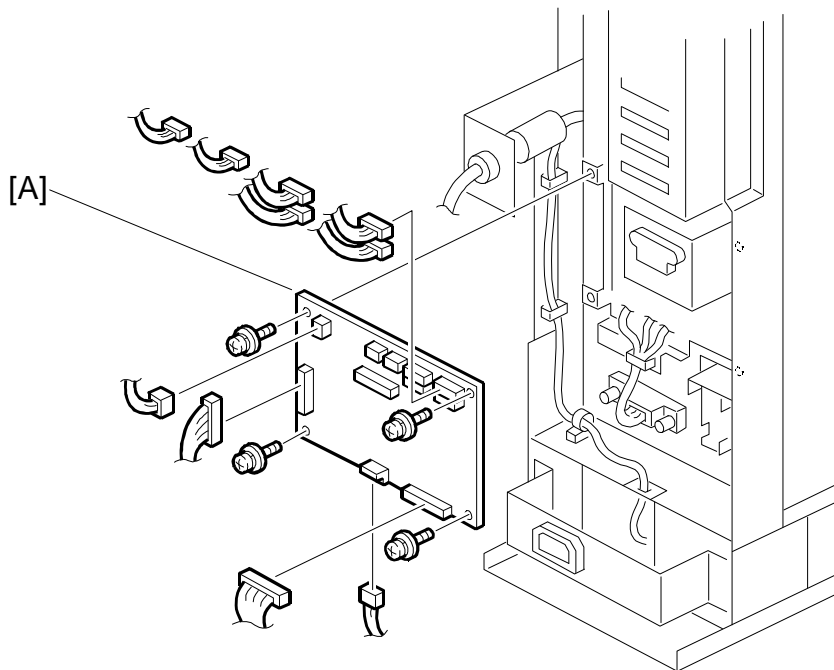

Remove:

- Rear cover. (☛1.2)

[A] Main control board [A] (🔩 x 4, 📌 x 10)

Z-Folding Unit
B660

1.12 PSU

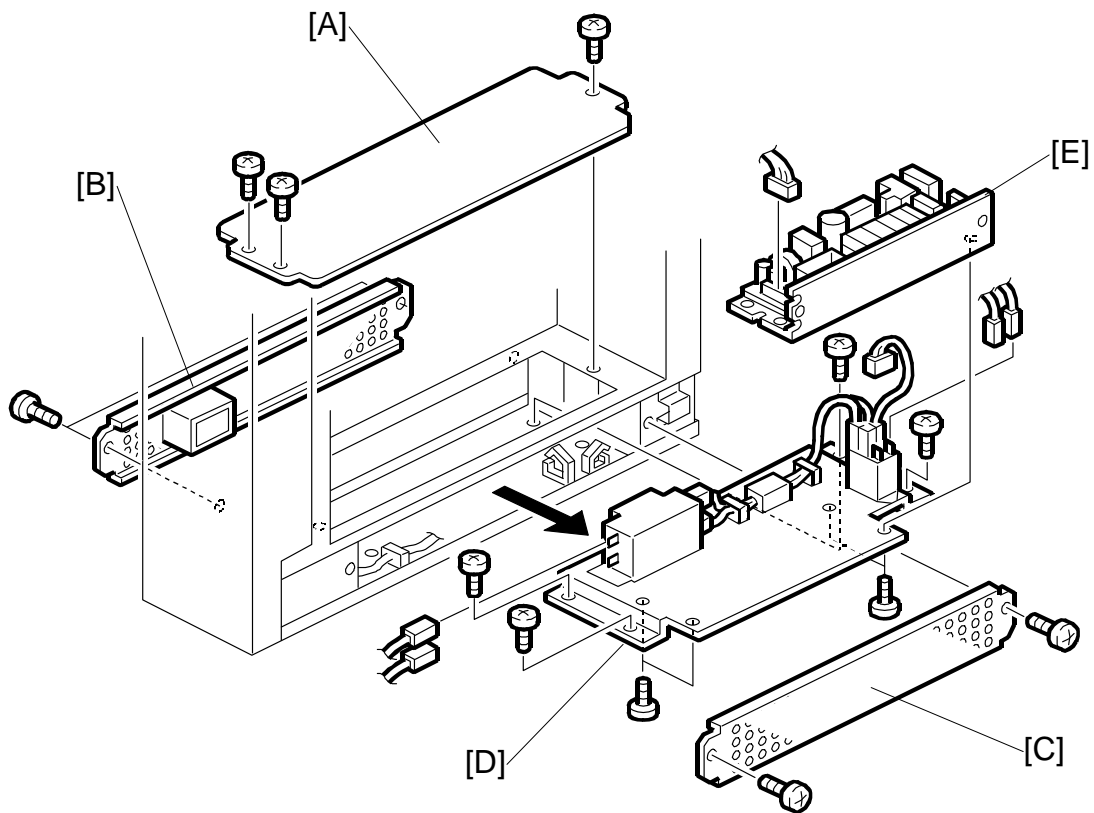

- Open the front door.
- Pull the Z-fold mechanism out of the unit.

Remove:

- Left cover and right cover. (☛1.2)

[A] Base top cover (☛ x 3).

[B] Base left cover (☛ x 2).

[C] Base right cover (☛ x 2).

- Make a mark at the positions of the connectors, then disconnect them.

NOTE: These connectors do not have different colors. To help you connect them again correctly, make marks on them.

[D] Power supply unit (PSU) (☛ x 4, ☛ x 4).

- Pull the PSU out of the right side of the bottom.

[E] Power supply board (☛ x 4, ☛ x 1).

1.13 UNEVEN FOLDING ADJUSTMENT

1.13.1 OVERVIEW

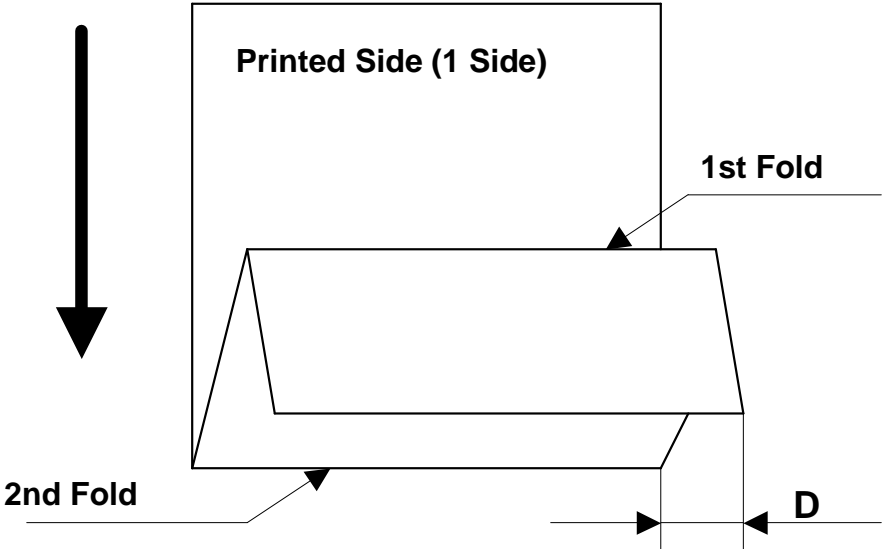

Z-Folding Unit
B660

This procedure describes how to correct uneven folding (D) in paper folded with the Z-Fold unit. Before doing this procedure, please note the names and positions of the 1st and 2nd Fold.

Section 3.2.2 provides a full description of how Z-folding is done.

REPLACEMENT AND ADJUSTMENT

1.13.2 Z-FOLD ADJUSTMENT SCREWS

The adjustment of the 1st fold is done by turning an adjustment screw linked to the paper stopper.

Pull out the Z-fold mechanism.

Open the right cover to see the adjustment screw located at [A].

This is the screw used to adjust the 1st fold.

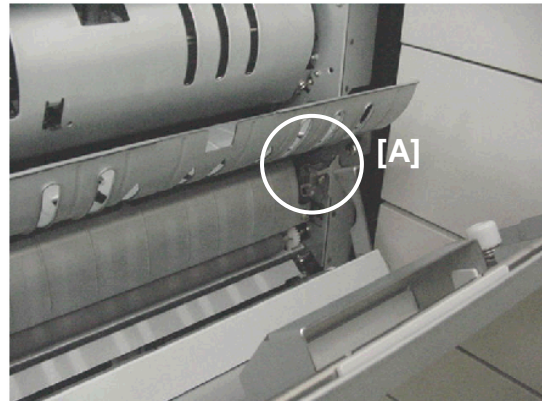

Open the left cover to see the screw located at [B].

This is the screw used to adjust the 2nd fold.

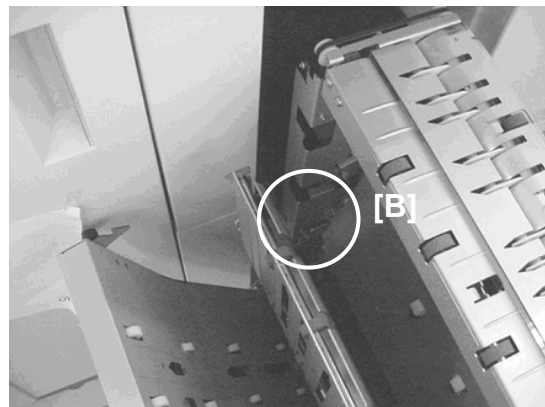

1.13.3 Z-FOLD ADJUSTMENT PROCEDURE

1st Fold Adjustment

1. Print one A3 copy and send it through the Z-fold unit.
2. Open the 2nd fold ②.
3. Turn the paper over so the edge ③ is aligned with the crease of the 2nd fold.
4. Open the right door and locate the screw that adjusts the 1st fold (see previous page).
5. Use a plus screwdriver to turn the screw [A] to the left to loosen the nut.
 - If the corner is over the right edge, turn the screw to the right.
 - If the corner is over the left edge, turn the screw to the left.

NOTE:

- The illustration above shows the corner over the right edge.
 - You can see the pointer [B] change position on the notches of the adjustment scale as you turn the screw.
6. Close the Z-Fold unit.
 7. Do another test print.
 8. If the 1st fold is still misaligned, repeat this procedure until the alignment is correct.
 9. After the adjustment is completed, use a screw driver to hold the screw in position, then retighten the nut you loosened in Step 2. Do not turn the screw.

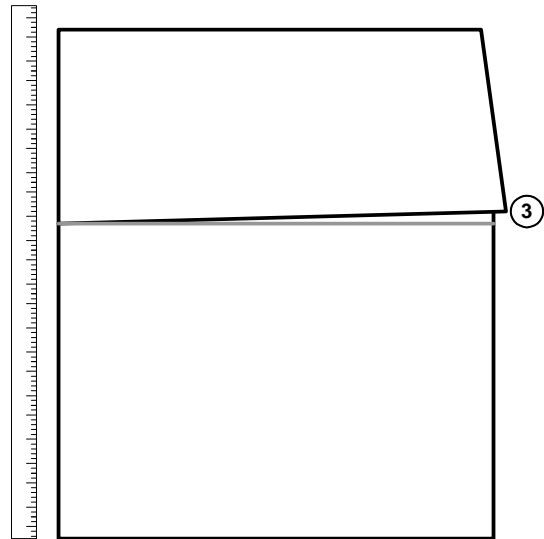
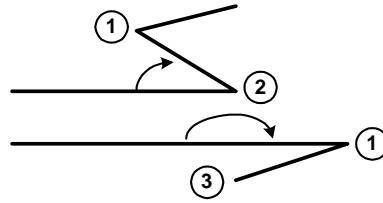

Z-Folding Unit
B660

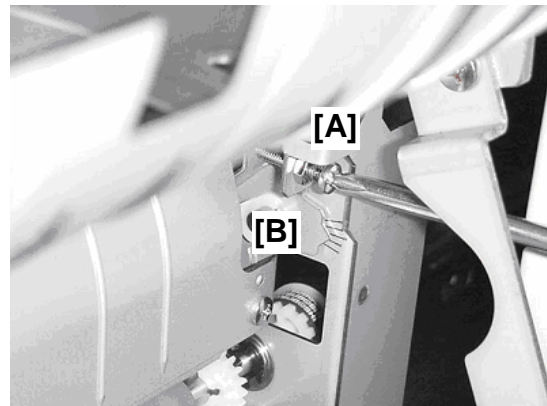

2nd Fold Adjustment

1. Print one A3 copy and send it through the Z-fold unit.
 2. Open the folded sheet at the 1st fold ❶ then lay it down flat.
 3. Stand the sheet on its end so the edge ❸ is up and the crease of the 1st fold is facing out.
 4. Open the left door and locate the screw that adjusts the 2nd fold (see previous page).
 5. Use a plus screwdriver to turn the screw [A] to the left to loosen the nut.
 - If the corner is over the right edge, turn the screw to the right.
 - If the corner is over the left edge, turn the screw to the left.
- NOTE:**
- The illustration shows the corner over the right edge.
 - You can see the pointer [B] change position on the notches of the adjustment scale as you turn the screw.
6. Close the Z-Fold unit.
 7. Do another test print.
 8. If the 1st fold is still misaligned, repeat this procedure until the alignment is correct.
 9. After the adjustment is completed, use a screw driver to hold the screw in position, then retighten the nut you loosened in Step 2. Do not turn the screw.

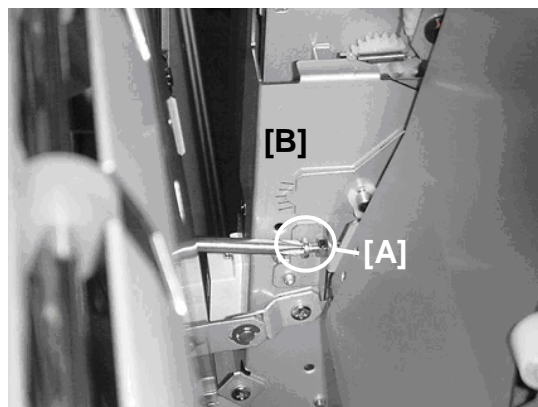
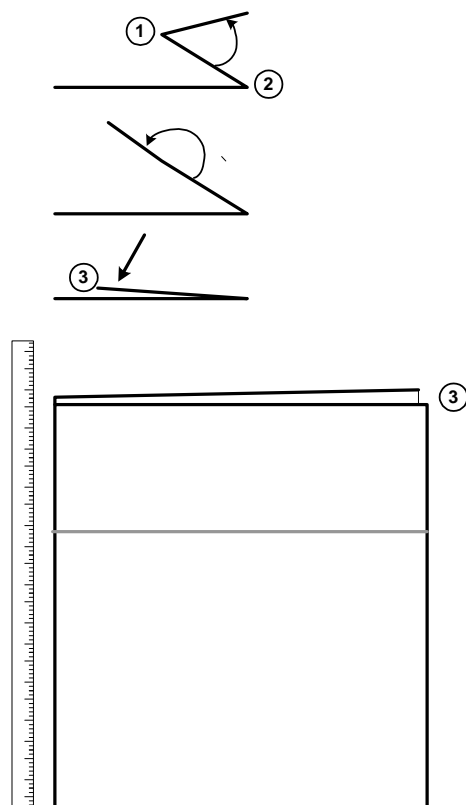

1.13.4 Z-FOLD ADJUSTMENT REFERENCE TABLE

1st Fold Adjustment

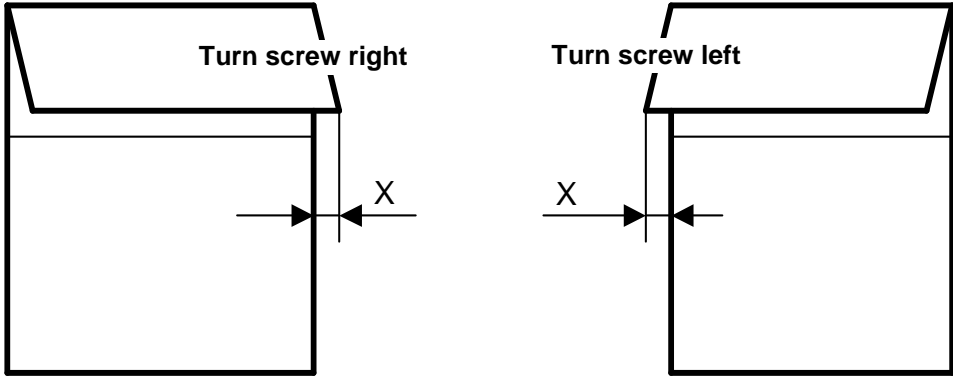

2nd Fold Adjustment

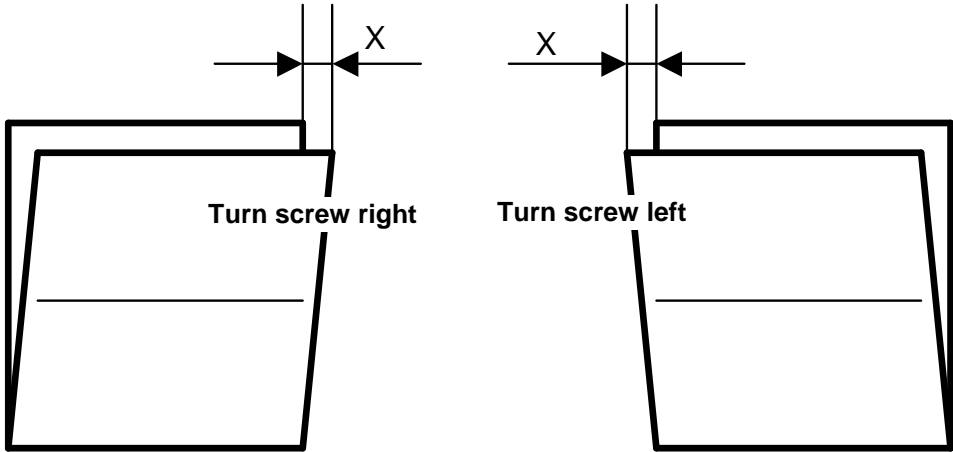

Z-Folding Unit
B660

NOTE: A one-notch adjustment on the scale means the alignment is corrected by about 1 mm.

2. SERVICE TABLES

Two SP codes have been added for the Z-folding unit, to adjust the positions of the folds.

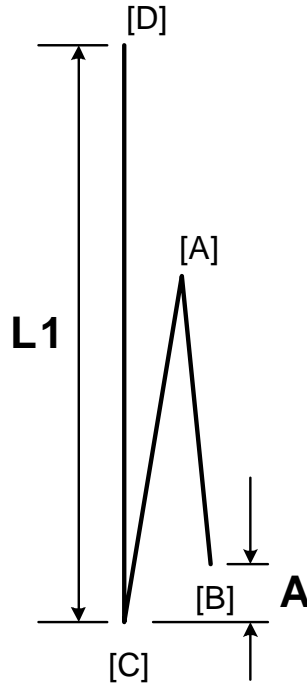

Use these SPs to adjust the locations of the first fold and the second fold.

The illustration shows the position of the sheet while it goes through the lower exit rollers after it has been folded.

SP6301 001 to 008	Fine Adjustment – 1st Fold Position
	[-4 ~ +4/0/ 0.2 mm] Adjusts the position of the first fold [A] to decrease or increase the distance (A) between the leading edge [B] and the crease of the 2nd fold [C].
SP6301 009 to 016	Fine Adjustment – 2nd Fold Position
	[-4 ~ +4/0/ 0.2 mm] Adjusts the position of the 2nd fold [C] to decrease or increase the length (L1) of the sheet between the trailing edge [D] and the 2nd fold.

3. DETAILS

3.1 OVERVIEW

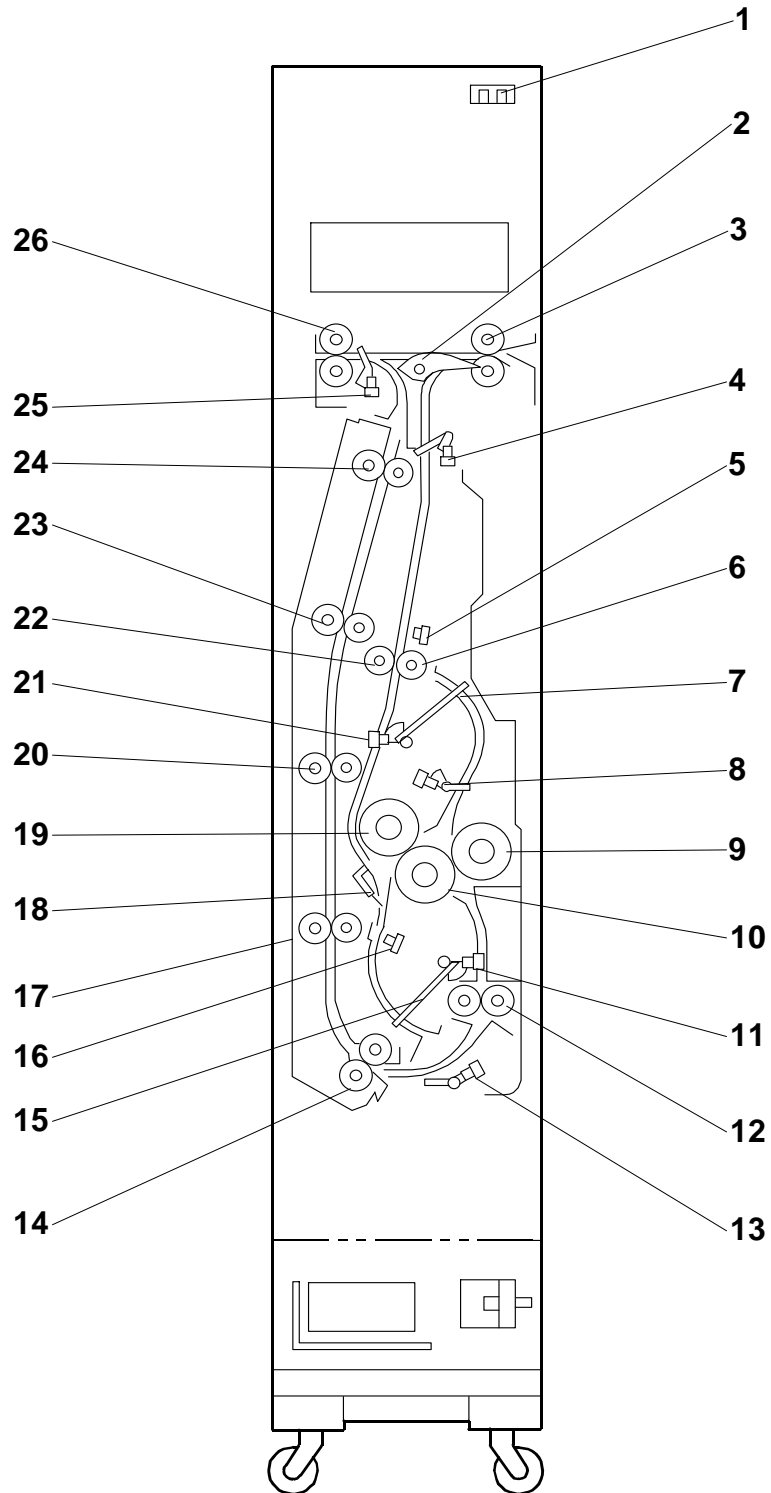

Z-Folding Unit
B660

DETAILS

1. Front Door Sensor
2. Junction Gate
3. Feed Rollers
4. Feed Sensor
5. Fold Timing Sensor
6. Pinch Idle Roller
7. Upper Stopper
8. Upper Stopper Path Sensor
9. 3rd Fold Roller
10. 2nd Fold Roller
11. Lower Stopper HP Sensor
12. Lower Exit Rollers
13. Lower Exit Sensor
14. Grip Rollers
15. Lower Stopper
16. Leading Edge Sensor
17. Vertical Feed Rollers – 1
18. Anti-Static Brush
19. 1st Fold Roller
20. Vertical Feed Rollers – 2
21. Upper Stopper HP Sensor
22. Pinch Feed Roller
23. Vertical Feed Rollers – 3
24. Vertical Feed Rollers – 4
25. Upper Exit Sensor
26. Upper Exit Rollers

3.2 Z-FOLDING UNIT PAPER PATH

3.2.1 PAPER PATH WITH NO FOLDING

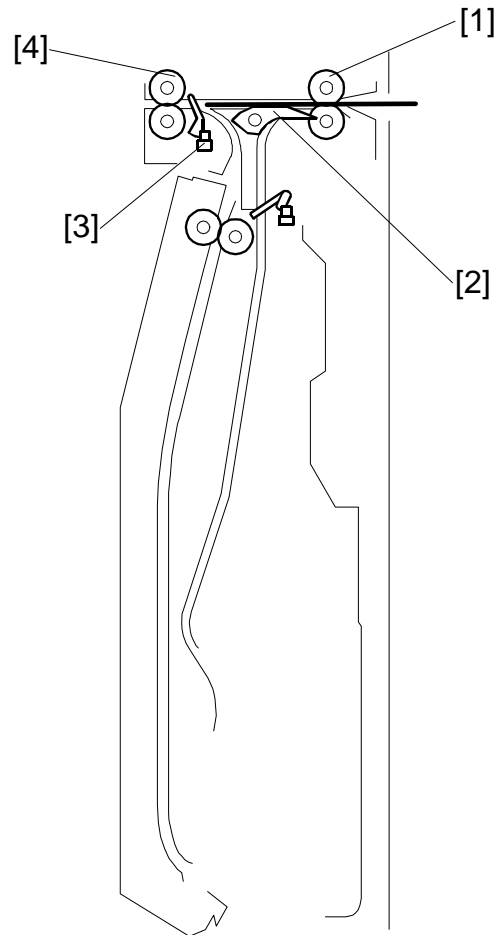

The feed rollers [1] feed the paper from the main machine into the Z-folding unit.

If Z-folding was not used for the job, the sheet feeds above the closed junction gate [2].

The upper exit sensor [3] detects the leading and trailing edge of the unfolded sheet.

The upper exit rollers [4] feed the unfolded sheet out of the Z-folding unit and into the finisher.

Z-Folding Unit
B660

3.2.2 PAPER PATH WITH Z-FOLDING

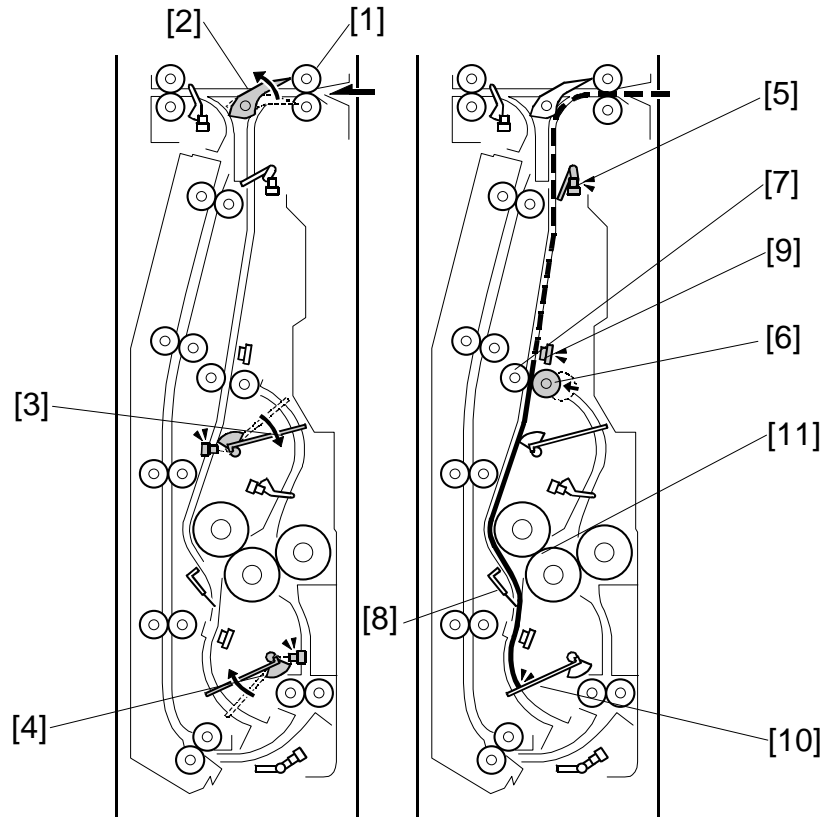

The feed rollers [1] feed the paper from the main machine into the Z-folding unit.

The junction gate solenoid energizes and opens the junction gate [2]. The junction gate sends the sheet down into the Z-folding paper path.

The upper and lower stopper motors move the upper stopper [3] and lower stopper [4] to the positions for the paper size that was used for the job.

The feed sensor [5] detects the leading edge and trailing edge of the sheet. The pinch idle roller solenoid (upper) pulls the pinch idle roller [6] away from the pinch feed roller [7] and the paper can fall between the pinch rollers.

The anti-static brush [8] removes static electricity from the sheet.

When the fold timing sensor [9] detects the trailing edge of the sheet, it energizes the pinch idle roller solenoid (lower). This pushes the pinch idle roller [6] against the opposite pinch feed roller [7].

The lower stopper [10] stops the sheet and buckles it slightly toward the nip [11] of the 1st and 2nd fold rollers.

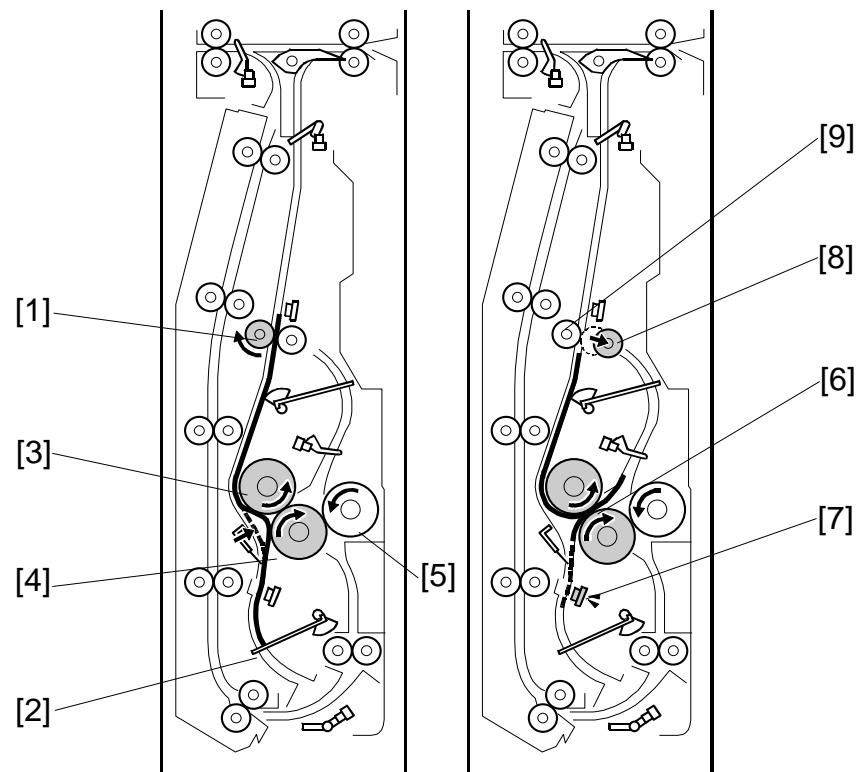

Z-Folding Unit
B660

The pinch feed roller [1] turns and feeds the sheet down against the lower stopper [2]

At the correct time, the fold roller motor switches on and turns the:

- 1st fold roller [3]
- 2nd fold roller [4]
- 3rd fold roller [5]

The sheet continues to buckle until it feeds into the nip [6] of the 1st and 2nd fold rollers. These two rollers fold the sheet.

The leading edge sensor [7] detects the leading edge of the sheet:

- When the leading edge goes by while the paper feeds down (to the lower stopper).
- When the leading edge goes by again while the paper feeds up into the nip of the 1st and 2nd fold rollers.

If the leading edge sensor does not detect the leading edge at the correct time, this sensor signals a jam.

At the correct time, the pinch idle roller [8] is pulled away from the pinch feed roller [9] by the pinch idle roller solenoid (upper).

DETAILS

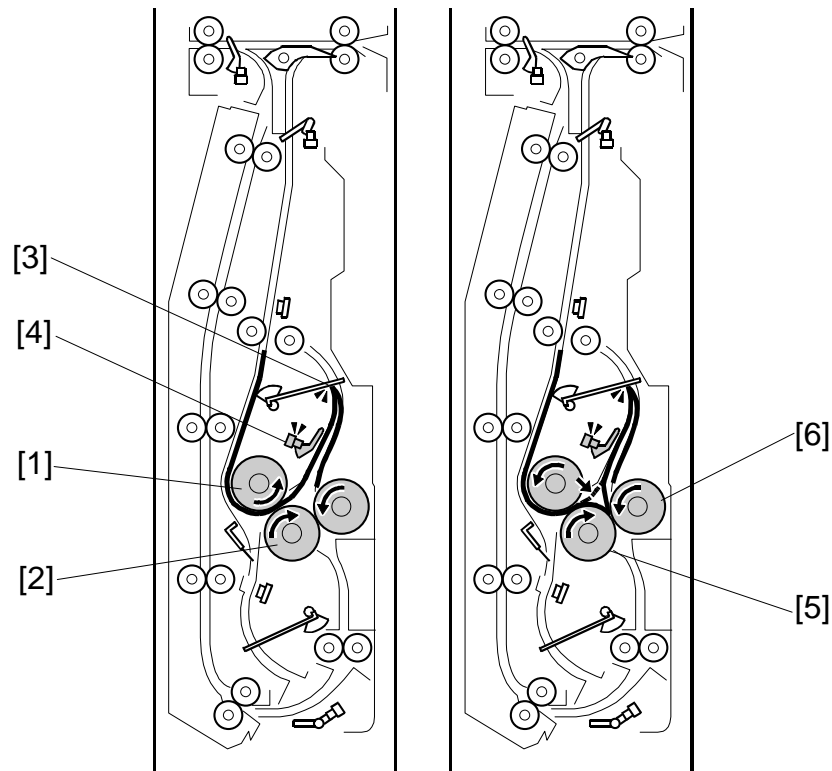

The 1st fold roller [1] and 2nd fold roller [2] continue to turn. This feeds the edge of the 1st fold up until it hits the upper stopper [3].

The sheet lifts the feeler of the upper stopper path sensor [4]. This sensor:

- Detects when the sheet comes to the upper stopper path.
- Detects when the sheet goes out of the upper stopper path.

The upper stopper sensor detects a jam if it does not detect that the sheet comes and goes at the correct times.

When the sheet feeds between the 1st and 2nd fold rollers, this pushes the first fold against the upper stopper. The sheet buckles down into the gap between the 2nd fold roller [5] and 3rd fold roller [6]. The second fold is made when the sheet feeds between the 2nd and 3rd feed rollers.

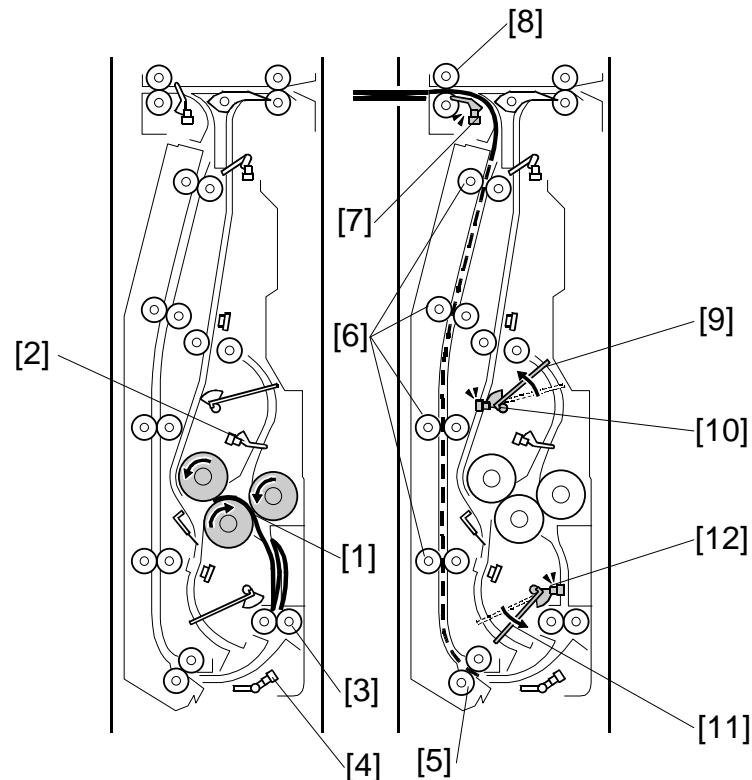

The 2nd and 3rd fold rollers [1] continue to turn and feed the sheet down.

The feeler of the upper stopper path sensor [2] falls and the sensor detects that the sheet is gone. The fold rollers feed the folded sheet to the lower exit rollers [3].

The lower exit sensor [4] detects the leading edge and trailing edge of the sheet. If the trailing edge is not detected during the correct time interval, the sensor detects a jam.

The grip rollers [5] feed the folded sheet to the four pairs of vertical feed rollers [6].

The upper exit sensor [7] detects the leading edge and trailing edge of each folded sheet. If the leading and trailing edge are not detected during the correct time interval, this sensor detects a jam.

The upper exit rollers [8] feed the folded sheet into the finisher.

At the correct time:

- The upper stopper motor lifts the upper stopper [9] until the upper stopper sensor [10] detects that the upper stopper is at its home position. This stops the motor.
- The lower stopper motor lowers the lower stopper [11] until the lower stopper sensor [12] detects that the lower stopper is at its home position. This stops the motor.

3.3 DRIVE LAYOUT

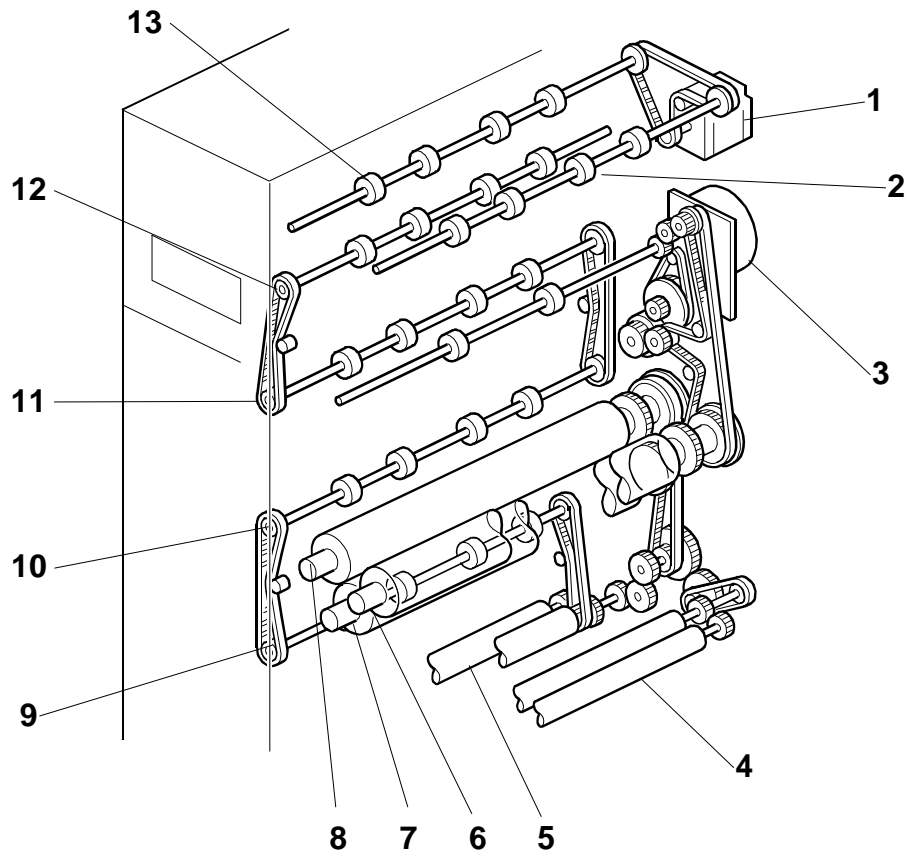

- | | |
|-----------------------|-------------------------------|
| 1. Feed Motor | 8. 1st Fold Roller |
| 2. Feed Rollers | 9. Vertical Feed Rollers – 1 |
| 3. Fold Roller Motor | 10. Vertical Feed Rollers – 2 |
| 4. Lower Exit Rollers | 11. Vertical Feed Rollers – 3 |
| 5. Grip Rollers | 12. Vertical Feed Rollers – 4 |
| 6. 3rd Fold Roller | 13. Upper Exit Rollers |
| 7. 2nd Fold Roller | |

3.4 ELECTRICAL COMPONENTS

3.4.1 OVERVIEW

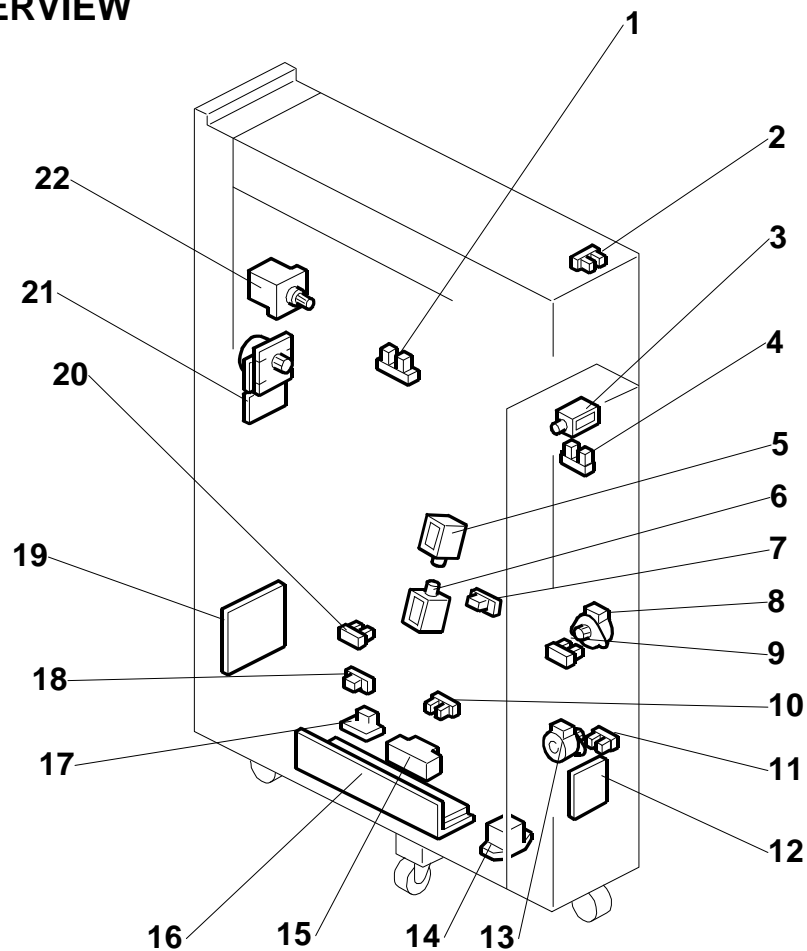

Z-Folding Unit
B660

- | | |
|---------------------------------------|-------------------------------|
| 1. Upper Exit Sensor | 12. DC Relay Board |
| 2. Front Door Sensor | 13. Lower Stopper Motor |
| 3. Junction Gate Solenoid | 14. Relay |
| 4. Feed Sensor | 15. Breaker |
| 5. Pinch Idle Roller Solenoid – Upper | 16. Power Supply Unit |
| 6. Pinch Idle Roller Solenoid – Lower | 17. Surge Protector Board |
| 7. Fold Timing Sensor | 18. Leading Edge Sensor |
| 8. Upper Stopper Motor | 19. Main Control Board |
| 9. Upper Stopper HP Sensor | 20. Upper Stopper Path Sensor |
| 10. Lower Exit Sensor | 21. Fold Roller Motor |
| 11. Lower Stopper HP Sensor | 22. Feed Motor |

3.4.2 ELECTRICAL COMPONENT SUMMARY

Motors		
No.	Name	Description
M1	Feed Motor	Drives the feed rollers and exit rollers of the Z-folding unit.
M2	Fold Roller Motor	Drives the 1st, 2nd, and 3rd fold rollers.
M3	Lower Stopper Motor	Raises and lowers the lower stopper. It 1) Raises the upper stopper to the proper position for the size of the paper selected for the job, and 2) Lowers the lower stopper until the lower stopper sensor detects that the lower stopper is at its home position where it remains until the start of the next job.
M4	Upper Stopper Motor	Lowers and raises the upper stopper. It 1) Lowers the upper stopper to the proper position for the size of the paper selected for the job, and 2) Raises the upper stopper until the upper stopper sensor detects that the upper stopper is at its home position where it remains until the start of the next job.

PCBs		
No.	Name	Description
PCB1	Main Control Board	Controls the operation of the Z-folding unit.
PCB2	PSU	Supplies the dc power for the Z-folding unit.
PCB3	Surge Protector Board	AC input and breaker relay board.
PCB4	DC Relay Board	PSU DC output and DC motors and sensor relay board.

Sensors		
No.	Name	Description
S1	Feed Sensor	Detects the leading edge and trailing edge of the sheet at the top of the paper path before Z-Folding. When the feed sensor detects the leading edge, it energizes the pinch idle roller solenoid. The solenoid pulls the pinch idle roller away from the pinch feed roller so the paper can fall below these opposing rollers.
S2	Fold Timing Sensor	(1) Detects the leading edge of the sheet and energizes the pinch idle roller solenoid (upper) to pull the pinch idle roller away from the pinch feed roller so the sheet falls through the gap between these rollers. (2) Detects the trailing edge of the sheet and energizes the pinch idle roller solenoid (lower) to push the pinch idle roller against the pinch feed roller.
S3	Front Door Sensor	Detects when the top cover of the Z-folding unit is closed and signals an alert that the cover is open. The unit cannot be used until this cover is closed.
S4	Leading Edge Sensor	Mounted above the lower stopper. The leading edge sensor 1) detects the leading edge of the sheet when drops onto the lower stopper, 2) detects the leading edge again when the paper is pulled up into the nip of the 1st and 2nd fold rollers. If the leading edge sensor does not detect the edge at the prescribed times, it will signal an error.
S5	Lower Exit Sensor	Mounted below the lower exit rollers. Detects the leading/trailing edges of the folded sheet as it passes below. If these edges do not pass at the times prescribed for the selected paper size, the sensor will signal a jam alert.
S6	Lower Stopper HP Sensor	Detects the lower stopper when it reaches its home position and turns off the lower stopper motor.
S7	Upper Exit Sensor	1) Detects the leading/trailing edges of each sheet unfolded sheet after it passes over the closed junction gate, 2) Detects the leading/trailing edge of each folded sheet as it leaves the vertical feed path below. If the edges do not go by for the time prescribed for the paper size, the sensor will send a jam alert.
S8	Upper Stopper HP	Detects the upper stopper when it reaches its home position and

Sensors		
No.	Name	Description
	Sensor	turns off the upper stopper motor.
S9	Upper Stopper Path Sensor	Mounted below the upper stopper. 1) When the feeler of the upper stopper path sensor detects the paper when the crease of the first fold stops at the upper stopper, it delays long enough so the 1st/2nd feed rollers can continue to rotate and buckle the trailing edge of the paper below at the nip of the 2nd/3rd feed rollers, then the sensor switches off the 1st/2nd feed rollers and switches on the 2nd/3rd feed roller pair. The 2nd/3rd feed rollers pull the buckle into the nip and create the 2nd crease. 2) Detects the paper when it leaves the upper stopper path and signals an error if the paper does not leave at the prescribed time.

Solenoids		
No.	Name	Description
SOL1	Junction Gate Solenoid	Opens and closes the junction gate solenoid. When not energized, the junction gate remains closed and paper passes over the back of the closed junction gate and through the Z-folding unit. When energized it opens the junction gate which guides paper down and into the paper path of the Z-folding unit.
SOL2	Pinch Idle Roller Solenoid (Lower)	Attached to the pinch idle roller, this solenoid pushes the pinch idle roller and closes the gap between the pinch idle/pinch feed rollers when the fold timing sensor at the above the pinch idle roller detects the trailing edge of the sheet so the rollers can pinch and stop the paper in the paper path.
SOL3	Pinch Idle Roller Solenoid (Upper)	Attached to the pinch idle roller, this solenoid pulls the pinch idle roller away from the pinch feed roller when the feed sensor at the top of the Z-fold paper path detects the leading edge of the sheet so the paper can drop between these opposing rollers.

Z-Folding Unit
B660

Switches		
No.	Name	Description
SW1	Breaker	Opens and breaks the power circuit if the Z-folding unit overheats.

Relays		
No.	Name	Description
RA1	Relay	Switch relay

B704

COVER INTERPOSER TRAY

B704 COVER INTERPOSER TYPE 3260 REVISION HISTORY		
Page	Date	Added/Updated/New
		None

COVER INTERPOSER TRAY B704

TABLE OF CONTENTS

1. REPLACEMENT AND ADJUSTMENT.....	1
1.1 EXTERNAL COVERS	1
1.2 FEED UNIT AND PICK-UP ROLLER	2
1.3 FEED BELT	3
1.4 GUIDE PLATE ADJUSTMENT.....	4
1.5 MAIN BOARD.....	5
1.6 MOTOR REPLACEMENT	6
1.6.1 VERTICAL TRANSPORT MOTOR.....	6
1.6.2 BOTTOM PLATE LIFT MOTOR	6
1.6.3 FEED MOTOR, TRANSPORT MOTOR	7
2. DETAILS	8
2.1 OVERVIEW	8
2.1.1 MAIN LAYOUT	8
2.1.2 DRIVE LAYOUT	9
2.1.3 PAPER SIZE DETECTION.....	10
2.1.4 PAPER PATH.....	13
2.2 PAPER FEED.....	14
Power On.....	14
Paper Separation and Feed.....	14
Bottom Tray Lift	14
Paper Near-end	14
Paper End.....	14

1. REPLACEMENT AND ADJUSTMENT

1.1 EXTERNAL COVERS

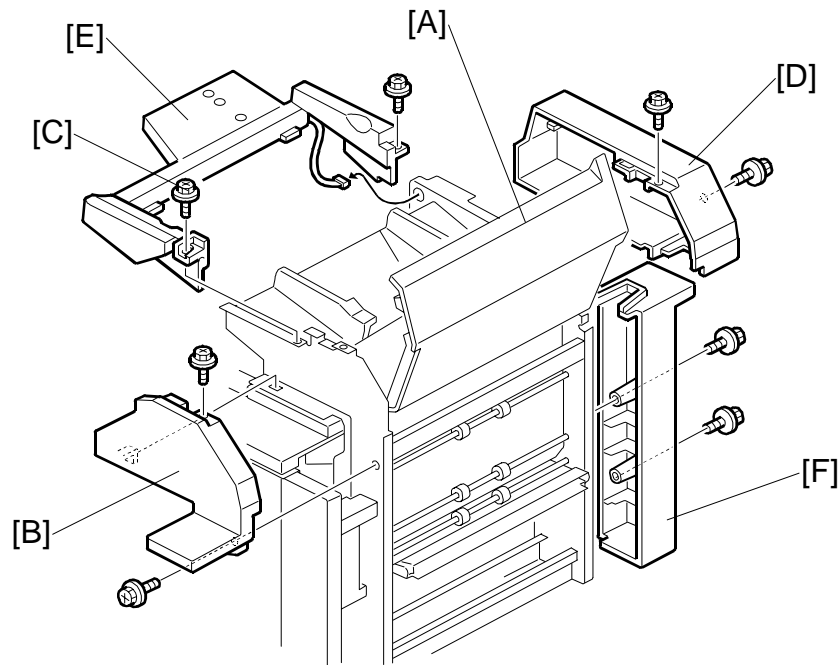

[A]: Open the feed cover.

[B]: Upper front cover (⚙️ x 2)

NOTE: To remove the upper front cover, screw [C] must be removed.

[D]: Rear upper cover (⚙️ x 2)

[E]: Slip sheet tray (⚙️ x 2, 📄 x 1)

[F]: Rear middle cover (⚙️ x 2)

1.2 FEED UNIT AND PICK-UP ROLLER

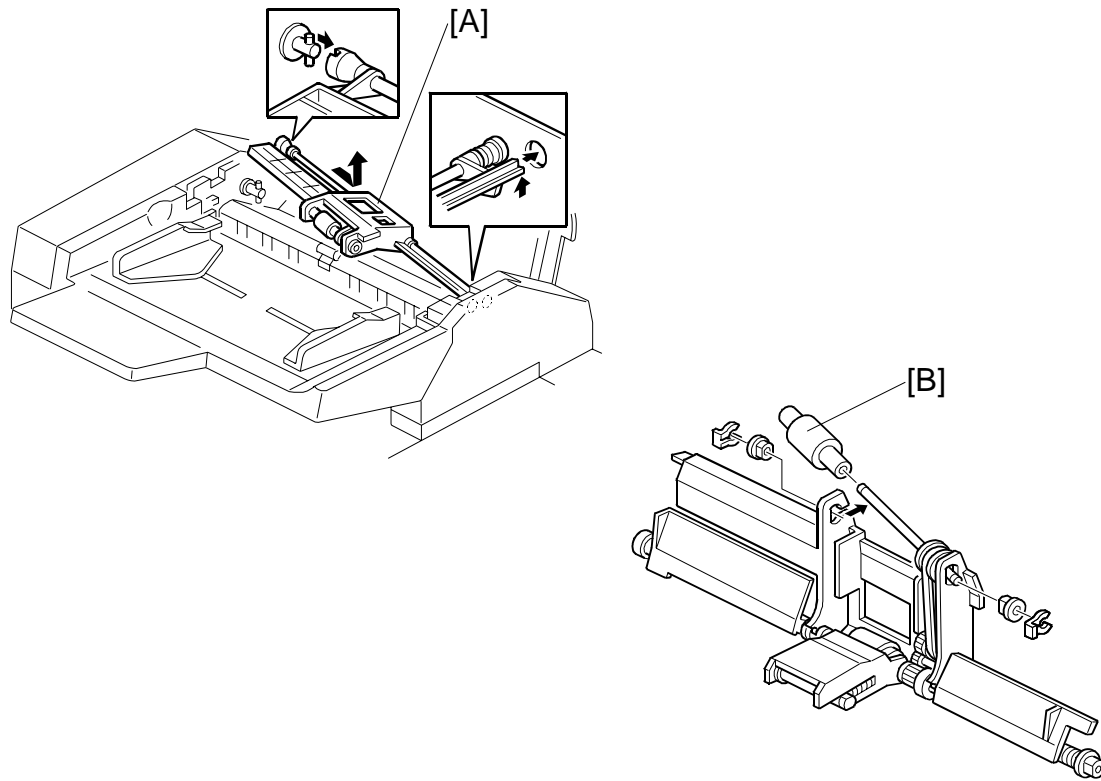

Open the feed cover.

[A]: Feed unit

- The unit is spring loaded. Push it to the right to release it, then lift it out.

[B]: Pick-up roller (🌀 x 2, bushings x 2)

1.3 FEED BELT

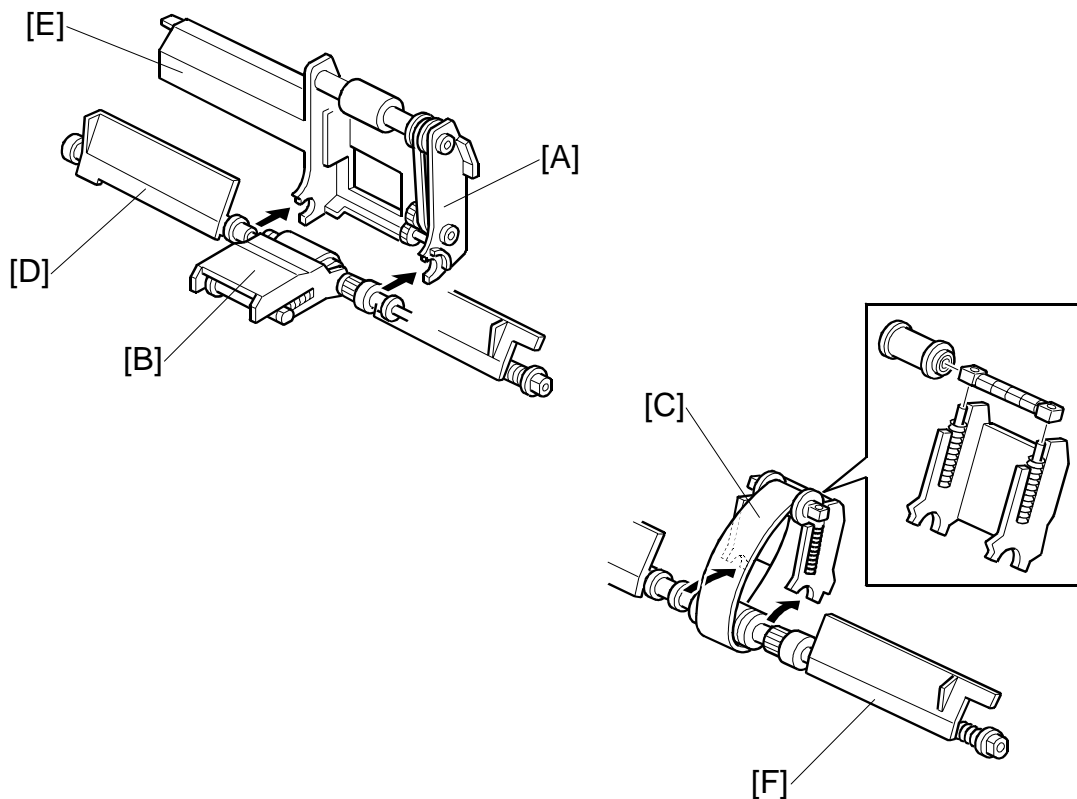

Feed unit (☛ 1.2)

[A]: Pick-up roller unit.

- Pull the unit away from the bushings in the direction of the arrow.

[B]: Feed belt holder

- Hold the feed belt holder by the sides, then lift up to separate from the holder.
- Pull slowly to avoid losing the springs.

[C]: Feed belt.

Re-assembly

1. Position the pick-up roller unit [A] and feed belt holder [B] as shown above.
2. On the rear side, slide out the bushing, and rotate [D] until its flat side is parallel with [E], then snap it on.
3. On the front side, rotate [F] until its flat side is parallel with [D], then snap it on. Viewed from the bottom, the plates must be aligned.

1.4 GUIDE PLATE ADJUSTMENT

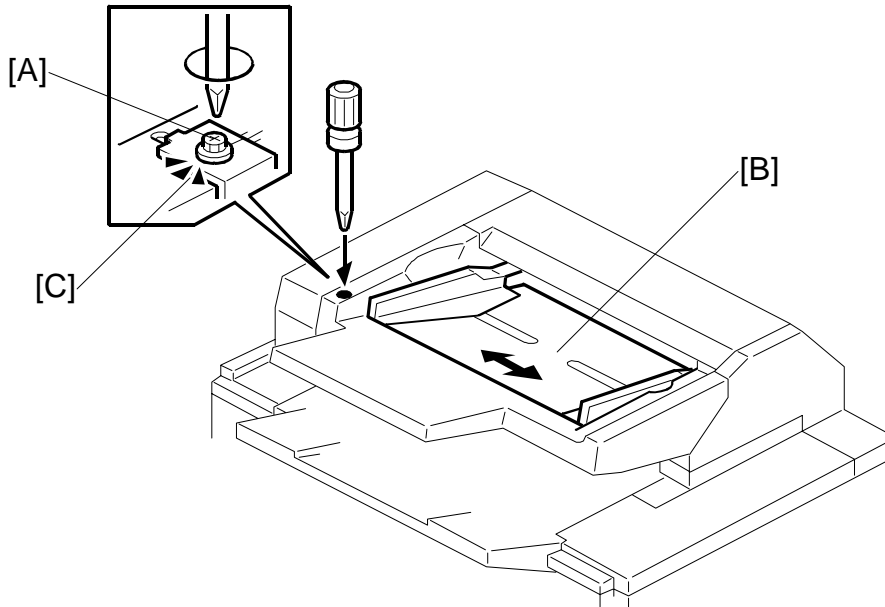

Adjust the guide plate if the holes punched in the covers or slip sheets are not correctly aligned with holes punched in the other sheets.

1. Open the feed cover.
2. Loosen the screw [A].
3. Push the table [B] left or right to change its position, then tighten the screw.

NOTE: If you want to see the scale [C], you must remove the rear cover and the support tray.

1.5 MAIN BOARD

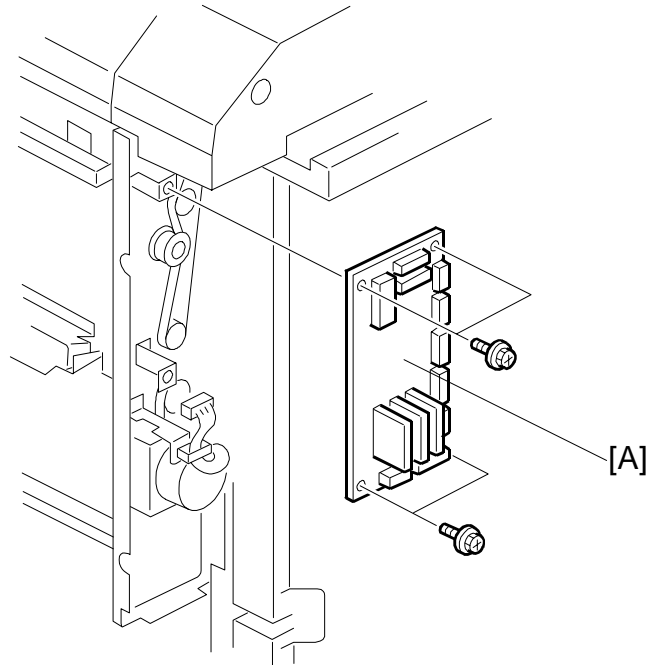

Open the top cover.

Rear cover (🔩 x 1)

[A]: Main board (🔩 x 9, 🛠️ x 4)

NOTE: All DIP switch settings on the main board of the cover sheet unit should be set to OFF.

MOTOR REPLACEMENT

1.6 MOTOR REPLACEMENT

1.6.1 VERTICAL TRANSPORT MOTOR

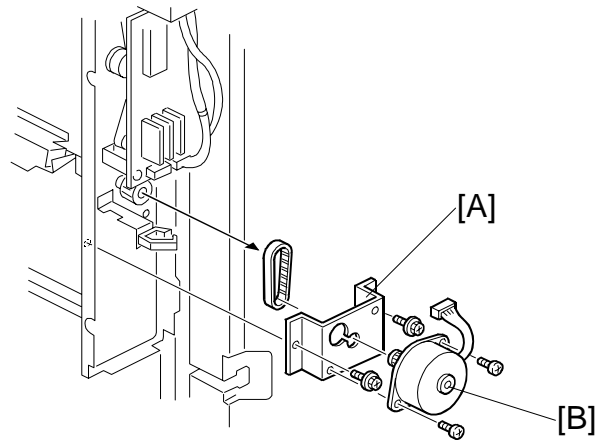

Open the top cover.

Rear middle cover (🔩 x 1) (👁 1.1)

[A]: Motor bracket (🔩 x 1, harness x 1, 🛠 x 2, timing belt x 1)

[B]: Motor (🛠 x 2)

1.6.2 BOTTOM PLATE LIFT MOTOR

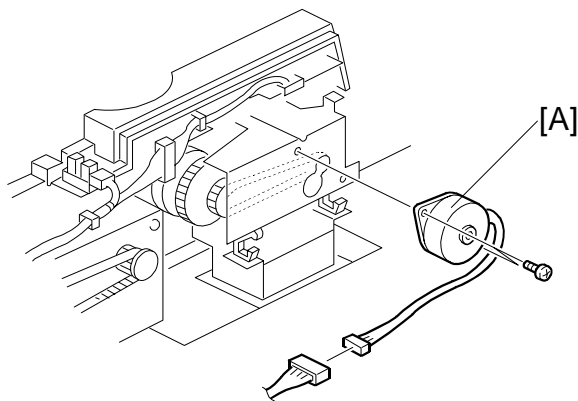

Rear upper cover (👁 1.1)

[A]: Bottom plate lift motor (harness x 2, 🛠 x 1, 🛠 x 2)

1.6.3 FEED MOTOR, TRANSPORT MOTOR

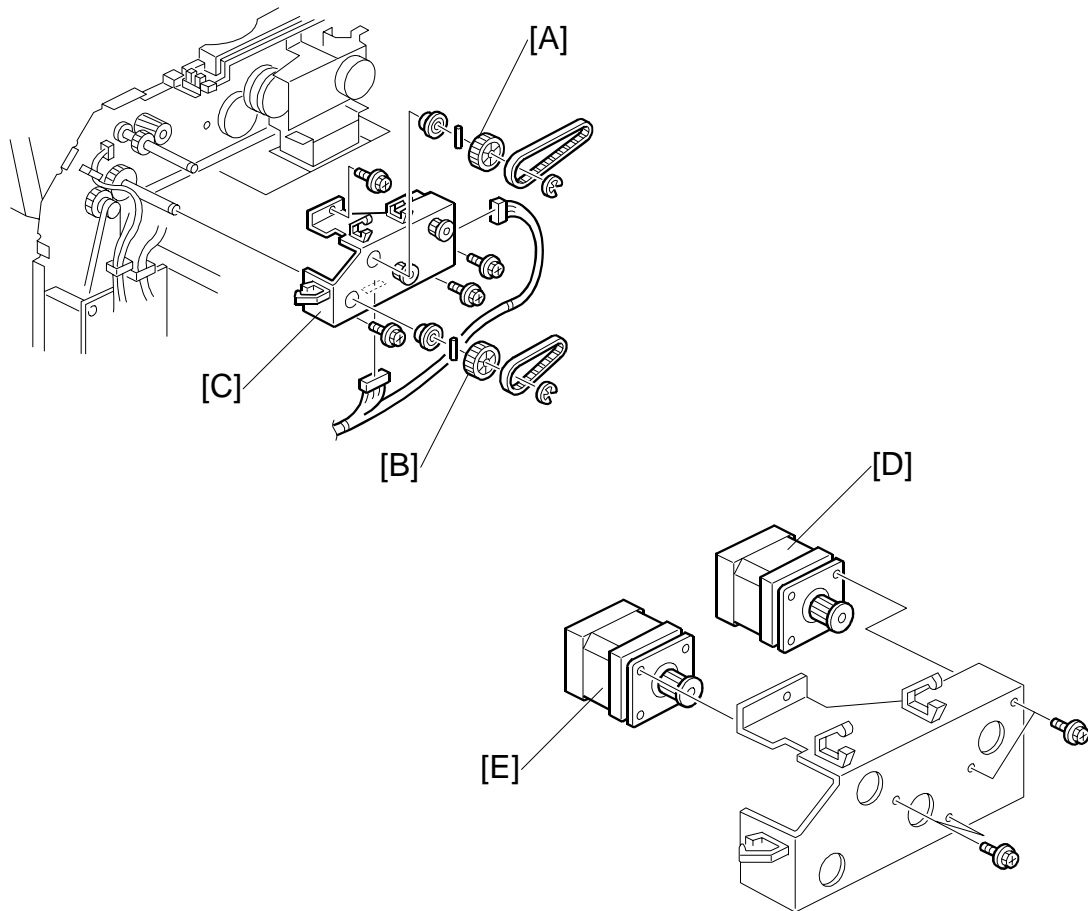

Rear upper cover (☛ 1.1)

NOTE: When removing the feed gear and transport gear, hold one hand under the gear to catch the pin as it falls from the hole in the shaft.

- [A]: Feed gear (☉ x 1, pin x 1, timing belt x 1, bushing x 1)
- [B]: Transport gear (☉ x 1, pin x 1, timing belt x 1, bushing x 1)
- [C]: Motor bracket (harness x 5, ⚙ x 4)
- [D]: Feed motor (⚙ x 1, ⚙ x 2)
- [E]: Transport motor (⚙ x 1, ⚙ x 2)

2. DETAILS

2.1 OVERVIEW

2.1.1 MAIN LAYOUT

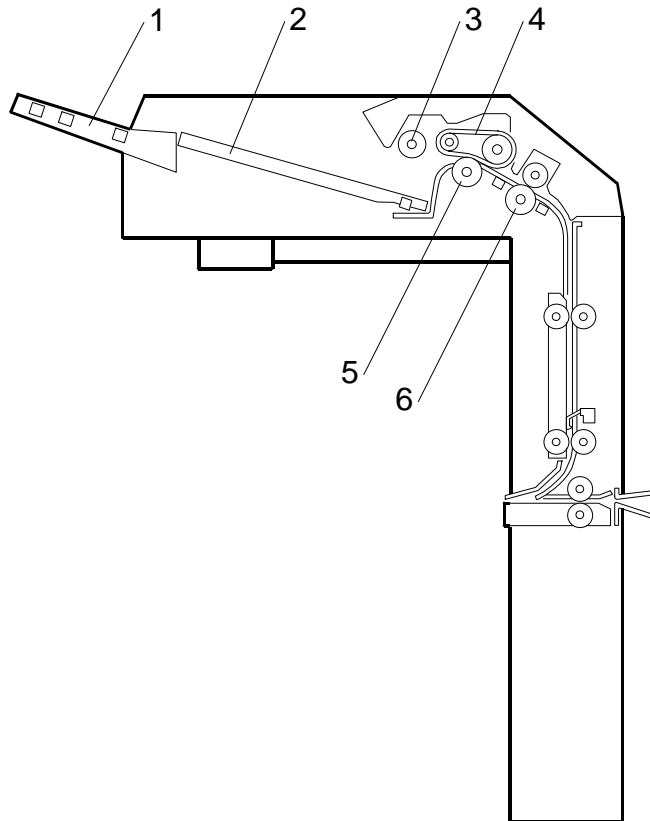

1. Support tray
2. Slip sheet tray
3. Pick-up roller
4. Feed belt
5. Separation roller
6. Grip roller

2.1.2 DRIVE LAYOUT

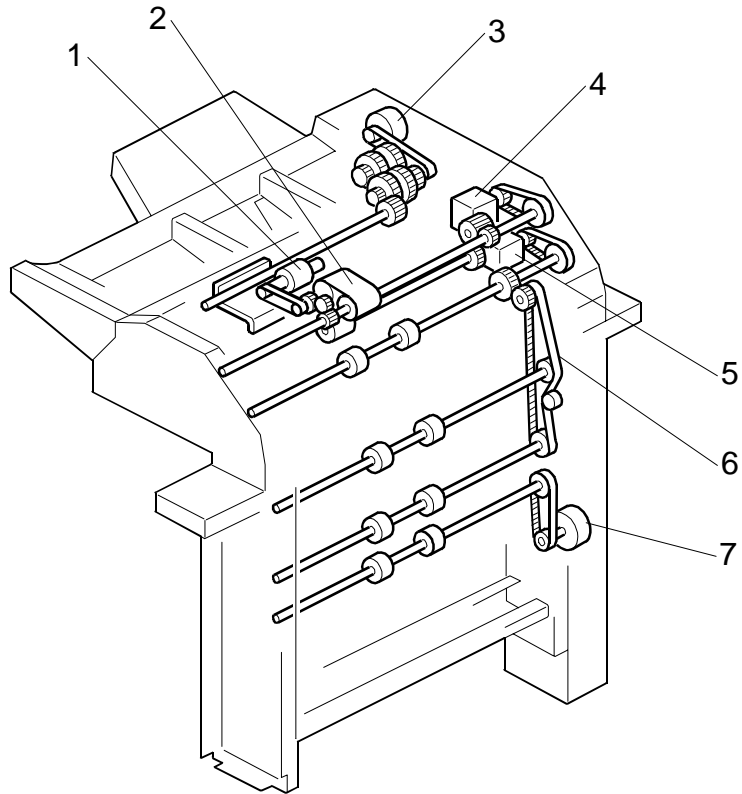

1. Pick-up Roller
2. Feed Belt
3. Bottom Plate Lift Motor
4. Feed Motor
5. Transport Motor
6. Timing Belt
7. Vertical Transport Motor

Cover
Interposer
Tray
B704

OVERVIEW

2.1.3 PAPER SIZE DETECTION

The width sensors [A] (S1, S2, S3) and length sensors [B] (S4, S5, S6) detect the width and length of the original on the interposer feed tray.

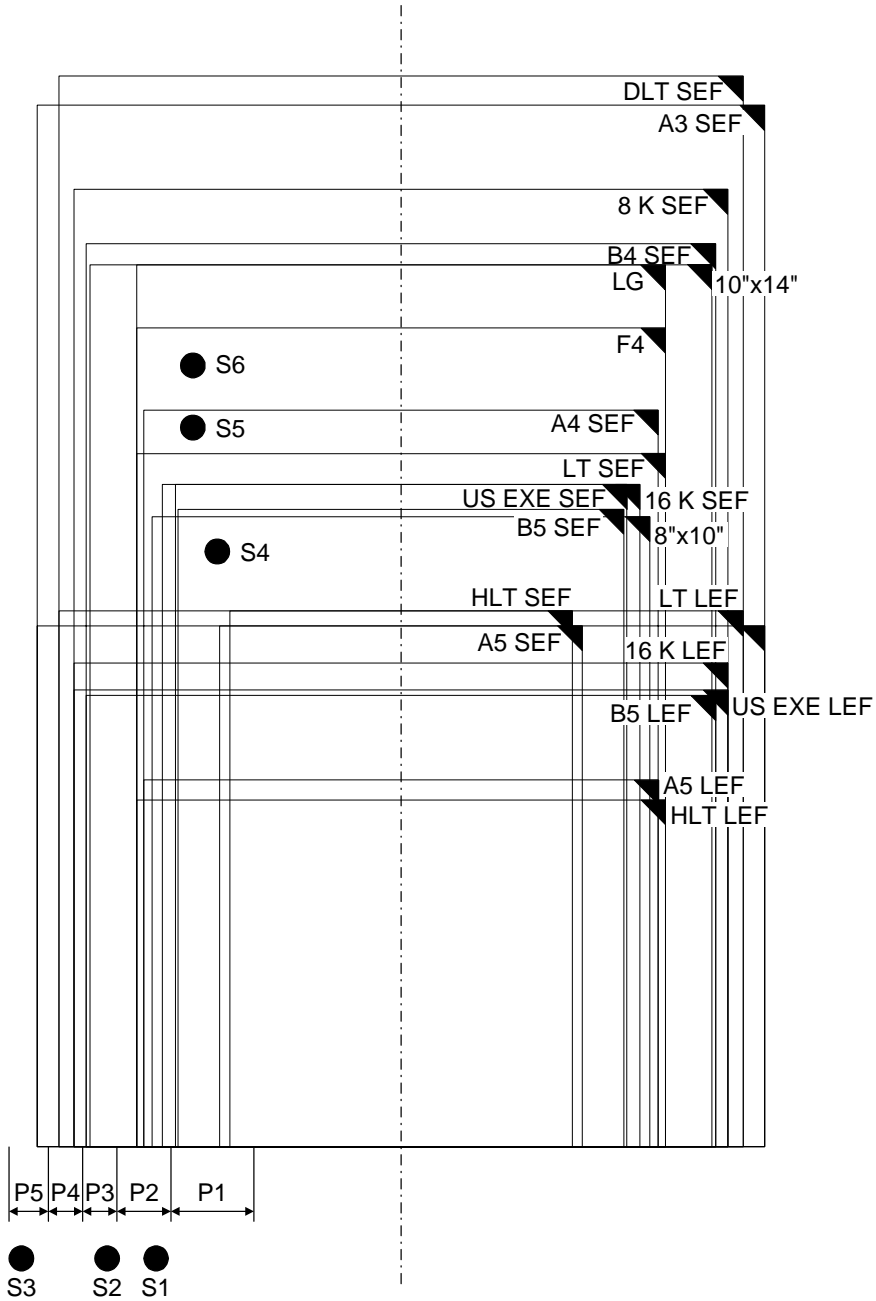

The table below lists the sensor output for each paper size.

	S1	S2	S3	S4	S5	S6
A3	0	1	1	1	1	1
B4	1	1	0	1	1	1
A4 SEF	1	0	0	1	1	0
A4 LEF	0	1	1	0	0	0
B5 SEF	0	0	0	1	0	0
B5 LEF	1	1	0	0	0	0
A5 SEF	0	0	0	0	0	0
A5 LEF	1	0	0	0	0	0
11" x 17"	1	1	1	1	1	1
10" x 14" SEF	1	1	0	1	1	1
8 1/2" x 14"	1	0	0	1	1	1
8 1/2" x 13"	1	0	0	1	1	1
8 1/2" x 11"	1	0	0	1	0	0
11" x 8 1/2"	1	1	1	0	0	0
8" x 10"	1	0	0	1	0	0
5 1/2" x 8 1/2"	0	0	0	0	0	0
8 1/2" x 5 1/2"	1	0	0	0	0	0
7 1/2" x 10 1/2" (US Exec.)	0	0	0	1	0	0
10 1/2" x 7 1/2" (US Exec.)	1	1	1	0	0	0
8 K	1	1	1	1	1	1
16 K SEF	1	0	0	1	0	0
16 K LEF	1	1	1	0	0	0

The cover interposer tray detects all the paper sizes listed above. However, there are some limitations on the display of the correct paper size.

		North America	Europe/Asia
B4 SEF	257 x 364 mm	Displays 10"x14" ^{*1}	
B5 SEF	182 x 257	Displays "US Exec." ^{*1}	
A5 SEF	148 x 210	Displays "HLT SEF" ^{*1}	
A5 LEF	210 x 148	Displays "HLT LEF" ^{*1}	
DLT SEF	11" x 17"		Displays "8K LEF" ^{*2}
LG SEF	8 1/2" x 14"		Displays "F4 SEF" ^{*2}
LT SEF	8 1/2" x 11"		Displays "16 K SEF" ^{*2}
LT LEF	11" x 8 1/2"		Displays "16 K LEF" ^{*2}

^{*1}: Cannot be corrected.

^{*2}: B064 series: Can be corrected with SP5959 006 (Paper Size – Cover Sheet).
B140 series: Can be corrected with SP5158

Cover
Interposer
Tray
B704

OVERVIEW

B064 series: Paper Size Detection

North America

Execute SP5959 006 and enter the correct number for the size of the paper loaded for feeding from the cover interposer tray.

Loaded	Display (Default)	To Select for Display	Enter
8 1/2" x 13"	8 1/2" x 14"	8 1/2" x 13"	165
10 1/2" x 7 1/2"	8 1/2" x 11"	10 1/2" x 7 1/2"	173
8" x 10"	8 1/2" x 11"	8" x 10"	171

Europe/Asia

Execute SP5959 006 and enter the correct number for the size of the paper loaded for feeding from the cover interposer tray.

Loaded	Display (Default)	To Select for Display	Enter
11" x 17"	8 K	11" x 17"	160
8 1/2" x 11"	16 K SEF	8 1/2" x 11"	166
11" x 8 1/2"	16 K LEF	11" x 8 1/2"	38
8 1/4" x 13"	8 1/2" x 13" SEF	8 1/4" x 13"	168

B070/B071, B140 series: Paper Size Detection

Some paper sizes are almost the same and cannot be detected as different sizes by the sensors. To select the sizes that are detected, use SP 5158.

2.1.4 PAPER PATH

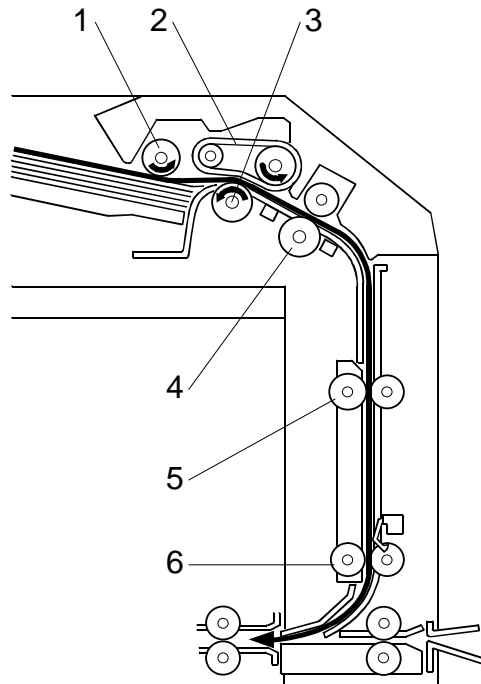

1. Pick-up Roller
2. Feed Belt
3. Separation Roller
4. Grip Roller
5. Transport Roller 1
6. Transport Roller 2

The paper feeds from the tray, to the feed belt, then to the grip roller and down into the paper path to the finisher below.

Cover
Interposer
Tray
B704

2.2 PAPER FEED

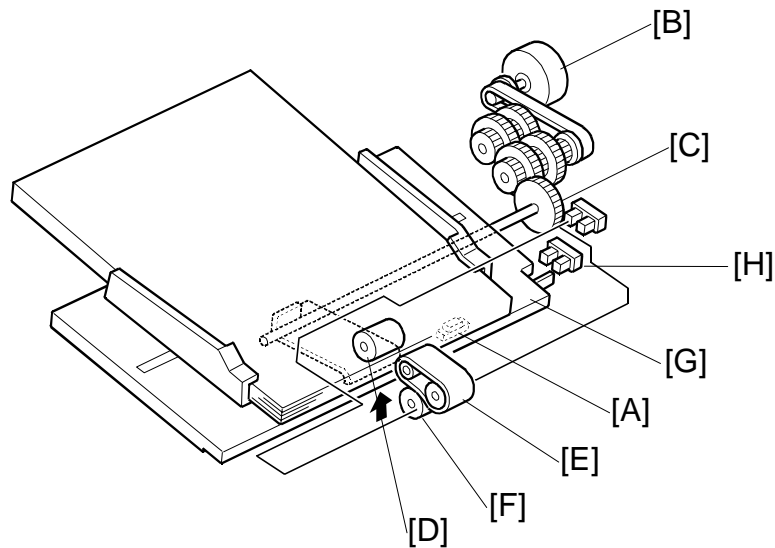

Power On

When paper is placed on the tray, the paper set sensor [A] in the tray actuates and switches on the bottom plate lift motor [B]. The top of the stack raises the pick-up roller unit until the actuator on this unit actuates the pick-up roller position sensor [C] and switches the motor off.

Paper Separation and Feed

The pick-up roller [D] picks up the original, and the feed belt [E] feeds the sheet to the grip roller. The separation roller [F] reverses if more than one sheet is fed

Bottom Tray Lift

As sheets feed from the top of the stack:

- The pick-up roller unit descends until the actuator on the pick-up roller unit drops out of the pick-up roller position sensor [C].
- The bottom plate lift motor switches on to raise the stack until the actuator enters the pick-up roller unit position sensor again and switches the motor off.
- This repeats until the end of the job or until paper runs out.

Paper Near-end

Near-end is detected when the actuator [G] on the bottom plate enters the near-end sensor [H].

Paper End

After the last sheet feeds the paper set sensor [A] goes off and signals paper out.

B475

A3/DLT TRAY KIT

B475 A3/DLT TRAY KIT REVISION HISTORY		
Page	Date	Added/Updated/New
		None

A3/DLT TRAY KIT B475

TABLE OF CONTENTS

1. REPLACEMENT AND ADJUSTMENT.....	1
1.1 BOTTOM PLATE LIFT WIRE REPLACEMENT	1
1.1.1 REMOVING THE LIFT WIRE	1
1.1.2 INSTALLING THE LIFT WIRE.....	2
2. DETAILS	3

1. REPLACEMENT AND ADJUSTMENT

1.1 BOTTOM PLATE LIFT WIRE REPLACEMENT

1.1.1 REMOVING THE LIFT WIRE

NOTE: The procedures for front and rear wire removal are the same.

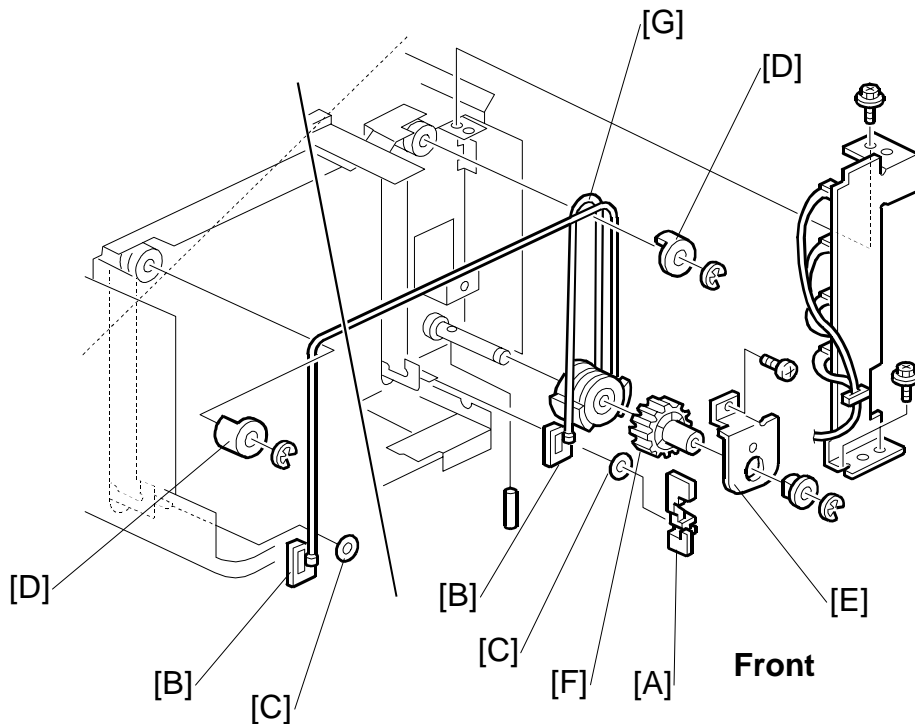

Remove the A3/DLT tray from the machine.

Inner cover (🔩 x 2)

[A]: Sensor bracket (🔩 x 1)

[B]: Wire stoppers

[C]: Wire stopper rings

[D]: Wire covers x 2 (🌀 x 1 each)

[E]: Bracket (🔩 x 1, 🌀 x 1, Bushing x 1)

[F]: Gear

[G]: Bottom plate lift wire

A3/DLT Tray
Kit
B475

BOTTOM PLATE LIFT WIRE REPLACEMENT

1.1.2 INSTALLING THE LIFT WIRE

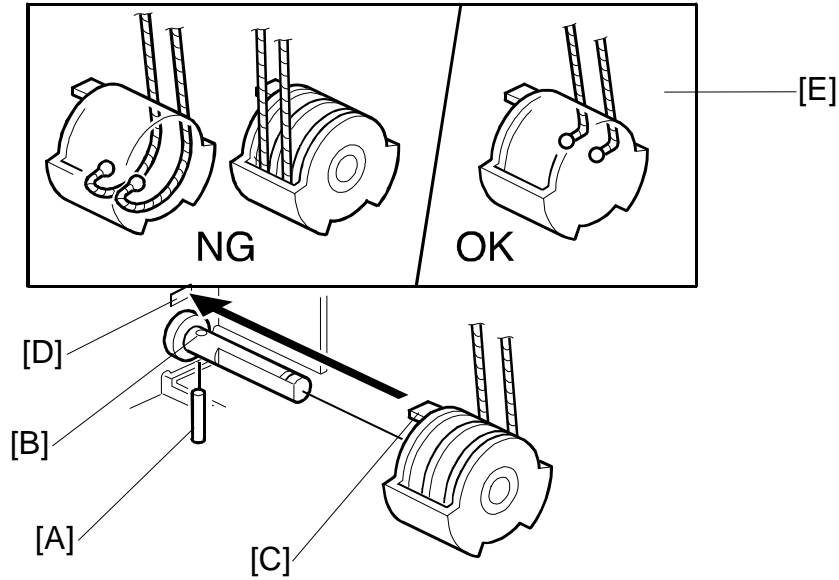

1. Put the positioning pin [A] in hole [B]
 2. Fit the projection [C] into slot [D].
 3. Attach the wire as shown [E].
- NOTE:** Make sure that the wires are not crossed.

2. DETAILS

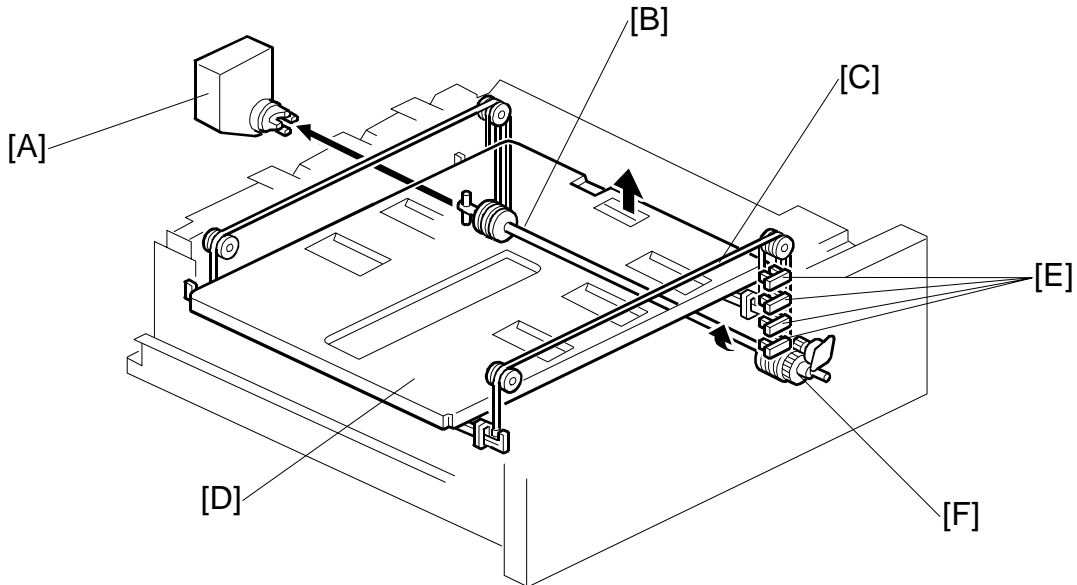

With this option installed, only one stack of paper can be loaded.

Lift motor [A] → Shaft and pulleys [B] → Tray wires [C] → Tray bottom plate [D].

An array of four paper height sensors [E] provide paper supply detection. As each sensor is actuated, a message (percent of paper remaining) alerts the user about the remaining amount of paper. When the bottom sensor [F] of the four sensors is actuated, the paper end message is displayed.

COVER INTERPOSER TRAY CI5000 B835

B835 COVER INTERPOSER TRAY CL5000 REVISION HISTORY		
Page	Date	Added/Updated/New
		None

COVER INTERPOSER TRAY B835

TABLE OF CONTENTS

1. REPLACEMENT AND ADJUSTMENT	1
1.1 COVERS.....	1
1.2 1ST, 2ND TRAYS	4
1.3 FEED UNITS.....	5
1.4 BOARDS.....	6
1.4.1 TRAY UNIT CONTROL BOARD	6
1.4.2 MAIN CONTROL BOARD.....	7
1.5 MOTORS	8
1.5.1 VERTICAL TRANSPORT MOTOR	8
1.5.2 HORIZONTAL TRANSPORT MOTOR.....	9
1.5.3 1ST, 2ND LIFT MOTORS	10
1.5.4 1ST, 2ND FEED MOTORS	11
1.5.5 1ST, 2ND TRANSPORT MOTORS.....	12
1.5.6 1ST, 2ND PICK-UP MOTORS	13
1.6 SENSORS	14
1.6.1 PAPER WIDTH SWITCH, SET SENSORS, LENGTH SENSOR.....	14
1.6.2 TRAY COVER SENSORS	16
1.6.3 1ST TRANSPORT SENSOR	17
1.6.4 FEED UNIT SENSORS.....	18
1.6.5 2ND VERTICAL TRANSPORT, EXIT SENSORS.....	19
1.6.6 ENTRANCE SENSOR	20
1.7 ROLLERS.....	21
1.7.1 SEPARATION ROLLER.....	21
1.7.2 FEED BELT UNIT AND PICK-UP ROLLER.....	22
1.7.3 FEED BELT.....	23
2. DETAILS.....	24
2.1 PAPER PATH	24
2.2 PAPER FEED	25
2.2.1 FEED MECHANISM.....	25
2.2.2 PAPER NEAR END/PAPER END.....	26
2.2.3 PAPER SIZE DETECTION	27
3. OVERALL MACHINE INFORMATION.....	29
3.1 MAIN LAYOUT.....	29
3.2 DRIVE LAYOUT.....	30
3.3 ELECTRICAL COMPONENTS	31
3.3.1 FEED MOTORS, PCB	31
3.3.2 LIFT MOTORS, TRAY SENSORS	32
3.3.3 PAPER PATH SENSORS 1	33
3.3.4 PAPER PATH SENSORS 2, PCB.....	34
3.3.5 ELECTRICAL COMPONENT SUMMARY	35

1. REPLACEMENT AND ADJUSTMENT

1.1 COVERS

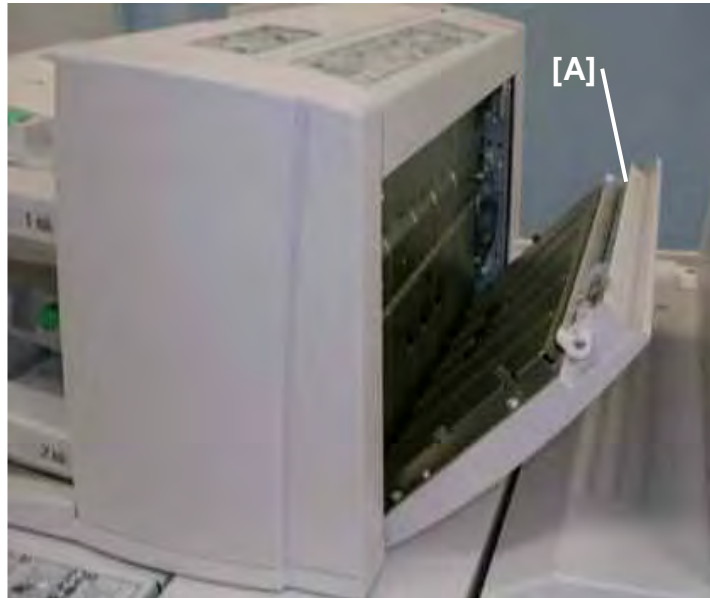

1. Open the vertical feed cover [A].

Cover
Interposer
Tray
B835

REPLACEMENT AND ADJUSTMENT

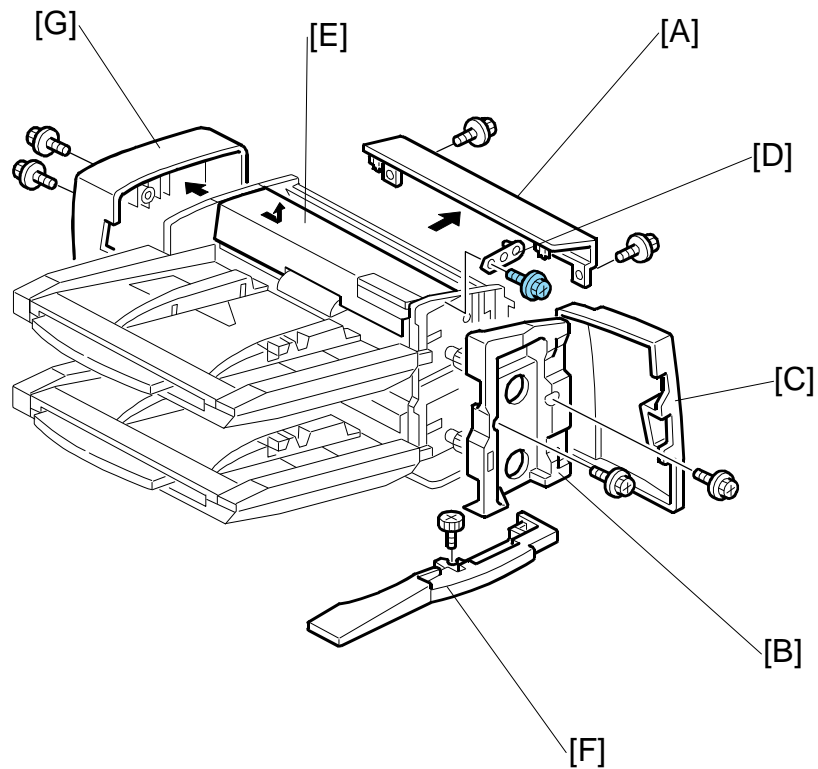

2. Remove:

[A] Top cover (⚙️ x2)

[B] Inner cover with front door [C] (⚙️ x2)

[D] 1st tray cover holder (⚙️ x1)

[E] 1st tray cover. Slide the cover toward you to remove it from the inside pins.

[F] Base cover (Knob ⚙️ x1)

[G] Tray unit rear cover (⚙️ x2)

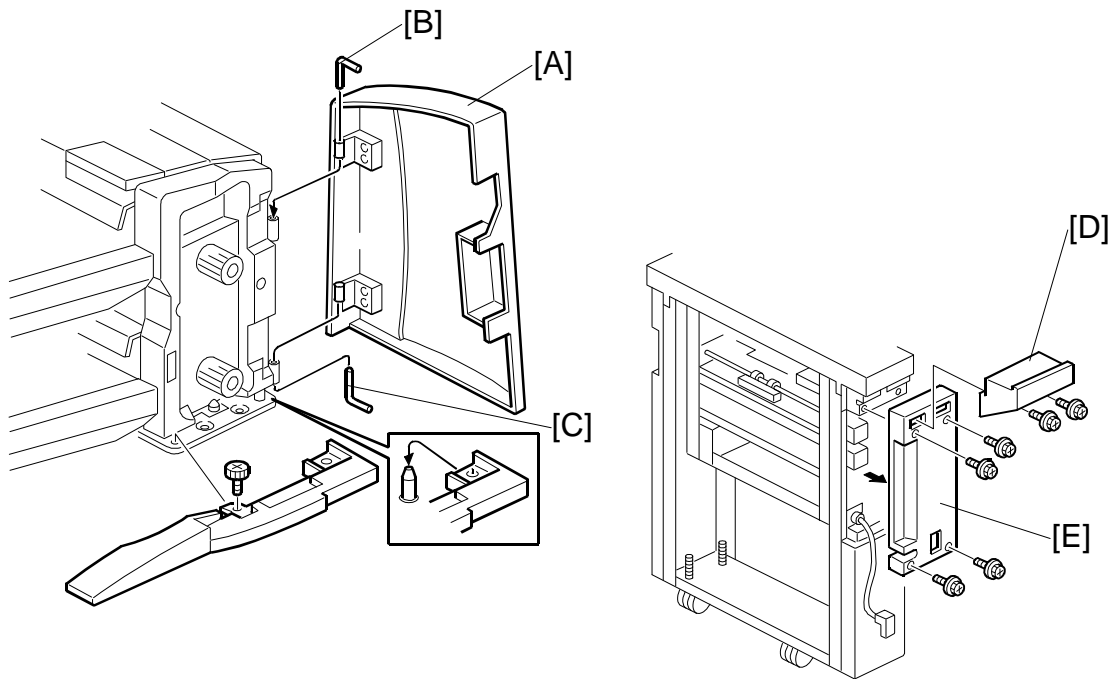

3. Remove:

[A] Front door (L-pins x2)

- Swing the upper L-pin [B] out of its groove and pull it up.
- Swing the lower L-pin [C] out of its groove and pull it down.

[D] Rear top cover of the feed unit (⚙️ x2)

[E] Feed unit rear upper cover (⚙️ x4)

1.2 1ST, 2ND TRAYS

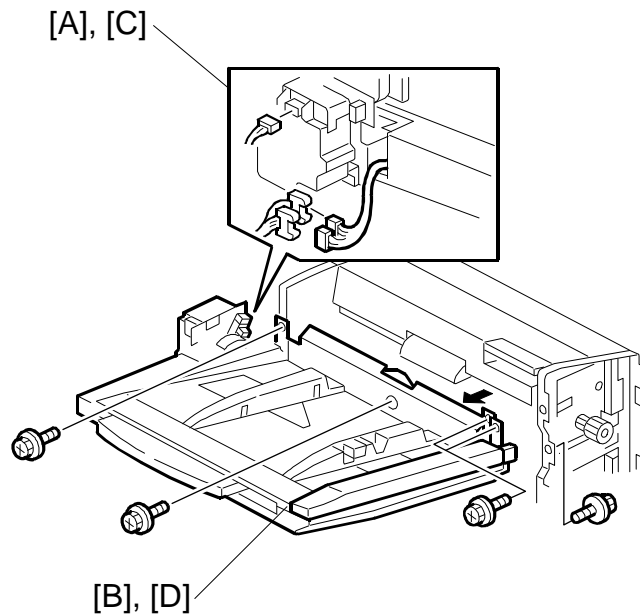

Remove:

- Inner cover with tray unit front door (☛1.1)
- Tray unit rear cover (☛1.1)

1st Tray

[A] Disconnect:

- 1st lift motor (☛1x, ☛x1)
- White connectors (☛x2)

[B] 1st tray (☛ x5)

2nd Tray

Remove:

- Inner cover with tray unit front door (☛1.1)
- Tray unit rear cover (☛1.1)

[C] Disconnect:

- 2nd lift motor (☛1x, ☛x1)
- Red, blue connectors (☛x2)

[D] 2nd tray (☛ x5)

1.3 FEED UNITS

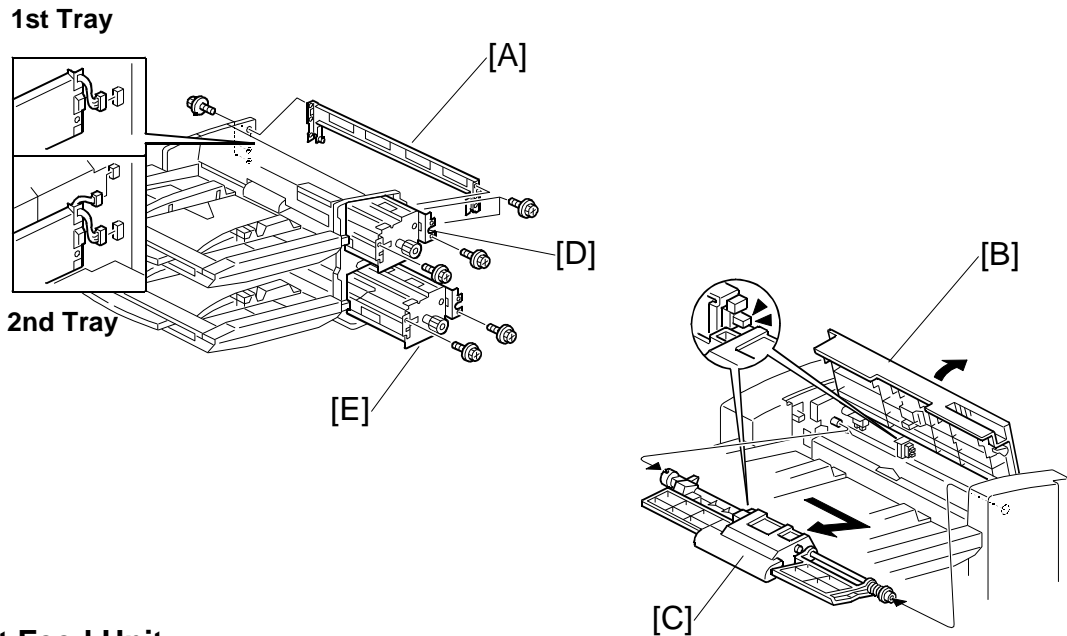

1st Feed Unit

Remove:

- Top cover (☛1.1)
- Inner cover with front door (☛1.1)
- Tray unit rear cover (☛1.1)

[A] Stay (🔩 x5)

[B] Open the 1st tray cover and hold it open

[C] 1st feed belt unit

[D] 1st feed unit (🔩 x, 📐 x)

2nd Feed Unit

- Open the vertical feed cover (☛1.1)
- Remove inner cover with tray unit front door (☛1.1)
- 2nd feed belt unit (same as [C])

[E] 2nd feed unit (🔩 x2, 📐 x2)

1.4 BOARDS

1.4.1 TRAY UNIT CONTROL BOARD

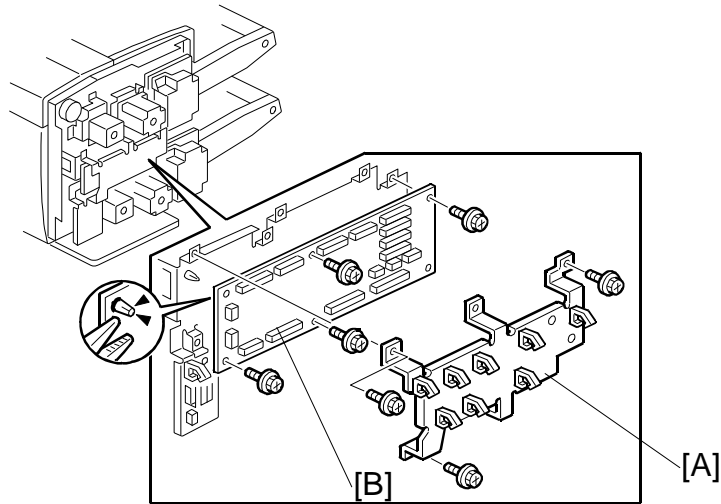

Remove:

- Tray unit rear cover (🔩 x2) (👉1.1)
[A] Board cover (🔩 x3, 🏠x8)
[B] Tray unit control board (🏠 x 17, 🔩 x5, Standoff x1)

1.4.2 MAIN CONTROL BOARD

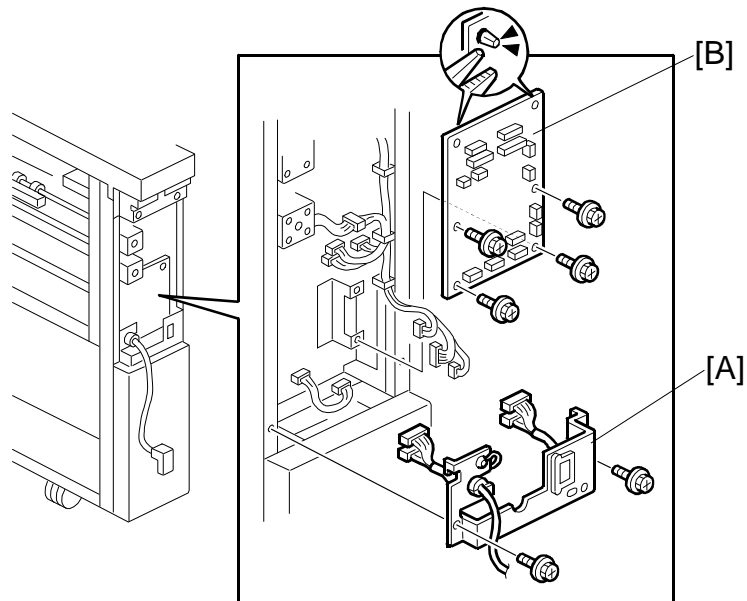

- Transport unit rear upper cover (☛1.1)
 - [A] Connector bracket (🔩 x2)
 - [B] Main control board (🔩 x4, ⏏x2, 📡 x14, Standoff x2)

1.5 MOTORS

1.5.1 VERTICAL TRANSPORT MOTOR

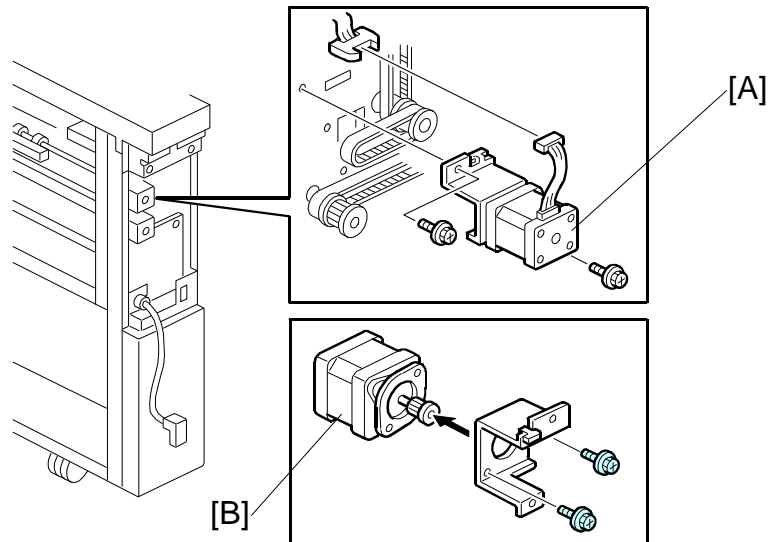

Remove:

- Transport unit rear cover (➡1.1)
- [A] Motor unit (🔩 x2, ⚙️ x1, Timing belt x1)
- [B] Vertical transport motor (🔩 x2)

1.5.2 HORIZONTAL TRANSPORT MOTOR

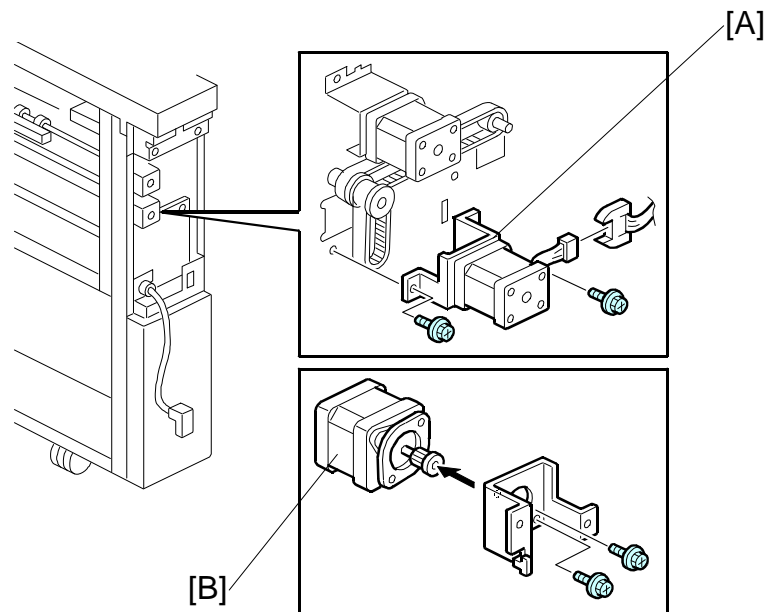

Remove:

- Transport unit rear cover (1.1)
- [A] Motor unit (Screw x2, Timing belt x1)
- [B] Horizontal transport motor (Screw x2)

REPLACEMENT AND ADJUSTMENT

1.5.3 1ST, 2ND LIFT MOTORS

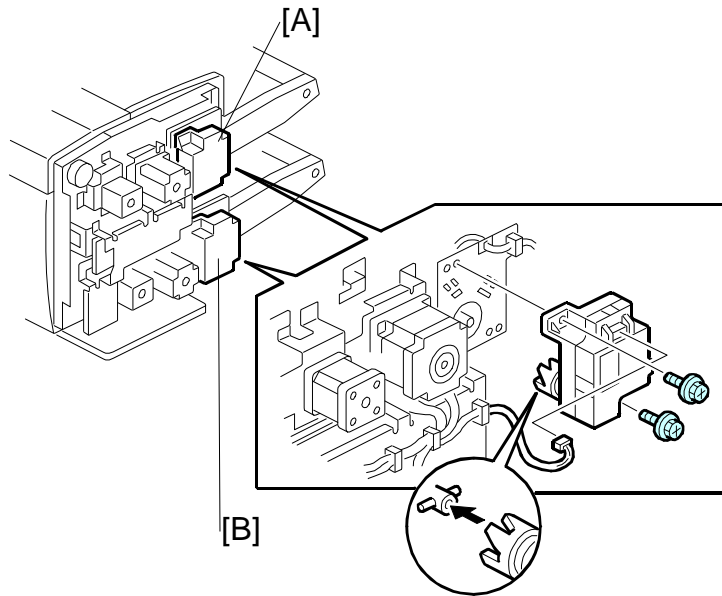

- Tray unit rear cover (☛1.1)
[A] 1st lift motor (⚙️ x2, 📏 x1)
[B] 2nd lift motor (⚙️ x2, 📏 x1)

1.5.4 1ST, 2ND FEED MOTORS

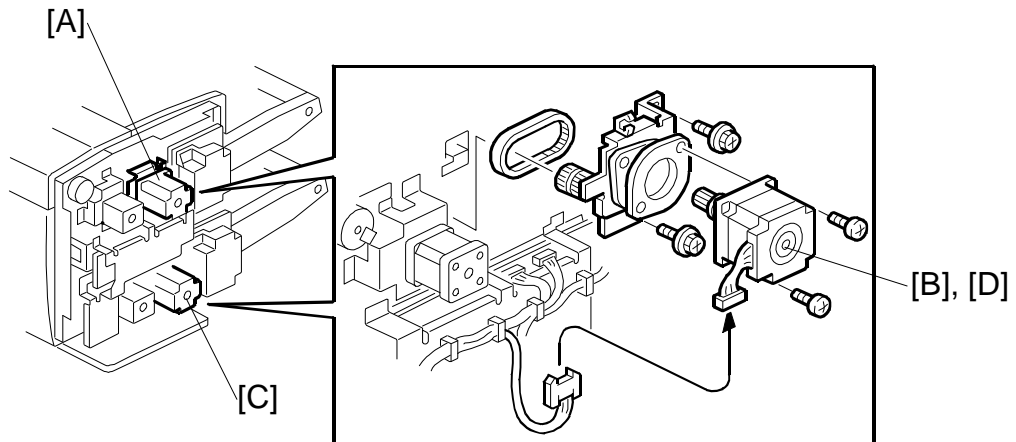

- Tray unit rear cover (☛1.1)
 - [A] 1st feed motor unit (⚙️ x3, ⚙️ x2, ⚙️ x1)
 - [B] 1st feed motor (⚙️ x2, Timing belt x1)
 - [C] 2nd feed motor unit (⚙️ x3, ⚙️ x1)
 - [D] 2nd feed motor unit (⚙️ x2, Timing belt x1)

1.5.5 1ST, 2ND TRANSPORT MOTORS

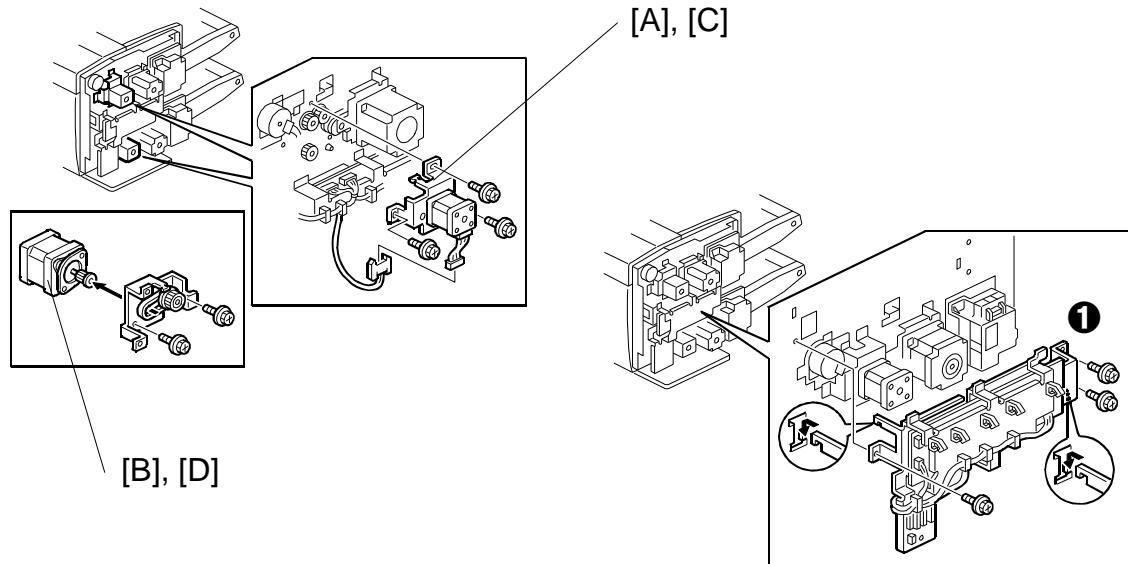

- Tray unit rear cover (☛1.1)

1st Transport Motor

- [A] 1st transport motor unit (☛ x3, ☛☛ x1)
- [B] 1st transport motor (☛ x2, Timing belt x1)

2nd Transport Motor

- 1 Tray unit control board unit (Hooks, ☛ x3, ☛☛ x9 (Motor x8, CN216))
- [C] 2nd transport motor unit (☛ x3)
- [D] 2nd transport motor (☛ x2, Timing belt x1)

1.5.6 1ST, 2ND PICK-UP MOTORS

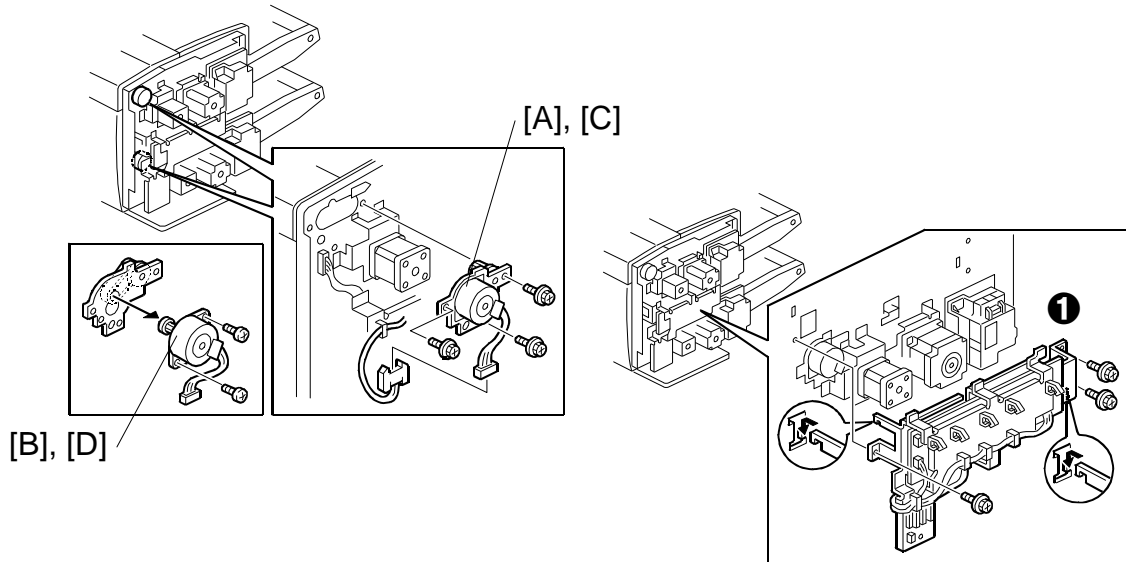

- Tray unit rear cover (☛1.1)

1st Pick-up Motor

[A] 1st pick-up motor unit (☛ x1, ⚙ x3)

[B] 1st pick-up motor (⚙ x2, Timing belt x1)

2nd Pick-up Motor

❶ Tray unit control board unit (Hooks, ⚙ x3, ☛ x9 (Motor x8, CN216))

[C] 2nd pick-up motor unit (☛ x1, ⚙ x3)

[D] 2nd pick-up motor (⚙ x2, Timing belt x1)

1.6 SENSORS

1.6.1 PAPER WIDTH SWITCH, SET SENSORS, LENGTH SENSOR

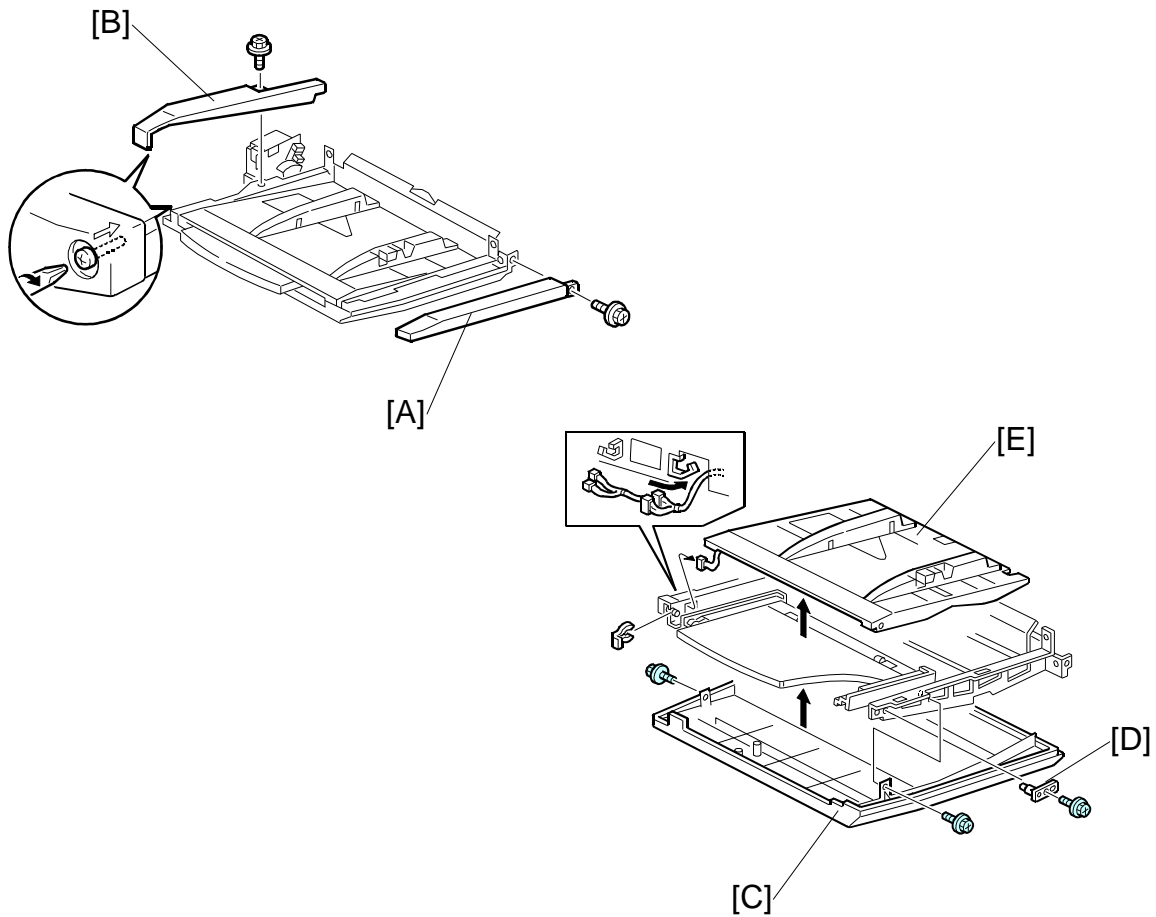

Remove:

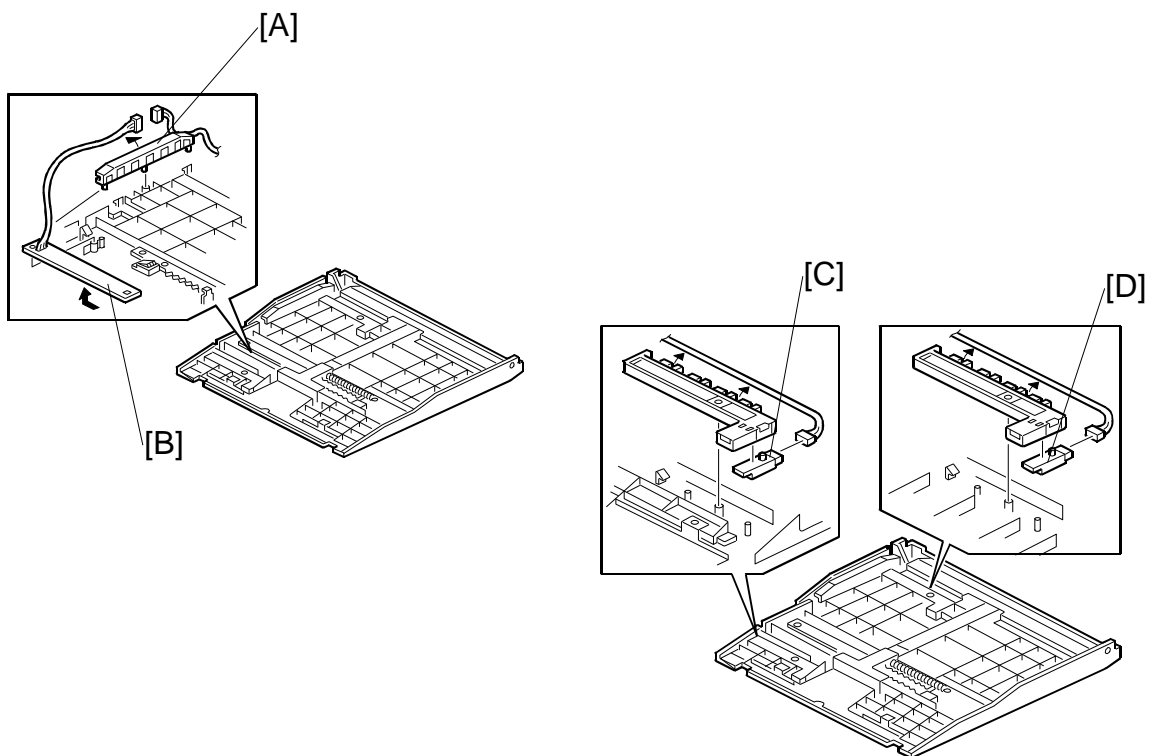

- 1st or 2nd paper tray (☛1.2)
 - [A] Front cover (🔩 x1)
 - [B] Rear cover (🔩 x1)
 - [C] Bottom cover (🔩 x2)
 - [D] Holder pin (🔩x1, Spring x1)
 - [E] Bottom plate (🔩 x1)
- Turn over the bottom plate so it is facing up.

REPLACEMENT AND ADJUSTMENT



Remove:

[A] Harness cover (Hooks x2)

[B] Paper width switch (Hooks x2, x4,  x1)

[C] Paper set sensor (Hook x1,  x1)

[D] Paper length sensor (Hooks x1,  x1)

Cover
Interposer
Tray
B835

1.6.2 TRAY COVER SENSORS

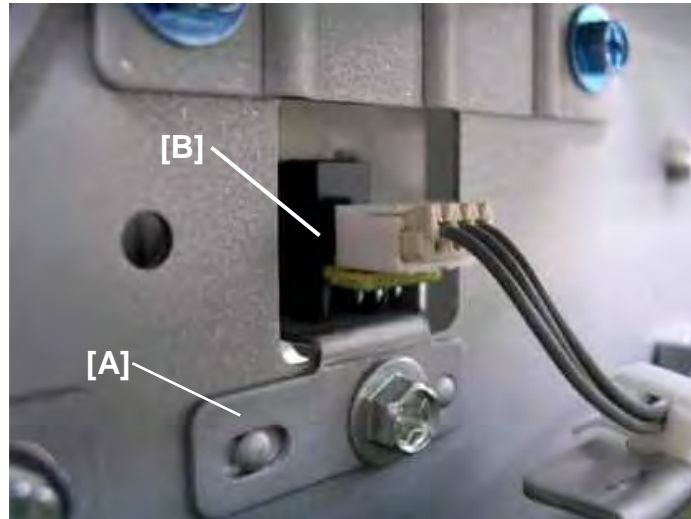

1st Tray Cover Sensor

- Remove the tray unit rear cover (☛1.1)
- Open the 1st tray cover

Remove:

[A] Sensor unit (🔧 x1, 📦 x1)

[B] Tray cover sensor (Pawls x2)

2nd Tray Cover Sensor

Remove the tray unit control board unit (☛1.5.5)

Remove:

[A] Sensor unit (🔧 x1, 📦 x1). Remove with the 2nd tray cover open.

[B] Tray cover sensor (Pawls x2)

1.6.3 1ST TRANSPORT SENSOR

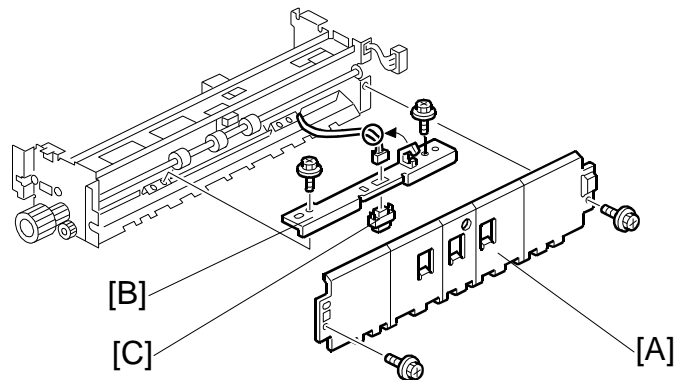

- Top cover
- Vertical feed cover
- Stay (☛1.5)

Remove:

- [A] Upper paper guide (☛ x2)
- [B] Sensor unit (☛ x2, ☛ x1, ☛ x1)
- [C] 1st transport sensor (Pawls x2)

1.6.4 FEED UNIT SENSORS

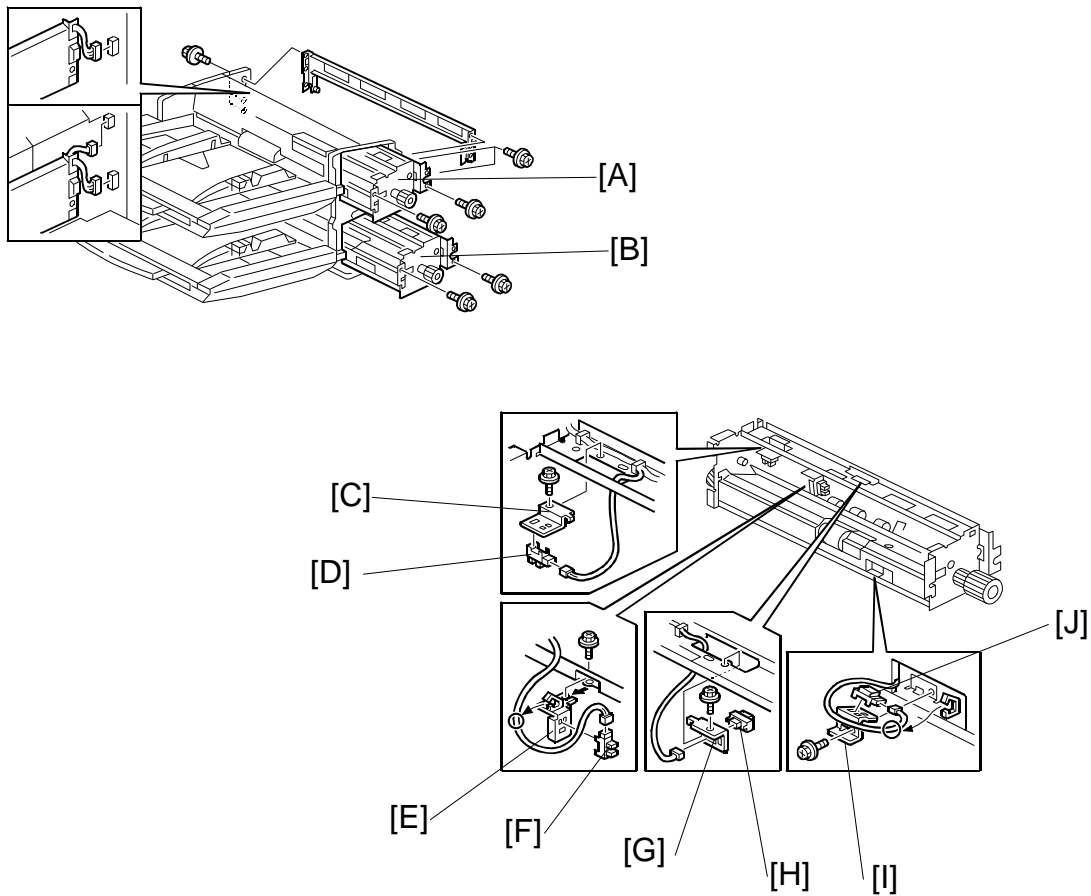

Remove:

- [A] 1st feed unit (☛1.3)
- [B] 2nd feed unit (☛1.3)
- [C] Sensor bracket (🔧 x1, 🛠️ x1)
- [D] Pick-up roller HP sensor (Pawls x2)
- [E] Sensor bracket (🔧 x1, 🛠️ x1, 🛠️ x1)
- [F] Bottom plate position sensor (Pawls x2)
- [G] Sensor bracket (🔧 x1, 🛠️ x1) (2nd feed unit only)
- [H] 1st Vertical transport sensor (Pawls x2) (2nd feed unit only)
- [I] Sensor bracket (🔧 x1, 🛠️ x1, 🛠️ x1)
- [J] Paper Feed sensor (Pawls x2)

1.6.5 2ND VERTICAL TRANSPORT, EXIT SENSORS

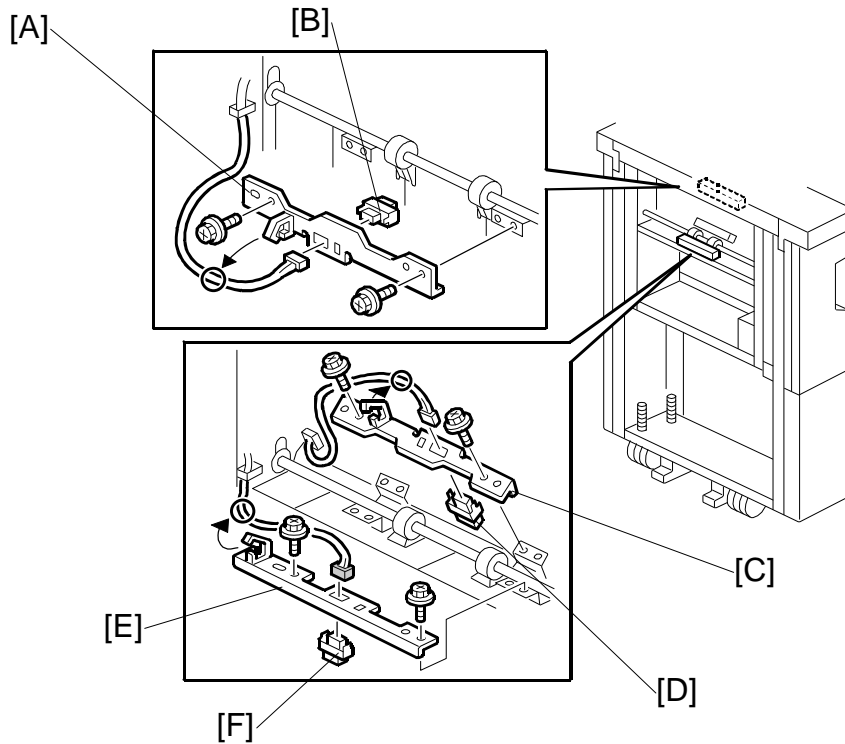

Remove:

- [A] Sensor unit (⚙️ x1, 📡 x1, 📡x1)
- [B] 2nd vertical transport sensor (Pawls x2)
- [C] Sensor unit (⚙️ x2, 📡 x1, 📡x1)
- [D] Vertical exit sensor (Pawls x2)
- [E] Sensor unit (⚙️ x2, 📡 x1, 📡x1)
- [F] Exit sensor (Pawls x2)

REPLACEMENT AND ADJUSTMENT

1.6.6 ENTRANCE SENSOR

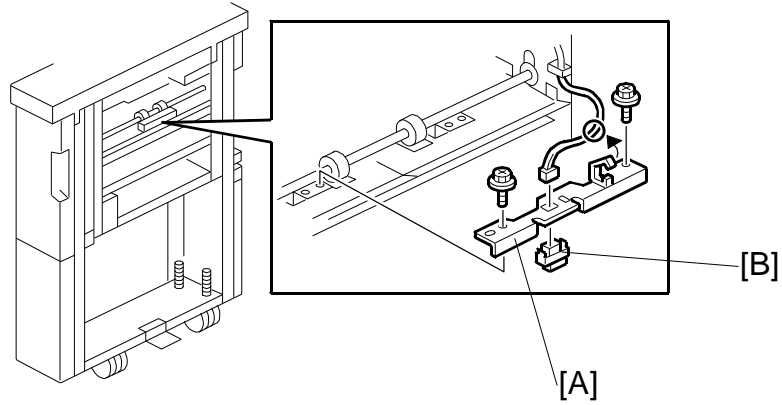

[A] Sensor unit (🔩 x2, 📏 x1, 📏 x1)

[B] Entrance sensor (Pawls x2)

1.7 ROLLERS

1.7.1 SEPARATION ROLLER

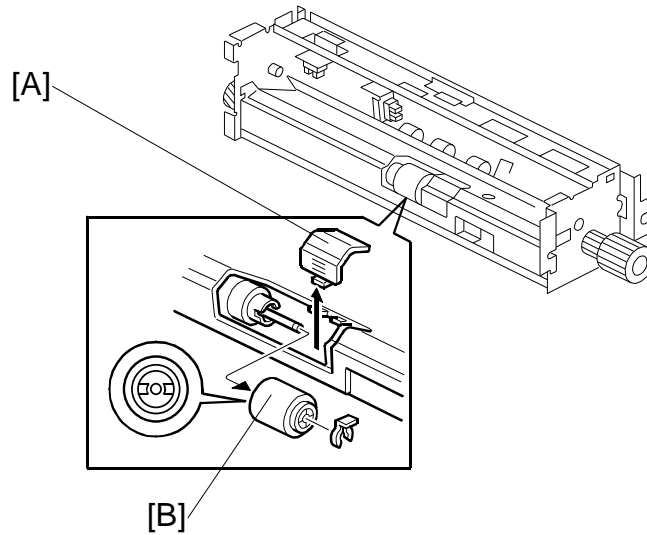

- 1st (or 2nd) feed unit (☛1.3)
- [A] Cover
[B] Separation Roller (☞ x1)

1.7.2 FEED BELT UNIT AND PICK-UP ROLLER

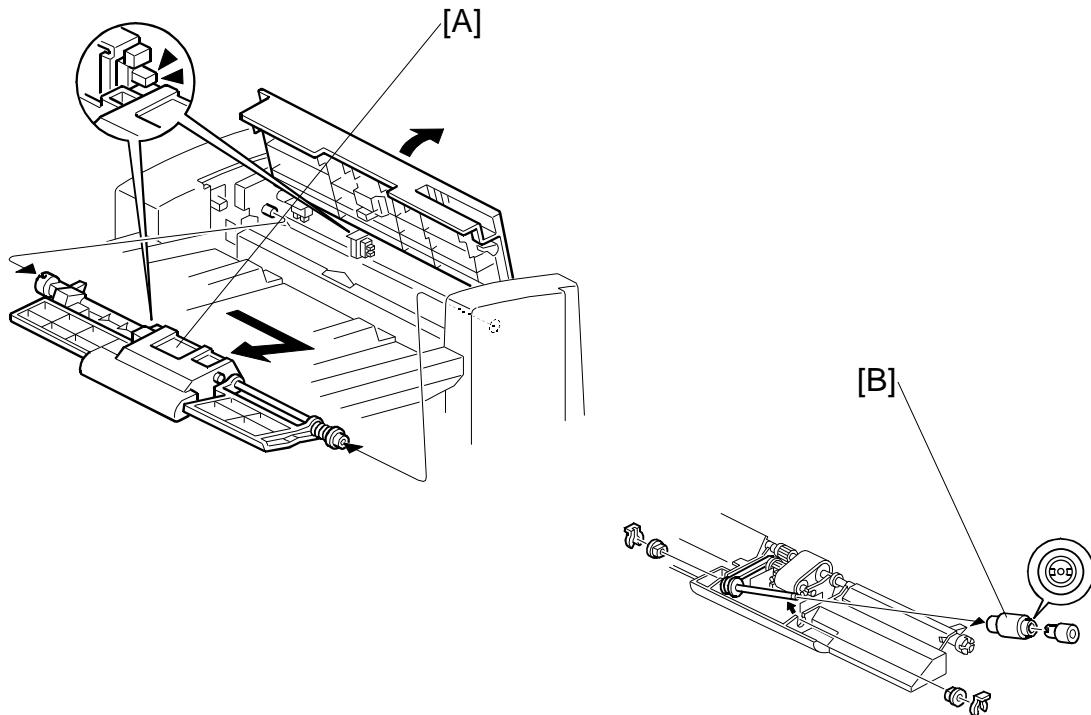

- Open the 1st tray cover.

[A]: Feed belt unit

- The unit is spring loaded. Push it to the right to release it, then lift it out.

[B]: Pick-up roller (⌀ x 2, bushings x 2)

1.7.3 FEED BELT

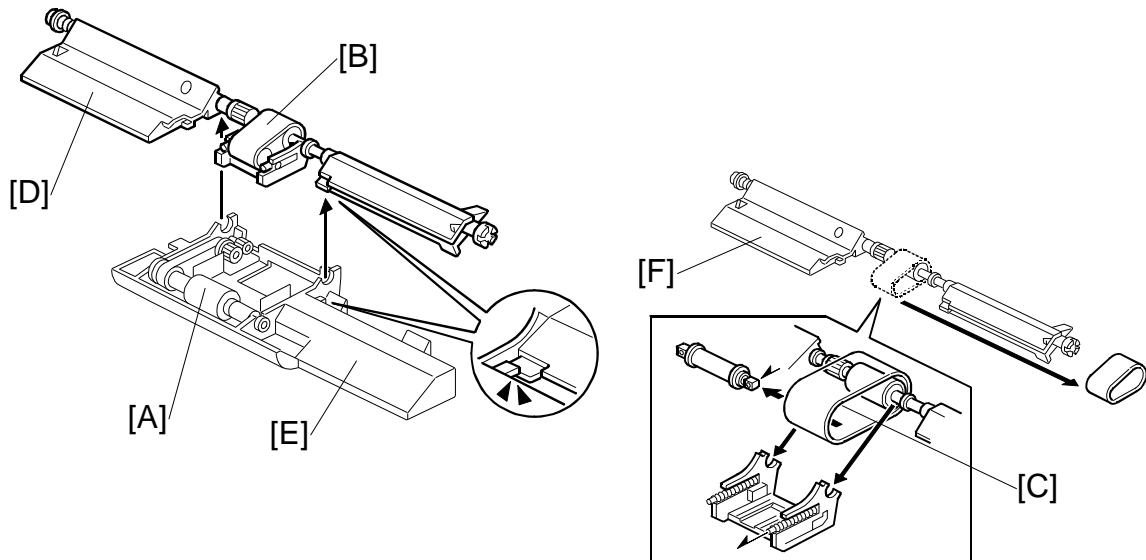

- Feed belt unit (☛1.7.2)

[A]: Pick-up roller unit.

- Pull the unit away from the bushings in the direction of the arrow.

[B]: Feed belt holder

- Hold the feed belt holder by the sides, then lift up to separate from the holder.
- Pull slowly to avoid losing the springs.

[C]: Feed belt.

Re-assembly

1. Position the pick-up roller unit [A] and feed belt holder [B] as shown above.
2. On the rear side, slide out the bushing, and rotate guide plate [D] until its stepped side attaches at [E] as shown above, then snap the guide plate on.
3. On the front side, rotate guide plate [F] until its flat side is parallel with [D], then snap it on. Viewed from the bottom, the plates must be aligned.

2. DETAILS

2.1 PAPER PATH

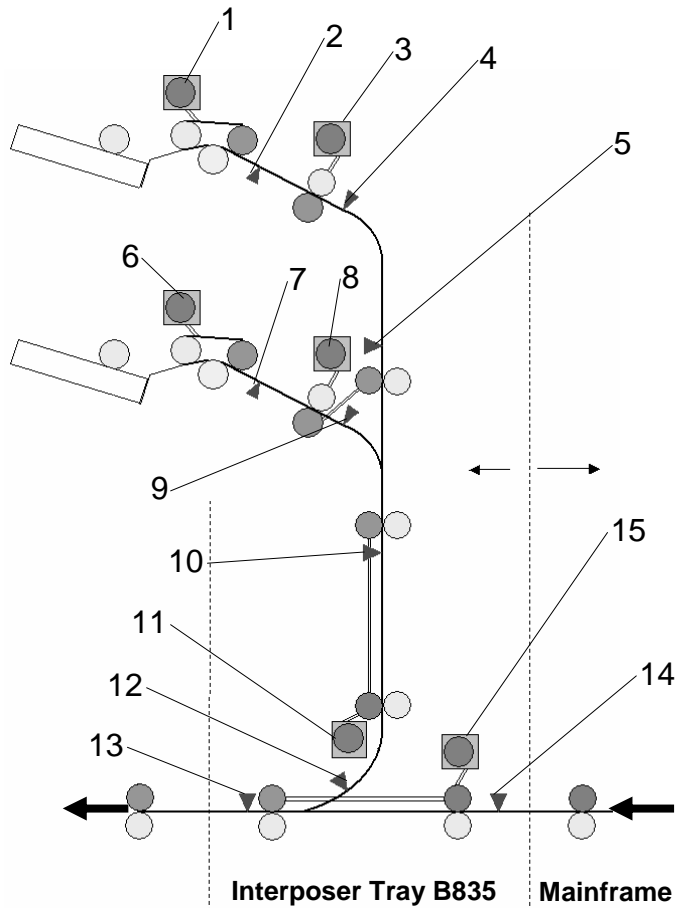

- | | |
|----------------------------------|-----------------------------------|
| 1. 1st Paper Feed Motor | 9. 2nd Transport Sensor |
| 2. 1st Paper Feed Sensor | 10. 2nd Vertical Transport Sensor |
| 3. 1st Transport Motor | 11. Vertical Transport Motor |
| 4. 1st Transport Sensor | 12. Vertical Exit Sensor |
| 5. 1st Vertical Transport Sensor | 13. Interposer Exit Sensor |
| 6. 2nd Paper Feed Motor | 14. Interposer Entrance Sensor |
| 7. 2nd Paper Feed Sensor | 15. Horizontal Transport Motor |
| 8. 2nd Transport Motor | |

2.2 PAPER FEED

2.2.1 FEED MECHANISM

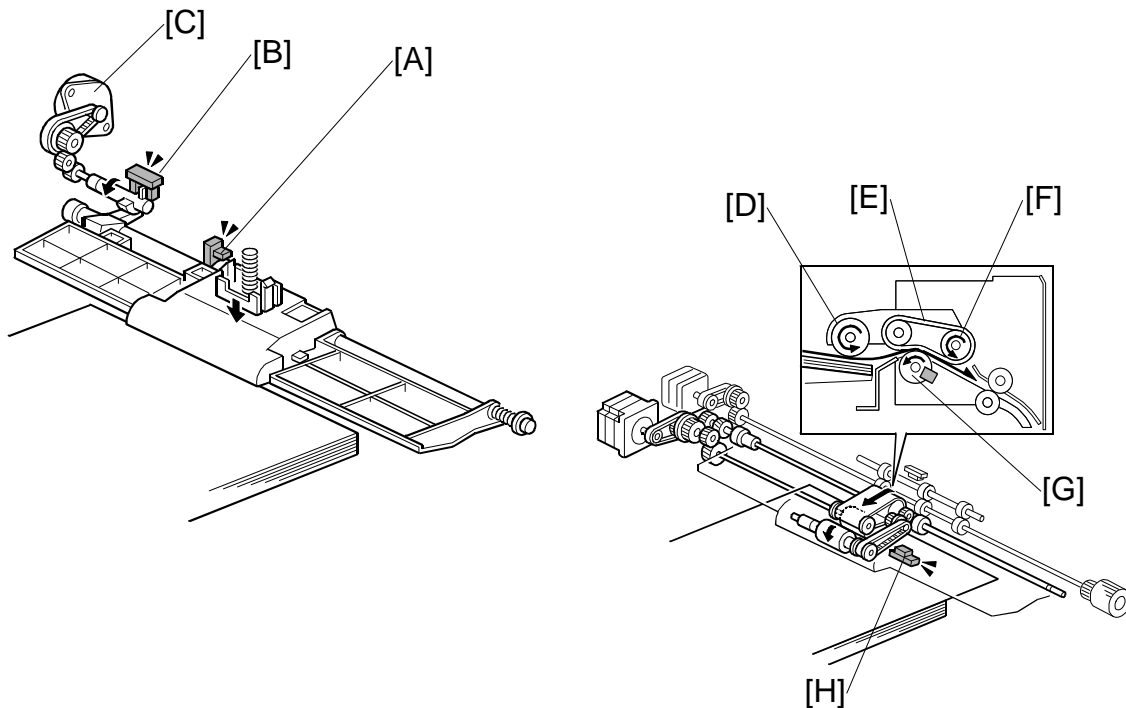

When paper is placed on the tray, the 1st paper set sensor in the tray actuates and switches on the 1st tray lift motor. The pick-up roller unit drops and the top of the stack in the tray pushes up the pick-up roller unit until its actuator actuates the 1st bottom plate position sensor [A] and switches the motor 1st tray lift motor off.

The 1st pick-up roller HP sensor [B] controls the operation of the 1st pick-up motor [C]. The 1st pick-up motor is off when the actuator is up and there is no paper in the tray. This is the pick-up roller home position. When the actuator de-actuates the sensor after the tray lifts, this switches on the 1st pick-up roller motor. At the end of the job, the actuator descends with the bottom plate and switches the motor off.

The pick-up roller [D] picks up the sheet, and the feed belt [E] feeds the sheet to the paper feed roller [F]. The separation roller [G] reverses if more than one sheet is fed. This is a standard FFR device.

The paper feed sensor [H] detects the timing of the feed and signals a jam if the paper does not arrive or if the paper stops.

As sheets feed from the top of the stack:

- The pick-up roller unit descends until the actuator on the pick-up roller unit drops out of the 1st bottom plate position sensor [A]. This activates the 1st tray lift motor.
- The 1st tray lift motor switches on to raise the stack until the actuator enters the pick-up roller unit position sensor again and switches the lift motor off.
- This cycle repeats until the end of the job or until paper runs out.

DETAILS

2.2.2 PAPER NEAR END/PAPER END

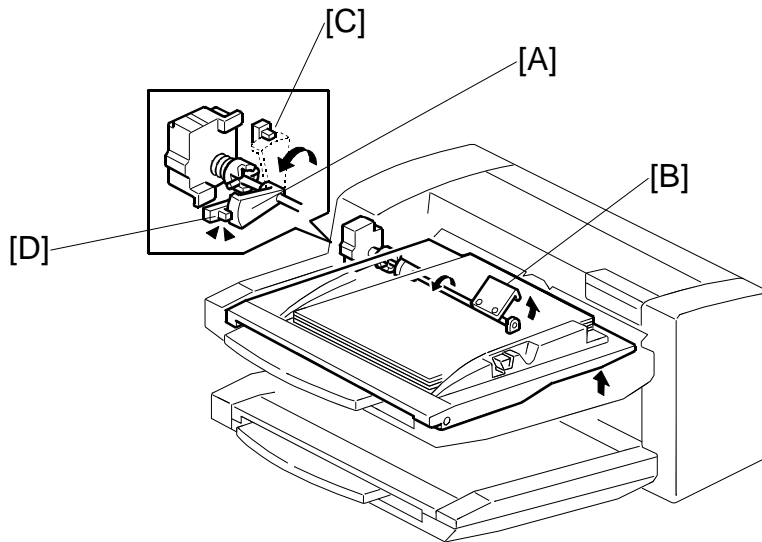

When feed starts with a full tray, the actuator [A] on the rotating shaft of the bottom plate lift arm [B] is at the 1st tray lower limit sensor [C].

As paper feeds and the stack grows smaller, the lift arm rises and the actuator descends until the actuator reaches the 1st tray upper limit sensor [D]. At this time the operation panel signals near-end for the 1st tray.

When the last sheet feeds, the paper feed sensor, a photosensor (not shown) signals that paper has run out.

2.2.3 PAPER SIZE DETECTION

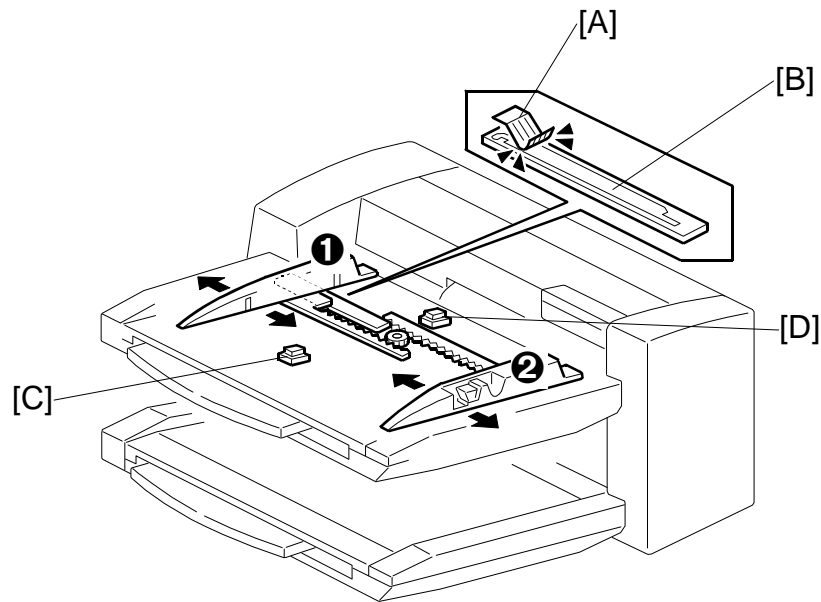

The side fences ❶ and ❷ can be adjusted to standard and non-standard paper sizes.

When the side fences are moved to match the paper width, a feeler [A] slides along the wiring patterns on the paper width switch terminal plate [B].

The combination of the following two factors determines the paper size:

- The position where the feeler activates the terminal
- The status of the paper length sensor [C] (ON or OFF).

The paper end sensor [D] de-activates when the last sheet is fed and reports that the paper tray is empty.

DETAILS

The paper size is detected by six sensors whose combined readings are used to detect the following paper sizes.

		Paper Size Detection Bits						Area	
Paper Size		W1	W2	W3	W4	W5	L1	NA	EU
Large Size	12×18 in.	H	H	H	H	L	L	YES	YES
Large Size	13×19 in.	H	H	H	H	L	L	*	*
Large Size	320×450 mm	H	H	H	H	L	L	*	*
A3 SEF	297×420 mm	H	H	H	L	L	L	YES	YES
A4 LEF	297×210 mm	H	H	H	L	L	H	YES	YES
DLT SEF	11×17 in.	H	H	H	L	H	L	YES	YES
LT LEF	11×8½ in.	H	H	H	L	H	H	YES	YES
B4 SEF	257×364 mm	H	H	L	L	H	L	YES	YES
B5 LEF	257×182 mm	H	H	L	L	H	H	YES	YES
A4 SEF	210×297 mm	H	H	L	H	H	L	YES	YES
LT SEF	8½×11 in.	H	H	L	H	H	L	YES	*
A5 LEF	210×148 mm	H	H	L	H	H	H	*	YES
HLT LEF	8½×5½ in.	H	H	L	H	H	H	YES	*
B5 SEF	182×257 mm	H	L	L	H	H	L	*	*
F SEF	8×13 in.	H	L	L	H	H	L	YES	YES
A5 SEF	148×210 mm	H	L	H	H	H	H	YES	YES
HLT SEF	5½×8½ in.	L	L	H	H	H	H	YES	YES

Yes : Width and length sensors can detect paper sizes automatically.

* : Accurate paper size detection requires setting with the "Tray Paper Setting" key on the operation panel.

H: 5V

L: 0V

3. OVERALL MACHINE INFORMATION

3.1 MAIN LAYOUT

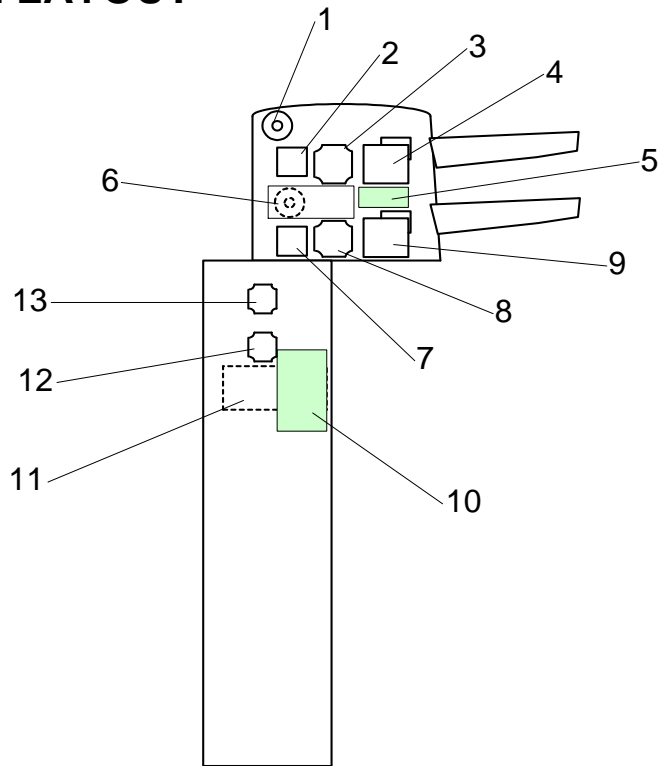

- | | |
|-------------------------|----------------------------------|
| 1. 1st Pick-up Motor | 8. 2nd Paper Feed Motor |
| 2. 1st Transport Motor | 9. 2nd Lift Motor |
| 3. 1st Paper Feed Motor | 10. Control Board |
| 4. 1st Lift Motor | 11. Door Open Switch (Interlock) |
| 5. Driver Board | 12. Horizontal Transport Motor |
| 6. 2nd Pick-up Motor | 13. Vertical Transport Motor |
| 7. 2nd Transport Motor | |

Cover
Interposer
Tray
B835

3.2 DRIVE LAYOUT

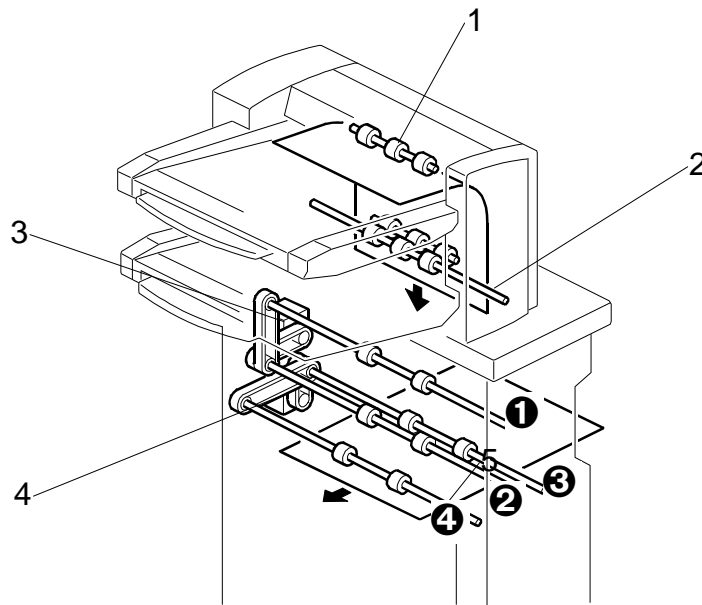

1. 1st Transport roller
2. 2nd Transport roller
3. Vertical Transport Motor
4. Horizontal Transport Motor

The 1st transport roller [1] (driven by the 1st transport motor) pulls the paper from the 1st tray and feeds it into the vertical paper path.

The 2nd transport roller [2] (driven by the 2nd transport motor) pulls the paper from the 2nd tray and feeds it into the vertical path.

The vertical transport motor [3] drives the vertical transport rollers ① and ② that feed the sheets into the horizontal feed path.

The horizontal transport motor [4] drives the horizontal transport rollers ③ and ④ that feed the covers (and paper passing straight through) out of the cover interposer tray.

3.3 ELECTRICAL COMPONENTS

3.3.1 FEED MOTORS, PCB

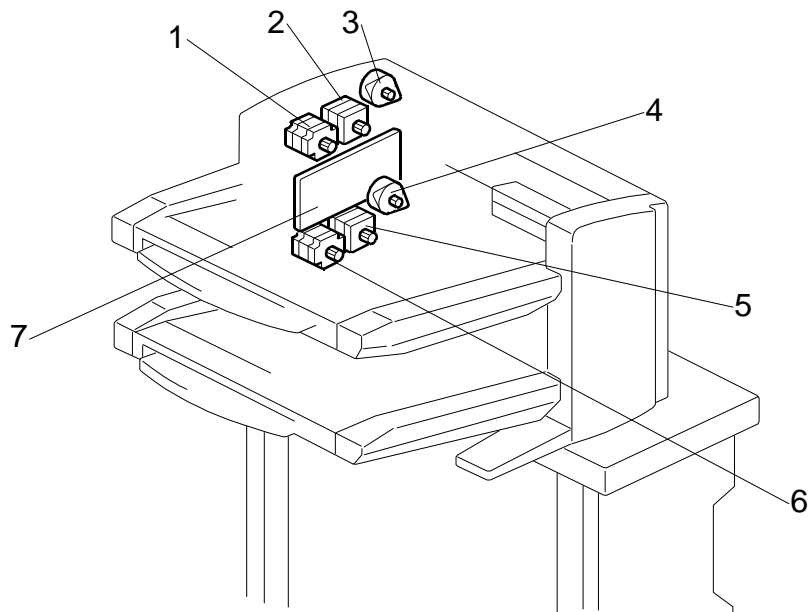

1. 1st Paper Feed Motor
2. 1st Transport motor
3. 1st Pick-Up Motor
4. 2nd Pick-Up Motor
5. 2nd Transport motor
6. 2nd Paper Feed Motor
7. Tray Unit Control Board

Cover
Interposer
Tray
B835

3.3.2 LIFT MOTORS, TRAY SENSORS

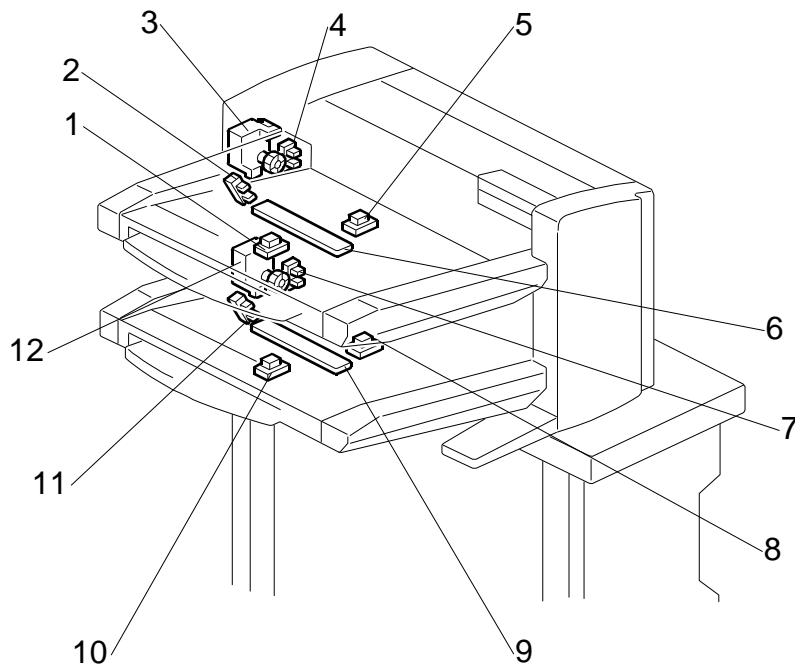

- | | |
|---------------------------------|----------------------------------|
| 1. 1st Paper Length Sensor | 7. 2nd Lower Limit Sensor |
| 2. 1st paper upper limit sensor | 8. 2nd paper set sensor |
| 3. 1st Lift Motor | 9. 2nd Paper Width Sensor |
| 4. 1st Lower Limit Sensor | 10. 2nd Paper Length Sensor |
| 5. 1st paper set sensor | 11. 2nd paper upper limit sensor |
| 6. 1st Paper Width Sensor | 12. 2nd Lift Motor |

3.3.3 PAPER PATH SENSORS 1

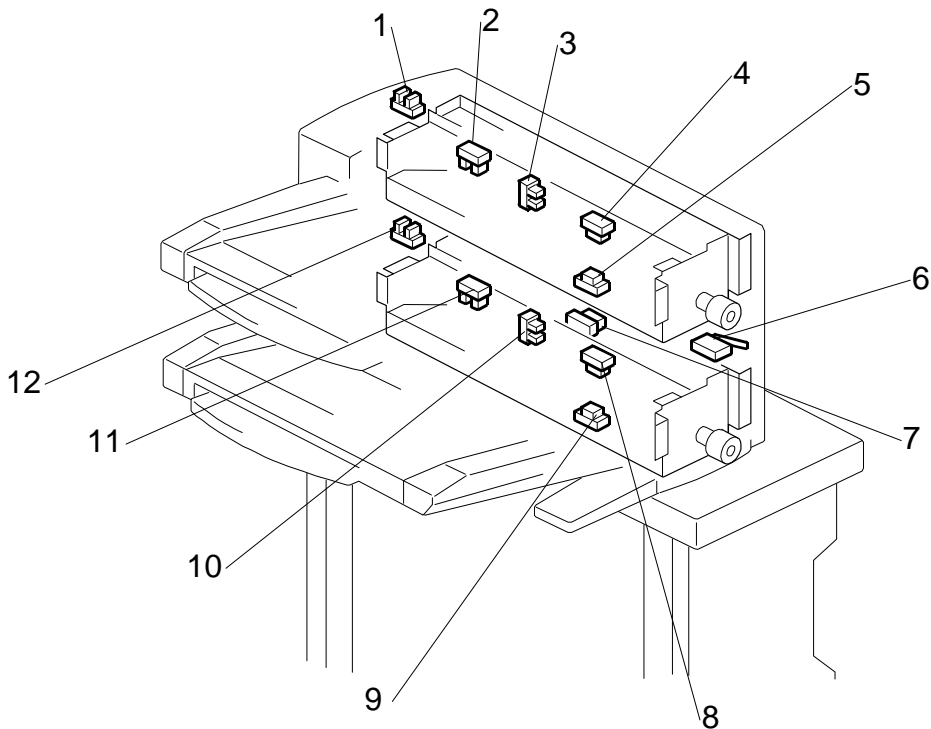

- | | |
|-------------------------------------|--------------------------------------|
| 1. 1st Tray Cover Sensor | 7. 1st Vertical Transport Sensor |
| 2. 1st Pick-Up Roller HP Sensor | 8. 2nd Transport Sensor |
| 3. 1st bottom plate position sensor | 9. 2nd Paper Feed Sensor |
| 4. 1st Transport Sensor | 10. 2nd bottom plate position sensor |
| 5. 1st Paper Feed Sensor | 11. 2nd Pick-Up Roller HP Sensor |
| 6. Vertical Feed Cover Switch | 12. 2nd Tray Cover Sensor |

Cover
Interposer
Tray
B835

3.3.4 PAPER PATH SENSORS 2, PCB

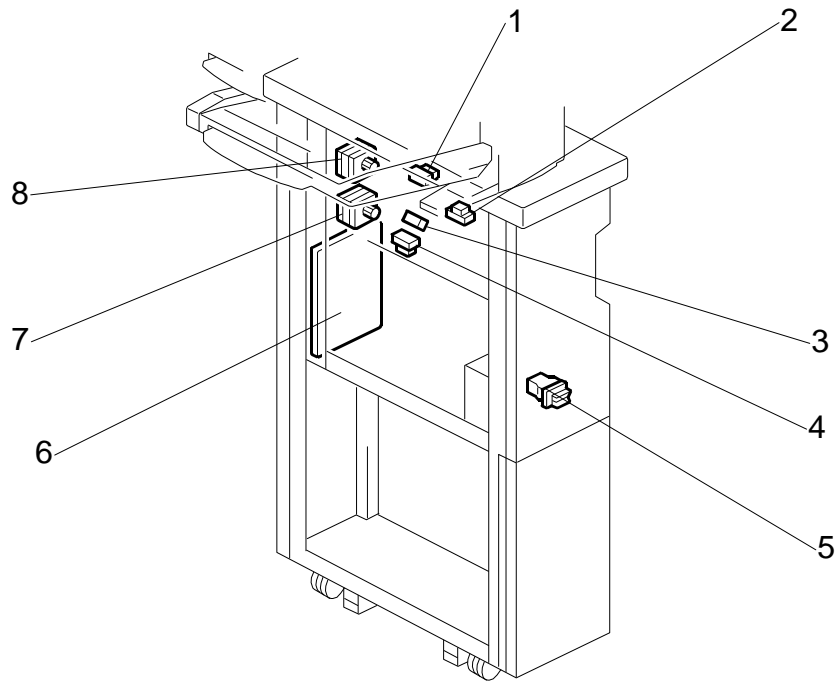

1. 2nd Vertical Transport Sensor
2. Entrance Sensor
3. Vertical Exit Sensor
4. Exit Sensor
5. Feed Unit Front Door Safety Switch
6. Main Control Board
7. Horizontal Transport Motor
8. Vertical Transport Motor

3.3.5 ELECTRICAL COMPONENT SUMMARY

Motors		
No.	Name	Description
M1	1st Lift Motor	Drives the bottom plate of the 1st tray up and down.
M2	1st Paper Feed Motor	Rotates the feed rollers that feed paper from the 1st tray.
M3	1st Pick-up Motor	Moves the 1st pick-up roller up and down.
M4	1st Transport Motor	Drives the 1st Transport roller that takes the paper fed from the 1st feed roller and feeds it to the vertical path.
M5	2nd Feed Motor	Rotates the feed rollers that feed paper from the 2nd tray.
M6	2nd Lift Motor	Drives the bottom plate of the 2nd tray up and down.
M7	2nd Pick-up Motor	Moves the 2nd pick-up roller up and down.
M8	2nd Transport Motor	Drives the 2nd Transport roller that takes the paper fed from the 1st feed roller and feeds it to the vertical path.
M9	Horizontal Transport Motor	Drives the rollers in the horizontal path that feed paper from the copier and covers from the vertical path out of the cover interposer tray.
M10	Vertical Transport Motor	Drives the rollers in the vertical path that feed the covers down to the horizontal path.

PCBs		
No.	Name	Description
PCB1	Driver Board	Controls operation of the unit. (All DIP SWs should be set to OFF.)
PCB2	Main Control Board	

Sensors		
No.	Name	Description
S1	1st Tray Cover Sensor	Detects when the 1st tray cover is open/closed.
S2	1st Lower Limit Sensor	Detects 1) whether the 1st tray is down or not when the tray is not operating, and 2) detects when the tray is full when the 1st tray is operating.
S3	1st paper set sensor	Detects paper end after the last sheet feeds from the 1st tray.
S4	1st Paper Feed Sensor	Detects paper placed on the tray and starts the 1st lift motor to raise the bottom plate. This sensor also detects a jam if the paper stops and does not leave the 1st tray
S5	1st Paper Length Sensors	Used in combination with 1st tray width sensors to determine the size of paper in the 1st tray.
S6	1st paper upper limit sensor	When an actuator falls into the gap of this sensor, this signals paper near end in the 1st tray.
S7	1st Pick-up Roller HP Sensor	Detects whether the 1st pick-up roller is up or not.
S8	1st Transport Sensor	Detects jams at the point where the 1st Transport roller pulls paper from the 1st tray.
S9	1st Transport Sensor	Detects jams in the path of the 1st tray.

Cover Interposer Tray B835

OVERALL MACHINE INFORMATION

Sensors		
No.	Name	Description
S10	1st bottom plate position sensor	Detects the top of the paper stack in the 1st tray when it is at the proper height for feeding and stops the 1st lift motor.
S11	2nd Lower Limit Sensor	Detects 1) whether the 2nd tray is down or not when the tray is not operating, and 2) detects when the tray is full when the 2nd tray is operating.
S12	2nd tray cover sensor	Detects when the 2nd tray cover is open/closed.
S13	2nd paper set sensor	Detects paper placed on the tray and starts the 2nd lift motor to raise the bottom plate. This sensor also detects a jam if the paper stops and does not leave the 2nd tray
S14	2nd Paper Feed Sensor	Detects jams when the feed roller feeds paper from the 2nd tray.
S15	2nd Paper Length Sensor	Used in combination with 1st tray width sensors to determine the size of paper in the 1st tray.
S16	2nd paper upper limit sensor	When an actuator falls into the gap of this sensor, this signals paper near end in the 2nd tray.
S17	2nd Pick-up Roller HP Sensor	Detects whether the 2nd pick-up roller is up or not.
S18	2nd Transport Sensor	Detects jams at the point where the 2nd Transport roller pulls paper from the 1st tray.
S19	2nd bottom plate position sensor	Detects the top of the paper stack in the 2nd tray when it is at the proper height for feeding and stops the 2nd lift motor.
S20	2nd Vertical Transport Sensor	Detects jams in the vertical path after a sheet is fed from the 2nd tray.
S21	Entrance Sensor	Detects paper jams where paper from the copier enters the unit in the horizontal feed path.
S22	Exit Sensor	Detects jams where through-paper and covers exit the unit.
S23	Vertical Exit Sensor	Detects jams where through-paper and covers exit the vertical feed path.

Switches		
No.	Name	Description
SW1	Front Door Switch	Detects whether the front door is properly closed. The unit will not operate when the front door is open.
SW2	Transport Cover Switch	This is the cover on the right side of the tray unit. Detects whether the cover is opened or closed.
SW3	1st Paper Width Switch	Used in combination with the length sensors to determine the size of paper in the 1st tray.
SW4	2nd Paper Width Switch	Used in combination with the length sensors to determine the size of paper in the 2nd tray.

B762

9-BIN MAILBOX

B762 MAILBOX CS391 REVISION HISTORY		
Page	Date	Added/Updated/New
		None

9-BIN MAILBOX B762

TABLE OF CONTENTS

1. REPLACEMENT AND ADJUSTMENT.....	1
1.1 COVERS AND TRAYS.....	1
1.2 SENSORS.....	2
1.3 MAIN MOTOR AND CONTROL BOARD.....	3
2. DETAILS	4
2.1 OVERVIEW	4
2.1.1 MAIN COMPONENT LAYOUT	4
2.1.2 DRIVE LAYOUT	5
2.1.3 PAPER PATH.....	6
2.2 BASIC OPERATION.....	7
2.2.1 PAPER PATH.....	7
2.3 OVERFLOW DETECTION	8
2.3.1 OVERVIEW	8
2.3.2 DETECTION TIMING	9
2.4 PAPER MISFEED DETECTION TIMING	10
2.4.1 A4 SIDEWAYS (LEF) → 1ST BIN TRAY.....	10
2.4.2 A4 SIDEWAYS (LEF) → 2ND ~ 9TH BIN TRAY	10

1. REPLACEMENT AND ADJUSTMENT

⚠ CAUTION

Switch the machine off and unplug the machine before starting and procedure in this section.

1.1 COVERS AND TRAYS

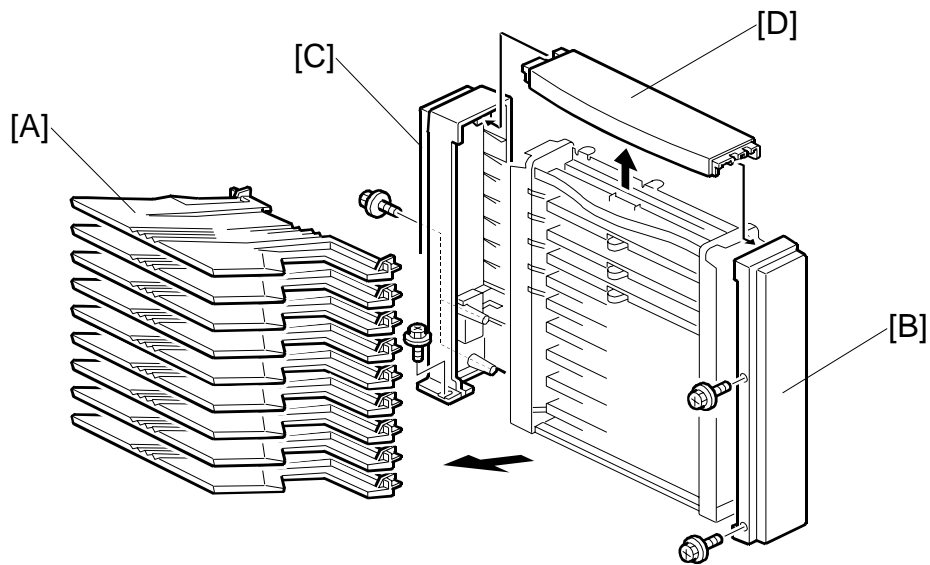

- [A]: Trays
- Grip each tray by the front and lift out.
- [B]: Front cover (🔩 x 2)
- [C]: Rear cover (🔩 x 3)
- [D]: Top cover

9-Bin Mailbox
B762

SENSORS

1.2 SENSORS

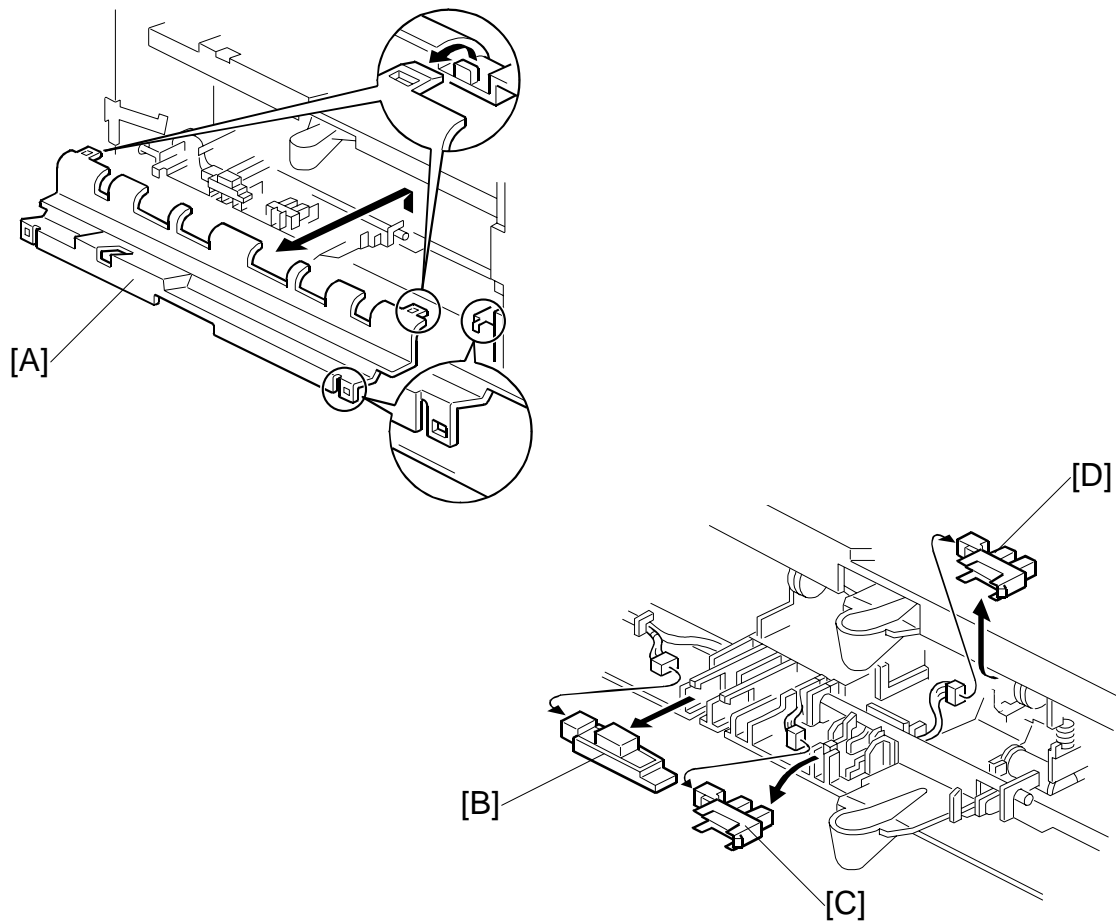

Remove the tray (☛ 1.1)

[A]: Bin cover

[B]: Tray sensor (☛ x 1)

[C]: Tray overflow sensor (☛ x 1)

[D]: Vertical transport sensor (☛ x 1)

- Raise the pawl, then grip the bottom of the sensor to remove.

1.3 MAIN MOTOR AND CONTROL BOARD

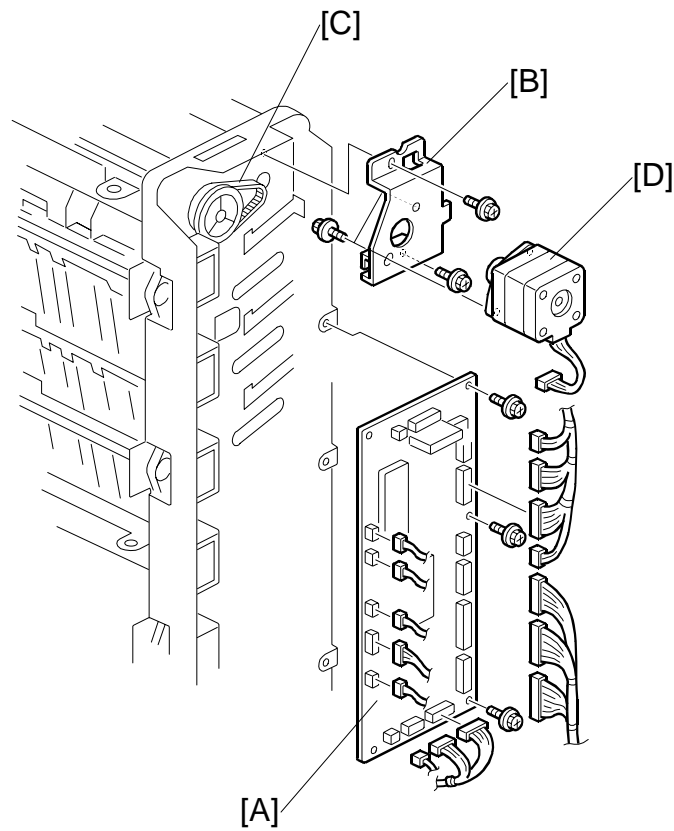

Rear cover (➔ 1.1)

[A]: Control board (⚙️ x 3, 📡 x 17)

[B]: Main motor bracket (main motor 📡 x 1, ⚙️ x 2)

[C]: Timing belt

[D]: Main motor (⚙️ x 1)

9-Bin Mailbox
B762

2. DETAILS

2.1 OVERVIEW

2.1.1 MAIN COMPONENT LAYOUT

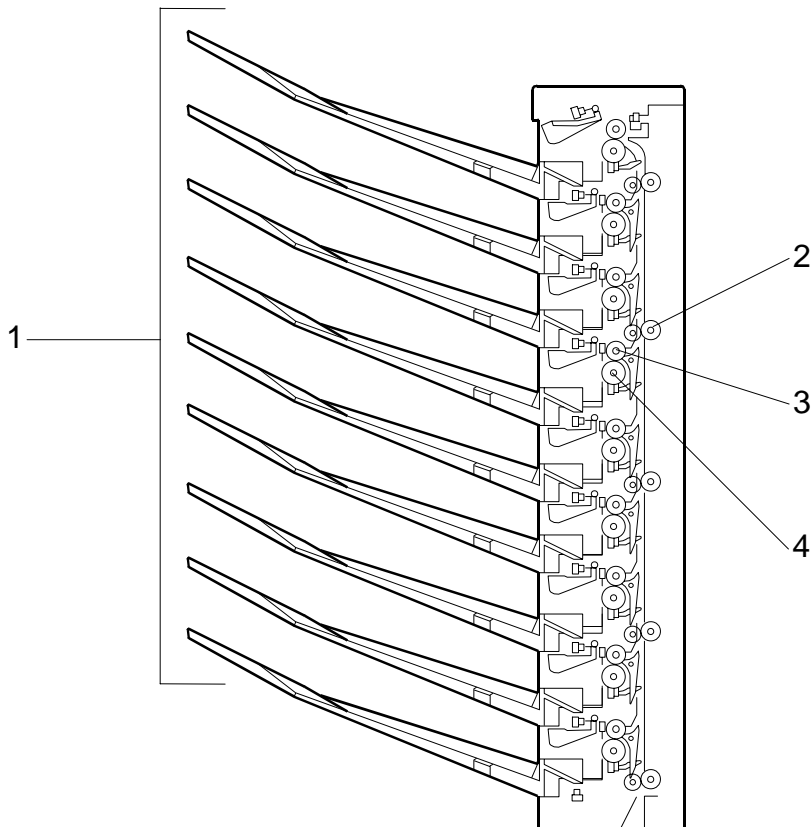

1. Bins (x 9)
2. Vertical Transport Rollers (x 5)
3. Turn Gates (x 8)
4. Exit Rollers (x 9)

The trays are 1 to 9 (bottom to top). The numbers are clearly marked on the side of the unit. The top tray does not require a turn gate. When the top tray is selected for output, all turn gates remain closed, leaving only the top bin open.

2.1.2 DRIVE LAYOUT

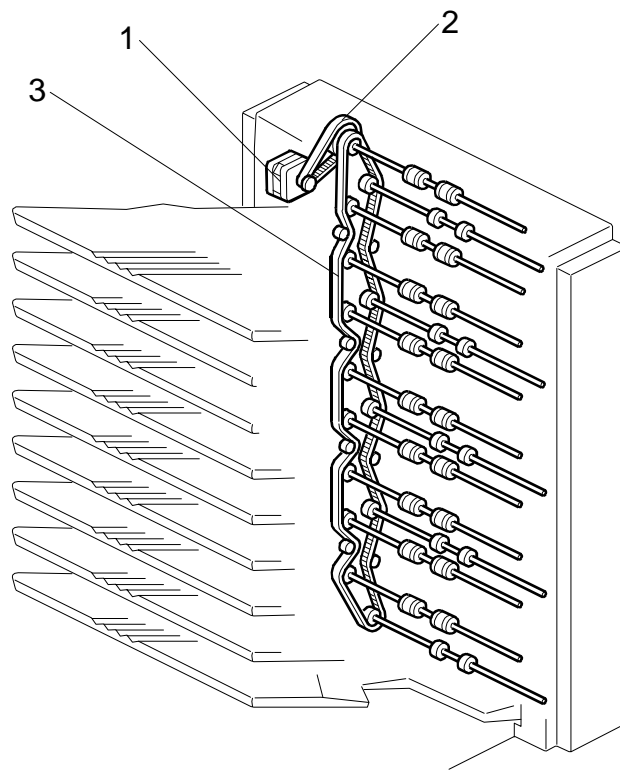

1. Main Motor
2. Main Timing Belt
3. Timing Belt

9-Bin Mailbox
B762

OVERVIEW

2.1.3 PAPER PATH

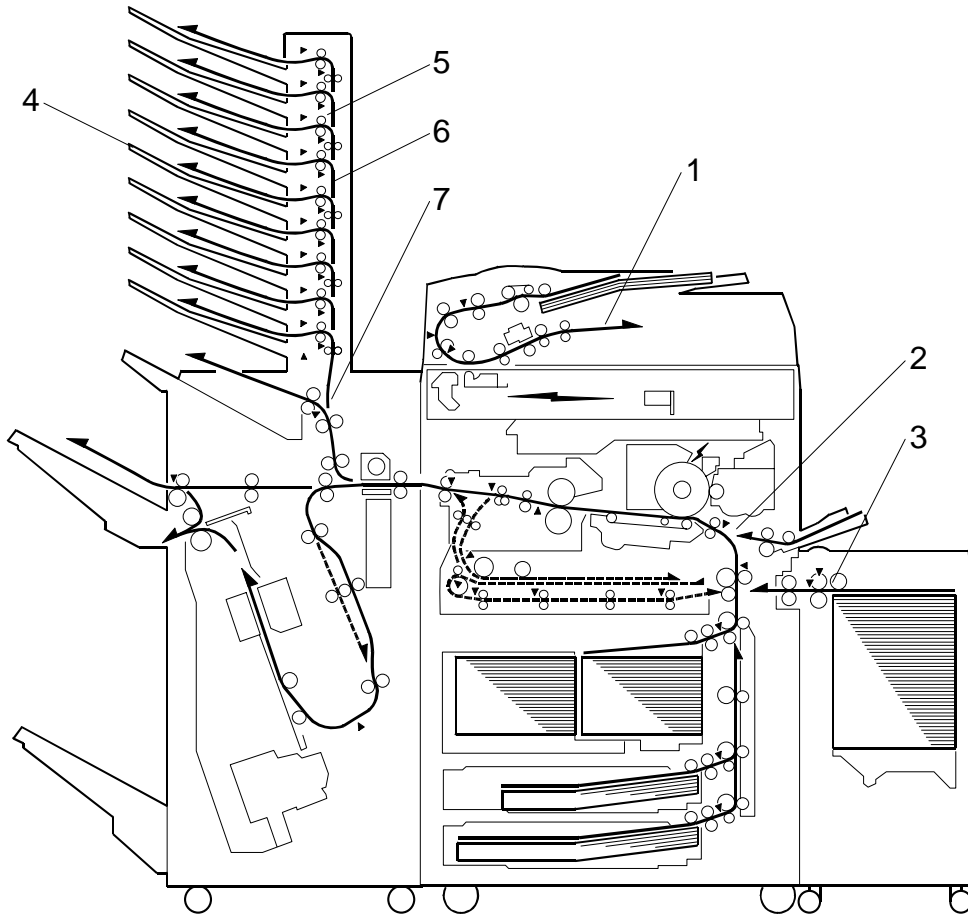

1. Original Paper Path
2. Vertical Transport Path
3. LCT Feed
4. Selected Trays
5. Turn Gates
6. Mailbox Paper Path
7. Junction Gate (paper goes either up to the mailbox or out to the finisher's proof tray)

The solenoid for the junction gate (7) is part of the mailbox.

2.2 BASIC OPERATION

2.2.1 PAPER PATH

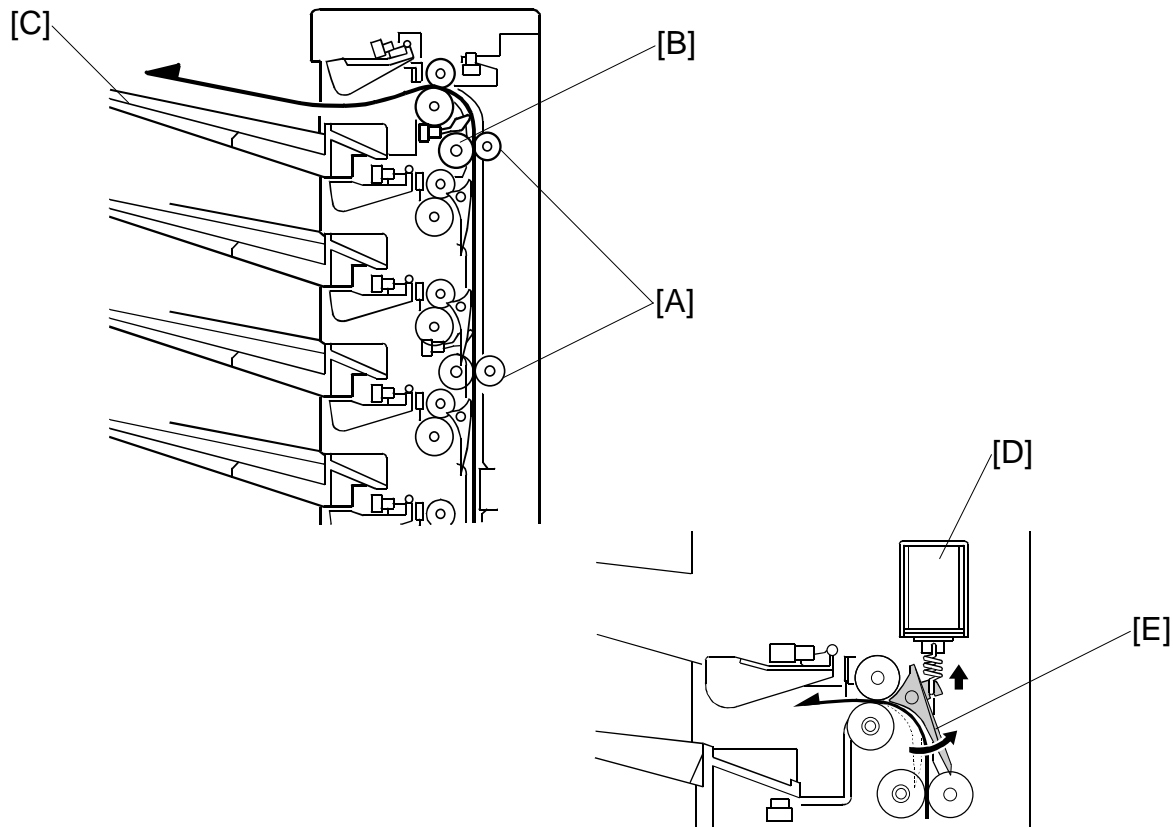

9-Bin Mailbox
B762

The unit is mounted on top the finisher and connected to the finisher by a 14-pin connector. When the leading edge of the paper passes and activates the entrance sensor of the finisher, the mailbox main motor switches on and the mailbox vertical transport rollers [A] begin to turn. The exit roller [B] feeds the paper out to the selected tray [C].

A solenoid [D] opens and closes the junction gate [E]. When a solenoid switches on, the gate opens and directs to the paper to the tray.

NOTE: When the top tray (bin 9) is selected, all solenoids are off and closed, allowing the paper to pass to the top tray (bin 9 does not require a solenoid).

When the last sheet is fed out, it switches off the vertical transport sensor, and both the mailbox main motor and the junction gate solenoid of the selected bin switch off. The mailbox normally feeds paper at 372 mm/s, about the same speed as the finisher. (The finisher speed is 370 mm/s.)

2.3 OVERFLOW DETECTION

2.3.1 OVERVIEW

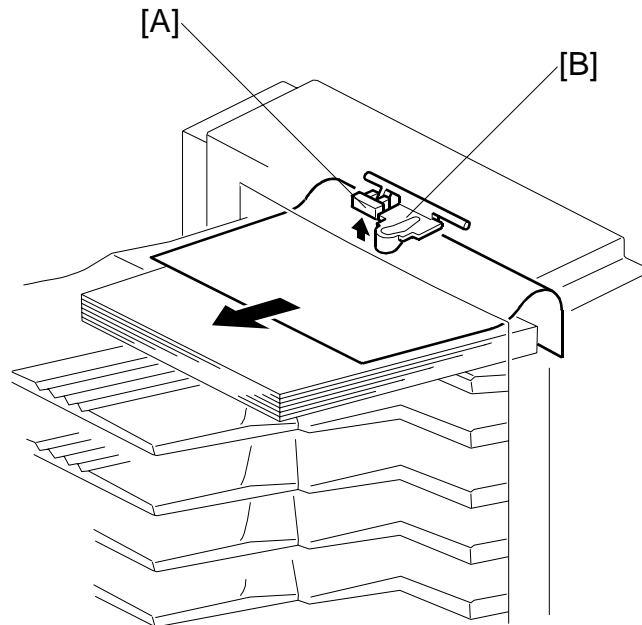

An overflow sensor [A] and actuator [B] are above the exit of each paper tray. The actuator, mounted on a swivel arm, remains in contact with the top of the stack. The actuator rises as the stack becomes higher until it activates the sensor. Then, a tray full message appears on the operation panel and the job halts. If the paper is removed before the tray is full, the job continues.

2.3.2 DETECTION TIMING

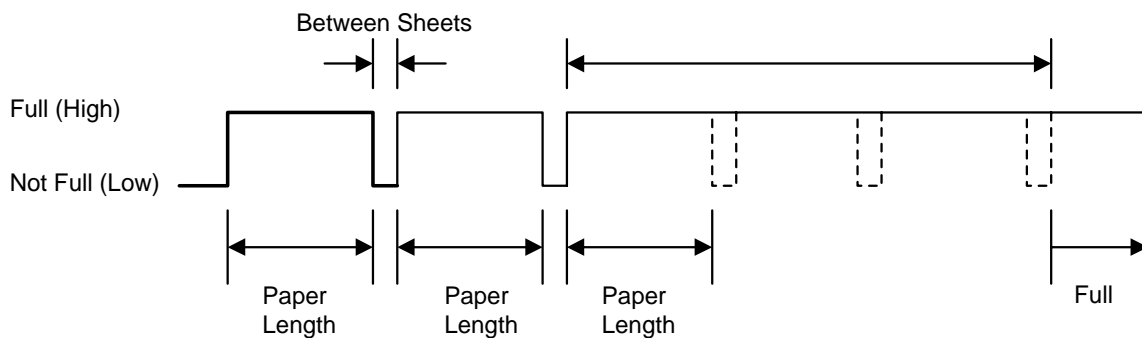

When the mailbox exit sensor goes high for the prescribed time (T), the machine determines that the tray is full. The value of T is calculated, regardless of paper size, as follows:

$$T (s) = (60/s \times \text{max. size ppm}) \times 3 s$$

After the tray full sensor switches on, if it remains on for the feeding of eight additional sheets, then this notifies the machine that the tray is full.

“T” is calculated as shown below. For example, for a minimum ppm of 12 prints (regardless of paper size), the value T is 15 s. Then, if the sensor detects paper for 15 s or more, the machine stops the copy job.

2.4 PAPER MISFEED DETECTION TIMING

2.4.1 A4 SIDEWAYS (LEF) → 1ST BIN TRAY

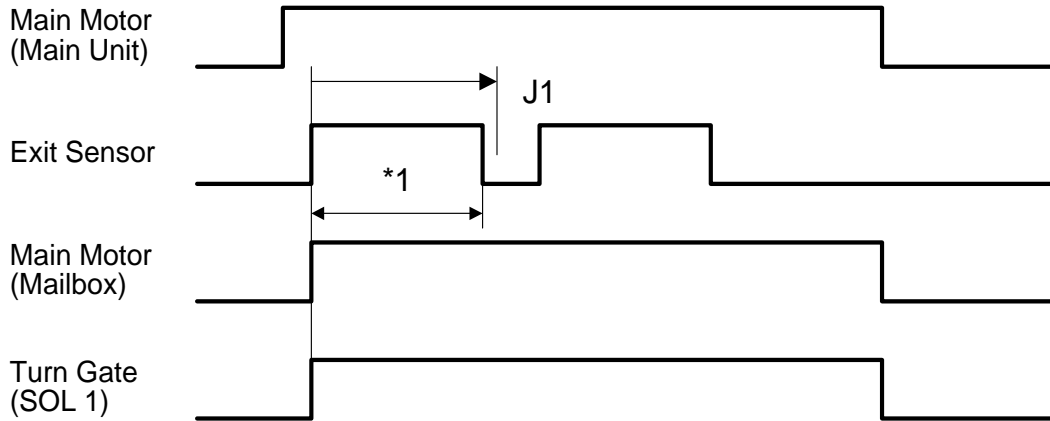

*1: Time required for A4 LEF

2.4.2 A4 SIDEWAYS (LEF) → 2ND ~ 9TH BIN TRAY

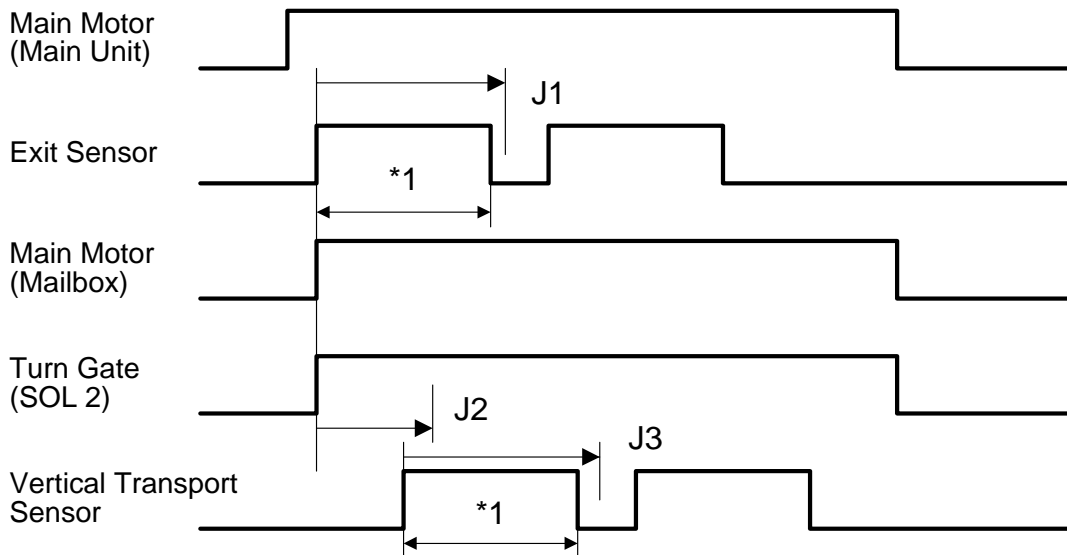

*1: Time required for A4 Sideways (LEF)

*2: Feed to 9th Tray: All SOLs OFF.

J1 Timing: After the leading edge of the sheet activates the mailbox exit sensor, a misfeed is detected if the sensor does not switch off within:

$$X+0.5 \text{ s}$$

Where X = The amount of time prescribed for the paper size to pass the sensor. (X = 1.74 s for A4 Sideways for example)

J2 Timing: After the mailbox paper exit sensor is activated, the machine determines that the paper has not yet fed and detects a misfeed if the vertical transport sensor does not activate within the time prescribed for the paper size (1.94 s for A4 paper, for example)

J3 Timing: After the vertical transport sensor is activated, a misfeed is detected if the vertical transport sensor does not turn off within:

$$X+0.52 \text{ s}$$

Where X = The amount of time prescribed for the paper size to pass the sensor. (X = 2.26 s for A4 Sideways for example)

**BOOKLET FINISHER & FINISHER
SR3020/SR3030/SR4010/SR4020
B804/B805/D373/D374**

D373/D374 SADDLE STITCH FINISHER SR4010/4020 REVISION HISTORY		
Page	Date	Added/Updated/New
		None

BOOKLET FINISHER & FINISHER SR3020/SR3030/SR4010/SR4020

TABLE OF CONTENTS

1. REPLACEMENT AND ADJUSTMENT	1
1.1 COVERS	1
1.1.1 EXTERIOR COVERS	1
1.1.2 UPPER TRAY, END FENCE	2
1.2 MAIN UNIT	3
1.2.1 UPPER TRAY LIMIT SENSOR, LIMIT SWITCH.....	3
1.2.2 POSITIONING ROLLER	4
1.2.3 PROOF TRAY EXIT SENSOR.....	4
1.2.4 UPPER TRAY HEIGHT SENSORS 1, 2	5
1.2.5 EXIT GUIDE PLATE, UPPER TRAY EXIT SENSOR	5
1.2.6 PROOF TRAY FULL SENSOR.....	6
1.2.7 FINISHER ENTRANCE SENSOR	7
1.2.8 PRE-STACK TRAY EXIT SENSOR.....	7
1.3 STAPLER UNIT	8
1.3.1 CORNER STAPLER	8
1.3.2 POSITIONING ROLLER	9
1.4 FOLD UNIT	10
1.4.1 FOLD UNIT	10
1.4.2 FOLD UNIT ENTRANCE SENSOR	12
1.4.3 FOLD UNIT EXIT SENSOR.....	12
1.4.4 STACK PRESENT SENSOR	13
1.4.5 FOLDING HORIZONTAL SKEW ADJUSTMENT (FOR B804 ONLY)	
14	
1.4.6 FOLD VERTICAL SKEW ADJUSTMENT (FOR B804 ONLY)	17
1.5 BOOKLET STAPLER UNIT	19
1.5.1 BOOKLET STAPLER.....	19
1.5.2 BOOKLET STAPLER MOTOR	19
2. DETAILED SECTION DESCRIPTIONS.....	22
2.1 COMPONENT LAYOUT	22

2.1.1 GENERAL LAYOUT	22
2.1.2 ELECTRICAL COMPONENTS	24
2.1.3 SUMMARY OF ELECTRICAL COMPONENTS	28
2.1.4 DRIVE LAYOUT.....	38
2.2 JUNCTION GATES.....	40
2.2.1 PROOF MODE	40
2.2.2 SHIFT MODE	40
2.2.3 STAPLE MODE	41
2.3 PRE-STACKING	42
2.4 TRAY MOVEMENT MECHANISM.....	44
2.4.1 UPPER TRAY	44
2.4.2 LOWER TRAY (B804 ONLY).....	46
2.5 CORNER STAPLING.....	49
2.5.1 STACKING AND JOGGING.....	49
2.5.2 STAPLER MOVEMENT	50
2.5.3 CORNER STAPLING.....	52
2.6 BOOKLET STAPLING (B804 ONLY).....	53
2.6.1 BOOKLET PRESSURE MECHANISM	53
2.6.2 BOOKLET STAPLING AND FOLDING	54
2.6.3 BOOKLET STAPLING AND FOLDING MECHANISMS.....	60
2.7 UPPER TRAY OUTPUT	63
2.7.1 FEED OUT	63
2.7.2 FEED OUT STACKING.....	64
2.8 PUNCH UNIT B702 (FOR B804/B805)	65
2.8.1 OVERVIEW OF OPERATION.....	65
2.8.2 PUNCH MECHANISMS	67
2.8.3 PUNCH HOPPER MECHANISM	70
2.9 FINISHER JAM DETECTION	72

Read This First

Safety and Symbols

Replacement Procedure Safety

CAUTION

- Turn off the main power switch and unplug the machine before beginning any of the replacement procedures in this manual.

Symbols Used in this Manual

This manual uses the following symbols.

: See or Refer to

: Screws

: Connector

: Clip ring

: E-ring

1. REPLACEMENT AND ADJUSTMENT

1.1 COVERS

1.1.1 EXTERIOR COVERS

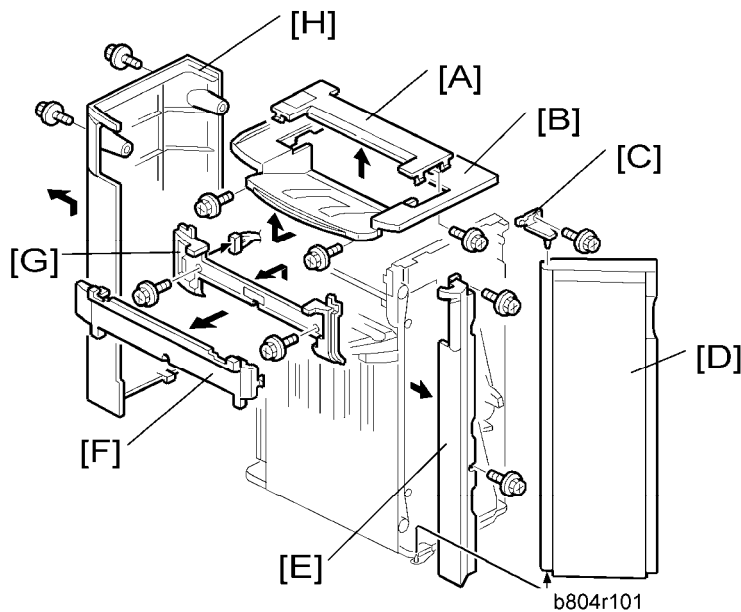

1. Open the front door [D].
2. Small upper cover [A] (⚙️ x1)
3. Upper cover [B] (⚙️ x2)
4. Front door bracket [C] (⚙️ x1)
5. Front door [D]
6. Front left side cover [E] (⚙️ x2)
7. Cover [F]
8. Paper exit cover [G] (⚙️ x2)
9. Rear cover [H] (⚙️ x2)

Booklet
Finisher/
Finisher
B804/B805/
D373/D374

1.1.2 UPPER TRAY, END FENCE

1. Remove the rear cover. (* "Exterior Covers")

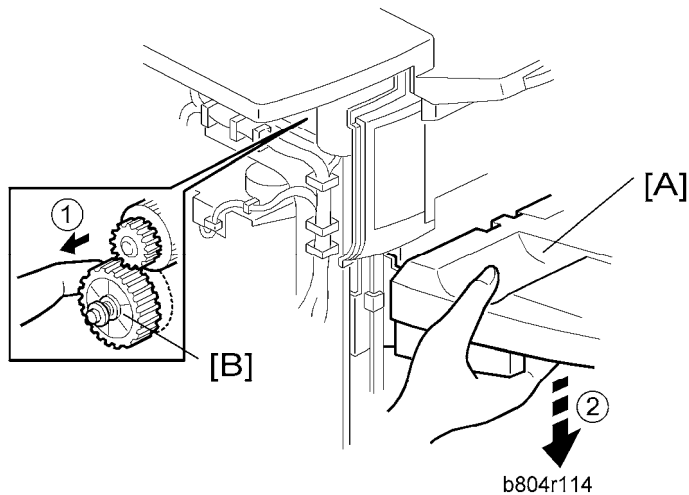

1. Support the tray [A] with your right hand.
2. Pull gear [B] toward you ① to release.
3. Slowly lower the tray ② until it stops.

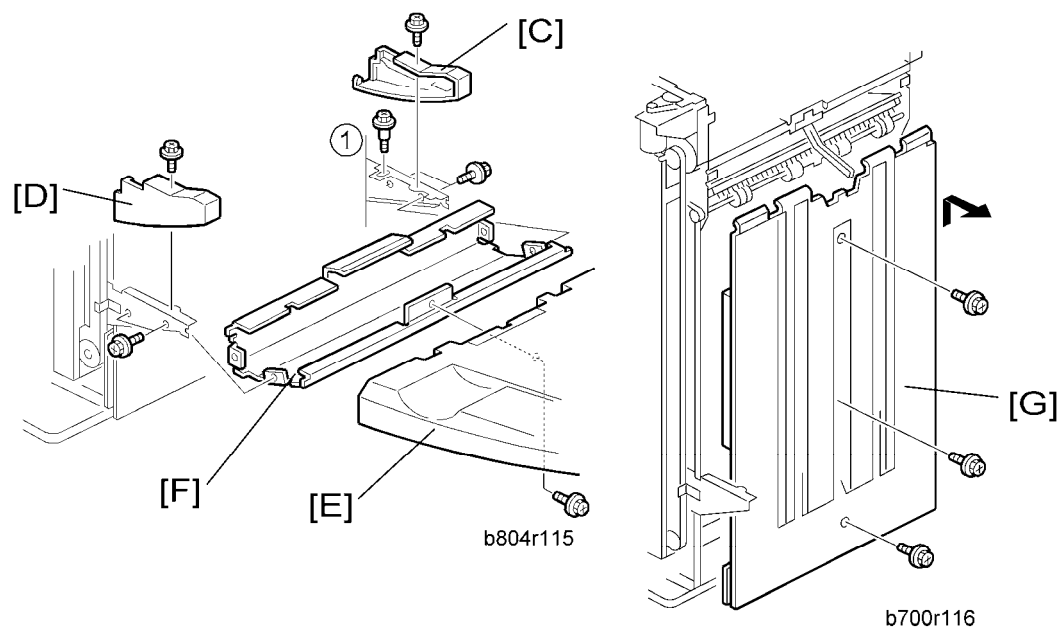

4. Front side cover [C] (⚙️ x1)
5. Rear side cover [D] (⚙️ x1)
6. Upper tray [E] (⚙️ x1)
7. Tray bracket [F] (⚙️ x4, ⚙️ x1 shoulder screw ①)
8. End Fence [G](⚙️ x3)

1.2 MAIN UNIT

1.2.1 UPPER TRAY LIMIT SENSOR, LIMIT SWITCH

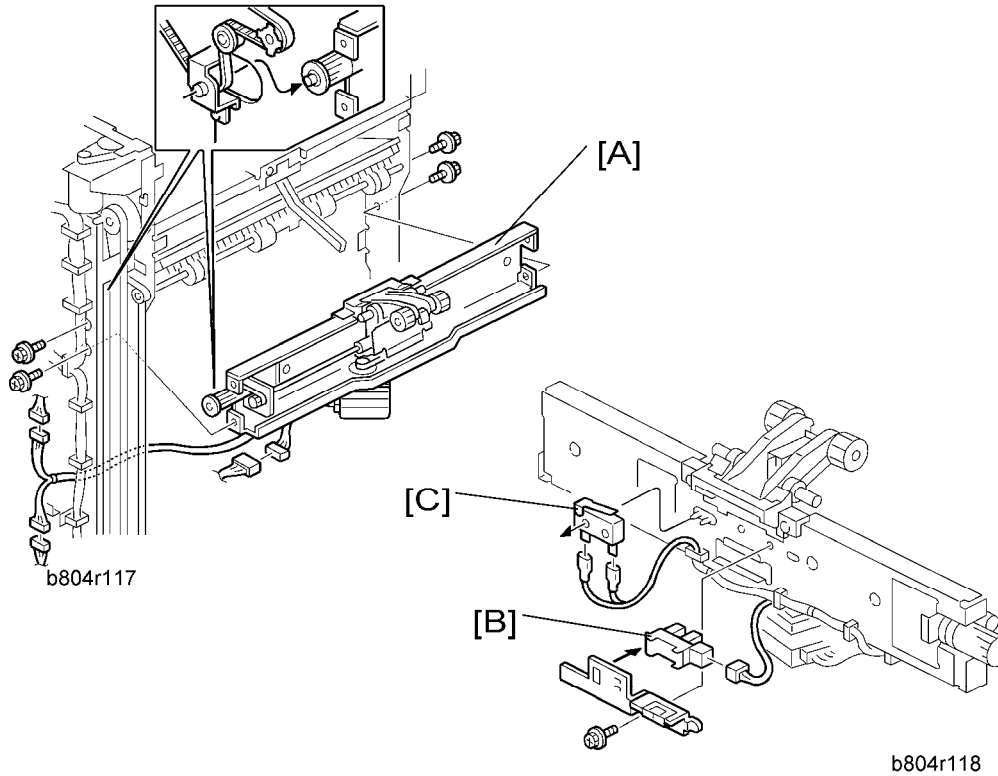

1. Front door, front left side cover, rear cover, upper cover (☛ "Exterior Cover")
2. End fence (☛ 1.1.2 "Upper Tray, End Fence")
3. Upper tray exit mechanism [A] (🔩 x4, 🛠️ x3)
4. Upper tray limit sensor [B] (🔩 x1, 🛠️ x1)
5. Upper tray limit switch [C] (🛠️ x2)

1.2.2 POSITIONING ROLLER

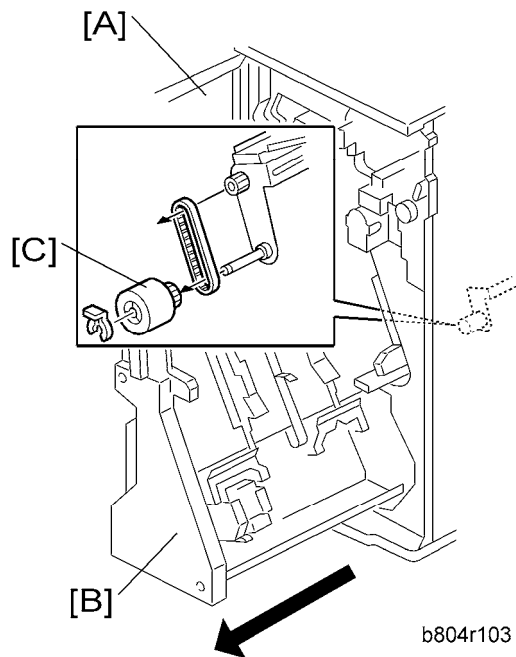

1. Open the front door [A].
2. Pull out the stapling unit [B].
3. Positioning roller [C] (⌀ x1, timing belt x1)

1.2.3 PROOF TRAY EXIT SENSOR

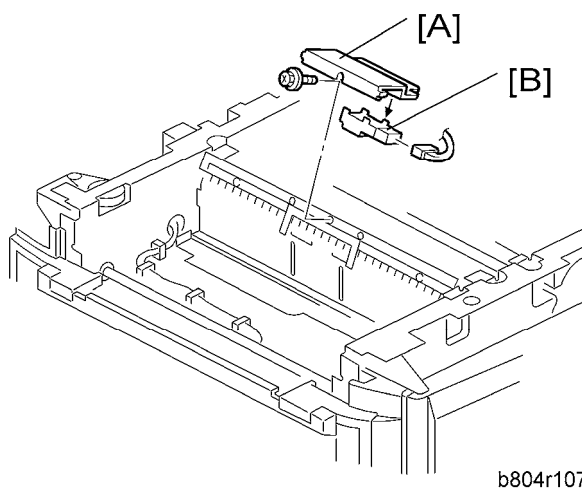

1. Small upper cover (☛ 1.1.1 "Exterior Cover")
2. Proof tray exit sensor bracket [A] (⌀ x1)

Main Unit

3. Proof tray exit sensor [B] (🔧 x1)

1.2.4 UPPER TRAY HEIGHT SENSORS 1, 2

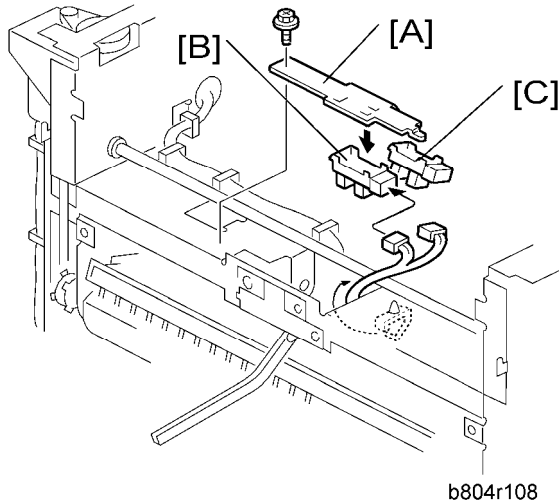

1. Small upper cover, upper cover (🔧 1.1.1 "Exterior Cover")
2. Upper tray paper height sensor bracket [A] (🔧 x1)
3. Upper tray paper height sensor [B] – staple mode (S08) (🔧 x1)
4. Upper tray paper height sensor [C] – non-staple mode (S09) (🔧 x1)

Booklet
Finisher/
Finisher
B804/B805/
D373/D374

1.2.5 EXIT GUIDE PLATE, UPPER TRAY EXIT SENSOR

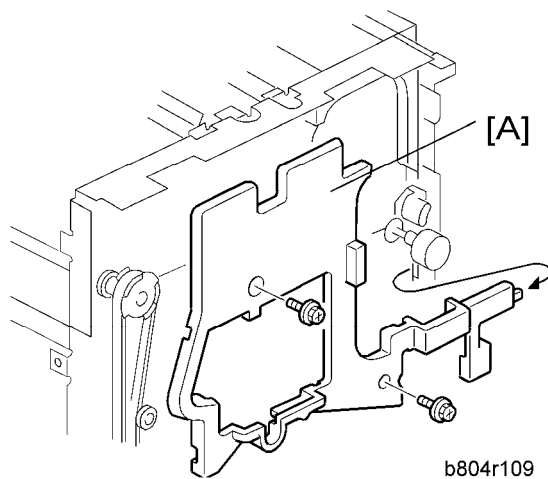

1. Rear cover, Upper covers, Front door, Cover, Paper exit cover (🔧 1.1.1 "Exterior Cover")
2. Inner cover [A] (🔧 x2)

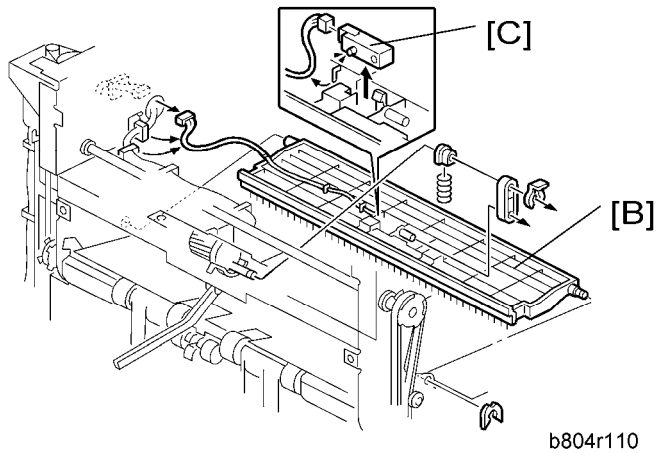

3. Exit guide plate [B] (⌘ x1, Link and spring, ⌘ x1, ⌘ x1)
4. Upper tray exit sensor [C] (S6) (⌘ x1)

1.2.6 PROOF TRAY FULL SENSOR

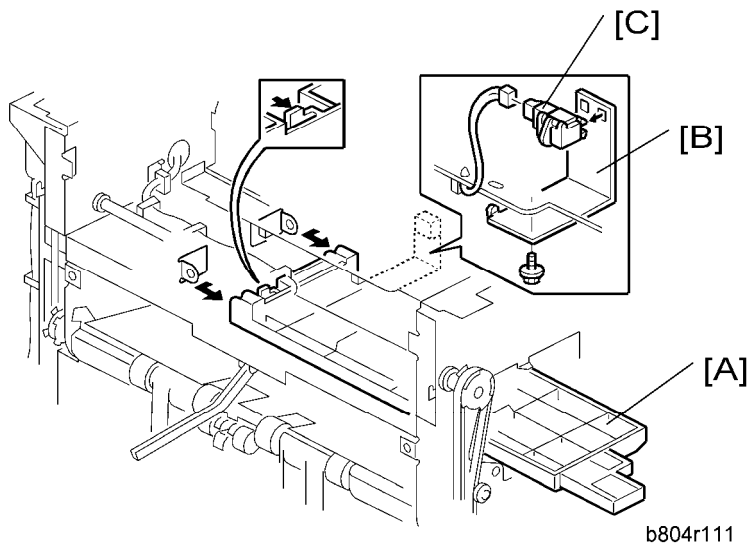

1. Exit guide plate. (☛1.2.5 "Exit Guide Plate, Upper Tray Exit Sensor")
2. Guide plate [A] (hook x 2)
3. Sensor bracket [B] (⌘ x1)
4. Proof tray full sensor [C] (S11) (⌘ x1)

1.2.7 FINISHER ENTRANCE SENSOR

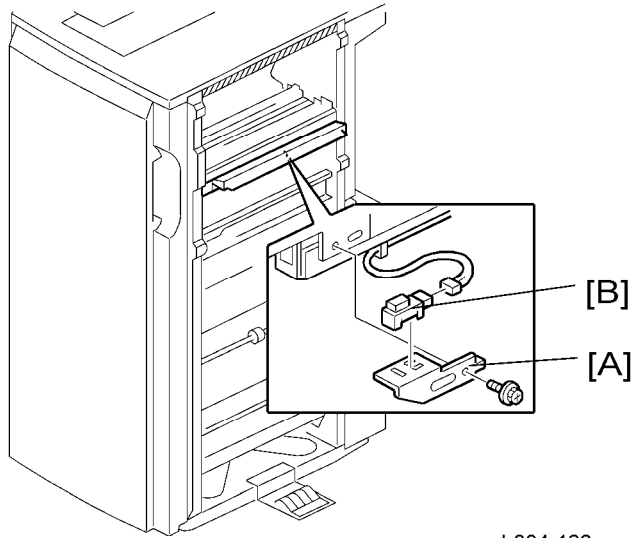

b804r133

1. Disconnect the finisher if it is connected to the copier.
2. Sensor bracket [A] (🔩 x1)
3. Finisher entrance sensor [B] (S1) (🔌 x1)

1.2.8 PRE-STACK TRAY EXIT SENSOR

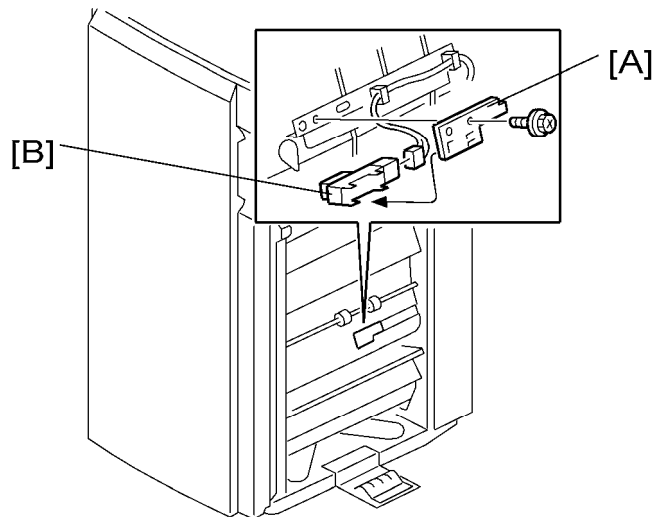

b804r102

1. Disconnect the finisher if it is connected to the copier.
2. Sensor bracket [A]
3. Pre-stack tray exit sensor [B] (S2)

1.3 STAPLER UNIT

1.3.1 CORNER STAPLER

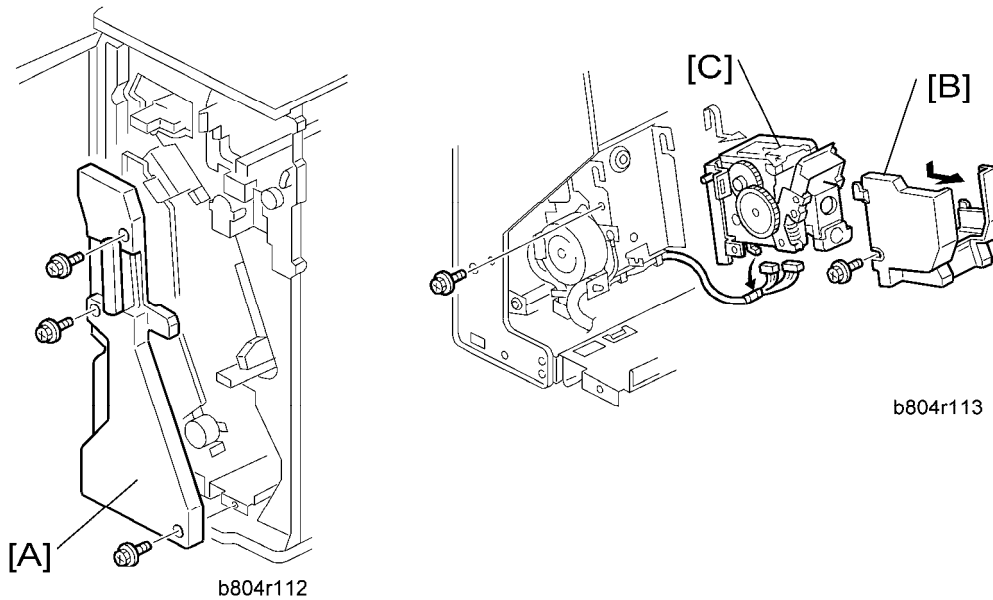

1. Open the front door.
2. Pull out the stapler unit.
3. Inner cover [A] (⚙️ x3)
4. Stapler unit holder [B] (⚙️ x1)
5. Corner stapler [C] (M20) (⚙️ x1)

Stapler Unit

1.3.2 POSITIONING ROLLER

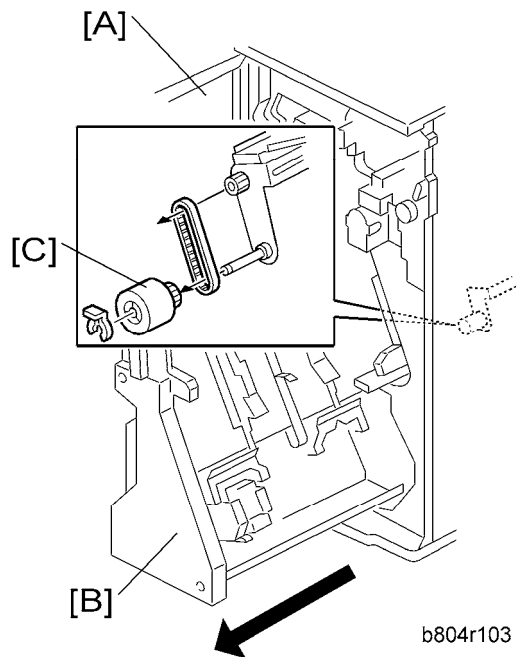

1. Open the front door [A].
2. Pull out the stapling unit [B].
3. Positioning roller [C] (⌀ x1, timing belt x1)

Booklet
Finisher/
Finisher
B804/B805/
D373/D374

1.4 FOLD UNIT

1.4.1 FOLD UNIT

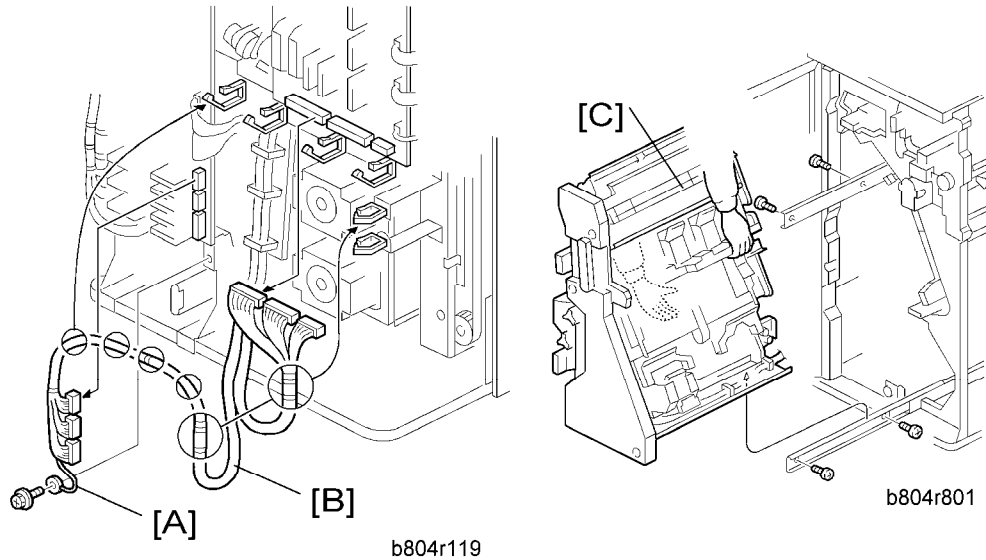

1. Remove the back cover (☛ 1.1.1 "Exterior Covers").
2. Open the front door.

⚠ CAUTION

- The stapler unit is heavy.

3. Ground cable [A] (🔩 x1)
4. Harness [B] (🔩 x6, 📌 x6)
5. Stapler unit [C] (🔩 x4)

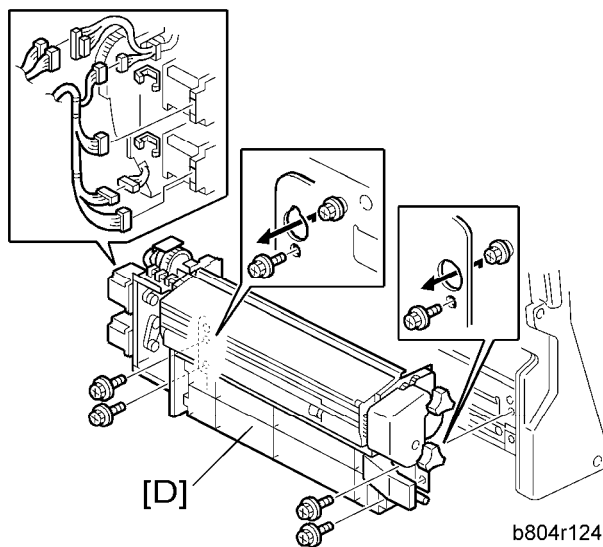

Fold Unit

★ Important

- Support the fold unit with your hand to prevent it from falling.

⚠ CAUTION

- The fold unit is heavy.

6. Folding unit [D] (🔧 x4, 🛠️ x2, 📦 x6)

If you have replaced the folding unit:

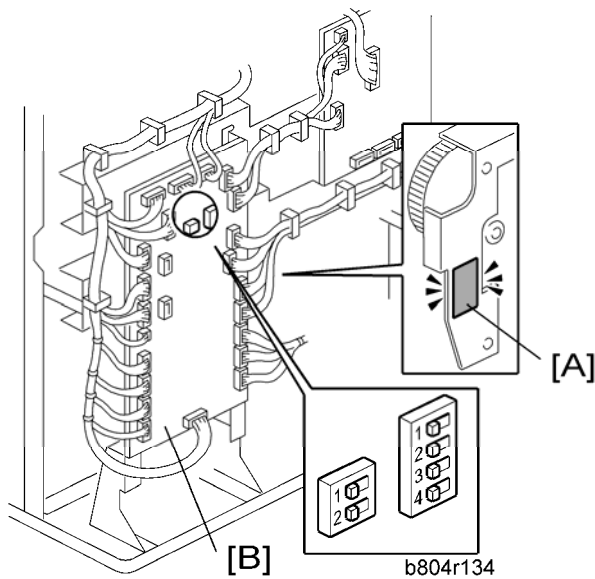

1. Read the DIP SW settings on the decal [A] attached to the back of the new folding unit.
2. Check the DIP SW settings on the main board [B] of the finisher.
3. If these settings are different, change these settings to match the settings printed on the decal attached to the folding unit.

↓ Note

- Set DIP switches 1 to 4 (the switch set on the right). Do not touch the other DIP switches.

1.4.2 FOLD UNIT ENTRANCE SENSOR

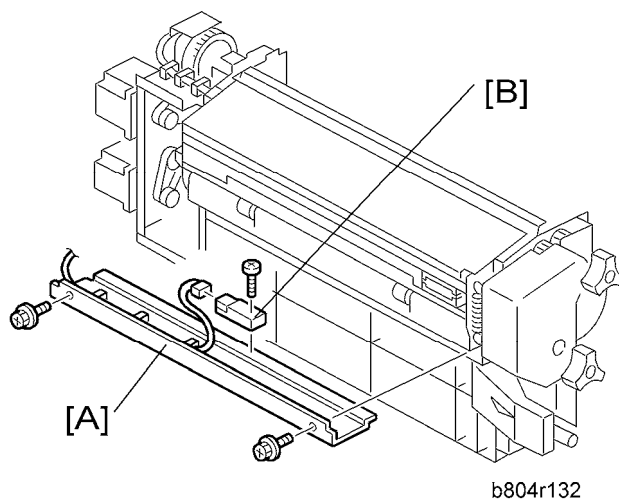

1. Pull out the stapler unit (☛1.3.2 "Positioning Roller").
2. Fold unit entrance sensor bracket [A] (🔩 x2)
3. Fold unit entrance sensor [B] (S26) (🔩 x1, 📌 x1)

1.4.3 FOLD UNIT EXIT SENSOR

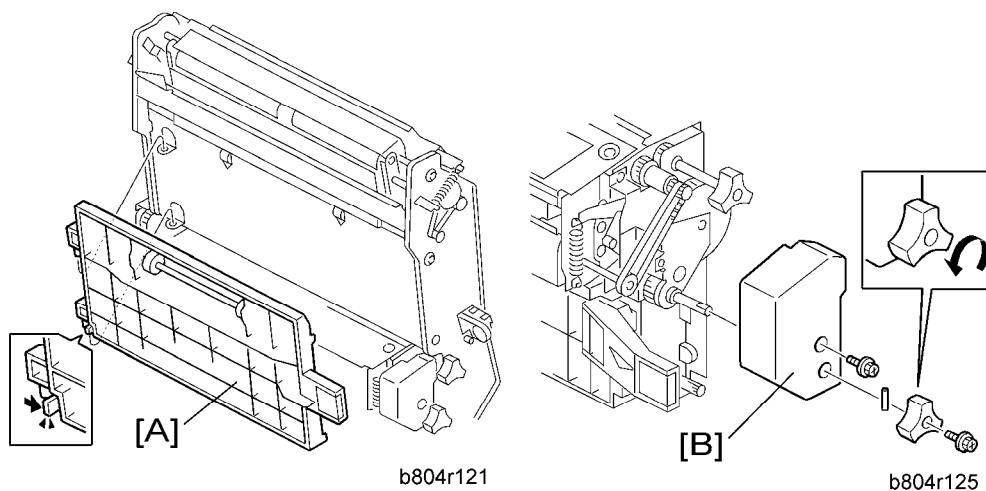

1. Open the front door.
2. Pull out the stapler unit (☛1.3.2 "Positioning Roller").
3. Fold unit vertical guide plate [A]
4. Fold unit inner cover [B] (🔩 x2, Spring pin x1)

Fold Unit

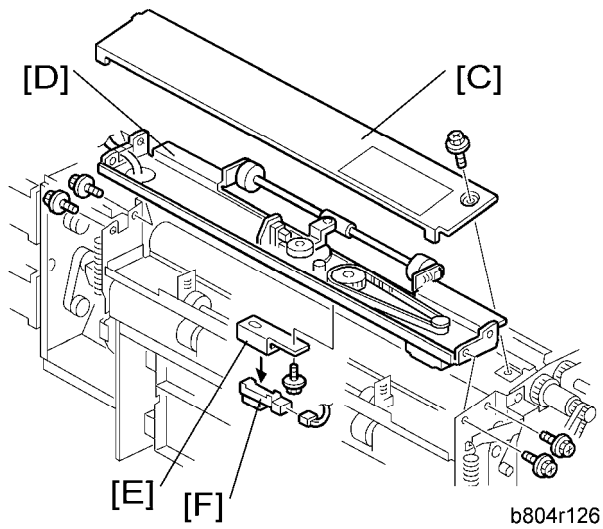

5. Fold unit upper cover [C] (🔩 x1)
6. Paper clamp mechanism [D] (🔩 x4)
7. Fold unit exit sensor bracket [E] (🔩 x1)
8. Fold unit exit sensor [F] (S31) (🔩 x1)

Booklet
 Finisher/
 Finisher
 B804/B805/
 D373/D374

1.4.4 STACK PRESENT SENSOR

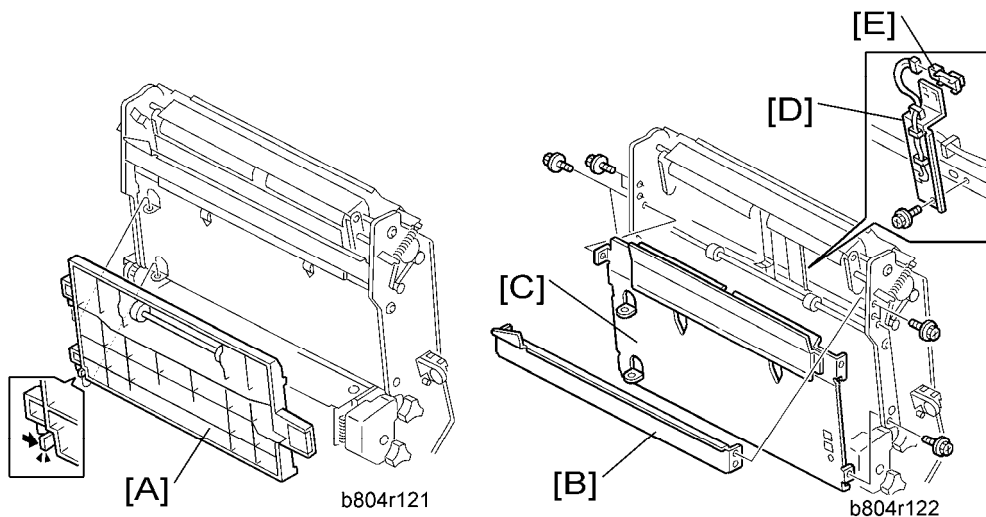

★ Important

- If you intend to correct the horizontal and vertical skew for the fold unit at the same time, do those adjustments first, then replace the sensor. (☞ 1.4.5 "Folding Horizontal Skew Adjustment" or "Fold Vertical Skew Adjustment")

1. Remove the stapler unit (☞ 1.4.1 "Fold Unit")

2. Guide plate [A].
3. Stay [B] (⌘ x4)
4. Left plate [C] (⌘ x4)
5. Sensor bracket [D] (⌘ x1)
6. Stack present sensor [E] (S32) (⌘ x1)

1.4.5 FOLDING HORIZONTAL SKEW ADJUSTMENT (FOR B804 ONLY)

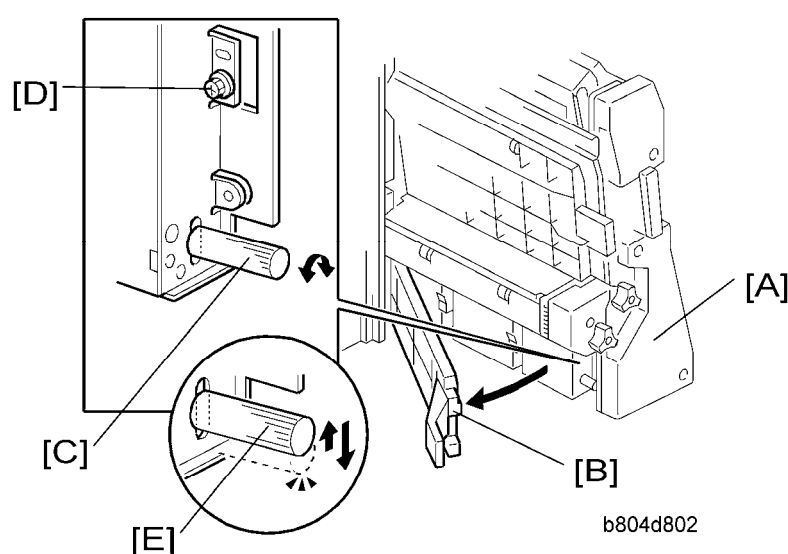

★ Important

- The fold unit is adjusted for optimum performance before the finisher is shipped from the factory. Do this adjustment only if the edges of folded booklets are not even.

1. Switch the copier on and enter the SP mode.
2. Europe, Asia: Use **SP6-134-001** (this is for A3 paper). North America: Use **SP6-134-005** (this is for DLT paper).

↓ Note

- If the original setting of SP6-134-001 or -005 is not "0", then you must do the vertical skew adjustment (● 1.4.6 "Fold Vertical Skew Adjustment") after you finish this horizontal skew procedure.
3. Use the 10-key pad to input "-2" (mm) for the SP value. (Press  to enter the minus sign.)
 4. Press [#] then exit the SP mode.

Fold Unit

5. Open the front door and pull the stapler unit [A] out of the finisher.
6. Open the guide plate [B].
7. Loosen the adjustment screw [C] and then tighten until it stops. (Do not over tighten.)
8. Remove the lock screw [D].
9. Raise the tip [E] of the adjustment screw very slightly and allow it to descend under its own weight.

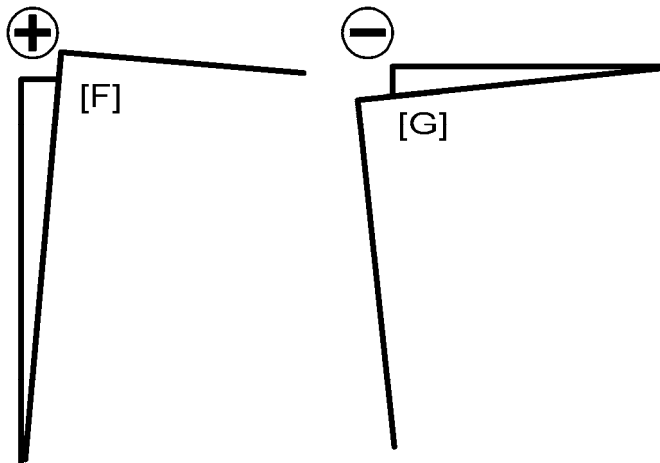

b804r901

10. Push the stapler unit into the finisher and close the front door.
11. Do a folding test.
 - Switch the copier on.
 - Put one page of A3 or DLT paper in the ARDF.
 - On the copier operation panel, select booklet stapling.
 - Press [Start]. One sheet is folded.
12. Remove the sheet from the lower tray.
13. Hold the folded sheet with the creased side pointing down and face-up (the same way that it came out of the finisher).
14. Referring to the diagram, determine if the skew is + [F] or - [G].

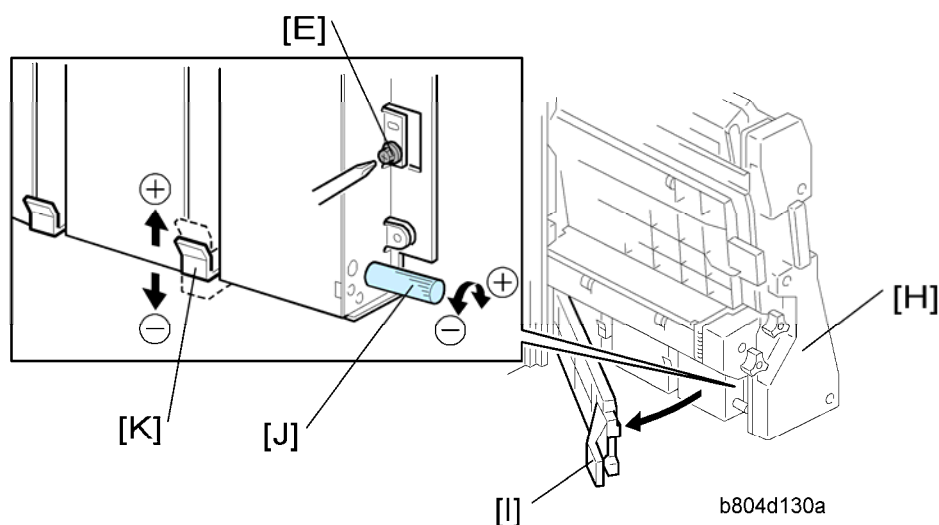

15. Open the front door of the finisher and pull the stapler unit [H] out.
16. Open the guide plate [I].
17. Turn the adjustment screw [J] to correct the amount of skew you measured from the test sheet.
 - For + skew [F], turn the adjustment screw (clockwise).
 - For – skew [G], turn the adjustment screw to the left (counter-clockwise).
 - Every click in the +/- direction adjusts the fold position by 0.1 mm by moving the bottom fence [K].
18. Raise the tip of the adjustment screw [J] and allow it to lower under its own weight.
19. Attach and tighten the lock screw [L].
20. Push the stapler unit into the machine, close the front door, then turn the copier on.
21. Europe, Asia: Do **SP6-134-001** (this is for A3 paper). North America: **Do SP6-134-005** (this is for DLT paper).
22. Reset it to "0".
23. Do the test again.
24. If the result is satisfactory, this completes the adjustment. -or- If some skew remains, repeat this adjustment.

↓ Note

- After doing this adjustment, adjust for vertical skew, if necessary. (See 1.4.6 "Fold Vertical Skew Adjustment")

1.4.6 FOLD VERTICAL SKEW ADJUSTMENT (FOR B804 ONLY)

★ Important

- The fold unit is adjusted for optimum performance before the finisher is shipped from the factory. Do this adjustment only if the edges of folded booklets are not even.
1. Switch the copier on.
 2. Do a folding test.
 - Switch the copier on.
 - Put one page of A3 or DLT paper in the ARDF.
 - On the copier operation panel, select booklet stapling.
 - Press [Start]. One sheet is folded.
 3. Hold the folded sheet with the creased side pointing down, and face-up (the same way that it came out of the finisher).

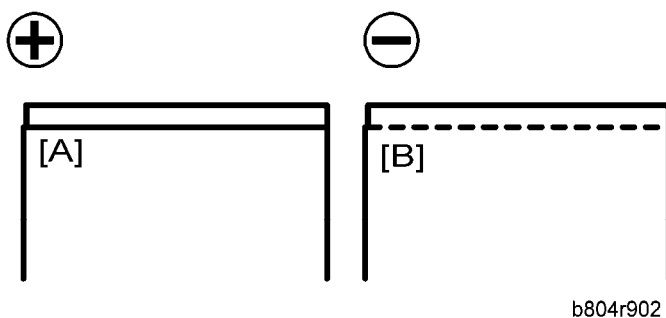

4. Referring to the diagram, determine if the skew is positive [A] or negative [B].
5. Measure the amount of skew.
6. Enter the SP mode
 - Europe, Asia: Use **SP6-134-001** (this is for A3 paper).
 - North America: Use **SP6-134-005** (this is for DLT paper).
7. Enter one-half the measured amount of skew. Example: If the measure amount of skew is -1.2 mm, enter -0.6 mm

↓ Note

- The range for measurement is -3.0 mm to +3.0 mm in 0.2 mm steps for every notch adjustment.
8. Exit the SP mode and do the test again (steps 2 to 5).
 9. Repeat this procedure until the skew is corrected.
- The illustration below shows the effects of +/- adjustment with SP6113. (The vertical arrows show the direction of paper feed.)

Fold Unit

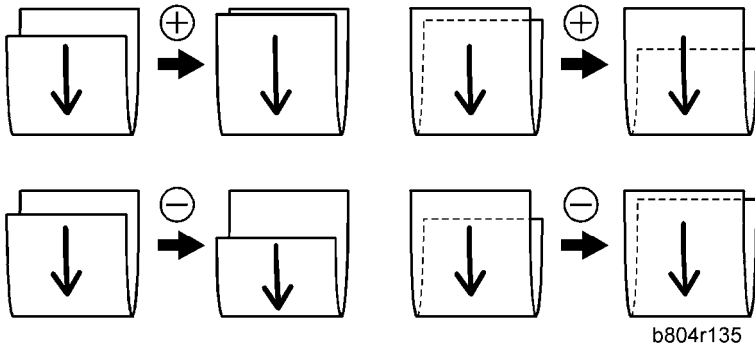

1.5 BOOKLET STAPLER UNIT

1.5.1 BOOKLET STAPLER

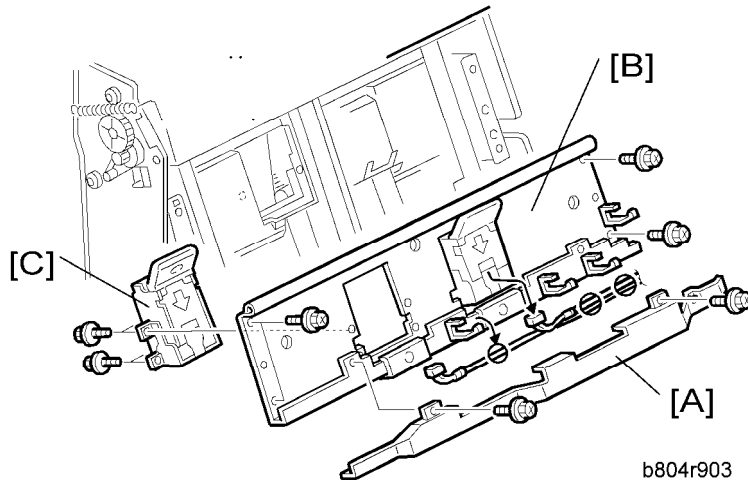

1. Open the front door.
2. Pull out the stapler unit (☛1.2.2 "Positioning Roller").
3. Harness cover [A] (🔩 x2)
4. Booklet stapler support stay [B] (🔩 x4, 🏠 x2, 🏠 x4)
5. Stapler [C] (🔩 x4)

1.5.2 BOOKLET STAPLER MOTOR

1. Open the front door.
2. Remove the stapler unit. (☛1.4.1 "Fold Unit")

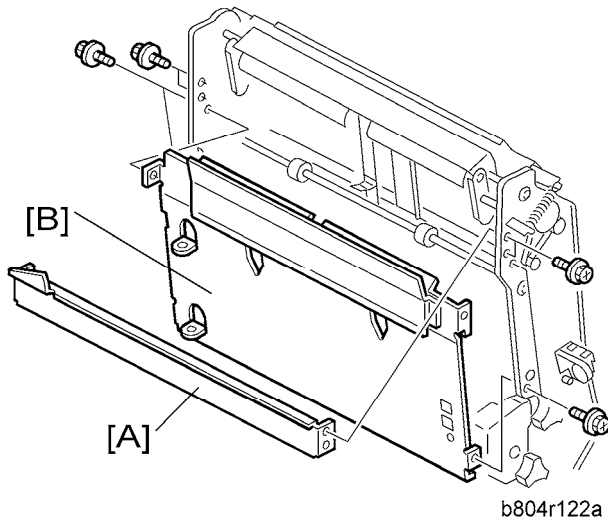

3. Stay [A] (⚙️ x4).
4. Left plate [B] (⚙️ x4)

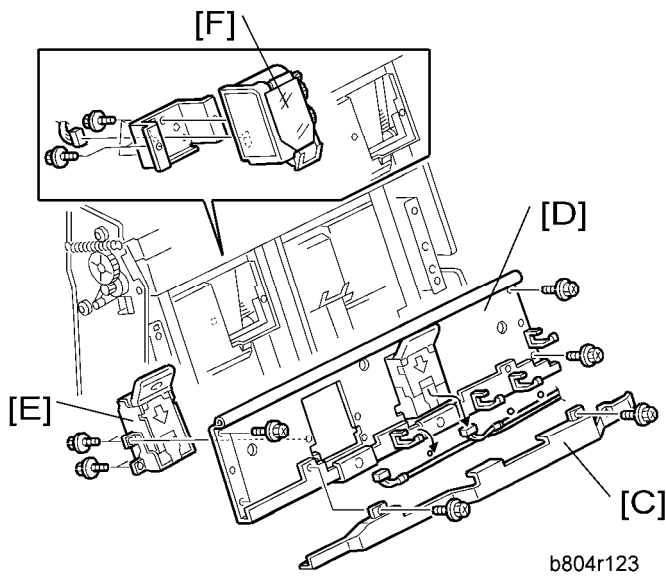

5. Harness cover [C] (⚙️ x2)
6. Booklet stapler support stay [D] (⚙️ x4, ⚙️ x2, ⚙️ x4)
7. Booklet stapler [E] (⚙️ x4)
8. Booklet stapler motor [F] (⚙️ x2, ⚙️ x1)

To Reattach the Booklet Stapler Motor

1. Reattach the booklet stapler motor.



- Do not tighten the screws.

Booklet Stapler Unit

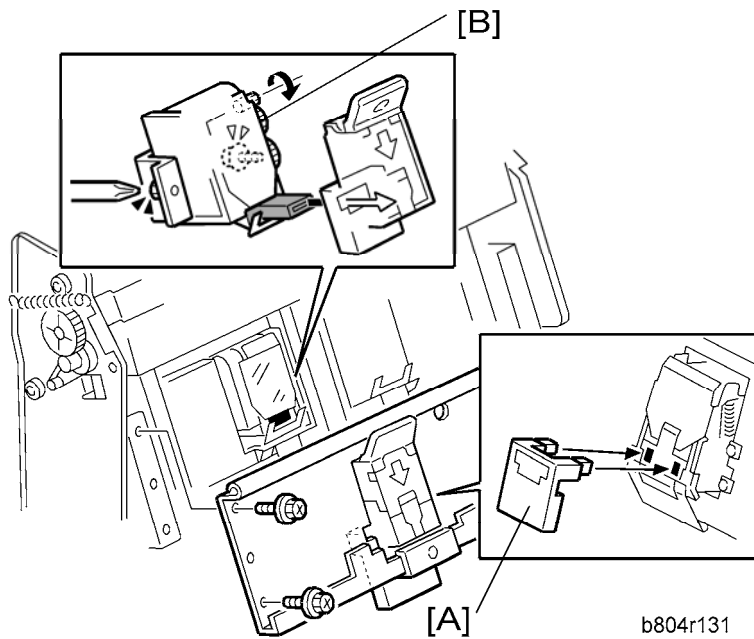

2. Attach the special tool [A] and reattach the booklet stapler stay.

↓ Note

- This tool is included with the stapler spare part.
3. Turn the gear [B] with your finger until it stops.
 4. Tighten the screws to attach to the booklet stapler motor.
 5. Remove the stay again and remove the special tool.
 6. Reattach the booklet stapler stay.
 7. Push the stapler unit into the machine.

Booklet
Finisher/
Finisher
B804/B805/
D373/D374

2. DETAILED SECTION DESCRIPTIONS

2.1 COMPONENT LAYOUT

2.1.1 GENERAL LAYOUT

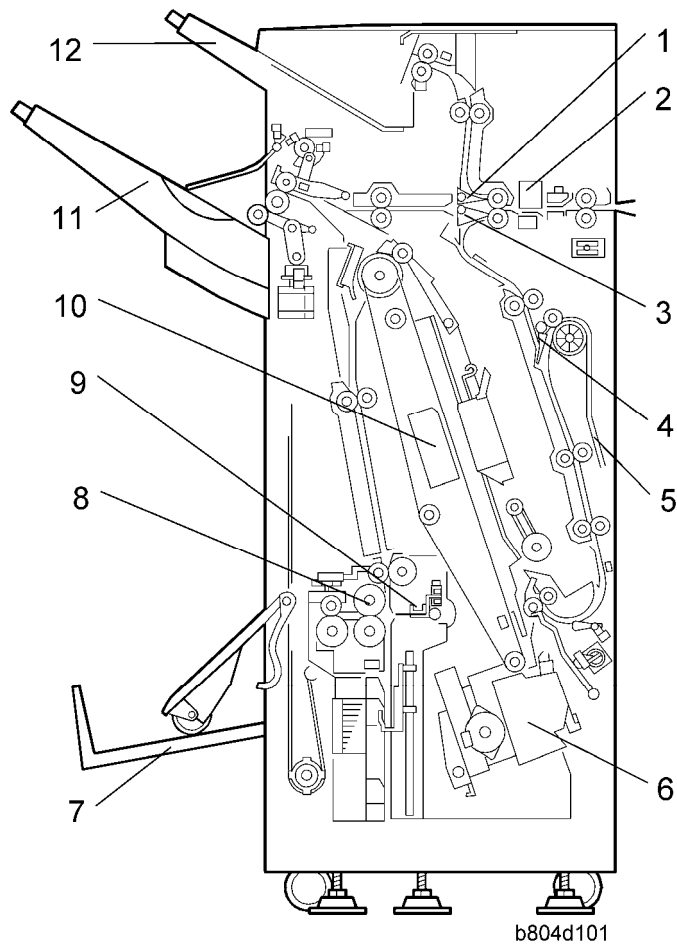

1. Proof Tray Junction Gate	7. Lower Tray (Booklet)* ¹
2. Punch Unit	8. Folder Rollers* ¹
3. Stapler Junction Gate	9. Folder Plate* ¹
4. Pre-Stack Junction Gate	10. Booklet Stapler* ¹
5. Pre-Stack Tray	11. Upper Tray (Shift)
6. Corner Stapler (M20)	12. Proof Tray

Component Layout

*1: B804 Only

Paper direction

The operation of the proof tray and stapler junction gates direct the flow of the paper once it enters the finisher:

Proof Junction Gate	Stapler Junction Gate	Paper Feeds
Closed	Closed	Paper feeds straight through
Open	Closed	Paper feeds to the proof tray
Closed	Open	Paper feeds to the staple tray

Proof tray

Copies are sent to the proof tray (12) when neither sorting nor stapling are selected for the job.

Upper tray

The upper tray (11) receives copies that are sorted and shifted and also receives copies that have been corner stapled. Corner stapling is provided on both the B804 and the B805.

Pre-stack tray

The pre-stack tray (5) has a switchback mechanism to increase the productivity of stapling. (2.3 "Pre-Stacking) Pre-stacking is done for corner stapling in the B804/B805 and for booklet stapling in the B804.

Lower tray

The lower tray (7) receives copies that have been center folded and stapled (booklet stapling). Booklet stapling is not provided on the B805.

Booklet
Finisher/
Finisher
B804/B805/
D373/D374

2.1.2 ELECTRICAL COMPONENTS

Upper Area B804/B805

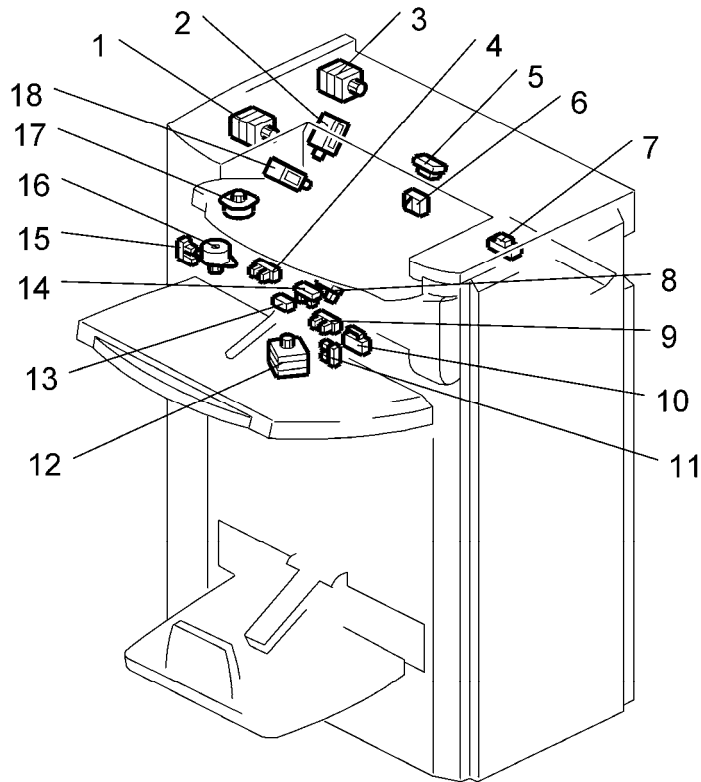

b804d201

1. Upper/Proof Exit Motor (M4)	10. Upper Tray Limit Switch (SW2)
2. Stapling Tray Junction Gate Solenoid (SOL2)	11. Stacking Roller HP Sensor (S13)
3. Upper Transport Motor (M2)	12. Stacking Sponge Roller Motor (M10)
4. Exit Guide Plate HP Sensor (S7)	13. Upper Tray Exit Sensor (S6)
5. Proof Tray Exit Sensor (S10)	14. Upper Tray Paper Height Sensor (S8) (Staple Mode)
6. Proof Tray Full Sensor (S11)	15. Shift Roller HP Sensor (S5)
7. Finisher Entrance Sensor (S1)	16. Shift Roller Motor (M18)
8. Upper Tray Paper Height Sensor (S9) (Non-Staple Mode)	17. Exit Guide Plate Motor (M19)
9. Upper Tray Limit Sensor (S12)	18. Proof Junction Gate Solenoid (SOL1)

Component Layout

Lower Area B804/B805

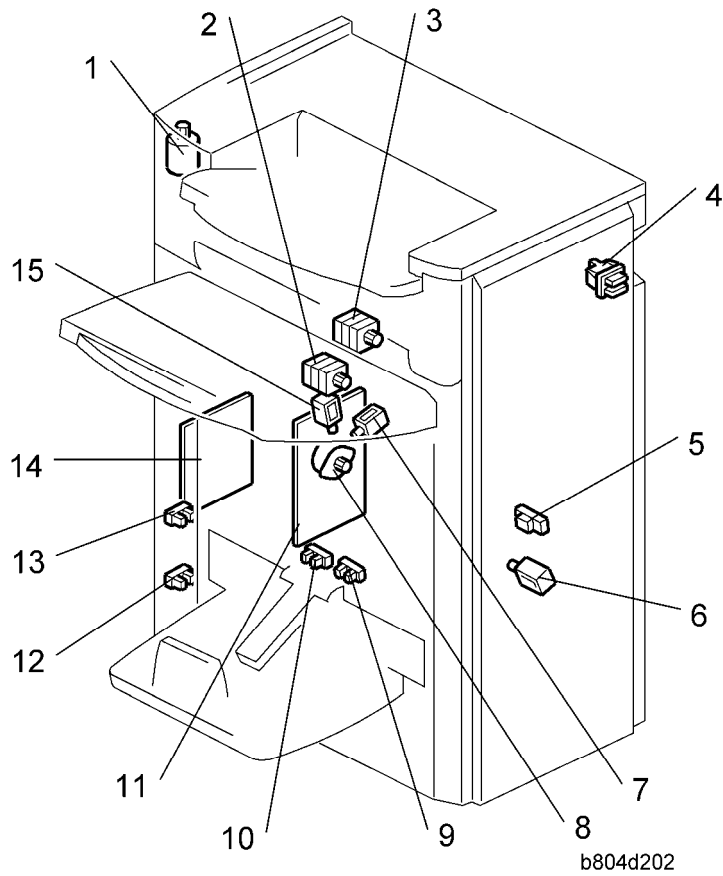

Booklet
Finisher/
Finisher
B804/B805/
D373/D374

<p>1. Upper Tray Lift Motor (M21)</p> <p>2. Lower Transport Motor (M3)</p> <p>3. Entrance Motor (M1)</p> <p>4. Front Door Safety Switch (SW1)</p> <p>5. Pre-Stack Tray Exit Sensor (S2)</p> <p>6. Stapling Edge Pressure Plate Solenoid (SOL4)</p> <p>7. Positioning Roller Solenoid (SOL3)</p>	<p>8. Positioning Roller Motor (M14)</p> <p>9. Lower Tray Full Sensor – Front (S34)^{*1}</p> <p>10. Lower Tray Full Sensor – Rear (S33)^{*1}</p> <p>11. Main Board (PCB1)</p> <p>12. Upper Tray Full Sensor – (S20) ^{*2}</p> <p>13. Upper Tray Full Sensor – (S19)</p> <p>14. Booklet Stapler Board (PCB2)^{*1}</p> <p>15. Booklet Pressure Roller Solenoid – (SOL5)^{*1}</p>
---	--

^{*1}: B804 Only, ^{*2}: B805 Only

Punch Unit B702

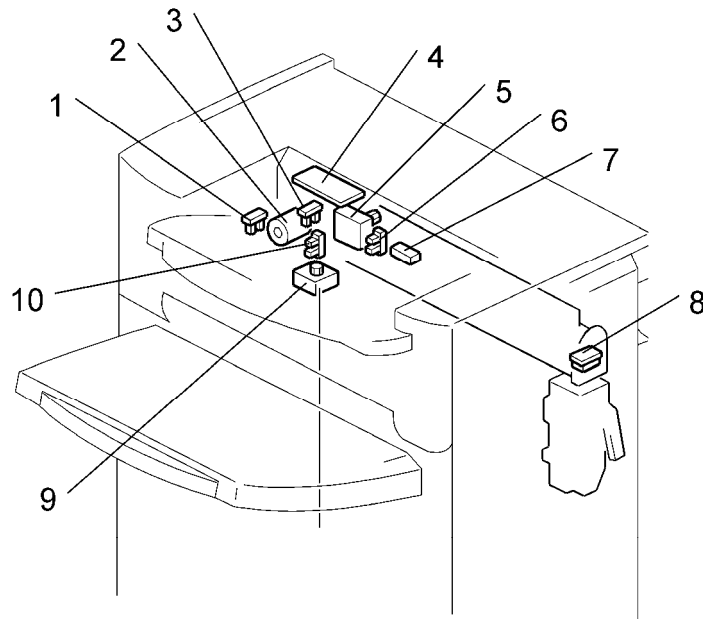

b804d203a

<ol style="list-style-type: none"> 1. Punch Encoder Sensor (S24) 2. Punch Drive Motor (M24) 3. Punch HP Sensor (S24) 4. Punch Unit Board (PCB3) 5. Paper Position Sensor Slide Motor (M7) 	<ol style="list-style-type: none"> 6. Paper Position Slide HP Sensor (S22) 7. Paper Position Sensor (S3) 8. Punch Hopper Full Sensor (S4) 9. Punch Movement Motor (M9) 10. Punch Movement HP Sensor (S21)
--	--

Component Layout

Stacker/Stapler - B804/B805

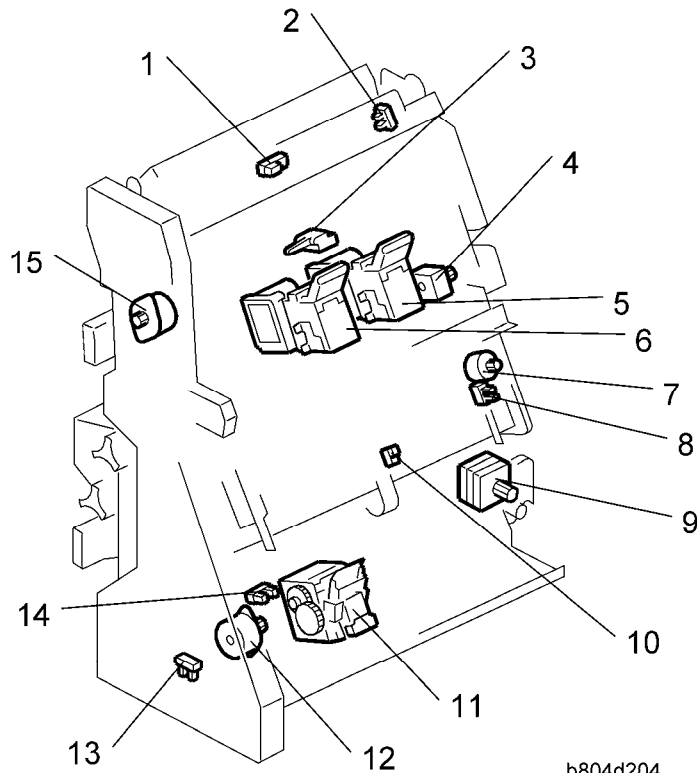

b804d204

Booklet
Finisher/
Finisher
B804/B805/
D373/D374

1. Stack Present Sensor (S32)* ¹	7. Jogger Fence Motor (M15)
2. Stack Junction Gate HP Sensor (S27)* ¹	8. Jogger Fence HP Sensor (S15)
3. Stack Feed Out Belt HP Sensor (S16)	9. Corner Stapler Movement Motor (M6)
4. Feed Out Belt Motor (M5)	10. Stapling Tray Paper Sensor (S14)
5. Booklet Stapler EH185R – Rear (M23)* ¹	11. Corner Stapler EH530 (M20)
6. Booklet Stapler EH185R – Front (M22)* ¹	12. Corner Stapler Rotation Motor (M13)
	13. Corner Stapler HP Sensor (S17)
	14. Stapler Rotation HP Sensor (S18)
	15. Stack Junction Gate Motor (M17) * ¹

*¹: B804 Only

B804 Fold unit

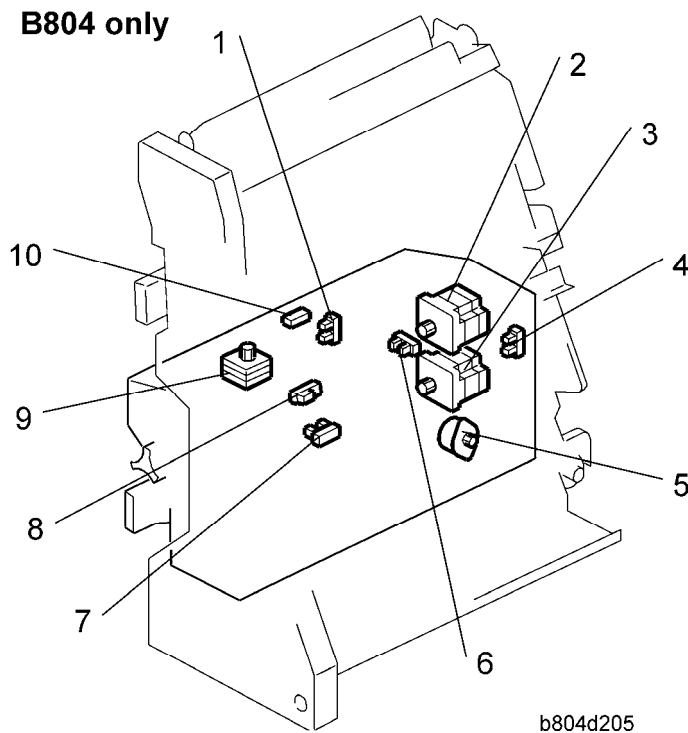

1. Clamp Roller HP Sensor (S25)	6. Fold Cam HP Sensor (S30)
2. Fold Roller Motor (M12)	7. Fold Bottom Fence HP Sensor (S28)
3. Fold Plate Motor (M11)	8. Fold Unit Entrance Sensor (S26)
4. Fold Plate HP Sensor (S29)	9. Clamp Roller Retraction Motor (M8)
5. Fold Unit Bottom Fence Lift Motor (M16)	10. Fold Unit Exit Sensor (S31)

2.1.3 SUMMARY OF ELECTRICAL COMPONENTS

Here is a general summary of all the electrical components of the B804/B805 finishers.

Note

- In the table below a number that appears in bold text (**M8**, etc.) denotes a component that is on the 2000/3000 Sheet Finisher B804 only.

Component Layout

No.	Component	Function
Boards (PCB)		
PCB1	Main Board	The main board that controls the finisher
PCB2	Booklet Stapler Board	A separate board that controls booklet finishing.
PCB3	Punch Unit Board	The board that controls the punch unit.
Motors		
M1	Finisher Entrance Motor	Drives 1) the finisher entrance rollers, 2) and the punch waste transport belt of the punch unit.
M2	Upper Transport Motor	Drives the paper feed rollers that feed paper 1) to the proof tray, 2) straight-through to the upper tray, 3) the pre-stack tray entrance roller.
M3	Lower Transport Motor	Drives paper feed rollers forward and reverse in the pre-stack tray for the switchback, and drives the other rollers in the lower transport area.
M4	Upper/Proof Tray Exit Motor	Drives 1) proof tray exit rollers, 2) extension and retraction of the stacking sponge roller, 3) upper tray exit rollers.
M5	Feed Out Belt Motor	Drives the feed out belt that moves the stapled stacks out of the stapling tray after stapling.
M6	Corner Stapler Movement Motor	Moves the corner stapler horizontally on a steel rod to position the stapler at the stapling position at 1) the front, 2) the rear (straight stapling), 3) the rear (diagonal stapling), or 4) the front and rear for double stapling.
M7	Paper Position Sensor Slide Motor	Drives the movement of the paper position slide that holds the paper position sensor (S3) that detects the position of the paper.
M8	Clamp Roller Retraction Motor	Drives a large cam that alternately clamps and unclamps the clamp retraction roller, the idle roller of the clamp roller pair. When these rollers are clamped, they

Booklet
Finisher/
Finisher
B804/B805/
D373/D374

No.	Component	Function
		are part of the paper feed path and feed the stack toward the bottom fence of the fold unit. When the idle roller is retracted, the stacks falls a very short distance (3 mm) onto the fold unit bottom fence below. These rollers remain unclamped while the bottom fence positions the stack for folding and while the stack is folded by the fold rollers.
M9	Punch Movement Motor	Drives the front/back movement of the punch unit to position it correctly for stapling the paper below.
M10	Stacking Sponge Roller Motor	Rotates the stacking roller that drags each sheet back against the end fence to jog the bottom of each sheet after feed out to the upper tray.
M11	Fold Plate Motor	Drives the fold plate that pushes the center of the stack into the nip of the fold rollers to start the fold.
M12	Fold Roller Motor	Rotates forward and drives the fold rollers that fold the stack and feed it out of the fold unit, reverses to feed the fold once more into the fold unit, and then rotates forward again to feed the fold out of the fold unit.
M13	Corner Stapler Rotation Motor	Swivels the corner stapler and positions it so the staple fires at an oblique angle at the rear corner of the paper stack.
M14	Positioning Roller Motor	Drives the positioning roller in the stapling tray.
M15	Jogger Fence Motor	Drives the jogger fences in the stapling tray to jog both sides of the stack before stapling.
M16	Fold Unit Bottom Fence Lift Motor	Raises the bottom fence and stops when the center of the vertical stack is opposite the edge of the horizontal fold blade. The distance for raising the blade is prescribed as one-half the size of the paper selected for the job. For large paper, (A3, B4) the bottom fence first

Component Layout

No.	Component	Function
		lowers the stack 10 mm below the fold position, and then raises it to the fold position.
M17	Stack Junction Gate Motor	Drives the large cam that operates the stack junction gate at the top of the stapling tray. When this gate is open, it directs the ascending stack to the upper tray if it has been corner stapled, or if it is closed the gate turns the booklet stapled stack down so it falls onto the bottom fence of the folding unit.
M18	Shift Roller Motor	Drives the shift roller that operates in shift mode to stagger document sets as they feed out to the upper tray (making them easier to separate).
M19	Exit Guide Plate Motor	Drives the mechanism that raises and lowers the exit guide plate.
M20	Corner Stapler EH530	This is the roving corner stapler, mounted on a steel rail that staples 1) at the front, 2) at the rear (straight staple), 3) at the rear (diagonal staple), and 4) front and rear (two staples).
M21	Upper Tray Lift Motor	Raises and lowers the upper tray during feed out to keep the tray at the optimum height until it is full.
M22	Booklet Stapler EH185R: Front	Booklet stapler. Staples paper stacks in the center before they are folded.
M23	Booklet Stapler EH185R: Rear	Booklet stapler. Staples paper stacks in the center before they are folded.
M24	Punch Drive Motor	Fires the punches that punch the holes in the paper.
Sensors		
S1	Finisher Entrance Sensor	Provides two functions: (1) Detects paper entering the finisher from the copier, and (2) Signals a jam if it detects paper at the entrance when the copier is switched on.

Booklet
Finisher/
Finisher
B804/B805/
D373/D374

No.	Component	Function
S2	Pre-stack Tray Exit Sensor	Detects 1) paper fed from the pre-stack tray to the stapling tray, and detects 2) paper in the pre-stack when the copier is switched on. (This sensor performs no timing function. The entire flow of paper through the pre-stacking mechanism is controlled by motor pulse counts.)
S3	Paper Position Sensor	The photosensor that detects the edge of the paper and sends this information to the punch unit board where it is used to position the punch for punching the holes in the paper.
S4	Punch Hopper Full Sensor	1) A photosensor that detects and signals that the punch hopper is filled with punch waste and needs emptying, and 2) confirms the presence of the punch hopper and signals an error if it is missing or not installed completely.
S5	Shift Roller HP Sensor	Located near the shift roller motor, controls the front-to-back movement of the shift roller as shifts paper during straight-through feed.
S6	Upper Tray Exit Sensor	A flat, photo sensor located inside the guide plate, detects the leading edge and trailing edge of the paper as it feeds out to the upper tray during straight-through jobs (with and without stapling). When paper is fed to the upper tray, at the paper output slot this sensor signals an error when it detects (1) paper has failed to leave the paper exit (lag error), (2) detects paper has failed to arrive at the paper exit (late error), (3) detects paper is in the exit slot when the machine is turned on.
S7	Exit Guide Plate HP Sensor	Controls the vertical movement of the control exit guide . The guide plate is in the home position when the guide plate is down and the actuator interrupts the sensor gap.

Component Layout

No.	Component	Function
S8	Upper Tray Paper Height Sensor (Staple Mode)	This is the upper sensor of the upper/lower paper height sensor pair that controls the lift of the upper tray. This sensor detects the paper height of the stack in the upper tray when the copier is operating in the staple mode.
S9	Upper Tray Paper Height Sensor (Non-Staple Mode)	This is the lower sensor of the upper/lower paper height sensor pair that controls the lift of the upper tray. When the machine is switched on, the upper tray rises until the actuator on the tray triggers this sensor to switch off the upper tray lift motor.
S10	Proof Tray Exit Sensor	This sensor detects and times the feeding of paper to the proof tray. It also detects whether paper is present at the proof tray exit when the copier is switched on.
S11	Proof Tray Full Sensor	The top of the stack in the proof tray increases until it nudges the feeler of this sensor. The sensor then signals that the proof tray is full and the job halts until some paper is removed from the proof tray.
S12	Upper Tray Limit Sensor	This sensor controls the position of the upper tray 1) during straight-through feed out, 2) during shift feed out, 3) when the machine is turned on. The machine obeys the signal of whichever sensor is actuated first. An actuator attached to an arm triggers this sensor. The tip of the same arm depresses the upper tray limit switch. If the sensor fails, the tip of the arm will activate the upper tray limit microswitch (SW2) and stop the lift of the upper tray. Note: When the machine is turned on, the upper tray position is controlled by either this sensor or the upper tray paper height sensor (S9).
S13	Stacking Roller HP Sensor	Controls the forward and back motion of the stacking roller (a sponge roller) located at the output slot of the upper tray. The sponge roller drags each ejected sheet

Booklet
Finisher/
Finisher
B804/B805/
D373/D374

No.	Component	Function
		back against the end fence of the upper tray to keep the bottom of the stack aligned.
S14	Stapling Tray Paper Sensor	A photo sensor that detects whether paper is in the stapling tray. When this sensor detects paper, the bottom fence motor raises or lowers the bottom fence to position the selected paper size for booklet stapling.
S15	Jogger Fence HP Sensor	Detects the home position of the jogger fences. When the actuator on the jogger fence interrupts this sensor, the jogger fence is in its home position and the jogger fence motor (M15) stops.
S16	Stack Feed-Out Belt HP Sensor	Controls the position of the stack feed-out pawl on the stack feed-out belt. Once the actuator on the feed belt nudges the feeler of this sensor near the top of the stapling unit, the feed out belt motor (M5) remains on for the time prescribed to position the pawl at the home position to catch the next stack.
S17	Corner Stapler HP Sensor	Located at the front the stapling tray and mounted above the steel rod where the corner stapler travels, this sensor detects the home position of the corner stapler. The corner stapler is in its home position when the actuator on the corner stapler unit interrupts this sensor.
S18	Stapler Rotation HP Sensor	Controls the angle of the position of the corner stapler during oblique stapling.
S19	Upper Tray Full Sensor (B804/B805)	<p>B804: When the actuator on the side of the upper fence enters the gap of this sensor, the sensor signals that the upper tray is at its lowest position (full) and stops the job.</p> <p>B805: One of two upper tray full sensors. This is the higher tray full sensor for A3 and other heavy paper. The other upper tray full sensor (20) is for lighter paper.</p>

Component Layout

No.	Component	Function
S20	Upper Tray Full Sensor (B805 only)	B804: This sensor is not used on the booklet finisher. There is only one upper tray full sensor (S18). B805: One of two upper tray full sensors. This is the lower tray full sensor for A4 and smaller paper. The other upper tray full sensor (19) is for larger paper.
S21	Punch Unit HP Sensor	Switches off the punch movement motor when the punch unit returns to its home position. Pulse counts determine where the punch unit pauses for punching and reversing.
S22	Paper Position Side HP Sensor	Controls the movement of the paper position detection unit. Switches on when the horizontal detection unit is at the home position (HP is the reference point).
S23	Punch HP Sensor	Detects the home position of the punch unit and controls the vertical movement of the punches when they fire.
S24	Punch Encoder Sensor	When the punch mode is selected for the job (2-hole, 3-hole, etc.), the machine controls the operation of the punch drive (M24) motor which drives a small encoder shaped like a notched wheel. This wheel is rotated forward and reverse precisely to select which punches are moved up and down during the punch stroke.
S25	Clamp Roller HP Sensor	Controls the movement of the clamp retraction roller (the idle roller of the clamp roller pair).
S26	Fold Unit Entrance Sensor	Detects 1) the leading edge of the stack during booklet stapling, and 2) also used to signal an alarm if a paper is detected at the entrance of the fold unit when the copier is turned on.
S27	Stack Junction Gate HP Sensor	Controls the opening and closing of the stack junction gate. Switches on when the stack junction gate is open and at the home position.

Booklet
Finisher/
Finisher
B804/B805/
D373/D374

No.	Component	Function
S28	Fold Bottom Fence HP Sensor	Controls the movement of the bottom fence in the folding unit using pulse counts based on the size of the paper selected for the job to position the stack correctly for feeding.
S29	Fold Plate HP Sensor	Along with the fold plate cam HP sensor (S30) this sensor controls the movement of the fold plate . The fold plate has arrived at the home position when the edge of the plate enters the gap of this sensor.
S30	Fold Plate Cam HP Sensor	Along with the fold plate HP sensor (S29), this sensor controls the movement of the fold plate. The actuator mounted on the end of the roller that drives the folder plate forward and back makes three full rotations, i.e. the actuator passes the sensor gap twice and stops on the 3rd rotation and reverses. This accounts for the left and right movement of fold plate.
S31	Fold Unit Exit Sensor	1) Detects the folded edge of the stack as it feeds out from the nip of the fold rollers, stops the rollers, and reverses them so the fold feeds back into the nip, 2) when the folded booklet finally emerges from the nip of the fold rollers, detects the leading and trailing edge of the booklet to make sure that it feeds out correctly.
S32	Stack Present Sensor	This sensor determines whether there is paper at the turn junction gate when the machine is turned on. If a stack is present, this triggers a jam alert. (This sensor performs no dynamic function such as pulse counting, etc. It only detects whether paper is at the top of the folding unit when power its turned on.)
S33	Lower Tray Full Sensor - Rear	This rear sensor is the lower sensor of the lower tray full sensor pair. Two actuators are attached to the actuator arm that touches the top of stapled and folded booklets as they feed out. The on/off combinations of the two

Component Layout

No.	Component	Function
		sensors are used to detect when the tray is full and stop the job. (The lower tray is stationary. At tray full, the job halts until booklets are removed from the lower tray.)
S34	Lower Tray Full Sensor - Front	This front sensor is the higher sensor of the lower tray full sensor pair. Two actuators are attached to the actuator arm that touches the top of stapled and folded booklets as they feed out. The on/off combinations of the two sensors are used to detect when the tray is full and stop the job. (The lower tray is stationary. At tray full, the job halts until booklets are removed from the lower tray.)
Solenoids		
SOL1	Proof Junction Gate Solenoid	Opens and closes the proof tray junction gate. When the solenoid switches on, it opens the gate and paper is diverted to the proof tray. When this gate is closed, the paper goes straight to the upper tray. I
SOL2	Stapling Tray Junction Gate Solenoid	Directs paper to the stapling tray. When this solenoid is on, paper feeds straight through. When this solenoid is off, paper feeds to the stapler tray below.
SOL3	Positioning Roller Solenoid	Engages the stapler transport motor and the positioning roller of the stapling tray. The positioning roller pushes each sheet down against the bottom fence to align the bottom the stack for stapling. (The jogger fences align the sides.)
SOL4	Stapling Edge Pressure Plate Solenoid	Operates the pressure plate of the stapling unit. The pressure plate presses down the edge of stack in the stapling tray so it is tight for stapling.
SOL5	Booklet Pressure Roller Solenoid	When the paper stack in the stapling tray feeds to the folding unit, this solenoid turns on and operates the roller that pushes on the surface of the stack to flatten it.

**Booklet
Finisher/
Finisher
B804/B805/
D373/D374**

No.	Component	Function
Switches		
SW1	Front Door Safety Switch	The safety switch cuts the dc power when the front door is opened.
SW2	Upper Tray Limit SW	A micro-switch cuts the power to the upper tray lift motor when the upper tray reaches its upper limit. This switch duplicates the function of the upper tray limit sensor (S12) and stops the upper tray if S12 fails.

2.1.4 DRIVE LAYOUT

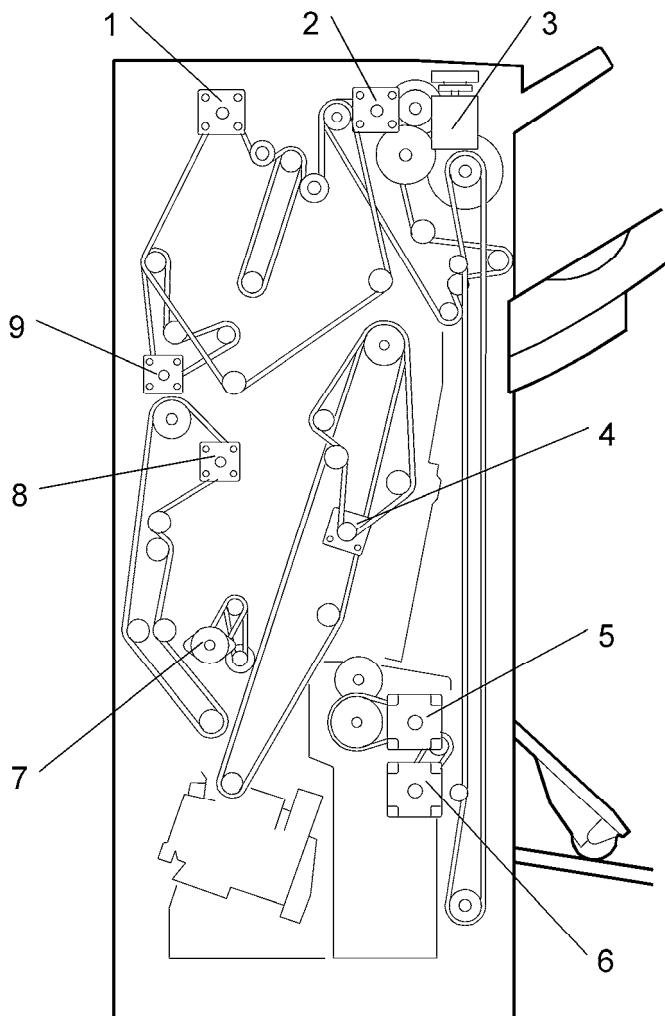

b804d206

Component Layout

<ol style="list-style-type: none">1. Upper Transport Motor (M2)2. Upper/Proof Exit Motor (M4)3. Upper Tray Lift Motor (M21)4. Feed-Out Belt Motor (M5)5. Fold Roller Motor*¹ (M12)	<ol style="list-style-type: none">6. Folder Plate Motor*¹ (M11)7. Positioning Roller Motor (M14)8. Lower Transport Motor (M3)9. Entrance Motor (M1)
---	---

*¹: B804 Only

Booklet
Finisher/
Finisher
B804/B805/
D373/D374

2.2 JUNCTION GATES

The positions of the proof tray and staple tray junction gates determine the direction of paper feed after paper enters the finisher.

2.2.1 PROOF MODE

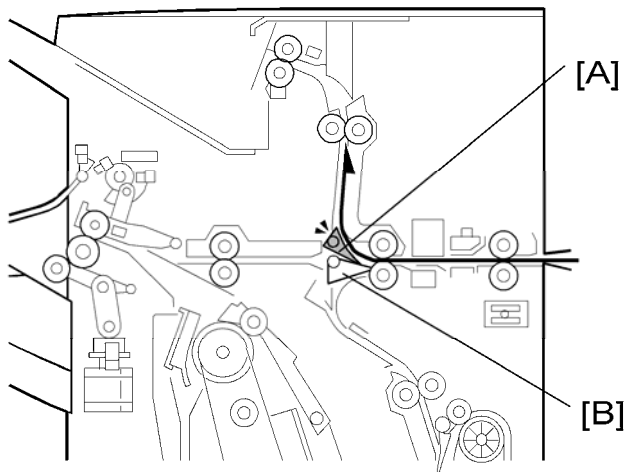

b804d301

Proof tray junction gate [A] opens. Staple tray junction gate [B] remains closed. The proof tray junction gate directs paper to the proof tray above.

2.2.2 SHIFT MODE

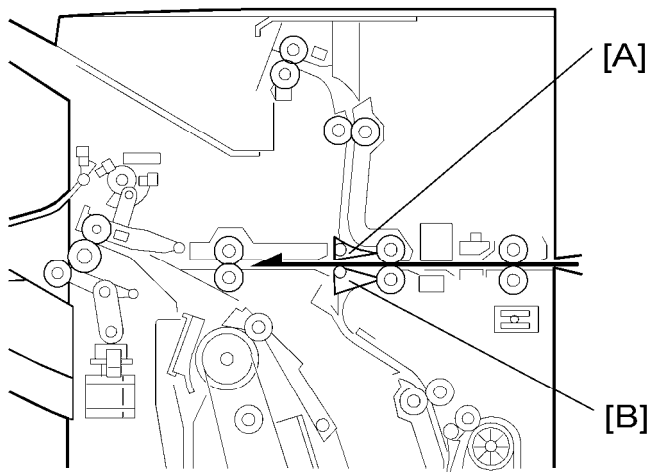

b804d302

Proof tray junction gate [A] remains closed. Staple tray junction gate [B] remains closed. With both junction gates closed, the paper goes to the upper tray.

Junction Gates

2.2.3 STAPLE MODE

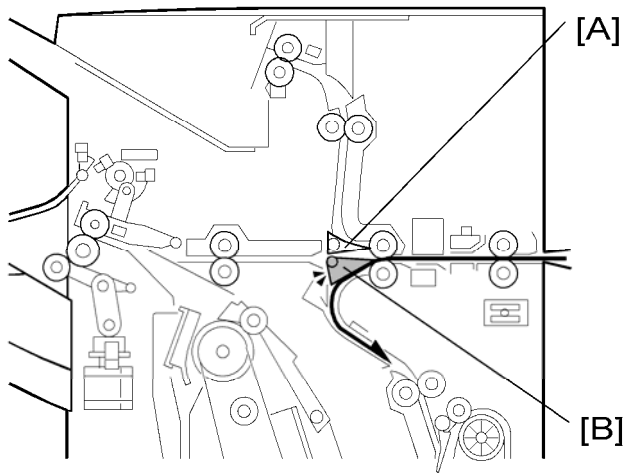

b804d303

Proof tray junction gate [A] remains closed. Staple tray junction gate [B] opens
The staple tray junction gate directs the paper to the staple tray below for jogging and stapling.

Booklet
Finisher/
Finisher
B804/B805/
D373/D374

2.3 PRE-STACKING

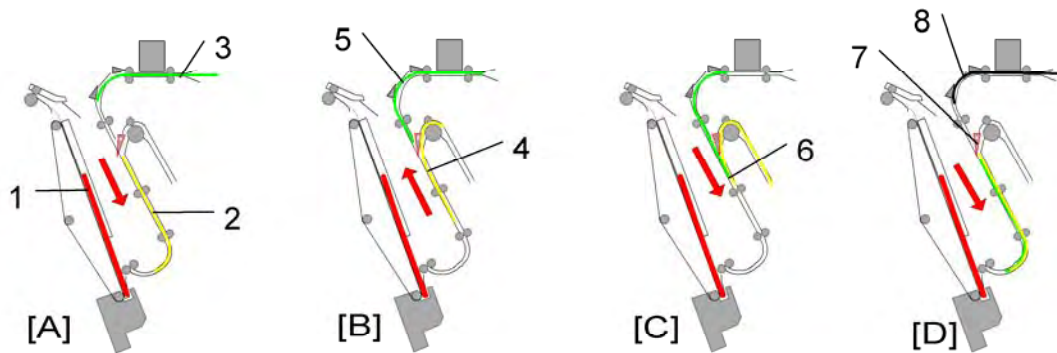

b804d992

This example describes what happens to Set 2 during the feed and stapling cycle of sets that contain three pages.

- [A]: While the Set 1 is being stapled in the staple tray [1], the 1st sheet of Set 2 [2] feeds to the pre-stack tray, and the 2nd sheet of Set 2 [3] enters the finisher.
- [B]: The pre-stack junction gate opens and the 1st sheet of Set 2 [4] switches back to the top of the pre-stack tray as the 2nd sheet of Set 2 [5] starts to descend.
- [C]: As the 2nd sheet of Set 2 continues to descend, the 1st sheet of Set 2 is fed from the pre-stack tray. At this time the leading edges [6] of both sheets are even.
- [D]: The trailing edges of the 1st and 2nd sheets of Set 2 pass the junction gate [7] as the 3rd sheet of Set 2 [8] enters the finisher.

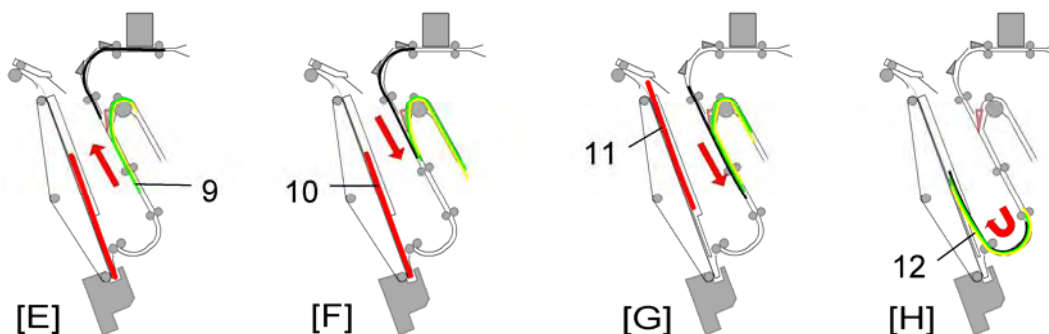

b804d993

- [E]: The 1st and 2nd sheets of Set 2 [9] switch back together into the top of the pre-stack and wait for the 3rd of Set 2 sheet to arrive.
- [F]: The stapling of Set 1 in the staple tray [10] is completed.
- [G]: Set 1 [11] exits the staple tray.
- [H]: The three sheets of Set 2 [12] feed together into the stapler tray for stapling.

Pre-stacking is only done for A4, B5, and LT paper.

Pre-Stacking

In one-staple mode, one sheet goes to the pre-stacking tray. Then two sheets go to the stapler tray at the same time.

In two-staple mode and booklet mode, three sheets go to the pre-stacking tray. Then four sheets go to the stapler tray at the same time.

Booklet
Finisher/
Finisher
B804/B805/
D373/D374

2.4 TRAY MOVEMENT MECHANISM

2.4.1 UPPER TRAY

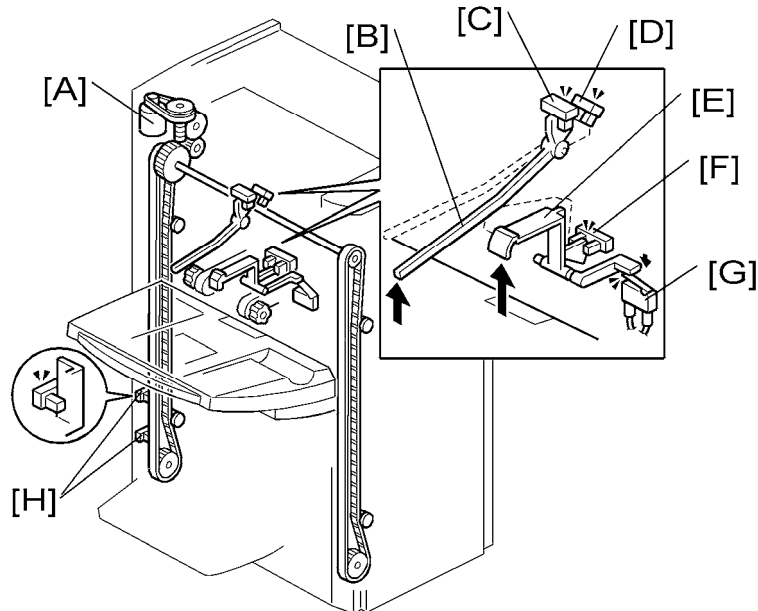

b804d108

[A]: Upper Tray Lift Motor

[B]: Upper Feeler

[C]: Upper Tray Paper Height Sensor 1 (Staple Mode)

[D]: Upper Tray Paper Height Sensor 2 (Non-Staple Mode)

[E]: Lower Feeler

[F]: Upper Tray Limit Sensor

[G]: Upper Tray Limit Switch

[H]: Upper Tray Full Sensors

★ Important

- The B804 (shown above) has only one upper tray full sensor (the higher sensor at [H]).
- The B805 has two upper tray full sensors (the upper and lower sensor at [H]). On the B805 the upper sensor detects tray full for heavier paper (A3, DLT, B4, LG, 12 x 18"), and the lower sensor detects tray full for lighter paper (A4, LT, etc.).
- The tray full capacity is 2,000 sheets (B804) for A4, LT and 3,000 sheets (B805) for

Tray Movement Mechanism

A4, LT.

Five sensors and one switch control the operation of the upper tray lift motor [A].

Upper Tray Raising and Lowering

Operation Mode	Sensors, Switch				Action
	[C]	[D]	[F]	[G]	
Standby (Non-Staple Mode)	OFF	OFF			Stops the lift motor at the standby position when the actuator of the upper feeler deactivates sensor [C] (when it is between sensors [C] and [D]). Note: Sensor [F] and switch [G] are used as backup if sensor [C] fails or if the upper tray is not attached.
Straight Through			ON		Non-staple mode operation: During operation, tray lift is controlled only by sensor [F]. When the actuator leaves sensor [F], the tray lowers until the actuator reactivates sensor [F].
Shift			ON		
Standby (Staple Mode)	ON				Standby: The upper tray stops and waits for the paper output when the actuator activates sensor [C]. [D] is not used for staple mode Staple Mode Operation: <ul style="list-style-type: none"> ▪ The upper tray lowers the prescribed distance immediately after the stack exits. ▪ The upper tray rises until the actuator activates sensor [C] and stops the tray lift motor (and the tray) to wait for the next set. ▪ Sensor [F] and switch [G] are used as backup if sensor [C] fails.

Booklet
 Finisher/
 Finisher
 B804/B805/
 D373/D374

Tray Full

B804	When the actuator on the tray activates the upper tray full sensor [H] the tray lift motor [A] switches off. Operation resumes after some copies are removed from the tray. Upper Tray Capacity: 2,000 sheets (A4, LT)
B805	The operation of the upper tray full sensor is the same as the B804. Capacity: 1,500 sheets for A3, B4 or other large paper. An additional upper tray full sensor (below sensor [H]) allows more sheets to stack on the upper tray. Capacity: 3,000 sheets (A4, LT)

2.4.2 LOWER TRAY (B804 ONLY)

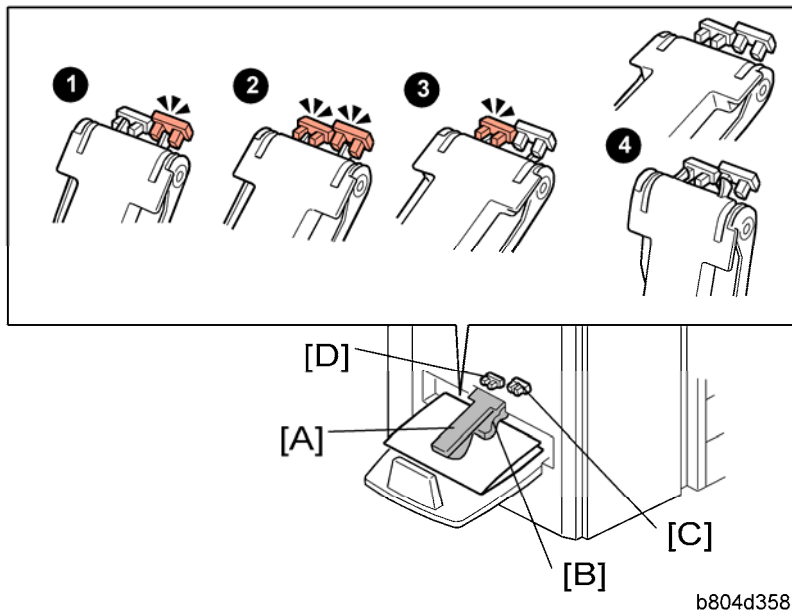

The lower tray sensor actuator arm [A] rests on the top of the stack of stapled booklets as they are output to the lower tray. A flap depressor [B] keeps the open ends of the booklets down.

The front lower tray full sensor (S34) [C] and rear lower tray full sensor (S33) [D] detect when the lower tray is full of booklets.

★ Important

- The front lower tray full sensor is mounted higher than the rear lower tray full sensor.
- The lower tray is stationary. When it becomes full, the stapling and folding job stops until booklets are removed from the tray.

Tray Movement Mechanism

- If the lower tray is not installed (this is detected if the front and rear sensors remain OFF), the machine will not operate in the booklet staple and fold mode. When booklet mode is selected, the tray full message appears on the operation panel.

The combinations of the two actuators and two sensors as the actuator arm rises determines the number of booklets that the lower tray can hold before the job stops.

The tray full detection depends on the size of the paper and the number of sheets in one stapled and folded booklet.

In the table below, the conditions (① Ready ② Full 1, ③ Full 2 ④ Full 3: See the illustration on the previous page) refer to the states of the sensors described on the previous page.

Condition	Front Sensor	Rear Sensor
Ready	ON	OFF
Full 1	ON	ON
Full 2	OFF	ON
Full 3 (or lower tray not installed)	OFF	OFF

In the tables below:

- "Sht" denotes "sheets in a stack".
- "Cnt" denotes "Count" (see below for an explanation).

After a booklet is feed out, the fold roller motor stops the exit roller. The machine then monitors the tray full sensors every 100 ms. The machine checks for a certain condition, based on the size of the paper and the number of sheets in the booklet.

An example is shown below. Tell the operators that the number of sheets that the lower tray can hold will vary greatly.

Lower Tray Full Condition Table

A3 (DLT)

	1 Sht	2 Sht	3 Sht	4 Sht	5 Sht	6 Sht	7 Sth	8 Sht	9 Sht	...
Full 1	3 Cnt	—	—	—	—	—	—	—	—	...
Full 2	—	5 Cnt	15 Cnt	—	—	—	—	—	—	...
Full 3	—	—	—	7 Cnt	13 Cnt	4 Cnt	2 Cnt	2 Cnt	2 Cnt	...

A4 (LT)

	1 Sht	2 Sht	3 Sht	4 Sht	5 Sht	6 Sht	7 Sth	8 Sht	9 Sht	...
Full1	16 Cnt	—	—	—	—	—	—	—	—	...
Full 2	—	10 Cnt	10 Cnt	15 Cnt	20 Cnt	15 Cnt	10 Cnt	8 Cnt	8 Cnt	...
Full 3	—	—	—							...

Examples:

After the copier makes a booklet with 1 sheet of A3/DLT paper, the machine checks every 100 ms for the 'Full 1' condition. If the Full 1 condition occurs 3 times, the machine detects that the tray is full.

After the copier makes a booklet with 5 sheets of A4/LT paper, the machine checks every 100 ms for the 'Full 2' condition. If the Full 2 condition occurs 20 times, the machine detects that the tray is full.

2.5 CORNER STAPLING

2.5.1 STACKING AND JOGGING

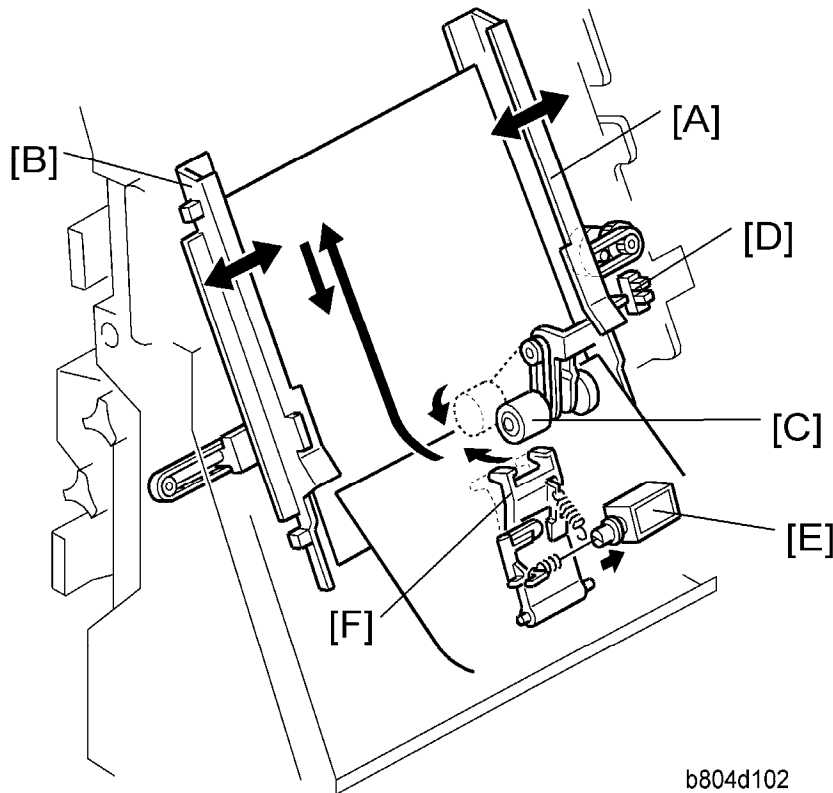

b804d102

- | |
|---|
| [A]: Jogger Fence Motor (M15) |
| [B]: Jogger Fences |
| [C]: Positioning Roller |
| [D]: Jogger Fence HP Sensor (S15) |
| [E]: Stapling Edge Pressure Plate Solenoid (SOL4) |
| [F]: Pressure Plate |

At the beginning of the job, the jogger fence motor (M15) [A] switches on and moves the jogger fences [B] to the standby position (7.5 mm from the sides of the selected paper size). When each sheet passes the pre-stack tray exit sensor (S2) and enters the stapling tray:

- The jogger fence motor switches on and moves the jogger fences to within 5.5 mm of the sides of the selected paper size.
- The positioning roller solenoid (SOL3) switches on for the time prescribed for the paper

size. This pushes the positioning roller [C] onto the sheet and pushes it down onto bottom fence. This aligns the edge of the stack.

Next, the jogger fence motor:

- Switches on again and moves the jogger fences to within 2.6 mm of the sides of the stack to align the sides of the stack.
- Reverses and moves the fences to the standby position (7.5 mm away for the sides) and waits for the next sheet.
- The jogger fence HP sensor [D] switches off the jogger motor at the end of the job.

After the last sheet feeds:

- The stapling edge pressure plate solenoid [E] (SOL4) switches on and pushes the pressure plate [F] onto the stack to press down the edge for stapling.
- The corner stapler staples the stack.

2.5.2 STAPLER MOVEMENT

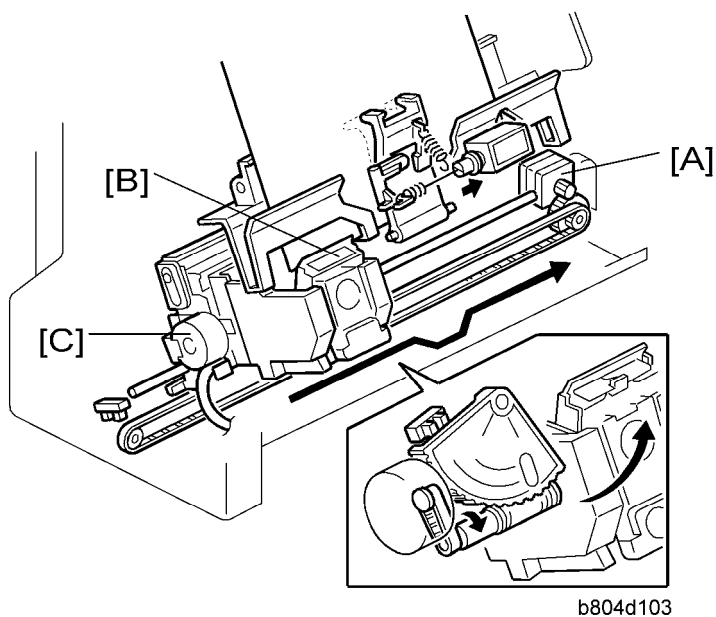

- | |
|---|
| <p>[A]: Stapler Movement Motor
 [B]: Stapler
 [C]: Stapler Rotation Motor</p> |
|---|

Corner Stapling

The stapler performs horizontal and rotational movement in each of the four staple modes:

- Front 1 staple
- Rear 1 staple
- Rear diagonal staple
- Rear/Front 2 staples

The stapler movement motor [A] drives a timing belt that moves stapler [B] left and right on its stainless steel rail.

The stapler rotation motor [C] rotates the stapler into position for diagonal stapling at the rear.

- The stapler movement motor switches on and moves the stapler the standby stapling position. (This is the stapling position for the paper size selected for the job.)
- The stapler movement motor switches off and the stapler waits for the signal to fire (or swivel and for diagonal stapling).

If the stack is to be stapled at two positions:

- The stapler movement motor moves the stapler to the front position and staples the front.
- The stapler movement motor moves the stapler to the rear and the stapler staples the rear.

If the stack is stapled at the rear with a diagonal staple, the staple moves to the rear. When it is time for stapling, the rotation motor rotates the stapler to the correct angle and holds the stapler in that position while the stapler fires.

The stapling positions can be fine adjusted with **SP6-133-001**.

2.5.3 CORNER STAPLING

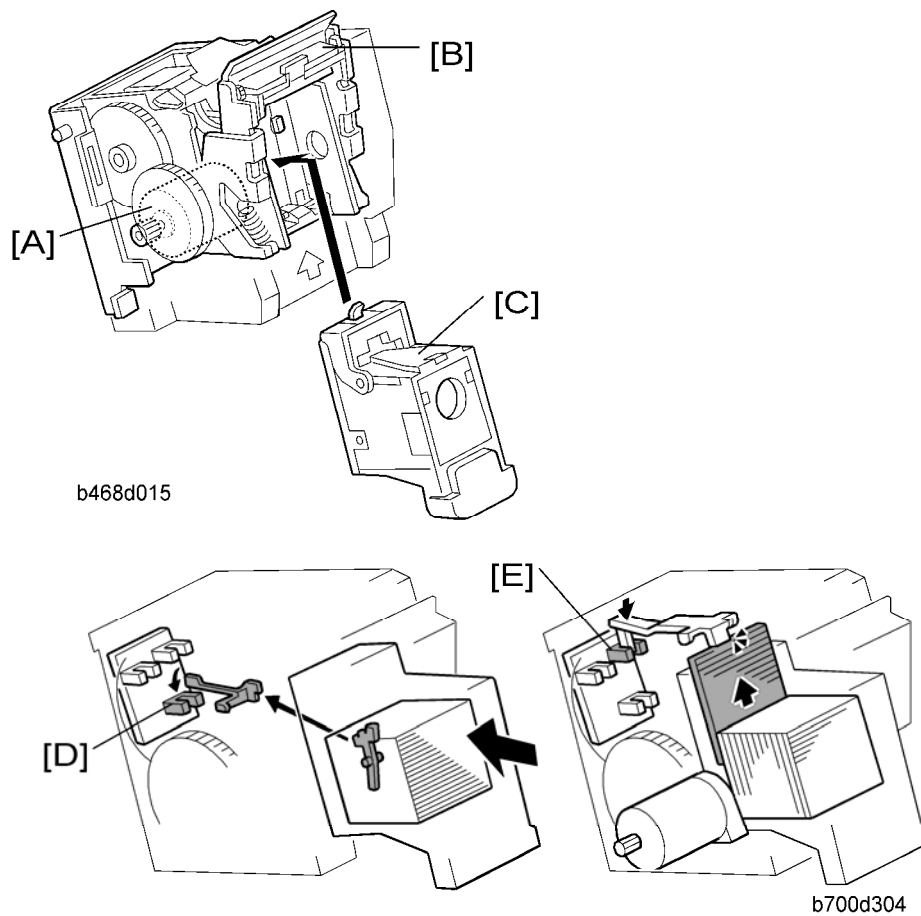

Staple firing is driven by the stapler motor [A] inside the stapler unit. The stapler hammer [B] fires the stapler [C].

The cartridge set sensor [D] detects the cartridge at the correct position.

The staple end sensor [E] detects the staple end condition.

2.6 BOOKLET STAPLING (B804 ONLY)

2.6.1 BOOKLET PRESSURE MECHANISM

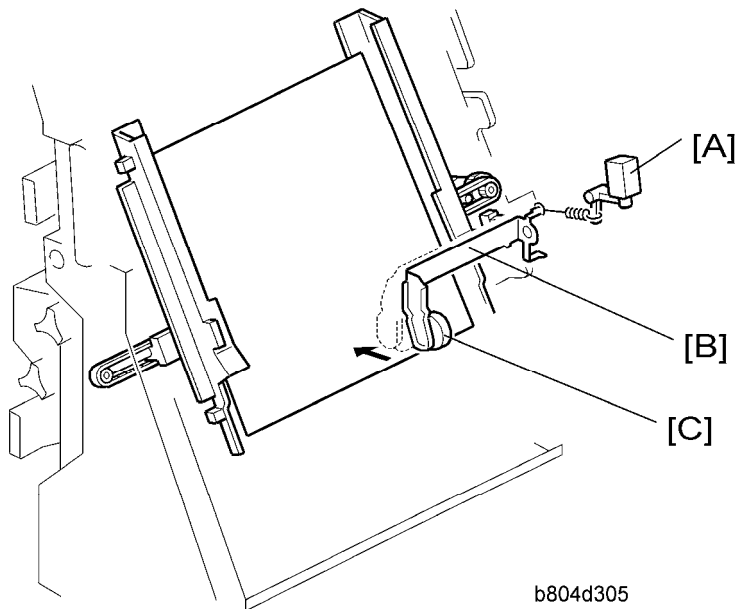

- [A]: Booklet Pressure Roller Solenoid (SOL5)
- [B]: Booklet Pressure Roller Arm
- [C]: Booklet Pressure Roller

As soon as the edges are aligned by the positioning roller and the jogger fences, the stack feed out belt moves.

In booklet mode, immediately after the edges are aligned by the positioning roller and jogger fences, the booklet pressure solenoid switches on and the booklet pressure roller presses down on the stack until booklet stapling is finished. This prevents the stack from shifting during stapling.

2.6.2 BOOKLET STAPLING AND FOLDING

Overview

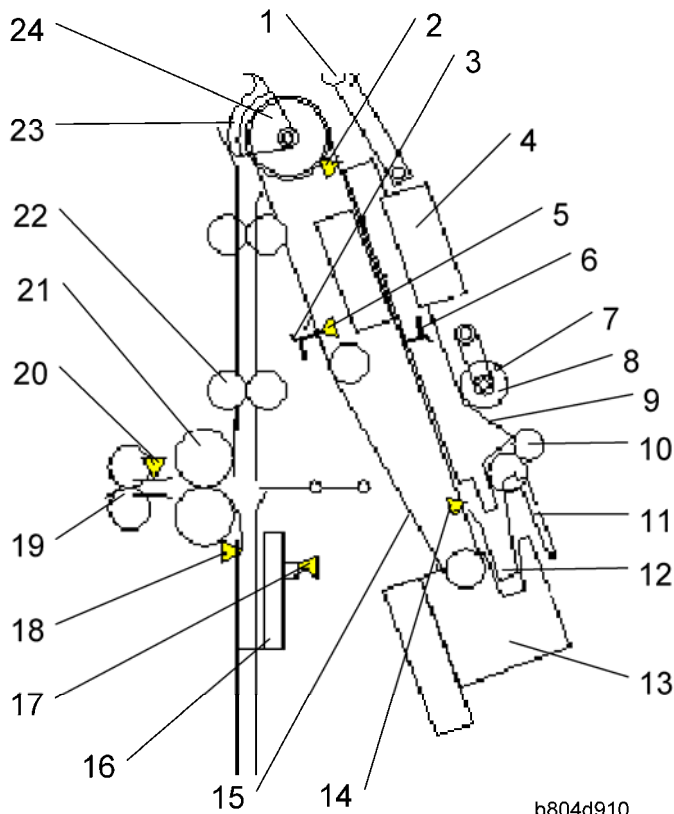

b804d910

1. Leading Edge Pressure Roller	13. Corner Stapler (M20)
2. Stack Present Sensor (S32)	14. Stapling Tray Paper Sensor (S14)
3. Feed Out Belt Pawl 1	15. Feed Out Belt
4. Booklet Staplers x2 (M22, M23)	16. Fold Unit Bottom Fence
5. Stack Feed Out Belt HP Sensor (S16)	17. Fold Bottom Fence HP Sensor (S28)
6. Feed Out Belt Pawl 2	18. Fold Unit Entrance Sensor (S26)
7. Positioning Roller	19. Fold Unit Exit Rollers x2
8. Booklet Pressure Roller (Rear)	20. Fold Unit Exit Sensor (S31)
9. Jogger Fences x2	21. Fold Rollers x2
10. Pre-Stack Exit Roller	22. Clamp Rollers x2
11. Pressure Plate	23. Stack Junction Gate
12. Stapling Tray Bottom Fence	24. Stack Transport Roller

Booklet Stapling (B804 Only)

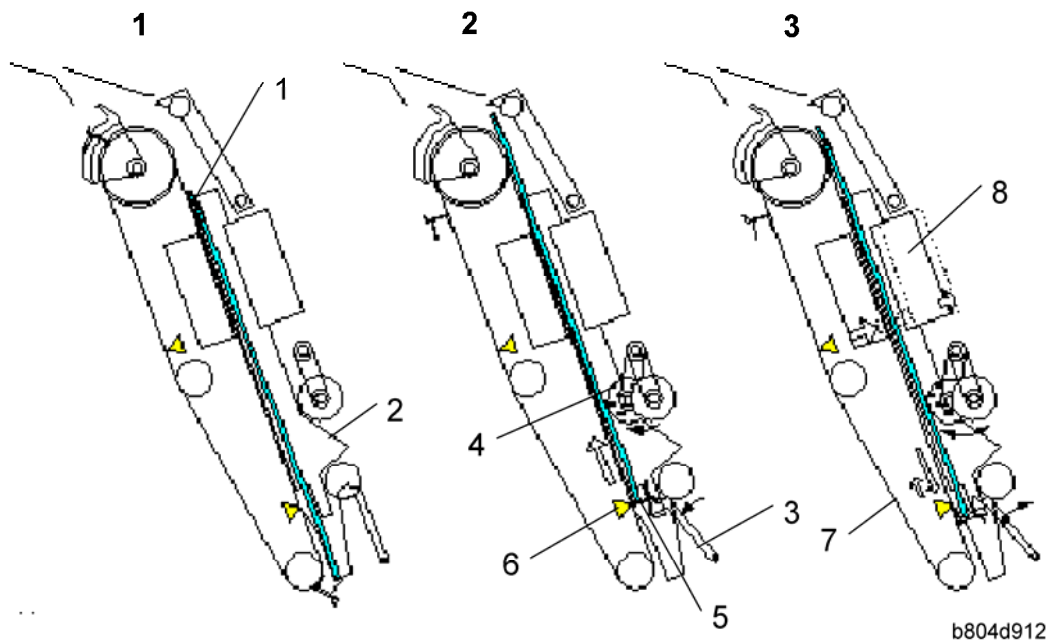

1:

The last sheet of the stack [1] enters the stapling tray. The jogger fences [2] jog the last sheet into position (based on the width of the selected paper size) and then retract and stop 1 mm away from the sides of the stack.

2:

The pressure plate [3] and booklet pressure roller [4] press down on the sheet. The stack feed out belt switches on and the pawl [5] on the feed out belt catches the bottom of the stack and raises it. The stapling tray sensor [6] detects the trailing edge of the paper stack.

3:

The feed out belt [7] raises the stack to the prescribed stapling position and stops. The jogger fences move to the sides of the stack and the booklet staplers [8] staple the stack.

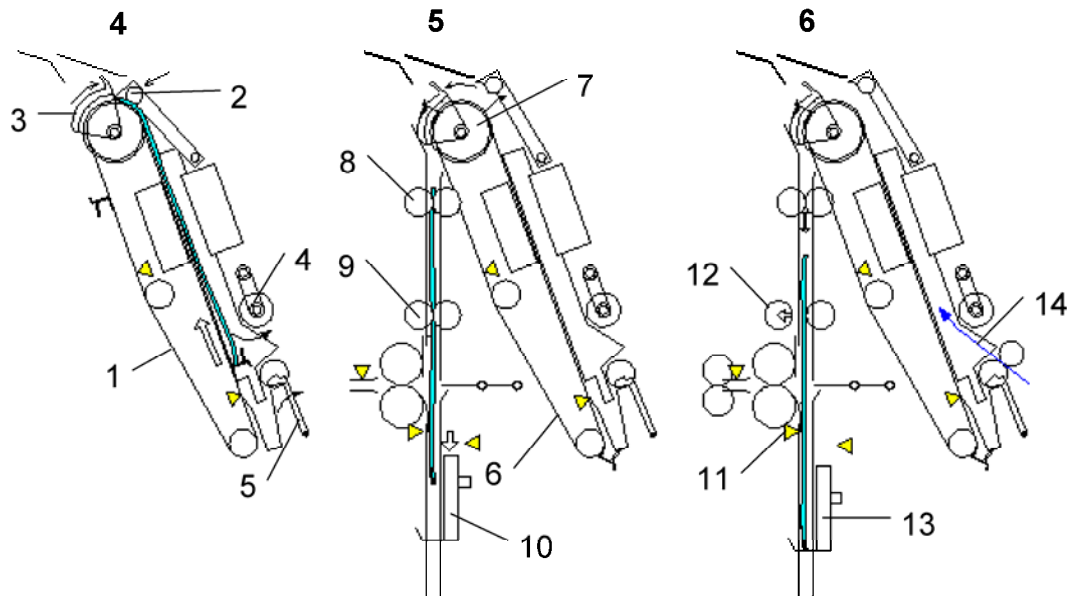

b804d913

4:

The jogger fences remain 1 mm away from the sides of the stack. The feed out belt [1] raises the stack until the top of the stack is 10 mm past the leading edge pressure roller [2] and stops. The leading edge pressure roller descends and applies pressure to the top of the stack. The stack junction gate [3] (normally open) closes. The pressure roller [4] and pressure plate [5] retract.

5:

The feed out belt [6], transport rollers [7], [8], and clamp rollers [9] rotate and feed the stack past the closed stack junction, over the top and down toward the bottom fence [10]. At the same time, the fold unit bottom fence descends from its home position and stops 10 mm below the fold position.

6:

The rollers feed the leading edge of the stack to within 3 mm of the stack stopper of the bottom fence [13]. The fold unit entrance sensor [11] detects the stack and opens the clamp rollers [12]. The stack drops 3 mm onto the fold unit bottom fence [13]. At this time, the first sheet [14] of the next stack feeds to the stapling tray.

Booklet Stapling (B804 Only)

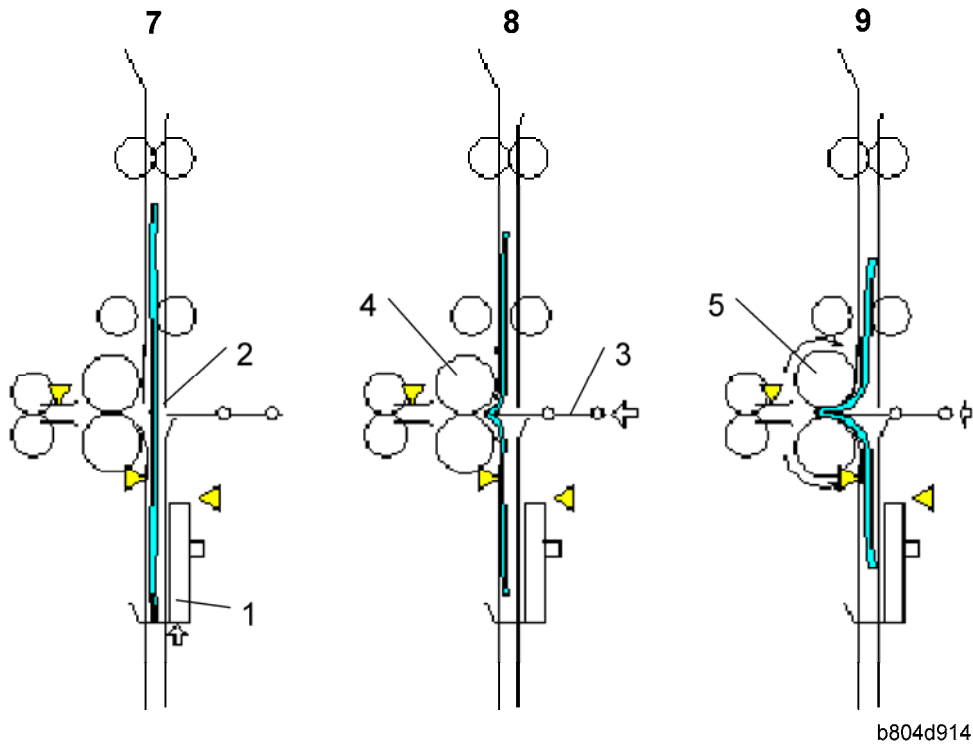

7:

The bottom fence [1] raises the stack to the prescribed fold position [2].

8:

The fold plate [3] moves to the left and advances 1/3 its maximum horizontal stroke and exerts 20 kg (44 lb.) of pressure at the fold rollers [4].

9:

With the fold plate pushing the stack into nip of the fold rollers [5], the fold rollers begin to rotate and fold the stack as it feeds out.

Booklet
Finisher/
Finisher
B804/B805/
D373/D374

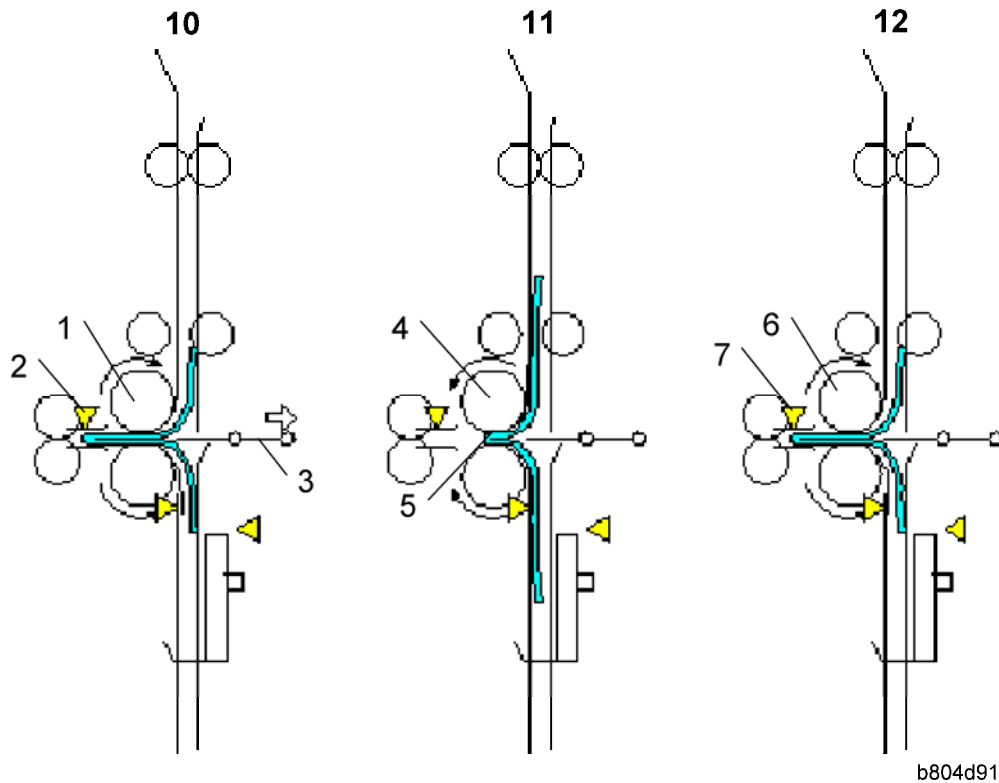
**10:**

When the fold rollers [1] feed the stack 10 mm past the nip, the fold plate retracts until it no longer touches the stack. The fold unit exit sensor [2] detects the folded edge of the stack and stops the fold rollers.

11:

The rotation of the fold rollers [4] reverses and feeds the folded edge back until only 3 mm of the fold [5] remains at the nip.

12:

The fold rollers [6] rotate forward once again feed out. The fold unit exit sensor [7] once again detects the edge of the fold.

↓ Note

- You can do **SP6-136-001** to increase the sharpness of the fold. The number of forward and reverse feeds can be set in the range of 2 to 30. The machine repeats Steps 11 and 12. For more, please refer to Section "Service Tables".

Booklet Stapling (B804 Only)

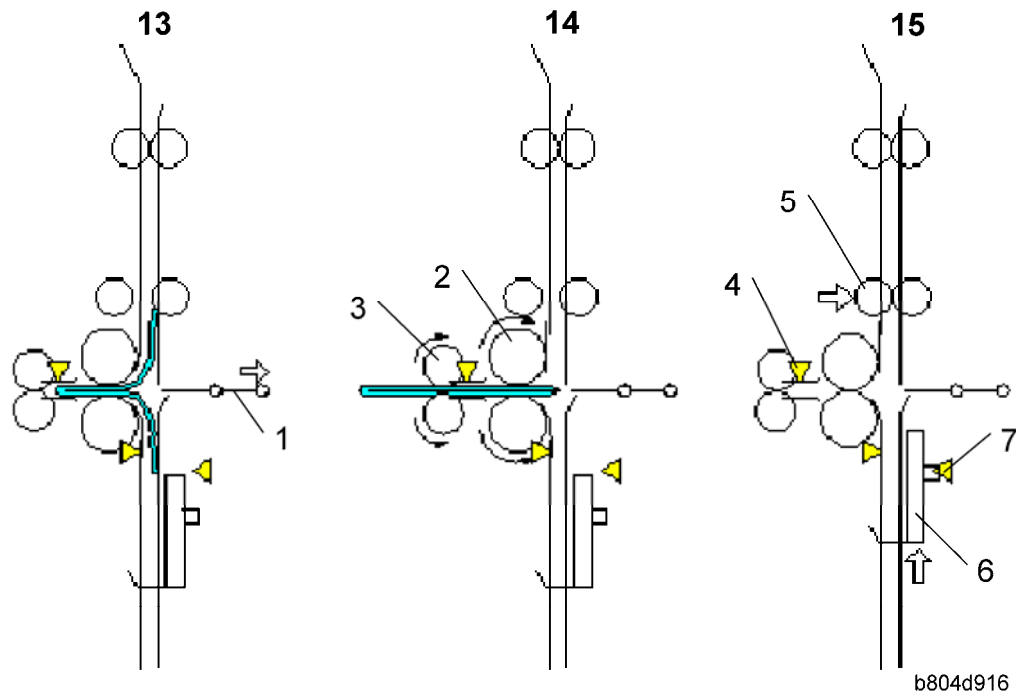

13:

With the feed of the stack halted, the fold plate [1] retracts. The fold plate HP sensor (not shown) detects the fold plate and stops it at its home position.

14:

The fold rollers [2] and fold unit exit rollers [3] begin to rotate together and feed out the folded booklet to the lower tray.

15:

Once the trailing edge of the stack passes the fold unit exit sensor [4], the clamp rollers [5] close to be ready to feed the next stack. The fold unit bottom fence [6] descends. The bottom fence HP sensor [7] stops the bottom fence when it detects the actuator on the bottom fence.

Booklet
Finisher/
Finisher
B804/B805/
D373/D374

2.6.3 BOOKLET STAPLING AND FOLDING MECHANISMS

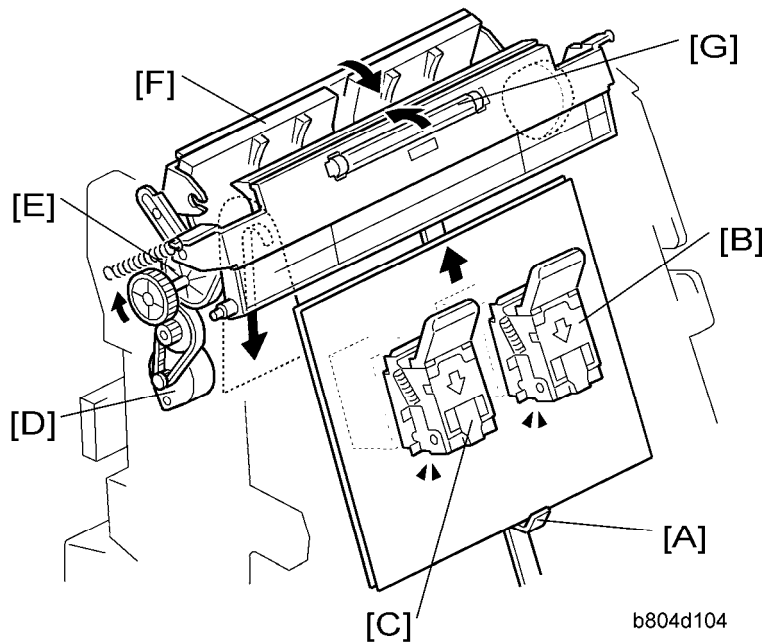

Booklet Stapler

[A]: Feed Out Belt Pawl. Raises the stack to stapling position.

[B]: Booklet Stapler EH185R – Rear

[C]: Booklet Stapler EH185R – Front

Stack Junction Gate

[D]: Stack Junction Gate Motor. Drives a timing belt and stack junction gate cam.

[E]: Stack Junction Gate Cam. Opens and closes the stack junction gate.

[F]: Stack Junction Gate. The stack junction gate motor and stack junction gate cam close the stack junction gate. The feed out belt pawl raises the stapled stack and sends it over the top and down to the fold unit.

[G]: Leading Edge Pressure Roller. Presses down on the leading edge of the stack after booklet stapling.

Booklet Stapling (B804 Only)

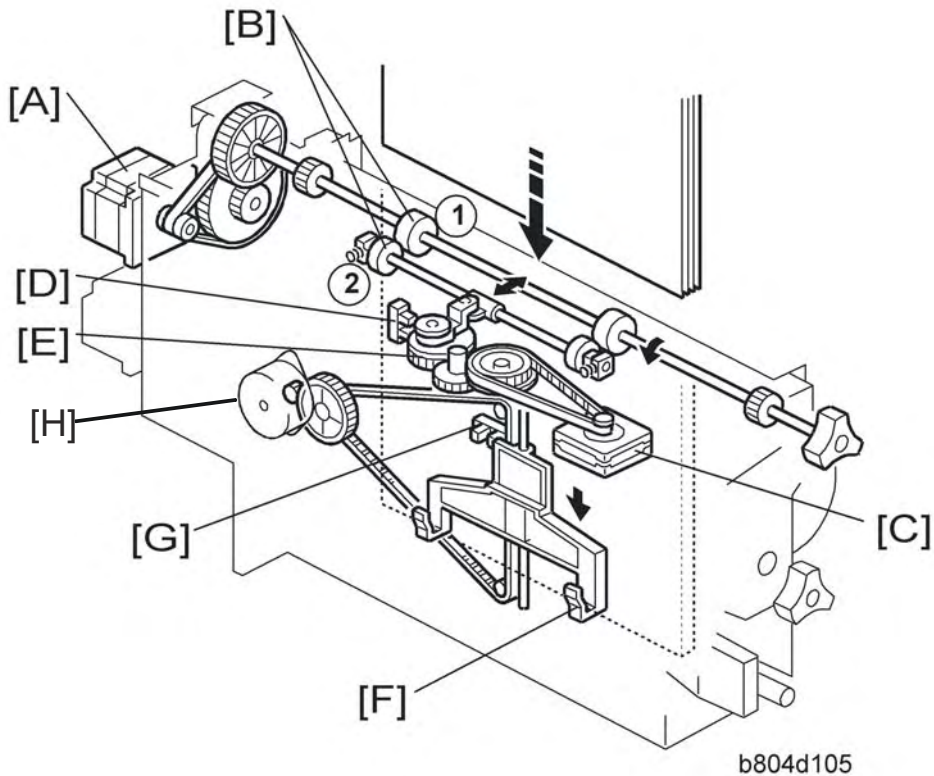

Clamp Roller

[A]: Fold Roller Motor. Drives the stationary clamp drive roller ① as well as the fold rollers (see next page).

[B]: Clamp Rollers.

① Clamp Roller – Drive. Rotated by the fold roller motor, this stationary roller feeds the stack down with the retracting roller closed.

② Clamp Roller – Retracting. Opened and closed by the retraction motor [C].

[C]: Clamp Roller Retraction Motor. Operates the clamp roller cam that retracts the retracting clamp roller. The clamp rollers feed the stack to within 3 mm of the bottom fence when closed and then open to drop the stack onto the bottom fence.

[D]: Clamp Roller HP Sensor. Controls the rotation of the clamp roller retraction motor and cam that open and close the retracting clamp roller.

[E]: Clamp Roller Cam. Forces open the spring loaded retracting clamp roller.

Bottom Fence

[F]: Bottom Fence. Raises the booklet stapled stack to the fold position.

[G]: Bottom Fence HP Sensor. Detects the actuator on the bottom fence and stops it at the home position after folding.

[H]: Bottom Fence Lift Motor. Raises the bottom fence and stapled stack to the fold position prescribed for the paper size.

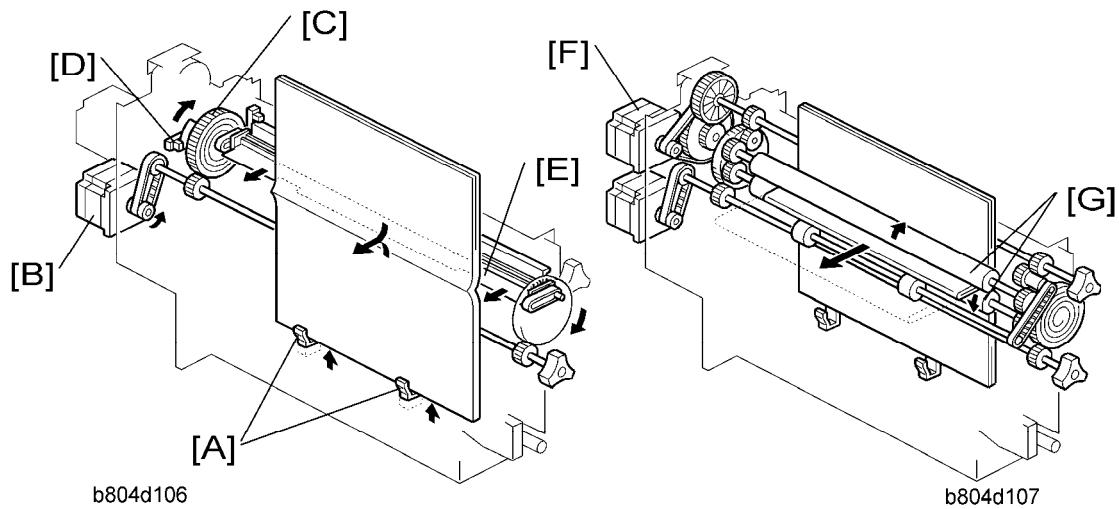

Fold Plate

[A]: Bottom Fence Stack Stoppers. Catches the stack after it is released by the clamp rollers.

[B]: Fold Plate Motor. Drives the timing belt and gears that move the fold plate.

[C]: Fold Plate Cam. Controls the movement of the fold plate to the left (into the nip of the fold rollers) and right (toward the fold plate home position).

[D]: Fold Plate HP Sensor. Controls operation of the fold plate motor.

[E]: Fold Plate. Moves left and pushes the stack into the nip of the fold rollers and then moves right to retract.

Fold Rollers

[F]: Fold Roller Motor. Drives forward to feed out the stack at the fold and then reverses to feed the fold in to sharpen the crease, and then drives forward again to feed out the folded stack. This reverse/forward cycle is done once.

↓ Note

- This cycle can be repeated by changing the setting of SP6114.

[G]: Fold Rollers. Driven by the fold roller motor, this roller pair feeds out the stack at its fold, reverses to feed in the stack to, and then feeds forward again (assisted by the fold unit exit rollers – not shown) to feed out the stack to the lower tray.

2.7 UPPER TRAY OUTPUT

2.7.1 FEED OUT

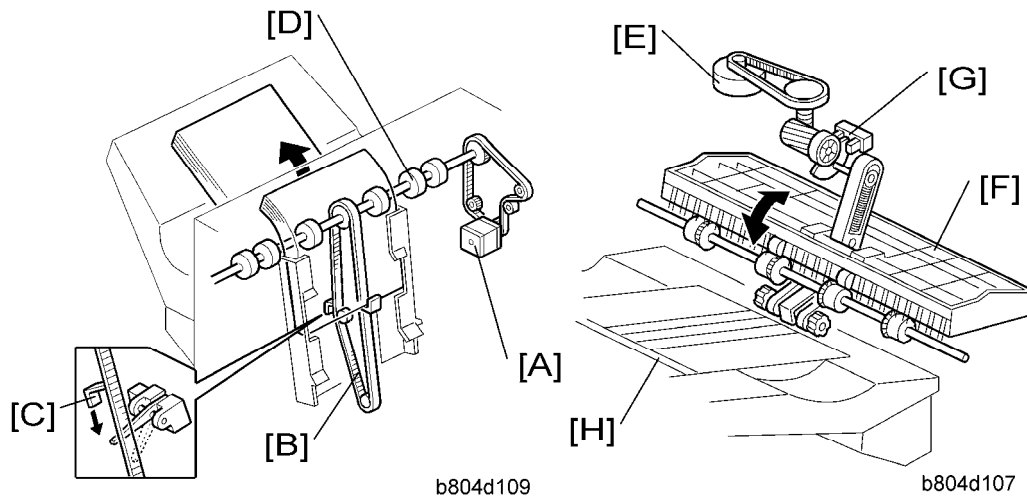

- [A]: Feed Out Belt Motor
- [B]: Stack Feed-Out Belt
- [C]: Pawl
- [D]: Exit Rollers
- [E]: Exit Guide Plate Motor
- [F]: Exit Guide Plate
- [G]: Exit Guide Plate HP Sensor
- [H]: Upper Tray

After the stack is stapled, the feed out belt motor [A] switches on and drives the feed out belt [B].

The pawl [C] attached to the feed out belt catches on the stack and lifts the stack toward the feed out slot.

The exit guide plate [F] remains open as the stack emerges at a prescribed distance away from the exit roller.

Next, the exit guide plate closes and the exit roller feeds the stack out.

The opening and closing of the exit guide plate is controlled by the rising and falling of a link driven by a rotating cam attached to the shaft of the exit guide plate motor [E].

The feed out belt motor stops 300 ms to prevent the stapled stack from rising too high.

Next, the feed out belt motor switches on again, then the pawl actuates its home position sensor and switches off the motor.

There are two output pawls on the feed out belt to improve the productivity of the feed out operation.

2.7.2 FEED OUT STACKING

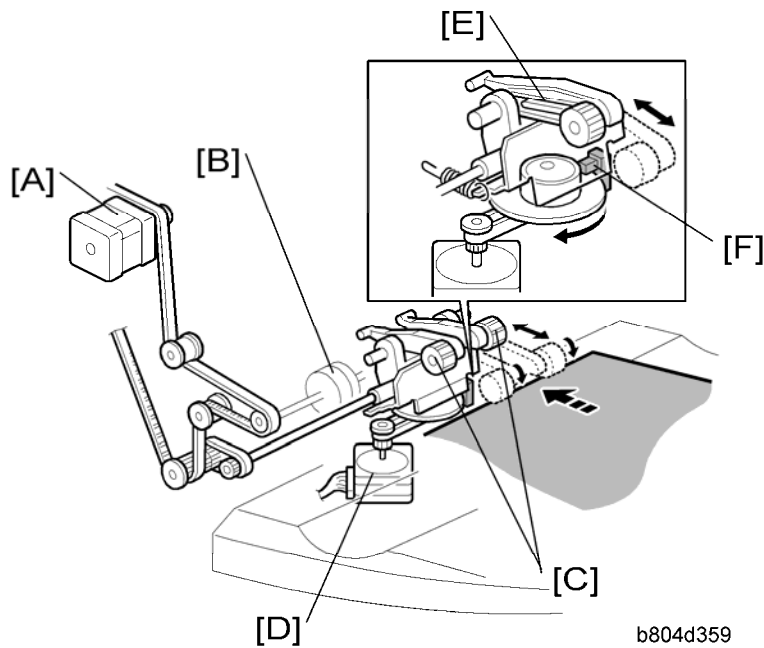

Upper/proof exit motor [A] drives feed roller [B] and stacking sponge roller [C].

Stacking sponge roller motor [D] moves the sponge roller forward and back with link [E].

The position of the stacking sponge roller [C] is controlled by the stacking sponge roller motor which is switched on and off by the stacking roller HP sensor [F].

2.8 PUNCH UNIT B702 (FOR B804/B805)

2.8.1 OVERVIEW OF OPERATION

Skew Correction before Punching

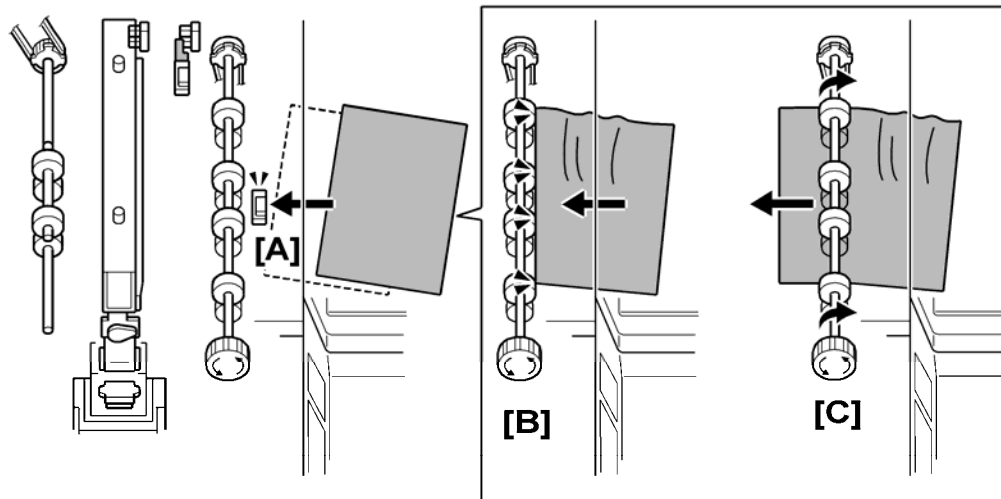

b804d351

This punch unit corrects for paper skew and then positions the punch unit to punch holes at the correct position. Each sheet is punched one at a time.

Paper feeds out of the copier. The finisher entrance sensor [A] detects the leading edge of the sheet.

The finisher entrance roller [B] stops rotating briefly while the copier exit rollers continue to rotate. This buckles the paper against the finisher entrance roller to correct skew. The finisher entrance roller [C] starts to rotate again and feeds the sheet into the finisher.

These SP codes adjust the skew operation in the punch unit:

- **SP6130.** This SP corrects the punch hole alignment. To do this, it corrects the skew of each sheet by adjusting the amount of time the finisher entrance roller remains off while the exit roller of the machine remains on. For more, see Section "Service Tables".
- **SP6131.** This SP determines whether the finisher entrance roller stops to correct skew when paper enters the finisher. You can use this SP to disable the skew correction. For more, see Section "Service Tables".

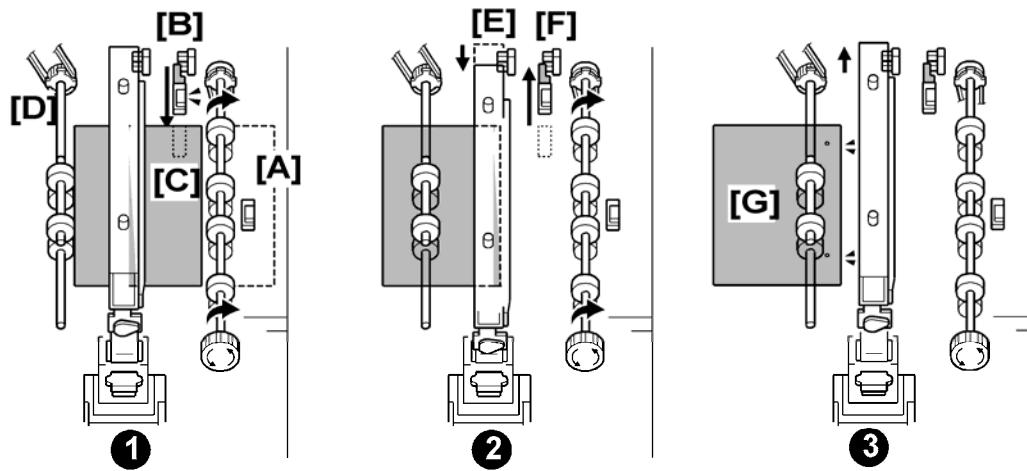
Punch Unit Position Correction

b804d352

These operations (skew correction before punching, and punch unit position correction) increase the accuracy of the punch alignment.

❶:

The trailing edge of the sheet passes the finisher entrance sensor [A].

The paper position slide unit [B] moves the paper position sensor [C] forward to the edge of the paper.

The paper position sensor detects the position of the paper edge and sends this information to the punch unit board. The machine uses the detected position of the paper edge to calculate the correct position for punching.

The upper transport motor switches on and rotates the feed rollers [D] the prescribed distance to position the paper under the punch unit.

❷:

Using the result of the position calculation, the punch unit control board moves the punch unit [E] to the adjusted punch position.

The paper position slide unit and its paper sensor, move back to the paper position slide home position sensor [F], and the punch unit fires the punches to make the holes.

❸:

The feed rollers [G] feed the punched paper out of the punch unit and into the paper path.

Punch Unit B702 (For B804/B805)

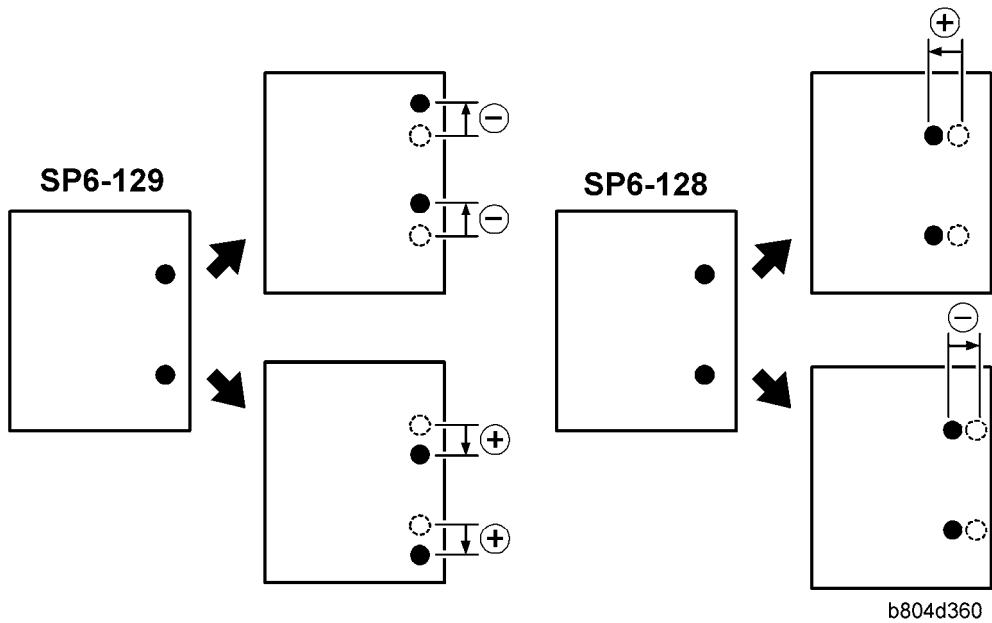

These SP codes adjust the punch hole alignment:

- **SP6-128** Adjusts the punch positions in the direction of paper feed.
- **SP6-129** Adjusts the punch position perpendicular to the direction of feed.

For more, see Section "Service Tables".

2.8.2 PUNCH MECHANISMS

Paper Position Detection

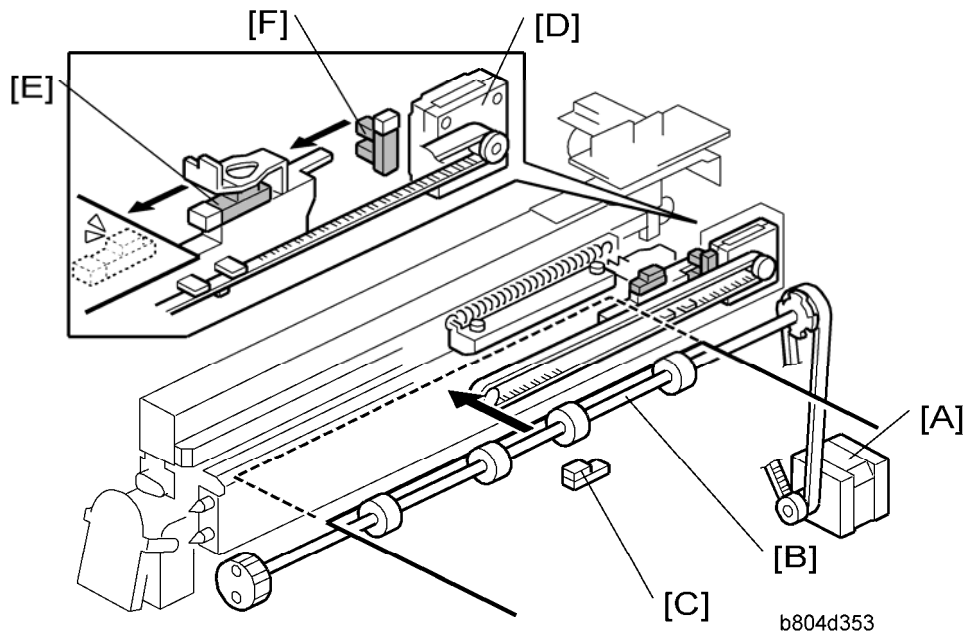

- [A]: Finisher Entrance Motor (M1)
- [B]: Finisher Entrance Roller
- [C]: Finisher Entrance Sensor (S1)
- [D]: Paper Position Sensor Slide Motor (M7)
- [E]: Paper Position Sensor (S27)
- [F]: Paper Position Sensor Slide HP Sensor (S22)

The finisher entrance motor (M1) [A] drives the finisher entrance rollers [B] that feed paper from the copier into the finisher. The finisher entrance sensor (S1) [C] detects paper when it enters the finisher, and detects paper jams.

The paper position slide sensor motor (M7) [D] extends and retracts the paper position slide that holds the paper position sensor (S27) [E]. The paper position sensor detects the position of the paper edge. The detected position of the paper is used to calculate and position the punch unit for punching.

The paper position slide HP sensor (S22) [F] detects the paper position slide when it retracts and stops the paper position slide motor so the slide stops at its home position.

Punch Unit Movement

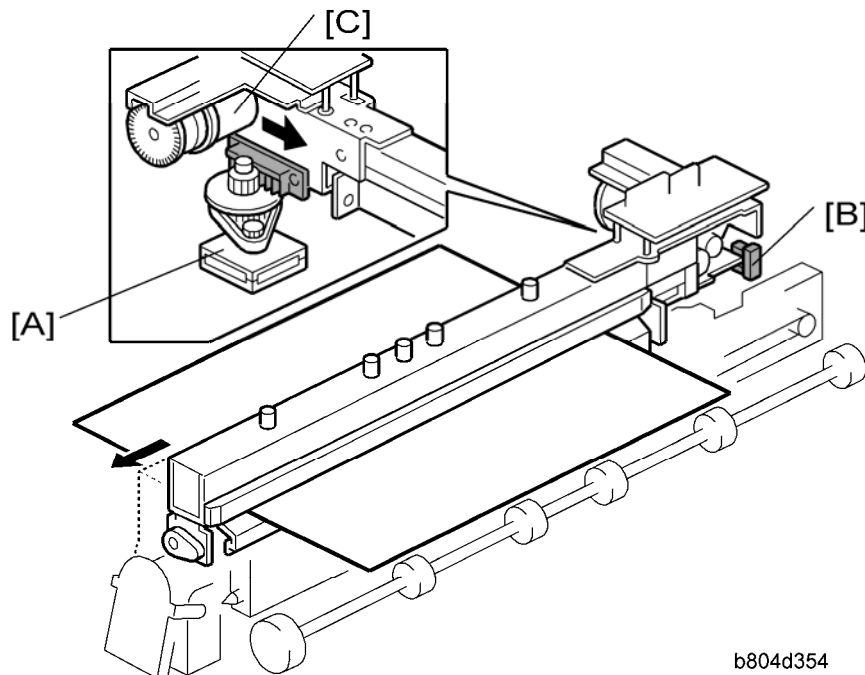

b804d354

Punch Unit B702 (For B804/B805)

- [A]: Punch Movement Motor (M9)
- [B]: Punch Movement HP Sensor (S21)
- [C]: Punch Drive Motor (M24)

The punch movement motor (M9) [A] extends and retracts the punch unit to position it at the correct position for punching.

The punch movement HP sensor (S21) [B] detects the position when it retracts, switches off the punch position movement motor, and stops the punch unit at its home position.

The punch drive motor (M24) [C] fires the punches that punch holes in the paper below.

Punch Selection and Firing

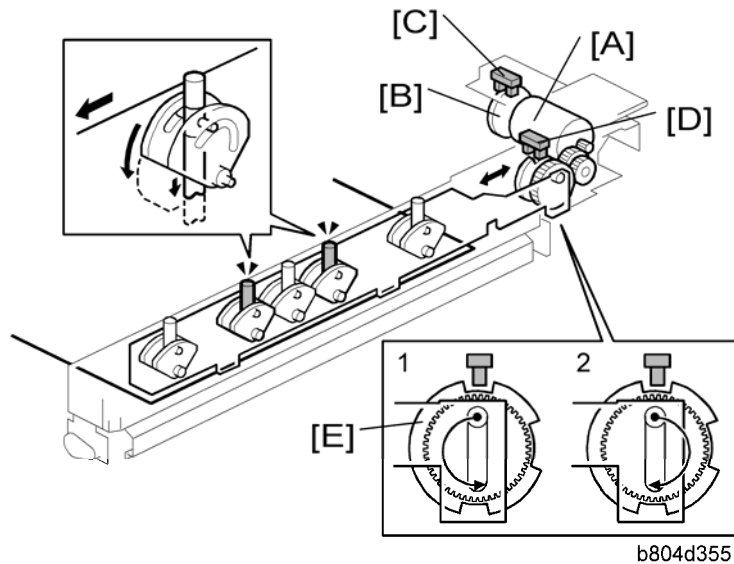

- [A]: Punch Drive Motor (M24)
- [B]: Punch Encoder Wheel
- [C]: Punch Encoder Sensor (S24)
- [D]: Punch HP Sensor (S23)

The punch drive motor (M24) [A] turns the small, notched encoder wheel [B] through the gap in the punch encoder sensor [C] (S24). The sensor output is used to control the punch timing.

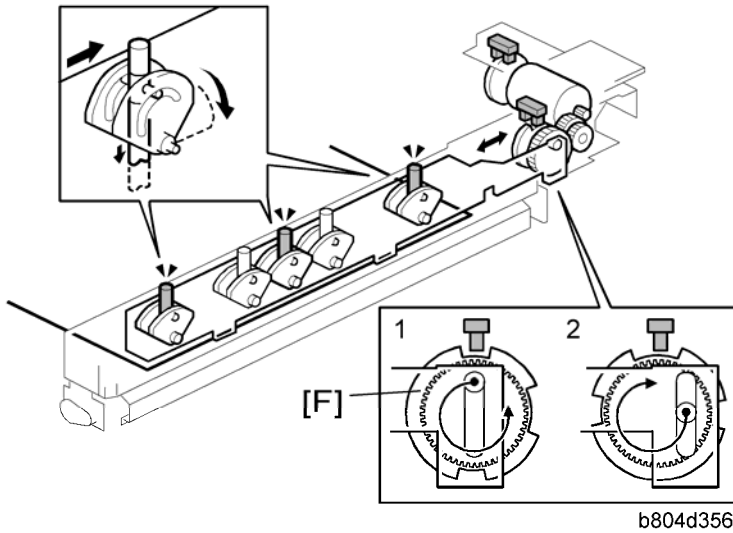

The timing for 2-hole punching [E] is different from 3-hole punching [F].

When the punch unit is at the punching position, the punch motor turns until the encoder detects the starting position for 2-hole or 3-hole punching.

- This is the '1' position in the diagrams (the top diagram is for 2-hole punching, and the bottom diagram is for 3-hole punching).

Then, the punch drive motor turns counter-clockwise to the '2' position. This movement punches the holes in the paper.

Then, the punch drive motor turns clockwise to the '1' position, to be ready for the next sheet of paper.

2.8.3 PUNCH HOPPER MECHANISM

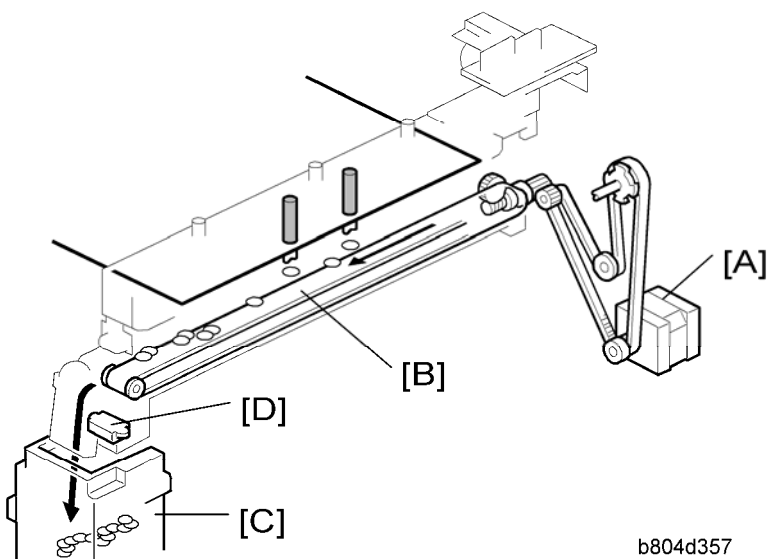

Punch Unit B702 (For B804/B805)

[A]: Finisher Entrance Motor (M1)
[B]: Punch Waste Belt
[C]: Punch Waste Hopper
[D]: Punch Hopper Full Sensor (S4)

The finisher entrance motor (M1) [A] drives the timing belt and gears that rotate the punch waste belt [B].

The punchouts fall from the punch unit onto the belt. The belt moves the punchouts to the front and dumps them in the punch waste hopper [C].

The punch hopper full sensor [D]:

- Signals that the hopper is full when it detects the top of the stack of punchouts that have collected in the hopper.
- It also detects when the punch hopper is set properly.

2.9 FINISHER JAM DETECTION

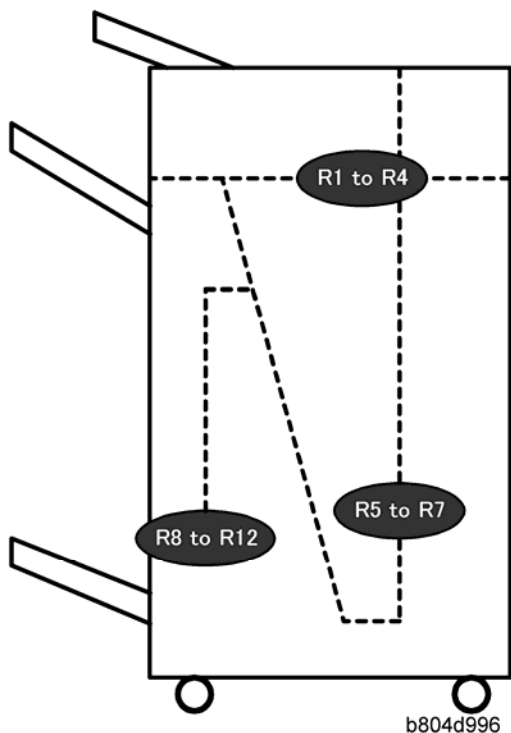

Display	Mode	Jam	What It Means
R1 to R3	Proof Shift Staple	Finisher entrance sensor late	After main machine exit sensor goes OFF, finisher entrance sensor does not go ON even after enough time to feed 450 mm.
		Finisher entrance sensor lag	After finisher entrance sensor goes ON, it does not go OFF after enough time to feed a sheet 1.5 times its length has elapsed.
R3	Proof	Proof exit sensor late	After finisher entrance sensor goes ON, proof exit sensor does not go ON even after enough time to feed 450 mm.
		Proof exit sensor lag	After finisher entrance sensor goes OFF, proof exit sensor does not go OFF even after enough time to feed 450 mm.

Finisher Jam Detection

Display	Mode	Jam	What It Means
R4	Shift	Upper tray exit sensor late	After finisher entrance sensor goes ON, upper tray exit sensor does not go ON even after enough time to feed 485 mm.
		Upper tray exit sensor lag	After finisher entrance sensor goes OFF, upper tray exit sensor does not go OFF even after enough time to feed 650 mm.
R5 to R7	Staple	Pre-stack tray exit sensor lag	After finisher entrance sensor goes ON, pre-stack tray exit sensor does not go ON even after enough time to feed 650 mm.
		Pre-stack tray exit sensor late	After finisher entrance sensor goes ON, pre-stack tray exit sensor does not go OFF even after enough time to feed 1650 mm.
R8 to R12	Booklet Staple (B700 Only)	Fold unit entrance sensor late (S26)	The fold unit entrance sensor goes not go ON after enough time has elapsed to feed 1.5 times the length of the stack after the leading edge of the stack reaches the stack present sensor (S32).
		Fold unit exit sensor late (S31)	The fold unit exit sensor does not go ON after enough time has elapsed for the stack to feed 1.5 times its length from the fold position.
		Fold unit exit sensor lag (S31)	After the fold unit exit sensor goes ON, it does not go OFF after enough time has elapsed to feed 442.9 mm.

Booklet
Finisher/
Finisher
B804/B805/
D373/D374

FINISHER SR5000 B830

B830 Finisher SR5000 REVISION HISTORY		
Page	Date	Added/Updated/New
		None

FINISHER B830

TABLE OF CONTENTS

1. REPLACEMENT AND ADJUSTMENT.....	1
1.1 COVERS.....	1
1.1.1 FRONT DOOR, INNER COVER.....	1
Front Door.....	1
Left Inner Cover	1
Inner Cover	1
1.1.2 SIDE TABLE AND UPPER TRAY.....	2
1.1.3 LEFT COVERS, REAR COVER	3
1.1.4 TOP COVER.....	3
1.1.5 SHIFT TRAY.....	3
1.1.6 JOGGER UNIT COVER.....	4
1.2 ROLLERS.....	5
1.2.1 DRAG ROLLER.....	5
1.2.2 POSITIONING ROLLER.....	6
1.2.3 ALIGNMENT BRUSH ROLLER	7
1.3 JOGGER FENCE	8
1.4 SENSORS	9
1.4.1 PAPER HEIGHT SENSORS.....	9
1.4.2 EXIT GUIDE HP SENSOR	10
1.4.3 UPPER TRAY FULL AND EXIT SENSORS	11
Upper Tray Full Sensor.....	11
Upper Tray Exit Sensor.....	11
1.4.4 SHIFT TRAY EXIT SENSOR.....	12
1.4.5 ENTRANCE AND STAPLER TRAY ENTRANCE SENSORS.....	13
Entrance Sensor	13
Stapler Tray Entrance Sensor.....	13
1.4.6 MAIN BOARD, PRE-STACK PAPER SENSOR	14
1.4.7 STAPLE TRIMMINGS HOPPER FULL SENSOR.....	16
1.4.8 STAPLER ROTATION HP AND STAPLER RETURN SENSORS.....	17
1.5 STAPLER	18
1.6 SHIFT TRAY.....	19
1.6.1 SHIFT TRAY EXIT, SHIFT TRAY LIFT MOTOR	19
Shift Tray Exit Motor.....	19
Shift Tray Lift Motor.....	20
1.6.2 DRAG ROLLER/DRAG DRIVE MOTORS, DRAG DRIVE HP SENSOR	21
1.6.3 SHIFT MOTOR AND SENSORS	24
1.6.4 JOGGER TOP FENCE MOTOR.....	25
1.6.5 JOGGER UNIT	26
1.6.6 JOGGER BOTTOM FENCE MOTOR.....	27
1.7 PUNCH UNIT.....	28
1.7.1 PUNCH POSITION ADJUSTMENT	28

Front to Rear Adjustment	28
Right to Left Adjustment.....	28
1.8 SHIFT TRAY JOGGER UNIT	29
1.8.1 SHIFT TRAY JOGGER UNIT	29
1.8.2 SHIFT TRAY JOGGER UNIT PCB	30
1.8.3 SHIFT TRAY JOGGER UNIT MOTORS.....	31
1.9 MOTORS.....	32
1.9.1 TRANSPORT MOTORS, EXIT GUIDE MOTOR	32
Upper Tray Transport Motor.....	32
Lower Transport Motor.....	33
Exit Guide Motor	33
1.9.2 UPPER TRAY MOTORS	34
Upper Tray Exit Motor	34
Upper Tray Junction Gate Motor	35
1.9.3 PRE-STACK MOTORS.....	36
Pre-Stack Transport Motor.....	36
Pre-Stack Junction Gate Motor	37
Pre-Stack Stopper Motor.....	37
1.9.4 PUNCH MOTOR.....	38
Punch Motor.....	38
1.9.5 STAPLE MOTORS	39
Staple Junction Gate Motor.....	39
Stapler Exit Motor.....	40
2. SERVICE TABLES.....	41
2.1 DIP SWITCHES.....	41
2.2 TEST POINTS	41
2.3 FUSES.....	41
3. DETAILS.....	42
3.1 UPPER TRAY AND STAPLER JUNCTION GATES.....	42
3.2 PAPER PRE-STACKING.....	43
3.3 JOGGER UNIT PAPER POSITIONING.....	44
3.4 STAPLING	45
3.5 STAPLER UNIT MOVEMENT	46
Side-to-Side	46
Rotation (1)	47
Rotation (2)	47
3.6 STAPLER	48
3.7 FEED-OUT	50
3.8 PAPER EXIT STACKING	51
3.9 SHIFT TRAY OPERATION.....	52
3.9.1 OVERVIEW	52
3.9.2 SHIFT TRAY OPERATION: STAND-BY MODE	54
3.9.3 SHIFT TRAY OPERATION: SHIFT MODE.....	55
3.9.4 SHIFT TRAY OPERATION: STAPLE MODE	56
3.9.5 SHIFT TRAY OPERATION: Z-FOLDED PAPER.....	57
3.9.6 SHIFT TRAY FULL AND NEAR-FULL DETECTION	58
3.10 SHIFT TRAY SIDE-TO-SIDE MOVEMENT	59

3.11 PUNCH UNIT.....	60
3.11.1 PUNCH UNIT DRIVE.....	60
3.11.2 PUNCH WASTE COLLECTION.....	61
3.12 SHIFT TRAY JOGGER UNIT	62
3.12.1 JOGGER UNIT MECHANICAL LAYOUT.....	62
3.12.2 JOGGER UNIT DRIVE	63
4. OVERALL MACHINE INFORMATION	64
4.1 MECHANICAL COMPONENT LAYOUT	64
4.2 DRIVE LAYOUT	65
4.2.1 MAIN DRIVE.....	65
4.2.2 STAPLING TRAY DRIVE.....	66
4.3 ELECTRICAL COMPONENTS.....	67
4.4 ELECTRICAL COMPONENT SUMMARY	70

1. REPLACEMENT AND ADJUSTMENT

1.1 COVERS

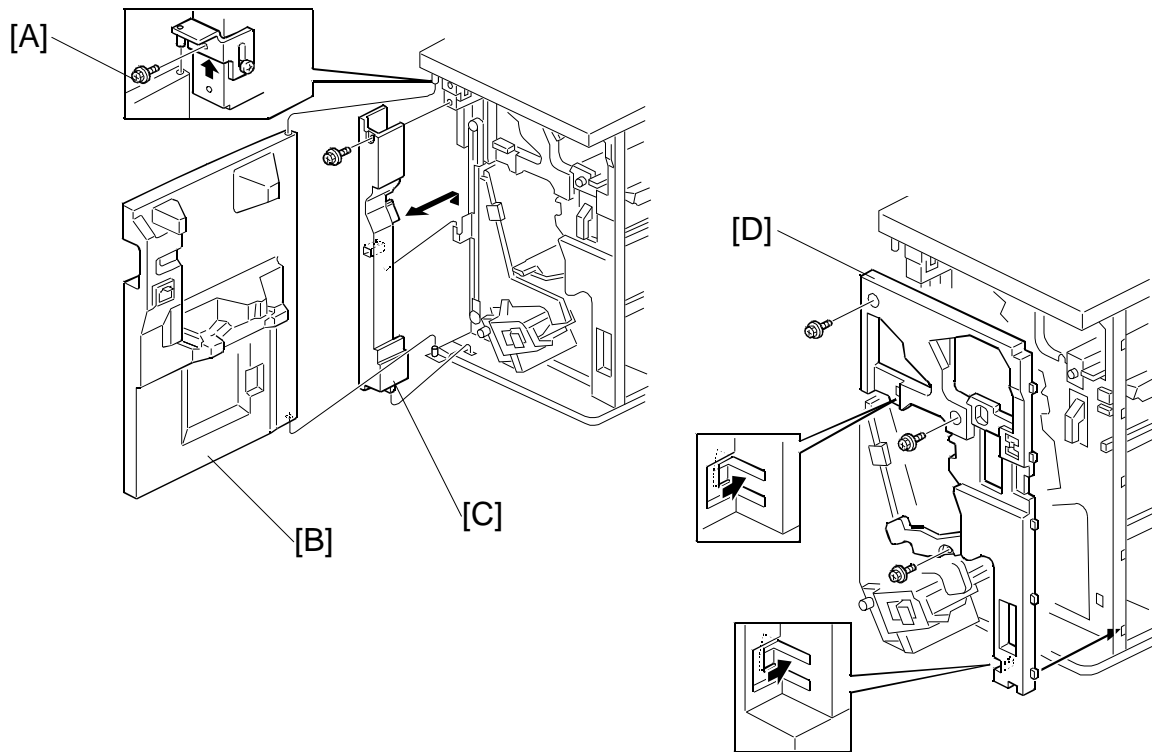

1.1.1 FRONT DOOR, INNER COVER

Front Door

1. Remove the front door screw [A] (⌀ x 1).
2. Remove the front door [B].

Left Inner Cover

1. Remove the front door.
2. Remove the left inner cover [C] (⌀ x 1).

Inner Cover

1. Remove the inner cover [D] (⌀ x 3).

Finisher
B830

REPLACEMENT AND ADJUSTMENT

1.1.2 SIDE TABLE AND UPPER TRAY

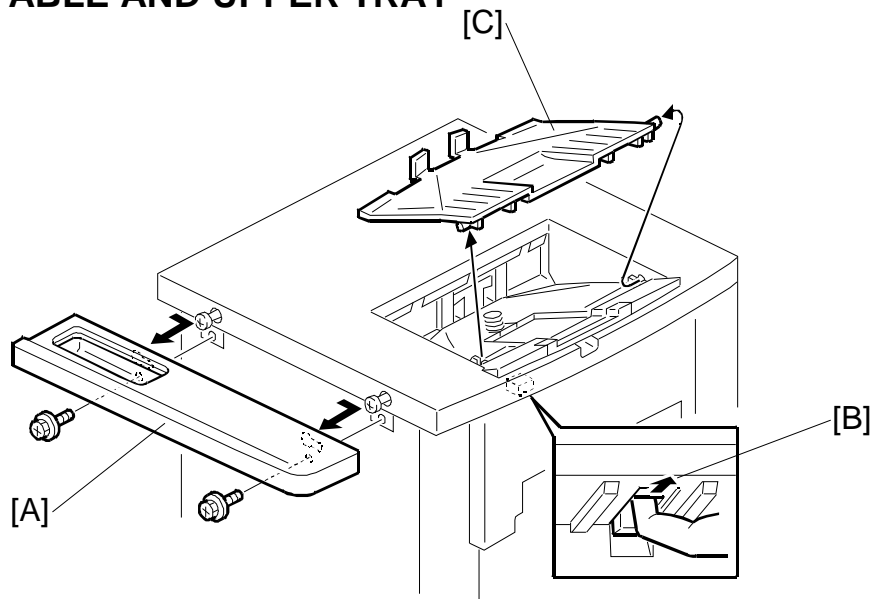

1. Remove the side table [A] (⌀ x 2). Slide to the right to remove it.
2. Click the release lever [B] and remove the upper tray [C].

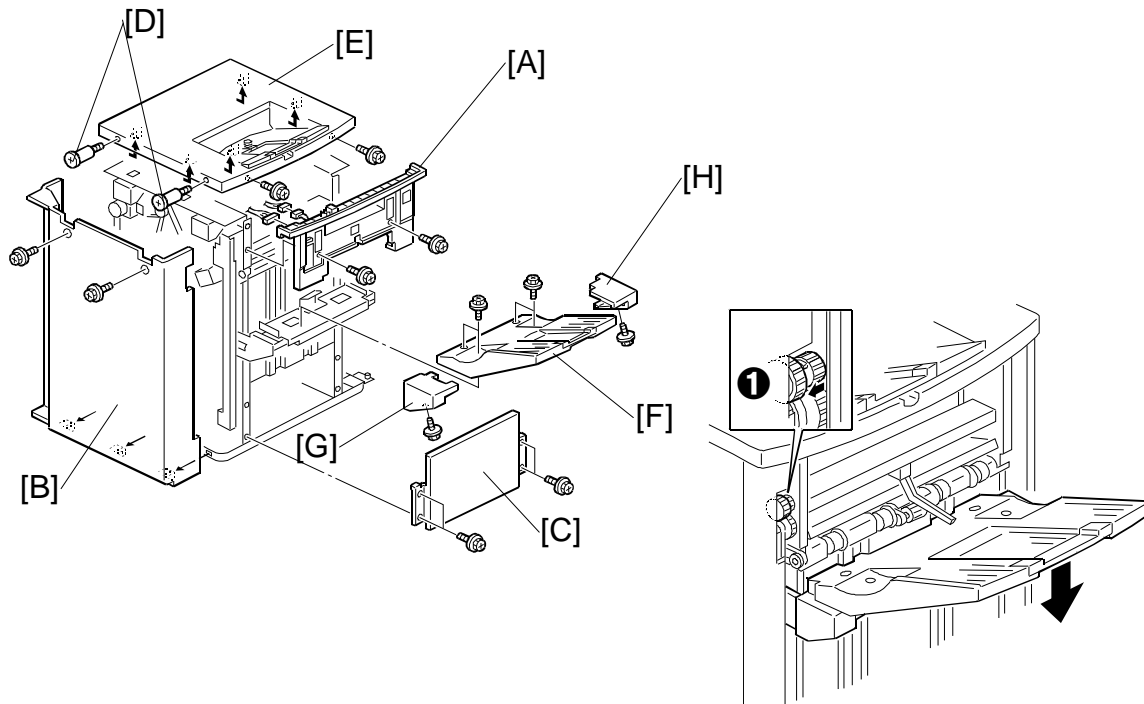

1.1.3 LEFT COVERS, REAR COVER

Remove:

- Shift tray jogger unit (☛1.8.1)
- Remove the door and left inner cover. (☛1.1.1)
- [A] Remove the left upper cover (⚙ x 2, 🛠 x 2).
- [B] Remove the rear cover (⚙ x 2).
- [C] Remove the left lower cover (⚙ x 4).

1.1.4 TOP COVER

Remove:

- Side table, upper tray (☛1.1.2)
- [D] Step screws (⚙ x 2).
- [E] Top cover (⚙ x 2). Slide to the right to remove.

1.1.5 SHIFT TRAY

- If you need to lower the shift tray, support the bottom of the tray with your hand, then pull the gear toward you ❶ to release the tray and lower it.

Remove:

- [F] Remove the shift tray (⚙ x 4).
- [G] Shift tray rear cover (⚙ x 1)
- [H] Shift tray front cover [H] (⚙ x 1).

REPLACEMENT AND ADJUSTMENT

1.1.6 JOGGER UNIT COVER

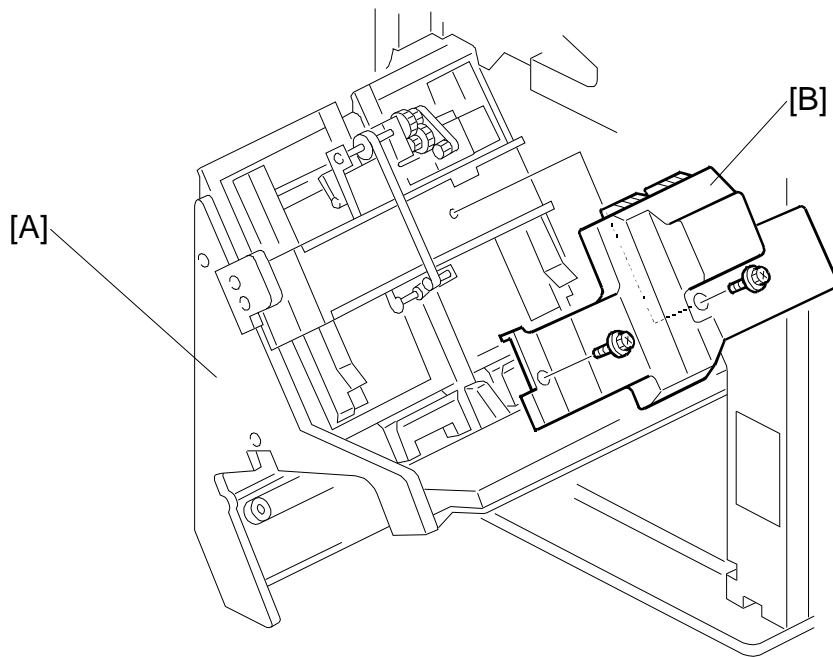

1. Open the front door.
2. Pull out the stapler tray unit [A].
3. Remove the jogger unit cover [B] (⚙️ x2)

1.2 ROLLERS

1.2.1 DRAG ROLLER

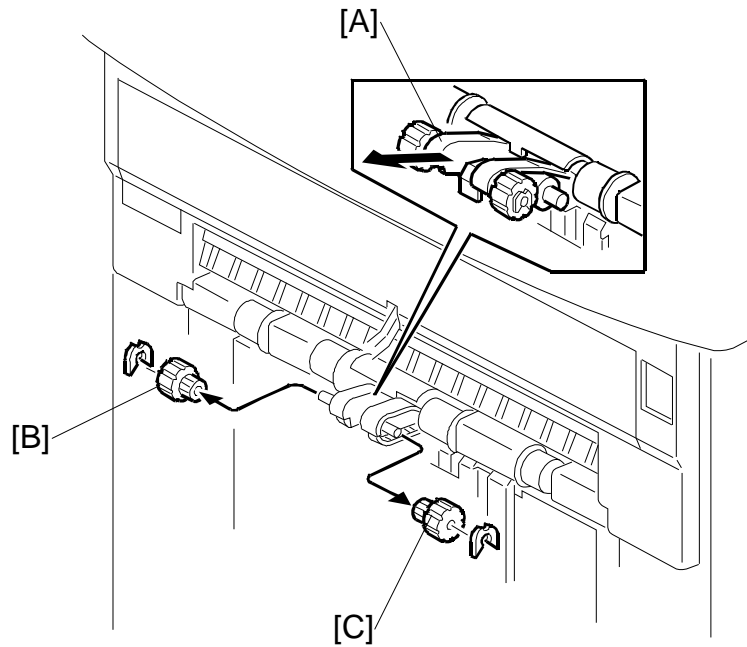

1. Above the shift tray, pull the roller mount [A] out.
2. Remove the rollers [B] and [C] (⌀ x 1 each)

REPLACEMENT AND ADJUSTMENT

1.2.2 POSITIONING ROLLER

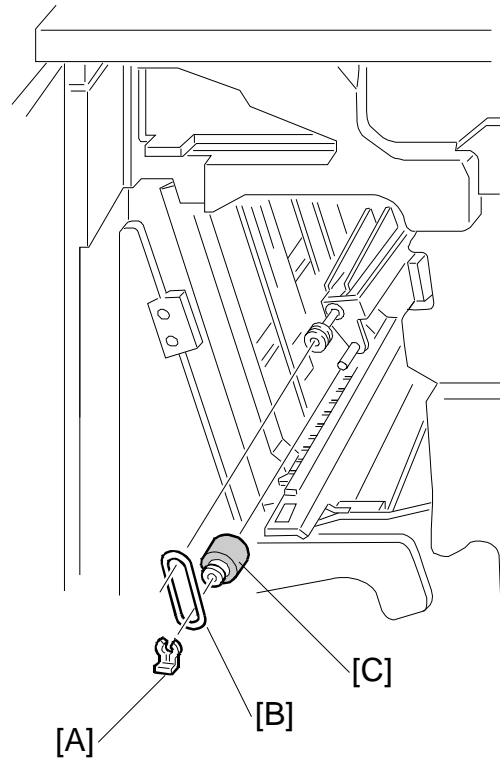

1. Remove the jogger unit cover (➔1.1.6)
2. Remove the snap ring [A].
3. Release the rubber belt [B].
4. Replace the positioning roller [C].

1.2.3 ALIGNMENT BRUSH ROLLER

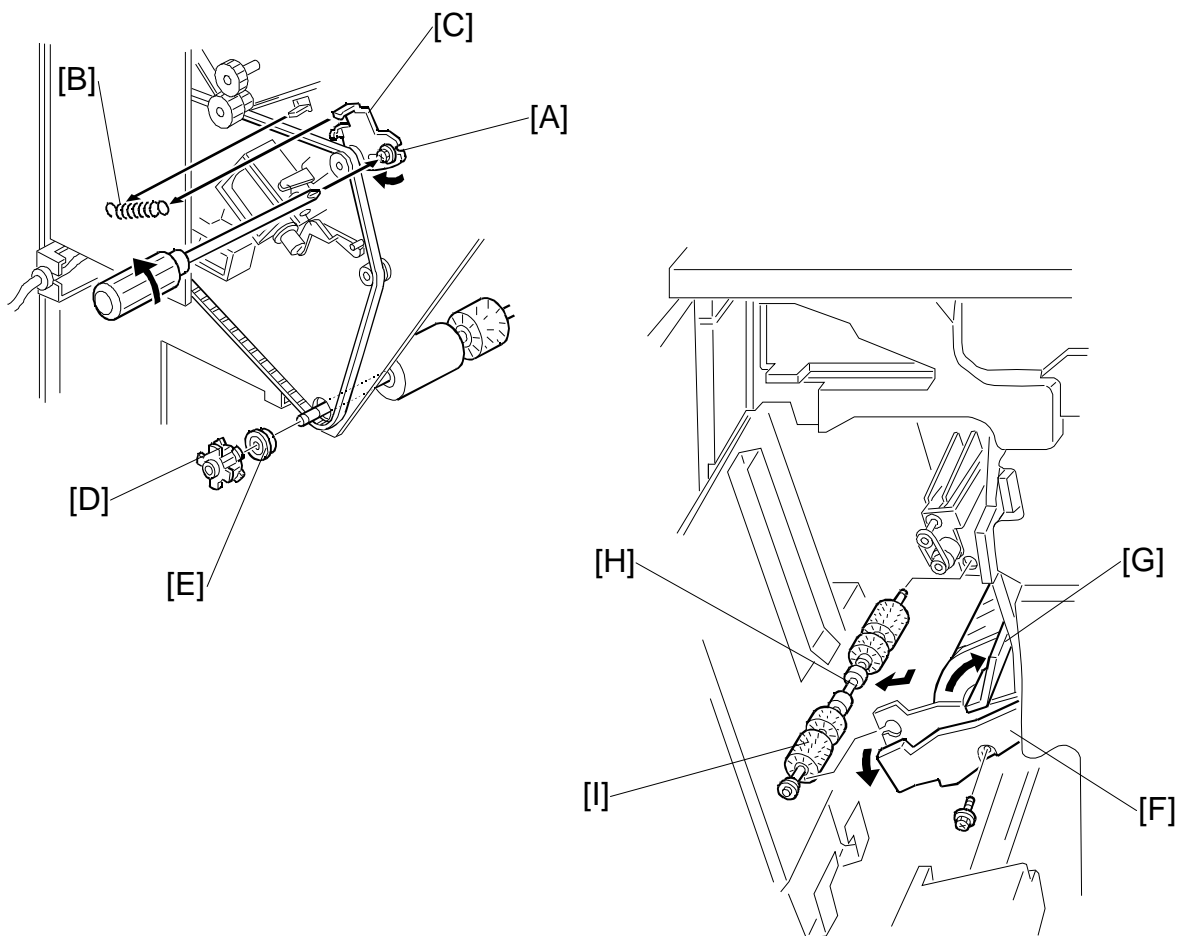

Finisher
B830

1. Open the front door and pull out the staple unit.
2. Remove the rear cover.
3. Remove the main board bracket and all connectors (⚙ x 8). (☞1.4.6)
4. Remove the screw [A] and tension spring [B] for the tension bracket [C], and release the tension of the timing belt.
5. Remove the pulley [D] and bearing [E].
6. Remove the inner cover [F] (⚙ x 1).
7. Open the guide [G], then remove the alignment brush roller assembly [H].
8. Remove the alignment brush roller [I] (⚙ x2, Bearing x 1 front/back, ⚙x1).

1.3 JOGGER FENCE

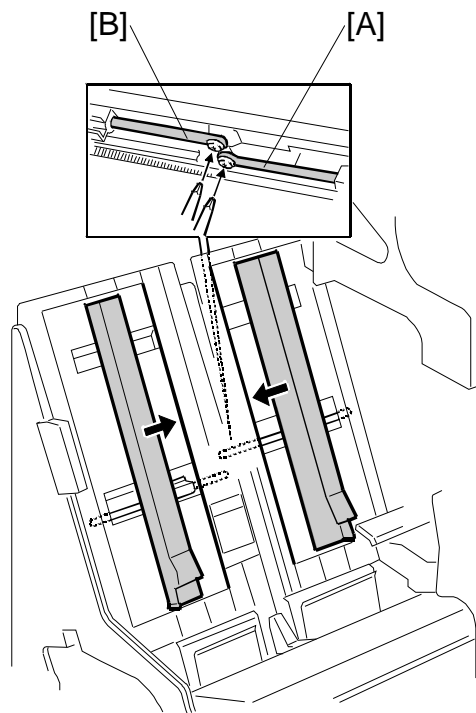

1. Open the front door.
2. Pull out the jogger and stapler unit.
3. Push both fences to the center.
4. Remove the left jogger fence [A] (⚙ x 1)
5. Remove the right jogger fence [B] (⚙ x 1).

NOTE: If the screws are difficult to remove or re-attach, remove the jogger fence belt and spring plate.

1.4 SENSORS

1.4.1 PAPER HEIGHT SENSORS

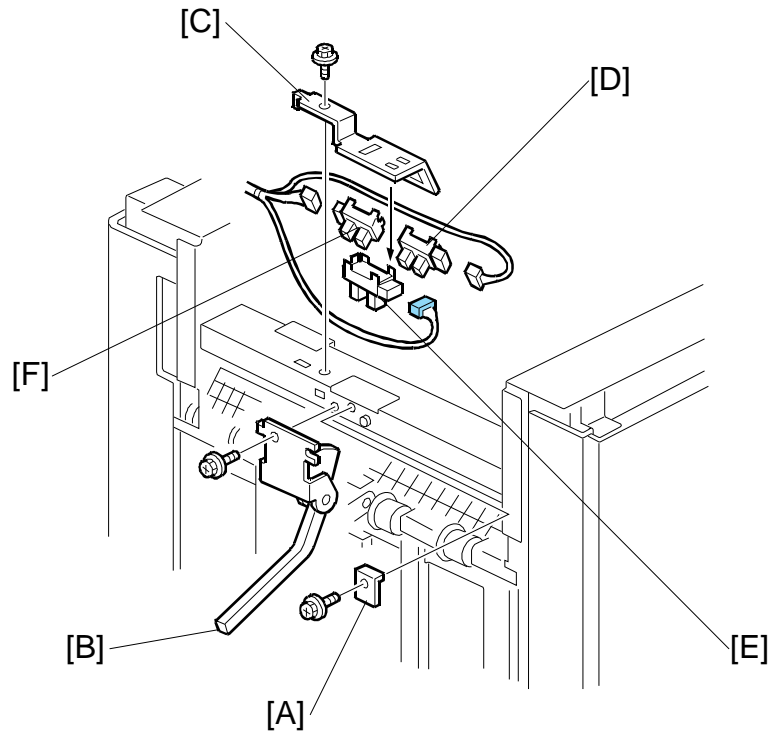

Remove:

- Top cover. (☛1.1.1)
- Left upper panel and left upper cover (🔩 x 2, 🛠 x 2) (☛1.1.3)
- [A] Protector plate (🔩 x 1).
- [B] Feeler (🔩 x 1).
- [C] Sensor bracket (🔩 x 1).
- [D] Paper height sensor – staple mode (🛠 x 1, Pawls x4)
- [E] Paper height sensor – standby mode (🛠 x 1, Pawls x4)
- [F] Paper height sensor – shift/Z-Fold(🛠 x 1, Pawls x4).

REPLACEMENT AND ADJUSTMENT

1.4.2 EXIT GUIDE HP SENSOR

1. Remove the top cover. (☛1.1.1)
2. Remove the left upper panel and left upper cover (🔩 x 2, 🏹 x 2).
3. Remove:
[A] Sensor bracket [A] (🔩 x 1).

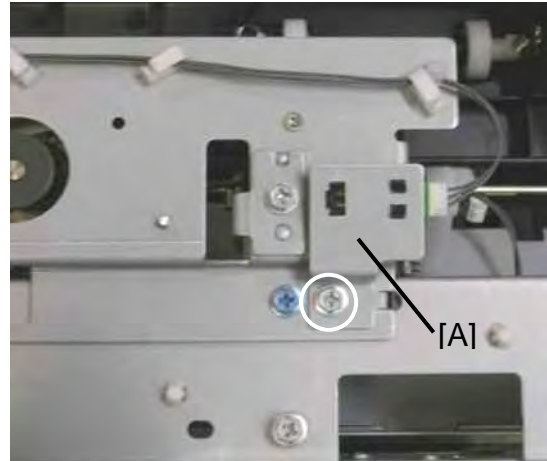

- [B] Exit guide HP sensor (🏹 x 1, Pawls x3).

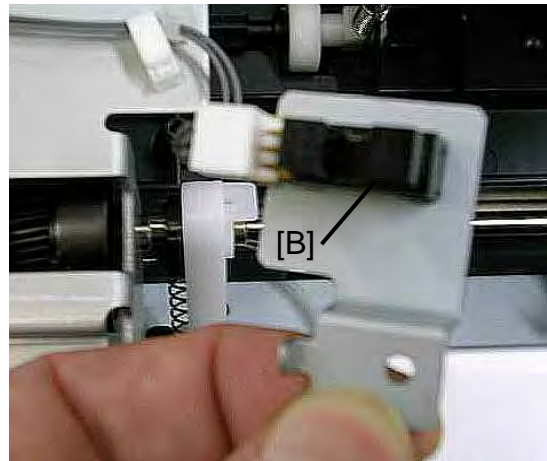

1.4.3 UPPER TRAY FULL AND EXIT SENSORS

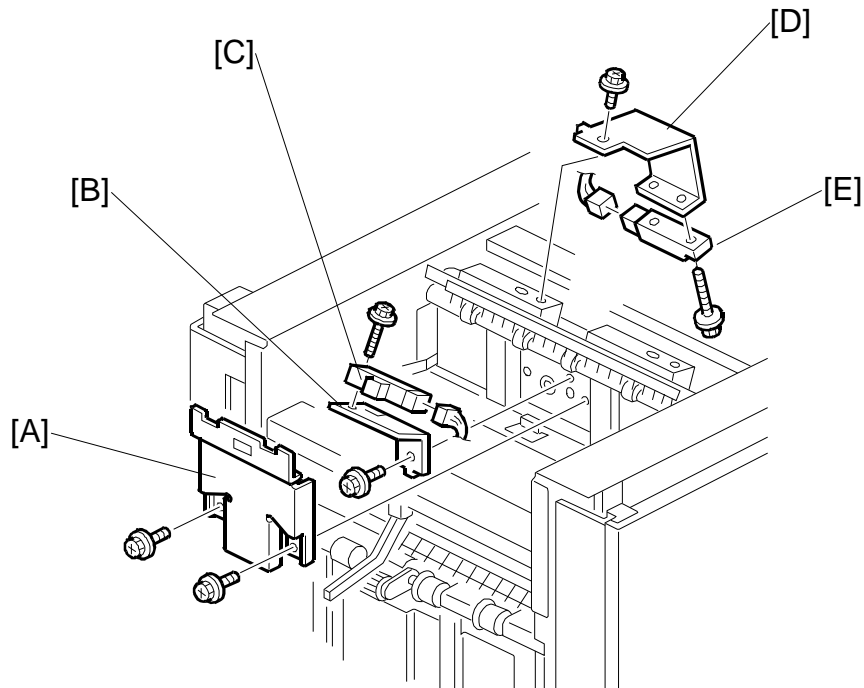

Upper Tray Full Sensor

1. Remove the top cover.
2. Remove the sensor cover [A] (⚙️ x 2).
3. Remove the sensor bracket [B] (⚙️ x 1).
4. Replace the upper tray full sensor [C] (🔌 x 1, ⚙️ x1).

Upper Tray Exit Sensor

5. Remove the sensor bracket [D] (⚙️ x 1).
6. Replace the upper tray exit sensor [E] (🔌 x 1, ⚙️ x 1).

REPLACEMENT AND ADJUSTMENT

1.4.4 SHIFT TRAY EXIT SENSOR

Remove the top cover (☛1.1.4)

Remove:

[A] Sensor bracket (🔩 x1)

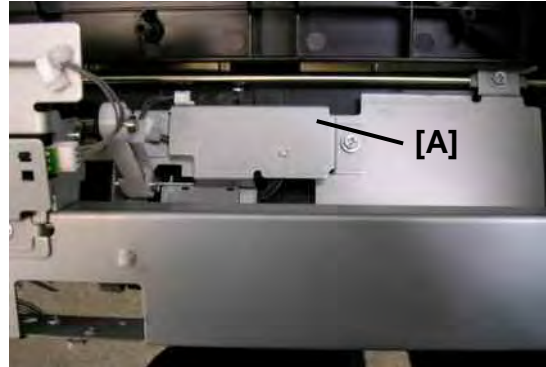

[B] Shift tray exit sensor 1 (🔩 x1, 📡 x1)

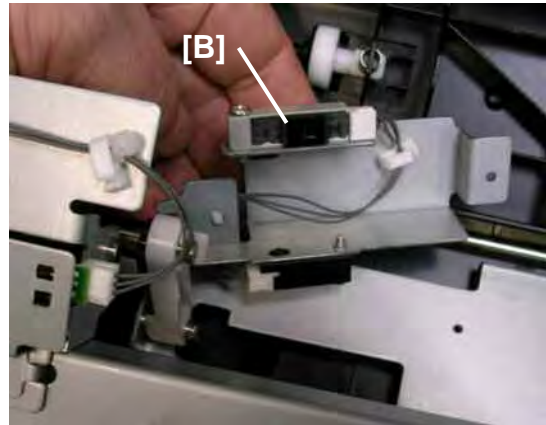

[C] Shift tray exit sensor 2 (🔩 x1, 📡 x1)

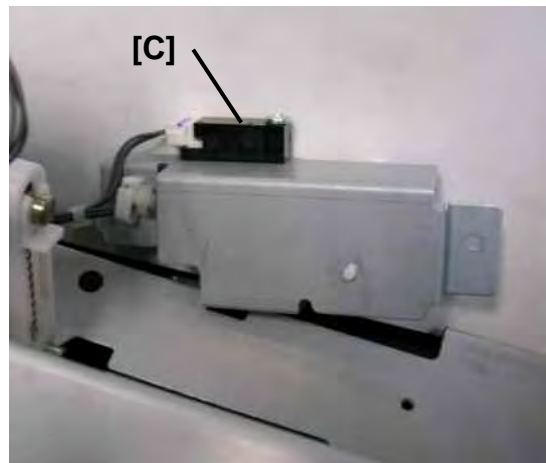

1.4.5 ENTRANCE AND STAPLER TRAY ENTRANCE SENSORS

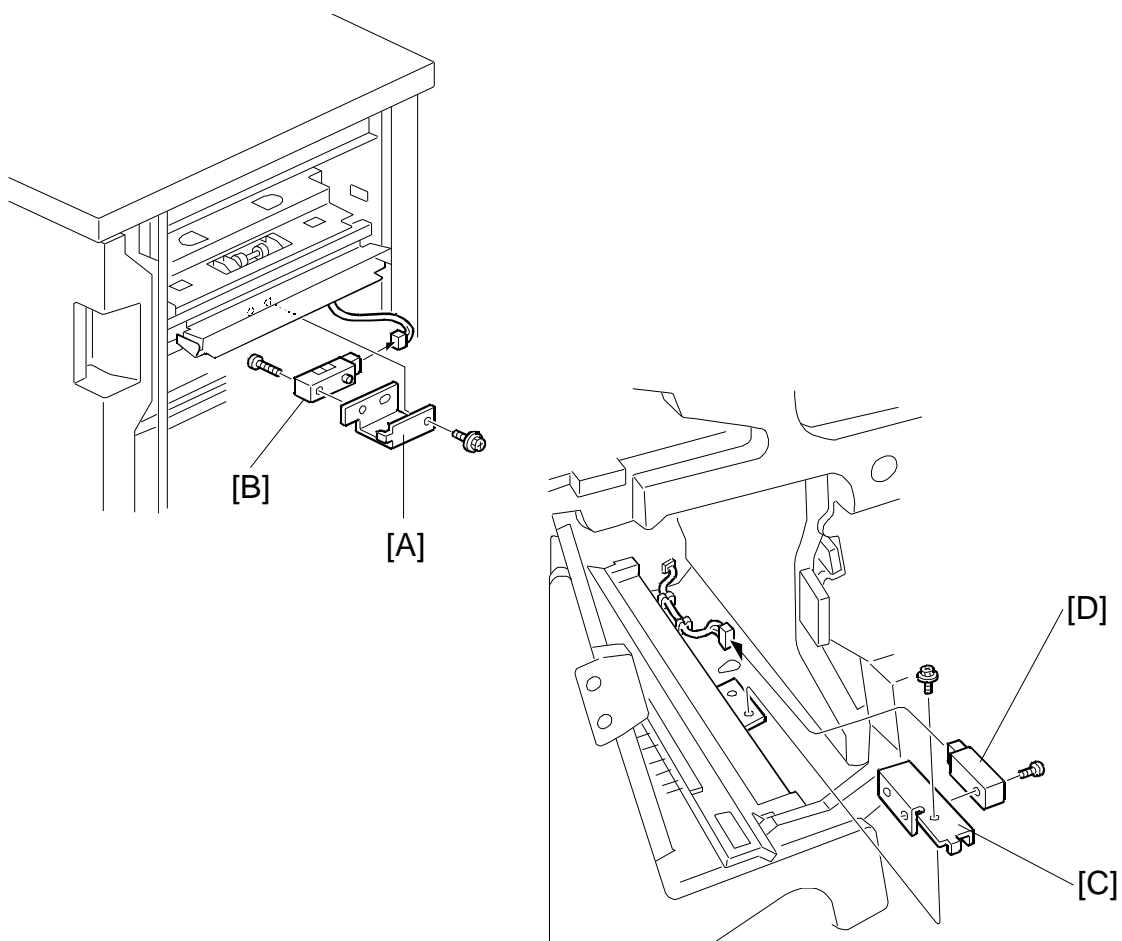

Finisher
B830

Entrance Sensor

1. Disconnect the finisher from the copier.
2. Remove the sensor bracket [A] (⚙️ x 1).
3. Replace the entrance sensor [B] (⚙️ x 1) (🔌 x 1).

Stapler Tray Entrance Sensor

1. Open the front door.
2. Remove the sensor bracket [C] (⚙️ x 1).
3. Replace the stapler tray entrance sensor [D] (⚙️ x 1) (🔌 x 1).

REPLACEMENT AND ADJUSTMENT

1.4.6 MAIN BOARD, PRE-STACK PAPER SENSOR



1. Remove the rear cover. (☛1.1.4)
2. Remove the main board bracket (🔩 x 4, ⏏x8, 📏 x All).
3. Open the front door.

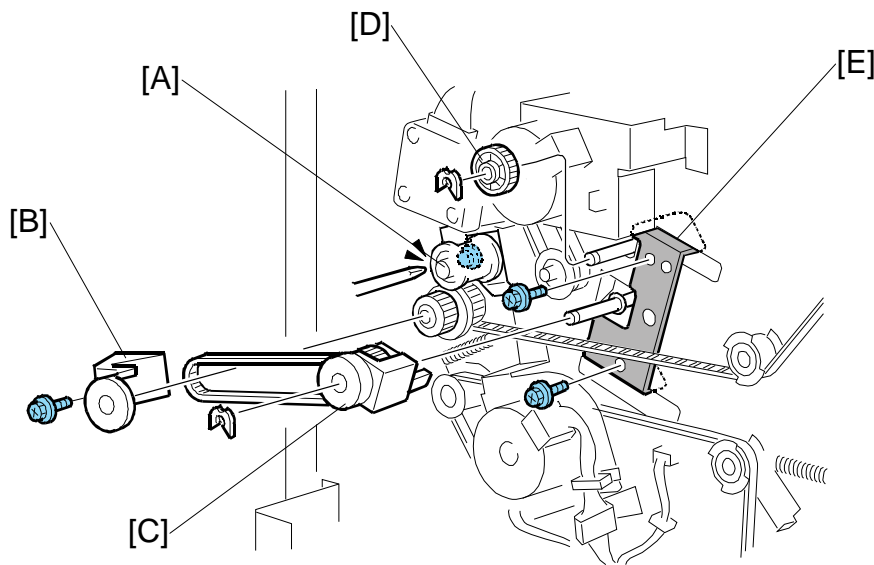

Loosen the screw [A] (⚙️ x1)

Remove:

- [B] Gear cover (⚙️ x1)
- [C] Gear (⚙️ x1, Timing belt x1)
- [D] Gear (⚙️ x1)
- [E] Plate (⚙️ x2)
- [F] Left vertical transport guide
- [G] Middle vertical transport guide
- [H] Pre-stack paper sensor (📄 x1)

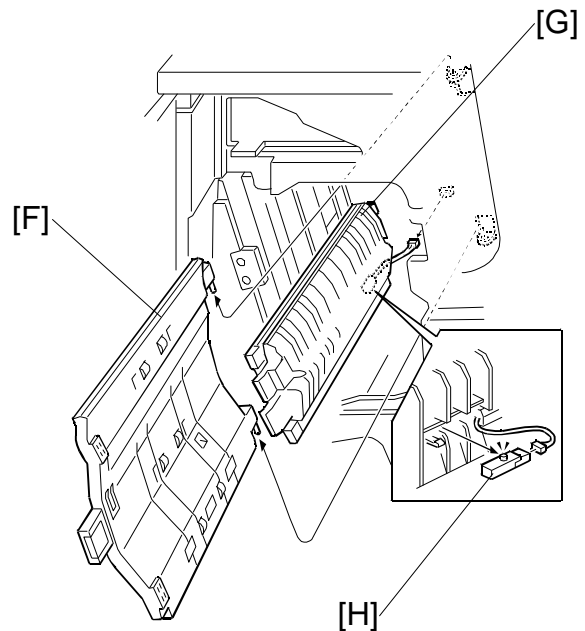

Finisher
B830

1.4.7 STAPLE TRIMMINGS HOPPER FULL SENSOR

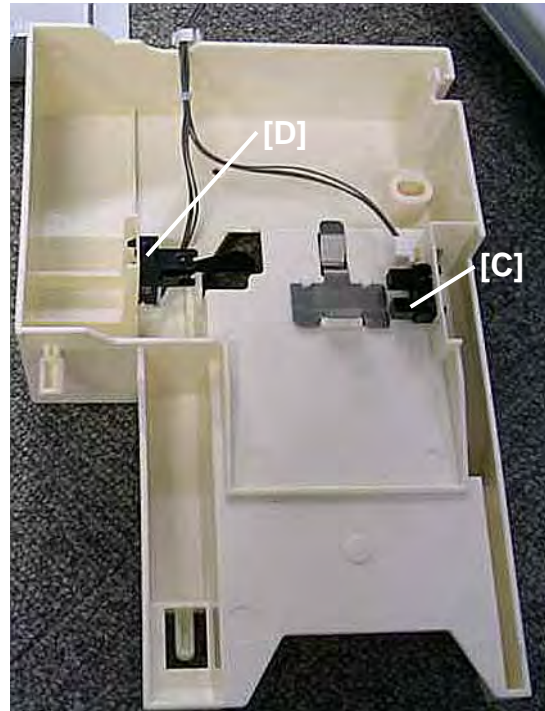
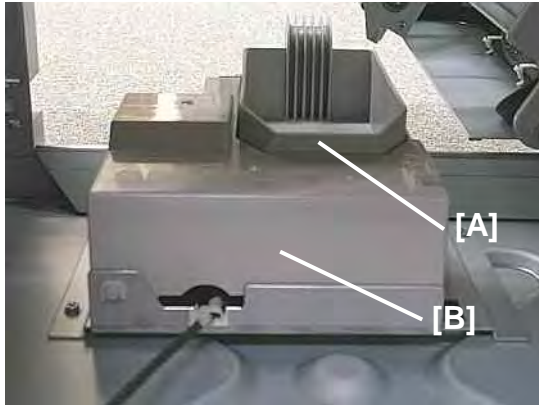

- Open the front door
- Pull out the stapler unit
- Remove the rear cover (🔧 x 2).

Remove:

[A] Staple trimmings hopper

[B] Hopper holder (🔧x1, Hook x1, 🌀 x1)

[C] Hopper full sensor (🔧 x 1)

[D] Hopper set sensor (🔧 x 1)

1.4.8 STAPLER ROTATION HP AND STAPLER RETURN SENSORS

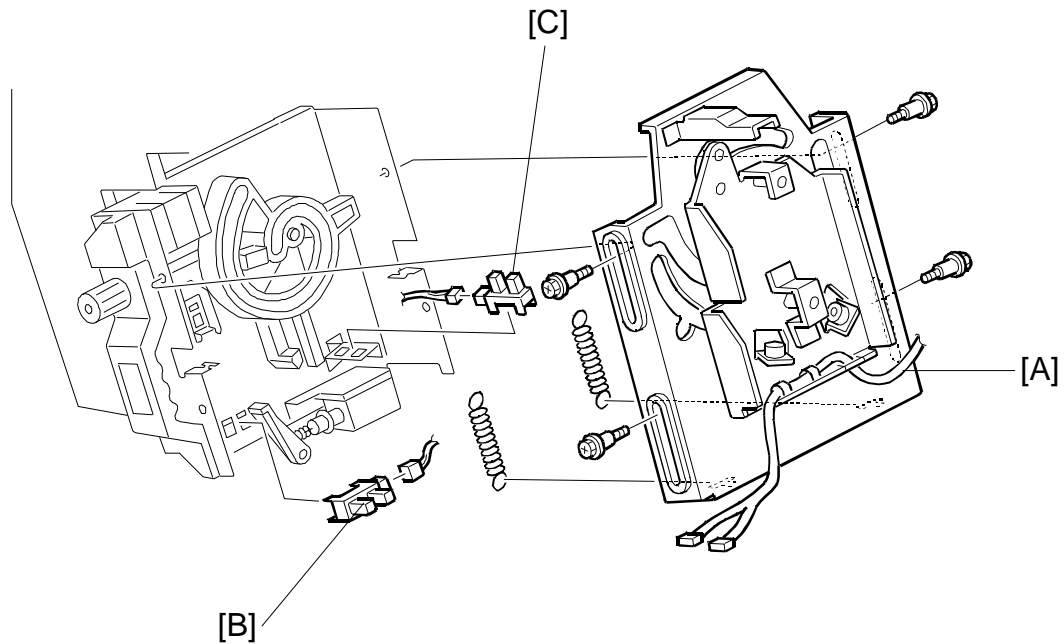

1. Remove the stapler unit. (See next page.)
2. Remove the stapler mount bracket [A] (⚙ x 4) (Springs x 2).
3. Replace the stapler rotation HP sensor [B] (🔌 x 1).
4. Replace the stapler return sensor [C] (🔌 x 1).

1.5 STAPLER

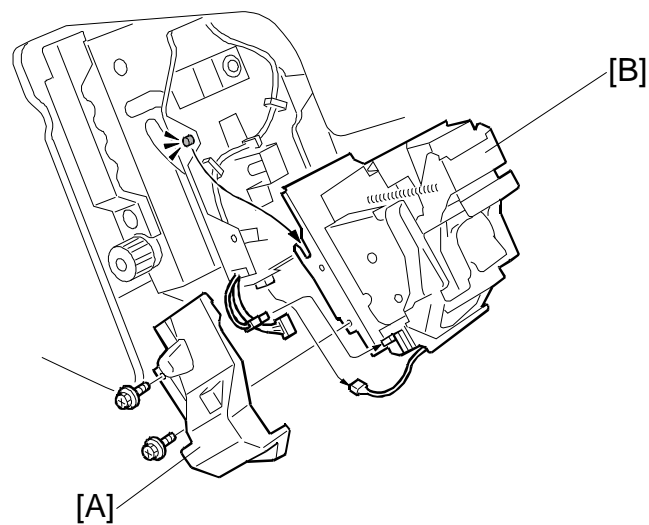

1. Open the front door and pull out the staple tray.
2. Remove the stapler unit harness cover [A] (⚙ x 2).
3. Lift the stapler [B] off of its pegs (📌 x 2)
4. Remove plate [C] (⚙ x 2).
5. Attach this plate to the new stapler with the same screws (⚙ x 2)

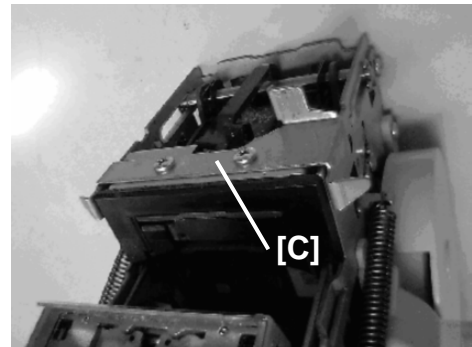

6. Replace the frame guard [D] with the one provided with the new stapler.

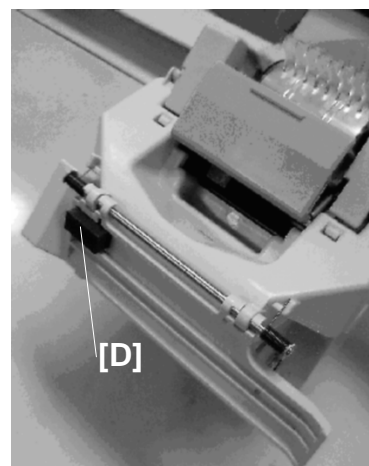

1.6 SHIFT TRAY

1.6.1 SHIFT TRAY EXIT, SHIFT TRAY LIFT MOTOR

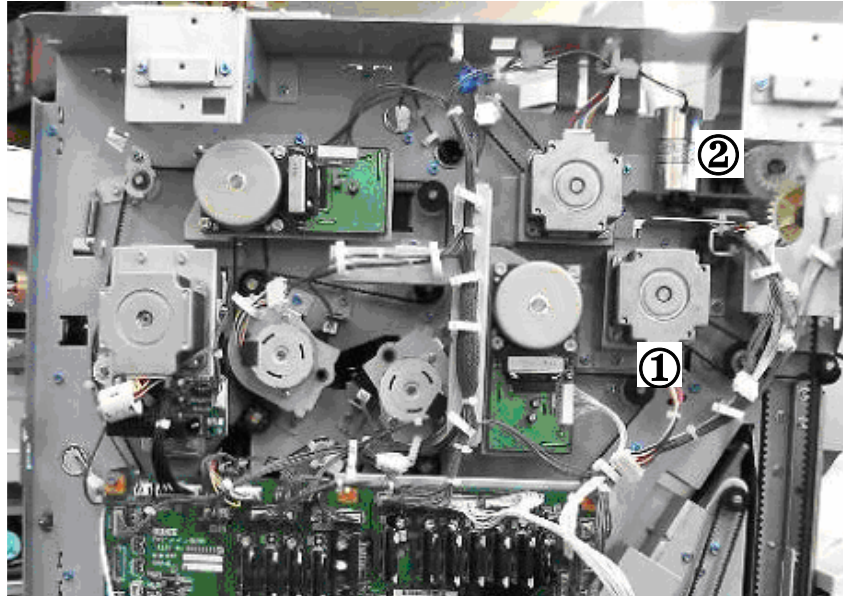

Finisher
B830

- ① Shift Tray Exit Motor
- ② Shift Tray Lift Motor

Shift Tray Exit Motor

- Rear cover (☛1.1.4)
- [A] Shift tray exit motor bracket
(🔩 x2, 📏 x1, 📏 X1, Timing belt x1)
- [B] Shift tray exit motor (🔩 x2)

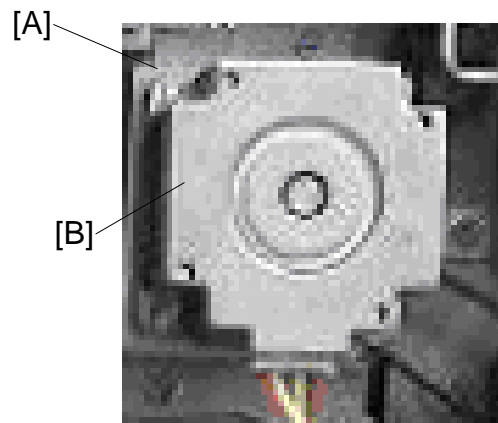

REPLACEMENT AND ADJUSTMENT

Shift Tray Lift Motor

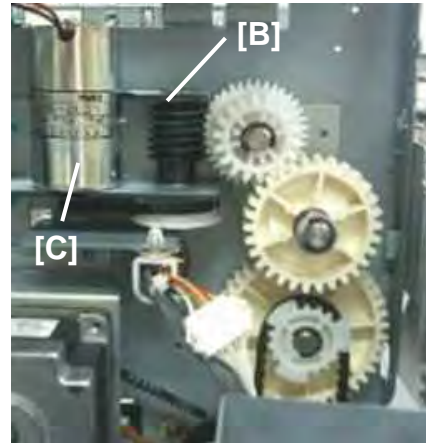

- Rear cover (☛1.1.4)
- [A] Gear cover (🔩 x2)
- [B] Shift tray lift motor bracket (🔩 x2)
- [C] Shift tray lift motor (🔩 x,2 📏 x1, Timing belt x1)

1.6.2 DRAG ROLLER/DRAG DRIVE MOTORS, DRAG DRIVE HP SENSOR

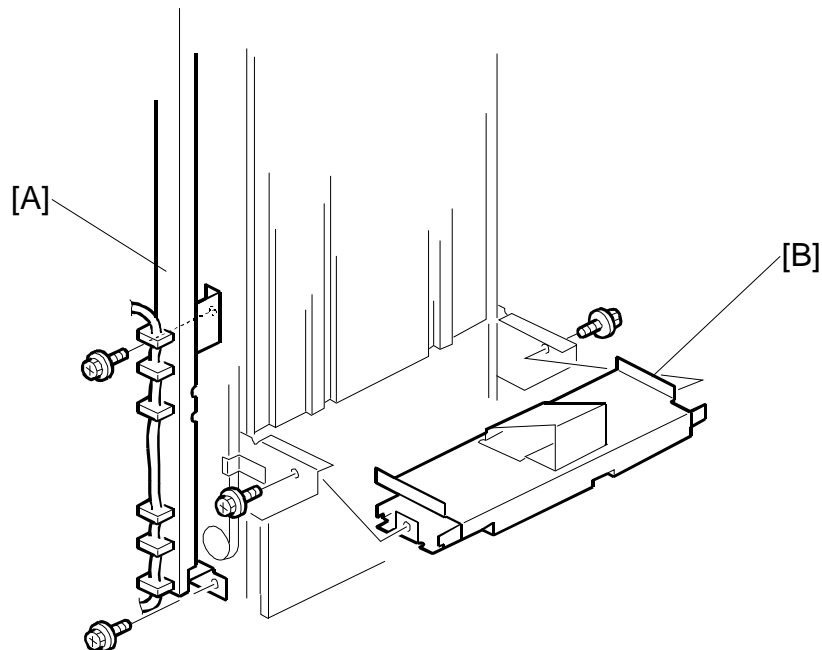

Remove:

- Front door and all covers, except the left lower cover, top cover (☛1.1)
NOTE: Be sure to lower the shift tray by pulling the gear toward you. The shift tray must be down.
1. Remove the left stay [A] (☛ x 2)
 2. Remove the shift tray mounting plate [B] (☛ x 2).

Finisher
B830



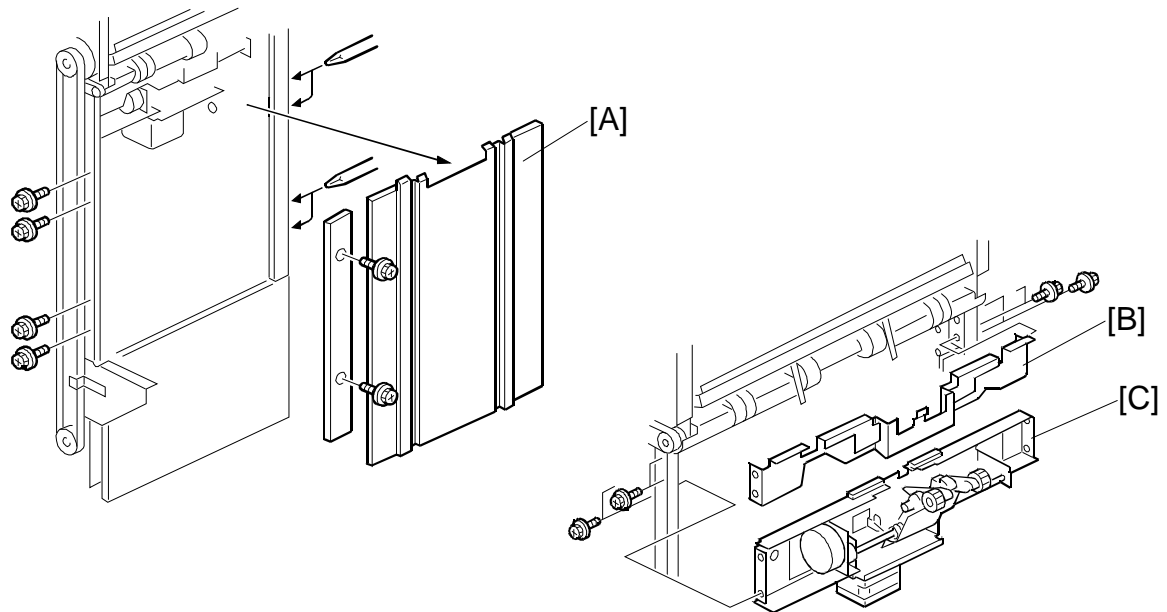





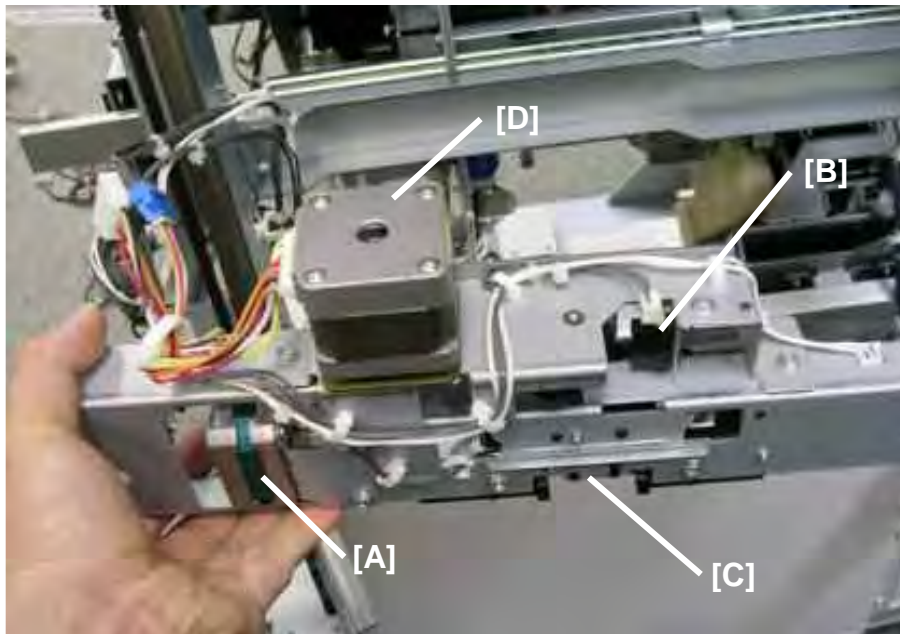

REPLACEMENT AND ADJUSTMENT



3. Remove the end fence [A] and plate (⚙ x8, ⚙ x6, ⚙ x2).
4. Remove cover [B] (⚙ x 4).
5. Remove the motor stay [C] (⚙ x4, ⚙ x7, ⚙ x4).

NOTE: Make sure the motor and sensor connectors are disconnected before removing.



6. Remove the drag roller motor unit [A] (Bearing x1,  x2,  x1)
7. Remove the drag roller motor ( x2)
8. Remove the drag roller HP sensor unit [B] ( x1)
9. Remove the drag roller HP sensor ( x1, Pawls x3)
10. Remove the paper height sensor – shift/Z-fold unit [C] ( x2,  x2)
11. Remove the paper height sensor shift/Z-fold ( x1, Pawls x3)
12. Remove the drag drive motor unit ( x4,  x2)
13. Remove the drag drive motor ( x2)

1.6.3 SHIFT MOTOR AND SENSORS

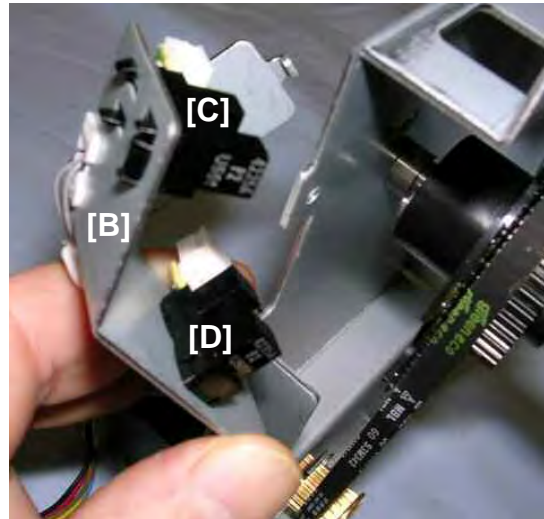
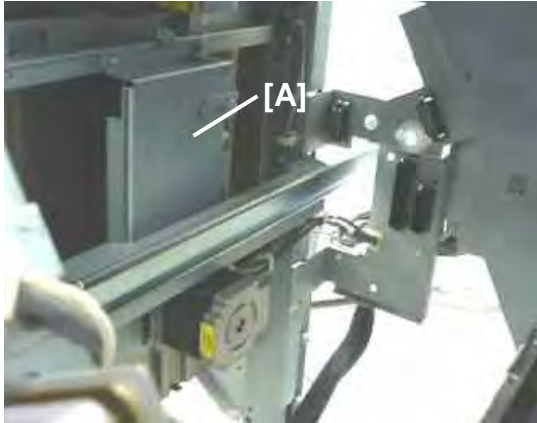

1. Remove the end fence (☛1.6.2)
2. Remove the shift motor bracket [A] (with motor) (🔩 x 4, ⏪x1, 🛠️x1)
3. Remove the shift motor (🔩 x4)
4. Remove the half-turn sensor bracket [B] (🔩 x 1)
5. Remove half-turn sensor 1 [C] (🛠️ x1, Pawls x3)
6. Remove half-turn sensor 2 [D] (🛠️ x1, Pawls x3)

1.6.4 JOGGER TOP FENCE MOTOR

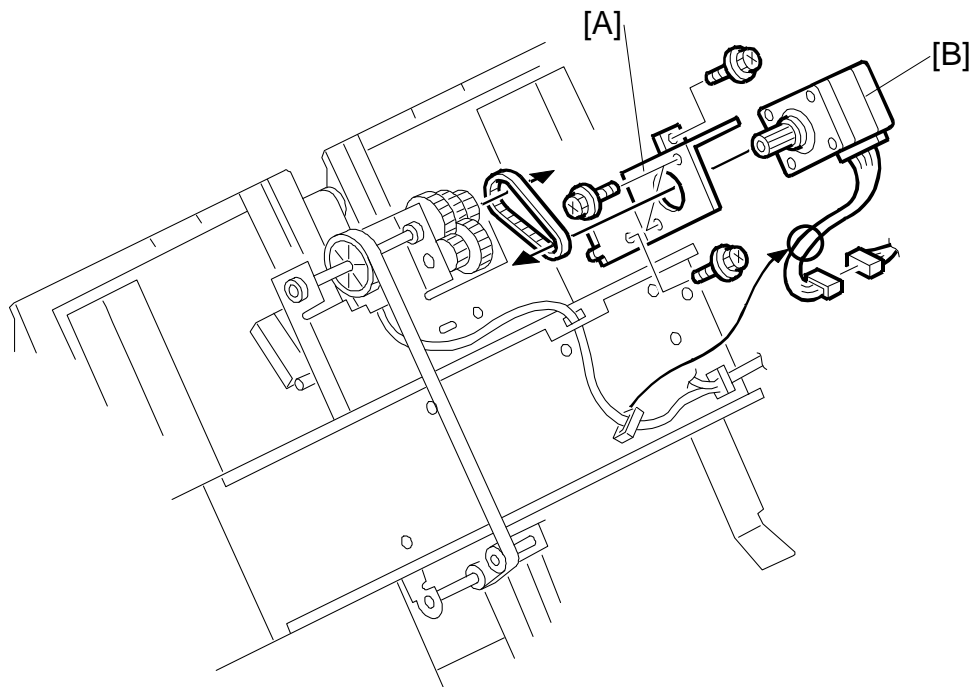

1. Open the front door and pull out the stapler tray unit. (➔1.1.6)
2. Remove the jogger unit cover (🔧 x2)
3. Remove the motor bracket [A] (🔧 x2, timing belt x1)
4. Remove the jogger top fence motor [B] (🔧 x2 ⬅️x1 📡 x1)

Finisher
B830

REPLACEMENT AND ADJUSTMENT

1.6.5 JOGGER UNIT

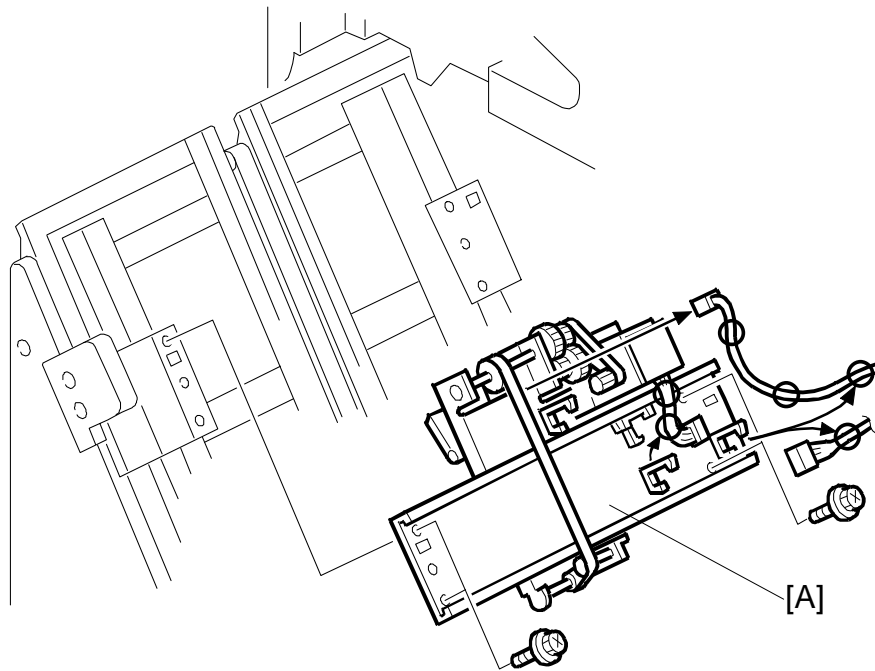

1. Open the front door and pull out the stapler tray unit.
2. Remove the jogger unit cover (🔩 x2)
3. Remove the jogger unit [A] (🔩 x4, ⚙️ x5, 🛠️ x5)

1.6.6 JOGGER BOTTOM FENCE MOTOR

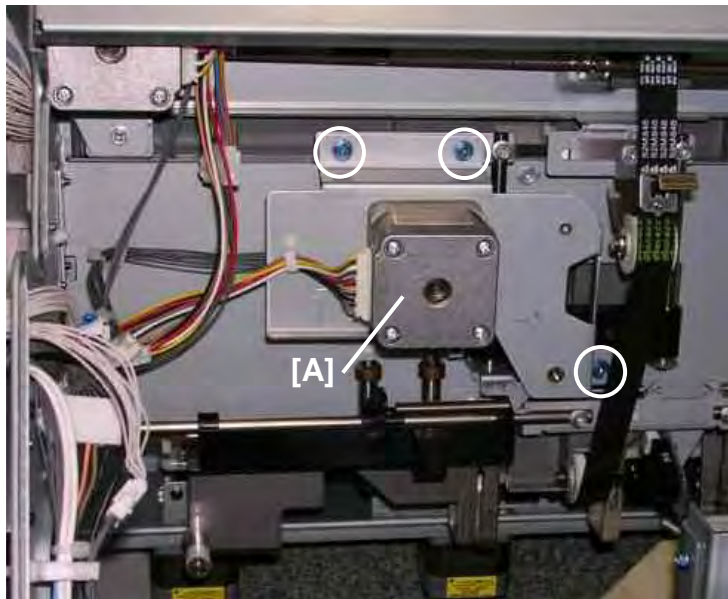

1. Open the front door and pull out the stapler tray unit.
2. Remove the jogger bottom fence motor unit [A] (⚙️ x3, timing belt x1, ⏪ x1, ⏩ x1).

Finisher
B830

1.7 PUNCH UNIT

1.7.1 PUNCH POSITION ADJUSTMENT

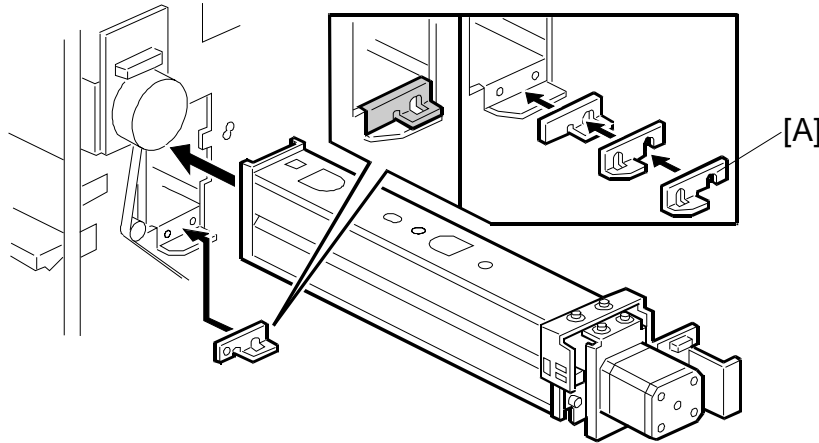

The position of the punched holes can be adjusted in two ways.

Front to Rear Adjustment

Three spacers [A] are provided with the punch unit for manual adjustment of the hole position in the main scan direction:

- 2 mm (x 1)
- 1 mm (x 2)

NOTE: One spacer was installed at installation and the remaining spacers were fastened with a screw to the rear frame of the finisher under the rear cover and slightly above the lock bar.

Right to Left Adjustment

The position of the punched holes can be adjusted right to left in the sub scan direction with **SP6101** Punch Hole Position Adjustment. The position can be adjusted in the range ± 7.5 mm in 0.5 mm steps. The default setting is 0.

Press the  key to toggle the \pm selection. A +ve value shifts the punch holes left toward the edge of the paper, and a -ve value shifts the holes right away from the edge.

1.8 SHIFT TRAY JOGGER UNIT

1.8.1 SHIFT TRAY JOGGER UNIT

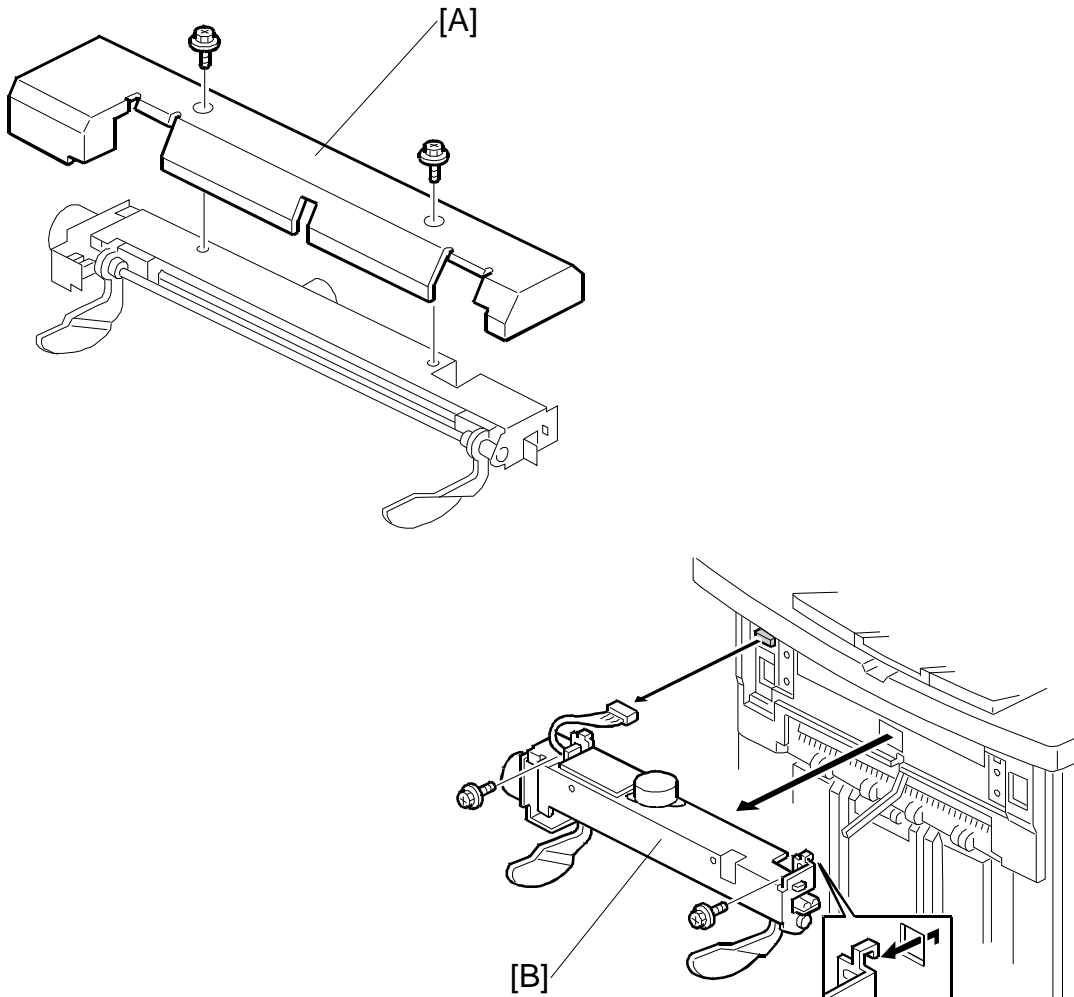

1. Remove the jogger unit cover [A] (⚙️ x 2).
2. Remove the jogger unit [B] (⚙️ x 2, 🗑️ x 1).

REPLACEMENT AND ADJUSTMENT

1.8.2 SHIFT TRAY JOGGER UNIT PCB

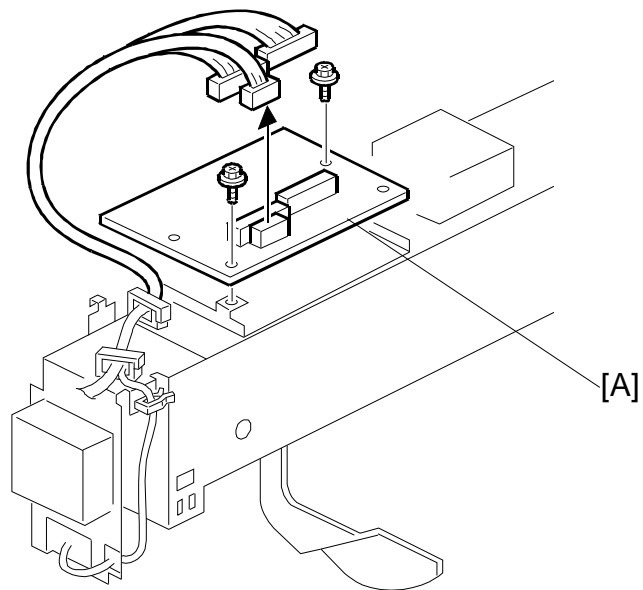

1. Remove the jogger unit from the finisher. (☛ 1.8.1)
2. Remove the jogger unit control PCB [A] (🔩 x 2, 🛠 x 3)

1.8.3 SHIFT TRAY JOGGER UNIT MOTORS

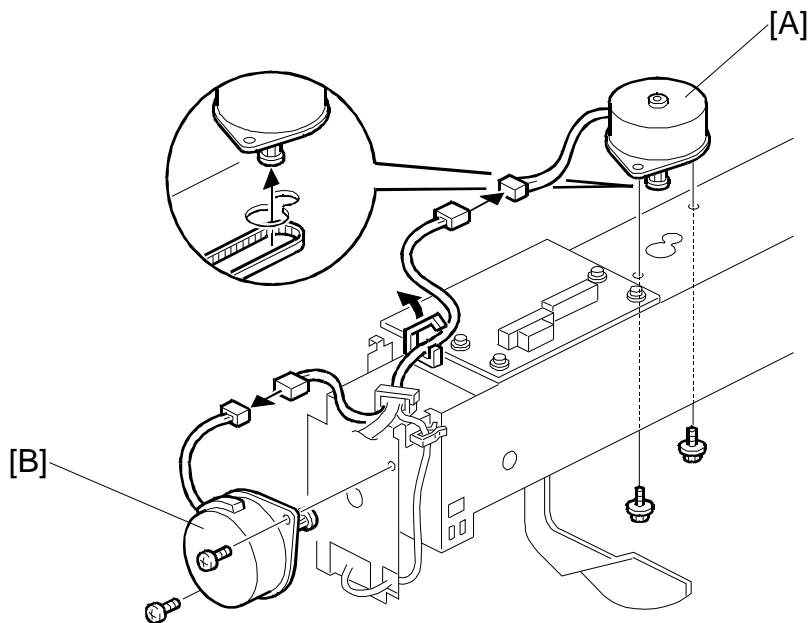

1. Remove the jogger unit from the finisher. (☛ 1.8.1)
2. Remove the shift tray jogger motor [A] (🔧 x 2, 🛠️ x 1).
3. Remove the shift tray jogger retraction motor [B] (🔧 x 2, 🛠️ x 1).

1.9 MOTORS

1.9.1 TRANSPORT MOTORS, EXIT GUIDE MOTOR

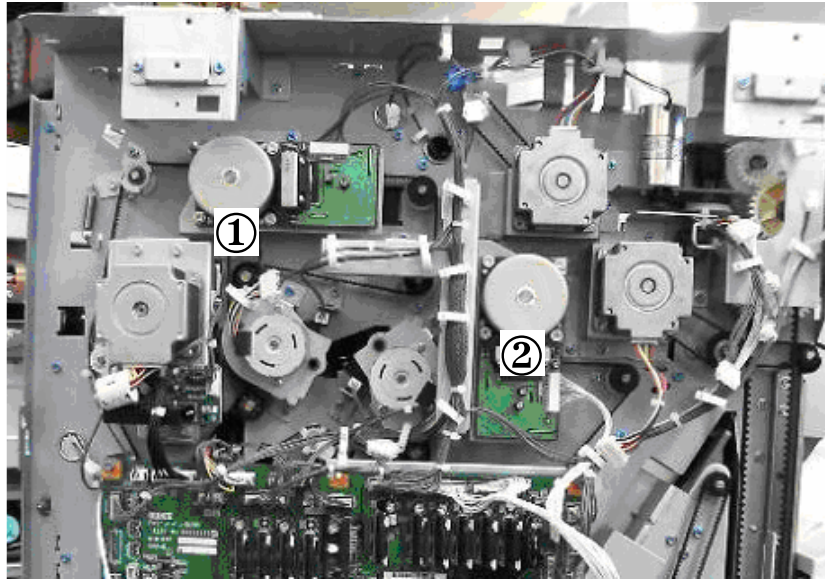

①	Upper Transport Motor
②	Lower Transport Motor

Upper Tray Transport Motor

- Rear cover (🔧 1.1.4)
- [A] Upper transport motor (🔧 x4, 📏 x1)

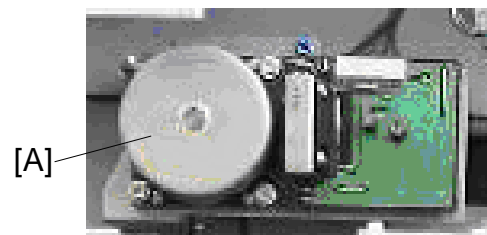

Lower Transport Motor

- Rear cover (☛1.1.4)
- [A] Lower transport motor (🔩 x4, 📏 x1)

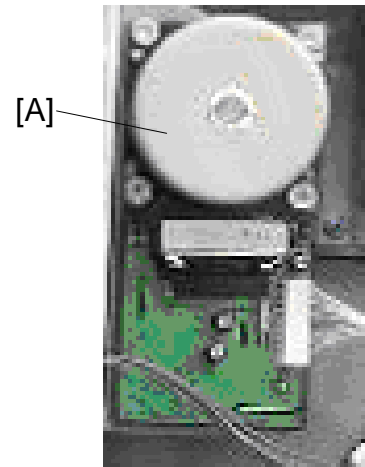

Exit Guide Motor

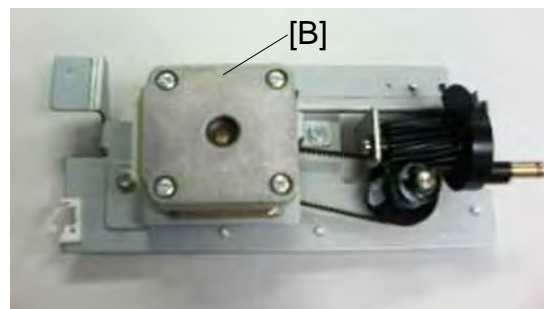
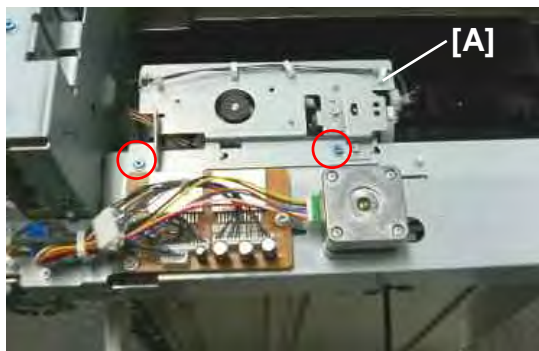

- Top cover (☛1.1.4)
- [A] Bracket (🔩 x2, 📏 x1)
- [B] Exit guide motor (🔩 x2, 📏 x1, Timing belt x1)

Finisher
B830

1.9.2 UPPER TRAY MOTORS

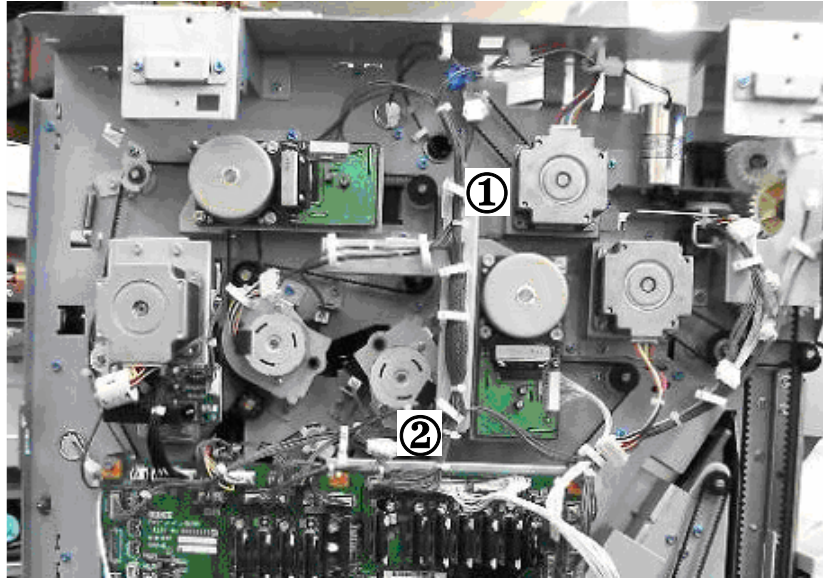

①	Upper Tray Exit Motor
②	Upper Tray Junction Gate Motor

Upper Tray Exit Motor

- ⇒ • Rear cover (☛ 1.1.4)
 [A] Motor bracket (🔩 x2, 📏 x1)
 [B] Upper tray exit motor (🔩 x2, Timing belt x1)

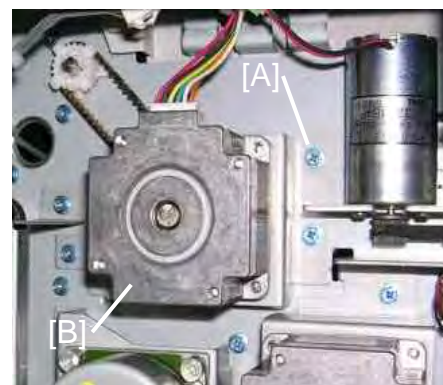

Upper Tray Junction Gate Motor

- Rear cover (☛1.1.4)
- [A] Upper tray junction gate motor(☛ x2, ☛x1)

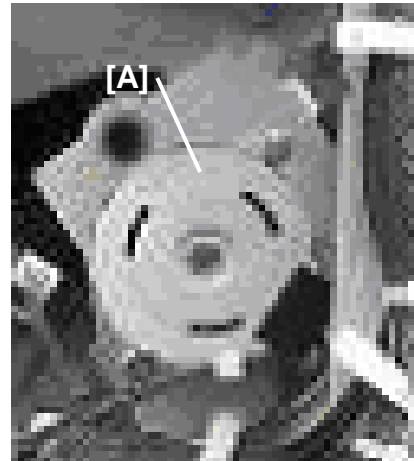

Finisher
B830

1.9.3 PRE-STACK MOTORS

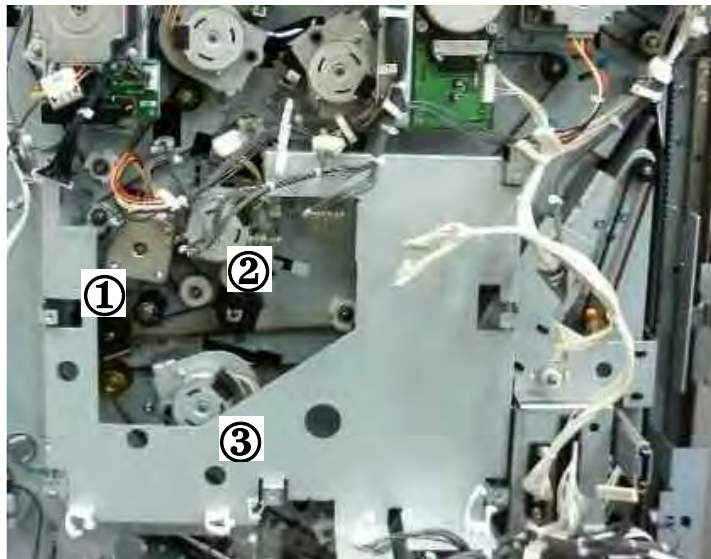

The photograph above shows the main control board removed (⚙️ x4, 🛠️ x All).

①	Pre-Stack Transport Motor
②	Pre-Stack Junction Gate Motor
③	Pre-Stack Stopper Motor

Pre-Stack Transport Motor

- Rear cover (👉1.1.4)
 - Main control board bracket
(⚙️ x4, 🛠️ x All, 🔍x8)
 - Motor unit (⚙️ x2, 🛠️ x1)
- [A] Pre-stack transport motor (⚙️ x2)

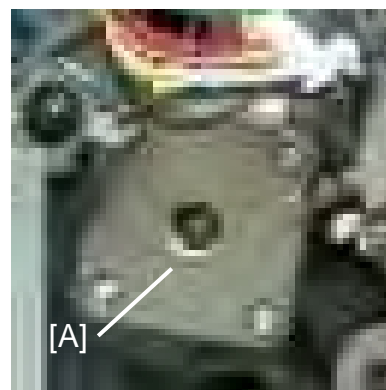

Pre-Stack Junction Gate Motor

- Rear cover (☛1.1.4)
- Main control board bracket
(🔩 x4, 📏 x All, 📏x8)

[A] Pre-stack junction gate motor (🔩 x2, 📏x1, 📏 x1)

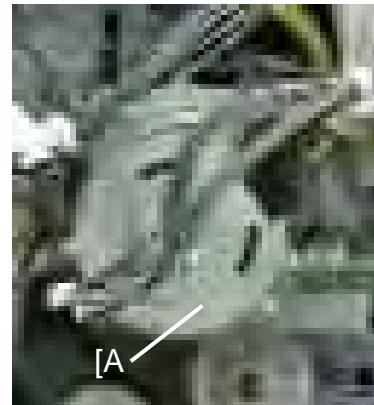

Pre-Stack Stopper Motor

- Rear cover (☛1.1.4)
- Main control board bracket (🔩 x4, 📏 x All, 📏x8)

[A] Pre-stack stopper motor (🔩 x2, 📏x1, 📏 x1)

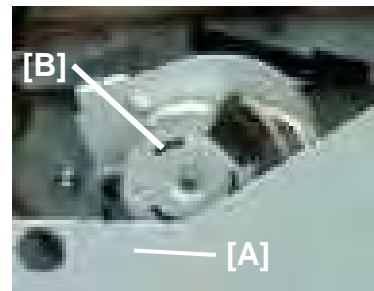

Finisher
B830

1.9.4 PUNCH MOTOR

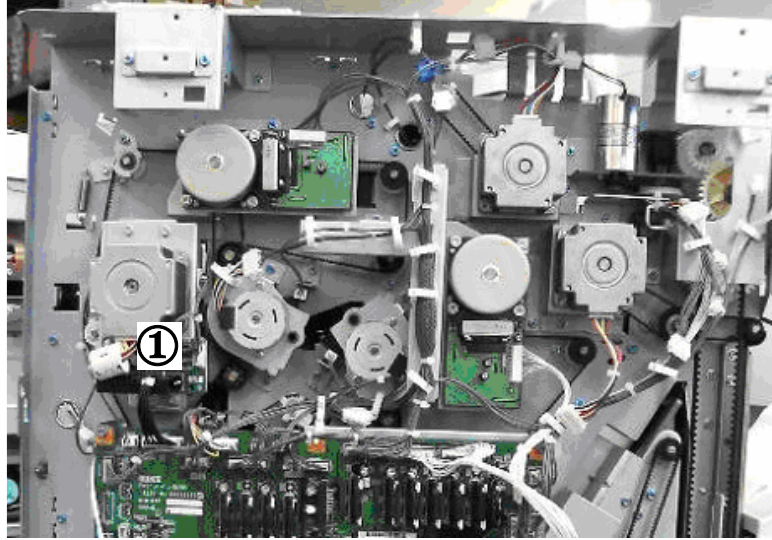

①	Punch Motor
---	-------------

Punch Motor

- Rear cover (☛1.1.4)
- [A] Punch motor bracket (🔩 x3, ⏏x2, 📏 x1, Timing belt x1)
- [B] Punch motor (🔩 x2)

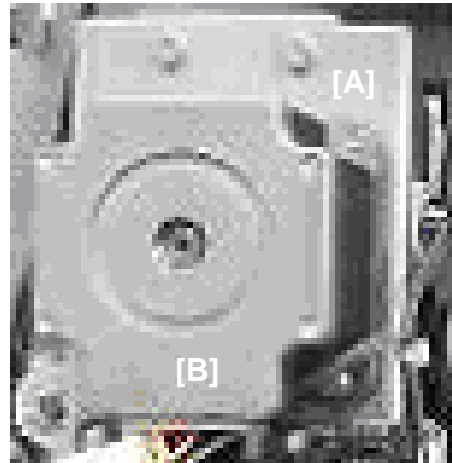

1.9.5 STAPLE MOTORS

*

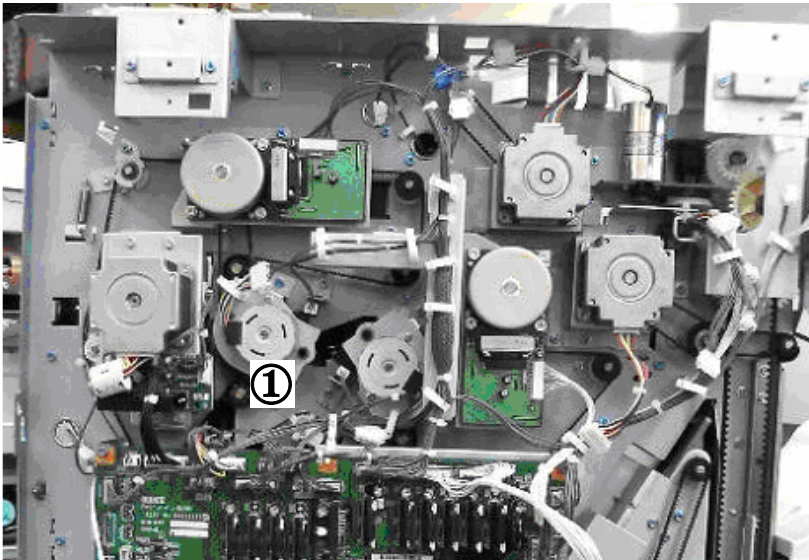

① Staple Junction Gate Motor

Finisher
B830

Staple Junction Gate Motor

- Rear cover (☛1.1.4)
- [A] Staple junction gate motor (🔧 x2, ⏪x1, 📡x1)

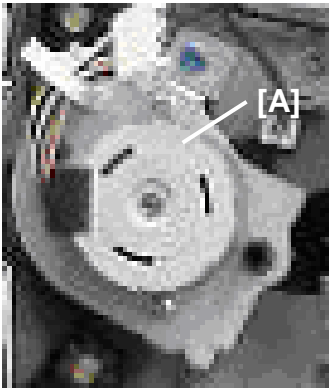

REPLACEMENT AND ADJUSTMENT

Stapler Exit Motor

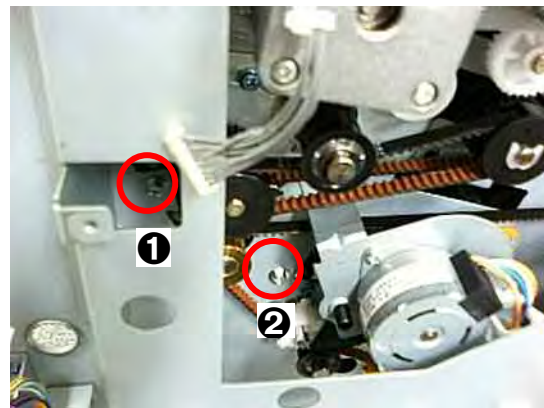

①	Stapler Exit Motor
---	--------------------

- Main control board bracket (🔧 x4, ⬅️ x 8, 📏 x All)
1. Remove the stapler exit motor ① (🔧 x2 ①, ②, 📏 x2, Timing belt x1)

2. SERVICE TABLES

For details about 3000-Sheet Finisher B830 SP codes, please refer to “5. Service Tables” in the main machine service manual.

2.1 DIP SWITCHES

DIP SW100

This DIP SW100 settings are for designer and factory use only. Do not change them.

DIP SW 101: 1 to 4

DPS100				Description
1	2	3	4	
0	0	0	0	Default
1	0	0	0	Free run: 135 ppm (649 mm/s) A4 LEF, 5 sheets
0	1	0	0	Proof tray free run for durability testing: proof tray + punch + junction gate operation + proof tray output.:
0	0	1	0	Shift free run: Shift mode simulation 136 ppm (649 mm/s) A4 SEF, 5 sheets, continuous punching 110 ppm (515mm/s)
0	0	0	1	Sensor check before shipping, lowering the tray before shipping. DFU . Do not change.

Finisher
B830

2.2 TEST POINTS

100 to 110

No.	Label	Monitored Signal	Comment
TP100	(5V)	+5 V	Used for sensor point testing, lowering the tray to shipping position. DFU .
TP101	(GND)	Ground	
TP102	(RXD)	RXD	
TP103	(TXD)	TXD	

2.3 FUSES

No.	Function
FU100	Protects 24 V.

3. DETAILS

3.1 UPPER TRAY AND STAPLER JUNCTION GATES

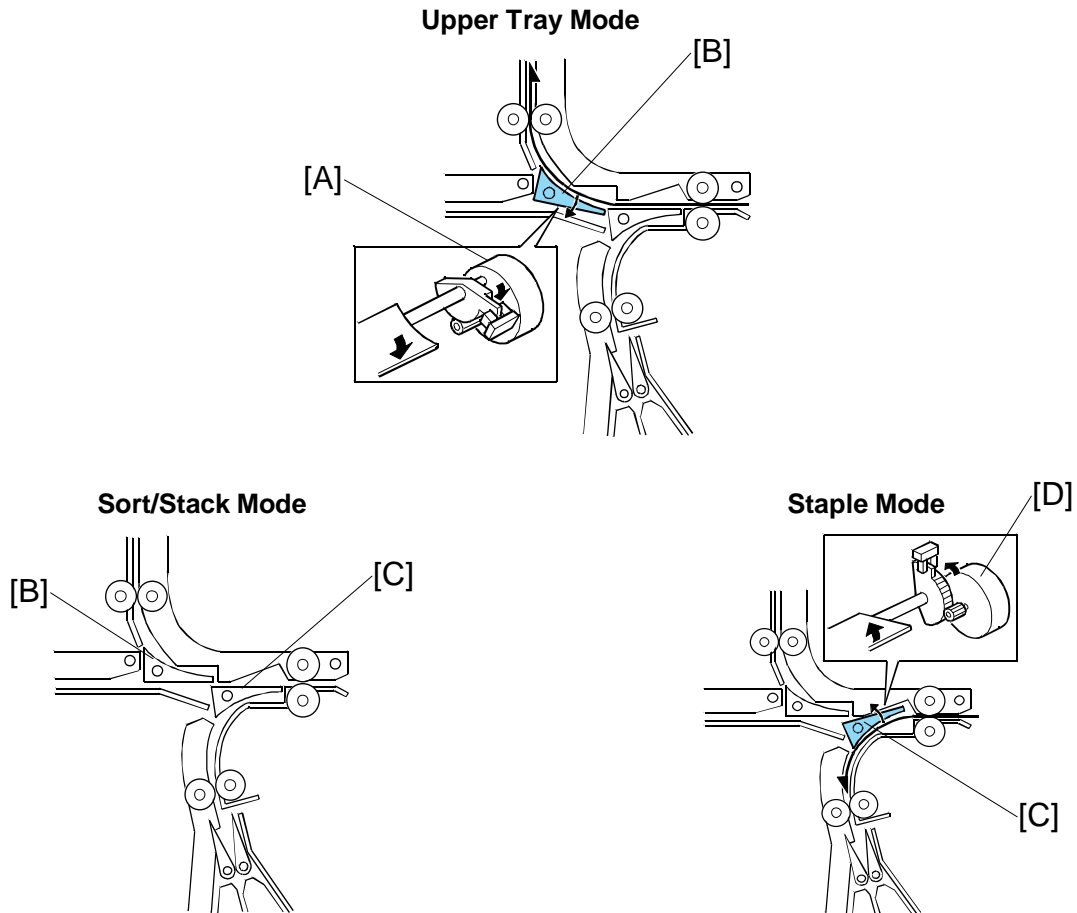

Depending on the finishing mode, the copies are directed up, straight through, or down by the combinations of open and closed junction gates.

Solenoid/Gate		Selected Operation Mode		
		Upper Tray	Sort/Stack	Staple
[A]	Upper tray junction gate motor	ON	Off	Off
[B]	Upper tray junction gate	OPEN	Closed	Closed
[C]	Stapler junction gate	Closed	Closed	OPEN
[D]	Stapler junction gate motor	Off	Off	ON

3.2 PAPER PRE-STACKING

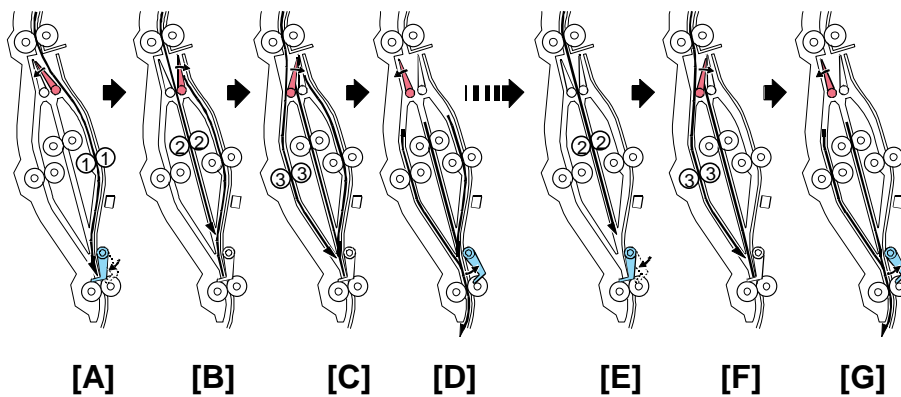

Sequence 1

The first three sheets of each job feed to trays ① → ② → ③ ([A], [B], [C]), then the first three sheets feed together to the staple tray [D].

Sequence 2

Thereafter, the remaining sheets feed to trays ② → ③ ([E], [F]), then the two sheets feed together to the staple tray [G]. Sequence 2 continues until the end of the job.

Junction gate mechanism:

- Three junction gates at the top of the pre-stack tray send the sheet of paper down path ①, ②, or ③.
- The pre-stack junction gate motor controls the junction gates.
- The pre-stack junction gate HP sensor detects when the junction gates are at home position.
- The pre stack paper sensor – left detects paper jams in path ③.
- The pre stack paper sensor – right detects paper jams in path ①.

Stopper mechanism:

- The pre-stack stopper releases the three sheets of paper from the pre-stack tray after the previous set is stapled.
- The pre-stack stopper motor controls the stopper at the bottom of the tray.
- The pre-stack stopper HP sensor detects when the stopper is at home position.

3.3 JOGGER UNIT PAPER POSITIONING

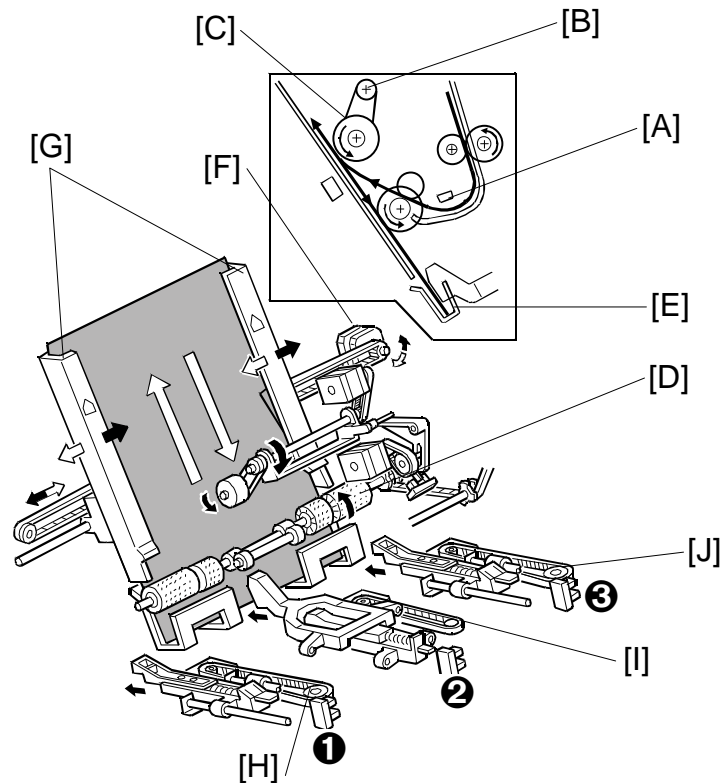

In the staple mode, as every sheet of paper arrives in the jogger unit, it is vertically and horizontally aligned, then the staple edge is pressed flat to ensure the edge of the stack is aligned correctly for stapling.

Vertical Paper Alignment: About 60 ms after the trailing edge of the copy passes the staple tray entrance sensor [A], the positioning roller motor [B] is energized to push the positioning roller [C] into contact with the paper. The positioning roller and alignment brush roller [D] rotate to push the paper back and align the trailing edge of the paper against the stack stopper [E].

Horizontal Paper Alignment: When the print key is pressed, the jogger motor [F] turns on and the jogger fences [G] move to the wait position about 7.2 mm wider than the selected paper size on both sides. When the trailing edge of the paper passes the staple tray entrance sensor, the jogger motor moves the jogger fences 3.7 mm towards the paper. Next, the jogger motor turns on again for 3.5 mm for the horizontal paper alignment then goes back to the wait position.

Paper Stack Correction: After the paper is aligned in the stapler tray, the left [H], center [I], and right [J] stack plate motors switch on briefly and drive the front stack, center stack, and rear stack plates against the edge of the stack to flatten the edge completely against the staple tray for stapling. When the next copy paper turns on the stapler entrance sensor, the stack plate motors turn on and return to their home positions. The home positions are detected by stack plate HP sensors ①, ②, ③.

3.4 STAPLING

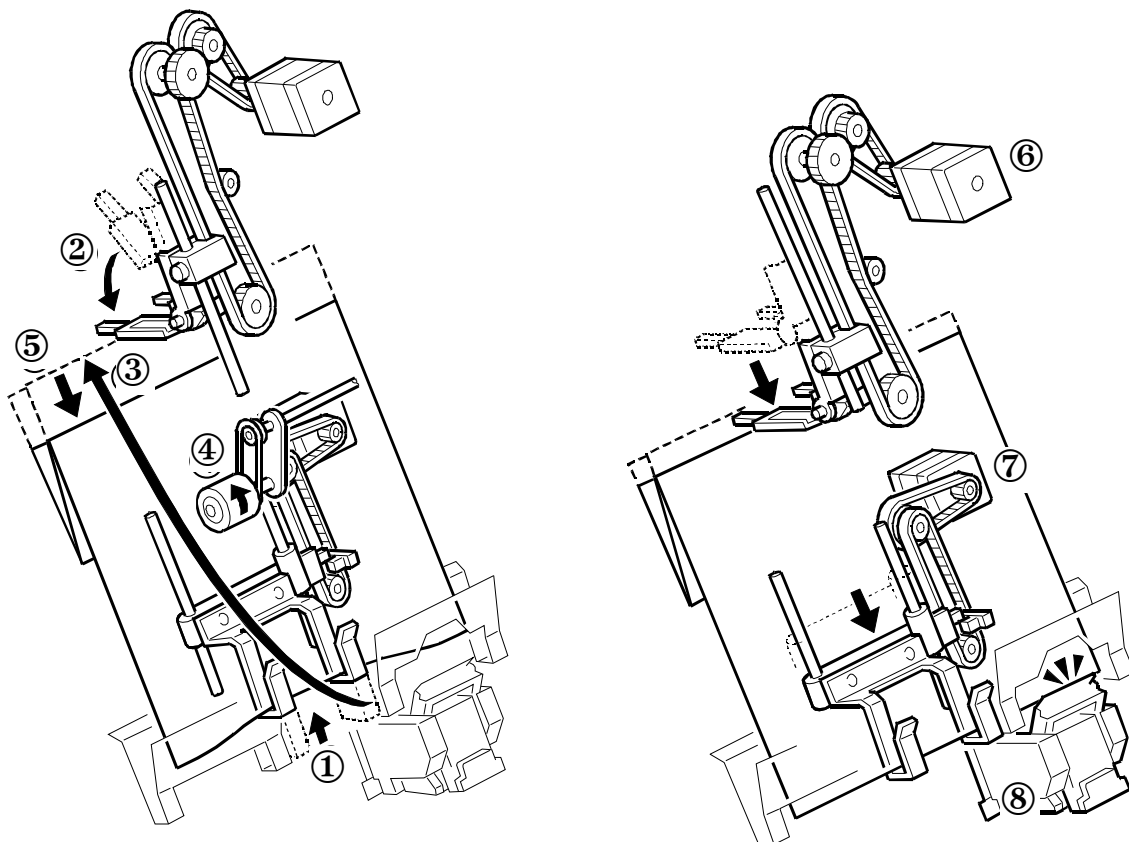

Finisher
B830

Here is the operation sequence for jogging and stapling:

- ① The lower jogger fence lifts to receive the sheets.
- ② The top fence moves down, to the horizontal position.
- ③ A sheet of paper goes into the stapler tray.
- ④ The positioning roller turns when each sheet is fed to the stapler tray.
- ⑤ Each sheet is fed down against the lower jogger fence to align the bottom edge.
- ⑥ After the set number of sheets come in, the top fence motor switches on and lowers the top fence against the top of the stack. This aligns the stack for stapling.
- ⑦ The bottom fence motor lowers the aligned stack to the stapling position.
- ⑧ The stapler staples the stack.

3.5 STAPLER UNIT MOVEMENT

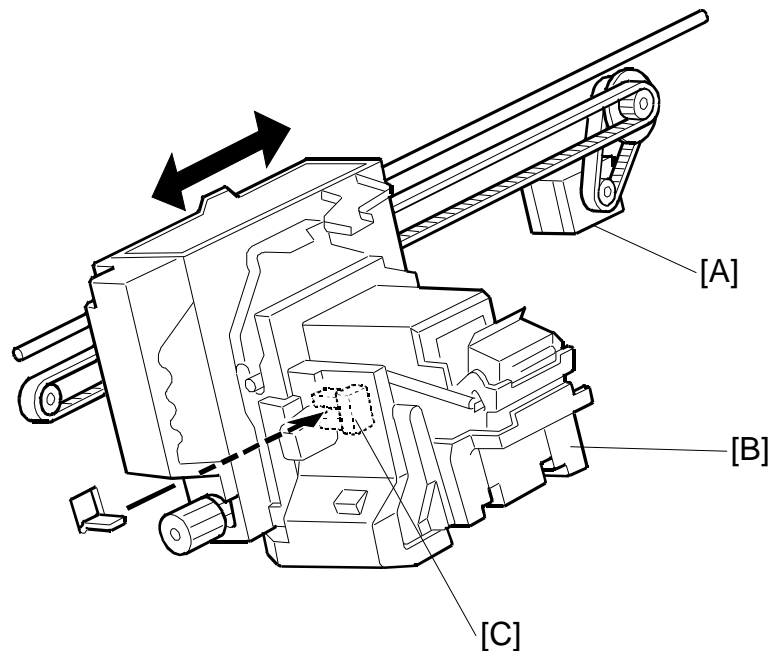

Side-to-Side

The stapler motor [A] moves the stapler [B] from side to side. After the start key is pressed, the stapler moves from its home position to the stapling position.

If two-staple-position mode is selected, for the first stack the stapler moves to the rear stapling position first, staples, moves to the front position, staples and waits at the front. For the second stack, the stapler staples the front corner first, then moves to the rear corner and staples.

NOTE: For continuous stapling jobs, the corners are stapled rear then front for the odd number stacks and stapled front then rear for even number stacks.

After the job is completed, the stapler returns to its home position. This is detected by the stapler HP sensor [C].

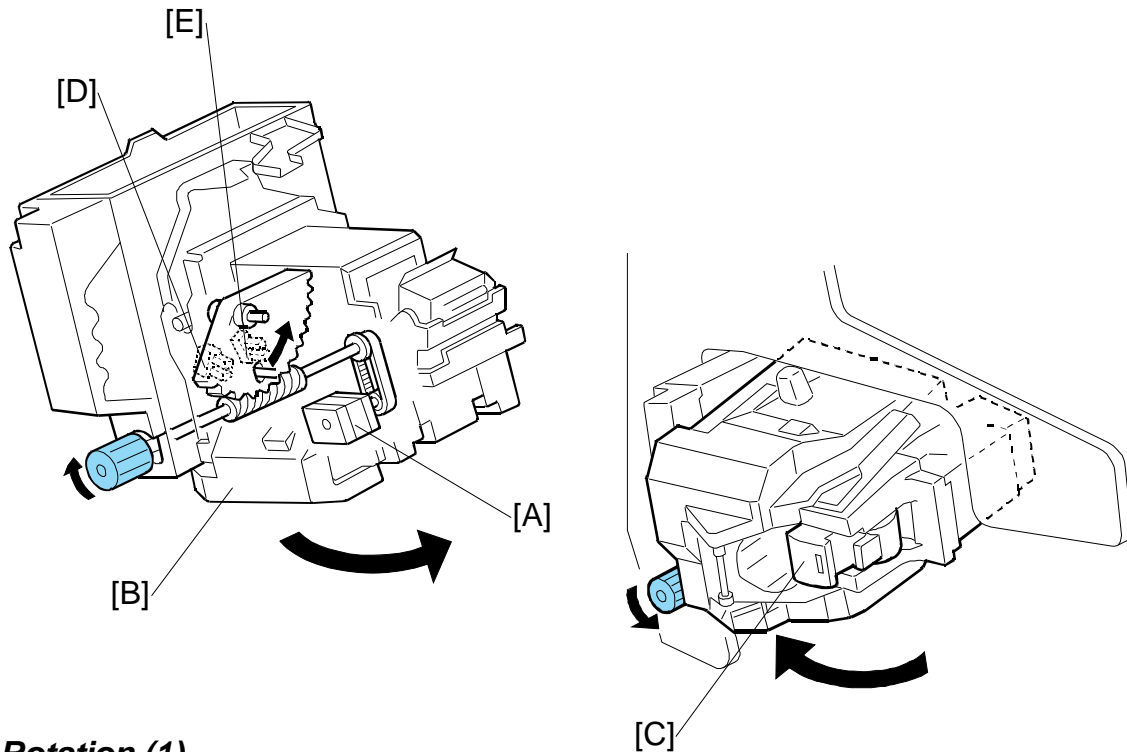

Rotation (1)

In the oblique staple position mode, the stapler rotation motor [A] rotates the stapler unit [B] 45° to counterclockwise after it moves to the stapling position.

Rotation (2)

When the staple end condition arises, the stapler motor moves the stapler to the front and the stapler rotation motor rotates the stapler unit to clockwise to remove the staple cartridge [C]. This allows the user to add new staples.

Once the staples have been installed, and the front door closed, the stapler unit returns to its home position.

Sensors

Two sensors [D] and [E] detect the angle of the stapler. There are three positions: horizontal, 45 degrees, 75 degrees.

Finisher
B830

3.6 STAPLER

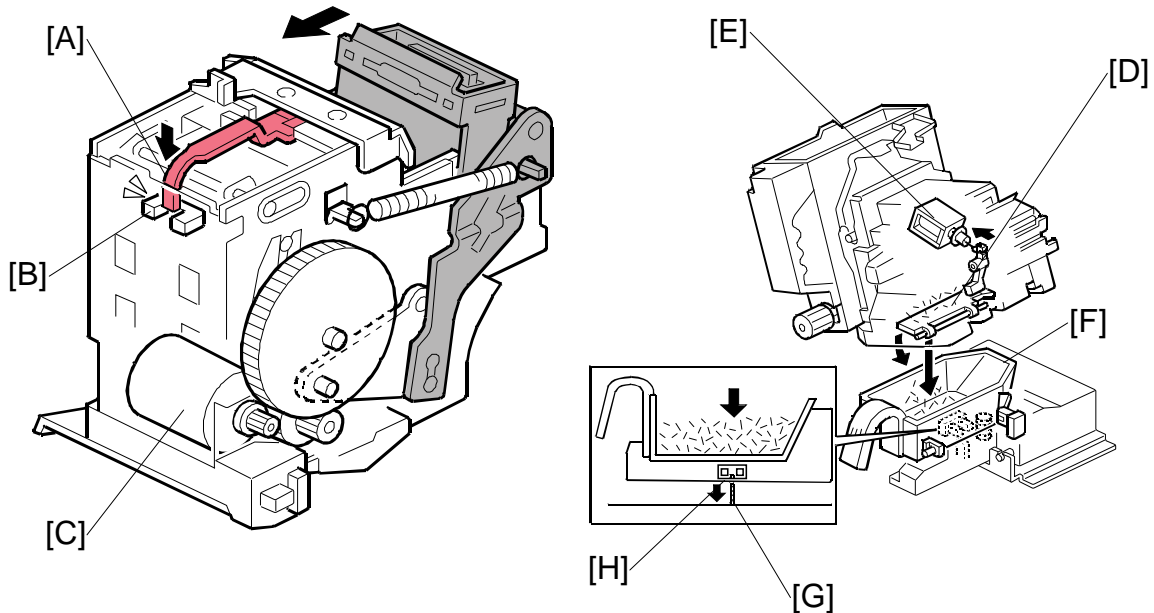

When the stapler cartridge is locked and in position, actuator [A] deactivates the cartridge set sensor [B] and the stapler is ready for operation.

When aligned copies are brought to the stapling position by the positioning roller and jogger fences, the staple hammer motor [C] starts stapling.

During stapling, the stapler trims off the excess length of the staples. This length of the trimmings depends on the number of copies in the set. They will be very small for a stack containing 100 sheets.

The staple trimmings drop into the trap door [D] inside the stapler. When the stapler unit returns to its home position, solenoid [E] energizes opens the trap door.

The staple trimmings drop into the staple trimmings hopper [F].

The staple trimmings hopper descends as it fills, until actuator [G] activates the staple trimmings hopper full sensor [H]. A message asks the user to empty the staple trimmings.

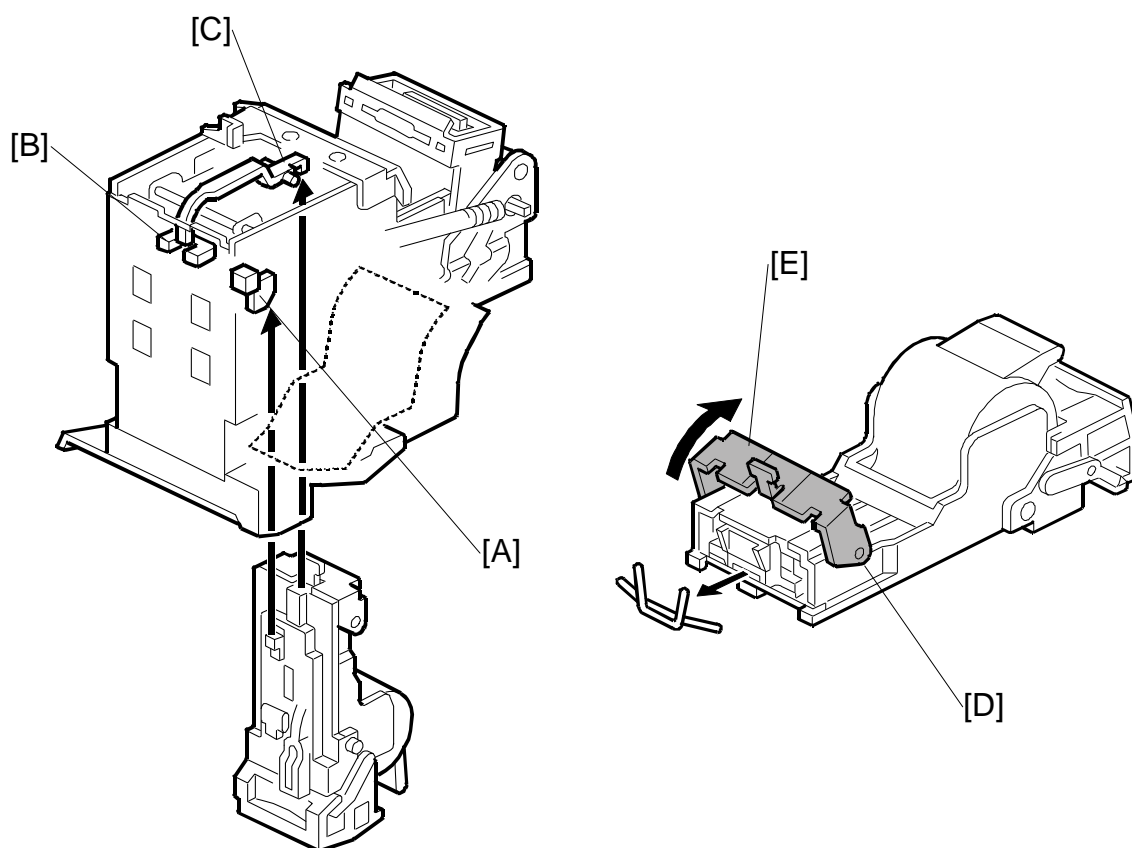

The stapler has a staple end sensor [A] and cartridge set sensor [B]. When the staple cartridge is inserted, it pushes the actuator [C] into the gap of the cartridge set sensor. This tells the machine the stapler is ready for operation.

When a staple end or no cartridge condition is detected, a message is displayed advising the operator to install a staple cartridge. If this condition is detected during a copy job, the indication will appear, and the copy job will stop.

The staple cartridge has a clinch area [D] where jammed staples collect. The operator can remove the jammed staples from the clinch area by raising and lowering bracket lever [E].

3.7 FEED-OUT

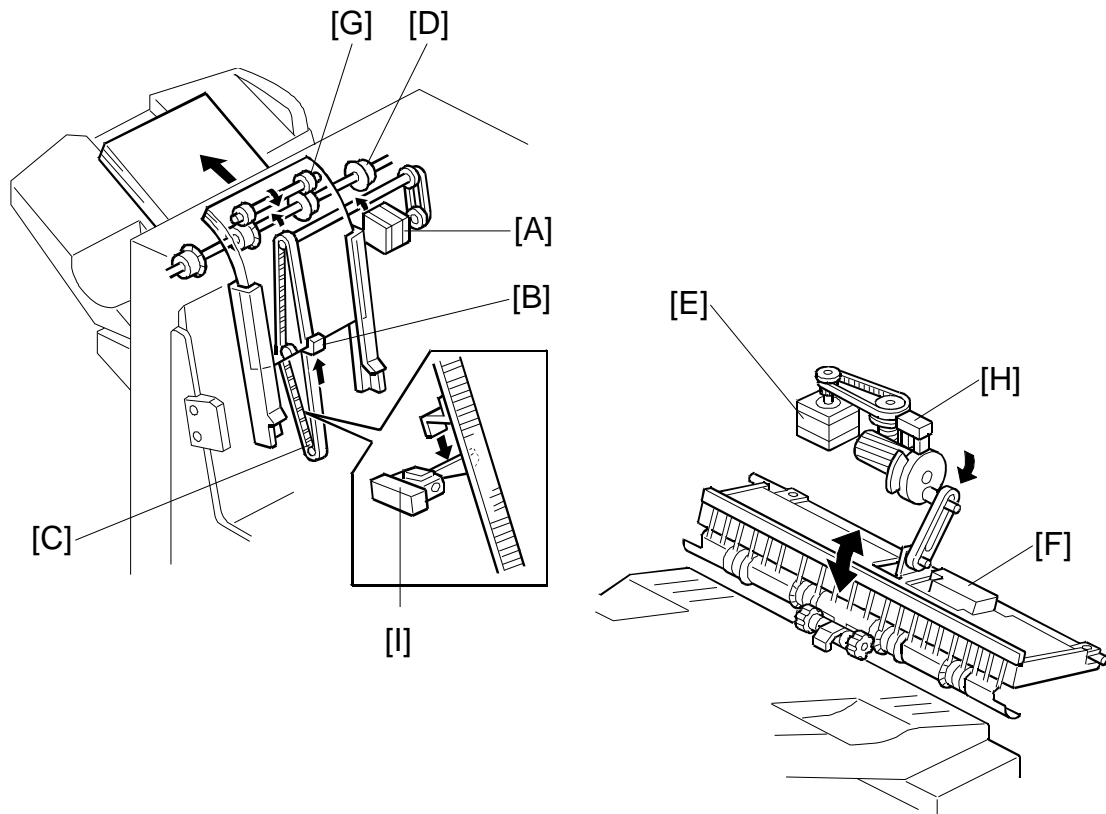

After the copies have been stapled, the stack feed-out motor [A] starts.

The pawl [B] on the stack feed-out belt [C] transports the set of stapled copies up and feeds it to the shift tray exit roller [D].

When stapling starts, the exit guide motor [E] opens the upper exit guide [F], which includes the upper shift tray exit roller [G], in order to feed out the leading edge of the copy set smoothly.

The exit guide motor turns on again at the prescribed time after stapling finishes, and the upper exit guide plate is lowered. Then the shift tray exit roller takes over the stack feed-out.

The on-off timing of the exit guide motor is detected by the exit guide open sensor [H].

The stack-feed-out motor turns off when the pawl actuates the stack feed-out belt home position sensor [I].

3.8 PAPER EXIT STACKING

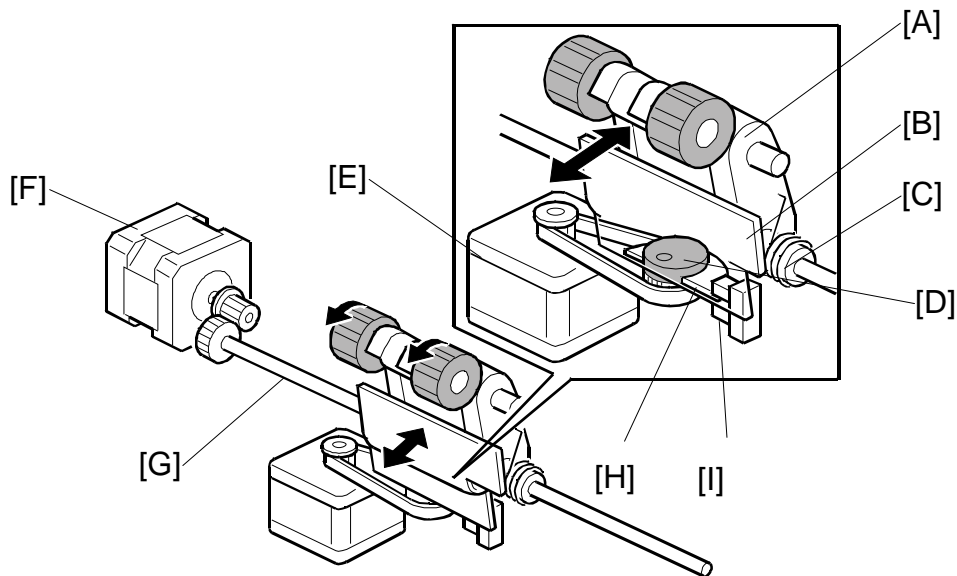

The drag roller assembly [A] is fastened to a plate [B] on a shaft by a spring [C]. The cam [D], in contact with the bottom of the plate, is connected to the drag drive motor [E] via a timing belt.

The drag drive motor and timing belt rotate the cam against the bottom of the plate to move the rollers forward and back with each sheet ejected onto the shift tray.

The drag roller motor [F] drives the shaft [G] that rotates the drag rollers counter-clockwise as the rollers move back. The simultaneous rotation and backward movement of the roller assembly pulls each sheet back toward the copier to align the edges of the stack on the shift tray.

The actuator [H] is mounted on the cam and rotating with both rotating clockwise) and detects the roller assembly home position when the actuator leaves the gap of the drag drive HP sensor [I] and signals the machine that the rollers are at the home position. The machine uses this information to control paper feed timing and confirm that the mechanism is operating correctly. The cam and actuator make one complete rotation for every sheet fed out of the machine onto the shift tray.

3.9 SHIFT TRAY OPERATION

3.9.1 OVERVIEW

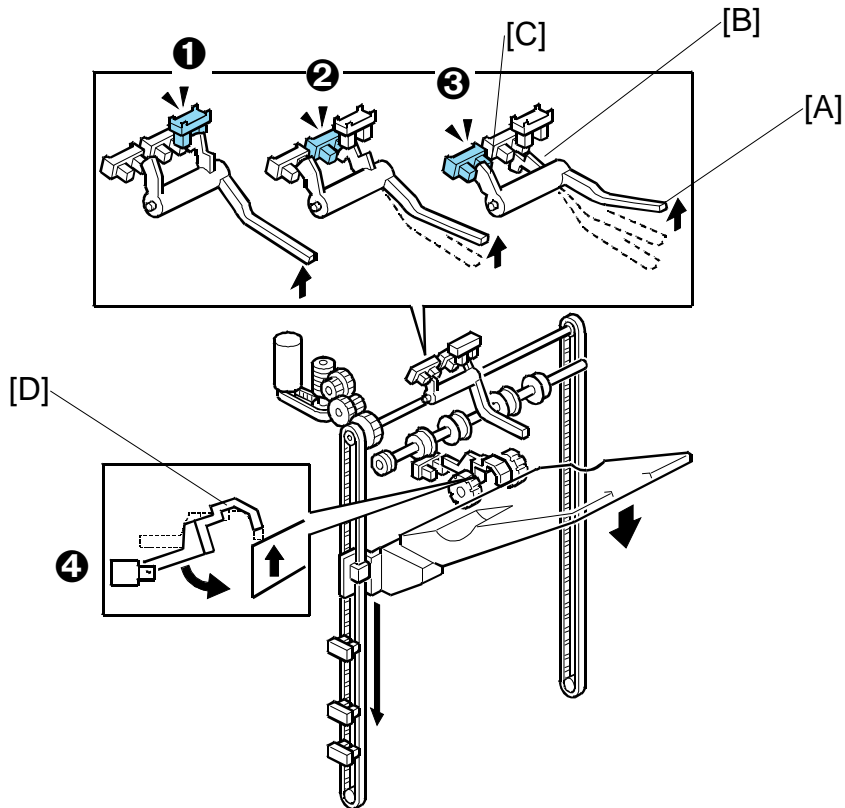

The movement of the shift tray is controlled by four sensors ❶, ❷, ❸, and ❹ and a feeler [A] with two actuators [B] and [C].

- The notched actuator [B] is used with sensors ❶ and ❷.
- The flat actuator [C] is used with sensor ❸.
- Sensor ❹ is provided with its own actuator [D].

The operation mode determines which parts are used to control the movement of the shift tray.

Sensor Names

No.	Name
❶	Paper Height Sensor – Staple Mode
❷	Paper Height Sensor – Standby Mode
❸	Paper Height Sensor – Z-Fold Full
❹	Paper Height Sensor – Shift/Z-Fold

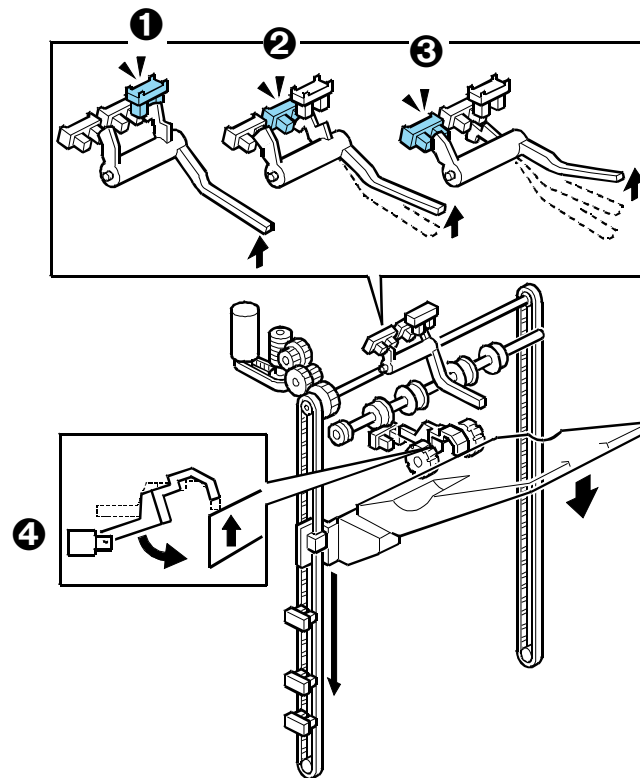

Finisher
B830

Sensors and Operation Modes

Mode	Function
Shift	Sensor ④ detects the amount of paper on the shift tray in shift mode to control operation of the tray lift motor.
Staple	Sensor ① detects the amount of paper on the shift tray in staple mode to control the tray lift motor.
Standby	<ul style="list-style-type: none"> When the machine is turned on, Sensor ② is used to position the tray at the standby position and keep it there when the shift is not in use or when the upper tray (proof tray) is used. If the shift tray is not attached to the machine (if it has been removed for servicing, for example), if the machine is switched on the tray mount will push up the feeler and switch off Sensor ② to switch off the tray lift motor. (Sensor ④ cannot operate if the tray has been removed.)
Z-Fold, Z-Fold Staple	<ul style="list-style-type: none"> Sensor ④ detects the height of the tray when the output includes Z-folded sheets with and without stapling. Sensor ③ detects when the tray is full when the output includes Z-folded sheets with and without stapling.

These operations are described in more detail in the following sections.

3.9.2 SHIFT TRAY OPERATION: STAND-BY MODE

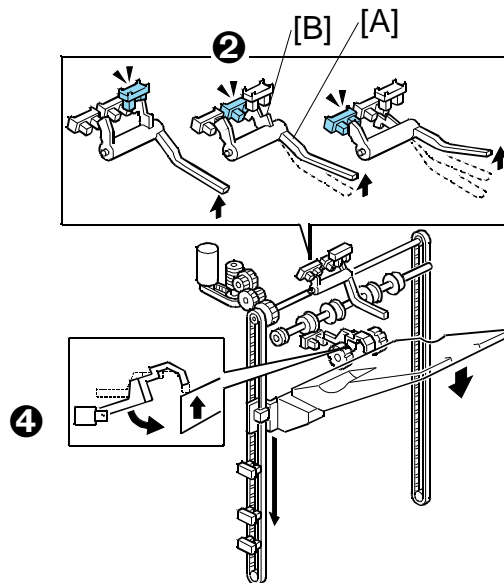

Standby Mode

When the machine is switched on:

1. The shift tray lift motor switches on and lowers the tray.
2. The feeler [A] descends and raises the hooked actuator [B] out of the gap of Sensor 2 and switches Sensor 2 ON.
3. When Sensor 2 switches ON this reverses the shift tray motor.
4. The shift tray motor raises the shift tray and pushes up the feeler, the actuator descends into the gap of Sensor 2, and switches Sensor 2 OFF
5. When Sensor 2 switches OFF, this stops the shift tray lift motor with the shift tray at the standby position.

This sequence repeats every time the machine is powered on.

Sensor 2 also switches off the shift tray lift motor when the machine is switched on with the shift tray removed for servicing. When the machine is switched on without the shift tray attached to the side of the finisher:

1. The shift tray mount will push the feeler [A] up until the actuator [B] enters the gap of Sensor 2 and switches Sensor 2 ON.
2. When Sensor 2 switches ON this switches the shift tray motor OFF and stops the tray.

NOTE: Sensor 2 cannot operate with the shift tray removed so Sensor 2 is used to switch off the shift tray motor and stop the shift tray mount.

3.9.3 SHIFT TRAY OPERATION: SHIFT MODE

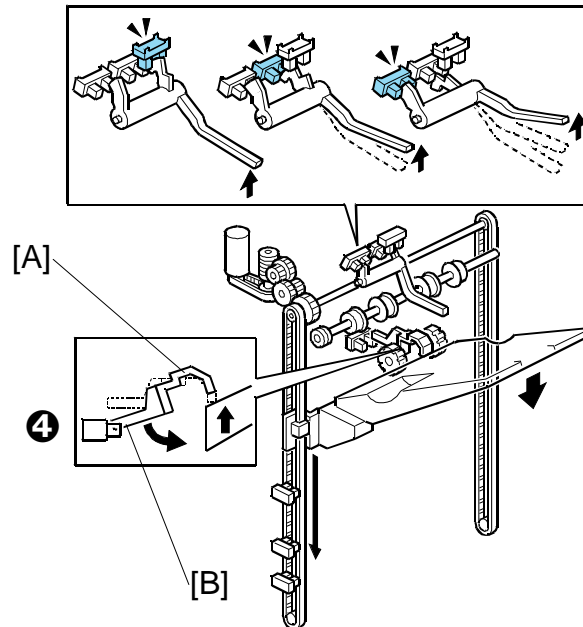

Sensor ④ and its feeler [A] and actuator [B] control the movement of the shift tray when paper is output in the sort/stack mode:

1. Paper is output to the tray.
2. As the height of the stack increases, this pushes up the feeler [A].
3. When the actuator [B] of the ascending feeler actuates Sensor ④, this switches the sensor OFF and switches the tray lift motor ON.
4. The tray lift motor lowers the tray until the feeler descends far enough to raise the actuator out of the gap of Sensor ④.
5. When the actuator leaves the gap of Sensor ④, this switches Sensor ④ ON, switches the motor OFF, and stops the tray.

The sequence repeats until the end of the job or until the tray becomes full.

(☛3.9.6)

3.9.4 SHIFT TRAY OPERATION: STAPLE MODE

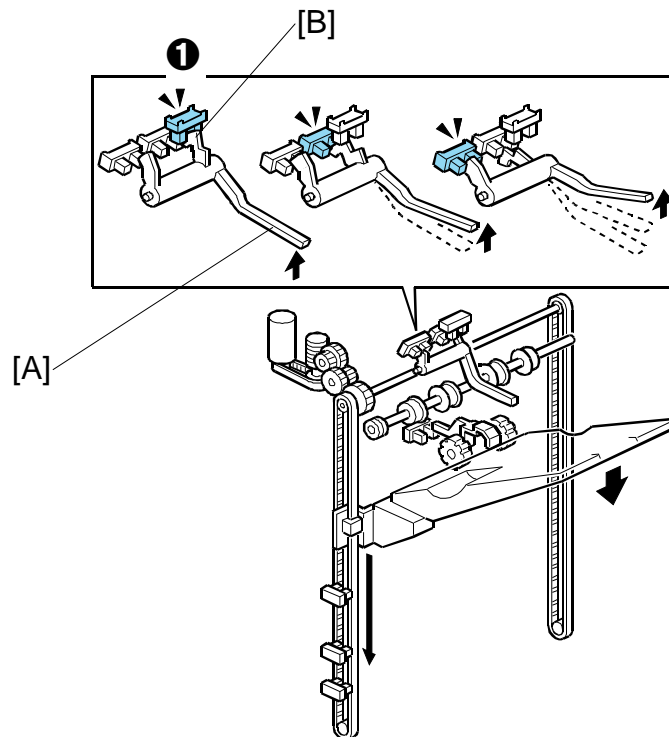

Sensor ❶, feeler [A] and its notched actuator [B] control the movement of the shift tray when paper is output to the shift tray in the staple mode:

1. A stapled stack is output to the tray.
2. The tray lift motor switches ON and lowers the tray the prescribed distance.
3. Next, the tray lift motor raises the tray and feeler [A] until actuator [B] leaves the gap of Sensor ❶.
4. When the actuator [b] leaves the gap of sensor ❶, this switches Sensor ❶ OFF and switches the tray lift motor OFF.

This sequence repeats every time a stack is output to the tray until the end of the job or until the tray becomes full. (➡3.9.6)

3.9.5 SHIFT TRAY OPERATION: Z-FOLDED PAPER

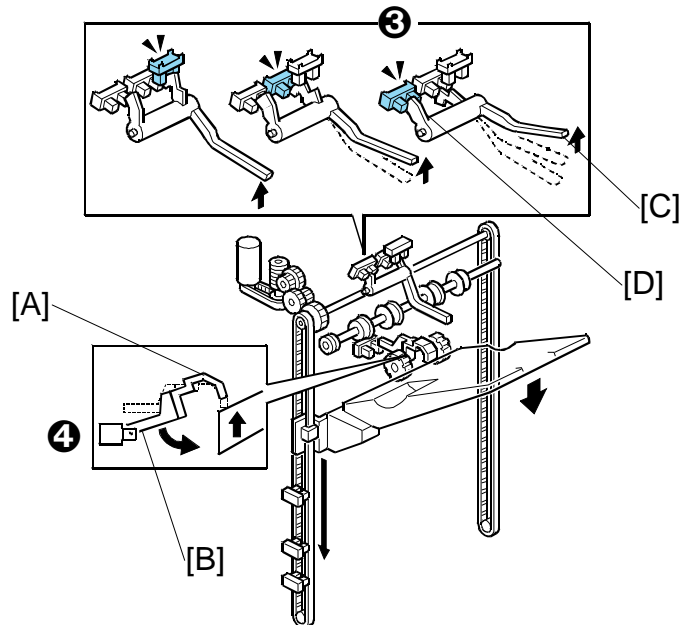

Sensor ④ and its feeler [A] and actuator [B], and Sensor ③ with its feeler [C] and flat actuator [D] control the movement of the shift tray when Z-folded paper is output to the shift tray.

1. Z-folded paper is output to the tray.
2. As the height of the stack increases, this pushes up feeler [A] of Sensor ④.
3. When the actuator [B] of the ascending feeler enters the gap of Sensor ④, this switches the sensor OFF and switches the tray lift motor ON.
4. The tray lift motor lowers the tray until the feeler descends far enough to raise the actuator out of the gap of Sensor ④.
5. When the actuator leaves the gap of Sensor ④, this switches Sensor ④ ON, switches the motor OFF, and stops the tray.
6. Steps 1 to 5 repeat until the top of the paper stack pushes feeler [C] up and actuator [C] into the gap of Sensor ③.
7. When the actuator enters the gap of Sensor ③, this switches the sensor off and switches Sensor ③ OFF, signals that the tray is full and stops the job.

Finisher
B830

3.9.6 SHIFT TRAY FULL AND NEAR-FULL DETECTION

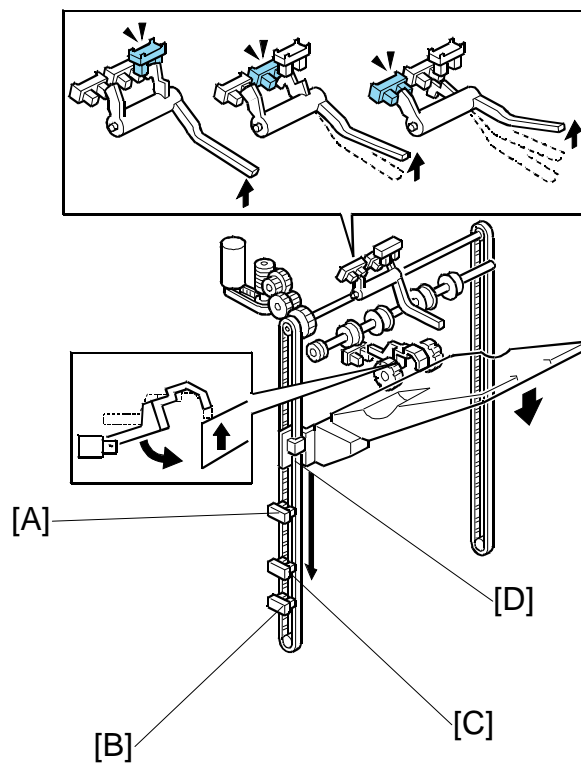

This machine has two shift tray full sensors: the shift tray full sensor (large paper) [A] for B4 and larger, and the shift tray full sensor [B] for small paper (smaller than B4).

NOTE: Sensor [C] (S20) is the near-full sensor.

When the actuator [D] enters sensor [A] while using large paper (about 1500 sheets are on the tray), a message will be displayed and copying will stop.

When the actuator [D] enters sensor [B] while using small paper (about 3,000 sheets are on the tray), a message will be displayed and copying will stop.

3.10 SHIFT TRAY SIDE-TO-SIDE MOVEMENT

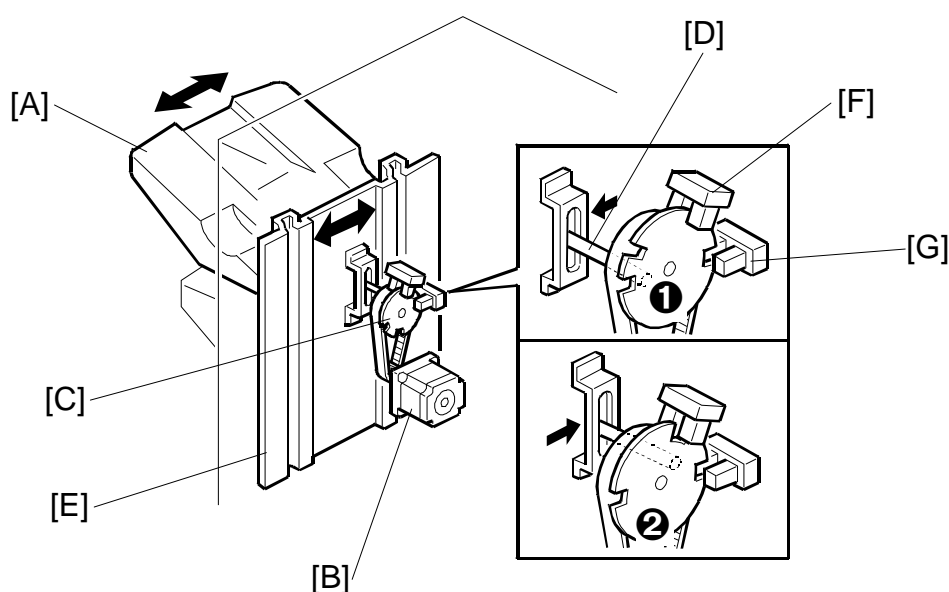

In sort/stack mode, the shift tray [A] moves from side to side to separate the sets of copies.

The horizontal position of the shift tray is controlled by the shift motor [B] and shift gear disk [C]. After one set of copies is made and delivered to the shift tray, the shift motor turns on, driving the shift gear disk and the shaft [D]. The end fence [E] is positioned by the shaft, creating the side-to-side movement.

The next set of copies is then delivered. The motor turns on, repeating the same process and moving the tray back to the previous position.

The disk is rotated alternately clockwise and counter-clockwise through an arc of 180 degrees.

The notches cut into the shift gear disk control the operation of the shift motor, using shift tray half-turn sensors [F] and [G].

If the job ends with the disk at ❶ with only one sensor deactivated, the motor rotates the disk to the ❷ position where both sensors are deactivated. This is the home position.

3.11 PUNCH UNIT

3.11.1 PUNCH UNIT DRIVE

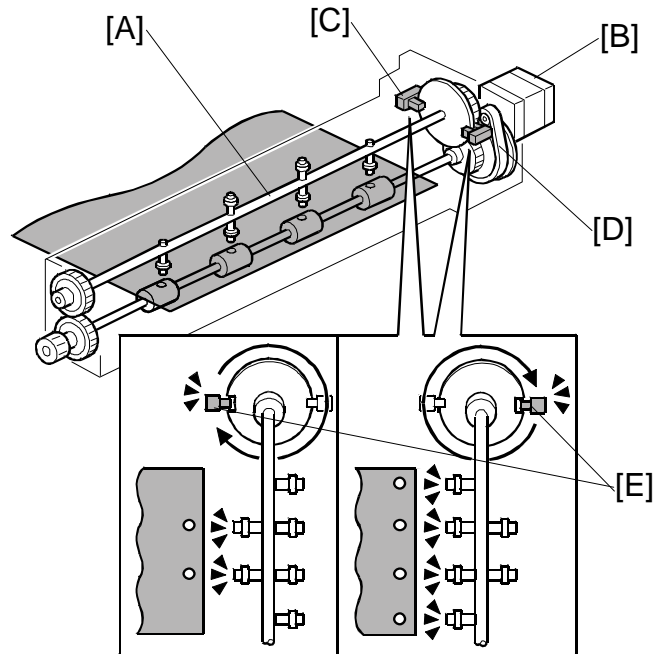

The punch unit makes 2 or 3 holes at the trailing edge of the paper. The number of holes depends on a selection made on the operation panel.

The cam [A] has 2 punches on one side and 3 punches on the other, and is turned by the punch motor [B]. The punch motor turns on immediately after the trailing edge of the paper passes the entrance sensor. The punches on the cam rotate downward and punch holes in the paper.

After punching a sheet of paper, the cam returns to home position and stops. Home position depends on whether 2 holes or 3 holes are being made, so there are two punch HP sensors. Punch HP sensor 1 [C] is used when 2-hole punching is selected, and punch HP sensor 2 [D] is used when 3-hole punching is selected. When the cut-out [E] enters the slot of the punch HP in use (sensor 1 or 2-hole punching) the motor stops.

The knob (not shown) on the front end of the punch unit can be turned in either direction to clear paper jammed in the punch unit.

3.11.2 PUNCH WASTE COLLECTION

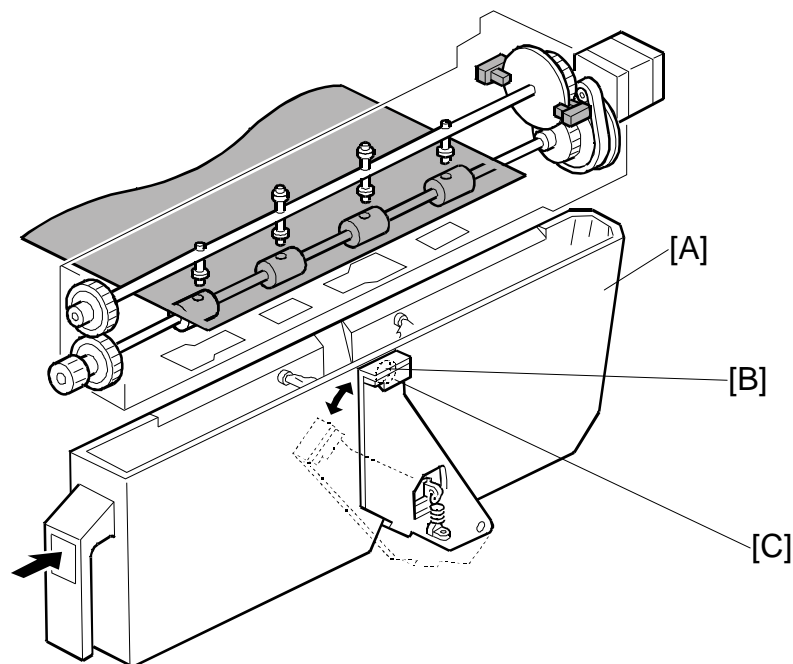

Punch waste is collected in the punch waste hopper [A] positioned under the punch unit.

When the level of the punch waste in the hopper rises as far as the hole [B] in the hopper, the punch hopper full sensor [C] turns on, stops the job, and triggers a message on the operation to indicate that the hopper is full and must be removed and emptied.

The job resumes automatically after the hopper is emptied and returned to the finisher.

The punch hopper full sensor also functions as the hopper set sensor. When the hopper is not in the finisher, or if it is not inserted completely, the spring loaded sensor arm rotates up and to the right with the punch waste sensor away from the hole in the hopper holder and a message is displayed. The message in this case is the same as the hopper full message.

3.12 SHIFT TRAY JOGGER UNIT

3.12.1 JOGGER UNIT MECHANICAL LAYOUT

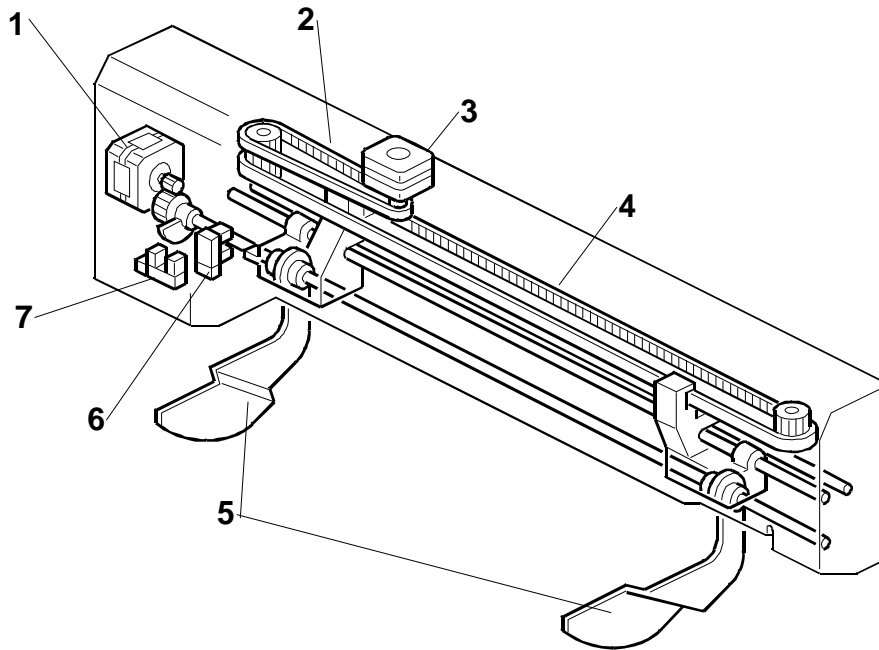

1. Shift Tray Jogger Retraction Motor
2. Shift Tray Jogger Motor Timing Belt
3. Shift Tray Jogger Motor
4. Shift Tray Jogger Fence Timing Belt
5. Shift Tray Jogger Fences
6. Shift Tray Jogger HP Sensor
7. Shift Tray Jogger Lift HP Sensor

3.12.2 JOGGER UNIT DRIVE

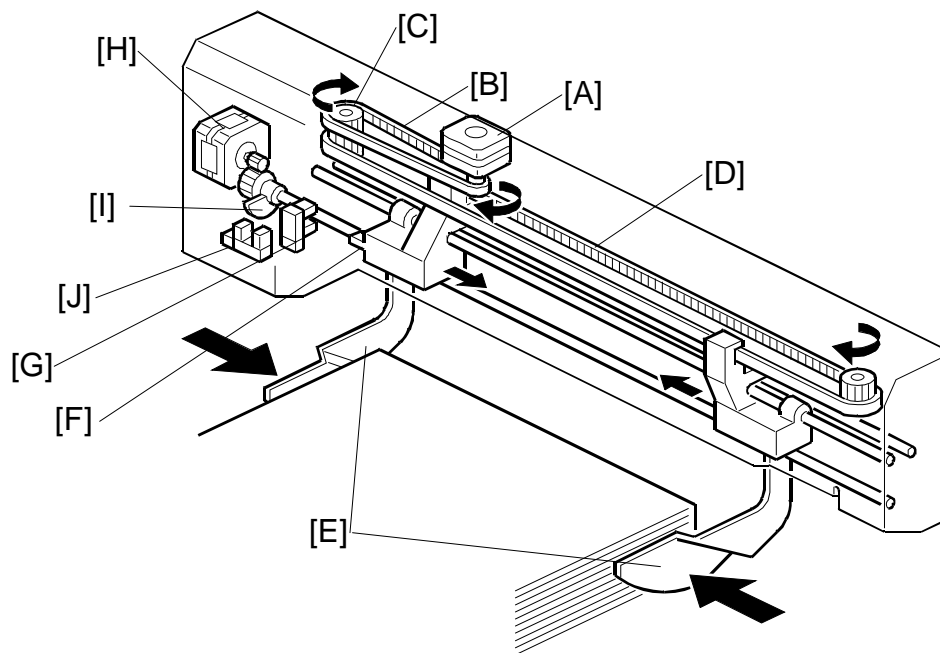

After the first sheet exits, the shift tray jogger motor [A] switches on and rotates the jogger timing belt [B], gear [C] and jogger fence timing belt [D]. This closes the jogger fences [E] against the sides of the first sheet to align it and stops. Next, the motor reverses to open the fences for the next sheet. The jogger motor alternates its direction of rotation to open and close the jogger fences. The timing is prescribed by the width of the paper selected for the job.

At the end of the job, the actuator [F] activates the shift tray jogger HP sensor [G] which shuts off the jogger motor and starts the jogger fence retraction motor [H].

The jogger fence retraction motor rotates the shaft which raises the jogger fences and lowers the actuator [I] into the slot of the jogger fence retraction HP sensor [J]. The activated sensor turns off the jogger fence retraction motor and the jogger fences remain at the raised position.

4. OVERALL MACHINE INFORMATION

4.1 MECHANICAL COMPONENT LAYOUT

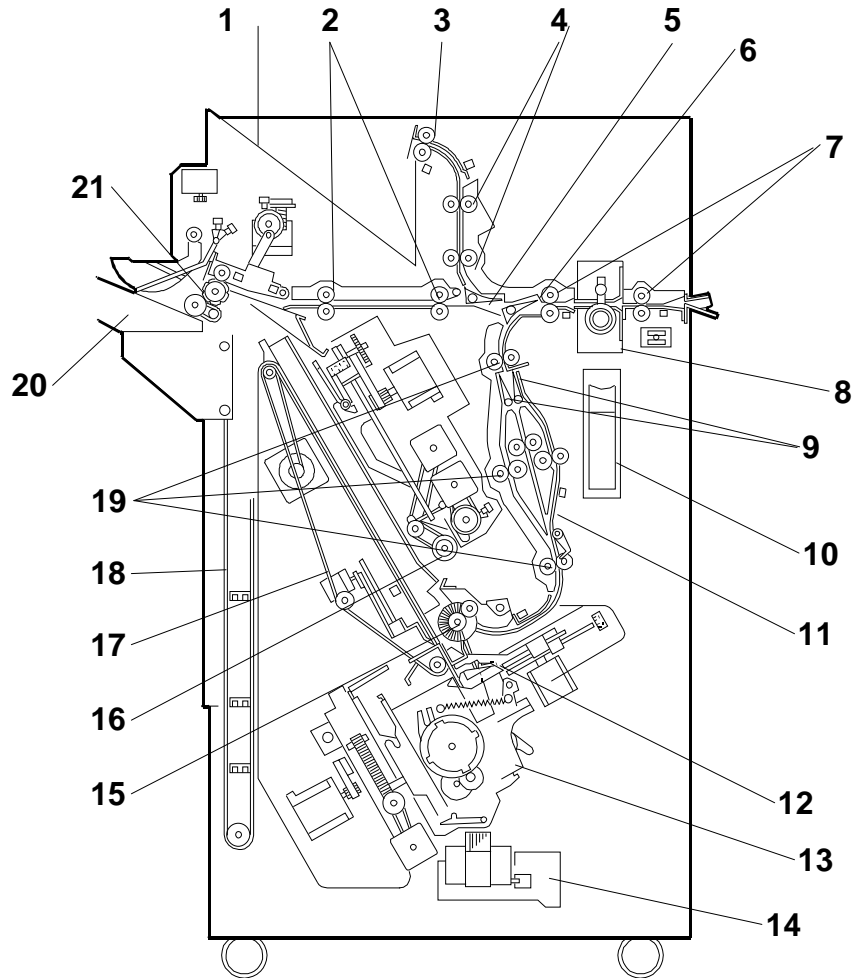

- | | |
|----------------------------------|-----------------------------|
| 1. Upper Tray | 12. Stack Plate |
| 2. Middle Transport Rollers | 13. Stapler |
| 3. Upper Tray Exit Roller | 14. Staple Trimmings Hopper |
| 4. Upper Transport Rollers | 15. Alignment Brush Roller |
| 5. Upper Tray Junction Gate | 16. Positioning Roller |
| 6. Stapler Junction Gate | 17. Stack Feed-out Belt |
| 7. Entrance Rollers | 18. Shift Tray Drive Belt |
| 8. Punch Unit | 19. Lower Transport Rollers |
| 9. Pre-stack Junction Gates (x2) | 20. Shift Tray |
| 10. Punch Waste Hopper | 21. Shift Tray Exit Roller |
| 11. Pre-stack Tray | |

4.2 DRIVE LAYOUT

4.2.1 MAIN DRIVE

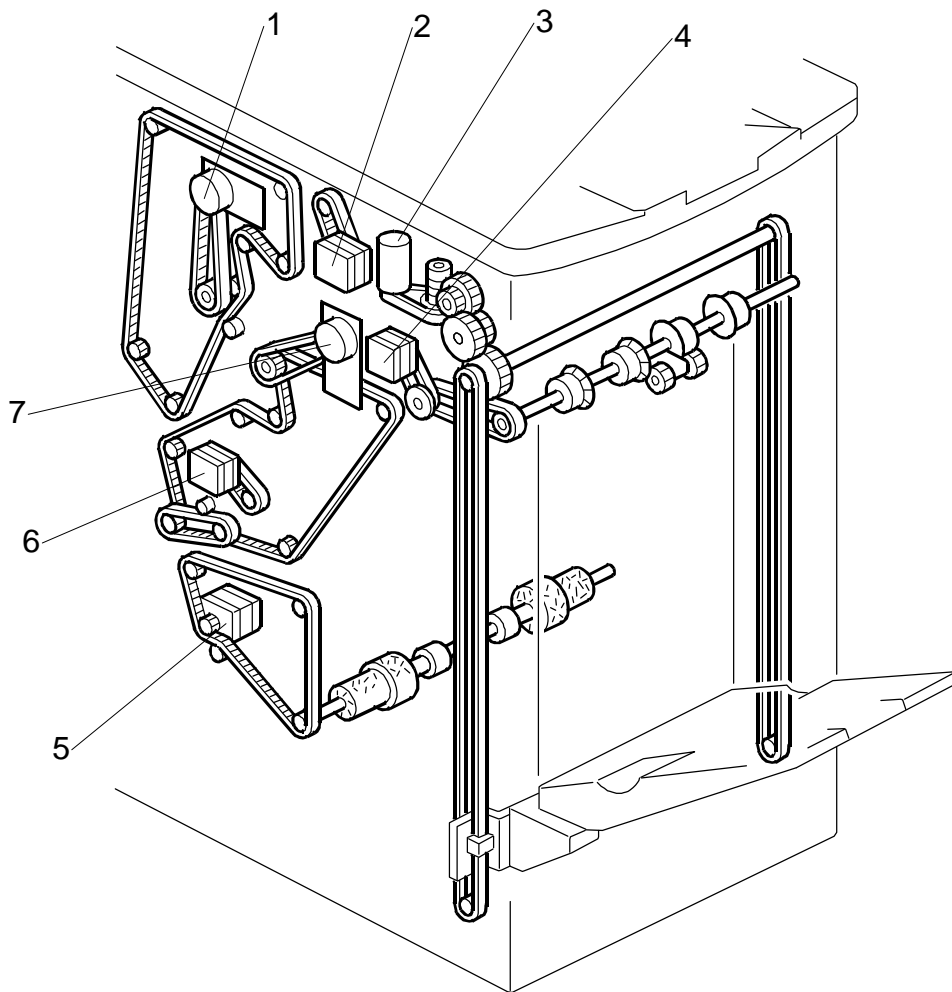

1. Upper Transport Motor
2. Upper Tray Exit Motor
3. Shift Tray Lift Motor
4. Shift Tray Exit Motor
5. Stapler Exit Motor
6. Pre-Stack Transport Motor
7. Lower Transport Motor

Finisher
B830

4.2.2 STAPLING TRAY DRIVE

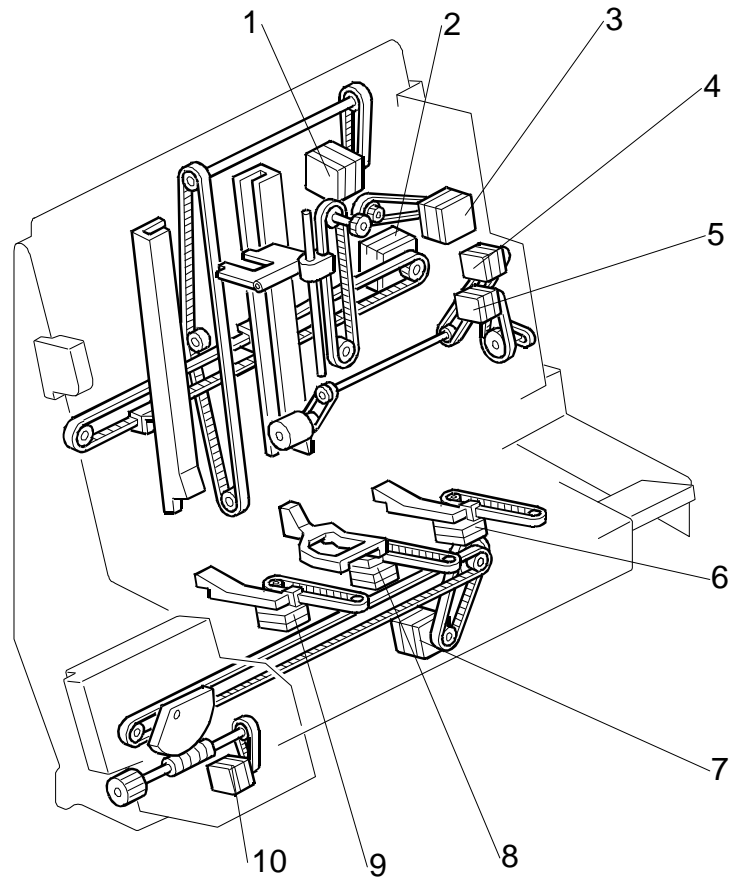

1. Stack Feed-Out Belt Motor
2. Jogger Motor
3. Top Fence Motor
4. Positioning Roller Drive Motor
5. Positioning Roller Motor
6. Stack Plate Motor (Rear)
7. Stapler Movement Motor
8. Stack Plate Motor (Center)
9. Stack Plate Motor (Front)
10. Stapler Rotation Motor

4.3 ELECTRICAL COMPONENTS

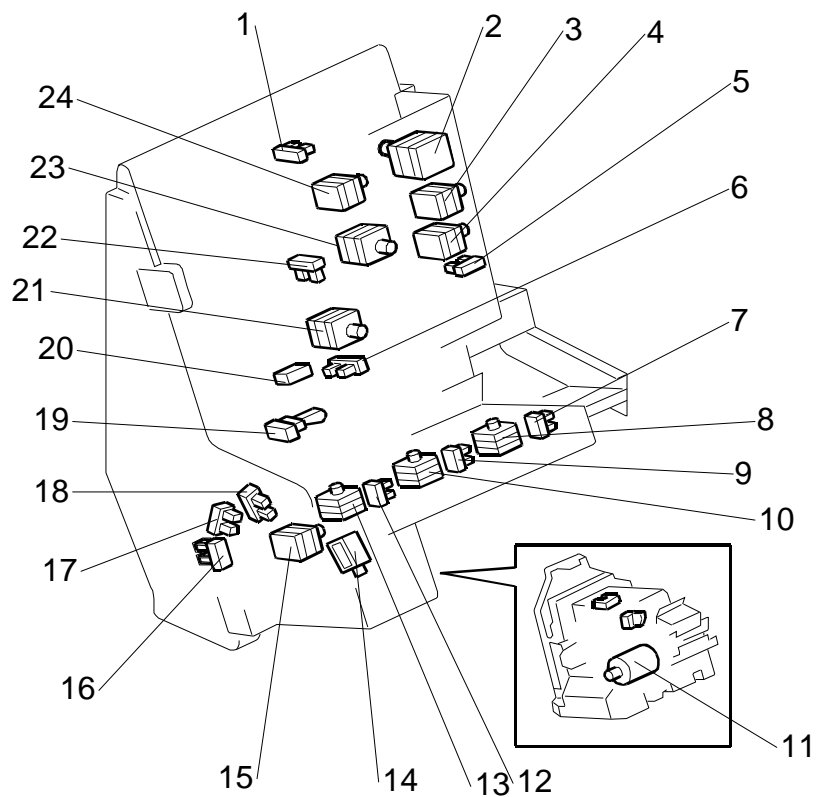

- | | |
|-----------------------------------|------------------------------------|
| 1. Top Fence HP Sensor | 13. Stack Plate Motor (Front) |
| 2. Top Fence Motor | 14. Staple Trimming Chute Solenoid |
| 3. Positioning Roller Drive Motor | 15. Stapler Rotation Motor |
| 4. Positioning Roller Motor) | 16. Stapler HP Sensor (Front/Rear) |
| 5. Positioning Roller HP Sensor | 17. Stapler Rotation Sensor 2 |
| 6. Bottom Fence HP Sensor | 18. Stapler Rotation Sensor 1 |
| 7. Stack Plate HP Sensor (Rear) | 19. Stack Feed-Out Belt HP Sensor |
| 8. Stack Plate Motor (Rear) | 20. Staple Tray Full Sensor |
| 9. Stack Plate HP Sensor (Center) | 21. Bottom Fence Motor |
| 10. Stack Plate Motor (Center) | 22. Jogger HP Sensor |
| 11. Staple Hammer Motor | 23. Jogger Motor |
| 12. Stack Plate HP Sensor (Front) | 24. Stack Feed-Out Belt Motor |

Finisher
B830

OVERALL MACHINE INFORMATION

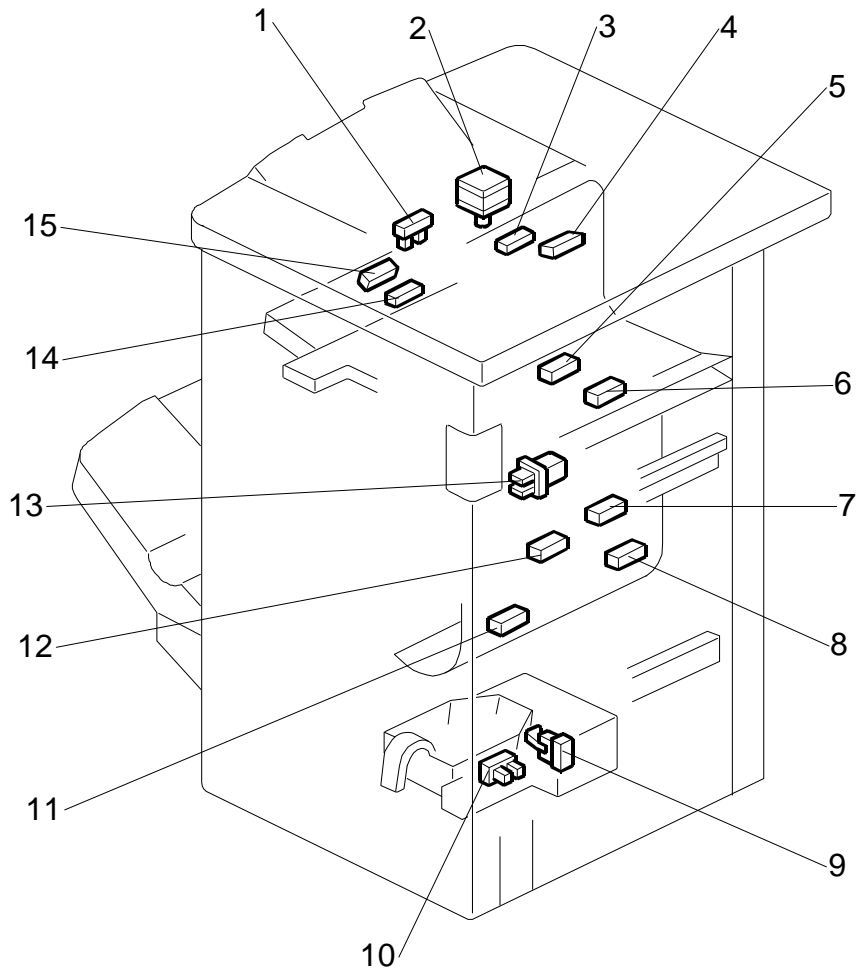

- | | |
|---------------------------------------|---|
| 1. Exit Guide HP Sensor | 9. Staple Trimmings Hopper Set Sensor |
| 2. Exit Guide Motor | 10. Staple Trimmings Hopper Full Sensor |
| 3. Upper Tray Full Sensor | 11. Stapler Tray Exit Sensor |
| 4. Upper Tray Exit Sensor | 12. Pre-Stack Tray Paper Sensor (Right) |
| 5. Stapler Tray Entrance Sensor | 13. Front Door Safety Switch |
| 6. Entrance Sensor | 14. Shift Tray Exit Sensor 2 |
| 7. Punch-Out Hopper Full Sensor | 15. Shift Tray Exit Sensor 1 |
| 8. Pre-Stack Tray Paper Sensor (Left) | |

OVERALL MACHINE INFORMATION

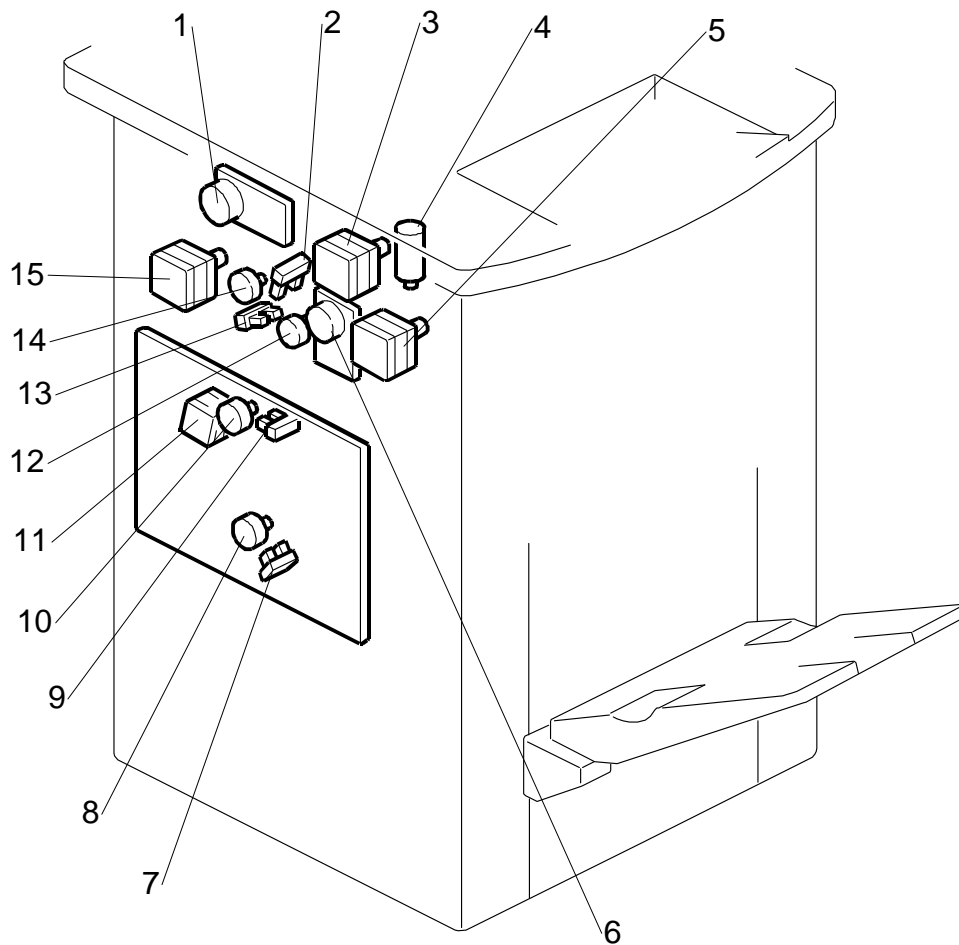

Finisher
B830

1. Upper Transport Motor
2. Stapler Junction Gate HP Sensor
3. Upper Tray Exit Motor
4. Shift Tray Lift Motor
5. Shift Tray Exit Motor
6. Lower Transport Motor
7. Pre-Stack Stopper HP Sensor
8. Pre-Stack Stopper Motor
9. Pre-Stack Junction Gate HP Sensor
10. Pre-Stack Junction Gate Motor)
11. Pre-Stack Transport Motor
12. Upper Tray Junction Gate Motor
13. Upper Tray Junction Gate HP Sensor
14. Stapler Junction Gate Motor
15. Punch Motor

4.4 ELECTRICAL COMPONENT SUMMARY

Motors		
No.	Name	Description
M01	Shift Tray Exit Motor	Drives the exit roller for the shift tray.
M02	Shift Tray Lift Motor	Moves the shift tray up or down.
M03	Exit Guide Motor	Opens and closes the upper exit guide. When stapling starts, the exit guide motor opens the upper exit guide, which includes the upper shift tray exit roller, in order to feed out the leading edge of the copy set smoothly. The exit guide motor turns on again a certain time after stapling is complete, and the upper exit guide plate is lowered. Then the shift tray exit roller takes over the stack feed-out. The on-off timing of the exit guide motor is detected by the exit guide HP sensor.
M04	Stapler Exit Motor	Drives the rollers that feed stapled stacks out of the stapling unit.
M05	Upper Tray Exit Motor	Drives the rollers that output paper to the proof tray (top tray).
M06	Shift Motor	Moves the shift tray from side to side.
M07	Upper Tray Junction Gate Motor	Operates the upper tray junction gate.
M08	Stapler Junction Gate Motor	Operates the staple junction gate that directs paper into the stapling path.
M09	Pre-Stack Junction Gate Motor	Operates the pre-stack junction gates that direct paper into path 1, 2, or 3 of the pre-stack unit.
M10	Pre-Stack Transport Motor	Drives the rollers that feed paper into the pre-stack paper paths.
M11	Pre-Stack Stopper Motor	Controls the stopper that stops the sheets in the pre-stack unit and then releases them to the staple tray.
M12	Positioning Roller Motor	Moves the positioning roller into contact with the paper.
M13	Positioning Roller Drive Motor	Rotates the positioning roller.
M14	Drag Drive Motor	Extends the sponge roller that drags the stapled stack on the shift tray toward the finisher so that the edge of the stack is aligned against the back of the shift tray.
M15	Drag Roller Motor	Rotates the drag roller counter-clockwise to pull the ejected paper toward the machine so that the edge of the stack on the shift tray is aligned against the back of the shift tray.
M16	Jogger Motor	Moves the jogger fences of the stapling tray.
M17	Stack Feed-Out Belt Motor	Drives the stack feed-out belt which lifts the stapled stack and feeds it out of the finisher. The stack-feed-out motor turns off when the pawl actuates the stack feed-out belt home position sensor.
M18	Stack Plate Motor (Center)	Presses down the center of the edge for stapling.
M19	Stack Plate Motor (Front)	Presses down the front corner of the edge for stapling.
M20	Stack Plate Motor (Rear)	Presses down the rear corner of the edge for stapling.
M21	Stapler Movement Motor	Moves the staple unit side-to-side.
M22	Stapler Rotation Motor	Rotates the stapler 45 degrees for oblique stapling.
M23	Staple Hammer Motor	Drives the staple hammer.
M24	Top Fence Motor	After the specified number of sheets has been fed, this motor lowers the top fence against the leading edges of the sheets to align them for stapling and then raises the top fence to its home position after stapling. Operates the top fence that jogs pre-stacked paper vertically (in the direction of paper feed).
M25	Bottom Fence Motor	After the specified number of sheets has been fed, this motor lowers the bottom fence to position the stack for stapling and then raises the bottom fence to its home position after stapling.
M27	Upper Transport Motor	Feeds paper in the upper transport area. Drives the rollers that transport paper toward the proof tray (top tray).

OVERALL MACHINE INFORMATION

Motors		
No.	Name	Description
M28	Lower Transport Motor	Drives the rollers that transport paper in the shift and stapling paper path.
M29	Punch Motor	Drives the punch shaft and roller.
M30	Shift Tray Jogger Motor	Drives the shift tray jogger fences against the sides of the sheets to align the stack, then reverses to return them to the home position
M31	Shift Tray Jogger Retraction Motor	Raises the shift tray jogger fences after aligning the stack, then reverses and lowers them to them to the home position.

PCBs		
No.	Name	Description
PCB	Main Board (Output Jogger)	Controls operation of the shift and output jogger mechanisms.
PCB	Main Board	Controls the finisher and communicates with the copier.

Sensors		
No.	Name	Description
S01	Entrance Sensor	Detects the copy paper entering the finisher and checks for misfeeds.
S02	Upper Tray Exit Sensor	Checks for misfeeds at the upper tray.
S03	Upper Tray Full Sensor	Detects when the upper tray is full.
S04	Shift Tray Exit Sensor 1	Controls the output timing of stapled stacks and detects jams.
S05	Shift Tray Exit Sensor 2	Controls the timing of paper in the shift path and detects paper jams.
S06	Exit Guide HP Sensor	Detects whether the guide plate is opened or not.
S07	Paper Height Sensor – Standby Mode	Detects the height of the tray when the machine is turned on to position the tray at the standby position.
S08	Paper Height Sensor – Staple Mode	Detects the height of the paper output on the shift tray and adjusts the height of the tray in the staple mode.
S09	Paper Height Sensor – Z-Fold Full	Detects the height of the paper output on the shift tray and signals when the tray is full when Z-folded paper is output to the shift tray.
S10	Paper Height Sensor – Shift/Z-Fold	Detects the amount of paper on the shift tray 1) in shift mode to control operation of the tray lift motor, and 2) when Z-folded paper is output to the shift tray.
S11	Drag Drive HP Sensor	Controls the push and pull movement of the drag roller when it extends and drags paper back against the back of the shift tray to keep the edge of the stack aligned on the shift tray.
S12	Shift Tray Half-Turn Sensor 1	Detects whether the shift tray is at either the front or back position. Controls the side-to-side movement of the shift tray. (This pair of sensors is used to detect the positions of the leading and trailing edges of the sheets controls operation of the shift mechanism.)
S13	Shift Tray Half-Turn Sensor 2	Detects whether the shift tray is at either the front or back position. Controls the side-to-side movement of the shift tray.
S14	Upper Tray Junction Gate HP Sensor	Detects the upper tray junction gate at its home position.
S15	Stapler Junction Gate HP Sensor	Detects the staple junction gate at its home position.
S16	Pre-Stack Junction Gate HP Sensor	Detects the pre-stack junction gate mechanism at its home position.
S17	Pre-Stack Tray Paper Sensor (Right)	Detects paper feed in the right side of the pre-stack unit and detects jams.
S18	Shift Tray Full Sensor	Detects when the shift tray is full for paper smaller than B4. The tray is at its lower limit.
S19	Shift Tray Full Sensor (Large Paper)	Detects when the shift tray is full for large size paper (B4 or larger).
S20	Shift Tray Near-Full Sensor	Detects when the shift tray is nearly full.
S21	Stapler Tray Exit Sensor	Detects jams at the staple tray exit.
S22	Staple Trimmings Hopper	Detects when the staple trimmings hopper is full.

Finisher
B830

Sensors		
No.	Name	Description
	Full Sensor	
S23	Staple Trimmings Hopper Set Sensor	Detects if the hopper that holds stapling trimmings is set correctly or incorrectly.
S24	Pre-Stack Stopper HP Sensor	Detects the pre-stack stopper mechanism at its home position.
S25	Pre-Stack Tray Paper Sensor (Left)	Detects paper feed in the right side of the pre-stack unit. Controls the release timing of the pre-stack stopper, and starts the pre-stack transport motor. Also detects paper jams.
S26	Stapler Tray Entrance Sensor	Detects a paper jam if there is paper at the entrance of the stapler unit junction gate when the machine is turned on or after the door is closed.
S27	Stack Feed-Out Belt HP Sensor	Detects the home position of the stack feed-out belt.
S28	Staple Tray Full Sensor	Detects paper in the stapler tray.
S29	Jogger HP Sensor	Detects the home position of the jogger fence in the stapler tray.
S30	Bottom Fence HP Sensor	Detects the bottom fence at its home position.
S31	Top Fence HP Sensor	Detects the top fence at its home position.
S32	Positioning Roller HP Sensor	Detects the home position of the positioning roller.
S33	Stack Plate HP Sensor (Center)	Detects the home position of the center stack plate.
S34	Stack Plate HP Sensor (Front)	Detects the home position of the front stack plate.
S35	Stack Plate HP Sensor (Rear)	Detects the home position of the rear stack plate.
S36	Stapler HP Sensor (Front/Rear)	Detects the home position of the staple unit for side-to-side movement.
S37	Stapler Rotation Sensor 1	Paired with Stapler Rotation Sensor 2. This sensor pair controls the positioning of the corner stapler for the horizontal, 45° angle, and 75° angle stapling positions.
⇒ S38	Stapler Rotation Sensor 2	Paired with Stapler Rotation Sensor 1. This sensor pair controls the positioning of the corner stapler for the horizontal and 45° angle stapling positions.
S39	Punch-out Hopper Full Sensor	Detects when the punch-out hopper is full and detects when the punch tray is set.
S40	Punch HP Sensor 1	Detects the cam home position for the 2-hole punch. After punching a sheet of paper, the cam returns to home position and stops. Home position depends on whether 2 holes or 3 holes are being made, so there are two punch HP sensors. Punch HP sensor 1 is used when 2-hole punching is selected, and punch HP sensor 2 is used when 3-hole punching is selected. When the cut-out enters the slot of the punch HP in use (sensor 1 or 2-hole punching) the motor stops.
S41	Punch HP Sensor 2	Detects the cam home position for 3-hole punch. After punching a sheet of paper, the cam returns to home position and stops. Home position depends on whether 2 holes or 3 holes are being made, so there are two punch HP sensors. Punch HP sensor 1 is used when 2-hole punching is selected, and punch HP sensor 2 is used when 3-hole punching is selected. When the cut-out enters the slot of the punch HP in use (sensor 1 or 2-hole punching) the motor stops.
S42	Shift Tray Jogger HP Sensor	Detects the actuator on the rear shift tray jogger fence and switches off the shift tray jogger motor, and signals the machine to turn on the shift tray jogger retraction motor to raise the fences at the end of a job.
S43	Shift Tray Jogger Retraction HP Sensor	Detects the jogger fences of the shift tray jogger unit at their home positions.

OVERALL MACHINE INFORMATION

Solenoids		
No.	Name	Description
SOL	Staple Trimming Chute Solenoid	Opens and closes the trap door that drops staple trimmings into the stapling trimmings hopper.

Switches		
No.	Name	Description
SW	Front Door Safety Switch	Detects when the front door is open. The finisher does not operate until the front door has been closed.
SW	Emergency Stop Switch	Switches the current job off and on to allow time for the operator to remove paper from the shift tray.
SW	Shift Tray Upper Limit Switch	Cuts the power to the shift tray lift motor when the shift tray position is at its upper limit.

Finisher
B830

RT4000 A3/12 x 18 LCT (D350)

D350 A3/12X18 LCT RT4000 REVISION HISTORY		
Page	Date	Added/Updated/New
32	04/20/10	Image Skew Specification

RT4000 A3/12 x 18 LCT (D350)

TABLE OF CONTENTS







1. REPLACEMENT AND ADJUSTMENT	1
1.1 COMMON PROCEDURES	1
1.1.1 TRAYS	1
1.1.2 COVERS	2
1.1.3 SIDE REGISTRATION ADJUSTMENT	3
1.2 PAPER FEED UNIT	4
1.3 ROLLERS	5
1.3.1 PAPER FEED ROLLER	5
1.4 MOTORS	6
1.4.1 LCT EXIT MOTOR	6
1.4.2 FEED MOTOR, GRIP MOTOR	7
1.4.3 LIFT MOTOR	8
1.5 SENSORS	9
1.5.1 LCT EXIT SENSOR	9
1.5.2 PAPER HEIGHT, PAPER WIDTH SENSORS	10
Paper Height Sensors	10
Paper Width Sensors	10
1.6 BOARDS	11
1.6.1 MAIN BOARD	11
2. DETAILS	12
2.1 MECHANICAL LAYOUT	12
2.1.1 OVERVIEW	12
2.1.2 DRIVE LAYOUT	13
2.1.3 ELECTRICAL COMPONENTS	14
2.1.4 ELECTRICAL COMPONENT SUMMARY	16
2.2 PAPER HANDLING	19
2.2.1 PAPER FEED ROLLERS	19
2.2.2 PAPER FEED MOTORS	20

2.2.3 PAPER SEPARATION.....	21
2.2.4 PAPER DETECTION/LIFT.....	22
2.2.5 LIFT SENSOR	23
2.2.6 PAPER SIZE DETECTION	24
2.2.7 REMAINING PAPER DETECTION.....	27
2.2.8 PAPER END DETECTION.....	29
2.2.9 AIR-ASSISTED FEED MECHANISM.....	30
2.2.10 PAPER EXIT	31

Read This First

Safety, Conventions, Trademarks

Conventions

Symbol	What it means
	Core Tech Manual
	Screw
	Connector
	E-ring
	C-ring
	Harness clamp
FFC	Flexible Film Cable

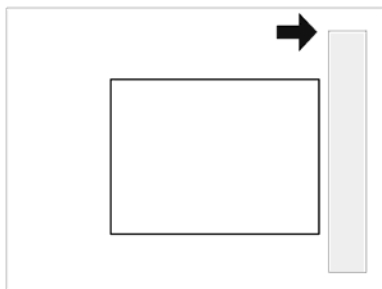

SEF (Short Edge Feed)

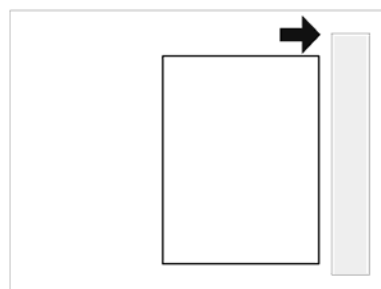

LEF (Long Edge Feed)

The notations "SEF" and "LEF" describe the direction of paper feed. The arrows indicate the direction of paper feed.

Warnings, Cautions, Notes

In this manual, the following important symbols and notations are used.

WARNING

- A Warning indicates a potentially hazardous situation. Failure to obey a Warning could result in death or serious injury.

CAUTION

- A Caution indicates a potentially hazardous situation. Failure to obey a Caution could result in minor or moderate injury or damage to the machine or other property.

Important

- Obey these guidelines to avoid problems such as misfeeds, damage to originals, loss of valuable data and to prevent damage to the machine

Note

- This information provides tips and advice about how to best service the machine.

General Safety Instructions

For your safety, please read this manual carefully before you use this product. Keep this manual handy for future reference.

Safety Information

Always obey the following safety precautions when using this product.

Safety During Operation

In this manual, the following important symbols and notations are used.

Switches and Symbols

Where symbols are used on or near switches on machines for Europe and other areas, the meaning of each symbol conforms with IEC60417.

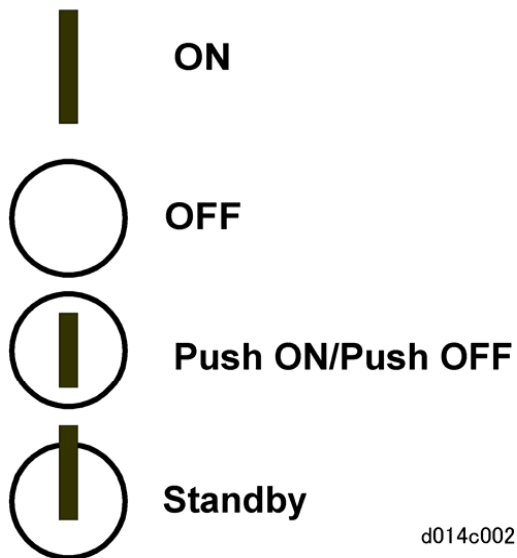

d014c002

Responsibilities of the Customer Engineer

Customer Engineer

Maintenance shall be done only by trained customer engineers who have completed service training for the machine and all optional devices designed for use with the machine.

Reference Material for Maintenance

- Maintenance shall be done using the special tools and procedures prescribed for maintenance of the machine described in the reference materials (service manuals, technical bulletins, operating instructions, and safety guidelines for customer engineers).
- In regard to other safety issues not described in this document, all customer engineers shall strictly obey procedures and recommendations described in the “CE Safety Guide”.
- Use only consumable supplies and replacement parts designed for use of the machine.

Before Installation, Maintenance

Shipping and Moving the Machine

- Work carefully when lifting or moving the machine. If the machine is heavy, two or more customer engineers may be required to prevent injuries (muscle strains, spinal injuries, etc.) or damage to the machine if it is dropped or tipped over.
- Personnel moving or working around the machine should always wear proper clothing and footwear. Never wear loose fitting clothing or accessories (neckties, loose sweaters, bracelets, etc.) or casual footwear (slippers, sandals, etc.) when lifting or moving the machine.
- Always unplug the power cord from the power source before you move the product. Before you move the product, arrange the power cord so it will not fall under the product.

Power

- Always disconnect the power plug before doing any maintenance procedure. After switching off the machine, power is still supplied to the main machine and other devices. To prevent electrical shock, switch the machine off, wait for a few seconds, then unplug the machine from the power source.
- Before you do any checks or adjustments after turning the machine off, work carefully to avoid injury. After removing covers or opening the machine to do checks or

adjustments, never touch electrical components or moving parts (gears, timing belts, etc.).

- After turning the machine on with any cover removed, keep your hands away from electrical components and moving parts. Never touch the cover of the fusing unit, gears, timing belts, etc.

Installation, Disassembly, and Adjustments

- After installation, maintenance, or adjustment, always check the operation of the machine to make sure that it is operating normally. This ensures that all shipping materials, protective materials, wires and tags, metal brackets, etc., removed for installation, have been removed and that no tools remain inside the machine. This also ensures that all release interlock switches have been restored to normal operation.
- Never use your fingers to check moving parts causing spurious noise. Never use your fingers to lubricate moving parts while the machine is operating.

Special Tools

- Use only standard tools approved for machine maintenance.
- For special adjustments, use only the special tools and lubricants described in the service manual. Using tools incorrectly, or using tools that could damage parts, could damage the machine or cause injuries.

During Maintenance

General

- Before you begin a maintenance procedure: 1) Switch the machine off, 2) Disconnect the power plug from the power source, 3) Allow the machine to cool for at least 10 minutes.
- Avoid touching the components inside the machine that are labeled as hot surfaces.

Safety Devices

- Never remove any safety device unless it requires replacement. Always replace safety devices immediately.
- Never do any procedure that defeats the function of any safety device. Modification or removal of a safety device (fuse, switch, etc.) could lead to a fire and personal injury. Always test the operation of the machine to ensure that it is operating normally and safely after removal and replacement of any safety device.
- For replacements use only the correct fuses or circuit breakers rated for use with the machine. Using replacement devices not designed for use with the machine could lead

to a fire and personal injuries.

Organic Cleaners

- During preventive maintenance, never use any organic cleaners (alcohol, etc.) other than those described in the service manual.
- Make sure the room is well ventilated before using any organic cleaner. Use organic solvents in small amounts to avoid breathing the fumes and becoming nauseous.
- Switch the machine off, unplug it, and allow it to cool before doing preventive maintenance. To avoid fire or explosion, never use an organic cleaner near any part that generates heat.
- Wash your hands thoroughly after cleaning parts with an organic cleaner to avoid contamination of food, drinks, etc. which could cause illness.
- Clean the floor completely after accidental spillage of silicone oil or other materials to prevent slippery surfaces that could cause accidents leading to hand or leg injuries. Use "My Ace" Silicone Oil Remover (or dry rags) to soak up spills. For more details, please refer to Technical Bulletin "Silicone Oil Removal" (A024-50).

Power Plug and Power Cord

- Before serving the machine (especially when responding to a service call), always make sure that the power plug has been inserted completely into the power source. A partially inserted plug could lead to heat generation (due to a power surge caused by high resistance) and cause a fire or other problems.
- Always check the power plug and make sure that it is free of dust and lint. Clean it if necessary. A dirty plug can generate heat which could cause a fire.
- Inspect the length of the power cord for cuts or other damage. Replace the power cord if necessary. A frayed or otherwise damaged power cord can cause a short circuit which could lead to a fire or personal injury from electrical shock.
- Check the length of the power cord between the machine and power supply. Make sure the power cord is not coiled or wrapped around any object such as a table leg. Coiling the power cord can cause excessive heat to build up and could cause a fire.
- Make sure that the area around the power source is free of obstacles so the power cord can be removed quickly in case of an emergency.
- Make sure that the power cord is grounded (earthed) at the power source with the ground wire on the plug.
- Connect the power cord directly into the power source. Never use an extension cord.
- When you disconnect the power plug from the power source, always pull on the plug, not the cable.

After Installation, Servicing

Disposal of Used Items

- Never incinerate used toner or toner cartridges.
- Toner or toner cartridges thrown into a fire can ignite or explode and cause serious injury. At the work site always carefully wrap used toner and toner cartridges with plastic bags to avoid spillage before disposal or removal.
- Always dispose of used items (developer, toner, toner cartridges, OPC drums, etc.) in accordance with the local laws and regulations regarding the disposal of such items.
- To protect the environment, never dispose of this product or any kind of waste from consumables at a household waste collection point. Dispose of these items at one of our dealers or at an authorized collection site.
- Return used selenium drums to the service center for handling in accordance with company policy regarding the recycling or disposal of such items.

Safety Instructions for this Machine

PREVENTION OF PHYSICAL INJURY

1. Before disassembling or assembling parts of the machine and peripherals, make sure that the machine and peripheral power cords are unplugged.
2. The plug should be near the machine and easily accessible.
3. Note that some components of the machine and the paper tray unit are supplied with electrical voltage even if the main power switch is turned off.
4. If any adjustment or operation check has to be made with exterior covers off or open while the main switch is turned on, keep hands away from electrified or mechanically driven components.
5. If the [Start] key is pressed before the machine completes the warm-up period (the [Start] key starts blinking red and green), keep hands away from the mechanical and the electrical components as the machine starts making copies as soon as the warm-up period is completed.
6. The inside and the metal parts of the fusing unit become extremely hot while the machine is operating. Be careful to avoid touching those components with your bare hands.
7. To prevent a fire or explosion, keep the machine away from flammable liquids, gases, and aerosols.

OBSERVANCE OF ELECTRICAL SAFETY STANDARDS

1. The machine and its peripherals must be installed and maintained by a customer service representative who has completed the training course on those models.
2. The NVRAM on the system control board has a lithium battery which can explode if replaced incorrectly. Replace the NVRAM only with an identical one. The manufacturer recommends replacing the entire NVRAM. Do not recharge or burn this battery. Used NVRAM must be handled in accordance with local regulations.

Trademarks

- Microsoft[®], Windows[®], and MS-DOS[®] are registered trademarks of Microsoft Corporation in the United States and /or other countries.
- PostScript[®] is a registered trademark of Adobe Systems, Incorporated.
- PCL[®] is a registered trademark of Hewlett-Packard Company.
- Ethernet[®] is a registered trademark of Xerox Corporation.
- PowerPC[®] is a registered trademark of International Business Machines Corporation.
- Other product names used herein are for identification purposes only and may be trademarks of their respective companies. We disclaim any and all rights involved with those marks.

1. REPLACEMENT AND ADJUSTMENT

1.1 COMMON PROCEDURES

1.1.1 TRAYS

⚠ CAUTION

- The tray weighs 27 kg (60 lb.) empty.
- To prevent damage to the tray and personal injury, never attempt to lift the tray alone or without attaching the carrying handles, especially if it is loaded with paper. (The carrying handles are attached to the side of the tray.)
- One person on each side of the tray should use the handles to carry or move the tray.
- Never remove the tray if the LCT is not docked to the copier. Removing the tray while the LCT is standing alone can unbalance the LCT and cause it to fall over.

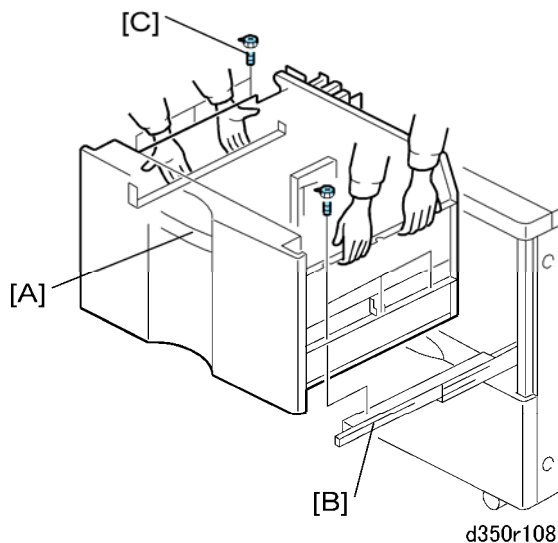

1. Pull the tray [A] out of the LCT until it stops.
2. Remove the screws from the right rail [B] (⚙ x3)
3. Remove the screws from the left rail [C] (⚙ x3)

↓ Note

- You do not need to remove screw for the stopper pin bracket at the back of the left rail.

D350
RT4000
A3/12 x 18
LCT

1.1.2 COVERS

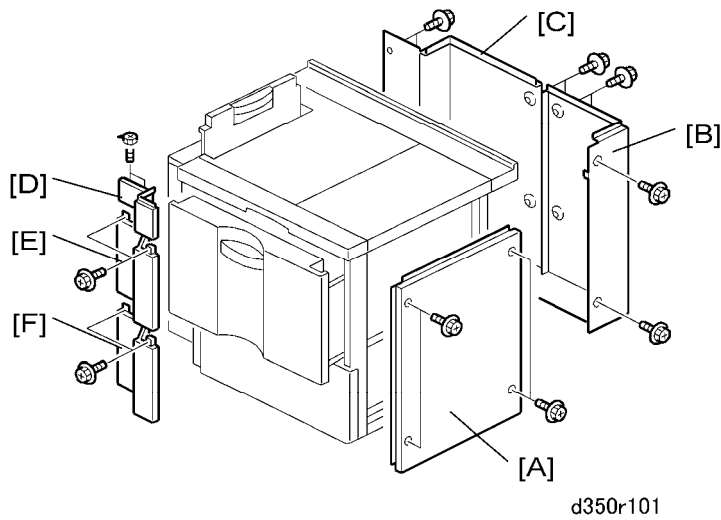

Before You Begin...

- The frame is held together by 8 blue screws.
- To avoid weakening or warping the shape of the frame, never remove these blue screws.
- The upper inner cover must be removed before the top cover.

1. Remove:

- [A] Right cover (⚙ x 4)
- [B] Right rear cover (⚙ x 4)
- [C] Left rear cover (⚙ x 5)
- [D] Top front cover (⚙ x 2)
- [E] Middle front cover (⚙ x 2)
- [F] Bottom front cover (⚙ x 2)

1.1.3 SIDE REGISTRATION ADJUSTMENT

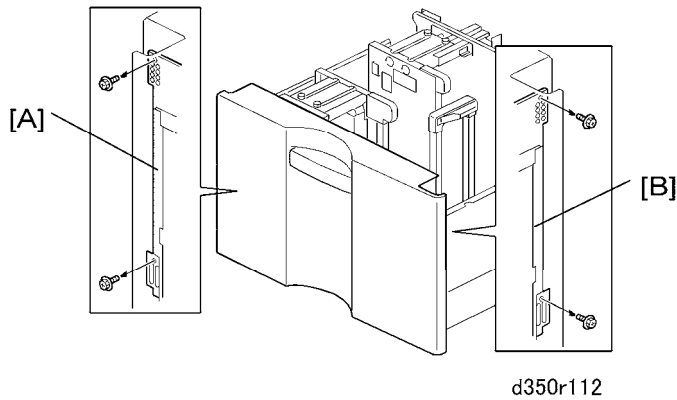

The side-to-side registration for this LCIT can be adjusted with SP1003-8.

However, if punched hole positions are not aligned on paper fed from this LCIT, you can first adjust the side registration by changing the tray cover position as described below, and then adjust the side registration of the image with the SP1003-8 (Side-to-Side Reg: WIDE LCT).

1. Pull out the tray.
2. Change the screw positions at both the right [A] and left [B] sides as shown.

Adjustment range: 0 ± 2.0 mm, Step: 0.5 mm

D350
 RT4000
 A3/12 x 18
 LCT

Paper Feed Unit

1.2 PAPER FEED UNIT

1. Remove:
 - Paper feed drive bracket (🔩x2)
 - Timing belt (🔩x1)
2. Remove the paper tray.

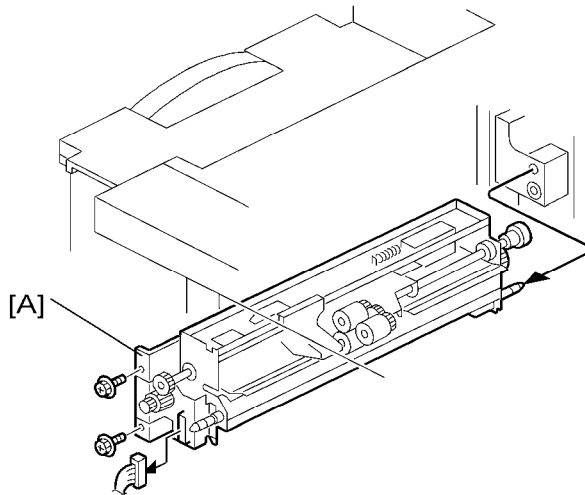

d350r903

3. Remove:
 - [A] Paper feed unit (🔩 x1, (🔩 x2)

1.3 ROLLERS

1.3.1 PAPER FEED ROLLER

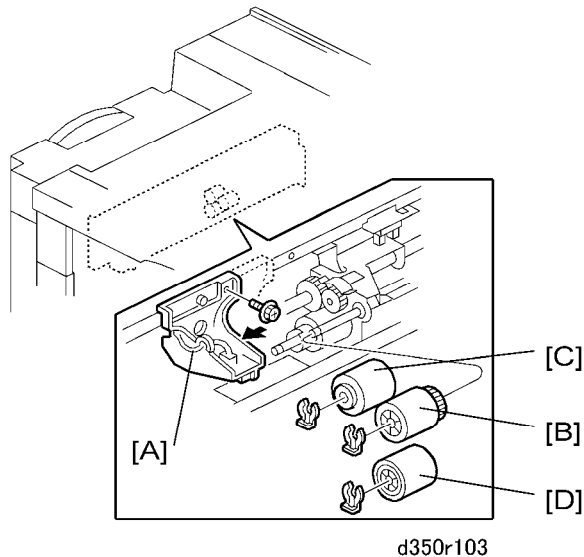

1. Remove:
 - Paper feed unit
2. Remove:
 - [A] Bracket (⌘ x1)
 - [B] Pick-up roller (⌘ x 1).
 - [C] Feed roller (⌘ x 1).
 - [D] Separation roller (⌘ x 1).

Note:

- Never touch the surface of the rollers with bare hands.
- The LCT pick-up and separation rollers are the same as the pick-up and separation rollers in the paper trays of the main machine. These rollers are interchangeable.
- The feed rollers of the LCT and main machine paper trays are different because they are designed to rotate in the opposite direction. The feed rollers of the LCT and main machine are not interchangeable.

D350
RT4000
A3/12 x 18
LCT

1.4 MOTORS

1.4.1 LCT EXIT MOTOR

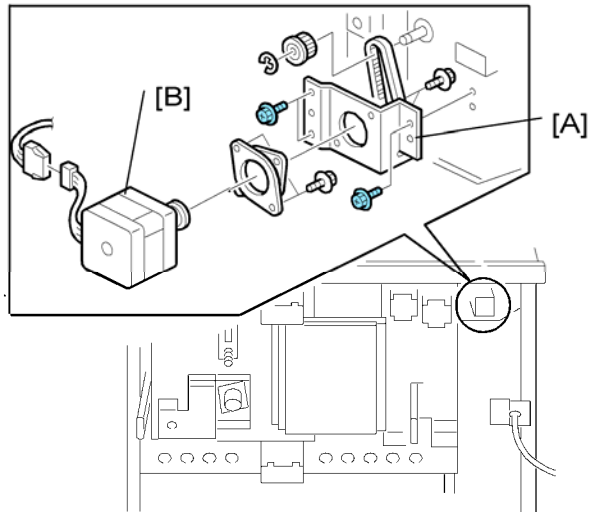

d350r109a

1. Remove the left rear cover
2. Remove:
 - [A] Motor unit (⚙️ x1, Gear ⚙️ x 1, Timing belt x1, ⚙️ x2)
 - [B] Motor (⚙️ x5)

1.4.2 FEED MOTOR, GRIP MOTOR

1. Remove the left rear cover

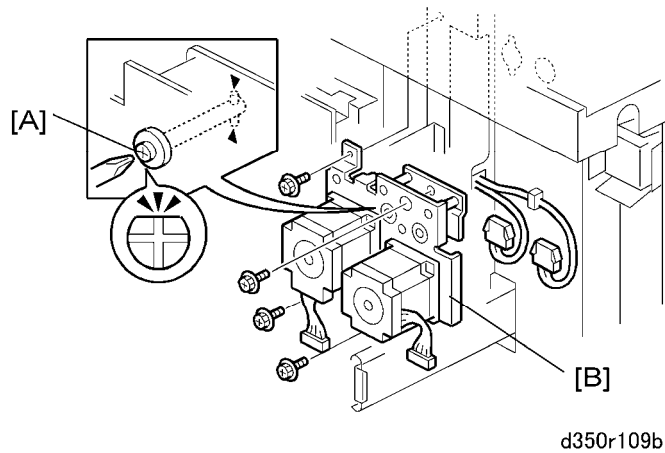

2. Use a small screwdriver to turn the shaft [A] so the pin can slip out of the keyhole.
3. Remove the motor unit [B] (⚙️ x4, ⚙️ x2, ⚙️ x2)

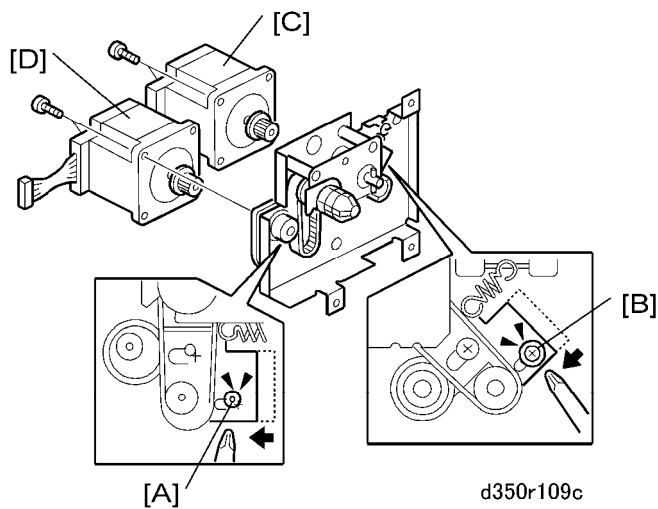

4. Remove:
 - [A] Spring x1. First, loosen screw.
 - [B] Spring x1. First, loosen screw.
 - [C] Paper feed motor (⚙️ x2, Timing belt x1)
 - [D] Grip motor (⚙️ x2, Timing belt x1)

Reinstallation

- First, attach the tension springs.
- Second, tighten the screws to tighten the belts.

D350
RT4000
A3/12 x 18
LCT

Motors

1.4.3 LIFT MOTOR

1. Remove:

- Rear cover

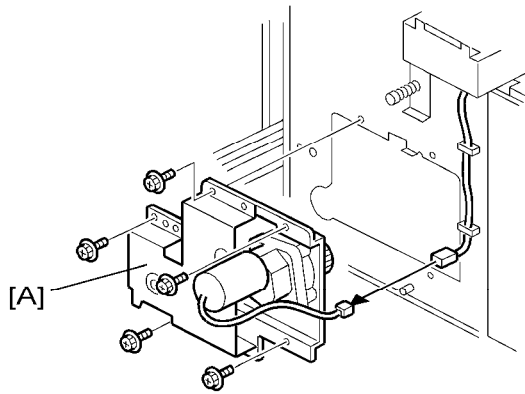

d350r109d

2. Remove:

- [A] Motor unit (⚙️ x5, 📌 x1)

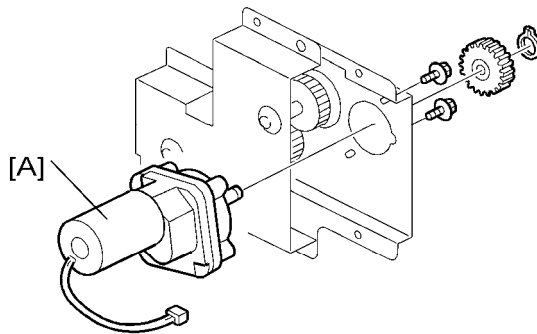

d350r109e

3. Remove:

- [A] Lift motor (⚙️ x2, Clip x1, Gear x1)

1.5 SENSORS

1.5.1 LCT EXIT SENSOR

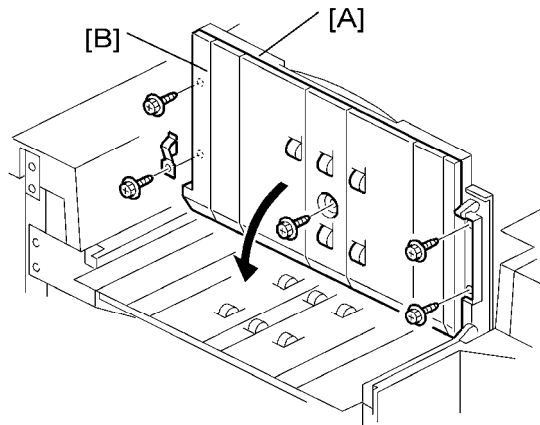

d350r105

1. Disconnect the LCT from the copier.
2. Open the exit cover [A].
3. Disconnect the bottom of the exit cover [B] (⚙ x5).
4. Lower the bottom of the cover.

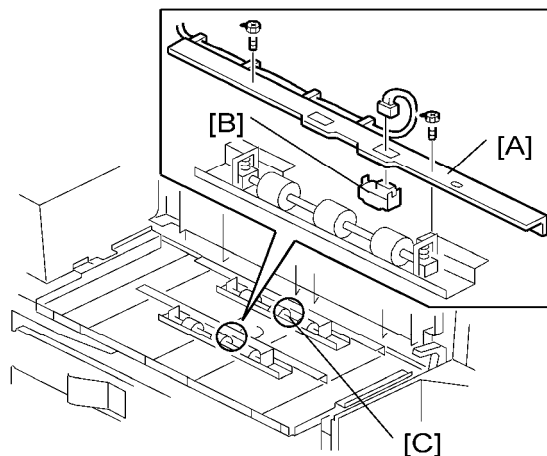

d350r105a

5. Remove:
 - [A] Relay sensor bracket (⚙ x2).
 - [B] Relay sensor (⚙ x1, Pawls x2)
 - [C] LCT exit sensor

D350
RT4000
A3/12 x 18
LCT

Sensors

1.5.2 PAPER HEIGHT, PAPER WIDTH SENSORS

Paper Height Sensors

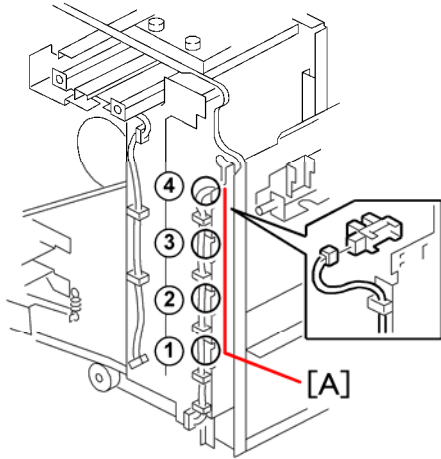

d350r106

1. Remove the rear left cover.
2. Remove:
[A] Paper height sensors (x4) (⌘ x1, Pawls x 4 each)

Paper Width Sensors

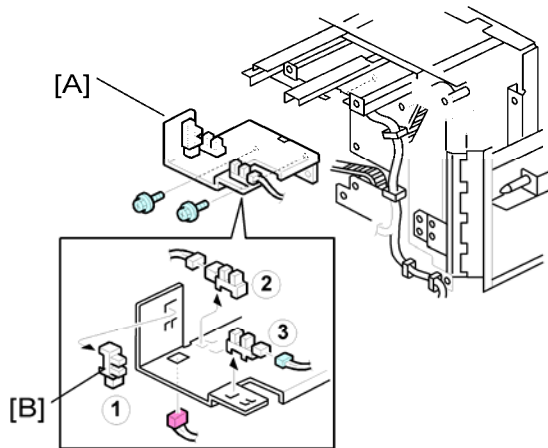

d350r106a

1. Remove the rear left cover.
[A] Paper width sensor unit (⌘ x2, ⌘ x3)
[B] Paper width sensors (x3) (⌘ x1 each, Pawls x2 each)

1.6 BOARDS

1.6.1 MAIN BOARD

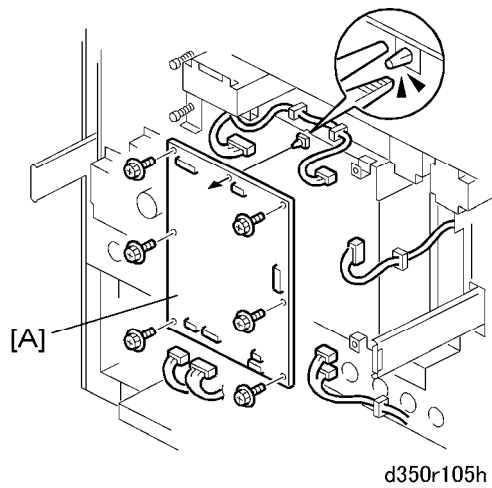

1. Remove:
 - Rear covers
- [A] Main control board (⚙ x7, Standoff x1, ⚙ x All).

D350
RT4000
A3/12 x 18
LCT

2. DETAILS

2.1 MECHANICAL LAYOUT

2.1.1 OVERVIEW

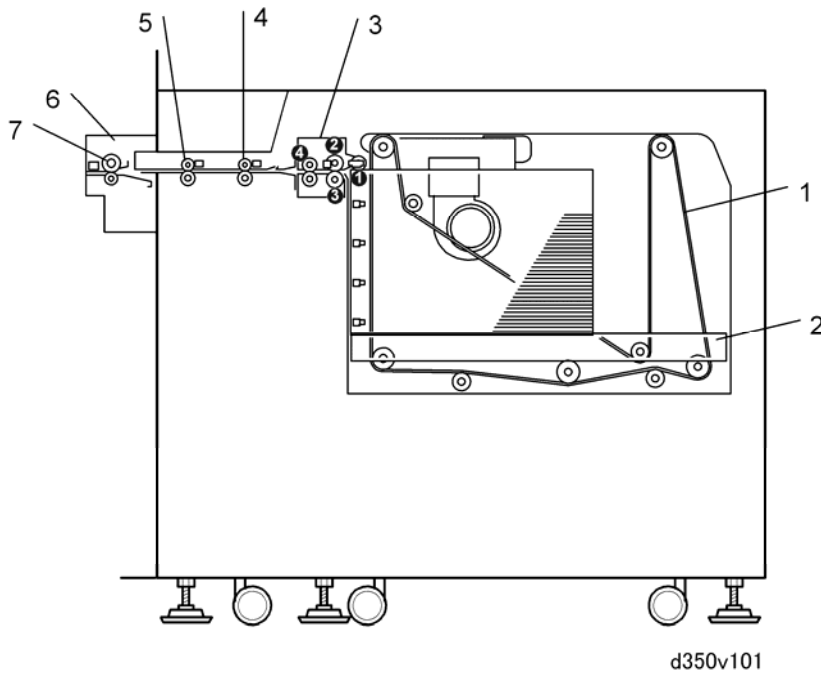

1.	Tray Drive Belt
2.	Tray Bottom Plate
3.	Paper Feed Unit* ¹
4.	Horizontal Transport Motor
5.	LCT Exit Roller
6.	Relay Unit (Main Machine)
7.	Entrance Roller (Main Machine)

*¹ The tray has 1 paper feed motor that drives the pick-up roller ① and paper feed roller ②, and 1 grip motor that drives the grip roller ④ (③ is the separation roller).

2.1.2 DRIVE LAYOUT

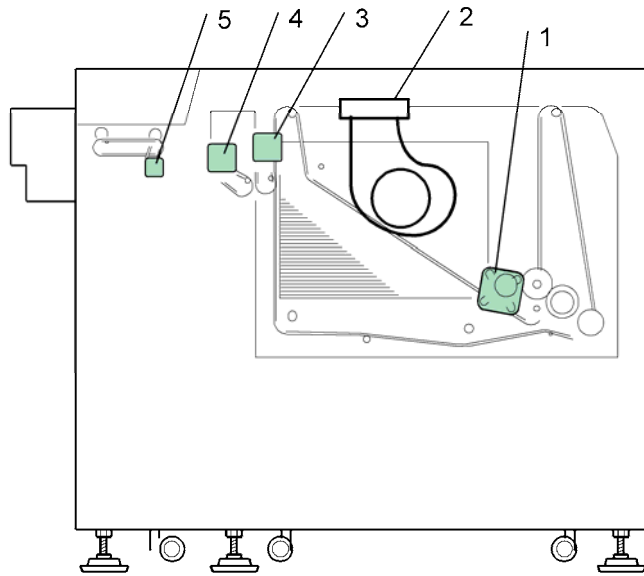

d350v102

D350
RT4000
A3/12 x 18
LCT

1.	Lift Motor
2.	Air Assist Fan Motor
3.	Paper Feed Motor
4.	Grip Motor
5.	LCT Exit Motor

2.1.3 ELECTRICAL COMPONENTS

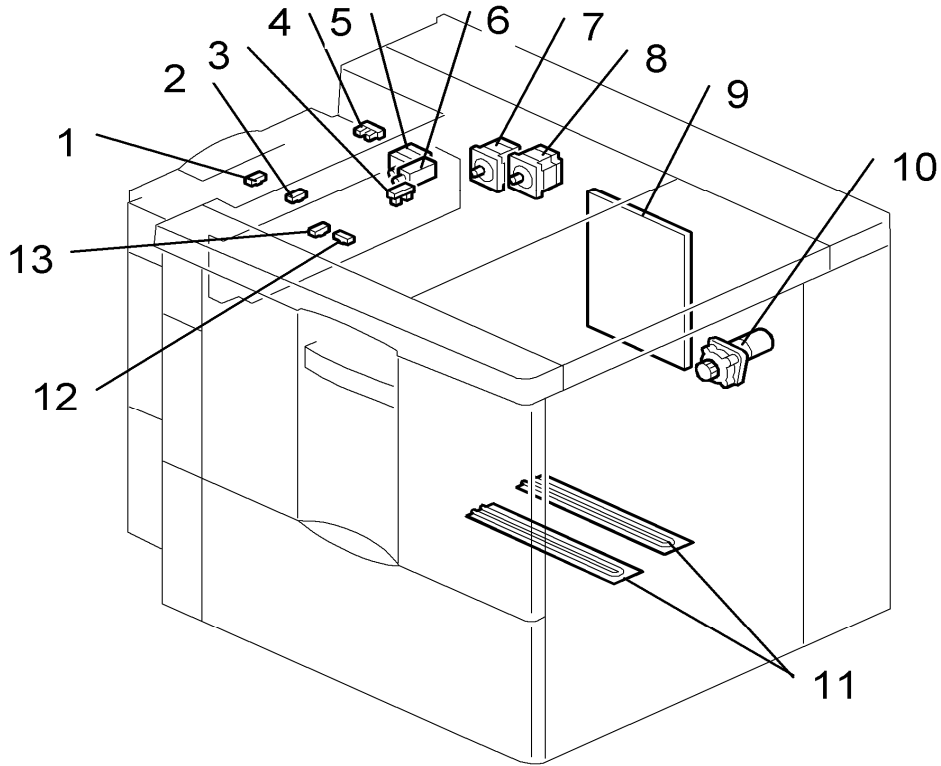

d350v102a

1.	LCT Exit Sensor	8.	Paper Feed Motor
2.	Relay Sensor	9.	Main Board
3.	Lift Sensor	10.	Lift Motor
4.	Exit Cover Sensor	11.	Anti-Condensation Heaters x2
5.	LCT Exit Motor	12.	Paper End Sensor
6.	Pickup Solenoid	13.	Paper Feed Sensor
7.	Grip Motor		

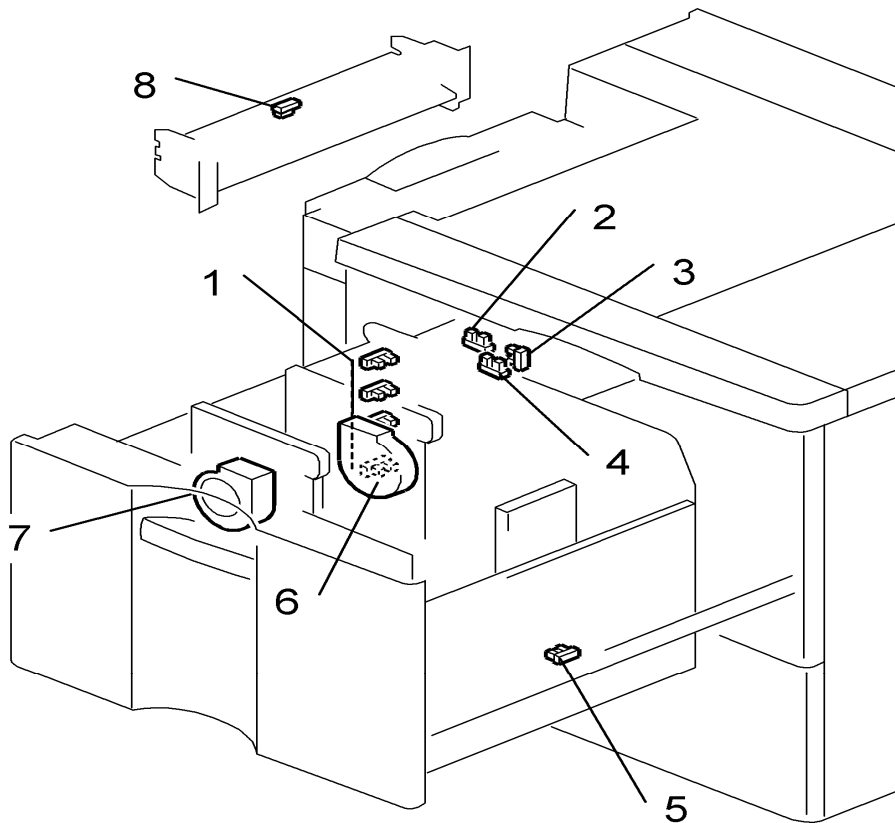

d350v102b

D350
RT4000
A3/12 x 18
LCT

1.	Paper Height Sensors ④, ③, ②, ①
2.	Paper Width Sensor 3
3.	Paper Width Sensor 2
4.	Paper Width Sensor 1
5.	Lift Sensor
6.	Paper Assist Fan (Rear)
7.	Paper Assist Fan (Front)
8.	Entrance Sensor (Main Machine)

2.1.4 ELECTRICAL COMPONENT SUMMARY

Heater		
No.	Name	Description
H	Anti-Condensation Heater	Heat elements that provide heat to keep the paper tray and paper stack dry.

Motors		
No.	Name	Description
M	Air Assist Fan (Front)	1 of 2 fans that cool the tray.
M	Air Assist Fan (Rear)	1 of 2 fans that cool the tray.
M	Grip Motor	Drives the transport rollers in the feed path that feed the paper from the tray to the LCT exit motor.
M	LCT Exit Motor	Feeds the paper out the LCT and into the entrance of the copier.
M	Lift Motor	Raises and lowers the bottom plate of the paper tray.
M	Paper Feed Motor	Drives the pick-roller and feed roller that picks up each sheet and starts to feed it out of the 1st tray.

Board		
No.	Name	Description
PCB	Main Board	Controls the operation of all motors and sensors in the LCT unit.

Sensors		
No.	Name	Description
S	Exit Cover Sensor	An interlock safety switch that detects when the front door is opened and closed.
S	Grip Sensor	Detects jams in the paper path where the grip motor pulls the paper from the tray.
S	LCT Exit Sensor	Detects jams at the exit of the LCT unit.
S	Lift Sensor	Detects when the paper in the tray is at the correct height for paper feed and switches the lift motor off.
S	Paper End Sensor	Detects when the last sheet feeds from the tray.
S	Paper Feed Sensor	Detects the paper when it arrives at the paper feed roller and checks for misfeeds.
S	Paper Height Sensor 1	1st from the bottom of the 1st tray, detects stack height: 100%
S	Paper Height Sensor 2	2nd from the bottom of the 1st tray, detects stack height: 75%
S	Paper Height Sensor 3	3rd from the bottom of the 1st tray, detects stack height: 50%
S	Paper Height Sensor 4	4th from the bottom of the 1st tray, detects stack height: 25% and signals near-end.
S	Paper Length Sensor	Detects the length of the paper in the tray (operates in combination with the paper width sensors).
S	Paper Width Sensor 1	1 of a set of 3 sensors that detect the width the paper in the 1st tray.
S	Paper Width Sensor 2	1 of a set of 3 sensors that detect the width the paper in the 1st tray.
S	Paper Width Sensor 3	1 of a set of 3 sensors that detect the width the paper in the 1st tray.

D350
RT4000
A3/12 x 18
LCT

Mechanical Layout

Sensors		
S	Relay Sensor	Detects the leading and trailing edge of each to detect jams in the horizontal paper path just before the paper exits the LCIT.

Solenoid		
No.	Name	Description
SOL	Pick-up Solenoid	Engages/disengages rotation of the pick-up roller in the tray.

2.2 PAPER HANDLING

2.2.1 PAPER FEED ROLLERS

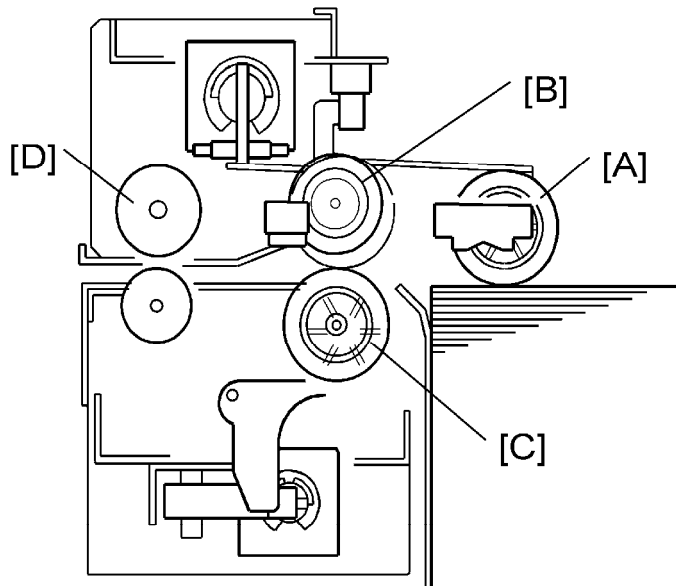

D350
RT4000
A3/12 x 18
LCT

d350d930

This LCT has one paper tray feed tray. Capacity: 2,000 sheets.

The tray contains four rollers:

[A] Pick-up roller

[B] Paper feed roller

[C] Separation roller

[D] Grip roller

The pick-up roller, paper feed roller, and separation roller use the standard FRR paper feed system.

2.2.2 PAPER FEED MOTORS

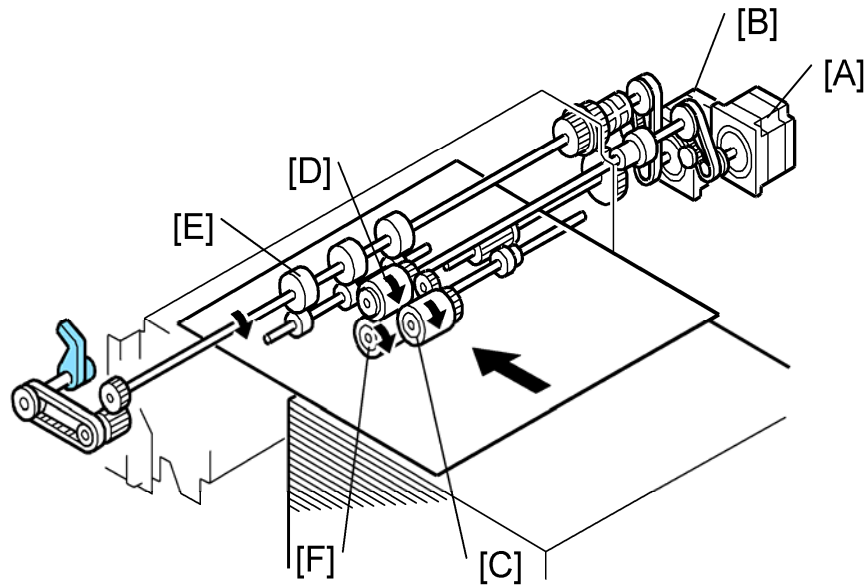

d350d931

Two stepper motors control paper feed: Paper feed motor [A] and the grip motor [B]. The paper feed motor [A] drives the pick-up roller [C] and the paper feed roller [D]. The grip motor [B] drives the grip roller [E] that feeds the paper out of the tray, and also drives the separation roller [F].

2.2.3 PAPER SEPARATION

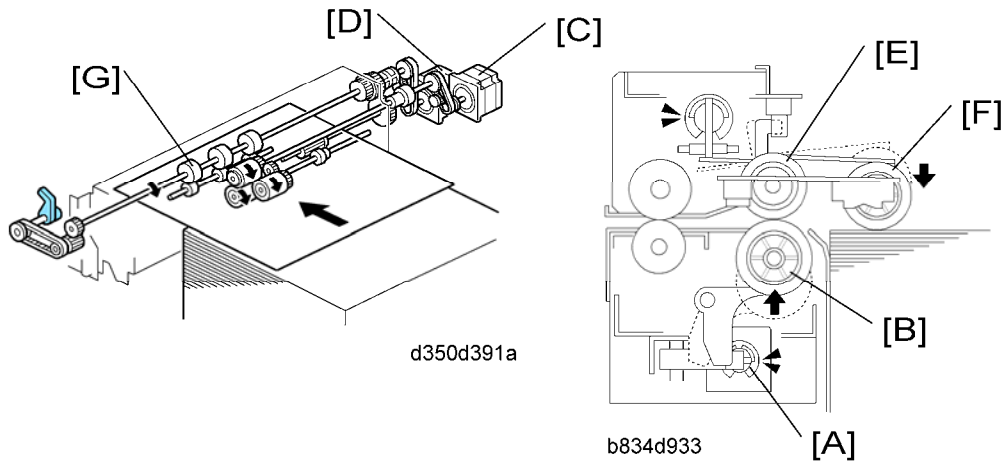

When a paper feed station is not selected:

- Separation roller solenoid [A] is de-activated
- Separation roller [B] turns freely.

When the paper feed station is selected for a job, the paper feed motor [C] and grip motor [D] turn on.

- When the feed motor [C] turns on, it drives the feed roller [E]. It also drives the pick-up roller [F] because the pick-up roller is linked to the feed roller by an idle gear.
- When the separation solenoid [A] turns on, the separation roller [B] contacts the paper feed roller [E] and turns with the feed roller, unless more than one sheet of paper is fed. The three trays of the LCT unit use the standard FRR mechanism.
- When the paper feed motor turns on, the pick-up solenoid turns on and the pick-up roller [F] lowers until it contacts the top sheet of the paper stack and then sends it to the paper feed and separation rollers.
- When the paper feed sensor detects the leading edge of the paper, the paper feed motor switches off, the pick-up roller lifts, and the grip rollers [G] feed the paper out of the tray.

D350
RT4000
A3/12 x 18
LCT

2.2.4 PAPER DETECTION/LIFT

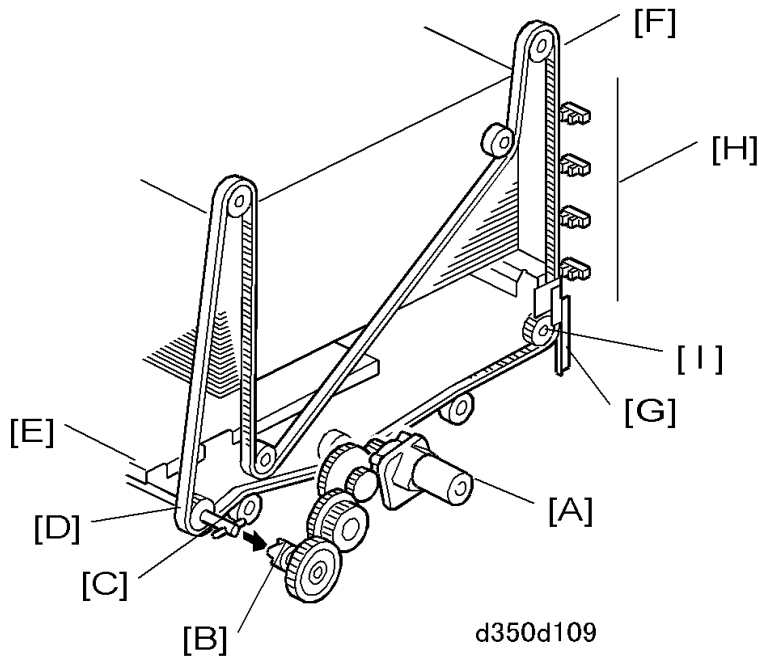

Detection

When the tray is set in the machine, the tray is detected by the drawer connector on the back side of the tray.

Lift

When the machine detects that the paper tray is set in the machine:

- The tray lift motor [A] rotates forward
- Coupling gear [B] on the tray lift motor engages pin [C] of the lift drive shaft.
- The tray drive belts [D], connected to the tray bottom plate [E], are driven by the tray lift motor via the lift drive shaft and tray lift pulleys [F].
- When the lift motor rotates forward, the tray bottom plate [E] rises. The tray rises until the top of the paper stack pushes up the pick-up roller and the lift sensor in the feed unit is de-activated.
- When the actuator [G] on the rear end of the bottom plate activates the paper height sensors [H], the remaining paper capacity is detected.

When the tray is pulled out:

- Coupling gear [B] separates from pin [C] and the tray bottom plate goes down.
- A damper [I] slows the descent of the bottom plate.

2.2.5 LIFT SENSOR

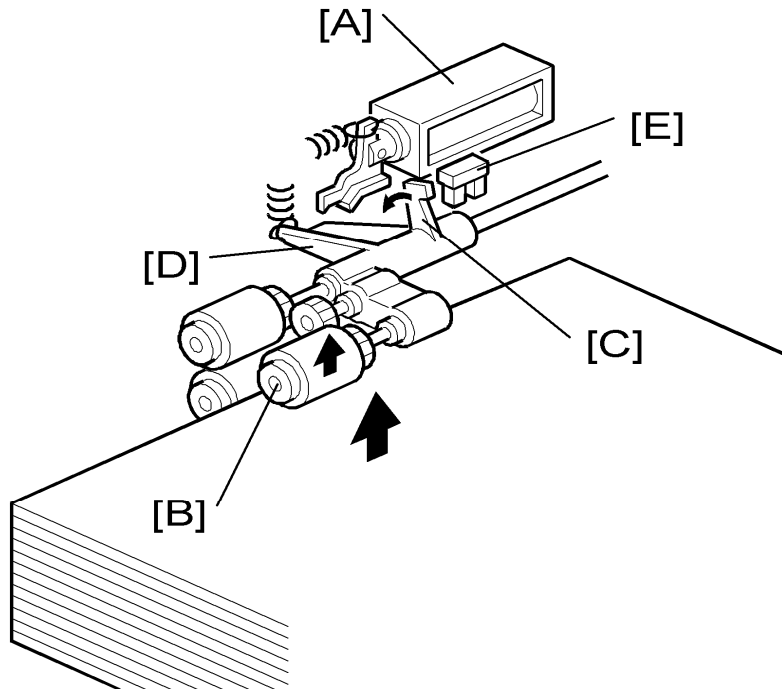

d350d934

When the lift motor turns on, the pick-up solenoid [A] activates to lower the pick-up roller [B]. When the top sheet of paper reaches the proper paper feed level, the paper pushes up the pick-up roller and the actuator [C] on the pick-up roller supporter [D] de-activates the lift sensor [E] to stop the lift motor.

After several paper feeds, the paper level gradually lowers, then the lift sensor is activated and the lift motor turns on again until the lift sensor is de-activated again.

D350
RT4000
A3/12 x 18
LCT

2.2.6 PAPER SIZE DETECTION

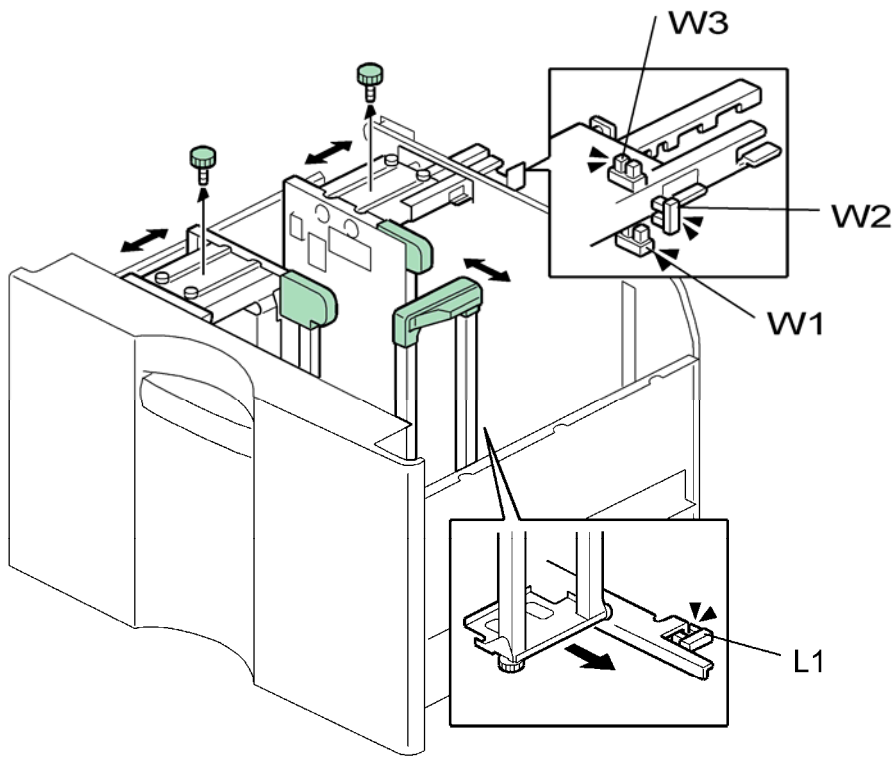

d350d111

W3	Paper Width Sensor 3
W2	Paper Width Sensor 2
W1	Paper Width Sensor 1
L1	Paper Length Sensor

The tray has three paper width sensors and one paper length sensor. The illustration above shows how these sensors are arranged in the tray.

This table below describes how the three width sensors and one length sensor are used to determine the paper size in the paper tray.

Paper Size		Width Sensors			Length Sensor	Area	
		W1	W2	W3	L1	NA	EU
Large Size	12"×18"					YES	YES
	13"×19"	L	L	L	H	NO	NO
	320×450 mm					NO	NO
A3 SEF	297×420 mm	L	L	H	H	YES	YES
A4 LEF	297×210 mm	L	L	H	L	YES	YES
DLT SEF	11"×17"	L	H	L	H	YES	YES
LT LEF	11"×8½"	L	H	L	L	YES	YES
B4 SEF	257×364 mm	L	H	H	H	YES	YES
B5 LEF	257×182 mm	L	H	H	L	YES	YES
A4 SEF	210×297 mm	H	L	L	H	NO	YES
LT SEF	8½"×11"	H	L	L	H	YES	NO
A5 LEF	210×148 mm	H	L	L	L	NO	YES
HLT LEF	8½"×5½"	H	L	L	L	YES	NO
B5 SEF	182×257 mm	H	L	H	H	NO	NO
F SEF	8"×13"	H	L	H	H	YES	YES
A5 SEF	148×210 mm	H	H	L	L	YES	YES
HLT SEF	5½"×8½"	H	H	H	L	YES	YES

D350
RT4000
A3/12 x 18
LCT

Paper Handling

Table Key

YES:	Detected automatically
NO:	Not detected automatically. Requires size setting change with the "Tray Paper Setting" key on the copier operation panel to detect the desired paper size.
H:	Sensor OFF
L:	Sensor ON

2.2.7 REMAINING PAPER DETECTION

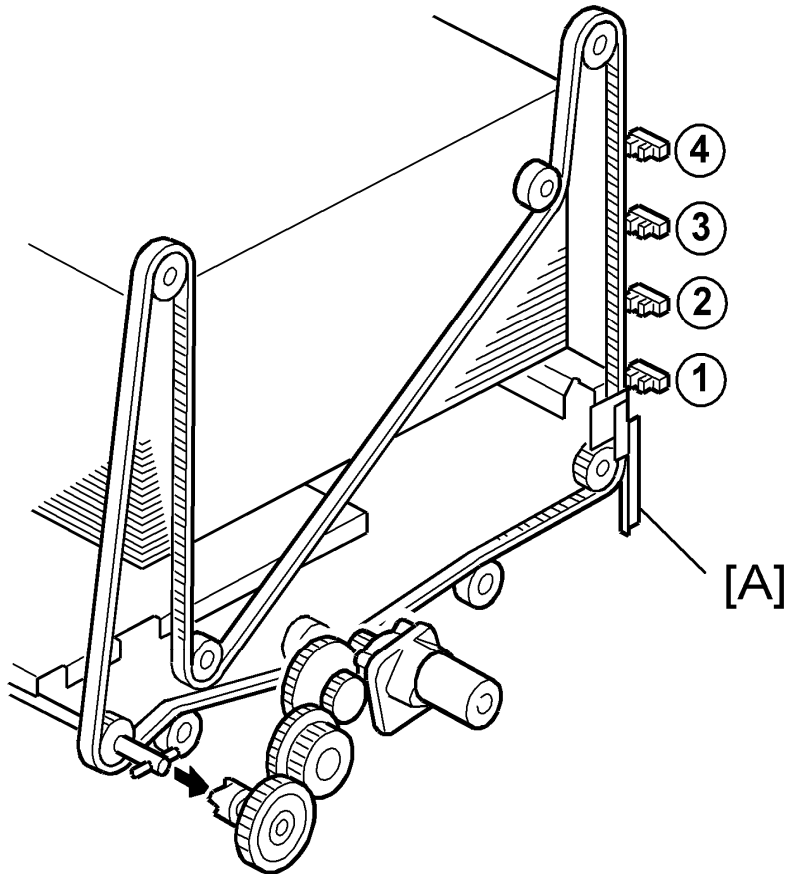

D350
RT4000
A3/12 x 18
LCT

d350d109a

[A]	Paper Height Sensor Actuator
①	Paper Height Sensor 1
②	Paper Height Sensor 2
③	Paper Height Sensor 3
④	Paper Height Sensor 4 (Near End)

Paper Handling

The tray has four paper height sensors. The amount of paper remaining in the tray is detected by the three paper height photo-interrupter sensors on the left rail as the bottom plate rises. Five states, determined by the position of the actuator [A] are possible.

1. With the actuator [A] below paper height sensor ①, no sensor is actuated and the display indicates 100%.
2. When the actuator passes paper height sensor ①, the display indicates 75% of the paper supply remaining.
3. When the actuator passes paper height sensor ②, the display indicates 50% of the paper supply remaining.
4. When the actuator passes paper height sensor ③, the display indicates 25% of the paper supply remaining.
5. When the actuator enters the gap of the near end sensor ④, and then passes paper height sensor ③, the machine signals near end.
6. Finally, when the last sheet feeds, the paper end sensor (a photosensor) signals that the tray is empty.

2.2.8 PAPER END DETECTION

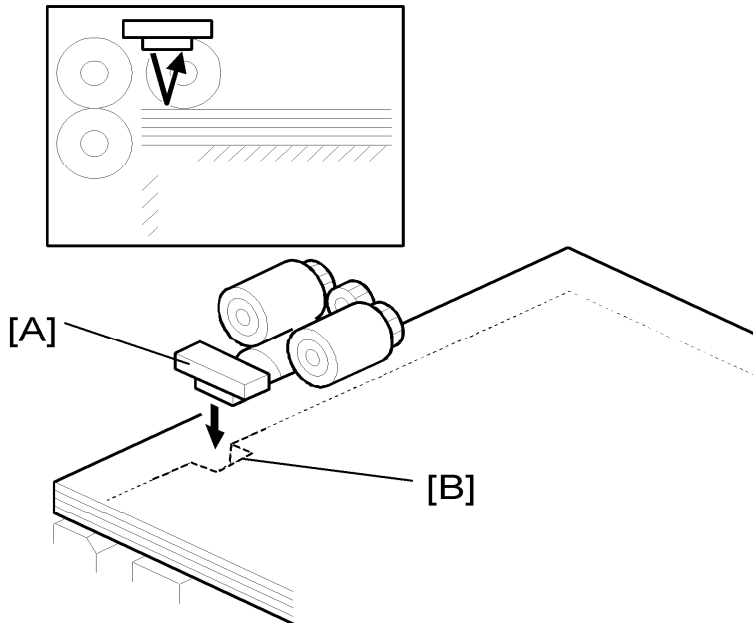

d350d936

The paper end sensor [A] (a photosensor) detects the top sheet of the paper in the tray by monitoring the reflected light. After the last sheet in the tray leaves the tray, the paper end sensor does not receive the reflected light due to cutout [B]. This causes the tray lift motor to reverse for 2 seconds and lower the tray bottom plate.

D350
RT4000
A3/12 x 18
LCT

2.2.9 AIR-ASSISTED FEED MECHANISM

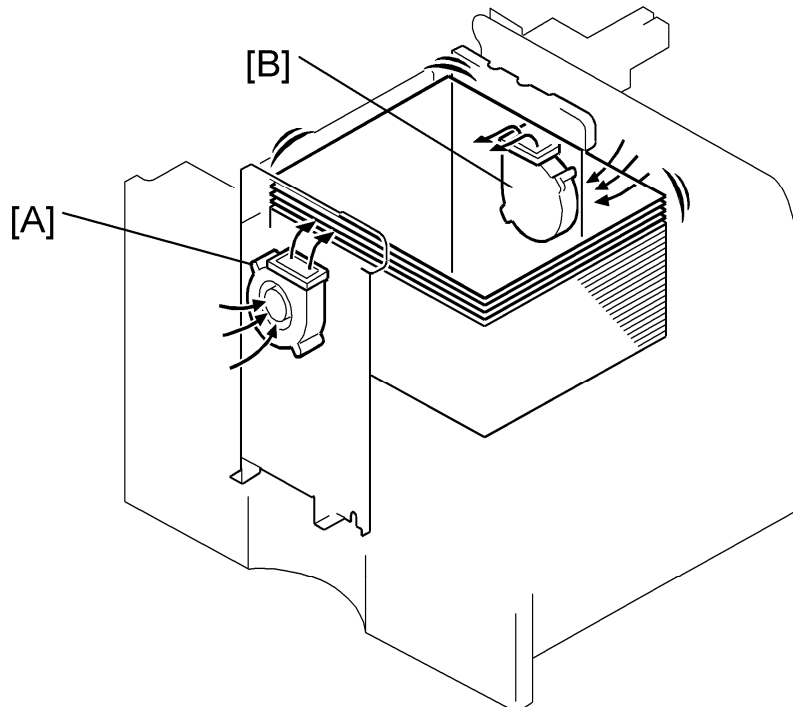

d350d935a

Two air assist fans [A] and [B] comprise the air assist mechanism.

The air flow created by the opposing fans floats the first sheet off the top of the stack. This assists in the separation of the top sheet from the sheet below and prevents double-feeding.

This only works when feeding the following paper types: Thick 2, Thick 3, Special 2.

2.2.10 PAPER EXIT

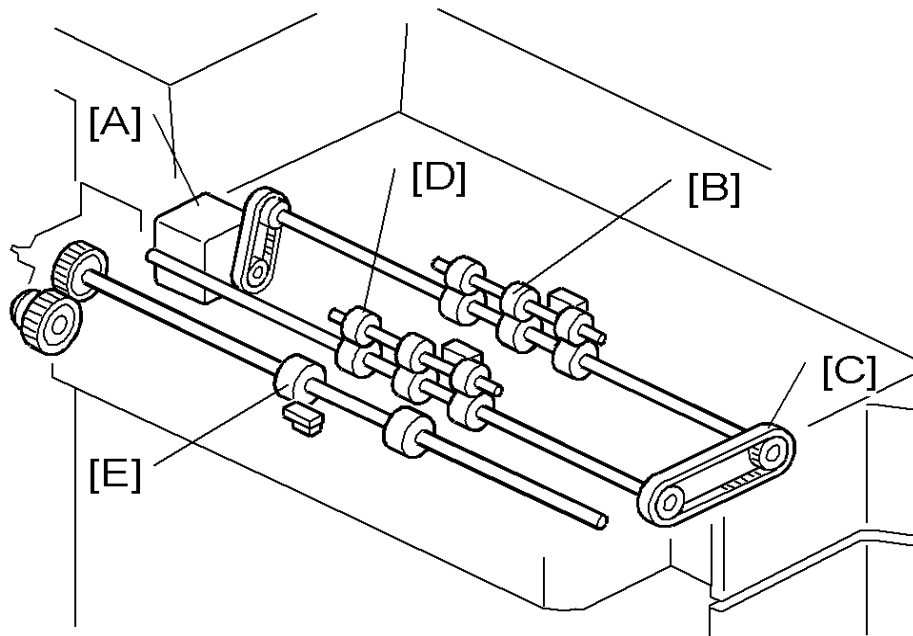

d350d935

The LCT exit motor [A] drives the first set of exit rollers [B] and timing belt [C] which in turn drives the second set of exit rollers [D]. The entrance roller of the main machine [E] feeds the paper as soon as it exits the LCIT.

D350
RT4000
A3/12 x 18
LCT

Paper Handling

2.2.11 IMAGE SKEW

Image skew may occur when using the LCT RT4000. The following is the specification (allowed margin of error) for image skew:

+/- 1mm (B5 SEF, A4 SEF, LT SEF, A3, DLT)

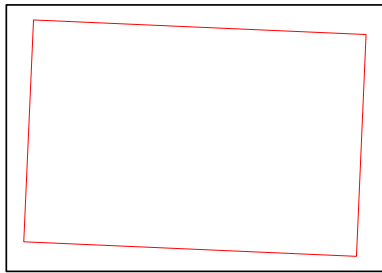

D498

FAX OPTION TYPE C7501

REVISION HISTORY		
Page	Date	Added/Updated/New
174	06/14/2010	Corrected description for User Parameter Switch 21 Bit 3

D498 FAX OPTION TYPE C7501

TABLE OF CONTENTS

1. INSTALLATION	1
1.1 INSTALLATION.....	1
1.1.1 FAX UNIT (D459).....	1
Component Check.....	1
Installation Procedure.....	2
1.1.2 G3 INTERFACE UNIT (D357).....	7
Component Check.....	7
2. REPLACEMENT AND ADJUSTMENT	14
2.1 FCU.....	14
3. TROUBLESHOOTING	15
3.1 ERROR CODES	15
3.2 IFAX TROUBLESHOOTING	36
3.3 IP-FAX TROUBLESHOOTING	40
3.3.1 IP-FAX TRANSMISSION	40
Cannot send by IP Address/Host Name	40
Cannot send via VoIP Gateway.....	41
Cannot send by Alias Fax number.	43
3.3.2 IP-FAX RECEPTION	45
Cannot receive by IP Address/Host name.....	45
Cannot receive by VoIP Gateway.....	46
Cannot receive by Alias Fax number.....	47
4. SERVICE TABLE	49
4.1 CAUTIONS	49
4.2 SERVICE PROGRAM TABLES	50
4.2.1 SP1-XXX (BIT SWITCHES).....	50
4.2.2 SP2-XXX (RAM DATA).....	52
4.2.3 SP3-XXX (TEL LINE SETTINGS).....	53

4.2.4 SP4-XXX (ROM VERSIONS).....	55
4.2.5 SP5-XXX (INITIALIZING).....	56
4.2.6 SP6-XXX (REPORTS)	57
4.2.7 SP7-XXX (TEST MODES)	60
4.2.8 SP9-XXX (DESIGN SWITCH MODE).....	62
4.3 BIT SWITCHES.....	63
4.3.1 SYSTEM SWITCHES	63
4.3.2 I-FAX SWITCHES	82
4.3.3 PRINTER SWITCHES	91
4.3.4 COMMUNICATION SWITCHES.....	100
4.3.5 G3 SWITCHES	113
4.3.6 G3-2 AND G3-3 SWITCHES.....	124
4.3.7 G4 INTERNAL SWITCHES.....	134
4.3.8 G4 PARAMETER SWITCHES	134
4.3.9 IP FAX SWITCHES.....	134
4.4 NCU PARAMETERS.....	143
4.5 DEDICATED TRANSMISSION PARAMETERS.....	159
4.5.1 PROGRAMMING PROCEDURE	159
4.5.2 PARAMETERS	160
Fax Parameters.....	160
E-mail Parameters.....	164
4.6 SERVICE RAM ADDRESSES	168
5. DETAILED SECTION DESCRIPTIONS.....	179
5.1 OVERVIEW.....	179
5.2 BOARDS	180
5.2.1 FCU	180
5.2.2 MBU	181
5.2.3 SG3 BOARD	182
5.3 VIDEO DATA PATH.....	184
5.3.1 TRANSMISSION.....	184
Memory Transmission and Parallel Memory Transmission	184
Immediate Transmission	185
JBIG Transmission	185
Adjustments.....	185
5.3.2 RECEPTION	186

5.4 FAX COMMUNICATION FEATURES	187
5.4.1 MULTI-PORT	187
5.4.2 DOCUMENT SERVER.....	188
5.4.3 INTERNET MAIL COMMUNICATION.....	189
Mail Transmission	189
Mail Reception.....	191
Handling Mail Reception Errors.....	193
Secure Internet Reception.....	194
Transfer Request: Request By Mail.....	194
E-Mail Options (Sub TX Mode).....	195
5.5 IP-FAX	199
5.5.1 WHAT IS IP-FAX?	199
5.5.2 T.38 PACKET FORMAT	199
UDP Related Switches.....	199
5.5.3 SETTINGS	199
6. SPECIFICATIONS.....	200
6.1 GENERAL SPECIFICATIONS	200
6.2 CAPABILITIES OF PROGRAMMABLE ITEMS	202
6.3 IFAX SPECIFICATIONS	204
6.4 IP-FAX SPECIFICATIONS.....	205
6.5 FAX UNIT CONFIGURATION.....	206

Read This First

Important Safety Notices

WARNING

- Never install telephone wiring during a lightning storm.
- Never install telephone jacks in wet locations unless the jack is specifically designed for wet locations.
- Never touch uninsulated telephone wires or terminals unless the telephone line has been disconnected at the network interface.
- Use caution when installing or modifying telephone lines.
- Avoid using a telephone (other than a cordless type) during an electrical storm. There may be a remote risk of electric shock from lightning.
- Do not use a telephone or cellular phone to report a gas leak in the vicinity of the leak.

CAUTION

- Before installing the fax unit, switch off the main switch, and disconnect the power cord.
- The fax unit contains a lithium battery. The danger of explosion exists if a battery of this type is incorrectly replaced. Replace only with the same or an equivalent type recommended by the manufacturer. Discard batteries in accordance with the manufacturer's instructions and local regulations.







Note

- **Note for Australia:**
- Unit must be connected to Telecommunication Network through a line cord which meets the requirements of ACA Technical Standard TS008.

Symbols and Abbreviations

Conventions Used in this Manual

This manual uses several symbols.

Symbol	What it means
	Refer to section number
	Screw
	Connector
	E-ring
	Clip ring
	Clamp

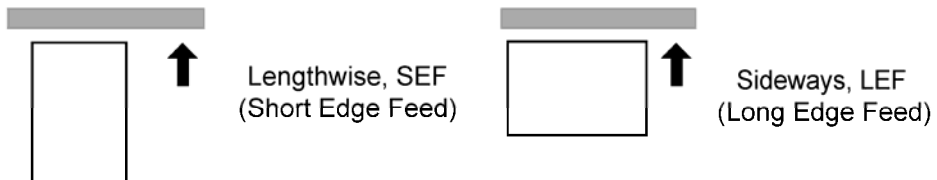

Cautions, Notes, etc.

The following headings provide special information:

WARNING

- Failure to obey warning information could result in serious injury or death.

CAUTION

- Obey these guidelines to ensure safe operation and prevent minor injuries.

Important

- Obey these guidelines to avoid problems such as misfeeds, damage to originals, loss of valuable data and to prevent damage to the machine.
- Always obey these guidelines to avoid serious problems such as misfeeds, damage to originals, loss of valuable data and to prevent damage to the machine. **bold** is added for emphasis.

Note

- This document provides tips and advice about how to best service the machine.

1. INSTALLATION

1.1 INSTALLATION

1.1.1 FAX UNIT (D459)

Component Check

Check the quantity and condition of the components against the following list.

No.	Description	Q'ty
1	PCB: Interface Board	1
2	PCB: FCU	1
3	Speaker	1
4	Ferrite Core	1
5	Screws	10
6	Fax Key	2
7	S/N Decal	1
8	G3 Decal	1
9	Telephone Cable (NA only)	1
10	Multi-Language Decals (EU only)	2
11	Fax NA Decal (NA, AA only)	1
12	EMC Address Decal (EU only)	1
13	Quick Reference Fax Guide (NA, AA only)	1
14	FCC Decal (NA only)	1

Installation

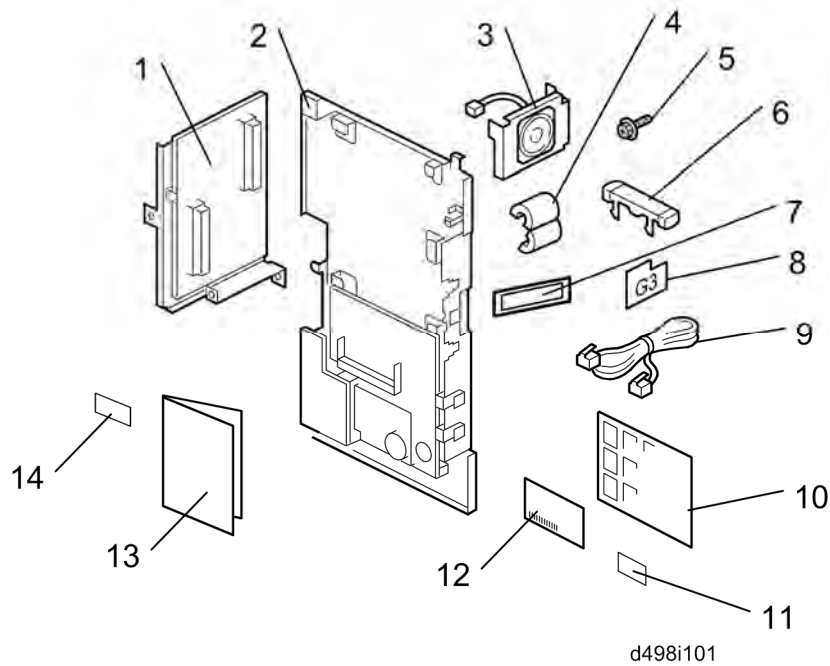

Installation Procedure

Important!

Before installing this fax unit,

1. Print out all data in the printer buffer.
2. Turn off the main power switch and disconnect the power cord and the network cable.

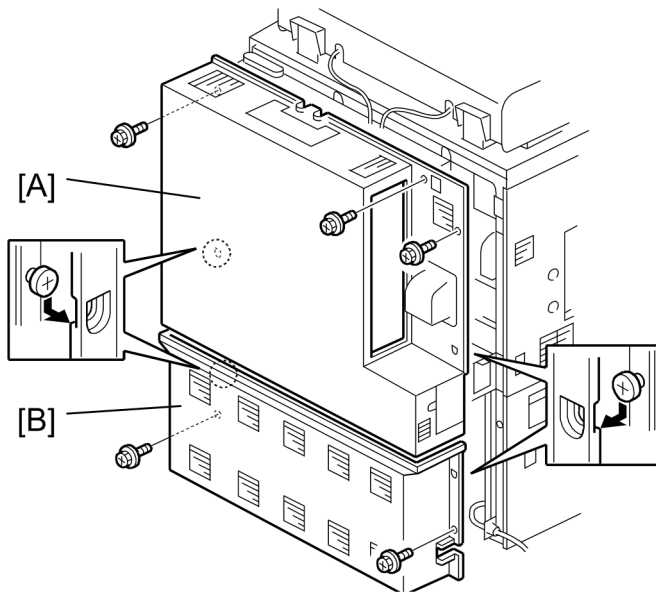

d498i102

1. Remove:

- [A] Upper cover (⚙️x3, Stepped ⚙️x2)
- [B] Lower Cover (⚙️x2)

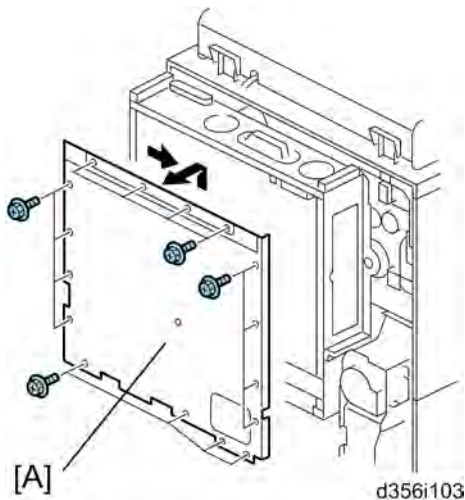

d356i103

- 2. Remove the controller box cover [A] (⚙️x16).

Installation

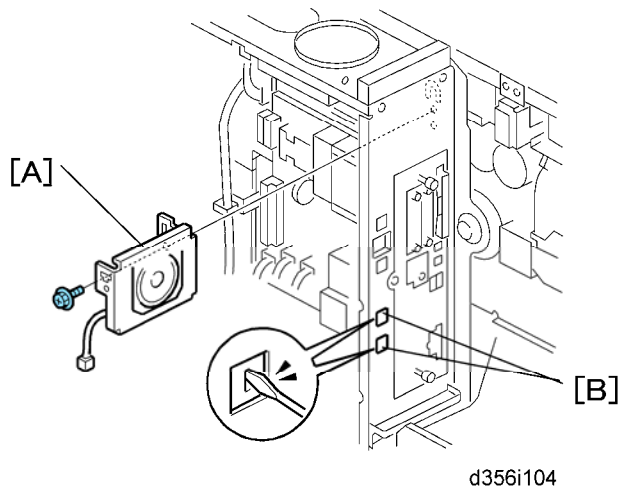

3. Attach the speaker [A] (⚙️x1)
4. Use the tip of a small screwdriver to break out plastic covers [B] of the "TEL" and "LINE" 1" jacks.

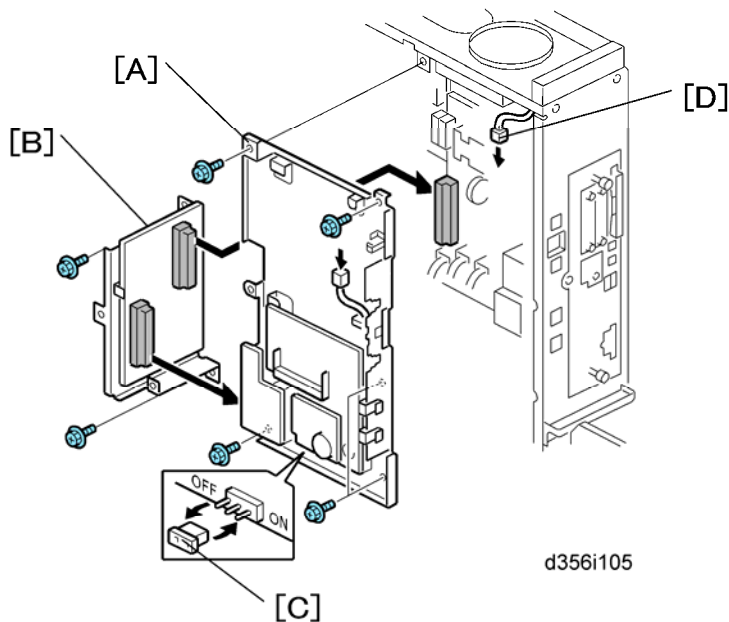

5. Attach the FCU [A] to the controller box (⚙️x4).
6. Attach the interface board [B] to the FCU and controller box (⚙️x2)
7. Detach the MBU battery jumper [C] and reattach it at the "ON" position.

↓ Note

- If the MBU jumper is not set to ON, this can cause SC819 or SC820 when the main power switch is turned on. Also, when the main power switch is turned off, fax memory will be cleared.
8. Press down on the MBU to confirm that it is seated correctly.

9. Connect the speaker harness [D] to the FCU (Ⓜ x1).
10. Check the FCU connection and confirm that it is secure.

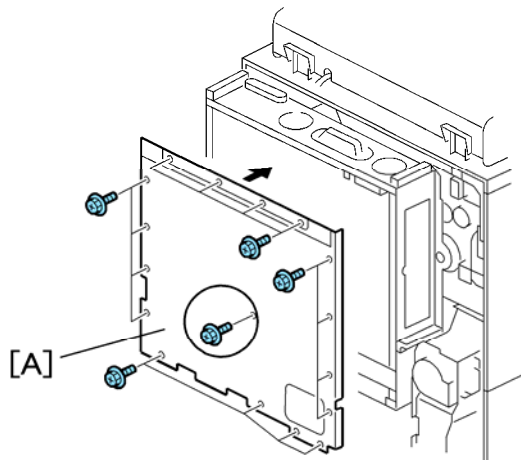

d356i106

11. Reattach:
 - Controller box [A] (Ⓜ x16)
 - Rear lower cover (Ⓜ x2)
 - Rear upper cover (Ⓜ x3, Stepped Ⓜ x2)
12. Connect the telephone cable to the "LINE 1" jack.

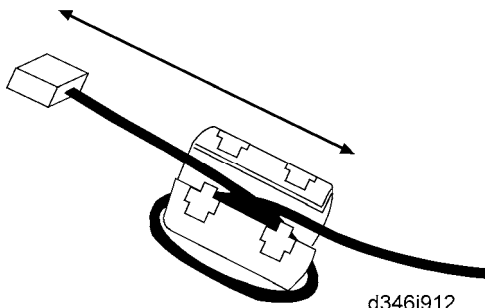

d346i912

13. Attach the ferrite core to the telephone cable.

↓ Note

- The end of the ferrite core must be about 5 cm (2.1") from the end of the cable.

Installation

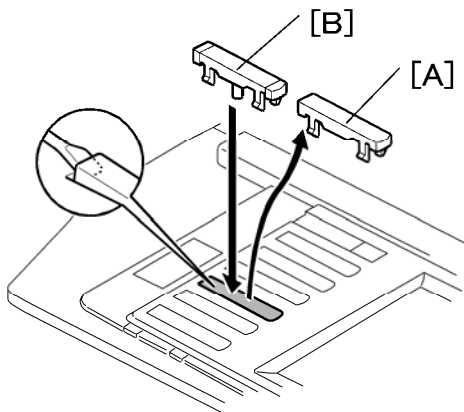

d356i107

14. Replace the key slot cover [A] (fourth from the bottom) with the fax key [B].

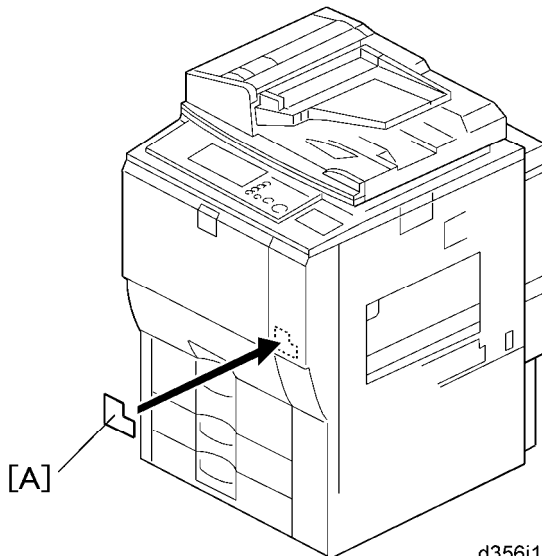

d356i108

15. Write down the serial number of the fax unit to the serial number decal.
16. Attach:
 - Super G3 decal [A]
 - Serial number decal, under the machine serial number decal
17. Attach the FCC decal on the rear cover of the copier (NA only).
18. Confirm that the machine is grounded correctly at the power source.
19. Switch on the machine and confirm that it is operating correctly.
20. Confirm that the date and time settings (User Tools) are correct.
21. Keep the EMC address decal at the customer site (EU only).

1.1.2 G3 INTERFACE UNIT (D357)

Component Check

Check the quantity and condition of the components against the following list.

No.	Description	Q'ty
1	PCB: CCUIF	1
2	PCB: SG3	1
3	Screws	7
4	Harness Clamp	1
5	Ferrite Core	1
6	Telephone Cable (NA only)	1
7	Harness	1
8	Flat Cable	1
9	EMC Address Decal (EU only)	1
10	FCC Decal (NA only)	1

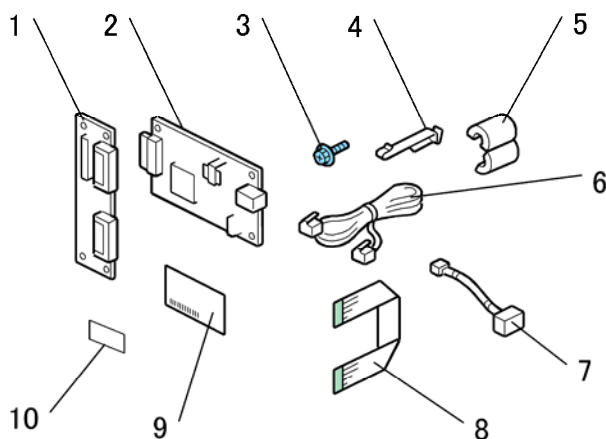

d357i101

Installation

Important!

Before installing this optional unit,

1. Print out all data in the printer buffer.
2. Turn off the main switch and disconnect the power cord and the network cable.

You can add two more SG3 boards to this model. Follow the procedures for adding the single SG3 board installation or double SG3 boards installation.

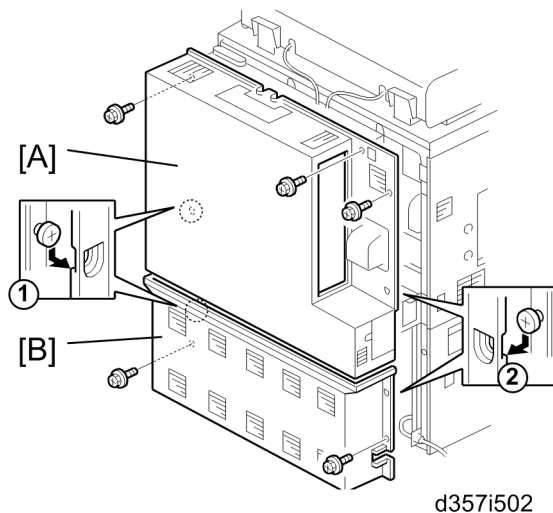

1. Remove:
[A] Upper cover (⚙️x3, Stepped ⚙️x2)
[B] Lower Cover (⚙️x2)

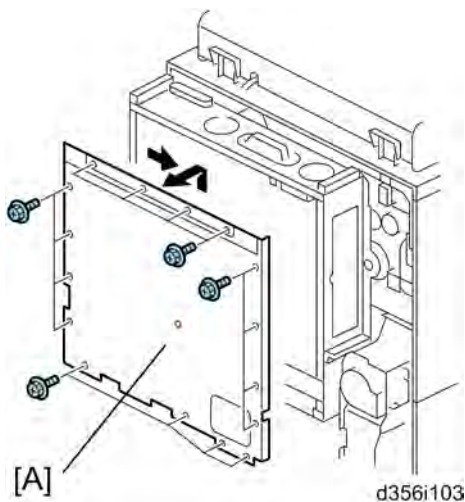

2. Remove the controller box cover [A] (⚙️x16)

★ Important

- If the Fax Unit (D498) has already been installed, skip Steps 4, 5 and go to

Step 6.

3. Disconnect the speaker harness (🔧x1).
4. Remove the FCU and interface board (🔧x5),

To install a Single G3 Board:

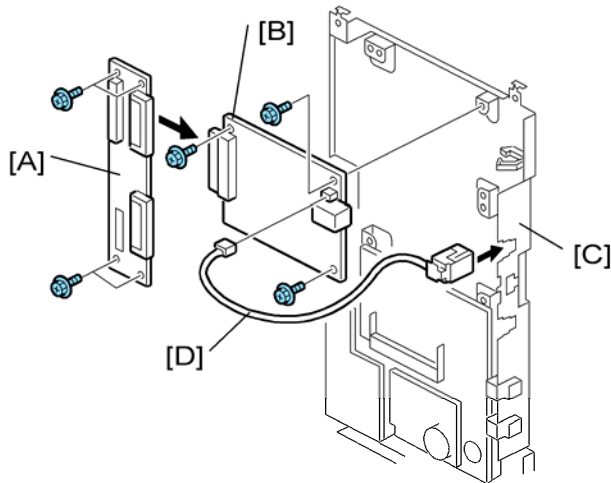

d357i102

1. Attach the CCUIF [A] to the SG3 board [B].
2. Attach the assembled CCUIF/SG3 board to the FCU [C] (🔧x7).
3. Connect harness [D] to the FCU [C].

To install the Double SG3 Boards:

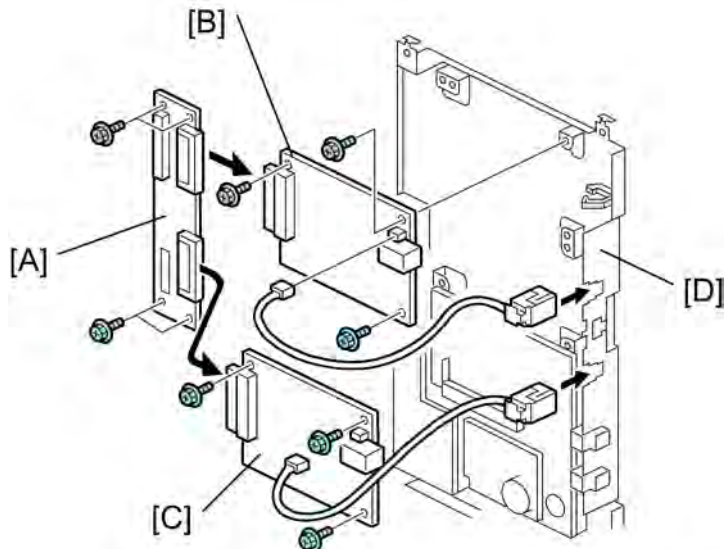

d357i102a

1. Connect the CCUIF [A] to the SG3 boards [B].
2. Attach the assembled CCUIF/SG3 boards to the FCU [C] (🔧x9).

Installation

To complete the installation:

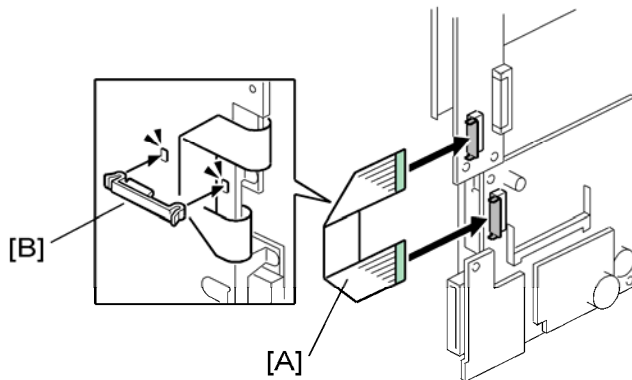

d357i103

1. Connect the flat cable [A] to the CCUIF and FCU.
2. Attach the clamp [B] as shown.

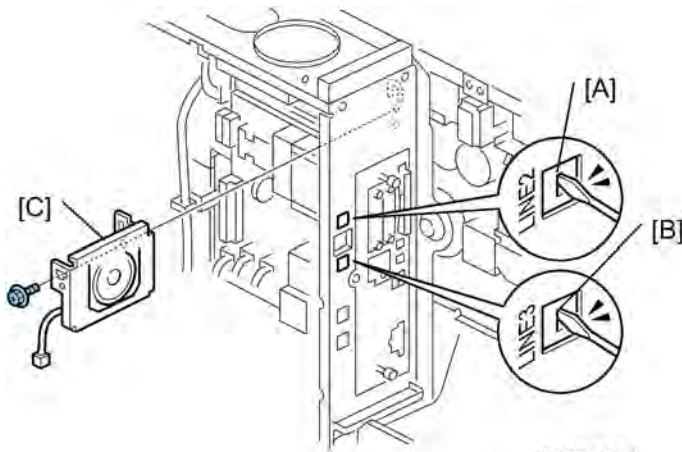

d357i104A

3. Use the tip of a small screwdriver to break out the "LINE2" jack cover [A] (for one SG3 board), or the "LINE2" and "LINE3" jack covers [A] and [B] (for two SG3 boards).
4. Attach the speaker [C] (⚙️x1).

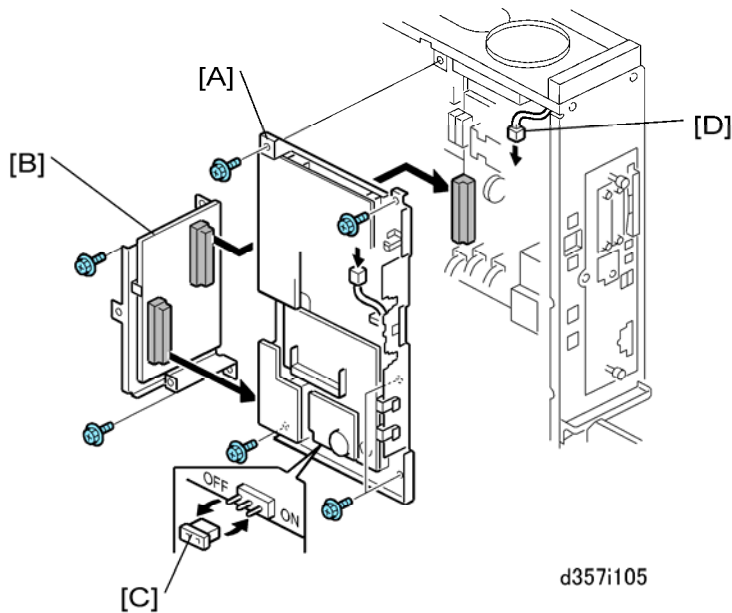

5. Install the FCU [A] on the controller board (⚙️ x4).
6. Attach the interface board [B] to the FCU and controller box (⚙️ x2).
7. Detach the MBU battery jumper [C] and reattach it at the "ON" position.

↓ Note

- If the MBU jumper is not set to ON, this can cause SC819 or SC820 when the main power switch is turned on. Also, when the main power switch is turned off, fax memory will be cleared.

8. Press down on the MBU to confirm that it is seated correctly.

↓ Note

- If the MBU is not attached correctly, this will cause SC672.

9. Connect the speaker harness [D] to the FCU (🔌 x1).
10. Check the FCU connection and confirm that it is secure.

Installation

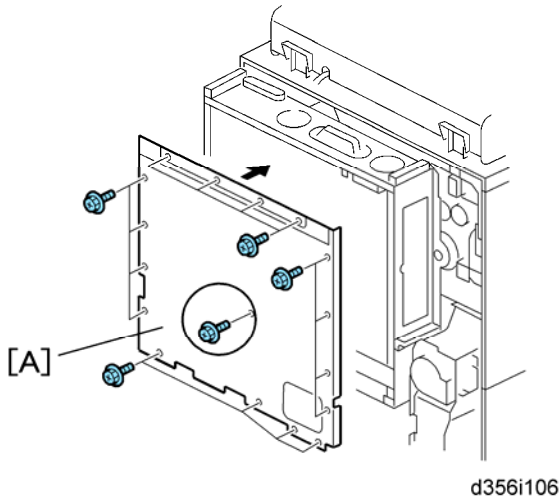

11. Reattach:

- Controller box [A] (⚙️x16)
- Rear lower cover (⚙️x2)
- Rear upper cover (⚙️x3, Stepped ⚙️x2)

12. Connect the telephone cable to the "LINE 2" or "LINE 3" jack.

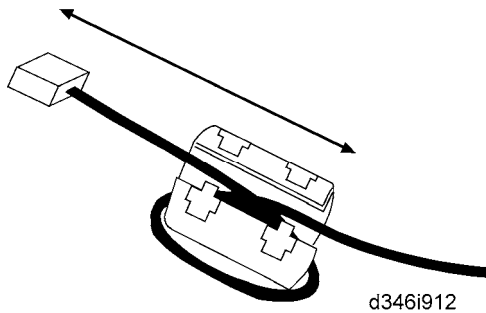

13. Attach the ferrite core to the telephone cable.

↓ Note

- The end of the ferrite core must be about 5 cm (2.1") from the end of the cable.

14. Attach the FCC decal to the rear cover of the copier (NA only).

15. Confirm that the machine is grounded correctly at the power source.

16. Switch on the machine and confirm that it is operating correctly.

17. Confirm that the date and time settings (User Tools) are correct.

18. Enter the SP mode.

19. Do either of these settings:

If one SG3 board is installed:

- Do SP1104-23
- Set Bit 1 of Communication Switch 16 to "1".

-or-

If two SG3 boards are installed:

- Do SP1104-23
- Set Bit 1 and Bit 3 of the Communication Switch 16 to "1".

20. Exit the SP mode.
21. Cycle the machine off/on.
22. Print out the system parameter list and confirm that "G3" is listed as an option.
23. Do the program settings required for PSTN-2 communication.
24. Keep the EMC address decal at the customer site (EU only).

2. REPLACEMENT AND ADJUSTMENT

2.1 FCU

1. When you replace the FCU board, remove the MBU board from the old FCU board and install it on the new FCU board.
2. Set the correct date and time with the User Tools:
 - User Tools> System Settings> Timer Setting> Set Date/Time

 Note

- Do not turn off the battery switch (SW1).
- Do SP6101 to print the system parameters. Then check the settings.

3. TROUBLESHOOTING

3.1 ERROR CODES

If an error code occurs, retry the communication. If the same problem occurs, try to fix the problem as suggested below. Note that some error codes appear only in the error code display and on the service report.

Code	Meaning	Suggested Cause/Action
0-00	DIS/NSF not detected within 40 s of Start being pressed	<ul style="list-style-type: none"> ▪ Check the line connection. ▪ Check the NCU - FCU connectors. ▪ The machine at the other end may be incompatible. ▪ Replace the NCU or FCU. ▪ Check for DIS/NSF with an oscilloscope. ▪ If the rx signal is weak, there may be a bad line.
0-01	DCN received unexpectedly	<ul style="list-style-type: none"> ▪ The other party is out of paper or has a jammed printer. ▪ The other party pressed Stop during communication.
0-03	Incompatible modem at the other end	<ul style="list-style-type: none"> ▪ The other terminal is incompatible.
0-04	CFR or FTT not received after modem training	<ul style="list-style-type: none"> ▪ Check the line connection. ▪ Check the NCU - FCU connectors. ▪ Try changing the tx level and/or cable equalizer settings. ▪ Replace the FCU or NCU. ▪ The other terminal may be faulty; try sending to another machine. ▪ If the rx signal is weak or defective, there may be a bad line.

Error Codes

Code	Meaning	Suggested Cause/Action
		<p>Cross reference</p> <ul style="list-style-type: none"> ▪ Tx level - NCU Parameter 01 (PSTN) ▪ Cable equalizer - G3 Switch 07 (PSTN) ▪ Dedicated Tx parameters - Section 4
0-05	Unsuccessful after modem training at 2400 bps	<ul style="list-style-type: none"> ▪ Check the line connection. ▪ Check the NCU - FCU connectors. ▪ Try adjusting the tx level and/or cable equalizer. ▪ Replace the FCU or NCU. ▪ Check for line problems. <p>Cross reference</p> <ul style="list-style-type: none"> ▪ See error code 0-04.
0-06	The other terminal did not reply to DCS	<ul style="list-style-type: none"> ▪ Check the line connection. ▪ Check the FCU - NCU connectors. ▪ Try adjusting the tx level and/or cable equalizer settings. ▪ Replace the NCU or FCU. ▪ The other end may be defective or incompatible; try sending to another machine. ▪ Check for line problems. <p>Cross reference</p> <ul style="list-style-type: none"> ▪ See error code 0-04.
0-07	No post-message response from the other end after a page was sent	<ul style="list-style-type: none"> ▪ Check the line connection. ▪ Check the FCU - NCU connectors. ▪ Replace the NCU or FCU. ▪ The other end may have jammed or run out of paper. ▪ The other end user may have disconnected the call. ▪ Check for a bad line. ▪ The other end may be defective; try sending to another machine.

Code	Meaning	Suggested Cause/Action
0-08	The other end sent RTN or PIN after receiving a page, because there were too many errors	<ul style="list-style-type: none"> ▪ Check the line connection. ▪ Check the FCU - NCU connectors. ▪ Replace the NCU or FCU. ▪ The other end may have jammed, or run out of paper or memory space. ▪ Try adjusting the tx level and/or cable equalizer settings. ▪ The other end may have a defective modem/NCU/FCU; try sending to another machine. ▪ Check for line problems and noise. <p>Cross reference</p> <ul style="list-style-type: none"> ▪ Tx level - NCU Parameter 01 (PSTN) ▪ Cable equalizer - G3 Switch 07 (PSTN) ▪ Dedicated Tx parameters - Section 4
0-14	Non-standard post message response code received	<ul style="list-style-type: none"> ▪ Check the FCU - NCU connectors. ▪ Incompatible or defective remote terminal; try sending to another machine. ▪ Noisy line: resend. ▪ Try adjusting the tx level and/or cable equalizer settings. ▪ Replace the NCU or FCU. <p>Cross reference</p> <ul style="list-style-type: none"> ▪ See error code 0-08.
0-15	The other terminal is not capable of specific functions.	<ul style="list-style-type: none"> ▪ The other terminal is not capable of accepting the following functions, or the other terminal's memory is full. ▪ Confidential rx ▪ Transfer function ▪ SEP/SUB/PWD/SID
0-16	CFR or FTT not detected after modem training in	<ul style="list-style-type: none"> ▪ Check the line connection. ▪ Check the FCU - NCU connectors.

Error Codes

Code	Meaning	Suggested Cause/Action
	confidential or transfer mode	<ul style="list-style-type: none"> ▪ Replace the NCU or FCU. ▪ Try adjusting the tx level and/or cable equalizer settings. ▪ The other end may have disconnected, or it may be defective; try calling another machine. ▪ If the rx signal level is too low, there may be a line problem. <p>Cross reference</p> <ul style="list-style-type: none"> ▪ See error code 0-08.
0-20	Facsimile data not received within 6 s of retraining	<ul style="list-style-type: none"> ▪ Check the line connection. ▪ Check the FCU - NCU connectors. ▪ Replace the NCU or FCU. ▪ Check for line problems. ▪ Try calling another fax machine. ▪ Try adjusting the reconstruction time for the first line and/or rx cable equalizer setting. <p>Cross reference</p> <ul style="list-style-type: none"> ▪ Reconstruction time - G3 Switch 0A, bit 6 ▪ Rx cable equalizer - G3 Switch 07 (PSTN)
0-21	EOL signal (end-of-line) from the other end not received within 5 s of the previous EOL signal	<ul style="list-style-type: none"> ▪ Check the connections between the FCU, NCU, & line. ▪ Check for line noise or other line problems. ▪ Replace the NCU or FCU. ▪ The remote machine may be defective or may have disconnected. <p>Cross reference</p> <ul style="list-style-type: none"> ▪ Maximum interval between EOLs and between ECM frames - G3 Bit Switch 0A, bit 4
0-22	The signal from the other end was interrupted for more than the acceptable modem carrier drop time	<ul style="list-style-type: none"> ▪ Check the line connection. ▪ Check the FCU - NCU connectors. ▪ Replace the NCU or FCU. ▪ Defective remote terminal.

Code	Meaning	Suggested Cause/Action
	(default: 200 ms)	<ul style="list-style-type: none"> ▪ Check for line noise or other line problems. ▪ Try adjusting the acceptable modem carrier drop time. <p>Cross reference</p> <ul style="list-style-type: none"> ▪ Acceptable modem carrier drop time - G3 Switch 0A, bits 0 and 1
0-23	Too many errors during reception	<ul style="list-style-type: none"> ▪ Check the line connection. ▪ Check the FCU - NCU connectors. ▪ Replace the NCU or FCU. ▪ Defective remote terminal. ▪ Check for line noise or other line problems. ▪ Try asking the other end to adjust their tx level. ▪ Try adjusting the rx cable equalizer setting and/or rx error criteria. <p>Cross reference</p> <ul style="list-style-type: none"> ▪ Rx cable equalizer - G3 Switch 07 (PSTN) ▪ Rx error criteria - Communication Switch 02, bits 0 and 1
0-30	The other terminal did not reply to NSS(A) in AI short protocol mode	<ul style="list-style-type: none"> ▪ Check the line connection. ▪ Check the FCU - NCU connectors. ▪ Try adjusting the tx level and/or cable equalizer settings. ▪ The other terminal may not be compatible. <p>Cross reference</p> <ul style="list-style-type: none"> ▪ Dedicated tx parameters - Section 4
0-32	The other terminal sent a DCS, which contained functions that the receiving machine cannot handle.	<ul style="list-style-type: none"> ▪ Check the protocol dump list. ▪ Ask the other party to contact the manufacturer.
0-52	Polarity changed during communication	<ul style="list-style-type: none"> ▪ Check the line connection. ▪ Retry the communication.

Error Codes

Code	Meaning	Suggested Cause/Action
0-55	FCE does not detect the SG3-V34.	<ul style="list-style-type: none"> ▪ FCU firmware or board defective. ▪ SG3-V34 firmware or board defective.
0-56	The stored message data exceeds the capacity of the mailbox in the SG3-V34.	<ul style="list-style-type: none"> ▪ SG3-V34 firmware or board defective.
0-70	The communication mode specified in CM/JM was not available (V.8 calling and called terminal)	<ul style="list-style-type: none"> ▪ The other terminal did not have a compatible communication mode (e.g., the other terminal was a V.34 data modem and not a fax modem.) ▪ A polling tx file was not ready at the other terminal when polling rx was initiated from the calling terminal.
0-74	The calling terminal fell back to T.30 mode, because it could not detect ANSam after sending CI.	<ul style="list-style-type: none"> ▪ The calling terminal could not detect ANSam due to noise, etc. ▪ ANSam was too short to detect. ▪ Check the line connection and condition. ▪ Try making a call to another V.8/V.34 fax.
0-75	The called terminal fell back to T.30 mode, because it could not detect a CM in response to ANSam (ANSam timeout).	<ul style="list-style-type: none"> ▪ The terminal could not detect ANSam. ▪ Check the line connection and condition. ▪ Try receiving a call from another V.8/V.34 fax.
0-76	The calling terminal fell back to T.30 mode, because it could not detect a JM in response to a CM (CM timeout).	<ul style="list-style-type: none"> ▪ The called terminal could not detect a CM due to noise, etc. ▪ Check the line connection and condition. ▪ Try making a call to another V.8/V.34 fax.
0-77	The called terminal fell	<ul style="list-style-type: none"> ▪ The calling terminal could not detect a JM due

Code	Meaning	Suggested Cause/Action
	back to T.30 mode, because it could not detect a CJ in response to JM (JM timeout).	<p>to noise, etc.</p> <ul style="list-style-type: none"> ▪ A network that has narrow bandwidth cannot pass JM to the other end. ▪ Check the line connection and condition. ▪ Try receiving a call from another V.8/V.34 fax.
0-79	The called terminal detected CI while waiting for a V.21 signal.	<ul style="list-style-type: none"> ▪ Check for line noise or other line problems. ▪ If this error occurs, the called terminal falls back to T.30 mode.
0-80	The line was disconnected due to a timeout in V.34 phase 2 – line probing.	<p>The guard timer expired while starting these phases. Serious noise, narrow bandwidth, or low signal level can cause these errors.</p> <p>If these errors happen at the transmitting terminal:</p> <ul style="list-style-type: none"> ▪ Try making a call at a later time. ▪ Try using V.17 or a slower modem using dedicated tx parameters. ▪ Try increasing the tx level. ▪ Try adjusting the tx cable equalizer setting. <p>If these errors happen at the receiving terminal:</p> <ul style="list-style-type: none"> ▪ Try adjusting the rx cable equalizer setting. ▪ Try increasing the tx level. ▪ Try using V.17 or a slower modem if the same error is frequent when receiving from multiple senders.
0-81	The line was disconnected due to a timeout in V.34 phase 3 – equalizer training.	
0-82	The line was disconnected due to a timeout in the V.34 phase 4 – control channel start-up.	
0-83	The line was disconnected due to a timeout in the V.34 control channel restart sequence.	
0-84	The line was disconnected due to abnormal signaling in V.34 phase 4 – control channel start-up.	
		<ul style="list-style-type: none"> ▪ The signal did not stop within 10 s. ▪ Turn off the machine, then turn it back on. ▪ If the same error is frequent, replace the FCU.

Error Codes

Code	Meaning	Suggested Cause/Action
0-85	The line was disconnected due to abnormal signaling in V.34 control channel restart.	<ul style="list-style-type: none"> ▪ The signal did not stop within 10 s. ▪ Turn off the machine, then turn it back on. ▪ If the same error is frequent, replace the FCU.
0-86	The line was disconnected because the other terminal requested a data rate using MPh that was not available in the currently selected symbol rate.	<ul style="list-style-type: none"> ▪ The other terminal was incompatible. ▪ Ask the other party to contact the manufacturer.
0-87	The control channel started after an unsuccessful primary channel.	<ul style="list-style-type: none"> ▪ The receiving terminal restarted the control channel because data reception in the primary channel was not successful. ▪ This does not result in an error communication.
0-88	The line was disconnected because PPR was transmitted/received 9 (default) times within the same ECM frame.	<ul style="list-style-type: none"> ▪ Try using a lower data rate at the start. ▪ Try adjusting the cable equalizer setting.
2-11	Only one V.21 connection flag was received	<ul style="list-style-type: none"> ▪ Replace the FCU.
2-12	Modem clock irregularity	<ul style="list-style-type: none"> ▪ Replace the FCU.
2-13	Modem initialization error	<ul style="list-style-type: none"> ▪ Turn off the machine, then turn it back on. ▪ Update the modem ROM. ▪ Replace the FCU.

Code	Meaning	Suggested Cause/Action
2-23	JBIG compression or reconstruction error	<ul style="list-style-type: none"> ▪ Turn off the machine, then turn it back on. ▪ Replace the EXFUNC board if the error is frequent.
2-24	JBIG ASIC error	<ul style="list-style-type: none"> ▪ Turn off the machine, then turn it back on. ▪ Replace the EXFUNC board if the error is frequent.
2-25	JBIG data reconstruction error (BIH error)	<ul style="list-style-type: none"> ▪ JBIG data error ▪ Check the sender's JBIG function. ▪ Update the MBU ROM.
2-26	JBIG data reconstruction error (Float marker error)	
2-27	JBIG data reconstruction error (End marker error)	
2-28	JBIG data reconstruction error (Timeout)	
2-29	JBIG trailing edge maker error	<ul style="list-style-type: none"> ▪ FCU defective ▪ Check the destination device.
2-50	The machine resets itself for a fatal FCU system error	<ul style="list-style-type: none"> ▪ If this is frequent, update the ROM, or replace the FCU.
2-51	The machine resets itself because of a fatal communication error	<ul style="list-style-type: none"> ▪ If this is frequent, update the ROM, or replace the FCU.
2-53	Snd msg() in the manual task is an error because the mailbox for the operation task is full.	<ul style="list-style-type: none"> ▪ The user did the same operation many times, and this gave too much load to the machine.
4-01	Line current was cut	<ul style="list-style-type: none"> ▪ Check the line connector. ▪ Check the connection between FCU and NCU. ▪ Check for line problems.

Error Codes

Code	Meaning	Suggested Cause/Action
		<ul style="list-style-type: none"> Replace the FCU or the NCU.
4-10	Communication failed because of an ID Code mismatch (Closed Network) or Tel. No./CSI mismatch (Protection against Wrong Connections)	<ul style="list-style-type: none"> Get the ID Codes the same and/or the CSIs programmed correctly, then resend. The machine at the other end may be defective.
5-10	DCR timer expired	<ul style="list-style-type: none"> Replace the FCU.
5-20	Storage impossible because of a lack of memory	<ul style="list-style-type: none"> Temporary memory shortage. Test the SAF memory. Replace the FCU or optional EXMEM board
5-21	Memory overflow	
5-23	Print data error when printing a substitute rx or confidential rx message	<ul style="list-style-type: none"> Test the SAF memory. Ask the other end to resend the message. Replace the FCU or optional EXMEM board.
5-25	SAF file access error	<ul style="list-style-type: none"> Replace the FCU or EXMEM board.
6-00	G3 ECM - T1 time out during reception of facsimile data	<ul style="list-style-type: none"> Try adjusting the rx cable equalizer. Replace the FCU or NCU.
6-01	G3 ECM - no V.21 signal was received	
6-02	G3 ECM - EOR was received	
6-04	G3 ECM - RTC not detected	<ul style="list-style-type: none"> Check the line connection. Check connections from the NCU to the FCU. Check for a bad line or defective remote terminal. Replace the FCU or NCU.

Code	Meaning	Suggested Cause/Action
6-05	G3 ECM - facsimile data frame not received within 18 s of CFR, but there was no line fail	<ul style="list-style-type: none"> ▪ Check the line connection. ▪ Check connections from the NCU to the FCU. ▪ Check for a bad line or defective remote terminal. ▪ Replace the FCU or NCU. ▪ Try adjusting the rx cable equalizer <p>Cross reference</p> <ul style="list-style-type: none"> ▪ Rx cable equalizer - G3 Switch 07 (PSTN)
6-06	G3 ECM - coding/decoding error	<ul style="list-style-type: none"> ▪ Defective FCU. ▪ The other terminal may be defective.
6-08	G3 ECM - PIP/PIN received in reply to PPS.NULL	<ul style="list-style-type: none"> ▪ The other end pressed Stop during communication. ▪ The other terminal may be defective.
6-09	G3 ECM - ERR received	<ul style="list-style-type: none"> ▪ Check for a noisy line. ▪ Adjust the tx levels of the communicating machines. ▪ See code 6-05.
6-10	G3 ECM - error frames still received at the other end after all communication attempts at 2400 bps	<ul style="list-style-type: none"> ▪ Check for line noise. ▪ Adjust the tx level (use NCU parameter 01 or the dedicated tx parameter for that address). ▪ Check the line connection. ▪ Defective remote terminal.
6-21	V.21 flag detected during high speed modem communication	<ul style="list-style-type: none"> ▪ The other terminal may be defective or incompatible.
6-22	The machine resets the sequence because of an abnormal handshake in the V.34 control channel	<ul style="list-style-type: none"> ▪ Check for line noise. ▪ If the same error occurs frequently, replace the FCU. ▪ Defective remote terminal.
6-99	V.21 signal not stopped	<ul style="list-style-type: none"> ▪ Replace the FCU.

Error Codes

Code	Meaning	Suggested Cause/Action
	within 6 s	
13-17	SIP user name registration error	<ul style="list-style-type: none"> ▪ Double registration of the SIP user name. ▪ Capacity for user-name registration in the SIP server is not sufficient.
13-18	SIP server access error	<ul style="list-style-type: none"> ▪ Incorrect initial setting for the SIP server. ▪ Defective SIP server.
13-24	SIP authentication error	<ul style="list-style-type: none"> ▪ Registered password in the device does not match the password in the SIP server.
13-25	Network I/F setting error	<ul style="list-style-type: none"> ▪ IPV4 is not active in the active protocol setting. ▪ IP address of the device is not registered.
13-26	Network I/F setting error at power on	<ul style="list-style-type: none"> ▪ Active protocol setting does not match the I/F setting for SIP server. ▪ IP address of the device is not registered.
13-27	IP address setting error	<ul style="list-style-type: none"> ▪ IP address of the device is not registered.
14-00	SMTP Send Error	Error occurred during sending to the SMTP server. Occurs for any error other than 14-01 to 16. For example, the mail address of the system administrator is not registered.
14-01	SMTP Connection Failed	Failed to connect to the SMTP server (timeout) because the server could not be found. <ul style="list-style-type: none"> ▪ The PC is not ready to transfer files. ▪ SMTP server not functioning correctly. ▪ The DNS IP address is not registered. ▪ Network not operating correctly. ▪ Destination folder selection not correct.
14-02	No Service by SMTP Service (421)	SMTP server operating incorrectly, or the destination for direct SMTP sending is not correct. <ul style="list-style-type: none"> ▪ Contact the system administrator and check that the SMTP server has the correct settings

Code	Meaning	Suggested Cause/Action
		<p>and operates correctly.</p> <ul style="list-style-type: none"> ▪ Contact the system administrator for direct SMTP sending and check the sending destination.
14-03	Access to SMTP Server Denied (450)	<p>Failed to access the SMTP server because the access is denied.</p> <ul style="list-style-type: none"> ▪ SMTP server operating incorrectly. Contact the system administrator to determine if there is a problem with the SMTP server and to check that the SMTP server settings are correct. ▪ Folder send destination is incorrect. Contact the system administrator to determine that the SMTP server settings and path to the server are correct. ▪ Device settings incorrect. Confirm that the user name and password settings are correct. ▪ Direct SMTP destination incorrect. Contact the system administrator to determine if there is a problem at the destination at that the settings at the destination are correct.
14-04	Access to SMTP Server Denied (550)	<ul style="list-style-type: none"> ▪ SMTP server operating incorrectly ▪ Direct SMTP sending not operating correctly
14-05	SMTP Server HDD Full (452)	<p>Failed to access the SMTP server because the HDD on the server is full.</p> <ul style="list-style-type: none"> ▪ Insufficient free space on the HDD of the SMTP server. Contact the system administrator and check the amount of space remaining on the SMTP server HDD. ▪ Insufficient free space on the HDD where the destination folder is located. Contact the system administrator and check the amount of

Error Codes

Code	Meaning	Suggested Cause/Action
		<p>space remaining on the HDD where the target folder is located.</p> <ul style="list-style-type: none"> Insufficient free space on the HDD at the target destination for SMTP direct sending. Contact the system administrator and check the amount of space remaining on the target HDD.
14-06	User Not Found on SMTP Server (551)	<p>The designated user does not exist.</p> <ul style="list-style-type: none"> The designated user does not exist on the SMTP server. The designated address is not for use with direct SMTP sending.
14-07	Data Send to SMTP Server Failed (4XX)	<p>Failed to access the SMTP server because the transmission failed.</p> <ul style="list-style-type: none"> PC not operating correctly. SMTP server operating incorrectly Network not operating correctly. Destination folder setting incorrect. Direct SMTP sending not operating correctly.
14-08	Data Send to SMTP Server Failed (5XX)	<p>Failed to access the SMTP server because the transmission failed.</p> <ul style="list-style-type: none"> SMTP server operating incorrectly Destination folder setting incorrect. Direct SMTP sending not operating correctly. Software application error.
14-09	Authorization Failed for Sending to SMTP Server	<ul style="list-style-type: none"> POP-Before-SMTP or SMTP authorization failed. Incorrect setting for file transfer
14-10	Addresses Exceeded	Number of broadcast addresses exceeded the limit for the SMTP server.
14-11	Buffer Full	The send buffer is full so the transmission could

Code	Meaning	Suggested Cause/Action
		not be completed. Buffer is full due to using Scan-to-Email while the buffer is being used send mail at the same time.
14-12	Data Size Too Large	Transmission was cancelled because the detected size of the file was too large.
14-13	Send Cancelled	Processing is interrupted because the user pressed Stop.
14-30	MCS File Creation Failed	Failed to create the MCS file because: <ul style="list-style-type: none"> ▪ The number of files created with other applications on the Document Server has exceeded the limit. ▪ HDD is full or not operating correctly. ▪ Software error.
14-31	UFS File Creation Failed	UFS file could not be created: <ul style="list-style-type: none"> ▪ Not enough space in UFS area to handle both Scan-to-Email and IFAX transmission. ▪ HDD full or not operating correctly. ▪ Software error.
14-32	Cancelled the Mail Due to Error Detected by N FAX	Error detected with N FAX and send was cancelled due to a software error.
14-33	No Mail Address For the Machine	Neither the mail address of the machine nor the mail address of the network administrator is registered.
14-34	Address designated in the domain for SMTP sending does not exist	Operational error in normal mail sending or direct SMTP sending. <ul style="list-style-type: none"> ▪ Check the address selected in the address book for SMTP sending. ▪ Check the domain selection.
14-50	Mail Job Task Error	Due to an FCU mail job task error, the send was

Error Codes

Code	Meaning	Suggested Cause/Action
		<p>cancelled:</p> <ul style="list-style-type: none"> ▪ Address book was being edited during creation of the notification mail. ▪ Software error.
14-51	UCS Destination Download Error	<p>Not even one return notification can be downloaded:</p> <ul style="list-style-type: none"> ▪ The address book was being edited. ▪ The number for the specified destination does not exist (it was deleted or edited after the job was created).
14-60	Send Cancel Failed	The cancel operation by the user failed to cancel the send operation.
14-61	Notification Mail Send Failed for All Destinations	All addresses for return notification mail failed.
15-01	POP3/IMAP4 Server Not Registered	At startup, the system detected that the IP address of the POP3/IMAP4 server has not been registered in the machine.
15-02	POP3/IMAP4 Mail Account Information Not Registered	The POP3/IMAP4 mail account has not been registered.
15-03	Mail Address Not Registered	The mail address has not been registered.
15-10	DCS Mail Receive Error	Error other than 15-11 to 15-18.
15-11	Connection Error	<p>The DNS or POP3/IMAP4 server could not be found:</p> <ul style="list-style-type: none"> ▪ The IP address for DNS or POP3/IMAP4 server is not stored in the machine. ▪ The DNS IP address is not registered. ▪ Network not operating correctly.

Code	Meaning	Suggested Cause/Action
15-12	Authorization Error	POP3/IMAP4 send authorization failed: <ul style="list-style-type: none"> ▪ Incorrect IFAX user name or password. ▪ Access was attempted by another device, such as the PC. ▪ POP3/IMAP4 settings incorrect.
15-13	Receive Buffer Full	Occurs only during manual reception. Transmission cannot be received due to insufficient buffer space. The buffer is being used for mail send or Scan-to-Email.
15-14	Mail Header Format Error	The mail header is not standard format. For example, the Date line description is incorrect.
15-15	Mail Divide Error	The e-mail is not in standard format. There is no boundary between parts of the e-mail, including the header.
15-16	Mail Size Receive Error	The mail cannot be received because it is too large.
15-17	Receive Timeout	May occur during manual receiving only because the network is not operating correctly.
15-18	Incomplete Mail Received	Only one portion of the mail was received.
15-31	Final Destination for Transfer Request Reception Format Error	The format of the final destination for the transfer request was incorrect.
15-39	Send/Delivery Destination Error	The transmission cannot be delivered to the final destination: <ul style="list-style-type: none"> ▪ Destination file format is incorrect. ▪ Could not create the destination for the file transmission.
15-41	SMTP Receive Error	Reception rejected because the transaction

Error Codes

Code	Meaning	Suggested Cause/Action
		exceeded the limit for the "Auth. E-mail RX" setting.
15-42	Off Ramp Gateway Error	The delivery destination address was specified with Off Ramp Gateway OFF.
15-43	Address Format Error	Format error in the address of the Off Ramp Gateway.
15-44	Addresses Over	The number of addresses for the Off Ramp Gateway exceeded the limit of 30.
15-61	Attachment File Format Error	The attached file is not TIFF format.
15-62	TIFF File Compatibility Error	<p>Could not receive transmission due to:</p> <ul style="list-style-type: none"> ▪ Resolution error ▪ Image of resolution greater than 200 dpi without extended memory. ▪ Resolution is not supported. ▪ Page size error ▪ The page size was larger than A3. ▪ Compression error ▪ File was compressed with other than MH, MR, or MMR.
15-63	TIFF Parameter Error	<p>The TIFF file sent as the attachment could not be received because the TIFF header is incorrect:</p> <ul style="list-style-type: none"> ▪ The TIFF file attachment is a type not supported. ▪ The TIFF file attachment is corrupted. ▪ Software error.
15-64	TIFF Decompression Error	<p>The file received as an attachment caused the TIFF decompression error:</p> <ul style="list-style-type: none"> ▪ The TIFF format of the attachment is corrupted.

Code	Meaning	Suggested Cause/Action
		<ul style="list-style-type: none"> Software error.
15-71	Not Binary Image Data	The file could not be received because the attachment was not binary image data.
15-73	MDN Status Error	Could not find the Disposition line in the header of the Return Receipt, or there is a problem with the firmware.
15-74	MSDN Message ID Error	Could not find the Original Message ID line in the header of the Return Receipt, or there is a problem with the firmware.
15-80	Mail Job Task Read Error	Could not receive the transmission because the destination buffer is full and the destination could not be created (this error may occur when receiving a transfer request or a request for notification of reception).
15-81	Repeated Destination Registration Error	Could not repeat receive the transmission because the destination buffer is full and the destination could not be created (this error may occur when receiving a transfer request or a request for notification of reception).
15-91	Send Registration Error	<p>Could not receive the file for transfer to the final destination:</p> <ul style="list-style-type: none"> The format of the final destination or the transfer destination is incorrect. Destinations are full so the final and transfer destinations could not be created.
15-92	Memory Overflow	Transmission could not be received because memory overflowed during the transaction.
15-93	Memory Access Error	Transaction could not complete due to a malfunction of SAF memory.

Error Codes

Code	Meaning	Suggested Cause/Action
15-94	Incorrect ID Code	The machine rejected an incoming e-mail for transfer request, because the ID code in the incoming e-mail did not match the ID code registered in the machine.
15-95	Transfer Station Function	The machine rejected an incoming e-mail for transfer because the transfer function was unavailable.
22-00	Original length exceeded the maximum scan length	<ul style="list-style-type: none"> ▪ Divide the original into more than one page. ▪ Check the resolution used for scanning. Lower the scan resolution if possible. ▪ Add optional page memory.
22-01	Memory overflow while receiving	<ul style="list-style-type: none"> ▪ Wait for the files in the queue to be sent. ▪ Delete unnecessary files from memory. ▪ Transfer the substitute reception files to another fax machine, if the machine's printer is busy or out of order. ▪ Add an optional SAF memory card or hard disk.
22-02	Tx or rx job stalled due to line disconnection at the other end	<ul style="list-style-type: none"> ▪ The job started normally but did not finish normally; data may or may not have been received fully. ▪ Restart the machine.
22-04	The machine cannot store received data in the SAF	<ul style="list-style-type: none"> ▪ Update the ROM ▪ Replace the FCU.
22-05	No G3 parameter confirmation answer	<ul style="list-style-type: none"> ▪ Defective FCU board or firmware.
23-00	Data read timeout during construction	<ul style="list-style-type: none"> ▪ Restart the machine. ▪ Replace the FCU
25-00	The machine software	<ul style="list-style-type: none"> ▪ Update the ROM

Code	Meaning	Suggested Cause/Action
	resets itself after a fatal transmission error occurred	<ul style="list-style-type: none"> ▪ Replace the FCU.
F0-xx	V.34 modem error	<ul style="list-style-type: none"> ▪ Replace the FCU.
F6-xx	SG3-V34 modem error	<ul style="list-style-type: none"> ▪ Update the SG3-V34 modem ROM. ▪ Replace the SG3-V34 board. ▪ Check for line noise or other line problems. ▪ Try communicating another V.8/V.34 fax.

3.2 IFAX TROUBLESHOOTING

Use the following procedures to determine whether the machine or another part of the network is causing the problem.

Communication Route	Item	Action	Remarks
General LAN	1. Connection with the LAN	<ul style="list-style-type: none"> ▪ Check that the LAN cable is connected to the machine. ▪ Check that the LEDs on the hub are lit. 	
	2. LAN activity	<ul style="list-style-type: none"> ▪ Check that other devices connected to the LAN can communicate through the LAN. 	
Between IFAX and PC	1. Network settings on the PC	<ul style="list-style-type: none"> ▪ Check the network settings on the PC. 	<ul style="list-style-type: none"> ▪ Is the IP address registered in the TCP/IP properties in the network setup correct? Check the IP address with the administrator of the network.
	2. Check that PC can connect with the machine	<ul style="list-style-type: none"> ▪ Use the "ping" command on the PC to contact the machine. 	<ul style="list-style-type: none"> ▪ At the MS-DOS prompt, type ping then the IP address of the machine, then

Communication Route	Item	Action	Remarks
			press Enter.
	3. LAN settings in the machine	<ul style="list-style-type: none"> ▪ Check the LAN parameters ▪ Check if there is an IP address conflict with other PCs. 	<ul style="list-style-type: none"> ▪ Use the “Network” function in the User Tools. ▪ If there is an IP address conflict, inform the administrator.
Between machine and e-mail server	1. LAN settings in the machine	<ul style="list-style-type: none"> ▪ Check the LAN parameters ▪ Check if there is an IP address conflict with other PCs. 	<ul style="list-style-type: none"> ▪ Use the “Network” function in the User Tools. ▪ If there is an IP address conflict, inform the administrator.
	2. E-mail account on the server	<ul style="list-style-type: none"> ▪ Make sure that the machine can log into the e-mail server. ▪ Check that the account and password stored in the server are the same as in the machine. 	<ul style="list-style-type: none"> ▪ Ask the administrator to check.
	3. E-mail server	<ul style="list-style-type: none"> ▪ Make sure that the client devices which have an account in the server can send/receive 	<ul style="list-style-type: none"> ▪ Ask the administrator to check. ▪ Send a test e-mail with the machine’s own number as

IFAX Troubleshooting

Communication Route	Item	Action	Remarks
		e-mail.	the destination. The machine receives the returned e-mail if the communication is performed successfully.
Between e-mail server and internet	1. E-mail account on the Server	<ul style="list-style-type: none"> ▪ Make sure that the PC can log into the e-mail server. ▪ Check that the account and password stored in the server are the same as in the machine. 	<ul style="list-style-type: none"> ▪ Ask the administrator to check.
	2. E-mail server	<ul style="list-style-type: none"> ▪ Make sure that the client devices which have an account in the server can send/receive e-mail. 	<ul style="list-style-type: none"> ▪ Ask the administrator to check. ▪ Send a test e-mail with the machine's own number as the destination. The machine receives the returned e-mail if the communication is performed successfully.
	3. Destination e-mail address	<ul style="list-style-type: none"> ▪ Make sure that the e-mail address is 	

Communication Route	Item	Action	Remarks
		<p>actually used.</p> <ul style="list-style-type: none"> ▪ Check that the e-mail address contains no incorrect characters such as spaces. 	
4. Router settings	<ul style="list-style-type: none"> ▪ Use the “ping” command to contact the router. ▪ Check that other devices connected to the router can send data over the router. 	<ul style="list-style-type: none"> ▪ Ask the administrator of the server to check. 	
	5. Error message by e-mail from the network of the destination.	<ul style="list-style-type: none"> ▪ Check whether e-mail can be sent to another address on the same network, using the application e-mail software. ▪ Check the error e-mail message. 	<ul style="list-style-type: none"> ▪ Inform the administrator of the LAN.

3.3 IP-FAX TROUBLESHOOTING

3.3.1 IP-FAX TRANSMISSION

Cannot send by IP Address/Host Name

Check Point		Action
1	LAN cable connected?	Check the LAN cable connection.
2	Specified IP address/host name correct?	Check the IP address/host name.
3	Firewall/NAT is installed?	Cannot breach the firewall. Send by using another method (Fax, Internet Fax)
4	Transmission sent manually?	Manual sending not supported.
5	IP address of local machine registered?	Register the IP address.
6	Remote terminal port number setting other than 1720?	Send by specifying the port number.
7	Specified port number correct?	Confirm the port number of the remote fax.
8	DNS server registered when host name specified?	Contact the network administrator.
9	Remote fax a T.38 terminal?	Check whether the remote fax is a T38 terminal.
10	Remote fax switched off or busy?	Check that the remote fax is switched on.
11	Network bandwidth too narrow?	Request the network administrator to increase the bandwidth.
		Raise the delay level. IPFAX SW 01 Bit 0 to 3

Check Point		Action
		IP-Fax bandwidth is the same as the DCS speed. Set IP-Fax SW00 Bit 6 to 1.
12	Remote fax cancelled transmission?	Check whether the remote fax cancelled the transmission.

Cannot send via VoIP Gateway

Check Point		Action
1	LAN cable connected?	Check the LAN cable connection.
2	VoIP Gateway T.38 standard?	Contact the network administrator.
3	VoIP Gateway installed correctly?	Contact the network administrator.
4	VoIP Gateway power switched on?	Contact the network administrator.
5	Is the IP address/host name of the specified Gateway correct?	Check the IP address/host name.
6	Number of the specified fax correct?	Check the remote fax number.
7	Firewall/NAT is installed?	Cannot breach the firewall. Send by using another method (Fax, Internet Fax)
8	Transmission sent manually?	Manual sending not supported.
9	IP address of local fax registered?	Register the IP address.
10	DNS registered when host name specified?	Contact the network administrator.
11	Remote fax a G3 fax?	Check that the remote fax is a G3 fax.
12	G3 fax is connected to VoIP gateway?	Check that G3 fax is connected.

IP-Fax Troubleshooting

Check Point		Action
13	Remote G3 fax turned on?	Check that G3 fax is switched on.
14	Network bandwidth too narrow?	Request the network administrator to increase the bandwidth.
		Raise the network delay level. IPFAX SW 01 Bit 0 to 3
		IP-Fax bandwidth is the same as the DCS speed. Set IP-Fax SW00 Bit 6 to 1.

Cannot send by Alias Fax number.

Check Point		Action
1	LAN cable connected?	Check the LAN cable connection.
2	Number of specified Alias fax correct?	Confirm the Alias of the remote fax. Error Code: 13-14
3	Firewall/NAT installed?	Cannot breach the firewall. Send by using another method (Fax, Internet Fax)
4	Transmission sent manually?	Manual sending not supported.
5	Gatekeeper installed correctly?	Contact the network administrator.
6	Gatekeeper power switched on?	Contact the network administrator.
7	IP address/host name of Gatekeeper correct?	Check the IP address/host name.
8	DNS server registered when Gatekeeper host name specified?	Contact the network administrator.
9	Enable H.323 SW is set to on?	Check the settings. See User Parameter SW 34 Bit 0
10	IP address of local fax registered?	Register the IP address of the local fax.
11	Alias number of local fax registered?	Register the Alias number of the local fax.
12	Remote fax registered in Gatekeeper?	Contact the network administrator.
13	Remote fax a T.38 terminal?	Check whether the remote fax is a T38 terminal.
14	Remote fax switched off or busy?	Contact the network administrator.
15	Network bandwidth too narrow?	Request the system administrator to increase the bandwidth.

IP-Fax Troubleshooting

Check Point		Action
		Raise the delay level. IPFAX SW 01 Bit 0 to 3
		Lower the modem transmission baud rate. IPFAX SW 05
16	Remote fax cancelled transmission?	Check whether the remote fax cancelled the transmission.

3.3.2 IP-FAX RECEPTION

Cannot receive by IP Address/Host name

Check Point		Action
1	LAN cable connected?	Check the LAN cable connection.
2	Firewall/NAT is installed?	Cannot breach the firewall. Send by using another method (Fax, Internet Fax)
3	IP address of local fax registered?	Register the IP address.
4	Port number specified at remote sender fax (if required)?	Request the sender to specify the port number.
5	Specified port number correct (if required)?	Request the sender to check the port number.
6	DNS server registered when host name specified on sender side?	Contact the network administrator. Note: The sender machine displays this error code if the sender fax is a Ricoh model.
7	Network bandwidth too narrow?	Request the system administrator to increase the bandwidth.
		Lower the start modem reception baud rate on the receiving side. IPFAX SW06
8	Remote fax cancelled transmission?	Check whether the remote fax cancelled the transmission.

Cannot receive by VoIP Gateway.

Check Point		Action
1	LAN cable connected?	Check the LAN cable connection.
2	Firewall/NAT is installed?	Cannot breach the firewall. Request the remote fax to send by using another method (Fax, Internet Fax)
3	VoIP Gateway installed correctly?	Contact the network administrator.
4	VoIP Gateway power switched on?	Contact the network administrator.
5	IP address/host name of specified VoIP Gateway correct on sender's side?	Request the remote fax to check the IP address/host name.
6	DNS server registered when host name specified on sender side?	Contact the network administrator.
7	Network bandwidth too narrow?	Request the network administrator to increase the bandwidth.
8	G3 fax connected?	Check that G3 fax is connected.
9	G3 fax power switched on?	Check that G3 fax is switched on.

Cannot receive by Alias Fax number.

Check Point		Action
1	LAN cable connected?	Check the LAN cable connection.
2	Firewall/NAT is installed?	Cannot the breach firewall. Request the remote fax to send by using another method (Fax, Internet Fax)
3	Gatekeeper installed correctly?	Contact the network administrator. Note: The sender machine displays this error code if the sender fax is a Ricoh model.
4	Power to Gatekeeper switched on?	Contact the network administrator. Note: The sender machine displays this error code if the sender fax is a Ricoh model.
5	IP address/host name of Gatekeeper correct on the sender's side?	Request the sender to check the IP address/host name. Note: The sender machine displays this error code if the sender fax is a Ricoh model.
6	DNS server registered when Gatekeeper host name specified on sender's side?	Contact the network administrator. Note: The sender machine displays this error code if the sender fax is a Ricoh model.
7	Enable H.323 SW is set to on?	Request the sender to check the settings. User Parameter SW 34 Bit 0 Note: Only if the remote sender fax is a Ricoh fax.
8	Local fax IP address registered?	Register the IP address.
9	Local fax Alias number registered?	Register the Alias number.

IP-Fax Troubleshooting

Check Point		Action
10	Network bandwidth too narrow?	Request the system administrator to increase the bandwidth.
		Lower the start modem reception baud rate on the receiving side. IPFAX SW06
11	Remote fax cancelled transmission?	Check whether the remote fax cancelled the transmission.
12	Local fax registered in Gatekeeper?	Contact the network administrator. Note: The sender machine displays this error code if the sender fax is a Ricoh model.

4. SERVICE TABLE

4.1 CAUTIONS

CAUTION

- Never turn off the main power switch when the power LED is lit or flashing. To avoid damaging the hard disk or memory, press the operation power switch to switch the power off, wait for the power LED to go off, and then switch the main power switch off.

Note

- The main power LED lights or flashes while the platen cover or ARDF is open, while the main machine is communicating with a facsimile or the network server, or while the machine is accessing the hard disk or memory for reading or writing data.

4.2 SERVICE PROGRAM TABLES

4.2.1 SP1-XXX (BIT SWITCHES)

1	Mode No.	Function
101	System Switch	
	001 – 032	00 – 1F Changes the bit switches for system settings for the fax option. See section 4.2 Bit Switches
102	Ifax Switch	
	001 – 016	00 – 0F Changes the bit switches for internet fax settings for the fax option. See section 4.2 Bit Switches
103	Printer Switch	
	001 – 016	00 – 0F Changes the bit switches for printer settings for the fax option. See section 4.2 Bit Switches
104	Communication Switch	
	001 – 032	00 – 1F Changes the bit switches for communication settings for the fax option. See section 4.2 Bit Switches
105	G3-1 Switch	
	001 – 016	00 – 0F Changes the bit switches for the protocol settings of the standard G3 board. See section 4.2 Bit Switches
106	G3-2 Switch	
	001 – 016	00 – 0F Changes the bit switches for the protocol settings of the optional G3 board.

1	Mode No.		Function
			See section 4.2 Bit Switches
107	G3-3 Switch		
	001 – 016	00 – 0F	Changes the bit switches for the protocol settings of the optional G3 board. See section 4.2 Bit Switches
108	G4 Internal Switch		
	001 – 032	00 – 1F	Not used (Do not change the bit switches)
109	G4 Parameter Switch		
	001 – 016	00 – 0F	Not used (Do not change the bit switches)
111	IP fax Switch		
	001 – 016	00 – 0F	Changes the bit switches for optional IP fax parameters. See section 4.2 Bit Switches

4.2.2 SP2-XXX (RAM DATA)

2	Mode No.		Function
101	RAM Read/Write		
	001		Changes RAM data for the fax board directly. See section 4.5 Service RAM Addresses.
102	Memory Dump		
	001	G3-1 Memory Dump	Prints out RAM data for the fax board. See section 4.5 Service RAM Addresses.
	002	G3-2 Memory Dump	Prints out RAM data for the optional SG3 board.
	003	G3-3 Memory Dump	Prints out RAM data for the optional SG3 board.
	004	G4 Memory Dump	Prints out RAM data for the SiG4 board.
103	G3-1 NCU Parameters		
	001 – 023	CC, 01 – 22	NCU parameter settings for the standard G3 board. See section 4.3 NCU Parameters.
104	G3-2 NCU Parameters		
	001 – 023	CC, 01 – 22	NCU parameter settings for the optional G3 board. See section 4.3 NCU Parameters.
105	G3-3 NCU Parameters		
	001 – 023	CC, 01 – 22	NCU parameter settings for the optional G3 board. See section 4.3 NCU Parameters.

4.2.3 SP3-XXX (TEL LINE SETTINGS)

3	Mode No.		Function
101	Service Station		
	001	Fax Number	Enter the fax number of the service station.
	002	Select Line	Select the line type.
102	Serial Number		
	000		Enter the fax unit's serial number.
103	PSTN-1 Port Settings		
	001	Select Line	Select the line type setting for the G3-1 line. If the machine is installed on a PABX line, select "PABX", "PABX(GND)" or "PABX(FLASH)".
	002	PSTN Access Number	Enter the PSTN access number for the G3-1 line.
	003	Memory Lock Disabled	If the customer does not want to receive transmissions using Memory Lock on this line, turn this SP on.
104	PSTN-2 Port Settings		
	001	Select Line	Select the line setting for the G3-2 line. If the machine is installed on a PABX line, select "PABX", "PABX(GND)" or "PABX(FLASH)".
	002	PSTN Access Number	Enter the PSTN access number for the G3-2 line.
	003	Memory Lock Disabled	If the customer does not want to receive transmissions using Memory Lock on this line, change this SP to on.

Service Program Tables

3	Mode No.		Function
	004	Transmission Disabled	If you turn this SP on, the machine does not send any fax messages on the G3-2 line.
105	PSTN-3 Port Settings		
	001	Select Line	Select the line setting for the G3-3 line. If the machine is installed on a PABX line, select "PABX", "PABX(GND)" or "PABX(FLASH)".
	002	PSTN Access Number	Enter the PSTN access number for the G3-3 line.
	003	Memory Lock Disabled	If the customer does not want to receive transmissions using Memory Lock on this line, change this SP to on.
	004	Transmission Disabled	If you turn this SP on, the machine does not send any fax messages on the G3-3 line.
106	ISDN Port Settings		
	001	Select Line	Not used (Do not change the bit switches)
	002	PSTN Access Number	
	003	Memory Lock Disabled	
004	Transmission Disabled		
107	IPFAX Port Settings		
	001	H323 Port	
	002	SIP Port	
	003	RAS Port	

3	Mode No.		Function
	004	Gatekeeper port	
	005	T.38 Port	
	006	SIP Server Port	
	007	IPFAX Protocol Priority	Select "H323" or "SIP".
201	FAX SW		
	001 – 032	00 – 1F	

4.2.4 SP4-XXX (ROM VERSIONS)

4	Mode No.		Function
101	001	FCU ROM Version	Displays the FCU ROM version.
102	001	Error Codes	Displays the latest 64 fax error codes.
103	001	G3-1 ROM Version	Displays the G3-1 modem version.
104	001	G3-2 ROM Version	Displays the G3-2 modem version.
105	001	G3-3 ROM Version	Displays the G3-3 modem version.
106	001	G4 ROM Version	Not used (Do not change the bit switches)
107	001	Charge ROM Version	Not used (Do not change the bit switches)

4.2.5 SP5-XXX (INITIALIZING)

5	Mode No.	Function
101	Initialize SRAM	
	000	Initializes the bit switches and user parameters, user data in the SRAM, files in the SAF memory, and clock.
102	Erase All Files	
	000	Erases all files stored in the SAF memory.
103	Reset Bit Switches	
	000	Resets the bit switches and user parameters.
104	Factory setting	
	000	Resets the bit switches and user parameters, user data in the SRAM and files in the SAF memory.
105	Initialize All Bit Switches	
	000	Initializes all the current bit switch settings.
106	Initialize Security Bit Switches	
	000	Initializes only the security bit switches. If you select automatic output/display for the user parameter switches, the security settings are initialized.

4.2.6 SP6-XXX (REPORTS)

6	Mode No.		Function
101	System Parameter List		
	000		Touch the "ON" button to print the system parameter list.
102	Service Monitor Report		
	000		Touch the "ON" button to print the service monitor report.
103	G3 Protocol Dump List		
	001	G3 All Communications	Prints the protocol dump list of all communications for all G3 lines.
	002	G3-1 (All Communications)	Prints the protocol dump list of all communications for the G3-1 line.
103	003	G3-1 (1 Communication)	Prints the protocol dump list of the last communication for the G3-1 line.
	004	G3-2 (All Communications)	Prints the protocol dump list of all communications for the G3-2 line.
	005	G3-2 (1 Communication)	Prints the protocol dump list of the last communication for the G3-2 line.
	006	G3-3 (All Communications)	Prints the protocol dump list of all communications for the G3-3 line.
	007	G3-3 (1 Communication)	Prints the protocol dump list of the last communication for the G3-3 line.
104	G4 Protocol Dump List		
	001	Dch + Bch 1	Not used (Do not change the bit switches)

Service Program Tables

6	Mode No.		Function
	002	Dch	
	003	Bch 1 Link Layer	
	004	Dch Link Layer	
	005	Dch +Bch 2	
	006	Bch 2 Link Layer	
105	All Files print out		
	000		
106	Journal Print out		
	001	All Journals	
	002	Specified Date	
107	Log List Print out		
	001	All log files	
	002	Printer	
	003	SC/TRAP Stored	
	004	Decompression	
	005	Scanner	
	006	JOB/SAF	
	007	Reconstruction	

6	Mode No.		Function
	008	JBIG	
	009	Fax Driver	
	010	G3CCU	
	011	Fax Job	
	012	CCU	
	013	Scanner Condition	
108	IP Protocol Dump List		
	001	All Communications	
	002	1 Communication	

D498
Fax Option
Type C7501

4.2.7 SP7-XXX (TEST MODES)

These are the test modes for PTT approval.

7	Function
101	G3-1 Modem Tests
102	G3-1 DTMF Tests
103	Ringer Test
104	G3-1 V34 (S2400baud)
105	G3-1 V34 (S2800baud)
106	G3-1 V34 (S3000baud)
107	G3-1 V34 (S3200baud)
108	G3-1 V34 (S3429baud)
109	Recorded Message Test
110	G3-2 Modem Tests
111	G3-2 DTMF Tests
112	G3-2 V34 (S2400baud)
113	G3-2 V34 (S2800baud)
114	G3-2 V34 (S3000baud)
115	G3-2 V34 (S3200baud)
116	G3-2 V34 (S3429baud)
117	G3-3 Modem Tests
118	G3-3 DTMF Tests
119	G3-3 V34 (S2400baud)
120	G3-3 V34 (S2800baud)

7	Function
121	G3-3 V34 (S3000baud)
122	G3-3 V34 (S3200baud)
123	G3-3 V34 (S3429baud)
124	IG3-1 Modem Tests - Not used
125	IG3-1 DTMF Tests - Not used
126	IG3-1 V34 (S2400baud) - Not used
127	IG3-1 V34 (S2800baud) - Not used
128	IG3-1 V34 (S3000baud) - Not used
129	IG3-1 V34 (S3200baud) - Not used
130	IG3-1 V34 (S3429baud) - Not used
131	IG3-2 Modem Tests - Not used
132	IG3-2 DTMF Tests - Not used
133	IG3-2 V34 (S2400baud) - Not used
134	IG3-2 V34 (S2800baud) - Not used
135	IG3-2 V34 (S3000baud) - Not used
136	IG3-2 V34 (S3200baud) - Not used
137	IG3-2 V34 (S3429baud) - Not used

4.2.8 SP9-XXX (DESIGN SWITCH MODE)

9	Mode No.	Function
702	Design Switch DFU	

4.3 BIT SWITCHES

↓ None

- Do not adjust a bit switch or use a setting that is described as "Not used", as this may cause the machine to malfunction or to operate in a manner that is not accepted by local regulations. Such bits are for use only in other areas, such as Japan.

Default settings for bit switches are not listed in this manual. Refer to the System Parameter List printed by the machine.

4.3.1 SYSTEM SWITCHES

System Switch 00 (SP No. 1-101-001)		
No	Function	Comments
0	Dedicated transmission parameter programming 0: Disabled 1: Enabled	Set this bit to 1 before changing any dedicated transmission parameters. Reset this bit to 0 after programming dedicated transmission parameters.
1	Not used	Do not change
2	Technical data printout on the Journal 0: Disabled 1: Enabled	1: Instead of the personal name, the following data are listed on the Journal for each G3 communication.
	Example: 0000 32V34 288/264 L0100 03 04 (1) (2)(3) (4) (5) (6) (7) (8) (1): EQM value (Line quality data). A larger number means more errors. (2): Symbol rate (V.34 only) (3): Final modem type used (4): Starting data rate (for example, 288 means 28.8 kbps) (5): Final data rate (6): Rx revel (see below for how to read the rx level)	

Bit Switches

System Switch 00 (SP No. 1-101-001)		
No	Function	Comments
	<p>(7): Total number of error lines that occurred during non-ECM reception. (8): Total number of burst error lines that occurred during non-ECM reception.</p> <p> Note</p> <ul style="list-style-type: none"> EQM and rx level are fixed at "FFFF" in tx mode. The seventh and eighth numbers are fixed at "00" for transmission records and ECM reception records. 	
	<p>Rx level calculation Example: 0000 32V34 288/264 L0100 03 04 (1) (2)(3) (4) (5) (6) (7) (8)</p> <p>The four-digit hexadecimal value (N) after "L" indicates the rx level. The high byte is given first, followed by the low byte. Divide the decimal value of N by -16 to get the rx level. In the above example, the decimal value of N (= 0100 [H]) is 256. So, the actual rx level is 256/-16 = -16 dB</p>	
3	Not used	Do not change this setting.
4	Line error mark print 0: OFF, 1: ON (print)	When "1" is selected, a line error mark is printed on the printout if a line error occurs during reception.
5	G3/G4 communication parameter display 0: Disabled 1: Enabled	This is a fault-finding aid. The LCD shows the key parameters (see below). This is normally disabled because it cancels the CSI display for the user. Be sure to reset this bit to 0 after testing.
6	Protocol dump list output after each communication 0: Off 1: On	This is only used for communication troubleshooting. It shows the content of the transmitted facsimile protocol signals. Always reset this bit to 0 after finishing testing. If system switch 09 bit 6 is at "1", the list is only printed if there was an error during the

System Switch 00 (SP No. 1-101-001)		
No	Function	Comments
		communication.
7	Not used	Do not change the setting.

D498
Fax Option
Type C7501

Bit Switches

G3 Communication Parameters

Modem rate	<p>336: 33600 bps 168: 16800 bps 312: 31200 bps 144: 14400 bps 288: 28800 bps 120: 12000 bps 264: 26400 bps 96: 9600 bps 240: 24000 bps 72: 7200 bps 216: 21600 bps 48: 4800 bps 192: 19200 bps 24: 2400 bps</p>
Resolution	<p>S: Standard (8 x 3.85 dots/mm) D: Detail (8 x 7.7 dots/mm) F: Fine (8 x 15.4 dots/mm) SF: Superfine (16 x 15.4 dots/mm) 21: Standard (200 x 100 dpi) 22: Detail (200 x 200 dpi) 44: Superfine (400 x 400 dpi)</p>
Compression mode	<p>MMR: MMR compression MR: MR compression MH: MH compression JBO: JBIG compression (Optional mode) JBB: JBIG compression (Basic mode)</p>
Communication mode	<p>ECM: With ECM NML: With no ECM</p>
Width and reduction	<p>A4: A4 (8.3"), no reduction B4: B4 (10.1"), no reduction A3: A3 (11.7"), no reduction</p>
I/O rate	<p>0: 0 ms/line 5: 5 ms/line 10: 10 ms/line 20: 20 ms/line 25: 2.5 ms/line 40: 40 ms/line</p> <p> Note</p>

	<ul style="list-style-type: none"> ▪ "40" is displayed while receiving a fax message using AI short protocol.
--	--

System Switch 01 - Not used (Do not change the factory settings.)

System Switch 02 (SP No. 1-101-003)				
No	Function			Comments
0	Not used			Do not change these settings.
2	Forced reset after transmission stalls 0: Off 1: On			With this setting on, the machine resets itself automatically if a transmission stalls and fails to complete the job.
3	Not used			Do not change these settings.
4	File retention time 0: Depends on User Parameter 24 [18(H)] 1: No limit			1: A file that had a communication error will not be erased unless the communication is successful.
5	Not used			Do not change this setting.
6-7	Memory read/write by RDS			(0,0): All RDS systems are always locked out. (0,1), (1,0): Normally, RDS systems are locked out, but the user can temporarily switch RDS on to allow RDS operations to take place. RDS will automatically be locked out again after a certain time, which is stored in System Switch 03. Note that if an RDS operation takes place, RDS will not switch off until this time limit has expired. (1,1): At any time, an RDS system can access the machine.
	Bit 7	Bit 6	Setting	
	0	0	Always disabled	
	0	1	User selectable	
	1	0	User selectable	
	1	1	Always enabled	

D498
 Fax Option
 Type C7501

Bit Switches

System Switch 03 (SP No. 1-101-004)		
No	Function	Comments
0 to 7	Length of time that RDS is temporarily switched on when bits 6 and 7 of System Switch 02 are set to "User selectable"	00 - 99 hours (BCD). This setting is only valid if bits 6 and 7 of System Switch 02 are set to "User selectable". The default setting is 24 hours.

System Switch 04 (SP No. 1-101-005)		
No	Function	Comments
0-2	Not used	Do not change these settings.
3	Printing dedicated tx parameters on Quick/Speed Dial Lists 0: Disabled 1: Enabled	1: Each Quick/Speed dial number on the list is printed with the dedicated tx parameters (10 bytes each). The first 10 bytes of data are the programmed dedicated tx parameters; 34 bytes of data are printed (the other 24 bytes have no use for service technicians).
4-7	Not used	Do not change these settings.

System Switch 05 - Not used (Do not change the factory settings.)
--

System Switch 06 (SP No. 1-101-007)		
No	Function	Comments
0 to 7	Margin setting for Create Margin Transmission	71 to 99 (BCD) %. This setting determines the reduction ratio when the user uses the Create Margin Transmission feature. Default setting: 1001 0011 (93%)

System Switch 07 - Not used (Do not change the factory settings.)

System Switch 08 - Not used (Do not change the factory settings.)

System Switch 09 (SP No. 1-101-010)		
No	Function	Comments
0	Addition of image data from confidential transmissions on the transmission result report 0: Disabled 1: Enabled	If this feature is enabled, the top half of the first page of confidential messages will be printed on transmission result reports.
1	Inclusion of communications on the Journal when no image data was exchanged. 0: Disabled 1: Enabled	0: Communications that reached phase C (message tx/rx) of the T.30 protocol are listed on the Journal. 1: Communications that reached phase A (call setup) of T.30 protocol are listed on the Journal. This will include telephone calls.
2	Automatic error report printout 0: Disabled 1: Enabled	0: Error reports will not be printed. 1: Error reports will be printed automatically after failed communications.
3	Printing of the error code on the error report 0: No 1: Yes	1: Error codes are printed on the error reports.
4	Not used	Do not change this setting.

Bit Switches

System Switch 09 (SP No. 1-101-010)		
No	Function	Comments
5	Power failure report 0: Disabled 1: Enabled	1: A power failure report will be automatically printed after the power is switched on if a fax message disappeared from the memory when the power was turned off last.
6	Conditions for printing the protocol dump list 0: Print for all communications 1: Print only when there is a communication error	This switch becomes effective only when system switch 00 bit 6 is set to 1. 1: Set this bit to 1 when you wish to print a protocol dump list only for communications with errors.
7	Priority given to various types of remote terminal ID when printing reports 0: RTI > CSI > Dial label > Tel. number 1: Dial label > Tel. number > RTI > CSI	This bit determines which set of priorities the machine uses when listing remote terminal names on reports. Dial Label: The name stored, by the user, for the Quick/Speed Dial number.

System Switch 0A (SP No. 1-101-011)		
No	Function	Comments
0	Automatic port selection 0: Disabled, 1: Enabled	When "1" is selected, a suitable port is automatically selected if the selected port is not used.
1-2	Not used	Do not change these settings.
3	Continuous polling reception 0: Disabled 1: Enabled	This feature allows a series of stations to be polled in a continuous cycle. This will continue until the polling reception file is erased. The dialing interval is the same as memory transmission.
4	Dialing on the ten-key pad when the external telephone is off-hook 0: Disabled 1: Enabled	0: Prevents dialing from the ten-key pad while the external telephone is off-hook. Use this setting when the external telephone is not by the machine, or if a wireless telephone is connected as an external telephone. 1: The user can dial on the machine's ten-key pad when the handset is off-hook.
5	On hook dial 0: Disabled 1: Enabled	0: On hook dial is disabled.
6-7	Not used	Do not change the factory settings

System Switch 0B - Not used (Do not change the factory settings.)
System Switch 0C - Not used (Do not change the factory settings.)
System Switch 0D - Not used (Do not change the factory settings.)

Bit Switches

System Switch 0E (SP No. 1-101-015)		
No	Function	Comments
0-1	Not used	Do not change the settings.
2	Enable/disable for direct sending selection 0: Direct sending off 1: Direct sending on	Direct sending cannot operate when the capture function is on during sending. Setting this switch to "1" enables direct sending without capture. Setting this switch to "0" masks the direct sending function on the operation panel so it cannot be selected.
3	Action when the external handset goes off-hook 0: Manual tx and rx operation 1: Memory tx and rx operation (the display remains the same)	0: Manual tx and rx are possible while the external handset is off-hook. However, memory tx is not possible. 1: The display stays in standby mode even when the external handset is used, so that other people can use the machine for memory tx operation. Note that manual tx and rx are not possible with this setting.
4-7	Not used	Do not change these settings.

System Switch 0F (SP No. 1-101-016)			
No	Function	Comments	
0 to 7	Country/area code for functional settings (Hex)	<p>This country/area code determines the factory settings of bit switches and RAM addresses. However, it has no effect on the NCU parameter settings and communication parameter RAM addresses.</p> <p>Cross reference NCU country code: SP No. 2-103-001 for G3-1 SP No. 2-104-001 for G3-2 SP No. 2-105-001 for G3-3</p>	
	00: France		11: USA
	01: Germany		12: Asia
	02: UK		13: Japan
	03: Italy		14: Hong Kong
	04: Austria		15: South Africa
	05: Belgium		16: Australia
	06: Denmark		17: New Zealand
	07: Finland		18: Singapore
	08: Ireland		19: Malaysia
	09: Norway		1A: China
	0A: Sweden		1B: Taiwan
	0B: Switz.		1C: Korea
	0C: Portugal		20: Turkey
	0D: Holland		21: Greece
	0E: Spain		22: Hungary
0F: Israel	23: Czech		
10: ---	24: Poland		

Bit Switches

System Switch 10 (SP No. 1-101-017)		
No	Function	Comments
0-7	Threshold memory level for parallel memory transmission	Threshold = N x 128 KB + 256 KB N can be between 00 - FF(H) Default setting: 02(H) = 512 KB

System Switch 11 (SP No. 1-101-018)		
No	Function	Comments
0	TTI printing position 0: Superimposed on the page data 1: Printed before the data leading edge	Change this bit to 1 if the TTI overprints information that the customer considers to be important (G3 transmissions).
1	TSI (G3) printing position 0: Superimposed on the page data 1: Printed before the data leading edge	Change this bit to 1 if the TSI (G3) overprints information that the customer considers to be important.
2	Not used	Do not change the factory settings.
3	TTI used for broadcasting 0: The TTIs selected for each Quick/Speed dial are used 1: The same TTI is used for all destinations	1: The TTI (TTI_1 or TTI_2) which is selected for all destinations during broadcasting.
4-7	Not used	Do not change the factory settings.

System Switch 12 (SP No. 1-101-019)		
No	Function	Comments
0-7	TTI printing position in the main scan direction	TTI: 08 to 92 (BCD) mm Input even numbers only. This setting determines the print start position for the TTI from the left edge of the paper. If the TTI is moved too far to the right, it may overwrite the file number which is on the top right of the page. On an A4 page, if the TTI is moved over by more than 50 mm, it may overwrite the page number.

System Switch 13 - Not used (do not change these settings)

System Switch 14 - Not used (do not change these settings)

Bit Switches

System Switch 15 (SP No. 1-101-022)				
No	Function		Comments	
0	Not used		Do not change the settings.	
1	Going into the Energy Saver mode automatically 0: Enabled 1: Disabled		1: The machine will restart from the Energy Saver mode quickly, because the +5V power supply is active even in the Energy Saver mode.	
2-3	Not used		Do not change these settings.	
4-5	Interval for preventing the machine from entering Energy Saver mode if there is a pending transmission file.		If there is a file waiting for transmission, the machine does not go to Energy Saver mode during the selected period. After transmitting the file, if there is no file waiting for transmission, the machine goes to the Energy Saver mode.	
	Bit 5	Bit 4		Setting
	0	0		1 min
	0	1		30 min
	1	0		1 hour
	1	1	24 hours	
6-7	Not used		Do not change	

System Switch 16 (SP No. 1-101-023)		
No	Function	Comments
0	Parallel Broadcasting 0: Disabled 1: Enabled	1: The machine sends messages simultaneously using all available ports during broadcasting.
1	Priority setting for the G3 line. 0: PSTN-1 > PSTN-2 or 3 1: PSTN-2 or 3 > PSTN-1	This function allows the user to select the default G3 line type. The optional SG3 units are required to use the PSTN-2 or 3 setting.
2-7	Not used	Do not change these settings.

System Switch 17 - Not used (do not change these settings)
System Switch 18 - Not used (do not change these settings)

Bit Switches

System Switch 19 (SP No. 1-101-026)		
No	Function	Comments
0-5	Not used	Do not change the settings.
6	Extended scanner page memory after memory option is installed 0: Disabled 1: Enabled	0: After installing the memory expansion option, the scanner page memory is extended to 4 MB from 2 MB. 1: If this bit is set to 1 after installing the memory expansion option, the scanner page memory is extended to 12 MB. But the SAF memory decreases to 18 MB.
7	Special Original mode 0: Disabled 1: Enabled	1: If the customer frequently wishes to transmit a form or letterhead which has a colored or printed background, change this bit to "1". "Original 1" and "Original 2" can be selected in addition to the "Text", "Text/Photo" and "Photo" modes.

System Switch 1A (SP No. 1-101-027)		
No	Function	Comments
0 to 7	LS RX memory capacity threshold setting 00-FF (0-1020 Kbyte: Hex)	Sets the value to x4KB. When the amount of available memory drops below this setting, RX documents are printed to conserve memory. Initial setting 0x80 (512 KB)

System Switch 1B - Not used (do not change these settings)
System Switch 1C - Not used (do not change these settings)

System Switch 1D (SP No. 1-101-030)		
No	Function	Comments
0	RTI/CSI/CPS code display 0: Enable 1: Disable	0: RTI, CSI, CPS codes are displayed on the top line of the LCD panel during communication. 1: Codes are switched off (no display)
1-7	Not used	Do not change these settings.

System Switch 1E (SP No. 1-101-031)		
No	Function	Comments
0	Communication after the Journal data storage area has become full 0: Impossible 1: Possible	0: When this switch is on and the journal history becomes full, the next report prints. If the journal history is not deleted, the next transmission cannot be received. This prevents overwriting communication records before the machine can print them. 1: If the buffer memory of the communication records for the Journal is full, fax communications are still possible. But the machine will overwrite the oldest communication records. <div style="border: 1px solid blue; padding: 2px; display: inline-block;"> Note </div> <ul style="list-style-type: none"> ▪ This setting is effective only when Automatic Journal printout is enabled but the machine cannot print the report (e.g., no paper).
1	Action when the SAF memory has become full during scanning 0: The current page is erased. 1: The entire file is erased.	0: If the SAF memory becomes full during scanning, the successfully scanned pages are transmitted. 1: If the SAF memory becomes full during scanning, the file is erased and no pages are

Bit Switches

System Switch 1E (SP No. 1-101-031)		
No	Function	Comments
		<p>transmitted.</p> <p> Note</p> <ul style="list-style-type: none"> This setting is effective only when Automatic Journal printout is enabled but the machine cannot print the report (e.g., no paper).
2	RTI/CSI display priority 0: RTI 1: CSI	This bit determines which identifier, RTI or CSI, is displayed on the LCD while the machine is communicating in G3 non-standard mode.
3	File No. printing 0: Enabled 1: Disabled	1: File numbers are not printed on any reports.
4	Action when authorized reception is enabled but authorized RTIs/CSIs are not yet programmed 0: All fax reception is disabled 1: Faxes can be received if the sender has an RTI or CSI	<p>If authorized reception is enabled but the user has stored no acceptable sender RTIs or CSIs, the machine will not be able to receive any fax messages.</p> <p>If the customer wishes to receive messages from any sender that includes an RTI or CSI, and to block messages from senders that do not include an RTI or CSI, change this bit to "1", then enable Authorized Reception. Otherwise, keep this bit at "0 (default setting)".</p>
5-7	Not used	Do not change the settings

System Switch 1F (SP No. 1-101-032)		
No	Function	Comments
0	Not used	Do not change the settings.
1	Report printout after an original jam during SAF storage or if the SAF memory fills up 0: Enabled 1: Disabled	0: When an original jams, or the SAF memory overflows during scanning, a report will be printed. Change this bit to "1" if the customer does not want to have a report in these cases. Memory tx – Memory storage report Parallel memory tx – Transmission result report
2	Not used	Do not change the settings.
3	Received fax print start timing (G3 reception) 0: After receiving each page 1: After receiving all pages	0: The machine prints each page immediately after the machine receives it. 1: The machine prints the complete message after the machine receives all the pages in the memory.
4-6	Not used	Do not change the factory settings.
7	Action when a fax SC has occurred 0: Automatic reset 1: Fax unit stops	0: When the fax unit detects a fax SC code other than SC1201 and SC1207, the fax unit automatically resets itself. 1: When the fax unit detects any fax SC code, the fax unit stops. Cross Reference Fax SC codes - See "Troubleshooting"

4.3.2 I-FAX SWITCHES

I-fax Switch 00 (SP No. 1-102-001)		
No	Function	Comments
Original Width of TX Attachment File		This setting sets the maximum size of the original that the destination can receive. (Bits 3~7 are reserved for future use or not used.)
0	A4	0: Off (not selected), 1: On (selected) If more than one of these three bits is set to "1", the larger size has priority. For example, if both Bit 2 and Bit 1 are set to "1" then the maximum size is "A3" (Bit 2). When mail is sent, there is no negotiation with the receiving machine at the destination, so the sending machine cannot make a selection for the receiving capabilities (original width setting) of the receiving machine. The original width selected with this switch is used as the RX machine's original width setting, and the original is reduced to this size before sending. The default is A4. If the width selected with this switch is higher than the receiving machine can accept, the machine detects this and this causes an error.
1	B4	
2	A3	
3-6	Reserved	
7	Not used	

I-fax Switch 01 (SP No. 1-102-002)		
No	Function	Comments
Original Line Resolution of TX Attachment File		These settings set the maximum resolution of the original that the destination can receive.
0	200x100 Standard	0: Not selected

I-fax Switch 01 (SP No. 1-102-002)		
No	Function	Comments
1	200x200 Detail	1: Selected If more than one of these three bits is set to "1", the higher resolution has priority. For example, if both Bit 0 and Bit 2 are set to "1" Then The Resolution is set for "Bit 2 200 x 400.
2	200x400 Fine	
3	300 x 300 Reserve	
4	400 x 400 Super Fine	
5	600 x 600 Reserve	
6	Reserve	
7	mm/inch	<p>This setting selects mm/inch conversion for mail transmission. 0: Off (No conversion), 1: On (Conversion)</p> <p>When on (set to "1"), the machine converts millimeters to inches for sending mail. There is no switch for converting inches to millimeters.</p> <p>Unlike G3 fax transmissions which can negotiate between sender and receiver to determine the setting, mail cannot negotiate between terminals; the mm/inch selection is determined by the sender fax.</p> <p>When this switch is Off (0):</p> <ul style="list-style-type: none"> ▪ Images scanned in inches are sent in inches. ▪ Images scanned in mm are sent in mm. ▪ Images received in inches are transmitted in inches. ▪ Images received in mm are transmitted in mm. <p>When this switch is On (1):</p> <ul style="list-style-type: none"> ▪ Images scanned in inches are sent in inches. ▪ Images scanned in mm are converted to inches. ▪ Images received in inches are transmitted in inches. ▪ Images received in mm are converted to inches.

Bit Switches

I-fax Switch 02 (SP No. 1-102-003)		
No	Function	Comments
0	RX Text Mail Header Processing	
		<p>This setting determines whether the header information is printed with text e-mails when they are received.</p> <p>0: Prints only text mail. 1: Prints mail header information attached to text mail.</p> <p>When a text mail is received with this switch On (1), the "From" address and "Subject" address are printed as header information.</p> <p>When a mail with only binary data is received (a TIFF-F file, for example), this setting is ignored and no header is printed.</p>
1	Output from Attached Document at E-mail TX Error	
		<p>This setting determines whether only the first page or all pages of an e-mail attachment are printed at the sending station when a transmission error occurs.</p> <p>This allows the customer to see which documents have not reached their intended destinations if sent to the wrong e-mail addresses, for example.</p> <p>0: Prints 1st page only. 1: Prints all pages.</p>
2-3	Text String for Return Receipt	
		<p>This setting determines the text string output for the Return Receipt that confirms the transmission was received normally at the destination.</p>
		<p>00: "Dispatched"</p> <p>Sends from PC mail a request for a Return Receipt. Receives the Return Receipt with "dispatched" in the 2nd part: Disposition: Automatic-action/MDN-send automatically; dispatched The "dispatched" string is included in the Subject string.</p> <p>01: "Displayed"</p> <p>Sends from PC mail a request for a Return Receipt. Receives the Return Receipt with "displayed" in the 2nd part: Disposition: Automatic-action/MDN-send automatically; displayed</p>

I-fax Switch 02 (SP No. 1-102-003)		
No	Function	Comments
		<p>The "displayed" string is included in the Subject string.</p> <p>10: Reserved</p> <p>11: Reserved</p> <p>A mail requesting a Return Receipt sent from an IFAX with this switch set to "00" (for "dispatched") received by Microsoft Outlook 2000 may cause an error. If any setting other than "displayed" (01) causes a problem, change the setting to "01" to enable normal sending of the Return Receipt.</p>
4	Media accept feature	
		<p>This setting adds or does not add the media accept feature to the answer mail to confirm a reception.</p> <p>0: Does not add the media accept feature to the answer mail</p> <p>1: Adds the media accept feature to the answer mail.</p> <p>Use this bit switch if a problem occurs when the machine receives an answer mail, which contains the media accept feature field.</p>
5-6	Not Used	
7	Image Resolution of RX Text Mail	
		<p>This setting determines the image resolution of the received mail.</p> <p>0: 200 x 200</p> <p>1: 400 x 400</p> <p>The "1" setting requires installation of the Function Upgrade Card in order to have enough SAF (Store and Forward) memory to receive images at 400 x 400 resolution.</p>

Bit Switches

I-fax Switch 03 (SP No. 1-102-004)		
No	Function	Comments
0	Original Output at Transfer Station	
		<p>This setting determines whether the original is output at the transfer station when it is received from the sender that initiated the transfer transmission. This feature is the same as for G3 transfer transmissions.</p> <p>0: Received original not output at the transfer station.</p> <p>1: Received original output. The original is printed after the transfer station has transferred it to the destinations, so its output confirms that the original has been transferred.</p>
1	Transfer Result Report	
		<p>This setting determines when a Transfer Result Report is generated and returned to the transfer requestor.</p> <p>0: Returns the report after each transfer.</p> <p>1: Returns the report only if an error occurred during transfer.</p>
2	Destination Error Handling for Reception Transfer Request	
		<p>This setting restricts transfer transmission based on whether the final destinations are correct or not.</p> <p>0: The transfer station transmits to correct destinations only (addresses with no errors in them).</p> <p>1: If any address has an error in it, the transfer station transfers no transmissions and returns a transfer transmission failure report to the requestor that initiated the transfer.</p> <p>There is no negotiation between the transfer initiator and the transfer station to determine whether the final destination addresses are correct or not. This setting determines whether or not the transfer station transfers the transmissions if there is a mistake in even one of the final destination addresses.</p>
3	Polling ID Check for Reception of Transfer Request	
		<p>This setting determines whether the polling IDs of incoming transmissions are checked to ensure that the polling IDs match.</p>

I-fax Switch 03 (SP No. 1-102-004)		
No	Function	Comments
	0: Receives and transfers only messages that have matching polling IDs. 1: Receives and transfers all messages, even if the polling IDs do not match.	
4-7	Not Used	

Bit Switches

I-fax Switch 04 (SP No. 1-102-005)		
No	Function	Comments
0	Subject for Delivery TX/Memory Transfer	<p>This setting determines whether the RTI/CSI registered on this machine or the RTI/CSI of the originator is used in the subject lines of transferred documents.</p> <p>0: Puts the RTI/CSI of the originator in the Subject line. If this is used, either the RTI or CSI is used. Only one of these can be received for use in the subject line.</p> <p>1: Puts the RTI/CSI registered on this machine in the Subject line.</p> <p>When this switch is used to transfer and deliver mail to a PC, the information in the Subject line that indicates where the transmission originated can be used to determine automatically the destination folder for each e-mail.</p>
1	Subject corresponding to mail post database	<p>0: Standard subject</p> <p>1: Mail post database subject</p> <p>The standard subject is replaced by the mail post database subject in the following three cases:</p> <ol style="list-style-type: none"> 1) When the service technician sets the service (software) switch. 2) When memory sending or delivery specified by F code is applied by the SMTP server 3) With relay broadcasting (1st stage without the Schmidt 4 function). <p>Note</p> <ul style="list-style-type: none"> ▪ This switch does not apply for condition 3) when the RX system is set up for memory sending, delivery by F-code, sending with SMTP RX and when operators are using FOL (to prevent problems when receiving transmissions).
2-7	Not Used	

I-fax Switch 05 (SP No. 1-102-006)		
No	Function	Comments
0	Mail Addresses of SMTP Broadcast Recipients	
	Determines whether the e-mail addresses of the destinations that receive transmissions broadcasted using SMTP protocol are recorded in the Journal. For example: "1st destination + Total number of destinations: 9" in the Journal indicates a broadcast to 9 destinations. 0: Not recorded 1: Recorded	
1-7	Not Used	

I-fax Switch 06 - Not used (do not change the settings)
I-fax Switch 07 - Not used (do not change the settings)

I-fax Switch 08 (SP No. 1-102-009)		
No	Function	Comments
0-7	Memory Threshold for POP Mail Reception	
	This setting determines the amount of SAF (Store and Forward) memory. (SAF stores fax messages to send later for transmission to more than one location, and also holds incoming messages if they cannot be printed.) When the amount of SAF memory available falls below this setting, mail can no longer be received; received mail is then stored on the mail server. 00-FF (0 to 1024 KB: HEX) The hexadecimal number you enter is multiplied by 4 KB to determine the amount of memory.	

Bit Switches

I-fax Switch 09 (SP No. 1-102-010)		
No	Function	Comments
0-3	Not used	Do not change the settings
4-7	Restrict TX Retries	This setting determines the number of retries when connection and transmission fails due to errors. 01-F (1-15 Hex)

I-fax Switch 0A - Not used (do not change the settings)
I-fax Switch 0B - Not used (do not change the settings)
I-fax Switch 0C - Not used (do not change the settings)
I-fax Switch 0D - Not used (do not change the settings)
I-fax Switch 0E - Not used (do not change the settings)

I-fax Switch 0F (SP No. 1-102-016)		
No	Function	Comments
0	Delivery Method for SMTP RX Files	
		This setting determines whether files received with SMTP protocol are delivered or output immediately. 0: Off. Files received via SMTP are output immediately without delivery. 1: On. Files received via SMTP are delivered immediately to their destinations.
1-7	Not used	

4.3.3 PRINTER SWITCHES

Printer Switch 00 (SP No. 1-103-001)		
No	Function	Comments
0	Select page separation marks 0: Off 1: On	<p>0: If a 2 page RX transmission is split, [*] is printed in the bottom right corner of the 1st page and only a [2] is printed in the upper right corner of the 2nd page.</p> <p>1: If a 2 page RX transmission is split into two pages, for example, [*] [2] is printed in the bottom right corner of the 1st page and only a [2] is printed in the upper right corner of the 2nd page.</p> <p> Note</p> <ul style="list-style-type: none"> This helps the user to identify pages that have been split because the size of the paper is smaller than the size of the document received. (When A5 is used to print an A4 size document, for example.)
1	Repetition of data when the received page is longer than the printer paper 0: Off 1: On	<p>1: Default. 10 mm of the trailing edge of the previous page are repeated at the top of the next page.</p> <p>0: The next page continues from where the previous page stopped without any repeated text.</p>
2	Prints the date and time on received fax messages 0: Disabled 1: Enabled	<p>This switch is only effective when user parameter 02 - bit 2 (printing the received date and time on received fax messages) is enabled.</p> <p>1: The machine prints the received and printed date and time at the bottom of each received page.</p>
3-7	Not used	Do not change the settings.

Bit Switches

Printer Switch 01 (SP No. 1-103-002)				
No	Function			Comments
0-2	Not used			Do not change the settings.
3-4	Maximum print width used in the setup protocol			These bits are only effective when bit 7 of printer switch 01 is "1".
	Bit 4	Bit 3	Setting	
	0	0	Not used	
	0	1	A3	
	1	0	B4	
	1	1	A4	
5-6	Not used			Do not change the settings.
7	Received message width restriction in the protocol signal to the sender 0: Disabled 1: Enabled			0: The machine informs the transmitting machine of the print width depending on the paper size available from the paper feed stations. Refer to the table on the next page for how the machine chooses the paper width used in the setup protocol (NSF/DIS). 1: The machine informs the transmitting machine of the fixed paper width which is specified by bits 3 and 4 above.

Relationship between available paper sizes and printer width used in the setup protocol

Available Paper Size	Printer width used in the Protocol (NSF/DIS)
A4 or 8.5" x 11"	297 mm width
B5	256 mm width
A5 or 8.5" x 5.5"	216 mm width
No paper available (Paper end)	216 mm width

Printer Switch 02 (SP No. 1-103-003)		
No	Function	Comments
0	1st paper feed station usage for fax printing 0: Enabled 1: Disabled	<p>0: The paper feed station can be used to print fax messages and reports.</p> <p>1: The specified paper feed station will not be used for printing fax messages and reports.</p> <p>Note</p> <ul style="list-style-type: none"> Do not disable usage for a paper feed station which has been specified by User Parameter Switch 0F (15), or which is used for the Specified Cassette Selection feature.
1	2nd paper feed station usage for fax printing 0: Enabled 1: Disabled	
2	3rd paper feed station usage for fax printing 0: Enabled 1: Disabled	
3	4th paper feed station usage for fax printing 0: Enabled 1: Disabled	
4	LCT usage for fax printing 0: Enabled 1: Disabled	
5-7	Not used	
		Do not change the settings.

Bit Switches

Printer Switch 03 (SP No. 1-103-004)		
No	Function	Comments
0	Length reduction of received data 0: Disabled 1: Enabled	0: Incoming pages are printed without length reduction. (Page separation threshold: Printer Switch 03, bits 4 to 7) 1: Incoming page length is reduced when printing. (Maximum reducible length: Printer Switches 04, bits 0 to 4)
1-3	Not used	Do not change the settings
4 to 7	Page separation setting when sub scan compression is forbidden 00-0F (0-15 mm: Hex) Default: 6 mm	Page separation threshold (with reduction disabled with switch 03-0 above). For example, if this setting is set to "10", and A4 is the selected paper size: If the received document is 10 mm or less longer than A4, then the 10 mm are cut and only 1 page prints. If the received document is 10 mm longer than A4, then the document is split into 2 pages.

Printer Switch 04 (SP No. 1-103-005)						
No	Function			Comments		
0 to 4	Maximum reducible length when length reduction is enabled with switch 03-0 above. [Maximum reducible length] = [Paper length] + (N x 5mm) "N" is the decimal value of the binary setting of bits 0 to 4.					
	Bit 4	Bit 3	Bit 2	Bit 1	Bit 0	Setting
	0	0	0	0	0	0 mm
	0	0	0	0	1	5 mm
	0	0	1	0	0	20 mm
	1	1	1	1	1	155 mm
For A5 sideways and B5 sideways paper [Maximum reducible length] = [Paper length] + 0.75 x (N x 5mm)						
5 6	Length of the duplicated image on the next page, when page separation has taken place.					
	Bit 6		Bit 5		Setting	
	0		0		4 mm	
	0		1		10 mm	
	1		0		15 mm	
1		1		Not used		
7	Not used.			Do not change the setting.		

Printer Switch 05 - Not used (do not change the settings)

Bit Switches

Printer Switch 06 (SP No. 1-103-007)		
No	Function	Comments
0	Printing while a paper cassette is pulled out, when the Just Size Printing feature is enabled. 0: Printing will not start 1: Printing will start if another cassette has a suitable size of paper, based on the paper size selection priority tables.	Cross reference Just size printing on/off – User switch 05, bit 5
1-7	Not used.	Do not change the settings.

Printer Switch 07 (SP No. 1-103-008)		
No	Function	Comments
0	Reduction for Journal printing 0: Off 1: On	1: The Journal is reduced to 91% to ensure that there is enough space in the left margin for punch holes or staples.
2-3	Not used.	Do not change the settings.
4	List of destinations in the Communication Failure Report for broadcasting 0: All destinations 1: Only destinations where communication failure occurred	1: Only destinations where communication failure occurred are printed on the Communication Failure Report.
5-7	Not used.	Do not change the settings.

Printer Switch 08 - Not used (do not change the settings)
Printer Switch 09 - Not used (do not change the settings)
Printer Switch 0A - Not used (do not change the settings)
Printer Switch 0B - Not used (do not change the settings)
Printer Switch 0C - Not used (do not change the settings)
Printer Switch 0D - Not used (do not change the settings)

Bit Switches

Printer Switch 0E (SP No. 1-103-015)				
No	Function		Comments	
0	Paper size selection priority 0: Width 1: Length		0: A paper size that has the same width as the received data is selected first. 1: A paper size which has enough length to print all the received lines without reduction is selected first.	
1	Paper size selected for printing A4 width fax data 0: 8.5" x 11" size 1: A4 size		This switch determines which paper size is selected for printing A4 width fax data, when the machine has both A4 and 8.5" x 11" size paper.	
2	Page separation 0: Enabled 1: Disabled		1: If all paper sizes in the machine require page separation to print a received fax message, the machine does not print the message (Substitute Reception is used). After a larger size of paper is set in a cassette, the machine automatically prints the fax message.	
3-4	Printing the sample image on reports		"Same size" means the sample image is printed at 100%, even if page separation occurs. User Parameter Switch 19 (13H) bit 4 must be set to "0" to enable this switch. Refer to Detailed Section Descriptions for more on this feature.	
	Bit 4	Bit 3		Setting
	0	0		The upper half only
	0	1		50% reduction (sub-scan only)
	1	0		Same size
	1	1	Not used	
5-6	Not used		Do not change the settings.	
7	Equalizing the reduction ratio among separated pages		0: When page separation has taken place, all the pages are reduced with the	

Printer Switch 0E (SP No. 1-103-015)		
No	Function	Comments
	(Page Separation) 0: Enabled 1: Disabled	same reduction ratio. 1: Only the last page is reduced to fit the selected paper size when page separation has taken place. Other pages are printed without reduction.

Printer Switch 0F (SP No. 1-103-016)				
No	Function			Comments
0-1	Smoothing feature			(0, 0) (0, 1): Disable smoothing if the machine receives halftone images from other manufacturers fax machines frequently.
	Bit 1	Bit 0	Setting	
	0	0	Disabled	
	0	1	Disabled	
	1	0	Enabled	
1	1	Not used		
2	Duplex printing 0: Disabled 1: Enabled			1: The machine always prints received fax messages in duplex printing mode:
3	Binding direction for Duplex printing 0: Left binding 1: Top binding			0: Sets the binding for the left edge of the stack. 1: Sets the binding for the top of the stack.
4-7	Not used			Do not change the settings.

4.3.4 COMMUNICATION SWITCHES

Communication Switch 00 (SP No. 1-104-001)				
No	Function			Comments
0-1	Compression modes available in receive mode			These bits determine the compression capabilities to be declared in phase B (handshaking) of the T.30 protocol.
	Bit 1	Bit 0	Modes	
	0	0	MH only	
	0	1	MH/MR	
	1	0	MH/MR/MMR	
	1	1	MH/MR/MMR/JBIG	
2-3	Compression modes available in transmit mode			These bits determine the compression capabilities to be used in the transmission and to be declared in phase B (handshaking) of the T.30 protocol.
	Bit 3	Bit 2	Modes	
	0	0	MH only	
	0	1	MH/MR	
	1	0	MH/MR/MMR	
	1	1	MH/MR/MMR/JBIG	
4	Not used			Do not change the settings.
5	JBIG compression method: Reception 0: Only basic supported 1: Basic and optional both supported			Change the setting when communication problems occur using JBIG compression.
6	JBIG compression method: Transmission 0: Basic mode priority 1: Optional mode priority			Change the setting when communication problems occur using JBIG compression.

Communication Switch 00 (SP No. 1-104-001)		
No	Function	Comments
7	Closed network (reception) 0: Disabled 1: Enabled	1: Reception will not go ahead if the polling ID code of the remote terminal does not match the polling ID code of the local terminal. This function is only available in NSF/NSS mode.

Communication Switch 01 (SP No. 1-104-002)				
No	Function			Comments
0	ECM 0: Off 1: On			If this bit is set to 0, ECM is switched off for all communications. In addition, V.8 protocol and JBIG compression are switched off automatically.
1	Not used			Do not change the setting.
2-3	Wrong connection prevention method			(0,1): The machine will disconnect the line without sending a fax message, if the last 8 digits of the received CSI do not match the last 8 digits of the dialed telephone number. This does not work when manually dialed. (1,0): The same as above, except that only the last 4 digits are compared. (1,1): The machine will disconnect the line without sending a fax message, if the other end does not identify itself with an RTI or CSI. (0,0): Nothing is checked; transmission will always go ahead. <div style="border: 1px solid blue; padding: 2px; display: inline-block;"> Note </div> <ul style="list-style-type: none"> ▪ This function does not work when dialing is done from the external telephone.
	Bit 3	Bit 2	Setting	
	0	0	None	
	0	1	8 digit CSI	
	1	0	4 digit CSI	
	1	1	CSI/RTI	

Bit Switches

Communication Switch 01 (SP No. 1-104-002)				
No	Function			Comments
4-5	Not used			Do not change the setting.
6-7	Maximum printable page length available			The setting determined by these bits is informed to the transmitting terminal in the pre-message protocol exchange (in the DIS/NSF frames).
	Bit 7	Bit 6	Setting	
	0	0	No limit	
	0	1	B4 (364 mm)	
	1	0	A4 (297 mm)	
	1	1	Not used	

Communication Switch 02 (SP No. 1-104-003)			
No	Function		Comments
0	G3 Burst error threshold 0: Low 1: High		If there are more consecutive error lines in the received page than the threshold, the machine will send a negative response. The Low and High threshold values depend on the sub-scan resolution, and are as follows.
			100 dpi 6(L) → 12(H)
			200 dpi 12(L) → 24(H)
			300 dpi 18(L) → 36(H)
			400 dpi 24(L) → 48(H)
1	Acceptable total error line ratio 0: 5% 1: 10%		If the error line ratio for a page exceeds the acceptable ratio, RTN will be sent to the other end.

Communication Switch 02 (SP No. 1-104-003)		
No	Function	Comments
2	Treatment of pages received with errors during G3 reception 0: Deleted from memory without printing 1: Printed	0: Pages received with errors are not printed.
3	Hang-up decision when a negative code (RTN or PIN) is received during G3 immediate transmission 0: No hang-up, 1: Hang-up	0: The next page will be sent even if RTN or PIN is received. 1: The machine will send DCN and hang up if it receives RTN or PIN. This bit is ignored for memory transmissions or if ECM is being used.
4-7	Not used	Do not change the settings.

Communication Switch 03 (SP No. 1-104-004)		
No	Function	Comments
0-7	Maximum number of page retransmissions in a G3 memory transmission	00 - FF (Hex) times. This setting is not used if ECM is switched on. Default setting - 03(H)

Communication Switch 04 - Not used (do not change the settings)
Communication Switch 05 - Not used (do not change the settings)
Communication Switch 06 - Not used (do not change the settings)
Communication Switch 07 - Not used (do not change the settings)
Communication Switch 08 - Not used (do not change the settings)
Communication Switch 09 - Not used (do not change the settings)

Bit Switches

Communication Switch 0A (SP No. 1-104-011)		
No	Function	Comments
0	Point of resumption of memory transmission upon redialing 0: From the error page 1: From page 1	0: The transmission begins from the page where transmission failed the previous time. 1: Transmission begins from the first page, using normal memory transmission.
1-7	Not used	Do not change the settings.

Communication Switch 0B (SP No. 1-104-012)		
No	Function	Comments
0	Use of Economy Transmission during a Transfer operation to end receivers 0: Disabled, 1: Enabled	These bits determine whether the machine uses the Economy Transmission feature when it is carrying out a Transfer operation as a Transfer Station.
1	Use of Economy Transmission during a Transfer operation to the Next Transfer Stations 0: Disabled, 1: Enabled	
2	Use of Label Insertion for the End Receivers in a Transfer operation 0: Disabled, 1: Enabled	This bit determines whether the machine uses the Label Insertion feature when it is carrying out a Transfer operation as a Transfer Station.
3	Conditions required for Transfer Result Report transmission 0: Always transmitted 1: Only transmitted if there was an error	0: When acting as a Transfer Station, the machine will always send a Transfer Result Report back to the Requesting Station after completing the Transfer Request, even if there were no problems. 1: The machine will only send back a Transfer Result Report if there were errors during communication, meaning one or more of the End Receivers could not be contacted.

Communication Switch 0B (SP No. 1-104-012)		
No	Function	Comments
4	Printout of the message when acting as a Transfer Station 0: Disabled, 1: Enabled	When the machine is acting as a Transfer Station, this bit determines whether the machine prints the fax message coming in from the Requesting Terminal.
5	Action when there is no fax number in the programmed Quick/Speed dials which meets the requesting terminal's own fax number 0: Transfer is disabled 1: Transfer is enabled	After the machine receives a transfer request, the machine compares the last N digits of the requesting terminal's own fax number with all the Quick/Speed dials programmed in the machine. (N is the number programmed in communication switch 0C.) 0: If there is no matching number programmed in the machine, the machine rejects the transfer request. 1: Even if there is no matching number programmed in the machine, the machine accepts the transfer request. The result report will be printed at the transfer terminal, but will not be sent back to the requesting terminal.
6-7	Not used	Do not change the settings.

Bit Switches

Communication Switch 0C (SP No. 1-104-013)		
No	Function	Comments
0-4	Number of digits compared to find the requester's fax number from the programmed Quick/Speed Dials when acting as a Transfer Station	<p>00 – 1F (0 to 31 digits)</p> <p>After the machine receives a transfer request, the machine compares the own telephone number sent from the Requesting Terminal with all Quick/Speed Dials programmed in the machine, starting from Quick Dial 01 to the end of the Speed Dials.</p> <p>This number determines how many digits from the end of the telephone numbers the machine compares.</p> <p>If it is set to 00, the machine will send the report to the first Quick/Speed Dial that the machine compared. If Quick Dial 01 is programmed, the machine will send the report to Quick 01. If Quick Dial 01 through 04 are not programmed and Quick Dial 05 is programmed, the machine will send the report to Quick 05.</p> <p>Default setting – 05(H) = 5 digits</p>
5-7	Not used	Do not change the settings.

Communication Switch 0D (SP No. 1-104-014)		
No	Function	Comments
0-7	The available memory threshold, below which ringing detection (and therefore reception into memory) is disabled	<p>00 to FF (Hex), unit = 4 kbytes (e.g., 06(H) = 24 kbytes) One page is about 24 kbytes.</p> <p>The machine refers to this setting before each fax reception. If the amount of remaining memory is below this threshold, the machine cannot receive any fax messages.</p> <p>If this setting is kept at 0, the machine will detect ringing signals and go into receive mode even if there is no memory available. This will result in communication failure.</p>

Communication Switch 0E (SP No. 1-104-015)		
No	Function	Comments
0-7	Minimum interval between automatic dialing attempts	<p>06 to FF (Hex), unit = 2 s (e.g., 06(H) = 12 s)</p> <p>This value is the minimum time that the machine waits before it dials the next destination.</p>

Communication Switch 0F – Not used (do not change the settings.)

Bit Switches

Communication Switch 10 (SP No. 1-104-017)		
No	Function	Comments
0-7	Memory transmission: Maximum number of dialing attempts to the same destination	01 – FE (Hex) times

Communication Switch 11 – Not used (do not change the settings.)

Communication Switch 12 (SP No. 1-104-019)		
No	Function	Comments
0-7	Memory transmission: Interval between dialing attempts to the same destination	01 – FF (Hex) minutes

Communication Switch 13 – Not used (do not change the settings.)

Communication Switch 14 (SP No. 1-104-021)				
No	Function		Comments	
0	Inch-to-mm conversion during transmission 0: Disabled, 1: Enabled		<p>0: In immediate transmission, data scanned in inch format are transmitted without conversion.</p> <p>In memory transmission, data stored in the SAF memory in mm format are transmitted without conversion.</p> <p>Note: When storing the scanned data into SAF memory, the fax unit always converts the data into mm format.</p> <p>1: The machine converts the scanned data or stored data in the SAF memory to the format which was specified in the set-up protocol (DIS/NSF) before transmission.</p>	
1-5	Not used		Do not change the factory settings.	
6-7	Available unit of resolution in which fax messages are received		<p>For the best performance, do not change the factory settings.</p> <p>The setting determined by these bits is informed to the transmitting terminal in the pre-message protocol exchange (in the DIS/NSF frames).</p>	
	Bit 7	Bit 6		Unit
	0	0		mm
	0	1		inch
	1	0		mm and inch
1	1	Not used		

Communication Switch 15 – Not used (do not change the settings)

Bit Switches

Communication Switch 16 (SP No. 1-104-023)		
No	Function	Comments
0	Not used	Do not change the settings.
1	Optional G3 unit (G3-2) 0: Not installed 1: Installed	Change this bit to 1 when installing the first optional G3 unit.
2	Not used	
3	Select PSTN connection 0: Off 1: On	This switch enables the G3-2. 0: Off, no connection 1: Recognizes and enables G3-2. This switch can be used only after G3-2 has been installed.
4-7	Not used	Do not change the settings.

Communication Switch 17 (SP No. 1-104-024)		
No	Function	Comments
0	SEP reception 0: Disabled 1: Enabled	0: Polling transmission to another maker's machine using the SEP (Selective Polling) signal is disabled.
1	SUB reception 0: Disabled 1: Enabled	0: Confidential reception to another maker's machine using the SUB (Sub-address) signal is disabled.
2	PWD reception 0: Disabled 1: Enabled	0: Disables features that require PWD (Password) signal reception.
3-6	Not used	Do not change the settings.
7	Action when there is no box with an F-code that matches the received SUB code 0: Disconnect the line 1: Receive the message (using normal reception mode)	Change this setting when the customer requires.

Communication Switch 18 - Not used (do not change the settings)
Communication Switch 19 - Not used (do not change the settings)
Communication Switch 1A - Not used (do not change the settings)

Bit Switches

Communication Switch 1B (SP No. 1-104-028)		
No	Function	Comments
0-7	Extension access code (0 to 7) to turn V.8 protocol On/Off 0: On 1: Off	If the PABX does not support V.8/V.34 protocol procedure, set this bit to "1" to disable V.8. Example: If "0" is the PSTN access code, set bit 0 to 1. When the machine detects "0" as the first dialed number, it automatically disables V.8 protocol. (Alternatively, if "3" is the PSTN access code, set bit 3 to 1.)

Communication Switch 1C (SP No. 1-104-029)		
No	Function	Comments
0-1	Extension access code (8 and 9) to turn V.8 protocol On/Off 0: On 1: Off	Refer to communication switch 1B. Example: If "8" is the PSTN access code, set bit 0 to 1. When the machine detects "8" as the first dialed number, it automatically disables V.8 protocol. (If "9" is the PSTN access code, use bit 1.)
2-7	Not used	Do not change the settings.

Communication Switch 1D - Not used (do not change the settings)
Communication Switch 1E - Not used (do not change the settings)
Communication Switch 1F - Not used (do not change the settings)

4.3.5 G3 SWITCHES

G3 Switch 00 (SP No. 1-105-001)				
No	Function			Comments
0 1	Monitor speaker during communication (tx and rx)			(0, 0): The monitor speaker is disabled all through the communication. (0, 1): The monitor speaker is on up to phase B in the T.30 protocol. (1, 0): Used for testing. The monitor speaker is on all through the communication. Make sure that you reset these bits after testing.
	Bit 1	Bit 0	Setting	
	0	0	Disabled	
	0	1	Up to Phase B	
	1	0	All the time	
	1	1	Not used	
2	Monitor speaker during memory transmission 0: Disabled 1: Enabled			1: The monitor speaker is enabled during memory transmission.
3-7	Not used			Do not change the settings.

Bit Switches

G3 Switch 01 (SP No. 1-105-002)		
No	Function	Comments
0	Not used	Do not change the settings.
1	Select V.8 protocol for manual RX function 0: No 1: Yes	This switch switches the V.8 protocol for manual receiving off and on.
2-3	Not used	Do not change the settings.
4	DIS frame length 0: 10 bytes 1: 4 bytes	1: The bytes in the DIS frame after the 4th byte will not be transmitted (set to 1 if there are communication problems with PC-based faxes which cannot receive the extended DIS frames).
5	Not used	Do not change the setting.
6	Forbid CED/AMsam output 0: Off 1: On (Forbid output)	Do not change this setting (Default: 0: Off), unless communication problem is caused by a CED or ANSam transmission.
7	Not used	Do not change the setting.

G3 Switch 02 (SP No. 1-105-003)		
No	Function	Comments
0	G3 protocol mode used 0: Standard and non-standard 1: Standard only	Change this bit to 1 only when the other end can only communicate with machines that send T.30-standard frames only. 1: Disables NSF/NSS signals (these are used in non-standard mode communication)
1-4	Not used	Do not change the settings.
5	Use of modem rate history for transmission using	0: Communications using Quick/Speed Dials always start from the highest modem rate.

G3 Switch 02 (SP No. 1-105-003)		
No	Function	Comments
	Quick/Speed Dials 0: Disabled 1: Enabled	1: The machine refers to the modem rate history for communications with the same machine when determining the most suitable rate for the current communication.
6	Not Used	Do not change the settings.
7	Short preamble 0: Disabled 1: Enabled	Refer to Appendix B in the Group 3 Facsimile Manual for details about Short Preamble.

G3 Switch 03 (SP No. 1-105-004)		
No	Function	Comments
0	DIS detection number (Echo countermeasure) 0: 1 1: 2	0: The machine will hang up if it receives the same DIS frame twice. 1: Before sending DCS, the machine will wait for the second DIS which is caused by echo on the line.
1	Not Used	Do not change the settings.
2	V.8 protocol 0: Disabled 1: Enabled	0: V.8/V.34 communications will not be possible.  Note <ul style="list-style-type: none"> Do not set to 0 unless the line condition is always bad enough to slow down the data rate to 14.4 kbps or lower.
3	ECM frame size 0: 256 bytes 1: 64 bytes	Keep this bit at "0" in most cases.
4	CTC transmission conditions 0: After one PPR signal received 1: After four PPR signals	0: When using ECM in non-standard (NSF/NSS) mode, the machine sends a CTC to drop back the modem rate after receiving a PPR, if the following condition is met in communications at 14.4, 12.0,

Bit Switches

G3 Switch 03 (SP No. 1-105-004)		
No	Function	Comments
	received (ITU-T standard)	9.6, and 7.2 kbps. $\sqrt{N_{\text{Transmit}} \leq N_{\text{Resend}}}$ NTransmit- Number of transmitted frames NResend- Number of frames to be retransmitted 1: When using ECM, the machine sends a CTC to drop back the modem rate after receiving four PPRs. PPR, CTC: These are ECM protocol signals. This bit is not effective in V.34 communications.
5	Modem rate used for the next page after receiving a negative code (RTN or PIN) 0: No change 1: Fallback	1: The machine's tx modem rate will fall back before sending the next page if a negative code is received. This bit is ignored if ECM is being used.
6	Not used	Do not change the settings
7	Select detection of reverse polarity in ringing 0: Off 1: On	This switch is used to prevent reverse polarity in ringing on the phone line (applied to PSTN-G3 ringing). Do not change this setting 0: No detection (Outside Japan) 1: Detection (Inside Japan only)

G3 Switch 04 (SP No. 1-105-005)		
No	Function	Comments
0-3	Training error detection threshold	0 - F (Hex); 0 - 15 bits If the number of error bits in the received TCF is below this threshold, the machine informs the sender that training has succeeded.
4-7	Not used	Do not change the settings.

G3 Switch 05 (SP No. 1-105-006)						
No	Function				Comments	
0-3	Initial Tx modem rate (kbps)					<p>These bits set the initial starting modem rate for transmission. Use the dedicated transmission parameters if you need to change this for specific receivers. If a modem rate 14.4 kbps or slower is selected, V.8 protocol should be disabled manually. Cross reference V.8 protocol on/off - G3 switch 03, bit 2</p>
	Bit 3	Bit 2	Bit 1	Bit 0	kbps	
	0	0	0	1	2.4	
	0	0	1	0	4.8	
	0	0	1	1	7.2	
	0	1	0	0	9.6	
	0	1	0	1	12.0	
	0	1	1	0	14.4	
	0	1	1	1	16.8	
	1	0	0	0	19.2	
	1	0	0	1	21.6	
	1	0	1	0	24.0	
	1	0	1	1	26.4	
	1	1	0	0	28.8	
	1	1	0	1	31.2	
0	0	1	1	33.6		
Other settings - Not used						
4-5	Initial modem type for 9.6 k or 7.2 kbps.					<p>These bits set the initial modem type for 9.6 and 7.2 kbps, if the initial modem rate is set at these speeds.</p>
	Bit 5	Bit 4	Setting			
	0	0	V.29			
	0	1	V.17			

Bit Switches

G3 Switch 05 (SP No. 1-105-006)				
No	Function			Comments
	1	0	V.34	
	1	1	Not used	
6-7	Not used			Do not change the settings.

G3 Switch 06 (SP No. 1-105-007)					
No	Function				Comments
0-3	Initial Rx modem rate(kbps)				
	Bit 3	Bit 2	Bit 1	Bit 0	kbps
	0	0	0	1	2.4
	0	0	1	0	4.8
	0	0	1	1	7.2
	0	1	0	0	9.6
	0	1	0	1	12.0
	0	1	1	0	14.4
	0	1	1	1	16.8
	1	0	0	0	19.2
	1	0	0	1	21.6
	1	0	1	0	24.0
	1	0	1	1	26.4
	1	1	0	0	28.8
	1	1	0	1	31.2
Other settings - Not used					

These bits set the initial starting modem rate for reception.
 Use a lower setting if high speeds pose problems during reception.
 If a modem rate 14.4 kbps or slower is selected, V.8 protocol should be disabled manually.
 Cross reference
 V.8 protocol on/off - G3 switch 03, bit2

G3 Switch 06 (SP No. 1-105-007)					
No	Function			Comments	
4-7	Modem types available for reception The setting of these bits is used to inform the transmitting terminal of the available modem type for the machine in receive mode. If V.34 is not selected, V.8 protocol must be disabled manually. Cross reference V.8 protocol on/off - G3 switch 03, bit 2				
	Bit 7	Bit 6	Bit 5	Bit 4	Types
	0	0	0	1	V.27ter
	0	0	1	0	V.27ter, V.29
	0	0	1	1	V.27ter, V.29, V.33
	0	1	0	0	V.27ter, V.29, V.17/V.33
	0	1	0	1	V.27ter, V.29, V.17/V33, V.34
	Other settings - Not used				

Bit Switches

G3 Switch 07 (SP No. 1-105-008)					
No	Function				Comments
0-1	PSTN cable equalizer (tx mode: Internal)				Use a higher setting if there is signal loss at higher frequencies because of the length of wire between the modem and the telephone exchange. Use the dedicated transmission parameters for specific receivers. Also, try using the cable equalizer if one or more of the following symptoms occurs. Communication error Modem rate fallback occurs frequently. ↓ Note <ul style="list-style-type: none"> This setting is not effective in V.34 communications.
	Bit 1	Bit 0	Setting		
	0	0	None		
	0	1	Low		
	1	0	Medium		
	1	1	High		
2-3	PSTN cable equalizer (rx mode: Internal)				Use a higher setting if there is signal loss at higher frequencies because of the length of wire between the modem and the telephone exchange. Also, try using the cable equalizer if one or more of the following symptoms occurs. Communication error with error codes such as 0-20, 0-23, etc. Modem rate fallback occurs frequently. ↓ Note <ul style="list-style-type: none"> This setting is not effective in V.34 communications.
	Bit 3		Bit 2	Setting	
	0		0	None	
	0		1	Low	
	1		0	Medium	
	1		1	High	
4	PSTN cable equalizer (V.8/V.17 rx mode: External)				Keep this bit at "1".

G3 Switch 07 (SP No. 1-105-008)		
No	Function	Comments
	0: Disabled 1: Enabled	
5-7	Not used	Do not change the settings.

G3 Switch 08 - Not used (do not change the settings)

G3 Switch 09 - Not used (do not change the settings)

G3 Switch 0A (SP No. 1-105-011)				
No	Function		Comments	
0-1	Maximum allowable carrier drop during image data reception		These bits set the acceptable modem carrier drop time. Try a longer setting if error code 0-22 is frequent.	
	Bit 1	Bit 0		Value (ms)
	0	0		200
	0	1		400
	1	0		800
	1	1	Not used	
2	Select cancellation of high-speed RX if carrier signal lost while receiving 0: Off 1: On		This switch setting determines if high-speed receiving ends if the carrier signal is lost when receiving during non-ECM mode	
3	Not used		Do not change the settings	
4	Maximum allowable frame interval during image data reception.		This bit set the maximum interval between EOL (end-of-line) signals and	

Bit Switches

G3 Switch 0A (SP No. 1-105-011)		
No	Function	Comments
	0: 5 s 1: 13 s	the maximum interval between ECM frames from the other end. Try using a longer setting if error code 0-21 is frequent.
5	Not used	Do not change the settings.
6	Reconstruction time for the first line in receive mode 0: 6 s 1: 12 s	When the sending terminal is controlled by a computer, there may be a delay in receiving page data after the local machine accepts set-up data and sends CFR. This is outside the T.30 recommendation. But, if this delay occurs, set this bit to 1 to give the sending machine more time to send data. Refer to error code 0-20. ITU-T T.30 recommendation: The first line should come within 5 s of CFR.
7	Not used	Do not change the settings.

G3 Switch 0B Not used (do not change the settings).
G3 Switch 0C Not used (do not change the settings).
G3 Switch 0D Not used (do not change the settings).

G3 Switch 0E (SP No. 1-105-015)		
No	Function	Comments
0-7	Set CNG send time interval Some machines on the receiving side may not be able to automatically switch the 3-second CNG interval.	
	High order bit	3000-2250ms: 3000-50xNms 3000 – 50 x Nms 0F (3000 ms) <= N <= FF (2250 ms)
	Low order bit	00-0E(3000-3700ms: 3000+50xNms 3000 – 50 x Nms 0F (3000 ms) <= N <= 0F (3700 ms)

G3 Switch 0F (SP No. 1-105-016)		
No	Function	Comments
0	Alarm when an error occurred in Phase C or later 0: Disabled 1: Enabled	If the customer wants to hear an alarm after each error communication, change this bit to "1".
1	Alarm when the handset is off-hook at the end of communication 0: Disabled 1: Enabled	If the customer wants to hear an alarm if the handset is off-hook at the end of fax communication, change this bit to "1".
2-7	Not used	Do not change the settings.

4.3.6 G3-2 AND G3-3 SWITCHES

These switches require an optional G3 interface unit.

G3-3 switches are the same as for G3-2 switches.

G3-2 Switch 00 (SP No. 1-106-001)				
No	Function			Comments
0 1	Monitor speaker during communication (tx and rx)			(0, 0): The monitor speaker is disabled all through the communication. (0, 1): The monitor speaker is on up to phase B in the T.30 protocol. (1, 0): Used for testing. The monitor speaker is on all through the communication. Make sure that you reset these bits after testing.
	Bit 1	Bit 0	Setting	
	0	0	Disable	
	0	1	Up to Phase B	
	1	0	All the time	
	1	1	Not used	
2	Monitor speaker during memory transmission 0: Disabled 1: Enabled			1: The monitor speaker is enabled during memory transmission.
3-7	Not used			Do not change the settings.

G3-2 Switch 01 (SP No. 1-106-002)		
No	Function	Comments
0-3	Not used	Do not change the settings.
4	DIS frame length 0: 10 bytes 1: 4 bytes	1: The bytes in the DIS frame after the 4th byte will not be transmitted (set to 1 if there are communication problems with PC-based faxes which cannot receive the extended DIS frames).
5	Not used	Do not change the setting.
6	Forbid CED/AMsam output 0: Off 1: On (Forbid output)	Do not change this setting (Default: 0: Off), unless communication problem is caused by a CED or ANSam transmission.
7	Not used	Do not change the setting.

G3-2 Switch 02 (SP No. 1-106-003)		
No	Function	Comments
0	G3 protocol mode used 0: Standard and non-standard 1: Standard only	Change this bit to 1 only when the other end can only communicate with machines that send T.30-standard frames only. 1: Disables NSF/NSS signals (these are used in non-standard mode communication)
1-4	Not used	Do not change the settings.
5	Use of modem rate history for transmission using Quick/Speed Dials 0: Disabled 1: Enabled	0: Communications using Quick/Speed Dials always start from the highest modem rate. 1: The machine refers to the modem rate history for communications with the same machine when determining the most suitable rate for the current communication.
6	Not Used	Do not change the settings.

Bit Switches

G3-2 Switch 02 (SP No. 1-106-003)		
No	Function	Comments
7	Short preamble 0: Disabled 1: Enabled	Refer to Appendix B in the Group 3 Facsimile Manual for details about Short Preamble.

G3-2 Switch 03 (SP No. 1-106-004)		
No	Function	Comments
0	DIS detection number (Echo countermeasure) 0: 1 1: 2	0: The machine will hang up if it receives the same DIS frame twice. 1: Before sending DCS, the machine will wait for the second DIS which is caused by echo on the line.
1	Not Used	Do not change the settings.
2	V.8 protocol 0: Disabled 1: Enabled	0: V.8/V.34 communications will not be possible. Note <ul style="list-style-type: none"> Do not set to 0 unless the line condition is always bad enough to slow down the data rate to 14.4 kbps or lower.
3	ECM frame size 0: 256 bytes 1: 64 bytes	Keep this bit at "0" in most cases.
4	CTC transmission conditions 0: After one PPR signal received 1: After four PPR signals received (ITU-T standard)	0: When using ECM in non-standard (NSF/NSS) mode, the machine sends a CTC to drop back the modem rate after receiving a PPR, if the following condition is met in communications at 14.4, 12.0, 9.6, and 7.2 kbps. $\sqrt{N_{\text{Transmit}} \leq N_{\text{Resend}}}$ <p>N_{transmit} = Number of transmitted frames N_{resend} = Number of frames to be retransmitted</p> 1: When using ECM, the machine sends a CTC to

G3-2 Switch 03 (SP No. 1-106-004)		
No	Function	Comments
		drop back the modem rate after receiving four PPRs. PPR, CTC: These are ECM protocol signals. This bit is not effective in V.34 communications.
5	Modem rate used for the next page after receiving a negative code (RTN or PIN) 0: No change 1: Fallback	1: The machine's tx modem rate will fall back before sending the next page if a negative code is received. This bit is ignored if ECM is being used.
6	Not used	Do not change the settings
7	Select detection of reverse polarity in ringing 0: Off 1: On	This switch is used to prevent reverse polarity in ringing on the phone line (applied to PSTN-G3 ringing). Do not change this setting 0: No detection (Outside Japan) 1: Detection (Inside Japan only)

G3-2 Switch 04 (SP No. 1-106-005)		
No	Function	Comments
0-3	Training error detection threshold	0 - F (Hex); 0 - 15 bits If the number of error bits in the received TCF is below this threshold, the machine informs the sender that training has succeeded.
4-7	Not used	Do not change the settings.

Bit Switches

G3-2 Switch 05 (SP No. 1-106-006)						
No	Function				Comments	
0-3	Initial Tx modem rate (kbps)					<p>These bits set the initial starting modem rate for transmission.</p> <p>Use the dedicated transmission parameters if you need to change this for specific receivers.</p> <p>If a modem rate 14.4 kbps or slower is selected, V.8 protocol should be disabled manually.</p> <p>Cross reference V.8 protocol on/off - G3 switch 03, bit 2</p>
	Bit 3	Bit 2	Bit 1	Bit 0	kbps	
	0	0	0	1	2.4	
	0	0	1	0	4.8	
	0	0	1	1	7.2	
	0	1	0	0	9.6	
	0	1	0	1	12.0	
	0	1	1	0	14.4	
	0	1	1	1	16.8	
	1	0	0	0	19.2	
	1	0	0	1	21.6	
	1	0	1	0	24.0	
	1	0	1	1	26.4	
	1	1	0	0	28.8	
	1	1	0	1	31.2	
Other settings - Not used						
4-5	Initial modem type for 9.6 k or 7.2 kbps.					
	Bit 5	Bit 4	Setting			
	0	0	V.29			
	0	1	V.17			
	1	0	V.34			
					<p>These bits set the initial modem type for 9.6 and 7.2 kbps, if the initial modem rate is set at these speeds.</p>	

G3-2 Switch 05 (SP No. 1-106-006)				
No	Function			Comments
	1	1	Not used	
6-7	Not used			Do not change the settings.

G3-2 Switch 06 (SP No. 1-106-007)					
No	Function			Comments	
0-3	Initial Rx modem rate(kbps)				These bits set the initial starting modem rate for reception. Use a lower setting if high speeds pose problems during reception. If a modem rate 14.4 kbps or slower is selected, V.8 protocol should be disabled manually. Cross reference V.8 protocol on/off - G3 switch 03, bit2
	Bit 3	Bit 2	Bit 1	Bit 0	
	0	0	0	1	
	0	0	1	0	
	0	0	1	1	
	0	1	0	0	
	0	1	0	1	
	0	1	1	0	
	0	1	1	1	
	1	0	0	0	
	1	0	0	1	
	1	0	1	0	
	1	0	1	1	
	1	1	0	0	
1	1	0	1		
Other settings - Not used					
4-7	Modem types available for reception				

Bit Switches

G3-2 Switch 06 (SP No. 1-106-007)					
No	Function			Comments	
0	The setting of these bits is used to inform the transmitting terminal of the available modem type for the machine in receive mode.				
	If V.34 is not selected, V.8 protocol must be disabled manually.				
	Cross reference				
	V.8 protocol on/off - G3 switch 03, bit 2				
	Bit 7	Bit 6	Bit 5	Bit 4	Types
	0	0	0	1	V.27ter
	0	0	1	0	V.27ter
	0	0	1	1	V.27ter
0	1	0	0	V.27ter	
0	1	0	1	V.27ter	
Other settings - Not used					

G3-2 Switch 07 (SP No. 1-106-008)				
No	Function			Comments
0-1	PSTN cable equalizer (tx mode: Internal)			Use a higher setting if there is signal loss at higher frequencies because of the length of wire between the modem and the telephone exchange.
	Bit 1	Bit 0	Setting	
	0	0	None	Use the dedicated transmission parameters for specific receivers.
	0	1	Low	
	1	0	Medium	
	1	1	High	Also, try using the cable equalizer if one or more of the following symptoms occurs.
				Communication error Modem rate fallback occurs frequently.

G3-2 Switch 07 (SP No. 1-106-008)				
No	Function			Comments
				<p>↓ Note</p> <ul style="list-style-type: none"> This setting is not effective in V.34 communications.
2-3	PSTN cable equalizer (rx mode: Internal)			<p>Use a higher setting if there is signal loss at higher frequencies because of the length of wire between the modem and the telephone exchange.</p> <p>Also, try using the cable equalizer if one or more of the following symptoms occurs.</p> <p>Communication error with error codes such as 0-20, 0-23, etc.</p> <p>Modem rate fallback occurs frequently.</p> <p>↓ Note</p> <ul style="list-style-type: none"> This setting is not effective in V.34 communications.
	Bit 3	Bit 2	Setting	
	0	0	None	
	0	1	Low	
	1	0	Medium	
	1	1	High	
4	PSTN cable equalizer (V.8/V.17 rx mode: External) 0: Disabled 1: Enabled			Keep this bit at "1".
5-7	Not used			Do not change the settings.

G3-2 Switch 08 - Not used (do not change the settings)
G3-2 Switch 09 - Not used (do not change the settings)

Bit Switches

G3-2 Switch 0A (SP No. 1-106-011)				
No	Function			Comments
0-1	Maximum allowable carrier drop during image data reception			These bits set the acceptable modem carrier drop time. Try a longer setting if error code 0-22 is frequent.
	Bit 1	Bit 0	Value (ms)	
	0	0	200	
	0	1	400	
	1	0	800	
	1	1	Not used	
2	Select cancellation of high-speed RX if carrier signal lost while receiving 0: Off 1: On			This switch setting determines if high-speed receiving ends if the carrier signal is lost when receiving during non-ECM mode
3	Not used			Do not change the settings
4	Maximum allowable frame interval during image data reception. 0: 5 s 1: 13 s			This bit set the maximum interval between EOL (end-of-line) signals and the maximum interval between ECM frames from the other end. Try using a longer setting if error code 0-21 is frequent.
5	Not used			Do not change the settings.
6	Reconstruction time for the first line in receive mode 0: 6 s 1: 12 s			When the sending terminal is controlled by a computer, there may be a delay in receiving page data after the local machine accepts set-up data and sends CFR. This is outside the T.30 recommendation. But, if this delay occurs, set this bit to 1 to give the

G3-2 Switch 0A (SP No. 1-106-011)		
No	Function	Comments
		<p>sending machine more time to send data. Refer to error code 0-20. ITU-T T.30 recommendation: The first line should come within 5 s of CFR.</p>
7	Not used	Do not change the settings.

G3-2 Switch 0B - Not used (do not change the settings)
G3-2 Switch 0C - Not used (do not change the settings)
G3-2 Switch 0D - Not used (do not change the settings)
G3-2 Switch 0E - Not used (do not change the settings)
G3-2 Switch 0F - Not used (do not change the settings)

4.3.7 G4 INTERNAL SWITCHES

The G4 internal switches (SW00 to 1F) are displayed but do not change these settings.

4.3.8 G4 PARAMETER SWITCHES

The G4 parameter switches (SW00 to 0F) are displayed but do not change these settings.

4.3.9 IP FAX SWITCHES

IP Fax Switch 00 (SP No. 1-111-001)		
No.	Function	Comments
0	Not used	Do not change this setting.
1	IP Fax Transport 0: TCP, 1: UDP	Selects TCP or UDP protocol for IP-Fax
2	IP Fax single port selection 0: OFF, 1: ON (enable)	Selects single data port.
3	IP Fax double ports (single data port) selection 0: OFF, 1: ON (enable)	Selects whether IP-Fax uses a double port.
4	IP Fax Gatekeeper 0: OFF, 1: ON (enable)	Enables/disables the gatekeeper for IP-Fax.
5	IP Fax T30 bit signal reverse 0: LSB first, 1: MSB first	Reverses the T30 bit signal.
6	IP Fax max bit rate setting 0: Not affected, 1: Affected	When "0" is selected, the max bit rate does not affect the value of the DIS/DCS. When "1" is selected, the max bit rate affects the value of the DIS/DCS.
7	IP Fax received telephone number confirmation	When "0" is selected, fax data is received without checking the telephone number.

IP Fax Switch 00 (SP No. 1-111-001)		
No.	Function	Comments
	0: No confirmation, 1: Confirmation	When "1" is selected, fax data is received only when confirming that the telephone number from the sender matches the registered telephone number in this machine. If this confirmation fails, the line is disconnected.

IP Fax Switch 01 (SP No. 1-111-002)					
No.	Function				Comments
0-3	IP Fax delay level setting Selects the acceptable delay level. Level 0 is the highest quality Default is "0000" (level 0).				
	Bit 3	Bit 2	Bit 1	Bit 0	
	0	0	0	0	Level 0
	0	0	0	1	Level 1
	0	0	1	0	Level 2
	0	0	1	1	Level 3
4-7	IP Fax preamble wait time setting				Selects the preamble wait time. [00 to 0f] There are 16 values in this 4-bit binary switch combination. Waiting time: set value level x 100 ms Max: 0f (1500 ms) Min: 00 (No wait time) The default is "0000" (00H).

Bit Switches

IP Fax Switch 02 (SP No. 1-111-003)		
No.	Function	Comments
0	IP Fax bit signal reverse setting 0: Maker code setting 1: Internal bit switch setting	When "0" is selected, the bit signal reverse method is decided by the maker code. When "1" is selected, the bit signal reverse method is decided by the internal bit switch. (When communicating between IP Fax devices, LSB first is selected.)
1	IP Fax transmission speed setting 0: Modem speed 1: No limitation	Selects the transmit speed for IP Fax communication.
2	SIP transport setting 0: TCP 1: UDP	This bit switch sets the transport that has priority for receiving IP Fax data. This function is activated only when the sender has both TCP and UDP.
3-7	Not used	Do not change these settings.

IP Fax Switch 03 (SP No. 1-111-004)		
No.	Function	Comments
0	Effective field limitation for G3 standard function information 0: OFF, 1: 4byte (DIS)	Limits the effective field for standard G3 function information.
1	Switching between G3 standard and G3 non standard 0: Enable switching 1: G3 standard only	Enables/disables switching between G3 standard and G3 non-standard.
2	AI modem rate function 0: OFF, 1: ON (enable)	Enables/disables the AI modem rate.
3	ECM frame size selection at	Selects the ECM frame size for sending.

IP Fax Switch 03 (SP No. 1-111-004)		
No.	Function	Comments
	transmitting 0: 256byte, 1: 64byte	
4	DIS detection times for echo prevention 0: 1 time, 1: 2 times	Sets the number of times for DIS to detect echoes.
5	CTC transmission selection 0: PPRx1 1: PPRx4	When "0" is selected, the transmission condition is decided by error frame numbers. When "1" is selected, the transmission condition is based on the ITU-T method.
6	Shift down setting at receiving negative code 0: OFF, 1: ON	Selects whether to shift down when negative codes are received.
7	Not used	Do not change this setting.

IP Fax Switch 04 (SP No. 1-111-005)		
No.	Function	Comments
0-3	TCF error threshold	Sets the TCF error threshold level. [00 to 0f] The default is "1111" (0fH).
4-7	Not used	Do not change these settings.

Bit Switches

IP Fax Switch 05 (SP No. 1-111-006)						
No.	Function					Comments
0-3	Modem bit rate setting for transmission (kbps)					Sets the modem bit rate for transmission. The default is "0110" (14.4K bps).
	Bit 3	Bit 2	Bit 1	Bit 0	kbps	
	0	0	0	1	2.4	
	0	0	1	1	4.8	
	0	0	1	1	7.2	
	0	1	0	0	9.6	
	0	1	0	1	12.0	
	0	1	1	0	14.4	
4-5	Modem setting for transmission					Sets the modem type for transmission. The default is "00" (V29).
	Bit 5	Bit 4	Types			
	0	0	V29			
	0	1	V17			
	1	0	Not used			
	1	1	Not used			
6-7	Not used					Do not change these settings.

IP Fax Switch 06 (SP No. 1-111-007)					
No.	Function				Comments
0-3	Modem bit rate setting for reception Sets the modem bit rate for reception. The default is "0110" (14.4K bps).				
4-7	Modem setting for reception Sets the modem type for reception. The default is "0100" (V27ter, V29, V17).				
	Bit 7	Bit 6	Bit 5	Bit 4	Types
	0	0	0	1	V.27ter
	0	0	1	0	V.27ter, V.29
	0	0	1	1	V.27ter, V.29, V.33
	0	1	0	0	V.27ter, V.29, V.17/V.33
Other settings - Not used					

Bit Switches

IP Fax Switch 07 (SP No. 1-111-008)		
No.	Function	Comments
0	TSI information 0: Not added, 1: Added	Adds or does not add TSI information to NSS(S).
1	DCN transmission setting at T1 timeout 0: Not transmitted 1: Transmitted	Transmits or does not transmit DCN at T1 timeout.
2	Not used	Do not change this setting.
3	Hang up setting at DIS reception disabled 0: No hang up 1: Hang up after transmitting DCN	Sets whether the machine disconnects after DIS reception.
4	Number of times for training 0: 1 time, 1: 2 times	Selects the number of times training is done at the same bit rate.
5	Space CSI transmission setting at no CSI registration 0: Not transmitted 1: Transmitted	When "0" is selected, frame data is enabled. When "1" is selected, the transmitted data is all spaces.
6-7	Not used	Do not change these settings.

IP Fax Switch 08 (SP No. 1-111-009)				
No.	Function			Comments
0-1	T1 timer adjustment			Adjusts the T1 timer. The default is "00" (35 seconds).
	Bit 1	Bit 0		
	0	0	35 s	
	0	1	40 s	
	1	0	50 s	
	1	1	60 s	
2-3	T4 timer adjustment			Adjust the T4 timer. The default is "00" (3 seconds).
	Bit 3	Bit 2		
	0	0	3 s	
	0	1	3.5 s	
	1	0	4 s	
	1	1	5 s	
4-5	T0 timer adjustment			Adjusts the fail safe timer. This timer sets the interval between "setup" data transmission and T.38 phase decision. If your destination return is late on the network or G3 fax return is late, adjust the longer interval timer. The default is "00" (75 seconds).
	Bit 5	Bit 4		
	0	0	75 s	
	0	1	120 s	
	1	0	180 s	
	1	1	240 s	
6-7	Not used			Do not change these settings.

Bit Switches

IP Fax Switch 09 (SP No. 1-111-010)		
No.	Function	Comments
0	Network I/F setting for SIP connection 0: IPv4 1: IPv6.	Selects the connection type (IPV4 or IPV6) to connect to the SIP server.
1	Network I/F setting for Fax communication 0: Same setting as SIP server connection 1: Automatic setting	0: The I/F setting for fax communication follows the setting for SIP server connection. 1: The negotiation between the SIP server and the device decides whether IPv4 or IPv6 is used for the I/F setting for fax communication.
2	Record-route setting 0: Disable 1: Enable	0: Disables the record-route function of the SIP server. 1: Enables the record-route function of the SIP server.
3-7	Not used.	Do not change these settings.

4.4 NCU PARAMETERS

The following tables give the RAM addresses and the parameter calculation units that the machine uses for ringing signal detection and automatic dialing. The factory settings for each country are also given. Most of these must be changed by RAM read/write (SP2-102), but some can be changed using NCU Parameter programming (SP2-103, 104 and 105); if SP2-103, 104 and 105 can be used, this will be indicated in the Remarks column. The RAM is programmed in hex code unless (BCD) is included in the Unit column.

Note

- The following addresses describe settings for the standard NCU.
- Change the fourth digit from "5" to "6" (e.g. 680500 to 680600) for the settings for the first optional G3 interface unit and from "5" to "7" (e.g. 680700) for the settings for the second optional G3 interface unit.

Address	Function		Unit			Remarks
680500	Country/Area code for NCU parameters					
	Use the Hex value to program the country/area code directly into this address, or use the decimal value to program it using SP2-103-001					
	Country/Area	Decimal	Hex	Country/Area	Decimal	Hex
	France	00	00	Hong Kong	20	14
	Germany	01	01	South Africa	21	15
	UK	02	02	Australia	22	16
	Italy	03	03	New Zealand	23	17
	Austria	04	04	S'pore	24	18
	Belgium	05	05	Malaysia	25	19
	Denmark	06	06	China	26	1A
	Finland	07	07	Taiwan	27	1B

NCU Parameters

Address	Function		Unit	Remarks		
	Ireland	08	08	Korea	28	1C
	Norway	09	09	Turkey	32	20
	Sweden	10	0A	Greece	33	21
	Switz.	11	0B	Hungary	34	22
	Portugal	12	0C	Czech	35	23
	Country/Area	Decimal	Hex	Country/Area	Decimal	Hex
	Holland	13	0D	Poland	36	24
	Spain	14	0E			
	Israel	15	0F			
	USA	17	11			
680501	Line current detection time		20 ms	Line current detection is disabled. Line current is not detected if 680501 contains FF.		
680502	Line current wait time					
680503	Line current drop detect time					
680504	PSTN dial tone frequency upper limit (high byte)		Hz (BCD)	If both addresses contain FF(H), tone detection is disabled.		
680505	PSTN dial tone frequency upper limit (low byte)					
680506	PSTN dial tone frequency lower limit (high byte)		Hz (BCD)	If both addresses contain FF(H), tone detection is disabled.		
680507	PSTN dial tone frequency lower limit (low byte)					
680508	PSTN dial tone detection time		20 ms	If 680508 contains FF(H), the machine		
680509	PSTN dial tone reset time (LOW)					

Address	Function	Unit	Remarks
68050A	PSTN dial tone reset time (HIGH)		pauses for the pause time (address 68050D / 68050E). Italy: See Note 2.
68050B	PSTN dial tone continuous tone time		
68050C	PSTN dial tone permissible drop time		
68050D	PSTN wait interval (LOW)		
68050E	PSTN wait interval (HIGH)		
68050F	PSTN ring-back tone detection time	20 ms	Detection is disabled if this contains FF.
680510	PSTN ring-back tone off detection time	20 ms	
680511	PSTN detection time for silent period after ring-back tone detected (LOW)	20 ms	
680512	PSTN detection time for silent period after ring-back tone detected (HIGH)	20 ms	
680513	PSTN busy tone frequency upper limit (high byte)	Hz (BCD)	If both addresses contain FF(H), tone detection is disabled.
680514	PSTN busy tone frequency upper limit (low byte)		
680515	PSTN busy tone frequency lower limit (high byte)	Hz (BCD)	If both addresses contain FF(H), tone detection is disabled.
680516	PSTN busy tone frequency lower limit (low byte)		
680517	PABX dial tone frequency upper limit (high byte)	Hz (BCD)	If both addresses contain FF(H), tone detection is disabled.
680518	PABX dial tone frequency upper limit (low byte)		
680519	PABX dial tone frequency lower limit (high byte)	Hz (BCD)	If both addresses contain FF(H), tone detection is

NCU Parameters

Address	Function	Unit	Remarks
68051A	PABX dial tone frequency lower limit (low byte)		disabled.
68051B	PABX dial tone detection time	20 ms	If 68051B contains FF, the machine pauses for the pause time (680520 / 680521).
68051C	PABX dial tone reset time (LOW)		
68051D	PABX dial tone reset time (HIGH)		
68051E	PABX dial tone continuous tone time		
68051F	PABX dial tone permissible drop time		
680520	PABX wait interval (LOW)		
680521	PABX wait interval (HIGH)		
680522	PABX ringback tone detection time	20 ms	If both addresses contain FF(H), tone detection is disabled.
680523	PABX ringback tone off detection time	20 ms	
680524	PABX detection time for silent period after ringback tone detected (LOW)	20 ms	If both addresses contain FF(H), tone detection is disabled.
680525	PABX detection time for silent period after ringback tone detected (HIGH)	20 ms	
680526	PABX busy tone frequency upper limit (high byte)	Hz (BCD)	If both addresses contain FF(H), tone detection is disabled.
680527	PABX busy tone frequency upper limit (low byte)		
680528	PABX busy tone frequency lower limit (high byte)	Hz (BCD)	If both addresses contain FF(H), tone detection is disabled.
680529	PABX busy tone frequency lower limit (low byte)		
68052A	Busy tone ON time: range 1	20 ms	

Address	Function	Unit	Remarks
68052B	Busy tone OFF time: range 1		
68052C	Busy tone ON time: range 2		
68052D	Busy tone OFF time: range 2		
68052E	Busy tone ON time: range 3		
68052F	Busy tone OFF time: range 3	20 ms	
680530	Busy tone ON time: range 4		
680531	Busy tone OFF time: range 4		
680532	Busy tone continuous tone detection time		
680533	Busy tone signal state time tolerance for all ranges, and number of cycles required for detection (a setting of 4 cycles means that ON-OFF-ON or OFF-ON-OFF must be detected twice). Tolerance (±)		
	Bit 1	Bit 0	
	0	0	75%
	0	1	50%
	1	0	25%
	1	1	12.5%
	Bits 2 and 3 must always be kept at 0. Bits 7, 6, 5, 4 - number of cycles required for cadence detection		
680534	International dial tone frequency upper limit (high byte)	Hz (BCD)	If both addresses contain FF(H), tone detection is disabled.
680535	International dial tone frequency upper limit (low byte)		

NCU Parameters

Address	Function	Unit	Remarks
680536	International dial tone frequency lower limit (high byte)	Hz (BCD)	If both addresses contain FF(H), tone detection is disabled.
680537	International dial tone frequency lower limit (low byte)		
680538	International dial tone detection time	20 ms	If 680538 contains FF, the machine pauses for the pause time (68053D / 68053E). Belgium: See Note 2.
680539	International dial tone reset time (LOW)		
68053A	International dial tone reset time (HIGH)		
68053B	International dial tone continuous tone time		
68053C	International dial tone permissible drop time		
68053D	International dial wait interval (LOW)		
68053E	International dial wait interval (HIGH)		
68053F	Country dial tone upper frequency limit (HIGH)	Hz (BCD)	If both addresses contain FF(H), tone detection is disabled.
680540	Country dial tone upper frequency limit (LOW)		
680541	Country dial tone lower frequency limit (HIGH)		If both addresses contain FF(H), tone detection is disabled.
680542	Country dial tone lower frequency limit (LOW)		
680543	Country dial tone detection time	20 ms	If 680543 contains FF,

Address	Function	Unit	Remarks
680544	Country dial tone reset time (LOW)		the machine pauses for the pause time (680548 / 680549).
680545	Country dial tone reset time (HIGH)		
680546	Country dial tone continuous tone time		
680547	Country dial tone permissible drop time	20 ms	
680548	Country dial wait interval (LOW)		
680549	Country dial wait interval (HIGH)		
68054A	Time between opening or closing the DO relay and opening the OHDI relay	1 ms	See Notes 3, 6 and 8. SP2-103-012 (parameter 11).
68054B	Break time for pulse dialing	1 ms	See Note 3. SP2-103-013 (parameter 12).
68054C	Make time for pulse dialing	1 ms	See Note 3. SP2-103-014 (parameter 13).
68054D	Time between final OHDI relay closure and DO relay opening or closing	1 ms	See Notes 3, 6 and 8. SP2-103-015 (parameter 14). This parameter is only valid in Europe.
68054E	Minimum pause between dialed digits (pulse dial mode)	20 ms	See Note 3 and 8. SP2-103-016 (parameter 15).

NCU Parameters

Address	Function	Unit	Remarks
68054F	Time waited when a pause is entered at the operation panel		SP2-103-017 (parameter 16). See Note 3.
680550	DTMF tone on time	1 ms	SP2-103-018 (parameter 17).
680551	DTMF tone off time		SP2-103-019 (parameter 18).
680552	Tone attenuation level of DTMF signals while dialing	-N x 0.5 -3.5 dBm	SP2-103-020 (parameter 19). See Note 5.
680553	Tone attenuation value difference between high frequency tone and low frequency tone in DTMF signals	-dBm x 0.5	SP2-103-021 (parameter 20). The setting must be less than -5dBm, and should not exceed the setting at 680552h above. See Note 5.
680554	PSTN: DTMF tone attenuation level after dialling	-N x 0.5 -3.5 dBm	SP2-103-022 (parameter 21). See Note 5.
680555	ISDN: DTMF tone attenuation level after dialling	-dBm x 0.5	See Note 5
680556	Not used		Do not change the settings.
680557	Time between 68054Dh (NCU parameter 14) and 68054Eh (NCU parameter 15)	1 ms	This parameter takes effect when the country code is set to France.
680558	Not used		Do not change the setting.
680559	Grounding time (ground start mode)	20 ms	The Gs relay is closed for this interval.

NCU Parameters

Address	Function	Unit	Remarks
680567 to 680571	Not used		Do not change the settings.
680572	Acceptable ringing signal frequency: range 1, upper limit	1000/ N (Hz).	SP2-103-003 (parameter 02).
680573	Acceptable ringing signal frequency: range 1, lower limit		SP2-103-004 (parameter 03).
680574	Acceptable ringing signal frequency: range 2, upper limit		SP2-103-005 (parameter 04).
680575	Acceptable ringing signal frequency: range 2, lower limit		SP2-103-006 (parameter 05).
680576	Number of rings until a call is detected	1	SP2-103-007 (parameter 06). The setting must not be zero.
680577	Minimum required length of the first ring	20 ms	See Note 4. SP2-103-008 (parameter 07).
680578	Minimum required length of the second and subsequent rings	20 ms	SP2-103-009 (parameter 08).
680579	Ringing signal detection reset time (LOW)	20 ms	SP2-103-010 (parameter 09).
68057A	Ringing signal detection reset time (HIGH)		SP2-103-011 (parameter 10).
68057B to 680580	Not used		Do not change the settings.
680581	Interval between dialing the last	20 ms	Factory setting: 500 ms

Address	Function	Unit	Remarks
	digit and switching the Oh relay over to the external telephone when dialing from the operation panel in handset mode.		
680582	Bits 0 and 1 - Handset off-hook detection time		
	Bit 1	Bit 0	Setting
	0	0	200 ms
	0	1	800 ms
	Other		Not used
	Bits 2 and 3 - Handset on-hook detection time		
	Bit 3	Bit 2	Setting
	0	0	200 ms
	0	1	800 ms
	Other		Not used
	Bits 4 to 7 - Not used		
680583 to 6805A0	Not used		Do not change the settings.
6805A1	Acceptable CED detection frequency upper limit (high byte)	BCD (Hz)	If both addresses contain FF(H), tone detection is disabled.
6805A2	Acceptable CED detection frequency upper limit (low byte)		
6805A3	Acceptable CED detection frequency lower limit (high byte)	BCD (Hz)	If both addresses contain FF(H), tone detection is

NCU Parameters

Address	Function	Unit	Remarks
6805A4	Acceptable CED detection frequency lower limit (low byte)		disabled.
6805A5	CED detection time	20 ms ± 20 ms	Factory setting: 200 ms
6805A6	Acceptable CNG detection frequency upper limit (high byte)	BCD (Hz)	If both addresses contain FF(H), tone detection is disabled.
6805A7	Acceptable CNG detection frequency upper limit (low byte)		
6805A8	Acceptable CNG detection frequency lower limit (high byte)	BCD (Hz)	If both addresses contain FF(H), tone detection is disabled.
6805A9	Acceptable CNG detection frequency lower limit (low byte)		
6805AA	Not used		Do not change the setting.
6805AB	CNG on time	20 ms	Factory setting: 500 ms
6805AC	CNG off time	20 ms	Factory setting: 3000 ms
6805AD	Number of CNG cycles required for detection		The data is coded in the same way as address 680533.
6805AE	Not used		Do not change the settings.
6805AF	Acceptable AI short protocol tone (800Hz) detection frequency upper limit (high byte)	Hz (BCD)	If both addresses contain FF(H), tone detection is disabled.
6805B0	Acceptable AI short protocol tone (800Hz) detection		

Address	Function	Unit	Remarks
	frequency upper limit (low byte)		
6805B1	Acceptable AI short protocol tone (800Hz) detection frequency lower limit (high byte)	Hz(BCD)	If both addresses contain FF(H), tone detection is disabled.
6805B2	Acceptable AI short protocol tone (800Hz) detection frequency lower limit (low byte)		
6805B3	Detection time for 800 Hz AI short protocol tone	20 ms	Factory setting: 360 ms
6805B4	PSTN: Tx level from the modem	-N – 3 dBm	SP2-103-002 (parameter 01).
6805B5	PSTN: 1100 Hz tone transmission level	- N 6805B4 - 0.5N 6805B5 –3.5 (dB) See Note 7.	
6805B6	PSTN: 2100 Hz tone transmission level	- N6805B4 - 0.5N 6805B6 –3 (dB) See Note 7.	
6805B7	PABX: Tx level from the modem	- dBm	
6805B8	PABX: 1100 Hz tone transmission level	- N 6805B7 - 0.5N 6805B8 (dB)	
6805B9	PABX: 2100 Hz tone transmission level	- N 6805B7 - 0.5N 6805B9 (dB)	
6805BD	Modem turn-on level (incoming signal detection level)	-37-0.5N (dBm)	
6805BE to 6805C6	Not used		Do not change the settings.
6805C7	Bits 0 to 3 – Not used. Bit 4 – V.34 protocol dump - 0: Simple, 1: Detailed (default) Bits 5 to 7 – Not used.		

NCU Parameters

Address	Function	Unit	Remarks												
6805C8 to 6805D9	Not used		Do not change the settings.												
6805DA	T.30 T1 timer	1 s													
6805E0 bit 3	Maximum wait time for post message	0: 12 s 1: 30 s	1: Maximum wait time for post message (EOP/EOM/MPS) can be changed to 30 s. Change this bit to "1" if communication errors occur frequently during V.17 reception.												
6805E3	Voltage setting to detect off-hook for voltage/DP detection for an externally connected line.	0: Auto 1: Fixed V	Do not change these settings												
	Here is a summary of the fixed voltage settings (1: Fixed) for an externally connected line.														
	Bit 7	Bit 6	Bit 5	Bit 4											
	0	0	0	0	Not used										
	0	0	0	1	2.75 V										
	0	0	1	0	5.5 V										
	1	0	0	0	22 V										
				1	1	1	1	41.25 V							
6805E4	Bit 1 sets the level of the call signal, Bit 3 sets the call signal impedance	Bit 1	0	RT=0 (Low)											
			1	RT=1 (High)											
		Bit 3	0	RZ=0 (High)											

Address	Function				Unit	Remarks				
				1	RZ=1 (Composite)					
6805E5	Bit 0 sets the ring detection method, Bit 1 sets the ring detection method when fixed.			Bit 0	0	RT=0 (Low)	If any setting is changed, select a setting that is higher than the default setting.			
					1	RT=1 (High)				
				Bit 1	0	Use RDTP				
					1	Use RDTN				
	Here is a summary of the voltages for the detection of off-hook for DP detection.									
	Bit 7	Bit 6	Bit 5	Bit 4						
	0	0	0	0	Not used					
	0	0	0	1	2.75 V					
	0	0	1	0	5.5 V					
	1	0	0	0	22 V					
1	1	1	1	41.25 V						

Notes

1. If a setting is not required, store FF in the address.
2. Italy and Belgium only

RAM address 68055E: the lower four bits have the following meaning.

Bit 2 - 1: International dial tone cadence detection enabled (Belgium)

Bit 1 - Not used

Bit 0 - 1: PSTN dial tone cadence detection enabled (Italy)

If bit 0 or bit 2 is set to 1, the functions of the following RAM addresses are changed.

680508 (if bit 0 = 1) or 680538 (if bit 2 = 1): tolerance for on or off state duration (%), and number of cycles required for detection, coded as in address 680533.

68050B (if bit 0 = 1) or 68053B (if bit 2 = 1): on time, hex code (unit = 20 ms)

68050C (if bit 0 = 1) or 68053C (if bit 2 = 1): off time, hex code (unit = 20 ms)

NCU Parameters

3. Pulse dial parameters (addresses 68054A to 68054F) are the values for 10 pps. If 20 pps is used, the machine automatically compensates.
4. The first ring may not be detected until 1 to 2.5 wavelengths after the time specified by this parameter.
5. The calculated level must be between 0 and 10.
The attenuation levels calculated from RAM data are:
High frequency tone: $-0.5 \times N680552/680554 - 3.5$ dBm
 $-0.5 \times N680555$ dBm
Low frequency tone: $-0.5 \times (N680552/680554 + N680553) - 3.5$ dBm
 $-0.5 \times (N680555 + N680553)$ dBm
N680552, for example, means the value stored in address 680552(H)
6. Ds and Di relay timing
68054A: Europe - Between Ds opening and Di opening, France - Between Ds closing and Di opening
68054D: Europe - Between Ds closing and Di closing, France - Between Ds opening and Di closing
7. Tone signals which frequency is lower than 1500Hz (e.g., 800Hz tone for AI short protocol) refer to the setting at 6805B5h. Tones which frequency is higher than 1500Hz refer to the setting at 6805B6h.
8. 68054A, 68054D, 68054E: The actual inter-digit pause (pulse dial mode) is the sum of the period specified by the RAM addresses 68054A, 68054D, and 68054E.

4.5 DEDICATED TRANSMISSION PARAMETERS

There are two sets of transmission parameters: Fax and E-mail

Each Quick Dial Key and Speed Dial Code has eight bytes of programmable parameters allocated to it. If transmissions to a particular machine often experience problems, store that terminal's fax number as a Quick Dial or Speed Dial, and adjust the parameters allocated to that number.

The programming procedure will be explained first. Then, the eight bytes will be described.

4.5.1 PROGRAMMING PROCEDURE

1. Set the bit 0 of System Bit Switch 00 to 1.
2. Enter Address Book Management mode ([User Tools]> System Settings> Key Operator> Address Book Management).
3. Select the address book that you want to program.
4. For the fax parameter, select "Fax Dest.", for the E-mail parameter, select "E-mail", then press "Start". Make sure that the LED of the Start button lights green.
5. The settings for the switch 00 are now displayed. Press the bit number that you wish to change.
6. To scroll through the parameter switches, either:
7. Do one of the following:
Select the next switch: press "Next"
or
Select the previous switch: "Prev." until the correct switch is displayed. Then go back to step 6.
8. After the setting is changed, press "OK".
9. After finishing, reset bit 0 of System Bit Switch 00 to 0.

4.5.2 PARAMETERS

Fax Parameters

The initial settings of the following fax parameters are all FF(H). This means that all the parameters are disabled.

Switch 00	
Function and Comments	
<p>ITU-T T1 time (for PSTN G3 mode)</p> <p>If the connection time to a particular terminal is longer than the NCU parameter setting, adjust this byte. The T1 time is the value stored in this byte (in hex code), multiplied by 1 second.</p> <p>Range: 0 to 120 s (00h to 78h)</p> <p>FFh - The local NCU parameter factory setting is used.</p> <p>Do not program a value between 79h and FEh.</p>	

Switch 01							
No	Function					Function	
0 to 4	Tx level						<p>If communication with a particular remote terminal often contains errors, the signal level may be inappropriate. Adjust the Tx level for communications with that terminal until the results are better.</p> <p>If the setting is "Disabled", the NCU parameter 01 setting is used.</p> <p>↓ Note</p> <ul style="list-style-type: none"> Do not use settings other than listed on the left.
	Bit 4	Bit 3	Bit 2	Bit 1	Bit 0		
	0	0	0	0	0	0	
	0	0	0	0	1	-1	
	0	0	0	1	0	-2	
	0	0	0	1	1	-3	
	0	0	1	0	0	-4	
	. . . and so on until . . .						
0	1	1	1	1	-15		

Switch 01									
No	Function					Function			
	If all five bits are at 1, the setting is 'Disabled'.								
5 to 7	Cable equalizer					Use a higher setting if there is signal loss at higher frequencies because of the length of wire between the modem and the telephone exchange when calling the number stored in this Quick/Speed Dial. Also, try using the cable equalizer if one or more of the following symptoms occurs. <ul style="list-style-type: none"> ▪ Communication error with error codes such as 0-20, 0-23, etc. ▪ Modem rate fallback occurs frequently. <div style="border: 1px solid blue; padding: 2px; display: inline-block; margin: 5px 0;"> ↓ Note </div> <ul style="list-style-type: none"> ▪ Do not use settings other than listed on the left. ▪ If the setting is "Disabled", the bit switch setting is used. 			
	Bit 7	Bit 6	Bit 5						
	0	0	0	None					
	0	0	1	Low					
	0	1	0	Medium					
	0	1	1	High					
	1	1	1	Disabled					

Dedicated Transmission Parameters

Switch 02						
No	Function					Comments
0 to 3	Initial Tx modem rate (kbps)					<p>If training with a particular remote terminal always takes too long, the initial modem rate may be too high. Reduce the initial Tx modem rate using these bits.</p> <p>For the settings 14.4 or kbps slower, Switch 04 bit 4 must be changed to 0.</p> <p>↓ Note</p> <ul style="list-style-type: none"> Other settings: Not used <p>If the setting is "Disabled", the bit switch setting is used.</p>
	Bit 3	Bit 2	Bit 1	Bit 0		
	0	0	0	0	Not used	
	0	0	0	1	2.4	
	0	0	1	0	4.8	
	0	0	1	1	7.2	
	0	1	0	0	9.6	
	0	1	0	1	12.0	
	0	1	1	0	14.4	
	0	1	1	1	16.8	
	1	0	0	0	19.2	
	1	0	0	1	21.6	
	1	0	1	0	24.0	
	1	0	1	1	26.4	
	1	1	0	0	28.8	
1	1	0	1	31.2		
<p>If all bits are at '1', the setting is 'Disabled'</p> <p>↓ Note</p> <ul style="list-style-type: none"> Other settings: Not used 						
4-7	Not used					Do not change the settings.

Switch 03				
No	Function			Comments
0-1	Inch-mm conversion before tx			<p>The machine uses inch-based resolutions for scanning. If "inch only" is selected, the printed copy may be slightly distorted at the other end if that machine uses mm-based resolutions.</p> <p>If the setting is "Disabled", the bit switch setting is used.</p>
	Bit 1	Bit 0	Setting	
	0	0	Inch-mm conversion available	
	0	1	Inch only	
	1	0	Not used	
	1	1	Disabled	
2-3	DIS/NSF detection method			<p>(0, 1): Use this setting if echoes on the line are interfering with the set-up protocol at the start of transmission.</p> <p>The machine will then wait for the second DIS or NSF before sending DCS or NSS.</p> <p>If the setting is "Disabled", the bit switch setting is used.</p>
	Bit 3	Bit 2	Setting	
	0	0	First DIS or NSF	
	0	1	Second DIS or NSF	
	1	0	Not used	
	1	1	Disabled	
4	<p>V.8 protocol</p> <p>0: Off</p> <p>1: Disabled</p>			<p>If transmissions to a specific destination always end at a lower modem rate (14,400 bps or lower), disable V.8 protocol so as not to use V.34 protocol.</p> <p>0: V.34 communication will not be possible.</p> <p>If the setting is "Disabled", the bit switch setting is used.</p>

Dedicated Transmission Parameters

Switch 03				
No	Function			Comments
5	Compression modes available in transmit mode 0: MH only 1: Disabled			This bit determines the capabilities that are informed to the other terminal during transmission. If the setting is "Disabled", the bit switch setting is used.
6 7	ECM during transmission			For example, if ECM is switched on but is not wanted when sending to a particular terminal, use the (0, 0) setting. Note that V.8/V.34 protocol and JBIG compression are automatically disabled if ECM is disabled. If the setting is "Disabled", the bit switch setting is used.
	Bit 7	Bit 6	Setting	
	0	0	Off	
	0	1	On	
	1	0	Not used	
	1	1	Disabled	

Switch 04 - Not used (do not change the settings)
Switch 05 - Not used (do not change the settings)
Switch 06 - Not used (do not change the settings)
Switch 07 - Not used (do not change the settings)
Switch 08 - Not used (do not change the settings)
Switch 09 - Not used (do not change the settings)

E-mail Parameters

The initial settings of the following e-mail parameters are all "0" (all parameters disabled).

Switch 00		
No	Function	Comments
0	HM Compression mode for e-mail attachments 0: Off 1: On	Switches HM compression on and off for files attached to e-mails for sending.
1	HR Compression mode for e-mail attachments 0: Off 1: On	Switches HR compression on and off for files attached to e-mails for sending.
2	MMR Compression mode for e-mail attachments 0: Off 1: On	Switches MMR compression on and off for files attached to e-mails for sending.
3-6	Not used	Do not change these settings.
7	Designates the bits to reference for compression method of e-mail attachments 0: Registered (Bit 0 to 6) 1: No registration.	The "0" selection (default) references the settings for Bits 00, 01, 02 above. The "1" selection ignores the selections of Bits 00, 01, 02.

Dedicated Transmission Parameters

Switch 01		
No	Function	Comments
0	Original width of e-mail attachment: A4 0: Off 1: On	Sets the original width of the e-mail attachment as A4.
1	Original width of e-mail attachment: B4 0: Off 1: On	Sets the original width of the e-mail attachment as B4.
2	Original width of e-mail attachment: A3 0: Off 1: On	Sets the original width of the e-mail attachment as A3.
3-6	Not used	Do not change these settings.
7	Designates the bits to reference for original size of e-mail attachments 0: Registered (Bit 0 to 6) 1: No registration.	The "0" selection (default) references the settings for Bits 00, 01, 02 above. The "1" selection ignores the selections of Bits 00, 01, 02.

Switch 02		
No	Function	Comments
0	Line resolution of e-mail attachment: 200 x 100 0: Off 1: On	Sets the line resolution of the e-mail attachment as 200 x100.
1	Line resolution of e-mail attachment: 200 x 200	Sets the line resolution of the e-mail attachment as 200 x 200.

Switch 02		
No	Function	Comments
	0: Off 1: On	
2	Line resolution of e-mail attachment: 200 x 400 0: Off 1: On	Sets the line resolution of the e-mail attachment as 200 x 400.
3	Not used	Do not change these settings.
4	Line resolution of e-mail attachment: 400 x 400 0: Off 1: On	Sets the line resolution of the e-mail attachment as 400 x 400.
5-6	Not used	Do not change these settings.
7	Designates the bits to reference for original size of e-mail attachments 0: Registered (Bit 0 to 6) 1: No registration.	The "0" selection (default) references the settings for Bits 00, 01, 02, 04 above. The "1" selection ignores the selections of Bits 00, 01, 02, 04.

Switch 03 - Not used (do not change the settings)
Switch 04 - Not used (do not change the settings)
Switch 05 - Not used (do not change the settings)
Switch 06 - Not used (do not change the settings)
Switch 07 - Not used (do not change the settings)
Switch 08 - Not used (do not change the settings)
Switch 09 - Not used (do not change the settings)

4.6 SERVICE RAM ADDRESSES

 Note

- Do not change the settings which are marked as "Not used" or "Read only".

680001 to 680004(H) - ROM version (Read only)

- 680001(H) - Revision number (BCD)
- 680002(H) - Year (BCD)
- 680003(H) - Month (BCD)
- 680004(H) - Day (BCD)

680006 to 680015(H) - Machine's serial number (16 digits - ASCII)

680018(H) - Total program checksum (low)

680019(H) - Total program checksum (high)

680020 to 68003F(H) - System bit switches

680050 to 68005F(H) - Printer bit switches

680060 to 68007F(H) - Communication bit switches

680080 to 68008F(H) - G3 bit switches

680090 to 68009F(H) - G3-2 bit switches

6800A0 to 6800AF(H) - G3-3 bit switches

6800D0(H) - User parameter switch 00 (SWUER_00): Not used

6800D1(H) - User parameter switch 01 (SWUSR_01): Not used

6800D2(H) - User parameter switch 02 (SWUSR_02)

- Bit 0: Forwarding mark printing on forwarded messages, 0: Disabled, 1: Enabled
- Bit 1: Center mark printing on received copies (this switch is not printed on the user parameter list), 0: Disabled, 1: Enabled
- Bit 2: Reception time printing (this switch is not printed on the user parameter list), 0: Disabled, 1: Enabled
- Bit 3: TSI print on received messages, 0: Disabled, 1: Enabled
- Bit 4: Checkered mark printing (this switch is not printed on the user parameter list), 0: Disabled, 1: Enabled
- Bit 5: Not used
- Bit 6: Not used
- Bit 7: Not used

6800D3(H) - User parameter switch 03 (SWUSR_03: Automatic report printout)

- Bit 0: Transmission result report (memory transmissions), 0: Off, 1: On
- Bit 1: Not used

- Bit 2: Memory storage report, 0: Off, 1: On
- Bit 3: Polling reserve report (polling reception), 0: Off, 1: On
- Bit 4: Polling result report (polling reception), 0: Off, 1: On
- Bit 5: Transmission result report (immediate transmissions), 0: Off, 1: On
- Bit 6: Polling clear report, 0: Off, 1: On
- Bit 7: Journal, 0: Off, 1: On

6800D4(H) - User parameter switch 04 (SWUSR_04: Automatic report printout)

- Bit 0: Automatic confidential reception report output, 0: Off, 1: On
- Bit 1: Automatic communication failure report and transfer result report output, 0: Off, 1: On
- Bits 2 to 3: Not used
- Bit 4: Indicates the parties, 0: Not indicated, 1: Indicated
- Bit 5: Include sender's name on reports, 0: Off, 1: On
- Bit 6: Not used
- Bit 7: Inclusion of a sample image on reports, 0: Off, 1: On

6800D5(H) - User parameter switch 05 (SWUSR_05)

- Bit 0: Substitute reception when the base copier is in an SC condition, 0: Enabled, 1: Disabled
- Bits 1 and 2: Condition for substitute rx when the machine cannot print messages (Paper end, toner end, jam, and during night mode)

Bit 2	Bit 1	Setting
0	0	The machine receives all the fax messages.
0	1	The machine receives fax messages with RTI or CSI.
1	0	The machine receives fax messages with the same ID code.
1	1	The machine does not receive anything.

- Bit 3: Not used
- Bit 4: Not used
- Bit 5: Just size printing, 0: Off, 1: On
- Bit 6: Not used
- Bit 7: Add paper display when a cassette is empty. 0: Off, 1: On

6800D6(H) - User parameter switch 06 (SWUSR_06)

Service RAM Addresses

- Bits 0 to 5: Not used
- Bit 6: Scan sequence in Book transmission, 0: Left page then right page, 1: Right page then left page
- Bit 7: Not used

6800D7(H) - User parameter switch 07 (SWUSR_07)

- Bits 0 and 1: Not used
- Bit 2: Parallel memory transmission, 0: Off, 1: On
- Bits 3 to 7: Not used

6800D8(H) - User parameter switch 08 (SWUSR_08)

- Bits 0 and 1: Not used
- Bit 2: Authorized reception
0: Only faxes from senders whose RTIs/CSIs are specified for this feature are accepted.
1: Only faxes from senders whose RTIs/CSIs are not specified for this feature are accepted.
- Bits 3 to 7: Not used

6800D9(H) - User parameter switch 09 (SWUSR_09): Not used

6800DA(H) - User parameter switch 10 (SWUSR_0A)

- Bit 0: Not used
- Bit 1: 2 into 1, 0: Off, 1: On
- Bit 2: Not used
- Bit 3: Page reduction, 0: Off, 1: On
- Bit 4: Not used
- Bit 5: Reception file printout, 0: Disabled, 1: Enabled
- Bit 6: Use both e-mail notification and printed reports to confirm the transmission results, 0: Off, 1: On
- Bit 7: Not used

6800DB(H) - User parameter switch 11 (SWUSR_0B)

- Bit 0: Not used
- Bit 1: Not used
- Bits 2 to 5: Not used
- Bit 6: Printout of messages received while acting as a forwarding station, 0: Off, 1: On
- Bit 7: Polling Standby duration, 0: Once, 1: No limit

6800DC(H) - User parameter switch 12 (SWUSR_0C): Not used

6800DD(H) - User parameter switch 13 (SWUSR_0D): Not used

6800DE(H) - User parameter switch 14 (SWUSR_0E)

- Bit 0: Message printout while the machine is in Night Printing mode, 0: On, 1: Off
- Bit 1: Maximum document length detection
0: Double letter, 1: Longer than double-letter (well log) – up to 1,200 mm
- Bit 2: Batch transmission, 0: Off, 1: On
- Bit 3: Fax mode settings, such as resolution, before a mode key (Copy, Fax, Printer, or Scanner) is pressed, 0: Not cleared, 1: Cleared
- Bits 4 to 6: Not used
- Bit 7: Manual service call (sends the system parameter list to the service station), 0: Off, 1: On

6800DF(H) - User parameter switch 15 (SWUSR_0F)
 Note

- This switch is not printed on the user parameter list.

Bits 0, 1 and 2: Cassette for fax printout

Bit 2	Bit 1	Bit 0	Setting
0	0	1	1st paper feed station
0	1	0	2nd paper feed station
0	1	1	3rd paper feed station
1	0	0	4th paper feed station
1	0	1	LCT

Other settings: Not used

- Bits 3 and 4: Not used
- Bit 5: Using the cassette specified by bits 0, 1 and 2 above only, 0: On, 1: Off
- Bits 6 and 7: Not used

6800E0(H) – User parameter switch 16 (SWUSR_10)
 Note

- This switch is not printed on the user parameter list.
- Bits 0 and 1: Not used
- Bit 2: Paper size selection priority for an A4 size fax message when A4/LT size paper is not available, 0: A3 has priority, 1: B4 has priority
- Bits 3 to 7: Not used

6800E1(H) – User parameter switch 17 (SWUSR_11)

Service RAM Addresses

- Bit 0: IFAX Group Destination Selection/Release Method

0	Priority Select Mode
	Select the priority destination according to input mode. The Group button reflects either email or fax input mode. Released as soon as the entry mode is selected, regardless of the current entry mode.
1	All Select Mode
	Acquires all registered members regardless of entry mode. If both email and fax are registered, both are selected. The Group button reflects either email or fax input mode. All registered members are released, regardless of the entry mode. If both email/fax are registered, both are released.

- Bit 1: Not used
- Bit 2: Inclusion of the "Add" button when a sequence of Quick/Speed dials is selected for broadcasting, 0:Not needed, 1: Needed
- Bits 3 to 6: Not used
- Bit 7: Press "Start" key without an original when using the on hook dial or the external telephone
0: Displays "Cannot detect original size"
1: Receives fax messages.

6800E2(H) - User parameter switch 18 (SWUSR_12)

- Bit 0: TTI date, 0: Off, 1: On
- Bit 1: TTI sender, 0: Off, 1: On
- Bit 2: TTI file number, 0: Off, 1: On
- Bit 3: TTI page number, 0: Off, 1: On
- Bit 4 to 7: Not used

6800E3(H) - User parameter switch 19 (SWUSR_13)

- Bit 0: Offset sort function for the fax (only using the shift tray on the 1,000 sheet finisher), 0: Disabled, 1: Enabled
- Bit 1: Journal format
0: The Journal is separated into transmissions and receptions
1: The Journal is separated into G3-1, G3-2, and G3-3 communications
- Bit 2: Action when the paper cassette that was selected by the specified cassette selection feature becomes empty.

(This switch is not printed on the user parameter list.)

0: The machine will not print any received files until paper is added.

1: The machine will use other cassettes to print received files that are not specified by this feature.

- Bit 3: 90° image rotation during B5 portrait Tx, 0: Off, 1: On
(This switch is not printed on the user parameter list.)
- Bit 4: Reduction of sample images on reports to 50% in the main scan and sub-scan directions. (This switch is not printed on the user parameter list.)
0: Technician adjustment (printer switch 0E bits 3 and 4)
1: 50% reduction
- Bit 5: Use of A5 size paper for reports (This switch is not printed on the user parameter list.)
0: Off, 1: On
- Bits 6 and 7: Not used

6800E4(H) - User parameter switch 20 (SWUSR_14)

- Bit 0: Automatic printing of the LAN fax result report, 0: Off, 1: On
- Bit 1: Not used
- Bits 2 to 5: Store documents in memory which could not be printed from PC fax (LAN fax) driver

Bit 5	Bit 4	Bit 3	Bit 2	Setting (minutes)
0	0	0	0	0
0	0	0	1	1
. . . and so on, until . . .				
1	1	1	0	14
1	1	1	1	15

- Bits 6 and 7: Not used.

6800E5(H) - User parameter switch 21 (SWUSR_15)

- Bit 0: Print results of sending reception notice request message, 0: Disabled (print only when error occurs), 1: Enabled
- Bit 1: Respond to e-mail reception acknowledgment request, 0: Disabled, 1: Enabled
- Bit 2: Not used

- ⇒ Bit 3: File format for forwarded folders to e-mail destinations or folder destinations, 0: TIFF, 1:PDF
- Bit 4: Transmit Journal by E-mail, 0: Disabled, 1: Enabled
- Bit 5: Limit printing of specified data in normal e-mail (attached TIFF files), 0: No, 1: Yes
- Bit 6: Network error display, 0: Displayed, 1: Not displayed
- Bit 7: Transmit error mail notification, 0: Enabled, 1: Disabled

6800E6(H) - User parameter switch 22 (SWUSR_16)

↓ Note

- This switch is not printed on the user parameter list.
- Bit 0: Dial tone detection (PSTN 1), 0: Disabled, 1: Enabled
- Bit 1: Dial tone detection (PSTN 2), 0: Disabled, 1: Enabled
- Bit 2: Dial tone detection (PSTN 3), 0: Disabled, 1: Enabled
- Bits 3 to 7: Not used

6800E7(H) - User parameter switch 23 (SWUSR_17) : Not used

6800E8(H) - User parameter switch 24 (SWUSR_18)

- Bits 0 and 1: File retention time (Cross reference: System switch 02 bit 4)

Bit 1	Bit 0	Setting
0	0	File retention impossible
0	1	24 hours
1	0	File retention impossible
1	1	72 hours

- Bit 2: Not used
- Bit 3: Limit printing of fixed form text in normal e-mail (attached TIFF files), 0: No, 1: Yes
- Bits 4 to 7: Not used

6800E9(H) - User parameter switch 25 (SWUSR_19)

- Bit 0 and 1: Not used
- Bit 2: Not used
- Bit 3: Not used
- Bit 4: RDS operation
0: Not acceptable
1: Acceptable for the limit specified by system switch 03

 Note

- This bit is only effective when RDS operation can be selected by the user (see system switch 02).

- Bits 5 to 7: Not used

6800EA(H) to 6800EF(H) - User parameter switches 26 to 31 (SWUSR_1A to 1F): Not used

6800F0(H) - User parameter switch 32 (SWUSR_20)

- Bit 0: Quotation priority for a destination when there is no destination of the specified type

0: Paper output priority

Priority order

1. IP-fax destination, 2. Fax Number, 3. E-mail address, 4. Folder

1: Electric output order

Priority order

1. E-mail address, 2. Folder, 3. IP-fax destination, 4. Fax number

- Bits 1 to 7: Not used

6800F1(H) - User parameter switch 33 (SWUSR_21): Not used

6800F2(H) - User parameter switch 34 (SWUSR_22)

- Bit 0: Gatekeeper server used with IP-Fax, 0: Disabled, 1: Enabled
- Bit 1: SIP server used with IP-Fax, 0: Disabled, 1: Enabled

680100 to 68010F(H) - G4 Parameter Switches – Not used

680110 to 68012F(H) - G4 Internal Switches – Not used

680170 to 68017F(H) - IFAX Switches

680180 to 68018F(H) - IP-FAX Switches

680190 to 6801AF(H) - Service station's fax number (SP3-101)

6801B0 to 6801B9(H) - Own fax PABX extension number

6801BA to 6801C3(H) - Own fax number (PSTN)

6801C4 to 6801D7(H) - Own fax number (ISDN G4) – Not used

6801D8 to 6801E3(H) - The first subscriber number (ISDN G3) – Not used

6801E4 to 6801EF(H) - The second subscriber number (ISDN G3) – Not used

6801F0 to 6801FB(H) - The first subscriber number (ISDN G4) – Not used

6801FC to 680207(H) - The second subscriber number (ISDN G4) – Not used

680208 to 68021B(H) - PSTN-1 RTI (Max. 20 characters - ASCII) - See the following note.

68021C to 68022F(H) - PSTN-2 RTI (Max. 20 characters - ASCII) - See the following note.

680230 to 680246(H) - PSTN-3 RTI (Max. 20 characters - ASCII) - See the following note.

680247 to 680286(H) - TTI 1 (Max. 64 characters - ASCII) - See the following note.

Service RAM Addresses

680287 to 6802C6(H) - TTI 2 (Max. 64 characters - ASCII) - See the following note.

6802C7 to 680306(H) - TTI 3 (Max. 64 characters - ASCII) - See the following note.

680307 to 68031A(H) - PSTN-1 CSI (Max. 20 characters - ASCII)

68031B to 68032E(H) - PSTN-2 CSI (Max.20 characters - ASCII)

68032F to 680342(H) - PSTN-3 CSI (Max.20 characters - ASCII)

680343(H) - Number of PSTN-1 CSI characters (Hex)

680344(H) - Number of PSTN-2 CSI characters (Hex)

680345(H) - Number of PSTN-3 CSI characters (Hex)-

- If the number of characters is less than the maximum (20 for RTI, 64 for TTI), add a stop code (00[H]) after the last character.

680380 to 680387(H) - Last power off time (Read only)

- 680380(H) - 01(H) - 24-hour clock, 00(H) - 12-hour clock (AM), 02(H) - 12-hour clock (PM)
- 680381(H) - Year (BCD)
- 680382(H) - Month (BCD)
- 680383(H) - Day (BCD)
- 680384(H) - Hour
- 680385(H) - Minute
- 680386(H) - Second
- 680387(H) - 00: Monday, 01: Tuesday, 02: Wednesday, . . . and so on until . . . , 06: Sunday

680394(H) - Optional equipment (Read only – Do not change the settings)

- Bit 0: Page Memory, 0: Not installed, 1: Installed
- Bit 1: SAF Memory, 0: Not installed, 1: Installed
- Bits 2 to 7: Not used

680395(H) - Optional equipment (Read only – Do not change the settings)

- Bits 0 to 3: Not used
- Bit 4: G3-2, 0: Not installed, 1: Installed
- Bit 5: G3-3, 0: Not installed, 1: Installed
- Bit 6 and 7: Not used

680406 to 68040A - Option G3 board (G3-2) ROM information (Read only)

- 680406(H) - Suffix (BCD)
- 680407(H) - Version (BCD)
- 680408(H) - Year (BCD)
- 680409(H) - Month (BCD)
- 68040A(H) - Day (BCD)

68040B to 68040F - Option G3 board (G3-3) ROM information (Read only)

- 68040B(H) - Suffix (BCD)
- 68040C(H) - Version (BCD)
- 68040D(H) - Year (BCD)
- 68040E(H) - Month (BCD)
- 68040F(H) - Day (BCD)

680410(H) - G3-1 Modem ROM version (Read only)**680412(H)** - G3-2 Modem ROM version (Read only)**680414(H)** - G3-3 Modem ROM version (Read only)**680420(H)** - Number of multiple sets print (Read only)**680476(H)** - Time for economy transmission (hour in 24h clock format - BCD)**680477(H)** - Time for economy transmission (minute - BCD)**680492(H)** - Transmission monitor volume, 00 - 07(H)**680493(H)** - Reception monitor volume, 00 - 07(H)**680494(H)** - On-hook monitor volume, 00 - 07(H)**680495(H)** - Dialing monitor volume, 00 - 07(H)**680496(H)** - Buzzer volume, 00 - 07(H)**680497(H)** - Beeper volume, 00 - 07(H)**69ED04 to 69F003(H)** - SIP server address (Read only)

- 69ED04(H) - Proxy server - Main (Max. 128 characters - ASCII)
- 69ED84(H) - Proxy server - Sub (Max. 128 characters - ASCII)
- 69EE04(H) - Redirect server - Main (Max. 128 characters - ASCII)
- 69EE84(H) - Redirect server - Sub (Max. 128 characters - ASCII)
- 69EF04(H) - Registrar server - Main (Max. 128 characters - ASCII)
- 69EF84(H) - Registrar server - Sub (Max. 128 characters - ASCII)

69F004(H) - Gatekeeper server address - Main (Max. 128 characters - ASCII)**69F084(H)** - Gatekeeper server address - Sub (Max. 128 characters - ASCII)**69F104(H)** - Alias Number (Max. 128 characters - ASCII)**69F184(H)** - SIP user name (Max. 128 characters - ASCII)**69F204(H)** - Gateway address information (Max. 128 characters - ASCII)**6A0DC0(H)** - Stand-by port number for H.232 connection**6A0DC2(H)** - Stand-by port number for SIP connection**6A0DC4(H)** - RAS port number**6A0DC6(H)** - Gatekeeper port number**6A0DC8(H)** - Port number of data waiting for T.38**6A0DCA(H)** - Port number of SIP server

Service RAM Addresses

6A0DCC(H) - Priority for SIP and H.323, 0: H.323, 1: SIP

6A0DCD(H) - SIP function, 0: Disabled, 1: Enabled

6A0DCE(H) - H.323 function, 0: Disabled, 1: Enabled

6BEBFE(H) - Dial tone detection frequency – Upper limit (High)

Defaults: NA: 06, EU: 06, ASIA: 06

6BEBFF(H) - Dial tone detection frequency – Upper Limit (Low)

Defaults: NA: 50, EU: 50, ASIA: 50

6BEC00(H) - Dial tone detection frequency – Lower Limit (High)

Defaults: NA: 03, EU: 02, ASIA: 02

6BEC01(H) - Dial tone detection frequency – Lower Limit (Low)

Defaults: NA: 60, EU: 90, ASIA: 90

6BEC02(H) - Dial tone detection waiting time (20 ms)

Defaults: NA: 64, EU 64, ASIA: 64

6BEC03 to 6BEC04 - Dial tone detection monitoring time (20 ms)

Defaults

Area	6BEC03	6BEC04
NA	F4	01
EU	F4	01
ASIA	F4	01

6BEC05(H) - Dial tone detect judge time (20 ms)

Defaults: NA: 64, EU: 1B, ASIA: 32

6BEC06(H) - Dial tone disconnect permission time (20 ms)

Defaults: NA: 11, EU: 0F, ASIA: 11

5. DETAILED SECTION DESCRIPTIONS

5.1 OVERVIEW

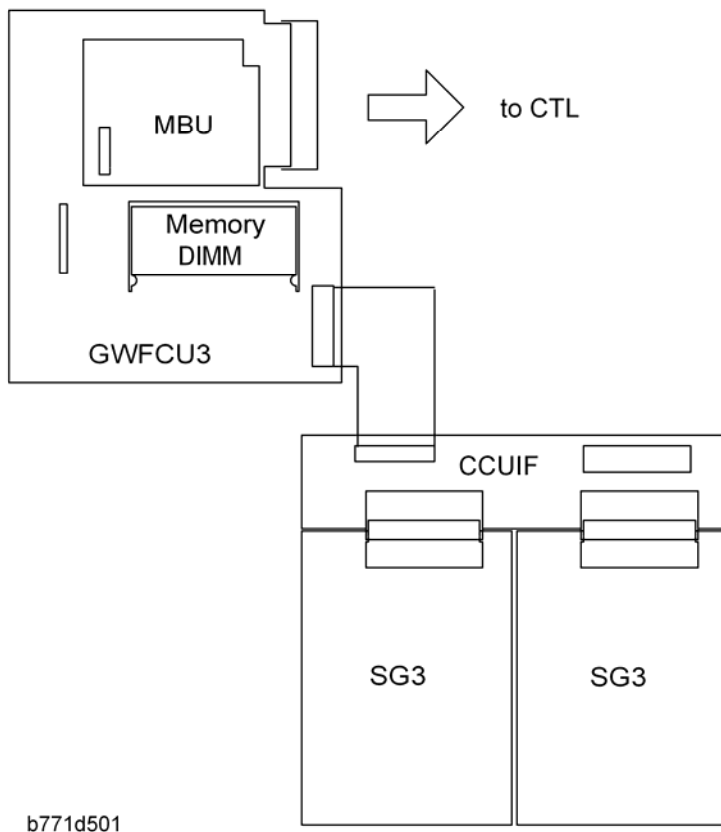

b771d501

The basic fax unit consists of two PCBs: an FCU and an MBU.

The FCU controls all the fax communications and fax features, in cooperation with the controller board. The MBU contains the ROM and SRAM. Also, the FCU has an NCU circuit.

Fax Options:

- Extra G3 Interface option: This provides one more analog line interface. This allows full dual access. Two extra G3 interface options can be installed.
- Memory Expansion: This expands the SAF memory and the page memory (used for image rotation); without this expansion, the page memory is not big enough for image rotation at 400 dpi, so transmission at 400 dpi is not possible.

5.2 BOARDS

5.2.1 FCU

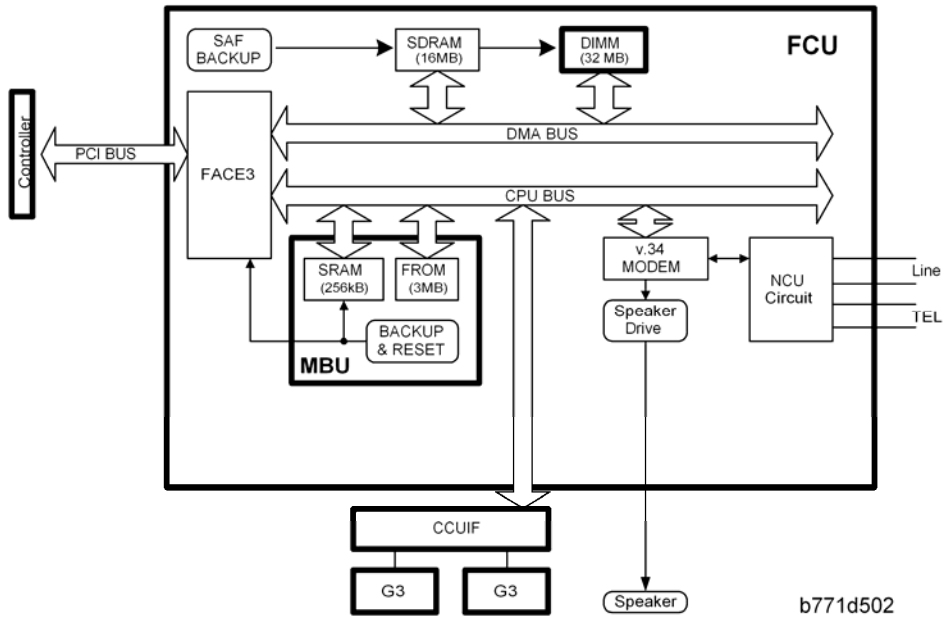

The FCU (Facsimile Control Unit) controls fax communications, the video interface to the base copier's engine, and all the fax options.

FACE3 (Fax Application Control Engine)

- CPU
- Data compression and reconstruction (DCR)
- DMA control
- Clock generation
- DRAM backup control

Modem (FAME)

- V.34, V.33, V.17, V.29, V.27ter, V.21, and V.8

DRAM

- The 16 MB of DRAM is shared as follows.
 - SAF memory: 4MB
 - Working memory: 4MB
 - Page memory: 8MB
 - The SAF memory is backed up by a rechargeable battery.

Memory Back-up

- A rechargeable battery backs up the SAF memory (DRAM) for 1 hour.

5.2.2 MBU

On this board, the flash ROM contains the FCU firmware, and the SRAM contains the system data and user parameters. Even if the FCU is changed, the system data and user parameters are kept on the MBU board.

ROM

- 3MB flash ROMs for system software storage
- 2MB (16bit x 1MB) + 1MB (16bit x 512K)

SRAM

- The 256 KB SRAM for system and user parameter storage is backed up by a lithium battery.

Memory Back-up

- A lithium battery backs up the system parameters and programmed items in the SRAM, in case the base copier's main switch is turned off.

Switches

Item	Description
SW1	Switches the SRAM backup battery on/off.

5.2.3 SG3 BOARD

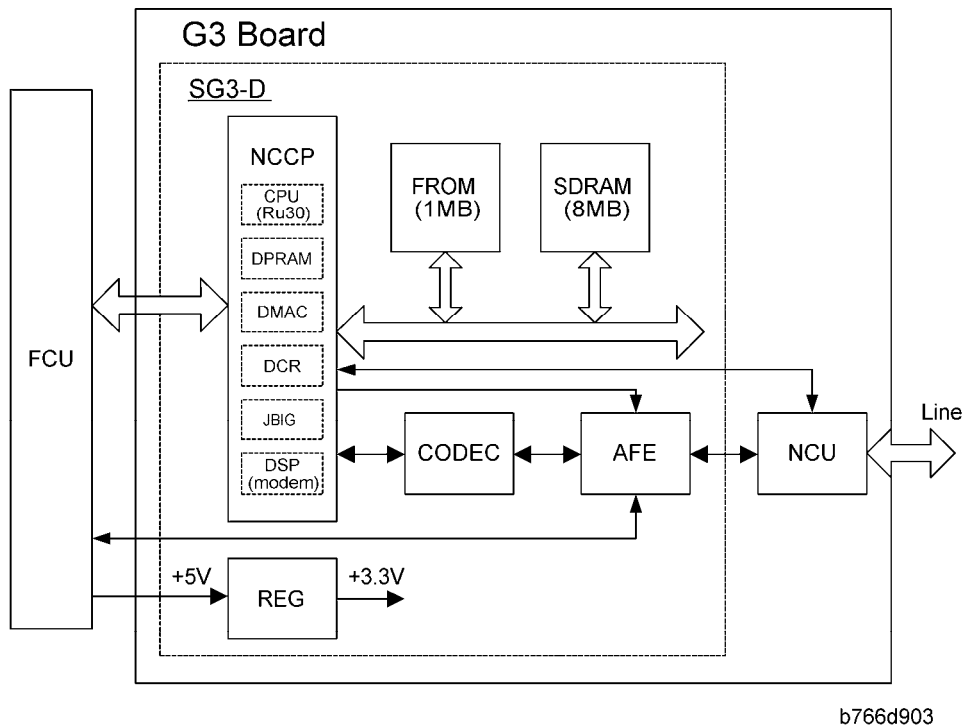

The SG3 board allows up to three simultaneous communications when used in combination with the FCU and optional G3 boards. The NCU is on the same board as the common SG-3 board. This makes the total board structure smaller. But, the specifications of the SG3 board do not change.

NCCP (New Communication Control Processor)

- Controls the SG3 board.
- CPU (RU30)
- DPRAM (Dual Port RAM): Handshaking with the FCU is done through this block.
- DMA controller
- JBIG
- DSP V34 modem (RL5T892): Includes the DTMF Receiver function
- DCR for MH, MR, MMR, and JBIG compression and decompression

FROM

- 1Mbyte flash ROM for SG3 software storage and modem software storage

SDRAM

- 4Mbyte DRAM shared between ECM buffer, line buffer, and working memory

AFE (Analog Front End)

- Analog processing

CODEC (COder-DECoder)

- A/D & D/A conversions for modem

REG

- Generates +3.3 V from the +5V from the FCU

5.3 VIDEO DATA PATH

5.3.1 TRANSMISSION

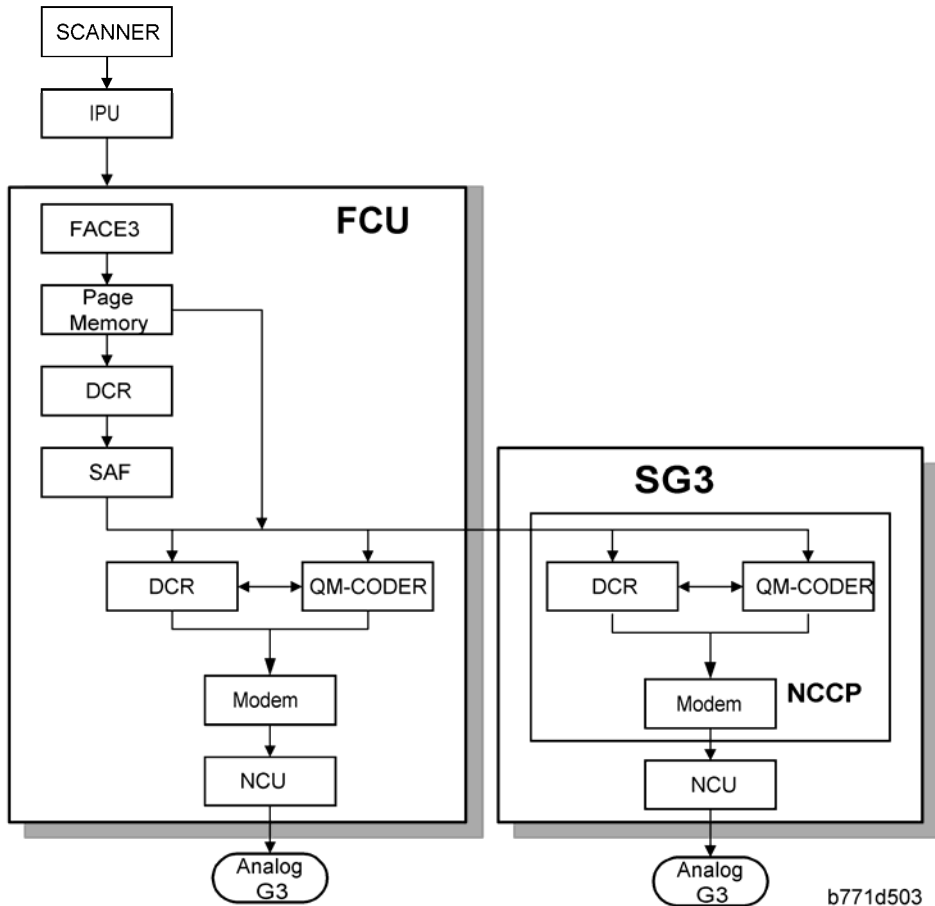

Memory Transmission and Parallel Memory Transmission

The base copier's scanner scans the original at the selected resolution in inch format. The IPU processes the data and transfers it to the FCU.

Note

- When scanning a fax original, the IPU uses the MTF, independent dot erase and thresholding parameter settings programmed in the fax unit's scanner bit switches, not the copier's SP modes.

Then, the FCU converts the data to mm format, and compresses the data in MMR or raw format to store it in the SAF memory. If image rotation will be done, the image is rotated in page memory before compression.

At the time of transmission, the FCU decompresses the stored data, then re-compresses

and/or reduces the data if necessary for transmission. The NCU transmits the data to the line.

Immediate Transmission

The base copier's scanner scans the original at the resolution agreed with the receiving terminal. The IPU video processes the data and transfers it to the FCU.

Note

- When scanning a fax original, the IPU uses the MTF, independent dot erase and thresholding parameter settings programmed in the fax unit's scanner bit switches, not the copier's SP modes.

Then the FCU stores the data in page memory, and compresses the data for transmission. The NCU transmits the data to the line.

JBIG Transmission

Memory transmission: If the receiver has JBIG compression, the data goes from the DCR to the QM-Coder. Then the NCU transmits the data to the line. When an optional G3 unit (SG3) is installed and PSTN2 is selected as the line type, JBIG compression is available, but only for the PSTN-2 line.

Immediate transmission: If the receiver has JBIG compression, the data goes from the page memory to the QM-Coder. Then the NCU transmits the data to the line. When an optional G3 unit (SG3) is installed and PSTN2 is selected as the line type, JBIG compression is available, but only for the PSTN-2 line.

Adjustments

- Priority for the line used for G3 transmissions (PSTN 1/PSTN 2 or 3): System switch 16 bit 1

5.3.2 RECEPTION

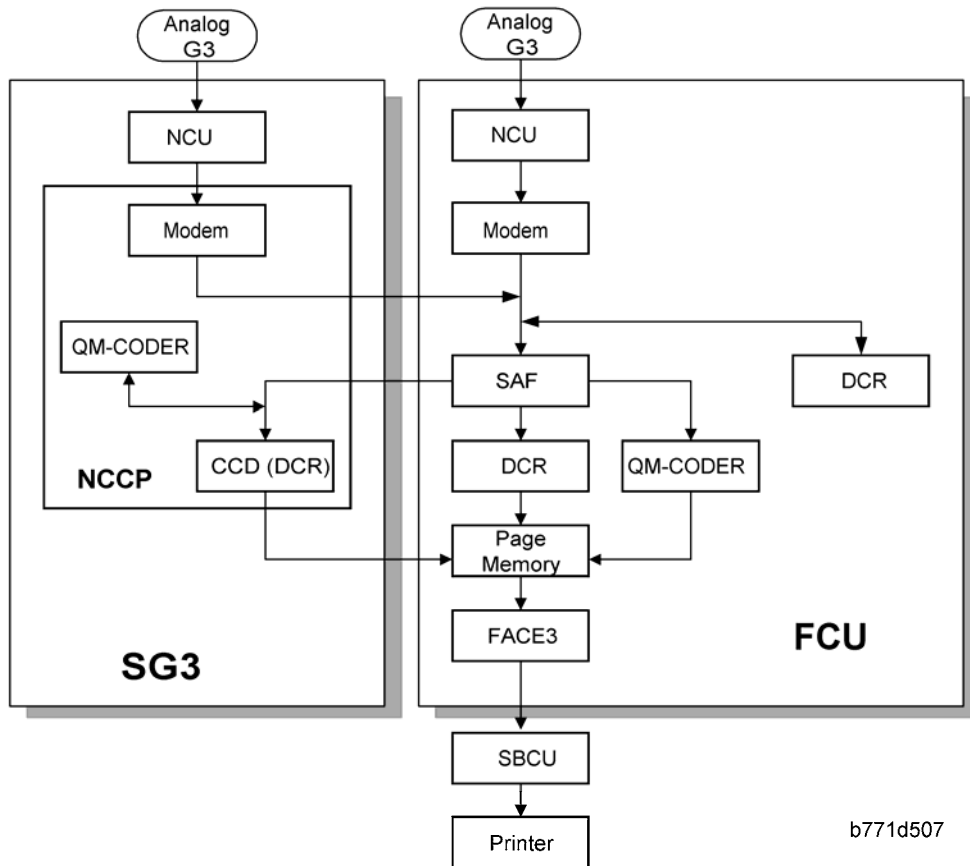

b771d507

First, the FCU stores the incoming data from either an analog line to the SAF memory. (The data goes to the FACE3 at the same time, and is checked for error lines/frames.)

The FCU then decompresses the data and transfers it to page memory. If image rotation will be done, the image is rotated in the page memory. The data is transferred to the IPU. If the optional G3 unit is installed, the line that the message comes in on depends on the telephone number dialled by the other party (the optional G3 unit has a different telephone number from the main fax board).

JBIG Reception

When data compressed with JBIG comes in on PSTN-1 (the standard analog line), the data is sent to the QM-CODER for decompression. Then the data is stored in the page memory, and transferred to the IPU.

When data compressed with JBIG comes in on PSTN-2 (optional extra analog line), the data is sent to the QM-CODER on the SG3 board for decompression.

5.4 FAX COMMUNICATION FEATURES

5.4.1 MULTI-PORT

When the optional extra G3 Interface Unit is installed, communication can take place at the same time through the two or three lines at once.

Option	Available Line Type	Available protocol Combinations
Standard only	PSTN	G3
Extra G3 Interface Unit (single)	PSTN + PSTN	G3 + G3
Extra G3 Interface Unit (double)	PSTN + PSTN +PSTN	G3 + G3 +G3

Note

- The compression method of the fax application is different from the copy application. The storing time is longer than the copier storing.
- When selecting "Print 1st page", the stored document will be reduced to A4 size.

5.4.3 INTERNET MAIL COMMUNICATION

Mail Transmission

T.37 simple and full modes

This machine supports T.37 full mode. (ITU-RFC232). The difference between T.37 simple mode and full mode is as follows.

Function	T.37 Simple Mode	T.37 Full Mode
Resolution	200 x 100 200 x 200	200 x100 200 x 200 200 x 400 400 x 400 (if available)
RX Paper Width	A4	A4, B4, A3
RX Data Compression Method	MH	MH (default), MR, MMR,
Signals	Image data transmission only	Image data transmission, exchange of capability information between the two terminals, and acknowledgement of receipt of fax messages

Fax Communication Features

Data Formats

The scanned data is converted into a TIFF-F formatted file.

The fields of the e-mail and their contents are as follows:

Field	Content
From	Mail address of the sender
Reply To	Destination requested for reply
To	Mail address of the destination
Bcc	Backup mail address
Subject	From CSI or RTI (Fax Message No. xxxx)
Content Type	Multipart/mixed Attached files: image/tiff
Content Transfer Encoding	Base 64, 7-bit, 8-bit, Quoted Printable
Message Body	MIME-converted TIFF-F (MIME standards specify how files are attached to e-mail messages)

Direct SMTP Transmission

Internet Fax documents can be sent directly to their destinations without going through the SMTP server. (Internet Faxes normally transmit via the SMTP server.)

For example:

e-mail address:	gts@ricoh.co.jp
SMTP server address:	gts.abcd.com

In this case, this feature destination e-mail address (gts@ricoh.co.jp) is read as the SMTP server address "gts.abcd.com", and the transmissions bypass the SMTP server.

Selectable Options

These options are available for selection:

- With the default settings, the scan resolution can be either standard or detail. Inch-mm conversion before TX depends on IFAX SW01 Bit 7. Detail resolution will be used if

Super Fine resolution is selected, unless Fine resolution is enabled with IFAX SW01.

- The requirements for originals (document size, scan width, and memory capacity) are the same as for G3 fax memory TX.
- The default compression is TIFF-F format.
- IFAX SW00: Acceptable paper widths for sending
- IFAX SW09: Maximum number of attempts to the same destination

Secure Internet Transmission

SMTP Authentication:

- User Tools> System Settings> File Transfer> SMTP Authentication

POP Before SMTP:

- User Tools> System Settings> File Transfer> POP Before SMTP

Mail Reception

Three Types

This machine supports three types of e-mail reception:

- POP3 (Post Office Protocol Ver. 3.)
- IMAP4 (Internet Messaging Access Protocol)
- SMTP (Simple Mail Transfer Protocol)

Note

- For details: Core Technology Manual – Facsimile Processes – Faxing from a PC – Internet/LAN Fax Boards – Mail Reception

POP3/IMAP4 Mail Reception Procedure

The machine automatically picks up e-mail from the server at an interval which is adjustable in the range 2 to 1440 min. in 1-minute steps:

- User Tools> System Settings> File Transfer> E-mail Reception Interval

SMTP Reception

1. The IFAX must be registered as an SMTP server in the MX record of the DNS server, and the address of the received mail must specify the IFAX.
2. To enable SMTP reception: User Tools> System Settings> File Transfer> Reception Protocol
 - Even if the MX record on the DNS server includes the IFAX, mail cannot be received with SMTP until SMTP reception is enabled:
 - However, if SMTP reception is selected and the machine is not registered in the MX record of the DNS server, then either IMAP4 or POP3 is used, depending on the setting: User Tools> System Settings> File Transfer> Reception Protocol

Fax Communication Features

Mail Delivery Conditions: Transferring Mail Received With SMTP

1. The machine must be set up for SMTP mail delivery:
 - User Tools> Facsimile Features> E-mail Settings> SMTP RX File Delivery Settings
1. If the user wishes to limit this feature so that the machine will only deliver mail from designated senders, the machine's "Auth. E-mail RX" feature must be set (User Tools> Facsimile Features> E-mail Settings> SMTP RX File Delivery Settings).
2. If the "SMTP RX File Delivery Setting" is set to 0 to prohibit SMTP receiving, and if there is mail designated for delivery, then the machine responds with an error. (User Tools> Facsimile Features> E-mail Settings> SMTP RX File Delivery Settings)
3. If the quick dial, speed dial, or group dial entry is incorrect, the mail transmission is lost, and the IFAX issues an error to the SMTP server and outputs an error report.

Auth. E-mail RX

In order to limit access to mail delivery with IFAX, the addresses of senders must be limited using the Access Limit Entry. Only one entry can be registered.

1. Access Limit Entry

For example, to limit access to @IFAX.ricoh.co.jp:

gts@IFAX.ricoh.co.jp	Matches and is delivered.
gts@IFAX.abcde.co.jp	Does not match and is not delivered.
IFAX@ricoh.co.jp	Does not match and is not delivered.

1. Conditions
 - The length of the Access Limit Entry is limited to 127 characters.
 - If the Access Limit Entry address and the mail address of the incoming mail do not match, the incoming mail is discarded and not delivered, and the SMTP server responds with an error. However, in this case an error report is not output.
 - If the Access Limit Entry address is not registered, and if the incoming mail specifies a delivery destination, then the mail is delivered unconditionally.

Handling Mail Reception Errors

Abnormal files

When an error of this type occurs, the machine stops receiving and commands the server to erase the message. Then the machine prints an error report and sends information about the error by e-mail to the sender address (specified in the "From" or "Reply-to" field of the message). If there is an incomplete received message in the machine memory, it will be erased.

The machine prints an error message when it fails to send the receive error notification after a certain number of attempts.

The following types of files are judged to be abnormal if one or more of the following are detected:

1. Unsupported MIME headers.

Supported types of MIME header

Header	Supported Types
Content-Type	Multipart/mixed, text/plain, message/rfc822 Image/tiff
Charset	US-ASCII, ISO 8859 X. Other types cannot be handled, and some garbage may appear in the data.
Content-Transfer-Encoding	Base 64, 7-bit, 8-bit, Quoted Printable

1. MIME decoding errors
2. File format not recognized as TIFF-F format
3. Resolution, document size, or compression type cannot be accepted

Remaining SAF capacity error

The machine calls the server but does not receive e-mail if the remaining SAF capacity is less than a certain value (the value depends on IFAX Switch 08. The e-mail will be received when the SAF capacity increases (for example, after substitute reception files have been printed). The error handling method for this type of error is the same as for "Abnormal files".

If the capacity of the SAF memory drops to zero during reception, the machine operates in the same way as when receiving an abnormal file (refer to "Abnormal files" above).

Fax Communication Features

Secure Internet Reception

To enable password encryption and higher level security: User Tools> System Settings> File Transfer> POP3/IMAP4 Settings> Encryption (set to "On")

Transfer Request: Request By Mail

For details: Core Technology Manual – Facsimile Processes – Faxing from a PC – Internet/LAN Fax Boards – Transfer Request

The fields of the e-mail and their contents are as follows:

Field	Content
From	E-mail address of the requesting terminal
To	Destination address (Transfer Station address)
Bcc	Backup mail address
Subject	From TSI (Fax Message No. xxxx)
Content-Type	Multipart/mixed Text/Plain (for a text part), image/tiff (for attached files)
Content-Transfer-Encoding	Base 64, 7-Bit, 8-bit, Quoted Printable
Mail body (text part)	RELAY-ID:- xxxx (xxxx: 4 digits for an ID code) RELAY: #01#*X#**01....
Message body	MIME-converted TIFF-F.

E-Mail Options (Sub TX Mode)

The following features are available as options for mail sending: entering a subject, designating the level of importance, confirming reception of the mail.

Subject and Level of Importance

You can enter a subject message with: Sub TX Mode> E-mail Options

The Subject entry for the mail being sent is limited to 64 characters. The subject can also be prefixed with an "Urgent" or "High" notation.

- How the Subject Differs According to Mail Type -

Mail Type	Item 1	Item 2		Item 3
Subject Entry	---	Entry Condition		Fax Message No. + File No.
No Subject Entry		1. "CSI" ("RTI")		
		2. "RTI"	CSI not registered	
		3. "CSI"	RTI not registered	
		4. None	CSI, RTI not registered	
Confirmation of Reception	From	1. "CSI" ("RTI")		Normal: Return Receipt (dispatched). You can select "displayed" with IFAX SW02 Bits 2 and 3.
		2. "RTI"	CSI not registered	
		3. "CSI"	RTI not registered	Error: Return Receipt (processed/error)
		4. None	CSI, RTI not registered	
Mail delivery, memory transfer, SMTP	From	RTI or CSI of the station designated for delivery	Mail delivery	Fax Message No. + File Number

Fax Communication Features

Mail Type	Item 1	Item 2		Item 3
receiving and delivery		RTI or CSI of sender	Mail sending from G3 memory	
		Mail address of sender	Memory sending	
		Mail address of sender	SMTP receiving and delivery (Off Ramp Gateway)	
Mail error notification	---	Error Message No. xxxx From CSI (RTI)		

Items 1, 2, and 3 in the table above are in the Subject.

- Subjects Displayed on the PC -

Sender	Date	Size	Subject
Substation 2	04/25/2002	1,513	Parts List
Substation 2	04/26/2002	1,147	Specifications
Main Station	05/09/2002	33,551	[Urgent] Memo 2041
		21,624,288	

b766d907

E-mail Messages

After entering the subject, you can enter a message with: Sub TX Mode> E-mail Options

An e-mail message (up to 5 lines) can be pre-registered with: User Tools> System

Settings> File Transfer> Program/Change/Delete E-mail Message

- Limitations on Entries -

Item	Maximum
Number of Lines	5 lines
Line Length	80 characters
Name Length	20 characters

Message Disposition Notification (MDN)

For details: Core Technology Manual – Facsimile Processes – Faxing from a PC – Internet/LAN Fax Boards – E-mail Options

The network system administrator can confirm whether a sent mail has been received correctly or not. This confirmation is done in four steps.

1. Send request for confirmation of mail reception. To enable or disable this request (known as MDN): Sub TX Mode> E-mail Options
2. Mail reception (receive confirmation request)
3. Send confirmation of mail reception
4. Receive confirmation of mail reception

The other party's machine will not respond to the request unless the two conditions below are met:

- The other party's machine must be set up to respond to the confirmation request.
- The other party's machine must support MDN (Message Disposition Notification).

- Setting up the Receiving Party -

The receiving party will respond to the confirmation request if:

1. The "Disposition Notification To" field is in the received mail header (automatically inserted in the 4th line in the upper table on the previous page, if MDN is enabled), and
1. Sending the disposition notification must be enabled (User Parameter Setting SW21 (15 [H]) Bit 1 for this model). The content of the response is as follows:

Normal reception:	"Return Receipt (dispatched)" in the Subject line
IFAX SW02 (Bit 2, 3)	"Return Receipt (displayed)" in the Subject line
Error:	"Return Receipt (processed/error)" in the Subject line

Handling Reports

- Sending a Request for a Return Receipt by Mail -

After the mail sender transmits a request for a return receipt, the mail sender's journal is annotated with two hyphens (--) in the Result column and a "Q" in the Mode column.

- Mail Receipt (Request for Receipt Confirmation) and Sending Mail Receipt Response -

After the mail receiver sends a response to the request for a return receipt, the mail receiver's journal is annotated with two hyphens (--) in the Result column and an "A" in the Mode column.

- Receiving the Return Receipt Mail -

- After the mail sender receives a return receipt, the information in the mail sender's journal about the receipt request is replaced, i.e. the journal is annotated with "OK" in the Result column.
- When the return receipt reports an error, the journal is annotated with an "E" in the

Fax Communication Features

Result column.

- The arrival of the return receipt is not recorded in the journal as a separate communication. Its arrival is only reported by the presence of "OK" or "E" in the Result column.
- If the mail address used by the sender specifies a mailing list (i.e., a Group destination; the machine sends the mail to more than one location. See "How to set up Mail Delivery"), the Result column of the Journal is updated every time a return receipt is received. For example, if the mailing list was to 5 destinations, the Result column indicates the result of the communication with the 5th destination only. The results of the communications to the first 4 destinations are not shown.

Exceptions:

If one of the communications had an error, the Result column will indicate E, even if subsequent communications were OK.

If two of the communications had an error, the Journal will indicate the destination for the first error only.

- Report Sample -

DATE	TIME	ADDRESS	RESULT	MODE	TIME	PAGE
MAY. 5	10:15	fuser_01@domlg. ricoh. co.		Mail SM	0'09"	2
	10:16	fuser_01@domlg. ricoh. co.		Mail SMQ	0'05"	1
	10:17	s_tadashi@domlg. ricoh. co.		Mail SMQ	0'09"	2
	10:19	m_masataka@domlg. ricoh. co.	OK	Mail SMA	0'05"	1
			--			

b771d506

5.5 IP-FAX

5.5.1 WHAT IS IP-FAX?

For details: Core Technology Manual – Facsimile Processes – Faxing from a PC – Internet/LAN Fax Boards – IP-FAX

5.5.2 T.38 PACKET FORMAT

TCP is selected by default for this machine, but you can change this to UDP with IPFAX SW 00 Bit 1.

UDP Related Switches

IP-Fax Switch 01						
No.	Function					Comments
0-3	Select IP FAX Delay Level					Raise the level by selecting a higher setting if too many transmission errors are occurring on the network. If TCP/UDP is enabled on the network, raise this setting on the T.30 machine. Increasing the delay time allows the recovery of more lost packets. If only UDP is enabled, increase the number of redundant packets. Level 1 to 2: 3 Redundant packets Level 3: 4 Redundant packets
	Bit 3	Bit 2	Bit 1	Bit 0	Level	
	0	0	0	0	0	
	0	0	0	1	1	
	0	0	1	0	2	
	0	0	1	1	3	

5.5.3 SETTINGS

User parameter switch 34 (22[H]), bit 0

IP-Fax Gate Keeper usage, 0: No, 1: Yes

IP Fax Switches: Various IP-FAX settings (see the bit switch table)

6. SPECIFICATIONS

6.1 GENERAL SPECIFICATIONS

Type:	Desktop type transceiver
Circuit:	PSTN (max. 3ch.) PBX
Connection:	Direct couple
Original Size:	<p>Book (Face down)</p> <ul style="list-style-type: none"> ▪ Maximum Length: 432 mm [17 ins] ▪ Maximum Width: 297 mm [11.7 ins] <p>ARDF (Face up)</p> <p>Single-sided document</p> <ul style="list-style-type: none"> ▪ Length: 128 - 1200 mm [5.0 - 47.2 ins] ▪ Width: 105 - 297 mm [4.1 - 11.7 inch] <p>Double-sided document</p> <ul style="list-style-type: none"> ▪ Length: 128 - 432 mm [5.0 - 17 inch] ▪ Width: 105 - 297 mm [4.1 - 11.7 inch]
Scanning Method:	Flat bed, with CCD
Resolution:	<p>G3</p> <ul style="list-style-type: none"> ▪ 8 x 3.85 lines/mm (Standard) ▪ 8 x 7.7 lines/mm (Detail) ▪ 8 x 15.4 line/mm (Fine) Note1 ▪ 16 x15.4 line/mm (Super Fine) See Note. ▪ 200 x 100 dpi (Standard) ▪ 200 x 200 dpi (Detail) ▪ 400 x 400 dpi (Super Fine) Note - Optional Expansion <p>Memory required.</p>
Transmission Time:	G3: 3 s at 28800 bps; Measured with G3 ECM using memory for an ITU-T #1 test document (Slerexe letter) at standard

	resolution
Data Compression:	MH, MR, MMR JBIG
Protocol:	Group 3 with ECM
Modulation:	V.34, V.33, V.17 (TCM), V.29 (QAM), V.27ter (PHM), V.8, V.21 (FM)
Data Rate:	G3: 33600/31200/28800/26400/24000/21600/ 19200/16800/14400/12000/9600/7200/4800/2400 bps Automatic fallback
I/O Rate:	With ECM: 0 ms/line Without ECM: 2.5, 5, 10, 20, or 40 ms/line
Memory Capacity:	ECM: 128 KB SAF <ul style="list-style-type: none"> ▪ Standard: 4 MB ▪ With optional Expansion Memory: 28 MB (4 MB+ 24 MB) Page Memory <ul style="list-style-type: none"> ▪ Standard: 4 MB (Print: 2 MB + Scanner: 2 MB) ▪ With optional Expansion Memory: 12 MB (4 MB + 8 MB) (Print 8 MB + Scanner: 4 MB)

D498
Fax Option
Type C7501

6.2 CAPABILITIES OF PROGRAMMABLE ITEMS

The following table shows how the capabilities of each programmable item will change after the optional Fax Function Upgrade Unit is installed.

Item	Standard
Quick Dial	2000
Groups	100
Destination per Group	500
Destinations dialed from the ten-key pad overall	500
Programs	100
Auto Document	6
Communication records for Journal stored in the memory	200
Specific Senders	30

The following table shows how the capabilities of the document memory will change after the optional Fax Function Upgrade Unit and the Expansion Memory are installed.

	Without the Expansion Memory	With the Expansion Memory
Memory Transmission files	400	400
Maximum number of pages for memory transmission	1000	1000
Memory capacity for memory transmission (see the Note below)	320	2240

↓ Note

- Measured using an ITU-T #1 test document (Slerexe letter) at standard resolution, with auto image density mode, and in Text mode.

6.3 IFAX SPECIFICATIONS

<p>Connectivity Local area network Ethernet 100base-Tx/10base-T IEEE1394 (IP over 1394) IEEE802.11b (wireless LAN)</p> <p>Resolution Main scan: 400 dpi, 200 dpi Sub scan: 400 dpi, 200 dpi, 100 dpi Note: To use 400 dpi, IFAX SW01 Bit 4 must be set to "1".</p> <p>Transmission Time 1 s (through a LAN to the server) Conditions:</p> <ul style="list-style-type: none"> ▪ ITU-T #1 test document (Slerexe Letter) ▪ MTF correction: OFF ▪ TTI: None ▪ Resolution: 200 x 100 dpi ▪ Communication speed: 10 Mbps ▪ Correspondent device: E-mail server ▪ Line conditions: No terminal access <p>Document Size Maximum message width is A4/LT. Note: To use B4 and A3 width, IFAX SW00 Bit 1 (B4) and/or Bit 2 (A3) must be set to "1".</p> <p>E-mail File Format Single/multi-part MIME conversion Image: TIFF-F (MH, MR, MMR)</p>	<p>Protocol Transmission: SMTP, TCP/IP Reception: POP3, SMTP, IMAP4, TCP/IP</p> <p>Data rate 100 Mbps(100base-Tx) 10 Mbps (10base-T)</p> <p>Authentication method SMTP-AUTH POP before SMTP A-POP</p> <p>Remark The machine must be set up as an e-mail client before installation. Any client PCs connected to the machine through a LAN must also be e-mail clients, or some features will not work (e.g. Autorouting).</p>
---	---

6.4 IP-FAX SPECIFICATIONS

Network:	LAN: Ethernet/10base-T, 100base-TX IEEE1394 (IP over 1394), IEEE802.11b (wireless LAN)
Scan line density:	8 x 3.85 lines/mm, 200x100dpi (standard character), 8 x 7.7lines/mm, 200x200dpi (detail character), 8 x 15.4lines/mm (fine character: optional expansion memory required), 16 x 15.4lines/mm, 400x400dpi (super fine character: optional expansion memory required)
Original size:	Maximum A3 or 11"x 17" (DLT)
Maximum scanning size:	Standard: A3, 297mm x 432mm Irregular: 297mm x 1200mm
Transmission protocol:	Recommended: T.38 Annex protocol, TCP, UDP/IP communication
Compatible machines:	IP-Fax compatible machines
IP-Fax transmission:	Specify IP address and send fax to an IP-Fax compatible fax through a network. Also capable of sending fax from a G3 fax connected to the public telephone lines via a VoIP gateway.
IP-Fax reception:	Receive a fax sent from an IP-Fax compatible fax through a network. Also capable of receiving fax from a G3 fax connected the public telephone lines via a VoIP gateway.

6.5 FAX UNIT CONFIGURATION

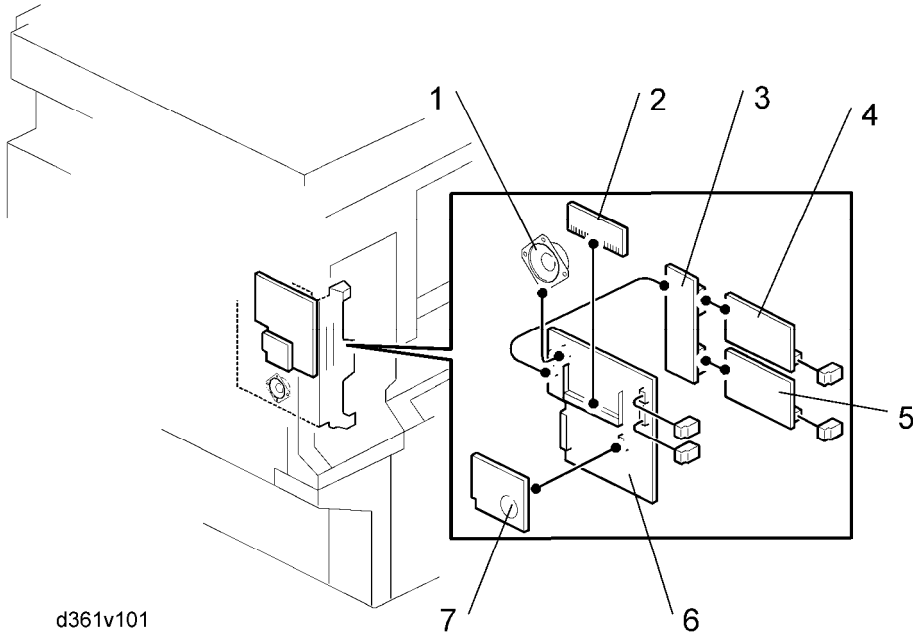

d361v101

Component	Code	No.	Remarks
FCU	D498	6	Included with fax unit
MBU		7	
Speaker		1	
CCU I/F Board	D357	3	Included with optional G3 unit. Common with D014/D015
G3 Board		4	
G3 Board	D357	5	Included with optional G3 unit. Common with D014/D015
Expansion Memory	G578	2	Common with D014/D015