

# RICOH



MOC3/MOC4/MOC5/  
MOC6/MOC7

***SERVICE MANUAL***

**LANIER RICOH SAVIN®**

It is the reader's responsibility when discussing the information contained within this document to maintain a level of confidentiality that is in the best interest of Ricoh USA, Inc. and its member companies.

***NO PART OF THIS DOCUMENT MAY BE REPRODUCED IN ANY FASHION AND DISTRIBUTED WITHOUT THE PRIOR PERMISSION OF RICOH USA, Inc.***

All product names, domain names or product illustrations, including desktop images, used in this document are trademarks, registered trademarks or the property of their respective companies.

They are used throughout this book in an informational or editorial fashion only and for the benefit of such companies. No such use, or the use of any trade name, or web site is intended to convey endorsement or other affiliation with Ricoh products.

## **WARNING**

The Service Manual contains information regarding service techniques, procedures, processes and spare parts of office equipment distributed by Ricoh USA, Inc. Users of this manual should be either service trained or certified by successfully completing a Ricoh Technical Training Program.

Untrained and uncertified users utilizing information contained in this service manual to repair or modify Ricoh equipment risk personal injury, damage to property or loss of warranty protection.

***Ricoh USA, Inc.***

# LEGEND

PRODUCT CODE	COMPANY		
	LANIER	RICOH	SAVIN
M0C3	SP 330DN	SP 330DN	SP 330DN
M0C4	SP 330SN	SP 330SN	SP 330SN
M0C5	SP 330SFN	SP 330SFN	SP 330SFN
M0C6	SP 3710DN	SP 3710DN	SP 3710DN
M0C7	SP 3710SF	SP 3710SF	SP 3710SF

# DOCUMENTATION HISTORY

REV. NO.	DATE	COMMENTS
*	09/2018	Original Printing

# M0C3/M0C4/M0C5/M0C6/M0C7

## TABLE OF CONTENTS

<b>1. PRODUCT INFORMATION .....</b>	<b>1-1</b>
1.1 MACHINE CODES AND PERIPHERALS CONFIGURATION .....	1-1
1.1.1 MAIN FRAME .....	1-1
1.1.2 OPTIONS .....	1-1
<b>2. INSTALLATION .....</b>	<b>2-1</b>
2.1 INSTALLATION REQUIREMENTS.....	2-1
2.1.1 ENVIRONMENT .....	2-1
2.1.2 MAIN MACHINE INSTALLATION.....	2-1
2.1.3 MOVING AND TRANSPORTING THE MACHINE.....	2-2
2.2 SETTINGS FOR @REMOTE SERVICE (FOR PRINTER MODELS).....	2-4
2.3 SETTINGS FOR @REMOTE SERVICE (FOR MF MODELS) .....	2-10
<b>3. PREVENTIVE MAINTENANCE .....</b>	<b>3-1</b>
3.1 PREVENTIVE MAINTENANCE TABLES .....	3-1
3.2 IMAGE QUALITY STANDARDS.....	3-2
3.3 PAPER TRANSFER QUALITY STANDARDS .....	3-4
<b>4. REPLACEMENT AND ADJUSTMENT .....</b>	<b>4-1</b>
4.1 GENERAL CAUTIONS .....	4-1
4.2 EXTERIOR COVERS (PRINTER MODELS).....	4-2
4.2.1 FRONT COVER .....	4-2
4.2.2 LEFT COVER .....	4-3
4.2.3 REAR COVER.....	4-6
4.2.4 RIGHT COVER.....	4-6
4.2.5 TOP COVER.....	4-9
4.2.6 OPERATION PANEL UNIT.....	4-10
4.3 EXTERIOR COVERS (MF MODELS) .....	4-11
4.3.1 FRONT COVER .....	4-11
4.3.2 LEFT COVER .....	4-13
4.3.3 REAR COVER.....	4-15
4.3.4 RIGHT COVER.....	4-16
4.3.5 TOP COVER.....	4-19
Fax models: .....	4-19
Models with No Fax:.....	4-20

4.4	SCANNER UNIT (ONLY MF MODELS).....	4-21
4.4.1	SCANNER UNIT.....	4-21
4.4.2	OPERATION PANEL UNIT.....	4-24
	Four-line LCD models: .....	4-24
	Touch panel models: .....	4-25
4.5	ADF/ARDF UNIT (ONLY MF MODELS) .....	4-26
4.5.1	ADF UNIT (FOR FOUR-LINE LCD MODELS).....	4-26
	ADF Unit.....	4-26
	Original Tray .....	4-27
	ADF Pick-Up Roller .....	4-27
	ADF Feed Roller.....	4-28
	ADF Separation Pad .....	4-28
	ADF Front Cover .....	4-29
	ADF Rear Cover .....	4-30
	ADF Motor .....	4-31
	ADF Top Cover .....	4-32
	Original Set Sensor .....	4-32
	ADF Feed Sensor.....	4-33
4.5.2	ARDF UNIT (FOR TOUCH PANEL MODELS).....	4-34
	ARDF Unit .....	4-34
	Original Tray .....	4-34
	ARDF Pick-Up Roller, ARDF Feed Roller .....	4-35
	ARDF Separation Pad.....	4-36
	ARDF Front Cover.....	4-36
	ARDF Rear Cover .....	4-37
	ARDF Motor.....	4-38
	ARDF Top Cover .....	4-40
	Original Set Sensor .....	4-41
	ARDF Feed Sensor .....	4-42
4.6	LASER UNIT .....	4-43
4.6.1	CAUTION DECAL LOCATIONS.....	4-43
4.6.2	LASER UNIT .....	4-43
4.6.3	LASER UNIT THERMISTOR.....	4-44
4.7	PAPER FEED.....	4-45
4.7.1	PAPER FEED ROLLER .....	4-45
4.7.2	FRICTION PAD .....	4-46
4.7.3	PAPER END SENSOR.....	4-46
4.7.4	BY-PASS FEED SOLENOID .....	4-47
4.7.5	BY-PASS FEED ROLLER .....	4-47

4.7.6	BY-PASS FEED ROLLER FRICTION PAD.....	4-49
4.7.7	BY-PASS FEED SENSOR.....	4-50
4.7.8	PAPER FEED CLUTCH.....	4-50
4.7.9	RELAY CLUTCH.....	4-51
4.7.10	REGISTRATION CLUTCH.....	4-51
4.7.11	REGISTRATION ROLLER.....	4-52
4.7.12	REGISTRATION SENSOR.....	4-58
4.8	IMAGE TRANSFER.....	4-59
4.8.1	TRANSFER ROLLER.....	4-59
4.8.2	TONER END SENSOR.....	4-60
4.8.3	QUENCHING LAMP.....	4-61
4.9	FUSING AND EXIT.....	4-62
4.9.1	FUSING UNIT.....	4-62
4.9.2	FUSING UPPER COVER.....	4-64
4.9.3	THERMOSTAT.....	4-65
4.9.4	FUSING THERMISTOR.....	4-66
4.9.5	FUSING LAMP.....	4-67
4.9.6	HOT ROLLER STRIPPER PAWLS.....	4-69
4.9.7	PAPER EXIT SENSOR.....	4-69
4.10	DUPLEX.....	4-70
4.10.1	DUPLEX SENSOR.....	4-70
4.11	DRIVE.....	4-71
4.11.1	MAIN MOTOR.....	4-71
4.11.2	DRIVE UNIT.....	4-72
4.11.3	DUPLEX MOTOR.....	4-75
4.12	ELECTRICAL COMPONENTS.....	4-76
4.12.1	MAIN BOARD.....	4-76
	Main Board (Printer Models).....	4-76
	Main Board (MF Four-line LCD Models).....	4-77
	Main Board (MF Touch Panel Models).....	4-78
	When Installing the New Main Board.....	4-79
4.12.2	PSU.....	4-80
4.12.3	HVP.....	4-81
4.12.4	COOLING FAN.....	4-82
4.12.5	ENVIRONMENT THERMISTOR.....	4-82
4.12.6	ID CHIP BOARD.....	4-83
4.12.7	FRONT COVER SWITCH, REAR COVER SWITCH.....	4-83
4.12.8	USB PORT (ONLY FOR MF MODELS).....	4-84
4.12.9	FCU (ONLY FOR FAX MODELS).....	4-84

4.12.10	SPEAKER (ONLY FOR FAX MODELS)	4-85
4.13	IMAGE ADJUSTMENT	4-86
4.13.1	REGISTRATION ADJUSTMENT	4-86
	User Adjustment	4-86
	Service Adjustment	4-86

## **5. SYSTEM MAINTENANCE..... 5-1**

5.1	MAINTENANCE MODE (FOR FOUR-LINE LCD MODELS)	5-1
5.1.1	OVERVIEW	5-1
5.1.2	MENU LIST	5-2
	Display Info	5-2
	Engine Maintenance	5-2
	Scan Maintenance (Only for MF Models)	5-8
	Factory Default	5-9
	CTL Maintenance	5-9
	System Maintenance	5-10
	@Remote	5-10
5.2	MAINTENANCE MODE (FOR TOUCH PANEL MODELS)	5-14
5.2.1	OVERVIEW	5-14
5.2.2	MENU LIST	5-14
	Information Display	5-14
	Engine Service Setting	5-15
	Scanner Service Setting	5-21
	Fax Service Setting	5-22
	Print Reports	5-26
	CTL SP	5-26
	Factory Default	5-26
	@Remote	5-27
5.3	SMART ORGANIZING MONITOR (SOM)	5-31
5.3.1	OVERVIEW	5-31
5.3.2	MENU LIST	5-32
	Paper Input	5-33
	Maintenance	5-35
	System	5-36
	IPv6	5-38
	Network 1	5-39
	Network 2	5-41
	Network 3	5-42
	Wireless	5-43
	Printer	5-44



@Remote .....	5-45
SP Mode 1 .....	5-46
SP Mode 2.....	5-48
SP Mode 3.....	5-50
SP Mode 4.....	5-52
5.4 FAX SERVICE TEST (ONLY FOR FAX MODELS) .....	5-53
5.4.1 FAX SERVICE TEST MENU .....	5-53
5.4.2 MENU LIST .....	5-53
5.5 REPORTS.....	5-55
5.5.1 TYPES OF REPORTS .....	5-55
5.5.2 TO PRINT THE REPORTS .....	5-56
5.5.3 REPORT EXAMPLES .....	5-56
5.5.4 TEST PAGE.....	5-59
To Print the Test Page .....	5-59
5.5.5 TEST PATTERN PRINTING.....	5-60
To Print the Test Pattern.....	5-61
5.6 UPDATING THE FIRMWARE.....	5-62
5.6.1 BEFORE UPDATING THE FIRMWARE .....	5-62
5.6.2 UPDATING THE MAIN FIRMWARE .....	5-63
Procedure.....	5-64
5.6.3 TROUBLESHOOTING .....	5-65
If Initialization Does Not End Following a Firmware Update.....	5-65
Firmware Update Tool Messages.....	5-68
Control Panel Display.....	5-71
Control Panel Indicator Patterns (Only for Four-line LCD Models) .....	5-71
5.7 CAPTURING THE DEBUG LOGS.....	5-72
5.7.1 OVERVIEW .....	5-72
Retrieving the Debug Logs.....	5-72
Debug Item List: .....	5-73
<b>6. TROUBLESHOOTING .....</b>	<b>6-1</b>
6.1 SELF-DIAGNOSTIC MODE.....	6-1
6.1.1 SELF-DIAGNOSTIC MODE AT POWER ON.....	6-1
6.2 SERVICE CALL .....	6-2
6.2.1 SERVICE CALL CONDITIONS .....	6-2
6.2.2 SC 2XX (LASER OPTICS ERRORS) .....	6-3
6.2.3 SC 4XX (IMAGE TRANSFER AND TRANSFER ERRORS) .....	6-5
6.2.4 SC 5XX (MOTOR AND FUSING ERRORS) .....	6-5
6.2.5 SC 6XX (COMMUNICATION AND OTHER ERRORS) .....	6-11
6.3 ERROR MESSAGES.....	6-12

6.3.1 OVERVIEW .....	6-12
6.3.2 ERROR MESSAGES .....	6-12
6.4 FAX ERROR CODES .....	6-20
6.4.1 FAX ERROR CODE STRUCTURE.....	6-20
6.4.2 FAX ERROR CODE TABLE .....	6-21
6.5 JAM DETECTION .....	6-24
6.5.1 PAPER JAM.....	6-24
6.5.2 ORIGINAL JAM (ADF/ARDF).....	6-26
6.6 IMAGE QUALITY .....	6-27
6.6.1 PROBLEM AT REGULAR INTERVALS .....	6-27
6.7 OTHER PROBLEMS .....	6-28
6.7.1 DARK LINES IN HALFTONE AREAS AT 75MM INTERVALS.....	6-28
6.7.2 RECYCLED OR THIN PAPER IS SEVERELY CURLED AFTER PRINTING ..	6-28
6.7.3 WHEN FLUORESCENT/ LED LAMPS FLICKER (ONLY FOR 100V MODELS)	6-29
6.7.4 STAIN APPEARS IN THE RIGHT AND THE LEFT EDGES.....	6-30
6.7.5 POOR PRINTING (OFFSET).....	6-31
6.7.6 WRINKLES APPEAR WHEN USING LIMP PAPER .....	6-31
6.7.7 LOW IMAGE DENSITY ON SOLID IMAGES .....	6-32
6.7.8 MOTTLED IMAGE ON SOLID IMAGES .....	6-33
6.7.9 TONER SCATTERED ON HORIZONTAL LINES .....	6-33

## **7. DETAILED DESCRIPTIONS ..... 7-1**

7.1 GUIDANCE FOR THOSE WHO ARE FAMILIAR WITH PREDECESSOR PRODUCTS	7-1
7.1.1 PRINTER MODELS: .....	7-1
7.1.2 MF MODELS: .....	7-2
7.2 PRODUCT OVERVIEW .....	7-3
7.2.1 COMPONENT LAYOUT .....	7-3
7.2.2 PAPER PATH.....	7-4
7.2.3 DRIVE LAYOUT .....	7-5
7.2.4 COMPONENT LAYOUT (PRINTER MODELS) .....	7-6
Laser Exposure .....	7-6
Paper Feed.....	7-7
Fusing, Duplex, Paper Exit.....	7-8
Boards, Switches.....	7-9
7.2.5 COMPONENT LAYOUT (MF MODELS).....	7-10
ADF, Scanner .....	7-10
Laser Exposure .....	7-11
Paper Feed.....	7-12
Fusing, Duplex, Paper Exit.....	7-13
Boards, Switches.....	7-14

7.3 ADF/ARDF (FOR MF MODELS) .....	7-15
7.3.1 OVERVIEW .....	7-15
ADF.....	7-15
ARDF.....	7-16
7.3.2 MECHANISM.....	7-17
ADF Paper Path .....	7-17
ARDF Paper Path.....	7-17
7.4 SCANNER (FOR MF MODELS).....	7-19
7.4.1 OVERVIEW .....	7-19
7.4.2 MECHANISM.....	7-19
7.5 PRINTING PROCESS .....	7-20
7.5.1 OVERVIEW .....	7-20
7.6 LASER EXPOSURE .....	7-21
7.6.1 OVERVIEW .....	7-21
7.6.2 MECHANISM.....	7-22
7.7 PRINT CARTRIDGE (AIO).....	7-23
7.7.1 OVERVIEW .....	7-23
7.7.2 MECHANISM.....	7-24
Drum Charge.....	7-24
Toner Supply and Development.....	7-25
Toner End Detection.....	7-26
7.8 PAPER FEED.....	7-28
7.8.1 OVERVIEW .....	7-28
7.8.2 MECHANISM.....	7-29
Paper Tray.....	7-29
By-pass Tray.....	7-31
7.9 IMAGE TRANSFER .....	7-33
7.9.1 OVERVIEW .....	7-33
7.9.2 MECHANISM.....	7-34
7.10 FUSING AND EXIT .....	7-36
7.10.1 OVERVIEW .....	7-36
7.10.2 MECHANISM.....	7-37
Fusing Drive .....	7-37
Parts Layout of the Fusing Unit.....	7-38
Envelope Lever .....	7-38
Fusing Temperature Control.....	7-39
Overheat Protection .....	7-40
Paper Exit.....	7-41
7.11 DUPLEX.....	7-42

7.11.1 OVERVIEW .....	7-42
7.11.2 MECHANISM.....	7-43
Duplex Printing Process.....	7-43
Printing Order .....	7-44
7.12 ELECTRICAL COMPONENTS .....	7-45
7.12.1 OVERVIEW .....	7-45
Block Diagram Printer Models.....	7-45
Block Diagram MF Models .....	7-46
Board Outline.....	7-46
7.13 ENERGY SAVE .....	7-48
7.13.1 ENERGY SAVER MODES .....	7-48
Timer Settings .....	7-48
Return to Stand-by Mode .....	7-49
Recommendation .....	7-49

# IMPORTANT SAFETY NOTICES

## Warnings, Cautions, Notes

In this manual, the following important symbols and notations are used.

### **WARNING**

- A Warning indicates a potentially hazardous situation. Failure to obey a Warning could result in death or serious injury.

### **CAUTION**

- A Caution indicates a potentially hazardous situation. Failure to obey a Caution could result in minor or moderate injury or damage to the machine or other property.

### **Important**

- Obey these guidelines to avoid problems such as misfeeds, damage to originals, loss of valuable data and to prevent damage to the machine.

### **Note**

- This information provides tips and advice about how to best service the machine.

## General Safety Instructions

For your safety, please read this manual carefully before you use this product. Keep this manual handy for future reference.

### Safety Information

Always obey the following safety precautions when using this product.

### Safety During Operation

In this manual, the following important symbols and notations are used.

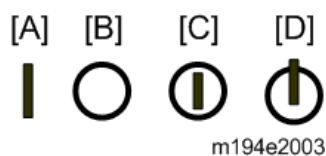

[A]: ON

[B]: OFF

[C]: Push ON/Push OFF

[D]: Standby

# Switches and Symbols

Where symbols are used on or near switches on machines for Europe and other areas, the meaning of each symbol conforms with IEC60417.

## Safety

### Prevention of Physical Injury

1. Before disassembling or assembling parts of the machine and peripherals, make sure that the machine and peripheral power cords are unplugged.
2. The plug should be near the machine and easily accessible.
3. Note that some components of the machine and the paper tray unit are supplied with electrical voltage even if the main power switch is turned off.
4. Always unplug the power cord from the power source before you move the product. Before you move the machine, arrange the power cord so it will not fall under the machine.
5. Disconnect all peripheral units (finisher, LCT, etc.) from the mainframe before you move the machine.
6. If any adjustment or operation check has to be made with exterior covers off or open while the main switch is turned on, keep hands away from electrified or mechanically driven components.
7. The machine drives some of its components when it completes the warm-up period. Be careful to keep hands away from the mechanical and electrical components as the machine starts operation.
8. The inside and the metal parts of the fusing unit become extremely hot while the machine is operating. Be careful to avoid touching those components with your bare hands.
9. To prevent a fire or explosion, keep the machine away from flammable liquids, gases, and aerosols.
10. Do not use flammable sprays or solvent in the vicinity of the machine. Also, avoid placing these items in the vicinity of the machine. Doing so could result in fire or electric shock.
11. To avoid fire or explosion, never use an organic cleaner near any part that generates heat.
12. Clean the floor completely after accidental spillage of silicone oil or other materials to prevent slippery surfaces that could cause accidents leading to hand or leg injuries.
13. Never remove any safety device unless it requires replacement. Always replace safety devices immediately.
14. Never do any procedure that defeats the function of any safety device.

15. Modification or removal of a safety device (fuse, switch, etc.) could lead to a fire and personal injury. Always test the operation of the machine to ensure that it is operating normally and safely after removal and replacement of any safety device.
16. For replacements use only the correct fuses or circuit breakers rated for use with the machine. Using replacement devices not designed for use with the machine could lead to a fire and personal injuries.
17. For machines installed with the ADF/ARDF:

When a thick book or three-dimensional original is placed on the exposure glass and the ARDF cover is lowered, the back side of the ARDF rises up to accommodate the original. Therefore, when closing the ARDF, please be sure to keep your hands away from the hinges at the back of the ARDF.
18. When using a vacuum cleaner around the machine, keep others away from the cleaner, especially small children.
19. For machines installed with the anti-tip components:

The anti-tip components are necessary for meeting the requirements of IEC60950-1, the international standard for safety. The aim of these components is to prevent the products, which are heavy in weight, from toppling as a result of people running into or leaning onto the products, which can lead to serious accidents such as persons becoming trapped under the product. (U.S.: UL60950-1, Europe: EN60950-1) Therefore, removal of such components must always be with the consent of the customer. Do not remove them at your own judgment.
20. **NEVER touch** the AC circuits on the PSU board to prevent electric shock caused by residual charge. Residual charge of about 100V-400V remains in the AC circuits on the PSU board for several months even when the board has been removed from the machine after turning off the machine power and unplugging the power cord.

### **Health Safety Conditions**

21. For the machines installed with the ozone filters:
  - Never operate the machine without the ozone filters installed.
  - Always replace the ozone filters with the specified types at the proper intervals.
22. The machine, which use high voltage power source, can generate ozone gas. High ozone density is harmful to human health. Therefore, locate the machine in a large well ventilated room that has an air turnover rate of more than 50m<sup>3</sup>/hr/person.
23. Toner and developer are non-toxic, but if you get either of them in your eyes by accident, it may cause temporary eye discomfort. Try to remove with eye drops or flush with water as first aid. If unsuccessful, get medical attention.

## Observance of Electrical Safety Standards

24. The machine and its peripherals must be installed and maintained by a customer service representative who has completed the training course on those models with exceptions on some machines where the installation can be handled by the user.

## Safety and Ecological Notes for Disposal

- Do not incinerate toner bottles or used toner. Toner dust may ignite suddenly when exposed to an open flame.
- Dispose of used toner, developer, organic photoconductors, and AIO unit in accordance with local regulations. (These are non-toxic supplies.)
- Dispose of replaced parts in accordance with local regulations.
- When keeping used lithium batteries in order to dispose of them later, do not put more than 100 batteries per sealed box. Storing larger numbers or not sealing them apart may lead to chemical reactions and heat build-up.

### CAUTION

The danger of explosion exists if a battery of this type is incorrectly replaced. Replace only with the same or an equivalent type recommended by the manufacturer. Discard used batteries in accordance with the manufacturer's instructions.

## Handling Toner

- Work carefully when removing paper jams or replacing toner bottles or cartridges to avoid spilling toner on clothing or the hands.
- If toner is inhaled, immediately gargle with large amounts of cold water and move to a well-ventilated location. If there are signs of irritation or other problems, seek medical attention.
- If toner gets on the skin, wash immediately with soap and cold running water.
- If toner gets into the eyes, flush the eyes with cold running water or eye wash. If there are signs of irritation or other problems, seek medical attention.
- If toner is swallowed, drink a large amount of cold water to dilute the ingested toner. If there are signs of any problem, seek medical attention.
- If toner spills on clothing, wash the affected area immediately with soap and cold water. Never use hot water! Hot water can cause toner to set and permanently stain fabric.
- Always store toner and developer supplies such as toner and developer packages, cartridges, bottles (including used toner and empty bottles and cartridges), and AIO unit out of the reach of children.
- Always store fresh toner supplies or empty bottles or cartridges in a cool, dry location that is not exposed to direct sunlight.



- Do not use a vacuum cleaner to remove spilled toner (including used toner). Vacuumed toner may cause a fire or explosion due to sparks or electrical contact inside the cleaner. However, it is possible to use a cleaner designed to be dust explosion-proof. If toner is spilled over the floor, sweep up spilled toner slowly and clean up any remaining toner with a wet cloth.

### **Handling the development unit cooling system**

For the machines installed the development cooling system:

25. The development unit cooling system circulates propylene glycol from a sealed tank through hoses that pass behind cooling plates on the sides of each development unit.
26. The coolant tank is located at the bottom of the cooling box on the back of the main machine.
27. Always obey local laws and regulations if you need to dispose of a tank or the propylene glycol coolant.
28. The tank must never be emptied directly into a local drainage system, river, pond, or lake.
29. Contact a professional industrial waste disposal organization and ask them to dispose of the tank.

### **Lithium Batteries for Taiwan**

#### **警告**

本機器內的鋰電池如果更換不正確型號會有爆炸的危險。  
只能使用相同或製造商推薦同等類型的電池進行更換。  
請依製造商說明書處理用過之廢棄電池。

# Laser Safety

The Center for Devices and Radiological Health (CDRH) prohibits the repair of laser-based optical units in the field. The optical housing unit can only be repaired in a factory or at a location with the requisite equipment. The laser subsystem is replaceable in the field by a qualified Customer Engineer. The laser chassis is not repairable in the field. Customer engineers are therefore directed to return all chassis and laser subsystems to the factory or service depot when replacement of the optical subsystem is required.

## ⚠️ WARNING

- Use of controls, or adjustment, or performance of procedures other than those specified in this manual may result in hazardous radiation exposure.

### WARNING FOR LASER UNIT

#### WARNING:

Turn off the main switch before attempting any of the procedures in the Laser Unit section. Laser beams can seriously damage your eyes.

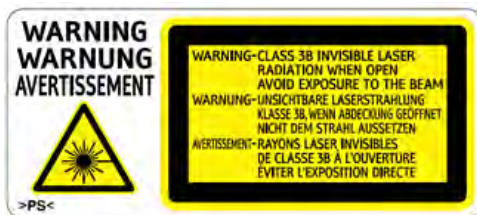

\_safe006

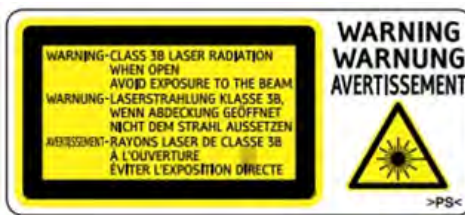

\_safe007



\_safe008

# Safety Instructions for the Color Controller

## Fuse

The color controller uses a double pole fuse. If this fuse blows, be sure to replace it with an identical fuse.

## Batteries







### CAUTION

Always replace a battery with the same type of battery prescribed for use with the color controller unit. Replacing a battery with any type other than the one prescribed for use could cause an explosion.

- Never discard used batteries by mixing them with other batteries or other refuse.
- Always remove used batteries from the work site and dispose of them in accordance with local laws and regulations regarding the disposal of such items.

# SYMBOLS AND ABBREVIATIONS

This manual uses several symbols and abbreviations. The meaning of those symbols and abbreviations are as follows:

Symbol	What it means
	Clip ring
	Screw
	Connector
	Clamp
	E-ring
	Flat Flexible Cable
	Timing Belt
SEF	Short Edge Feed
LEF	Long Edge Feed
K	Black
C	Cyan
M	Magenta
Y	Yellow
B/W, BW	Black and White
FC	Full color

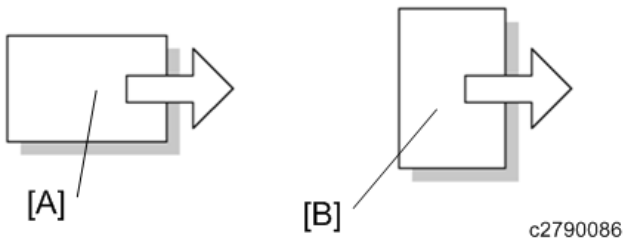

[A] Short Edge Feed (SEF)

[B] Long Edge Feed (LEF)

## Trademarks

Adobe and Acrobat are either registered trademarks or trademarks of Adobe Systems Incorporated in the United States and/or other countries.

Android and Google Play are trademarks or registered trademarks of Google Inc.

OS X, TrueType, App Store, and Safari are trademarks of Apple Inc., registered in the U.S. and other countries.

Firefox® is a registered trademark of the Mozilla Foundation.

iOS is a trademark or registered trademark of Cisco in the U.S. and other countries and is used under license.

Java is a registered trademark of Oracle and/or its affiliates.

LINUX® is the registered trademark of Linus Torvalds in the U.S. and other countries.

Microsoft®, Windows®, Windows Server®, Windows Vista®, and Internet Explorer® are either registered trademarks or trademarks of Microsoft Corporation in the United States and/or other countries.



Mopria and the Mopria logo are trademarks of Mopria Alliance, Inc.

PCL® is a registered trademark of Hewlett-Packard Company.

PictBridge is a trademark.

QR Code is a registered trademark of DENSO WAVE INCORPORATED in Japan and in other countries.

Red Hat is a registered trademark of Red Hat, Inc.

Wi-Fi® and Wi-Fi Direct® are registered trademarks of Wi-Fi Alliance.

The proper name of Internet Explorer 6 is Microsoft® Internet Explorer® 6.

The proper names of the Windows operating systems are as follows:

- The product names of Windows Vista are as follows:
  - Microsoft® Windows Vista® Ultimate
  - Microsoft® Windows Vista® Business
  - Microsoft® Windows Vista® Home Premium

Microsoft® Windows Vista® Home Basic

Microsoft® Windows Vista® Enterprise

- The product names of Windows 7 are as follows:

Microsoft® Windows® 7 Starter

Microsoft® Windows® 7 Home Premium

Microsoft® Windows® 7 Professional

Microsoft® Windows® 7 Ultimate

Microsoft® Windows® 7 Enterprise

- The product names of Windows 8.1 are as follows:

Microsoft® Windows® 8.1

Microsoft® Windows® 8.1 Pro

Microsoft® Windows® 8.1 Enterprise

- The product names of Windows 10 are as follows:

Microsoft® Windows® 10 Home Premium

Microsoft® Windows® 10 Pro

Microsoft® Windows® 10 Enterprise

Microsoft® Windows® 10 Education

- The product names of Windows Server 2008 are as follows:

Microsoft® Windows Server® 2008 Foundation

Microsoft® Windows Server® 2008 Standard

Microsoft® Windows Server® 2008 Enterprise

Microsoft® Windows Server® 2008 Datacenter

Microsoft® Windows Server® 2008 for Itanium-based Systems

Microsoft® Windows® Web Server 2008

Microsoft® Windows® HPC Server 2008

- The product names of Windows Server 2008 R2 are as follows:

Microsoft® Windows Server® 2008 R2 Foundation

Microsoft® Windows Server® 2008 R2 Standard

Microsoft® Windows Server® 2008 R2 Enterprise

Microsoft® Windows Server® 2008 R2 Datacenter

Microsoft® Windows Server® 2008 R2 for Itanium-based Systems

Microsoft® Windows® Web Server R2 2008

Microsoft® Windows® HPC Server R2 2008

- The product names of Windows Server 2012 are as follows:
  - Microsoft® Windows Server® 2012 Foundation
  - Microsoft® Windows Server® 2012 Essentials
  - Microsoft® Windows Server® 2012 Standard
  - Microsoft® Windows Server® 2012 Datacenter
- The product names of Windows Server 2012 R2 are as follows:
  - Microsoft® Windows Server® 2012 R2 Foundation
  - Microsoft® Windows Server® 2012 R2 Essentials
  - Microsoft® Windows Server® 2012 R2 Standard
  - Microsoft® Windows Server® 2012 R2 Datacenter
- The product names of Windows Server 2016 are as follows:
  - Microsoft® Windows Server® 2016 Datacenter
  - Microsoft® Windows Server® 2016 Standard
  - Microsoft® Windows Server® 2016 Essentials

Other product names used herein are for identification purposes only and might be trademarks of their respective companies. We disclaim any and all rights to those marks.

Microsoft product screen shots reprinted with permission from Microsoft Corporation.

# PRODUCT INFORMATION

REVISION HISTORY		
Page	Date	Added/Updated/New
		None



# 1. PRODUCT INFORMATION

## 1.1 MACHINE CODES AND PERIPHERALS CONFIGURATION

### 1.1.1 MAIN FRAME

#### *Printer Models:*

Name	Machine Code	Operation Panel	Remarks
SP 330DN	M0C3	Four-line LCD	For NA/EU/AA/CHN/TWN
SP 3710DN	M0C6	Four-line LCD	For NA/EU/AA

#### *MF Models:*

Name	Machine Code	Operation Panel	ADF	Fax	Remarks
SP 330SN	M0C4	Four-line LCD	ADF	Not supported	For EU/AA/CHN
SP 330SFN	M0C5	4.3" touch panel	ARDF	Supported	For NA/EU/AA/CHN/TWN
SP 3710SF	M0C7	4.3" touch panel	ARDF	Supported	For NA/EU/AA

#### Note

NA = North America, EU = Europe, AA = Asia-Pacific, CHN = China, TWN = Taiwan

### 1.1.2 OPTIONS

Name	Machine Code	Remarks
Paper Feed Unit PB1130	M534-17	New Paper Capacity: 250 sheets
IEEE 802.11 Interface Unit Type P16	M542-01	New USB dongle type

# INSTALLATION

REVISION HISTORY		
Page	Date	Added/Updated/New
		None

## 2. INSTALLATION

### 2.1 INSTALLATION REQUIREMENTS

#### 2.1.1 ENVIRONMENT

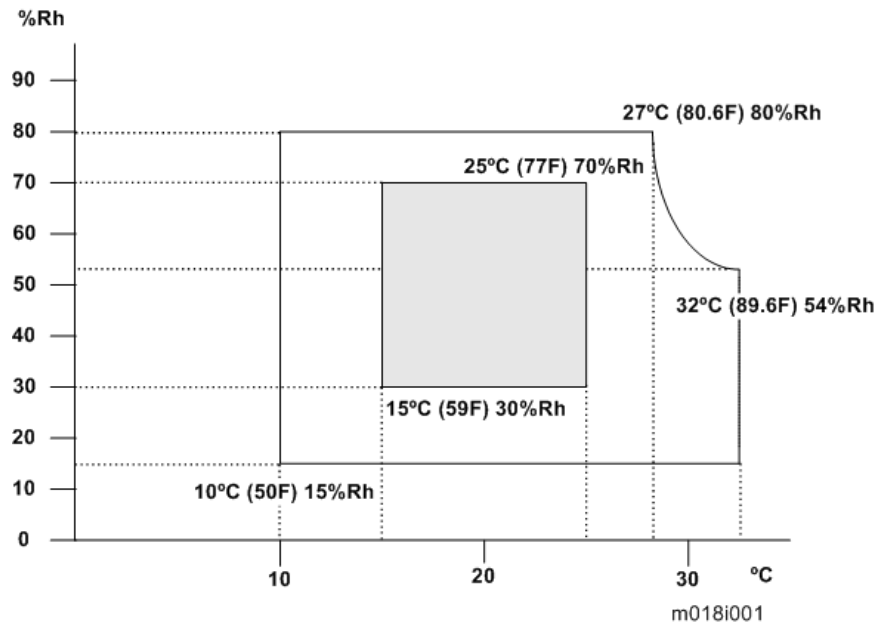

30. Temperature Range: 10°C to 32°C (50°F to 89.6°F)
31. Humidity Range: 15% to 80% RH
32. Ambient Illumination: Less than 2,000 lux (do not expose to direct sunlight)
33. Ventilation: 3 times/hr/person
34. Do not install the machine at locations over 2,000 m (6,562 ft.) above sea level.
35. Atmospheric pressure: more than 740 hPa.

#### 2.1.2 MAIN MACHINE INSTALLATION

This machine is installed by the user.

## 2.1.3 MOVING AND TRANSPORTING THE MACHINE

### **WARNING**

- It is dangerous to handle the power cord plug with wet hands. Doing so could result in electric shock.

### **CAUTION**

- Unplug the power cord from the wall outlet before you move the machine. While moving the machine, take care that the power cord is not damaged under the machine. Failing to take these precautions could result in fire or electric shock.

### **CAUTION**

- When disconnecting the power cord from the wall outlet, always pull the plug, not the cord. Pulling the cord can damage the power cord. Use of damaged power cords could result in fire or electric shock.

### **CAUTION**

- The printer weighs approximately 17.5 kg (38.6 lb.). When moving the printer, use the inset grips on both sides, and lift slowly. The printer will break or cause injury if dropped.

### **CAUTION**

- When moving the printer after use, do not take out the toner bottle or the waste toner bottle, to prevent toner spill inside the printer.

### **CAUTION**

- Do not hold the control panel while moving the printer. Doing so may damage the control panel, cause a malfunction, or result in injury.

### **Important**

Be careful when moving the printer. Take the following precautions:

- Turn off the main power.
- Close all covers and trays, including the front cover and bypass tray.
- If optional paper feed units are attached, remove them from the printer and move them separately.
- Be sure to place the printer on a smooth and stable place.
- Keep the printer level and carry it carefully, taking care not to shake or tilt it. Rough handling may cause a malfunction or damage the hard disk or memory, resulting in loss of stored files.

- Protect the printer from strong shocks. Impact can damage the hard disk and cause stored files to be lost. As a precautionary measure, files should be copied to another computer.

1. Be sure to check the following:

The power switch is turned off.

The power cord is unplugged from the wall outlet.

The interface cable is unplugged from the printer.

2. Lift the printer by using the inset grips on both sides of the printer, and then move it horizontally to the place where you want to install it.

 Note

- Be sure to move the printer horizontally. To prevent toner from scattering, move the printer slowly.

## 2.2 SETTINGS FOR @REMOTE SERVICE (FOR PRINTER MODELS)

**Note**

- Prepare the necessary equipment and check the following points before you visit the customer site. For details, ask the @Remote key person.
- For information on how to enter the "Maintenance Mode (SP mode)", contact the supervisor in your branch office.
- Install the SOM (Smart Organizing Monitor) utility on a PC in advance.
- Make sure that the latest version of the firmware is installed on the machine.

### ***Check Points before Making @Remote Settings***

1. Connect a PC and the machine with a crossed wiring LAN cable or a USB cable.
2. Check the IP address of the machine. (When using a USB cable, skip this step.)
3. Check the IP address of the customer engineer's PC.
4. Set an IP address for the customer engineer's PC which is  $\pm 1$  from the machine's IP address. (When using a USB cable, skip this step.)

**Note**

Example:

Machine's IP address: 192.168.000.001

Set the IP address for the PC: 192.168.000.002

5. Start the SOM utility.

- Click [Connect Printer] in the SOM menu.

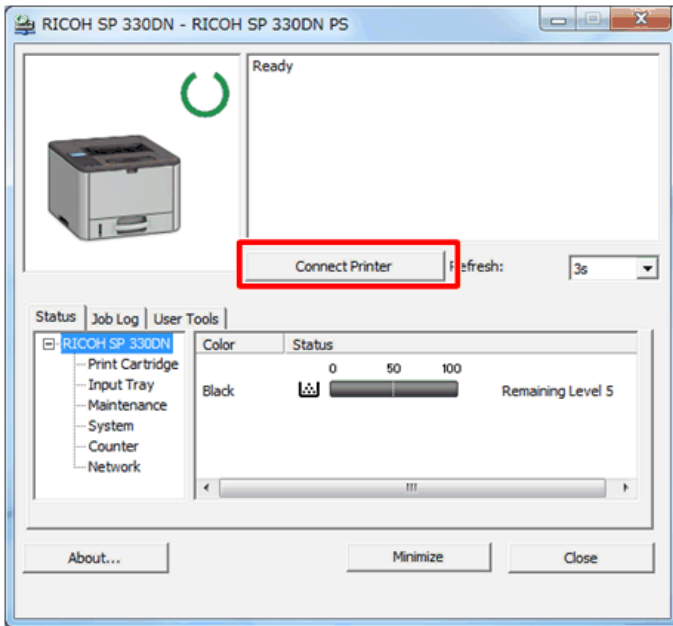

m0c3c2010

- Select [Connect Printer] in the printer driver selection screen, input the IP address of the machine and click [OK].

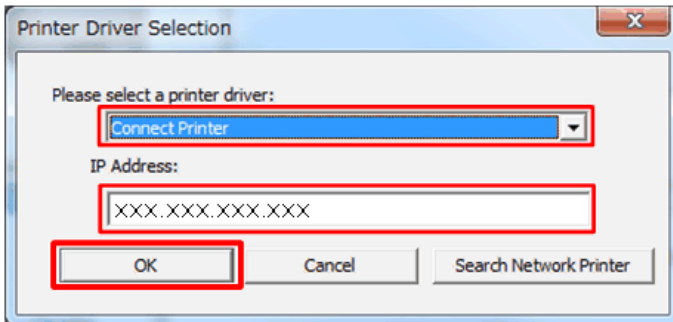

m0c3c2011

When using a USB cable, select "USB port".

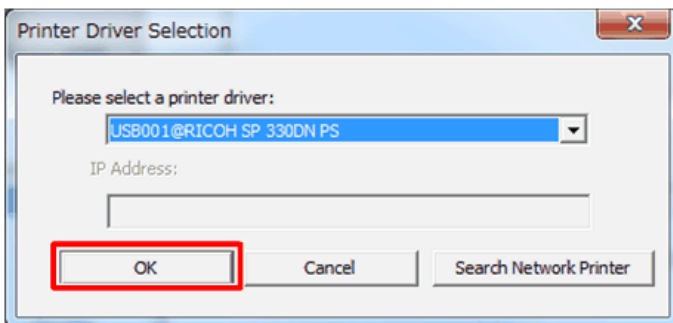

m0c3c2012

- Click [Printer Configuration] in the [User Tools] tab.

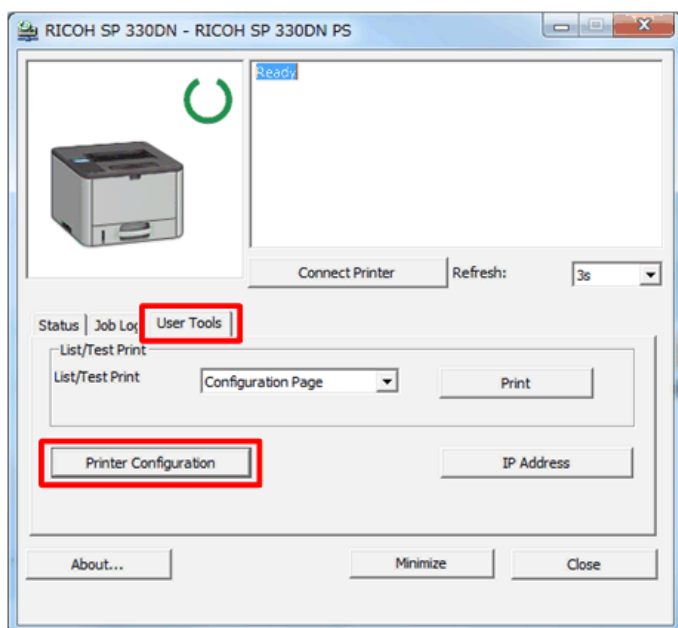

m0c3c5044

- Input the access code in the access code input screen and click [OK]. (Administrator's password: Admin)

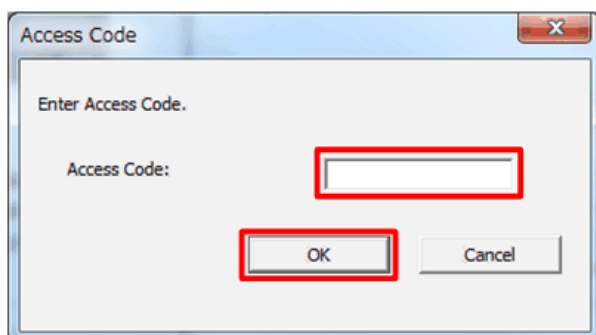

m0c3c5057

- Select the [@Remote] tab in the printer setting screen.

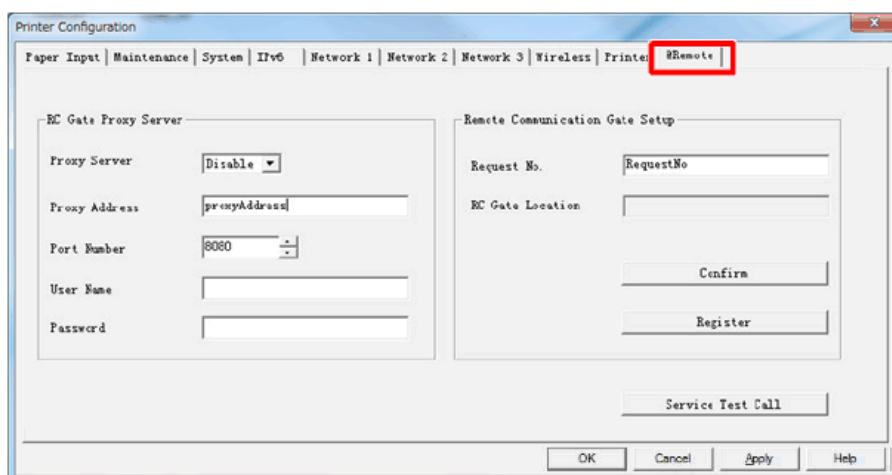

m0c3c5058

- Input the following items if necessary, then click [OK].



[RC Gate Proxy Server: Proxy Server]: Select [Enable] in the pull down menu.

[RC Gate Proxy Server: Proxy Address]: Input the address of the proxy server.

[RC Gate Proxy Server: Port Number]: Input the HTTP proxy port number.

[RC Gate Proxy Server: User Name]: Enter the HTTP proxy authentication user name.

[RC Gate Proxy Server: Password]: Enter the HTTP proxy authentication password.

[Remote Communication Gate Setup: Request No.]: Input the request No.

12. Enter the "Maintenance Mode (SP mode)".

13. Check if the function flag is "Disable (Default)".

SP menu > [@Remote] > [Remote Service] > [Function Flag]

14. Remove the USB cable from the machine, and connect to the user's LAN.

Restore the IP address of the customer engineer's PC. (When using a USB cable, skip this step.)

### **Execute the @Remote Settings**

1. Enter the "Maintenance Mode (SP mode)".

2. Check if the @Remote status is "0".

SP menu > [@Remote] > [Remote Service] > [Instl:Condition]

If the @Remote status is not "0", ask the @Remote Center Administrator.

3. Confirm the Request Number.

SP menu > [@Remote] > [Remote Service] > [Instl:Reference]

4. Check the confirmation result.

SP menu > [@Remote] > [Remote Service] > [Instl:Ref Rslt]

Value	Meaning	Solution/ Workaround
0	Succeeded	-
1	Request number error	Check the request number again.
3	Communication error (proxy enabled)	Check the network condition.
4	Communication error (proxy disabled)	Check the network condition.
5	Proxy error (authentication error)	Check the proxy user name and password.
8	Other error	See "Error Codes" below this.
9	Request number confirmation executing	Processing... Please wait.

5. Make sure that the screen displays the Location Information only when it has been input at the Center GUI.

SP menu > [@Remote] > [Remote Service] > [Instl:Ref Section]

**6. Execute the registration.**

SP menu > [@Remote] > [Remote Service] > [Instl:Rgstltn]

**7. Check the registration result.**

SP menu > [@Remote] > [Remote Service] > [Instl:Rgstltn Rst]

Value	Meaning	Solution/ Workaround
0	Succeeded	-
2	Already registered	Check the registration status.
3	Communication error (proxy enabled)	Check the network condition.
4	Communication error (proxy disabled)	Check the network condition.
5	Proxy error (Authentication error)	Check the proxy user name and password.
8	Other error	See "Error Codes" below this.
9	Request number registration executing	Processing... Please wait.

**8. Make sure that the function flag is "Enable".**

SP menu > [@Remote] > [Remote Service] > [Function Flag]

***After Setting***

The first manual call after setting is considered as a test call. Be sure to execute the test call, or the first manual call from the customer will be considered as the test call.

**1. Enter the "Maintenance Mode (SP mode)".**

**2. Execute the "Manual Call".**

SP menu > [@Remote] > [Remote Service] > [Remote Diagnostics]

**3. "Running..." is displayed for about 3 seconds. This message disappears automatically after 3 seconds, and then returns to [Remote Service] menu.**

**Error Codes**

When other errors occur, check the following error code list.

SP menu > [@Remote] > [Remote Service] > [Instl: ErrorCode]

**Caused by Operation Error, Incorrect Setting**

Code	Meaning	Solution/ Workaround
-12003	Attempted registration without execution of a confirmation and no previous registration.	Perform Confirmation before attempting the Registration.
-12004	Attempted setting with illegal entries for certification and ID2.	Check the ID2 of the machine.
-12006	A confirmation request was made after the confirmation had been already completed.	Execute registration.
-12008	Update certification failed because mainframe was in use.	Check the machine condition. If the machine is in use, try again later.

**Error Caused by Response from GW URL**

Code	Meaning	Solution/ Workaround
-2387	Not supported at the Service Center	
-2389	Database out of service	
-2390	Program out of service	
-2391	Two registrations for the same mainframe	Check the registration condition of the machine
-2392	Parameter error	
-2393	External RCG not managed	
-2394	Mainframe not managed	
-2395	Box ID for external RCG is illegal.	
-2396	Mainframe ID for external RCG is illegal.	
-2397	Incorrect ID2 format	Check the ID2 of the machine.
-2398	Incorrect request number format	Check the Request No.

## 2.3 SETTINGS FOR @REMOTE SERVICE (FOR MF MODELS)

### Note

- Prepare the necessary equipment and check the following points before you visit the customer site. For details, ask the @Remote key person.
- For information on how to enter the "Maintenance Mode (SP mode)", contact the supervisor in your branch office.
- Make sure that the latest version of the firmware is installed on the machine.

### **Check Points before Making @Remote Settings**

1. The following settings must be correctly programmed.

- Using Proxy server is enabled
- Proxy server IP address
- Proxy server Port number
- Proxy User ID
- Proxy Password

Item	Settings
Using Proxy server is enabled	<b>Four-line LCD panel:</b> SP menu > [@Remote] > [Remote Service] > [HTTP Proxy Use] <b>Touch panel:</b> SP menu > [@Remote] > [Remote Service] > [Use Proxy]
Proxy server IP address	<b>Four-line LCD panel:</b> SP menu > [@Remote] > [Remote Service] > [HTTP Proxy Host] <b>Touch panel:</b> SP menu > [@Remote] > [Remote Service] > [Proxy Host]
Proxy server Port number	<b>Four-line LCD panel:</b> SP menu > [@Remote] > [Remote Service] > [HTTP Proxy Port] <b>Touch panel:</b> SP menu > [@Remote] > [Remote Service] > [Proxy PortNumber]
Proxy User ID	<b>Four-line LCD panel:</b> SP menu > [@Remote] > [Remote Service] > [HTTP Prox AutUsr] <b>Touch panel:</b> SP menu > [@Remote] > [Remote Service] > [Proxy User Name]
Proxy Password	<b>Four-line LCD panel:</b> SP menu > [@Remote] > [Remote Service] > [HTTP Prox AutPass]

Item	Settings
	<b>Touch panel:</b> SP menu > [@Remote] > [Remote Service] > [Proxy Password]

2. Get a Request Number.
3. Enter the "Maintenance Mode (SP mode)".
4. Check if the function flag is "Disable (Default)".

**Four-line LCD panel:** SP menu > [@Remote] > [Remote Service] > [Function Flag]

**Touch panel:** SP menu > [@Remote] > [Remote Service] > [Function Flag]

### **Execute the @Remote Settings**

1. Enter the "Maintenance Mode (SP mode)".
2. Check if the @Remote status is "0".

**Four-line LCD panel:** SP menu > [@Remote] > [Remote Service] > [Instl:Condition]

**Touch panel:** SP menu > [@Remote] > [Remote Service] > [Regist Status]

If the @Remote status is not "0", ask the @Remote Center Administrator.

3. Check that the device ID2 has been programmed correctly.

**Four-line LCD panel:** SP menu > [@Remote] > [Machine No. Setting] > [ID2 Code Display]

**Touch panel:** SP menu > [@Remote] > [Machine No. Setting] > [ID2 Code Display]

- 6 spaces must be put between the 3-digit prefix and the following 8-digit number (e.g. xxx\_\_\_\_xxx).
- ID2 and the serial number must be the same (e.g. ID2: A01\_\_\_\_23456789 = serial No. A0123456789)

#### **Note**

The procedure for checking the serial number is as follows;

**Four-line LCD panel:** SP menu > [Engine Maintenance] > [Serial No.]

**Touch panel:** SP menu > [Engine SN SP] > [Serial No.]

4. Input the request number which you have obtained from the @Remote Center GUI, and then enter [OK].

**Four-line LCD panel:** SP menu > [@Remote] > [Remote Service] > [Instl:ID #]

**Touch panel:** SP menu > [@Remote] > [Remote Service] > [Letter Number]

5. Confirm the Request Number.

**Four-line LCD panel:** SP menu > [@Remote] > [Remote Service] > [Instl:Reference]

**Touch panel:** SP menu > [@Remote] > [Remote Service] > [Confirm Execute]

**6. Check the confirmation result.****Four-line LCD panel:** SP menu > [@Remote] > [Remote Service] > [Instl:Reference]**Touch panel:** SP menu > [@Remote] > [Remote Service] > [Confirm Result]

Value	Meaning	Solution/ Workaround
0	Succeeded	-
1	Request number error	Check the request number again.
3	Communication error (proxy enabled)	Check the network condition.
4	Communication error (proxy disabled)	Check the network condition.
5	Proxy error (authentication error)	Check the proxy user name and password.
8	Other error	See "Error Codes" below this.
9	Request number confirmation executing	Processing... Please wait.

**7. Make sure that the screen displays the Location Information only when it has been input at the Center GUI.****Four-line LCD panel:** SP menu > [@Remote] > [Remote Service] > [Instl:Ref Section]**Touch panel:** SP menu > [@Remote] > [Remote Service] > [Confirm Place]**8. Execute the registration.****Four-line LCD panel:** SP menu > [@Remote] > [Remote Service] > [Instl:Rgstltn]**Touch panel:** SP menu > [@Remote] > [Remote Service] > [Register Execute]**9. Check the registration result.****Four-line LCD panel:** SP menu > [@Remote] > [Remote Service] > [Instl:Rgstltn Rst]**Touch panel:** SP menu > [@Remote] > [Remote Service] > [Register Result]

Value	Meaning	Solution/ Workaround
0	Succeeded	-
2	Already registered	Check the registration status.
3	Communication error (proxy enabled)	Check the network condition.
4	Communication error (proxy disabled)	Check the network condition.
5	Proxy error (Authentication error)	Check the proxy user name and password.
8	Other error	See "Error Codes" below this.
9	Request number registration executing	Processing... Please wait.

## After Settings

The first manual call after setting is considered as a test call. Be sure to execute the test call, or the first manual call from the customer will be considered as the test call.

1. Enter the "Maintenance Mode (SP mode)".

2. Execute the "Manual Call".

**Four-line LCD panel:** SP menu > [@Remote] > [Remote Service] > [Remote Diagnostics]

**Touch panel:** SP menu > [@Remote] > [Remote Service] > [Remote Diagnostics]

3. "Running..." is displayed for about 3 seconds. This message disappears automatically after 3 seconds, and then returns to [Remote Service] menu.

## Error Codes

When other errors occur, check the following error code list.

**Four-line LCD panel:** SP menu > [@Remote] > [Remote Service] > [Instl: ErrorCode]

**Touch panel:** SP menu > [@Remote] > [Remote Service] > [Error Code]

### Caused by Operation Error, Incorrect Setting

Code	Meaning	Solution/ Workaround
-12003	Attempted registration without execution of a confirmation and no previous registration.	Perform Confirmation before attempting the Registration.
-12004	Attempted setting with illegal entries for certification and ID2.	Check the ID2 of the machine.
-12006	A confirmation request was made after the confirmation had been already completed.	Execute registration.
-12008	Update certification failed because mainframe was in use.	Check the machine condition. If the machine is in use, try again later.

### Error Caused by Response from GW URL

Code	Meaning	Solution/ Workaround
-2387	Not supported at the Service Center	
-2389	Database out of service	
-2390	Program out of service	
-2391	Two registrations for the same mainframe	Check the registration condition of the machine
-2392	Parameter error	

Settings for @Remote Service (for MF Models)

Code	Meaning	Solution/ Workaround
-2393	External RCG not managed	
-2394	Mainframe not managed	
-2395	Box ID for external RCG is illegal.	
-2396	Mainframe ID for external RCG is illegal.	
-2397	Incorrect ID2 format	Check the ID2 of the machine.
-2398	Incorrect request number format	Check the Request No.



# PREVENTIVE MAINTENANCE

REVISION HISTORY		
Page	Date	Added/Updated/New
		None

---

### 3. PREVENTIVE MAINTENANCE

#### 3.1 PREVENTIVE MAINTENANCE TABLES

There are no PM parts in this machine.



### 3.2 IMAGE QUALITY STANDARDS

**Engine**

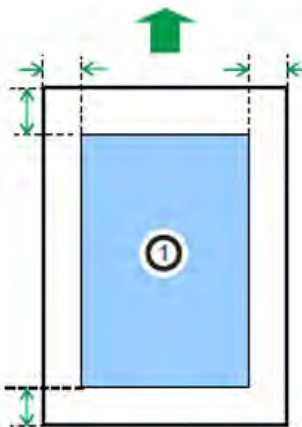
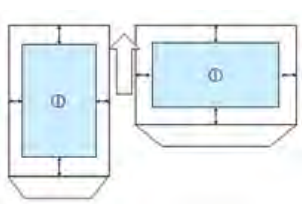
Item	Specification	Remarks
Assured Image Area	<p><b>Except Envelopes</b></p> <p>Leading edge: 4.2 mm                      Left/Right: 4.2 mm                      Trailing edge: 4.2 mm</p> <p><b>Envelopes</b></p> <p>Leading edge: 15 mm                      Left/Right: 10 mm                      Trailing edge: 10 mm</p>	<p><b>Except Envelopes</b></p>  <p><b>Envelopes</b></p> 
Magnification Error	±0.75% or less	Except when duplexing.
Perpendicularity	± 0.7 mm/100 mm	
Linearity	± 0.25 mm/100 mm	

**Copy**

Item	Specification	Remarks
Resolution	100%/Enlargement: Min 3.6 lines/mm or more Reduction: Min 3.6 × M lines /mm or more	M: Magnification Not applicable when using the ADF
Assured Image Area	Leading edge: 4.2 mm Left/Right: 4.2 mm Trailing edge: 4.2 mm	<b>Envelopes</b> Leading edge: 15 mm Left/Right: 10 mm Trailing edge: 10 mm
Magnification Error	Main: ± 1.25% or less Sub: ± 1.25% or less	Except when duplexing.
Perpendicularity	± 1.2 mm/100 mm or less	
Missing Image Area	Left: 3.0 ± 2.5 mm Right: 3.0 ± 2.0 mm (Reference value) Leading edge: 4.0 ± 2.0 mm Trailing edge: 4.0 ± 3.0 mm (Reference value)	

**Scan**

Item	Specification	Remarks
Magnification Error	Main: ± 0.5% Sub: ± 1.5%	
Magnification Error Deviation	Main: ±2.0% Sub: ± 3.0%	
Perpendicularity	± 0.55 deg	

### 3.3 PAPER TRANSFER QUALITY STANDARDS

Item	Specification	Remarks
Registration	<p><b>Single Side:</b>            Width: 0±2.5mm (Main Scan Direction)            Vertical: 0±2.0mm (Sub Scan Direction)</p> <p><b>Duplex:</b>            Width: 0±2.5mm (Main Scan Direction)            Vertical: 0±2.0mm (Sub Scan Direction)</p>	Scale
Skew	<p><b>Single Side:</b>            ±1.0mm/100mm or less (Less than B5 SEF)            ±1.2mm/200mm or less (B5 SEF or more)</p> <p><b>Duplex:</b>            ±1.0mm/100mm or less</p>	Except by-pass tray.

These standards are determined using the standard paper with the standard conditions. The values may change depending on environmental conditions such as temperature, humidity, and paper type.

# REPLACEMENT AND ADJUSTMENT

REVISION HISTORY		
Page	Date	Added/Updated/New
		None

---

## 4. REPLACEMENT AND ADJUSTMENT

### 4.1 GENERAL CAUTIONS

**⚠ CAUTION**

- If there are printer jobs in the machine, print out all jobs in the printer buffer.
- Turn off the main power switch and unplug the machine before you do the procedures in this section.

## 4.2 EXTERIOR COVERS (PRINTER MODELS)

### 4.2.1 FRONT COVER

1. Pull out the standard paper tray [A].



2. Open the bypass tray and push in the two tabs [A].



3. Pull out the bypass tray [A].

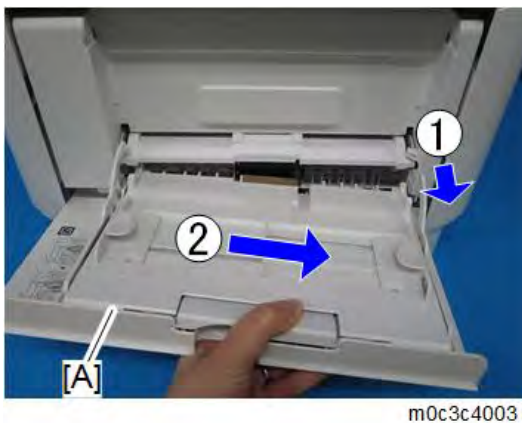



4. Push the cover release button [B] and open the front cover [A].

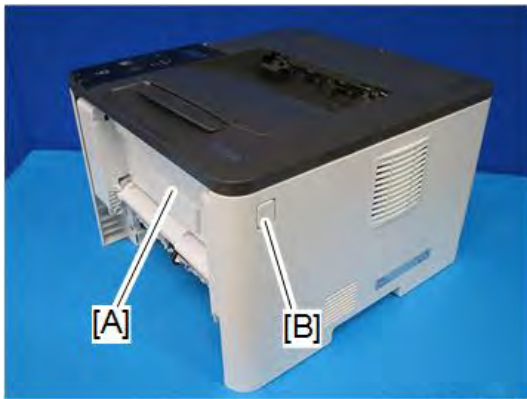

m0c3c4004

5. Push the right hinge [A] to release it, and then remove the front cover [B].

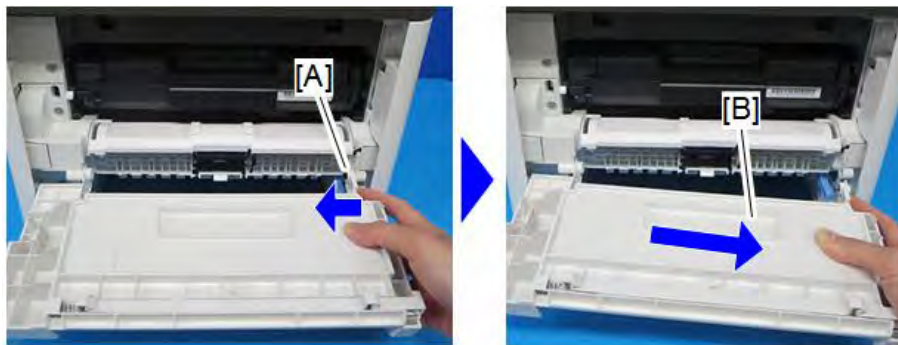

m0c 3c4005

## 4.2.2 LEFT COVER

1. Remove the front cover (*Front Cover*).
2. Remove two screws on the front side of the left cover [A].

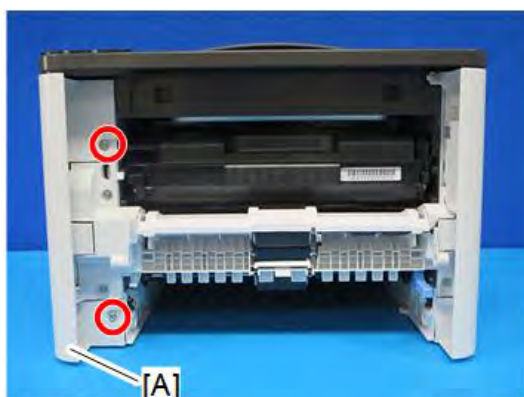

 x2

m0c3c4006

3. Pull the front upper part of the left cover [A] to release the hook.

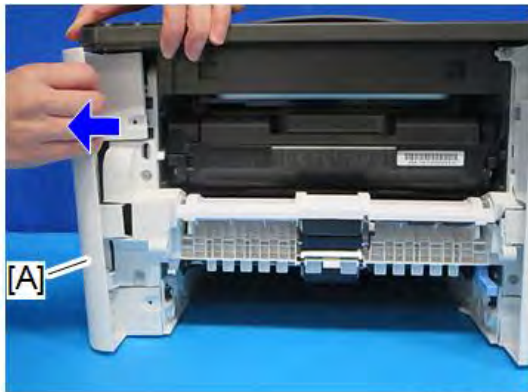

m0c3c4007

**Note**

- The outside of the cover has marks indicating the position of the hooks.

4. Pull the front bottom part of the left cover [A] to release the hook.

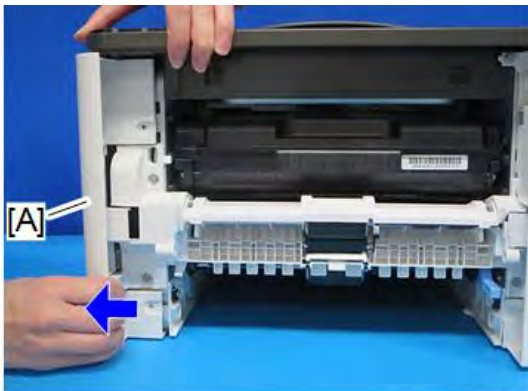

m0c3c4008

5. Lift the machine, and release the two hooks of the left cover [A].

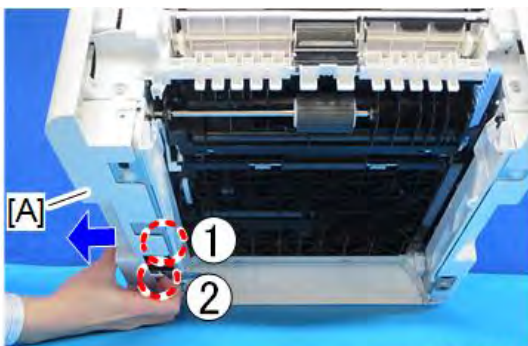

m0c3c4009

- Open the left cover [A] about 30 degrees, and then slide it backward to remove it.

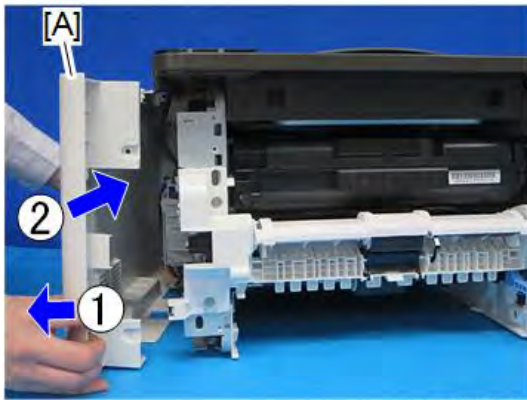

m0c3c4010

**Note**

- There are many hooks and tabs inside the left cover. Before removing the left cover, see the photos below.

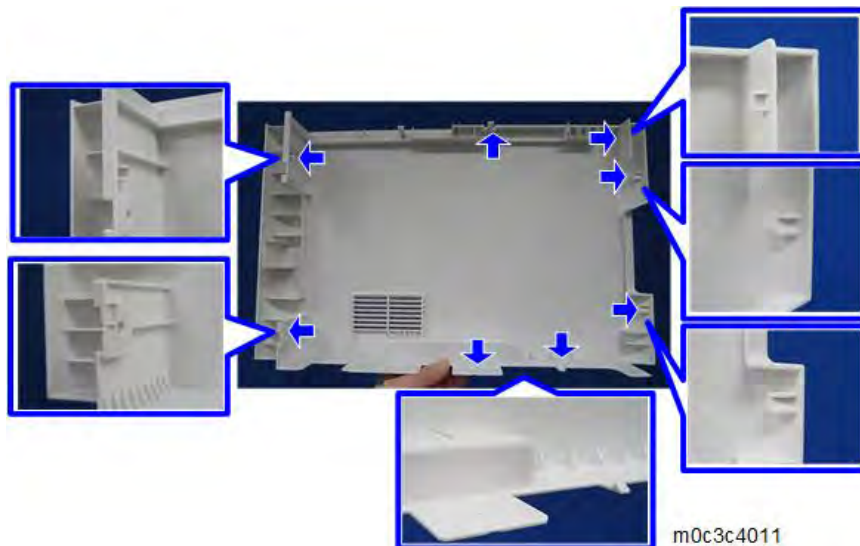

m0c3c4011

### 4.2.3 REAR COVER

1. Open the rear cover [A].
2. Slide the shaft [B] in the direction of the blue arrow, and remove the rear cover.



m0c3c4012

### 4.2.4 RIGHT COVER

1. Remove the front cover (*Front Cover*).
2. Remove the rear cover (*Rear Cover*).
3. Remove the three screws of the right cover [A].

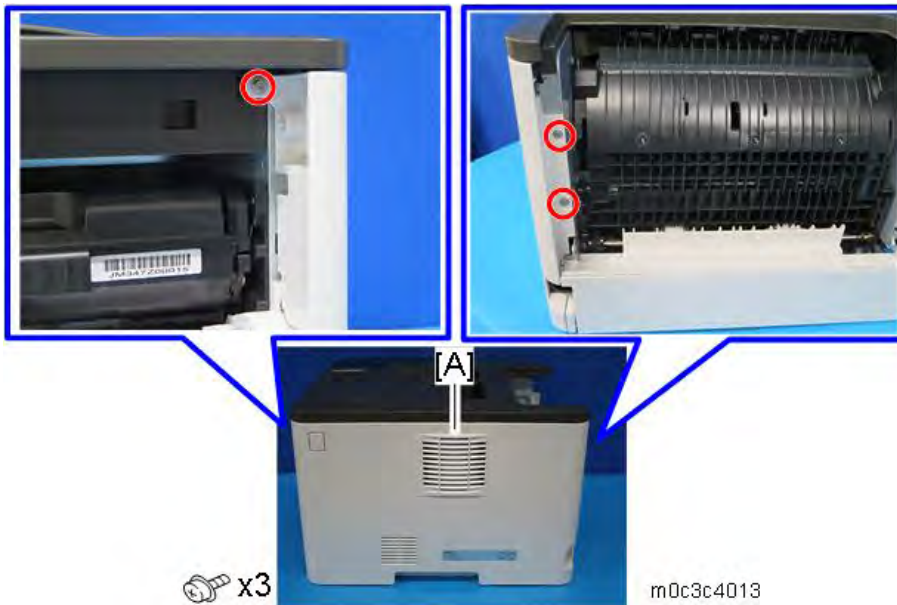

m0c3c4013

4. Pull the rear part of the right cover [A] to release the hook.



m0c3c4014

**Note**

The outside of the cover has marks indicating the position of the hooks.

5. Lift the machine, and release the hook of the right cover [A].

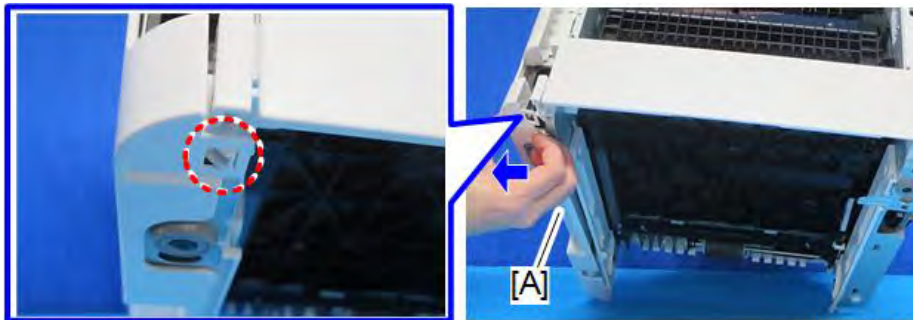

m0c3c4015

6. Pull the front bottom part of the right cover [A] to release the hook.



m0c3c4016



7. Remove the right cover [A].



**Note**

- There are many hooks and tabs inside the right cover. Before removing the right cover, see the photos below.

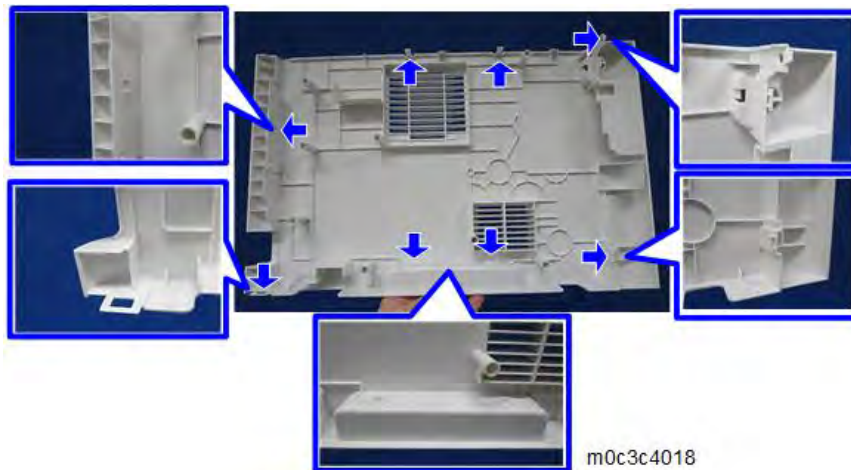

## 4.2.5 TOP COVER

1. Remove the front cover (*Front Cover*).
2. Remove the left cover (*Left Cover*).
3. Remove the rear cover (*Rear Cover*).
4. Remove the right cover (*Right Cover*).
5. Remove the four screws and a connector, and release the three hooks, and then remove the top cover [A].

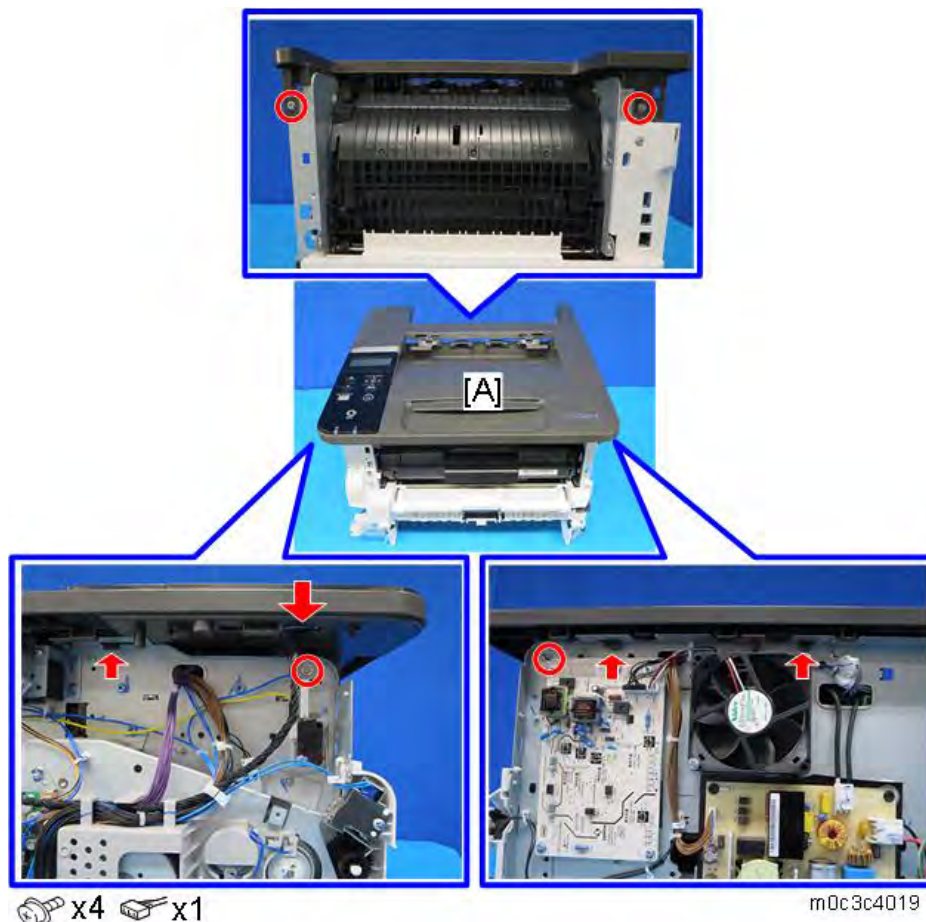

### Note

- When re-installing the top cover, always verify that the two paperweights [A] are lifted. If they are not lifted to fit into the paper slot, the paperweights could be damaged.
- Make sure that these paperweights can be moved smoothly (up and down) after installing the top cover. If these paperweights do not move smoothly, try installing the top cover again.

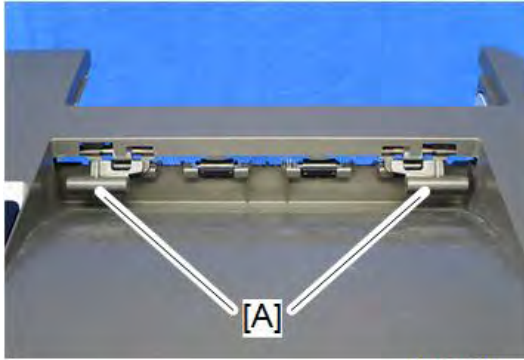

m0c3c4020

#### 4.2.6 OPERATION PANEL UNIT

1. Remove the top cover (*Top Cover*).
2. Turn the top cover over, and release the two hooks to remove the operation panel [A].

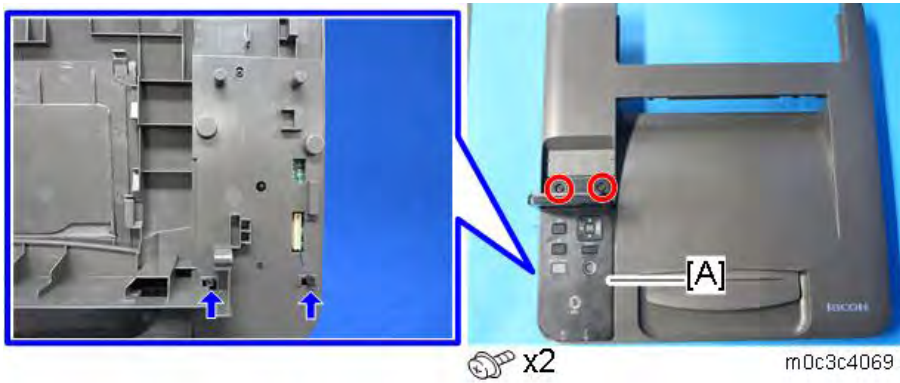

m0c3c4069



## 4.3 EXTERIOR COVERS (MF MODELS)

### 4.3.1 FRONT COVER

1. Pull out the standard paper tray [A].



m0c3c4101

2. Open the bypass tray and push in the two tabs [A].

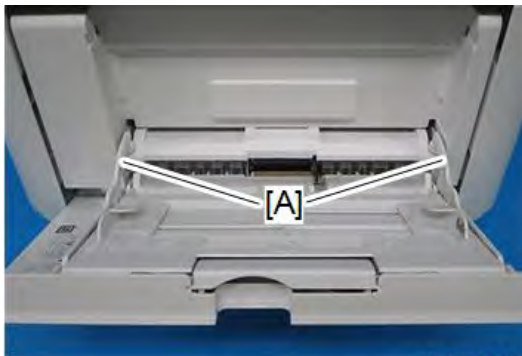

m0c3c4002

3. Pull out the bypass tray [A].



m0c3c4003

Exterior Covers (MF Models)

4. Push the cover release button [B], and open the front cover [A].

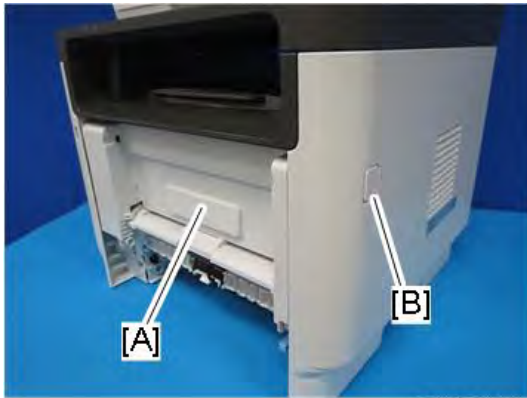

m0c3c4102

5. Push the right hinge [A] to release it, and then remove the front cover [B].

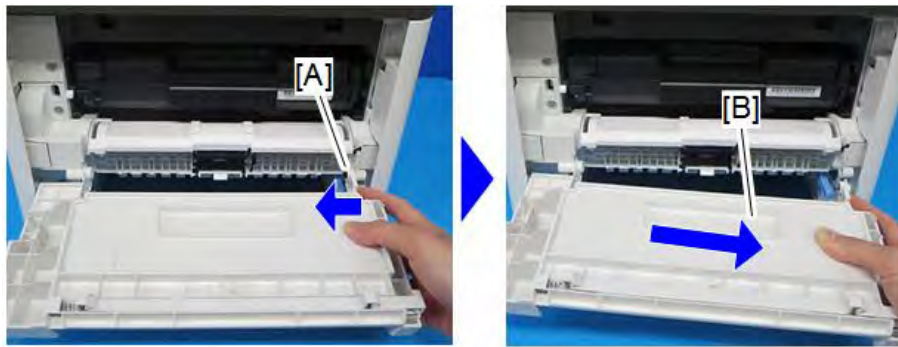

m0c 3c4005

### 4.3.2 LEFT COVER

1. Remove the front cover (*Front Cover*).
2. Remove the two screws on the front side of the left cover [A].



3. Pull the front upper part of the left cover [A] to release the hook.



**Note**

- The outside of the cover has marks indicating the position of the hooks.

4. Pull the front bottom part of the left cover [A] to release the hook.



## Exterior Covers (MF Models)

5. Lift the machine, and release the two hooks of the left cover [A].

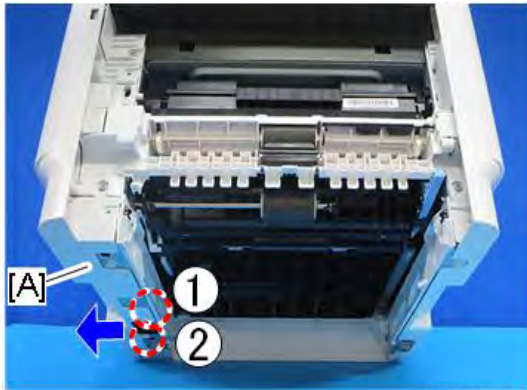

m0c3c4106

6. Open the scanner unit, and pull the upper part of the left cover [A] to release the hook.



m0c3c4107

7. Open the left cover [A] about 30 degrees, and then slide it backward to remove it.

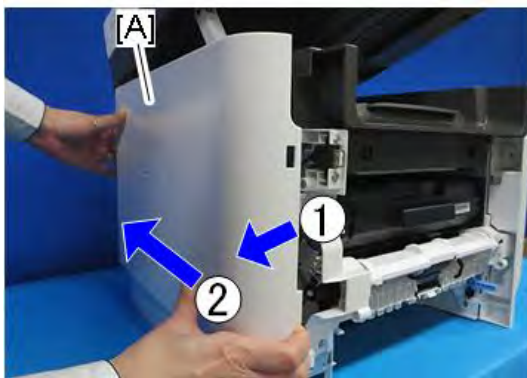

m0c3c4108

### Note

- There are many hooks and tabs inside the left cover. Before removing the left cover, see the photos below.

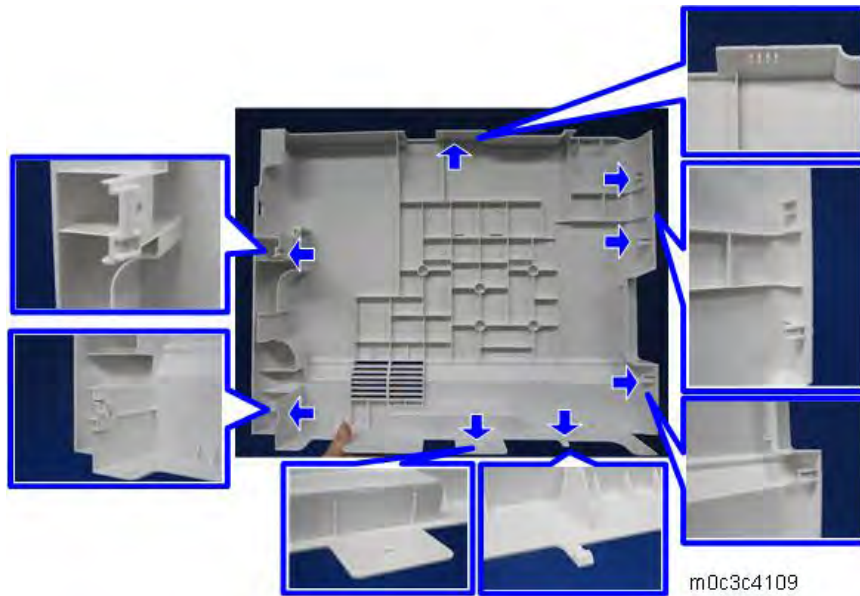

Replacement  
and  
Adjustment

### 4.3.3 REAR COVER

1. Open the rear cover [A].
2. Slide the shaft [B] in the direction of the blue arrow, and remove the rear cover [A].

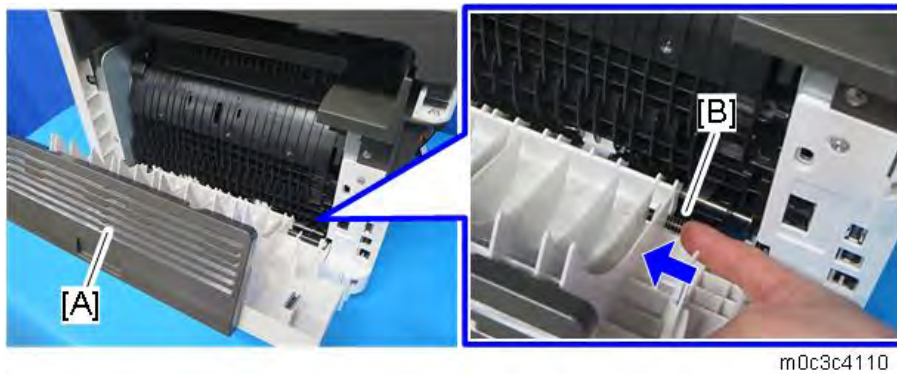



### 4.3.4 RIGHT COVER

1. Remove the front cover (*Front Cover*).
2. Remove the rear cover (*Rear Cover*).
3. Remove the three screws of the right cover [A].

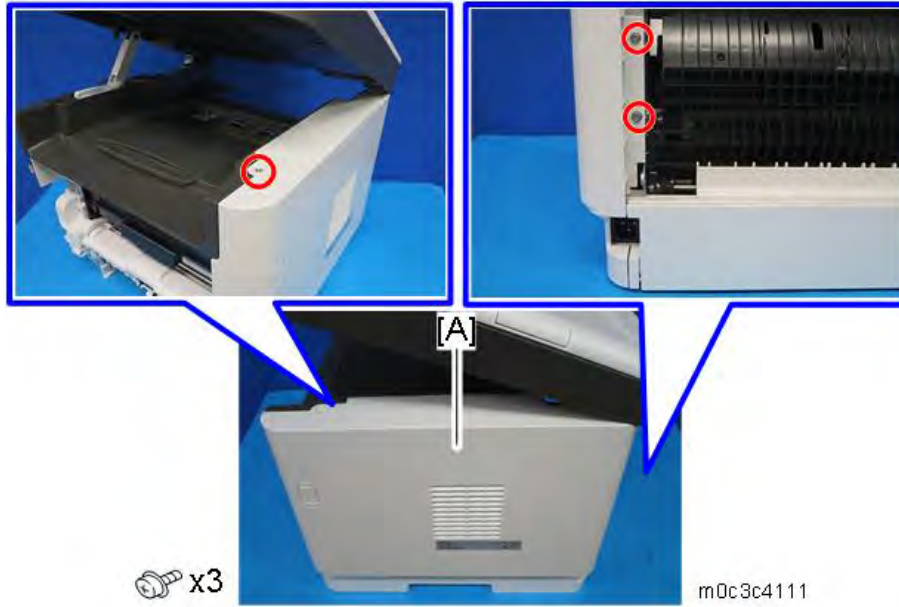

4. Pull the rear part of the right cover [A] to release the hook.



**Note**

The outside of the cover has marks indicating the position of the hooks.

- Lift the machine, and release the hook of the right cover [A].

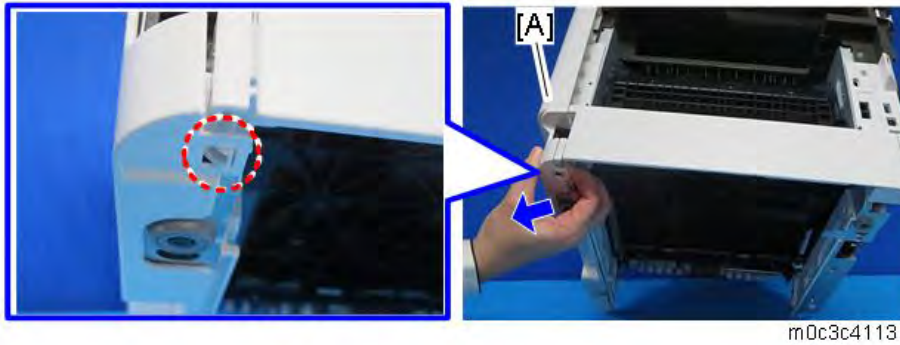

- Pull the front bottom part of the right cover [A] to release the hook.



- Remove the right cover [A].



Note

- There are many hooks and tabs inside the right cover. Before removing the right cover, see the photos below.

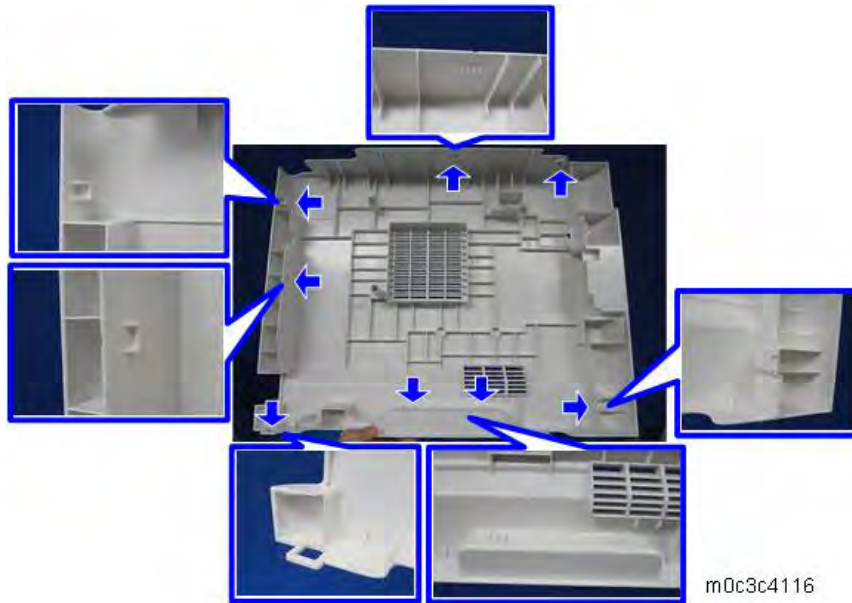



### 4.3.5 TOP COVER

1. Remove the front cover (*Front Cover*).
2. Remove the left cover (*Left Cover*).
3. Remove the rear cover (*Rear Cover*).
4. Remove the right cover (*Right Cover*).
5. Remove the scanner unit (*Scanner Unit*).
6. Remove the top cover [A].

#### ***Fax models:***

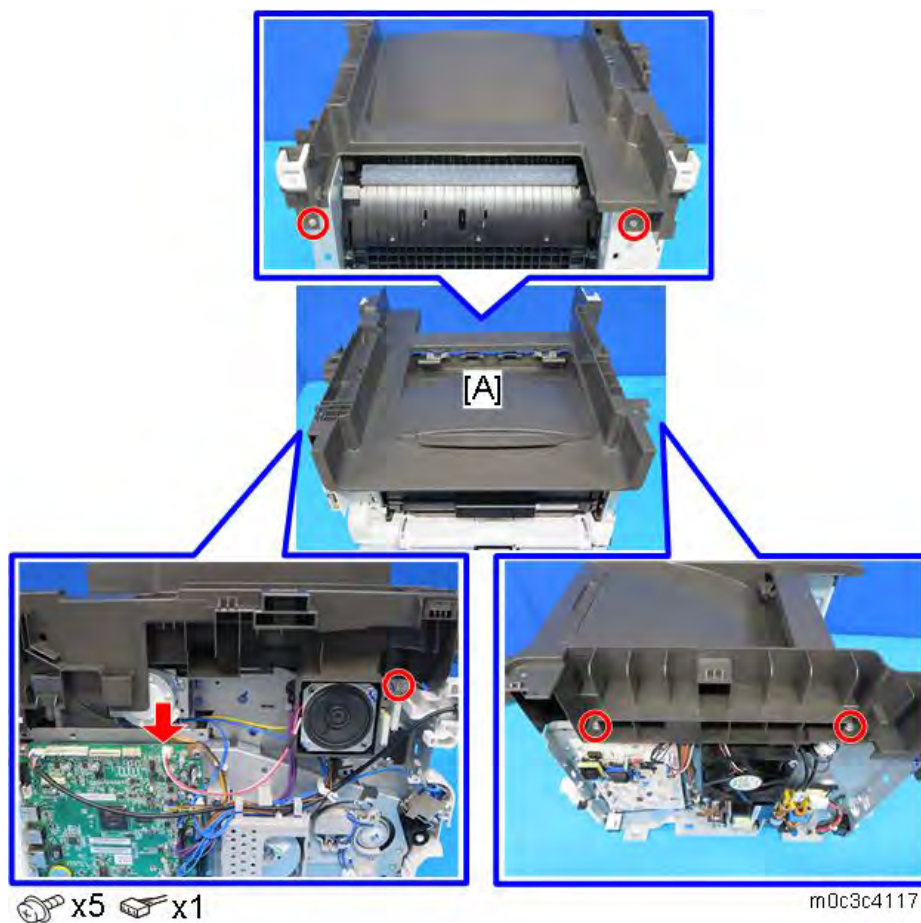

**Models with No Fax:**

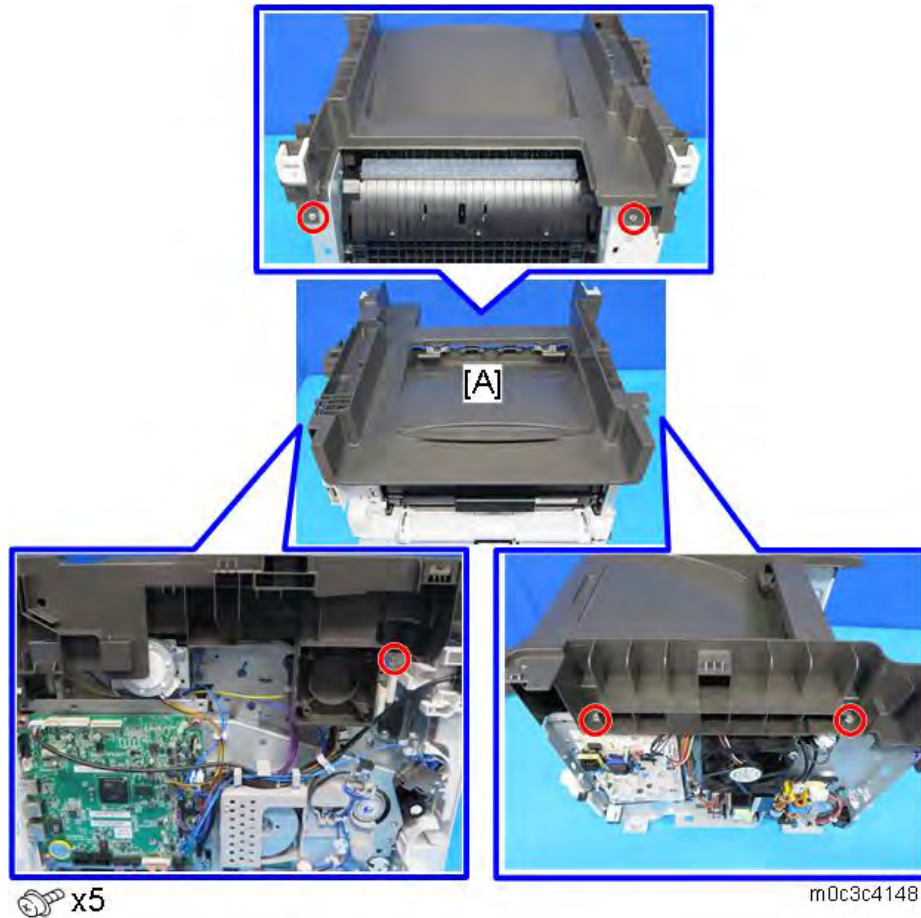

**Note**

- When re-installing the top cover, always verify that the two paperweights [A] are lifted. If they are not lifted to fit into the paper slot, the paperweights [A] could be damaged.
- Make sure that these paperweights [A] can be moved smoothly (up and down) after installing the top cover. If these paperweights do not move smoothly, try installing the top cover again.

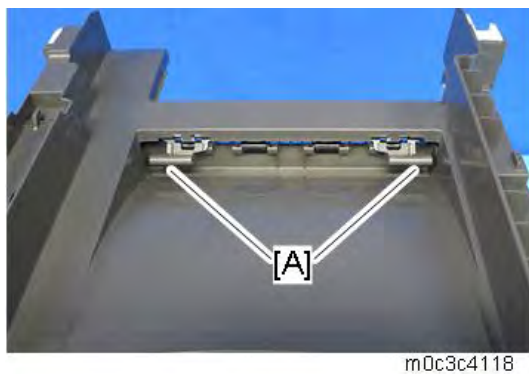

## 4.4 SCANNER UNIT (ONLY MF MODELS)

### 4.4.1 SCANNER UNIT

1. Remove the front cover (*Front Cover*).
2. Remove the left cover (*Left Cover*).
3. Disconnect the harnesses, FFCs, and ground wires.

#### Four-line LCD models:

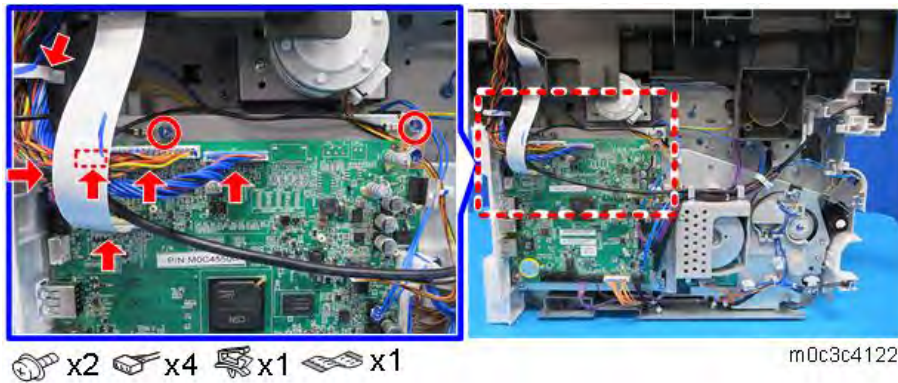

#### Touch panel models:

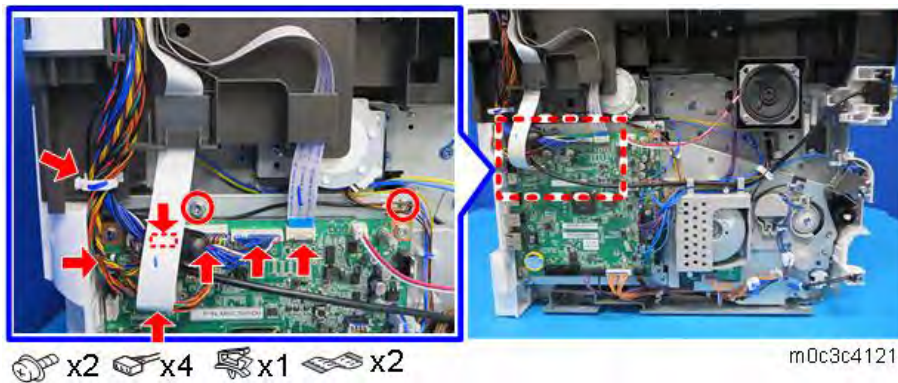

#### Note

Disconnect the scanner FFC by pulling it out straight, because it does not have a lock mechanism.





## Scanner Unit (Only MF Models)

Disconnect the touch panel FFC while pressing the lock release button.



Move the harnesses out of the frame so that they do not interfere when lifting the scanner unit.

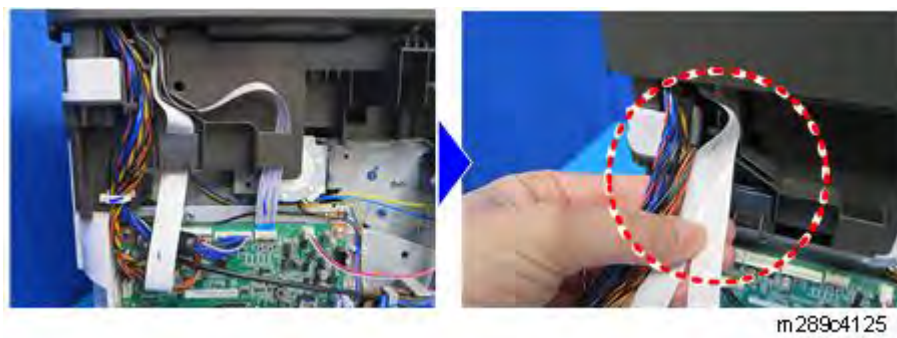

4. Open the scanner unit [A] and remove the stopper [B].



5. Remove the spring [A] and the guide plate [B], and then lift the scanner unit while in the wide-open state.

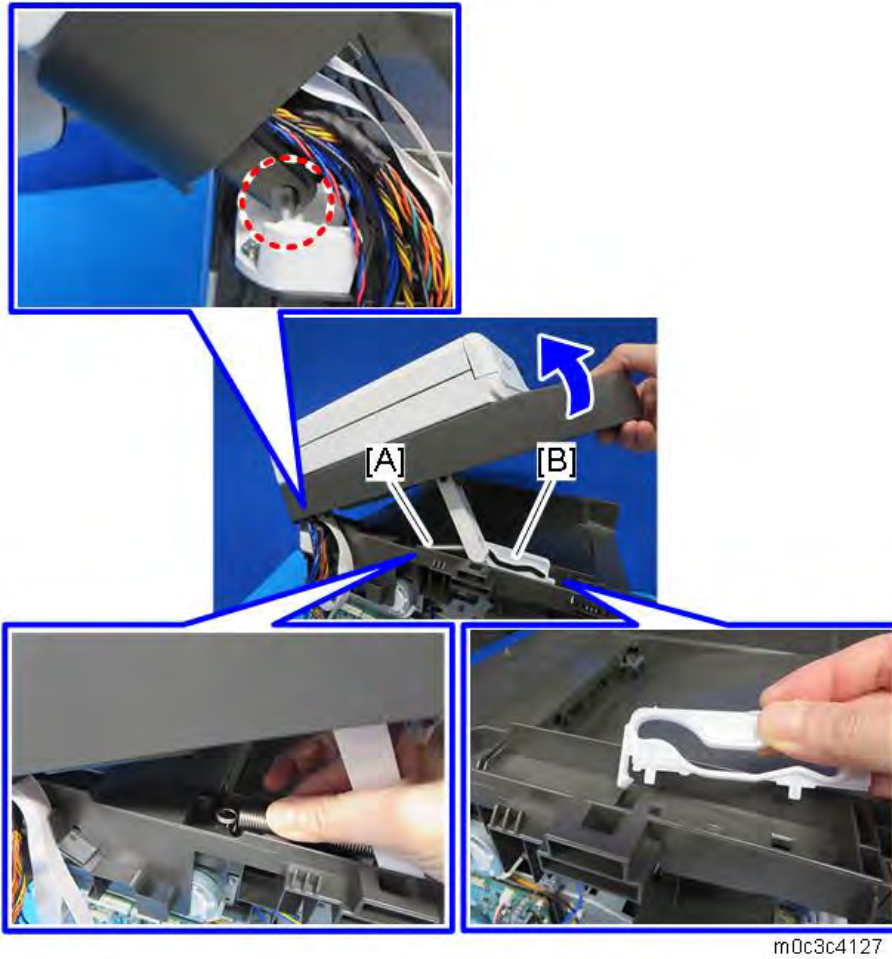

6. Remove the ADF unit [B] (*ADF/ARDF Unit (Only MF Models)*) and the operation panel unit [C] (*Operation Panel Unit*) from the scanner unit [A].



## 4.4.2 OPERATION PANEL UNIT

1. Remove the scanner unit (*Scanner Unit*).
2. Turn the scanner unit [A] over, and remove the seven screws.

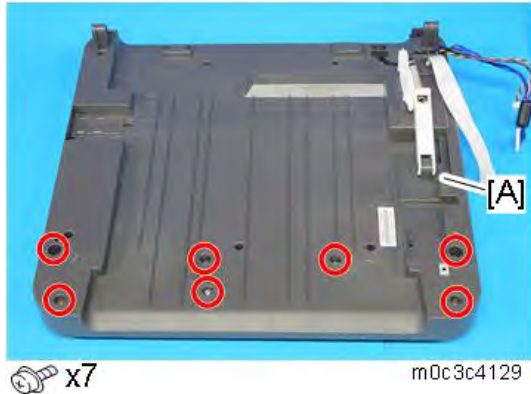

3. Turn the scanner unit over, and release the hooks of the operation panel [A] with a flat head screwdriver.

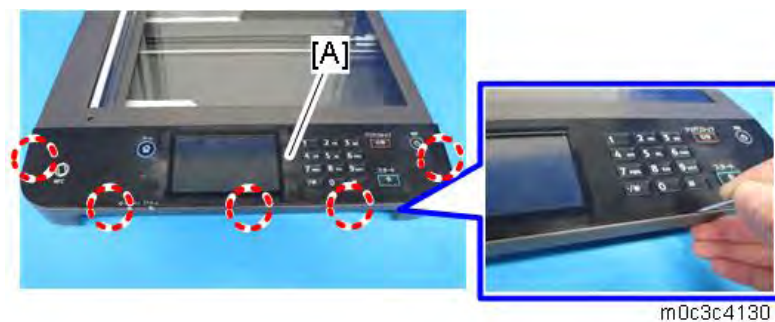

4. Remove the operation panel unit [A].

### ***Four-line LCD models:***

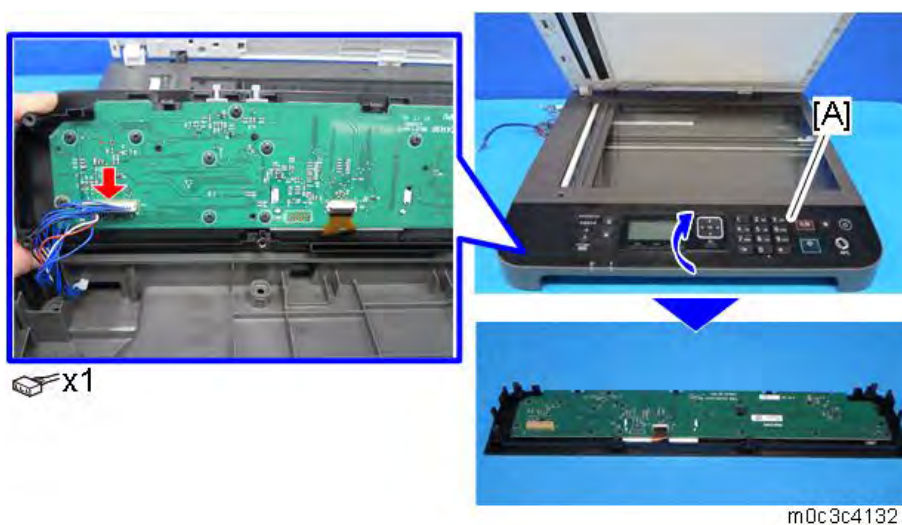



Touch panel models:



m0c3c4131

Note

Disconnect the FFC while pressing the lock release button.



m0c3c4133

## 4.5 ADF/ARDF UNIT (ONLY MF MODELS)

### 4.5.1 ADF UNIT (FOR FOUR-LINE LCD MODELS)

#### **ADF Unit**

1. Remove the scanner unit (*Scanner Unit*).
2. Turn the scanner unit over, and move the harnesses out of the frame.

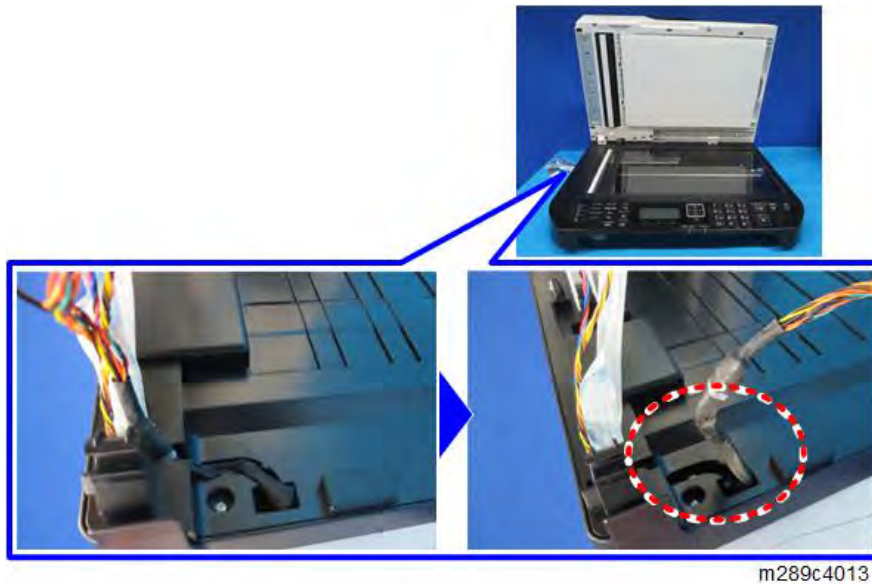

3. Open the ADF unit [A] and remove it in the direction of the blue arrow (hooks).

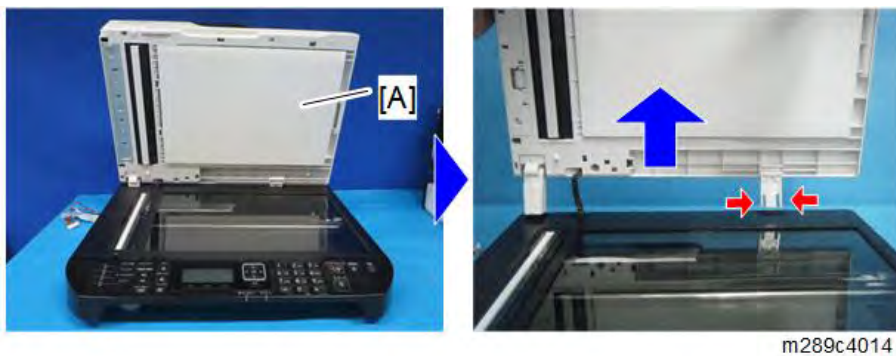



### Original Tray

1. Open the original tray [A] and remove it (two tabs).



m1562031

### ADF Pick-Up Roller

1. Open the ADF top cover [A].
2. Remove the ADF feed unit [B] (tab).

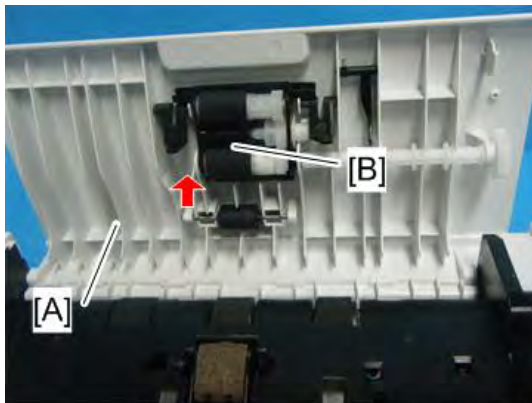

m1562032

3. Remove the ADF pick-up roller [A].

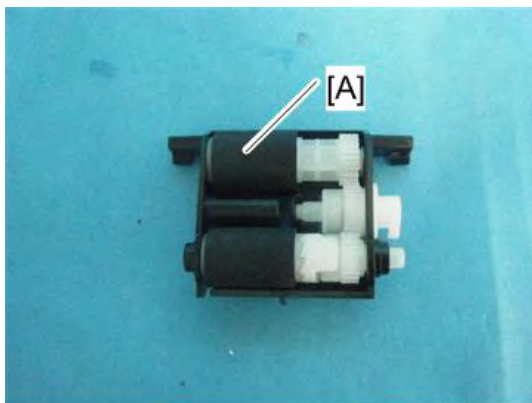

m1562033

### **ADF Feed Roller**

1. Remove the ADF feed unit (**ADF Pick-Up Roller**).
2. Remove the ADF feed roller [A].

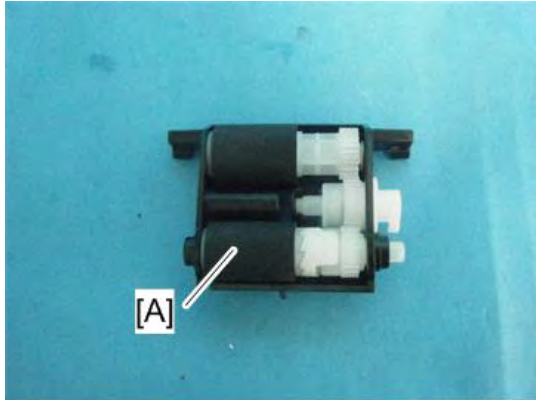

m1562034

### **ADF Separation Pad**

1. Open the ADF top cover.
2. Remove the ADF separation pad [A] (2 hooks, spring x 1).

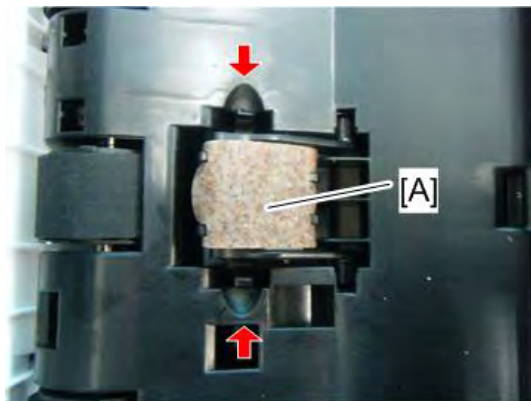

m1562035

**ADF Front Cover**

1. Remove the ADF unit (*ADF Unit*).
2. Turn the ADF unit over.
3. Remove the ADF front cover [A] (🔩 x 3).



m1562036

**Note**

- There are many hooks and tabs inside the ADF front cover [A]. Before removing the ADF front cover, see the photos below.

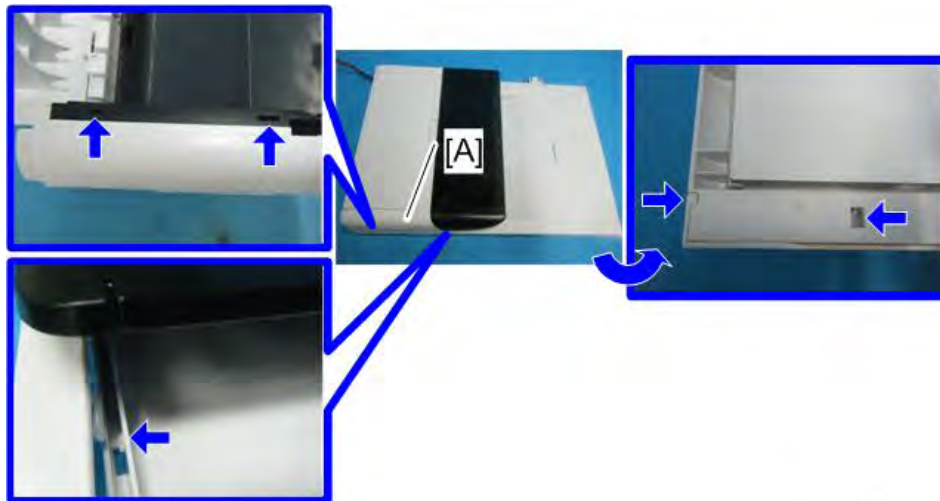

m1562037

### ADF Rear Cover

1. Remove the ADF unit (**ADF Unit**).
2. Turn the ADF unit over.
3. Remove the ADF rear cover [A] (🔩 x 1).

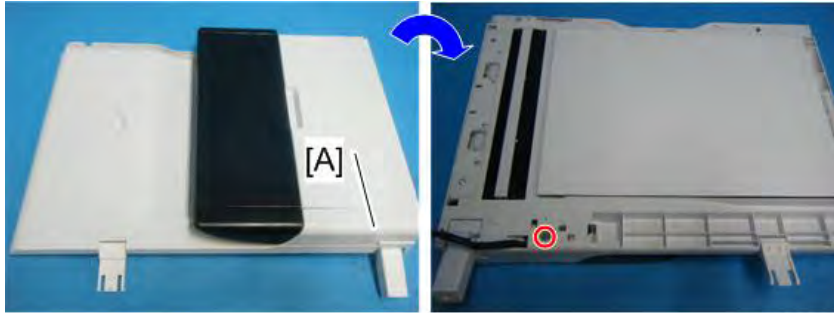

m1562038

#### Note

- There are many hooks and tabs inside the ADF rear cover [A]. Before removing the ADF rear cover, see the photos below.

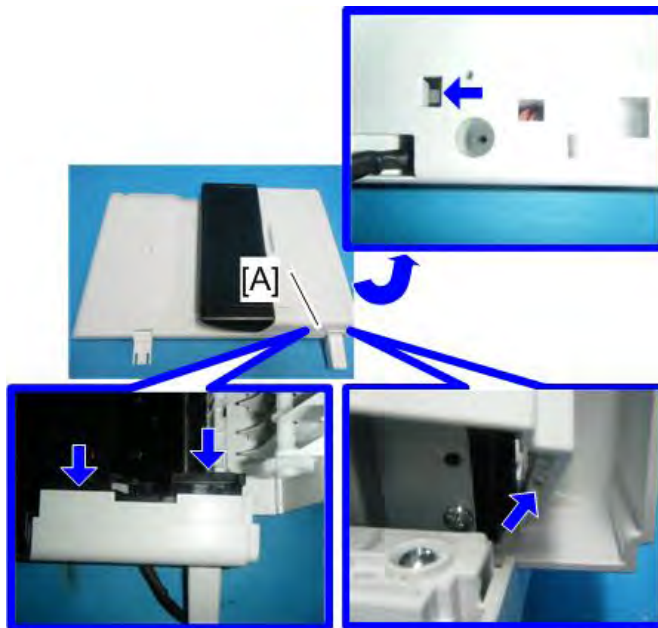

m1562039

**ADF Motor**

1. Remove the ADF unit (**ADF Unit**).
2. Remove the ADF front cover (**ADF Front Cover**).
3. Remove the ADF rear cover (**ADF Rear Cover**).
4. Remove the ADF drive unit [A] while the ADF top cover [B] remains closed (⊙ x 2).

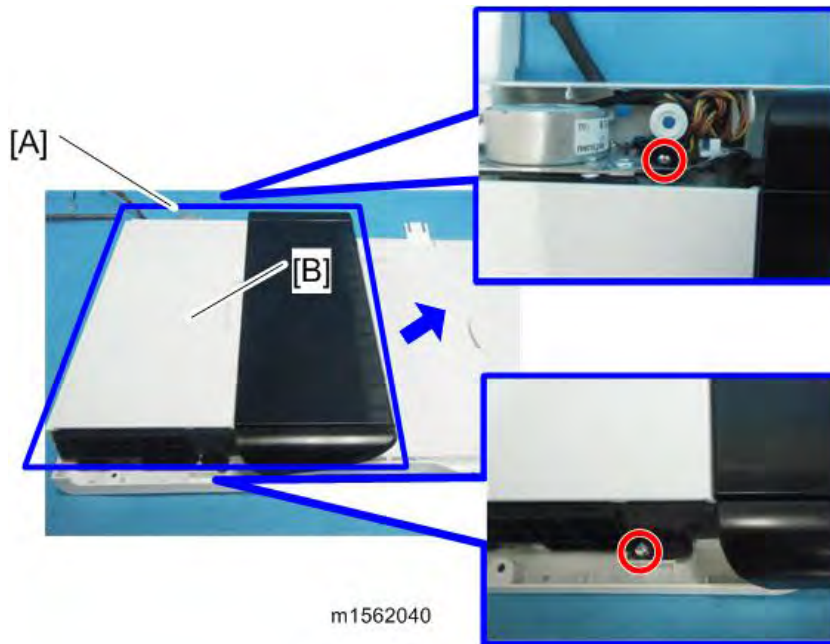

5. Remove the ADF motor assembly [A] (⊙ x 2, ground screw x 1, ⊞ x 1, ground plate, discharge brush).

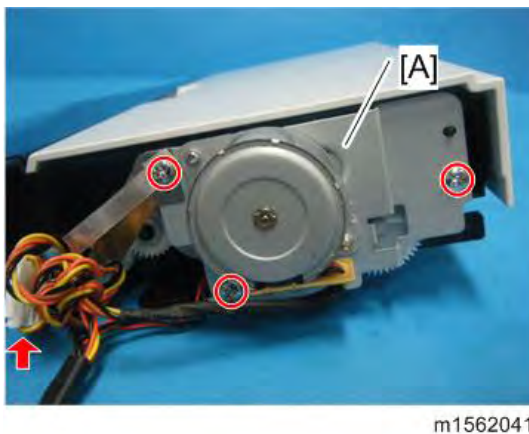

## ADF/ARDF Unit (Only MF Models)

6. Remove the ADF motor [A] (⚙️ x 2).

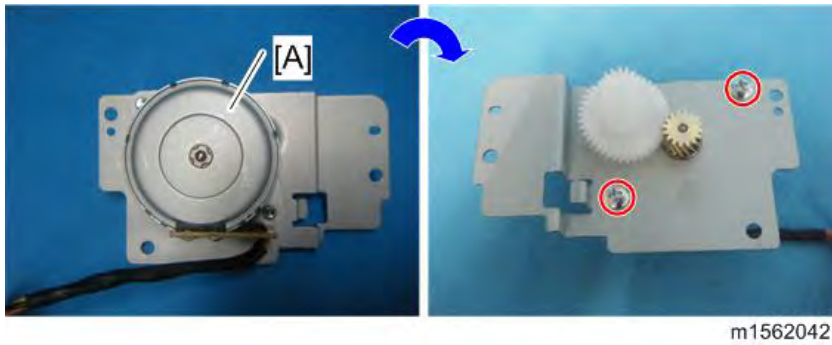

### **ADF Top Cover**

1. Remove the ADF drive unit (**ADF Motor**).
2. Open the ADF top cover [A] and remove it (two tabs).



### **Original Set Sensor**

1. Remove the ADF drive unit (**ADF Motor**).
2. Turn the ADF drive unit over.
3. Remove the pressure plate [A] (4 hooks, 2 springs).

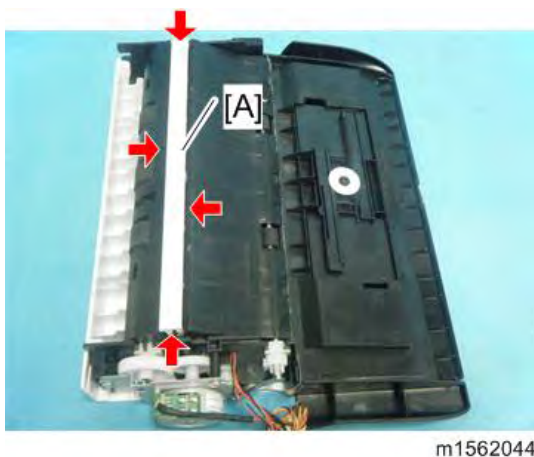



4. Remove the lower guide (🔩 x 3, ground plate, 6 hooks, 2 tabs).

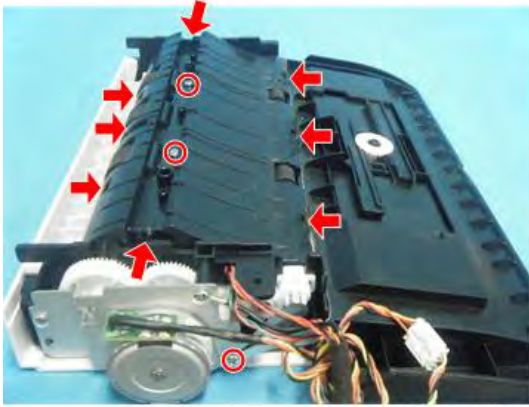

m1562045

5. Remove the original set sensor [A] (🔩 x 1).

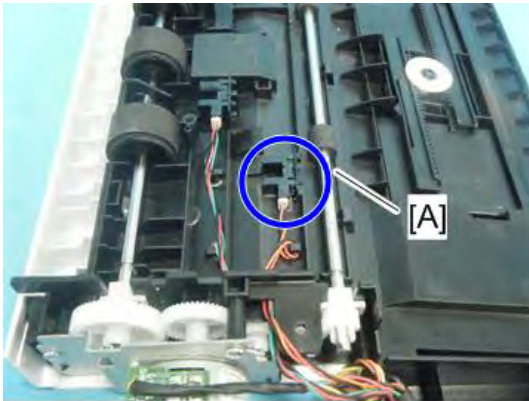

m1562046

### ADF Feed Sensor

1. Remove the ADF drive unit (**ADF Motor**).
2. Remove the lower guide (**Original Set Sensor**).
3. Remove the ADF feed sensor [A] (🔩 x 1).

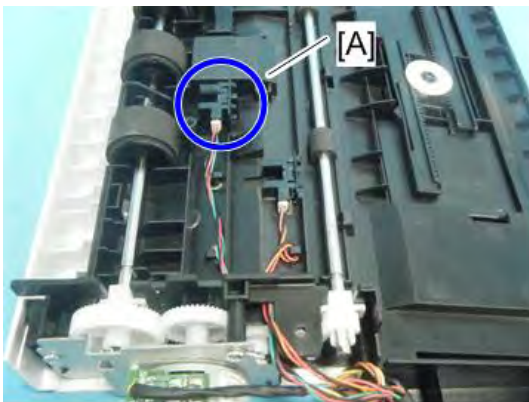

m1562047

## 4.5.2 ARDF UNIT (FOR TOUCH PANEL MODELS)

### **ARDF Unit**

1. Remove the scanner unit ([Scanner Unit](#)).
2. Turn the scanner unit over, and move the harnesses out of the frame.



3. Open the ARDF unit [A] and remove it in the direction of the blue arrow (hooks).



### **Original Tray**

1. Open the original tray [A] and remove it (two tabs).





### **ARDF Pick-Up Roller, ARDF Feed Roller**

1. Open the ARDF top cover [A].
2. Remove the ARDF feed unit [B] (tab).



3. Remove the ARDF pick-up roller [A].
4. Remove the ARDF feed roller [B].



### **ARDF Separation Pad**

1. Open the ARDF top cover.
2. Remove the ARDF separation pad [A] (2 hooks, spring x 1).



### **ARDF Front Cover**

1. Remove the ARDF unit ([ARDF Unit](#)).
2. Turn the ARDF unit over.
3. Remove the ARDF front cover [A].

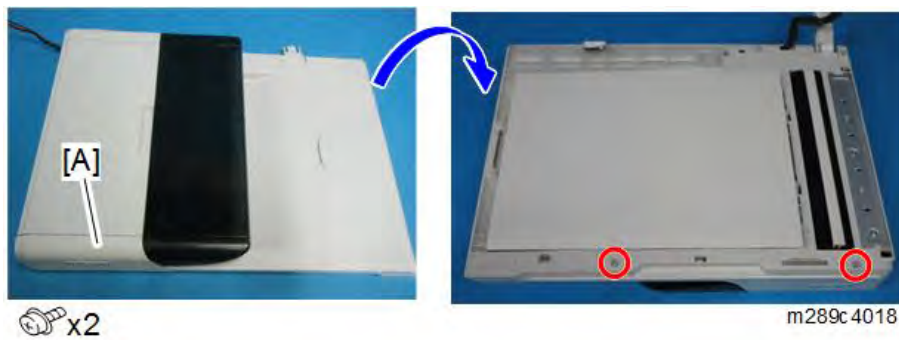

Note

- There are many hooks and tabs inside the ARDF front cover. Before removing the ARDF front cover, see the photos below.

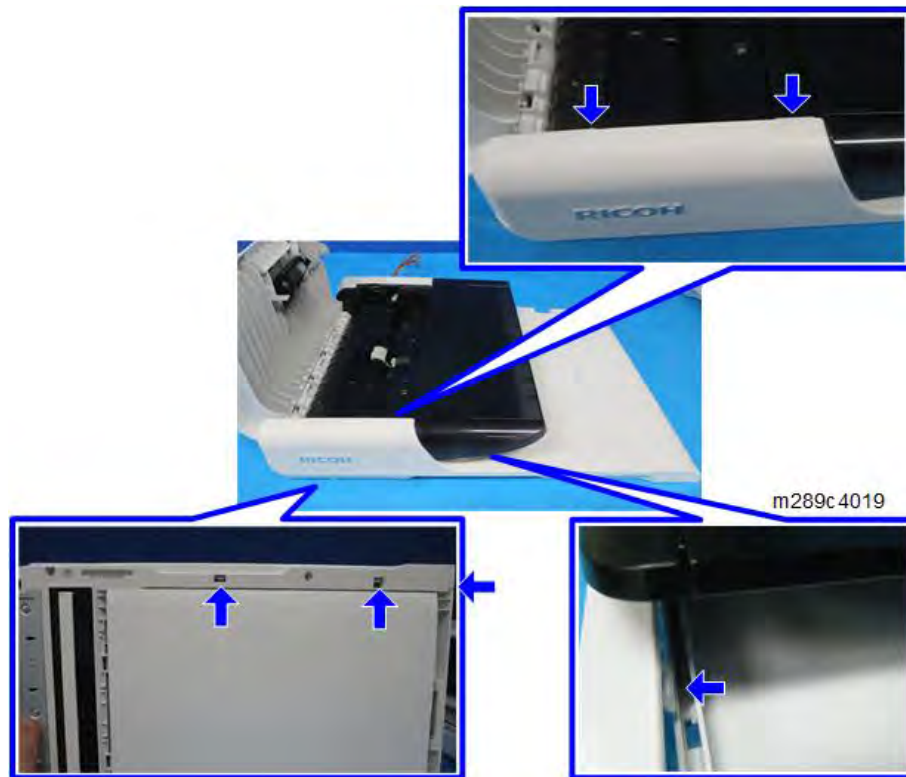

Replacement  
and  
Adjustment

**ARDF Rear Cover**

1. Remove the ARDF unit (*ARDF Unit*).
2. Turn the ARDF unit over.
3. Remove the ARDF rear cover [A].

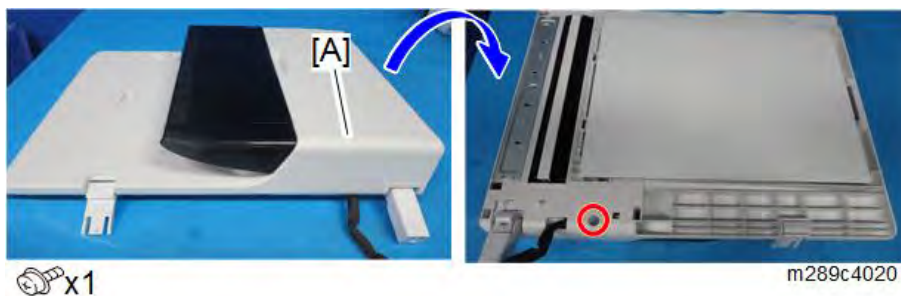

**Note**

- There are many hooks and tabs inside the ARDF rear cover. Before removing the ARDF rear cover, see the photos below.



### **ARDF Motor**

1. Remove the ARDF unit (**ARDF Unit**).
2. Remove the ARDF front cover (**ARDF Front Cover**).
3. Remove the ARDF rear cover (**ARDF Rear Cover**).
4. Remove the original tray [A].

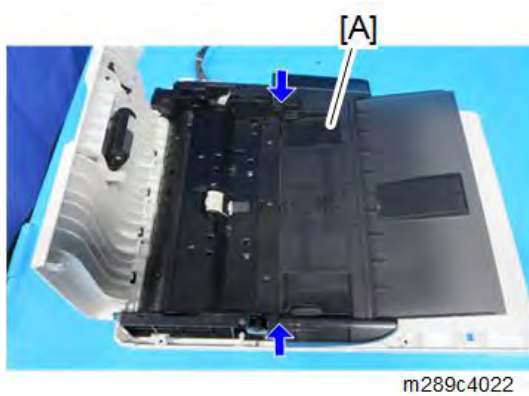

5. Remove the ARDF drive unit [A].

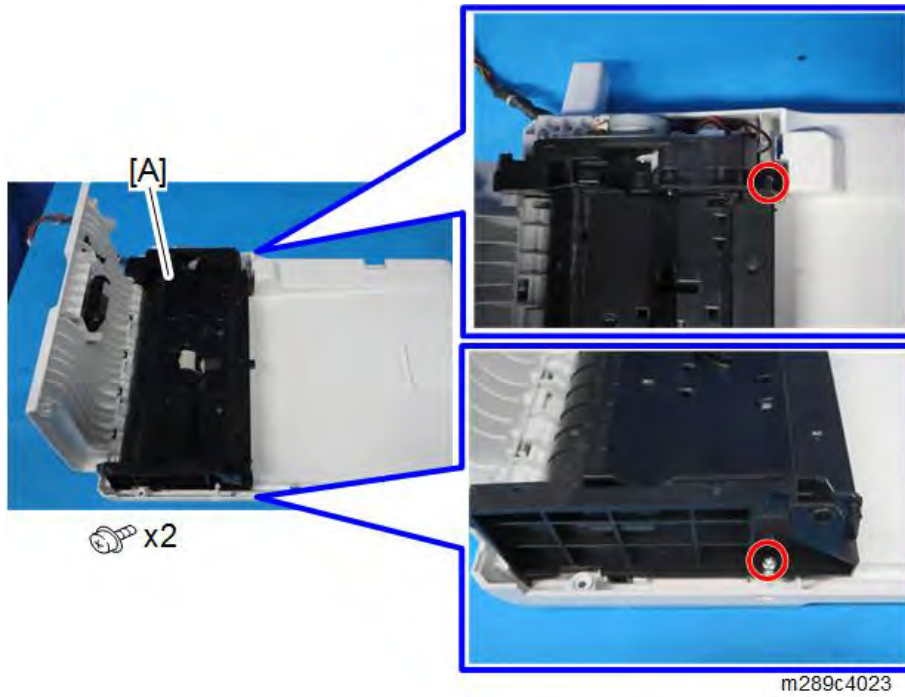

**Note**

When removing/attaching the ARDF drive unit, make sure to route the harnesses carefully so that they will not be damaged.

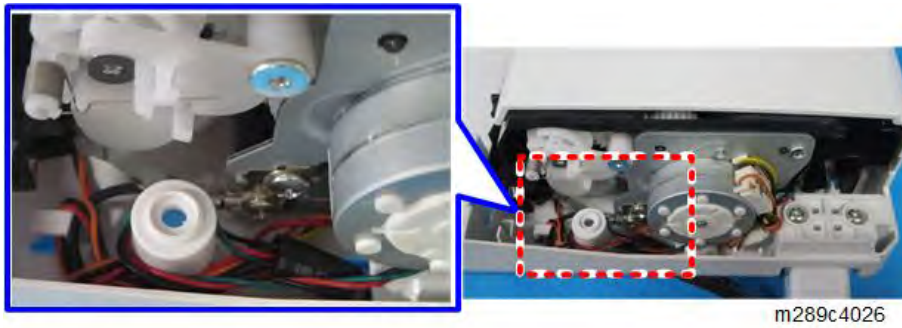

6. Remove the ARDF motor assembly [A].

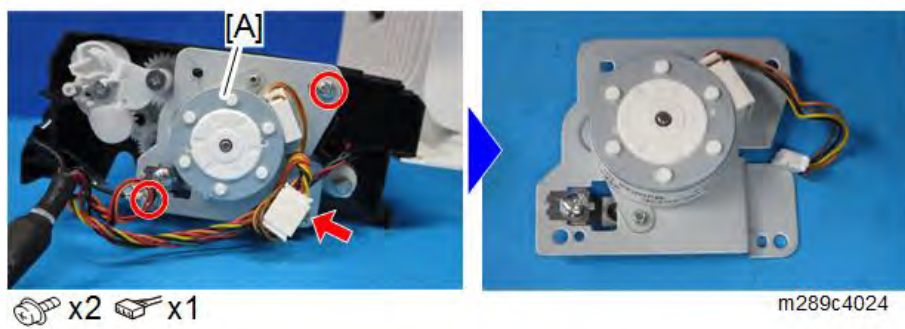



7. Remove the ARDF motor [A].

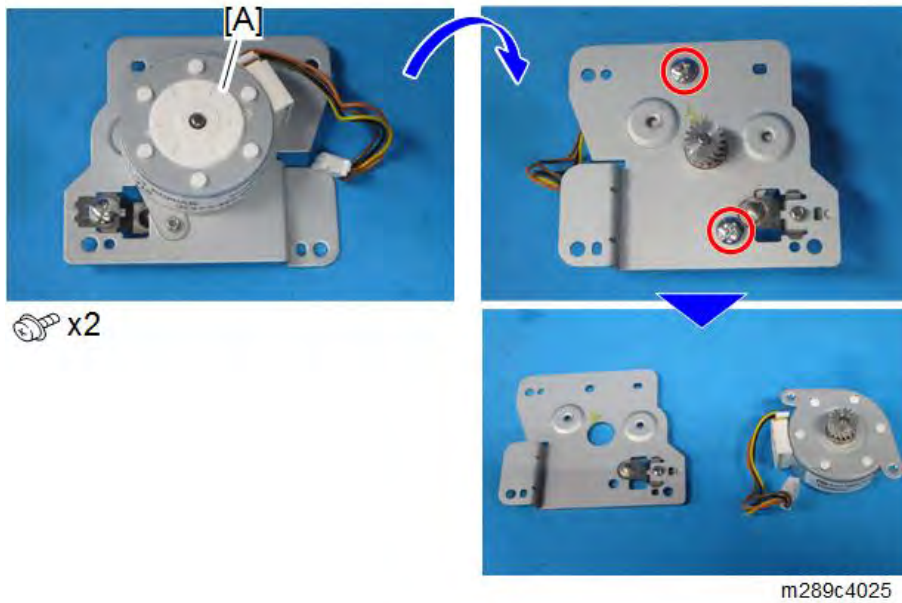

### **ARDF Top Cover**

1. Remove the ARDF drive unit (**ARDF Motor**).
2. Open the ARDF top cover [A] and remove it (two tabs).

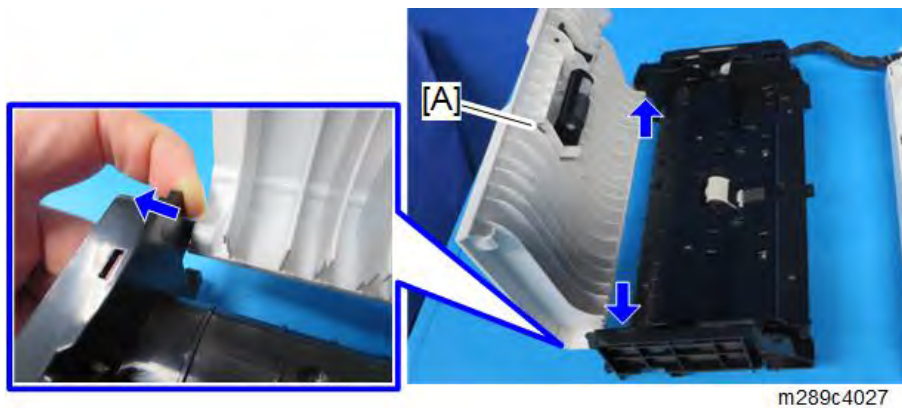

### Original Set Sensor

1. Remove the ARDF drive unit (*ARDF Motor*).
2. Turn the ARDF drive unit over.
3. Remove the sensor cover [A].

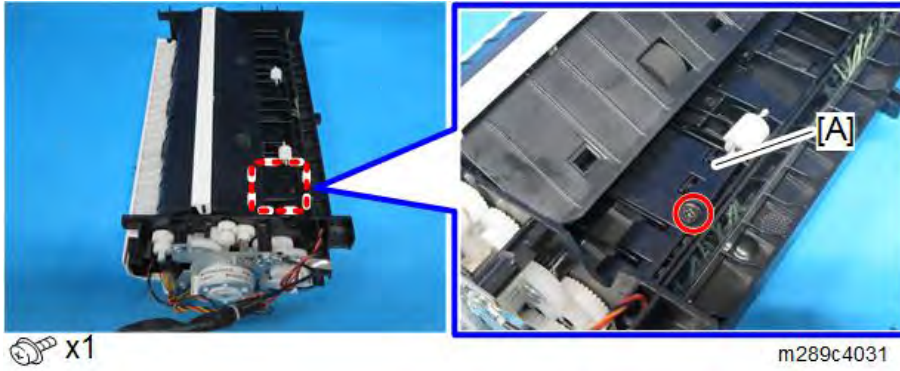

4. Remove the original set sensor [A].



### ARDF Feed Sensor

1. Remove the ARDF drive unit (*ARDF Motor*).
2. Turn the ARDF drive unit over.
3. Remove the pressure plate [A] (4 hooks).

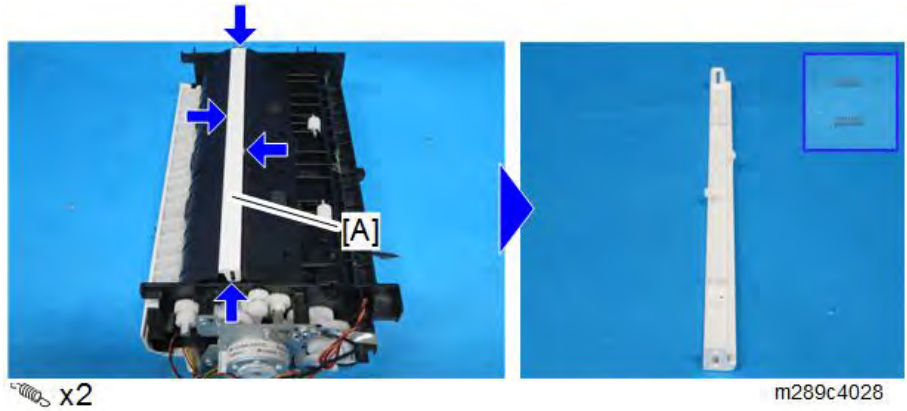

4. Remove the lower guide [A] (6 hooks).



5. Remove the ARDF feed sensor [A].

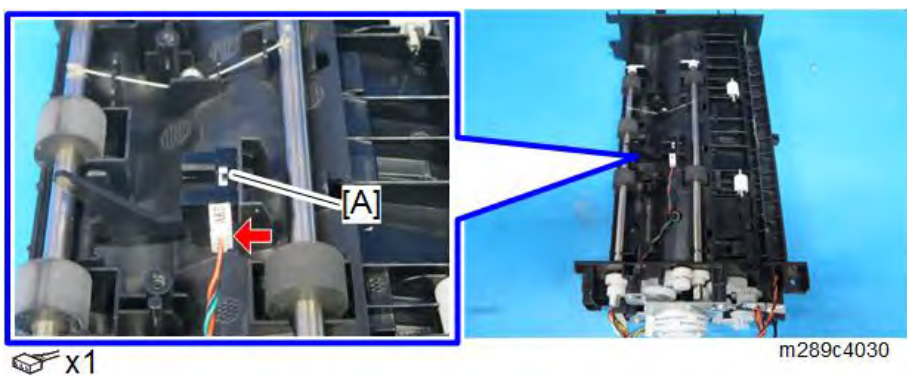



## 4.6 LASER UNIT

### ⚠ CAUTION

- Turn off the main power switch and unplug the machine before attempting any of the procedures in this section. Laser beams can seriously damage your eyes.

### 4.6.1 CAUTION DECAL LOCATIONS

A caution decal is attached as shown below.



### ⚠ WARNING

- Be sure to turn off the main switch and disconnect the power plug from the power outlet before beginning any disassembly or adjustment of the laser unit. This machine uses a class IIIB laser beam. The laser can cause serious eye injury.

### 4.6.2 LASER UNIT

1. Remove the top cover (Printer models: *Top Cover*, MF models: *Top Cover*).
2. Remove the laser unit [A].

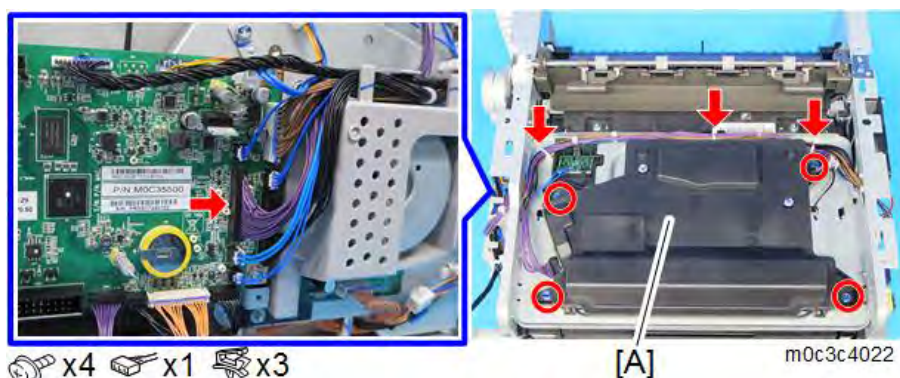

#### ↓ Note

After replacing the laser unit, check the registration by printing the test pattern. (*Test Pattern Printing*)

### 4.6.3 LASER UNIT THERMISTOR

1. Remove the top cover (Printer models: *Top Cover*, MF models: *Top Cover*).
2. Release the four hooks, and remove the laser unit top cover [A].

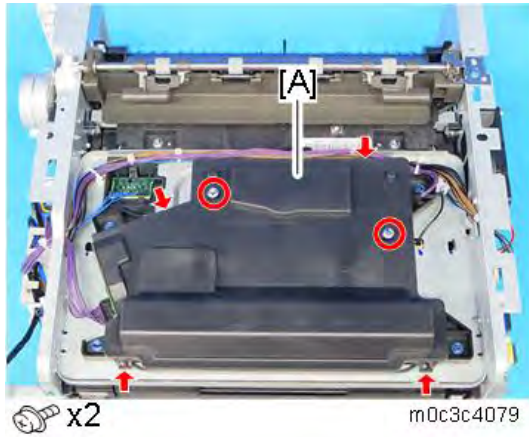

3. Remove the laser unit thermistor [A].

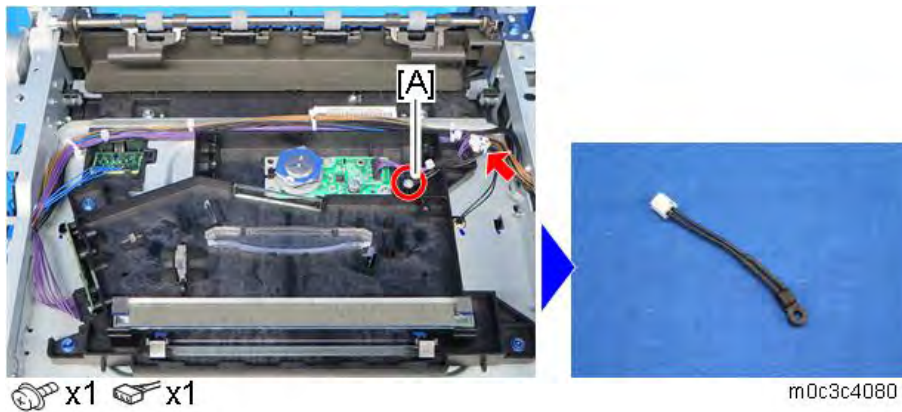

## 4.7 PAPER FEED

### 4.7.1 PAPER FEED ROLLER

1. Pull out the standard paper tray.
2. Remove the AIO.
3. Set the machine with the rear side facing down, resting on the table.



m0c3c4027

4. Remove the two clips, and slide the paper feed shaft [A] to the left side.
5. Release the hook, and slide the paper feed roller [B] to the right side to remove it.



x2

m0c3c4028

#### Note

Do not remove the hook of the paper feed roller too strongly or it might be broken.

## 4.7.2 FRICTION PAD

1. Remove the paper tray unit from the machine before removing the friction pad.
2. Remove the friction pad [A] (2 hooks, spring x 1).

From the bottom side of the paper tray, release the hooks with a flat head screwdriver.

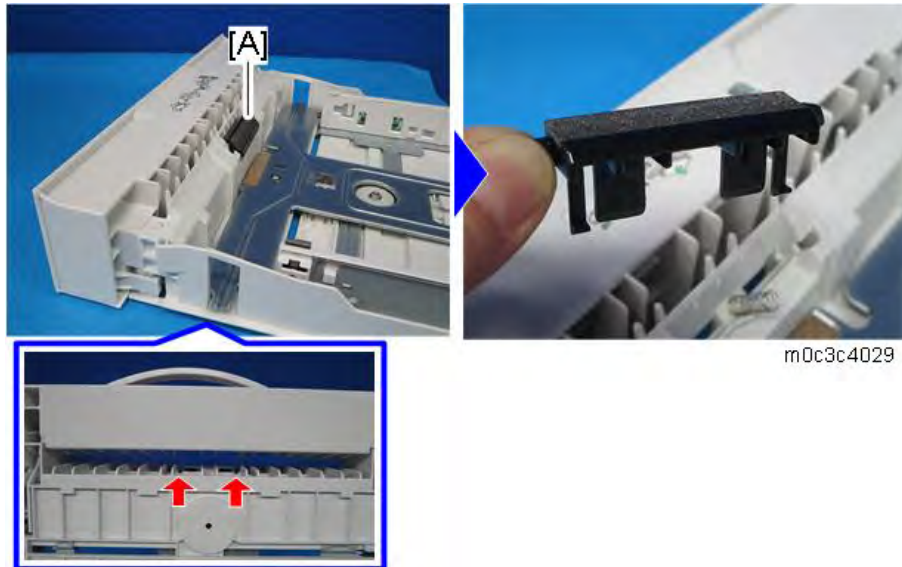

### Note

The spring is a different service part from the friction pad. If the spring has no problems, it can continue to be used.

## 4.7.3 PAPER END SENSOR

1. Remove the paper feed roller (*Paper Feed Roller*).
2. Remove the paper end sensor [A].



### Note

If it is difficult to remove it, pull out the shaft of the paper feed roller completely before removing.



## 4.7.4 BY-PASS FEED SOLENOID

1. Remove the left cover (Printer models: *Left Cover*, MF models: *Left Cover*).
2. Remove the solenoid cover [A].



3. Remove the by-pass feed solenoid [A].

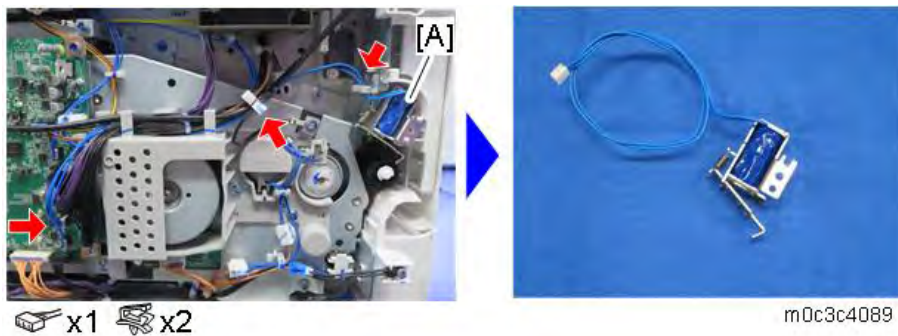

## 4.7.5 BY-PASS FEED ROLLER

1. Remove the left cover (Printer models: *Left Cover*, MF models: *Left Cover*).
2. Remove the right cover (Printer models: *Right Cover*, MF models: *Right Cover*).
3. Remove the by-pass lower guide plate [A].

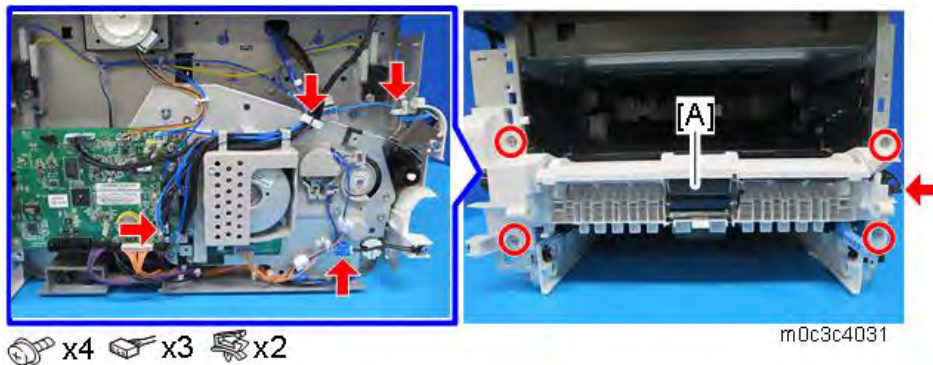

**Note**

- When re-installing the by-pass lower guide plate [A], align the lower pins with the hole in the frame, and then attach the upper hooks.

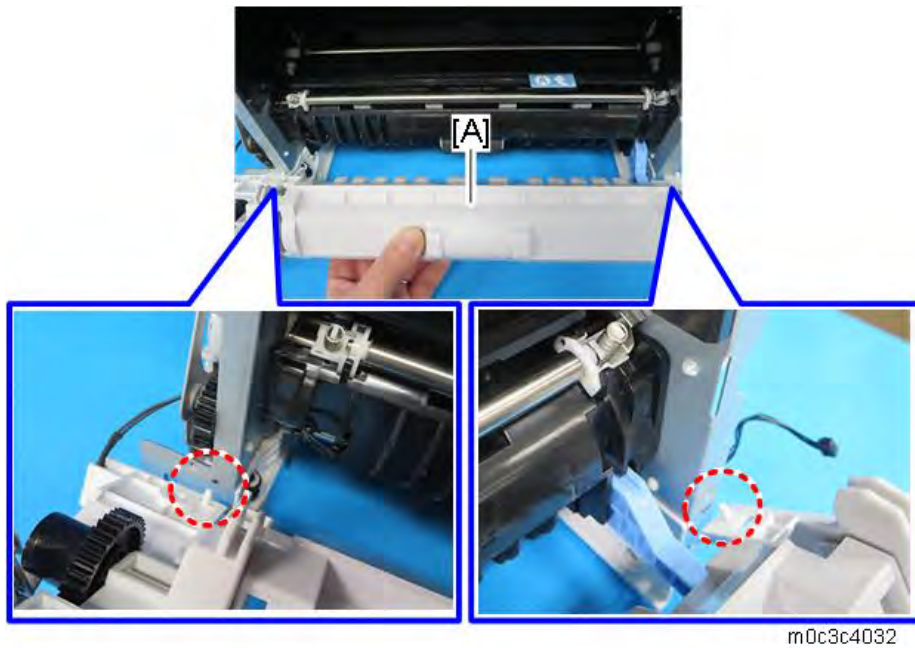

- Be careful that the springs [B] and the ground plate [C] do not fall inside the machine during re-installation.

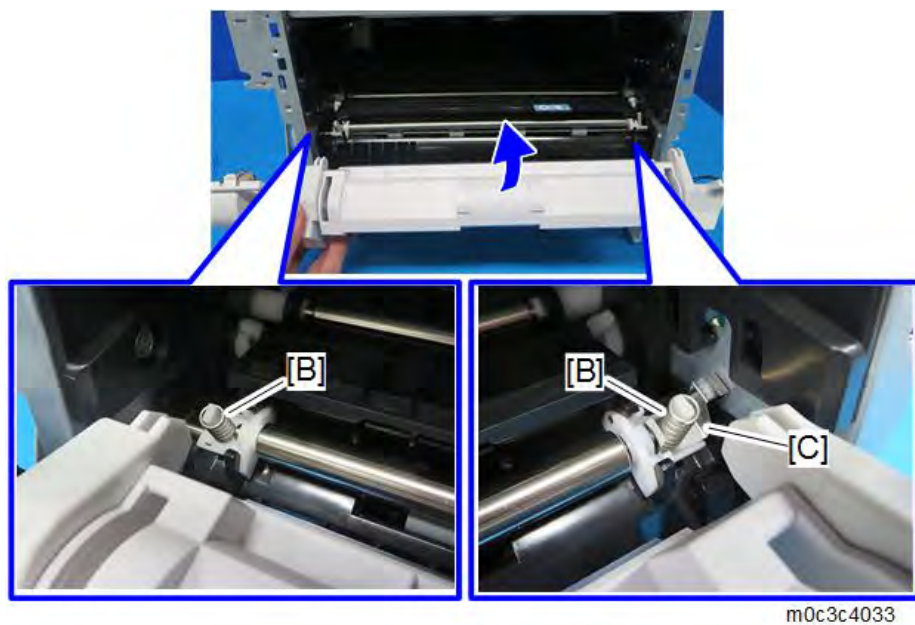

4. Remove the by-pass upper guide plate [A].
5. Remove the by-pass solenoid cover, and the by-pass solenoid [B] (⚙️ x 1).

- Remove the gear [C] (hook).

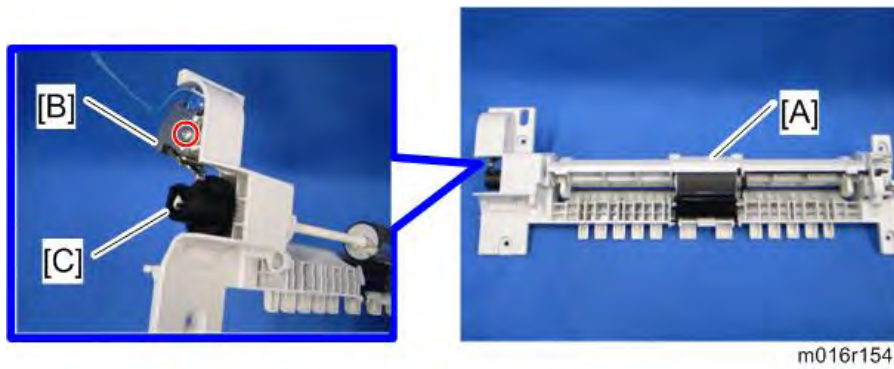

- Slide the by-pass feed roller shaft [A] to the left side, and remove it.
- Remove the metal cover [B] from the by-pass feed roller [C].

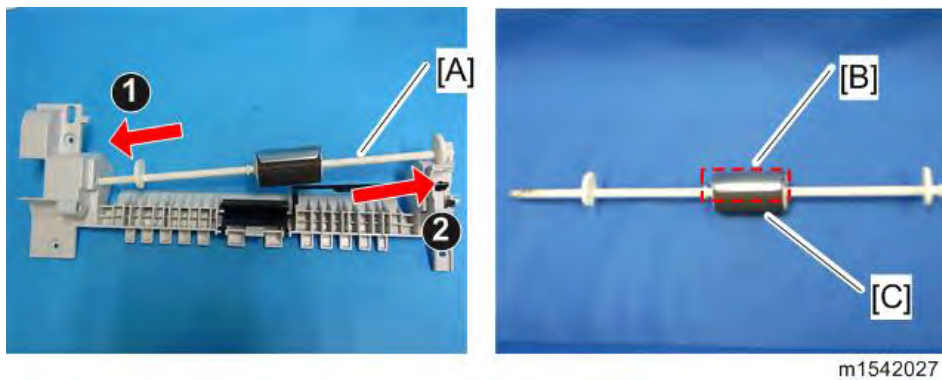

#### 4.7.6 BY-PASS FEED ROLLER FRICTION PAD

- Remove the by-pass feed roller (*By-pass Feed Roller*).
- Remove the by-pass feed roller friction pad [A] (2 hooks, spring x 1).

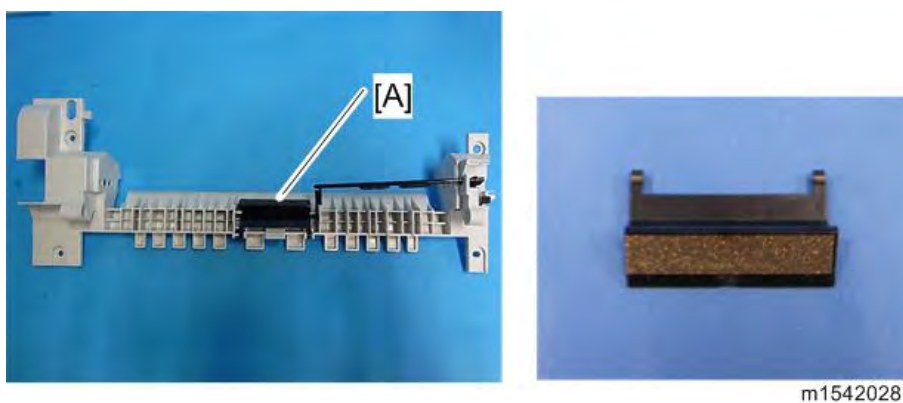



### 4.7.7 BY-PASS FEED SENSOR

1. Remove the right cover (Printer models: *Right Cover*, MF models: *Right Cover*).
2. Remove the by-pass feed sensor [A].

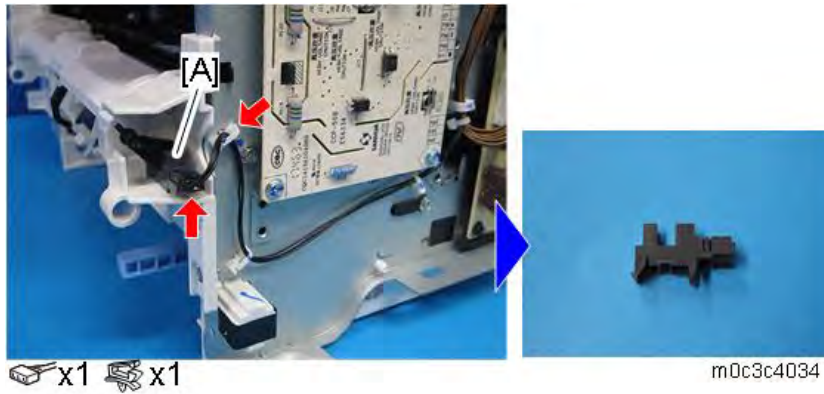

### 4.7.8 PAPER FEED CLUTCH

1. Remove the drive unit (*Drive Unit*).
2. Remove the paper feed clutch [A].

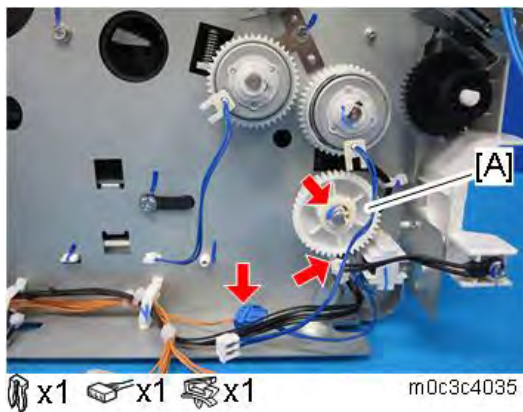

↓ Note

Fit the stopper of the paper feed clutch over the tab on the machine.





## 4.7.9 RELAY CLUTCH

1. Remove the drive unit (*Drive Unit*).
2. Remove the relay clutch [A].

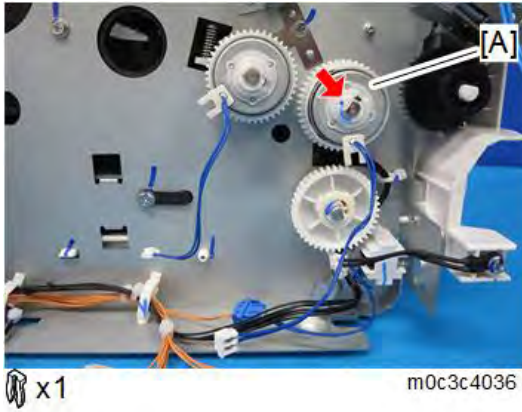

## 4.7.10 REGISTRATION CLUTCH

1. Remove the drive unit (*Drive Unit*).
2. Remove the registration clutch [A].

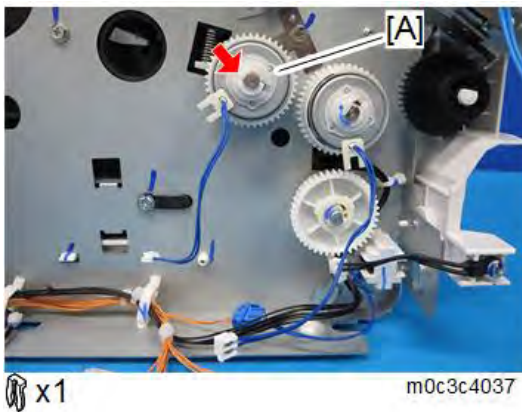

## 4.7.11 REGISTRATION ROLLER

1. Remove the AIO.
2. Only for MF models, remove the scanner unit (*Scanner Unit*).
3. Remove the top cover (**Printer models: *Top Cover*, MF models: *Top Cover***).
4. Remove the fusing unit (*Fusing Unit*).
5. Remove the PSU (*PSU*).
6. Remove the HVP (*HVP*).
7. Remove the by-pass lower guide plate (*By-pass Feed Roller*).
8. Remove the paper feed clutch (*Paper Feed Clutch*).
9. Remove the relay clutch (*Relay Clutch*).
10. Remove the registration clutch (*Registration Clutch*).
11. Remove the heat insulating plate [A].

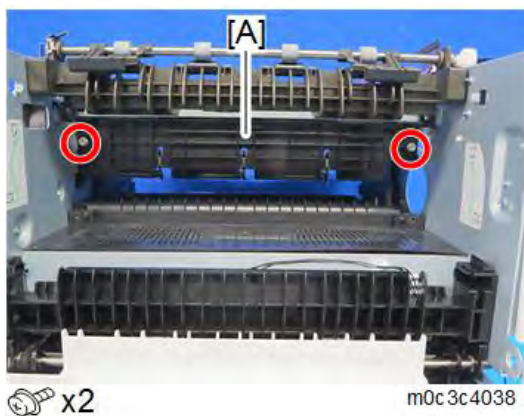

12. Remove the duplex motor base [A].

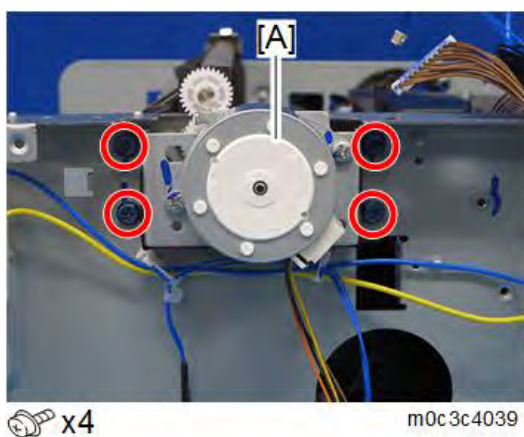

13. Slightly flex the side frames outward, and remove the exit roller base [A] and grounding plate [B].

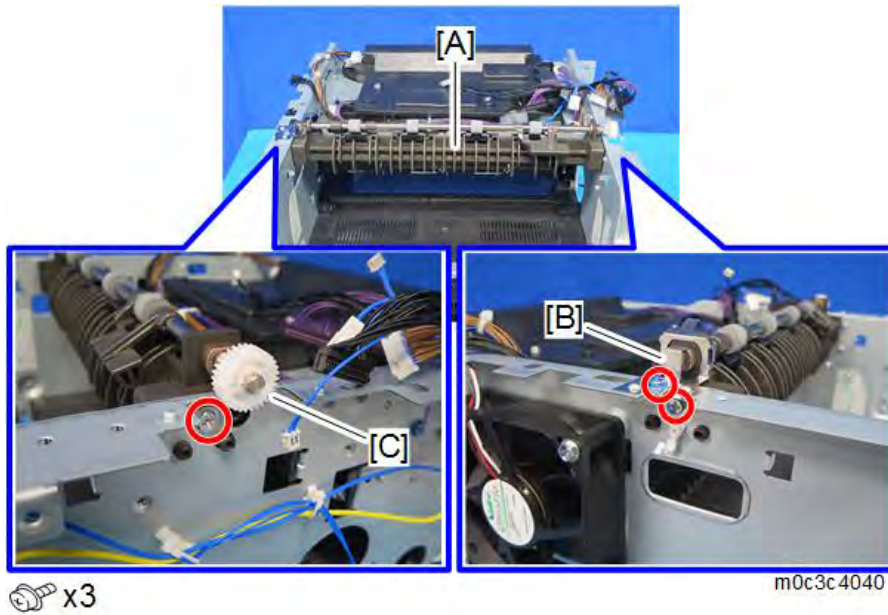

**Note**

When re-installing the exit roller base, remove the gear [C] temporarily so that it does not get damaged.

14. Pass the harnesses through the hole inside the machine.
15. Slightly flex the side frames outward, and remove the laser unit base [A].

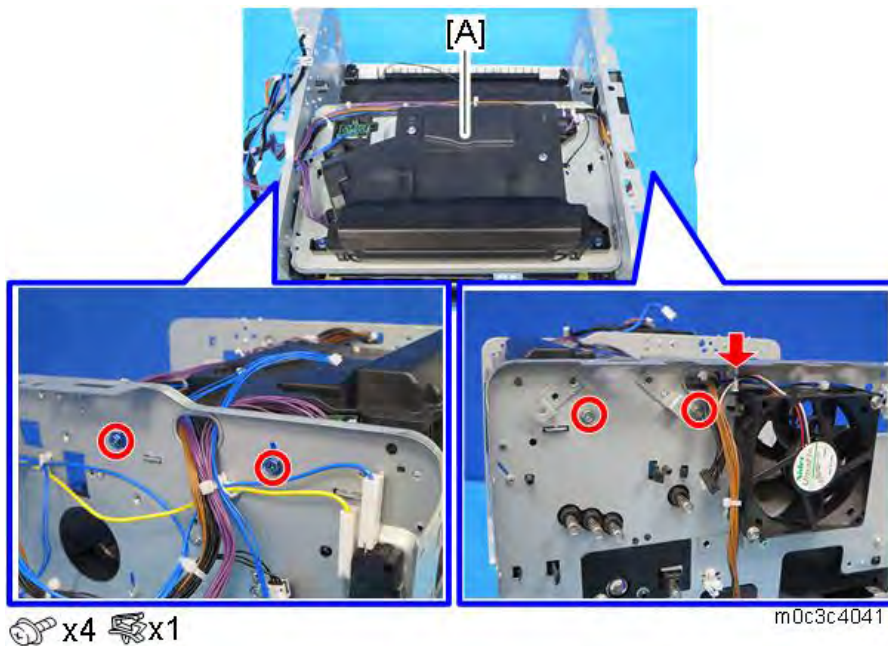

16. Remove the main power cord [A] on the right side.

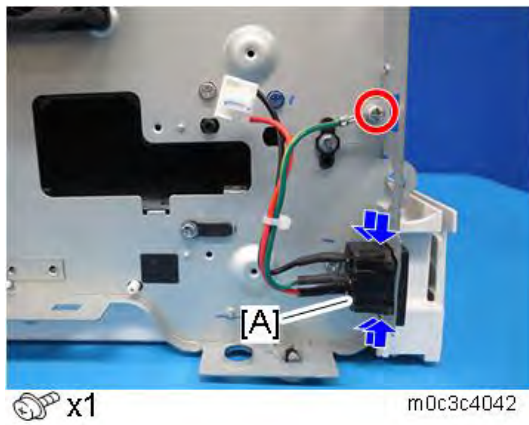

17. Remove the rear lower cover [A]. There is a screw behind the tray cover [B].

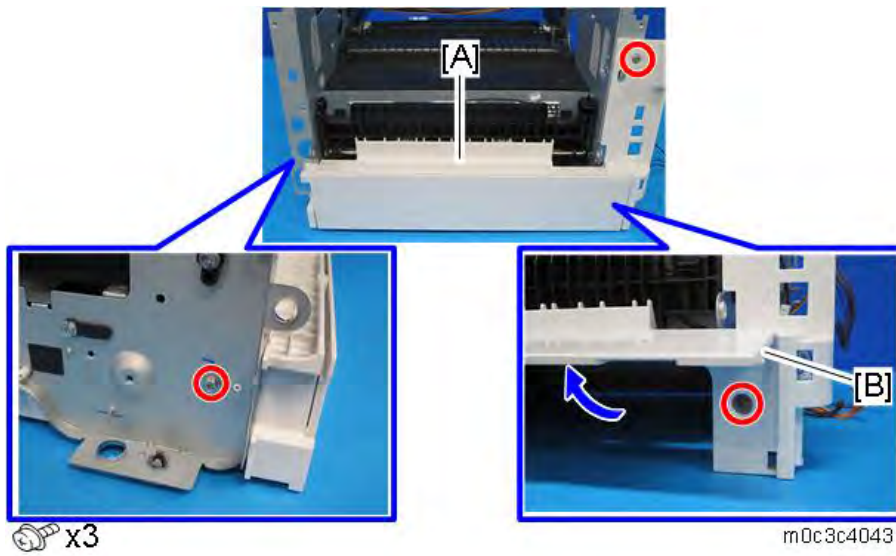

18. Remove the bushings on both sides, and remove the duplex cover [A].

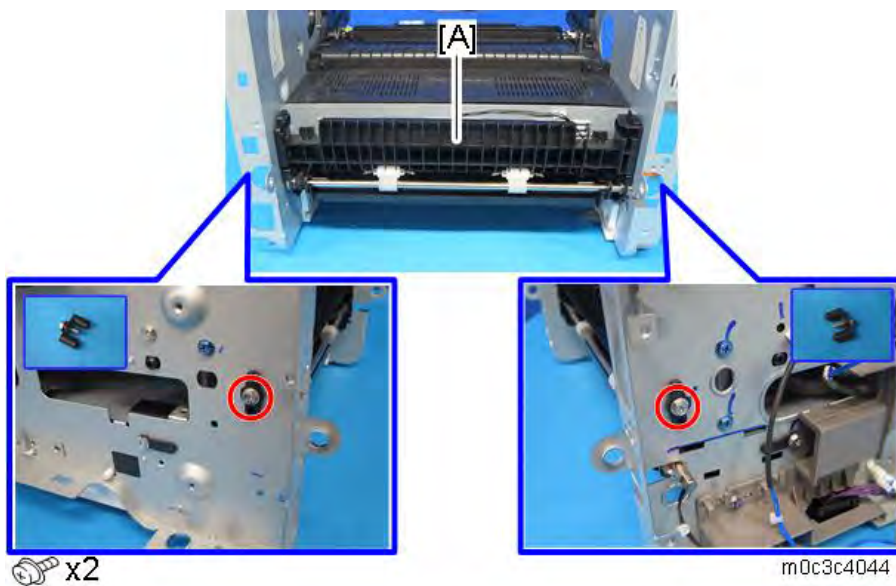



19. Set the machine with the front side facing down, resting on the table.
20. Release the link [A].

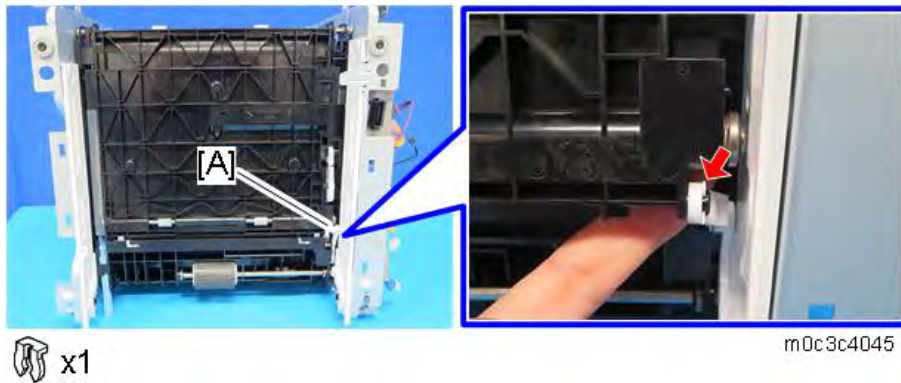

21. Remove the bracket [A] on the left side.

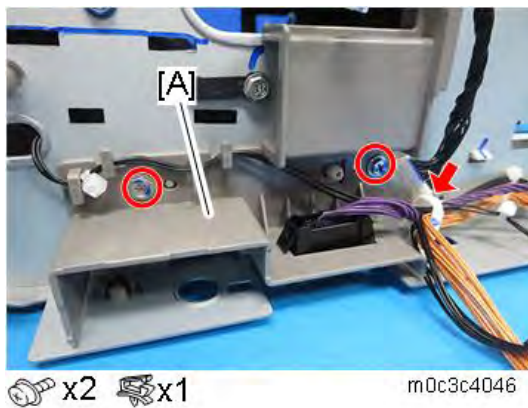

22. Remove the bushings on both sides and pass the harness [B] through the hole inside the machine, and then remove the duplex transport guide [A].

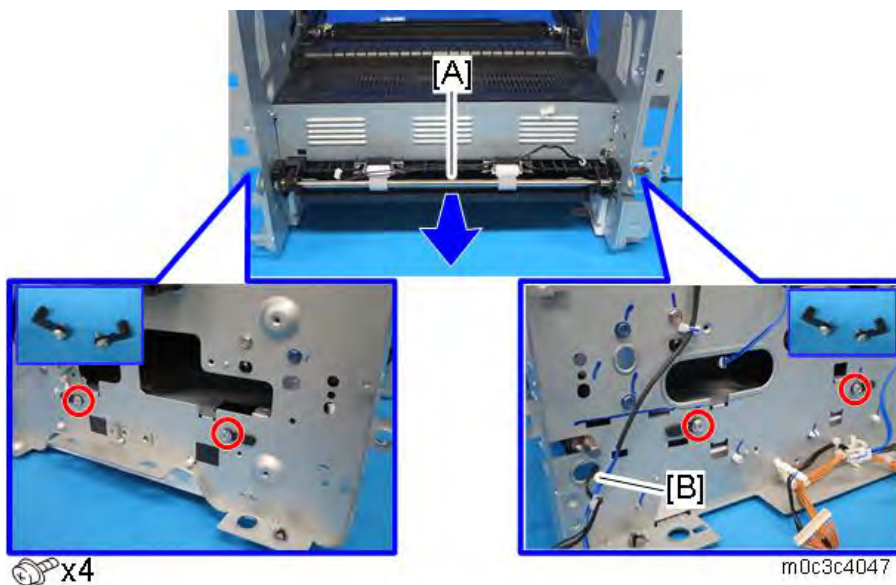

23. Remove the clamp [B], and then remove the bracket [A].

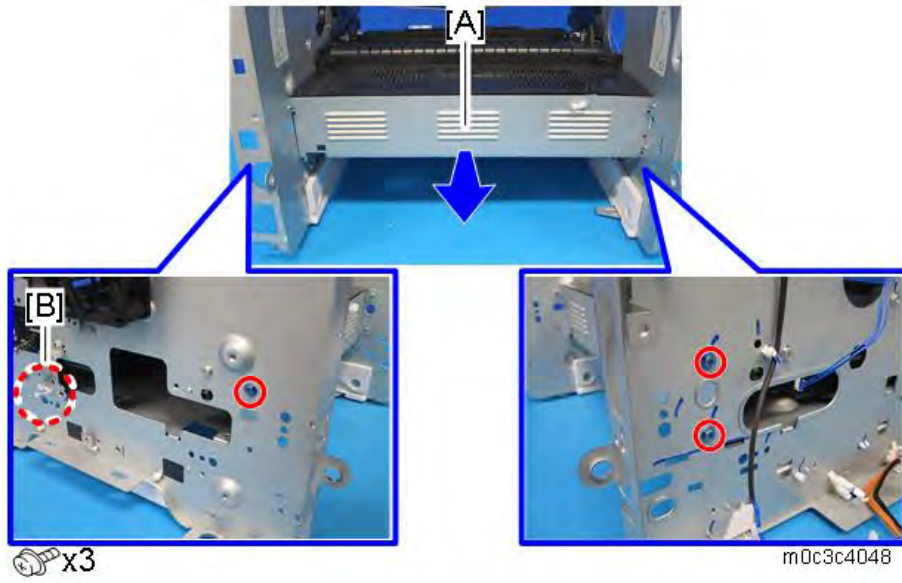

24. Pass the harness [B] through the hole inside the machine, and remove the registration unit [A].

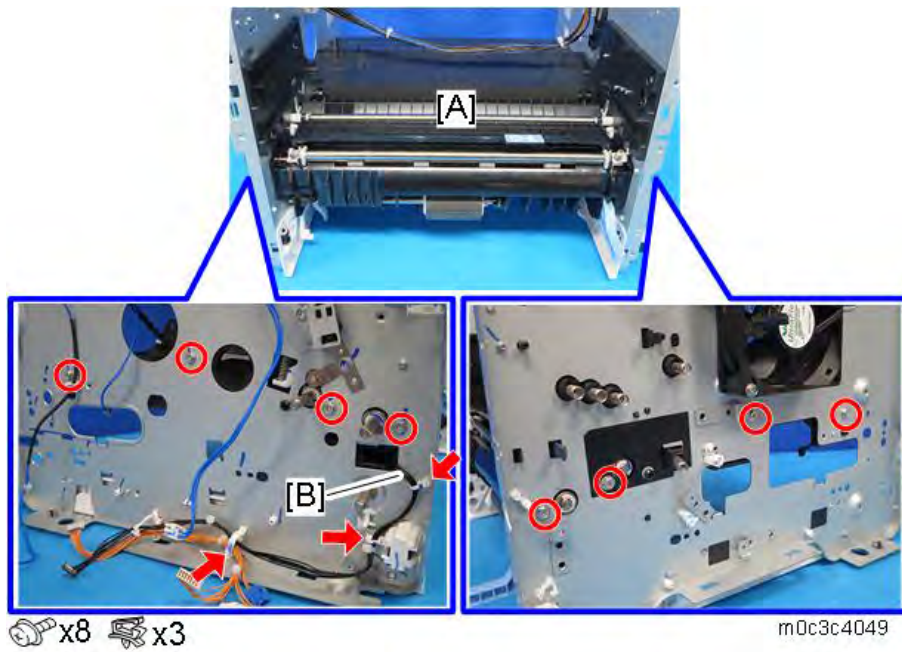

25. Remove the upper guide plate [A] (2 hooks).



m1542038

26. Remove the registration roller (follower) [A] as shown below (spring x 2, plastic parts x 2).

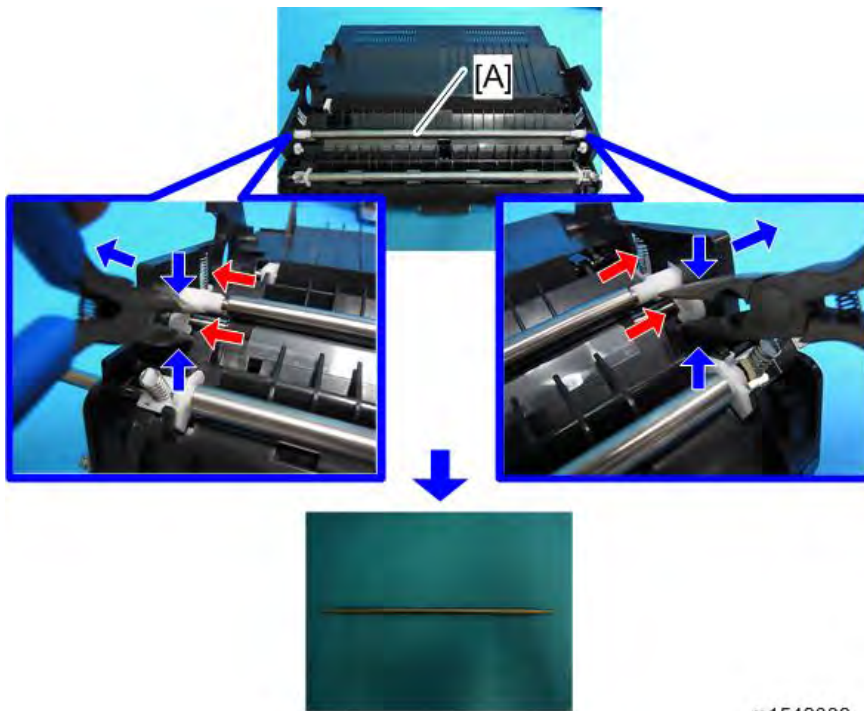

m1542039

27. Remove the registration roller (drive) [A] (Ⓒx 2, bushing x 2).

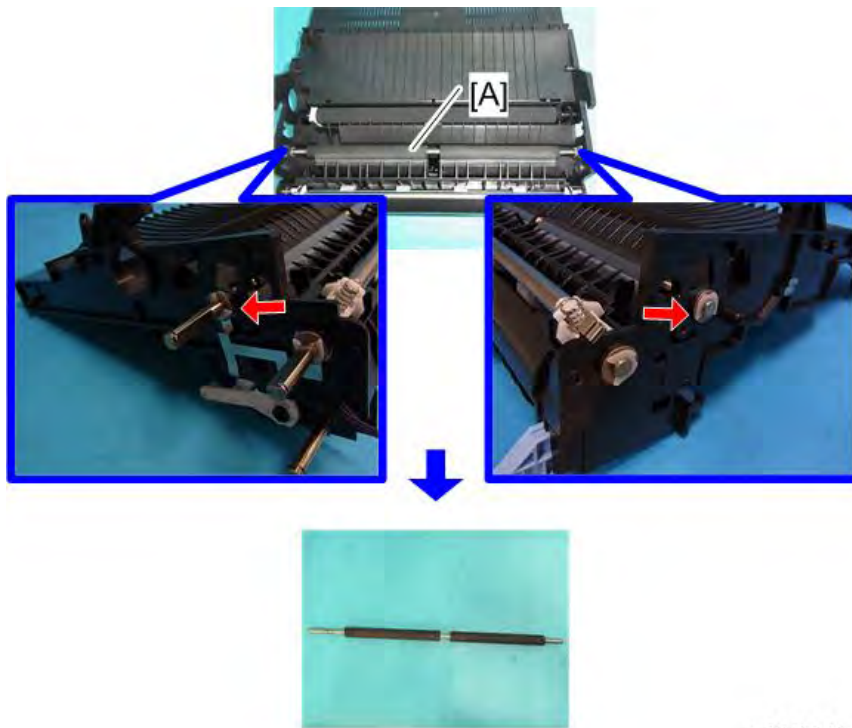

m1542040

#### 4.7.12 REGISTRATION SENSOR

1. Remove the registration unit (*Registration Roller*).
2. Turn the registration unit over.
3. Remove the registration sensor [A] (🔗 x 1, 3 hooks).

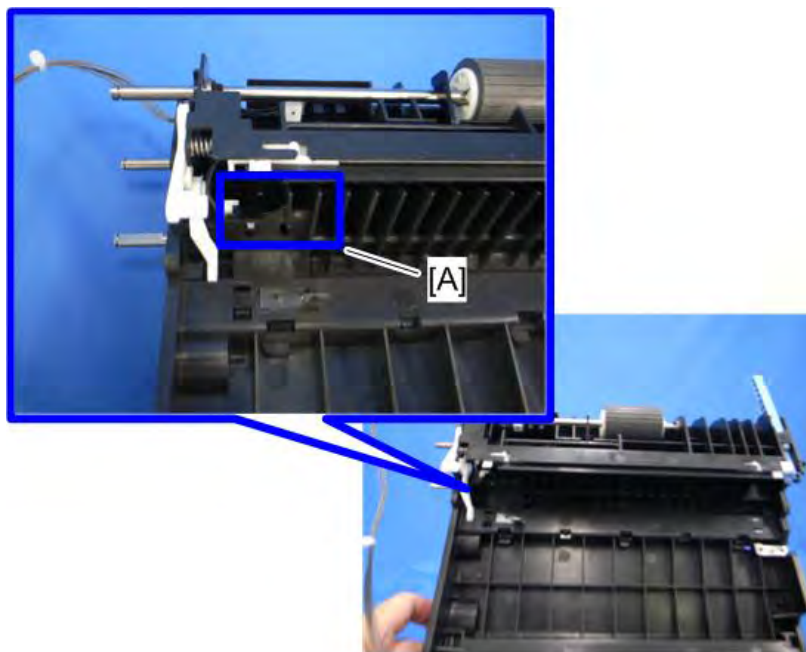

m1542041



## 4.8 IMAGE TRANSFER

### 4.8.1 TRANSFER ROLLER

1. Remove the front cover (Printer models: *Front Cover*, MF models: *Front Cover*).
2. Remove the AIO.
3. Remove the transfer roller [A] as shown below.

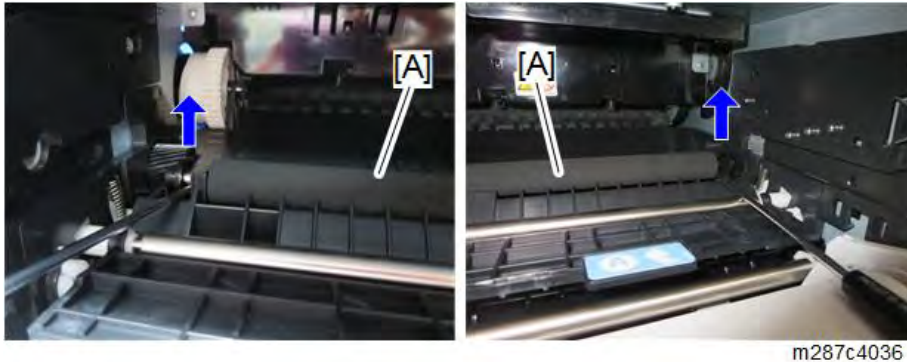

4. Remove the bushing x 2 [C], spring x 2 [D], gear x 1 [B], collar x 1 [A] from the transfer roller.

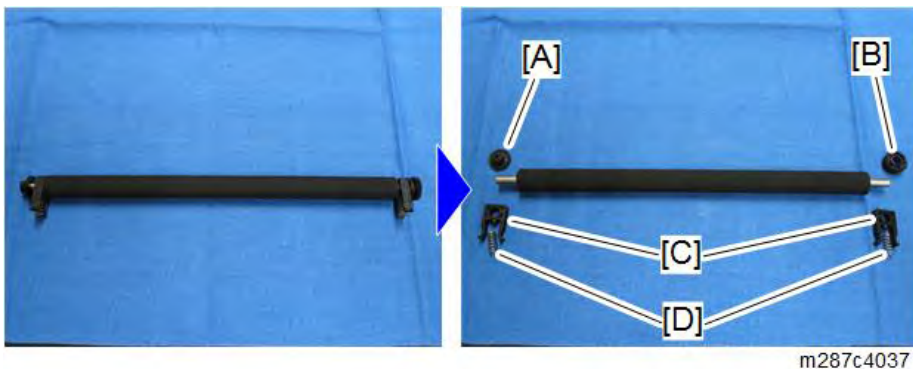

#### Note

- Do not touch the new transfer roller surface.
- When reinstalling the transfer roller, align the bushings of the transfer roller with the guide of the machine.
- Make sure that the left and right sides of the transfer roller are installed correctly.  
Left side: [A] : collar  
Right side: [B] : gear

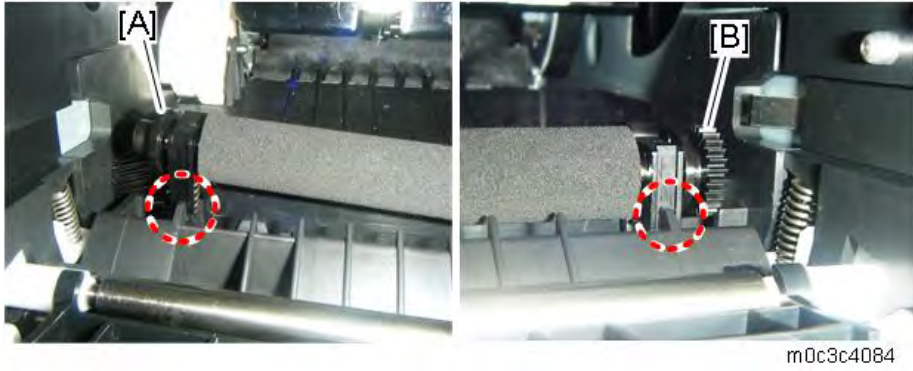

## 4.8.2 TONER END SENSOR

1. Remove the left cover (**Printer models: *Left Cover* MF models: *Left Cover***).
2. Remove the drive unit (***Drive Unit***).
3. Remove the toner end sensor [A].

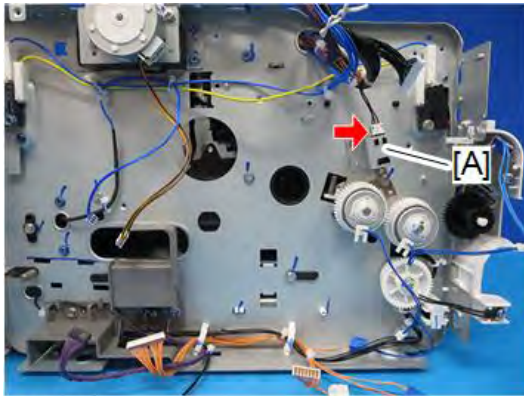

### 4.8.3 QUENCHING LAMP

1. Remove the top cover (Printer models: *Top Cover* MF models: *Top Cover*).
2. Remove the AIO.
3. Remove the quenching lamp with the case [A] (2 hooks).

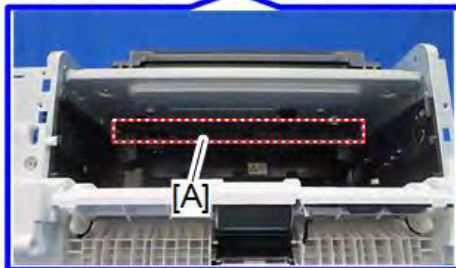
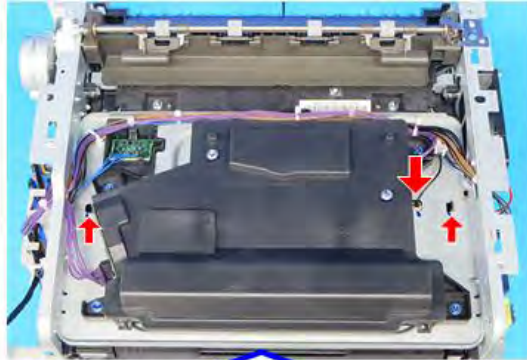

x1

m0c3c4024

4. Remove the quenching lamp [A] from the case (hook x 3).

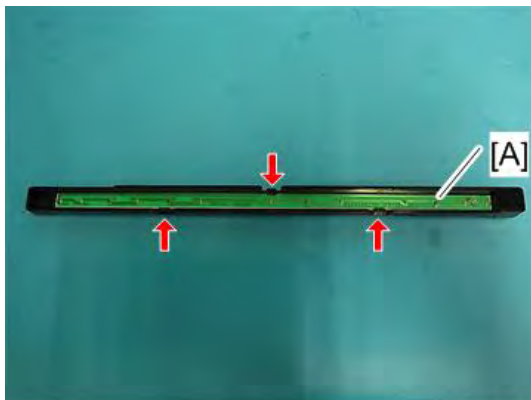

m1542046

## 4.9 FUSING AND EXIT

### ⚠ CAUTION

- Switch off the main power, unplug the machine from its power source, and allow the fusing unit to cool before removing it.

### 4.9.1 FUSING UNIT

#### ★ Important

The non-contact thermistor is installed so that there is a gap of 1 mm between it and the surface of the hot roller. To maintain this gap of 1 mm, do not remove the non-contact thermistor, and do not remove the hot roller and the pressure roller, which cannot be removed without the removal of the non-contact thermistor.

Replace the fusing unit when the non-contact thermistor, the hot roller, or the pressure roller are broken.

1. Remove the right cover (**Printer models:** *Right Cover*, **MF models:** *Right Cover*).
2. Release the lock [A], and then remove the entrance guide [B] (📦 x 1).

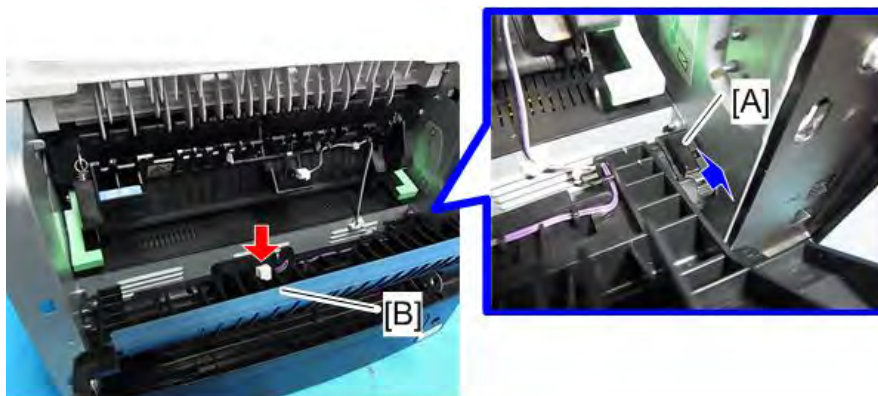

m1542047

#### ↓ Note

A harness is routed on the entrance guide. Remove the entrance guide carefully.



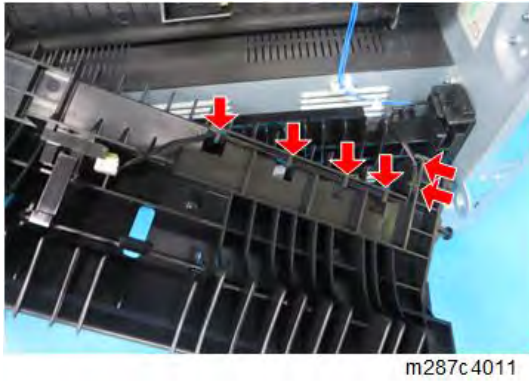

3. Disconnect the connectors from the fusing unit [A].

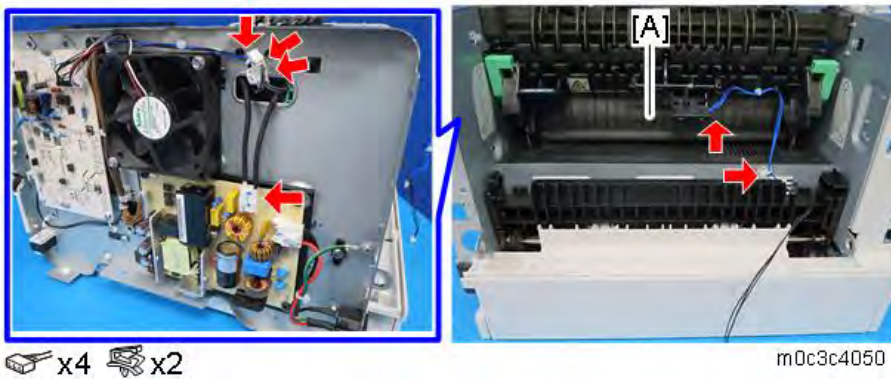

4. Pass the harnesses through the hole [A] inside the machine.

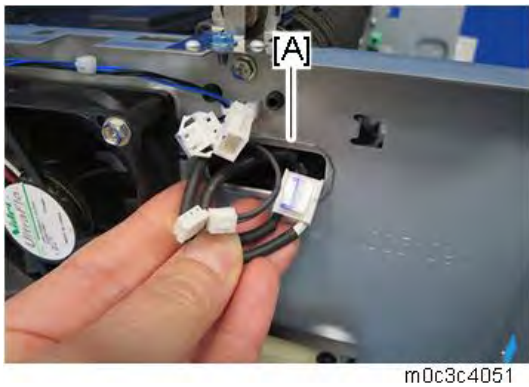

5. Remove the fusing unit [A] (x 4).

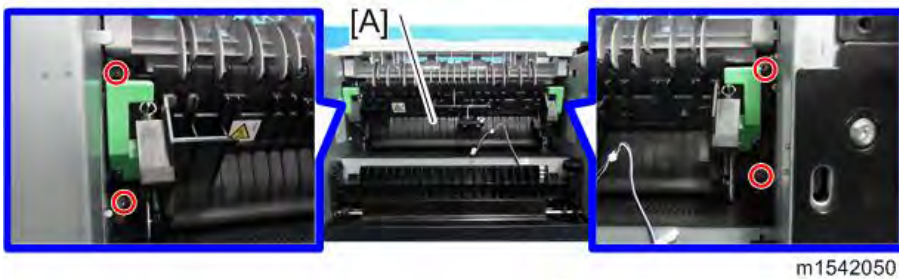

**Note**

- Make sure that the two bushings [A] on both sides remain in position.

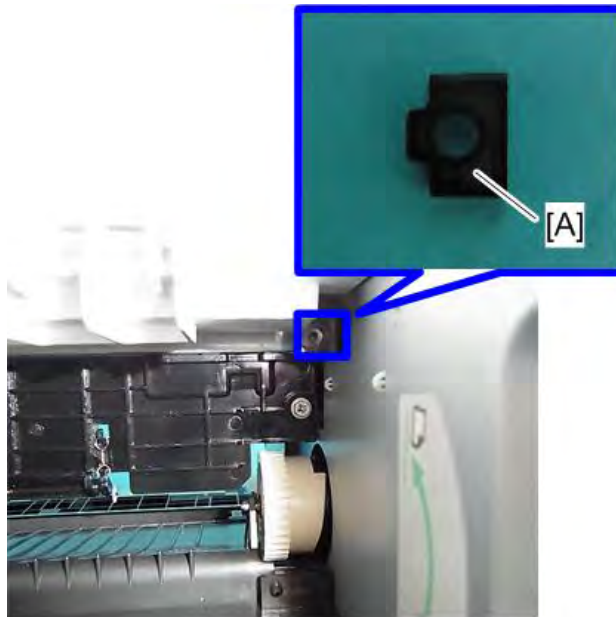

m1542051

## 4.9.2 FUSING UPPER COVER

1. Remove the fusing unit (*Fusing Unit*).
2. Remove the fusing upper cover [A].

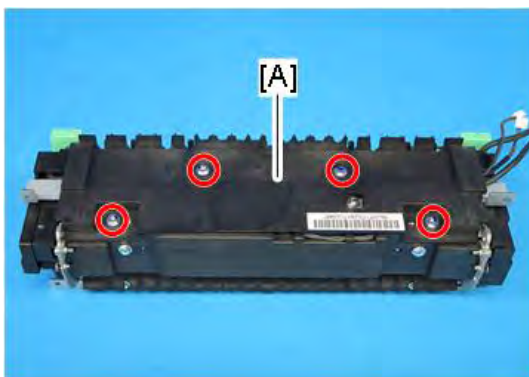

 x4

m0c3c4083

### 4.9.3 THERMOSTAT

1. Remove the fusing unit (*Fusing Unit*).
2. Remove the fusing upper cover (*Fusing Upper Cover*)
3. Remove the thermostat [A].

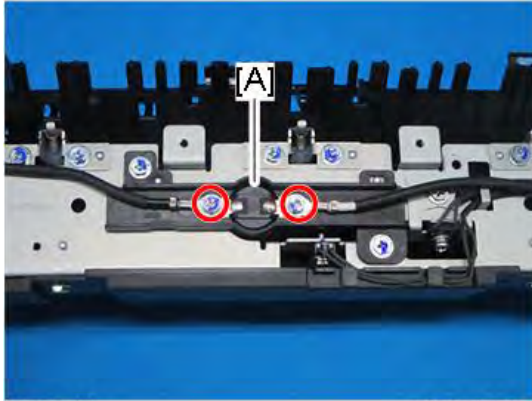

 x2

m0c3c4052

## 4.9.4 FUSING THERMISTOR

1. Remove the fusing unit (*Fusing Unit*).
2. Remove the fusing upper cover (*Fusing Upper Cover*).
3. Remove the fusing front cover [A].

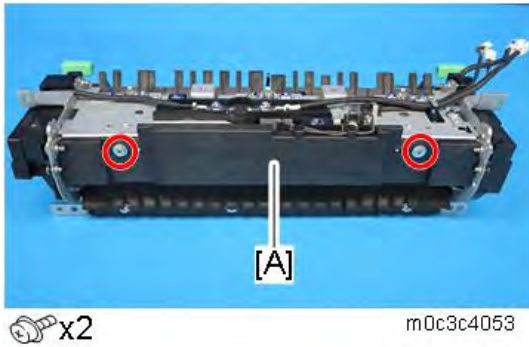

4. Remove the fusing thermistor [A].

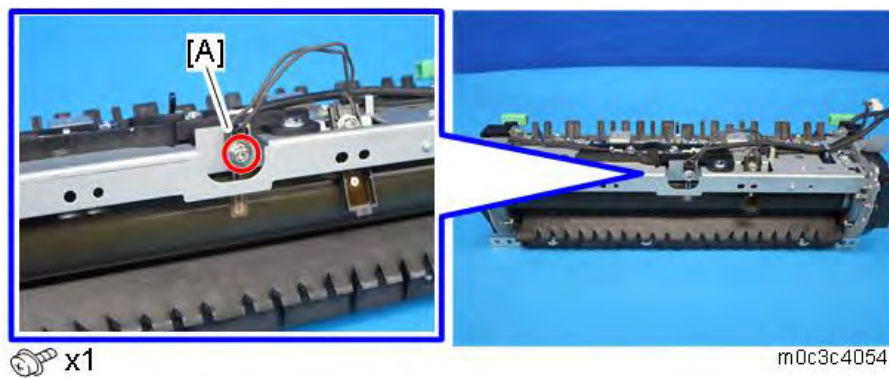



## 4.9.5 FUSING LAMP

1. Remove the fusing unit (*Fusing Unit*).
2. Remove the fusing side covers [A] (🔩 x 2 each).

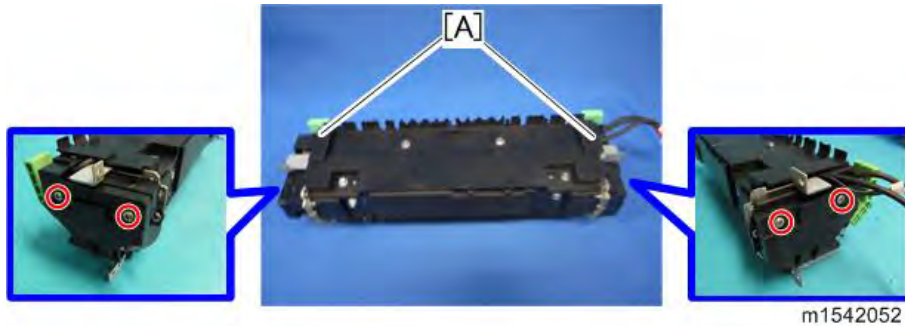

3. Turn the fusing unit over.
4. Remove the screws on both sides (🔩 x 1 each).



### ⬇ Note

Hold the terminal and flat nut with your finger firmly. Otherwise, the lamp secured together with the flat nut moves with rotation of the screw, which causes the lamp to break.



5. Remove the fusing lamp [A].

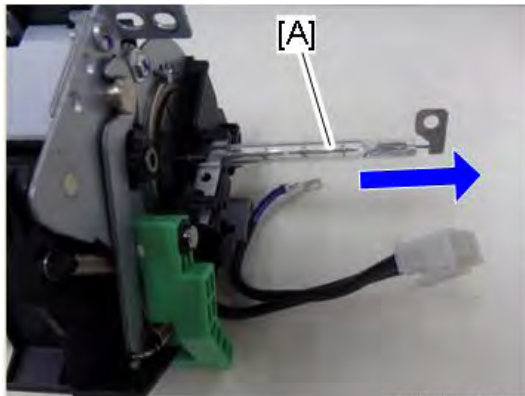

m0c3c4057

**Note**

Pull out the fusing lamp while aligning the flat terminal [B] with the notch [A] on the right side of the hot roller.

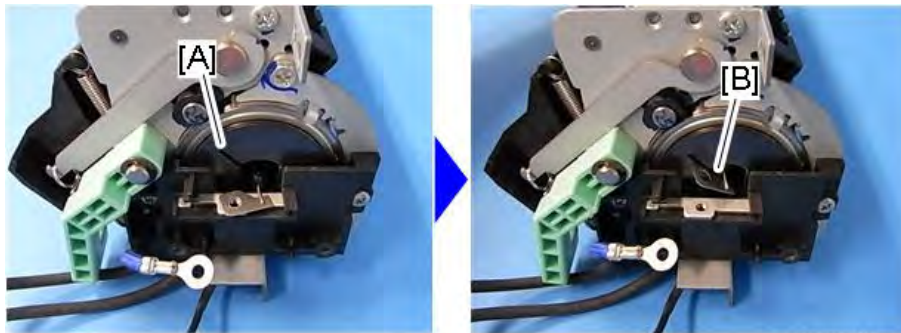

m0c3c4085

When installing a new lamp, the flat terminal [A] as shown below must be on the right side of the fusing unit (fusing cable side).



m1542055

### 4.9.6 HOT ROLLER STRIPPER PAWLS

1. Remove the fusing unit (*Fusing Unit*).
2. Remove the fusing upper cover (*Fusing Upper Cover*).
3. Remove the metal holders [A] (1 holder for each pawl:  x 2 each).

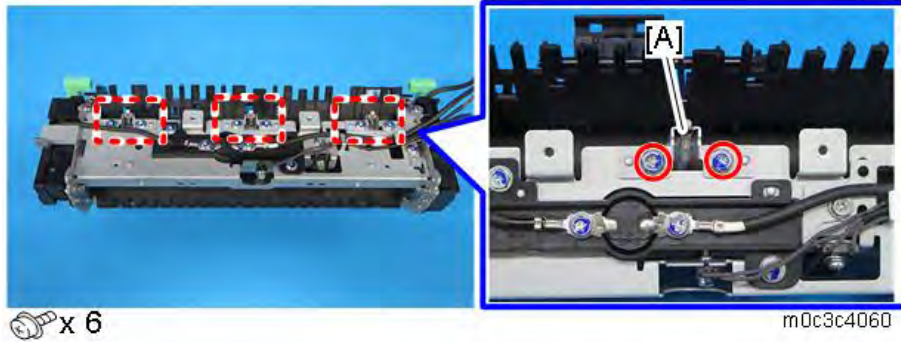

4. Remove the hot roller stripper pawls [A] (1 spring for each pawl).

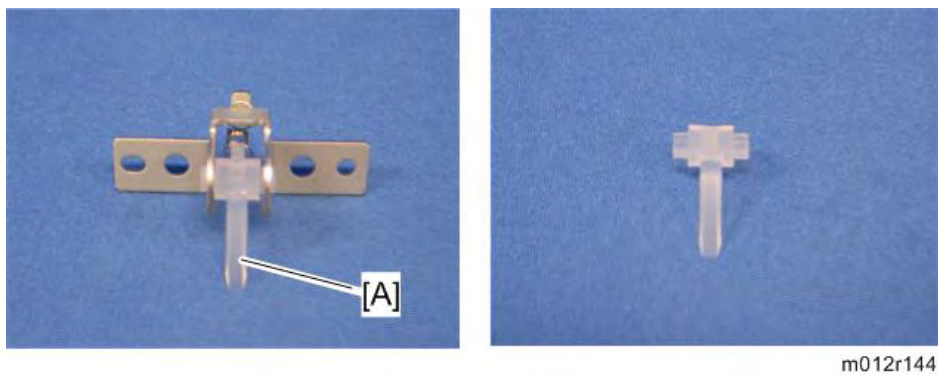

### 4.9.7 PAPER EXIT SENSOR

1. Open the rear cover.
2. Remove the paper exit sensor [A].

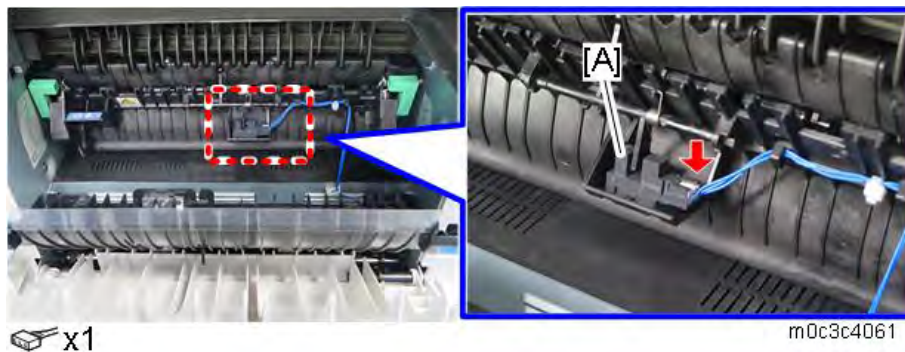

## 4.10 DUPLEX

### 4.10.1 DUPLEX SENSOR

1. Open the rear cover.
2. Remove the duplex sensor [A].





## 4.11 DRIVE

### 4.11.1 MAIN MOTOR

1. Remove the left cover (**Printer models: *Left Cover*, MF models: *Left Cover***).
2. Remove the main board (***Main Board***).
3. For MF models, remove the main board bracket (***FCU (Only for Fax Models)***).
4. Remove the harness guide plate [A].

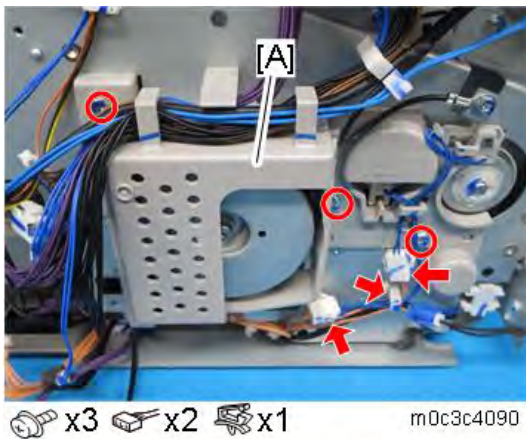

5. Remove the main motor [A].

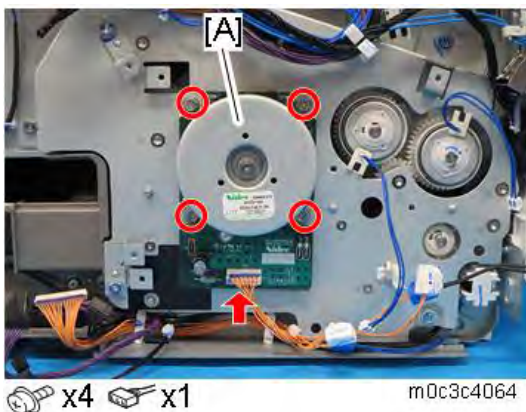

#### Note

When re-installing the harness guide plate, first set the stopper of the relay clutch [A] over the projection.

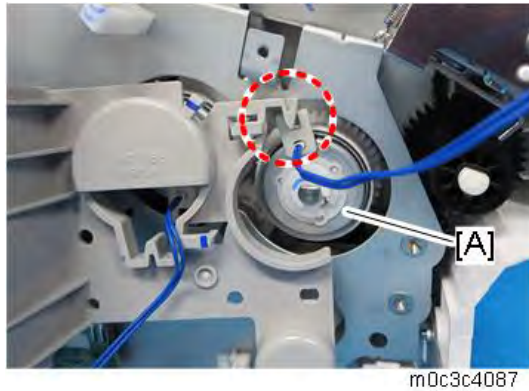

Make sure that the stoppers of the clutches are set over the projections on the harness guide plate.



## 4.11.2 DRIVE UNIT

1. Remove the left cover (**Printer models: *Left Cover* MF models: *Left Cover***).
2. Remove the main board (***Main Board (Printer Models)***).
3. For MF models, remove the main board bracket (***FCU (Only for Fax Models)***).
4. Remove the harness guide plate [A].

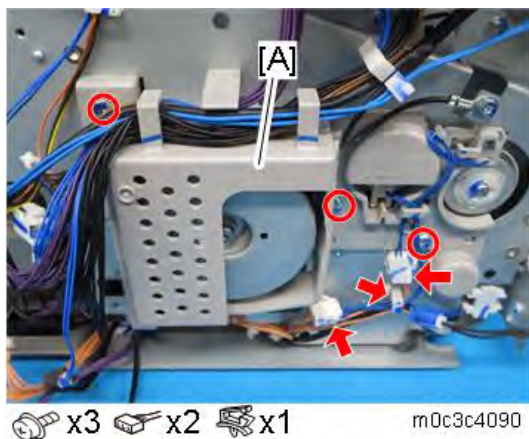

5. Release the four hooks, and remove the timing belt cover [A].
6. Remove the gear [B] and loosen the timing belt [C].

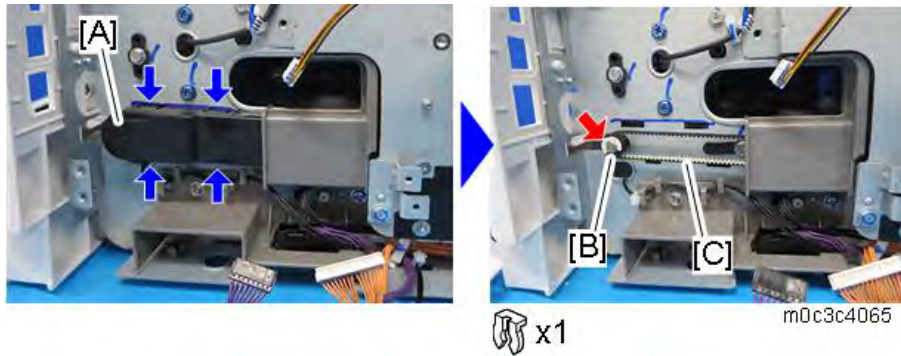

7. Remove the drive unit [A].

**Printer models:**

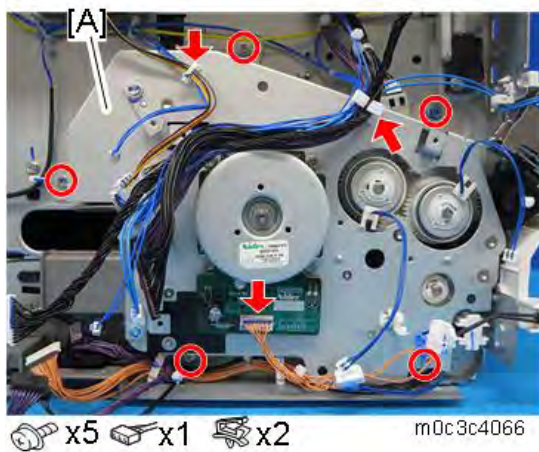

**MF models:**

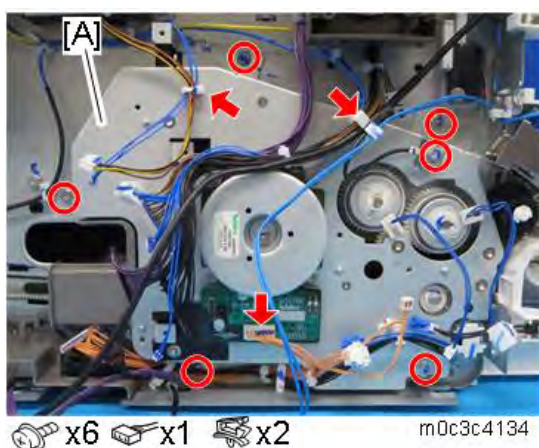

**Note**

When re-installing the harness guide plate, first set the stopper of the relay clutch [A] over the projection.



## Drive

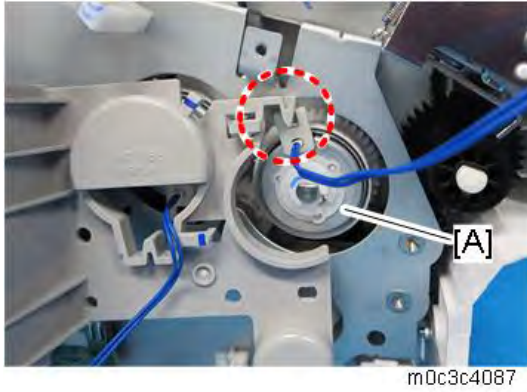

Make sure that the stoppers of the clutches are set over projections on the harness guide plate.

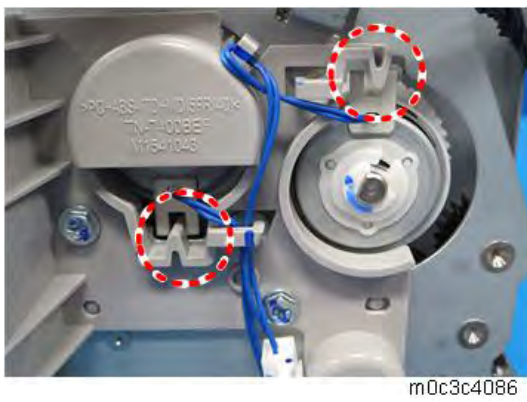

### 4.11.3 DUPLEX MOTOR

1. Remove the top cover (Printer models: *Top Cover* MF models: *Top Cover*).
2. Remove the duplex motor [A].

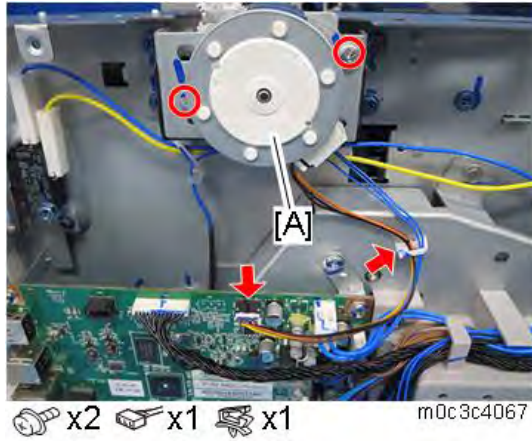

## 4.12 ELECTRICAL COMPONENTS

### 4.12.1 MAIN BOARD

Settings such as network settings and initial settings are registered in the flash memory on the main board.

When replacing the main board, ask the customer to back up/restore the settings in Administrator Tools in the WIM.

Backup Setting:

- Back up Network Settings
- Back up Menu Settings
- Back up Scan Destination
- Back up Address Book

#### ***Main Board (Printer Models)***

1. Remove the left cover (**Left Cover**).
2. Remove the main board [A].

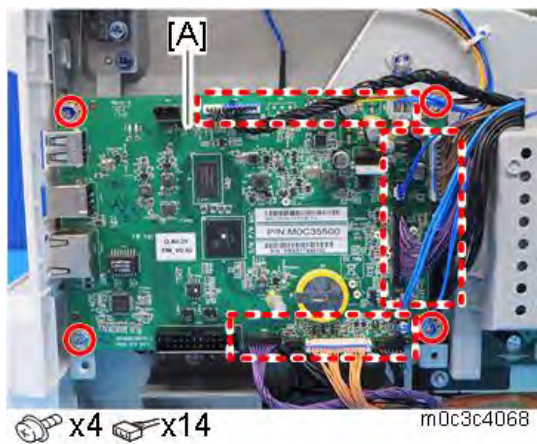

### Main Board (MF Four-line LCD Models)

1. Remove the left cover (**Left Cover**).
2. Remove the main board [A].

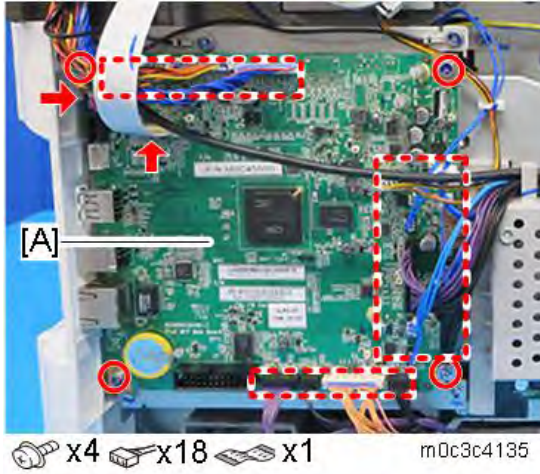

#### Note

Disconnect the scanner FFC by pulling it out straight, because it does not have a lock mechanism.



### Main Board (MF Touch Panel Models)

1. Remove the left cover (**Left Cover**).
2. Remove the main board [A].

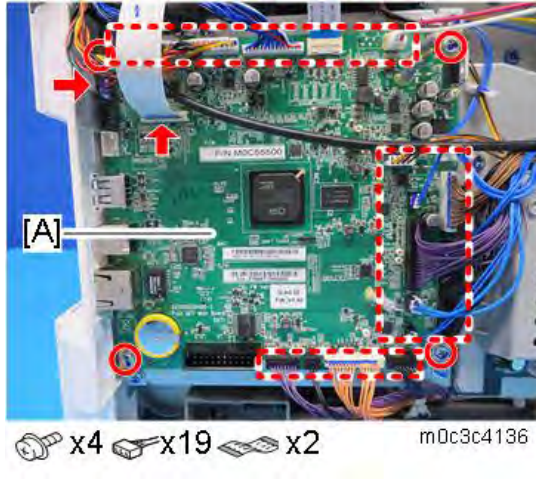

**Note**

Disconnect the scanner FFC by pulling it out straight, because it does not have a lock mechanism.



Disconnect the touch panel FFC while pressing the lock release button.

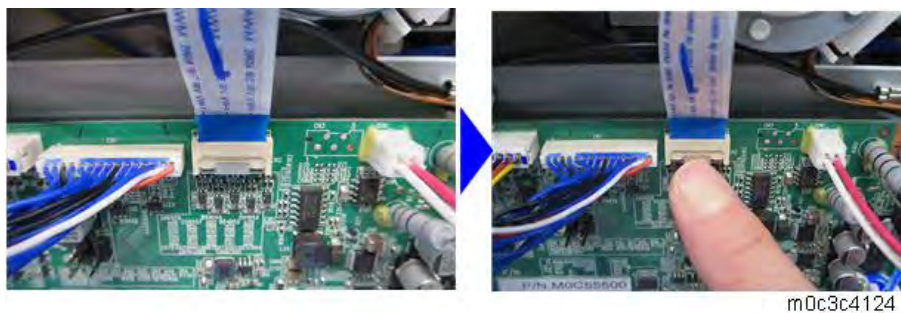

When installing the main board [A], be careful of the connection to the FCU behind it.

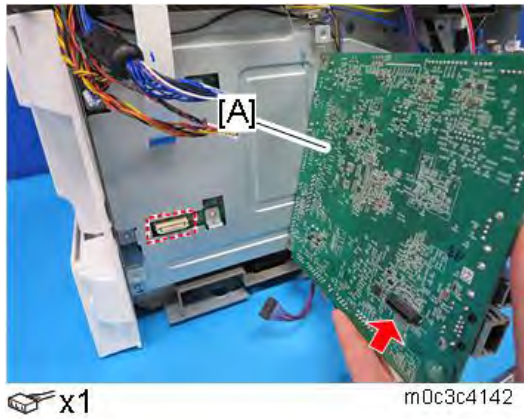

### When Installing the New Main Board

After replacing the main board, the following settings must be made correctly.

1. Enter the "Maintenance Mode", and set the SPs below;

- Destination

**Four-line LCD models:** SP menu > [Engine Maintenance] > [Destination]

**Touch panel models:** SP menu > [Engine Service Setting] > [Destination]

Destination	Machine Code	Setting Value
NA	M0C3-17, M0C6-17, M0C4-17, M0C5-17, M0C7-17	1
EU/AA	M0C3-27, M0C6-27, M0C4-27, M0C5-27, M0C7-27	2
CHN	M0C3-21, M0C4-21, M0C5-21	4
TWN	M0C3-19, M0C5-19	5

- Serial No.

**Four-line LCD models:** SP menu > [Engine Maintenance] > [Serial No.]

**Touch panel models:** SP menu > [Engine Service Setting] > [Serial No.]

**Note**

Ask your supervisor about how to enter the "Maintenance Mode".

2. Do the registration adjustment ([Registration Adjustment](#))
3. For @Remote models, make sure that the manual call can be performed.

**Note**

If the serial number is not input correctly, @Remote service cannot be connected.



## 4.12.2 PSU

### ⚠ CAUTION

Do not touch the areas outlined in red in the following diagrams when replacing the PSU. Residual charge on the board may cause electric shock.

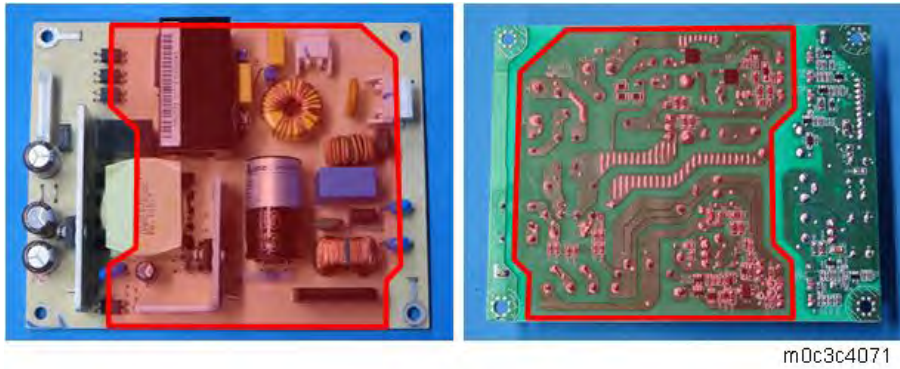

1. Remove the right cover (**Printer models:** *Right Cover*, **MF models:** *Right Cover*).
2. Remove the PSU [A].

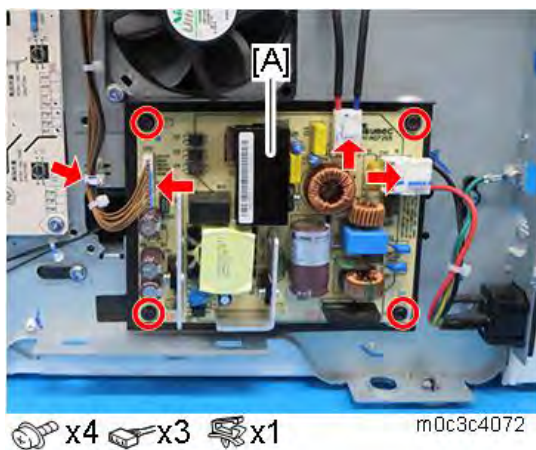

### 4.12.3 HVP

1. Remove the right cover (Printer models: *Right Cover*, MF models: *Right Cover*).
2. Remove the HVP [A].

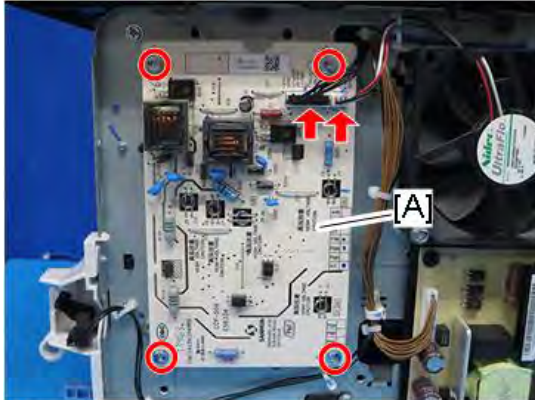

🔑 x4 🔑 x2

m0c3c4073

#### Note

After removing the HVP, the terminal pins are left in the machine, so be careful not to lose them.

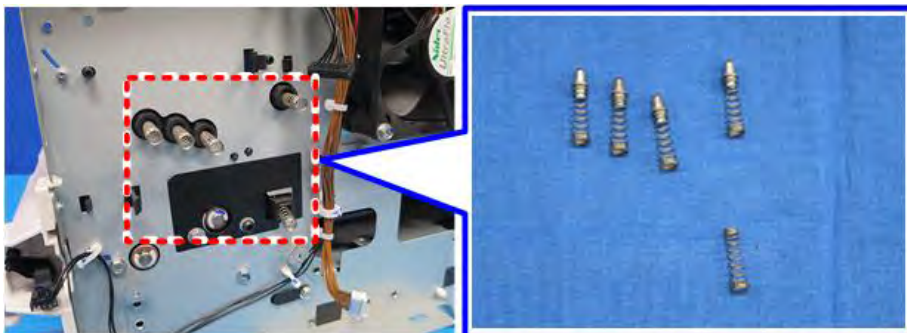

m0c3c4074

When installing the HVP, make sure that the terminal pins contact the terminals of the HVP straight, and not at an angle.

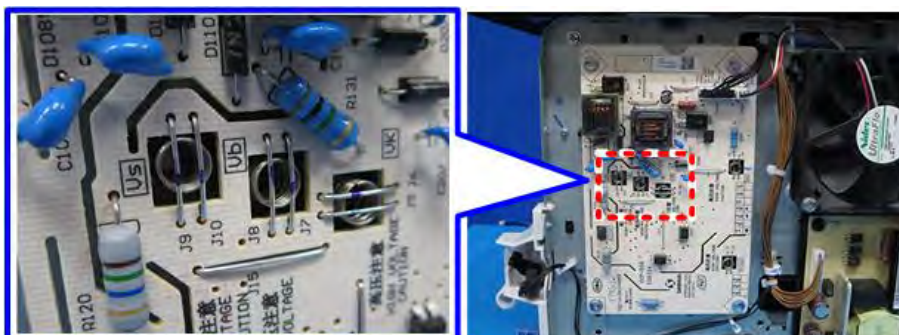

m0c3c4075

## 4.12.4 COOLING FAN

1. Remove the right cover (Printer models: *Right Cover*, MF models: *Right Cover*).
2. Remove the cooling fan [A].

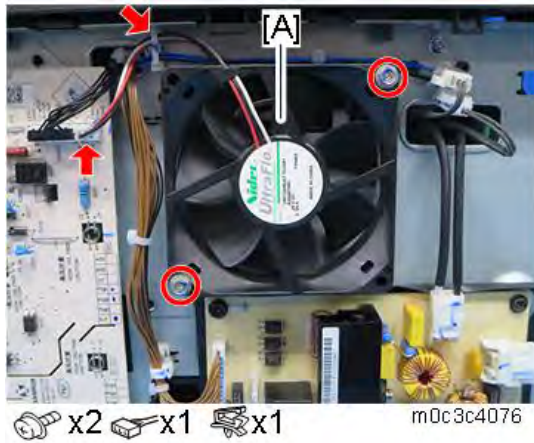

### ⚠ CAUTION

- Install the cooling fan with its decal facing the outside of the machine.

## 4.12.5 ENVIRONMENT THERMISTOR

1. Remove the left cover (Printer models: *Left Cover*, MF models: *Left Cover*).
2. Remove the environment thermistor [A].

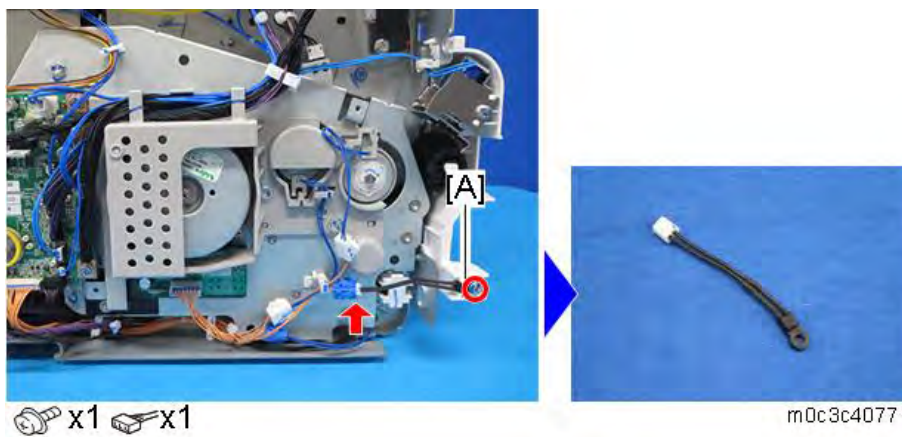



### 4.12.6 ID CHIP BOARD

1. Remove the top cover (Printer models: *Top Cover*, MF models: *Top Cover*).
2. Release the three hooks, and remove the ID chip board [A].

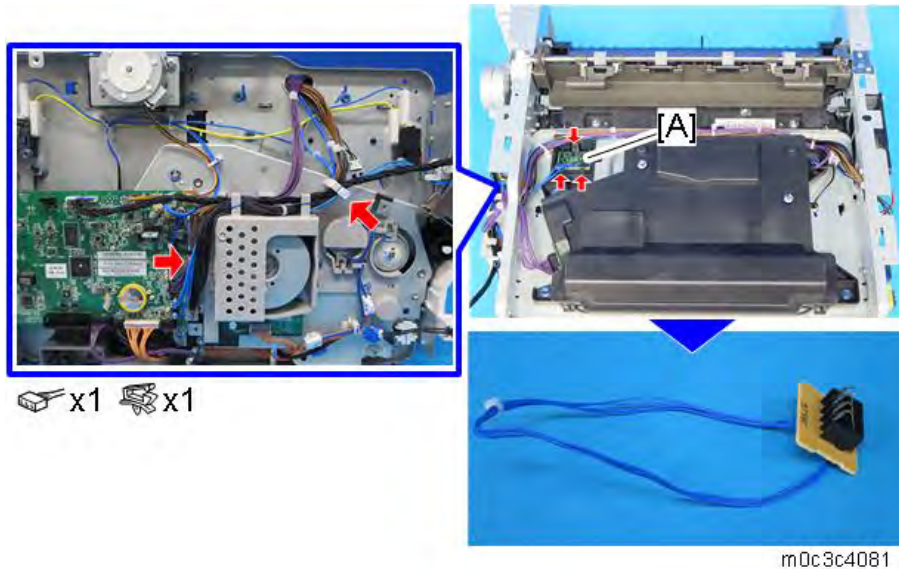

### 4.12.7 FRONT COVER SWITCH, REAR COVER SWITCH

1. Remove the left cover (Printer models: *Left Cover*, MF models: *Left Cover*).
2. For MF models, remove the main board (*Main Board*).
3. For MF models, remove the main board bracket (*FCU (Only for Fax Models)*).
4. Remove the front cover switch [A] and the rear cover switch [B].

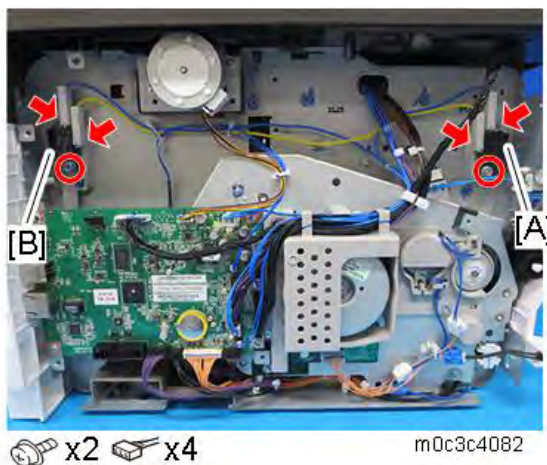

### 4.12.8 USB PORT (ONLY FOR MF MODELS)

1. Remove the left cover (*Left Cover*).
2. Remove the USB port [A].

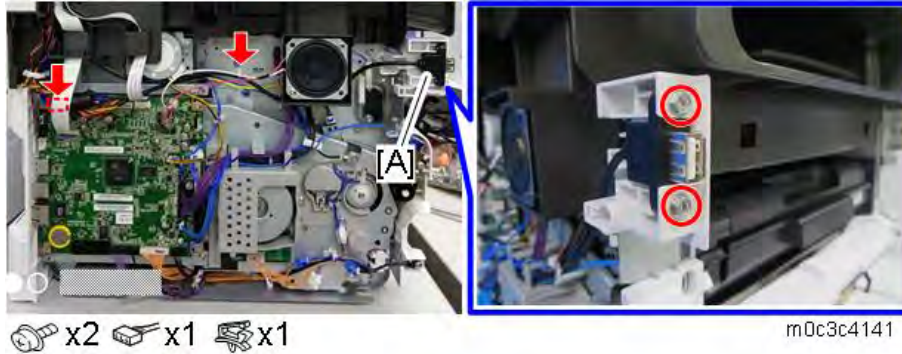

### 4.12.9 FCU (ONLY FOR FAX MODELS)

1. Remove the main board (*Main Board (MF Touch Panel Models)*).
2. Remove the main board bracket [A].

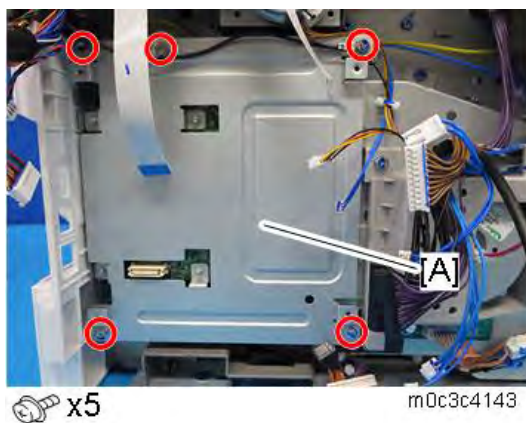

3. Remove the FCU [A].

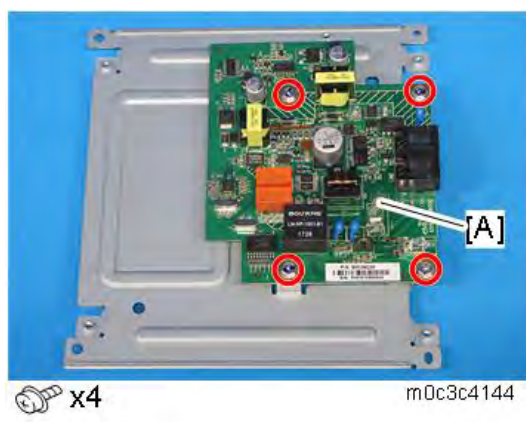

#### 4.12.10 SPEAKER (ONLY FOR FAX MODELS)

1. Remove the left cover (*Left Cover*).
2. Remove the speaker [A].

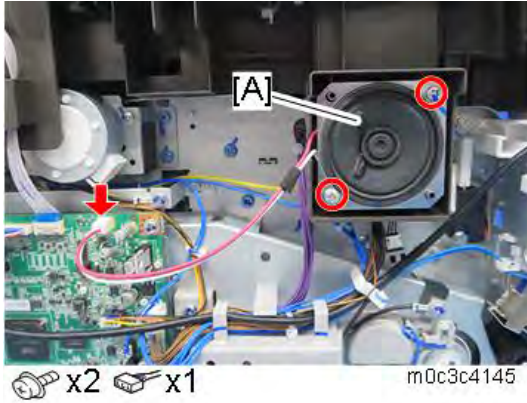



## 4.13 IMAGE ADJUSTMENT

### 4.13.1 REGISTRATION ADJUSTMENT

#### ***User Adjustment***

The paper registration can also be adjusted with the user mode ("User Tools "). For details, see the "User Guide".

#### ***Service Adjustment***

1. Enter the "Maintenance Mode (SP mode)".



For information on how to enter the "Maintenance Mode (SP mode)", contact the supervisor in your branch office.

2. Print test pattern pages. ([To Print the Test Pattern](#))
3. Select [Registration].
4. Select the item you want to adjust.
5. Press the [▲] or [▼] keys (for touch panel models, press [+] or [-]) to set the registration value (mm).



- Increase the value to shift the print area in the plus direction.
- Decrease to shift in the minus direction.

- Adjust the margins of the test page so that they are equal in size.

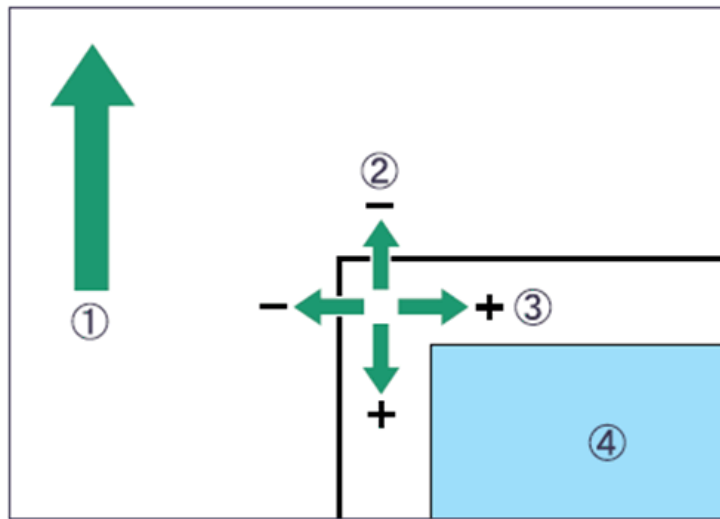

m0161500

- (1): Feed Direction
- (2): Vertical Adjustment
- (3): Horizontal Adjustment
- (4): Print Area

# SYSTEM MAINTENANCE

REVISION HISTORY		
Page	Date	Added/Updated/New
5	10/17/2018	Added DFU Message to EM Life Display
19	10/17/2018	Added DFU Message to EM Life Display
51	10/17/2018	Added DFU Message to EM Life Display

---

## 5. SYSTEM MAINTENANCE

### 5.1 MAINTENANCE MODE (FOR FOUR-LINE LCD MODELS)

#### 5.1.1 OVERVIEW

This model has several service menus. Each service menu has several adjustment items.

##### ***Maintenance Mode Menu***

- Display Info
- Engine Maintenance
- Scan Maintenance (only for MF models)
- Factory Default
- CTL Maintenance
- System Maintenance
- @Remote

##### ***Entering the Maintenance Mode***

For information on how to enter the "Maintenance Mode", contact the supervisor in your branch office.

##### ***Selecting an Item***

To select an item, press the [▲] or [▼] key.

##### ***Going into the Next Level/ Returning to the Previous Level***

To go into the next level of an item, select an item then press the [OK] key.

To return to the previous level of an item, press the [Back] key.

##### ***Exiting the Maintenance Mode Menu***

To exit the maintenance mode menu, press the [Clear/Stop] or [Back] key until the "Ready" display appears.

## 5.1.2 MENU LIST

### *Display Info*

Menu		Description	
Model Name		Displays the model name, depends on engine firmware settings	
FW Version	CTL FW Version	Displays the firmware version	
	FAX FW Version	Displays the fax firmware version. (Only for fax models)	
	Engine FW Version	Displays the engine firmware version	
Counter	Printer Counter	Black image	Displays the total counters of the printer engine.
		Scanner Counter	
	Total Page		
	Color Image		
	Black Image		
	ADF Used		
	Jam Counter	Jam Total	Displays the number of paper jams at each location.
		ADF	
		Printer Out Bin	
		Internal	
Tray1			
Tray2			
Duplex			
WiFi Channel Type		Displays the WiFi channel type.	

### *Engine Maintenance*

Menu	Description
PnP Name	<b>DFU</b> (Designed for Factory Use). [0x00 to 0x7F]
2Beam LD Power	Adjusts the LD power. [74 to 137 / 106 / 1/step]

Menu		Description
Interval Setting		<p>Corrects the face curl of paper.</p> <p>0: OFF (32ppm)</p> <p>1: Sets the engine speed to half after printing 1 minute.</p> <p>2: Sets the engine speed at 13ppm.</p> <p>[0 to 2 / 0 / 1 /step]</p>
Toner Near End	Sheets	<p>Adjusts the printable sheets between "toner near end" and "toner end".</p> <p>[50 to 250 / 200 / 25 sheet/step]</p>
	Dot Count	<p>Adjusts the printable dot count between "toner near end" and "toner end".</p> <p>[50 to 150 / 100 / 25 dot/step]</p>
Subscan Magnification		<p>Adjusts the sub scan magnification.</p> <p>[-8 to 8 / 0 / 1/step]</p>
Trans Roller Bias		<p>Adjusts the transfer roller bias.</p> <p>[-6 to 6 / 0 / 1/step]</p>
Developer Bias		<p>Adjusts the developer bias.</p> <p>[270 to 330 / 250 / 15/step]</p>
Charge Bias		[1100 to 1300 / 1200 / 25/step]
Fusing Unit Temperature	Plain Paper	<p>Adjusts the fusing temperature for plain paper.</p> <p>[150 to 200 / 175 / 1°C/step]</p>
	Recycled	<p>Adjusts the fusing temperature for recycled paper.</p> <p>[160 to 180 / 170 / 1°C/step]</p>
	Postcard	<p>Adjusts the fusing temperature for postcards.</p> <p>[170 to 200 / 185 / 1°C/step]</p>
	Envelope	<p>Adjusts the fusing temperature for envelopes.</p> <p>[170 to 200 / 185 / 1°C/step]</p>
	Thin Paper	<p>Adjusts the fusing temperature for thin paper.</p> <p>[155 to 180 / 170 / 1°C/step]</p>
	Low Power	<p>Adjusts the fusing temperature in the low power mode.</p> <p>[80 to 135 / 120 / 1°C/step]</p>
	Standby	<p>Adjusts the fusing temperature in the standby mode.</p>



Menu	Description
	[120 to 175 / 155 / 1°C/step]
Thick2 Paper	Adjusts the fusing temperature for thick 2 paper. [170 to 200 / 185 / 1°C/step]
Thick1 Paper	Adjusts the fusing temperature for thick 1 paper. [175 to 200 / 185 / 1°C/step]
Paper Buckle Amo.	Vert .Bp Plain Paper Adjusts the amount of paper buckle at the registration roller for each tray and paper type. [-8 to 8 / -2 (Default) / 1mm/step]
Vert .Bp Thick Paper	[-8 to 8 / 0 (Default) / 1mm/step]
Vert .Bp Thin Paper	[-8 to 8 / -2 (Default) / 1mm/step]
Vert .Tray1 Plain Paper	[-8 to 8 / -2 (Default) / 1mm/step]
Vert .Tray1 Thick Paper	[-8 to 8 / 0 (Default) / 1mm/step]
Vert .Tray1 Thin Paper	[-8 to 8 / -2 (Default) / 1mm/step]
Vert .Dup. Plain Paper	[-8 to 8 / 0 (Default) / 1mm/step]
Vert .Dup. Thick Paper	[-8 to 8 / 0 (Default) / 1mm/step]
Vert .Dup.1 Thin Paper	[-8 to 8 / 0 (Default) / 1mm/step]
Output Check	Main Motor Output check (Main motor)
	Middle Clutch Output check (Relay clutch)
	Tray1 Clutch Output check (Paper feed clutch)
	Bypass Solenoid Output check (By-pass feed solenoid)
	Regist Clutch Output check (Registration clutch)
	Fan High Speed Output check (Cooling fan high speed)
	Fan Low Speed Output check (Cooling fan low speed)
	Erase Lamp Output check (Quenching lamp)
	Polygon Output check (Polygon mirror motor)

Menu		Description
	Motor	
	Dup Motor Normal	Output check (Duplex motor normal)
	Dup Motor Revers	Output check (Duplex motor reverse)
⇒	EM Life Display DFU (Designed for Factory Use)	Sets whether to display an alert when each EM parts yield of this machine is reached. [On or Off (Default)]
	SC559 Detection	[On or Off (Default)]
	Clear Engine Memory	Resets the engine settings stored in the EEPROM to factory default.
	Total Counter Info	Displays the total counter (Engine).
EM Counter Info	Transfer Roller - Time	Displays the EM counter (Transfer Roller: Time).
	Paper Feed Roller – Pages	Displays the EM counter (Paper Feed Roller: pages).
	Fusing Unit - Time	Displays the EM counter (Fusing Unit: time).
	Transfer Roller - Pages	Displays the EM counter (Transfer Roller: pages).
	Fusing Unit - Pages	Displays the EM counter (Fusing Unit: pages).
	Transfer Roller Remain	Displays the remainder until the service life (Transfer roller: %)
	Paper Feed Roller Remain	Displays the remainder until the service life (Paper feed roller: %)
	Fusing Unit Remain	Displays the remainder until the service life (Fusing unit: %)
OPC Life Info	OPC Rotation Time	Displays the OPC life information (OPC rotation time).
	Pre-OPC Rotation	Displays the OPC life information (Pre-OPC rotation time)

Menu		Description
	Time	
	OPC Alert Status	Displays the OPC life information (Alert status)
	OPC Pre-Alert Status	Displays the OPC life information (Pre-Alert status)
Prt Cartridge Info	Kind ID	Displays the toner cartridge (AIO) information (Kind ID).
	Toner End History	Displays the toner cartridge (AIO) information (Toner End History).
	Refill Flag Status	Displays the toner cartridge (AIO) information (Refill flag status).
	Unit Print Counter	Displays the toner cartridge (AIO) information (Unit Print Counter).
Motor Rotation Time		Displays the main motor rotation time.
Reset Fuser Unit		Clears the EM counter of the fusing unit.
Reset Paper Feed Rol Life		Clears the EM counter of the paper feed roller.
Reset Transfer Unit		Clears the EM counter of the transfer roller.
Fuser SC Reset		This menu is for resetting an SC related to a fusing error.
Brand ID		<b>DFU</b> Displays the current brand ID number. [0x00 – 0x7F]
Registration	Horiz. Tray1	Adjusts the horizontal registration for each tray and paper type. If the machine settings are reset to the factory defaults, this value does not change. [-40.0 to 40.0 / -7.0 (Default) / 0.1 mm/step]
	Vert. Tray1 Plain	[-40.0 to 40.0 / 23.0 (Default) / 0.1 mm/step]
	Vert. Tray1 Thick	[-40.0 to 40.0 / 23.0 (Default) / 0.1 mm/step]
	Vert. Tray1 Thin	[-40.0 to 40.0 / 23.0 (Default) / 0.1 mm/step]
	Horiz. Tray2	[-40.0 to 40.0 / -7.0 (Default) / 0.1 mm/step]
	Vert. Tray2 Plain	[-40.0 to 40.0 / 23.0 (Default) / 0.1 mm/step]
	Vert. Tray2 Thick	[-40.0 to 40.0 / 23.0 (Default) / 0.1 mm/step]
	Vert. Tray2 Thin	[-40.0 to 40.0 / 23.0 (Default) / 0.1 mm/step]

Menu		Description
	Horiz Bypass tray	[-40.0 to 40.0 / -7.0 (Default) / 0.1 mm/step]
	Vert Bypass Plain	[-40.0 to 40.0 / 23.0 (Default) / 0.1 mm/step]
	Vert Bypass Thick	[-40.0 to 40.0 / 23.0 (Default) / 0.1 mm/step]
	Vert Bypass Thin	[-40.0 to 40.0 / 23.0 (Default) / 0.1 mm/step]
	Horiz. Dup. Back	[-40.0 to 40.0 / 0 (Default) / 0.1 mm/step]
	Vert Dup Plain	[-40.0 to 40.0 / 21.0 (Default) / 0.1 mm/step]
	Vert Dups Thick	[-40.0 to 40.0 / 21.0 (Default) / 0.1 mm/step]
	Vert Dup Thin	[-40.0 to 40.0 / 21.0 (Default) / 0.1 mm/step]
Destination		<b>DFU</b> Sets the destination and updates the engine setting. [DOM/ NA/ EU/ ASIA/ CHN/ TAIWAN]
Test Pattern		Prints the test pattern.
Toner Disposal		Sets the machine operation at "waste toner full" of the refilled AIO. [On or Off (Default)]  With the main motor rotation count feature, the machine can be set to stop printing after the print total exceeds a certain set value. If the print count exceeds this value, then "Replace Print Cartridge" remains in the display. Then a new AIO cartridge must be installed. This feature is a safety measure to prevent the used toner tank from becoming full (there is no toner overflow detection mechanism).
1200DPI Power		Adjusts print density (density levels by increasing the number) [42 to 106 / 74 (Default) / 1 /step]
Refill Mode		<b>DFU</b> [Auto refill mode/ Pure refill mode]
Page Dot Coverage	0%-2%	Displays the number of pages printed with coverage 0 to 2%.
	3%-4%	Displays the number of pages printed with coverage 3 to 4%.

Menu		Description
	5%-7%	Displays the number of pages printed with coverage 5 to 7%.
	8%-9%	Displays the number of pages printed with coverage 8 to 9%.
	10%-19%	Displays the number of pages printed with coverage 10 to 19%.
	20%-29%	Displays the number of pages printed with coverage 20 to 29%.
	Above 30%	Displays the number of pages printed with coverage above 30%.
Power On Count		Displays the power on counter.
Sleep Recover Count		Displays the sleep recover counter.
Machine Series Number		<b>DFU</b> Displays the machine series number.
Serial No		<b>DFU</b> Displays the machine serial No.
Inrush Control		Sets the Inrush Control mode. When using with an external power supply instead of a commercial power supply, set to "On". [Off (Default)/ On]
Flicker Control		Sets the Flicker Control mode. [Off (Default)/ On]

**Scan Maintenance (Only for MF Models)**

Menu		Description
Mono Compression		Sets the monochrome compression type for scanning. MH (Default)/ MR/ MMR
Registration Adjust	ADF Main Reg.	Adjusts the ADF Scan main-scan registration. [-2.0 to 2.0 / 0 (Default)/ 0.1 mm/step]
	ADF Sub Reg.	Adjusts the ADF Scan sub-scan registration. [-2.0 to 2.0 / 0 (Default)/ 0.1mm/step]
	Flatbed Main Reg.	Adjusts the Flatbed Scan main-scan registration. [-2.0 to 2.0 / 0 (Default)/ 0.1mm/step]
	Flatbed Sub Reg.	Adjusts the Flatbed Scan sub-scan registration. [-2.0 to 2.0 / 0 (Default)/ 0.1mm/step]
Size Adjust	ADF Main Reg.	Adjusts the ADF Scan main-scan magnification. [-0.9 to 0.9 / 0 (Default)/ 0.1 %/step]
	ADF Sub Reg.	Adjusts the ADF Scan sub-scan magnification.

Menu		Description
		[-0.9 to 0.9 / 0 (Default)/ 0.1 %/step]
	Flatbed Main Reg.	Adjusts the Flatbed Scan main-scan magnification. [-0.9 to 0.9 / 0 (Default)/ 0.1 %/step]
	Flatbed Sub Reg.	Adjusts the Flatbed Scan sub-scan magnification. [-0.9 to 0.9 / 0 (Default)/ 0.1 %/step]

### Factory Default

Menu		Description
Factory Default	Return	Does not execute anything. Returns to an upper level.
	Execute	Resets all the settings to factory default. <div style="border: 1px solid blue; border-radius: 10px; padding: 2px; display: inline-block; margin-top: 5px;"> <span style="color: blue;">↓</span> Note         </div> <p>Clears/ resets the contents of the controller memory (all data programmed by the user, log data application counters) to factory default. After executing, initial setup menu starts after power-on.</p>

### CTL Maintenance

Menu	Description
PDL Mode	ON = "PDL Settings" is shown in [Print List/Report] menu (Default) OFF = "PDL Settings" is hidden
FW Update Mode	If updating firmware on a machine in which LDAP authentication is set, execute this mode. [Execute/ Return] After pressing "Execute", the display shows "Please Restart Machine...." Turn the machine's main power off, and then on. Then the machine activates in a special boot loader mode. After that, update the firmware via USB cable.
Auto IP	ON = Automatically set an IP address when an IP address cannot be acquired (Default) OFF = Continually try to obtain an IP address by DHCP
Disable USB Port	Sets whether the USB port function is valid or invalid [Off (Default)/On]
Paas Validity Setting	When used to set Paas (Only for CHN) [Inactive (Default)/ Active]



**System Maintenance**

Menu	Description
Air Print Enable	Sets whether the Air Print function is enabled or disabled  [Disable/ Enable (Default)]
Debug Tools	[Off (Default)/ NIC/ USB]

**@Remote**

Menu	Description
Supply Alarm	Toner Supply Alarm Sets the toner supply alarm. [Disable (Default)/ Enable]
	Toner Call Timing [At rplcment / At NearEnd]
SC/Alarm Setting	SC Call Sets the SC call. [Disable/ Enable (Default)]
	User Call Sets the user call. [Disable/ Enable (Default)]
	Comm. Test Call Sets the communication test call. [Disable/ Enable (Default)]
	Machine Info Notice Sets the machine information notice. [Disable/ Enable (Default)]
	Supply Auto Ordering Call Sets the supply auto ordering call. [Disable/ Enable (Default)]
Machine No. Setting	ID2 Code Display Displays the ID2 code (ASCII 17digits).
Remote Service	CE Call Performs the CE Call at the start or end of the service.
	Function Flag Enables or disables the remote service function. [Disable (Default)/ Enable]
	Communication Test Executes the communication test.
	Device Info Executes the device information notification.
	RCG Reg. State Displays the RCG registration status. [0 to 2]
	GW URL Displays the URL for RCG center.
	Polling Interval Sets the polling interval.

Menu	Description
	[0 to 4294967295 / 60 / 1 sec/step]
HTTP Con Timeout	Specifies the connect timeout interval when calling the RCG. [1 to 90 / 30 / 1 sec/step]
HTTP Sen Timeout	Specifies the send timeout interval when calling the RCG. [0 to 100 / 30 / 1 sec/step]
HTTP Rec Timeout	Specifies the receive timeout interval when calling the RCG. [0 to 100 / 30 / 1 sec/step]
HTTP Retry Interval	If the HTTP connection fails, specify the interval at which the connection will be retried again.[0 to 65535 / 3 / 1 sec/step]
HTTP Retry #	If the HTTP connection fails, specify the number of times to retry the connection. [0 to 255 / 3 / 3 counts/step]
HTTP Con Delay	Specifies the connection request sending delay. [0 to 255 / 5 / 1 sec/step]
Max Multipart	Specifies the maximum number of multipart. [0 to 10 / 10 / 1/step]
Rescue G/W URL	Displays the rescue URL.
Per Notice Mode	Sets the periodic notification mode. [0 to 5 / 0 / 1/step]
Cnt Notice Mode	Sets the counter notification mode. [0 to 5 / 0 / 1/step]
Per Notice Time	Displays the periodic notification date and time.
Cnt Notice Time	Displays the counter notification date and time.
Cnt End Time	Displays the counter closing date and time.
Next Per NotiTime	Displays the next periodic notification date and time.
Next Cnt NotiTime	Displays the next counter notification date and time.
Next Cnt End Time	Displays the next counter closing date and time.
Fix CntPol Time	Displays the center control polling date and time.
Test Flag	Sets the test flag. [0 to 255 / 0 / 1/step]

Menu	Description
Update Result	Displays the center information update results.
Mgn Expir Time	Specifies the margin to notify the proximity of the expiration of the certification. [2592000 to 15552000 / 2592000 / 1 sec/step]
NotiTime ExpTime	Displays the date and time to notify the proximity of the expiration of the certification.
HTTP Proxy use	Determines if the proxy server is used when the machine communicates with the service center.
HTTP Proxy Host	Inputs the address of the proxy server used for communication between the RCG Device and the gateway.
HTTP Proxy Port	Sets the HTTP proxy port number. [0 to 65535 / 8080 / 1/step]
HTTP Prox AutUsr	Displays the HTTP proxy authentication user.
HTTP Prox AutPass	Displays the HTTP proxy authentication password.
Cer Updt Cond	Displays the certificate renewal status.
Cer Abnml Cause	Displays the certificate renewal error reason.
Cer Updt ReqID	Displays the certificate update request ID.
CERT:MacroVsn	Displays the Macro Version.
CERT:PAC Vsn	Displays the PAC Version.
Svr CNCheck	Sets the server authentication CN check.
CERT:GW URL	Displays the NRS Gateway URL.
CERT:Use Pass	Displays the availability of PassPhrase.
CERT:Use MAC	Displays the availability of MAC.
CountNotify Int.	Display periodic notification timing (interval).
CountNotify Week	Displays periodic notification timing (day of the week).
Reg. Notify Int.	Displays the counter notification timing (interval).
Reg. Notify Week	Displays the counter notification timing (day of the week).
SSL Port	Specifies the SSL communication port. [0 to 65535 / 443 / 1/step]
Poling Man Exc	Executes poling.
Instl:Condition	Displays the @Remote status.
Instl:ID #	Inputs the request number.
Instl:Reference	Executes the reference.
Instl:Ref Rslt	Displays the reference result.

Menu	Description
Instl:Ref Section	Displays the section name.
Instl:Rgstltn	Executes registration.
Instl:Rgstltn Rst	Displays the registration result.
Instl:ErrorCode	Displays the error code.
Instl Clear	Clears the @Remote installation.
Common KeyInfo Init	Performs initialization of common key information.
Remote Diagnostics	Executes repair request notification.
CE Working Start	Displays the work start time by CE.
CE Working Total	Displays the total working time by CE.

## 5.2 MAINTENANCE MODE (FOR TOUCH PANEL MODELS)

### 5.2.1 OVERVIEW

This model has several service menus. Each service menu has several adjustment items.

#### ***Maintenance Mode Menu***

- Information Display
- Engine Service Setting
- Scanner Service Setting
- FAX Service Setting
- Print Reports
- CTL SP
- Factory Default
- @Remote

#### ***Entering the Maintenance Mode***

For information on how to enter the "Maintenance Mode", contact the supervisor in your branch office.

### 5.2.2 MENU LIST

#### ***Information Display***

Menu		Description
Model Name		Displays the model name, depends on engine firmware settings
FW Version	CTL FW Version	Displays the firmware version
	FAX FW Version	Displays the fax firmware version.
	Engine FW Version	Displays the engine firmware version
Printer Counter	Black image	Displays the total counters of the printer engine.
Scanner Counter	Total Page	Displays the sum total of scanner counters for each mode.
	Color Image	
	Black Image	
	ADF Used	

Menu		Description
Jam Counter	Jam Total	Displays the number of paper jams at each location.
	ADF	
	Printer Out Bin	
	Internal	
	Tray1	
	Tray2	
	Duplex	
WiFi Channel Type		Displays the WiFi channel type.

### Engine Service Setting

Menu		Description
PnP Name		<b>DFU</b> (Designed for Factory Use). [0x00 to 0x7F]
Destination		<b>DFU</b> Sets the destination and updates the engine setting. [DOM/ NA/ EU/ ASIA/ CHN/ TAIWAN]
Brand ID		<b>DFU</b> Displays the current brand ID number. [0x00 – 0x7F]
Registration	Horiz. Tray1	Adjusts the horizontal registration for each tray and paper type. If the machine settings are reset to the factory defaults, this value does not change. [-40.0 to 40.0 / 1.0 (Default) / 0.1 mm/step]
	Vert. Tray1 Plain	[-40.0 to 40.0 / 17.0 (Default) / 0.1 mm/step]
	Vert. Tray1 Thick	[-40.0 to 40.0 / 17.0 (Default) / 0.1 mm/step]
	Vert. Tray1 Thin	[-40.0 to 40.0 / 17.0 (Default) / 0.1 mm/step]
	Horiz. Tray2	[-40.0 to 40.0 / 2.0 (Default) / 0.1 mm/step]
	Vert. Tray2 Plain	[-40.0 to 40.0 / 17.0 (Default) / 0.1 mm/step]



Maintenance Mode (for Touch Panel Models)

Menu		Description
	Vert. Tray2 Thick	[-40.0 to 40.0 / 17.0 (Default) / 0.1 mm/step]
	Vert. Tray2 Thin	[-40.0 to 40.0 / 17.0 (Default) / 0.1 mm/step]
	Horiz. Bypass	[-40.0 to 40.0 / -5.0 (Default) / 0.1 mm/step]
	Vert. Bypass Plain	[-40.0 to 40.0 / 17.0 (Default) / 0.1 mm/step]
	Vert. Bypass Thick	[-40.0 to 40.0 / 17.0 (Default) / 0.1 mm/step]
	Vert. Bypass Thin	[-40.0 to 40.0 / 17.0 (Default) / 0.1 mm/step]
	Horiz. Dup. Back	[-40.0 to 40.0 / 8.0 (Default) / 0.1 mm/step]
	Vert. Dup. Plain	[-40.0 to 40.0 / 17.0 (Default) / 0.1 mm/step]
	Vert. Dup. Thick	[-40.0 to 40.0 / 17.0 (Default) / 0.1 mm/step]
	Vert. Dup. Thin	[-40.0 to 40.0 / 17.0 (Default) / 0.1 mm/step]
Reset Transfer Unit		Clears the EM counter of the transfer roller.
Reset Fuser Unit		Clears the EM counter of the fusing unit.
Fuser SC Reset		This menu is for resetting an SC related to a fusing error.
2 Beam LD Power		Adjusts the LD power. [74 to 137 / 106 (Default) / 1/step]
Interval Setting		Corrects the face curl of paper. 0: OFF (32ppm) 1: Sets the engine speed to half after printing 1 minute. 2: Sets the engine speed at 13ppm. [0 to 2 / 0 / 1 /step]
Toner Near End To End	Sheets	Adjusts the printable sheets between "toner near end" and "toner end". [50 to 250 / 200 / 25 sheet/step]
	Dot Count	Adjusts the printable dot count between "toner near end" and

Menu		Description
		"toner end". [50 to 150 / 100 / 25 dot/step]
Trans. Roller Bias		Adjusts the transfer roller bias. [-6 to 6 / 0 / 1/step]
Developer Bias		Adjusts the developer bias. [270 to 330 / 250 / 15/step]
Charge Bias		[1100 to 1300 / 1200 / 25/step]
Fusing Unit Temperature	Plain Paper	Adjusts the fusing temperature for plain paper. [150 to 200 / 175 / 1°C/step]
	Recycled	Adjusts the fusing temperature for recycled paper. [160 to 180 / 170 / 1°C/step]
	Postcard	Adjusts the fusing temperature for postcards. [170 to 200 / 185 / 5°C/step]
	Envelope	Adjusts the fusing temperature for envelopes. [170 to 200 / 185 / 1°C/step]
	Thin Paper	Adjusts the fusing temperature for thin paper. [155 to 180 / 170 / 1°C/step]
	Low Power	Adjusts the fusing temperature in the low power mode. [80 to 135 / 120 / 1°C/step]
	Standby	Adjusts the fusing temperature in the standby mode. [120 to 175 / 155 / 1°C/step]
	Thick2 Paper	Adjusts the fusing temperature for thick 2 paper. [170 to 200 / 185 / 1°C/step]
	Thick1 Paper	Adjusts the fusing temperature for thick 1 paper. [175 to 200 / 185 / 1°C/step]
Paper Buckle Amount	Vert .Bp Plain Paper	Adjusts the amount of paper buckle at the registration roller for each tray and paper type. [-8 to 8 / -2 (Default) / 1mm/step]
	Vert .Bp Thick Paper	[-8 to 8 / 0 (Default) / 1mm/step]
	Vert .Bp Thin	[-8 to 8 / -2 (Default) / 1mm/step]

Maintenance Mode (for Touch Panel Models)

Menu		Description
	Paper	
	Vert .Tray1 Plain Paper	[-8 to 8 / -2 (Default) / 1mm/step]
	Vert .Tray1 Thick Paper	[-8 to 8 / 0 (Default) / 1mm/step]
	Vert .Tray1 Thin Paper	[-8 to 8 / -2 (Default) / 1mm/step]
	Vert .Tray2 Plain Paper	[-8 to 8 / -2 (Default) / 1mm/step]
	Vert .Tray2 Thick Paper	[-8 to 8 / 0 (Default) / 1mm/step]
	Vert .Tray2 Thin Paper	[-8 to 8 / -2 (Default) / 1mm/step]
	Vert .Dup. Plain Paper	[-8 to 8 / 0 (Default) / 1mm/step]
	Vert .Dup. Thick Paper	[-8 to 8 / 0 (Default) / 1mm/step]
	Vert .Dup.1 Thin Paper	[-8 to 8 / 0 (Default) / 1mm/step]
Output Check	Main Motor	Output check (Main motor)
	Middle Clutch	Output check (Relay clutch)
	Tray1 Clutch	Output check (Paper feed clutch)
	Bypass Solenoid	Output check (By-pass feed solenoid)
	Regist Clutch	Output check (Registration clutch)
	Fan High Speed	Output check (Cooling fan high speed)
	Fan Low Speed	Output check (Cooling fan low speed)
	Erase Lamp	Output check (Quenching lamp)
	Polygon Motor	Output check (Polygon mirror motor)
	Dup Motor Normal	Output check (Duplex motor normal)
	Dup Motor Revers	Output check (Duplex motor reverse)
EM Life Display	Sets whether to display an alert when each EM parts yield of this	

Menu		Description
DFU (Designed for Factory Use)		machine is reached. [On or Off (Default)]
SC559 Detection		[On or Off (Default)]
Clear Engine Memory		Resets the engine settings stored in the EEPROM to factory default.
Total Counter Info		Displays the total counter (Engine).
EM Counter Info	Transfer Roller - Time	Displays the EM counter (Transfer Roller: Time).
	Paper Feed Roller – Pages	Displays the EM counter (Paper Feed Roller: pages).
	Fusing Unit - Time	Displays the EM counter (Fusing Unit: time).
	Transfer Roller - Pages	Displays the EM counter (Transfer Roller: pages).
	Fusing Unit - Pages	Displays the EM counter (Fusing Unit: pages).
	Transfer Roller Remain	Displays the remainder until the service life (Transfer roller: %)
	Paper Feed Roller Remain	Displays the remainder until the service life (Paper feed roller: %)
	Fusing Unit Remain	Displays the remainder until the service life (Fusing unit: %)
Prt Cartridge Info	Kind ID	Displays the toner cartridge (AIO) information (Kind ID).
	Toner End History	Displays the toner cartridge (AIO) information (Toner End History).
	Refill Flag Status	Displays the toner cartridge (AIO) information (Refill flag status).
	Unit Print Counter	Displays the toner cartridge (AIO) information (Unit Print Counter).
Motor Rotation Time		Displays the main motor rotation time.
Reset Paper Feed Rol Life		Clears the EM counter of the paper feed roller.
Waste Toner Disposal		Sets the machine operation at "waste toner full" of the refilled AIO.

Menu		Description
		[On or Off (Default)] With the main motor rotation count feature, the machine can be set to stop printing after the print total exceeds a certain set value. If the print count exceeds this value, then "Replace Print Cartridge" remains in the display. Then a new AIO cartridge must be installed. This feature is a safety measure to prevent the used toner tank from becoming full (there is no toner overflow detection mechanism).
Test Pattern		Prints the test pattern.
1200dpi LD Power		Adjusts print density (density levels by increasing the number) [42 to 106 / 74 (Default) / 1 /step]
Refill mode setting		<b>DFU</b> [Auto refill mode/ Pure refill mode]
OPC Life Info	OPC Rotation Time	Displays the OPC life information (OPC rotation time).
	Pre-OPC Rotation Time	Displays the OPC life information (Pre-OPC rotation time)
	OPC Alert Status	Displays the OPC life information (Alert status)
	OPC Pre-Alert Status	Displays the OPC life information (Pre-Alert status)
Subscan Magnification		Adjusts the sub scan magnification. [-8 to 8 / 0 / 1/step]
Page Dot Coverage	0%-2%	Displays the number of pages printed with coverage 0 to 2%.
	3%-4%	Displays the number of pages printed with coverage 3 to 4%.
	5%-7%	Displays the number of pages printed with coverage 5 to 7%.
	8%-9%	Displays the number of pages printed with coverage 8 to 9%.
	10%-19%	Displays the number of pages printed with coverage 10 to 19%.
	20%-29%	Displays the number of pages printed with coverage 20 to 29%.
	Above 30%	Displays the number of pages printed with coverage above 30%.
Power On Count		Displays the power on counter.
Sleep Recover Count		Displays the sleep recover counter.
Machine Series Number		<b>DFU</b>

Menu	Description
	Displays the machine series number.
Serial No	<b>DFU</b> Displays the machine serial No.
Inrush Control	Sets the Inrush Control mode. When using with an external power supply instead of a commercial power supply, set to "On". [Off (Default)/ On]
Flicker Control	Sets the Flicker Control mode. [Off (Default)/ On]

### Scanner Service Setting

Menu	Description
Mono Compression	Sets the monochrome compression type for scanning. MH (Default)/ MR/ MMR
Registration Adjust	ADF Main Reg. Adjusts the ADF Scan main-scan registration. [-2.0 to 2.0 / 0 (Default)/ 0.1 mm/step]
	ADF Sub Reg. Adjusts the ADF Scan sub-scan registration. [-2.0 to 2.0 / 0 (Default)/ 0.1mm/step]
	Flatbed Main Reg. Adjusts the Flatbed Scan main-scan registration. [-2.0 to 2.0 / 0 (Default)/ 0.1mm/step]
	Flatbed Sub Reg. Adjusts the Flatbed Scan sub-scan registration. [-2.0 to 2.0 / 0 (Default)/ 0.1mm/step]
Size Adjust	ADF Sub Reg. Adjusts the ADF Scan sub-scan magnification. [-0.9 to 0.9 / 0 (Default)/ 0.1 %/step]
	Flatbed Sub Reg. Adjusts the Flatbed Scan sub-scan magnification. [-0.9 to 0.9 / 0 (Default)/ 0.1 %/step]
	ADF Main Reg. Adjusts the ADF Scan main-scan magnification. [-0.9 to 0.9 / 0 (Default)/ 0.1 %/step]
	Flatbed Main Reg. Adjusts the Flatbed Scan main-scan magnification. [-0.9 to 0.9 / 0 (Default)/ 0.1 %/step]



**Fax Service Setting**

Menu		Description
Modem Settings	RX Level	Sets the reception level. [-43 dBm (Default)/ -33 dBm/ -26 dBm/ -16 dBm]
	TX Level	Sets the transmission level. [-15 to -1 / -9(Default)/ 1dBm/ step]
	Cable Equalizer	These selectors are used to improve the pass-band characteristics of analogue signals on the telephone line. [0Km (Default)/ 1.8Km/ 3.6Km/ 7.2Km]
Protocol Definition	Training Retries	This sets the number of training retries to be repeated before automatic fallback. [1 Time/ 2 Times (Default)/ 3 Times/ 4 Times]
	Encoding	Sets the compression method for Tx/Rx. [MMR+MR+MH (Default)/ MR+MH/ MH]
Protocol Definition Timer	T0 Timer	Timeout for response from the called station in automatic sending mode [35 Sec/ 45 Sec/ 55 Sec (Default)/ 60 Sec/ 90 Sec/ 140 Sec]
	T1 Timer	Set the time length for the T1 timer. [40 Sec (Default)/ 50 Sec]
	T4 Timer	Set the time length for the T4 timer. [3 Sec (Default)/ 4.5 Sec]
RX Settings	CNG Tone Detection	CNG tone detection time (RX mode : FAX / TEL, FAX / TAD Only)  After the line is connected via the external telephone, the machine can detect a CNG signal for the time length specified by this setting. [5 Sec (Default)/ 10 Sec]
	CNG Cycles	Number of CNG cycles to be detected  This setting is only effective for FAX/TAD mode. [1.5 Cycle (Default)/ 2.0 Cycle]
	Tone Sound Monitoring	Determines the period when tones from the line are monitored.

Menu		Description
		[No Monitoring/ Up To Phase B (Default)/ All TX Phases]
	Stop/Clear Key	Pressing the Stop/Clear key can stop the current receiving operation. Received data is lost. [No Functional (Default)/ Functional]
	Off-Hook Detection	Sets the Off-Hook detection period. [200 msec (Default)/ 800 msec]
	Number for Remote Switch	[0~9 / 2 (Default/ 1digit/step)]
	Number of time to press	[1~3 / 2 (Default/ 1time/step)]
	Period: TEL to Fax	[Limitless / 10 sec (Default/ 20 sec / 30 sec / 40 sec)]
TX Settings	Redial Interval	Sets the redial interval when Tx fails. [5 Min (Default)/ 6 Min]
	Redialings	Sets the number of redials when Tx fails. [2 times (Default)/ 3 Times/ 4 Times/ 5 Times]
Overseas Comm Mode Settings	Overseas Comm Mode	This sets the machine to ignore a DIS signal sent from the called station once in a sending operation. [Off (Default)/ Ignore DIS Once]
	Minimum Time Length	If this setting is set to "On", the machine detects the CNG signal after the line is connected. If it is set to "Off", the machine detects the CNG signal as long as the line is connected. [100 Ms/ 200 Ms/ 300 Ms/ 400 Ms (Default)]
Dial Pulse Setting	Dial Pulse Type	This sets the number of pulses that are generated during dialing. <ul style="list-style-type: none"> <li>• N: Dialing '0' generates 10 pulses --- Dialing '9' generates 9 pulses. (Default)</li> <li>• N+1: Dialing '0' generates 1 pulses --- Dialing '9' generates 10 pulses.</li> <li>• 10-N: Dialing '0' generates 10 pulses --- Dialing '9' generates 1 pulse.</li> </ul>
Tone Signal	Tone Signal	Sets the tone signal transmission time length

Menu		Description
Settings	Transmission T	[100 ms (Default)]
	Minimum Pause In Tone Dial	Sets the minimum pause during tone dialing [100 ms (Default)/ 150 ms/ 200 ms]
	Attenuator of Pseudo Ring	Sets the attenuator for pseudo ringback tone to the line [0 to 15 / 10 (Default)/ 1 dB/step]
	DTMF Level	Sets the transmission level of DTMF tones. [-12 dBu / -11 dBu/ -10 dBu (Default)/ -8 dBu/ -6 dBu]
	DTMF Delta	Sets the level difference between high band frequency signals and low band frequency signals when sending DTMF tones. [1 dBu/ 2 dBu (Default)/ 3 dBu]
1Dial Tone Detection	Wait Time	The machine starts dialing after the specified interval without detection of a dial tone when dial tone detection is set to "No detection". [3.5 Sec (Default)/ 7.0 Sec/ 10.5 Sec/ 14.0 Sec]
	Timeout Length	This setting sets the time-out length for the 1st dial tone detection. The machine waits for a dial tone for the specified time and disconnects itself from the line when no dial tone is input. [10 Sec (Default)/ 15 Sec/ 20 Sec/ 30 Sec]
BT (Busy Tone) Detection	BT Setting	<b>DFU</b> [Off/ On(Default)]
	BT Frequency	<b>DFU</b> [300-550 Hz/ 300-650 Hz/ 325-525 Hz/ 340-550 Hz/ 350-500 Hz (Default)/ 350-550 Hz/ 375-475 Hz/ 380-520 Hz]
	BT Level	<b>DFU</b> [-35 dB/ -36 dB/ -37 dB/ -38 dB/ -39 dB (Default)]
	BT Cadence	<b>DFU</b> [0.10/ 0.15/ 0.20/ 0.25/ 0.30/ 0.35/ 0.40/ 0.45/ 0.50 (Default)/ 0.75]
Comm	RTN Rate	The machine checks the actual data reconstruction errors

Menu		Description
Settings		and then transmits an RTN depending on the decoding error rate that is set by this setting (Number of lines containing an error per page / Total number of lines per page). [10% (Default)/ 15%]
	V34 Modem	<b>DFU</b> [Permitted (Default)/ Prohibited]
	V17 Modem	<b>DFU</b> [Permitted (Default)/ Prohibited]
V34 Settings	Equalizer	<b>DFU</b> These selectors set the equalizer's training level to be applied if training fails due to poor line connection. [Automatic (Default)/ 4 Points/ 16 Points]
	Redialing	Resend when a communication error occurs. [Disabled (Default)/ Not Disabled]
	First TX Speed	Sets the first transmission speed choice, before fallback. [2400 Bps/ 4800 Bps/ 7200 Bps/ 9600 Bps/ 12000 Bps/ 14400 Bps/ 16800 Bps/ 19200 Bps/ 21600 Bps/ 24000 Bps/ 26400 Bps/ 28800 Bps/ 31200 Bps/ 33600 Bps (Default)]
	Symbol Rate	This setting limits the transmission speed range in V.34 mode by masking the desired symbol rate(s). [Not Used (Default)/ 3429 Sym/Sec/ 3200 Sym/Sec/ 3000 Sym/Sec/ 2800 Sym/Sec/ 2400 Sym/Sec]
All Document Transfer		Transfers all documents in fax memory to another fax machine. Emergency use only. Input the forwarding fax number. Max. 40 digits (includes #, *) To start transferring all documents, press the "Start" key. To cancel all documents from transferring and go back to the Fax Maintenance menu, press the "Clear/Stop" key.

**Print Reports**

Menu	Description
G3 Protocol dump list	G3 protocol dump of the latest communication is printed. Off (Default)/ Error/ On

**CTL SP**

Menu	Description
Air Print Enable	Sets whether the Air Print function is enabled or disabled.  [Disable/ Enable (Default)]
Debug Tools	[Off (Default)/ NIC/ USB]
Disable USB Port	Sets the USB port function is valid or invalid [Off (Default)/On]
Pas Validity Setting	When used to set Paas (Only for CHN) [Inactive (Default)/ Active]
PDL Mode	ON = "PDL Settings" is shown in [Print List/Report] menu (Default) OFF = "PDL Settings" is hidden
FW Update Mode	If updating the firmware for a machine in which LDAP authentication is set, execute this mode.  [Execute/ Return]  After pressing "Execute", the display shows "Please Restart Machine..." Turn the machine's main power off, and then on. Then the machine activates in a special boot loader mode. After that, update the firmware via USB cable.
Auto IP	ON = Automatically set the IP address when the IP address cannot be acquired (Default) OFF = Continually try to obtain the IP address by DHCP

**Factory Default**

Menu	Description
Factory Default	Return Does not execute anything. Returns to an upper level.
	Execute Resets all the settings to factory default.

Menu		Description
		 <b>Note</b> Clears/ resets the contents of the controller memory (all data programmed by the user, log data application counters) to factory default. After executing, initial setup menu starts after power-on.

**@Remote**

Menu		Description
Supply Alarm	Toner Supply Alarm	Sets the toner supply alarm. [Disable (Default)/ Enable]
	Toner Call Timing	[At rplcment / At NearEnd]
SC/Alarm Setting	SC Call	Sets the SC call. [Disable/ Enable (Default)]
	User Call	Sets the user call. [Disable/ Enable (Default)]
	Comm. Test Call	Sets the communication test call. [Disable/ Enable (Default)]
	Machine Info Notice	Sets the machine information notice. [Disable/ Enable (Default)]
	Supply Auto Ordering Call	Sets the supply auto ordering call. [Disable/ Enable (Default)]
Machine No. Setting	ID2 Code Display	Displays the ID2 code (ASCII 17digits).
Remote Service	CE Call	Performs the CE Call at the start or end of the service.
	Function Flag	Enables or disables the remote service function. [Disable (Default)/ Enable]
	Communication Test	Executes the communication test.
	Device Information Call	Executes the device information notification.
	RCG Reg. State	Displays the RCG registration status. [0 to 2]
	GW URL	Displays the URL for RCG center.
	Polling Interval	Sets the polling interval.



Menu	Description
	[0 to 4294967295 / 60 / 1 sec/step]
Connection Timeout	Specifies the connect timeout interval when calling the RCG. [1 to 90 / 30 / 1 sec/step]
Send Timeout	Specifies the send timeout interval when calling the RCG. [0 to 100 / 30 / 1 sec/step]
Receive Timeout	Specifies the receive timeout interval when calling the RCG. [0 to 100 / 30 / 1 sec/step]
Retry Interval	If the HTTP connection fails, specify the interval at which the connection will be retried again.[0 to 65535 / 3 / 1 sec/step]
Retry Count	If the HTTP connection fails, specify the number of times to retry the connection. [0 to 255 / 3 / 3 counts/step]
Connect Send Delay	Specifies the connection request sending delay. [0 to 255 / 5 / 1 sec/step]
Max Multipart	Specifies the maximum number of multipart. [0 to 10 / 10 / 1/step]
Rescue URL	Displays the rescue URL.
Regular Notify Kind	Sets the periodic notification mode. [0 to 5 / 0 / 1/step]
Counter Notify Kind	Sets the counter notification mode. [0 to 5 / 0 / 1/step]
Regular Notify Timing	Displays the periodic notification date and time.
Counter Notify Timing	Displays the counter notification date and time.
Counter Closing Timing	Displays the counter closing date and time.
Next Regular Notify	Displays the next periodic notification date and time.
Next Counter Notify	Displays the next counter notification date and time.
Next Counter Closing	Displays the next counter closing date and time.

Menu	Description
Center Polling	Displays the center control polling date and time.
Test Flag	Sets the test flag. [0 to 255 / 0 / 1/step]
Update Result	Displays the center information update results.
Valid Adv.Notice	Specifies the margin to notify the proximity of the expiration of the certification. [2592000 to 15552000 / 2592000 / 1 sec/step]
CertExpireTiming	Displays the date and time to notify the proximity of the expiration of the certification.
Use Proxy	Determines if the proxy server is used when the machine communicates with the service center.
Proxy Host	Inputs the address of the proxy server used for communication between the RCG Device and the gateway.
Proxy PortNumber	Sets the HTTP proxy port number.. [0 to 65535 / 8080 / 1/step]
Proxy User Name	Displays the HTTP proxy authentication user.
Proxy Password	Displays the HTTP proxy authentication password.
CERT:Up State	Displays the certificate renewal status.
CERT:Error	Displays the certificate renewal error reason.
CERT:Up ID	Displays the certificate update request ID.
CERT:Macro Ver.	Displays the Macro Version.
CERT:PAC Ver.	Displays the PAC Version.
Server CN Check	Sets the server authentication CN check.
CERT:GW URL	Displays the NRS Gateway URL.
CERT:Use Pass	Displays the availability of PassPhrase.
CERT:Use MAC	Displays the availability of MAC.
CountNotify Int.	Display periodic notification timing (interval).
CountNotify Week	Displays periodic notification timing (day of the week).
Reg. Notify Int.	Displays the counter notification timing (interval).
Reg. Notify Week	Displays the counter notification timing (day of the week).
SSL Port	Specifies the SSL communication port. [0 to 65535 / 443 / 1/step]
Manual Polling	Executes polling.
Regist Status	Displays the @Remote status.

Maintenance Mode (for Touch Panel Models)

Menu	Description
Letter Number	Inputs the request number.
Confirm Execute	Executes the reference.
Confirm Result	Displays the reference result.
Confirm Place	Displays the section name.
Register Execute	Executes registration.
Register Result	Displays the registration result.
Error Code	Displays the error code.
Instl:Clear	Clears the @Remote installation.
Common KeyInfo Init	Performs initialization of common key information.
Remote Diagnostics	Executes the repair request notification.
CE Working Start	Displays the work start time by CE.
CE Working Total	Displays the total working time by CE.

## 5.3 SMART ORGANIZING MONITOR (SOM)

### 5.3.1 OVERVIEW

This machine has an operation panel, so the machine status can be checked and setup can be performed from the operation panel.

However, as in the previous product, the SOM (Smart Organizing Monitor) utility can be executed from a PC.

#### Note

The SOM utility can ONLY be executed when the machine does not have jobs waiting. For details, refer to the "User's Guide".

#### **Entering the Printer Configuration**

1. Start the SOM utility.
2. Click the [User Tools] tab.
3. Click [Printer Configuration].

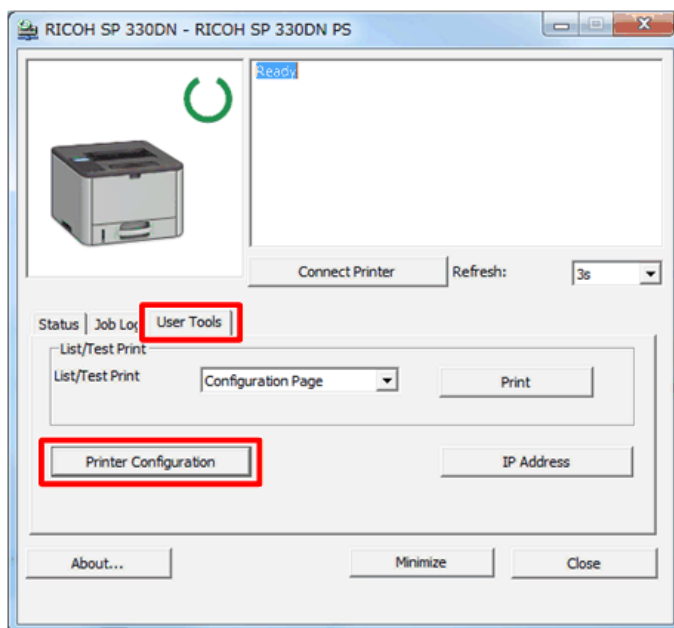

m0c3c5044

4. Input the access code in the [Access Code] entry dialog, and click [OK].

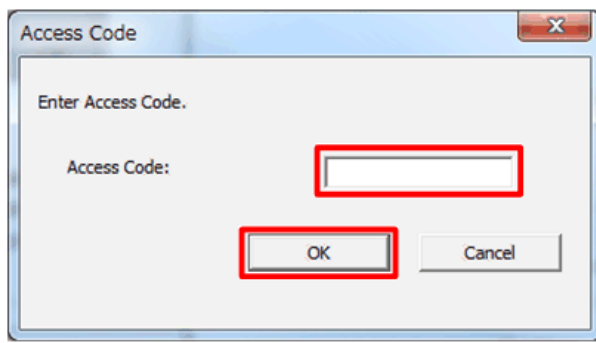

m0c3c5057

**Note**

Each mode has a different access code.

- Guest mode: (none)
- Administrator mode: Admin
- Service engineer mode: Contact the supervisor in your branch office.

### 5.3.2 MENU LIST

The displayed menu depends on the login mode

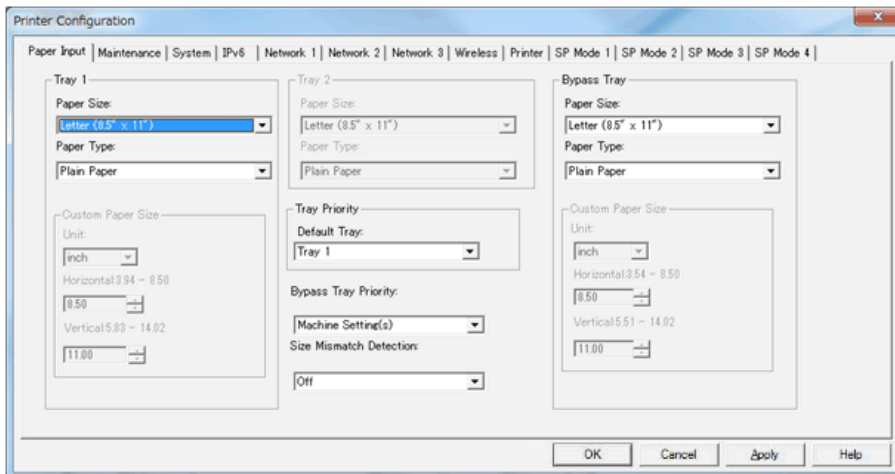

m0c3c5030

Menu	Description	Guest mode	Admin mode	Service mode
Paper Input	Adjusts the paper type and size settings.	✓	✓	✓
Maintenance	Adjusts the image registration and executes the color registration adjustment.	-	✓	✓
System	Adjusts the system settings of the machine.	-	✓	✓
IPv6	Adjusts the system settings of the machine.	-	✓	✓

Menu	Description	Guest mode	Admin mode	Service mode
Network 1	Adjusts network settings (Information, Interface, TCP/IP).	-	✓	✓
Network 2	Adjusts network settings (IPX, SMTP).	-	✓	✓
Network 3	Adjusts network settings (SNMP, Apple Talk).	-	✓	✓
Wireless	Adjusts network settings (Wireless).	-	✓	✓
Printer	Adjusts the printer driver settings (PCL, PS).	-	✓	✓
@Remote	Sets the @Remote settings.	-	✓	✓
SP mode 1	Adjusts and executes service program modes.	-	-	✓
SP mode 2	Adjusts and executes service program modes.	-	-	✓
SP mode 3	Adjusts and executes service program modes.	-	-	✓
SP mode 4	Adjusts and executes service program modes.	-	-	✓

### Paper Input

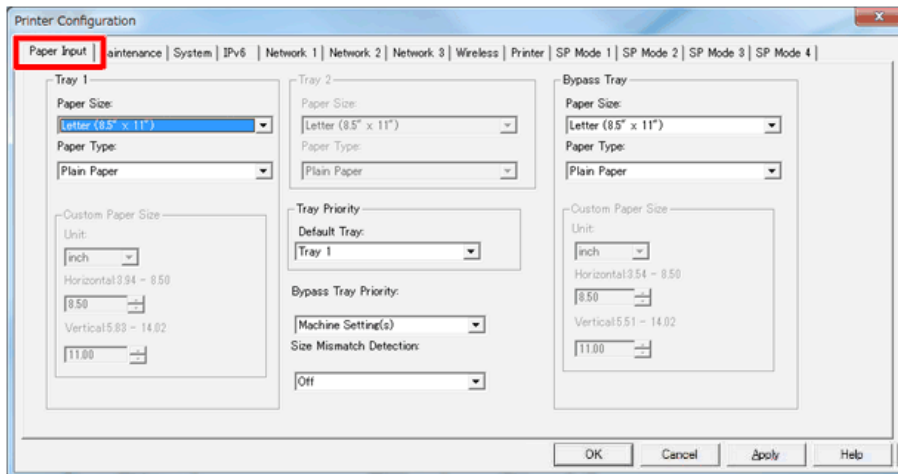

m0c3c5031

Item	Selections	Remarks
Tray 1 Paper Size	A4 */ Letter */ B5/ B6/ A5/ A6/ Legal/ 8.5" x 13"/ 8.5" x 13.4"/ 8.5" x 13.6"/ 16K/ 8.11" x 13.3"/ 5.5" x 8.5"/ Com10Envelope	*: Default (NA: Letter, EU: A4) The selectable paper sizes depend on the model.
Tray 1 Paper Type	Plain Paper */ Recycled Paper/ Thick Paper 1/ Thick Paper 2 / Thin Paper/ Letterhead/ Preprinted Paper/ Envelope/ Labels/ Prepunched Paper/ Bond	*: Default The selectable paper types depend on the

Item	Selections	Remarks
	Paper/ Cardstock/ Color Paper	model.
Tray 2 Paper Size	A4 */ Letter *	-
Tray 2 Paper Type	Plain Paper */ Recycled Paper/ Thick Paper 1/ Thick Paper 2 / Thin Paper/ Letterhead/ Preprinted Paper/ Prepunched Paper/ Color Paper	-
Bypass Tray Paper Size	A4 */ Letter */ B5/ B6/ A5/ A6/ Legal/ 8.5" x 13"/ 8.5" x 13.4"/ 8.5" x 13.6"/ 16K/ 8.11" x 13.3"/ 5.5" x 8.5"/ Com10Envelope/ Manarch Envelope/ DL Envelope/ C5 Envelope/ C6 Envelope/ Custom	-
Bypass Tray Paper Type	Plain Paper */ Recycled Paper/ Thick Paper 1/ Thick Paper 2 / Thin Paper/ Letterhead/ Preprinted Paper/ Envelope/ Labels/ Prepunched Paper/ Bond Paper/ Cardstock/ Color Paper	-
(Tray 1, Bypass Tray) Custom Paper Size: Unit	mm */ Inch *	If the paper size factory default is A4, then the custom size factory default unit is mm.  If the paper size factory default is Letter, then the custom size factory default unit is inch.
(Tray 1, Bypass Tray) Custom Paper Size: Horizontal	100–216 mm (3.94–8.50 inch)	Precision is two digits after the decimal point in inch or one digit after the decimal point in mm.  If an input value is more than the maximum value, then it will be treated as the maximum value.  If an input value is less than the minimum value, then it will be treated as the minimum value.
(Tray 1, Bypass Tray)	148–356mm (5.83–14.02 inch.)	Precision is two digits after the decimal point in inch or



Item	Selections	Remarks
Custom Paper Size: Vertical		one digit after the decimal point in mm.  If an input value is more than the maximum value, then it will be treated as the maximum value.  If an input value is less than the minimum value, then it will be treated as the minimum value.
Tray Priority: Default Tray	Tray1 */ Bypass Tray	-
Bypass Tray Priority	Machine Setting(s)/ Any Size/Type/ Any Custom Size/Type	-
Size Mismatch Detection	On / Off*	-

\*: Default

**Maintenance**

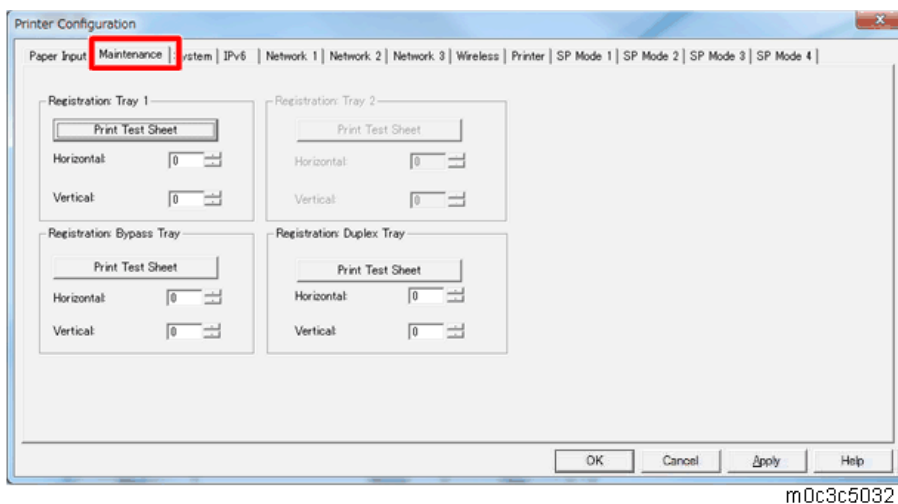

Group	Item	Selections	Remarks
Registration Tray 1	Print Test Sheet	-	Sends a PCL command to the printer to print a test sheet.
	Adjustment	(-15 to +15)	0.34 mm per step. Range is -5.4 mm

Group	Item	Selections	Remarks
	Horizontal *	step	to +5.1 mm.
	Adjustment Vertical *	(-15 to +15) step	0.24 mm per step. Range is -3.6 mm to +3.6 mm
Registration Tray 2	Print Test Sheet	-	Sends a PCL command to the printer to print a test sheet.  It is disabled when tray 1 is not installed.
	Adjustment Horizontal *	(-15 to +15) step	0.34 mm per step. Range is -5.4 mm to +5.1 mm.
	Adjustment Vertical *	(-15 to +15) step	0.24 mm per step. Range is -3.6 mm to +3.6 mm
Registration Bypass Tray	Print Test Sheet	-	Sends a PCL command to the printer to print a test sheet.
	Adjustment Horizontal *	(-15 to +15) step	0.34 mm per step. Range is -5.4 mm to +5.1 mm.
	Adjustment Vertical *	(-15 to +15) step	0.24 mm per step. Range is -3.6 mm to +3.6 mm
Registration Duplex Tray	Print Test Sheet	-	Sends a PCL command to the printer to print a test sheet.
	Adjustment Horizontal *	(-15 to +15) step	0.34 mm per step. Range is -5.4 mm to +5.1 mm.
	Adjustment Vertical *	(-15 to +15) step	0.24 mm per step. Range is -3.6 mm to +3.6 mm

\*: If the machine settings are reset to the factory defaults, this value does not change.

## System

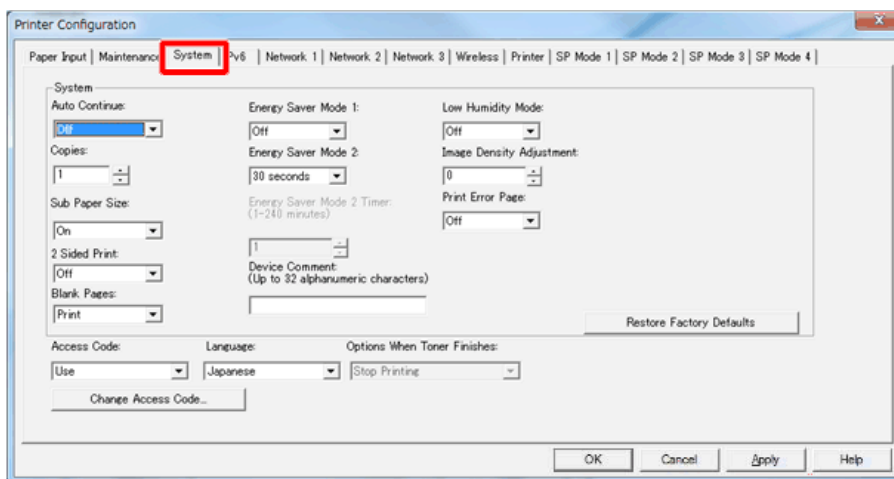

m0c3c5033

Item	Selections	Remarks
Auto Continue	On/ Off *	-
Copies	1*-999	-
Sub Paper Size	Off */ Auto	-
2 Sided Print	Off */ Short Edge Bind/ Long Edge Bind	-
Blank Page Print	Print */ Not Print	"Manual Duplex/Cover" has higher priority than the "Blank Pages" setting.
Energy Saver Mode 1	On/ Off *	-
Energy Saver Mode 2	On */ Off	-
Energy Saver Mode 2 Timer	30 sec*, 1 - 240 min	-
Low Humidity Mode	On/ Off *	-
Image Density Adjustment	-3 to 3 (0*)	-
Print Error Page	On/ Off *	-
Device Comment	Null string*	Up to 32 alphanumeric characters. The factory default is 'null string'.
Restore to Factory Default button	-	Restores all settings to the factory default settings for the market area setting.
Language	English */ French/ German/ Italian/ Spanish/ Dutch/ Danish/ Swedish/ Norwegian/ Portuguese/ Polish/ Czech/ Hungarian/ Finnish/ Japanese/ Simpl.Chinese/ Trad.Chinese Russian/ Turkish/ Brazilian/Arabic/ Kazakh	The factory setting is English if the market is NA, EU or ASIA.
Access Code	Use */ Do not use	-
Access code change button	-	Changes the access code. The button is grey if the Access code is set to "Do

Item	Selections	Remarks
		not use".
Language	English */ French/ German/ Italian/ Spanish/ Dutch/ Danish/ Swedish/ Norwegian/ Portuguese/ Polish/ Czech/ Hungarian/ Finnish/ Japanese/ Simpl.Chinese/ Trad.Chinese Russian/ Turkish/ Brazilian/Arabic/ Kazakh	The factory setting is English if the market is NA, EU or ASIA.
Options When Toner Finished	Stop Printing *	-

\*: Default

## IPv6

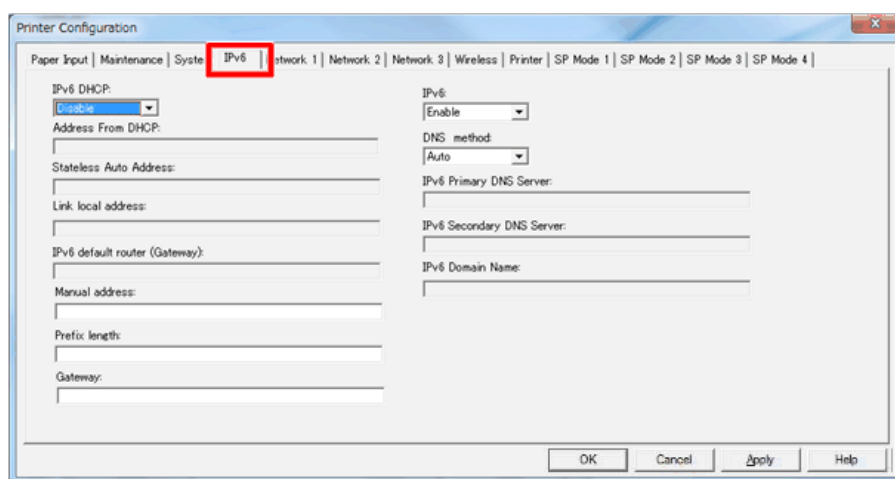

m0c3c5034

Menu	Selections	Remarks
IPv6 DHCP	Disable */ Enable	-
Address From DHCP	-	Displays Address from DHCP
Stateless Auto Address	-	Displays Stateless Auto Address.
Link Local Address	-	Displays Link Local Address.
IPv6 default router (Gateway)	-	Displays IPv6 Default Gateway.
Manual Address	-	Input IPv6 Address Manually.
Prefix length	-	Input Prefix length.
Gateway	-	Input Gateway.
IPv6	Disable */ Enable	-
DNS method	Auto */ Manual	-
IPv6 Primary DNS Server	-	-
IPv6 Secondary DNS Server	-	-
IPv6 Domain Name	-	-

\*: Default

### Network 1

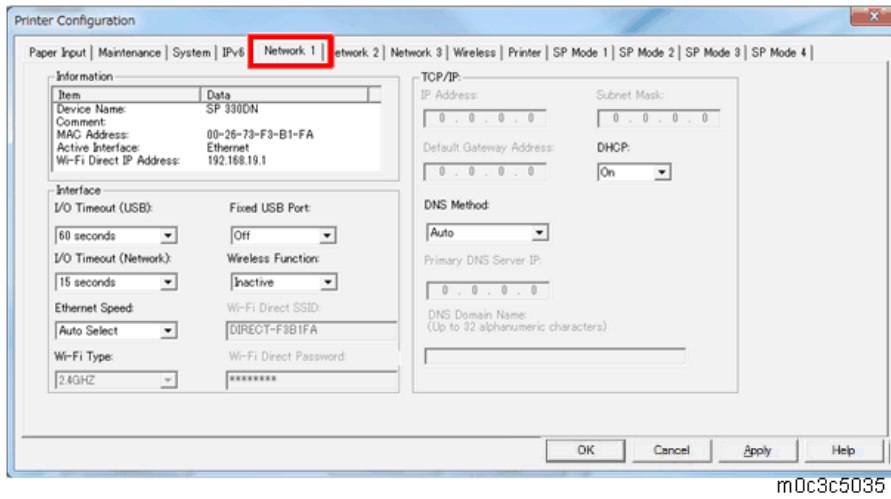

Group	Item	Selections	Remarks
Information	Device Name	-	String length is 32
	Comment	-	String length is 32
	Mac Address	-	-
	Active Interface	-	-
	Wi-Fi Direct Address	-	-
TCP/IP	IP Address	xxx.xxx.xxx.xxx	This setting is not available if DHCP is enabled.  If this setting is changed, the printer power must be turned off/on for the new setting to take effect.
	Subnet Mask	xxx.xxx.xxx.xxx	This setting is not available if DHCP is enabled.  If this setting is changed, the printer power must be turned off/on for the new setting to take effect.  Will show all zero if network initialization is not finished. Any change will be ignored before the end of network initialization.

Group	Item	Selections	Remarks
	Default Gateway Address	xxx.xxx.xxx.xxx	<p>This setting is not available if DHCP is enabled.</p> <p>If this setting is changed, the printer power must be turned off/on for the new setting to take effect.</p> <p>Will show all zero if network initialization is not finished. Any change will be ignored before the end of network initialization.</p>
	DHCP	On */ Off	If this setting is changed, the printer power must be turned off/on for the new setting to take effect.
	DNS Method	Auto */ Manual	-
	Primary DNS Server IP	xxx.xxx.xxx.xxx	<p>Up to 32 alphanumeric characters. This setting is not available if DHCP is enabled. The default setting is "0.0.0.0" when DHCP is off.</p> <p>The setting when DHCP is changed from on to off is the previous setting when DHCP was on.</p> <p>If this setting is changed, the printer power must be turned off/on for the new setting to take effect.</p>
	DNS Domain Name	-	<p>Up to 32 alphanumeric characters. This setting is not available if DHCP is enabled. The default setting when DHCP is off is null string.</p> <p>The setting when DHCP is changed from on to off is the previous setting when DHCP was on.</p> <p>If this setting is changed, the printer power must be turned off/on for the new setting to take effect.</p>
Interface	I/O Timeout (USB)	15 */ 60/ 300	-

Group	Item	Selections	Remarks
	I/O Timeout (Network)	15 / 60 * / 300	-
	Ethernet Speed	Auto Select * / 10M half / 10M full / 100M half / 100M full	-
	Wi-Fi Type	2.4 GHZ *	-
	Fixed USB Port	On / Off *	-
	Wireless Function	Active / Inactive *	-
	Wi-Fi Direct ID	-	-
	Wi-Fi Direct Password	-	-

\*: Default

### Network 2

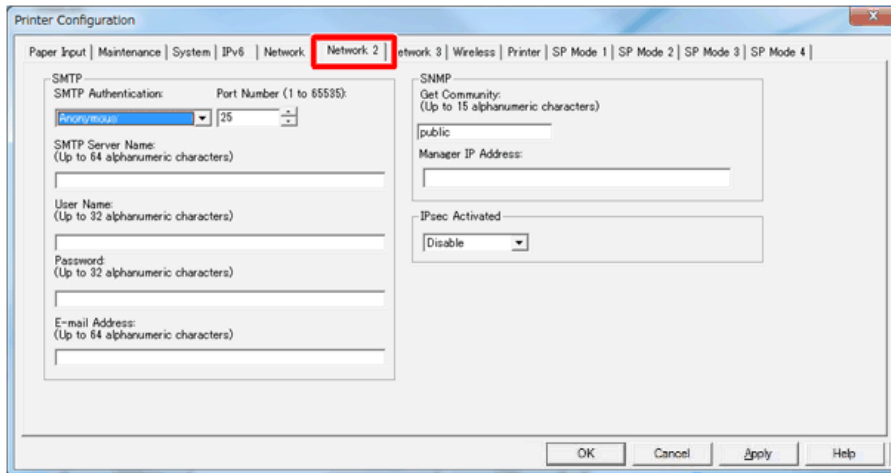

m0c3c5036

Group	Item	Selections	Remarks
SMTP	SMTP Authentication	Anonymous * / SMTP Authentication / POP before SMTP	-
	SMTP Server Name	Null string*	Up to 32 alphanumeric characters. The factory default is 'null string'.
	Port Number	25*	1 to 65535



Group	Item	Selections	Remarks
			The factory default is 25.
	User Name	Null string*	Up to 32 alphanumeric characters. The factory default is 'null string'.
	Password	Null string*	Up to 32 alphanumeric characters. The factory default is 'null string'. User-input characters and characters read back from the printer will show "*" in order to protect the user password.
	E-mail Address	Null string*	Up to 64 alphanumeric characters. (address for receiving e-mail) The factory default is 'null string'.
SNMP	Get Community	public	Up to 15 alphanumeric characters.
	Manager IP Address	0.0.0.0 *	The factory default is 0.0.0.0 If this setting is changed, the printer power must be turned off/on for the new setting to take effect.
IPsec Activated		Disable */ Enable	-

\*: Default

### Network 3

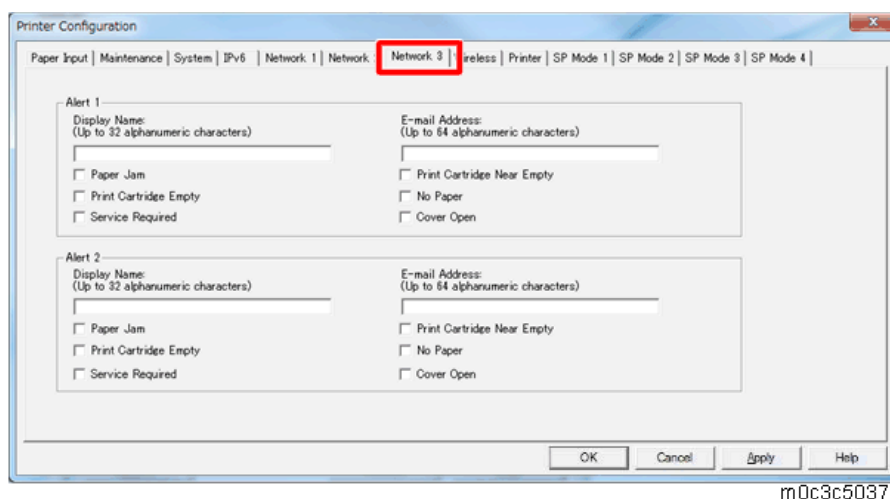

Group	Item	Selections	Remarks
Alert 1	Display Name	-	Up to 32 alphanumeric characters.
	Paper Jam	-	-
	Print Cartridge Empty	-	-

Group	Item	Selections	Remarks
	Service Required	-	-
	E-mail Address	-	Up to 64 alphanumeric characters.
	Print Cartridge Near Empty	-	-
	No Paper	-	-
	Cover Open	-	-
Alert 2	Display Name	-	Up to 32 alphanumeric characters.
	Paper Jam	-	-
	Print Cartridge Empty	-	-
	Service Required	-	-
	E-mail Address	-	Up to 64 alphanumeric characters.
	Print Cartridge Near Empty	-	-
	No Paper	-	-
	Cover Open	-	-

**Wireless**

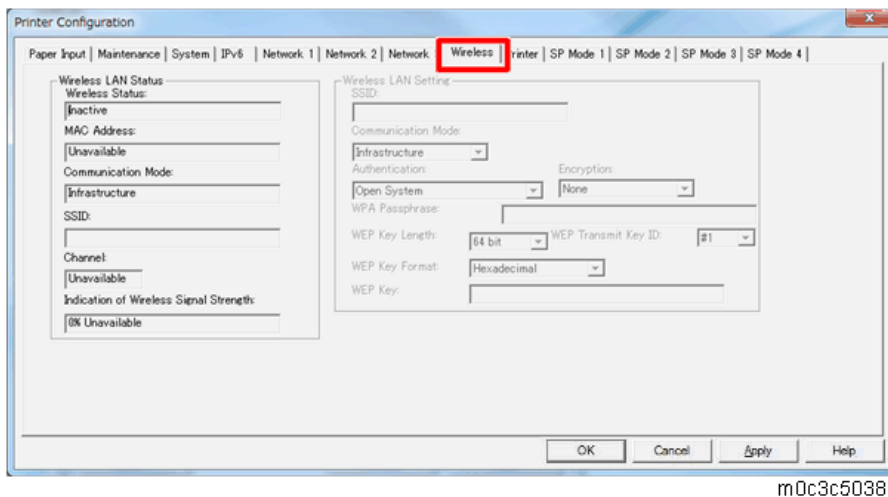

m0c3c5038

Group	Item	Selections	Remarks
Wireless LAN Status	Wireless Status	-	Displays the Wireless LAN Status.
	MAC Address	-	
	Communication Mode	-	
	SSID	-	
	Channel	-	
	Indication of Wireless Signal Strength	-	
Wireless LAN Setting	SSID	-	Input the SSID.
	Communication Mode	Infrastructure *	Selects the communication

Group	Item	Selections	Remarks
			method.
	Authentication	Open System */ Shared Key/ WP A2-PSK/ Mix Mode WPA/WPA2	Selects the authentication method.
	Encryption	None */ WEP/ CCMP (AES)/ TKIP/AES	Selects the encryption method.
	WPA Passphrase	-	Input the WPA passphrase.
	WEP Key Length	64bit */ 128bit	Selects the WEP key length.
	WEP Transmit Key ID	#1 * to #4	-
	WEP Key Format	Hexadecimal */ ASCII	-
	WEP Key	-	Input the WEP key.

\*: Default

### Printer

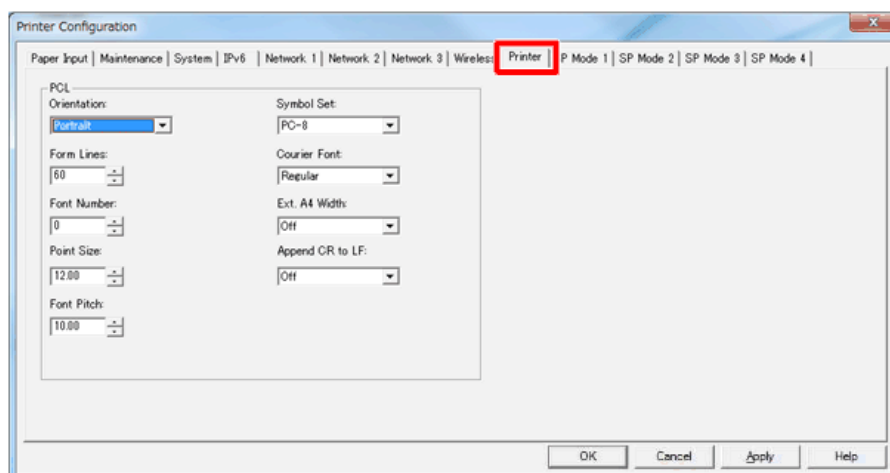

m0c3c5039

Group	Item	Selections	Remarks
PCL	Orientation	Portrait */ Landscape	-
	Form Lines	5 to 128 by 1 (60 *)	If the machine settings are reset to the factory defaults, this value does not change.
	Font Number	0 * to 89	-

Group	Item	Selections	Remarks
	Font Size	4.00 to 999.75 by 0.25 (12.00 *)	-
	Font Pitch	0.44~99.99 by 0.01 (10.00 *)	-
	Symbol Set	Roman-8, Roman-9, ISO L1, ISO L2, ISO L5, PC-8* , PC-8 D/N, PC-850, PC-852, PC-858, PC-8 TK, Win L1, Win L2, Win L5, Desktop, PS Text, VN Intl, VN US, MS Publ, Math-8, PS Math, VN Math, Pi Font, Legal, ISO 4, ISO 6, ISO 11, ISO 15, ISO 17, ISO 21, ISO 60, ISO 69, Win 3.0, MC Text, ISO L6, ISO L9, PC-775, PC-1004, Win Balt	-
	Courier Font	Regular */ Dark	-
	Ext. A4 Width	Off */ On	-
	Append CR to LF	Off */ On	-

\*: Default

**@Remote**

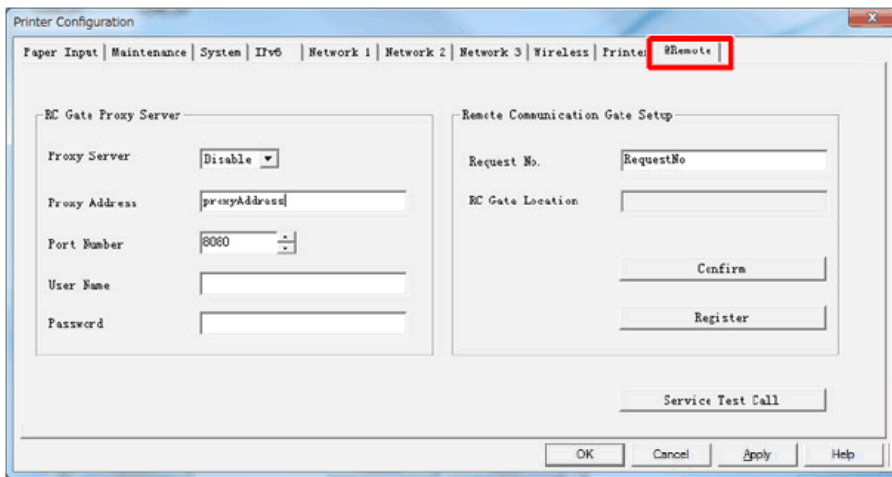

m0c3c5058

Group	Item	Selections	Remarks
RC Gate Proxy Server	Proxy Server	Disable */ Enable	-
	Proxy Address	-	Max length is 127.
	Port Number	1 to 65535	-
	User Name	-	Max length is 31.
	Password	-	Max length is 31.

Group	Item	Selections	Remarks
Remote Communication Gate Setup	Request No.	-	Max length is 31.
	RC Gate Location	-	Display only. Max length is 127.
	Confirm	-	-
	Register	-	-
Service Test Call		-	-

\*: Default

### SP Mode 1

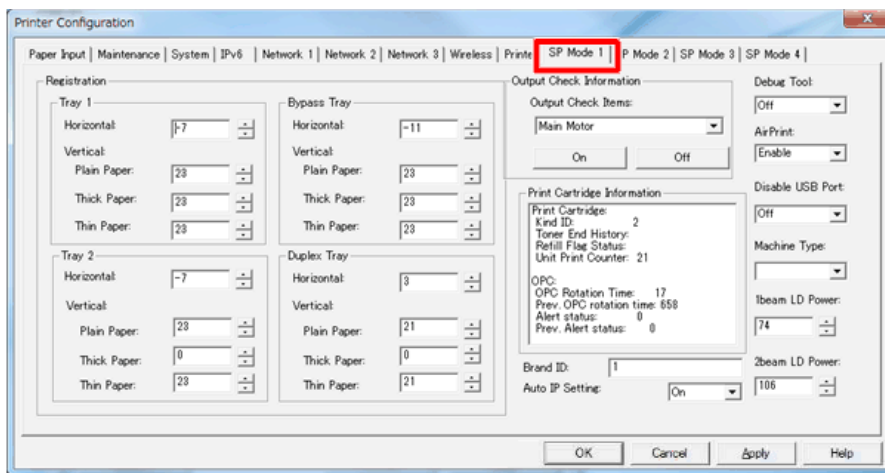

m0c3c5040

Group	Item	Remarks
Registration: Tray 1	Horizontal	Adjusts the horizontal registration for each tray and paper type. If the machine settings are reset to the factory defaults, this value does not change. [-40 to 40 / 1* / 0.1 mm/step]
	Vertical: Plain Paper	[-40 to 40 / 23* / 0.1 mm/step]
	Vertical: Thick Paper	[-40 to 40 / 23* / 0.1 mm/step]
	Vertical: Thin Paper	[-40 to 40 / 23* / 0.1 mm/step]
Registration: Tray 2	Horizontal	[-40 to 40 / 2* / 0.1 mm/step]
	Vertical: Plain Paper	[-40 to 40 / 23* / 0.1 mm/step]
	Vertical: Thick Paper	[-40 to 40 / 23* / 0.1 mm/step]

Group	Item	Remarks
	Vertical: Thin Paper	[-40 to 40 / 23* / 0.1 mm/step]
Registration: Bypass Tray	Horizontal	[-40 to 40 / -5* / 0.1 mm/step]
	Vertical: Plain Paper	[-40 to 40 / 23* / 0.1 mm/step]
	Vertical: Thick Paper	[-40 to 40 / 23* / 0.1 mm/step]
	Vertical: Thin Paper	[-40 to 40 / 23* / 0.1 mm/step]
Registration: Duplex Tray	Horizontal	[-40 to 40 / 8* / 0.1 mm/step]
	Vertical: Plain Paper	[-40 to 40 / 23* / 0.1 mm/step]
	Vertical: Thick Paper	[-40 to 40 / 23* / 0.1 mm/step]
	Vertical: Thin Paper	[-40 to 40 / 23* / 0.1 mm/step]
Output check	Main Motor	Output check (Main motor)
	Middle Clutch	Output check (Relay clutch)
	Tray1 Clutch	Output check (Paper feed clutch)
	Bypass solenoid	Output check (Bypass solenoid)
	Registration clutch	Output check (Registration clutch)
	Fan High Speed	Output check (Fan high speed)
	Fan Low Speed	Output check (Fan low speed)
	Erase Lamp	Output check (Quenching lamp)
	Polygon Motor	Output check (Polygon motor)
	Duplex Motor Normal	Output check (Duplex motor normal)
Duplex Motor Reverse	Output check (Duplex motor reverse)	
Print Cartridge Information	Displays Print Cartridge Information. Displays: Print cartridge: Kind ID, Toner End History, Refill Flag Status, Unit Print Counter OPC: OPC Rotation Time, Prev. OPC rotation time, Alert	

Group	Item	Remarks
		Status, Prev. Alert Status
Brand ID		0* – 15 Displays the current brand ID number. <b>DFU</b>
Auto IP Setting		On */ Off
Debug Tool		Off */ NIC/ USB
AirPrint		Enable */ Disable
Disable USB port		Off */ On
Machine Type		Inactive */ Active
1Beam LD Power		[42 to 108 / 74 (Default) / 1 /step]
2Beam LD Power		[74 to 137 / 106 (Default) / 1/step]

\*: Default

### SP Mode 2

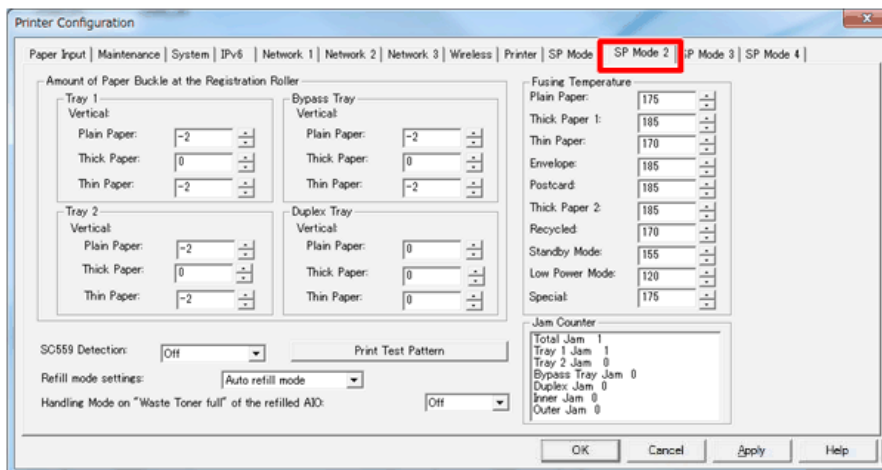

m0c3c5041

Group	Item	Remarks
Amount of Paper Buckle at the Registration Roller: Tray 1	Vertical: Plain Paper	Adjusts the amount of paper buckle at the registration roller for each tray and paper type. [-8 to 8 / -2* / 1 mm/step]
	Vertical: Thick Paper	[-8 to 8 / 0* / 1 mm/step]
	Vertical: Thin Paper	[-8 to 8 / -2* / 1 mm/step]
Amount of Paper Buckle at the	Vertical: Plain	[-8 to 8 / -2* / 1 mm/step]



Group	Item	Remarks
Registration Roller: Tray 2	Paper	
	Vertical: Thick Paper	[-8 to 8 / 0* / 1 mm/step]
	Vertical: Thin Paper	[-8 to 8 / -2* / 1 mm/step]
Amount of Paper Buckle at the Registration Roller: Bypass Tray	Vertical: Plain Paper	[-8 to 8 / -2* / 1 mm/step]
	Vertical: Thick Paper	[-8 to 8 / 0* / 1 mm/step]
	Vertical: Thin Paper	[-8 to 8 / -2* / 1 mm/step]
Amount of Paper Buckle at the Registration Roller: Duplex Tray	Vertical: Plain Paper	[-8 to 8 / 0* / 1 mm/step]
	Vertical: Thick Paper	[-8 to 8 / 0* / 1 mm/step]
	Vertical: Thin Paper	[-8 to 8 / 0* / 1 mm/step]
Fusing Temperature	Plain Paper	Adjusts the fusing temperature for each paper type. [150 to 200 / 175* / 1°C/step]
	Thick Paper 1	[170 to 200 / 185* / 1°C/step]
	Thin Paper	[155 to 180 / 170* / 1°C/step]
	Envelope	[170 to 200 / 185* / 1°C/step]
	Thick Paper 2	[175 to 200 / 185* / 1°C/step]
	Recycled	[160 to 180 / 170* / 1°C/step]
	Standby Mode	[120 to 175 / 155* / 1°C/step]
	Low Power Mode	[80 to 135 / 120* / 1°C/step]
SC559 Detection		[On or Off *]
Print Test Pattern		Prints the test pattern.
Refill Mode Setting		[Auto refill mode * / Pure refill mode] <b>DFU</b>
Handling Mode on "Waste Toner full" of the refilled AIO		Sets the machine operation at "waste toner full" of the refilled AIO. [On or Off *]

Smart Organizing Monitor (SOM)

Group	Item	Remarks
Jam Counter		Displays Jam Counter for each location. Total Jam, Tray 1 Jam, Tray 2 Jam, Bypass Tray Jam, Duplex Jam, Inner Jam, Outer Jam

\*: Default

**SP Mode 3**

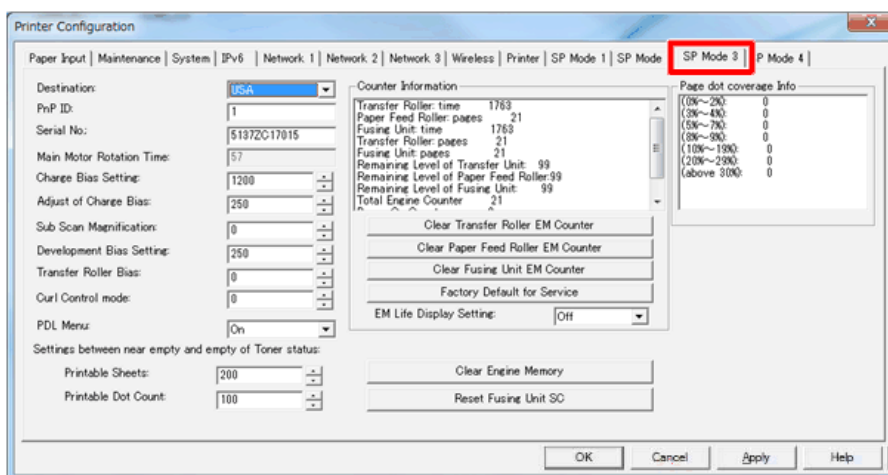

m0c3c5042

Item	Remarks
Destination	<b>DFU</b> [JPN/ NA/ EU / ASIA/ CHN/ TAIWAN]
PnP ID	<b>DFU</b>
Serial No	<b>DFU</b>
Main Motor Rotation Time	Displays the main motor rotation time.
Charge Bias Setting	[1100 to 1300 / 1200* / 24/step]
Sub Scan Magnification	Adjusts the sub scan magnification. [-8 to 8 / 0* / 1 /step]
Development Bias Setting	Adjusts the developer bias. [270 to 330 / 250* / 15 /step]
Transfer Roller Bias	Adjusts the transfer roller bias. [-6 to 6 / 0* / 1 /step]
Interval Setting	Corrects the face curl of paper. 0: OFF (32ppm)

Item		Remarks
		1: Sets the engine speed at half after printing 1 minute. 2: Sets the engine speed at 13ppm. [0 to 2 / 0* / 1 /step]
PDL Menu		[On * or Off]
Settings between near empty and empty of Toner status	Printable Sheets	Adjusts the printable sheets between "toner near end" and "toner end". [0 to 255 / 200 / 1 sheet/step]
	Printable Dot Count	Adjusts the printable dot count between "toner near end" and "toner end". [0 to 255 / 100 / 1 dot/step]
Counter Information		Display the counter information.
Clear Transfer Roller EM Counter		Clears the EM counter of the transfer roller.
Clear Paper Feed Roller EM Counter		Clears the EM counter of the paper feed roller.
Clear Fusing Unit EM Counter		Clears the EM counter of the fusing unit.
Factory Default for Service		Resets all the settings to factory default.
⇒ EM Life Display DFU (Designed for Factory Use)		Sets the alert display when each EM parts yield of this machine is reached. [On or Off *]
Clear Engine Memory		Resets the engine settings stored in the EEPROM to factory default.
Reset Fusing Unit SC		This menu is for resetting an SC related to a fusing error.
Page Dot Coverage Info		Displays the number of pages printed with each coverage.

\*: Default

### SP Mode 4

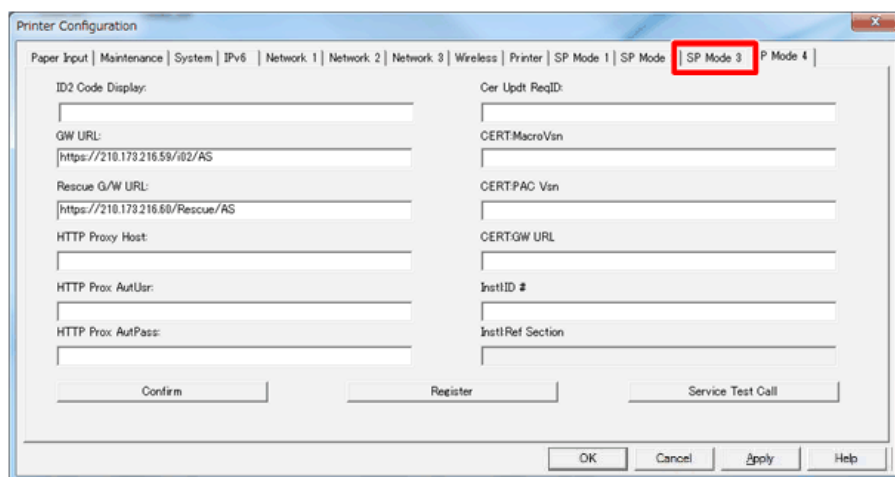

m0c3c5043

Item	Remarks
ID2 Code Display	Displays the ID2 code.
GW URL	Displays the URL for RCG center.
Rescure G/W URL	Displays the rescue URL.
HTTP Proxy Host	Displays the address of the proxy server
HTTP Proxy AutUsr	Displays the HTTP proxy authentication user.
HTTP Proxy AutPass	Displays the HTTP proxy authentication password.
Cer Updt ReqID	Displays the certificate update request ID.
CERT:MacroVsn	Displays the Macro Version.
CERT:PAC Vsn	Displays the PAC Version.
CERT:GW URL	Displays the NRS Gateway URL.
Instl:ID #	Displays the request number.
InstlRef Section	Displays the section name.
Confirm	Executes the reference.
Register	Executes the registration.
Service Test Call	Executes the test call.

## 5.4 FAX SERVICE TEST (ONLY FOR FAX MODELS)

### 5.4.1 FAX SERVICE TEST MENU

#### *Entering the Fax Service Test Menu*

Turn on the machine while pressing the [Home] key, and hold on pressing it until displayed "Fax Service Test".

#### *Selecting an Item*

Select the item which you want to execute.

#### *Exiting the Fax Service Test Menu*

Press [Exit].

### 5.4.2 MENU LIST

Menu		Description
Off-Hook Test	On Hook	Executes the on hook test.
	Off Hook	Executes the off hook test
CED Test		Executes the CED test.
CNG Test	1100 Hz	Executes the CNG test
ANSam Test		Executes the ANSam test.
Ring Tone Test		Executes the ring tone test.
DTMF Test	Tone [0] to [9]	Executes the DTMF tone 0 to 9 test.
	Tone [*]	Executes the DTMF tone * test.
	Tone [#]	Executes the DTMF tone # test.
	Tone Stop	Executes the Stop DTMF tone test.
Modem Test	[V34] 33600 Bps	Generates the [V34] 33600 bps signal.
	[V34] 28800 Bps	Generates the [V34] 28800 bps signal.
	[V17] 14400 Bps	Generates the [V17] 14400 bps signal.
	[V17] 12000 Bps	Generates the [V17] 12000 bps signal.
	[V17] 9600 Bps	Generates the [V17] 9600 bps signal.

Fax Service Test (Only for Fax Models)

Menu		Description
	[V17] 7200 Bps	Generates the [V17] 7200 bps signal.
	[V29] 9600 Bps	Generates the [V29] 9600 bps signal.
	[V29] 7200 Bps	Generates the [V29] 7200 bps signal.
	[V27] 4800 Bps	Generates the [V27] 4800 bps signal.
	[V27] 2400 Bps	Generates the [V27] 2400 bps signal.
	[V21] 300 Bps	Generates the [V21] 300 bps signal.
	Signal Stop	Generates the Stop signal.

## 5.5 REPORTS

### 5.5.1 TYPES OF REPORTS

You can check reports with [Print List/Report] in the "User Tools".

Item	Description
Configuration Page	Prints the information about the machine's status.
Fax Journal	Only for Fax models. Prints a fax transmission and reception journal for the last 50 jobs.
TX/RX Standby Files List	Only for Fax models. Prints a list of fax jobs remaining in the machine's memory to be printed, sent, or forwarded.
Fax/Scanner Quick Dial Dest. List	Only for MF models. Prints a list of fax and scanner Quick Dial entries.
Fax Speed Dial List	Only for Fax models. Prints a list of Speed Dial entries. - Sort by Speed Dial No. Prints the list with the entries sorted by Speed Dial registration number. - Sort by Name
Scanner Destination List	Only for MF models. Prints a list of scan destinations.
Scanner Journal	Only for MF models. Prints a scanner journal for the last 100 Scan to E-mail, Scan to FTP, and Scan to Folder transmissions.
Maintenance Page	Prints the maintenance status.
Special Sender List	Only for Fax models. Prints a list of fax special senders.



## 5.5.2 TO PRINT THE REPORTS

### For Printer Models:

1. Press the [Menu] key.
2. Press the [▲] or [▼] key to select [Print List/Report], and then press the [OK] key.
3. Press the [▲] or [▼] key to select the report you want, and then press the [OK] key.

The configuration page is printed. The [Print List/Report] screen appears on completion of printing.

### For MF Four-Line LCD Models:

1. Press the [User Tools] key.
2. Press the [▲] or [▼] key to select [Print List/Report], and then press the [OK] key.
3. Press the [▲] or [▼] key to select the report you want, and then press the [OK] key.

The configuration page is printed. The [Print List/Report] screen appears on completion of printing.

### For MF Touch Panel Models:

1. Press the [Setting] icon on the [Home] screen.
2. Press [Print List/Report].
3. Press the report name you want.
4. Press [Yes].

## 5.5.3 REPORT EXAMPLES

### Configuration Page

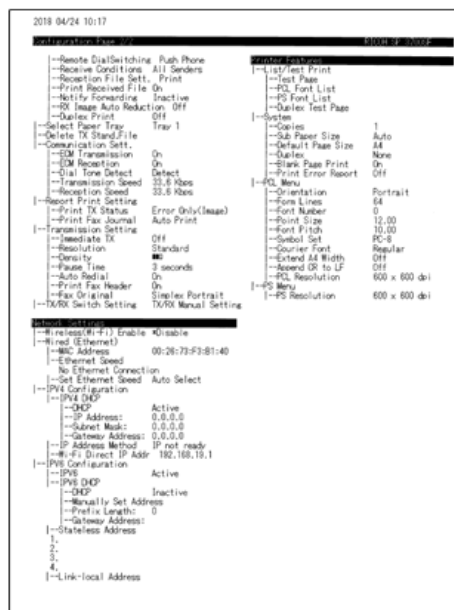
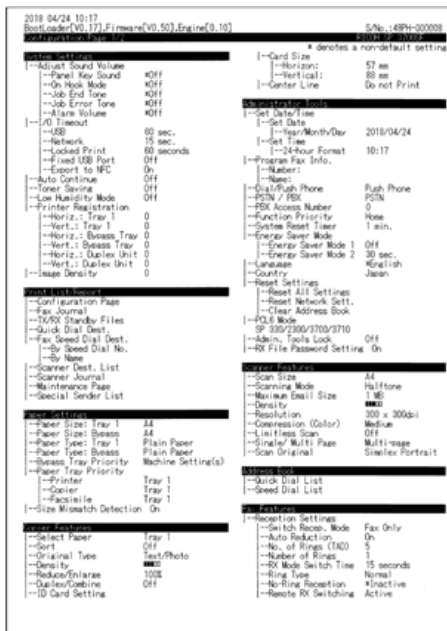

m0c3c5045

### Fax Journal

Fax Journal						
No.	Date/Time	Comm. Type	Duration	Sender/Destination	Pages	Results
				Date: 2018 03/01 12:47		
				Name:		
				ID:		

m0c3c5046

### TX/RX Standby Files

TX/RX Standby Files				
No.	Date/Time	Type	Sender/Destination	Pages
				Date: 2018 03/01 12:47
				Name:
				ID:

m0c3c5047

### Fax/Scanner Quick Dial Dest. List

Fax Quick Dial Dest. List					
Quick Name	Number		Date: 2018 03/01 12:47		
1			Name:		
2			ID:		
3					
4					
5					
6					
7					
8					
Scanner Quick Dial Dest. List			Color Format	B&W Format	
Quick Name	Type	Destination			
1					
2					
3					
4					
5					
6					
7					
8					

m0c3c5048

### Fax Speed Dial List

Fax Speed Dial List			Date: 2018 03/01 12:48
Speed	Name	Number	Name:
			ID:

m0c3c5049

### Scanner Destination List

## Reports

Scanner Destination List							
No.	Name	Type	Destination	Scan Size	Quick No.	Color Format	B&W Format
-----							

m0c3c5050

## Scanner Journal

Scanner Journal							
No.	Date	Time	Type	Destination	Files	Color	Format Results
-----							

m0c3c5051

## Maintenance Page

```

2018 02/23 18:32
-----
Maintenance Page
-----
- - - - System Reference
Model Name      :RICOH SP 3700SF
MAC Address     :00:26:73:f3:b1:40
Total Memory    :256MB
Bootloader Version :V0.17
Firmware Version :V0.50
Engine FW Version :0.10

- - - - Paper Input
- - - Tray 1
Paper Size      :A4
Paper Type      :Plain Paper

- - - Bypass Tray
Paper Size      :A4
Paper Type      :Plain Paper

- - - - Supplies Status
Print Cartridge :■■■■■ (H)

Fusing Unit     :■■■■■
Paper Feed Roller :■■■■■
Transfer Roller  :■■■■■

- - - - Call Service
01: 11:
02: 12:
03: 13:
04: 14:
05: 15:
06: 16:
07: 17:
08: 18:
09: 19:
10: 20:

10.61.35.187

0200 1800000000 00 3230313830323232 3030303030303030 313731324A4D33353030303032370000
343850482D3030303030303820 6100 0000 0000 00 0030 0011 0000
-----

```

- - - - Counter	
- - - Total Counter	
Page Total	:24
Dot Coverage(0-2%)	:88
Dot Coverage(3-4%)	:1
Dot Coverage(5-7%)	:14
Dot Coverage(8-9%)	:5
Dot Coverage(10-13%)	:9
Dot Coverage(20-23%)	:0
Dot Coverage(30-100%)	:3
P/J Information (AVE)	:0.4

- - - Scanner Engine	
Page Total	:13
Color	:0
Black	:13
ADF Used	:13
ADF Parts	:13

- - - Printer	
Print Page Total	:10

- - - Scanner	
Page Total	:0
Color	:0
Black	:0

- - - Copier	
Page Total	:12

- - - Facsimile	
Page Total	:0
Fax TX	:0
Fax RX	:0

- - - Paper Misfeed	
Paper Misfeed Total	:0
ADF	:0
Standard Tray	:0
Tray 1	:0
Bypass Tray	:0
- - - Internal	
Paper Input	:0
Before Paper Output	:0
Paper Output	:0
Before Duplex Unit	:0

m0c3c5052

### Note

#### Total Counter:

The total counter is incremented by the main board each time the board issues a print command to the engine.

The value is calculated as follows:

Total counter = Copier counter + Printer counter + Fax counter + Reports printed

#### Application Counters:

Application counters exist for each individual primary machine function (Printer, Scanner, Copier, Facsimile, and paper misfeed), and are incremented by the main board each time the board issues a print request for the function in question.

The application counters are set to 0 if you select "Factory Default" in the "Maintenance Mode (SP mode)".

### Special Sender list

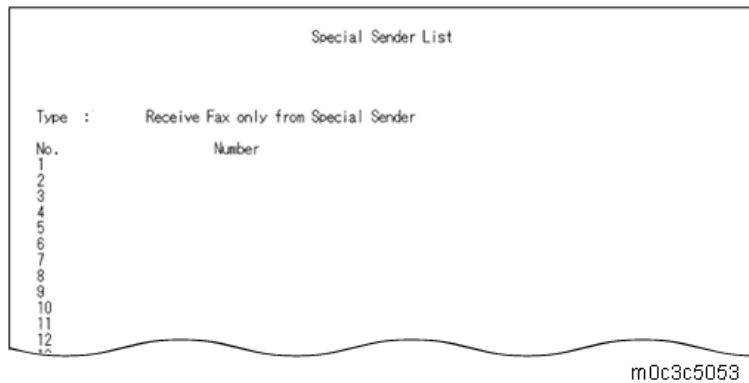

## 5.5.4 TEST PAGE

When you check an image problem or other problems, it might be necessary to print a test page. Follow the test page print procedure below to print a test page.

### *To Print the Test Page*

#### *For Printer Models*

1. Press the [Menu] key.
2. Press the [▲] or [▼] key to select [Printer Features], and then press the [OK] key.
3. Press the [▲] or [▼] key to select [List/Test Print], and then press the [OK] key.
4. Press the [▲] or [▼] key to select [Test page], and then press the [OK] key.

The test page is printed.

### ***For MF Four-Line LCD Models***

1. Press the [User Tools] key.
2. Press the [▲] or [▼] key to select [Printer Features], and then press the [OK] key.
3. Press the [▲] or [▼] key to select [List/Test Print], and then press the [OK] key.
4. Press the [▲] or [▼] key to select [Test page], and then press the [OK] key.

The test page is printed.

### ***For MF Touch Panel Models***

1. Press the [Setting] icon on the [Home] screen.
2. Press [Printer Features].
3. Press [List/Test Print].
4. Press [Test Page].

The test page is printed.

### ***Test Page Example***

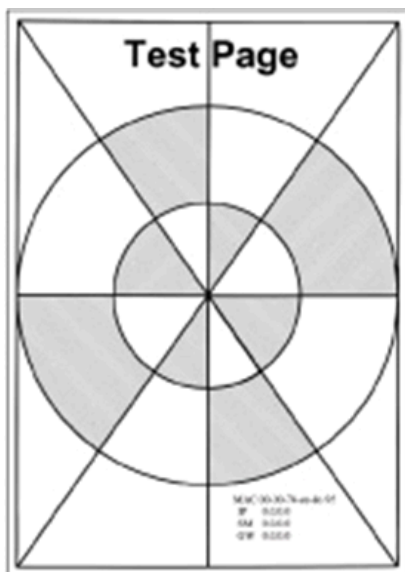

m118t100

## **5.5.5 TEST PATTERN PRINTING**

Follow the test pattern print procedure below to print a test pattern.

## To Print the Test Pattern

### Note

For information on how to enter the "Maintenance Mode (SP mode)", contact the supervisor in your branch office.

### For Four-Line LCD Models

1. Enter the "Maintenance Mode (SP mode)".
2. Press the [▲] or [▼] key to select [Engine Maintenance], and then press the [OK] key.
3. Press the [▲] or [▼] key to select [Test Pattern], and then press the [OK] key.

The three test pattern pages are printed.

### For Touch Panel Models

1. Enter the "Maintenance Mode (SP mode)".
2. Press [Engine Service Setting].
3. Press [Test Pattern].

The three test pattern pages are printed.

### Test Pattern Examples

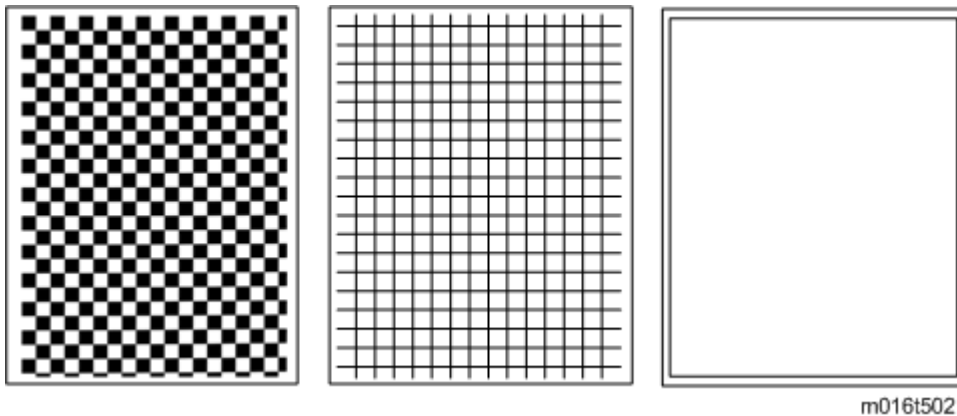

## 5.6 UPDATING THE FIRMWARE

### ★ Important

- Never turn the machine's main power off while the firmware is being updated, because this could damage the main board.

### 5.6.1 BEFORE UPDATING THE FIRMWARE

Check your operating environment before beginning the update.

#### ***Compatible Operating Systems***

The computer must be running one of the following operating systems:

- Windows Vista (32/64 bit)/ 7 (32/64 bit)/ 8.1 (32/64 bit)/ 10 (32/64 bit)
- Windows Server 2008/ Server 2008 R2/ Server 2012/ Server 2012 R2/ Server 2016
- OS X 10.10 or later
- Linux OS
  - Ubuntu 16.04LTS/ 16.10 (x86 & x64)
  - openSUSE 13.1/ 13.2 (x86 & x64)
  - Red Hat Enterprise Linux 6/ 7 (x86 & x64)

#### ***Backing Up the Machine's Settings***

After the firmware update, the machine's settings may return to their factory defaults.

Before you reconnect the machine for the update, back up the machine's settings by accessing the machine using a web browser from a computer connected via a network. For details, refer to the "User's Guide".

Also, print out a configuration page using [Print List/Report] on the control panel or a web browser. For details, refer to the "[Reports](#)".

#### ***Connection***

Connect your computer and the machine through a network or directly by USB.

### ★ Important

- Make sure a computer is securely connected to the machine with the USB or network cable that you will be using for the firmware update.
- We recommend that you update the firmware via USB. If updating the firmware over the network, the machine may receive data over the network such as a print job during the updates, which can interfere with the update process.
- If updating the firmware via USB, the printer driver for USB connection must be installed on a computer beforehand. However, if updating via a network, no printer



driver is necessary.

- Disconnect any other cables that are not necessary for the firmware update, such as a telephone cable, from the machine.

### **Computer Settings**

Make sure that the computer does not enter standby or hibernation mode during the update process.

The following is the procedure for Windows 10.

1. On the [Start] menu, click [Settings].
2. Click [System].
3. Click [Power & sleep].
4. Make sure [Sleep] is set to "Never".

## **5.6.2 UPDATING THE MAIN FIRMWARE**

Using the following procedure to update the main firmware, be sure to print the configuration page both before and after the update. Comparing pre- and post-update configuration pages allows you to check whether or not the update was successful.

Follow the procedure carefully, and note that it will vary in parts depending on which version of the firmware is currently installed.

### **★ Important**

When using a computer running on a Windows operating system, you must have an account that has Manage Printers permission. Log on as an Administrators group member to acquire this permission.

Do not operate the machine using the control panel, access the machine using Web Image Monitor, or perform fax transmissions, printing, or TWAIN scanning during the update process.

The update may take a while to complete. Do not turn off the power during the update. Turn off the power only when an update completion message appears on the machine's control panel.

Never disconnect the cable using for the updates during the update process.

## Procedure

### CAUTION

Do not turn off the main power from this point until the update procedure is completed.

#### Note

If updating a machine in which LDAP authentication is set, it is necessary to activate the machine in a special boot loader mode before doing the firmware update procedure.

Refer to the [FW Update Mode] in the Maintenance Mode sections of the manual.

**Four-line LCD panel:** SP menu > [CTL Maintenance] > [FW Update Mode] (*CTL Maintenance*)

**Touch panel:** SP menu > [CTL SP] > [FW Update Mode] (*CTL SP*)

1. Connect a computer securely to the machine with the USB or network cable that you will be using for the firmware update. Disconnect any other non-essential cables.
2. Print the configuration page. (*Reports*)  
Take note of the current firmware version (shown under "Firmware Version" on the configuration page).
3. Double-click the [FwUpdateTool.exe] (Windows) or [Firmware Update Tool] (OS X) icon to launch the firmware update tool. A dialog box with cautionary statements appears.
4. Read the cautionary statements, and then click [OK].

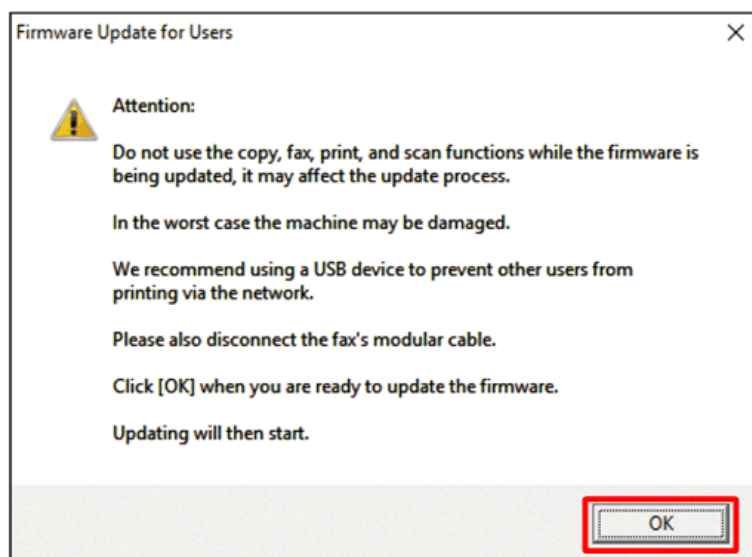

m0c3c5054

5. For a USB connection, click [Firmware Update (USB)] [A]. For a network connection, enter the machine's IP address in [Machine IP Address] [B], and then click [Firmware Update (LAN)] [C].

When connecting via USB, an IP address is unnecessary.

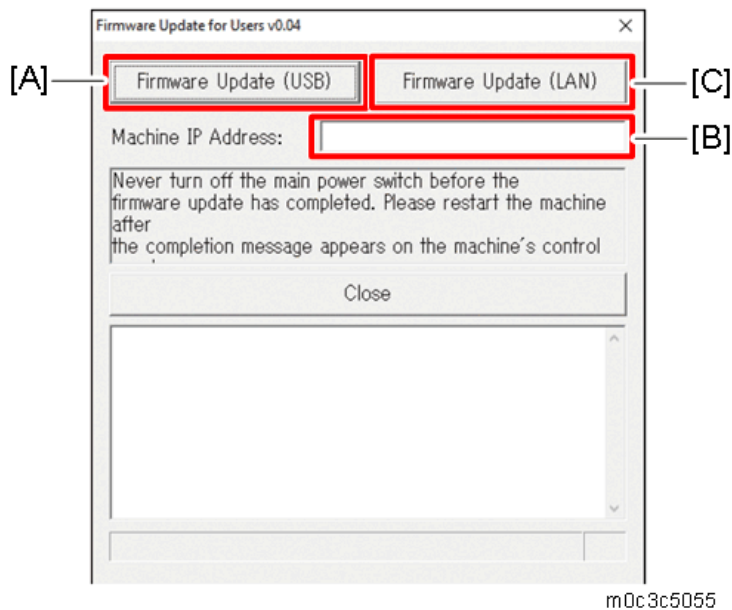

6. Check the machine's control panel for messages and the update's current percentage of completion.
7. Wait until the update completion message "Restart machine..." appears on the machine's control panel.
8. Click [Close] to close the update tool. The machine restarts following a firmware update.
9. Wait until the machine restarts. The machine performs initialization after restarting.

**Touch panel models:** "Please wait." appears on the machine's control panel.

**Four-line LCD models:** "Warming up..." appears on the machine's control panel.

10. Wait until the Home screen (touch panel models) or "Ready" (four-line LCD models) appears on the machine's control panel.

If the Home screen or "Ready" does not appear on the machine's control panel after one minute, the update is not complete. Refer to "[If Initialization Does Not End Following a Firmware Update](#)".

11. Print the configuration page again.

Confirm that the firmware has been updated by checking its version (shown under "Firmware Version" on the configuration page).

12. Reconnect the cables as they were before the update.

### 5.6.3 TROUBLESHOOTING

This section provides solutions to common update-related problems.

#### ***If Initialization Does Not End Following a Firmware Update***

If the Home screen (touch panel models) or "Ready" (four-line LCD models) does not appear on the machine's control panel after one minute following a firmware update, a power failure or

similar interruption prevented the update from completing.

If this happens, check “**Before Updating the Firmware**” again, and then use the following procedure to recover from the failure and complete the update.

**★ Important**

To be recovered following a failed update, the machine must be connected to a computer by USB.

When using a computer running on a Windows operating system, you must have an account that has Manage Printers permission. Log on as an Administrators group member to acquire this permission.

1. If you performed the update through a network connection, disconnect the network cable, and then connect the machine to a computer using a USB cable.
2. After confirming that “blank page” or “Initializing...” has been shown on the machine’s control panel for more than one minute, double-click the [FwUpdateTool.exe] (Windows) or [Firmware Update Tool] (OS X) icon to launch the firmware update tool.

A dialog box with cautionary statements appears.

3. Read the cautionary statements, and then click [OK].

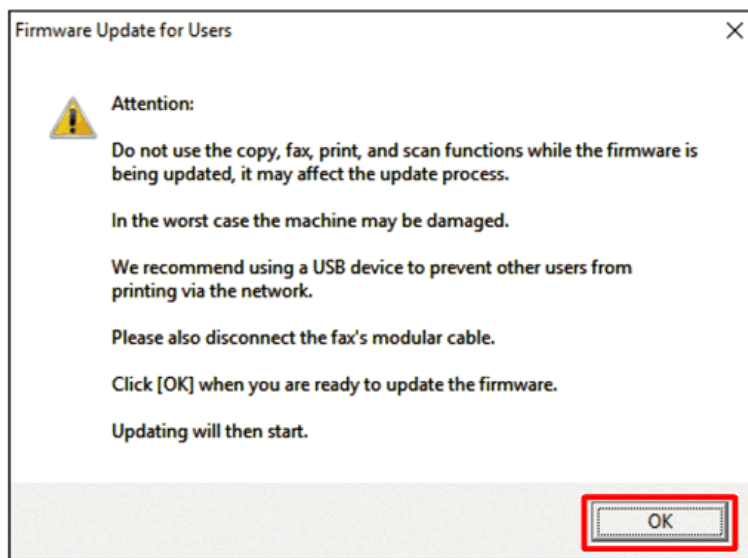

m0c3c5054

- Click [Firmware Update (USB)] [A].

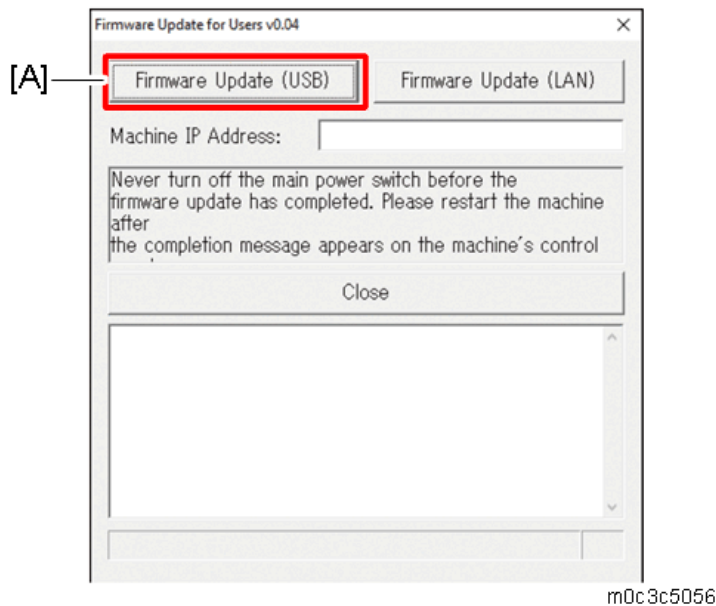

Make sure that you keep the power of the machine turned on.

Wait until the Home screen (touch panel models) or "Ready" (four-line LCD models) appears on the machine's control panel.

- When the Home screen (touch panel models) or "Ready" (four-line LCD models) appeared, click [Firmware Update (USB)] again.
- Wait until the update completion message "Restart machine..." appears on the machine's control panel.
- Click [Close] to close the update tool.
- Wait until the machine restarts. The machine performs initialization after restarting.
  - Touch panel models:** "Please wait." appears on the machine's control panel.
  - Four-line LCD models:** "Warming up..." appears on the machine's control panel.
- Wait until the Home screen (touch panel models) or "Ready" (four-line LCD models) appears on the machine's control panel.
- Print the configuration page again.
  - Confirm that the firmware has been updated by checking its version (shown under "Firmware Version" on the configuration page).
- Reconnect the cables as they were before the update.

### ***Firmware Update Tool Messages***

The following table lists the firmware update tool messages that can appear during a firmware update, and explains the likely causes of those messages and what action to take when they appear.

Messages are alphabetically ordered.

Messages	Causes	Solutions
Cannot open the firmware update file. Please check the file.	The firmware file (*.brn) or setting file (*.ini) is not stored in the same folder as the update tool.  (Note that the setting file only exists when using a computer running a Windows operating system.)	Make sure that the firmware file (*.brn) and setting file (*.ini) are stored in the same folder as the update tool.  Also, make sure that you do not modify the setting file.
	The path to the location of the update tool is too long.	Make sure that the path to the update tool is not too long. For convenience, save the update tool in a subfolder directly under the computer's C: drive.
Connecting...	The computer is searching the network for the machine.	Wait a while until the machine is found.
LAN Upload: Failed	The network cable was disconnected immediately after the [Firmware Update (LAN)] button was clicked.	Turn the machine's power off, wait a moment, and then turn it back on again. Disconnect any unnecessary cables from the machine, and then try again.
LAN Upload: Finished	The firmware has been transferred to the machine successfully.	Wait until the machine restarts.
The connection with the machine has been broken.  ***Please check the machine's control panel to see if updating the firmware has already completed. If the firmware	The firmware update tool is no longer able to acquire update progress from the machine because the connection between the machine and computer has been terminated.	Disconnecting the machine from the computer should not interrupt any ongoing update. Check the machine's control panel to see if the update has completed.

Messages	Causes	Solutions
update has completed then restart the machine.***		
The downloaded file is damaged. Using the copy, fax, print, and scan functions while updating the firmware may damage the file.	The [Firmware Update (USB)] or [Firmware Update (LAN)] button was clicked while the machine was faxing, printing, scanning, or copying.	Wait for the current job to finish, disconnect any unnecessary cables from the machine, and then try again.
	The firmware file is damaged.	Download the firmware package from our website again.
The machine is busy.	The machine is being operated through the control panel.	Cancel any operations being performed through the control panel. Put the machine into standby mode, and then perform the update again
	<ul style="list-style-type: none"> <li>• There is an unsent fax in the machine's memory.</li> <li>• There is a received fax waiting to be printed.</li> </ul>	<ul style="list-style-type: none"> <li>• Send or delete the unsent fax, and then try again.</li> <li>• Print the received fax, and then try again.</li> </ul>
	The [Firmware Update (USB)] or [Firmware Update (LAN)] button was clicked when the update was already in progress.	Clicking the [Firmware Update (USB)] or [Firmware Update (LAN)] button during the update process does not interfere with any ongoing update. Ignore this error message and complete the update using the procedure shown in this manual.
The machine is not ready.	The USB cable is not connected.	Make sure the USB connection between the machine and computer is secure. If this message persists, try another USB cable.



Messages	Causes	Solutions
	The USB printer driver is not installed in the computer.	Install the USB printer driver in the computer.
	The machine is turned off or an error has occurred.	Turn the machine's power off, wait a moment, and then turn it back on again. Then perform the update again.
	The IP address specified for either the machine or the computer is invalid.	Check that both IP addresses are valid.
	The machine is not connected to the network properly.	Check that the machine is properly connected to the network.
The models are not the same.	The machine you were trying to update was not the correct model for the firmware you have downloaded from the website.	The firmware packages on the website are each designed to be used for a specific model, and cannot be used for any other model.  Check the model of the customer's machine, and download the appropriate firmware package for its model.
USB Upload: Failed	The USB cable was disconnected immediately after the [Firmware Update (USB)] button was clicked.	Turn the machine's power off, wait a moment, and then turn it back on again. Disconnect any unnecessary cables from the machine, and then try again.
USB Upload: Finished	The firmware has been transferred to the machine successfully.	Wait until the machine restarts.

### **Control Panel Display**

The following table lists the control panel display that can appear if an error occurred during a firmware update, and explains the likely causes of the display and what action to take when they appear.

Display	Likely Cause	Solution
The Home screen (touch panel models) or "Ready" (four-line LCD models) does not appear on the control panel after one minute following a firmware update.	A power failure or similar interruption prevented the update from completing.	Refer to " <b><i>If Initialization Does Not End Following a Firmware Update</i></b> ".

### **Control Panel Indicator Patterns (Only for Four-line LCD Models)**

The indicators of the control panel show the machine's status during and after firmware updates. If an update fails or does not complete normally, refer to the following table to resolve the problem.

Indicator Pattern	Likely Cause	Solution
The Alert and Data in indicators light up simultaneously	If the Alert and Data in indicators light up simultaneously after you turn the machine's power back on following a firmware update, the update did not complete due to a power failure or similar interruption.	Refer to " <b><i>If Initialization Does Not End Following a Firmware Update</i></b> ".

## 5.7 CAPTURING THE DEBUG LOGS

### 5.7.1 OVERVIEW

You can use the Web Image Monitor to get debug logs.

#### *Retrieving the Debug Logs*

##### ↓ Note

A PC is necessary to acquire the debug log.

1. Enter the following URL in the browser:

http://<ip address>/Primax-debug-info.asp?en-us

2. After going to the "Webpage Debug Page", select the following items one at a time.

- Get Debug Message
- Get Event Log
- Get Error Log

##### ↓ Note

Multiple items cannot be selected at the same time on the Debug Item List.

Regarding the "Debug Message", old log data is overwritten by new log data because of the buffer size limitation. Therefore, please conduct "Get Debug Message" immediately after a problem occurs.

3. Select the debug item, press OK, and the .bin file will be downloaded.

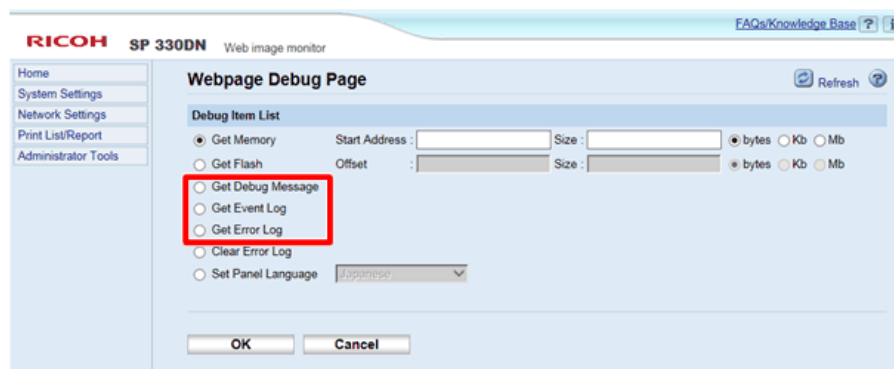

m0c3c5064

##### ↓ Note

If the output speed for the log data is slower than the generated speed for the log data, some logs might be lost.

**Debug Item List:**

Item name	Description
Get Memory	When this item is selected, Start Address, Size, and the unit (bytes, Kb, or Mb) can also be selected. Start Address and Size should be smaller than the total engine memory size.
Get Flash	When this item is selected, Offset, Size, and the unit (bytes, Kb, or Mb) can also be selected. Offset and Size should be smaller than the total engine flash memory size.
Get Debug Message	Get the debug log data from the log buffer. The log buffer is set to 3000 lines by default for MF models and 2000 lines by default for P models.
Get Event Log	Get the log data from the event buffer.
Get Error Log	Get the log data from the error buffer.
Clear Error Log	Reset the error buffer to erase all data from the flash memory.
Set Panel Language	Set the panel supported language list.

# TROUBLESHOOTING

REVISION HISTORY		
Page	Date	Added/Updated/New
		None

---

## 6. TROUBLESHOOTING

### 6.1 SELF-DIAGNOSTIC MODE

#### 6.1.1 SELF-DIAGNOSTIC MODE AT POWER ON

As soon as the main machine is powered on, the controller waits for the initial settings of the copy engine to take effect and then starts an independent self-diagnostic test program.

The self-diagnostic test checks the CPU, memory and so on. An SC code is displayed if the self-diagnostic program detects any malfunction or abnormal condition. If it is an error with which the machine can start, the machine records it in the System Error Log.

## 6.2 SERVICE CALL

### 6.2.1 SERVICE CALL CONDITIONS

The 'SC Table' section shows the SC codes for controller errors and other errors. The latter are put into four types. The type is determined by their reset procedures. The table shows the classification of the SC codes.

Level	Definition	Reset Procedure
A	To prevent damage to the machine, the main machine cannot be operated until the SC has been reset by a service representative (see the note below).	Enter "Maintenance mode (SP menu)", and select [Fuser SC Reset], and turn the main power switch off and on. *
B	SCs that disable only the features that use the defective item. Although these SCs are not shown to the user under normal conditions, they are displayed on the operation panel only when the defective feature is selected.	Turn the main power switch off and on.
C	The SC history is updated. The machine can be operated as usual.	The SC will not be displayed. Only the SC history is updated.
D	Turning the main power switch off then on resets SCs displayed on the operation panel. These are re-displayed if the error occurs again.	Turn the main power switch off and on.

#### Note

To prevent damage to the machine, the machine cannot be operated until the fusing related SC has been reset by a service representative.

The SC reset procedure is as follows ;

1. Enter the "Maintenance mode (SP menu)".
2. Select [Fuser SC Reset]
  - Four-line LCD panel:** [Engine maintenance] > [Fuser SC Reset].
  - Touch panel:** [Engine Service Setting] > [Fuser SC Reset].
3. Press "Execute", and then turn the machine off and on.



## 6.2.2 SC 2XX (LASER OPTICS ERRORS)

No.	Type	Error Name/Error Condition/Major Cause/Solution
SC202	D	Polygon mirror motor on timeout error
		The polygon mirror motor does not reach the targeted operating speed within 10 sec. after turning on.
		<ul style="list-style-type: none"> <li>• Polygon mirror motor/LD driver board harness loose or disconnected</li> <li>• Polygon mirror motor/LD driver board defective</li> </ul>
		<ol style="list-style-type: none"> <li>1. Turn the power OFF and ON.</li> <li>2. Replace the polygon mirror motor/ laser unit.</li> <li>3. Replace the interface harness of the laser unit.</li> <li>4. Replace the main board.</li> </ol>

No.	Type	Error Name/Error Condition/Major Cause/Solution
SC203	D	Polygon mirror motor off timeout error
		The polygon mirror motor does not leave the READY status within 20 sec. after the polygon mirror motor was switched off.
		<ul style="list-style-type: none"> <li>• Polygon mirror motor/LD driver board harness loose or disconnected</li> <li>• Polygon mirror motor/LD driver board defective</li> </ul>
		<ol style="list-style-type: none"> <li>1. Turn the power OFF and ON.</li> <li>2. Replace the polygon mirror motor/ laser unit.</li> <li>3. Replace the interface harness of the laser unit.</li> <li>4. Replace the main board.</li> </ol>

No.	Type	Error Name/Error Condition/Major Cause/Solution
SC204	D	Polygon mirror motor lock signal error
		The signal remains HIGH for 0.2 sec. (or 4 times in 50msec of polling) while the polygon mirror motor is rotating.
		Polygon mirror motor/LD driver board defective
		<ol style="list-style-type: none"> <li>1. Turn the power OFF and ON.</li> <li>2. Replace the polygon mirror motor/ laser unit.</li> <li>3. Replace the interface harness of the laser unit.</li> </ol>

No.	Type	Error Name/Error Condition/Major Cause/Solution
SC220	D	Beam synchronization error
		The laser synchronization detection signal for the LD is not output within 0.4 sec. after the laser unit has turned on.
		<ul style="list-style-type: none"> <li>• Disconnected cable from the laser synchronization detector defective connection</li> <li>• Defective laser synchronization detector/ main board</li> <li>• The beam does not enter the laser synchronization detector</li> </ul>
		<ol style="list-style-type: none"> <li>1. Turn the power OFF and ON.</li> <li>2. Replace the polygon mirror motor/ laser unit.</li> <li>3. Replace the interface harness of the laser unit.</li> <li>4. Replace the main board.</li> </ol>

No.	Type	Error Name/Error Condition/Major Cause/Solution
SC268	D	Laser unit thermistor error
		<ul style="list-style-type: none"> <li>• The laser unit thermistor detected a temperature lower than -30°C for more than 4 sec.</li> <li>• The laser unit thermistor detected a temperature higher than 105°C for more than 1 sec.</li> </ul>
		<ul style="list-style-type: none"> <li>• Thermistor disconnected (causes an extremely low temperature reading)</li> <li>• Defective harness</li> <li>• Defective main board</li> </ul>
		<ol style="list-style-type: none"> <li>1. Turn the power OFF and ON.</li> <li>2. Replace the laser unit thermistor.</li> </ol>

### 6.2.3 SC 4XX (IMAGE TRANSFER AND TRANSFER ERRORS)

No.	Type	Error Name/Error Condition/Major Cause/Solution
SC491	D	Bias leak
		An error signal is detected for 0.2 seconds when changing the development unit.
		<ul style="list-style-type: none"> <li>• HVP harness damaged and short circuited</li> <li>• Defective the HVP</li> <li>• AIO terminal damaged and short circuited</li> </ul>
		<ol style="list-style-type: none"> <li>1. Turn the power OFF and ON.</li> <li>2. Replace the main board.</li> <li>3. Replace the transfer roller.</li> <li>4. Replace the interface harness of the HVP.</li> <li>5. Replace the HVP.</li> </ol>

### 6.2.4 SC 5XX (MOTOR AND FUSING ERRORS)

No.	Type	Error Name/Error Condition/Major Cause/Solution
SC520	D	Main motor error
		<ul style="list-style-type: none"> <li>• The machine does not detect a main motor lock signal within 2 seconds after the main motor started to rotate.</li> <li>• The machine does not release a main motor lock signal within 2 seconds after the main motor switched off.</li> <li>• The machine detects a main motor lock signal every 100 msec. for seven times consecutively, after the main motor started to rotate stably.</li> </ul>
		<ul style="list-style-type: none"> <li>• Torque overload</li> <li>• Defective main motor</li> <li>• Disconnected or defective motor harness</li> </ul>
		<ol style="list-style-type: none"> <li>1. Turn the power OFF and ON.</li> <li>2. Replace the main motor if the torque load is normal.</li> <li>3. Clean/replace the AIO and/or fusing unit if the torque load is abnormal.</li> <li>4. Replace the motor harness.</li> </ol>

No.	Type	Error Name/Error Condition/Major Cause/Solution
SC530	D	Cooling fan error
		The FAN lock signal – High for 10 seconds, after the cooling fan motor started to rotate.
		Disconnected or defective fan motor harness
		<ol style="list-style-type: none"> <li>1. Turn the power OFF and ON.</li> <li>2. Replace the cooling fan.</li> <li>3. Replace the fan motor harness.</li> </ol>

No.	Type	Error Name/Error Condition/Major Cause/Solution
SC541	A	Fusing thermistor error
		The thermistor output is less than 0°C for 5 seconds after the fusing lamp turns ON.
		Disconnected or defective fusing thermistor
		<ol style="list-style-type: none"> <li>1. Reset the SC.</li> <li>2. Replace the fusing unit.</li> <li>3. Replace the drawer harness.</li> <li>4. Replace the PSU.</li> </ol>

No.	Type	Error Name/Error Condition/Major Cause/Solution
SC542-01	A	Fuser reload error
		The fusing temperature rises 6°C or less in 1.5 seconds; and this continues 5 times consecutively.
		<ul style="list-style-type: none"> <li>• Defective or deformed thermistor</li> <li>• Incorrect power supply input at the main power socket</li> </ul>
SC542-02	A	Fuser reload error
		The fusing temperature has not reached 45°C within 9 seconds (after the fusing lamp comes ON while the machine is warming-up).
		<ul style="list-style-type: none"> <li>• Defective or deformed thermistor</li> <li>• Incorrect power supply input at the main power socket</li> </ul>
SC542-03	A	Fuser reload error
		The fusing unit does not attain reload temperature within a predetermined time after the fusing temperature control starts.

No.	Type	Error Name/Error Condition/Major Cause/Solution
		<ul style="list-style-type: none"> <li>Defective fusing lamp</li> <li>The overheat protection mechanism started working</li> </ul>
		<ol style="list-style-type: none"> <li>Reset the SC.</li> <li>Replace the fusing unit.</li> <li>Replace the drawer harness.</li> <li>Replace the PSU.</li> </ol>

No.	Type	Error Name/Error Condition/Major Cause/Solution
SC543	A	High temperature error (soft)
		The detected temperature stays at 235°C for 0.5 second, and this consecutively occurs 10 times.
		<ul style="list-style-type: none"> <li>Defective main board</li> <li>Defective PSU</li> </ul>
		<ol style="list-style-type: none"> <li>Reset the SC.</li> <li>Replace the main board.</li> <li>Replace the PSU.</li> <li>Replace the fusing unit.</li> <li>Replace the drawer harness.</li> </ol>

No.	Type	Error Name/Error Condition/Major Cause/Solution
SC544	A	High temperature error (hard)
		The detected temperature stays at 250°C for 0.2 second, and this consecutively occurs 4 times.
		<ul style="list-style-type: none"> <li>Defective main board</li> <li>Defective PSU</li> <li>Defective fusing unit</li> </ul>
		<ol style="list-style-type: none"> <li>Reset the SC.</li> <li>Replace the fusing unit.</li> <li>Replace the drawer harness.</li> <li>Replace the PSU.</li> </ol>

No.	Type	Error Name/Error Condition/Major Cause/Solution
SC545	A	Fuser full heater error
		The fuser full heater remained ON at full capacity for more than 9 seconds after the fusing temperature attains reload temperature.
		<ul style="list-style-type: none"> <li>• Deformed thermistor</li> <li>• Thermistor not in the correct position</li> <li>• Defective fusing lamp</li> </ul>
		<ol style="list-style-type: none"> <li>1. Reset the SC.</li> <li>2. Replace the fusing unit.</li> <li>3. Replace the drawer harness.</li> <li>4. Replace the PSU.</li> </ol>

No.	Type	Error Name/Error Condition/Major Cause/Solution
SC546	D	Unstable fusing thermistor temperature
		While the machine is warming-up or printing, the detected temperature stays at 100°C or less than the target temperature for 5.2 seconds, and this consecutively occurs 104 times.
		Unstable connector contact of fusing thermistor
		None

No.	Type	Error Name/Error Condition/Major Cause/Solution
SC547	D	Zero cross error
		<ul style="list-style-type: none"> <li>• The zero cross signal is detected 3 times even though the fusing lamp relay is off when turning on the main power.</li> <li>• The number of zero cross signal interrupts do not reach a specified value during frequency detection.</li> <li>• The zero cross signal is not detected for 3 seconds even though the fusing lamp relay is on.</li> </ul>
		<ul style="list-style-type: none"> <li>• Defective fusing relay</li> <li>• Defective fusing relay circuit</li> <li>• Unstable frequency of the power supply line</li> </ul>
		<ol style="list-style-type: none"> <li>1. Check the power supply source.</li> <li>2. Replace the PSU</li> </ol>

No.	Type	Error Name/Error Condition/Major Cause/Solution
SC551	A	Non-contact thermistor error
		The thermistor output is less than 0°C for 5 seconds after the fusing lamp turns ON.
		Disconnected or defective non-contact thermistor
		<ol style="list-style-type: none"> <li>1. Reset the SC.</li> <li>2. Replace the fusing unit.</li> <li>3. Replace the drawer harness.</li> <li>4. Replace the PSU.</li> </ol>

No.	Type	Error Name/Error Condition/Major Cause/Solution
SC552	A	Fuser reload error (non-contact thermistor)
		The fusing temperature rises 1°C or less in 1.5 seconds; and this continues 5 times consecutively.
		<ul style="list-style-type: none"> <li>• Defective or deformed non-contact thermistor</li> <li>• Incorrect power supply input at the main power socket</li> </ul>
		<ol style="list-style-type: none"> <li>1. Reset the SC.</li> <li>2. Replace the fusing unit.</li> <li>3. Replace the drawer harness.</li> <li>4. Replace the PSU.</li> </ol>

No.	Type	Error Name/Error Condition/Major Cause/Solution
SC553	A	High temperature error (soft) (non-contact thermistor)
		The detected temperature stays at 220°C for 0.5 second, and this consecutively occurs 10 times.
		<ul style="list-style-type: none"> <li>• Defective main board</li> <li>• Defective PSU</li> </ul>
		<ol style="list-style-type: none"> <li>1. Reset the SC.</li> <li>2. Replace the main board.</li> <li>3. Replace the PSU.</li> <li>4. Replace the fusing unit.</li> <li>5. Replace the drawer harness.</li> </ol>



No.	Type	Error Name/Error Condition/Major Cause/Solution
SC554	A	High temperature error (hard) (non-contact thermistor)
		The detected temperature stays at 228°C for 0.2 second, and this consecutively occurs 4 times.
		<ul style="list-style-type: none"> <li>• Defective main board</li> <li>• Defective PSU</li> <li>• Defective fusing unit</li> </ul>
		<ol style="list-style-type: none"> <li>1. Reset the SC.</li> <li>2. Replace the fusing unit.</li> <li>3. Replace the drawer harness.</li> <li>4. Replace the PSU.</li> </ol>

No.	Type	Error Name/Error Condition/Major Cause/Solution
SC557	B	Zero-crossing frequency exceeded
		The number of zero cross signal interrupts do not reach a specified value during frequency detection.
		<ul style="list-style-type: none"> <li>• Unstable frequency of the power supply line</li> </ul>
		None

No.	Type	Error Name/Error Condition/Major Cause/Solution
SC559	A	Fuser 3 times jam error
		The paper jam counter for the fusing unit reaches 3. The paper jam counter is cleared if the paper is fed correctly.
		<ul style="list-style-type: none"> <li>• Defective fusing unit</li> <li>• Defective fusing control</li> </ul>
		<p>This SC is activated only when this function is enabled with "SC559 Detection" in "Engine Maintenance" (default "OFF").</p> <p>Turn off this function after a jam removal.</p>

No.	Type	Error Name/Error Condition/Major Cause/Solution
SC580	A	Environment thermistor error
		The thermistor output is less than 0°C for 5 seconds after the fusing lamp turns ON.
		Disconnected or defective environment thermistor

No.	Type	Error Name/Error Condition/Major Cause/Solution
		<ol style="list-style-type: none"> <li>1. Reset the SC.</li> <li>2. Replace the environment thermistor.</li> </ol>

### 6.2.5 SC 6XX (COMMUNICATION AND OTHER ERRORS)

No.	Type	Error Name/Error Condition/Major Cause/Solution
SC688	D	PRREQ signal not asserted
		The print request signal (PRREQ) signal is not asserted within the prescribed time after paper reaches the registration stand-by position,
		<ul style="list-style-type: none"> <li>• Main board error</li> <li>• Communication error</li> </ul>
		<ol style="list-style-type: none"> <li>1. Turn the power OFF and ON.</li> <li>2. Check the interface harness of the main board.</li> </ol>

## 6.3 ERROR MESSAGES

### 6.3.1 OVERVIEW

Error codes will be displayed on the operation panel if the machine has a problem. These can be viewed by a customer.

Messages are listed in alphabetical order in the table.

"X" indicates a number in an error code that appears differently depending on a specific situation.

#### When using the four-line LCD model:

If the alert indicator lights up continuously or flashes, switch to copier mode and check the displayed message.

#### When using the touch panel model:

If the alert indicator lights up continuously or flashes, press the [Status] icon on the [Home] screen and check the displayed message.

### 6.3.2 ERROR MESSAGES

Message	Causes	Solutions
2XXX14	The machine was not able to print the received fax, or the machine's memory reached capacity while receiving a fax because the document was too large.	<ul style="list-style-type: none"> <li>• The paper tray was empty. Load paper in the paper tray.</li> <li>• The paper tray did not contain A4, Letter, or Legal size paper. Load valid size paper in the tray, and configure the paper size settings under [Paper Settings] accordingly.</li> <li>• A cover or tray was open. Close the cover or tray.</li> <li>• There was a paper jam. Remove the jammed paper.</li> <li>• A print cartridge was empty. Replace the print cartridge.</li> <li>• The received fax was too large. Ask the sender to resend the</li> </ul>

Message	Causes	Solutions
		document in parts as several smaller individual faxes, or to send at a lower resolution.
ADF Original Misfeed Open ADF Cover and remove paper.	An original has jammed inside the ADF.	<ul style="list-style-type: none"> <li>Remove jammed originals, and then place them again.</li> <li>Check the originals are suitable for scanning.</li> </ul>
ADF Orig. Misfeed Open ADF Cover and remove paper.		
Available: IDCard Copy A4/A5 SEF/A6/8.5x11/5.5x8.5	ID card copy could not be performed because the tray does not contain the valid sizes of paper, which are A4, Letter, A5, 5.5x8.5 inches, or A6 size.	<ul style="list-style-type: none"> <li>Set the machine to print copies using A4 or Letter size paper in the [Select Paper] settings.</li> <li>Specify A4 or Letter size paper for the tray selected for printing copies.</li> </ul>
Available: 2 Sided Copy A4, LG, LT, 8x13, 8 1/4x13, 8 1/2x13, 16K	<p>Only when using the touch panel models.</p> <p>2-sided copying could not be performed because the tray does not contain a valid size of paper, which are A4, Letter, Legal, 8 x 13 inches, 8 1/2 x 13 inches, Folio, or 16K.</p>	<ul style="list-style-type: none"> <li>Select the tray containing A4, B5, Letter, or Legal size paper in the [Select Paper] setting.</li> <li>Specify A4, Letter, Legal, 8 x 13 inches, 8 1/2 x 13 inches, Folio, or 16K size for the tray selected for printing copies.</li> </ul>
Available: 2 Sided Copy A4/LG/LT	<p>Only when using the four-line LCD models.</p> <p>2-sided copy could not be performed because the tray does not contain a valid size of paper, which are A4, Legal, or Letter.</p>	<ul style="list-style-type: none"> <li>Select the tray containing A4, Letter, or Legal size paper in the [Select Paper] setting.</li> <li>Specify A4, Letter, or Legal size for the tray selected for printing copies.</li> </ul>
Busy	Fax transmission could not be completed because the destination's line was busy.	Wait for a while and send the fax again.
Cannot Copy This Setting	Combined copying could not be performed because the	<ul style="list-style-type: none"> <li>Set the machine to print copies using A4, Letter, or Legal size</li> </ul>

## Error Messages

Message	Causes	Solutions
Comb.: 2 on 1 / 4 on 1	tray does not contain a valid size of paper, which are A4, Letter, or Legal size.	<p>paper in the [Select Paper] settings.</p> <ul style="list-style-type: none"> <li>Specify A4, Letter, A5, 5.5x8.5, or A6 size paper for the tray selected for printing copies.</li> </ul>
Cannot copy. Set original to ADF.	Combined copying could not be performed because the originals were not placed in the ADF.	<ul style="list-style-type: none"> <li>Use the ADF, even when copying a single sheet.</li> <li>If you need to use the exposure glass, select [Off] or [Manual 2Sd Scan Mode] in [Duplex/Combine] under [Copier Features], and then try again.</li> </ul>
Check Paper Size	The paper size set for the document differs from the size of the paper in the indicated tray.	<ul style="list-style-type: none"> <li>When using the touch panel models Press [Form Feed] to begin printing, or press [Job Reset] to cancel the job.</li> <li>When using the Four-line LCD models Press the [OK] key to begin printing, or press the [Back] key to cancel the job.</li> </ul>
Check Paper Type	The paper type set for the document differs from the type of the paper in the indicated tray.	
Connection Failed	The line could not be connected correctly.	<ul style="list-style-type: none"> <li>Confirm that the telephone line is properly connected to the machine.</li> <li>Disconnect the telephone line from the machine, and connect a standard telephone in its place. Confirm that you can make calls using the telephone. If you cannot make calls this way, contact your telephone company.</li> </ul>
Cover open	A cover is open.	Close the cover completely.
Dial Failed	The fax could not be sent.	<ul style="list-style-type: none"> <li>Confirm that the fax number you</li> </ul>

Message	Causes	Solutions
		<p>dialed is correct.</p> <ul style="list-style-type: none"> <li>• Confirm that the destination is a fax machine.</li> <li>• Confirm that the line is not busy.</li> <li>• You may need to insert a pause between certain digits. Press the [Redial] after, for example, the area code.</li> <li>• When using the touch panel models           <p>Check that [PSTN / PBX] in [Administrator Tools] has been specified in accordance with the telephone line in use.</p> </li> <li>• When using the four-line LCD models           <p>Check that [PSTN / PBX] in [Admin. Tools] has been specified in accordance with the telephone line in use.</p> </li> </ul>
Exceeded MaxE-mail Size	The scan file exceeds the size limit for files that can be sent through e-mail.	<ul style="list-style-type: none"> <li>• Configure [Resolution] under [Scanner Settings] to reduce the scanning resolution.</li> <li>• Configure [Max. E-mail Size] under scanner settings to increase the allowed size.</li> </ul>
Independent-supply Toner: Black	<p>Only when using the touch panel models.</p> <p>A non-supported print cartridge is installed.</p>	Remove and replace it with a print cartridge specified by an authorized dealer.
Indep.Sply.Prt.Cart.	<p>Only when using the four-line LCD models.</p> <p>A non-supported print cartridge is installed.</p>	
Internal Misfeed	Paper has jammed in the	Remove the jammed paper.

## Error Messages

Message	Causes	Solutions
	machine.	
Memory Overflow	The number of fax jobs in memory (unsent or unprinted faxes) has reached maximum, so new jobs cannot be stored.	Wait until pending jobs have been transmitted or printed.
Memory Overflow	The data is too large or complex to print.	<ul style="list-style-type: none"> <li>• Select [600 × 600 dpi] in [Resolution] under [Printer Features] to reduce the size of the data.</li> <li>• If using the PCL6 printer driver, set [Resolution] in the Print Quality tab to [600 × 600 dpi].</li> </ul>
Memory Overflow	<ul style="list-style-type: none"> <li>• The machine's memory reached capacity while scanning the first page of the original to store a fax job in memory before transmission.</li> <li>• The machine's memory reached capacity while storing a fax in memory in Memory Transmission mode.</li> </ul>	Resend the fax in parts as several smaller individual faxes, or send at a lower resolution.
Memory Overflow TX Cancel	Memory has reached capacity while scanning the second or later pages of the original when trying to send a fax in Memory Transmission mode.	Press [TX] to send only the pages that have been scanned in memory, or press [Cancel] to cancel.
Misfeed: BypassTray	Paper has jammed in the bypass tray.	Remove the jammed paper.
Misfeed: Duplex Unit Remove Paper	<p>Only when using the touch panel models.</p> <p>Paper has jammed in the</p>	Remove the jammed paper.



Message	Causes	Solutions
	duplex unit.	
Misfeed: Dup. Unit	Only when using the four-line LCD models. Paper has jammed in the duplex unit.	
Misfeed: Standard Tray	Only when using the touch panel models. Paper has jammed in the paper exit area.	Remove the jammed paper.
Misfeed: Main Tray	Only when using the four-line LCD models. Paper has jammed in the paper exit area.	
Misfeed: Tray 1	Paper has jammed in the tray 1 paper input area.	Remove the jammed paper.
Misfeed: Tray 2	Paper has jammed in the tray 2 paper input area.	Remove the jammed paper.
Net Communication Error	Connection with the server was lost while sending or receiving data.	Contact the network administrator.
Network is not Ready	A scanned file could not be sent because the machine has not received IP address information from the DHCP server completely.	Wait until the machine receives the IP address information completely, and then try the operation again.
On Hook or Stop key	The machine has been off-hook for an extended period of time.	Put down the handset phone or press the [Clear/ Stop] key.
Out of Paper: X	The indicated tray has run out of paper.	Load paper in the indicated tray.
Please Restart Machine	The machine needs to be restarted.	Turn off the power, and then turn it back on.
Replace Required Soon: Toner(Black)	Only when using the touch panel models.	Prepare a new print cartridge.

## Error Messages

Message	Causes	Solutions
	The print cartridge is almost empty.	
Replace Required Soon: Print Cartridge	Only when using the four-line LCD models.  The print cartridge is almost empty.	
Out of Toner: Black	Only when using the touch panel models.  The machine has run out of toner.	Replace the print cartridge.
Replacement Required: Print Cartridge	Only when using the four-line LCD models.  The machine has run out of toner.	
Replacement Required: Paper Feed Roller	The paper feed roller is no longer usable, and must be replaced.	Replace the paper feed roller.
RX Communication Error	A reception error occurred, and the fax could not be received correctly.	If possible, contact the sender of the fax and ask them to resend it.
Scan (NW) Disconnected	A scanned file could not be sent because the Ethernet cable was not connected properly.	Reconnect the Ethernet cable properly, and then try the operation again.
Scan (USB) Disconnected	The USB cable was disconnected while scanning from a computer.	Reconnect the USB cable properly, and then try the operation again.
Server Connection Failed	A scanned file could not be sent because the destination could not be reached.	Confirm that the destination is registered correctly, and then try the operation again.
Server Response Error	An error occurred in communication with the server before beginning transmission.	Confirm that the destination is registered correctly, and then try the operation again.  If the problem could not be solved,

Message	Causes	Solutions
		contact the network administrator.
SCXXX	A fatal hardware error has occurred, and the machine cannot function.	Refer to " <a href="#">Service Call</a> ".
Service call - X		
Set Correct Paper	The tray selected in [Select Paper Tray] under [Fax Features] does not contain A4, Letter, or Legal size paper.	<p>While the message is displayed, press [Set Size]. A menu for changing the paper size in the current tray appears.</p> <p>Load A4/Letter/ Legal size paper in the tray, and then select the corresponding paper size.</p> <p>Note that the paper size setting for the tray under system settings will be changed.</p>
Set Original to ADF Cannot use exposure glass with set. in [Scan Size].	Scanning could not be performed because the originals were not placed in the ADF, even though the machine is set to scan originals larger than A4/Letter size.	<ul style="list-style-type: none"> <li>• Use the ADF, even when scanning A4/Letter or smaller size originals.</li> <li>• If you need to use the exposure glass, set A4/Letter or smaller size in [Scan Size] under [Scan Settings], and then try again.</li> </ul>
Sort Copy was Cancelled	The machine's memory reached capacity while originals were being scanned from the ADF to perform sort copying.	Press [Exit] to print the originals that were successfully scanned into memory. Then, copy again the originals left in the ADF.
TX Communicarion Error	A transmission error occurred, and the fax could not be transmitted correctly.	If the [Auto Redial] setting is enabled, the machine will redial the number and try again. If all attempts fail, or if the machine is in Immediate Transmission mode, the fax will not be transmitted. Try the operation again.

## 6.4 FAX ERROR CODES

### 6.4.1 FAX ERROR CODE STRUCTURE

This section describes the dial, transmission (TX), and reception (RX) error codes that are printed on the TX Report/Activity Report.

Error codes consist of six hexadecimal digits (0-5).

Digit 5 (far left)	TX or RX
1xxxxx	TX (Fax)
2xxxxx	RX (Fax)

Digit 4	Coding (MH/MR/MMR/JBIG)
x1xxxx	MH
x2xxxx	MR
x3xxxx	MMR
x4xxxx	JBIG

Digit 3	Modem mode
xx1xxx	V27ter non-ECM
xx2xxx	V29 non-ECM
xx3xxx	V17 non-ECM
xx4xxx	V33 non-ECM
xx5xxx	V34
xx9xxx	V27ter ECM
xxaxxx	V29 ECM
xxbxxx	V17 ECM
xxcxxx	V33 ECM

Digit 2	Modem speed
xxx1xx	2400
xxx2xx	4800
xxx3xx	7200

Digit 2	Modem speed
xxx4xx	9600
xxx5xx	12000
xxx6xx	14400
xxx7xx	16800
xxx8xx	19200
xxx9xx	21600
xxxaxx	24000
xxxbxx	26400
xxxcxx	28800
xxxdxx	31200
xxxexx	33600

#### 6.4.2 FAX ERROR CODE TABLE

Error Code	Error Type	Error Description
0	General	Normal (No Error)
xxxx01		STOP
Xxxx1f		H/W Error
Not logged in activity report		RX T1 Time Out
1xxx11		Scanner Error during TX
2xxx14		Memory Full during RX
xxxx06		Authorized Reception = Enable, Since the received TSI did not match, reception was refused.
xxxx21		Dial failure
xxxx22	Dial Failed	
xxxx23	Redial All Failed	
xxxx31	Comm. Error	TX T1 Time Out
xxxx32	1. Phase-B Error	V8 negotiation Failed

Fax Error Codes

Error Code	Error Type	Error Description
xxxx40	Comm. Error	Retry Out
xxxx41	1. Phase-B Error	Too many FTTs
xxxx42		Too many CRPs
xxxx43		T2 Time Out
xxxx44		DCN received
xxxx45		Command Rec Error
xxxx46		Resp Rec Error
xxxx47		Invalid Command/Response RX
xxxx48		Remoter No RX capability
xxxx49		T1 time out after EOM
xxxx50		Comm. Error
xxxx51	2. Phase-C Error	Image Data not ready
xxxx52		Phase-C Time Out
xxxx53		JBIG Buffer Full
xxxx60	Comm. Error	Retry Out
xxxx61	3. Phase-D Error	T2 Time Out
xxxx62		DCN received
xxxx63		Too many CRPs
xxxx64		Too many PPRs
xxxx65		RNR Time Out
xxxx66		RTN/PIN Received, EOR/ERR/DCN
xxxx67		Invalid Command/Response RX
xxxx68		Command Rec Error
xxxx69		Resp Rec Error
xxxx70		Comm. Error 4. Phase-E Error
xxxx80	Comm. Error	Modem hang-up

Error Code	Error Type	Error Description
xxxx81	5. Other general Comm Error	V34 abort received
xxxx82		V34 t1 timeout, control channel error
xxxx83		V34 t1 timeout, primary channel error
xxxx84		Data not sent until guard timer expires





## 6.5 JAM DETECTION

### 6.5.1 PAPER JAM

#### *Jam Sensor Layout*

The sensors used for jam detection are shown below.

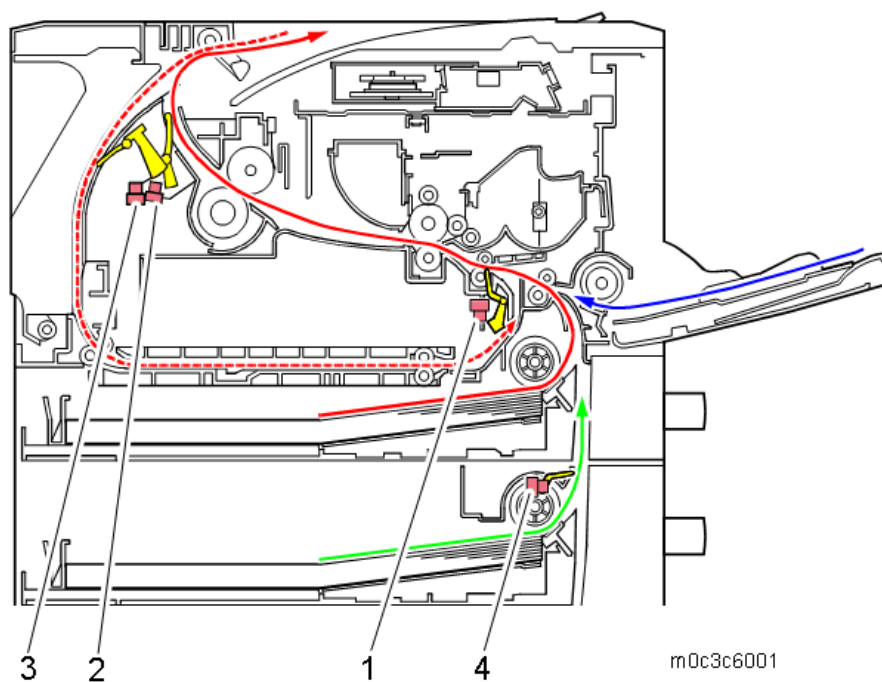

1. Registration sensor
2. Paper exit sensor
3. Duplex sensor
4. Paper feed sensor (optional tray)

#### *Jam Message List*

Here is a list of common jam messages, and descriptions of the causes.

See the drawings shown above to check the sensor locations.

Jam message	Cause	Sensor
Misfeed: Paper Tray (Touch panel models)	Paper does not reach the registration sensor (bypass tray)	Registration sensor [1]
Misfeed: BypassTray (Four-line LCD models)		
Misfeed: Tray 1	Paper does not reach the registration sensor (tray 1)	Registration sensor [1]
Misfeed: Tray 2	Paper does not reach the registration	Registration



## 6.5.2 ORIGINAL JAM (ADF/ARDF)

### *Jam Sensor Layout*

The sensors used for jam detection are shown below.

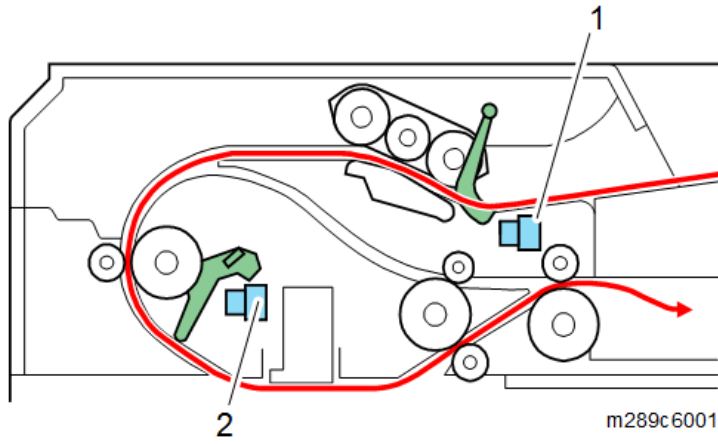

1. Original set sensor
2. ADF feed sensor (ARDF feed sensor)

### *Jam Message List*

Jam message	Cause
ADF Original Misfeed	Original set sensor [1] ADF feed sensor (ARDF feed sensor) [2]

## 6.6 IMAGE QUALITY

### 6.6.1 PROBLEM AT REGULAR INTERVALS

Image problems may appear at regular intervals that depend on the circumference of certain components. The following diagram shows the possible symptoms (black or white dots at regular intervals).

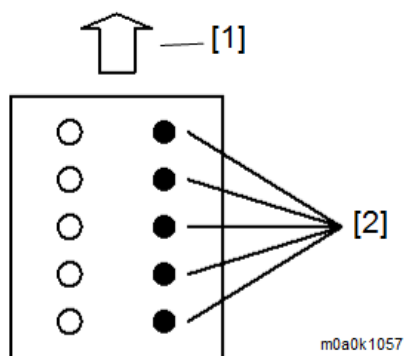

1. Paper feed direction
2. Problems at regular intervals

Problems	Intervals	Defective parts
Problems with the printed result (other than black or white dots)	29.8 mm	Charge roller
	37.7 mm	Registration roller
	45.8 mm	Transfer roller
	94.2 mm	Fusing unit (Pressure roller)
	93.1 mm	Fusing unit (Hot roller)
	100.5 mm	Paper feed roller
Black or white dots	27.0 mm	AIO (Development roller)
	75.3 mm	AIO (OPC drum)

## 6.7 OTHER PROBLEMS

### 6.7.1 DARK LINES IN HALFTONE AREAS AT 75MM INTERVALS

Using the machine in a room where the humidity is too low may cause dark lines in halftone areas at 75mm intervals. This is because low-humidity conditions tend to cause variations in light sensitivity across the surface of the drum.

Selecting [On] for [Low Humidity Mode] under [System Settings] (User Tools) may help to prevent these lines from appearing.

When the low humidity mode setting is enabled, the drum is rotated slightly every 15 minutes. This keeps the light sensitivity constant across the entire surface of the drum.

### 6.7.2 RECYCLED OR THIN PAPER IS SEVERELY CURLED AFTER PRINTING

If the delivered paper is curled, it cannot be stacked properly. In such a case, raise the paper stopper on the output tray and remove the paper frequently.

Setting “1” or “2” for [Interval Setting] in the SP menu may help to control the face curl of paper. (Default: 0 (OFF))

[Interval Setting] is enabled when using normal paper or recycled paper in A4 or LT size.

**Four-line LCD panel:** SP menu > [Engine Maintenance] > [Interval Setting]

**Touch panel:** SP menu > [Engine Service Setting] > [Interval Setting]

When setting “1” for [Interval setting], the printing speed becomes half after printing for 1 minute.

When setting “2” for [Interval setting], the printing speed becomes 13ppm. The intervals between sheets are changed, and the service life of the parts is shortened as shown in the table below.

	PPM	Interval (mm)	Time for 1 job (sec)	Service life (K pages)
Normal	32	58	10.414	105
When setting “2” for [Interval Setting]	13	402	12.269	89

### 6.7.3 WHEN FLUORESCENT/ LED LAMPS FLICKER (ONLY FOR 100V MODELS)

#### **Problem**

Under the usage environment of this machine, at the installation location, fluorescent and/or LED lamps flicker.

#### **Causes**

A voltage drop occurs when an electrical current is applied to the fusing lamp. It depends on the electrical power environment at the customer's installation location.

#### **Solutions**

Set [Flicker Control] to "On".

**Four-line LCD panel:** SP menu > [Engine Maintenance] > [Flicker Control]

**Touch panel:** SP menu > [Engine Service Setting] > [Flicker Control]

#### **Side Effect**

- The power consumption is increased: When using thinner paper than Thick 1, the fusing temperature is controlled to increase 5°C (\*).
- The face curl of paper may become worse.

\*: To control the flicker, the machine slowly raises/drops the fusing temperature when turning the fusing lamp ON/OFF. The fusing temperature rise becomes slow when printing continuously, so the fusing efficiency of a solid image in the right or the left edges may become worse. To maintain the fusing efficiency, the fusing temperature is controlled to increase 5°C.

When the paper in use is thicker than Thick 2, the printing speed becomes half. The fusing efficiency is not affected even if not increasing the fusing temperature.

## 6.7.4 STAIN APPEARS IN THE RIGHT AND THE LEFT EDGES

### **Problem**

The stain may occur in the left and the right edges of the printed paper.

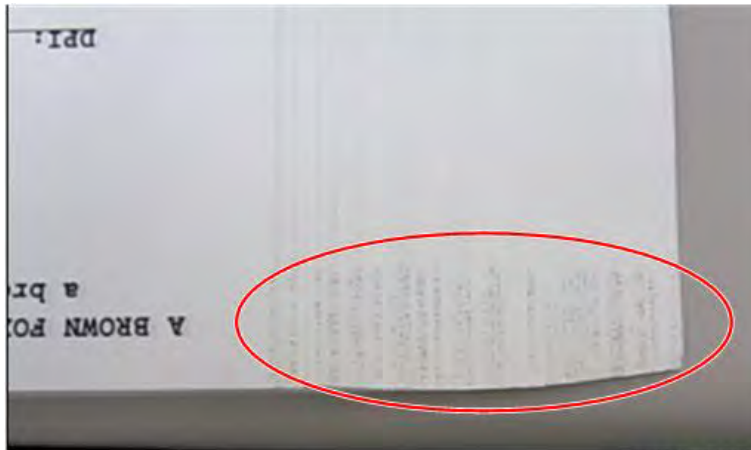

m0c3c6003

### **Cause**

Contact with outside of the image area of the drum (the red circled area illustrated below) because of paper skew.

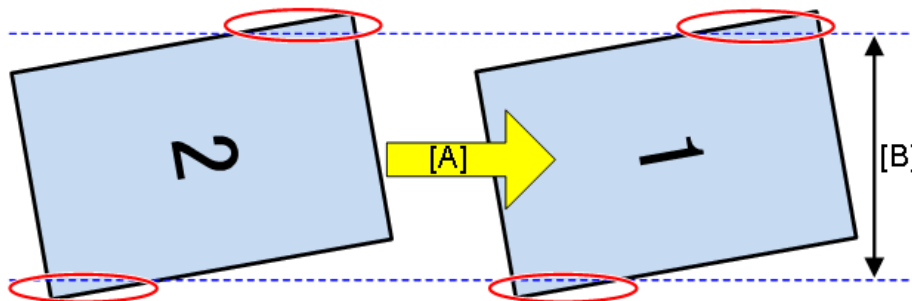

m0c3c6004

[A]: Paper feed direction

[B]: Image area of the drum

### **Solution**

When there are gaps between the paper and the side or the end fences of the paper tray, adjust the side or the end fences of the paper tray to remove the gaps.

If the problem still exists, set [Interval Setting] of SP. Refer to "[Recycled or Thin Paper Is Severely Curled after Printing](#)".

## 6.7.5 POOR PRINTING (OFFSET)

### **Problem**

Poor printing (offset) may occur.

### **Causes**

The fusing temperature is too high for some paper types.

### **Solutions**

When poor printing occurs with the same paper types, change the settings of the fusing temperatures of the paper type in the following SPs.

- When occurring with Plain/Thin paper: Set the fusing temperature 5 degrees lower.

**Four-line LCD panel:** SP menu > [Engine Maintenance] > [Fusing Unit Temperature] > [Plain paper]/[Thin Paper]s

**Touch panel:** SP menu > [Engine Service Setting] > [Fusing Unit Temperature] > [Plain paper]/[Thin Paper]

- When occurring with Thick 1 paper: Set the fusing temperature 5 to 10 degrees lower and make sure that toner has fused sufficiently on the printed paper.

**Four-line LCD panel:** SP menu > [Engine Maintenance] > [Fusing Unit Temperature] > [Thick1 Paper]

**Touch panel:** SP menu > [Engine Service Setting] > [Fusing Unit Temperature] > [Thick1 Paper]

When offset occurs with a specific paper type, change the target paper type (without changing the setting of the fusing temperature in SP).

Set the Paper type to one level thinner than the paper now being used (e.g., change "Normal" to "Thin").

## 6.7.6 WRINKLES APPEAR WHEN USING LIMP PAPER

The wrinkles may occur in the ejected paper.

Set the [Paper Buckle Amount] in the SP menu to between [-3] and [-8] and set the appropriate value while checking the status of the wrinkles and the skew.

**Four-line LCD panel:** SP menu > [Engine Maintenance] > [Paper Buckle Amount]

**Touch panel:** SP menu > [Engine Service Setting] > [Paper Buckle Amount]



## 6.7.7 LOW IMAGE DENSITY ON SOLID IMAGES

### **Problem**

Low image density may occur after 81 mm from the leading edge of a solid image.

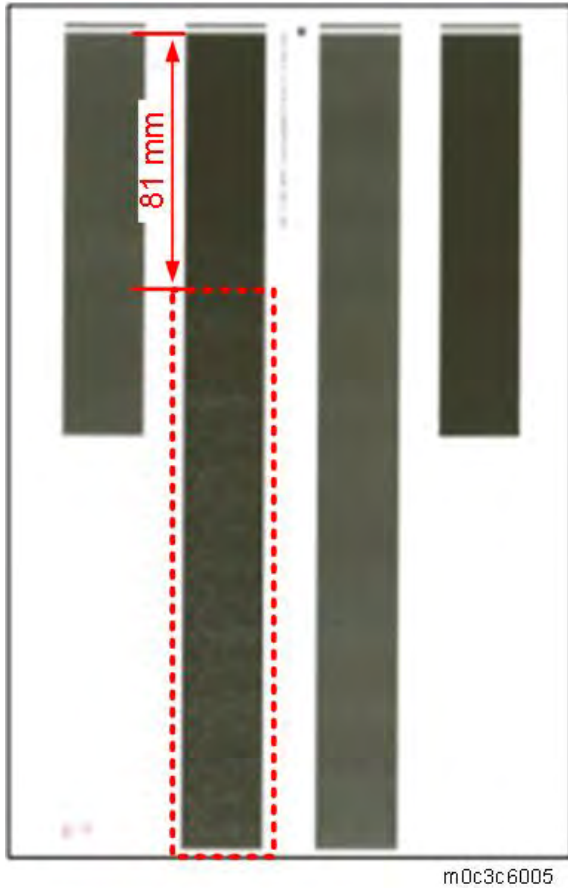

### **Causes**

Toner unevenness on the development roller occurs because not enough toner is provided to the development roller.

### **Solutions**

Lower the image density in UP mode.

**Four-line LCD panel:** UP menu > [System Settings] > [Image Density]: Set to [-3].

**Touch panel:** UP menu > [Setting] > [System Settings] > [Image Density]: Set to [-3].

## 6.7.8 MOTTLED IMAGE ON SOLID IMAGES

### **Problem**

Mottled image may occur around the toner near end alert of a 7K cartridge on solid images on the second page in duplex mode.



m0c3c6006

### **Causes**

Toner inside the cartridge has deteriorated.

### **Solutions**

Replace the AIO with a new one.

## 6.7.9 TONER SCATTERED ON HORIZONTAL LINES

### **Problem**

Toner may spread below horizontal lines.

### **Causes**

Toner is scattered because of water contained in the paper.

### **Solutions**

1. Ask the customer to write the horizontal lines thicker.
2. Lower the image density in UP mode.

**Four-line LCD panel:** UP menu > [System Settings] > [Image Density]

**Touch panel:** UP menu > [Setting] > [System Settings] > [Image Density]

# DETAILED DESCRIPTIONS

REVISION HISTORY		
Page	Date	Added/Updated/New
		None

## 7. DETAILED DESCRIPTIONS

### 7.1 GUIDANCE FOR THOSE WHO ARE FAMILIAR WITH PREDECESSOR PRODUCTS

#### 7.1.1 PRINTER MODELS:

Function	New Series		Previous Series		
	SP 330DN	DP 3710DN	SP 320DN	SP 325DNw	SP 377DNwX
Print Speed	32 ppm		26 ppm	28 ppm	
Operation Panel	Four-line LCD		No LCD		
Optional Tray	Supported		Not supported		
Wi-Fi	Optional unit (USB dongle)		Not supported	Wi-Fi board is built in	
HVP	Installed on the left side of the machine		Installed on the bottom of the machine		
NFC	Supported		Not supported		
@Remote	Supported		Not supported		

### 7.1.2 MF MODELS:

Function	New Series			Previous Series				
	SP 330SN	SP 330SF N	SP 3710S F	SP 320SN	SP 320SFN	SP 325SNw	SP 325SFN w	SP 377SFNw X
Print Speed	32 ppm			26 ppm		28 ppm		
ADF	ADF	ARDF		Not supported	ADF	ARDF		
Operation Panel	Four-line LCD	4.3" Touch panel		Four-line LCD				
Fax	Not supported	Supported		Not supported	Supported	Not supported	Supported	
Optional Tray	Supported			Not supported				
Wi-Fi	Optional unit (USB dongle)			Not supported		Wi-Fi board is built in		
HVP	Installed on the left side of the machine			Installed on the bottom of the machine				
NFC	Supported			Not supported				
@Remote	Supported			Not supported				

## 7.2 PRODUCT OVERVIEW

### 7.2.1 COMPONENT LAYOUT

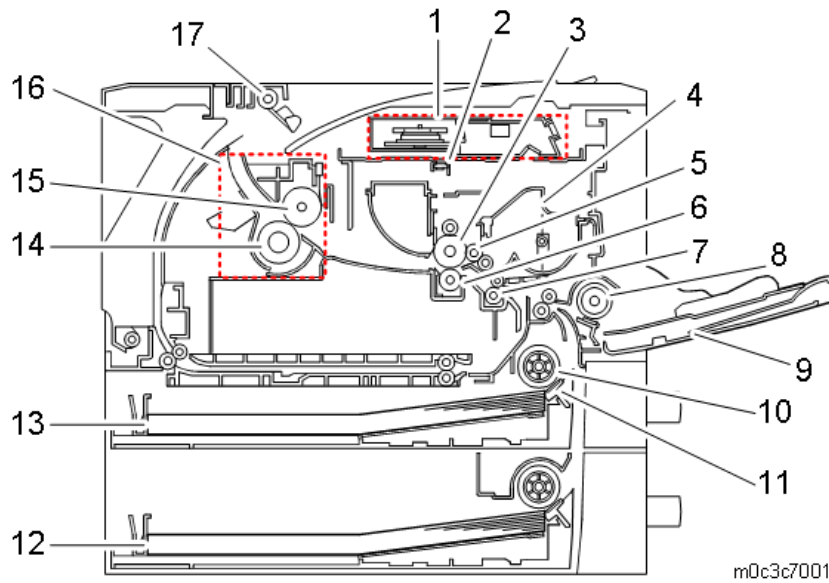

1.	Laser unit	10.	Paper feed roller
2.	Quenching lamp	11.	Friction pad
3.	Drum	12.	Optional paper tray
4.	Cartridge (AIO-type)	13.	Paper tray
5.	Development roller	14.	Pressure roller
6.	Transfer roller	15.	Hot roller
7.	Registration roller	16.	Fusing unit
8.	By-pass feed roller	17.	Paper exit roller
9.	By-pass feed tray		

Detailed Descriptions

## 7.2.2 PAPER PATH

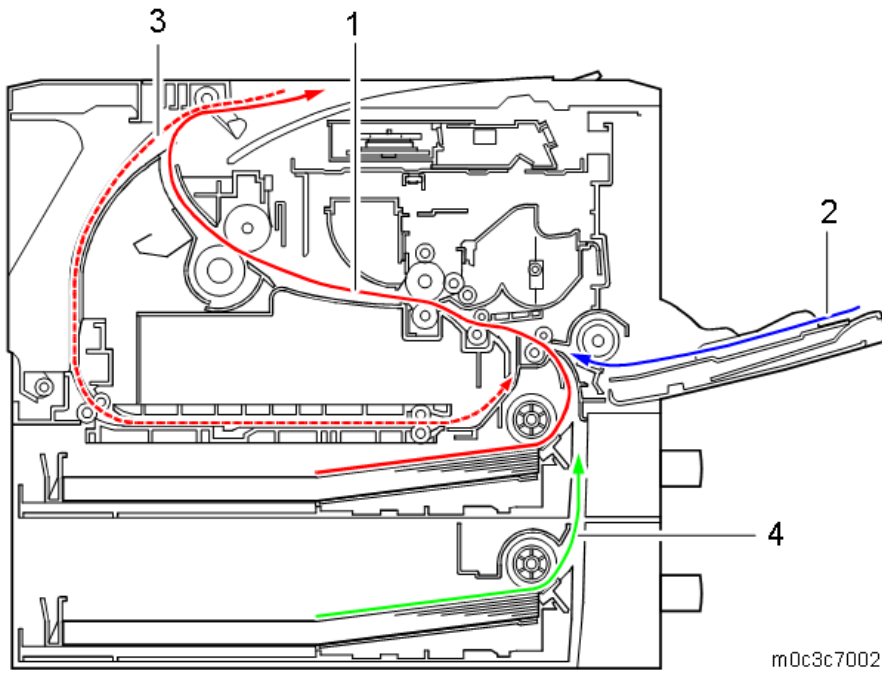

No.	Item
1.	Standard paper tray path
2.	Bypass paper feed path
3.	Duplex paper transport path
4.	Optional paper feed unit path

### 7.2.3 DRIVE LAYOUT

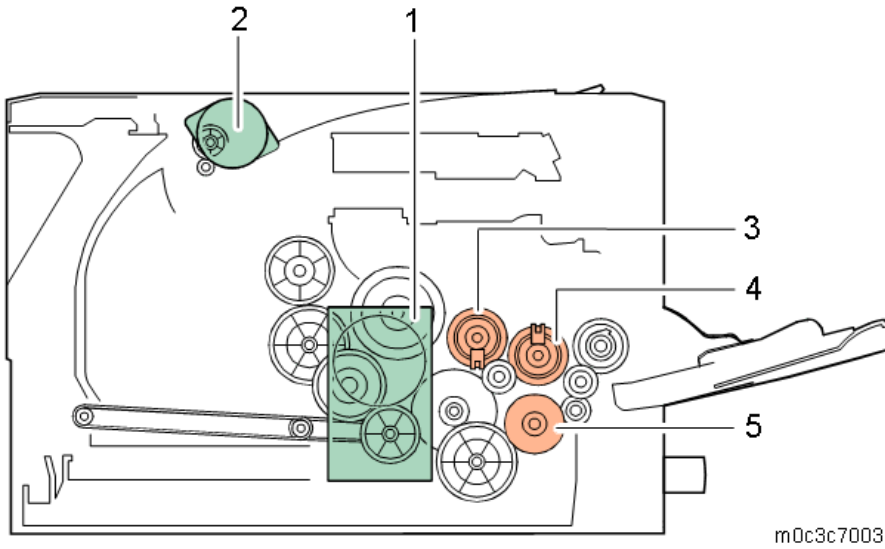

No.	Item
1.	Main motor
2.	Duplex motor
3.	Registration clutch
4.	Relay clutch
5.	Paper feed clutch



## 7.2.4 COMPONENT LAYOUT (PRINTER MODELS)

### *Laser Exposure*

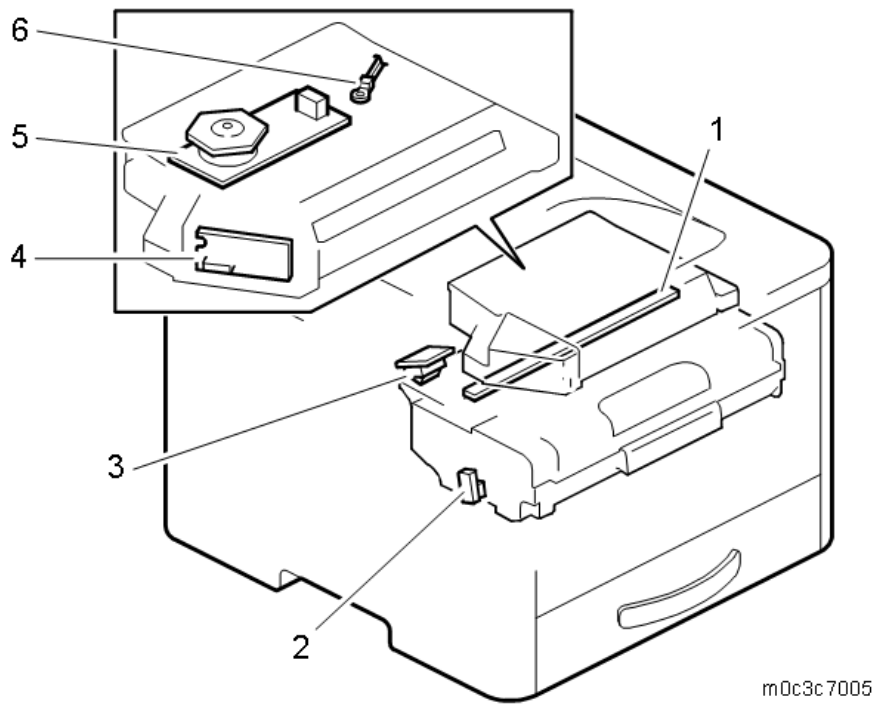

No.	Description
1	Quenching lamp
2	Toner end sensor
3	ID chip board
4	LD driver board
5	Polygon mirror motor
6	Laser unit thermistor

**Paper Feed**

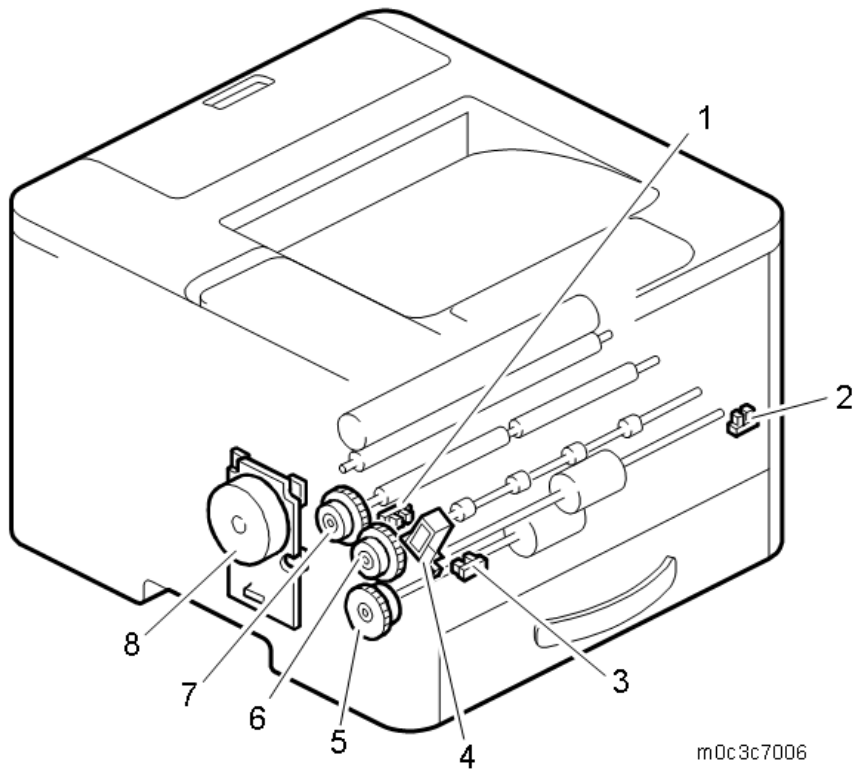

m0c3c7006

Detailed Descriptions

No.	Description	No.	Description
1	Registration sensor	5	Paper feed clutch
2	By-pass feed sensor	6	Relay clutch
3	Paper end sensor	7	Registration clutch
4	By-pass feed solenoid	8	Main motor

**Fusing, Duplex, Paper Exit**

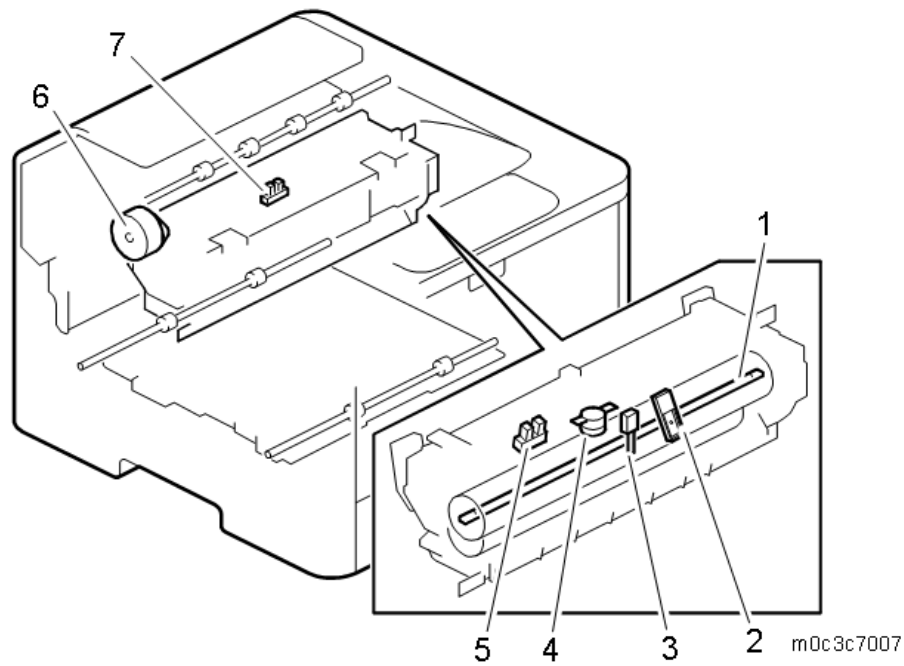

No.	Description	No.	Description
1	Fusing lamp	5	Paper exit sensor
2	Non-contact thermistor	6	Duplex motor
3	Fusing thermistor	7	Duplex sensor
4	Thermostat		

**Boards, Switches**

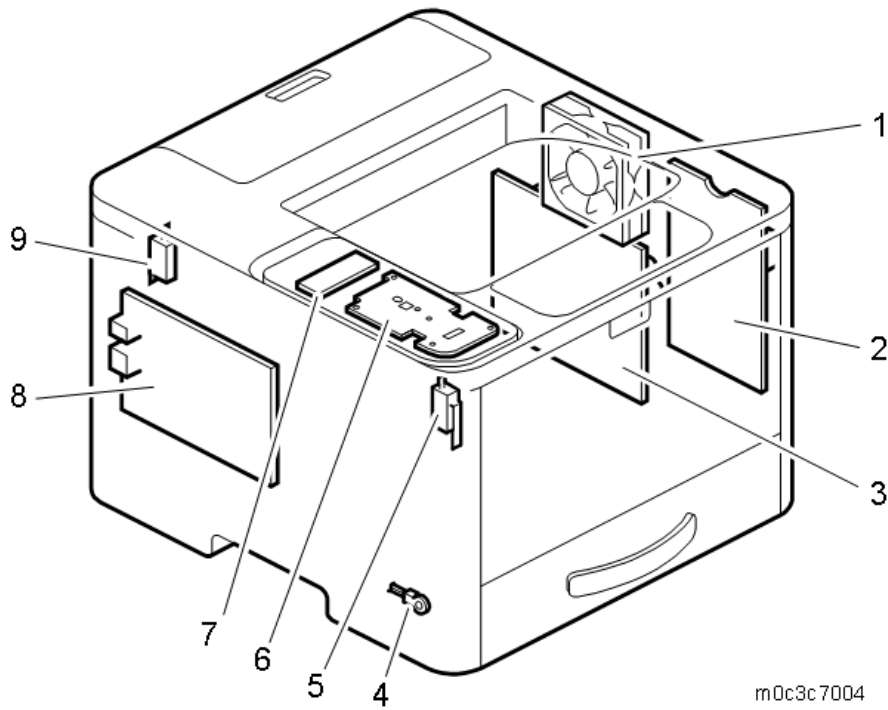

Detailed Descriptions

No.	Description	No.	Description
1	Cooling fan	6	Operation panel board
2	HVP	7	LCD
3	PSU	8	Main board
4	Environment thermistor	9	Rear cover switch
5	Front cover switch		

## 7.2.5 COMPONENT LAYOUT (MF MODELS)

### **ADF, Scanner**

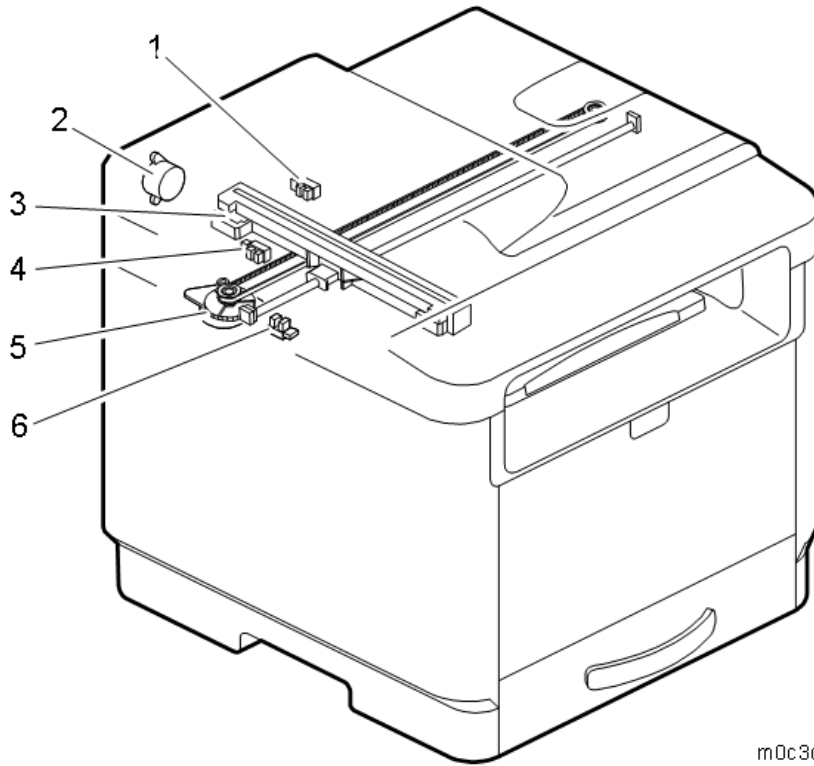

m0c3c7008

No.	Description
1	Original set sensor
2	ADF motor (ARDF motor)
3	Scanner carriage unit
4	ADF feed sensor (ARDF feed sensor)
5	Scanner motor
6	Home position sensor

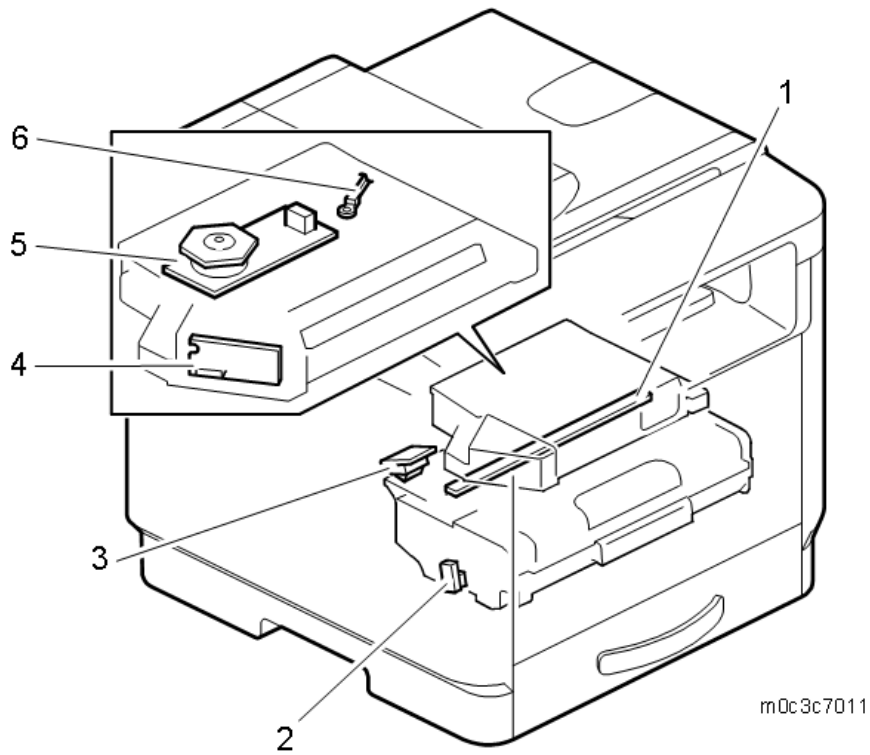
**Laser Exposure**

No.	Description
1	Quenching lamp
2	Toner end sensor
3	ID chip board
4	LD driver board
5	Polygon mirror motor
6	Laser unit thermistor

## Paper Feed

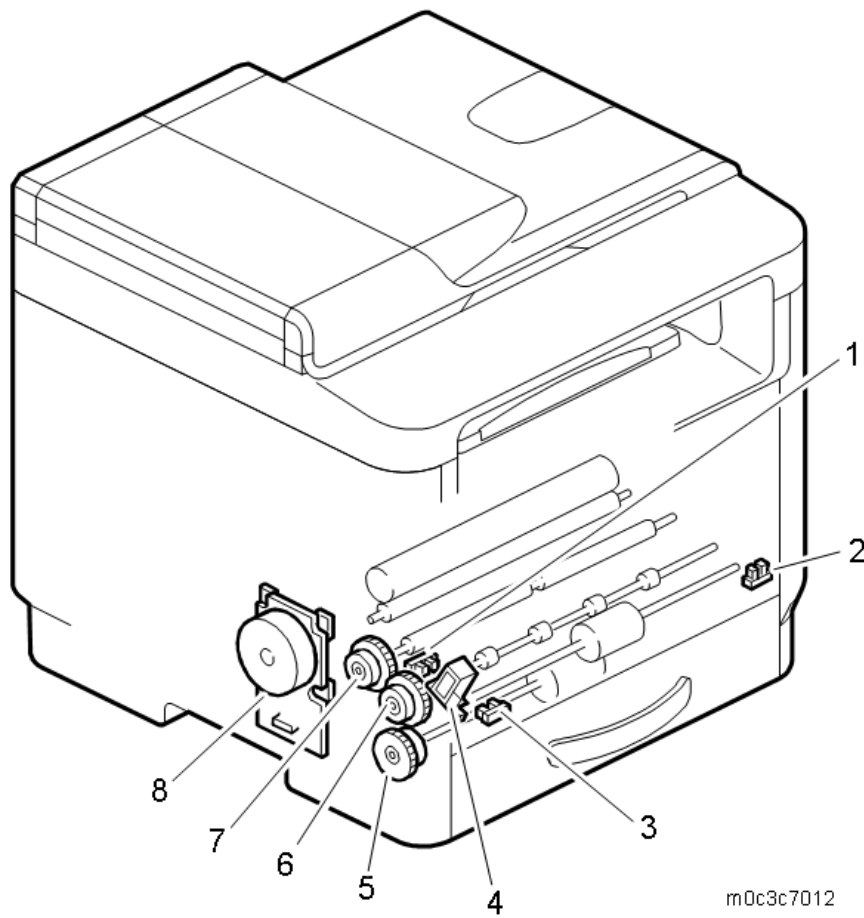

No.	Description	No.	Description
1	Registration sensor	5	Paper feed clutch
2	By-pass feed sensor	6	Relay clutch
3	Paper end sensor	7	Registration clutch
4	By-pass feed solenoid	8	Main motor

**Fusing, Duplex, Paper Exit**

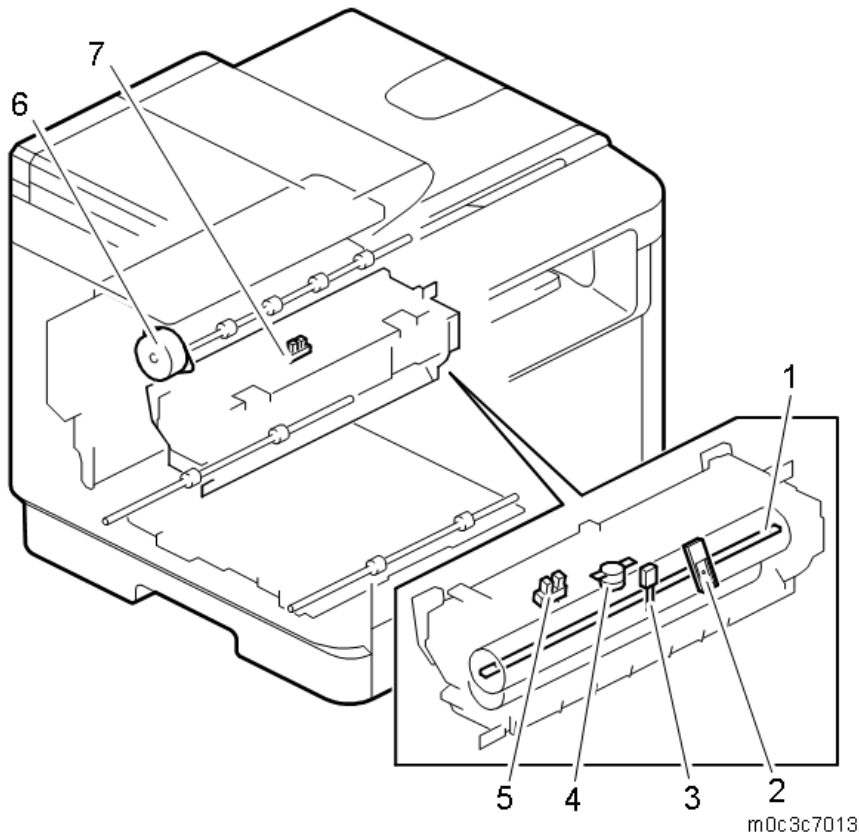

Detailed Descriptions

No.	Description	No.	Description
1	Fusing lamp	5	Paper exit sensor
2	Non-contact thermistor	6	Duplex motor
3	Fusing thermistor	7	Duplex sensor
4	Thermostat		



## Boards, Switches

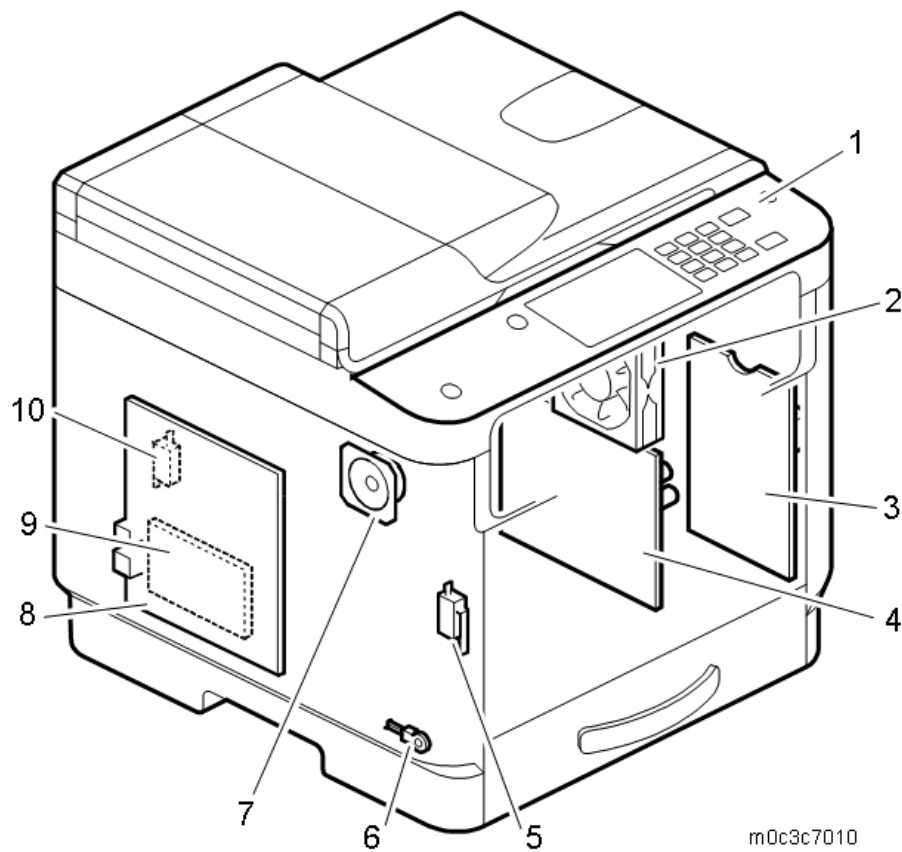

m0c3c7010

No.	Description	No.	Description
1	Operation panel unit	6	Environment thermistor
2	Cooling fan	7	Speaker
3	HVP	8	Main board
4	PSU	9	Fax board
5	Front cover switch	10	Rear cover switch

## 7.3 ADF/ARDF (FOR MF MODELS)

### 7.3.1 OVERVIEW

#### ADF

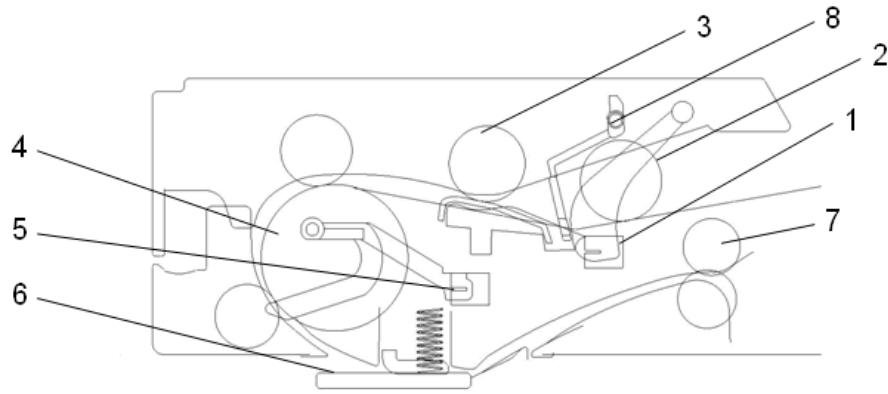

m1562026

No.	Item
1.	Original set sensor
2.	Pick-up roller
3.	Separation roller
4.	Feed roller
5.	ADF feed sensor
6.	Exposure glass
7.	Exit roller
8.	Stopper

**ARDF**

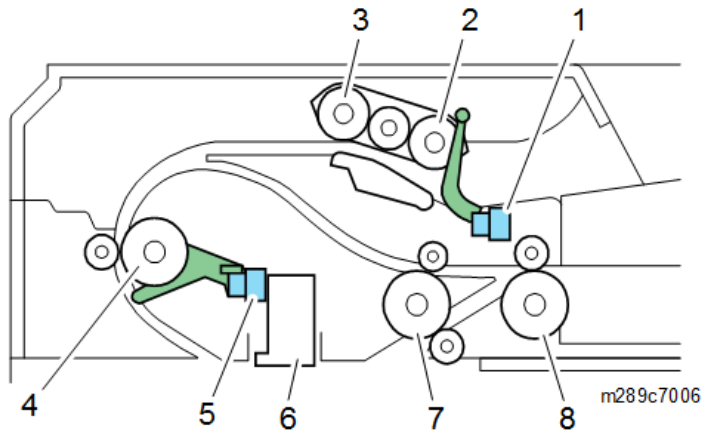

No.	Item
1.	Original set sensor
2.	Pick-up roller
3.	Feed roller
4.	Registration roller
5.	ARDF feed sensor
6.	Scanning guide plate
7.	Transport roller
8.	Original exit roller

## 7.3.2 MECHANISM

### *ADF Paper Path*

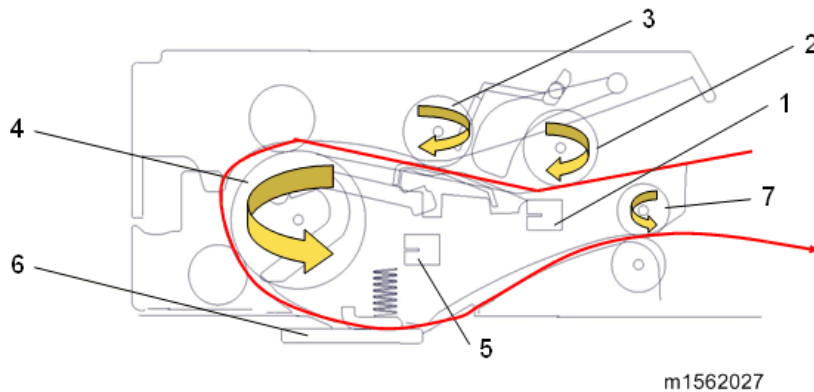

When the original set sensor [1] detects an original and the machine has a copying or scanning job, the ADF motor rotates to drive the pick-up roller [2], separation roller [3] and feed roller [4] to feed the original to the ADF feed sensor [5]. If the ADF feed sensor [5] does not detect paper after this sequence, the machine determines that an original jam has occurred.

If the ADF feed sensor [5] detects paper, then the CIS starts scanning through the exposure glass [6]. After scanning, the output roller [7] will eject the paper to finish the job.

### *ARDF Paper Path*

#### *Front Side*

When an original is placed on the original tray correctly, the original set sensor actuator is pushed up and the original set sensor [A] turns off (not interrupted). The machine judges this state as the placement of an original. When [Start] is pressed, the ARDF motor rotates the pick-up roller and the feed roller, and the original can be fed. When [Start] is pressed while the machine has not judged that an original was placed, scanning starts and then copying.

The image information is scanned on the sheet-through glass and the original is ejected by the transport roller and the original exit roller.

After starting paper feeding, if the ARDF feed sensor [B] does not detect paper after this sequence, the machine determines that an original jam has occurred.

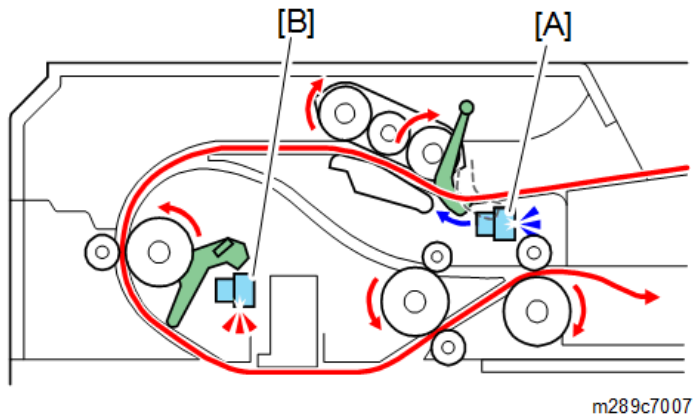

### **Back Side**

After a certain time passes since the original reached the ARDF feed sensor [A], the original exit roller [B] is reversed and the back side of the original is fed. There is no switching mechanism such as a junction gate; the original is delivered to the duplex scanning path by the curved surface of the paper path.

The image information of the back side is scanned on the sheet-through glass and the original is ejected by the transport roller.

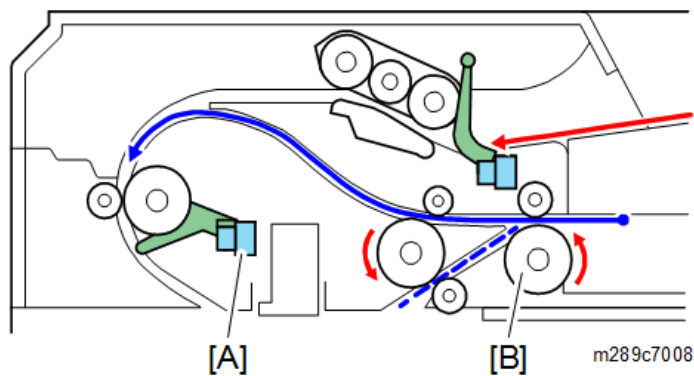

## 7.4 SCANNER (FOR MF MODELS)

### 7.4.1 OVERVIEW

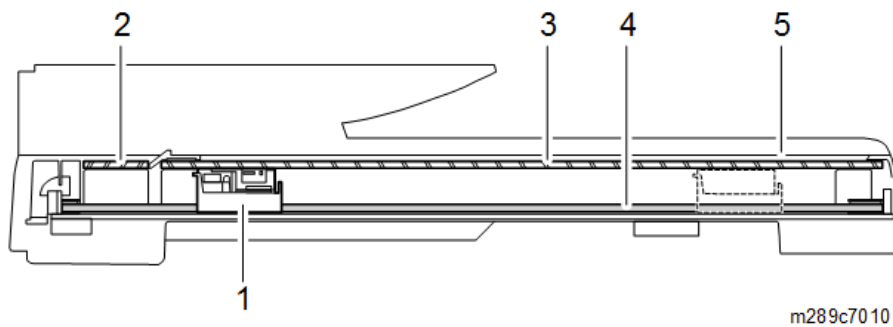

Callout	Item
1.	Scanner carriage unit
2.	DF exposure glass
3.	Scanner exposure glass
4.	Carriage drive shaft
5.	White sheet

### 7.4.2 MECHANISM

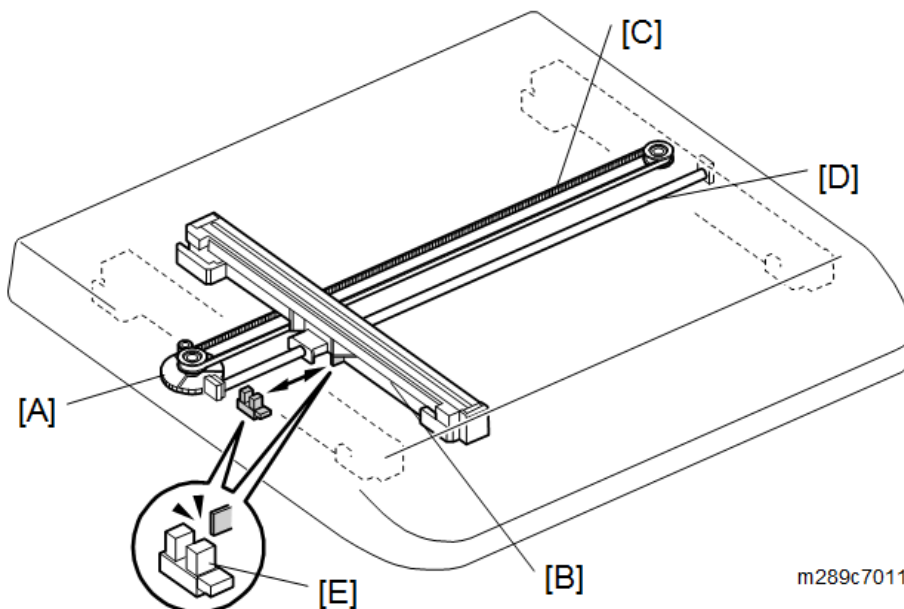

The scanner motor [A] drives the scanner carriage unit [B] through gears and a timing belt [C]. The scanner carriage unit moves along the carriage drive shaft [D]. The carriage home position sensor [E] in the scanner detects the home position of the carriage unit when initializing the scanner or before/after scanning. The scanner carriage unit moves to read the white sheet before every scan mode to adjust the white level.

## 7.5 PRINTING PROCESS

### 7.5.1 OVERVIEW

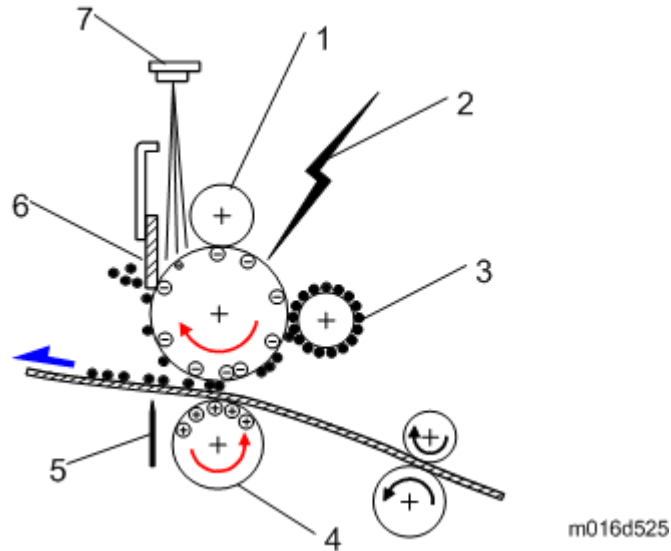

No.	Note
1.	<b>Drum Charge:</b> The charge roller gives the drum a negative charge.
2.	<b>Laser Exposure:</b> A laser beam writes the print data on the drum.
3.	<b>Toner:</b> The development roller moves toner to the latent image on the drum surface.
4.	<b>Image Transfer:</b> The transfer roller moves the toner from the drum to the paper.
5.	<b>Separation:</b> The separation plate helps to remove the paper from the drum.
6.	<b>Cleaning:</b> The cleaning blade removes remaining toner on the drum surface after the image is moved to the paper.
7.	<b>Quenching:</b> The light from the quenching lamp cancels the charge that stays on the drum.

## 7.6 LASER EXPOSURE

### 7.6.1 OVERVIEW

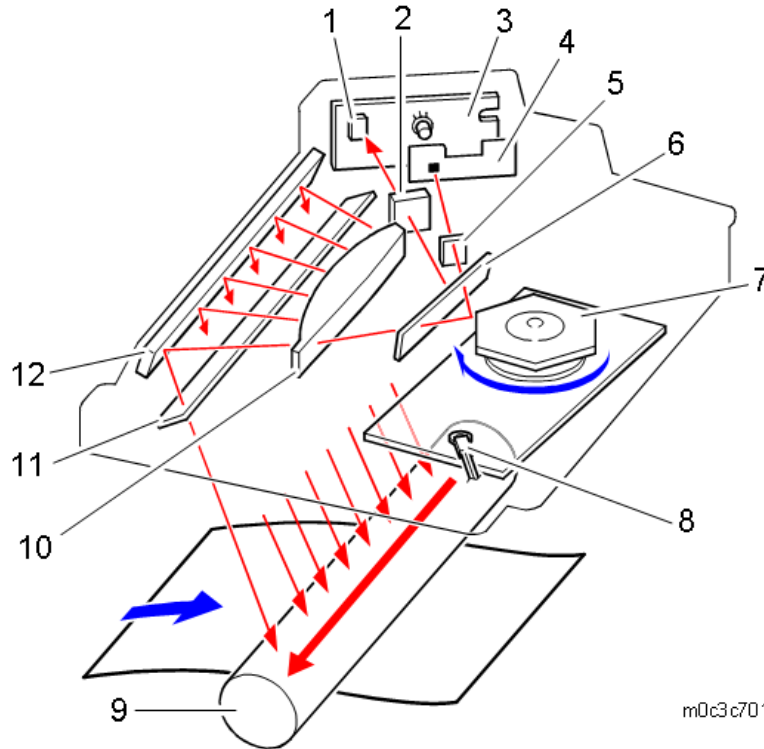

m0c3c7014

No.	Item	No.	Item
1.	Synchronization detector	7.	Polygon mirror motor
2.	Laser synchronization detector lens	8.	Laser unit thermistor
3.	LD driver board	9.	Drum
4.	Aperture	10.	FTL lens
5.	Cylindrical lens	11.	Shield glass
6.	Shield glass	12.	Mirror



## 7.6.2 MECHANISM

### *Synchronization Detector*

The mirror reflects the beam from the LD unit to the synchronization detector.

### *Automatic Power Control (APC)*

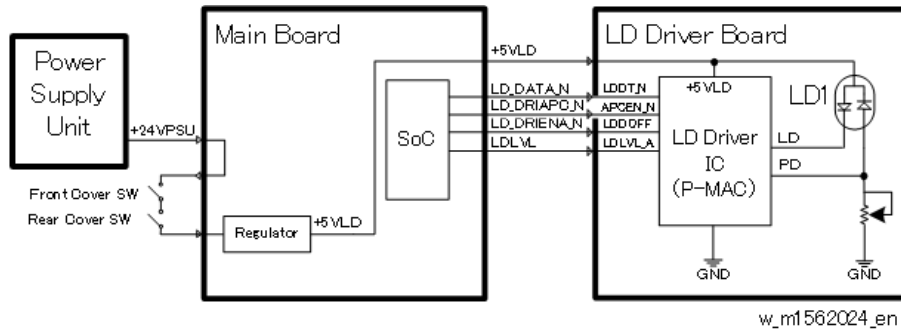

The LD driver on the LD drive board automatically controls power for the laser diodes. The laser diode power is adjusted at the factory.

### *LD Safety Mechanisms*

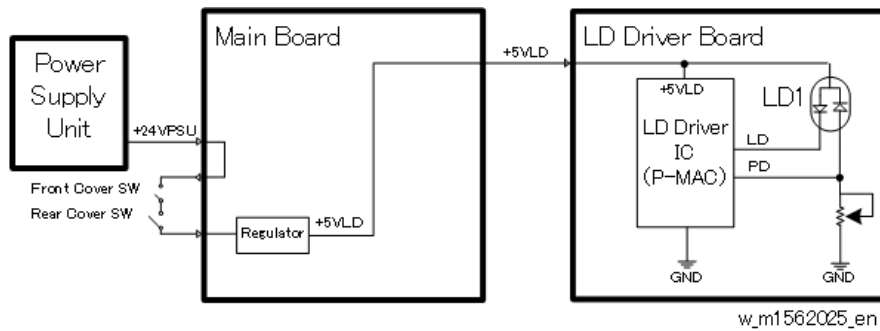

**Laser Safety Switch:** There are safety switches on the front and rear covers. These switches stop the laser while the cover is open. If the user opens one of these covers, the +5VLD power to the laser diodes is stopped.

## 7.7 PRINT CARTRIDGE (AIO)

### 7.7.1 OVERVIEW

This type of cartridge is known as an “All-in One” (AIO) cartridge.

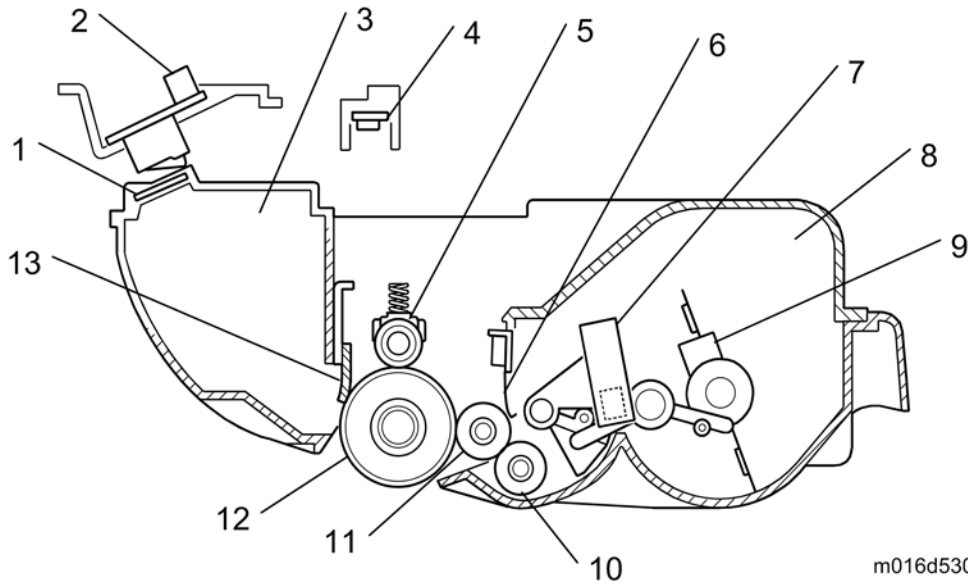

m016d530

Callout	Item	Callout	Item
1.	ID Chip	8.	Toner tank
2.	ID chip PCB	9.	Agitator
3.	Waste toner tank	10.	Toner supply roller
4.	Quenching lamp	11.	Development roller
5.	Charge roller	12.	Drum
6.	Scraper	13.	Cleaning blade
7.	Toner end sensor		

## 7.7.2 MECHANISM

### *Drum Charge*

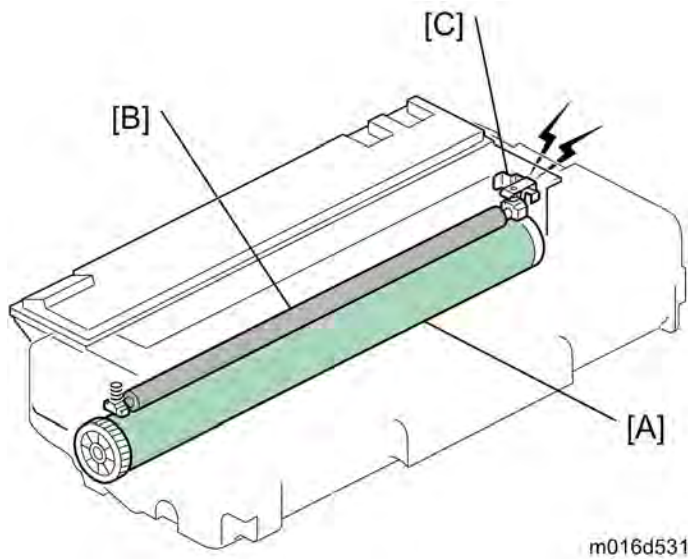

The charge roller [B] gives the drum surface [A] a negative charge of approximately  $-550V$ . High voltage is supplied from the power pack (HVP) flow bias plate [C].

**Toner Supply and Development**

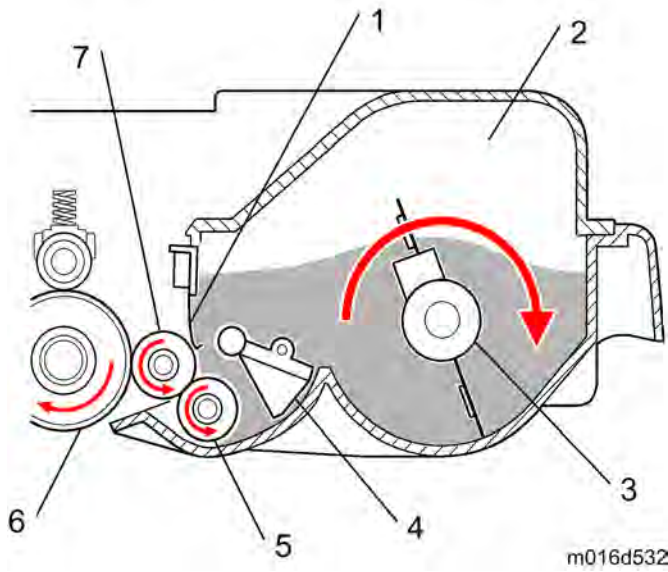

No.	Item
1.	Scraper
2.	Toner tank
3.	Agitator
4.	Toner detection feeler
5.	Toner supply roller
6.	Drum
7.	Development roller

**Toner Supply:**

The agitator mixes toner and sends it to the toner supply roller and development roller.

**Toner End:**

The toner detection feeler [4] detects toner end. The toner end sensor is on the outside of the development unit.

**Development Unit:**

This machine uses a one-roller development system. The high voltage supply applies approximately -300V to the development roller.

This machine does not use a TD sensor or ID sensor to control toner density. The scraper controls the toner density.

### Toner End Detection

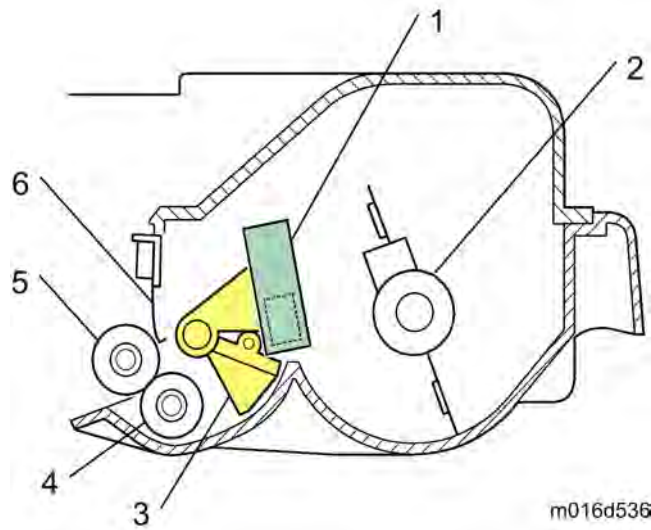

m016d536

No.	Item
1.	Toner end sensor
2.	Agitator
3.	Toner detection feeler
4.	Toner supply roller
5.	Development roller
6.	Scraper

### Toner end sensor

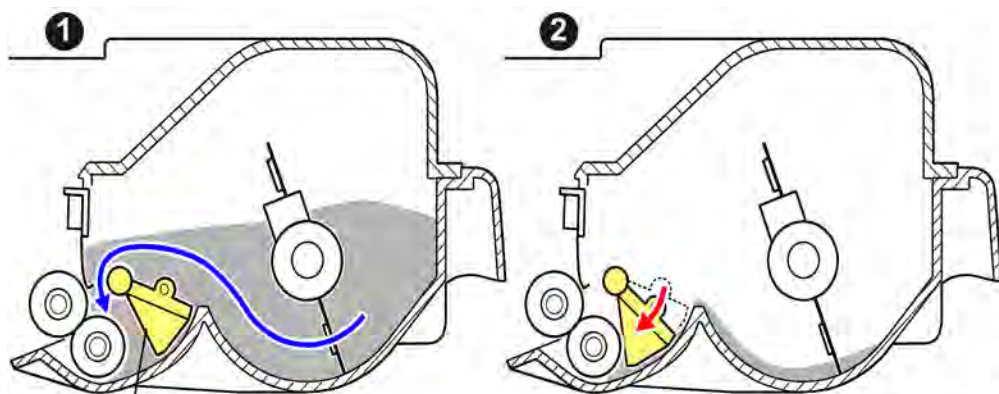

m016d536a

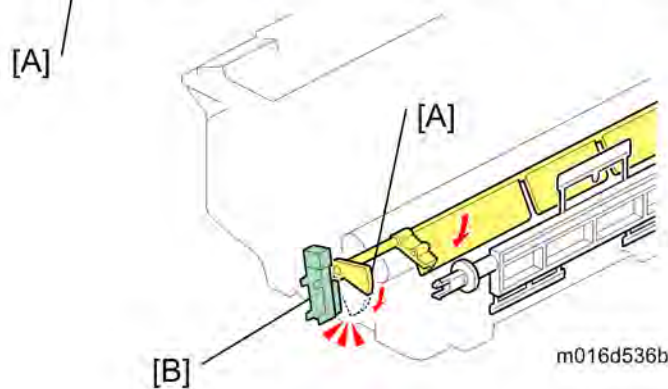

m016d536b

The agitator mixes toner and sends it to the toner supply roller and development roller as shown above [1]. The toner detection feeler comes down when the toner tank is out of toner as shown [2], and then the toner end sensor [B] detects toner end.

The toner end sensor detects toner end by the voltage output. When the output from the toner end sensor is below a given level, the machine displays “Replace Required Soon: Print Cartridge”.

After the additional pages have printed, printing stops and then the “Replacement Required: Print Cartridge” message remains on the display.

### ***Main Motor Rotation Count***

The time to replace the AIO cartridge can also be determined by the length of time the main motor has been rotating.

When toner end is detected, “Replacement Required: Print Cartridge” is displayed alternately with ‘Ready’.

### ***Toner Overflow Prevention***

With the main motor rotation count feature, the machine can be set to stop printing after the print total exceeds a certain set value. If the print count exceeds this value, then “Replacement Required: Print Cartridge” remains in the display. Then a new AIO cartridge must be installed.

This feature is a safety measure to prevent the used toner tank from becoming full (there is no toner overflow detection mechanism).

### **Why do we need this feature?**

Normally, the AIO is replaced by the user. But some users will refill the old AIO with toner, and use the same AIO again. If this occurs, the used toner tank will not be emptied. So there must be a way to stop users from repeatedly filling the old AIO with fresh toner.

### **How does the machine know if the AIO is a new one?**

The AIO has serial number information on a chip. The machine checks this number when the AIO is placed in the machine.

## 7.8 PAPER FEED

### 7.8.1 OVERVIEW

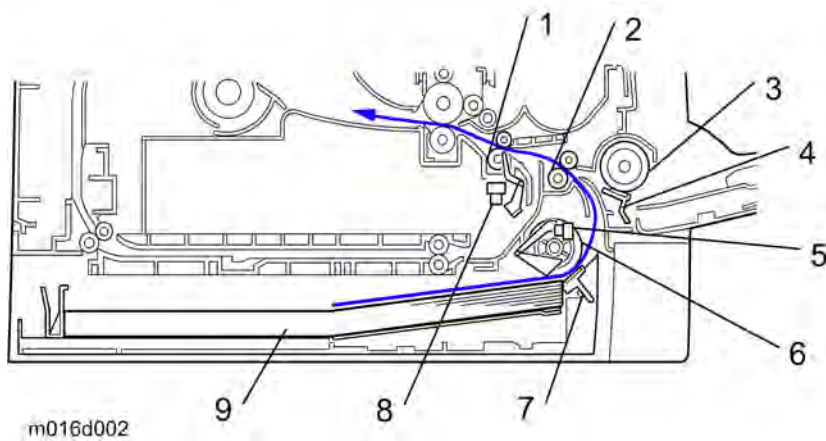

Callout	Item	Callout	Item
1.	Registration roller	6.	Feed roller
2.	Relay roller	7.	Friction pad
3.	By-pass feed roller	8.	Registration sensor
4.	By-pass friction pad	9.	Paper tray
5.	Paper end sensor		

## 7.8.2 MECHANISM

### Paper Tray

#### Tray Extension

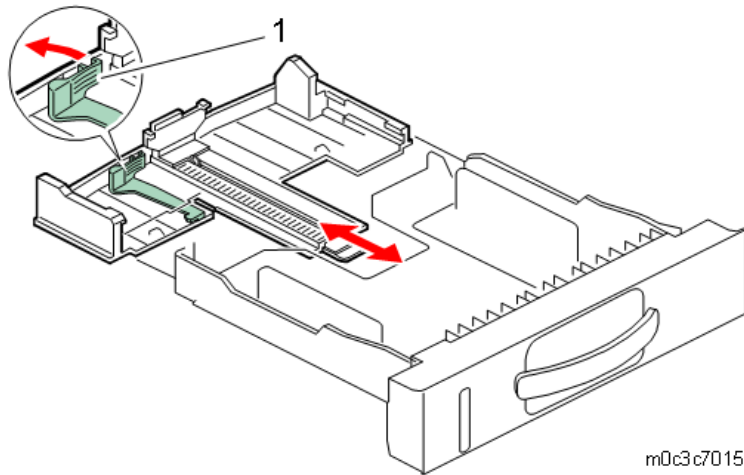

No.	Item
1.	Lock lever

When using paper longer than A4/Letter size, release the lock lever on the paper feed tray and extend the paper feed tray.

#### Paper Lift

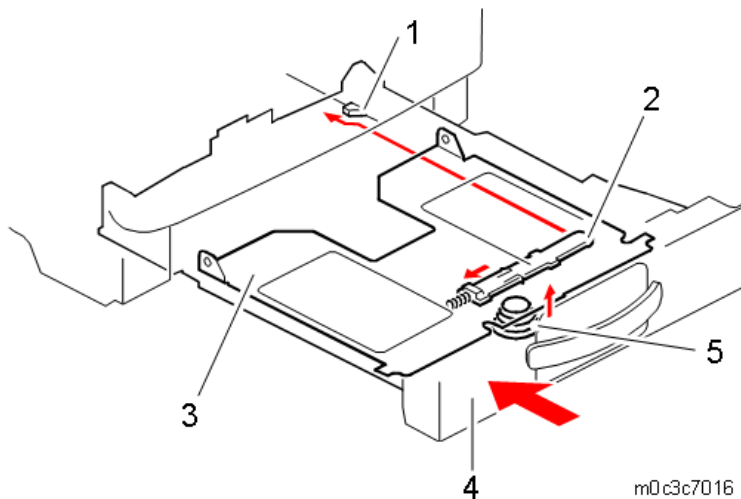

No.	Item
1.	Projection
2.	Release arm
3.	Bottom plate
4.	Paper tray
5.	Compressed spring



## Paper Feed

When the paper tray is inserted into the machine, a projection on the copier frame pushes the latch release arm (on the bottom part of the paper tray), enabling the compressed spring to lift the bottom plate.

### ***Paper End Detection***

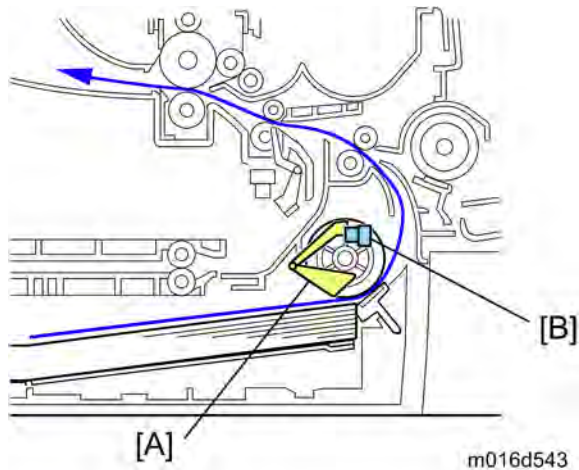

When there is no paper in the tray, the feeler [A] falls into the cutout in the bottom plate, and the paper end sensor [B] comes on.

## By-pass Tray

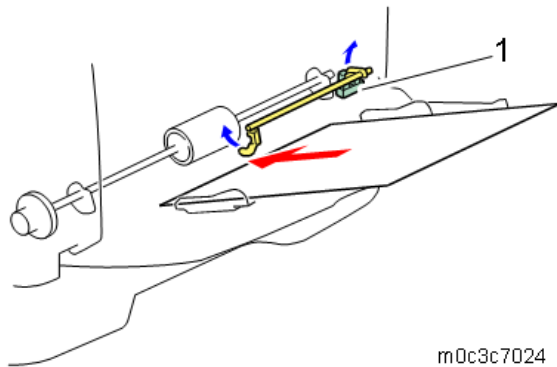

No.	Item
1.	By-pass feed sensor

The by-pass paper sensor detects when paper is placed on the tray.

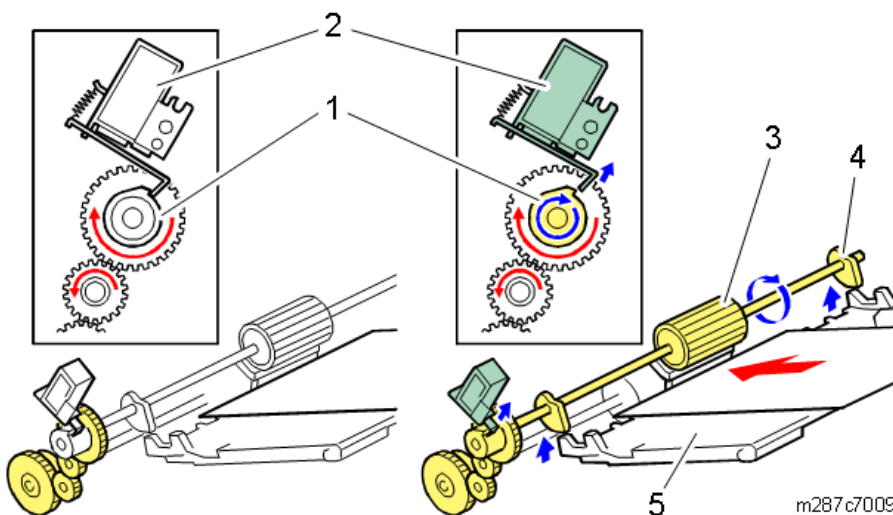

No.	Item
1.	By-pass feed clutch
2.	By-pass feed solenoid
3.	By-pass feed roller
4.	Cam
5.	By-pass tray

Driving power for the by-pass feed roller is provided from the main motor, via the paper feed clutch and the by-pass feed clutch. The feed process begins when the by-pass feed solenoid releases a latch on the by-pass feed clutch, enabling the by-pass feed roller to turn. At this time, two cams on the by-pass feed roller shaft lift the by-pass tray, pushing the paper up against the by-pass feed roller.

## Paper Feed

The by-pass paper feed roller stops after each rotation due to the on/off movement of the solenoid (when off, spring pressure pulls the latch back down so that it catches on a cog).

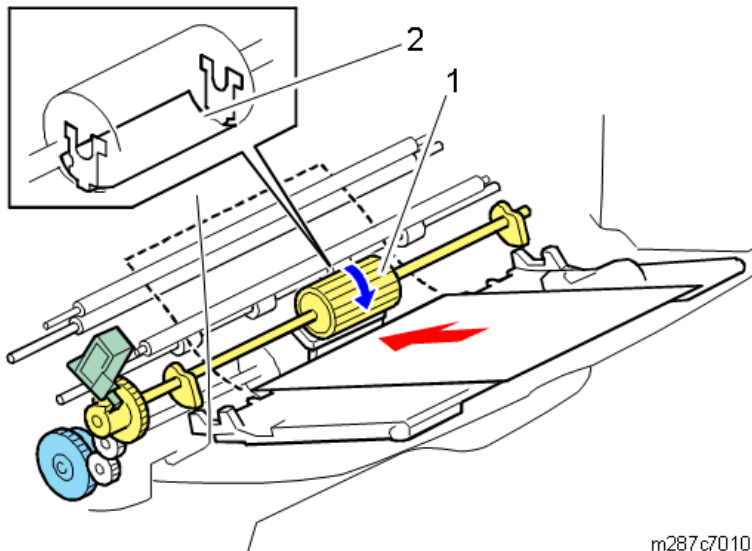

No.	Item
1.	By-pass feed roller
2.	Metal plate

In addition to the two cams allowing the by-pass tray to lower slightly after feeding, a curved metal plate (attached to one side of the by-pass feed roller) allows paper to slide past the roller upon completion of each single rotation of the roller while the paper is still feeding.

# 7.9 IMAGE TRANSFER

## 7.9.1 OVERVIEW

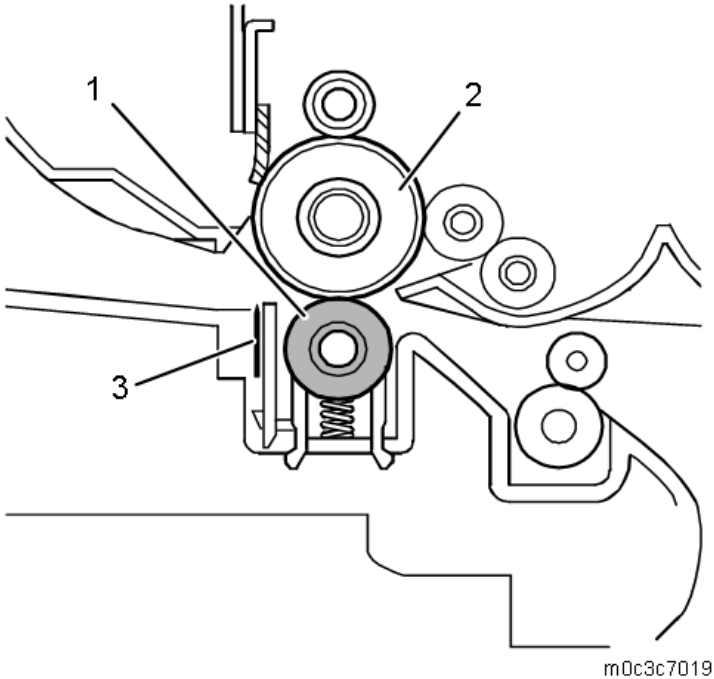

No.	Item
1.	Transfer roller
2.	Drum
3.	Discharge plate

Detailed Descriptions

## 7.9.2 MECHANISM

### *Transfer/Separation*

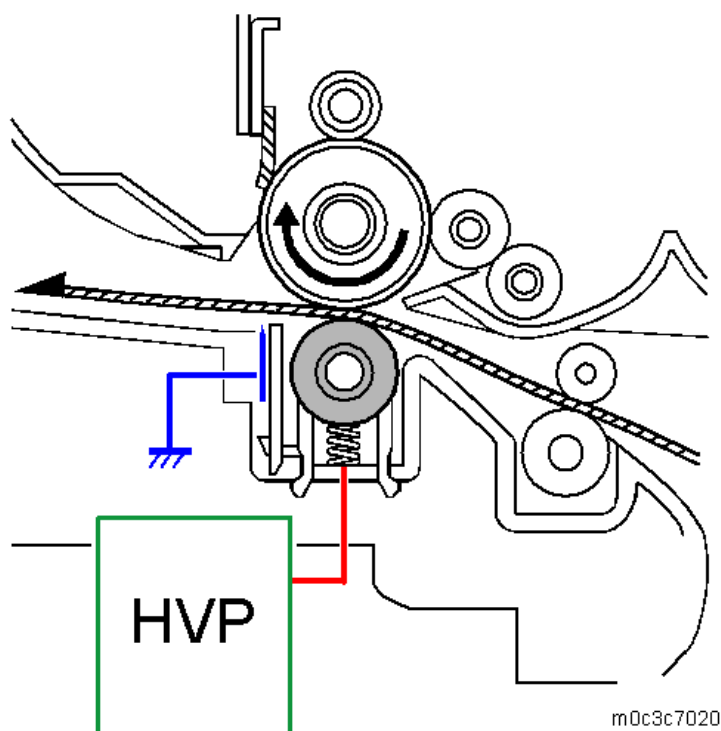

The transfer roller is pressed against the OPC drum. The HVP supplies a positive current to the transfer roller, attracting the toner from the drum onto the paper. The current is set in accordance with the paper's type, size, and feed tray.

Separation of the paper from the drum is aided by the drum's own curvature and by a high AC voltage applied to the discharge plate.

#### **Note**

You can adjust the transfer current levels with “Trans. Roller Bias” in the SP Mode (Engine Maintenance). When increasing a transfer current level, use caution:

- Increasing a transfer current level may produce ghost images—some part of the image near the leading edge reappears in another part of the page.
- Increasing a transfer current level might damage the OPC drum.

### ***Transfer Roller Cleaning***

Toner may transfer to the roller surface following a paper jam or if the paper is smaller than the image. Periodic cleaning of the roller is required to prevent this toner from migrating back to the rear of new printouts.

The machine cleans the roller at the following times:

- At the end of a job, if at least 10 sheets have been printed since the last cleaning
- After initial power on

- After clearing of a copy jam

The HVP first supplies a negative cleaning current to the transfer roller, causing negatively charged toner on the roller to move back to the drum. It then applies a positive cleaning current to the roller, causing any positively charged toner to migrate back to the drum.

## 7.10 FUSING AND EXIT

### 7.10.1 OVERVIEW

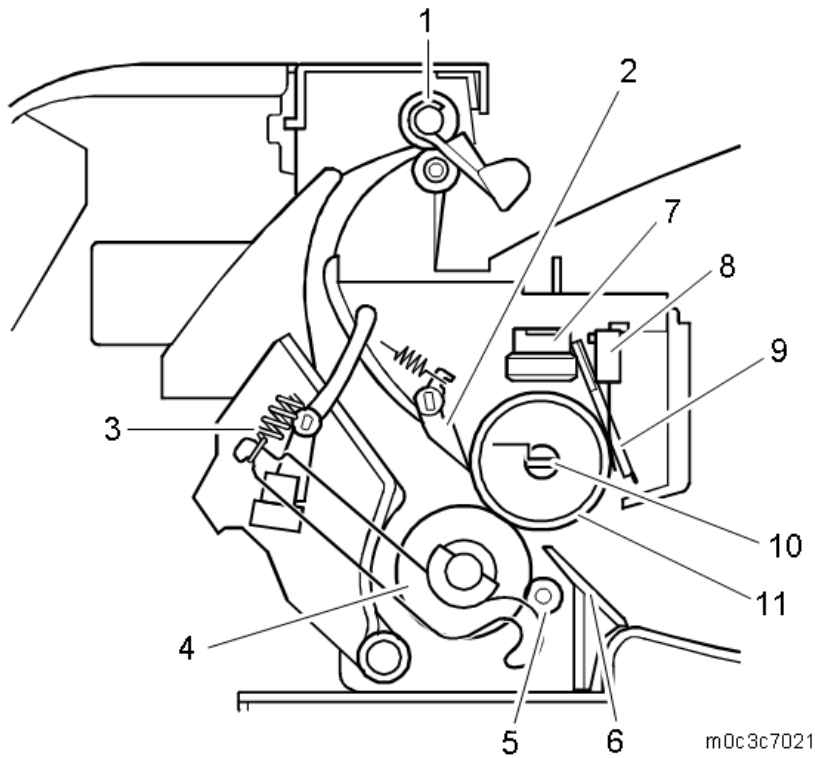

No.	Item	No.	Item
1.	Paper exit roller	7.	Thermostat
2.	Stripper pawls	8.	Fusing thermistor
3.	Pressure spring	9.	Non-contact thermistor
4.	Pressure roller	10.	Fusing lamp
5.	Cleaning roller	11.	Hot roller
6.	Paper entrance guide		

## 7.10.2 MECHANISM

### *Fusing Drive*

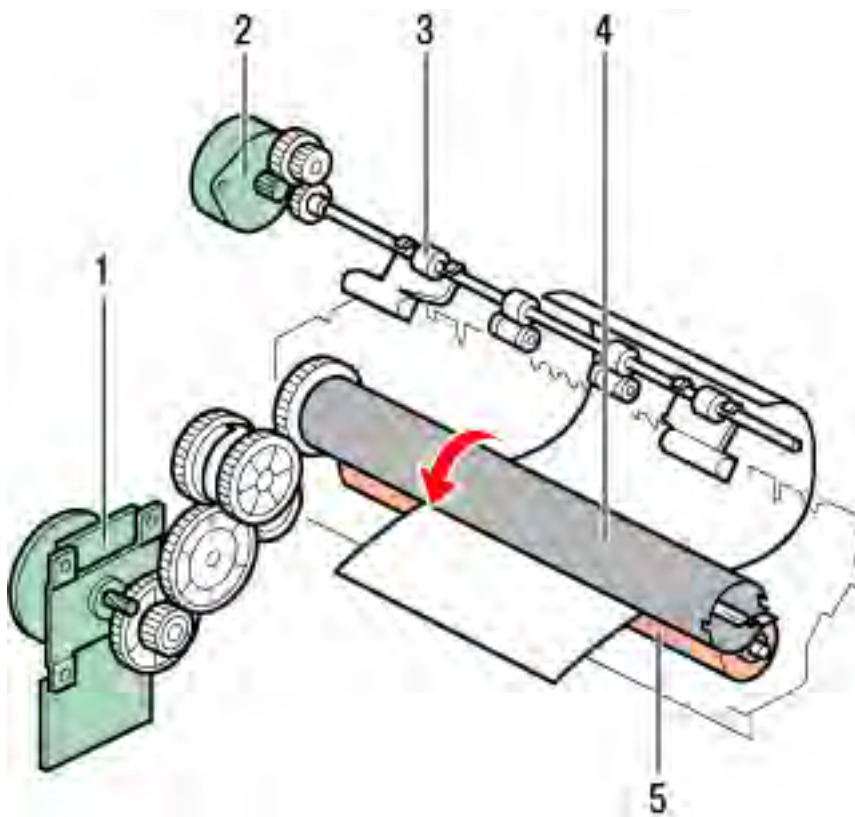

No.	Item
1.	Main motor
2.	Duplex motor
3.	Paper exit roller
4.	Hot roller
5.	Pressure roller

The main motor drives the fusing unit through a gear train.



### Parts Layout of the Fusing Unit

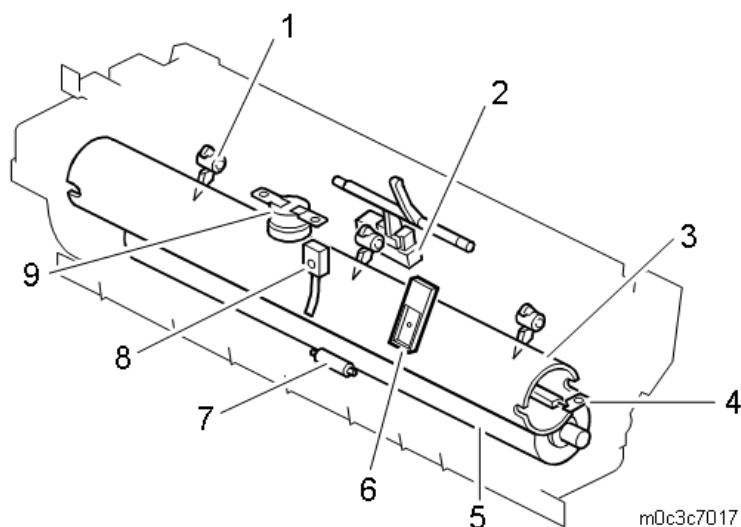

No.	Item	No.	Item
1.	Hot roller stripper pawl	6.	Non-contact thermistor
2.	Paper exit sensor	7.	Cleaning roller
3.	Hot roller	8.	Fusing thermistor
4.	Fusing lamp	9.	Thermostat
5.	Pressure roller		

### Envelope Lever

Envelope levers are provided on the right and left side of the fusing unit. When the lever is pulled down, the fusing pressure decreases (approx. 55% of the usual), and wrinkles on the envelope are controlled. Since no sensor to detect the lever position is provided, make sure to pull up the lever after printing on an envelope.

At the time of shipment, the lever is lowered (Envelope mode) to prevent deformation of the pressure roller. When not using the machine for a long time, leave the lever down.

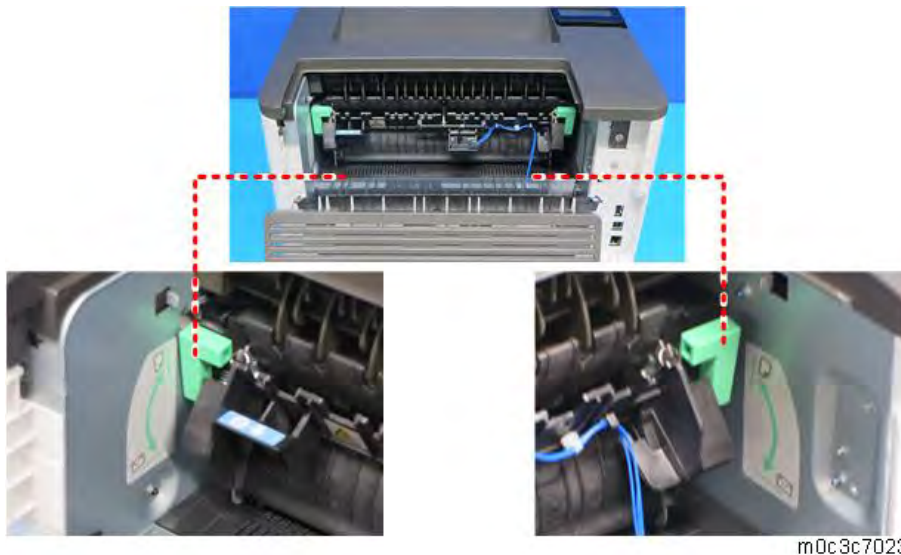

m0c3c7023

### Fusing Temperature Control

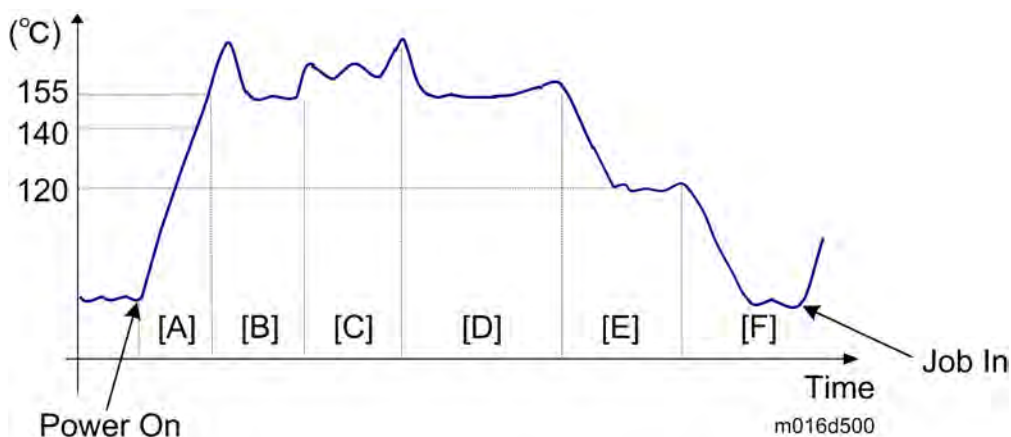

m016d500

Callout	Item
A	Warm up mode
B	Standby mode
C	Print mode
D	Standby mode
E	Energy saver mode 1
F	Energy saver mode 2

When the main switch is turned on, the CPU turns on the fusing lamp using the soft start process. (The soft start process prevents the room lights from flickering.) The lamp stays on until the thermistor detects the standby temperature. Then the CPU maintains this temperature using on-off control. To start printing, the CPU raises the temperature to the printing temperature.

The fusing temperature for each condition is as follows:

Condition	Temperature (degree)
Standby	155
Energy saver mode 1 (Low power)	120
Energy saver mode 2	Ambient temperature
Plain paper	175
Thick 1 paper	185
Thick 2 paper	185
Thin paper	170
Envelopes	185
Postcards	185
Recycled	170

**Note**

The fusing temperature for each condition (except "Energy saver mode 2") can be adjusted with "Fusing Unit Temperature" in the "Maintenance Mode (SP menu)".

### Overheat Protection

The surface temperature of the hot roller is monitored with the fusing thermistor and the non-contact thermistor (which is kept at a gap of 1mm from the surface of the hot roller).

If the fusing thermistor temperature becomes greater than 235 °C or the non-contact thermistor temperature becomes greater than 220°C, the CPU cuts off the power to the fusing lamp. At this time, SC543 or SC553 will be generated.

If the thermistor overheat protection fails, there is a thermostat in series with the common ground line of the fusing lamp. If the temperature of the thermostat becomes greater than 185 °C, the thermostat opens, removing power from the fusing lamp. At this time, the machine stops.

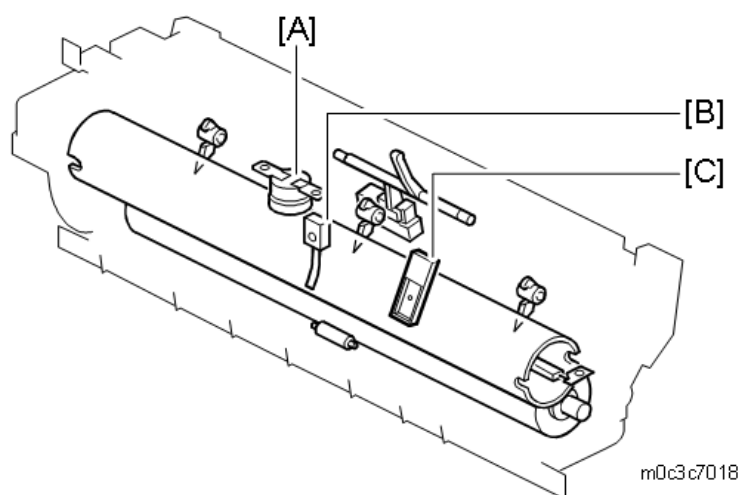

[A]: Thermostat: Operation stops when the temperature surrounding the hot roller is more than 185°C.

[B]: Fusing thermistor: SC543 will be generated when the surface temperature of the hot roller is more than 235°C.

[C]: Non-contact thermistor: SC553 will be generated when the surface temperature of the hot roller is more than 220°C.

### ***Paper Exit***

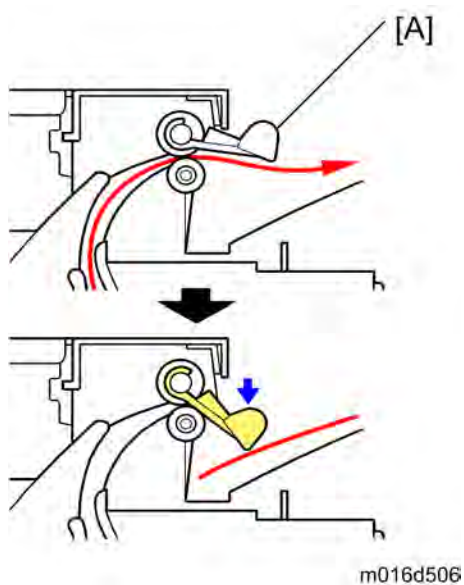

The paper exit guide-plate [A] holds down the trailing edge of each sheet of paper after it exits in order to prevent it from obstructing following sheets of paper as they exit.

## 7.11 DUPLEX

### 7.11.1 OVERVIEW

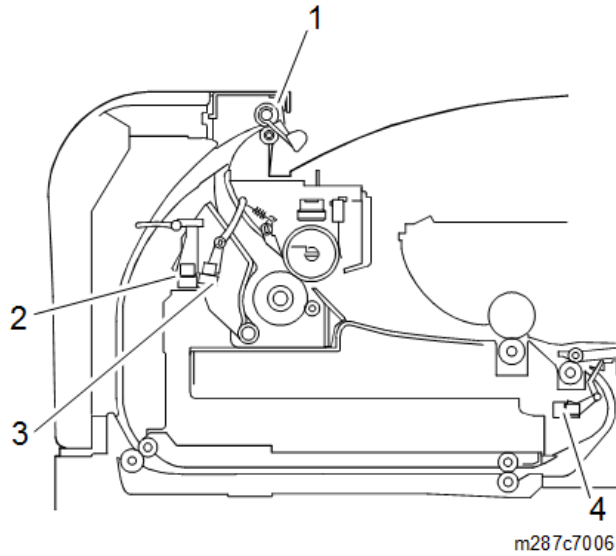

No.	Item
1.	Paper exit roller
2.	Duplex sensor
3.	Paper exit sensor
4.	Registration sensor

## 7.11.2 MECHANISM

### *Duplex Printing Process*

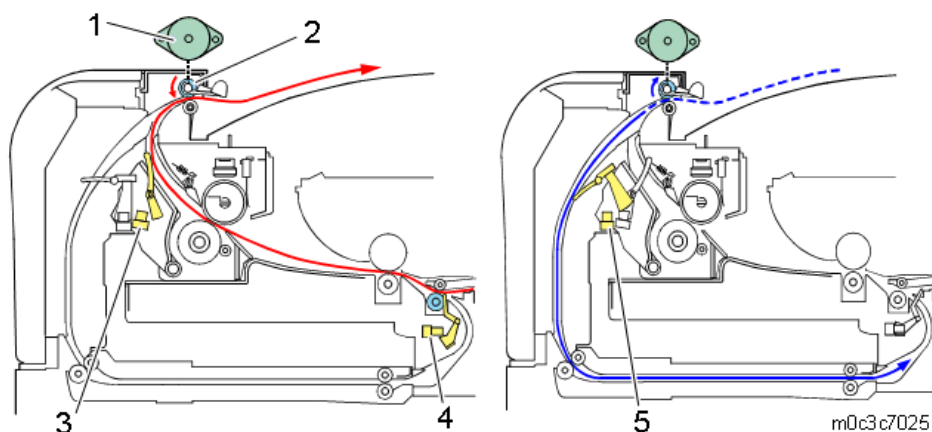

No.	Item
1	Duplex motor
2	Paper exit roller
3	Paper exit sensor
4	Registration sensor
5	Duplex sensor

An independent drive motor in the duplex machine handles paper ejection and reversing. Paper from the registration roller is sent to the paper exit roller. The paper exit roller reverses its rotation after the trailing edge of the paper has passed the paper exit sensor (but the paper has not fully exited into the output tray), and then sends the paper into the duplex paper path. When the trailing edge of the paper passes the duplex sensor, the paper exit roller again reverses rotation (reverting to its original direction), and ejects the paper into the output tray.

The duplex sensor is also used to detect paper jams.

### Printing Order

When duplex printing, the following operations are repeated until the end of printing.

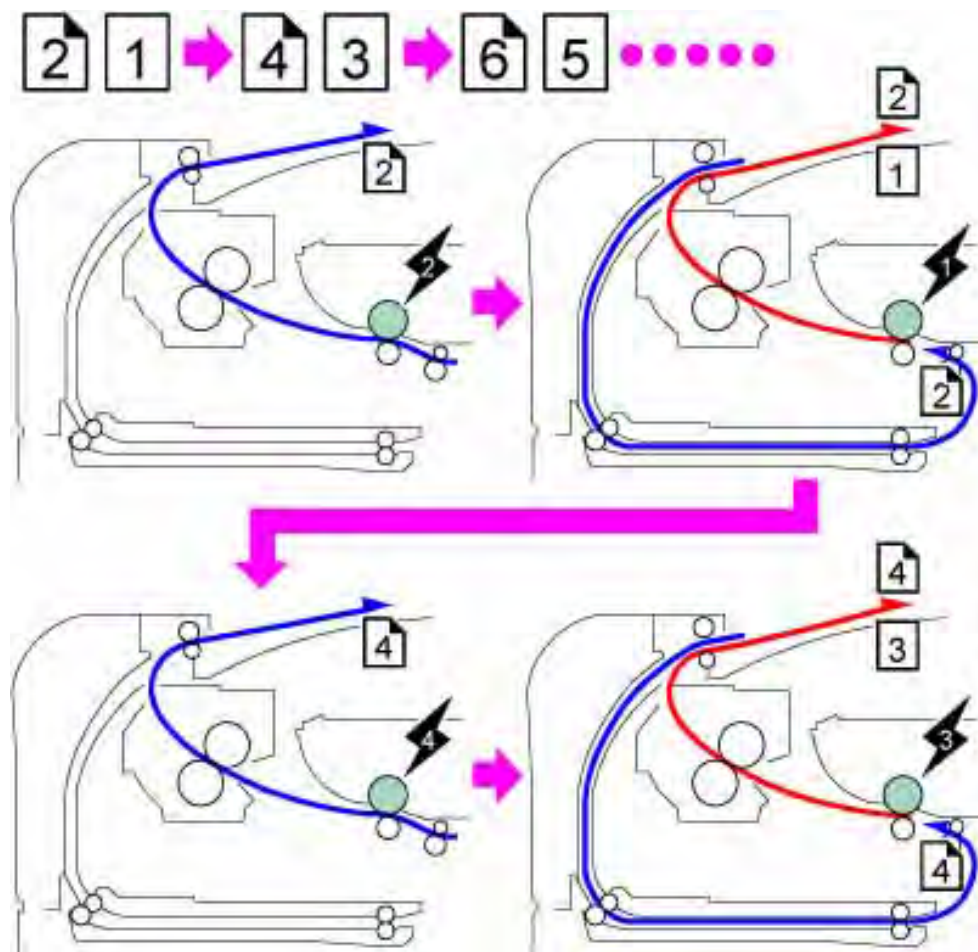

The printing is done as shown above: 2nd side of 1st page → 1st side of 1st page → 2nd side of 2nd page → 1st side of 2nd page → ----.

## 7.12 ELECTRICAL COMPONENTS

### 7.12.1 OVERVIEW

#### Block Diagram Printer Models

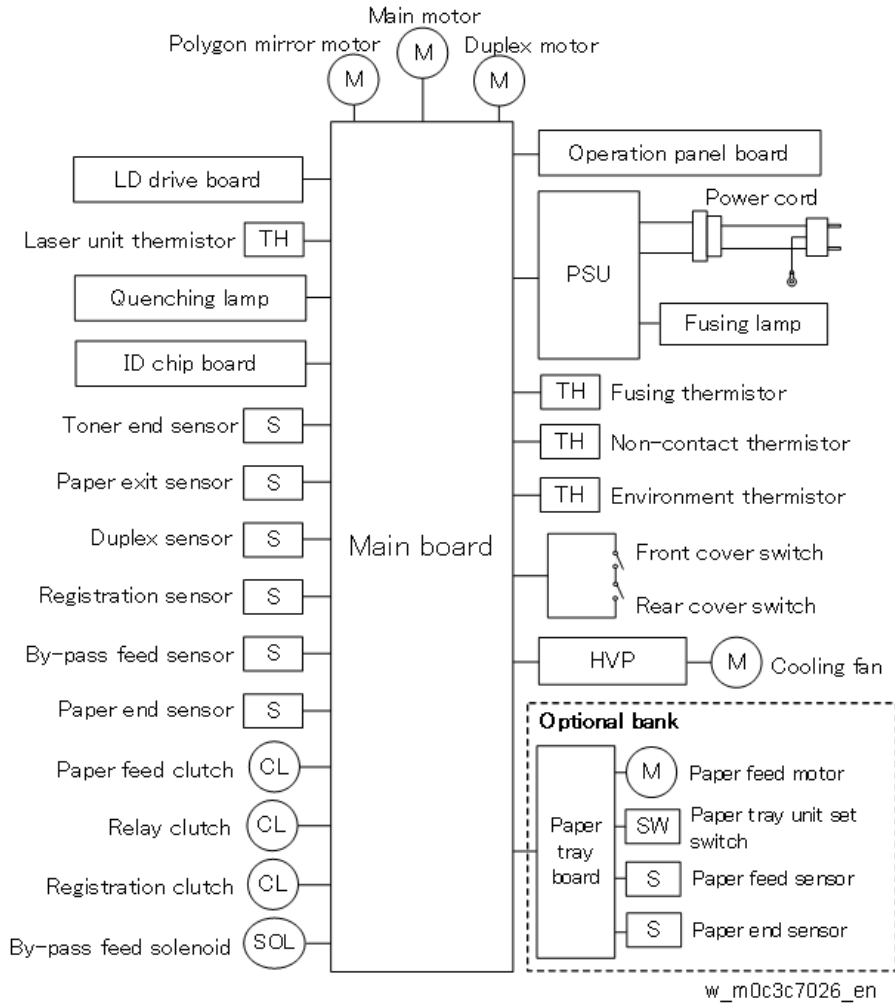

Detailed Descriptions



## Block Diagram MF Models

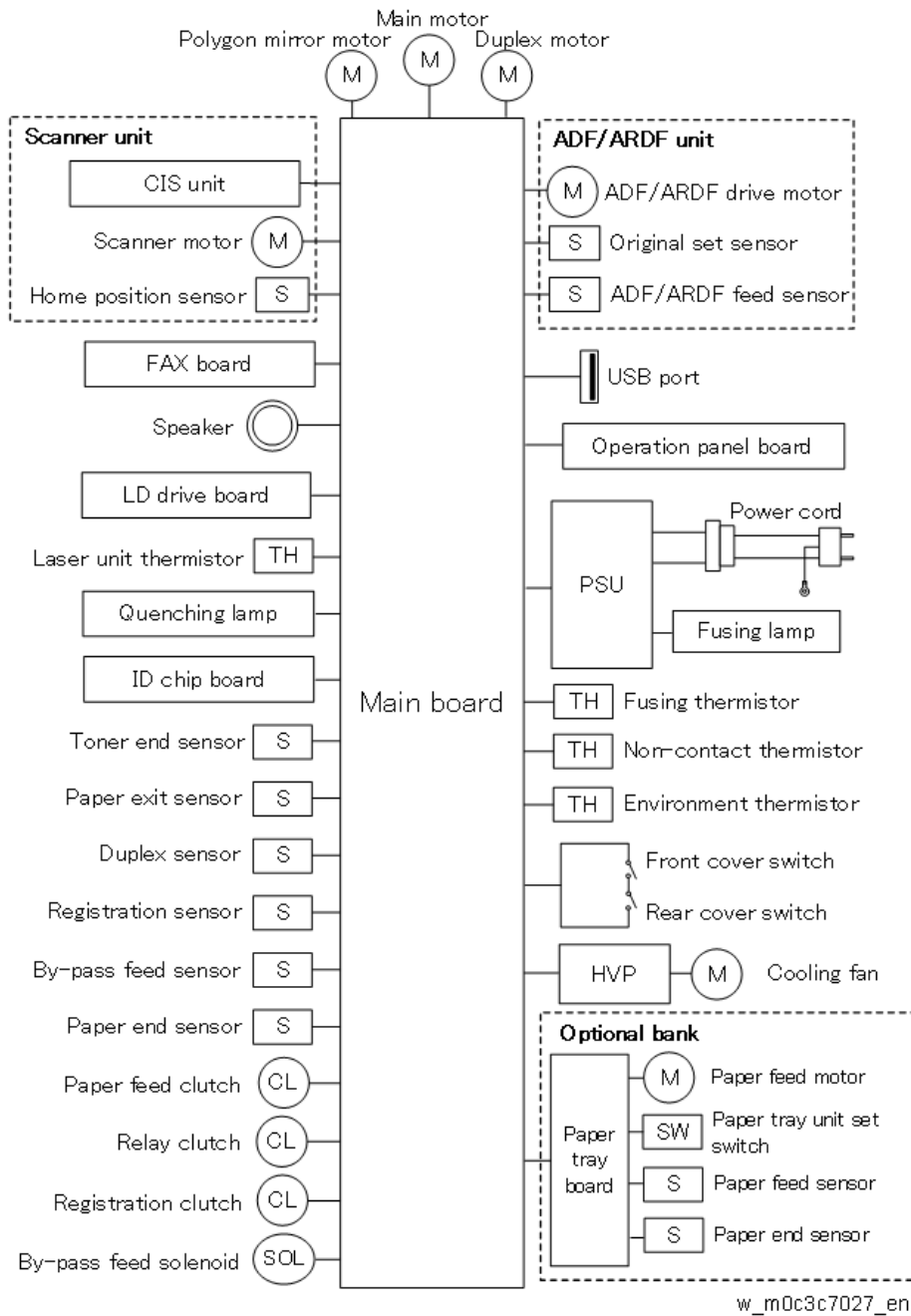

## Board Outline

### Main Board

#### Printer models:

Controls overall operation of the printer, mainly:

- SDRAM
- Ethernet (10BASE-T/100BASE-TX)

- USB 2.0
- Controller I/F
- Engine
- Image data processing
- LD (Laser Diode)

#### Main Board Specifications

- CPU: Quatro 5305-350MHz
- Memory: 128 MB

#### **MF models:**

Controls overall operation of the printer, mainly:

- SDRAM
- Ethernet (10BASE-T/100BASE-TX)
- USB 2.0
- Controller I/F
- Engine
- Image data processing
- LD (Laser Diode)
- Storing address data for FAX and scanner

#### Main Board Specifications

- CPU: Quatro 5310-400MHz
- Memory: 256 MB

#### ***LD Drive Board***

Controls the LD (Laser Diode).

#### ***PSU***

Supplies DC current to the machine. Also, contains the AC drive that controls the power supply to the fusing lamps.

#### ***HVP***

The high voltage power supply provides power to electrical components in the machine.

Generates the high voltage power supply required for the printing process.

#### ***FCU (Only for Fax Models)***

Controls fax communication.

## 7.13 ENERGY SAVE

### 7.13.1 ENERGY SAVER MODES

Customers should use energy saver modes properly, to save energy and protect the environment.

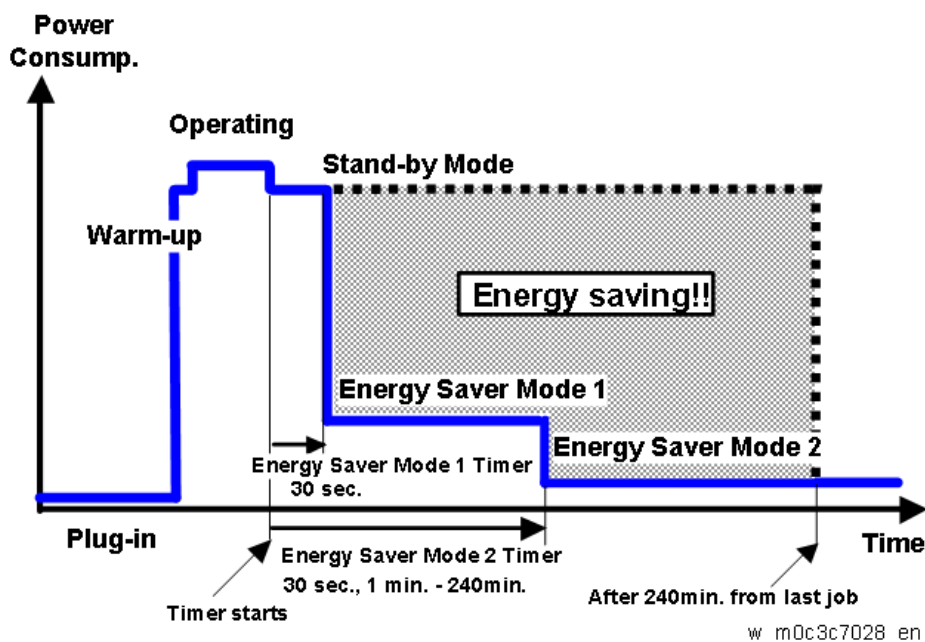

The backlight of the screen is turned off and "Energy Saver Mode1" appears on the screen, and then the fusing lamp is turned off and "Energy Saver Mode2" appears on the screen.

The area shaded grey in this diagram represents the amount of energy that is saved when the timers are at the default settings. If the timers are changed, then the energy saved will be different. For example, if the timers are all set to 240 min., the grey area will disappear, and no energy is saved before 240 min. expires.

#### **Timer Settings**

The user can set these timers with User Tools (Admin. Tools > [Energy Saver Mode] > [Energy Saver Mode1] or [Energy Saver Mode2])

- Energy Saver Mode 1 (30 sec.): This can be only turned on or off.
- Energy Saver Mode 2 (30 sec. , 1 to 240 min.): This can be turned on or off and timer setting is adjustable (default: 30 sec.).

## ***Return to Stand-by Mode***

### **Energy Saver Mode 1**

- Recovery time: 10 sec.

### **Energy Saver Mode 2**

- Recovery time: 20 sec.

## ***Recommendation***

We recommend that the default settings should be kept.

- If the customer requests that these settings should be changed, please explain that their energy costs could increase, and that they should consider the effects on the environment of extra energy use.
- If it is necessary to change the settings, please try to make sure that the Energy Saver Mode 2 Timer is not too long. Try with a shorter setting first, such as 30 min., then go to a longer one (such as 60 min.) if the customer is not satisfied.
- If the timers are all set to the maximum value, the machine will not begin saving energy until 240 minutes has expired after the last job. This means that after the customer has finished using the machine for the day, energy will be consumed that could otherwise be saved.

**M0C3/M0C4/M0C5/M0C6/M0C7  
SERVICE MANUAL APPENDICES**

# M0C3/M0C4/M0C5/M0C6/M0C7

## APPENDICES

### TABLE OF CONTENTS

<b>1. SPECIFICATIONS</b> .....	<b>1-1</b>
1.1 GENERAL SPECIFICATIONS .....	1-1
1.1.1 SYSTEM (FOR PRINTER MODELS) .....	1-1
1.1.2 SYSTEM (FOR MF MODELS) .....	1-4
1.1.3 PRINTER .....	1-7
1.1.4 COPIER (ONLY FOR MF MODELS) .....	1-8
1.1.5 SCANNER (ONLY FOR MF MODELS).....	1-9
1.1.6 FAX (ONLY FOR FAX MODELS).....	1-10
1.1.7 OPTION.....	1-11
Paper Feed Unit .....	1-11
1.2 SUPPORTED PAPER SIZES .....	1-12
<b>2. SETTING FOR PAAS (ONLY FOR CHINA)</b> .....	<b>2-1</b>
2.1 PAAS SETUP PROCEDURE.....	2-1
2.1.1 CHECK THE NETWORK ENVIRONMENT .....	2-1
2.1.2 SWITCH TO PAAS MODE .....	2-1
2.1.3 PAAS REGISTRATION .....	2-2
2.2 UNREGISTERING PAAS.....	2-5
2.3 CHANGING REGISTERED DEVICE/ MAIN BOARD .....	2-6
2.3.1 CHECK THE NETWORK ENVIRONMENT .....	2-6
2.3.2 SWITCH TO PAAS MODE .....	2-7
2.3.3 OVERWRITE REGISTRATION ON SERVER .....	2-7
2.4 TECHNICAL TIPS.....	2-11

# **APPENDIX: SPECIFICATIONS**

<b>REVISION HISTORY</b>		
<b>Page</b>	<b>Date</b>	<b>Added/Updated/New</b>
		None

# 1. SPECIFICATIONS

## 1.1 GENERAL SPECIFICATIONS

### 1.1.1 SYSTEM (FOR PRINTER MODELS)

Item	Description	
Configuration	Desktop	
Laser type	Class 1	
CPU	ARM11-350MHz	
Memory	128MB	
Interface	Ethernet (100BASE-TX/10BASE-T) x1, USB2.0 TypeB  <b>Option:</b> Wireless LAN (IEEE 802.11 a/b/g/n/ac)	
Operating system	Windows: Windows Vista (SP 2 or later), Windows 7 (SP 1 or later), Windows 8.1, Windows 10 RS1 or later,  Windows Server 2008 (SP2 or later), Windows Server 2008R2, Windows Server 2012/2012R2, Windows Server 2016  Mac OS: 10.10 or later  Linux: Ubuntu 16.04LTS, Ubuntu 16.10, openSUSE 13.1, openSUSE 13.2, Red Hat Enterprise Linux 6, Red Hat Enterprise Linux 7	
Input paper size	Standard tray	A4 SEF, A5 SEF/LEF, A6 SEF, B5 SEF, B6 SEF, 8 1/2"x14" (LG) SEF, 8 1/2"x13" (Foolscap) SEF, 8 1/2"x11" (LT) SEF, 8 1/4"x14" (Government LG)SEF, 8 1/4"x13" (Folio) SEF, 8"x13" (F/GL) SEF, 8"x10" (Eng Quatro) SEF, 7 1/4"x10 1/2" (Executive) SEF, 5 1/2"x8 1/2" (HLT) SEF, 16K SEF, 8 1/2"x13 2/5" SEF  <b>Custom size:</b> Width: 100 - 216 mm (3.94" - 8.50") length: 148 - 356 mm (5.83" - 14.02")
	By-pass tray	A4 SEF, A5 SEF/LEF, A6 SEF, B5 SEF, B6 SEF, 8 1/2"x14" (LG) SEF, 8 1/2"x13" (Foolscap) SEF, 8 1/2"x11" (LT) SEF, 8 1/4"x14" (Government LG)SEF, 8 1/4"x13" (Folio) SEF, 8"x13" (F/GL) SEF, 8"x10" (Eng Quatro) SEF, 7 1/4"x10 1/2" (Executive) SEF, 5 1/2"x8 1/2" (HLT) SEF, Com10 SEF, Monarch SEF, C5 SEF, C6



General Specifications

Item		Description
		SEF, 16K SEF, 8 1/2"x13 2/5" SEF <b>Custom size:</b> Width: 90 - 216 mm (3.54" - 8.50") Length: 140 - 356 mm (5.51" -14.02")
	Optional tray	See " <a href="#">Paper Feed Unit</a> ".
Paper type	Standard Tray/ Duplex	Plain 1 (64-74g/m <sup>2</sup> ), Plain 2 (75-90g/m <sup>2</sup> ), Middle Thick (91-105g/m <sup>2</sup> ), Thick 1 (106-120g/m <sup>2</sup> ), Recycled Paper, Colored Paper, Special Paper 1, Special Paper 2, Special Paper 3, Letterhead, Pre-printed Paper, Bond Paper
	By-pass tray	Thin (60-63g/m <sup>2</sup> ), Plain 1 (64-74g/m <sup>2</sup> ), Plain 2 (75-90g/m <sup>2</sup> ), Middle Thick (91-105g/m <sup>2</sup> ), Thick 1 (106-135g/m <sup>2</sup> ), Thick 2 (136-170g/m <sup>2</sup> ), Thick 3 (171-220g/m <sup>2</sup> ), Recycled Paper, Colored Paper, Special Paper 1, Special Paper 2, Special Paper 3, Letterhead, Pre-printed Paper, Bond Paper, OHP, Label Paper, Envelopes (171-220g/m <sup>2</sup> )
	Optional tray	See " <a href="#">Paper Feed Unit</a> ".
Paper weight	Standard tray	52-162 g/m <sup>2</sup> (14-43 lb)
	By-pass tray	52-162 g/m <sup>2</sup> (14-43 lb)
	Duplex	60-105 g/m <sup>2</sup> (16-28 lb)
	Optional tray	See " <a href="#">Paper Feed Unit</a> ".
Input paper capacity (80g/m <sup>2</sup> , 20lb.Bond)		Standard tray: 250 sheets By-pass tray: 50 sheets
Output paper capacity (80g/m <sup>2</sup> , 20lb.Bond)		Face Down: 125 sheets or more (Normal), 150 sheets or more (only selected paper types)
Warm-up time (Nominal value)		Less than 30sec (Conditions: 23°C/50%, NA: 120V, EU/CHN: 230V)
Sound power level	Stand by/Energy Saving	30.0dB(A) or less
	Copying	67.2dB(A) or less
Sound pressure level (Bystander)	Stand by/Energy Saving	21.5dB(A) or less
	Copying	57.5dB(A) or less

Item		Description
Power requirement		NA: 120-127V, 60Hz, 7.7A EU: 220-240V, 50/60Hz, 4A China: 220-240V, 50/60Hz, 4.3A Taiwan: 110V, 60Hz, 8A
Power consumption	Operating (Max) (Guaranteed value)	960 W
	Operating/ in use of printing (Nominal value)	EU: 512 W NA: 555 W
	Ready (Nominal value)	EU: 63.8 W NA: 64.9 W
	Energy saver (sleep) (Nominal value)	EU: 0.711 W NA: 0.655 W
Dimensions (W x D x H)		370 x 392 x 262mm (14.6" x 15.4" x 10.3")
Weight		Less than 13Kg / 28.7lb.

## 1.1.2 SYSTEM (FOR MF MODELS)

Item		Description
Configuration		Desktop
Laser type		Class 1
CPU		ARM11-400MHz
Memory		256MB
Interface		Ethernet (100BASE-TX/10BASE-T) x1, USB2.0 TypeB x2  <b>Option:</b> Wireless LAN (IEEE 802.11 a/b/g/n/ac)
Operating system		Windows: Windows Vista (SP 2 or later), Windows 7 (SP 1 or later), Windows 8.1, Windows 10 RS1 or later,  Windows Server 2008 (SP2 or later), Windows Server 2008R2, Windows Server 2012/2012R2, Windows Server 2016  Mac OS: 10.10 or later  Linux: Ubuntu 16.04LTS, Ubuntu 16.10, openSUSE 13.1, openSUSE 13.2, Red Hat Enterprise Linux 6, Red Hat Enterprise Linux 7
Input paper size	Standard tray	A4 SEF, A5 SEF/LEF, A6 SEF, B5 SEF, B6 SEF, 8 1/2"x14" (LG) SEF, 8 1/2"x13" (Foolscap) SEF, 8 1/2"x11" (LT) SEF, 8 1/4"x14" (Government LG)SEF, 8 1/4"x13" (Folio) SEF, 8"x13" (F/GL) SEF, 8"x10" (Eng Quatro) SEF, 7 1/4"x10 1/2" (Executive) SEF, 5 1/2"x8 1/2" (HLT) SEF, 16K SEF, 8 1/2"x13 2/5" SEF  <b>Custom size:</b> Width: 100 - 216 mm (3.94" -8.50") Length: 148 - 356 mm (5.83" -14.02")
	By-pass tray	A4 SEF, A5 SEF/LEF, A6 SEF, B5 SEF, B6 SEF, 8 1/2"x14" (LG) SEF, 8 1/2"x13" (Foolscap) SEF, 8 1/2"x11" (LT) SEF, 8 1/4"x14" (Government LG)SEF, 8 1/4"x13" (Folio) SEF, 8"x13" (F/GL) SEF, 8"x10" (Eng Quatro) SEF, 7 1/4"x10 1/2" (Executive) SEF, 5 1/2"x8 1/2" (HLT) SEF, Com10 SEF, Monarch SEF, C5 SEF, C6 SEF, DL Env SEF, 16K SEF, 8 1/2"x13 2/5" SEF  <b>Custom size:</b> Width: 90 - 216 mm (3.54" -8.50") length: 140 - 356 mm (5.51" -14.02")

Item	Description	
	Option tray	See " <i>Paper Feed Unit</i> ".
Paper type	Standard Tray/ Duplex	Plain 1 (64-74g/m <sup>2</sup> ), Plain 2 (75-90g/m <sup>2</sup> ), Middle Thick (91-105g/m <sup>2</sup> ), Thick 1 (106-120g/m <sup>2</sup> ), Recycled Paper, Colored Paper, Special Paper 1, Special Paper 2, Special Paper 3, Letterhead, Pre-printed Paper, Bond Paper
	By-pass tray	Thin (60-63g/m <sup>2</sup> ), Plain 1 (64-74g/m <sup>2</sup> ), Plain 2 (75-90g/m <sup>2</sup> ), Middle Thick (91-105g/m <sup>2</sup> ), Thick 1 (106-135g/m <sup>2</sup> ), Thick 2 (136-170g/m <sup>2</sup> ), Thick 3 (171-220g/m <sup>2</sup> ), Recycled Paper, Colored Paper, Special Paper 1, Special Paper 2, Special Paper 3, Letterhead, Pre-printed Paper, Bond Paper, OHP, Label Paper, Envelopes (171-220g/m <sup>2</sup> )
	Option tray	See " <i>Paper Feed Unit</i> ".
Paper weight	Standard tray	52-162 g/m <sup>2</sup> (14-43 lb)
	By-pass tray	52-162 g/m <sup>2</sup> (14-43 lb.)
	Duplex	60-105 g/m <sup>2</sup> (16-28 lb.)
	Option tray	See " <i>Paper Feed Unit</i> ".
Input paper capacity (80g/m <sup>2</sup> , 20lb.Bond)	Standard tray: 250 sheets By-pass tray: 50 sheets	
Output paper capacity (80g/m <sup>2</sup> , 20lb.Bond)	Face Down: 50 sheets or more	
Original set capacity (80g/m <sup>2</sup> , 20lb.Bond)	35 sheets	
Warm-up time (Nominal value)	Less than 30sec (Conditions: 23°C/50%, NA: 120V, EU/CHN: 230V)	
Sound power level	Stand by/Energy Saving: 30.0dB(A) or less Copying: 67.0dB(A) or less	
Sound pressure level (Bystander)	Stand by/Energy Saving: 21.5dB(A) or less Copying: 57.0dB(A) or less	
Power requirement	NA: 120-127V, 60Hz, 7.7A EU: 220-240V, 50/60Hz, 4A China: 220-240V, 50/60Hz, 4.3A Taiwan: 110V, 60Hz, 8A	

General Specifications

Item		Description
Power consumption	Operating (Max) (Guaranteed value)	960 W
	Operating/ in use of printing (Nominal value)	EU: 514 W (SP 330SN) 520 W (SP 330SFN/SP 3710SF) NA: 527 W (SP 330SFN/SP 3710SF)
	Ready (Nominal value)	EU: 68.6 W (SP 330SN) 69.4 W (SP 330SFN/SP 3710SF) NA: 65.7 W (SP 330SFN/SP 3710SF)
	Energy saver (sleep) (Nominal value)	EU: 0.715 W (SP 330SN) 0.928 W (SP 330SFN/SP 3710SF) NA: 0.871 W (SP 330SFN/SP 3710SF)
Dimensions (W x D x H)		405 x 392 x 407mm (15.9" x 15.4" x 16.0") (SP 330SN (ADF)) 405 x 392 x 420 mm (15.9" x 15.4" x 16.5") (SP 330SFN/SP 3710SF(ARDF))
Weight		Less than 18Kg / 40lb.

### 1.1.3 PRINTER

Item		Description
Print speed	1-sided	32ppm(600dpi), 14ppm(1200dpi) /A4 LEF 34ppm(600dpi), 15ppm(1200dpi) /LT LEF
	2-sides	14ppm(600dpix600dpi, 1,200dpix600dpi), 8ppm(1200dpix1,200dpi) /A4 SEF 14ppm(600dpi), 14ppm(1200dpi) /LT SEF
First print (Nominal value)		Guaranteed Value: Less than 7.5 sec (A4/LT)
Resolution		600x600dpi, 1200x600dpi (Normal speed) 1200x1200dpi (Half speed) Depending on the OS, applicable values are different <ul style="list-style-type: none"> <li>• Windows: 1200x1200dpi, 1200x600dpi, 600x600dpi</li> <li>• MAC: only 600x600dpi</li> <li>• Linux: 600x600dpi, 1200x1200dpi</li> </ul>
Printer Description Language		PCL5e, PCL6, PostScript3 (only for Fax models)
Printer Driver		Windows: PCL6 (600x600dpi, 1200x600dpi, 1200x1200dpi), PS3 Clone (600x600dpi, 1200x1200dpi) Mac: PCL5e (600x600dpi) Linux: PCL6 (1200x1200dpi, 600x600dpi)
Network Protocols		TCP/IP
Font		PCL: Scalable 45 fonts + Bitmapped: 10 fonts PS3: Scalable 35 fonts

**1.1.4 COPIER (ONLY FOR MF MODELS)**

Item		Description	
1st copy speed		Book	Less than 13.0 sec (A4 SEF/LT SEF)
		ADF/ARDF	Less than 16.0 sec (A4 SEF/LT SEF)
Copy speed	Single document multiple copy	Book	32cpm(600dpi), 14cpm(1200dpi) /A4 SEF 34cpm(600dpi), 15cpm(1200dpi) /LT SEF
		ADF	13 cpm
		ARDF	6 cpm
	Multiple document single copy	ARDF	6 cpm
Reduction / Enlargement	Fix		NA: 400%, 200%, 155%, 129%, 100%, 93%, 78%, 65%, 50%  EU/AP/CHN/TWN: 400%, 200%, 141%, 122%, 100%, 93%, 82%, 71%, 50%
	Zoom	Book	25-400% (When the resolution is 600x600dpi), 1% steps
		ADF/ARDF	25-400% (When the resolution is 600x300dpi), 1% steps
	Resolution (H x V)	Scanning	Book
ADF/ARDF			300 x 600 dpi
Printing		Default: 600x600dpi, 1200x600dpi Half speed: 1200x1200dpi	
Grayscale		256 levels	
Copy quantity		Up to 99 copies	

### 1.1.5 SCANNER (ONLY FOR MF MODELS)

Item		Description
Scanning method		CIS
Scan area	Main scan (Width)	215.6 mm (Image guaranteed range A4: 204mm, LT: 210mm)
	Sub scan (Length)	FB: 297mm ARDF/ADF: 355.6
Resolution	Std	Copy: FB: 600x600dpi ARDF/ADF: 600x300dpi Fax: 200x200dpi/ 200x100dpi Scan: 75 to 19200dpi
	Default	FB: 600x600dpi DF: 300x600dpi
Scanning speed	B&W	FB: 145mm/s (300x300dpi), 36mm/s (600x600dpi) ADF/ARDF: 64mm/s 13ipm (600x300dpi)
	Color	FB: 48 mm/s (300x300dpi), 12mm/s (600x600dpi) ADF/ARDF: 22 mm/s 4.5ipm (600x300dpi)
Network interface		Ethernet 10BASE-T/ 100BaseTX/ 1000BASE-T, Wireless LAN (IEEE802.11a,b,g,n,ac)
Scan depth		16bit color processing (input) 8bit color processing (output)
Interface		USB2.0, Ethernet (10Base-T, 100Base-TX) , Wireless LAN (IEEE802.11a,b,g,n,ac)
File format		Color/gray scale: PDF (Default)/ JPEG B&W: PDF/ TIFF (Default)
Scanner utilities & Drivers		TWAIN, WIA Driver



**1.1.6 FAX (ONLY FOR FAX MODELS)**

Item	Description
Compatibility	ITU-T G3
SAF memory size	4MB (Approx. 320 pages)
Network	PSTN, PBX
Resolution	Standard: 200dpi x 100dpi (8 dot/mm x 3.85 line/mm) Fine/Photo: 200dpi x 200dpi (8 dot/mm x 7.7 line/mm)
Transmission speed	G3: Approx.2 seconds (200x100 dpi, JBIG, ITUT #1 chart TTI off, memory transmission) G3: Approx.3 seconds (200x100dpi, MMR, ITUT #1 chart, TTI off, memory transmission)
Compression method	MH, MR, MMR
Modem speed	Automatic Fallback: 33600, 31200, 28800, 26400, 24000, 21600, 19200, 16800, 14400, 12000, 9600, 7200, 4800, 2400bps
Quick dial	8 locations
Speed dial	100 locations

## 1.1.7 OPTION

### ***Paper Feed Unit***

Item		Description
Paper Tray	Paper Size	A4 SEF, A5 SEF, B5 SEF, 8 1/2"x14" (LG) SEF, 8 1/2"x13" (Foolscap) SEF, 8 1/2"x11" (LT) SEF, 8 1/4"x14" (Government LG) SEF, 8 1/4"x13" (Folio) SEF, 8"x13" (F/GL) SEF, 8"x10" (Eng Quatro) SEF, 7 1/4"x10 1/2" (Executive) SEF, 5 1/2"x8 1/2" (HLT) SEF, 16K SEF, 8 1/2"x13 2/5" SEF
	Paper type	Plain 1 (64-74g/m <sup>2</sup> ), Plain 2 (75-90g/m <sup>2</sup> ), Middle Thick (91-105g/m <sup>2</sup> ), Thick 1 (106-120g/m <sup>2</sup> ), Recycled Paper, Colored Paper, Special Paper 1 to 3, Letterhead, Pre-printed Paper
	Paper Weight	60 to 105 g/m <sup>2</sup> (16 to 28 lb.)
	Paper capacity	250 sheets x 1 tray
	Dimensions (W x D x H)	370 x 392 x 89 mm (14.6 x 15.4 x 3.5 inches)
	Weight	Less than 3 kg (6.6 lb.)

## 1.2 SUPPORTED PAPER SIZES

Paper	SEF/LEF	Size	Standard Tray (Tray 1)	Optional Tray (Tray 2)	By-pass Tray	Duplex
A4	SEF	210 x 297 mm	C	C	D	E
	LEF	297 x 210 mm	N	N	N	N
B5	SEF	182 x 257 mm	C	C	D	N
	LEF	257 x 182 mm	N	N	N	N
A5	SEF	148 x 210 mm	C	C	D	N
	LEF	210 x 148 mm	C	N	D	N
B6	SEF	128 x 182 mm	C	N	D	N
	LEF	182 x 128 mm	N	N	N	N
A6	SEF	105 x 148 mm	D	N	D	N
	LEF	148 x 105 mm	N	N	N	N
LG	SEF	8.5" x 14"	C	C	D	E
Indian LG	SEF	8.5" x 13.6"	D	D	D	E
Foolscap	SEF	8.5" x 13"	D	D	D	E
Australian Foolscap	SEF	8.11" x 13.3"	D	D	D	E
LT	SEF	8.5" x 11"	C	C	D	E
Government LG	SEF	8.25" x 14"	D	D	N	N
Folio	SEF	8.25" x 13"	D	D	N	E

Paper	SEF/LEF	Size	Standard Tray (Tray 1)	Optional Tray (Tray 2)	By-pass Tray	Duplex
Mexican Oficio	SEF	8.25" x 13.4"	C	C	D	E
F/GL	SEF	8" x 13"	D	D	N	E
Eng Quatro	SEF	8" x 10"	D	D	D	N
Executive	SEF	7.25" x 10.5"	C	C	D	N
HLT	SEF	5.5" x 8.5"	D	D	D	N
8K	SEF	267 x 390 mm	N	N	N	N
16K	SEF	195 x 267 mm	D	D	D	N
Com10	SEF	4.125" x 9.5"	N	N	D	N
Monarch	SEF	3.875" x 7.5"	N	N	D	N
C5	SEF	162 x 229 mm	N	N	D	N
C6	SEF	114 x 162 mm	N	N	D	N
Custom	-	Width	100 - 216 mm (3.94"-8.5")	N	90 - 216 mm (3.54"-8.5")	N
	-	Length	148 - 356 mm (5.83"-14.02")	N	140 - 356 mm (5.51"-14.02")	N

## Supported Paper Sizes

### Remarks: Standard Tray, Optional Tray

C	Supported and the size is molded in the tray. Need to set the paper size dial to the paper size on the tray and select the paper size by driver.
D	Supported but the cut size is not molded in the tray. Need to set the paper size dial to "*" on the tray and select the paper size by operation panel and driver.
N	Not supported.

### Remarks: By-pass Tray

D	Supported. Need to select the Bypass Tray and the paper size on operation panel and driver.
N	Not supported.

### Remarks: Duplex

E	Supported.
N	Not supported.

# SETTING FOR PAAS (ONLY FOR CHINA)

REVISION HISTORY		
Page	Date	Added/Updated/New
		None

## 2. SETTING FOR PAAS (ONLY FOR CHINA)

PaaS (Printer as a service) is a system that ensures device uptime is maximized through real time monitoring of machine status and proactive handling of maintenance requirements.

### 2.1 PAAS SETUP PROCEDURE

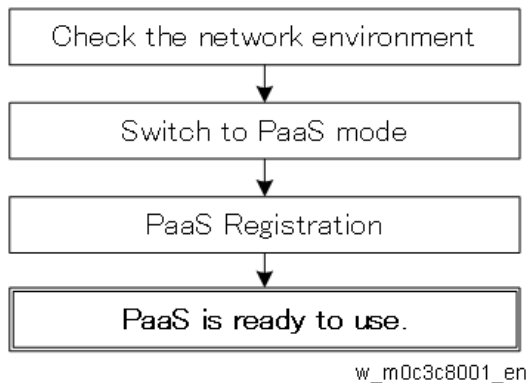

#### Preparation

The customer Contract ID and the customer authentication key are required for authentication.

#### 2.1.1 CHECK THE NETWORK ENVIRONMENT

1. Specify the network settings (IP address, Subnet mask, Gateway, and DNS) in the following menu:

Open **User Tools > Network Settings > IPv4 Configuration**, specify the IP address, Subnet, Gateway, DHCP, and DNS settings according to the customer's network environment.

#### 2.1.2 SWITCH TO PAAS MODE

1. Enter the "Maintenance mode (SP menu)".

#### Note

For information on how to enter the "Maintenance Mode (SP mode)", contact the supervisor in your branch office.

2. Set the "PaaS Validity Setting" to active.

**Four-line LCD panel:** SP menu > [CTL Maintenance] > [PaaS Validity Setting]

**Touch panel:** SP menu > [CTL SP] > [PaaS Validity Setting]

## 2.1.3 PAAS REGISTRATION

**Note**

Make sure the machine's main power is always turned on and connected to the internet during registration.

1. Launch the web browser.
2. In the web browser's address bar, enter http://(machine's IP address)/ to access the machine.
3. On the Web Image Monitor menu, select NPB Settings.



m0c3c8003

4. Check that [Operation] is set to "Contract Registration".

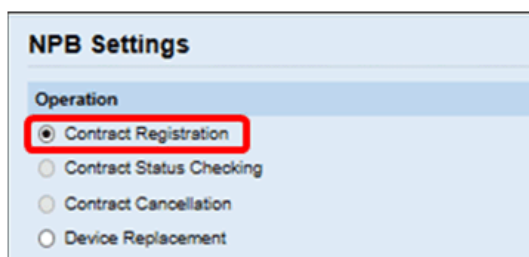

m0c3c8004

**Operation List:**

Item	Description
Contract Registration	Select this to enter the ID and Authentication Key after registration.
Contract Status Checking	Select this if the machine stops operating. The machine asks the server about the registration status.
Contract Cancellation	Select this to cancel the registration.
Device Replacement	Select this to replace the machine being used.



5. Check and enter [Contract ID], [Authentication Key], and [NPB URL].

The screenshot shows a 'Registration Configurations' form with the following fields and values:

- Contract ID: aaaaaa
- Device ID: 36157523004
- Authentication Key: 12345abc
- Data Upload Time: Hour: 00, Minute: 00
- NPB URL: rpaasdev.online.tj.cn

m0c3c8005

**Registration Configurations List:**

Item	Description
Contract ID	Enter the customer Contract ID.
Authentication Key	Enter the customer Authentication Key.
NPB URL	China: rpaasdev.online.tj.cn If no NPB URL is specified, enter the PaaS URL above.

6. If using a proxy server, enter the proxy information.

The screenshot shows a 'Proxy Function' form with the following fields and values:

- Enable Proxy Function:
- Proxy URL: [Empty field]
- Proxy Port: 0
- Authorization: None
- User Name: [Empty field]
- Password: [Masked field]

m0c3c8006

**Proxy Function List:**

Item	Description
Enable Proxy Function	Check this box to enable the proxy server.
Proxy URL	Set the proxy server address. The characters that can be input are: 0-9, A-Z, a-z.
Proxy Port Number	Enter the proxy server port number. The range is 1-65535.
Authorization	The authorization method of linking to the proxy server. The options are: -None -Basic

Item	Description
	<p>-Digest</p> <p>The default value is "None".</p> <p>When "Basic" or "Digest" is selected, the User Name and Password can be edited and should not be left blank.</p> <p>When "None" is selected, the User Name and Password are read only.</p>
User Name	<p>The account connecting to the proxy server.</p> <p>Use ASCII characters only. The max. length is 32.</p>
Password	<p>The password for the user name connecting to the proxy server.</p> <p>Use ASCII characters only. The max. length is 32.</p>

7. After entering the information, click [OK].
8. If the message "Operation Successful" appears, PaaS registration is complete. For other messages, check the following list table:

**PaaS Error Message List:**

Message	Description
Registration Configuration is not correct	The Contract ID or Authentication Key you have entered is either wrong or already being used. Check that the Contract ID and Authentication Key are correct.
Operation failed, please contact service center (Code: xxx)	Contact the service center.

## 2.2 UNREGISTERING PAAS

### ★ Important

To unregister, it is necessary to follow the cancellation procedure on the PaaS server side in advance.

1. Launch the web browser.
2. In the web browser's address bar, enter `http://(machine's IP address)/` to access the machine.
3. On the Web Image Monitor menu, select NPB Settings.



m0c3c8003

4. Check that Operation is set to "Contract Cancellation".

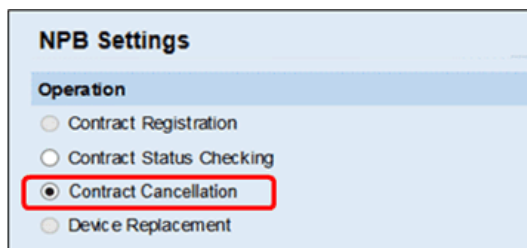

m0c3c8007

5. Click [OK].
6. If the message "Operation Successful" appears, PaaS unregistration is complete.
7. Set the [PaaS Validity Setting] to inactive.

**Four-line LCD panel:** SP menu > [CTL Maintenance] > [PaaS Validity Setting]

**Touch panel:** SP menu > [CTL SP] > [PaaS Validity Setting]

## 2.3 CHANGING REGISTERED DEVICE/ MAIN BOARD

To change the PaaS registered device or if the main board has been replaced, follow the procedure below on the new device.

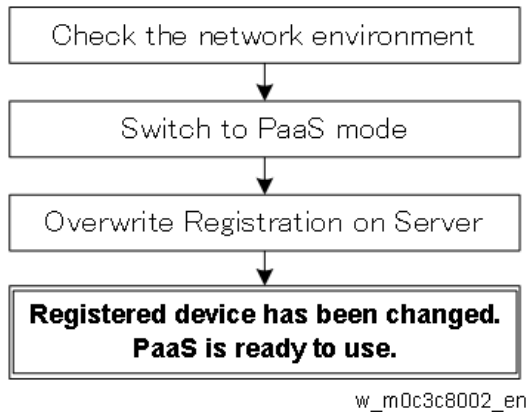

### Preparation

The existing customer Contract ID and customer authentication key are required for authentication.

**Note:** It is not necessary to obtain a new contract ID and authentication key to change a registered device or main board.

### 2.3.1 CHECK THE NETWORK ENVIRONMENT

1. Specify the network settings (IP address, Subnet mask, Gateway, and DNS) in the following menu:

Open **User Tools > Network Settings > IPv4 Configuration**, specify the IP address, Subnet, Gateway, DHCP, and DNS settings according to the customer's network environment.

### 2.3.2 SWITCH TO PAAS MODE

1. Enter the "Maintenance mode (SP menu)".

**Note**

For information on how to enter the "Maintenance Mode (SP mode)", contact the supervisor in your branch office.

2. Set the "PaaS Validity Setting" to active.

**Four-line LCD panel:** SP menu > [CTL Maintenance] > [PaaS Validity Setting]

**Touch panel:** SP menu > [CTL SP] > [PaaS Validity Setting]

### 2.3.3 OVERWRITE REGISTRATION ON SERVER

**Note**

Make sure the machine's main power is always turned on and connected to the internet during registration.

1. Launch the web browser.
2. In the web browser's address bar, enter http://(machine's IP address)/ to access the machine.
3. On the Web Image Monitor menu, select NPB Settings.



m0c3c8003

4. Check that [Operation] is set to "Device Replacement".

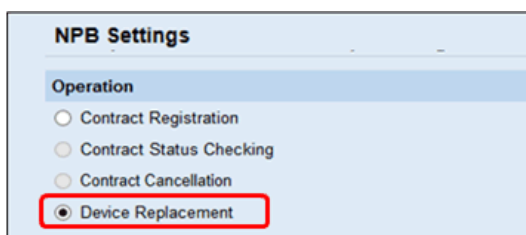

m0c3c8008

**Operation List:**

Item	Description
Contract Registration	Select this to enter the ID and Authentication Key after registration.
Contract Status Checking	Select this if the machine stops operating. The machine asks the server about the registration status.
Contract Cancellation	Select this to cancel the registration.
Device Replacement	Select this to replace the machine being used.

5. Check and enter [Contract ID], [Authentication Key], and [NPB URL].

The screenshot shows a 'Registration Configurations' form with the following fields and values:

- Contract ID: aaaaaa
- Device ID: 35157529004
- Authentication Key: 12345abc
- Data Upload Time: Hour: 00, Minute: 00
- NPB URL: rpaasdev.online.tj.cn

m0c3c8005

**Registration Configurations List:**

Item	Description
Contract ID	Enter the customer Contract ID.
Authentication Key	Enter the customer Authentication Key.
NPB URL	China: rpaasdev.online.tj.cn If no NPB URL is specified, enter the PaaS URL above.

6. If using a proxy server, enter the proxy information.

The screenshot shows a 'Proxy Function' form with the following fields and values:

- Enable Proxy Function:
- Proxy URL: [Empty field]
- Proxy Port: 0
- Authorization: None
- User Name: [Empty field]
- Password: [Masked field]

m0c3c8006

**Proxy Function List:**

Item	Description
Enable Proxy Function	Check this box to enable the proxy server.
Proxy URL	Set the proxy server address. The characters that can be input are: 0-9, A-Z, a-z.
Proxy Port Number	Enter the proxy server port number. The range is 1-65535.
Authorization	The authorization method of linking to the proxy server. The options are: -None -Basic -Digest The default value is "None". When "Basic" or "Digest" is selected, the User Name and Password can be edited and should not be left blank. When "None" is selected, the User Name and Password are read only.
User Name	The account connecting to the proxy server. Use ASCII characters only. The max. length is 32.
Password	The password for the user name connecting to the proxy server. Use ASCII characters only. The max. length is 32.

7. After entering the information, click [OK].
8. If the message "Operation Successful" appears, PaaS registration is complete. For other messages, check the following list table:

**PaaS Error Message List:**

Message	Description
Registration Configuration is not correct	The Contract ID or Authentication Key you have entered is either wrong or already being used. Check that the Contract ID and Authentication Key are correct.
Operation failed, please contact service center (Code: xxx)	Contact the service center.



## 2.4 TECHNICAL TIPS

- Only execute the “Factory Default” when it is necessary. If the machine is reset by the Factory Default operation, the PaaS settings will be reset and deleted.  
In the event that the Factory Default is executed, set the PaaS again through the procedure in "[Overwrite Registration on Server](#)".
- Unless PaaS registration is completed by the PaaS platform server, and the message “Operation Successful” appears on the Web Image Monitor, Print/Fax/Scan/Copy can only use up to 100 pages, and if over 100 pages are used, the applications will become unusable.  
However, if just one job containing more than 100 pages is performed, the job will be completed.
- Never change the PaaS Validity Setting to inactive without unregistering PaaS. For the unregistration process, refer to "[Unregistering PaaS](#)".

# M534

## PAPER FEED UNIT PB1130

REVISION HISTORY		
Page	Date	Added/Updated/New
		None

# PAPER FEED UNIT PB1130 (M534)

## TABLE OF CONTENTS

<b>1. REPLACEMENT AND ADJUSTMENT .....</b>	<b>1</b>
1.1 EXTERNAL COVERS AND PAPER FEED UNIT .....	1
1.1.1 REAR COVER.....	1
1.1.2 RIGHT COVER.....	1
1.1.3 PAPER FEED UNIT.....	2
1.2 PAPER FEED ROLLER .....	3
1.2.1 REMOVE THE PAPER FEED ROLLER .....	3
1.2.2 REINSTALL THE PAPER FEED ROLLER.....	4
1.3 FRICTION PAD .....	5
1.4 PAPER FEED MOTOR AND GEARS.....	6
1.4.1 PAPER FEED MOTOR.....	6
1.4.2 PAPER FEED GEARS .....	7
1.5 PAPER TRAY BOARD .....	8
1.6 PAPER TRAY UNIT SET SWITCH .....	9
1.7 SENSORS.....	10
1.7.1 PAPER FEED SENSOR.....	10
1.7.2 PAPER END SENSOR.....	10

# READ THIS FIRST

## Safety and Symbols











### Replacement Procedure Safety

#### CAUTION

- Turn off the main power switch and unplug the machine before beginning any of the procedures in this manual.

### Symbols

This manual uses the following symbols.

Symbol	What it means
	Bushings
	C-ring
	Connector
	Clamp
	E-ring
	Harness clamp
	Pointer
	Screw
	Standoff
	Hook
	Spring

# 1. REPLACEMENT AND ADJUSTMENT

## 1.1 EXTERNAL COVERS AND PAPER FEED UNIT

### ⚠ CAUTION

- Turn off the main power switch and unplug the machine before attempting any procedure in this section.

### 1.1.1 REAR COVER

1. Remove the paper tray unit from the main unit.
2. Pull out the paper tray.
3. Remove the rear cover [A] (🔩 x2).

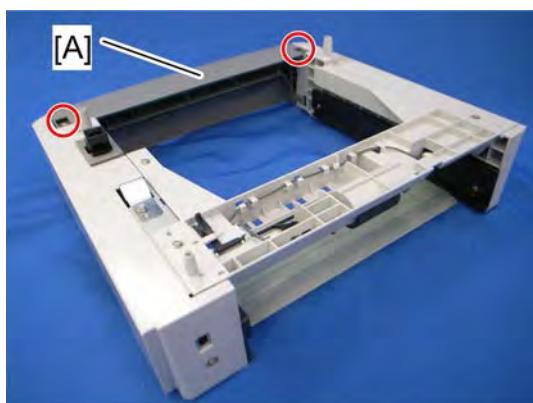

m355r500

### 1.1.2 RIGHT COVER

1. Remove the rear cover (*Rear Cover*).
2. Remove the right cover [A] (🔩 x2).

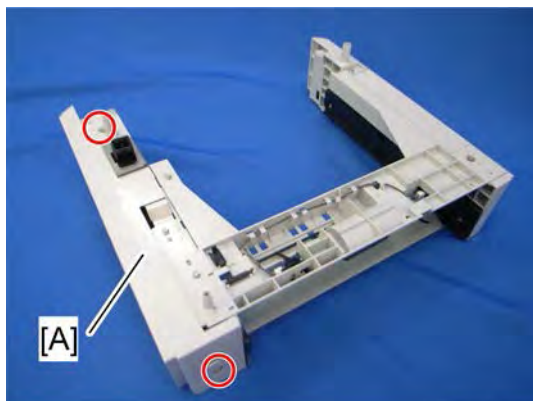

m355r501

### 1.1.3 PAPER FEED UNIT

1. Remove the right cover (*Right Cover*).
2. Remove the paper feed motor bracket (*Paper Feed Gears*).
3. Remove the paper feed roller shaft gear [A] (C-ring x1).

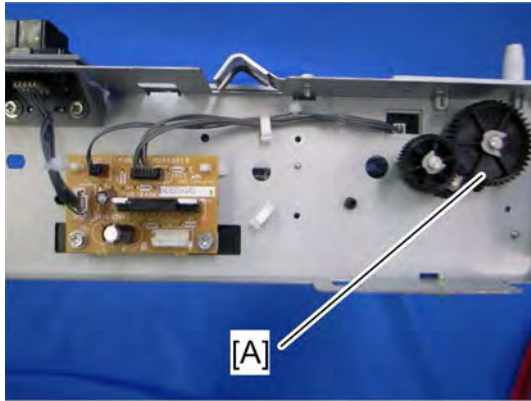

m355r502

4. Release paper feed roller shaft [A] (C-ring x1, bushing x1).

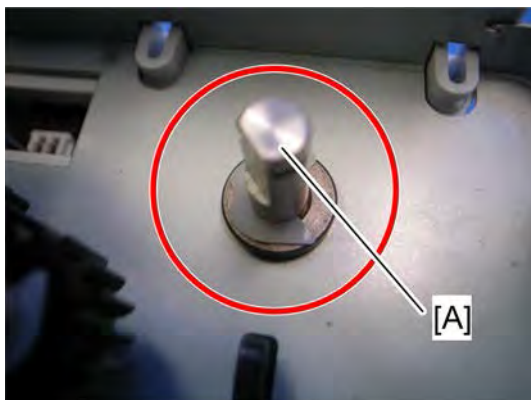

m355r503

5. Remove the paper feed unit [A] (⚙️ x4).

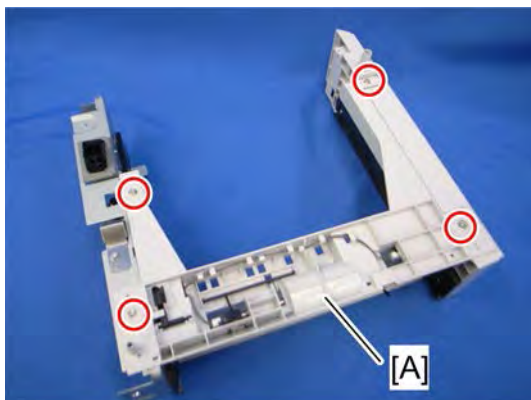

m355r505

## 1.2 PAPER FEED ROLLER

### 1.2.1 REMOVE THE PAPER FEED ROLLER

1. Remove the right cover (*Right Cover*).
2. Remove a C-ring [A] and a bushing [B].

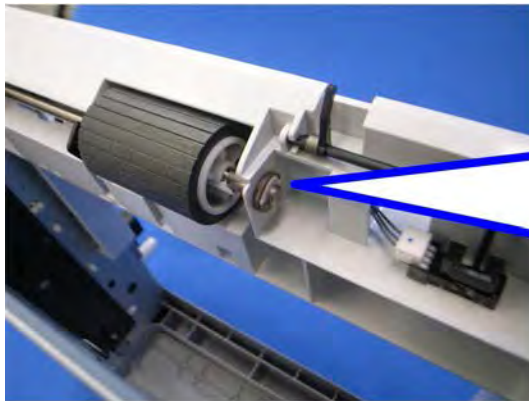

m355r510

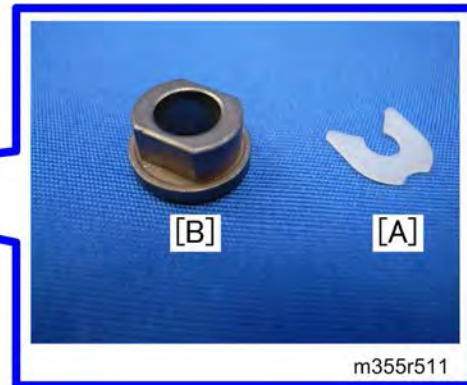

m355r511

3. Release the paper feed roller shaft [A].

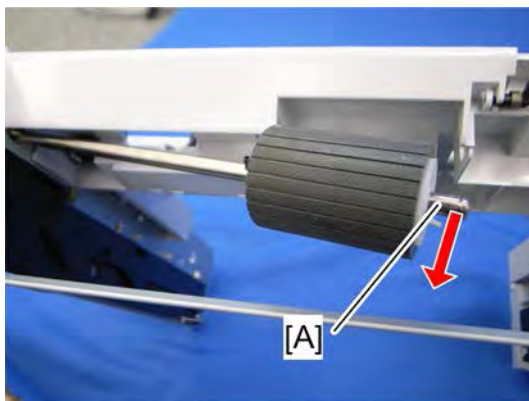

m355r512

4. Release the hook [A] and then move the paper feed roller [B] to the right.

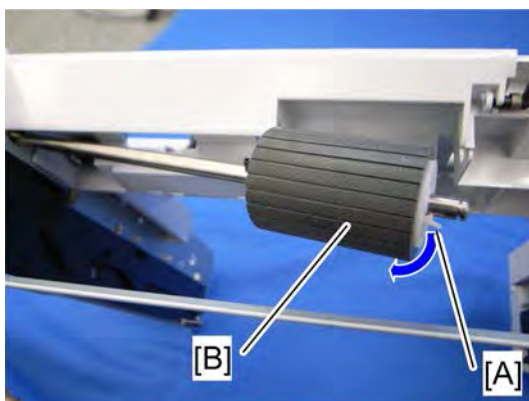

m355r513

## 1.2.2 REINSTALL THE PAPER FEED ROLLER

1. Attach the paper feed roller to the paper feed roller shaft.
2. Reinstall the paper feed roller shaft correctly.

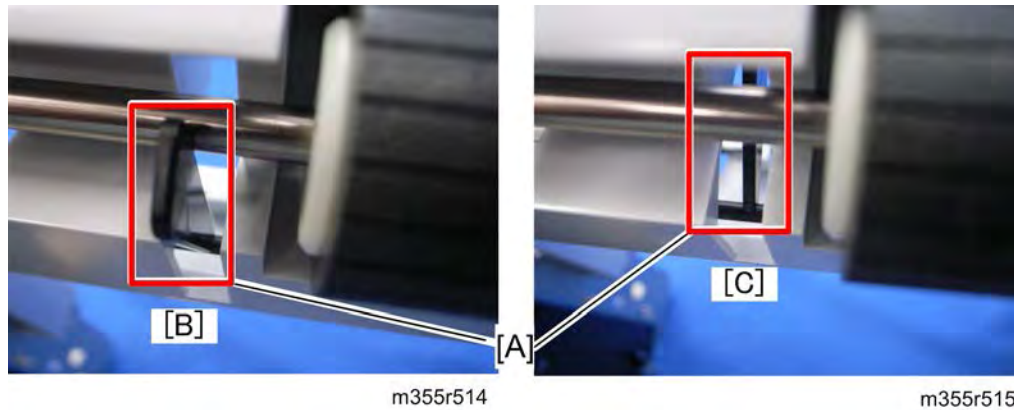

### ↓ Note

- As shown in the above pictures, the paper feed roller shaft must be installed behind the feeler [A]. The left picture [B] is correct. The right picture [C] is incorrect.

3. Close the right cover first, and then close the rear cover.



## 1.3 FRICTION PAD

1. Pull out the paper tray.
2. Turn the paper feed unit over, and release two hooks [A].
3. Turn the unit over again and remove the friction pad [B].

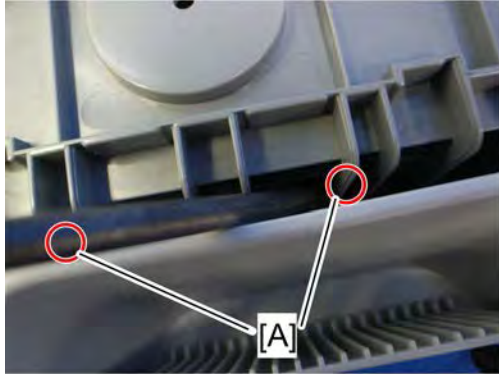

m355r516

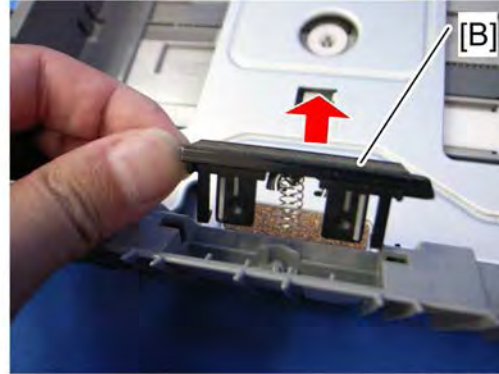

m355r517

## 1.4 PAPER FEED MOTOR AND GEARS

### 1.4.1 PAPER FEED MOTOR

1. Remove the right cover (*Right Cover*).
2. Remove the paper feed motor [A] (🔩 x2, 🛠️ x1, 📦 x1).

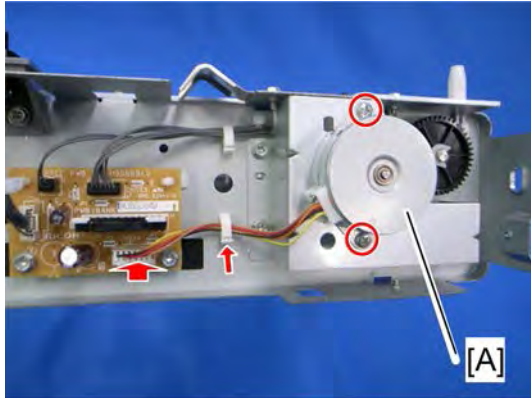

m355r520

## 1.4.2 PAPER FEED GEARS

1. Remove the right cover (*Right Cover*).
2. Remove the paper feed motor bracket [A] (🔩 x3, 🛠️ x1, 📦 x1).

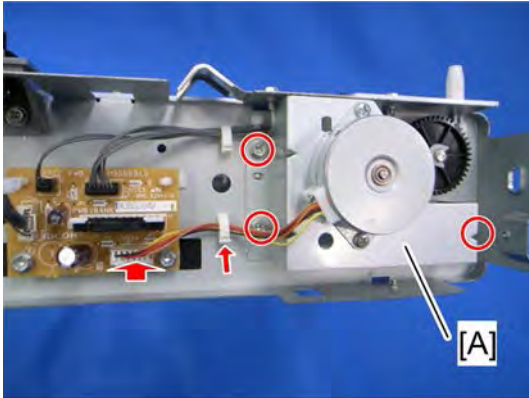

m355r521

3. Remove the paper feed gears [A] (each C-ring x1).

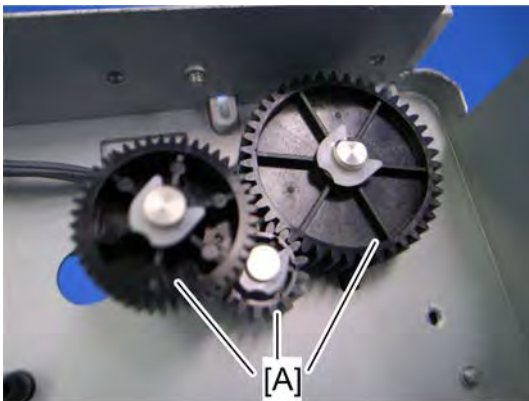

m355r522

## 1.5 PAPER TRAY BOARD

1. Remove the right cover (*Right Cover*).
2. Remove the paper tray board (🔩 x2, locking support x2, 📦 x 4).

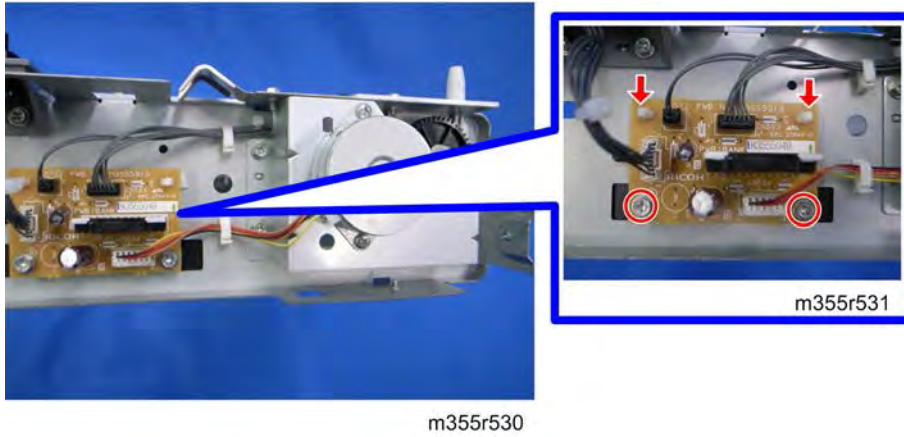

## 1.6 PAPER TRAY UNIT SET SWITCH

1. Remove the paper feed unit (*Paper Feed Unit*).
2. Remove the feeler [A].

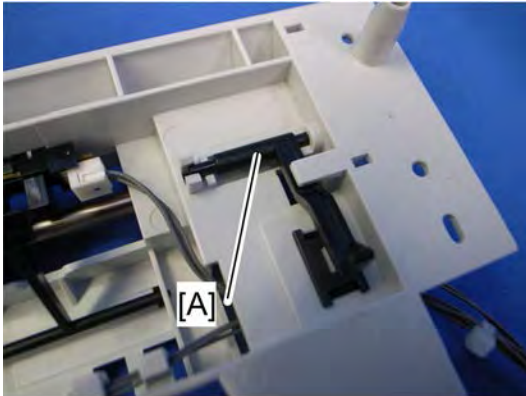

m355r540

3. Remove the paper tray unit set switch [A] (hook x2).

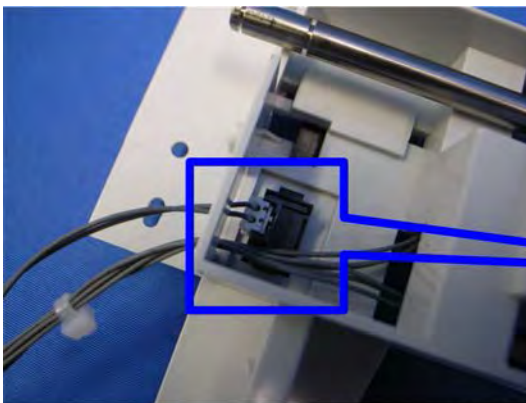

m355r541

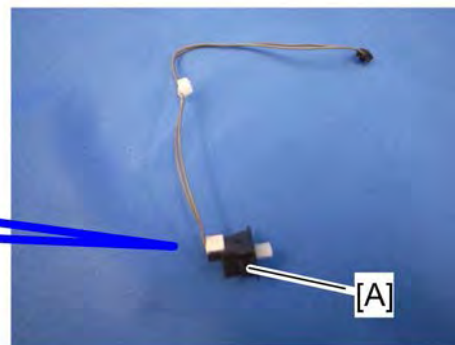

m355r542

## 1.7 SENSORS

### 1.7.1 PAPER FEED SENSOR

1. Remove the right cover (*Right Cover*).
2. Release the actuator [A] from the slot of the paper feed sensor [B].
3. Remove the paper feed sensor [B] (all hooks,  x1).

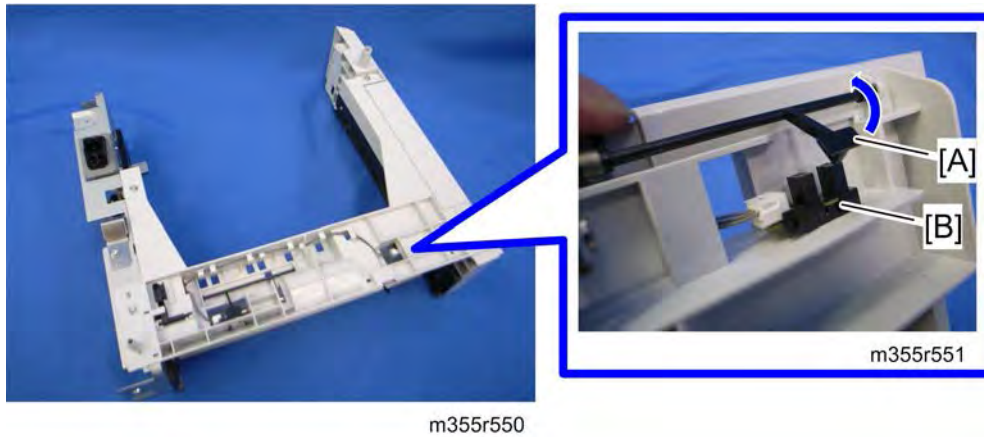

### 1.7.2 PAPER END SENSOR

1. Remove the right cover (*Right Cover*).
2. Release the actuator [A] from the slot of the paper exit sensor [B].
3. Remove the paper end sensor [B] (all hooks,  x1).

